ABB INDUSTRIAL DRIVES

ACS880-31 drives

Hardware manual



ACS880-31 drives

Hardware manual

Table of contents



1. Safety instructions



4. Mechanical installation



6. Electrical installation – IEC



7. Electrical installation – North America (NEC)



10. Start-up



Table of contents

1 Safety instructions

Contents of this chapter	15
Use of warnings and notes	15
General safety in installation, start-up and maintenance	16
General safety in operation	18
Electrical safety in installation, start-up and maintenance	19
Electrical safety precautions	19
Additional instructions and notes	20
Printed circuit boards	20
Grounding	21
Additional instructions for permanent magnet motor drives	21
Safety in installation, start-up, maintenance	21
Safety in operation	22

2 Introduction to the manual

Contents of this chapter	23
Target audience	23
Categorization by frame size and option code	23
Quick installation, commissioning and operation flowchart	23
Terms and abbreviations	25
Related documents	26

3 Operation principle and hardware description

Contents of this chapter	29
Operation principle	30
DC voltage boost function	30
DC connection	31
Layout	32
Overview of power and control connections	34
Control panel	35
Control panel door mounting kits	36
Control panel mounting platform cover	36
Control of several drives	36
Type designation label	37
Type designation key	37
Basic code	38
Option codes	38



4 Mechanical installation

Contents of this chapter 41
 Cabinet installation (options +P940 and +P944) 41
 Flange mounting (option +C135) 41
 Safety 42
 Examining the installation site 42
 Installation orientations 42
 Required tools 44
 Moving the drive 45
 Unpacking and examining delivery 45
 Installing the drive vertically 51
 Installing the drive vertically side by side 53
 Installing the drive horizontally 53

5 Guidelines for planning the electrical installation

Contents of this chapter 55
 Limitation of liability 55
 Selecting the main supply disconnecting device 55
 European Union and United Kingdom 56
 North America 56
 Other regions 56
 Selecting the main contactor 56
 North America 56
 Other regions 56
 Examining the compatibility of the motor and drive 57
 Protecting the motor insulation and bearings 57
 Requirements table 57
 Availability of du/dt filter and common mode filter by drive type 60
 Additional requirements for explosion-safe (EX) motors 60
 Additional requirements for ABB motors of types other than M2_,
 M3_, M4_, HX_ and AM_ 60
 Additional requirements for braking applications 60
 Additional requirements for the regenerative and low harmonics
 drives 60
 Additional requirements for ABB high-output and IP23 motors 60
 Additional requirements for non-ABB high-output and IP23 motors .. 61
 Additional data for calculating the rise time and the peak line-to-line
 voltage 62
 Additional note for sine filters 64
 Selecting the power cables 64
 General guidelines 64
 Typical power cable sizes 64
 Power cable types 65
 Preferred power cable types 65



Alternate power cable types	66
Not allowed power cable types	67
Additional guidelines, North America	68
Metal conduit	68
Power cable shield	69
Selecting the control cables	69
Shielding	69
Signals in separate cables	70
Signals that can be run in the same cable	70
Relay cable	70
Control panel to drive cable	70
PC tool cable	70
Routing the cables	70
General guidelines – IEC	70
General guidelines – North America	71
Continuous motor cable shield/conduit or enclosure for equipment on the motor cable	72
Separate control cable ducts	73
DC voltage boost function	73
Protecting the drive, input power cable, motor and motor cable in short circuit situations and against thermal overload	73
Protecting the drive and the input power cable in short-circuits	73
Circuit breakers	74
Protecting the motor and motor cable in short-circuits	74
Protecting the motor cables against thermal overload	74
Protecting the motor against thermal overload	75
Protecting the motor against overload without thermal model or temperature sensors	75
Implementing a motor temperature sensor connection	76
Connecting motor temperature sensor to the drive via an option module	77
Protecting the drive against ground faults	77
Residual current device compatibility	77
Implementing the emergency stop function	78
Implementing the Safe torque off function	78
Implementing the power loss ride-through function	78
Implementing the functions provided by the FSO-xx safety functions module	79
Using power factor compensation capacitors with the drive	79
Using a safety switch between the drive and the motor	80
Implementing an ATEX-certified motor thermal protection	80
Controlling a contactor between drive and motor	80
Implementing a bypass connection	81
Protecting the contacts of relay outputs	81
6 Electrical installation – IEC	
Contents of this chapter	83



Safety	83
Required tools	83
Grounding the motor cable shield at the motor end	83
Measuring the insulation	84
Measuring the insulation resistance of the drive	84
Measuring the insulation resistance of the input power cable	84
Measuring the insulation resistance of the motor and motor cable	84
Measuring the insulation resistance of the brake resistor circuit	85
Grounding system compatibility check	85
EMC filter option +E200 or +E202	85
Ground-to-phase varistors	86
Corner-grounded and midpoint-grounded 525...690 V delta systems	86
When to disconnect EMC filter (options +E200 and +E202) or ground-to-phase varistor: TN-S, IT, corner-grounded delta and midpoint-grounded delta systems and TT systems	86
Identifying the grounding system of the electrical power network	89
Disconnecting integrated EMC filter (option +E200 or +E202) and ground-to-phase varistor – frame R3	90
Disconnecting integrated EMC filter (option +E200 or +E202) and ground-to-phase varistor – frame R6	91
Disconnecting integrated EMC filter and ground-to-phase varistor – frame R8	92
Connecting the power cables	93
Connection diagram	93
Connection procedure	94
R8 power cable connection if you detach the cable connectors	101
Connecting the control cables	102
Connection diagram	102
Connection procedure	102
Installing option modules	106
Mechanical installation of option modules	106
Wiring option modules	107
Installation of safety functions modules	107
Installation procedure into Slot 2	107
Installation next to the control unit on frames R6 and R8	108
Reinstalling cover(s)	110
Connecting a PC	111
Panel bus (Control of several units from one control panel)	111

7 Electrical installation – North America (NEC)

Contents of this chapter	115
Safety	115
Required tools	115
Required tools	115
Measuring the insulation	116



Grounding system compatibility check	116
Connecting the power cables	116
Connection diagram	116
Connection procedure	117
R8 power cable connection if you detach the connectors	125
Connecting the control cables	126
Connection diagram	126
Connection procedure	126
Installing option modules	129
Reinstalling cover(s)	129
Connecting a PC	130
Controlling several drives through the panel bus	130

8 Control units of the drive

Contents of this chapter	131
ZCU-12 layout	132
Default I/O diagram of the drive control unit (ZCU-1x)	133
Additional information on the connections	135
External power supply for the control unit (XPOW)	135
DI6 as a PTC sensor input	135
AI1 or AI2 as a Pt100, Pt1000, PTC or KTY84 sensor input	135
DIIL input	136
The XD2D connector	136
Safe torque off (XSTO)	137
FSO-xx safety functions module connection (X12)	137
Connector data	138
ZCU-1x ground isolation diagram	140

9 Installation checklist

Contents of this chapter	143
Checklist	143

10 Start-up

Contents of this chapter	147
Start-up procedure	147

11 Maintenance

Contents of this chapter	149
Maintenance intervals	149
Description of symbols	149
Recommended maintenance intervals after start-up	150
Cleaning the exterior of the drive	151
Cleaning the heatsink	151



Fans	152
Replacing the main cooling fan, frame R3	153
Replacing the main cooling fan, frame R6	154
Replacing the main cooling fan, frame R8	155
Replacing the auxiliary cooling fan, IP55 (UL Type 12) frame R3	156
Replacing the auxiliary cooling fans, frame R6	157
Replacing the internal auxiliary cooling fan, frame R8	158
Replacing the second internal auxiliary cooling fan, IP55 (UL Type 12) frame R8	159
Replacing the auxiliary cooling fan in the IP55 (UL Type 12) cover, frame R8	160
Capacitors	162
Reforming the capacitors	162
Control panel	162
Drive LEDs	162
Control unit	163
Replacing the memory unit of ZCU-12	163
Replacing the ZCU-12 control unit battery	164
Replacing safety functions modules (FSO-12, option +Q973 and FSO-21, option +Q972)	165
Functional safety components	166

12 Technical data

Contents of this chapter	167
Ratings	167
Deratings	170
Surrounding air temperature derating	170
Altitude derating	172
Deratings for special settings in the drive control program	173
Derating for output voltage boost	177
Fuses (IEC)	178
aR fuses DIN 43653 stud-mount	178
aR fuses DIN 43620 blade style	179
gG fuses DIN 43620 blade style	180
Quick guide for selecting between gG and aR fuses	181
Calculating the short-circuit current of the installation	182
Calculation example	182
Fuses (UL)	183
Circuit breakers (IEC)	184
Circuit breakers (UL)	185
ABB inverse time circuit breakers	185
.....	185
Dimensions, weights and free space requirements	186
Free space requirements	188
Package dimensions	188



Losses, cooling data and noise	189
IEC	189
UL (NEC)	190
Cooling air flow and heat dissipation for flange mounting (option +C135)	190
Terminal and entry data for the power cables	191
UL listed cable lugs and tools	192
Terminal and entry data for the control cables	193
IEC	193
North America	194
Power cables	194
Electrical power network specification	196
Motor connection data	198
Control unit (ZCU-12) control unit connection data	198
Efficiency	198
Energy efficiency (ecodesign)	198
Protection classes for module	199
Materials	199
Applicable standards	200
Ambient conditions	200
Markings	202
Compliance with the EN 61800-3:204 + A1:2012	203
Definitions	203
Category C2	203
Category C3	204
Category C4	204
UL checklist	205
Declarations of conformity	206
Design lifetime expectancy	206
Disclaimers	207
Generic disclaimer	207
Cybersecurity disclaimer	207

13 Dimension drawings

Contents of this chapter	209
R3, IP21 (UL Type 1)	210
R3 – Option +B056 (IP55, UL Type 12)	211
R6, IP21 (UL Type 1)	212
R6 – Option +B056 (IP55, UL Type 12)	213
R8, IP21 (UL Type 1)	214
R8 – Option +B056 (IP55, UL Type 12)	215

14 The Safe torque off function

Contents of this chapter	217
--------------------------------	-----



Description	217
Compliance with the European Machinery Directive and the UK Supply of Machinery (Safety) Regulations	218
Wiring	219
Activation switch	219
Cable types and lengths	219
Grounding of protective shields	219
Single drive (internal power supply)	220
Multiple drives	221
Internal power supply	221
External power supply	222
Operation principle	223
Start-up including validation test	224
Competence	224
Validation test reports	224
Validation test procedure	224
Use	226
Maintenance	228
Competence	228
Fault tracing	229
Safety data	230
Terms and abbreviations	231
TÜV certificate	232
Declarations of conformity	233

15 Resistor braking

Contents of this chapter	235
Operation principle	235
Planning the braking system	235
Selecting the default brake system components	235
Selecting a custom brake resistor	236
Selecting and routing the brake resistor cables	237
Minimizing electromagnetic interference	237
Maximum cable length	237
Placing the brake resistors	238
Protecting the system against thermal overload	238
Protecting the system in fault situations	238
Protecting the resistor cable against short-circuits	239
Mechanical installation	239
Electrical installation	239
Measuring the installation	239
Connection diagram	240
Connection procedure	240
Start-up	240



Technical data	241
Ratings	241
Terminals and cable entry data	241

16 Common mode, du/dt and sine filters

Contents of this chapter	243
Common mode filters	243
du/dt filters	243
When is a du/dt filter needed?	243
du/dt filter types	244
Description, installation and technical data of the filters	244
Sine filters	244
Selecting a sine filter for the drive	244
Definitions	245
Derating	245
Description, installation and technical data	246

Further information



1

Safety instructions

Contents of this chapter

This chapter contains the safety instructions which you must obey when you install, start-up, operate and do maintenance work on the drive. If you ignore the safety instructions, injury, death or damage can occur.



Use of warnings and notes

Warnings tell you about conditions which can cause injury or death, or damage to the equipment. They also tell you how to prevent the danger. Notes draw attention to a particular condition or fact, or give information on a subject.

The manual uses these warning symbols:

**WARNING!**

Electricity warning tells about hazards from electricity which can cause injury or death, or damage to the equipment.

**WARNING!**

General warning tells about conditions other than those caused by electricity, which can cause injury or death, or damage to the equipment.

**WARNING!**

Electrostatic sensitive devices warning tells you about the risk of electrostatic discharge which can cause damage to the equipment.

General safety in installation, start-up and maintenance

These instructions are for all personnel who do work on the drive.



WARNING!

Obey these instructions. If you ignore them, injury or death, or damage to the equipment can occur.

- Keep the drive in its package until you install it. After unpacking, protect the drive from dust, debris and moisture.
- Use the required personal protective equipment: safety shoes with metal toe cap, safety glasses, protective gloves and long sleeves, etc. Some parts have sharp edges.
- Lift a heavy drive with a lifting device. Use the designated lifting points. See the dimension drawings.
- Be careful when handling a tall module. The module overturns easily because it is heavy and has a high center of gravity. Whenever possible, secure the module with chains. Do not leave an unsupported module unattended especially on a sloping floor.



- Beware of hot surfaces. Some parts, such as heatsinks of power semiconductors, and brake resistors, remain hot for a while after disconnection of the electrical supply.
 - Vacuum clean the area around the drive before the start-up to prevent the drive cooling fan from drawing the dust inside the drive.
 - Make sure that debris from drilling, cutting and grinding does not enter the drive during the installation. Electrically conductive debris inside the drive may cause damage or malfunction.
 - Make sure that there is sufficient cooling. See the technical data.
 - Before you connect voltage to the drive, make sure that all covers are in place. Do not remove the covers when voltage is connected.
 - Before you adjust the drive operation limits, make sure that the motor and all driven equipment can operate throughout the set operation limits.
-

- Before you activate the automatic fault reset or automatic restart functions of the drive control program, make sure that no dangerous situations can occur. These functions reset the drive automatically and continue operation after a fault or supply break. If these functions are activated, the installation must be clearly marked as defined in IEC/EN/UL 61800-5-1, subclause 6.5.3, for example, "THIS MACHINE STARTS AUTOMATICALLY".
- The maximum drive power cycles is five times in ten minutes. Power cycling the drive too often can damage the charging circuit of the DC capacitors.
- If you have connected safety circuits to the drive (for example, Safe torque off or emergency stop), validate them at start-up. See separate instructions for the safety circuits.
- Beware of hot air exiting from the air outlets.
- Do not cover the air inlet or outlet when the drive is running.

Note:

- If you select an external source for the start command and it is on, the drive will start immediately after fault reset unless you configure the drive for pulse start. See the firmware manual.
- If the drive is in remote control mode, you cannot stop or start the drive with the control panel.
- Only authorized persons are allowed to repair a malfunctioning drive.



■ General safety in operation

These instructions are for all personnel that operate the drive.



WARNING!

Obey these instructions. If you ignore them, injury or death, or damage to the equipment can occur.

- If you have a cardiac pacemaker or other electronic medical device, keep away from the area near motor, drive, and the drive power cabling when the drive is in operation. There are electromagnetic fields present which can interfere with the function of such devices. This can cause a health hazard.
- Give a stop command to the drive before you reset a fault. If you have an external source for the start command and the start is on, the drive will start immediately after the fault reset, unless you configure the drive for pulse start. See the firmware manual.
- Before you activate the automatic fault reset or automatic restart functions of the drive control program, make sure that no dangerous situations can occur. These functions reset the drive automatically and continue operation after a fault or supply break. If these functions are activated, the installation must be clearly marked as defined in IEC/EN/UL 61800-5-1, subclause 6.5.3, for example, "THIS MACHINE STARTS AUTOMATICALLY".



Note:

- The maximum drive power cycles is five times in ten minutes. Power cycling the drive too often can damage the charging circuit of the DC capacitors. If you need to start or stop the drive, use the control panel keys or commands through the I/O terminals of the drive.
 - If the drive is in remote control mode, you cannot stop or start the drive with the control panel.
-

Electrical safety in installation, start-up and maintenance

■ Electrical safety precautions

These electrical safety precautions are for all personnel who do work on the drive, motor cable or motor.



WARNING!

Obey these instructions. If you ignore them, injury or death, or damage to the equipment can occur.

If you are not a qualified electrical professional, do not do installation or maintenance work.

Go through these steps before you begin any installation or maintenance work.

1. Clearly identify the work location and equipment.
2. Disconnect all possible voltage sources. Make sure that re-connection is not possible. Lock out and tag out.
 - Open the main disconnecting device of the drive.
 - If you have a permanent magnet motor connected to the drive, disconnect the motor from the drive with a safety switch or by other means.
 - Disconnect all dangerous external voltages from the control circuits.
 - After you disconnect power from the drive, always wait 5 minutes to let the intermediate circuit capacitors discharge before you continue.
3. Protect any other energized parts in the work location against contact.
4. Take special precautions when close to bare conductors.
5. Measure that the installation is de-energized. Use a quality voltage tester.
 - Before and after measuring the installation, verify the operation of the voltage tester on a known voltage source.
 - Make sure that the voltage between the drive input power terminals (L1, L2, L3) and the grounding (PE) busbar is zero.
 - Make sure that the voltage between the drive output terminals (T1/U, T2/V, T3/W) and the grounding (PE) busbar is zero.
 - Make sure that the voltage between the drive DC terminals (UDC+ and UDC-) and the grounding (PE) terminal is zero.

Note: If cables are not connected to the drive DC terminals, measuring the voltage from the DC terminal screws can give incorrect results.



6. Install temporary grounding as required by the local regulations.
7. Ask for a permit to work from the person in control of the electrical installation work.

■ **Additional instructions and notes**



WARNING!

Obey these instructions. If you ignore them, injury or death, or damage to the equipment can occur.

If you are not a qualified electrical professional, do not do installation or maintenance work.

- Make sure that the electrical power network, motor/generator, and environmental conditions agree with the drive data.
- Do not do insulation or voltage withstand tests on the drive.
- If you have a cardiac pacemaker or other electronic medical device, keep away from the area near motor, drive, and the drive power cabling when the drive is in operation. There are electromagnetic fields present which can interfere with the function of such devices. This can cause a health hazard.



Note:

- When the drive is connected to the input power, the motor cable terminals and the DC bus are at a dangerous voltage.
The brake circuit, including the brake chopper and brake resistor (if installed) are also at a dangerous voltage.
After disconnecting the drive from the input power, these remain at a dangerous voltage until the intermediate circuit capacitors have discharged.
- External wiring can supply dangerous voltages to the relay outputs of the control units of the drive.
- The Safe torque off function does not remove the voltage from the main and auxiliary circuits. The function is not effective against deliberate sabotage or misuse.

Printed circuit boards



WARNING!

Use a grounding wristband when you handle printed circuit boards. Do not touch the boards unnecessarily. The boards contain components sensitive to electrostatic discharge.

■ Grounding

These instructions are for all personnel who are responsible for the grounding of the drive.



WARNING!

Obey these instructions. If you ignore them, injury or death, or equipment malfunction can occur, and electromagnetic interference can increase.

If you are not a qualified electrical professional, do not do grounding work.

- Always ground the drive, the motor and adjoining equipment. This is necessary for the personnel safety.
- Make sure that the conductivity of the protective earth (PE) conductors is sufficient and that other requirements are met. See the electrical planning instructions of the drive. Obey the applicable national and local regulations.
- When using shielded cables, make a 360° grounding of the cable shields at the cable entries to reduce electromagnetic emission and interference.
- In a multiple-drive installation, connect each drive separately to the protective earth (PE) busbar of the power supply.

Additional instructions for permanent magnet motor drives



■ Safety in installation, start-up, maintenance

These are additional warnings concerning permanent magnet motor drives. The other safety instructions in this chapter are also valid.



WARNING!

Obey these instructions. If you ignore them, injury or death, or damage to the equipment can occur.

If you are not a qualified electrical professional, do not do installation or maintenance work.

- Do not do work on the drive when a rotating permanent magnet motor is connected to it. A rotating permanent magnet motor energizes the drive including its input and output power terminals.

Before installation, start-up and maintenance work on the drive:

- Stop the drive.
 - Disconnect the motor from the drive with a safety switch or by other means.
-

22 Safety instructions

- If you cannot disconnect the motor, make sure that the motor cannot rotate during work. Make sure that no other system, like hydraulic crawling drives, can rotate the motor directly or through any mechanical connection like felt, nip, rope, etc.
- Do the steps in section *Electrical safety precautions (page 19)*.
- Install temporary grounding to the drive output terminals (T1/U, T2/V, T3/W). Connect the output terminals together as well as to the PE.

During the start-up:

- Make sure that the motor cannot run overspeed, for example, driven by the load. Motor overspeed causes overvoltage that can damage or destroy the capacitors in the intermediate circuit of the drive.

■ Safety in operation



WARNING!

Make sure that the motor cannot run overspeed, for example, driven by the load. Motor overspeed causes overvoltage that can damage or destroy the capacitors in the intermediate circuit of the drive.



2

Introduction to the manual

Contents of this chapter

This chapter describes the intended audience and contents of the manual. It contains a flowchart of steps in examining the delivery, installing and commissioning the drive. The flowchart refers to chapters/sections in this manual and other manuals.

Target audience

This manual is intended for people who plan the installation, install, commission and do maintenance work on the drive, or create instructions for the end user of the drive concerning the installation and maintenance of the drive.

Read the manual before working on the drive. You are expected to know the fundamentals of electricity, wiring, electrical components and electrical schematic symbols.

Categorization by frame size and option code

The frame size identifies information which concerns only a certain frame size of the drive. The frame size is shown on the type designation label. All frame sizes are listed in the technical data.

The option code (A123) identifies information which concerns only a certain optional selection. The options included in the drive are listed on the type designation label.

Quick installation, commissioning and operation flowchart

Task	See
Identify the frame of your drive: R3, R6 or R8.	<i>Type designation label (page 37)</i>

Task

See

Plan the electrical installation and acquire the accessories needed (cables, fuses, etc.).
Check the ratings, required cooling air flow, input power connection, compatibility of the motor, motor connection, and other technical data.

Guidelines for planning the electrical installation (page 55)
Technical data (page 167)

Unpack and examine the drive.

Mechanical installation (page 41)

The standard drive can be installed to a symmetrically grounded TN-S system. If you install the drive to another system, you may need to disconnect the EMC filter and ground-to-phase varistor.

Grounding system compatibility check (page 85)

Install the drive on a wall.

Mechanical installation (page 41)

Route the cables.

Routing the cables (page 70)

Measure the insulation of the input cable and the motor and the motor cable.

Electrical installation – IEC (page 83)
or *Electrical installation – North America (NEC) (page 115)*

Connect the power cables.

Electrical installation – IEC (page 83)
or *Electrical installation – North America (NEC) (page 115)*

Connect the control cables.

Electrical installation – IEC (page 83)
or *Electrical installation – North America (NEC) (page 115)*

Check the installation.

Installation checklist (page 143)

Task

Commission the drive.

See

Firmware manual
Quick start-up guide for the drive

Terms and abbreviations

Term	Description
ACS-AP-I	Industrial assistant non-Bluetooth control panel
ACS-AP-W	Industrial assistant control panel with Bluetooth interface
Brake chopper	Conducts the surplus energy from the intermediate circuit of the drive to the brake resistor when necessary. The chopper operates when the DC link voltage exceeds a certain maximum limit. The voltage rise is typically caused by deceleration (braking) of a high inertia motor.
Brake resistor	Dissipates the drive surplus braking energy conducted by the brake chopper to heat
Capacitor bank	The capacitors connected to the DC link
Control unit	The part in which the control program runs.
DC link	DC circuit between rectifier and inverter
DC link capacitors	Energy storage which stabilizes the intermediate circuit DC voltage
DPMP	Optional mounting platform for door mounting of control panel
DPMP-01	Mounting platform for control panel (flush mounting)
DPMP-02, DPMP-03	Mounting platform for control panel (surface mounting)
Drive	Frequency converter for controlling AC motors
EFB	Embedded fieldbus
EMC	Electromagnetic compatibility
FAIO-01	Analog I/O extension module
FCAN	Optional CANopen® adapter module
FCNA-01	Optional ControlNet™ adapter module
FDIO-01	Optional digital I/O extension module
FECA-01	Optional EtherCAT® adapter module
FENA-21	Optional Ethernet adapter module for EtherNet/IP™, Modbus TCP® and PROFINET IO® protocols, 2-port
FEPL-02	Optional Ethernet POWERLINK adapter module
FIO-01	Optional digital I/O extension module
FIO-11	Optional analog I/O extension module
FPBA-01	Optional PROFIBUS DP® adapter module
Frame, frame size	Physical size of the drive or power module
FSO-21	Safety functions module which supports the FSE-31 module and the use of safety encoders
FSO-12	Safety functions module which does not support the use of encoders
FSO-12, FSO-21	Optional functional safety modules
IGBT	Insulated gate bipolar transistor

Term	Description
Intermediate circuit	DC circuit between rectifier and inverter
Inverter	Converts direct current and voltage to alternating current and voltage.
NETA-21	Remote monitoring tool
Network control	With fieldbus protocols based on the Common Industrial Protocol (CIPTM), such as DeviceNet and Ethernet/IP, denotes the control of the drive using the Net Ctrl and Net Ref objects of the ODVA AC/DC Drive Profile. For more information, see www.odva.org .
Parameter	In the drive control program, user-adjustable operation instruction to the drive, or signal measured or calculated by the drive. In some (for example fieldbus) contexts, a value that can be accessed as an object. For example, variable, constant, or signal.
PLC	Programmable logic controller
PTC	Positive temperature coefficient
Rectifier	Converts alternating current and voltage to direct current and voltage
STO	Safe torque off (IEC/EN 61800-5-2)
ZCU	Type of control unit

Related documents

Name	Code (English/Multilingual)	Code (Translation)
Drive hardware manuals and guides		
<i>Drive/converter/inverter safety instructions</i>	3AXD50000037978	
<i>ACS880-31 drives hardware manual</i>	3AXD50000045933	
<i>ACS880-31 quick installation and start-up guide</i>	3AXD50000803033	
<i>ACS880...+P940 and +P944 drive modules supplement</i>	3AUA0000145446	
<i>Drive modules cabinet design and construction instructions</i>	3AUA0000107668	
<i>ACx-AP-x Assistant control panels user's manual</i>	3AUA0000085685	
<i>ACS880-11, ACS880-31, ACH580-31 and ACQ580-31 UK gland plate (+H358) installation guide</i>	3AXD50000110711	
<i>ACS880-01..., ACS880-04..., ACS880-11..., ACS880-31..., ACS880-14... and ACS880-34... +C132 marine type approved drives</i>	3AXD50000010521	
<i>ACS880-11..., ACS880-31..., ACH580-31... and ACQ580-31...+C135 drives with flange mounting kit supplement</i>	3AXD50000349838	

Name	Code (English/Multilingual)	Code (Translation)
<i>ACS880-11..., ACS880-31..., ACH580-31... and ACQ580-31...+C135 frame R3 flange mounting kit quick installation guide</i>	3AXD50000181506	
<i>ACS880-11...+C135, ACS880-31...+C135, ACH580-31...+C135 and ACQ580-31...+C135 frames R6 and R8 flange mounting kit quick installation guide</i>	3AXD50000133611	
<i>Common mode filter kit for ACS880-01 frame R7, and for ACS880-11, ACS880-31, ACH580-31 and ACQ580-31 frame R8 installation instructions</i>	3AXD50000015179	
<i>Common DC systems with ACS880-01, -04, -11, -14, -31 and -34 drives application guide</i>	3AUA0000127818	
<i>ACS880-11, ACS880-31, ACS880-14, ACS880-34, ACS880-17, ACS880-37 drives product note on DC voltage boost</i>	3AXD50000691838	
<i>Converter modules capacitor reforming instructions</i>	3BFE64059629	
<i>ACS880-11, ACS880-31, ACH580-31 and ACQ580-31 drives recycling instructions and environmental information</i>	3AXD50000137671	
Drive firmware manuals and guides		
<i>ACS880 primary control program firmware manual</i>	3AUA0000085967	
Option manuals and guides		
Manuals and quick guides for I/O extension modules, fieldbus adapters, etc.		

See www.abb.com/drives/documents for all manuals on the Internet.

The code below opens an online listing of the manuals applicable to the product:



[ACS880-31 manuals](#)



3

Operation principle and hardware description

Contents of this chapter

This chapter briefly describes the operation principle and construction of the drive.

Operation principle

The ACS880-31 is an ultra-harmonic drive for controlling asynchronous AC induction motors, AC induction servomotors, permanent magnet motors and synchronous reluctance motors.

The drive includes a line-side converter and a motor-side converter. The parameters and signals for both converters are combined into one primary user program.

The figure below shows the simplified main circuit diagram of the drive.

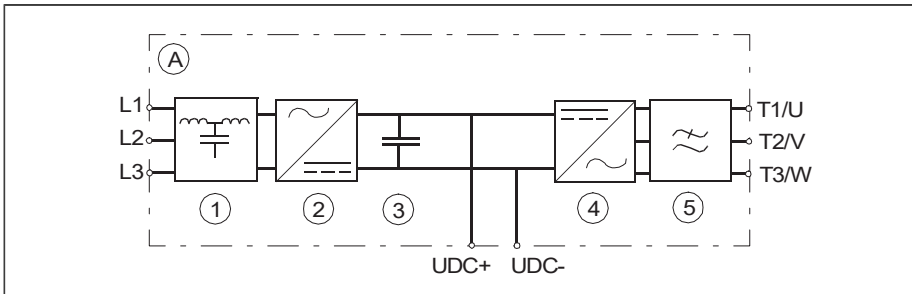

A	Drive
1	LCL filter
2	Line-side converter
3	DC link. DC circuit between the line-side converter and motor-side converter.
4	Motor-side converter
5	Common mode filter (option +E208)

The line-side converter rectifies three phase AC current to direct current for the intermediate DC link of the drive. The intermediate DC link further supplies the motor-side converter that runs the motor.

Both converters consist of six insulated gate bipolar transistors (IGBT) with free wheeling diodes. The content of AC voltage and current harmonics is low. The LCL filter suppresses the harmonics further.

The line-side and motor-side converters have their own control programs. The parameters of both programs can be viewed and changed using a control panel.

■ DC voltage boost function

The drive can boost their DC link voltage. In other words, it can increase the operating voltage of the DC link from its default value.

To take the DC voltage boost function in use:

1. adjust the user DC voltage reference value (94.22) and

2. select the user-defined reference (94.22) as the source for the drive DC voltage reference (94.21).

Benefits of the DC voltage boost function are:

- possibility to supply nominal voltage to the motor even when the supply voltage of the drive is below the motor nominal voltage level
- compensation of voltage drop due to output filter, motor cable or input supply cables
- increased motor torque in the field weakening area (ie, when the drive operates the motor in the speed range above the motor nominal speed)
- possibility to use a motor with higher nominal voltage than the actual supply voltage of the drive. Example: A drive that is connected to 415 V can supply 460 V to a 460 V motor.

For more information, see *ACS880-11, ACS880-31, ACS880-14, ACS880-34, ACS880-17, ACS880-37 drives product note on DC voltage boost* ([3AXD50000691838](#) [English]).





■ DC connection

You can connect an external brake chopper to the drive via the DC terminals. See chapter *Resistor braking* (page 235).

You can connect drive frames R3 and R6 to a common DC system, see *Common DC systems with ACS880-01, -04, -11, -14, -31 and -34 drives application guide* ([3AUA0000127818](#) [English]).

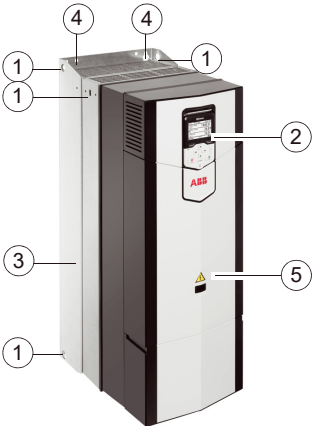
Layout

The layout of the drive is shown below.

			
IP21 (UL Type 1) R6		IP55 (UL Type 12) option +B056, R6	
			
UL Type 12 (R6)		IP20 (UL Open Type) option +P940 R8	
1	Lifting eyes (2 pcs in frame R3, 6 pcs in frames R6 and R8)	5	Front cover
2	Control panel	6	Control panel behind the control panel cover
3	Heatsink	7	Hood in frames R6 and R8
4	Mounting points (4 pcs)		

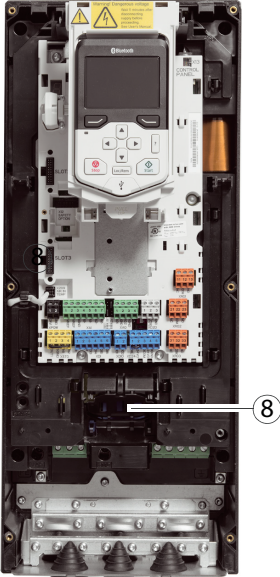
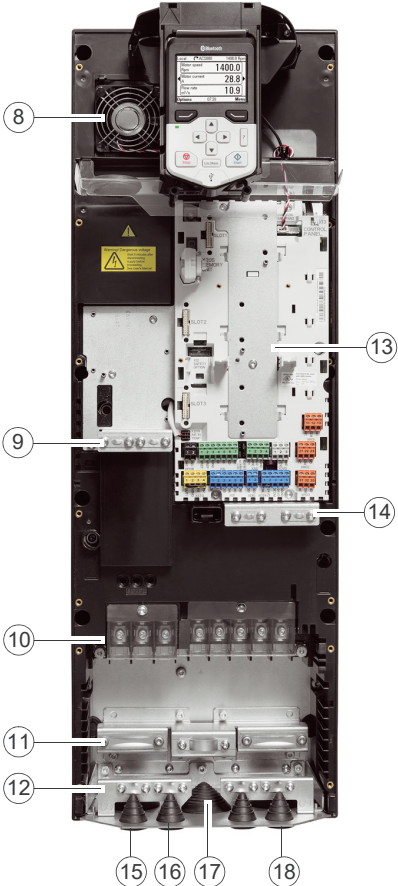
<p style="text-align: center;">R3</p> 	<p style="text-align: center;">R6</p> 
<p>8 Auxiliary cooling fan. For frame R3 in IP55 (UL Type 12 drives) only. For frame R6 another auxiliary cooling fan at right-hand side of the control panel in IP55 (UL Type 12) drives.</p>	<p>14 Clamps for securing the control cables mechanically</p>
<p>9 Clamps for securing the FSO wiring mechanically</p>	<p>15 Input power cable entry behind the 360-degree grounding clamps</p>
<p>10 Power cable connection terminals behind the shroud</p>	<p>16 Control cable entry (4 pcs)</p>
<p>11 360-degree grounding clamps for power cable shields</p>	<p>17 DC cable entry</p>

12	360-degree grounding clamps for control cable shields	18	Motor cable entry behind the 360-degree grounding clamps
13	Control unit with I/O cable connection terminals		

Overview of power and control connections

The logical diagram below shows the power connections and control interfaces of the drive.

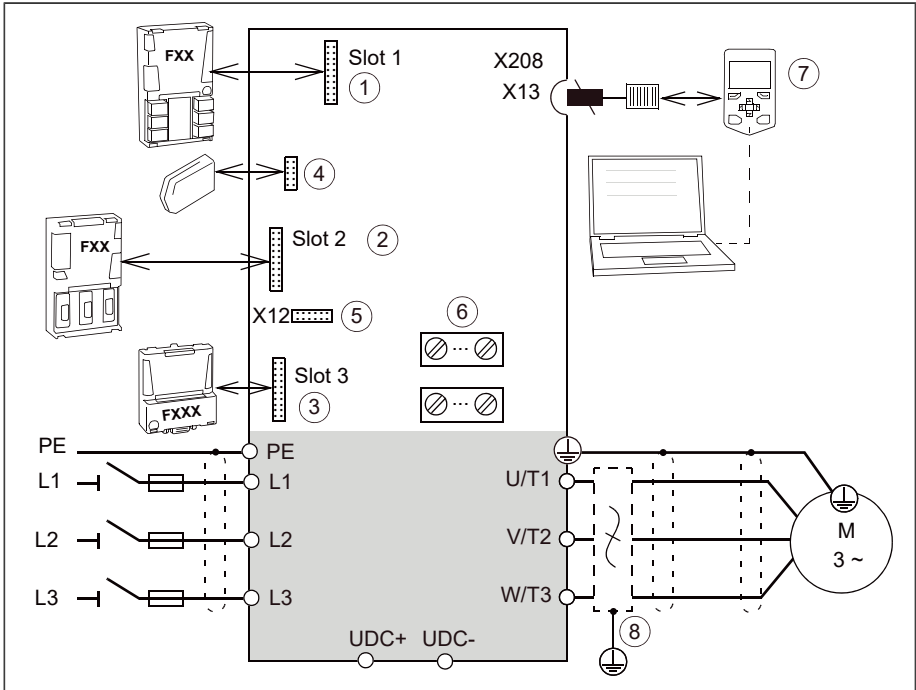

1	Analog and digital I/O extension modules, feedback interface modules and fieldbus communication modules can be inserted into slots 1, 2 and 3.
2	
3	
4	Memory unit
5	Connector for safety functions modules.
6	See <i>Default I/O diagram of the drive control unit (ZCU-1x)</i> (page 133) and <i>Connector data</i> (page 138).
7	Control panel
8	du/dt, common mode or sine filter (optional). See <i>Common mode, du/dt and sine filters</i> (page 243).

Control panel

To remove the control panel, press the retaining clip at the top (1a) and pull the panel forward from the top edge (1b).

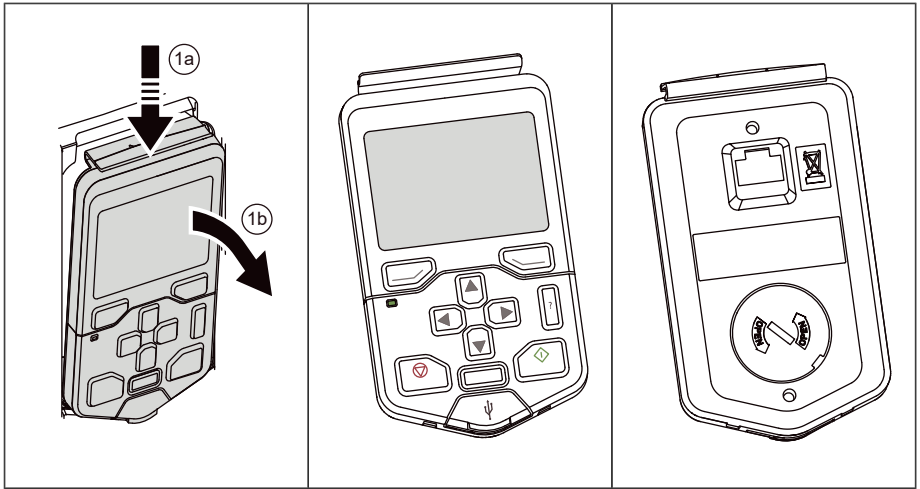

To reinstall the control panel, put the bottom of the container in position (2a), press the retaining clip at the top (2b) and push the control panel in at the top edge (2c).

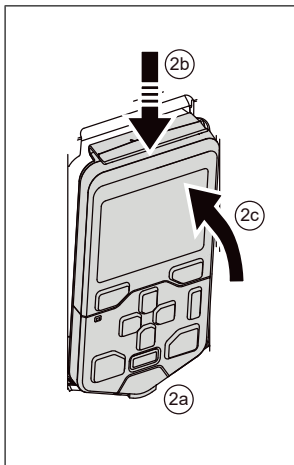

For the use of the control panel, see the firmware manual and *ACx-AP-x assistant control panel user's manual* ([3AUA0000085685](https://www.3com.com/3AUA0000085685) [English]).

■ Control panel door mounting kits

You can use a mounting platform to mount the control panel on the cabinet door. Mounting platforms for control panels are available as options from ABB. For more information, see

Manual	Code (English)
<i>DPMP-01 mounting platform for control panels installation guide</i>	3AJA0000100140
<i>DPMP-02/03 mounting platform for control panels installation guide</i>	3AJA0000136205
<i>DPMP-04 and DPMP-05 mounting platform for control panels installation guide</i>	3AXD50000308484
<i>DPMP-06 / 07 mounting platform for control panels installation guide</i>	3AXD50000289561

■ Control panel mounting platform cover

In deliveries without control panel (option + 0J400) the control panel mounting platform is covered. The indication LEDs on the platform are visible through the protective cover.

Note: The cover is not included with options +0J400+P940.



■ Control of several drives

One control panel can be used to control several drives through a panel bus. See section [Panel bus \(Control of several units from one control panel\) \(page 111\)](#).

Type designation label

<p>ACS880-31-09A4-3 (1)</p> <p>Origin Finland Made in Finland ABB Oy Hiomatie 13 (2) 00380 Helsinki Finland</p> <table border="1"> <tr><td>FRAME</td></tr> <tr><td>R3</td></tr> </table> <p>Air cooling (4) IP21 Icc 100 kA (7) UL type 1 (5)</p> <p>Input U1 3~ 400 VAC I1 8 A f1 50/60 Hz</p> <p>Output U2 3~ 0...U1 (6) I2 10 A f2 0...500 Hz Sn 6.9 kVA</p> <p>R-REI-Abb-ACS880-12A6-3 S/N: 1213801760</p>		FRAME	R3
FRAME			
R3			
1	Type designation		
2	Name and address of the manufacturer		
3	Frame size		
4	Cooling method and additional information		
5	Degree of protection		
6	Nominal ratings in the supply voltage range, see the technical data.		
7	Rated conditional short-circuit current, see the technical data.		
8	Valid markings		
9	<p>S/N: Serial number of format MYYWWXXXX, where</p> <p>M: Manufacturer</p> <p>YY: 16, 17, 18, ... for 2016, 2017, 2018, ...</p> <p>WW: 01, 02, 03, ... for week 1, week 2, week 3, ...</p> <p>XXXXX: Integer starting every week from 0001</p>		
10	Link to product information		

Type designation key

The type designation contains information on the specifications and configuration of the drive. You find the type designation on the type designation label attached to the drive. The first digits from the left express the basic configuration, for example, ACS880-31-025A-3. The optional selections are given after that, separated by plus signs, for example, +K454. The main selections are described below. Not all selections are available for all types.

■ Basic code

Code	Description
ACS880	Product series
Type	
31	Low-harmonic wall-mounted drive. When no options are selected: IP21 (UL type 1), cable entry from bottom, ACS-AP-W Assistant control panel with a bluetooth interface, no EMC filter, common mode filter for frame R8 690 V drives, ACS880 primary control program, Safe torque-off, coated boards, quick installation and start-up guide.
Size	
xxxx	See section <i>Ratings (page 167)</i> in the technical data.
Voltage range	
3	380...415 V. This is indicated in the type designation label as typical input voltage level 3 ~ 400 V AC.
5	380...500 V. This is indicated in the type designation label as typical input voltage levels 3 ~ 400/480/500 V AC.

■ Option codes

Code	Description
B056	IP55 (UL Type 12)
C135	Flange mounting
E200	EMC filter for 2nd environment TN (grounded) system, category C3
E201	EMC filter for second environment IT (ungrounded) system, category C3
E202	EMC filter for 1st environment TN (grounded) system, category C2
E208	Common mode filter <u>Frames R3 and R6</u> : Built-in as standard. +E208 not shown in the type designation label. <u>Frame R8</u> : +E208 option to be ordered. Installation by customer.
H358	Cable conduit entry (US/UK).
0J400	No control panel
J410	DPMP-01 door mounting kit
J413	DPMP-02 door mounting kit (surface mounting) for the panel
J425	ACS-AP-I control panel
K451	FDNA-01 DeviceNet™ adapter module
K454	FPBA-01 PROFIBUS DP adapter module

Code	Description
K457	FCAN-01 CANOpen adapter module
K458	FSCA-01 RS-485 (Modbus/RTU) adapter module
K462	FCNA-01 ControlNet™ adapter module
K469	FECA-01 EtherCat adapter module
K470	FEPL-02 EtherPOWERLINK adapter module
K475	FENA-21 Ethernet adapter module for EtherNet/IP™, Modbus TCP and PROFINET IO protocols, 2-port
K490	FEIP-21 EtherNet/IP adapter module
K491	FMBT-21 Modbus/TCP adapter module
K492	FPNO-21 PROFINET IO adapter module
L500	FIO-11 analog I/O extension module (1, 2 or 3 pcs)
L501	FIO-01 digital I/O extension module
L502	FEN-31 HTL incremental encoder interface module
L503	FDCO-01 optical DDCS communication adapter module
L508	FDCO-02 optical DDCS communication adapter module
L516	FEN-21 resolver interface module
L517	FEN-01 TTL incremental encoder interface module
L525	FAIO-01 analog I/O extension module
L536	FPTC-01 thermistor protection module
L537	FPTC-02 ATEX-certified thermistor protection module
P904	Extended warranty 24/30
P931	Extended warranty 36 months from delivery
P932	Extended warranty 60 months from delivery
P940	Version for cabinet mounting (Drive module without front covers)
Q971	ATEX-certified safe disconnection function
Q972	FSO-21 safety functions module
Q973	FSO-12 safety functions module
Q982	PROFIsafe with FSO-xx safety functions module and FENA-21 Ethernet adapter module
R700	Documentation/manuals in English

40 Operation principle and hardware description

Code	Description
R701	German
R702	Italian
R703	Dutch
R704	Danish
R705	Swedish
R706	Finnish
R707	French
R708	Spanish
R709	Portuguese
R711	Russian
R712	Chinese
R714	Turkish

4

Mechanical installation

Contents of this chapter

This chapter tells how to examine the installation site, unpack and examine the delivery and install the drive mechanically.

Cabinet installation (options +P940 and +P944)

See also *ACS880...+P940 and +P944 drive modules supplement* ([3AUA0000145446](#) [English]).

For generic guidelines for planning the installation of the drive modules into a user-defined cabinet, see *Drive modules cabinet design and construction instructions* ([3AUA0000107668](#) [English]).

Flange mounting (option +C135)

See also:

Manual name	Code (English)
<i>ACS880-11..., ACS880-31..., ACH580-31... and ACQ580-31...+C135 drives with flange mounting kit supplement</i>	3AXD50000349838
<i>ACS880-11..., ACS880-31..., ACH580-31... and ACQ580-31...+C135 frame R3 flange mounting kit quick installation guide</i>	3AXD50000181506
<i>ACS880-11...+C135, ACS880-31...+C135, ACH580-31...+C135 and ACQ580-31...+C135 frames R6 and R8 flange mounting kit quick installation guide</i>	3AXD50000133611



Safety

WARNING!
Frames R6 and R8: Lift the drive with a lifting device. Use the lifting eyes of the drive. Do not tilt the drive. **The drive is heavy and its center of gravity is high. An overturning drive can cause physical injury.**

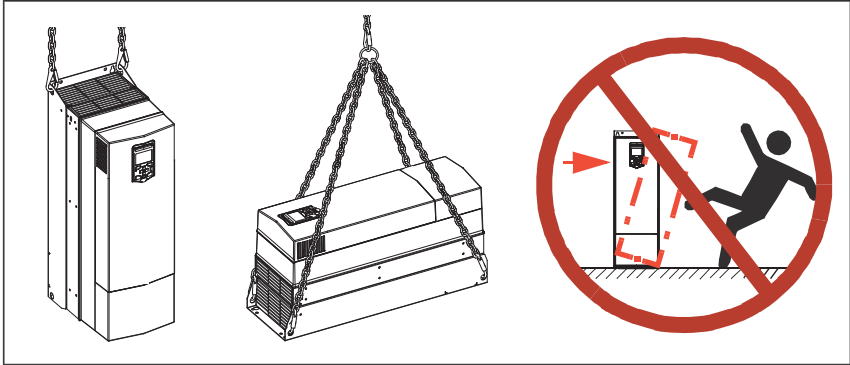

Examining the installation site

Examine the installation site. Make sure that:

- The installation site is sufficiently ventilated or cooled to remove heat from the drive. See the technical data.
- The ambient conditions of the drive meet the specifications. See the technical data.
- The wall behind the drive and the material above and below the unit is of non-flammable material.
- The installation surface is as close to vertical as possible and strong enough to support the drive.
- There is sufficient free space around the drive for cooling, maintenance, and operation. See the free space specifications for the drive.
- Make sure that there are no sources of strong magnetic fields such as high-current single-core conductors or contactor coils near the drive. A strong magnetic field can cause interference or inaccuracy in the operation of the drive.

Installation orientations

The drive must be installed on a wall or mounting plate. There are three alternative ways to install it:

- vertically alone. Do not install the drive upside down.

- vertically side by side
- horizontally alone, IP21 (UL Type 1) only.

Note: The vibration specification in the technical data may not be fulfilled.

Note: IP21 (UL Type 1) construction only meets IP20 (UL Type Open) in horizontal orientation.

Free space requirements are shown in the drawings below.

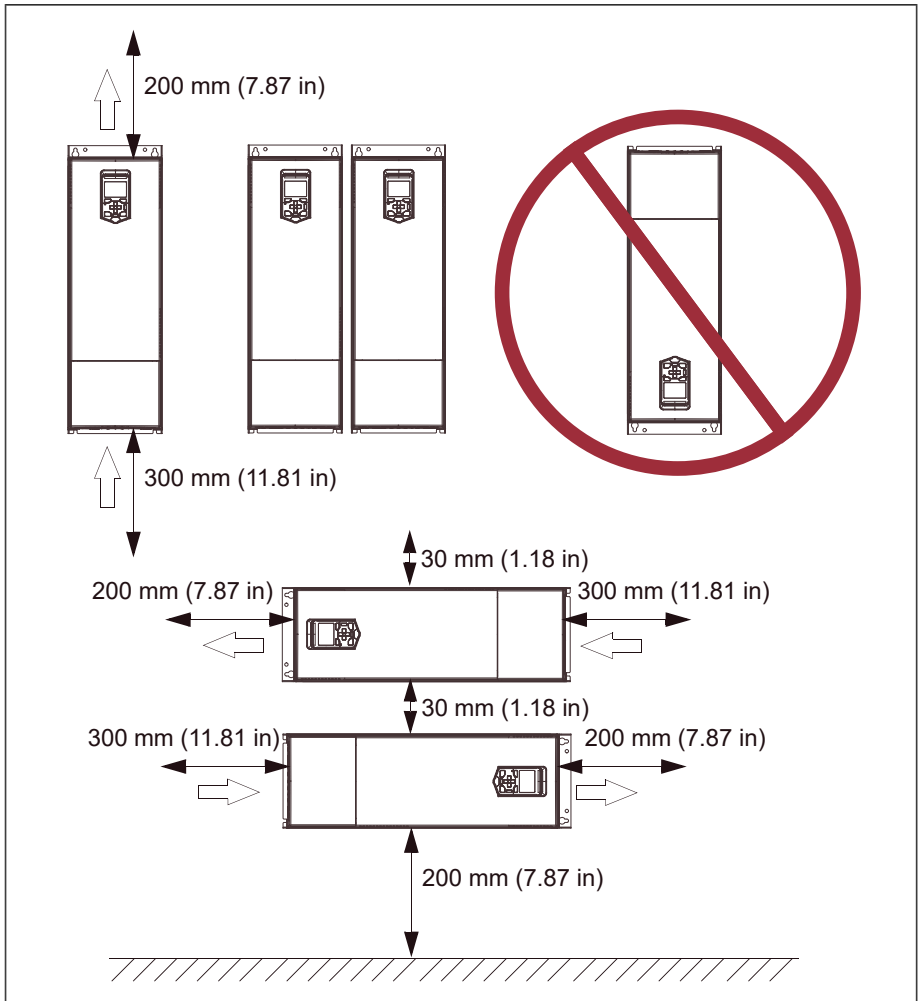

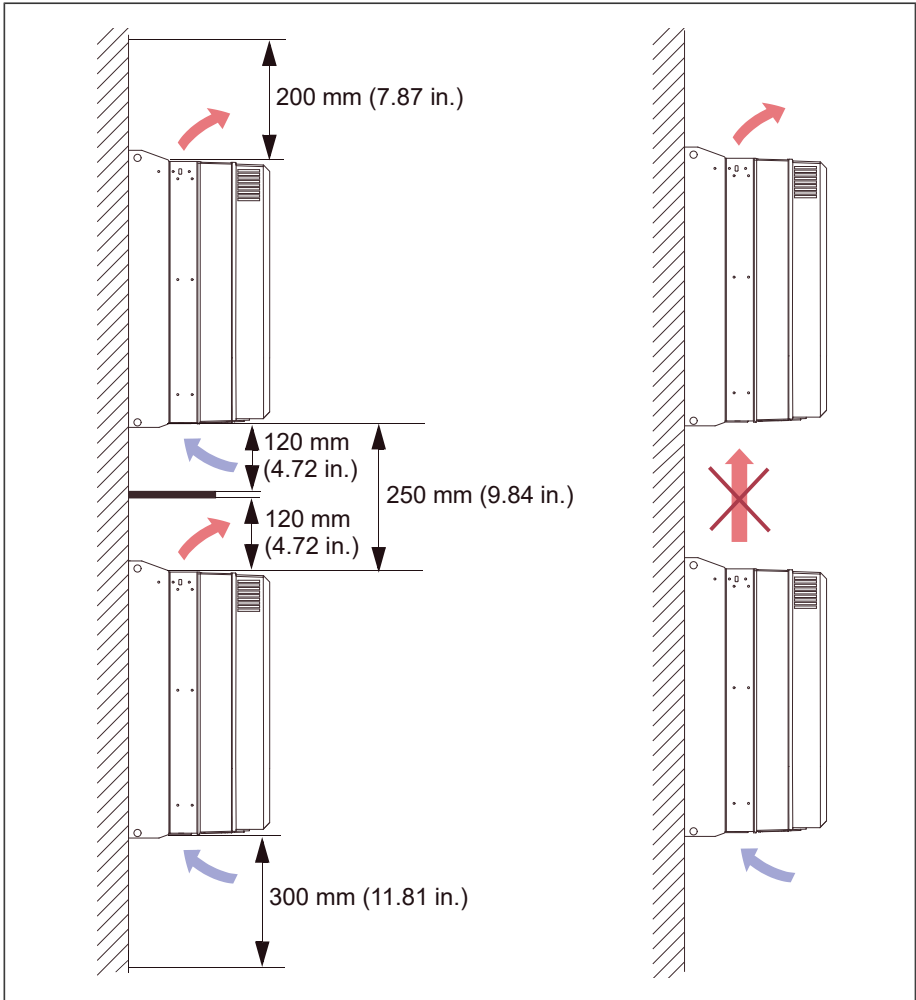

Required tools

To install the drive mechanically, you need the following tools:

- drill with suitable bits
- screwdriver set (Torx, flat and/or Phillips, as appropriate)
- socket set (metric)
- tape measure, if you will not be using the provided mounting template.

Moving the drive

Move the drive in its transport package to the installation site. Use a pallet truck when you move a heavy drive package.

Unpacking and examining delivery

The figure below shows the drive package with its contents. Examine that all items are present and there are no signs of damage. Read the data on the type designation label of the drive to make sure that the drive is of the correct type.



R3 IP21 (UL Type 1) and IP55 (UL Type 12)

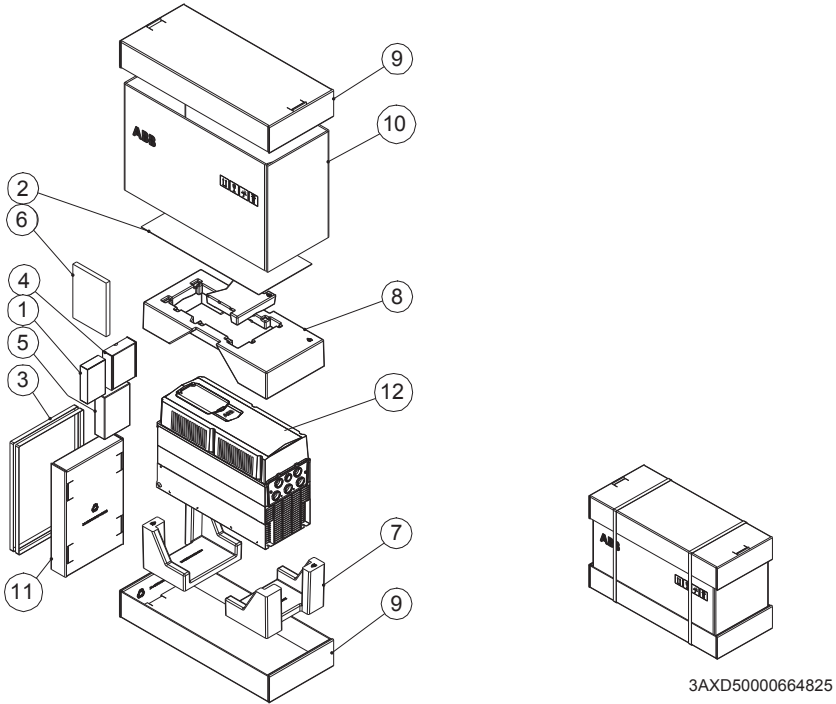

3AXD50000664825



1	Control panel	7	Package cushion
2	Mounting template	8	Foam cushion
3	Package straps	9	Cardboard tray
4	I/O option module	10	Cardboard sleeve
5	Fieldbus option module	11	Cardboard box which contains control panel box 1 and option boxes 4 and 5
6	Printed quick installation and start-up guide and manuals, multilingual residual voltage warning sticker	12	Drive

To unpack:

- Cut the straps (3).
- Remove the tray (9) and sleeve (10).
- Remove the cover-protecting film.
- Lift the drive.

R6 IP21 (UL Type 1)

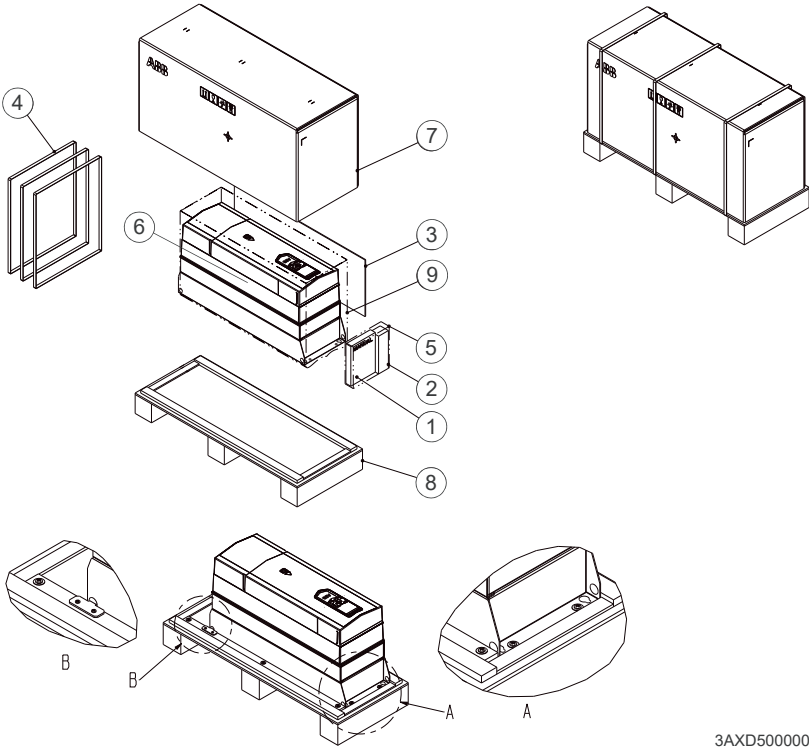

3AXD50000038252

1	Printed quick installation and start-up guide and manuals, multilingual residual voltage warning sticker	6	Drive with factory installed options
2	Accessories	7	Outer box
3	Mounting template	8	Pallet
4	Package straps	9	VCI bag
5	Plastic bag		

To unpack:

- Cut the straps (4).
- Remove the outer box (7).
- Open the VCI bag (9).
- Undo the attaching screws (A, B).
- Lift the drive.



R6 IP55 (UL Type 12)

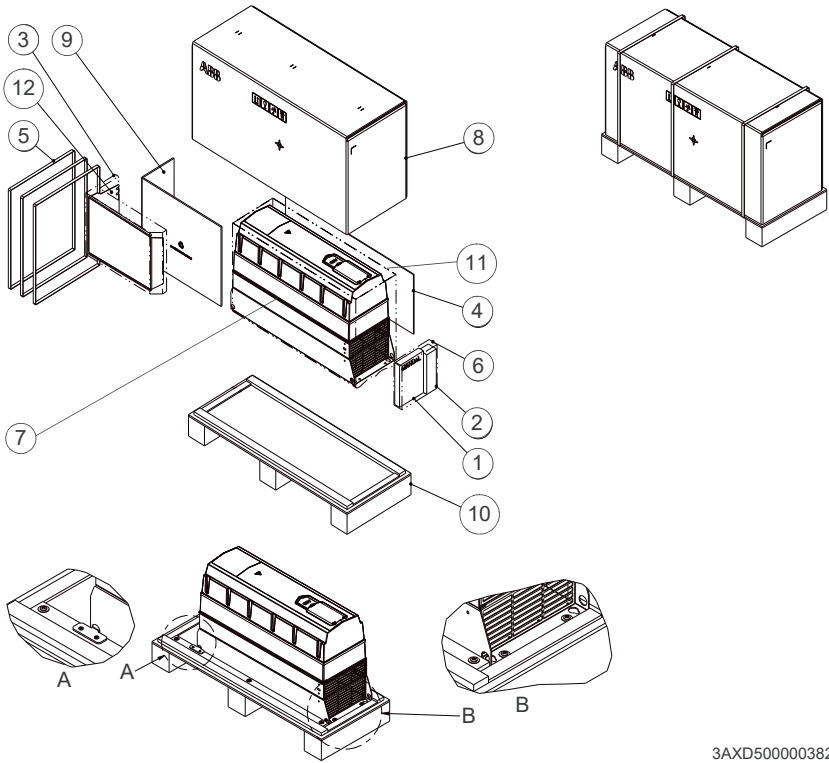

3AXD50000038252

1	Printed quick installation and start-up guide and manuals, multilingual residual voltage warning sticker	7	Drive with factory installed options
2	Accessories	8	Outer box
3	Bubble wrap	9	Cardboard insert
4	Mounting template	10	Pallet
5	Package straps	11	VCI bag
6	Plastic bag	12	UL Type 12 hood

To unpack:

- Cut the straps (5).
- Remove the outer box (8).
- Open the VCI bag (11).
- Undo the attaching screws (A, B).
- Lift the drive.

R8 IP21 (UL Type 1)

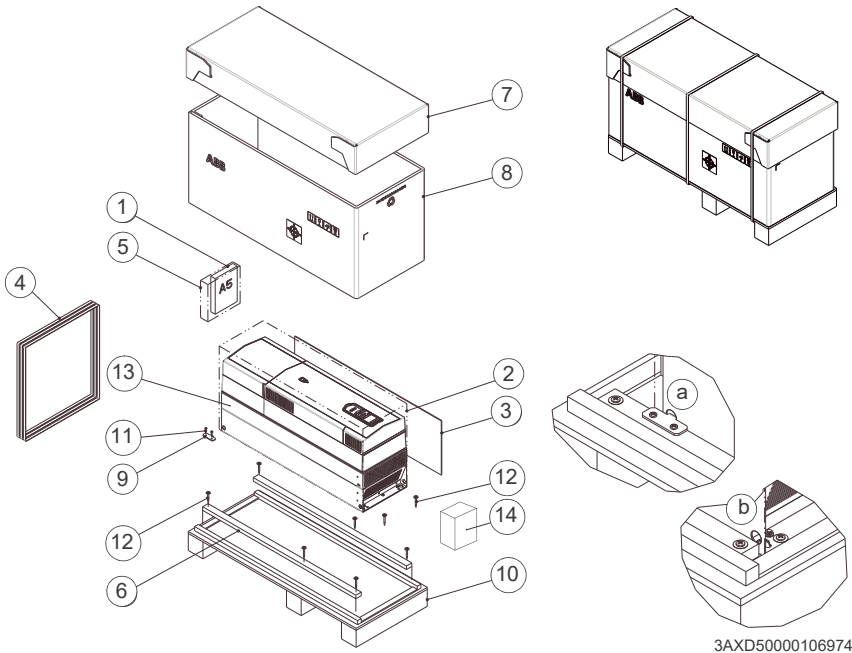

3AXD5000106974

1	Printed quick installation and start-up guide and manuals, multilingual residual voltage warning sticker	8	Cardboard sleeve
2	VCI bag	9	Plywood support
3	Mounting template	10	Pallet
4	Package straps	11	Screw
5	Plastic bag	12	Screw
6	Packing bracket	13	Drive with factory installed options
7	Tray	14	Common mode filter (option +E208)

To unpack:

- Cut the straps (4).
- Remove the tray (7) and cardboard sleeve (8).
- Open the VCI bag (2).
- Undo the attaching screws (a, b).
- Lift the drive.



R8 IP55 (UL Type 12)

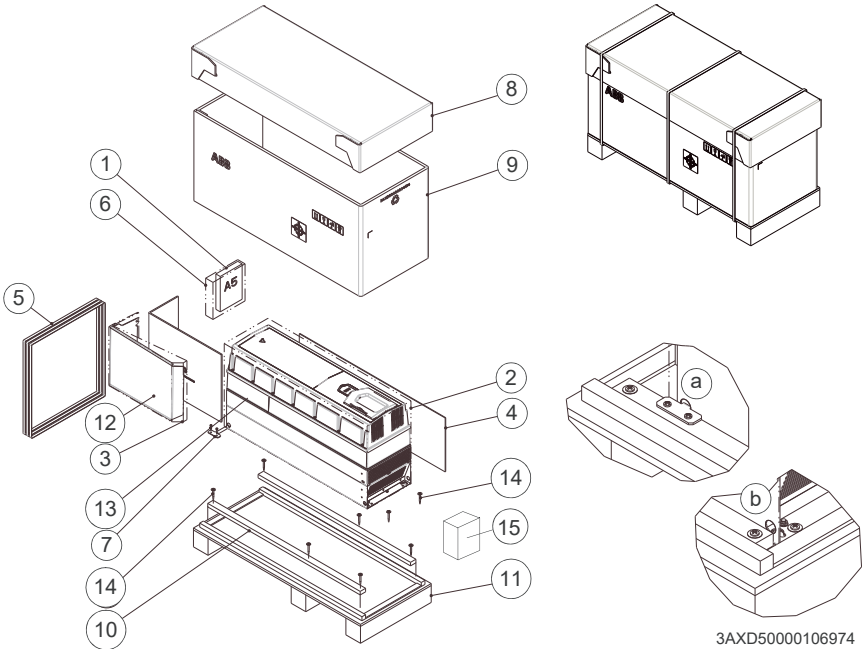

3AXD50000106974



1	Printed quick installation and start-up guide and manuals, multilingual residual voltage warning sticker	9	Cardboard sleeve
2	VCI bag	10	Plywood support
3	Bubble wrap	11	Pallet
4	Mounting template	12	UL Type 12 hood
5	Package straps	13	Drive with factory installed options
6	Plastic bag	14	Screws
7	Packing bracket	15	Common mode filter (option +E208)
8	Tray	-	

To unpack:

- Cut the straps (5).
- Remove the tray (8) and cardboard sleeve (9).
- Open the VCI bag (2).
- Undo the attaching screws (a, b).
- Lift the drive.

Installing the drive vertically

1. Mark the hole locations using the mounting template included in the package. Do not leave the mounting template under the drive. The drive dimensions and hole locations are also shown in the dimension drawings.

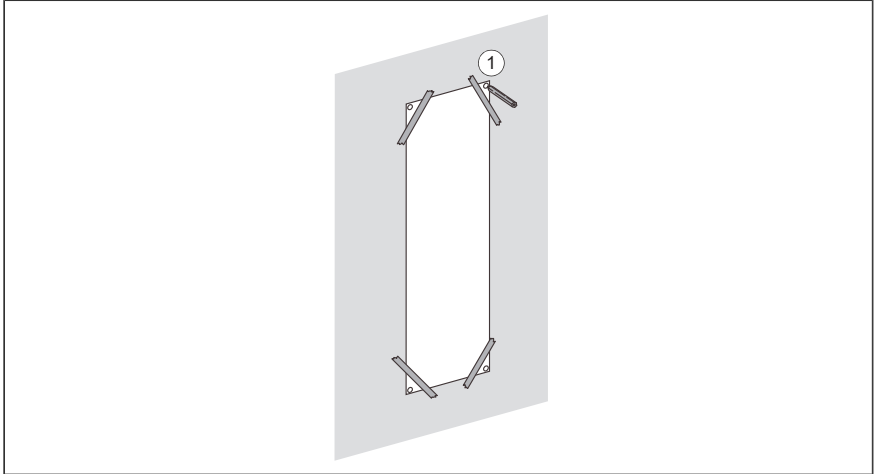

2. Drill the mounting holes.
3. Insert anchors or plugs into the holes and start the screws or bolts into the anchors or plugs. Drive the screws or bolts long enough into the wall to make them carry the weight of the drive.
4. Position the drive onto the bolts on the wall.
5. For R6 and R8 with option +B056 (UL Type 12): Install the hood on top of the drive before you tighten the upper fastening bolts. Place the vertical edge of the hood in between the wall and the drive back plate.

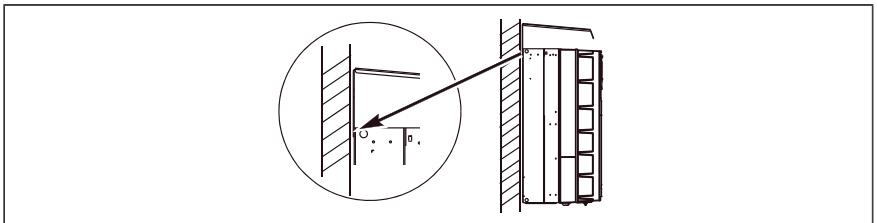

6. Tighten the bolts in the wall securely.

52 Mechanical installation

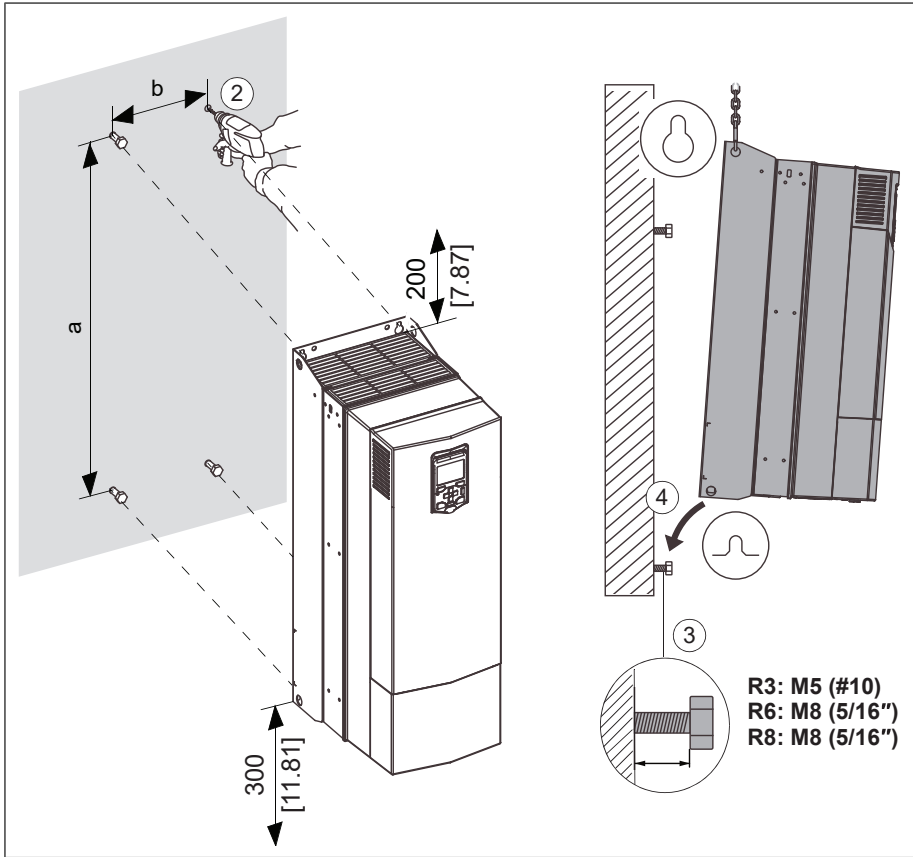

	R3		R6		R8	
	mm	in	mm	in	mm	in
a	474	18.7	753	29.6	945	37.2
b	160	6.3	212.5	8.4	262.5	10.3

	R3		R6		R8	
	kg	lb	kg	lb	kg	lb
IP21, UL Type 1	21.3	46.97	61.0	134.51	112	246.96
IP55, UL Type 12	23.3	51.38	63	138.92	118	260.19

Installing the drive vertically side by side

Drives can be installed side by side. Follow the steps in section [Installing the drive vertically \(page 51\)](#).

Installing the drive horizontally

The drive can be installed with either the left or right side up. Follow the steps in section [Installing the drive vertically \(page 51\)](#). For free space requirements, see section [Installation orientations \(page 42\)](#).





5

Guidelines for planning the electrical installation

Contents of this chapter

This chapter contains guidelines for planning the electrical installation of the drive.

Limitation of liability

The installation must always be designed and made according to applicable local laws and regulations. ABB does not assume any liability whatsoever for any installation which breaches the local laws and/or other regulations. Furthermore, if the recommendations given by ABB are not followed, the drive may experience problems that the warranty does not cover.

Selecting the main supply disconnecting device

You must equip the drive with a main supply disconnecting device which meets the local safety regulations. You must be able to lock the disconnecting device to the open position for installation and maintenance work.

■ European Union and United Kingdom

To meet the European Union Directives and United Kingdom Regulations, according to standard EN 60204-1, *Safety of Machinery*, the disconnecting device must be one of the following types:

- switch-disconnector of utilization category AC-23B (IEC 60947-3)
- disconnector that has an auxiliary contact that in all cases causes switching devices to break the load circuit before the opening of the main contacts of the disconnector (EN 60947-3)
- circuit-breaker suitable for isolation in accordance with IEC 60947-2.

■ North America

Installations must be compliant with NFPA 70 (NEC)¹⁾ and/or Canadian Electrical Code (CE) along with state and local codes for your location and application.

¹⁾ National Fire Protection Association 70 (National Electric Code).

■ Other regions

The disconnecting device must conform to the applicable local safety regulations.

Selecting the main contactor

You can equip the drive with a main contactor.

Follow these guidelines when you select a customer-defined main contactor:

- Dimension the contactor according to the nominal voltage and current of the drive. Also consider the environmental conditions such as surrounding air temperature.
- IEC devices only: Select contactor with utilization category AC-1 (number of operations under load) according to IEC 60947-4, *Low-voltage switch gear and control gear*.
- Consider the application life time requirements.

■ North America

Installations must be compliant with NFPA 70 (NEC)¹⁾ and/or Canadian Electrical Code (CE) along with state and local codes for your location and application.

¹⁾ National Fire Protection Association 70 (National Electric Code).

■ Other regions

The disconnecting device must conform to the applicable local safety regulations.

Examining the compatibility of the motor and drive

Use asynchronous AC induction motors, permanent magnet synchronous motors, AC induction servomotors or ABB synchronous reluctance motors (SynRM motors) with the drive.

Select the motor size and drive type from the rating table on basis of the AC line voltage and motor load. You can find the rating table in the appropriate hardware manual. You can also use the DriveSize PC tool.

Make sure that the motor can be used with an AC drive. See [Requirements table \(page 57\)](#). For basics of protecting the motor insulation and bearings in drive systems, see [Protecting the motor insulation and bearings \(page 57\)](#).

Note:

- Consult the motor manufacturer before using a motor with nominal voltage that differs from the AC line voltage connected to the drive input.
- The voltage peaks at the motor terminals are relative to the supply voltage of the drive, not to the drive output voltage.

■ Protecting the motor insulation and bearings

The drive employs modern IGBT inverter technology. Regardless of frequency, the drive output comprises pulses of approximately the drive DC bus voltage with a very short rise time. The pulse voltage can almost double at the motor terminals, depending on the attenuation and reflection properties of the motor cable and the terminals. This can cause additional stress on the motor and motor cable insulation.

Modern variable speed drives with their fast rising voltage pulses and high switching frequencies can generate current pulses that flow through the motor bearings. This can gradually erode the bearing races and rolling elements.

du/dt filters protect motor insulation system and reduce bearing currents. Common mode filters mainly reduce bearing currents. Insulated N-end (non-drive end) bearings protect the motor bearings.

■ Requirements table

These tables show how to select the motor insulation system and when a drive du/dt and common mode filters and insulated N-end (non-drive end) motor bearings are required. Ignoring the requirements or improper installation may shorten motor life or damage the motor bearings and voids the warranty.

This table shows the requirements when an ABB motor is in use.

Motor type	Nominal AC line voltage	Requirement for			
		Motor insulation system	ABB du/dt and common mode filters, insulated N-end motor bearings		
			$P_n < 100 \text{ kW}$ and frame size < IEC 315	$100 \text{ kW} \leq P_n < 350 \text{ kW}$ or IEC 315 \leq frame size < IEC 400	$P_n \geq 350 \text{ kW}$ or frame size \geq IEC 400
$P_n < 134 \text{ hp}$ and frame size < NEMA 500	$134 \text{ hp} \leq P_n < 469 \text{ hp}$ or NEMA 500 \leq frame size \leq NEMA 580	$P_n \geq 469 \text{ hp}$ or frame size > NEMA 580			
Random-wound M2_, M3_ and M4_	$U_n \leq 500 \text{ V}$	Standard	-	+ N	+ N + CMF
	$500 \text{ V} < U_n \leq 600 \text{ V}$	Standard	+ du/dt	+ N + du/dt	+ N + du/dt + CMF
		or	Reinforced	-	+ N
	$600 \text{ V} < U_n \leq 690 \text{ V}$ (cable length $\leq 150 \text{ m}$)	Reinforced	+ du/dt	+ N + du/dt	+ N + du/dt + CMF
	$600 \text{ V} < U_n \leq 690 \text{ V}$ (cable length > 150 m)	Reinforced	-	+ N	+ N + CMF
Form-wound HX_ and AM_	$380 \text{ V} < U_n \leq 690 \text{ V}$	Standard	n.a.	+ N + CMF	$P_n < 500 \text{ kW}$: +N + CMF
					$P_n \geq 500 \text{ kW}$: +N + du/dt + CMF
Old ¹⁾ form-wound HX_ and modular	$380 \text{ V} < U_n \leq 690 \text{ V}$	Check with the motor manufacturer.	+ N + du/dt with voltages over 500 V + CMF		
Random-wound HX_ and AM_ ²⁾	$0 \text{ V} < U_n \leq 500 \text{ V}$	Enamelled wire with fiber glass taping	+ N + CMF		
	$500 \text{ V} < U_n \leq 690 \text{ V}$		+ N + du/dt + CMF		
HDP	Consult the motor manufacturer.				

1) manufactured before 1.1.1998

2) For motors manufactured before 1.1.1998, check for additional instructions with the motor manufacturer.

This table shows the requirements when a non-ABB motor is in use.

Motor type	Nominal AC line voltage	Requirement for			
		Motor insulation system	ABB du/dt and common mode filters, insulated N-end motor bearings		
			$P_n < 100$ kW and frame size $< IEC 315$	$100 \text{ kW} \leq P_n < 350$ kW or $IEC 315 \leq$ frame size $< IEC 400$	$P_n \geq 350$ kW or frame size $\geq IEC 400$
$P_n < 134$ hp and frame size $< NEMA 500$	$134 \text{ hp} \leq P_n < 469$ hp or $NEMA 500 \leq$ frame size $\leq NEMA 580$	$P_n \geq 469$ hp or frame size $> NEMA 580$			
Random-wound and form-wound	$U_n \leq 420$ V	Standard: $\dot{U}_{LL} = 1300$ V	-	+ N or CMF	+ N + CMF
	$420 \text{ V} < U_n \leq 500$ V	Standard: $\dot{U}_{LL} = 1300$ V	+ du/dt	+ du/dt + (N or CMF)	+ N + du/dt + CMF
		or	Reinforced: $\dot{U}_{LL} = 1600$ V, 0.2 microsecond rise time	-	+ N or CMF
	$500 \text{ V} < U_n \leq 600$ V	Reinforced: $\dot{U}_{LL} = 1600$ V	+ du/dt	+ du/dt + (N or CMF)	+ N + du/dt + CMF
		or	Reinforced: $\dot{U}_{LL} = 1800$ V	-	+ N or CMF
	$600 \text{ V} < U_n \leq 690$ V	Reinforced: $\dot{U}_{LL} = 1800$ V	+ du/dt	+ du/dt + N	+ N + du/dt + CMF
		Reinforced: $\dot{U}_{LL} = 2000$ V, 0.3 microsecond rise time ¹⁾	-	+ N + CMF	+ N + CMF

1) If the intermediate DC circuit voltage of the drive is increased from the nominal level due to long term resistor braking cycles, check with the motor manufacturer if additional output filters are needed.

The abbreviations used in the tables are defined below.

Abbr.	Definition
U_n	Nominal AC line voltage
\hat{U}_{LL}	Peak line-to-line voltage at motor terminals which the motor insulation must withstand
P_n	Motor nominal power
du/dt	du/dt filter at the output of the drive
CMF	Common mode filter of the drive
N	N-end bearing: insulated motor non-drive end bearing
n.a.	Motors of this power range are not available as standard units. Consult the motor manufacturer.

Availability of du/dt filter and common mode filter by drive type

See chapter *Common mode, du/dt and sine filters* (page 243).

Additional requirements for explosion-safe (EX) motors

If you use an explosion-safe (EX) motor, follow the rules in the requirements table above. In addition, consult the motor manufacturer for any further requirements.

Additional requirements for ABB motors of types other than M2_, M3_, M4_, HX_ and AM_

Use the selection criteria given for non-ABB motors.

Additional requirements for braking applications

When the motor brakes the machinery, the intermediate circuit DC voltage of the drive increases, the effect being similar to the motor supply voltage increasing by up to 20 percent. Consider this voltage increase when specifying the motor insulation requirements if the motor will be braking a large part of its operation time.

Example: Motor insulation requirement for a 400 V AC line voltage application must be selected as if the drive were supplied with 480 V.

Additional requirements for the regenerative and low harmonics drives

It is possible to increase the intermediate circuit DC voltage from the nominal (standard) level with a parameter in the control program. If you choose to do this, select the motor insulation system which withstands the increased DC voltage level.

Additional requirements for ABB high-output and IP23 motors

The rated output power of high output motors is higher than what is stated for the particular frame size in EN 50347 (2001).

This table shows the requirements for protecting the motor insulation and bearings in drive systems for ABB random-wound motor series (for example, M3AA, M3AP and M3BP).

Nominal AC supply voltage	Motor insulation system	Requirement for		
		ABB du/dt and common mode filters, insulated N-end motor bearings		
		$P_n < 100 \text{ kW}$	$100 \text{ kW} \leq P_n < 200 \text{ kW}$	$P_n \geq 200 \text{ kW}$
		$P_n < 140 \text{ hp}$	$140 \text{ hp} \leq P_n < 268 \text{ hp}$	$P_n \geq 268 \text{ hp}$
$U_n \leq 500 \text{ V}$	Standard	-	+ N	+ N + CMF
$500 \text{ V} < U_n \leq 600 \text{ V}$	Standard	+ du/dt	+ du/dt + N	+ du/dt + N + CMF
	or			
	Reinforced	-	+ N	+ N + CMF
$600 \text{ V} < U_n \leq 690 \text{ V}$	Reinforced	+ du/dt	+ du/dt + N	+ du/dt + N + CMF

Additional requirements for non-ABB high-output and IP23 motors

The rated output power of high-output motors is higher than what is stated for the particular frame size in EN 50347 (2001).

If you plan to use a non-ABB high-output motor or an IP23 motor, consider these additional requirements for protecting the motor insulation and bearings in drive systems:

- If motor power is below 350 kW: Equip the drive and/or motor with the filters and/or bearings according to the table below.
- If motor power is above 350 kW: Consult the motor manufacturer.

Nominal AC supply voltage	Requirement for		
	Motor insulation system	ABB du/dt and common mode filters, insulated N-end motor bearings	
		$P_n < 100 \text{ kW}$ or frame size < IEC 315	$100 \text{ kW} < P_n < 350 \text{ kW}$ or IEC 315 < frame size < IEC 400
	$P_n < 134 \text{ hp}$ or frame size < NEMA 500	$134 \text{ hp} < P_n < 469 \text{ hp}$ or NEMA 500 < frame size < NEMA 580	
$U_n \leq 420 \text{ V}$	Standard: $\hat{U}_{LL} = 1300 \text{ V}$	+ N or CMF	+ N or CMF
$420 \text{ V} < U_n < 500 \text{ V}$	Standard: $\hat{U}_{LL} = 1300 \text{ V}$	+ du/dt + (N or CMF)	+ N + du/dt + CMF
	or Reinforced: $\hat{U}_{LL} = 1600 \text{ V}$, 0.2 micro-second rise time	+ N or CMF	+ N or CMF
$500 \text{ V} < U_n \leq 600 \text{ V}$	Reinforced: $\hat{U}_{LL} = 1600 \text{ V}$	+ du/dt + (N or CMF)	+ N + du/dt + CMF
	or Reinforced: $\hat{U}_{LL} = 1800 \text{ V}$	+ N or CMF	+ N + CMF
$600 \text{ V} < U_n \leq 690 \text{ V}$	Reinforced: $\hat{U}_{LL} = 1800 \text{ V}$	+ N + du/dt	+ N + du/dt + CMF
	Reinforced: $\hat{U}_{LL} = 2000 \text{ V}$, 0.3 micro-second rise time ¹⁾	+ N + CMF	+ N + CMF

1) If the intermediate DC circuit voltage of the drive is increased from the nominal level due to long term resistor braking cycles, check with the motor manufacturer if additional output filters are needed.

Additional data for calculating the rise time and the peak line-to-line voltage

The diagrams below show the relative peak line-to-line voltage and rate of change of voltage as a function of the motor cable length. If you need to calculate the actual peak voltage and voltage rise time considering the actual cable length, proceed as follows:

- Peak line-to line voltage: Read the relative \hat{U}_{LL}/U_n value from the diagram below and multiply it by the nominal supply voltage (U_n).
- Voltage rise time: Read the relative values \hat{U}_{LL}/U_n and $(du/dt)/U_n$ from the diagram below. Multiply the values by the nominal supply voltage (U_n) and substitute into equation $t = 0.8 \cdot \hat{U}_{LL}/(du/dt)$.

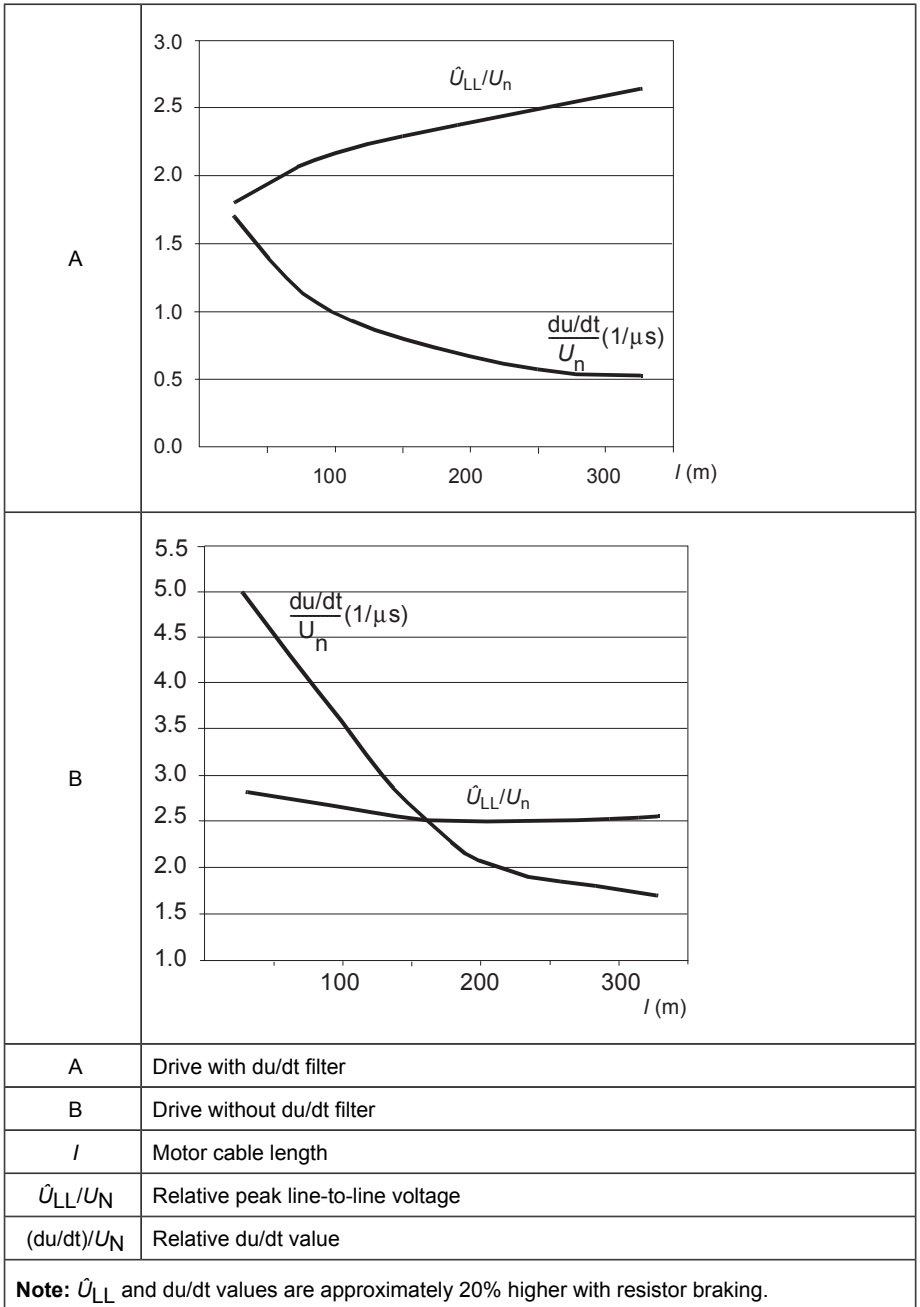

Additional note for sine filters

A sine filter also protects the motor insulation system. The peak phase-to-phase voltage with a sine filter is approximately $1.5 \cdot U_n$.

Selecting the power cables

■ General guidelines

Select the input power and motor cables according to local regulations.

- **Current:** Select a cable capable of carrying the maximum load current and suitable for the prospective short-circuit provided by the supply network. The method of installation and ambient temperature affect the cable current carrying capacity. Obey local regulations and laws.
- **Temperature:** For an IEC installation, select a cable rated for at least 70 °C (158 °F) maximum permissible temperature of conductor in continuous use.
For North America, select a cable rated for at least 75 °C (167 °F).
Important: For certain product types or option configurations higher temperature rating may be required. See the technical data for details.
- **Voltage:** 600 V AC cable is accepted for up to 500 V AC. 750 V AC cable is accepted for up to 600 V AC. 1000 V AC cable is accepted for up to 690 V AC.

To comply with the EMC requirements of the CE mark, use one of the preferred cable types. See [Preferred power cable types \(page 65\)](#).

Symmetrical shielded cable reduces electromagnetic emission of the whole drive system as well as the stress on motor insulation, bearing currents and wear.

Metal conduit reduces electromagnetic emission of the whole drive system.



■ Typical power cable sizes

See the technical data.

■ **Power cable types**

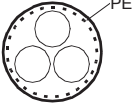
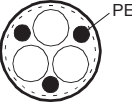

Preferred power cable types



This section presents the preferred cable types. Make sure that the selected cable type also complies with local/state/country electrical codes.

Cable type	Use as input power cabling	Use as motor cabling
 <p>Symmetrical shielded (or armored) cable with three phase conductors and concentric PE conductor as shield (or armor)</p>	Yes	Yes
 <p>Symmetrical shielded (or armored) cable with three phase conductors and symmetrically constructed PE conductor and a shield (or armor)</p>	Yes	Yes
 <p>Symmetrical shielded (or armored) cable with three phase conductors and a shield (or armor), and separate PE conductor/cable¹⁾</p>	Yes	Yes

1) A separate PE conductor is required if the conductivity of the shield (or armor) is not sufficient for the PE use.

Alternate power cable types

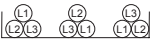
Cable type	Use as input power cabling	Use as motor cabling
 <p>PVC</p> <p>Four-conductor cabling in PVC conduit or jacket (three phase conductors and PE)</p>	<p>Yes with phase conductor smaller than 10 mm² (8 AWG) Cu.</p>	<p>Yes with phase conductor smaller than 10 mm² (8 AWG) Cu, or motors up to 30 kW (40 hp). Note: Shielded or armored cable, or cabling in metal conduit is always recommended to minimize radio frequency interference.</p>
 <p>EMT</p> <p>Four-conductor cabling in metal conduit (three phase conductors and PE). For example, EMT, or four-conductor armored cable</p>	<p>Yes</p>	<p>Yes with phase conductor smaller than 10 mm² (8 AWG) Cu, or motors up to 30 kW (40 hp)</p>
 <p>Shielded (Al/Cu shield or armor)¹⁾ four-conductor cable (three phase conductors and a PE)</p>	<p>Yes</p>	<p>Yes with motors up to 100 kW (135 hp). A potential equalization between the frames of motor and driven equipment is required.</p>

Cable type	Use as input power cabling	Use as motor cabling
 <p>A single-core cable system: three phase conductors and PE conductor on cable tray</p>  <p>Preferable cable arrangement to avoid voltage or current unbalance between the phases</p>	<p>Yes</p>  <p>WARNING! If you use unshielded single-core cables in an IT network, make sure that the non-conductive outer sheath (jacket) of the cables have good contact with a properly grounded conductive surface. For example, install the cables on a properly grounded cable tray. Otherwise voltage may become present on the non-conductive outer sheath of the cables, and there is even a risk of an electric shock.</p>	<p>No</p>

1) Armor may act as an EMC shield, as long as it provides the same performance as a concentric EMC shield of a shielded cable. To be effective at high frequencies, the shield conductivity must be at least 1/10 of the phase conductor conductivity. The effectiveness of the shield can be evaluated based on the shield inductance, which must be low and only slightly dependent on frequency. The requirements are easily met with a copper or aluminum shield/armor. The cross-section of a steel shield must be ample and the shield helix must have a low gradient. A galvanized steel shield has a better high-frequency conductivity than a non-galvanized steel shield.

Not allowed power cable types

Cable type	Use as input power cabling	Use as motor cabling
 <p>Symmetrical shielded cable with individual shields for each phase conductor</p>	<p>No</p>	<p>No</p>

■ **Additional guidelines, North America**

ABB recommends the use of conduit for power wiring to the drive and between the drive and the motor(s). Due to the variety of application needs, metallic and non-metallic conduit can be used. ABB recommends the use of metallic conduit.

The following table shows examples of various materials and methods for wiring the drive in the intended application. See NEC 70 along with state and local codes for the appropriate materials for your application.

In all applications, ABB prefers the use of symmetrical shielded VFD cable between drive and motor(s).

Wiring method	Notes
Conduit - Metallic ^{1) 2)}	
Electrical metallic tubing: Type EMT	Prefer symmetrical shielded VFD cable. Use separate conduit run for each motor. Do not run input power wiring and motor wiring in the same conduit.
Rigid metal conduit: Type RMC	
Liquid-tight flexible metal electrical conduit: Type LFMC	
Conduit - Non-metallic ^{2) 3)}	
Liquid-tight flexible non-metallic conduit: Type LFNC	Prefer symmetrical shielded VFD cable. Use separate conduit run for each motor. Do not run input power wiring and motor wiring in the same conduit.
Wireways ²⁾	
Metallic	Prefer symmetrical shielded VFD cable. Separate motor wiring from input power wiring and other low voltage wiring. Do not run outputs of multiple drives parallel. Bundle each cable (wiring) together and use separators where possible.
Free air ²⁾	
Enclosures, air handlers, etc.	Prefer symmetrical shielded VFD cable. Allowed internally in enclosures when in accordance with UL.

- 1) Metallic conduit may be used as an additional ground path, provided this path is a solid path capable of handling ground currents.
- 2) See NFPA NEC 70, UL, and local codes for your application.
- 3) Non-metallic conduit use underground is allowed; however, these installations inherently have an increased chance for nuisance problems due to the potential for water/moisture in the conduit. Water/moisture in the conduit increases the likelihood of VFD faults or warnings. Proper installation is required to make sure there is no intrusion of water/moisture.

Metal conduit

Couple separate parts of a metal conduit together: bridge the joints with a ground conductor bonded to the conduit on each side of the joint. Also bond the conduits to the drive enclosure and motor frame. Use separate conduits for input power, motor, brake

resistor, and control wiring. Do not run motor wiring from more than one drive in the same conduit.

■ **Power cable shield**

If the cable shield is used as the sole protective earth (PE) conductor, make sure that its conductivity agrees with the PE conductor requirements.

To effectively suppress radiated and conducted radio-frequency emissions, the cable shield conductivity must be at least 1/10 of the phase conductor conductivity. The requirements are easily met with a copper or aluminum shield. The minimum requirement of the motor cable shield of the drive is shown below. It consists of a concentric layer of copper wires with an open helix of copper tape or copper wire. The better and tighter the shield, the lower the emission level and bearing currents.

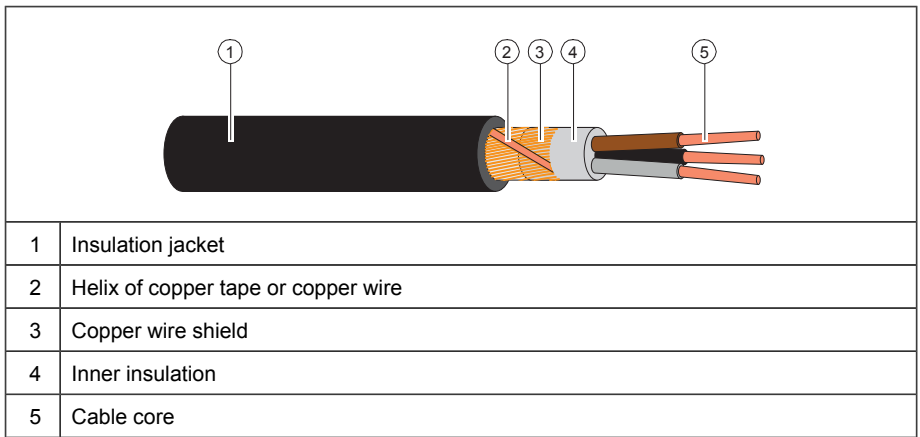

Selecting the control cables

■ **Shielding**

Only use shielded control cables.

Use a double-shielded twisted pair cable for analog signals. ABB recommends this type of cable also for the pulse encoder signals. Use one individually shielded pair for each signal. Do not use common return for different analog signals.

A double-shielded cable (a) is the best alternative for low-voltage digital signals, but single-shielded (b) twisted pair cable is also acceptable.

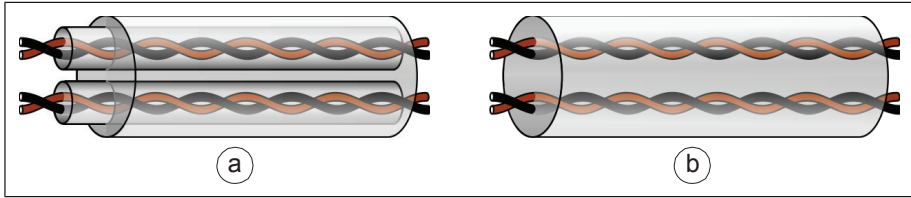

■ Signals in separate cables

Run analog and digital signals in separate, shielded cables. Do not mix 24 V DC and 115/230 V AC signals in the same cable.

■ Signals that can be run in the same cable

If their voltage does not exceed 48 V, relay-controlled signals can be run in the same cables as digital input signals. The relay-controlled signals should be run as twisted pairs.

■ Relay cable

The cable type with braided metallic shield (for example ÖLFLEX by LAPPKABEL, Germany) has been tested and approved by ABB.

■ Control panel to drive cable

Use EIA-485, Cat 5e (or better) cable with male RJ-45 connectors. The maximum length of the cable is 100 m (328 ft).

■ PC tool cable

Connect the Drive composer PC tool to the drive through the USB port of the control panel. Use a USB Type A (PC) - Type Mini-B (control panel) cable. The maximum length of the cable is 3 m (9.8 ft).

Routing the cables

■ General guidelines – IEC

- Route the motor cable away from other cables. Motor cables of several drives can be run in parallel installed next to each other.
 - Install the motor cable, input power cable and control cables on separate trays.
 - Avoid long parallel runs of motor cables with other cables.
-

- Where control cables must cross power cables, make sure that they are arranged at an angle as near to 90 degrees as possible.
- Do not run extra cables through the drive.
- Make sure that the cable trays have good electrical bonding to each other and to the grounding electrodes. Aluminum tray systems can be used to improve local equalizing of potential.

The following figure illustrates the cable routing guidelines with an example drive.

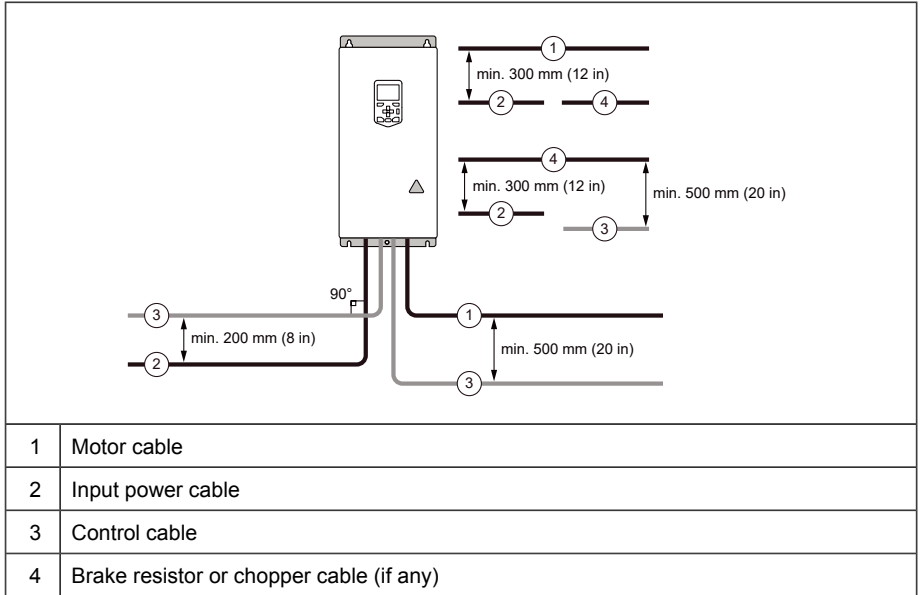

■ General guidelines – North America

Make sure that the installation is in accordance with national and local codes. Obey these general guidelines:

- Use separate conduits for the input power, motor, brake resistor (optional), and control cabling.
- Use separate conduit for each motor cabling.

The following figure illustrates the cable routing guidelines with an example drive.

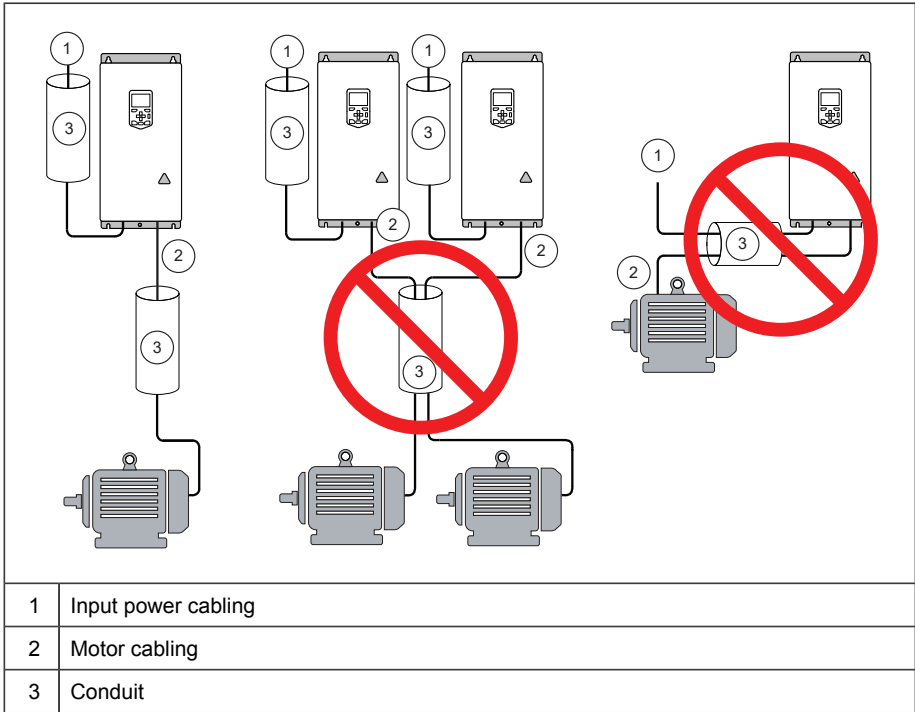

■ **Continuous motor cable shield/conduit or enclosure for equipment on the motor cable**

To minimize the emission level when safety switches, contactors, connection boxes or similar equipment are installed on the motor cable between the drive and the motor:

- Install the equipment in a metal enclosure.
- Use either a symmetrical shielded cable, or install the cabling in a metal conduit.
- Make sure that there is a good and continuous galvanic connection in the shield/conduit between drive and motor.
- Connect the shield/conduit to the protective ground terminal of the drive and the motor.

■ Separate control cable ducts

Put 24 V DC and 230 V AC (120 V AC) control cables in separate ducts, unless the 24 V DC cable is insulated for 230 V AC (120 V AC) or insulated with an insulation sleeving for 230 V AC (120 V AC).

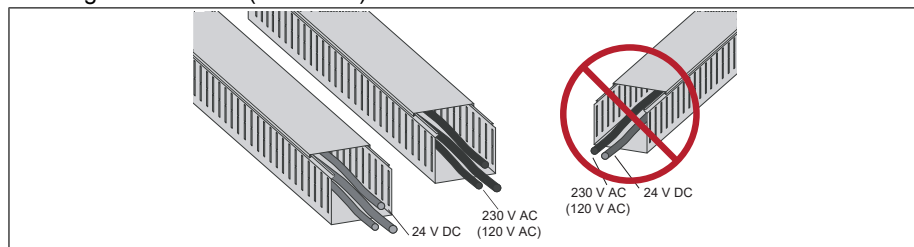

DC voltage boost function

The drive can boost their DC link voltage. In other words, it can increase the operating voltage of the DC link from its default value.

To take the DC voltage boost function in use:

1. adjust the user DC voltage reference value (94.22) and
2. select the user-defined reference (94.22) as the source for the drive DC voltage reference (94.21).

Benefits of the DC voltage boost function are:

- possibility to supply nominal voltage to the motor even when the supply voltage of the drive is below the motor nominal voltage level
- compensation of voltage drop due to output filter, motor cable or input supply cables
- increased motor torque in the field weakening area (ie, when the drive operates the motor in the speed range above the motor nominal speed)
- possibility to use a motor with higher nominal voltage than the actual supply voltage of the drive. Example: A drive that is connected to 415 V can supply 460 V to a 460 V motor.

For more information, see ACS880-11, ACS880-31, ACS880-14, ACS880-34, ACS880-17, ACS880-37 drives product note on DC voltage boost ([3AXD50000691838](https://www.aegiautomation.com/3AXD50000691838) [English]).

Protecting the drive, input power cable, motor and motor cable in short circuit situations and against thermal overload

■ Protecting the drive and the input power cable in short-circuits

Protect the drive with fuses and the input cable with fuses or a circuit breaker.

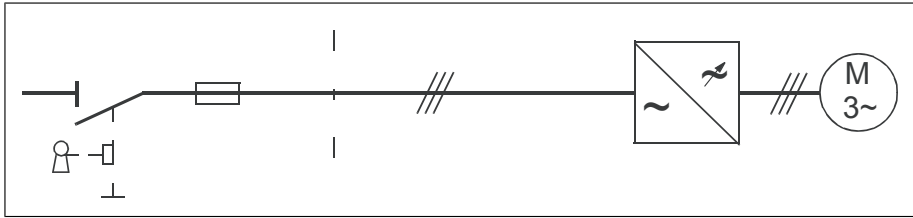

Size the fuses or circuit breakers according to local regulations for the input cable protection. Select the fuses or circuit breakers for the drive according to the instructions given in the technical data. The fuses for the drive protection will restrict drive damage and prevent damage to adjoining equipment in case of a short-circuit inside the drive.

Note: If the fuses or circuit breakers for the drive protection are placed at the distribution board and the input cable is dimensioned according to the nominal input current of the drive given in the technical data, the fuses or circuit breakers protect also the input cable in short-circuit situations, restrict drive damage and prevent damage to adjoining equipment in case of a short-circuit inside the drive. No separate fuses or circuit breakers for the input cable protection are needed.

 **WARNING!** Due to the inherent operating principle and construction of circuit breakers, independent of the manufacturer, hot ionized gases can escape from the breaker enclosure in case of a short-circuit. To ensure safe use, pay special attention to the installation and placement of the breakers. Obey the manufacturer's instructions.

■ Circuit breakers

See section *Circuit breakers (IEC) (page 184)* or *Circuit breakers (UL) (page 185)*.

■ Protecting the motor and motor cable in short-circuits

The drive protects the motor cable and motor in a short-circuit situation when the motor cable is sized according to the nominal output current of the drive.

■ Protecting the motor cables against thermal overload

The drive protects the motor cables against thermal overload when the cables are sized according to the nominal output current of the drive. No additional thermal protection devices are needed.

 **WARNING!** If the drive is connected to multiple motors, use a separate overload protection for each motor cable and motor. The drive overload protection is tuned for the total motor load. It may not detect an overload in one motor circuit only.

North America: The local code (NEC) requires an overload protection and a short-circuit protection for each motor circuit. Use, for example:

- a manual motor protector
 - circuit breaker, contactor and overload relay or
 - fuses, contactor and overload relay.
-

■ **Protecting the motor against thermal overload**

According to regulations, the motor must be protected against thermal overload and the current must be switched off when overload is detected. The drive includes a motor thermal protection function that protects the motor and switches off the current when necessary. Depending on a drive parameter value, the function either monitors a calculated temperature value (based on a motor thermal model) or an actual temperature indication given by motor temperature sensors.

The motor thermal protection model supports thermal memory retention and speed sensitivity. The user can tune the thermal model further by feeding in additional motor and load data.

The most common temperature sensor types are PTC or Pt100.

For more information, see the firmware manual.

■ **Protecting the motor against overload without thermal model or temperature sensors**

Motor overload protection protects the motor against overload without using motor thermal model or temperature sensors.

Motor overload protection is required and specified by multiple standards including the US National Electric Code (NEC) and the common UL/IEC 61800-5-1 standard in conjunction with UL/IEC 60947-4-1. The standards allow for motor overload protection without external temperature sensors.

The protection feature allows the user to specify the class of operation in the same manner as the overload relays are specified in standards UL/IEC 60947-4-1 and NEMA ICS 2.

The motor overload protection supports thermal memory retention and speed sensitivity.

For more information, see drive firmware manual.

Implementing a motor temperature sensor connection



WARNING!

IEC 61800-5-1 requires double or reinforced insulation between live parts and accessible parts when:

- the accessible parts are not conductive, or
- the accessible parts are conductive, but not connected to the protective earth.

Obey this requirement when you plan the connection of the motor temperature sensor to the drive.

You have these implementation alternatives:

1. If there is double or reinforced insulation between the sensor and the live parts of the motor: You can connect the sensor directly to the analog/digital input(s) of the drive. See the control cable connection instructions. Make sure that the voltage does not exceed the maximum allowed voltage over the sensor.
2. If there is basic insulation between the sensor and the live parts of the motor: You can connect the sensor to the analog/digital input(s) of the drive. All other circuits connected to the digital and analog inputs (typically extra-low voltage circuits) must be:
 - protected against contact, and
 - insulated with basic insulation from other low-voltage circuits. The insulation must be rated for the same voltage level as the drive main circuit.

Note: Extra-low voltage circuits (for example, 24 V DC) typically do not meet these requirements.

Make sure that the voltage does not exceed the maximum allowed voltage over the sensor.

As an alternative, you can connect the sensor with basic insulation to the analog/digital input(s) of the drive, if you do not connect any other external control circuits to the drive digital and analog inputs.

3. You can connect the sensor to the drive via an option module. The sensor and the module must form a double or reinforced insulation between the motor live parts and the drive control unit. See [Connecting motor temperature sensor to the drive via an option module \(page 77\)](#). Make sure that the voltage does not exceed the maximum allowed voltage over the sensor.
 4. You can connect a sensor to a digital input of the drive via an external relay. The sensor and the relay must form a double or reinforced insulation between the motor live parts and the digital input of the drive. Make sure that the voltage does not exceed the maximum allowed voltage over the sensor.
-

■ Connecting motor temperature sensor to the drive via an option module

This table shows:

- option module types that you can use for the motor temperature sensor connection
- insulation or isolation level that each option module forms between its temperature sensor connector and other connectors
- temperature sensor types that you can connect to each option module
- temperature sensor insulation requirement in order to form, together with the insulation of the option module, a reinforced insulation between the motor live parts and the drive control unit.

Option module		Temperature sensor type			Temperature sensor insulation requirement
Type	Insulation/Isolation	PTC	KTY	Pt100, Pt1000	
FIO-11	Galvanic isolation between sensor connector and other connectors (including drive control unit connector)	-	x	x	Reinforced insulation
FEN-xx	Galvanic isolation between sensor connector and other connectors (including drive control unit connector)	x	x	-	Reinforced insulation
FAIO-01	Basic insulation between sensor connector and drive control unit connector. No insulation between sensor connector and other I/O connectors.	x	x	x	Basic insulation. Connectors of option module other than sensor connector must be left unconnected.
FPTC-xx ¹⁾	Reinforced insulation between sensor connector and other connectors (including drive control unit connector).	x	-	-	No special requirement

¹⁾ Suitable for use in safety functions (SIL2 / PL c rated).

Protecting the drive against ground faults

The drive is equipped with an internal ground fault protective function to protect the unit against ground faults in the motor and motor cable. This function is not a personnel safety or a fire protection feature. See the firmware manual for more information.

■ Residual current device compatibility

The drive is suitable to be used with residual current devices of Type B.

Note: As standard, the drive contains capacitors connected between the main circuit and the frame. These capacitors and long motor cables increase the ground leakage current and may cause nuisance faults in residual current devices.

Implementing the emergency stop function

For safety reasons, install the emergency stop devices at each operator control station and at other operating stations where the emergency stop may be needed. Implement the emergency stop according to relevant standards.

Note: You can use the Safe torque off function of the drive to implement the Emergency stop function.

Implementing the Safe torque off function

See [The Safe torque off function \(page 217\)](#).

Implementing the power loss ride-through function

If the incoming supply voltage is cut off, the drive will continue to operate by utilizing the kinetic energy of the rotating motor. The drive will be fully operational as long as the motor rotates and generates energy to the drive.

If you equip the drive with a main contactor or breaker, make sure that it restores the drive input power after a short break. The contactor must either re-connect after the break automatically, or remain closed over the break. Depending on the contactor control circuit design, this can require an additional hold circuit, uninterruptible auxiliary power supply or auxiliary power supply buffering.

Note: If the power loss lasts so long that the drive trips on undervoltage, a fault reset and a fresh start command is required to continue operation.

Implement the power-loss ride-through function as follows:

1. Enable the power-loss ride-through function of the drive (parameter 30.31).
2. If the installation is equipped with a main contactor, prevent its tripping at the input power break. For example, use a time delay relay (hold) in the contactor control circuit.
3. Enable the automatic restart of the motor after a short power supply break:
 - Set the start mode to automatic (parameter 21.01 or 21.19, depending on the motor control mode being used).
 - Define the automatic restart time (parameter 21.18).



WARNING!

Make sure that a flying restart of the motor will not cause any danger. If you are in doubt, do not implement the power loss ride-through function.

Implementing the functions provided by the FSO-xx safety functions module

You can order the drive with an FSO-12 or FSO-21 safety functions module (option +Q972 or +Q973) which enables the implementation of functions such as Safe brake control (SBC), Safe stop 1 (SS1), Safe stop emergency (SSE), Safely limited speed (SLS) and Safe maximum speed (SMS).

The settings of the FSO-xx module have default values when delivered from the factory. The wiring of the external safety circuit and configuration of the FSO-xx module are the responsibility of the user.

The FSO-xx module reserves the standard Safe torque off (STO) connection of the drive control unit. STO can still be utilized by other safety circuits through the FSO-xx.

See the appropriate manual for more information.

Name	Code
<i>FSO-12 safety functions module user's manual</i>	3AXD50000015612
<i>FSO-21 safety functions module user's manual</i>	3AXD50000015614

Using power factor compensation capacitors with the drive

Power factor compensation is not needed with AC drives. However, if a drive is to be connected in a system with compensation capacitors installed, note the following restrictions.



WARNING!

Do not connect power factor compensation capacitors or harmonic filters to the motor cables (between the drive and the motor). They are not meant to be used with AC drives and can cause permanent damage to the drive or themselves.

If there are power factor compensation capacitors in parallel with the input of the drive:

1. Do not connect a high-power capacitor to the power line while the drive is connected. The connection will cause voltage transients that may trip or even damage the drive.
 2. If capacitor load is increased/decreased step by step when the AC drive is connected to the power line, make sure that the connection steps are low enough not to cause voltage transients that would trip the drive.
 3. Make sure that the power factor compensation unit is suitable for use in systems with AC drives, ie, harmonic generating loads. In such systems, the compensation unit should typically be equipped with a blocking reactor or harmonic filter.
-

Using a safety switch between the drive and the motor

ABB recommends to install a safety switch between the permanent magnet motor and the drive output. The switch is needed to isolate the motor from the drive during maintenance work on the drive.

Implementing an ATEX-certified motor thermal protection

With option +Q971, the drive provides ATEX-certified safe motor disconnection without contactor using the drive Safe torque off function. To implement the thermal protection of a motor in explosive atmosphere (Ex motor), you must also:

- use an ATEX-certified Ex motor
- order an ATEX-certified thermistor protection module for the drive (option +L537), or acquire and install an ATEX-compliant protection relay
- do the necessary connections.

For more information, see:

User's manual	Manual code (English)
<i>ATEX-certified Safe disconnection function, Ex II (2) GD for ACS880 drives (+Q971) application guide</i>	3AJA0000132231
<i>FPTC-02 ATEX-certified thermistor protection module, Ex II (2) GD (option +L537+Q971) for ACS880 drives user's manual</i>	3AXD50000027782

Controlling a contactor between drive and motor

The control of the output contactor depends on how you use the drive, that is, which motor control mode and which motor stop mode you select.

If you have the DTC motor control mode and the motor ramp stop mode selected, use this operation sequence to open the contactor:

1. Give a stop command to the drive.
2. Wait until the drive decelerates the motor to zero speed.
3. Open the contactor.

If you have the DTC motor control mode and the motor coast stop, or scalar control mode selected, open the contactor as follows:

1. Give a stop command to the drive.
 2. Open the contactor.
-



WARNING!

When the DTC motor control mode is in use, never open the output contactor while the drive controls the motor. The DTC motor control operates extremely fast, much faster than it takes for the contactor to open its contacts. When the contactor starts opening while the drive controls the motor, the DTC control will try to maintain the load current by immediately increasing the drive output voltage to the maximum. This will damage, or even burn, the contactor completely.

Implementing a bypass connection

If bypassing is required, employ mechanically or electrically interlocked contactors between the motor and the drive and between the motor and the power line. Make sure with interlocking that the contactors cannot be closed simultaneously. The installation must be clearly marked as defined in IEC/EN/UL 61800-5-1, subclause 6.5.3, for example, "THIS MACHINE STARTS AUTOMATICALLY".



WARNING!

Never connect the drive output to the electrical power network. The connection may damage the drive.

Protecting the contacts of relay outputs

Inductive loads (relays, contactors, motors) cause voltage transients when switched off.

The relay contacts on the drive control unit are protected with varistors (250 V) against overvoltage peaks. In spite of this, it is highly recommended that inductive loads are equipped with noise attenuating circuits (varistors, RC filters [AC] or diodes [DC]) to minimize the EMC emission at switch-off. If not suppressed, the disturbances may connect capacitively or inductively to other conductors in the control cable and form a risk of malfunction in other parts of the system.

Install the protective component as close to the inductive load as possible. Do not install protective components at the relay outputs.

82 Guidelines for planning the electrical installation

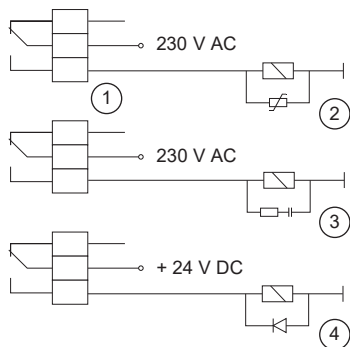

1	Relay output
2	Varistor
3	RC filter
4	Diode

6

Electrical installation – IEC

Contents of this chapter

This chapter contains instructions on how to wire the drive.

Safety



WARNING!

If you are not a qualified electrical professional, do not do installation or maintenance work. Obey the safety instructions of the drive. If you ignore them, injury or death, or damage to the equipment can occur.

Required tools

To do the electrical installation, you need these tools:

- wire stripper
- screwdriver set (Torx, flat and/or Phillips, as appropriate)
- torque wrench.

Grounding the motor cable shield at the motor end

For minimum radio-frequency interference, ground the cable shield 360 degrees at the cable entry of the motor terminal box.



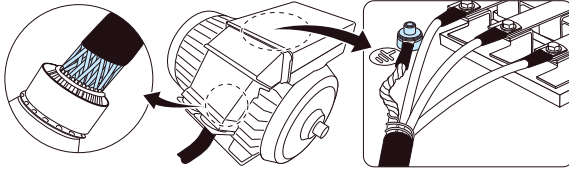

Measuring the insulation

■ Measuring the insulation resistance of the drive



WARNING!

Do not do any voltage withstand or insulation resistance tests on any part of the drive as testing can damage the drive. Every drive has been tested for insulation between the main circuit and the chassis at the factory. Also, there are voltage-limiting circuits inside the drive which cut down the testing voltage automatically.

■ Measuring the insulation resistance of the input power cable

Before you connect the input power cable to the drive, measure its insulation resistance according to local regulations.

■ Measuring the insulation resistance of the motor and motor cable



WARNING!

Obey the safety instructions of the drive. If you ignore them, injury or death, or damage to the equipment can occur. If you are not a qualified electrical professional, do not do installation, commissioning or maintenance work.

1. Do the steps in section [Electrical safety precautions \(page 19\)](#) before you start the work.
2. Make sure that the motor cable is disconnected from the drive output terminals.
3. Measure the insulation resistance between each phase conductor and the protective earth conductor. Use a measuring voltage of 1000 V DC. The insulation resistance of an ABB motor must be more than 100 Mohm (reference value at 25 °C [77 °F]). For the insulation resistance of other motors, refer to the manufacturer's instructions.

Note: Moisture inside the motor reduces the insulation resistance. If you think that there is moisture in the motor, dry the motor and do the measurement again.

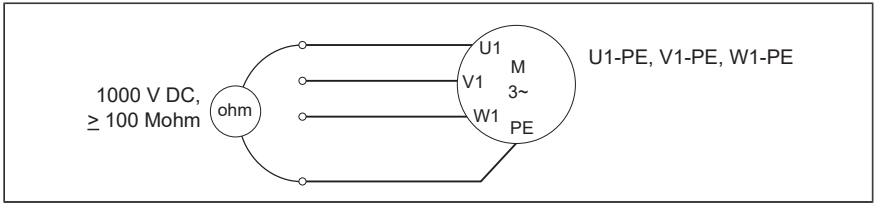

■ Measuring the insulation resistance of the brake resistor circuit



WARNING!

Obey the safety instructions of the drive. If you ignore them, injury or death, or damage to the equipment can occur. If you are not a qualified electrical professional, do not do installation, commissioning or maintenance work.

1. Stop the drive and do the steps in section [Electrical safety precautions \(page 19\)](#) before you start the work.
2. Make sure that the resistor cable is connected to the resistor and disconnected from the drive output terminals.
3. At the drive end, connect the R+ and R- conductors of the resistor cable together. Measure the insulation resistance between the conductors and the PE conductor with a measuring voltage of 1000 V DC. The insulation resistance must be more than 1 Mohm.

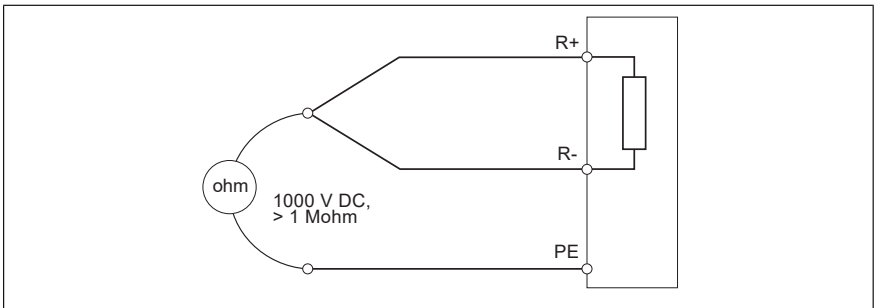

Grounding system compatibility check

The standard drive can be installed to a symmetrically grounded TN-S system.

For other systems, see sections [EMC filter option +E200 or +E202](#) and [Ground-to-phase varistors](#) below.

■ EMC filter option +E200 or +E202

A drive with EMC filter options +E200 and +E202 connected can be installed to a symmetrically grounded TN-S system. If you install the drive to another system, you

may need to disconnect the EMC filter. See section *When to disconnect EMC filter (options +E200 and +E202) or ground-to-phase varistor: TN-S, IT, corner-grounded delta and midpoint-grounded delta systems and TT systems (page 86)*.



WARNING!

Do not install the drive with the EMC filter options +E200 and +E202 connected to a system that the filter is not suitable for. This can cause danger, or damage the drive.

Note: When EMC filter +E200 or +E202 is disconnected, the drive EMC compatibility is considerably reduced.

■ **Ground-to-phase varistors**

A standard drive with the ground-to-phase varistor connected can be installed to a symmetrically grounded TN-S system. If you install the drive to another system, you may need to disconnect the varistor. See sections *When to disconnect EMC filter (options +E200 and +E202) or ground-to-phase varistor: TN-S, IT, corner-grounded delta and midpoint-grounded delta systems and TT systems (page 86)*.



WARNING!

Do not install the drive with the ground-to-phase varistor connected to a system that the varistor is not suitable for. If you do, the varistor circuit can be damaged.

■ **Corner-grounded and midpoint-grounded 525...690 V delta systems**



WARNING!

Do not install the drive on a 525...690 V corner-grounded or midpoint-grounded delta system. Disconnecting the EMC filter and ground-to-phase varistor does not prevent damage to the drive.

■ **When to disconnect EMC filter (options +E200 and +E202) or ground-to-phase varistor: TN-S, IT, corner-grounded delta and midpoint-grounded delta systems and TT systems**

Requirements for disconnecting EMC filter and varistor and additional requirements for different electrical power systems are given below.

Symmetrically grounded TN systems (TN-S systems, ie, center-grounded wye)

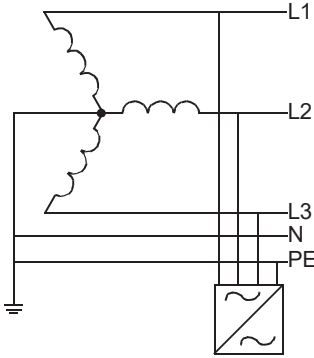
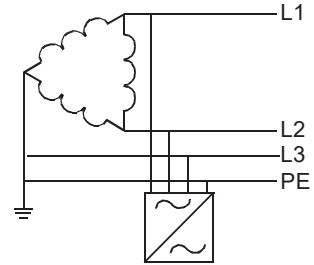
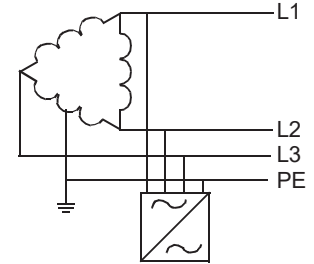
	<p>Do not remove EMC or VAR screws.</p>
<p>Corner-grounded delta systems ≤ 600 V</p>	
	<p><u>R3</u>: Do not remove EMC or VAR screws. <u>R6</u>: Remove EMC DC screw. Do not remove EMC AC or VAR screws. See Note 1 below. <u>R8</u>: Remove EMC DC and VAR screws.</p>
<p>Midpoint-grounded delta systems ≤ 600 V</p>	
	<p><u>R3</u>: Do not remove EMC or VAR screws. <u>R6</u>: Remove EMC DC screw. Do not remove EMC AC or VAR screws. See Note 1 below. <u>R8</u>: Remove EMC DC and VAR screws.</p>
<p>IT systems (ungrounded or high-resistance grounded [>30 ohms])</p>	



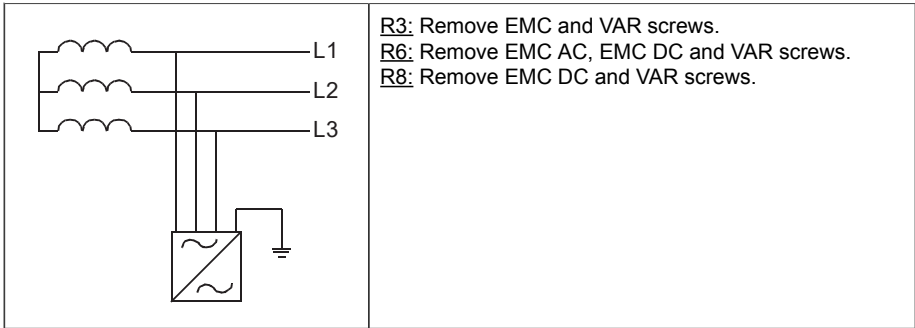

R3: Remove EMC and VAR screws.
R6: Remove EMC AC, EMC DC and VAR screws.
R8: Remove EMC DC and VAR screws.

TT systems

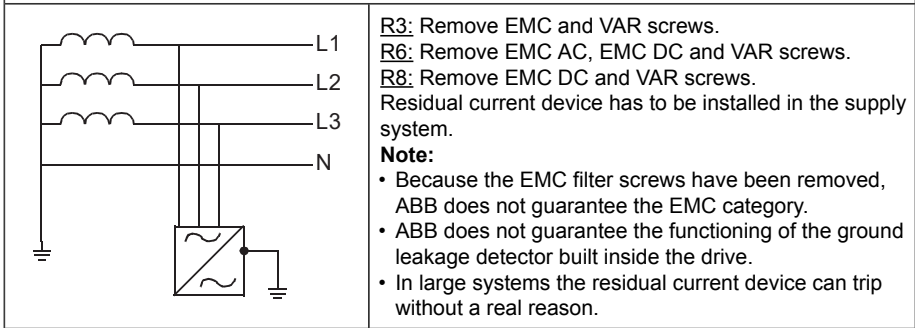

R3: Remove EMC and VAR screws.
R6: Remove EMC AC, EMC DC and VAR screws.
R8: Remove EMC DC and VAR screws.
 Residual current device has to be installed in the supply system.
Note:

- Because the EMC filter screws have been removed, ABB does not guarantee the EMC category.
- ABB does not guarantee the functioning of the ground leakage detector built inside the drive.
- In large systems the residual current device can trip without a real reason.

Note 1: Frames R3 and R6 are evaluated for use on corner-grounded systems and midpoint-grounded delta systems by UL standards. They are not evaluated by IEC standards for use on corner-grounded or midpoint-grounded systems.

Note 2: These are the EMC filter and varistor screws of different drive frame sizes.

Frame size	EMC filter (options +E200 and +E202) screws	Ground-to-phase varistor screws
R3	EMC	VAR
R6	EMC AC, EMC DC	VAR
R8	EMC DC	VAR ¹⁾

1) VAR screw functions also as EMC AC screws in frame R8.

■ Identifying the grounding system of the electrical power network



WARNING!

Only a qualified electrical professional may do the work instructed in this section. Depending on the installation site, the work may even be categorized as live working. Continue only if you are an electrical professional certified for the work. Obey the local regulations. If you ignore them, injury or death can occur.

To identify the grounding system, examine the supply transformer connection. See the applicable electrical diagrams of the building. If that is not possible, measure these voltages at the distribution board, and use the table to define the grounding system type.

1. input voltage line to line (U_{L-L})
2. input voltage line 1 to ground (U_{L1-G})
3. input voltage line 2 to ground (U_{L2-G})
4. input voltage line 3 to ground (U_{L3-G}).

The table below shows the line-to-ground voltages in relation to the line-to-line voltage for each grounding system.

U_{L-L}	U_{L1-G}	U_{L2-G}	U_{L3-G}	Electrical power system type
X	$0.58 \cdot X$	$0.58 \cdot X$	$0.58 \cdot X$	Symmetrically grounded TN system (TN-S system)
X	$1.0 \cdot X$	$1.0 \cdot X$	0	Corner-grounded delta system (nonsymmetrical)
X	$0.866 \cdot X$	$0.5 \cdot X$	$0.5 \cdot X$	Midpoint-grounded delta system (nonsymmetrical)
X	Varying level versus time	Varying level versus time	Varying level versus time	IT systems (ungrounded or high-resistance-grounded [>30 ohms]) nonsymmetrical
X	Varying level versus time	Varying level versus time	Varying level versus time	TT system (the protective earth connection for the consumer is provided by a local earth electrode, and there is another independently installed at the generator)



■ **Disconnecting integrated EMC filter (option +E200 or +E202) and ground-to-phase varistor – frame R3**

1. Stop the drive and do the steps in section *Electrical safety precautions (page 19)* before you start the work.
2. Remove the front cover.
3. Remove the EMC screw.
4. Remove the VAR screw.

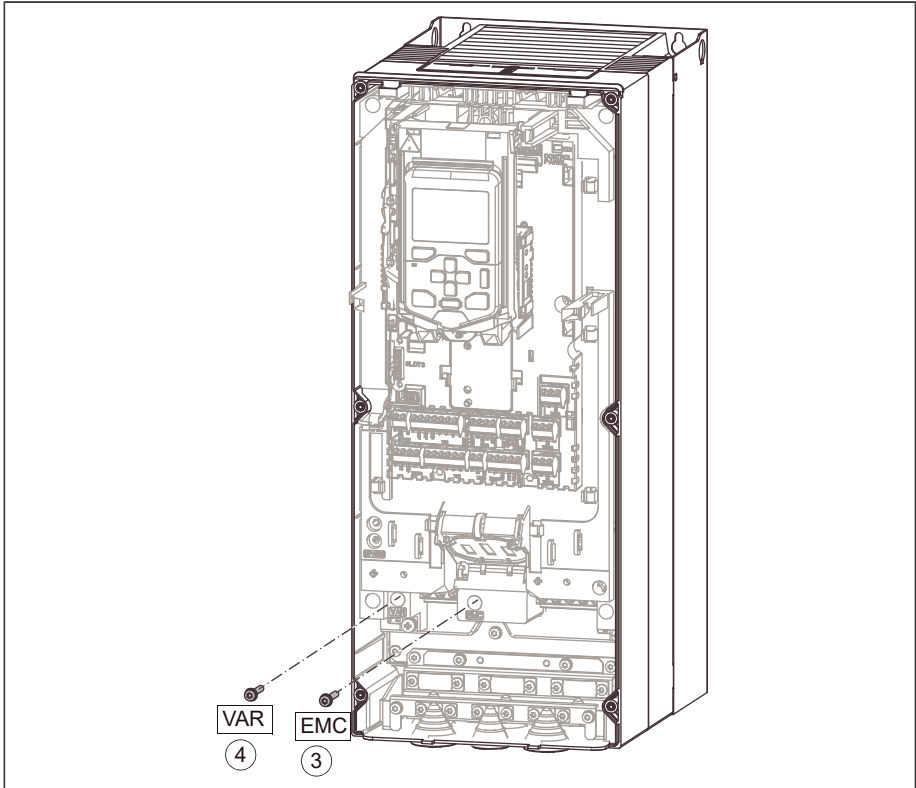

■ **Disconnecting integrated EMC filter (option +E200 or +E202) and ground-to-phase varistor – frame R6**

1. Stop the drive and do the steps in section *Electrical safety precautions (page 19)* before you start the work.
2. Remove the front cover.
3. Remove the VAR screw.
4. Remove the EMC AC and/or EMC DC screw.

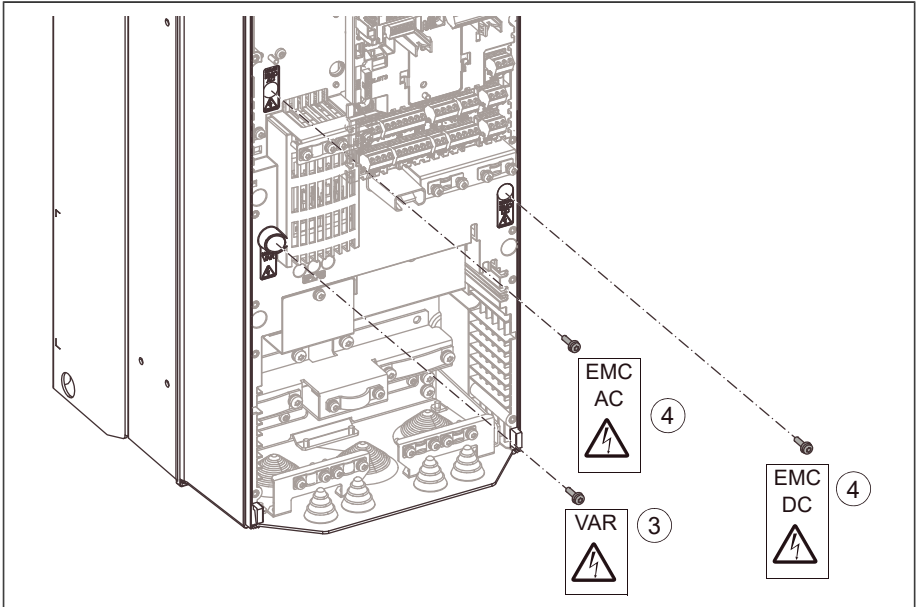

■ **Disconnecting integrated EMC filter and ground-to-phase varistor – frame R8**

1. Stop the drive and do the steps in section *Electrical safety precautions (page 19)* before you start the work.
2. Remove the front cover if it is not already removed.
3. Remove the VAR screw.
4. Remove the EMC DC screw.

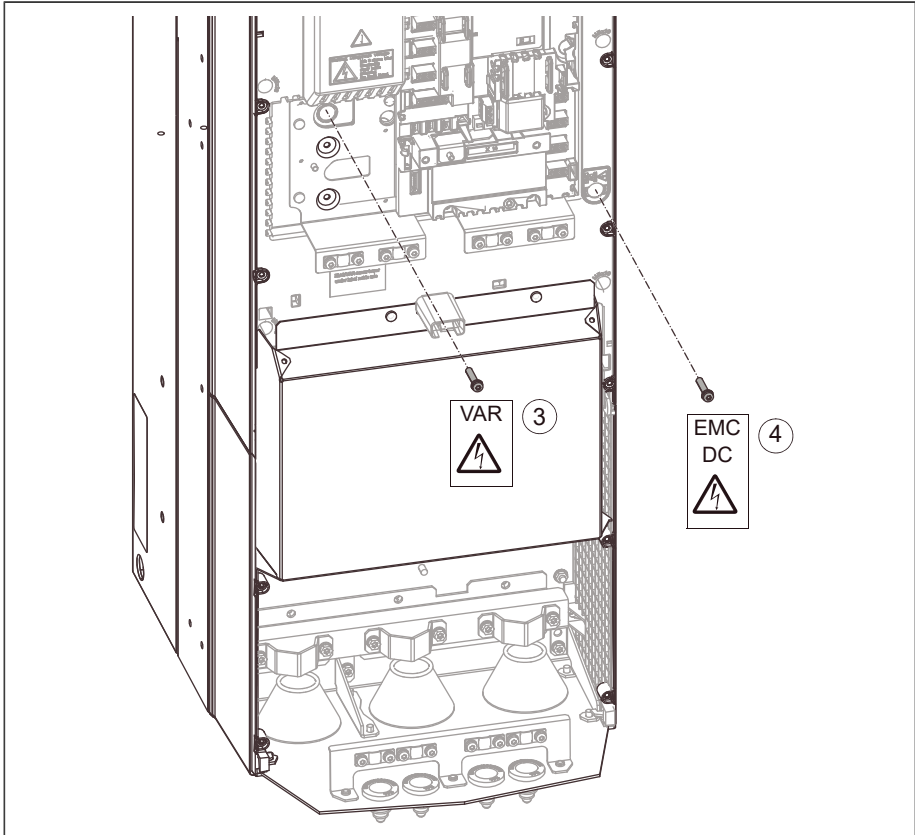

Connecting the power cables

■ Connection diagram

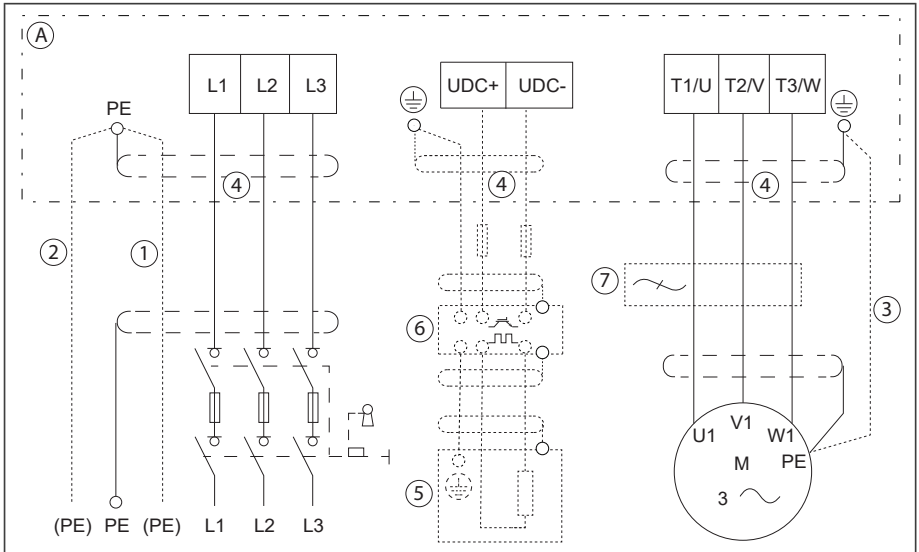

A	Drive
1	Two protective earth (ground) conductors. Drive safety standard IEC/ EN 61800-5-1 requires two PE conductors, if the cross-sectional area of the PE conductor is less than 10mm ² Cu or 16 mm ² Al. For example, you can use the cable shield in addition to the fourth conductor.
2	Use a separate grounding cable or a cable with a separate PE conductor for the line side, if the conductivity of the fourth conductor or shield does not meet the requirements for the PE conductor.
3	Use a separate grounding cable for the motor side, if the conductivity of the shield is not sufficient, or if there is no symmetrically constructed PE conductor in the cable.
4	ABB requires 360-degree grounding of the cable shield for the motor cable and brake resistor cable (if used). ABB also recommends it for the input power cable.
5	External brake resistor (optional)
6	External brake chopper (optional)
7	If necessary, install an external filter (du/dt, common mode, or sine filter). Filters are available from ABB.

Note: If there is a symmetrically constructed grounding conductor on the motor cable in addition to the conductive shield, connect the grounding conductor to the grounding terminal at the drive and motor ends.

Do not use an asymmetrically constructed motor cable for motors above 30 kW. See section [Selecting the power cables \(page 64\)](#).

Connecting its fourth conductor at the motor end increases bearing currents and causes extra wear.



■ Connection procedure

The procedure of connecting the power cables to the standard drive is described below. For the procedure with UK gland plate (option +H358), see also ACS880-11, ACS880-31, ACH580-31 and ACQ580-31 UK gland plate (+H358) installation guide ([3AXD50000110711](#) [English]).

1. **For frame R3:** To remove the front cover, lift the cover from the bottom outwards (1a) and then up (1b).

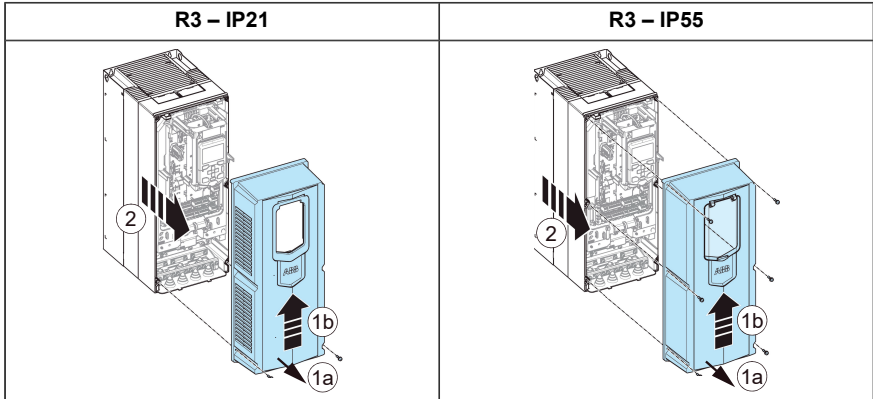

For frame R6 and R8 (IP21): Remove the cover as follows:

- Release the retaining clip with a screwdriver.
- Remove the middle front cover.
- Remove the lower front cover.

For frame R6 and R8 (IP55): Remove the covers as follows:

- Loosen the screws that attach the front cover to the frame.
- Remove the cover.
- For frame R8, disconnect the power supply wire of the auxiliary cooling fan.



R6, R8 – IP21

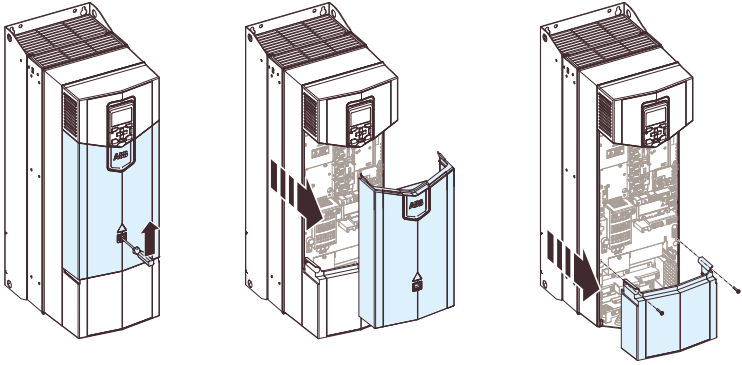

R6, R8 – IP55

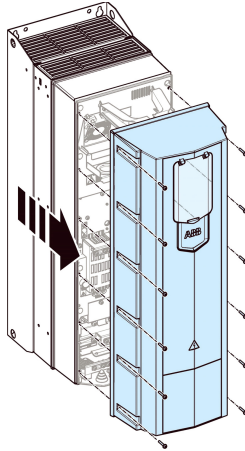

2. Attach the residual voltage warning sticker in the local language.

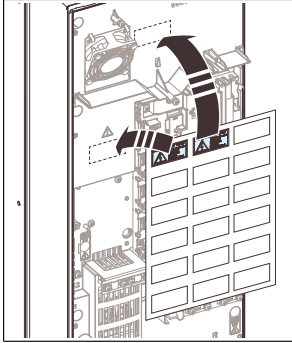

3. For frames R6 and R8: Remove the shroud on the power cable terminals.

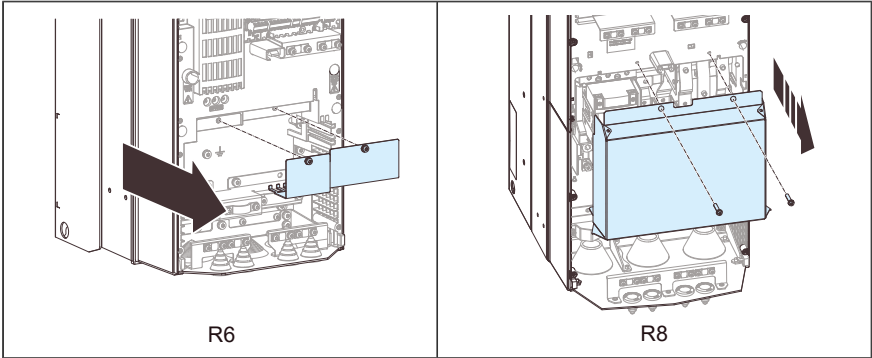

4. For frame R8: For easier installation, you can remove the side plates.

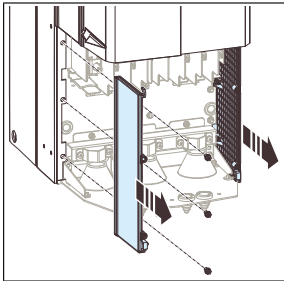

5. Remove the rubber grommets of the cables to be installed from the cable entry plate. Install the grommets downwards also in unused holes.

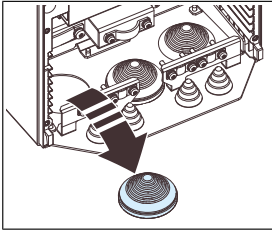

6. Cut an adequate hole into the rubber grommet. Slide the grommet onto the cable.

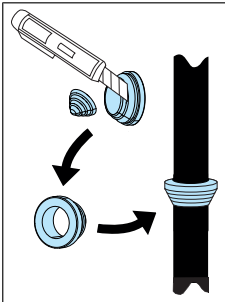

7. Prepare the ends of the cables as shown in the figure. Two different motor cable types are shown. If you use aluminum cables, put grease onto the peeled aluminum cable before you connect it to the drive.

Note: The bare shield will be grounded 360 degrees.

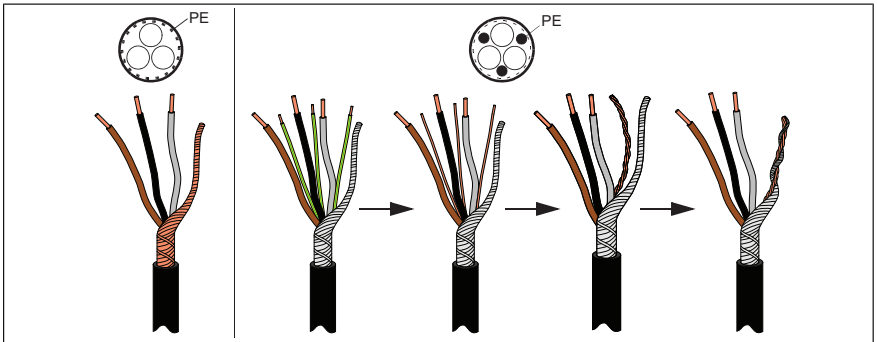

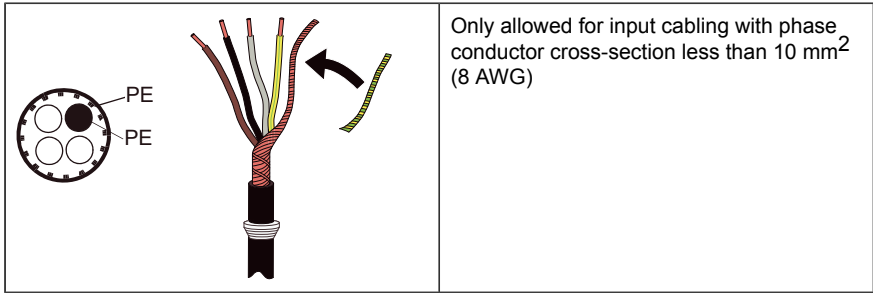

8. Put the cable through the hole of the cable entry plate and attach the grommet to the hole.
9. Connect the cables:
 - Ground the shield 360 degrees by tightening the clamp of the power cable grounding shelf onto the stripped part of the cable.
 - Connect the twisted shield of the cable to the grounding terminal.
 - Connect the additional PE conductors (if any).
 - For frame R8 (option +E208): Install the common mode filter. For instructions, see *Common mode filter kit for ACS880-01 frame R7, and for ACS880-11, ACS880-31, ACH580-31 and ACQ580-31 frame R8 installation instructions* ([3AXD50000015179](#) [English]).
 - Connect the phase conductors of the motor cable to the T1/U, T2/V and T3/W terminals and the phase conductors of the input cable to the L1, L2 and L3 terminals.
 - If the DC cables are present, cut off one phase conductor and isolate the end. Connect the remaining conductors to the UDC+ and UDC- terminals.

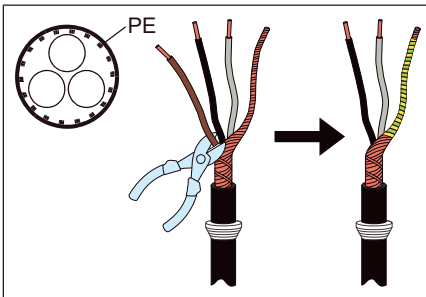

- Tighten the screws to the torque given in the installation drawing below.

R3

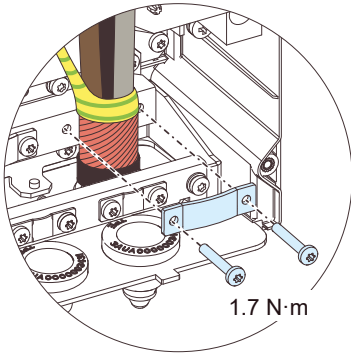

1.7 N·m

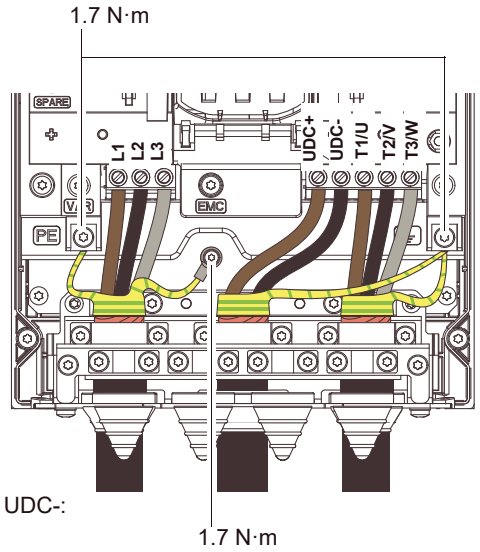

L1, L2, L3, T1/U, T2/V, T3/W, UDC+, UDC-:
1.7 N·m

1.7 N·m

R6

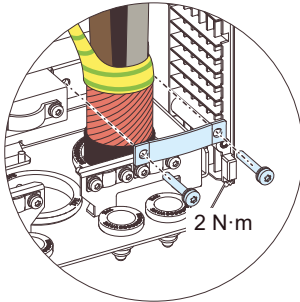

2 N·m

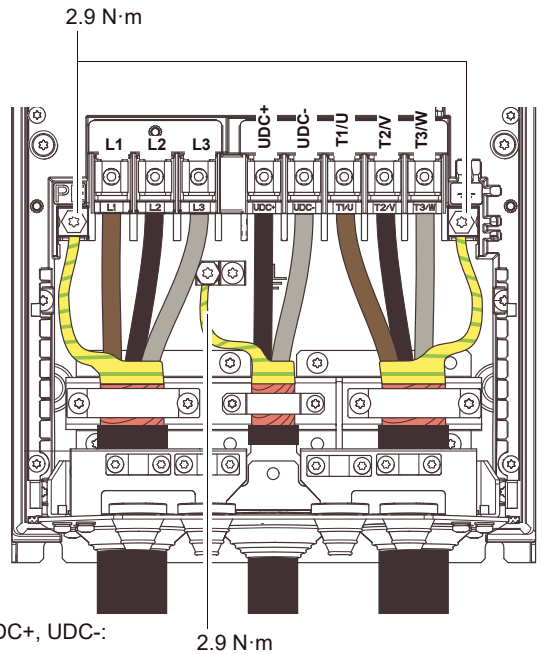

L1, L2, L3, T1/U, T2/V, T3/W, UDC+, UDC-:
5.6 N·m

2.9 N·m



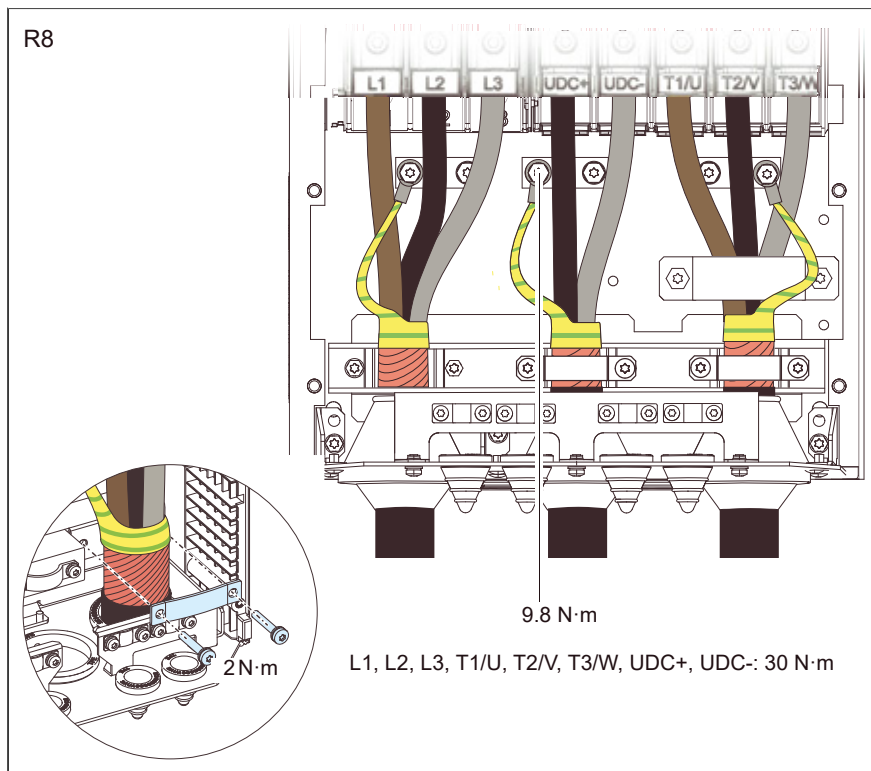

Note: For frame R8: Install the side plates if removed.

Note: For frame R8: The power cable connectors can be detached. For the instructions, see section [R8 power cable connection if you detach the cable connectors \(page 101\)](#).

10. For frame R6 types bigger than -040A-x: Cut tabs in the shroud for the installed cables.

11. Install the shroud onto the power cable connection terminals.

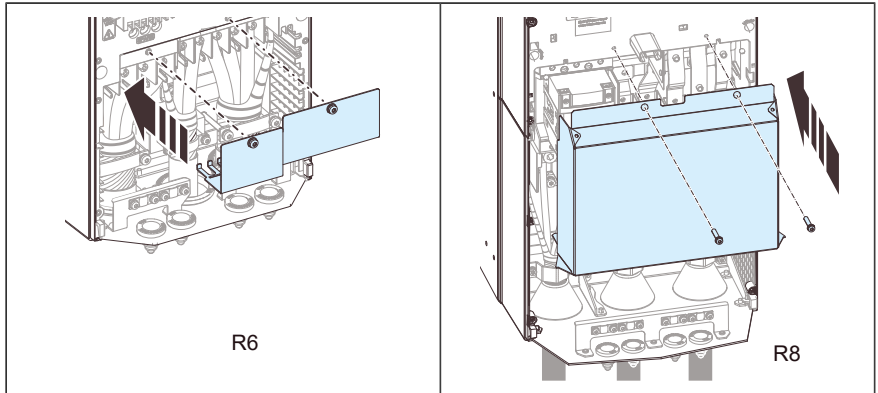

R8 power cable connection if you detach the cable connectors

The power cable connectors of frame R8 are detachable. If you detach them, you can connect the cables with cable lugs as follows:

- Remove the nut that attaches the connector to the terminal post and remove the connector.
- Alternative 1: Put the conductor to the connector. Tighten to a torque of 30 N·m. Put the connector back onto the post. Tighten the connector to 30 N·m.
- Alternative 2: Attach a cable lug to the conductor. Put the cable lug onto the post. Tighten the nut to a torque of 30 N·m.



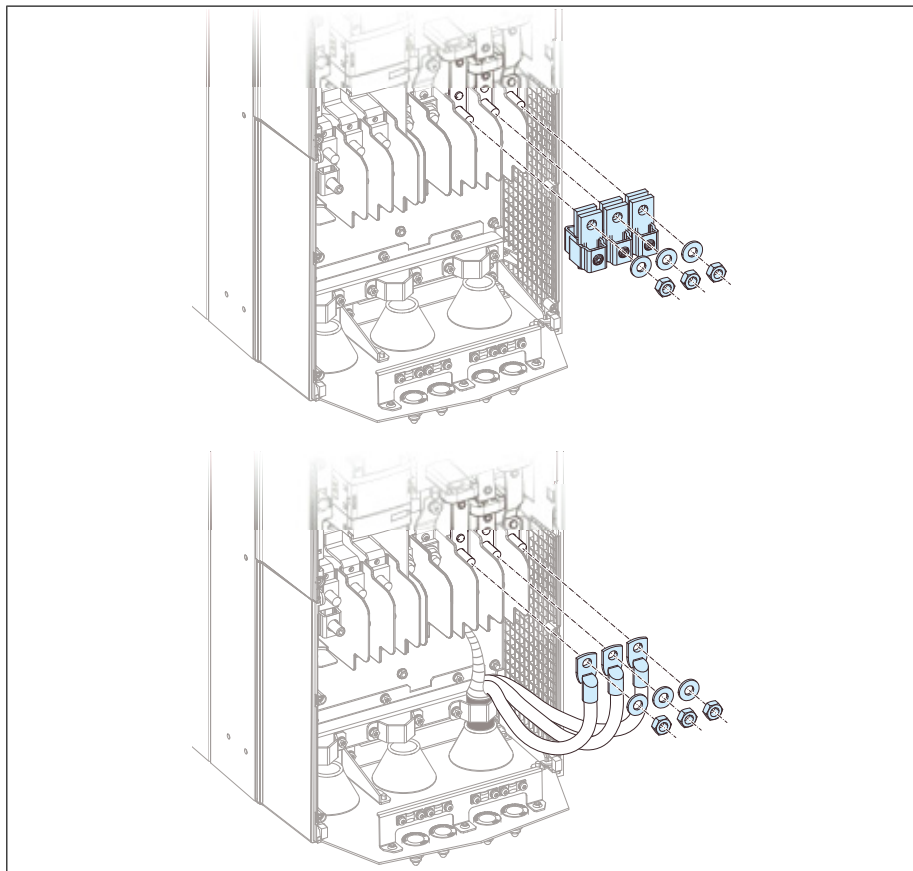

Connecting the control cables

■ Connection diagram

See section *Default I/O diagram of the drive control unit (ZCU-1x) (page 133)* for the default I/O connections of the drive.

■ Connection procedure



WARNING!

Obey the safety instructions of the drive. If you ignore them, injury or death, or damage to the equipment can occur. If you are not a qualified electrical professional, do not do installation, commissioning or maintenance work.

1. Stop the drive and do the steps in section [Electrical safety precautions \(page 19\)](#) before you start the work.
2. Remove the front cover(s) if not already removed.
3. For frame R3: Pull the control panel holder up.

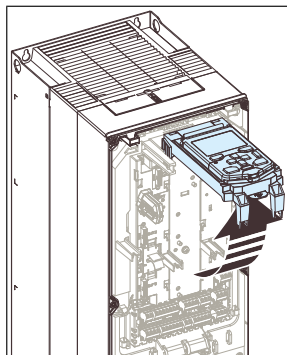

4. Cut an adequate hole into the rubber grommet and slide the grommet onto the cable. Slide the cable through a hole in the bottom plate and attach the grommet to the hole.
5. Route the cable as shown in the figures below.
6. Ground the outer shield of the cable 360 degrees under the grounding clamp at the cable entry. Keep the cable unstripped as close to the terminals of the control unit as possible. Secure the cables inside the drive mechanically.
7. Frame R3: Ground the pair cable shields and grounding wires under the grounding clamp screw at the cable entry.
Frame R6 and R8: Ground the pair cable shields and grounding wire under the clamp screw below the control unit.
8. Connect the conductors to the appropriate terminals of the control unit and tighten to 0.5 ... 0.6 N·m. See [Default I/O diagram of the drive control unit \(ZCU-1x\) \(page 133\)](#).

Note:

- Leave the other ends of the control cable shields unconnected or ground them indirectly through a high-frequency capacitor with a few nanofarads, eg, 3.3 nF / 630 V. The shield can also be grounded directly at both ends if they are in the same ground line with no significant voltage drop between the end points.
- Keep any signal wire pairs twisted as close to the terminals as possible. Twisting the wire with its return wire reduces disturbances caused by inductive coupling.

Example wirings are shown below.



R6

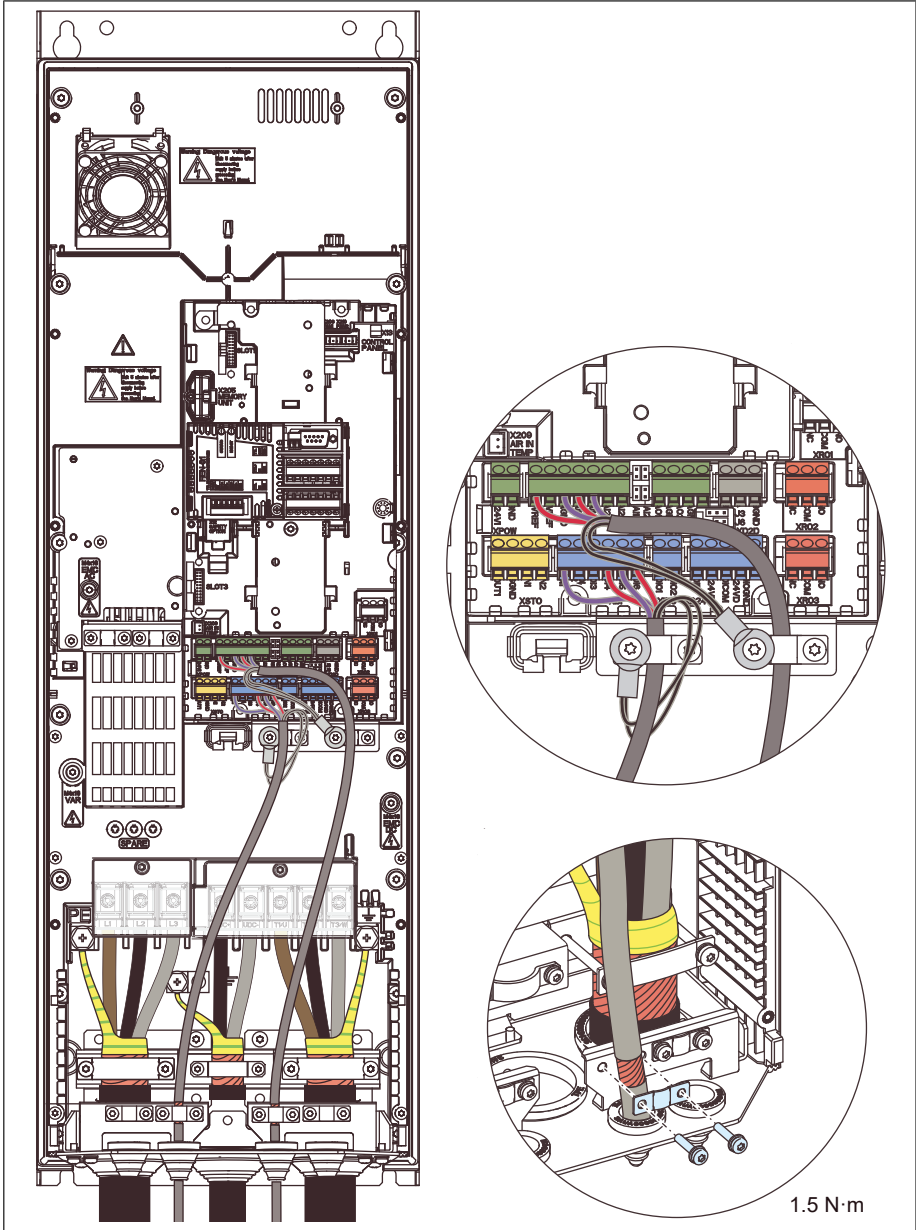

R8

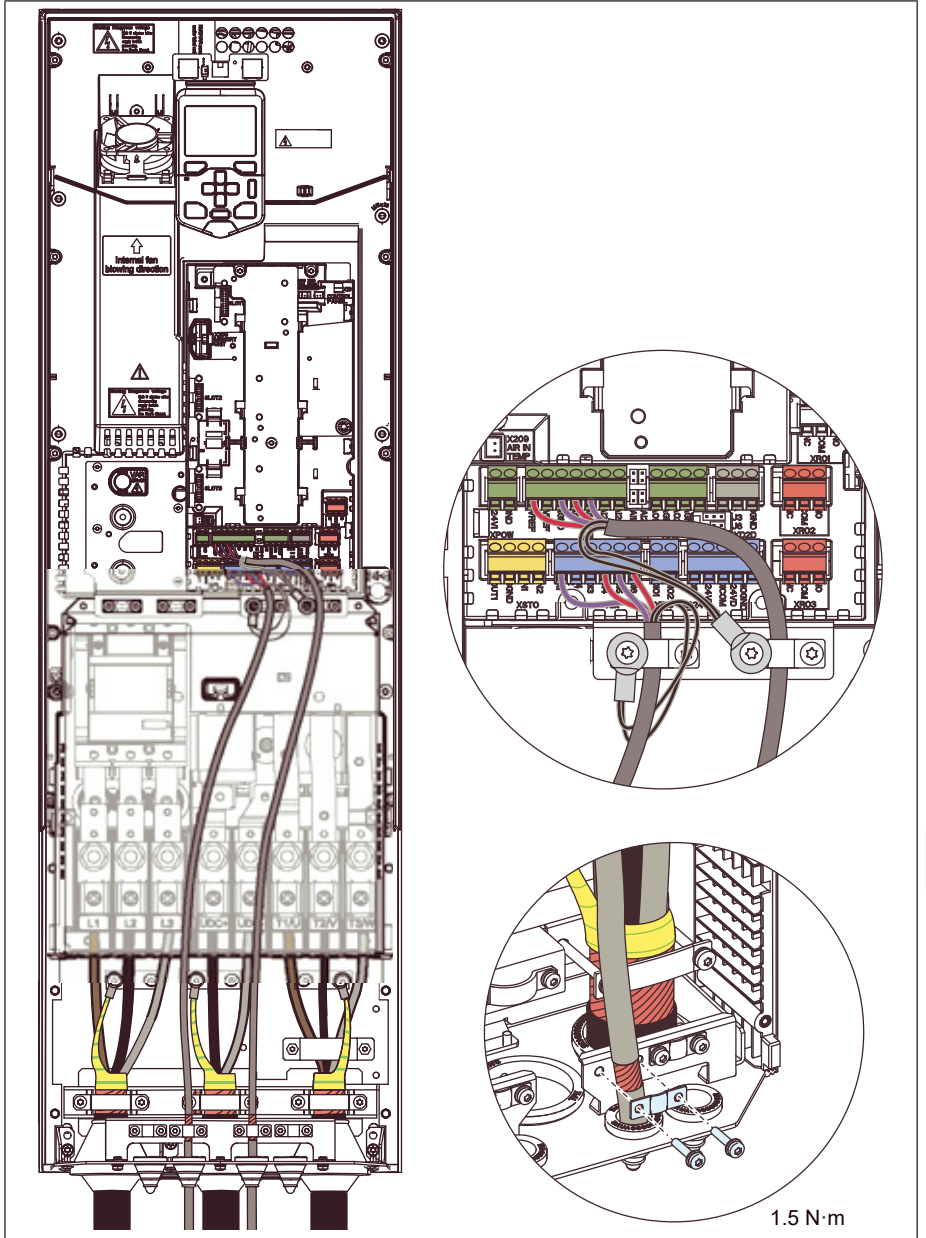

Installing option modules

■ Mechanical installation of option modules

See section [Overview of power and control connections \(page 34\)](#) for the available slots for each module. Install the option modules as follows:



WARNING!

Obey the safety instructions of the drive. If you ignore them, injury or death, or damage to the equipment can occur.

1. Stop the drive and do the steps in section [Electrical safety precautions \(page 19\)](#) before you start the work.
2. Remove the front cover(s) if not already removed.
3. For frame R3: Pull the control panel holder up.

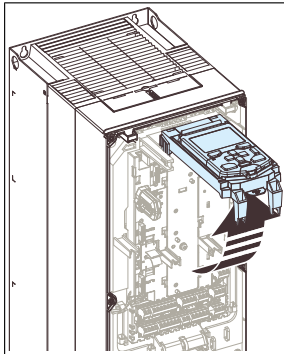

- 
4. Insert the module carefully into its position on the control unit.
 5. Tighten the mounting screw torque of 0.8 N·m.
-

Note: The screws tightens the connections and grounds the module. It is essential for fulfilling the EMC requirements and for proper operation of the module.

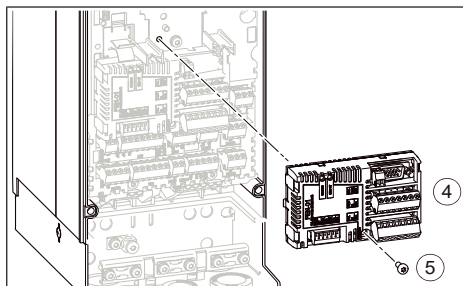

■ Wiring option modules

See the appropriate option module manual for specific installation and wiring instructions. See section [Connection procedure \(page 102\)](#) for the routing of the cables.

■ Installation of safety functions modules

The safety functions module can be mounted onto Slot 2 on the control unit or, in frames R6 and R8, also next to the control unit.

Installation procedure into Slot 2



WARNING!

Obey the safety instructions of the drive. If you ignore them, injury or death, or damage to the equipment can occur.

1. Stop the drive and do the steps in section [Electrical safety precautions \(page 19\)](#) before you start the work.
2. Remove the front cover.
3. For frame R3: Pull the control panel stand up.
4. Insert the module carefully into its position on the control unit.
5. Attach the module with four screws.
6. Tighten the grounding screw of the electronics to 0.8 N·m.

Note: The grounding screw (a) is essential for fulfilling the EMC requirements and for proper operation of the module.

7. Connect the flat cable to connector X110 on the module and to connector X12 on the drive control unit.

8. Connect the Safe torque off (STO) cable to connector X111 on the module and to connector XSTO on the drive module control unit as shown in [Wiring \(page 219\)](#).
9. Connect the external +24 V power supply cable to connector X112.
10. Connect the other wires as shown in *FSO-12 safety functions module user's manual* ([3AXD50000015612](#) [English]) or in *FSO-21 safety functions module user's manual* ([3AXD50000015614](#) [English]).

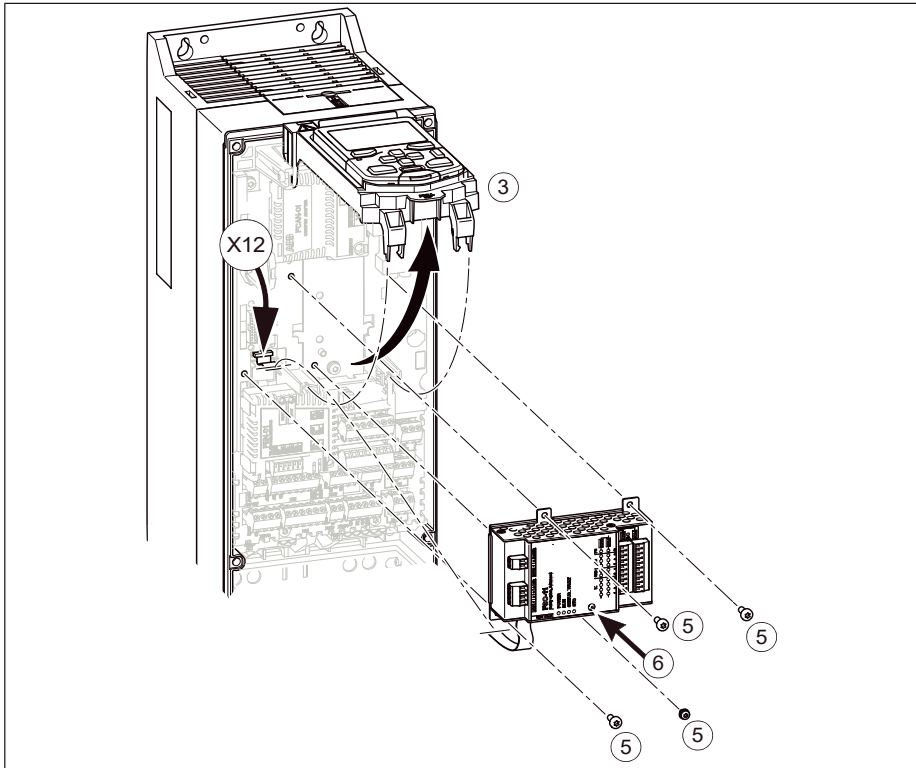

Installation next to the control unit on frames R6 and R8



WARNING!

Obey the safety instructions of the drive. If you ignore them, injury or death, or damage to the equipment can occur.

1. Stop the drive and do the steps in section [Electrical safety precautions \(page 19\)](#).
2. Remove the front cover.
3. Insert the module carefully into its position.

4. Attach the module with four screws.
5. Tighten the grounding screw of the electronics to 0.8 N·m.
Note: Correct installation of the grounding screw (a) is essential for fulfilling the EMC requirements and for proper operation of the module.
6. Connect the flat cable to connector X110 on the module and to connector X12 on the drive control unit.
7. Connect the Safe torque off (STO) cable to connector X111 on the module and to connector XSTO on the drive module control unit as shown in *Wiring (page 219)*.
8. Connect the external +24 V power supply cable to connector X112.
9. Connect the other wires as shown in *F50-12 safety functions module user's manual (3AXD5000015612 [English])* or in *F50-21 safety functions module user's manual (3AXD5000015614 [English])*.

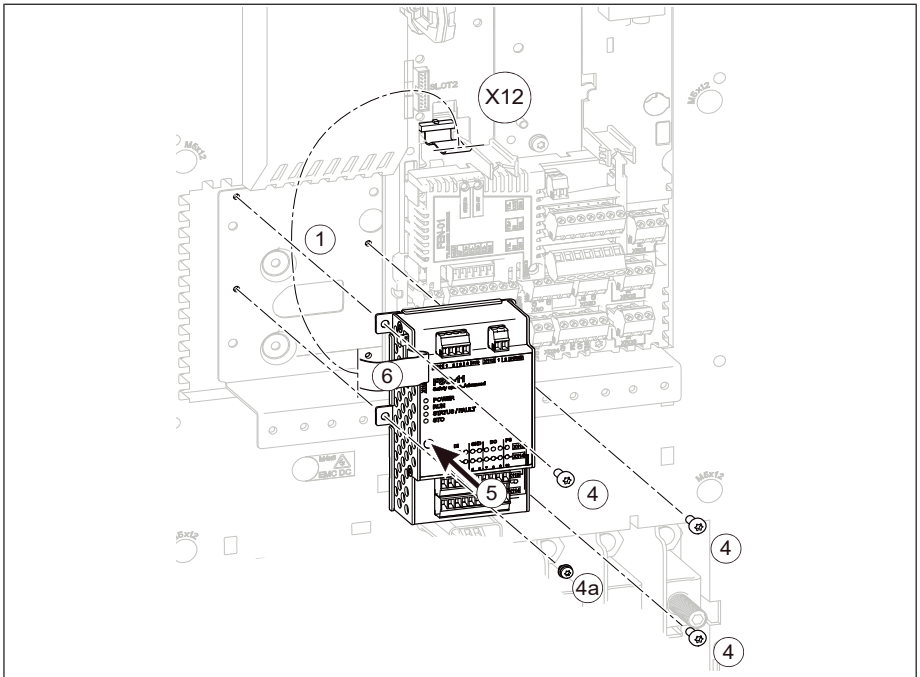

Reinstalling cover(s)

After installation, reinstall the covers. For IP55 (UL Type 12) frame R8, connect the cooling fan power supply wire, see section *Replacing the auxiliary cooling fan in the IP55 (UL Type 12) cover, frame R8 (page 160)*.

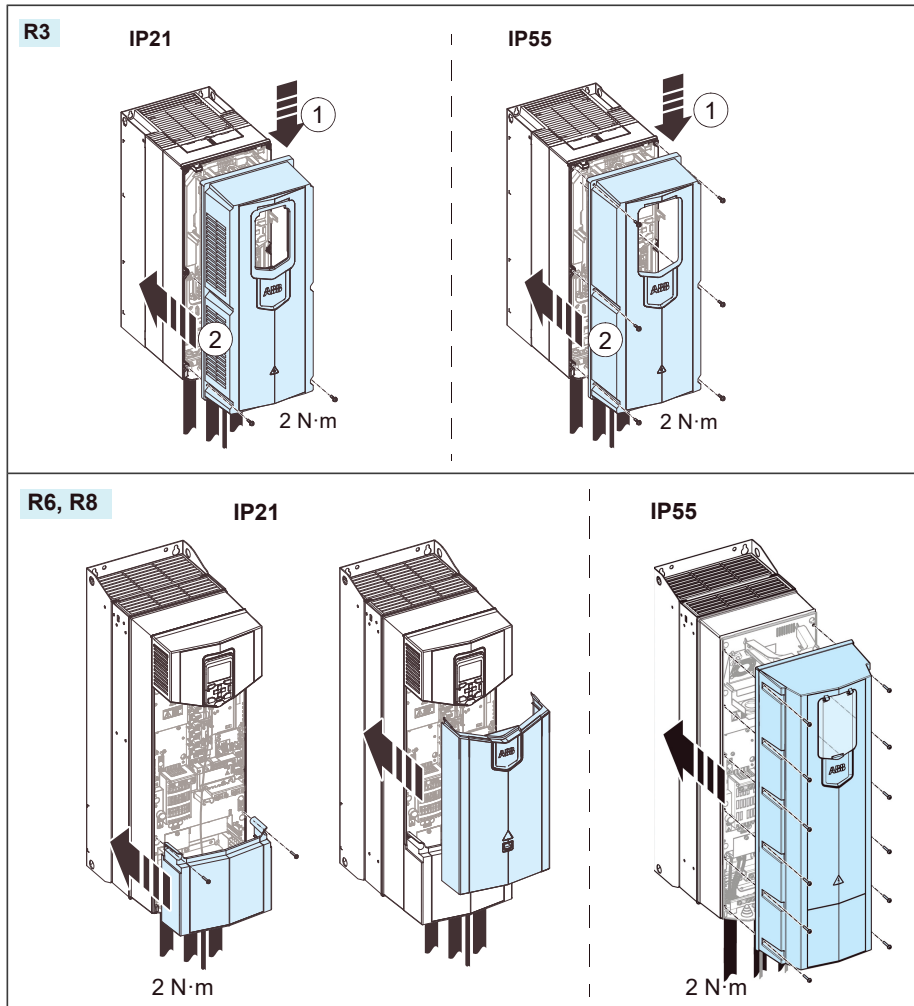

Connecting a PC



WARNING!

Do not connect the PC directly to the control panel connector of the control unit as this can cause damage.

A PC (with eg, the Drive composer PC tool) can be connected as follows:

1. Connect an ACx-AP-x control panel to the unit either
 - by inserting the control panel into the panel holder or platform, or
 - by using an Ethernet (eg, Cat 5e) networking cable.
2. Remove the USB connector cover on the front of the control panel.
3. Connect an USB cable (Type A to Type Mini-B) between the USB connector on the control panel (3a) and a free USB port on the PC (3b).
4. The panel will display an indication whenever the connection is active.
5. See the documentation of the PC tool for setup instructions.

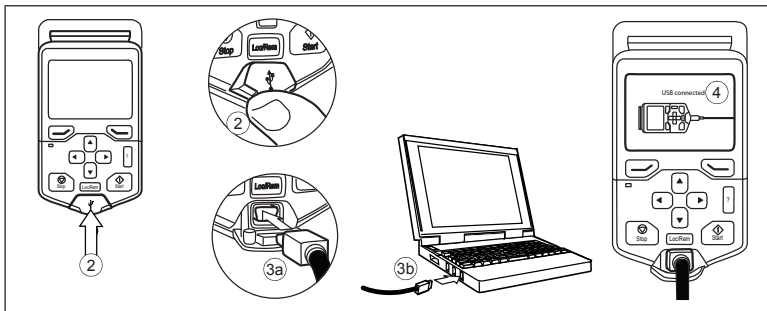

Panel bus (Control of several units from one control panel)

One control panel (or PC) can be used to control several drives (or inverter units, supply units etc.) by constructing a panel bus. This is done by daisy-chaining the panel connections of the drives. Some drives have the necessary (twin) panel connectors in the control panel holder; those that do not require the installation of an FDPI-02 module (available separately). For further information, see the hardware description and *FDPI-02 diagnostics and panel interface user's manual* ([3AUA0000113618](#) [English]).

The maximum allowed length of the cable chain is 100 m (328 ft).

1. Connect the panel to one drive using an Ethernet (for example Cat 5e) cable.
 - Use Menu - Settings - Edit texts - Drive to give a descriptive name to the drive
 - Use parameter 49.01* to assign the drive with a unique node ID number

- Set other parameters in group 49* if necessary
- Use parameter 49.06* to validate any changes.

*The parameter group is 149 with supply (line-side), brake or DC/DC converter units.

Repeat the above for each drive.

2. With the panel connected to one unit, link the units using Ethernet cables.
 3. Switch on the bus termination on the drive that is farthest from the control panel in the chain.
 - With drives that have the panel mounted on the front cover, move the terminating switch into the outer position.
 - With an FDPI-02 module, move termination switch S2 into the TERMINATED position.
- Make sure that bus termination is off on all other drives.
4. On the control panel, switch on the panel bus functionality (Options - Select drive - Panel bus). The drive to be controlled can now be selected from the list under Options - Select drive.

If a PC is connected to the control panel, the drives on the panel bus are automatically displayed in the Drive composer tool.

With twin connectors in the control panel holder:

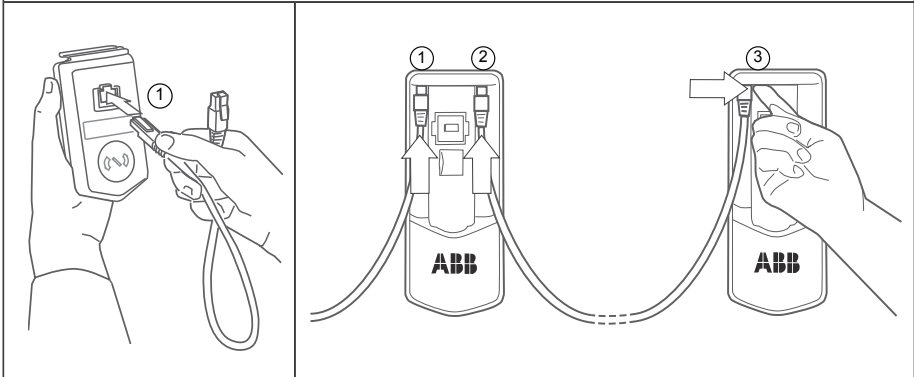

With FDPI-02 modules:

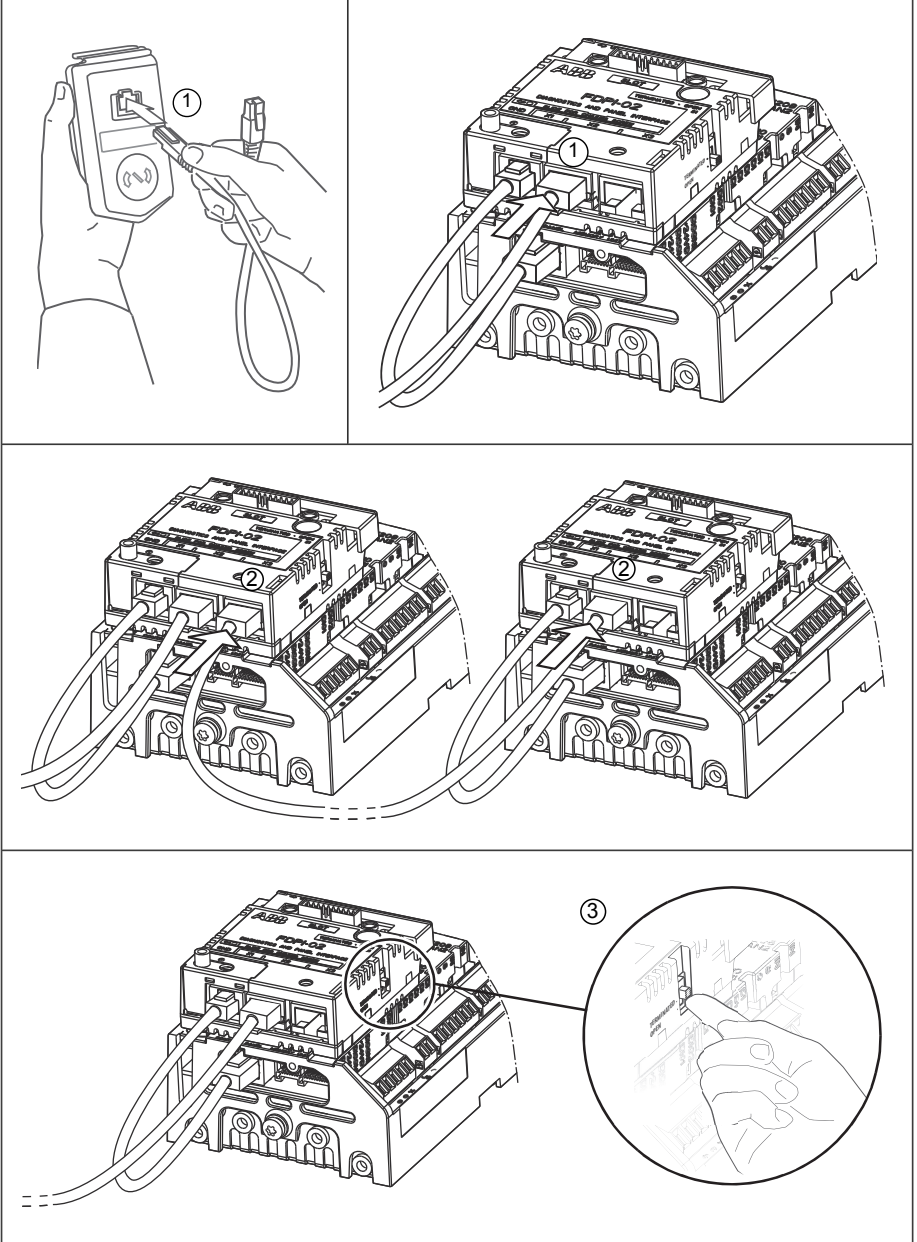

7

Electrical installation – North America (NEC)

Contents of this chapter

This chapter gives instructions on wiring the drive.

Safety



WARNING!

If you are not a qualified electrical professional, do not do installation or maintenance work. Obey the safety instructions of the drive. If you ignore them, injury or death, or damage to the equipment can occur.

Required tools

To do the electrical installation, you need these tools:

- wire stripper
- screwdriver set (Torx, flat and/or Phillips, as appropriate)
- torque wrench.

Required tools

- wire stripper
 - screwdriver and/or wrench with a set of suitable bits
-



Measuring the insulation

See section *Measuring the insulation* (page 84).

Grounding system compatibility check

See section *Grounding system compatibility check* (page 85).

Connecting the power cables

■ Connection diagram

Note: NEC installation can include separate insulated conductors inside a conduit, shielded VFD cable in conduit, or shielded VFD cable without conduit. The normal dashed symbol (c) in this diagram represents the shield of shielded VFD cable. The same solid symbol (b) represents conduit.

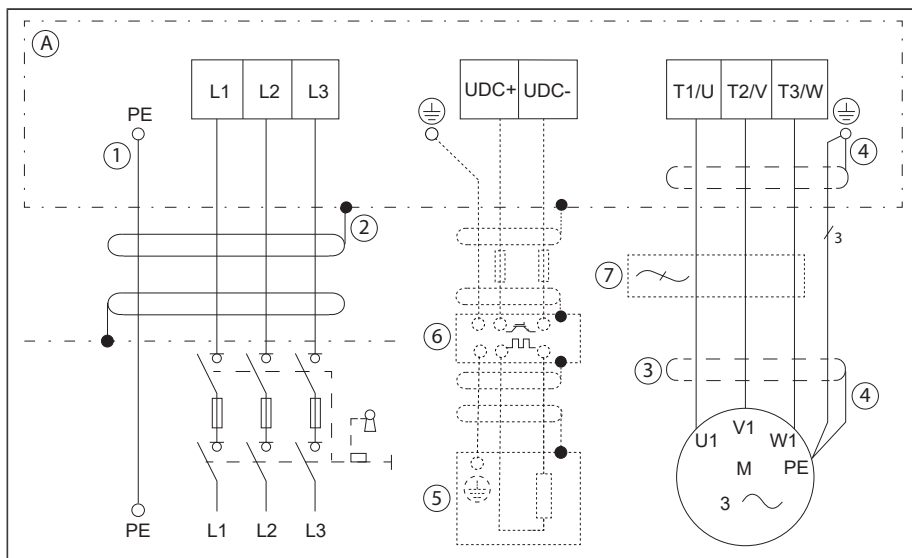

A	Drive
1	Insulated ground conductor in a conduit: Ground to drive's PE terminal and to the distribution panel ground bus. For a VFD cable installation see 4.
2	Conduit ground: Bond the conduit to the drive's conduit box and to the distribution panel enclosure. For a VFD cable installation see 3.
3	Shield of a VFD shielded cable: Ground the shield 360° under drive's grounding clamp. Then twist with the ground conductors and connect under the drive's ground terminal. Ground the shield also 360° at the motor end, then twist and connect under the motor's ground terminal. For a conduit installation see 2.

4	<u>Symmetrically constructed grounding conductors inside a VFD shielded cable</u> : Twist together, combine with the shield and connect under the drive's ground terminal and under the motor's ground terminal. For a conduit installation see 2.
5	External brake resistor connection (if used). For a conduit installation: See 1 and 2. For a VFD cable installation: See 3 and 4. In addition, cut the third phase conductor which is not needed for the brake resistor connection. See chapter <i>Resistor braking (page 235)</i> .
6	External brake chopper (if used). See chapter <i>Resistor braking (page 235)</i> .
7	If necessary, install an external filter (du/dt, common mode, or sine filter). Filters are available from ABB.

Note: All openings in the drive enclosure must be closed with UL listed devices having the same Type rating as the drive Type.

■ Connection procedure

The procedure of connecting the power cables to the standard drive is described below.

1. For frame R3: To remove the front cover, lift the cover from the bottom outwards (1a) and then up (1b).

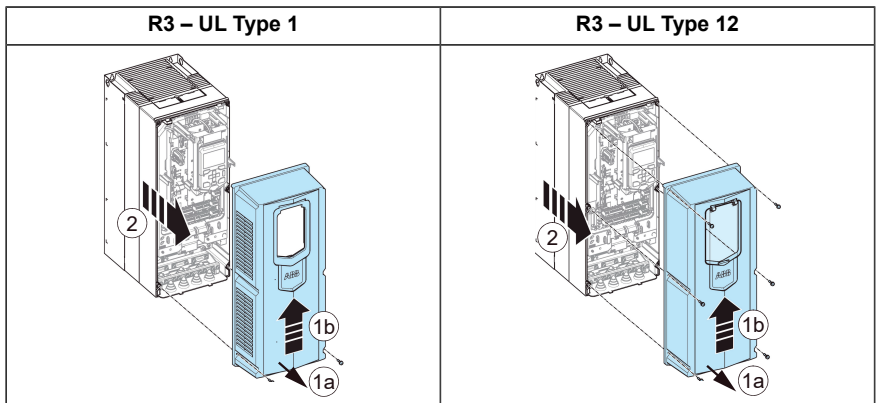

For frame R6 and R8 (UL Type 1): Remove the cover as follows:

- Release the retaining clip with a screwdriver.
- Remove the middle front cover.
- Remove the lower front cover.

For frame R6 and R8 (UL Type 12): Remove the covers as follows:

- Loosen the screws that attach the front cover to the frame.
- Remove the cover.
- For frame R8, disconnect the power supply wire of the auxiliary cooling fan.



R6, R8 – UL Type 1

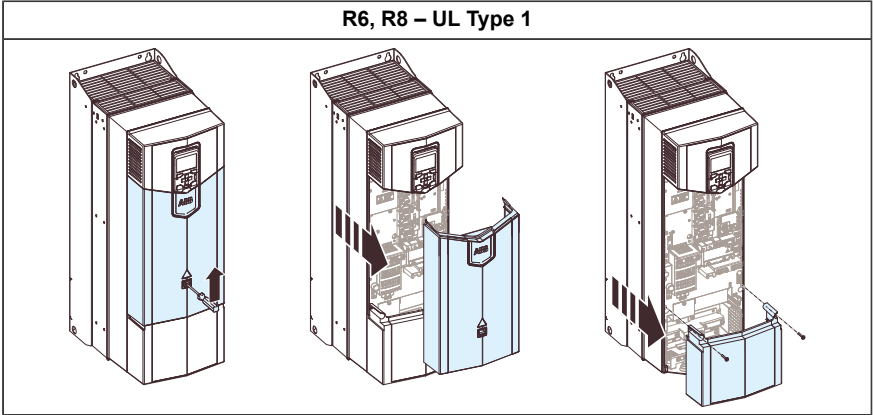

R6, R8 – UL Type 12

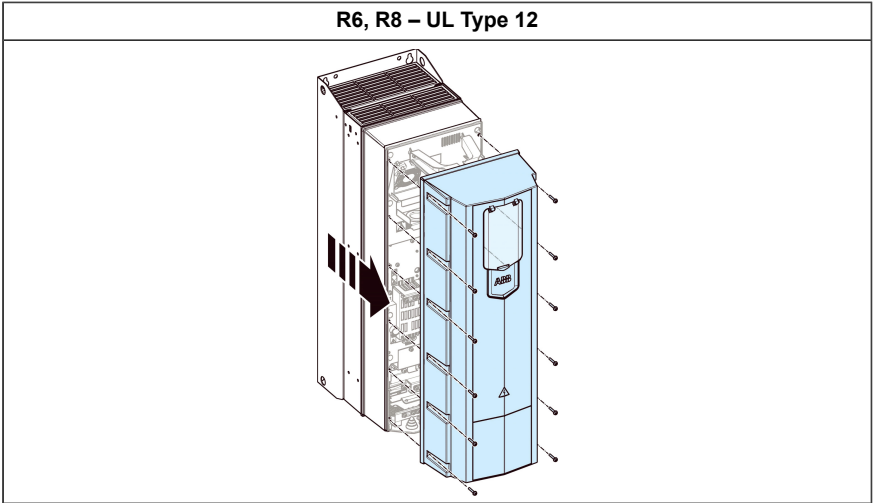

2. Attach the residual voltage warning sticker in the local language.

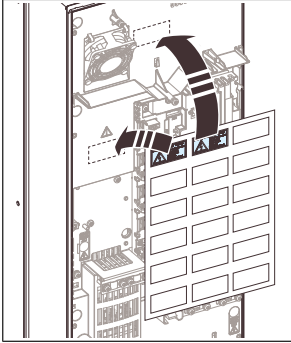

3. For frames R6 and R8: Remove the shroud on the power cable terminals.

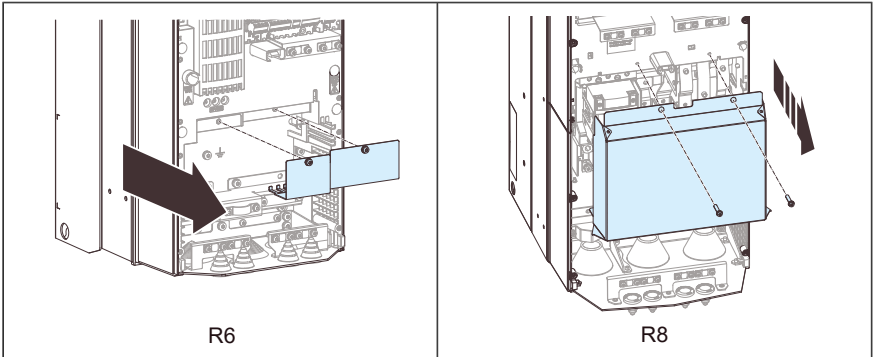

4. For frame R8: For easier installation, you can remove the side plates.

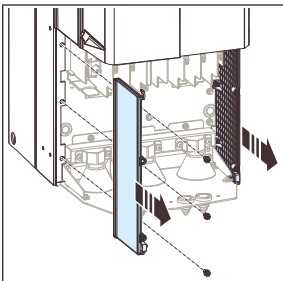

- Remove the rubber grommets of the cables to be installed from the cable entry plate. Install the grommets downwards also in unused holes.

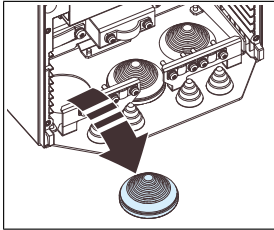

- Attach the cable conduits to the conduit plate. Make sure the conduit is correctly bonded at both ends and that conductivity is consistent throughout the conduit. Slide the cables through the conduit.

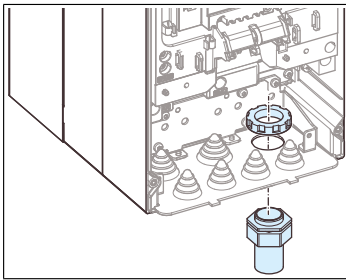

- Cut the cables to suitable length (note the extra length of the grounding conductors). If you use a symmetrically shielded VFD cable, twist the grounding wires together with the cable shield and connect them to the grounding terminals. Ground the shield 360 degrees at the clamp. If you use discrete conductors connect the insulated ground conductor to the grounding terminal.

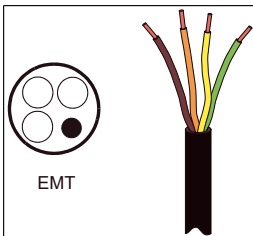

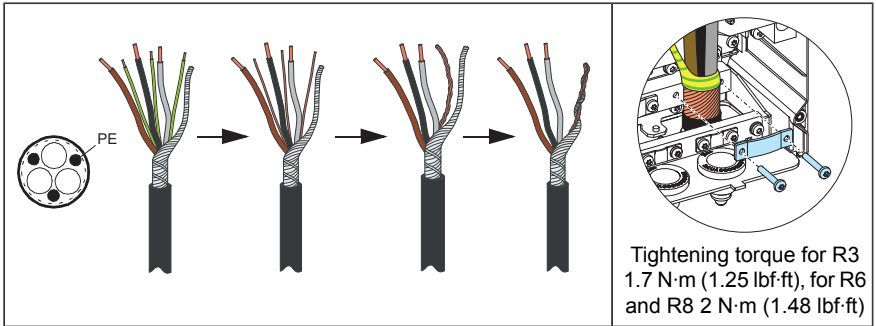

8.
 - Connect the phase conductors of the motor cable to the T1/U, T2/V and T3/W terminals and the phase conductors of the input cable to the L1, L2 and L3 terminals.
 - For frame R8 (option +E208): Install the common mode filter. For instructions, see *Common mode filter kit for ACS880-01 frame R7, and for ACS880-11, ACS880-31, ACH580-31 and ACQ580-31 frame R8 installation instructions* ([3AXD50000015179](https://www.aegiautomation.com/3AXD50000015179) [English]).
 - If DC cables are present, use only two phase conductors and the ground conductor. Connect the phase conductors to the UDC+ and UDC- terminals.

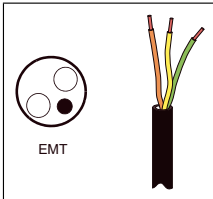

- Tighten the screws to the torque given in the installation drawing below.



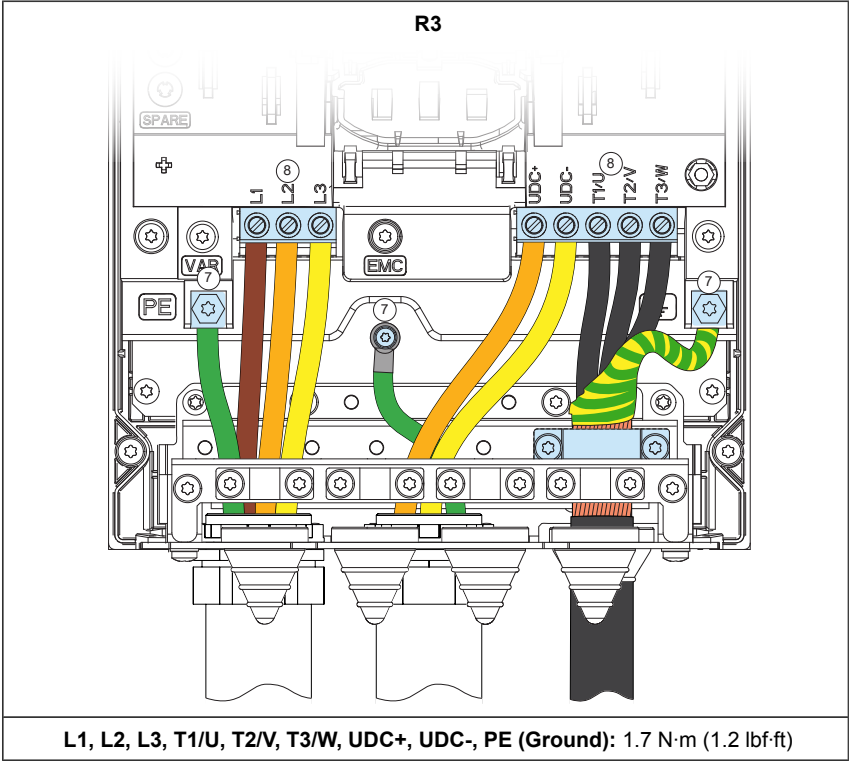

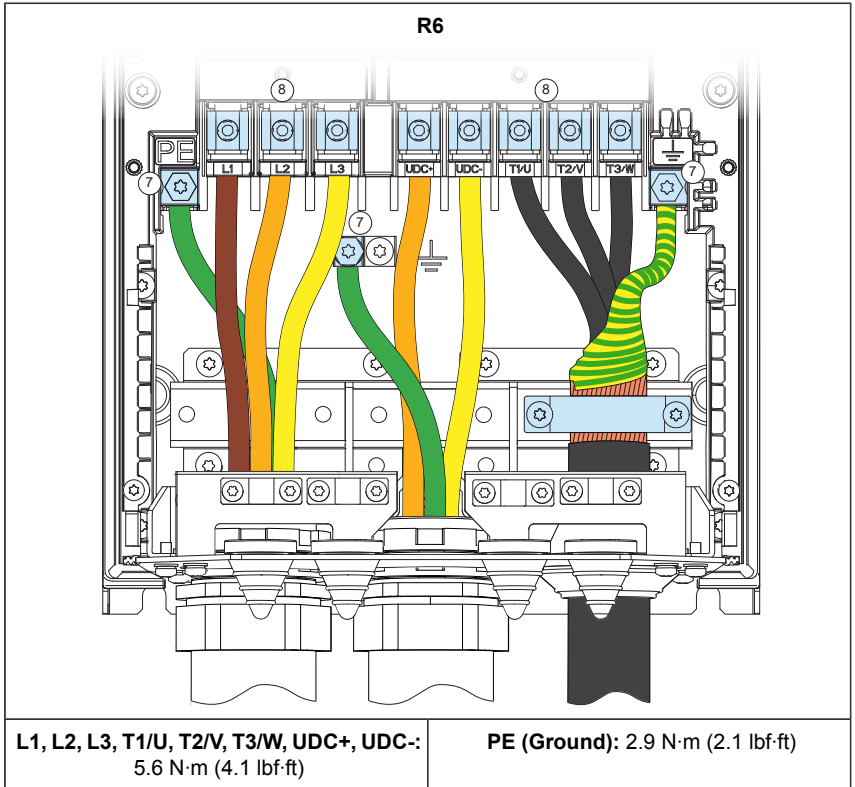

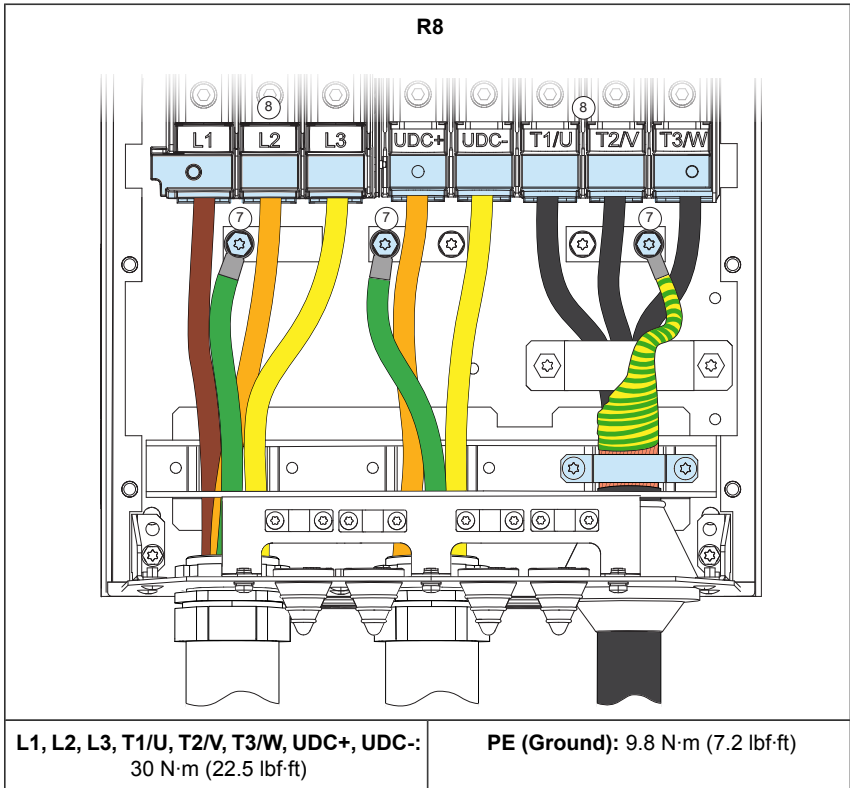

Note: For frame R8: Install the side plates if removed.

Note: For frame R8: The power cable connectors can be detached. For the instructions, see section [R8 power cable connection if you detach the connectors](#) (page 125).

9. For frame R6 types bigger than -040A-x: Cut tabs in the shroud for the installed cables.



10. Install the shroud onto the power cable connection terminals.

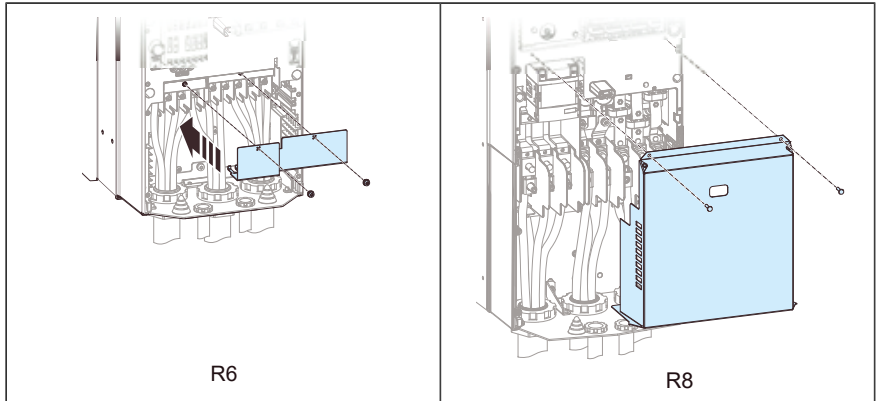

R8 power cable connection if you detach the connectors

The power cable connection connectors of frame R8 are detachable. If you detach them, you can connect the cables with cable lugs as follows. For UL installations, see also [UL listed cable lugs and tools \(page 192\)](#) in the technical data.

Cable lug installation for T1/U, T2/V, T3/W, UDC+ and UDC-:

- Remove the nut that attaches the connector to its terminal post and remove the connector.
- **Alternative 1:** Put the conductor to the connector. Tighten to a torque of 30 N·m (22 lbf·ft). Put the connector back onto the post. Tighten the connector to 30 N·m (22 lbf·ft).
- **Alternative 2:** Attach a cable lug to the conductor. Put the cable lug onto the post. Tighten the nut to a torque of 30 N·m (22 lbf·ft).



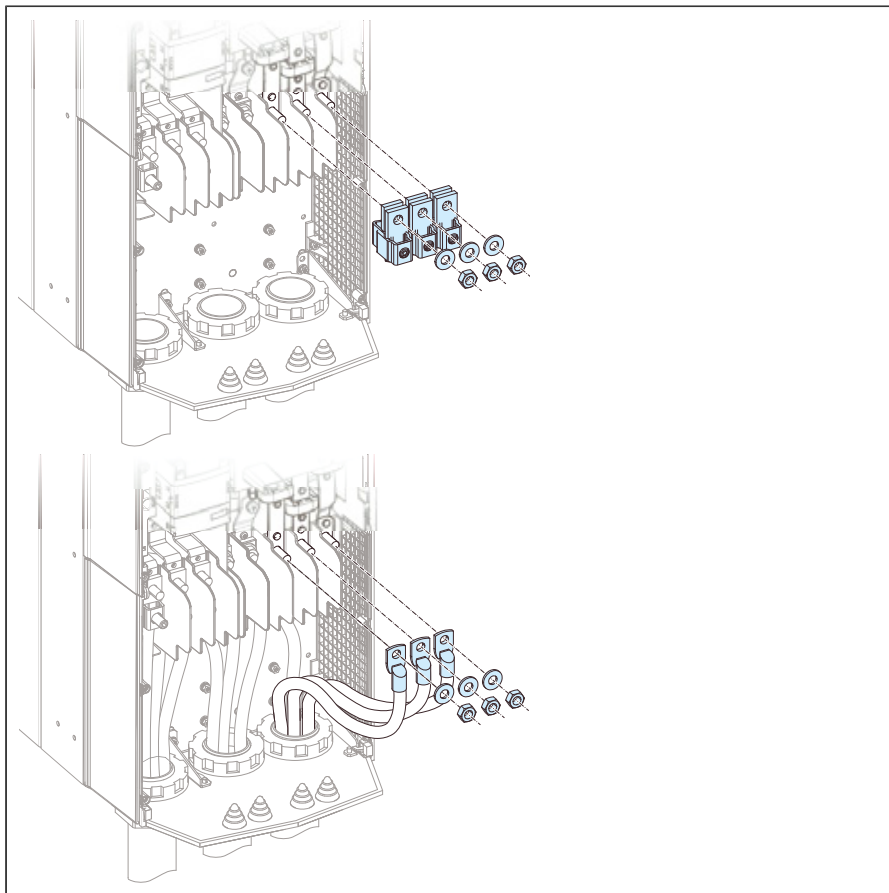

Connecting the control cables



■ Connection diagram

See *Default I/O diagram of the drive control unit (ZCU-1x)* (page 133).

■ Connection procedure



WARNING!

Obey the safety instructions of the drive. If you ignore them, injury or death, or damage to the equipment can occur.

1. Stop the drive and do the steps in section *Electrical safety precautions (page 19)* before you start the work.
2. Remove the front cover(s) if not already removed.
3. **Frame R3:** Pull the control panel holder up.

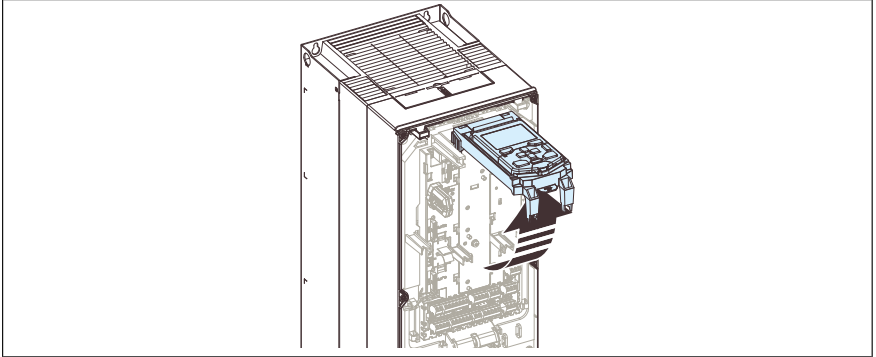

4. Attach the cable conduits to the conduit plate. Make sure the conduit is correctly bonded at both ends and that conductivity is consistent throughout the conduit. Slide the control cables through the conduit. Cut to suitable length (note the extra length of the grounding conductors) and strip the conductors.
5. Ground the outer shields of all control cables 360 degrees at a grounding clamp.
6. Route the cables as shown below.
7. Secure the cables inside the drive mechanically.
8. **Frame R3:** Ground the pair cable shields and grounding wires under the grounding clamp screw at the cable entry.



Frame R6 and R8: Ground the pair-cable shields and grounding wire under the clamp below the control unit.

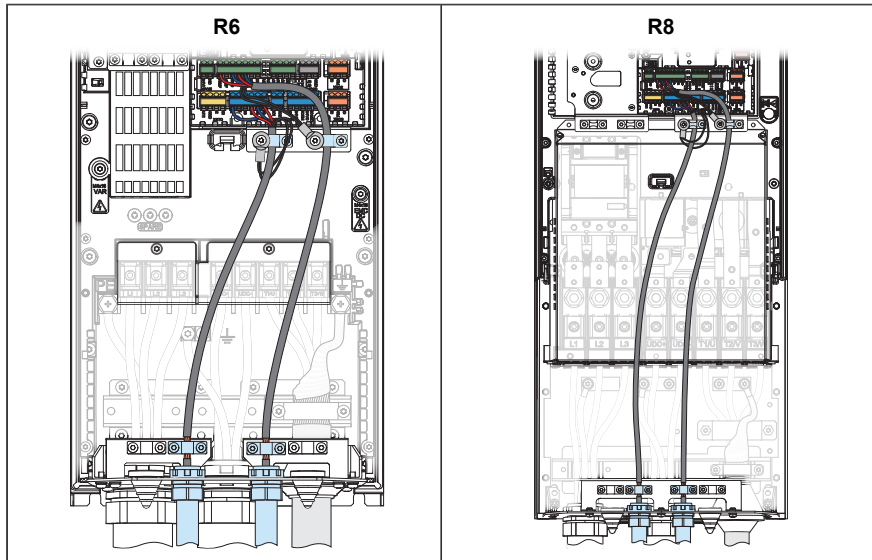
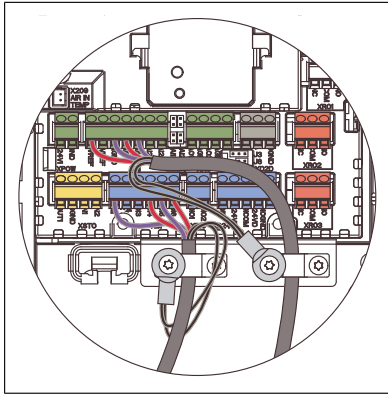

9. Connect the conductors to the appropriate terminals of the control unit and tighten to 0.5 ... 0.6 N·m (0.4 lbf·ft).
See [Default I/O diagram of the drive control unit \(ZCU-1x\)](#) (page 133).

Note:

- Leave the other ends of the control cable shields unconnected or ground them indirectly through a high-frequency capacitor with a few nanofarads, eg, 3.3 nF / 630 V. The shield can also be grounded directly at both ends if they are in the same ground line with no significant voltage drop between the end points.
- Keep any signal wire pairs twisted as close to the terminals as possible. Twisting the wire with its return wire reduces disturbances caused by inductive coupling.

Installing option modules

See section *Installing option modules (page 106)*.

Reinstalling cover(s)

After installation, reinstall the covers.

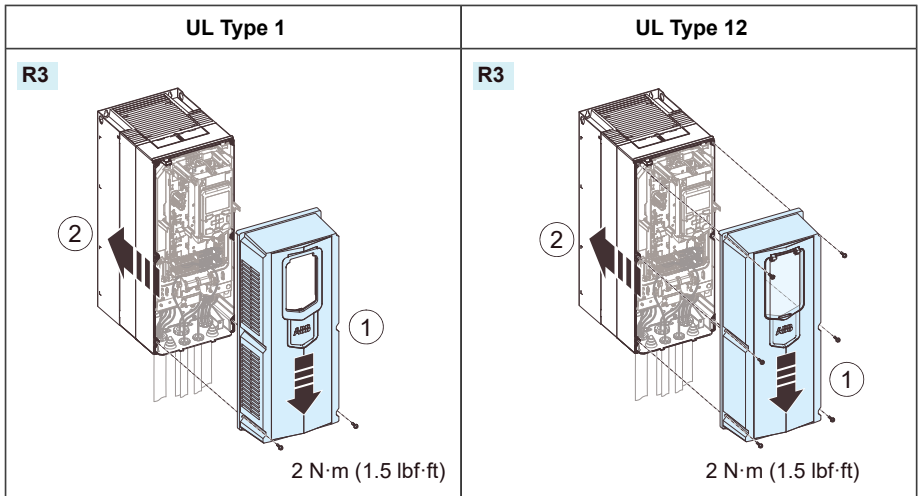

For UL Type 12 frame R8, connect the auxiliary cooling fan power supply wire, see section *Replacing the auxiliary cooling fan in the IP55 (UL Type 12) cover, frame R8* (page 160).

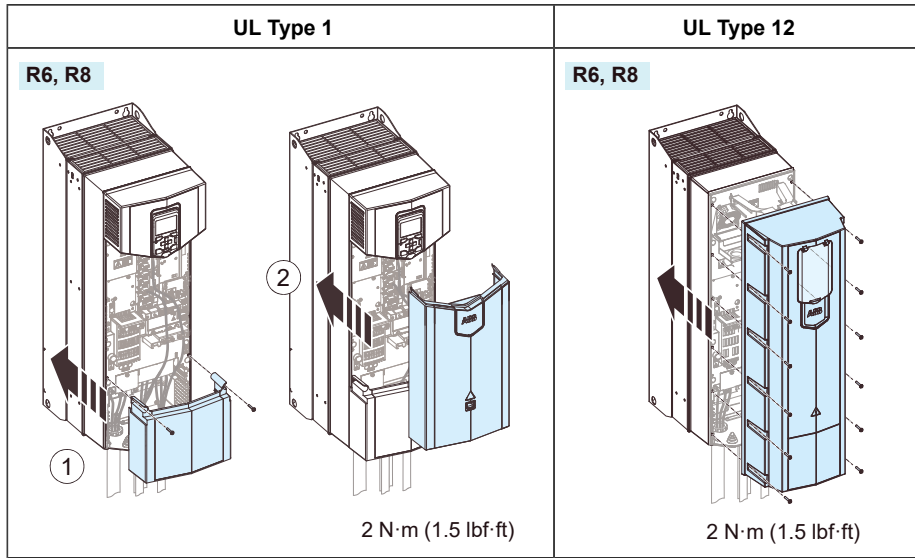

Connecting a PC

See section *Connecting a PC* (page 111).

Controlling several drives through the panel bus

See section *Panel bus (Control of several units from one control panel)* (page 111).





Control units of the drive

Contents of this chapter

This chapter

- describes the connections of the control unit(s) used in the drive,
- contains the specifications of the inputs and outputs of the control unit(s).

ZCU-12 layout

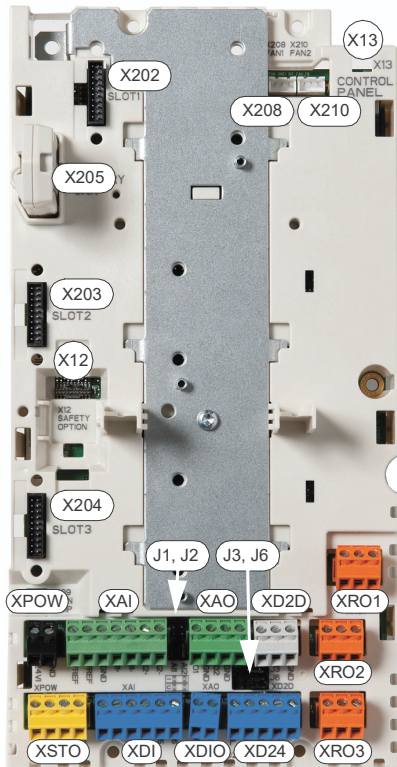

	Description
XAI	Analog inputs
XAO	Analog outputs
XDI	Digital inputs
XDIO	Digital input/outputs
XD24	Digital input interlock (DIIL) and +24 V output
XD2D	Drive-to-drive link
XPOW	External power input
XRO1	Relay output RO1
XRO2	Relay output RO2
XRO3	Relay output RO3
XSTO	Safe torque off connection
X12	Connection for FSO-xx safety functions module
X13	Control panel connection
X202	Option slot 1
X203	Option slot 2
X204	Option slot 3
X205	Memory unit connection (memory unit inserted in the picture)
X208	Cooling fan 1 connection
X210	Cooling fan 2 connection
J1, J2	Voltage/Current selection jumpers (J1, J2) for analog inputs
J3	Drive-to-drive link termination switch (J3)
J6	Common digital input ground selection switch (J6)

Default I/O diagram of the drive control unit (ZCU-1x)

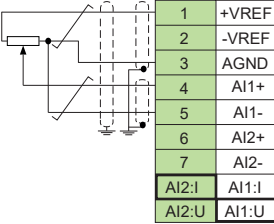
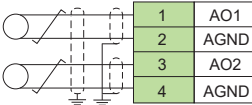
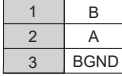
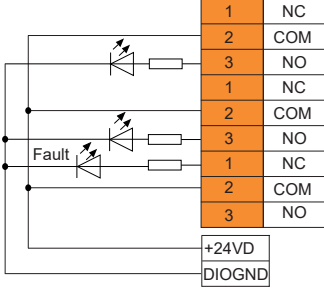
Connection	Term	Description
XPOW External power input		
	+24VI	24 V DC, 2 A min. (without optional modules)
	GND	
J1, J2, XAI Reference voltage and analog inputs		
	+VREF	10 V DC, R_L 1...10 kohm
	-VREF	-10 V DC, R_L 1...10 kohm
	AGND	Ground
	AI1+	Speed reference
	AI1-	0(2)...10 V, $R_{iN} > 200$ kohm ¹⁾ selected by switch AI1.
	AI2+	By default not in use.
	AI2-	0(4)...20 mA, $R_{iN} = 100$ ohm ²⁾
	AI1: I AI1: U	AI1/AI2 current/voltage selection
XAO Analog outputs		
	AO1	Motor speed rpm
	AGND	0...20 mA, $R_L < 500$ ohm
	AO2	Motor current
	AGND	0...20 mA, $R_L < 500$ ohm
XD2D Drive-to-drive link		
	B	Master/follower, drive-to-drive or embedded fieldbus connection ³⁾
	A	
	BGND	
	J3	Drive-to-drive link termination ³⁾
XRO1, XRO2, XRO3 Relay outputs		
	NC	Ready run
	COM	250 V AC / 30 V DC
	NO	2 A
	NC	Running
	COM	250 V AC / 30 V DC
	NO	2 A
	NC	Fault (-1)
	COM	250 V AC / 30 V DC
	NO	2 A
	+24VD	
	DIOGND	

134 Control units of the drive

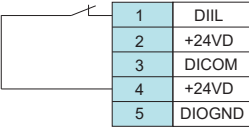
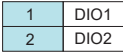
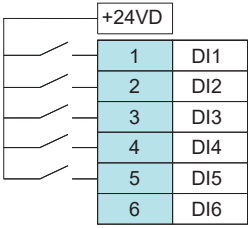
Connection	Term	Description
XD24 Auxiliary voltage output, digital interlock ⁴⁾		
	1 DIIL	DIIL Run enable ⁴⁾
	2 +24VD	+24VD +24 V DC 200 mA
	3 DICOM	DICOM Digital input ground
	4 +24VD	+24VD +24 V DC 200 mA ⁵⁾
	5 DIOGND	DIOGND Digital input/output ground
XDIO Digital input/outputs		
	DIO1	Output: Ready run
	DIO2	Output: Running
	J6	Ground selection ⁶⁾
XDI Digital inputs		
	DI1	Stop (0) / Start (1)
	DI2	Forward (0) / Reverse (1)
	DI3	Reset
	DI4	Acc/Dec time select ⁷⁾
	DI5	Constant speed 1 (1 = On) ⁸⁾
	DI6	By default, not in use.
XSTO	Safe torque off circuits must be closed for the drive to start. ⁹⁾	
X12	Safety options connection	
X13	Control panel connection	
X205	Memory unit connection	

- 1) Current [0(4)...20 mA, $R_{in} = 100 \text{ ohm}$] or voltage [0(2)...10 V, $R_{in} > 200 \text{ kohm}$] input selected by switch AI1. Change of setting requires reboot of control unit.
- 2) Current [0(4)...20 mA, $R_{in} = 100 \text{ ohm}$] or voltage [0(2)...10 V, $R_{in} > 200 \text{ kohm}$] input selected by switch AI2. Change of setting requires reboot of control unit.
- 3) See section [The XD2D connector \(page 136\)](#)
- 4) See section [DIIL input \(page 136\)](#).
Total load capacity of these outputs is 4.8 W (200 mA at 24 V) minus the power taken by DIO1 and DIO2.
- 6) Determines whether DICOM is separated from DIOGND (ie. common reference for digital inputs floats; in practice, selects whether the digital inputs are used in current sinking or sourcing mode). See also [ZCU-1x ground isolation diagram \(page 140\)](#). DICOM=DIOGND ON: DICOM connected to DIOGND. OFF: DICOM and DIOGND separate.
- 7) 0 = Acceleration/deceleration ramps defined by parameters 23.12/23.13 in use. 1 = Acceleration/deceleration ramps defined by parameters 23.14/23.15 in use.
- 8) Constant speed 1 is defined by parameter 22.26.
- 9) See chapter [The Safe torque off function \(page 217\)](#).

The wire size accepted by all screw terminals (for both stranded and solid wire) is 0.5 ... 2.5 mm² (24...12 AWG). The torque is 0.5 N·m (5 lbf·in).

Additional information on the connections

■ External power supply for the control unit (XPOW)

The control unit is powered from a 24 V DC, 2 A supply through terminal block XPOW.

Using an external supply is recommended if

- the control unit needs to be kept operational during input power breaks, for example, because of continuous fieldbus communication
- immediate restart is needed after a power break (that is, no control unit power-up delay is allowed).

■ DI6 as a PTC sensor input

PTC sensors can be connected to this input for motor temperature measurement as follows. The sensor can alternatively be connected to FEN-xx encoder interface module. At the sensor end of the cable, leave the shields unconnected or ground them indirectly via a high-frequency capacitor with a few nanofarads, for example 3.3 nF / 630 V. The shield can also be grounded directly at both ends if they are in the same ground line with no significant voltage drop between the end points. See the firmware manual of the inverter unit for parameter settings.

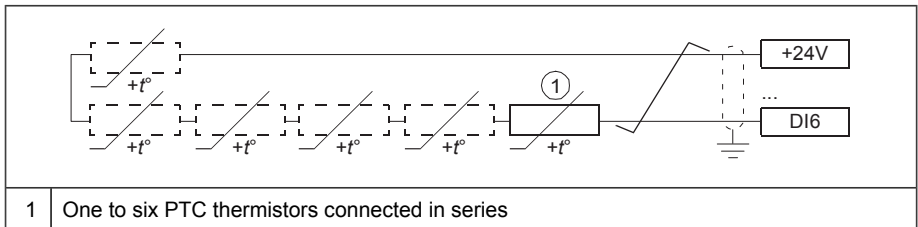

WARNING!

As the inputs pictured above are not insulated according to IEC 60664, the connection of the motor temperature sensor requires double or reinforced insulation between motor live parts and the sensor. If the assembly does not fulfill the requirement, protect the I/O board terminals against contact and do not connect them to other equipment, or isolate the temperature sensor from the I/O terminals. Make sure that the voltage does not exceed the maximum allowed voltage over the PTC sensor.

■ AI1 or AI2 as a Pt100, Pt1000, PTC or KTY84 sensor input

Sensors for motor temperature measurement can be connected between an analog input and output, an example connection is shown below. (Alternatively, you can connect the KTY to an FIO-11 or FAIO-01 analog I/O extension module or FEN-xx encoder interface module.) At the sensor end of the cable, leave the shields unconnected or

ground them indirectly via a high-frequency capacitor with a few nanofarads, for example 3.3 nF / 630 V. The shield can also be grounded directly at both ends if they are in the same ground line with no significant voltage drop between the end points.

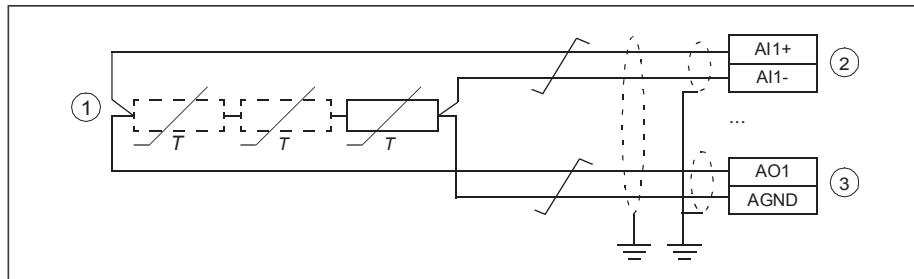

1	One, two or three Pt100, Pt1000 or PTC sensors; or one KTY84 sensor
2	Set the input type to voltage with the appropriate switch or jumper on the control unit. Make the corresponding setting in the control program in parameter group <i>12 Standard AI</i> .
3	Select the excitation mode in parameter group <i>13 Standard AO</i> .



WARNING!

As the inputs pictured above are not insulated according to IEC/EN 60664, the connection of the motor temperature sensor requires double or reinforced insulation between motor live parts and the sensor. If the assembly does not fulfill the requirement, protect the I/O board terminals against contact and do not connect them to other equipment, or isolate the temperature sensor from the I/O terminals. Make sure that the current does not exceed the maximum allowed current through the Pt100/Pt1000 sensor.

■ **DIIL input**

The DIIL input is used for the connection of safety circuits. The input is parametrized to stop the unit when the input signal is lost.

Note: This input is NOT SIL or PL certified.

■ **The XD2D connector**

The XD2D connector provides an RS-485 connection that can be used for

- basic master/follower communication with one master drive and multiple followers,
- fieldbus control through the embedded fieldbus interface (EFB), or
- drive-to-drive (D2D) communication implemented by application programming.

See the firmware manual of the drive for the related parameter settings.

Enable bus termination on the units at the ends of the drive-to-drive link. Disable bus termination on the intermediate units.

Use shielded twisted-pair cable with a twisted pair for data and a wire or another pair for signal ground (nominal impedance 100 to 165 ohm, for example Belden 9842) for the wiring. For best immunity, ABB recommends high quality cable. Keep the cable as short as possible. Avoid unnecessary loops and parallel runs near power cables such as motor cables.

The following diagram shows the wiring between control units.

ZCU-12

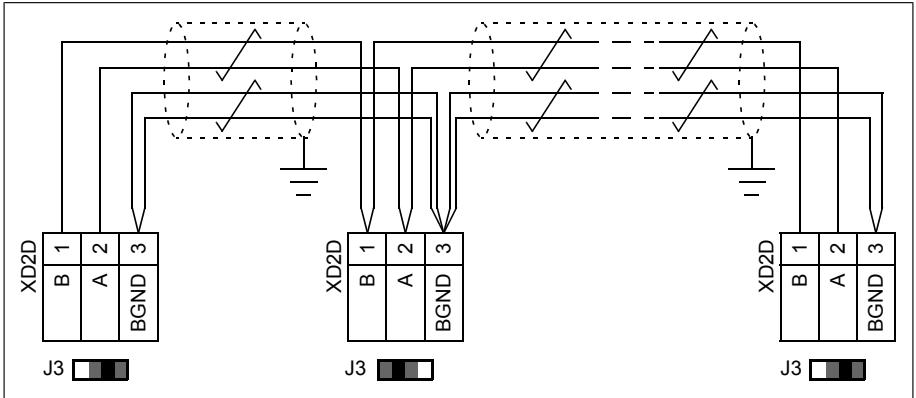

■ Safe torque off (XSTO)

See chapter [The Safe torque off function \(page 217\)](#).

Note: The XSTO input only acts as a true Safe torque off input on the inverter control unit. De-energizing the IN1 and/or IN2 terminals of other units (supply, DC/DC converter, or brake unit) will stop the unit but not constitute a true safety function.

■ FSO-xx safety functions module connection (X12)

See the user manual of the FSO-xx module.

Connector data

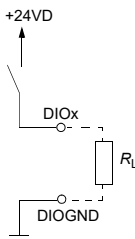
Power supply (XPOW)	Connector pitch 5 mm, wire size 2.5 mm ² 24 V (±10%) DC, 2 A External power input.
Relay outputs RO1...RO3 (XRO1...XRO3)	Connector pitch 5 mm, wire size 2.5 mm ² 250 V AC / 30 V DC, 2 A Protected by varistors
+24 V output (XD24:2 and XD24:4)	Connector pitch 5 mm, wire size 2.5 mm ² Total load capacity of these outputs is 4.8 W (200 mA / 24 V) minus the power taken by DIO1 and DIO2.
Digital inputs DI1...DI6 (XDI:1...XDI:6)	Connector pitch 5 mm, wire size 2.5 mm ² 24 V logic levels: "0" < 5 V, "1" > 15 V R_{in} : 2.0 kohm Input type: NPN/PNP (DI1...DI5), PNP (DI6) Hardware filtering: 0.04 ms, digital filtering up to 8 ms DI6 (XDI:6) can alternatively be used as an input for a PTC sensor. "0" > 4 kohm, "1" < 1.5 kohm. I_{max} : 15 mA (DI1...DI5), 5 mA (DI6)
Start interlock input DIIL (XD24:1)	Connector pitch 5 mm, wire size 2.5 mm ² 24 V logic levels: "0" < 5 V, "1" > 15 V R_{in} : 2.0 kohm Input type: NPN/PNP Hardware filtering: 0.04 ms, digital filtering up to 8 ms
Digital inputs/outputs DIO1 and DIO2 (XDIO:1 and XDIO:2) Input/output mode selection by parameters. DIO1 can be configured as a frequency input (0...16 kHz with hardware filtering of 4 microseconds) for 24 V level square wave signal (sinusoidal or other wave form cannot be used). DIO2 can be configured as a 24 V level square wave frequency output. See the firmware manual, parameter group 111/11.	Connector pitch 5 mm, wire size 2.5 mm ² <u>As inputs:</u> 24 V logic levels: "0" < 5 V, "1" > 15 V. R_{in} : 2.0 kohm. Filtering: 1 ms. <u>As outputs:</u> Total output current from +24VD is limited to 200 mA 
Reference voltage for analog inputs +VREF and -VREF (XAI:1 and XAI:2)	Connector pitch 5 mm, wire size 2.5 mm ² 10 V ±1% and -10 V ±1%, R_{load} 1...10 kohm Maximum output current: 10 mA

<p>Analog inputs AI1 and AI2 (XAI:4 ... XAI:7). Current/voltage input mode selection by jumpers</p>	<p>Connector pitch 5 mm, wire size 2.5 mm² Current input: -20...20 mA, $R_{in} = 100 \text{ ohm}$ Voltage input: -10...10 V, $R_{in} > 200 \text{ kohm}$ Differential inputs, common mode range $\pm 30 \text{ V}$ Sampling interval per channel: 0.25 ms Hardware filtering: 0.25 ms, adjustable digital filtering up to 8 ms Resolution: 11 bit + sign bit Inaccuracy: 1% of full scale range</p>
<p>Analog outputs AO1 and AO2 (XAO)</p>	<p>Connector pitch 5 mm, wire size 2.5 mm² 0...20 mA, $R_{load} < 500 \text{ ohm}$ Frequency range: 0...300 Hz Resolution: 11 bit + sign bit Inaccuracy: 2% of full scale range</p>
<p>XD2D connector</p>	<p>Connector pitch 5 mm, wire size 2.5 mm² Physical layer: RS-485 Transmission rate: 8 Mbit/s Cable type: Shielded twisted-pair cable with a twisted pair for data and a wire or another pair for signal ground (nominal impedance 100 ... 165 ohm, for example Belden 9842) Maximum length of link: 50 m (164 ft) Termination by jumper</p>
<p>Safe torque off connection (XSTO)</p>	<p>Connector pitch 5 mm, wire size 2.5 mm² Input voltage range: -3...30 V DC Logic levels: "0" < 5 V, "1" > 17 V. Note: For the unit to start, both connections must be "1". This applies to all control units (including drive, inverter, supply, brake, DC/DC converter etc. control units), but true Safe torque off functionality is only achieved through the XSTO connector of the drive/inverter control unit. EMC (immunity) according to IEC 61326-3-1</p>
<p>Control panel connection (X13)</p>	<p>Connector: RJ-45 Cable length < 3 m</p>
<p>The terminals of the control unit fulfill the Protective Extra Low Voltage (PELV) requirements. The PELV requirements of a relay output are not fulfilled if a voltage higher than 48 V is connected to the relay output.</p>	

■ ZCU-1x ground isolation diagram

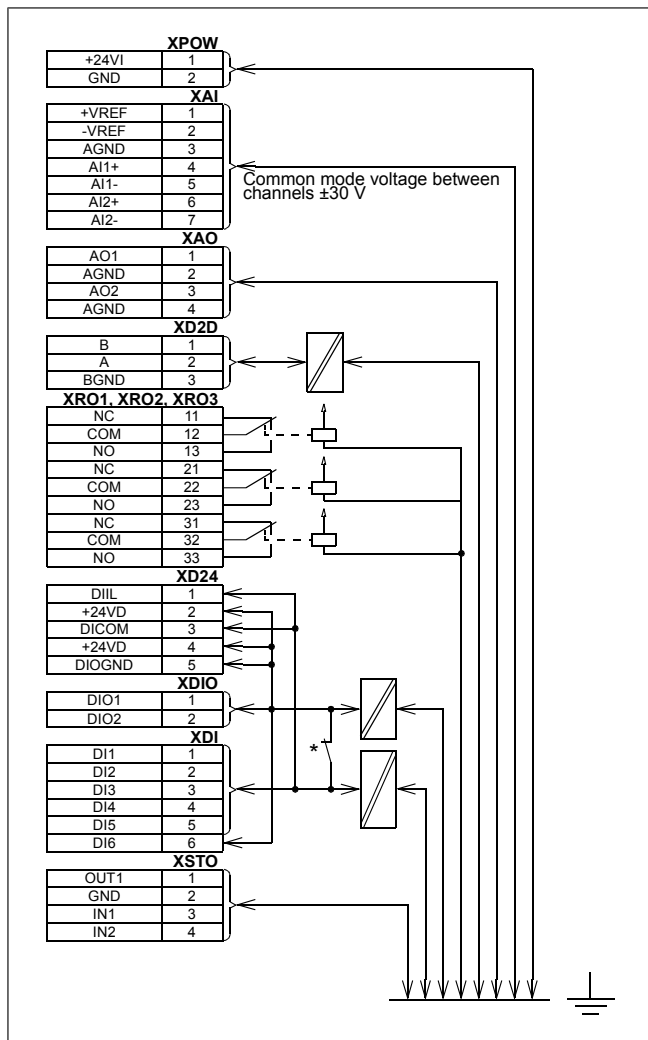

* Ground selector (J6) settings



All digital inputs share a common ground (DICOM connected to DIOGND). This is the default setting.



Ground of digital inputs DI1...DI5 and DIIL (DICOM) is isolated from DIO signal ground (DIOGND).
Isolation voltage 50 V.

9

Installation checklist

Contents of this chapter

This chapter contains a checklist of the mechanical and electrical installation of the drive.

Checklist

Examine the mechanical and electrical installation of the drive before start-up. Go through the checklist together with another person.



WARNING!

Obey the safety instructions of the drive. If you ignore them, injury or death, or damage to the equipment can occur. If you are not a qualified electrical professional, do not do installation, commissioning or maintenance work.



WARNING!

Stop the drive and do the steps in section *Electrical safety precautions (page 19)* before you start the work.

Make sure that ...	<input checked="" type="checkbox"/>
The ambient operating conditions meet the drive ambient conditions specification and enclosure rating (IP code).	<input type="checkbox"/>
The supply voltage matches the nominal input voltage of the drive. See the type designation label.	<input type="checkbox"/>

144 Installation checklist

Make sure that ...	<input checked="" type="checkbox"/>
The insulation resistance of the input power cable, motor cable and motor is measured according to local regulations and the manuals of the drive.	<input type="checkbox"/>
The drive is attached securely on an even, vertical and non-flammable wall.	<input type="checkbox"/>
The cooling air flows freely in and out of the drive.	<input type="checkbox"/>
<u>If the drive is connected to a network other than a symmetrically grounded TN-S system:</u> You have done all the required modifications (for example, you may need to disconnect the EMC filter or ground-to-phase varistor). See the electrical installation instructions.	<input type="checkbox"/>
Appropriate AC fuses and main disconnecting device are installed.	<input type="checkbox"/>
There is an adequately sized protective earth (ground) conductor(s) between the drive and the switchboard, the conductor is connected to correct terminal, and the terminal is tightened to the correct torque. Proper grounding has also been measured according to the regulations.	<input type="checkbox"/>
The input power cable is connected to the correct terminals, the phase order is correct, and the terminals are tightened to the correct torque.	<input type="checkbox"/>
There is an adequately sized protective earth (ground) conductor between the motor and the drive, and the conductor is connected to the correct terminal, and the terminal is tightened to the correct torque. Proper grounding has also been measured according to the regulations.	<input type="checkbox"/>
The motor cable is connected to the correct terminals, the phase order is correct, and the terminals are tightened to the correct torque.	<input type="checkbox"/>
The motor cable is routed away from other cables.	<input type="checkbox"/>
No power factor compensation capacitors are connected to the motor cable.	<input type="checkbox"/>
<u>If an external brake resistor is connected to the drive:</u> There is an adequately sized protective earth (ground) conductor between the brake resistor and the drive, and the conductor is connected to the correct terminal, and the terminals are tightened to the correct torque. Proper grounding has also been measured according to the regulations.	<input type="checkbox"/>
<u>If an external brake resistor is connected to the drive:</u> The brake resistor cable is connected to the correct terminals, and the terminals are tightened to the correct torque.	<input type="checkbox"/>
<u>If an external brake resistor is connected to the drive:</u> The brake resistor cable is routed away from other cables.	<input type="checkbox"/>
The control cables are connected to the correct terminals, and the terminals are tightened to the correct torque.	<input type="checkbox"/>
<u>If a drive bypass connection will be used:</u> The Direct On Line contactor of the motor and the drive output contactor are either mechanically and/or electrically interlocked, that is, they cannot be closed at the same time. A thermal overload device must be used for protection when bypassing the drive. Refer to local codes and regulations.	<input type="checkbox"/>
There are no tools, foreign objects or dust from drilling inside the drive.	<input type="checkbox"/>

Make sure that ...	<input checked="" type="checkbox"/>
The area in front of the drive is clean: the drive cooling fan cannot draw any dust or dirt inside.	<input type="checkbox"/>
Drive covers and cover of the motor connection box are in place.	<input type="checkbox"/>
The motor and the driven equipment are ready for power-up.	<input type="checkbox"/>

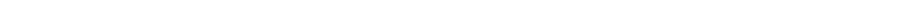

10

Start-up

Contents of this chapter

This chapter describes the start-up procedure of the drive.

Start-up procedure

1. Run setup of the drive control program according to the start-up instructions given in *ACS880 with primary control program quick start-up guide* ([3AUA0000098062](#) [English]) or in the firmware manual.
 - For drives with resistor braking: See also chapter *Resistor braking* (page 235).
 - For drives with ABB sine filter: Check that parameter 95.15 *Special HW settings* is set to ABB sine filter.
For other sine filters: See *Sine filter hardware manual* ([3AXD50000016814](#) [English]).
 - For drives with ABB motors in explosive atmospheres: See *ACS880 drives with ABB motors in explosive atmospheres supplement* ([3AXD50000019585](#) [English]).
2. Validate the Safe torque off function according to the instructions given in chapter *The Safe torque off function* (page 217).
3. Validate the safety functions (options +Q923, +Q973 and +Q982) as described in *FSO-12 safety functions module user's manual* ([3AXD50000015612](#) [English]), *FSO-21 safety functions module user's manual* ([3AXD50000015614](#) [English]) or *FSPS-21 PROFIsafe safety functions module user's manual* ([3AXD500000158638](#) [English]).



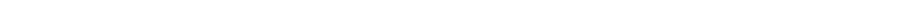

11

Maintenance

Contents of this chapter

This chapter contains maintenance instructions.

Maintenance intervals

The tables below show the maintenance tasks which can be done by the end user. The complete maintenance schedule is available on the Internet (<https://new.abb.com/drives/services/maintenance/preventive-maintenance>). For more information, consult your local ABB Service representative (www.abb.com/searchchannels).

■ Description of symbols

Action	Description
I	Inspection (visual inspection and maintenance action if needed)
P	Performance of on/off-site work (commissioning, tests, measurements or other work)
R	Replacement

■ Recommended maintenance intervals after start-up

Recommended annual actions by the user	
Action	Description
P	Quality of supply voltage
I	Spare parts
P	Capacitor reforming for spare modules and spare capacitors
I	Tightness of terminals
I	Dustiness, corrosion or temperature
P	Heatsink cleaning

Recommended maintenance actions by the user							
Component	Years from start-up						
	3	6	9	12	15	18	21
Cooling							
Main cooling fan							
Main cooling fans			R			R	
Auxiliary cooling fan							
Auxiliary cooling fan			R			R	
Second auxiliary cooling fan (IP55, UL Type 12)			R			R	
Aging							
Control unit battery (real-time clock)		R		R		R	
Control panel battery (real-time clock)			R			R	
Functional safety							
Safety function test	I See the maintenance information of the safety function						
Safety component expiry (Mission time, T_M)	20 years						
4FPS10000309652							

Note:

- Maintenance and component replacement intervals are based on the assumption that the equipment is operated within the specified ratings and ambient conditions. ABB recommends annual drive inspections to ensure the highest reliability and optimum performance.
- Long term operation near the specified maximum ratings or ambient conditions may require shorter maintenance intervals for certain components. Consult your local ABB Service representative for additional maintenance recommendations.

Cleaning the exterior of the drive

**WARNING!**

Obey the safety instructions of the drive. If you ignore them, injury or death, or damage to the equipment can occur. If you are not a qualified electrical professional, do not do installation, commissioning or maintenance work.

1. Stop the drive and do the steps in section *Electrical safety precautions (page 19)* before you start the work.
 2. Clean the exterior of the drive. Use:
 - vacuum cleaner with an antistatic hose and nozzle
 - soft brush
 - dry or damp (not wet) cleaning cloth. Moisten with clean water, or mild detergent (pH 5-9 for metal, pH 5-7 for plastic).
-

**WARNING!**

Prevent water from entering the drive. Never use excessive amount of water, a hose, steam, etc.

Cleaning the heatsink

The drive module heatsink fins pick up dust from the cooling air. The drive runs into overtemperature warnings and faults if the heatsink is not clean. When necessary, clean the heatsink as follows.

**WARNING!**

Use the required personal protective equipment. Wear protective gloves and long sleeves. Some parts have sharp edges.

**WARNING!**

Use a vacuum cleaner with antistatic hose and nozzle, and wear a grounding wristband. Using a normal vacuum cleaner creates static discharges which can damage circuit boards.

1. Stop the drive and do the steps in section *Electrical safety precautions (page 19)* before you start the work.
 2. Remove the module cooling fan(s). See the separate instructions.
-

3. Blow dry, clean and oil-free compressed air from bottom to top and simultaneously use a vacuum cleaner at the air outlet to trap the dust. If there is a risk of dust entering adjoining equipment, do the cleaning in another room.
4. Reinstall the cooling fan.

Fans

In a speed-controlled fan, the speed of the fan matches the cooling needs. This increases the life span of the fan.

In a speed-controlled fan, the speed of the fan matches the cooling needs. This increases the life span of the fan.

Main fans are speed controlled. When the drive is stopped, the main fan is kept running at low speed to cool the control unit. IP21 (UL Type 1) frames R6...R8 and all IP55 (UL Type 12) frames have auxiliary fans that are not speed controlled and run all the time when the control unit is powered.

Replacement fans are available from the manufacturer. Do not use other than specified spare parts.

■ Replacing the main cooling fan, frame R3

1. Stop the drive and do the steps in section *Electrical safety precautions (page 19)* before you start the work.
2. To release the locking, turn clockwise with a screwdriver.
3. Turn the fan assembly off.
4. Install the new fan in reverse order.

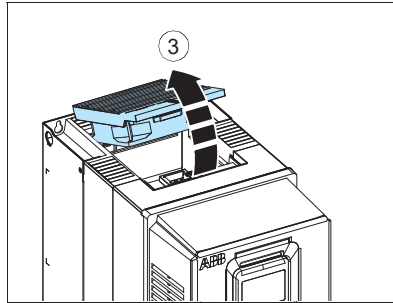
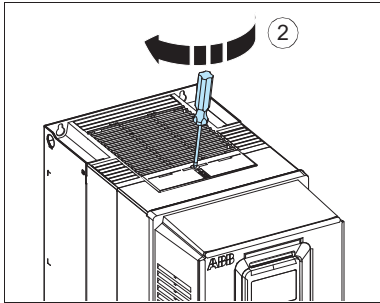

■ Replacing the main cooling fan, frame R6

1. Stop the drive and do the steps in section *Electrical safety precautions* (page 19) before you start the work.
2. Lever the fan assembly off the drive frame with for example a screwdriver (2a) and pull out the fan assembly (2b).
3. Pull the fan assembly down.
4. Unplug the fan power supply and grounding wires from the drive.
5. Install the new fan in reverse order.

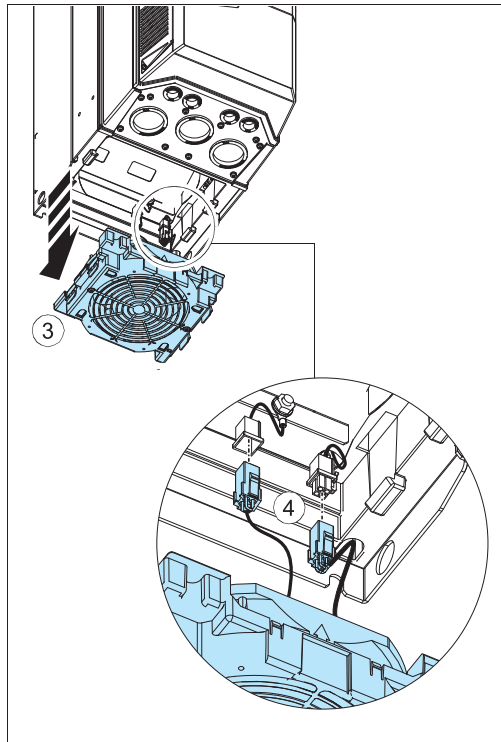
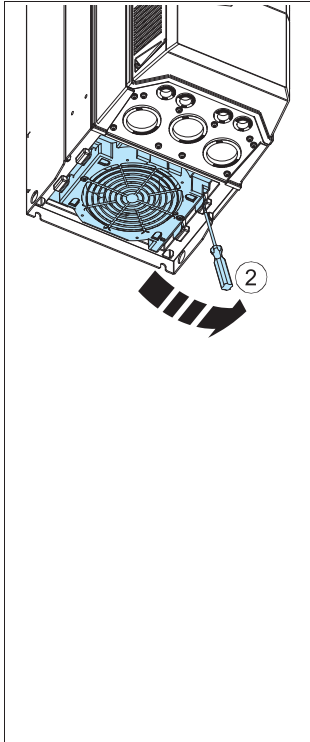

■ Replacing the main cooling fan, frame R8

1. Stop the drive and do the steps in section *Electrical safety precautions (page 19)* before you start the work.
2. Undo the mounting screws of the fan assembly.
3. Unplug the fan power supply and grounding wires from the drive.
4. Pull the fan assembly down.
5. Undo the mounting screws of the fan.
6. Install the new fan in reverse order.

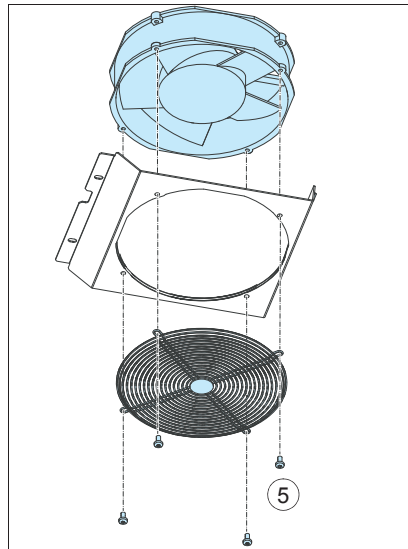
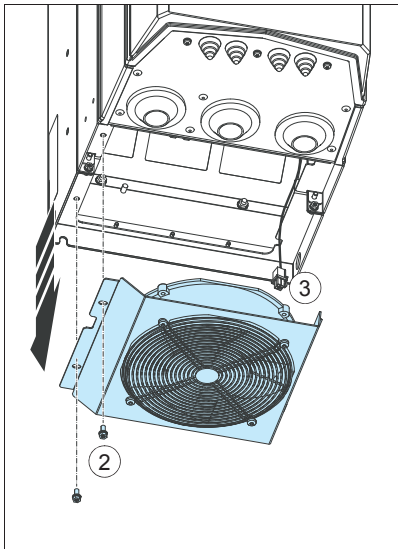

■ Replacing the auxiliary cooling fan, IP55 (UL Type 12) frame R3

1. Stop the drive and do the steps in section *Electrical safety precautions (page 19)* before you start the work.
2. Remove the front cover. See section *Connection procedure (page 94)*.
3. Release the retaining clips.
4. Lift the fan off.
5. Unplug fan power supply wires.
6. Install the new fan in reverse order.

Note: Make sure that the arrow on the fan points down.

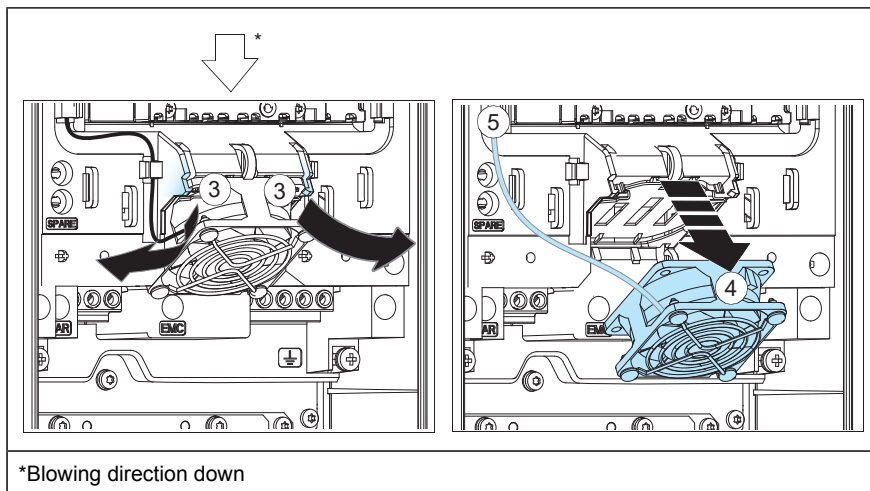

■ Replacing the auxiliary cooling fans, frame R6

1. Stop the drive and do the steps in section *Electrical safety precautions (page 19)* before you start the work.
 2. Remove the upper front covers. See section *Connection procedure (page 94)*.
 3. Release the retaining clips.
 4. Lift the fan off.
 5. Unplug fan power supply wires.
 6. Remove the grille from the fan.
 7. Install the new fan in reverse order.
- Note:** Make sure that the arrow on the fan points up.
8. Reinstall the front covers. See section *Reinstalling cover(s) (page 110)*.

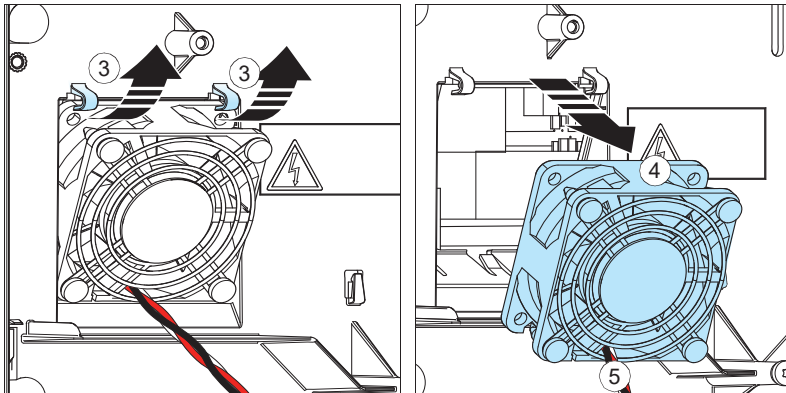

■ **Replacing the internal auxiliary cooling fan, frame R8**

1. Stop the drive and do the steps in section *Electrical safety precautions (page 19)* before you start the work.
2. Remove the upper front covers. See section Connection procedure on page 90.
3. Release the retaining clips.
4. Lift the fan off.
5. Unplug fan power supply wires.
6. Install the new fan in reverse order.

Note: Make sure that the arrow on the fan points up.

7. Replace the front covers.

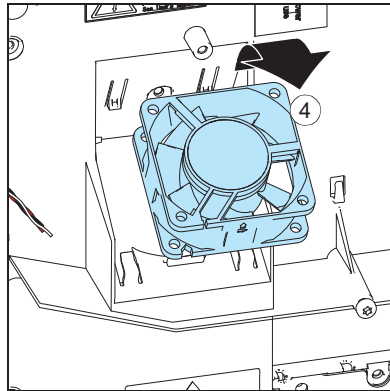
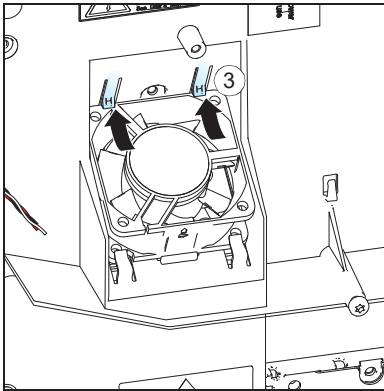

■ **Replacing the second internal auxiliary cooling fan, IP55 (UL Type 12) frame R8**

1. Stop the drive and do the steps in section *Electrical safety precautions (page 19)* before you start the work.
 2. Remove the IP55 front cover, disconnect the power supply wire of the auxiliary cooling fan in the cover (see section *Replacing the auxiliary cooling fan the IP55 (UL Type 12) cover, frame R8*).
 3. Release the retaining clips.
 4. Lift the fan off.
 5. Unplug the power supply wire from the branching plug.
 6. Install the new fan in reverse order.
Note: Make sure that the arrow on the fan points out.
 7. Replace the front cover.
-

■ **Replacing the auxiliary cooling fan in the IP55 (UL Type 12) cover, frame R8**

1. Stop the drive and do the steps in section *Electrical safety precautions (page 19)* before you start the work.
 2. Remove the IP55 front cover. Unplug the auxiliary cooling fan power supply wire.
 3. Remove the lower front cover from the IP55 cover.
 4. Pull the fan supply wire through the grommet.
 5. Remove the fan.
 6. Install the new fan in reverse order. Make sure that the arrow on the fan points up.
-

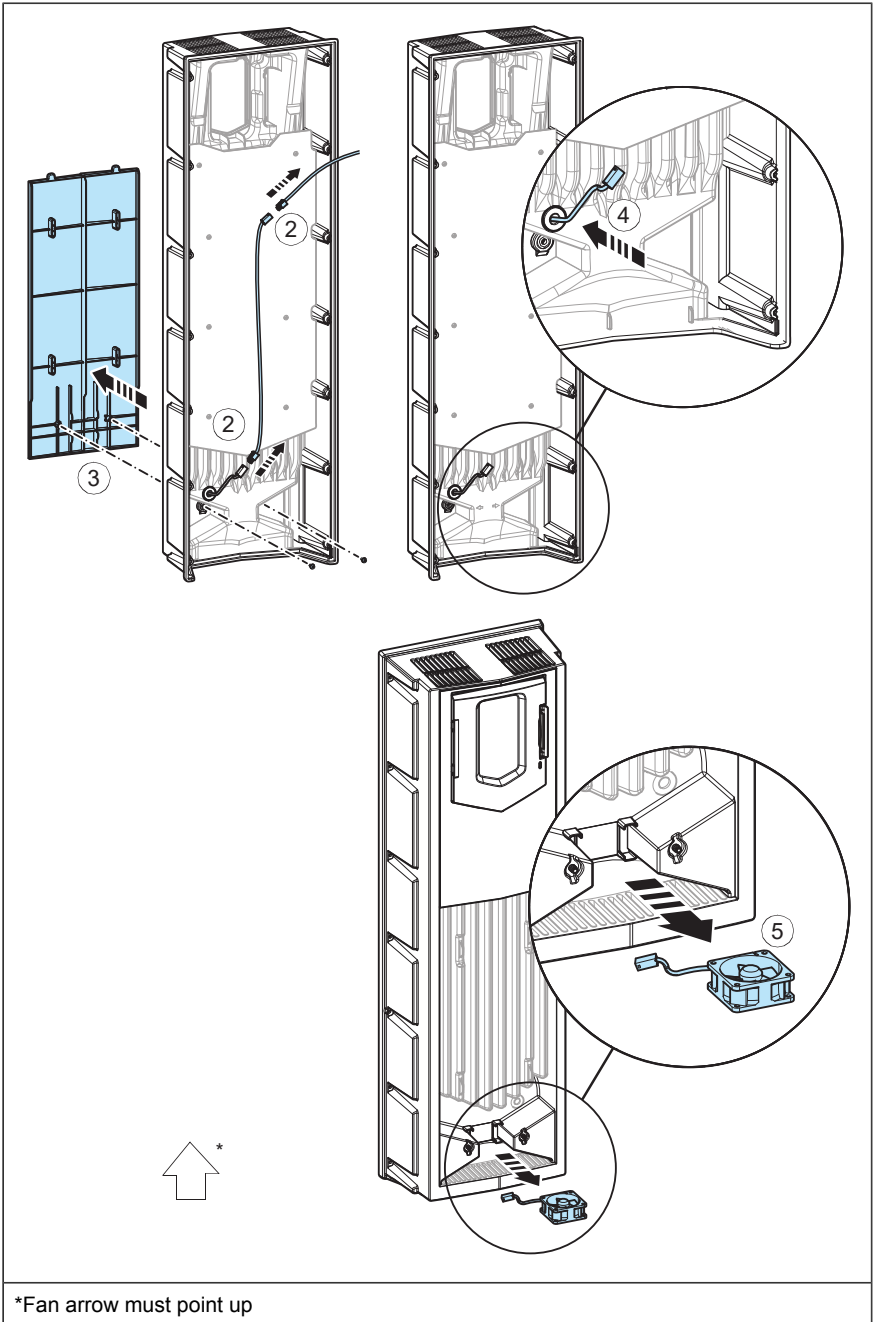

Capacitors

The DC link of the drive contains several electrolytic capacitors. Operating time, load, and surrounding air temperature have an effect on the life of the capacitors. Capacitor life can be extended by decreasing the surrounding air temperature.

Capacitor failure is usually followed by damage to the unit and an input cable fuse failure, or a fault trip. If you think that any capacitors in the drive have failed, contact ABB.

■ Reforming the capacitors

The capacitors must be reformed if the drive has not been powered (either in storage or unused) for a year or more. The manufacturing date is on the type designation label. For information on reforming the capacitors, see *Capacitor reforming instructions* ([3BFE64059629](https://library.abb.com/en) [English]) in the ABB Library (<https://library.abb.com/en>).

Control panel

See *ACx-AP-x Assistant control panels user's manual* ([3AUJA0000085685](https://library.abb.com/en) [English]).

Drive LEDs

There is a green POWER and a red FAULT LED visible when the control panel is removed. If a control panel is attached to the drive, switch to remote control otherwise a fault will be generated, and then remove the panel to be able to see the LEDs. See the firmware manual on how to switch to remote control.

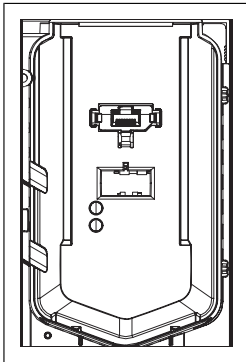

The table below describes the drive LED indications.

LEDs off	LED lit and steady		LED blinking	
	No power	Green (POWER)	Power supply on the unit OK	Green (POWER)
	Red (FAULT)	Active fault in the drive. To reset the fault, press RESET from the control panel or switch off the drive power.	Red (FAULT)	Active fault in the drive. To reset the fault, switch off the drive power.

Control unit

■ Replacing the memory unit of ZCU-12

After replacing a control unit, you can retain the existing parameter settings by transferring the memory unit from the defective control unit to the new control unit. After power-up, the drive will scan the memory unit. This can take several minutes.



WARNING!

Do not remove or insert the memory unit when the control unit is powered.

1. Stop the drive and do the steps in section [Electrical safety precautions \(page 19\)](#) before you start the work.
2. Pull the clip at the side of the memory up.

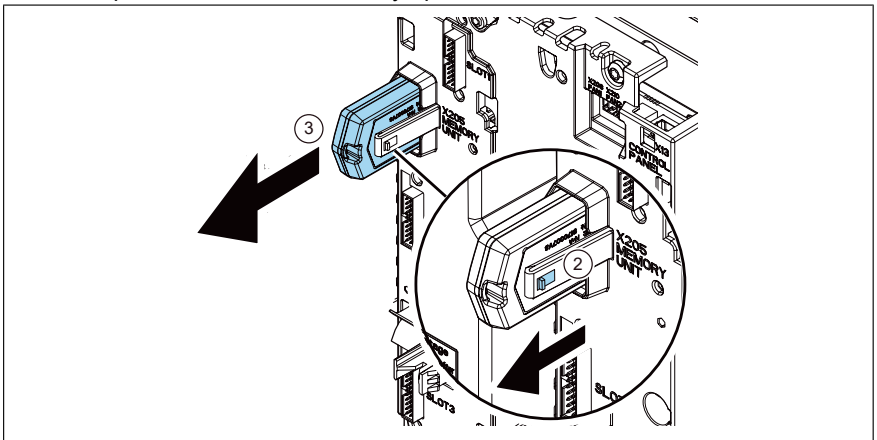

3. Take the unit off.

4. Install the unit in reverse order.

■ **Replacing the ZCU-12 control unit battery**

The control unit battery can be changed with the help of the battery ejector (a in the drawing below). The ejector is included on the battery slot. The battery is of type CR2032.

1. Stop the drive and do the steps in section *Electrical safety precautions (page 19)* before you start the work.
 2. Move the battery ejector into the battery slot on the battery.
 3. Carefully pull the battery out of the battery holder.
 4. Carefully put a new CR2032 battery into the battery holder.
-

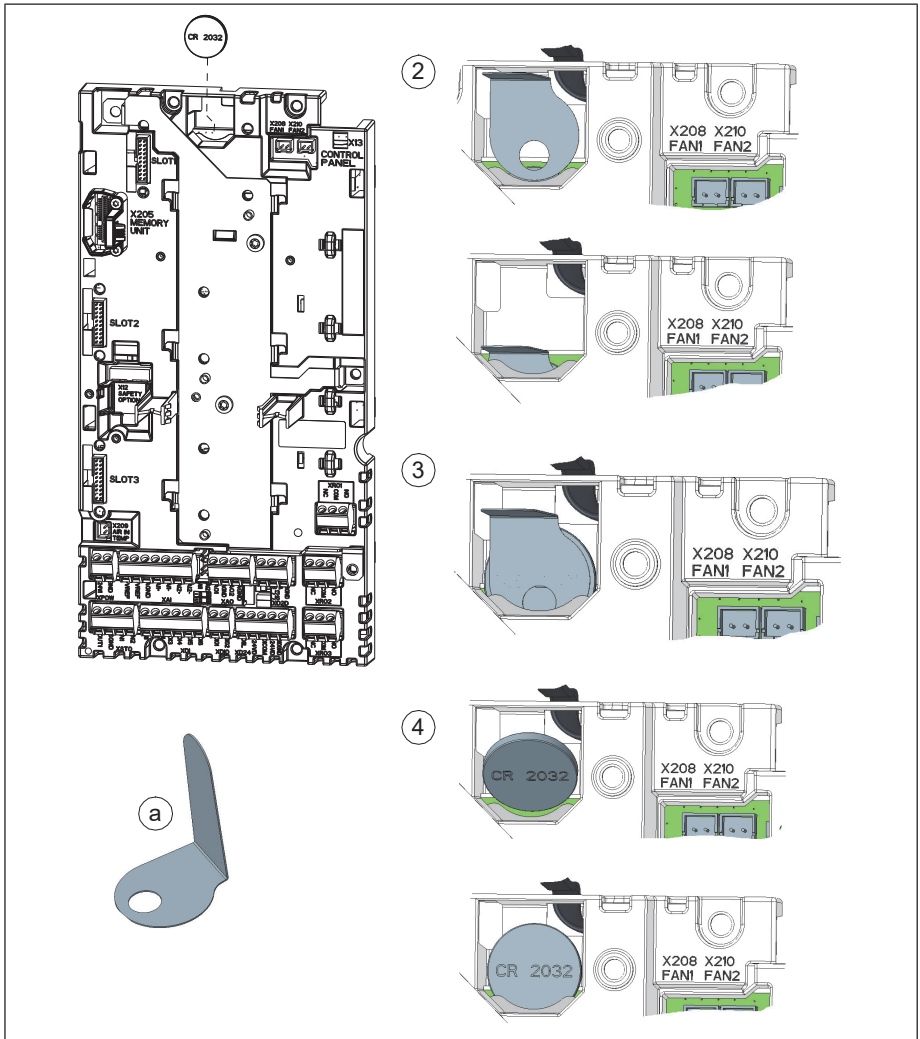

Replacing safety functions modules (FSO-12, option +Q973 and FSO-21, option +Q972)

Do not repair safety functions modules. Replace a faulty module with a new one as described in section [Installation of safety functions modules \(page 107\)](#).

Functional safety components

The mission time of functional safety components is 20 years which equals the time during which failure rates of electronic components remain constant. This applies to the components of the standard Safe torque off circuit as well as any modules, relays and, typically, any other components that are part of functional safety circuits.

The expiry of mission time terminates the certification and SIL/PL classification of the safety function. The following options exist:

- Renewal of the whole drive and all optional functional safety module(s) and components.
- Renewal of the components in the safety function circuit. In practice, this is economical only with larger drives that have replaceable circuit boards and other components such as relays.

Note that some of the components may already have been renewed earlier, restarting their mission time. The remaining mission time of the whole circuit is however determined by its oldest component.

Contact your local ABB service representative for more information.

12

Technical data

Contents of this chapter

This chapter contains the technical specifications of the drive including the ratings, sizes and technical requirements, provisions for fulfilling the requirements for CE, UL and other approval marks.

Ratings

The nominal ratings for the drive with 50 Hz and 60 Hz supply are given below.

IEC RATINGS											
ACS880-31-	Frame size	Input current	Output ratings								
			Nominal use				Light-duty use		Heavy-duty use		
			I_1	I_{max}	S_n	I_2	P_n	I_{Ld}	P_{Ld}	I_{Hd}	P_{Hd}
			A	A	kVA	A	kW	A	kW	A	kW
$U_n = 400\text{ V}$											
09A4-3	R3	8	13.6	6.9	10.0	4.0	9.5	4.0	8.0	3.0	
12A6-3	R3	10	17.0	8.9	12.9	5.5	12.0	5.5	10.0	4.0	
017A-3	R3	14	21.9	12	17.0	7.5	16	7.5	12.9	5.4	
025A-3	R3	20	28.8	17	25	11	24	11	17	7.5	
032A-3	R6	27	42.5	22	32	15	30	15	25	11	
038A-3	R6	33	54.4	26	38	18.5	36	18.5	32	15.0	
045A-3	R6	40	64.6	31	45	22	43	22	38	18.5	
061A-3	R6	51	76.5	42	61	30	58	30	45	22	
072A-3 ¹⁾	R6	63	103.7	50	72	37	68	37	61	30	

IEC RATINGS											
ACS880-31-	Frame size	Input current	Output ratings								
			Nominal use				Light-duty use		Heavy-duty use		
			I_1	I_{max}	S_n	I_2	P_n	I_{Ld}	P_{Ld}	I_{Hd}	P_{Hd}
			A	A	kVA	A	kW	A	kW	A	kW
087A-3 ¹⁾	R6	76	122.4	60	87	45	83	45	72	37	
105A-3	R8	88	148	73	105	55	100	55	87	45	
145A-3	R8	120	178	100	145	75	138	75	105	55	
169A-3	R8	144	247	117	169	90	161	90	145	75	
206A-3	R8	176	287	143	206	110	196	110	169	90	
$U_n = 500 \text{ V}$											
07A6-5	R3	7	9.5	6.6	7.6	4.0	7.2	4.0	5.2	2.2	
11A0-5	R3	9	13.8	9.5	11.0	5.5	10.4	5.5	7.6	4.0	
014A-5	R3	12	18.7	12	14	7.5	13	7.5	11.0	5.5	
021A-5	R3	17	26.3	18	21	11.0	19	11.0	14	7.5	
027A-5	R6	24	35.7	23	27	15.0	26	15.0	21	11.0	
034A-5	R6	29	45.9	29	34	18.5	32	18.5	27	15.0	
040A-5	R6	34	57.8	35	40	22.0	38	22.0	34	18.5	
052A-5	R6	44	68.0	45	52	30.0	49	30.0	40	22.0	
065A-5 ¹⁾	R6	54	88.4	56	65	37.0	62	37.0	52	30.0	
077A-5 ¹⁾	R6	66	110.5	67	77	45.0	73	45.0	65	37.0	
101A-5	R8	71	148	87	101	55.0	91	55.0	77	45.0	
124A-5	R8	96	178	107	124	75.0	118	75.0	96	55.0	
156A-5	R8	115	247	135	156	90.0	148	90.0	124	75.0	
180A-5	R8	141	287	156	180	110.0	171	110.0	156	90.0	

3AXD0000588487

¹⁾ These ratings are not to be used for drives with degree of protection of IP55 (UL Type 12) option +B056.

UL (NEC) RATINGS									
ACS880-31-	Frame size	Input current	Max. current	Output ratings					
				App. power	Light-duty use		Heavy-duty use		
					I_{Ld}	P_{Ld}	I_{Hd}	P_{Hd}	
					A	hp	A	hp	
$U_n = 480 \text{ V}$									
07A6-5	R3	7.0	9.5	6.6	7.6	5.0	5.2	3.0	
11A0-5	R3	9.0	13.8	9.5	11.0	7.5	7.6	5.0	
014A-5	R3	12.0	18.7	12	14.0	10.0	11.0	7.5	

UL (NEC) RATINGS											
ACS880-31-	Frame size	Input current	Max. current	Output ratings							
				I_1	I_{max}	App. power	Light-duty use		Heavy-duty use		
							S_n	I_{Ld}	P_{Ld}	I_{Hd}	P_{Hd}
021A-5	R3	17.0	26.3	18	21.0	15.0	14.0	10.0			
027A-5	R6	24.0	35.7	23	27.0	20.0	21.0	15.0			
034A-5	R6	29.0	45.9	29	34.0	25.0	27.0	20.0			
040A-5	R6	34.0	57.8	35	40.0	30.0	34.0	25.0			
052A-5	R6	44.0	68.0	45	52.0	40.0	40.0	30.0			
065A-5 ¹⁾	R6	54.0	88.4	56	65.0	50.0	52.0	40.0			
077A-5 ¹⁾	R6	66.0	110.5	67	77.0	60.0	65.0	50.0			
101A-5	R8	74.0	148	87	96.0	75.0	77.0	60.0			
124A-5	R8	100.0	178	107	124.0	100.0	96.0	75.0			
156A-5	R8	120.0	247	135	156.0	125.0	124.0	100.0			
180A-5	R8	147.0	287	156	180.0	150.0	156.0	125.0			

3AXD00000588487

1) These ratings are not to be used for drives with degree of protection of IP55 (UL Type 12) option +B056.

U_n	Nominal voltage of the drive
I_1	Nominal input current (rms) at 40 °C (104 °F)
I_{max}	Maximum output current. Available for 10 seconds at start, otherwise as long as allowed by drive temperature. 140% ... 200% of I_{Hd} , depending on power rating.
I_2	Continuous rms output current. No overload capability at 40 °C (104 °F). This is indicated in the type designation label as output current I_2 .
P_n	Typical motor power in no-overload use
S_n	Apparent power (no overload)
I_{Ld}	Continuous rms output current allowing 10% overload for 1 minute every 5 minutes
P_{Ld}	Typical motor power for light-overload use
I_{Hd}	Continuous rms output current allowing 50% overload for 1 minute every 5 minutes
P_{Hd}	Typical motor power for heavy-duty use

Note: To achieve the rated motor power given in the table, the rated current of the drive must be higher than or equal to the rated motor current. The power ratings apply to most IEC 34 motors at the nominal voltage of the drive.

ABB recommends to select the drive, motor and gear combination for the required motion profile with the DriveSize dimensioning tool available from ABB.

■ Deratings

Surrounding air temperature derating

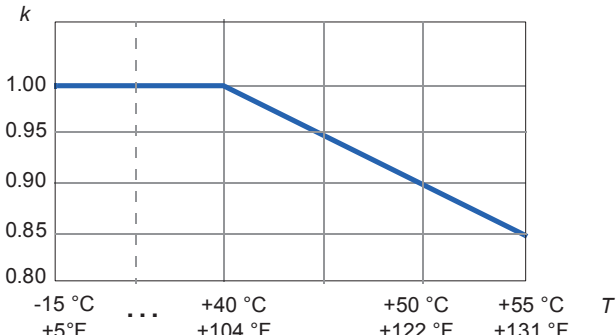
Temperature range	Derating												
All drives except IP55 (UL Type 12) drive types -87A-3 and -77A-5 except IP21 (UL Type 1) and IP55 (UL Type 12) drive types -206A-3 and -180A-5													
up to +40 °C up to +104 °F	No derating												
+40 ... +55 °C +104 ... +131 °F	Derate 1% for every 1 °C (1.8 °F): Calculate the output by multiplying the current given in the rating table by the derating factor (<i>k</i> , in the diagram below). <div style="text-align: center; margin-top: 10px;">  <table border="1" style="margin: 0 auto; border-collapse: collapse;"> <tr> <td style="padding: 2px 10px;">-15 °C</td> <td style="padding: 2px 10px;">...</td> <td style="padding: 2px 10px;">+40 °C</td> <td style="padding: 2px 10px;">+50 °C</td> <td style="padding: 2px 10px;">+55 °C</td> <td style="padding: 2px 10px;"><i>T</i></td> </tr> <tr> <td style="padding: 2px 10px;">+5 °F</td> <td></td> <td style="padding: 2px 10px;">+104 °F</td> <td style="padding: 2px 10px;">+122 °F</td> <td style="padding: 2px 10px;">+131 °F</td> <td></td> </tr> </table> </div>	-15 °C	...	+40 °C	+50 °C	+55 °C	<i>T</i>	+5 °F		+104 °F	+122 °F	+131 °F	
-15 °C	...	+40 °C	+50 °C	+55 °C	<i>T</i>								
+5 °F		+104 °F	+122 °F	+131 °F									

Temperature range	Derating																					
IP55 (UL Type 12) drive types -087A-3+B056 and -077A-5+B056																						
up to +40 °C up to +104 °F	No derating																					
+40 ... +55 °C +104 ... +131 °F	Derate 1% for every 1 °C (1.8 °F) up to 45 °C (113 °F); Derate 2% for every 1 °C (1.8 °F) up to 55 °C (131 °F). Calculate the output by multiplying the current given in the rating table by the derating factor (<i>k</i> , in the diagram below).																					
<p>The graph shows the derating factor <i>k</i> as a function of temperature <i>T</i>. The y-axis represents the derating factor <i>k</i>, ranging from 0.75 to 1.00 in increments of 0.05. The x-axis represents temperature <i>T</i> in both Celsius and Fahrenheit. The derating factor is constant at 1.00 for temperatures up to +40 °C (+104 °F). Beyond +40 °C, the derating factor decreases linearly, reaching 0.75 at +55 °C (+131 °F).</p> <table border="1"> <caption>Derating Factor Data for IP55 Drives</caption> <thead> <tr> <th>Temperature (°C)</th> <th>Temperature (°F)</th> <th>Derating Factor (<i>k</i>)</th> </tr> </thead> <tbody> <tr> <td>-15</td> <td>+5</td> <td>1.00</td> </tr> <tr> <td>...</td> <td>...</td> <td>...</td> </tr> <tr> <td>+40</td> <td>+104</td> <td>1.00</td> </tr> <tr> <td>+45</td> <td>+113</td> <td>0.95</td> </tr> <tr> <td>+50</td> <td>+122</td> <td>0.85</td> </tr> <tr> <td>+55</td> <td>+131</td> <td>0.75</td> </tr> </tbody> </table>		Temperature (°C)	Temperature (°F)	Derating Factor (<i>k</i>)	-15	+5	1.00	+40	+104	1.00	+45	+113	0.95	+50	+122	0.85	+55	+131	0.75
Temperature (°C)	Temperature (°F)	Derating Factor (<i>k</i>)																				
-15	+5	1.00																				
...																				
+40	+104	1.00																				
+45	+113	0.95																				
+50	+122	0.85																				
+55	+131	0.75																				

Temperature range	Derating																		
IP21 (UL Type 1) and IP55 (UL Type 12) drive types -206A-3 and -180A-5																			
up to +40 °C up to +104 °F	No derating																		
+40 ... +55 °C +104 ... +131 °F	Derate 1.5% for every 1 °C (1.8 °F): Calculate the output by multiplying the current given in the rating table by the derating factor (<i>k</i> , in the diagram below).																		
<p>The graph shows the derating factor <i>k</i> as a function of temperature <i>T</i>. The y-axis represents the derating factor <i>k</i>, ranging from 0.75 to 1.00 in increments of 0.05. The x-axis represents temperature <i>T</i> in both Celsius and Fahrenheit. The derating factor is constant at 1.00 for temperatures up to +40 °C (+104 °F). Beyond +40 °C, the derating factor decreases linearly, reaching 0.775 at +55 °C (+131 °F).</p> <table border="1"> <caption>Derating Factor Data for IP21 and IP55 Drives</caption> <thead> <tr> <th>Temperature (°C)</th> <th>Temperature (°F)</th> <th>Derating Factor (<i>k</i>)</th> </tr> </thead> <tbody> <tr> <td>-15</td> <td>+5</td> <td>1.00</td> </tr> <tr> <td>...</td> <td>...</td> <td>...</td> </tr> <tr> <td>+40</td> <td>+104</td> <td>1.00</td> </tr> <tr> <td>+50</td> <td>+122</td> <td>0.85</td> </tr> <tr> <td>+55</td> <td>+131</td> <td>0.775</td> </tr> </tbody> </table>		Temperature (°C)	Temperature (°F)	Derating Factor (<i>k</i>)	-15	+5	1.00	+40	+104	1.00	+50	+122	0.85	+55	+131	0.775
Temperature (°C)	Temperature (°F)	Derating Factor (<i>k</i>)																	
-15	+5	1.00																	
...																	
+40	+104	1.00																	
+50	+122	0.85																	
+55	+131	0.775																	

Note: For surrounding air temperatures above +40 °C (+104 °F), the power cables must be rated for +90 °C (+194 °F) minimum.

Altitude derating

At altitudes from 1000...4000 m (3300...13123 ft) above sea level, the derating is 1% for every 100 m (328 ft). If ambient temperature is below +40 °C (+104 °F), the derating can be reduced by 1.5% for every 1 °C (1.8 °F) reduction in temperature. For a more accurate derating, use the DriveSize PC tool.

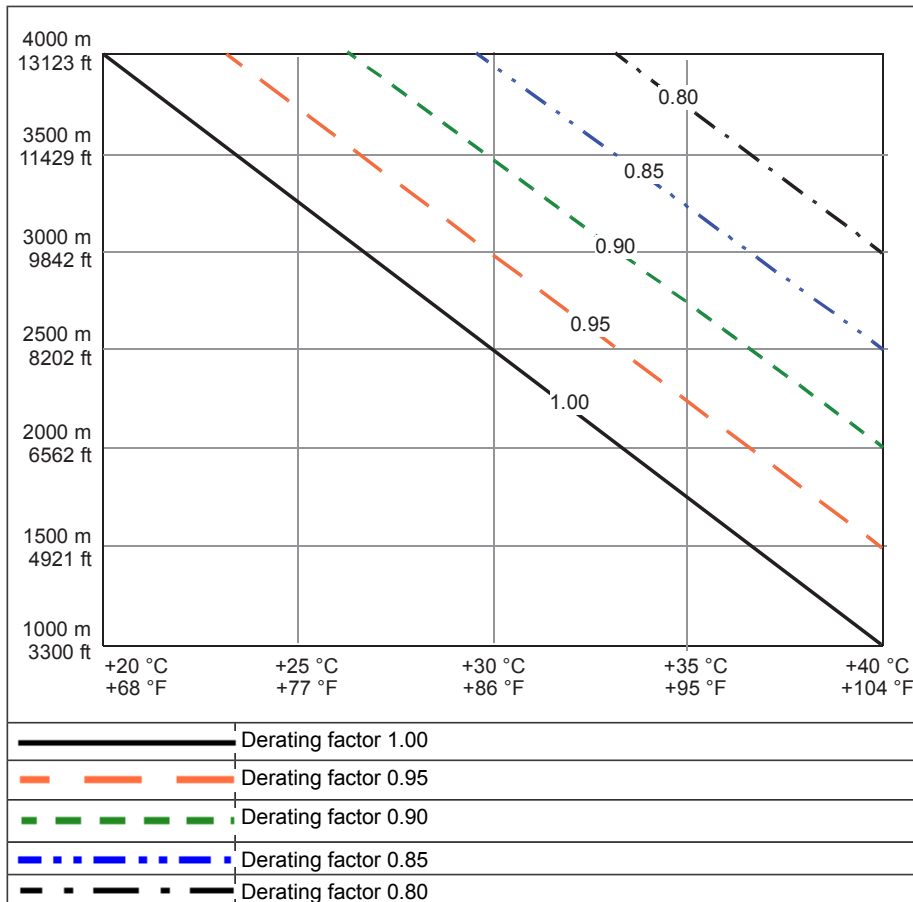

Example 1: Drive type -045A-3, $I_2 = 45$ A, altitude 4000 m and temperature +40 °C. The derating 1% for 30 × 100 m is 30%. The derated current = 45 A - 0.3 × 45 A = 31.5 A.

Example 2: Drive type -045A-3, $I_2 = 45$ A, altitude 4000 m and temperature +30 °C. The derating factor is 1 - 1.5% × 10 = 0.85. The derated current = 0.85 × 45 A = 38.25 A.

Deratings for special settings in the drive control program

Ex motor, sine filter, low noise

Deratings are needed in these cases:

- drive is used with an ABB motor for explosive atmospheres (Ex) and *EX motor* in parameter 95.15 *Special HW settings* is enabled
- sine filter given in the selection table in chapter *Filters* is used and *ABB Sine filter* in parameter 95.15 *Special HW settings* is enabled
- *Low noise optimization* is selected in parameter 97.09 *Switching freq mode*.

Note: If Ex motors are used together with sine filters, *EX motor* in parameter 95.15 *Special HW settings* is disabled and *ABB Sine filter* in parameter 95.15 *Special HW settings* is enabled. Obey the instructions of the motor manufacturer.

ACS880-31-...	Output ratings ¹⁾			
	EX motor (ABB Ex motors)			
	Nominal use		Light-duty use	Heavy-duty use
	I_N	P_N	I_{Ld}	I_{Hd}
	A	kW	A	A
$U_N = 400\text{ V}$				
09A4-3	10.0	4.0	9.5	8.0
12A6-3	12.9	5.5	12.0	10.0
017A-3	17	8	16	12.6
025A-3	25	11	24	17
032A-3	32	15	30	25
038A-3	38	19	36	32
045A-3	45	22	43	38
061A-3	61	30	58	45
072A-3	72	37	68	61
087A-3	87	45	83	72
$U_N = 500\text{ V}$				
07A6-5	7.6	4.0	7.2	5.2
11A0-5	11.0	5.5	10.4	7.6
014A-5	14	7.5	13	11
021A-5	21	11.0	19	14
027A-5	27	15	26	21
034A-5	34	18.5	32	27.0
040A-5	40	22	38	34
052A-5	52	30	49	40
065A-5	65	37	62	52

ACS880-31-...	Output ratings ¹⁾			
	EX motor (ABB Ex motors)			
	Nominal use		Light-duty use	Heavy-duty use
	I_N	P_N	I_{Ld}	I_{Hd}
	A	kW	A	A
077A-5	77	45	73	65

¹⁾ For R8 deratings with Ex motors and non-ABB Ex motors, contact ABB. For deratings with sine filters, contact ABB.

Definitions

U_n Supply voltage range

I_N Nominal output current (available continuously with no over-loading)

P_N Typical motor power in no-overload use

I_{Ld} Continuous rms output current allowing 10% overload for 1 minute every 5 minutes

I_{Hd} Continuous rms output current allowing 50% overload for 1 minute every 5 minutes.

* Continuous rms output current allowing 30% overload for 1 minute every 5 minutes.

** Continuous rms output current allowing 25% overload for 1 minute every 5 minutes.

P_{Hd} Typical motor power in heavy-duty use

Note 1: The ratings apply at an ambient temperature of 40 °C (104 °F).

ACS880-31-	Output ratings with selection Low noise optimization of parameter 97.09 Switching freq mode		
	Nominal use	Light-duty use	Heavy-duty use
	I_N	I_{Ld}	I_{Hd}
	A	A	A
$U_n = 400\text{ V}$			
09A4-3	8.5	8.1	6.5
12A6-3	11.3	10.7	8.5
017A-3	15	14.3	11.3
025A-3	22	20.9	15.0
032A-3	30	29	22
038A-3	35	33	30
045A-3	41	39	35
061A-3	56	53	41
072A-3	56	53	47
087A-3	67	64	56
105A-3	105	100	87
145A-3	145	138	105
169A-3	169	161	145
206A-3	206	196	169

ACS880-31-	Output ratings with selection Low noise optimization of parameter 97.09 Switching freq mode		
	Nominal use	Light-duty use	Heavy-duty use
	I_N	I_{Ld}	I_{Hd}
	A	A	A
$U_n = 500 \text{ V}$			
07A6-5	6.5	6.2	4.4
11A0-5	9.4	8.9	6.5
014A-5	12.0	11.4	9.4
021A-5	18.0	17.1	12.0
027A-5	23.0	21.9	18.0
034A-5	29	28	23
040A-5	29	28	23
052A-5	37	35	29
065A-5	39	37	33
077A-5	46	44	39
101A-5	101	91	77
124A-5	124	118	96
156A-5	156	148	124
180A-5	180	171	156

U_n	Nominal voltage of the drive
I_n	Continuous rms output current. No overload capability at 40 °C (104 °F)
I_{Ld}	Continuous rms output current allowing 10% overload for 1 minute every 5 minutes
I_{Hd}	Continuous rms output current allowing 50% overload for 1 minute every 5 minutes

Note: The ratings apply at an ambient temperature of 40 °C (104 °F).

High speed mode

Selection *High speed mode* of parameter 95.15 *Special HW settings* improves control performance at high output frequencies. ABB recommends it to be selected with output frequency of 120 Hz and above.

This table gives the drive ratings for the maximum output frequency when *High speed mode* in parameter 95.15 *Special HW settings* is enabled: With output frequencies smaller than this recommended maximum output frequency, the current derating is less than the values given in the table. Contact ABB for operation above the recommended maximum output frequency or for the output current derating with output frequencies above 120 Hz and below the maximum output frequency.

At the output frequency 120 Hz no derating.

ACS880-31-	Output ratings with selection High speed mode of parameter 95.15 Special HW settings			
	Maximum output frequency	Nominal use	Light-duty use	Heavy-duty use
	f_{\max}	I_N	I_{Ld}	I_{Hd}
	Hz	A	A	A
$U_n = 400\text{ V}$				
09A4-3	500	8.5	8.1	6.5
12A6-3	500	11.3	10.7	8.5
017A-3	500	15	14.3	11.3
025A-3	500	22	20.9	15.0
032A-3	500	30	29	22
038A-3	500	35	33	30
045A-3	500	41	39	35
061A-3	500	56	53	41
072A-3	500	56	53	47
087A-3	500	67	64	56
105A-3	500	105	100	87
145A-3	500	145	138	105
169A-3	500	156	148	122
206A-3	500	192	180	155
$U_n = 500\text{ V}$				
07A6-5	500	6.5	6.2	4.4
11A0-5	500	9.4	8.9	6.5
014A-5	500	12.0	11.4	9.4
021A-5	500	18.0	17.1	12.0
027A-5	500	23.0	21.9	18.0
034A-5	500	29	28	23
040A-5	500	29	28	23
052A-5	500	37	35	29
065A-5	500	39	37	33
077A-5	500	46	44	39
101A-5	500	101	91	77
124A-5	500	124	118	96
156A-5	500	144	136	87
180A-5	500	169	160	147

U_n	Nominal voltage of the drive
f_{\max}	Maximum output frequency with High speed mode

I_n	Continuous rms output current. No overload capability at 40 °C (104 °F).
I_{Ld}	Continuous rms output current allowing 10% overload for 1 minute every 5 minutes
I_{Hd}	Continuous rms output current allowing 50% overload for 1 minute every 5 minutes

Derating for output voltage boost

The drive can output a higher motor voltage than the supply voltage. This may require derating of the drive output power depending on the difference between the supply voltage and the output voltage to the motor for continuous operation.

400 V and 500 V drive types

This graph shows the required derating for -3 and -5 (400 V and 500 V) drive types.

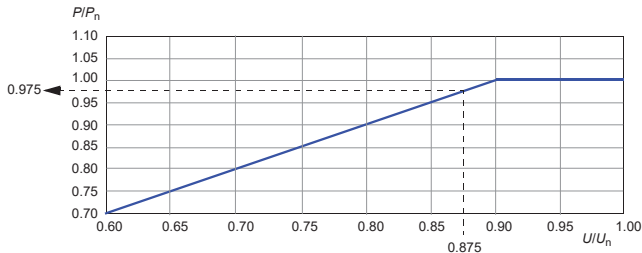

Example 1: P_n for -045A-3 is 22 kW. The supply voltage (U) is 350 V.

$U/U_n = 350 \text{ V} / 400 \text{ V} = 0.875$. From the graph we can see that $P/P_n = 0.975$.

The derated power $P = 0.975 \times 22 \text{ kW} = 21.45 \text{ kW}$.

To boost the output voltage to correspond the nominal supply voltage 400 V, increase the DC voltage to $400 \text{ V} \times \sqrt{2} = 567 \text{ V}$.

Example 2: P_n for -124A-5 is 55 kW. The supply voltage (U) is 450 V.

$U/U_n = 450 \text{ V} / 500 \text{ V} = 0.9$. From the graph we can see that $P/P_n = 1.00$.

The derated power $P = 1.00 \times 55 \text{ kW} = 55 \text{ kW}$.

To boost the output voltage to correspond the nominal supply voltage 500 V, increase the DC voltage to $500 \text{ V} \times \sqrt{2} = 707 \text{ V}$.

For more information, see ACS880-11, ACS880-31, ACS880-14, ACS880-34, ACS880-17, ACS880-37 drives product note on DC voltage boost ([3AXD50000691838](#) [English]).

Fuses (IEC)

Fuses protect the input cable in short-circuit situations. They also restrict drive damage and prevent damage to adjoining equipment in case of a short-circuit inside the drive. ABB recommends the high speed aR fuses specified below. The gG fuses can be used for frames R3 and R6 if they operate rapidly enough (max. 0.1 seconds). The operating time depends on the supply network impedance and the cross-sectional area and length of the supply cable. Obey the local regulations.

Note: Fuses from other manufacturers can be used if they meet the ratings and the melting curve of the fuse does not exceed the melting curve of the fuse mentioned in the table.

■ aR fuses DIN 43653 stud-mount

ACS880-31-...	Min. short-circuit current ¹⁾	Input current	Ultrarapid (aR) fuses (stud-mount, one fuse per phase)				
			Nominal current	I^2t	Voltage rating	Bussmann type	Type DIN 43653
	A	A	A	A ² s	V		
3-phase $U_n = 400$ V							
09A4-3	70	8	25	130	690	170M1311	000
12A6-3	70	10	25	130	690	170M1311	000
017A-3	70	14	25	130	690	170M1311	000
025A-3	100	20	32	270	690	170M1312	000
032A-3	110	27	40	460	690	170M1313	000
038A-3	210	33	63	1450	690	170M1315	000
045A-3	300	40	80	2550	690	170M1316	000
061A-3	300	51	80	2550	690	170M1316	000
072A-3	400	63	100	4650	690	170M1317	000
087A-3	400	76	125	8500	690	170M1318	000
105A-3	700	88	160	16000	690	170M1319	000
145A-3	970	120	200	28000	690	170M1320	000
169A-3	1100	144	250	42000	690	170M2618	00
206A-3	1600	176	315	68500	690	170M2619	00
3-phase $U_n = 500$ V							
07A6-5	32	7.0	10	25.5	690	170M1308	000
11A0-5	42	9.0	16	48	690	170M1309	000
014A-5	65	12.0	25	130	690	170M1311	000
021A-5	65	17.0	25	130	690	170M1311	000
027A-5	120	24.0	40	460	690	170M1313	000
034A-5	170	29.0	63	1450	690	170M1315	000
040A-5	170	34.0	63	1450	690	170M1315	000
052A-5	280	44.0	80	2550	690	170M1316	000

ACS880-31-...	Min. short-circuit current ¹⁾	Input current	Ultrarapid (aR) fuses (stud-mount, one fuse per phase)				
			Nominal current	I^2t	Voltage rating	Bussmann type	Type DIN 43653
			A	A ² s	V		
065A-5	400	54.0	100	4650	690	170M1317	000
077A-5	400	66.0	125	8500	690	170M1318	000
101A-5	700	71.0	160	16000	690	170M1319	000
124A-5	970	96.0	200	28000	690	170M1320	000
156A-5	1100	115.0	250	42000	690	170M2618	00
180A-5	1600	141.0	315	68500	690	170M2619	00

¹⁾ Minimum short-circuit current of the electrical power system

■ aR fuses DIN 43620 blade style

ACS880-31-...	Min. short-circuit current ¹⁾	Input current	Ultra-rapid (aR) fuses (blade style, one fuse per phase)				
			Nominal current	I^2t	Voltage rating	Bussmann type	Type DIN 43620
			A	A ² s	V		
3-phase $U_n = 400$ V							
09A4-3	65	8	25	130	690	170M1561	000
12A6-3	65	10	25	130	690	170M1561	000
017A-3	120	14	40	460	690	170M1563	000
025A-3	120	20	40	460	690	170M1563	000
032A-3	170	27	63	1450	690	170M1565	000
038A-3	170	33	63	1450	690	170M1565	000
045A-3	280	40	80	2550	690	170M1566	000
061A-3	380	51	100	4650	690	170M1567	000
072A-3	500	63	125	8500	690	170M1568	000
087A-3	700	76	160	16000	690	170M1569	000
105A-3	1200	88	315	46500	690	170M3817	1
145A-3	1200	120	315	46500	690	170M3817	1
169A-3	1900	144	450	105000	690	170M5809	2
206A-3	2200	176	500	145000	690	170M5810	2
3-phase $U_n = 500$ V							
07A6-5	65	7.0	25	130	690	170M1561	000
11A0-5	65	9.0	25	130	690	170M1561	000
014A-5	120	12.0	40	460	690	170M1563	000
021A-5	120	17.0	40	460	690	170M1563	000
027A-5	170	24.0	63	1450	690	170M1565	000

ACS880-31-...	Min. short-circuit current ¹⁾	Input current	Ultra-rapid (aR) fuses (blade style, one fuse per phase)				
			Nominal current	I^2t	Voltage rating	Bussmann type	Type DIN 43620
			A	A ² s	V		
034A-5	170	29.0	63	1450	690	170M1565	000
040A-5	280	34.0	80	2550	690	170M1566	000
052A-5	380	44.0	100	4650	690	170M1567	000
065A-5	500	54.0	125	8500	690	170M1568	000
077A-5	700	66.0	160	16000	690	170M1569	000
101A-5	1000	71.0	250	28500	690	170M3816	1
124A-5	1200	96.0	315	46500	690	170M3817	1
156A-5	1600	115.0	400	74000	690	170M5808	2
180A-5	2200	141.0	500	155000	690	170M5810	2

¹⁾ Minimum short-circuit current of the electrical power system

■ gG fuses DIN 43620 blade style

gG fuses can be used for frames R3 and R6 if they operate rapidly enough (max. 0.1 seconds). ABB recommends, however, aR fuses. gG fuses are not allowed for frame R8.

ACS880-31-...	Min. short-circuit current ¹⁾	Input current	gG fuses (one fuse per phase)				
			Nominal current	I^2t	Voltage rating	ABB type	Size DIN 43620
			A	A ² s	V		
3-phase $U_n = 400$ V							
09A4-3	120	8.0	16	700	500	OFAF000H16	000
12A6-3	120	10.0	16	700	500	OFAF000H16	000
017A-3	200	14.0	25	2500	500	OFAF000H25	000
025A-3	250	20.0	32	4500	500	OFAF000H32	000
032A-3	350	27.0	40	7700	500	OFAF000H40	000
038A-3	400	33.0	50	15400	500	OFAF000H50	000
045A-3	500	40.0	63	21300	500	OFAF000H63	000
061A-3	800	51.0	80	37000	500	OFAF000H80	000
072A-3	1000	63.0	100	63600	500	OFAF000H100	000
087A-3	1000	76.0	100	63600	500	OFAF000H100	000
3-phase $U_n = 500$ V							
07A6-5	120	7.0	16	700	500	OFAF000H16	000
11A0-5	120	9.0	16	700	500	OFAF000H16	000
014A-5	200	12.0	25	2500	500	OFAF000H25	000

ACS880-31-...	Min. short-circuit current ¹⁾	Input current	gG fuses (one fuse per phase)				
			Nominal current	I _{2t}	Voltage rating	ABB type	Size DIN 43620
			A	A2s	V		
021A-5	250	17.0	32	4500	500	OFAF000H32	000
027A-5	350	24.0	40	7700	500	OFAF000H40	000
034A-5	400	29.0	50	15400	500	OFAF000H50	000
040A-5	500	34.0	63	21300	500	OFAF000H63	000
052A-5	800	44.0	80	37000	500	OFAF000H80	000
065A-5	1000	54.0	100	63600	500	OFAF000H100	000
077A-5	1000	66.0	100	63600	500	OFAF000H100	000

1) Minimum short-circuit current of the installation

■ Quick guide for selecting between gG and aR fuses

The combinations (cable size, cable length, transformer size and fuse type) in this table fulfill the minimum requirements for the correct operation of the fuse. Use this table to select between gG and aR fuses or calculate the short-circuit current of the installation as described in section *Calculating the short-circuit current of the installation (page 182)*.

ACS880-31-...	Cable type		Supply transformer minimum apparent power S _n (kVA)					
	Copper mm ²	Aluminum mm ²	Maximum cable length with gG fuses			Maximum cable length with aR fuses		
			10 m	50 m	100 m	10 m	100 m	200 m
U_n = 400 V								
09A4-3	3×1.5	-	5.8	6.2	8.4	3.1	3.4	5.0
12A6-3	3×1.5	-	5.8	6.2	8.4	3.1	3.4	5.0
017A-3	3×6	-	9.6	9.8	10	5.8	5.9	6.2
025A-3	3×6	-	12	12	13	5.8	5.9	6.2
032A-3	3×10	-	17	17	18	8.2	8.3	8.7
038A-3	3×10	-	19	20	21	8.2	8.3	8.7
045A-3	3×16	3×25	24	24	26	13	14	15
061A-3	3×25	3×25	39	39	42	18	19	20
072A-3	3×35	3×35	48	49	52	23	24	25
087A-3	3×35	3×50	48	49	52	34	35	38
U_n = 500 V								
07A6-5	3×1.5	-	7.2	7.5	8.9	3.9	4.1	5.0
11A0-5	3×1.5	-	7.2	7.5	8.9	3.9	4.1	5.0
014A-5	3×6	-	12	12	12	7.2	7.3	7.6
021A-5	3×6	-	15	15	16	7.2	7.3	7.6
027A-5	3×10	-	21	21	22	10	10	11

ACS880-31-...	Cable type		Supply transformer minimum apparent power S_n (kVA)					
	Copper	Aluminum	Maximum cable length with gG fuses			Maximum cable length with aR fuses		
	mm ²	mm ²	10 m	50 m	100 m	10 m	100 m	200 m
034A-5	3×10	-	24	24	25	10	10	11
040A-5	3×16	3×35	30	30	31	17	17	18
052A-5	3×25	3×35	48	49	51	18	18	19
065A-5	3×35	3×50	60	61	63	29	29	30
077A-5	3×35	3×70	60	61	63	42	43	46

■ Calculating the short-circuit current of the installation

Check that the short-circuit current of the installation is at least the value given in the fuse table.

The short-circuit current of the installation can be calculated as follows:

$$I_{k2-ph} = \frac{U}{2 \cdot \sqrt{R_c^2 + (Z_k + X_c)^2}}$$

where

- I_{k2-ph} Short-circuit current in symmetrical two-phase short-circuit
- U Network line-to-line voltage (V)
- R_c Cable resistance (ohm)
- Z_k $Z_k = z_k \cdot U_N^2 / S_N =$ transformer impedance (ohm)
- z_k Transformer impedance (%)
- U_N Transformer rated voltage (V)
- S_N Nominal apparent power of the transformer (kVA)
- X_c Cable reactance (ohm)

Calculation example

Drive:

- ACS880-31-...
- supply voltage = 410 V

Transformer:

- rated power $S_n = 600$ kVA
- rated secondary voltage (supply for drive supply) $U_n = 430$ V

- transformer impedance $z_k = 7.2\%$

Supply cable:

- length = 170 m
- resistance/length = 0.398 ohm/km
- reactance/length = 0.082 ohm/km.

$$Z_k = z_k \cdot \frac{U_N^2}{S_N} = 0.072 \cdot \frac{(430 \text{ V})^2}{600 \text{ kVA}} = 22.19 \text{ mohm}$$

$$R_c = 170 \text{ m} \cdot 0.398 \frac{\text{ohm}}{\text{km}} = 67.66 \text{ mohm}$$

$$X_c = 170 \text{ m} \cdot 0.082 \frac{\text{ohm}}{\text{km}} = 13.94 \text{ mohm}$$

$$I_{k2\text{-ph}} = \frac{410 \text{ V}}{2 \cdot \sqrt{(67.66 \text{ mohm})^2 + (22.19 \text{ mohm} + 13.94 \text{ mohm})^2}} = 2.7 \text{ kA}$$

The calculated short-circuit current 2.7 kA is higher than the minimum short-circuit current of the drive gG fuse type OFAF000H100 (1000 A). -> The 500 V gG fuse (ABB Control OFAF000H100) can be used.

Fuses (UL)

The UL Listed fuses in this manual are required for branch circuit protection and required per NEC. The drives are suitable for use on a circuit capable of delivering not more than 100 kA symmetrical amperes (RMS) at 480 V maximum when protected by the fuses described below.

Class T fuses are recommended below. Also allowed are UL Listed 248-8 Class J fast acting, time delay, and high speed fuses, 248-4 Class CC fast acting fuses and 248-17 Class CF fast acting and time delay fuses of the same nominal voltage and current rating.

Refer to notes below the tables.

ACS880-31-...	Input current	UL (one fuse per phase)			
		Nominal current	Voltage rating	Busmann type	UL class
	A	A	V		
3-phase $U_n = 480 \text{ V}$					
07A6-5	7.0	15	600	JJS-15	T

ACS880-31-...	Input current	UL (one fuse per phase)			
		Nominal current	Voltage rating	Bussmann type	UL class
	A	A	V		
11A0-5	9.0	20	600	JJS-20	T
014A-5	12.0	25	600	JJS-25	T
021A-5	17.0	35	600	JJS-35	T
027A-5	24.0	40	600	JJS-40	T
034A-5	29.0	50	600	JJS-50	T
040A-5	34.0	60	600	JJS-60	T
052A-5	44.0	80	600	JJS-80	T
065A-5	54.0	90	600	JJS-90	T
077A-5	66.0	110	600	JJS-110	T
101A-5	74.0	150	600	JJS-150	T
124A-5	100.0	200	600	JJS-200	T
156A-5	120.0	225	600	JJS-225	T
180A-5	147.0	300	600	JJS-300	T

1. Fuses are required as part of the installation, are not included in the base drive configuration and must be provided by others.
2. Fuses with a higher current rating than specified must not be used.
3. The UL listed fuses recommended by ABB are the required branch circuit protection per NEC. Circuit breakers listed in section *Circuit breakers (UL)* are also acceptable as branch circuit protection.
4. The recommended size or smaller UL listed 248 fast acting, time delay, or high speed fuses must be used to maintain the UL listing of the drive. Additional protection can be used. Refer to local codes and regulations.
5. A fuse of a different class can be used at the high fault rating where the I_{peak} and I^2t of the new fuse is not greater than that of the specified fuse.
6. UL listed 248 fast acting, time delay, or high speed fuses from other manufacturers can be used if they meet the same class and rating requirements specified in the rules above.
7. When installing a drive, always follow ABB installation instructions, NEC requirements and local codes.
8. Alternative fuses can be used if they meet certain characteristics. For acceptable fuses, see the manual supplement ([3AXD50000645015](#)).

Circuit breakers (IEC)

Contact ABB.

Circuit breakers (UL)

■ ABB inverse time circuit breakers

The drives are suitable for use on a circuit capable of delivering not more than 65 kA symmetrical amperes (RMS) at 480 V maximum when protected by circuit breakers in the tables below.

Additional fuse protection is not required when using the circuit breakers herein.

Circuit breakers are not required to be in the same enclosure as the drive.

For more information see the manual supplement ([3AXD50000645015 \[English\]](#))

1. For UL Type Open, Type 1 or UL Type 12 drives no Enclosure Minimum Volume is required but the drive must be mounted inside an enclosure.
 2. If combining a drive with no Enclosure Minimum Volume and others with an Enclosure Minimum Volume specified, start with the largest specified Enclosure Minimum Volume listed and add the drive volumes for the other drives.
 3. When only mounting drives with no Enclosure Minimum Volume specified, there are no restrictions on the enclosure size. Always follow air clearances specified in the drive hardware manuals for sufficient ventilation around each drive.
 4. UL Type Open, Type 1 and Type 12 drives can be used inside of the enclosure. Listed drive volumes in the table apply for all three UL Types when installing multiple drives in the enclosure.
 5. The ABB circuit breaker part number listed in the table is a base part number.
 - Symbol α represents 80% or 100% allowable continuous current. Options allowed are U, Q, C and D.
 - Symbol β represents the number of poles for the breaker. Options allowed are 3 and 4.
 - Symbol # represents trip units. Trip units allowed include A through C, E through L, P through Z. If using Ekip breakers, set the overload current of the circuit breaker equal to or less than the value shown in the “CB Maximum Current” column in the tables below.
 - The digits indicated with an “*” represent accessories for the breakers and have no impact on the drive UL listing or performance or rating of the breaker.
 6. Ratings in the tables are maximum for the given circuit breaker frame size. Breakers with lower current ratings are also allowed if they have the same frame size, interrupting rating, and voltage rating.
 7. Using a circuit breaker with a lower kAIC rating is not allowed even if the available short-circuit current is less than 65 kA.
-

8. When designing UL 508A panels, Article SB 4.2.3 Exception No. 3 allows the use of other manufacturers' current limiting inverse time circuit breakers which have the same voltage, current and interrupting rating, if I_{peak} and I^2t are the same or less than the ABB specified circuit breaker.
9. Only current limiting inverse time circuit breakers can be used.
10. The drives listed below have no Enclosure Minimum Volume unlike 480 V and 600 V ACS880-01 drives.

ACS880-31-...	Frame	Input current	CB Maximum current	CB Voltage	Drive volume	ABB circuit breaker	Max. I^2t	Max. I_{peak}
		A	A	V	in ³		A ² s	kA
$U_n = 480\text{ V}$								
07A6-5	R3	5.8	20	480	1638	XT2Hαβ020#*****	0.512×10^6	23.2
11A0-5	R3	7.8	20	480	1638	XT2Hαβ020#*****	0.512×10^6	23.2
014A-5	R3	10.6	35	480	1638	XT2Hαβ035#*****	0.512×10^6	23.2
021A-5	R3	15.6	35	480	1638	XT2Hαβ035#*****	0.512×10^6	23.2
027A-5	R6	21.3	70	480	3507	XT2Hαβ070#*****	0.512×10^6	23.2
034A-5	R6	26.2	70	480	3507	XT2Hαβ070#*****	0.512×10^6	23.2
040A-5	R6	31.2	70	480	3507	XT2Hαβ070#*****	0.512×10^6	23.2
052A-5	R6	40.1	125	480	3507	XT2Hαβ125#*****	0.512×10^6	23.2
065A-5	R6	49.5	125	480	3507	XT2Hαβ125#*****	0.512×10^6	23.2
077A-5	R6	60.2	125	480	3507	XT2Hαβ125#*****	0.512×10^6	23.2
101A-5	R8	74	225	480	6602	XT4Hαβ225#*****	0.98×10^6	30
124A-5	R8	100	225	480	6602	XT4Hαβ225#*****	0.98×10^6	30
156A-5	R8	120	250	480	6602	XT4Hαβ250#*****	0.98×10^6	30
180A-5	R8	147	250	480	6602	XT4Hαβ250#*****	0.98×10^6	30

Dimensions, weights and free space requirements

Frame size	Height	Width	Depth	Weight
	mm	mm	mm	kg
IP21				
R3	495	203	356	21.3
R6	771	252	382	61
R8	965	300	430	118 ¹⁾
IP55 (option +B056)				
R3	495	203	360	23
R6	771	252	445	63

Frame size	Height	Width	Depth	Weight
	mm	mm	mm	kg
R8	965	300	496	124 ²⁾
IP20 (option +P940)				
R3	490	203	349	18.3
R6	771	252	358	59
R8	964	300	430	100-115 ³⁾

1) for types -105A-3, 145A-3, -101A-5, -124A-5: 103 kg

2) for types -105A-3, 145A-3, -101A-5, -124A-5: 109 kg

3) for types -105A-3, 145A-3, -101A-5, -124A-5: 100 kg

Frame size	Height	Width	Depth	Weight
	in	in	in	lb
UL Type 1				
R3	19.49	7.99	14.02	50.72
R6	30.35	9.92	15.03	161.85
UL Type 12				
R3	19.29	7.99	14.17	50.72
R6	30.35	9.92	17.54	161.85
UL Open Type (option +P940)				
R3	19.29	7.99	13.74	40.34
R6	30.35	9.92	14.09	130.07
R8	37.95	11.81	16.94	253.53 ¹⁾

1) for types -105A-3, 145A-3, -101A-5, -124A-5: 220.46 lb

Frame size	Drive weight with flange kit (option +C135)	
	IP21	IP55
	kg	kg
R3	25.45	27.45
R6	66.80	68.88
R8	125.90	131.90

Frame size	Drive weight with flange kit (option +C135)	
	UL Type 1	UL Type 12
	lb	lb
R3	56.11	60.52
R6	147.27	151.85
R8	277.56	290.79

* Hood not included

■ Free space requirements

See section *Installation orientations* (page 42).

■ Package dimensions

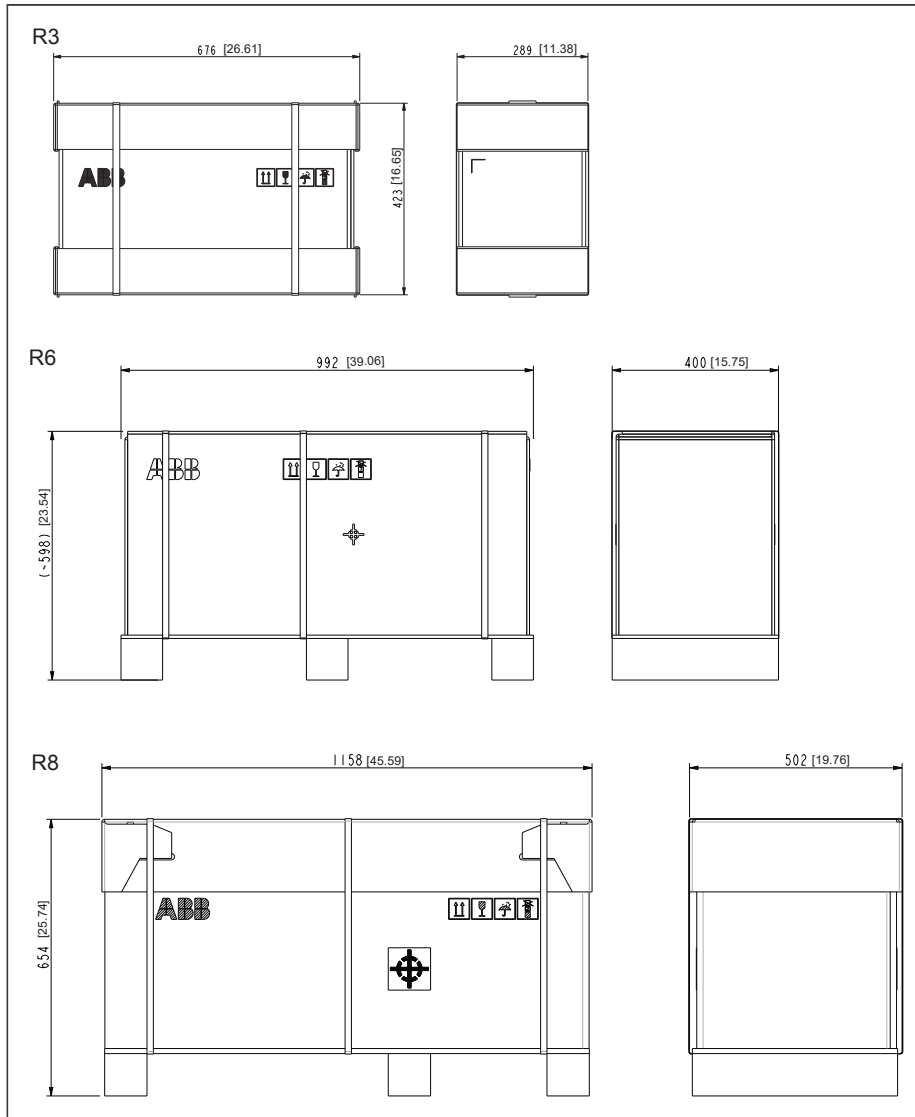

Losses, cooling data and noise

The air flow direction is from bottom to top.

This table shows typical heat loss values, required air flow and noise at the nominal ratings of the drive. The heat loss values can vary depending on voltage, cable conditions, motor efficiency and power factor. To obtain more accurate values for given conditions, use ABB DriveSize tool (<http://new.abb.com/drives/software-tools/drivesize>).

■ IEC

ACS880-31-...	Power losses	Air flow		Noise	Frame size
	W	m ³ /h	ft ³ /min	dB(A)	
<i>U_n</i> = 400 V					
09A4-3	226	361	212	57	R3
12A6-3	329	361	212	57	R3
017A-3	395	361	212	57	R3
025A-3	579	361	212	57	R3
032A-3	625	550	324	71	R6
038A-3	751	550	324	71	R6
045A-3	912	550	324	71	R6
061A-3	1088	550	324	71	R6
072A-3	1502	550	324	71	R6
087A-3	1904	550	324	71	R6
105A-3	1877	913	537	68	R8
145A-3	2963	913	537	68	R8
169A-3	3168	913	537	68	R8
206A-3	3990	913	537	68	R8
<i>U_n</i> = 500 V					
07A6-5	219	361	212	57	R3
11A0-5	278	361	212	57	R3
014A-5	321	361	212	57	R3
021A-5	473	361	212	57	R3
027A-5*	625	550	324	71	R6
034A-5*	711	550	324	71	R6
040A-5*	807	550	324	71	R6
052A-5*	960	550	324	71	R6
065A-5*	1223	550	324	71	R6
077A-5*	1560	550	324	71	R6
101A-5	1995	913	537	68	R8
124A-5	2800	913	537	68	R8
156A-5	3168	913	537	68	R8
180A-5	3872	913	537	68	R8

These losses are not calculated according to IEC 61800-9-2.

■ UL (NEC)

ACS880-31-...	Power losses	Air flow		Noise	Frame size
	W	m ³ /h	ft ³ /min	dB(A)	
$U_n = 480 \text{ V}$					
07A6-5	219	361	212	57	R3
11A0-5	278	361	212	57	R3
014A-5	321	361	212	57	R3
021A-5	473	361	212	57	R3
027A-5	625	550	324	71	R6
034A-5	711	550	324	71	R6
040A-5	807	550	324	71	R6
052A-5	960	550	324	71	R6
065A-5	1223	550	324	71	R6
077A-5	1560	550	324	71	R6
101A-5	1995	913	537	68	R8
124A-5	2800	913	537	68	R8
156A-5	3168	913	537	68	R8
180A-5	3872	913	537	68	R8

These losses are not calculated according to IEC 61800-9-2.

■ Cooling air flow and heat dissipation for flange mounting (option +C135)

ACS880-31-...	Heat dissipation		Cooling air flow		Frame size
	Heatsink	Front	Heatsink	Front	
	W	W	m ³ /h	m ³ /h	
$U_n = 400 \text{ V}$					
09A4-3	186	40	361	-	R3
12A6-3	288	41	361	-	R3
017A-3	353	42	361	-	R3
025A-3	533	46	361	-	R3
032A-3	578	47	498	52	R6
038A-3	702	49	498	52	R6
045A-3	860	52	498	52	R6
061A-3	1032	56	498	52	R6
072A-3	1437	65	498	52	R6
087A-3	1829	75	498	52	R6
105A-3	1803	74	740	60	R8
145A-3	2858	105	740	60	R8

ACS880-31-...	Heat dissipation		Cooling air flow		Frame size
	Heatsink	Front	Heatsink	Front	
	W	W	m ³ /h	m ³ /h	
169A-3	3056	112	740	60	R8
206A-3	3849	141	740	60	R8
$U_n = 500 \text{ V}$					
07A6-5	180	39	361	-	R3
11A0-5	238	40	361	-	R3
014A-5	280	41	361	-	R3
021A-5	429	44	361	52	R3
027A-5	578	47	498	52	R6
034A-5	663	48	498	52	R6
040A-5	757	50	498	52	R6
052A-5	907	53	498	52	R6
065A-5	1164	59	498	52	R6
077A-5	1494	66	498	52	R6
101A-5	1918	77	740	60	R8
124A-5	2700	100	740	60	R8
156A-5	3056	112	740	60	R8
180A-5	3736	136	740	60	R8

These losses are not calculated according to IEC 61800-9-2.

Terminal and entry data for the power cables

Input, motor and DC cable entries, maximum wire sizes (per phase) and terminal screw sizes and tightening torques are given below. \varnothing = Maximum cable diameter accepted.

- For the bottom plate hole diameters, see chapter *Dimension drawings (page 209)*.
- The minimum specified wire size does not necessarily have sufficient current carrying capacity at maximum load.
- The terminals do not accept a conductor that is one size larger than the maximum specified wire size.
- The maximum number of conductors per terminal is 1.

Frame	Cable entries		L1, L2, L3, T1/U, T2/V, T3/W, UD+, UDC- terminals			PE terminal	
	pcs	Ø	Min wire size (solid/ stranded) ¹⁾	Max wire size (solid/ stranded)	T	Wire size	T
		mm	mm ²	mm ²	N·m	mm ²	N·m
R3	3	23	0.5	16.0	1.7	25	1.7
R6	3	45	6.0	70.0	5.6	35	2.9
R8	3	50	25	150	30	185	9.8

1) **Note:** Only copper cables are allowed for drive types up to -032A-3 and up to -027A-5.

For tightening torques of 360 degree grounding clamps, see section [Connection procedure \(page 94\)](#).

Frame	Screwdrivers for the terminals of the main circuit
R3	Flat blade 0.6 x 3.5 mm

Frame	Cable entries		L1, L2, L3, T1/U, T2/V, T3/W, UD+, UDC- terminals			PE terminal	
	pcs	Ø	Min wire size (solid/ stranded)	Max wire size (solid/ stranded)	T	Wire size	T
		in	AWG	AWG/kcmil	lbf·ft	AWG/kcmil	lbf·ft
R3	3	0.91	20	6	1.2	4	1.2
R6	3	1.77	10	2/0	4.1	2	2.1
R8	3	1.97	4	300	22.5	350 MCM	7.2

For tightening torques of 360-degree grounding clamps terminals, see section [Connection procedure \(page 117\)](#).

■ UL listed cable lugs and tools

Wire size kcmil/AWG	Compression lug		Crimping tool		
	Manufacturer	Type	Manufacturer	Type	No. of crimps
6	Thomas & Betts	E10731 54136	Thomas & Betts	TBM4S TBM45S	1
	Burndy	YAV6C-L2	Burndy	MY29-3	1
	IlSCO	CCL-6-38	IlSCO	ILC-10	2

Wire size kcmil/AWG	Compression lug		Crimping tool		
	Manufacturer	Type	Manufacturer	Type	No. of crimps
4	Thomas & Betts	54140	Thomas & Betts	TBM4S	1
	Burndy	YA4C-L4BOX	Burndy	MY29-3	1
	IlSCO	CCL-4-38	IlSCO	MT-25	1
2	Thomas & Betts	54143TB 54142TB	Thomas & Betts	TBM4S TBM4S	1
	Burndy	YA2C-L4BOX	Burndy	MY29-3	2
	IlSCO	CRC-2	IlSCO	IDT-12	1
	IlSCO	CCL-2-38	IlSCO	MT-25	1
1	Thomas & Betts	54148	Thomas & Betts	TBM-8	3
	Burndy	YA1C-L4BOX	Burndy	MY29-3	2
	IlSCO	CRA-1-38	IlSCO	IDT-12	1
	IlSCO	CCL-1-38	IlSCO	MT-25	1
1/0	Thomas & Betts	54109	Thomas & Betts	TBM-8	3
	Burndy	YA25-L4BOX	Burndy	MY29-3	2
	IlSCO	CRB-0	IlSCO	IDT-12	1
	IlSCO	CCL-1/0-38	IlSCO	MT-25	1
2/0	Thomas & Betts	54110	Thomas & Betts	TBM-8	3
	Burndy	YAL26T38	Burndy	MY29-3	2
	IlSCO	CRA-2/0	IlSCO	IDT-12	1
	IlSCO	CCL-2/0-38	IlSCO	MT-25	1

Terminal and entry data for the control cables

■ IEC

Control cable entries, wire sizes and tightening torques (*T*) are given below.

Frame size	Cable entries		Control cable entries and terminal sizes			
	Holes	Max cable size	+24V, DCOM, DGND, EXT. 24V terminals		DI, AI/O, AGND, RO, STO terminals	
			Wire size	<i>T</i>	Wire size	<i>T</i>
	pcs	mm	mm ²	N·m	mm ²	N·m
R3	4	17	0.2...2.5	0.5...0.6	0.14...2.5	0.5...0.6
R6	4	17	0.14...2.5	0.5...0.6	0.14...2.5	0.5...0.6
R8	4	17	0.14...2.5	0.5...0.6	0.14...2.5	0.5...0.6

■ North America

Control cable entries, wire sizes and tightening torques (T) are given below.

Frame size	Cable entries		Control cable entries and terminal sizes			
	Holes	Max cable size	+24V, DCOM, DGND, EXT. 24V terminals		DI, AI/O, AGND, RO, STO terminals	
			Wire size	T	Wire size	T
	pcs	in	AWG	lbf-ft	AWG	lbf-ft
R3	4	0.67	24...14	0.4	26...14	0.4
R6	4	0.67	26...14	0.4	26...14	0.4
R8	4	0.67	26...14	0.4	26...14	0.4

Power cables

The table below gives typical copper and aluminum cable types with concentric copper shield for the drives with nominal current. For terminal and entry data for power cables, see [Terminal and entry data for the power cables \(page 191\)](#).

Drive type ACS880- 31-...	Frame size	IEC ¹⁾		UL (NEC) ³⁾
		Cu cable type	Al cable type ²⁾	Cu cable type
		mm ²	mm ²	AWG/kcmil
$U_n = 400\text{ V}$				
09A4-3	R3	3×1.5	-	-
12A6-3	R3	3×1.5	-	-
017A-3	R3	3×6	-	-
025A-3	R3	3×6	-	-
032A-3	R6	3×10	3×16	-
038A-3	R6	3×10	3×16	-
045A-3	R6	3×16	3×35	-
061A-3	R6	3×25	3×35	-
072A-3	R6	3×35	3×35	-
087A-3	R6	3×35	3×50	-
105A-3	R8	3×50	3×70	-
145A-3	R8	3×95	3×120	-
169A-3	R8	3×120	3×150	-
206A-3	R8	3×150	-	-
$U_n = 500\text{ V}$				
07A6-5	R3	3×1.5	-	14
11A0-5	R3	3×1.5	-	14
014A-5	R3	3×6	-	10
021A-5	R3	3×6	-	10

Drive type ACS880- 31-...	Frame size	IEC ¹⁾		UL (NEC) ³⁾
		Cu cable type	Al cable type ²⁾	Cu cable type
		mm ²	mm ²	AWG/kcmil
027A-5	R6	3×10	3×16	8
034A-5	R6	3×10	3×16	8
040A-5	R6	3×16	3×35	6
052A-5	R6	3×25	3×35	4
065A-5	R6	3×35	3×35	2
077A-5	R6	3×35	3×50	2
101A-5	R8	3×50	3×70	1
124A-5	R8	3×95	3×95	2/0
156A-5	R8	3×120	3×150	3/0
180A-5	R8	3×150	-	250MCM

1) The cable sizing is based on max. 9 cables laid on a cable ladder side by side, three ladder type trays one on top of the other, ambient temperature 30 °C, PVC insulation, surface temperature 70 °C (EN 60204-1 and IEC 60364-5-52/2001). For other conditions, size the cables according to local safety regulations, appropriate input voltage and the load current of the drive.

2) Aluminum cables must not be used with drives of frame size R3.

3) The cable sizing is based on NEC Table 310-16 for copper wires, 75 °C (167 °F) wire insulation at 40 °C (104 °F) ambient temperature. Not more than three current-carrying conductors in raceway or cable or earth (directly buried). For other conditions, size the cables according to local safety regulations, appropriate input voltage and the load current of the drive.

4) In the USA, aluminum cables must not be used.

Temperature: For IEC, select a cable rated for at least 70 °C maximum permissible temperature of conductor in continuous use. For North America, power cables must be rated for 75 °C (167 °F) or higher.

For surrounding air temperatures above 40 °C (104 °F) or frame R6 with option +B056 (UL Type 12), select a cable rated for at least 90 °C (194 °F) maximum permissible temperature of conductor in continuous use.

Voltage: 600 V AC cable is accepted for up to 500 V AC.

Electrical power network specification

Voltage (U_1)	<p><u>ACS880-31-xxxx-3 drives:</u> 380...415 V AC 3-phase +10%...-15%. This is indicated in the type designation label as typical input voltage level 3~400 V AC.</p> <p><u>ACS880-31-xxxx-5 drives:</u> 380...500 V AC 3-phase +10%...-15%. This is indicated in the type designation label as typical input voltage levels 3~400/480/500 V AC.</p>
Network type	Public low voltage networks. TN (grounded) and IT (ungrounded) systems. See section Compatibility with IT (ungrounded), corner-grounded delta, midpoint-grounded delta and TT systems.
Rated conditional short-circuit current (IEC 61439-1)	65 kA when protected by the fuses given in the fuse table.
Short-circuit current protection (UL 61800-5-1)	The drive is suitable for use on a circuit capable of delivering not more than 100,000 rms symmetrical amperes at 480 V maximum when protected by the fuses given in the fuse table.
Frequency (f_1)	47...63 Hz. This is indicated in the type designation label as typical input frequency f_1 (50/60 Hz).
Imbalance	Max. \pm 3% of nominal phase to phase input voltage
Fundamental power factor ($\cos \phi_1$)	1 (at nominal load)

Harmonic distortion

Harmonics are below the limits defined in IEEE 519-2014, and G5/4. The drive complies with IEC 61000-3-2, IEC 61000-3-4 and IEC 61000-3-12.

The table below shows typical values of the drive for short-circuit ratio (I_{sc}/I_1) of 20 to 100. The values will be met if the supply network voltage is not distorted by other loads and when the drive operates at nominal load.

Nominal bus voltage V at PCC	THDi (%)	THDv (%)
V ≤ 690 V	3*	< 3**

PCC Point on a public power supply system, electrically nearest to a particular load, at which other loads are, or could be, connected. The PCC is a point located upstream of the considered installation.

THDi Indicates the total harmonic current distortion of the wave form. This value is defined as the ratio (in %) of the harmonic current to the fundamental (non-harmonic) current measured at a load point at the particular moment when the measurement is taken:

$$THDi = \frac{\sqrt{\sum_{n=2}^{40} I_n^2}}{I_1} \cdot 100\%$$

THDv Indicates the total magnitude of the voltage distortion. This value is defined as the ratio (in %) of the harmonic voltage to the fundamental (non-harmonic) voltage:

$$THDv = \frac{\sqrt{\sum_{n=2}^{40} U_n^2}}{U_1} \cdot 100\%$$

I_{sc}/I_1 Short-circuit ratio

I_{sc} Maximum short-circuit current at PCC

I_1 Continuous rms input current of the drive

I_n Amplitude of the current harmonic n

U_1 Supply voltage

U_n Amplitude of the voltage harmonic n

* The short-circuit ratio can influence the THDi value

** Other loads can influence the THDv value

Motor connection data

Motor types	Asynchronous AC induction motors, permanent magnet synchronous motors in open loop control, AC induction servomotors, synchronous reluctance motors
Short-circuit current protection (IEC/EN/UL 61800-5-1)	The drive provides solid state short circuit protection for the motor connection per IEC/EN 61800-5-1 and UL 61800-5-1.
Frequency (f_2)	0...500 Hz For drives with du/dt filter: 120 Hz For drives with sine filter: 120 Hz
Frequency resolution	0.01 Hz
Current	See section <i>Ratings</i> .
Switching frequency	2 kHz, 4 kHz, 8 kHz, 12 kHz, (depends on the frame and parameter settings)
Maximum recommended motor cable length	For frame R3: 150 m (492 ft) For frames R6 and R8: 300 m (984 ft). Note 1: With motor cables longer than 150 m (492 ft) or switching frequencies higher than default, the EMC Directive requirements may not be fulfilled. Note 2: Longer motor cables cause a motor voltage decrease which limits the available motor power. The decrease depends on the motor cable length and characteristics. Contact ABB for more information. Note that a sine filter (optional) at the drive output also causes a voltage decrease.

Control unit (ZCU-12) control unit connection data

See *Control units of the drive*.

Efficiency

Efficiency at nominal power level:

Approximately 96% for frame R3

Approximately 96.5% for frame R6

Approximately 97% for frame R8

Energy efficiency (ecodesign)

Energy efficiency data is not provided for the drive. The low-harmonic drives are exempt from the EU ecodesign requirements (Regulation EU/2019/1781, §2.3.d) and the UK ecodesign requirements (Regulation SI 2021 No. 745).

Protection classes for module

Degrees of protection (IEC/EN 60529)	IP21 (standard) IP20 (option +P940) IP55 (option +B056)
Enclosure types (UL 50/50E)	UL Type 1 UL Type Open (option +P940) UL Type 12 (option +B056)
Drive types not available for IP55 (UL Type 12)	ACS880-31-...
	072A-3
	087A-3
	065A-5
	077A-5
Overvoltage category (IEC/EN 60664-1)	III
Protective class (IEC/EN 61800-5-1)	I

Materials

Drive enclosure	<ul style="list-style-type: none"> • PC/ABS 3 mm, color RAL 9002 and RAL 9017 • PC+10%GF 3.0mm, color RAL 9017 (in two smallest R3 frames only) • Plastic parts are made of UV resistant f1 classified plastics • Zinc coated steel sheet 1.5 to 2.5 mm, thickness of coating 100 micrometers, color RAL 9002
Package	Plywood, cardboard and molded pulp. Foam cushions PE, PP-E, bands PP.
Disposal	<p>The main parts of the drive can be recycled to preserve natural resources and energy. Product parts and materials should be dismantled and separated.</p> <p>Generally all metals, such as steel, aluminum, copper and its alloys, and precious metals can be recycled as material. Plastics, rubber, cardboard and other packaging material can be used in energy recovery. Printed circuit boards and large electrolytic capacitors need selective treatment according to IEC 62635 guidelines. To aid recycling, plastic parts are marked with an appropriate identification code.</p> <p>Contact your local distributor for further information on environmental aspects and recycling instructions for professional recyclers. End of life treatment must follow international and local regulations.</p>

Applicable standards

The drive complies with the following standards. The compliance with the European Low Voltage Directive is verified according to standard EN 61800-5-1.

EN 60204-1:2006 + A1:2009 + AC:2010	<i>Safety of machinery. Electrical equipment of machines. Part 1: General requirements. Provisions for compliance:</i> The final assembler of the machine is responsible for installing - emergency-stop device - supply disconnecting device.
IEC/EN 60529:1981 + A1:1999 + A2: 2013	<i>Degrees of protection provided by enclosures (IP code)</i>
IEC 61000-3-2:2018, EN 61000-3-2:2014	<i>Electromagnetic compatibility (EMC) – Limits for harmonic current emissions (input current < 16 A per phase)</i>
IEC/EN 61000-3-12:2011	<i>Electromagnetic compatibility (EMC) - Part 3-12: Limits - Limits for harmonic currents produced by equipment connected to public low-voltage systems with input current > 16 A and < 75 A per phase.</i>
IEC 61000-3-4:1998	<i>Limits - Limitation of emission of harmonic currents in low-voltage power supply systems for equipment with rated current greater than 16 A</i>
IEC/EN 61800-3:2004 + A1:2012	<i>Adjustable speed electrical power drive systems. Part 3: EMC requirements and specific test methods</i>
IEC 61800-5-1:2007 + A1:2016 EN 61800-5-1:2007 + A1:2017	<i>Adjustable speed electrical power drive systems. Part 5-1: Safety requirements – electrical, thermal and energy</i>
IEC 61800-9-2: 2017	<i>Adjustable speed electrical power drive systems – Part 9-2: Ecodesign for power drive systems, motor starters, power electronics and their driven applications – Energy efficiency indicators for power drive systems and motor starters</i>
IEC/EN 60664-1:2007	<i>Insulation coordination for equipment within low-voltage systems. Part 1: Principles, requirements and tests.</i>
UL 61800-5-1: First edition 2012	<i>Standard for Adjustable Speed Electrical Power Drive Systems - Part 5-1: Safety Requirements - Electrical, Thermal and Energy</i>
NEMA 250:2014	<i>Enclosures for Electrical Equipment (1000 Volts Maximum)</i>
CSA C22.2 No. 274-17	<i>Industrial control equipment</i>

Ambient conditions

Environmental limits for the drive are given below. The drive is to be used in a heated, indoor, controlled environment. All printed circuit boards are conformal coated.

	Operation installed for stationary use	Storage in the protective package	Transportation in the protective package
Installation site altitude	0 to 4000 m (13123 ft) above sea level ¹⁾ 0 to 2000 m (6561 ft) above sea level ²⁾ Output derated above 1000 m (3281 ft), see Altitude derating (page 172) .	-	-
Surrounding air temperature	-15 to +55 °C (5 to 131 °F). No frost allowed. See section Ratings (page 167) .	-40 to +70 °C (-40 to +158 °F)	-40 to +70 °C (-40 to +158 °F)
Relative humidity	5 to 95%	Max. 95%	Max. 95%
	No condensation allowed. Maximum allowed relative humidity is 60% in the presence of corrosive gases.		
Contamination levels (IEC 60721-3-x)	IEC 60721-3-3: 2002	IEC 60721-3-1: 1997	IEC 60721-3-2: 1997
Chemical gases	Class 3C2.	Class 1C2	Class 2C2
Solid particles	Class 3S2. No conductive dust allowed.	Class 1S3 (packing must support this, otherwise 1S2)	Class 2S2
Pollution degree (IEC/EN 60664-1)	2	-	-
Atmospheric pressure	70 to 106 kPa 0.7 to 1.05 atmospheres	70 to 106 kPa 0.7 to 1.05 atmospheres	60 to 106 kPa 0.6 to 1.05 atmospheres
Vibration (IEC 60068-2:6)	10...150 Hz Amplitude ±0.075 mm, 10...57.56 Hz Constant peak acceleration 10 m/s ² (1 gn), 57.56...150 Hz	-	-
Vibration (ISTA)	-	<u>R3</u> : Displacement, 25 mm peak to peak, 14200 vibratory impacts <u>R6, R8</u> ISTA 3E): Random, overall Grms level of 0.54	

Shock/Drop (ISTA)	Not allowed	R3 (ISTA 1A): Drop, 6 faces, 3 edges and 1 corner, 460 mm (18.1 in) R6, R8 (ISTA 3E): Shock, incline impact: 1.2 m/s (3.94 ft/s) Shock, rotational edge drop: 230 mm (9.1 in)
-------------------	-------------	---

- 1) For neutral-grounded TN and TT systems and non-corner grounded IT systems
- 2) For corner-grounded TN, TT and IT systems

Markings

These markings are attached to the drive:

	CE mark Product complies with the applicable European Union legislation. For fulfilling the EMC requirements, see the additional information concerning the drive EMC compliance (IEC/EN 61800-3).
--	---

	TÜV Safety Approved mark (functional safety) Product contains Safe Torque Off and possibly other (optional) safety functions which are certified by TÜV according to the relevant functional safety standards. Applicable to drives and inverters; not applicable to supply, brake or DC/DC converter units or modules.
--	--



	UKCA (UK Conformity Assessed) mark Product complies with the applicable United Kingdom's legislation (Statutory Instruments). Marking is required for products being placed on the market in Great Britain (England, Wales and Scotland).
--	--

	UL Listed mark for USA and Canada Product has been tested and evaluated against the relevant North American standards by the Underwriters Laboratories. Valid with rated voltages up to 600 V.
--	---

	RCM mark Product complies with Australian and New Zealand requirements specific to EMC, telecommunications and electrical safety. For fulfilling the EMC requirements, see the additional information concerning the drive EMC compliance (IEC/EN 61800-3).
--	--

	EAC (Eurasian Conformity) mark Product complies with the technical regulations of the Eurasian Customs Union. EAC mark is required in Russia, Belarus and Kazakhstan.
--	--

	KC mark Product complies with Korea's product safety requirements for electrical and electronic equipment and components that utilize power from 50...1000 V AC.
--	---

	<p>Electronic Information Products (EIP) symbol including an Environment Friendly Use Period (EFUP) Product is compliant with the People's Republic of China Electronic Industry Standard (SJ/T 11364-2014) about hazardous substances. The EFUP is 20 years.</p>
	<p>WEEE mark At the end of life the product should enter the recycling system at an appropriate collection point and not placed in the normal waste stream.</p>

Compliance with the EN 61800-3:204 + A1:2012

■ Definitions

EMC stands for Electromagnetic Compatibility. It is the ability of electrical/electronic equipment to operate without problems within an electromagnetic environment. Likewise, the equipment must not disturb or interfere with any other product or system within its locality.

First environment includes establishments connected to a low-voltage network which supplies buildings used for domestic purposes.

Second environment includes establishments connected to a network not supplying domestic premises.

Drive of category C1: drive of rated voltage less than 1000 V and intended for use in the first environment.

Drive of category C2: drive of rated voltage less than 1000 V and intended to be installed and started up only by a professional when used in the first environment.

Note: A professional is a person or organization having necessary skills in installing and/or starting up power drive systems, including their EMC aspects.

Drive of category C3: drive of rated voltage less than 1000 V and intended for use in the second environment and not intended for use in the first environment.

Drive of category C4: drive of rated voltage equal to or above 1000 V, or rated current equal to or above 400 A, or intended for use in complex systems in the second environment.

■ Category C2

The emission limits are complied with the following provisions (frames R3 and R8)

1. The drive is equipped with EMC filter option +E202.
2. The motor and control cables are selected as specified in this manual.
3. The drive is installed according to the instructions given in this manual.

4. For the maximum motor cable length with 4 kHz switching frequency, see section [Motor connection data \(page 198\)](#).



WARNING! The drive may cause radio interference if used in residential or domestic environment. The user is required to take measures to prevent interference, in association to the requirements for the CE compliance listed above, if necessary.

Note: Note: Do not install a drive with the EMC filter connected to a system that the filter is not suitable for. This can cause danger, or damage the drive.

Note: Do not install a drive with the ground-to-phase varistor connected to a system that the varistor is not suitable for. If you do, the varistor circuit can be damaged. If you install the drive to any other system than symmetrically grounded TN-S system, you may need to disconnect the EMC filter or the ground-to-phase varistor. See section [Grounding system compatibility check \(page 85\)](#).

■ Category C3

The drive complies with the standard with the following provisions:

1. The drive is equipped with EMC filter option +E200 or +E201.
2. The motor and control cables are selected as specified in this manual.
3. The drive is installed according to the instructions given in this manual.
4. For the maximum motor cable length with 4 kHz switching frequency, see section [Motor connection data \(page 198\)](#).



WARNING! A drive of category C3 is not intended to be used on a low-voltage public network which supplies domestic premises. Radio frequency interference is expected if the drive is used on such a network.

Note: Do not install a drive with the EMC filter connected to a system that the filter is not suitable for. This can cause danger, or damage the drive.

Note: Do not install a drive with the ground-to-phase varistor connected to a system that the varistor is not suitable for. If you do, the varistor circuit can be damaged. If you install the drive to any other system than symmetrically grounded TN-S system, you may need to disconnect the EMC filter or the ground-to-phase varistor. See section [Grounding system compatibility check \(page 85\)](#).

■ Category C4

The drive complies with the C4 category with these provisions:

1. It is ensured that no excessive emission is propagated to neighboring low-voltage networks. In some cases, the natural suppression in transformers and cables is
-

sufficient. If in doubt, the supply transformer with static screening between the primary and secondary windings can be used.

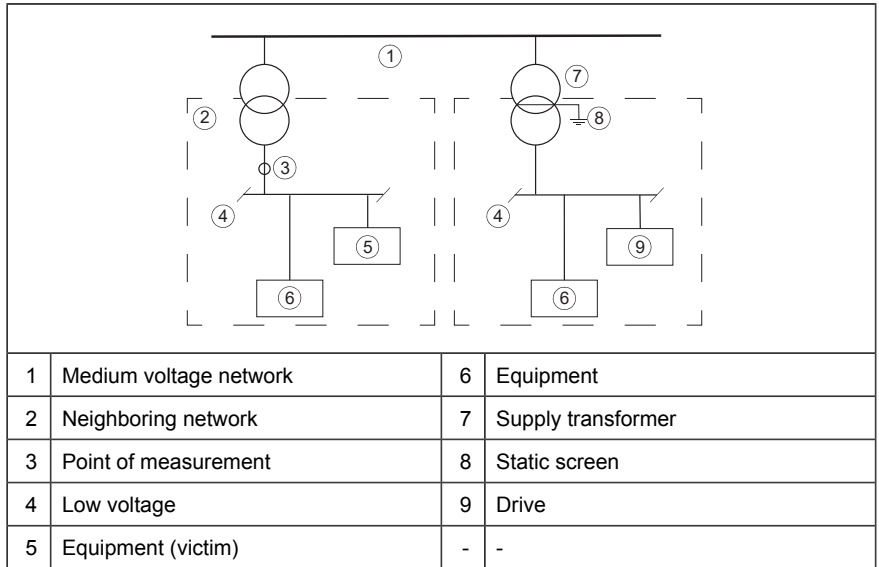

- An EMC plan for preventing disturbances is drawn up for the installation. A template is available in *Technical guide No. 3 EMC compliant installation and configuration for a power drive system* ([3AFE61348280](#) (English)).
- The motor and control cables are selected, and routed according to the electrical planning guidelines of the drive. The EMC recommendations are obeyed.
- The drive is installed according to its installation instructions. The EMC recommendations are obeyed.



WARNING!

A drive of category C4 is not intended to be used on a low-voltage public network which supplies domestic premises. Radio frequency interference is expected if the drive is used on such a network.

UL checklist



WARNING!

Operation of this drive requires detailed installation and operation instructions provided in the hardware and software manuals. The manuals are provided in electronic format in the drive package or on the Internet. Keep the manuals with

the drive at all times. Hard copies of the manuals can be ordered through the manufacturer.

- Make sure that the drive type designation label includes the applicable marking.
 - **DANGER - Risk of electric shock.** After disconnecting the input power, always wait for 5 minutes to let the intermediate circuit capacitors discharge before you start working on the drive, motor or motor cable.
 - The drive is to be used in a heated, indoor controlled environment. The drive must be installed in clean air according to the enclosure classification. Cooling air must be clean, free from corrosive materials and electrically conductive dust.
 - The cables located within the motor circuit must be rated for at least 75 °C in UL-compliant installations.
 - The input cable must be protected with fuses or circuit breakers. These protective devices provide branch circuit protection in accordance with the national regulations (National Electrical Code (NEC) or Canadian Electrical Code). Obey also any other applicable local or provincial codes.
Suitable UL fuses are listed in section *Fuses (UL) (page 183)* and circuit breakers in section *Circuit breakers (UL) (page 185)*.
-



WARNING!

The opening of the branch-circuit protective device may be an indication that a fault current has been interrupted. To reduce the risk of fire or electric shock, current-carrying parts and other components of the device should be examined and replaced if damaged.

- The drive provides motor overload protection. The protection is not enabled when the drive leaves the ABB factory. For enabling the protection, see the firmware manual.
- The drive overvoltage category according to IEC 60664-1 is III
- To maintain the environment integrity of the enclosure, replace the cable grommets with field-installed industrial conduit hubs or closure plates required by the enclosure type (or better).

Declarations of conformity

See the chapter *The Safe torque off function (page 217)*.

Design lifetime expectancy

The design lifetime expectancy of the drive and its overall components exceeds ten (10) years in normal operating environments. In some cases, the drive can last 20 years or more. To achieve a long lifetime of the product the manufacturer's instructions for sizing

the drive, installation, operational conditions and preventive maintenance schedule shall be followed.

Disclaimers

■ Generic disclaimer

The manufacturer shall have no obligation with respect to any product which (i) has been improperly repaired or altered; (ii) has been subjected to misuse, negligence or accident; (iii) has been used in a manner contrary to the manufacturer's instructions; or (iv) has failed as a result of ordinary wear and tear.

■ Cybersecurity disclaimer

This product can be connected to and to communicate information and data via a network interface. The HTTP protocol, which is used between the commissioning tool (Drive Composer) and the product, is an unsecured protocol. For independent and continuous operation of product such connection via network to commissioning tool is not necessary. However it is Customer's sole responsibility to provide and continuously ensure a secure connection between the product and Customer network or any other network (as the case may be). Customer shall establish and maintain any appropriate measures (such as but not limited to the installation of firewalls, prevention of physical access, application of authentication measures, encryption of data, installation of anti-virus programs, etc) to protect the product, the network, its system and the interface against any kind of security breaches, unauthorized access, interference, intrusion, leakage and/or theft of data or information.

Notwithstanding any other provision to the contrary and regardless whether the contract is terminated or not, ABB and its affiliates are under no circumstances liable for damages and/or losses related to such security breaches, any unauthorized access, interference, intrusion, leakage and/or theft of data or information.

13

Dimension drawings

Contents of this chapter

This chapter shows the dimension drawings of the drive. The dimensions are given in millimeters and [inches].

R3, IP21 (UL Type 1)

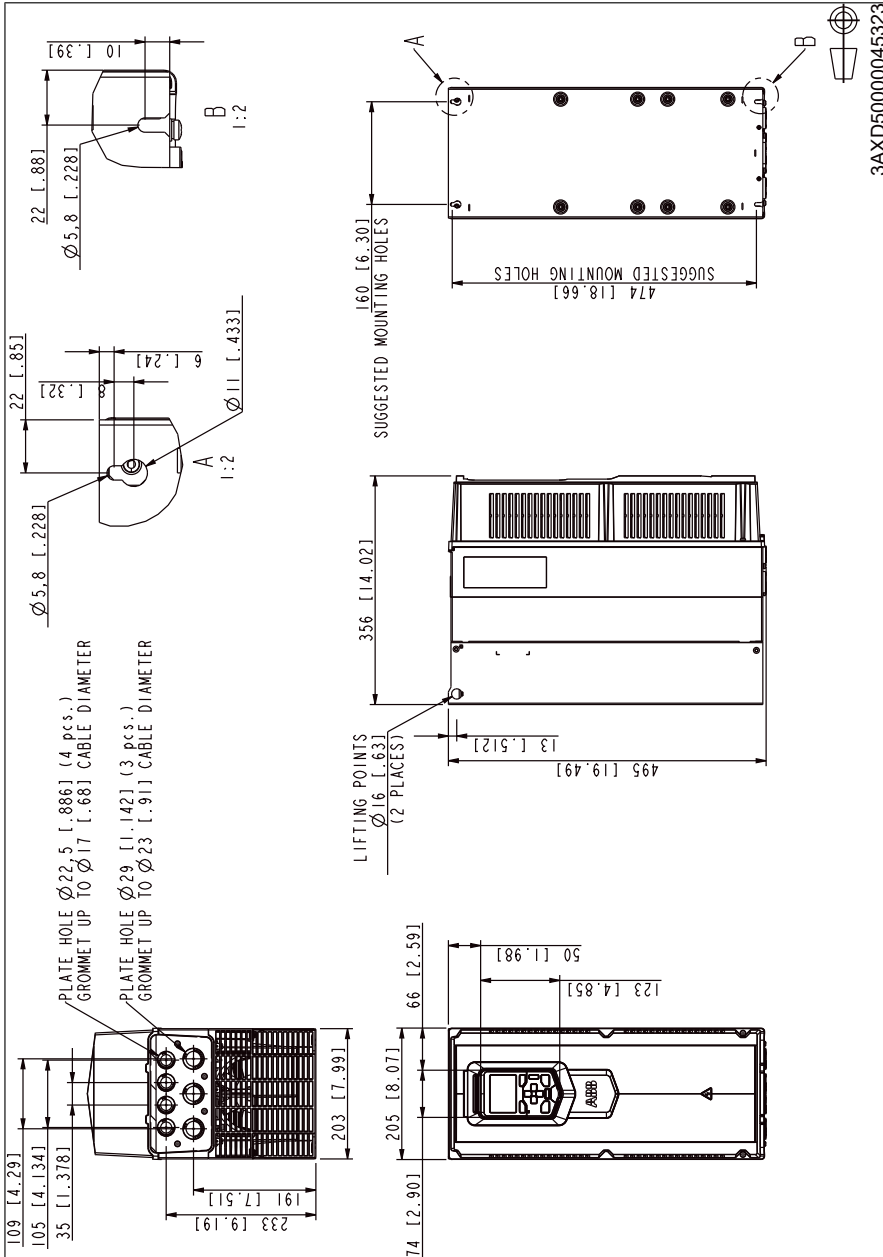

R3 – Option +B056 (IP55, UL Type 12)

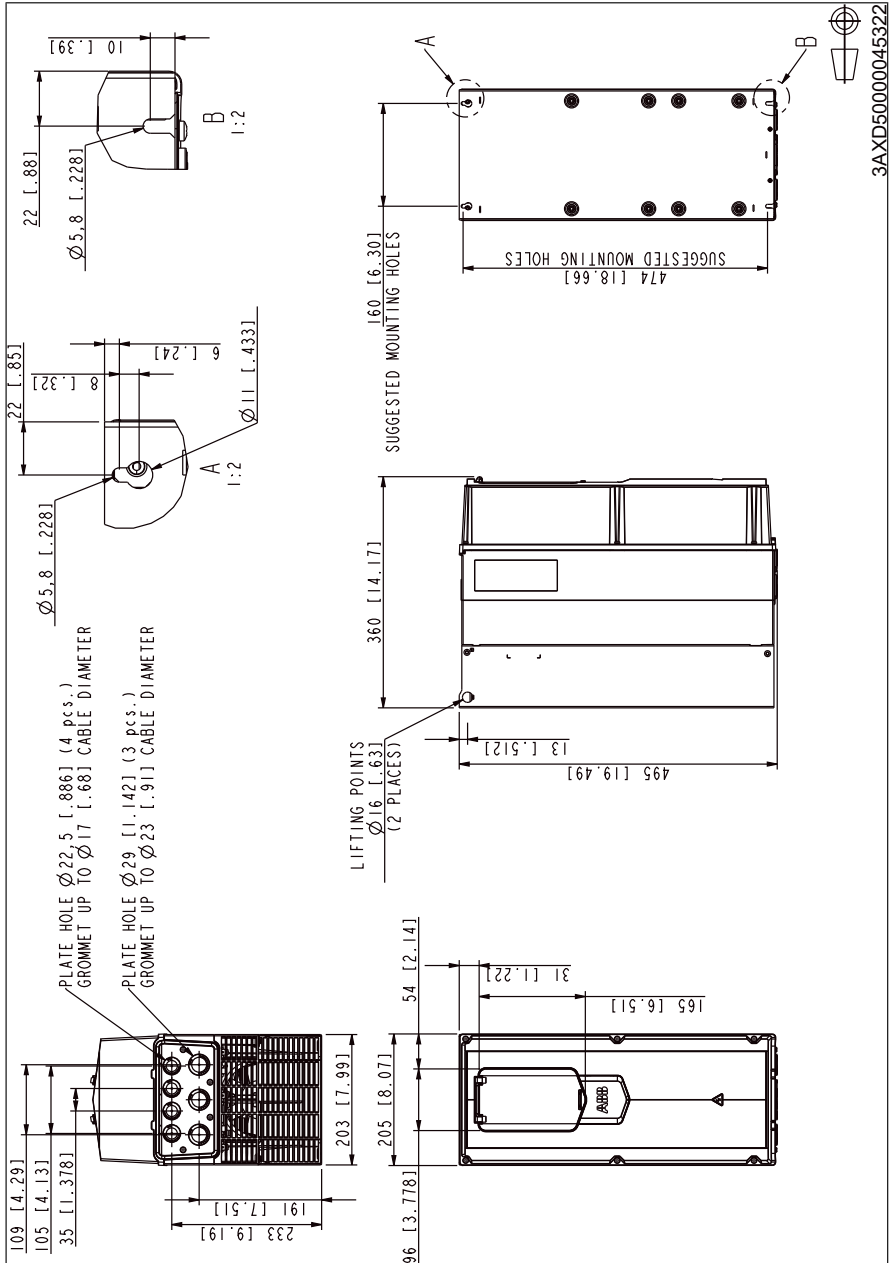

R6 – Option +B056 (IP55, UL Type 12)

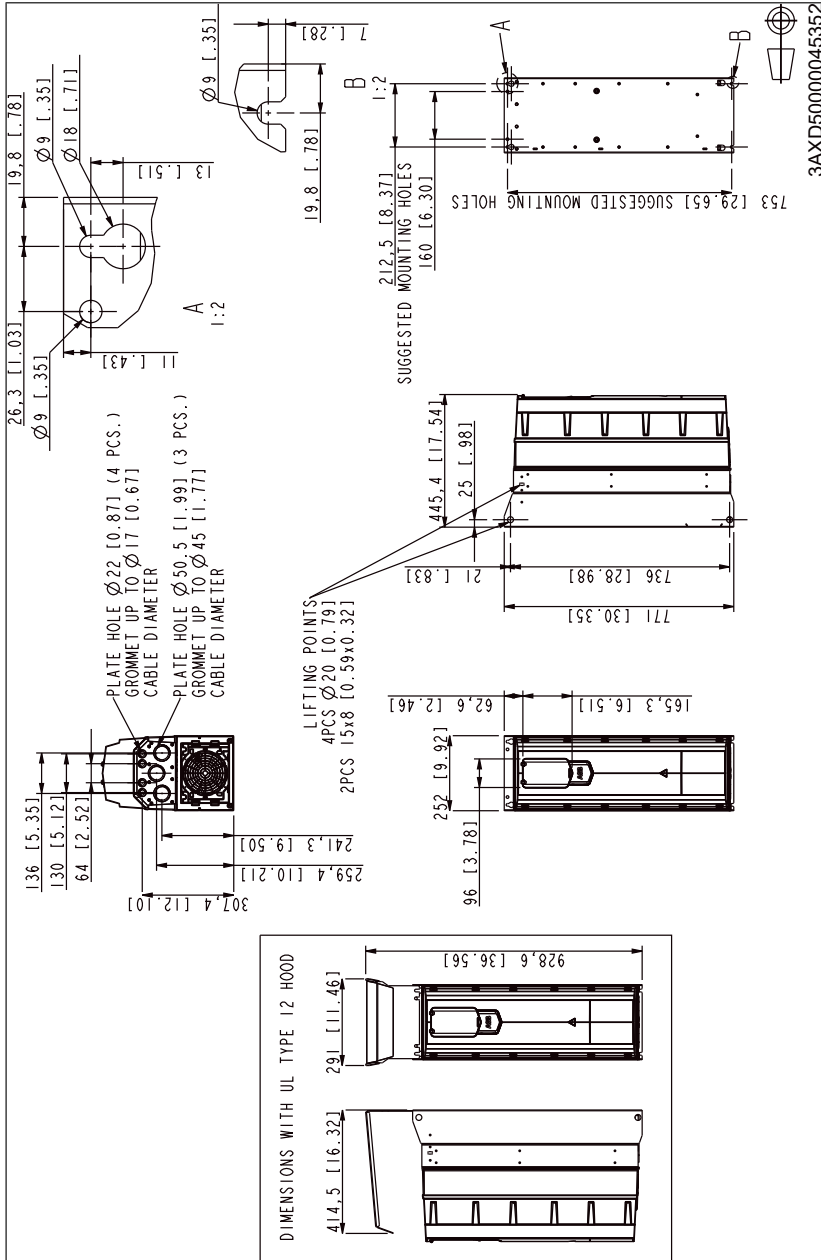

R8 – Option +B056 (IP55, UL Type 12)

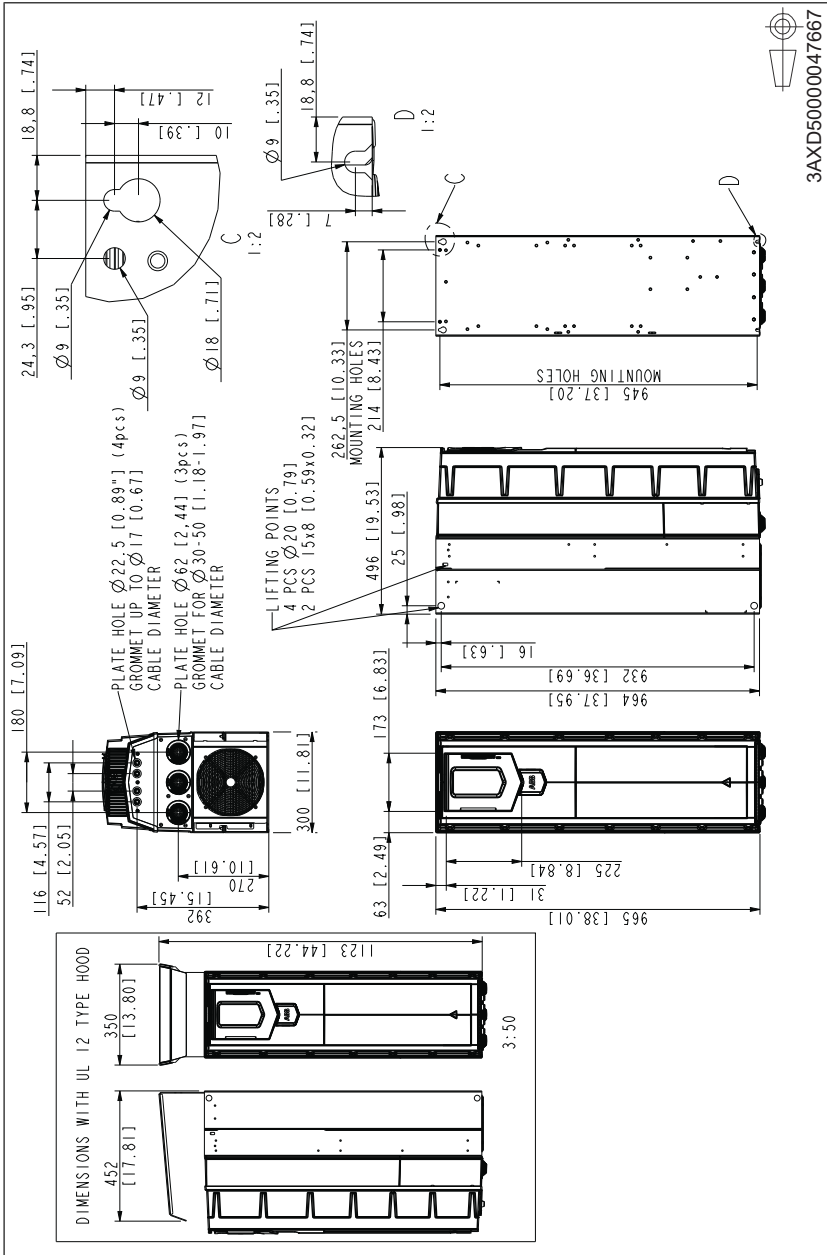

14

The Safe torque off function

Contents of this chapter

This chapter describes the Safe torque off (STO) function of the drive and gives instructions for its use.

Description



WARNING!

In case of parallel-connected drives or dual-winding motors, the STO must be activated on each drive to remove the torque from the motor.

The Safe torque off function can be used, for example, as the final actuator device of safety circuits that stop the drive in case of danger (such as an emergency stop circuit). Another typical application is a prevention of unexpected start-up function that enables short-time maintenance operations like cleaning or work on non-electrical parts of the machinery without switching off the power supply to the drive.

When activated, the Safe torque off function disables the control voltage for the power semiconductors of the drive output stage (A, see the diagrams below), thus preventing the drive from generating the torque required to rotate the motor. If the motor is running when Safe torque off is activated, it coasts to a stop.

The Safe torque off function has a redundant architecture, that is, both channels must be used in the safety function implementation. The safety data given in this manual is calculated for redundant use, and does not apply if both channels are not used.

The Safe torque off function complies with these standards:

Standard	Name
IEC 60204-1:2016 EN 60204-1:2018	<i>Safety of machinery – Electrical equipment of machines – Part 1: General requirements</i>
IEC 61000-6-7:2014	<i>Electromagnetic compatibility (EMC) – Part 6-7: Generic standards – Immunity requirements for equipment intended to perform functions in a safety-related system (functional safety) in industrial locations</i>
IEC 61326-3-1:2017	<i>Electrical equipment for measurement, control and laboratory use – EMC requirements – Part 3-1: Immunity requirements for safety-related systems and for equipment intended to perform safety-related functions (functional safety) – General industrial applications</i>
IEC 61508-1:2010	<i>Functional safety of electrical/electronic/programmable electronic safety-related systems – Part 1: General requirements</i>
IEC 61508-2:2010	<i>Functional safety of electrical/electronic/programmable electronic safety-related systems – Part 2: Requirements for electrical/electronic/programmable electronic safety-related systems</i>
IEC 61511-1:2017	<i>Functional safety – Safety instrumented systems for the process industry sector</i>
IEC 61800-5-2:2016 EN 61800-5-2:2007	<i>Adjustable speed electrical power drive systems – Part 5-2: Safety requirements – Functional</i>
IEC 62061:2005 + A1:2012 + A2:2015 EN 62061:2005 + AC:2010 + A1:2013 + A2:2015	<i>Safety of machinery – Functional safety of safety-related electrical, electronic and programmable electronic control systems</i>
EN ISO 13849-1:2015	<i>Safety of machinery – Safety-related parts of control systems – Part 1: General principles for design</i>
EN ISO 13849-2:2012	<i>Safety of machinery – Safety-related parts of control systems – Part 2: Validation</i>

The function also corresponds to Prevention of unexpected start-up as specified by EN ISO 14118:2018 (ISO 14118:2017), and Uncontrolled stop (stop category 0) as specified in EN/IEC 60204-1.

■ **Compliance with the European Machinery Directive and the UK Supply of Machinery (Safety) Regulations**

See the technical data.

The Declarations of conformity are shown at the end of this chapter.

Wiring

For the electrical specifications of the STO connection, see the technical data of the control unit.

■ Activation switch

In the wiring diagrams, the activation switch has the designation [K]. This represents a component such as a manually operated switch, an emergency stop push button switch, or the contacts of a safety relay or safety PLC.

- In case a manually operated activation switch is used, the switch must be of a type that can be locked out to the open position.
- The contacts of the switch or relay must open/close within 200 ms of each other.
- An FSO-xx safety functions module or an FPTC-0x thermistor protection module can also be used. For more information, see the module documentation.

■ Cable types and lengths

- Double-shielded twisted-pair cable is recommended.
- Maximum cable lengths:
 - 300 m (1000 ft) between activation switch [K] and drive control unit
 - 60 m (200 ft) between multiple drives
 - 60 m (200 ft) between external power supply and first control unit

Note: A short-circuit in the wiring between the switch and an STO terminal causes a dangerous fault. Therefore, it is recommended to use a safety relay (including wiring diagnostics) or a wiring method (shield grounding, channel separation) which reduces or eliminates the risk caused by the short-circuit.

Note: The voltage at the STO input terminals of the control unit must be at least 17 V DC to be interpreted as “1”.

The pulse tolerance of the input channels is 1 ms.

■ Grounding of protective shields

- Ground the shield in the cabling between the activation switch and the control unit at the control unit only.
 - Ground the shield in the cabling between two control units at one control unit only.
-

■ Single drive (internal power supply)

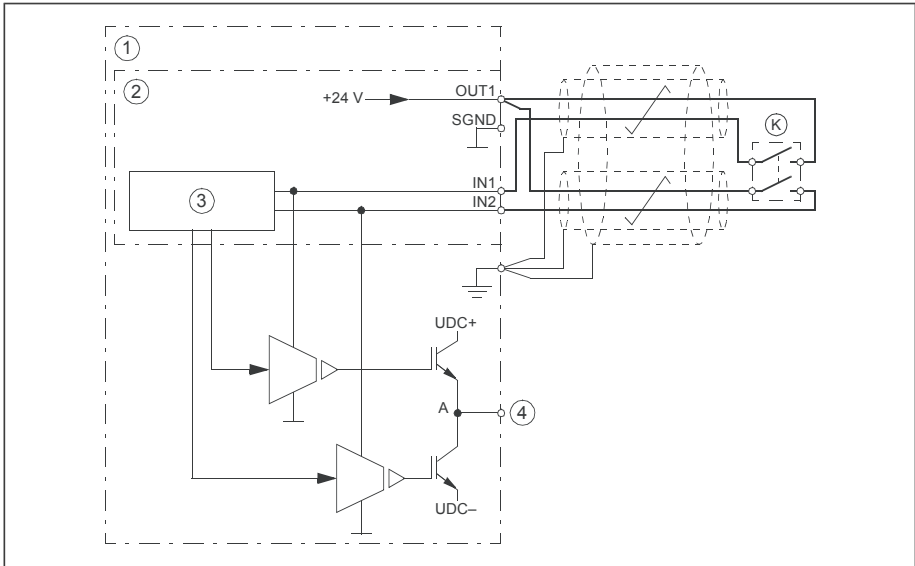

1	Drive
2	Control unit
3	Control logic
4	To motor
K	Activation switch

■ Multiple drives

Internal power supply

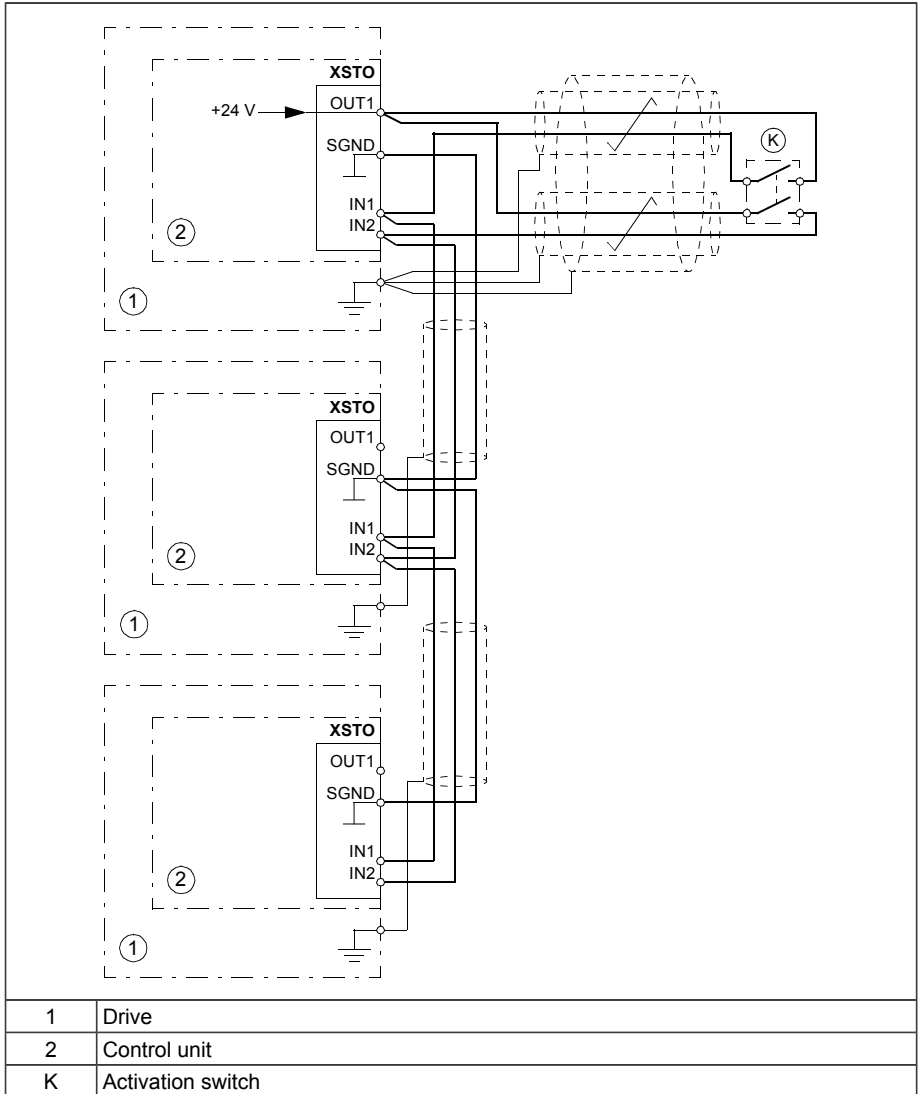

External power supply

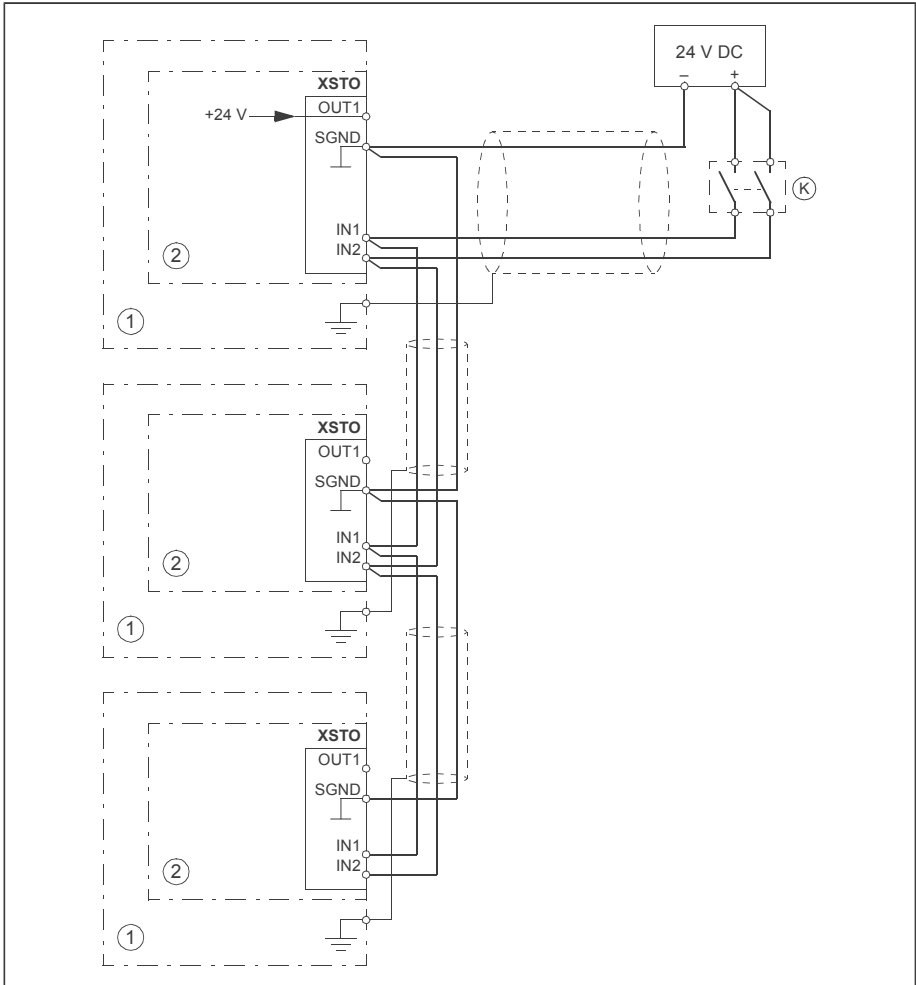

1	Drive
2	Control unit
K	Activation switch

Operation principle

1. The Safe torque off activates (the activation switch is opened, or safety relay contacts open).
 2. The STO inputs of the drive control unit de-energize.
 3. The control unit cuts off the control voltage from the output IGBTs.
 4. The control program generates an indication as defined by parameter 31.22 (see the firmware manual of the drive).
The parameter selects which indications are given when one or both STO signals are switched off or lost. The indications also depend on whether the drive is running or stopped when this occurs.
Note: This parameter does not affect the operation of the STO function itself. The STO function will operate regardless of the setting of this parameter: a running drive will stop upon removal of one or both STO signals, and will not start until both STO signals are restored and all faults reset.
Note: The loss of only one STO signal always generates a fault as it is interpreted as a malfunction of STO hardware or wiring.
 5. The motor coasts to a stop (if running). The drive cannot restart while the activation switch or safety relay contacts are open. After the contacts close, a reset may be needed (depending on the setting of parameter 31.22). A new start command is required to start the drive.
-

Start-up including validation test

To ensure the safe operation of a safety function, validation is required. The final assembler of the machine must validate the function by performing a validation test. The test must be performed

- at initial start-up of the safety function
- after any changes related to the safety function (circuit boards, wiring, components, settings, etc.)
- after any maintenance work related to the safety function
- at the proof test of the safety function
- after a drive firmware update.

■ Competence

The validation test of the safety function must be carried out by a competent person with adequate expertise and knowledge of the safety function as well as functional safety, as required by IEC 61508-1 clause 6. The test procedures and report must be documented and signed by this person.

■ Validation test reports

Signed validation test reports must be stored in the logbook of the machine. The report shall include documentation of start-up activities and test results, references to failure reports and resolution of failures. Any new validation tests performed due to changes or maintenance shall be logged into the logbook.

■ Validation test procedure

After wiring the Safe torque off function, validate its operation as follows.

Note: If the drive is equipped with safety option +Q972, +Q973 or +Q982, also do the procedure shown in the FSO-xx module documentation.

Action	<input checked="" type="checkbox"/>
 WARNING! Obey the safety instructions. If you ignore them, injury or death, or damage to the equipment can occur.	<input type="checkbox"/>
Make sure that the drive can be run and stopped freely during start-up.	<input type="checkbox"/>
Stop the drive (if running), switch the input power off and isolate the drive from the power line using a disconnecter.	<input type="checkbox"/>
Check the STO circuit connections against the wiring diagram.	<input type="checkbox"/>
Close the disconnecter and switch the power on.	<input type="checkbox"/>

Action	<input checked="" type="checkbox"/>
<p>Test the operation of the STO function when the motor is stopped.</p> <ul style="list-style-type: none"> • Give a stop command for the drive (if running) and wait until the motor shaft is at a standstill. <p>Make sure that the drive operates as follows:</p> <ul style="list-style-type: none"> • Open the STO circuit. The drive generates an indication if one is defined for the 'stopped' state in parameter 31.22 (see the firmware manual). • Give a start command to verify that the STO function blocks the drive's operation. The drive generates a warning. The motor should not start. • Close the STO circuit. • Reset any active faults. Restart the drive and check that the motor runs normally. 	<input type="checkbox"/>
<p>Test the operation of the STO function when the motor is running.</p> <ul style="list-style-type: none"> • Start the drive and make sure the motor is running. • Open the STO circuit. The motor should stop. The drive generates an indication if one is defined for the 'running' state in parameter 31.22 (see the firmware manual). • Reset any active faults and try to start the drive. • Make sure that the motor stays at a standstill and the drive operates as described above in testing the operation when the motor is stopped. • Close the STO circuit. • Reset any active faults. Restart the drive and check that the motor runs normally. 	<input type="checkbox"/>
<p>Test the operation of the failure detection of the drive. The motor can be stopped or running.</p> <ul style="list-style-type: none"> • Open the 1st channel of the STO circuit. If the motor was running, it should coast to a stop. The drive generates a <i>FA81 Safe Torque Off 1 loss</i> fault indication (see the firmware manual). • Give a start command to verify that the STO function blocks the drive's operation. The motor should not start. • Close the STO circuit. • Reset any active faults. Restart the drive and check that the motor runs normally. • Open the 2nd channel of the STO circuit. If the motor was running, it should coast to a stop. The drive generates a <i>FA82 Safe Torque Off 2 loss</i> fault indication (see the firmware manual). • Give a start command to verify that the STO function blocks the drive's operation. The motor should not start. • Close the STO circuit. • Reset any active faults. Restart the drive and check that the motor runs normally. 	<input type="checkbox"/>
<p>Document and sign the validation test report which verifies that the safety function is safe and accepted for operation.</p>	<input type="checkbox"/>

Use

1. Open the activation switch, or activate the safety functionality that is wired to the STO connection.
2. The STO inputs on the drive control unit de-energize, and the control unit cuts off the control voltage from the output IGBTs.
3. The control program generates an indication as defined by parameter 31.22 (see the firmware manual of the drive).
4. The motor coasts to a stop (if running). The drive will not restart while the activation switch or safety relay contacts are open.
5. Deactivate the STO by closing the activation switch, or resetting the safety functionality that is wired to the STO connection.
6. Reset any faults before restarting.



WARNING!

The Safe torque off function does not disconnect the voltage of the main and auxiliary circuits from the drive. Therefore maintenance work on electrical parts of the drive or the motor can only be carried out after isolating the drive from the supply and all other voltage sources.



WARNING!

The drive cannot detect or memorize any changes in the STO circuitry when the drive control unit is not powered. If both STO circuits are closed and a level-type start signal is active when the power is restored, it is possible that the drive starts without a fresh start command. Take this into account in the risk assessment of the system.



WARNING!

(With permanent magnet or synchronous reluctance [SynRM] motors only)

In case of a multiple IGBT power semiconductor failure, the drive can produce an alignment torque which maximally rotates the motor shaft by $180/p$ degrees (with permanent magnet motors) or $180/2p$ degrees (with synchronous reluctance [SynRM] motors) regardless of the activation of the Safe torque off function. p denotes the number of pole pairs.

Notes:

- If a running drive is stopped by using the Safe torque off function, the drive will cut off the motor supply voltage and the motor will coast to a stop. If this causes danger or is not otherwise acceptable, stop the drive and machinery using the appropriate stop mode before activating the Safe torque off function.
-

- The Safe torque off function overrides all other functions of the drive.
 - The Safe torque off function is ineffective against deliberate sabotage or misuse.
 - The Safe torque off function has been designed to reduce the recognized hazardous conditions. In spite of this, it is not always possible to eliminate all potential hazards. The assembler of the machine must inform the final user about the residual risks.
-

Maintenance

After the operation of the circuit is validated at start-up, the STO function shall be maintained by periodic proof testing. In high demand mode of operation, the maximum proof test interval is 20 years. In low demand mode of operation, the maximum proof test interval is 5 or 2 years; see section *Safety data (page 230)*. It is assumed that all dangerous failures of the STO circuit are detected by the proof test. To perform the proof test, do the *Validation test procedure (page 224)*.

Note: See also the Recommendation of Use CNB/M/11.050 (published by the European co-ordination of Notified Bodies) concerning dual-channel safety-related systems with electromechanical outputs:

- When the safety integrity requirement for the safety function is SIL 3 or PL e (cat. 3 or 4), the proof test for the function must be performed at least every month.
- When the safety integrity requirement for the safety function is SIL 2 (HFT = 1) or PL d (cat. 3), the proof test for the function must be performed at least every 12 months.

The STO function of the drive does not contain any electromechanical components.

In addition to proof testing, it is a good practice to check the operation of the function when other maintenance procedures are carried out on the machinery.

Include the Safe torque off operation test described above in the routine maintenance program of the machinery that the drive runs.

If any wiring or component change is needed after start-up, or the parameters are restored, do the test given in section *Validation test procedure (page 224)*.

Use only spare parts approved by ABB.

Record all maintenance and proof test activities in the machine logbook.

■ Competence

The maintenance and proof test activities of the safety function must be carried out by a competent person with adequate expertise and knowledge of the safety function as well as functional safety, as required by IEC 61508-1 clause 6.

Fault tracing

The indications given during the normal operation of the Safe torque off function are selected by drive control program parameter 31.22.

The diagnostics of the Safe torque off function cross-compare the status of the two STO channels. In case the channels are not in the same state, a fault reaction function is performed and the drive trips on an “STO hardware failure” fault. An attempt to use the STO in a non-redundant manner, for example activating only one channel, will trigger the same reaction.

See the firmware manual of the drive control program for the indications generated by the drive, and for details on directing fault and warning indications to an output on the control unit for external diagnostics.

Any failures of the Safe torque off function must be reported to ABB.

Safety data

The safety data for the Safe torque off function is given below.

Note: The safety data is calculated for redundant use, and does not apply if both STO channels are not used.

Frame size	SIL	PL	SFF (%)	PFH ($T_1 = 20$ a) (1/h)	PFD _{avg} ($T_1 = 2$ a)	PFD _{avg} ($T_1 = 5$ a)	MTTF _D (a)	DC (%)	Cat.	SC	HFT	CCF	T _M (a)
R3	3	e	91.5	2.68E-09	2.23E-05	5.58E-05	36908	≥90	3	3	1	80	20
R6	3	e	91.5	2.68E-09	2.23E-05	5.58E-05	36908	≥90	3	3	1	80	20
R8	3	e	99.1	3.21E-09	2.67E-05	6.67E-05	9630	≥90	3	3	1	80	20

3AXD10000606249 B, 3AXD10000006217 M

- The following temperature profile is used in safety value calculations:
 - 670 on/off cycles per year with $\Delta T = 71.66$ °C
 - 1340 on/off cycles per year with $\Delta T = 61.66$ °C
 - 30 on/off cycles per year with $\Delta T = 10.0$ °C
 - 32 °C board temperature at 2.0% of time
 - 60 °C board temperature at 1.5% of time
 - 85 °C board temperature at 2.3% of time.
- The STO is a type A safety component as defined in IEC 61508-2.
- Relevant failure modes:
 - The STO trips spuriously (safe failure)
 - The STO does not activate when requested
 - A fault exclusion on the failure mode “short circuit on printed circuit board” has been made (EN 13849-2, table D.5). The analysis is based on an assumption that one failure occurs at one time. No accumulated failures have been analyzed.
- STO response times:
 - STO reaction time (shortest detectable break): 1 ms
 - STO response time:
 - Frames R3 and R6: 2 ms (typical), 10 ms (maximum)
 - Frame R8: 2 ms (typical), 15 ms (maximum)
 - Fault detection time: Channels in different states for longer than 200 ms
 - Fault reaction time: Fault detection time + 10 ms

- Indication delays:
 - STO fault indication (parameter 31.22) delay: < 500 ms
 - STO warning indication (parameter 31.22) delay: < 1000 ms

■ **Terms and abbreviations**

Term or abbreviation	Reference	Description
Cat.	EN ISO 13849-1	Classification of the safety-related parts of a control system in respect of their resistance to faults and their subsequent behavior in the fault condition, and which is achieved by the structural arrangement of the parts, fault detection and/or by their reliability. The categories are: B, 1, 2, 3 and 4.
CCF	EN ISO 13849-1	Common cause failure (%)
DC	EN ISO 13849-1	Diagnostic coverage
HFT	IEC 61508	Hardware fault tolerance
MTTF _D	EN ISO 13849-1	Mean time to dangerous failure: (Total number of life units) / (Number of dangerous, undetected failures) during a particular measurement interval under stated conditions
PFD _{avg}	IEC 61508	Average probability of dangerous failure on demand, that is, mean unavailability of a safety-related system to perform the specified safety function when a demand occurs
PFH	IEC 61508	Average frequency of dangerous failures per hour, that is, average frequency of a dangerous failure of a safety related system to perform the specified safety function over a given period of time
PL	EN ISO 13849-1	Performance level. Levels a...e correspond to SIL
Proof test	IEC 61508, IEC 62061	Periodic test performed to detect failures in a safety-related system so that, if necessary, a repair can restore the system to an "as new" condition or as close as practical to this condition
SC	IEC 61508	Systematic capability
SFF	IEC 61508	Safe failure fraction (%)
SIL	IEC 61508	Safety integrity level (1...3)
STO	IEC/EN 61800-5-2	Safe torque off

Term or abbreviation	Reference	Description
T_1	IEC 61508-6	Proof test interval. T_1 is a parameter used to define the probabilistic failure rate (PFH or PFD) for the safety function or subsystem. Performing a proof test at a maximum interval of T_1 is required to keep the SIL capability valid. The same interval must be followed to keep the PL capability (EN ISO 13849) valid. See also section Maintenance.
T_M	EN ISO 13849-1	Mission time: the period of time covering the intended use of the safety function/device. After the mission time elapses, the safety device must be replaced. Note that any T_M values given cannot be regarded as a guarantee or warranty.

■ **TÜV certificate**

The TÜV certificate is available on the Internet at www.abb.com/drives/documents.

■ **Declarations of conformity**



EU Declaration of Conformity

Machinery Directive 2006/42/EC

We

Manufacturer: ABB Oy
 Address: Hiomotie 13, 00380 Helsinki, Finland.
 Phone: +358 10 22 11

declare under our sole responsibility that the following product:

Frequency converter(s)
 ACS880-01/-11/-31
 ACS880-04/-04F/-M04/-14/-34

with regard to the safety function(s)

- Safe Torque Off
- Safe stop 1, Safe stop emergency, Safely-limited speed, Safe maximum speed, Safe brake control, Prevention of unexpected start-up (with FSO-12 option module, +Q973, encoderless)
- Safe stop 1, Safe stop emergency, Safely-limited speed, Safe maximum speed, Safe brake control, Safe speed monitor, Safe direction, Prevention of unexpected start-up (with FSO-21 and FSE-31 option modules, +Q972 and +L521, encoder supported)
- Safe motor temperature (with FPTC-01 thermistor protection module, +L536)
- Safe stop 1 (SS1-t, with FSPS-21 PROFIsafe module, +Q986)

is/are in conformity with all the relevant safety component requirements of EU Machinery Directive 2006/42/EC, when the listed safety function is used for safety component functionality.

The following harmonized standards have been applied:

EN 61800-5-2:2007	Adjustable speed electrical power drive systems – Part 5-2: Safety requirements - Functional
EN 62061:2005 + AC:2010 + A1:2013 + A2:2015	Safety of machinery – Functional safety of safety-related electrical, electronic and programmable electronic control systems
EN ISO 13849-1:2015	Safety of machinery – Safety-related parts of control systems. Part 1: General requirements
EN ISO 13849-2:2012	Safety of machinery – Safety-related parts of the control systems. Part 2: Validation
EN 60204-1:2018	Safety of machinery – Electrical equipment of machines – Part 1: General requirements

The following other standards have been applied:

IEC 61508:2010, parts 1-2	Functional safety of electrical / electronic / programmable electronic safety-related systems
IEC 61800-5-2:2016	Adjustable speed electrical power drive systems – Part 5-2: Safety requirements - Functional

The product(s) referred in this Declaration of conformity fulfil(s) the relevant provisions of other European Union Directives which are notified in Single EU Declaration of conformity 3AXD10000497831.

Person authorized to compile the technical file:
 Name and address: Jussi Vesti, Hiomotie 13, 00380 Helsinki, Finland.

Helsinki, 20.10.2020
 Signed for and on behalf of:

 Tuomo Tarula
 Vice president, ABB

 Vesa Tuomainen
 Product Engineering manager, ABB

Document number 3AXD1000099646



Declaration of Conformity

Supply of Machinery (Safety) Regulations 2008

We

Manufacturer: ABB Oy
Address: Hiomotie 13, 00380 Helsinki, Finland.
Phone: +358 10 22 11

declare under our sole responsibility that the following products:

Frequency converters

ACS880-01/-11/-31
ACS880-04/-04F/-M04/-14/-34

with regard to the safety functions

- Safe Torque Off
- Safe stop 1, Safe stop emergency, Safely-limited speed, Safe maximum speed, Safe brake control, Prevention of unexpected start-up (with FSO-12 option module, +Q973, encoderless)
- Safe stop 1, Safe stop emergency, Safely-limited speed, Safe maximum speed, Safe brake control, Safe speed monitor, Safe direction, Prevention of unexpected start-up (with FSO-21 and FSE-31 option modules, +Q972 and +L521, encoder supported)
- Safe motor temperature (with FPTC-01 thermistor protection module, +L536)
- Safe stop 1 (SS1-t, with FSPS-21 PROFIsafe module, +Q986)

are in conformity with all the relevant safety component requirements of the Supply of Machinery (Safety) Regulations 2008, when the listed safety functions are used for safety component functionality.

The following harmonized standards have been applied:

EN 61800-5-2:2007	Adjustable speed electrical power drive systems – Part 5-2: Safety requirements - Functional
EN 62061:2005 + AC:2010 + A1:2013 + A2:2015	Safety of machinery – Functional safety of safety-related electrical, electronic and programmable electronic control systems
EN ISO 13849-1:2015	Safety of machinery – Safety-related parts of control systems. Part 1: General requirements
EN ISO 13849-2:2012	Safety of machinery – Safety-related parts of the control systems. Part 2: Validation
EN 60204-1:2018	Safety of machinery – Electrical equipment of machines – Part 1: General requirements
The following other standards have been applied:	
IEC 61508:2010, parts 1-2	Functional safety of electrical / electronic / programmable electronic safety-related systems
IEC 61800-5-2:2016	Adjustable speed electrical power drive systems – Part 5-2: Safety requirements - Functional

The product(s) referred in this declaration of conformity fulfil(s) the relevant provisions of other UK statutory requirements, which are notified in a single declaration of conformity 3AXD10001326405.

Authorized to compile the technical file: ABB Limited, Daresbury Park, Cheshire, United Kingdom, WA4 4BT.

Helsinki, May 7, 2021
Signed for and on behalf of:

Tuomo Tarula
Local Division Manager, ABB Oy

Aaron D. Wade
Product Unit Manager, ABB Oy

Document number 3AXD10001329538

15

Resistor braking

Contents of this chapter

This chapter describes how to select, protect and wire brake choppers and resistors. The chapter also contains technical data.

Operation principle

The brake chopper handles the energy generated by a decelerating motor. The extra energy increases the DC link voltage. The chopper connects the brake resistor to the intermediate DC circuit whenever the voltage in the circuit exceeds the limit defined by the control program. Energy consumption by the resistor losses lowers the voltage until the resistor can be disconnected.

Planning the braking system

The drive needs external brake chopper and resistors.

■ Selecting the default brake system components

1. Calculate the maximum power generated by the motor during braking.
 2. Select a suitable drive, brake chopper and brake resistor combination for the application from the brake ratings table in section *Technical data*. The braking power of the chopper must be greater than or equal to the maximum power generated by the motor during the braking.
 3. Make sure that the resistor selection is correct: The energy generated by the motor during a 400-second period must not exceed the resistor heat dissipation capacity E_R .
-

Note: If the E_R value is not sufficient, it is possible to use a four-resistor assembly in which two standard resistors are connected in parallel, two in series. The E_R value of the four-resistor assembly is four times the value specified for the standard resistor.

■ **Selecting a custom brake resistor**

If you use other than ABB resistor,

1. make sure that the resistance of the custom resistor is greater than or equal to the resistance of the default ABB resistor.

$$R \geq R_{min}$$

where

R Resistance of the custom resistor



WARNING!

Never use a brake resistor with a resistance smaller than R_{min} . The drive and the chopper are not able to handle the overcurrent caused by the small resistance.

R_{min} Resistance of the default resistor



WARNING!

Never use a brake resistor with a resistance smaller than R_{min} . This will cause overcurrent that will damage the brake chopper and the drive.

2. make sure that the resistance of the custom resistor does not restrict the braking capability needed, ie.

$$P_{max} < \frac{U_{DC}^2}{R}$$

where

P_{max} Maximum power generated by the motor during braking

U_{DC} Drive intermediate DC circuit voltage.
 1.35 · 1.2 · 415 V DC (when supply voltage is 380 to 415 V AC)
 1.35 · 1.2 · 500 V DC (when supply voltage is 440 to 500 V AC) or
 1.35 · 1.2 · 690 V DC (when supply voltage is 525 to 690 AC)

R Resistance of the custom resistor

3. make sure that the resistor can dissipate the energy transferred to it during the braking:
 - Braking energy is not greater than the resistor heat dissipation capacity (E_T) during the period specified. See the custom resistor specification.
 - The resistor is installed in a correctly ventilated and cooled space. Otherwise the resistor cannot meet its heat dissipation capacity and overheats.

4. make sure that the instantaneous load capacity of the custom resistor is greater than the maximum power taken by the resistor when it is connected to the drive intermediate DC circuit by the chopper:

$$P_{R,inst} > \frac{U_{DC}^2}{R}$$

where

$P_{R,inst}$ Instantaneous load capacity of the custom resistor

U_{DC} Drive intermediate DC circuit voltage:
 1.35 · 1.2 · 415 V DC (when supply voltage is 380 to 415 V AC)
 1.35 · 1.2 · 500 V DC (when supply voltage is 440 to 500 V AC) or
 1.35 · 1.2 · 690 V DC (when supply voltage is 525 to 690 AC)

R Resistance of the custom resistor

■ Selecting and routing the brake resistor cables

Use the same cable type for the resistor cabling as for the drive input cabling to ensure that the input fuses also protect the resistor cable. Alternatively, a two conductor shielded cable with the same cross-sectional area can be used.

Minimizing electromagnetic interference

Obey these rules in order to minimize electromagnetic interference caused by the rapid current changes in the resistor cables:

- Shield the braking power line completely, either by using shielded cable or a metallic enclosure. Unshielded single-core cable can only be used if it is routed inside a cabinet that efficiently suppresses the radiated emissions.
- Install the cables away from other cable routes.
- Avoid long parallel runs with other cables. The minimum parallel cabling separation distance is 0.3 meters (1 ft).
- Cross the other cables at 90 degree angles.
- Keep the cable as short as possible in order to minimize the radiated emissions and stress on chopper IGBTs. The longer the cable the greater the radiated emissions, inductive load and voltage peaks over the IGBT semiconductors of the brake chopper.

Note: ABB has not verified that the EMC requirements are fulfilled with custom brake resistors and cabling. The customer must consider the EMC compliance of the complete installation.

Maximum cable length

The maximum cable length of the resistor cable(s) is 10 m(33 ft).

■ Placing the brake resistors

Install the resistor assembly outside the drive in a place where it is able to cool effectively. Arrange the cooling of the resistor so that:

- no danger of overheating is caused to the resistor or nearby materials, and
- the temperature of the room the resistor is located in does not exceed the allowed maximum.

Supply the resistor with cooling air or coolant according to the resistor manufacturer's instructions.



WARNING!

The materials near the brake resistor must be non-flammable. The surface temperature of the resistor is high. Air flowing from the resistor is of hundreds of degrees Celsius. If the exhaust vents are connected to a ventilation system, make sure that the material withstands high temperatures. Protect the resistor against contact.

■ Protecting the system against thermal overload

The brake chopper protects itself and the resistor cables against thermal overload when the cables are dimensioned according to the nominal current of the drive. The drive control program includes a resistor and resistor cable thermal protection function which can be tuned by the user. See the firmware manual.

ABB requires that the resistor has a thermal switch (standard in ABB resistors) which is wired to the chopper for safety reasons. The thermal switch cable must be shielded and may not be longer than the resistor cable.

■ Protecting the system in fault situations

The drive has a brake thermal model which protects the brake resistor against overload. ABB recommends to enable the thermal model at start up.

ABB recommends to equip the drive with a main contactor for safety reasons even when you have enabled the resistor thermal model. Wire the contactor so that it opens in case the resistor overheats. This is essential for safety since the drive will not otherwise be able to interrupt the main supply if the chopper remains conductive in a fault situation. An example wiring diagram is shown below. ABB recommends that you use resistors equipped with a thermal switch (1) inside the resistor assembly. The switch indicates overtemperature.

ABB recommends that you also wire the thermal switch to a digital input of the drive, and configure the input to cause a fault trip at resistor overtemperature indication.

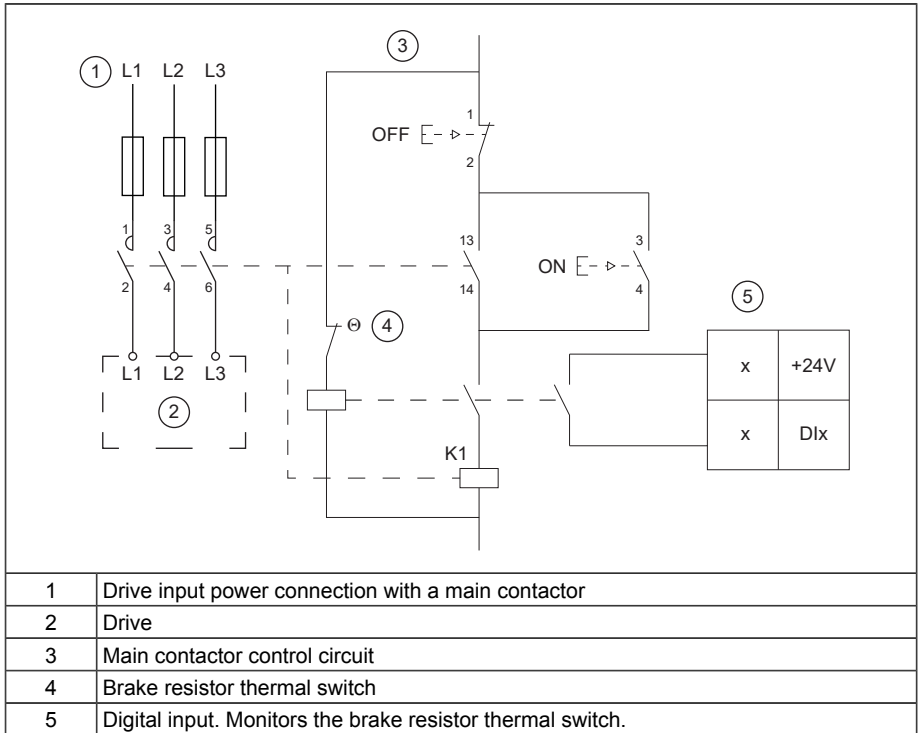

■ Protecting the resistor cable against short-circuits

The input fuses will also protect the resistor cable when it is identical with the input cable.

Mechanical installation

The brake chopper and brake resistors must be installed outside the drive. Obey the resistor manufacturer's instructions.

Electrical installation

■ Measuring the installation

Follow the instructions given under *Measuring the insulation resistance of the brake resistor circuit* (page 85).

■ Connection diagram

See section [Connection diagram \(page 93\)](#).

■ Connection procedure

Connect the brake chopper the DC+ and DC- terminals of the drive. Connect the resistor cables to the brake chopper as described in the brake chopper manual. If a shielded three-conductor cable is used, cut the third conductor, insulate it, and ground the twisted shield of the cable (protective earth conductor of the resistor assembly) at both ends.

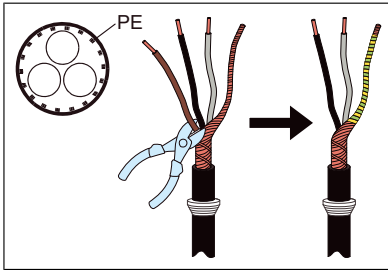

Note: For NEC installations the shield is not allowed as PE conductor. A separate insulated conductor is required.

Start-up

Note: New brake resistors may be coated with storage grease. As the brake chopper operates for the first time, the grease burns off and may produce some smoke. Make sure there is sufficient ventilation.

Set the following parameters (ACS880 primary control program)

- Disable the overvoltage control of the drive by parameter *30.30 Overvoltage control*.
- Set parameter *31.01 External event 1 source* to point to the digital input where the thermal switch of the brake resistor is wired.
- Set parameter *31.02 External event 1 type* to Fault.
- Enable the brake chopper by parameter *43.06 Brake chopper enable*. If Enabled with thermal model is selected, set also the brake resistor overload protection parameters *43.08* and *43.09* according to the application.
- Check the resistance value of parameter *43.10 Brake resistance*.

With these parameter settings, the drive stops by coasting on brake resistor overtemperature.



WARNING!

If the drive is equipped with a brake chopper but the chopper is not enabled by the parameter setting, the internal thermal protection of the drive against resistor overheating is not in use. In this case, the brake resistor must be disconnected.

For settings of other control programs, see the appropriate firmware manual.

Technical data

■ Ratings

Contact ABB for the brake chopper and resistor specifications.

■ Terminals and cable entry data

See section *Terminal and entry data for the power cables (page 191)*.

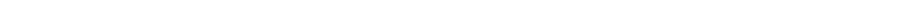

16

Common mode, du/dt and sine filters

Contents of this chapter

This chapter describes how to select additional filters for the drive.

Common mode filters

For need of common mode filter, see section *Examining the compatibility of the motor and drive (page 57)*. Common mode filter for frame R8 is available with option code +E208 also with order number 3AXD50000017270. For frames R3 and R6 the filter is built-in.

For installation instructions, see *Common mode filter kit for ACS880-01 frame R7, and for ACS880-11, ACS880-31 frame R8 (option +E208) installation instructions (3AXD50000015179 [English])*.

du/dt filters

■ When is a du/dt filter needed?

See section *Examining the compatibility of the motor and drive (page 57)*.

■ **du/dt filter types**

Type ACS880-31	du/dt filter type	Type ACS880-31	du/dt filter type
$U_n = 400\text{ V}$		$U_n = 500\text{ V}$	
09A4-3	NOCH0016-6X	07A6-5	NOCH0016-6X
12A6-3	NOCH0016-6X	11A0-5	NOCH0016-6X
017A-3	NOCH0030-6X	014A-5	NOCH0030-6X
025A-3	NOCH0030-6X	021A-5	NOCH0030-6X
032A-3	NOCH0070-6X	027A-5	NOCH0070-6X
038A-3	NOCH0070-6X	034A-5	NOCH0070-6X
045A-3	NOCH0070-6X	040A-5	NOCH0070-6X
061A-3	NOCH0070-6X	052A-5	NOCH0070-6X
072A-3	NOCH0120-6X	065A-5	NOCH0120-6X
087A-3	NOCH0120-6X	077A-5	NOCH0120-6X
105A-3	NOCH0120-6X	101A-5	NOCH0120-6X
145A-3	FOCH0260-70	124A-5	FOCH0260-7X
169A-3	FOCH0260-70	156A-5	FOCH0260-7X
206A-3	FOCH0260-70	180A-5	FOCH0260-7X
3AXD00000588487			

■ **Description, installation and technical data of the filters**

See AOCCH and NOCH du/dt filters hardware manual ([3AFE58933368](#) [English]) or FOCHxxx-xx du/dt filters hardware manual ([3AFE68577519](#) [English]).

Sine filters

See section *Examining the compatibility of the motor and drive* (page 57).

■ **Selecting a sine filter for the drive**

The table below lists the preselected sine filters by Epcos.

Type ACS880-31	Sine filter type	I_2	P_n	Heat dissipation			Noise
				Drive	Filter	Total	
				A	kW	W	W
$U_n = 400\text{ V}$							
09A4-3	B84143V0011R229	9.2	4.0	226	80	316	72
12A6-3	B84143V0016R229	12.1	5.5	329	80	409	72
017A-3	B84143V0025R229	16	7.5	395	140	535	75
025A-3	B84143V0025R229	24	11	579	140	719	75
032A-3	B84143V0033R229	31	15	625	160	785	75

Type ACS880-31	Sine filter type	I_2	P_n	Heat dissipation			Noise
				Drive	Filter	Total	
		A	kW	W	W	W	dB(A)
038A-3	B84143V0050R229	37	18.5	751	220	971	78
045A-3	B84143V0050R229	43	22	912	220	1132	78
061A-3	B84143V0066R229	58	30	1088	250	1338	78
072A-3	B84143V0075R229	64	30	1502	310	1812	79
087A-3	B84143V0095R229	77	37	1904	400	2304	79
105A-3	B84143V0130S230	91	55	1877	600	2477	80
145A-3	B84143V0162S229	126	75	2963	550	3513	80
169A-3	B84143V0162S229	153	90	3168	550	3718	80
206A-3	B84143V0230S229	187	110	3990	900	4890	80
$U_n = 500 \text{ V}$							
07A6-5	B84143V0011R229	7.0	3.0	219	90	309	72
11A0-5	B84143V0011R229	10.2	4.0	278	90	368	72
014A-5	B84143V0016R229	13	5.5	321	80	401	70
021A-5	B84143V0025R229	20	7.5	473	140	613	75
027A-5	B84143V0033R229	25	11.0	625	160	785	75
034A-5	B84143V0050R229	32	15	711	220	931	78
040A-5	B84143V0050R229	35	18.5	807	220	1027	78
052A-5	B84143V0066R229	44	22	960	250	1210	78
065A-5	B84143V0066R229	52	30	1223	250	1473	78
077A-5	B84143V0075R229	61	37	1560	310	1870	78
101A-5	B84143V0130S230	80	45.0	1995	630	2625	80
124A-5	B84143V0130S230	104	55.0	2800	630	3430	80
158A-5	B84143V0162S229	140	75.0	3168	550	3718	80
180A-5	B84143V0162S229	161	90.0	3872	550	4422	80
3AXD00000588487							

Definitions

P_n Typical motor power

I_2 Rated current of the drive-filter combination available continuously without overload at 40 °C.

Noise Noise level is a combined value for the drive and the filter. Heat dissipation is a value for the filter.

■ Derating

See section *Deratings for special settings in the drive control program (page 173)*.

■ **Description, installation and technical data**

For the filter data sheets, go to <http://en.tdk.eu/>. See also *Sine filters hardware manual* ([3AXD50000016814](#) [English]).



Further information

Product and service inquiries

Address any inquiries about the product to your local ABB representative, quoting the type designation and serial number of the unit in question. A listing of ABB sales, support and service contacts can be found by navigating to www.abb.com/searchchannels.

Product training

For information on ABB product training, navigate to new.abb.com/service/training.

Providing feedback on ABB manuals

Your comments on our manuals are welcome. Navigate to new.abb.com/drives/manuals-feedback-form.

Document library on the Internet

You can find manuals and other product documents in PDF format on the Internet at www.abb.com/drives/documents.



www.abb.com/drives



3AXD50000045933G