

1SFC132081M0201

# Softstarters Type PSTX30...PSTX1250

## Installation and commissioning manual



# Original instruction

This is the Installation and commissioning manual for Softstarters Type PSTX30...PSTX1250.

Document number: 1SFC132081M0201

Revision: 0

Issue date: 2021-09-15

Data can be changed without notice.

We reserve all rights to this document, even in the event that a patent is issued and a different commercial proprietary right is registered. Improper use, in particular reproduction and dissemination to third parties, is not permitted.

This document is written carefully. If you find an error, please notify us as soon as possible.

The data contained in this manual is intended solely for the product description and is not to be deemed to be a statement of guaranteed properties. In the interests of our customers, we constantly seek to ensure that our products are developed to the latest technological

Author's address:

**ABB Electrification Sweden AB**  
**Smart Power - Motor Starting & Safety**  
SE-721 61 VÄSTERÅS, Sweden  
<https://solutions.abb/softstarters>

© Copyright 2021. All rights reserved. Data can be changed without notice.

# Read this first

## Warning and safety

Thank you for selecting this ABB PSTX Softstarter.

Carefully read and make sure that you understand all instructions before you install, connect, configure the Softstarter.

This manual is intended for installation and advanced usage of the PSTX Softstarter. For quick and easy installation, see 1SFC132082M9901 - Softstarters Type PSTX30...PSTX1250 User Manual short form. The manual is available on: <https://solutions.abb/softstarters>

- Only authorized and appropriately trained personnel are permitted to install and make the electrical connection of the Softstarter. Obey all laws and regulations.
- Only authorized personnel are permitted to do service and repair on the Softstarter.
- Unauthorized repair will have an effect on the warranty.
- ABB personnel must obey the instructions in **ABB CISE 15.4**.
- This manual is a part of the PSTX Softstarter. Always keep this manual available when you work with the PSTX Softstarter.
- Examine the Softstarter and the package when you unpack your new PSTX Softstarter. If there are damages, please speak to the transportation company or the ABB reseller/office immediately.

### Safety notes

In the manual, these symbols are used



#### WARNING

General warning symbol indicates the presence of a hazard which could result in personal injury and damage to equipment or property.



#### WARNING

Warning symbol indicates the presence of hazardous voltage which could result in personal injury.



#### WARNING

Approved personnel are allowed to install and make the electrical connection of the Softstarter in accordance with existing laws and regulations.



#### INFORMATION

Information sign tells the reader important facts and conditions.

Changes to data in this manual can be applied without notice.

### General safety information



#### WARNING

Approved personnel are allowed to install and make the electrical connection of the Softstarter in accordance with existing laws and regulations.



#### WARNING

Examine the Softstarter and the package when you unpack your new PSTX Softstarter. If there are damages, please speak to the transportation company or the ABB reseller/office immediately.



#### WARNING

Only approved personnel are allowed to do service and repair.

Note: not approved repair can effect the warranty.

### Legal Disclaimer

The PSTX Softstarter is designed to be connected to and to communicate information and data via a network interface. It is customers sole responsibility to provide and continuously ensure a secure connection between the product and your network or any other network (as the case may be) and to establish and maintain any appropriate measures (such as but not limited to the installation of firewalls, application of authentication measures, encryption of data, installation of anti-virus programs, etc) to protect the PSTX Softstarter, the network, its system and the interface against any kind of security breaches, unauthorized access, interference, intrusion, leakage and/or theft of data or information.

ABB Ltd and its affiliates are not liable for damages and/or losses related to such security breaches, any unauthorized access, interference, intrusion, leakage and/or theft of data or information.





# Softstarters Type PSTX

## Installation and commissioning manual

<a href="#">1 Introduction</a>	<b>1</b>
<a href="#">2 Quick start</a>	<b>2</b>
<a href="#">3 Description</a>	<b>3</b>
<a href="#">4 Installation</a>	<b>4</b>
<a href="#">5 Connection</a>	<b>5</b>
<a href="#">6 Human machine interface (HMI)</a>	<b>6</b>
<a href="#">7 Functions</a>	<b>7</b>
<a href="#">8 Communication</a>	<b>8</b>
<a href="#">9 Maintenance</a>	<b>9</b>
<a href="#">10 Troubleshooting</a>	<b>10</b>
<a href="#">11 Wiring and application diagrams</a>	<b>11</b>
<a href="#">12 Third party licenses</a>	<b>12</b>
<a href="#">13 Revision</a>	<b>13</b>
<a href="#">14 Index</a>	<b>14</b>



# 1 Introduction

## 1.1 Documentation for Softstarter PSTX30...PSTX12500

8

1

### 1.1.1 Installation and commissioning manual

1.2 Intended audience ..... 9

1.3 Revision notes and other documents ..... 9

1.4 Acronyms and abbreviations ..... 9

This chapter gives an introduction to the Softstarter documentation manuals and its chapters, releases, intended audience and it tells about concepts.

## 1.1 Documentation for Softstarter PSTX30...PSTX1250

For the Softstarter types PSTX30...PSTX1250, these manuals and catalogs are available:

### 1SFC132081M0201

This document. Installation and commissioning manual (English version). See chapter **1.1.1 Installation and commissioning manual** more information.

### 1SFC132082M9901

Installation and commissioning manual - Short form. See chapter **1.1.2 Installation and commissioning manual - Short form** for more information.

These documents are available online in PDF format. A printed version of the "Installation and commissioning - Short form" is included with the Softstarter.

These manuals are available as online PDF-files:

**Table 1** Languages

Document ID	Language
1SFC132081M1301	AR Arabic
1SFC132081M2001	ZH Chinese
1SFC132081M4601	CS Czech
1SFC132081M0101	DE German
1SFC132081M0201	EN English
1SFC132081M0701	ES Spanish
1SFC132081M1801	FI Finnish
1SFC132081M0301	FR French
1SFC132081M0901	IT Italian
1SFC132081M3101	NL Dutch
1SFC132081M4001	PL Polish
1SFC132081M1601	PT Portuguese
1SFC132081M1101	RU Russian
1SFC132081M3401	SV Swedish
1SFC132081M1901	TR Turkish

These documents can be found at:  
<https://solutions.abb/softstarters>.

## 1.1.1 Installation and commissioning manual

This manual, "Softstarters Type PSTX30...PSTX1250 Installation and commissioning manual", contains instructions on how to install, commission and maintain the Softstarter. It gives procedures for mechanical and electrical installation, and installation of communication devices. It also gives information about energizing, settings and configuration.

To start quickly, see chapter **2 Quick start** or use the short form manual (1SFC132082M9901). For chapter content, see **Table 2 Chapter contents** below:

**Table 2** Chapters contents

Chapters	Description
1. Introduction	Introduces the reader to this manual.
2. Quick start	Contains information for quick installation of the Softstarter and get it into operation.
3. Description	Gives a description of the Softstarter with specifications and a list of functions.
4. Installation	Contains information of the delivery, how to unpack and install the Softstarter.
5. Connection	Contains instructions to make the electrical connections, and connections for communication devices.
6. Human-Machine Interface	Gives a description of the Human-Machine Interface. Gives a description of all settings and navigation of the menu systems.
7. Functions	Gives a description of all functions of the Softstarter, with their minimum, maximum and default values. This chapter is intended for the experienced user.
8. Communication	Gives a description of the communication ports of the Softstarter.
9. Maintenance	Gives a description of the necessary maintenance and how to do it.
10. Troubleshooting	Contains instructions to find and correct the most common errors.
11. Wiring diagrams	Contains electrical and application diagrams for the Softstarter.
12. Third party Licenses	3 <sup>rd</sup> party licenses used by Softstarter
13. Revision	Shows all revisions of the manual
<b>14. Index</b>	<b>Index of the content of this manual</b>

## 1.1.2 Installation and commissioning manual - Short form

The "Softstarters Type PSTX30...PSTX1250 Installation and commissioning manual - Short form" contains brief information about the Softstarter:

- Installation
- Electrical connections
- Basic functions
- Troubleshooting

The short form contains the languages shown in **Table 1 Languages**. The short form has document ID 1SFC132082M9901.

## 1.2 Intended audience

### 1.2.1 General

The Installation and commissioning manual is intended for authorized installation, commissioning, and maintenance personnel.

### 1.2.2 Requirements for personnel

The installation personnel must have a basic knowledge in how to handle electrical equipment. The commissioning and maintenance personnel must have good experience in how to use electrical equipment. ABB personnel must obey the instructions in **ABB CISE 15.4**.

## 1.3 Revision notes and other documents

For latest information on revisions and other documents related to the PSTX Softstarters, please see <https://solutions.abb/softstarters>.

## 1.4 Acronyms and abbreviations

**Table 3** Acronyms and abbreviations

Acronym/ Abbreviation	Description
BP	Bypass
DOL	Direct-on-line
EOL	Electronic overload
FB	Fieldbus
FBP	Fieldbus Plug
HMI	Human-Machine Interface
$I_e$	Rated operation current
IT	Information Technology
LED	Light Emitting Diode
PCBA	Printed Circuit Board Assembly
PLC	Programmable Logic Controller
PTC	Positive Temperature Coefficient
SC	Short Circuit
SCR	Silicon Controlled Rectifier (thyristor)
THD	Total Harmonic Distortion
TOR	Top of Ramp (full voltage/Full-On)
$U_c$	Rated control circuit voltage, used for controlling the Softstarter. *
$U_e$	Rated operation voltage on the motor (3 phase main voltage feeding the motor). *
$U_s$	Rated control supply voltage, feeding the electronics in the Softstarter. *

\*) For definition see IEC 60947-1 edition 5.0



## 2 Quick start

<b>2.1 Connection</b>	12
<b>2.2 Configuration</b>	14
2.2.1 Basic set-up	14
2.2.2 Application set-up	15
<b>2.3 How to start/stop the motor</b>	15

This chapter is a short guide on how to connect, configure and start the Softstarter in an easy way.

This product was carefully manufactured and tested, but damage can occur during transportation. Therefore, obey these instructions:

**⚠ WARNING**  
 Dangerous voltage: Can cause death or serious injury. Always set the power switch to off and lock out all power to this device before you start to work on the equipment.

**⚠ WARNING!**  
 Installation of electrical connections must be done by authorized personnel. Obey all laws and regulations.

**⚠ WARNING!**  
 Before you connect the Softstarters PSTX30... PSTX170 to the operation voltage for the first time, apply control supply voltage to open the bypass relays. (see 2.1 Connection). This is necessary to avoid an accidental start of the equipment while it is connected to operation voltage.

**i INFORMATION**  
 ABB personnel must obey the instructions in **ABB CISE 15.4**.

**2.1 Connection**

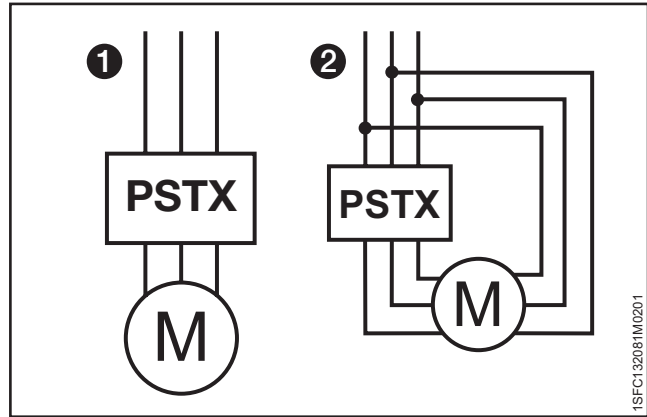
1. To install the Softstarter see chapter 4 Installation.

**i INFORMATION**  
 You can connect PSTX Softstarters In Line **1** and Inside Delta **2**, see **Figure 2.1**.

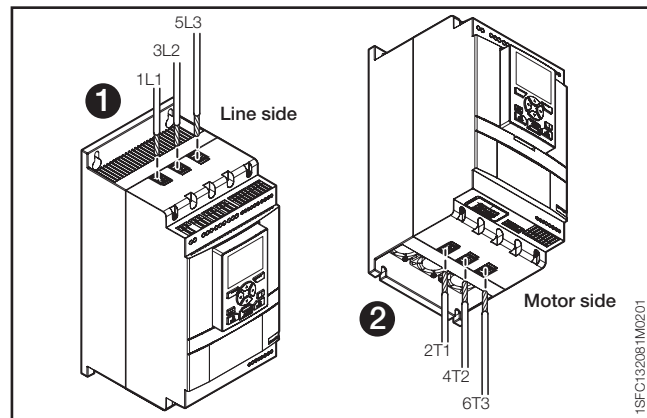
2. Connect the main circuit: terminals 1L1 - 3L2 - 5L3 to the line side **1**, and terminals 2T1 - 4T2 - 6T3 to the motor side **2**, see **Figure 2.2**. Use wire connection for PSTX30...105, see **Figure 2.2** and terminal connection for PSTX142...570, see **Figure 2.3**.
3. Connect the line side to terminals 1L1, 3L2, 5L3. see **1** and **Figure 2.2**. Connect the motor to terminals 2T1, 4T2, 6T3 on the motor side, see **2** **Figure 2.2** and **Figure 2.3**.

**⚠ WARNING!**  
 When using a softstarter in a network with high harmonic disturbances, there is a risk to damage the softstarter. An example could be installations were VSDs (variable speed drives) are connected to the same transformer as the softstarter.

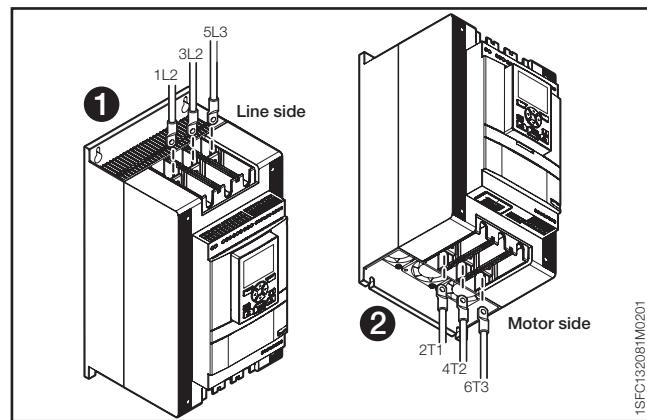
The harmonics are only harmful to the softstarter when it is not running a motor. To avoid problem with harmonics, a line contactor can be used to switch off the line voltage when the softstarter is not running a motor, see figures in chapter **11.2.9 Softstarter in network with high harmonic disturbances**.



**Figure 2.1**  
 In Line (1) and Inside Delta (2) connection



**Figure 2.2**  
 Terminal connection clamps



**Figure 2.3**  
 Terminal connection bars





### INFORMATION

Use only wires of the same dimension when you connect 2 wires to each terminal. (Possible for PSTX30...105 only).

- Connect the control supply voltage (100-250V 50/60Hz) to terminal 1 and 2.
- Connect the functional ground (terminal 22), to a ground point close to the Softstarter, see **Figure 2.4**.



### INFORMATION

The ground is not a protective ground, it is a functional ground. The maximum length of the ground cable is 0.5 m. Connect the ground cable to the installation plate where the Softstarter is attached. The installation plate must also be grounded.

### INFORMATION

Do not use functional ground in IT-networks, commonly found in for instance marine applications.

- Look at the diagram, see **Figure 2.7**, and connect the start/stop circuits: terminal 13, 14, 18, 19 and 20/21, with the internal 24 V DC terminal. When you use internal 24 V DC (terminals 20 or 21), the terminals 18 and 19 must be connected to each other. For external control circuit voltage, see chapter **5.1.2.3 Start and Stop - terminals 13, 14, 18, 19, 20, 21**.



### WARNING

Use 24 V DC only when you connect terminal 13, 14, 15, 16 and 17. Other voltages can cause damage to the Softstarter and the warranty will no longer be valid. For more information about terminal 15, 16 and 17, see chapter **5.1.2.4 Programmable inputs - terminals 15, 16 and 17**.

- Connect terminals 4, 5, 6, 7, 8, 9, 10, 11 and 12 to use the signal output relays. These are potential-free contacts for maximum 250 V AC, 1.5 A AC-15 and 30 V DC, 5 A DC-12. See **Figure 2.5**.
- Make sure that the operation voltage and control supply voltage agree with the Softstarter ratings.
- Set the control supply voltage switch to ON.
- The green Ready LED is constant lit if the following conditions are fulfilled:
  - Control supply voltage is detected
  - Mains three phase voltage is detected
  - Mains frequency is within range (40-72Hz)
  - Motor connection is detected
  - Phase sequence is detected
  - No events are active
  - Enable signal is active
  - If the max nbr of starts per hour function is enabled and set to stop manual or stop automatic, the remaining time to start counter (which can be shown in the HMI homeview) has to be zero
 Otherwise the ready LED is flashing, see **Figure 2.6**.

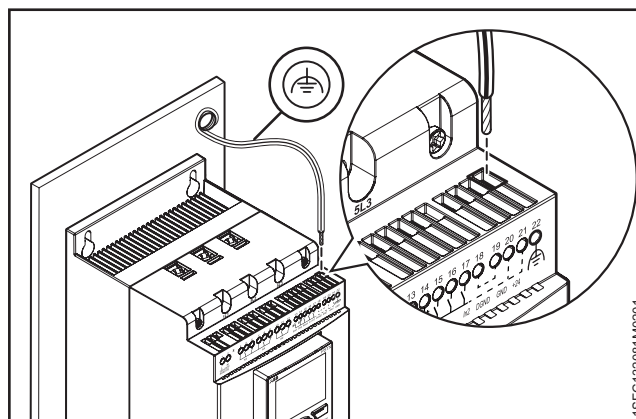


Figure 2.4  
Functional ground, terminal 22

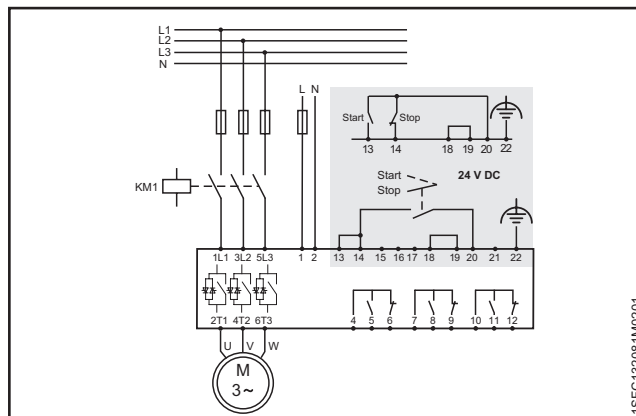


Figure 2.7  
Circuit diagram (Fuse and contactor version)

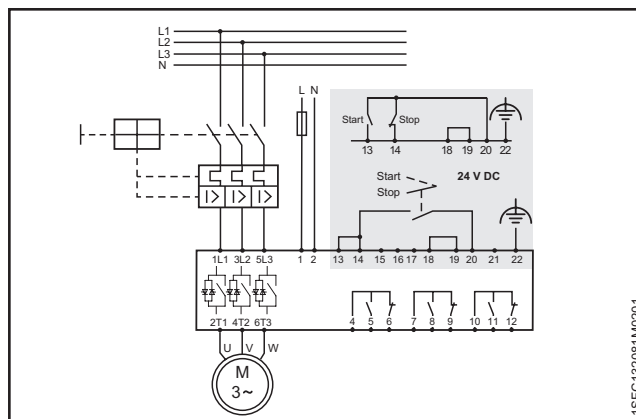


Figure 2.5  
Circuit diagram (MCCB version)

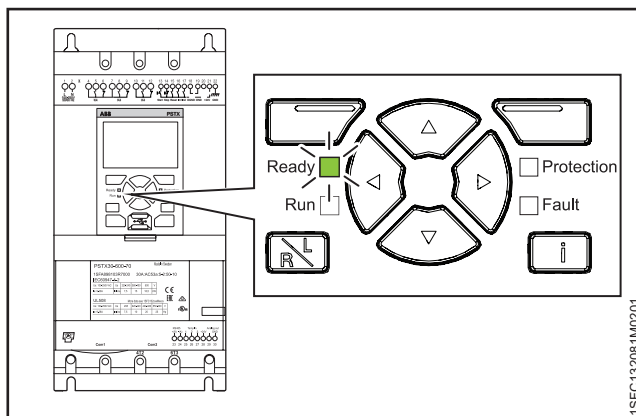


Figure 2.6  
Flashing "Ready" LED

11. The language settings appear on the screen. Select your language and push the selection soft key "OK". The HMI now downloads the language data from the Softstarter. This can take some minutes. When this is done the HMI shows the Home view.
12. Configure applicable parameters as given in chapter **7 Functions** or use the assistants as given in chapter **2.2 Configuration**.

## 2.2 Configuration
















For a quick configuration of the Softstarter, use the Assistants menu.

The Assistants menus are divided into:







- **Basic set-up**
  - The Basic set-up menu is divided into 4 steps:
    1. Language
    2. Date and time
    3. Motor data
    4. System configuration
- **Application set-up**
  - The Application set-up is divided into 3 steps:
    1. Application set-up
    2. Keep/Change values
    3. Tune settings

### 2.2.1 Basic set-up

You see this set-up when you start the Softstarter. To disable this set-up, see step 6 below.

1. Find the Assistants menu by pushing  "Menu". Scroll to Assistants with the Navigation keys. Push  "Select" to enter the Assistants menu.
2. Scroll to the Basic set-up menu with the Navigation keys. Push  "Select" to enter the menu.
3. The Basic set-up starts with step 1 of 5, Language. Push  "Edit" to change language. Use the Navigation keys to select language and then push  "Save".
4. Push  to enter step 2(5), Date and time. Push  "Edit" and use the Navigation keys to edit date and time, then push  "Save".
5. Push  to enter step 3(5), Motor data. Push  "Edit" to change the Motor rated current le. Use the Navigation keys to change the value and then push  "Save".
6. Push  to enter step 4(5), System configuration. Here you can set if the Softstarter enters the Basic set-up at power on or not. Use the Navigation keys to select Yes or No and then push  "Save".
7. Push  to enter step 5(5) and then Push  "Done" to finish the Basic setup. For more settings, enter Application set-up.





## 2.2.2 Application set-up

1. Find the Assistants menu from the Home view by pushing  "Menu". Scroll to Assistants with the Navigation keys. Push  "Select" to enter the Assistants menu.
2. Scroll to the Application set-up menu with the Navigation keys and then enter the menu by pushing  "Select".
3. The Application set-up will start with step 1, Application type. Scroll to the appropriate application type and then push  "Select". For a full Application list, see chapter **7.25 Complete parameter list**.
4. Push  to enter step 2, Values. You can select "Keep actual values" or "Change to recommended values". Scroll to the selection of your choice and Push  "Select" to apply.



### WARNING!

Note that your saved parameter values are lost if you select "Change to recommended values".

5. Push  to enter step 3, Tune settings. In most cases the recommended values are sufficient, but sometimes fine tuning is necessary. For fine tuning, push  "Edit" and then use the navigation keys to set:
  - Start ramp time: 1 - 120s
  - Stop ramp time: 1 - 120s
  - Start ramp initial level: 10 - 99%
  - Stop ramp end level: 10 - 99%
  - Current limit level: 1.5 - 7.5 x I<sub>e</sub>
  - Start mode: Voltage ramp, Torque ramp or Full voltage start
  - Stop mode: No ramp, Voltage ramp, Torque ramp, Dynamic brake
6. Push  and then push  "Done" to finish the Application set-up. If necessary, fine tuning can also be done in the Parameters menu.

## 2.3 How to start/stop the motor



### WARNING

Dangerous voltage: Can cause death or serious injury. Always set the power switch to off and lock out all power to this device before you start to work on the equipment.



### WARNING

Approved personnel are allowed to install and make the electrical connection of the Softstarter in accordance with existing laws and regulations.



### WARNING!

Before you connect the Softstarters PSTX30... PSTX170 to the operation voltage for the first time, apply control supply voltage to open the bypass relays. (see 2.1 Connection). This is necessary to avoid an accidental start of the equipment while it is connected to operation voltage.



### INFORMATION

ABB personnel must obey the instructions in **ABB CISE 15.4**.

1. Set the operation voltage switch to ON.
2. To start the Softstarter from the keypad, push the R/L-key to select local control, then push the Start key on the keypad. Push Stop to stop the Softstarter
3. To start from hard wire control, push the R/L-key to select hard wire control, then push the remote Start key. Push Stop to stop the Softstarter.



# 3 Description

<b>3.1 Overview</b>	18
3.1.1 Operation functions	18
3.1.2 Protection functions	18
3.1.2.1 User defined protection	19
3.1.3 Warning functions	19
3.1.4 Fault detection functions	19
3.1.5 Softstarter overview	20
3.1.6 Type designation	21
3.1.7 Environmental influence	21
3.1.8 Specifications	21
<b>3.2 Technical data</b>	22
3.2.1 General	22
3.2.2 Technical data for external keypad	22
3.2.3 Semi-conductor fuses	22
3.2.4 Weights	22
3.2.5 Softstarter ratings	23
3.2.6 Dimensions	25

This chapter gives a description of the Softstarter in general, specifications and available components and spare parts.

## 3.1 Overview

The PSTX Softstarter has the latest technology for soft start and soft stop of squirrel cage motors. The Softstarter has multiple advanced motor protection features as standard.



### WARNING

If using the Rated Operational Voltage  $U_e$  (Phase /N) as source for Control Supply Voltage  $U_s$  make sure to not exceed  $U_s$  250V AC,50/60Hz.

### Bypass

Softstarter range PSTX30...1250 have integrated bypass components.

### User interface

The keypad on the front has Navigation keys, Selection soft keys, Start and Stop keys, Local or Remote key, Information key and a clear information screen. You can select 15 user languages.

You can control the Softstarter in 3 different ways:

- Hardwire inputs control
- Keypad control (either attached to the Softstarter front or detached and connected with the cable included)
- Fieldbus communication interface (by built in Modbus, Anybus module or the FieldBus Plug with adapter)

You can use only one type of control at the same time. Default selection is hardwire inputs control.



### INFORMATION

Keypad control has the highest priority and overrides all other control methods.

### Fans

The integrated fans for cooling will start after reaching TOR or Standby and run for 3 min.

Fans will never run during the transition from ramp to bypass or bypass to ramp.

The fans are temperature dependent

- on PSTX30...370 the fans will start when heatsink temp is over 60 °C and stop at 55 °C or after 30 min if the temp have not dropped >5 °C in TOR or idle.
- on PSTX470...1250 the fans will start when heatsink temp is over 50 °C and stop at 45 °C or after 30 min if the temp have not dropped >5 °C in TOR or idle.

For PSTX1050...1250 the fans will always run in TOR.

## 3.1.1 Operation functions

Available functions are listed below:

- Voltage start ramp
- Voltage stop ramp
- Torque start ramp
- Torque stop ramp
- Full voltage start
- No ramp
- Stand-still brake
- Current limit
- Kick start
- Slow speed
- Motor heating
- Motor braking
- Sequence start
- Automatic restart

## 3.1.2 Protection functions

The PSTX Softstarter has protection functions to protect the Softstarter, motor and other equipment. All protections can have automatic reset or manual reset. You can enable or disable the protection.

Available protections are listed below:

- Electronic overload protection
- Locked rotor protection
- Phase reversal protection
- Current imbalance protection
- Overvoltage protection
- Undervoltage protection
- Ground fault protection
- Voltage imbalance protection
- 24V output protection
- External thermal sensor - PT100 protection
- External thermal sensor - PTC protection
- Power factor underload protection
- Current underload protection
- User defined protection
- Too long current limit protection
- Bypass open protection
- Fieldbus failure protection
- Extension I/O failure protection
- HMI failure protection

- Max number of starts
- Frequency range protection
- Phase reversal protection
- Too long start time protection
- Auto restart protection
- IO Controller protection

### 3.1.2.1 User defined protection

You can use your own specified protection, with the programmable digital input and an external device/sensor. The protection operates when the input signal comes at high level (fieldbus or physical I/O).

### 3.1.3 Warning functions

The Softstarter has warning functions for potential risks, that operate before a protection function operates.

A warning cannot stop the Softstarter. A reset of a warning is not necessary.

You can change the warning level and other parameters for the warning functions. Warnings are stored in the event list.

#### Available warnings are listed below:

- Current imbalance warning
- Overvoltage warning
- Undervoltage warning
- EOL time-to-trip warning
- EOL warning
- Total Harmonic Distortion (THD) warning
- Voltage imbalance warning
- Power factor underload warning
- Current underload warning
- Locked rotor warning
- Thyristor overload warning
- Short circuit warning
- Number of starts warning
- Modbus configuration warning
- Phase loss warning
- Motor runtime warning
- Parameter storage warning

### 3.1.4 Fault detection functions

The Softstarter has a number of fault detection functions to signal malfunction at Softstarter, motor or power network level. The Softstarter identifies external and internal faults.

#### Available internal faults are listed below:

- Shunt fault
- Short circuit fault
- Open circuit thyristor fault
- Thyristor overload fault
- Heatsink overtemperature fault
- Unspecified fault
- Electronics failure
- Invalid Id

#### Available external faults are listed below:

- Phase loss fault
- Bad network fault
- Low supply voltage fault
- High current fault
- Faulty usage
- Faulty connection

### 3.1.5 Softstarter overview

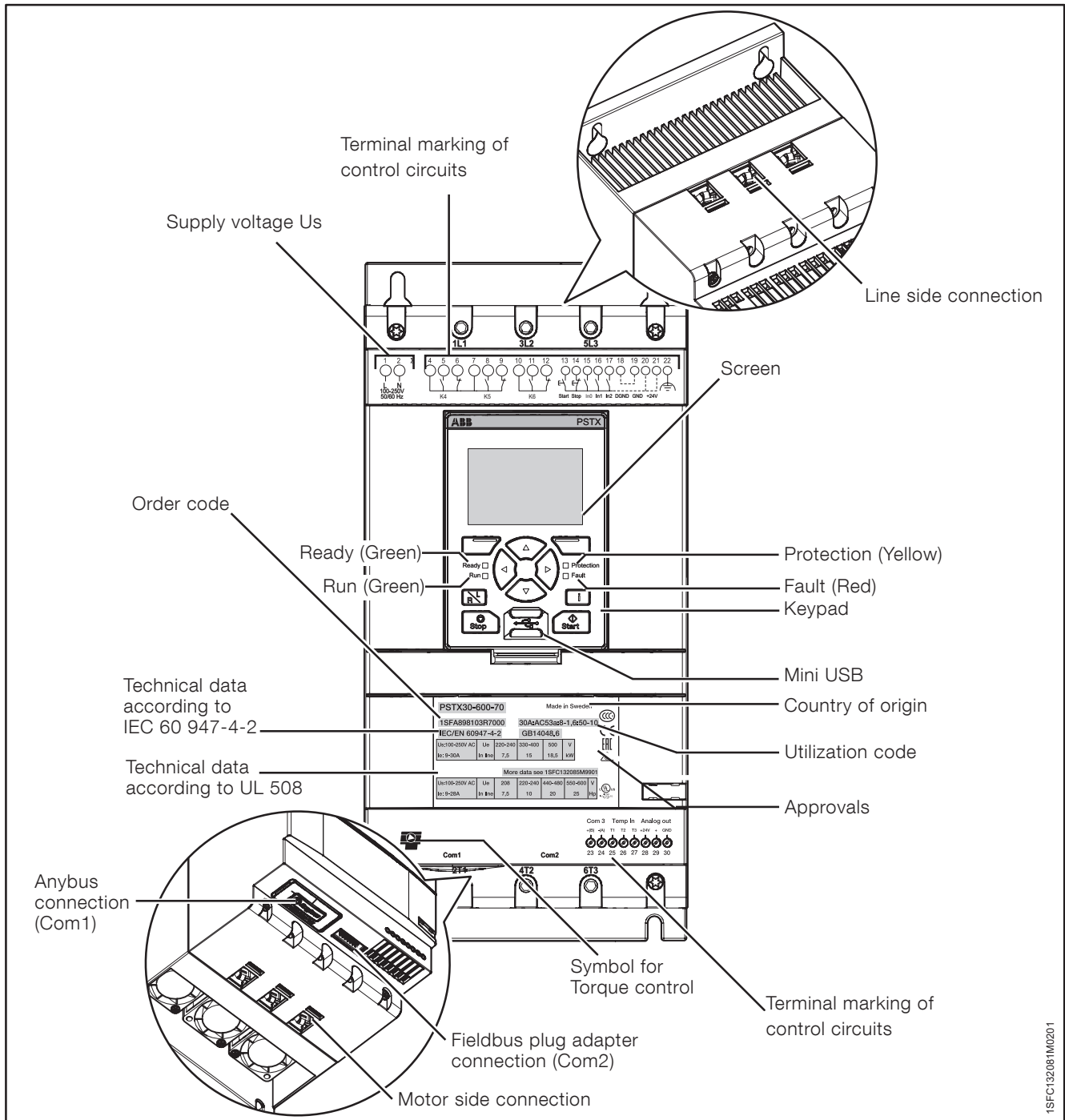
Change the settings through Keypad and Fieldbus communication.

Use the keypad to change settings for each parameter alone or as a selection of default parameters for different applications.

Most parameters have one possible setting, but some parameters have extra settings for sequence start. The default parameter settings are stored in the unit for a reset to default.

When the fieldbus communication is selected, most parameters can also be changed from this interface.

Overview, See **Figure 3.1**.

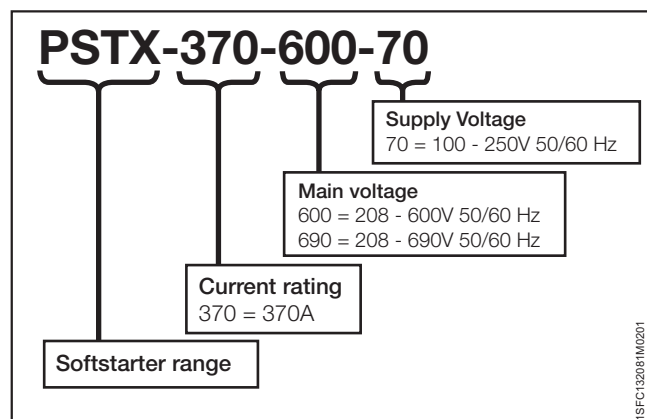


**Figure 3.1**  
Softstarter overview



Designation (i.e. PSTX370-600-70)	Description
PSTX	Softstarter type
370	Current rating 370 = 370A
600	Main voltage 600 = 208 - 600 V 50/60 Hz 690 = 208 - 690 V 50/60 Hz
70	Supply Voltage 70 = 100 - 250 V 50/60 Hz

Type designation, see **Figure 3.2**.



**Figure 3.2**  
Type designation

### 3.1.7 Environmental influence

The product is designed to reduce the effects on the environment during manufacturing and use of the product.

Most of the materials used are recyclable. Obey local laws when you handle and recycle the materials.

You can find further information about used material and recycling of the product at:

<https://solutions.abb/softstarters>

General data	Description	
Degree of protection:	<b>PSTX30...105:</b>	<b>PSTX142...1250:</b>
Main circuit	IP10	IP00
Degree of protection:	<b>PSTX30...105:</b>	<b>PSTX142...1250:</b>
Supply and control circuit	IP20	IP20
Operating position	Vertical at ± 30°	
Ambient temperature	<b>Storage:</b> -40 °C to +70 °C (-40 °F to 158 °F) <b>Operation:</b> -25 °C to +60 °C (-13 °F to 140 °F) <b>De-rating:</b> Above 40 °C (104 F) up to max. 60 °C (140 F) reduce the rated current with 0,8% per °C (0,44% per F).	
Altitude	1000 m (3281 ft.) above sea level without derating. 1000 - 4000 m (3281 - 13123 ft.) with derating 0,7%/100 m (0,22%/100ft)	
Pollution degree	3	
Relative humidity	5 - 95% (non condensing)	
Standards	IEC 60529 IEC 60947-1 IEC60947-4-2	
Standards UL	UL508	
PTC input	IEC 60947-8 Mark A detectors DIN 44081 and DIN 44082	
EMC	IEC 60947-4-2 Class A <b>1</b>	
Marine approvals	Speak to your ABB sales office	

**1** The Softstarter is designed for class A equipment. Use of the product in domestic environments can cause radio interference. If so, it can be necessary to use more mitigation procedures.

## 3.2 Technical data

### 3.2.1 General

**Table 3** General

General data	Description
24 V output	24 V ± 5% Max 250 mA
Rated insulation voltage, U <sub>i</sub>	600 V / 690 V
Rated operation voltage, U <sub>e</sub>	208-600 / 690 V, 50 / 60 Hz
Rated supply voltage, U <sub>s</sub>	100-250 V, 50 / 60 Hz
Thyristor Peak Inverse Voltage (PIV):	600 V version: 1600 V 690 V version: 1800 V
Voltage tolerance	+10% to -15%
Rated frequency	50 / 60 Hz
Frequency tolerances	± 10%
Rated impulse withstand voltage	6 kV Operation circuit 4 kV Control and supply circuit
Relay outputs	3 programmable
Number of controlled phases	3
Inputs	Start, stop, 3 programmable inputs (Digital I/O: In0, In1, In2), temperature sensor input.
Outputs	Relay outputs: K4 K5 K6.
Output relay performance	250 V AC, I <sub>th</sub> = 5A, I <sub>e</sub> = 1.5A (AC-15)
Analog output	4-20 mA, 0-20 mA, 0-10 V, 0-10 mA
PTC input	2825 ohm ± 20% switch off resistance 1200 ohm ± 20% switch on resistance
Cooling system	Fan
Recommended fuse	6 A Delayed
Control supply circuit	MCB use C characteristics
Communication	3 Fieldbus ports, Extension I/O
Communication protocols	DeviceNet / Profibus DP / Modbus / EtherNET/IP / Modbus TCP/ Profinet / BACnet IP / BACnet MS/TP / EtherCAT

### 3.2.2 Technical data for external keypad

**Table 4** Technical data for external keypad

Display	Display type
Status indicating LEDs	<b>Ready:</b> Green <b>Run:</b> Green <b>Protection:</b> Yellow <b>Fault:</b> Red
Ambient temperature	<b>Storage:</b> -25 °C to +70 °C (-13 °F to 158 °F) <b>Operation:</b> -25 °C to +60 °C (-13 °F to 140 °F)
Degree of protection	IP66
UL approval	Type 1 Type 4X Type 12
Marine approvals	Speak to your ABB sales office

### 3.2.3 Semi-conductor fuses



#### WARNING!

Semiconductor fuses must be used to keep the warranty on the thyristors.



#### INFORMATION

To achieve a type 2 coordination, semiconductor fuses must be used.

**Table 5** Fuses ratings and power losses

Type	Current range	Max power loss at rated I <sub>e</sub>	Max fuse rating - main circuit <sup>1)2)</sup> Bussmann fuses, DIN43 620 (Knife)			Power requirements supply circuit Holding (VA) / Pull-in (VA)
			A	W	Type	
PSTX30	9.0...30.0	0.8	100	170M1567D	000	49/51
PSTX37	11.1...37.0	1.2	125	170M1568D	000	49/51
PSTX45	13.5...45.0	1.8	160	170M1569D	000	49/51
PSTX60	18.0...60.0	3.2	160	170M1569D	000	49/51
PSTX72	21.6...72.0	4.7	250	170M1571D	000	49/51
PSTX85	22.5...85.0	6.5	315	170M1572D	000	49/51
PSTX105	31.8...106.0	10	400	170M3819D	1	49/51
PSTX142	42.9...143.0	18	500	170M5810D	2	49/53
PSTX170	51.3...171.0	26	630	170M5812D	2	49/53
PSTX210	63.0...210.0	48	630	170M5812D	2	56/276
PSTX250	75.0...250.0	68	700	170M5813D	2	56/276
PSTX300	90.0...300.0	97	800	170M6812D	3	56/276
PSTX370	111.0...370.0	148	900	170M6813D	3	56/276
PSTX470	141.0...470.0	99	900	170M6813D	3	67/434
PSTX570	171.0...570.0	146	1000	170M6814D	3	67/434
PSTX720	216.0...720.0	78	1250	170M8554D	3	61/929
PSTX840	252.0...840.0	106	1500	170M6018D	3	61/929
PSTX1050 <sup>3)</sup>	315.0...1050.0	165	1800	170M6020D	3	68/929
PSTX1250 <sup>3)4)</sup>	375.0...1250.0	234	2000	170M6021D	3	68/929

<sup>1)</sup> For the supply circuit 6 A delayed, for MCB use C characteristics.

<sup>2)</sup> For inside delta connection the fuses shall be placed inside the delta. Contact ABB for more information.

<sup>3)</sup> 170M6019 with fuse rating 1600 A should be used for 690 V version.

<sup>4)</sup> For 690 V version, Bussmann fuses are only available for motors with rated current up to 1150 A.

You can find more detailed information at:

<http://applications.it.abb.com/SOC/>

### 3.2.4 Weights

**Table 6** Weights

Type	Weight in kg	Weight in lbs
PSTX30...105	6,1	13,5
PSTX142...170	9,6	21,2
PSTX210...370	12,7	27,9
PSTX470	25,5	55,1
PSTX570	27,5	59,5
PSTX720 ...840	46,2	101,4
PSTX1050	64,5	141,1
PSTX1250	65	143,3


### 3.2.5 Softstarter ratings

**PSTX30...1250** Temp ≤ + 40 °C (104 °F), 4 \* I<sub>e</sub> in 10 sec.

IEC	Softstarter type	Order number	I <sub>e</sub> range	Motor power when connected In Line				Motor power when connected Inside Delta				Rated current I <sub>e</sub>	
				220-230V	380-400V	500V	690V	220-230V	380-400V	500V	690V	In Line	Inside Delta
				kW	kW	kW	kW	kW	kW	kW	kW	A	A
PSTX30...105	PSTX30-600-70	1SFA898103R7000	9-30A	7,5	15	18,5		12,5	25	30		30	52
	PSTX30-690-70	1SFA898203R7000	9-30A		15	18,5	25		25	30	45	30	52
	PSTX37-600-70	1SFA898104R7000	11,1-37A	9	18,5	22		15	30	37		37	64
	PSTX37-690-70	1SFA898204R7000	11,1-37A		18,5	22	30		30	37	55	37	64
	PSTX45-600-70	1SFA898105R7000	13,5-45A	12,5	22	25		25	37	45		45	76
	PSTX45-690-70	1SFA898205R7000	13,5-45A		22	25	37		37	45	59	45	76
	PSTX60-600-70	1SFA898106R7000	18-60A	15	30	37		30	55	75		60	105
	PSTX60-690-70	1SFA898206R7000	18-60A		30	37	55		55	75	90	60	105
	PSTX72-600-70	1SFA898107R7000	21,6-72A	18,5	37	45		37	59	80		72	124
	PSTX72-690-70	1SFA898207R7000	21,6-72A		37	45	59		59	80	110	72	124
	PSTX85-600-70	1SFA898108R7000	25,5-85A	22	45	55		40	75	90		85	147
	PSTX85-690-70	1SFA898208R7000	25,5-85A		45	55	75		75	90	132	85	147
PSTX142-170	PSTX105-600-70	1SFA898109R7000	31,8-106A	30	55	75		55	90	110		106	181
	PSTX105-690-70	1SFA898209R7000	31,8-106A		55	75	90		90	110	160	106	181
	PSTX142-600-70	1SFA898110R7000	42,9-143A	37	75	90		75	132	160		143	245
	PSTX142-690-70	1SFA898210R7000	42,9-143A		75	90	132		132	160	220	143	245
PSTX210...370	PSTX170-600-70	1SFA898111R7000	51,3-171A	45	90	110		90	160	200		171	300
	PSTX170-690-70	1SFA898211R7000	51,3-171A		90	110	160		160	200	257	171	300
	PSTX210-600-70	1SFA898112R7000	63-210A	59	110	132		102	184	250		210	360
	PSTX210-690-70	1SFA898212R7000	63-210A		110	132	184		184	250	315	210	360
PSTX210...370	PSTX250-600-70	1SFA898113R7000	75-250A	75	132	160		132	220	295		250	430
	PSTX250-690-70	1SFA898213R7000	75-250A		132	160	220		220	295	400	250	430
	PSTX300-600-70	1SFA898114R7000	90-300A	90	160	200		160	257	355		300	515
	PSTX300-690-70	1SFA898214R7000	90-300A		160	200	257		257	355	500	300	515
	PSTX370-600-70	1SFA898115R7000	111-370A	110	200	257		200	355	450		370	640
	PSTX370-690-70	1SFA898215R7000	111-370A		200	257	355		355	450	600	370	640
PSTX470...570	PSTX470-600-70	1SFA898116R7000	141-470A	132	250	315		250	450	600		470	814
	PSTX470-690-70	1SFA898216R7000	141-470A		250	315	450		450	600	800	470	814
	PSTX570-600-70	1SFA898117R7000	171-570A	160	315	400		295	540	700		570	987
	PSTX570-690-70	1SFA898217R7000	171-570A		315	400	560		540	700	960	570	987
PSTX720...840	PSTX720-600-70	1SFA898118R7000	216-720A	200	400	500		355	710	880		720	1247
	PSTX720-690-70	1SFA898218R7000	216-720A		400	500	710		710	880	1200	720	1247
	PSTX840-600-70	1SFA898119R7000	252-840A	250	450	600		450	800	1000		840	1455
	PSTX840-690-70	1SFA898219R7000	252-840A		450	600	800		800	1000	1400	840	1455
PSTX1050...1250	PSTX1050-600-70	1SFA898120R7000	315-1050A	315	560	730		500	1000	1250		1050	1810
	PSTX1050-690-70	1SFA898220R7000	315-1050A		560	730	1000		1000	1250	1700	1050	1810
	PSTX1250-600-70	1SFA898121R7000	375-1250A	400	710	880		670	1200	1500		1250	2160
	PSTX1250-690-70	1SFA898221R7000	375-1250A		710	880	1200		1200	1500	2000	1250	2160

1) All data for 40 °C ambient. Above 40 °C (104 F) up to max. 40 °C (140 F) reduce the rated current with 0,8% per degree C above 40 °C (0,44% per F).

**PSTX30...1250** Temp ≤ + 40 °C (104 °F), 4 \* Ie in 10 sec.

		Order number	Motor power when connected In Line				Motor power when connected Inside Delta				Rated current Ie	
			208V	220-240V	440-480V	550-600V	208V	220-240V	440-480V	550-600V	In Line	Inside Delta
Softstarter type			hp	hp	hp	hp	hp	hp	hp	hp	A	A
PSTX30...105	PSTX30-600-70	1SFA898103R7000	7,5	10	20	25	10	15	30	40	28	48
	PSTX30-690-70	1SFA898203R7000			20	25			30	40	28	48
	PSTX37-600-70	1SFA898104R7000	10	10	25	30	15	20	40	50	34	58
	PSTX37-690-70	1SFA898204R7000			25	30			40	50	34	58
	PSTX45-600-70	1SFA898105R7000	10	15	30	40	20	25	50	60	42	72
	PSTX45-690-70	1SFA898205R7000			30	40			50	60	42	72
	PSTX60-600-70	1SFA898106R7000	20	20	40	50	30	40	75	100	60	103
	PSTX60-690-70	1SFA898206R7000			40	50			75	100	60	103
	PSTX72-600-70	1SFA898107R7000	20	25	50	60	30	40	75	100	68	117
	PSTX72-690-70	1SFA898207R7000			50	60			75	100	68	117
	PSTX85-600-70	1SFA898108R7000	25	30	60	75	40	50	100	125	80	138
	PSTX85-690-70	1SFA898208R7000			60	75			100	125	80	138
PSTX105-600-70	PSTX105-600-70	1SFA898109R7000	30	40	75	100	60	60	150	150	104	180
	PSTX105-690-70	1SFA898209R7000			75	100			150	150	104	180
PSTX142-170	PSTX142-600-70	1SFA898110R7000	40	50	100	125	75	75	150	200	130	225
	PSTX142-690-70	1SFA898210R7000			100	125			150	200	130	225
	PSTX170-600-70	1SFA898111R7000	50	60	125	150	75	100	200	250	169	292
	PSTX170-690-70	1SFA898211R7000			125	150			200	250	169	292
PSTX210...370	PSTX210-600-70	1SFA898112R7000	60	75	150	200	100	125	250	300	192	332
	PSTX210-690-70	1SFA898212R7000			150	200			250	300	192	332
	PSTX250-600-70	1SFA898113R7000	75	100	200	250	150	150	350	450	248	429
	PSTX250-690-70	1SFA898213R7000			200	250			350	450	248	429
	PSTX300-600-70	1SFA898114R7000	100	100	250	300	150	200	450	500	302	523
	PSTX300-690-70	1SFA898214R7000			250	300			450	500	302	523
	PSTX370-600-70	1SFA898115R7000	125	150	300	350	200	250	500	600	361	625
PSTX370-690-70	PSTX370-690-70	1SFA898215R7000			300	350			500	600	361	625
PSTX470...570	PSTX470-600-70	1SFA898116R7000	150	200	400	500	250	300	600	700	480	830
	PSTX470-690-70	1SFA898216R7000			400	500			600	700	480	830
	PSTX570-600-70	1SFA898117R7000	200	200	500	600	300	350	700	800	590	1020
	PSTX570-690-70	1SFA898217R7000			500	600			700	800	590	1020
PSTX720...840	PSTX720-600-70	1SFA898118R7000	250	300	600	700	400	500	1000	1200	720	1240
	PSTX720-690-70	1SFA898218R7000			600	700			1000	1200	720	1240
	PSTX840-600-70	1SFA898119R7000	300	350	700	800	500	600	1200	1500	840	1450
	PSTX840-690-70	1SFA898219R7000			700	800			1200	1500	840	1450
PSTX1050...1250	PSTX1050-600-70	1SFA898120R7000	400	450	900	1000	600	700	1500	1900	1062	1830
	PSTX1050-690-70	1SFA898220R7000			900	1000			1500	1900	1062	1830
	PSTX1250-600-70	1SFA898121R7000	400	500	1000	1200	800	900	1800	2000	1250	2160
	PSTX1250-690-70	1SFA898221R7000			1000	1200			1800	2000	1250	2160

4 \* Ie in 10 sec

Ordering data according to UL (40°C ambient)

### 3.2.6 Dimensions

#### PSTX30...105

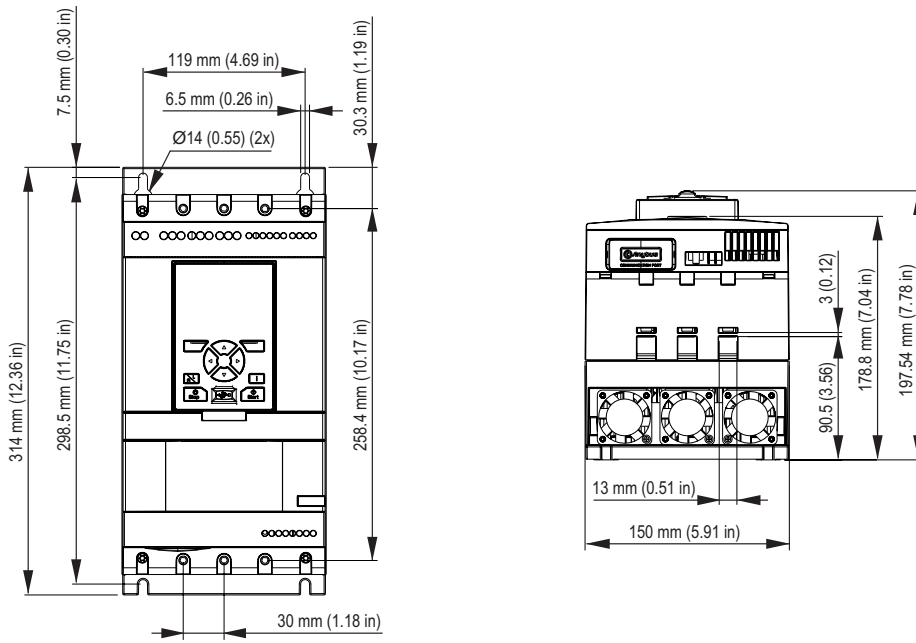


Figure 3.3  
Dimensions PSTX30...105

#### PSTX142...170

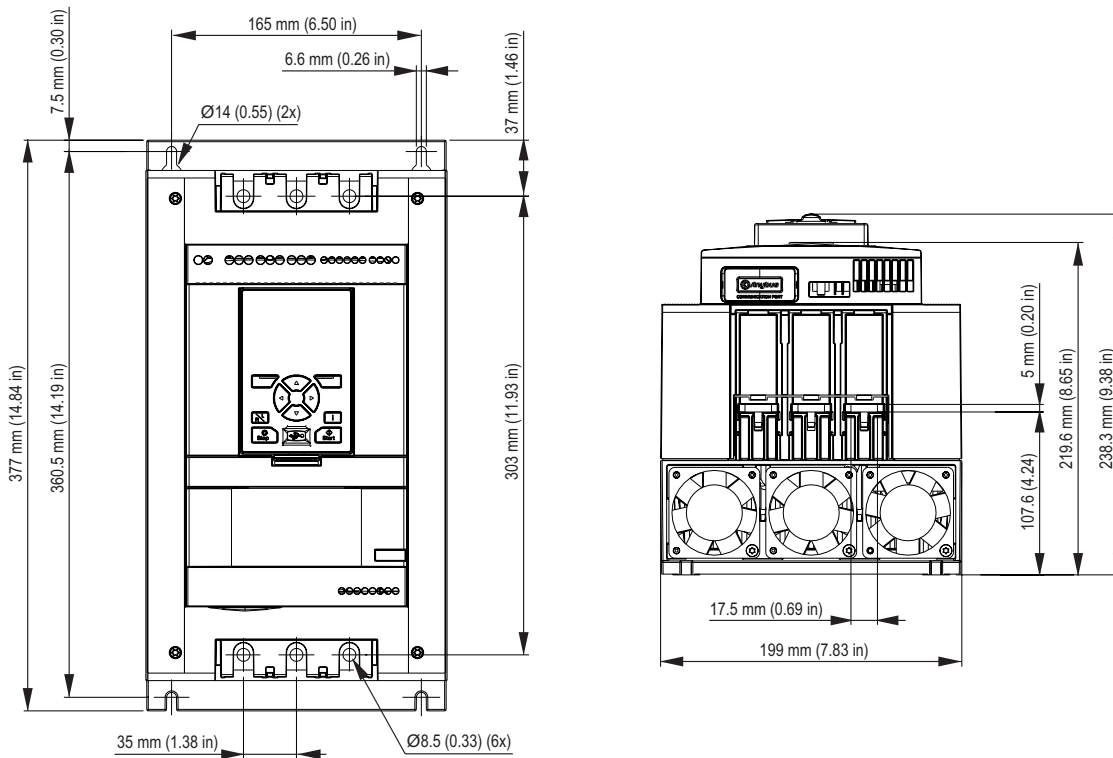


Figure 3.4  
Dimensions PSTX142...170

PSTX210...370

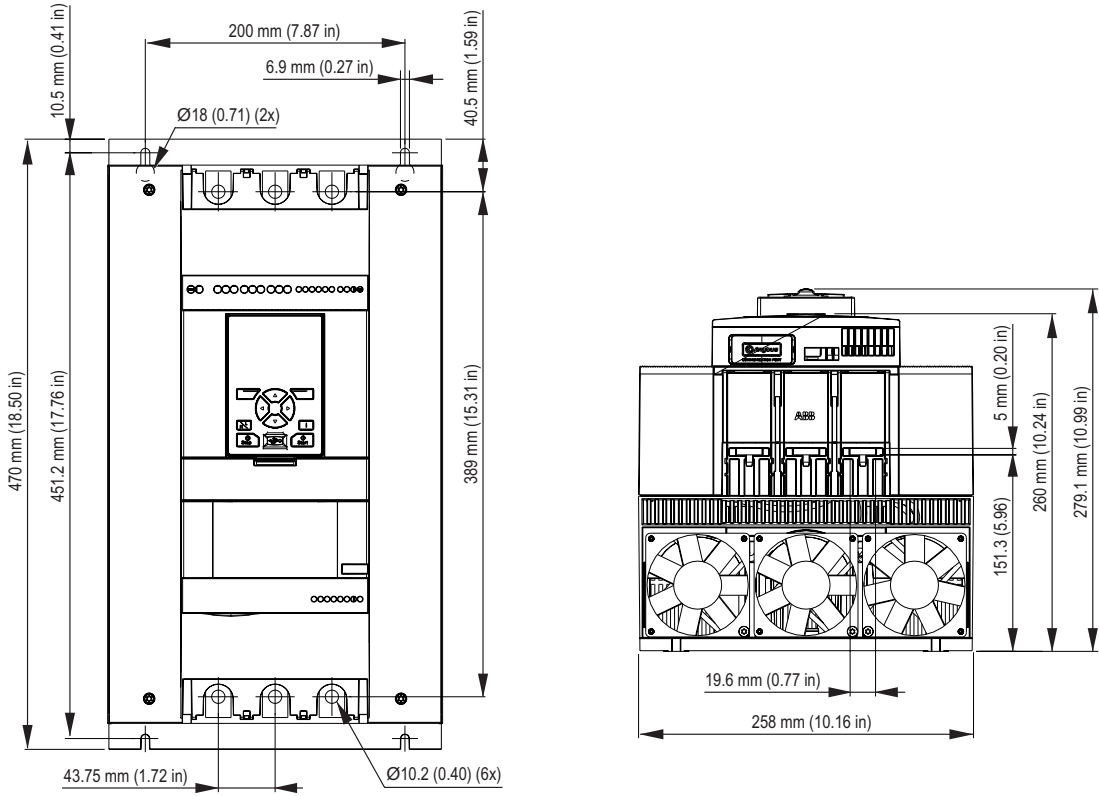


Figure 3.5  
Dimensions PSTX210..370

PSTX470...570

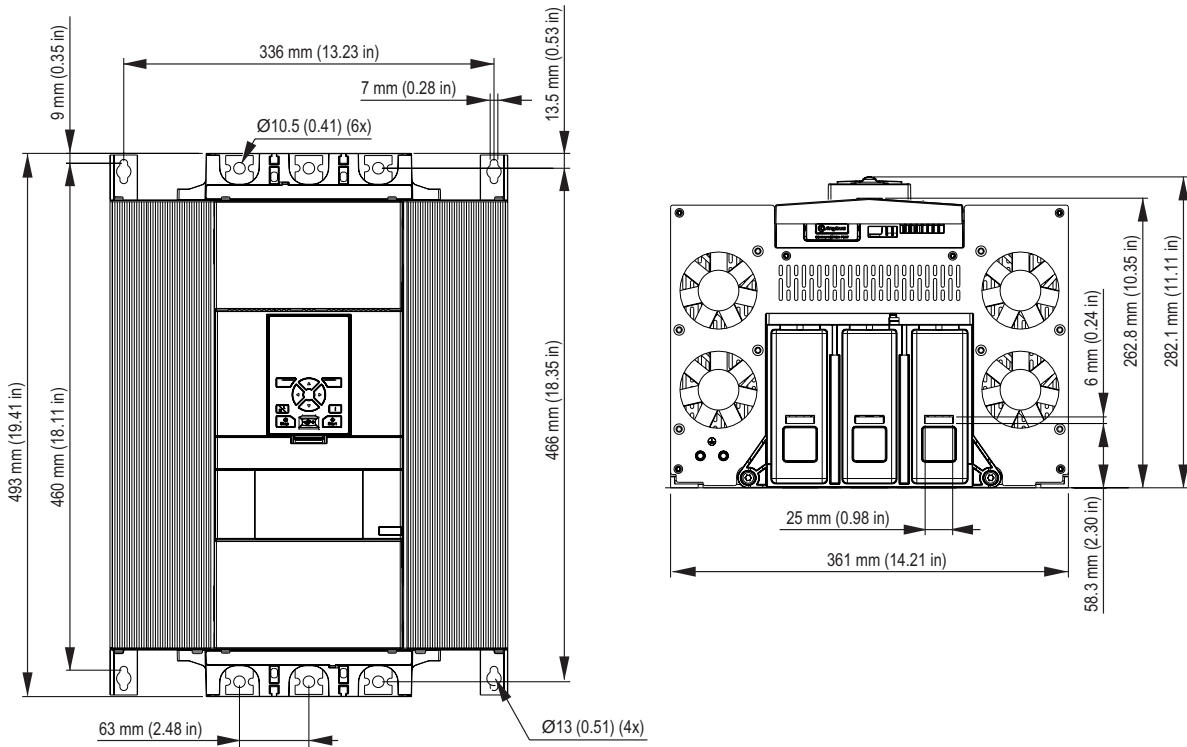


Figure 3.6  
Dimensions PSTX470..570

PSTX720...PSTX840

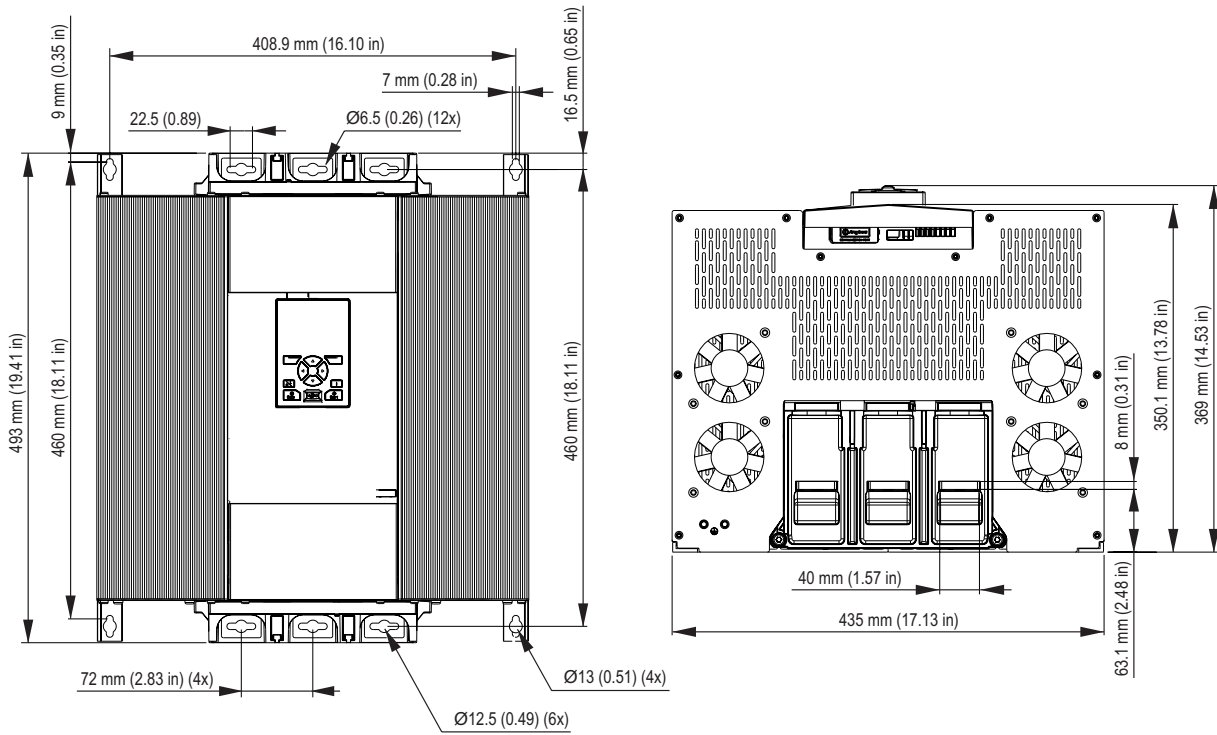


Figure 3.7  
Dimensions PSTX720..840

PSTX1050

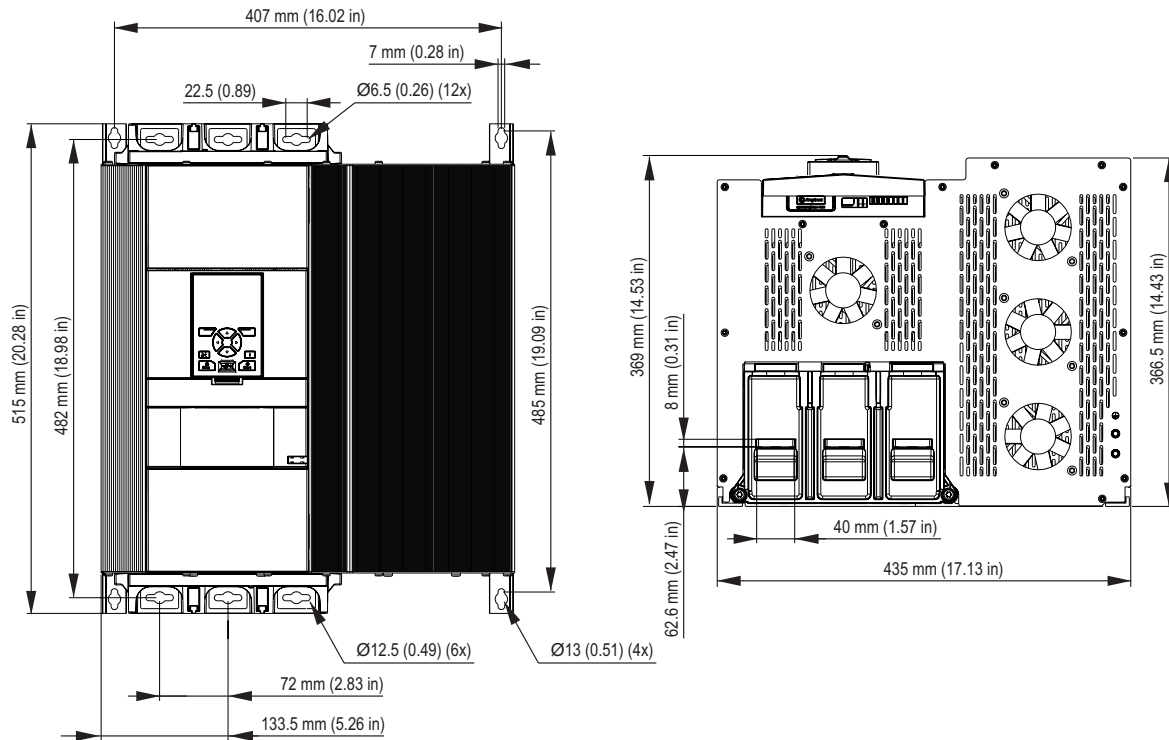


Figure 3.8  
Dimensions PSTX1050

# PSTX1250

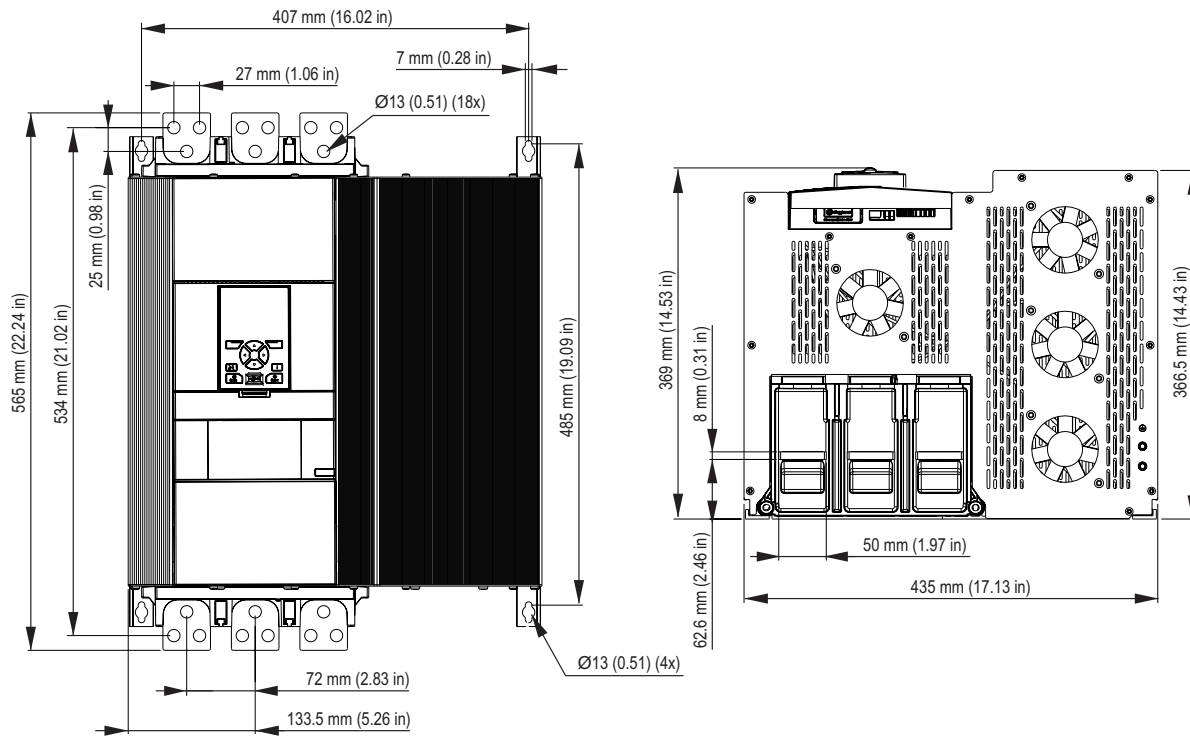


Figure 3.9  
Dimensions PSTX1250

3







# 4 Installation

## 4.1 Receive, unpack and examine

32

## 4.2 Install

33

4.2.1 Lifting the Softstarter ..... 33

4.2.2 Minimum distance to wall/front ..... 33

4.2.3 Minimum enclosure dimensions ..... 34

4.2.4 Maximum installation angle ..... 34

4.2.5 Dimensions and drilling plan ..... 34

4.2.6 Movable keypad ..... 34

4.2.6.1 Installation Movable HMI ..... 35

This chapter contains instructions to receive and install the Softstarter.



**WARNING**

If you do not obey these instructions, it can cause the Softstarter to overheat or not operate correctly.

**4.1 Receive, unpack and examine**



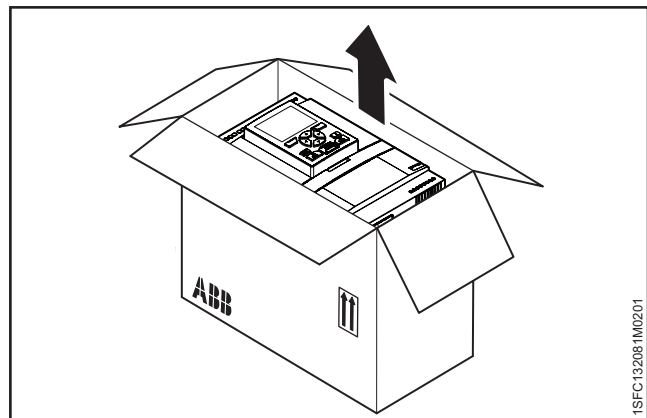
**WARNING**

Risk of damage to property. Make sure that no liquids, dust or conductive parts can go into the Softstarter.

4

Make sure that the package is placed with the correct side up, see **Figure 4.1**.

- Remove the transport casing.
- Make sure that the order code agrees with the delivery documents.
- Make sure that all items are included, see the delivery note. See **Table 1 Delivery note**.
- Examine the Softstarter and the packaging. In case of damages, speak to the transport company or the ABB reseller/Office immediately.
- Keep the Softstarter in its packaging until installation.



**Figure 4.1**  
Receiving, unpacking and checking

**Table 1** Delivery note

Softstarter type	Items included with the Softstarter
PSTX30...105	<ul style="list-style-type: none"> <li>• 1SFB262001D1000 – HMI Mounting Kit</li> <li>• 1SFC132082M9901 – PSTX Short Form Manual</li> </ul>
PSTX142...170	<ul style="list-style-type: none"> <li>• 1SFB262001D1000 – HMI Mounting Kit</li> <li>• 1SFC132082M9901 – PSTX Short Form Manual</li> <li>• 1SFA899221R1002 – Terminal Kit # PSLE-185</li> </ul>
PSTX210...370	<ul style="list-style-type: none"> <li>• 1SFB262001D1000 – HMI Mounting Kit</li> <li>• 1SFC132082M9901 – PSTX Short Form Manual</li> <li>• 1SFA899221R1003 – Terminal Kit # PSLE-300</li> </ul>
PSTX470...570	<ul style="list-style-type: none"> <li>• 1SFB262001D1000 – HMI Mounting Kit</li> <li>• 1SFC132082M9901 – PSTX Short Form Manua</li> <li>• 1SFA899221R1004 - Terminal Kit # PSLE-460I</li> <li>• 2191323-A - Mounting kit</li> </ul>
PSTX720...840	<ul style="list-style-type: none"> <li>• 11SFB262001D1000 – HMI Mounting Kit</li> <li>• 1SFC132082M9901 – PSTX Short Form Manual</li> <li>• 1SFA899221R1005 - Terminal Kit#PSLE-750</li> <li>• 2191323-A - Mounting kit</li> </ul>
PSTX1050...1250	<ul style="list-style-type: none"> <li>• 11SFB262001D1000 – HMI Mounting Kit</li> <li>• 1SFC132082M9901 – PSTX Short Form Manual</li> <li>• 1SFA899221R1005 - Terminal Kit#PSLE-750</li> <li>• 2191323-A - Mounting kit</li> </ul>

## 4.2 Install

The Softstarters are available in different physical sizes and all of them should be mounted with M6 bolts, or bolts with the same dimension and strength.

### 4.2.1 Lifting the Softstarter

Use lifting equipment to install the models PSTX470...1250. See chapter **3.2.4 Weights**, for weights. You can install the PSTX30...370 without lifting equipment

### 4.2.2 Minimum distance to wall/front



#### WARNING

Risk of damage to property. Make sure that no liquids, dust or conductive parts enter the Softstarter.



#### WARNING

If you do not obey these instructions, this can cause the Softstarter to overheat or not operate correctly.

For sufficient cooling, install the Softstarter vertically. Perfect blockage of the airways, see **Figure 4.2**.

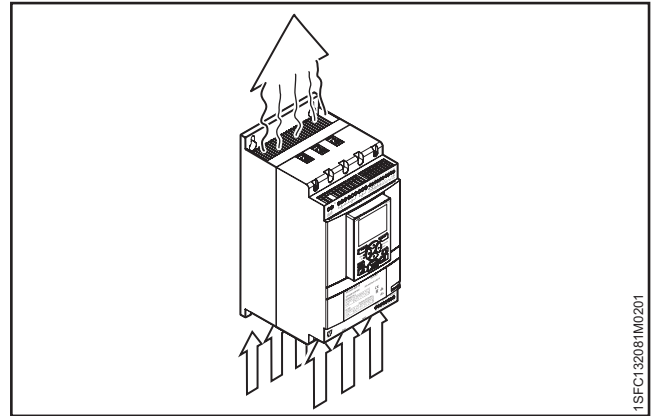


#### INFORMATION

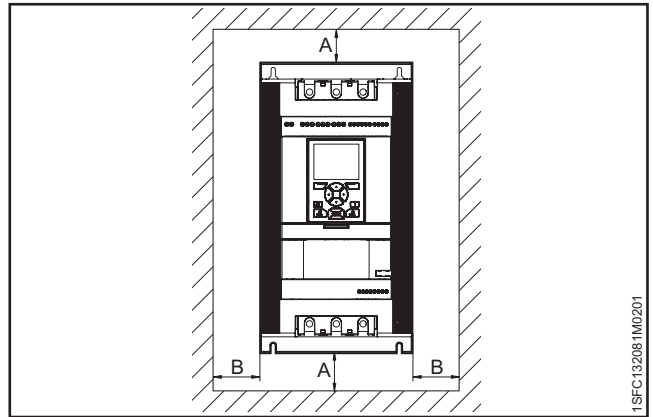
Make sure that the distances to the surrounding walls are sufficient. For the minimum distance to front and wall, see **Figure 4.3**, **Figure 4.4** and **Table 2**.

**Table 2** Minimum distance to wall/front

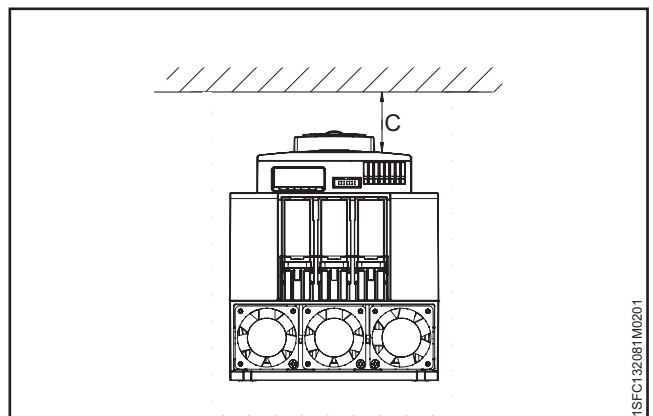
Softstarter type	A (mm)	B (mm)	C (mm)	A (in)	B (in)	C (in)
PSTX30...105	100	10	35	3.94	0.39	1.38
PSTX142...170	100	10	35	3.94	0.39	1.38
PSTX210...370	100	10	35	3.94	0.39	1.38
PSTX470...570	150	15	35	5.905	0.590	1.38
PSTX720...840	150	15	35	5.905	0.590	1.38
PSTX1050...1250	150	15	35	5.905	0.590	1.38



**Figure 4.2**  
Flow of air for cooling purpose



**Figure 4.3**  
Minimum distances to wall



**Figure 4.4**  
Minimum distances to front

### 4.2.3 Minimum enclosure dimensions

In applications where the Softstarter is installed in an enclosure, use these minimum enclosure dimensions. See **Figure 4.5** and **Table 3** and **4**.

**Table 3** Minimum enclosure dimensions (IEC)

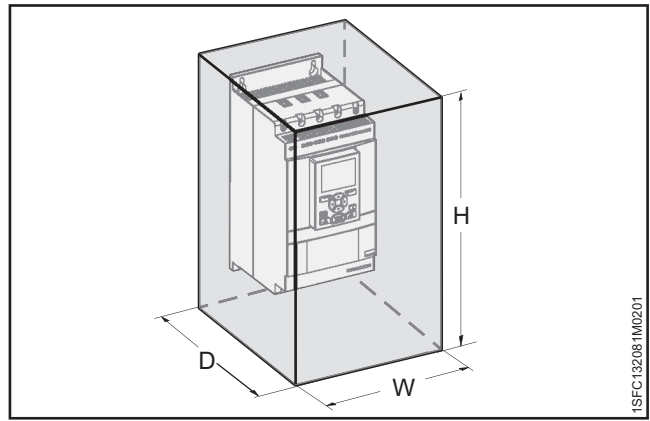
IEC	Minimum enclosure dimensions		
	Softstarter type	W (mm)	H (mm)
PSTX30...105	508	508	305
PSTX142...170	508	508	305
PSTX210...370	762	914	305
PSTX470...570	914	1219	405
PSTX720...840	914	1524	405
PSTX1050...1250*	914	1524	405

\*) PSTX1250 Recommended fan capacity 230m3/h

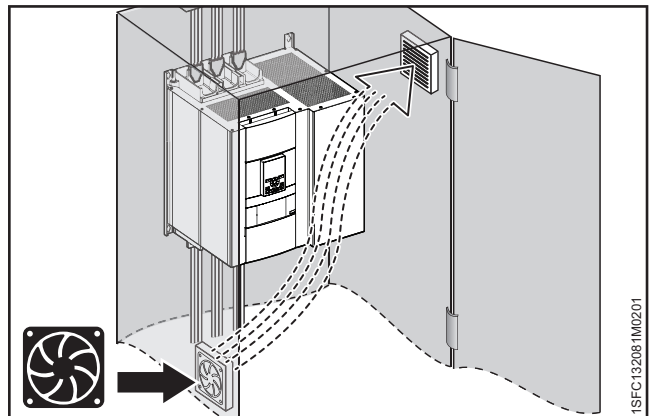
**Table 4** Minimum enclosure dimensions (UL)

cULus	Minimum enclosure dimensions			
	Softstarter type	W (in)	H (in)	D (in)
PSTX30...105	20	20	10	2
PSTX142...170	20	20	12	2
PSTX210...370	30	24	12	7
PSTX470...570	36	48	16	8
PSTX720...840	36	60	16	8
PSTX1050...1250*	36	60	16	8

\*) PSTX1250 Recommended fan capacity 230m3/h



**Figure 4.5**  
Minimum enclosure size



**Figure 4.6**  
Airflow

### 4.2.4 Maximum installation angle

**i** Make sure that the distances to the walls are sufficient. Use the installation angle given in **Figure**.

### 4.2.5 Dimensions and drilling plan

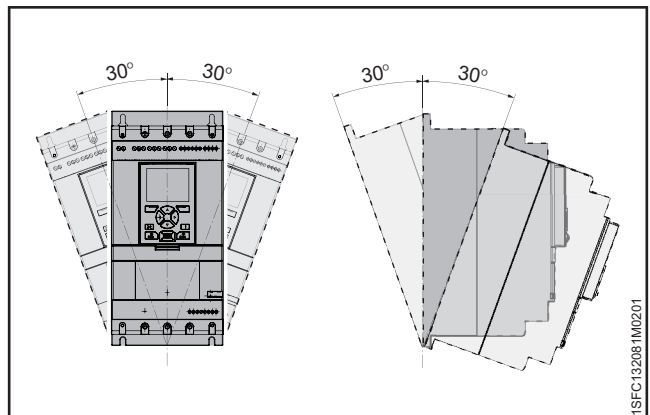
For dimensions and drilling plan see chapter **3.2.6 Dimensions**. Drilling plan is also printed on the box.

**⚠ WARNING**  
Risk of damage to property. Ensure that no liquids, drilling particles, dust or conductive parts enter the Softstarter.

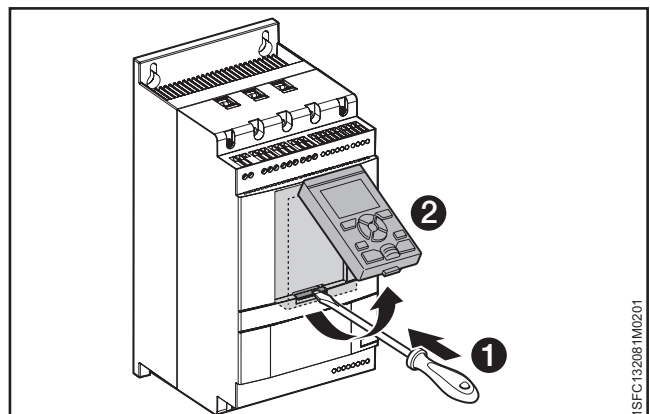
**⚠ WARNING**  
When the enclosure is too small and/or you do not obey the instructions, the Softstarter can overheat or not operate correct.

### 4.2.6 Movable keypad

If you remove the PSTX keypad, connect it with the included 3 meter cable for serial communication and power supply. Connect the cable to the network port on the front of the Softstarter. To remove the keypad, push the lock with a screwdriver, see **1** and **2** in **Figure 4.8**.



**Figure 4.7**  
Maximum mounting angle



**Figure 4.8**  
Detach the keypad

#### 4.2.6.1 Installation Movable HMI



##### INFORMATION

Do not use shielded RJ45 cables. Use a cable length of maximum 3m to reduce distortion of the communication.



##### INFORMATION

The Softstarter HMI is IP66 approved when installed on the enclosure door.

You can use the movable HMI to copy parameters from one Softstarter to another during commissioning (temporarily handheld).

Included with the Softstarter comes:

- Rubber gasket
- Plastic screw-nut
- RJ45 Network cable

1. To remove the movable HMI from the Softstarter, loosen the plastic latch below the movable HMI, see **1** and **2** in **Figure 4.9**.
2. Drill a hole where to attach the movable HMI. Maximum dimension of the hole is  $\varnothing 26$  ( $\varnothing 1.02$ " ), see **1** in **Figure 4.9**. Put the rubber packing around the threaded network connector on the movable HMI, see **2** in **Figure 4.9**. Push the threaded network connector through the drilled hole. See **3** in **Figure 4.9**. Fasten the plastic screw-nut on the threaded network connector, with 2 Nm (17.7 lb/in).
3. Remove the RJ45 plug see **4**. Connect one end of the network cable to the network port on the front of the Softstarter **5** in **Figure 4.10**.
4. Connect the other end of the network cable to the network port on the back of the movable HMI, see **6** in **Figure 4.11**.
5. Make sure that the network cable is properly inserted into the 2 ports. Prevent the rest of the cable to get caught between the door, see **7** in **Figure 4.12**. Close the door of the enclosure and set the operation voltage switch to ON. Make sure that the external HMI works.

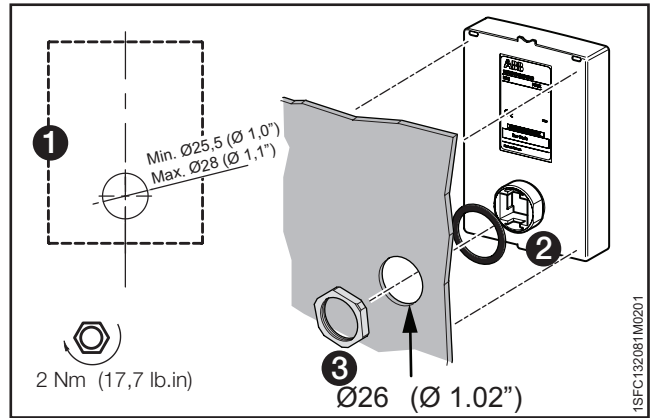


Figure 4.9

Drill a hole for the detachable keypad

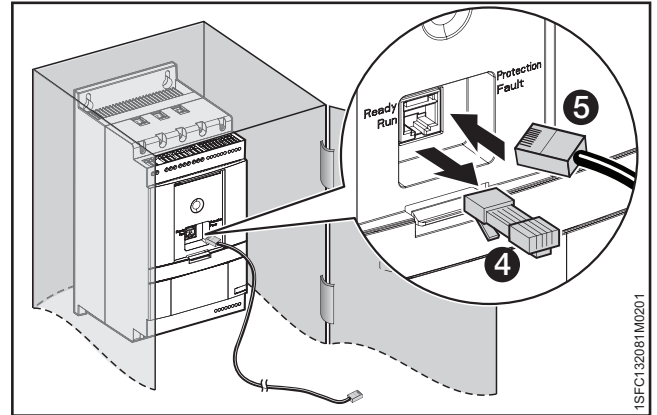


Figure 4.10

Connect one end of the network cable

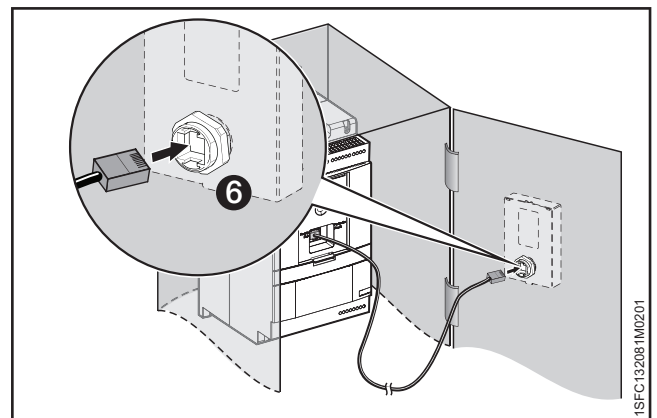


Figure 4.11

Connect the other end of the network cable

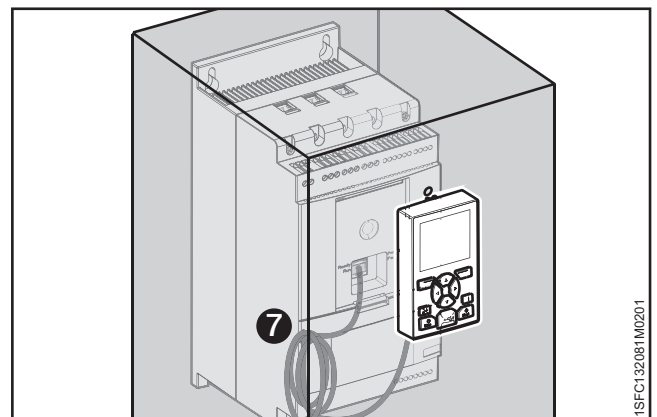


Figure 4.12

Roll the rest of the hanging cable





# 5 Connection

## 5.1 Electrical connection

	38
5.1.1 Main circuit	38
5.1.1.1 Tightening torques and cable dimensions	39
5.1.1.2 Softstarter connections	39
5.1.2 Control supply and control circuit	40
5.1.2.1 Control supply voltage - terminals 1 and 2	40
5.1.2.2 Functional ground - terminal 22	40
5.1.2.3 Start and Stop - terminals 13, 14, 18, 19, 20, 21	41
5.1.2.4 Programmable inputs - terminals 15, 16 and 17	43
5.1.2.5 Programmable inputs (Sequence start)	44
5.1.2.6 Programmable output relay - K4, terminals 4, 5 and 6	45
5.1.2.7 Programmable output relay - K5, terminals 7, 8 and 9	45
5.1.2.8 Programmable output relay - K6, terminals 10, 11 and 12	45
5.1.2.9 Close bypass PSTX470...PSTX1250	46
5.1.2.10 Modbus RTU	46
5.1.2.11 Temperature sensor input	47
5.1.2.12 Analog output	48
5.1.3 Extension I/O	49

This chapter gives a description of the electrical connections and connections for communication devices.



**WARNING**

Installation of electrical connections must be done by authorized personnel. Obey all laws and regulations.



**WARNING**

Dangerous voltage. Can cause death or serious injury. Always set the power switch to off and lock out all power to this device before you start to work on the equipment.



**WARNING!**

Before you connect the Softstarters PSTX30...PSTX170 to the operation voltage for the first time, apply control supply voltage to open the bypass relays. (see 2.1 Connection). This is necessary to avoid an accidental start of the equipment while it is connected to operation voltage.



**INFORMATION**

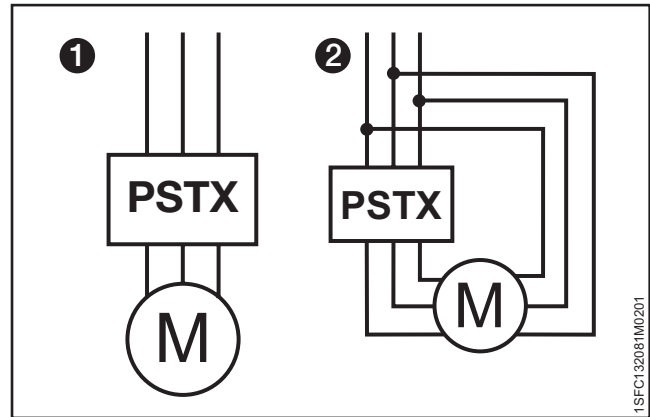
ABB personnel must obey the instructions in **ABB CISE 15.4**.

For basic connection, see chapter 2 **Quick start**.  
For wiring diagrams, see chapter 11 **Wiring and application diagrams**.

Softstarters PSTX30...PSTX1250 can be connected In Line, see **1** **Figure 5.1**, and Inside Delta, see **2** **Figure 5.1**. Use wire connection for PSTX30...105 see **Figure 5.2** Terminal connection for PSTX142...1250 see **Figure 5.3**.

- Connect the line side to terminals 1L1, 3L2, 5L3, see **1** in **Figure 5.2** and **Figure 5.3**.
- Connect the motor to terminals 2T1, 4T2, 6T3 on the motor side, see **2** in **Figure 5.2** and **Figure 5.3**.

The terminal marking is printed on the front of the Softstarter. For tightening torques and cable thickness, see chapter **5.1.1.1 Tightening torques and cable dimensions**.



**Figure 5.1**  
In line (1) and inside delta (2) connection

**5.1 Electrical connection**



**WARNING**

Capacitors for power factor compensation are not permitted in between the Softstarter and the motor, because this can cause current peaks which can burn the thyristors in the Softstarter. If you must use such capacitors, connect them on the line side of the Softstarter.

**5.1.1 Main circuit**

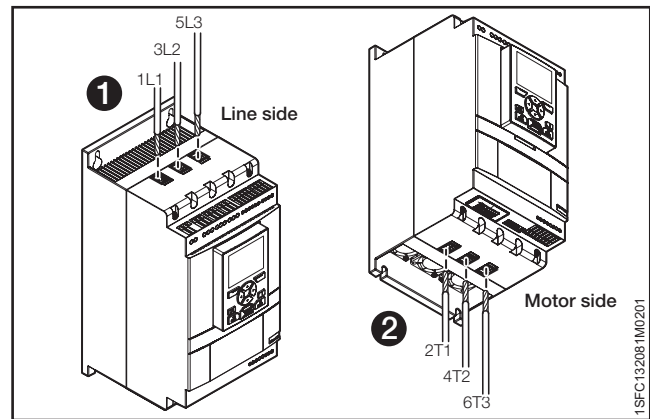


**INFORMATION**

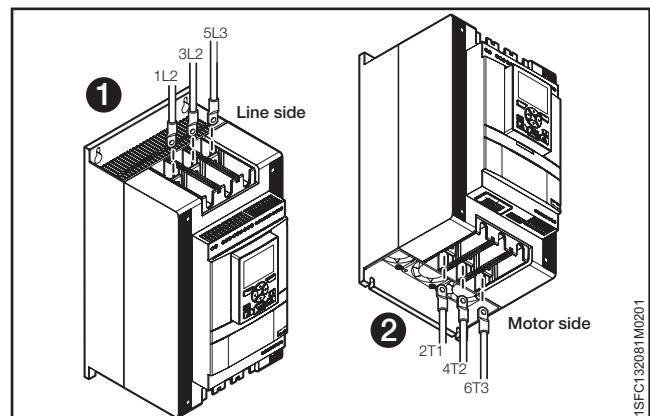
From the softstarter perspective, there are no specific restrictions when it comes to motor cable lengths except from the implications that comes from using long cables which include the quality of the voltage, the current and the phase angle between them. An incorrect phase angle may reduce the efficiency of the motor and long cables can reduce the phase angle so that the load becomes capacitive.

PSTX can control a motor as long as the load is inductive or resistive, but not capacitive. The other thing to consider is the voltage drop that may occur when using long motor cables. A voltage drop can impact both the current draw and the motor power.

The maximum allowed voltage drop should be 5%.



**Figure 5.2**  
Clamp connection



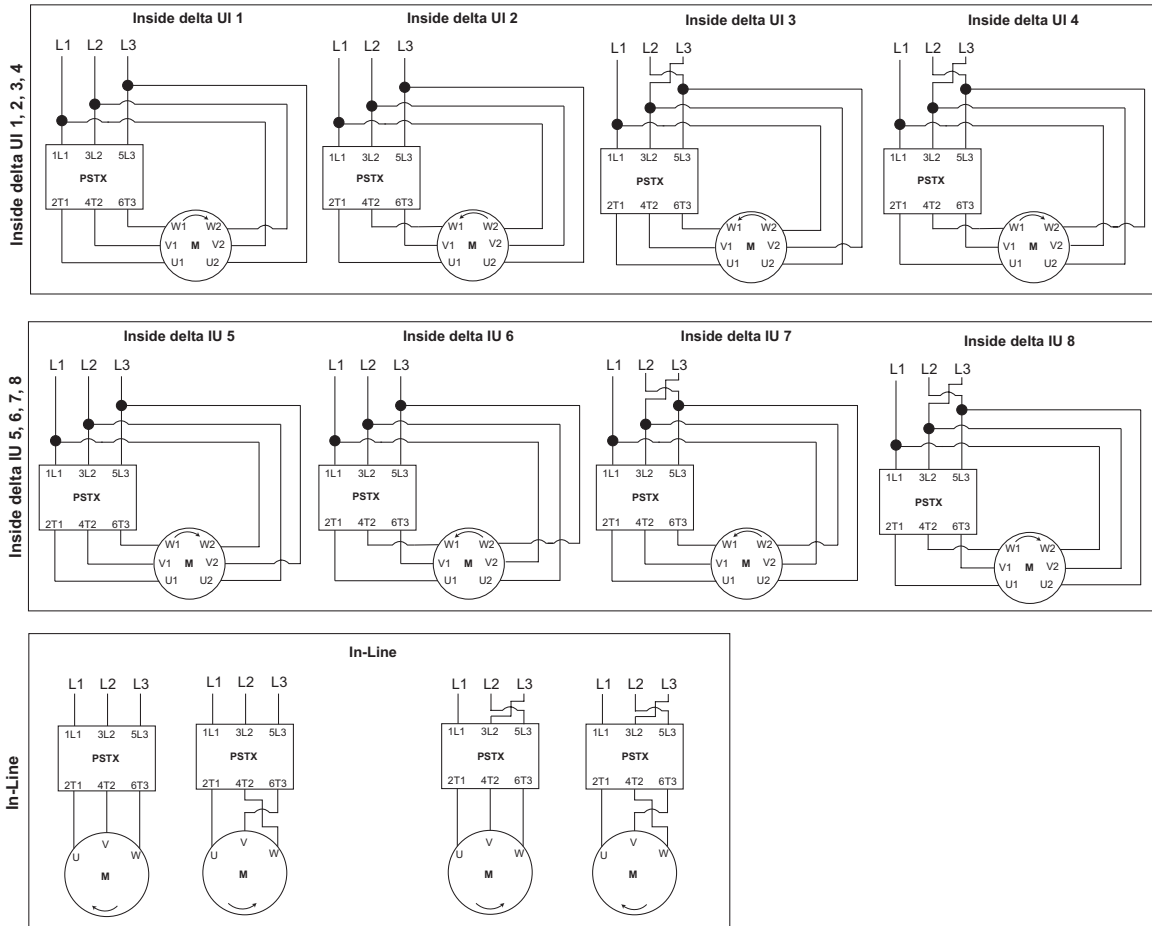
**Figure 5.3**  
Terminal connection bar

### 5.1.1.1 Tightening torques and cable dimensions

<b>PSTX30...105</b>   <b>8 Nm - 71 lb.in</b>	<b>Using built-in clamp</b> AWG6 ... 2/0 Cu 75 °C only Rigid: 10 ... 95 mm <sup>2</sup> Flexible: 10 ... 70 mm <sup>2</sup> Rigid/flexible: 2x6 ... 2x35 mm <sup>2</sup>	<b>M8</b> <b>18 Nm - 160 lb.in</b> 
<b>PSTX142...170</b>   <b>275 lb.in</b>	<b>Using cable clamp/lug</b> ATK185: AWG4 to 300kcmil   Cu 75 °C only	<b>M10</b> <b>28 Nm - 240 lb.in</b> 
<b>PSTX210...370</b>   <b>375 lb.in</b>	<b>Using cable clamp/lug</b> ATK300: AWG4 to 400kcmil   ATK300/2: AWG4 to 500kcmil or 2xAWG4 to 2x500kcmil   Cu 75 °C only	<b>M10</b> <b>35 Nm - 310 lb.in</b> 
<b>PSTX470...570</b>   <b>275 lb.in</b>  <b>375 lb.in</b>	<b>Using cable clamp/lug</b> ATK580/2: 2xAWG2/0 to 2x500 kcmil ATK750/3: 3xAWG2/0 to 3x500 kcmil CU 75 °C only	<b>M12</b> <b>45 Nm - 398 lb.in</b> 
<b>PSTX720...840</b>   <b>275 lb.in</b>  <b>375 lb.in</b>	<b>Using cable clamp/lug</b> ATK580/2: 2xAWG2/0 to 2x500 kcmil ATK750/3: 3xAWG2/0 to 3x500 kcmil CU 75 °C only	<b>M12</b> <b>45 Nm - 398 lb.in</b> 
<b>PSTX1050...1250</b>   <b>45 Nm - 398 lb.in</b>	<b>Using bars</b> 1x 40 mm (1.57 in) + 2x 50 mm (1.96 in) 5 mm (0.19 in) + 6 mm (0.23 in)	<b>M12</b> <b>45 Nm - 398 lb.in</b> 

1SFC132081M0201

### 5.1.1.2 Softstarter connections



## 5.1.2 Control supply and control circuit

Wires in industrial control applications are divided into 3 groups: main power supply, control supply and control circuit.

Main power supply (1L1, 3L2, 5L3, 2T1, 4T2, 6T3)

Control supply voltage (terminals 1 and 2)

Control circuit (terminals 13 - 21).

### 5.1.2.1 Control supply voltage - terminals 1 and 2

Connect neutral and phase to terminal 1 and 2.

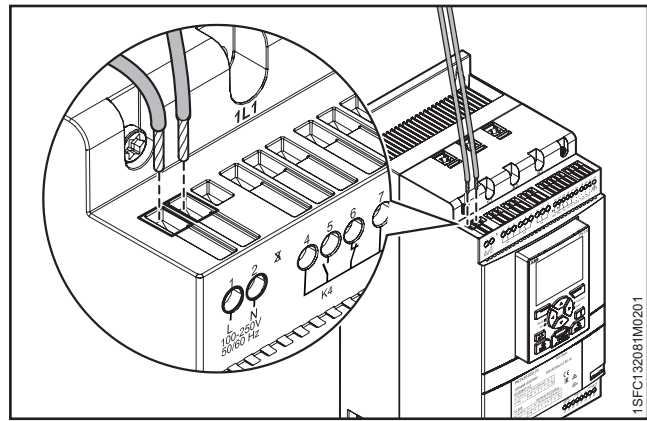
See **Figure 5.4**.

#### **i** INFORMATION

Make sure that you have the correct supply voltage  $U_s$ . See chapter **3.2.1 General**.

The control supply voltage for all PSTX Softstarters is  $U_s$  100-250V AC, 50/60Hz.

If using the operational voltage (Phase /N) as source for control voltage make sure to not exceed  $U_s$  250V –AC, 50/60Hz



**Figure 5.4**

Supply voltage and control circuit

5

Tightening torques and cable dimensions.

	<p>M3.5 0,5 Nm 4,3 lb.in</p>	<p>3,5 x 0,6 mm (0.138 x 0.024 in)</p>	<p>AWG 12 ... 24 0,2 .. 2,5 mm<sup>2</sup> 2x0,2 .. 1,5 mm<sup>2</sup> 0,2 .. 2,5 mm<sup>2</sup> 2x0,2 .. 1,5 mm<sup>2</sup></p>
--	--------------------------------------	--	--

### 5.1.2.2 Functional ground - terminal 22

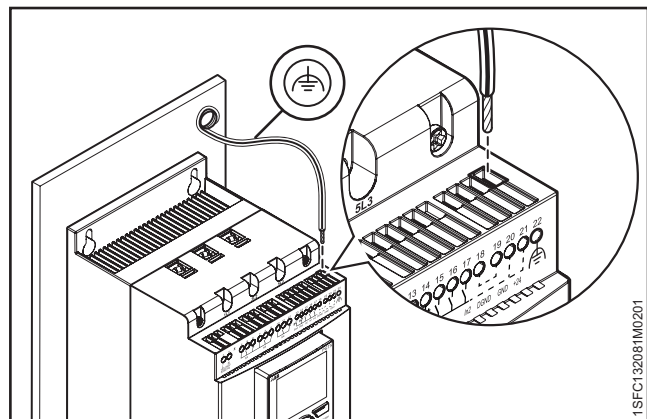
Ground the Softstarters with the terminals as shown in **Figure 5.5** (one connection is sufficient). Connect the cable to a ground point close to the Softstarter. A suitable ground point is next to the Softstarter on the installation plate. Ground the installation plate.

#### **i** INFORMATION

This is not a protective ground, it is a function ground. The grounding cable must be as short as possible. Maximum length 0,5m.

#### **i** INFORMATION

Do not use functional ground in IT-networks, commonly found in for instance marine applications.



**Figure 5.5**

Functional ground, terminal 22

Tightening torques and cable dimensions.

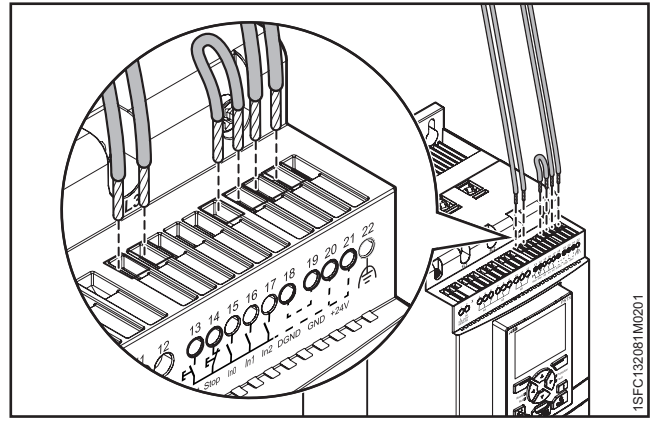
	<p>M3 0,5 Nm 4,3 lb.in</p>	<p>3,5 x 0,6 mm (0.138 x 0.024 in)</p>	<p>AWG 12 ... 24 0,2 .. 2,5 mm<sup>2</sup> 2x0,2 .. 1,5 mm<sup>2</sup> 0,2 .. 2,5 mm<sup>2</sup> 2x0,2 .. 1,5 mm<sup>2</sup></p>
--	------------------------------------	--	--

### 5.1.2.3 Start and Stop - terminals 13, 14, 18, 19, 20, 21

#### Internal control voltage

The PSTX Softstarter has a built-in holding circuit and does not require sustained signals on start input. Use internal control supply voltage from terminals 20 or 21.

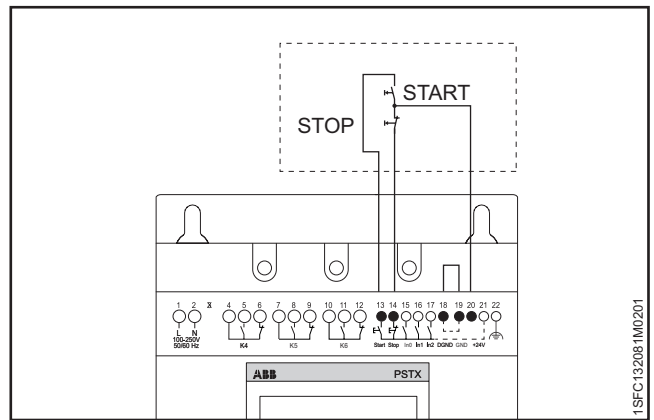
Connect start and stop terminals using conventional circuit with push buttons. See **Figure 5.6** and **Figure 5.7**.



**Figure 5.6**  
Start and Stop, terminals 13, 14, 18, 19, 20, 21

Tightening torques and cable dimensions.

	<p>0,5 Nm 4,3 lb.in</p>	<p>3,5 x 0,6 mm (0.138 x 0.024 in)</p>	<p>AWG 12 ... 24</p> <p>0,2 .. 2,5 mm<sup>2</sup> 2x0,2 .. 1,5 mm<sup>2</sup></p> <p>0,2 .. 2,5 mm<sup>2</sup> 2x0,2 .. 1,5 mm<sup>2</sup></p>
--	-----------------------------	--	--

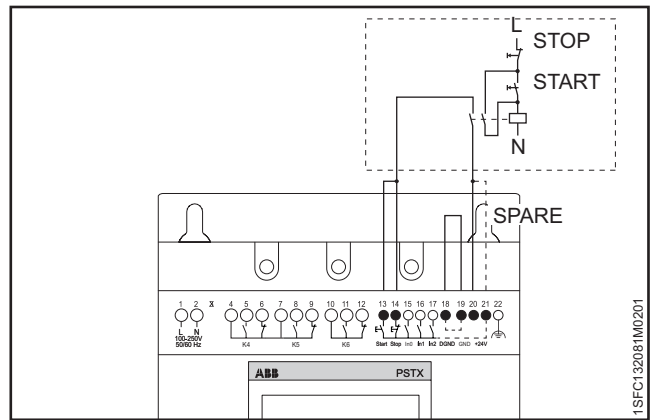


**Figure 5.7**  
Holding circuit (pulse for start is enough)

Tightening torques and cable dimensions.

	<p>0,5 Nm 4,3 lb.in</p>	<p>3,5 x 0,6 mm (0.138 x 0.024 in)</p>	<p>AWG 12 ... 24</p> <p>0,2 .. 2,5 mm<sup>2</sup> 2x0,2 .. 1,5 mm<sup>2</sup></p> <p>0,2 .. 2,5 mm<sup>2</sup> 2x0,2 .. 1,5 mm<sup>2</sup></p>
--	-----------------------------	--	--

A conventional circuit with auxiliary relay is also possible. See **Figure 5.8**.



**Figure 5.8**  
Conventional circuit (maintained start signal required)

Tightening torques and cable dimensions.

	<p>0,5 Nm 4,3 lb.in</p>	<p>3,5 x 0,6 mm (0.138 x 0.024 in)</p>	<p>AWG 12 ... 24</p> <p>0,2 .. 2,5 mm<sup>2</sup> 2x0,2 .. 1,5 mm<sup>2</sup></p> <p>0,2 .. 2,5 mm<sup>2</sup> 2x0,2 .. 1,5 mm<sup>2</sup></p>
--	-----------------------------	--	--

## External control voltage

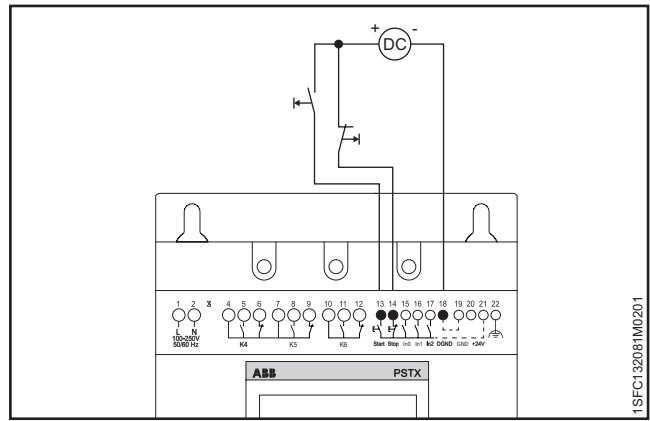
You can control the Softstarter with an external 24 V DC source from a PLC or similar, if necessary.

Connect the cables. See **Figure 5.9** to use the internal holding circuit, or **Figure 5.10** to use an external holding circuit.

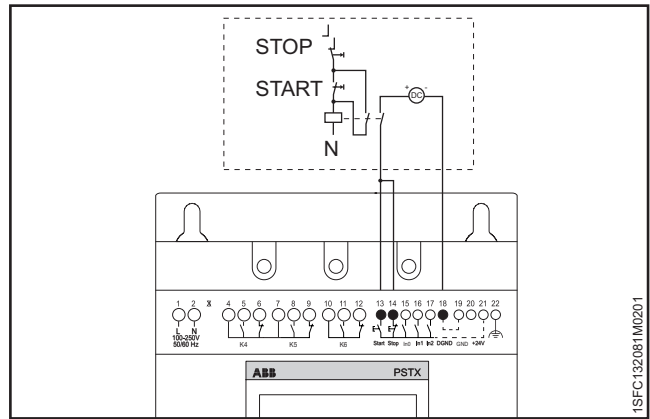


### WARNING

Use only 24 V DC to connect terminal 13, 14, 15, 16 and 17. Other voltages can damage the Softstarter and the warranty will no longer be valid.



**Figure 5.9**  
Holding circuit with external control voltage  
(pulse for start is enough)



**Figure 5.10**  
Conventional circuit with external control voltage  
(maintained start signal is required)

Tightening torques and cable dimensions.

	<p>M3 0,5 Nm 4,3 lb.in</p>	<p>3,5 x 0,6 mm (0.138 x 0.024 in)</p>	<p>AWG 12 ... 24</p> <p>0,2 .. 2,5 mm<sup>2</sup> 2x0,2 .. 1,5 mm<sup>2</sup></p> <p>0,2 .. 2,5 mm<sup>2</sup> 2x0,2 .. 1,5 mm<sup>2</sup></p>
--	------------------------------------	--	--

1SFC132081M0201

### 5.1.2.4 Programmable inputs - terminals 15, 16 and 17



#### WARNING

Use only 24 V DC to connect terminal 13, 14, 15, 16 and 17. Other voltages can damage the Softstarter and the warranty will no longer be valid.

The Softstarter has 3 programmable inputs.

- In0, default reset event.
- In1, default none
- In2, default none

For programming the Softstarter inputs, see chapter 7.14 **Inputs/outputs**.

Connect the cables, see **Figure 5.11**, and **Figure 5.12** to use the internal control supply voltage, or **Figure 5.11** and **Figure 5.13** to use an external source.



#### INFORMATION

Connections for sequence start, see chapter 5.1.2.5 **Programmable inputs (Sequence start)**

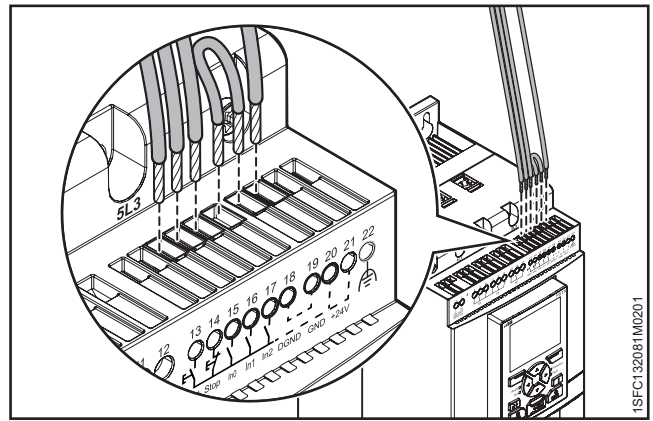


Figure 5.11  
Terminals 16 and 17

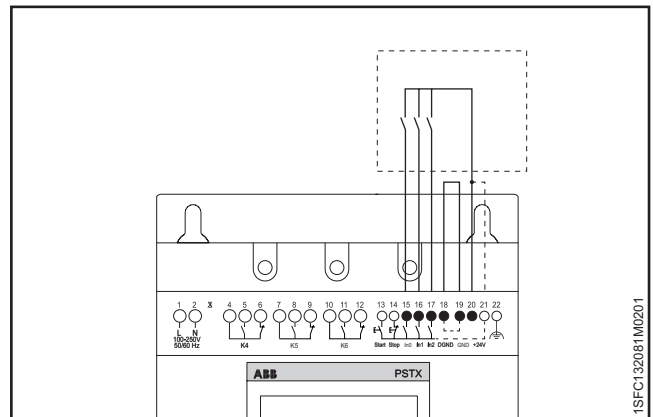


Figure 5.12  
Programmable inputs, terminals 15, 16 and 17

Tightening torques and cable dimensions.

	<p>M3</p> <p>0,5 Nm 4,3 lb.in</p>	<p>3,5 x 0,6 mm (0.138 x 0.024 in)</p>	<p>AWG 12 ... 24</p> <p>0,2 .. 2,5 mm<sup>2</sup> 2x0,2 .. 1,5 mm<sup>2</sup> 0,2 .. 2,5 mm<sup>2</sup> 2x0,2 .. 1,5 mm<sup>2</sup></p>
--	---------------------------------------	--	---

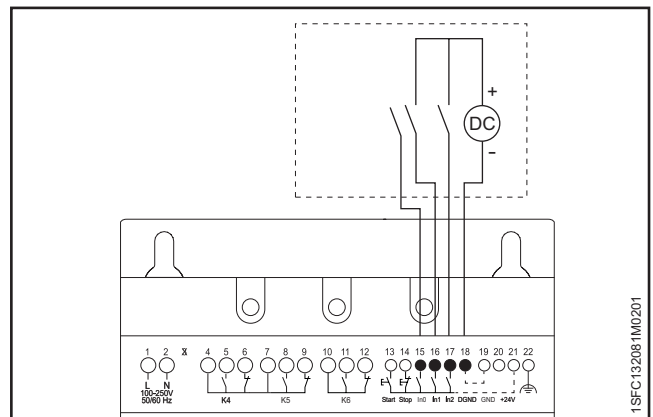


Figure 5.13  
External control voltage

Tightening torques and cable dimensions.

	<p>M3</p> <p>0,5 Nm 4,3 lb.in</p>	<p>3,5 x 0,6 mm (0.138 x 0.024 in)</p>	<p>AWG 12 ... 24</p> <p>0,2 .. 2,5 mm<sup>2</sup> 2x0,2 .. 1,5 mm<sup>2</sup> 0,2 .. 2,5 mm<sup>2</sup> 2x0,2 .. 1,5 mm<sup>2</sup></p>
--	---------------------------------------	--	---

### 5.1.2.5 Programmable inputs (Sequence start)

The Softstarter can start up to 3 different motors used in different applications with different parameter sets. The parameter set is chosen through input signals to the Softstarter.

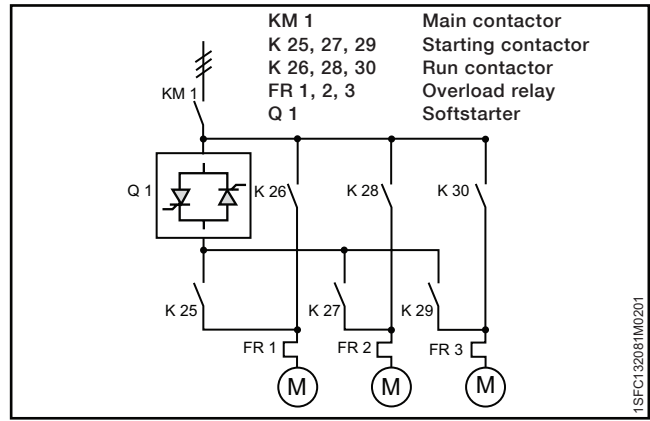
See **Figure 5.14**, Sequential start of motors using a Softstarter.

If the Softstarter trips for any reason, and the trip must stop the motor, all motors are stopped.

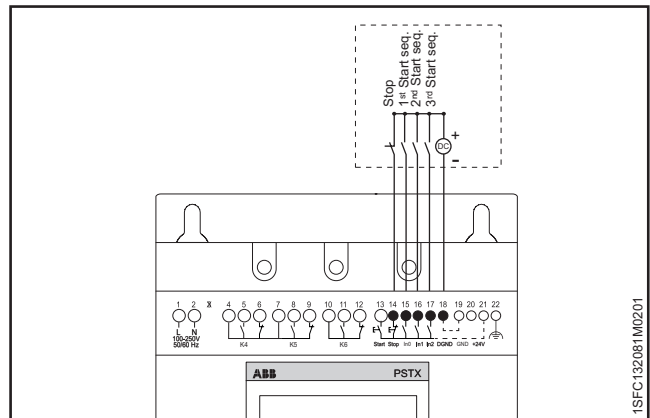
When you use sequence start, see **Figure 5.15** or **Figure 5.16** for the connection.

The start command (terminal 13, 14, 16 and 17) must be maintained during operation, otherwise a direct stop is done.

Soft stop can only be done for the motor currently fed by the Softstarter, by giving a stop command (terminal 14).

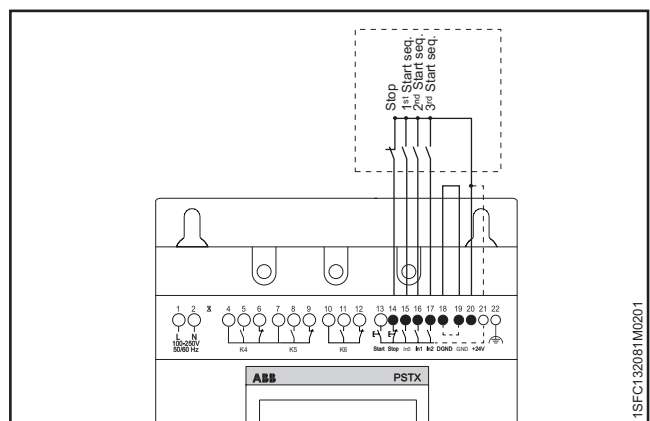
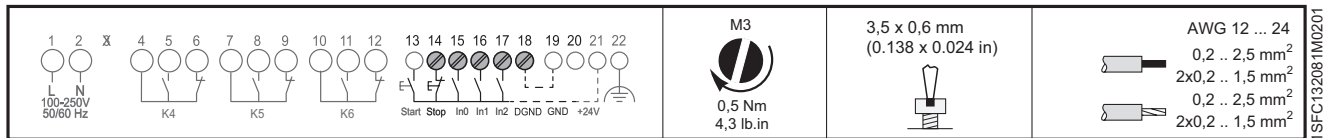


**Figure 5.14**  
Sequential start of motors using a Softstarter



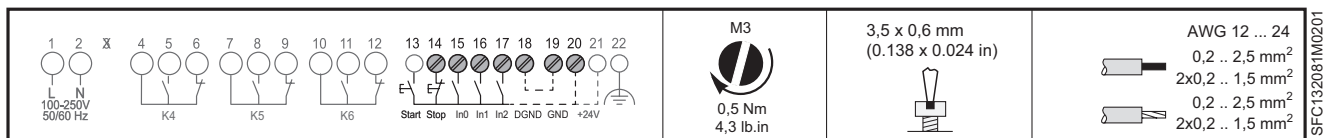
**Figure 5.15**  
External control voltage

Tightening torques and cable dimensions.



**Figure 5.16**  
Internal control voltage

Tightening torques and cable dimensions.





### 5.1.2.6 Programmable output relay - K4, terminals 4, 5 and 6

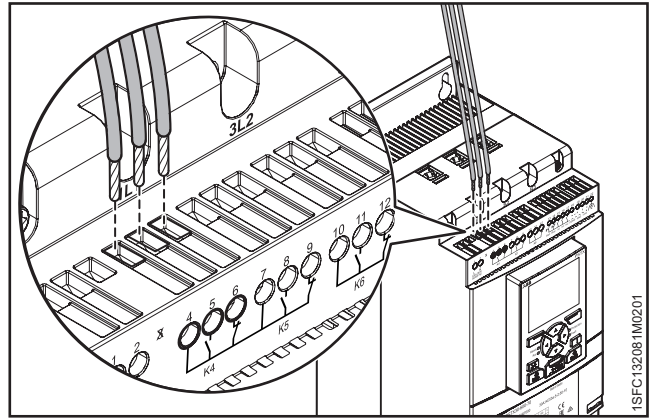
See chapter **7.14 Inputs/outputs** to set the function of the output relay.

Default: Run

Connect the cables to terminal 4, 5 and 6.

See **Figure 5.17**.

Recommended to control line contactor.



**Figure 5.17**  
Programmable output relay K4, terminals 4, 5 and 6

Tightening torques and cable dimensions.

	<p>M3,5</p> <p>0,5 Nm 4,3 lb.in</p>	<p>3,5 x 0,6 mm (0.138 x 0.024 in)</p>	<p>AWG 12 ... 24</p> <p>0,2 .. 2,5 mm<sup>2</sup></p> <p>2x0,2 .. 1,5 mm<sup>2</sup></p> <p>0,2 .. 2,5 mm<sup>2</sup></p> <p>2x0,2 .. 1,5 mm<sup>2</sup></p>
--	---	--	--

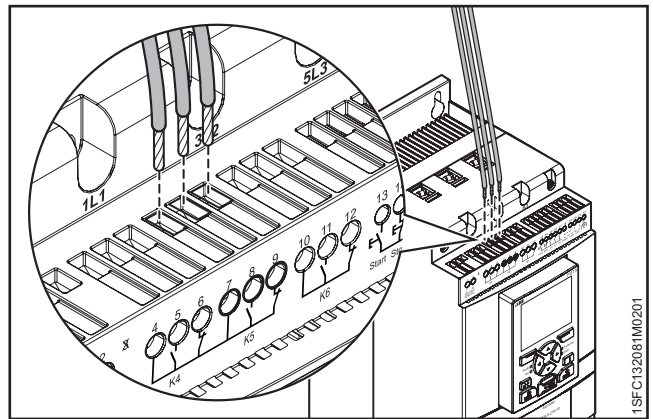
### 5.1.2.7 Programmable output relay - K5, terminals 7, 8 and 9

See chapter **7.14 Inputs/outputs** to set the function of the output relay.

Default: Top of ramp

Connect the cables to terminal 7, 8 and 9.

See **Figure 5.18**.



**Figure 5.18**  
Programmable output relay K5, terminals 7, 8 and 9

Tightening torques and cable dimensions.

	<p>M3,5</p> <p>0,5 Nm 4,3 lb.in</p>	<p>3,5 x 0,6 mm (0.138 x 0.024 in)</p>	<p>AWG 12 ... 24</p> <p>0,2 .. 2,5 mm<sup>2</sup></p> <p>2x0,2 .. 1,5 mm<sup>2</sup></p> <p>0,2 .. 2,5 mm<sup>2</sup></p> <p>2x0,2 .. 1,5 mm<sup>2</sup></p>
--	---	--	--

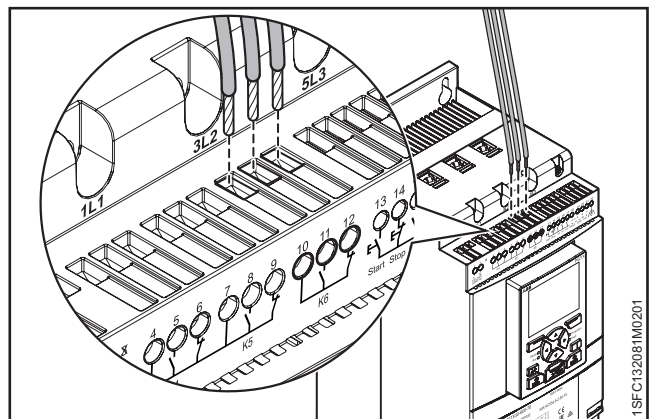
### 5.1.2.8 Programmable output relay - K6, terminals 10, 11 and 12

See chapter **7.14 Inputs/outputs** to set the function of the output relay.

Default: Event

Connect the cables to terminal 10, 11 and 12.

See **Figure 5.19**.



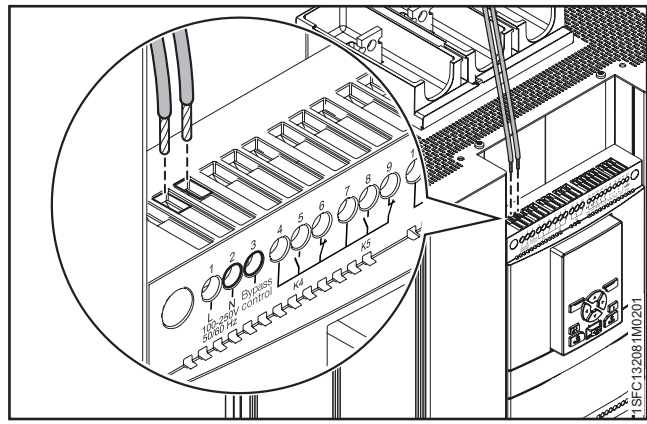
**Figure 5.19**  
Programmable output relay K6, terminals 10, 11 and 12

Tightening torques and cable dimensions.

	<p>M3</p> <p>0,5 Nm 4,3 lb.in</p>	<p>3,5 x 0,6 mm (0.138 x 0.024 in)</p>	<p>AWG 12 ... 24</p> <p>0,2 .. 2,5 mm<sup>2</sup></p> <p>2x0,2 .. 1,5 mm<sup>2</sup></p> <p>0,2 .. 2,5 mm<sup>2</sup></p> <p>2x0,2 .. 1,5 mm<sup>2</sup></p>
--	---------------------------------------	--	--

### 5.1.2.9 Close bypass PSTX470...PSTX1250

The built-in bypass contactor in PSTX470..1250 can be controlled externally for an direct on line (across the line) start. The built-in bypass contactor is closed by applying voltage (100VAC/DC – 250VAC/DC) between terminal 2 and 3. See **Figure 5.20**. A direct line on line start should only be done up to the AC-3 rating of the internal bypass contactor.



**Figure 5.20**  
Close bypass PSTX470...PSTX1250

### PSTX Integrated bypass ratings

Softstarter	PSTX Integrated bypass ratings					
	PSTX470	PSTX570	PSTX720	PSTX840	PSTX1050	PSTX1250
Intergrated contactor	AF370			AF750		AF1250
AC-3 rating at 400 V (A)	370			750		-
AC-3 rated operational power at 400 V (kW)	200			400		-
UL/CSA 3-phase motor rating at 480 V (hp)	300			600		-

Tightening torques and cable dimensions.

--	--	--	--

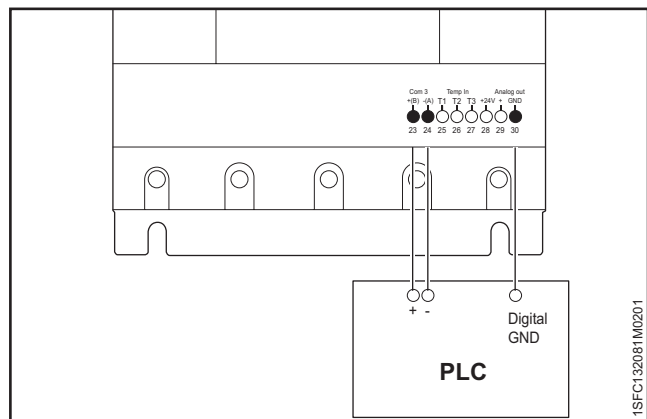
### 5.1.2.10 Modbus RTU

Connect digital ground from PLC to the PSTX ground, terminal 19, 22 or 30.

Terminal 23 to 29 is non-isolated to GND. Terminal 30 is the same as terminal 19 and terminal 22. If voltage is applied to any terminal 23-29 it may break depending on the amplitude of the voltage.

Terminal 23 and 24 will break down if voltage are higher than  $\pm 5,5V$  (relative ground) and have a current more than 150mA. If using different grounds between master and PSTX make sure that they are totally isolated grounds and that the master has isolated power. The master must not have any offset to the PSTX ground. See **Figure 5.21**.

See chapter **8 Communication** for communication components.



**Figure 5.21**  
Modbus RTU

### 5.1.2.11 Temperature sensor input

If the motor has bi-metal switch, PTC or PT100 elements, connect the cables to terminals 25, 26 and 27. See chapter **7.17.14 Temperature sensors** for programming.

#### 3-wire measurement for PT100

To reduce the influence of the wire resistance, you can use a 3-wire connection. This creates 2 measuring circuits. One circuit is used for reference. This way, the tripping device can calculate the wire resistance. See **Figure 5.22**.

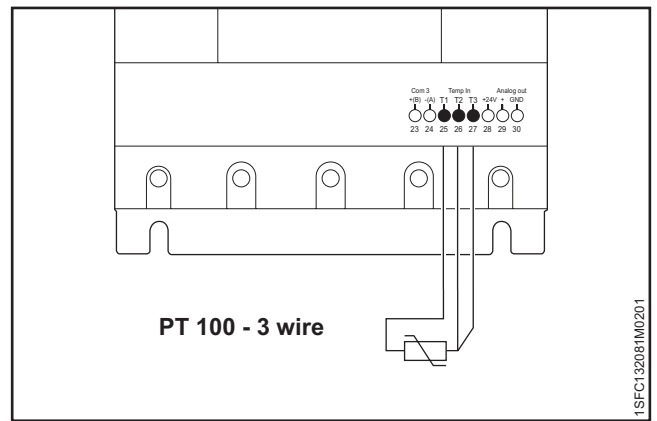


Figure 5.22  
PT100 - 3 wire

Tightening torques and cable dimensions.

	<p>M3 0,5 Nm 4,3 lb.in</p>	<p>3,5 x 0,6 mm (0.138 x 0.024 in)</p>	<p>AWG 12 ... 24 0,2 .. 2,5 mm<sup>2</sup> 2x0,2 .. 1,5 mm<sup>2</sup> 0,2 .. 2,5 mm<sup>2</sup> 2x0,2 .. 1,5 mm<sup>2</sup></p>
--	------------------------------------	--	--

#### 2-wire measurement for PT100

When using 2-wire temperature sensors, the sensor resistance and the wire resistance are added. Correct for the resulting systematic errors when you change the tripping device. Connect a jumper between the terminals 26 and 27. See **Figure 5.23**. See chapter **7.17.14 Temperature sensors** for programming.

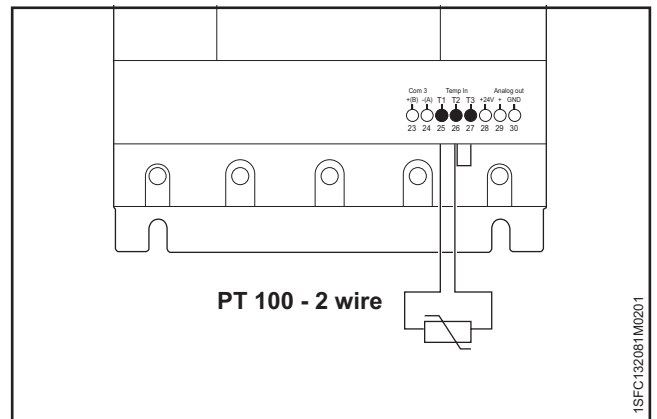


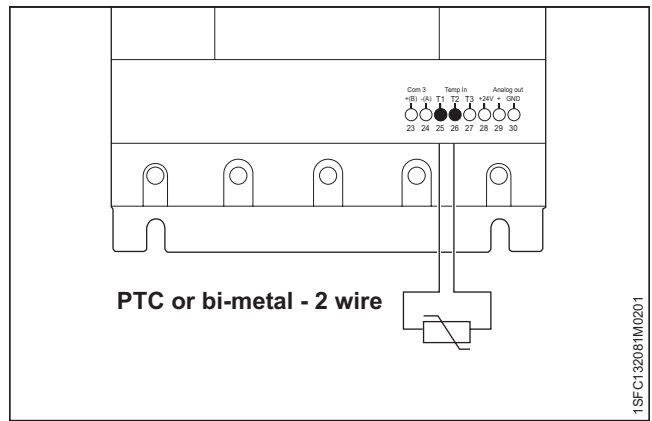
Figure 5.23  
PT100 - 2 wire

Tightening torques and cable dimensions.

	<p>M3 0,5 Nm 4,3 lb.in</p>	<p>3,5 x 0,6 mm (0.138 x 0.024 in)</p>	<p>AWG 12 ... 24 0,2 .. 2,5 mm<sup>2</sup> 2x0,2 .. 1,5 mm<sup>2</sup> 0,2 .. 2,5 mm<sup>2</sup> 2x0,2 .. 1,5 mm<sup>2</sup></p>
--	------------------------------------	--	--

## 2-wire measurement for PTC or bi-metal switch

See **Figure 5.24**. See chapter **7.17.14 Temperature sensors** for programming.



**Figure 5.24**

PTC or bi-metal - 2 wire

Tightening torques and cable dimensions.

	<p>M3 0,5 Nm 4,3 lb.in</p>	<p>3,5 x 0,6 mm (0.138 x 0.024 in)</p>	<p>AWG 12 ... 24 0,2 .. 2,5 mm<sup>2</sup> 2x0,2 .. 1,5 mm<sup>2</sup> 0,2 .. 2,5 mm<sup>2</sup> 2x0,2 .. 1,5 mm<sup>2</sup></p>
--	------------------------------------	--	--

5

### 5.1.2.12 Analog output

The Softstarter has one output for a configurable analog output signal (terminals 29 and 30). The load resistance is maximum 500 ohm for current output, and minimum 500 ohm for voltage output.

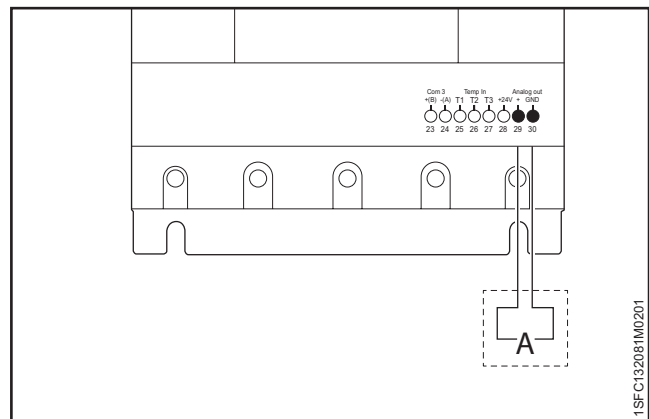
The output signal ranges available are 0-10 V, 0 – 20mA or 4-20mA. The default setting is 4-20mA.

You can select the analog output to show:

I (A), U (V), P (kW), P (Hp), Q (kVA), S (kVA),

cos Phi, Motor temp, SCR temp and Energy (kWh).

If you use the analog output, connect the cables to terminals 29 and 30. See **Figure 5.25**.



**Figure 5.25**

Analog output

See chapter **7.14 Inputs/outputs** for programming.

Tightening torques and cable dimensions.

	<p>M3 0,5 Nm 4,3 lb.in</p>	<p>3,5 x 0,6 mm (0.138 x 0.024 in)</p>	<p>AWG 12 ... 24 0,2 .. 2,5 mm<sup>2</sup> 2x0,2 .. 1,5 mm<sup>2</sup> 0,2 .. 2,5 mm<sup>2</sup> 2x0,2 .. 1,5 mm<sup>2</sup></p>
--	------------------------------------	--	--

### 5.1.3 Extension I/O

If more inputs and outputs are necessary, you can connect components:

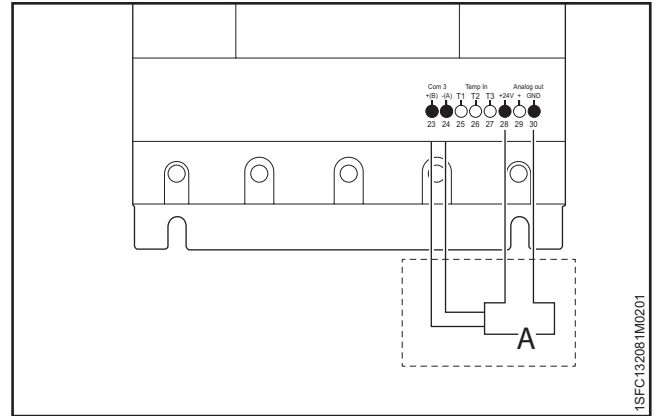
- ABB Stotz DX1xx-FBP extension module

This will give additional:

- 8 digital input
- 4 output relay
- 1 analog output

Connect the cables to terminals 23,24, 28 and 30. See **Figure 5.26**.

See chapter **8 Communication** for communication components.



**Figure 5.26**  
Optional accessories

Tightening torques and cable dimensions.

<p>Com 3 +(B) -(A)</p> <p>Temp In T1 T2 T3</p> <p>Analog out +24V + GND</p> <p>23 24 25 26 27 28 29 30</p>	<p>M3</p> <p>0,5 Nm 4,3 lb.in</p>	<p>3,5 x 0,6 mm (0.138 x 0.024 in)</p>	<p>AWG 12 ... 24 0,2 .. 2,5 mm<sup>2</sup> 2x0,2 .. 1,5 mm<sup>2</sup></p> <p>0,2 .. 2,5 mm<sup>2</sup> 2x0,2 .. 1,5 mm<sup>2</sup></p>
--	---------------------------------------	--	---

1SFC132081M0201



# 6 Human machine interface (HMI)

## 6.1 Navigation Overview

	52
6.1.1 LED indicators	52
6.1.2 Keypad	53
6.1.2.1 Lock/Unlock keypad	53
6.1.3 Navigation screen	54
6.1.3.1 Edit parameter values	54
6.1.4 Configure HMI	55
6.1.5 Symbols in screen	56
6.1.4.1 Changing the Rated motor current (Setting le)	55

## 6.2 Local control from keypad

	57
6.2.1 Start key	57
6.2.2 Stop key	57
6.2.3 R/L-key	57
6.2.4 Motor jog	58

## 6.3 Options screen

	59
6.3.1 Overview	59
6.3.2 Edit home view	43
6.3.2.1 Add information screens to home view	59
6.3.2.2 Edit information screens in home view	59
6.3.2.3 Display slot	59
6.3.2.4 Scale value range	60
6.3.3 Active faults/protections and warnings	60
6.3.4 Configure HMI	61

## 6.4 Menu screen

	62
6.4.1 Parameters	62
6.4.1.1 Complete list	62
6.4.1.2 Favorites	64
6.4.1.3 Modified	64
6.4.2 Assistants	65
6.4.3 Event log	66
6.4.4 Backup	67
6.4.4.1 Create backup	67
6.4.4.2 Uploading of parameters	67
6.4.5 System info	68
6.4.6 Settings	68
6.4.6.1 Language	69
6.4.6.2 Date and time	70
6.4.6.3 Display settings	70
6.4.6.4 Reset to defaults	71

This chapter gives a description of how the Human-machine interface (keypad and screen) works. For detailed description of each function, see chapter 7

## Functions.

### 6.1 Navigation Overview

You can use the Human-machine interface (HMI) to change the settings of the Softstarter, such as inputs and outputs, protections, warnings, and communications. You can also use the HMI to monitor, control and read status information of the Softstarter.

See **Figure 6.1**.

The HMI contains of:

- Screen
- Selection and Navigation keys
- Mini USB port
- LED status indicators

#### 6.1.1 LED indicators

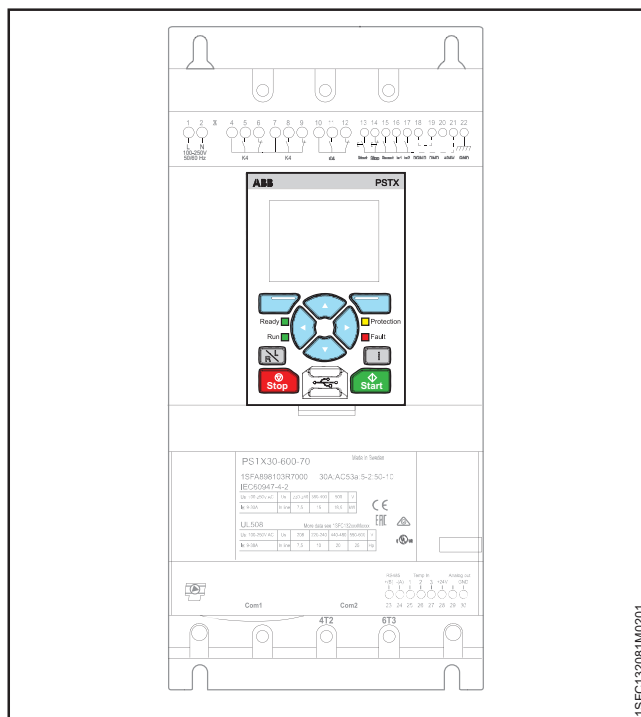
The LED status indicators work as in **Table 1 LED status**:

LED	Color	Description
<b>Ready</b> ①	Green	<ul style="list-style-type: none"> <li>• <b>Off:</b> When control supply voltage <math>U_s</math> is off or unconnected.</li> <li>• <b>Flashing light:</b> When control supply voltage <math>U_s</math> is On and operation voltage <math>U_e</math> is Off.</li> <li>• <b>Steady light:</b> When control supply voltage <math>U_s</math> is On, and operation voltage <math>U_e</math> is On.</li> </ul>
<b>Run</b> ②	Green	<ul style="list-style-type: none"> <li>• <b>Off:</b> When the motor does not run.</li> <li>• <b>Flashing light:</b> When Softstarter is controlling operation voltage <math>U_e</math> during start or stop ramp.</li> <li>• <b>Steady light:</b> When full operation voltage <math>U_e</math> is on at Top of Ramp.</li> </ul>
<b>Protection</b> ③	Yellow	<ul style="list-style-type: none"> <li>• <b>Off:</b> When the Softstarter did not trip on protection</li> <li>• <b>Flashing light:</b> The protection tripped and reset is possible.</li> <li>• <b>Steady light:</b> The protection tripped and reset is not possible.</li> </ul>
<b>Fault</b> ④	Red	<ul style="list-style-type: none"> <li>• <b>Off:</b> When the Softstarter did not trip on fault</li> <li>• <b>Flashing light:</b> Fault occurred and reset is possible.</li> <li>• <b>Steady light:</b> Fault occurred and reset is not possible.</li> </ul>

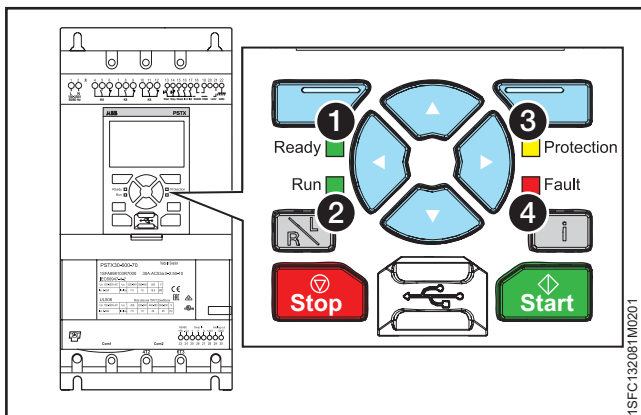
See **Figure 6.2**.

When fault or protection LED is on, the screen shows the fault or protection as an event code and an indication text. Push information-key for further information.

See chapter 10 **Troubleshooting** for description of fault, protections and warnings.



**Figure 6.1**  
HMI



**Figure 6.2**  
LED Status



## 6.1.2 Keypad

The Softstarter has 10 keys on the keypad, see **Figure 6.3**. This chapter gives a description of the function of each key.

### Selection soft keys

The Selection soft keys have a specified function for each dialogue, such as to select, to exit, to change or to store. The screen above the key shows the current function. See **1** in **Figure 6.3**.

### Navigation keys

Use the Navigation keys for navigation in the menu and change the parameter values. A menu/value that is highlighted black on the screen can be changed or scrolled. To select from a list, you can scroll in a closed loop. See **2** in **Figure 6.3**.

### R\L-key

R\L-key stands for Remote or Local. Use this key to change the control of the Softstarter between local control from the HMI and remote control from hardware input or fieldbus. See **3** in **Figure 6.3**.

### i-key

Use the i-key to get information about the HMI, and the Softstarter status and settings. Push this key for help and general information about the current setting in the HMI. See **4** in **Figure 6.3**.

### Stop key

The Stop key is the stop switch for the Softstarter. When you push this key, the motor stops with the set parameters. You can push stop command during the start ramp if necessary. (Only active in local control mode). See **5** in **Figure 6.3**.

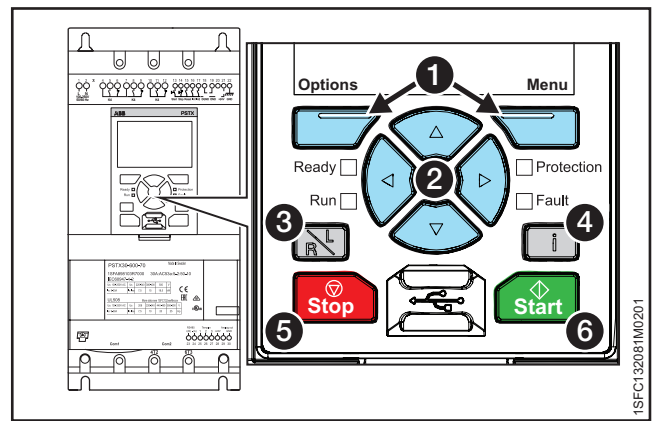
### Start key

When you push this key, the motor starts and operates with the set parameters. (Only active in local control mode). See **6** in **Figure 6.3**.

### 6.1.2.1 Lock/Unlock keypad

Be aware of that the different lock mechanisms provided by PSTX provide no security level whatsoever. The only intention is to prevent the user from making changes by mistake.

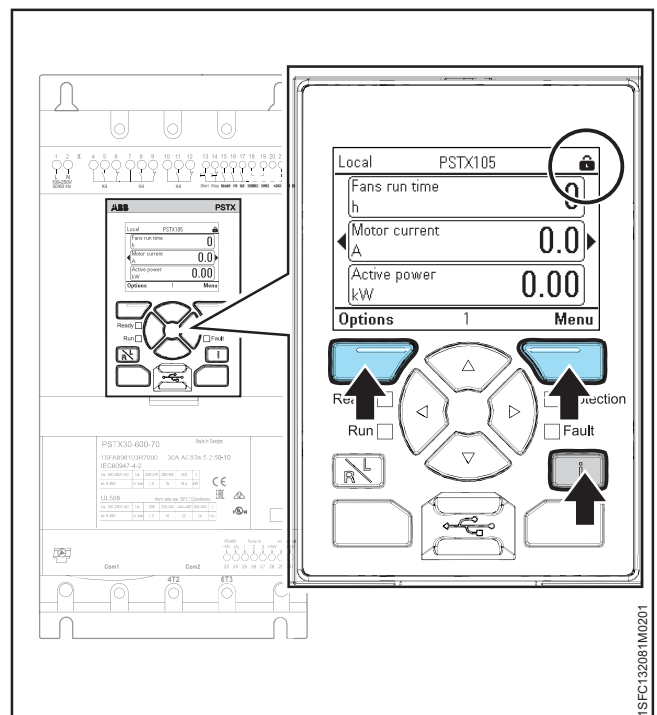
Push and hold the Options-key, Menu-key and i-key Simultaneously for 2 seconds in order to lock/unlock the keypad. **Figure 6.4**. The lock prevents only accidental use of keys. The display will show the home view and the only keys that can be used are the left and right keys in order to step through the home view.



**Figure 6.3**  
Keypad

**Table 2** Keypad, Figure 46





Position	Key
<b>1</b>	Selection soft keys
<b>2</b>	Navigation keys
<b>3</b>	R\L-key
<b>4</b>	i-key
<b>5</b>	Stop key
<b>6</b>	Start key



**Figure 6.4**  
HMI

## 6.1.3 Navigation screen






With the keypad, you can change the settings for each item or as a selection of default parameters for different applications. The default set of parameters is stored in the unit for a possible reset to default values. When the fieldbus communication is selected, you can change parameters from this interface.

Push  "Menu" to go to the menu and then use  and  to navigate. Push the  "Select" to make your selection.

See **Figure 6.5**.





### 6.1.3.1 Edit parameter values

#### The numerical setting

Use the numerical setting to change a numerical value. Use  and  on the Navigation keys to select the number, the selected number is highlighted black. Then push  or  to change the value of the selected number. Push  "Save" to save.

See **Figure 6.6**.


#### On/off switch

Use  or  to navigate  or  to change the value of the selected switch, (1=on, 0=off).

Push  "Save" to save.

See **Figure 6.7**.

#### Selection list

Use the Navigation keys to navigate up and down in the lists. The selected option is highlighted black. Push  "Save" to save.

See **Figure 6.8**.



Figure 6.5  
Navigation screen

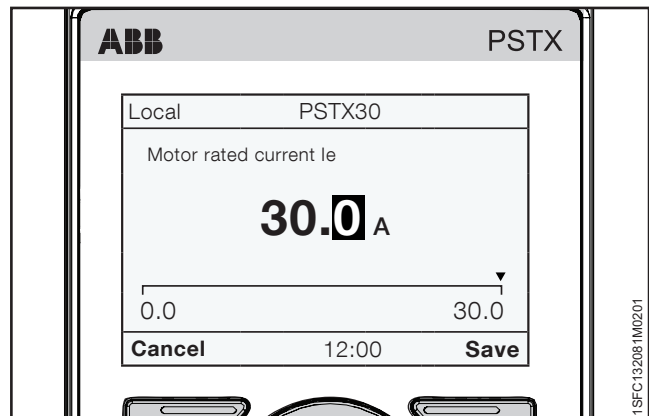


Figure 6.6  
Numerical setting



Figure 6.7  
Switch setting

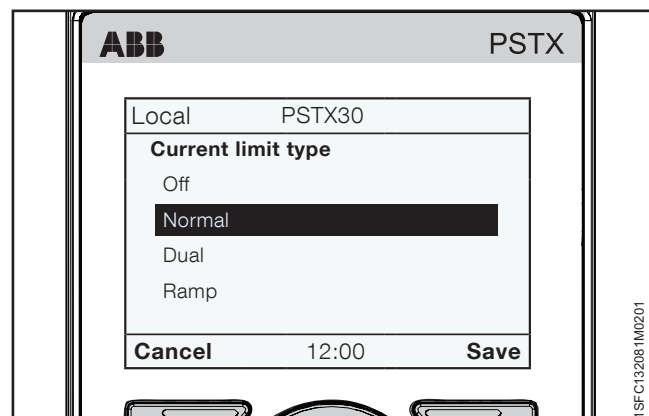


Figure 6.8  
Selection list

## 6.1.4 Configure HMI

This chapter shows some examples of parameters that you can set on the PSTX Softstarter.

Some of the service parameters in 28 Service are protected by a service code, see chapter 6.3.4












### Configure HMI.

#### 6.1.4.1 Changing the Rated motor current (Setting le)

Path in menu:

Menu ▶ Parameters ▶ Complete list ▶ 01 Motor rated current le

For more information about Motor Current le, see chapter 7 Functions.

1. The Home view is the top level. Push  "Menu" to enter the menu. The screen now appears as in **Figure 6.9**.
2. Push  "Select" to select Parameters menu.
3. Push  "Select" to select Complete list.
4. Push  "Select" to select 01 Motor rated current le.
5. Push  "Edit" to edit the rated current in Motor rated current le.
6. Use  and  to select number, the current selected number is highlighted black. Then push  or  to change the value of the selected number. Save the new setting by selecting  "Save".  
See **Figure 6.9**. If you want to quit, you select  "Cancel".

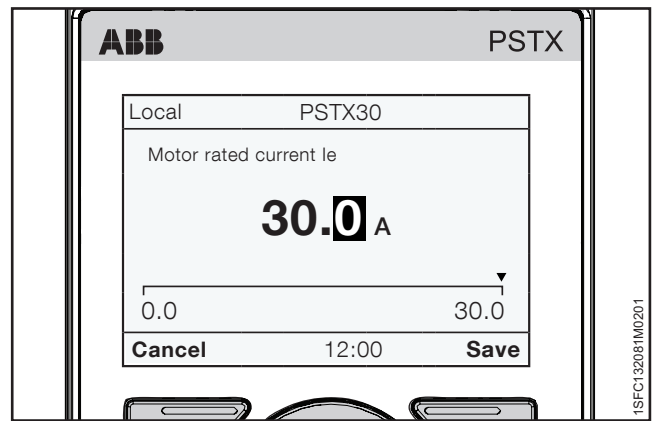


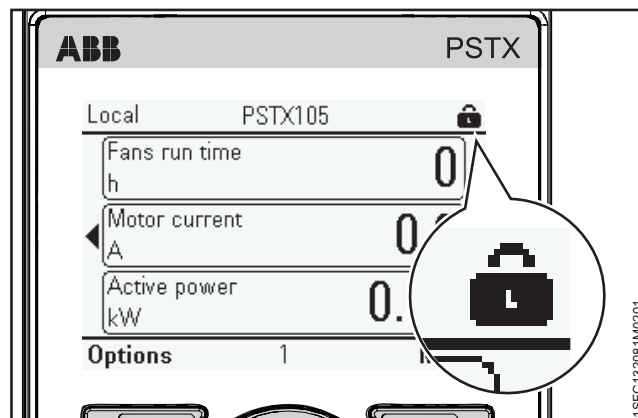
Figure 6.9

Motor current le

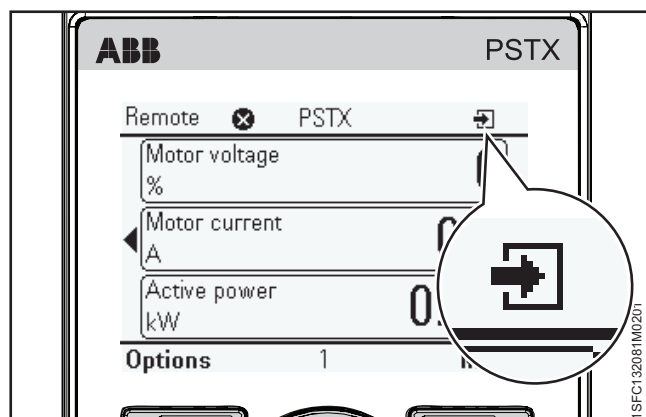
## 6.1.5 Symbols in screen

This chapter describes the different symbols that can appear in the upper right corner of the HMI screen.

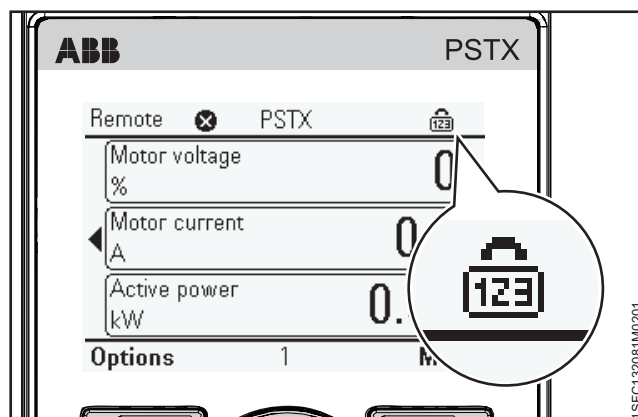
1. Lock / Unlock keypad, See **Figure 6.10**
2. Service profile. See **Figure 6.11**
3. Lock parameter by a lock code, See **Figure 6.12**
4. Lock keys by a lock code, See **Figure 6.13**
5. Emergency mode, See **Figure 6.14**
6. Fault(s) set to off, See **Figure 6.15**



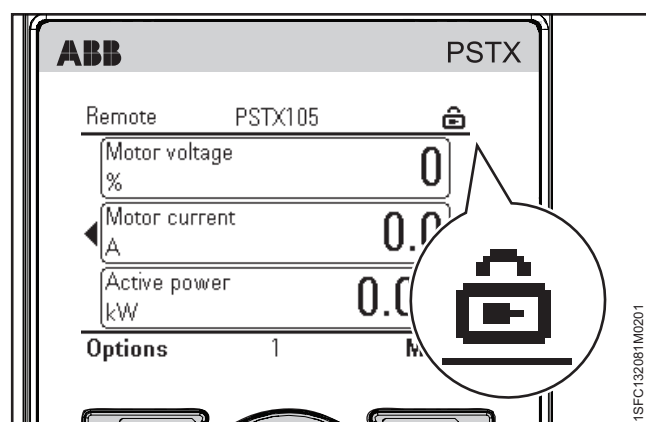
**Figure 6.10**  
Lock / Unlock keypad



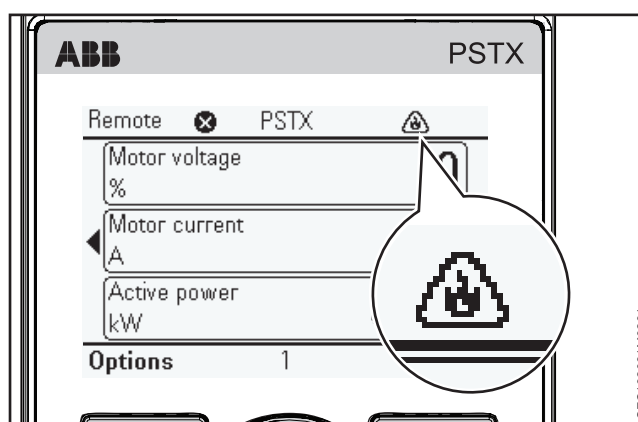
**Figure 6.11**  
Service profile



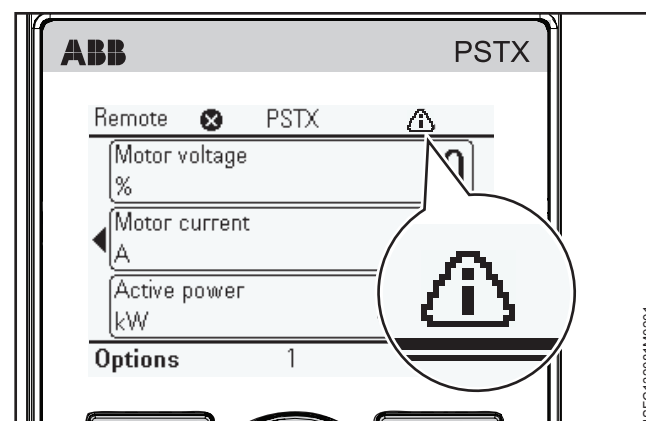
**Figure 6.12**  
Lock parameter by a lock code



**Figure 6.13**  
Lock keys by a lock code



**Figure 6.14**  
Emergency mode



**Figure 6.15**  
Fault(s) set to off

## 6.2 Local control from keypad



### WARNING

When you change from local control to remote control, the setting applies immediately. If the remote setting has direct motor start it can start the motor automatically and can cause personal injury.



### WARNING

After a power loss, software upgrade or cycling of the PSTX Control supply, the PSTX automatically is set in remote control. Remote control is the default control of the PSTX.



### INFORMATION

Keypad control has the highest priority and overrides all other control methods

This chapter gives a description of how the local control interface works. Use the local control to start and stop the motor from the keypad. When local control is selected, you can only control the Softstarter with the keypad.

**Table 3** Local control from keypad

Function	Description
Start/stop	Start and stop the motor with the keypad.
R\L	Change between local and remote control
Motor Jog *	Run the motor as long as Jog is pushed.

\*) For information about Motor jog see **chapter 6.2.4 Motor jog**.

To go to the Motor Jog, follow this path in menu:

**Menu ► Motor jog**

### 6.2.1 Start key

The start key is the start switch for the Softstarter. Push this key to start the motor and operate with the set parameters. See **1** in **Figure 6.16**.

### 6.2.2 Stop key

The stop key is the stop switch for the Softstarter. Push this key to stop the motor with the set parameters. You can push stop command during the start ramp if necessary. See **2** in **Figure 6.16**.

### 6.2.3 R\L-key

R\L-key stands for Remote or local control. Use this key to control the Softstarter remote from digital input, fieldbus or local from the HMI.

See **3** in **Figure 6.16**.



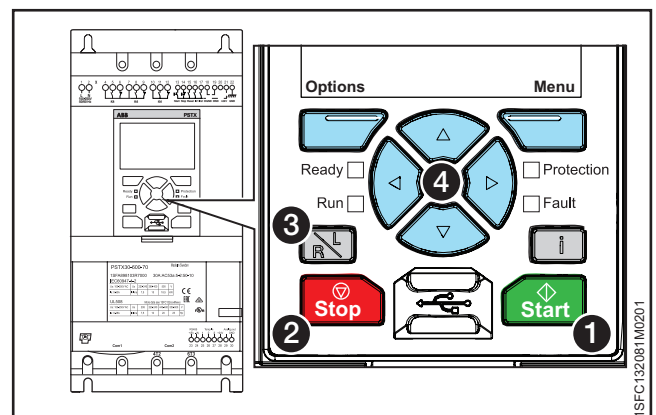
### WARNING

When changing from remote control to local control, the softstarter stays in present state. That means, if the the softstarter is running the motor when switching between the remote control and local control, the softstarter will continue to run the motor.



### WARNING

Since the keypad has highest priority, when in local control, neither the digital inputs nor the fieldbus communication can stop the motor if it is running. When in local control the only stop command that can stop the motor is the stop key on the keypad.



**Figure 6.16**  
Local control

## 6.2.4 Motor jog

Path in menu:

Menu ▶ Motor jog

For navigation see **Figure 6.17**.




For Motor jog parameter settings, see chapter **7.9 Slow speed**.



Jog is a slow speed drive function to drive the motor with low voltage output. Use this feature for example to put a conveyor belt into position.

The jog has 3 default speeds:

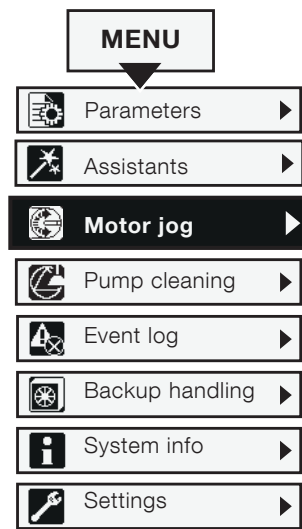
- Fast Jog
- Jog
- Creep

You can change the speeds with separate parameters. For example: Fast jog backward and jog forward. You can use this function through the HMI, I/O or Fieldbus.

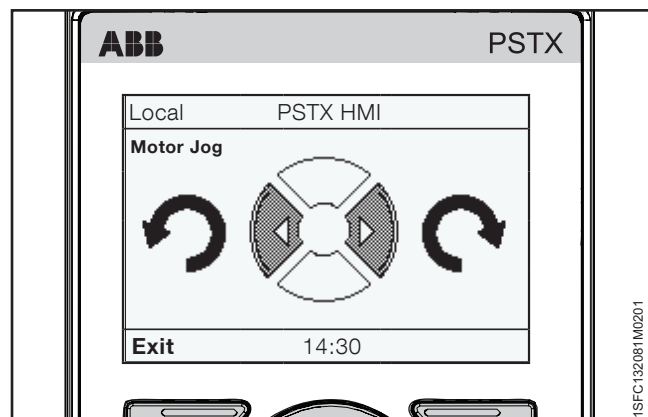
Push  "Menu" to enter the Motor jog menu and then select Motor Jog. Use  and  to jog forward or backwards. See **Figure 6.18**. The motor starts and accelerates to the rated speed with the set parameters as long as the Jog command is in operation.

The motor stops immediately when you release the push button,  and .

You can run the motor in the forward and reverse direction with 3 different speeds.



**Figure 6.17**  
Motor jog navigation



**Figure 6.18**  
Keypad

## 6.3 Options screen

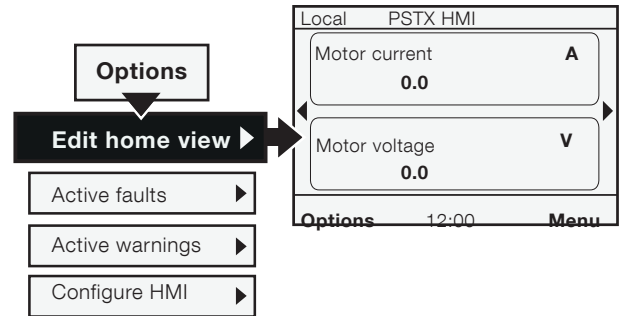
### 6.3.1 Overview

In Options screen, you can change the appearance of the Home view of the Softstarter and read Active faults/ protections and Active warnings.

Option screen includes these menus:

- Edit home view
- Active faults/ protections
- Active warnings

Push  "Options" to enter the Options screen.



**Figure 6.19**  
Edit home view navigation

### 6.3.2 Edit home view



Path in menu:

Options ► Edit home view



For navigation, see **Figure 6.19**.

Use Edit home view to change the view of the home view.

#### 6.3.2.1 Add information screens to home view

1. Push  "Options" to select Edit home view.
2. Use the Navigation keys to select where you want to add an information screen.
3. Push  "Add" to add the new information screen to the home view.



#### 6.3.2.2 Edit information screens in home view

1. Push  "Options" and then select Edit home view.
2. Use the Navigation keys to select the display slot you want to edit.
3. Push  "Edit" and enter the Display slot menu. See chapter **6.3.2.3 Display slot** to set the new screen in the Display slot menu.

#### 6.3.2.3 Display slot

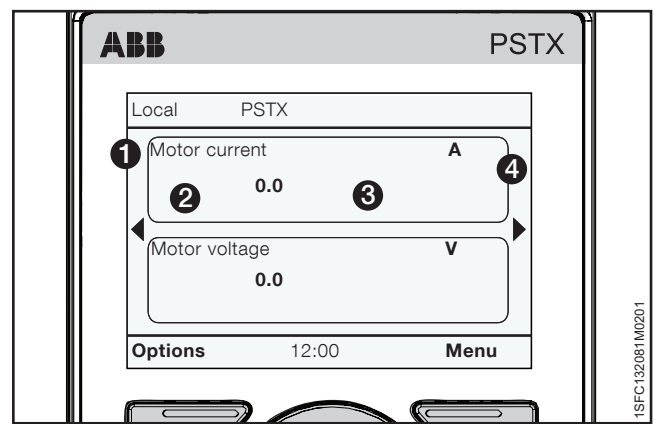
In the Display slot menu, you can set the new screen with these options:

##### Signal

Push  "Edit" to see the list of signals available for the home view. Use the Navigation keys and then push  "Select" to select the signal. Selected signal is shown by **1** in **Figure 6.20**.

Select 1 of these signals:

- Empty
- Motor voltage
- Motor current
- Active power
- Active power (hp)
- Power factor
- Reactive power
- Apparent power
- Mains voltage
- Mains frequency
- Motor connection
- Phase sequence



**Figure 6.20**  
Display slot


- Phase L1 current
- Phase L2 current
- Phase L3 current
- L1L2 phase-to-phase voltage
- L2L3 phase-to-phase voltage
- L3L1 phase-to-phase voltage
- Thyristor temperature
- Motor temperature
- EOL time to trip
- EOL time to cool
- Active energy
- Active energy (resettable)
- Reactive energy
- Reactive energy (resettable)
- Voltage imbalance
- Mains voltage THD
- PT100 temperature
- PTC resistance
- Remaining time to start
- Number of starts (resettable)
- Number of starts
- Motor run time (resettable)
- Motor run time
- Thyristor run time (resettable)
- Thyristor run time
- Fans run time
- Pre-start function
- Start mode
- Stop mode

### Display style

Select the display style for the home view. The selected display style is shown by ② in **Figure 6.21**.

Select numeric, gauge or graph data:

- Numeric
- Gauge/bar
- Graph 15 minutes
- Graph 30 minutes
- Graph 1 hour
- Graph 24 hours
- N/A

Use the Navigation keys to select display style, push  "Select" to set the parameter.

### Display decimals


Select the amount of decimal numbers in the home view. Use the Navigation keys to change the amount.

Push "Save" to save the value. Decimal numbers are shown in ③ in **Figure 6.21**.

### Display name


You can change the name of the selected signal. The new name can have maximum 20 characters.

Use the Navigation keys to change the characters.

Push  "Save" to save the display name. Display name is shown by ① in **Figure 6.21**.


### Signal min

Select the minimum value that can be shown in the gauge/bar or graph in the Home view. Use the Navigation keys to change the value.


Push  "Save" to save the value. Value is shown by ③ in **Figure 6.21**.

### Signal max



Select the maximum value that can be shown in the gauge/bar or graph in the Home view. Use the Navigation keys to change the value.



Push  "Save" to save the value. Value is shown by ③ in **Figure 6.21**.


#### 6.3.2.4 Scale value range

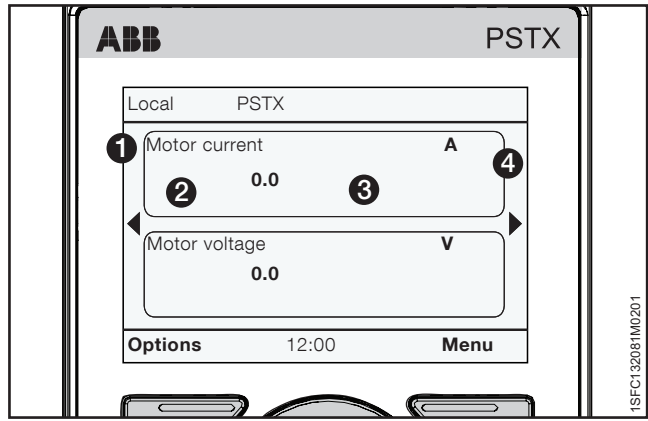
Use Navigation keys to mark Scale value range and push  "Select" to enable Scale value range. 3 more options show in the display slot menu:

- Display signal min as
- Display signal max as
- Display unit

**Display signal min as** - Push  "Edit" to select the scaled minimum value in the Home view. Use the Navigation keys to change the value, Push  "Save" to save the value. See ③ in **Figure 6.21**.

**Display signal max as** - Push  "Edit" to select the scaled maximum value to show in the Home view. Use the Navigation keys to change the value, Push  "Save" to save the value. See ③ in **Figure 6.21**.

**Display unit** - Type in the unit to show in the Home view. You can type a unit with up to 10 characters. Use the Navigation keys to change the characters. Push  "Save"



**Figure 6.21**  
Display slot

to save the Home view unit name. See ④ in **Figure 6.21**.

### 6.3.3 Active faults/protectations and warnings

Path in menu:

**Options** ▶ **Active faults / protections**

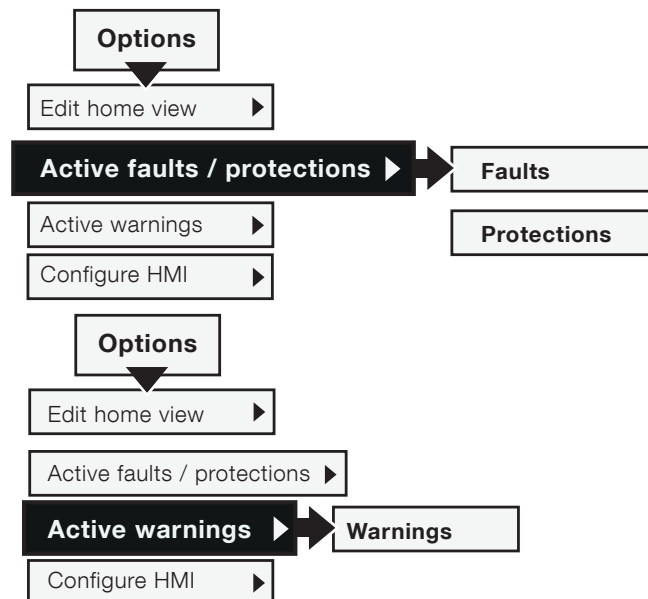
**Options** ▶ **Active warnings**

You can find **active faults/protectations/warnings** in the Options menu. The menus contain information about faults and warnings that occurred during operation, and what protections are active.

Active faults/protectations and warnings menus are highlighted black when a fault protection or warning occurred.

For navigation see **Figure 6.22**.

For more information about fault/warnings/protectations, see chapter **10 Troubleshooting**.



**Figure 6.22**  
Active fault/warnings/protectations navigation



## 6.3.4 Configure HMI

Path in menu:

Options ► Configure HMI

Configure HMI let you Lock parameters (write protect parameters) and Lock keys on the HMI. The service profile overrides these configurations.

### Lock/Unlock parameters by a lock code

All parameters can be locked by a lock code to prevent users to change any settings. To unlock the parameters, the user needs to know the lock code.

Select Lock parameters and enter the lock code when prompted. Use arrow keys to enter value. The parameter lock icon will be visible in the upper right corner, see chapter 6.1.5 **Symbols in screen**. The same steps applies for Unlock parameters and the parameter lock icon will disappear. If you have entered the service profile you will not be asked to provide the lock code and the configuration is not activated until you exit the service profile.

Note: when the motor control lock is active, it is not possible to use jog with slow speed or pump cleaning with the HMI.

### Lock/Unlock keys by a lock code

Start key, Stop key and R\L key can be locked by a code to prevent a motor start from HMI by mistake. When Lock keys is enabled and start, stop or R\L key is pressed a message will be displayed, "Motor control lock is enabled". To unlock these keys the user needs to know the lock code.

Select Lock keys and enter the lock code when prompted. Use arrow keys to enter value. The key lock icon will be visible in the upper right corner, see chapter 6.1.5 **Symbols in screen**. Unlock keys requires the lock code to be re-entered and then the key lock icon disappears. If you have entered the service profile you will not be asked to provide the lock code and the configuration is not activated until you exit the service profile.

### Change lock code

The default lock code is 12345 and to change it select Change lock code and enter first the current code and then the new code when prompted. Use arrow keys to enter value. If you have forgotten the lock code you can reset all parameters to default, see chapter 6.4.6.4 **Reset to defaults**

If you have entered the service profile you will not be asked to provide the current lock code.



#### INFORMATION

If you use Reset all parameters, you will not only reset the lock code for Basic or Advanced user profile, but also all the other parameters that have changed value from default.



#### INFORMATION

You will automatically exit the user profile after 1h.



#### WARNING

By changing any of the Service parameters, which are locked by user profile Service, could result in personal injury and damage to equipment or property and the warranty will no longer be valid.

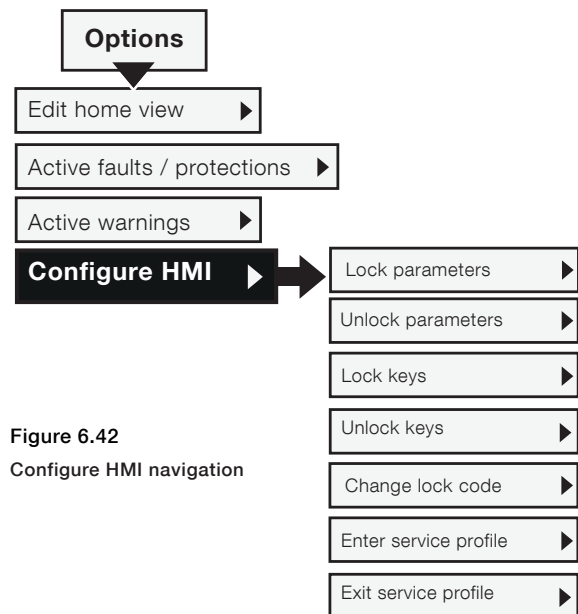


Figure 6.42  
Configure HMI navigation

### Enter/Exit service profile

Enter service profile to be able to edit the service parameters that are locked for normal users (see list below). It will also override parameter lock and key lock if any of them are activated.

Service profile code is available in the Service manuals:

- 1SFC13105M0201-Service manual PSTX210...570
- 1SFC132115M0201-Service manual PSTX720...840
- 1SFC132116M0201-Service manual PSTX1050...1250

### Service profile





The below listed parameters can only be changed when logged in as user profile "Service". Please see PSTX service manual for more information.

- 28.14 Mains lock setting
- 28.15 Minimum trig time
- 28.17 U start ramp switch level
- 28.18 T start ramp switch level
- 28.19 Stop ramp switch level
- 28.20 In-Line gain
- 28.21 Inside delta gain
- 28.22 Phase loss
- 28.23 Phase loss during TOR
- 28.24 Phase loss trip time
- 28.25 Phase loss trip angle 1
- 28.26 Phase loss trip angle 2
- 28.27 Bad network quality
- 28.28 Low supply voltage
- 28.29 High current fault
- 28.30 Shunt fault
- 28.31 Short circuit thyristor
- 28.32 Open circuit thyristor
- 28.33 Thyristor overload
- 28.34 Heat sink overtemp
- 28.35 Faulty connection
- 28.36 Faulty usage
- 28.37 Close bypass curr lvl
- 28.49 Shunt fault trip time
- 28.50 Shunt fault trip level
- 28.63 Flux support min speed
- 28.64 Electronics failure

## 6.4 Menu screen

The menu screen has 7 submenus, given in these chapters:

Chapter	Description
6.4.1 Parameters	Parameter settings for different types of Softstarters.
6.4.2 Assistants	Default parameters for common applications.
6.2.4 Motor jog	See chapter 6.2.4 Motor jog
6.4.3 Event Log	Show the Event Log, Faults, Protections and Warnings.
6.4.4 Backup	Backup parameter settings.
6.4.5 System info	Show product name, type, Firmware version etc.
6.4.6 Settings	Softstarter settings such as Language, Date and Display.

Use Navigation keys to navigate in the submenus. Push  "Select" to enter a menu. Push  "Save" to save a new setting. Push  "Cancel" to exit a setting without saving. Push  "Back" to go back.

6





### 6.4.1 Parameters

Path in menu:

Menu ► Parameters

The parameter menu has 3 submenus, given in these chapters:

Chapter	Description
6.4.1.1 Complete list	Shows all parameters for advanced setup
6.4.1.2 Favorites	Select favorite parameter functions for quick selection.
6.4.1.3 Modified	Shows changed parameters.





Navigation keys to navigate in the submenus. Push  "Select" to enter a menu. Push  "Save" to save a new setting. Push  "Cancel" to exit a setting without saving. Push  "Back" to go back.

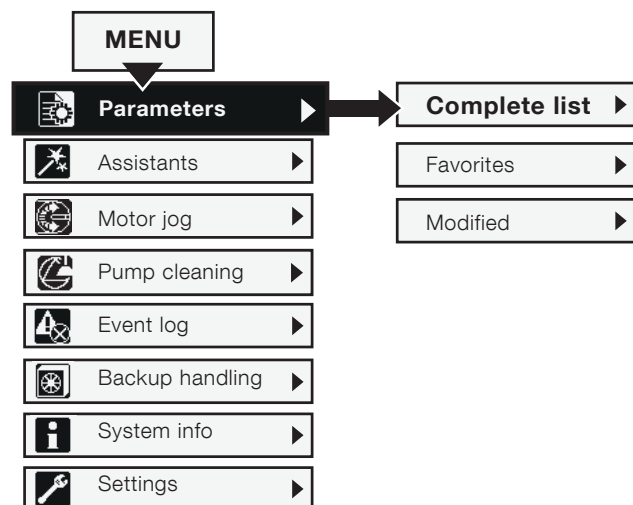
#### 6.4.1.1 Complete list

Path in menu:

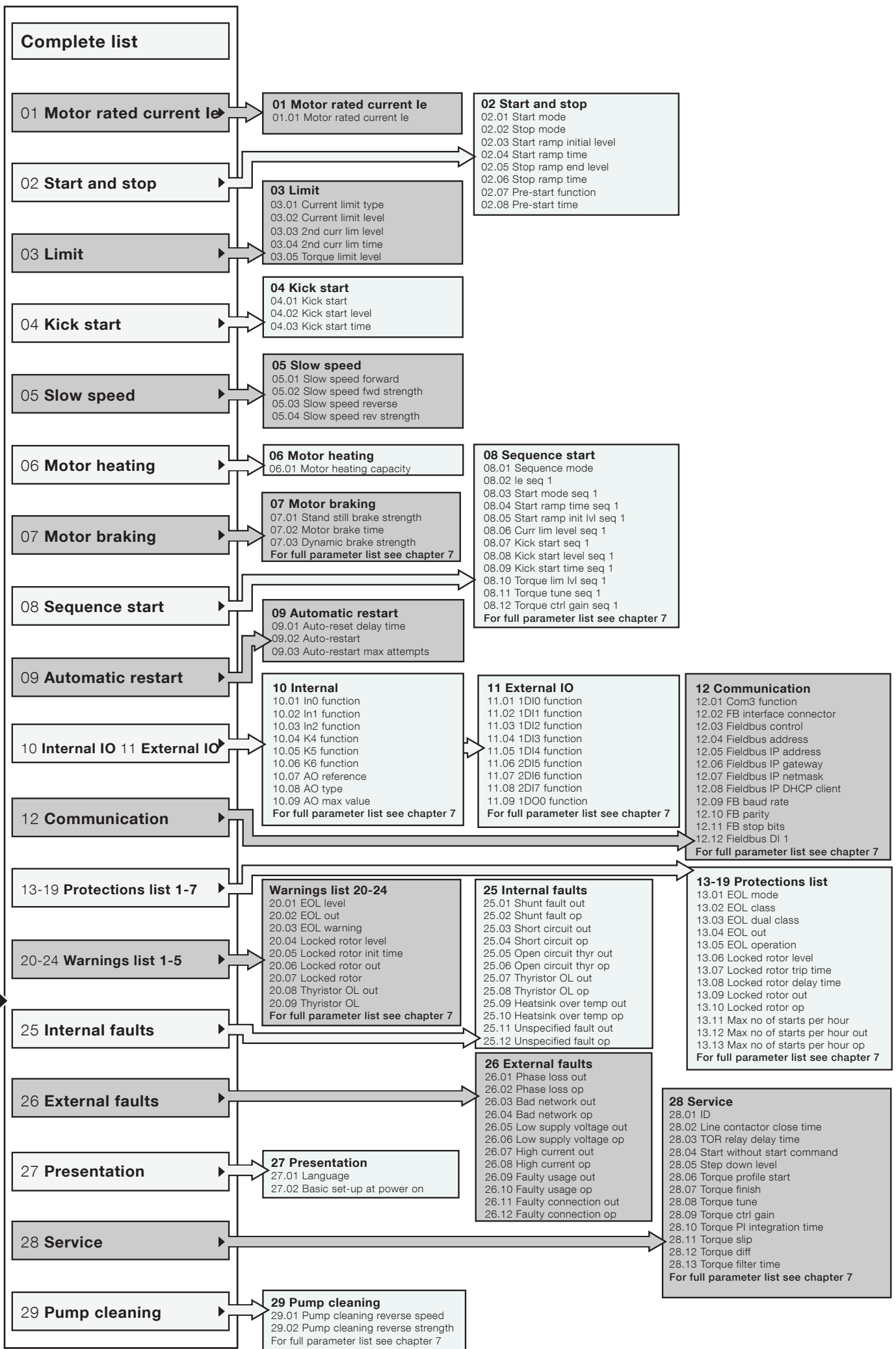
Menu ► Parameters ► Complete list

Use the Complete list menu if a more advanced parameter setup is necessary. The complete list menu contains groups of parameters put in function order, such as Start and Stop, Communication etc. For navigation, see **Figure 6.23**.

Use the Navigation keys to navigate the submenus. Push  "Select" to enter a menu. Push  "Save" to save a new setting. Push  "Cancel" to exit a setting without saving. Push  "Back" to go back. For function settings and full parameter list, see chapter 7 **Functions**.



**Figure 6.23**  
Complete list navigation



### 6.4.1.2 Favorites

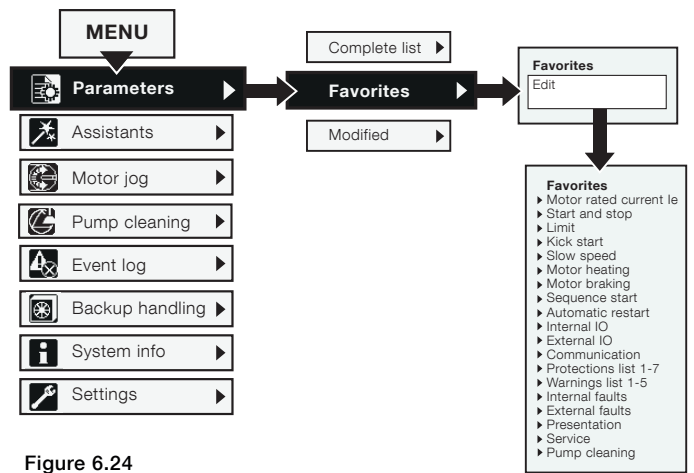
Path in menu:

Menu ▶ Parameters ▶ Favorites

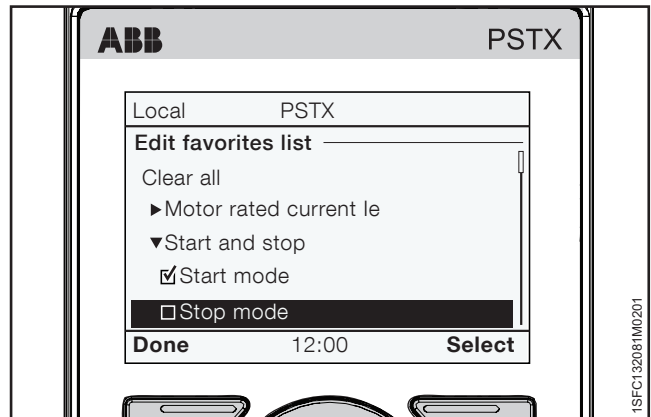
For navigation, see **Figure 6.24**.

In the Favorites menu you can add favorite parameters for quick selection. Select parameters such as Start and stop, Current limit, Kick start, Torque control, etc

1. Push "Select" to enter the Favorites menu and then push "Select" to edit the Favorites list.
2. Use the Navigation keys to select a parameter group. Push "Open" to open the group.
3. Push "Select" to select parameters. A check mark shows in front of the selected parameter. Push "Unselect" to unselect the parameter. Push "Done" to save and exit. See **Figure 6.25**.
4. The selected Favorites show directly in Favorites menu for quick selection. Push "Back" to go back.



**Figure 6.24**  
Favorites navigation



**Figure 6.25**  
Favorites menu

### 6.4.1.3 Modified

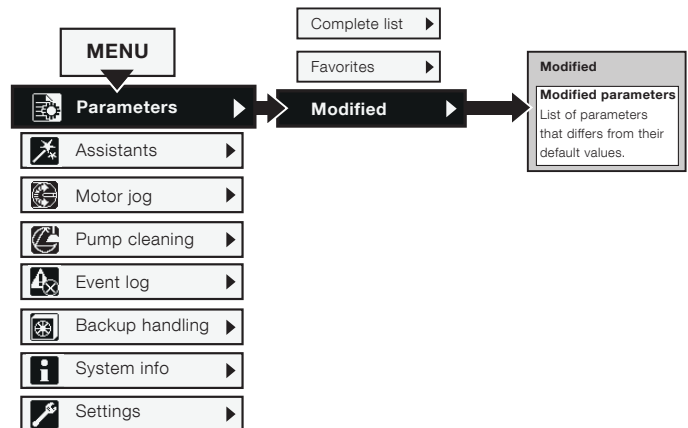
Path in menu:

Menu ▶ Parameters ▶ Modified

For navigation, see **Figure 6.26**.

The Modified menu contains changed parameters that are different from defaults.

Push "Select" and then "Edit" to edit the different parameter. Push "Save" to save and go back. Or push "Cancel" to go back without saving.



**Figure 6.26**  
Modified navigation

## 6.4.2 Assistants

Path in menu:

Menu ► Assistants

For navigation, see **Figure 6.27**.

For more details on how to set Basic set-up and Application set-up, see chapter 2 **Quick start**.

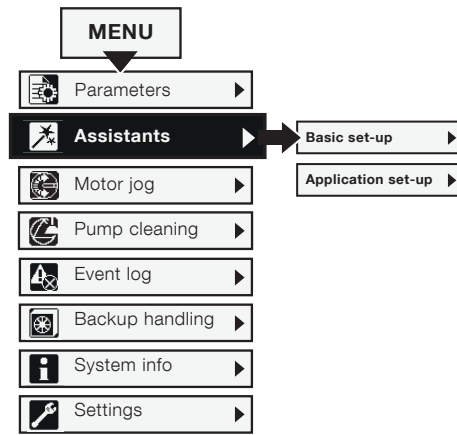
For more information about Assistants and Application list, see **chapter 7.24 Assistants**.

The Assistants menu contains default settings and parameters. Use this menu to set only the necessary parameters before you can start the motor. All necessary input data shows up in an automatic loop. The Assistants menu is divided in:

- **Basic set-up**
- **Application set-up**

### **i** INFORMATION

After you select an application and make your changes, do not select this application again because this resets the application to the default settings.



**Figure 6.27**  
Assistants navigation

### Enter the Assistants menu

Push “Menu” and select Assistants with the Navigation keys.

Push “Select” to enter the Assistants menu.

### Basic set-up

Use the Navigation keys to select Basic set-up.

Push “Select” to enter the Basic set-up.

The Basic set-up menu is divided in 5 steps: Language, Date and time, Motor data, System configuration and Setup complete.

### Application set-up

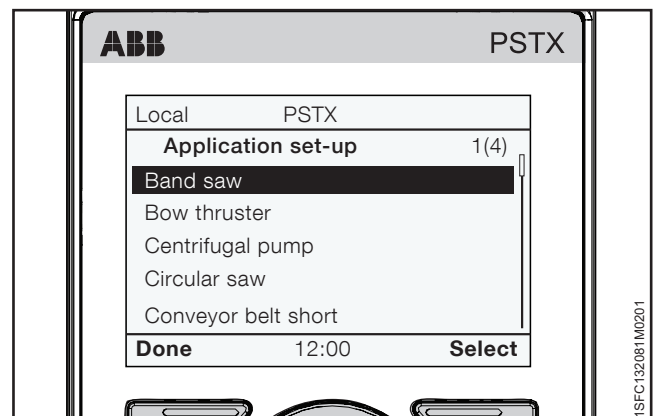
The Application set-up are quick settings for Applications, Values and Tune settings.

Use the Navigation keys to select Application set-up.

Push “Select” to enter the Application set-up.

Select for what type of application you use the Softstarter by pushing “Select”.

See **Figure 6.28**.



**Figure 6.28**  
Application set-up

### 6.4.3 Event log

Path in menu:

Menu ▶ Event log

For navigation, see **Figure 6.29**.



The Event log menu shows the event log in the Softstarter. The log shows the 100 latest events in chronological order, with “type of event” and date. For details about all events push details.

Use navigation keys to view all entries in the event log. The types of event logs are:



- **Faults**
- **Protections**
- **Warnings**
- **Parameter changed**
- **Run**

See **Figure 6.30**.



#### Faults

Use the Navigation keys to select a Fault and push  “Details” to read details about the Fault (Name, On time and Event count). Then push the i-key to see information about the Fault. Push  “Back” to go back to Faults log menu.



#### Protections

Use the Navigation keys to select a Protection and push  “Details” to read details about the Protection (Name, On time and Event count). Push the i-key to see information about the Protection. Push  “Back” to go back to Protections log menu.



#### Warnings

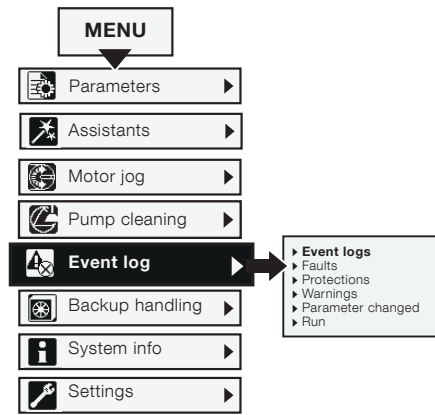
Use the Navigation keys to select a Warning and push  “Details” to read details about the Warning (Name, On time and Event count). Then push the i-key to see further information about the Warning. Push  “Back” to go back to Warning log menu.

#### Parameter changed

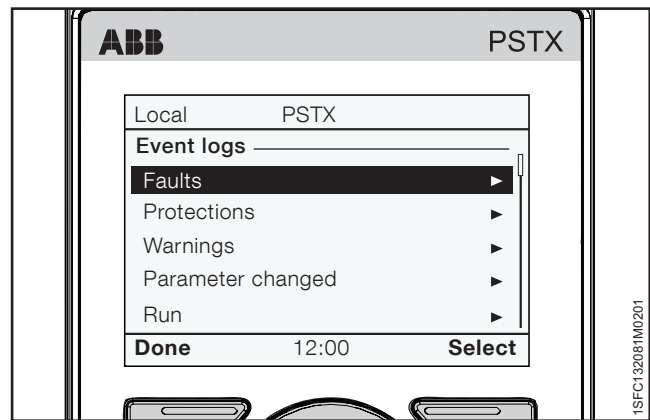
Use the Navigation keys to select a parameter and push  “Details” to read details about the changed parameter (Name, On time and Event count). Push  “Back” to go back to Warning log menu.

#### Run

Use the Navigation keys to select a run event and push  “Details” to read details about the run event (Name, On time and Event count). Push  “Back” to go back to Warning log menu.



**Figure 6.29**  
Event log navigation



**Figure 6.30**  
Event log

## 6.4.4 Backup

Path in menu:

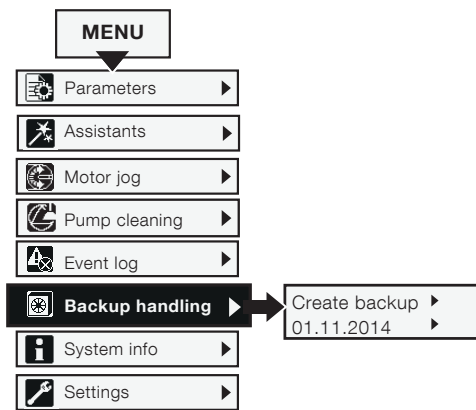
Menu ► Backup handling

For navigation, see **Figure 6.31**.

You can use the movable keypad to transfer parameters from one Softstarter to another during commissioning.

### Transfer of parameters

To transfer (or copy) parameters from one Softstarter to another, connect the keypad to the selected Softstarter and follow the instructions in chapter **6.4.4.1 Create backup** and chapter **6.4.4.2 Uploading of parameters** below:



**Figure 6.31**  
Backups handling

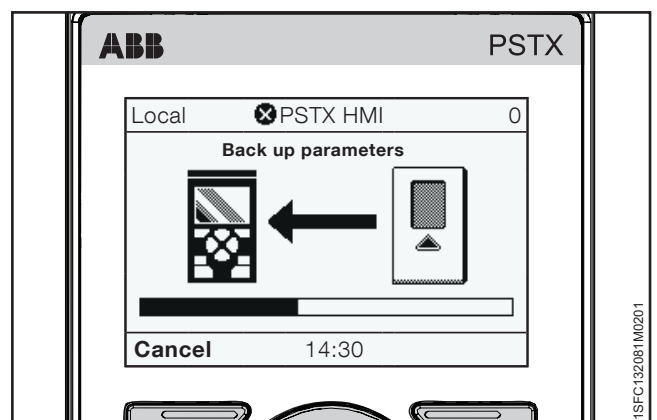
#### 6.4.4.1 Create backup

1. Push "Select" to enter the Backup menu.
2. Push "Create backup" to create a backup.
3. The download of parameters shows as in **Figure 6.32**. The name of the backup file shows as the day, month and year it was created.

#### Replace backup

The Softstarter can store 2 backups. Use the Navigation keys to select an earlier backup and push "Replace", to replace a backup.

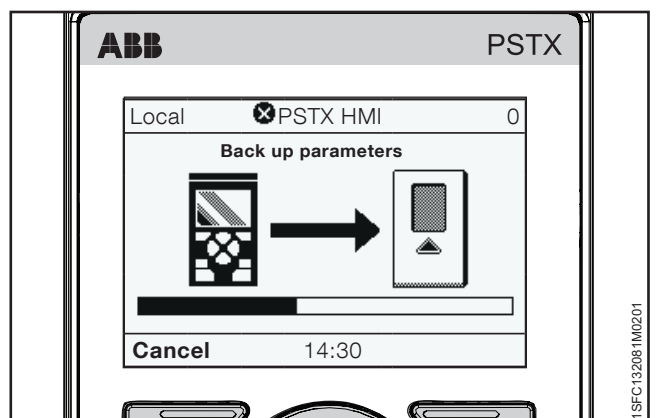
A backup does not change the ID and Motor rated current le.



**Figure 6.32**  
Downloading parameters

#### 6.4.4.2 Uploading of parameters

1. When you complete the download of parameters, remove the HMI from the Softstarter.
2. Connect the HMI to the Softstarter that must receive the backup.
3. Enter the Backup menu and use the Navigation keys to select the backup.
4. Push "Select" for the upload of the parameters. This shows as in **Figure 6.33**.





**Figure 6.33**  
Uploading parameters

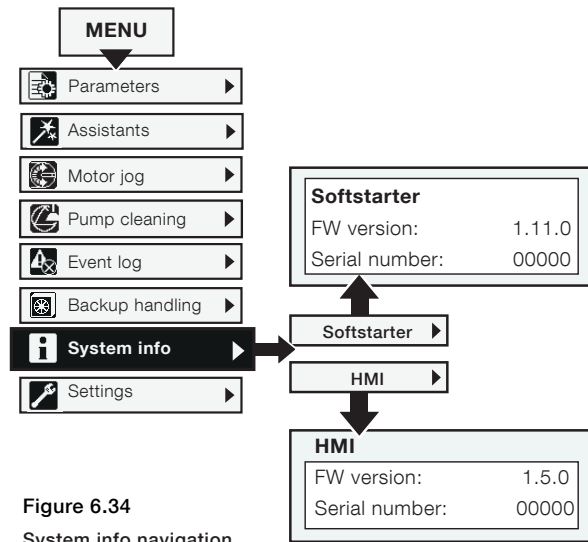
## 6.4.5 System info

Path in menu:

Menu ► System info

For navigation, see **Figure 6.34**.

The System info menu contains system info such as Firmware version and Serial number. The System info menu shows system info of the Softstarter and HMI. Push  “Select” to enter the System info menu. Use the Navigation keys to make your selection. Push  “Back” to go back.



**Figure 6.34**  
System info navigation

## 6.4.6 Settings

Path in menu:

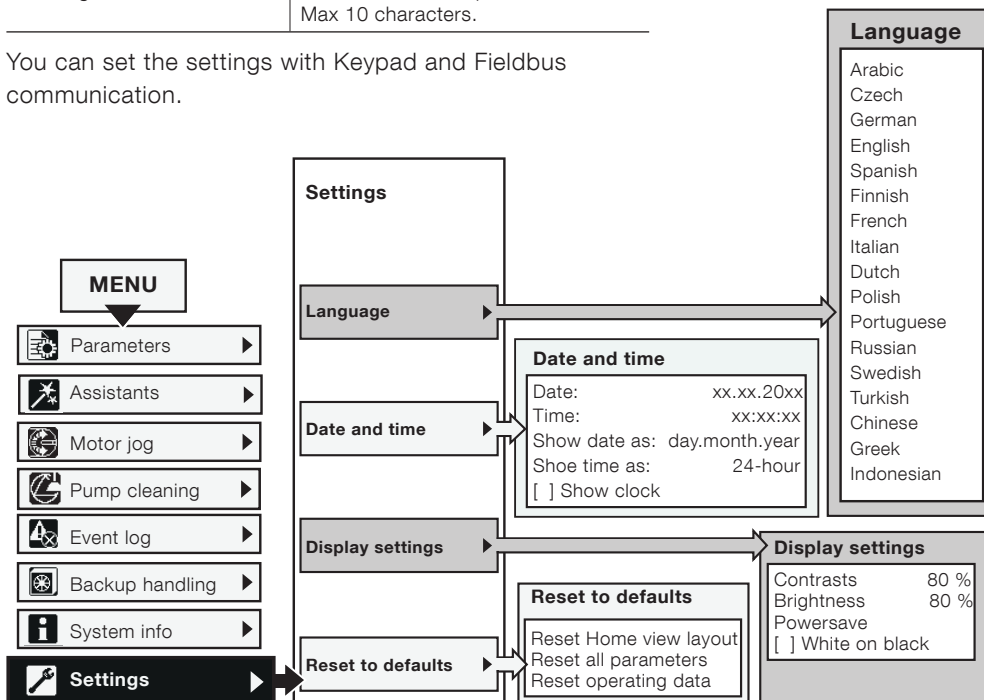
Menu ► Settings

For navigation, see **Figure 6.35**.

The settings menu contains Softstarter set-up parameters. The settings are given in these chapters:

Chapter	Description
6.4.6.1 Language	Change language of the HMI
6.4.6.2 Date and time	Set date and time for the Softstarter
6.4.6.3 Display settings	Change Contrast, brightness etc.
6.4.6.4 Reset to defaults	Reset Home view layout Reset all parameters Reset operating data
6.4.6.5 Change HMI heading	The HMI heading is displayed in the status bar at the top of the HMI. Max 10 characters.

You can set the settings with Keypad and Fieldbus communication.



**Figure 6.35**  
Settings navigation









### 6.4.6.1 Language

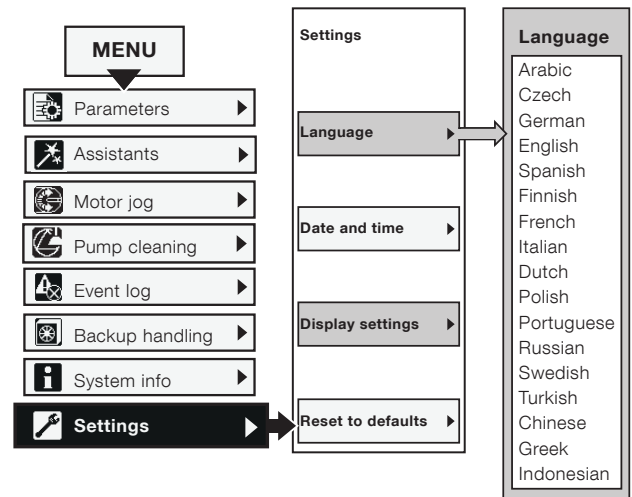
Path in menu:

Menu ▶ Settings ▶ Language

For navigation, see **Figure 6.36**.

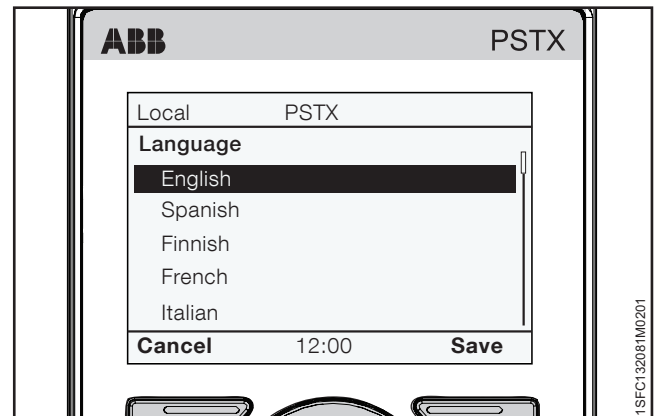
Follow the instructions below for access to the language settings menu (start from Home view):

1. Push  "Select" to enter the menu.
2. Use Navigation keys to navigate to the Settings menu. (The icon symbol is a wrench).
3. Push  "Select" to enter the Settings menu. Use Navigation keys to navigate to the Settings menu. (The icon symbol is a wrench).
4. Highlight the first alternative and push  "Select" and then "Edit" to enter Language settings.
5. Use  and  to select language. See **Figure 6.37**.
6. Push  "Save" to save the selected language.



**Figure 6.36**

Language navigation



**Figure 6.37**

Language menu

### 6.4.6.2 Date and time

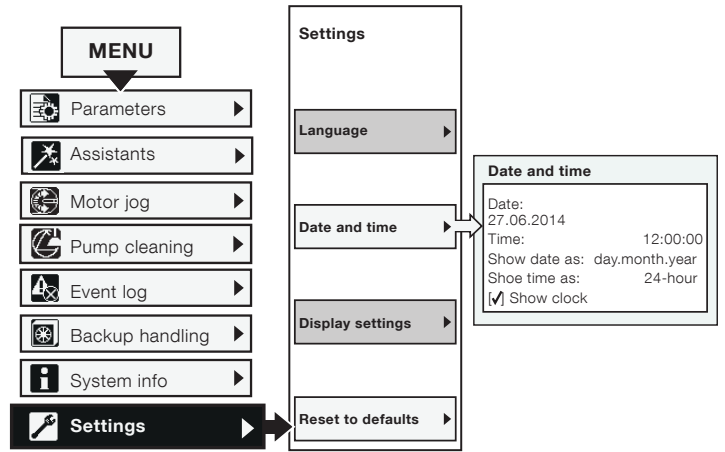
Path in menu:

Menu ► Settings ► Date and time

For navigation see **Figure 6.38**.

Date and Time settings include all date and time configurations for the Softstarter.

To change the settings in the Date and Time menu, push “Edit” to enter the setting. Push “Save” to save the set value. See **Figure 6.39**.



**Figure 6.38**  
Date and time

**Table 7** Date and time settings

Option	Function
Date	Set date: Day, month and year.
Time	Set time: Hour, minutes and seconds.
Show date as	Show the date at top level in this format:  CE      day . month . year US      month/day/Year SO      year-month-day
Show time as	Show the time in 12-hour or 24-hour
Show clock	Show clock On / Off

### Real time clock

The Real time clock is the local time in the Softstarter. The clock runs 2 hours after control supply power is turned off. Set date and time again if a longer power failure occurs.

When the configuration of the time setting is completed, push “Back” 3 times to go back to the Home view, top level.



**Figure 6.39**  
Date and time menu

### 6.4.6.3 Display settings

Path in menu:

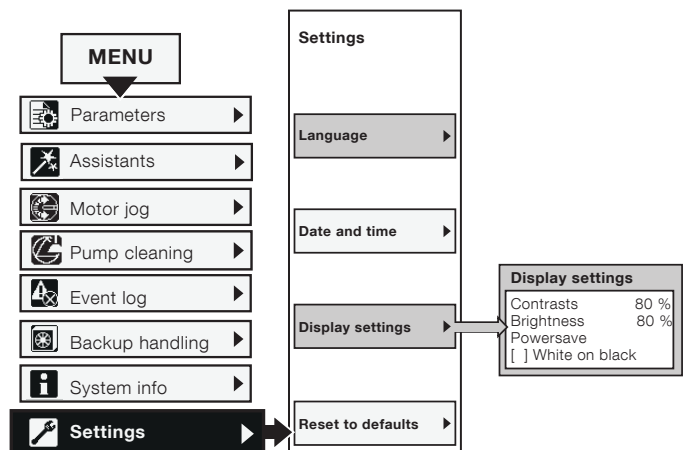
Menu ► Settings ► Display settings

For navigation, see **Figure 6.40**.

The Display settings include all display configurations of the Softstarter. To change the Display settings, Push “Edit” to enter the setting level. Push “Save” to save the set value.

**Table 8** Display settings

Option	Function
Contrast	Set the contrast intensity 0 ... 100%
Brightness	Set the brightness intensity 0 ... 100%
Power save	Turn off the display backlight after 30 minutes, 1, 2, or 5 hours or Never
White on black	White on black display On / Off



**Figure 6.40**  
Display settings

#### 6.4.6.4 Reset to defaults




Path in menu:

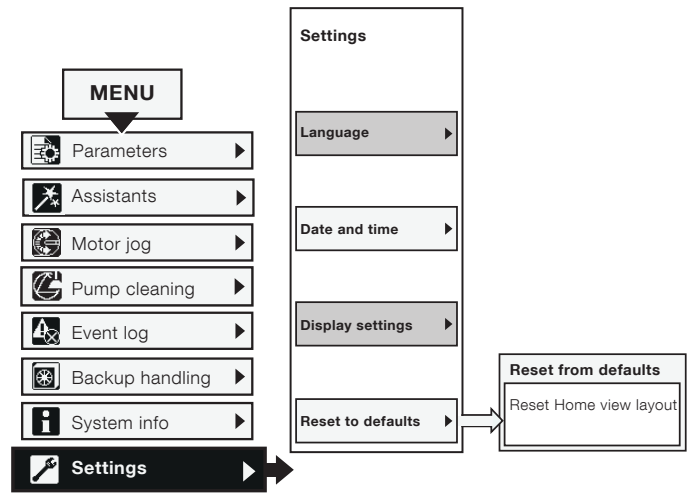
Menu ► Settings ► Reset to defaults

For navigation, see **Figure 6.41**.

Use the Reset to defaults menu to reset home view layout, parameters or operating data back to factory default settings.

The reset does not change the real time clock, the hour run meter, the number of starts and the presentation language.

1. Push  “Select” to enter the Reset to defaults menu.
2. Use the Navigation keys to select;  
Home view layout  
Parameters  
Operating data
3. Push  “Select” to select the data which must be reset.
4. Push  “Yes” to reset, or push “No” to cancel.
5. Confirmation of reset shows as “Done” on the screen.





**Figure 6.41**  
Reset to defaults

#### Reset operating data

Reset operating data is divided in:

- Active energy
- Reactive energy
- Number of starts
- Motor run time
- Thyristor run time

Use the Navigation keys to select which data to reset. Push  “Reset” to reset, or push  “Back” to go back to Reset to defaults menu.

Confirmation of reset shows as “Done” on the screen.



# 7 Functions

<b>7.1 Introduction</b>	74
7.1.1 Setting parameters	74
7.1.2 Softstarter states	74
7.1.3 Motor Current le	75
<b>7.2 Voltage ramp</b>	76
7.2.1 Voltage start ramp	76
7.2.2 Voltage stop ramp	77
7.1.1 Setting parameters	74
<b>7.3 Torque ramp</b>	78
7.3.1 Torque start ramp	79
7.3.2 Torque stop ramp	80
<b>7.4 Full voltage start</b>	81
<b>7.5 Direct stop</b>	81
<b>7.6 Stand still brake</b>	82
<b>7.7 Current limit</b>	83
<b>7.8 Kick start</b>	84
<b>7.9 Slow speed</b>	85
<b>7.10 Motor heating</b>	86
<b>7.11 Motor braking</b>	86
<b>7.12 Sequence start</b>	89
<b>7.13 Automatic restart</b>	90
<b>7.14 Inputs/outputs</b>	91
7.14.1 Signal priority order	92
7.14.3 Relay outputs	94
7.14.4 Analog output	95
7.14.5 Temperature sensor	96
<b>7.16 Event groups</b>	101
<b>7.17 Protections</b>	102
<b>7.18 Warnings</b>	101
<b>7.19 Faults</b>	119
<b>7.20 Special feature</b>	124
<b>7.21 Pump cleaning</b>	128
<b>7.23 SettingsFast take off</b>	133129
<b>7.24 AssistantsSettings</b>	133
<b>7.25 Complete parameter listAssistants</b>	132130
<b>7.25 Complete parameter list</b>	132132

This chapter contains descriptions of all the Softstarter functions and the parameters for configuration.

## 7.1 Introduction

### 7.1.1 Setting parameters

#### Set the parameters via HMI

With the HMI Keypad, you can set parameters for each item, or as a selection of default parameters for different applications.

The HMI complete list shows all parameter groups:

---

01 Motor rated current $I_e$
02 Start and stop
03 Limit
04 Kick start
05 Slow speed
06 Motor heating
07 Motor braking
08 Sequence start
09 Automatic restart
10 Internal IO
11 External IO
12 Communication
13 ... 19 Protections list 1-7
20 ... 24 Warnings list 1-5
25 Internal faults
26 External faults
27 Presentation
28 Service
29 Pump cleaning

---

For navigation sheets, see chapter **6.4.1 Parameters**.

**i** **Lock/Unlock parameters**

Push and hold the Options -key, Menu-key and i-key simultaneous for 2 seconds in order to lock / unlock the keypad.

This prevents accidental changes of parameters. Parameters are read-only. Still Start / Stop and R/L is active.

#### Set the parameters via Fieldbus/PLC

When Fieldbus is used, you can change parameters from the PLC.

A different document specification shows more details about parameter settings changed through Fieldbus/PLC, see **chapter 8 Communication**.

### 7.1.2 Softstarter states

The Softstarter has multiple operation states, in which different functions are available.

Functions can operate in one or more Softstarter states. If a function does not operate in all states, this is noted in the respective function description.

The Softstarter has these states:

- Individual function
- Stand by
- Pre-start
- Start ramp
- TOR (Top of ramp)
- Stop ramp

#### Individual function

In Individual function state, the Softstarter runs individual functions.

Individual functions are:

- Motor heating
- Stand-still brake
- Slow speed forward
- Slow speed reverse

#### Stand by

In Stand by state the Softstarter runs no functions except diagnostics.

#### Pre-start

In Pre-start state the Softstarter runs functions that are intended to run before the Softstarter goes into Start ramp state. A pre start function runs during a pre-set time. Then the Softstarter continues to Start ramp state:

Pre-start functions are:

- Motor heating
- Stand-still brake
- Slow speed forward
- Slow speed reverse

The pre-start functions can also be run as individual functions.

### Start ramp

In Start ramp state the Softstarter runs one of the start functions to soft start a motor by controlling the output voltage or torque. The Start ramp ends and goes into Top of ramp state when the output voltage comes at 100% voltage.

Available start functions are:

- Voltage start ramp
- Torque start ramp
- Full voltage start ramp

### Top of ramp

When the motor comes at Top of ramp, (100% motor voltage) the Softstarter closes the bypass and does not control the motor. In Top of ramp state the Softstarter only runs diagnostics.

### Stop ramp

In Stop ramp state the Softstarter runs stop functions to soft stop a motor by controlling the output voltage or torque. The stop ramp state ends and goes into stand by state when the output voltage comes at the pre-set Stop ramp end level.

Available stop functions are:

- **No ramp**
- **Voltage stop ramp**
- **Torque stop ramp**
- **Dynamic brake**

## 7.1.3 Motor Current I<sub>e</sub>

Set the motor current when you install the Softstarter.

This is the rated nominal current of the motor.



#### **WARNING**

All PSTX Softstarters must be set to the rated current of the motor.

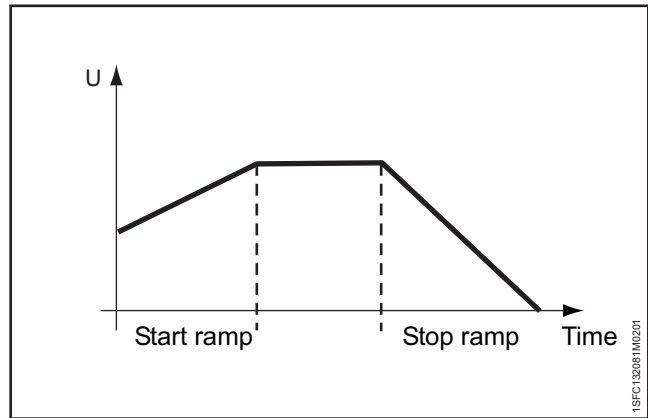
#### **Configuration of the Motor Current I<sub>e</sub> with these parameters:**

Parameter	Description	Setting range	Default value
01.01 Motor Current I <sub>e</sub>	Set the nominal current of the motor. For good performance it is important that it is set to the correct value. For Inside Delta connection, set this parameter to 58% of the nominal motor current.	Individual (type related)	30 A...1250 A, divided into 19 overlapping ranges

## 7.2 Voltage ramp

When using the Voltage ramp, the voltage increases linearly from Initial start level to full voltage during start, and decreases linearly from the Step down level to Stop end voltage level during stop, see **Figure 7.1**.

The torque not always follows the voltage curve, because the torque is also subject to the current. This has the effect that the torque does not increase or decrease linearly.



**Figure 7.1**  
Start and stop ramp

### 7.2.1 Voltage start ramp

When the Softstarter receives a start signal, the Softstarter quickly increases the voltage to the Start ramp initial level. The Softstarter then controls the output voltage in a start ramp.

When the output voltage comes at Top of ramp, the Softstarter closes the bypass, see **Figure 7.2**.

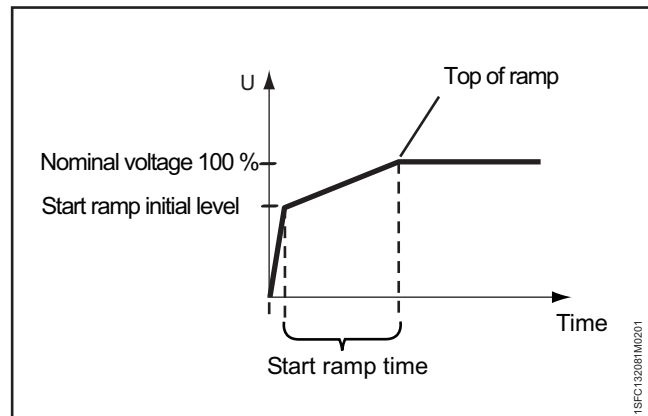
To come at Top of ramp these conditions are necessary:

- The Start ramp time passed, i.e. 100% output voltage.
- The current is below  $1.2 \times$  nominal motor current.

The Start ramp time is the time it takes to go from Start ramp initial level to full voltage. The time to come at Top of ramp can be longer than the set Voltage ramp time, because this is subject to the current.

If the motor starts with a very heavy load, the start ramp time can be longer than usual.

Example: If the Start ramp time is set to 2 seconds and the motor starts a heavy load, this can cause the output current to not go below the set 120% of nominal motor current when the pre-set start ramp time is reached.



**Figure 7.2**  
Voltage start ramp

Configuration of the Voltage start ramp with these parameters:

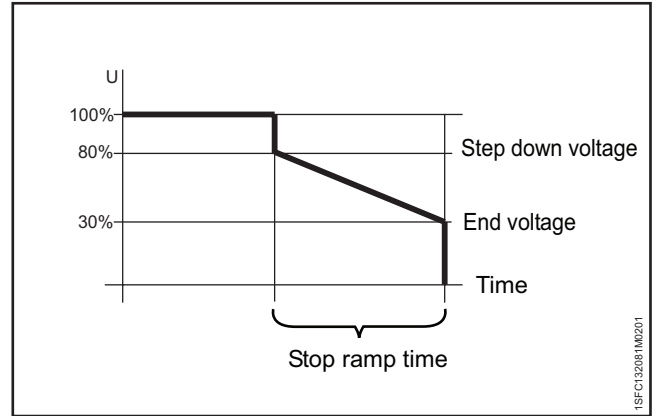
Parameter	Description	Setting range	Default value
02.01 Start mode	Set the Start mode to Voltage ramp.	Voltage ramp, Torque ramp, Full voltage ramp	Voltage ramp
02.03 Start ramp Initial level	Set the voltage level from where the start ramp initiates	10 ... 99%	30%
02.04 Start ramp time	Set the effective time it takes for the voltage to reach 100%.	1 ... 120 s	10 s



## 7.2.2 Voltage stop ramp

When the Softstarter receives a stop signal, the Softstarter decreases the output voltage to the motor in a quick stop ramp, from full voltage down to set Step down voltage level. For best performance, set the step down level to 80%.

When step down level is reached, the Softstarter controls the output voltage during preset Stop ramp time to End voltage level and cuts the output voltage to the motor, see **Figure 7.3**.



**Figure 7.3**  
Voltage stop ramp

### Configuration of the Voltage stop ramp with these parameters:

Parameter	Description	Setting range	Default value
02.02 Stop mode	Set to voltage ramp.	No ramp, Voltage ramp, Torque ramp, Dynamic brake	No ramp
02.05 Stop ramp end level	Sets the level from where the stop ramp ends and the power to the motor is cut (voltage level for Voltage stop and torque level for Torque stop).	10 ... 99%	30%
02.06 Stop ramp time	Sets the effective time it takes for the voltage to come at end level	1 ... 120 s	10 s
28.05 Step down level	Sets the level from where the stop ramp initiates.	10 ... 100%	80%

## 7.3 Torque ramp

When using the Torque ramp, the Softstarter controls the output voltage so that the output torque follows a specified optimal torque curve during start and stop ramp.

For Torque start ramp there are 4 different adjustable torque curves. See description of torque profile parameters for examples on when to use which curve.

The curves are:

- Constant
- Linear
- High inertia
- Progressive

When using the Torque start ramp, the acceleration is constant if the set torque curve is the same as the actual load curve. The output voltage does not increase linearly like when using the voltage start ramp, see **Figure 7.4**.

The Torque ramp makes the equipment that the motor drives stop much softer than the Voltage start ramp.

For Torque stop ramp there is one fixed torque curve. This fixed torque curve is optimized for pump applications.

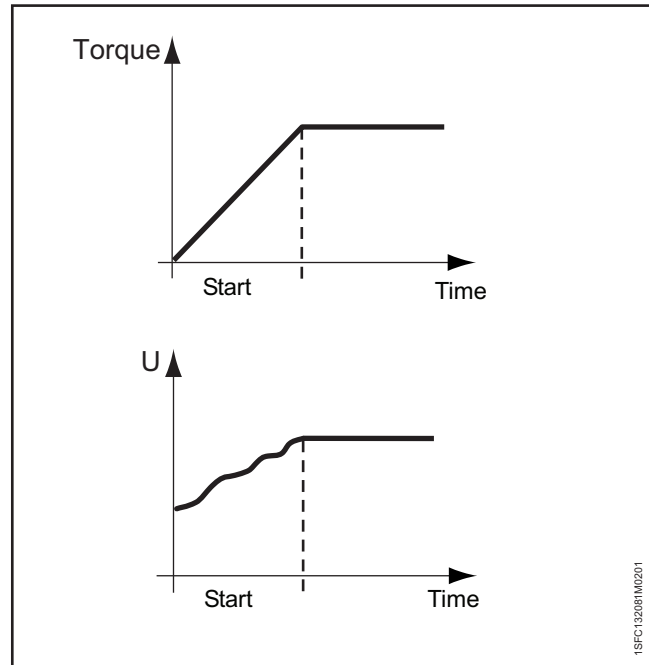


Figure 7.4  
Torque start ramp

### 7.3.1 Torque start ramp

When the Softstarter receives a start signal, the Softstarter makes a quick ramp to set Start ramp initial level. Then the Softstarter controls the output voltage so that the output torque follows a specified optimal torque curve during pre-set time to 100% nominal torque.

When the output voltage comes at 100% nominal voltage (Top of ramp), the Softstarter closes the bypass.

To come at Top of ramp these conditions need to be met:

- The output voltage comes at 100% nominal voltage.
- The current is below  $1.2 \times$  nominal motor current.

The time between the start signal and when nominal torque is reached is the start ramp time.

The start ramp time can be longer if the motor starts with a very heavy load.

Example: If the Start ramp time is set to 2 seconds and the motor starts with a heavy load. This can cause that the output current does not go below set 120% of nominal motor current when the pre-set start ramp time is reached.

#### Configuration of the Torque start ramp with these parameters:

Parameter	Description	Setting range	Default value
02.01 Start mode	Set to Torque ramp.	Voltage ramp, Torque ramp, Full voltage start	Voltage ramp
02.03 Start ramp Initial level	Sets the torque level from where the start ramp initiates.	10 ... 99%	30%
02.04 Start ramp time	Sets the time it takes for the voltage to come at 100%.	1 ... 120 s	10 s
03.05 Torque limit level	Sets the limit for the torque during soft start with torque control	20 ... 200%	150%
28.06 Torque profile start	Sets the shape of the torque ramp during start. <ul style="list-style-type: none"> <li>• Constant setpoint is for centrifuge</li> <li>• Linear is for compressor</li> <li>• High inertia curve is for long conveyor belts</li> <li>• Progressive curve is for centrifugal pump</li> </ul>	Constant setpoint, Linear ramp, Progressive curve, High inertia curve	Linear ramp
28.07 Torque finish	Sets the operation torque for Torque start ramp setting in percentage of base torque.	30 ... 500%	100%
28.08 Torque tune	Sets the integration time of PI controller.	0 ... 1000%	100%
28.09 Torque ctrl gain	Sets the speed of the voltage regulator during torque start and stop. It seldom needs to be changed, but if a dip occur in the torque curve during stop, increasing this value might solve it.	0.01 ... 10.00	0.02
28.10 Torque PI integration time	Sets the integration time of PI controller.	0.001 ... 10.000 s	0.004 s
28.11 Torque slip	Sets the slip difference from nominal to pull-out torque in percentage.	0.1 ... 100%	1.0%
28.12 Torque diff	Sets the maximum desired difference between reference and actual torque in percentage.	0.1 ... 100%	2.0%
28.13 Torque filter time	Sets the Torque control filter time in seconds.	0.01 ... 10 s	0.02 s

### 7.3.2 Torque stop ramp

When using the Torque stop ramp, the output voltage to the motor the torque follows a specified optimal curve from the Step down level to end voltage during stop. The Torque stop ramp makes the equipment that the motor drives stop much softer than when using voltage ramp. See **Figure 7.5**.

This can be especially useful in pump applications where a sudden stop can cause water hammering and pressure surges.

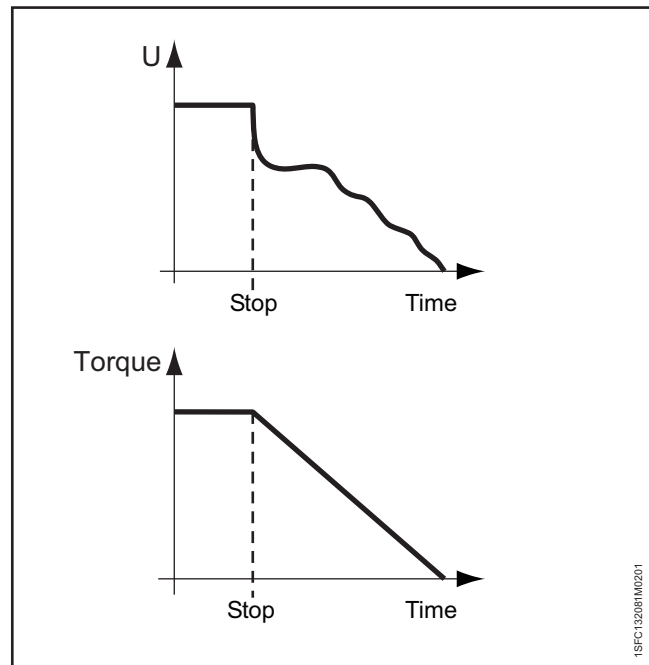


Figure 7.5

Torque stop ramp

7

#### Configuration of the Torque stop ramp with these parameters:

Parameter	Description	Setting range	Default value
02.02 Stop mode	Set to Torque ramp.	No ramp, Voltage ramp, Torque ramp, Dynamic brake	No ramp
02.05 Stop ramp end level	Sets the level from where the stop ramp ends and the power to the motor is cut(voltage level for Voltage stop and torque level for Torque stop).	10 ... 99%	30%
02.06 Stop ramp time	Sets the time it takes for the voltage to come at end level.	1 ... 120 s	10 s
28.05 Step down level	Sets the level from where the stop ramp initiates.	10 ... 100%	80%
28.08 Torque tune	Sets the adjustment of resistive losses.	0...1000%	100%
28.09 Torque ctrl gain	Sets the speed of the voltage regulator during torque start and stop. It seldom needs to be changed, but if a dip occur in the torque curve during stop, increasing this value might solve it.	0.01 ... 10	0.02
28.10 Torque PI integration time	Sets the integration time of PI controller.	0.001 ... 10 s	0.004 s
28.11 Torque slip	Sets the slip difference from nominal to pull-out torque in percentage.	0.1 ... 100%	1.0%
28.12 Torque diff	Sets the maximum desired difference between reference and actual torque in percentage.	0.1 ... 100%	2.0%
28.13 Torque filter time	Sets the Torque control filter time in seconds.	0.01 ... 10 s	0.02 s

## 7.4 Full voltage start

When using the full voltage start, the Softstarter increases the motor speed as fast as possible. The motor voltage ramps up to full voltage in 1/2 seconds.



### INFORMATION

Full voltage start ignores the Current limit.

Configuration of the Full voltage start with these parameters:

Parameter	Description	Setting range	Default value
02.01 Start mode	Set to Full voltage start.	Voltage ramp, Torque ramp, Full voltage start	Voltage ramp

## 7.5 Direct stop

When using the Direct stop the output voltage to the motor is 0.

Configuration of the Direct stop with these parameters:

Parameter	Description	Setting range	Default value
02.02 Stop mode	Set to No ramp.	No ramp, Voltage ramp, Torque ramp, Dynamic brake	No ramp

## 7.6 Stand still brake

The Stand-still brake function brakes the motor. Use this during pre-start to make sure that the motor does not run before you start the Start ramp. You can also control the Stand-still brake from a digital I/O or a Fieldbus.



### WARNING

If the Softstarter is connected inside-delta, use of the Stand-still brake can cause damage to the equipment.



### WARNING

Because this function makes the motor warm, we recommend to use a PTC or PT100 element to monitor the temperature.

In some conditions, the built-in EOL is not accurate for this feature.



### INFORMATION

Stand-still brake only works when the Softstarter is connected in-line.

### Configuration of the Stand-still brake with these parameters:

Parameter	Description	Setting range	Default value
02.07 Pre-start function	Set to Stand-still brake.	Pre start off, Motor heating, Stand still brake, Slow speed forward, Slow speed reverse	Pre start off
02.08 Pre-start time	Set the duration of the pre-start function.	0.0 ... 7200.0 s	10.0 s
07.01 Stand still brake strength	Set the Braking strength 10-100%. Select a suitable value for the application.	10 ... 100%	50%

## 7.7 Current limit

Current limit sets a maximum value of the starting current output to the motor. The time to come at full voltage can be longer than the set Start ramp Time when Current limit is enabled.

There are 3 different Current limit functions:

- Normal current limit
- Dual current limit
- Ramp current limit



### WARNING

If the load is very heavy, current limit can prevent the current to decrease below the set current level and cause overheating.

#### Normal current limit

When using Normal current limit and the set current limit is reached, the output voltage stays stable until the current level falls below the set current limit. Then the start ramp continues.

#### Dual current limit

Dual current level has 2 current limit levels. When the Current limit is reached, the output voltage stay constant until the set time expires or the current decreases. If the current decreases, the Softstarter continues the voltage ramp. If the second current limit time expires and the current has not decreased, the Softstarter increases the current to the Dual current limit. See **Figure 7.6** . When the current comes at the Dual current limit the Softstarter behaves as for normal Current limit.

Dual current limit can be used as a back-up function to prevent overheating.

#### Ramp current limit

When the current comes at the first current limit level the output voltage restricts the current from increasing at a maximum linearly curve up to the second current limit. The set time determines the time it takes for the current limit to come at the second current level.

When the current comes at the second current limit, the Softstarter behaves as for the normal current limit.

You can use Ramp current limit as a back-up function to prevent overheating.

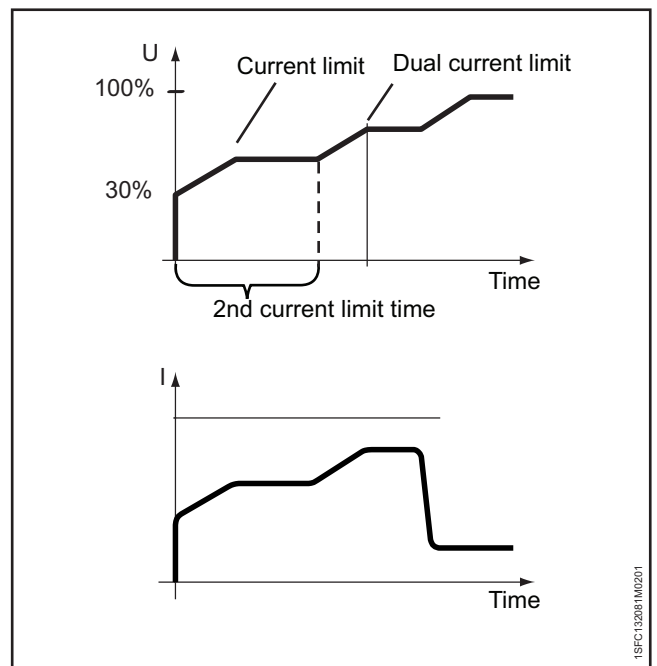


Figure 7.6

Dual current limit

### Current limit has these parameters:

Parameter	Description	Setting range	Default value
03.01 Current limit type	Set the Current limit type.	Off, Normal, Dual, Ramp	Normal
03.02 Current limit level	Sets the first level to which the current is limited during start.	1.5 ... 7.5 x I <sub>e</sub>	4.0 x I <sub>e</sub>
03.03 2nd curr lim level	Sets the level of the second current limit.	1.5 ... 7.5 x I <sub>e</sub>	7.0 x I <sub>e</sub>
03.04 2nd curr lim time	Sets the time limit from the start signal when the second current limitation comes in operation.	2 ... 120 s	8 s

## 7.8 Kick start

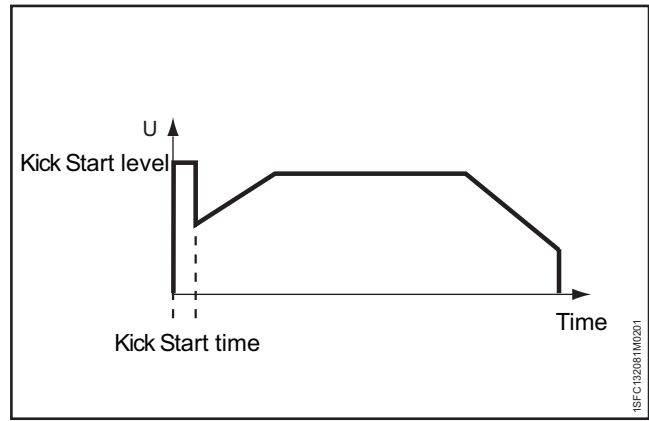
Kick start function is a function to kick loose the motor initial friction during a set time and level. If Kick start is enabled, the start ramp starts directly after Kick start.

See **Figure 7.7** .



### INFORMATION

Current limit function does not work during kick start.



**Figure 7.7**  
Kick start

**Kick start has these parameters:**

Parameter	Description	Setting range	Default value
04.01 Kick start	Enables a voltage peak at the beginning of the start ramp.	On, Off	Off
04.02 Kick start level	Sets the level of the Kick start in percentage of rated voltage.	50 ... 100%	70%
04.03 Kick start time	Sets the duration of the Kick start in seconds.	0.20 ... 2.00 s	0.20 s



## 7.9 Slow speed

Slow speed is an individual function, or a pre-start function to run the motor with low voltage output. You can use this feature for example to position a traverse or mill band.

Operate this function through the HMI, I/O or Fieldbus.

Slow speed has 3 pre-specified speeds:

- Fast jog
- Jog
- Creep

The motor strength can be adjusted with separate parameters. Select a suitable value for the application.



### WARNING

The torque when using Slow speed is maximum  $\frac{1}{3}$  of the full motor torque. This is achieved when using Fast jog and the strength parameter set to 100%. Too high value of the motor strength could cause oscillations and if set to too low value, the motor may not start.



### WARNING

Because Slow speed function warms up the motor we recommend to use a PTC or PT100 element for temperature monitoring.

In some conditions, the built-in EOL is not accurate for this feature.

You can run the motor in the forward and reverse direction, with different slow speed speeds in each direction. When the Softstarter receives a Slow speed signal, the motor accelerates up to a constant speed that is slower than the nominal speed, for as long as the slow speed signal remains active. When the Slow speed signal is deactivated, the Softstarter immediately cuts the voltage applied to the motor and the motor stops. For navigation, see **6.2.4 Motor jog**.

**Slow speed is configured with the following parameters:**

Parameter	Description	Setting range	Default value
02.07 Pre-start function	Set to Slow speed forward or Slow speed reverse.	Pre start off, Motor heating, Stand still brake, Slow speed forward, Slow speed reverse	Pre start off
02.08 Pre-start time	Sets the duration of the pre-start function.	0.0 ... 7200.0 s	10.0 s
05.01 Slow speed forward	Sets the Slow speed forward. Fast jog forward is 33%, Jog forward is 15% and Creep forward is 8% of the nominal motor speed.	Fast jog, Jog, Creep	Jog
05.02 Slow speed forward strength	Parameter related to the torque that is generated during Slow speed in the forward direction.	10 ... 100%	50%
05.03 Slow speed reverse	Sets the Slow speed reverse. Fast jog reverse is 33%, Jog reverse is 20% and Creep reverse is 9% of the nominal motor speed.	Fast jog, Jog, Creep	Jog
05.04 Slow speed rev strength	Parameter related to the torque that is generated during Slow speed in the reverse direction.	10 ... 100%	50%



### INFORMATION

Do not use slow speed for more than 2 minutes, as this will cause the motor to heat up excessively.



### INFORMATION

Slow speed is only working when the Softstarter is connected in-line.

## 7.10 Motor heating

Use the Motor heating as a pre-start function to heat the motor before actual start without rotation to the motor. Or use it as an individual function operated from a digital input or Fieldbus.

The Softstarter supplies a current to the motor, without coming at the torque level that starts the motor.



### WARNING

If the Softstarter is connected inside-delta and using the Motor heating, this can cause damage to the equipment.



### WARNING

Because Motor heating function warms up the motor we recommend to use a PTC or PT100 element for temperature monitoring.

In some conditions the built-in EOL is not accurate for this feature.



### INFORMATION

Motor heating only works when the Softstarter is connected in-line.

7

#### Motor heating has these parameters:

Parameter	Description	Setting range	Default value
02.07 Pre-start function	Set to Motor heating.	Pre start off, Motor heating, Stand still brake, Slow speed forward, Slow speed reverse	Pre start off
02.08 Pre-start time	Sets the duration of the pre-start function.	0.0 ... 7200.0 s	10.0 s
06.01 Motor heating capacity	Sets the heating power to the motor. Select a suitable value for the application.	10 ... 100000 W	10 W

## 7.11 Motor braking

### Stand still brake

Stand still brake prevents a motor from spinning when in standstill condition. It can be activated through IO, fieldbus or as a pre-start function.

### Dynamic brake

Dynamic brake is an intelligent variant of DC brake starting with a period of dynamic braking followed by a switch to DC brake. During the dynamic brake the firing angle and thyristor firing sequence are continuously recalculated depending on operating conditions. During DC brake these are pre-determined. The reason for switching to DC brake is because it is effective at low speed but ineffective at high speed. During both dynamic- and DC-brake the kinetic energy of the motor is converted to heat that is dissipated in the rotor.

Motor braking with Softstarter is not an exact science. Trial and error testing is required to find the optimal parameter values.



#### WARNING

Braking exerts a lot of stress on the thyristors so from a thermal perspective a brake shortly after a start can be counted as two consecutive starts.

If the dynamic brake strength is set close to 100% the current can reach peak level above the motor's locked rotor current. This means that the internal thyristor overload fault or electronic overload protection can trip.



#### INFORMATION

Using a Softstarter to brake the motor will cause noise and vibrations just like any other braking method. If a fast stop time is required the brake strength will have to be set to a large value which will result in increased noise and vibration.



#### INFORMATION

Parameter 07.03 (Dynamic brake strength) and 07.04 (DC brake strength) are the ones that affect the motor deceleration time. Parameter 07.02 (Motor brake time) only works as a timeout. The goal should be to choose the lowest possible braking strength and still fulfill the user's deceleration time requirements.



#### INFORMATION

To use Dynamic brake set parameter 02.02 (Stop mode) to Dynamic brake.



#### INFORMATION

An external PTC or PT100 sensor to monitor the motor temperature is recommended. Does not work when connected Inside delta - see **Figure 5.1**.



#### INFORMATION

Motor heating only works when the Softstarter is connected in-line.

### 7.11.2.1 How to use

Parameter 7.3 (Dynamic brake strength) and 7.4 (DC brake strength) are the ones that affect the motor deceleration time. Parameter 7.2 (Motor brake time) only works as a timeout. The goal should be to choose the lowest possible braking strength and still fulfill the user's deceleration time requirements.

1. Set parameter 2.2 (Stop mode) to Dynamic brake.
2. Set parameter 7.2 (Motor brake time) to be equal to the desired stop time.
3. Set parameter 7.3 (Dynamic brake strength) to 40%.
4. Set parameter 7.4 (DC brake strength) to 40%.
5. Perform the first test and do two measurements:
  - 5.1 Time it takes for the motor to decelerate from full speed to the value specified by parameter 7.5 (DC brake switch speed threshold, default value is 28%).
  - 5.2 Time it takes for the motor to decelerate from full speed to near zero speed.
6. Check if motor deceleration time is longer or shorter than desired.
  - 6.1 If deceleration time is longer than desired, increase dynamic brake strength and DC brake strength by 10% and try again. Continue like this until the actual stop time is equal to the desired stop time.
  - 6.2 If deceleration time is shorter than desired, decrease dynamic brake strength and DC brake strength by 10% and try again. Continue like this until the actual stop time is equal to the desired stop time.
7. Optional configuration: It can be heard when the DC brake is activated, the motor will sound different then. If DC brake is activated too soon (before the motor speed is below the value specified by parameter 7.5), increase parameter 7.6 (DC brake switch delay time) by 5-10s and try again.
8. Optional configuration: If it takes too long time for the motor to decelerate when DC brake is active, increase the motor brake time by 10s and increase only parameter 7.4 (DC brake strength) by 10% and try again.
9. Optional configuration: One of the digital inputs In0, In1 or In2 can be configured as "Cancel brake". When a logic high (flank) is detected, the motor brake will be cancelled.

### 7.11.2.2 How long time does it take to stop the motor?

Depends on the moment of inertia of the motor and load.

Field test example: Motor: 61A, 400V, 50Hz; Load: Fan, large flywheel. With stop mode equal to no ramp, the deceleration time was 1min.

With stop mode equal to dynamic brake and dynamic brake strength and DC brake strength equal to 40%, the deceleration time was 30s.

With dynamic brake strength and DC brake strength equal to 50%, the deceleration time was 20s.

Motor braking has these parameters:

Parameter	Description	Setting range	Default value
07.01 Stand still brake strength	Sets the braking strength, choose suitable value for application.	10–100%	50%
07.02 Motor brake time	Sets the motor brake time.	1.0–900.0 s	1.0 s
07.03 Dynamic brake strength	Sets the Dynamic braking strength.	10–100%	40%
07.04 DC brake strength	Sets the DC braking strength.	10–100%	40%
07.05 DC brake switch speed threshold	The approximate speed when the switch from dynamic brake to DC brake occurs.	10–100%	28%
07.06 DC brake switch delay time	Sets the time that the speed has be below the threshold before the switch to DC brake occurs. Configure this parameter only if the switch occurs too soon or too late.	0.1–100.0 s	3.0 s
02.02 Stop mode	Sets the desired stop mode: No ramp = Immediately cuts power to the motor, Voltage stop ramp = Decreases voltage linearly, Torque stop ramp = Decreases torque in a pre-defined pattern, Dynamic brake = Applies brake to the motor	No ramp, Voltage ramp, Torque ramp, Dynamic brake	No ramp
28.52 Auxiliary condition	Enables additional thyristor trig occasions of dynamic brake	Off, On	Off
28.55 Fast take-off	Reduces the time from the start signal to the current starts flowing in the main circuit.	Off, On	Off
28.63 Flux support min speed	Minimum estimated speed for allowing additional flux supporting current pulses to motor during dynamic brake	10–100%	35%

## 7.12 Sequence start

The Softstarter can start up to 3 different motors sequentially, sequence 1, 2 and 3. This is suitable when setting up the Softstarter with different applications. Select the parameter set through input signal to the Softstarter.

Parameter settings and physical connections for programmable inputs must agree.



### WARNING

EOL does not work during Sequence start.  
Recommended to add separate overload protections for each motor.

For connections, see chapter **5.1.2.5 Programmable inputs (Sequence start)**.

Parameters set for sequence start 1, 2 and 3 are equal.

If the Softstarter trips, and the trip must stop the motor, all motors stop.

Sequence start has these parameters:

*Example: Start 1, (Start mode seq 1) is set to Run 1 relay, (K4, K5 or K6) the relay closes when the start signal is given, which leads to a power transfer. This can change between Softstarters and their specific parameter settings.*

Parameter	Description	Setting range	Default value
08.01 Sequence mode	Enable sequence start of motors.	Off, Start several motors	Off
08.02 I <sub>e</sub> seq 1 08.30 seq 2 08.60 seq 3	Sets the nominal current for the motor. For good performance, it is important that the nominal current is set to the correct value. For Inside Delta connection, set this parameter to 58% of the nominal motor current.	Individual (different for each type)	9.0 A...1250 A, divided into 19 overlapping ranges
08.03 Start mode seq 1 08.31 seq 2 08.61 seq 3	Sets the desired start mode.	Voltage ramp, Torque ramp, Full voltage start	Voltage ramp
08.04 Start ramp time seq 1 08.32 seq 2 08.62 seq 3	Sets the time it takes for the voltage to come at 100%.	1 ... 120 s	10 s
08.05 Start ramp init lev seq 1 08.33 seq 2 08.63 seq 3	Sets the level from where the start ramp initiates (voltage level for Voltage start and torque level for Torque start).	10 ... 99%	30%
08.06 Curr lim lev seq 1 08.34 seq 2 08.64 seq 3	Sets the level to which the current is limited during start.	0.5 ... 7.5 × I <sub>e</sub>	7.0 × I <sub>e</sub>
08.07 Kick start seq 1 08.35 seq 2 08.65 seq 3	Enables a voltage peak at the beginning of the start ramp.  Information: The function Current Limit is not in operation during Kick start.	Off, On	Off
08.08 kick start level seq 1 08.36 seq 2 08.66 seq 3	Sets the level of the Kick start in percentage of rated voltage.	50 ... 100%	70%
08.09 Kick start time seq 1 08.37 seq 2 08.67 seq 3	Sets the duration of the Kick start in seconds.	0.20 ... 2.00 s	0.20 s
08.10 Torque lim lvl seq 1 08.38 seq 2 08.68 seq 3	Sets the level to which the torque is limited during the start with torque control.	20 ... 200%	150%
08.11 Torque tune seq 1 08.39 seq 2 08.69 seq 3	Adjustment of resistive losses.	0 ... 1000%	100%
08.12 Torque ctrl gain seq 1 08.40 seq 2 08.70 seq 3	Sets the speed of the voltage regulator during torque start and stop. It seldom needs to be changed, but if a dip occur in the torque curve during stop, increasing this value might solve it.	0.01 ... 10.0	0.02

## 7.13 Automatic restart

The Softstarter automatically starts the motor again after a fault or protection occurred.



### INFORMATION

Automatic restart does not work for:

Shunt fault, Short circuit fault, Open circuit thyristor fault, Faulty usage, Faulty connection, Electronics failure, Max number of starts, Phase reversal protection, Bypass open protection, Auto restart protection and IO Controller protection.

The primary requirement is that if a fault or protection was asserted, the Softstarter automatically starts the motor again in order to ensure an uninterrupted process.

The event only resets after the Auto-reset delay time passed. If Auto-restart is enabled, the Softstarter does not start the fault relay directly, because the fault relay can sometimes be connected to a breaker upstream.

The Softstarter makes multiple attempts to start again, with a fixed time interval between each, and ignores the start digital input signal during this time.

If the fault still remains after a restart, this is a failed attempt to start again.

The fault relay is only on after the number of failed restarts is higher than the given number.

Upon a stop signal the auto-restart sequence is aborted and the fault relay is off.

The programmable options are:

- None - No function on the digital input.
- Reset - Fault/protection reset.
- Enable - When In0=0, the Softstarter stops immediately. When In0=1, the Softstarter is in normal operation. Overrides all other inputs, except LOCAL CONTROL.
- Slow speed forward - While the digital input is high, the motor will slowly move forward.
- Slow speed reverse - While the digital input is high, the motor will slowly move in the reverse direction.
- Motor heating - While the digital input is high, the motor heating is active.
- Stand still brake - While the digital input is high, the stand still brake is active.
- Start reverse - While the digital input is high, the Softstarter will start in the reverse direction, using external reversing contactors.
- User defined protection - When activated (the protection can be programmed to be active low or high) the User defined protection will be activated.
- Emergency mode - Active high, Emergency mode is activated when digital input is high. - Active low, Emergency mode is activated when digital input is low.
- Fieldbus disable control - When the digital input is set high, the motor cannot be controlled from the fieldbus. Instead the start/stop digital input must be used, or the HMI.
- Start 1 - Start motor 1. See chapter **7.12 Sequence start**.
- Start 2 - Start motor 2. See chapter **7.12 Sequence start**.
- Start 3 - Start motor 3. See chapter **7.12 Sequence start**.
- Switch to remote control - A positive flank from low to high on digital input takes the control from the HMI, i.e. local control is changed to remote control.
- **Cancel brake,**  
Pump cleaning automatic,  
Pump cleaning forward,  
Pump cleaning backward,  
Hold in Remote (Active High),  
Hold in Remote (Active Low).
- Hold in Remote (Active High) - Then the digital input is set high the control from HMI, i.e. local control is changed to remote control and can not be changed back to local as long as the digital input is high.
- Hold in Remote (Active Low) - The same as above except that it is active low instead of active high.

Automatic restart has these parameters:

Parameter	Description	Setting range	Default value
09.01 Auto-reset delay time	Delay time after which the event is reset.	0 ... 3600 s	10 s
09.02 Auto-restart	Enable auto-restart function.	Off,On	Off
09.03 Auto-restart max attempts	Max number of auto-restart attempts.	1 ... 10	5

## 7.14 Inputs/outputs

This chapter gives a description of input and output signals (I/O) such as digital inputs, relay outputs, analog outputs, temperature inputs, and external digital inputs.

Chapter	Function
7.12.1	Digital inputs
7.12.2	Relay outputs
7.12.3	Analog outputs
7.12.4	Temperature sensor

### Internal I/O

Internal I/O are the integrated signals to the Softstarter.

The internal I/O provides these:

- 5 Digital inputs
- 3 Relay output
- 1 Analog output

### Extension I/O (Option)

The Softstarter can be extended with more inputs and outputs by using the I/O Extension module. The I/O Extension module provides these:

- 8 Digital input
- 4 Relay output
- 1 Analog output

To use an extension I/O provides the same possibilities to use all the Softstarters functions as for the programmable internal I/O.

Available I/O Extensions. See chapter **5.1.3 Extension I/O**.

For example, an extension I/O is useful when a sequence start is necessary.

### Connect the I/O Extension

- Set parameter Com3 function (12.01) to the I/O Extension.
- Connect the DX111 or the DX122 1Ca and 1Cb to Com3 terminals.
- Use parameter group 11 to program the function of each DX111/DX122 input and output.

**External digital inputs (extension I/O) have these parameters:**

Parameter	Description	Setting range	Default value
12.01 Com3 function	Set the function of the Com3 port to Extension I/O	None, Test, modbus RTU slave, Extension I/O.	Test

## 7.14.1 Signal priority order

The default priority order for all signals is HMI, fieldbus and then wired input.

### Detailed list of signal priorities:

Input	HMI in local control	HMI in remote control
Start <sup>2</sup>	HMI	Fieldbus <sup>1</sup> / Wired
Stop	HMI	Fieldbus <sup>1</sup> / Wired
Reset	All inputs have the same priority	All inputs have the same priority
Enable	Wired	Wired
Slow speed forward <sup>2</sup>	HMI	Fieldbus <sup>1</sup> / Wired
Slow speed reverse <sup>2</sup>	HMI	Fieldbus <sup>1</sup> / Wired
Motor heating <sup>2</sup>	Wired	Fieldbus <sup>1</sup> / Wired
Stand still brake <sup>2</sup>	Wired	Fieldbus <sup>1</sup> / Wired
Start reverse <sup>2</sup>	Wired	Fieldbus <sup>1</sup> / Wired
User defined protection	Wired	Fieldbus <sup>1</sup> / Wired
Emergency mode active high	Wired	Fieldbus <sup>1</sup> / Wired
Emergency mode active low	Wired	Fieldbus <sup>1</sup> / Wired
Fieldbus disable control	Wired	Wired
Start1 <sup>2</sup>	Wired	Fieldbus <sup>1</sup> / Wired
Start2 <sup>2</sup>	Wired	Fieldbus <sup>1</sup> / Wired
Start3 <sup>2</sup>	Wired	Fieldbus <sup>1</sup> / Wired
Switch to remote control	Wired	Fieldbus <sup>1</sup> / Wired
Cancel Brake	Wired	Fieldbus <sup>1</sup> / Wired
Pump cleaning automatic <sup>2</sup>	HMI	Fieldbus <sup>1</sup> / Wired
Pump cleaning forward <sup>2</sup>	HMI	Fieldbus <sup>1</sup> / Wired
Pump cleaning backward <sup>2</sup>	HMI	Fieldbus <sup>1</sup> / Wired
Hold in Remote (Active High)	Wired	Wired
Hold in Remote (Active Low)	Wired	Wired

1) Fieldbus signal is regarded if:

- Wired input "Fieldbus disable control" (see Setting range) is low.
- "Auto Mode" signal on fieldbus is high (Bit 3 in Digital Output Telegram from PLC to the Softstarter)
- Parameter "12.03 Fieldbus Control" is set to On.

2) All wired inputs that are configured as 'Enable' need to be high or this signal is ignored.



## 7.14.2 Digital inputs (DI)

The Softstarter has 5 digital inputs for basic control of the unit.

The 5 digital inputs are terminal 13, 14, 15, 16 and 17.

The inputs are named

- Start
- Stop
- In0
- In1
- In2

Start and Stop inputs are fixed to start and stop function and cannot be changed.

In0, In1 and In2 are programmable inputs. Functions can be related to the physical signal through a drop down menu on the HMI.

Use the inputs with 24 V and current sinking type, 10 mA. The digital input is isolated and can withstand up to 100 V in potential difference between the Softstarter functional ground and the ground of the interconnected system. You can use the input with internal 24 V or external 24 V supply.

The digital input values for respective input voltage:

“0” = 0 – 5 V

“1” = 15 – 33 V

Maximum voltage input is 33 V and minimum is -0.5 V. Outside these voltage ranges the digital value is undefined and can be either “0” or “1”.

### Internal digital Inputs (Internal I/O) have these parameters:

Parameter	Description	Setting range	Default value
10.01 In0 function	Function of programmable digital input.	None, Reset, Enable, Slow speed forward, Slow speed reverse, Motor heating, Stand-still brake, Start reverse, User defined protection, Emergency mode (active high), Emergency mode (active low), Fieldbus disable control, Start 1, Start 2, Start 3, Switch to remote control, Cancel brake, Pump cleaning automatic, Pump cleaning forward, Pump cleaning backward, Hold in Remote (Active High), Hold in Remote (Active Low), Lock Parameters (Active High), Lock Parameters (Active Low).	Reset
10.02 In1 function		Same as In0	None
10.03 In2 function		Same as In0	None

### External digital Inputs (extension I/O) have these parameters:

Parameter	Description	Setting range	Default value
11.01 1DI0 function	Function of programmable digital input.	None, Reset, Enable, Slow speed forward, Slow speed reverse, Motor heating, Stand-still brake, Start reverse, User defined protection, Emergency mode (active high), Emergency mode (active low), Fieldbus disable control, Start 1, Start 2, Start 3, Switch to remote control, Cancel brake, Pump cleaning automatic, Pump cleaning forward, Pump cleaning backward, Hold in Remote (Active High), Hold in Remote (Active Low), Lock Parameters (Active High), Lock Parameters (Active Low).	None
11.02 1DI1 function	Same as 1DI0	Same as 1DI0	None
11.03 1DI2 function	Same as 1DI0	Same as 1DI0	None
11.04 1DI3 function	Same as 1DI0	Same as 1DI0	None
11.05 1DI4 function	Same as 1DI0	Same as 1DI0	None
11.06 2DI5 function	Same as 1DI0	Same as 1DI0	None
11.07 2DI6 function	Same as 1DI0	Same as 1DI0	None
11.08 2DI7 function	Same as 1DI0	Same as 1DI0	None

### 7.14.3 Relay outputs

The Softstarter has 3 relay outputs. The relay outputs are K4, K5 and K6. The relays outputs are: 30VDC/250VAC  
I<sub>th</sub> = 5A , I<sub>e</sub>= 1,5Amp (AC-15).

You can set the function of these relay output signals Functions or an event group can be related to the physical signal through a drop down menu on the HMI.

The programmable options for each relays are:

- None – No function on the relay output.
- Run – Indicates when the Softstarter gives voltage to the motor.
- Top of ramp (TOR) – Indicates that motor runs on full voltage.
- Event group (0-6) – Faults, protections, warning are all selectable by customer.
- Sequence 1-3 Run – Used to control the line contactors during sequence start.
- Sequence 1-3 TOR – Used to control the bypass contactors during sequence start.
- Run reverse – Used to close the reversing contactor.
- Ready to Start – Indicates when
  - Control supply voltage is detected
  - Mains three phase voltage is detected
  - Mains frequency is within range (40-72Hz)
  - Motor connection is detected
  - Phase sequence is detected
  - No events are active
  - Enable signal is active
  - If the max nbr of starts per hour function is enabled and set to stop manual or stop automatic, the remaining time to start counter.
- Fieldbus – Control the relay through the fieldbus communication. See the fieldbus manuals for more info.

As default K4 is set to function Run, K5 to Top of ramp and K6 to Eventgroup 0.

Description of the relay terminals

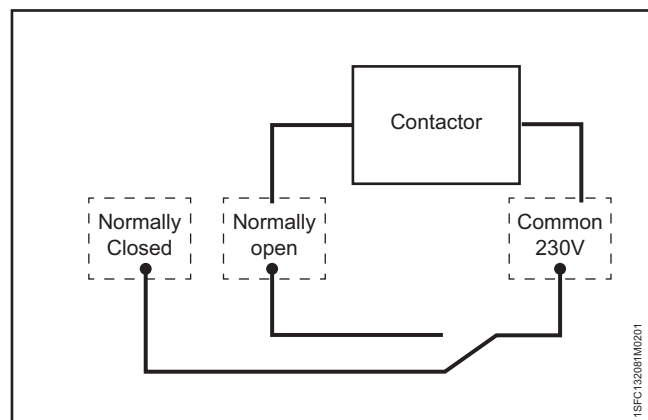
Each relay has 3 terminals: 1 common terminal (COM), 1 normally open terminal (NO) and 1 normally closed terminal (NC). . See **Figure 7.8** .

Normally open – Circuit is open in normal mode (circuit is not shorted to common).

Normally closed – Circuit is closed in normal mode (the circuit is continuously shorted to common).

Internal relay outputs (internal I/O) have these parameters:

Parameter	Description	Setting range	Default value
10.04 K4 function	Function of programmable output relay K4, K5, K6.	None, Run, Top of ramp, Eventgroup 0 -6, Sequence 1-3 Run, Sequence 1-3 TOR, Run reverse, Ready to start, Fieldbus	Run
10.05 K5 function	Same as K4 function	Same as K4 function	Top of ramp
10.06 K6 function	Same as K4 function	Same as K4 function	Event group 0



**Figure 7.8**

A contactor may for example be connected (230 volts)

**External relay outputs (extension I/O) have these parameters:**

Parameter	Description	Setting range	Default value
11.09 1DO0 function	Function of programmable output relay 1DO0 (extension I/O).	None, Run, Top of ramp, Eventgroup 0 -6, Sequence 1-3 Run, Sequence 1-3 TOR, Run reverse, Ready to start, Fieldbus	None
11.10 1DO1 function	Same as 1DO0	Same as 1DO0	Top of ramp
11.11 2DO2 function	Same as 1DO0	Same as 1DO0	Event group 0
11.12 2DO3 function	Same as 1DO0	Same as 1DO0	Motor Current, A

### 7.14.4 Analog output

The Softstarter has 1 analog output for an analog meter, or the PLC.

Configuration of the parameter analog output type, AO type, to show:

- Motor current, A
- Mains voltage, V
- Active power, kW
- Active power, HP
- Reactive power, kVar
- Apparent power, kVA
- Active energy, kWh
- Reactive energy, kVARh
- $\cos \Phi$
- Motor temperature, %
- Thyristor temperature, %
- Motor voltage, %
- Mains frequency, Hz
- PT100 temperature, centigrade
- PTC resistance, Ohm

The voltage or current output can be set by a configuration parameter, AO reference in the Softstarter. The selection of voltage or current must be set to adapt to the analog meter or the PLC.

The settings are:

- 0-10 voltage output, V
- 0-10 current output, mA
- 0-20 current output, mA
- 4-20 current output, mA

AO is the reference to the output voltage in 0-100% of the set parameter AO max and AO min.

**Internal Analog output has these parameters:**

Parameter	Description	Setting range	Default value
10.07 AO reference	Sets the Analog output reference	0-10 mA, 0-20 mA, 4-20 mA, 0-10 V	4-20 mA
10.08 AO type	Sets the Analog output type.	Motor current [A], Mains voltage [V], Active power [kW], Active power [HP], Reactive power [kVAR], Apparent power [kVA], Active energy [kWh], Reactive energy [kVARh], $\cos \Phi$ , Motor temperature [%], Thyristor temperature [%], Motor voltage [%], Mains frequency [Hz], PT100 temperature [centigrade], PTC resistance [ $\Omega$ ], Fieldbus [%]	Motor current [A]
10.09 AO max value	Sets the max analog output value.	0 ... 1000000	500
10.10 AO min value	Sets the min analog output value.	0 ... 1000000	0

*Example:*

- *AO type is set to Motor current.*
- *AO reference is set to 0-10 V*
- *AO min to 0, and AO max to 3000.*

*This means that when the motor current is:*

- *3000 A, the output voltage is 10 V.*
- *0 A, the output voltage is 0 V.*
- *1500 A, the output voltage is 5 V.*

**External Analog output (Extension I/O) has these parameters:**

Description	Description	Setting range	Default value
11.13 1AO0 reference	Sets the Analog output reference.	0-10 mA, 0-20 mA, 4-20 mA, 0-10 V	4-20 mA
11.14 1AO0 type	Sets the Analog output type.	Motor current [A], Mains voltage [V], Active power [kW], Active power [HP], Reactive power [kVAr], Apparent power [kVA], Active energy [kWh], Reactive energy [kVArh], cos Φ, Motor temperature [%], Thyristor temperature [%], Motor voltage [%], Mains frequency [Hz], PT100 temperature [centigrade], PTC resistance [Ω], Fieldbus [%]	Motor current [A]
11.15 1AO0 max value	Sets the max Analog output value.	0 ... 1000000	500
11.16 1AO0 min value	Sets the min Analog output value.	0 ... 1000000	0

### 7.14.5 Temperature sensor

#### Temperature inputs

There is 1 temperature input. The user can set 3 different types of temperature sensors: See **chapter** Temperature sensors 7.17.14

- PTC
- PT100
- Bi-metal switch

These can be connected to different protections. A protection can come on if a particular temperature occurs.

## 7.15 Fieldbus

PSTX has 1 Anybus port, 1 Fieldbus plug adaptor port (FBPA), and 1 modbus RTU port. You can use only 1 bus at a time: the user cannot connect the Softstarter to multiple Fieldbuses.

The port used for modbus RTU is a multifunction port that you can use to connect an Extension I/O module. If an Extension I/O module is necessary you cannot use the port for modbus RTU. Use an Anybus modbus RTU module instead.

In the IP-based Fieldbuses, such as modbus TCP, the user must set IP address, gateway, subnet mask and DHCP client.

### Fieldbus type

When you use Fieldbus communication, select the present type of Fieldbus:

- Internal Modbus RTU
- Anybus
- Fieldbus plug



### INFORMATION

If there is no message passed between the PSTX softstarter and the Anybus module for more than the configured fieldbus failure timeout time (parameter 19.12), the PSTX softstarter will trip on fieldbus communication failure protection (P1E00) and with the default configuration the motor will be stopped.



### INFORMATION

If the fieldbus communication system is setup in such a way that commands/requests are not continuously passed between the PLC and Softstarter, this protection function should be disabled. Set parameter 19.4 (Fieldbus failure op) to "Off".

### Fieldbus control

If you use the Softstarter with Fieldbus communication, set the Fieldbus interface to ON before it can take action

### Fieldbus address

If you use the Softstarter with Fieldbus communication, set a Fieldbus address for the Softstarter. Select a suitable and unoccupied number as the address.



### WARNING

The motor can start unexpectedly if there is a start signal present during one of the actions below.

- Changing from 1 type of control to another (Fieldbus control / hardwire control).
- Remember that when Fieldbus auto disable is active, this change can occur automatically.
- Re-programming of the programmable inputs.
- Reset all Settings (sets programmable input to Enable).

### Fieldbus failure operation

See chapter 7.17.21 Fieldbus failure protection.

## Fieldbus Inputs/Outputs

Functions set in the Softstarter as Fieldbus digital inputs (DI) are in fact the digital inputs to the PLC i.e. the data flow from the Softstarter through the network to the PLC.

Fieldbus digital outputs (DO) are not configurable. The output (DO) gives a description of data flow from the network to the Softstarter i.e. appears as an input, from the Softstarter point of view.

**Fieldbus communication has these parameters:**

Parameter	Description	Setting range	Default value
12.01 Com3 function	Sets the function of the Com3 port. The default value "Test" is needed during production test. It should be changed to "None" if not Modbus or Extension I/O is used.	None, Test, Modbus RTU slave, Extension I/O	Test
12.02 FB interface connector	Sets the Fieldbus interface selection.	FbPlug, Modbus RTU, Anybus, None	None
12.03 Fieldbus control	Enables control from fieldbus.	Off, On	Off
12.04 Fieldbus address	Sets the Bus address.	0 ... 65535	0
12.05 Fieldbus ip address	Fieldbus IP: Sets the IP-address.	0.0.0.0 ... 255.255.255.255	0.0.0.0
12.06 Fieldbus ip gateway	Fieldbus IP: Sets the default gateway.	0.0.0.0 ... 255.255.255.255	0.0.0.0
12.07 Fieldbus ip netmask	Fieldbus IP: Sets the netmask.	0.0.0.0 ... 255.255.255.255	255.255.255.0
12.08 Fieldbus ip dhcp client	Fieldbus IP: Enables dhcp.	Off, On	Off
12.09 FB baud rate*	Sets the baud rate of internal modbus-RTU interface, Anybus DeviceNet and Anybus modbus-RTU.	1200, 2400, 4800, 9600, 19200, 38400, 57600, 76800, 115200, 125000, 250000, 500000, auto	* 19200
12.10 FB parity	Sets parity for Anybus modbus-RTU.	No parity, Odd parity, Even parity	Even parity
12.11 FB stop bits	Select stop bits for Anybus modbus-RTU.	1 Stop bit, 2 Stop bits	1 Stop bit

Parameter	Description	Setting range	Default value
12.12 Fieldbus DI 1	Sets the DI 1 programmable digital input signal.	None, Start feedback, Stop feedback, Fault reset feedback,	Run status
12.13 Fieldbus DI 2	Sets the DI 2 programmable digital input signal.	Slow speed rev feedback, Slow speed forw feedback, Start 1 feedback, Start 2 feedback,	TOR status
12.14 Fieldbus DI 3	Sets the DI 3 programmable digital input signal.	Start 3 feedback, Motor heating feedback, User defined feedback,	Line
12.15 Fieldbus DI 4	Sets the DI 4 programmable digital input signal.	Stand still brake feedback, Emergency mode feedback,	Phase sequence
12.16 Fieldbus DI 5	Sets the DI 5 programmable digital input signal.	Start reverse feedback, Run status, TOR status, Line,	Start feedback
12.17 Fieldbus DI 6	Sets the DI 6 programmable digital input signal.	Phase sequence, Event group 0 status, Event group 1 status,	Stop feedback
12.18 Fieldbus DI 7	Sets the DI 7 programmable digital input signal.	Event group 2 status, Event group 3 status, Event group 4 status, Event group 5 status,	Event group 0 status
12.19 Fieldbus DI 8	Sets the DI 8 programmable digital input signal.	Event group 6 status, Sequence 1 Run status, Sequence 2 Run status,	Event group 1 status
12.20 Fieldbus DI 9	Sets the DI 9 programmable digital input signal.	Sequence 3 Run status, Sequence 1 TOR status, Sequence 2 TOR status,	Event group 2 status
12.21 Fieldbus DI 10	Sets the DI 9 programmable digital input signal.	Sequence 3 TOR status, Run reverse status, Enable status, Digital In0 status, Digital In1 status, Digital In2 status, Local control status, Cancel brake status, Pump cleaning auto status, Pump cleaning forward status, Pump cleaning backward status, External digital 1DI0 status, External digital 1DI1 status, External digital 1DI2 status, External digital 1DI3 status, External digital 1DI4 status, External digital 2DI5 status, External digital 2DI6 status, External digital 2DI7 status, HW DI Start status, HW DI Stop status, Ready to start (line contactor)	Event group 3 status
12.22 Fieldbus AI 1	Sets the AI 1 programmable analog input signal.	None, Phase L1 current, Phase L2 current, Phase L3 current,	Phase L1 current
12.23 Fieldbus AI 2	Sets the AI 2 programmable analog input signal.	Active power (HP), Active power, Apparent power, Mains voltage, Power factor, Motor voltage,	Phase L2 current
12.24 Fieldbus AI 3	Sets the AI 3 programmable analog input signal.	Active energy (resettable), EOL time to trip, Mains frequency,	Phase L3 current
12.25 Fieldbus AI 4	Sets the AI 4 programmable analog input signal.	Max phase current, Motor current, Motor run time (resettable), Motor temperature, Motor temperature percent, Number of starts (resettable), Phase sequence, PT100 temperature, PTC resistance, Reactive energy (resettable), Reactive power, Remaining time to start, Thyristor temperature, Thyristor temperature percent, EOL time to cool, Top event code, Motor current percent, Thyristor run time (resettable), Motor connection, Phase L1 current (high range), Phase L2 current (high range), Phase L3 current (high range), Active power (HP) (high range), Active power (high range), Apparent power (high range), Reactive power (high range), Max phase current (high range), Motor current (high range), Active energy (high range), Reactive energy (high range), Number of starts (high precision)	Max phase current
12.26 Fieldbus AI 5	Sets the AI 5 programmable analog input signal.		Mains frequency
12.27 Fieldbus AI 6	Sets the AI 6 programmable analog input signal.		Motor voltage
12.28 Fieldbus AI 7	Sets the AI 7 programmable analog input signal.		Motor temperature percent
12.29 Fieldbus AI 8	Sets the AI 8 programmable analog input signal.		Number of starts (resettable)
12.30 Fieldbus AI 9	Sets the AI 9 programmable analog input signal.		Motor run time (resettable)
12.31 Fieldbus AI 10	Sets the AI 10 programmable analog input signal.		Top event code
12.32 Allow CIP reset	Sets if CIP reset is allowed or not	Yes, No	No

Parameter	Description	Setting range	Default value
12.33 Fieldbus BACnet Device Instance	Fieldbus BACnet Device Instance	0 ... 4194303	4194303
12.34 BACnet FDR IP address	DBACnet foreign device registration IP address	0.0.0.0 ... 255.255.255.255	0.0.0.0
12.35 BACnet foreign device registration UDP port	BACnet foreign device registration UDP port	1 ... 65535	47808
12.36 BACnet foreign device registration time interval	BACnet foreign device registration time interval	0 ... 65535 s	0 s
12.37 Fieldbus AO 1	Sets the AO 1 programmable analog output signal	FBT argument 2, Internal analog out	FBT argument 2
12.38 Fieldbus AO 2	Sets the AO 2 programmable analog output signal	FBT argument 3, External analog out	FBT argument 3
12.39 Change SNMP community string	Change the Profinet SNMP default community strings (both read-only and read-write)	Yes, No	No
12.40 SNMP community string part 1	Profinet SNMP community string part 1	0 ... 4294967295	1094861357
12.41 SNMP community string part 2	Profinet SNMP community string part 2	0 ... 4294967295	1347638360

\*) Restrictions on which baud rates you can use for different protocols.

Baudrate	Modbus RTU on Com 3	Modbus RTU Anybus	Devicenet on Anybus
1200		x	
2400		x	
4800		x	
9600	x	x	
19200	x	x	
38400	x	x	
57600	x	x	
76800	x	x	
115200	x	x	
125000			x
250000			x
500000			x
Auto baud			x



## 7.16 Event groups

An event group consists of a number of supervision functions that have been assigned to it.

There are three different types of supervision functions:

- Faults, default Eventgroup 0 (0000001)
- Protections, default Eventgroup 1 (0000010)
- Warnings, default Eventgroup 2 (0000100)

The supervision functions generate events based on different conditions in the motor and in the Softstarter itself. Each different event can be assigned to 1 or more Event groups. An Event group can be mapped to a relay output or/and a Fieldbus signal.

For each supervision function there is a parameter for assigning the related event to 1 or more Event groups.

In PSTX there are 7 Event groups, numbered from 0 to 6. All supervision functions are set as default to 1 Event group.

There are 7 event groups that you can use in any way. Event groups 4-6 are completely unassigned by default and are convenient to use for custom applications. The other groups have events assigned to them by default.

### Example:

In this example the user collects all internal faults in the event group 6 and connects the event group to relay output K6. The faults are connected to event group 0 by default (indicated with value 0000001). The new value (1000001) assigns the fault to both event group 0 and event group 6.

### Parameter Default value New value :

Parameter	Default value	New value
25.01 Shunt fault out	0000001	1000001
25.03 Short circuit out	0000001	1000001
25.05 Open circuit thyr out	0000001	1000001
25.07 Thyristor OL out	0000001	1000001
25.09 Heat sink over temp out	0000001	1000001
25.11 Unspecified fault out	0000001	1000001
25.13 Electronics failure out	0000001	1000001
10.06 K6 function	Event group 0	Event group 6

## 7.17 Protections

The Softstarter has a number of protection functions to protect the Softstarter, motor and other equipment.

In addition to the type of operations mentioned below, which are available for all protections, some protections have more options.

Protections can be enabled or disabled by the user. The protection parameters can only be changed if the protection is in operation.

When a protection function senses a risk of damage, the unit does these actions:

- Protection LED comes ON
- The unit shows the type of event
- The unit stores the type of event in the event list

Protections can be set to have automatic reset or manual reset. For every protection, there is a parameter called Operation, which can be set to:

- Stop-Automatic – The engine stops, and resets automatic when the fault condition is inactive \*.
- Stop-Manual – The engine stops, and must be reset manually when the fault condition is inactive \*.
- Off
- Indication

\*) You cannot reset a fault when the fault condition is still active.  
Example: If you set EOL Operation (engine is too warm) to stop-manual, you can only reset the Softstarter when the temperature of the engine has decreased to the correct temperature.

Protections can be set to an Event group by the Out parameter. The Event group can be set for relay output to control other devices in an application

By default all parameters are set to the same Eventgroup.

## 7.17.1 Electronic overload protection

The motor is overloaded because of too high current during a certain time. The Electronic overload protection resets when the motor temperature decreases to 60% of EOL trip level.

**Electronic overload protection has these parameters:**

Parameter	Description	Setting range	Default value
13.01 EOL mode	Set the EOL mode to Normal or Dual.	Normal/ Dual	Normal
13.02 EOL class	Sets the EOL trip class.	10 A, 10, 20, 30	10
13.03 EOL dual class	Sets the protection class used when in top of ramp. This parameter is only applicable when EOL protection mode is set to dual.	10 A, 10, 20, 30	10 A
13.04 EOL out	Identifies the Event groups this protection is part of.	Eventgroup 0 ...6	0000010
13.05 EOL operation	Sets the operation of this protection.	Off, Stop-Manual, Stop-Automatic, Indication	Stop-Manual

## 7.17.2 Locked rotor protection

The motor is running stiff.

This protection only operates in the Top of ramp state.

**Locked rotor protection has these parameters:**

Parameter	Description	Setting range	Default value
13.06 Locked rotor level	Set the locked rotor trip level	0.5 ... 8.0 x I <sub>e</sub>	4.0 x I <sub>e</sub>
13.07 Locked rotor trip time	Sets the time that the current is above the trip level to trip.	0.20 ... 10.00 s	1.00 s
13.08 Locked rotor delay time	Sets the time after top of ramp that the protection is enabled.	1.00 ... 30.00 s	5.00 s
13.09 Locked rotor out	Identifies the Event groups this protection is part of.	Eventgroup 0 ... 6	0000010
13.10 Locked rotor op	Sets the operation of this protection.	Off, Stop-Manual, Stop-Automatic, Indication	Off

## 7.17.3 Max number of starts per hour protection

Sets the minimum time between 2 consecutive starts.

This protection is connected to the signal Remaining time to start, that you can add in the Home view through the Options menu

**Max number of starts protection has these parameters:**

Parameter	Description	Setting range	Default value
13.11 Max no of starts per hour	Sets the limitation in number of starts per hour. When you set this parameter to 6, the minimum time between starts is 10 minutes, allowing a maximum of 6 starts per hour.	1 ... 100	6
13.12 Max no of starts per hour out	Identifies the Event groups this protection is part of.	Eventgroup 0 ... 6	0000010
13.13 Max no of starts per hour op	Sets the operation of this protection.	Off, Stop-Manual, Stop-Automatic, Indication	Off

## 7.17.4 Current underload protection

The motor current is below the specified value.

This protection only operates in the Top of ramp state

**Current underload protection has these parameters:**

Parameter	Description	Setting range	Default value
14.01 Curr underload level	Sets the Current underload trip level.	0.3 ... $0.9 \times I_e$	$0.5 \times I_e$
14.02 Curr underload trip time	Sets the time that the current is below the trip level to trip..	0 ... 30 s	10 s
14.03 Curr underload delay time	Sets the time after Top of ramp that the protection is enabled.	0 ... 30 s	5 s
14.04 Curr underload out	Identifies the Event groups this protection is part of.	Eventgroup 0 ... 6	0000010
14.05 Curr underload op	Sets the operation of this protection.	Off, Stop-Manual, Stop-Automatic, Indication	Off

## 7.17.5 Power factor underload protection

The power factor is below the normal level.

Use the Power factor underload protection to supervise the load of the motor. If the load decreases the power factor also decreases.

This protection only operates in the Top of ramp state.

**Power factor underload protection has these parameters:**

Parameter	Description	Setting range	Default value
14.06 Pwr factor underload level	Sets the Power factor underload trip level.	0.00 ... 1.00	0.50
14.07 Pwr factor underload trip time	Sets the time that the Power factor is below the trip level to trip.	0 ... 30 s	10 s
14.08 Pwr factor underload delay time	Sets the time after Top of ramp that the protection is enabled.	0 ... 30 s	5 s
14.09 Pwr factor underload out	Identifies the Event groups this protection is part of.	Eventgroup 0 ... 6	0000010
14.10 Pwr factor underload op	Sets the operation of this protection.	Off, Stop-Manual, Stop-Automatic, Indication	Off

## 7.17.6 Current imbalance protection

This protection senses if there is imbalance in the currents. Correctly all 3 phases have the same current.

This protection only operates in the Top of ramp state.

**Current imbalance protection has these parameters:**

Parameter	Description	Setting range	Default value
14.11 Curr imb level	Sets the permitted Current imbalance level between the phase with the highest current and the phase with the lowest current.	10 ... 80%	80%
14.12 Curr imb trip time	Sets the time that the Current imbalance is below the trip level to trip.	1 ... 30 s	10 s
14.13 Curr imb delay time	Sets the time after Top of ramp that the protection is enabled.	1 ... 30 s	5 s
14.14 Curr imb out	Identifies the Event groups this protection is part of.	Eventgroup 0 ...6	0000010
14.15 Curr imb operation	Sets the operation of this protection.	Off, Stop-Manual, Stop-Automatic, Indication	Off

## 7.17.7 Overvoltage protection

This protection senses if the main voltage is too high.  
This protection does not operate in the Standby state.

**Overvoltage protection has these parameters:**

Parameter	Description	Setting range	Default value
15.01 Overvoltage level	Sets the Overvoltage trip level.	165 ... 850 V	760 V
15.02 Overvoltage trip time	Sets the time that the voltage is above the trip level to trip.	0.1 ... 100.0 s	1.0 s
15.03 Overvoltage out	Identifies the Event groups this protection is part of.	Eventgroup 0 ... 6	0000010
15.04 Overvoltage op	Sets the operation of this protection.	Off, Stop-Manual, Stop-Automatic, Indication	Off

## 7.17.8 Undervoltage protection

This protection only operates in the Top of ramp state.

**Undervoltage protection has these parameters:**

Parameter	Description	Setting range	Default value
15.05 Undervoltage level	Sets the Undervoltage trip level.	165 ... 760 V	165 V
15.06 Undervoltage trip time	Sets the time that the voltage is below the trip level to trip.	0.1 ... 100.0 s	1.0 s
15.07 Undervoltage op	Sets the operation of this protection.	Off, Stop manual, Stop auto, Indication.	Off
15.08 Undervoltage out	Identifies the Event groups this protection is part of.	Eventgroup 0 ... 6	0000010

## 7.17.9 Voltage imbalance protection

This protection senses voltage imbalance. Normally there is the same voltage in all 3 phases. If the voltage is different in the phases, the engine can run bumpy.

**Voltage imbalance protection has these parameters:**

Parameter	Description	Setting range	Default value
15.09 Voltage imb level	Sets the permitted voltage imbalance level between the phase with the highest voltage and the phase with the lowest voltage.	1 ... 100%	10%
15.10 Voltage imb out	Identifies the Event groups this protection is part of.	Eventgroup 0 ... 6	0000010
15.11 Voltage imb op	Sets the operation of this protection.	Off, Stop manual, Stop auto, Indication.	Off
15.11 Voltage imb trip time	Sets the time of voltage imbalance in order to trip.	1...100 s	10 s

## 7.17.10 Phase reversal protection

7

This protection senses if the phases are connected incorrectly.

The order in which the phases are connected to the in-stream power has no effect on the Softstarter, but it may be relevant to the motor, which is connected to the Softstarter. The motor can for example run in the wrong direction if the phases are connected incorrectly. This protection senses if the phases are connected in the wrong order and then prevents the engine from starting.

**Phase reversal protection has these parameters**

Parameter	Description	Setting range	Default value
16.01 Phase rev out	Identifies the Event groups this protection is part of.	Eventgroup 0 ... 6	0000010
16.02 Phase rev operation	Sets the operation of this protection.	Off, Stop-Manual, Stop-Automatic, Indication	Off
16.12 Phase rev expected sequence	Expected phase sequence	L1->L2->L3, L1->L3->L2	L1->L2->L3

### 7.17.11 Frequency range protection

Sets the trip level for the frequency.

**Frequency range protection has these parameters:**

Parameter	Description	Setting range	Default value
16.03 Freq range lower trip lvl	Sets the lower trip level for the frequency.	40 ...72 Hz	45 Hz
16.04 Freq range upper trip lvl	Sets the upper trip level for the frequency.	40 ...72 Hz	66 Hz
16.05 Freq range trip time	Sets the time that the frequency is outside the trip range to trip.	0 ... 60 s	5 s
16.06 Freq range out	Identifies the Event groups this protection is part of.	Eventgroup 0 ... 6	0000010
16.07 Freq range operation	Sets the operation of this protection.	Off, Stop-Manual, Stop-Automatic, Indication	Off

### 7.17.12 Bypass open protection

This protection senses if the Bypass contactor or relay did not close when Top of ramp is reached.

Speak to ABB Sales Offices for service.

**Bypass open protection has these parameters:**

Parameter	Description	Setting range	Default value
16.08 Bypass open out	Identifies the Event groups this protection is part of.	Eventgroup 0 ... 6	0000010
16.09 Bypass open operation	Sets the operation of this protection.	Off, Stop-Manual, Stop-Automatic, Indication	Indication
16.13 Bypass open trip time	Sets the time that the bypass contactor may be detected as open before tripping.	1 ... 300 s	10 s

### 7.17.13 24V output protection

This protection senses if the 24 V voltage output is overloaded or shorted.

**24V output protection has these parameters:**

Parameter	Description	Setting range	Default value
16.10 24V output out	Identifies the Event groups this protection is part of.	Eventgroup 0 ... 6	0000010
16.11 24V output operation	Sets the operation of this protection.	Off, Stop manual, Stop auto, Indication.	Indication

## 7.17.14 Temperature sensors

### PTC

The PTC temperature input can measure a motor temperature in the range of -25° to 250°. The PTC measurement obeys the standard for a Mark-A detector. Refer to IEC60947-8.

### PT100

The Softstarter has a 3-wire PT100 input. The trip temperature is set by the user. The maximum trip temperature is 250° and lowest is -25°. The PT100 measurement must have an accuracy of +/-3° with 3 wires measuring if the 3 connecting cables have the same resistance.

### Bi-metal switch

You can combine temperature input with bi-metal switches for detecting overtemperature. These temperature sensors behave like a switch that opens or close at the trip temperature. Each type (NO – normally open or NC – normally closed) is supported. The maximum current through the bi-metal switches is 100 mA.

**External thermal sensor has these parameters:**

Parameter	Description	Setting range	Default value
10.11 Ext therm sensor - ID	Sets the External thermal sensor modes. it is required to change it to the used type of sensor.	No sensor, PTC element, Three-wire PT100, Two-wire PT100, Bimetal switch (NC), Bimetal switch (NO)	No sensor

#### 7.17.14.1 External thermal sensor - PTC/Bi-metal switch protection

The external thermal sensor detected a temperature higher than the trip level. The Softstarter has a temperature input where a PTC element can be connected. See chapter **5.1.2.11 Temperature sensor input**. This can be set to trip if it goes above a certain temperature.

For Bi-metal switch protection: 10.11 = Bimetal switch (NO) or (NC). Use 17.01 and 17.02 to set functionality for the protection

#### Error caused by the line

The error caused by the line resistance is to approximately 2.5 Kelvin per ohm. If you don't know the resistance of the line and you cannot measure it, you can make an estimation of the error caused by the line with

**Table 1 Temperature errors in ohm.**



### Temperature errors in ohm

The table below shows temperature errors in ohms, at an ambient temperature of 20 °C, for different line lengths and conductor cross sections for PT100 sensors. Set this number in parameter 17.03 PT100 2wire res.

**Table 1** Temperature errors in ohm

Line length in m	Wire size mm <sup>2</sup>			
	0.50	0.75	1	1.5
10	0.72	0.48	0.36	0.24
25	1.80	1.20	0.92	0.60
50	3.60	2.40	1.80	1.20
75	5.44	3.60	2.72	1.80
100	7.24	4.84	3.60	2.40
200	15.72	9.68	7.24	4.84
500	36.64	24.32	18.20	12.08

### External thermal sensor - PTC/Bi-metal switch protection has these parameters:

Parameter	Description	Setting range	Default value
17.01 PTC out	Identifies the Event groups this protection is part of.	Eventgroup 0 ... 6	0000010
17.02 PTC op	Sets the operation of this protection.	Off, Stop-Manual, Stop-Automatic, Indication	Off

### 7.17.14.2 External thermal sensor - PT100 protection

The external thermal sensor detected a temperature higher than the trip level.

The Softstarter has a temperature input where a PTC100 element can be connected. See chapter **5.1.2.11**

**Temperature sensor input.** This can be set to trip if it goes above a certain temperature.

### External thermal sensor - PT100 protection has these parameters:

Parameter	Description	Setting range	Default value
17.03 PT100 2wire res	Sets the 2-wire resistance for PT100.	0.0 ... 100.0 Ohm	5.0 Ohm
17.04 PT100 trip temp	Sets the PT100 trip temperature level.	-50° ... 250°	60°
17.05 PT100 PT100 reset temp	Sets the PT100 reset temperature.	-50° ... 250°	40°
17.06 PT100 out	Identifies the Event groups this protection is part of.	Eventgroup 0 ... 6	0000010
17.07 PT100 op	Sets the operation of this protection.	Off, Stop-Manual, Stop-Automatic, Indication	Off

## 7.17.15 User defined protection

You can use a Programmable digital input in combination with an external device/sensor to use your own specified protection. An example is the CEM11-FBP ground fault sensor.

**User defined protection has these parameters:**

Parameter	Description	Setting range	Default value
18.01 User defined DI status	Sets if the signal is active high or active low.	Active low, Active high	Active high
18.02 User defined trip time	Sets the time to trip.	0.0 ... 60.0 s	1.0 s
18.03 User defined out	Identifies the Event groups this protection is part of.	Eventgroup 0 ... 6	0000010
18.04 User defined op	Sets the operation of this protection.	Off, Stop-Manual, Stop-Automatic, Indication	Off

## 7.17.16 Ground fault protection

This protection senses if the absolute value of the sum of the 3 line currents is too high, which indicates that there is a ground fault.

Note that the currents measurement in the Softstarter is not accurate or fast enough to protect people. The only purpose of this function is to protect equipment.

**Ground fault protection has these parameters:**

Parameter	Description	Setting range	Default value
18.05 Ground fault trip time	Sets the trip time for the ground fault protection.	0.1 ... 10.0 s	0.5 s
18.06 Ground fault out	Identifies the Event groups this protection is part of.	Eventgroup 0 ... 6	0000010
18.07 Ground fault op	Sets the operation of this protection.	Off, Stop-Manual, Stop-Automatic, Indication	Off

## 7.17.17 Too long current limit protection

This protection sense if the current limit is longer in operation than the set trip time. The starting condition is too heavy for the set current limit.

**Too long current limit protection has these parameters:**

Parameter	Description	Setting range	Default value
18.08 Too long curr lim trip time	Sets the trip time for the too long time at current limit protection.	1 ... 600 s	10 s
18.09 Too long curr lim out	Identifies the Event groups this protection is part of.	Eventgroup 0 ... 6	0000010
18.10 Too long curr lim op	Sets the operation of this protection.	Off, Stop-Manual, Stop-Automatic, Indication	Off

## 7.17.18 Too long start time protection

Too long start time protection

**Too long start time protection has these parameters:**

Parameter	Description	Setting range	Default value
18.11 Too long start trip time	Trip time in seconds.	1.0 ... 500.0 s	500.0 s
18.12 Too long start out	Specifies the Event groups this protection belongs to.	Eventgroup 0 ... 6	0000010
18.13 Too long start op	Sets the operation of this protection.	Off, Stop-Manual, Stop-Automatic, Indication, Fast ramp	Off

## 7.17.19 Auto restart protection

Auto restart protection

**Auto restart protection has these parameters:**

Parameter	Description	Setting range	Default value
18.14 Auto restart max delay	Max restart time in seconds	2 ... 3600 s	3600 s
18.15 Auto restart time-out out	Specifies the Event groups this protection belongs to.	Eventgroup 0 ... 6	0000010
1816 Auto restart time-out op	Sets the operation of this protection.	Off, Stop-Manual, Stop-Automatic, Indication	Off

7

## 7.17.20 HMI failure protection

This protection senses errors in communication between the Softstarter and the HMI, while the Softstarter is in local control.

If the communication with the HMI is lost for more than approximately 600 ms this protection is on.

This protection has a special action in addition to the common types of operation:

Stop HMI control - stop the local control and change to remote control i.e digital input or Fieldbus.

**HMI failure protection has these parameters:**

Parameter	Description	Setting range	Default value
19.01 HMI failure out	Identifies the Event groups this protection is part of.	Eventgroup 0 ... 6	0000010
19.02 HMI failure op	Sets the operation of this protection.	Off, Stop-Manual, Stop-Automatic, Indication, Stop HMI control	Stop-Manual

## 7.17.21 Fieldbus failure protection

This protection senses errors in Fieldbus communication between the Softstarter and the PLC.

This protection is on when all following criteria are met

- 12.02 FB interface connector is set to FBPlug, Modbus RTU or Anybus (see chapter **7.15 Fieldbus**)
- 12.03 Fieldbus control is set to ON
- The Fieldbus communication is lost for a specified time.

For FBPlug the specified communication lost time is 300 ms.

For internal Modbus RTU and Anybus modules the specified time is configurable with 19.12 Fieldbus failure timeout. This parameter has to be set before the Anybus module is started.

This protection has a special action in addition to the common types of operation:

Switch to I/O control.

With the Change to I/O control set to enable, the control of the Softstarter automatically changes from the Fieldbus to the hard wire inputs when the Fieldbus malfunctions. When the Fieldbus starts to work again, the control is automatically switched back to the Fieldbus.

**Fieldbus failure protection has these parameters:**

Parameter	Description	Setting range	Default value
19.03 Fieldbus failure out	Identifies the Event groups this protection is part of.	Eventgroup 0 ... 6	0000010
19.04 Fieldbus failure op	Sets the operation of this protection.	Off, Stop-Manual, Stop-Automatic, Indication, Switch to I/O control	Stop-Manual
19.12 Fieldbus failure timeout	Sets the fieldbus failure timeout.	0.5 ... 60.0 s	0.5 s

## 7.17.22 Extension I/O failure protection

This protection senses errors in communication between the Softstarter and the Extension I/O module.

If Com3 function is set to Extension I/O and the communication to the Extension I/O is lost during the set trip time this protection is on.

**Extension I/O failure protection has these parameters:**

Parameter	Description	Setting range	Default value
19.05 Ext IO failure trip time	Sets the trip time for extension I/O failure protection.	300 ... 30000 ms	1000 ms
19.06 Ext IO failure out	Identifies the Event groups this protection is part of.	Eventgroup 0 ... 6	0000010
19.07 Ext IO failure op	Sets the operation of this protection.	Off, Stop-Manual, Stop-Automatic, Indication	Stop-Manual

## 7.17.23 IO controller protection

Profinet IO controller with an established connection is set in STOP mode.



### WARNING

When fieldbus failure protection is used in combination with IO controller protection do not set 19.12 Fieldbus failure timeout to more than 3 seconds. Otherwise you might get a restart, after IO controller protection trip, before tripping on fieldbus failure.

### IO controller protection has these parameters:

Parameter	Description	Setting range	Default value
19.13 IO controller stop out	Identifies the Event groups this protection is part of.	Eventgroup 0 ... 6	0000010
19.14 IO controller stop op	Sets the operation of this protection.	Off, Stop-Manual, Stop-Automatic, Indication	Off

## 7.18 Warnings

The Softstarter has a number of warning functions to signal malfunctioning or other potential risks, before asserting the protection or fault. The difference between a warning and a protection is that a warning cannot stop the Softstarter and a reset of a warning is not necessary. The warning level and all other additional information to enable the warning can be set by the user.

A warning is stored in the event list. Warnings can be Enable or Disable. There is sometimes a percentage setting where the user can set at which percentage level the warning occurs.

Set warnings to an Event group by the Out parameter. The Event group can be set for relay output to control other devices in an application.

As default, all parameters are set to the same Eventgroup.

Warnings show on the HMI, but do not change the behavior of the Softstarter.

### 7.18.1 Electronic overload warning

Electronic overload warning is dependent of Electronic overload protection configuration (see **7.17.1 Electronic overload protection**). The EOL level is temperature in percentage of the temperature where Electronic overload protection will trip (100% will trigger a protection). Electronic overload warning is a warning of being close to trip on Electronic overload protection.

Electronic overload warning is disabled when Electronic overload protection is disabled.

**Electronic overload warning has these parameters:**

Parameter	Description	Setting range	Default value
20.01 EOL level	Sets the EOL warning level.	40.0 ... 99.0%	90.0%
20.02 EOL out	Identifies the Event groups this warning is part of.	Eventgroup 0 ... 6	0000100
23.03 EOL warning	Enables EOL warning.	Off, On	Off

### 7.18.2 Locked rotor warning

A warning signal will be given if the current exceeds the settable warning level.

The motor is running stiff.

**Locked rotor warning is configured with the following parameters:**

Parameter	Description	Setting range	Default value
20.04 Locked rotor level	Sets the Locked rotor warning level.	0.2 ... 10.0 x $I_e$	1.2 x $I_e$
20.05 Locked rotor init time	Sets the time delay after top of ramp when the warning is enabled.	1.0 ... 30.0 s	5.0 s
20.06 Locked rotor out	Identifies the Event groups this warning is part of.	Eventgroup 0 ... 6	0000100
20.07 Locked rotor	Enables locked rotor warning.	Off, On	Off
20.10 Locked rotor trip time	Sets the time that the rotor is locked before trip.	0.1...100.0 s	0.1 s

### 7.18.3 Thyristor overload warning

The thyristor temperature is higher than 90 % of the trip level.

**Thyristor overload warning has these parameters:**

Parameter	Description	Setting range	Default value
20.08 Thyristor OL out	Identifies the Event groups this warning is part of.	Eventgroup 0 ... 6	0000100
20.09 Thyristor OL	Enables thyristor overload warning.	Off, On	Off

### 7.18.4 Current underload warning

The line current decreases below the specified value during continuous operation.

**Current underload warning has these parameters:**

Parameter	Description	Setting range	Default value
21.01 Curr underload level	Sets the Current underload warning level.	0.1 ... $1.0 \times I_e$	$0.8 \times I_e$
21.02 Curr underload trip time	Sets the time that the current is lower than the Warning level to trip.	0 ... 30 s	1 s
21.03 Curr underload delay time	Sets the time delay after Top of ramp when the warning is enabled.	0 ... 30 s	5 s
21.04 Curr underload out	Identifies the Event groups this warning is part of.	Eventgroup 0 ... 6	0000100
21.05 Curr underload	Enables Current underload warning.	Off, On	Off

### 7.18.5 Power factor underload warning

The power factor is below the warning level.

**Power factor underload warning has these parameters:**

Parameter	Description	Setting range	Default value
21.06 Pwr factor underload level	Sets the Power factor underload limit.	0.0 ... 1.0	0.7
21.07 Pwr factor underload trip time	The time it is below limit until trip.	0 ... 30 s	1 s
21.08 Pwr factor underload delay time	The time until diagnoser starts to work in Top of ramp.	0 ... 30 s	5 s
21.09 Pwr factor underload out	Identifies the Event groups this warning is part of.	Eventgroup 0 ... 6	0000100
21.10 Pwr factor underload	Enables Power factor underload warning.	Off, On	Off

### 7.18.6 Current imbalance warning

The phase imbalance between the currents (in %) is higher than the set value.

**Current imbalance warning has these parameters**

Parameter	Description	Setting range	Default value
21.11 Current imb level	Sets the permitted Current imbalance warning level between the phase with the highest current and the phase with the lowest current.	10 ... 80%	70%
21.12 Current imb out	Identifies the Event groups this warning is part of.	Eventgroup 0 ... 6	0000100
21.13 Current imbalance	Enables the Current imbalance warning.	Off, On	Off
21.14 Current imbalance trip time	User set time until warning in seconds.	0.1...100.0 s	5.0 s

## 7.18.7 Overvoltage warning

The voltage is higher than the set value.

**Overvoltage warning has these parameters:**

Parameter	Description	Setting range	Default value
22.01 Overvoltage level	User set warning level in Volts.	208 ... 760 V	650 V
22.02 Overvoltage trip time	User set time until warning in seconds.	0.1 ... 100.0 s	1.0 s
22.03 Overvoltage out	Identifies the Event groups this warning is part of.	Eventgroup 0 ... 6	0000100
22.04 Overvoltage	Parameter to enable Overvoltage warning.	Off, On	Off

## 7.18.8 Undervoltage warning

The main voltage is lower than the set warning level.

**Undervoltage warning has these parameters:**

Parameter	Description	Setting range	Default value
22.05 Undervoltage level	User set warning level in Volts.	208 ... 850 V	208 V
22.06 Undervoltage trip time	User set time until warning in seconds.	0.1 ... 100.0 s	0.5 s
22.07 Undervoltage out	Identifies the Event groups this warning is part of.	Eventgroup 0 ... 6	0000100
22.08 Undervoltage	Parameter to enable Undervoltage warning.	Off, on	Off

## 7.18.9 Voltage imbalance warning

The voltage imbalance between the phases is higher than the set warning level.

**Voltage imbalance warning has these parameters:**

Parameter	Description	Setting range	Default value
22.09 Voltage imb level	Sets the permitted Voltage imbalance level between the phase with the highest voltage and the phase with the lowest voltage.	1 ... 10 %	5 %
22.10 Voltage imb out	Identifies the Event groups this warning is part of.	Eventgroup 0 .. 6	0000100
22.11 Voltage imbalance	Enables Voltage imbalance warning.	Off, On	Off
22.12 Voltage imbalance trip time	User set time until warning in seconds.	0.1...100.0 s	5.0 s



### 7.18.10 Electronic overload time-to-trip warning

The predicted time before EOL trip is below the set warning level. The predicted time to trip assumes that the current stays on existing level.

**Electronic overload time-to-trip warning has these parameters:**

Parameter	Description	Setting range	Default value
23.01 EOL time-to-trip time	Sets how long time before the EOL protection trips the warning is on.	1 ... 1000 s	5 s
23.02 EOL time-to-trip out	Identifies the Event groups this warning is part of.	Eventgroup 0 ... 6	0000100
23.03 EOL time-to-trip	Enables EOL time to trip warning.	Off, On	Off

### 7.18.11 Total Harmonic Distortion warning

The actual power system voltage differs from the ideal sine wave. Total Harmonic Distortion (THD) is higher than the warning level.

**Total Harmonic distortion warning has these parameters:**

Parameter	Description	Setting range	Default value
23.04 THD(U) level	Sets the warning level for Total Harmonic Distortion (U).	1 ... 10%	10%
23.05 THD(U) out	Identifies the Event groups this warning is part of.	Eventgroup 0 ... 6	0000100
23.06 THD(U)	Enables Total Harmonic Distortion warning.	Off, On	Off
23.09 THD(U) trip time	User set time until warning in seconds.	0.1 ... 100.0 s	10.0 s

### 7.18.12 Short circuit warning

There is an internal short circuit and limp mode is enabled. If limp mode is off, this is a short circuit fault instead. Speak to ABB Sales Offices for service.

**Short circuit warning has these parameters:**

Parameter	Description	Setting range	Default value
23.07 Short circuit out	Identifies the Event groups this warning is part of.	Eventgroup 0 ... 6	0000100
23.08 Short circuit	Enables Short circuit warning.	Off, On	On

### 7.18.13 Number of starts warning

User configurable limit of Number of starts (resettable). When the Number of starts exceeds the limit a warning will be generated.

**Number of starts warning has these parameters:**

Parameter	Description	Setting range	Default value
24.01 Number of starts limit	Max number of starts	1 ... 65535	65535
24.02 Number of starts out	Specifies the Event groups this warning belongs to.	Eventgroup 0 ... 6	0000100
24.03 Number of starts	Enables Number of starts warning	Off, On	Off

## 7.18.14 Phase loss warning

Phase loss warning.

**Phase loss warning has these parameters:**

Parameter	Description	Setting range	Default value
24.07 Phase loss trip time	Trip time in seconds	0.5 ... 100.0 s	3.0 s
24.08 Phase loss out	Specifies the Event groups this warning belongs to.	Eventgroup 0 ... 6	0000100
24.09 Phase loss	Enables Phase loss warning	Off, On	Off

## 7.18.15 Motor runtime warning

User configurable limit of Motor run time (resettable).

When the Motor run time exceeds the limit a warning will be generated.

**Motor runtime warning has these parameters:**

Parameter	Description	Setting range	Default value
24.10 Motor runtime limit	Max runtime in hours	1 ... 100 000 h	10 000 h
24.11 Motor runtime out	Specifies the Event groups this warning belongs to.	Eventgroup 0 ... 6	0000100
24.12 Motor runtime	Enables Motor runtime warning	Off, On	Off

7

## 7.18.16 Parameter storage warning

Parameters could not be stored. Will not impact current run cycle, but a power cycle may restore default settings.

Contact ABB sales office for service.

**Parameter storage warning has these parameters:**

Parameter	Description	Setting range	Default value
24.13 Storage warning out	Specifies the Event groups this warning belongs to.	Eventgroup 0 ... 6	0000100
24.14 Storage warning	Enables Parameter storage warning	Off, On	Off

## 7.19 Faults

The Softstarter has a number of fault detection functions to protect the Softstarter. Faults detection always runs as default. The user cannot set the fault detection to off. If a signal malfunctions in the Softstarter, the motor or in the power network level, a fault occurs. Supervised faults can be internal or external faults.

### Internal fault:

The Softstarter has a fault. see chapter **10 Troubleshooting**, and speak to ABB sales office if necessary.

### External fault:

There is a fault in the equipment that is connected to the Softstarter. see chapter **10 Troubleshooting**, and speak to ABB sales office if necessary.

When a fault occur, the type of fault will be described on the home screen and the red Fault LED light will illuminate.

When a fault occurs, the unit does these basic actions:

1. The fault LED illuminates
2. The home screen gives the type of fault
3. The type of event is stored on the event list
4. The power supply to the motor which is connected to the Softstarter is set to off (Direct stop).

You can set faults to have automatic reset or manual reset. Every fault has a parameter option called **Operation**, that you can set as:

- **Stop-Automatic** – The engine stops and resets automatically after you correct the fault condition\*.
- **Stop-Manual** – The engine stops and must be reset manually after you correct the fault condition\*.
- **Indication** – Emergency mode only, see chapter **7.20.1 Emergency mode**.

\*) You cannot reset a fault before you correct the fault condition.

You can set faults to an Event group by a parameter option called Out. You can set the Event group for relay output to control other devices in an application.

As default all parameters are set to the same Eventgroup.

You can add further actions for each fault, or change the basic actions. If multiple faults occur they are all stored in a sequence. Do a reset for each fault if manual reset is selected.

## 7.19.1 Internal faults

### 7.19.1.1 Shunt fault

The Softstarter has been shorted and cannot stop the power to the motor.

If Softstarter is connected in-line, shunt fault is on if 2 or 3 phases are shorted.

If Softstarter is connected inside-delta, shunt fault is on if 1 or more phases are shorted.

If the user puts shunt fault on 1 relay and connect it to a line contactor or a circuit breaker, the user can break off the motor.

Shunt fault trip time is set with parameter 28.49.

Shunt fault trip level is set with parameter 28.50.

Speak to ABB sales office for service.

#### Shunt fault has these parameters:

Parameter	Description	Setting range	Default value
25.01 Shunt fault out	Identifies the Event groups this fault is part of.	Eventgroup 0 ... 6	0000001
25.02 Shunt fault op	Sets the operation of this fault.	Stop-Manual, Stop Automatic	Stop-Manual

7

### 7.19.1.2 Short circuit fault

The Softstarter has a short circuit or bypass. The Softstarter can run in Limp mode function, even if 1 phase become shorted.



#### INFORMATION

If Automatic restart is set to on, a short circuit fault will automatically start the motor again.

For more information about Automatic restart, see **chapter 7.13 Automatic restart**.

If 1 or multiple thyristors are shorted, speak to ABB sales office for service.

Short circuit thyristor trip time is 1s.

#### Short circuit fault has these parameters:

Parameter	Description	Setting range	Default value
25.03 Short circuit out	Identifies the Event groups this fault is part of.	Eventgroup 0 ... 6	0000001
25.04 Short circuit fault op	Sets the operation of this fault.	Stop-Manual, Stop Automatic	Stop-Manual

### 7.19.1.3 Open circuit thyristor fault

The Softstarter cannot close 1 or more thyristors. There will be a trip on open circuit thyristor after 100 consecutive failed attempts to trigger the thyristor.



#### INFORMATION

If Automatic restart is set to on, an open circuit thyristor fault will automatically start the motor again.

For more information about Automatic restart see chapter **7.13 Automatic restart.**

**Open circuit thyristor fault has these parameters:**

Parameter	Description	Setting range	Default value
25.05 Open circuit thyr out	Identifies the Event groups this fault is part of.	Eventgroup 0 ... 6	0000001
25.06 Open circuit thyr op	Sets the operation of this fault.	Stop-Manual, Stop Automatic	Stop-Manual

### 7.19.1.4 Thyristor overload fault

The thyristors in the Softstarter are overloaded. If the estimated thyristor junction temperature is higher than the maximum permitted value, this fault is signaled, to protect thyristors from overheating.



#### INFORMATION

If Automatic restart is set to on, a thyristor overload fault will automatically start the motor again.

For more information about Automatic restart see chapter **7.13 Automatic restart.**

**Thyristor overload fault has these parameters:**

Parameter	Description	Setting range	Default value
25.07 Thyristor OL out	Identifies the Event groups this fault is part of.	Eventgroup 0 ... 6	0000001
25.08 Thyristor OL op	Sets the operation of this fault.	Stop-Manual, Stop Automatic	Stop-Manual

### 7.19.1.5 Heatsink overtemperature fault

The Softstarter measures the heatsink temperature. If the temperature gets to high this fault is signaled. The purpose of the heatsink is to keep the thyristors cool.

For a trip to occur, the heat sink temperature has to be greater than 105 degrees for more than 1 s.

**Heatsink overtemperature fault has these parameters:**

Parameter	Description	Setting range	Default value
25.09 Heatsink overtemp out	Identifies the Event groups this fault is part of.	Eventgroup 0 ... 6	0000001
25.10 Heatsink overtemp op	Sets the operation of this fault.	Stop-Manual, Stop Automatic	Stop-Manual

### 7.19.1.6 Unspecified fault

**Unspecified fault has these parameters:**

Parameter	Description	Setting range	Default value
25.11 Unspecified fault out	Identifies the Event groups this fault is part of.	Eventgroup 0 ... 6	0000001
25.12 Unspecified fault op	Set the operation of this fault.	Stop-Manual, Stop Automatic	Stop-Manual

### 7.19.1.7 Electronics failure

Circuit fault detected during hardware initialization.

**Electronics failure has these parameters:**

Parameter	Description	Setting range	Default value
25.13 Electronics failure out	Identifies the Event groups this fault is part of.	Eventgroup 0 ... 6	0000001
25.14 Electronics failure op	Set the operation of this fault.	Stop-Manual, Stop Automatic	Stop-Manual

## 7.19.2 External faults

7

### 7.19.2.1 Phase loss fault

Voltage to one or more phases are missing.

When motor is not running, the trip time is equal to 5 s.

When motor is running the trip time is equal to 500 ms.

**Phase loss fault has these parameters:**

Parameter	Description	Setting range	Default value
26.01 Phase loss out	Identifies the Event groups this fault is part of.	Eventgroup 0 ... 6	0000001
26.02 Phase loss op	Set the operation of this fault.	Stop-Manual, Stop Automatic	Stop-Manual

### 7.19.2.2 Bad network fault

Bad network quality fault is signaled if there is too much frequency interference in the network. During these conditions the softstarter will experience issues with the thyristor control algorithm, and for safety reasons, the softstarter will not continue to operate until the conditions are resolved.

For this trip to occur, the bad network quality conditions have to be present for more than 1 s.

**Bad network fault has these parameters:**

Parameter	Description	Setting range	Default value
26.03 Bad network out	Identifies the Event groups this fault is part of.	Eventgroup 0 ... 6	0000001
26.04 Bad network op	Set the operation of this fault.	Stop-Manual, Stop Automatic	Stop-Manual

### 7.19.2.3 Low supply voltage fault

Low supply voltage fault is signaled if the control supply voltage is too low. The Softstarter will stop the motor.

There will be a trip on low supply voltage as soon the internal 24 VDC supply voltage dips below 19 V.

**Low supply fault has these parameters:**

Parameter	Description	Setting range	Default value
26.05 Low supply voltage out	Identifies the Event groups this fault is part of.	Eventgroup 0 ... 6	0000001
26.06 Low supply voltage op	Sets the operation of this fault.	Stop-Manual, Stop Automatic	Stop-Manual

### 7.19.2.4 High current fault

A fault signal will be given if the motor current exceeds the fixed set level which is  $8 \cdot I_r$  for the duration of the fixed set time which is 200 ms.

**High current fault is configured with the following parameters:**

Parameter	Description	Setting range	Default value
26.07 High current out	Specifies the Event groups this fault belongs to.	Eventgroup 0 ... 6	0000001
26.08 High current op	Sets the operation of this fault.	Stop-Manual, Stop Automatic	Stop-Manual

### 7.19.2.5 Faulty usage fault

Faulty usage fault is on if the user tries to use motor heating, stand-still brake and slow speed functions when the motor is connected inside delta or if the user tries to use demo mode when mains three phase voltage is connected.

There will be a trip as soon as faulty usage is detected.

**Faulty usage fault has these parameters:**

Parameter	Description	Setting range	Default value
26.09 Faulty usage out	Identifies the Event groups this fault is part of.	Eventgroup 0 ... 6	0000001
26.10 Faulty usage op	Sets the operation of this fault.	Stop-Manual, Stop Automatic	Stop-Manual

### 7.19.2.6 Connection fault

Connection fault signals a fault when a faulty connection is detected for each type of connection, in line and inside delta.

Trip time is 5 s.

**Connection fault has these parameters:**

Parameter	Description	Setting range	Default value
26.11 Faulty connection out	Identifies the Event groups this fault is part of.	Eventgroup 0 ... 6	0000001
26.12 Faulty connection op	Sets the operation of this fault.	Stop-Manual, Stop Automatic	Stop-Manual

## 7.20 Special feature

This chapter gives a description of features that are available to all users, but beyond the normal range of use for the Softstarter.

The features are:

- Emergency mode
- Line contactor close time
- Limp mode
- Start without start command
- Step down level
- System mode
- TOR relay delay time
- Voltage sag detection

### 7.20.1 Emergency mode

The normal operation of the Softstarter when a fault is detected is to do a direct stop. The programmable digital input can be set to Emergency mode (active low) or Emergency mode (active high), see chapter 7.14.2 Digital Inputs When Emergency mode is active, a symbol in the upper right corner of the HMI screen will be visible, see chapter 6.1.5 Symbols in the screen

When the Softstarter is in Emergency mode, and a fault or protection is detected, the Softstarter will try to run the motor with the start and stop signals, ignore safety and continue to run regardless of consequences. This can be done as long as the PCBA is not broken.

The programmable output relays can be programmed to Event group 0...6 but will not be activated to an event during Emergency mode. This is important in the case the output relays is used to control a line contactor or circuit breaker All events will be stored in the event log.

- If the build-in bypass is not working the circuit to the motor is closed by using the thyristors
- If the thyristors are not working the circuit to the motor is closed by using the built-in bypass.



---

#### **WARNING**

Warranty for damage on the thyristors or the built-in bypass are not valid during Emergency mode.

---



## 7.20.2 Line contactor close time

This feature allow time for the line contactor to close before the Softstarter assumes that it has correct 3 phase supply.

This is useful to avoid timing problems that can lead to unnecessary trips on for example Phase loss protection.

### Line contactor close time has these parameters:

Parameter	Description	Setting range	Default value
28.02 Line contactor close time	Allow time for line contactor to close. Sets the time between start signal and beginning of diagnostic measurements.	0 ... 65535 ms	250 ms

## 7.20.3 Limp mode

This feature allows the PSTX to operate with only 2 controlled phases in case of short circuit of 1 set of thyristors. When PSTX trips for fault "Short circuit thyristor" and error code F0900 the customer can check with external equipment which phase is shorted. Always verify the fault by measuring the phase.

If error code is: F0901 - L1 is shorted, F0902 - L2 is shorted, F0903 - L3 is shorted. Set parameter Limp mode and Motor connection as described. The fault will be replaced with a warning to enable start in limp mode. Replace the thyristors when this warning is on (if the short circuit warning is enabled).

### Limp mode has these parameters:

Parameter	Description	Setting range	Default value
28.42 Limp mode	Set to On if a phase is shorted.	Off, On	Off
28.43 Motor connection	When Limp mode is On, set depending on which phase that is shorted, Two phase (Lx shorted)	Inline, Inside delta UI, Inside delta IU, Two phase (L1 shorted), Two phase (L2 shorted), Two phase (L3 shorted)	-

## 7.20.4 Start without start command

This feature can be used for a customer that would like to use the Softstarter in the same way as a contactor is used, i.e. as soon as the control supply to the Softstarter is turned on the Softstarter will automatically start the motor. No wiring of start and stop signals is necessary.

### Start without start command has these parameters:

Parameter	Description	Setting range	Default value
28.04 Start without start command	Starts the motor without needing an external start command.	Off, On	Off

## 7.20.5 Step down level

When the Softstarter receives a stop signal the Softstarter first decreases the output voltage to the motor in a quick stop ramp, from full voltage down to set Step down voltage level. Then the Softstarter controls the output voltage in a stop ramp.

You can adjust the step down level for torque control.

When using voltage ramp, set it to 80%. It can be necessary to adjust the step down level if the load is too high or too low.

### Step down level has these parameters:

Parameter	Description	Setting range	Default value
28.05 Step down level	Set the level from where the stop ramp initiates.	10% ... 100%	80%

## 7.20.6 System mode

Select between:

- Normal mode
- Demo mode
- Small motor mode

### Normal mode

Normal mode is the default setting and is used in all situations except the ones given below.

### Demo mode

Demo is used mainly for training purposes to simulate a load condition without having the Softstarter connected to main power.



### INFORMATION

When the Softstarter is connected to three phase voltage it will not be possible to start a motor in demo mode.

### Small motor mode

Small motor mode is used for basic testing purposes, when using a smaller motor than the PSTX is specified for. The Softstarter is able to start the motor, but some functions and protections are disabled.



### INFORMATION

The current through the Softstarter has to be at least 3A when using small motor mode.

### System mode has these parameters:

Parameter	Description	Setting range	Default value
28.41 System mode	Sets the run mode.	Normal, Demo, small motor	Normal

## 7.20.7 TOR relay delay time

Set the delay time from Top Of Ramp until the Top Of Ramp relay is on

**TOR relay delay time has these parameters:**

Parameter	Description	Setting range	Default value
28.03 TOR relay delay time	Set the delay time from Top Of Ramp until the Top Of Ramp relay is on	0.0 ... 300.0 s	0.0 s

## 7.20.8 Voltage sag detection

This function makes it possible to monitor the quality of the mains voltage.

A voltage dip under 65% of nominal voltage for more than 200 ms combined with a fault or protection generates a Voltage sag detection-event in the Run log. This event indicates that the original fault or protection was triggered by a voltage sag.

A voltage dip under 65% of nominal voltage for more than 200 ms and immediately followed by increase up to 90% of nominal voltage also generates a Voltage sag detection-event in the Run log. Common reoccurrence of such events can indicate poor quality of mains voltage.

## 7.21 Pump cleaning

Pump cleaning function makes the pump motor alternate between forward and reverse direction. This sequence can release or cut through solid objects and flush away effluent.

The pump cleaning function can be used to solve these two problems which are common especially in waste water plants.

- **Jamming:** Occurs when a semi large solid object like a piece of plastic or wood gets stuck in the pump blades.
- **Clogging:** When the liquid that is being pumped contains small particles and effluent, the risk is that this material will over time get permanently attached within the pipes and cause water flow problems which will decrease the pump efficiency and can damage the pump.

Solving these problems will result in an overall improved pump efficiency, reduced down time and low maintenance costs.

To detect when a pump is jammed or clogged, it's recommended to use one of the following methods.

- When an object is stuck in the pump, the motor uses more current and the Softstarter will trip on EOL (Electronic overload), see chapter **7.17.1 Electronic overload protection** or Locked rotor protection, see chapter **7.17.2 Locked rotor protection**.
- During a soft start the Too long starting time, see chapter **7.17.18 Too long start time protection**, or Too long time at current limit, see chapter **7.17.17 Too long current limit protection**, can be used to indicate that an object is stuck in the pump.
- A water flow sensor can be used to detect if the pipes are clogged. The sensor output can be connected to one of the PSTX programmable inputs and configure it as user defined protection, see chapter **7.17.15 User defined protection**



### INFORMATION

The Softstarter cannot automatically start the pump cleaning sequence when the fault events mentioned above occur. External logic have to be used to give the pump cleaning commands if and when the protection events occur.

Pump cleaning can also be used as preventive maintenance by running the function once a day/week.

## 7.21.1 Manual pump cleaning

Manual means that the user at any point in time decides which direction the motor shall rotate by activating the forward and reverse pump cleaning commands. The commands can be given in the HMI, or using hardware I/O's or the fieldbus. The same parameters that are used for Automatic pump cleaning are also used for Manual pump cleaning, see chapter **7.21.2 Automatic pump cleaning**

## 7.21.2 Automatic pump cleaning

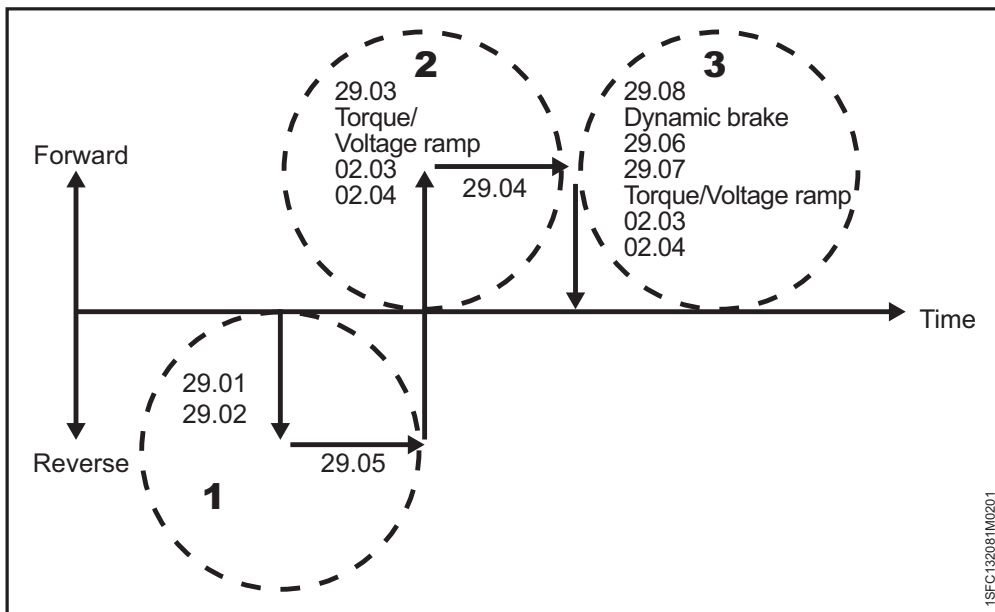
Automatic means that the Softstarter runs the pump cleaning sequence only when the automatic pump cleaning command is activated and stops as soon as it is deactivated. When automatic pump cleaning is run, the motor first starts rotating in the backward direction.

Different motor control functions are combined to achieve the forward and reverse run of the motor.

1. Slow speed jog reverse. Parameter 29.01 (Pump clean reverse speed) decides which slow speed should be used. The parameter 29.02 (Pump clean reverse strength) decides how fast the motor accelerates to the slow speed in the reverse direction. It is recommended to set it to a high value (60 – 100%) to achieve an aggressive acceleration for clogging or enough torque for jamming.
2. Forward direction. Parameter 29.03 (Pump clean forward start mode) decides which start method should be used to accelerate the motor in the forward direction. Default is Full voltage start which very quickly accelerated the motor up to full speed in the forward direction. If a softer start is needed parameter 29.03 (Pump clean forward start mode) can be set to Torque ramp or Voltage ramp, then the parameter 02.03 (Start ramp initial level) and 02.04 (Start ramp time) are used in the pump cleaning forward start. 29.04 (Pump clean auto forward time) decides how long time the motor should be run in the forward direction.
3. When it is time to switch direction from forward to reverse the parameter 29.08 (Pump clean stop mode) decides if a stop ramp should be run to avoid any water hammering that might otherwise occur. Immediately after the stop ramp a dynamic brake quickly bring the motor to stand still. Parameter 29.08 (Pump clean stop mode) is set default to Torque ramp and brake. The Torque ramp or Voltage ramp in the Pump clean stop mode can be adjusted by parameter 02.05 (Stop ramp end level) and parameter 02.06 (Stop ramp time). The Dynamic brake in the Pump clean stop mode can be adjusted by the parameter 29.06 (Pump clean brake strength) and parameter 29.07 (Pump clean brake timeout). The parameter 29.06 (Pump clean brake strength) decides how fast the motor will decelerate from full speed. It is recommended to set a high value (50 – 60%) to achieve an aggressive deceleration. If the brake takes longer time than 10s, increase the parameter 29.07 (Pump clean brake timeout).

4. The whole sequence is repeated and start from 1 again until the Auto button on the HMI is released or signal from I/O or fieldbus is removed.

See **Figure 7.9** .



**Figure 7.9**

Automatic pump sequence

7

### Water hammering

If water hammering is not a problem parameter 29.08 (Pump clean stop mode) can be set to Dynamic brake which will ensure a quicker deceleration and therefore better pump cleaning performance. The Dynamic brake can be adjusted by the parameter 29.06 (Pump clean brake strength) and parameter 29.07 (Pump clean brake timeout).

However if water hammering, which can damage the pipes, is a problem the parameter 29.08 (Pump clean stop mode) can be set to Voltage ramp and brake or Torque ramp and brake. The parameter 02.05 (Stop ramp end level) and parameter 02.06 (Stop ramp time) are also used in the Voltage ramp and Torque ramp.

### 7.21.3 Pump cleaning control

Operate this function through the HMI, I/O or Fieldbus.




#### HMI

Pump cleaning menu, see **Figure 7.10** .

Control the pump cleaning menu, see **Figure 7.11**

#### Path in menu:

**Menu > Pump cleaning**

- Press left button  for manual backward pump cleaning
- Press right button  for manual forward pump cleaning
- Press up button  for automatic pump cleaning

#### Hardware I/O

**Path in menu: Menu > Parameters > Complete list > 10 Internal In0, In1, In2 / 11 External IO 1DI0, 1DI1, 1DI2, 1DI3, 1DI4, 2DI5, 2DI6, 2DI7**

Configure the parameters to either Pump cleaning automatic, Pump cleaning forward or Pump cleaning backward.



#### INFORMATION

An Extension I/O module, see chapter 5.1.3 Extension I/O, is necessary if the **11 External IO** is going to be used.

#### Fieldbus configuration

Fieldbus digital outputs (from PLC to Softstarter) can be used to run Pump cleaning automatic, Pump cleaning forward or Pump cleaning backward.

For more information about the communication, see chapter **8 Communication**

#### Pump cleaning is configured with the following parameters:

Parameter	Description	Setting range	Default value
29.01 Pump clean reverse speed	Sets the slow speed reverse. Fast jog reverse is 33 %, jog reverse is 20 % and creep reverse is 9 % of the nominal motor speed.	Fast jog, Jog, Creep	Jog
29.02 Pump clean reverse strength	Parameter related to the torque that is generated during slow speed in the reverse direction. Choose suitable value for the application. Too high value could cause oscillations and if too low the motor may not start.	10 ... 100 %	45 %
29.03 Pump clean forward start mode	Sets the desired start mode: Voltage start ramp = Increases voltage linearly, Torque start ramp = Increases torque in a pre-defined pattern, Full Voltage start = Ramps up to full voltage within one third of a second	Voltage ramp, Torque ramp, Full voltage start	Full voltage start
29.04 Pump clean auto forward time	Sets the number of seconds to run forward per sequence for automatic pump cleaning.	1.0 ... 100.0 s	5.0 s
29.05 Pump clean auto reverse time	Sets the number of seconds to run reverse per sequence for automatic pump cleaning.	1.0 ... 100.0 s	5.0 s
29.06 Pump clean brake strength	Sets the pump cleaning braking strength to 10-100 %. Only used for pump cleaning in forward direction.	10 ... 100 %	45 %
29.07 Pump clean brake timeout	Sets the motor brake timeout used when pump cleaning forward has finished.	1.0 ... 100.0 s	10.0 s
29.08 Pump clean stop mode	Sets the mode for stop used when pump cleaning forward has finished: Stop ramp followed by dynamic brake, or dynamic brake only. See chapter <b>7.2.2 Voltage stop ramp</b> and <b>7.3.2 Torque stop ramp</b> for stop ramp parameters. See chapter <b>7.11 Motor braking</b> for speed threshold and delay time.	Voltage ramp and brake, Torque ramp and brake, Dynamic brake	Torque ramp and brake

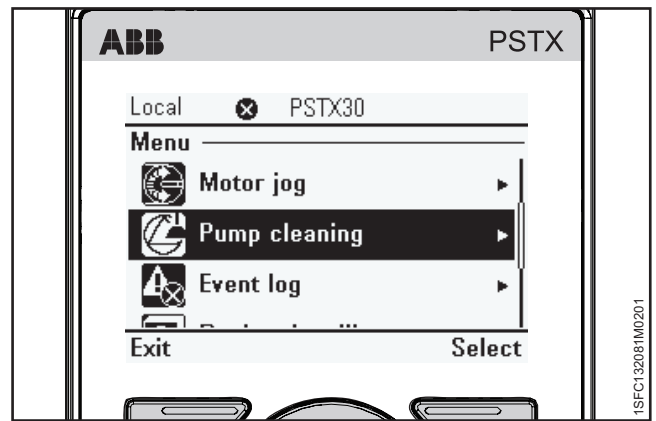


Figure 7.10

Pump cleaning menu

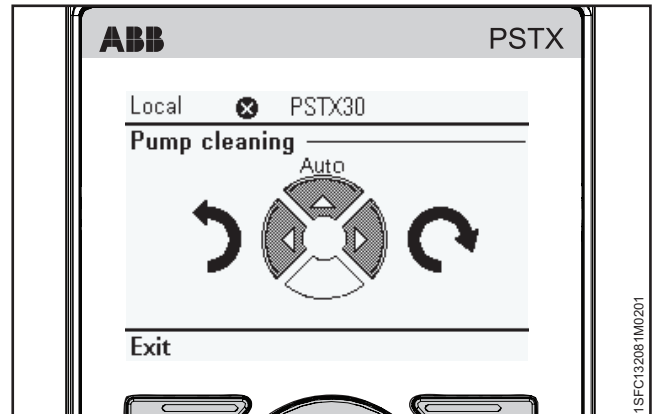


Figure 7.11

Control the pump cleaning menu



---

**INFORMATION**

If many pump cleaning cycles are used and run often, it is recommended to use a one size larger Softstarter.

---

**WARNING**

Pump cleaning is only working when the Softstarter is connected in-line

---

**WARNING**

Because the Pump clean reverse function warms up the motor we recommend to use a PTC or PT100 element for temperature monitoring. In some conditions, the built-in EOL is not accurate for this feature.

---

**WARNING**

Do not use pump cleaning on pumps which have impeller or rotating shaft parts which can loosen or jam during reverse rotation. If you do not obey these instructions, this can cause equipment damage.

---

## 7.22 Fast take-off

The PSTX is equipped with a fast take-off functionality. This means that by delaying some non-critical functions, the time from the start signal is given until the voltage is applied to the motor is reduced. The Fast take-off enables motor voltage after approximate 600 ms from received start signal, which is approximate 500 ms faster than the regular operation of 1100 ms .

To reduce this time even more the parameter 28.02 Line contactor close time can be set to 0, default is 250 ms, see chapter 7.20.2. Then the time for received start to voltage is applied will approximately be 350 ms and the regular operation time will approximately be 850 ms.

The parameter 28.43 Motor connection is default Auto this can be set to the actual motor connection then the time for received start to voltage will be decreased by approximately 100 ms.

**Note:** Torque control- and dynamic brake performance might be affected in a minor way in specific situations.



## 7.23 Settings

The settings menu contains these Softstarter set-up parameters:

- Language
- Date and time
- Display settings (for HMI)
- Reset from defaults

For settings and navigation, **see chapter 6.4.6 Settings.**

## 7.24 Assistants

The Assistants menu contains default settings and parameters. Use this menu to set only the necessary parameters before you can start the motor. All necessary input data shows up in an automatic loop. The Assistants menu is divided in:

- **Basic set-up**
- **Application set-up**



---

### INFORMATION

After you select an application and make your changes, do not select this application again because this resets the application to the default settings.

---

### Enter the Assistants menu

Push “Menu” and select Assistants with the Navigation keys.

Push “Select” to enter the Assistants menu.

### Basic set-up

The Basic set-up menu is divided in 5 steps: Language, Date and time, Motor data and System configuration.

### Application set-up

The Application set-up are quick settings for Applications, Values and Tune settings. Use the Navigation keys to select Application set-up. Push “Select” to enter the Application set-up.

Select for what type of application you use the Softstarter by pushing “Select”.

For more details, see chapter **2 Quick start.**

## 7.24.1 Table Application settings

		Recommended basic settings						
		Start ramp time	Stop ramp time	Start ramp initial level	Stop ramp end level	Current limit level	Start mode	Stop mode
Normal start (class 10)	Band saw	10	-	30	30	4	Voltage ramp	No ramp
	Bow thruster	10	-	30	30	3	Voltage ramp	No ramp
	Centrifugal pump	10	10	30	30	4	Voltage ramp	Torque ramp
	Circular saw	10	-	30	30	4	Voltage ramp	No ramp
	Conveyor belt short	10	-	40	30	3,5	Voltage ramp	No ramp
	Cutter	10	-	30	30	4	Voltage ramp	No ramp
	Escalator	10	-	30	30	3,5	Voltage ramp	No ramp
	High pressure pump	10	10	40	30	4,5	Voltage ramp	Torque ramp
	Hydraulic pump	10	-	30	30	3	Voltage ramp	No ramp
	Lift/Elevator	10	-	30	30	3,5	Voltage ramp	No ramp
	Piston compressor	5	-	50	30	3	Voltage ramp	No ramp
	Scroll compressor	2	-	50	30	3	Voltage ramp	No ramp
Heavy duty start (class 30)	Axial fan	10	-	30	30	4	Voltage ramp	No ramp
	Conveyor belt long	10	-	40	30	3,5	Voltage ramp	No ramp
	Crusher	10	-	30	30	4	Voltage ramp	No ramp
	Centrifugal fan	10	-	30	30	4	Voltage ramp	No ramp
	Grinder	10	-	30	30	4	Voltage ramp	No ramp
	Mixer	10	-	30	30	3,5	Voltage ramp	No ramp

Note: These parameter are a rough indication. Often it is necessary to tune the unit because of variations in load conditions.

## 7.25 Complete parameter list

Parameter number	Description	Setting range	Number of decimals	Fieldbus ID	Default value	Actual setting
<b>01</b>	<b>Motor rated current I<sub>e</sub></b>					
01.01	Motor rated current I <sub>e</sub>	9.0 ... 1250.0 A	1	1	30 A	
<b>02</b>	<b>Start and stop</b>					
02.01	Start mode	Voltage ramp, Torque ramp, Full voltage start	0	2	Voltage ramp	
02.02	Stop mode	No ramp, Voltage ramp, Torque ramp, Dynamic brake	0	3	No ramp	
02.03	Start ramp initial level	10 ... 99%	0	4	30%	
02.04	Start ramp time	1 ... 120 s	0	5	10 s	
02.05	Stop ramp end level	10 ... 99%	0	6	30%	
02.06	Stop ramp time	1 ... 120 s	0	7	10 s	
02.07	Pre-start function	Pre start off, Motor heating, Stand still brake Slow speed forward, Slow speed reverse	0	93	Pre start off	
02.08	Pre-start time	0.0 ... 7200.0 s	1	128	10.0 s	
<b>03</b>	<b>Limit</b>					
03.01	Current limit type	Off, Normal, Dual, Ramp	0	18	Normal	
03.02	Current limit level	1.5 ... 7.5 x I <sub>e</sub>	1	19	4.0 x I <sub>e</sub>	
03.03	2nd curr lim level	0.5 ... 7.5 x I <sub>e</sub>	1	20	7.0 x I <sub>e</sub>	
03.04	2nd curr lim time	2 ... 120 s	0	21	8 s	
03.05	Torque limit level	20 ... 200%	0	170	150%	
<b>04</b>	<b>Kick start</b>					
04.01	Kick start	On / Off	0	22	Off	
04.02	Kick start level	50 ... 100%	0	23	70%	
04.03	Kick start time	0.20 ... 2.00 s	2	24	0.20 s	
<b>05</b>	<b>Slow speed</b>					
05.01	Slow speed forward	Fast jog, Jog, Creep	0	184	Jog	
05.02	Slow speed fwd strength	10 ... 100%	0	187	50%	
05.03	Slow speed reverse	Fast jog, Jog, Creep	0	188	Jog	
05.04	Slow speed rev strength	10 ... 100%	0	189	50%	
<b>06</b>	<b>Motor heating</b>					
06.01	Motor heating capacity	10 ... 100000 W	0	304	10 W	
<b>07</b>	<b>Motor braking</b>					
07.01	Stand still brake strength	10 ... 100%	0	305	50%	
07.02	Motor brake time	1.0 ... 900.0 s	1		1.0 s	
07.03	Dynamic brake strength	10 ... 100%	0		40%	
07.04	DC brake strength	10 ... 100%	0		40%	
07.05	DC brake switch speed threshold	10 ... 100%	0		28%	
07.06	DC brake switch delay time	0.1 ... 100.0 s	1		3.0 s	
<b>08</b>	<b>Sequence start</b>					
08.01	Sequence mode	Off, Start several motors	0	8	Off	
08.02	I <sub>e</sub> seq 1	9.0 ... 1250.0 A	1	190	30 A	
08.03	Start mode seq 1	Voltage ramp, Torque ramp, Full voltage start	0	191	Voltage ramp	
08.04	Start ramp time seq 1	1 ... 120 s	0	192	10 s	
08.05	Start ramp init lvl seq 1	10 ... 99%	0	193	30%	
08.06	Curr lim level seq 1	0.5 ... 7.5 x I <sub>e</sub>	1	194	7.0 x I <sub>e</sub>	
08.07	Kick start seq 1	On, Off	0	195	Off	
08.08	Kick start level seq 1	50 ... 100%	0	196	70%	
08.09	Kick start time seq 1	0.20 ... 2.0 s	2	197	0.20 s	
08.10	Torque lim lvl seq 1	20 ... 200%	0	198	150%	
08.11	Torque tune seq 1	0 ... 1000%	0	199	100%	
08.12	Torque ctrl gain seq 1	0.01 ... 10.00	2	200	0.02	
08.30	I <sub>e</sub> seq 2	9.0 ... 1250.0 A	1	201	30 A	
08.31	Start mode seq 2	Voltage ramp, Torque ramp, Full voltage start	0	202	Voltage ramp	
08.32	Start ramp time seq 2	1 ... 120 s	0	203	10 s	
08.33	Start ramp init lvl seq 2	10 ... 99%	0	204	30%	

Parameter number	Description	Setting range	Number of decimals	Fieldbus ID	Default value	Actual setting
08.34	Curr lim level seq 2	0.5 ... 7.5 x I <sub>e</sub>	1	205	7.0 x I <sub>e</sub>	
08.35	Kick start seq 2	On / Off	0	206	Off	
08.36	Kick start level seq 2	50 ... 100%	0	207	70%	
08.37	Kick start time seq 2	0.20 ... 2.00 s	2	208	0.20 s	
08.39	Torque tune seq 2	0 ... 1000%	0	210	100%	
08.40	Torque ctrl gain seq 2	0.01 ... 10.00	2	211	0.02	
08.60	I <sub>e</sub> seq 3	9.0 ... 1250 A	1	212	30 A	
08.61	Start mode seq 3	Voltage ramp, Torque ramp, Full voltage start	0	213	Voltage ramp	
08.62	Start ramp time seq 3	1 ... 120 s	0	214	10 s	
08.63	Start ramp init I <sub>l</sub> seq 3	10 ... 99%	0	215	30%	
08.64	Curr lim level seq 3	0.5 ... 7.5 x I <sub>e</sub>	1	216	7.0 x I <sub>e</sub>	
08.65	Kick start seq 3	On, Off	0	217	Off	
08.66	Kick start level seq 3	50 ... 100%	0	218	70%	
08.67	Kick start time seq 3	0.20 ... 2.00 s	2	219	0.20 s	
08.68	Torque limit I <sub>l</sub> seq 3	20 ... 200%	0	220	150%	
08.69	Torque tune seq 3	0 ... 1000%	0	221	100%	
08.70	Torque ctrl gain seq 3	0.01 ... 10.00	2	222	0.02	
<b>09</b>	<b>Automatic restart</b>					
09.01	Auto-reset delay time	0 ... 3600 s	0	223	10 s	
09.02	Auto-restart	On, Off	0	224	Off	
09.03	Auto-restart max attempts	1 ... 10	0	225	5	
<b>10</b>	<b>Internal IO</b>					
10.01	In0 function	None, Reset, Enable, Slow speed forward, Slow speed reverse, Motor heating, Stand still brake, Start reverse, User defined protection, Emergency mode (active high), Emergency mode (active low), Fieldbus disable control, Start 1, Start 2, Start 3. Switch to remote control, Cancel brake, Pump cleaning automatic, Pump cleaning forward, Pump cleaning backward, Hold in Remote (Active High), Hold in Remote (Active Low), Lock Parameters (Active High), Lock Parameters (Active Low)	0	130	Reset	
10.02	In1 function	Same settings as for In0 function.	0	131	None	
10.03	In2 function	Same settings as for In0 function.	0	132	None	
10.04	K4 function	None, Run, Top of ramp, Event group 0, Event group 1, Event group 2, Event group 3, Event group 4, Event group 5, Event group 6, Sequence 1 RUN, Sequence 2 RUN, Sequence 3 RUN, Sequence 1 TOR, Sequence 2 TOR, Sequence 3 TOR, Run reverse, Ready to start, Fieldbus[%]	0	133	Run	
10.05	K5 function	Same settings as for K4 function.	0	134	Top of ramp	
10.06	K6 function	Same settings as for K4 function.	0	135	Event group 0	
10.07	AO reference	0-10 mA, 0-20 mA, 4-20 mA, 0-10 V	0	137	4-20 mA	
10.08	AO type	Motor current [A], Mains voltage [V], Active power [kW], Active power [HP], Reactive power [kVAr], Apparent power [kVA], Active energy [kWh], Reactive energy [kVARh], COS Φ, Motor temperature [%], Thyristor temperature [%], Motor voltage [%], Mains frequency [Hz], PT100 temperature [centigrade], PTC resistance [Ω], Fieldbus[%]	0	138	Motor current [A]	
10.09	AO max value	0 ... 1000000	0	139	500	
10.10	AO min value	0 ... 1000000	0	140	0	
10.11	Ext therm sensor - ID	No sensor, PTC element, 3-wire PT100, 2-wire PT100, Bi-metal switch (NC), Bimetal switch (NO)	0	226	No sensor	

Parameter number	Description	Setting range	Number of decimals	Fieldbus ID	Default value	Actual setting
<b>11</b>	<b>External IO</b>					
11.01	1DI0 function	None, Reset, Enable, Slow speed forward, Slow speed reverse, Motor heating, Stand still brake, Start reverse, User defined protection, Emergency mode (active high), Emergency mode (active low), Fieldbus disable control, Start 1, Start 2, Start 3. Switch to remote control, Cancel brake, Pump cleaning automatic, Pump cleaning forward, Pump cleaning backward, Hold in Remote (Active High), Hold in Remote (Active Low), Lock Parameters (Active High), Lock Parameters (Active Low)	0	145	None	
11.02	1DI1 function	Same settings as for 1DI0 function.	0	146	None	
11.03	1DI2 function	Same settings as for 1DI0 function.	0	147	None	
11.04	1DI3 function	Same settings as for 1DI0 function.	0	148	None	
11.05	1DI4 function	Same settings as for 1DI0 function.	0	149	None	
11.06	2DI5 function	Same settings as for 1DI0 function.	0	150	None	
11.07	2DI6 function	Same settings as for 1DI0 function.	0	151	None	
11.08	2DI7 function	Same settings as for 1DI0 function.	0	152	None	
11.09	1DO0 function	Same settings as for 1DI0 function.	0	153	None	
11.10	1DO1 function	Same settings as for 1DI0 function.	0	154	None	
11.11	2DO2 function	Same settings as for 1DI0 function.	0	155	None	
11.12	2DO3 function	Same settings as for 1DI0 function.	0	156	None	
11.13	1AO0 reference	0-10 mA, 0-20 mA, 4-20 mA, 0-10 V	0	157	4-20 mA	
11.14	1AO0 type	Motor current [A], Mains voltage [V], Active power [kW], Active power [HP], Reactive power [kVar], Apparent power [kVA], Active energy [kWh], Reactive energy [kVAh], COS $\Phi$ , Motor temperature [%], Thyristor temperature [%], Motor voltage [%], Mains frequency [Hz], PT100 temperature [centigrade], PTC resistance [ $\Omega$ ], Fieldbus[%]	0	158	Motor current [A]	
11.15	1AO0 max value	0 ... 1000000	0	159	500	
11.16	1AO0 min value	0 ... 1000000	0	160	0	
<b>12</b>	<b>Communication</b>					
12.01	Com3 function	None, Test, Modbus RTU slave. Extension I/O	0	26	Test	
12.02	FB interface connector	FbPlug, Modbus RTU, Anybus, None	0	32	None	
12.03	Fieldbus control	On, Off	0	45	Off	
12.04	Fieldbus address	0 ... 65535	0	51	0	
12.05	Fieldbus IP address	0.0.0.0 ... 255.255.255.255	0	58	0.0.0.0	
12.06	Fieldbus IP gateway	0.0.0.0 ... 255.255.255.255	0	59	0.0.0.0	
12.07	Fieldbus IP netmask	255.255.255.000	0	83	255.255.255.0	
12.08	Fieldbus IP DHCP client	On, Off	0	92	Off	
12.09	FB baud rate	1200, 2400, 4800, 9600, 19200, 38400, 57600, 76800, 115200, 125000, 250000, 500000, auto	0	185	19200	
12.10	FB parity	No parity, Odd parity, Even parity	0	136	Even parity	
12.11	FB stop bits	1 Stop bit, 2 Stop bits	0	141	1 Stop bit	

Parameter number	Description	Setting range	Number of decimals	Fieldbus ID	Default value	Actual setting
12.12	The functions of the programmable Digital inputs are controlled by the parameters Fieldbus DI 1 through Fieldbus DI 10. The following functions are available for selection:	None, Start feedback, Stop feedback, Fault reset feedback, Slow speed rev feedback, Slow speed forw feedback, Start 1 feedback, Start 2 feedback, Start 3 feedback, Motor heating feedback, User defined feedback, Stand-still brake feedback, Emergency mode feedback, Start reverse feedback, Run status, TOR status, Line, Phase sequence, Event group 0 status, Event group 1 status, Event group 2 status, Event group 3 status, Event group 4 status, Event group 5 status, Event group 6 status, Sequence 1 Run status, Sequence 2 Run status, Sequence 3 Run status, Sequence 1 TOR status, Sequence 2 TOR status, Sequence 3 TOR status, Run reverse status, Enable status, Digital In0 status, Digital In1 status, Digital In2 status, Local control status, Cancel brake status, Pump cleaning auto status, Pump cleaning forward status, Pump cleaning backward status	0	142	Run status	
12.13	Fieldbus DI 2	Same settings as for Fieldbus DI 1.	0	143	TOR status	
12.14	Fieldbus DI 3	Same settings as for Fieldbus DI 1.	0	144	Line	
12.15	Fieldbus DI 4	Same settings as for Fieldbus DI 1.	0	161	Phase sequence	
12.16	Fieldbus DI 5	Same settings as for Fieldbus DI 1.	0	162	Start feedback	
12.17	Fieldbus DI 6	Same settings as for Fieldbus DI 1.	0	163	Stop feedback	
12.18	Fieldbus DI 7	Same settings as for Fieldbus DI 1.	0	164	Event group 0 status	
12.19	Fieldbus DI 8	Same settings as for Fieldbus DI 1.	0	165	Event group 1 status	
12.20	Fieldbus DI 9	Same settings as for Fieldbus DI 1.	0	166	Event group 2 status	
12.21	Fieldbus DI 10	Same settings as for Fieldbus DI 1.	0	167	Event group 3 status	
12.22	Fieldbus AI 1	None, Phase L1 current, Phase L2 current, Phase L3 current, Active power (HP), Active power, Apparent power, Mains voltage, Power factor, Motor voltage, Active energy (resettable), EOL time to trip, Mains frequency, Max phase current, Motor current, Motor run time (resettable), Motor temperature, Motor temperature percent, Number of starts (resettable), Phase sequence, PT100 temperature, PTC resistance, Reactive energy (resettable), Reactive power, Remaining time to start, Thyristor temperature, Thyristor temperature percent, EOL time to cool, Top event code, Motor current percent, Thyristor run time (resettable), Motor connection, Phase L1 current (high range), Phase L2 current (high range), Phase L3 current (high range), Active power (HP) (high range), Active power (high range), Apparent power (high range), Reactive power (high range), Max phase current (high range), Motor current (high range), Active energy (high range), Reactive energy (high range), Number of starts (high precision)	0	168	Phase L1 current	
12.23	Fieldbus AI 2	Same settings as for Fieldbus AI 1.	0	169	Phase L2 current	

Parameter number	Description	Setting range	Number of decimals	Fieldbus ID	Default value	Actual setting
12.24	Fieldbus AI 3	Same settings as for Fieldbus AI 1.	0	172	Phase L3 current	
12.25	Fieldbus AI 4	Same settings as for Fieldbus AI 1.	0	174	Max phase current	
12.26	Fieldbus AI 5	Same settings as for Fieldbus AI 1.	0	177	Mains frequency	
12.27	Fieldbus AI 6	Same settings as for Fieldbus AI 1.	0	178	Motor voltage	
12.28	Fieldbus AI 7	Same settings as for Fieldbus AI 1.	0	179	Motor temperature percent	
12.29	Fieldbus AI 8	Same settings as for Fieldbus AI 1.	0	180	Number of starts (resettable)	
12.30	Fieldbus AI 9	Same settings as for Fieldbus AI 1.	0	183	Motor run time (resettable)	
12.31	Fieldbus AI 10	Same settings as for Fieldbus AI 1.	0	186	Top event code	
12.32	Allow CIP reset	Yes, No	0	322	No	
12.33	Fieldbus BACnet Device Instance	0 ... 4194303	0	323	4194303	
12.34	BACnet FDR IP address	0.0.0.0 ... 255.255.255.255	0	324	0.0.0.0	
12.35	BACnet foreign device registration UDP port	1 ... 65535	0	325	47808	
12.36	BACnet foreign device registration time interval	0 ... 65535 s	0	326	0 s	
12.37	Fieldbus AO 1	FBT argument 2, Internal analog out	0	327	FBT argument 2	
12.38	Fieldbus AO 2	FBT argument 3, External analog out	0	328	FBT argument 3	
12.39	Change SNMP community string	Yes, No	0	357	No	
12.40	SNMP community string part 1	0 ... 4294967295	0	358	1094861357	
12.41	SNMP community string part 2	0 ... 4294967295	0	359	1347638360	
<b>13</b>	<b>Protections list 1</b>					
13.01	EOL mode	Normal, Dual	0	55	Normal	
13.02	EOL class	10A, 10, 20, 30	0	56	10	
13.03	EOL dual class	10A, 10, 20, 30	0	57	10A	
13.04	EOL out	Eventgroup 0 ... 6	0	84	0000010	
13.05	EOL operation	Off, Stop-Manual, Stop-Automatic, Indication	0	227	Stop-Manual	
13.06	Locked rotor level	0.5 ... 8.0 x I <sub>e</sub>	1	54	4.0 x I <sub>e</sub>	
13.07	Locked rotor trip time	0.20 ... 10.00 s	2	53	1.00 s	
13.08	Locked rotor delay time	1.00 ... 30.00 s	2	52	5.00 s	
13.09	Locked rotor out	Eventgroup 0 ... 6	0	85	0000010	
13.10	Locked rotor op	Off, Stop-Manual, Stop-Automatic, Indication	0	228	Off	
13.11	Max no of starts per hour	1 ... 100	0	229	6	
13.12	Max no of starts per hour out	Eventgroup 0 ... 6	0	230	0000010	
13.13	Max no of starts per hour op	Off, Stop-Manual, Stop-Automatic, Indication	0	231	Off	
<b>14</b>	<b>Protections list 2</b>					
14.01	Curr underload level	0.3 ... 0.9 x I <sub>e</sub>	1	232	0.5 x I <sub>e</sub>	
14.02	Curr underload trip time	0 ... 30 s	0	233	10 s	
14.03	Curr underload delay time	0 ... 30 s	0	234	5 s	
14.04	Curr underload out	Eventgroup 0 ... 6	0	87	0000010	
14.05	Curr underload op	Off, Stop-Manual, Stop-Automatic, Indication	0	235	Off	
14.06	Pwr factor underload level	0.00 ... 1.00	2	236	0.50	
14.07	Pwr factor underload trip time	0 ... 30 s	0	237	10 s	
14.08	Pwr factor underload delay time	0 ... 30 s	0	238	5 s	
14.09	Pwr factor underload out	Eventgroup 0 ... 6	0	86	0000010	



Parameter number	Description	Setting range	Number of decimals	Fieldbus ID	Default value	Actual setting
14.10	Pwr factor underload op	Off, Stop-Manual, Stop-Automatic, Indication	0	239	Off	
14.11	Curr imb level	10 ... 80%	0	61	80%	
14.12	Curr imb trip time	1 ... 30 s	0	63	10 s	
14.13	Curr imb delay time	1 ... 30 s	0	62	5 s	
14.14	Curr imb out	Eventgroup 0 ... 6	0	64	0000010	
14.15	Curr imb operation	Off, Stop-Manual, Stop-Automatic, Indication	0	60	Off	
<b>15</b>	<b>Protections list 3</b>					
15.01	Overvoltage level	170 ... 850 V	0	67	760 V	
15.02	Overvoltage trip time	0.1 ... 100.0 s	1	65	1.0 s	
15.03	Overvoltage out	Eventgroup 0 ... 6	0	68	0000010	
15.04	Overvoltage op	Off, Stop-Manual, Stop-Automatic, Indication	0	66	Off	
15.05	Undervoltage level	165 ... 760 V	0	71	165 V	
15.06	Undervoltage trip time	0.1 ... 100.0 s	1	69	1.0 s	
15.07	Undervoltage op	Off, Stop-Manual, Stop-Automatic, Indication	0	70	Off	
15.08	Undervoltage out	Eventgroup 0 ... 6	0	72	0000010	
15.09	Voltage imb level	1 ... 100%	0	77	10%	
15.10	Voltage imb out	Eventgroup 0 ... 6	0	78	0000010	
15.11	Voltage imb op	Off, Stop-Manual, Stop-Automatic, Indication	0	76	Off	
15.12	Voltage imb trip time	1 ... 100 s	0	329	10 s	
<b>16</b>	<b>Protections list 4</b>					
16.01	Phase rev out	Eventgroup 0 ... 6	0	89	0000010	
16.02	Phase rev operation	Off, Stop-Manual, Stop-Automatic, Indication	0	240	Off	
16.03	Freq range lower trip lvl	40 ... 72 Hz	0	241	45 Hz	
16.04	Freq range upper trip lvl	40 ... 72 Hz	0	242	66 Hz	
16.05	Freq range trip time	0.0 ... 60.0 s	1	243	5.0 s	
16.06	Freq range out	Eventgroup 0 ... 6	0	91	0000010	
16.07	Freq range operation	Off, Stop-Manual, Stop-Automatic, Indication	0	244	Off	
16.08	Bypass open out	Eventgroup 0 ... 6	0	95	0000010	
16.09	Bypass open operation	Off, Stop-Manual, Stop-Automatic, Indication	0	245	Indication	
16.10	24V output out	Eventgroup 0 ... 6	0	82	0000010	
16.11	24V output operation	Off, Stop-Manual, Stop-Automatic, Indication	0	81	Indication	
16.12	Phase rev expected sequence	L1->L2->I3, L1->L3->L2, Unknown	0	330	L1->L2->L3	
16.13	Bypass open trip time	1 ... 300 s	0	-	10 s	
<b>17</b>	<b>Protections list 5</b>					
17.01	PTC out	Eventgroup 0 ... 6	0	88	0000010	
17.02	PTC op	Off, Stop-Manual, Stop-Automatic, Indication	0	246	Off	
17.03	PT100 2wire res	0.0 ... 100.0 ohm	1	247	5.0 ohm	
17.04	PT100 trip temp	-50 ... 250 °C	0	248	60 °C	
17.05	PT100 reset temp	-50 ... 250 °C	0	240	40 °C	
17.06	PT100 out	Eventgroup 0 ... 6	0	98	0000010	
17.07	PT100 op	Off, Stop-Manual, Stop-Automatic, Indication	0	250	Off	
<b>18</b>	<b>Protections list 6</b>					
18.01	User defined DI status	Active low, Active high	0	251	Active high	
18.02	User defined trip time	0.0 ... 60.0 s	1	252	1.0 s	
18.03	User defined out	Eventgroup 0 ... 6	0	90	0000010	
18.04	User defined op	Off, Stop-Manual, Stop-Automatic, Indication	0	253	Off	
18.05	Ground fault trip time	0.1 ... 1.0 s	1	73	0.5 s	
18.06	Ground fault out	Eventgroup 0 ... 6	0	75	0000010	
18.07	Ground fault op	Off, Stop-Manual, Stop-Automatic, Indication	0	74	Off	
18.08	Too long curr lim trip time	1 ... 600 s	0	254	10 s	
18.09	Too long curr lim out	Eventgroup 0 ... 6	0	255	0000010	
18.10	Too long curr lim op	Off, Stop-Manual, Stop-Automatic, Indication. Fast ramp	0	256	Off	
18.11	Too long start trip time	1.0 ... 500.0 s	1		500.0 s	
18.12	Too long start out	Eventgroup 0 ... 6	0		0000010	



Parameter number	Description	Setting range	Number of decimals	Fieldbus ID	Default value	Actual setting
18.13	Too long start op	Off, Stop-Manual, Stop-Automatic, Indication, Fast ramp	0		Off	
18.14	Auto-restart max delay	2 ... 3600 s	0		3600	
18.15	Auto-restart time-out out	Eventgroup 0 ... 6	0		0000010	
18.16	Auto-restart time-out op	Off, Stop-Manual, Stop-Automatic, Indication	0		Off	
<b>19</b>	<b>Protections list 7</b>					
19.01	HMI failure out	Eventgroup 0 ... 6	0	100	0000010	
19.02	HMI failure op	Off, Stop-Manual, Stop-Automatic, Indication, Switch of HMI control	0	257	Stop-Manual	
19.03	Fieldbus failure out	Eventgroup 0 ... 6	0	97	0000010	
19.04	Fieldbus failure op	Off, Stop-Manual, Stop-Automatic, Indication, Switch to I/O control	0	258	Stop-Manual	
19.05	Ext IO failure trip time	300 ... 30000 ms	0	259	1000 ms	
19.06	Ext IO failure out	Eventgroup 0 ... 6	0	99	0000010	
19.07	Ext IO failure op	Off, Stop-Manual, Stop-Automatic, Indication	0	260	Stop-Manual	
19.12	Fieldbus failure timeout	0.5 ... 60.0 s	1	337	0.5 s	
19.13	IO controller stop out	Eventgroup 0 ... 6	0	365	0000010	
19.14	IO controller stop op	Off, Stop-Manual, Stop-Automatic, Indication	0	366	Off	
<b>20</b>	<b>Warnings list 1</b>					
20.01	EOL level	40.0 ... 99.0%	1	181	90.0%	
20.02	EOL out	Eventgroup 0 ... 6	0	123	0000100	
20.03	EOL warning	On, Off	0	182	Off	
20.04	Locked rotor level	0.2 ... 10.0 x I <sub>e</sub>	1	261	1.2 x I <sub>e</sub>	
20.05	Locked rotor init time	1.0 ... 30.0 s	1	262	5.0 s	
20.06	Locked rotor out	Eventgroup 0 ... 6	0	125	0000100	
20.07	Locked rotor	On, Off	0	263	Off	
20.08	Thyristor OL out	Eventgroup 0 ... 6	0	124	0000100	
20.09	Thyristor OL	On, Off	0	122	Off	
20.10	Locked rotor trip time	0.1 ... 100.0 s	1	-	0.1 s	
<b>21</b>	<b>Warnings list 2</b>					
21.01	Curr underload level	0.4 ... 1.0 x I <sub>e</sub>	1	264	0.8 x I <sub>e</sub>	
21.02	Curr underload trip time	0 ... 30 s	0	265	1 s	
21.03	Curr underload delay time	0 ... 30 s	0	266	5 s	
21.04	Curr underload out	Eventgroup 0 ... 6	0	126	0000100	
21.05	Curr underload	On, Off	0	267	Off	
21.06	Pwr factor underload level	0.00 ... 1.00	2	268	0.70	
21.07	Pwr factor underload trip time	0 ... 30 s	0	269	1 s	
21.08	Pwr factor underload delay time	0 ... 30 s	0	270	5 s	
21.09	Pwr factor underload out	Eventgroup 0 ... 6	0	127	0000100	
21.10	Pwr factor underload	On, Off	0	271	Off	
21.11	Current imb level	10 ... 80%	0	102	70%	
21.12	Current imb out	Eventgroup 0 ... 6	0	103	0000100	
21.13	Current imbalance	On, Off	0	101	Off	
21.14	Current imbalance trip time	0.1 ... 100.0	1		5.0 s	
<b>22</b>	<b>Warnings list 3</b>					
22.01	Overvoltage level	208 ... 760 V	0	104	650 V	
22.02	Overvoltage trip time	0.1 ... 100.0 s	1	105	1.0 s	
22.03	Overvoltage out	Eventgroup 0 ... 6	0	107	0000100	
22.04	Overvoltage	On, Off	0	106	Off	
22.05	Undervoltage level	208 ... 760 V	0	108	208 V	
22.06	Undervoltage trip time	0.1 ... 100.0 s	1	109	0.5 s	
22.07	Undervoltage out	Eventgroup 0 ... 6	0	111	0000100	
22.08	Undervoltage	On, Off	0	110	Off	
22.09	Voltage imb level	1 ... 10	0	119	5	
22.10	Voltage imb out	Eventgroup 0 ... 6	0	120	0000100	
22.11	Voltage imbalance	On, Off	0	118	Off	
22.12	Voltage imbalance trip time	0.1 ... 100.0 s	1		5.0 s	

Parameter number	Description	Setting range	Number of decimals	Fieldbus ID	Default value	Actual setting
<b>23</b>	<b>Warnings list 4</b>					
23.01	EOL time-to-trip time	1 ... 1000 s	0	114	5 s	
23.02	EOL time-to-trip out	Eventgroup 0 ... 6	0	112	0000100	
23.03	EOL time-to-trip	On, Off	0	113	Off	
23.04	THD(U) level	1 ... 10%	0	116	10%	
23.05	THD(U) out	Eventgroup 0 ... 6	0	117	0000100	
23.06	THD(U)	On, Off	0	115	Off	
23.07	Short circuit out	Eventgroup 0 ... 6	0	129	0000100	
23.08	Short circuit	On, Off	0	121	Off	
23.09	THD(U) trip time	0.1 ... 100.0 s	1		10.0 s	
<b>24</b>	<b>Warnings list 5</b>					
24.01	Number of starts limit	1 ... 65535	0	-	65535	
24.02	Number of starts out	Eventgroup 0 ... 6	0	-	0000100	
24.03	Number of starts	On, Off	0	-	Off	
24.07	Phase loss trip time	0.5 ... 100.0	1		3.0	
24.08	Phase loss out	Eventgroup 0 ... 6	0		0000100	
24.09	Phase loss	On, Off	0		Off	
24.10	Motor run time limit	0 ... 100000 h	0		10000 h	
24.11	Motor run time out	Eventgroup 0 ... 6	0		0000100	
24.12	Motor run time	On, Off	0		Off	
24.13	Storage warning out	Eventgroup 0 ... 6	0	362	0000100	
24.14	Storage warning	On, Off	0	363	On	
<b>25</b>	<b>Internal faults</b>					
25.01	Shunt fault out	Eventgroup 0 ... 6	0	42	0000001	
25.02	Shunt fault op	Stop-Manual, Stop-Automatic	0	272	Stop-Manual	
25.03	Short circuit out	Eventgroup 0 ... 6	0	50	0000001	
25.04	Short circuit fault op	Stop-Manual, Stop-Automatic	0	273	Stop-manual	
25.05	Open circuit thyr out	Eventgroup 0 ... 6	0	44	0000001	
25.06	Open circuit thyr op	Stop-Manual, Stop-Automatic	0	274	Stop-Manual	
25.07	Thyristor OL out	Eventgroup 0 ... 6	0	47	0000001	
25.08	Thyristor OL op	Stop-Manual, Stop-Automatic	0	275	Stop-Manual	
25.09	Heatsink over temp out	Eventgroup 0 ... 6	0	48	0000001	
25.10	Heatsink over temp op	Stop-Manual, Stop-Automatic	0	276	Stop-Manual	
25.11	Unspecified fault out	Eventgroup 0 ... 6	0	43	0000001	
25.12	Unspecified fault op	Stop-Manual, Stop-Automatic	0	277	Stop-Manual	
25.13	Electronics failure out	Eventgroup 0 ... 6	0	360	0000001	
25.14	Electronics failure op	Stop-Manual, Stop-Automatic	0	361	Stop-Manual	
<b>26</b>	<b>External faults</b>					
26.01	Phase loss out	Eventgroup 0 ... 6	0	96	0000001	
26.02	Phase loss op	Stop-Manual, Stop-Automatic	0	278	Stop-Manual	
26.03	Bad network out	Eventgroup 0 ... 6	0	36	0000001	
26.04	Bad network op	Stop-Manual, Stop-Automatic	0	279	Stop-Manual	
26.05	Low supply voltage out	Eventgroup 0 ... 6	0	46	0000001	
26.06	Low supply voltage op	Stop-Manual, Stop-Automatic	0	280	Stop-Manual	
26.07	High current out	Eventgroup 0 ... 6	0	49	0000001	
26.08	High current op	Stop-Manual, Stop-Automatic	0	281	Stop-Manual	
26.09	Faulty usage out	Event group 0 ... 6	0	282	Event group 0	
26.10	Fault usage op	Stop-Manual, Stop-Automatic	0	283	Stop-Manual	
26.11	Faulty connection out	Eventgroup 0 ... 6	0	282	0000001	
26.12	Faulty connection op	Stop-Manual, Stop-Automatic	0	283	Stop-Manual	
<b>27</b>	<b>Presentation</b>					
27.01	Language	English, Spanish, Finnish, French, Italian, Dutch, Polish, Portuguese, Russian, Swedish, Turkish, Indonesian, Chinese (simplified Chinese), Arabic, Czech, German, Greek	0	173	English	
27.02	Basic set-up at power on	Yes, No	0	284	Yes	

Parameter number	Description	Setting range	Number of decimals	Fieldbus ID	Default value	Actual setting
<b>28</b>	<b>Service</b>					
28.01	ID	Invalid ID, 30, 37, 45, 60, 72, 85, 105, 142, 170, 210, 250, 300, 370, 470, 570, 720, 840, 1050, 1250	0		-	
28.02	Line contactor close time	0 ... 65535 ms	0	175	250 ms	
28.03	TOR relay delay time	0.0 ... 300.0 s	1	286	0.0 s	
28.04	Start without start command	On / Off	0	287	Off	
28.05	Step down level	10 ... 100%	0	9	80%	
28.06	Torque profile start	Constant setpoint, Linear ramp, Progressive curve, High inertia curve	0	10	Linear ramp	
28.07	Torque finish	30 ... 500%	0	17	100%	
28.08	Torque tune	0 ... 1000%	0	11	100%	
28.09	Torque ctrl gain	0.01 ... 10.00	2	12	0.02	
28.10	Torque PI integration time	0.001 ... 10.000 s	3	13	0.004 s	
28.11	Torque slip	0.1 ... 100%	1	14	1.0%	
28.12	Torque diff	0.1 ... 100%	1	15	2.0%	
28.13	Torque filter time	0.01 ... 10.00 s	2	16	0.02 s	
28.14	Mains lock setting	Automatic lock, 50 Hz manual lock 60 Hz manual lock	0	-	Automatic lock	
28.15	Minimum trig time	0.000 ... 1.000 ms	3	-	0.208 ms	
28.16	Accel adapt U start ramp	On, Off	0	290	Off	
28.17	U start ramp switch level	10 ... 100%	0	-	22%	
28.18	T start ramp switch level	10 ... 100%	0	-	30%	
28.19	Stop ramp switch level	10 ... 100%	0	-	52%	
28.20	In-Line gain	0.0 ... 30.0	1	-	0.0	
28.21	Inside delta gain	0.0 ... 30.0	1	-	3.0	
28.22	Phase loss	On, Off	0	-	On	
28.23	Phase loss during TOR	On, Off	0	-	On	
28.24	Phase loss trip time	20 ... 4000 ms	0	-	500 ms	
28.25	Phase loss trip angle 1	1 ... 240	0	-	12	
28.26	Phase loss trip angle 2	1 ... 240	0	-	70	
28.27	Bad network quality	On, Off	0	-	On	
28.28	Low supply voltage	On, Off	0	-	On	
28.29	High current fault	On, Off	0	-	On	
28.30	Shunt fault	On, Off	0	-	On	
28.31	Short circuit thyristor	On, Off	0	-	On	
28.32	Open circuit thyristor	On, Off	0	-	On	
28.33	Thyristor overload	On, Off	0	-	On	
28.34	Heatsink over temp	On, Off	0	-	On	
28.35	Faulty connection	On, Off	0	-	On	
28.36	Faulty usage	On, Off	0	-	On	
28.37	Close bypass curr lvl	0.5 ... 4.0 x I <sub>e</sub>	1	-	1.2 x I <sub>e</sub>	
28.38	Simulation motor	M3AA 100L 2 (I <sub>e</sub> = 5.2 A), M3BP 112M 4 (I <sub>e</sub> = 7.4 A), M2AA 180MLA 6G (I <sub>e</sub> = 29.3 A), M2AA 180MLB 4G (I <sub>e</sub> = 39.9 A), M3AA 250SMA 8 (I <sub>e</sub> = 62.3 A), M3AA 200MLB 2 (I <sub>e</sub> = 59.2 A), M2AA 225SMA 2G (I <sub>e</sub> = 74.7 A), M2BP 250SMA 4G (I <sub>e</sub> = 96.6 A), M2BA 280SMB 2L (I <sub>e</sub> = 144.9 A), M2BA 315SMB 4L (I <sub>e</sub> = 221.8 A), M2BA 315MLA 2L (I <sub>e</sub> = 319.6A), M4BP 200MLB 2G (I <sub>e</sub> = 59.3 A), M3BP 315LKB 4K (I <sub>e</sub> = 330.4 A), M3BP 315MLA 2M (I <sub>e</sub> = 255.4 A), M3BP 280MLA 4M (I <sub>e</sub> = 151.5 A), M3BP 355SMC 6K (I <sub>e</sub> = 325.6 A),	0	29	M3AA 250SMA 8 (I <sub>e</sub> = 62.3 A)	
28.39	Simulation load	No load, Linear Load, Progressive load, High inertia load	0	30	Progressive load	
28.40	Simulation connection	Auto, In line, Inside delta UI, Inside delta IU, Two phase (L1 shorted), Two phase (L2 shorted), Two phase (L2 shorted), Unknown	0	303	In line	

Parameter number	Description	Setting range	Number of decimals	Fieldbus ID	Default value	Actual setting
28.41	System mode	Normal, Demo, Small motor	0	31	Normal	
28.42	Limp mode	On, Off	0	25	Off	
28.43	Motor connection	Auto, In line, Inside delta UI, Inside delta IU, Two phase (L1 shorted), Two phase (L2 shorted), Two phase (L2 shorted), Unknown	0	27	Auto	
28.48	Disable service profile	Yes, No	0		No	
28.49	Shunt fault trip time	0.1 ... 120.0 s	1		5.0 s	
28.50	Shunt fault trip level	0.1 ... 100.0%	1		3.0%	
28.52	Auxiliary condition	On, Off	0		Off	
28.55	Fast take-off	Off, On	0	355	Off	
28.63	Flux support min speed	10 ... 100%	0	0	35%	
28.64	Electronics failure	On, Off	0	-	On	
<b>29</b>	<b>Pump clean</b>					
29.01	Pump clean reverse speed	Fast jog, Jog, Creep	0	306	Jog	
29.02	Pump clean reverse strength	10 ... 100%	0	307	45%	
29.03	Pump clean forward start mode	Voltage ramp, Torque ramp, Full voltage start	0	308	Full voltage start	
29.04	Pump clean auto forward time	1.0 ... 100.0 s	1	309	5.0 s	
29.05	Pump clean auto reverse time	1.0 ... 100.0 s	1	310	5.0 s	
29.06	Pump clean brake strength	20 ... 100%	0	311	45%	
29.07	Pump clean brake timeout	1.0 ... 100.0 s	1	312	10.0 s	
29.08	Pump clean stop mode	Voltage ramp and brake, Torque ramp and brake, Dynamic brake	0	313	Torque ramp and brake	

# 8 Communication

<b>8.1 Built in modbus RTU</b>	146
<hr/>	
<b>8.2 Anybus CompactCom (option)</b>	146
<hr/>	
8.3.1 Instructions	147
8.3.2 Necessary components	146
<hr/>	
<b>8.3 ABB Fieldbus plug interface (option)</b>	147
<hr/>	
8.3.1 Instructions	147
8.3.2 Necessary components	147
<hr/>	
<b>8.4 MINI USB interface</b>	147
<hr/>	

## 8.1 Built in modbus RTU

The PSTX Softstarter has a non-isolated RS485 physical interface, com 3, for external devices with support for RS485 based communication.

You can use this interface to control the Softstarter, get status information, and for the upload and download of parameters.

The Softstarter uses the RS485 interface for a modbus RTU slave connection.

### 8.1.1 Instructions

Instructions for the set-up of input and output telegrams, parameter settings, instructions, etc. are available at:

<https://solutions.abb/softstarters>

- Built-in Modbus RTU 1SFC132089M0201

## 8.2 Anybus CompactCom (option)

The PSTX Softstarter has an interface on the front, com 1, for connecting the Anybus CompactCom (CC) module, used for Fieldbus communication. You can use this interface to control the Softstarter, get status information, and for the upload and download of parameters.



### INFORMATION

When fastening the module into the com1 port, make sure that the module is properly aligned into the com 1 and the socket prior to applying any force. Rough handling and/or excessive force in combination with misalignment may cause mechanical damage to the module and/or the com1 and socket.



### INFORMATION

The ports used for communication are the standard ports for each Ethernet based communication protocol. Ethernet/IP: TCP port number 44818 : UDP port number 2222  
The PROFINET use any of the standardized ports.  
Modbus TCP: TCP port number 502

When replacing or retrofitting an Anybus communication module with any of the modules listed in **Table 1** a software upgrade of the PSTX Softstarter with a control board (CB) firmware version below v.1.36.2 is needed to ensure compatibility. The ordering code and product ID is found printed on the Anybus module package and product label respectively. Please refer to section 6.4.5 and 9.3 for instructions on how to both determine and upgrade the PSTX Softstarter firmware if necessary.

**Table 1**

Module	Ordering Code	Product ID
Anybus Ethernet/IP (Dual ports)	1SFA899300R1006	AB6966-B
Anybus Modbus TCP (Dual ports)	1SFA899300R1008	AB6967-B

### 8.2.1 Instructions

Instructions for the set-up of input and output telegrams, parameter settings, instructions, etc. are available at:

<https://solutions.abb/softstarters>

- DeviceNet 1SFC132084M0201
- Profibus (DPV1) 1SFC132085M0201
- Modbus RTU 1SFC132086M0201
- Modbus TCP 1SFC132087M0201
- EtherNet/IP 1SFC132088M0201
- Profinet 1SFC132094M0201
- BACnet MS/TP 1SFC132381M0201
- BACnet IP 1SFC132381M0201
- EtherCAT 1SFC132382M0201

### 8.2.2 Necessary components

These Anybus CC connection devices are available:

- DeviceNet
- Profibus (DPV1)
- Modbus RTU
- Modbus TCP
- EtherNet/IP
- Profinet
- BACnet MS/TP
- BACnet IP
- EtherCAT

## 8.3 ABB Fieldbus plug interface (option)

The PSTX Softstarter has an interface, com 2, on the front for connecting the ABB Fieldbus Plug Adapter (FBPA) used for Fieldbus communication.

You can use this interface to control the Softstarter, get status information, and for the upload and download of parameters.

The interface between the Softstarter and the FieldBus Plug is independent of the Fieldbus protocol used. Independent of Softstarter type or delivery date, you can connect 1 of the available Fieldbus protocols, because this is specified in the FieldBus Plug itself.

Connect the Fieldbus communication plug to the ABB Fieldbus Plug Adapter (FBPA).

Make sure that the plug is in the correct position and tighten the screw with 0,8 Nm (7,1 lb in) and additional 1/4 turn.

These Fieldbus protocols are available:

- DeviceNet
- Profibus (DPV0/DPV1)
- Modbus RTU

### 8.3.1 Instructions

Instructions for the set-up of input and output telegrams, parameter settings, instructions, etc. are available at:

**<https://solutions.abb/softstarters>**

- DeviceNet 1SFC132090M0201
- Profibus (DPV0/DPV1) 1SFC132091M0201
- Modbus RTU 1SFC132092M0201

### 8.3.2 Necessary components

To connect the PSTX Softstarter to a Fieldbus system, these components are necessary:

- ABB Fieldbus Plug Adapter, for presenting Fieldbus protocol (make sure that the cable length is sufficient).
- Connectors for bus connection.
- End plug (some protocols).
- Software for PLC set-up.

## 8.4 MINI USB interface

The PSTX Softstarter has an USB interface for communication with PC. The USB interface is on the front of the movable HMI.

You can use this interface to get status information, and for the upload and download of parameters.





# 9 Maintenance

9.1 Regular maintenance	150
9.2 Service and repair	151
9.3 Firmware upgrade	152

This chapter gives a description of basic maintenance for the PSTX Softstarter.



---

### WARNING

Dangerous voltage: Can cause death or serious injury.

Make sure that the Softstarter is de-energized before doing maintenance, service or repair.

Do not open the Softstarter or touch live parts when the main and supply voltage is connected.

---



---

### WARNING

Service and repair must be done by authorized personnel only. Note that unauthorized repair has an effect on safety and warranty.

---



---

### INFORMATION

ABB personnel must obey the instructions in **ABB CISE 15.4**.

---

## 9.1 Regular maintenance

- Make sure that all installation bolts/screws are fastened. Tighten if necessary.
- Tighten the terminal screws and bolts on the connection bars, if necessary.  
For tightening torques, see chapter **5.1.1.1 Tightening torques and cable dimensions**.



---

### WARNING

- Make sure that the Softstarter is de-energized before tightening the bolts/screws.
- 

- Make sure that all connections of control- and supply circuits are fastened.  
For tightening torques, see chapter **5.1.1.1 Tightening torques and cable dimensions**.
- If the Softstarter is installed inside a cabinet, do a check of the external filters. Clean them, if necessary.
- Make sure that the airways are free from dirt and dust.



---

### WARNING

Do not use pressurized air to clean the Softstarter.

---

- Check that the fans are running for at least 3 minutes after each start and stop cycle.
- Make sure that the fan works and rotates freely. The blades must rotate without resistance.
- Do a check of the time of the Softstarter and adjust if necessary.
- In case of a fault, or if a fault cannot be reset, see chapter **10 Troubleshooting**.

## 9.2 Service and repair

For repair of the PSTX Softstarter, speak to your ABB reseller/Office or speak to ABB through <https://solutions.abb/softstarters>



---

### **WARNING**

A short circuit on the load side of the Softstarter can cause large damage to the unit and cause danger to personnel.

---

By using a correctly rated short circuit protection device, e.g. a fuse or a circuit breaker, the damage is limited to 1 of the 2 categories, specified in IEC 60947-4-2 and EN 60947-4-2:

Type 1: The Softstarter can have damage and it can be necessary to replace some or all parts.

Type 2: The device can operate after a short circuit.

Type 2: Use a semiconductor fuse to get coordination. A coordination table is found in the catalogue and online through:

<https://solutions.abb/softstarters>

For warranty for damage on the thyristors, the coordination type 2 is necessary.

## 9.3 Firmware upgrade

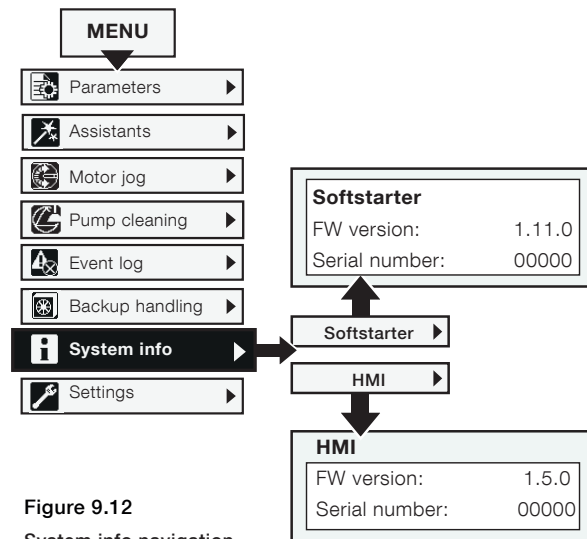
The firmware for the PSTX Softstarter is divided into two parts with separate firmware for both the HMI module and the Control Board (CB). Both firmwares are supplied in the same zip-package. To upgrade the PSTX Softstarter with new firmwares, the software SoftstarterCare™ – Service Engineer Tool is required and the firmware package, both can be downloaded from the ABB library. Use your ABB login or contact your ABB Service representative.

The Service Engineer Tool can access all HMI parameters, the event log, status information, trouble shooting, and upgrade the PSTX Softstarter firmware from a PC.

The procedure for upgrading the PSTX Softstarter firmware differ depending on the CB firmware currently installed in the PSTX Softstarter.

The current firmware versions is found using the HMI. Navigate to **Menu ▶ System info ▶ Softstarter**, se **Figure 9.12**, or section **6.4.5 System info** for more information.

If the HMI cannot be used, then connect the PSTX Softstarter to a PC with SoftstarterCare and find the firmware version through **Menu ▶ Information ▶ DEVICE INFORMATION**.



**Figure 9.12**  
System info navigation

### 9.3.1 Upgrade from a CB firmware version higher than 1.22.0

#### 9.3.1.1 Preparation

1. Make sure a standard USB cable - "Mini-USB to USB" is available.
2. Download and install the x86 version (32-bits) of the Microsoft Visual C++ Redistributable for Visual Studio 2015 package.

**i** **INFORMATION**  
Download the Visual C++ Redistributable package (vc\_redist.x86.exe) from [microsoft.com](http://microsoft.com).

3. Unzip and Install SoftstarterCare onto the PC.
4. Unzip the PSTX firmware package.

### 9.3.1.2 Upgrade firmware

1. Make sure that the PSTX Softstarter is disconnected from both operational voltage and control supply voltage (100-250V).
2. Set the HMI in boot mode.  
Hold both the **Stop** and **L/R button** when connecting the USB cable between the PC and the HMI, see **Figure 9.13**. All four LEDs (Ready, Run, Protection and Fault) will light up. Release the buttons and verify that all 4 LEDs are still lit.
3. Start the SoftstarterCare™ - Service Engineer Tool and confirm that the PSTX Softstarter is connected by checking the bottom status bar in Service Engineer Tool.
4. Click on “Firmware upgrade” on the tool bar of the Service Engineer Tool to start the firmware upgrade wizard.
5. Select the firmware (.cab) files that were unzipped during the preparation and then Click “Next”.
6. An information dialog opens with the text “Set HMI in boot mode...”. The PSTX Softstarter is already in boot mode, Click “Next” to proceed.
7. Click “Next” to use the default directory and start the firmware upgrade.



#### INFORMATION

The firmware upgrade can take up to 15 minutes to complete.

8. An information dialog opens and asks whether to restore parameters or not. Click “Yes” to restore parameters.
9. The upgrade is now completed. In order to set parameters etc. in SoftstarterCare the SoftstarterCare should first be restarted.

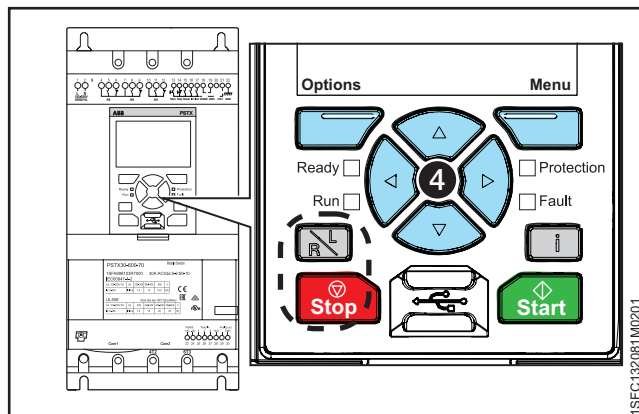


Figure 9.13  
Boot mode

## 9.3.2 Upgrade from a CB firmware version lower than 1.22.0

SoftstarterCare is limited in its support for softstarters with older CB firmware, i.e. parameters backup/restore is not supported. These parameters must be manually restored after the firmware upgrade.

### 9.3.2.1 Preparation

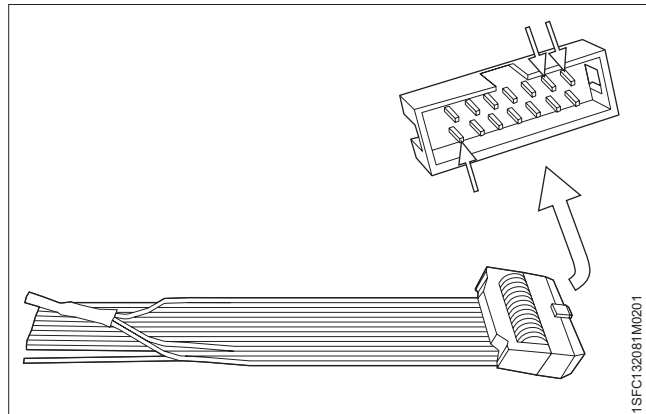
1. Make sure a standard USB cable - "Mini-USB to USB" is available.
2. Order a special jumper cable from the Softstarter support (se-softstarters-support@abb.com) or modify an existing cable by connecting three pins from the COM2 port together as shown in **Figure 9.14**. The special jumper cable will set the PSTX Softstarter into boot mode.
3. Download and install the x86 version (32-bits) of the Microsoft Visual C++ Redistributable for Visual Studio 2015 package.



#### INFORMATION

Download the Visual C++ Redistributable package (vc\_redist.x86.exe) from [microsoft.com](http://microsoft.com).

4. Unzip and Install SoftstarterCare onto the PC.
5. Unzip the PSTX firmware package.



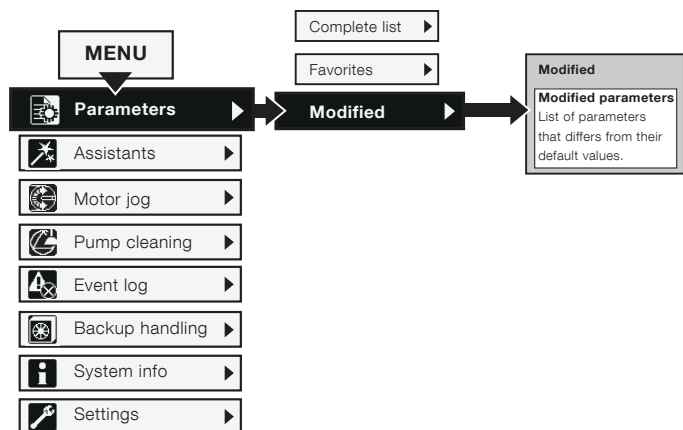
**Figure 9.14**  
Jumper cable for boot mode

### 9.3.2.2 Backup parameters

Make a note of all modified parameters in the PSTX Softstarter to manually restore them after the firmware upgrade.

Use the HMI and navigate to **Menu ▶ Parameters ▶ Modified** to list the modified parameters. See **Figure 9.15** or section **6.4.1.3 Modified** for more information.

If the HMI cannot be used for some reason, it is possible to connect another HMI to the PSTX Softstarter.



**Figure 9.15**  
Modified parameters

### 9.3.2.3 Upgrade firmware

1. Make sure that the PSTX Softstarter is disconnected from both operational voltage and control supply voltage (100-250V).
2. Connect the jumper cable to the Control Board COM2 port, see section **3.1.5 Softstarter overview**.
3. Set the HMI in boot mode.  
Hold both the **Stop** and **L/R button** when connecting the USB cable between the PC and the HMI, see **Figure 9.16**. All four LEDs (Ready, Run, Protection and Fault) will light up. Release the buttons and verify that all 4 LEDs are still lit.
4. Remove the jumper cable.



#### INFORMATION

The Control Board need to restart itself into application mode during the upgrade. If the jumper cable is not removed this is not possible.

5. Start the SoftstarterCare™ - Service Engineer Tool.
6. An information dialog opens with the text “Your PSTX Control Board is disconnected or is running in boot mode”. Click “OK”.
7. Click on “Firmware upgrade” on the tool bar of the Service Engineer Tool to start the firmware upgrade wizard.
8. Select the firmware (.cab) files that where unzipped during the preparation and then Click “Next”.
9. An information dialog opens with the text “Set HMI in boot mode...”. The PSTX Softstarter is already in boot mode, Click “Next” to proceed.
10. An information dialog opens with the text “Your PSTX device is using an old Firmware...”. Click “Select” and set the PSTX model number manually. Then Click “OK” to start the firmware upgrade.
11. An information dialog opens with the text “Failed to backup the parameters...”. Click “Yes” to continue with firmware upgrade.



#### INFORMATION

The firmware upgrade can take up to 15 minutes to complete.

12. An information dialog opens with the text “Failed to backup and restore the parameters...”. Click “Finish” to exit the upgrade wizard.
13. Restart the SoftstarterCare software.
14. Restore all modified parameters by setting each parameter to the value stored before the firmware upgrade, see section **9.3.2.2 Backup parameters**.
15. Done.

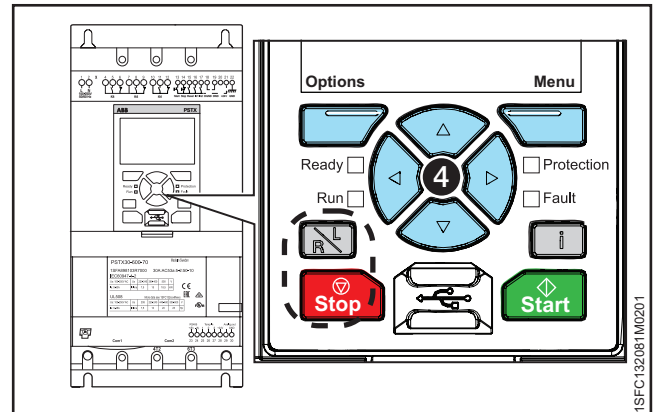


Figure 9.16  
Boot mode





# 10 Troubleshooting

10.1 General	158
10.2 Troubleshooting	158
10.3 Overview of faults, protections and warnings	161
10.4 Protection indication shown on screen	163
10.5 Fault indication shown on screen	164
10.6 Warning indication shown on screen	167

## 10.1 General

Use this chapter when problems occur with the Softstarter or the application.



### WARNING

Dangerous voltage: Can cause death or serious injury. Always set the power switch to off and lock out all power to this device before you start to work on the equipment.



### WARNING

Make sure that the Softstarter is de-energized before you do maintenance.  
Do not open the Softstarter or touch live parts when the main and supply voltage is connected.



### INFORMATION

ABB personnel must follow the **ABB CISE 15.4** instructions

The Softstarter indicates a fault with LED Fault, and the screen shows which type of fault occurred. When a protection is on, the LED Protection illuminates and the screen shows which type of protection is active. When a warning occurs, the screen shows the type of warning. In this chapter you can also find issues that the Softstarter does not show, such as humming sounds.

## 10.2 Troubleshooting

**Table 1** Troubleshooting

Status	Possible cause	Solution
Motor humming / starts without given start signal.	Bypass relay closed, because of inaccurate handling. (PSTX30...170 only).	<ul style="list-style-type: none"> <li>Disconnect the operation voltage and the control supply voltage. Remove USB cable from the computer if connected. Connect voltage in this sequence:                             <ol style="list-style-type: none"> <li>Control supply voltage on terminals 1 and 2. See chapter <b>5.1.2 Control supply and control circuit</b>.</li> <li>Wait 4 seconds, and then connect operation voltage on terminals L1, L2 and L3.</li> </ol> </li> <li>If the fault stays, speak to your ABB Sales Office.</li> </ul>
	Bypass contactor/relay stuck in closed position.	<ul style="list-style-type: none"> <li>Speak to your ABB Sales Office.</li> </ul>
	Shorted thyristor.	<ul style="list-style-type: none"> <li>Speak to your ABB Sales Office.</li> </ul>
Bad motor sound during start.	The motor connection is not correct.	<ul style="list-style-type: none"> <li>Examine and correct the wiring. Check jumper connectors in motor's terminal box. Connect the control supply voltage. Refer to the circuit diagram. See chapter <b>11 Wiring and application diagrams</b>.</li> </ul>
	Inside delta connection and one gate cable disconnected	<ul style="list-style-type: none"> <li>Make sure all six gate cables are connected.</li> </ul>
	Incorrect ramp time for start.	<ul style="list-style-type: none"> <li>Try different ramp times (some adjustments can be necessary for best result). See chapter <b>7 Functions</b>.</li> </ul>

Status	Possible cause	Solution
<b>Bad motor sound during start.</b>	Incorrect Initial/End level.	<ul style="list-style-type: none"> <li>Try different settings for the parameter Initial /End Voltage. See chapter <b>7 Functions</b>, or speak to your ABB Sales Office..</li> </ul>
	Incorrect Current limit level or Torque limit level.	<ul style="list-style-type: none"> <li>Try different settings for the parameter Current limit level or Torque limit level. See chapter <b>7 Functions</b>, or speak to your ABB Sales Office.</li> </ul>
	The motor is too small. (Current is out of measuring range.)	<ul style="list-style-type: none"> <li>Make sure that you have the correct Softstarter for this motor size. For test purposes you can use small motor mod. See chapter <b>7 Functions</b>.</li> </ul>
	Thyristor conductivity is bad.	<ul style="list-style-type: none"> <li>Contact your ABB Sales Office.</li> </ul>
	Incorrect ramp time for start.	<ul style="list-style-type: none"> <li>Make sure that you have the correct Softstarter for this motor size. For test purposes you can use small motor mode. See chapter <b>7 Functions</b>.</li> </ul>
	Start and stop command given at the same time.	<ul style="list-style-type: none"> <li>Make sure that start and stop command is not given at the same time.</li> </ul>
	The operation voltage is below 175 V.	<ul style="list-style-type: none"> <li>Do a check of the operation voltage.</li> </ul>
<b>Motor does not start when given start command by the hardwire inputs.</b>	Control wiring is not correct. Start and stop command given at the same time. Keypad is in Local control mode.	<ul style="list-style-type: none"> <li>Do a check of the connections for start and stop.</li> <li>Make sure that start and stop command is not given at the same time.</li> <li>Make sure that the keypad is not in Local Control mode.</li> <li>Push the R\L-key to change to Remote Control mode.</li> <li>Make sure that parameter Fieldbus control is set to No.</li> <li>Do a reset on an active event.</li> <li>Reset tripping events.</li> </ul>
<b>Motor does not start with Fieldbus.</b>	Softstarter has tripped on fault or protection.	<ul style="list-style-type: none"> <li>Do a reset on an active event. Reset tripping events.</li> </ul>
	Softstarter is in Local mode.	<ul style="list-style-type: none"> <li>Make sure that the Stop bit of the binary output telegram setting is set to 1.</li> <li>Make sure that parameters match between the PLC and the Softstarter Fieldbus documentation for the used Fieldbus protocol.</li> <li>Make sure that the Auto mode bit of the binary output telegram setting is set to 1.</li> <li>Do a check if the HMI is set to remote mode.</li> <li>Make sure that the Local Mode digital input on the ABB FieldBus Plug adapter is set to Remote.</li> <li>Make sure that Fieldbus disable control in DI is not connected.</li> <li>Make sure that the Fieldbus control parameter is set to On.</li> </ul>
	Fieldbus operation when fault parameter is set to Change to I/O control.	<ul style="list-style-type: none"> <li>If the parameter Fieldbus failure op is set to Change to I/O control when fault occurs, there is a 10 seconds delay before you can re-start after communication is connected.</li> </ul>

Status	Possible cause	Solution
Loading of parameters with Fieldbus does not work correctly.	Fieldbus settings.	<ul style="list-style-type: none"> <li>• Make sure that parameters match between the PLC and the Softstarter Fieldbus documentation for the used Fieldbus protocol.</li> <li>• Make sure that the Auto mode bit of the binary output telegram setting is 1.</li> <li>• Do a check if the HMI is set to remote control.</li> <li>• Make sure that the Local Mode digital input on the ABB FieldBus Plug adapter is set to Remote.</li> <li>• Make sure that Fieldbus disable control in DI is not connected.</li> <li>• Make sure that the Fieldbus control parameter is set to On.</li> </ul>
Shown phase currents in screen do not agree with motor current.	Inside Delta connection.	<ul style="list-style-type: none"> <li>• If the Softstarter is connected Inside Delta, the phase currents shown are = 58% (<math>1 / \sqrt{3}</math>) of the motor current.</li> </ul>
Shown current in screen is not stable.	The motor is too small. The load on the motor is too small. (Current is out of measuring range.)	<ul style="list-style-type: none"> <li>• Make sure that you have the correct Softstarter for this motor size..</li> </ul>
Dark screen and LED is active	Power save mode.	<ul style="list-style-type: none"> <li>• Touch a key on the keypad.</li> </ul>
Blank screen and no LED is active	Supply voltage is not connected.  <ul style="list-style-type: none"> <li>• The RJ45 plug is missing between the HMI and the Softstarter.</li> <li>• RJ45 Network cable is damaged.</li> </ul>	<ul style="list-style-type: none"> <li>• Connect the Supply voltage. Refer to the circuit diagram.</li> <li>• If problem stays, speak to your ABB Sales Office.</li> <li>• Do a check of the RJ45 plug.</li> <li>• Do a check of the RJ45 Network cable</li> </ul>

## 10.3 Overview of faults, protections and warnings

This table shows in which state the different indications for protections, faults and warnings can show.

		Event code*	Softstarter states **					
		(Hexadecimal)	Stand by	Pre-start	Start Ramp	Top of ramp	Stop ramp	Individual function
Protections	Electronic overload	P0Fxx	X	X	X	X	X	X
	Locked rotor	P10xx				X		
	Phase reversal	P11xx		X	X	X	X	X
	Current imbalance	P12xx				X		
	Current underload	P13xx				X		
	User defined protection	P14xx	X	X	X	X	X	X
	Ground fault	P15xx		X	X	X	X	X
	Overvoltage	P16xx				X		
	Undervoltage	P17xx				X		
	Voltage imbalance	P18xx		X	X	X	X	X
	PT100 protection	P19xx	X	X	X	X	X	X
	PTC protection	P1Axx	X	X	X	X	X	X
	Power factor underload	P1Bxx				X		
	Too long current limit	P1Cxx			X			
	Bypass open	P1Dxx				X		
	Fieldbus communication failure	P1Exx	X	X	X	X	X	X
	24V output	P1Fxx	X	X	X	X	X	X
	HMI failure	P20xx	X	X	X	X	X	X
	Extension I/O failure	P21xx	X	X	X	X	X	X
	Max number of starts per hour	P22xx						
Auto-restart time-out	P31xx	X	X	X	X	X	X	
Too long start time	P32xx			X				
Frequency range	P33xx		X	X	X	X	X	

\*) Only the first 2 digits are important

\*\*) For softstarter states description, see chapter **7.1.2 Softstarter states**

		Event code*	Softstarter states **					
		(Hexadecimal)	Stand by	Pre-start	Start Ramp	Top of ramp	Stop ramp	Individual function
Faults	High current	F02xx	X	X	X	X	X	X
	Phase loss	F03xx		X	X	X	X	X
	Heatsink overtemperature	F04xx	X	X	X	X	X	X
	Bad network quality	F05xx		X	X		X	
	Shunt fault	F06xx	X		X		X	
	Low supply voltage	F07xx	X	X	X	X	X	X
	Thyristor overload	F08xx	X	X	X	X	X	X
	Short circuit thyristor	F09xx		X	X		X	X
	Open circuit thyristor	F0Axx		X	X			X
	Unspecified fault	F0Bxx	X	X	X	X	X	X
	Invalid ID	F0Cxx	X	X	X	X	X	X
	Faulty connection	F0Dxx						
	Faulty usage	F0Exx					X	X
	Electronics failure	F36xx	X	X	X	X	X	X
Warnings	Current imbalance	W23xx				X		
	Current underload	W24xx				X		
	EOL warning	W26xx	X	X	X	X	X	X
	Locked rotor	W27xx				X		
	Overvoltage	W28xx				X		
	Undervoltage	W29xx				X		
	Power factor underload	W2Axx				X		
	THD(U)	W2Bxx				X		
	Thyristor overload	W2Cxx	X	X	X	X	X	X
	Voltage imbalance	W2Dxx		X	X	X	X	X
	Short circuit	W2Exx		X	X		X	X
	EOL time-to-trip	W2Fxx				X		
	Phase loss	W30xx	X					
	Number of starts limit	W34xx	X	X	X	X	X	X
	Motor run time limit	W35xx	X	X	X	X	X	X

\*) Only the first 2 digits are important

\*\*) For softstarter states description, see chapter 7.1.2 Softstarter states

## 10.4 Protection indication shown on screen

For a description of the protections, see chapter **7.17 Protections**.

**Table 2** Protection indication

Status	Code	Possible cause	Solution
Electronic overload	P0Fxx	The motor got an overload because the current is too high during some time. (The load on the motor shaft is too high)	<b>In Line / Inside Delta</b> <b>At start</b> <ul style="list-style-type: none"> <li>Examine start conditions and EOL settings.</li> <li>Examine and correct the reason for the overload.</li> <li>Make sure that Current limit level is not set too low.</li> <li>Make sure that the ramp time for start is not too long.</li> <li>Make sure that correct overload class is used.</li> <li>Make sure that parameter Setting le is correct.</li> </ul>
			<b>Continuous run</b> <ul style="list-style-type: none"> <li>Do a check of the rating of the plate for le.</li> <li>Do a check of the operation voltage.</li> <li>Use a motor with more power, and a Softstarter rated for higher current.</li> <li>Examine and correct the reason for the overload.</li> <li>Make sure that correct EOL Class is used.</li> </ul>
Locked rotor	P10xx	The motor does not run easily. A possible cause is a damaged bearing or a load stock.	<ul style="list-style-type: none"> <li>Examine the bearings of the motor and load.</li> <li>Make sure that the load runs easily.</li> </ul>
Phase reversal	P11xx	The phase sequence is not correct. Current imbalance between the phases.	<ul style="list-style-type: none"> <li>Change the phase sequence on the line side to (L1-L2-L3).</li> <li>Start the motor again and do a check of the main currents and voltage.</li> </ul>
Current imbalance	P12xx	Current imbalance between the phases.	<ul style="list-style-type: none"> <li>Start the motor again and do a check of the main currents and voltage.</li> </ul>
Current underload	P13xx	The motor current is below the specified value.	<ul style="list-style-type: none"> <li>Examine and correct the reason for the underload.</li> <li>Make sure that the motor current parameter (le) is set correctly.</li> </ul>
User defined protection	P14xx	With the programmable digital input and an external device/ sensor the user can use his own specified protection.	<ul style="list-style-type: none"> <li>Set the programmable input signal to inactive state before you reset the protection event.</li> </ul>
Ground fault	P15xx	Equipment protection. In a symmetrical 3-phase system, the sum of the instantaneous line currents is equal to zero. Ground fault indicates if the sum differs more than the specified value. This can indicate a serious condition of the motor.	<ul style="list-style-type: none"> <li>Examine motor cables.</li> <li>Examine the motor.</li> </ul>
Overvoltage	P16xx	The main voltage is too high	<ul style="list-style-type: none"> <li>Do a check of the main voltage.</li> </ul>
Undervoltage	P17xx	The main voltage is too low.	<ul style="list-style-type: none"> <li>Do a check of the main voltage.</li> </ul>
Voltage imbalance	P18xx	Voltage imbalance between the phases.	<ul style="list-style-type: none"> <li>Do a check of the main voltage and start the motor again.</li> </ul>
External thermal sensor - PTC protection - PT100 protection	P1Axx P19xx	The external thermal sensor detected a temperature higher than the trip level in the motor or PT100.	<ul style="list-style-type: none"> <li>Make sure that the PTC, Bi-metal switch or PT100 circuit is closed and that the inputs are connected.</li> <li>Examine and correct the reason for the high temperature.</li> <li>Wait for the temperature of the motor to decrease sufficiently and start again.</li> </ul>

Status	Code	Possible cause	Solution
Power factor underload	P1Bxx	The power factor is below the normal level.	<ul style="list-style-type: none"> <li>Examine and correct the reason for the underload.</li> </ul>
Too long current limit	P1Cxx	The time at current limit is higher than the set value. The starting condition is too heavy for the set current limit.	<ul style="list-style-type: none"> <li>Do a check of the starting conditions and parameters.</li> </ul>
Bypass open	P1Dxx	Bypass contactor or relay does not close when reached TOR.	<ul style="list-style-type: none"> <li>Do a check and speak to your ABB sales office.</li> </ul>
Fieldbus communication failure	P1Exx	There is a communication error between the Softstarter and PLC.	<ul style="list-style-type: none"> <li>Make sure that the FieldBus Plug is connected correctly.</li> <li>Make sure that correct type of FieldBus Plug is used.</li> <li>Make sure that the parameter Fieldbus Type is set for the present Fieldbus type.</li> </ul>
24V output	P1Fxx	The 24V voltage output is overloaded or shorted.	<ul style="list-style-type: none"> <li>Do a check of the connections.</li> </ul>
HMI failure	P20xx	There is a communication error between the Softstarter and the HMI. The HMI is removed.	<ul style="list-style-type: none"> <li>Do a check of the connections and correct it.</li> <li>Put the HMI back.</li> </ul>
Extension I/O failure	P21xx	There is a communication error between the Softstarter and the extension I/O module.	<ul style="list-style-type: none"> <li>Do a check of the connections and correct it.</li> </ul>
Max number of start per hour	P22xx	The Softstarter made more starts than the pre-set limited number of starts.	<ul style="list-style-type: none"> <li>Wait for the next start interval. For parameter, see chapter <b>7 Functions</b>.</li> </ul>
Auto-restart time-out	P31xx	The time between trip and auto-restart attempt exceeds setting.	<ul style="list-style-type: none"> <li>Do a check of the automatic restart parameters and correct it.</li> </ul>
Too long start time	P32xx	The time to soft start the motor is longer than the set value.	<ul style="list-style-type: none"> <li>Do a check of the starting conditions and current limit..</li> </ul>
Frequency range	P33xx	The frequency has been outside the allowed range longer than the allowed time.	<ul style="list-style-type: none"> <li>Do a check of the main voltage.</li> </ul>

## 10.5 Fault indication shown on screen

For a description of the faults, see chapter **7.19 Faults**

**Table 3** Fault indication

Status	Code	Possible cause	Solution
High current	F02xx	A fault current, higher than 8 times the Softstarter rated current, has occurred..	<ul style="list-style-type: none"> <li>Do a check of the circuits and the motor for an insulation fault phase to phase or ground fault.</li> </ul>
Phase loss	F03xx	Voltage to 1 or more phases is missing.	<ul style="list-style-type: none"> <li>Make sure that the mains are connected and that no line contactor or breaker is open.</li> </ul>
		Fuse is blown.	<ul style="list-style-type: none"> <li>Do a check of the fuses for all 3 phases. Replace blown fuse.</li> </ul>
		Power loss on operation current for 1 or multiple phases.	<ul style="list-style-type: none"> <li>Do a check of the operation network supply. Correct it.</li> </ul>
		The line contactor or circuit breaker is open.	<ul style="list-style-type: none"> <li>Do a check of the contactor/breaker or an external switch device. Close it.</li> </ul>
		Line contactor opens too quickly at stop.	<ul style="list-style-type: none"> <li>Control Line contactor with Run signal relay on terminal 4. See <b>chapter 5.1.2.6 Programmable output relay - K4, terminals 4, 5 and 6</b>.</li> <li>Add a time relay before contactor opens.</li> <li>If Stop Ramp is not necessary, set Stop mode to direct stop.</li> </ul>



Status	Code	Possible cause	Solution
Heatsink overtemperature	F04xx	The heatsink temperature is too high. If the fault stays after reset, the heatsink is too hot and the temperature must decrease.	<ul style="list-style-type: none"> <li>• Make sure that the fans work correctly.</li> <li>• Make sure that airways are free from dirt and dust.</li> <li>• Make sure that the ambient temperature is not too high.</li> </ul>
Bad network quality	F05xx	Excessive interference in the operation supply network.	<ul style="list-style-type: none"> <li>• Do a check for harmonics or frequency interference in the supply network and correct supply operation network.</li> </ul>
		Short power loss on all 3 phases in the operation network.	<ul style="list-style-type: none"> <li>• Do a check of the supply operation network. Correct it.</li> </ul>
Shunt fault	F06xx	The Softstarter cannot stop the motor because of internal short circuit.	<ul style="list-style-type: none"> <li>• Speak to ABB sales office for service.</li> </ul>
		Bypass relay closed, because of inaccurate handling. (PSTX30...170 only).	<ul style="list-style-type: none"> <li>• Disconnect operation voltage and control supply voltage. Connect voltage in correct order. <ol style="list-style-type: none"> <li>1. Control supply voltage on terminals 1 and 2. See chapter <b>5.1.2 Control supply and control circuit</b>.</li> <li>2. Wait 4 seconds, and then connect operation voltage on terminals L1, L2 and L3.</li> </ol> </li> <li>• If same fault stays, speak to your ABB Sales Office.</li> </ul>
Low supply voltage	F07xx	The control supply voltage is too low on terminals 1 and 2.	<ul style="list-style-type: none"> <li>• Do a check for voltage dips or interruptions and correct control supply voltage.</li> </ul>
		Short power loss on the control supply network.	<ul style="list-style-type: none"> <li>• Do a check of the control supply network for short interruptions.</li> </ul>
Thyristor overload	F08xx	The thyristors are too hot.	<ul style="list-style-type: none"> <li>• Do a check of the start conditions and the fans.</li> <li>• Decrease current limit if possible.</li> <li>• Let the temperature of the thyristors decrease before you start again.</li> </ul>
Short circuit thyristor	F09xx	One or multiple thyristors are shorted due to: <ul style="list-style-type: none"> <li>- Short circuit in the main circuit</li> <li>- Usage of thyristors outside the softstarter specification</li> <li>- Incorrect size of softstarter</li> </ul>	<ul style="list-style-type: none"> <li>• Speak to your ABB sales office for service.</li> <li>• If possible, measure the resistance on each phase between motor and load side of the Softstarter. If one phase is shorted there might be a shorted thyristor or a welded contactor, see below for test.</li> </ul>
		Incorrect connections	<ul style="list-style-type: none"> <li>• Check motor wiring</li> <li>• Check jumper connectors in motor's terminal box</li> </ul>
		Harmonics outside softstarter specification makes false trip	<ul style="list-style-type: none"> <li>• Measure harmonics levels and reduce them with filters</li> </ul>
		Bypass is closed/welded	<ul style="list-style-type: none"> <li>• Speak to your ABB sales office</li> <li>• Test the bypass contactor: <ol style="list-style-type: none"> <li>1. Disconnect main. Be 100% sure that main will not become active during the test. If it does, the Softstarter can be harmed.</li> <li>2. Maintain supply (100-250 VAC, 50/60 Hz)</li> <li>3. Change parameter 28.41 to demo mode</li> <li>4. Change parameter 28.38 to a motor with <math>I_e</math> corresponding to the softstarter (62.3 A by default)</li> <li>5. Press L/R button to set it in local mode</li> <li>6. Press green start button to make a "fake start"</li> <li>7. Let it ramp up</li> <li>8. Listen for the bypass relay click</li> <li>9. Measure the voltage and resistance over each phase (between L1-T1, between L2-T2 and between L3-T3) with a megger/multimeter</li> <li>10. The resistance should be close to zero since if the bypass is closed there will be a closed circuit and the bypass relay will work.</li> </ol> </li> </ul>

Status	Code	Possible cause	Solution
Open circuit thyristor	F0Axx	One or multiple thyristors do not conduct.	<ul style="list-style-type: none"> <li>• Speak to your ABB sales office for service.</li> </ul>
		The Operation voltage is below 175 V.	<ul style="list-style-type: none"> <li>• Make sure that you have the correct Softstarter for this motor size.</li> </ul>
		The motor or load is too small	<ul style="list-style-type: none"> <li>• For test purposes you can use small motor mode. See chapter <b>7 Functions</b>.</li> </ul>
		Control card is broken	<ul style="list-style-type: none"> <li>• Speak to your ABB sales office</li> </ul>
		The control card has been replaced and the gate cables are not attached	<ul style="list-style-type: none"> <li>• Verify the gate cables connections if possible</li> <li>• Speak to your ABB sales office for service</li> </ul>
Unspecified fault	F0Bxx	N/A	<ul style="list-style-type: none"> <li>• Disconnect the supply voltage (Us). Connect it again and start again.</li> <li>• If the same fault stays, speak to your ABB sales office.</li> </ul>
Invalid ID	F0Cxx	ID parameter out of range	<ul style="list-style-type: none"> <li>• Cycle the control power (power off and then power on), this will "restart" the Softstarter.</li> <li>• If you get Invalid ID after every power off, then the parameters are not set correctly before the Softstarter is power off.</li> <li>• Note that changing the ID parameter will result in all le parameters being set to their default value followed by a restart of the device.</li> <li>• The reason why we have several le parameters is because of the sequence start function.</li> <li>• Procedure on how to restore the ID parameter               <ol style="list-style-type: none"> <li>1. Set Softstarter ID (parameter 28.01)</li> <li>2. Wait for the device to restart.</li> </ol> <p>Note: this will result in all le values being set to default. On next power on you won't get the Invalid ID fault.</p> </li> </ul>
Faulty connection	F0Dxx	Motor connection unknown when trying to start motor.	<ul style="list-style-type: none"> <li>• Change motor connection from Auto detection to the motor connection that is used (parameter 28.43)</li> </ul>
Faulty usage	F0E01	Inside delta motor connection or one phase shorted when you try to jog forward.	<ul style="list-style-type: none"> <li>• Do not use these functions with Inside delta motor connection or one phase shorted.</li> </ul>
	F0E02	Inside delta motor connection or one phase shorted when you try to jog backward.	
	F0E03	Inside delta motor connection or one phase shorted when you try to heat motor.	
	F0E04	Inside delta motor connection or one phase shorted when you try to do a stand still brake.	
	F0E05	Inside delta motor connection or one phase shorted when you try to use a prestart function.	
	F0E06	One phase shorted when you try to use dynamic brake.	
	F0E10	Demo mode when mains three phase voltage is connected.	
Electronics failure	F36xx	Circuit fault detected during hardware initialization.	<ul style="list-style-type: none"> <li>• Speak to your ABB sales office for service.</li> </ul>

## 10.6 Warning indication shown on screen

For a description of the warnings, see chapter **7.18 Warnings**.

**Table 4 Warning indication**

Status	Code	Cause/Possible cause
Current imbalance	W23xx	Current imbalance between the phases is higher than the warning level.
Current underload	W24xx	The motor current is below the warning level. Make sure that the motor current parameter (Ie) is set correctly.
EOL warning	W26xx	The calculated motor temperature is higher than the warning level.
Locked rotor	W27xx	The motor current is higher than the warning level. A damaged bearing or a stuck load can be possible causes.
Overvoltage	W28xx	The RMS phase to phase voltage in the line side is higher than the adjustable value.
Undervoltage	W29xx	The RMS phase to phase voltage in the line side decreased below the adjustable value.
Power factor underload	W2Axx	The power factor decreased below the adjustable value during continuous operation.
THD(U)	W2Bxx	THD(U) is higher than the warning level. Do a check of the quality of the network.
Thyristor overload	W2Cxx	The calculated thyristor temperature is higher than the warning level
Voltage imbalance	W2Dxx	Voltage imbalance between the phases is higher than the warning level.
Short circuit	W2Exx	There is an internal short circuit and the Softstarter runs in limp mode. See chapter 7 Functions.
EOL time-to-trip	W2Fxx	The predicted time before EOL trip is at the warning level.
Phase loss	W30xx	Voltage to one or more phases missing. Check that the mains are connected and that no line contactor or breaker is open.
Number of starts limit	W34xx	The number of starts exceeds the warning level. Time for service!. The warning will stay active until the Number of starts (resettable) value have been reset. Use menu: Menu → Settings → Reset to defaults → Reset operating data and select Number of starts (resettable) to perform the reset.
Motor run time limit	W35xx	The Motor runtime exceeds warning level. Time for service! The warning will stay active until the Motor run time (resettable) value have been reset. Use menu: Menu → Settings → Reset to defaults → Reset operating data and select Motor run time (resettable) to perform the reset.



# 11 Wiring and application diagrams

## 11.1 Circuit diagram PSTX

	170
11.1.1 Circuit diagram	
PSTX30...PSTX1250 (IEC version)	170
11.1.2 Circuit diagram	
PSTX30...PSTX1250 (UL version)	170

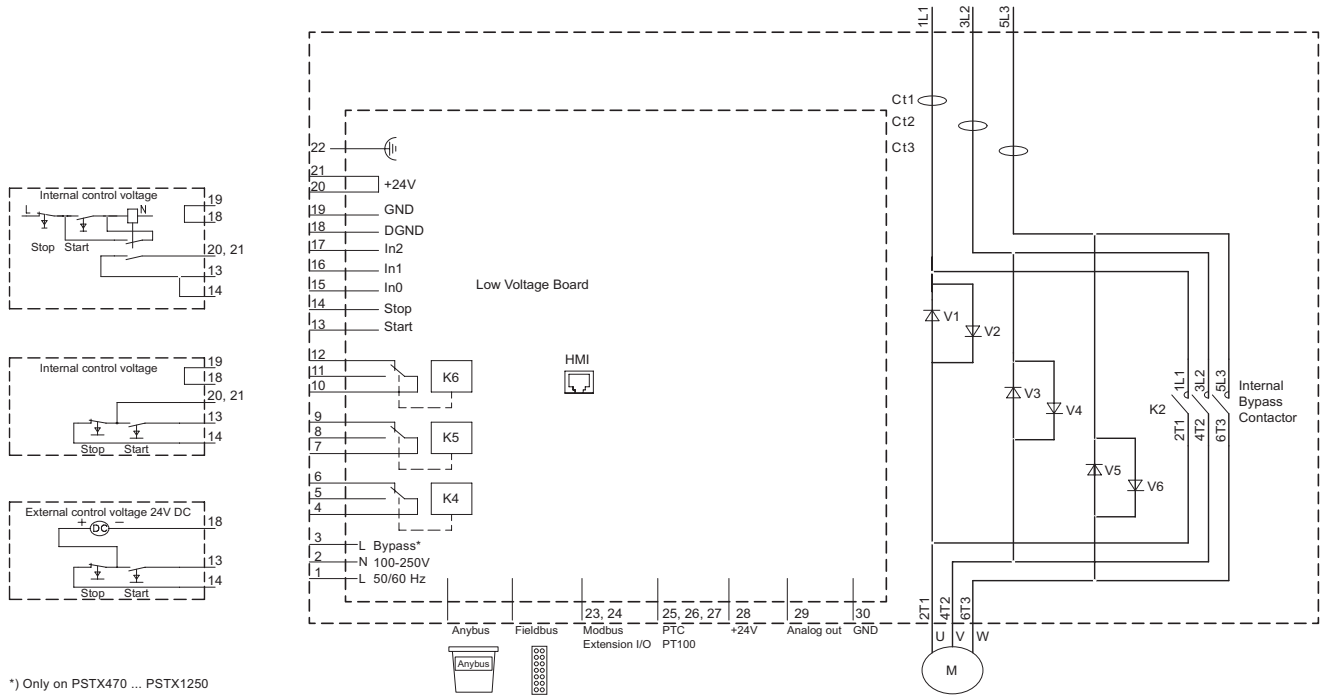
## 11.2 Application diagrams

	170
11.2.1 Inside Delta	171
11.2.2 Start at optional direction	171
11.2.3 Start at optional direction, alternative	172
11.2.4 With pole change, one winding motor	172
11.2.5 With pole change, two winding motor	173
11.2.6 InLine contactor control	173
11.2.7 Dual motor start	174
11.2.8 Sequence start	175
11.2.9 Softstarter in network with high harmonic disturbances	176

# 11.1 Circuit diagram PSTX

## 11.1.1 Circuit diagram PSTX30...PSTX1250 (IEC version)

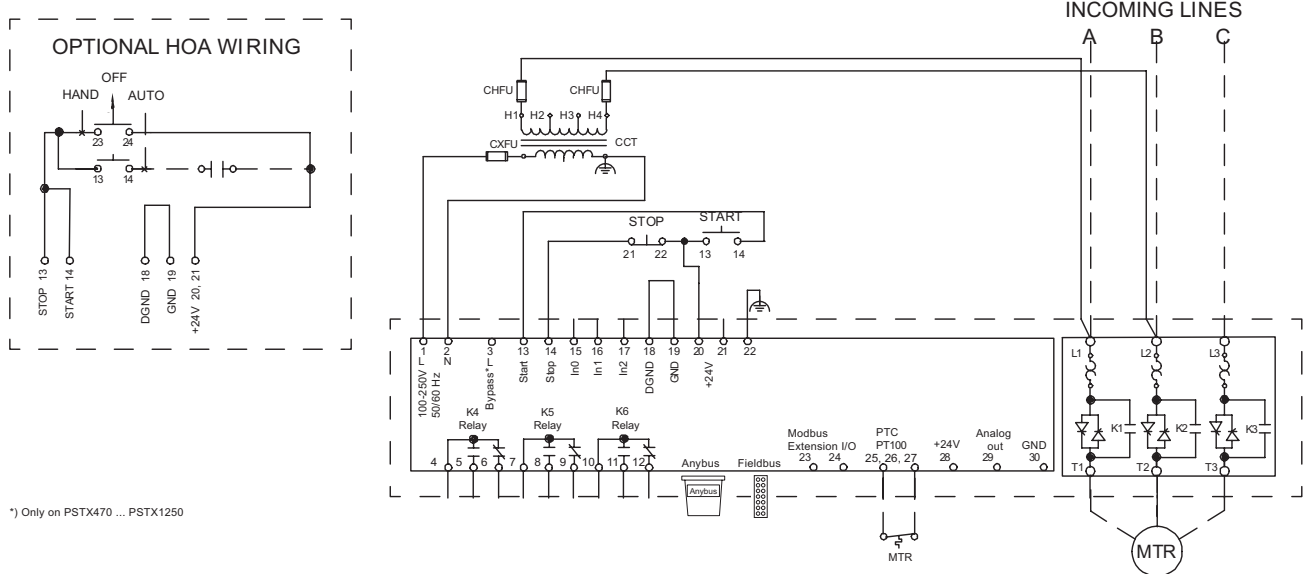
**WARNING**  
Terminal 22 is a function ground, it is not a protection ground. It shall be connected to the mounting plate.



\*) Only on PSTX470 ... PSTX1250

## 11.1.2 Circuit diagram PSTX30...PSTX1250 (UL version)

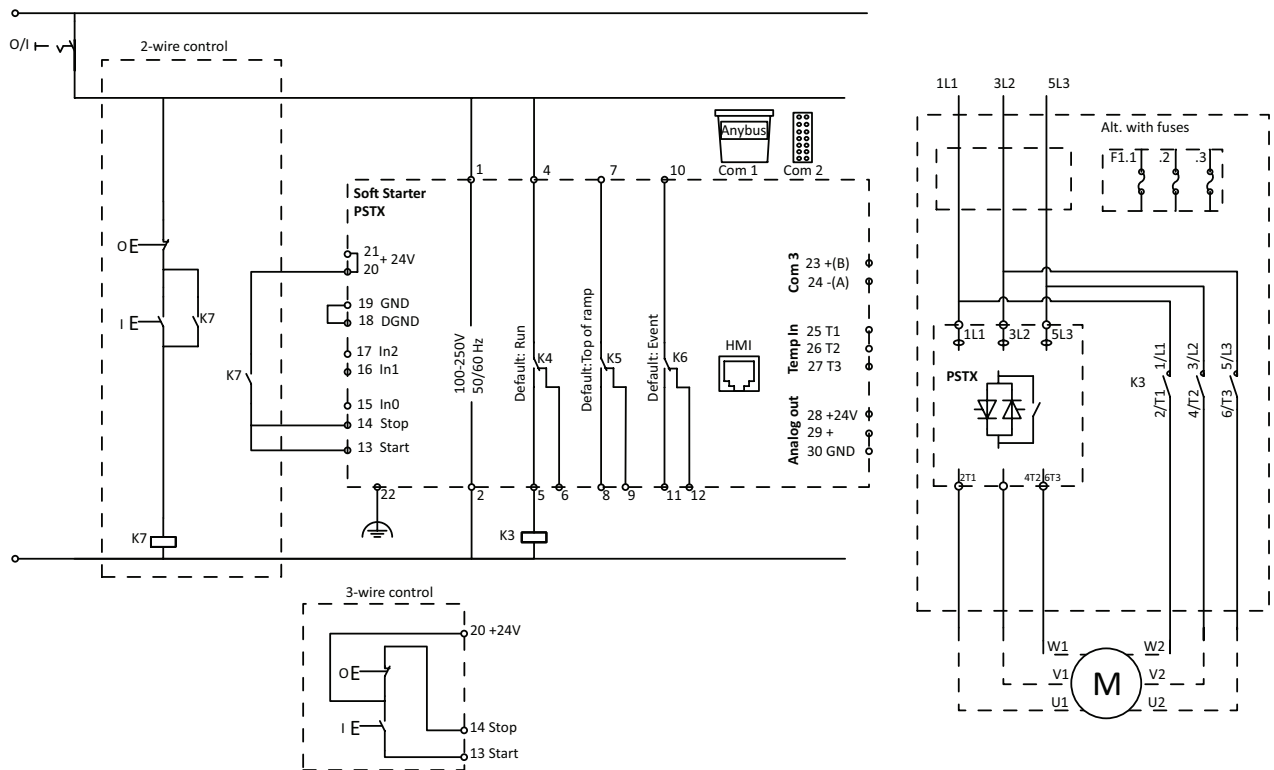
11



\*) Only on PSTX470 ... PSTX1250

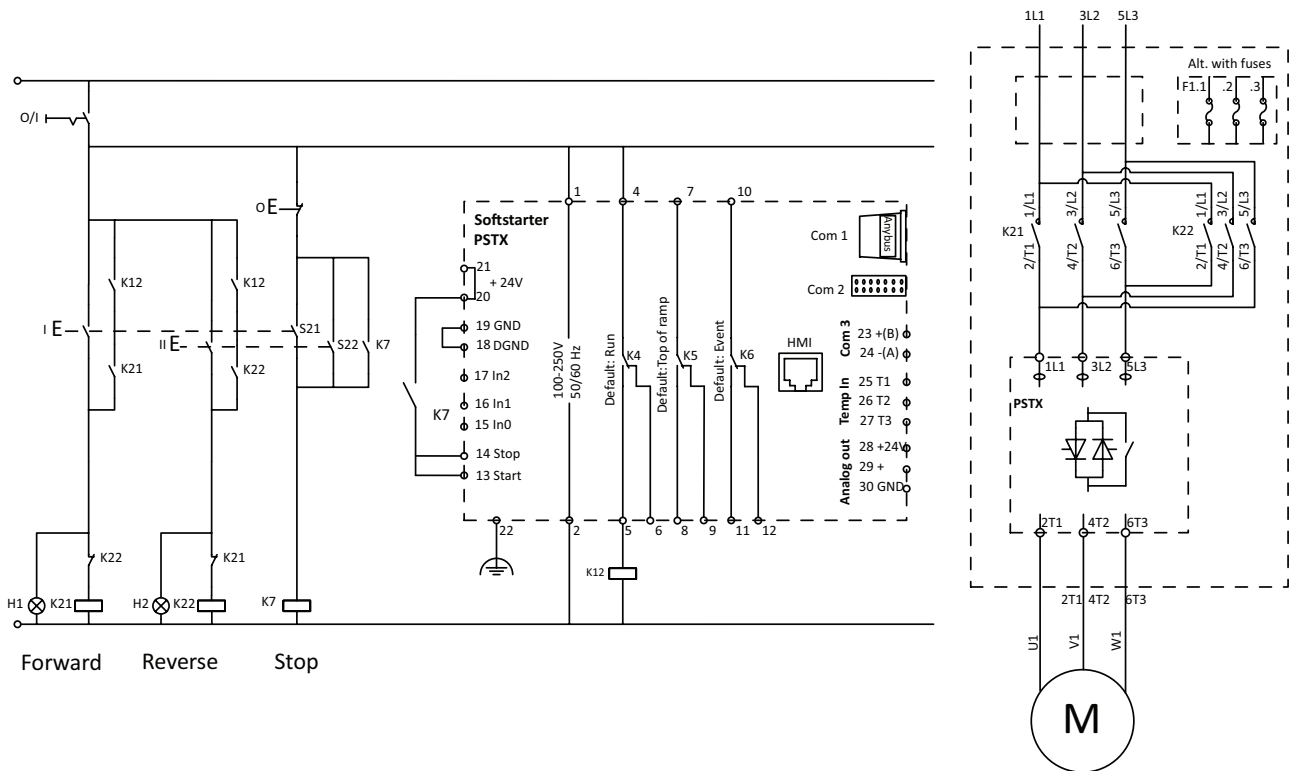
## 11.2 Application diagrams

### 11.2.1 Inside Delta



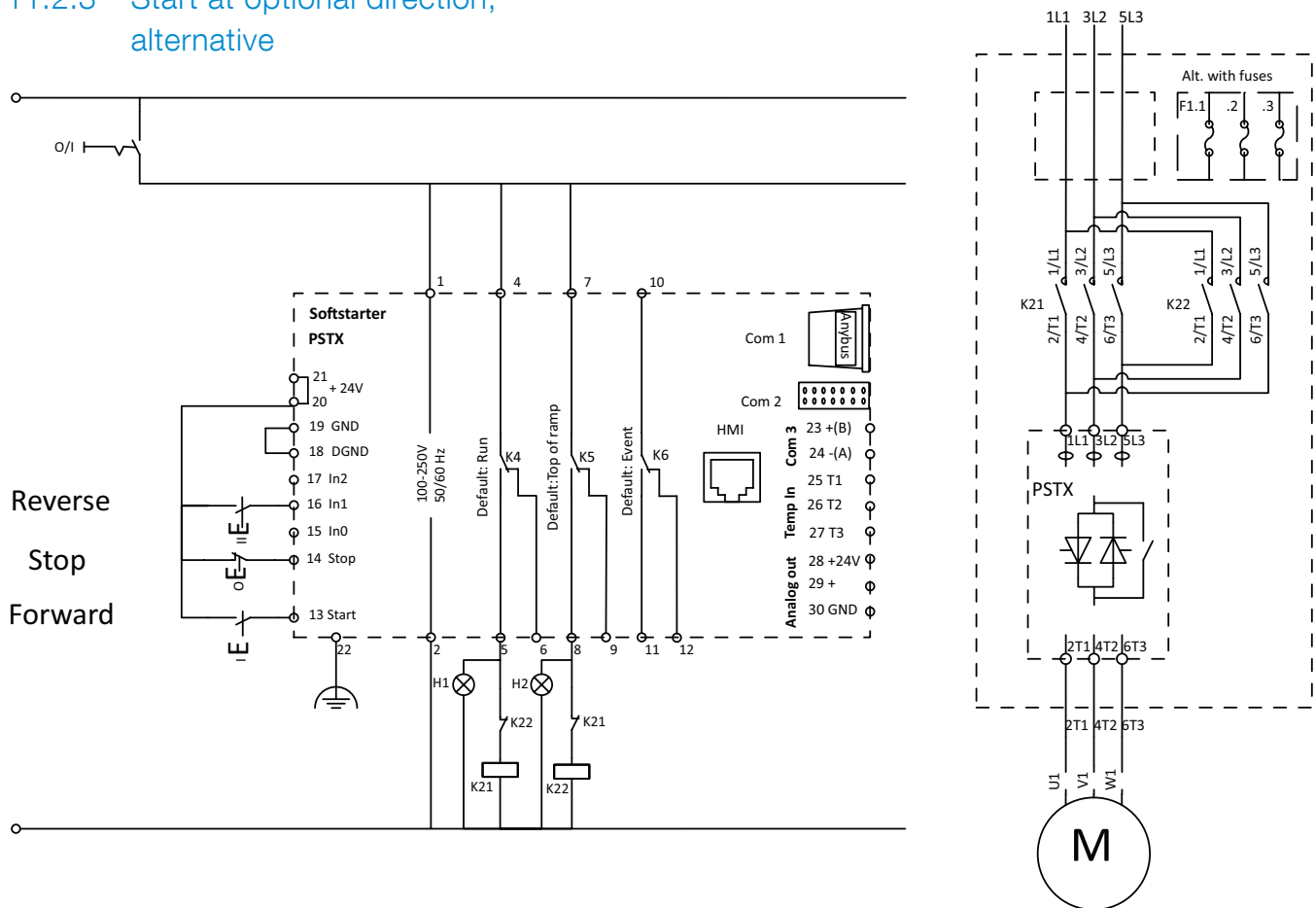
Inside Delta can be used with a lower rated Softstarter than for Inline. Parameter O1.01 Motor rated current  $I_e = 58\%$  of the Motor rated current listed in the Motor number plate. Coil consumption for Inside Delta contactor, Pull-in max 15A, Holding max 1.5 A. If the pull-in or holding values are higher, the Inside Delta contactor must be controlled via an auxillary contactor.

### 11.2.2 Start at optional direction



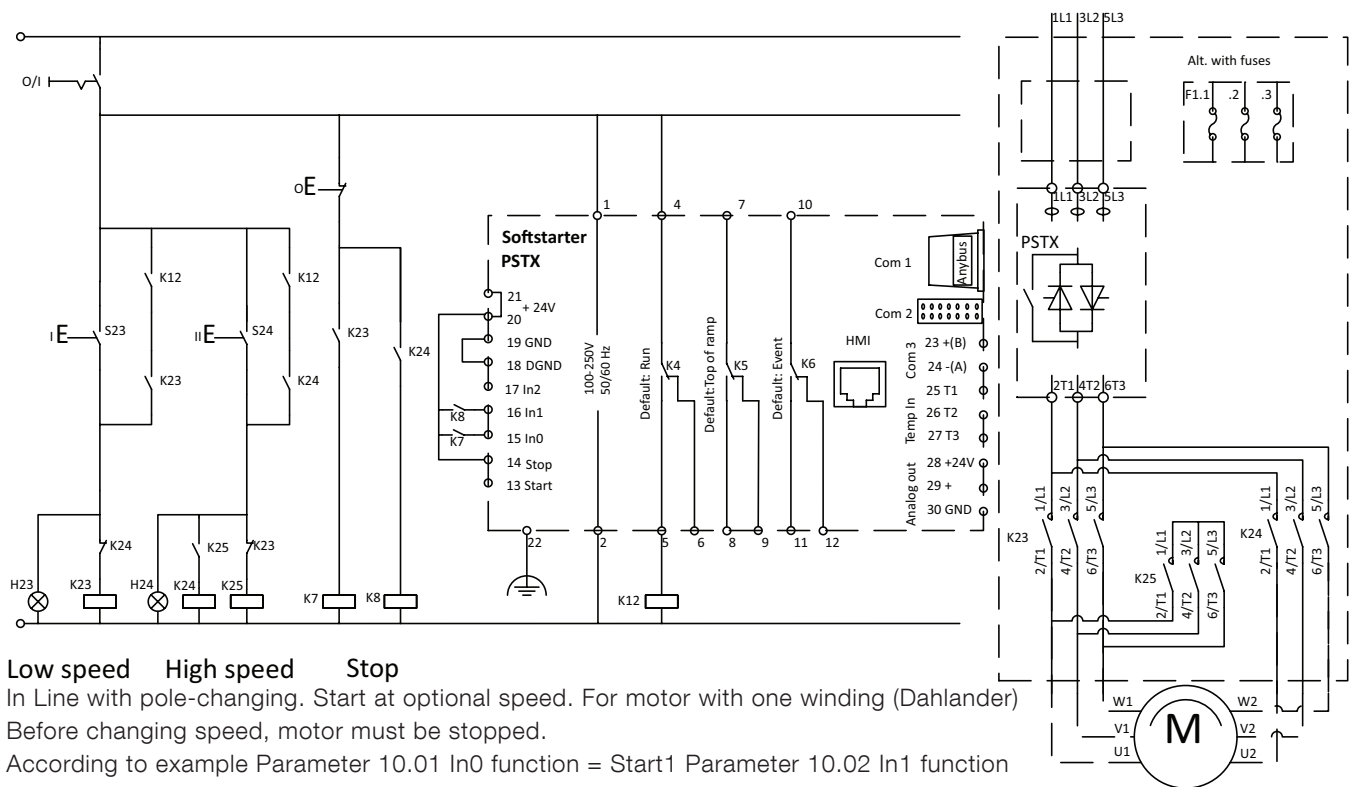
Start at optional direction must be used to achieve the ability to run the motor at full speed both forward and reverse. Before changing direction, motor must be stopped.

### 11.2.3 Start at optional direction, alternative



Alternative In Line with reversing, less external connections. Before changing direction, motor must be stopped. According to example Parameter 10.02 In1 function = Start reverse Parameter 10.05 K5 function = Run reverse

### 11.2.4 With pole change, one winding motor



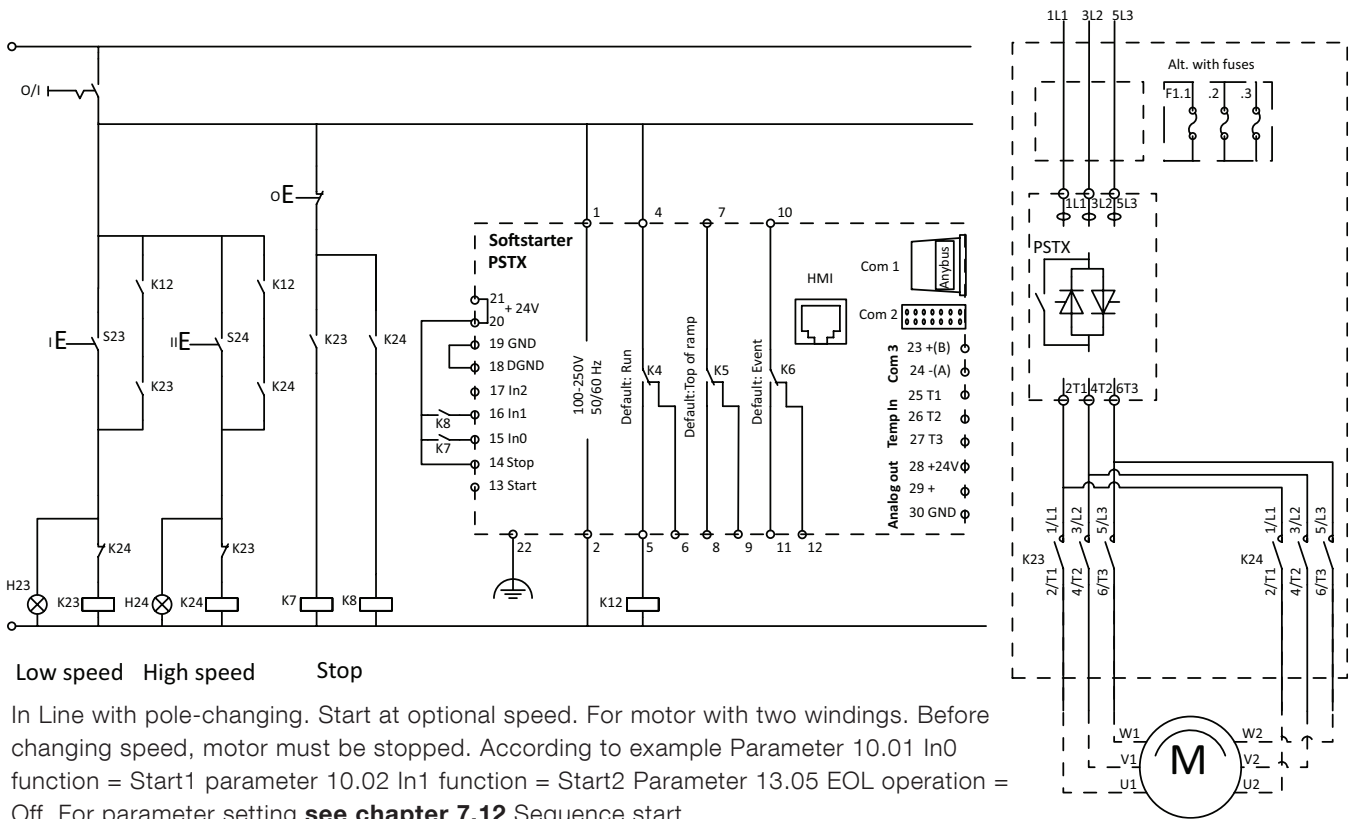
Low speed High speed Stop

In Line with pole-changing. Start at optional speed. For motor with one winding (Dahlander) Before changing speed, motor must be stopped.

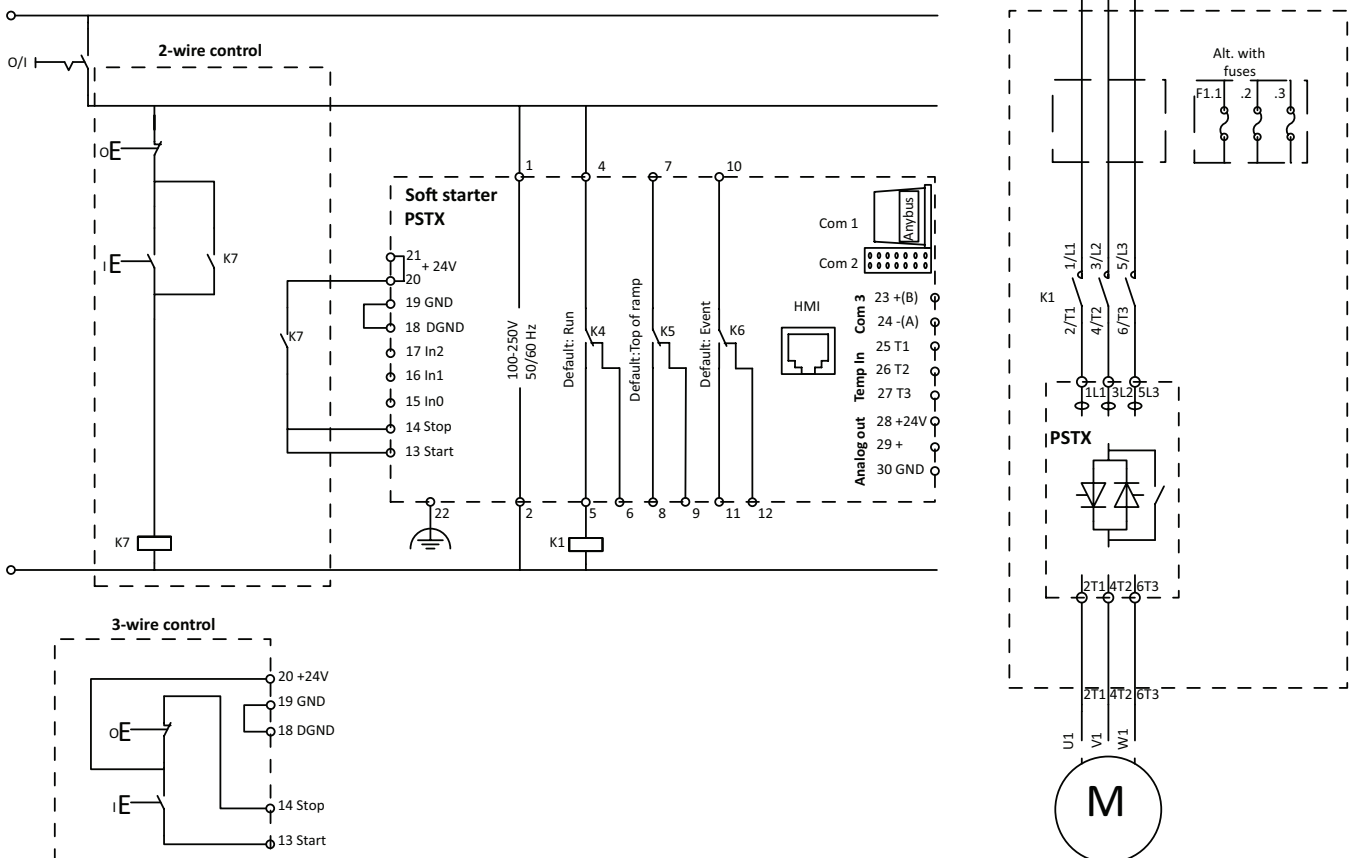
According to example Parameter 10.01 In0 function = Start1 Parameter 10.02 In1 function = Start2 Parameter 13.05 EOL operation = Off. For parameter setting **see chapter 7.12** Sequence start.



## 11.2.5 With pole change, two winding motor

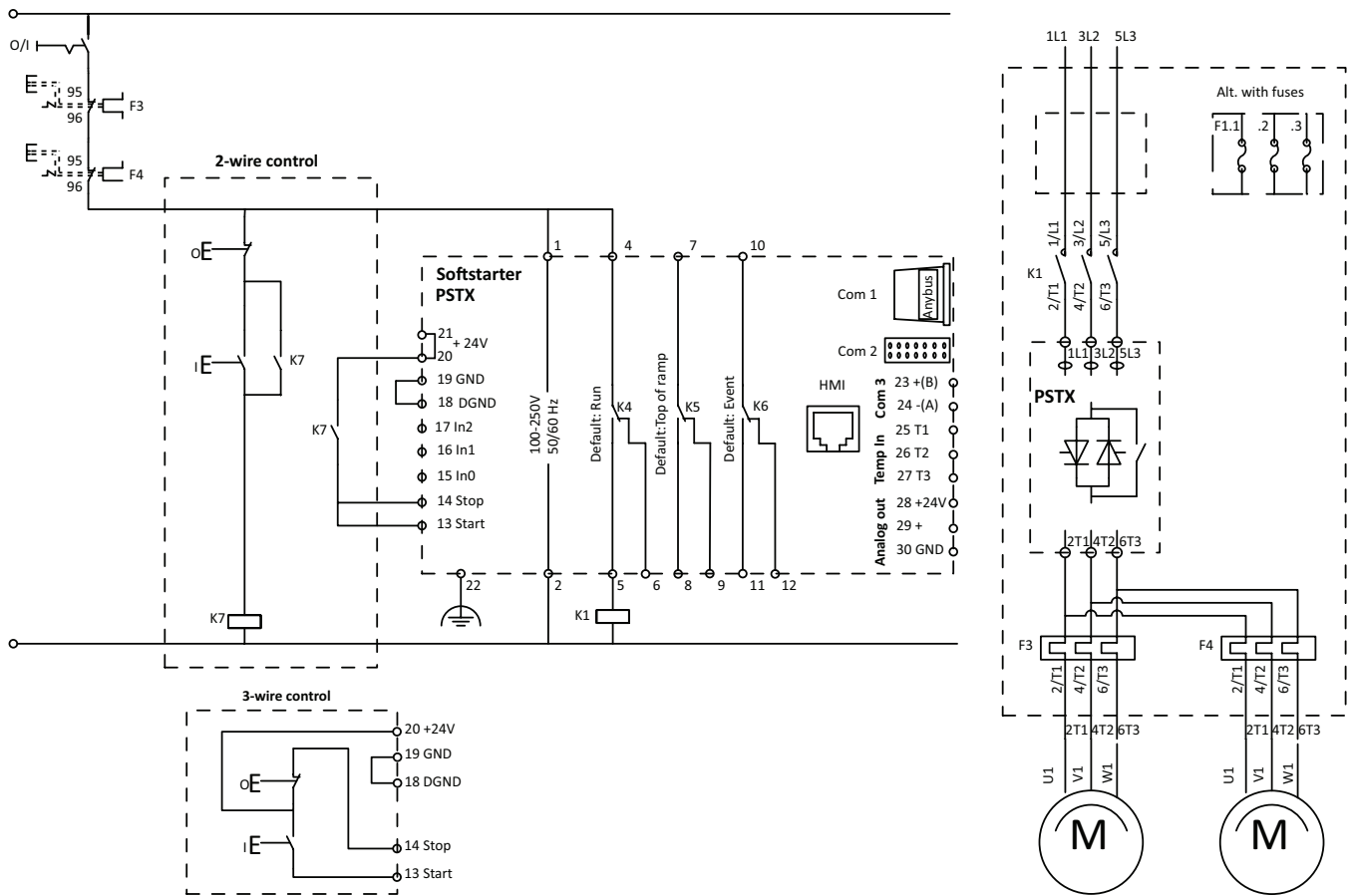


## 11.2.6 InLine contactor control



In Line with main contactor closed only during operation.  
 Coil consumption for main contactors, Pull-in max 15A, Holding max 1.5 A. If the pull-in or holding values are higher, the main contactors must be controlled via an auxiliary contactor.

## 11.2.7 Dual motor start

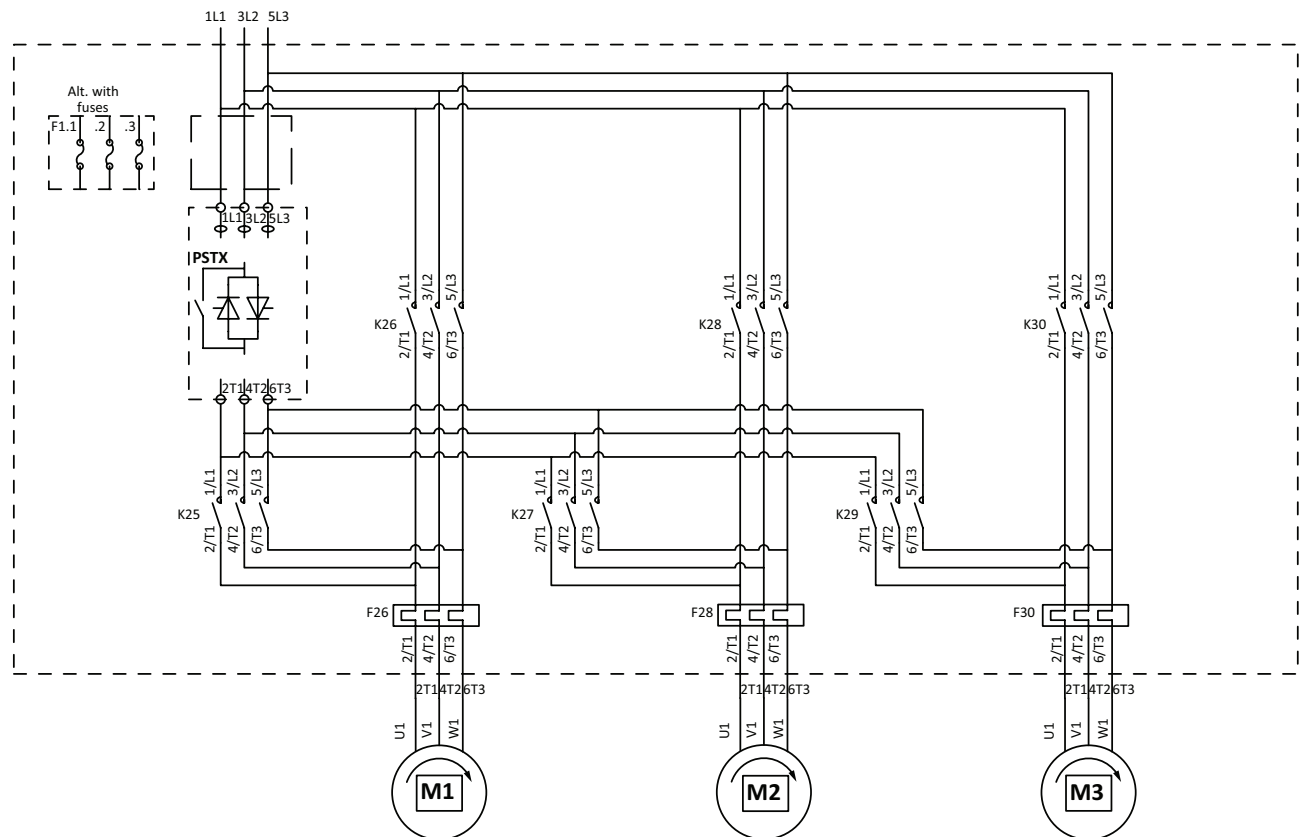
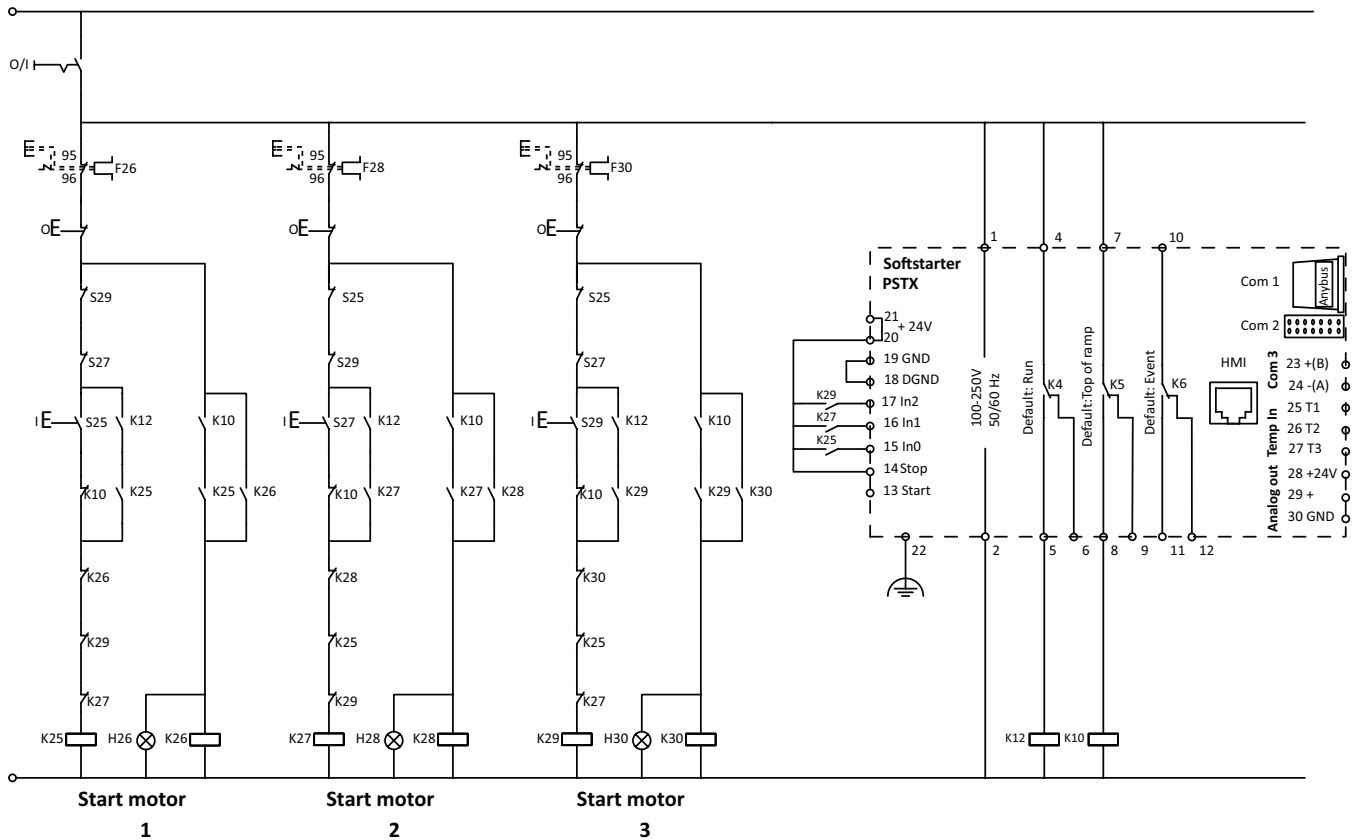


In Line with main contactor for start of 2 motors in parallell. Internal EOL shall be deactivated.

Parameter 13.05 EOL operation = Off

Coil consumption for main contactors, Pull-in max 15A, Holding max 1.5 A. If the pull-in or holding values are higher, the main contactors must be controlled via an auxillary contactor.

## 11.2.8 Sequence start



In Line for sequential start of 3 motors, no soft stop.

Internal EOL shall be deactivated. 13.05 EOL operation = Off

Start of optional motor. According to example 10.01 In0 function = Start1. 10.02 In1 function = Start2. 10.03 In2 function = Start3 For parameter settings see chapter 7.12 Sequence start.

## 11.2.9 Softstarter in network with high harmonic disturbances

When using a softstarter in a network with high harmonic disturbances, there is a risk to damage the softstarter. An example could be installations where VSDs (variable speed drives) are connected to the same transformer as the softstarter.

The harmonics are only harmful for the softstarter when it's not running the motor. To avoid problems with harmonics, either reduce the harmonics with filters on the line side, or install a line contactor to switch off the line side when the softstarter isn't running the motor.

# 12 Third party licenses

The 3rd party software components in the following sections are all part of the PSTX HMI firmware.

## 12.1 Pawn AMX Abstract Machine Wrapper

---

12.1 Pawn AMX Abstract Machine Wrapper	178
12.2 Zlib	180

## 12.1 Pawn AMX Abstract Machine Wrapper

PSTX HMI use the Pawn AMX Abstract Machine Wrapper as is. The software is licensed under the Apache license Version 2.0.

### Apache License Version 2.0, January 2004

<http://www.apache.org/licenses/>

TERMS AND CONDITIONS FOR USE, REPRODUCTION,  
AND DISTRIBUTION

#### 1. Definitions

“License” shall mean the terms and conditions for use, reproduction, and distribution as defined by Sections 1 through 9 of this document.

“Licensor” shall mean the copyright owner or entity authorized by the copyright owner that is granting the License.

“Legal Entity” shall mean the union of the acting entity and all other entities that control, are controlled by, or are under common control with that entity. For the purposes of this definition, “control” means (i) the power, direct or indirect, to cause the direction or management of such entity, whether by contract or otherwise, or (ii) ownership of fifty percent (50%) or more of the outstanding shares, or (iii) beneficial ownership of such entity.

“You” (or “Your”) shall mean an individual or Legal Entity exercising permissions granted by this License.

“Source” form shall mean the preferred form for making modifications, including but not limited to software source code, documentation source, and configuration files.

“Object” form shall mean any form resulting from mechanical transformation or translation of a Source form, including but not limited to compiled object code, generated documentation, and conversions to other media types.

“Work” shall mean the work of authorship, whether in Source or Object form, made available under the License, as indicated by a copyright notice that is included in or attached to the work (an example is provided in the Appendix below).

“Derivative Works” shall mean any work, whether in Source or Object form, that is based on (or derived from) the Work and for which the editorial revisions, annotations, elaborations, or other modifications represent, as a whole, an original work of authorship. For the purposes of this License, Derivative Works shall not include works that remain separable from, or merely link (or bind by name) to the interfaces of, the Work and Derivative Works thereof.

“Contribution” shall mean any work of authorship, including the original version of the Work and any modifications or additions to that Work or Derivative Works thereof, that is intentionally submitted to Licensor for inclusion in the Work by the copyright owner or by an individual or Legal Entity authorized to submit on behalf of the copyright owner. For the purposes of this definition, “submitted” means any form of electronic, verbal, or written communication sent to the Licensor or its representatives, including but not limited to communication on electronic mailing lists, source code control systems, and issue tracking systems that are managed by, or on behalf of, the Licensor for the purpose of discussing and improving the Work, but excluding communication that is conspicuously marked or otherwise designated in writing by the copyright owner as “Not a Contribution.”

“Contributor” shall mean Licensor and any individual or Legal Entity on behalf of whom a Contribution has been received by Licensor and subsequently incorporated within the Work.

#### 2. Grant of Copyright License

Subject to the terms and conditions of this License, each Contributor hereby grants to You a perpetual, worldwide, non-exclusive, no-charge, royalty-free, irrevocable copyright license to reproduce, prepare Derivative Works of, publicly display, publicly perform, sublicense, and distribute the Work and such Derivative Works in Source or Object form.

### 3. Grant of Patent License

Subject to the terms and conditions of this License, each Contributor hereby grants to You a perpetual, worldwide, non-exclusive, no-charge, royalty-free, irrevocable (except as stated in this section) patent license to make, have made, use, offer to sell, sell, import, and otherwise transfer the Work, where such license applies only to those patent claims licensable by such Contributor that are necessarily infringed by their Contribution(s) alone or by combination of their Contribution(s) with the Work to which such Contribution(s) was submitted. If You institute patent litigation against any entity (including a cross-claim or counterclaim in a lawsuit) alleging that the Work or a Contribution incorporated within the Work constitutes direct or contributory patent infringement, then any patent licenses granted to You under this License for that Work shall terminate as of the date such litigation is filed.

### 4. Redistribution

You may reproduce and distribute copies of the Work or Derivative Works thereof in any medium, with or without modifications, and in Source or Object form, provided that You meet the following conditions:

- a. You must give any other recipients of the Work or Derivative Works a copy of this License; and
- b. You must cause any modified files to carry prominent notices stating that You changed the files; and
- c. You must retain, in the Source form of any Derivative Works that You distribute, all copyright, patent, trademark, and attribution notices from the Source form of the Work, excluding those notices that do not pertain to any part of the Derivative Works; and
- d. If the Work includes a “NOTICE” text file as part of its distribution, then any Derivative Works that You distribute must include a readable copy of the attribution notices contained within such NOTICE file, excluding those notices that do not pertain to any part of the Derivative Works, in at least one of the following places: within a NOTICE text file distributed as part of the Derivative Works; within the Source form or documentation, if provided along with the Derivative Works; or, within a display generated by the Derivative Works, if and wherever such third-party notices normally appear. The contents of the NOTICE file are for informational purposes only and do not modify the License. You may add Your own attribution notices within Derivative Works that You distribute, alongside or as an addendum to the NOTICE text from the Work, provided that such additional attribution notices cannot be construed as modifying the License.

You may add Your own copyright statement to Your modifications and may provide additional or different license terms and conditions for use, reproduction, or distribution of Your modifications, or for any such Derivative Works as a whole, provided Your use, reproduction, and distribution of the Work otherwise complies with the conditions stated in this License.

### 5. Submission of Contributions

Unless You explicitly state otherwise, any Contribution intentionally submitted for inclusion in the Work by You to the Licensor shall be under the terms and conditions of this License, without any additional terms or conditions. Notwithstanding the above, nothing herein shall supersede or modify the terms of any separate license agreement you may have executed with Licensor regarding such Contributions.

### 6. Trademarks

This License does not grant permission to use the trade names, trademarks, service marks, or product names of the Licensor, except as required for reasonable and customary use in describing the origin of the Work and reproducing the content of the NOTICE file.

### 7. Disclaimer of Warranty.

Unless required by applicable law or agreed to in writing, Licensor provides the Work (and each Contributor provides its Contributions) on an “AS IS” BASIS, WITHOUT WARRANTIES OR CONDITIONS OF ANY KIND, either express or implied, including, without limitation, any warranties or conditions of TITLE, NON-INFRINGEMENT, MERCHANTABILITY, or FITNESS FOR A PARTICULAR PURPOSE. You are solely responsible for determining the appropriateness of using or redistributing the Work and assume any risks associated with Your exercise of permissions under this License.

### 8. Limitation of Liability

In no event and under no legal theory, whether in tort (including negligence), contract, or otherwise, unless required by applicable law (such as deliberate and grossly negligent acts) or agreed to in writing, shall any Contributor be liable to You for damages, including any direct, indirect, special, incidental, or consequential damages of any character arising as a result of this License or out of the use or inability to use the Work (including but not limited to damages for loss of goodwill, work stoppage, computer failure or malfunction, or any and all other commercial damages or losses), even if such Contributor has been advised of the possibility of such damages.

## 9. Accepting Warranty or Additional Liability

While redistributing the Work or Derivative Works thereof, You may choose to offer, and charge a fee for, acceptance of support, warranty, indemnity, or other liability obligations and/or rights consistent with this License. However, in accepting such obligations, You may act only on Your own behalf and on Your sole responsibility, not on behalf of any other Contributor, and only if You agree to indemnify, defend, and hold each Contributor harmless for any liability incurred by, or claims asserted against, such Contributor by reason of your accepting any such warranty or additional liability.

END OF TERMS AND CONDITIONS

## 12.2 Zlib

PSTX HMI use the inflate component PUFF from the compression library zlib. The component has been adapted by ABB. The software is licensed under the zlib/libpng license.

### The zlib/libpng License

Copyright (c) 2002-2010 Mark Adler

This software is provided 'as-is', without any express or implied warranty. In no event will the authors be held liable for any damages arising from the use of this software.

Permission is granted to anyone to use this software for any purpose, including commercial applications, and to alter it and redistribute it freely, subject to the following restrictions:

1. The origin of this software must not be misrepresented; you must not claim that you wrote the original software. If you use this software in a product, an acknowledgment in the product documentation would be appreciated but is not required.
2. Altered source versions must be plainly marked as such, and must not be misrepresented as being the original software.
3. This notice may not be removed or altered from any source distribution.





# 13 Revision

The following revisions is done on this document:

Document number	Revision	Chapter	Description	Date
1SFC132081M0201	A	-	First release	2014-06-27
1SFC132081M0201	B	4-11	New numbering of images	201x-xx-xx
1SFC132081M0201	B	5 -10	Updated technical description	2014-09-19
1SFC132081M0201	C	5, 7	Text and illustration updated	2014-11-14
1SFC132081M0201	D	3, 7	Text and illustration updated	2015-06-26
1SFC132081M0201	E	-	Text and illustration updated	2015-09-30
1SFC132081M0201	F	5	Illustrations updated	2015-10-23
1SFC132081M0201	G	-	ABB Update	201x-xx-xx
1SFC132081M0201	H	-	Text and illustration updated. New chapters: 11.2	2016-07-21
1SFC132081M0201	I	7, 12	Chapter 7-20-1 edited. Chapter 12 Third party licenses added.	2016-11-28
1SFC132081M0201	J		ABB Update	2017-09-01
1SFC132081M0201	K		ABB Update	2017-09-07
1SFC132081M0201	L	1, 7-9	ABB Update	2018-07-06
1SFC132081M0201	M		ABB Update	2019-10-02
1SFC132081M0201	N	0-1, 3-11, 13-14	ABB Update	2021-09-15



# 14 Index

## Symboler

- 2-wire measurement for PT100 47
- 2-wire measurement for PTC 48
- 3-wire measurement for PT100 47

## A

- ABB Fieldbus plug interface (option) 147
- Acronyms and abbreviations 9
- Active faults/protections and warnings 60
- Add information screens to home view 59
- Analog output 48, 95
- Anybus CompactCom 146
- Application Setting 14, 15, 65, 133
- Application set-up 15, 65
- Assistants 65, 132
  - Application set-up 65
  - Basic set-up 65
- Automatic restart 90
- Available protections 18. Se även Protections
- Available warnings 19. Se även Warnings

## B

- Backup handling 67
  - Create backup 67, 152, 153, 154, 155
  - Replace backup 67
  - Uploading of parameters 67
- Bad network fault 122
- Basic set-up 14, 65
- Bi-metal switch 108
- Built in modbus RTU 146
- Bypass 18
- Bypass open protection 107

## C

- Changing the Rated motor current (Setting le). 55
- Communication 145
- Communication protocols 22
- Complete list 62
- Complete parameter list 135
- Configuration 14
- Connection 12
- Connection fault 123
- control circuit 9
- Control supply and control circuit 40
- Control supply voltage 9
- Control supply voltage - terminals 1 and 2 40
- cooling 33
- Cooling system 22
- Create backup 67, 152, 153, 154, 155
- current 9
- Current imbalance protection 105
- Current imbalance warning 115
- Current Lim
  - Dual current limit 83
  - Ramp current limit 83

- Current limit 83
  - Normal current limit 83, 87
- Current underload protection 104
- Current underload warning 115

## D

- Date and time 70
- Delivery note 32
- Description 17
- Detachable keypad 34
- Dimensions and drilling plan 34
- Direct stop 81
- Display decimals 60
- Display name 60
- Display settings 70
- Display slot 59
- Display style 60
- Document number 2
- Drilling plan 34
- Dual current limit 83

## E

- Earth fault protection 110
- Edit home view 59
- Edit information screens in home view 59
- Edit parameter values 54
- Electrical connection 38
- Electronic overload protection 103
- Electronic overload time-to-trip warning 117
- Electronic overload warning 114
- Electronics failure 122
- Emergency mode 124
- Environmental influence 21
- EOL 9
- Error caused by the line 108
- Event groups 101
- Event log
  - Faults 66
  - Parameter changed 66
  - Protections 66
  - Run 66
  - Warnings 66
- Extension I/O failure protection 112
- Extension IO (Option) 91
- External control voltage 42
- External fault 119
- External faults 122
- External thermal sensor - PT100 protection 109
- External thermal sensor - PTC protection 108

## F

- Fault 22
- Fault detection functions 19
- Faults 66, 119
  - External fault 119
  - Internal fault 119
- Faults indication 164
- Faulty usage fault 123
- Favorites 64
- Fieldbus 97
  - Fieldbus address 97

- Fieldbus control 97
- Fieldbus Inputs/Outputs 98

Fieldbus control 97

Fieldbus failure operation 97. Se även Fieldbus failure protection

Fieldbus failure protection 112

Fieldbus Inputs/Outputs 98

Frequency range protection 107

Full voltage 9

Full voltage start 81

Functional earth - terminal 22 40

Functions 73

## H

Handling when mounting 33

Heat sink over temperature fault 121

High current fault 123

HMI 9

How to set a parameter 55

How to start/stop the motor 15

Human-Machine Interface 9

Humidity 21

## I

le 9

i-key 53

Individual function 74

Inputs/outputs 91

- Analog output 95
- Relay outputs 94
- Temperature sensor 96

Insulation 22

Internal fault 119

- Internal fault 119

Internal faults 120

Internal IO 91

IO controller protection 113

## K

Keypad

- i-key 53
- Navigation keys 53
- R\L-key 53
- Start key 53
- Stop key 53

Kick start 84

## L

Language 69

LED 9

LED indicators 52

LED status 52

Limp mode 125

Line contactor close time 125

Local control from keypad 57

- R\L-key 57
- Start key 57
- Stop key 57

Locked rotor protection 103

Locked rotor warning 114

Low supply voltage fault 123

## M

Maintenance 149

Maximum mounting angle 34

Max number of starts protection 103

Menu screen 62

- Favorites 64
- Modified 64
- Parameters 62

Minimum distance to wall/fron 33

Minimum enclosure size 34

MINI USB interface 147

Motor Current le 75

Motor heating 86, 87

Motor jog 58

Mount 33

Mounting Detachable HMI 35

## N

Navigation keys 53

Navigation Overview 52

Normal current limit 83, 87

## O

On/off switch 54

Open circuit thyristor fault 121

Optional accessories 49

Options screen 59

Output relay 22

Overview 18

Overview of faults, protections and warnings 161

Overvoltage protection 105

Overvoltage warning 116

## P

Parameter changed 66

Parameters 62

- Complete list 62

Parameter storage warning 118

Phase loss fault 122

Phase reversal protection 106

PLC 9

Pollution degree 21

Power factor underload protection 104

Power factor underload warning 115

Presentation settings 68

Pre-start 74

Programmable inputs (Sequence start) 44

Programmable inputs - terminals 15, 16 and 17 43

Programmable output relay - K4, terminals 4, 5 and 6 45

Programmable output relay - K5, terminals 7, 8 and 9 45

Programmable output relay - K6, terminals 10, 11 and 12 45

Protection 21

Protection functions 18

Protection indication 163, 167

Protection indication shown on screen 163

Protections 66, 102

PT100 108

PTC 96

PTC/PT100 input 47

## Q

Quick start 11

## R

Ramp current limit 83  
Real time clock 70  
Receive, unpack and check 32  
Relay outputs 94  
Replace backup 67  
Reset operating data 71  
Reset to defaults 71  
R\L-key 53, 57  
Run 66

## S

Scale value range 60  
Selection list 54  
Selection softkeys 53  
Semi-conductor fuses 22  
Sequence start 89  
Service and repair 151, 152  
Settings 68, 128

- Date and time 70
- Display settings 70
- Language 69
- Reset to defaults 71

Short circuit fault 120  
Short circuit warning 117  
Signal 59  
Signal max 60  
Signal min 60  
Slow speed 85  
Softstarter overview 20  
Softstarter ratings 23  
Softstarter states 74

- Individual function 74
- Pre-start 74
- Stand by 74
- Start ramp 75
- Stop ramp 75
- Top of ramp 75

Special feature 124

- Emergency mode 124
- Limp mode 125
- Line contactor close time 125
- Start without start command 125
- Step down level 126
- System mode 126
- TOR relay delay time 127

Specifications 21  
Stand by 74  
Stand still brake 82  
Start and Stop - terminals 13, 14, 18, 19, 20, 21 41  
Start key 53, 57  
Start ramp 75  
Start without start command 125  
Step down level 126  
Stop key 53, 57  
Stop ramp 75  
Storage 21, 22  
System info 68

System mode 126

## T

Table Application settings 134  
Technical data 22  
Technical data for external keypad 22  
Temperature 9, 21, 22  
Temperature errors in °C / K 109  
Temperature sensor 96

- External thermal sensor - PT100 protection 109
- External thermal sensor - PTC protection 108
- PT100 108
- PTC 96
- Thermistor switch 108

Temperature sensors 108  
The numerical setting 54  
Thyristor 9  
Thyristor overload fault 121  
Thyristor overload warning 115  
Too long current limit protection 110  
Top level 57  
Top of ramp 75  
Shunt fault TOR 9  
Torque ramp 78

- Torque stop ramp 80

Torque start ramp 79  
Torque stop ramp 80  
TOR relay delay time 127  
Total Harmonic Distortion warning 117  
Troubleshooting 157

- Overview of faults, protections and warnings 161
- Protection indication shown on screen 163

Type designation 21

## U

Uc 9  
Ue 9  
Undervoltage protection 105  
Undervoltage warning 116  
Unspecified fault 122  
Uploading of parameters 67  
Us 9  
User defined protection 19  
User interface 18

## V

Voltage imbalance warning 116  
Voltage outputs protection 107  
Voltage ramp 76

- Voltage start ramp 76
- Voltage stop ramp 77

Voltage sag detection 127  
Voltage start ramp 76  
Voltage stop ramp 77

## W

Warning functions 19  
Warnings 66, 114  
Weights 22



—  
**ABB Electrification Sweden AB**  
**Smart Power - Motor Starting & Safety**  
SE-721 61 Västerås  
Sweden  
E-mail: sales@se.abb.com

<https://solutions.abb/softstarters>

