



VFD-V

User Manual

Flux Vector Control AC Motor Drivers



230V Series

0.75 ~ 37KW

1.0 ~ 50HP

460V Series

0.75 ~ 75KW

1.0 ~ 100HP



DELTA ELECTRONICS, INC.

www.delta.com.tw/industrialautomation

ASIA

DELTA ELECTRONICS, INC.

Taoyuan Plant

31-1, SHIEN PAN ROAD,
KUEI SAN INDUSTRIAL ZONE,
TAOYUAN SHIEN

TEL: 886-3-362-6301

FAX: 886-3-362-7267

EUROPE

DELTRONICS (NETHERLANDS) B.V.

INDUSTRIEGEBIED VENLO NR. 9031
COLUMBUSWEG 20
NL-5928 LC VENLO
THE NETHERLANDS

TEL: 31-77-324-1930

FAX: 31-77-324-1931

NORTH/SOUTH AMERICA

DELTA PRODUCTS CORPORATION

Sales Office

P.O. BOX 12173
5101 DAVIS DRIVE
RESEARCH TRIANGLE PARK,
NC 27709, U.S.A.

TEL: 1-919-767-3813

FAX: 1-919-767-3969

5011608405

2016-04



V E 0 5

* We reserve the right of this manual contained information change without prior notice



VFD-V

User Manual

Flux Vector Control AC Motor Drivers

Preface

Thank you for choosing DELTA's high-performance VFD-V Series. VFD-V Series are manufactured by adopting high-quality components, material and incorporating the latest microprocessor technology available.

Getting Started

This manual will be helpful in the installation, parameter setting, troubleshooting, and daily maintenance of the AC motor drives. To guarantee safe operation of the equipment, read the following safety guidelines before connecting power to the AC drives. Keep this operating manual handy and distribute to all users for reference.



WARNING



Always read this manual thoroughly before using VFD-V series AC Motor Drives.



DANGER! AC input power must be disconnected before any maintenance. Do not connect or disconnect wires and connectors while power is applied to the circuit. Maintenance must be performed by qualified technicians.



CAUTION! There are highly sensitive MOS components on the printed circuit boards. These components are especially sensitive to static electricity. To avoid damage to these components, do not touch these components or the circuit boards with metal objects or your bare hands.



DANGER! A charge may still remain in the DC-link capacitor with hazardous voltages even if the power has been turned off. To avoid personal injury, please ensure that power has turned off before operating AC drive and wait ten minutes for capacitors to discharge to safe voltage levels.



CAUTION! Ground the VFD-V using the ground terminal. The grounding method must comply with the laws of the country where the AC drive is to be installed. Refer to Basic Wiring Diagram.



DANGER! The AC drive may be destroyed beyond repair if incorrect cables are connected to the input/output terminals. Never connect the AC drive output terminals U/T1, V/T2, and W/T3 directly to the AC main circuit power supply.



CAUTION! The final enclosures of the AC drive must comply with EN50178. (Live parts shall be arranged in enclosures or located behind barriers that meet at least the requirements of the Protective Type IP20. The top surface of the enclosures or barrier that is easily accessible shall meet at least the requirements of the Protective Type IP40). (VFD-V series corresponds with this regulation.)



CAUTION! Heat sink may heat up over 70°C (158°F), during the operation. Do not touch the heat sink.

CHAPTER 1 RECEIVING AND INSPECTION

1.1 Nameplate Information	1 - 1
1.2 Model Explanation	1 - 1
1.3 Serial Number Explanation	1 - 2

CHAPTER 2 STORAGE AND INSTALLATION

2.1 Storage	2 - 1
2.2 Installation	2 - 2

CHAPTER 3 WIRING

3.1 Basic Wiring Diagram	3 - 2
3.2 External Wiring	3 - 5
3.3 Main Circuit Terminal Explanations.....	3 - 6
3.4 Control Terminal Explanations	3 - 6
3.5 Component Explanations	3 - 8
3.6 Wiring Notice	3 - 14

CHAPTER 4 DIGITAL KEYPAD (VFD-PU05) OPERATION

4.1 Description of the Digital Keypad VFD-PU05	4 - 1
4.2 Explanations of Display Messages	4 - 1
4.3 Operation steps of the Digital Keypad VFD-PU05	4 - 3

CHAPTER 5 DESCRIPTION OF PARAMETER SETTINGS

5.1 Group 0: System Parameter	5 - 1
5.2 Group 1: Basic Parameter	5 - 13
5.3 Group 2: Digital Output/Input Parameter	5 - 18
5.4 Group 3: Analog Output/Input Parameter	5 - 27
5.5 Group 4: Multi-Step Speed and Procedural Operation Parameter	5 - 35

5.6 Group 5: Motor Modulation Parameter	5 - 40
5.7 Group 6: Protection Parameter.....	5 - 45
5.8 Group 7: Special Parameter	5 - 52
5.9 Group 8: High-Performance Parameter.....	5 - 58
5.10 Group 9: Communication Parameter	5 - 62
5.11 Group 10: Speed Feedback Parameter	5 - 73
CHAPTER 6 MAINTENANCE AND INSPECTIONS.....	6 - 1
CHAPTER 7 TROUBLESHOOTING.....	7 - 1
CHAPTER 8 PARAMETER SUMMARY	8 - 1
APPENDIX A SPECIFICATIONS	A - 1
APPENDIX B ACCESSORIES	B - 1
B.1 Fuse Specification Chart.....	B - 1
B.2 Braking Resistors	B - 3
B.3 AMD - EMI Filter Cross Reference.....	B - 7
B.4 PG Card.....	B - 13
B.5 Zero Phase Reactor.....	B - 17
APPENDIX C DIMENSIONS.....	C - 1
APPENDIX D EC DECLARATION OF CONFORMITY	D - 1

CHAPTER 1 RECEIVING AND INSPECTION

This VFD-V AC drive has gone through rigorous quality control tests at the factory before shipment. After receiving the AC drive, please check for the following:

Receiving

- ✓ Check to make sure that the package includes an AC drive, the User Manual, dust covers and rubber bushings.
- ✓ Inspect the unit to insure it was not damaged during shipment.

Make sure that the part number indicated on the nameplate corresponds with the part number of your order.

1.1 Nameplate Information → Example for 5HP/3.7kW 230V 3-Phase

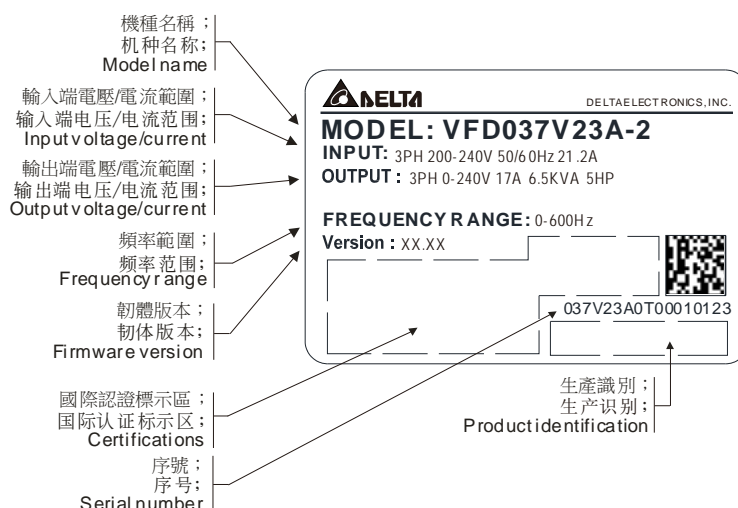

1.2 Model Explanation

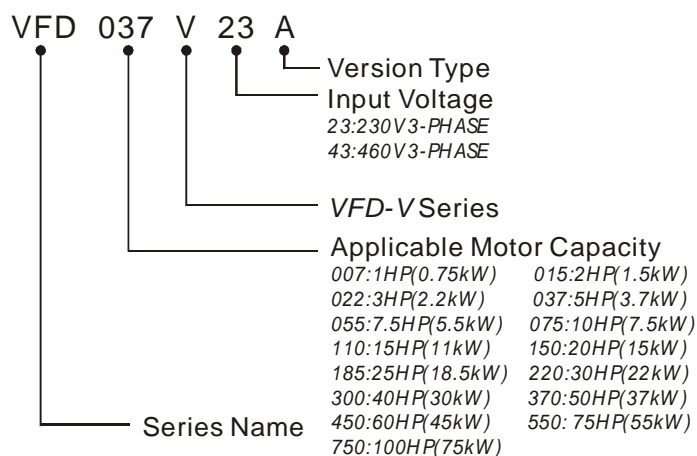

1.3 Serial Number Explanation

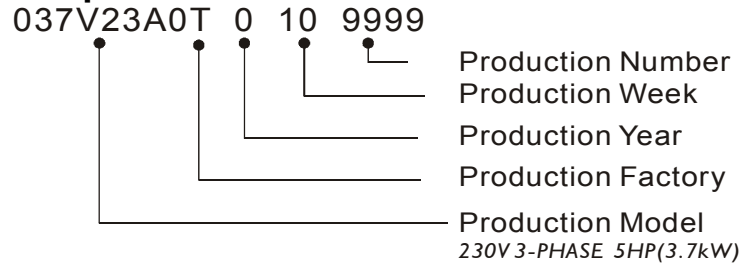

● Please contact the dealers immediately should any discrepancy occurred.

CHAPTER 2 STORAGE AND INSTALLATION

2.1 Storage

The AC drive should be kept in the shipping carton before installation. In order to retain the warranty coverage, the AC drive should be stored properly when it is not to be used for an extended period of time.

Ambient Conditions:

Operation	Air Temperature: -10°C to +40°C (14°F to 104°F) +50°C (122°F) without dust cover. Atmosphere pressure: 86 to 106 kPa Installation Site Altitude: below 1000m Vibration: Maximum 9.80 m/s ² (1G) at less than 20Hz Maximum 5.88 m/s ² (0.6G) at 20Hz to 50Hz
Storage	Temperature: -20°C to +65°C (-4°F to 149°F) Relative Humidity: Less than 90%, no condensation allowed Atmosphere pressure: 86 to 106 kPa
Transportation	Temperature: -20°C to +60°C (-4°F to 140°F) Relative Humidity: Less than 90%, no condensation allowed Atmosphere pressure: 86 to 106 kPa Vibration: Maximum 9.80 m/s ² (1G) at less than 20Hz, Maximum 5.88 m/s ² (0.6G) at 20Hz to 50Hz
Pollution Degree	2: good for a factory type environment.

2.2 Installation



CAUTION

The control, power supply and motor leads must be laid separately. They must not be fed through the same cable conduit / trunking.

High voltage insulation test equipment must not be used on cables connected to the drive.

Improper installation of the AC drive will greatly reduce its life. Be sure to observe the following precautions when selecting a mounting location.

Failure to observe these precautions may void the warranty!

- ◆ Do not mount the AC drive near heat-radiating elements or in direct sunlight.
- ◆ Do not install the AC drive in a place subjected to high temperature, high humidity, excessive vibration, corrosive gases or liquids, or airborne dust or metallic particles.
- ◆ Mount the AC drive vertically and do not restrict the air flow to the heat sink fins.

The AC drive generates heat. Allow sufficient space around the unit for heat dissipation.

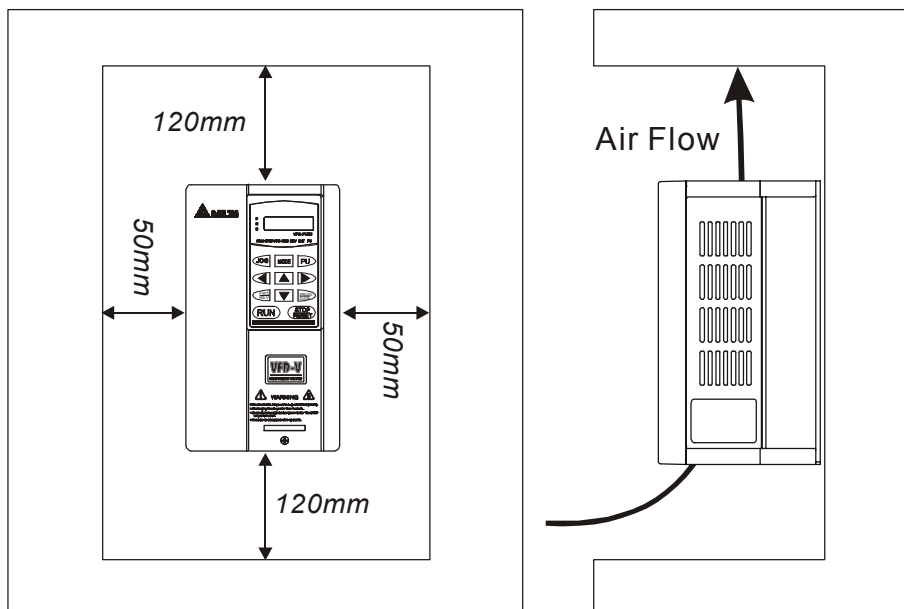

CHAPTER 3 WIRING



DANGER

3

Hazardous Voltage

Before accessing the AC drive:

- ◆ Disconnect all power to the AC drive.
- ◆ Wait five minutes for DC bus capacitors discharge.

Any electrical or mechanical modification to this equipment without prior written consent of Delta Electronics, Inc. will void all warranties and may result in a safety hazard in addition to voiding the UL listing.

Short Circuit Withstand:

The rated voltage must be equal to or less than 240V (460V model is 480Volts) and the current must be equal to or less than 5000A RMS. (the model of 51HP or above is 10000A RMS)

General Wiring Information

Applicable Codes

VFD-V AC drives (007V23/43A, 015V23/43A, 022V23/43A, 037V23/43A, 055V23/43A, 075V23/43A, 110V43B, 110V23/43A, 150V23/43A, 185V23/43A, 220V23/43A, 300V23/43A, 370V23/43A, 450V43A) are Underwriters Laboratories, Inc. (UL) and Canadian Underwriters Laboratories (cUL) listed, and therefore comply with the requirements of the National Electrical Code (NEC) and the Canadian Electrical Code (CEC).

Installation intended to meet the UL and cUL requirements must follow the instructions provided in "Wiring Notes" as a minimum standard. Follow all local codes that exceed UL and cUL requirements. Refer to the technical data label affixed to the AC drive and the motor nameplate for electrical data.

The "Line Fuse Specification" in Appendix B, lists the recommended fuse part number for each V-Series part number. These fuses (or equivalent) must be used on all installations where compliance with U.L. standards is a required.

3.1 Basic Wiring Diagram

For wiring of the inverter, it is divided into the main circuit and the control circuit. Users could open the case cover, and could inspect the main circuit terminal and the control circuit terminal; users connect the circuit in compliance with the following wiring method.

The following diagram is the standard wiring diagram for the VFD-V inverter.

Wiring Diagram 1
10HP(7.5kW) and below

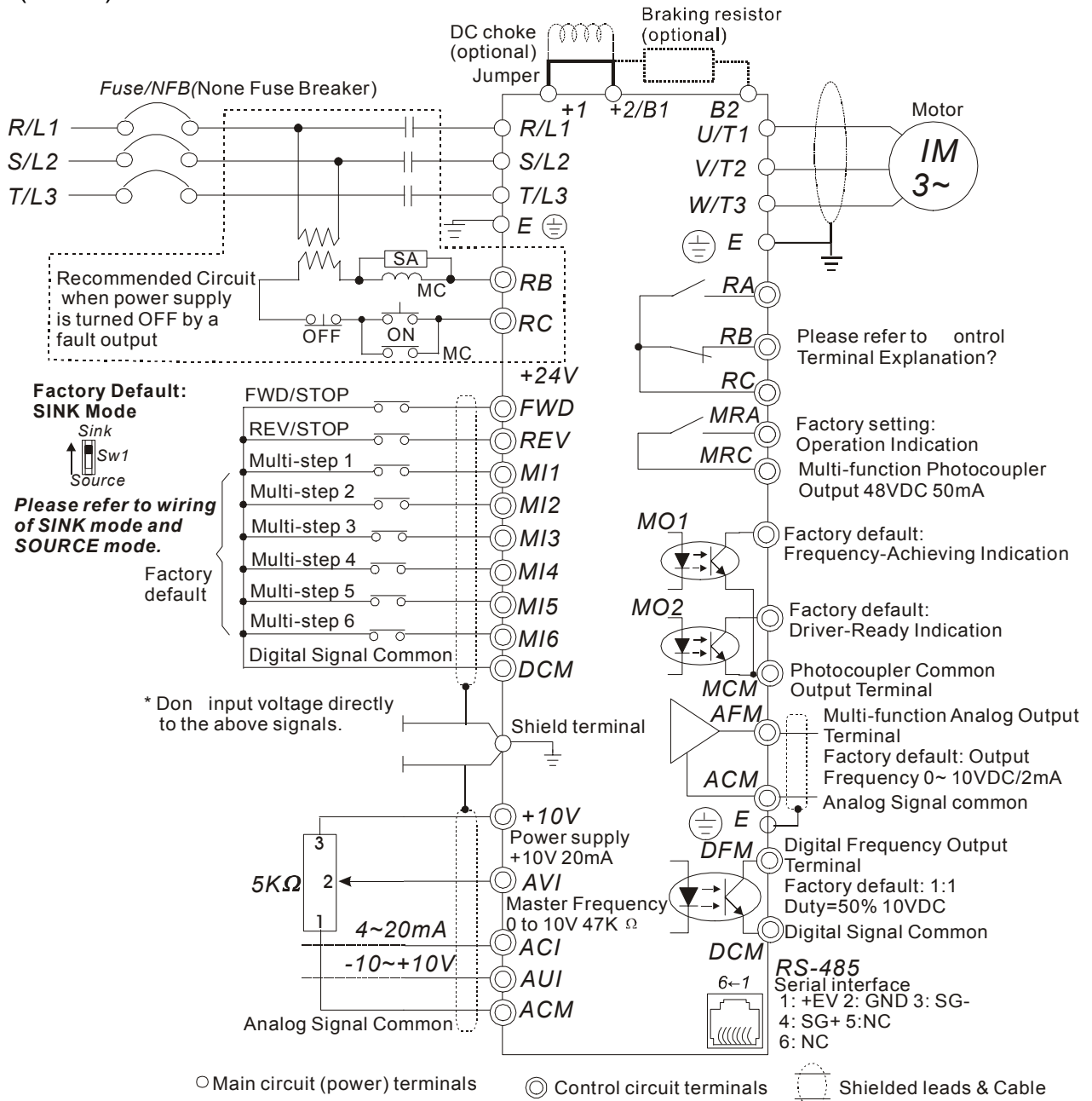

Wiring Diagram 2

15HP(11kW) and above

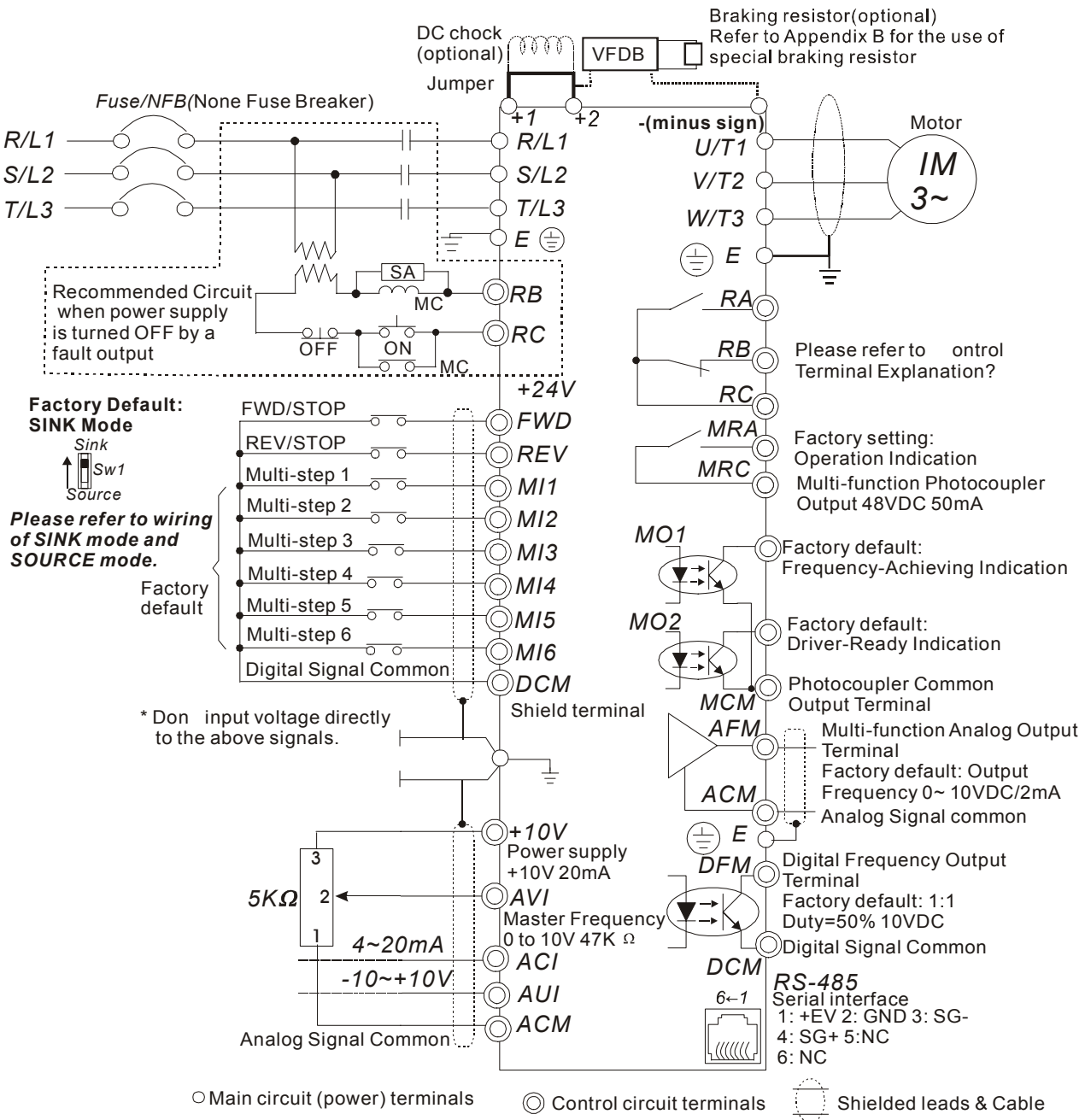

3

Wiring of SINK mode and SOURCE mode

SINK Mode

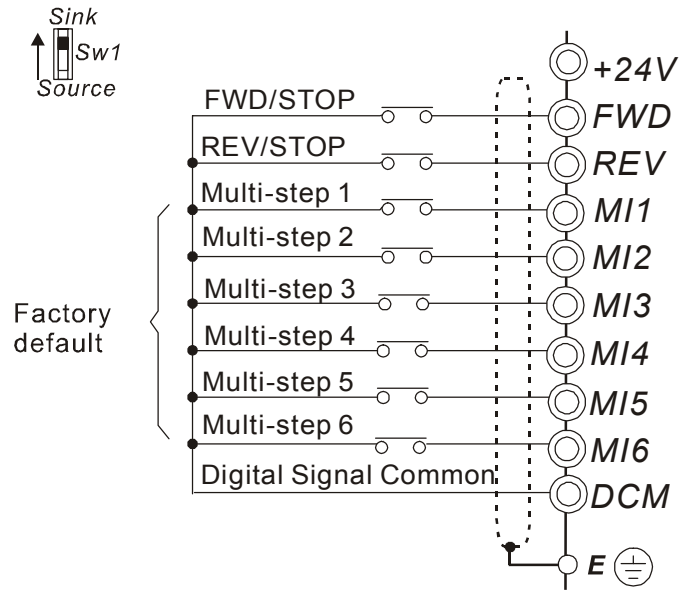

SOURCE Mode

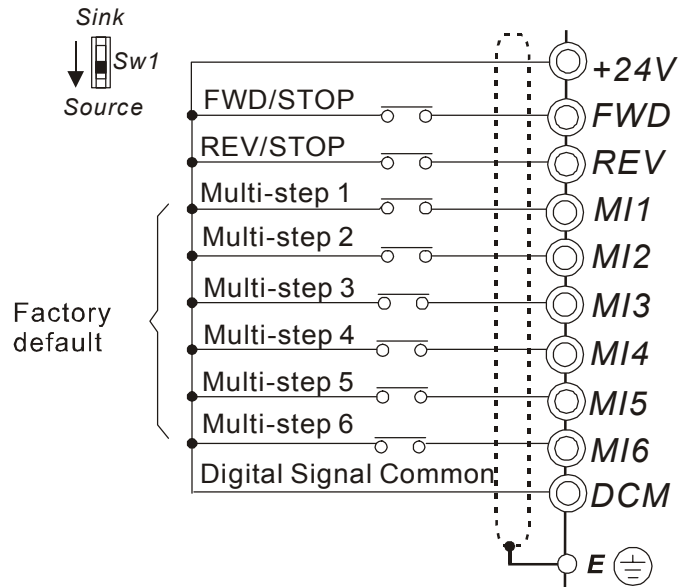

3.2 External Wiring

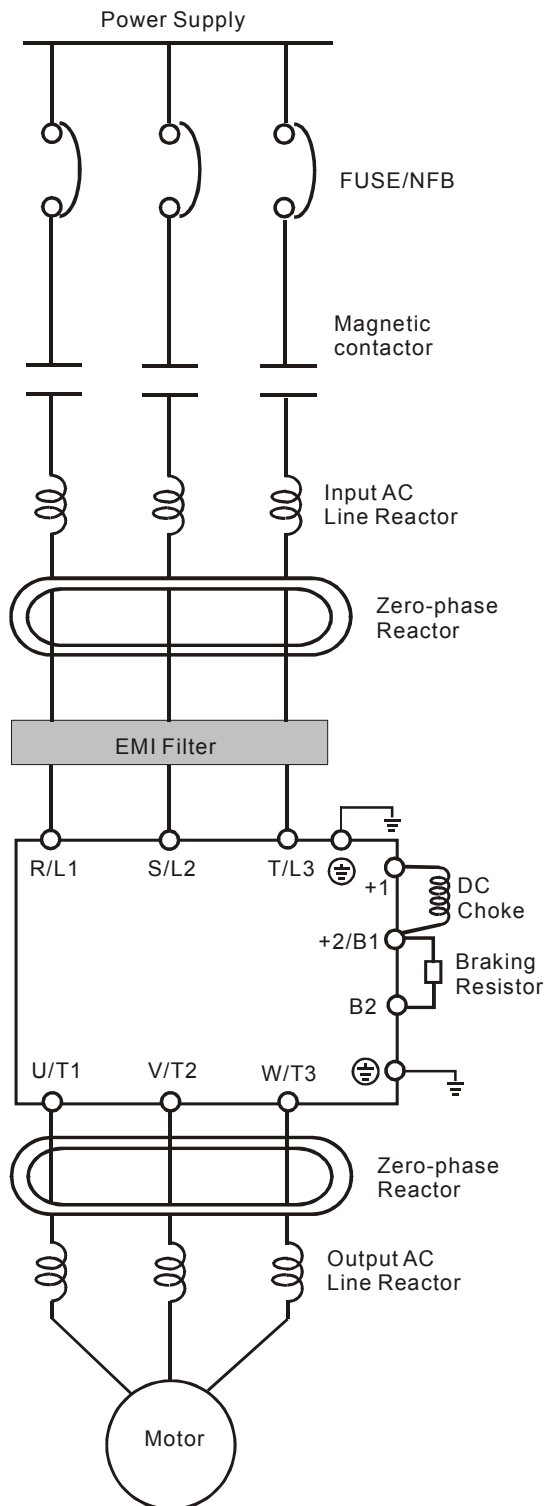

Items	Explanations
Power supply	Please follow the specific power supply requirement shown in APPENDIX-A.
Fuse/NFB (Optional)	There may be inrush current during power up. Please check the chart of APPENDIX B and select the correct fuse with rated current. NFB is optional.
Magnetic contactor (Optional)	Please do not use a Magnetic contactor as the I/O switch of the AC drive, this will reduce the operating life cycle of the AC drive.
Input AC Line Reactor (Optional)	In order to improve the input power factor, reduces harmonics and protection from AC line disturbances. (Surge, switching spike, power flick, etc.) AC line reactor should be installed when the power supply capacity is 500kVA or more and exceeds 6 times of the inverter capacity, or the wiring distance within 10m.
Zero-phase Reactor (Ferrite Core Common Choke) (Optional)	Zero phase reactors are used to reduce radio noise specify when the audio equipments installed near the inverter. Good effective for noise reduction on both the input and output sides. Attenuation quality is good in a wide range from AM band to 10Mhz. Appendix B for specifies zero phase reactors. (RF220X00A)
EMI filter (Optional)	To reduce the electromagnetic interference. Please refer to Appendix B for detail.
Braking Resistor (Optional)	Used to reduce stopping time of the motor. Please refer to the chart on Appendix B for specific Braking Resistors.
Output AC Line Reactor (Optional)	Motor surge voltage amplitudes depending on the motor cable length. For long motor cable application, it is necessary installed on the inverter output side.

3.3 Main Circuit Terminal Explanations

Terminal Symbol	Content Explanation
R/L1, S/L2, T/L3	Input terminals for business-used power supply
U/T1, V/T2, W/T3	Output terminals for the AC motor drivers (at the side of the motor)
+1~+2/B1	Power-improved continuing terminals of the DC reactor; disconnect the short-circuit piece when the device is installed
+2/B1~B2	Connecting terminals of the braking resistor; purchase and install these devices according to the selection chart
+2/B1~ —	Continuing terminals of the braking module (the VFDB series)
	Ground terminals, please have these terminals grounded following the third-type grounding of 230V series and the special grounding of 460V series within the electrician regulations

3.4 Control Terminal Explanations

Terminal Symbol	Explanation on the Terminal Function	Factory Setting
FWD	FWD RUN-STOP command	
REV	REV RUN-STOP command	
MI1	Multi-function input selection 1 (3-wire STOP-designated terminal)	Multi-step 1 command
MI2	Multi-function input selection 2	Multi-step 2 command
MI3	Multi-function input selection 3	Multi-step 3 command
MI4	Multi-function input selection 4	Multi-step 4 command
MI5	Multi-function input selection 5	Abnormal reset command
MI6	Multi-function input selection 6 (TRG-designated terminal)	EF
DFM	Digital frequency signal output	1 : 1
+24V	Digital control signal – the common end	+24V 20mA
DCM	Digital control signal – the common end	
RA	Multi-function relay output contact (NO a)	Resistive Load 5A(N.O.)/3A(N.C.) 240VAC 5A(N.O.)/3A(N.C.) 24VDC
RB	Multi-function relay output contact (NC b)	
RC	Multi-function relay output contact	
MRA	Multi-function relay output contact (NO a)	
MRC	Multi-function relay output contact – the common end	
MO1	Multi-function output terminal 1 (photo coupler)	Instruction during operation

Terminal Symbol	Explanation on the Terminal Function	Factory Setting
MO2	Multi-function output terminal 2 (photo coupler) (Max 48VDC 50mA)	Set up the frequency attained
MO3	Multi-function output terminal 3 (photo coupler) (Max 48VDC 50mA)	Driver ready
MCM	Multi-function output terminal – the common end	Max 48VDC 50mA
+10V	Auxiliary reference power	+10V 20mA
AVI	Analog voltage frequency command	The greatest operation frequency corresponding to 0~+10V
ACI	Analog current frequency command	The greatest operation frequency corresponding to 4~20mA
AUI	Auxiliary analog voltage frequency command	The greatest operation frequency corresponding to -10~+10V
AFM	Multi-function analog voltage output	The greatest operation frequency corresponding to -10~10V
ACM	Analog control signal – the common end	

* Analog control signal wire specification: 18 AWG (0.8 mm²), cover the isolation twisted wire.

3.5 Component Explanations

1 HP to 5 HP (VFD007V23A/43A, VFD015V23A/43A, VFD022V23A/43A, VFD037V23A/43A)

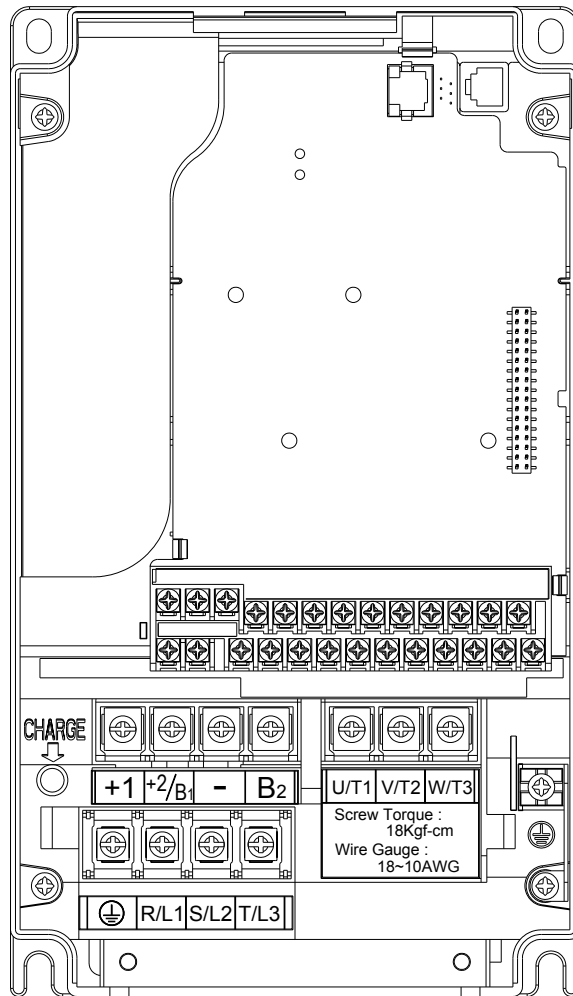

Control Terminal

Torque: 8Kgf-cm (6.9 in-lbf)

Wire: 22-14 AWG

Power Terminal

Torque: 18 kgf-cm (15.6 in-lbf)

Wire Gauge: 18-10 AWG

Wire Type: Stranded Copper only, 75°C

7.5 HP to 15 HP (VFD055V23A/43A, VFD075V23A/43A, VFD110V43B)

3

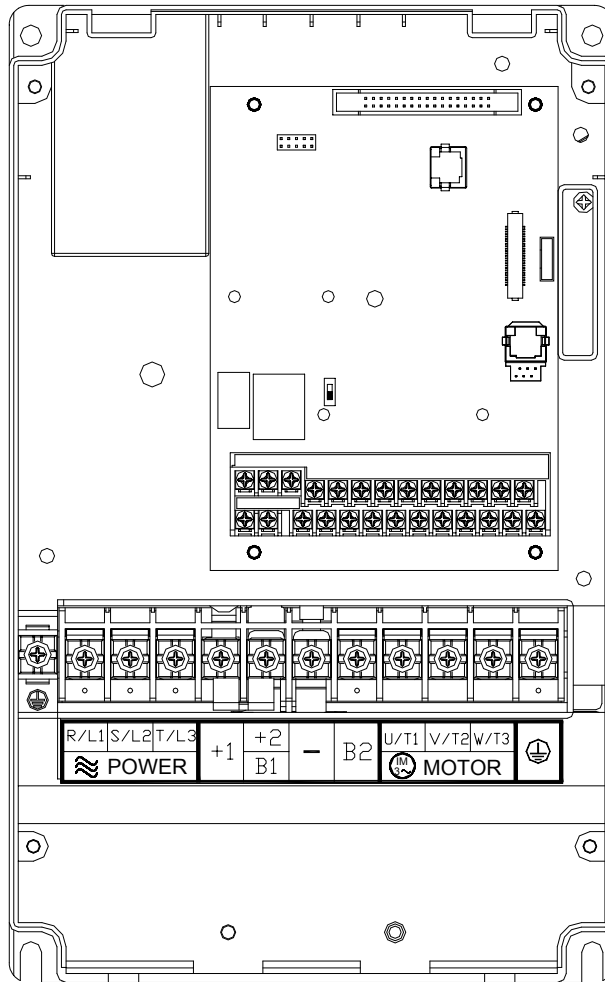

Control Terminal

Torque: 8Kgf-cm (6.9 in-lbf)

Wire: 22-14 AWG

Power Terminal

Torque: 30 kgf-cm (26 in-lbf)

Wire Gauge: 12-8 AWG

Wire Type: Stranded Copper only, 75°C

Note: If wiring of the terminal utilizes the wire with a 6AWG-diameter, it is thus necessary to use the Recongized Ring Terminal to conduct a proper wiring.

**15HP to 30HP (VFD110V23A/43A, VFD150V23A/43A, VFD185V23A/43A,
VFD220V23A/43A)**

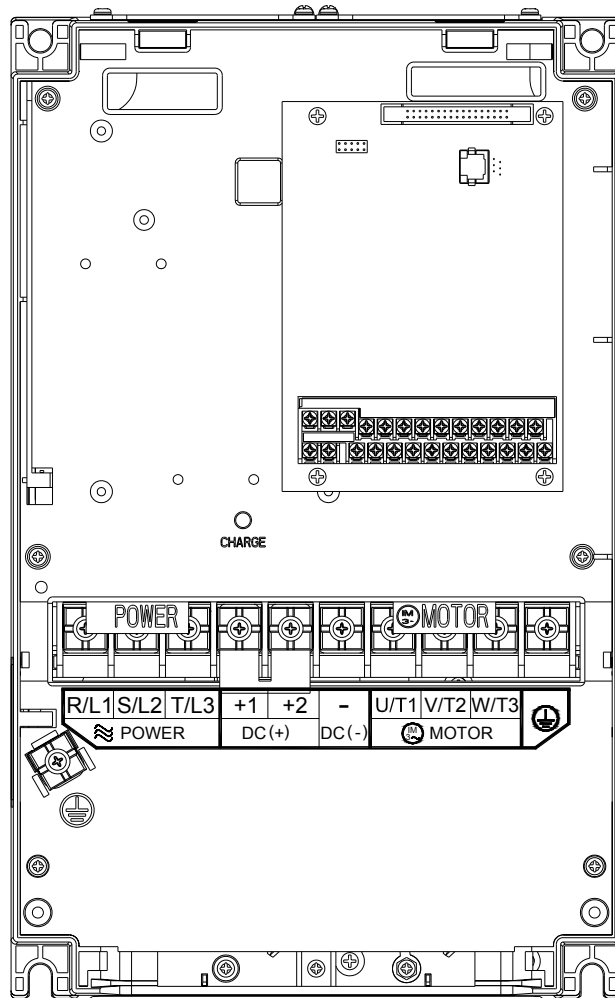

Control Terminal

Torque: 8Kgf-cm (6.9 in-lbf)

Wire: 22-14 AWG

Power Terminal

Torque: 30 kgf-cm (26 in-lbf)

Wire Gauge: 8-2 AWG

Wire Type: Stranded Copper only, 75°C

NOTE: If wiring of the terminal of VFD220V23A utilizes the wire with a 1AWG-diameter, it is thus necessary to use the Recognized Ring Terminal to conduct a proper wiring.

40 to 50 HP 230V (VFD300V23A, VFD370V23A)

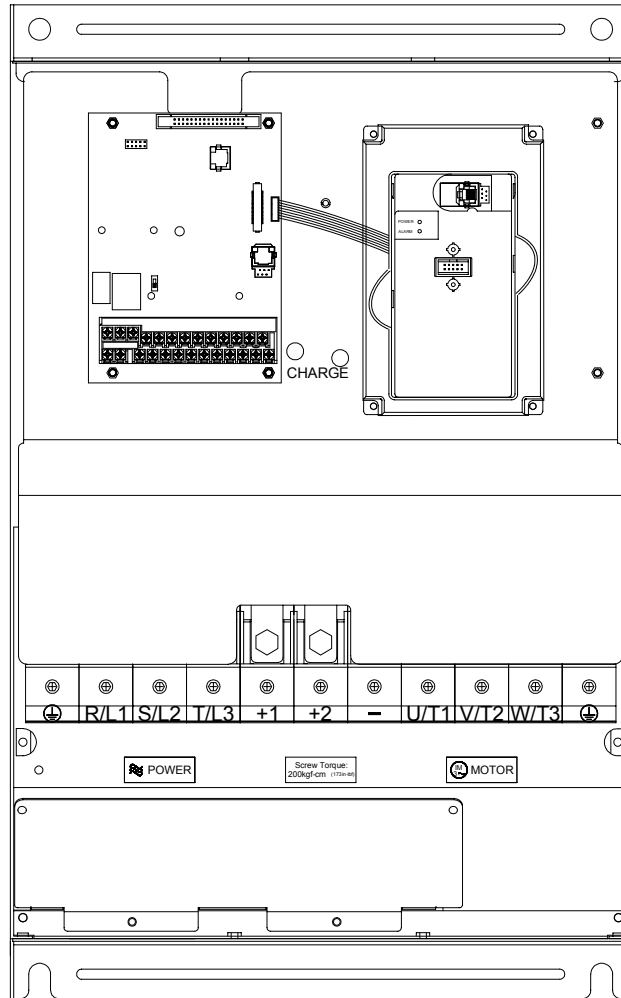

3

Control Terminal

Torque: 8Kgf-cm (6.9 in-lbf)

Wire: 22-14 AWG

Power Terminal

Torque: 200 kgf-cm (173.6 in-lbf)

Wire Gauge: 1/0 – 4/0 AWG

Wire Type: Stranded Copper only, 75°C

40HP to 60HP 460V (VFD300V43A, VFD370V43A, VFD450V43A)

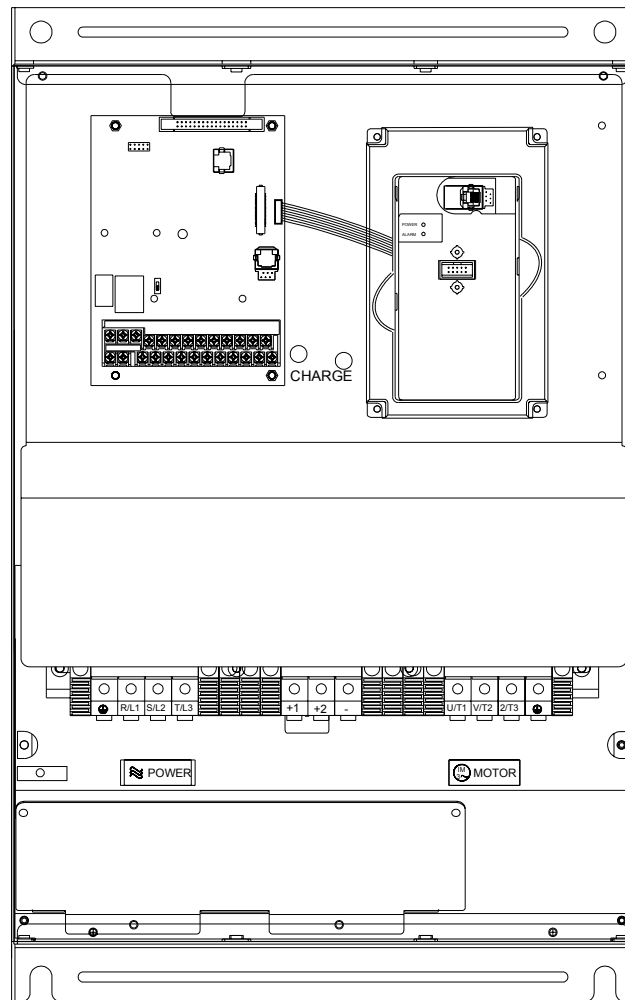

Control Terminal

Torque: 8Kgf-cm (6.9 in-lbf)

Wire: 22-14 AWG

Power Terminal

Torque: 57 kgf-cm (49.5 in-lbf)

Wire Gauge: 4-2 AWG

Wire Type: Stranded Copper only, 75°C

75-100 HP 460V (VFD550V43A, VFD750V43A)

3

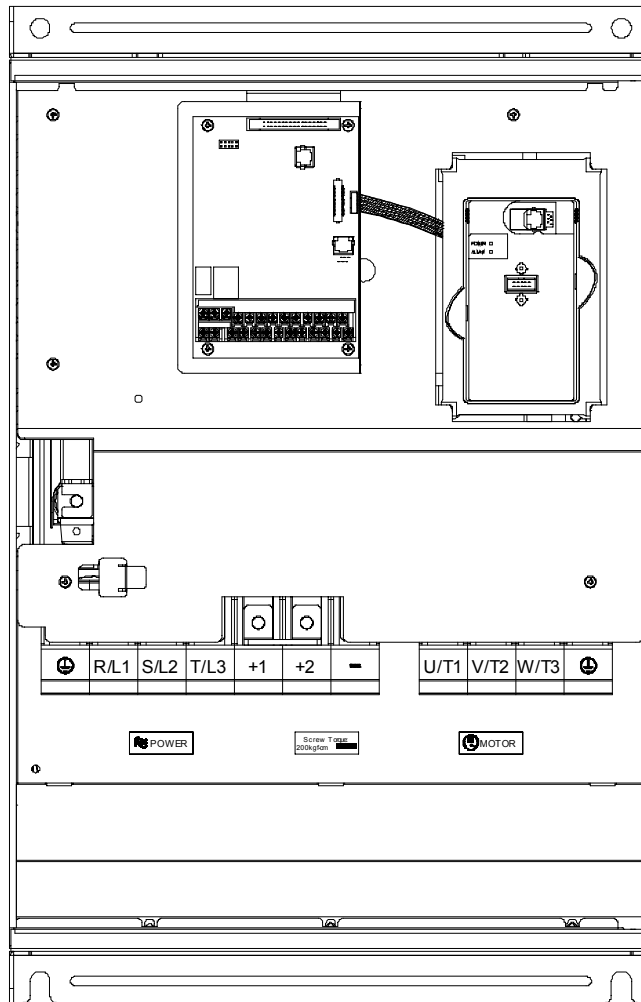

Control Terminal

Torque: 8Kgf-cm (6.9 in-lbf)

Wire: 22-14 AWG

Power Terminal

Torque: 200 kgf-cm (173.6 in-lbf)

Wire Gauge: 1/0 – 4/0 AWG

Wire Type: Stranded Copper only, 75°C

3.6 Wiring Notice

1. There are corresponding ring terminals which will be included with each unit (15-30HP), and please use the proper crimping tool by KST INC. P/N: KST-HDC38A for securing the conductor.
2. When wiring up, and that the wiring route specifications are settled, please conduct the wiring following the electrician regulations.
3. The connection between the three-phase AC input power and the main circuit terminal R/L1, S/L2, T/L3 has to set up a none-fusing switch in between. The best is to series connect with an electro-magnetic contactor (MC) so as to cut off the power supply at the same time when the inverter protection function acts. (The two ends of the electro-magnetic contactor should have the R-C Varistor).
4. There is no phase-order differentiation in the input power R/L1, S/L2, T/L3 and users could connect with either one of use.
5. The ground terminal E is grounded with the third-type grounding method (with the grounding impedance under 100Ω).
6. The grounding wire of the inverter could not be grounded at the same time with machinery with grand current loading, like that of the electric soldering machine and of the motor with grand horsepower; they have to be grounded individually.
7. The shorter the ground wire, the better it is.
8. When several inverters are grounded at the same time, be sure not to make it into a ground circuit. Please refer to the following diagram:

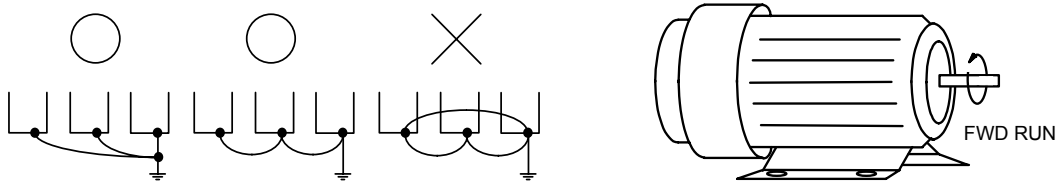

9. If the output terminals U/T1, V/T2 and W/T3 of the inverter are connecting relatively to the U, V, and W terminals of the motor, the FWD indicator located on the digital control panel of the inverter will be lit, and that means the inverter is running forward, and the rotation direction of the motor will be shown as the right hand side diagram above; if the REV indicator is lit, it means that the inverter is running in reverse direction, and the rotation direction will be of the opposite direction compared with the above diagram. If users are not sure of whether the connection between output terminals U/T1, V/T2 and W/T3 of the inverter is of one-to-one connection with U, V, and W terminals of the motor, simply swap either two wires among the U, V, and W terminals of the motor for correction if the inverter is running forward while the motor is running at reverse direction.

10. Be sure of the power voltage and the greatest current possible supplied.
11. When the “Digital Hand-held Programming Panel” is displayed, please do not disconnect or disassemble any wiring.
12. No braking resistor is installed within the VFD-V inverter (selective purchasing item), therefore, be sure to purchase and install the braking resistor if to be used on occasions when the loading inertia is great or that it is of frequent start/stop.
13. Be sure not to connect the AC power with the terminals U/T1, V/T2 and W/T3 on the power-generating side of the inverter.
14. Please tightly fasten the screws of the main circuit terminals so as to prevent sparks generated due to the vibration and loosening of the screws.
15. Wiring of the main circuit and of the control circuit should be separated so as to prevent erroneous actions. If the interlock connection is needed, please make it an intersection of 90°.
16. If terminals U/T1, V/T2 and W/T3 on the power-generating side of the inverter is in need of the noise wave-filter, it is then necessary to use the induction-type L-Varistor, but be sure not to add in the phase-carrying capacitor or the L-C- and R-C-type wave filters.
17. Please use the separating wire as much as possible during control wiring, and be sure not to expose the peeled-off separation net in front of the terminal to the external.
18. Please use the separating wire or tube as much as possible during power wiring, and ground these two ends of the separating layer or tube to the ground.
19. If the installation site of the inverter is sensitive to interferences, please have the RFI wave filters installed, and the nearer the inverter to the installation site, the better. In addition, the lower the carrier wave frequency of, the less the interferences.
20. If the electric-leakage circuit breaker is installed in the inverter, it could serve as the protection for the electric-leakage error, and as the prevention on the erroneous actions of the electric-leakage circuit breaker; please select the sensor current above 200mA with the action time of more than 0.1 second to have these actions accessible.

CHAPTER 4 DIGITAL KEYPAD (VFD-PU05) OPERATION



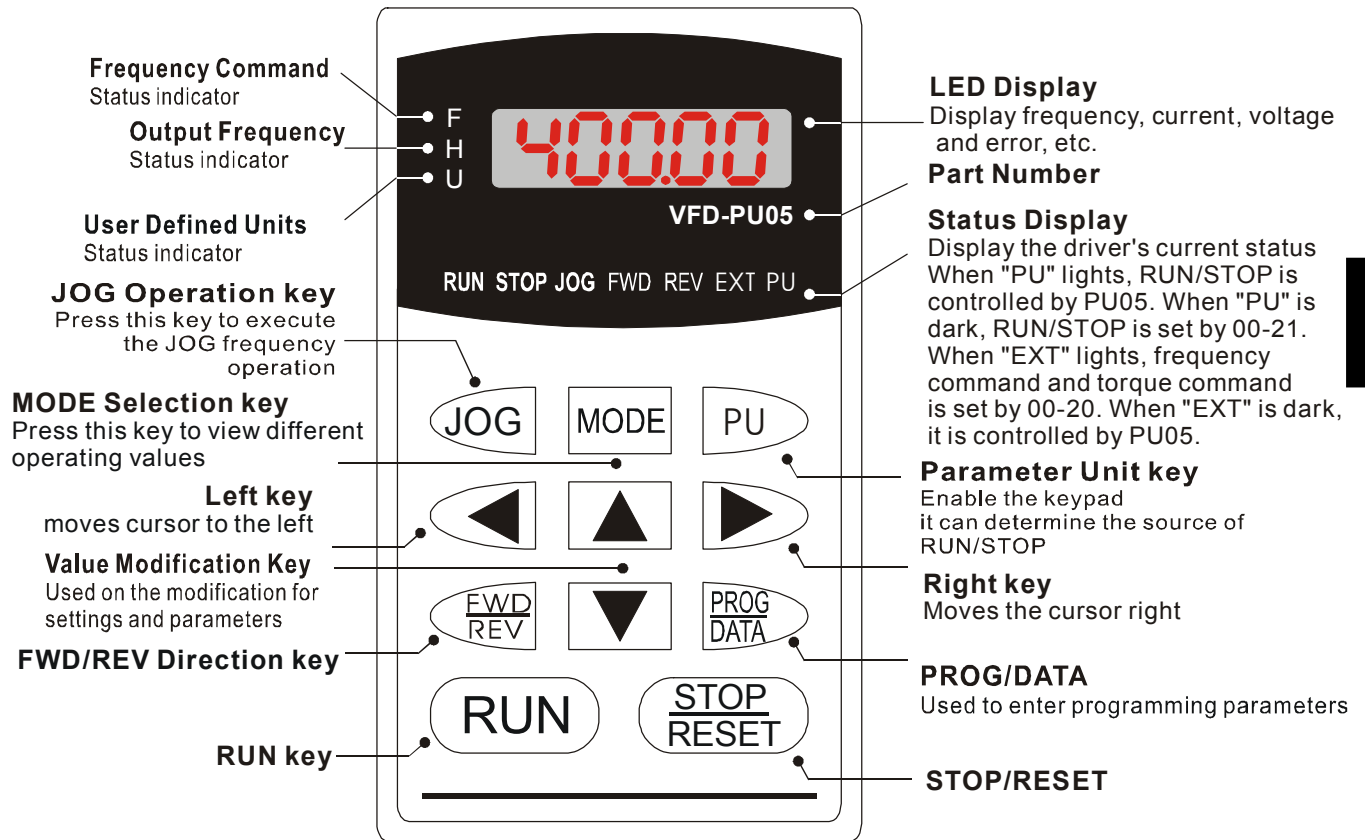



4.1 Description of the Digital Keypad VFD-PU05



4

4.2 Explanations of Display Messages

Messages Displayed	Descriptions
	Master frequency of the drive
	Actual operation frequency output to the motor from the drive
	User-selected content (the side DC-BUS voltage)

Messages Displayed	Descriptions
	Output current
	<p>Parameter duplication function: press PROG/DATA and hold still for about 2~3 seconds, it will start blinking and will duplicate the parameter to PU-05.</p> <p>Press the “Up” or “Down” key to switch to the “SAVE” function</p>
	<p>Parameter duplication function: press PROG/DATA and hold still for about 2~3 seconds, it will start blinking and will write the parameter into the drive.</p> <p>Press the “Up” or “Down” key to switch to the “READ” function</p>
	The specified parameter item
	Value of the parameter content
	<p>If the “End” message is displayed (as shown in the figure), for about 1 second, it is an indication that the data has been accepted and saved to the internal memory automatically.</p>
	Displayed when the preset data is not accepted or that the value goes over the limit

4.3 Operation steps of the Digital Keypad VFD-PU05

VFD-PU05 Operation Flow Chart

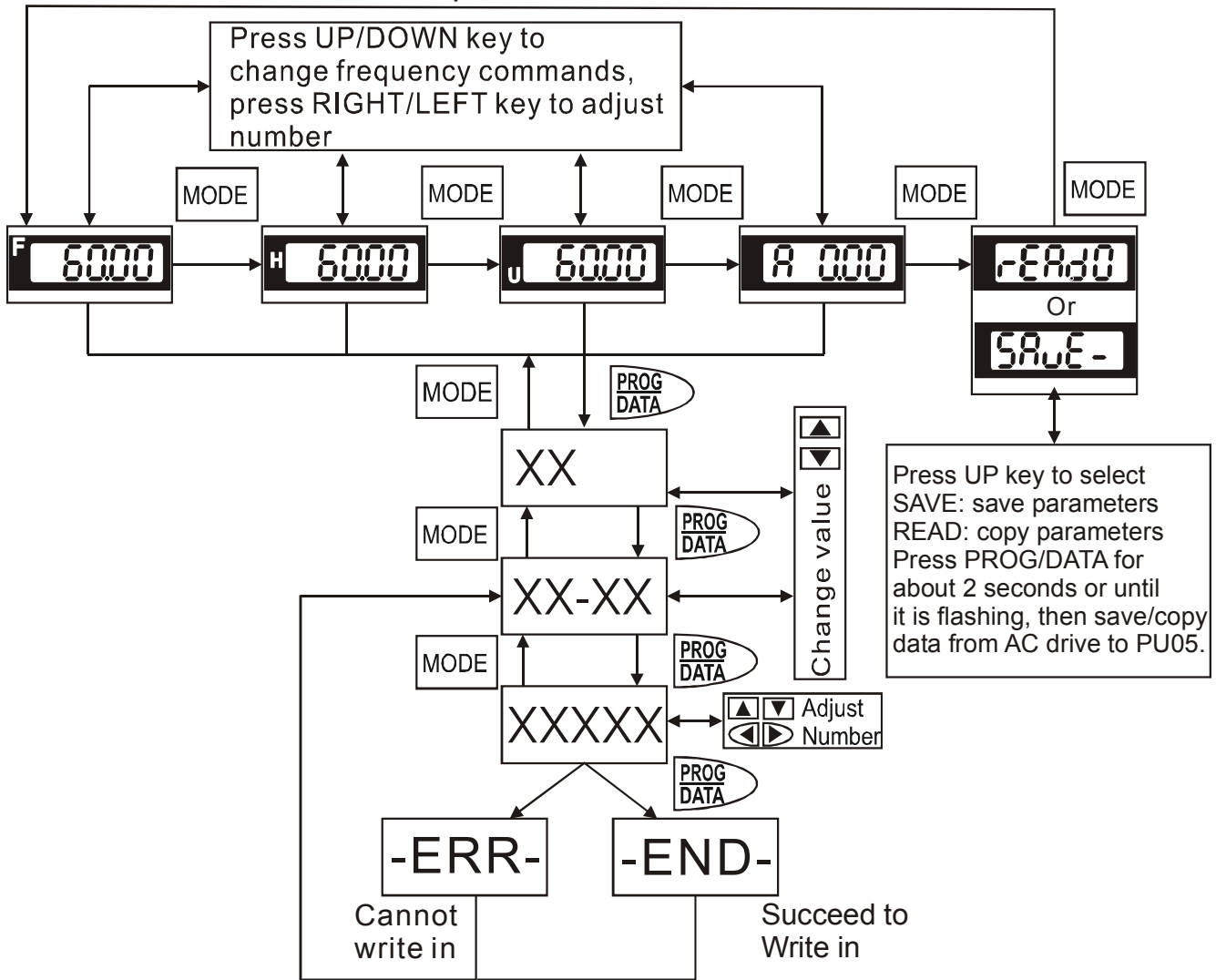

4

CHAPTER 5 DESCRIPTION OF PARAMETER SETTINGS

5.1 Group 0: System Parameter

00-00	Identity Code	Factory setting	Read Only
	Settings	Based on the model type	
00-01	Rated Current Display	Factory setting	Read Only
	Settings	Based on the model type	

230V Series Power [HP]	0.75 [1]	1.5 [2]	2.2 [3]	3.7 [5]	5.5 [7.5]	7.5 [10]	11 [15]	15 [20]	18.5 [25]	22 [30]	30 [40]	37 [50]
Model Code	4	6	8	10	12	14	16	18	20	22	24	26
Rated Current of the Fixed Torque	5	7.5	11	17	25	33	49	65	75	90	120	146
Rated Current of the Variable Torque	6.25	9.375	13.75	21.25	31.25	41.25	61.25	81.25	93.75	112.5	150	182.5
The Greatest Carrier Wave Frequency	15KHz										10KHz	

5

460V Series Power [HP]	0.75 [1]	1.5 [2]	2.2 [3]	3.7 [5]	5.5 [7.5]	7.5 [10]	11 [15]	15 [20]	18.5 [25]	22 [30]	30 [40]	37 [50]	45 [60]	55 [75]	75 [100]
Model Code	5	7	9	11	13	15	17	19	21	23	25	27	29	31	33
Rated Current of the Fixed Torque	3	4.2	6	8.5	13	18	24	32	38	45	60	73	91	110	150
Rated Current of the Variable Torque	3.75	5.25	7.5	10.625	16.25	22.5	30	40	47.5	56.25	75	91.25	113.75	137.5	187.5
The Greatest Carrier Wave Frequency	15KHz										10KHz		6KHz		

📖 Pr. 00-00 and Pr. 00-01 offer the user the ability to verify the drive's capacity and current rating which has been preset by the factory.

Note 1: This parameter is read only.

Note 2: The factory setting is a constant torque rating. If a variable torque rating is desired, please refer to Pr. 00-12.

00-02	Parameter Reset			Factory setting	0	
	Settings	10	Parameter reset (for 60Hz input)			
		9	Parameter reset (for 50Hz input)			
	Bit settings	Bit 0	1	Parameters are read only	2^0	1
		Bit 1	1	Disable Frequency and Torque Command changes.	2^1	2
		Bit 2	1	Keypad disable	2^2	4

 This parameter offers several functions.

- 1) The user may reset all parameters to their original factory settings.
- 2) The user may disable the keypad function.
- 3) The user may lock the parameters and allow them to be read only.
- 4) The user may disable the drive from accepting frequency or torque command changes.

Throughout this manual, there are parameters such as this one, which use a term called Bit Setting. This is simply the ability to have one parameter conduct multiple functions.

 Example 1: Assume the function of Pr. 00-02 is set for “Disable Frequency and Torque Command changes.” By referring to the above chart, we know Bit 1 is equal to “2”, because the hex to decimal conversion is ($2^{\text{the bit}} = \text{the decimal value}$). Therefore $2^1 = 2$, and the decimal “2”, should be set in Pr. 00-02 to disable the frequency and torque commands.

 Example 2: Assume Pr. 00-02 is set for “Disable Frequency and Torque Command changes” + “Keypad Disabled”. If we follow what we have learned, “Disable Frequency and Torque Command changes” must be set to decimal “2”; and “Keypad Disabled” must be set to decimal “4”. The summation of the two decimal numbers gives us 6. By entering the number 6 in the parameter, both functions are enabled.

 A setting of 1 enables the “Parameters are Read Only” feature, but Pr. 00-00~00-23, continue to be accessed.

 If users would like to reset the parameters to original factory-settings, simply set the Pr. 00-02 to “9” or “10”. If a password was entered, this must first be decoded to allow the parameters to be reset.

00-03	Start-up Display of the Drive		↗	Factory setting	0
	Settings	0	F (Master frequency command)		
		1	H (Output frequency)		
		2	U (multi-function display of Pr. 00-04)		
		3	Output current		

 This parameter allows the start-up display to be customized. The display may still be changed, but during each power on, the display will default to the setting in this parameter.

00-04	Definitions of the Multi-Function Display	↗	Factory setting	0
--------------	---	---	-----------------	---

Settings

0	output voltage	1	DC-BUS voltage
2	voltage command	3	multi-step speed
4	Speed command for the Process Control Operation step	5	Time remaining for the Process Control Operation step
6	Remaining number of times for the “restart after fault” feature	7	counter value
8	torque loading	9	power factor ±1.000
10	Power factor angle (0~180 degrees)	11	Output power (Kw)
12	Output power (Kva)	13	Motor speed (rpm)
14	IGBT module temperature	15	Braking resistor temperature
16	Digital terminal input status	17	PID output command
18	PID feedback value	19	the q axis voltage (V/F and vector)
20	the d axis voltage (Vector only)	21	Magnetic flux
22	Overload accumulated time	23	Electronic thermal relay accumulated time
24	Execution time of the multi-step speed	25	quiescence stage
26	over-torque accumulated time	27	DC braking time
28	Compensated voltage	29	Slip compensation frequency
30	Running number of Encoder (Channel 1)	31	PG position (position control)
32	Remaining pulses to reach position control (home position)	33	DC voltage upon a fault
34	The output AC voltage upon a fault	35	The output frequency upon a fault
36	The current value upon a fault	37	the frequency command upon a fault
38	day (power-up time)	39	hour, minute
40	The upper bound frequency value	41	Over-torque level
42	Stall level limitation	43	Torque compensation gain

44	torque limit (Pr. 06-12)	45	the q axis current (V/F and vector)
46	Frequency of Encoder (Channel 1)	49	PID error value
51	AVI input voltage	52	ACI input current
53	AUI input voltage	55	Auxiliary frequency value
60	Input state of digital terminals	61	Output state of digital terminals
84	Input frequency of pulse (Channel 2)	85	Input position of pulse (Channel 2)
86	OL3 timer		

 This parameter defines the display content the User Defined setting. The User Defined setting may be displayed upon power up (Pr. 00-03) or by pressing the Mode key on the keypad and scrolling until the “U” is illuminated.

00-05	User-Defined Coefficient Setting		↗	Factory setting	0
	Settings	4 digit	0-3: the number of the decimal places		
		3-0 digit	40~9999		

 This parameter allows the user to define a special value relative to the output frequency.
 4th digit: Setting of the decimal places; 0 means that there is no decimal place and 3 stands for three decimal places.

3~0 digit: The actual value the maximum output frequency should correspond to.

 Example: To display rpm’s for a 4-pole 60Hz motor with a base speed 1800rpm and no slip, Pr 00-05 must be set as follows.

Set the 4th bit = 0, 3rd bit = 1, 2nd bit = 8, 1st bit = 0, 0 bit = 0.

The result of setting 01800 in Pr. 00-05 determines the value at 60Hz (Maximum Output Frequency).

 After this parameter is set, all functions relative to the frequency (except for the V/F Curve frequency parameters) will automatically be changed to an RPM sale. RPM, instead of Hz, will now be the unit for the keypad, and thus, if it is displayed as 60.00 before the setup, it will now display 1800 after the setup. Other parameters such as the multi-step speed and JOG will be automatically changed also.

00-06	Software Version				
	Settings	Read-only			
00-07	Password Input		↗	Factory setting	0
	Settings	0~9999			
00-08	Password Setting		↗	Factory setting	0
	Settings	0~9999			

- 📖 Pr. 00-07: This parameter allows the user to input their password and disable the parameter lockout. An incorrect password may be entered 3 times and then a “Pcode” will flash on the display, alerting the user the password is incorrect. The drive must be powered off and then powered on again to clear the Pcode display.
- 📖 Pr. 00-08: This parameter allows the user to input their password to lock out the parameters from further changes.





To enter a password, the same password must be input twice within two minutes. To verify the password was entered correctly, display the content of Pr. 00-08. If the content is “1”, the password is entered. If the content is “0”, no password is entered.

- 📖 To permanently disable the password. Enter the password in Pr. 00-07, then enter 0 into Pr. 00-08 twice within two minutes.
- 📖 To re-activate the password, either enter an incorrect password into Pr. 00-07 or power down and then re apply power to the AC drive.

00-09	Frequency and the Operation Method of PU05			↗	Factory setting	00000
Settings	Bit 0	0	Frequency via the up/down keys	2^0	0	0
		1	Frequency command enabled after pressing the data/prog key			1
	Bit 1	0	PU05&RS485 frequency memorized	2^1	0	0
		1	PU05&RS485 frequency not memorized			2
	Bit 2	0	Up/down pin frequency memorized	2^2	0	0
		1	Up/down pin frequency not memorized			4
	Bit 3	0	FWD/REV direction memorized	2^3	0	0
		1	FWD/REV direction not memorized			8
	Bit 4	0	Parameter memorized	2^4	0	0
		1	Parameter not memorized			16

This parameter allows the user to define the PU05 function. It also allows the user to determine if the drive retains the direction and speed command after power has been removed.

- 📖 Pr. 00-09 = Bit 4 Bit 3 Bit 2 Bit 1 Bit 0 = xxxxx
- 📖 Bit0 = This setting determines if it is necessary to press the PROG/DATA key first, to enable the frequency/torque commands via up/down keys on the PU05.

-  Bit1 = This setting allows the frequency/torque commands of PU05 and RS485 to either be retained or forgotten after power has been removed.
-  Bit2 = This setting allows the frequency/torque commands of the UP/DOWN external terminals to either be retained or forgotten after power has been removed.
-  Bit3 = This setting allows the FWD/REV direction to either be retained or forgotten after power has been removed.
-  Bit4 = This parameter does not have to be memorized into EEPROM; its original value will be recovered after the power is turned back on.

Example: If the frequency is to be controlled by the UP/DOWN keys (bit 0 = 0) and the frequency is to be retained after power off (bit 1 = 1) and the direction is also to be retained (bit3=1) then Pr. 00-09 must be set to 01010.

00-10	Control Methods		Factory setting	0
	Settings	0	V/F Control	
		1	V/F Control + PG	
		2	Vector Control (open loop)	
		3	Vector Control + PG (closed loop)	
		4	Torque Control	
		5	Torque Control + PG	

 This parameter determines the control mode for the AC motor drive

0: **V/F control**: Drive will follow the V/F curve described by Pr. 01-00 to 01-08.

1: **V/F control + PG**: Drive will follow the V/F curve described by Pr. 01-00 to 01-08, but will have more speed accuracy.

2: **Vector Control**: Enables Open Loop Vector control. To acquire the best results, it is recommended to use the auto-tuning feature of the drive Pr. 05-00. By using this feature, 200% rated torque may be obtained at 0.5Hz. For more open loop vector control, refer to group 5 parameters. While in Vector Control, Pr. 01-03 to 01-08 and Pr. 05-04 are not used.

3: **Vector control + PG**: Enables the Closed Loop Flux Vector Control. The Closed Loop Flux Vector Control will offer the highest torque and speed accuracy control. 200% torque at 0Hz and a 1:1000 turn down ratio. While in Vector Control, Pr. 01-03 to 01-08 and Pr. 05-04 are not used.

4: **Torque control:** Enables Torque (current) Control. Torque control allows the user to run the AC drive based on current instead of frequency.

5: **Torque control + PG:** Enables the Closed Loop Torque Control. This will increase the torque accuracy throughout the speed range and disabled Pr. 05-04.

Note: PI **values** for PG (closed loop), vector control (open loop) and torque control are determined by Pr. 05-21~05-25.

00-11	Forward Reverse transition in V/F mode		Factory setting	0
Settings	0	Follow Pr. 01-00 to 01-08 Settings	Do not skip the start-up frequency	
	1	Follow Pr. 01-00 to 01-08 Settings	Skip the start-up frequency	
	2	V/F1.5 power curve	Do not skip the start-up frequency	
	3	V/F1.5 power curve	Skip the start-up frequency	
	4	2 power curve	Do not skip the start-up frequency	
	5	2 power curve	Skip the start-up frequency	

5

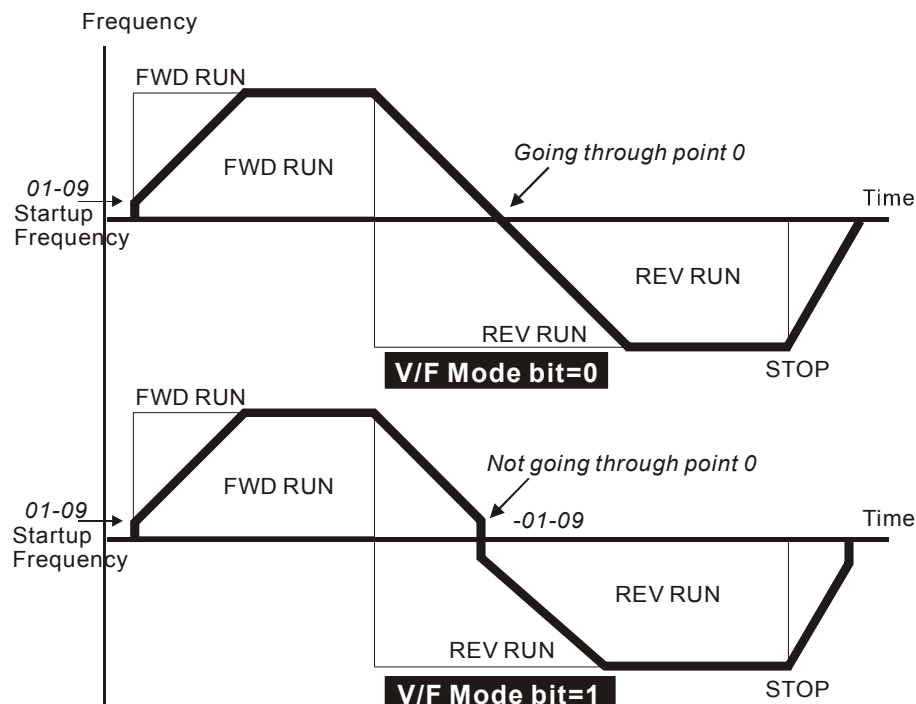

This parameter selects the transition mode between Forward and Reverse. By skipping the start up frequency range, there will be a short time where the motor has not flux and very little power. It is recommended for all non-horizontal movement to choose “do not skip the start up frequency”.

📖 This parameter may also be used in Vector control to determine if the drive will skip the zero point. If the drive skips the zero point, it will stop at the frequency determined by Pr.01-09 and then start again in the opposite direction at Pr.01-09. The Vector control will generate its own V/F curve, therefore please select 0 or 1 for this parameter setting when in Vector mode.

00-12	Constant Torque Operation Selection		↗	Factory setting	0
	Settings	0	oL (100%) Constant torque operation		
		1	oL (125%) Variable torque operation		

📖 When “1” is selected, the oL fault level is 125% of rated drive current. All other over load ratings will not change, example: 150% of rated drive current for 60 sec.

00-13	Optimal Acceleration/Deceleration Setting		↗	Factory setting	0
	Settings	0	Linear acceleration/deceleration (follow Pr. 01-12 to 01-21)		
		1	Auto acceleration (follow Pr. 07-09), Linear deceleration		
		2	Linear acceleration, Auto deceleration (follow Pr. 06-02)		
		3	Auto acceleration (follow Pr. 07-09), Auto deceleration (follow Pr. 06-02)		
		4	Linear acceleration/deceleration, but conduct the stall prevention throughout the auto acceleration/deceleration function.		

📖 Optimal Acceleration/Deceleration settings could ease the drive’s vibration during loaded starts and stops. Also if the detected torque is small, the processor will speed up the acceleration time and reach the set frequency at the fastest and smoothest startup possible. At deceleration, the processor will monitor regenerated voltage and automatically stop the drive at the fastest and smoothest time possible. Pr. 07-09 (Maximum Current Level for Speed Search) is regarded as the target of the output current upon acceleration.

00-14	Time Unit for Acceleration/Deceleration and S Curve		Factory setting	0
	Settings	0	Unit: 0.01 sec	
		1	Unit: 0.1 sec	

📖 This parameter determines the time unit for the Acceleration/Deceleration setting. This allows the user to choose either high resolution or long acceleration/deceleration times. Refer to parameters (Pr. 01-12~01-19), the 1st to the 4th Acceleration/Deceleration Time, (Pr. 01-20, 01-21) the JOG Acceleration/Deceleration Time and (Pr. 01-24~01-27) the S Curve Acceleration/Deceleration Time.

00-15	Carrier Frequency Upper Bound	↗	Factory setting	10
	Settings	0: soft pwm 1~15KHz		
00-16	Carrier Frequency Lower Bound	↗	Factory setting	10
	Settings	1-15KHz (disabled during soft PWM)		
00-17	Center Frequency of Soft pwm	↗	Factory setting	3
	Settings	1~7KHz		

📖 This parameter is utilized in setting the carrier frequency of the PWM output.

Carrier Frequency	Electromagnetic Noise	Interference, Leakage Current	Heat Dissipation
1kHz	Maximum	Minimum	Minimum
8kHz	↕	↕	↕
15kHz	Minimum	Maximum	Maximum

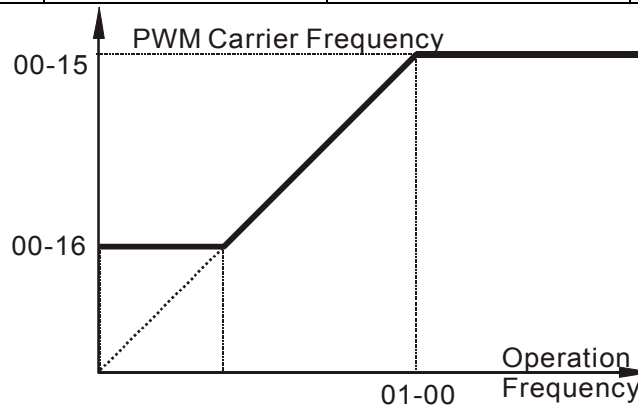

Carrier Frequency Distribution Chart

📖 The PWM carrier frequency has a direct effect on the electromagnetic noise of the motor and heat dissipation of the drive. Therefore, if the surrounding noise is greater than the electromagnetic noises of the motor, it is suggested to lower the carrier frequency, to decrease the temperature of the drive. Although a quiet operation may be achieved with a higher carrier frequency, it is necessary to take into consideration the relative wiring length between the motor and drive and the effect this high frequency may have on the motor windings.

📖 During SOFT PWM, the electromagnetic noises are less annoying at the same carrier frequency for standard operation.

If the carrier frequency's lower bound (Pr. 00-16) > the carrier frequency's upper bound (Pr. 00-15), then the carrier frequency will be operated at the upper bound level.

00-18	Auto Voltage Regulation (AVR) Function		↗	Factory setting	0
	Settings	0	AVR function enabled		
		1	AVR function disabled		
		2	AVR function disabled during deceleration		

This parameter selects the AVR mode. AVR is used to regulate the output voltage to the motor.

The input voltage to the AC motor drive could range from AC180V-264V at, 50Hz/60Hz. When this occurs, the output voltage to the motor will also vary from 180 to 264 unless the AVR function is enabled. When enabled, the AVR function will limit the voltage to the motor, based on Pr. 01-02.

00-19	Automatic Energy-Saving Operation		↗	Factory setting	00010
	Settings	Bit 0	0	Disable automatic energy-saving operation	
			1	Enable automatic energy-saving operation	
		Bit 1	0	Maximum output voltage equals to the input power voltage	
			1	Maximum output voltage could be greater than the input power voltage (over-modulation available)	

When the Auto Energy-Saving function is enabled, the drive will operate with full voltage during acceleration and deceleration. At constant speed the AC drive will calculate the optimal output voltage value for the load. It is possible for the output voltage to be 25% below Maximum Output Voltage during auto energy saving operation. This function should not be used with variable loads or continuous rated output loads. During these types of conditions, the operation will cycle on and off, giving poor energy saving results.

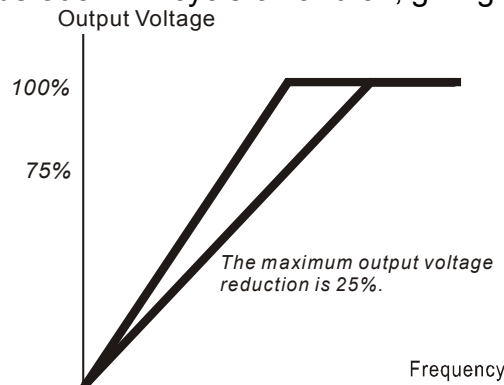

Auto Energy-Saving Operation

00-20	Source of the Frequency Command		↗	Factory setting	0
	Settings	0	The digital keypad		
		1	The RS485 communication input		
		2	The external analog input		
		3	The external up/down pins (multi-function input terminals)		
		4	The pg (encoder) input or clock		
		5	The RS485 and PU05 at the same time (dual source)		
		6	The clock and direction (set by 10-12)		

📖 This parameter determines the drive's master frequency source and Master torque source.

00-21	Source of the Operation Command		↗	Factory setting	0
	Settings	0	The RS485 communication		
		1	The external terminal operation (2 wire or three wire)		
		2	The digital keypad operation		

📖 This parameter sets the drive's operation command source, which may also be switched via the PU key on the digital keypad. When the PU led on the keypad is illuminated the Keypad has control over the drives operation.

00-22	Stop Methods		↗	Factory setting	0
	Settings	0	Ramp to stop		
		1	Coast to stop		

📖 When a "STOP" command is received, the drive will follow the stop method programmed this parameter.

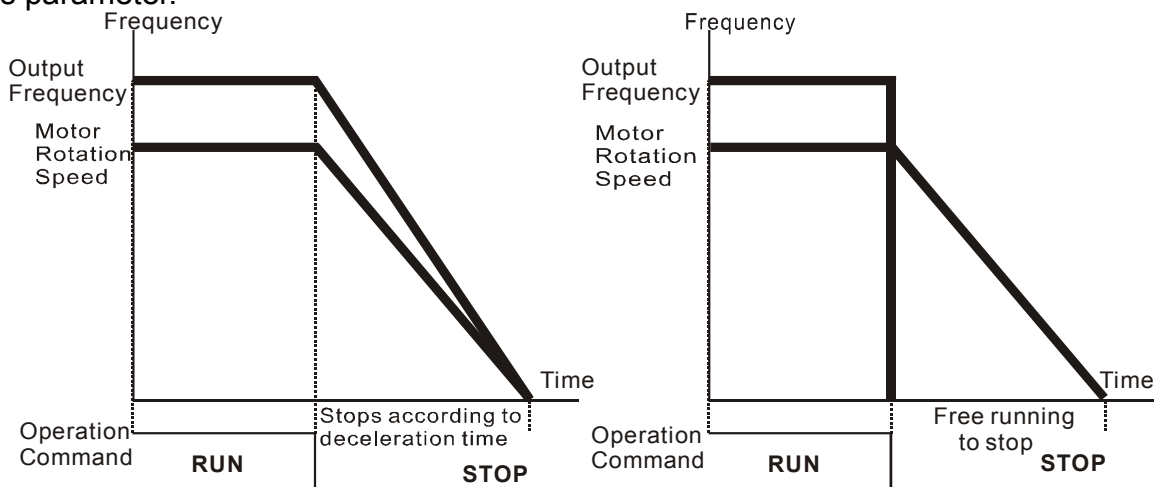

Ramp to Stop and Coast to Stop

Ramp to stop: The drive will ramp down from maximum output frequency (Pr. 01-00) to minimum output frequency (Pr. 01-09) based on the deceleration time (Pr. 01-13).

Coast to stop: the drive will stop the output instantly upon a STOP command and the motor will coast to stop according to its inertia (time unknown).

(1) In applications where the motor must stop after the drive is stopped, please select “Ramp to Stop”. This is often a safety consideration.

(2) If the inertial load is large, it is recommended to set the drive for “Coast to Stop” to eliminate nuisance Over Voltage faults.

00-23	Reverse Operation		↗	Factory setting	0
	Setting	0	REV enabled		
		1	REV disabled		
		2	FWD disabled		

 This parameter enables the AC drives ability to run in the Reverse Direction. It may be used to prevent a motor from running in a direction that would consequently injure humans or damage the equipment.

5.2 Group 1: Basic Parameter

01-00	Maximum Output Frequency	Factory setting	60.00/50.00
	Settings	50.0~400.00Hz	

 This parameter determines the drive's maximum output frequency.

01-01	Maximum Voltage Frequency (Base Frequency)	Factory setting	60.00/50.00
	Settings	0.00~400.00 Hz	

 This parameter must be set to the motor's nameplate frequency rating.

01-02	Maximum Output Voltage	Factory setting	220.0
	Settings	230V: 0.0~255.0V	Factory setting
		460V: 0.0~510.0V	Factory setting
			440.0

 This parameter must be set to the motor's nameplate voltage rating.

01-03	Upper Midpoint Output Frequency	Factory setting	0.50
	Settings	0.00~400.00Hz	
01-04	Upper Midpoint Output Voltage	Factory setting	5.0
	Settings	230V: 0.0~255.0V	↗
		460V: 0.0~510.0V	↗
		Factory setting	10.0
01-05	Lower Midpoint Output Frequency	Factory setting	0.50
	Settings	0.00~400.00Hz	
01-06	Lower Midpoint Output Voltage	Factory setting	5.0
	Settings	230V: 0.0~255.0V	↗
		460V: 0.0~510.0V	↗
		Factory setting	10.0
01-07	Minimum Output Frequency	Factory setting	0.00
	Settings	0.00~400.00Hz	
01-08	Minimum Output Voltage	Factory setting	0.0
	Settings	230V: 0.0~255.0V	↗
		460V: 0.0~510.0V	↗
		Factory setting	0.0

 Setting of the V/F curve figure is usually based upon the motor's allowable loading characteristics. Pay special attention to the motor's heat dissipation, dynamic balance, and bearing lubricity, if the loading characteristics exceed the loading limit of the motor.

When setting the V/F curve, please follow this hierarchy for frequency: 01-01≥01-03≥01-05≥01-07. There is no hierarchy for the voltage setting, but a high voltage at low output frequencies may cause motor failure. At low frequencies, always use the lowest voltage necessary for the application.

01-09	Startup Frequency	↗	Factory setting	0.50
	Settings	0.00~400.00Hz		

The Start-up Frequency is the initial frequency output upon a RUN command. If the startup frequency setting is greater than the Maximum Output Frequency (Pr. 01-00), the drive will default to Pr. 01-00 as the start point.

When the Pr. 07-12 (Speed-Tracing Function) is enabled, Pr. 01-09 (Start-up frequency) is disabled.



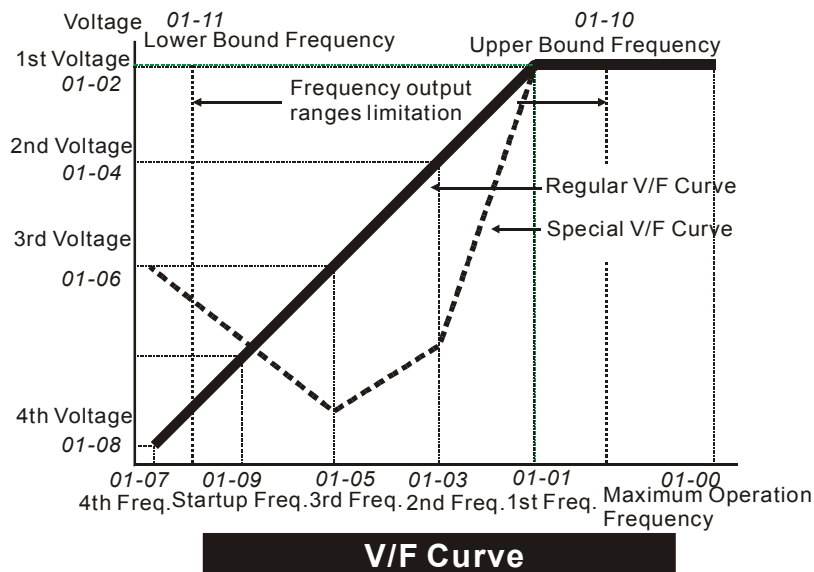

01-10	Upper Bound Frequency	↗	Factory setting	100.0
	Settings	0.0~110.0%		
01-11	Lower Bound Frequency	↗	Factory setting	0.0
	Settings	0.0~100.0%		

These parameters set the upper and lower limits of the output frequency. If the command frequency is lower than the Lower Bound frequency, the motor will be operating at ZERO speed; if the command frequency is greater than the Upper Bound frequency, the motor will then operate at the Upper Bound frequency.



This function is disabled if the Lower Bound > the Upper Bound.

01-12	1 st Acceleration Time	↗	Factory setting	10.00/60.00
01-13	1 st Deceleration Time	↗	Factory setting	10.00/60.00
01-14	2 nd Acceleration Time	↗	Factory setting	10.00/60.00
01-15	2 nd Deceleration Time	↗	Factory setting	10.00/60.00
01-16	3 rd Acceleration Time	↗	Factory setting	10.00/60.00
01-17	3 rd Deceleration Time	↗	Factory setting	10.00/60.00
01-18	4 th Acceleration Time	↗	Factory setting	10.00/60.00
01-19	4 th Deceleration Time	↗	Factory setting	10.00/60.00
01-20	JOG Acceleration Time	↗	Factory setting	10.00/60.00
01-21	JOG Deceleration Time	↗	Factory setting	10.00/60.00
	Settings	0.00~600.00 Sec/0.0~6000.0 Sec		

-  The Acceleration Time the time needed for the drive to ramp from 0.0Hz to Maximum Output Frequency (Pr. 01-00). The Deceleration Time is the time needed for the drive to ramp down from Maximum Output Frequency (Pr. 01-00) to 0.00Hz.
-  The acceleration/deceleration times will be disabled if Pr. 00-13 (Auto acceleration/deceleration Selection) is set for automatic operation.
-  Acceleration/Deceleration times 2 to 4 are enabled by using a multi-function terminal (Pr.02-01 to 02-06) set to 8 or 9. Acceleration/Deceleration time 4 may also be selected via Pr. 01-23.
-  Acceleration/Deceleration time 1 are the factory default for out-of-the-box operation.
-  The acceleration time has a direct effect on the rise of current upon a RUN command. If the application load is large and the acceleration time is short (1 second) it is possible the drive will fault with an “oc”. Similarly if the deceleration time is short (1 second) it is possible the drive will fault with an “ov” due to motor regeneration.

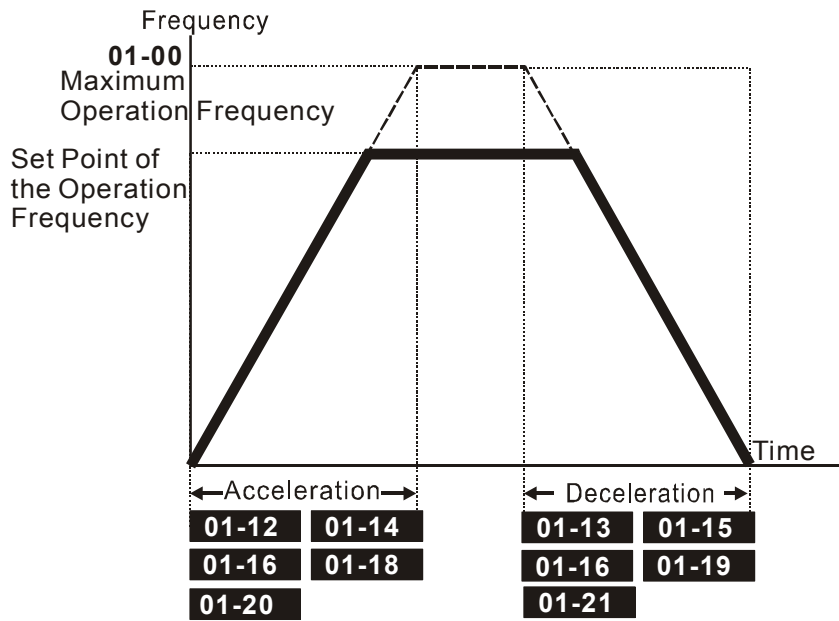

Definition of the Acceleration/Deceleration Time

01-22	JOG Frequency	↗ Factory setting	6.00
	Settings	0.00Hz~400.00Hz	

📖 This parameter determines the Jog frequency. The Jog function may be selected by the JOG key on the PU05 keypad or the external I/O terminals. When the drive is operating under a RUN command, the JOG operation is disabled. Likewise, the drive will not accept a RUN command while the JOG command is enabled.

01-23	1 st /4 th Acceleration/Deceleration Frequency	↗ Factory setting	0.00
	Settings	0.00Hz~400.00Hz	

- 📖 This parameter selects the frequency point for transition from acceleration/deceleration time 1 to acceleration/deceleration time 4.
- 📖 The transition from acceleration/deceleration time 1 to acceleration/deceleration time 4, may also be enabled by the external terminals (Pr. 02-01 to 02-06). The external terminal has priority over Pr. 01-23.

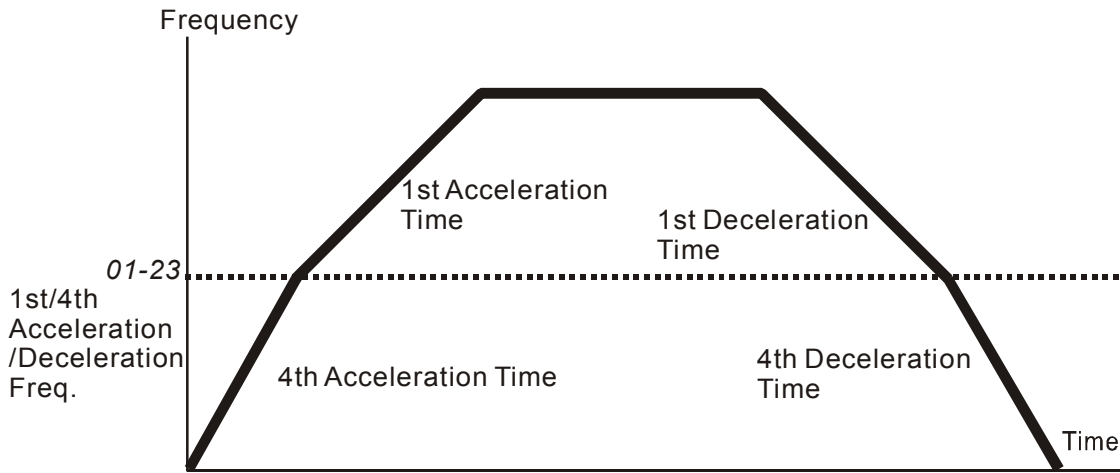

1st/4th Acceleration/Deceleration Switching

5

01-24	S-Curve for Acceleration Departure Time	↗	Factory setting	0.00
01-25	S-Curve for Acceleration Arrival Time	↗	Factory setting	0.00
01-26	S-Curve for Deceleration Departure Time	↗	Factory setting	0.00
01-27	S-Curve for Deceleration Arrival Time	↗	Factory setting	0.00
	Settings	0.00~25.00 Sec/0.0~250.0 Sec		



📖 This parameter determines the S curve strength. A large S curve time will give the smoothest transition between speed changes. Please note the S curve settings increase the actual acceleration/deceleration times as follows:

$$\text{Actual acceleration time} = [\frac{1}{2}(\text{Pr.01-24}) + \frac{1}{2}(\text{Pr.01-25}) + \text{Pr.01-12}]$$

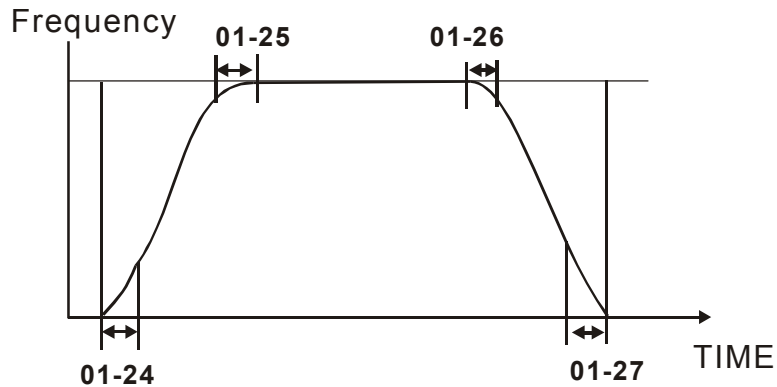
📖 The S curve is disabled when Pr. 00-13 (Auto Acceleration/Deceleration Speed Selection) is set to Auto or Pr 01-12 to 01-19 (acceleration/deceleration times) is set to 0.



01-28	Skip Frequency 1 (upper limit)	Factory setting	0.00
01-29	Skip Frequency 1 (lower limit)	Factory setting	0.00
01-30	Skip Frequency 2 (upper limit)	Factory setting	0.00
01-31	Skip Frequency 2 (lower limit)	Factory setting	0.00
01-32	Skip Frequency 3 (upper limit)	Factory setting	0.00
01-33	Skip Frequency 3 (lower limit)	Factory setting	0.00
	Settings	0.00~400.00Hz	

-  These parameters determine the skip frequencies of the AC drive.
-  Please use the following hierarchy when setting these parameters: Pr. 01-28 > Pr. 01-29 > Pr. 01-30 > Pr. 01-31 > Pr. 01-32 > Pr. 01-33. The Skip frequency will be disabled if this rule is not followed.
-  The Skip Frequencies are useful when a motor has vibration at a specific frequency bandwidth. By skipping this frequency, the vibration will be avoided.

5.3 Group 2: Digital Output/Input Parameter

02-00	2-Wire/3-Wire Operation Control		Factory setting	0
	Settings	0	FWD/STOP, REV/STOP	
		1	FWD/STOP, REV/STOP (Line Start Lockout)	
		2	RUN/STOP, REV/FWD	
		3	RUN/STOP, REV/FWD (Line Start Lockout)	
		4	3-wire (momentary push button)	
		5	3-wire (momentary push button and Line Start Lockout)	

The VFD-V drive offers six types of external operation control.

Three of the six methods include a “Line Start Lockout” feature. When Line start lock out is enabled, the drive will not recognize a RUN command upon power up. The VFD-V must see the terminal state change from low to high. This is a safety feature for applications where applying power does not determine a RUN command.

The Line Start Lockout feature does not guarantee the motor will never start under this condition. It is possible the motor may be set in motion by a malfunctioning switch.

5

02-00	Control Circuits of the External Terminal	
0, 1 2-wire operation control (1) FWD/STOP REV/STOP		FWD: ("OPEN": STOP) ("CLOSE": FWD) REV: ("OPEN": STOP) ("CLOSE": REV) DCM VFD-V
2, 3 2-wire operation control (2) RUN/STOP REV/FWD		FWD: ("OPEN": STOP) ("CLOSE": RUN) REV: ("OPEN": FWD) ("CLOSE": REV) DCM VFD-V
4, 5 3-wire operation control		FWD "CLOSE": RUN EF/MI1 "OPEN": STOP REV/FWD "OPEN": FWD "CLOSE": REV DCM VFD-V

02-01	Multi-Function Input Command 1 (MI1) (NOTE 1)	Factory setting	1
02-02	Multi-Function Input Command 2 (MI2)	Factory setting	2
02-03	Multi-Function Input Command 3 (MI3)	Factory setting	3
02-04	Multi-Function Input Command 4 (MI4)	Factory setting	4
02-05	Multi-Function Input Command 5 (MI5)	Factory setting	5
02-06	Multi-Function Input Command 6 (MI6) (NOTE 2)	Factory setting	10
02-23	Multi-Function Input Command 7	Factory setting	0
02-24	Multi-Function Input Command 8	Factory setting	0
02-25	Multi-Function Input Command 9	Factory setting	0
02-26	Multi-Function Input Command 10	Factory setting	0
02-27	Multi-Function Input Command 11	Factory setting	0
02-28	Multi-Function Input Command 12	Factory setting	0
02-29	Multi-Function Input Command 13	Factory setting	0
02-30	Multi-Function Input Command 14	Factory setting	0
	Settings	0 to 44	

 This parameter selects the functions for each multi-function terminal.

Note 1: If Pr.02-00 is set to 3-wire operation control. Terminal MI1 is needed for the third wire position. Therefore MI1 is not allowed for any other operation.

Note 2: Multi-Function Input Commands 7-14 are the extension terminals of 02-01-02-06. There are 14 terminals but the terminals 7-14 are virtual terminals and you can set the state of bit 8-15 of 02-10 to ON or OFF by PU05 or communication.

Full List of the Functions

Settings	Functions	Explanations
0	No Function	
1	Multi-step Speed Command 1	15 step speeds could be conducted through the digital statuses of the 4 terminals, and 17 in total if the master speed and JOG are included.
2	Multi-step Speed Command 2	
3	Multi-step Speed Command 3	
4	Multi-step Speed Command 4	
5	Reset	After the error of the drive is eliminated, use this terminal to reset the drive
6	JOG Command	JOG operation

Settings	Functions	Explanations
7	Acceleration/deceleration Speed Inhibit	When the acceleration/deceleration speed inhibition function is executed, the drive will stop the acceleration/deceleration immediately; the drive will go on with the acceleration/deceleration from where it stopped earlier after this command is removed
8	The 1 st , 2 nd acceleration or deceleration time selection	The acceleration/deceleration time of the drive could be selected from this function or the digital statuses of the terminals; there are 4 acceleration/deceleration speeds in total for selection.
9	The 3 rd , 4 th acceleration or deceleration time selection	
10	EF Input	External fault input terminal
11	Disable Vector(stop)	
12	B.B. traces from the bottom upward	If the ON/OFF function of the terminal is pre-determined, output of the drive will be cut off immediately, and the motor will then be of the B.B. status. And once the ON/OFF function is restored, the drive will then trace from the bottom upward to catch up with its mutual rotation speed with the same frequency before B.B., then speed up to the pre-set frequency. Even if the motor is of a complete stop after B.B., as long as the ON/OFF status is restored, the speed-tracing function could still be operated.
13	B.B. traces from the top downward	
14	Cancel the setting of the optimal acceleration/deceleration time	
15	Switch between drive settings 1 and 2	Used in the vector control
16	Operation speed command form AVI	
17	Operation speed command from ACI	
18	Operation speed command from AUI	
19	Emergency Stop	
20	Digital Up command	Refer to Pr. 02-07

Settings	Functions	Explanations
21	Digital Down Command	
22	Auto procedural operation function disabled	
23	Auto procedural operation suspended	
24	PID function disabled	
25	Clear counter	When this terminal is functioning, the currently displayed counter value will be cleared and "0" is then displayed; the drive could only accept the trigger signals to keep counting upward after this signal disappeared.
26	Input the counter value (multi-function input command 6)	
27	FWD JOG command	
28	REV JOG command	
29	Braking Module Breakdown	Accommodating the braking module breakdown output
30	Position Control	Use with PG03/PG04
31	PG feedback control function disable	
32	Torque/Speed Switch	
33	EEPROM write function disable	
34	Zero speed is replaced by DC current control	It is a zero speed command and it is valid during running. It is used to improve the vibration by using DC mode at zero speed when AC drive is not matched with motor or parameter settings of motor is not very well.
35	04-35,04-36 disable	
36	Position control 2 (PG2 input)	It can be used as position function of clock input when using with CH2 of PG04.
37	Dwell function disable	
38	Pause Stop	AC drive stops at this moment and it will run after closing the function of this terminal.
39	P2P Position Control	It can be used to control the 8 default positions when using with PG03/PG04. But sub-function will be valid when d36 is set.

Settings	Functions	Explanations
40	P2P Hold	P2P is pause. AC drive keeps outputting at this moment. It will keep on unfinished jog after terminal is closed.
41	FWD Home Search	In speed mode, it will do FWD home search according to the setting of 10-09.
42	P2P FWD Limit	In P2P mode, it is used with FWD limit sensor. When it reaches FWD limit during running, it will stop free running.
43	P2P REV Limit	In P2P mode, it is used with REV limit sensor. When it reaches REV limit during running, it will stop free running.
44	REV Home Search	In speed mode, it will do REV home search according to the setting of 10-09.

02-07		UP/DOWN Key Mode		↗	Factory setting	00000
Settings	Bit 0	0	UP/DOWN following the acceleration/deceleration time			
		1	UP following the constant speed, and DOWN following the deceleration time			
	Bit 1	0	UP following the acceleration time, and DOWN following the constant speed			
		1	UP/DOWN following the constant speed			

 The maximum Up/Down acceleration/deceleration speed is 10.00Hz/Sec.

02-08		The Acceleration/Deceleration Speed of the UP/DOWN Key with Constant Speed		↗	Factory setting	0.01
	Settings	0.01~1.00Hz/msec				

02-09		Digital Input Responding Time		↗	Factory setting	0.005
	Settings	0.001~30.000 Sec				

 Function of this parameter is to delay or confirm the message of the digital input terminals; the delayed time is the confirmation time, which will be helpful in preventing some uncertain interferences that would consequently result in erroneous motions (except for the counter input) in the input of the digital terminals (FWD, REV, and MI1~6), and under this condition, confirmation for this parameter could be improved effectively, but the responding time will be somewhat delayed.

02-10	Digital Input Operation Direction			↗	Factory setting	0
	Settings	0~65535				
		Bit 0~7	1	High active		

 This parameter determines the level of the input signal operation.

02-11	Multi-Function Output 1	RA, RB, RC (Relay 1)	↗	Factory setting	15
02-12	Multi-Function Output 2	MRA, MRC (Relay 2)	↗	Factory setting	1
02-13	Multi-Function Output 3	MO1	↗	Factory setting	2
02-14	Multi-Function Output 4	MO2	↗	Factory setting	13
	Settings	0 to 72			

Settings	Functions	Explanations
0	No Function	
1	AC Drive Running	There is an output from the AC drive
2	Operation Speed Attained 1 (both directions)	
3	Operation Speed Attained 2 (both directions)	
4	Pre-set speed attained 1 (both directions)	
5	Pre-set speed attained 2 (forward only)	
6	Pre-set speed attained 1 (both directions)	
7	Pre-set speed attained 2 (forward direction)	
10	Zero speed	Drive output is below Min Frequency
11	Over-torque(oL2)	Please refer to 06-08
12	Base block (Pause)	
13	Drive ready for use	AC drive has no faults
14	Low voltage alarm (LV)	Please refer to 06-00
15	Error indication	
16	Drive operation mode	Output is on when the external terminals have command and off if keypad or RS485 have control.
17	PCO Run	
18	PCO suspended	
19	1 st step of PCO completed	
20	PCO completed	

Settings	Functions	Explanations
21	Pre-set counter value attained	Please refer to 02-16
22	Desired counter value attained	Please refer to 02-17
23	Heat sink overheat warning	Please refer to 06-15
24	Operation frequency attained 1 (both directions)	
25	Operation frequency attained 2 (both directions)	
26	Pre-set frequency attained 1 (both directions)	
27	Pre-set frequency attained 2 (forward only)	
28	Pre-set frequency attained 1 (both directions)	
29	Pre-set frequency attained 2 (forward only)	
30	Software braking output	Please refer to 07-00
31	Position Achieved	In position mode, position point can output a position achieved signal by setting this parameter. At this moment, AC drive achieves position and motor is in holding state.
32~47	PCO Step Indication	Corresponds to the 0~15 step speeds
48~63	Multi-step Indication	Corresponds to the 0~15 step speeds
64	PG Fault	
65	PG Stall	
69	Over-torque(oL3)	Please refer to 06-09
70	Zero speed (STOP)	
71	Position synchronization 1 (10-10)	In position mode, you can output a position synchronization signal by setting d71, d72 (please refer to 10-10, 10-23)
72	Position synchronization 2 (10-23)	

5

02-15	Multi-Function Output Direction	↗ Factory setting	00000
	Settings	0~15 (1 high)	

This function uses the Bit setting method.

Example: If Pr.02-10 is 1 (AC Drive running), and Relay 1 is set to N.O., then R1 close when the drive has an output and will open when the drive has stopped.

Settings	Bit content	Relay 1 03-07	Relay 2 03-08	MO1 03-09	MO2 03-10
0	0000	N.O.	N.O.	N.O.	N.O.
1	0001	N.O.	N.O.	N.O.	N.C.
2	0010	N.O.	N.O.	N.C.	N.O.
3	0011	N.O.	N.O.	N.C.	N.C.
4	0100	N.O.	N.C.	N.O.	N.O.
5	0101	N.O.	N.C.	N.O.	N.C.
6	0110	N.O.	N.C.	N.C.	N.O.
7	0111	N.O.	N.C.	N.C.	N.C.
8	1000	N.C.	N.O.	N.O.	N.O.
9	1001	N.C.	N.O.	N.O.	N.C.
10	1010	N.C.	N.O.	N.C.	N.O.
11	1011	N.C.	N.O.	N.C.	N.C.
12	1100	N.C.	N.C.	N.O.	N.O.
13	1101	N.C.	N.C.	N.O.	N.C.
14	1110	N.C.	N.C.	N.C.	N.O.
15	1111	N.C.	N.C.	N.C.	N.C.

Note: N.O. : normal open, N.C.: normal close

02-16	Counter Values Achieve the Pre-Set Values	↗	Factory setting	0
	Settings	0~65500		

 The input contact of the counter could set the multi-function terminal MI6 (with the designated terminal Pr. 02-06 as 26) as the trigger terminal, and when the counting is over (which reaches the destination), the signals could select one among the multi-function output terminals (with Pr. 02-10~02-13 set as 21) to be the motion contact.

02-17	Designated Counter Value Achieved	↗	Factory setting	0
	Settings	0~65500		

 When the counter value starts counting upward from 1 to the setting of this parameter, its corresponding multi-function output terminal contact with the “arbitrary counting achieves the output indication” function would start functioning. This parameter could be utilized at the moment when the counting is almost to an end, and then, set the output signal to enable the drive operating at a low speed till it stopped.

The Time-and-Order Diagram is shown as follows:

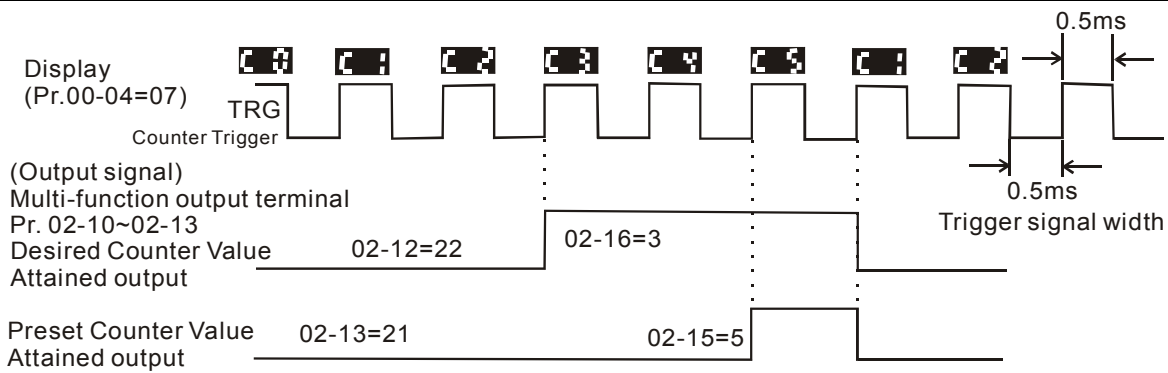

Diagram of the External Counter Terminal and the Arrival of the Counter Value

02-18	Digital Output Gain	↗	Factory setting	1
	Settings	1~40		

📖 This parameter determines the signals of the drive’s digital output terminal (DFM-DCM) and of the digital frequency output (pulse, work period = 50%). Output pulse per second = output frequency × (Pr. 02-17)。

📖 Setting of the multiple has a lot to do with the carrier frequency; the carrier frequency has to be greater than “2 x maximum operation frequency x multiplying rate”.

02-19	Pre-set Arrival Frequency 1	↗	Factory setting	60.00/50.00
	Settings	0.00~400.00Hz		
02-20	Pre-set Arrival Frequency 1 Width	↗	Factory setting	2.00
	Settings	0.00~400.00Hz		
02-21	Pre-set Arrival Frequency 2	↗	Factory setting	60.00/50.00
	Settings	0.00~400.00Hz		
02-22	Pre-set Arrival Frequency 2 Width	↗	Factory setting	2.00
	Settings	0.00~400.00Hz		

📖 Once the drive’s output speed (frequency) achieves the arbitrary designated (speed) frequency, and that if the corresponding multi-function output terminal is set as 2~7 or 24~27 (Pr. 02-10~02-14), then the multi-function output terminal contact will be “closed”.

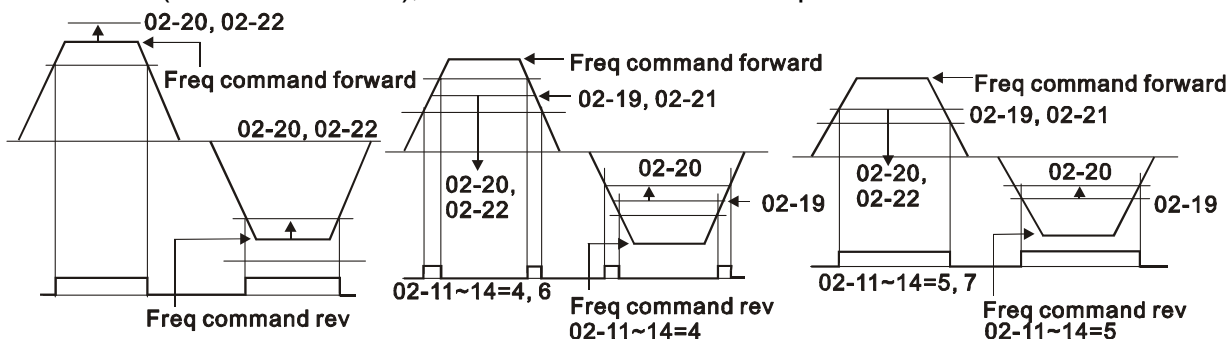

5.4 Group 3: Analog Output/Input Parameter

03-00	Analog Input 1 (AVI)	↗	Factory setting	1
03-01	Analog Input 2 (ACI)	↗	Factory setting	0
03-02	Analog Input 3 (AUI)	↗	Factory setting	0

Settings	Function
0	no function (analog input disabled)
1	frequency/torque command (See Pr.00-10)
2	torque limitations (increase or decrease torque limit Pr. 06-12)
3	acceleration/deceleration time gain (increase or decrease time base)
4	upper bound frequency (increase or decrease Pr.01-10)
5	over-torque current level (increase or decrease Pr.06-07)
6	torque compensation gain (increase or decrease Pr.05-03 / 05-13)
7	over-current stall prevention level during operation(06-04)
8	torque compensation(Vector)
9	AVI auxiliary frequency (multiplication by the ratio of AVI)
10	ACI auxiliary frequency (multiplication by the ratio of ACI)
11	AUI auxiliary frequency (multiplication by the ratio of AUI)
12	PID offset
13	Auxiliary frequency of master frequency

 The value (0~10V/4~20mA) of the setting 2 (torque limitations) corresponds to rated output current 0~100% can be adjusted by analog input gain 03-09~03-11.

 current stall level during running: when 03-00~03-02 is set to d7, the setting of 06-04 is disable.

03-03	(AVI) Analog Input Bias 1	↗	Factory setting	0.00
	Settings	-10.00~10.00V		

 This parameter determines the AVI voltage value that corresponds to 0Hz frequency.

03-04	(ACI) Analog Input Bias 2	↗	Factory setting	4.00
	Settings	0.00~20.00mA		

 This parameter determines the ACI current value that corresponds to 0Hz frequency.

03-05	(AUI) Analog Input Bias 3	↗	Factory setting	0.00
	Settings	-10.00~10.00V		

 This parameter determines the AUI voltage value that corresponds to 0Hz frequency.

03-06	(AVI) Positive/Negative Bias Mode		↗	Factory setting	0	
	Settings	0	zero bias			
		1	value lower than bias = bias			
		2	value greater than bias = bias			
		3	the absolute value of the bias voltage while serving as the center			

03-07	(ACI) Positive/Negative Bias Mode		↗	Factory setting	1	
	Settings	0	zero bias			
		1	value lower than bias = bias			
		2	value greater than bias = bias			
		3	the absolute value of the bias voltage while serving as the center			

03-08	(AUI) Positive/Negative Bias Mode		↗	Factory setting	0	
	Settings	0	zero bias			
		1	value lower than bias = bias			
		2	value greater than bias = bias			
		3	the absolute value of the bias voltage while serving as the center			

5

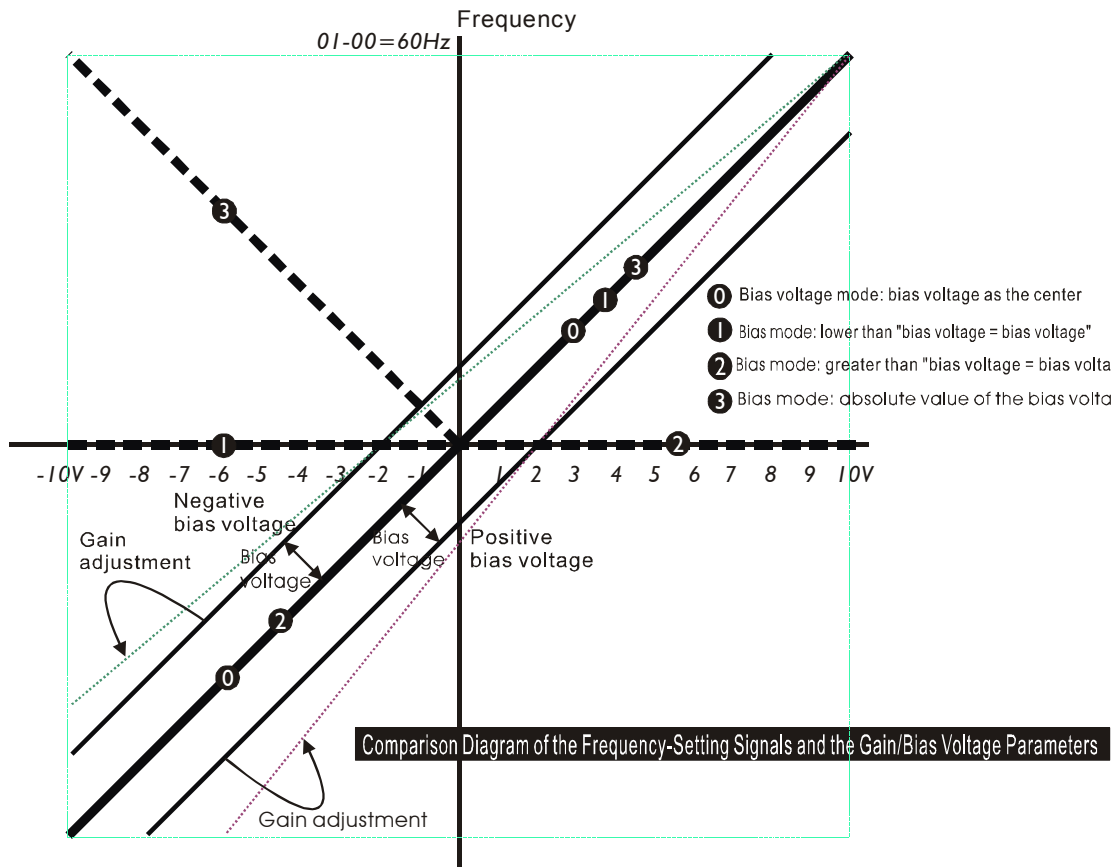

03-09	Analog Input 1 Gain (AVI)	↗	Factory setting	100.0
	Settings	-500.0~+500.0%		
03-10	Analog Input 2 Gain (ACI)	↗	Factory setting	125.0
	Settings	-500.0~+500.0%		
03-11	Analog Input 3 Gain (AUI)	↗	Factory setting	100.0
	Settings	-500.0~+500.0%		

📖 Pr.03-09 to 03-11 are used to adjust the 10V or 20mA corresponding frequency value.

Example:

If Pr.03-00 = 10, Pr.01-00 = 60, and you would like the 10V position of AVI (0-10V) to equal 60Hz, than use the following equation to program the Gain.

$$\text{Pr.03-09} = (1 + (\text{Pr.03-00}/\text{Pr.01-00})) \times 100$$

03-12	Addition Function of the Analog Inputs	↗	Factory setting	0
	Settings	0	disable addition function (AVI, ACI, AUI)	
		1	enable addition function	

📖 If the addition between AVI, ACI and AUI are disabled, and that the selections on the analog input setting function are similar among the three, the priority order of the analog input will be: AVI > ACI > AUI.

Example 1:

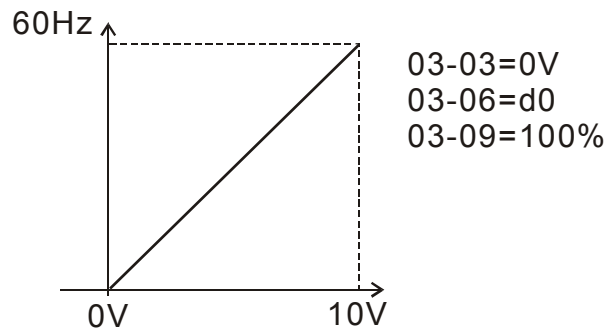

Example 2:

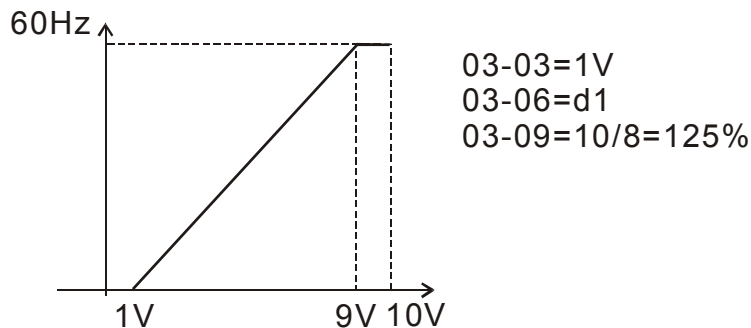

Example 3:

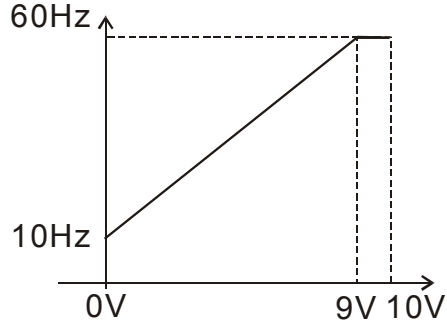

$$03-06=1$$

$$03-09 = \frac{50}{9} \div \frac{60}{10} \times 100\% = 92.5\%$$

$$03-03$$

$$\Rightarrow \frac{50}{9} = \frac{60}{X} \quad X=10.8$$

$$9-10.8=-1.8$$

Example 4:

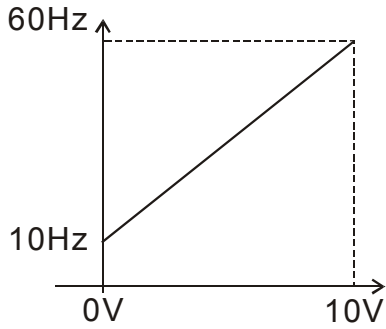

$$03-06=1$$

$$03-09 = \frac{50}{10} \div \frac{60}{10} \times 100\% = 83.3\%$$

$$03-03$$

$$\Rightarrow \frac{50}{10} = \frac{60}{X} \quad X=12$$

$$10-12=-2$$

Example 5:

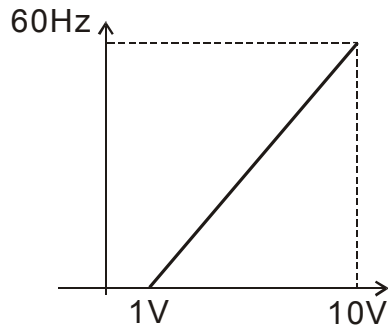

$$03-03=1$$

$$03-06=1$$

$$\frac{60}{9} \div \frac{60}{10} \times 100\% = 111.1\%$$

Example 6:

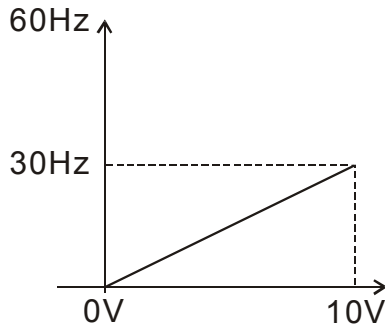

$$03-03=0$$

$$03-06=d0$$

$$\frac{30}{10} \div \frac{60}{10} \times 100\% = 50\%$$

Example 7:

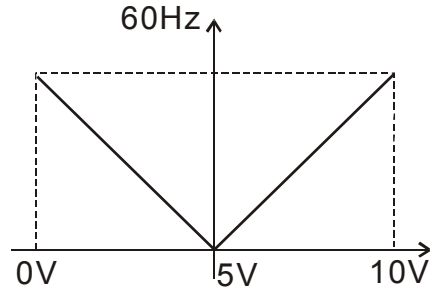

$$03-03=5$$

$$03-06=3$$

$$\frac{120}{20} \div \frac{60}{10} \times 100\% = 200\%$$

Example 8:

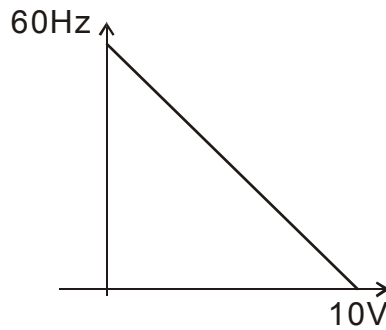

$$03-03=10$$

$$03-06=0$$

$$03-09=-100\%$$

Example 9:

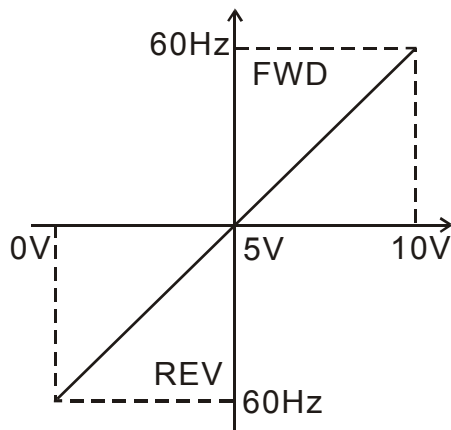

$$03-03=5$$

$$03-06=d 0$$

$$\frac{120}{10} \div \frac{60}{10} \times 100\% = 200\%$$

Example 10:

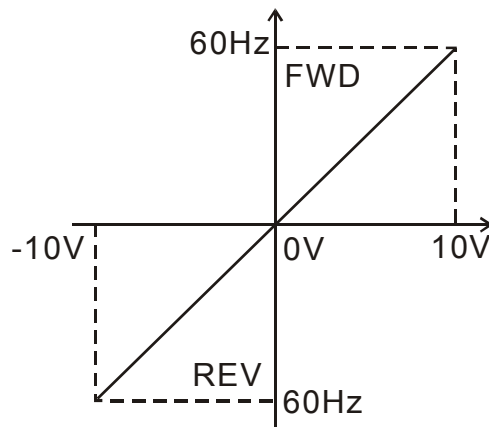

$$03-05=0$$

$$03-08=0$$

$$\frac{120}{20} \div \frac{60}{10} \times 100\% = 100\%$$

03-13	Analog Input Noise Filter		↗	Factory setting	0.10
	Settings	0.00~2.00 Sec			

📖 Interferences commonly exist with analog signals, such as those entering AVI, ACI and AUI. These interferences constantly affect the stability of analog control and using the Input Noise Filter will create a more stable system.

📖 If Pr. 03-13 is large, the control will be stable, yet the response to the input will be slow. If Pr. 03-13 is small, the control may be unstable, yet the response to the input will fast.

03-14	Loss of the ACI signal		↗	Factory setting	0
	Settings	0	disabled		
		1	continue operation at last known frequency		
		2	decelerate to a stop		
		3	stop immediately and display E.F.		

📖 This parameter determines the operation of the drive when the 4~20mA (ACI) signal is lost.

03-15	Analog Output Selection		↗	Factory setting	0
	Settings	0-24			

Full List of the Functions

Settings	Functions	Explanations
0	Output frequency	01-00=100%
1	Command frequency	01-00=100%
2	Speed	01-00=100%
3	Current	rated current of the inverter =100%
4	Output voltage	200V (400V) =100%
5	DC BUS voltage	400V (800V) =100%
6	Power factor	-1.000~1.000=100%
7	Power	rated power of the inverter =100%
8	Torque	full-load torque =100%
9	AVI	(0~10V=0~100%)
10	ACI	(0~20mA=0~100%)
11	AUI	(-10~10V=0~100%)
12	Torque current command	rated current of the inverter =100%
13	Torque current estimation	rated current of the inverter =100%
14	Exciting magnet current command	rated current of the inverter =100%
15	Magnetic flux current	rated current of the inverter =100%

Settings	Functions	Explanations
16	Q-axis voltage command	200V (400V) =100%
17	D-axis voltage command	200V (400V) =100%
18	Vector-controlled error measures	01-00=100%
19	Vector-controlled PID overall measures	01-00=100%
20	PID error measures	01-00=100% (full-load torque =100%: torque control)
21	PID total measures	01-00=100% (full-load torque =100%: torque control)
22	Torque command	full-load torque =100%
23	Pg frequency	01-00=100%
24	Voltage command	200V (400V) =100%

03-16	Analog Output Gain	↗	Factory setting	100.0
	Settings	-900.0~900.0%		

- 📖 This parameter adjusts the voltage level of the analog output signal (AFM = Pr. 03-13).
- 📖 The parameter sets the voltage range of the analog output signal at terminals AFM-ACM, that corresponds with either the output frequency or the output current of the VFD.

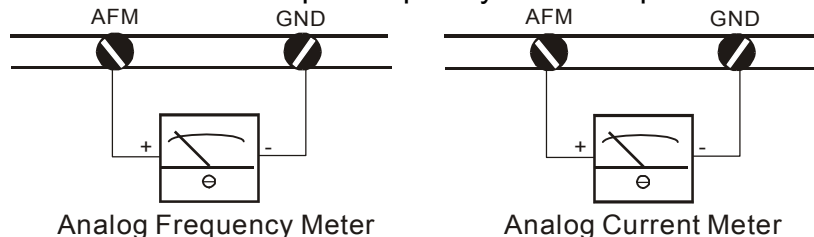

The analog output voltage is directly proportional to the output frequency of the AC drive. With the factory setting of 100%, the Maximum Output Frequency (Pr.01-00) of the AC drive corresponds to +10VDC analog voltage output. (The actual voltage is about +10VDC, and can be adjusted by Pr.03-16).

The analog output voltage is directly proportional to the output current of the AC drive. With the factory setting of 100%, the 2.5 times rated current of the AC drive corresponds to +10VDC analog voltage output. (The actual voltage is about +10VDC, and can be adjusted by Pr. 03-16)

Note: Voltmeter specification: The sourcing capability of the output is limited to 0.21mA. Sourcing voltage: 10V. Output resistance: 47kΩ.

If the meter reads full scale at a voltage less than 10 volts, then Pr.03-16 should be set by the following formula:

$$\text{Pr.03-16} = ((\text{meter full scale voltage})/10) \times 100\%$$

For Example: When using the meter with full scale of 5 volts, adjust Pr.03-16 to 50%.

03-17	Analog Output Bias Voltage		↗	Factory setting	0.00
	Settings	-10.00~10.00V			

This parameter determines the output voltage value corresponding to 0Hz.

03-18	Analog Output Value in REV Direction		↗	Factory setting	0
	Settings	0	absolute value in REV direction		
		1	output 0V in REV direction		
		2	output negative voltage in REV direction		

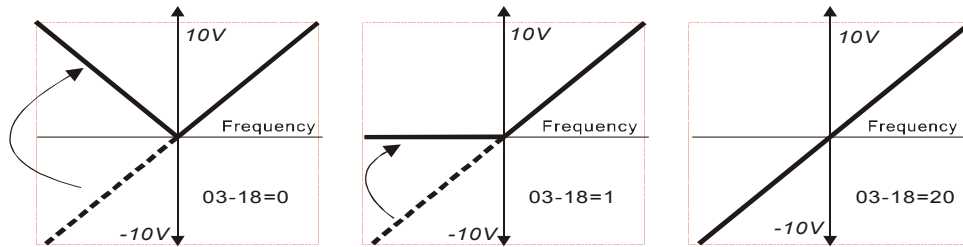

Selection of the Analog Output Direction

03-19	Reserved
--------------	----------

5.5 Group 04: Multi-Step Speed and Process Control Operation (PCO)

04-00	The 1 st Step Speed	↗	Factory setting	0.00
04-01	The 2 nd Step Speed	↗	Factory setting	0.00
04-02	The 3 rd Step Speed	↗	Factory setting	0.00
04-03	The 4 th Step Speed	↗	Factory setting	0.00
04-04	The 5 th Step Speed	↗	Factory setting	0.00
04-05	The 6 th Step Speed	↗	Factory setting	0.00
04-06	The 7 th Step Speed	↗	Factory setting	0.00
04-07	The 8 th Step Speed	↗	Factory setting	0.00
04-08	The 9 th Step Speed	↗	Factory setting	0.00
04-09	The 10 th Step Speed	↗	Factory setting	0.00
04-10	The 11 th Step Speed	↗	Factory setting	0.00
04-11	The 12 th Step Speed	↗	Factory setting	0.00
04-12	The 13 th Step Speed	↗	Factory setting	0.00
04-13	The 14 th Step Speed	↗	Factory setting	0.00
04-14	The 15 th Step Speed	↗	Factory setting	0.00
	Settings	0.00~400.00Hz		

The multi-function input terminals (refer to Pr. 02-01 to 02-06) are used to select one of the AC drive Multi-Step Speeds above. These speeds may also be used in conjunction with Pr. 04-15 - 04-32 to run the process control operation.

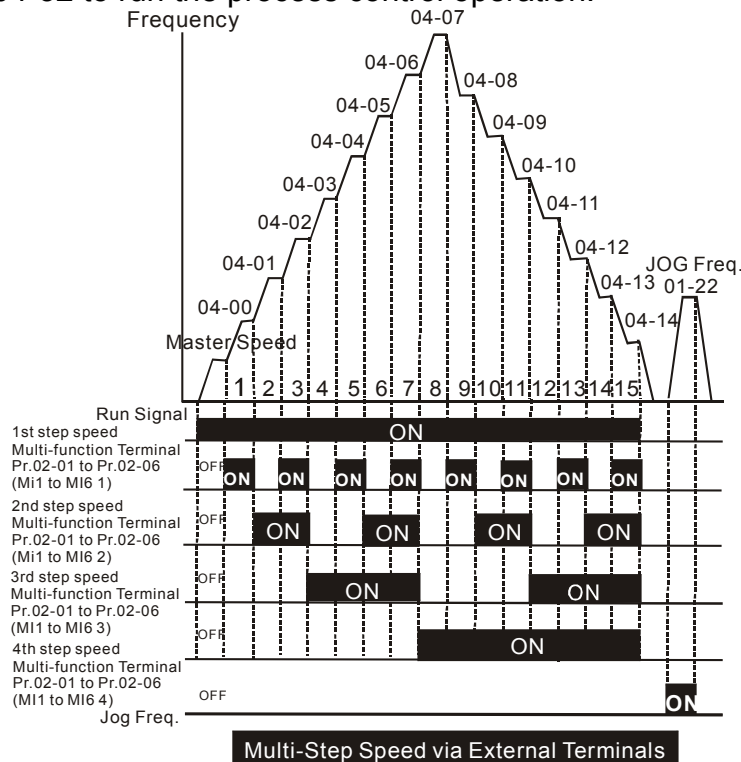

04-15	Time Duration of the PCO Master Speed	↗	Factory setting	0
04-16	Time Duration of PCO Step 1	↗	Factory setting	0
04-17	Time Duration of PCO Step 2	↗	Factory setting	0
04-18	Time Duration of PCO Step 3	↗	Factory setting	0
04-19	Time Duration of PCO Step 4	↗	Factory setting	0
04-20	Time Duration of PCO Step 5	↗	Factory setting	0
04-21	Time Duration of PCO Step 6	↗	Factory setting	0
04-22	Time Duration of PCO Step 7	↗	Factory setting	0
04-23	Time Duration of PCO Step 8	↗	Factory setting	0
04-24	Time Duration of PCO Step 9	↗	Factory setting	0
04-25	Time Duration of PCO Step 10	↗	Factory setting	0
04-26	Time Duration of PCO Step 11	↗	Factory setting	0
04-27	Time Duration of PCO Step 12	↗	Factory setting	0
04-28	Time Duration of PCO Step 13	↗	Factory setting	0
04-29	Time Duration of PCO Step 14	↗	Factory setting	0
04-30	Time Duration of PCO Step 15	↗	Factory setting	0
	Settings	0 - 65500 sec		
04-31	The PCO Time Multiplier	↗	Factory setting	1
	Settings	1 - 10		
04-32	The PCO Operation Direction	↗	Factory setting	0
	Settings	0 - 32767 (0: FWD; 1: REV)		

 This parameter controls the direction of Pr. 04-00~04-14, for the Process Control Operation.

Programming: A 15bit binary number determines the PCO direction. The binary number is then converted to decimal and entered into Pr. 04-32. Below is an example on how to generate the decimal value needed for this parameter.

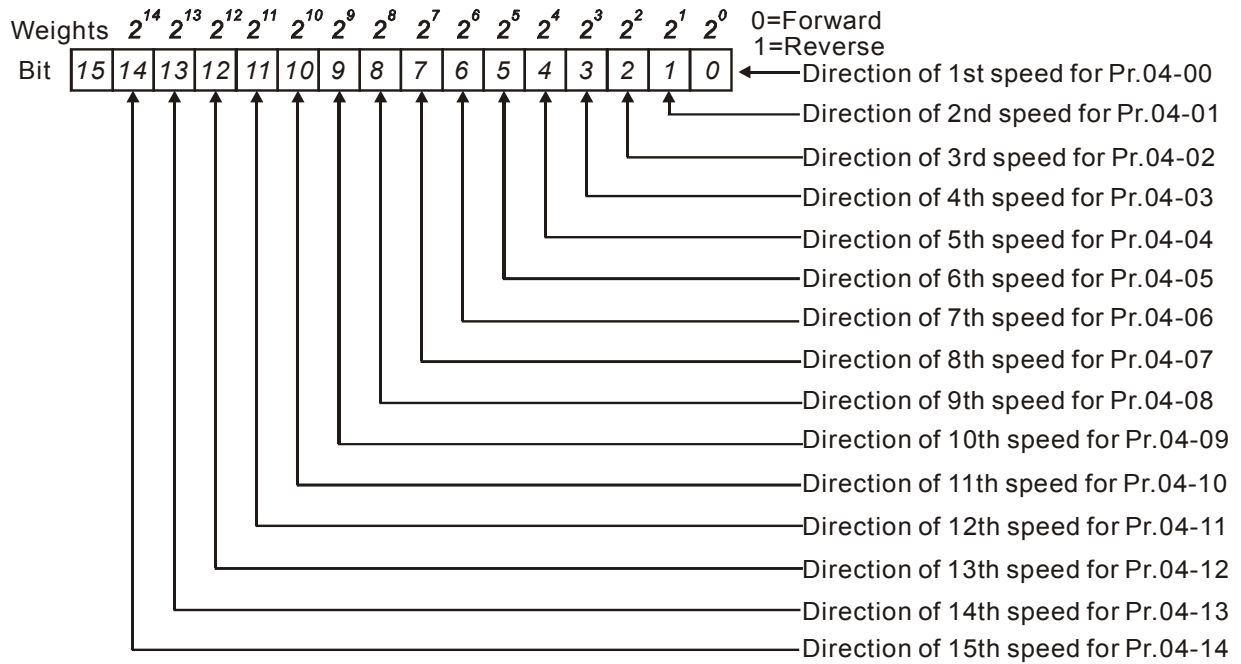

Simple Example

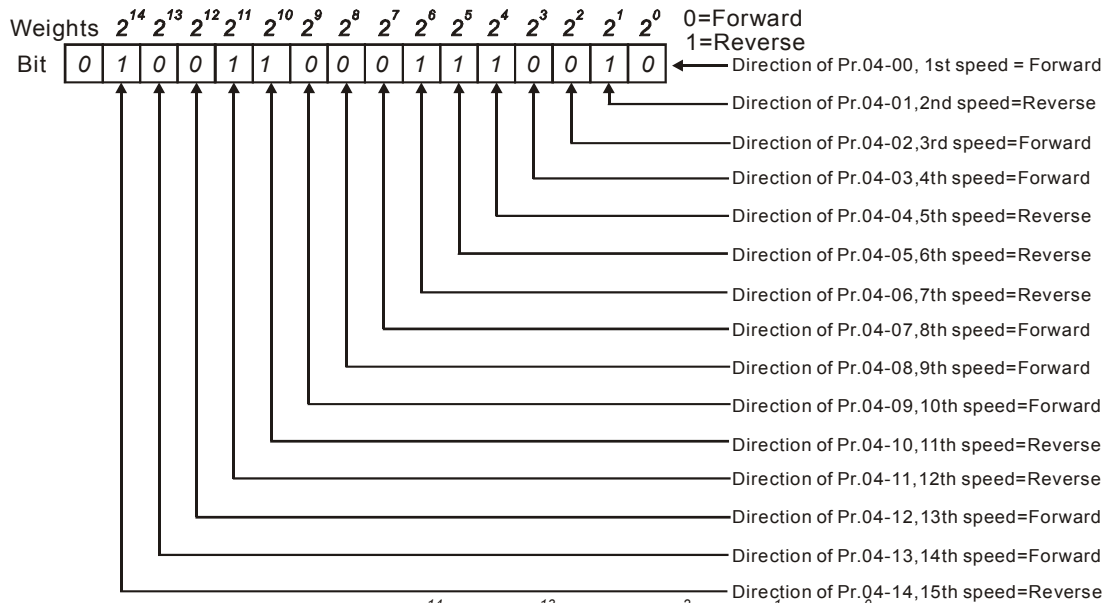

$$\begin{aligned}
 \text{The setting value} &= \text{bit}14 \times 2^{14} + \text{bit}13 \times 2^{13} + \dots + \text{bit}2 \times 2^2 + \text{bit}1 \times 2^1 + \text{bit}0 \times 2^0 \\
 &= 1 \times 2^{14} + 1 \times 2^{11} + 1 \times 2^{10} + 1 \times 2^6 + 1 \times 2^5 + 1 \times 2^4 + 1 \times 2^1 \\
 &= 16384 + 2048 + 1024 + 64 + 32 + 16 + 2 \\
 &= 19570 \\
 \text{Setting 04-32} &= 19570
 \end{aligned}$$

NOTE:				
$2^{14}=16384$	$2^{13}=8192$	$2^{12}=4096$	$2^{11}=2048$	$2^{10}=1024$
$2^9=512$	$2^8=256$	$2^7=128$	$2^6=64$	$2^5=32$
$2^4=16$	$2^3=8$	$2^2=4$	$2^1=2$	$2^0=1$

04-33 Process Control Operation Mode			↗	Factory setting	00000	
Bit setting	Bit 0	0	direction determined by Pr. 04-32		2 ⁰	1
		1	direction determined by the master speed control			
	Bit 1	0	continuously execute the process control operation		2 ¹	2
		1	execute only one process control operation cycle			
	Bit 2	0	zero speed intervals disabled		2 ²	4
		1	zero speed intervals enabled			
	Bit 3	0	operate at zero speed upon time extension (note 1)		2 ³	8
		1	operate at a constant speed upon time extension (note 1)			
	Bit 4	0	PCO disabled		2 ⁴	16
		1	PCO enabled			

Note: Please refer to Pr.02-01 to 02-06 and setting 23 “PCO time extension”.

5

04-34 Multi-Step Speed Operation Mode			↗	Factory setting	00001	
Bit setting	Bit 0	0	direction determined by Pr. 04-32		2 ⁰	1
		1	direction determined by the master speed control			
	Bit 1	0	continuously execute multi-step speed		2 ¹	2
		1	execute multi-step speed based on time (Pr. 4-15 to 4-30)			
	Bit 2	0	zero speed intervals disabled		2 ²	4
		1	zero speed intervals enabled			

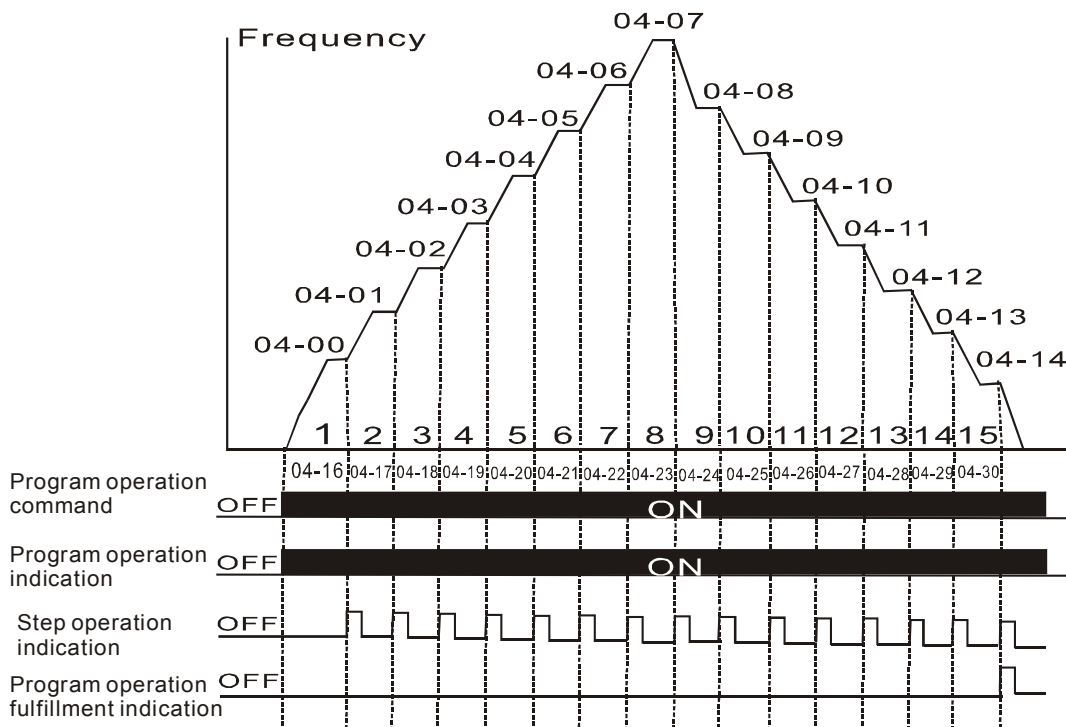

04-35	Disable Skip Frequency Width	⚡	Factory setting	0.00
	Settings	0.00~400.00Hz		

04-36	Interfere Jump Width	⚡	Factory setting	0.00
	Settings	0.00~400.00Hz		

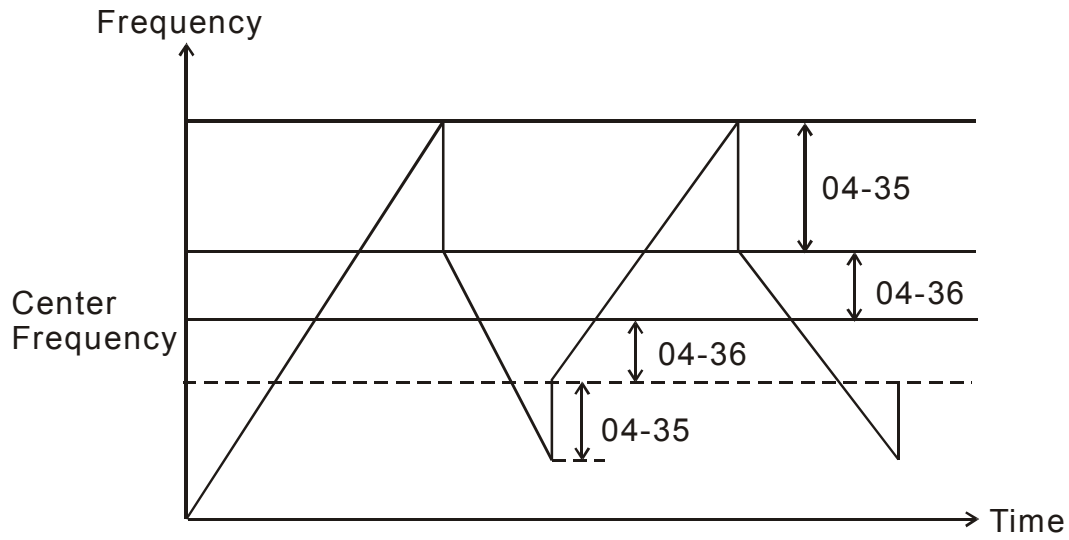

5.6 Group 5: Motor Parameters

05-00	Motor Auto Tuning		Factory setting	0
	Settings	0	no function	
		1	measures (R1, R2, Lm, Lc, no-load current)	
		2	measures (R1, R2, Lc)	
		3	measures (R1, R2, Lc, Lm, calculated by the motor's no-load current)	

 This parameter automatically measures the motor's characteristics and enters the values into Pr.05-02, Pr.05-06~09, Pr.05-12, Pr.05-16~19, respectively.

Note 1. The Torque/Vector control mode is not intended for use with multiple motors connected to one AC drive.

Note 2. If two motors will be connected to one drive and both must be auto tuned, it is necessary to set a multi-function input terminal to switch between Motors 1 and 2. This will enable the drive to enter the calculated values into the correct parameter positions.

Note 3. When using the Auto tune feature with a loaded motor, please set Pr05-00 = 2 or 3. A setting of 2 or 3 is a "Static tune" and no movement of the motor is necessary to calculate the motor characteristics. If a Static tune is desired, please make sure to input the correct No-Load and Full-Load current before conducting the Auto Tuning feature.

Motor Auto Tuning Procedure:

1. Make sure all the parameter settings are at the factory settings and all power wiring is correct.
2. Remove any load on the motor before proceeding with the auto tuning (Nothing should be connected to the motor shaft).
3. Enter the motor rated voltage in Pr. 01-02 and motor rated frequency in Pr. 01-01.
4. Set Pr. 05-00 = 1, 2, or 3, then press the "RUN" key on the keypad to execute the motor auto-tuning operation (Caution: the motor will begin to turn if Pr.05-00 is set to 1). The execution time is about 2 minutes. (The greater the horsepower of the motor, the longer the acceleration/deceleration time should be set).
5. After the auto tuning procedure is complete, verify the parameters (Pr.05-02, Pr.05-06~09, Pr.05-12 and Pr.05-16~19) have been updated. If not, set Pr.05-00 = 1 to 3 and press the "RUN" key again.

6. Set Pr.00-10 = 2~5 after any errors are eliminated. If needed, now adjust other parameters based on the requirement of the application.

05-01	Full-Load Current of Motor 1	Factory setting	A(100%)
	Settings	XXXA(30~120%)	

 This parameter will limit the AC drive output current in order to prevent the motor from overheating.

 The value entered must be in Amps, and should be found on the motor nameplate.

 This parameter and Pr. 05-01 must be programmed correctly if the drive is to operated in the Vector or Torque control mode, the Electronic Thermal Overload Relay is used (Pr. 06-09), or if the Slip Compensation function is used (Pr. 05-04).

05-02	No-Load Current of Motor 1	Factory setting	A(40%)
	Settings	XXXA(5~90%)	

 The motor's no-load current must be less than Pr. 05-01. This parameter directly effects the amount of the slip compensation generated and the no-load current during Vector control mode. Please set this parameter carefully.

05-03	Torque Compensation of Motor 1 (for the V/F Mode Only)	↗	Factory setting	0.0
	Settings	0.0~25.0%		

 This parameter increases the amount of voltage the drive will output to the motor during operation to increase motor torque. The V/F Torque Compensation is based on the setting of the parameter.

 Be careful when setting this parameter. Always start at the lowest setting and increase the value until sufficient torque is achieved. A large Torque Compensation may generate more voltage than needed and the motor will overheat and possibly be damaged.

05-04	Slip Compensation of Motor 1 (for V/F mode only)	↗	Factory setting	0.0
	Settings	0.0-10.0%		

 While driving an asynchronous motor, an increasing load will cause an increase in slip. This parameter may be used to compensate the nominal slip within a range of 0.0-10.0%.

When the output current of the drive is greater than the motor's no-load current (setting of Pr. 05-02), the drive will adjust the output frequency to the motor to compensate for slip.

Note 1. If Pr.05-02 > the rated current of the motor, the slip compensation will not work correctly.

Note 2. To obtain effective slip compensation, use the auto tune feature Pr.05-00.

05-05	Number of Poles for Motor 1	Factory setting	4
	Settings	2~20	

 This parameter sets the number of poles of your motor (must be an even number).

05-06	Line to Line resistance R1 of Motor 1	Factory setting	X _x
	Settings	mΩ	
05-07	Rotor resistance R2 of Motor 1	Factory setting	X _x
	Settings	mΩ	
05-08	LM of Motor 1	Factory setting	X _x
	Settings	MH	
05-09	LC of Motor 1	Factory setting	X _x
	Settings	MH	

 The settings of Pr.05-05 to 05-09 depend on the current rating of the inverter and the auto tune feature. Please do not change these settings as incorrect performance may occur.

05-10	Iron Loss of Motor 1	↗	Factory setting	1.5
	Settings	0.0~10.0%		

 This parameter is defined as the percentage of the rated power.

05-11	Full-Load Current of Motor 2	Factory setting	A(100%)	
	Settings	XXXA(30~120%)		
05-12	No-Load Current of Motor 2	Factory setting	A(40%)	
	Settings	XXXA(5~90%)		
05-13	Torque Compensation of Motor 2	↗	Factory setting	0.0
	Settings	0.0~25.0%		
05-14	Slip Compensation of Motor 2	↗	Factory setting	0.0
	Settings	0.0~10.0%		
05-15	Number of Poles for Motor 2	Factory setting	4	
	Settings	2~20		
05-16	Line to Line resistance R1 of Motor 2	Factory setting	X _x	
	Settings	mΩ		
05-17	Rotor resistance R2 of Motor 2	Factory setting	X _x	
	Settings	mΩ		
05-18	LM of Motor 2	Factory setting	X _x	
	Settings	MH		

05-19	LC of Motor 2	Factory setting	X _x
	Settings	MH	
05-20	Iron Loss of Motor 2	↗	Factory setting 1.5
	Settings	0.0~10.0%	

📖 For parameters 05-11~20, please refer to parameters 05-01~05-10.

05-21	ASR (Auto Speed Regulation) P (Gain) 1	↗	Factory setting 25.0
	Settings	0.0~500.0%	

📖 This parameter determines the error value gain while in vector, or vector w/PG control mode.

05-22	ASR I (Integration) Time 1	↗	Factory setting 0.250
	Settings	0.000~10.000 sec	
		0.000: no integration	

📖 This parameter determines the integration time during vector or vector w/PG control. There is no integration, if the integration time is set to 0.

05-23	ASR P (Gain) 2	↗	Factory setting 25.0
	Settings	0.0~500.0%	

📖 This setting determines the gain of the error value, and it is suitable for use with the vector control and the PG control.

05-24	ASR I (Integration) Time 2	↗	Factory setting 0.250
	Settings	0.000~10.000 sec	
		0.000: no integration	

📖 This setting is defined as the integration time of the integrating device, and it is suitable for use with the vector control and the PG control. The integration is invalid if the integration time is set as 0.

05-25	Frequency Switch between ASR1 and 2	↗	Factory setting 7.00
	Settings	0.0~400.00Hz	

📖 This parameter is defined as the frequency switching point between ASR1 (Pr. 05-21, 22) and ASR2 (Pr. 05-23, 24).

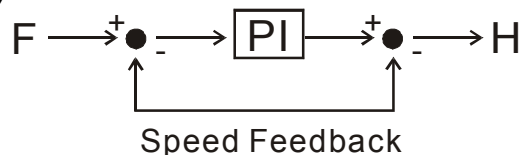

05-26	Low-Speed Excitation Magnet Compensation		↗	Factory setting	10
	Settings	0~100%			

 This parameter determines the amount of current applied to the motor to excite the magnetic field during vector control.

05-27	The Pre-Controlled Torque Feedback		↗	Factory setting	10
	Settings	0~100%			

 Used with the vector control to help with low speed torque control. The number is a gain and should be increased as more torque is needed.

05-28	Time Delay of the Pre-Controlled Torque Feedback		↗	Factory setting	0.010
	Settings	0.000~2.000 sec			

 The parameter determines the filtering time of Pr. 05-27, before any action is taken.

05-29	Vibration Compensation Factor		↗	Factory setting	100
	Settings	0~10000			

 This parameter will minimize vibration at low speed during vector control. The value of the parameter is a GAIN. The higher the value, the more vibration dampening that will occur.

05-30	R1 Detection Frequency		↗	Factory setting	00000
	Settings	Bit0=0	no R1 detection		
		Bit0=1	R1 detection		

 This parameter selects the frequency of detection for R1. If Pr05-30 is set to 1, the motor's line to line resistance will be detected during each "RUN" command.

Note: If the response time to a "RUN" command is critical, than Pr.05-30 should be set to 0.

05-31	Dynamic Response Gain		↗	Factory setting	0.0
	Settings	0.0~100.0%			

 This parameter is used to avoid frequency decrease rapidly when increasing load suddenly.

05-32	Response of current control gain		↗	Factory setting	10
	Settings	0~100%			

 This parameter should be used with 05-28 to increase running smooth in low speed and won't have run-stop-run-stop situation.

5.7 Group 6: Protection Parameter

06-00	Low Voltage Level				
	Settings	160~220V	↗	Factory setting	180
		360~440V	↗	Factory setting	360

This parameter determines the level for “LV” fault.

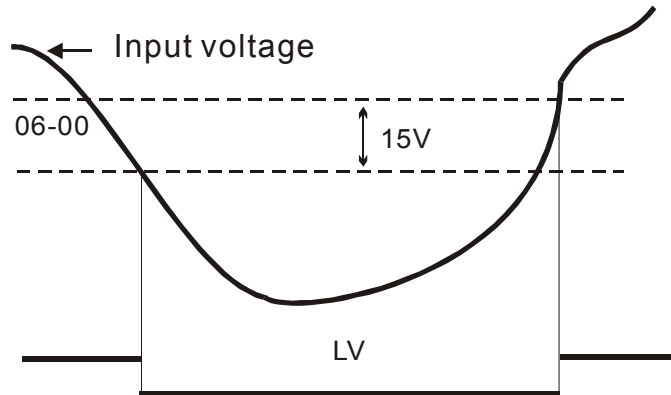

06-01	Over-Voltage Stall Prevention				
	Settings	350.0~450.0V	↗	Factory setting	380.0
		700.0~900.0V	↗	Factory setting	760.0

This parameter sets the voltage limit for use with the Over Voltage Stall prevention function. During deceleration, a heavy loaded motor will begin to regenerate voltage back to the drive. As the drive absorbs this regenerated voltage the DC bus will increase. If the DC bus reaches the value programmed in this parameter, the drive will stop deceleration, hold speed, and wait for the power to dissipate, before deceleration begins again.

*Twice the voltage for the 460V model

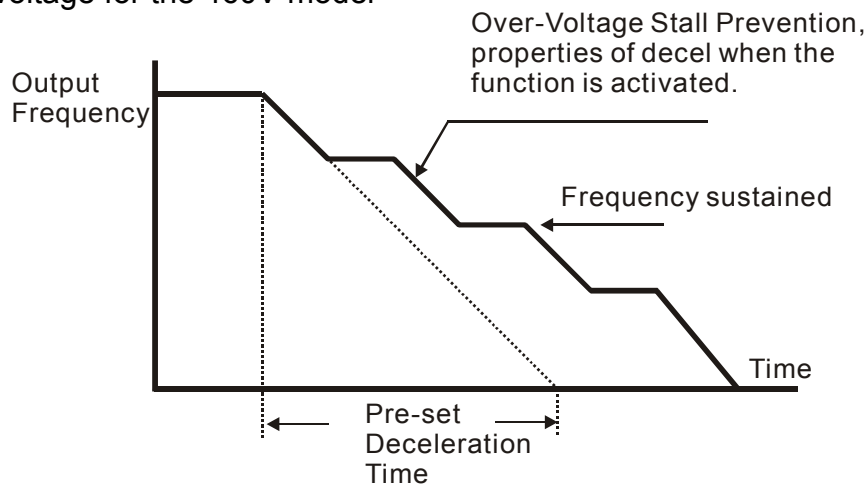

06-02	Phase-Loss Protection		⚡	Factory setting	0
	Settings	0	warn and keep operating		
		1	warn and ramp to stop		
		2	warn and coast to stop		

📖 The phase-loss protection is for the input side of the power phase-loss protection. The drive will have influence on control characteristics and driver life when it operates the input phase-loss. But it can be operated if its' output current is less than 50% of rated current.

06-03	Over-Current Stall Prevention during Acceleration		⚡	Factory setting	170
	Settings	10~250%			

📖 This value sets the current limit for the Over Current Stall Prevention function. During acceleration, a heavy loaded motor may require very high current. If the current reaches the value programmed in Pr 06-03, the drive will stop acceleration, hold speed and wait for the current to dissipate in the motor. Once the current has fallen below the limit set in 06-03, the drive will begin to accelerate to command speed as shown in the graph below.

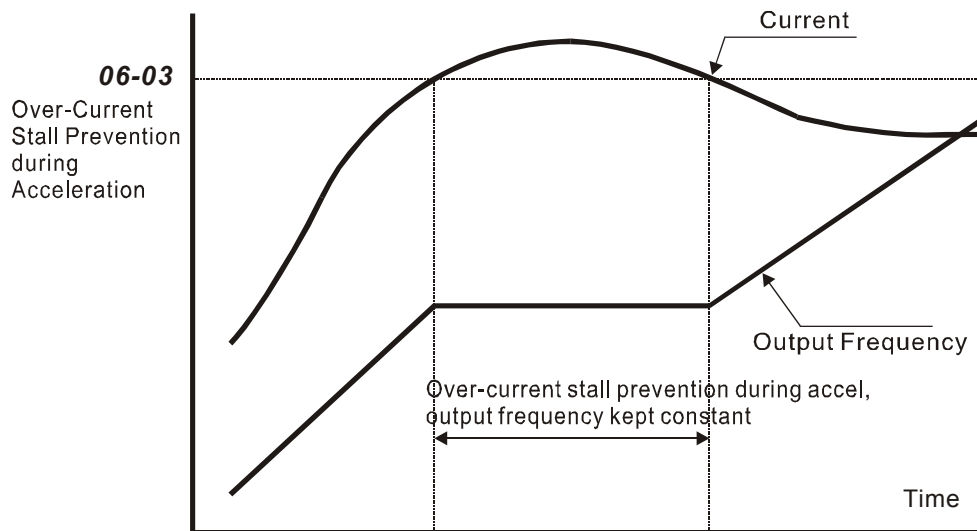

Function of the Over-Current Stall Prevention during Accel

06-04	Over-Current Stall Prevention during Operation	↗	Factory setting	170
	Settings	10~250%		

 This parameter sets the current limit for the Over-Current Stall Prevention during Operation function. If the load on the motor causes the current to rise above the value set in this parameter, the drive will lower its output frequency (therefore lowering current) to avoid the motor from stalling. After the current has fallen below the value set in Pr.06-04, the drive will begin to bring the motor back to command speed as shown in the graph below.

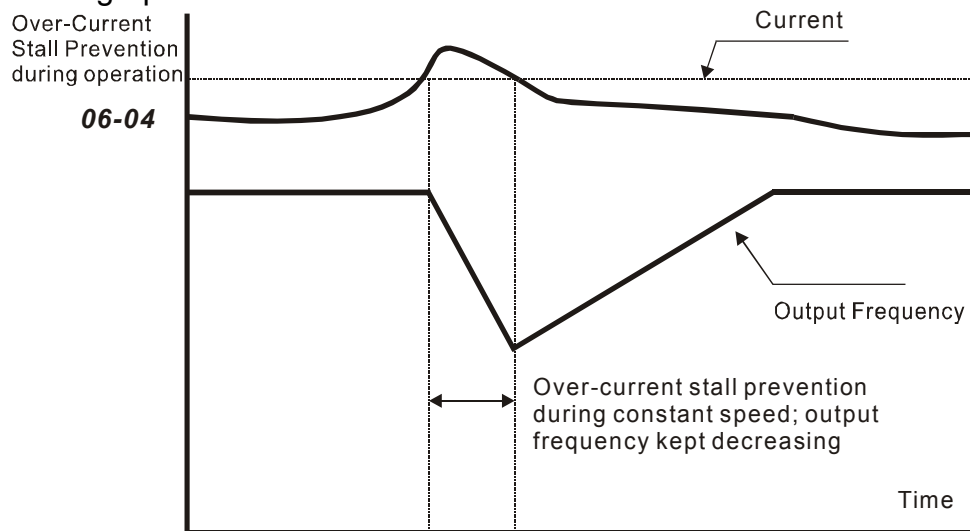

Function of the Over-Current Stall Prevention during Constant Speed

06-05	Over-Current Deceleration Time during Operation	↗	Factory setting	3.00										
	Settings	0.05~600.00 Sec												
06-06	Over-Torque Detection Selection (oL2)	↗	Factory setting	0										
	Settings	<table border="1"> <tr> <td>0</td> <td>disabled</td> </tr> <tr> <td>1</td> <td>Over-torque detection during constant speed operation, continue to operate after detection.</td> </tr> <tr> <td>2</td> <td>Over-torque detection during constant speed operation, stop operation after detection.</td> </tr> <tr> <td>3</td> <td>Over-torque detection during entire (acceleration, steady state, deceleration) operation, continue operation after detection.</td> </tr> <tr> <td>4</td> <td>Over-torque detection during entire (acceleration, steady state, deceleration) operation, stop operation after detection.</td> </tr> </table>			0	disabled	1	Over-torque detection during constant speed operation, continue to operate after detection.	2	Over-torque detection during constant speed operation, stop operation after detection.	3	Over-torque detection during entire (acceleration, steady state, deceleration) operation, continue operation after detection.	4	Over-torque detection during entire (acceleration, steady state, deceleration) operation, stop operation after detection.
0	disabled													
1	Over-torque detection during constant speed operation, continue to operate after detection.													
2	Over-torque detection during constant speed operation, stop operation after detection.													
3	Over-torque detection during entire (acceleration, steady state, deceleration) operation, continue operation after detection.													
4	Over-torque detection during entire (acceleration, steady state, deceleration) operation, stop operation after detection.													
06-07	Over-Torque Detection Level (oL2)	↗	Factory setting	150										
	Settings	10-250%												

06-08	Over-Torque Detection Time (oL2)	↗	Factory setting	0.1
	Settings	0.0-60.0 Second		

- 📖 These parameters define the current level and detection time for the Over Torque Detection function.
- 📖 The Over Torque Detection level is a percentage of the rated drive current. The factory setting is 150% of the drives rated current.
- 📖 The Over Torque Detection time is the length of time the drive may be in an over torque condition.

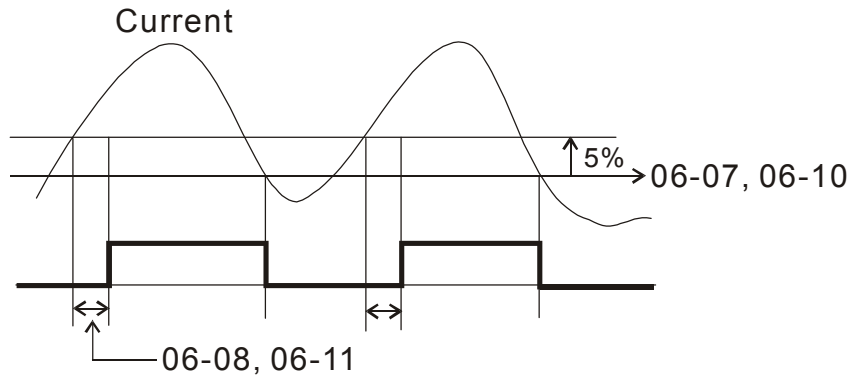

Example: When the output current exceeds the over torque detection level (Pr.06-07) and exceeds the over torque detection time (Pr.06-08), the drive will display oL2 on the keypad and will follow the setting in Pr.06-06.

06-09	Over-Torque Detection Selection 2 (OL3)	↗	Factory setting	0
	Settings	0	Disable	
		1	over-torque detection during constant speed operation, continue to operate after detection	
		2	over-torque detection during constant speed operation, stop operation after detection.	
		3	over-torque detection during operation, continue operation after detection.	
		4	over-torque detection during operation, stop operation after detection.	

06-10	Over-Torque Detection Level 2 (OL3)	↗	Factory setting	150
	Settings	10~250%		
06-11	Over-Torque Detection Time 2 (OL3)	↗	Factory setting	0.1
	Settings	0.0~60.0 Sec		

06-12	Over-Torque limit	↗	Factory setting	150
	Settings	0~250%		

📖 This parameter sets the over torque limit used during torque control, V/F control, and Vector control. When using an analog input set for “Torque Limit”, this parameter will set the actual limit. The value in this parameter is based on the AC drive output current in %.

06-13	Electronic Thermal Relay Selection (I²t)	↗	Factory setting	2
	Settings	0	Inverter/vector motor	
		1	Standard motor	
		2	Electronic thermal relay function disabled	

📖 This parameter selects the type electronic thermal relay function based on the motor characteristics.

Inverter/vector motor = windings designed for AC drive output and low speeds with high currents.

Standard motor = windings not designed for AC drives. Motor has a shaft mounted fan which offers poor cooling at low speeds

06-14	Electronic Thermal Relay Time (I²t)	↗	Factory setting	60
	Settings	30~600 Sec		

📖 This parameter sets the time period for the Electronic Thermal Relay (I²t) function.

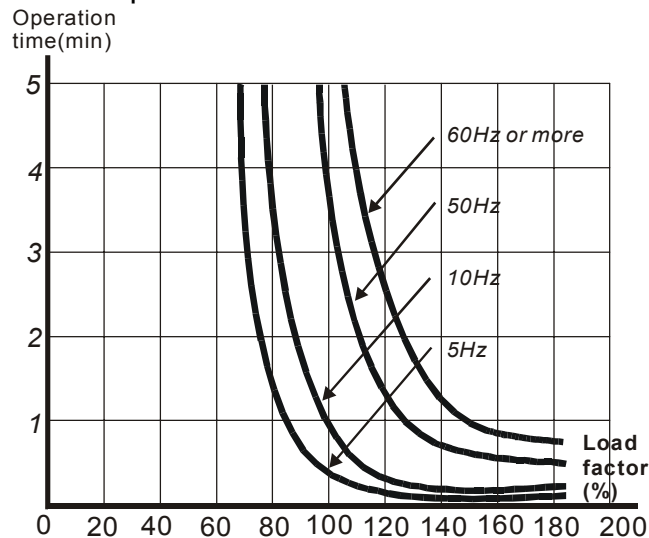

📖 The electronic thermal relay function is designed to protect the motor from overheating, due to low output frequency and high currents.

06-15	Heat Sink Over-Heat (oH) Warning	↗	Factory setting	85.0
	Settings	0.0~110.0		Unit
				°C

📖 The setting for parameters 02-10~02-13 is 23.

06-16	Op stall low limit	↗	Factory setting	120
	Settings	0~250%		

06-17	Most Recent Fault Record	Factory setting	0
06-18	2 nd Most Recent Fault Record	Factory setting	0
06-19	3 rd Most Recent Fault Record	Factory setting	0
06-20	4 th Most Recent Fault Record	Factory setting	0

	Content displayed	0	no fault
		1	oc (over-current)
		2	ov (over-voltage)
		3	oH1 (IGBT overheat)
		4	oL (drive overload)
		5	oL1 (electronic thermal relay)
		6	EF (external fault)
		7	CF3 (hardware circuit fault)
		8	HPF (protection circuit fault)
		9	ocA (over-current during accel)
		10	ocd (over-current during decel)
		11	ocn (over-current during constant speed)
		12	GFF (ground fault)
		13	pg error
		14	Lv (low voltage)
		15	CF1 (unable to write to memory)
		16	CF2 (unable to read memory)
		17	bb (Pause)
		18	oL2 (motor overload)
		19	sc (IGBT failure)
		20	brake (braking transistor failure)
		21	OL3 (motor overload)
		22	oh2 (brake overheat)
		23	Fuse failure
		24	CT2 (current sensor 2)
		25	CT1 (current sensor 1)
		26	PWM (upper and lower points at the same low level)
	27	Motor auto tuning failure	

		28	pid error
		29	ACI error
		30	P2P Over Limit
		31	CC
		33	VEC R1 out of range (Pr. 05-30)
		34	keypad error
		35	RS 485 watchdog timer
		36	FAN failure
		37	input phase loss

5.8 Group 7: Special Parameter

07-00	Software Braking Level				
	Settings	350.0~450.0VDC	↗	Factory setting	380.0
		700.0~900.0VDC	↗	Factory setting	760.0

 This parameter sets the level for dynamic braking to enable. The value must be higher than the steady state DC-BUS voltage, otherwise the braking transistor will have a 100% duty. At 100% duty the transistor and resistor will most likely fail.

*The factory setting is twice the value for the 460V model

07-01	DC Braking Current Level			↗	Factory setting	0
	Settings	0~100%				

 This parameter sets the DC braking current level in percentage, for use with DC injection braking. The percentage is based on the rated current of the AC drive. When programming this parameter, be sure to increase the percentage slowly from 0, until sufficient braking torque is obtained. A current level too high may damage the motor.

07-02	DC Braking Time at Start-up			↗	Factory setting	0.00
	Settings	0.00~60.00 Sec				

 This parameter determines the duration of DC braking current applied to the motor immediately following a START command.

07-03	DC Braking Time during a STOP			↗	Factory setting	0.00
	Settings	0.00~60.00 Sec				

 This parameter determines the duration of DC braking current applied to the motor upon a STOP command. This is often used to hold a motor shaft in position for a short time.

07-04	Frequency point for DC Braking			↗	Factory setting	0.00
	Settings	0.00~400.00Hz				

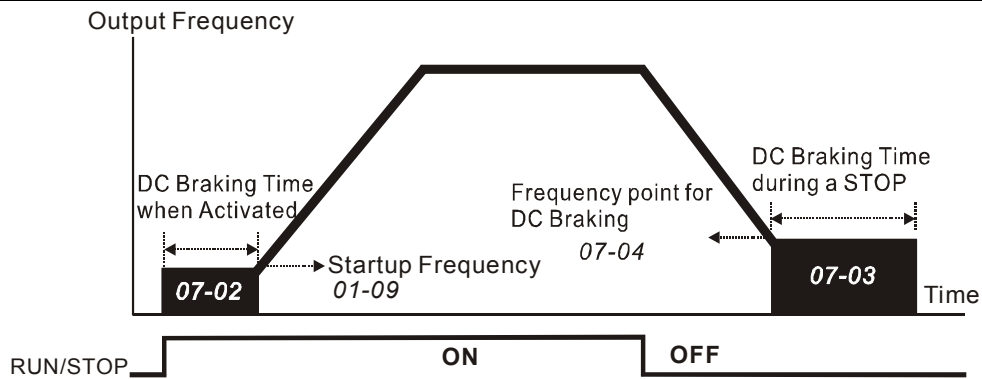

The Procedural Diagram of the DC Braking Output

- ☞ This parameter determines the frequency point of DC braking for both Pr. 07-02 and Pr. 07-03.
- ☞ During deceleration, the drive will begin to output a DC current once the frequency reaches the value set in this parameter.

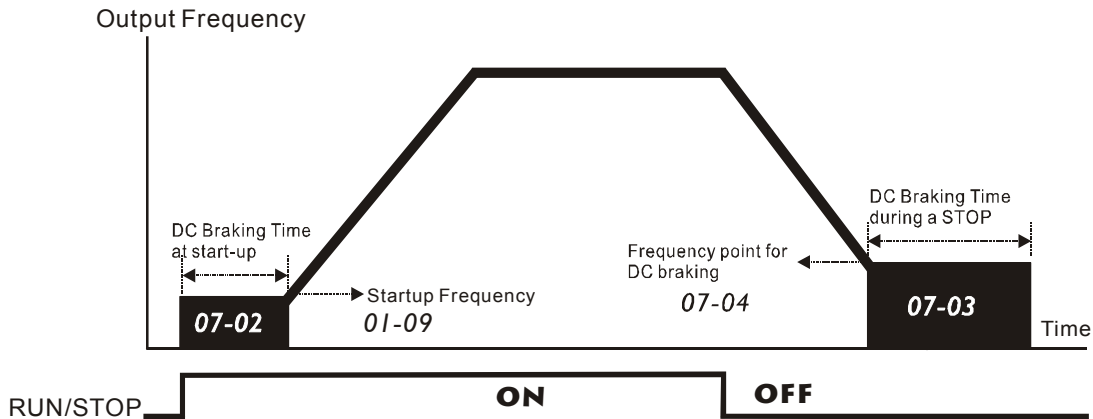

The Procedural Diagram of the DC Braking Output

- ☞ Immediately following a RUN command, the drive will output a DC current until the output frequency reaches the value set in this parameter.
- ☞ The DC braking is commonly used to help decrease the deceleration time. For the best stopping performance, it is recommended to use the Deceleration Time (Pr.01-13) to slow the motor and then apply the DC brake at speeds below 25hz.

07-05	Increasing Rate of the DC Voltage	↗	Factory setting	30
	Settings	1~500		

- ☞ This parameter determines the rate of increase for the DC voltage output during the DC injection braking function.

07-06	Re-activate after Momentary Power Loss	↗	Factory setting	0
	Settings	0	disable	
		1	begins from command frequency	
		2	begins from minimum output frequency	

 This parameter selects the speed search type after a momentary power loss.

07-07	Maximum Allowable Power Loss Time	↗	Factory setting	2.0
	Settings	0.1~5.0 Sec		

 During a power loss, if the power loss time is less than the time defined by this parameter, the AC drive will resume operation. If the Maximum Allowable Power Loss Time is exceeded, the AC drive output is then turned off.

 If the power loss occurs while the AC drive is under heavy load, it is possible all available ride through power will be dissipated in the motor and the AC drive will shut down quickly (less than 1 second).

 The Momentary Power Loss function is only enabled while the “Lu” is displayed on the keypad.

07-08	Base Block Time for Speed Search	↗	Factory setting	0.5
	Settings	0.1~5.0 Sec		

 When a momentary power loss is detected, the AC drive waits for a specified time interval determined by Pr.07-08 before resuming operation.

 This parameter also determines the wait time after performing an external Base Block and Fault Reset function.

07-09	Maximum Current Level for Speed Search	↗	Factory setting	150
	Settings	20~200%		

 This parameter determines the maximum current level used for the speed search function. The drive will only conduct a speed search if the drive’s output current is greater than the current level set in this parameter. If the current is below this value, then the drive will simply ramp up in a normal condition.

 When speed search is conducted, the drive will follow the V/F curve determined by Pr. 01-00 to Pr.01-09.

 This parameter is used for both the “Auto Acceleration/Deceleration Time” and “Speed Search” functions.

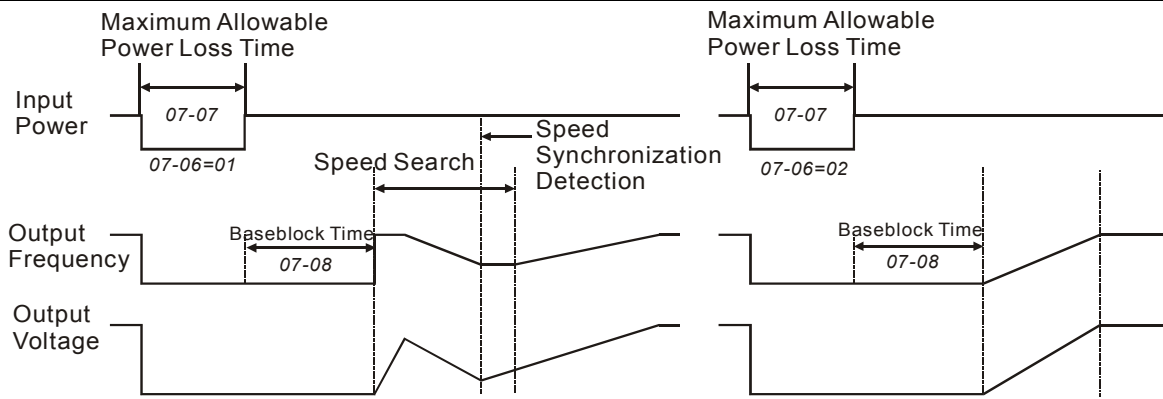

The Procedure Diagram of "Re-activate after Momentary Power Loss"

07-10	Deceleration Time for Speed Search	↗	Factory setting	3.00
	Settings	0.50~600.00 Sec		

- 📖 This parameter determines the rate at which the drive will decelerate the output frequency to find the motor speed, during the momentary speed search method “begins from command frequency”.
- 📖 If the speed search or momentary power loss is set for “begin from minimum output frequency”, then this parameter is not used.
- 📖 When speed search is executed, the Auto Deceleration and the S curve deceleration will not be conducted.

07-11	Auto Restart after Fault	↗	Factory setting	0
	Settings	0~10		

- 📖 This parameter determines the number of restarts after the following faults, “OC, GFF and OV”.
- 📖 The “Auto Restart after Fault” begins with the “Maximum Output Frequency Speed Search” method.
- 📖 If this parameter is set to 10 and 3 faults occur, the remaining number of faults for auto restart is 7. If there are no more faults within 10 minutes, the drive will reset this parameter to 10.

07-12	Speed Search Type		↗ Factory setting	0
	Settings	0	speed search disabled	
		1	speed search through the frequency command	
		2	FWD-speed search only (motor only runs in FWD direction)	
		3	REV-speed search only (motor only runs in REV direction)	
		4	FWD/REV speed search enabled in both directions (fwd first)	
		5	REV/FWD speed search enabled in both directions (rev first)	

📖 This parameter selects the method for speed search. Settings 2 and 3 are used when the motor direction is always guaranteed. If it is possible the motor direction may be either REV or FWD upon a speed search, then selection 4 or 5 should be used.

📖 The speed search function is most applicable to a large Punch Press machine, blower, or other high inertia application. While these applications normally stop, using the “Coast to Stop” method, this may take 2~5 minutes or the application comes to a complete stop. However, with the speed search function enabled, users could instantly start the drive without waiting for the flywheel to come to a stop and the drive would quickly find the speed and bring the motor to speed.

📖 By adding an encoder (PG) to the application, a faster and more speed search would occur.

07-13	Speed Search Frequency (FWD direction)		↗ Factory setting	60.00/50.00
	Settings	0.00~400.00Hz		

📖 This parameter is used as the frequency start point for the Speed Search function, when Pr. 07-12 is set to 2 or 4.

07-14	Speed Search Frequency (REV direction)		↗ Factory setting	60.00/50.00
	Settings	0.00~400.00Hz		

📖 This parameter is used as the frequency start point for the Speed Search function when Pr. 07-12 is set to 3 or 5.

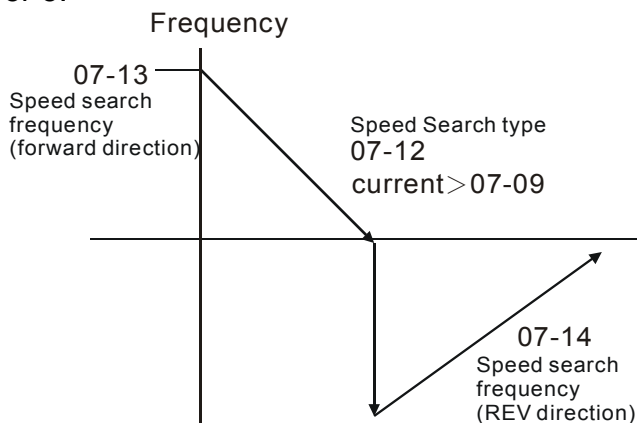

07-15	Gear Gap Acceleration-Interruption Time		↗	Factory setting	0.00
	Settings	0.00~400.00 Sec			
07-16	Gear Gap Acceleration-Interruption Frequency		↗	Factory setting	6.00
	Settings	0.00~400.00Hz			
07-17	Gear Gap Deceleration-Interruption Time		↗	Factory setting	0.00
	Settings	0.00~400.00 Sec			
07-18	Gear Gap Deceleration-Interruption Frequency		↗	Factory setting	6.00
	Settings	0.00~400.00Hz			

These parameters determine the time and frequency point for the drive to stop acceleration or deceleration to allow the motor to catch up to the ac drives output frequency. This is commonly used with heavy loaded applications where the motors rotor is lagging the stator.

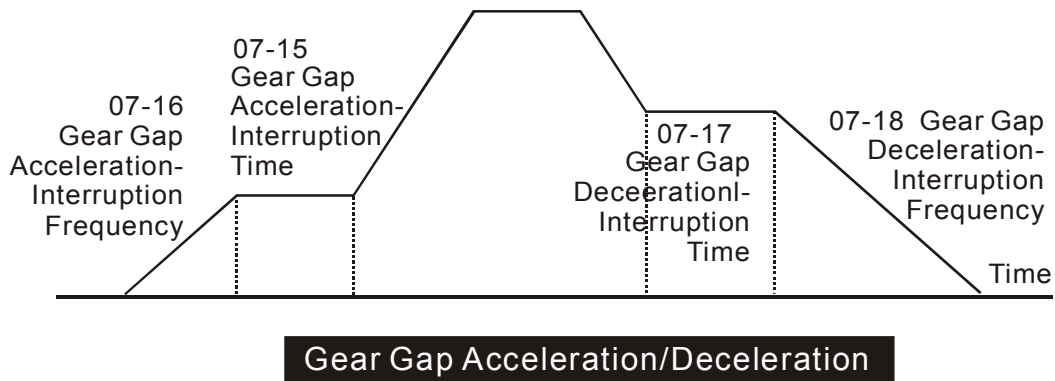

07-19	External Terminals RUN after Fault Reset		↗	Factory setting	0
	Settings	0	Invalid		
		1	If running command is still ON and it is running.		

When RUN command terminal of external terminal is ON and AC drive solve the fault after detecting fault, you can re-run by pressing RESET key.

5.9 Group 8: High-Performance Parameter

08-00	PID Feedback Terminal Selection		↗	Factory setting	0
	Settings	0	Disable		
		1	AVI (0~10V)		
		2	ACI (4~20mA)		
		3	AUI (+/-10V)		
		4	Clock (F/R--master speed)		
		5	Clock (F/R--A/B direction)		

 Select an input terminal to serve as the PID feedback position. Please verify the feedback position is different from the Frequency Set Point position.

08-01	Proportional Gain (P)		↗	Factory setting	80.0
	Settings	0.0~500.0%			

 This parameter determines the gain of the feedback loop. If the gain is large, the response will be strong and immediate (If the gain is too large, vibration may occur). If the gain is small, the response will be weak and slow.

08-02	Integral Time (I)		↗	Factory setting	1.00
	Settings	0.00~100.00 Sec			
		0.00: no integral			

 This parameter determines the speed of response for the PID feedback loop. If the integral time is long, the response will be slow. If the integral time is short, the response will be quick. Be careful not to set (I) too small, since a rapid response may cause oscillation in the PID loop.

 If the integral time is set as 0.00, Pr. 08-02 will be disabled.

08-03	Differential Time (D)		↗	Factory setting	0.00
	Settings	0.00~1.00 Sec			

 This parameter determines the damping effect for the PID feedback loop. If the differential time is long, any oscillation will quickly subside. If the differential time is short, the oscillation will subside slowly.

08-04	Integration's Upper Bound Frequency		↗	Factory setting	100.0
	Settings	0.0~100.0%			

 This parameter determines the integration's upper frequency limit while operating in the PID feedback loop. (Limit = 01-00×08-04 %). During a fast Integration response, it is possible for the frequency to spike beyond a reasonable point. This parameter will limit this frequency spike.

08-05	PID Frequency Output Command limit	↗	Factory setting	100.0
	Settings	0.0~100.0%		

📖 This parameter determines the limit of the PID Command frequency. If this parameter is set to 120%, then the maximum output frequency while in the PID operation will be (120% x Pr.01-00) 72%.

08-06	PID Deviation Range	↗	Factory setting	0.0
	Settings	-100.0~+100.0%		
08-07	One-Time Delay	↗	Factory setting	0.000
	Settings	0.000~0.005 Sec		

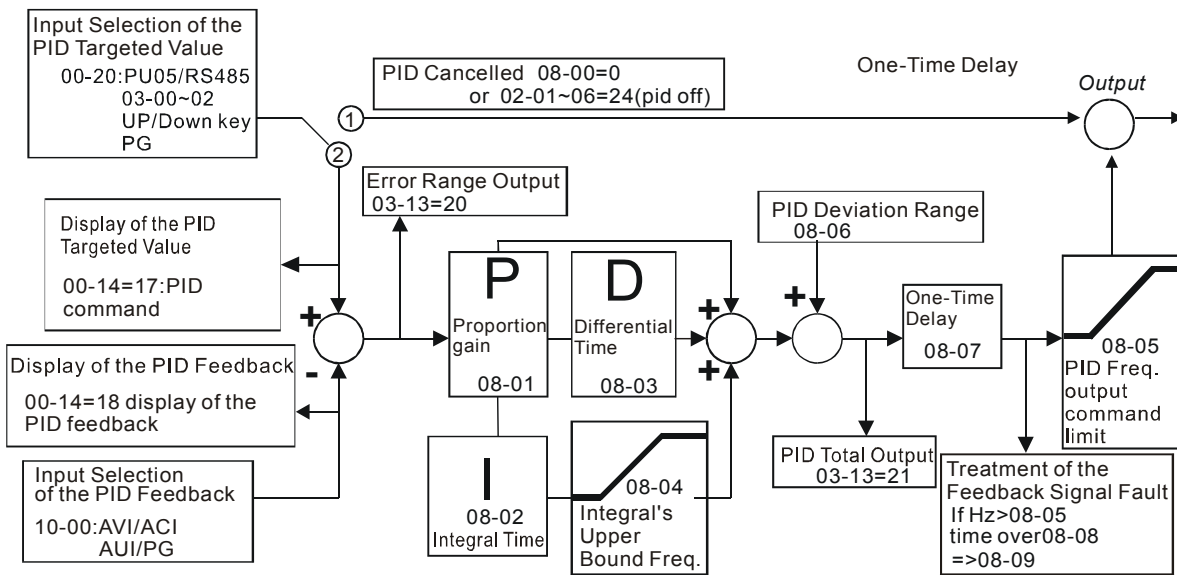



📖 **PI Control:** controlled by the P action only, and thus, the deviation cannot be eliminated entirely. To eliminate residual deviations, the P + I control will generally be utilized. And when the PI control is utilized, it could eliminate the deviation incurred by the targeted value changes and the constant external interferences. However, if the I action is excessively powerful, it will delay the responding toward the swift variation. The P action could be used solely on the loading system that possesses the integral components.

 PD Control: when deviation occurred, the system will immediately generate some operation load that is greater than the load generated single handedly by the D action to restrain the increment of the deviation. If the deviation is small, the effectiveness of the P action will be decreasing as well. The control objects include occasions with integral component loads, which are controlled by the P action only, and sometimes, if the integral component is functioning, the whole system will be vibrating. On such occasions, in order to make the P action's vibration subsiding and the system stabilizing, the PD control could be utilized. In other words, this control is good for use with loadings with no braking functions over the processes.

 PID Control: Utilize the I action to eliminate the deviation and the D action to restrain the vibration, thereafter, combine with the P action to construct the PID control. Use of the PID method could obtain a control process with no deviations, high accuracies and a stable system.

08-08	Detection Time of the Feedback Error		↗	Factory setting	0.0
	Settings	0.0~6000.0 Sec			

 This parameter defines the detection time for the loss of a feedback analog signal. The drive will follow the operating procedure programmed in Pr.08-09 if the feedback signal is lost for more than the time set in Pr. 08-08.

 A setting of 0.0 disables this function.

08-09	Feedback Signal Fault Treatment		↗	Factory setting	0
	Settings	0	warn and keep operating		
		1	warn and RAMP to stop		
		2	warn and COAST to stop		

 This parameter selects the operation of the drive upon a loss of PID feedback signal.

08-10	Dwell (sleep) Frequency		↗	Factory setting	0.00
	Settings	0.00~400.00Hz			
08-11	Revival Frequency		↗	Factory setting	0.00
	Settings	0.00~400.00Hz			
08-12	Dwell (sleep) Period		↗	Factory setting	0.0
	Settings	0.0~6000.0 Sec			

These parameters determine Dwell (sleep) functions of the AC drive. If the command frequency falls below the Dwell frequency, for the specified time in Pr. 08-12, then the drive will shut off the output and wait until the command frequency rises above Pr. 08-11. Please see the below diagram.

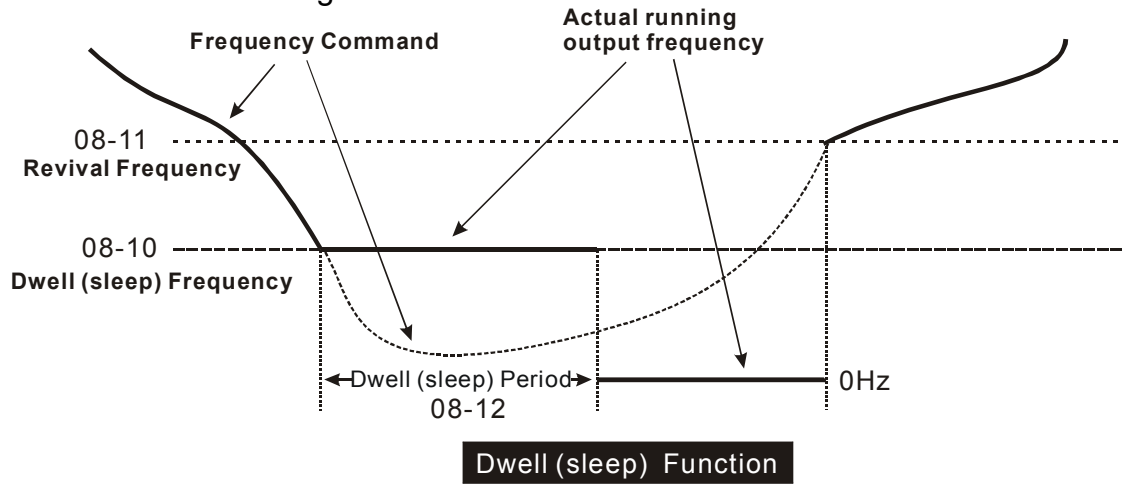

08-13	Fan control		↗	Factory setting	0
	Settings	0	When power is applied, the fan will turn on		
		1	When the run command is given, the fan will turn on		

5.10 Group 9: Communication Parameter

09-00	Communication Address	↗	Factory setting	1
	Settings	1-254		

📖 When the system is controlling or monitoring with the RS-485 series connection communication interface, every drive has to be determined with one communication address then and that the address connected to the network should be specific and could not be repeated.

09-01	Transmission Speed of the Communication	↗	Factory setting	9.6
	Settings	4.8~115.2 Kbits/Sec		

📖 Through the internal RS-485 series connection ports within the computer, users are to set and revise the parameters within the drive, and to control the operation of the drive, and further, to monitor the operation status of the drive. This parameter is utilized in setting up the transmission speed between the computer and the drive.

5

09-02	Transmission Fault Treatment	↗	Factory setting	3
	Settings	0	warn and keep operating	
		1	warn and RAMP to stop	
		2	warn and COAST to stop	
		3	no treatment and no display	

📖 This parameter is utilized in setting the drive's treatment toward transmission overtime fault (e.g. when the communication cord is broken) during the communication.

09-03	Overtime Detection	↗	Factory setting	0
	Settings	0	disabled	
			1~100 Sec	

📖 This parameter is utilized in setting the transmission overtime between the communication and the keypad.

09-04	Communication Protocol	↗	Factory setting	1
	Settings	0 to 17		

Settings	Function	Settings	Function
0	7, N, 1 for ASCII	9	8, O, 1 for ASCII
1	7, N, 2 for ASCII	10	8, E, 2 for ASCII
2	7, E, 1 for ASCII	11	8, O, 2 for ASCII
3	7, O, 1 for ASCII	12	8, N, 1 for RTU
4	7, E, 2 for ASCII	13	8, N, 2 for RTU
5	7, O, 2 for ASCII	14	8, E, 1 for RTU
6	8, N, 1 for ASCII	15	8, O, 1 for RTU
7	8, N, 2 for ASCII	16	8, E, 2 for RTU
8	8, E, 1 for ASCII	17	8, O, 2 for RTU

 Computer-controlled Link: when the RS-485 series connection communication interface is utilized, every VDF-V has to pre-determine the communication address at Pr. 09-00, and thereafter, the computer will proceed with the control based on respective addresses.

 The Communication Protocol is of the MODBUS ASCII (American Standard Code for Information Interchange) Mode: every byte is composed of 2 ASCII words. For example, if the numeric value is 64 Hex, the way to show it through the ASCII mode will be "64", which is composed respectively be "6" (36Hex) and "4" (34Hex).

1. Meaning of Encoding:

The communication protocol is of the Hexadecimal system, and thus, the meaning of the ASCII message words would be: "0"... "9", "A"... "F", which every Hexadecimal code represents every ASCII message word.

For instance:

WORD	'0'	'1'	'2'	'3'	'4'	'5'	'6'	'7'
ASCII code	30H	31H	32H	33H	34H	35H	36H	37H

WORD	'8'	'9'	'A'	'B'	'C'	'D'	'E'	'F'
ASCII code	38H	39H	41H	42H	43H	44H	45H	46H

2. WORD Structure

2.1 10-bit Word Frame (For ASCII)

Data Format 7.N.2

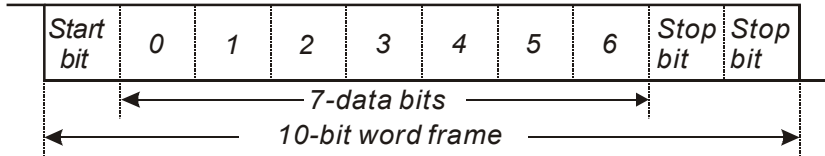

Data Format 7.E.1

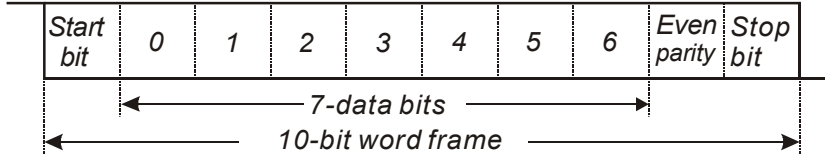

Data Format 7.O.1

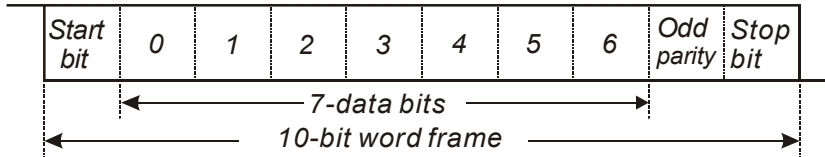

5

1.2 11-bit Word Frame (For RTU)

Data Format 8.N.2

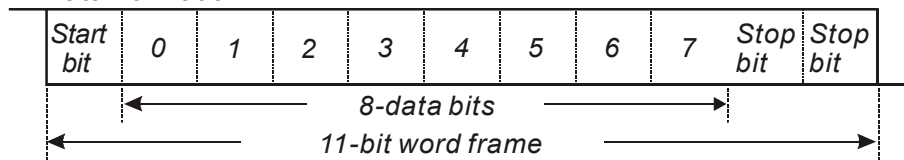

Data Format 8.E.1

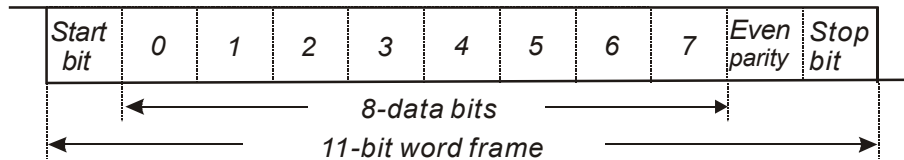

Data Format 8.O.1

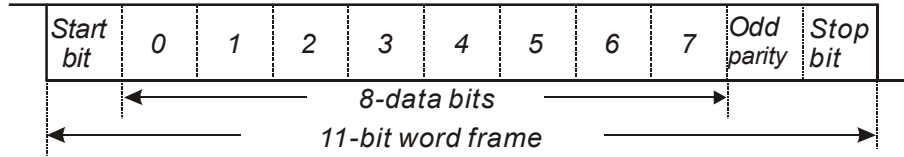

3. Communication Data Structure

3.1 The Data Format Frame

The ASCII Mode:

STX	Start Word = ' : ' (3AH)
Address Hi	Communication Address: The 8-bit address is composed of 2 ASCII codes
Address Lo	
Function Hi	Function Code: The 8-bit function code is composed of 2 ASCII codes
Function Lo	
DATA (n-1)	Data Contents: n×8-bit, the data contents is composed of 2n ASCII codes n≤16, 32 ASCII codes as the maximum
.....	
DATA 0	
LRC CHK Hi	LRC Check Sum: The 8-bit check sum is composed of 2 ASCII codes
LRC CHK Lo	
END Hi	End Word: END Hi = CR (0DH), END Lo = LF(0AH)
END Lo	

The RTU Mode:

START	Keep the non-input message greater or equal to 10 ms
Address	Communication Address: the 8-bit binary address
Function	Function Code: the 8-bit binary address
DATA (n-1)	Data Contents: n×8-bit data, n≤16
.....	
DATA 0	
CRC CHK Low	CRC Check Sum: The 16-bit CRC check sum is composed of 2 8-bit binary codes
CRC CHK High	
END	Keep the non-input message greater or equal to 10 ms

3.2 Communication Address

00H: all the drives are broadcasting

01H: toward the drive at the 01 address

0FH: toward the drive at the 15 address

10H: toward the drive at the 16 address

and consequently, the maximum to be reached is 254 (FEH).

3.3 Function Code and Data Contents

03H: read the contents of the register

06H: write one WORD into the register

3.3.1 Function Code 03H: read the contents of the register.

e.g.: When the address of the drive is set as 01H, read 2 data contents that exist successively within the register, as shown follows: the address of the start register is 2102H.

The ASCII Mode:

Inquiry message:

STX	' :
Address	'0'
	'1'
Function	'0'
	'3'
Starting address	'2'
	'1'
	'0'
	'2'
Number of data (count by word)	'0'
	'0'
	'0'
	'2'
LRC Check	'D'
	'7'
END	CR
	LF

Response message:

STX	' :
Address	'0'
	'1'
Function	'0'
	'3'
Number of data (count by byte)	'0'
	'4'
Content of starting address 2102H	'1'
	'7'
	'7'
	'0'
Content of address 2103H	'0'
	'0'
	'0'
	'0'
LRC Check	'7'
	'1'
END	CR
	LF

The RTU Mode:

Inquiry message:

Address	01H
Function	03H
Starting data address	21H
	02H
Number of data (count by word)	00H
	02H
CRC CHK Low	6FH
CRC CHK High	F7H

Response message:

Address	01H
Function	03H
Number of data (count by byte)	04H
Content of data address 8102H	17H
	70H
Content of data address 8103H	00H
	00H
CRC CHK Low	FEH
CRC CHK High	5CH

3.3.2 Function Code 06H: write a WORD into the register.

e.g.: aim at address 01H of the drive, and write 6000 (1770H) into the interior of the drive to set the parameter 0100H.

The ASCII Mode:

Inquiry message:

STX	‘.’
Address	‘0’
	‘1’
Function	‘0’
	‘6’
Data address	‘0’
	‘1’
	‘0’
	‘0’
Data content	‘1’
	‘7’
	‘7’
	‘0’
LRC Check	‘7’
	‘1’
END	CR
	LF

Response message:

STX	‘.’
Address	‘0’
	‘1’
Function	‘0’
	‘6’
Data address	‘0’
	‘1’
	‘0’
	‘0’
Data content	‘1’
	‘7’
	‘7’
	‘0’
LRC Check	‘7’
	‘1’
END	CR
	LF

The RTU Mode:

Inquiry message:

Address	01H
Function	06H
Data address	01H
	00H
Data content	17H
	70H
CRC CHK Low	86H
CRC CHK High	22H

Response message:

Address	01H
Function	06H
Data address	01H
	00H
Data content	17H
	70H
CRC CHK Low	86H
CRC CHK High	22H

3.4 The LRC Check of the ASCII Mode

The LRC Check is the added sum from “Address” to “Data Contents”. For example, in 3.3.1, the LRC Check for the inquiry message will be: 01H + 03H + 21H + 02H + 00H + 02H = 29H, then take the complementary of 2, D7H.

3.5 The CRC Check of the RTU Mode

The CRC Check starts from “Address” and ends in “Data Contents”. Its calculation is as follows:

- Step 1: Load the 16-bit register (the CRC register) with FFFFH.
- Step 2: Exclusive OR the first 8-bit byte message command with the 16-bit CRC register of the lower bit, then save the result into the CRC register.
- Step 3: Shift the CRC register one bit to the right and fill in 0 to the higher bit.
- Step 4: Check the value that shifts to the right. If it is 0, save the new value from Step 3 into the CRC register, otherwise, Exclusive OR A001H and the CRC register, then save the result into the CRC register.
- Step 5: Repeat Steps 3 and 4 and calculates the 8-bit.
- Step 6: Repeat Steps 2~5 for the next 8-bit message command, till all the message commands are processed. And finally, the obtained CRC register value is the CRC Check value. What should be noted is that the CRC Check must be placed interchangeably in the Check Sum of the message command.

What follows is the calculation example of the CRC Check using the C language:

```
unsigned char* data    ← // index of the message command
unsigned char length  ← // length of the message command
```

```

unsigned int crc_chk(unsigned char* data, unsigned char length)
{
    int j;
    unsigned int reg_crc=0Xffff;
    while(length--){
        reg_crc ^= *data++;
        for(j=0;j<8;j++){
            if(reg_crc & 0x01){ /* LSB(b0)=1 */
                reg_crc=(reg_crc>>1) ^ 0Xa001;
            }else{
                reg_crc=reg_crc >>1;
            }
        }
    }
    return reg_crc; // the value that sent back to the CRC register finally
}

```

4. Definition of the Parameters Addresses of the Communication Protocol:

Definition	Parameter Address	Function	
Parameter setting within the drive	GGnnH	GG suggests the parameter group whereas nn suggests the parameter code. For example, Pr. 04-01 is indicated as 0401H.	
Command toward the drive	2000H	Bit0~3	0: no function 1: STOP 2: RUN 3: JOG + RUN
		Bit4~5	00B: no function 01B: FWD 10B: REV 11B: direction change

Definition	Parameter Address	Function		
Command toward the drive	2000H	Bit8~9	00B: no function 01B: operation commands controlled by the digital keypad 10B: operation commands controlled by the RS485 communication or the external terminal command (Pr. 02-01) 11B: source change for the operation command	
		Bit6~7	Reserved	
		Bit12~15	Reserved	
		2001H	frequency/torque command	
		2002H	Bit0	1: E.F. ON
			Bit1	1: RESET command
			Bit2~15	Reserved
	Monitor the status of the drive	2100H	Error code: refer to Pr. 06-10~06-13	
2119H		Bit 0	1: RUN command	
		Bit 1	1: RUN state	
		Bit 2	1: JOG command	
		Bit 3	1: REV command	
		Bit 4	1: REV state	
			Bit 8	1: master frequency source from the communication interface
			Bit 9	1: master frequency source comes from the input of /plc/muit/avi/aci/ai through the analog/external terminal signals
			Bit 10	1: operation command from the communication interface/external terminals
			Bit 11	1: parameter locked
		Bit 14~15	Reserved	
	2102H	frequency/torque command (F)		
	2103H	output frequency/torque (H)		

Definition	Parameter Address	Function
	2104H	output current (XX.XX)
	2105H	DC-BUS voltage (XXX.X)
	2106H	output voltage (XXX.XX)
	2107H	presently-executed step speed
	2109H	residual time after procedural operating the step speed
	2116H	multi-function display (Pr. 00-04)
	2120H	(00-04=0)
	2122H	(00-04=1)
	217EH	(00-04=47)

5. Additional Response during Erroneous Communication:

If errors occurred when the drive is conducting the communication connection, the drive will respond to this error and then respond (send) the Function code AND 80H to the master control system so that the system will be informed of the error. And at the same time, the keypad display panel of the drive will show “CE-XX” as a warning message, and “XX” is then the error code. Please refer to “Meaning of the Error Codes” during the communication.

For example:

The ASCII Mode:

STX	‘.’
Address	‘0’
	‘1’
Function	‘8’
	‘6’
Exception code	‘0’
	‘2’
LRC CHK	‘7’
	‘7’
END	CR
	LF

The RTU Mode:

Address	01H
Function	86H
Exception code	02H
CRC CHK Low	C3H
CRC CHK High	A1H

Meaning of the Error Codes:

Error Codes	Explanations
1	Data Contents Error: If the value of the data contents is great, it is then not recognizable by the drive.
2	Parameter Address Error: Parameter addresses not recognizable by the drive.
3	Password Locked: parameter change disabled
4	Parameter change disabled during operation
5	E ² ROM Error when the parameter is written in
6	Data Length Error
7	The parameter is a fixed value, and thus, parameter read is enabled and parameter change disabled
8	When LV, parameter read enabled and parameter change disabled
9	Parameter Locked: parameter read disabled (Pr. 00-02)
10	Transmission Overtime
11	Frame Error: word frame error.

09-05	Keypad Transmission Fault Treatment		↗	Factory setting	0
	Settings	0	warn and keep operating		
		1	warn and RAMP to stop		
		2	warn and COAST to stop		

 This parameter is utilized to determine the treatment of the drive if errors occurred during the communication.

5.11 Group 10: Speed Feedback Parameter

10-00	PG (encoder) Pulses	Factory setting	600
	Settings	1~20000	

This parameter sets the encoder pulse per revolution.

10-01	Encoder Input Setting (channel 1)	Factory setting	0
Settings	0	Phase A leads in a forward run command and phase B leads in a reverse run command. (rising/falling edge trigger) (Pulses x 4)	
	1	Phase B leads in a forward run command and phase A leads in a reverse run command. (rising/falling edge trigger) (Pulses x 4)	
	2	Phase A is a pulse input and phase B is a direction input. (low input = reverse direction, high input = forward direction)	
	3	Phase A is a pulse input and phase B is a direction input. (low input = forward direction, high input = reverse direction)	
	4	Phase A is a forward run pulse, then phase B is High. Phase B is a reverse run pulse, then phase A is High.	

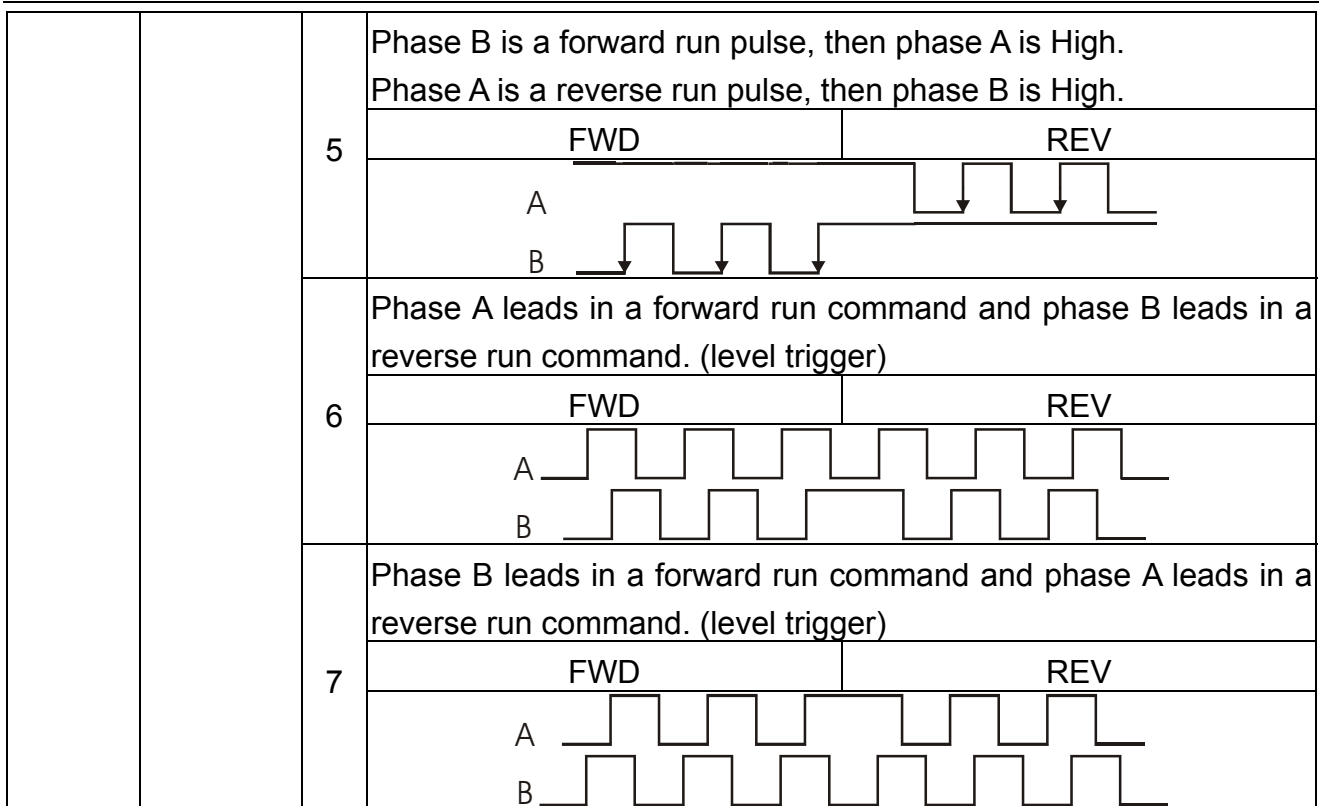

5

This parameter sets the type of feedback received from the encoder.

The direction is determined as follows:

Forward = motor shaft is turning counter clockwise as viewed from the motors shaft end.

Reverse = motor shaft is turning clockwise as viewed from the motors shaft end.

10-02	PG Feedback Fault Treatment	↗	Factory setting	0
	Settings	0	warn and keep operating	
		1	warn and RAMP to stop	
		2	warn and COAST to stop	

10-03	PG Feedback Fault Detection Time	↗	Factory setting	0.10
	Settings	0.00~10.00 sec		

This parameter sets the amount of time to the PG feedback signal may be in error.

The feedback signal is in error if it outside the Slip Range (Pr.10-05) or if is over the Stall Level (Pr.10-06). Once either of the errors are met, the drive will begin to accumulate time. If the feedback signal continues to be in error at the end of the Detection Time period(Pr.10-03) the drive will display a PGerr.

10-04	PG Feedback Filter Time	↗	Factory setting	0.003
	Settings	0.001~1.000 sec		

 This parameter determines the PG feedback filter time for the AC drive to process the motor's rotation speed.

10-05	PG Slip Range		↗	Factory setting	10.0
	Settings	0.0~50.0%			

 This parameter determines the maximum slip range (deviation) for the PG feedback signal.

 The slip range is calculated as follows (Pr. 10-05 x Pr. 01-00 = slip frequency). The slip frequency value is then added to and subtracted from the “command frequency” to give a “slip range”. If the encoder feedback gives a value outside this range, a PGerr will occur.

10-06	PG Stall Level (overspeed protection)		↗	Factory setting	110.0
	Settings	0.0~115.0%			

 This parameter determines the maximum PG feedback signal allowed before a fault will occur.

 The stall level is calculated as follows (Pr. 10-06 x Pr. 01-00 = maximum feedback frequency). If the feedback signal is higher than this value, a PGerr will occur.

10-07	PG Electrical Gear A		↗	Factory setting	100
	Settings	1~5000			
10-08	PG Electrical Gear B		↗	Factory setting	100
	Settings	1~5000			

 These parameters are used when multiple feedback signals are used. One feedback signal will trim the other. The actual output frequency will be based on the following equation.

Output frequency = [PG frequency/PG point (Pr. 10-00)] * PG Electrical Gear A/ PG Electrical Gear B.

10-09	PG Position Control Point (Home)		↗	Factory setting	0
	Settings	0~20000			
10-10	Range for PG Position Attained (Home range)		↗	Factory setting	10
	Settings	0~20000			

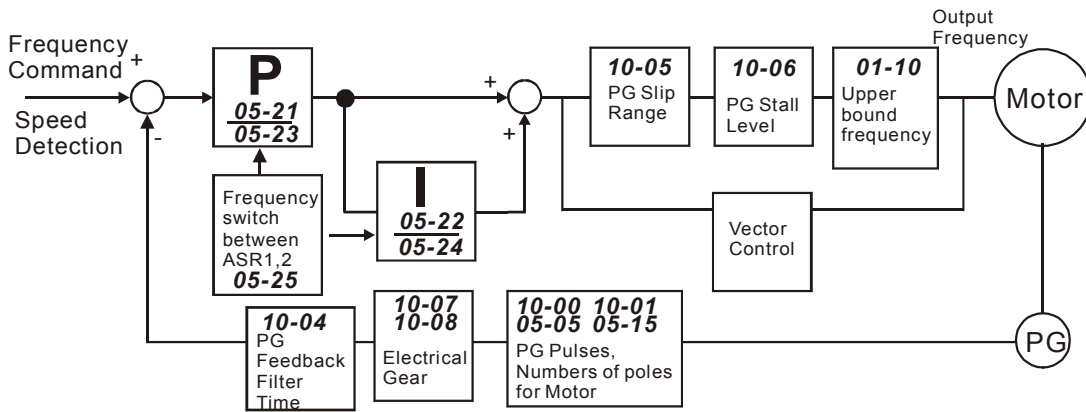

Speed Control Diagram

- 📖 These parameters are used for the positioning feature inside our AC Drive.
- 📖 The “PG Position Control Point” is the HOME position for the AC Drive. At zero speed the drive will always stop at this point.
- 📖 The “Range for PG Position Attained” is used for the Multi Function Output terminals. When the encoder is near the control point, (within a range set by this parameter), a multi function terminal will be enabled. The actual range = 2 x Pr.10-10. If Pr.10-10 is set to 20, then the range is 40 pulses (or 20pulses on either side of the Control Point).

10-11	PG Encoder input Filter Time	↗	Factory setting	0.003
	Settings	0.001~1.000 second		

📖 This parameter sets the filter time for the PG input. A larger time helps with noise but slows the response time of the drive to PG pulse changes.

10-12	PG04 encoder input selection (channel 2)	↗	Factory setting	0
	Settings	0	Phase A leads in a forward run command and phase B leads in a reverse run command. (rising/falling edge trigger)	
		1	Phase B leads in a forward run command and phase A leads in a reverse run command. (rising/falling edge trigger)	

		2	Phase A is a forward run pulse, then phase B is High. Phase B is a reverse run pulse, then phase A is High.
		3	Phase B is a forward run pulse, then phase A is High. Phase A is a reverse run pulse, then phase B is High.
		4	Phase A is a pulse input, phase B is a direction input, (low = reverse , high = forward)
5	Phase A is a pulse input, phase B is direction input. (low = forward, high = reverse)		

This parameter is used to define the encoder input type on channel 2 of the PG04/05.

◆ Position Control Parameter

10-13	Proportional (P) Gain	↗	Factory setting	50.0
	Settings	0.0~500.0%		
10-14	Integral (I) Time	↗	Factory setting	0.050
	Settings	0.000~100.000 Sec		
		0.000: no integral		
10-15	Differential (D) Time	↗	Factory setting	0.25
	Settings	0.00~1.00 Sec		
10-16	Orient Speed	↗	Factory setting	5.00
	Settings	0.00~400.00 Hz		
10-17	Creep point	↗	Factory setting	100
	Settings	0~20000		

10-18	Loop Speed	↗	Factory setting	1.00
	Settings	0.00~400.00 Hz		
10-19	Loop Point	↗	Factory setting	10
	Settings	0~20000		
10-20	Division (scaling) factor for PG04/05	↗	Factory setting	1
	Settings	1~128		

Parameter 10-20 is used when the drive must follow a second encoder for speed reference. The main encoder (A) is a factor of the second encoder (B) as follows.

If Pr.10-20 is set to 1, then the feedback from both encoders are 1:1, (1 pulse on encoder A = one pulse on encoder B). If encoder A is 1 pulse for every 100 pulses on encoder B, then Pr. 10-20 should be set at 100.

Drawing for position control.

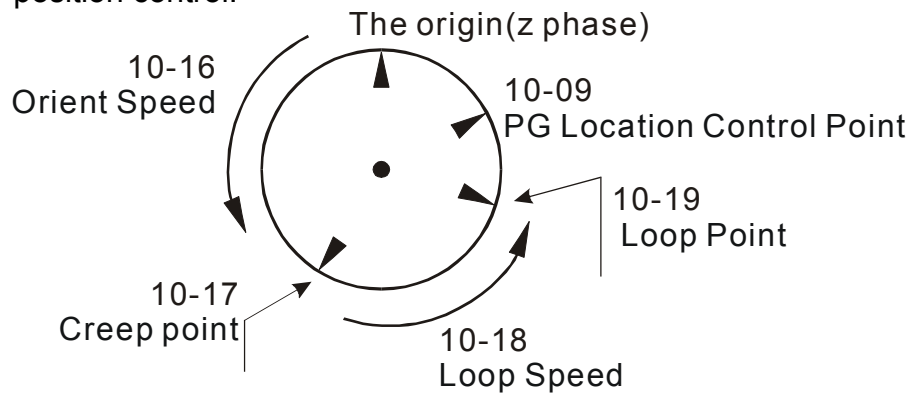

Position control timing:

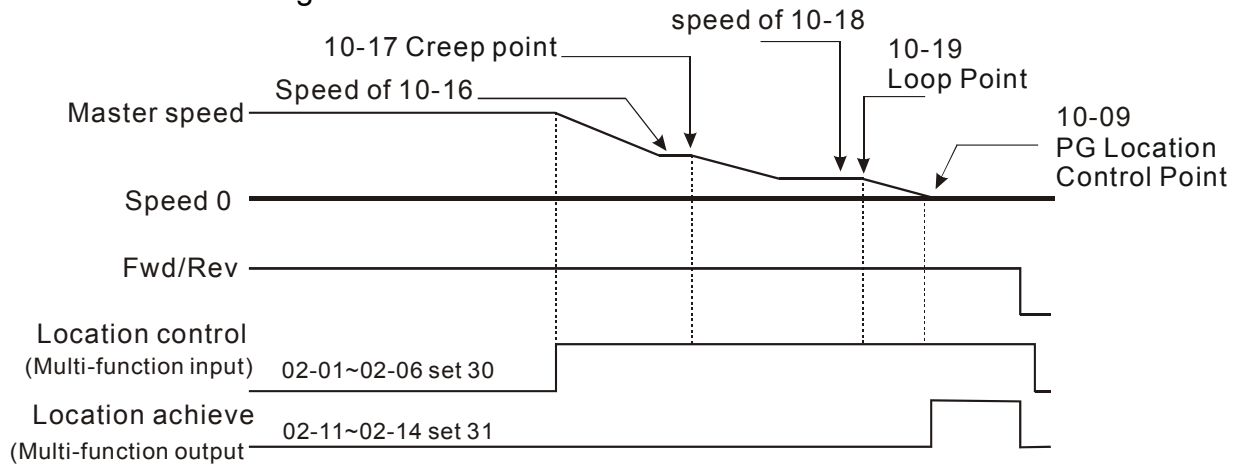

10-21	Feed Forward	↗	Factory setting	0
	Settings	0.0~100.0%		

10-22	Position Control Speed Gain	↗	Factory setting	100
	Settings	0.0~100.0%		

 There are speed LOOP and position LOOP in position mode. This parameter is used to adjust gain of speed LOOP (FX 10-22).

10-23	PG Position Attained 2	↗	Factory setting	100
	Settings	0~20000		

 It is used to set the range of position attained in P2P mode.

10-24	P2P Acceleration Time	↗	Factory setting	1.00
	Settings	0.00~100.00 s		

10-25	P2P Deceleration Time	↗	Factory setting	1.00
	Settings	0.00~100.00 s		

10-26	Delay Time for Position Command	↗	Factory setting	0.005
	Settings	0.00~100.00 s		

10-27	Position Control P Gain 2	↗	Factory setting	50.0
	Settings	0.0~1500.0%(05-25 switch)		

10-28	Position Control Integral (I) Time 2	↗	Factory setting	0.050
	Settings	0.001~10.000 s 0.000: no integral(0.5-25 switch)		

10-29	Selection of P2P Control Mode	↗	Factory setting	00000
	Settings	0: relative P2P 1: absolute P2P		

 It is used to position control of point to point. There are two modes (relative and absolute) for selection.

10-30	Direction Command of Absolute P2P	↗	Factory setting	0
	Settings	0~255 (10-33~40)		

 It is used to set the direction in absolute P2P mode. (the direction is determined by main control command in relative P2P mode)

10-31	FWD Limit of Absolute P2P	↗	Factory setting	0
	Settings	0: No Limit 1~60000		

10-32	REV Limit of Absolute P2P	↗	Factory setting	0
	Settings	0: No Limit		
		1~60000		

📖 10-31 and 10-32 are protective parameters. When the settings of 02-01~02-06 / 02-23~02-30 are set to d42 P2P FWD Limit/d 43 REV Limit and it is ON, AC drive will free stop when it is over the limit.

10-33	P2P Command 0	↗	Factory setting	0
	Settings	0~50000 (in position control 2 mode)		

10-34	P2P Command 1	↗	Factory setting	0
	Settings	0~50000 (in position control 2 mode)		

10-35	P2P Command 2	↗	Factory setting	0
	Settings	0~50000 (in position control 2 mode)		

10-36	P2P Command 3	↗	Factory setting	0
	Settings	0~50000 (in position control 2 mode)		

10-37	P2P Command 4	↗	Factory setting	0
	Settings	0~50000 (in position control 2 mode)		

10-38	P2P Command 5	↗	Factory setting	0
	Settings	0~50000 (in position control 2 mode)		

10-39	P2P Command 6	↗	Factory setting	0
	Settings	0~50000 (in position control 2 mode)		

10-40	P2P Command 7	↗	Factory setting	0
	Settings	0~50000 (in position control 2 mode)		

10-41	P2P Pulse	↗	Factory setting	1
	Settings	1~20000 (*4 for 10-00)		

10-42	P2P mm	↗	Factory setting	1
	Settings	1~20000		

 The distance that each pulse moves (mm) should use with 10-33~10-40 (8-point P2P command) for application.

CHAPTER 6 MAINTENANCE AND INSPECTIONS

Modern AC drives are based on solid state electronics technology, preventive maintenance is required to operate this AC drive in its optimal condition, and to ensure a long life. It is recommended to perform a monthly check up of the AC drive by a qualified technician. Before the check up, always turn off the AC Input Power to the unit. ***Wait at least 10 minutes after all display lamps have gone out, and then confirm that the capacitors have fully discharged by measuring the voltage between B1 and Ground using a multi meter set to measure DC.***

Periodic Inspection:

Basic check up items to detect if there were any abnormality during the operation.

1. Whether the motors are operating as expected.
2. Whether the installation environment is abnormal.
3. Whether the cooling system is operating as expected.
4. Whether any irregular vibration or sound occurred during the operation.
5. Whether the motors are overheated during the operation.
6. Always check the input voltage of the AC drive with Voltmeter.

Periodic Maintenance

 **WARNING!** Disconnecting AC power before processing!

1. Tighten and reinforce the screws of the AC drive if necessary because they might loose due to the vibration or temperature changes.
2. Whether the conductors or insulators were corroded and damaged.
3. Check the resistance of the insulation with Mega-ohm meters.
4. Often check and change the capacitors and relays.
5. If use of the AC drive is discontinued for a long period of time, turn the power on at least once every two years and confirm that it still functions properly. To confirm functionality, disconnect the motor and energize the AC drive for 5 hours or more before attempting to run a motor with it.
6. Clean off any dust and dirt with a vacuum cleaner. Place special emphasis on cleaning the ventilation ports and PCBs. Always keep these areas clean, as accumulation of dust and dirt can cause unforeseen failures.







CHAPTER 7 ERROR MESSAGE AND TROUBLESHOOTING

The AC drive has a comprehensive fault diagnostic system that includes various alarms and fault messages such as over-voltage, low-voltage and over-current. Once a fault is detected, the corresponding protective functions will be activated, and the AC drive will stop the output and the motor will then coast to stop. The following faults are displayed as shown on the AC drive digital keypad panel. Once the fault occurred, eliminate it first, and then press the RESET button after 5 seconds to reactivate the operation.

Problems and Solutions

Code Displayed	Error Explanations	Treatments
OC	OC: output current of the AC drive exceeds the OC level	<ul style="list-style-type: none"> ◆ Extend the accel/decel time ◆ Check whether the motor rating and the AC drive rating match up with each other ◆ Check whether there is short-circuit among U-V-W of the AC drive ◆ Check whether the wiring to the motor is short-circuited or grounded ◆ Check whether the screw between the AC drive and the motor is tightened or not ◆ Check whether the motor is over loaded
OV	OV: DC voltage of the main circuit exceeds the over-voltage detection level 230 V Series: about 400V 460 V Series: about 800V	<ul style="list-style-type: none"> ◆ Check whether the input voltage is within the scope of the rated input voltage of the AC drive, and monitor whether there is any occurrence of the voltage transients ◆ If it is of the motor inertia uprising voltage that caused the exceeding voltage on the DC high-voltage side within the AC drive, the solution is to extend the accel/decel time or install the braking resistor (optional)
OH !	OH1: radiation base over-heat Temperature of the cooling fan of the transistor module exceeds the allowable value	<ul style="list-style-type: none"> ◆ Check whether the fan is functioning right and whether its ambient temperature is within the rated temperature

Code Displayed	Error Explanations	Treatments
OL	OL: AC drive overload Output current exceeds the AC drive-bearable current; e.g. could sustain for 60 seconds if the output is 150% of the AC drive rated current.	<ul style="list-style-type: none"> ◆ Decrease the loading and extend the acceleration time ◆ Check whether the motor is overloaded ◆ Decrease the (Pr. 07-02) torque level-up setting ◆ Increase the AC drive output capacity
OL1	OL1: motor overload Internal electronic thermal relay protections	<ul style="list-style-type: none"> ◆ Decrease the loading ◆ Check whether the motor is overloaded ◆ Check whether the rated current value of the motor (Pr. 07-00) is appropriate ◆ Check the electronic thermal relay's function setup ◆ Increase the motor capacity
OL2	OL2: motor overload Motor with exceedingly great loading	<ul style="list-style-type: none"> ◆ Check whether the loading of the motor is too great ◆ Check the setting of the over-torque detection level (Pr. 06-03 ~ 06-05)
EF	External EF terminal closed, and the AC drive would stop the output	<ul style="list-style-type: none"> ◆ Eliminate the fault source and then press the RESET button
HPF	Fault occurred within the protection circuit of the controller	<ul style="list-style-type: none"> ◆ Check every appliance that connects to the AC drive ◆ Return to the factory
OCR	Over-current during accel	<ul style="list-style-type: none"> ◆ Check whether the screw between the AC drive and the motor is tightened or not ◆ Check whether the U-V-W output connection cord is of poor insulation ◆ Increase the decel time ◆ Decrease the (Pr. 07-02) torque level-up setting ◆ Replace with the AC drive that possesses greater output capacity

Code Displayed	Error Explanations	Treatments
	Over-current during decel	<ul style="list-style-type: none"> ◆ Check whether the output wiring is of poor insulation ◆ Extend the decel time ◆ Replace with the AC drive that possesses greater output capacity
	Over-current during operation	<ul style="list-style-type: none"> ◆ Check whether the output wiring is of poor insulation ◆ Check whether the motor is blocked during operation ◆ Replace with the AC drive that possesses greater output capacity
	Grounding circuit protections. This message is displayed when the AC drive detects that the output terminal is grounded and that the grounding current exceeds 50% of the AC drive's rated current. Note: This is a protection towards the AC drive rather than the personnel.	<ul style="list-style-type: none"> ◆ Check whether the connection to the motor is short circuited or grounded ◆ Check whether the IGBT power module is functioning right ◆ Check whether the wiring on the output side is of poor insulation
	PG with a broken cord	<ul style="list-style-type: none"> ◆ Check the PG connection and whether the motor is blocked
	DC high-voltage side is exceedingly low within the AC drive	<ul style="list-style-type: none"> ◆ Check whether the input power voltage is normal ◆ Check whether the loading will be put on another unexpected heavy loading ◆ Whether the 3-phase model is of the single-phase power input or the phase-lacking
	IC data WRITE fault within the interior memory	<ul style="list-style-type: none"> ◆ Return to the factory
	IC data READ fault within the interior memory	<ul style="list-style-type: none"> ◆ Press the RESET button to reset the parameter to the factory setting ◆ Return to the factory if the previous method is not working

Code Displayed	Error Explanations	Treatments
cF3	AC drive's detection circuit fault	◆ Return to the factory
bb	When this function is set for the external multi-function input terminals (MI1~MI6), the AC drive will stop the output	◆ After the signal source is eliminated, "bb" disappeared immediately
Sc	SC: loading with short circuit Output side of the AC drive is short circuited	◆ Check whether the motor's resistance and insulation are functioning right
bf	Braking transistor fault	◆ Return to the factory
oH2	Braking transistor over-heat	◆ Check the fan and the ambient temperature ◆ Review the braking time and the braking resistor's rate of usage
FUSE	Broken fuse The transistor module of the main circuit is broken A fused DC circuit fuse	◆ Check whether the fuse of the transistor module is functioning right ◆ Check whether the loading side is short circuited or grounded
ob1	The A/D1 changer within the CPU is defected	◆ Replace the controller or the current sensor
ct2	The A/D2 changer within the CPU is defected	◆ Replace the controller or the current sensor
PId	PID motion error	◆ Check the PID feedback wiring ◆ Check whether the setting of the parameter is appropriate
Ac I.	ACI with a broken cord	◆ Check the wiring of ACI
cc	Current message error while the drive is stopped	◆ Return to the factory

Code Displayed	Error Explanations	Treatments
uEc	R1 setting error	<ul style="list-style-type: none"> ◆ Re-do the setting or execute the Tuning function
FAn	Fan fault	<ul style="list-style-type: none"> ◆ Check whether the fan is blocked ◆ Return to the factory
PHL	Power input phase-lacking Phase-lacking within the input power of the AC drive Three imbalanced conditions existed within the input voltage	<ul style="list-style-type: none"> ◆ Check whether the power voltage is normal ◆ Check whether the screw at the input power terminal is tightened
Er-	Other faults	<ul style="list-style-type: none"> ◆ Reserved
ErEUn	The motor parameter -Tuning- failed	<ul style="list-style-type: none"> ◆ Re-check the wiring and reset the parameter
cE-	Communication error	<ul style="list-style-type: none"> ◆ Check whether the communication signal is counter-connected (RJ11) ◆ Check whether the communication form is correct
Er-26	Upper and lower legs of PWM are of the same LOW level	<ul style="list-style-type: none"> ◆ Return to the factory
ErPU	KEYPAD communication overtime	<ul style="list-style-type: none"> ◆ Check whether the communication circuit is well-conducted
Er485	RS485 communication overtime	<ul style="list-style-type: none"> ◆ Check whether the communication circuit is well-conducted

CHAPTER 8 PARAMETER SUMMARY

Group 0: System Parameter

Parameters	Functions	Settings	Factory Setting	Control Mode					
				VF	VG	SV	SG	T	TG
00-00	Identity Code	Based on the model type	Read Only	<input type="radio"/>	<input type="radio"/>	<input type="radio"/>	<input type="radio"/>	<input type="radio"/>	<input type="radio"/>
00-01	Rated Current Display	Based on the model type	Read Only	<input type="radio"/>	<input type="radio"/>	<input type="radio"/>	<input type="radio"/>	<input type="radio"/>	<input type="radio"/>
00-02	Parameter Reset	10: Parameter reset (for 60Hz input) 9: Parameter reset (for 50Hz input) bit 0=1: Parameters are read only bit 1=1: Disable Frequency and Torque Command changes. bit 2=1: Keypad disable	0	<input type="radio"/>	<input type="radio"/>	<input type="radio"/>	<input type="radio"/>	<input type="radio"/>	<input type="radio"/>
⚡ 00-03	Star-up Display of the Drive	0: F (Master frequency command) 1: H (Output frequency) 2: U (multi-function display of 00-04) 3: Output current	0	<input type="radio"/>	<input type="radio"/>	<input type="radio"/>	<input type="radio"/>	<input type="radio"/>	<input type="radio"/>
⚡ 00-04	Definitions of the Multi-Function Display	0: output voltage 1: DC-BUS voltage 2: voltage command 3: multi-step speed 4: Speed command for the Process Control Operation step 5: Time remaining for the Process Control Operation step 6: Remaining number of times for the "restart after fault" feature 7: counter value 8: torque loading 9: power factor ±1.000 10: Power factor angle (0~180 degrees) 11: Output power (Kw) 12: Output power (Kva) 13: Motor speed (rpm) 14: IGBT module temperature 15: Braking resistor temperature 16: Digital terminal input status 17: PID output command 18: PID feedback value 19: the q axis voltage (V/F and vector)	0	<input type="radio"/>	<input type="radio"/>	<input type="radio"/>	<input type="radio"/>	<input type="radio"/>	<input type="radio"/>

	Parameters	Functions	Settings	Factory	Control Mode						
				Setting	VF	VG	SV	SG	T	TG	
			20: the d axis voltage (Vector only) 21: Magnetic flux 22: Overload accumulated time 23: Electronic thermal relay accumulated time 24: Execution time of the multi-step speed 25: quiescence stage 26: over-torque accumulated time 27: DC braking time 28: compensated voltage 29: Slip compensation frequency 30: Running number of Encoder (Channel 1) 31: PG position (position control) 32: Remaining pulses to reach position control (home position) 33: DC voltage upon a fault 34: The output AC voltage upon a fault 35: The output frequency upon a fault 36: The current value upon a fault 37: the frequency command upon a fault 38: day (power-up time) 39: hour, minute 40: The upper bound frequency value 41: Over-torque level 42: Stall level limitation 43: Torque compensation gain 44: torque limit (Pr. 06-12) 45: the q axis current (V/F and vector) 46: Frequency of Encoder (Channel 1) 49: PID error value 51: AVI input voltage 52: ACI input current 53: AUI input voltage 55: Auxiliary frequency value 60: Input state of digital terminals 61: Output state of digital terminals 84: Input frequency of pulse (Channel 2)								
⚡	00-04	Definitions of the Multi-Function Display		0	○	○	○	○	○	○	○

	Parameters	Functions	Settings	Factory Setting	Control Mode					
					VF	VG	SV	SG	T	TG
⚡	00-04	Definitions of the Multi-Function Display	85: Input position of pulse (Channel 2) 86: OL3 timer	0	<input type="radio"/>	<input type="radio"/>	<input type="radio"/>	<input type="radio"/>	<input type="radio"/>	<input type="radio"/>
⚡	00-05	User-Defined Coefficient Setting	4 digit: 0-3: the number of the decimal places 3-0 digit: 40~9999	0	<input type="radio"/>	<input type="radio"/>	<input type="radio"/>	<input type="radio"/>	<input type="radio"/>	<input type="radio"/>
	00-06	Software Version	Read-only							
⚡	00-07	Password Input	0~9999	0	<input type="radio"/>	<input type="radio"/>	<input type="radio"/>	<input type="radio"/>	<input type="radio"/>	<input type="radio"/>
⚡	00-08	Password Setting	0~9999	0	<input type="radio"/>	<input type="radio"/>	<input type="radio"/>	<input type="radio"/>	<input type="radio"/>	<input type="radio"/>
⚡	00-09	Frequency and the Operation Method of PU05	Bit0=0: Frequency via the up/down keys Bit0=1: Frequency command enabled after pressing the data/prog key Bit1=0: PU05&RS485 frequency memorized Bit1=1: PU05&RS485 frequency not memorized Bit2=0: Up/down pin frequency memorized Bit2=1: Up/down pin frequency not memorized Bit3=0: FWD/REV direction memorized Bit3=1: FWD/REV direction not memorized Bit4=0: Parameter memorized Bit4=1: Parameter not memorized	00000	<input type="radio"/>	<input type="radio"/>	<input type="radio"/>	<input type="radio"/>	<input type="radio"/>	<input type="radio"/>
	00-10	Control Methods	0: V/F Control	0	<input type="radio"/>	<input checked="" type="checkbox"/>	<input checked="" type="checkbox"/>	<input checked="" type="checkbox"/>	<input checked="" type="checkbox"/>	<input checked="" type="checkbox"/>
			1: V/F Control + PG		<input checked="" type="checkbox"/>	<input type="radio"/>	<input checked="" type="checkbox"/>	<input checked="" type="checkbox"/>	<input checked="" type="checkbox"/>	<input checked="" type="checkbox"/>
			2: Vector Control (open loop)		<input checked="" type="checkbox"/>	<input checked="" type="checkbox"/>	<input type="radio"/>	<input checked="" type="checkbox"/>	<input checked="" type="checkbox"/>	<input checked="" type="checkbox"/>
			3: Vector Control + PG (closed loop)		<input checked="" type="checkbox"/>	<input checked="" type="checkbox"/>	<input checked="" type="checkbox"/>	<input type="radio"/>	<input checked="" type="checkbox"/>	<input checked="" type="checkbox"/>
			4: Torque Control		<input checked="" type="checkbox"/>	<input checked="" type="checkbox"/>	<input checked="" type="checkbox"/>	<input checked="" type="checkbox"/>	<input type="radio"/>	<input checked="" type="checkbox"/>
			5: Torque Control + PG		<input checked="" type="checkbox"/>	<input checked="" type="checkbox"/>	<input checked="" type="checkbox"/>	<input checked="" type="checkbox"/>	<input checked="" type="checkbox"/>	<input type="radio"/>
	00-11	Forward Reverse transition in V/F mode	0: Follow Pr. 01-00 to 01-08 Settings 1: Follow Pr. 01-00 to 01-08 Settings 2: V/F1.5 power curve (Do not skip the start-up frequency) 3: V/F1.5 power curve (skip) 4: 2 power curve (do not skip) 5: 2 power curve (skip)	0	<input type="radio"/>	<input type="radio"/>	<input checked="" type="checkbox"/>	<input checked="" type="checkbox"/>	<input checked="" type="checkbox"/>	<input checked="" type="checkbox"/>

	Parameters	Functions	Settings	Factory Setting	Control Mode					
					VF	VG	SV	SG	T	TG
⚡	00-12	Constant Torque Operation Selection	0: OL (100%) constant torque operation 1: OL (125%) variable torque operation	0	<input type="radio"/>	<input type="radio"/>	<input type="radio"/>	<input type="radio"/>	<input type="radio"/>	<input type="radio"/>
⚡	00-13	Optimal Acceleration /Deceleration Setting	0: Linear acceleration/deceleration 1: Auto acceleration, linear deceleration 2: Linear acceleration, auto deceleration 3: Auto acceleration/deceleration 4: Linear acceleration/deceleration, but conduct the stall prevention throughout the auto acceleration/deceleration function.	0	<input type="radio"/>	<input type="radio"/>	<input type="radio"/>	<input type="radio"/>	<input checked="" type="radio"/>	<input checked="" type="radio"/>
	00-14	Time Unit for Acceleration /Deceleration and S Curve	0: unit: 0.01 sec 1: unit: 0.1 sec	0	<input type="radio"/>	<input type="radio"/>	<input type="radio"/>	<input type="radio"/>	<input type="radio"/>	<input type="radio"/>
⚡	00-15	Carrier Frequency Upper Bound	0: soft pwm 1~15KHz	10	<input type="radio"/>	<input type="radio"/>	<input type="radio"/>	<input type="radio"/>	<input type="radio"/>	<input type="radio"/>
⚡	00-16	Carrier Frequency Lower Bound	1-15KHz (disabled during soft PWM)	10	<input type="radio"/>	<input type="radio"/>	<input type="radio"/>	<input type="radio"/>	<input type="radio"/>	<input type="radio"/>
⚡	00-17	Center Frequency of Soft pwm	1~7KHz	3	<input type="radio"/>	<input type="radio"/>	<input type="radio"/>	<input type="radio"/>	<input type="radio"/>	<input type="radio"/>
⚡	00-18	Auto Voltage Regulation (AVR) Function	0: AVR function enabled 1: AVR function disabled 2: AVR function disabled during deceleration	0	<input type="radio"/>	<input type="radio"/>	<input checked="" type="radio"/>	<input checked="" type="radio"/>	<input checked="" type="radio"/>	<input checked="" type="radio"/>
⚡	00-19	Automatic Energy-Saving Operation	BIT0=0: Disable automatic energy-saving operation BIT0=1: Enable automatic energy-saving operation BIT1=0: Maximum output voltage equals to the input power voltage BIT1=1: Maximum output voltage could be greater than the input power voltage (over-modulation available)	00010	<input type="radio"/>	<input type="radio"/>	<input type="radio"/>	<input type="radio"/>	<input type="radio"/>	<input type="radio"/>

	Parameters	Functions	Settings	Factory Setting	Control Mode					
					VF	VG	SV	SG	T	TG
⚡	00-20	Source of the Frequency Command	0: The digital keypad 1: The RS485 communication input 2: The external analog input 3: The external up/down pins (multi-function input terminal) 4: The pg (encoder) input or clock 5: The RS485 and PU05 at the same time (dual source) 6: The clock and direction (set by 10-12)	0	<input type="radio"/>	<input type="radio"/>	<input type="radio"/>	<input type="radio"/>	<input type="radio"/>	<input type="radio"/>
⚡	00-21	Source of the Operation Command	0: The RS485 communication 1: The external terminal operation (2 wire or three wire) 2: The digital keypad operation	0	<input type="radio"/>	<input type="radio"/>	<input type="radio"/>	<input type="radio"/>	<input type="radio"/>	<input type="radio"/>
⚡	00-22	Stop Methods	0: Ramp to stop 1: Coast to stop	0	<input type="radio"/>	<input type="radio"/>	<input type="radio"/>	<input type="radio"/>	<input type="radio"/>	<input type="radio"/>
⚡	00-23	Reverse Operation	0: REV enabled 1: REV disabled 2: FWD disabled	0	<input type="radio"/>	<input type="radio"/>	<input type="radio"/>	<input type="radio"/>	<input type="radio"/>	<input type="radio"/>

Group 1: Basic Parameter

Parameters	Functions	Settings	Factory Setting	Control Mode					
				VF	VG	SV	SG	T	TG
01-00	Maximum Operation Frequency	50.0~400.00Hz	60.00/ 50.00	○	○	○	○	○	○
01-01	Maximum Voltage Frequency (Base Frequency)	0.00~400.00Hz	60.00/ 50.00	○	○	○	○	○	○
01-02	Maximum Output Voltage	230V: 0.0~255.0V	220.0	○	○	○	○	○	○
		460V: 0.0~510.0V	440.0						
01-03	Upper Midpoint Output Frequency	0.00~400.00Hz	0.50	○	○	×	×	×	×
⚡ 01-04	Upper Midpoint Output Voltage	230V: 0.0~255.0V	5.0	○	○	×	×	×	×
		460V: 0.0~510.0V	10.0						
01-05	Lower Midpoint Output Frequency	0.00~400.00Hz	0.50	○	○	×	×	×	×
⚡ 01-06	Lower Midpoint Output Voltage	230V: 0.0~255.0V	5.0	○	○	×	×	×	×
		460V: 0.0~510.0V	10.0						
01-07	Minimum Output Frequency	0.00~400.00Hz	0.00	○	○	×	×	×	×
⚡ 01-08	Minimum Output Voltage	230V: 0.0~255.0V	5.0	○	○	×	×	×	×
		460V: 0.0~510.0V	10.0						
01-09	Startup Frequency	0.00~400.00Hz	0.50	○	○	○	○	×	×
⚡ 01-10	Upper Bound Frequency	0.0~110.0%	100.0	○	○	○	○	○	○
⚡ 01-11	Lower Bound Frequency	0.0~100.0%	0.0	○	○	○	○	×	×
⚡ 01-12	The 1 st Acceleration Time	0.00~600.00 /0.0~6000.0 Sec	10.00/ 60.00	○	○	○	○	×	×
⚡ 01-13	The 1 st Deceleration Time	0.00~600.00 /0.0~6000.0 Sec	10.00/ 60.00	○	○	○	○	×	×
⚡ 01-14	The 2 nd Acceleration Time	0.00~600.00 /0.0~6000.0 Sec	10.00/ 60.00	○	○	○	○	×	×
⚡ 01-15	The 2 nd Deceleration Time	0.00~600.00 /0.0~6000.0 Sec	10.00/ 60.00	○	○	○	○	×	×
⚡ 01-16	The 3 rd Acceleration Time	0.00~600.00 /0.0~6000.0 Sec	10.00/ 60.00	○	○	○	○	×	×
⚡ 01-17	The 3 rd Deceleration Time	0.00~600.00 /0.0~6000.0 Sec	10.00/ 60.00	○	○	○	○	×	×
⚡ 01-18	The 4 th Acceleration Time	0.00~600.00 /0.0~6000.0 Sec	10.00/ 60.00	○	○	○	○	×	×

	Parameters	Functions	Settings	Factory Setting	Control Mode					
					VF	VG	SV	SG	T	TG
⚡	01-19	The 4 th Deceleration Time	0.00~600.00 /0.0~6000.0 Sec	10.00/ 60.00	○	○	○	○	×	×
⚡	01-20	JOG Acceleration Time	0.00~600.00 /0.0~6000.0 Sec	10.00/ 60.00	○	○	○	○	×	×
⚡	01-21	JOG Deceleration Time	0.00~600.00 /0.0~6000.0 Sec	10.00/ 60.00	○	○	○	○	×	×
⚡	01-22	JOG Frequency	0.00 Hz ~ 400.00Hz	6.00	○	○	○	○	×	×
⚡	01-23	1 st /4 th Acceleration/Deceleration Frequency	0.00 Hz ~ 400.00Hz	0.00	○	○	○	○	×	×
⚡	01-24	S-Curve for Acceleration Departure Time	0.00~250.0 Sec	0.00	○	○	○	○	×	×
⚡	01-25	S-Curve for Acceleration Arrival Time	0.00~250.0 Sec	0.00	○	○	○	○	×	×
⚡	01-26	S-Curve for Deceleration Departure Time	0.00~250.0 Sec	0.00	○	○	○	○	×	×
⚡	01-27	S-Curve for Deceleration Arrival Time	0.00~250.0 Sec	0.00	○	○	○	○	×	×
	01-28	Skip Frequency 1 (upper limit)	0.00~400.00Hz	0.00	○	○	○	○	×	×
	01-29	Skip Frequency 1 (lower limit)	0.00~400.00Hz	0.00	○	○	○	○	×	×
	01-30	Skip Frequency 2 (upper limit)	0.00~400.00Hz	0.00	○	○	○	○	×	×
	01-31	Skip Frequency 2 (lower limit)	0.00~400.00Hz	0.00	○	○	○	○	×	×
	01-32	Skip Frequency 3 (upper limit)	0.00~400.00Hz	0.00	○	○	○	○	×	×
	01-33	Skip Frequency 3 (lower limit)	0.00~400.00Hz	0.00	○	○	○	○	×	×

Group 2: Digital Output/Input Parameter

Parameters	Functions	Settings	Factory Setting	Control Mode					
				VF	VG	SV	SG	T	TG
02-00	2-Wire/3-Wire Operation Control	0: FWD/STOP, REV/STOP 1: FWD/STOP, REV/STOP (Line Start Lockout) 2: RUN/STOP, REV/FWD 3: RUN/STOP, REV/FWD (Line Start Lockout) 4: 3-wire (momentary push button) 5: 3-wire (momentary push button and Line Start Lockout)	0	<input type="radio"/>	<input type="radio"/>	<input type="radio"/>	<input type="radio"/>	<input type="radio"/>	<input type="radio"/>
02-01	Multi-Function Input Command 1 (MI1)	0: no function	1	<input type="radio"/>	<input type="radio"/>	<input type="radio"/>	<input type="radio"/>	<input type="radio"/>	<input type="radio"/>
		1: multi-step speed command 1		<input type="radio"/>	<input type="radio"/>	<input type="radio"/>	<input type="radio"/>	<input checked="" type="radio"/>	<input checked="" type="radio"/>
		2: multi-step speed command 2		<input type="radio"/>	<input type="radio"/>	<input type="radio"/>	<input type="radio"/>	<input checked="" type="radio"/>	<input checked="" type="radio"/>
		3: multi-step speed command 3		<input type="radio"/>	<input type="radio"/>	<input type="radio"/>	<input type="radio"/>	<input checked="" type="radio"/>	<input checked="" type="radio"/>
		4: multi-step speed command 4		<input type="radio"/>	<input type="radio"/>	<input type="radio"/>	<input type="radio"/>	<input checked="" type="radio"/>	<input checked="" type="radio"/>
		5: Reset		<input type="radio"/>	<input type="radio"/>	<input type="radio"/>	<input type="radio"/>	<input type="radio"/>	<input type="radio"/>
02-02	Multi-Function Input Command 2 (MI2)	7: acceleration/deceleration speed inhibit	2	<input type="radio"/>	<input type="radio"/>	<input type="radio"/>	<input type="radio"/>	<input checked="" type="radio"/>	<input checked="" type="radio"/>
		8: the 1 st , 2 nd acceleration/deceleration time selection		<input type="radio"/>	<input type="radio"/>	<input type="radio"/>	<input type="radio"/>	<input checked="" type="radio"/>	<input checked="" type="radio"/>
02-03	Multi-Function Input Command 3 (MI3)	9: the 3 rd , 4 th acceleration/deceleration time selection	3	<input type="radio"/>	<input type="radio"/>	<input type="radio"/>	<input type="radio"/>	<input checked="" type="radio"/>	<input checked="" type="radio"/>
		10: EF input		<input type="radio"/>	<input type="radio"/>	<input type="radio"/>	<input type="radio"/>	<input type="radio"/>	<input type="radio"/>
		11: disable vector(stop)		<input type="radio"/>	<input type="radio"/>	<input type="radio"/>	<input type="radio"/>	<input type="radio"/>	<input type="radio"/>
		12: B.B. traces from the bottom upward		<input type="radio"/>	<input type="radio"/>	<input type="radio"/>	<input type="radio"/>	<input type="radio"/>	<input type="radio"/>
02-04	Multi-Function Input Command 4 (MI4)	13: B.B. traces from the top downward	4	<input type="radio"/>	<input type="radio"/>	<input type="radio"/>	<input type="radio"/>	<input type="radio"/>	<input type="radio"/>
		14: cancel the setting of the optimal acceleration/deceleration time		<input type="radio"/>	<input type="radio"/>	<input type="radio"/>	<input type="radio"/>	<input checked="" type="radio"/>	<input checked="" type="radio"/>
02-05	Multi-Function Input Command 5 (MI5)	15: switch between drive settings 1 and 2	5	<input type="radio"/>	<input type="radio"/>	<input type="radio"/>	<input type="radio"/>	<input type="radio"/>	<input type="radio"/>
		16: operation speed command form AVI		<input type="radio"/>	<input type="radio"/>	<input type="radio"/>	<input type="radio"/>	<input type="radio"/>	<input type="radio"/>
		17: operation speed command from ACI		<input type="radio"/>	<input type="radio"/>	<input type="radio"/>	<input type="radio"/>	<input type="radio"/>	<input type="radio"/>

Parameters	Functions	Settings	Factory Setting	Control Mode					
				VF	VG	SV	SG	T	TG
02-06	Multi-Function Input Command 6 (MI6)	18: operation speed command from AUI	10	<input type="radio"/>	<input type="radio"/>	<input type="radio"/>	<input type="radio"/>	<input type="radio"/>	<input type="radio"/>
		19: Emergency Stop		<input type="radio"/>	<input type="radio"/>	<input type="radio"/>	<input type="radio"/>	<input type="radio"/>	<input type="radio"/>
		20: Digital Up command		<input type="radio"/>	<input type="radio"/>	<input type="radio"/>	<input type="radio"/>	<input type="radio"/>	<input type="radio"/>
		21: Digital Down command		<input type="radio"/>	<input type="radio"/>	<input type="radio"/>	<input type="radio"/>	<input type="radio"/>	<input type="radio"/>
02-23	Multi-Function Input Command 7	22: auto procedural operation function disabled	0	<input type="radio"/>	<input type="radio"/>	<input type="radio"/>	<input type="radio"/>	<input checked="" type="checkbox"/>	<input checked="" type="checkbox"/>
		23: auto procedural operation suspended		<input type="radio"/>	<input type="radio"/>	<input type="radio"/>	<input type="radio"/>	<input checked="" type="checkbox"/>	<input checked="" type="checkbox"/>
02-24	Multi-Function Input Command 8	24: PID function disabled	0	<input type="radio"/>	<input type="radio"/>	<input type="radio"/>	<input type="radio"/>	<input type="radio"/>	<input type="radio"/>
		25: clear counter		<input type="radio"/>	<input type="radio"/>	<input type="radio"/>	<input type="radio"/>	<input type="radio"/>	<input type="radio"/>
		26: input the counter value (multi-function input command 6)		<input type="radio"/>	<input type="radio"/>	<input type="radio"/>	<input type="radio"/>	<input type="radio"/>	<input type="radio"/>
02-25	Multi-Function Input Command 9	27: FWD JOG command	0	<input type="radio"/>	<input type="radio"/>	<input type="radio"/>	<input type="radio"/>	<input checked="" type="checkbox"/>	<input checked="" type="checkbox"/>
		28: REV JOG command		<input type="radio"/>	<input type="radio"/>	<input type="radio"/>	<input type="radio"/>	<input checked="" type="checkbox"/>	<input checked="" type="checkbox"/>
02-26	Multi-Function Input Command 10	29: braking module breakdown	0	<input type="radio"/>	<input type="radio"/>	<input type="radio"/>	<input type="radio"/>	<input checked="" type="checkbox"/>	<input checked="" type="checkbox"/>
		30: position control		<input type="radio"/>	<input type="radio"/>	<input type="radio"/>	<input type="radio"/>	<input checked="" type="checkbox"/>	<input checked="" type="checkbox"/>
		31: no PG control		<input checked="" type="checkbox"/>	<input type="radio"/>	<input checked="" type="checkbox"/>	<input type="radio"/>	<input checked="" type="checkbox"/>	<input type="radio"/>
02-27	Multi-Function Input Command 11	32: torque/speed switch	0	<input checked="" type="checkbox"/>	<input checked="" type="checkbox"/>	<input type="radio"/>	<input type="radio"/>	<input type="radio"/>	<input type="radio"/>
		33: no EEPROM write		<input type="radio"/>	<input type="radio"/>	<input type="radio"/>	<input type="radio"/>	<input type="radio"/>	<input type="radio"/>
		34: DC current control		<input type="radio"/>	<input type="radio"/>	<input type="radio"/>	<input type="radio"/>	<input type="radio"/>	<input type="radio"/>
		35: 04-35,04-36 disable		<input type="radio"/>	<input type="radio"/>	<input type="radio"/>	<input type="radio"/>	<input type="radio"/>	<input type="radio"/>
02-28	Multi-Function Input Command 12	36: Position control 2 (PG2 input)	0	<input type="radio"/>	<input type="radio"/>	<input type="radio"/>	<input type="radio"/>	<input type="radio"/>	<input type="radio"/>
		37: dwell function disable		<input type="radio"/>	<input type="radio"/>	<input type="radio"/>	<input type="radio"/>	<input type="radio"/>	<input type="radio"/>
		38: PAUSE STOP		<input type="radio"/>	<input type="radio"/>	<input type="radio"/>	<input type="radio"/>	<input type="radio"/>	<input type="radio"/>
		39: P2P position control		<input type="radio"/>	<input type="radio"/>	<input type="radio"/>	<input type="radio"/>	<input type="radio"/>	<input type="radio"/>
02-29	Multi-Function Input Command 13	40: P2P Hold	0	<input type="radio"/>	<input type="radio"/>	<input type="radio"/>	<input type="radio"/>	<input type="radio"/>	<input type="radio"/>
		41: FWD Home Search		<input type="radio"/>	<input type="radio"/>	<input type="radio"/>	<input type="radio"/>	<input type="radio"/>	<input type="radio"/>
		42: P2P FWD Limit		<input type="radio"/>	<input type="radio"/>	<input type="radio"/>	<input type="radio"/>	<input type="radio"/>	<input type="radio"/>
02-30	Multi-Function Input Command 14	43: P2P REV Limit	0	<input type="radio"/>	<input type="radio"/>	<input type="radio"/>	<input type="radio"/>	<input type="radio"/>	<input type="radio"/>
		44: REV Home Search		<input type="radio"/>	<input type="radio"/>	<input type="radio"/>	<input type="radio"/>	<input type="radio"/>	<input type="radio"/>

	Parameters	Functions	Settings	Factory Setting	Control Mode					
					VF	VG	SV	SG	T	TG
⚡	02-07	UP/DOWN key mode	Bit 0=0: UP/DOWN following the acceleration/deceleration time Bit 0=1: UP following the constant speed, and DOWN following the deceleration time Bit 1=0: UP following the acceleration time, and DOWN following the constant speed Bit 1=1: UP/DOWN following the constant speed	00000	<input type="radio"/>	<input type="radio"/>	<input type="radio"/>	<input type="radio"/>	<input type="radio"/>	<input type="radio"/>
⚡	02-08	The Acceleration/Deceleration Speed of the UP/DOWN Key with Constant Speed	0.01~1.00Hz/msec	0.01	<input type="radio"/>	<input type="radio"/>	<input type="radio"/>	<input type="radio"/>	<input type="radio"/>	<input type="radio"/>
⚡	02-09	Digital Input Responding Time	0.001~30.000 Sec	0.005	<input type="radio"/>	<input type="radio"/>	<input type="radio"/>	<input type="radio"/>	<input type="radio"/>	<input type="radio"/>
⚡	02-10	Digital Input Operation Direction	0~65535 Bit 0~7=1 high active	0	<input type="radio"/>	<input type="radio"/>	<input type="radio"/>	<input type="radio"/>	<input type="radio"/>	<input type="radio"/>
⚡	02-11	Multi-Function Output 1 RA, RB, RC (Relay 1)	0: no function	15	<input type="radio"/>	<input type="radio"/>	<input type="radio"/>	<input type="radio"/>	<input type="radio"/>	<input type="radio"/>
1: AC drive running			<input type="radio"/>		<input type="radio"/>	<input type="radio"/>	<input type="radio"/>	<input type="radio"/>	<input type="radio"/>	
2: operation speed attained 1 (both directions)			<input type="radio"/>		<input type="radio"/>	<input type="radio"/>	<input type="radio"/>	<input checked="" type="radio"/>	<input checked="" type="radio"/>	
3: operation speed attained 2 (both directions)			<input type="radio"/>		<input type="radio"/>	<input type="radio"/>	<input type="radio"/>	<input checked="" type="radio"/>	<input checked="" type="radio"/>	
⚡	02-12	Multi-Function Output 2 MRA, MRC (Relay 2)	4: pre-set speed attained 1 (both directions)	1	<input type="radio"/>	<input type="radio"/>	<input type="radio"/>	<input type="radio"/>	<input type="radio"/>	<input type="radio"/>
5: pre-set speed attained 2 (forward only)			<input type="radio"/>		<input type="radio"/>	<input type="radio"/>	<input type="radio"/>	<input type="radio"/>	<input type="radio"/>	
6: pre-set speed attained 1 (both directions)			<input type="radio"/>		<input type="radio"/>	<input type="radio"/>	<input type="radio"/>	<input type="radio"/>	<input type="radio"/>	
⚡	02-13	Multi-Function Output 3 MO1	7: pre-set speed attained 2 (forward direction)	2	<input type="radio"/>	<input type="radio"/>	<input type="radio"/>	<input type="radio"/>	<input type="radio"/>	<input type="radio"/>
10: zero speed			<input type="radio"/>		<input type="radio"/>	<input type="radio"/>	<input type="radio"/>	<input type="radio"/>	<input type="radio"/>	
11: over-torque(oL2)			<input type="radio"/>		<input type="radio"/>	<input type="radio"/>	<input type="radio"/>	<input type="radio"/>	<input type="radio"/>	
12: base block (Pause)			<input type="radio"/>		<input type="radio"/>	<input type="radio"/>	<input type="radio"/>	<input type="radio"/>	<input type="radio"/>	
13: drive ready for use			<input type="radio"/>		<input type="radio"/>	<input type="radio"/>	<input type="radio"/>	<input type="radio"/>	<input type="radio"/>	
14: low voltage alarm (LV)			<input type="radio"/>		<input type="radio"/>	<input type="radio"/>	<input type="radio"/>	<input type="radio"/>	<input type="radio"/>	
15: error indication			<input type="radio"/>		<input type="radio"/>	<input type="radio"/>	<input type="radio"/>	<input type="radio"/>	<input type="radio"/>	
16: drive operation mode	<input type="radio"/>	<input type="radio"/>	<input type="radio"/>	<input type="radio"/>	<input type="radio"/>	<input type="radio"/>				

	Parameters	Functions	Settings	Factory Setting	Control Mode					
					VF	VG	SV	SG	T	TG
⚡	02-14	Multi-Function Output 4 (MO2)	17: PCO Run	13	<input type="radio"/>	<input type="radio"/>	<input type="radio"/>	<input type="radio"/>	<input checked="" type="checkbox"/>	<input checked="" type="checkbox"/>
			18: PCO suspended		<input type="radio"/>	<input type="radio"/>	<input type="radio"/>	<input type="radio"/>	<input checked="" type="checkbox"/>	<input checked="" type="checkbox"/>
			19: 1 st step of PCO completed		<input type="radio"/>	<input type="radio"/>	<input type="radio"/>	<input type="radio"/>	<input checked="" type="checkbox"/>	<input checked="" type="checkbox"/>
			20: PCO completed		<input type="radio"/>	<input type="radio"/>	<input type="radio"/>	<input type="radio"/>	<input checked="" type="checkbox"/>	<input checked="" type="checkbox"/>
			21: pre-set counter value attained		<input type="radio"/>	<input type="radio"/>	<input type="radio"/>	<input type="radio"/>	<input type="radio"/>	<input type="radio"/>
			22: desired counter value attained		<input type="radio"/>	<input type="radio"/>	<input type="radio"/>	<input type="radio"/>	<input type="radio"/>	<input type="radio"/>
			23: heat sink overheat warning		<input type="radio"/>	<input type="radio"/>	<input type="radio"/>	<input type="radio"/>	<input type="radio"/>	<input type="radio"/>
			24: operation frequency attained 1 (both directions)		<input type="radio"/>	<input type="radio"/>	<input type="radio"/>	<input type="radio"/>	<input checked="" type="checkbox"/>	<input checked="" type="checkbox"/>
			25: operation frequency attained 2 (both directions)		<input type="radio"/>	<input type="radio"/>	<input type="radio"/>	<input type="radio"/>	<input checked="" type="checkbox"/>	<input checked="" type="checkbox"/>
			26: pre-set frequency attained 1 (both directions)		<input type="radio"/>	<input type="radio"/>	<input type="radio"/>	<input type="radio"/>	<input type="radio"/>	<input type="radio"/>
			27: pre-set frequency attained 2 (forward only)		<input type="radio"/>	<input type="radio"/>	<input type="radio"/>	<input type="radio"/>	<input type="radio"/>	<input type="radio"/>
			28: pre-set frequency attained 1 (both directions)		<input type="radio"/>	<input type="radio"/>	<input type="radio"/>	<input type="radio"/>	<input type="radio"/>	<input type="radio"/>
			29: pre-set frequency attained 2 (forward only)		<input type="radio"/>	<input type="radio"/>	<input type="radio"/>	<input type="radio"/>	<input type="radio"/>	<input type="radio"/>
			30: software braking output		<input type="radio"/>	<input type="radio"/>	<input type="radio"/>	<input type="radio"/>	<input type="radio"/>	<input type="radio"/>
			31: position achieved		<input type="radio"/>	<input checked="" type="checkbox"/>	<input type="radio"/>	<input checked="" type="checkbox"/>	<input type="radio"/>	<input checked="" type="checkbox"/>
			32~47: PCO step indication		<input type="radio"/>	<input type="radio"/>	<input type="radio"/>	<input type="radio"/>	<input checked="" type="checkbox"/>	<input checked="" type="checkbox"/>
			48~63: multi-step indication		<input type="radio"/>	<input type="radio"/>	<input type="radio"/>	<input type="radio"/>	<input checked="" type="checkbox"/>	<input checked="" type="checkbox"/>
			64: PG Fault		<input type="radio"/>	<input checked="" type="checkbox"/>	<input type="radio"/>	<input checked="" type="checkbox"/>	<input type="radio"/>	<input checked="" type="checkbox"/>
			65: PG Stall		<input type="radio"/>	<input checked="" type="checkbox"/>	<input type="radio"/>	<input checked="" type="checkbox"/>	<input type="radio"/>	<input checked="" type="checkbox"/>
			69: over-torque(oL3)		<input type="radio"/>	<input type="radio"/>	<input type="radio"/>	<input type="radio"/>	<input type="radio"/>	<input type="radio"/>
			70: Zero speed (STOP)		<input type="radio"/>	<input type="radio"/>	<input type="radio"/>	<input type="radio"/>	<input type="radio"/>	<input type="radio"/>
71: Position synchronization 1 (10-10)	<input type="radio"/>	<input type="radio"/>	<input type="radio"/>	<input type="radio"/>	<input type="radio"/>	<input type="radio"/>				
72: Position synchronization 2 (10-23)	<input type="radio"/>	<input type="radio"/>	<input type="radio"/>	<input type="radio"/>	<input type="radio"/>	<input type="radio"/>				
⚡	02-15	Multi-Function Output Direction	0~15 (1 high)	00000	<input type="radio"/>	<input type="radio"/>	<input type="radio"/>	<input type="radio"/>	<input type="radio"/>	<input type="radio"/>
⚡	02-16	Counter Values Achieve the Pre-Set Values	0~65500	0	<input type="radio"/>	<input type="radio"/>	<input type="radio"/>	<input type="radio"/>	<input type="radio"/>	<input type="radio"/>
⚡	02-17	Designated Counter Value Achieved	0~65500	0	<input type="radio"/>	<input type="radio"/>	<input type="radio"/>	<input type="radio"/>	<input type="radio"/>	<input type="radio"/>
⚡	02-18	Digital Output Gain	1~40	1	<input type="radio"/>	<input type="radio"/>	<input type="radio"/>	<input type="radio"/>	<input type="radio"/>	<input type="radio"/>

	Parameters	Functions	Settings	Factory Setting	Control Mode					
					VF	VG	SV	SG	T	TG
⚡	02-19	Pre-set Arrival Frequency 1	0.00~400.00HZ	60.00/ 50.00	<input type="radio"/>	<input type="radio"/>	<input type="radio"/>	<input type="radio"/>	<input type="radio"/>	<input type="radio"/>
⚡	02-20	Pre-set Arrival Frequency 1 Width	0.00~400.00HZ	2.00	<input type="radio"/>	<input type="radio"/>	<input type="radio"/>	<input type="radio"/>	<input type="radio"/>	<input type="radio"/>
⚡	02-21	Pre-set Arrival Frequency 2	0.00~400.00HZ	60.00/ 50.00	<input type="radio"/>	<input type="radio"/>	<input type="radio"/>	<input type="radio"/>	<input type="radio"/>	<input type="radio"/>
⚡	02-22	Pre-set Arrival Frequency 2 Width	0.00~400.00HZ	2.00	<input type="radio"/>	<input type="radio"/>	<input type="radio"/>	<input type="radio"/>	<input type="radio"/>	<input type="radio"/>

Group 3: Analog Output/Input Parameter

	Parameters	Functions	Settings	Factory Setting	Control Mode					
					VF	VG	SV	SG	T	TG
⚡	03-00	Analog Input 1 (AVI)	0: no functions	1	<input type="radio"/>	<input type="radio"/>	<input type="radio"/>	<input type="radio"/>	<input type="radio"/>	<input type="radio"/>
			1: frequency/torque command		<input type="radio"/>	<input type="radio"/>	<input type="radio"/>	<input type="radio"/>	<input type="radio"/>	<input type="radio"/>
			2: torque limitations		<input checked="" type="radio"/>	<input checked="" type="radio"/>	<input type="radio"/>	<input type="radio"/>	<input type="radio"/>	<input type="radio"/>
			3: acceleration/deceleration time gain		<input type="radio"/>	<input type="radio"/>	<input type="radio"/>	<input type="radio"/>	<input checked="" type="radio"/>	<input checked="" type="radio"/>
⚡	03-01	Analog Input 2 (ACI)	4: upper bound frequency	0	<input type="radio"/>	<input type="radio"/>	<input type="radio"/>	<input type="radio"/>	<input checked="" type="radio"/>	<input checked="" type="radio"/>
			5: over-torque current level		<input type="radio"/>	<input type="radio"/>	<input type="radio"/>	<input type="radio"/>	<input type="radio"/>	<input type="radio"/>
			6: torque compensation gain		<input type="radio"/>	<input type="radio"/>	<input checked="" type="radio"/>	<input checked="" type="radio"/>	<input checked="" type="radio"/>	<input checked="" type="radio"/>
			7: over-current stall prevention level during operation		<input type="radio"/>	<input type="radio"/>	<input type="radio"/>	<input type="radio"/>	<input checked="" type="radio"/>	<input checked="" type="radio"/>
⚡	03-02	Analog Input 3 (AUI)	8: torque compensation(Vector)	0	<input checked="" type="radio"/>	<input checked="" type="radio"/>	<input type="radio"/>	<input type="radio"/>	<input type="radio"/>	<input type="radio"/>
			9: AVI auxiliary frequency (multiplication by the ratio of AVI)		<input type="radio"/>	<input type="radio"/>	<input type="radio"/>	<input type="radio"/>	<input type="radio"/>	<input type="radio"/>
			10: ACI auxiliary frequency (multiplication by the ratio of ACI)		<input type="radio"/>	<input type="radio"/>	<input type="radio"/>	<input type="radio"/>	<input type="radio"/>	<input type="radio"/>
			11: AUI auxiliary frequency (multiplication by the ratio of AUI)		<input type="radio"/>	<input type="radio"/>	<input type="radio"/>	<input type="radio"/>	<input type="radio"/>	<input type="radio"/>
			12: PID offset		<input type="radio"/>	<input type="radio"/>	<input type="radio"/>	<input type="radio"/>	<input type="radio"/>	<input type="radio"/>
			13: Auxiliary frequency of master frequency		<input type="radio"/>	<input type="radio"/>	<input type="radio"/>	<input type="radio"/>	<input type="radio"/>	<input type="radio"/>
⚡	03-03	(AVI) Analog Input Bias 1	-10.00~10.00V	0.00	<input type="radio"/>	<input type="radio"/>	<input type="radio"/>	<input type="radio"/>	<input type="radio"/>	<input type="radio"/>
⚡	03-04	(ACI) Analog Input Bias 2	0.00~20.00mA	4.00	<input type="radio"/>	<input type="radio"/>	<input type="radio"/>	<input type="radio"/>	<input type="radio"/>	<input type="radio"/>
⚡	03-05	(AUI) Analog Input Bias 3	-10.00~10.00V	0.00	<input type="radio"/>	<input type="radio"/>	<input type="radio"/>	<input type="radio"/>	<input type="radio"/>	<input type="radio"/>
⚡	03-06	(AVI) Positive/Negative Bias Mode	0: zero bias	0	<input type="radio"/>	<input type="radio"/>	<input type="radio"/>	<input type="radio"/>	<input type="radio"/>	<input type="radio"/>
			1: value lower than bias = bias		<input type="radio"/>	<input type="radio"/>	<input type="radio"/>	<input type="radio"/>	<input type="radio"/>	<input type="radio"/>
			2: value greater than bias = bias		<input type="radio"/>	<input type="radio"/>	<input type="radio"/>	<input type="radio"/>	<input type="radio"/>	<input type="radio"/>
			3: the absolute value of the bias voltage while serving as the center		<input type="radio"/>	<input type="radio"/>	<input type="radio"/>	<input type="radio"/>	<input type="radio"/>	<input type="radio"/>
⚡	03-07	(ACI) Positive/Negative Bias Mode	0: zero bias	1	<input type="radio"/>	<input type="radio"/>	<input type="radio"/>	<input type="radio"/>	<input type="radio"/>	<input type="radio"/>
			1: value lower than bias = bias		<input type="radio"/>	<input type="radio"/>	<input type="radio"/>	<input type="radio"/>	<input type="radio"/>	<input type="radio"/>
			2: value greater than bias = bias		<input type="radio"/>	<input type="radio"/>	<input type="radio"/>	<input type="radio"/>	<input type="radio"/>	<input type="radio"/>
			3: the absolute value of the bias voltage while serving as the center		<input type="radio"/>	<input type="radio"/>	<input type="radio"/>	<input type="radio"/>	<input type="radio"/>	<input type="radio"/>

	Parameters	Functions	Settings	Factory Setting	Control Mode					
					VF	VG	SV	SG	T	TG
⚡	03-08	(AUI) Positive/Negative Bias Mode	0: zero bias 1: value lower than bias = bias 2: value greater than bias = bias 3: the absolute value of the bias voltage while serving as the center	0	<input type="radio"/>	<input type="radio"/>	<input type="radio"/>	<input type="radio"/>	<input type="radio"/>	<input type="radio"/>
⚡	03-09	Analog Input 1 Gain (AVI)	-500.0~+500.0%	100.0	<input type="radio"/>	<input type="radio"/>	<input type="radio"/>	<input type="radio"/>	<input type="radio"/>	<input type="radio"/>
⚡	03-10	Analog Input 2 Gain (ACI)	-500.0~+500.0%	125.0	<input type="radio"/>	<input type="radio"/>	<input type="radio"/>	<input type="radio"/>	<input type="radio"/>	<input type="radio"/>
⚡	03-11	Analog Input 3 Gain (AUI)	-500.0~+500.0%	100.0	<input type="radio"/>	<input type="radio"/>	<input type="radio"/>	<input type="radio"/>	<input type="radio"/>	<input type="radio"/>
⚡	03-12	Addition Function of the Analog Inputs	0: disable addition function (AVI, ACI, AUI) 1: enable addition function	0	<input type="radio"/>	<input type="radio"/>	<input type="radio"/>	<input type="radio"/>	<input type="radio"/>	<input type="radio"/>
⚡	03-13	Analog Input Noise Filter	0.00~2.00 Sec	0.10	<input type="radio"/>	<input type="radio"/>	<input type="radio"/>	<input type="radio"/>	<input type="radio"/>	<input type="radio"/>
⚡	03-14	Loss of the ACI signal	0: disabled 1: continue operation at last known frequency 2: decelerate to a stop 3: stop immediately and display E.F.	0	<input type="radio"/>	<input type="radio"/>	<input type="radio"/>	<input type="radio"/>	<input type="radio"/>	<input type="radio"/>
⚡	03-15	Analog Output Selection	0: output frequency	0	<input type="radio"/>	<input type="radio"/>	<input type="radio"/>	<input type="radio"/>	<input type="radio"/>	<input type="radio"/>
			1: command frequency		<input type="radio"/>	<input type="radio"/>	<input type="radio"/>	<input type="radio"/>	<input checked="" type="radio"/>	<input checked="" type="radio"/>
			2: speed		<input type="radio"/>	<input type="radio"/>	<input type="radio"/>	<input type="radio"/>	<input type="radio"/>	<input type="radio"/>
			3: current		<input type="radio"/>	<input type="radio"/>	<input type="radio"/>	<input type="radio"/>	<input type="radio"/>	<input type="radio"/>
			4: output voltage		<input type="radio"/>	<input type="radio"/>	<input type="radio"/>	<input type="radio"/>	<input type="radio"/>	<input type="radio"/>
			5: DC BUS voltage		<input type="radio"/>	<input type="radio"/>	<input type="radio"/>	<input type="radio"/>	<input type="radio"/>	<input type="radio"/>
			6: power factor		<input type="radio"/>	<input type="radio"/>	<input type="radio"/>	<input type="radio"/>	<input type="radio"/>	<input type="radio"/>
			7: power		<input type="radio"/>	<input type="radio"/>	<input type="radio"/>	<input type="radio"/>	<input type="radio"/>	<input type="radio"/>
			8: torque		<input checked="" type="radio"/>	<input checked="" type="radio"/>	<input type="radio"/>	<input type="radio"/>	<input type="radio"/>	<input type="radio"/>
			9: AVI		<input type="radio"/>	<input type="radio"/>	<input type="radio"/>	<input type="radio"/>	<input type="radio"/>	<input type="radio"/>
			10: ACI		<input type="radio"/>	<input type="radio"/>	<input type="radio"/>	<input type="radio"/>	<input type="radio"/>	<input type="radio"/>
			11: AUI		<input type="radio"/>	<input type="radio"/>	<input type="radio"/>	<input type="radio"/>	<input type="radio"/>	<input type="radio"/>
			12: torque current command		<input checked="" type="radio"/>	<input checked="" type="radio"/>	<input type="radio"/>	<input type="radio"/>	<input type="radio"/>	<input type="radio"/>
			13: torque current estimation		<input checked="" type="radio"/>	<input checked="" type="radio"/>	<input type="radio"/>	<input type="radio"/>	<input type="radio"/>	<input type="radio"/>
			14: exciting magnet current command		<input checked="" type="radio"/>	<input checked="" type="radio"/>	<input type="radio"/>	<input type="radio"/>	<input type="radio"/>	<input type="radio"/>

	Parameters	Functions	Settings	Factory Setting	Control Mode					
					VF	VG	SV	SG	T	TG
⚡	03-15	Analog Output Selection	15: magnetic flux current	0	×	×	○	○	○	○
			16: q-axis voltage command		×	×	○	○	○	○
			17: d-axis voltage command		×	×	○	○	○	○
			18: vector-controlled error measures		×	×	○	○	○	○
			19: vector-controlled PID overall measures		×	×	○	○	○	○
			20: PID error measures		○	○	○	○	○	○
			21: PID total measures		○	○	○	○	○	○
			22: torque command		×	×	×	×	○	○
			23: pg frequency		○	○	○	○	○	○
			24: voltage command		○	○	○	○	○	○
⚡	03-16	Analog Output Gain	-900.0~900.0%	100.0	○	○	○	○	○	○
⚡	03-17	Analog Output Bias Voltage	-10.00~10.00V	0.00	○	○	○	○	○	○
⚡	03-18	Analog Output Value in REV Direction	0: absolute value in REV direction 1: output 0V in REV direction 2: output negative voltage in REV direction	0	○	○	○	○	○	○
	03-19	Reserved								

Group 4: Multi-Step Speed and Process Control Operation (PCO) Parameter

	Parameters	Functions	Settings	Factory Setting	Control Mode					
					VF	VG	SV	SG	T	TG
⚡	04-00	The 1 st Step Speed	0.00~400.00Hz	0.00	○	○	○	○	×	×
⚡	04-01	The 2 nd Step Speed	0.00~400.00Hz	0.00	○	○	○	○	×	×
⚡	04-02	The 3 rd Step Speed	0.00~400.00Hz	0.00	○	○	○	○	×	×
⚡	04-03	The 4 th Step Speed	0.00~400.00Hz	0.00	○	○	○	○	×	×
⚡	04-04	The 5 th Step Speed	0.00~400.00Hz	0.00	○	○	○	○	×	×
⚡	04-05	The 6 th Step Speed	0.00~400.00Hz	0.00	○	○	○	○	×	×
⚡	04-06	The 7 th Step Speed	0.00~400.00Hz	0.00	○	○	○	○	×	×
⚡	04-07	The 8 th Step Speed	0.00~400.00Hz	0.00	○	○	○	○	×	×
⚡	04-08	The 9 th Step Speed	0.00~400.00Hz	0.00	○	○	○	○	×	×
⚡	04-09	The 10 th Step Speed	0.00~400.00Hz	0.00	○	○	○	○	×	×
⚡	04-10	The 11 th Step Speed	0.00~400.00Hz	0.00	○	○	○	○	×	×
⚡	04-11	The 12 th Step Speed	0.00~400.00Hz	0.00	○	○	○	○	×	×
⚡	04-12	The 13 th Step Speed	0.00~400.00Hz	0.00	○	○	○	○	×	×
⚡	04-13	The 14 th Step Speed	0.00~400.00Hz	0.00	○	○	○	○	×	×
⚡	04-14	The 15 th Step Speed	0.00~400.00Hz	0.00	○	○	○	○	×	×
⚡	04-15	Time Duration of the PCO Master Speed	0.0~65500 Sec	0.0	○	○	○	○	×	×
⚡	04-16	Time Duration of PCO Step 1	0.0~65500 Sec	0.0	○	○	○	○	×	×
⚡	04-17	Time Duration of PCO Step 2	0.0~65500 Sec	0.0	○	○	○	○	×	×
⚡	04-18	Time Duration of PCO Step 3	0.0~65500 Sec	0.0	○	○	○	○	×	×
⚡	04-19	Time Duration of PCO Step 4	0.0~65500 Sec	0.0	○	○	○	○	×	×
⚡	04-20	Time Duration of PCO Step 5	0.0~65500 Sec	0.0	○	○	○	○	×	×
⚡	04-21	Time Duration of PCO Step 6	0.0~65500 Sec	0.0	○	○	○	○	×	×
⚡	04-22	Time Duration of PCO Step 7	0.0~65500 Sec	0.0	○	○	○	○	×	×
⚡	04-23	Time Duration of PCO Step 8	0.0~65500 Sec	0.0	○	○	○	○	×	×
⚡	04-24	Time Duration of PCO Step 9	0.0~65500 Sec	0.0	○	○	○	○	×	×
⚡	04-25	Time Duration of PCO Step 10	0.0~65500 Sec	0.0	○	○	○	○	×	×
⚡	04-26	Time Duration of PCO Step 11	0.0~65500 Sec	0.0	○	○	○	○	×	×

	Parameters	Functions	Settings	Factory Setting	Control Mode					
					VF	VG	SV	SG	T	TG
⚡	04-27	Time Duration of PCO Step 12	0.0~65500 Sec	0.0	○	○	○	○	×	×
⚡	04-28	Time Duration of PCO Step 13	0.0~65500 Sec	0.0	○	○	○	○	×	×
⚡	04-29	Time Duration of PCO Step 14	0.0~65500 Sec	0.0	○	○	○	○	×	×
⚡	04-30	Time Duration of PCO Step 15	0.0~65500 Sec	0.0	○	○	○	○	×	×
⚡	04-31	The PCO Time Multiplier	1~10	1	○	○	○	○	×	×
⚡	04-32	The PCO Operation Direction	0~32767 (0: FWD; 1: REV)	0	○	○	○	○	×	×
⚡	04-33	Process Control Operation Mode	Bit0=0: direction determined by Pr. 04-32 Bit0=1: direction determined by the master speed control Bit1=0: continuously execute the process control operation Bit1=1: execute only one process control operation cycle Bit2=0: zero speed intervals disabled Bit2=1: zero speed intervals enabled Bit3=0: operate at zero speed upon time extension Bit3=1: operate at a constant speed upon time extension Bit4=0: PCO disabled Bit4=1: PCO enabled	00000	○	○	○	○	×	×

	Parameters	Functions	Settings	Factory Setting	Control Mode					
					VF	VG	SV	SG	T	TG
⚡	04-34	Multi-Step Speed Operation Mode	Bit0=0: direction determined by 04-32 Bit0=1: direction determined by the master speed Bit1=0: continuously execute multi-step speed Bit1=1: execute multi-step speed based on time (Pr. 4-15 to 4-30) Bit2=0: zero speed intervals disabled Bit2=1: zero speed intervals enabled	00001	○	○	○	○	×	×
⚡	04-35	Disable Skip Frequency Width	0.00~400.00Hz	0.00	○	○	○	○	×	×
⚡	04-36	Interfere Jump Width	0.00~400.00Hz	0.00	○	○	○	○	×	×

Group 5: Motor Parameter

	Parameters	Functions	Settings	Factory Setting	Control Mode					
					VF	VG	SV	SG	T	TG
	05-00	Motor Auto Tuning	0: no function 1: measures (R1, R2, Lm, Lc, no-load current) 2: measures (R1, R2, Lc) 3: measures (R1, R2, Lc, Lm, calculated by the motor's no-load current)	0	<input type="radio"/>	<input type="radio"/>	<input type="radio"/>	<input type="radio"/>	<input type="radio"/>	<input type="radio"/>
	05-01	Full-Load Current of Motor 1	XXXA (30~120%)	A(100%)	<input type="radio"/>	<input type="radio"/>	<input type="radio"/>	<input type="radio"/>	<input type="radio"/>	<input type="radio"/>
	05-02	No-Load Current of Motor 1	XXXA (5~90%)	A(40%)	<input checked="" type="radio"/>	<input checked="" type="radio"/>	<input type="radio"/>	<input type="radio"/>	<input type="radio"/>	<input type="radio"/>
⚡	05-03	Torque Compensation of Motor 1 (for the V/F Mode Only)	0.0~25.0%	0.0	<input type="radio"/>	<input type="radio"/>	<input checked="" type="radio"/>	<input checked="" type="radio"/>	<input checked="" type="radio"/>	<input checked="" type="radio"/>
⚡	05-04	Slip Compensation of Motor 1 (for V/F mode only)	0.0~10.0%	0.0	<input type="radio"/>	<input type="radio"/>	<input checked="" type="radio"/>	<input checked="" type="radio"/>	<input checked="" type="radio"/>	<input checked="" type="radio"/>
	05-05	Number of Poles for Motor 1	2~20	4	<input type="radio"/>	<input type="radio"/>	<input type="radio"/>	<input type="radio"/>	<input type="radio"/>	<input type="radio"/>
	05-06	Line to Line resistance R1 of Motor 1	mΩ	Xx	<input type="radio"/>	<input type="radio"/>	<input type="radio"/>	<input type="radio"/>	<input type="radio"/>	<input type="radio"/>
	05-07	Rotor resistance R2 of Motor 1	mΩ	Xx	<input checked="" type="radio"/>	<input checked="" type="radio"/>	<input type="radio"/>	<input type="radio"/>	<input type="radio"/>	<input type="radio"/>
	05-08	LM of Motor 1	MH	Xx	<input checked="" type="radio"/>	<input checked="" type="radio"/>	<input type="radio"/>	<input type="radio"/>	<input type="radio"/>	<input type="radio"/>
	05-09	LC of Motor 1	MH	Xx	<input checked="" type="radio"/>	<input checked="" type="radio"/>	<input type="radio"/>	<input type="radio"/>	<input type="radio"/>	<input type="radio"/>
⚡	05-10	Iron Loss of Motor 1	0.0~10.0%	1.5	<input checked="" type="radio"/>	<input checked="" type="radio"/>	<input type="radio"/>	<input type="radio"/>	<input type="radio"/>	<input type="radio"/>
	05-11	Full-Load Current of Motor 2	XXXA (30~120%)	A(100%)	<input type="radio"/>	<input type="radio"/>	<input type="radio"/>	<input type="radio"/>	<input type="radio"/>	<input type="radio"/>
	05-12	No-Load Current of Motor 2	XXXA (5~90%)	A(40%)	<input checked="" type="radio"/>	<input checked="" type="radio"/>	<input type="radio"/>	<input type="radio"/>	<input type="radio"/>	<input type="radio"/>
⚡	05-13	Torque Compensation of Motor 2	0.0~25.0%	0.0	<input type="radio"/>	<input type="radio"/>	<input checked="" type="radio"/>	<input checked="" type="radio"/>	<input checked="" type="radio"/>	<input checked="" type="radio"/>
⚡	05-14	Slip Compensation of Motor 2	0.0~10.0%	0.0	<input type="radio"/>	<input type="radio"/>	<input checked="" type="radio"/>	<input checked="" type="radio"/>	<input checked="" type="radio"/>	<input checked="" type="radio"/>
	05-15	Number of Poles for Motor 2	2~20	4	<input type="radio"/>	<input type="radio"/>	<input type="radio"/>	<input type="radio"/>	<input type="radio"/>	<input type="radio"/>
	05-16	Line to Line resistance R1 of Motor 2	mΩ	Xx	<input type="radio"/>	<input type="radio"/>	<input type="radio"/>	<input type="radio"/>	<input type="radio"/>	<input type="radio"/>
	05-17	Rotor resistance R2 of Motor 2	mΩ	Xx	<input checked="" type="radio"/>	<input checked="" type="radio"/>	<input type="radio"/>	<input type="radio"/>	<input type="radio"/>	<input type="radio"/>

	Parameters	Functions	Settings	Factory Setting	Control Mode					
					VF	VG	SV	SG	T	TG
	05-18	LM of Motor 2	MH	Xx	×	×	○	○	○	○
	05-19	LC of Motor 2	MH	Xx	×	×	○	○	○	○
↗	05-20	Iron Loss of Motor 2	0.0~10.0%	1.5	×	×	○	○	○	○
↗	05-21	ASR (Auto Speed Regulation) P (Gain) 1	0.0~500.0%	25.0	×	○	○	○	○	○
↗	05-22	ASR I (Integration) Time 1	0.000~10.000 Sec 0.000: no integration	0.250	×	○	○	○	○	○
↗	05-23	ASR P (Gain) 2	0.0~500.0%	25.0	×	○	○	○	○	○
↗	05-24	ASR I (Integration) Time 2	0.000~10.000 Sec 0.000: no integration	0.250	×	○	○	○	○	○
↗	05-25	Frequency Switch between ASR1 and 2	0.00~400.00Hz	7.00	×	○	○	○	○	○
↗	05-26	Low-Speed Excitation Magnet Compensation	0~100%	10	×	×	○	○	○	○
↗	05-27	The Pre-Controlled Torque Feedback	0~100%	10	×	×	○	○	○	○
↗	05-28	Time Delay of the Pre-Controlled Torque Feedback	0.000~2.000 Sec	0.010	×	×	○	○	○	○
↗	05-29	Vibration Compensation Factor	0~10000	100	○	○	○	○	○	○
↗	05-30	R1 Detection Frequency	Bit0=0: no R1 detection Bit0=1: R1 detection	00000	×	×	○	○	○	○
↗	05-31	Dynamic Response Gain	0.0~100.0%	0.0	×	×	○	○	○	○
↗	05-32	Response of current control gain	0~100%	10	○	○	○	○	○	○

Group 6: Protection Parameter

	Parameters	Functions	Settings	Factory Setting	Control Mode					
					VF	VG	SV	SG	T	TG
⚡	06-00	Low Voltage Level	160-220V 320-440V	180 360	<input type="radio"/>	<input type="radio"/>	<input type="radio"/>	<input type="radio"/>	<input type="radio"/>	<input type="radio"/>
⚡	06-01	Over-Voltage Stall Prevention	350.0-450.0V 700.0-900.0V	380.0 760.0	<input type="radio"/>	<input type="radio"/>	<input type="radio"/>	<input type="radio"/>	<input checked="" type="checkbox"/>	<input checked="" type="checkbox"/>
⚡	06-02	Phase-Loss Protection	0: warn and keep operating 1: warn and ramp to stop 2: warn and coast to stop	0	<input type="radio"/>	<input type="radio"/>	<input type="radio"/>	<input type="radio"/>	<input type="radio"/>	<input type="radio"/>
⚡	06-03	Over-Current Stall Prevention during Acceleration	10~250%	170	<input type="radio"/>	<input type="radio"/>	<input type="radio"/>	<input type="radio"/>	<input checked="" type="checkbox"/>	<input checked="" type="checkbox"/>
⚡	06-04	Over-Current Stall Prevention during Operation	10~250%	170	<input type="radio"/>	<input type="radio"/>	<input type="radio"/>	<input type="radio"/>	<input checked="" type="checkbox"/>	<input checked="" type="checkbox"/>
⚡	06-05	Over-Current Deceleration Time during Operation	0.05~600.00 Sec	3.00	<input type="radio"/>	<input type="radio"/>	<input type="radio"/>	<input type="radio"/>	<input checked="" type="checkbox"/>	<input checked="" type="checkbox"/>
⚡	06-06	Over-Torque Detection Selection (oL2)	0: disabled 1: Over-torque detection during constant speed operation, continue to operate after detection. 2: Over-torque detection during constant speed operation, stop operation after detection. 3: Over-torque detection during entire (acceleration, steady state, deceleration) operation, continue operation after detection. 4: Over-torque detection during entire (acceleration, steady state, deceleration) operation, stop operation after detection.	0	<input type="radio"/>	<input type="radio"/>	<input type="radio"/>	<input type="radio"/>	<input type="radio"/>	<input type="radio"/>
⚡	06-07	Over-Torque Detection Level (oL2)	10~250%	150	<input type="radio"/>	<input type="radio"/>	<input type="radio"/>	<input type="radio"/>	<input type="radio"/>	<input type="radio"/>
⚡	06-08	Over-Torque Detection Time (oL2)	0.0~60.0 Sec	0.1	<input type="radio"/>	<input type="radio"/>	<input type="radio"/>	<input type="radio"/>	<input type="radio"/>	<input type="radio"/>

	Parameters	Functions	Settings	Factory Setting	Control Mode					
					VF	VG	SV	SG	T	TG
⚡	06-09	Over-Torque Detection Selection 2 (OL3)	0: Disable 1: over-torque detection during constant speed operation, continue to operate after detection 2: over-torque detection during constant speed operation, stop operation after detection. 3: over-torque detection during operation, continue operation after detection. 4: over-torque detection during operation, stop operation after detection.	0	<input type="radio"/>	<input type="radio"/>	<input type="radio"/>	<input type="radio"/>	<input type="radio"/>	<input type="radio"/>
⚡	06-10	Over-Torque Detection Level 2 (OL3)	10~250%	150	<input type="radio"/>	<input type="radio"/>	<input type="radio"/>	<input type="radio"/>	<input type="radio"/>	<input type="radio"/>
⚡	06-11	Over-Torque Detection Time 2 (OL3)	0.0~60.0 Sec	0.1	<input type="radio"/>	<input type="radio"/>	<input type="radio"/>	<input type="radio"/>	<input type="radio"/>	<input type="radio"/>
⚡	06-12	Over-Torque limit	0 ~ 250%	150	<input checked="" type="radio"/>	<input checked="" type="radio"/>	<input type="radio"/>	<input type="radio"/>	<input type="radio"/>	<input type="radio"/>
⚡	06-13	Electronic Thermal Relay Selection (I ² t)	0: Inverter/vector motor 1: Standard motor 2: Electronic thermal relay function disabled	2	<input type="radio"/>	<input type="radio"/>	<input type="radio"/>	<input type="radio"/>	<input type="radio"/>	<input type="radio"/>
⚡	06-14	Electronic Thermal Relay Time (I ² t)	30~600 Sec	60	<input type="radio"/>	<input type="radio"/>	<input type="radio"/>	<input type="radio"/>	<input type="radio"/>	<input type="radio"/>
⚡	06-15	Heat Sink Over-Heat (oH) Warning	0.0~110.0°C	85.0	<input type="radio"/>	<input type="radio"/>	<input type="radio"/>	<input type="radio"/>	<input type="radio"/>	<input type="radio"/>
⚡	06-16	Op stall low limit	0~250%	120	<input type="radio"/>	<input type="radio"/>	<input type="radio"/>	<input type="radio"/>	<input type="radio"/>	<input type="radio"/>
	06-17	Most Recent Fault Record	0: no fault	0	<input type="radio"/>	<input type="radio"/>	<input type="radio"/>	<input type="radio"/>	<input type="radio"/>	<input type="radio"/>
			1: oc (over-current)		<input type="radio"/>	<input type="radio"/>	<input type="radio"/>	<input type="radio"/>	<input type="radio"/>	<input type="radio"/>
			2: ov (over-voltage)		<input type="radio"/>	<input type="radio"/>	<input type="radio"/>	<input type="radio"/>	<input type="radio"/>	<input type="radio"/>
			3: oH1 (IGBT overheat)		<input type="radio"/>	<input type="radio"/>	<input type="radio"/>	<input type="radio"/>	<input type="radio"/>	<input type="radio"/>
			4: oL (drive overload)		<input type="radio"/>	<input type="radio"/>	<input type="radio"/>	<input type="radio"/>	<input type="radio"/>	<input type="radio"/>

Parameters	Functions	Settings	Factory Setting	Control Mode					
				VF	VG	SV	SG	T	TG
06-18	2 nd Most Recent Fault Record	5: oL1 (electronic thermal relay)	0	<input type="checkbox"/>	<input type="checkbox"/>	<input type="checkbox"/>	<input type="checkbox"/>	<input type="checkbox"/>	<input type="checkbox"/>
		6: EF (external fault)		<input type="checkbox"/>	<input type="checkbox"/>	<input type="checkbox"/>	<input type="checkbox"/>	<input type="checkbox"/>	<input type="checkbox"/>
		7: CF3 (hardware circuit fault)		<input type="checkbox"/>	<input type="checkbox"/>	<input type="checkbox"/>	<input type="checkbox"/>	<input type="checkbox"/>	<input type="checkbox"/>
		8: HPF (protection circuit fault)		<input type="checkbox"/>	<input type="checkbox"/>	<input type="checkbox"/>	<input type="checkbox"/>	<input type="checkbox"/>	<input type="checkbox"/>
		9: ocA (over-current during accel)		<input type="checkbox"/>	<input type="checkbox"/>	<input type="checkbox"/>	<input type="checkbox"/>	<input type="checkbox"/>	<input type="checkbox"/>
		10: ocd (over-current during decel)		<input type="checkbox"/>	<input type="checkbox"/>	<input type="checkbox"/>	<input type="checkbox"/>	<input type="checkbox"/>	<input type="checkbox"/>
		11: ocn (over-current during constant speed)		<input type="checkbox"/>	<input type="checkbox"/>	<input type="checkbox"/>	<input type="checkbox"/>	<input type="checkbox"/>	<input type="checkbox"/>
		12: GFF (ground fault)		<input type="checkbox"/>	<input type="checkbox"/>	<input type="checkbox"/>	<input type="checkbox"/>	<input type="checkbox"/>	<input type="checkbox"/>
		13: pg error		<input type="checkbox"/>	<input type="checkbox"/>	<input type="checkbox"/>	<input type="checkbox"/>	<input type="checkbox"/>	<input type="checkbox"/>
		15: CF1 (unable to write to memory)		<input type="checkbox"/>	<input type="checkbox"/>	<input type="checkbox"/>	<input type="checkbox"/>	<input type="checkbox"/>	<input type="checkbox"/>
		16: CF2 (unable to read memory)		<input type="checkbox"/>	<input type="checkbox"/>	<input type="checkbox"/>	<input type="checkbox"/>	<input type="checkbox"/>	<input type="checkbox"/>
		17: bb (Pause)		<input type="checkbox"/>	<input type="checkbox"/>	<input type="checkbox"/>	<input type="checkbox"/>	<input type="checkbox"/>	<input type="checkbox"/>
		18: oL2 (motor overload)		<input type="checkbox"/>	<input type="checkbox"/>	<input type="checkbox"/>	<input type="checkbox"/>	<input type="checkbox"/>	<input type="checkbox"/>
		19: sc (IGBT failure)		<input type="checkbox"/>	<input type="checkbox"/>	<input type="checkbox"/>	<input type="checkbox"/>	<input type="checkbox"/>	<input type="checkbox"/>
		20: brake (braking transistor failure)		<input type="checkbox"/>	<input type="checkbox"/>	<input type="checkbox"/>	<input type="checkbox"/>	<input type="checkbox"/>	<input type="checkbox"/>
21: OL3 (motor overload)	<input type="checkbox"/>	<input type="checkbox"/>	<input type="checkbox"/>	<input type="checkbox"/>	<input type="checkbox"/>	<input type="checkbox"/>			
22: oh2 (brake overheat)	<input type="checkbox"/>	<input type="checkbox"/>	<input type="checkbox"/>	<input type="checkbox"/>	<input type="checkbox"/>	<input type="checkbox"/>			
23: Fuse failure	<input type="checkbox"/>	<input type="checkbox"/>	<input type="checkbox"/>	<input type="checkbox"/>	<input type="checkbox"/>	<input type="checkbox"/>			
06-19	3 rd Most Recent Fault Record	24: CT2 (current sensor 2)	0	<input type="checkbox"/>	<input type="checkbox"/>	<input type="checkbox"/>	<input type="checkbox"/>	<input type="checkbox"/>	<input type="checkbox"/>
		25: CT1 (current sensor 1)		<input type="checkbox"/>	<input type="checkbox"/>	<input type="checkbox"/>	<input type="checkbox"/>	<input type="checkbox"/>	<input type="checkbox"/>
		26: PWM (upper and lower points at the same low level)		<input type="checkbox"/>	<input type="checkbox"/>	<input type="checkbox"/>	<input type="checkbox"/>	<input type="checkbox"/>	<input type="checkbox"/>
		27: Motor auto tuning failure		<input type="checkbox"/>	<input type="checkbox"/>	<input type="checkbox"/>	<input type="checkbox"/>	<input type="checkbox"/>	<input type="checkbox"/>
06-20	4 th Most Recent Fault Record	28: PID error	0	<input type="checkbox"/>	<input type="checkbox"/>	<input type="checkbox"/>	<input type="checkbox"/>	<input type="checkbox"/>	<input type="checkbox"/>
		29: ACI error		<input type="checkbox"/>	<input type="checkbox"/>	<input type="checkbox"/>	<input type="checkbox"/>	<input type="checkbox"/>	<input type="checkbox"/>
		31: CC		<input type="checkbox"/>	<input type="checkbox"/>	<input type="checkbox"/>	<input type="checkbox"/>	<input type="checkbox"/>	<input type="checkbox"/>
		33: VEC R1 out of range (Pr. 05-30)		<input type="checkbox"/>	<input type="checkbox"/>	<input type="checkbox"/>	<input type="checkbox"/>	<input type="checkbox"/>	<input type="checkbox"/>
		34: keypad error		<input type="checkbox"/>	<input type="checkbox"/>	<input type="checkbox"/>	<input type="checkbox"/>	<input type="checkbox"/>	<input type="checkbox"/>
		35: RS 485 watchdog timer		<input type="checkbox"/>	<input type="checkbox"/>	<input type="checkbox"/>	<input type="checkbox"/>	<input type="checkbox"/>	<input type="checkbox"/>
		36: FAN failure		<input type="checkbox"/>	<input type="checkbox"/>	<input type="checkbox"/>	<input type="checkbox"/>	<input type="checkbox"/>	<input type="checkbox"/>
37: input phase loss	<input type="checkbox"/>	<input type="checkbox"/>	<input type="checkbox"/>	<input type="checkbox"/>	<input type="checkbox"/>	<input type="checkbox"/>			

Group 7: Special Parameter

	Parameters	Functions	Settings	Factory Setting	Control Mode					
					VF	VG	SV	SG	T	TG
⚡	07-00	Software Braking Level	350.0~450.0VDC 700.0~900.0VDC	380.0 760.0	<input type="radio"/>	<input type="radio"/>	<input type="radio"/>	<input type="radio"/>	<input type="radio"/>	<input type="radio"/>
⚡	07-01	DC Braking Current Level	0~100%	0	<input type="radio"/>	<input type="radio"/>	<input type="radio"/>	<input type="radio"/>	<input type="radio"/>	<input type="radio"/>
⚡	07-02	DC Braking Time at Start-up	0.00~60.00 Sec	0.00	<input type="radio"/>	<input type="radio"/>	<input type="radio"/>	<input type="radio"/>	<input type="radio"/>	<input type="radio"/>
⚡	07-03	DC Braking Time during a STOP	0.00~60.00 Sec	0.00	<input type="radio"/>	<input type="radio"/>	<input type="radio"/>	<input type="radio"/>	<input type="radio"/>	<input type="radio"/>
⚡	07-04	Frequency point for DC Braking	0.00~400.00Hz	0.00	<input type="radio"/>	<input type="radio"/>	<input type="radio"/>	<input type="radio"/>	<input type="radio"/>	<input type="radio"/>
⚡	07-05	Increasing Rate of the DC Voltage	1~500	30	<input type="radio"/>	<input type="radio"/>	<input type="radio"/>	<input type="radio"/>	<input type="radio"/>	<input type="radio"/>
⚡	07-06	Re-activate after Momentary Power Loss	0: disable 1: begins from command frequency 2: begins from minimum output frequency	0	<input type="radio"/>	<input type="radio"/>	<input type="radio"/>	<input type="radio"/>	<input type="radio"/>	<input type="radio"/>
⚡	07-07	Maximum Allowable Power Loss Time	0.1~5.0 Sec	2.0	<input type="radio"/>	<input type="radio"/>	<input type="radio"/>	<input type="radio"/>	<input type="radio"/>	<input type="radio"/>
⚡	07-08	Base Block Time for Speed Search	0.1~5.0 Sec	0.5	<input type="radio"/>	<input type="radio"/>	<input type="radio"/>	<input type="radio"/>	<input type="radio"/>	<input type="radio"/>
⚡	07-09	Maximum Current Level for Speed Search	20~200%	150	<input type="radio"/>	<input type="radio"/>	<input type="radio"/>	<input type="radio"/>	<input type="radio"/>	<input type="radio"/>
⚡	07-10	Deceleration Time for Speed Search	0.50~600.00 Sec	3.00	<input type="radio"/>	<input type="radio"/>	<input type="radio"/>	<input type="radio"/>	<input type="radio"/>	<input type="radio"/>
⚡	07-11	Auto Restart after Fault	0~10	0	<input type="radio"/>	<input type="radio"/>	<input type="radio"/>	<input type="radio"/>	<input type="radio"/>	<input type="radio"/>
⚡	07-12	Speed Search Type	0: speed search disabled 1: speed search through the frequency command 2: FWD-speed search only (motor only runs in FWD direction)	0	<input type="radio"/>	<input type="radio"/>	<input type="radio"/>	<input type="radio"/>	<input type="radio"/>	<input type="radio"/>

	Parameters	Functions	Settings	Factory Setting	Control Mode					
					VF	VG	SV	SG	T	TG
⚡	07-12	Speed Search Type	3: REV-speed search only (motor only runs in REV direction) 4: FWD/REV speed search enabled in both directions (fwd first) 5: REV/FWD speed search enabled in both directions (rev first)	0	○	○	○	○	○	○
⚡	07-13	Speed Search Frequency (FWD direction)	0.00~400.00Hz	60.00/50.00	○	○	○	○	×	×
⚡	07-14	Speed Search Frequency (REV direction)	0.00~400.00Hz	60.00/50.00	○	○	○	○	×	×
⚡	07-15	Gear Gap Acceleration-Interruption Time	0.00~400.00 Sec	0.00	○	○	○	○	×	×
⚡	07-16	Gear Gap Acceleration-Interruption Frequency	0.00~400.00Hz	6.00	○	○	○	○	×	×
⚡	07-17	Gear Gap Deceleration-Interruption Time	0.00~400.00 Sec	0.00	○	○	○	○	×	×
⚡	07-18	Gear Gap Deceleration-Interruption Frequency	0.00~400.00Hz	6.00	○	○	○	○	×	×
⚡	07-19	External Terminals RUN after Fault Reset	0: Invalid 1: If running command is still ON and it is running.	0	○	○	○	○	×	×

Group 8: High-Performance Parameter

	Parameters	Functions	Settings	Factory Setting	Control Mode					
					VF	VG	SV	SG	T	TG
⚡	08-00	PID Feedback Terminal Selection	0: Disable 1: AVI (0~10V) 2: ACI (4~20mA) 3: AUI (+/-10V) 4: Clock (F/R--master speed) 5: Clock (F/R--A/B direction)	0	<input type="radio"/>	<input type="radio"/>	<input type="radio"/>	<input type="radio"/>	<input type="radio"/>	<input type="radio"/>
⚡	08-01	Proportional Gain (P)	0.0~500.0%	80.0	<input type="radio"/>	<input type="radio"/>	<input type="radio"/>	<input type="radio"/>	<input type="radio"/>	<input type="radio"/>
⚡	08-02	Integral Time (I)	0.00~100.00 Sec 0.00: no integral	1.00	<input type="radio"/>	<input type="radio"/>	<input type="radio"/>	<input type="radio"/>	<input type="radio"/>	<input type="radio"/>
⚡	08-03	Differential Time (D)	0.00~1.00 Sec	0.00	<input type="radio"/>	<input type="radio"/>	<input type="radio"/>	<input type="radio"/>	<input type="radio"/>	<input type="radio"/>
⚡	08-04	Integration's Upper Bound Frequency	0.0~100.0%	100.0	<input type="radio"/>	<input type="radio"/>	<input type="radio"/>	<input type="radio"/>	<input type="radio"/>	<input type="radio"/>
⚡	08-05	PID Frequency Output Command limit	0.0~100.0%	100.0	<input type="radio"/>	<input type="radio"/>	<input type="radio"/>	<input type="radio"/>	<input type="radio"/>	<input type="radio"/>
⚡	08-06	PID Deviation Range	-100.0~+100.0%	0.0	<input type="radio"/>	<input type="radio"/>	<input type="radio"/>	<input type="radio"/>	<input type="radio"/>	<input type="radio"/>
⚡	08-07	One-Time Delay	0.000~0.005 Sec	0.000	<input type="radio"/>	<input type="radio"/>	<input type="radio"/>	<input type="radio"/>	<input type="radio"/>	<input type="radio"/>
⚡	08-08	Detection Time of the Feedback Error	0.0~6000.0 Sec	0.0	<input type="radio"/>	<input type="radio"/>	<input type="radio"/>	<input type="radio"/>	<input type="radio"/>	<input type="radio"/>
⚡	08-09	Feedback Signal Fault Treatment	0: warn and keep operating 1: warn and RAMP to stop 2: warn and COAST to stop	0	<input type="radio"/>	<input type="radio"/>	<input type="radio"/>	<input type="radio"/>	<input type="radio"/>	<input type="radio"/>
⚡	08-10	Dwell (sleep) Frequency	0.00~400.00Hz	0.00	<input type="radio"/>	<input type="radio"/>	<input type="radio"/>	<input type="radio"/>	<input checked="" type="checkbox"/>	<input checked="" type="checkbox"/>
⚡	08-11	Revival Frequency	0.00~400.00Hz	0.00	<input type="radio"/>	<input type="radio"/>	<input type="radio"/>	<input type="radio"/>	<input checked="" type="checkbox"/>	<input checked="" type="checkbox"/>
⚡	08-12	Dwell (sleep) Period	0.0~6000.0 Sec	0.0	<input type="radio"/>	<input type="radio"/>	<input type="radio"/>	<input type="radio"/>	<input checked="" type="checkbox"/>	<input checked="" type="checkbox"/>
⚡	08-13	Fan control	0: when power is applied, the fan will turn on 1: When the run command is given, the fan will turn on	0	<input type="radio"/>	<input type="radio"/>	<input type="radio"/>	<input type="radio"/>	<input type="radio"/>	<input type="radio"/>

Group 9: Communication Parameter

	Parameters	Functions	Settings	Factory Setting	Control Mode					
					VF	VG	SV	SG	T	TG
⚡	09-00	Communication Address	1~254	1	<input type="radio"/>	<input type="radio"/>	<input type="radio"/>	<input type="radio"/>	<input type="radio"/>	<input type="radio"/>
⚡	09-01	Transmission Speed of the Communication	4.8 ~ 115.2 Kbits/Sec	9.6	<input type="radio"/>	<input type="radio"/>	<input type="radio"/>	<input type="radio"/>	<input type="radio"/>	<input type="radio"/>
⚡	09-02	Transmission Fault Treatment	0: warn and keep operating 1: warn and RAMP to stop 2: warn and COAST to stop 3: no treatment and no display	3	<input type="radio"/>	<input type="radio"/>	<input type="radio"/>	<input type="radio"/>	<input type="radio"/>	<input type="radio"/>
⚡	09-03	Overtime Detection	0: disabled 1~100 Sec	0	<input type="radio"/>	<input type="radio"/>	<input type="radio"/>	<input type="radio"/>	<input type="radio"/>	<input type="radio"/>
⚡	09-04	Communication Protocol	0: 7, N, 1 for ASCII 1: 7, N, 2 for ASCII 2: 7, E, 1 for ASCII 3: 7, O, 1 for ASCII 4: 7, E, 2 for ASCII 5: 7, O, 2 for ASCII 6: 8, N, 1 for ASCII 7: 8, N, 2 for ASCII 8: 8, E, 1 for ASCII 9: 8, O, 1 for ASCII 10: 8, E, 2 for ASCII 11: 8, O, 2 for ASCII 12: 8, N, 1 for RTU 13: 8, N, 2 for RTU 14: 8, E, 1 for RTU 15: 8, O, 1 for RTU 16: 8, E, 2 for RTU 17: 8, O, 2 for RTU	1	<input type="radio"/>	<input type="radio"/>	<input type="radio"/>	<input type="radio"/>	<input type="radio"/>	<input type="radio"/>
⚡	09-05	Keypad Transmission Fault Treatment	0: warn and keep operating 1: warn and RAMP to stop 2: warn and COAST to stop	0	<input type="radio"/>	<input type="radio"/>	<input type="radio"/>	<input type="radio"/>	<input type="radio"/>	<input type="radio"/>

Group 10: Speed Feedback Parameter

Parameters	Functions	Settings	Factory Setting	Control Mode					
				VF	VG	SV	SG	T	TG
10-00	PG (encoder) Pulses	1~20000	600	×	○	×	○	×	○
10-01	Encoder Input Setting (channel 1)	<p>0: Phase A leads in a forward run command and phase B leads in a reverse run command. (rising/falling edge trigger) (Pulses x 4)</p> <p>1: Phase B leads in a forward run command and phase A leads in a reverse run command. (rising/falling edge trigger) (Pulses x 4)</p> <p>2: Phase A is a pulse input and phase B is a direction input. (low input = reverse direction, high input = forward direction)</p> <p>3: Phase A is a pulse input and phase B is a direction input. (low input = forward direction, high input = reverse direction)</p> <p>4: Phase A is a forward run pulse, then phase B is High. Phase B is a reverse run pulse, then phase A is High.</p> <p>5: Phase B is a forward run pulse, then phase A is High. Phase A is a reverse run pulse, then phase B is High.</p> <p>6: Phase A leads in a forward run command and phase B leads in a reverse run command. (level trigger)</p> <p>7: Phase B leads in a forward run command and phase A leads in a reverse run command. (level trigger)</p>	0	×	○	×	○	×	○
⚡ 10-02	PG Feedback Fault Treatment	<p>0: warn and keep operating</p> <p>1: warn and RAMP to stop</p> <p>2: warn and COAST to stop</p>	0	×	○	×	○	×	○
⚡ 10-03	PG Feedback Fault Detection Time	0.00~10.00 Sec	0.10	×	○	×	○	×	○
⚡ 10-04	PG Feedback Filter Time	0.001~1.000 Sec	0.003	×	○	×	○	×	○

	Parameters	Functions	Settings	Factory Setting	Control Mode					
					VF	VG	SV	SG	T	TG
⚡	10-05	PG Slip Range	0.0~50.0%	10.0	×	○	×	○	×	○
⚡	10-06	PG Stall Level (overspeed protection)	0.0~115.0%	110.0	×	○	×	○	×	○
⚡	10-07	PG Electrical Gear A	1~5000	100	×	○	×	○	×	○
⚡	10-08	PG Electrical Gear B	1~5000	100	×	○	×	○	×	○
⚡	10-09	PG Position Control Point (Home)	0 ~ 20000	0	×	○	×	○	×	○
⚡	10-10	Range for PG Position Attained (Home range)	0 ~ 20000	10	×	○	×	○	×	○
⚡	10-11	PG Encoder input Filter Time	0.001~1.000 second	0.003	×	○	×	○	×	○
⚡	10-12	PG04 encoder input selection (channel 2)	0: Phase A leads in a forward run command and phase B leads in a reverse run command. (rising/falling edge trigger) 1: Phase B leads in a forward run command and phase A leads in a reverse run command. (rising/falling edge trigger) 2: Phase A is a forward run pulse, then phase B is High. Phase B is a reverse run pulse, then phase A is High. 3: Phase B is a forward run pulse, then phase A is High. Phase A is a reverse run pulse, then phase B is High. 4: Phase A is a pulse input, phase B is a direction input, (low = reverse , high =forward) 5: Phase A is a pulse input, phase B is direction input. (low = forward, high = reverse)	0	×	○	×	○	×	○

8

Position Control Parameter

	Parameters	Functions	Settings	Factory Setting	Control Mode					
					VF	VG	SV	SG	T	TG
⚡	10-13	Proportional (P) Gain	0.0~500.0%	50.0	×	○	×	○	×	○
⚡	10-14	Integral (I) Time	0.00~100.00 Sec	0.050	×	○	×	○	×	○
			0.00: no integral							

	Parameters	Functions	Settings	Factory Setting	Control Mode					
					VF	VG	SV	SG	T	TG
⚡	10-15	Differential (D) Time	0.00~1.00 Sec	0.25	×	○	×	○	×	○
⚡	10-16	Orient Speed	0.00~400.00 Hz	5.00	×	○	×	○	×	○
⚡	10-17	Creep point	0~20000	100	×	○	×	○	×	○
⚡	10-18	Loop Speed	0.00~400.00 Hz	1.00	×	○	×	○	×	○
⚡	10-19	Loop Point	0~20000	10	×	○	×	○	×	○
⚡	10-20	Division (scaling) factor for PG04/05	1~128	1	×	○	×	○	×	○
⚡	10-21	Feed Forward	0.0~100.0%	0	×	○	×	○	×	○
⚡	10-22	Position Control Speed Gain	0.0~100.0%	100	×	○	×	○	×	○
⚡	10-23	PG Position Attained 2	0~20000	100	×	○	×	○	×	○
⚡	10-24	P2P Acceleration Time	0.00~100.00 s	1.00	×	○	×	○	×	○
⚡	10-25	P2P Deceleration Time	0.00~100.00 s	1.00	×	○	×	○	×	○
⚡	10-26	Delay Time for Position Command	0.00~100.00 s	0.005	×	○	×	○	×	○
⚡	10-27	Position Control Integral (I) Time 2	0.0~1500.0% (05-25 switch)	50.0	×	○	×	○	×	○
⚡	10-28	Position Control Integral (I) Time 2	0.001~10.000 s 000: no integral (0.5-25 switch)	0.050	×	○	×	○	×	○
⚡	10-29	Selection of P2P Control Mode	0: relative P2P 1: absolute P2P	00000	×	○	×	○	×	○
⚡	10-30	Direction Command of Absolute P2P	0~255 (10-33~40)	0	×	○	×	○	×	○
⚡	10-31	FWD Limit of Absolute P2P	1~60000 0: No Limit	0	×	○	×	○	×	○
⚡	10-32	REV Limit of Absolute P2P	1~60000 0: No Limit	0	×	○	×	○	×	○
⚡	10-33	P2P Command 0	0~50000 (in position control 2 mode)	0	×	○	×	○	×	○
⚡	10-34	P2P Command 1	0~50000 (in position control 2 mode)	0	×	○	×	○	×	○
⚡	10-35	P2P Command 2	0~50000 (in position control 2 mode)	0	×	○	×	○	×	○
⚡	10-36	P2P Command 3	0~50000 (in position control 2 mode)	0	×	○	×	○	×	○

	Parameters	Functions	Settings	Factory Setting	Control Mode					
					VF	VG	SV	SG	T	TG
↗	10-37	P2P Command 4	0~50000 (in position control 2 mode)	0	×	○	×	○	×	○
↗	10-38	P2P Command 5	0~50000 (in position control 2 mode)	0	×	○	×	○	×	○
↗	10-39	P2P Command 6	0~50000 (in position control 2 mode)	0	×	○	×	○	×	○
↗	10-40	P2P Command 7	0~50000 (in position control 2 mode)	0	×	○	×	○	×	○
↗	10-41	P2P Pulse	1~20000 (*4 for 10-00)	1	×	○	×	○	×	○
↗	10-42	P2P mm	1~20000	1	×	○	×	○	×	○

Specifications

230V Class

Model Number VFD-xxxV23A		230V Class											
		007	015	022	037	055	075	110	150	185	220	300	370
Output Rating	Max. Applicable Motor output (kW)	0.7	1.5	2.2	3.7	5.5	7.5	11	15	18.5	22	30	37
	Max. Applicable Motor output (HP)	1	2	3	5	7.5	10	15	20	25	30	40	50
	Constant Torque Output Current (A)	5.0	7.5	11	17	25	33	49	65	75	90	120	146
	Variable Torque Output Current (A)	6.25	9.4	13	21	31	41	61	81	93	112	150	182
	Rated Output Capacity kVA	1.9	2.7	4.2	6.5	9.5	12.5	19	25	29	34	46	55
	Maximum Output Voltage (V)	Proportional to the input voltage											
Input Rating	Rated Input Voltage/Frequency	200/208/220/230 VAC 3-phase, 50/60Hz											
	Operation Voltage Range/Frequency	180~265VAC, 47~63Hz											
	Input Current	6.4	10	14.9	21.2	25.2	33.2	58	69	83	100	120	146
Control Characteristics	Control System	1. Vector Control; 2. Torque Control; 3. V/F Control											
	Starting Torque	Starting Torque is 150% at 0.5Hz and above.											
	Speed Control Range	1:100 Sensorless Vector (1:1000 when using PG card and encoder feedback)											
	Speed Control Accuracy	0.5% Sensorless Vector (0.02% when using a PG card and encoder feedback)											
	Speed Response Ability	5Hz (connect externally with PG to achieve 30Hz)											
	Maximum Output Frequency (Hz)	0.00 to 400.00 Hz											
	Frequency Output Accuracy	Digital Command: $\pm 0.005\%$, Analog Command: $\pm 0.5\%$											
	Frequency-Set Resolution	Digital Command: 0.01Hz, Analog Command: 1/1000 (10bit) of the maximum output frequency											
	Torque Limit	Maximum allowable torque is 200%											
	Torque Accuracy	$\pm 5\%$											
	Accel/Decel Time	0.00~600.00/0.1~6000.0 sec											
	V/F Curve	Adjustable V/F curve using 4 independent points.											
Frequency Control Signal	0-10V, -10-+10V, 4-20mA, Square wave pulse input												
Braking Torque	Approx. 20%												
Protection Characteristics	Motor Protection	Electronic thermal relay protection											
	Over-Current Protection	The current forces 220% of the over-current protection and 300% of the rated current											
	Ground Current Leakage Protection	Current Leakage Protection: 50% peak value rated current											
	Over-Load Ability	Constant/Variable torque 150% for 60 seconds; 200% for 2 seconds											
	Voltage Protection 220V/440V	Over-voltage level: $V_{dc} > 400/800$ V; low-voltage level: $V_{dc} < 200/400$ V											
	Over-Voltage Protection for the Input Power	Varistor (MOV)											
	Over-Temperature Protection	Built-in temperature sensor											
	Momentary Power Loss	5 second maximum time setting											
Environment	Protection Level	NEMA 1/IP21											
	Ambient Temperature	$-10^{\circ}\text{C} \sim 40^{\circ}\text{C}$ for UL & $-10^{\circ}\text{C} \sim 50^{\circ}\text{C}$ for CE											
	Storage Temperature	$-20^{\circ}\text{C} \sim 60^{\circ}\text{C}$											
	Humidity	Below 90% RH (non-condensing)											
	Vibration	Below 20hz: 1G, above 20hz: 0.6G											
	Cooling System	Forced air cooling											
	Installation Location	Altitude of 1,000m or less, keep away from corrosive gas, liquid, and dust.											



460V Class

Model Number VFD-xxxV43x		460V Class														
		007	015	022	037	055	075	110	150	185	220	300	370	450	550	750
Output Rating	Max. Applicable Motor output (kW)	0.7	1.5	2.2	3.7	5.5	7.5	11	15	18.5	22	30	37	45	55	75
	Max. Applicable Motor output (HP)	1	2	3	5	7.5	10	15	20	25	30	40	50	60	75	100
	Constant Torque Output Current (A)	3.0	4.2	6	8.5	13	18	24	32	38	45	60	73	91	110	150
	Variable Torque Output Current (A)	3.8	5.3	7.5	10	16	22	30	40	47	56	75	91	113	138	188
	Rated Output Capacity kVA	2.3	3.2	4.6	6.5	9.9	13.7	18	24	29	34	46	56	69	84	114
	Maximum Output Voltage (V)	Proportional to the input voltage														
Input Rating	Rated Input Voltage/Frequency	380/400/415/460 VAC 3 phase, 50/60 Hz														
	Operation Voltage Range/Frequency	340~500VAC, 47~63 Hz														
	Input Current	4.0	5.7	7.3	9.9	12.2	17.2	25	32	39	49	60	73	91	130	175
Control Characteristics	Control System	1. Vector Control; 2. Torque Control; 3. V/F Control														
	Starting Torque	Starting Torque is 150% at 0.5Hz and above.														
	Speed Control Range	1:100 Sensorless Vector (1:1000 when using PG card and encoder feedback)														
	Speed Control Accuracy	0.5% Sensorless Vector (0.02% when using a PG card and encoder feedback)														
	Speed Response Ability	5Hz (connect externally with PG to achieve 30Hz)														
	Maximum Output Frequency (Hz)	0.00 to 400.00 Hz														
	Frequency Output Accuracy	Digital Command: $\pm 0.005\%$, Analog Command: $\pm 0.5\%$														
	Frequency-Set Resolution	Digital Command: 0.01Hz, Analog Command: 1/1000 (10bit) of the maximum output frequency														
	Torque Limit	Maximum allowable torque is 200%														
	Torque Accuracy	$\pm 5\%$														
	Accel/Decel Time	0.00~600.00/0.1~6000.0 sec														
	V/F Curve	Adjustable V/F curve using 4 independent points.														
Frequency Control Signal	0-10V, -10-+10V, 4-20mA, Square wave pulse input															
Braking Torque	Approx. 20%															
Protection Characteristics	Motor Protection	Electronic thermal relay protection														
	Over Current Protection	The current forces 220% of the over-current protection and 300% of the rated current														
	Ground Current Leakage Protection	Current Leakage Protection: 50% peak value rated current														
	Over-Load Ability	Constant/Variable 150% for 60 seconds; 200% for 2 seconds														
	Voltage Protection 220V/440V	Over-voltage level: $V_{dc} > 400/800$ V; low-voltage level: $V_{dc} < 200/400$ V														
	Over-Voltage Protection for the Input Power	Varistor (MOV)														
	Over-Temperature Protection	Built-in temperature sensor														
	Momentary Power Loss	5 second maximum time setting														
Environment	Enclosure type	NEMA 1/IP21														
	Ambient Temperature	-10°C~40°C for UL & -10°C~50°C for CE														
	Storage Temperature	-20°C~60°C														
	Humidity	Below 90% RH (non-condensing)														
	Vibration	Below 20hz: 1G, above 20hz: 0.6G														
	Cooling System	Forced air cooling														
	Installation Location	Altitude of 1,000m or less, keep away from corrosive gas, liquid, and dust.														

ACCESSORIES

B.1 Non-fuse Circuit Breaker Chart

Per UL 508C, paragraph 45.8.4, part a,

For 3-phase drives, the current rating of the breaker shall be four times maximum of output current rating.

(Note: According to our experience, we suggest to use 1.5 – 2 times maximum of output current rating.)

3-phase			
Model	Output Current (A)	Model	Output Current (A)
VFD007V23A	5	VFD150V23A	65
VFD007V43A	3	VFD150V43A	32
VFD015V23A	7.5	VFD185V23A	75
VFD015V43A	4.2	VFD185V43A	38
VFD022V23A	11	VFD220V23A	90
VFD022V43A	6	VFD220V43A	45
VFD037V23A	17	VFD300V23A	120
VFD037V43A	8.5	VFD300V43A	60
VFD055V23A	25	VFD370V23A	146
VFD055V43A	13	VFD370V43A	73
VFD075V23A	33	VFD450V43A	91
VFD075V43A	18	VFD550V43A	110
VFD110V23A	49	VFD750V43A	150
VFD110V43A	24		

Fuse Specification Chart (Smaller fuses than those shown in the table are permitted.)

Model	Input Current (A)	Output Current (A)	Line Fuse	
			I (A)	Bussmann P/N
VFD007V23A	6.4	5	20	JJN-20
VFD007V43A	4	3	10	JJS-10
VFD015V23A	10	7.5	30	JJN-30
VFD015V43A	5.7	4.2	15	JJS-15
VFD022V23A	14.9	11	40	JJN-40
VFD022V43A	7.3	6	20	JJS-20
VFD037V23A	21.2	17	60	JJN-60
VFD037V43A	9.9	8.5	30	JJS-30
VFD055V23A	25.2	25	100	JJN-100
VFD055V43A	12.2	13	50	JJS-50
VFD075V23A	33.2	33	125	JJN-125
VFD075V43A	17.2	18	70	JJS-70
VFD110V23A	58	49	175	JJN-175
VFD110V43A	25	24	90	JJS-90
VFD150V23A	69	65	250	JJN-250
VFD150V43A	32	32	125	JJS-125
VFD185V23A	83	75	300	JJN-300

B

Model	Input Current (A)	Output Current (A)	Line Fuse	
			I (A)	Bussmann P/N
VFD185V43A	39	38	150	JJS-150
VFD220V23A	100	90	350	JJN-350
VFD220V43A	49	45	175	JJS-175
VFD300V23A	120	120	450	JJN-450
VFD300V43A	60	60	225	JJS-225
VFD370V23A	146	146	500	JJN-500
VFD370V43A	73	73	250	JJS-250
VFD450V43A	91	91	350	JJS-350
VFD550V43A	130	110	400	JJS-400
VFD750V43A	175	150	600	JJS-600

B.2 All Braking Resistors & Braking Units Use in AC Drives

Note: Please only use DELTA resistors and recommended values. Other resistors and values will void Delta's warranty. Please contact your nearest Delta representative for use of special resistors. For instance, in 460 V series, 100 HP, AC drive has 2 braking units with total of 16 braking resistors, so each braking unit uses 8 braking resistors. There should be at least 10 cm away from AC drive to avoid possible noise. Refer to the "Braking Unit Module User Manual" for further detail.

Voltage	Applicable Motor		Full Load Torque KG-M	Equivalent Resistors Specification for Each AC Drive	Braking Unit Model VFDB No. of Unit Used		Braking Resistors Model No. of Units Used		Braking Torque 10%ED	Minimum Equivalent Resistor Value for Each AC Drive
	HP	kW								
230V Series	1	0.75	0.427	80W 200Ω			BR080W200	1	125	80Ω
	2	1.5	0.849	300W 100Ω			BR300W100	1	125	55Ω
	3	2.2	1.262	300W 70Ω			BR300W070	1	125	35Ω
	5	3.7	2.080	400W 40Ω			BR400W040	1	125	25Ω
	7.5	5.5	3.111	500W 30Ω			BR500W030	1	125	16Ω
	10	7.5	4.148	1000W 20Ω			BR1K0W020	1	125	12Ω
	15	11	6.186	2400W 13.6Ω			BR1K2W6P8	2	125	13.6Ω
	20	15	8.248	3000W 10Ω	2015	1	BR1K5W005	2	125	10Ω
	25	18.5	10.281	4800W 8Ω	2022	1	BR1K2W008	4	125	8Ω
	30	22	12.338	4800W 6.8Ω	2022	1	BR1K2W6P8	4	125	6.8Ω
	40	30	16.497	6000W 5Ω	2015	2	BR1K5W005	4	125	5Ω
	50	37	20.6	9600W 4Ω	2015	2	BR1K2W008	8	125	4Ω
460V Series	1	0.75	0.427	80W 750Ω			BR080W750	1	125	260Ω
	2	1.5	0.849	300W 400Ω			BR300W400	1	125	190Ω
	3	2.2	1.262	300W 250Ω			BR300W250	1	125	145Ω
	5	3.7	2.080	400W 150Ω			BR400W150	1	125	95Ω
	7.5	5.5	3.111	500W 100Ω			BR500W100	1	125	60Ω
	10	7.5	4.148	1000W 75Ω			BR1K0W075	1	125	45Ω
	15	11	6.186	1000W 50Ω			BR1K0W050	1	125	50Ω
	20	15	8.248	1500W 40Ω	4030	1	BR1K5W040	1	125	40Ω
	25	18.5	10.281	4800W 32Ω	4030	1	BR1K2W008	4	125	32Ω
	30	22	12.338	4800W 27.2Ω	4030	1	BR1K2W6P8	4	125	27.2Ω
	40	30	16.497	6000W 20Ω	4030	1	BR1K5W005	4	125	20Ω
	50	37	20.6	9600W 16Ω	4045	1	BR1K2W008	8	125	16Ω
60	45	24.745	9600W 13.6Ω	4045	1	BR1K2W6P8	8	125	13.6Ω	
75	55	31.11	12000W 10Ω	4030	2	BR1K5W005	8	125	10Ω	
100	75	42.7	19200W 6.8Ω	4045	2	BR1K2W6P8	16	125	6.8Ω	

Note:

1. Please select the factory default resistance value (Watt) and the frequency value (ED%).
2. If damage resulted in the drive or other equipments due to the fact that the braking resistors and the braking modules in use are not provided by DELTA, the warranty will be void.
3. Take into consideration the safety of the environment when installing the braking resistors.
4. If the minimum resistance value is to be utilized, consult local dealers for the calculation of the Watt figures.
5. Please select thermal relay trip contact to prevent resistor over load.
6. When using more than 2 braking units, equivalent resistor value of parallel braking unit can't be less than the value in the column "Minimum Equivalent Resistor Value for Each AC Drive" (the right-most column in the table).



Braking Resistors & Braking Units

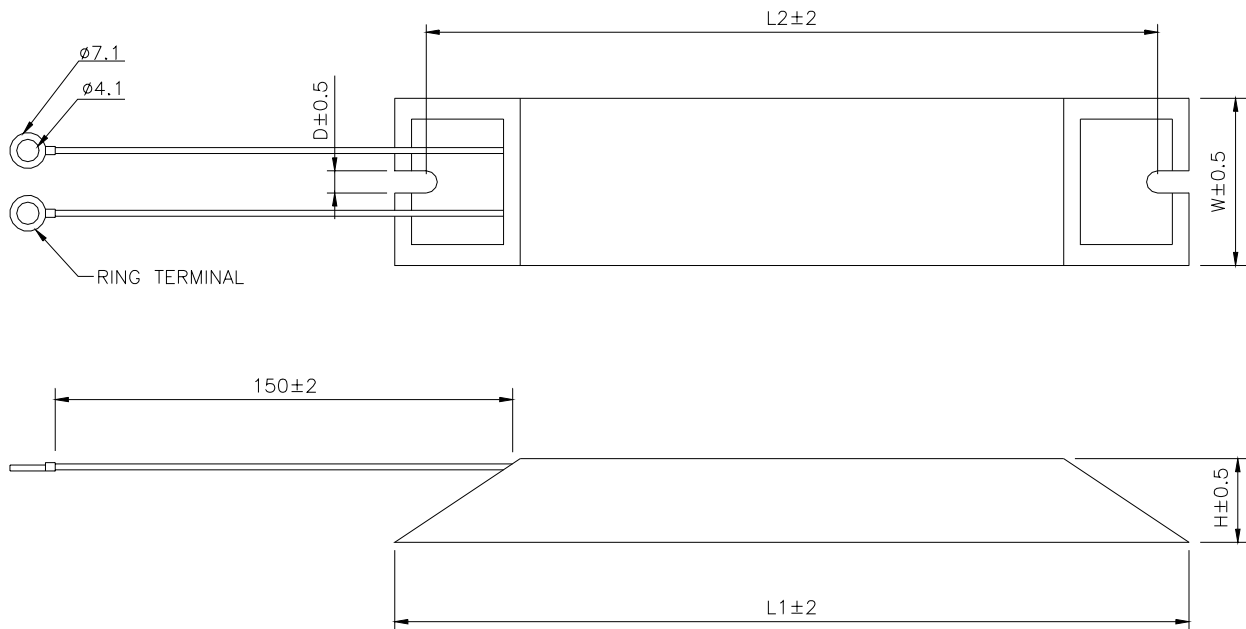

TYPE	L1	L2	H	D	W	MAX. WEIGHT (g)
MHR200W120	165	150	20	5.3	40	240
MHR400W120	165	150	20	5.3	40	240
BR080W200	140	125	20	5.3	60	160
BR080W750	140	125	20	5.3	60	160
BR300W070	215	200	30	5.3	60	750
BR300W100	215	200	30	5.3	60	750
BR300W250	215	200	30	5.3	60	750
BR300W400	215	200	30	5.3	60	750
BR400W150	265	250	30	5.3	60	930
BR400W040	265	250	30	5.3	60	930

Braking Resistors & Braking Units

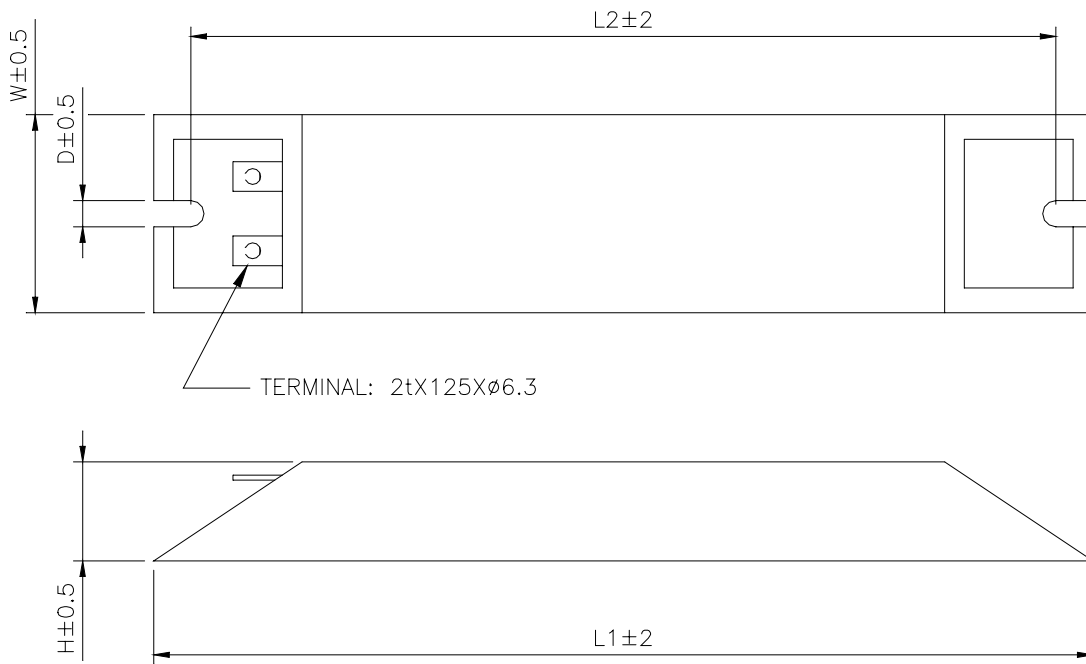

TYPE	L1	L2	H	D	W	MAX. WEIGHT (g)
MHR025W500	335	320	30	5.3	60	1100
MHR050W500	335	320	30	5.3	60	1100
MHR100W500	335	320	30	5.3	60	1100
BR500W030	335	320	30	5.3	60	1100
BR500W100	335	320	30	5.3	60	1100
BR1K0W020	400	385	50	5.3	100	2800
BR1K0W075	400	385	50	5.3	100	2800

B

Braking Resistors & Braking Units

Braking resistors model no.: **BR1K0W050, BR1K2W008, BR1K2W6P8, BR1K5W005, BR1K5W040**

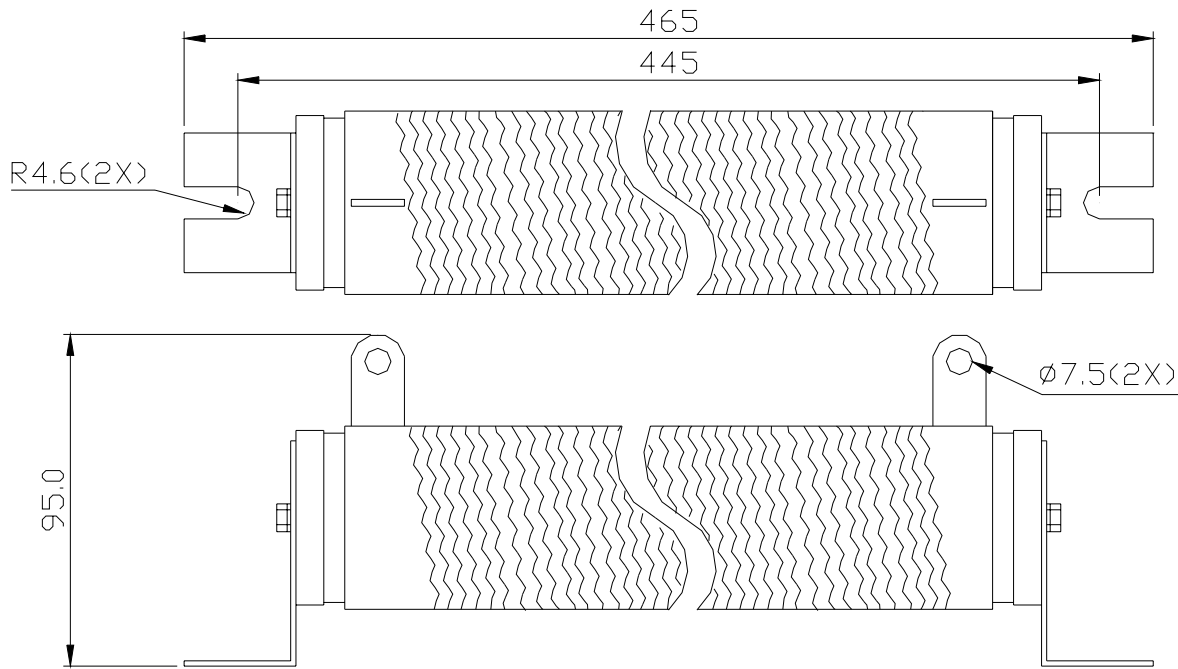

B.3 AMD - EMI Filter Cross Reference

Model of AC Motor Drive	EMI Filter with choke				EMI Filter w/o choke
	Filter	Output chock	QTY	Turn	
VFD007V23A, VFD015V23A, VFD022V23A, VFD037V23A	--	--	--	--	26TDT1W4C
VFD007V43A, VFD015V43A, VFD022V43A, VFD037V43A	--	--	--	--	15TDT1W44
VFD055V23A, VFD075V23A, VFD110V43A	--	--	--	--	50TDS4W4V4
VFD110V43B	--	--	--	--	26TDT1W4B4
VFD150V43A, VFD185V43A	--	--	--	--	50TDS4W4C
VFD110V23A, VFD150V23A, VFD220V43A, VFD300V43A, VFD370V43A	--	--	--	--	100TDS84C
VFD185V23A, VFD220V23A, VFD300V23A, VFD450V43A	--	--	--	--	150TDS84C
VFD370V23A, VFD550V43A	--	--	--	--	180TDS84C
VFD750V43A	--	--	--	--	200TDDS84C

B

EMI Filters (26TDT1W4C) Use on 1-5 HP, 230V, Three phase Models

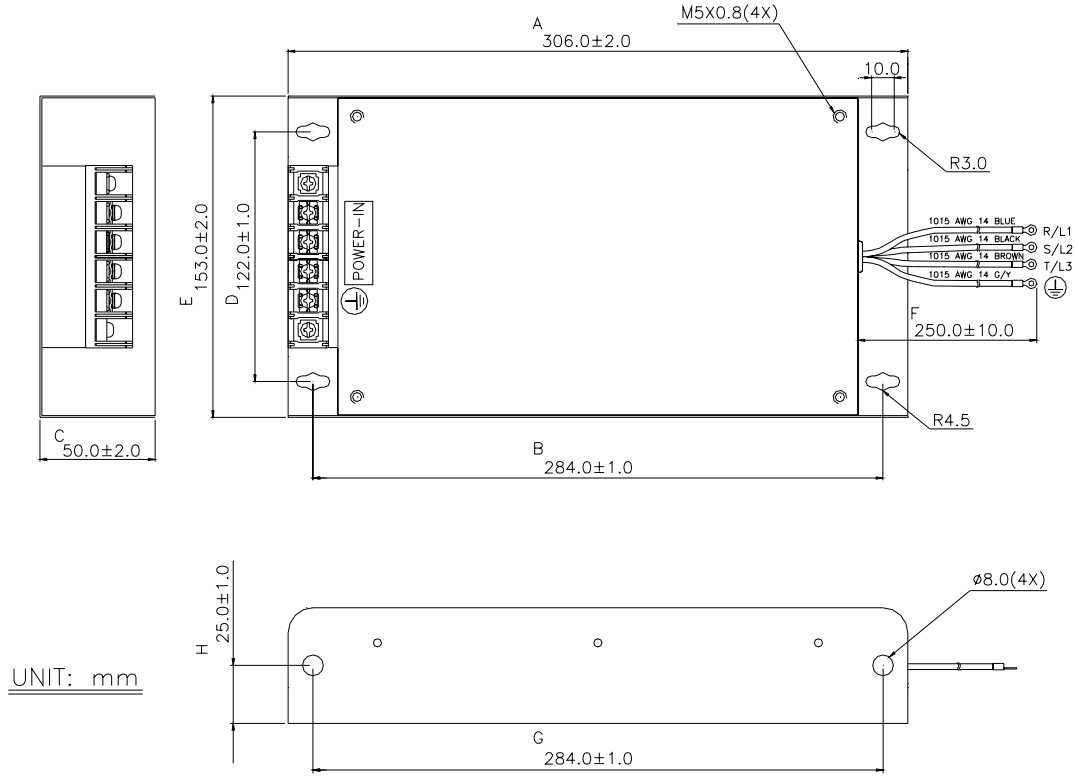

EMI Filters (15TDT1W44) Use on 1-5 HP, 460V, Three phase Models

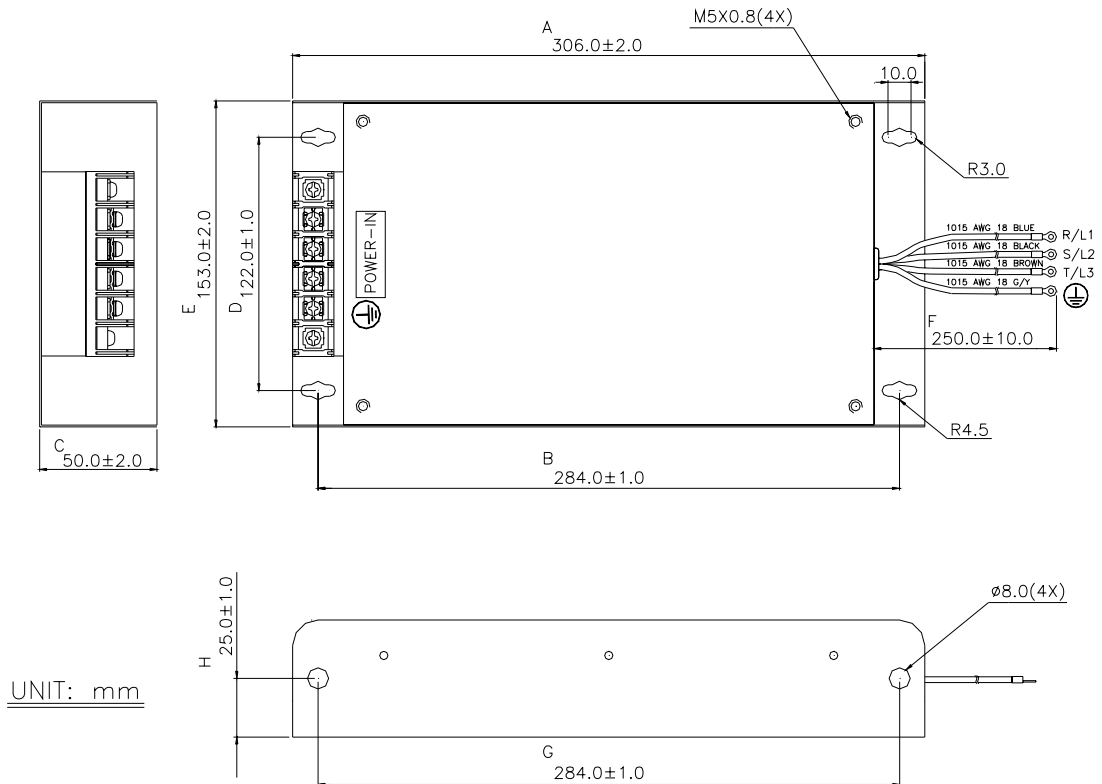

EMI Filters (50TDS4W4V4) Use on 7.5-10HP/230V, VFD110V43A, Three phase Models

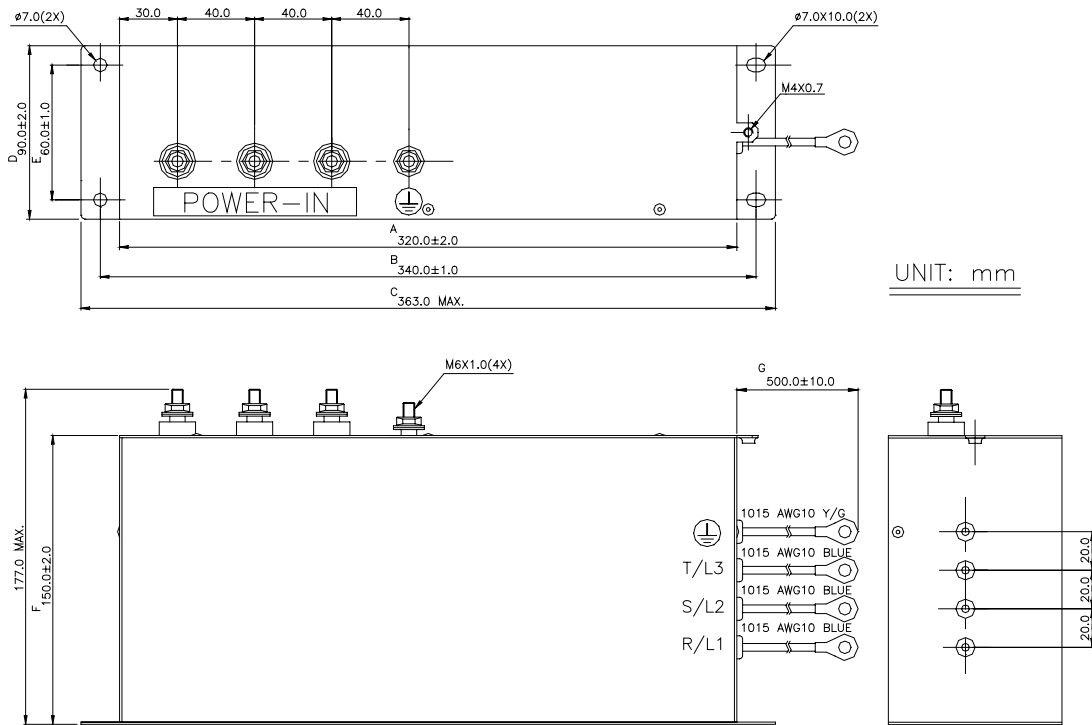

EMI Filters (26TDT1W4B4) Use on VFD110V43B

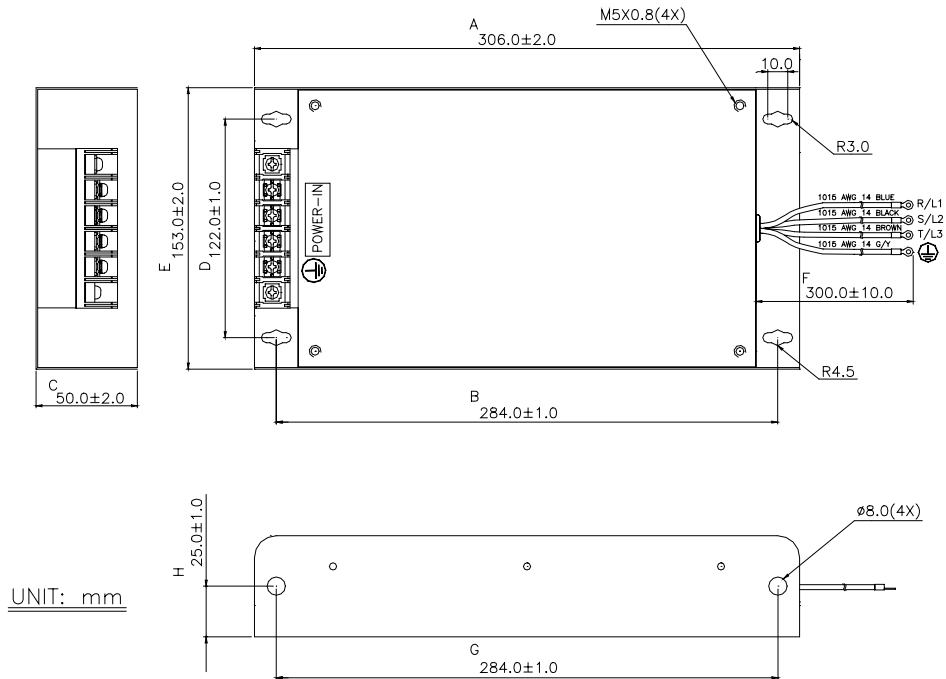

B

EMI Filters (50TDS4W4C) Use on 20-25 HP, 430V, Three phase Models

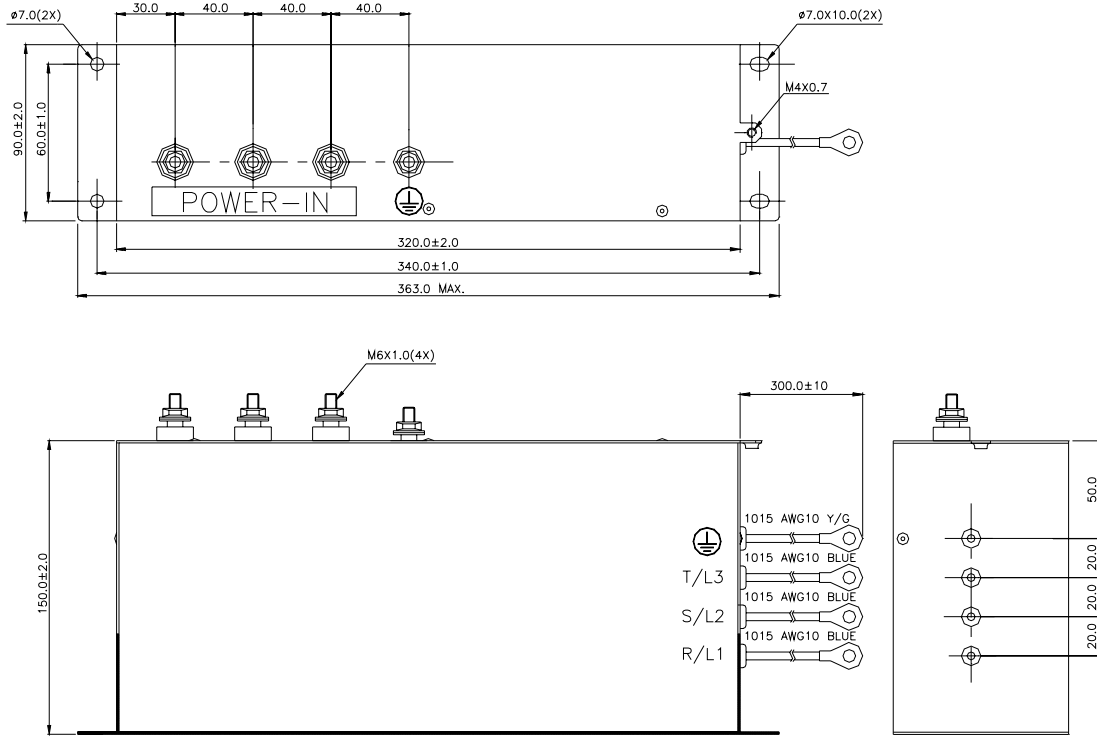

EMI Filters (100TDS84C) Use on 15-20 HP, 230V & 30-50 HP, 430V, Three phase Models

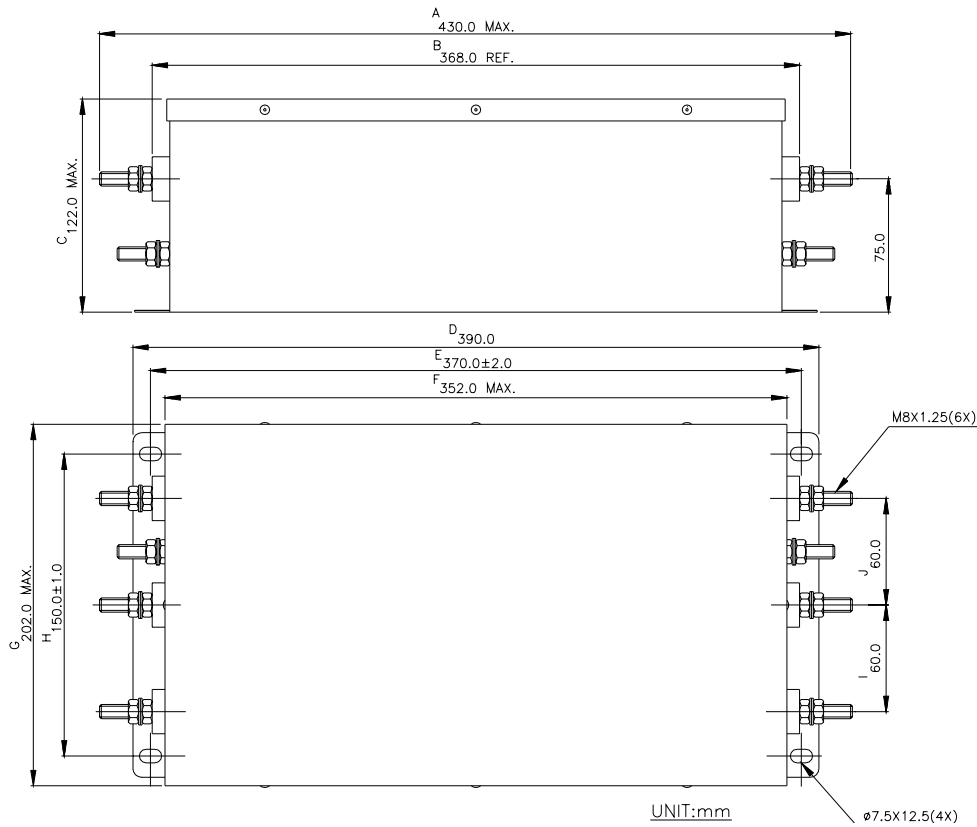

EMI Filters (150TDS84C) Use on 25-40 HP, 230V & 60HP, 430V, Three phase Models

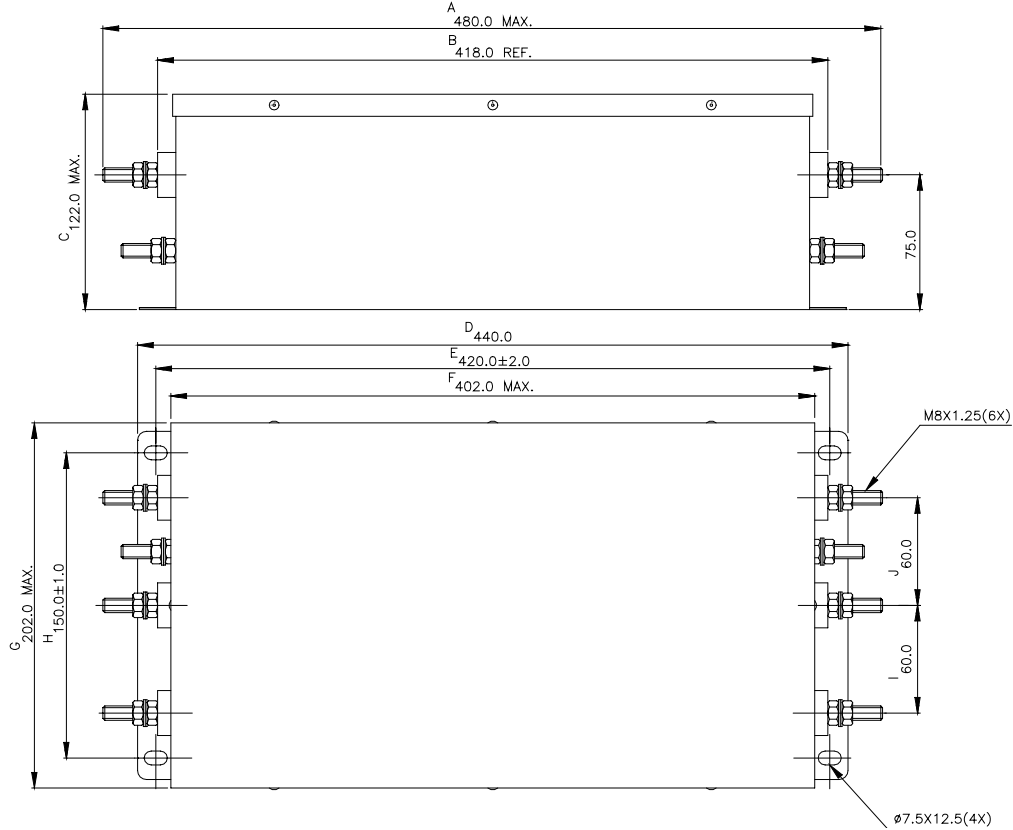

EMI Filters (180TDS84C) Use on 50 HP, 230V & 60 HP, 430V, Three phase Models

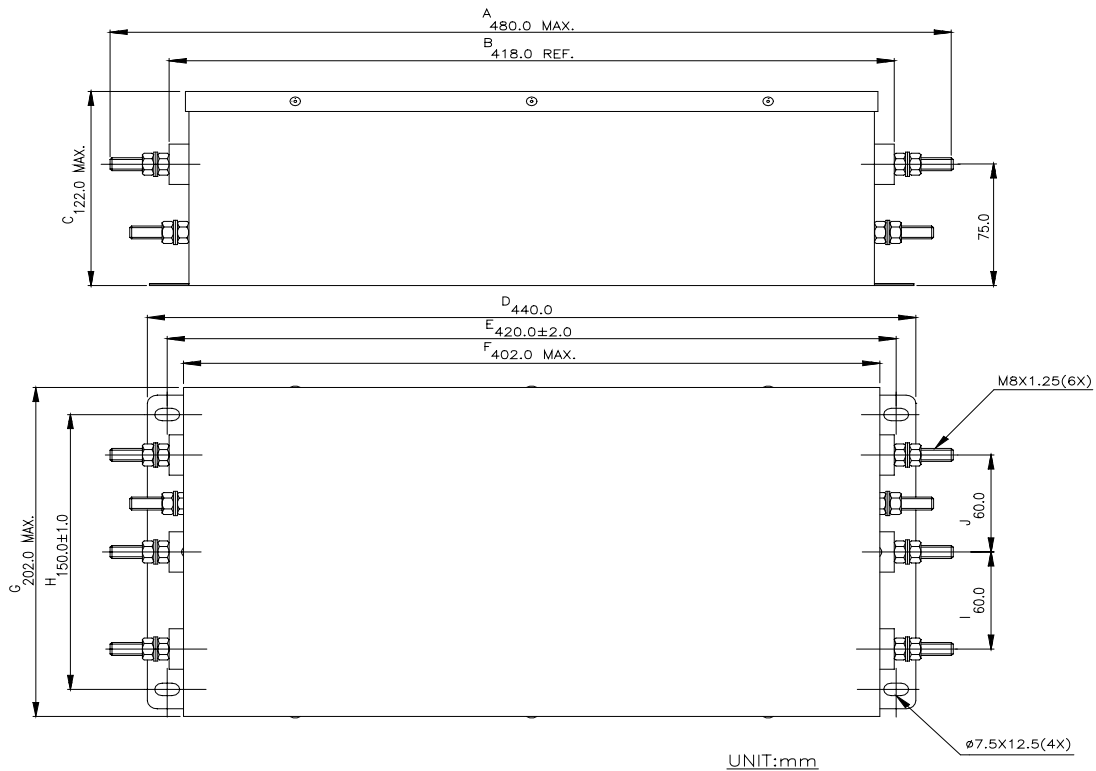

B

EMI Filters (200TDDS84C) Use on 100 HP, 430V, Three phase Models

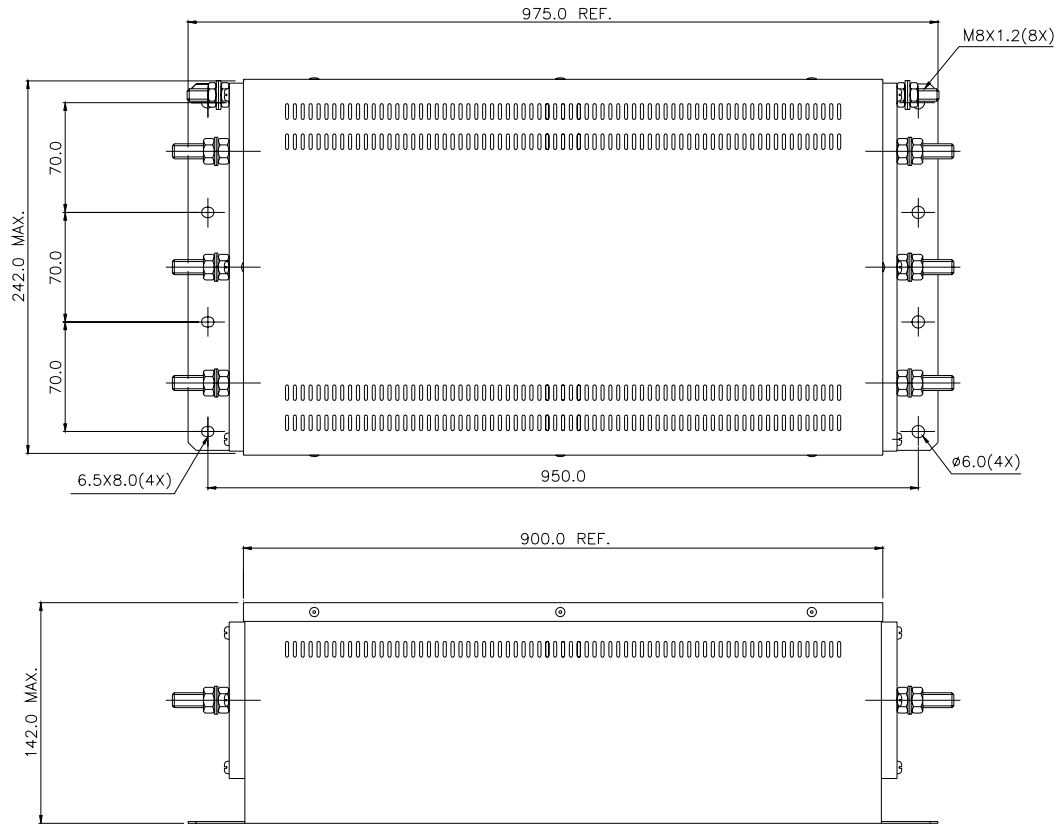

B.4 PG Card

Wiring Diagram

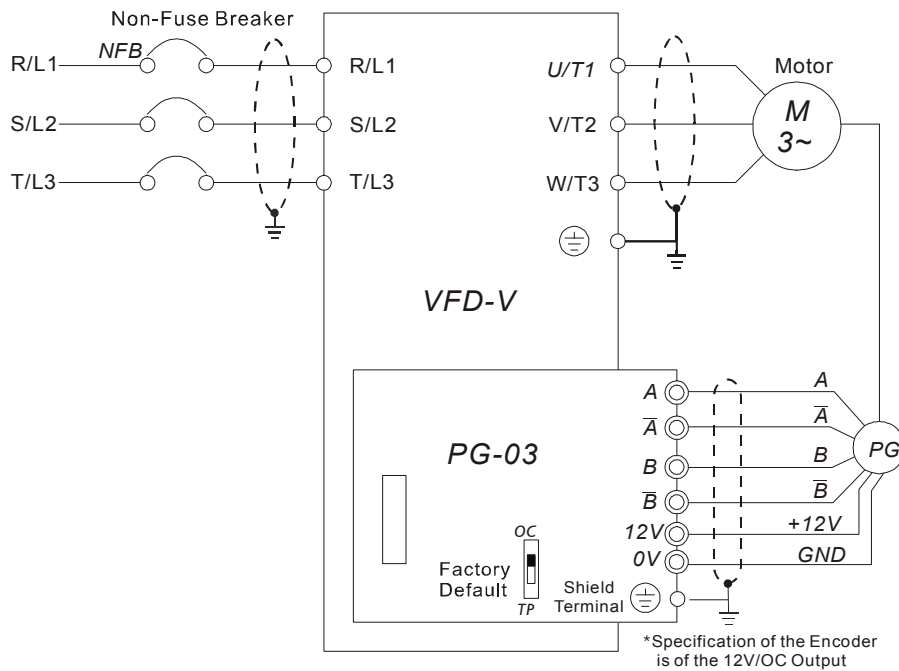

Connection between PG-03 and the Encoder

Connect Externally with the Encoder of 5V Power Supply and Output Signals to Additional Tachometer

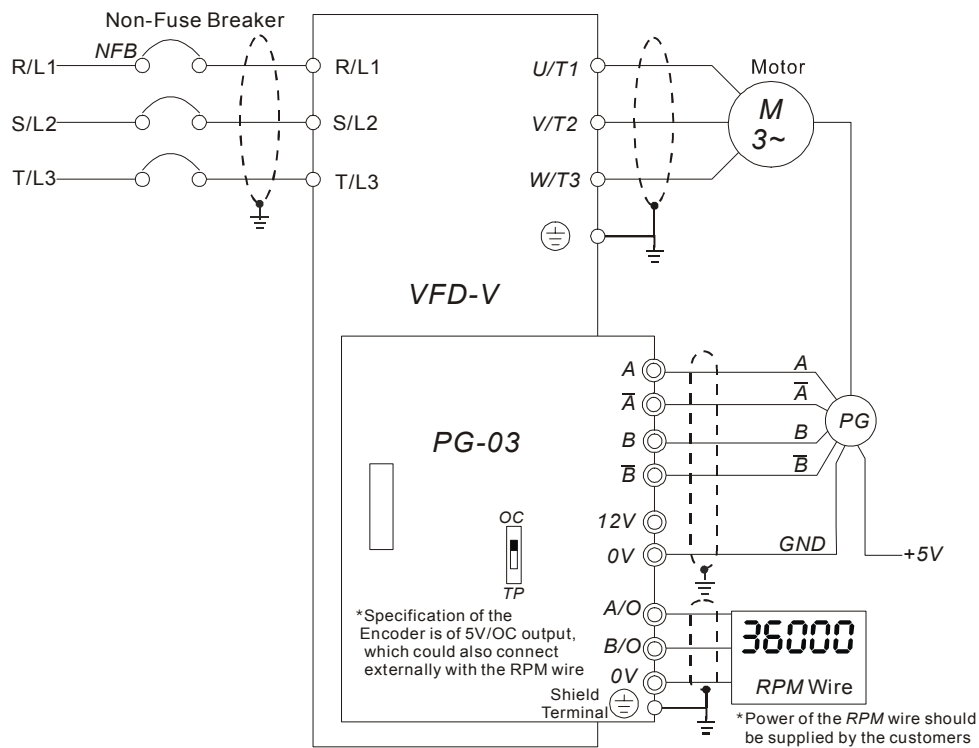

Connection between PG-03 and the Encoder



B.4.1 Explanations on the PG Card Terminals

Terminals	Explanation
12V	Power Supply of the Encoder: +12V Output Voltage: +12V±5% 200mA
0V	Common point for the power supply and the signal
A- \bar{A} , B- \bar{B}	Encoder signal input (select the output type of the Encoder from FSW2) Both single-phase input and two-phase input available Maximum: 500KP/Sec
A/O, B/O	The Encoder signal output Maximum: DC24V 300mA
	Common point for signal grounding

B.4.2 Wiring Notes

1. Use the shielded isolated wire to prevent interference, and do not line up in parallel with circuits of AC200V or above.
2. The shielded end of the isolated wire should connect to the “DCM” terminal.
3. Recommended wire size: 0.21~0.81mm²(AWG24~AWG18).
4. Wire length:

The Output Types of the Encoder	Maximum Wire Length	Wire Gauge
Voltage	50m	1.25mm ² (AWG18) or above
Open Collector	50m	
Line Driver	300m	
Complementary	70m	

B.4.3 Exterior of PG-03

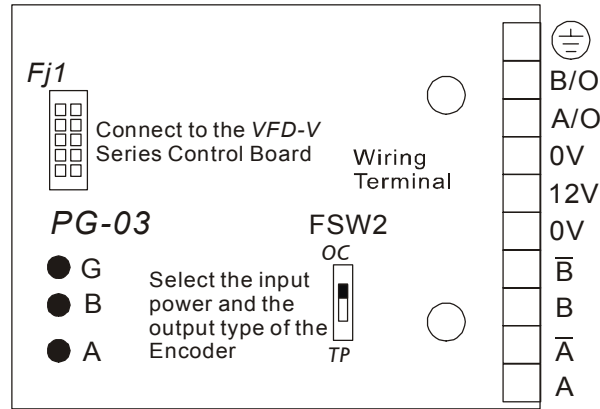

B.4.4 The Output Types to Accommodate the Encoder

Output Types of the Encoder		FSW2 Switch
Voltage		
Open collector		
Line driver		
Complementary		

B

B.4.5 VFD-V & VFD-B Series Speed Regulation Comparison

Char. \ Series	VFD-V		VFD-B	
	Sensorless-Vector Mode (without PG)	Flux Vector Mode (with PG)	Without PG	With PG
Speed Control Range	1:100	1:1000	1:40	1:40
Speed Regulation	± 0.2%	± 0.02%	± 3%	± 0.05%
Initial Speed	150% at 1Hz	150% at 0 RPM	150% at 3Hz	

Note: The speed regulation is based on rated speed.

B.5 Zero Phase Reactor (RF220X00A)

Dimension

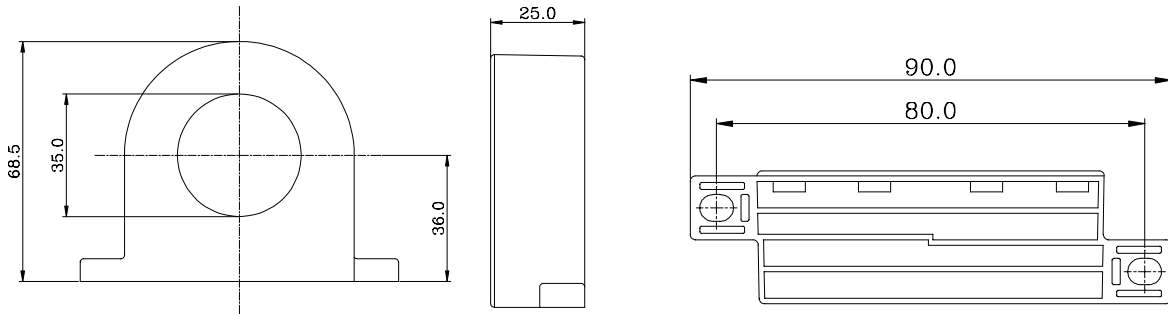

	Motor		Qty.	Recommended Wire Size (mm ²)	Wiring Method
	HP	kW			
230 V Series	1/4	0.2	1	0.5 - 5.5	Diagram A
	1/2	0.5			
	1	0.75			
	2	1.5			
	3	2.2			
	5	3.7			
	7.5	5.5	4	8	Diagram B
	10	7.5			
	15	11			
	20	15			
	25	18.5			
	30	22			
460 V Series	1/4	0.2	1	0.5 - 5.5	Diagram A
	1/2	0.5			
	1	0.75			
	2	1.5			
	3	2.2			
	5	3.7			
	7.5	5.5	4	8 - 14	Diagram B
	10	7.5			
	15	11			
	20	15			
	25	18.5			
	30	22			
40	30	4	22	Diagram B	
50	37				
60	45				
75	55				
100	75		38 - 100		

Diagram A

Please wind each wire **4 times** around the core. The reactor must be put at inverter side as close as possible.

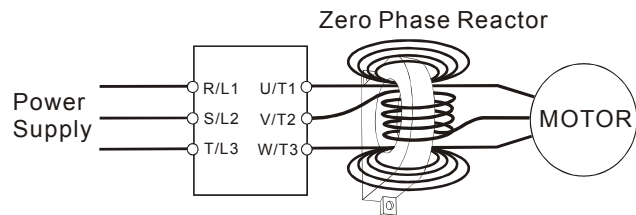
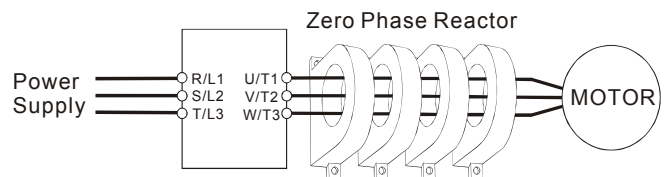

Diagram B

Please put all wires through 4 cores in series without winding.



DIMENSIONS

VFD007V23A/43A

Unit: mm (inches)

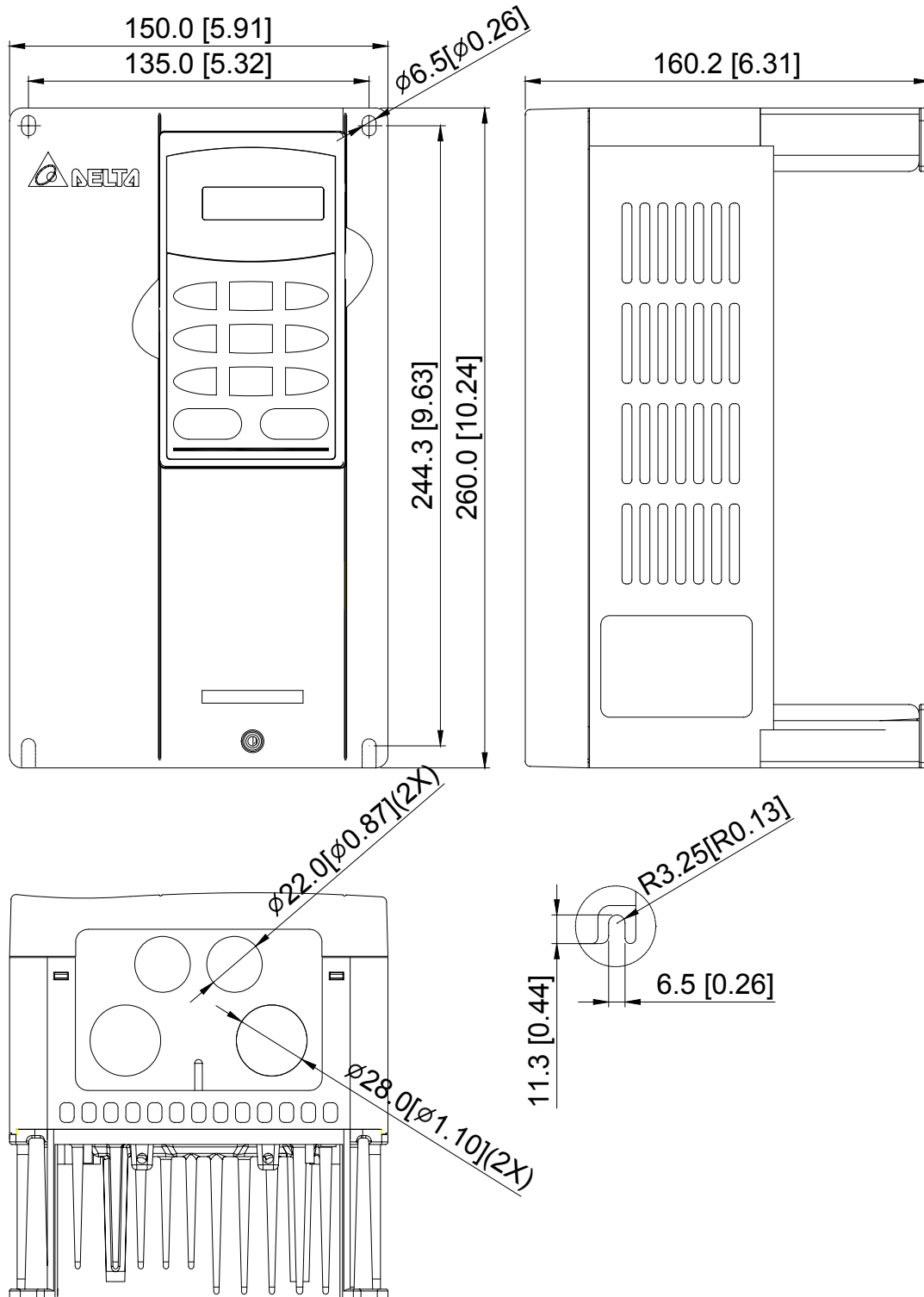

VFD015V23A/43A

VFD022V23A/43A

Unit: mm (inches)

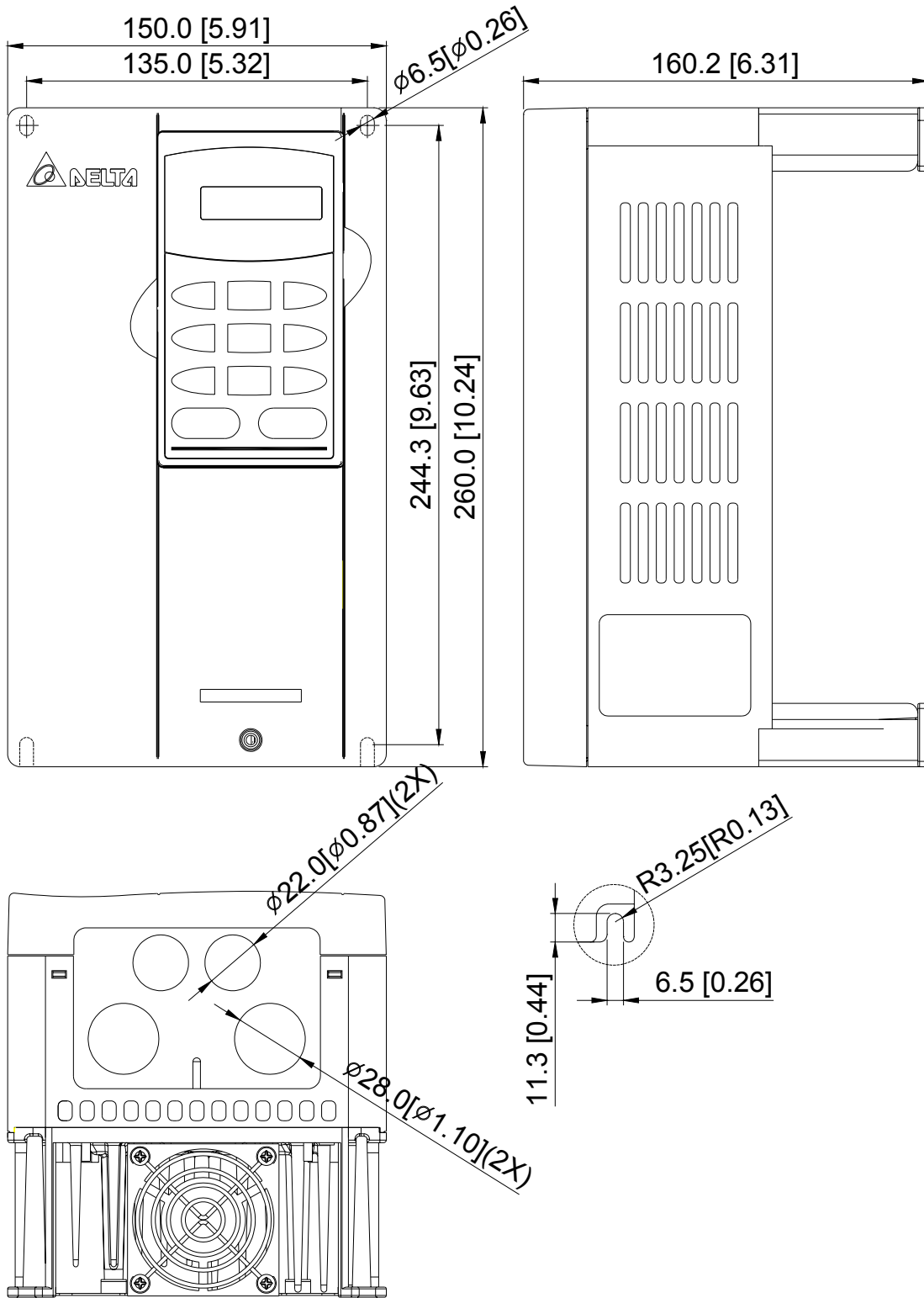

VFD037V23A/43A

Unit: mm (inches)

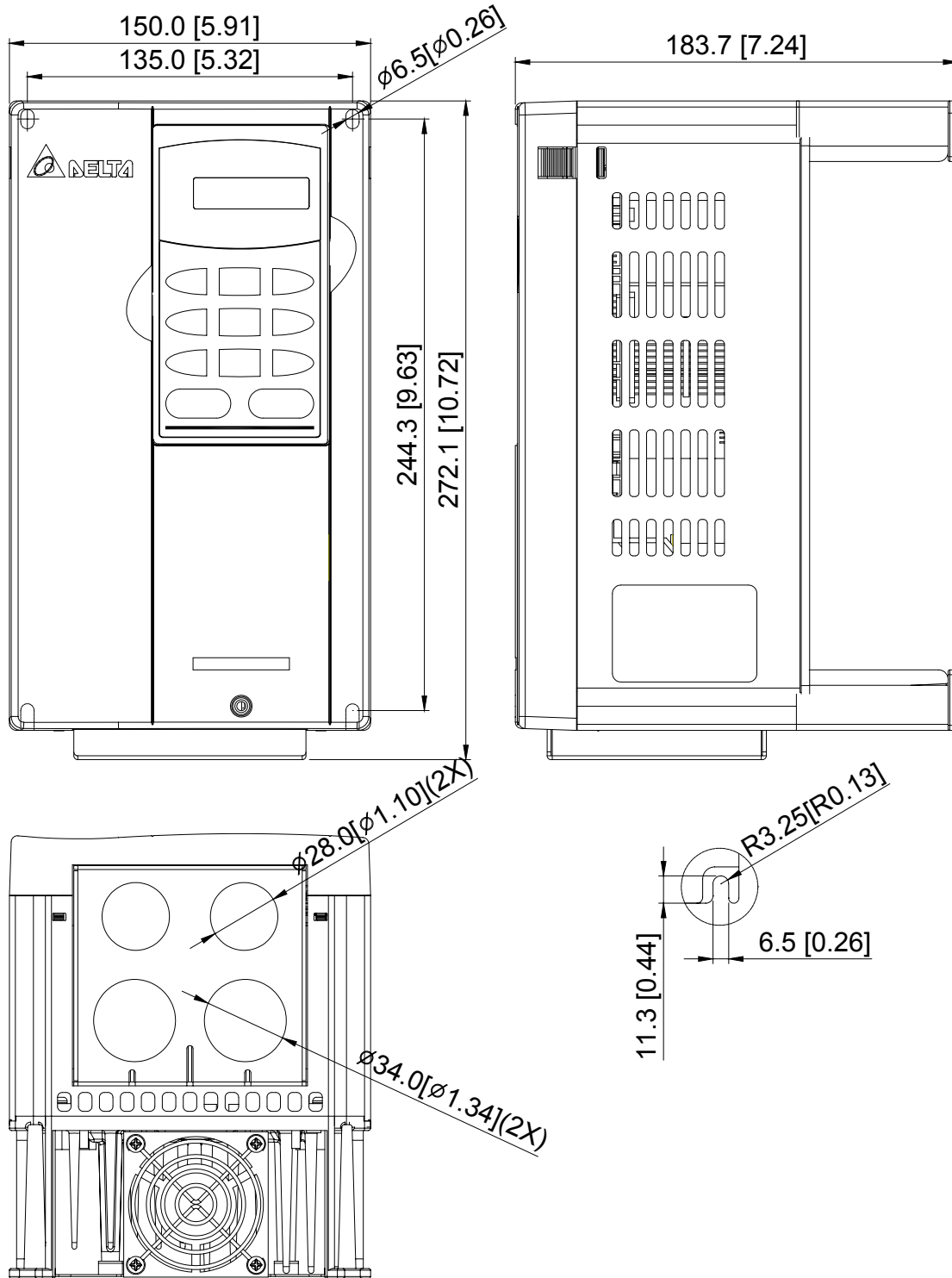

C

VFD055V23A/43A

VFD075V23A/43A

VFD110V43B

Unit: mm (inches)

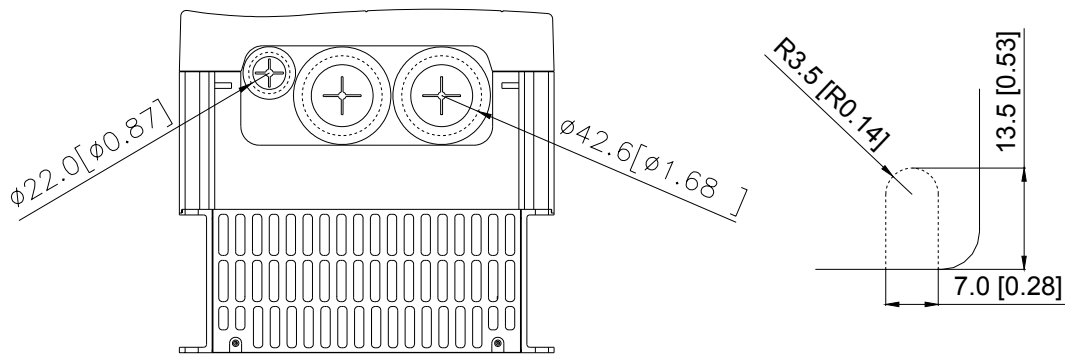
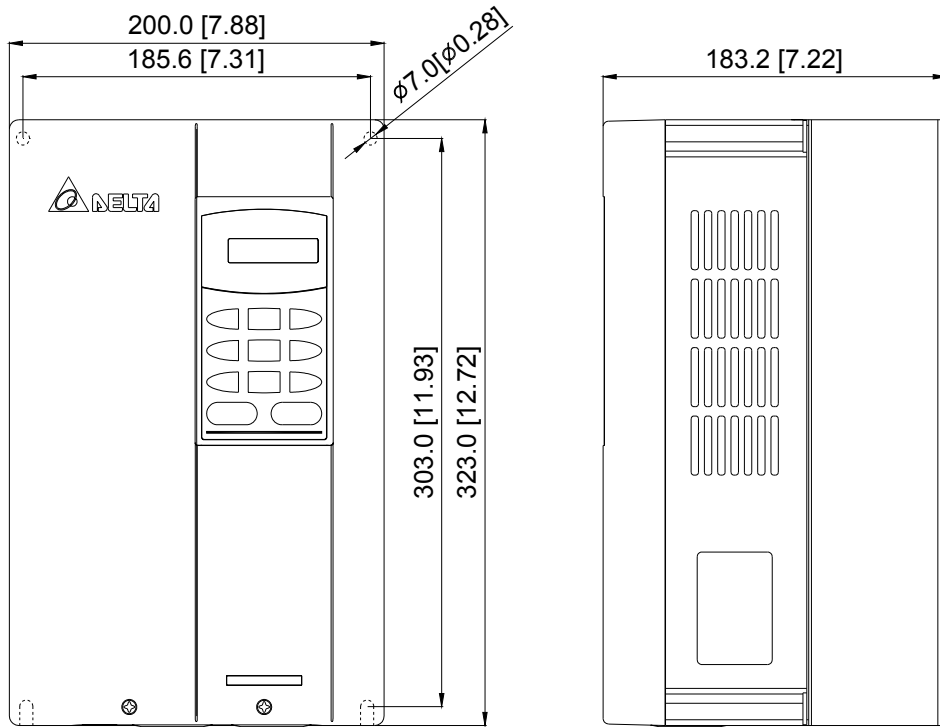

VFD110V23A/43A
 VFD150V23A/43A
 VFD185V23A/43A
 VFD220V23A/43A

Unit: mm (inches)

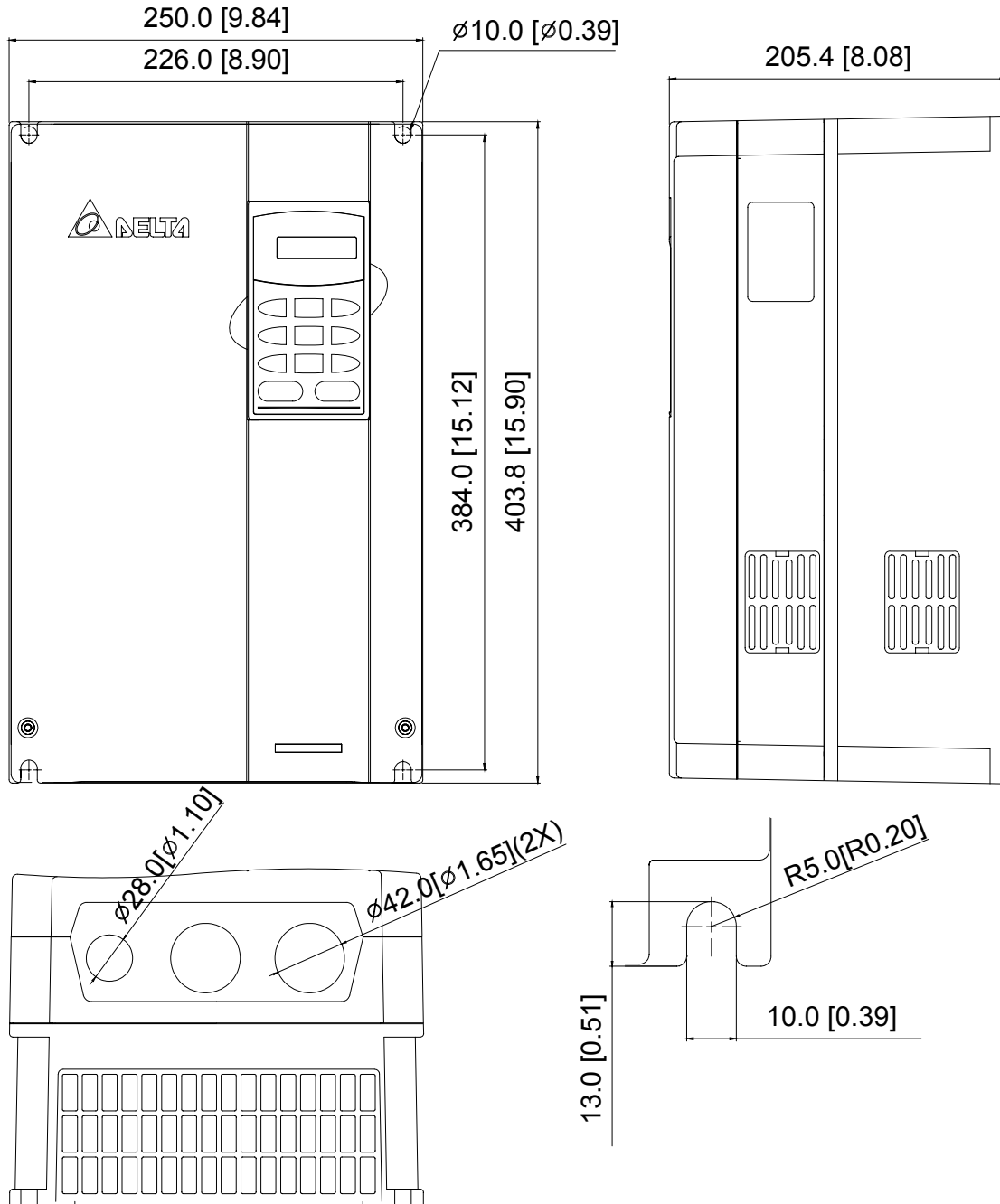

VFD300V23A

VFD370V23A

Unit: mm (inches)

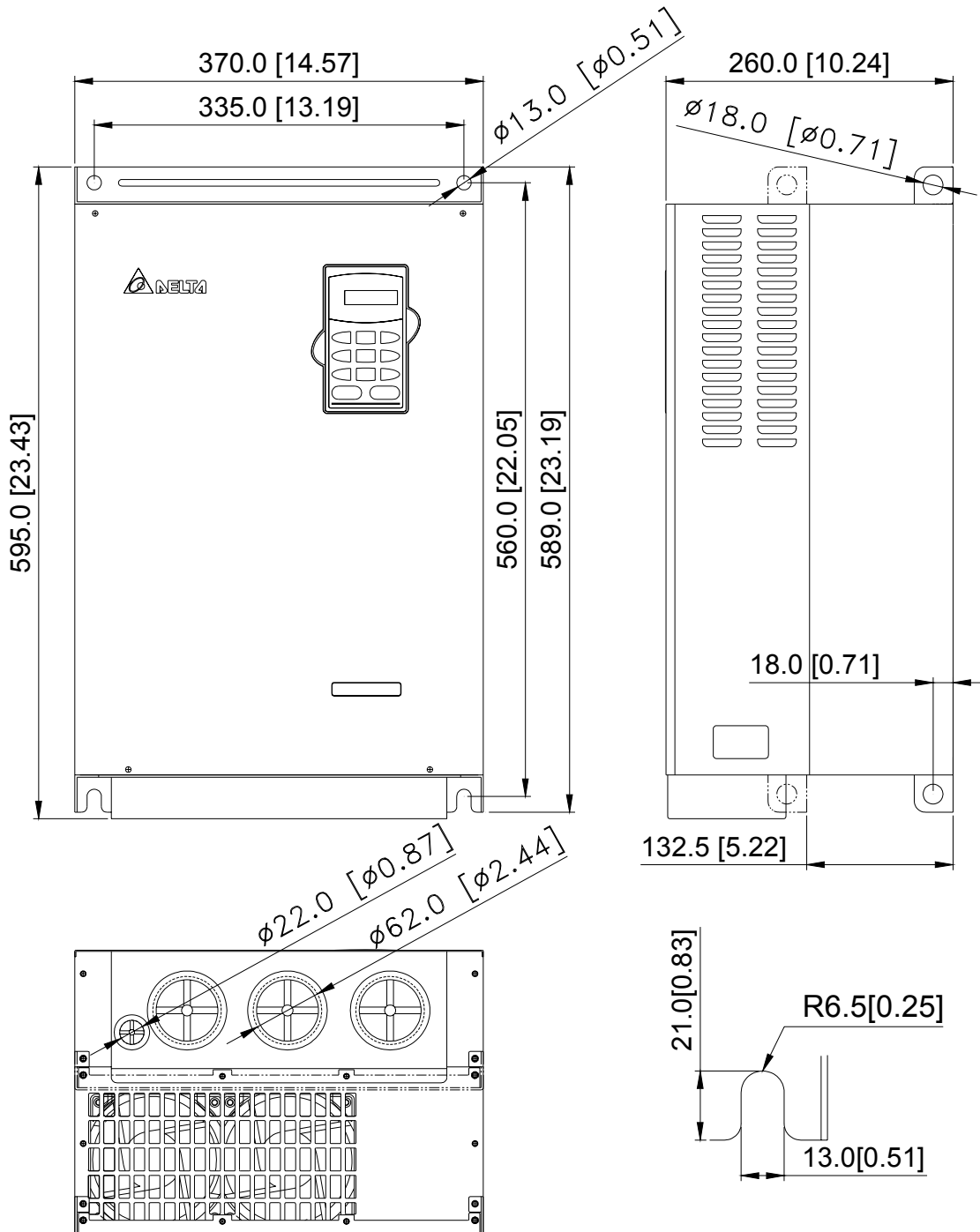

VFD300V43A
 VFD370V43A
 VFD450V43A

Unit: mm (inches)

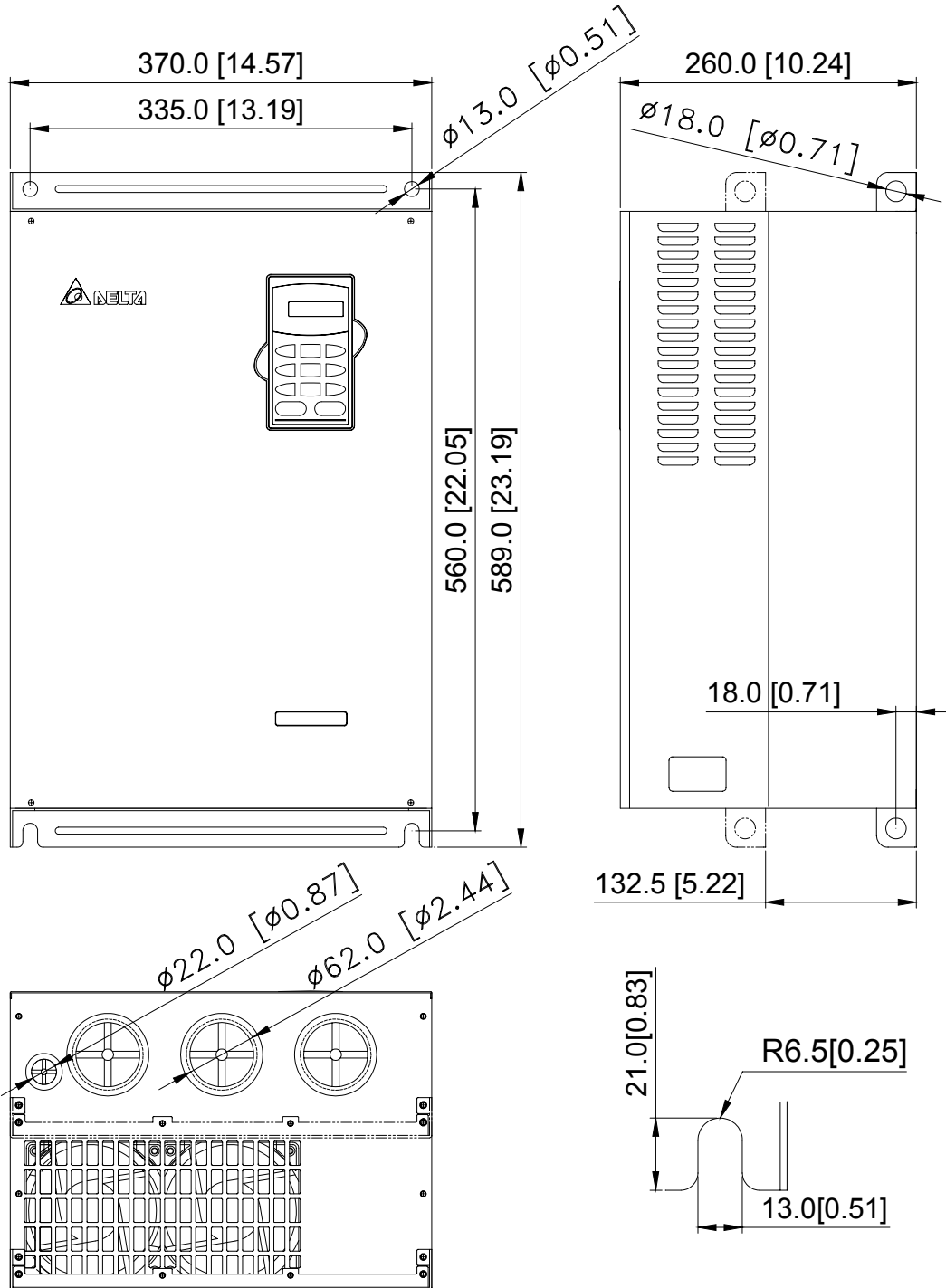

VFD550V43A

VFD750V43A

Unit: mm (inches)

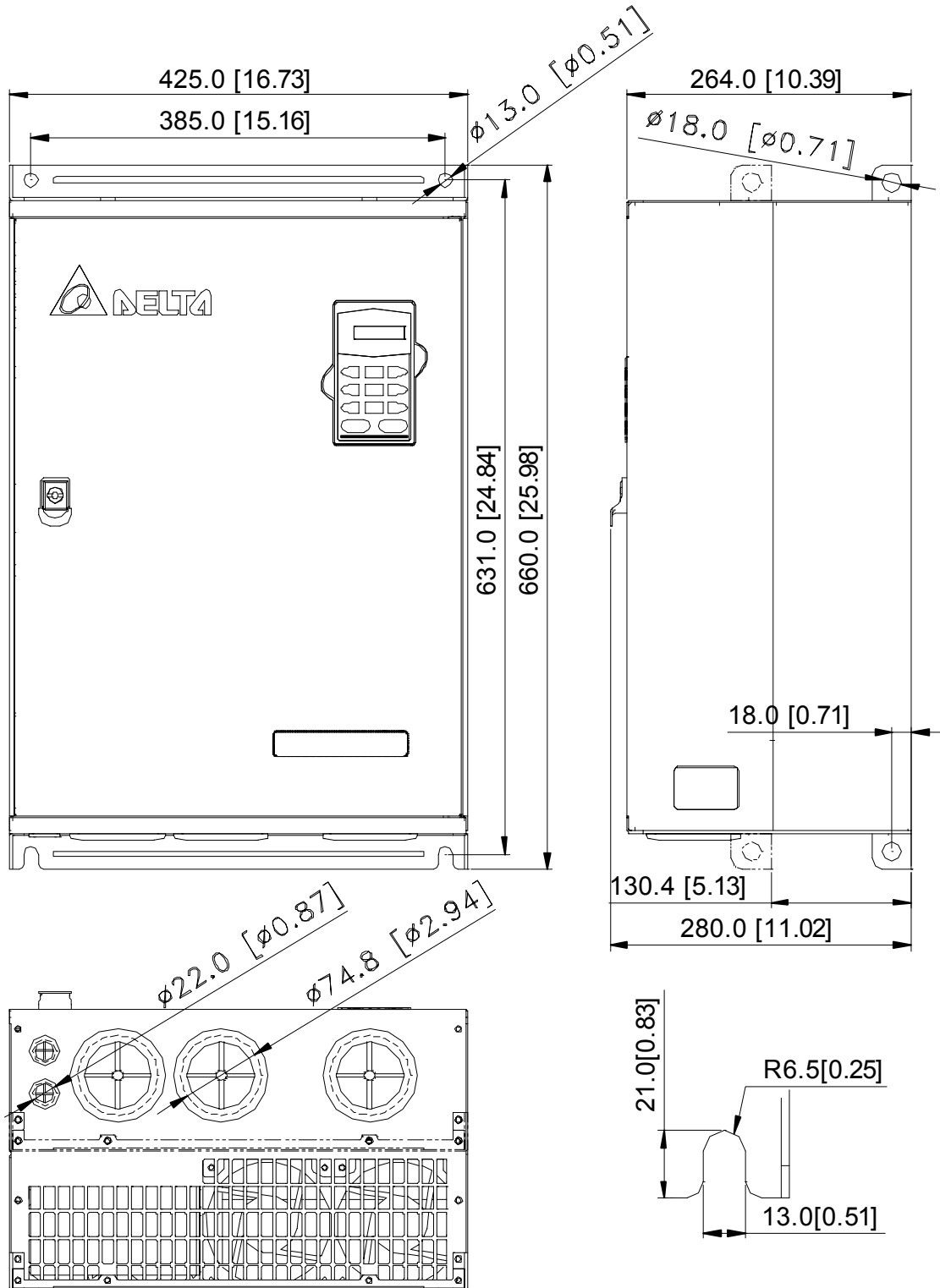

The Apparatus Size of the Digital Hand-Held Programming Panel VFD-PU05

Unit: mm (inches)

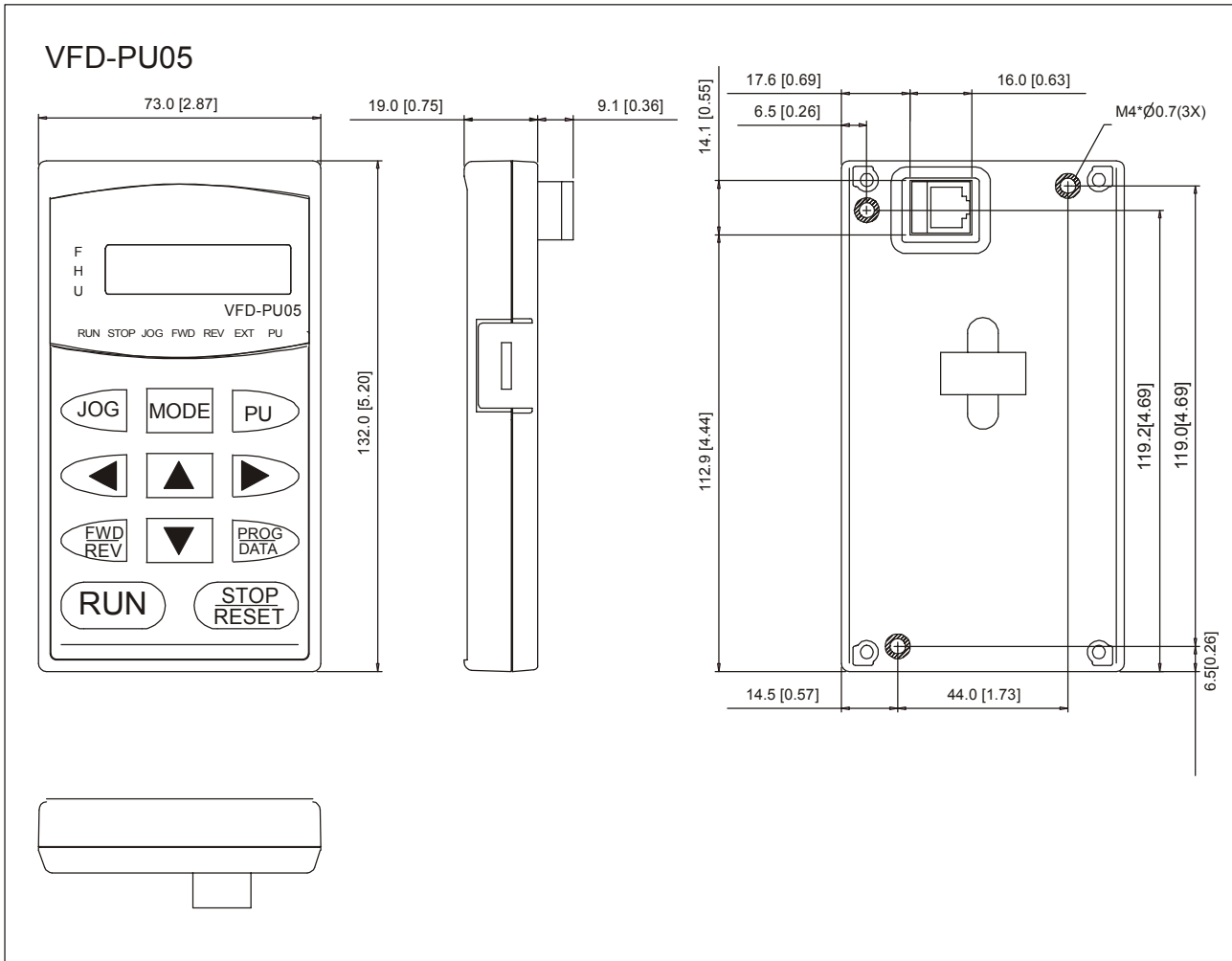



DELTA ELECTRONICS, INC.

**EC Declaration of Conformity
According to the Low Voltage Directive 73/23/EEC and the
Amendment Directive 93/68/EEC**

For the following equipment:

AC Motor Drive

(Product Name)

VFD007V23A, VFD007V43A, VFD015V23A, VFD015V43A, VFD022V23A,
VFD022V43A, VFD037V23A, VFD037V43A, VFD055V23A, VFD055V43A,
VFD075V23A, VFD075V43A, VFD110V23A, VFD110V43A, VFD110V43B,
VFD150V23A, VFD150V43A, VFD185V23A, VFD185V43A, VFD220V23A,
VFD220V43A, VFD300V23A, VFD300V43A, VFD370V23A, VFD370V43A,
VFD450V43A, VFD550V43A, VFD750V43A

(Model Name)

is herewith confirmed to comply with the requirements set out in the Council Directive 73/23/EEC for electrical equipment used within certain voltage limits and the Amendment Directive 93/68/EEC. For the evaluation of the compliance with this Directive, the following standard was applied:

EN 50178

The following manufacturer/importer is responsible for this declaration:

Delta Electronics, Inc.

(Company Name)





DELTA ELECTRONICS, INC.

**EC Declaration of Conformity
According to the Electromagnetic Compatibility 89/336/EEC and
the Amendment Directive 93/68/EEC**

For the following equipment:

AC Motor Drive
(Product Name)

VFD007V23A, VFD007V43A, VFD015V23A, VFD015V43A, VFD022V23A,
VFD022V43A, VFD037V23A, VFD037V43A, VFD055V23A, VFD055V43A,
VFD075V23A, VFD075V43A, VFD110V23A, VFD110V43A, VFD110V43B,
VFD150V23A, VFD150V43A, VFD185V23A, VFD185V43A, VFD220V23A,
VFD220V43A, VFD300V23A, VFD300V43A, VFD370V23A, VFD370V43A,
VFD450V43A, VFD550V43A, VFD750V43A

(Model Name)

is herewith confirmed to comply with the requirements set out in the Council Directive 89/336/EEC for electromagnetic compatibility and the Amendment Directive 93/68/EEC. For the evaluation of the compliance with this Directive, the following standard was applied:

EN61800-3, EN55011, EN61000-6-4, EN61000-6-2, EN61000-4-2, EN61000-4-3,
EN61000-4-4, EN61000-4-5, EN61000-4-6, EN61000-4-8

The following manufacturer/importer is responsible for this declaration:

Delta Electronics, Inc.
(Company Name)
