

High Performance Multifunctional Inverters

FRENIC - MEGA Series



New Standard

FRENIC-MEGA



FRENIC - MEGA

G2
SERIES

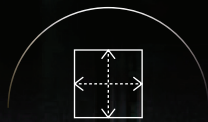

Same body and mounting dimensions

- » Stylish exterior design colors
- » Facilitates G1 Series replacement and mounting

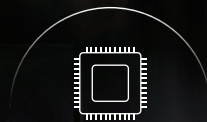

Additional control and functions

- » Comes standard with synchronous motor drive
- » Standard features include positioning and safety functions



Designed with new operation keypad

- » Comes standard with 7-segment, 5-digit LED display
- » Comes with large screen that facilitates ease-of-use and maintenance



Improved reliability and maintainability

- » Comes standard with functional safety (STO)
- » Compatibility mode enables smooth parameter migration

Application examples

Machine tools



- Improved speed response
- Orientation function

Press machines



- Sensorless vector control
- Improved current response

Fluid machines



- PID auto tuning function
- Comes standard with synchronous motor drive

Expansion of Mega Series applications

Supports a wide variety of applications and is useful in various situations.

Winding machines



- Improved speed response
- Expanded speed control range

Hoist



- Overload stoppage function
- Light-load double speed operation function

Stacker crane



- Positioning control function
- Servo lock function

Main changes

FRENIC-MEGA G1 SERIES >>> FRENIC-MEGA G2 SERIES

01 Same mounting dimensions

POINT

The inverter's external dimensions and mounting dimensions are fully compatible with the G1 Series, making it easy to mount it as a replacement of previous products.

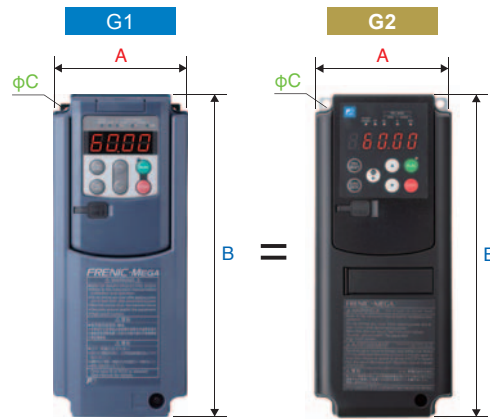

02 Utilizes a new operation keypad (touch panel)

POINT

Like the G1 Series, it comes with a 7-segment LED with 5-digit keypad. Its large screen is very intuitive and it enhances maintainability via improved key button operability and cursor digit control.

Standard keypad (touch panel)



Additional features

Character display

7-segment, 5-digit LED display

Shift key

The cursor can be moved to any position.
(Improves operability)

[M] LED display

Can use LEDs to monitor the digital output signals of inverters.

Multifunctional keypad (touch panel)



Additional features

Character display

Improves visibility via LCD display.
Supports a total of 19 languages, including Japanese hiragana, katakana and kanji.

Clock function

Time data can be added to the alarm history.

SD card slot

Can store traceback data on SD card.

Waterproof surface

The keypad front surface and sides are IP55 compliant. (Back surface is IP20)

Built-in Bluetooth

Parameter changes, maintenance and diagnosis can be performed remotely using a mobile device.

USB port

Mounts to both standard keypad and multifunctional keypad

03 Improves control performance

POINT

Comes standard with synchronous motor drive

It is now possible to operate it in combination with our induction motors (Premium Efficiency IE3/Standard Efficiency IE1) and various synchronous motors, as well as with the induction motors and synchronous motors made by other companies.

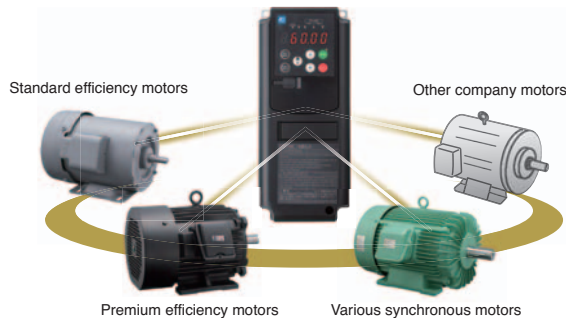

Expands the range of high-speed operation

The maximum output frequency has been increased to 599 Hz. This makes it useful for applications that require high-speed rotation and speed/torque control.

Example Machine tools, automotive testing equipment, etc.

Maximum output frequency

	MEGA (G1)	MEGA (G2)
V/f control	500 Hz	599 Hz
Vector control with high-speed sensor	200 Hz	599 Hz
Vector control without high-speed sensor	120 Hz	599 Hz

Improved output torque at low speeds

The speed control range has been partially enhanced to help stabilize constant speed torque and improve the accuracy of machine operation.

Example Press machines, conveyance machines, etc.

Speed control range

	High-speed sensor	MEGA (G1)	MEGA (G2)
V/f control	With	1:100*	1:200*
	Without	1:100*	1:200*
Vector control	With	Induction motor 1:1500 Synchronous motor 1:1000	1:1500
	Without	Induction motor 1:200 Synchronous motor 1:10	Induction motor 1:200 Synchronous motor 1:10
Constant torque and constant output area ratio	With	1:8	1:16
	Without	1:4	1:4

*During dynamic torque vector control

Reduces the impact of disturbance on machines

It improves speed and current response and contributes to stable product quality by reducing rotation irregularities.

Example Metalworking machines, wiredrawing machines, etc.

Current and velocity response

	High-speed sensor	MEGA (G1)	MEGA (G2)
Speed response	Yes	100 Hz	200 Hz
	No	20 Hz	40 Hz
Current response		500 Hz	1000 Hz

04 Comes standard with safety functions

POINT

- Conforms to European safety standards. (EN ISO 13849-1:2015, Cat3/PL:e IEC/EN61800-5-2:2016 SIL3 (Functional Safety:STO))
- The inverter comes with a function that enables it to adapt to machine safety. This facilitates the design of main circuit switching devices for ensuring safe stoppages.

05 Simple wiring

POINT

The control terminal block uses an industry-standard rod-shaped terminal type (⊖ screw) and comes with nine more terminals to facilitate wiring work.

It is also possible to mount or replace the G1 Series round terminal type (⊕ screw).

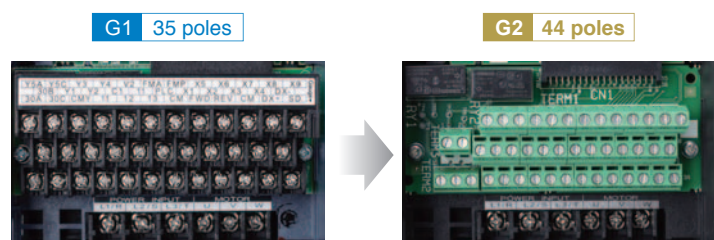

06 Easy parameter migration

POINT

Compatibility mode allows parameters read from the G1 Series to be written directly to the G2 Series.

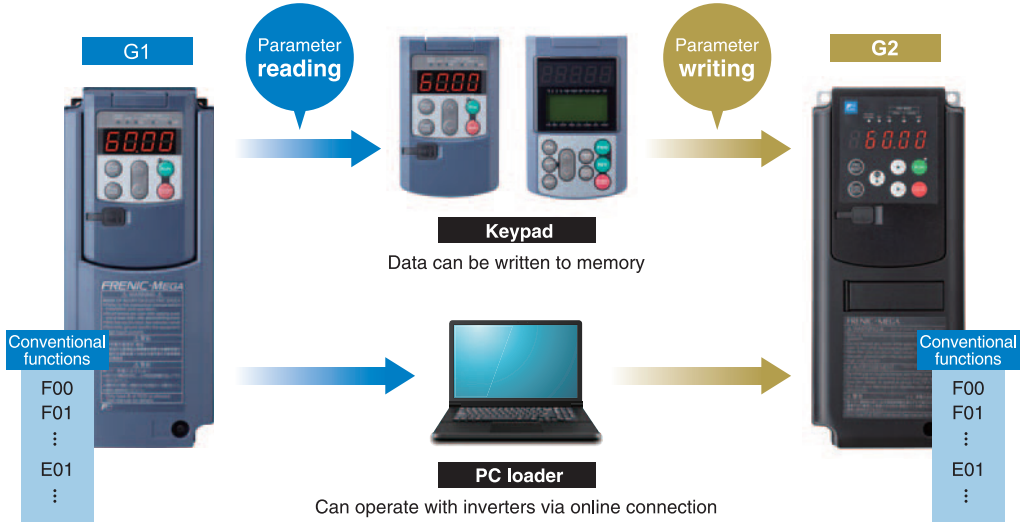

07

Enhanced PC loader functions

MAINTAINABILITY

The PC loader can be used by directly connecting the keypad to a PC using a commercially available USB cable (mini B). It makes it easy to store or check various types of information at the office, or send information and check abnormalities at

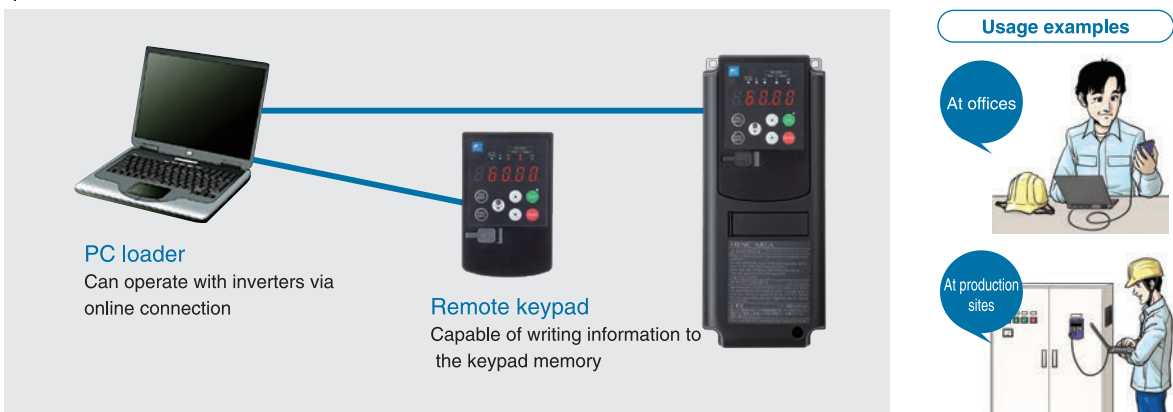

08

Improved environmental resistance

POINT

The following improvements have been made:

(1) **Ambient operating temperature up to +55°C**

Note) Derating is required when used at 50°C or higher.

(2) **Further strengthens PCB coating**

(JIS C 60721-3-3/IEC 60721-3-3 class 3C2)

(3) **IP55 protection for the inverter's main cooling unit, enabling enhanced cooling outside the panel**

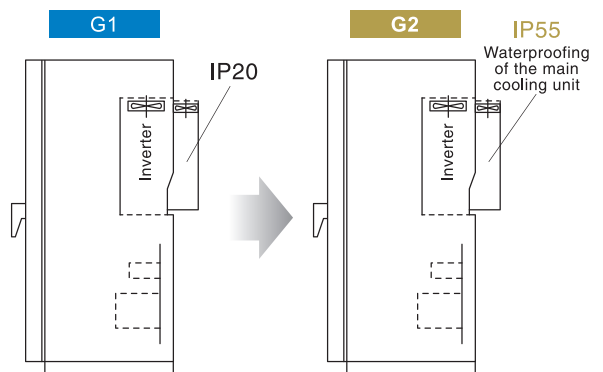

*Supports only 30 kW to 630 kW

Features

Various applications

Comes with feature-rich functionality and enhances compatibility with system networks.



01 Positioning function **NEW**

VARIOUS APPLICATIONS

Contributes to shortening machine tact time through high-precision positioning control for pulse string input and feedback output instructions.

Main features	
- Eight positioning data points	- Overtravel detection function
- Pulse train instruction	- Position preset function
- Origin return function	

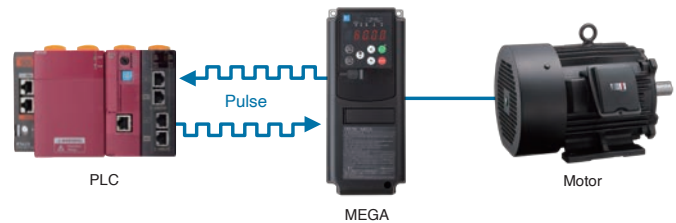

02 Orientation function **NEW**

VARIOUS APPLICATIONS

Capable of rotator positioning, enabling machinery to be held in place via servo locking after stoppage.

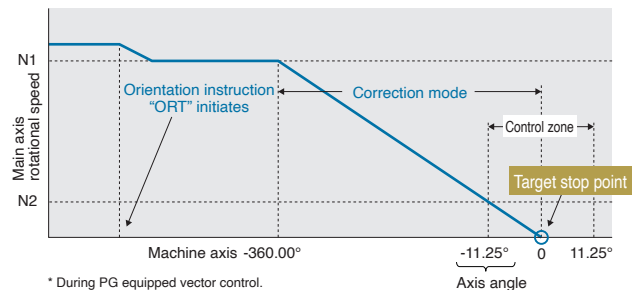

03 PID auto tuning function **NEW**

VARIOUS APPLICATIONS

Simplifies optimization via automatic adjustment of proportional and integral gains, resulting in shorter system start-up times, etc.

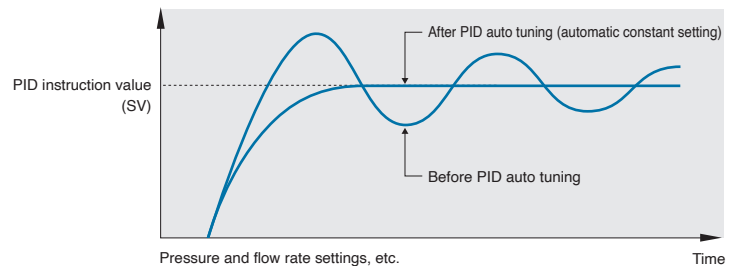

04 Load limiter **NEW**

VARIOUS APPLICATIONS

Improves system reliability by stopping when excessive torque is detected and by allowing operation only in the direction opposite to that in which the excessive load was detected.

05 Load adaptive control **NEW**

VARIOUS APPLICATIONS

When the actual load level is lower than the configured load level, the system can be operated at a ratio-multiplied frequency, resulting in significantly better efficiency.

06 Customizable logic functions Enhancement

VARIOUS APPLICATIONS

Customizable inverter functions to meet your own specific needs. Requires no PLC or external control equipment (relays, timers, etc.) circuits, and can be configured simply by setting and combining various parameters inside the inverter.

■ Comes with a wide variety of logic symbols and programming steps

Item	FRENIC-MEGA
Logic symbol type (Logical operations, counters, timers, arithmetic operations, comparators, limiters, selectors, holders, etc.)	<p>Total of 55 digital & analog types</p>
Number of programming steps	260 steps

* The programming tool software can be downloaded for free from our website.

■ Advantages

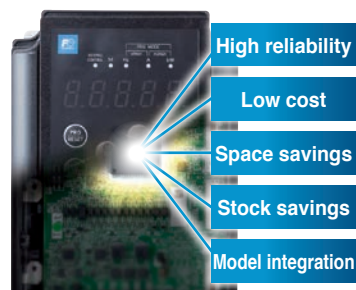

07 Supports a variety of networks Option cards

VARIOUS APPLICATIONS

Insert the option card into the connector inside the main unit.
Up to three cards can be inserted.

Optional communication card types

<ul style="list-style-type: none"> 1 DeviceNet 2 CC-Link 3 T-Link 	<ul style="list-style-type: none"> 4 PROFIBUS-DP 5 CANopen 6 SX bus 	<ul style="list-style-type: none"> 7 Ethernet Coming soon (Ethernet/IP, PROFINET RT, Modbus-TCP, BACnet/IP, and EtherCAT)
--	--	--

Note) There are some limitations to how option cards can be combined. Please contact us for details.

* For details on other options, refer to page 80.

08 Enhanced network functions

VARIOUS APPLICATIONS

■ Compatible with RS-485 communication (terminal block)

Comes standard with an RS-485 terminal in addition to a port (RJ-45 connector) that is shared with the keypad. Simplifies multi-drop connections via terminal connection.

Supports RS-485 terminal multi-drop connection

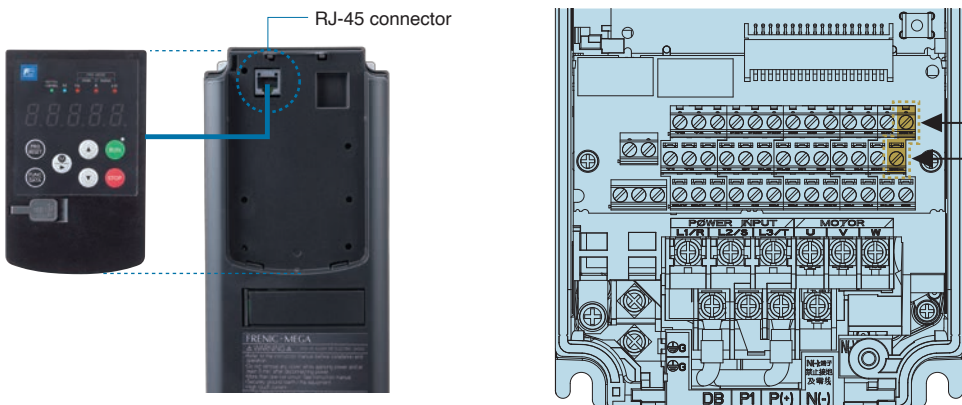

Features
Main application examples
Model variations
Type number nomenclature
Standard specifications
Common specifications
Terminal specifications
Basic wiring diagram
External dimensions
Keypad
Function codes
Options
Product warranty
Guideline for suppressing harmonics

Model Variations

Model list

HHD spec (High carrier frequency Heavy Duty) : 200%-3sec ,150%-1min
 HND spec (High carrier frequency Normal Duty) : 120%-1min

Standard applied motor (kW)	Basic type				EMC filter built-in type			
	3-phase 200 V series		3-phase 400 V series		3-phase 200 V series		3-phase 400 V series	
	HHD spec	HND spec	HHD spec	HND spec	HHD spec	HND spec	HHD spec	HND spec
0.4	FRN0002G2S-2G		FRN0002G2S-4G		FRN0002G2E-2G		FRN0002G2E-4G	
0.75	FRN0003G2S-2G		FRN0003G2S-4G		FRN0003G2E-2G		FRN0003G2E-4G	
1.5	FRN0004G2S-2G		FRN0004G2S-4G		FRN0004G2E-2G		FRN0004G2E-4G	
2.2	FRN0006G2S-2G		FRN0006G2S-4G		FRN0006G2E-2G		FRN0006G2E-4G	
3.7	FRN0009G2S-2G		FRN0009G2S-4G		FRN0009G2E-2G		FRN0009G2E-4G	
5.5	FRN0018G2S-2G		FRN0018G2S-4G		FRN0018G2E-2G		FRN0018G2E-4G	
7.5	FRN0023G2S-2G	FRN0018G2S-2G	FRN0023G2S-4G	FRN0018G2S-4G	FRN0023G2E-2G	FRN0018G2E-2G	FRN0023G2E-4G	FRN0018G2E-4G
11	FRN0031G2S-2G	FRN0023G2S-2G	FRN0031G2S-4G	FRN0023G2S-4G	FRN0031G2E-2G	FRN0023G2E-2G	FRN0031G2E-4G	FRN0023G2E-4G
15	FRN0038G2S-2G	FRN0031G2S-2G	FRN0038G2S-4G	FRN0031G2S-4G	FRN0038G2E-2G	FRN0031G2E-2G	FRN0038G2E-4G	FRN0031G2E-4G
18.5	FRN0045G2S-2G	FRN0038G2S-2G	FRN0045G2S-4G	FRN0038G2S-4G	FRN0045G2E-2G	FRN0038G2E-2G	FRN0045G2E-4G	FRN0038G2E-4G
22	FRN0060G2S-2G	FRN0045G2S-2G	FRN0060G2S-4G	FRN0045G2S-4G	FRN0060G2E-2G	FRN0045G2E-2G	FRN0060G2E-4G	FRN0045G2E-4G
30	FRN0075G2S-2G	FRN0060G2S-2G	FRN0075G2S-4G	FRN0060G2S-4G	FRN0075G2E-2G	FRN0060G2E-2G	FRN0075G2E-4G	FRN0060G2E-4G
37	FRN0091G2S-2G	FRN0075G2S-2G	FRN0091G2S-4G	FRN0075G2S-4G	FRN0091G2E-2G	FRN0075G2E-2G	FRN0091G2E-4G	FRN0075G2E-4G
45	FRN0112G2S-2G	FRN0091G2S-2G	FRN0112G2S-4G	FRN0091G2S-4G	FRN0112G2E-2G	FRN0091G2E-2G	FRN0112G2E-4G	FRN0091G2E-4G
55	FRN0150G2S-2G	FRN0112G2S-2G	FRN0150G2S-4G	FRN0112G2S-4G	FRN0150G2E-2G	FRN0112G2E-2G	FRN0150G2E-4G	FRN0112G2E-4G
75	FRN0180G2S-2G	FRN0150G2S-2G	FRN0180G2S-4G	FRN0150G2S-4G	FRN0180G2E-2G	FRN0150G2E-2G	FRN0180G2E-4G	FRN0150G2E-4G
90	FRN0216G2S-2G	FRN0180G2S-2G	FRN0216G2S-4G	FRN0180G2S-4G	FRN0216G2E-2G	FRN0180G2E-2G	FRN0216G2E-4G	FRN0180G2E-4G
110		FRN0216G2S-2G	FRN0260G2S-4G	FRN0216G2S-4G		FRN0216G2E-2G	FRN0260G2E-4G	FRN0216G2E-4G
132			FRN0325G2S-4G	FRN0260G2S-4G			FRN0325G2E-4G	FRN0260G2E-4G
160			FRN0377G2S-4G	FRN0325G2S-4G			FRN0377G2E-4G	FRN0325G2E-4G
200			FRN0432G2S-4G	FRN0377G2S-4G			FRN0432G2E-4G	FRN0377G2E-4G
220			FRN0520G2S-4G	FRN0432G2S-4G			FRN0520G2E-4G	FRN0432G2E-4G
280			FRN0650G2S-4G	FRN0520G2S-4G			FRN0650G2E-4G	FRN0520G2E-4G
315			FRN0740G2S-4G				FRN0740G2E-4G	
355			FRN0960G2S-4G	FRN0650G2S-4G			FRN0960G2E-4G	FRN0650G2E-4G
400			FRN1040G2S-4G	FRN0740G2S-4G			FRN1040G2E-4G	FRN0740G2E-4G
500			FRN1170G2S-4G	FRN0960G2S-4G			FRN1170G2E-4G	FRN0960G2E-4G
560				FRN1040G2S-4G				FRN1040G2E-4G
630			FRN1386G2S-4G	FRN1170G2S-4G			FRN1386G2E-4G	FRN1170G2E-4G
710				FRN1386G2S-4G				FRN1386G2E-4G

How to read the inverter model

FRN 0003 G 2 S - 2 G

Code	Series name
FRN	FRENIC series

Code	Applicable motor rating
0.4	0002A
1	1
630	1386A

Code	Applicable range
G	High performance, multifunctional type

Code	Destination
G	Global

Code	Input power source
2	3-phase 200V
4	3-phase 400V

Code	Enclosure
S	Standard (basic type)
E	EMC filter built-in type

Code	Order of development
2	Series

HHD (High carrier frequency Heavy Duty) spec for heavy load

Item		Specifications														
Type (FRN \times G2S-4G)		0002	0003	0004	0006	0009	0018	0023	0031	0038	0045	0060				
Output ratings	Nominal applied motor [kW] (*1)	0.4	0.75	1.5	2.2	3.7	5.5	7.5	11	15	18.5	22				
	Rated capacity [kVA] (*2)	1.1	1.9	3.2	4.5	6.8	10	14	18	24	29	34				
	Rated voltage [V] (*3)	Three-phase 380 to 480V (with AVR)														
	Rated current [A]	1.5	2.5	4.2	6	9	13.5	18.5	24.5	32	39	45				
	Overload capacity [A]	150%-1min, 200%-3.0s														
Input ratings	Rated frequency [Hz]	50, 60Hz														
	Main circuit power: Phases, voltage, frequency	Three-phase 380 to 480V, 50/60Hz														
	Auxiliary control power input: Phases, voltage, frequency	Single-phase 380 to 480V, 50/60Hz														
	Voltage, frequency variations	Voltage:(10 to -15% (Voltage unbalance:2% or less (*4)) Frequency:+5 to -5%														
	Rated current [A] (*5)	with DCR	0.85	1.6	3.0	4.5	7.5	10.6	14.4	21.1	28.8	35.5	42.2			
Braking	without DCR	1.7	3.1	5.9	8.2	13.0	17.3	23.2	33	43.8	52.3	60.6				
	Required power supply capacity [kVA] (*6) with DCR	0.6	1.2	2.1	3.2	5.2	7.4	10	15	20	25	30				
	Torque [%]	150%			100%				20%							
	Braking transistor	Built-in														
	Min. ohmic value [Ω]	200		160		96		64		48		32		24		16
Built-in braking resistance	Braking time[s]	720 Ω	470 Ω	160 Ω			80 Ω			Optional						
		5s														
	%ED	5	3	5	3	2	3	2	—							
DC injection braking	Starting frequency:0.0 to 60.0Hz, Braking time: 0.0 to 30.0s, Braking level:0 to 100%															
DC reactor (DCR)	Optional															
Applicable safety standards (Planned)	UL61800-5-1, C22.2No.274-17, IEC/EN 61800-5-1:2007+A1:2016															
Enclosure (IEC60529)	IP20 (IEC60529) closed type, UL open type (UL 50)															
Cooling method	Natural cooling					Fan cooling										
Weight/Mass [kg]	1.7	2.0	2.6	2.7	3.0	6.5	6.5	5.8	9.5	9.5	10					

HND (High carrier frequency Normal Duty) spec for light load

Item		Specifications											
Type (FRN \times G2S-4G)		0018	0023	0031	0038	0045	0060	0075	0091	0112	0150		
Output ratings	Nominal applied motor [kW] (*1)	7.5	11	15	18.5	22	30	37	45	55	75		
	Rated capacity [kVA] (*2)	13	17	23	28	34	45	57	69	85	114		
	Rated voltage [V] (*3)	Three-phase 380 to 480V (with AVR)											
	Rated current [A]	17.5	23	31	38	45	60	75	91	112	150		
	Overload capacity [A]	120%-1min											
Input ratings	Rated frequency [Hz]	50, 60Hz											
	Main circuit power: Phases, voltage, frequency	Three-phase 380 to 480V, 50/60Hz											
	Auxiliary control power input: Phases, voltage, frequency	Single-phase 380 to 480V, 50/60Hz											
	Voltage, frequency variations	Voltage:(10 to -15% (Voltage unbalance:2% or less (*4)) Frequency:+5 to -5%											
	Rated current [A] (*5)	with DCR	14.4	21.1	28.8	35.5	42.2	57.0	68.5	83.2	102	138	
Braking	without DCR	23.2	33.0	43.8	52.3	60.6	77.9	94.3	114	140	—		
	Required power supply capacity [kVA] (*6) with DCR	10	15	20	25	30	40	48	58	71	96		
	Torque [%]	70%			15%				7~12%				
	Braking transistor	Built-in											
	Min. ohmic value [Ω]	64	48	32	24	16	16	10	9	8	6.5		
Built-in braking resistance	Braking time[s]	80 Ω		Optional									
		3.7s	3.4s	—									
	%ED	2.2	1.4	—									
DC injection braking	Starting frequency:0.0 to 60.0Hz, Braking time: 0.0 to 30.0s, Braking level:0 to 100%												
DC reactor (DCR)	Optional										Optional (*7)		
Applicable safety standards (Planned)	UL61800-5-1, C22.2No.274-17, IEC/EN 61800-5-1:2007+A1:2016												
Enclosure (IEC60529)	IP20 (IEC60529) closed type, UL open type (UL 50)							IP00 open type, UL open type IP55 for the cooling part outside the panel					
Cooling method	Fan cooling												
Weight/Mass [kg]	6.5	6.5	5.8	9.5	9.5	10	25	26	31	33			

(*1) Fuji's 4-pole standard motor

(*2) Rated capacity is calculated by assuming the rated output voltage as 220 V for 200 V series and 440 V for 400 V series.

(*3) Output voltage cannot exceed the power supply voltage.

(*4) Voltage unbalance(%) = Max. voltage (V) - Min. voltage (V) / Three-phase average voltage (V) \times 67 (IEC 61800-3)

If this value is 2 to 3%, use an optional AC reactor (ACR).

(*5) These values are calculated on assumption that the inverter is connected to a power supply with a capacity of 500 kVA (or 10 times the inverter capacity when the inverter capacity exceeds 50 kVA) and %X is 5%.

(*6) Required when a DC reactor (DCR) is used.

(*7) When using a motor with a rating of 75 kW or more, be sure to use a DC reactor (option).

Specifications																	
0075	0091	0112	0150	0180	0216	0260	0325	0377	0432	0520	0650	0740	0960	1040	1170	1386	
30	37	45	55	75	90	110	132	160	200	220	280	315	355	400	500	630	
45	55	69	85	114	137	164	198	247	287	329	396	445	495	563	731	891	
Three-phase 380 to 480V (with AVR)																	
60	75	91	112	150	180	216	260	325	377	432	520	585	650	740	960	1170	
150%-1min, 200%-3.0s																	
50, 60Hz																	
Three-phase 380 to 480V, 50/60Hz																	
Single-phase 380 to 480V, 50/60Hz																	
Voltage:(10 to -15% (Voltage unbalance:2% or less (*4)) Frequency:+5 to -5%																	
57.0	68.5	83.2	102	138	164	201	238	286	357	390	500	559	628	705	881	1115	
77.9	94.3	114	140	—	—	—	—	—	—	—	—	—	—	—	—	—	
40	48	58	71	96	114	140	165	199	248	271	347	388	436	489	611	773	
10 to 15%																	
Built-in										—							
10	9	8	6.5	4.7	—												
Optional																	
—																	
—																	
Starting frequency:0.0 to 60.0Hz, Braking time: 0.0 to 30.0s, Braking level:0 to 100%																	
Optional						Optional (*7)											
UL61800-5-1, C22.2No.274-17, IEC/EN 61800-5-1:2007+A1:2016																	
IP00 open type, UL open type IP55 for the cooling part outside the panel																	
Fan cooling																	
25	26	31	33	42	62	64	94	98	129	140	245	245	330	330	552	552	

Specifications													
0180	0216	0260	0325	0377	0432	0520	0650	0740	0960	1040	1170	1386	
90	110	132	160	200	220	280	315	355	500	560	630	710	
137	164	198	247	287	329	396	445	495	563	731	891	1056	
Three-phase 380 to 480V (with AVR)													
180	216	260	325	377	432	520	650	740	960	1040	1170	1386	
120%-1min													
50, 60Hz													
Three-phase 380 to 480V, 50/60Hz													
Single-phase 380 to 480V, 50/60Hz													
Voltage:(10 to -15% (Voltage unbalance:2% or less (*4)) Frequency:+5 to -5%													
164	210	238	286	357	390	500	628	705	789	881	1115	1256	
—	—	—	—	—	—	—	—	—	—	—	—	—	
114	140	165	199	248	271	347	436	489	547	611	773	871	
7~12%													
Built-in		Optional											
4.7		—											
—													
—													
—													
Starting frequency:0.0 to 60.0Hz, Braking time: 0.0 to 30.0s, Braking level:0 to 100%													
Optional (*7)													
UL61800-5-1, C22.2No.274-17, IEC/EN 61800-5-1:2007+A1:2016													
IP00 open type, UL open type IP55 for the cooling part outside the panel													
Fan cooling													
42	62	64	94	98	129	140	245	245	330	330	552	552	

Standard Specifications

Three-phase | **200V series**

Basic type

HHD (High carrier frequency Heavy Duty) spec for heavy load

Item		Specifications																									
Type (FRN□□□G2S-2G)		0002	0003	0004	0006	0009	0018	0023	0031	0038	0045	0060	0075	0091	0112	0150	0180	0216									
Nominal applied motor [kW] (*1)		0.4	0.75	1.5	2.2	3.7	5.5	7.5	11	15	18.5	22	30	37	45	55	75	90									
Output ratings	Rated capacity [kVA] (*2)	1.1	1.9	3.0	4.1	6.8	10	14	18	24	28	34	45	55	68	81	109	131									
	Rated voltage [V] (*3)	Three-phase 200 to 240V (with AVR)										Three-phase 200 to 230V (with AVR)															
	Rated current [A]	3	5	8	11	18	27	37	49	63	76	90	119	146	180	215	288	346									
	Overload capacity [A]	150%-1min, 200%-3.0s																									
Rated frequency [Hz]		50, 60Hz																									
Main circuit power: Phases, voltage, frequency		Three-phase 200 to 240V, 50/60Hz										Three-phase 200 to 230V, 50/60Hz															
Auxiliary control power input: Phases, voltage, frequency		Single-phase 200 to 240V, 50/60Hz										Single-phase 200 to 230V, 50/60Hz															
Voltage, frequency variations		Voltage:(10 to -15% (Voltage unbalance:2% or less (*4)) Frequency:+5 to -5%																									
Input ratings	Rated current [A] (*5)	with DCR	1.6	3.2	6.1	8.9	15	21.1	28.8	42.2	57.6	71.0	84.4	114	138	167	203	282	334								
		without DCR	3.1	5.3	9.5	13.2	22.2	31.5	42.7	60.7	80.1	97.0	112	151	185	225	270	—	—								
	Required power supply capacity [kVA] (*6)	with DCR	0.6	1.2	2.2	3.1	5.2	7.4	10	15	20	25	30	40	48	58	71	98	116								
Braking	Torque [%]	150%			100%					20%				10 to 15%													
	Braking transistor	Built-in																									
	Min. ohmic value [Ω]	100			40			24		16		12		8		6		4		2.5		2.25		2		1.6	
	Built-in braking resistance	Braking time[s]	100Ω			40Ω			20Ω		—																
			5s																								
%ED		5	3	5	3	2	3	2	—																		
DC injection braking		Starting frequency:0.0 to 60.0Hz, Braking time: 0.0 to 30.0s, Braking level:0 to 100%																									
DC reactor (DCR)		Optional																Optional (*7)									
Applicable safety standards (Planned)		UL61800-5-1, C22.2No.274-17, IEC/EN 61800-5-1:2007+A1:2016																									
Enclosure (IEC60529)		IP20 closed type, UL open type										IP00 open type, UL open type IP55 for the cooling part outside the panel															
Cooling method		Natural cooling					Fan cooling																				
Weight/Mass [kg]		1.7	2.0	2.8	3.0	3.0	6.5	6.5	5.8	9.5	9.5	10	25	32	42	43	62	105									

HND (High carrier frequency Normal Duty) spec for light load

Item		Specifications													
Type (FRN□□□G2S-2G)		0018	0023	0031	0038	0045	0060	0075	0091	0112	0150	0180	0216		
Nominal applied motor [kW] (*1)		7.5	11	15	18.5	22	30	37	45	55	75	90	110		
Output ratings	Rated capacity [kVA] (*2)	12	17	22	28	33	43	55	68	81	109	131	164		
	Rated voltage [V] (*3)	Three-phase 200 to 240V (with AVR)						Three-phase 200 to 230V (with AVR)							
	Rated current [A]	31.8	46.2	59.4	74.8	88	115	146	180	215	288	346	432		
	Overload capacity [A]	120%-1min													
Rated frequency [Hz]		50, 60Hz													
Main circuit power: Phases, voltage, frequency		Three-phase 200 to 240V, 50/60Hz						Three-phase 200 to 230V, 50/60Hz							
Auxiliary control power input: Phases, voltage, frequency		Single-phase 200 to 240V, 50/60Hz						Single-phase 200 to 230V, 50/60Hz							
Voltage, frequency variations		Voltage:(10 to -15% (Voltage unbalance:2% or less (*4)) Frequency:+5 to -5%													
Input ratings	Rated current [A] (*5)	with DCR	28.8	42.2	57.6	71.0	84.4	114	138	167	203	282	334	410	
		without DCR	42.7	60.7	80.1	97.0	112	151	185	225	270	—	—	—	
	Required power supply capacity [kVA] (*6)	with DCR	10	15	20	25	30	40	48	58	71	98	116	143	
Braking	Torque [%]	70%			15%					7 to 12%					
	Braking transistor	Built-in													
	Min. ohmic value [Ω]	16	12	8	6	4	4	2.5	2.25	2	1.6	—			
	Built-in braking resistance	Braking time[s]	20Ω			—									
			3.7s	3.4s	—										
%ED		2.2	1.4	—											
DC injection braking		Starting frequency:0.0 to 60.0Hz, Braking time: 0.0 to 30.0s, Braking level:0 to 100%													
DC reactor (DCR)		Optional											Optional (*7)		
Applicable safety standards (Planned)		UL61800-5-1, C22.2No.274-17, IEC/EN 61800-5-1:2007+A1:2016													
Enclosure (IEC60529)		IP20 closed type, UL open type						IP00 open type, UL open type IP55 for the cooling part outside the panel							
Cooling method		Fan cooling													
Weight/Mass [kg]		6.5	6.5	5.8	9.5	9.5	10	25	32	42	43	62	105		

(*1) Fuji's 4-pole standard motor

(*2) Rated capacity is calculated by assuming the rated output voltage as 220 V for 200 V series and 440 V for 400 V series.

(*3) Output voltage cannot exceed the power supply voltage.

(*4) Voltage unbalance(%) =Max. voltage (V) - Min. voltage (V) / Three-phase average voltage (V) ×67 (IEC 61800-3)

If this value is 2 to 3%, use an optional AC reactor (ACR).

(*5) These values are calculated on assumption that the inverter is connected to a power supply with a capacity of 500 kVA (or 10 times the inverter capacity when the inverter capacity exceeds 50 kVA) and %X is 5%.

(*6) Required when a DC reactor (DCR) is used.

(*7) When using a motor with a rating of 75 kW or more, be sure to use a DC reactor (option).

Basic Wiring Diagram

Wiring of main circuit terminal and grounding terminal

Basic type

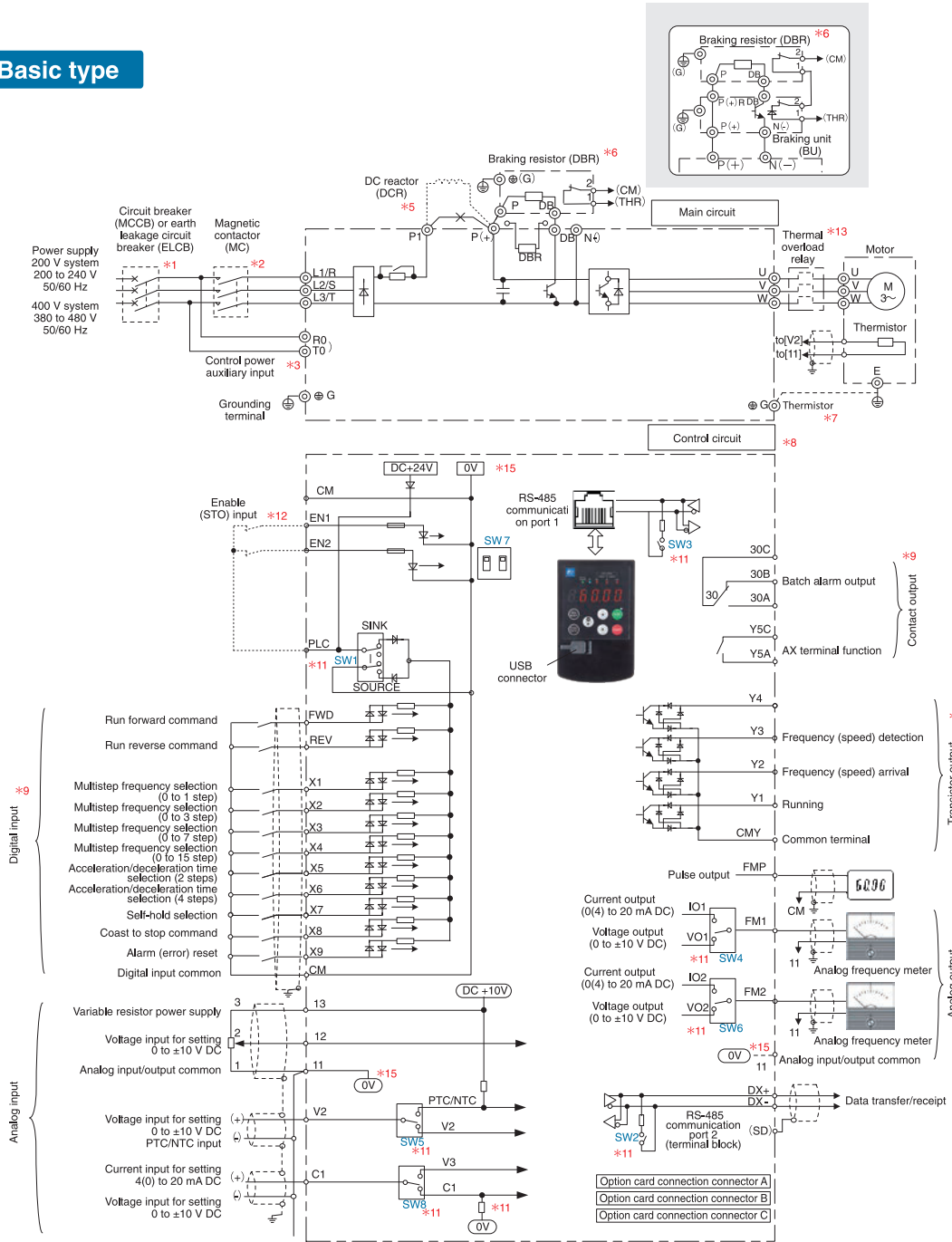

- *1 To protect the wiring, install the recommended molded case circuit breaker (MCCB), or residual-current-operated protective device (RCD)/earth leakage breaker (ELCB) (with overcurrent protection function) in the inverter primary circuit.
- *2 If necessary, install a magnetic contactor (MC) in each inverter, and separate the inverter and power supply in addition to the MCCB or RCD/ELCB. If installing a coil such as an MC or solenoid near the inverter, connect a surge absorber in parallel.
- *3 Prepare [R0] and [T0] terminals for 0004 type (400V class) and 0008 type (200V class) inverters with capacity of 1.5 kW or higher. Connect the terminals to the power supply line to retain alarm output signal ALM that occurs at the inverter programmable output terminal using a protective function, and to maintain keypad operation even if the main power supply is cut off.
- *5 If connecting an optional DC reactor (DCR), remove the jumper bar from between terminals [P0] and [P1]. It is necessary to connect a DCR to LD specification inverters with capacity of 55kW, or 75 kW or higher. Be sure to connect to these inverters.
- *6 A built-in braking resistor (DBR) is connected between terminals P(+) and DB on 7.5 kW or lower inverters. If connecting an external braking resistor (DBR), be sure to remove the built-in one.
- *7 This terminal is used for grounding the motor. Use this terminal to ensure safety.
- *8 Use twisted wire or shielded twisted wire for control signal lines. If using shielded twisted wire, connect the shields to a common terminal on the control circuit. To prevent malfunction due to noise, keep the control circuit wiring as far away from the main circuit wiring as possible (recommended distance: 10 cm or more). Never install the wiring in the same wiring duct. If crossing the control circuit wiring and main circuit wiring, set the angle.
- *9 The connection diagram shows the factory default functions assigned to digital input terminals [X1] to [X9], [FWD], and [REV], transistor output terminals [Y1] to [Y4], relay contact output terminals [Y5A/C], and [30A/B/C].
- *10 Changes the main circuit connector.
- *11 These are control board slide switches. Inverter operation is customized using these switches.
- *12 Set SW7 to the "ON" side if using the enable input (EN1, EN2) functions. Use approved, safe relay devices which conform to EN ISO 13849-1 PL-e and IEC/EN 61800-5-2 SIL3 for switching of the hardware circuit between terminals [EN1] and [EN2], and between terminals [EN2] and [PLC].
- *13 Make the circuit breakers (MCCB) or the magnetic contactors (MC) trip by the thermal relay auxiliary contacts (manual recovery).
- *15 [OV] and [OV] are separated and insulated.



NOTES

When running general-purpose motors

- **Driving a 400V general-purpose motor**
When driving a 400V general-purpose motor with an inverter using extremely long cables, damage to the insulation of the motor may occur. Use an output circuit filter (OFL) if necessary after checking with the motor manufacturer. Fuji's motors do not require the use of output circuit filters because of their reinforced insulation.
- **Torque characteristics and temperature rise**
When the inverter is used to run a general-purpose motor, the temperature of the motor becomes higher than when it is operated using a commercial power supply. In the low-speed range, the cooling effect will be weakened, so decrease the output torque of the motor. If constant torque is required in the low-speed range, use a Fuji inverter motor or a motor equipped with an externally powered ventilating fan.
- **Vibration**
When the motor is mounted to a machine, resonance may be caused by the natural frequencies, including that of the machine. Operation of a 2-pole motor at 60Hz or more may cause abnormal vibration.
* Study use of tier coupling or dampening rubber.
* It is also recommended to use the inverter jump frequency control to avoid resonance points.
- **Noise**
When an inverter is used with a general-purpose motor, the motor noise level is higher than that with a commercial power supply. To reduce noise, raise carrier frequency of the inverter. High-speed operation at 60Hz or more can also result in more noise.

When running special motors

- **High-speed motors**
When driving a high-speed motor while setting the frequency higher than 120Hz, test the combination with another motor to confirm the safety of high-speed motors.
- **Explosion-proof motors**
When driving an explosion-proof motor with an inverter, use a combination of a motor and an inverter that has been approved in advance.
- **Submersible motors and pumps**
These motors have a larger rated current than general-purpose motors. Select an inverter whose rated output current is greater than that of the motor.
These motors differ from general-purpose motors in thermal characteristics. Set a low value in the thermal time constant of the motor when setting the electronic thermal function.
- **Brake motors**
For motors equipped with parallel-connected brakes, their braking power must be supplied from the primary circuit (commercial power supply). If the brake power is connected to the inverter power output circuit (secondary circuit) by mistake, problems may occur.
Do not use inverters for driving motors equipped with series-connected brakes.
- **Geared motors**
If the power transmission mechanism uses an

oil-lubricated gearbox or speed changer/reducer, then continuous motor operation at low speed may cause poor lubrication. Avoid such operation.

- **Synchronous motors**
It is necessary to use software suitable for this motor type. Contact Fuji for details.
- **Single-phase motors**
Single-phase motors are not suitable for inverter-driven variable speed operation. Use three-phase motors.
* Even if a single-phase power supply is available, use a three-phase motor as the inverter provides three-phase output.

Environmental conditions

- **Installation location**
Use the inverter in a location with an ambient temperature range of -10 to 50°C.
The inverter and braking resistor surfaces become hot under certain operating conditions. Install the inverter on nonflammable material such as metal. Ensure that the installation location meets the environmental conditions specified in "Environment" in inverter specifications.

Combination with peripheral devices

- **Installing a molded case circuit breaker (MCCB)**
Install a recommended molded case circuit breaker (MCCB) or an earth leakage circuit breaker (ELCB) in the primary circuit of each inverter to protect the wiring. Ensure that the circuit breaker capacity is equivalent to or lower than the recommended capacity.
- **Installing a magnetic contactor (MC) in the output (secondary) circuit**
If a magnetic contactor (MC) is mounted in the inverter's secondary circuit for switching the motor to commercial power or for any other purpose, ensure that both the inverter and the motor are fully stopped before you turn the MC on or off. Remove the surge killer integrated with the MC.
- **Installing a magnetic contactor (MC) in the input (primary) circuit**
Do not turn the magnetic contactor (MC) in the primary circuit on or off more than once an hour as an inverter fault may result. If frequent starts or stops are required during motor operation, use FWD/REV signals.
- **Protecting the motor**
The electronic thermal function of the inverter can protect the motor. The operation level and the motor type (general-purpose motor, inverter motor) should be set. For high-speed motors or water-cooled motors, set a small value for the thermal time constant to protect the motor.
If you connect the motor thermal relay to the motor with a long cable, a high-frequency current may flow into the wiring stray capacitance. This may cause the relay to trip at a current lower than the set value for the thermal relay. If this happens, lower the carrier frequency or use the output circuit filter (OFL).
- **Regarding power-factor correcting capacitor**
Do not mount power factor correcting capacitors in the inverter (primary) circuit. Use the DC REACTOR to improve the inverter power factor. Do

not use power factor correcting capacitors in the inverter output circuit (secondary). An overcurrent trip will occur, disabling motor operation.

- **Discontinuance of surge killer**
Do not mount surge killers in the inverter output (secondary) circuit.
- **Reducing noise**
Use of a filter and shielded wires are typical measures against noise to ensure that EMC Directives are met.
- **Measures against surge currents**
If an overvoltage trip occurs while the inverter is stopped or operated under a light load, it is assumed that the surge current is generated by open/close of the phase-advancing capacitor in the power system.
We recommend connecting a DC REACTOR to the inverter.
- **Megger test**
When checking the insulation resistance of the inverter, use a 500V megger and follow the instructions contained in the Instruction Manual.

Wiring

- **Wiring distance of control circuit**
When performing remote operation, use twisted shield wire and limit the distance between the inverter and the control box to 20m.
- **Wiring length between inverter and motor**
If long wiring is used between the inverter and the motor, the inverter will overheat or trip as a result of overcurrent (high-frequency current flowing into the stray capacitance) in the wires connected to the phases. Ensure that the wiring is shorter than 50m. If this length must be exceeded, lower the carrier frequency or mount an output circuit filter (OFL).
- **Wiring size**
Select cables with a sufficient capacity by referring to the current value or recommended wire size.
- **Wiring type**
Do not use multicore cables that are normally used for connecting several inverters and motors.
- **Grounding**
Securely ground the inverter using the grounding terminal.

Selecting inverter capacity

- **Driving general-purpose motor**
Select an inverter according to the applicable motor ratings listed in the standard specifications table for the inverter. When high starting torque is required or quick acceleration or deceleration is required, select an inverter with a capacity one size greater than the standard.
- **Driving special motors**
Select an inverter that meets the following condition:
Inverter rated current > Motor rated current.

Transportation and storage

When transporting or storing inverters, follow the procedures and select locations that meet the environmental conditions that agree with the inverter specifications.

Fuji Electric India Pvt. Ltd.
Office No.1006 To 1009 & 1011, Centrum,
Plot No. C3, Opp. Wagle Prabhag Samiti Office,
MIDC Area, Wagle Estate,
Thane, Maharashtra 400 604
Phone : +91-22-69024500
Email : info-fei@fujielectric.com
Website : www.fujielectric.co.in



Scan QR code for
Service support

Authorized Channel Partner

