

AC Drive for Elevator  
***FRENIC-Lift***

FRENIC **Lift**

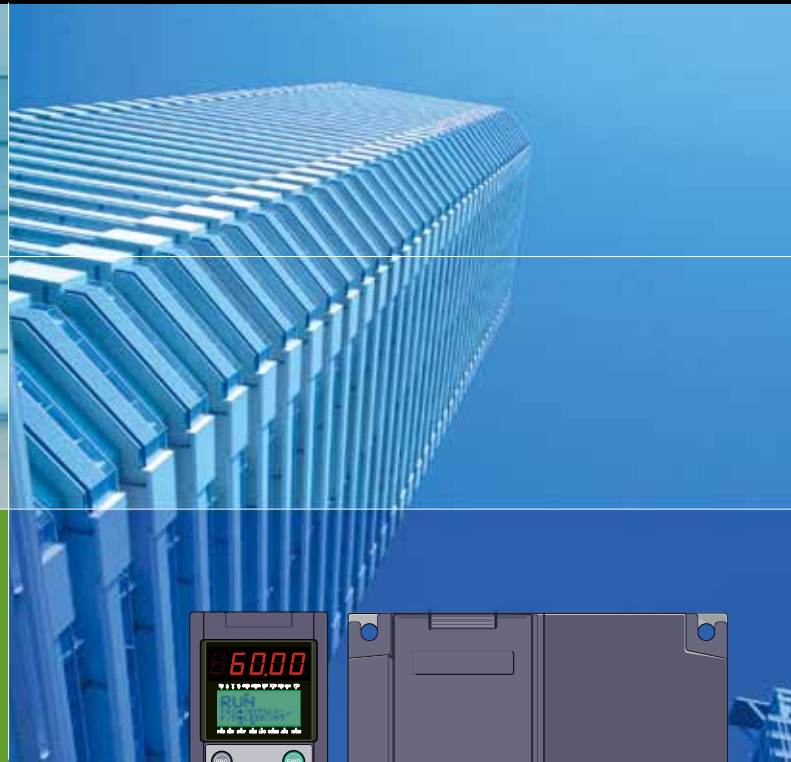

**FUJI INVERTERS**

GREAT PERFORMANCE THROUGH DEDICATED DESIGNS  
 WELCOME TO THE NEW GENERATION OF AC DRIVE FOR ELEVATOR

# FRENIC-Lift Elevator AC Drive

The **FRENIC-Lift** Series of exclusive AC Drives for operation of elevators are specially designed to have a number of improved features over previous elevator AC Drives, such as vastly lower torque ripple. We have incorporated the functions that customers find most necessary in elevator controls to provide an AC Drive that delivers performance that fits your elevator system.

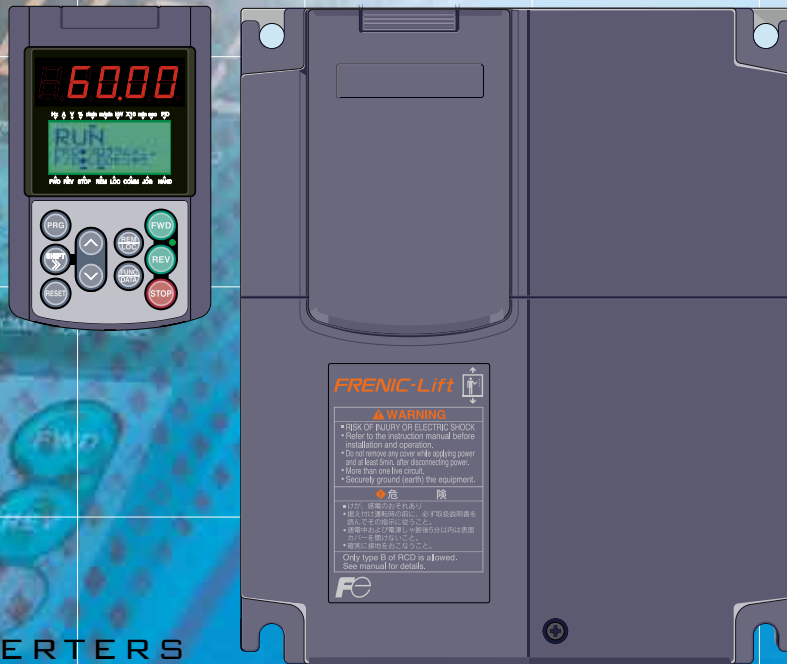

FUJI INVERTERS  
Great Performance through Dedicated Designs  
Welcome to The New Generation of ELEVATOR AC Drive

## Optimum Exclusive Design for Passenger Elevators

- A braking circuit is built in the AC Drives of all the capacities.
- Built-in PG feedback circuit is standard equipment.
- An optional keypad is available.

## Higher Performance

- Overload capacity: 200% for 10s\*1)
- Current response (ACR) : 500Hz
- Reduction of torque ripple realizes low vibration.
- Reduced roll-back during starting up.

\*1) Except for 200 V / 22 kW and 400 V / 30 kW

Motor capacity (kW)	2.2	4.0	5.5	7.5	11	15	18.5	22	30	37	45
Three-phase 200V			●	●	●	●	●	●			
Three-phase 400V		●	●	●	●	●	●	●	●	●	●
Single-phase 200V	●										

### High performance vector control

- Current response (ACR): 500Hz
- Speed control accuracy:  $\pm 0.01\%$

### High overload capacity

- 200% of rated current for 10s\*2)  
(Overload begins from 80% continuous operation with a carrier frequency of 10kHz.)

\*2) Except for 200 V / 22 kW and 400 V / 30 kW

### IM/PMSM common drive

- A single AC Drive can control an induction motor (open/closed loop control) and a synchronous motor (the optional PG interface card is required).

### Model variations

- FRENIC-Lift AC Drives are available in a series with capacities ranging from 5.5 to 22kW for three-phase 200V model. 4.0 to 45kW for three-phase 400V model. 2.2kW for single-phase 200V model.

### Applicable to the feedbacks from various pulse generators

- Applicable to the inputs by open collector/complementary output as a standard specification (Encoder power supply is switchable between +12V and +15V.)
- Applicable to the inputs from the 5V line driver as an option
- Applicable to Sin/Cos, Serial interface (EnDat2.1) and Parallel interface (4-bit gray code, UVM 3-bit code)

### Maintenance functions/ Long life design

- DC bus capacitor life: 7 years
- Electrolytic capacitor life on the printed circuit boards: 7 years
- Cooling fan life: 5 years
- Life warning signal
- Recording and display of cumulative operating time
- Recording and display of cumulative operations

### Globalization

- Safety standards EN61800-5-1:2003, EN954-1 Category3
- Sink/source switchable
- RS-485 communications (Modbus RTU) is adopted as standard equipment.
- CAN Bus is adopted as standard equipment.

### Peripheral support tools (Option)

- AC Drive support loader software is provided.
- A multi-function keypad (with backlit LCD) makes it possible to copy or edit the function code data.

# Specifications

## Standard specifications

### Three-phase 200V series

Item		Specifications							
Type (FRN□□LM1S-2□) *10		5.5	7.5	11	15	18.5	22		
Nominal applied motor *1 [kW]		5.5	7.5	11	15	18.5	22		
Output ratings	Rated capacity *2 [kVA]	10.2	14	18	24	28	34		
	Rated voltage *3 [V]	Three-phase 200V-240V, 50/60Hz							
	Rated current *4 [A]	27.0	37.0	49.0	63.0	74.0	90.0		
	Overload capacity [A] (Permissible energizing time)	54.0 (10s)	74.0 (10s)	98.0 (10s)	126.0 (10s)	148.0 (10s)	180.0 (5s)		
	Overload capacity at carrier frequency 16kHz *15 [A] (Permissible energizing time)	36 (10s)	49 (10s)	65 (10s)	84 (10s)	98 (10s)	120 (5s)		
	Rated frequency [Hz]	50, 60Hz							
Input ratings	Normal operation	Main power supply Phases, Voltage, Frequency	Three-phase, 200 to 240V, 50/60Hz						
		Auxiliary control power input Phases, Voltage, Frequency *11	Single-phase, 200 to 240V, 50/60Hz						
		Voltage/frequency variations *8	Voltage: +10 to -15% (Voltage unbalance: 2% or less *5) Frequency: +5 to -5%						
		Rated current *6 [A]	with DCR	21.1	28.8	42.2	57.6	71.0	84.4
	without DCR		31.5	42.7	60.7	80.1	97.0	112	
	Required power supply capacity *7 [kVA]	7.4	10	15	20	25	30		
	Battery operation	Main power supply	DC 24V or more in the direct current voltage conversion.						
		Auxiliary control power input *11	Phases, Voltage, Frequency	Single-phase, 200 to 240V, 50/60Hz					
			Voltage/frequency variations	Voltage: +10 to -15%, Frequency: +5 to -5%					
	Operation time *12 [s]	180							
Braking	Braking time *13 [s]	60							
	Braking duty-cycle (%ED) *13 [%]	50							
	Rated regenerative power *13 [kW]	4.4	6.0	8.8	12	14.8	17.6		
	Minimum resistance which can be connected [Ω] *9	15	10	7.5	6	4	3.5		
DC Reactor (DCR)	Option								
Applicable safety standard	EN61800-5-1:2003, EN954-1 Category3 *14								
Enclosure (IEC60529)	IP20								
Cooling method	Fan cooling								
Weight/Mass [kg]	5.7	5.9	7.4	11.0	11.3	11.8			

\*1) Fuji's 4-pole standard motor  
 \*2) Rated capacity is calculated by regarding the output rated voltage as 220V for three-phase 200V series.  
 \*3) Output voltage cannot exceed the power supply voltage.  
 \*4) It is a value in the condition of the carrier frequency 10kHz and the ambient temperature 45°C. Select the inverter capacity such that the square average current in cycle operation is 80% or less of the rated current of an inverter.  
 \*5) Voltage unbalance [%] = (Max. voltage [V] - Min. voltage [V]) / Three-phase average voltage [V] x 67 (IEC61800-3)  
 \*6) The power supply capacity is 500kVA (ten times the inverter capacity when the inverter capacity exceeds 50kVA), and the calculation value when connecting with the power supply of %X=5%.  
 \*7) Obtained when a DC Reactor is used.  
 \*8) An acceptable variation of the main power supply and the control power supply assistance input.  
 \*9) The admissible error of minimum resistance is ±5%.  
 \*10)

Type of inverter	Description
FRN_LM1S-2□	CAN versuion
FRN_LM1S-2□A	DCP versuion

\*11) The same AC power as the main power supply input is connected for the backup of the control circuit power source.

\*12) It is a value in the condition of the carrier frequency 10kHz and the ambient temperature 45°C. Use the inverter such that the square average current in battery operation is 80% or less of the rated current of an inverter.  
 \*13) Braking time and duty cycle (%ED) are defined by cycle operation at the rated regenerative power as shown in the figure below.

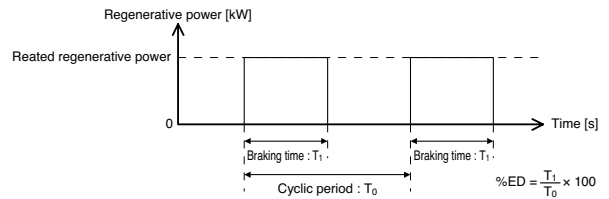

\*14) The inverter that last 2 digits of a software version are from 50 to 99 corresponds to this standard.  
 \*15) When output exceeds this overload capacity at carrier frequency 16kHz, carrier frequency is reduced automatically. The reduced carrier frequency is maintained until an inverter stops.

### ■ Three-phase 400V series

Item		Specifications												
Type (FRN□□LM1S-4□) *10		4.0	5.5	7.5	11	15	18.5	22	30	37	45			
Applicable motor rating *1 [kW]		3.7	5.5	7.5	11	15	18.5	22	30	37	45			
Output ratings	Rated capacity *2 [kVA]	6.8	10.2	14	18	24	29	34	45	57	69			
	Rated voltage *3 [V]	Three-phase 380V-480V, 50/60Hz							Three-phase 380V-460V, 50/60Hz					
	Rated current *4 [A]	9.0	13.5	18.5	24.5	32.0	39.0	45.0	60.0	75	91			
	Overload capacity [A] (Permissible energizing time)	18.0 (3s)	27.0 (10s)	37.0 (10s)	49.0 (10s)	64.0 (10s)	78.0 (10s)	90.0 (10s)	108 (5s)	135 (5s)	163 (5s)			
	Overload capacity at carrier frequency 16kHz *16 [A] (Permissible energizing time)	9.6 (3s)	19 (10s)	25 (10s)	33 (10s)	44 (10s)	53 (10s)	61 (10s)	65 (5s)	76 (5s)	115 (5s)			
	Rated frequency [Hz]	50, 60Hz												
Input ratings	Normal operation	Main power supply Phases, Voltage, Frequency	Three-phase, 380 to 480V, 50/60Hz											
		Auxiliary control power input *12 Phases, Voltage, Frequency	Single-phase, 200 to 480V, 50/60Hz							Single-phase, 380 to 480V, 50/60Hz *11				
		Voltage/frequency variations *8	Voltage: +10 to -15% (Voltage unbalance: 2% or less *5) Frequency: +5 to -5%											
		Rated current *6 [A]	with DCR	7.5	10.6	14.4	21.1	28.8	35.5	42.2	57.0	68.5	83.2	
			without DCR	13	17.3	23.2	33	43.8	52.3	60.6	77.9	94.3	114	
	Battery operation	Required power supply capacity *7 [kVA]	5.2	7.4	10	15	20	25	30	40	48	58		
		Main power supply	DC 48V or more in the direct current voltage conversion.											
		Auxiliary control power input *12 Phases, Voltage, Frequency	Single-phase, 200 to 480V, 50/60Hz							Single-phase, 380 to 480V, 50/60Hz *11				
			Voltage/frequency variations	Voltage: +10 to -15%, Frequency: +5 to -5%										
			Operation time *13 [s]	180										
Braking	Braking time *14 [s]	60												
	Braking duty-cycle (%ED) *14 [%]	50												
	Rated regenerative power *14 [kW]	3.2	4.4	6.0	8.8	12	14.8	17.6	24	29.6	36			
	Minimum resistance which can be connected [Ω] *9	96	64	48	24	24	16	16	10	10	8			
DC Reactor (DCR)	Option													
Applicable safety standard	EN61800-5-1:2003, EN954-1 Category3 *15								EN61800-5-1:2003					
Enclosure (IEC60529)	IP20							IP00						
Cooling method	Fan cooling													
Weight/Mass [kg]		3.0	5.6	5.7	7.5	11.1	11.2	11.7	24	33	34			

- \*1) Fuji's 4-pole standard motor
- \*2) Rated capacity is calculated by regarding the output rated voltage as 440V for three-phase 400V series.
- \*3) Output voltage cannot exceed the power supply voltage.
- \*4) It is a value in the condition of the career frequency 10kHz and the ambient temperature 45°C. Select the inverter capacity such that the square average current in cycle operation is 80% or less of the rated current of an inverter.
- \*5) Voltage unbalance [%] = (Max. voltage [V] - Min. voltage [V]) / Three-phase average voltage [V] x 67 (IEC61800-3)
- \*6) The power supply capacity is 500kVA (ten times the inverter capacity when the inverter capacity exceeds 50kVA), and the calculation value when connecting with the power supply of %X=5%.
- \*7) Obtained when a DC Reactor is used.
- \*8) An acceptable variation of the main power supply and the control power supply assistance input.
- \*9) The admissible error of minimum resistance is ±5%.
- \*10)

Type of inverter	Description
FRN_LM1S-4□	CAN versuion
FRN_LM1S-4□A	DCP versuion

- \*11) It is necessary to change the power-supply voltage change connector on the power supply printed wiring board depend on the power-supply voltage.
- \*12) 30kW or less  
The same AC power as the main power supply input is connected for the backup of the control circuit power source.  
37kW or more

- The same AC power as the main power supply input is connected for the control circuit, the fan, and the contactor.  
The inverter doesn't operate if the power supply is not input to the auxiliary control power input. Please supply power.
- \*13) It is a value in the condition of the career frequency 10kHz and the ambient temperature 45°C. Use the inverter such that the square average current in battery operation is 80% or less of the rated current of an inverter.
- \*14) Braking time and duty cycle (%ED) are defined by cycle operation at the rated regenerative power as shown in the figure below.

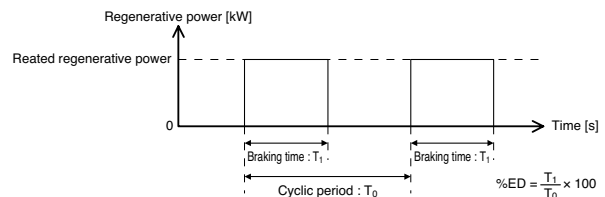

- \*15) The inverter that last 2 digits of a software version are from 50 to 99 corresponds to this standard.
- \*16) When output exceeds this overload capacity at carrier frequency 16kHz, carrier frequency is reduced automatically. The reduced carrier frequency is maintained until an inverter stops.

# Specifications

## Single-phase 200V series

Item		Specifications		
Type (FRN□□LM1S-7□) *9		2.2		
Applicable motor rating *1 [kW]		2.2		
Output ratings	Rated capacity *2 [kVA]	4.1		
	Rated voltage *3 [V]	Three -phase 200V-220V, 50/60Hz		
	Rated current *4 [A]	11		
	Overload capacity [A] (Permissible energizing time)	22 (3s)		
	Overload capacity at carrier frequency 16kHz *14 [A] (Permissible energizing time)	15 (3s)		
	Rated frequency [Hz]	50, 60Hz		
Input ratings	Normal operation	Main power supply Phases, Voltage, Frequency	Single -phase, 200 to 240V, 50/60Hz	
		Auxiliary control power input Phases, Voltage, Frequency *10	Single-phase, 200 to 240V, 50/60Hz	
		Voltage/frequency variations *7	Voltage: +10 to -15% ,Frequency: +5 to -5%	
		Rated current *5 [A]	with DCR	17.5
			without DCR	24
	Required power supply capacity *6 [kVA]	3.5		
	Battery operation	Main power supply	DC 24V or more in the direct current voltage conversion.	
		Auxiliary control power input *10	Phases, Voltage, Frequency	Single-phase, 200 to 240V, 50/60Hz
			Voltage/frequency variations	Voltage: +10 to -15%, Frequency: +5 to -5%
	Operation time *11 [s]	180		
Braking	Braking time *12 [s]	60		
	Braking duty-cycle (%ED) *12 [%]	50		
	Rated regenerative power *12 [kW]	1.76		
	Minimum resistance which can be connected [Ω] *8	33		
DC Reactor (DCR)		Option		
Applicable safety standard		EN61800-5-1:2003, EN954-1 Category3 *13		
Enclosure (IEC60529)		IP20		
Cooling method		Fan cooling		
Weight/Mass [kg]		3.0		

- \*1) Fuji's 4-pole standard motor
- \*2) Rated capacity is calculated by regarding the output rated voltage as 220V.
- \*3) Output voltage cannot exceed the power supply voltage.
- \*4) It is a value in the condition of the career frequency 10kHz and the ambient temperature 45°C. Select the inverter capacity such that the square average current in cycle operation is 80% or less of the rated current of an inverter.
- \*5) The power supply capacity is 500kVA (ten times the inverter capacity when the inverter capacity exceeds 50kVA), and the calculation value when connecting with the power supply of %X=5%.
- \*6) Obtained when a DC Reactor is used.
- \*7) An acceptable variation of the main power supply and the control power supply assistance input.
- \*8) The admissible error of minimum resistance is ±5%.
- \*9)

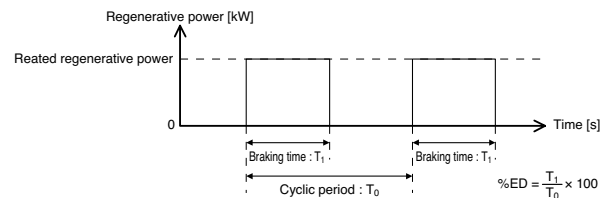

Type of inverter	Description
FRN_LM1S-7□	CAN versuion
FRN_LM1S-7□A	DCP versuion
- \*10) The same AC power as the main power supply input is connected for the backup of the control circuit power source.
- \*11) It is a value in the condition of the career frequency 10kHz and the ambient temperature 45°C. Use the inverter such that the square average current in battery operation is 80% or less of the rated current of an inverter.

\*12) Braking time and duty cycle (%ED) are defined by cycle operation at the rated regenerative power as shown in the figure below.



- \*13) The inverter that last 2 digits of a software version are from 50 to 99 corresponds to this standard.
- \*14) When output exceeds this overload capacity at carrier frequency 16kHz, carrier frequency is reduced automatically. The reduced carrier frequency is maintained until an inverter stops.

## Common specifications

Item		Explanation	Remarks	
Control method		Vector control with PG (Asynchronous Motor) Vector control with PG (Synchronous Motor) Torque Vector control (Open loop control for Asynchronous Motor) *1		
Setting range	Carrier frequency	Setting range: 5 to 16kHz Note) The carrier frequency may drop automatically according to the ambient temperature or output current to protect the inverter. (The automatic decrease stop function is provided.)		
Speed control	Maximum speed	It is 120Hz in inverter output frequency conversion. (2-pole: 7200r/min, 4-pole: 3600r/min, 6-pole: 2400r/min) PG frequency: 100kHz or less		
	Control range	It is 0 to 120Hz in inverter output frequency conversion. (4-pole:0 to 3600r/min)		
	Control response	100Hz (Max)		
	Control accuracy	Analog setting: $\pm 0.2\%$ or less at the maximum speed ( $25 \pm 10^\circ\text{C}$ ) Multistep speed and communication settings: $\pm 0.01\%$ or less at the maximum speed ( $-10$ to $+45^\circ\text{C}$ )	in case of Vector control with PG	
	Frequency setting resolution	Analog setting: 1/1000 at the maximum speed Multistep speed setting : It is 0.01Hz(99.99Hz or less), 0.1Hz(100.0 to 120.0Hz) in inverter output frequency conversion. Communication: 1/20000 at the maximum or 0.1Hz(fixation) in inverter output frequency conversion.		
Control function	Start / Stop	External signals (Digital input): Forward rotation and stop command, Reverse rotation and stop command, coast-to-stop command, external alarm, alarm reset, etc. Key operation: It is possible to operation and to stop with the RUN and STOP key by a remotely/local change. (Option)		
	Speed setting	Multistep speed: External signal (Digital input) Combination of 3 points (8 step) Analog signal: 0 to $\pm 10\text{V}$ Multi-function keypad (Option): It is possible to set with  and  keys by a remotely/local change. Communication: RS485		
	S-curve acceleration/ deceleration setting	Individual settings of each point of start, acceleration completion, deceleration beginning, and stop. (10 step) Setting range: 0 to 50%		
	Sequence function	Forced stop, The range of the S-curve, Acceleration and deceleration time, Multistep speed command setting simultaneously, Operation Command Agreement Timer, Multistep Speed Command Agreement Timer, Normal or negative logic selected function of digital input, Normal or negative logic selected function of digital output, Soft starting, Stop frequency continuance, Acceleration and deceleration operation function cancellation		
	Control function	Torque control, ASR feedforward compensation, Vibration control observer, ASR parameter change, Digital torque bias, Analog torque bias, Motor characteristics tuning, etc.		
	Special function	Password, Unbalanced load compensation, Creepless operation, Battery operation		
	Function for Synchronous Motor	Pole position offset tuning		
Environment	Installation location	Shall be free from corrosive gasses, flammable gasses, oil mist, dust, and direct sunlight (Pollution degree 2(IEC60664-1)). Indoor use only.		
	Ambient temperature	Opening: $-10$ to $+45^\circ\text{C}$		
	Ambient humidity	5 to 95%RH (no condensation)		
	Altitude	1000m or less		
	Vibration	3mm : 2 to less than 9Hz 9.8m/s <sup>2</sup> : 9 to less than 20Hz 2m/s <sup>2</sup> : 20 to less than 55Hz 1m/s <sup>2</sup> : 55 to less than 200Hz		
	Storage	Amb. Temp.	$-25$ to $+65^\circ\text{C}$	
		Amb. Humidity	5 to 95%RH (no condensation)	

\*1) Capacity that can use the torque vector control by software version is different. Do not operate it in capacity other than the table below.

Software version	200V series	400V series.	Single-phase 200V
1200 to 1209	Not available	5.5kW to 22kW	Not available
1210 to 1299	5.5kW to 22kW	4.0kW to 30kW	Not available
1300 or later	5.5kW to 22kW	4.0kW to 30kW	2.2kW

# Protective Functions

## ● Protective Functions

Function		Description	Symbol *1	Alarm output *2	
Protective function	Overcurrent protection	The inverter is stopped for protection against overcurrent caused by an overload.	During acceleration OC1	○	
	Short circuit protection	The inverter is stopped for protection against overcurrent caused by a short circuit in the output circuit.	During deceleration OC2	○	
	Grounding fault protection	The inverter is stopped for protection against overcurrent caused by a grounding fault in the output circuit. If the power supply is turned on with the grounding fault, the protection may be invalidated.	During move at a constant velocity OC3	○	
	Overvoltage protection	An excessive voltage (400V series: DC800V, 200V series: DC400V) in the DC link circuit is detected and the inverter is stopped. If a remarkably large voltage is applied by mistake, the protection cannot be made.	During acceleration OU1	○	
			During deceleration OU2		
			During move at a constant velocity OU3		
	Undervoltage protection	The voltage drop (400V series: DC400V, 200V series: DC200V) in the DC link circuit is detected to stop the inverter. However, when the battery operation, the Undervoltage detection is canceled. (The alarm is not output)	LV	△	
	Input phase loss protection	Detects input phase loss, stopping the inverter output. This function prevents the inverter from undergoing heavy stress that may be caused by input phase loss or inter-phase voltage unbalance and may damage the inverter. If connected load is light or a DC reactor is connected to the inverter, this function will not detect input phase loss if any.	L in	△	
	Output phase loss protection	Output phase loss detection operates before it begins to drive. When output phase loss detects it, the inverter is stopped.	OPL	○	
	Overheating protection	The temperature of the heat sink in the event of cooling fan trouble and overload is detected to stop the inverter. The temperature inside the inverter unit in the event of cooling fan trouble and overload is detected to stop the inverter.	OH1	○	
			OH3	○	
	Overload protection	The temperature inside the IGBT is calculated from the detection of output current and internal temperature, to shut off the inverter output.	OLU	○	
	External alarm input	With the digital input signal (THR), the inverter is stopped as for an alarm.	OH2	○	
	Motor protection	Electronic thermal	The inverter is stopped upon an electronic thermal function setting to protect the motor. The standard motor and the inverter motor are protected in the range of all the frequencies. The operation level and thermal time constant can be set.	OL1	○
		PTC thermistor	A PTC thermistor input stops the inverter to protect the motor. The PTC thermistor is connected between terminals V2 and 11 to set switch on the control PC board and function codes.	OH4	○
	Memory error	Data is checked upon power-on and writing to detect any fault in the memory and to stop the inverter if any.	Er1	○	
	Keypad communication error	Multi-function keypad (option) is used to detect a communication fault between the keypad and inverter main body during operation and so on and stop the inverter if any.	Er2	○	
	CPU error	Detect a CPU error caused by noise and so on and stops the inverter.	Er3	○	
	Option communication error	When the communication error between the inverter and the option card is detected, and the inverter is stopped.	Er4	○	
	Option error	When some models of PG interface card (option) is used, the option side detects a fault to stop the inverter.	Er5	○	
	Operation error	Brake status error If the braked status input (BRKE) does not follow the brake command (BRKS), the inverter stops. Speed command error If same speed data is set up in any of multistep speed commands (L11 to L18) the inverter stops. etc.	Er6	○	
	Tuning error	When tuning failure, interruption, or any fault as a result of tuning is detected while tuning the motor constant, the inverter is stopped.	Er7	○	
	RS485 communication error	When the connection port of the keypad is connected via RS485 communication to the network to detect a communication error, the inverter is stopped to display the error.	Er8	○	
	Data save error upon undervoltage	When the undervoltage protection works, an error is displayed if data cannot be stored.	ErF	○	
	Option hardware error	When using the option card upon an error in the option or due to a loose mounting of the card being detected the inverter stops itself.	ErH	○	
	EN terminal circuit error	The inverter detects an error on the EN terminal circuit, and stops itself. Note that due to the internal circuit error, the reset feature of inverter itself cannot clear the alarm	ECF	○	
	Broken wiring in the PG	The inverter detects a broken wiring connection in the pulse encoder and stops itself. This feature takes effect for some models of the PG interface card (option).	PG	○	
	CAN bus communication error	An abnormal communication with the main body of the inverter is detected when the CAN bus is used, and the inverter is stopped. Only the CAN version. (FRN_LM1S-□)	ErE	○	
	Overspeed prevention	If the motor has run at 120% or more of the maximum rated speed, the inverter stops.	OS	○	
	Speed mismatching (Out of speed control)	If difference between the reference speed and motor speed (ASR feedback) increases too much large to keep control, and this situation continues for the specified time, then the inverter stops.	ErE	○	
Charging circuit fault	The charging circuit fault in the inverter is detected to stop the inverter. (400V 37kW or more)	PbF	○		
Over torque current	The inverter is stop when reference torque current of the inverter exceeds the over torque current detection level and the reference torque current continues longer than the period specified by over torque current detection time.	OT	○		
Alarm output (for any fault)	The relay signals is output when the inverter stops upon alarm. The digital input signal (RST) is used to reset the alarm stoppage state. (Option: PRG/RESET key of Multi-function keypad is used to reset the alarm stoppage state)	-	○		
Retry	When the motor is tripped and stopped, this function automatically resets the tripping state and restarts operation. (The number of retries and the length wait before resetting can be set.)	-	-		
Safety function	The output of the inverter is cut off when EN is turned off, and the inverter is stopped surely.	-	-		
Surge protection	The inverter is protected against surge voltage intruding between the main circuit power line and ground.	-	-		
Momentary power failure protection	A protective function (inverter stoppage) is activated upon a momentary power failure for 15msec or longer.	-	-		

\*1) When Multi-function keypad of the option is connected, the sign is displayed in LED.

\*2) ○ is output to 30A and B and C. △ is not occasionally output according to the function.



# Terminal functions

## Terminal functions

Division	Symbol	Terminal name	Detailed specification	Remarks
Main circuit	L1/R, L2/S, L3/T	Power input	Connects a three-phase power supply	
	L1/L, L2/N		Connects a single-phase power supply (200V 2.2kW)	
	R0, T0	Auxiliary control power input	Connect a single-phase power supply.	Refer to 1. Standard specifications
	U, V, W	Inverter output	Connect a three-phase motor	
	P(+), P1	For DC Reactor	Connect the DC Reactor (DCR).	
	P(+), DB	External braking resistor connection terminal	Connects the external braking resistor.	
	P(+), N(-)	For DC bus connection	Used for DC bus connection.	
Analog input	⊕G (2 terminals)	Grounding	Terminal for inverter grounding.	
	12	Analog setting voltage input	Speed command: DC 0 to ±10V / 0 to ±100%, Torque bias command: DC 0 to ±10V/0 to ±100% Torque current command: DC 0 to ±10V / 0 to ±200%	Input impedance: 22kΩ Maximum input: DC+15V
	C1	Analog setting current input	Speed command: DC 4 to 20mA / 0 to 100% Torque bias command: DC 4 to 20mA / 0 to 100% Torque current command: DC 4 to 20mA / 0 to 200%	Input impedance: 250Ω Maximum input: DC30mA
	V2	Analog setting voltage input	Speed command: DC 0 to ±10V / 0 to ±100% Torque bias command: DC 0 to ±10V / 0 to ±100% Torque current command: DC 0 to ±10V / 0 to ±200% Connects PTC thermistor for motor protection. It is necessary to change SW on the printed wiring board to the PTC side.	Input impedance: 22kΩ Maximum input: DC+15V
11 (2 terminals)	Analog common	Common terminal to frequency setting signal (12, C1, V2).	Isolated from terminals CM and CMY.	
Digital input	FWD	Forward operation command	Used for forward operation (when FWD is ON) or deceleration and stop (when FWD is OFF)	ON state Operation current : 2.5 to 5mA (Input voltage: 2V)
	REV	Reverse operation command	Used for forward operation (when REV is ON) or deceleration and stop (when REV is OFF)	OFF state Allowable leakage current: 0.5mA or less
	X1	Digital input 1	(1) The following functions can be assigned to terminals X1 to X8. Select multistep speed (SS1, SS2, SS4), Enable coast-to-stop (BX), Reset alarm (RST), Enable external alarm trip (THR), Enable jogging operation (JOG), Enable communications link via RS485 or CAN (LE), Universal DI (U-DI), Enable PG vector control (PG/Hz), Select torque bias (TB1, TB2), Hold torque bias (H-TB), Enable battery operation (BATRY), Start creepless operation (CRPLS), Check brake control (BRKE), Force to decelerate (DRS), Start unbalance load compensation (UNBL), Pole position offset tuning operation (PPT), Enable external alarm trip 2 (THR2), Start reference torque decreasing (RTDEC), Check status MC control (CS-MC), CAN Enable (CAN_EN) etc.  Jogging is given to priority more than other speed command (multistep speed).	SINK mode state Operation voltage ON level: 0 to 2V OFF level: 21 to 27V
	X2	Digital input 2		
	X3	Digital input 3		
	X4	Digital input 4		
	X5	Digital input 5		
	X6	Digital input 6		
	X7	Digital input 7		
	X8	Digital input 8		
		(2) Input mode, Sink/Source can be switched. (3) The operation mode between digital each input terminals and terminal CM can be switched to "Turn on when short-circuit (active ON)" or "Turn off when short-circuit (active OFF)". (4) A part of functions of FWD and the REV function, etc. cannot reverse logic.	SOURCE mode state Operation current ON level: 21 to 27V OFF level: 0 to 2V	
		<p>Digital input circuit</p>		
EN	Enable	The output of the inverter is cut off when EN is turned off, and the inverter is stopped surely.		
PLC (2 terminals)	PLC terminal	Connect to PLC output signal power supply. Common for 24V power.	+24V(21 to 27V), Max 100mA (Total 2 terminals)	
CM (2 terminals)	Common	Common terminal for digital input signals	Terminal 11 and CM are insulated.	

# Terminal functions

Division	Symbol	Terminal name	Detailed specification	Remarks
Transistor output	(PLC)	Transistor output power	Power supply for transistor output load. (Note: Same terminal as digital input PLC terminal)	Short circuit across terminals CM and CMY to use.
	Y1 Y2 Y3 Y4	Transistor output	<p>(1) Outputs the selected signals from the following items.                      Inverter running (RUN), Speed arrival (FAR), Speed detected (FDT), Undervoltage detected (Inverter stopped) (LV), Inverter ready to run (RDY), MC control (SW52-2), Cooling fan in operation (FAN), Auto-resetting (TRY), Universal DO(U-DO), Overheat early warning (OH), Service life alarm (LIFE), Inverter output on (RUN2), Current detected (ID, ID2), Run command activated (AX2), Motor overheat detected (PTC) (THM), Brake control (BRKS), Speed existence (DNZS), Speed agreement (DSAG), Speed arrival 3 (FAR3), During acceleration (DACC), During deceleration (DDEC), During zero speed (DZR), PG abnormal (PG-ABN), Door control (DOPEN), Alarm output (for any alarm) (ALM), EN detection circuit fault (DECF), EN terminal off (ENOFF), Low voltage detected (LVD), Electrical angle cycle (EAC), During pole position offset tuning (DTUNE), Recommended running direction (RRD), Drive continuance alarm output (ALM2), Shutdown confirmation (SD), input power limitation (IPL), MC control 2 (SW52-3), Pole tuning done (PTD), Detected speed direction (DSD) etc.</p> <p>(2) The current direction is interactive. (The change is unnecessary.)                      (3) The operation mode between transistor output terminals Y1 to Y4 and terminal CMY can be switched to "Turn on when the signal is output" or "Turn off when the signal is output".</p>	ON state maximum load current : DC50mA OFF state Allowable leakage current : 0.1mA or less Operation voltage ON level: Max 3V OFF level: Max 27V
	CMY	Transistor output common	Common terminal for transistor output	The terminal is isolated from terminals 11 and CM
Contact output	Y5A, Y5C	General-purpose relay output	Multi-purpose relay output: signals similar to above-mentioned signals Y1 to Y4 can be selected. An alarm output issued upon either excitation or no excitation according to selection.	Contact capacity : 250V AC, 0.3A, cosΦ=0.3 48V DC, 0.5A
	30A 30B 30C	Alarm relay output (for any fault)	A no-voltage contact signal (1c) is issued when the inverter is stopped due to an alarm. Multi-purpose relay output: signals similar to above-mentioned signals Y1 to Y4 can be selected. An alarm output issued upon either excitation or no excitation according to selection.	

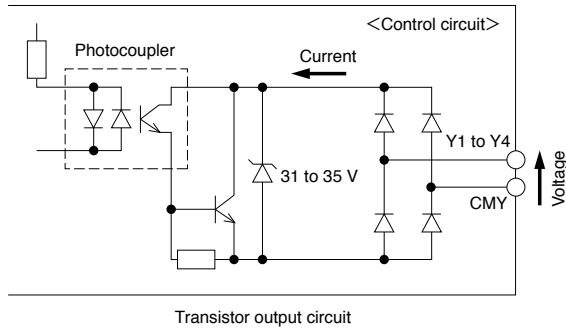

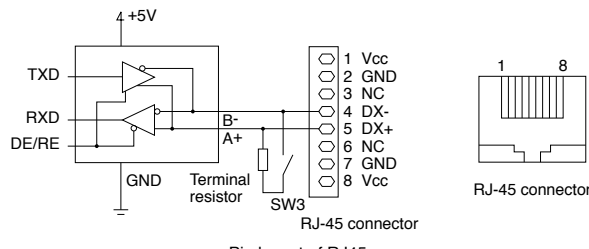
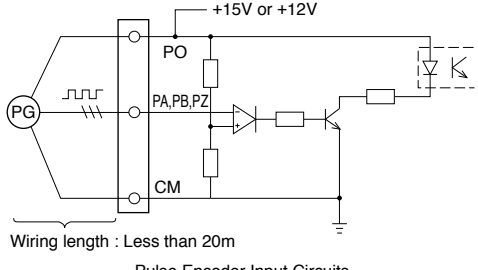
Classification	Symbol	Terminal name	Detailed specification	Remarks												
Communication		RS485 (RJ45 connector)	<p>One of the following protocols can be selected.                      Protocol exclusively for keypad (default selection)                      Modbus RTU                      SX protocol for PC loader                      DCP: Only the DPC version. (FRN_LM1S-□A)</p>  <p>Pin layout of RJ45</p>	Using combined for keypad connection												
	CAN+, CAN-, SHLD	CAN+, CAN-, CAN shield	CAN bus Only the CAN version. (FRN_LM1S-□)													
Encoder	PO	Power supply for encoder	12V, 15V (Change with jumper)	Max 120mA												
	PA PB PZ	PG input A PG input B	 <p>Wiring length : Less than 20m Pulse Encoder Input Circuits</p> <p>Specifications</p> <table border="1"> <thead> <tr> <th>Item</th> <th colspan="2">Specifications</th> </tr> </thead> <tbody> <tr> <td>Pulse encoder output circuits</td> <td>Open collector transistor</td> <td>Complementary transistor</td> </tr> <tr> <td>Allowable input pulse frequency (rate)</td> <td>25 kHz max.</td> <td>100 kHz max.</td> </tr> <tr> <td>Wiring length</td> <td colspan="2">Less than 20 m</td> </tr> </tbody> </table>	Item	Specifications		Pulse encoder output circuits	Open collector transistor	Complementary transistor	Allowable input pulse frequency (rate)	25 kHz max.	100 kHz max.	Wiring length	Less than 20 m		
	Item	Specifications														
	Pulse encoder output circuits	Open collector transistor	Complementary transistor													
	Allowable input pulse frequency (rate)	25 kHz max.	100 kHz max.													
Wiring length	Less than 20 m															
CM	Common for encoder	Common terminal to encoder power supply	It is common with terminal CM.													
PAO	Transistor output	Output terminal of Phase A pulse of PG. The output signal is a signal input to the terminal PA	Open collector output Common terminal: CM Max voltage: DC27V Max current: DC50mA Allowable leakage current : 0.1mA or less ON voltage: 2Vorless (Use 50mA)													
PBO	Transistor output	Output terminal of Phase B pulse of PG. The output signal is a signal input to the terminal PB														

# Basic wiring diagram

## Basic wiring diagram

FRN4.0LM1S-4□ to FRN45LM1S-4□, FRN5.5LM1S-2□ to FRN22LM1S-2□, FRN2.2LM1S-7□

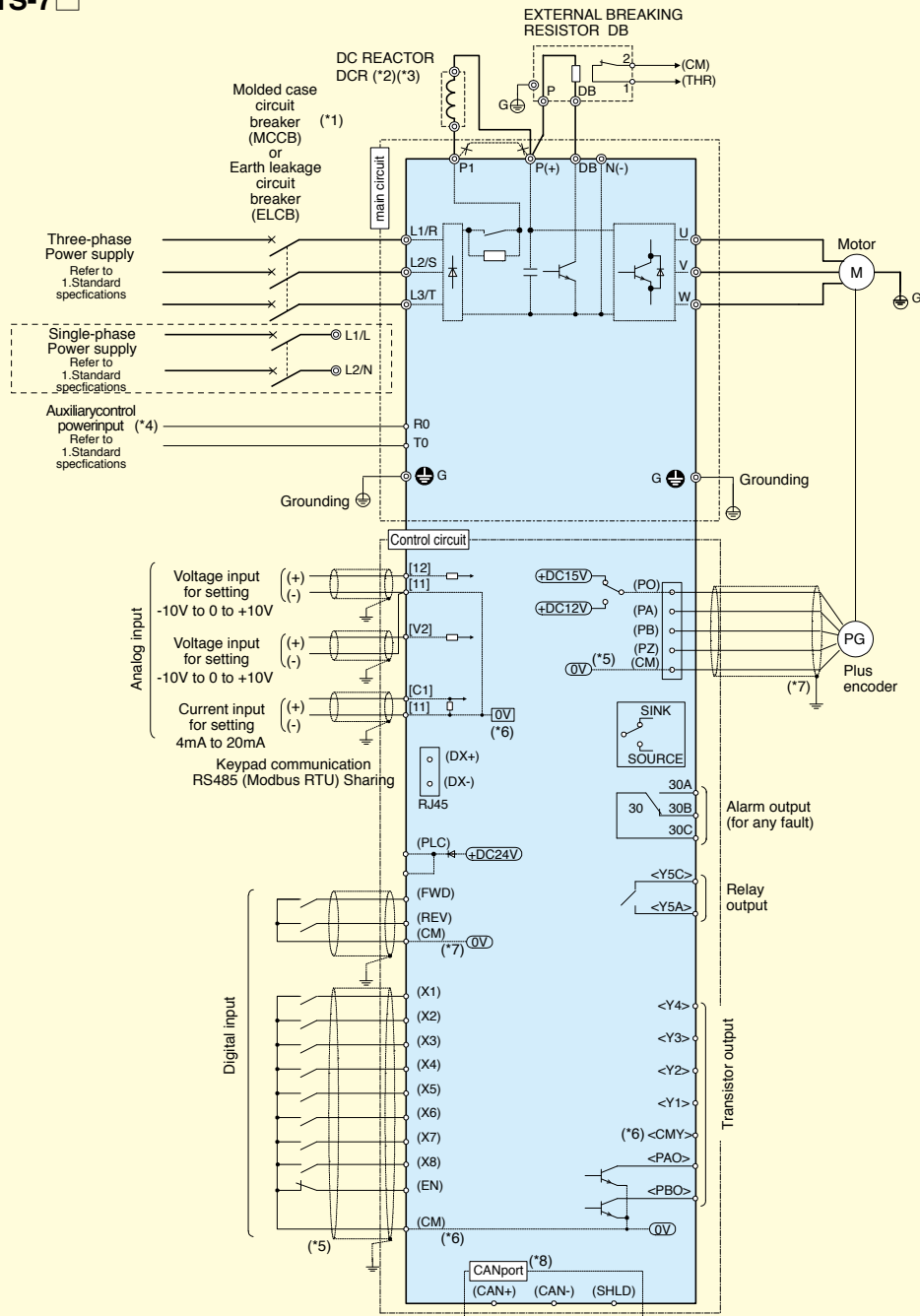

- (\*1) Install a recommended molded-case circuit-breaker (MCCB) or an earth-leakage circuit-breaker (ELCB) (with an overcurrent protection function) in the circuit breaker capacity is equivalent to or lower than the recommended capacity.
- (\*2) It is an option. Please use it if necessary.
- (\*3) When connecting a DC Reactor (DCR) (option), remove the jumper bar from across the terminals P1 and P(+).
- (\*4) Even if this terminal is not connected, the inverter can be operated with connection of the main circuit (L1/R, L2/S, L3/T or L1/L, L2/N). Please wire for this terminal to operate the control circuit of the inverter when there is no power supply. Connect terminal R0 and T0 with the output side on earth leakage circuit breaker when you connect earth leakage circuit breaker. When you connect terminal R0 and T0 with the input side of an earth leakage circuit breaker, an earth leakage circuit breaker malfunctions. Connect insulation transformer or auxiliary contact B of magnetic contactor with the position shown in the figure below whenever you connect R0 and T0 with the input side of an earth leakage circuit breaker.
- (\*5) For the control signal wires, use shielded or twisted wires. Ground shielded wires. To prevent malfunction due to noise, keep the control circuit wiring away from the main circuit wiring as far as possible (recommended: 10cm or more), and never set them in the same wire duct. When crossing the control circuit wiring with the main circuit wiring, set them at right angles.
- (\*6) Common terminal [11], (CM), and < CMY > of the control circuit are independent respectively (insulation).
- (\*7) Wiring must use the shield line. Please connect the shield appropriately according to the specification of the pulse encoder and the connection with the controller. In the above figure, the shield is connected with the earth line of the motor and opening of the inverter side. It is likely to be improved by connecting the inverter side with (CM) when malfunctioning because of the noise etc. When the wiring between the encoder and the inverter is long, the allophone and the torque ripple might be generated because the signal from the encoder malfunctions by interfering with A phase and B phase. In this case, please execute measures such as; wiring shorter cable, cable of smaller electrostatic capacity, etc.
- (\*8) Only type FRN\_LM1S-□ has the CAN port (not □□)

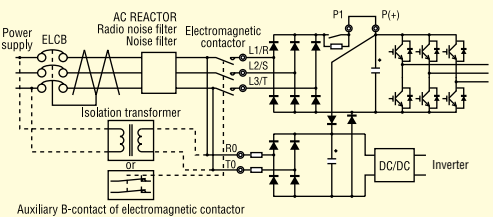

# External Dimensions

## External Dimensions

[ Unit: mm ]

### FRN5.5LM1S-4□ to FRN22LM1S-4□, FRN5.5LM1S-2□ to FRN22LM1S-2□

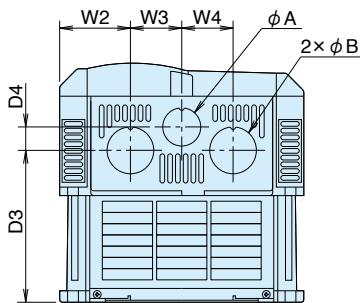
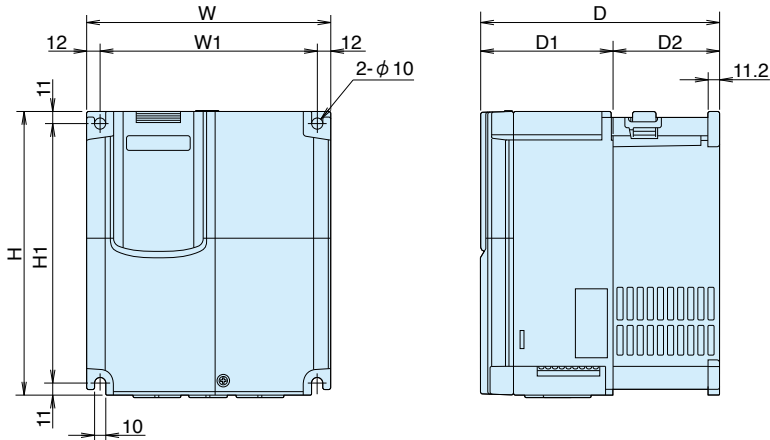

Power supply voltage	Type	Dimensions (mm)													
		W	W1	W2	W3	W4	H	H1	D	D1	D2	D3	D4	φA	φB
Three-phase 200V	FRN5.5LM1S-2□	220	196	63.5	46.5	46.5	260	238	215	118.5	96.5	136.7	21	34	42
	FRN7.5LM1S-2□														
	FRN11LM1S-2□														
	FRN15LM1S-2□														
	FRN18.5LM1S-2□														
FRN22LM1S-2□	250	226	67	58	58	400	378	85	130	166.2	2				
Three-phase 400V	FRN5.5LM1S-4□	220	196	63.5	46.5	46.5	260	238	215	118.5	96.5	136.7	21	34	42
	FRN7.5LM1S-4□														
	FRN11LM1S-4□														
	FRN15LM1S-4□														
	FRN18.5LM1S-4□														
FRN22LM1S-4□	250	226	67	58	58	400	378	85	130	166.2	2				

### FRN30LM1S-4□ to FRN45LM1S-4-□

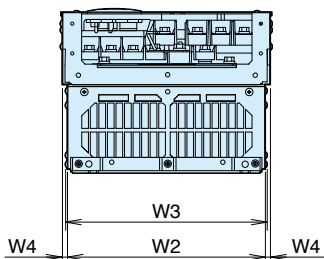
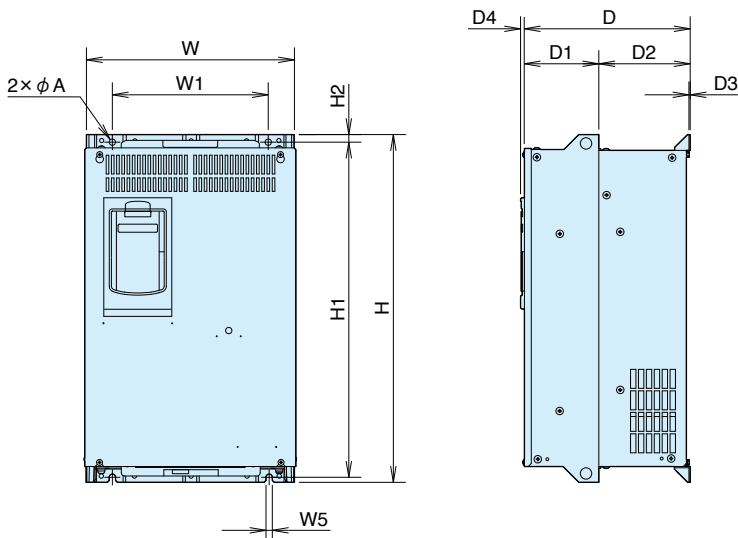

Power supply voltage	Type	Dimensions (mm)														
		W	W1	W2	W3	W4	W5	H	H1	H2	D	D1	D2	D3	D4	φA
Three-phase 400V	FRN30LM1S-4□	320	240	304	310.2	8	10	550	530	12	255	115	140	4	6	10
	FRN37LM1S-4□										270		155			
	FRN45LM1S-4□										270		155			



# External Dimensions

## ● External Dimensions

[ Unit: mm ]

■ FRN4.0LM1S-4 □ / FRN2.2LM1S-7 □

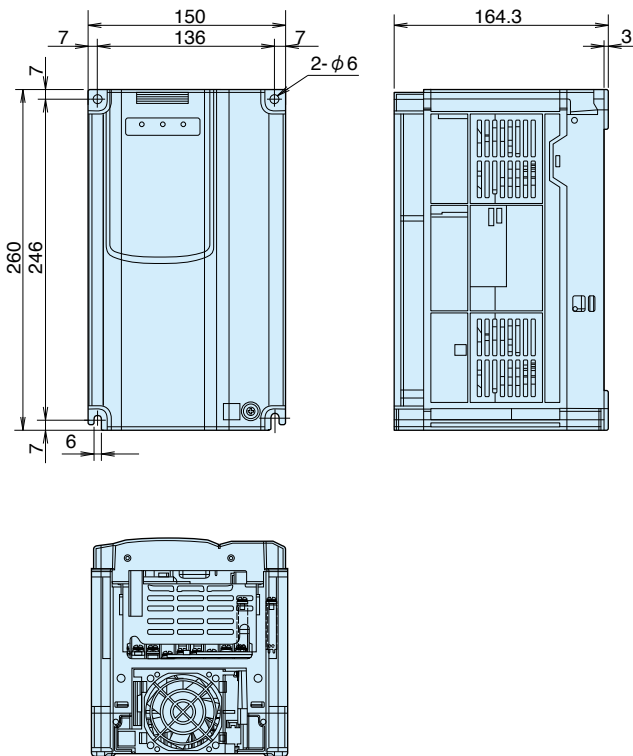

# Specifications

## ● Keypad (TP-G1-ELS)

Appearance	Specifications																				
<p><b>● Keypad (TP-G1-ELS)</b></p> <p>A liquid crystal panel can be mounted to check various status including the current, voltage and power consumption. Also, function codes can be copied to other FRENIC-Lift.</p> <p>[ Unit: mm ]</p> <p>Back view (80)</p> <p>Panel cut part</p> <p>2X#4</p> <p>Panel cut dimensional drawing (view on arrow A)</p>	<p><b>Communications</b></p> <p>Communications protocol: Modbus-RTU Connection terminal: RJ-45 connector</p> <p><b>Display</b></p> <p>Data display: 7-segment LED, 5 digits, LCD display</p> <p>Keypad operation keys: </p> <p>Motor operation keys: </p> <p>LED display: For Run ( FWD REV ) 1 LED</p> <p>LCD display: &lt;Indicator display&gt; Hz, A, V, %, r/min, m/min, kW, x10, min, sec, PID, FWD, REV, STOP, REM, LOC, COMM, JOG, HAND</p> <p>&lt;Display languages (compatible with 12 languages)&gt; · English, Chinese, Japanese, German, French, Spanish, Italian, Russian, Greek, Czech, Polish, Turkish.</p> <p><b>■ General specifications</b></p> <table border="1"> <thead> <tr> <th>Item</th> <th>Specifications</th> </tr> </thead> <tbody> <tr> <td>Protective structure</td> <td>Front side: IP40, Back (attachment surface) side: IP20</td> </tr> <tr> <td>Field of use</td> <td>Indoor, no corrosive gas, no flammable gas, no dust and no direct sunlight</td> </tr> <tr> <td>Ambient temperature</td> <td>-10 to +50°C</td> </tr> <tr> <td>Ambient humidity</td> <td>5 to 95% RH (no dew condensation)</td> </tr> <tr> <td>Altitude</td> <td>1000m or lower</td> </tr> <tr> <td>Vibration</td> <td>3 mm (amplitude): less than 2- to 9 Hz, 9.8m/s<sup>2</sup>: less than 9 to 20 Hz 2m/s<sup>2</sup>: less than 20 to 55 Hz, 1m/s<sup>2</sup>: less than 55 to 200 Hz</td> </tr> <tr> <td>Storage ambient temperature</td> <td>-25 to +65 °C</td> </tr> <tr> <td>Storage ambient humidity</td> <td>5 to 95% RH (no dew condensation)</td> </tr> <tr> <td>Mass</td> <td>129 g</td> </tr> </tbody> </table>	Item	Specifications	Protective structure	Front side: IP40, Back (attachment surface) side: IP20	Field of use	Indoor, no corrosive gas, no flammable gas, no dust and no direct sunlight	Ambient temperature	-10 to +50°C	Ambient humidity	5 to 95% RH (no dew condensation)	Altitude	1000m or lower	Vibration	3 mm (amplitude): less than 2- to 9 Hz, 9.8m/s <sup>2</sup> : less than 9 to 20 Hz 2m/s <sup>2</sup> : less than 20 to 55 Hz, 1m/s <sup>2</sup> : less than 55 to 200 Hz	Storage ambient temperature	-25 to +65 °C	Storage ambient humidity	5 to 95% RH (no dew condensation)	Mass	129 g
Item	Specifications																				
Protective structure	Front side: IP40, Back (attachment surface) side: IP20																				
Field of use	Indoor, no corrosive gas, no flammable gas, no dust and no direct sunlight																				
Ambient temperature	-10 to +50°C																				
Ambient humidity	5 to 95% RH (no dew condensation)																				
Altitude	1000m or lower																				
Vibration	3 mm (amplitude): less than 2- to 9 Hz, 9.8m/s <sup>2</sup> : less than 9 to 20 Hz 2m/s <sup>2</sup> : less than 20 to 55 Hz, 1m/s <sup>2</sup> : less than 55 to 200 Hz																				
Storage ambient temperature	-25 to +65 °C																				
Storage ambient humidity	5 to 95% RH (no dew condensation)																				
Mass	129 g																				

## ● DC Reactor

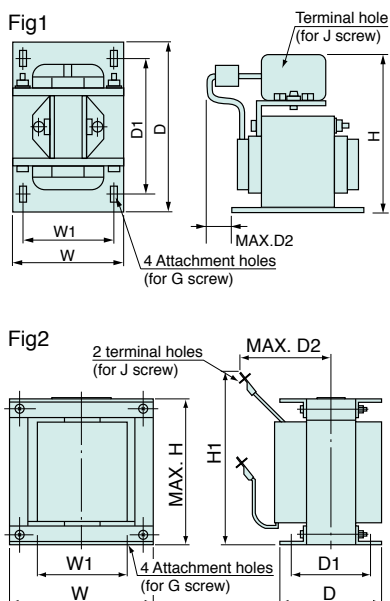







Power supply voltage	Nominal applied motor (kW)	AC Drive Type	Reactor Type	Dimensions (mm)								Mass (kg)	Fig
				W	W1	D	D1	D2	H	Mounting hole	Terminal screw		
Three-phase 200V	5.5	FRN5.5LM1S-2□	DCR2-5.5	111	95	100	80	20	130	7×11	M5	3.6	Fig1
	7.5	FRN7.5LM1S-2□	DCR2-7.5	111	95	100	80	23	130	7×11	M5	3.8	
	11	FRN11LM1S-2□	DCR2-11	111	95	100	80	24	137	7×11	M6	4.3	
	15	FRN15LM1S-2□	DCR2-15	146	124	120	96	15	171	7×11	M6	5.9	
	18.5	FRN18.5LM1S-2□	DCR2-18.5	146	124	120	96	25	180	7×11	M8	7.4	
	22	FRN22LM1S-2□	DCR2-22A	146	124	120	96	25	180	7×11	M8	7.5	
Three-phase 400V	4.0	FRN4.0LM1S-4□	DCR4-3.7	86	71	100	80	20	110	6×9	M4	2.6	Fig1
	5.5	FRN5.5LM1S-4□	DCR4-3.7	86	71	100	80	20	110	6×9	M4	2.6	
	7.5	FRN7.5LM1S-4□	DCR4-7.5	111	95	100	80	24	130	7×11	M5	4.2	
	11	FRN11LM1S-4□	DCR4-11	111	95	100	80	24	130	7×11	M5	4.3	
	15	FRN15LM1S-4□	DCR4-15	146	124	120	96	15	171	7×11	M5	5.9	
	18.5	FRN18.5LM1S-4□	DCR4-18.5	146	124	120	96	25	171	7×11	M6	7.2	
	22	FRN22LM1S-4□	DCR4-22A	146	124	120	96	25	171	7×11	M6	7.2	
	30	FRN30LM1S-4□	DCR4-30B	152	90	157	115	100	130	8	M8	13	
	37	FRN37LM1S-4□	DCR4-37B	171	110	150	110	100	150	8	M8	15	
Single-phase 200V	2.2	FRN2.2LM1S-7□	DCR2-2.2	86	71	100	80	10	110	6×9	M4	1.8	Fig1



# Options

## ● Option Card List

Option Type	Outline	Specifications	Motor
 <p>OPC-LM1-PP</p>	<p>•PG card for synchronous motor drive Parallel interface</p>	<p>Incremental signal: A-phase, B-phase Absolute position signal: Max. 4 bit PG power output: 5V ± 5% 300mA(Max.) Max. wiring length: 20m Max. input frequency: 100kHz Signal input method: Line receiver</p>	PMSM
 <p>OPC-LM1-PS</p>	<p>•PG card for synchronous motor drive Serial interface</p>	<p>Incremental signal: A-phase, B-phase (sine wave, 1Vpp) Absolute position signal: Serial interface EnDat 2.1 PG power output: 5V ± 5% 300mA(Max.) Max. wiring length: 20m Max. input frequency: 50kHz Applicable encoder: HEIDENHAIN, ECN1313 Signal input method: Line receiver</p>	PMSM
 <p>OPC-LM1-PS1</p>	<p>•PG card for synchronous motor drive Serial interface *With high performance function of unbalanced load compensation</p>	<p>Incremental signal: A-phase, B-phase (sine wave, 1Vpp) Absolute position signal: Serial interface EnDat 2.1 PG power output: 5V ± 5% 300mA(Max.) Max. wiring length: 20m Max. input frequency: 50kHz Applicable encoder: HEIDENHAIN, ECN1313 Signal input method: Line receiver</p>	PMSM
 <p>OPC-LM1-PR</p>	<p>•PG card for synchronous motor drive</p>	<p>Incremental signal: A-phase, B-phase (sine wave, 1Vpp) Absolute position signal: SIN/COS PG power output: 5V ± 5% 300mA(Max.) Max. wiring length: 20m Max. input frequency: 50kHz Applicable encoder: HEIDENHAIN, ERN1387 Signal input method: Line receiver</p>	PMSM
 <p>OPC-LM1-IL</p>	<p>•PG card The encoder of line receiver</p>	<p>Incremental signal: A-phase, B-phase, Z-Phase PG power output: 5V ± 5% 300mA(Max.) Max. wiring length: 20m Signal input method: Line receiver</p>	IM
 <p>OPC-LM1-ID</p>	<p>•Output of dividing frequency card This option outputs the signal which divides feedback pulse from encoder.</p>	<p>Division ratio: 1/1, 1/2, 1/4, 1/8, 1/16, 1/32, 1/64 Max. wiring length: 5m Max output frequency: 100kHz Signal output method: Open collector</p>	IM

## ● AC Drive Support Loader

Functionality: Operation monitoring, test operation, tracing (real-time and historical), function code editing, etc.  
 Supported operating systems: Windows 2000, Windows XP  
 Note: An RS232C/RS485 adapter or USB/RS485 adapter is required to connect the AC Drive to your computer.



# Options

## Option Card List

### Extension cable for remote operation (CB-□S)

This is a cable used for connection between the inverter main body and the remote touch panel or RS 485USB converter.

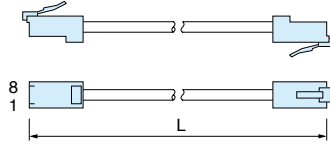

Connector shape: RJ-45

Option type	Length L (m)
CB-5S	5
CB-3S	3
CB-1S	1

### External cooling attachment (PB-F1-□□□)

This is an attachment for taking the cooling fin of the inverter out of the board. The Models of 37 kW or higher can accommodate even without an attachment by replacing the mounting leg.

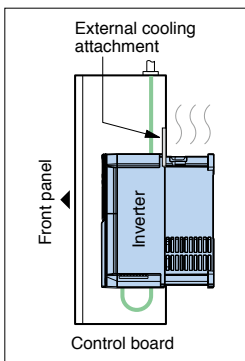

Option type	Applicable inverter type
PB-F1-5.5	FRN5.5LM1S-2□
	FRN5.5LM1S-4□
PB-F1-15	FRN7.5LM1S-2□
	FRN11LM1S-2□
	FRN15LM1S-2□
PB-F1-30	FRN7.5LM1S-4□
	FRN11LM1S-4□
	FRN15LM1S-4□
	FRN18.5LM1S-2□
PB-F1-30	FRN22LM1S-2□
	FRN18.5LM1S-4□
	FRN22LM1S-4□
	FRN30LM1S-4□

### Zero-phase reactor for radio noise reduction (ACL-40B, ACL-74B, F200160)

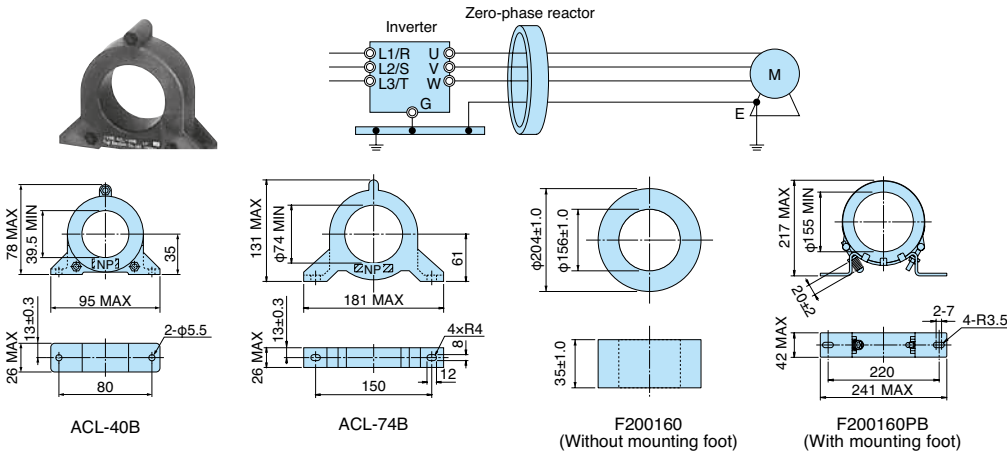

#### Applicable power supply size list

Type of zero-phase reactor for radio noise reduction	Number of pieces (pcs)	Number of turns (times)	Wire size [mm] Note
ACL-40B	1	4	2.0, 3.5, 5.5
	2	2	8, 14
ACL-74B	1	4	8, 14
	2	2	22, 38, 60, 5.5x2, 8x2, 14x2, 22x2
ACL-74B	4	1	100, 150, 200, 250, 38x2, 60x2, 100x2
	4	1	325, 150x2, 200x2, 250x2, 325x2, 150x3, 200x3, 250x3, 325x3, 250x4, 325x4

Note) Use the wire type of 600V HIV insulated wire (rated for 75°C)



— MEMO —

— MEMO —



## NOTES

### When running general-purpose motors

#### • Driving a 400V general-purpose motor

When driving a 400V general-purpose motor with an inverter using extremely long cables, damage to the insulation of the motor may occur. Use an output circuit filter (OFL) if necessary after checking with the motor manufacturer. Fuji's motors do not require the use of output circuit filters because of their reinforced insulation.

#### • Torque characteristics and temperature rise

When the inverter is used to run a general-purpose motor, the temperature of the motor becomes higher than when it is operated using a commercial power supply. In the low-speed range, the cooling effect will be weakened, so decrease the output torque of the motor. If constant torque is required in the low-speed range, use a Fuji inverter motor or a motor equipped with an externally powered ventilating fan.

#### • Vibration

When the motor is mounted to a machine, resonance may be caused by the natural frequencies, including that of the machine. Operation of a 2-pole motor at 60Hz or more may cause abnormal vibration.

\* Study use of tier coupling or dampening rubber.

\* It is also recommended to use the inverter jump frequencies control to avoid resonance points.

#### • Noise

When an inverter is used with a general-purpose motor, the motor noise level is higher than that with a commercial power supply. To reduce noise, raise carrier frequency of the inverter. High-speed operation at 60Hz or more can also result in more noise.

### When running special motors

#### • Explosion-proof motors

When driving an explosion-proof motor with an inverter, use a combination of a motor and an inverter that has been approved in advance.

#### • Brake motors

For motors equipped with parallel-connected brakes, their braking power must be supplied from the primary circuit (commercial power supply). If the brake power is connected to the inverter power output circuit (secondary circuit) by mistake, problems may occur.

Do not use inverters for driving motors equipped with series-connected brakes.

#### • Geared motors

If the power transmission mechanism uses an oil-lubricated gearbox or speed changer/reducer, then continuous motor operation at low speed may cause poor lubrication. Avoid such operation.

#### • Single-phase motors

Single-phase motors are not suitable for inverter-driven variable speed operation. Use three-phase motors.

### Environmental conditions

#### • Installation location

Use the inverter in a location with an ambient temperature range of -10 to 50°C.

The inverter and braking resistor surfaces become hot under certain operating conditions. Install the inverter on nonflammable material such as metal.

Ensure that the installation location meets the environmental conditions specified in "Environment" in inverter specifications.

### Combination with peripheral devices

#### • Installing a molded case circuit breaker (MCCB)

Install a recommended molded case circuit breaker (MCCB) or an earth leakage circuit breaker (ELCB) in the primary circuit of each inverter to protect the wiring. Ensure that the circuit breaker capacity is equivalent to or lower than the recommended capacity.

#### • Installing a magnetic contactor (MC) in the output (secondary) circuit

If a magnetic contactor (MC) is mounted in the inverter's secondary circuit for switching the motor to commercial power or for any other purpose, ensure that both the inverter and the motor are fully stopped before you turn the MC on or off. Remove the surge killer integrated with the MC.

#### • Installing a magnetic contactor (MC) in the input (primary) circuit

Do not turn the magnetic contactor (MC) in the primary circuit on or off more than once an hour as an inverter fault may result. If frequent starts or stops are required during motor operation, use FWD/REV signals.

#### • Protecting the motor

The electronic thermal facility of the inverter can protect the general-purpose motor. The operation level and the motor type (general-purpose motor, inverter motor) should be set. For high-speed motors or water-cooled motors, set a small value for the thermal time constant to protect the motor.

If you connect the motor thermal relay to the motor with a long cable, a high-frequency current may flow into the wiring stray capacitance. This may cause the relay to trip at a current lower than the set value for the thermal relay. If this happens, lower the carrier frequency or use the output circuit filter (OFL).

#### • Discontinuance of power-factor correcting capacitor

Do not mount power factor correcting capacitors in the inverter (primary) circuit. Use a DC reactor to improve the inverter power factor. Do not use power factor correcting capacitors in the inverter output circuit (secondary). An overcurrent trip will occur, disabling motor operation.

#### • Discontinuance of surge killer

Do not mount surge killers in the inverter output (secondary) circuit.

#### • Reducing noise

Use of a filter and shielded wires are typical measures against noise to ensure that EMC Directives are met.

#### • Measures against surge currents

If an overvoltage trip occurs while the inverter is stopped or operated under a light load, it is assumed that the surge current is generated by open/close of the phase-advancing capacitor in the power system.

We recommend connecting a DC REACTOR to the inverter.

#### • Megger test

When checking the insulation resistance of the inverter, use a 500V megger and follow the instructions contained in the Instruction Manual.

### Wiring

#### • Wiring distance of control circuit

When performing remote operation, use twisted shielded wire and limit the distance between the inverter and the control box to 20m.

#### • Wiring length between inverter and motor

If long wiring is used between the inverter and the motor, the inverter will overheat or trip as a result of overcurrent (high-frequency current flowing into the stray capacitance) in the wires connected to the phases. Ensure that the wiring is shorter than 50m. If this length must be exceeded, lower the carrier frequency or mount an output circuit filter (OFL).

When wiring is longer than 50m, and sensorless vector control or vector control with speed sensor is selected, execute off-line tuning.

#### • Wiring size

Select cables with a sufficient capacity by referring to the current value or recommended wire size.

#### • Wiring type

Do not use multicore cables that are normally used for connecting several inverters and motors.

#### • Grounding

Securely ground the inverter using the grounding terminal.

### Selecting inverter capacity

#### • Driving general-purpose motor

Select an inverter according to the applicable motor ratings listed in the standard specifications table for the inverter. When high starting torque is required or quick acceleration or deceleration is required, select an inverter with a capacity one size greater than the standard.

#### • Driving special motors

Select an inverter that meets the following condition: Inverter rated current > Motor rated current.

### Transportation and storage

When transporting or storing inverters, follow the procedures and select locations that meet the environmental conditions that agree with the inverter specifications.

## Fuji Electric India Pvt. Ltd.

(CIN:U31900TN1985PTCO11866)

119, 120, 120A, Electrical and Electronics Industrial Estate,  
Perungudi, Chennai - 600 096, Tamil Nadu, India

☎ +91 78100 09955

✉ enquiry.fei@fujielctric.com | info-fei@fujielctric.com

🌐 www.india.fujielctric.com



Scan QR code for  
Service support

Authorized Channel Partner

