

COMBIVERT

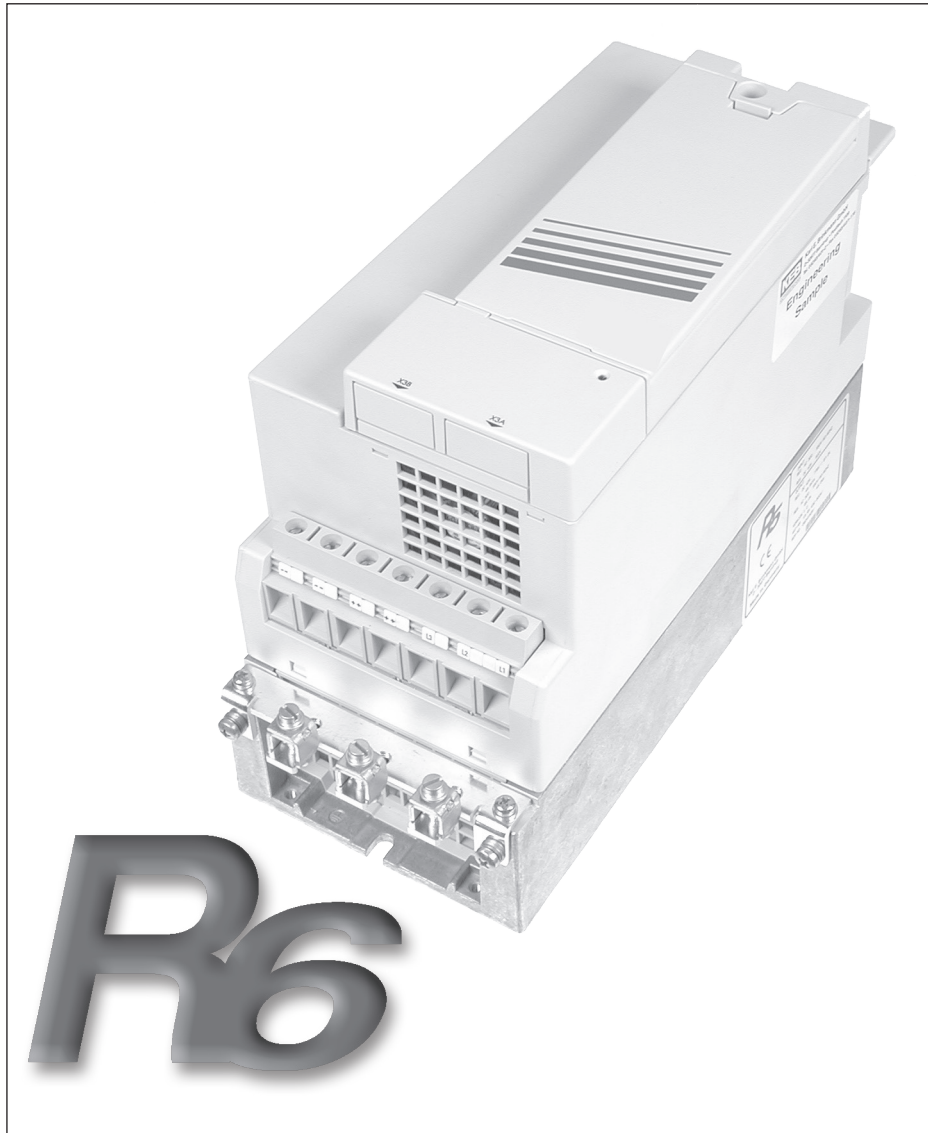

US INSTRUCTION MANUAL
Type R6-N

Power Supply and Regeneration Unit

Size 15/19
Version 1.0

Table of Contents

1. Introduction	4
1.1 Preface	4
1.2 Product description	4
1.3 Specified application	5
1.3.1 Standard operation	5
1.3.2 Abnormal operation	5
1.4 Unit identification	5
2. Safety Instructions	6
2.1 General instructions	6
2.2 Transport, storage and installation	6
2.3 Electrical connection	7
2.4 EMC instructions	10
2.5 EMC conforming installation	10
3. Technical Data	12
3.1 Power data	12
3.2 Operating Environment Specifications	13
3.3 Accessories	14
3.4 Options	14
3.5 Dimensions and weights	15
3.5.1 COMBIVERT R6-N	15
3.5.2 Regen Choke	15
3.5.3 Harmonic Filter	15
3.5.4 EMI sub-mount filter	16
3.5.5 Ferrite Rings	16
4. Installation	17
4.1 EMC-compatible control cabinet installation	17
4.2 Installation instructions	17
4.3 Connection of the R6	18
4.3.1 Connection terminals of the power circuit	18
4.3.2 Connection terminals of the input choke	18
4.4 Connection power circuit R6-N with internal fuses	19
4.4.1 Points for General Consideration	19
4.4.2.1 Wiring Scheme 'A' with Single Regen Unit and Commutation Choke	19
4.4.2.2 Wiring Scheme 'A' with Single Regen Unit and Harmonic Filter	19
4.4.3 Wiring Scheme 'A' with Parallel Regen Units and Commutation Chokes	20
4.4.4 Sizing for Wiring Scheme A	21
4.4.5 Sizing F5 DC Bus Capacitances	22
4.4.6 Wiring Scheme 'B' with Single Regen Unit	23
4.4.7 Wiring Scheme 'B' with Parallel Regen Units	23
4.4.8 Sizing for Wiring Scheme 'B'	23
4.4.9 Manual Motor Starter (MMS) for Capacitor Assembly with Harmonic Filter	24
4.5 Control connections	25
4.5.1 Assignment of the control terminal strip X2A	25
4.5.2 Assignment of RJ45 Socket X2D	25
4.5.3 Wiring example	26
4.6 Operator	27
5. Operation of the Unit	28
5.1 Keyboard	28
5.2 Operation with PC and programming software COMBIVIS	28
5.3 Turn-on and operation procedure	29
5.4 Parameter summary	30
5.5 Parameter description	31
6. Diagnosis and Troubleshooting	35

6.1 Status Display: Status and Error Messages.....	35
6.1.1 Status Messages	35
6.1.2 Error Messages.....	35
6.2 Troubleshooting.....	36
6.2.1 Troubleshooting Error Messages.....	36
6.2.2 Troubleshooting Operational Problems	39
A.1 Data Logging	40
A.2 UPS Wiring Example.....	42
A.2.1 Application Note - Using UPS (Uninterrupted Power Supply) with R6 in Wiring Scheme A.....	42
B.1 Certification	43
B.1.1 CE Marking.....	43
B.1.2 UL Marking	43
B.1.3 CSA Marking	43
QUICK PARAMETER LIST.....	45
Replacing the DC Bus Fuses	46

1. Introduction

1.1 Preface

First we would like to welcome you as a customer of KEB and congratulate you on the purchase of this product. You have decided on a product of the highest technical innovation.

The enclosed documents as well as the specified hardware and software are developments of KEB. KEB has created these documents, hardware and software and they are to the best of KEB's knowledge error free. KEB reserves the right to change specifications without prior notice. This statement is not exclusive.

The icons used throughout this document have following significance:



Danger
Caution
Discharge Time



Pay Attention
Important
Warning



Information
Help
Tip

1.2 Product description

This instruction manual describes the power supply and recovery unit KEB R6-N. The R6-N has the following technical features.

As a supply unit

- converts a three-phase input voltage into DC voltage.
- supplies a single KEB frequency inverter or multiple units via DC interconnection.
- can be connected in parallel, if higher supply power is required.
- increases the stability of the DC Bus voltage in shared DC Bus applications.

As a regeneration unit

- returns the excess energy from generating operation (i.e. overhauling load) to the utility supply system.
- reduces the net energy demand.
- reduces the heat dissipation.
- is environmentally friendly.
- replaces braking resistor and braking transistor.
- is cost saving and space saving.

The R6-N is generally protected against over current, ground fault and high temperature. Appropriately dimensioned DC fuses protect the DC Bus circuit against short-circuit. The following accessories are necessary for operation with the R6-N:

- Commutation Choke
- HF filter (for observance of European EMC standard)

1.3 Specified application

The R6-N serves exclusively for the supply of frequency inverters with DC input and/or regeneration of excess energy into the line supply system. The operation of other electrical loads is prohibited and can lead to malfunctions or destruction of the unit.

1.3.1 Standard operation

If the DC Bus voltage increases to a value above the peak value of the line voltage (negative power), regeneration of the current to the line occurs automatically. The line voltage is measured by the R6 unit. Regeneration occurs in a square-wave format, whereby the current flow period corresponds to the line frequency and the normal conduction times of a standard 6 pulse bridge rectifier circuit. Regeneration stops if the DC bus voltage decreases below the line supply peak voltage (positive power).

1.3.2 Abnormal operation

When exceeding the permissible limit values for voltage, current, or temperature the current flow between DC link and the line is blocked during regeneration. An appropriate error message is also displayed. When acting as a supply, the unit must be disconnected from the supply system in case of over current, as current flow can not be limited by the unit itself in when in this mode of operation.

With factory settings, the modulation is switched off in case of a line phase loss and the error message E.nEt is displayed.

Special adjustments from KEB are necessary if the modulation and/or the standard operation should start again within a defined time in case of return of power supply.

1.4 Unit identification

19	R6	N	3	E	R	0	0	A	
					Type	A: Heat sink (standard) B: Flat Heatsink			
					Design	0: default			
					reserved	0: default K: Kit (High speed class J fuses, choke, fuse holder)			
					Voltage	R: 3-ph.; 180...550V; AC			
					Housing	E			
					Options	0: without pre-charging 1: pre-charging		3: Pre-charging, DC-fuses	
					Control	N: 1N.R6 (NCM)			
					Series	R6			
					Unit size	15,19			

Safety Instructions

2. Safety Instructions

2.1 General instructions

 <p>CAUTION - Risk of Electrical Shock</p>	<p>The R6 power supply and recovery unit contains dangerous voltages which can cause death or serious injury.</p> <p>The R6 can be adjusted such that energy is returned to the line supply system even in case of power failure during generator operation. Therefore dangerous high voltage can exist in the unit even after disconnection from the line supply system.</p> <p>Before working with the unit always verify the voltage has dropped to a safe value by measuring both the DC bus voltage (50VDC) and the AC line voltage at the R6 unit.</p> <p>Care should be taken to ensure correct and safe operation and to minimise risk to personnel and equipment.</p>
--	---

 <p>Only Qualified Electrical Personnel</p>	<p>All work from the transport, to installation and start-up as well as maintenance may only be done by qualified personnel (IEC 364 and/or CENELEC HD 384 and IEC-Report 664 and note national safety regulations). According to this manual qualified personnel means those who are able to recognise and judge the possible dangers based on their technical training and experience as well as those with knowledge of the relevant standards and who are familiar with the field of power transmission or conversion.</p>
---	--

 <p>Observe Standards</p>	<p>The R6 must not be started until it is determined that the installation complies with 89/392/EEC (machine directive) as well as the EMC-directive (89/336/EEC)(note EN60204), the US - NEC, and the OSHA machine safety code.</p> <p>The R6 meets the requirements of the Low-Voltage Directive 73/231/EEC. The harmonized standard of the series EN 61800-5-1 (VDE 0160) is used.</p> <p>This is a product of limited interference susceptibility in accordance with IEC 61800-3. This product may cause radio interference in residential areas. In this case the installer/operator may need to take corresponding measures.</p>
---	--







2.2 Transport, storage and installation

The storage and transport of the R6 must be done in the original packing. It is to be protected against humidity and excessive cooling and thermal effects. Long-distance transportation must be carried out in the original packing. It is to be secured against physical impact and shock during transport. Verify the packaging for signs of mishandling before removal from the packaging. Contact the shipper in case of damage. After removing the final packing, the R6 must be mounted on a stable mounting base.



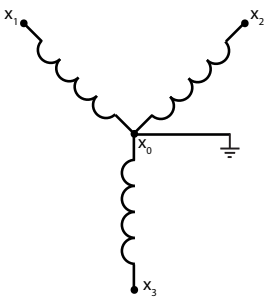

 <p>Protect Against Accidental Contact</p>	<p>The R6 must be protected against abnormal operation. Components and covers must not be bent or moved as this may affect insulation distances. The units contain electrostatically endangered components which can be destroyed by inappropriate handling. For that reason the contact of electronic components and circuit boards is to be avoided. The equipment must not be switched on if it is damaged as it may no longer comply with mandatory standards. Make sure during installation there is at least the minimum clearance and enough cooling. Climate conditions must be observed in accordance with this instruction manual.</p>
--	--



 <p>Hot Surface</p>	<p>Heatsinks can reach high temperatures, which can cause burns when touched. A warning notice "hot surface" must be mounted on the machine control panel if direct physical contact with the heatsink can not be avoided.</p>
---	--

2.3 Electrical connection

 <p>Note Capacitor Discharge Time</p>	<p>Before any installation and connection work, the system must be switched off and secured. After switch off, the intermediate circuit capacitors are still charged with high voltage for a short period of time. The unit can be worked on after it has been switched off for 5 minutes.</p>
 <p>Secure Isolation</p>	<p>The terminals of the control terminal strip are securely isolated in accordance with EN 61800-5-1. With existing or newly wired circuits the person installing the units or machines must ensure the EN requirements are met. When used together with frequency inverters that are not isolated from the supply circuit, all control lines must be secured by other protective measures (e.g. double insulation or shielded, earthed and insulated).</p>
 <p>Voltage With Respect To Ground</p>	<p>Connection of the R6 is only permissible on symmetrical networks with a maximum line voltage (L1, L2, L3) with respect to ground (N/GND) of 317V. An isolating transformer must be used for networks which exceed this value! The unit may be damaged if this is not observed.</p>
 <p>Mains Voltage Tolerance</p>	<p>The incoming mains voltage must remain constant with a tolerance of +/- 10% of the incoming voltage.</p>
 <p>Grounded Delta Supply</p>	<p>Connection of the R6 series inverters to voltage systems configured as a corner grounded delta, center tap grounded delta, open delta, or ungrounded delta may defeat the internal noise suppression of the inverter. Increased high frequency disturbance in the controller and on the line may be experienced. A balanced, neutral grounded wye connection is required. The three phase voltage imbalance must be less than 2% phase-to-phase. Greater imbalance can lead to damage of the inverter's power circuit. It is acceptable to use a transformer with a WYE connection on the secondary.</p> <p>Example of a center grounded wye transformer:</p> 
 <p>Only Fixed Connection</p>	<p>The R6 is designed for fixed connection only as high frequency ground leakage currents of > 3.5 mA may occur especially when using EMI filters. It is therefore necessary to use a ground conductor with a section of at least a #4 AWG (16mm²) copper conductor or a second ground conductor in compliance with EN 61800-5-1. Ground point-to-point with the shortest connection possible to the main ground point in the system (avoid ground loops).</p>
 <p>Insulation Measurement</p>	<p>When doing a high voltage insulation measurement in accordance with VDE 0100 / Part 620, the power semiconductor of the unit and existing radio interference filters must be disconnected because of the danger of destruction. This is permissible in compliance with the standard, since all units are given a high voltage test during the quality testing at KEB in accordance with EN 50178.</p>

Safety Instructions

 <p>Different Ground Potentials</p>	<p>When using components without isolated inputs / outputs, it is necessary that equal potential bonding exist between the components to be connected (e.g. through the equalizer). Disregard can cause destruction of the components by the equalizing currents.</p>
 <p>Fuse Sizing with Isolation Transformer</p>	<p>When the R6 unit is supplied through an isolation transformer, the maximum allowable fuse size is dictated by the size of the transformer as defined in the National Electric Code (NFPA-70 or CSA 22.1). As per Article 450-3(B) of NFPA-70 (similar statements can be found in CSA 22.1), the max fuse size is defined in table 450.3(B) with a rating not greater than 125% of the rated secondary current. In the case of multiple secondaries, it is the rated value of the winding which the unit is supplied from. In this case it is to be assumed that the end customer will fuse the transformer primary side with fuses exceeding 125% of transformer rated input current. The value of this secondary fuse may be less than the max fuse value listed in the technical data section 3.1 of this manual. The fusing of the transformer supercedes the fuse rating of the unit because the value required for the transformer is lower than the max value with which the unit was tested.</p>
 <p>Prevent Disturbances</p>	<p>Trouble-free and safe operation of the R6 is only guaranteed when the connection instructions below are strictly followed. Incorrect operation or damage may result from incorrect installation.</p> <ul style="list-style-type: none">• Pay attention to the line supply voltage.• Supply connection must be a symmetrical, center-grounded wye.• Install power cables and control cables separately (>6.0 inches (15 cm) separation).• Use shielded / twisted control lines. Connect the shield at one end to the R6-N GND terminal!• Only use suitable circuit elements to control the logic and analog inputs, whose contacts are rated for extra-low voltages.• The heatsink of the R6 must be well grounded. Shields of large power cables must be directly and securely attached to both the inverter GND terminal and the motor ground terminal. Remove paint finish where necessary.• Ground the cabinet or the system with the shortest connection to the main ground point (avoid ground loops)• Use exclusively the regen choke or harmonic filter specified by KEB.• The average value of the supplied DC current may not exceed the maximum DC current.• If several frequency inverters are connected to the R6, the maximum permissible DC bus capacities of all connected frequency inverters must be considered during supply operation (see technical data).• A ferrite ring must be installed over both + and - DC bus connections to the R6 unit to limit common mode noise on the DC bus.
 <p>Automatic Restart</p>	<p>The R6 can be adjusted in such a way that the unit will restart automatically after an error (e.g. single phase brown out or loss). System design must take this into account. If appropriate, additional monitoring or protective features should be added where necessary.</p>
 <p>Not Short-Circuit Proof (Supply)</p>	<p>The R6 is not short-circuit proof as a power supply input! If the I2t - protection is adapted with a class gR fuse, a conditional protection at supply input is possible. If necessary the short-circuit protection at DC output is ensured by internal class aR fuse.</p>

 <p>Conditionally Short-Circuit Proof (Regen)</p>	<p>The R6 is conditionally short-circuit proof (EN61800-5-1 / VDE 0160). After resetting the internal protection devices, the function as directed is guaranteed.</p> <p>Exception:</p> <ul style="list-style-type: none"> • A ground fault or short-circuit frequently occurring at the output, can lead to damage to the unit.
 <p>Cyclic Turn On and Turn Off</p>	<p>With applications requiring the R6 to be switched on and off cyclically, maintain an off-time of at least 5 min. If you require shorter cycle times please contact KEB.</p>
 <p>GFI (Ground Fault Interrupt Circuit-Breaker)</p>	<p>If personnel protection of the system against ground fault is required, the R6-N must be protected according to EN61800-5-1:</p> <ul style="list-style-type: none"> • 3-phase inverters (with B6 bridge-connected rectifier) by RCMA's with separation (use privileged) or RCD's type B (all-current sensitive GFI's) <p>The tripping current should be 300mA or more, in order to avoid a premature triggering by leakage currents (about 200mA. Dependent on the load, the length of the motor cable and the use of a radio interference filter, substantially higher leakage current can occur). The connection instructions from the manufacturer and the valid local requirements must be observed.</p> <p>Dependent on the available supply type (TN, IT, TT) further protective measures are necessary in accordance with VDE Part 410 4(Part4; Chapter 41).</p> <p>For example, with TN-mains this protection is made with over current protective devices, with IT-mains it is insulation monitoring with a pulse-code measuring method. A protective separation can be used with all mains forms as long as the required power and cable lengths permit this.</p> <p>The person setting up the unit must present proof of compatibility before installing the converter!</p>

2.4 EMC instructions

The R6-N represents electrical equipment designed for use in industrial and commercial installations. In accordance with the EMC directive 89/336/EEC, it is not mandatory to mark these devices as they represent components to be further handled by the respective machine and system manufacturer and are not operable independently according to the EMC directive. The person installing / operating the machine / system is obliged to prove the protective measures demanded by the EMC directive are complied with. The prescribed ratings can usually be complied with when using the radio interference voltage filters as specified by KEB, and when observing the following measures and installation guidelines.

2.5 EMC conforming installation

The R6 is designed to be used in a second environment as defined in EN 61800-3 (unit with its own supply transformer). Take additional measures when using it in the first environment (residential and commercial area connected to public low-voltage line)!

- Install the control cabinet or system in an appropriate and correct manner (see chapter "control cabinet installation")
- To avoid coupled noise, separate during installation high voltage supply lines, motor lines, control and data lines (low-voltage level < 48V) and leave a space of at least 6.0 inches, 15 cm between them.
- In order to maintain low-resistance high frequency connections, grounding and shielding, as well as other metallic connections (e.g. mounting plate, installed units) must be made with bare metal to metal contact with the mounting plate, over as large a surface area as possible. Use ground conductors with a section as large as possible, minimum #4 AWG (16mm²) or use thick ground straps.
- Only use shielded cable with copper or tin-plated braid, since steel braid is not suitable for high frequency ranges. The shield must always be connected to the ground bare on the unit or fastened with clamps to the bare metal of the sub mounting plate. Do not connect the shield using the drain wires alone, this reduces the effectiveness of the shield by 70%!
- If external interference suppression filters are used, then these must be installed as close as possible <12 inches (30 cm) to the interference source and must be in metal to metal contact with the sub mounting plate, over as large a surface area as possible.
- Always equip inductive control elements (contactors, relays etc.) with suppressors such as varistors, RC-elements or diodes.

All connections must be kept as short as possible and as close as possible to the ground plane. Free floating cables act as active and passive antenna.

- Keep connection cables straight (do not loop). Tie all spare unassigned wires at one end to the ground.
- The twisted pair cables should be used when the conductors are not shielded in order to dampen common-mode noise.
- Further information can be found on the internet, see "www.kebamerica.com".

2.6 Storage of the Unit

The DC bus of the KEB R6 is equipped with electrolytic capacitors. If the electrolytic capacitors are stored de-energized, the oxide film working as dielectric fluid reacts with the acidic electrolyte and destroys itself slowly. This affects the dielectric strength and capacity of the unit. If the capacitors start running with rated voltage again, the oxide film tries to build up quickly. This causes heat and gas and leads to the destruction of the capacitors.

In order to avoid failures, the KEB R6 must be started up according to the following specification based on duration of storage period (powered off):

Storage Period < 1 Year			
*	Start up normally, without any additional precautions		
Storage Period 1...2 Years			
*	Power on frequency inverter for one hour without modulation		
Storage Period 2...3 Years			
*	Remove all cables from power circuit		
*	Open control release		
*	Connect variable voltage supply to inverter input		
*	Increase voltage slowly to indicated input level and remain at for the specified time.		
	Voltage Class	Input Voltage	Minimum Time
	230V	0...160V	15 min
		160...220V	15 min
		220...260V	1 h
	460V	0...280V	15 min
		280...400V	15 min
		400...500V	1 h
Storage Period > 3 Years			
*	Input voltages same as above, however double the amount of time for each additional year. Eventually consider changing capacitors.		

Technical Data

3. Technical Data

3.1 Power data

Unit size		15	19
Housing size		E	
Phases		3	
Rated voltage	*) [V]	208/240/480	
Supply voltage	1) [V]	180...528 ±0 %	
Line frequency	[Hz]	50 / 60 ±2	
Regenerative operation			
Output rated power	*) [kVA]	18 (10.5)	45 (26)
Rated active power	*) [kW]	17 (10)	42 (23)
Max. power output	*) [kVA]	27 (15.5)	67.5 (39)
Max. active power	*) [kW]	25.5 (15)	63 (34.5)
Regenerative rated current	[A _{AC}]	26	65
Regenerative DC current	[A _{DC}]	32	80
Over load current (E.OL) 60 s	2) [A _{AC}]	39	97.5
Max. regenerative DC current 60 s	[A _{DC}]	48	120
Power supply operation			
Output rated power	*) [kVA]	18 (10.5)	48.5 (28)
Rated active power	*) [kW]	16 (10)	44.5 (25.5)
Max. power output	*) [kVA]	27 (15.5)	72.5 (42)
Max. active power	*) [kW]	24 (14.5)	67 (38)
Rated supply current	3) [A _{AC}]	26	70
DC supply current	[A _{DC}]	32	87 ⁴⁾
Over load current (E.OL)	[A _{AC}]	39	105
Max. DC supply current	[A _{DC}]	48	130
OC-tripping current	[A _{AC}]	42	112
DC output voltage	*) [V _{DC}]	180...680	
Max. permissible DC bus capacitance	*) [μF]	10,000 (55,000)	10,000 (55,000)
Max. permissible line fuse UL 248 Class J ⁶⁾	[A]	50	90
External DC Fuses: Siemens		Type Sitor 3NE8-717-1, rated 690Vac/700Vdc, 50A	Type Sitor 3NE8-722-1, rated 690Vac/700Vdc, 125A
Alternate external DC fuse: Bussmann		Type 170M1364-1	Type 170M1368-1
Short Circuit Current Rating (SCCR)	[kA]	10	10
I ² t Peak current ratings of the semiconductor	[A ² s]	1200	4500
AC semi-conductor fuse class aR Siemens Sitor		3NC2240	3NC2200
Supply conductor cross section (min for terminal)	[AWG]	#18 (0.5mm ²)	#14 (1.5mm ²)
Supply conductor section (max)	[AWG]	#6 (10mm ²)	#3 (25mm ²)
DC conductor cross section (min for terminal)	[AWG]	#18 (0.5mm ²)	#14 (1.5mm ²)
DC conductor cross section (max)	[AWG]	#6 (10mm ²)	#3 (25mm ²)
Power loss at nominal operation	[W]	200	470
Max. heat sink temperature	[°C]	70	88

*) Use bracketed values for operation at 230 V.

1) The supply voltage must be a center grounded wye connection with +/-10% mains voltage tolerance

2) The over load time is specified for 1 minute. The overload period is 300 seconds. This corresponds to duty class 2 EN 60146-1-1.

3) The current ratings are based on a displacement power factor of g=0.95. The displacement power factor or the effective value of the input current is dependent on load and line supply conditions. With uncontrolled diode bridge rectifiers, the power factor can be set to 1.0, so the value of the fundamental frequency components is equal to the value of the displacement power factor.

4) For installations according to the UL 508C standard and DC supply currents > 85A, the DC bus connection must use both ++ and -- terminals with a second parallel conductor.

5) The wire gauge is based on the maximum fuse rating, copper wire with a 75°C insulation rating, THHW or equivalent. If branch circuit protection is selected based on the continuous current below the rated value, the wire size could be reduced.

6) For installations with isolation transformers, follow fuse sizing guidelines of NEC NFPA-70. Fuse size may be lower than the fuse rating of the unit. The fusing of the transformer supercedes the fuse rating of the unit. See page 8 for further details.

 The units are not short circuit proof without correctly dimensioned fuses

 Exceeding the maximum DC bus capacitance can lead to failure.

 A load disconnection in the DC bus circuit may only occur after the operating status „Standby" is achieved.

3.2 Operating Environment Specifications

		Standard	Classification	Specifications
Definition According To		EN 61800-2		Inverter Product Standard: Measurement specs.
		EN 61800-5-1		Inverter Product Standard: General Safety
Operating Altitude				2000m above sea level with 1% power derating per 100m above 1000m
Specifications During Operation				
Environment	Temperature	60721-3-3	3K3	Range -10C ...45 °C (from 45°C to max. 55°C a power derating of 5% per 1°C can be applied.)
	Humidity		3K3	5...85% (no condensation)
Mechanical	Vibration	Railroad	EN50155	Max. oscillation amplitude 1 mm (5...13 Hz) max. accel. amplitude 7 m/s ² (13...200 Hz), sinewave
		Germ.Loyd	Part 7-3	
	Shock	EN60721-3-3	3M1	max. 50m/s ² ; 30msec; half sinewave
Contamination		Gas	3C2	
		Particle	3S2	
Specifications During Transport				
Environment	Temperature	60721-3-2	2K3	Range -25 ...70 °C
	Humidity		2K3	(no condensation)
Mechanical	Vibration	Railroad	EN50155	Max. oscillation amplitude 3.5 mm (2...9 Hz) max. acceleration amplitude 15 m/s ² (9...200 Hz), sinewave
		Germ.Loyd	Part 7-3	
		EN60721-3-3	2M1	
	Shock	EN60721-3-3	2M1	max. 100m/s ² ; 11msec; half sinewave
Contamination		Gas	2C2	
		Particle	2S2	
Specifications During Storage				
Environment	Temperature	60721-3-2	1K4	Range -25 ...70 °C
	Humidity		1K3	(no condensation)
Mechanical	Vibration	Railroad	EN50155	Max. oscillation amplitude 1 mm (5...13 Hz) max. acceleration amplitude 7 m/s ² (13...200 Hz), sinewave
		Germ.Loyd	Part 7-3	
		EN60721-3-3	1M1	
	Shock	EN60721-3-3	1M1	max. 100m/s ² ; 11msec; half sinewave
Contamination		Gas	1C2	
		Particle	1S2	
Construction / protection		EN60529	IP20	Chassis
Environment Class		IEC 664-1		Pollution degree 2
Definition According To		EN 61800-3		Inverter Product Standard: EMI
EMI disturbance creation (See instruction manual)				
Conducted disturbance		EN 55011	C3	Level A (Level B optional)
Radiated disturbance		EN55011	C3	Level A
EMI Susceptibility				
ESD		EN 61000-4-2	8kV	AD (air charge) and CD (contact charge)
Burst - Control wires and bus com.		EN 61000-4-4	2kV	
Burst - Line supply		EN 61000-4-4	4kV	
Surge - Line supply		EN 61000-4-5	1 / 2kV	Phase to phase / Phase to ground
EMF		EN6100-4-3	10 V/m	
Line supply fluctuations; collapse		EN 61000-2-1		+10 %, -15 %; 90 %
Line voltage symmetry / line frequency variation		EN 61000-2-4		3% / 2%

i Installation altitude maximum 6,562 ft (2000m). With installation altitudes over 3280 ft (1000m) a de-rating of 1% per 328 ft must be taken into consideration.

Technical Data

3.3 Accessories

Unit size	15	19
Rated voltage	480V (can also be used at 230V)	
Regen choke	14.Z1.B04-1000 15.Z1.B04-1000	16.Z1.B04-1000 17.Z1.B04-1000 18.Z1.B04-1000 19.Z1.B04-1000 20.Z1.B04-1000
Synchronization Cable*	00.F5.0C3-4010	

* Synchronization cables are only required to connect parallel regenerative units. They are not needed for single regen applications. Refer to section 4.4.3 for drawing.

3.4 Options

Unit size	15	19
Line EMI filter	15.R6.T60-1001 according to EN55011 class A	19.R6.T60-1001 according to EN55011 class A
Ferrite Rings	See section 3.5.4	
Internal DC fuses	600V / 50A (part number 00.90.25H-3459)	600V / 125A (part number 00.90.25H-3559)
Operators	Digital operator, Serial Interface operator	
Bus operators	CAN, ProfiBus, InterBus, Ethercat, Ethernet, Sercos, ModBus, Devicenet, HSP5	
Harmonic Filter (Sizing Based on Input Current and Line Voltage)	<u>230/208V</u> 13.Z1.C03-1001 14.Z1.C03-1001 15.Z1.C03-1001 16.Z1.C03-1001 17.Z1.C03-1001 18.Z1.C03-1001 19.Z1.C03-1001	<u>460V</u> 16.Z1.C05-1001 17.Z1.C05-1001 18.Z1.C05-1001 19.Z1.C05-1001 20.Z1.C05-1001 21.Z1.C05-1001 22.Z1.C05-1001 23.Z1.C05-1001
Line Regen Kits with Regen Unit, Commutation Choke, Fuses, and Fuse Holder	15.R6.N3E-RK0A	16.R6.N3E-RK0A 17.R6.N3E-RK0A 18.R6.N3E-RK0A 19.R6.N3E-RK0A 20.R6.N3E-RK0A <u>Parallel Units</u> 21.R6.N3E-RK0A 22.R6.N3E-RK0A 23.R6.N3E-RK0A 24.R6.N3E-RK0A

3.5 Dimensions and weights

3.5.1 COMBIVERT R6-N

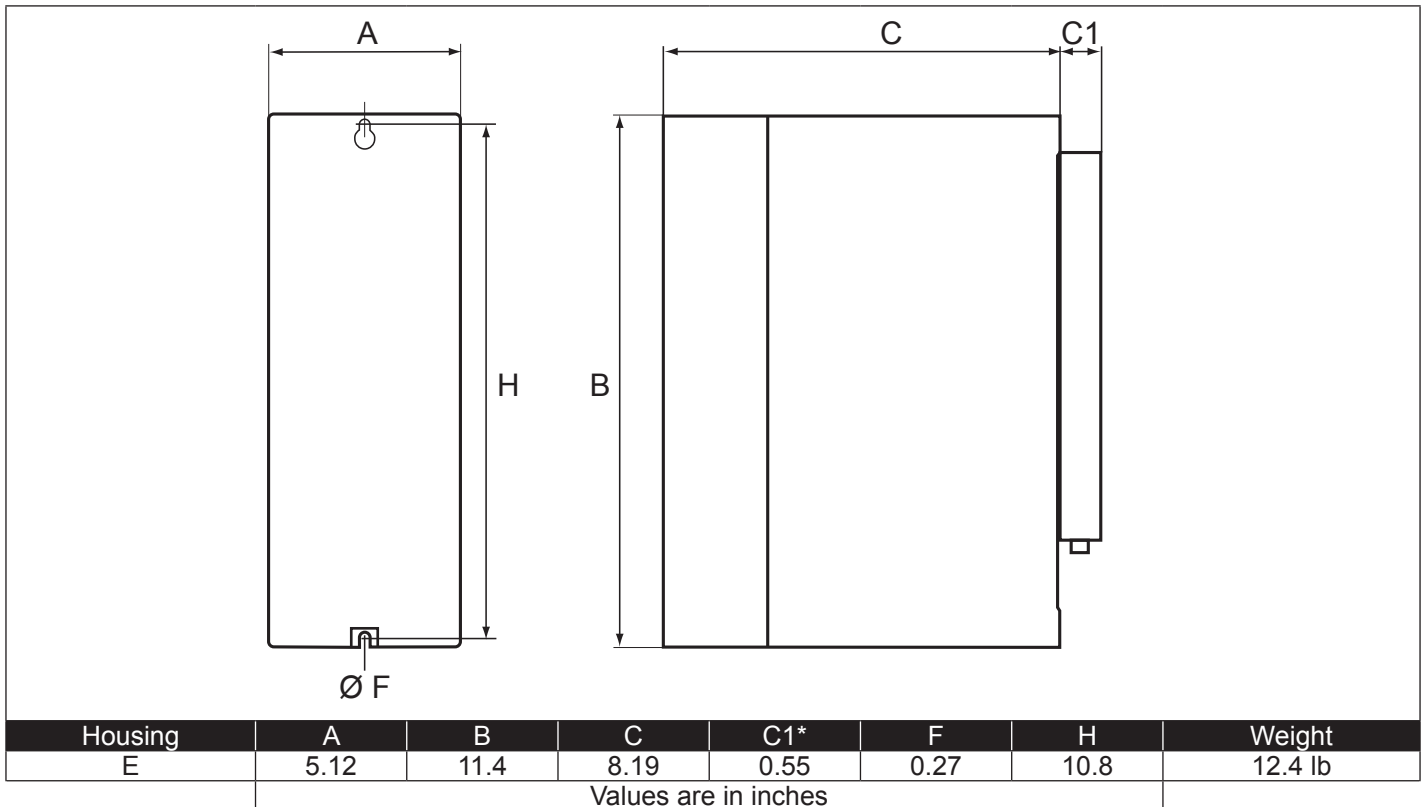

*C1 with operator

3.5.2 Regen Choke

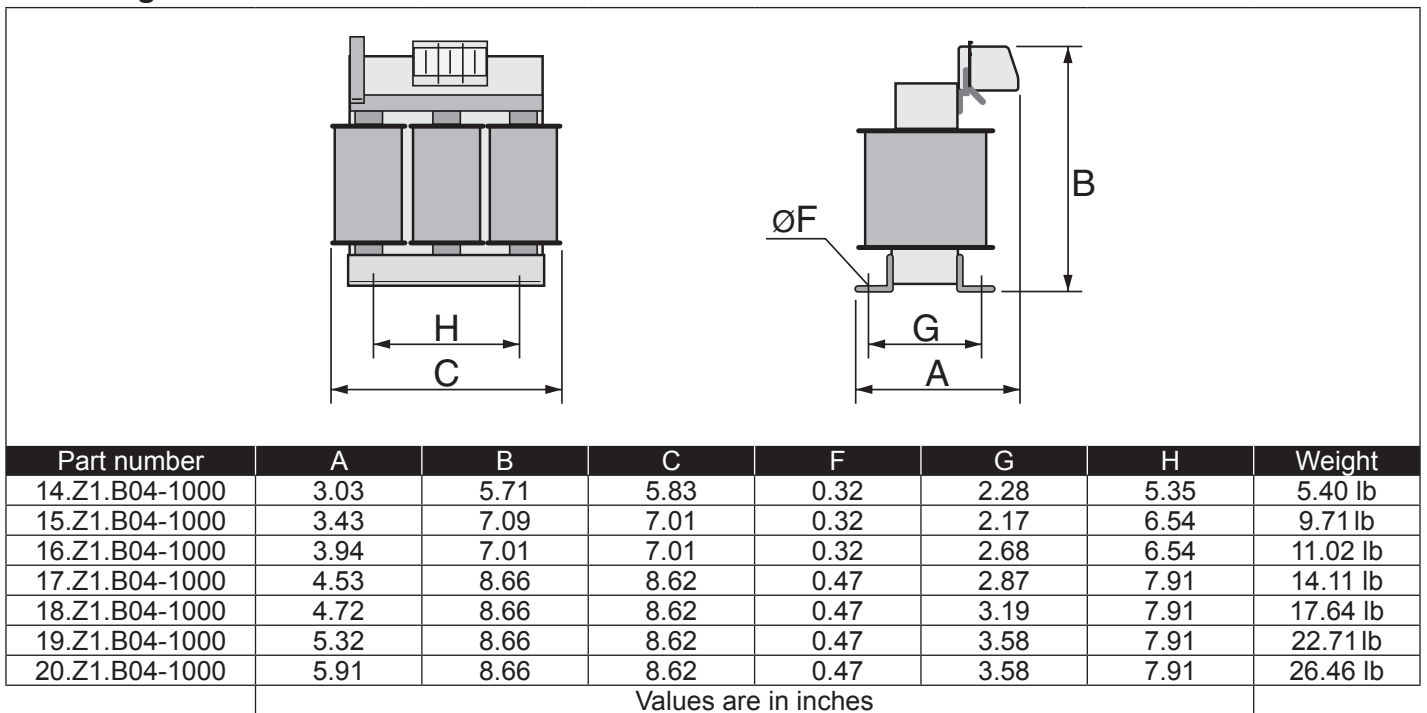

3.5.3 Harmonic Filter

See manual, part number 00.U0.HU0-K081

Technical Data

3.5.4 EMI sub-mount filter

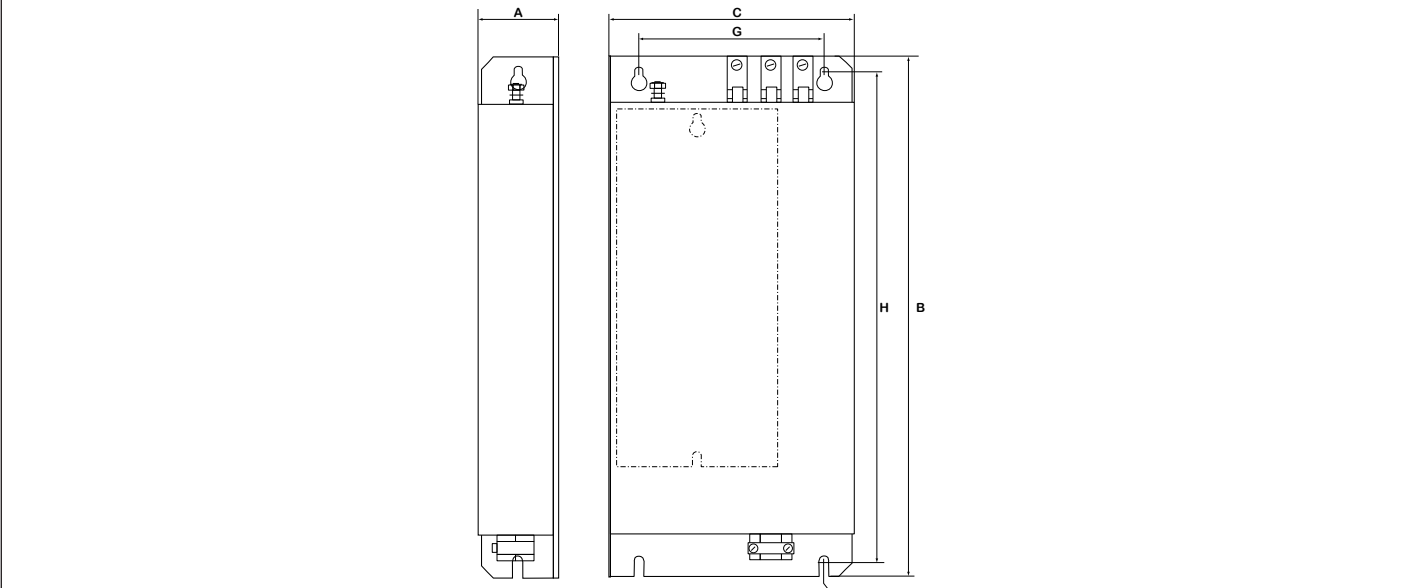

The drawing shows two views of the EMI sub-mount filter. The left view is a side profile showing a vertical rectangular component with a mounting bracket at the top and bottom. Dimension A indicates the width of the top section, and dimension B indicates the total height. The right view is a front view showing a rectangular frame with internal components. Dimension C is the width of the top section, G is the width of the central section, F is the thickness of the top section, and H is the height of the main body. A dimension line labeled 'ØF' points to a hole in the bottom right corner.

Part number	A	B	C	F	G	H	Weight
15.E4.T60-1000	1.97	13.9	5.14	0.28	3.94	13.0	4.4 lb
19.R6.T60-1001	2.56	16.6	7.80	0.28	5.91	15.6	16.8 lb

Values are in inches

3.5.5 Ferrite Rings

Ferrite rings are required to minimize electrical disturbances on the DC bus connections between the inverter(s) and the COMBIVERT R6 unit. The ferrite rings are to be installed over both the ++ and -- DC bus conductors. Do not use ferrite rings intended for the inverter(s)' motor leads on the DC bus as doing so negates the effect. Do not pass ground conductors through the ferrite rings. The ferrite rings are selected based on the size of the conductor and the inner diameter of the ring.

Part Number	Overall dimensions in mm	Opening cross section in mm
0090390-K000	R56/32/18	29.5

4. Installation

4.1 EMC-compatible control cabinet installation

1	Line fuse
2	Line contactor
3	Harmonic filter
4	R6
5	HF sub-mounting filter
6	Choke
7	Frequency inverter
8	If necessary, external DC fuses
9	Motor cables
10a	Protective ground on the sub mounting plate power circuit
10b	Protective ground on the mounting plate control circuit
10c	Equal potential bonding with the housing earth
11	Line connection power circuit
11 A	Line connection control circuit
12	Control circuit conductors
	Large area contact on the sub mount plate

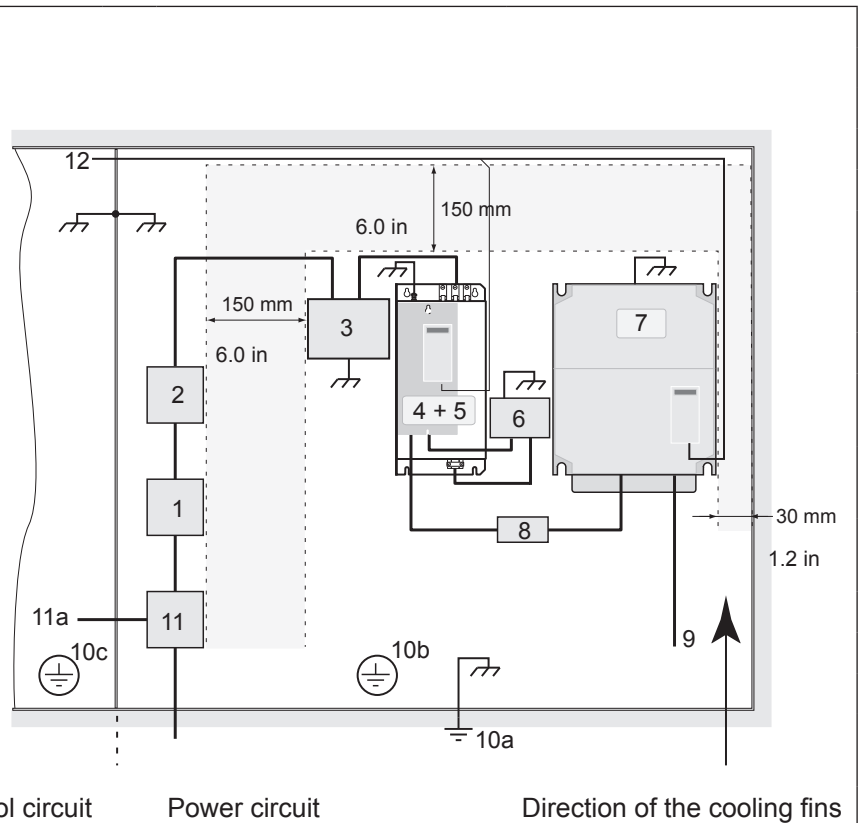

4.2 Installation instructions



- Install and ground the R6-N on a stationary system.
- Mist, water, or other liquids and vapors must not be allowed to permeate the device.
- Allow for sufficient heat dissipation if installed in a dust-proof housing.
- When operating the R6-N in an explosion proof environment, install the unit in an appropriate enclosure in accordance with the local regulations and codes.
- Protect the R6-N against conductive and aggressive gases and liquids.
- The conductors to the commutation choke must be limited to 39 inches (1m).

Connection Terminals

4.3 Connection of the R6

4.3.1 Connection terminals of the power circuit



Pay attention to the input voltage, since both 230V and 480V are possible!

Housing Size E		Tightening torque [Nm]	
Name	Function	Permissible line cross section [awg]	Size
	L12	3-phase supply input from the commutation choke	15
	L22		2
	L32		4
++	DC voltage input with in rush current limiting	#8	Size
			19
--			2
			4
	GND,	-	1.3 for philps. screws
			6 for cable clamps

4.3.2 Connection terminals of the input choke

15/19.Z1.B04-1000		Tightening torque [Nm]	
Name	Function	Permissible line cross section [awg]	Size
	L1.1	3-phase line connections	15
	L2.1		2
	L3.1		4
L1.2	Output to R6-N	#6	Size
			19
			6
L2.2			8
L3.2			
PE	Connection for shielding / ground	-	6

4.4 Connection power circuit R6-N with internal fuses

4.4.1 Points for General Consideration

Always use UL listed and CSA approved wire. Use 60/75°C copper conductors only. Use minimum 300V rated wire with 230V systems and minimum 600V rated wire with 480V systems. Suitable for use on a circuit capable of delivering not more than 10000 rms symmetrical amperes, 240 or 480 volts maximum when protected by fuses as listed in table 3.1.

4.4.2.1 Wiring Scheme 'A' with Single Regen Unit and Commutation Choke

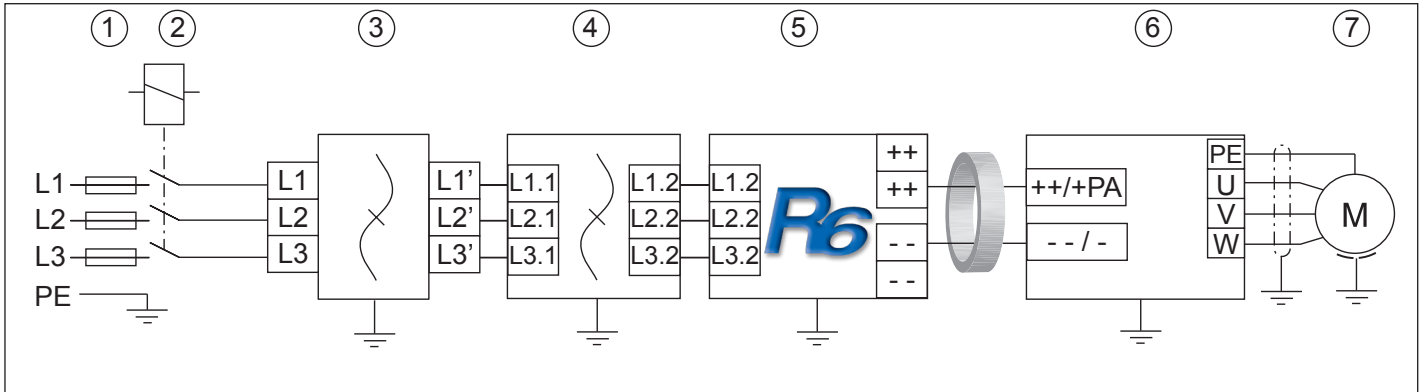

1	Line fuse UL Class J ¹⁾	5	R6-N
2	Main Line contactor	6	Frequency Inverter
3	EMI filter (optional)	7	Motor
4	Commutation Choke or Harmonic Filter ²⁾		
1) KEB recommends using fast acting class J fuses only (ex. Bussman type JKS). For applications with KEB Harmonic Filters and an isolation transformer, a high speed class J fuse must be used (only Ferraz type HSJ is approved).			
2) Harmonic filters must have the manual motor starter (MMS) turned on to include the capacitor assembly in the circuit. See section 4.4.9 for more details			

4.4.2.2 Wiring Scheme 'A' with Single Regen Unit and Harmonic Filter

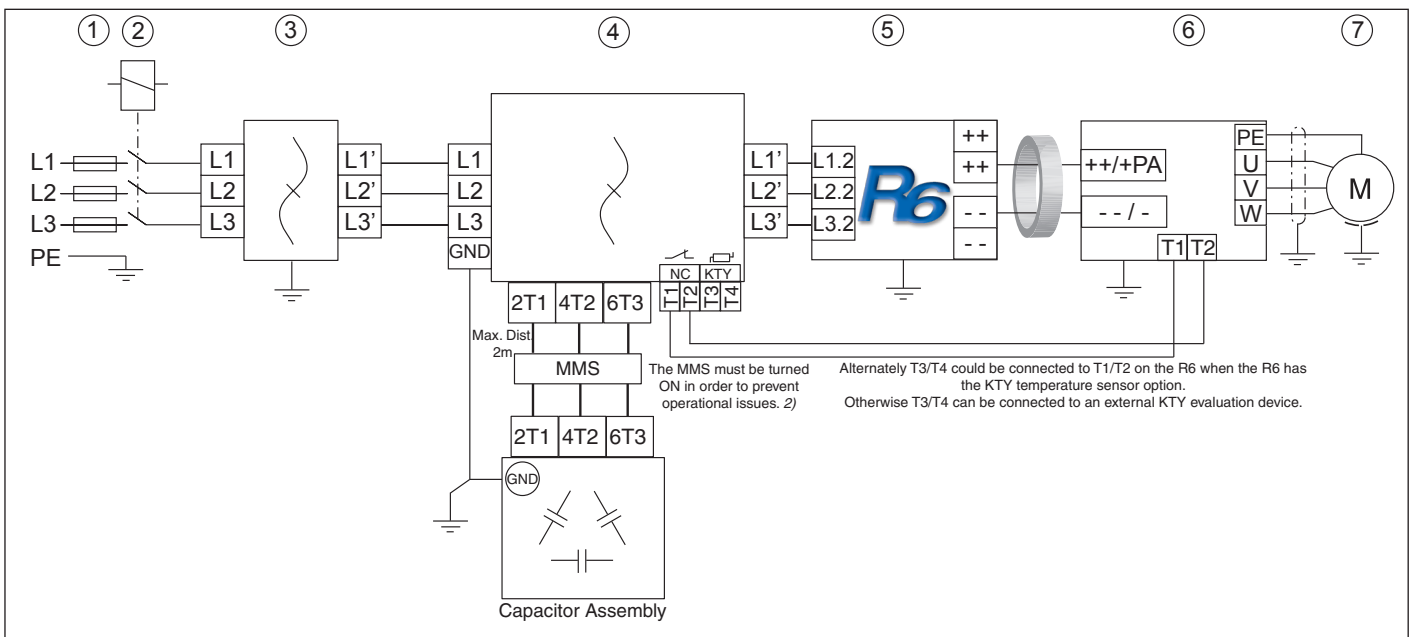

Connection Power Unit

4.4.3 Wiring Scheme 'A' with Parallel Regen Units and Commutation Chokes

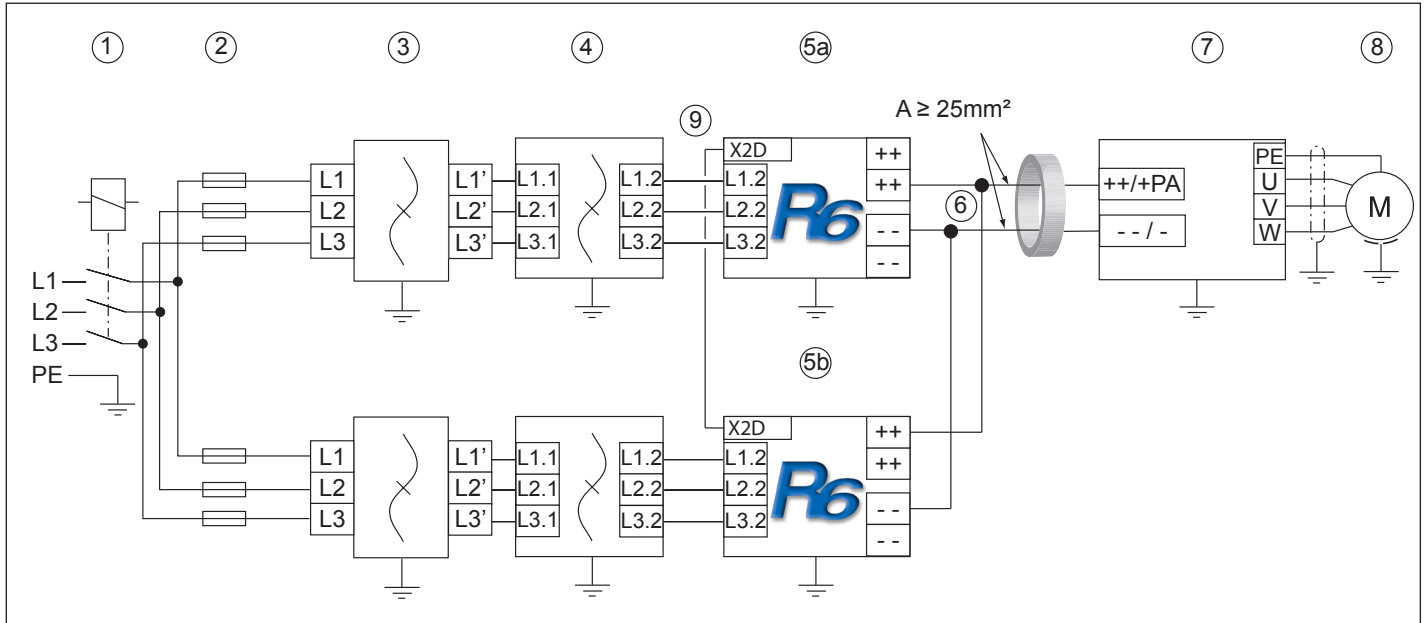

1	Main Line contactor	5	COMBIVERT R6-N a) Master b) Slave	9	Synch Cable ⁴⁾ (Pt # 00.F5.0C3-4010)
2	Line fuse UL class J ¹⁾	6	External terminal block ²⁾		
3	EMI filter (optional)	7	Frequency inverter		
4	Commutation Choke or Harmonic Filter ³⁾	8	Motor		

- 1) KEB recommends using fast acting class J fuses only (ex. Bussman type JKS). For applications with KEB Harmonic Filters and an isolation transformer, a high speed class J fuse must be used (only Ferraz type HSJ is approved).
- 2) If the inverter current is greater than the current of one COMBIVERT R6, the DC bus conductors from the inverter must be connected to an external terminal block to split the current to multiple R6 units. In this case the conductors to each R6 unit must be at least 6 AWG (10 AWG for the size 15R6) or larger based on the DC bus current to each unit.
- 3) Due to tolerances in the inductance values of the commutation choke or harmonic filter, the actual available power of each R6 unit must be reduced by 15% to account for unequal load sharing. Therefore the total power available is reduced. With parallel connection of different sized R6 units, it is necessary to use the same commutation choke or harmonic filter in order to maintain the same short circuit voltage (μK) across the chokes.
- 4) For parallel applications, a synch cable(s) must be used for a daisy chain connection to all units. These connections are only needed for parallel units and not used for single units.



Sizings with harmonic filters must utilize Wiring Scheme A (Sections 4.4.2 and 4.4.3) and should only be used in combination with harmonic filters from KEB.

4.4.4 Sizing for Wiring Scheme A

Below is regen system sizing for Wiring Scheme A (Sections 4.4.2.1, 4.4.2.2, and 4.4.3) by horsepower according to line voltage, motor type, and whether a regen choke or harmonic filter is used in conjunction with the R6 unit.

i KEB R6 regen units may be used with third-party drives. When sizing a KEB R6 regen unit, it may be necessary to know the DC bus capacitance of the drive for proper regen sizing. The drive DC bus capacitance should not exceed the max. permissible DC bus capacitance of the R6 unit, according to the Technical Data Section 3.1. The max. permissible DC bus capacitance for multiple R6 regen units in parallel is added (e.g. the max. permissible DC bus capacitance of a drive for a single R6 unit is 10,000 uf for 480V operation or 55,000 uf for 230V operation, whereas the max. permissible DC bus capacitance of a drive when two R6 units in parallel is 20,000 uf for 480V operation or 110,000 uf for 230V operation).

i The maximum suggested number of regen units in parallel is two. For larger sizings, it may be possible to utilize Wiring Scheme B or a larger regen size. Contact KEB applications engineering.

i Sizings with harmonic filters must utilize Wiring Scheme A (Section 4.4.2) and should only be used in combination with harmonic filters from KEB.

Filter Type: Commutation Choke

Filter Type: Harmonic Filter

Motor Type	Induction Geared	Permanent Magnet Gearless	
Line Voltage	Motor HP		R6 Size
208 / 230	0 - 7.5	0 - 6.5	15
	7.5 - 20	6.5 - 18	19
	20 - 30	18 - 36	2x19
	30 +	36 +	3x19
460 / 480	0 - 15	0 - 15	15
	15 - 40	15 - 40	19
	40 - 75	40 - 80	2x19
	75 +	80 +	3x19

Motor Type	Induction Geared	Permanent Magnet Gearless	
Line Voltage	Motor HP		R6 Size
208 / 230	0 - 7.5	0 - 7	15
	7.5 - 20	7 - 20	19
	20 - 40	20 - 40	2x19
	40 +	40 +	3x19
460 / 480	0 - 15	0 - 16.5	15
	15 - 40	16.5 - 45	19
	40 - 75	45 - 90	2x19
	75 +	90 +	3x19

*Consult KEB applications engineering for Wiring Scheme B or larger sizing.

Connection Power Unit

4.4.5 Sizing F5 DC Bus Capacitances

230V units		480V units	
Size	DC Bus Capacity (uF)	Size	DC Bus Capacity (uF)
13F5A1E-PLx2, B	3,280	13F5A1E-RLx2, B	705
14F5A1E-PLx2, B	4,100	14F5A1E-RLx2, B	820
14F5A1G-PLx2, B	3,280		
15F5A1G-PLx2, B	4,000	15F5A1E-RLx2, B	1,230
15F5A1G-PLx3, D	4,000	15F5A1G-RLx2, B	880
16F5A1H-PLx2, B	5,400	16F5A1G-RLx2, B	1,230
17F5A1H-PLx2, B	8,800	17F5A1G-RLx2, B	1,500
17F5A1H-PLx3, D	8,800	17F5A1H-RLx2, B	1,800
		18F5A1H-RLx2, B	1,800
19F5A1R-PLx2, B	15,600	19F5A1H-RLx2, B	2,700
19F5A1R-PLx3, D	15,600		
20F5A1R-PLx2, B	16,500	20F5A1H-RLx2, B	3,600
21F5A1R-PLx2, B	19,800		
23F5A1U-PLx2, B	33,600	22F5A1R-RLx2, B	4,950
		22F5A1R-RLx3, D	4,950
		23F5A1U-RLx2, B	8,250
		24F5A1U-RLx2, B	8,250
		26F5A1U-RLx2, B	14,100
		26F5A1U-RLx3, D	14,100
		28F5A1W-RLx2, B	19,800

4.4.6 Wiring Scheme 'B' with Single Regen Unit

Not yet available.

4.4.7 Wiring Scheme 'B' with Parallel Regen Units

Not yet available.

4.4.8 Sizing for Wiring Scheme 'B'

Not yet available.

Connection Power Unit

4.4.9 Manual Motor Starter (MMS) for Capacitor Assembly with Harmonic Filter



When using a harmonic filter, the MMS must be turned on to bring the capacitor assembly into the circuit. If the MMS is turned off, it may cause operational issues.

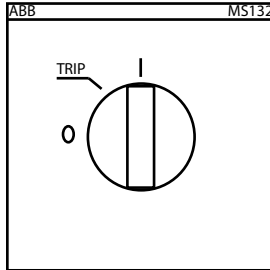

A figure showing the MMS in the ON position. If the dial is turned to 0 then the MMS is OFF.



There is the option to use auxiliary contacts to monitor the status of the MMS. One of the contacts contains normally open and normally closed contacts (Manufacturer's PN HKF1-11), and the other contact changes based on whether the MMS is in the "TRIP" position (Manufacturer's PN SK1-11). These auxiliary contacts can be used by the controller to monitor whether or not the MMS is on.

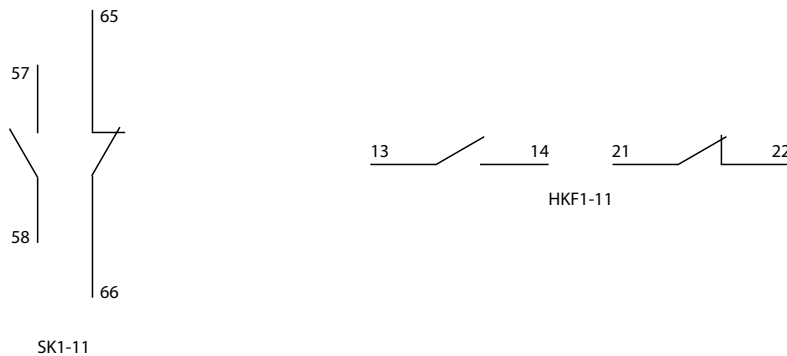

Below is a suggested wiring diagram using the auxiliary contacts

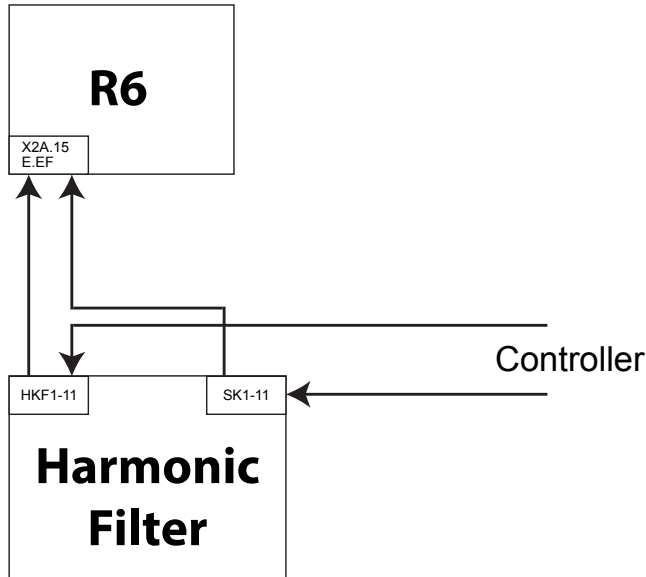

4.5 Control connections

4.5.1 Assignment of the control terminal strip X2A

X2A

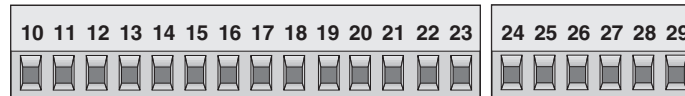

Tightening torque 0.5 Nm

PIN	Function	Name	Description	Specifications
10	24...30V input	Vin	External supply of the control board	
11	Common	COM	Reference potential	
12	Enable	ST	Enables the unit for operation	R _{in} : 4.4 kΩ
13	Reset	I1	Resets at the falling edge of a pulse	
14	Programmable Input	I2	Prog. function for advanced use	
15	External Fault	I3	Prog. function for advanced use (E.EF)	
16	Common	COM	Reference potential	
17	24 V-output	Vout	Voltage supply for in- and outputs	24V _{+/-1} /max.100 mA
18	Common	COM	Reference potential	
19	Digital output 1	O1	Transistor output	I _{max} : 25 mA
20	Ready (No Fault)	O2	Transistor output	I _{max} : 25 mA
21	Analog output	ANOUT	-	0...±10V / max. 5 mA
22	24 V-output	Vout	see terminal 17	
23	Mass	COM	Reference potential	
24	Relay 1 / NO contact	RLA	Relay output (RDY - Ready no Fault)	30 V DC 0.01...2 A
25	Relay 1 / NC contact	RLB		
26	Relay 1 / switching contact	RLC		
27	Relay 2 / NO contact	FLA	Relay output (CCC - Charge Contactor Control)	125VAC 0.01...2 A
28	Relay 2 / NC contact	FLB		
29	Relay 2 / switching contact	FLC		

4.5.2 Assignment of RJ45 Socket X2D

RJ45 socket for parallel units.	No.	Name
	1	IGBT off -> High
	2	IGBT off -> Low
	3	Slave Active -> High
	4	IGBT on -> High
	5	IGBT on -> Low
	6	Slave Active -> Low
	7	NC
	8	NC

Note: Applications with parallel regen units require an RJ45 daisy chain connection for phase synchronization. The connection is made with a shielded industrial ethernet patch cable (pt#: **00.F5.0C3-4010**) to the X2D socket. Single regen applications do not require these connections. Refer to section 4.4 for wiring diagrams.



If retaining an existing 19Z1B05-1000 or 15Z1B05-1000 commutation choke from an R6-S installation, DO NOT connect the line synchronization module to the R6-N X2D port as this will damage the unit. The R6-N does not require line synchronization from the commutation choke.

Connection of the Control Board

4.5.3 Wiring example

In order to prevent a malfunction caused by interference voltages on the control inputs, the following points should be observed:



EMC

- Use shielded / twisted control cables
- Connect the shield on the end connected to the inverter using the grounding bar
- Install control and power cable separately (about 6-8 inches (15...20 cm) apart)
control conductors should cross high voltage power conductors at right angles

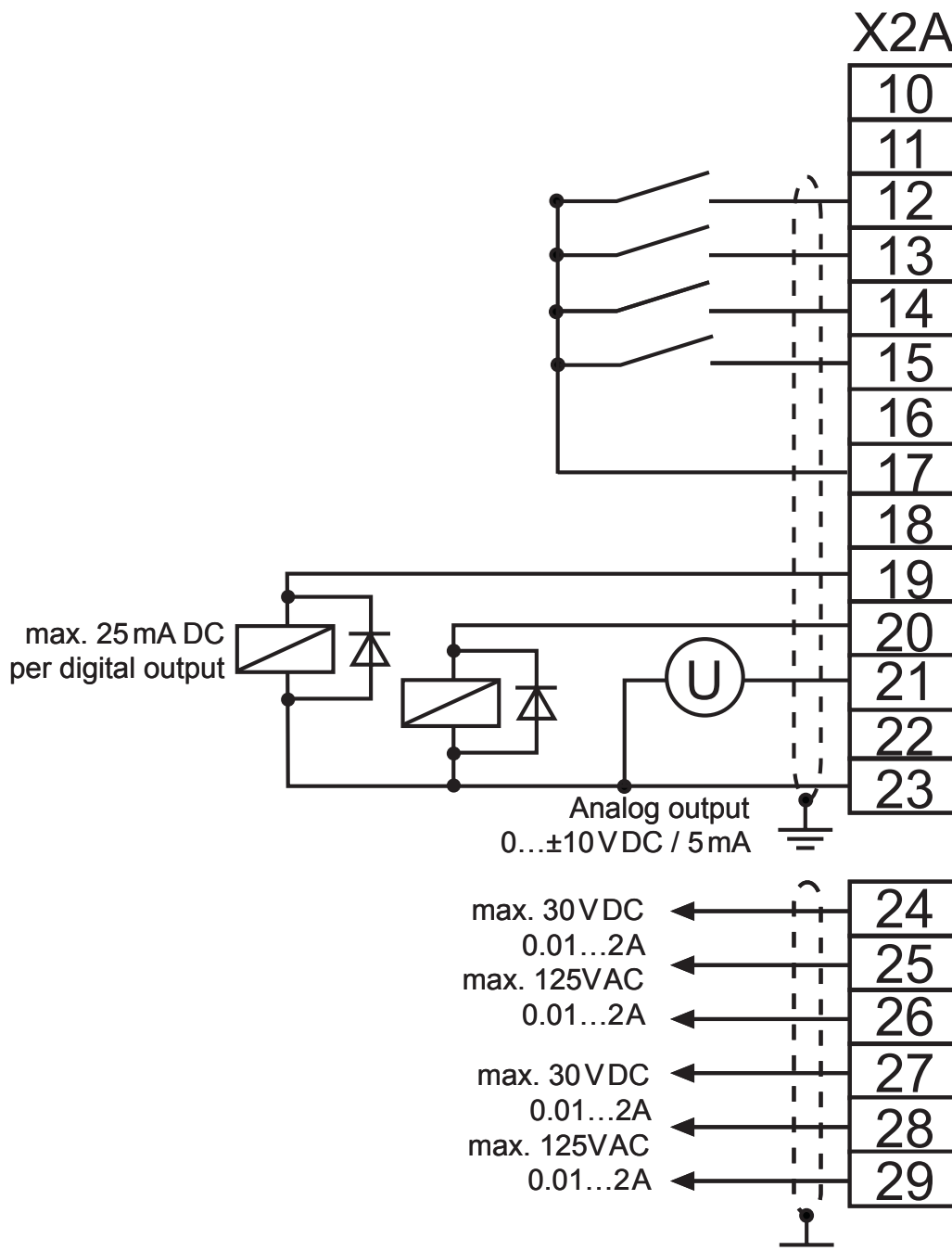

4.6 Operator

As an accessory a keypad operator can be installed. A digital operator (00.F5.060-K000) is provided with every regen unit. To prevent malfunctions, the COMBIVERT must be brought into nOP status before connecting or disconnecting the operator (de-activate the enable input). When starting the COMBIVERT R6, it is started with the last stored values or factory settings regardless of whether the operator is installed or not.



Do not place KEB F5 Elevator Drive Keypad on R6, it is not compatible and will display E.CArD.

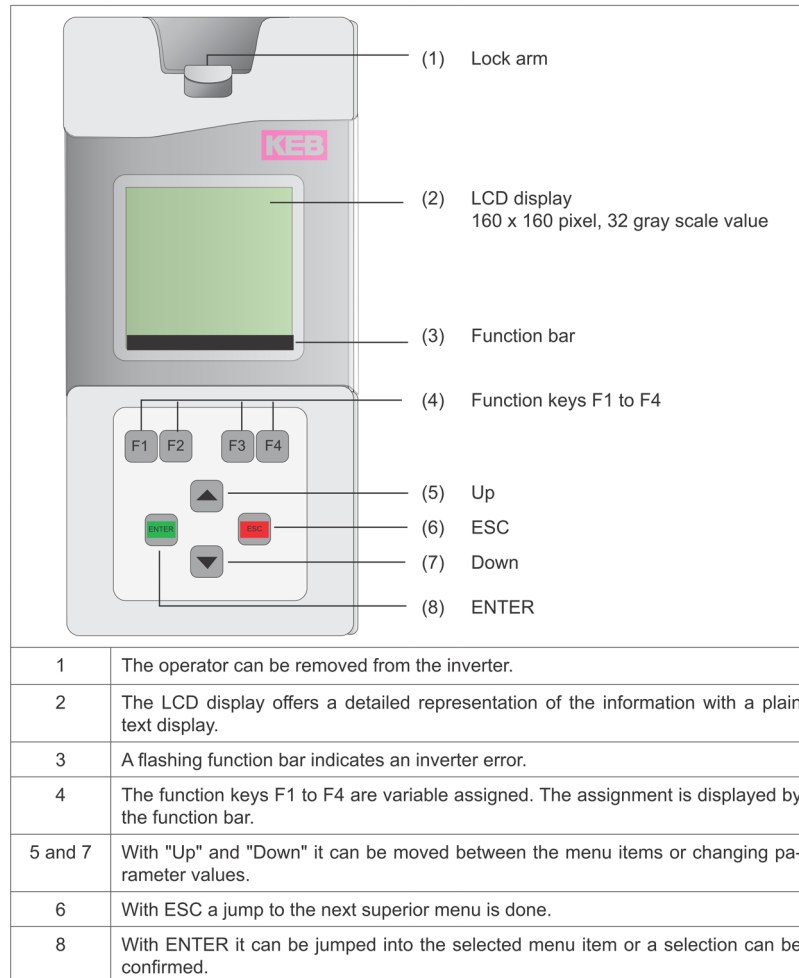

Operation of the Unit

5. Operation of the Unit

5.1 Keyboard

When switching on the KEB COMBIVERT R6-N the value of parameter CP.1 appears.

The enter key changes between the parameter name (CP.1) and parameter value or switches the parameter value into edit mode.



The escape key (Esc) exits out of the parameter value back into the parameter name.



With UP (▲) and DOWN (▼) the value of the parameter number is increased/decreased with changeable parameters in edit mode.



Generally, changes to parameter values are immediately accepted and stored non-volatile. However, with some parameters, due to their functionality, the adjusted value is not accepted immediately. With this parameters (see parameter overview) the adjusted value is accepted and stored non-volatile by pressing ENTER.

If an error occurs during operation, then the actual display is overwritten by the error message. The error message in the display is reset by ENTER.



With ENTER only the error message in the display is reset. The status display (CP.3) still displays the error. In order to reset the error itself, the cause must be corrected and a power-on reset must be made. Note: The R6 unit will attempt to reset errors on its own based on the auto reset parameter.

5.2 Operation with PC and programming software COMBIVIS

Instructions for the installation and operation of the programming software COMBIVIS are provided with the software

5.3 Turn-on and operation procedure

The COMBIVERT R6-N is initialized after connection of the main line supply. The power circuit identification is checked first. If an invalid power circuit is recognized, "ERROR pow. unit code inv." is triggered and displayed in the operator. This error cannot be reset, the power circuit must be checked.

If a valid power circuit is recognized, COMBIVERT R6-N changes into status "SYn". The following procedures take place one after another during this synchronization phase:

- Verification of correct synchronization to the line, ("ERROR net" is triggered, if the synchronization signals are missing)
 - Verification of the phasing of the synchronization signals to the main line phases. "Synchronization error" is triggered if a phase signal is missing or in case the phasing is not correct.
 - The actual line frequency is determined. The value must be positive; if not, "synchronization error" is triggered.
- To change the sign of the frequency swap L1.1 and L2.1 incoming phases at the commutation choke.

The unit is now ready for operation. If the enable (terminal X2A.12) is activated, the COMBIVERT R6-N is put into operation. Depending on the actual value of the DC bus voltage, the COMBIVERT R6-N is in status "regen active" or "standby".

Status "standby"

The R6-N detects the idle voltage level in the DC bus circuit of the connected frequency inverter (motor operation) and keeps the modulation signals of the regen unit deactivated.

Status "regen active"

If the DC bus voltage rises above 103% of the idle voltage (CP.9), the modulation signals are activated and the unit changes into regen operation. Alternately, if another R6 unit connected in parallel switches into "regen active" mode, the slave unit will immediately switch into regen mode simultaneously (master/slave operation of parallel units).

Operation of the Unit

5.4 Parameter summary

The CP parameters serve as the base level parameters to adjust and monitor operation of the COMBIVERT R6 unit.

Display	Parameter	Setting range	Resolution	Factory
CP.0	Password input	0...9999	1	–
CP.1	Status display	–	–	Read Only
CP.2	Main Line Frequency	–	0.1 Hz	Read Only
CP.3	AC-Phase current L1	–	0.1 A	Read Only
CP.4	AC-Phase current L2	–	0.1 A	Read Only
CP.5	AC-Phase current L3	–	0.1 A	Read Only
CP.6	Actual Load	–	1%	Read Only
CP.7	Actual Load / peak value	–	1%	Read Only
CP.8	DC output current	–	0.1 A	Read Only
CP.9	Actual DC voltage	–	1V	Read Only
CP.10	DC voltage / peak value	–	1V	Read Only
CP.11	Heat sink temperature	–	1°C	Read Only
CP.12	Over load counter	–	1%	Read Only
CP.13	Active power	–	0.1 kW	Read Only
CP.17	Apparent power / Line input	–	0.1 kVA	Read Only
CP.18	Analog output 1 / amplification factor	-20.00...20.00	0.01	1.00
CP.19	DC bus switching level	+/-30000.00	0.01	550.00
CP.20	Auto error reset counter	0...10	1	3
CP.21	Last Error	-	-	Read Only
CP.22	Last Error 1	-	-	Read Only
CP.23	Last Error 2	-	-	Read Only
CP.24	Last Error 3	-	-	Read Only
CP.25	Last Error 4	-	-	Read Only
CP.26	Last Error 5	-	-	Read Only
CP.27	Last Error 6	-	-	Read Only
CP.28	Last Error 7	-	-	Read Only
CP.29	Software version	-	-	2.0
CP.30	Software date code	DDMM.Y	-	Read Only
CP.31	Power part ID code	-	-	Read Only
CP.32	Pulse off level	-100kW...0,0kW	0.1kW	-0.8kW
CP.33	Operating mode	0...3	1	0
CP.34	Input Type	PNP/NPN	-	PNP
CP.35	Kp Harmonic Filter	2...18	1	Variable
CP.36	Ki Harmonic Filter	0...15	1	Variable

() Values in parenthesis correspond to size 15 R6.

5.5 Parameter description

The following parameters allow the user to monitor the functionality during operation.

CP.01 Status display

The status display shows the actual operating mode of the COMBIVERT R6. Refer to Section 6.0 for additional descriptions and troubleshooting faults.

CP.02 Actual line frequency

After switching on, the actual line frequency is determined during the initialization phase. Slowly, changes of the line frequency during operation are recognized and displayed in CP.02. CP.02 displays the actual regenerative frequency, if the COMBIVERT R6-N is in "netof" state, i.e. the main line is off. The rotating field of the mains frequency is displayed as follows: (+) right, (-) left



This value should be positive. If the value is negative the R6 unit will get a 'Synchronization error' - swap L1.1 and L2.1 legs of the incoming at the commutation choke to make the frequency positive.

CP.03 AC-Phase current L1

CP.03 displays the rms value of the current of phase L1 in amperes.

CP.04 AC-Phase current L2

CP.04 displays the rms value of the current of phase L2 in amperes.

CP.05 AC-Phase current L3

CP.05 displays the rms value of the current of phase L3 in amperes.

CP.06 Actual DC utilization

Parameter CP.06 displays the actual load of the COMBIVERT R6-N in percent. 100 % represents an output current, which corresponds to the rated current of the COMBIVERT R6-N. The absolute value of the load is displayed. The sign indicates the energy direction: (+) = supply, (-) = feedback

CP.07 Peak DC utilization

Parameter CP.07 stores the peak load value within an operating cycle. The highest value of CP.06 is stored in CP.07. The peak value can be cleared by pressing the UP and DOWN key or over bus by writing any value you like to the address of CP.07. Switching off COMBIVERT R6-N also clears the stored value.

CP.08 DC output current

Display of the actual DC current in amperes.

CP.09 Actual DC - voltage

Display of actual DC-Bus voltage in volts. The value is measured at the terminals "++" and "- -" of the COMBIVERT R6-N.

CP.10 Actual DC - voltage / peak value

Parameter CP.10 allows the user to recognize short-term peak values within an operating cycle. The highest value of CP.09 is stored in CP.10. The peak value can be cleared by pressing the UP and DOWN key or over bus by writing any value you like to the address of CP.10. Switching off COMBIVERT R6-N also clears the stored value.

CP.11 Power module temperature

Display of the actual heat sink temperature in °C. First a pre-warning can be given via digital output if the heat sink temperature is too high, so a controlled deceleration of the unit is possible. The modulation is shut off and the unit de-activated when reaching the max. heat sink temperature, if there is no reaction to the pre-warning.

CP.12 Over load counter

The average load of the COMBIVERT R6-N can be evaluated with this parameter in order to avoid an Error Overload (time based overload). When the actual load goes above 105%, the counter begins to increment. The Error Overload is triggered, if the overload counter reaches 100%.

CP.13 Actual power

CP.13 displays the actual active power of the COMBIVERT R6-N. Motor power is displayed with positive values, generated power is displayed with negative values.

CP.18 Analog output 1 / gain

This serves as a gain for the analog output 1. This output provides a signal in a range of 0...10VDC = 0...150% I_{DC} which corresponds to the DC-bus current. The gain can be adjusted with CP.18 in a range of 0...±20,00. With this parameter, the analog output signal can be adapted to individual requirements.

CP.19 DC Bus switching level

When the DC bus voltage drops below this level, the error E.EF(External Fault) will be triggered to indicate mainline voltage sag and high regenerative / supply current. Refer to section 6.2.2 for troubleshooting. This voltage threshold also controls the switching of the relay output R2. This level should be set according to the line supply:

208/230VAC supply - CP.19 = 230VDC
460/480VAC supply - CP.19 = 550VDC

CP.20 General fault reset



This parameter can be used to activate an auto reset counter to reset errors. Attention, an auto restart could allow the system to resume operation at any time! Protective measures must be implemented for service personel and machine operation to prevent injury or damage.



A value of 0 means no automatic reset. Errors can only be reset via the terminal strip or power cycle.

Values of 1...10 determine the maximum number of times per hour the unit will auto reset an error. If the number of errors exceeds this value, the unit will stop with the last error. Reset will then only be possible via the terminal strip.

CP.21...28 Last error(s)

The parameters CP.21...28 display the last eight triggered errors with the exception of "Error under voltage" which is not stored. The oldest error is found in CP.28. When a new error occurs, the error message is stored in CP.21. All previous error messages are shifted by one to the next parameter. The oldest error in CP.28 is lost. The meaning of the error codes can be found in the description for CP.1.



Same, subsequent errors are not uniquely logged. For example if the series of fault messages occurred was Error net, Error net, Error overcurrent, then the fault log would read CP.21 = Error net, CP.22 = Error overcurrent and NOT CP.21 = Error net, CP.22 = Error net, CP.23 = Error overcurrent.



The error log cannot be cleared, although jumpering X2A.15 and X2A.17 (if CP.34 = PNP, else if NPN, then X2A.15 and X2A.18) will force an Error External Fault (E.EF). This can be used to determine if any subsequent errors are the same as the fault prior to forcing E.EF or whether a new fault is occurring.

CP.29 Software version

This parameter displays the software version. Example: Version 1.02 = 1.02

CP.30 Software date code

This parameter displays the software compile date in the format DDMM.Y. Example: 2012.3

CP.31 Power part ID code

This parameter displays the identification code of the power part. When the unit is first turned on, the COMBIVERT R6 determines which line voltage it is connected to (230V/480V). Depending on that, various internal parameters are set. If the unit is then connected to another line voltage, the internal parameter settings are not correct. The unit then triggers the error "Error Power Unit Changed." To reset the fault, it is necessary to confirm the change by displaying the new value of this parameter and pressing enter. The unit will then configure itself for the new voltage level. The unit is tested on a 480V line at the factory.



Do NOT change this parameter. If necessary, display the value and press enter. This parameter is NOT a voltage setting, it is an arbitrary ID code corresponding to the voltage class of the line supply (i.e. 230V/480V).

CP.32 Pulse off level

This determines the reverse power level required to switch out of regen mode and back into stand-by mode. The adjustment is in kW. This parameter does not generally require adjustment

CP.33 Operating mode

Determines the operating mode of the unit. When more than one unit is connected in parallel it is necessary to set one unit as the master and the remaining unit(s) as slave(s).

- 0: Master with commutation choke
- 1: Master with harmonic filter
- 2: Slave with commutation choke
- 3: Slave with harmonic filter

CP.34 Input Type

This parameter adjusts the inputs for the type of signals, PNP (sourcing) or NPN (sinking).

CP.35 Harmonic Filter Proportional Gain

Proportional current gain in regen mode when using harmonic filter. Does not apply when using commutation choke.

The default value of 10 should be sufficient, particularly with high impedance line (eg. isolation transformer). Contact KEB if further adjustment is needed.

Operation of the Unit

CP.36 Harmonic Filter Integral Gain

Integral current gain in regen mode when using harmonic filter. Does not apply when using commutation choke.

The default value of 8 should be sufficient, particularly with high impedance line (eg. isolation transformer). Contact KEB if further adjustment is needed.

6. Diagnosis and Troubleshooting

6.1 Status Display: Status and Error Messages

6.1.1 Status Messages

The following are status messages for CP.1:

Status Messages	
regen active	Regen active (regeneration operation)
base block	base-block time, Unit is blocked from operation for a short period - precedes all errors.
no operation	"no Operation" the enable input is not activated, output modulation switched off
net off	"net off" Line power failure; Regen operation mode is possible
standby	The unit is enabled but in stand-by operation (motoric operation)
SYn	Phase synchronization mode, checks connection and phase angle of the line voltage
fault reset level reached	Fault reset level reached

6.1.2 Error Messages

The following are error messages for CP.1:

Error Messages	
9: ERROR drive overheat	Error: Over temperature commutation choke; temperature sensing on the commutation choke is indicating the choke is too hot and the overheat delay timer has run out.
31: ERROR External Fault	Error: External Fault. The R6 has been programmed to trigger this error for assistance in identifying high regenerative/supply current and line voltage sag - refer to CP.19 settings and section 6.2 for troubleshooting. Additionally, the error can be triggered by an external device through one of the digital inputs. This error can also be triggered manually by setting a temporary jumper across X2A.15-X2A.17(refer to CP.21 - CP.28 for use with the fault log.)
40: ERROR line frequency	Error: Main Line Frequency out of tolerance.
15: ERROR load shunt fault	Error: Load-shunt relay has not picked up, occurs for a short time during the switch-on phase, but will automatically reset immediately.
3: ERROR net	Error: Line, one or more phases are missing
36: no ERROR overheat	Error: NO Over Heat, over-temperature condition not present (E.OH error can be reset)
17: no ERROR overload	Error: NO Over load, cooling period after E.OL is over, error can now be reset
4: ERROR overcurrent	Error: Over current, output current too high or ground fault
8: ERROR overheat pow. mod.	Error: Over temperature, overheating of the heat sink (see "technical data")
6: ERROR overheat internal	Error: R6 Unit interior temperature too high, temperature in the interior > 95 °C
16: ERROR overload	Error: Over Load, the actual load was greater than 105% and the overload timer timed out.
1: ERROR: over voltage	Error: Over Voltage, DC bus voltage is too high, > 900VDC
49: ERROR pow. unit code inv.	Error: Power unit identification is invalid
50: ERROR pow. unit changed	Error: Power unit change. Refer to parameter CP.31.
59: synchronization error	Error: Synchronization, connection of line phasing is not correct
2: ERROR under voltage	Error: Under voltage, DC bus voltage too low
12: ERROR power unit	Error: General power circuit error

Troubleshooting and Diagnostics

6.2 Troubleshooting

6.2.1 Troubleshooting Error Messages

Fault	Cause	Solution
Synchronization error (E.Syn)	Line frequency calculated incorrectly	If the value in CP.02 is negative, swap L1.1 and L2.1 at the commutation choke so that CP.02 is positive.
Error net (E.nEt)	Refer to Sections 4.4.2 to determine the corresponding wiring of the regen unit. Wiring Scheme A Loss of a line phase Noise/EMI	Verify three-phase supply. Refer to Noise/EMI in Section 6.2.2.
Error overcurrent (E.OC)	Ground fault or short Noise/EMI Supply or regenerative current too high	Check for any loose or missing power connections. Check for similar errors on the (F5) Elevator Drive indicating a ground fault, short, or excessive current. This may indicate the cause of the fault is occurring from the end of to the drive, motor contactor, or motor. Refer to Noise/EMI in Section 6.2.2. Check to see if the utilization in CP.6 is high. Refer to High Regenerative/Supply Current in Section 6.2.2. Verify sizing with controller manufacturer
Error line frequency (E.FnEt)	Line frequency out of range (57-60Hz, based on 60Hz nominal line). Generator power operation causes voltage frequency swing. Noise/EMI	Monitor Main Line Frequency at CP.2. Output frequency from generator may be too high/low and may change as various other loads come on/offline. Refer to Noise/EMI in Section 6.2.2.
Error power unit changed (E.PuCH)	The voltage class of the line supply has changed since last power on and must be confirmed (cycling power will not clear).	Re-enter the value in CP.31 to clear the fault. The value displayed cannot be changed and is an arbitrary ID number and NOT a voltage setting.
Error overload (E.OL)	Supply or regenerative current too high	Check to see if the utilization in CP.6 is high. Refer to High Regenerative/Supply Current in Section 6.2.2. Verify sizing with controller manufacturer

Fault	Cause	Solution
Error DC Bus charge fault (E.LSF)	<p>If the error does not reset itself after power up and the fault remains, then the following causes may be applicable:</p> <ul style="list-style-type: none"> Load-shunt defective Input voltage wrong or too low High losses in the supply cable 	<p>Unit must be serviced.</p> <p>Verify line supply or transformer output supply and that there is not excessive sag or brown-out conditions.</p>
Error power unit (E.PU)	Error on the power stage.	General error on the power stage. Check grounding of the transformer. If the error is always active, then the unit must be sent in for evaluation. If intermittent, it may indicate excessive line sag conditions.
Error undervoltage (E.UP)	DC bus level is too low	<p>Likely indicates poor power quality.</p> <p>Verify line input voltage. Sagging voltage or loss of phase could cause E.UP error.</p> <p>Check all grounding including X0 of transformer.</p>
Error Overpotential (E.OP) faults on F5 Elevator Drive	<p>Regen unit unable to regen back to the line; CP.1 status not in 'regen' status during generating operation:</p> <ul style="list-style-type: none"> Enable input not present (CP.1 Status = nop) Input logic not set correctly to recognize enable input (i.e. di.00 = PNP vs. NPN) Regen unit in active fault; DC bus fuse(s) open. 	<p>Verify enable input at X2A.12. When active under normal operation, the CP.1 status should be either 'Stby' or 'rEgEn'.</p> <p>Verify di.00 setting according to input type.</p> <ul style="list-style-type: none"> PNP: inputs must be +24VDC to be active. NPN: inputs must be at 0VDC to be active. <p>CP.1 status displays fault message or if the fault message has been cleared from the screen by pressing ENTER on the operator keypad, a flashing red indicator LED on the keypad and R6 indicates an active fault remains. Reset (2AX.13) or resolve the cause of the fault.</p> <p>If the fault has been automatically reset, the last fault can be viewed in the fault log, CP.21. If it is unclear whether a fault actually occurred, refer to the note under CP.21...28 to force a specific fault in order to determine if a new fault is occurring.</p> <p>The DC bus fuse(s), internal to the R6, can be checked visibly whether they are open and replaced as needed. Before checking, ensure all safety measures necessary including powering down the unit from the mains disconnect and locking it out and allowing the DC bus to fully dissipate and verifying 0VDC across the DC bus terminals ++, --.</p>

Troubleshooting and Diagnostics

Fault	Cause	Solution
External Fault (E.EF)	Triggered by external device or use of jumper at X2A.15-X2A.17. High regenerative / supply current or excessive line voltage sag causing the DC bus voltage to drop below the level set in CP.19.	Refer to section 6.2.2 regarding high regenerative / supply current and excessive line voltage sag.

6.2.2 Troubleshooting Operational Problems

Problem	Cause	Solution
High regenerative or supply current	<p>High nominal motor current</p> <p>High peak motor current during acceleration/deceleration</p> <p>Low input voltage/Excessive line sag</p> <p>Overutilization</p>	<p>Check the current on the F5 Elevator Drive. Determine the cause of the high motor current, and troubleshoot accordingly.</p> <p>Check the peak current on the F5 Elevator Drive. Determine the cause of the high peak motor current and troubleshoot accordingly. Potentially adjust acceleration/deceleration rates.</p> <p>A decrease in input voltage causes a corresponding increase in supply current. Monitor CP.9 to see if the DC bus voltage is dropping below the CP.19 value during operation. Then, verify and ensure that the incoming line voltage is not sagging during operation.</p> <p>Check CP.6 and CP.7. If CP.7=160%, then the regen unit is being overutilized.</p>
Noise/EMI causing intermittent regen faults (Error overcurrent, Error net, Error line frequency).	<p>Imbalance line supply, Grounding</p> <p>Noise/EMI, Grounding</p>	<p>Line supply or transformer secondary MUST be a balanced, center-grounded wye connection.</p> <p>Check for actual connection of center-ground.</p> <p>Measure phase-ground voltage at R6; they should be balanced.</p> <p>Measure phase-phase voltage at R6; they should be balanced.</p> <p>Add additional R6 ferrite ring to DC bus connections. Installing the incorrect type of ferrite ring will not have an affect mitigating noise.</p> <p>Verify correct grounding connections and techniques as well as panel wire layout.</p> <p>Check for any loose or missing ground connections.</p> <p>Ground conductors must be minimum #4 AWG or thick ground strap.</p> <p>DC bus wires (++, --) should be tied together.</p> <p>Any DC, AC, Motor leads or switching power (e.g. brake or contactor coil) wires must be physically separated from each other and not run together.</p> <p>Add additional ferrite ring(s) around all motor lead connections at drive output (additional ferrites around individual motor leads is not necessary).</p>

Appendix

A.1 Data Logging

The KEB LCD regen keypad has internal data logging capabilities built in. The function can be activated from the 'Data Logging' menu under the Main Menu of the keypad. Once enabled, up to 10 trending parameters can be logged at a variable sample rate, as well as up to 4 fast-scanning parameters triggered by a fault in the regen unit. An SD card is required to store data and cards up to 8GB are acceptable to use. It is recommended the date and time are set in the keypad before proceeding to get an accurate time stamp.

1 - Setup

Datalogging Menu

Generic Parameters - Select up to 10 parameters for trending data.

General Logging - Enables/Disables General data trending. Takes a data point every cycle (.5s fixed sample time x Time Multiplier). Once enabled, General Logging immediately starts recording the parameters selected from the 'Generic Parameters'.

Fault Parameters - Select up to 4 parameters for fast-scanning fault data.

Fault Logging - Enables/Disables fast-scanning Fault logging. Event is triggered by a fault in regen unit. Once enabled, Fault Logging will start recording the parameters selected from the 'Fault Parameters' when triggered.

Base Block Checking - Base Block (BBL) is a message in the regen unit indicating the IGBT's have been locked for safety reasons. This occurs every time the unit is disabled or before a fault.

'On' - BBL will trigger an event and a fault file will be created.

'Off' - BBL is ignored and will not trigger an event. It is recommended to set this to 'Off' for most applications so a file is not created at the end of every run.

Sample Time - Base sample time for Fault Logging. Default is 1000 us.

Trigger Value - Percentage of time that will be displayed before the event occurred (ie if set to 40%, then 40% of the data will be displayed before the event and 60% will be displayed after). This can be adjusted to see more data either before or after the event occurs. Default is 50%.

Time Multiplier - Multiplier of the base sample time for General Logging. Default is 2.

Pre-Trigger Source - Allows the event for Fault Logging to be triggered by a digital input instead of a fault. Enter the decimal number for the desired input. Please note that the inputs have defined default functions. Default is 0.

Input 1 (terminal X2A 13) - '16'
Input 2 (terminal X2A 13) - '32'
Input 3 (terminal X2A 13) - '64'
Input 4 (terminal X2A 13) - '128'
Input A (internal) - '256'
Input B (internal) - '512'
Input C (internal) - '1024'
Input D (internal) - '2048'

Last Fault Code - Displays decimal code of the last fault. Refer to application manual for complete listing of codes.

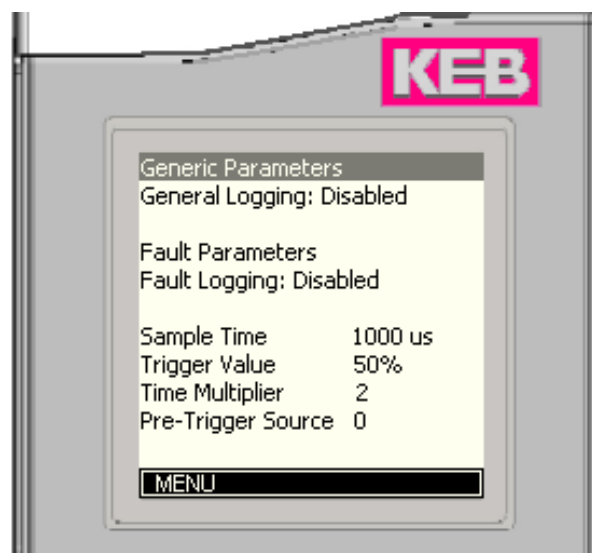

Generic Parameter Menu

Up to 10 parameters may be selected for General Logging. To change a parameter, move the cursor over the slot and hit 'Enter'. This will take you to the 'Group Menu'. To remove a parameter from the list, highlight the parameter name and hit F3 (delete). Hitting ESC will back out to the 'Data Logging Menu'. The first parameter cannot be removed.

Fault Parameter Menu

Up to 4 parameters may be selected for Fault Logging. To change a parameter, move the cursor over the slot and hit ENTER. This will take you to the 'Group Menu'. To remove a parameter from the list, highlight the parameter name and hit F3 (delete). Hitting ESC will back out to the 'Data Logging Menu'. The first parameter cannot be removed.

Group Menu

To select a parameter group, move the cursor over the desired group's name and hit ENTER. From here you can go in and select the individual parameter. Hitting ESC will back out to the previous menu.

Parameter Menu

To select a parameter for logging, move the cursor over the desired parameter's value and hit ENTER. Once a parameter is selected, the user will be returned to either the 'General Parameter Menu' or the 'Fault Parameter Menu'. Hitting ESC instead backs out to the 'Group Menu'.

2 - Recording Data

Once General and/or Fault logging is enabled, the user has selected the parameters and there is an SD card installed, the keypad is ready to begin taking data. It does not matter which screen the keypad is left at and can be returned to CP mode for real-time monitoring. Leave until ready to collect data. With default values, a 2 GB card will provide approximately 2 weeks worth of data storage. Different size cards or settings will change this time accordingly.

Warning Message

When the SD card is in use a message will display saying 'SD card in use do not remove or turn off power' or 'Fault Logging in process do not remove SD card or turn off power'. The message will go away if any action is taken by the user or if another system message needs to be displayed. In this case an icon will appear in the lower right hand corner of the display to notify the user that the SD card is still in use. When the SD card is no longer in use, both the message and icon will go away. There is also a message to indicate the SD card memory is full, 'Memory Full, Insert SD card or remove files'.

3 - Retrieving Data

Once data has been collected and is ready to analyze, the user must wait an hour before removing the SD card or powering down. This allows all temporary files to be written down to the SD card. Do not remove SD card or turn off power before this, as data will be lost. Once the SD card is removed, files can be accessed on a computer. Remember to turn off logging functions. Parameters will not be erased.

4 - Analyzing Data

General Logging files are stored as .txt files and Fault Logging files are stored as .XML's. The text files can be converted to .CSV (Comma Separated Value) to be viewed in Excel. Data is stored as raw data, so scaling may be necessary for some parameters. The fault files are scope traces which can be viewed in Combivis 6 for further analyzing.

Common Parameters for Logging

ID	Name	ID	Name	ID	Name
ru00	Inverter State	ru10	AC Current L3	ru19	DC Bus Voltage
ru03	Actual Line Frequency	ru11	Input Voltage		
ru08	AC Current L1	ru15	DC Current		
ru09	AC Current L2	ru17	AC Current		

Note: CP parameters cannot be logged. You must instead choose the corresponding background parameters. Please contact KEB America with any further questions.

Appendix

A.2 UPS Wiring Example

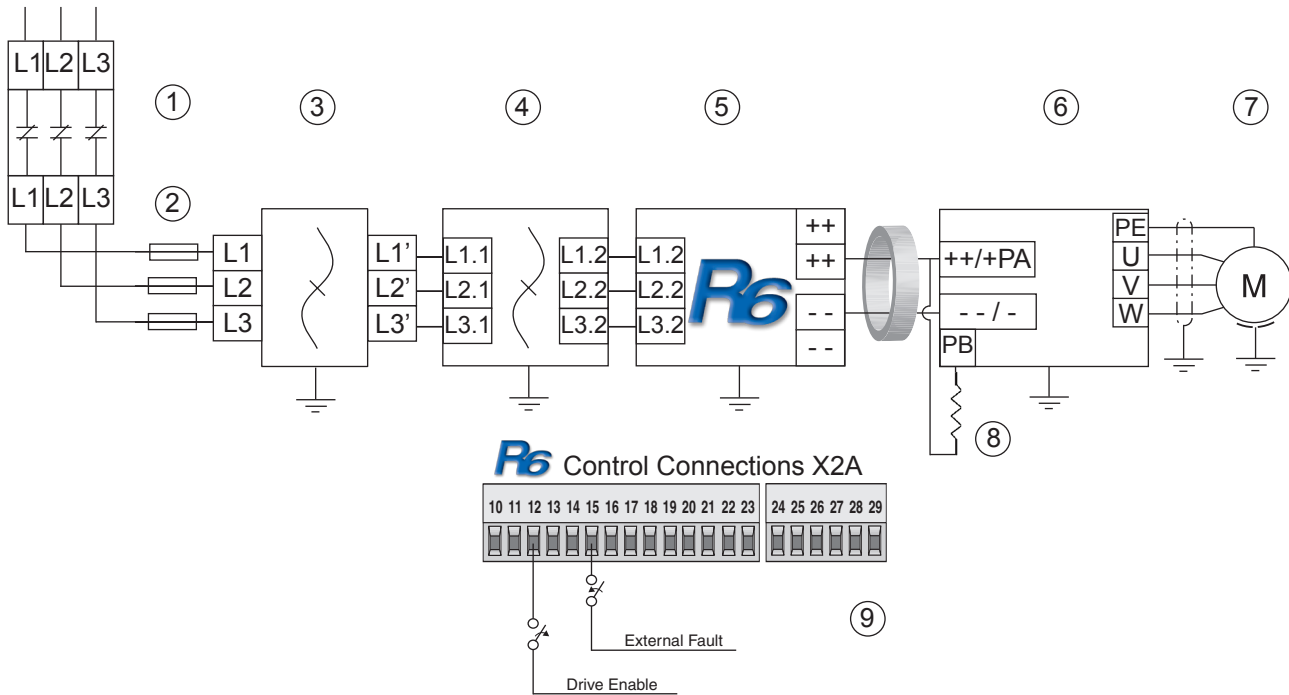

1	UPS Power Supply	5	COMBIVERT R6-N	9	R6-N Control Connections X2A ³⁾
2	Line fuse UL class J ¹⁾	6	Frequency Inverter		
3	EMI filter (optional)	7	Motor		
4	Commutation Choke or Harmonic Filter ²⁾	8	Braking Resistor ³⁾		
<p>1) KEB recommends using fast acting class J fuses only (ex. Bussman type JKS). For applications with KEB Harmonic Filters and an isolation transformer, a high speed class J fuse must be used (only Ferraz type HSJ is approved).</p> <p>2) Harmonic filters must have the manual motor starter (MMS) turned on to include the capacitor assembly in the circuit. See section 4.4.9 for more details</p> <p>3) See Application Note A.2.1 for more information.</p>					

A.2.1 Application Note - Using UPS (Uninterrupted Power Supply) with R6 in Wiring Scheme A

It is important to disable the regen capability of the R6 unit during UPS operation such as not to regen/modulate back to the UPS and cause potential damage to the unit. This can be done by having a relay contact open the R6 enable (X2A.12) when the UPS is activated. Additionally, another relay contact can activate an external fault (X2A.15) to further prevent modulation. This ensures that the R6 unit stays in a "passive" state and does not modulate/regenerate back to the UPS unit. However, the regen still acts as an input rectifier, supplying the F5 unit (even without the enable signal) to continue to drive the motor. Any excess DC bus voltage can be dissipated through a braking resistor on the F5 unit during UPS operation. The braking resistor can be permanently wired to the F5 unit. Under normal operation, no contactor is needed to deactivate the braking resistor since the regen unit would modulate at 103% of the nominal idel DC bus voltage (approximately 334VDC for a 230V unit and approximately 668VDC for a 460V unit). The braking transistor turns on at a much higher level, (380VDC for a 230V unit and 760VDC for a 460V unit).

B.1 Certification

B.1.1 CE Marking

	CE marked power supply-/regenerative units were developed and manufactured to comply with the regulations of the Low-Voltage Directive 2006/95/EC.
--	--

The described units must not be started until it is determined that the installation complies with the Machine directive (2006/42/EC) as well as the EMC-directive (2004/108/EC)(note EN 60204). The power supply-/regenerative units meet the requirements of the Low-Voltage Directive 2006/95/EC. The harmonized standards of the series EN 61800-5-1 in connection with EN 60439-1 and EN 60146 were used.

This is a product of limited availability in accordance with IEC 61800-3. This product may cause radio interference in residential areas. In this case the operator may need to take corresponding measures.

B.1.2 UL Marking

	Acceptance according to UL is marked on KEB power supply and regenerative units with the adjacent logo on the name plate.
--	---

This device has been investigated by UL according to United States Standard UL508C, Third Edition (Power Conversion Equipment) and to the Canadian Standard CSA C22.2 No.14-2010, 11th Edition (Industrial Control Equipment).

B.1.3 CSA Marking

	Acceptance according to CSA is marked on KEB power supply and regenerative units with the adjacent logo on the name plate.
--	--

This device has been investigated by CSA according to the Canadian Standard CSA C22.2 No.14-2010, 11th Edition (Industrial Control Equipment).

This page left blank intentionally

QUICK PARAMETER LIST

Display	Parameter
CP.0	Password input
CP.1	Status display
CP.2	Main Line Frequency
CP.3	AC-Phase current L1
CP.4	AC-Phase current L2
CP.5	AC-Phase current L3
CP.6	Actual Load
CP.7	Actual Load / peak value
CP.8	DC output current
CP.9	Actual DC voltage
CP.10	DC voltage / peak value
CP.11	Heat sink temperature
CP.12	Over load counter
CP.13	Active power
CP.17	Apparent power / Line input
CP.18	Analog output 1 / amplification factor
CP.19	DC bus switching level
CP.20	Auto error reset counter

Display	Parameter
CP.21	Last Error
CP.22	Last Error 1
CP.23	Last Error 2
CP.24	Last Error 3
CP.25	Last Error 4
CP.26	Last Error 5
CP.27	Last Error 6
CP.28	Last Error 7
CP.29	Software version
CP.30	Software date code
CP.31	Power part ID code
CP.32	Pulse off level
CP.33	Operating mode
CP.34	Input Type
CP.35	Kp Harmonic Filter
CP.36	Ki Harmonic Filter

Replacing the DC Bus Fuses

The following procedure describes how to replace the R6 Unit's DC Bus Fuses. ENSURE MAIN POWER HAS BEEN REMOVED AND SUFFICIENT TIME (AT LEAST 5 MINUTES) HAS BEEN ALLOWED FOR THE R6 DC BUS CAPACITORS TO DISCHARGE BEFORE SERVICING. If possible, use a grounding strap to prevent ESD damage to the R6 unit's sensitive electronic components.

1. Remove the Top Cover

After removing the keypad, X2D plug and X2A terminal strips, unfasten the cover and grounding bar screws. Then pull the cover off.



2. Verify the Condition of the Fuses

Each fuse has a tab that flips outward if the fuse has opened, indicating that it needs to be replaced. See pictures below.

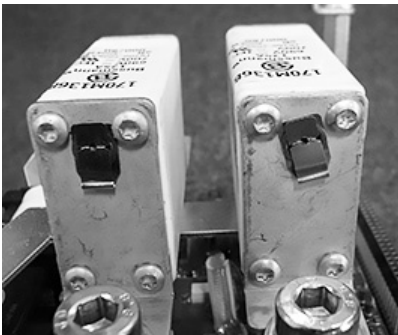

Intact Fuses



Open Fuses

3. Remove the Control Card

Unfasten the control card mounting screw and carefully pull the control card out.



4. Unplug the Housing Fan

Gently unplug the red and black wire lead that connects the housing fan to the power stage.



5. Remove the Housing

Unfasten the screw that secures the grounding bracket to the heat sink. Then pull the housing off of the heat sink. It may be necessary to use a flat head screwdriver to gently pry the housing from the mounting tabs.



6. Replace the Fuses

Remove the fuses by unfastening the four M8 hex bolts and washers that secure the fuses to the DC bus bars. Install the replacement fuses and fasten the four M8 hex bolts and washers. Ensure that all the bolts and washers are snug.

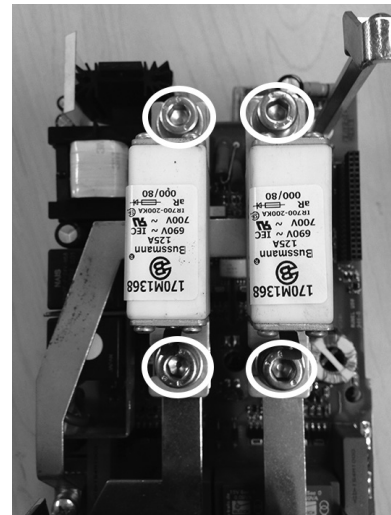

7. Re-assemble the R6

Re-install the housing components, control card, X2A terminal strips, X2D plug and keypad in the reverse order of disassembly. Be very careful when re-installing the control card - make sure the card's pins are properly aligned before pushing the card into the power stage connector.



KEB Automation KG.

Försterweg 36-38 • D-32683 Barntrup
fon: +49 5263 401-0 • fax: +49 5263 401-116
net: www.keb.de • mail: info@keb.de

KEB worldwide...

KEB Antriebstechnik Austria GmbH

Ritzstraße 8 • A-4614 Marchtrenk
fon: +43 7243 53586-0 • fax: +43 7243 53586-21
net: www.keb.at • mail: info@keb.at

KEB Antriebstechnik

Herenveld 2 • B-9500 Geraardsbergen
fon: +32 5443 7860 • fax: +32 5443 7898
mail: vb.belgien@keb.de

KEB Power Transmission Technology (Shanghai) Co.,Ltd.

No. 435 Qianpu Road, Chedun Town, Songjiang District,
CHN-Shanghai 201611, P.R. China
fon: +86 21 37746688 • fax: +86 21 37746600
net: www.keb.de • mail: info@keb.cn

KEB Antriebstechnik Austria GmbH

Organizační složka
K. Weise 1675/5 • CZ-370 04 České Budějovice
fon: +420 387 699 111 • fax: +420 387 699 119
mail: info.keb@seznam.cz

KEB Antriebstechnik GmbH

Wildbacher Str. 5 • D-08289 Schneeberg
fon: +49 3772 67-0 • fax: +49 3772 67-281
mail: info@keb-drive.de

KEB España

C/ Mitjer, Nave 8 - Pol. Ind. LA MASIA
E-08798 Sant Cugat Sesgarrigues (Barcelona)
fon: +34 93 897 0268 • fax: +34 93 899 2035
mail: vb.espana@keb.de

Société Française KEB

Z.I. de la Croix St. Nicolas • 14, rue Gustave Eiffel
F-94510 LA QUEUE EN BRIE
fon: +33 1 49620101 • fax: +33 1 45767495
net: www.keb.fr • mail: info@keb.fr

KEB (UK) Ltd.

Morris Close, Park Farm Industrial Estate
GB-Wellingborough, NN8 6 XF
fon: +44 1933 402220 • fax: +44 1933 400724
net: www.keb.co.uk • mail: info@keb.co.uk

KEB Italia S.r.l.

Via Newton, 2 • I-20019 Settimo Milanese (Milano)
fon: +39 02 3353531 • fax: +39 02 33500790
net: www.keb.de • mail: kebitalia@keb.it

KEB Japan Ltd.

15-16, 2-Chome, Takanawa Minato-ku
J-Tokyo 108-0074
fon: +81 33 445-8515 • fax: +81 33 445-8215
mail: info@keb.jp

KEB Korea Seoul

Room 1709, 415 Missy 2000
725 Su Seo Dong, Gang Nam Gu
ROK-135-757 Seoul/South Korea
fon: +82 2 6253 6771 • fax: +82 2 6253 6770
mail: vb.korea@keb.de

KEB RUS Ltd.

Lesnaya Str. House 30, Dzerzhinsky (MO)
RUS-140091 Moscow region
fon: +7 495 632 0217 • fax: +7 495 632 0217
net: www.keb.ru • mail: info@keb.ru

KEB America, Inc.

5100 Valley Industrial Blvd. South
USA-Shakopee, MN 55379
fon: +1 952 224-1400 • fax: +1 952 224-1499
net: www.kebamerica.com • mail: info@kebamerica.com

More information can be found at www.kebamerica.com

© KEB	
Document	20146460
Part/Version	USA 01
Date	2018/9