



Cx2000 | **User Manual** Variable Frequency Drive

0.1-11kW (230V, 415V)

 Read this manual carefully before installation, wiring, operating, servicing or inspecting this equipment. Keep this manual within easy reach for quick reference.



Thank you for purchasing L&T inverter!

Safety Instructions

- Read this manual carefully before installing, wiring, operating, servicing or inspecting this equipment.
- The safety instructions are divided into such two levels as Warning and Caution in the instruction manual.

 **WARNING:** Improper operation may result in serious personal injury or death.

 **CAUTION:** Improper operation may result in slight to medium personal injury or property damage.

- Throughout this manual we use the following two illustrations to make you aware of safety considerations:
 -  Identifies potential hazards under certain conditions. Read the message and follow the instructions carefully.
 -  Identifies shock hazards under certain conditions. Particular attention should be directed because dangerous voltage may be present.
- Keep operating instructions handy for quick reference.
- Read this manual carefully to maximize the performance of LTVF-Cx2000 series inverter and ensure its safe use.

WARNING

- Do not remove the cover while power is applied or the unit is in operation. Otherwise, electric shock could occur.
 - Do not run the inverter with the front cover removed. Otherwise, you may get an electric shock due to high voltage terminals or charged capacitor exposure.
 - Do not remove the cover except for periodic inspections or wiring, even if the input power is not applied. Otherwise, you may access the charged circuits and get an electric shock.

Safety Instructions

- Wiring and periodic inspections should be performed at least 10 minutes after disconnecting the input power and after checking the DC link voltage is discharged with a meter (below DC 30V).

Otherwise, you may get an electric shock.

- Operate the switches with dry hands.

Otherwise, you may get an electric shock.

- Do not use the cable when its insulating tube is damaged.

Otherwise, you may get an electric shock.

- Do not subject the cables to heavy loads.

Otherwise, you may get an electric shock.



CAUTION

- Install the inverter on a non-flammable surface.

Do not place flammable material nearby. Otherwise, fire could occur.

- Disconnect the input power if the inverter gets damaged.

Otherwise, it could result in fire.

- Do not touch the inverter if it is supplied with electricity or the power is cut off for a few moments.

Because the inverter is under high temperature status, it may cause scald.

- If the inverter is damaged or the part is damaged, do not operate the inverter even if the installation is complete.

Otherwise, electric shock could occur.

- Do not allow screw, metal, water, other conductive objects, oil and flammable objects into the inverter.

Otherwise, fire could occur.

[WARNING]

Risk of injury or Electric Shock: Read the manual and follow the safety instruction before use.

Risk of Electric Shock: More than one disconnect switch may be required to de-energize the equipment before servicing.

Risk of Electric Shock: Before opening the cover, disconnect all power and wait at least 10 minutes.

Risk of Electric Shock: Securely ground (earth) the inverter.

OTHER PRECAUTIONS

(1) Handling and installation

- Handle according to weight of the product.
- Do not stack the inverter boxes higher than the number recommended.
- Install according to instructions specified in this manual.
- Do not open the cover during delivery.
- Do not place heavy items on the inverter.
- Check the inverter mounting orientation is correct.
- The inverter is precise equipment. So do not drop the inverter or subject it to impact.
- Follow your national electrical code for grounding. Recommended ground impedance for 230V Drives is below 100 ohm and for 415V class below 10 ohm.
- This series inverter contains ESD sensitive parts. Take protective measures against ESD before touching the PCB for inspection or installation.

Use the inverter under the following environmental conditions:

Environment	Surrounding temperature	- 10°C ~ +50°C (non-freezing)
	Relative humidity	90% RH or less (non-condensing)
	Storage temperature	- 20°C ~ +65°C
	Environment	Protected from corrosive gas, combustible gas, oil mist or dust.
	Altitude, vibration	Max. 1,000m above sea level, Max. 5.9m/sec ² (=0.6g) or less
	Atmospheric pressure	70 ~ 106 kPa

(2) Wiring

- Do not connect a power factor correction capacitor, surge suppressor, or RFI filter to the output of the inverter.
- The connection orientation of the output cables U, V, W to the motor will affect the direction of rotation of the motor.
- Incorrect terminal wiring could result in the equipment damage.
- Wrong connection of input terminal (R, S, T) and output terminal (U, V, W) will damage the inverter.
- Only authorized personnel familiar with L&T inverter should perform wiring and inspections.
- Always install the inverter before wiring. Otherwise, you may get an electric shock or have bodily injury.

Safety Instructions

(3) Trial run

- Check all parameters during operations. Changing parameter values might be required depending on the load.
- Always apply permissible range of voltage to each terminal as indicated in this manual. Otherwise, it could lead to inverter damage.

(4) Operation methods

- When the Auto restart function is selected, stay away from the equipment as a motor will restart suddenly after an alarm stop.
- The Stop key on the keypad is valid only when the appropriate function setting has been made. Prepare an emergency Stop switch separately.
- If an alarm reset is made with the reference signal present, a sudden start will occur. Check that the reference signal is turned off in advance. Otherwise an accident could occur.
- Do not modify or alter anything inside the inverter.
- Motor might not be protected by electronic thermal function of inverter.
- Do not use a magnetic contactor on the inverter input for frequent starting/stopping of the inverter.
- Use a noise filter to reduce the effect of electromagnetic interference. Otherwise nearby electronic equipment may be affected.
- In case of input voltage unbalance, install AC reactor. Power Factor capacitors and generators may become overheated and damaged due to potential high frequency noise transmitted from inverter.
- Parameters will be set to default settings after parameter initializing. Do re-set necessary parameters before starting the inverter.
- Inverter can easily be set to high-speed operations, Verify capability of motor or machinery prior to operating unit.
- Stopping torque is not produced when using the DC-Break function. Install separate equipment when stopping torque is needed.

(5) Fault prevention precautions

- Provide a safety backup such as an emergency brake which will prevent the machine and equipment from hazardous conditions if the inverter fails

(6) Maintenance, inspection and parts replacement

- Do not conduct a megger (insulation resistance) test on the control circuit of the inverter.
- Refer to Chapter 12 for periodic inspection (parts replacement)

(7) Disposal

- Handle the inverter as an industrial waste when disposing of it.

(8) General instructions

- Many of the diagrams and drawings in this instruction manual show the inverter without a circuit breaker, a cover or partially open. Never run the inverter like this. Always place the cover with circuit breakers and follow this instruction manual when operating the inverter.

Instruction Manual...

- The instruction manual provides the overview of the LTVF-Cx2000 inverters, including the specification, installation, operation, functions, maintenance and etc. The instruction manual also shows the inexperienced operators how to operate the inverters safely and correctly.
- Please read the instruction manual carefully.
- Contents of the instructions:

Chapter	Title	Contents
1	Basic information	Safety rules and information to be mastered before use.
2	Installation wiring	Providing operation environment, installation method, power and control terminal wiring to inverter.
3	Peripheral equipment	Peripheral equipments connected with the inputs and outputs of the inverter.
4	Parameter setting	Displaying of panel of inverter and operation of key.
5	Parameter list	Detailed parameters list of inverter.
6	Control block diagram	Flow chart of control modules.
7	Basic function	Basic functions including frequency setting, operating commands and so on.
8	Application function	Necessary functions during operation of inverter.
9	Monitoring function	Monitoring of operation status and fault information
10	Protection function	Protection functions of motor and inverter.
11	Communication function	The specification and instructions of the RS-485 communication.
12	Troubleshooting & Maintenance	How to solve problems when there is a fault or the inverter is abnormal.
13	Product specification and option	Control specification of inverter, input and output rated and specification, EMC wave filter, DB resistor, remote keypad etc.

CHAPTER 1	Basic information & precautions		
1.1	Important precautions	- - - - -	1-1
1.2	Product Details	- - - - -	1-2
1.3	Product assembling & disassembling	- - - - -	1-4
CHAPTER 2	Installation & Wiring		
2.1	Installation precautions	- - - - -	2-1
2.2	External sizes	- - - - -	2-3
2.3	Terminal wiring	- - - - -	2-6
2.4	Specifications for power terminal block wiring	- - - - -	2-8
2.5	Control terminal specification	- - - - -	2-11
2.6	PNP/NPN selection and analog input V/I selection	- - - - -	2-12
CHAPTER 3	Basic configuration		
3.1	Connection of peripheral devices to the inverter	- - - - -	3-1
3.2	Recommended MCCB	- - - - -	3-2
3.3	Recommendable Fuse, Reactors	- - - - -	3-3
CHAPTER 4	Programming Keypad & Basic operation		
4.1	Keypad structure	- - - - -	4-1
4.2	Alpha-numeric table	- - - - -	4-2
4.3	Moving to other parameter groups	- - - - -	4-3
4.4	How to change the codes in a group	- - - - -	4-5
4.5	Parameter setting	- - - - -	4-7
4.6	Monitoring of operation status	- - - - -	4-10
4.7	Frequency Setting and Basic Operation	- - - - -	4-13
CHAPTER 5	Function list		
CHAPTER 6	CONTROL BLOCK DIAGRAM		
6.1	Frequency setting	- - - - -	6-2
6.2	Drive command setting	- - - - -	6-4
6.3	Accel/Decel setting and V/F control	- - - - -	6-5
CHAPTER 7	Basic Functions		
7.1	Frequency mode	- - - - -	7-1
7.2	Multi-Step Frequency setting	- - - - -	7-7
7.3	Operating command setting method	- - - - -	7-8
7.4	Accel/Decel time and pattern setting	- - - - -	7-12
7.5	V/F control	- - - - -	7-17
7.6	Stop method select	- - - - -	7-20

Content

7.7	Frequency limit	-----	7-21
CHAPTER 8	Advanced functions		
8.1	DC brake	-----	8-1
8.2	Jog operation	-----	8-3
8.3	UP-DOWN Drive	-----	8-4
8.4	3-Wire	-----	8-7
8.5	Dwell operation	-----	8-7
8.6	Slip compensation	-----	8-8
8.7	PID control	-----	8-10
8.8	Auto-tuning	-----	8-14
8.9	Sensorless Vector Control	-----	8-15
8.10	Energy-saving operation	-----	8-17
8.11	Speed search	-----	8-17
8.12	Auto restart try	-----	8-19
8.13	Operating sound select	-----	8-20
8.14	2 nd motor operation	-----	8-21
8.15	HD/ND Select	-----	8-22
8.16	Frequency setting and 2 nd drive method select	-----	8-22
8.17	Over voltage trip prevention deceleration and Power Braking	-----	8-25
8.18	External brake control	-----	8-26
8.19	Kinetic energy buffering	-----	8-27
8.20	DRAW drive	-----	8-27
8.21	2 Phase PWM drive	-----	8-29
8.22	Cooling fan control	-----	8-29
8.23	Operating mode select when cooling fan trip occurs	-----	8-29
8.24	Parameter read/write	-----	8-30
8.25	Parameter Initialize / Lock	-----	8-30
8.26	Start voltage for dynamic braking	-----	8-32
CHAPTER 9	Monitoring		
9.1	Operating status monitoring	-----	9-1
9.2	Monitoring the I/O terminal	-----	9-3
9.3	Monitoring fault condition	-----	9-4
9.4	Analog Output	-----	9-5
9.5	Multi-function output terminal and Relay Protective functions	-----	9-6





CHAPTER 10			
10.1	Electronic Thermal	- - - - -	10-1
10.2	Overload Warning and trip	- - - - -	10-2
10.3	Stall prevention	- - - - -	10-3
10.4	Output phase loss protection	- - - - -	10-5
10.5	External trip signal	- - - - -	10-5
10.6	Inverter Overload	- - - - -	10-6
10.7	Speed command loss	- - - - -	10-7
10.8	DB Resistor Enable Duty setting	- - - - -	10-8
CHAPTER 11			
	Communication		
11.1	Introduction	- - - - -	11-1
11.2	Specification	- - - - -	11-1
11.3	Installation	- - - - -	11-2
11.4	Operation	- - - - -	11-2
11.5	Communication protocol (MODBUS-RTU)	- - - - -	11-3
11.6	Parameter code list (Common area)	- - - - -	11-4
11.7	Troubleshooting	- - - - -	11-6
11.8	Miscellaneous(ASCII CODE LIST)	- - - - -	11-7
CHAPTER 12			
	Troubleshooting & Maintenance		
12.1	Protective functions.	- - - - -	12-1
12.2	Fault remedy	- - - - -	12-5
12.3	Precautions for maintenance and inspection	- - - - -	12-8
12.4	Check points	- - - - -	12-8
12.5	Part replacements	- - - - -	12-8
CHAPTER 13			
	Specifications		
13.1	Basic Specification	- - - - -	13-1
13.2	Rated current of inverter decreasing	- - - - -	13-4
13.3	Temperature Derating Information for side-by-side mounting	- - - - -	13-6
13.4	Braking resistor	- - - - -	13-6
13.5	Remote Keypad	- - - - -	13-7

1. BASIC INFORMATION & PRECAUTIONS

1.1 Important precautions

Inspect the inverter for any damage that may have occurred during shipping.

To verify the inverter unit is the correct one for the application you need, check the inverter type, output ratings on the nameplate and the inverter is intact.

Model Name ⇒	MOEL : LTVF-C40010BAA		Normal Duty Amps/ Heavy Duty Amps
Power source specification ⇒	APPLICABLE MOTOR : 3.7kW (ND) /4.0kW (HD) ←		
Output specification ⇒	INPUT : 380-480V 3 Phase 50/60Hz 14 A/10.4A		Software Version
Serial Number ⇒	OUTPUT : 0-Input V 3 Phase 0.01-400Hz 10A/08A		
Enclosure Type ⇒	MASS : 1.97 kg S/w Ver : 1.06 ←		
	S/N : 550390700DC		
	Enclosure : IP20		
			

<u>LTVF</u> - <u>C</u>	<u>4</u>	<u>0002</u>	<u>B</u>	<u>AA</u>	
L&T Variable Frequency Drive	Cx2000 Series	1: Single Phase 2: Three Phase 230V 4: Three Phase 415V	Normal Duty Ampere Round Off Values (HD Current for 1 Phase VFD)	B: IP 20	Reserved

Note: 1)	If you have found any discrepancy, damage, etc., please contact us (refer to the back cover of the Manual).
Peripheral equipment	Be sure of inverter types and select peripheral equipment according to the capacity.
Installation	To operate the inverter with high performance for a long time, install the inverter in a proper place in the correct direction and with proper clearances
Wiring	Connect the power supply, motor and operation signals to the terminal block. Note that incorrect connection may damage the inverter and peripheral devices

1.2 Product Details

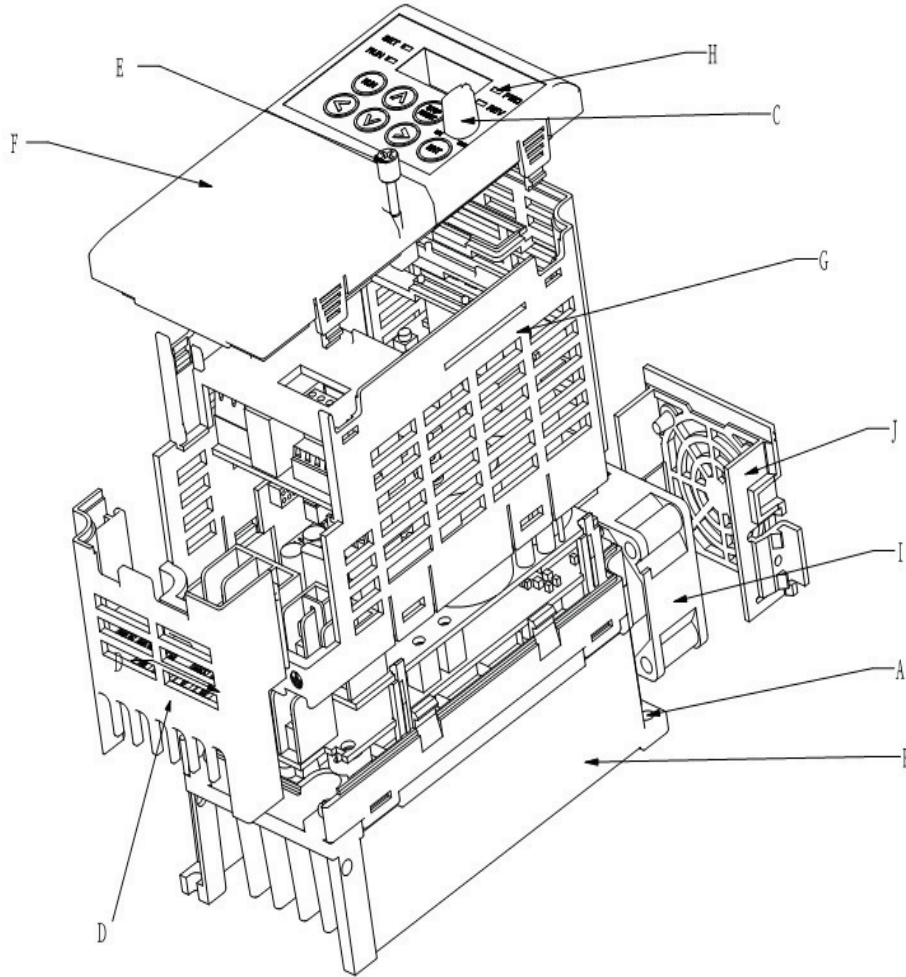

A -Mounting hole
B -Heat sink
C -Button cover
D -Terminal cover
E -Screw M3

F -Front cover
G -Sheath
H -Indicator light
I -Fan
J -Fan cover

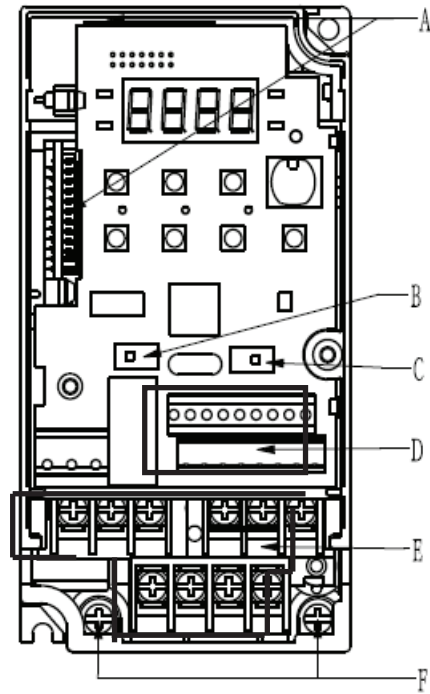

A –Download interface
B –PNP/NPN select switch
C –Analog Input V/I select

D –Control terminal
E –Power supply terminal
F –Ground terminal

1.3 Product assembling & disassembling

- To remove the front cover: Press the both indented sides of the cover lightly and pull up.

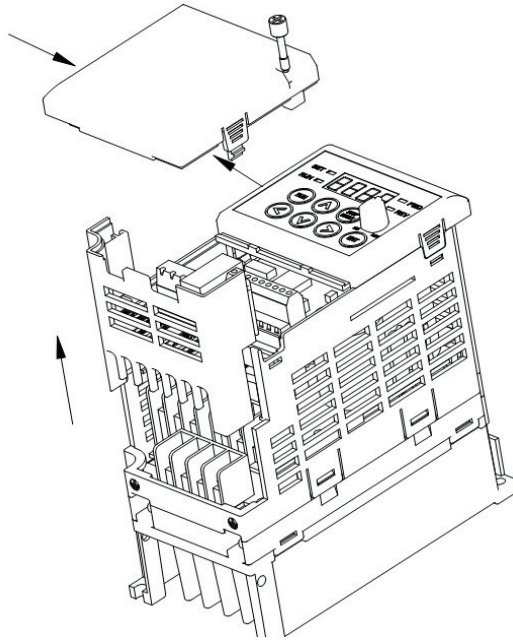

- To change the inverter fan: Press the both sides of bottom cover lightly and pull out to your side.

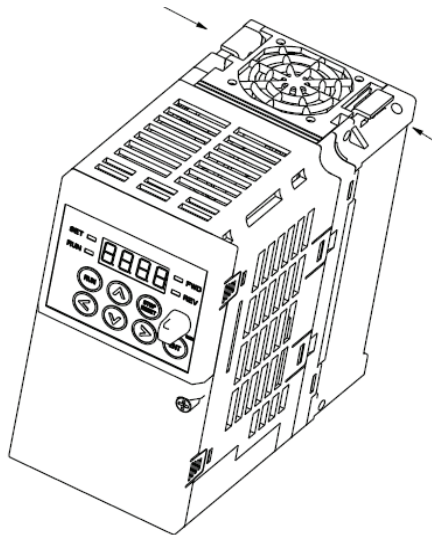

Chapter 2 INSTALLATION & WIRING

2 INSTALLATION & WIRING

2.1 Installation precautions



Caution

- Handle the inverter with care to prevent damage to the plastic components. Do not hold the inverter by the front cover. It may fall off.
- Install the inverter in a place where it is immune to vibration or extrusion under allowable temperature (-10°C~ 50°C)
- The installation environment of inverter will influence its service life directly, so the inverter shall be used in a condition with standard specification

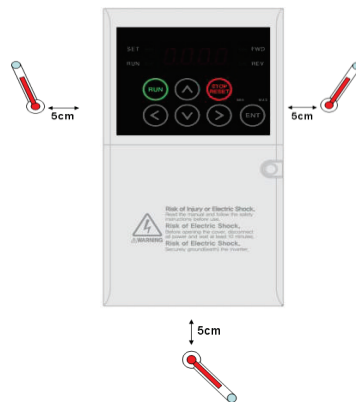

<Ambient Temp Checking Location>

- The inverter will be very hot during operation. Install it on a non-combustible surface, far away from hot sources and inflammables.
- Mount the inverter on a flat, vertical and level surface. Inverter orientation must be vertical. Also leave sufficient clearances around the inverter.
- Protect from moisture and direct sunlight.

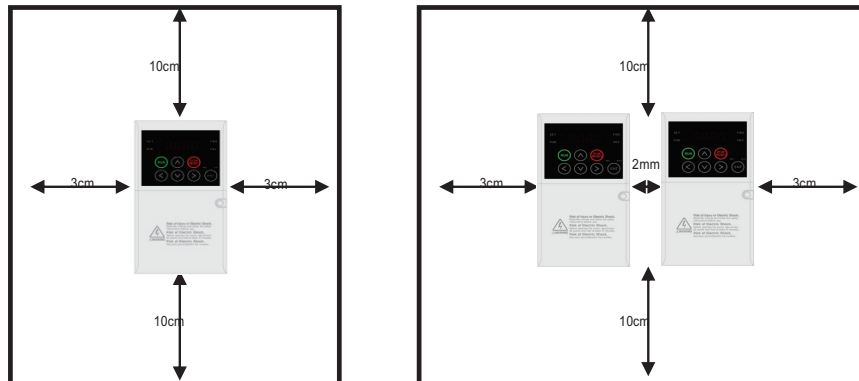

- When two or more inverters are installed, the inverters must be installed in proper positions away from the outlet, whose distance shall be 2mm or more (refer to the following figure)
- Installed the inverter using screws or bolts to insure the inverter is firmly fastened.
- Two or more inverters are installed in a location where ambient temperature is over 30°C , please refer to temperature derating curve in chapter 13.3.

< For installing multiple inverters in a panel >

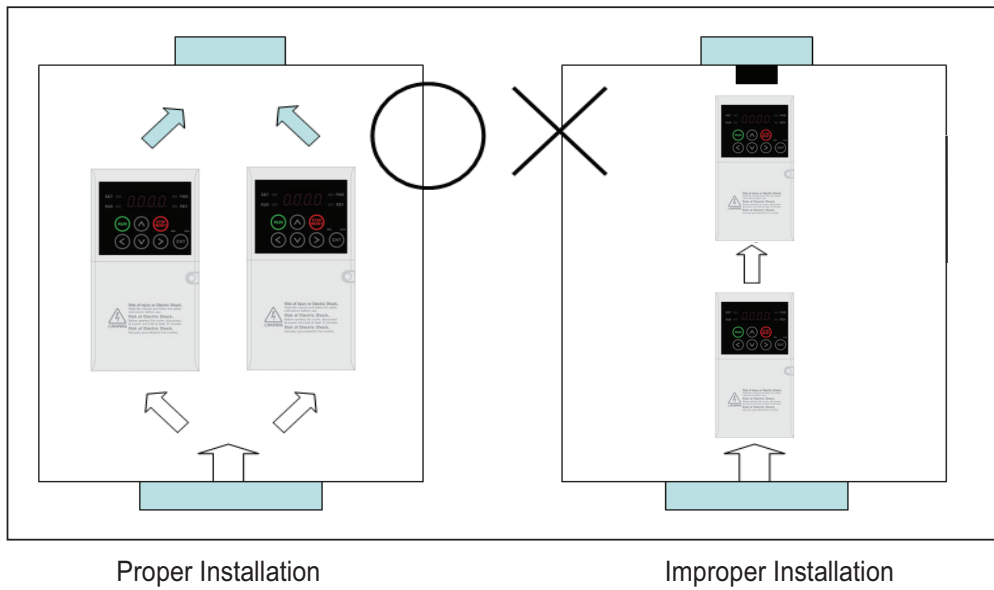

⚠ Caution

Take caution on proper heat ventilation when arranging control cabinet to form logical air convection to reduce the heat production of the inverter.

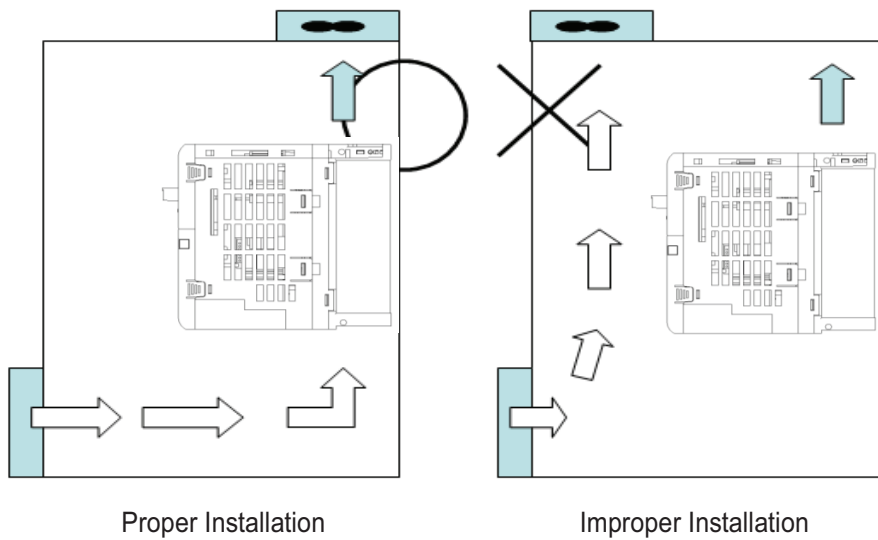

Chapter 2 INSTALLATION & WIRING

2.2 External sizes

LTVF-C10001BAA	LTVF-C10002BAA	LTVF-C10003BAA
LTVF-C20001BAA	LTVF-C20002BAA	LTVF-C20003BAA
LTVF-C20006BAA	LTVF-C40002BAA	LTVF-C40003BAA

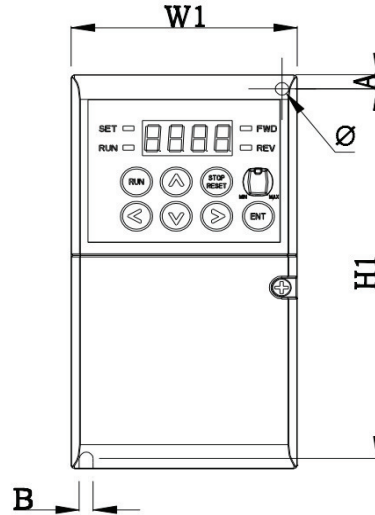
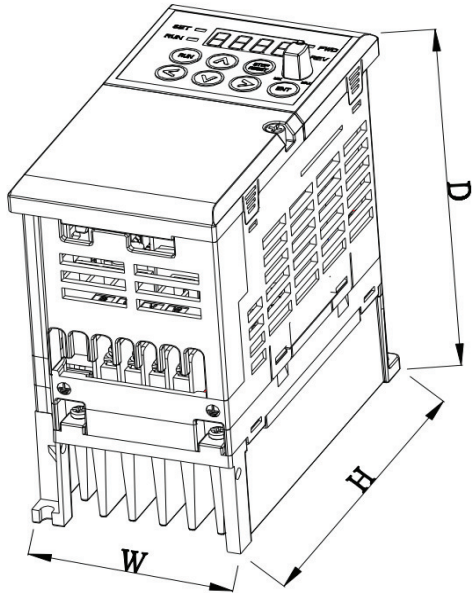

LTVF-C10005BAA	LTVF-C10008BAA	LTVF-C20010BAA
LTVF-C20012BAA	LTVF-C40005BAA	LTVF-C40007BAA

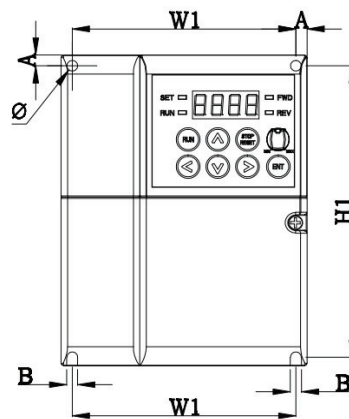
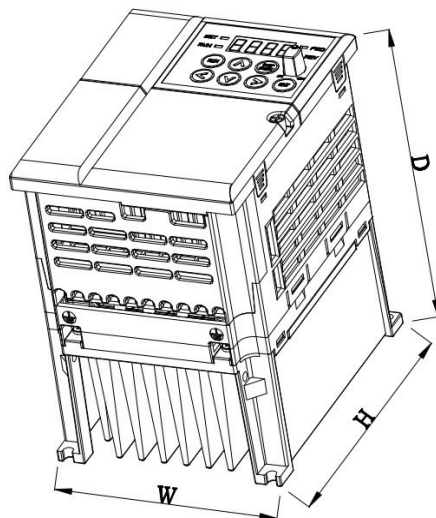

LTVF-C10011BAA
 LTVF-C20018BAA
 LTVF-C40010BAA

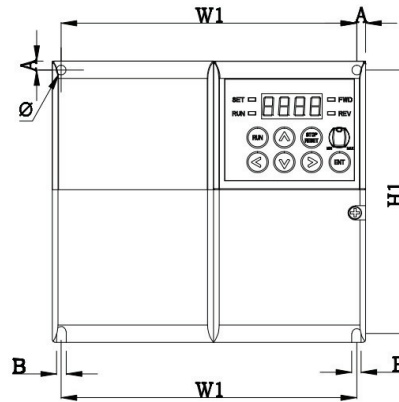
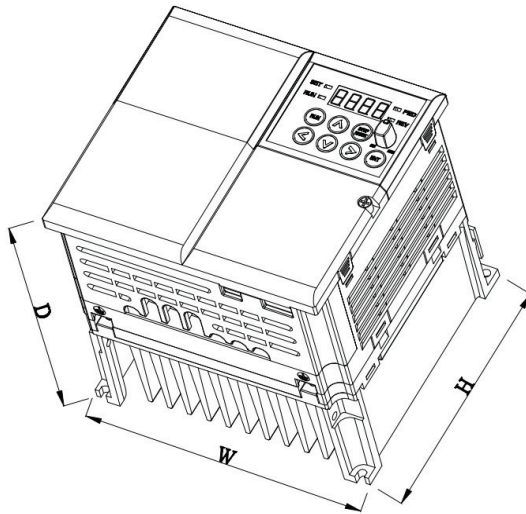

LTVF-C20030BAA
 LTVF-C20040BAA
 LTVF-C40016BAA
 LTVF-C40016BAA

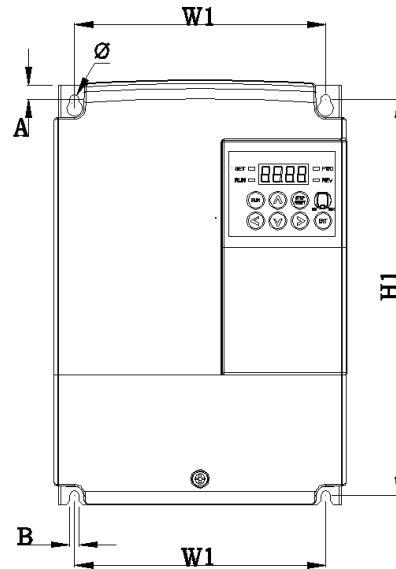
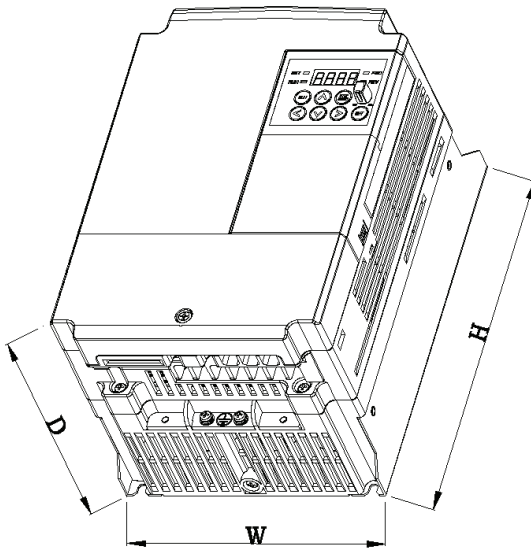

Chapter 2 INSTALLATION & WIRING

Inverter	Power [kW]	W [mm]	W1 [mm]	H [mm]	H1 [mm]	D [mm]	Φ [mm]	A [mm]	B [mm]	Weight [kg]
LTVF-C10001BAA	0.1	68	63.5	128	124.5	93	4.2	4.5	4.2	0.55
LTVF-C10002BAA	0.2	68	63.5	128	124.5	93	4.2	4.5	4.2	0.55
LTVF-C10003BAA	0.4	68	63.5	128	124.5	128	4.2	4.5	4.2	0.8
LTVF-C10005BAA	0.75	100	91	128	120	130	4.5	4.5	4.5	1.22
LTVF-C10008BAA	1.5	100	91	128	120	145	4.5	4.5	4.5	1.42
LTVF-C10011BAA	2.2	140	132	128	120	145	4.5	4	4.5	1.97
LTVF-C20001BAA	0.1	68	63.5	128	124.5	93	4.2	4.5	4.2	0.55
LTVF-C20002BAA	0.2	68	63.5	128	124.5	93	4.2	4.5	4.2	0.55
LTVF-C20003BAA	0.4	68	63.5	128	124.5	128	4.2	4.5	4.2	0.8
LTVF-C20006BAA	0.75	68	63.5	128	124.5	128	4.2	4.5	4.2	0.8
LTVF-C20010BAA	1.5	100	91	128	120	130	4.5	4.5	4.5	1.22
LTVF-C20012BAA	2.2	100	91	128	120	145	4.5	4.5	4.5	1.42
LTVF-C20018BAA	3.7	140	132	128	120	145	4.5	4	4.5	1.97
LTVF-C20030BAA	5.5	160	137	232	216.5	141	5	10.5	5	3.3
LTVF-C20040BAA	7.5	160	137	232	216.5	141	5	10.5	5	3.3
LTVF-C40002BAA	0.4	68	63.5	128	124.5	128	4.2	4.5	4.2	0.8
LTVF-C40003BAA	0.75	68	63.5	128	124.5	128	4.2	4.5	4.2	0.8
LTVF-C40005BAA	1.5	100	91	128	120	130	4.5	4.5	4.5	1.22
LTVF-C40007BAA	2.2	100	91	128	120	145	4.5	4.5	4.5	1.42
LTVF-C40010BAA	3.7	140	132	128	120	145	4.5	4	4.5	1.97
LTVF-C40016BAA	5.5	160	137	232	216.5	141	5	10.5	5	3.3
LTVF-C40023BAA	7.5	160	137	232	216.5	141	5	10.5	5	3.4

2.3 Terminal wiring
Control terminal

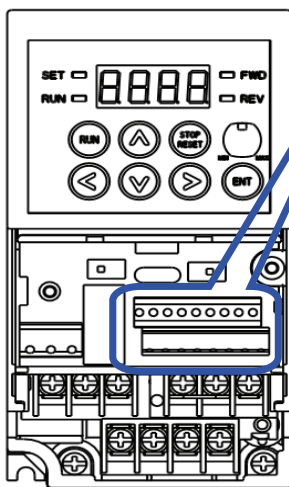
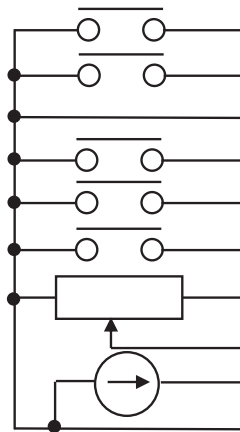

Name	Description	
24	24V Output	
P1	MF input terminal	FX: Forward run
P2	(Factory setting)	RX: Reverse run
CM	Input signal common	
P3	MF input terminal (Factory setting)	EST: Emergency stop
P4		RST: Trip reset
P5		JOG: Jog Operation
VR	10V power supply for potentiometer	
AI	Freq. Setting voltage signal input: 0~10V Freq. setting current signal input: 0~20mA	
CM	Input signal common	
AM	Multi-function analog out signal: 0~10V	
3A	Multi-function	A contact output
3B	relay output	B contact output
3C	terminal	A/B contact common
S+	RS485 communication terminal	
S-		
SA	Safe stop terminal A (and SC, often closed terminals, Inverter displays "SAFA" when breaking	
SB	Safe stop terminal B (and SC, often closed terminals, Inverter displays "SAFB" when breaking	
SC	Safe stop connection with public power source (24V)	

Wiring of power supply terminal (0.1~7.5 KW)

Chapter 2 INSTALLATION & WIRING

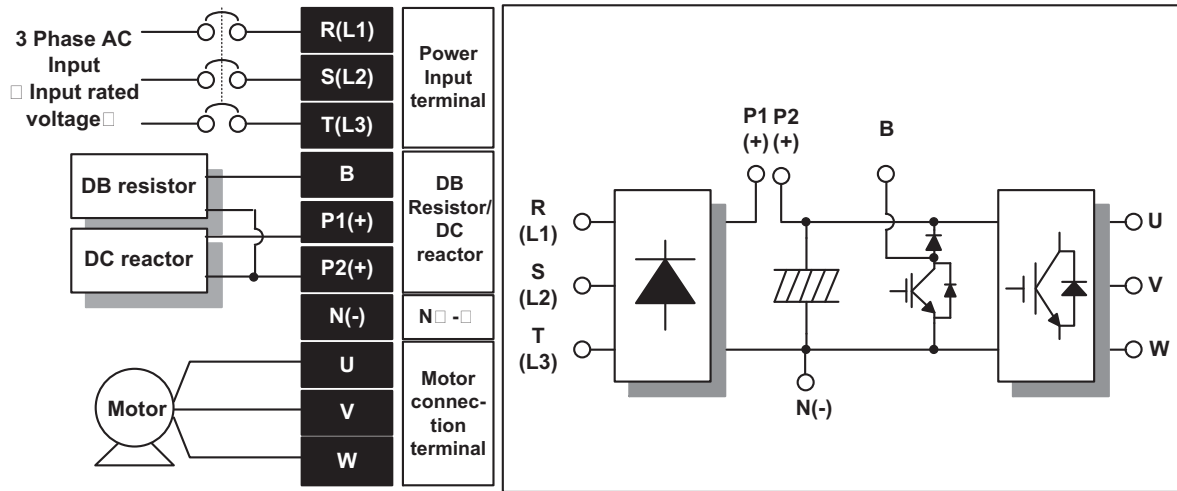

* Single phase inverter uses terminal R and T for power input (0.1~2.2KW)

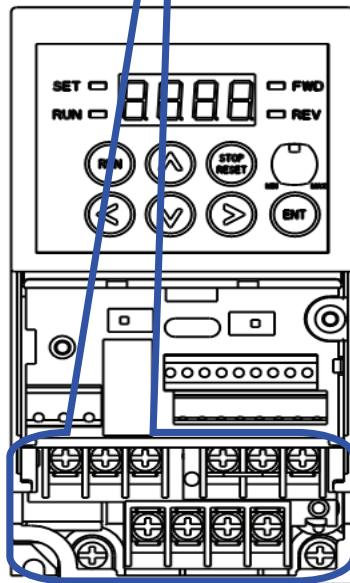

2.4 Specifications for power terminal block wiring

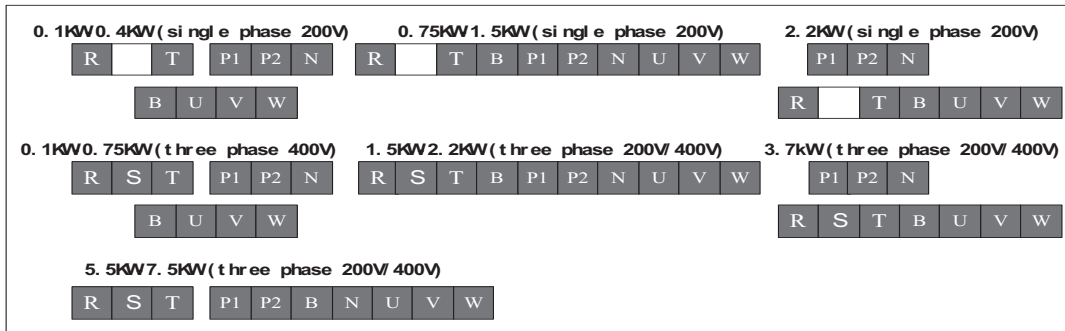

	R,S,T Size		U,V,W Size		Ground Size		Terminal Screw Size	Screw Torque (Kgf.cm)/lb-in
	mm ²	AWG	mm ²	AWG	mm ²	AWG		
LTVF-C10001BAA	2	14	2	14	3.5	12	M3.5	10/8.7
LTVF-C10002BAA	2	14	2	14	3.5	12	M3.5	10/8.7
LTVF-C10003BAA	2	14	2	14	3.5	12	M3.5	10/8.7
LTVF-C10005BAA	2	14	2	14	3.5	12	M3.5	10/8.7
LTVF-C10008BAA	2	14	2	14	3.5	12	M3.5	10/8.7
LTVF-C10011BAA	3.5	12	3.5	12	3.5	12	M4	12.2/10.6
LTVF-C20001BAA	2	14	2	14	3.5	12	M3.5	10/8.7
LTVF-C20002BAA	2	14	2	14	3.5	12	M3.5	10/8.7
LTVF-C20003BAA	2	14	2	14	3.5	12	M3.5	10/8.7
LTVF-C20006BAA	2	14	2	14	3.5	12	M3.5	10/8.7
LTVF-C20010BAA	2	14	2	14	3.5	12	M3.5	10/8.7
LTVF-C20012BAA	2	14	2	14	3.5	12	M3.5	10/8.7
LTVF-C20018BAA	3.5	12	3.5	12	3.5	12	M4	12.2/10.6
LTVF-C20030BAA	6	10	6	10	5.5	10	M4	15/13
LTVF-C20040BAA	6	10	6	10	5.5	10	M4	15/13
LTVF-C40002BAA	2	14	2	14	2	14	M3.5	10/8.7
LTVF-C40003BAA	2	14	2	14	2	14	M3.5	10/8.7
LTVF-C40005BAA	2	14	2	14	2	14	M3.5	10/8.7
LTVF-C40007BAA	2	14	2	14	2	14	M3.5	10/8.7
LTVF-C40010BAA	3.5	12	3.5	12	2	14	M4	12.2/10.6
LTVF-C40016BAA	3.5	12	3.5	12	3.5	12	M4	13.8/12
LTVF-C40023BAA	3.5	12	3.5	12	3.5	12	M4	13.8/12

Strip the sheaths of the wire insulation 7.0mm when a ring terminal is not used for power connection.

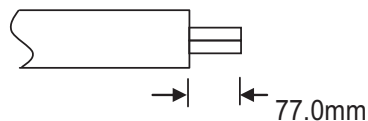

 Caution

- 1) Apply the rated torque to terminal screws. Loosen screws can cause of short circuit and malfunction. Tightening the screw too much can damage the terminals and cause short circuit and malfunction.
 - 2) Use copper wires only with 600V, 75°C ratings for wiring.
 - 3) Make sure the input power is off before wiring.
 - 4) When power supply is switched off following operation, wait at least 10 minutes after LED keypad display is off before you start working on it.
 - 5) Applying input power supply to the output terminals U, V and W causes internal inverter damage.
 - 6) Use ring terminals with insulated caps when wiring the input power and motor wiring.
 - 7) Do not leave wire fragments inside the inverter. Wire fragments can cause faults, breakdowns and malfunctions.
 - 8) When more than one motor is connected to one inverter, total wire length should be less than 150m (492ft). Do not use a 3-wire cable for long distances. Due to increased leakage capacitance between wires, over-current protective feature may operate or equipment connected to the output side may malfunction. In case of long wire length, it should be required to lower carrier frequency or use Micro Surge Filter.
 - 9) DC reactor connects with P1 and P2 terminals, if unused, short P1 and P2, otherwise, the inverter will have no power.
 - 10) Never short B and P1 terminals or Band P2, Shorting terminals may cause internal inverter damage.
 - 11) Do not install a power factor capacitor, surge suppressor or RFI filters in the output side of the inverter. Doing so may damage these components.
- [Warning]
- Power supply must be connected to the R, S, and T Terminals.
Connecting it to the U, V, W terminals causes internal damages to the inverter.
Arranging the phase sequence is not necessary.
Motor should be connected to the U, V, and W Terminals.
If the forward command (FX) is on, the motor should rotate counter clockwise when viewed from the load side of the motor. If the motor rotates in the reverse, switch the U and V terminals.

 Warning

Use the Type 3 grounding method (Ground impedance: Below 100Ω) for 230V drives.
 Use the Special Type 3 grounding method (Ground impedance: Below 10Ω) for 415V drives.
 Use the dedicated ground terminal to ground the inverter. Do not use the screw in the case or chassis, etc for grounding.

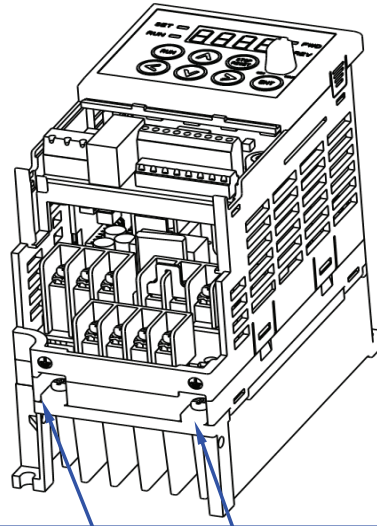

Special ground terminal: Opening to access

Note

Grounding procedure

- 1) Remove the front cover.
 - 2) Connect the Grounding wire to the ground terminal and secure the screw tightly.
- The grounding point shall be close to the inverter as possible as it can, and the grounding wire shall be short as possible as it can

Note Grounding work guidance

Inverter capacity	230V Drives			415 V Drives		
	Wire size	Terminal screw	Grounding type	Wire size	Terminal screw	Grounding type
0.1~3.7kW	3.5mm ²	M3	Type 3	2.0 mm ²	M3	Special type 3
5.5~7.5kw	5.5mm ²	M4	Type 3	3.5 mm ²	M4	Special type 3

Chapter 2 INSTALLATION & WIRING

2.5 Control terminal specification

T/M	Terminal Description	Wire size (mm ²)		Screw size	Torque [Nm]	Specification
		Single Wire	Stranded			
P1 ~ P5	Multi-function input terminal P1-P5	1.0	1.5	M2	0.2	
CM	Common terminal	1.0	1.5	M2	0.2	
VR	Power supply for analog	1.0	1.5	M2	0.2	Output voltage: 12V Max output current: 10mA Potentiometer: 1 ~ 5kohm
AI	Analog (voltage and current) input Terminal	1.0	1.5	M2	0.2	Input voltage: 0~10V Input current: 0 ~ 20mA Internal resistance: 250Ω
AM	Multi-function analog output terminal	1.0	1.5	M2	0.2	Max output voltage: 11[V] Max output current: 10mA
S+	RS485 communication terminal	1.0	1.5	M2	0.2	
S-	RS485 communication terminal	1.0	1.5	M2	0.2	
24	External 24V power supply	1.0	1.5	M2	0.2	Max output current: 100mA
3A	Multi-function relay output A	1.0	1.5	M2.6	0.4	AC 250V, less than 1A DC 30V, less than 1A
3B	Multi-function relay output B	1.0	1.5	M2.6	0.4	
3C	Multi-function relay common terminal	1.0	1.5	M2.6	0.4	
SA	Safe stop connection terminal A	1.0	1.5	M2	0.2	
SB	Safe stop connection terminal B	1.0	1.5	M2	0.2	
SC	Safety power supply (24V)	1.0	1.5	M2	0.2	

Note 1) Tie the control wires more than 15cm away from the control terminals. Otherwise, it interferes front cover reinstallation.

Note 2) Use Copper wires rated 600V, 75 °C and higher.

Note 3) Use the recommended tightening torque when securing terminal screws.

Note

When you use external power supply (24V) for multi-function input terminal (P1~P5), terminals will be active above 12V level. Take caution not to drop the voltage below 12V.

2.6 PNP/NPN selection and analog input V/I selection

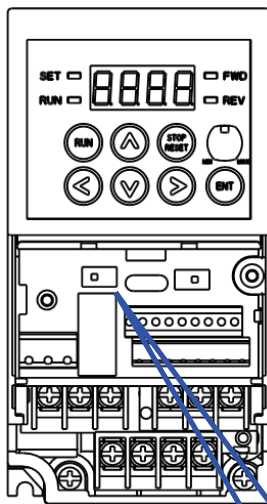

Keypad J3

P1 ~ P5 When using DC 24V inside inverter [NPN]

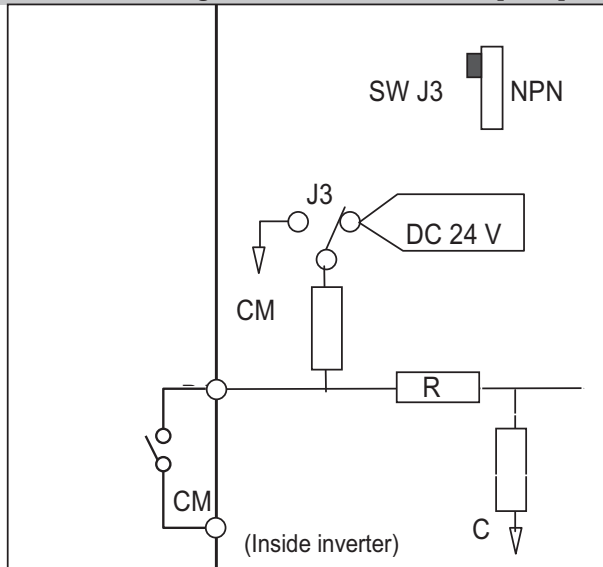

P1 ~ P5 When using external DC 24V [PNP]

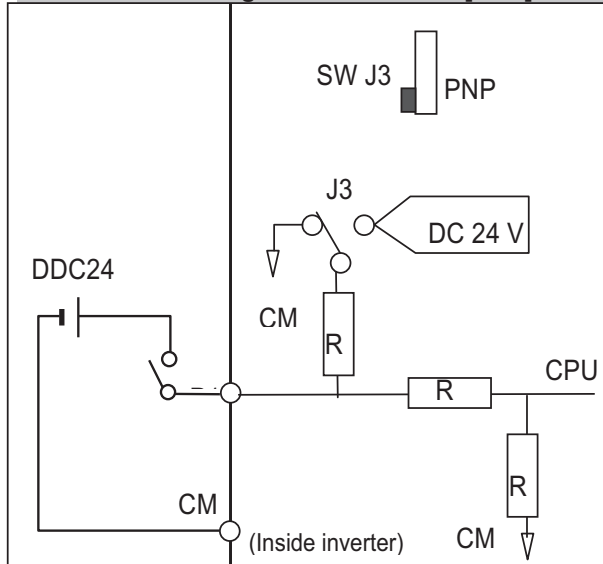

Chapter 2 INSTALLATION & WIRING

Analog input V/I select

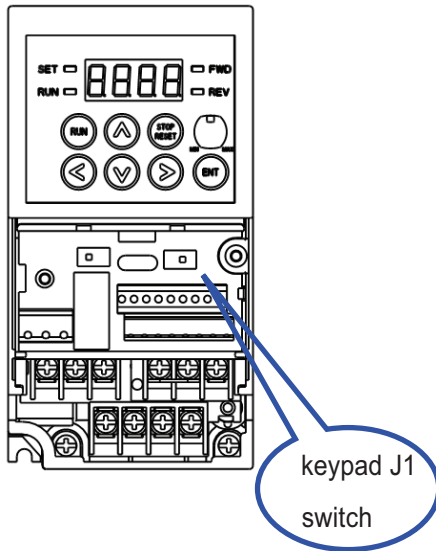





Selecting analog voltage V input: using external voltage source, J1 switches to V side, connect positive pole of voltage source to terminal AI, and negative pole to terminal CM. Max external voltage: 10V

Selecting analog voltage I input: using external current source, J1 switches to I side, connect positive pole of current source to terminal AI, and negative to terminal CM. Max external current: 20mA.

3. Peripheral equipment

3.1 Peripheral equipment

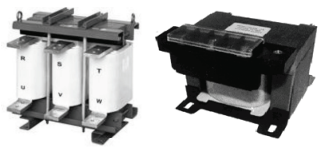
When applying inverter, please select appropriate peripheral equipment and install it correctly. Incorrect configuration and installation may cause system fault and loss of life span. It may even cause damage of inverter. Please carefully read and understand relevant notes of this manual. Apply inverter according to operation regulation.

	AC power	Please apply it within the allowable power range of inverter. 230V : 200 ~ 240V(- 15% ~ +10%) 415V : 380 ~ 480V(- 15% ~ +10%)
	MCCB or electric leakage breaker	When supplied with power, inverter may produce surging current. Please select breaker carefully.
	Electromagnetic contactor (optional)	Please don't start or stop inverter through electromagnetic contactor. Otherwise the operation lifetime of inverter will be shortened. (Electromagnetic contactor is only installed and used under necessary situations)
	AC and DC reactor (optional)	In order to increase power factor or install large capacity system in the surrounding area of inverter, it is necessary to install AC reactor. Please select appropriate reactor according to model of inverter. (More than 10 multiples of inverter capacity. Wiring distance is within 10 meters)
	Inverter installation and wiring	To make inverter run under high-performance status for a long time, please install inverter at the correct place, leave appropriate space. Incorrect wiring may damage the equipment
	Inverter output side	Please don't install electric capacity, surging controller or noise filter to output side of inverter. Otherwise, the equipment and inverter will be damaged.

3.2 Recommend breaker and breaker specification

Inverter model		L&T MCCB/Amp		Electromagnetic contactor
Single phase 230V	LTVF-C10001BAA	DM16/2.5		MNX 9-2P
	LTVF-C10002BAA	DM16/6.3		MNX 9-2P
	LTVF-C10003BAA	DM16/12		MNX 9-2P
	LTVF-C10005BAA	DM100/25		MNX 9-2P
	LTVF-C10008BAA	DM100/30		MNX 12-2P
	LTVF-C10011BAA	DM100/50		MNX 18-2P
		HD	ND	
Three phase 230V	LTVF-C20001BAA	DM16/1.6	DM16/2.5	MO9
	LTVF-C20002BAA	DM16/4	DM16/4	MO9
	LTVF-C20003BAA	DM16/4	DM16/7.5	MO9
	LTVF-C20006BAA	DM16/12	DM16/16	MO9
	LTVF-C20010BAA	DM16/16	DM100/25	MO-12
	LTVF-C20012BAA	DM100/25	DM100/25	MO-18
	LTVF-C20018BAA	DM100/35	DM100/50	MO-32
	LTVF-C20030BAA	DM100/50	DM100/60	MO-40
	LTVF-C20040BAA	DM100/60	DM100/80	MO-50
Three phase 415V	LTVF-C40002BAA	DM16/4	DM16/5	MO9
	LTVF-C40003BAA	DM16/7.5	DM16/10	MO9
	LTVF-C40005BAA	DM16/10	DM16/12	MO9
	LTVF-C40007BAA	DM16/12	DM16/16	MO-12
	LTVF-C40010BAA	DM100/25	DM100/30	MO-18
	LTVF-C40016BAA	DM100/25	DM100/30	MO-32
	LTVF-C40023BAA	DM100/30	DM100/50	MO-32

NOTE

- 1) The current of selected breaker shall be 1.5 to 2 times of rated current
- 2) In order to prevent the damage of AC equipment because of fault current, please use MCCB to replace overload protection device (150% rated output 1 minute protection)

3.3 Recommend fuse and reactor specification

Inverter model		AC input fuse (external)		AC reactor	DC reactor
		[Current]	[Voltage]		
Single phase 230V	LTVF-C10001BAA	10 A	600 V	1.20 mH, 10A	4mH, 8.67A
	LTVF-C10002BAA	10 A	600 V	1.20 mH, 10A	4mH, 8.67A
	LTVF-C10003BAA	10 A	600 V	1.20 mH, 10A	4mH, 8.67A
	LTVF-C10005BAA	10 A	600 V	1.20 mH, 10A	4mH, 8.67A
	LTVF-C10008BAA	15 A	600 V	0.88 mH, 14A	3mH, 13.05A
	LTVF-C10011BAA	20 A	600 V	0.56 mH, 20A	1.3mH, 18.45A
Three phase 230V	LTVF-C20001BAA	10 A	600 V	1.20 mH, 10A	4mH, 8.67A
	LTVF-C20002BAA	10 A	600 V	1.20 mH, 10A	4mH, 8.67A
	LTVF-C20003BAA	10 A	600 V	1.20 mH, 10A	4mH, 8.67A
	LTVF-C20006BAA	10 A	600 V	1.20 mH, 10A	4mH, 8.67A
	LTVF-C20010BAA	15 A	600 V	0.88 mH, 14A	3mH, 13.05A
	LTVF-C20012BAA	20 A	600 V	0.56 mH, 20A	1.3mH, 18.45A
	LTVF-C20018BAA	32 A	600 V	0.39 mH, 30A	1.3mH, 26.35A
	LTVF-C20030BAA	50 A	600 V	0.30 mH, 34A	1.6mH, 32A
Three phase 415V	LTVF-C40002BAA	10 A	600 V	4.81 mH, 4.8A	16mH, 4.27A
	LTVF-C40003BAA	10 A	600 V	4.81 mH, 4.8A	16mH, 4.27A
	LTVF-C40005BAA	10 A	600 V	3.23 mH, 7.5A	12mH, 6.41A
	LTVF-C40007BAA	15 A	600 V	2.34 mH, 10A	8mH, 8.9A
	LTVF-C40010BAA	20 A	600 V	1.22 mH, 15A	5.4mH, 13.2A
	LTVF-C40016BAA	32 A	600 V	1.12 mH, 19A	3.2mH, 17A
	LTVF-C40023BAA	35 A	600 V	0.78 mH, 27A	2.5mH, 25A

4 Parameter setting
4.1 Keypad structure

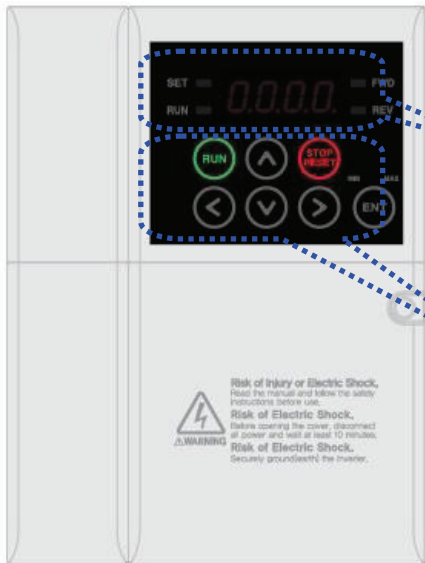

Display:
SET/RUN LED
FWD/REV LED
7-segment LED

Key :
RUN
STOP/RESET
Up/Down
Right/Left
Enter

Display		
FWD	Lit during forward run	Blinks when a fault occurs
REV	Lit during reverse run	
RUN	Lit during operation	
SET	Lit during parameter setting	
7-segment	Operation data and parameter information are displayed.	
Keys		
RUN	Run command	
STOP/RESET	STOP: Stop command during operation, RESET: Reset command when fault occurs.	
▲	Up	Used to move parameter codes or increase parameter values
▼	Down	Used to move parameter codes or increase parameter values
◀	Left	Used to switch parameter groups or move the cursor to the left when the parameters are written.
▶	Right	Used to switch parameter groups or move the cursor to the right when the parameters are written.
ENT	ENT	Used to read, write and keep the parameter values.
Knob		
Volume	The keypad potentiometer V2 is used for frequency setting.	

4.2 Alpha-numeric table

0	0	A	A	K	K	U	U
1	1	B	B	L	L	V	V
2	2	C	C	M	M	W	W
3	3	D	D	N	N	X	X
4	4	E	E	O	O	Y	Y
5	5	F	F	P	P	Z	Z
6	6	G	G	Q	Q		
7	7	H	H	R	R		
8	8	I	I	S	S		
9	9	J	J	T	T		

4.3 Moving to other parameter groups

- LTVF-Cx2000 series product consists of the following four parameter groups.

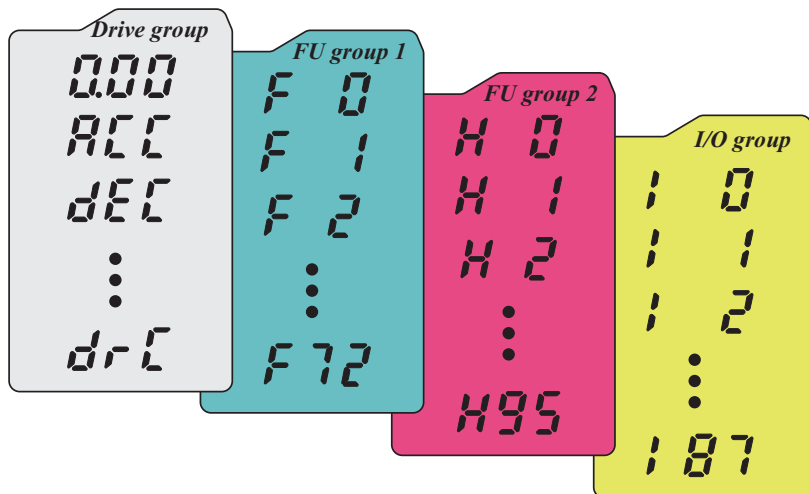

Drive group	Set Basic parameters necessary for inverter operation, including target frequency, Accel/Decel time and so on.
Function group 1	Set basic function parameters, such as adjustment of input frequency, voltage and so on.
Function group 2	Set advanced function parameters, for example, set application functions such as PID operation, second motor operation and so on.
I/O (input/output) terminal function group	Set multi-function input/ output terminals and analog input/output parameters.

- Moving to other parameter groups

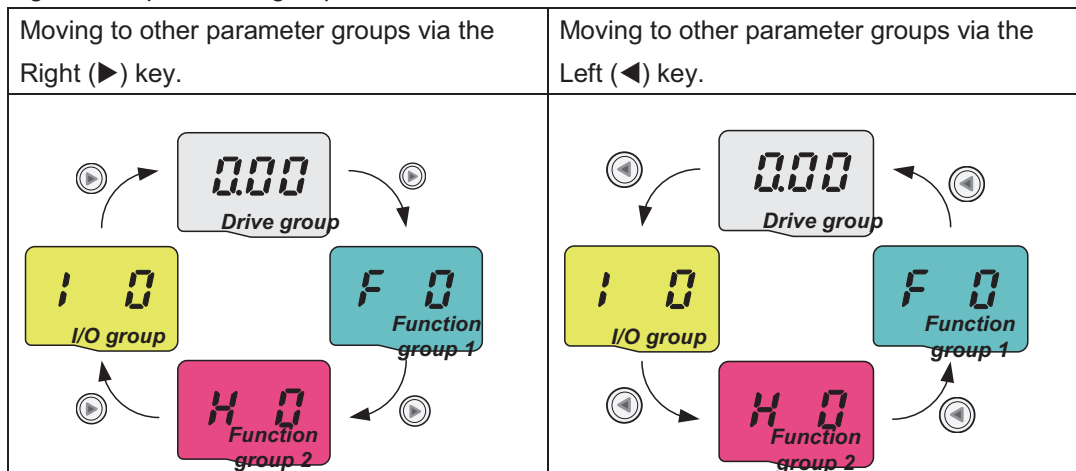

Note 1) Target frequency can be set at 0.0 (the 1st code of drive group). Even though the preset value is 0.0 while leaving factory, after setting of the target frequency, the changed frequency value will be displayed.

● Moving to other parameter groups at the 1st parameter of each group

1		- The 1 st code 0.00 in Drive group displayed is displayed after power is applied. -. Press the Right (▶) key once to go to the Function group 1.
2		- The 1 st code F0 in Function Group is displayed. -. Press the Right (▶) key once to go to Function group 2.
3		- The 1 st code H0 in Function group 2 is displayed. -. Press the Right (▶) key to go to I/O group.
4		- The 1 st input / output code I 0 is displayed. -. Press the Right (▶) key once to return to Drive group.
5		- Return to the 1 st code 0.00 of Drive group.

♣ If the Left (◀) key is used; the above will be executed in the reverse order.

● Moving to other parameter groups from any parameter code other than the 1st code

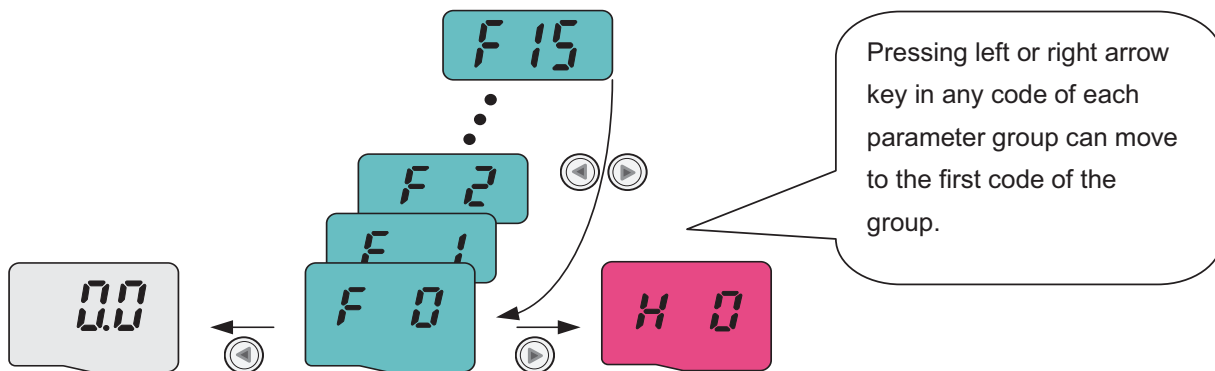

To move from F15 to function group 2

1		- F 15 of Function group 1 is displayed. -. Press the Right or Left key to return to the 1 st code of the parameter group.
2		- The 1 st code F 0 of Function group 1 is displayed. -. Press the Right key.

3		- The 1 st code H 0 of Function group 2 is displayed.
---	--	--

4.4 How to change the codes in a group

● Code change in Drive group

	1		- The 1 st code 0.00 of Drive group is displayed. - Press the Up (▲) key once.
	2		- The 2 nd code ACC of Drive group is displayed. - Press the Up (▲) key once.
	3		- The 3 rd code dEC of Drive group is displayed. - Keep pressing the Up (▲) key until the last code appears.
	4		- The last code drC of Drive group is displayed. - Press the Up (▲) key again.
	5		- Return to the first code of Drive group.
♣ Use Down (▼) key for the reverse order.			

● Code jump method

When moving from the “F 0” to the “F 15” in Function parameter group 1 directly			
	1		- The 1 st code F 0 of Function group 1 is displayed. - Press the ENT key.
	2		- 1 is displayed (F1 code), - Use the Up (▲) key to set to 8.
	3		- Move the cursor to the left by pressing the Left (◀) key, and “08” is displayed. If the number 0 is displayed brighter than 8, which means 0 is active. - Use the Up (▲) key to set to 2.
	4		- 28 has been set, - Press the ENT key.
	5		- F28 of Function group 1 is displayed.
♣ Function group 2 and I/O group are settable with the same method.			

- Navigating codes in the same parameter group

When moving from F 1 to F 15 in Function group 1			
	1		-. F1 of Function parameter group 1 is displayed, -. Continue pressing the Up (▲) key until F28 is displayed.
	2		-. F28 of Function parameter group 1 is displayed.
♣The same applies to Function group 2 and I/O group.			
♣ Some codes will be skipped when the Up(▲) or Down (▼) is used, that is because the codes have not been activated due to no use, or some codes intentionally left blank for future use. Refer to the Ch.5 for more specific contents For example, when F24 [High/low frequency limit select] is set to "O (No) ", F25 [High frequency limit] and F26 [Low frequency limit] are not displayed during code change. But When F24 is set to "1(Yes)", F25 and F26 will appear on the display.			

4.5 Parameter setting

Parameter setting in Drive group

When changing ACC time from 5.0 sec to 16.0 sec

1		- The 1 st code of the parameter group is displayed when the Power is applied - Press the Up (▲) key.
2		- The second code ACC of Drive group is displayed. - Press the ENT key.
3		- The default code is 5.0 and the cursor is in the digit 0. - Press the Left (◀) key once to move the cursor to the left.
4		- The digit 5 is active, and then the parameter value can be changed. - Press the Up (▲) key.
5		- The value is increased to 6.0. - Press the Left (◀) key to move the cursor to the left.
6		- 0.60 is displayed. The first 0 in 0.60 is active. - Press the Up (▲) key once.
7		- 16.0 is displayed. - Press the ENT key. - 16.0 is blinking (1) - Press the ENT key once again to return to the parameter name.
8		- ACC is displayed. Accel time is changed to 16.0.

♣ Pressing the Left (◀) or Right (▶) key while 16.0 is blinking will disable the setting.

Note 1) when the parameter value is changed, the blinking cursor means if any changed value is required, then Press the ENT key to complete the input of parameter change. Press any key of (◀)(▶)(▲)(▼) if any parameter change is cancelled.

- Frequency setting

When setting run frequency to 30.05 Hz in Drive group		
1		- The 1 st code is displayed when the power is applied. - Press the ENT key.
2		- The second decimal 0 becomes active. - Press the Up (▲) key until 5 is displayed.
3		- Press the left (◀) key once.
4		- Move the cursor to the left. - Press the Left (◀) key once.
5		- Press the Left (◀) key once.
6		- Set to 3 using Up (▲) key.
7		- Press the ENT key. - 30.05 is blinking. - Press the ENT key.
8		- Set operation frequency to 30.05□
<p>♣ LTVF-Cx2000 product displays 4 digits, but 5 digits can be displayed and set by using Left (◀) key and Right (▶) key.</p> <p>♣ Under the condition that 30.05 is blinking, pressing any key can cancel the parameter setting except the ENT key.</p>		

Chapter 4 Parameter setting

● Parameter setting in Function group

When changing the parameter value of F28 from 2 to 5

1		- The 1 st code F 0 of Function group 1 is displayed. - Press the ENT key.
2		- 1 (F1 code) is displayed - 8 is set by pressing the Up (▲) key.
3		- 8 is displayed. - Press the Left (◀) key once so that the cursor is moved for one digit to the left.
4		- 0 is active. - 2 is set by pressing the Up
5		- Means the current location is for No. 28 parameter of Function group 1. - Press the ENT key.
6		- F28 is displayed. - Press the ENT key.
7		- Present value of F28 is set to 2. - Increase the value to 5 by pressing Up (▲) key.
8		- Press the ENT key.
9		- Parameter number will appear after 5 is blinking. Parameter change is complete. - Press either Left (◀) or Right (▶) keys.
10		- Moving to first code of Function group 1 is complete.

♣ The above is also applied to parameter setting in function group 2 and I/O group.

4.6 Monitoring of operation status

● Output current display

Monitoring output current in Drive group		
1		<ul style="list-style-type: none"> - The 1st parameter of Drive group is displayed. - Press the Up (▲) or Down (▼) key until [CUr] is displayed.
2		<ul style="list-style-type: none"> - Monitoring output current code is displayed - Press the ENT key.
3		<ul style="list-style-type: none"> - Present output current of inverter is 5 [A]. - Press the ENT key again.
4		<ul style="list-style-type: none"> - Return to the output current monitoring code.
<p>♣ The same method is used to monitor dCL (Inverter DC side voltage) or vOL (Inverter output voltage) of Drive group and so on.</p>		

● Fault display

Monitoring faults in Drive group

1		- This message appears when an Over-current fault occurs. - Press the Enter key or UP (▲)/Down (▼) key once.
2		- The run frequency at the time of fault is displayed. - Press the Up (▲) key once.
3		- The output current at the time of fault is displayed. - Press the Up (▲) key once.
4		- Operating status is displayed. A fault occurred during acceleration. - Press the STOP/RST key.
5		- "nOn" is displayed after the fault condition is cleared.

More than one fault occur at the same time.

- Maximum three faults information is displayed as shown left when more than one fault occur at the same time.

Parameter initialize

Initializing all the parameters in H93 parameter of Function group 2.

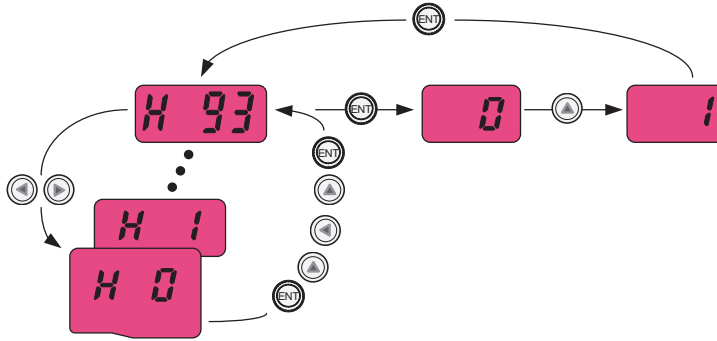





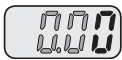

1		- The 1 st code of Function group 2 is displayed. - Press the ENT key once.
2		- The parameter number 1 to be moved is displayed. - Increase the value to 3 by pressing the Up (▲) key.
3		- The parameter number to be moved is 3 - Press the Left (◀) key once.
4		- 03 is displayed, and 0 is active. - Increase the value to 9 by pressing the Up (▲) key.
5		- The parameter number to be moved is 93. - Press the ENT key.
6		- The present setting is H93 of Function group 2. - Press the ENT key.
7		- The setting value is 0. - Press the Up (▲) key once.
8		- Press the ENT key. Press it again when the number is blinking, then the parameter initialization is active.
9		- The parameter number is displayed over again. The parameter initialization closes. - Press the Left (◀) or Right (▶) key.
10		- Return to the 1 st code H0 of Function group 2.

4.7 Frequency setting and Basic Operation

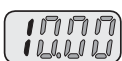
⚠ Caution

The following instructions are given based on the fact that all parameters are set to factory defaults. Results could not be consistent with the following contents if parameter values are changed after purchase of products by customers. In this case, initialize all parameter values and set them according to the instructions below.

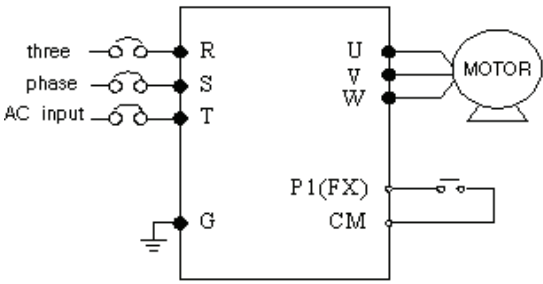
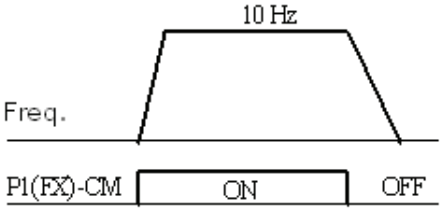
Frequency setting via key and driving via terminals	
1	- Apply power to the inverter.
2	 <ul style="list-style-type: none"> - The inverter keypad displays 0.00. - Press the ENT key.
3	 <ul style="list-style-type: none"> - 00.00 is displayed and the last 0 is lit. - Press the Left (◀) key three times.
4	 <ul style="list-style-type: none"> - 00.00 is displayed and the leftmost 0 is lit. - Press the Up (▲) key once.
5	 <ul style="list-style-type: none"> - 10.00 is displayed and then press the ENT key. - 10.00 is blinking. Press the ENT key again.
6	 <ul style="list-style-type: none"> - Run frequency is set to 10.00 Hz when 10.00 stops blinking. - Turn OFF (ON) the switch between P1 (FX) terminal and CM terminal on the connection diagram below.
7	 <ul style="list-style-type: none"> - RUN (operating) lamp on the inverter keypad is blinking, with FWD (Forward Run) indicator light lit and accelerating frequency displayed on the keypad. - The run frequency reaches 10Hz. - Turn off the switch between P1 (FX) and CM terminals.
8	 <ul style="list-style-type: none"> - RUN lamp begins to blink over again and decelerating frequency is displayed on the panel. - When run frequency is reached to 0Hz, Run (operating) and FWD (Forward Run) lamp is turned off and 10.00 is displayed on the keypad.
 <p style="text-align: center;">Connection diagram</p>	 <p style="text-align: center;">Run curve</p>

● Frequency Setting via Terminal AI (V) and Driving via Terminals

1		- Apply power to the inverter.
2		- 0.00 is displayed on the inverter keypad. - Press the Up (▲) key four times.
3		- Freq. is displayed. Frequency setting mode is selectable. - Press the ENT key.
4		- Present frequency setting method is set to 0 (frequency setting via keypad). - Press the Up (▲) key three times.
5		- 3 is displayed [frequency setting via terminal AIN (V1)] - Press the ENT key.
6		- Press the ENT key again after “3” is blinking. - Freq. is displayed; the frequency setting method is changed into terminal AIN (V) setting frequency. - Press the Down (▼) key four times to move to frequency display status. - V1 voltage is adjusted so that output frequency is 10.00 Hz.
7		- Turn off (ON) the switch between P1 (FX) and CM terminals. - RUN (operating) lamp on the inverter keypad begins to blink with FWD (Forward Run) lamp lit and accelerating frequency displayed on the keypad. - Run frequency reaches 10 Hz. - Turn off the switch between P1 (FX) and CM terminals.
8		- Run (operating) lamp on the inverter keypad is blinking over again, and the number displayed indicates the decelerating frequency. - After run frequency reaches 0Hz, Run (operating) and FWD (forward run) lamps are blacked out, 10.00 is displayed on the keypad.

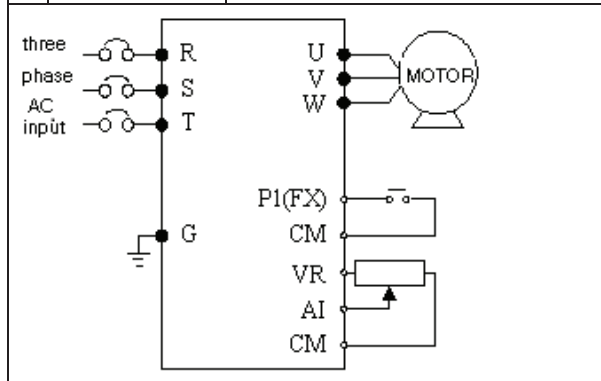

Connection diagram

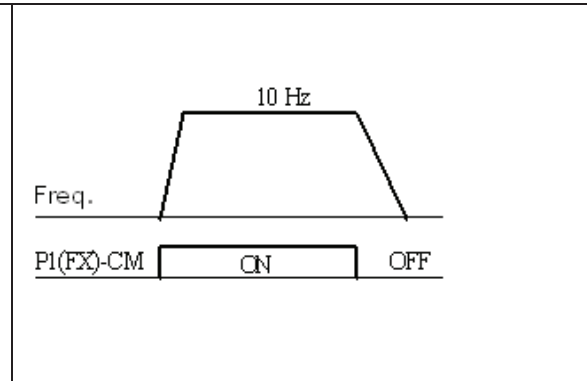

Run curve

Chapter 4 Parameter setting

● Frequency setting via Terminal AIN (V1) and Driving via Pressing Run Key		
1		- Apply power to the inverter.
2		- 0.00 is displayed on the inverter keypad. - Press the Up (▲) key three times.
3		- drv. is displayed and the drive pattern is selectable. - Press the ENT key.
4		- Present setting value is 1 (operation of inverter terminal). - Press the Down (▼) key once.
5		- Press the ENT key after 0 is displayed. - Press the ENT key again when 0 is blinking.
6		- drv is displayed, drive pattern is set via the Run key on the keypad. - Press the Up (▲) key once.
7		- Freq. is displayed. Frequency setting method is selectable. - Press the ENT key.
8		- Present frequency setting is 0 (frequency setting via keypad). - Press the Up (▲) key three times.
9		- Press the ENT key after 3 is displayed [Terminal AIN (V1)]. - Press the ENT key over again when 3 is blinking.
10		- Freq. is displayed; frequency setting method is made via Terminal AIN (V1). - Press the Down (▼) key four times to move the frequency display status. - V1 voltage is adjusted so that output frequency is 10.00 Hz.
11		- Press Run key on the inverter keypad. - Run lamp on the inverter keypad starts to blink with FWD lamp lit and accelerating frequency displayed on the keypad. - When frequency reaches 10 Hz, press (STOP/RST) key of inverter keypad once.
12		- RUN (operating) lamp on the inverter keypad blinks over again, with decelerating frequency displayed on the keypad. - When fun frequency reaches 0Hz, RUN and FWD lamps are blacked out and 10.00 is displayed on the keypad.
Connection diagram		Run curve

5 Parameter list

Drive Group

Drive Group	Address for comm	Parameter name	Set range	Description		Factory defaults	Adj. during run	Page	
0.00	1100	Frequency command	0.00 ~ 400.00 [Hz]	This parameter sets the frequency that the inverter is commands to output. During stop: frequency command During run: output frequency During Multi-step operation: It cannot be set greater than F21(Max. frequency)		0.00	O	7-1	
ACC	1101	Accel time	0.0~ 6000.0 [sec]	During Multi-Accel/Decel operation, this parameter serves as Accel/Decel time 0.		20.0	O	7-12	
dEC	1102	Decel time				20.0	O	7-12	
drv	1103	Drive Mode	0 ~ 3	0	RUN/STOP via RUN/STOP key on the keypad		1	X	7-8
				1	Terminal operation	FX: motor forward run RX: Motor reverse run			7-8
				2		FX: Run/Stop enable RX: reverse rotation select			7-9
				3	RS-485 communication				7-9
Frq	1104	Frequency Setting Method	0 ~ 8	0	Digital	Keypad setting 1	0	X	7-1
				1		Keypad setting 2			7-1
				2	Analog	Panel Potentiometer V2 set: 0 ~ 5 [V]			7-2
				3		Terminal A1 (J1 to V) : 0 ~ +10 [V]			7-2
				4		Terminal A1 set (J1 to I) :0 ~ 20 [mA]			7-3
				5		Panel Potentiometer V2 + Terminal A1 (J1 to I) setting			7-5
				6		Panel Potentiometer V2 + Terminal A1 (J1 to V) setting			7-5

Chapter 5 – Function list

				7	RS-485 communication			7-5
				8	Digital (UP/DOWN) rotation			8-4

Drive Group

LED display	Address for comm	Parameter name	Set range	Description	Factory defaults	Adj. during run	Page	
St1	1105	Multi-step frequency 1	0.00 ~ 400.00 [Hz]	Sets Multi-step frequency 1 during Multi-step operation	0.00	O	7-7	
St2	1106	Multi-step frequency 2		Sets multi-step frequency 2 during multi-step operation	0.00	O	7-7	
St3	1107	Multi-step frequency 3		Sets multi-step frequency 3 during multi-step operation	0.00	O	7-7	
CUr	1108	Output current	[A]	Displays the output current to the motor.	-	-	9-1	
rPM	1109	Motor RPM	[rPM]	Displays the number of Motor RPM.	-	-	9-1	
dCL	110A	DC link voltage	[V]	Displays DC link voltage inside the inverter	-	-	9-1	
vOL	110B	User display select	-	This parameter displays the item selected at H73- [Monitoring item select].		vOL	-	9-2
				vOL	Output voltage			
				POr	Output power			
				tOr	Torque			
nOn	110C	Fault Display	-	Displays the types of faults, frequency and operating status at the time of the fault	-	-	9-4	
drC	110D	Direction of motor rotation	F, r	Direction of motor rotation when drv (Drive mode) is set to 0.		F	O	7-8
				F	Forward			
				r	Reverse			
drv2 ₁₎	110E	Drive mode 2	0 ~	0	Run/Stop via Run/stop key on the keypad	1	X	8-22

			3	1	Terminal operation	FX: Motor forward run RX: Motor reverse run			
				2		FX: RUN/STOP enable RX: Reverse rotation select			
				3	RS-485 communication				

¹⁾ : Only displayed when one of the Multi-function input terminals 1-5 [I17~I21] is set to “22”.

Drive Group

LED display	Address for communication	Parameter name	Set range	Description		Factory defaults	Adj. during run	Page	
Frq2 ₁₎	110F	Frequency setting method 2	0 ~ 7	0	Digital	Keypad setting 1	0	X	8-22
				1		Keypad setting 2			
				2	Analog	Panel Potentiometer V2 : 0 ~ 5 [V]			
				3		Terminal A set (J1 to V) : 0 ~ +10 [V]			
				4		Terminal A1 set (J1 TO 1): 0 ~ 20 [mA]			
				5		Panel Potentiometer V2 +Terminal A1 (J1 to 1) setting			
				6		Panel potentiometer V2 + Terminal A1 (J1 to V) setting			
				7		RS-485 communication			

Chapter 5 – Function list

rEF ²⁾	1110	PID control standard value setting	0.00~ 400.00 [Hz] or 0~ 100[%]	If H58 is 0, it is expressed as a [Hz] unit. If H58 is 1, it is expressed as a [%] unit. In [Hz] unit, you can't set Max. Frequency more than (F21). In [%] unit, 100% means Max. Frequency.	0.00	0	8-10
Fbk ²⁾	1111	PID control Feedback amount	0.00~ 400.00 [Hz] or 0~ 100[%]	It indicates a feedback amount in PID control. If H58 is 0, it is expressed as a [Hz] unit. If H58 is 1, it is expressed as a [%] unit.	-	-	8-10

¹⁾ : Only displayed when one of the Multi-function input terminals 1-5 [I17~I22] is set to "22".

²⁾ : It is indicated when H49 (PID control selection) is 1.

Function group 1

LED display	Address for comm	Parameter name	Range	Description	Factory defaults	Adj. During run	Page	
F 0	1200	Jump code	0 ~ 72	Sets the parameter code number to jump	1	O	4-5	
F 1	1201	Forward/reverse run disable	0 ~ 2	0	Fwd and rev run enable	0	X	7-10
				1	Forward run disable			
				2	Reverse run disable			
F 2	1202	Accel pattern	0 ~ 1	0	Linear	1	X	7-15
F 3	1203	Stop mode select		1	S-curve			
F 4	1204	Stop mode Select	0 ~ 3	0	Decelerate to stop	0	X	7-20
				1	DC brake to stop			
				2	Free run to stop			
				3	Power Braking stop			8-25
F 8 ¹⁾	1208	DC brake start frequency	0.10~ 60.00 [Hz]	This parameter sets DC brake start frequency. It cannot be set below Start frequency (F23).	0.50	X	8-1	

F 9	1209	DC Brake wait time	0.00~ 60.00 [sec]	When DC brake frequency is reached, the inverter holds the output for the setting time before starting DC brake.	0.10	X	8-2
F10	120A	DC brake Voltage	0 ~ 200[%]	This parameter sets the amount of DC voltage applied to a motor. It is set in percent of Motor rated current (H33).	50	X	
F11	120B	DC brake Time	0.0~ 60.0 [sec]	The parameter sets the time taken to apply DC current to a motor while motor is at a stop.	1.0	X	
F12	120C	Brake start voltage	0 ~ 200[%]	This parameter sets the amount of DC voltage before a motor starts to run. It is set in percent of Motor rated current (H33).	50	X	
F13	120D	DC brake start time	0.0~ 60.0 [sec]	DC voltage is applied to the motor for DC brake start time before motor accelerates.	0.0	X	

¹⁾ : Only displayed when F4 (DC brake stop) is set to 1.

Function group 1

LED display	Address for comm	Parameter name	Range	Description	Factory defaults	Adj. During run	Page
F14	120E	Time for magnetizing a motor	0.0~ 60.0 [sec]	This parameter applies the current to a motor for the set time before motor accelerates during sensorless vector control	0.5	X	8-15
F20	1214	Jog frequency	0.00~ 400.00 [Hz]	This parameter sets the frequency for jog operation. It cannot be set above max frequency (F21)	10.00	O	8-3
F21 ¹⁾	1215	Max frequency	40.00~ 400.00 [Hz]	Highest frequency the inverter can output. It is frequency reference for Accel/Decel (See H70)	50.00	X	7-21
				 Caution			

Chapter 5 – Function list

				Except F22 (base frequency), any frequency which is set above F21 will automatically turn to the set value of F21			
F22	1216	Base frequency	30.00~ 400.00 [Hz]	The inverter outputs its rated voltage to the motor at this frequency (see motor nameplate)	50.00	X	7-17
F23	1217	Start frequency	0.10~ 10.00[Hz]	The inverter starts to output its voltage at This frequency. It is the frequency low limit.	0.50	X	7-21
F24	1218	Frequency high/low limit select	0 ~ 1	This parameter sets high and low limit of run frequency	0	X	7-21
F25 ²⁾	1219	Frequency high limit	0.00~ 400.00 [Hz]	This parameter sets high limit of the run frequency. It cannot be set above Max frequency (F21).	50.00	X	
F26	121A	Frequency Low limit	0.00~ 400.00 [Hz]	This parameter sets low limit of the run frequency. It cannot be set above Frequency high limit (F25) and below Start frequency (F23).	0.50	X	

¹⁾ : If H40 is set to 3 (sensorless vector), Max frequency is settable up to 120Hz.

²⁾ : Only displayed when F24 (Frequency high/low limit select) is set to 1.

Function group 1

LED display	Address for comm	Parameter name	Range	Description	Factory defaults	Adj. During run	Page
F27	121B	Torque boost select	0 ~ 1	0	Manual torque boost	0	X
				1	Auto torque boost		
F28	121C	Torque boost in forward direction	0.0~ 20.0 [%]	This parameter sets the amount of torque boost applied to a motor during forward run. It is set in percent of Max output voltage.	3.0	X	7-19

F29	121D	Torque boost in reverse direction	0.0~ 20.0 [%]	This parameter sets the amount of torque boost applied to a motor during reverse run. It is set as a percent of Max output voltage	3.0	X	
F30	121E	V/F pattern	0 ~ 2	0 Linear	0	X	7-17
				1 Square			7-17
				2 User V/F			7-18
F31 ¹⁾	121F	User V/F frequency 1	0.00~ 400.00 [Hz]	It is used only when V/F pattern is set to 2 user/V/F). It cannot be set above F21- Max frequency. The value of voltage is set in percent of motor rated voltage. The values of lower-numbered parameters cannot be set above those of higher-numbered.	12.50	X	7-18
F32	1220	User V/F voltage 1	0~ 100 [%]		25	X	
F33	1221	User V/F frequency 2	0.00~ 400.00 [Hz]		25.00	X	
F34	1222	User V/F voltage 2	0 ~ 100 [%]		50	X	
F35	1223	User V/F frequency 3	0.00~ 400.00 [Hz]		37.50	X	
F36	1224	User V/F voltage 3	0 ~ 100 [%]		75	X	
F37	1225	User V/F frequency 4	0.00~ 400.00 [Hz]		50.00	X	
F38	1226	User V/F voltage 4	0 ~ 100 [%]		100	X	

¹⁾ : Set F30 to 2(User V/F) to display this parameter

Chapter 5 – Function list

Function group 1

LED display	Address for comm	Parameter name	Range	Description	Factory defaults	Adj. During run	Page
F39	1227	Output voltage adjustment	40.0 ~ 110.0 [%]	This parameter adjusts the amount of output voltage. The set value is the percentage of input voltage.	100.0	X	7-18
F40	1228	Energy-saving level	0 ~ 30[%]	This parameter decreases output voltage according to load status.	0	0	8-17
F50	1232	Electronic thermal select	0 ~ 1	This parameter is activated when the motor is overheated (time-inverse).	0	0	10-1
F51 ¹⁾	1233	Electronic thermal level for 1 minute	100 ~ 200[%]	This parameter sets max current capable of flowing to the motor continuously for 1 minute. The set value is the percentage of Motor rated current (H33). It cannot be set below Electronic thermal level for continuous (F52).	150	0	10-1
F52	1234	Electronic thermal level for continuous	50 ~ 150[%]	This parameter sets the amount of current to keep the motor running continuously. It cannot be set higher than Electronic thermal level for 1 minute (F51).	100	0	
F53	1235	Motor cooling method	0 ~ 1	0 Standard motor having cooling fan directly connected to the shaft 1 A motor using a separate motor to power a cooling fan.	0	0	
F54	1236	Overload warning level	30 ~ 150[%]	This parameter sets the amount of current to issue an alarm signal at a relay or multifunction output terminal (see I55). The set value is the percentage of Motor rated current (H33).	150	0	10-2

¹⁾ : Set F50 to 1 to display this parameter.

Function group 1

LED display	Address for comm	Parameter name	Range	Description	Factory defaults	Adj. During run	Page			
F55	1237	Overload warning time	0.0~ 30.0 [Sec]	This parameter issues an alarm signal when the current greater than Overload warning level (F54) flows to the motor for Overload warning time (F55).	10.0	0	10-2			
F56	1238	Overload trip select	0 ~ 1	This parameter turns off the inverter output when motor is overloaded.	1	0	10-3			
F57	1239	Overload trip level	30 ~ 200[%]	This parameter sets the amount of overload current. The value is the percentage of Motor rated current (H33).	180	0				
F58	123A	Overload trip time	0.0~ 60.0 [Sec]	This parameter turns off the inverter output when the F57- [Overload trip level] of current flows to the motor for Overload trip time (F58).	60.0	0				
F59	123B	Stall prevention select	0 ~ 7	This parameter stops accelerating during acceleration, decelerating during constant speed run and stops decelerating during deceleration.	0	X	10-3			
								During Decel	During constant run	During Accel
								Bit 2	Bit 1	Bit 0
				0				-	-	-
				1				-	-	✓
				2				-	✓	-
				3				-	✓	✓
				4				✓	-	-
				5				✓	-	✓
6	✓	✓	-							
7	✓	✓	✓							

Chapter 5 – Function list

F60	123C	Stall prevention level	30 ~ 200[%]	This parameter sets the amount of current to activate stall prevention function during Accel, Constant or Decel run. The set value is the percentage of Motor rated current (H33).	150	X	10-3
-----	------	------------------------	-------------	---	-----	---	------

Function group 1

LED display	Address for comm	Parameter name	Range	Description	Factory defaults	Adj. During run	Page	
F61 ¹⁾	123D	When Stall prevention during deceleration, voltage limit select	0 ~ 1	In Stall prevention run during deceleration, if you want to limit output voltage, select 1	0	X	8-25	
F63	123F	Save up/down frequency select	0 ~ 1	This parameter decides whether to save the specified frequency during up/down operation. When 1 is selected, the up/down frequency is saved in F64.	0	X	8-4	
F64 ²⁾	1240	Save up/down frequency	-	If 'Save up/down frequency' is selected at F63, this parameter saves the frequency before the inverter stops or decelerated.	0.00	X	8-4	
F65	1241	Up-down Mode select	0 ~ 2	We can select up-down mode among three thing	0	X	8-5	
				0				Increases goal frequency as a standard of Max. frequency/Min. frequency
				1				Increases step frequency 66 according to edge input F 66.
2	Available to combine 0 and 1							
F66	1242	Up-Down step frequency	0.00~400.00 [Hz]	In case of choosing F65 as a 1 or 2, it means increase or decrease of frequency according to up-down input.	0.00	X	8-5	
F67 ³⁾	1243	200V input voltage	170 ~ 240[V]	200V inverter input voltage set	220	0	8-30	

F68 ³⁾	1244	400V input voltage	320 ~ 480[V]	400V inverter input voltage set	380	0	8-30
-------------------	------	--------------------	--------------	---------------------------------	-----	---	------

¹⁾ : It is indicated when setting bit 2 of F59 as 1

²⁾ : Set F63 to 1 to display this parameter.

³⁾ : 200V inverter displays F67, 400V inverter displays F68.

Function group 1

LED display	Address for comm	Parameter name	Range	Description	Factory defaults	Adj. During run	Page	
F70	1246	Draw run mode select	0 ~ 3	0	Inverter doesn't run as a draw mode	0	X	8-27
				1	Analog terminal AI V terminal (0-10 V) input drawn run			
				2	Analog terminal AIV terminal (0-20 V) input drawn run			
				3	Panel potentiometer V2 (0-5V) input draw run			
F71	1247	Draw rate	0 ~ 100[%]	Set rate of draw	0.0	O	8-27	
F72 ²⁾	1248	ND/HD selection	0 ~ 1	0: HD (CT) heavy load 1: ND (VT) light load	0	X	8-22	
F73 ¹⁾	1249	200V DB start voltage	300 ~ 400[V]	Set DB start voltage of 200V class inverter	390	0	8-32	
F74 ¹⁾	124A	400V DB start voltage	600 ~ 800[V]	Set DB start voltage of 400V class inverter	780	0	8-32	

¹⁾ : 200V inverter displays F73, 400V inverter displays F74.

²⁾ : only HD selection for single phase 200V inverter

Function group 2

LED display	Address for comm	Parameter name	Range	Description	Factory defaults	Adj. During run	Page
H 0	1300	Jump code	0 ~ 95	Sets the code number to jump.	1	O	4-5
H 1	1301	Fault history 1	-	Stores information on the types of faults, the frequency, the current and the Accel/Decel condition at the time of fault. The latest fault is automatically stored in	nOn	-	9-4
H 2	1302	Fault history 2	-		nOn	-	
H 3	1303	Fault history 3	-		nOn	-	
H 4	1304	Fault history 4	-		nOn	-	

Chapter 5 – Function list

H 5	1305	Fault history 5	-	Fault history 1.	nOn	-	
H 6	1306	Reset fault history	0 ~ 1	Clears the fault history saved in H 1-5.	0	O	
H 7	1307	Dwell frequency	0.10~ 400.00 [Hz]	When run frequency is issued, motor starts to accelerate after dwell frequency is applied to the motor during Dwell time (H8). Dwell frequency can be set within the range of Max frequency (F21) and Start frequency (F23).	5.00	X	8-7
H 8	1308	Dwell time	0.0~ 10.0 [sec]	Sets the time for dwell operation.	0.0	X	
H10	130A	Skip frequency select	0 ~ 1	Sets the frequency range to skip to prevent undesirable resonance and vibration on the structure of the machine.	0	X	
H11 ¹⁾	130B	Skip frequency low limit 1	0.10~ 400.00 [sec]	Run frequency cannot be set within the range of H11 thru H16. The frequency values of the low numbered parameters cannot be set above those of the high numbered ones. Settable within the range of F21 and F23.	10.00	X	7-22
H12	130C	Skip frequency high limit 1			15.00	X	
H13	130D	Skip frequency low limit 2			20.00	X	
H14	130E	Skip frequency high limit 2			25.00	X	
H15	130F	Skip frequency low limit 3			30.00	X	
H16	1310	Skip frequency high limit 3			35.00	X	

¹⁾ : only displayed when H10 is set to 1.

Function group 2

LED display	Address for comm	Parameter name	Range	Description	Factory defaults	Adj. During run	Page
H17	1311	S-Curve accel/decel start side	1 ~ 100[%]	Set the speed reference value to form a curve at the start during accel/decel. If it is set higher, linear zone gets smaller.	40	X	7-15

H18	1312	S-Curve accel/decel end side	1 ~ 100[%]	Set the speed reference value to form a curve at the end during accel/decel. If it is set higher, linear zone gets smaller.	40	X	
H19	1313	Input/output phase loss protection select	0 ~ 3	Inverter input output lack phase protection selection Bit0: inverter output lack phase selection Bit1: inverter input lack phase selection	3	O	10-5
H20	1314	Power On Start select	0 ~ 1	This parameter is activated when drv is set to 1 or 2 (Run/Stop via Control terminal). Motor starts acceleration after AC power is applied while FX or RX terminal is ON.	0	O	7-10
H21	1315	Restart after fault reset selection	0 ~ 1	This parameter is activated when drv is set to 1 or 2 (Run/Stop via Control terminal). Motor accelerates after the fault condition is reset while the FX or RX terminal is ON.	0	O	7-11

H17, H18 are used when F2, F3 are set to 1 (S-curve).

Chapter 5 – Function list

Function group 2

LED display	Address for comm	Parameter name	Range	Description	Factory defaults	Adj. During run	Page			
H22 ¹⁾	1316	Speed Search Select	0 ~ 15	This parameter is active to prevent any possible fault when the inverter outputs its voltage to the running motor.	0	X	8-17			
					Power On start	Restart after instant power failure	Operation after fault	Normal accel		
					bit 3	bit 2	bit 1	bit 0		
				0	-	-	-	-		
				1	-	-	-	✓		
				2	-	-	✓	-		
				3	-	-	✓	✓		
				4	-	✓	-	-		
				5	-	✓	-	✓		
				6	-	✓	✓	-		
				7	-	✓	✓	✓		
				8	✓	-	-	-		
				9	✓	-	-	✓		
				10	✓	-	✓	-		
				11	✓	-	✓	✓		
				12	✓	✓	-	-		
				13	✓	✓	-	✓		
14	✓	✓	✓	-						
15	✓	✓	✓	✓						

¹⁾: H22 Normal acceleration has first priority. It has no relation with others. In acceleration, speed tracking works.

Function group 2

LED display	Address for comm	Parameter name	Range	Description	Factory defaults	Adj. During run	Page
H23	1317	Current level During Speed search	80 ~ 200[%]	This parameter limits the amount of current during speed search. The set value is the percentage of Motor rated current (H33).	150	O	8-17
H24	1318	P gain during Speed search	0 ~ 9999	It is the Proportional gain used for Speed Search PI controller.	100	O	
H25	1319	I gain during Speed search	0 ~ 9999	It is the Integral gain used for Speed search PI controller.	200	O	
H26	131A	Number of Auto Restart try	0 ~ 10	This parameter sets the number of restart tries after a fault occurs. Auto Restart is deactivated if the fault outnumbers the restart tries. This function is active when [drv] is set to 1 or 2 {Run/Stop via control terminal}. Deactivated during active protection function (OHT, LVT, EXT, HWT etc.).	0	O	8-19
H27	131B	Auto restart time	0 ~ 60[sec]	This parameter sets the time between restart tries.	1.0	O	8-19
H30	131E	Motor type select	0.1 ~ 11.0	0.1 ~ 0.1kW ~ ~ 11.0 ~ 11.0kW	0.75 ¹⁾	X	8-15
H31	131F	Number of motor poles	2 ~ 12	This setting accords to nameplate of motor.	4	X	-
H32	1320	Rated slip frequency	0.00 ~ 10.00 [Hz]	Motor nameplate rated rotation speed conversion is frequency. The difference between input power frequency and this value.	2.33 ²⁾	X	8-15
H33	1321	Motor rated current	0.1 ~ 150.0[A]	Enter motor rated current on the nameplate.	1.8	X	

¹⁾ : H30 is preset based on inverter rating.

²⁾ : H32 ~ H36 factory default values are set based on 200V/400V HIGEN motor.

Chapter 5 – Function list

Function group 2

LED display	Address for comm	Parameter name	Range	Description	Factory defaults	Adj. During run	Page	
H34	1322	No load motor current	0.1~100.0[A]	Enter the current value detected when the motor is rotating in rated rpm after the load connected to the motor shaft is removed. Enter the 50% of the rated current value when it is difficult to measure no Load Motor Current.	0.7	X	8-15	
H36	1324	Motor efficiency	50 ~ 100[%]	Enter the motor efficiency (see motor nameplate).	72	X	-	
H37	1325	Load inertia rate	0 ~ 2	0	Less than 10 times	0	X	8-1
				1	About 10 times			
				2	More than 10 times			
H39	1327	Carrier frequency	1.0~15.0 [kHz]	This parameter affects the audible sound of the motor, noise emission from the inverter, inverter temp, and leakage current. If the set value is higher, the inverter sound is quieter but the noise from the inverter and leakage current will become greater.	5.0 ¹⁾	O	8-20	
					3.0 ¹⁾			
H40	1328	Control mode select	0 ~ 3	0	V/F Control}	0	X	7-17
				1	Slip compensation control			8-8
				2				
				3	Sensorless vector control			8-15
H41	1329	Auto tuning	0 ~ 1	If this parameter is set to 1, it automatically measures parameters of H42 and H44.	0	X	8-14	
H42	132A	Stator resistance (Rs)	0.000~56.000[Ω]	This is the value of the motor stator resistance.	-	X		
H44	132C	Leakage inductance (Lσ)	0.00~600.00 [mH]	This is leakage inductance of the stator and rotor of the motor.	-	X		

¹⁾:Default carrier frequency of 0.1~3.7KW series is 5KHz, and default value of 5.5~7.5KW series is 3 KHz.

Function group 2

LED display	Address for comm	Parameter name	Range	Description	Factory defaults	Adj. During run	Page
H45 ¹⁾	132D	Sensorless P gain	0 ~ 32767	P gain for Sensorless control	1000	O	-
H46	132E	Sensorless I gain		I gain for Sensorless control	100	O	
H47	132F	Sensorless Torque limit	100.0~220.0[%]	Limits output torque in sensorless mode.	180.0	X	
H48	1330	PWM mode select	0 ~ 1	If you want to limit a inverter leakage current, select 2 phase PWM mode. It has more noise in comparison to normal PWM mode. 0 Normal PWM mode 1 2 phase PWM mode	0	X	8-29
H49	1331	PID select	0 ~ 1	Selects whether using PID control or not	0	X	8-10
H50 ²⁾	1332	PID F/B select	0 ~ 2	0 Analog input terminal AI (I :0 ~ 20 mA) 1 Analog input terminal AI (V :0 ~ 10 V) 2 RS-485 communication	0	X	8-10
H51	1333	P gain for PID	0.0~999.9 [%]	This parameter sets the gains for the PID controller.	300.0	O	
H52	1334	Integral time for PID	0.10~32.00 [sec]		1.00	O	
H53	1335	Differential time for PID (D gain)	0.00~30.00 [sec]		0.00	O	
H54	1336	PID control mode select	0 ~ 1	Selects PID control mode 0 Normal PID control 1 Process PID control	0	X	8-10

¹⁾ : Set H40 to 3 (Sensorless vector control) to display this parameter.

²⁾ : Set H49 to 1 (PID control) to display this parameter.

Chapter 5 – Function list

Function group 2

LED display	Address for comm	Parameter name	Range	Description	Factory defaults	Adj. During run	Page
H55 ¹⁾	1337	PID output frequency high limit]	0.10~ 400.00 [Hz]	This parameter limits the amount of the output frequency through the PID control. The value is settable within the range of Max frequency (F21) and Start frequency (F23).	60.00	O	8-10
H56	1338	PID output frequency low limit	0.10~ 400.00 [Hz]		0.50	O	
H57	1339	PID standard value select	0 ~ 4	Selects PID standard value. Standard value is indicated in "rEF" of Drive group.	0	X	8-10
				0 Loader digital setting 1			
				1 Loader digital setting 2			
				2 V1 terminal setting : 0~10V			
				3 I terminal setting: 0~20mA			
4 Setting as a RS-485 communication							
H58	133A	PID control unit select	0 ~ 1	Selects a unit of the standard value or feedback amount.	0	X	
				0 Frequency [Hz]			
				1 Percentage [%]			
H61	133D	Sleep delay time	0.0~ 2000.0 [sec]	Sets a sleep delay time in PID drive.	60.0	X	
H62	133E	Sleep frequency	0.00~ 400.00 [Hz]	Sets a sleep frequency when executing a sleep function in PID control drive. You can't set more than Max. frequency (F21)	0.00	O	8-10
H63	133F	Wake up level	0.0~ 100.0[%]	Sets a wake up level in PID control drive.	35.0	O	
H64	1340	KEB drive select	0 ~ 1	Sets KEB drive.	0	X	
H65 ²⁾	1341	KEB action start level	110.0~ 140.0[%]	Sets KEB action start level according to level.	125.0	X	8-27

¹⁾ : Set H49 to 1 (PID control) to display this parameter.

²⁾ : It is indicated when setting H64 to 1.# KEB does not operate when cut power after loading ting input (about 10%).

Function group 2

LED display	Address for comm	Parameter name	Range	Description	Factory defaults	Adj. During run	Page	
H66 ¹⁾	1342	KEB action stop level	110.0~145.0[%]	Sets KEB action stop level according to level.	130.0	X	8-27	
H67	1343	KEB action gain	1 ~ 20000	Sets KEB action gain.	50	X		
H70	1346	Frequency reference for accel/decel	0 ~ 1	0	Based on Max freq (F21)	0	X	7-12
				1	Based on Delta freq.			
H71	1347	Accel/Decel time scale	0 ~ 2	0	Settable unit: 0.01 second.	1	O	7-12
				1	Settable unit: 0.1 second.			
				2	Settable unit: 1 second.			
H72	1348	Power on display	0 ~ 17	This parameter selects the parameter to be displayed on the keypad when the input power is first applied.		0	O	9-2
				0	Frequency command			
				1	Accel time			
				2	Decel time			
				3	Drive mode			
				4	Frequency mode			
				5	Multi-Step frequency 1			
				6	Multi-Step frequency 2			
				7	Multi-Step frequency 3			
				8	Output current			
				9	Motor rpm			
				10	Inverter DC link voltage			
				11	User display select (H73)			
				12	Fault display			
				13	Direction of motor rotation select			
				14	Output current 2			
				15	Motor rpm 2			
16	Inverter DC link voltage 2							
17	User display select 2 (H73 set)							

¹⁾ : It is indicated when setting H64 to 1.# KEB does not operate when cut power after loading ting input (about 10%).

Function group 2

Chapter 5 – Function list

LED display	Address for comm	Parameter name	Range	Description	Factory defaults	Adj. During run	Page			
H73	1349	Monitoring item select	0 ~ 2	One of the following can be monitored via vOL(User display select).				0	O	9-2
				0	Output voltage [V]					
				1	Output power [kW]					
			2	Torque [kgf · m]						
H74	134A	Gain for Motor rpm display	1~1000[%]	This parameter is used to change the motor rotating speed (r/min) to mechanical speed (m/mi) and display it.	100	O	9-1			
H75	134B	DB resistor operating rate limit select	0 ~ 1	0	Unlimited	1	O	10-8		
				1	Use DB resistor for the rate set in H76.					
H76	134C	DB resistor operating rate	0 ~ 30 [%]	Set the percent of DB resistor operating rate to be activated during one sequence of operation.	10	O				
H77 ¹⁾	134D	Cooling fan control	0 ~ 1	0	Cooling fan is always on	0	O	8-29		
				1	Keeps ON when its temp is higher than inverter protection limit temp. Activated only during operation when its temp is below that of inverter protection limit.					
H78	134E	Operating method select when cooling fan malfunctions	0 ~ 1	0	Continuous operation when cooling fan malfunctions.	1	O	8-29		
				1	Operation stopped when cooling fan malfunctions.					
H79	134F	S/W version	X.X	This parameter displays the inverter software version.	X.X	X				

¹⁾ : Single phase 0.1/0.2kW, three phase 200V 0.1/0.2/0.4KW and three phase 400V 0.4KW are NO FAN TYPE, so this parameter has no displaying.

Function group 2

LED display	Address for comm	Parameter name	Range	Description	Factory defaults	Adj. During run	Page
H81 ¹⁾	1351	2nd motor Accel time	0.0~ 6000.0	This parameter actives when the selected terminal is ON after I17-I24 is set to 12 {2nd motor select}.	5.0	O	8-21
H82	1352	2nd motor Decel time	[sec]		10.0	O	
H83	1353	2nd motor base frequency	30.00~ 400.00[Hz]		60.00	X	
H84	1354	2nd motor V/F pattern	0 ~ 2		0	X	
H85	1355	2nd motor forward Torque boost	0.0~15.0 [%]		5.0	X	
H86	1356	2nd motor reverse Torque boost			5.0	X	
H87	1357	2nd motor Stall prevention level	30 ~ 150 [%]	Multi-function terminal (1 17-121). When one set is 12 (No 2 motor selects), switch on the terminal. No. 2 motor parameter activates.	150	X	8-21
H88	1358	2nd motor Electronic thermal level for 1 min	50 ~ 200 [%]		150	O	
H89	1359	2nd motor Electronic thermal level for continuous	50 ~ 150 [%]		100	O	
H90	135A	2nd motor rated current	0.1 ~ 100.0[A]		1.8	X	

¹⁾ : It is indicated when choosing I17~I21 as a 12 (2nd motor select).

Chapter 5 – Function list

Function group 2

LED display	Address for comm	Parameter name	Range	Description	Factory defaults	Adj. During run	Page	
H93	135D	Parameter initialize	0 ~ 5	This parameter is used to initialize parameters back to the factory default value.		0	X	8-30
				0	-			
				1	All parameter groups are initialized to factory default value.			
				2	Only Drive group is initialized.			
				3	Only Function group 1 is initialized.			
				4	Only Function group 2 is initialized.			
				5	Only I/O group is initialized.			
H94	135E	Password register	0 ~ FFFF	Password for H95-[Parameter lock]. Set as Hexa value.		0	O	8-31
H95	135F	Parameter lock	0 ~ FFFF	This parameter is able to lock or unlock parameters by typing password registered in H94.		0	X	8-32
				UL (Unlock)	Parameter change enable			
				L (Lock)	Parameter change disable			

Input/output group

LED display	Address for comm	Parameter name	Range	Description	Factory defaults	Adj. During run	Page
I 0	1400	Jump code	0 ~ 87	Sets the code number to jump.	1	O	4-5
I 1	1401	V2 input wave filtering time constant	0 ~ 9999	Set panel potentiometer V2 input filtering wave time constant	10	O	7-2
I 2	1402	V2 input Min voltage	0.00~5.00[V]	Sets Min. voltage of V2 input.	0.00	O	
I 3	1403	V2 input Min voltage corresponding frequency	0.00~400.00 [Hz]	Sets the inverter output min. frequency at min. voltage of panel potentiometer input.	0.00	O	
I 4	1404	V2 input Max voltage]	0.00~5.00[V]	Sets the maximum voltage of panel potentiometer V2.	5.00	O	
I 5	1405	V2 input Max. voltage corresponding frequency	0.00 ~ 400.00 [Hz]	Sets the panel potentiometer V2 Max. input voltage, corresponding frequency.	60.00	O	
I 6	1406	Filter time constant for V1 input	0 ~ 9999	Sets simulation input A1 (terminal V) input filtering wave time constant.	10	O	7-2
I 7	1407	V1 input Min voltage	0.00~10.00[V]	Sets the minimum voltage of the V1 Input.	0.00	O	
I 8	1408	V1 input Min voltage corresponding frequency	0.00~400.00 [Hz]	Sets simulation input A1 (terminal V) min. input voltage, corresponding frequency.	0.00	O	
I 9	1409	V1 input Max voltage	0.00~10.00[V]	Sets simulation input A1 (terminal V) Max. input voltage.	10.00	O	
I10	140A	V1 input Max. voltage corresponding frequency	0.00~400.00 [Hz]	Sets simulation input A1 (Terminal V) Max. input voltage, corresponding frequency.	60.00	O	

Chapter 5 – Function list

Input/output group

LED display	Address for comm	Parameter name	Range	Description	Factory defaults	Adj. During run	Page
I11	140B	I input	0 ~ 9999	Sets simulation input A1 (terminal 1) input filtering wave time constant.	10	O	7-3
I12	140C	I input Min current	0.00~20.00 [mA]	Sets simulation input A1 (terminal 1) Min. input current	4.00	O	
I13	140D	1 input Min. current corresponding frequency	0.00~400.00 [Hz]	Sets simulation input A1 (terminal 1) Max. input current, corresponding frequency.	0.00	O	
I14	140E	I input Max current	0.00~20.00 [mA]	Sets the Maximum current of I input.	20.00	O	
I15	140F	1 input Max. current corresponding frequency	0.00~400.00 [Hz]	Sets simulation input A1 (terminal 1) Max. input current, corresponding frequency.	60.00	O	
I16	1410	Criteria for Analog Input Signal loss	0 ~ 2	0: Disabled 1: activated below half of set value. 2: activated below set value.	0	O	10-7

Input/output group

LED display	Address for comm	Parameter name	Range	Description	Factory defaults	Adj. During run	Page		
I17	1411	Multi-function input terminal P1 define		0	Forward run command	0	O	7-8	
				1	Reverse run command				
I18	1412	Multi-function input terminal P2 define		2	Emergency Stop Trip	1	O		
				3	Reset when a fault occurs				
I19	1413	Multi-function input terminal P3 define		4	Jog operation command	2	O	8-3	
				5	Multi-Step freq – Low			7-7	
I20	1414	Multi-function input terminal P4 define		6	Multi-Step freq – Mid	3	O		
				7	Multi-Step freq – High				
I21	1415	Multi-function input terminal P5 define		8	Multi Accel/Decel – Low	4	O	7-14	
				9	Multi Accel/Decel – Mid				
			0 ~ 27	10	Multi Accel/Decel – High				
				11	DC brake during stop			8-2	
				12	2nd motor select			8-21	
				13	-Reserved-				
				14	-Reserved-				
				15	Up- Down	Frequency increase command (UP)			8-4
				16		Frequency decrease command (DOWN)			
				17	3-wire operation			8-7	
				18	External trip: A Contact (EtA)			10-5	
				19	External trip: B Contact (EtB)				
				20	-Reserved-			-	

Chapter 5 – Function list

				2 1	Change from PID operation to V/F operation			8-11
				2 2	2nd Source			8-22
				2 3	Analog Hold			7-6
				2 4	Accel/Decel Disable			7-16
				2 5	Up/Down save freq. Initialization			8-4
				2 6	JOG-FX			8-3
				2 7	JOG-RX			

In I17-I21, please refer to “Chapter 6” for fault signal input displaying.

Two or above multi-function input terminal cannot be set, which has the same function.

Input/output group

LED display	Address for comm	Parameter name	Range	Description					Factory defaults	Adj. During run	Page
I25	1419	Input terminal status display		BIT	BIT	BIT	BIT	BIT	-	-	9-3
				4	3	2	1	0			
I26	141A	Output terminal status display		BIT					-	-	9-3
				0							
				3AC							
I27	141B	Filtering time Constant for Multifunction Input terminal	1 ~ 15	If the value is set higher, the responsiveness of the Input terminal is getting slower.					4	O	-
I30	141E	Multi-Step frequency 4	0.00~ 400.00 [Hz]	It cannot be set greater than F21 – [Max frequency].					0.00	O	7-7
I31	141F	Multi-Step frequency 5							0.00	O	
I32	1420	Multi-Step frequency 6							0.00	O	

I33	1421	Multi-Step frequency 7			0.00	O	
I34	1422	Multi-Accel time 1	0.0~ 6000.0 [sec]		3.0	O	7-14
I35	1423	Multi-Decel time 1			3.0	O	
I36	1424	Multi-Accel time 2			4.0	O	
I37	1425	Multi-Decel time 2			4.0	O	
I38	1426	Multi-Accel time 3			5.0	O	
I39	1427	Multi-Decel time 3			5.0	O	
I40	1428	Multi-Accel time 4			6.0	O	
I41	1429	Multi-Decel time 4			6.0	O	
I42	142A	Multi-Accel time 5			7.0	O	
I43	142B	Multi-Decel time 5			7.0	O	
I44	142C	Multi-Accel time 6			8.0	O	
I45	142D	Multi-Decel Time 6			8.0	O	
I46	142E	Multi-Accel time 7			9.0	O	
I47	142F	Multi-Decel time 7			9.0	O	

Input/output group

LED display	Address for comm	Parameter name	Range	Description		Factory defaults	Adj. During run	Page		
I50	1432	Analog output item select	0 ~ 3		Output item	Output to 10[V]		0	O	9-5
						200V	400V			
				0	Output freq.	Max frequency				
				1	Output current	150% inverter rated current				
				2	Output voltage	AC 282V	AC 564V			
		3	DC link voltage	DC 410V	DC 820V					
I51	1433	Analog output level adjustment	10 ~ 200[%]	Based on 10V		100	O	9-5		
I52	1434	Frequency detection level	0.00~ 400.00 [Hz]	Used when I54 or I55 is set to 0-4. Cannot be set higher than F21.		30.00	O	9-7		
I53	1435	Frequency detection bandwidth				10.00	O			

Chapter 5 – Function list

Input/output group

LED display	Address for comm	Parameter name	Range	Description			Factory defaults	Adj. During run	Page	
I55	1437	Multi-function relay select	0 ~ 19	0	FDT-1			17	0	9-7
				1	FDT-2					9-8
				2	FDT-3					
				3	FDT-4					
				4	FDT-5					
				5	Overload (OL)					
				6	Inverter Overload (IOL)					
				7	Motor stall (STALL)					
				8	Over voltage trip (Ovt)					9-10
				9	Low voltage trip (Lvt)					
				10	Inverter Overheat (Oht)					
				11	Command loss					
				12	During Run					9-10
				13	During Stop					
				14	During constant run					
				15	During speed searching					
				16	Wait time for run signal input					9-11
				17	Multi-function relay select					
				18	Warning for cooling fan trip					
				19	Brake signal select					
I56	1438	Fault Relay output	0 ~ 7		When setting Number of auto restart try (H26)	When the trip other than low voltage trip occurs	When the low voltage trip occurs	2	0	9-6
					bit 2	bit 1	bit 0			
				0	-	-	-			
				1	-	-	✓			
				2	-	✓	-			
				3	-	✓	✓			
				4	✓	-	-			
				5	✓	-	✓			
				6	✓	✓	-			
7	✓	✓	✓							

Input/output group

LED display	Address for comm	Parameter name	Range	Description	Factory defaults	Adj. During run	Page
I59	143B	Communication protocol select	0 ~ 1	Set communication protocol.	0	X	11-2
				0 Modbus RTU			
I60	143C	Inverter number	1~ 250	Set for RS485 communication	1	O	11-2
I61	143D	Baud rate	0 ~ 5	Set communication speed	3	O	11-2
				0 1200 [bps]			
				1 2400 [bps]			
				2 4800 [bps]			
				3 9600 [bps]			
				4 19200 [bps]			
5 38400 [bps]							
I62	143E	Drive mode Select after loss of frequency command	0 ~ 2	It is used when freq command is given via AI terminal or RS485.	0	O	10-7
				0 Continuous operation at the frequency before its command is lost.			
				1 Free Run stop (Output cut-off)			
				2 Decel to stop			
I63	143F	Wait time after loss of frequency command	0.10 ~ 120.0 [sec]	This is the time inverter determines whether there is the input frequency command or not. If there is no frequency command input during this time, inverter starts operation via the mode selected at I62.	1.0	O	10-7
I64	1440	Communication time setting	2 ~ 100 [ms]	Frame communication time	5	O	11-2
I65	1441	Parity/stop bit setting	0 ~ 3	When the protocol is set, the communication format can be set.	0	O	11-2
				0 Parity: None, Stop Bit: 1			
				1 Parity: None, Stop Bit: 2			
				2 Parity: Even, Stop Bit: 1			
3 Parity: Odd, Stop Bit: 1							

Chapter 5 – Function list

Input/output group

LED display	Address for communication	Parameter name	Range	Description	Factory defaults	Adj. During run	Page
I66	1442	Read address register 1	0 ~ 42239	The user can register up to 8 discontinuous addresses and read them all with one Read command.	5	0	11-6
I67	1443	Read address register 2			6		
I68	1444	Read address register 3			7		
I69	1445	Read address register 4			8		
I70	1446	Read address register 5			9		
I71	1447	Read address register 6			10		
I72	1448	Read address register 7			11		
I73	1449	Read address register 8			12		
I74	144A	Write address register 1	0 ~ 42239	The user can register up to 8 discontinuous addresses and write them all with one Write command	5	0	11-6
I75	144B	Write address register 2			6		
I76	144C	Write address register 3			7		

Input/output group

LED display	Address for communication	Parameter name	Range	Description	Factory defaults	Adj. During run	Page
I77	144D	Write address register 4	0 ~ 42239	The user can register up to 8 discontinuous addresses and write them all with one Write command	8	0	11-6
I78	144E	Write address register 5			5		
I79	144F	Write address register 6			6		
I80	1450	Write address register 7			7		
I81	1451	Write address register 8			8		
I82 ¹⁾	1452	Brake open current			0.0 ~ 180.0 [%]		
I83	1453	Brake open delay time	0.00~10.00[sec]	Sets Brake open delay time.	1.00	X	
I84	1454	Brake open FX frequency	0.00~400.00 [Hz]	Sets FX frequency to open the brake	1.00	X	
I85	1455	Brake open RX frequency	0.00~400.00 [Hz]	Sets RX frequency to open the brake	1.00	X	
I86	1456	Brake close delay time	0.00~10.00[sec]	Sets delay time to close the brake	1.00	X	
I87	1457	Brake close frequency	0.00~400.00 [Hz]	Sets frequency to close the brake	2.00	X	

¹⁾ : It is indicated when choosing I54~I55 as a 19 (Brake signal).

6. Control Block Diagram

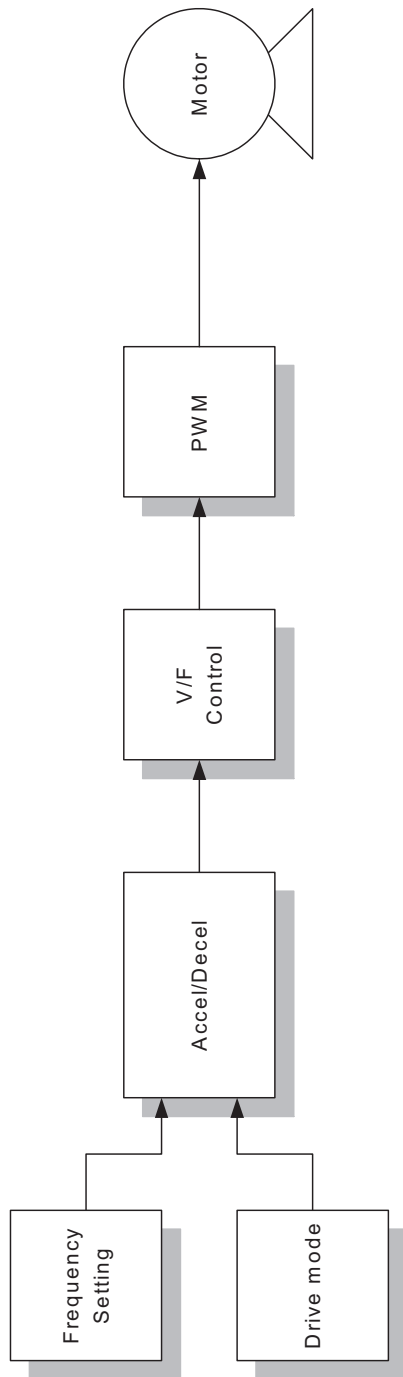

6.1 Frequency Setting

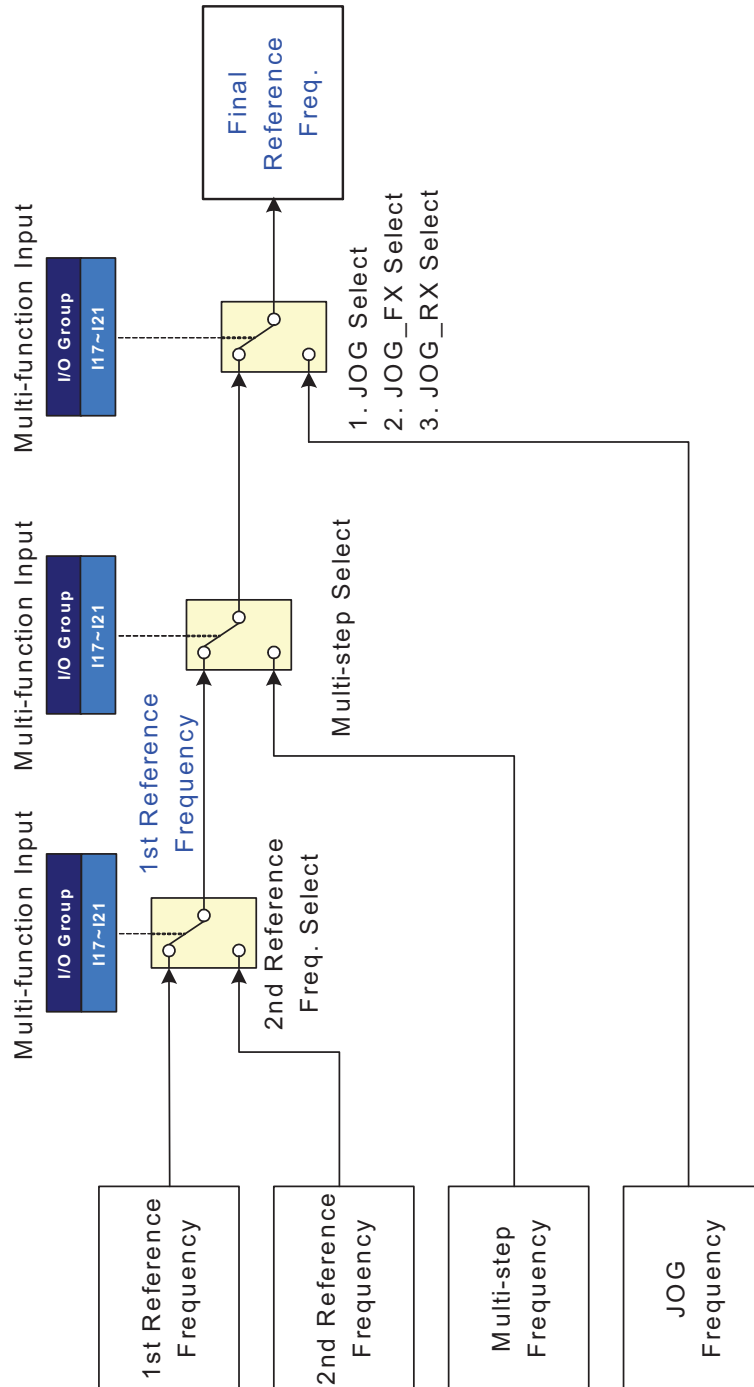

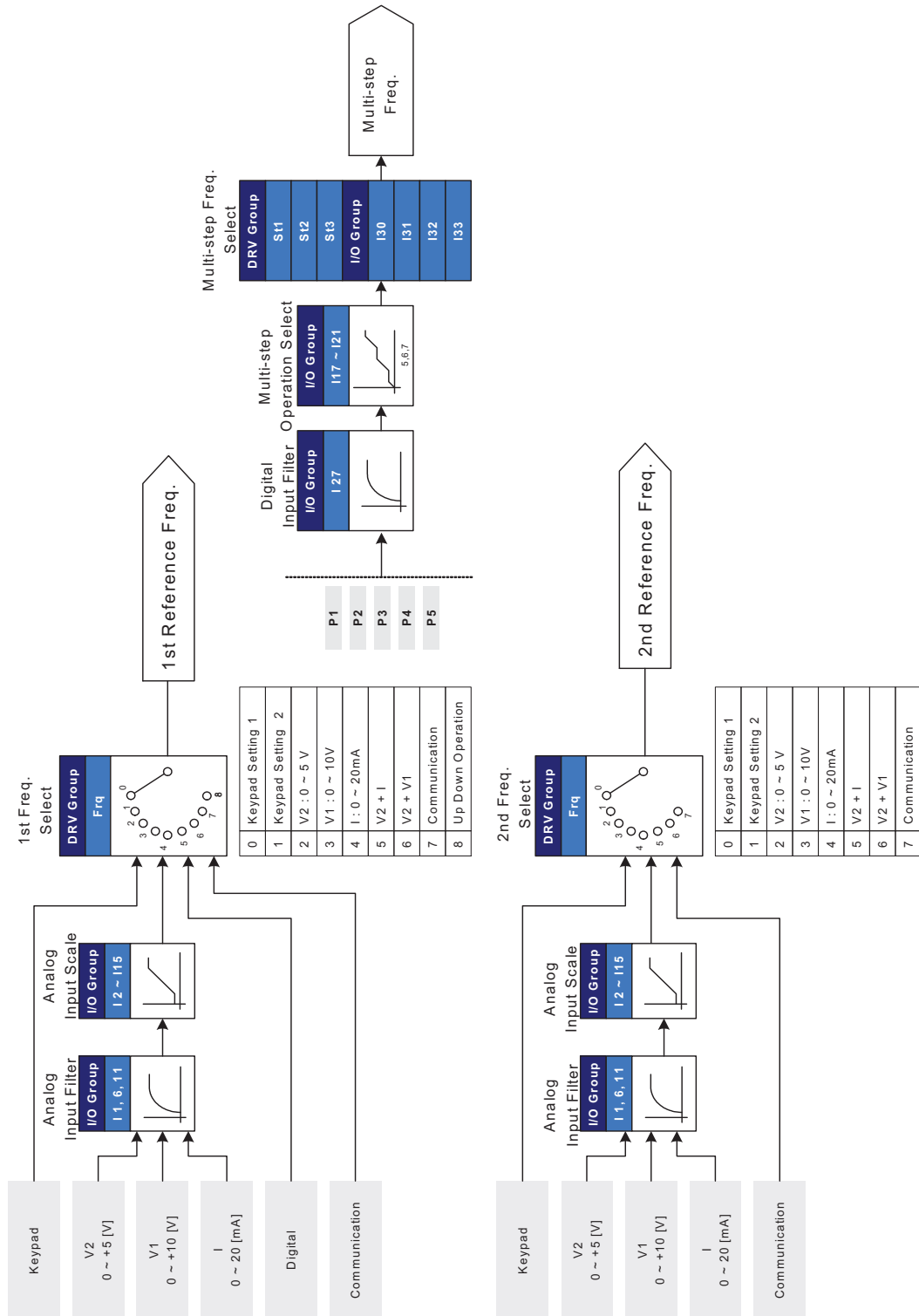

6.2 Drive command setting

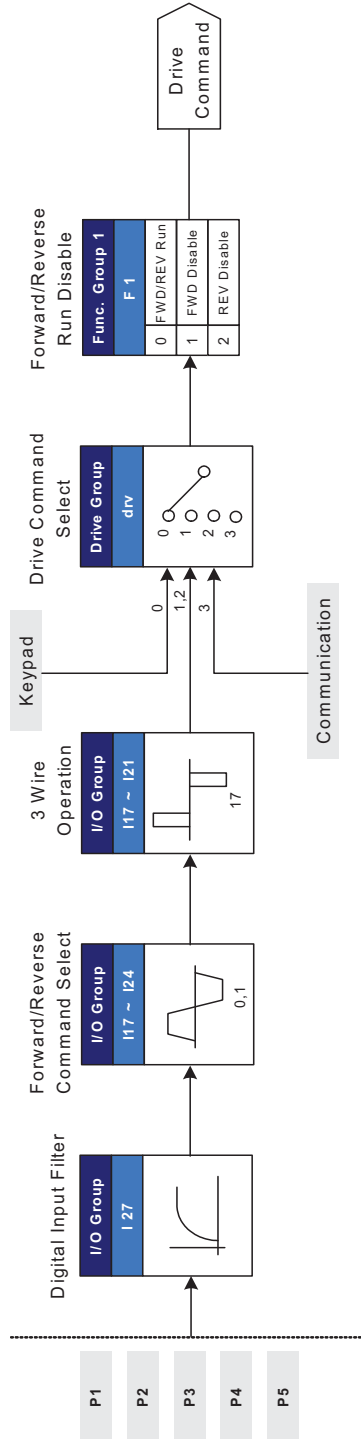

6.3 Accel/Decel setting and VF control

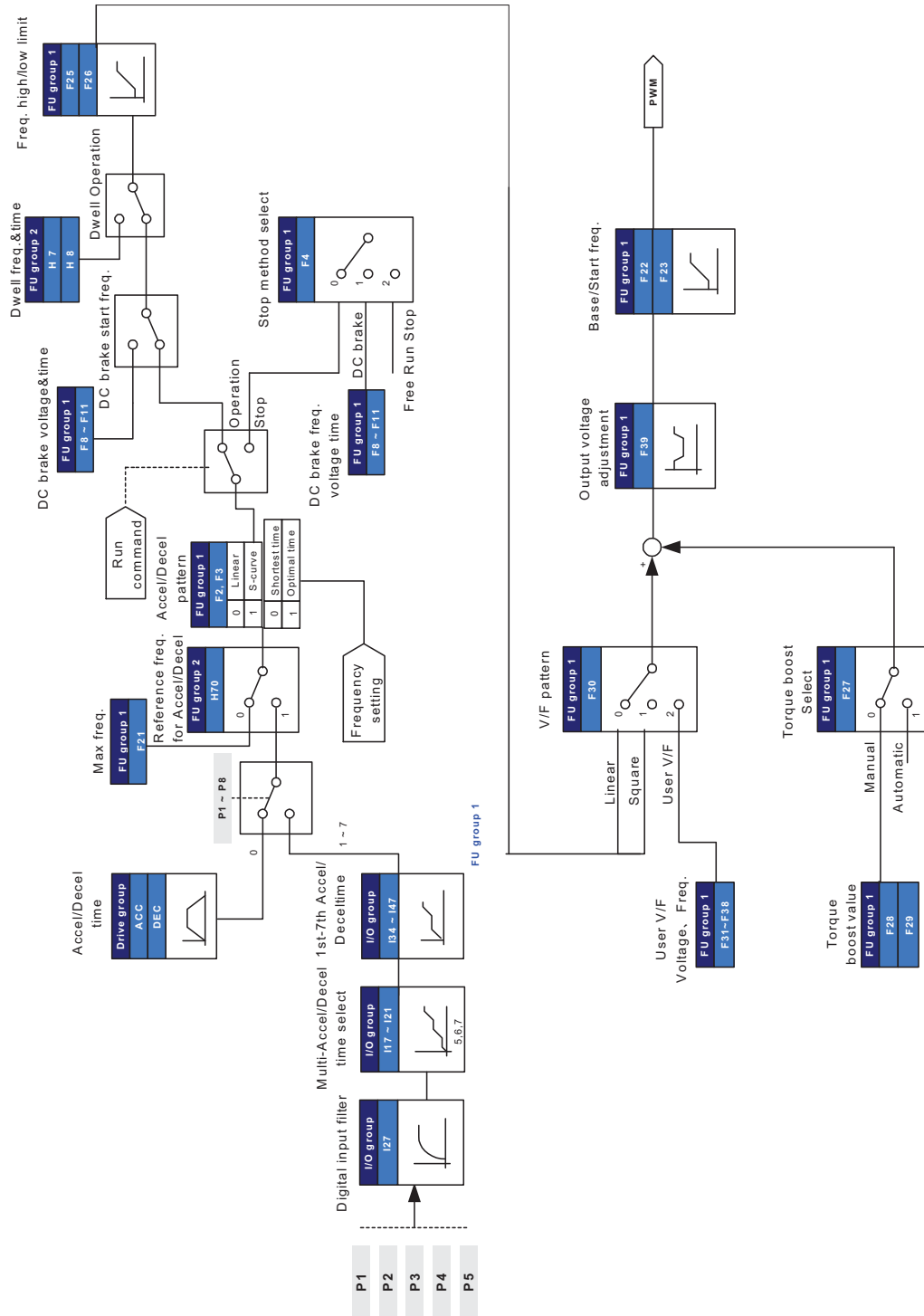

7. Basic Functions

7.1 Frequency setting method

Keypad frequency setting 1

Group	Code	Item	Set value	Range	Initial	Unit
Drive group	0.00	Target frequency	-	0.00 ~ 400.00	0.00	Hz
	Frq	Frequency setting mode	0	0 ~ 8	0	

Set Frq code of Drive group to 0.
 In the frequency command code (0.00), after setting of the operating frequency, press the Ent(●) key to complete the frequency change.
 The set value shall not exceed the maximum frequency (F21).

- ▶ When remote keypad is connected, keypad keys on the body are deactivated but controlled by the button on the remote keypad.

Keypad frequency setting 2

Group	Code	Item	Set value	Range	Initial	Unit
Drive group	0.00	Target frequency	-	0.00 ~ 400.00	0.00	Hz
	Frq	Frequency setting mode	1	0 ~ 8	0	

Set Frq code of Drive group to 1.
 When the operating frequencies are set in the frequency command code of Drive group, press Up(▲)/Down(▼) key for frequency change.
 Take Up/Down key as a potentiometer with the same functions.
 The set value shall not exceed the maximum frequency (F21).

- ▶ When remote keypad is connected, keypad keys on the body are deactivated but controlled by the button on the remote keypad.

Chapter 7 Basic Functions

Setting frequency for keypad potentiometer V2: 0 ~ 5 [V]

Group	Code	Item	Set value	Range	Initial	Unit
Drive group	0.00	Target frequency	-	0.00 ~ 400.00	0.00	Hz
	Frq	Frequency setting mode	2	0 ~ 8	0	
I/O group	I 1	Filter time constant for V2 input	-	0 ~ 9999	10	
	I 2	V2 input Min voltage	-	0.00~5.00	0.00	V
	I 3	Corresponding frequency for V2 input Min Voltage	-	0.00 ~ 400.00	0.00	Hz
	I 4	V2 input Max voltage	-	0.00 ~ 5.00	5.00	V
	I 5	Corresponding frequency for V2 input Max voltage	-	0.00 ~ 400.00	60.00	Hz

Set Frq code of Drive group to 2. Use the knob setting frequency on the keypad.
Monitor the frequency value set in the target frequency (0.00) of Drive group.

Terminal AI setting frequency(dial J1 to V terminal): input 0 ~ +10[V]

Group	Code	Item	Set value	Range	Initial	Unit
Drive group	0.00	Target frequency	-	0.00 ~ 400.00	0.00	Hz
	Frq	Frequency setting mode	3	0 ~ 8	0	
I/O group	I 6	Filter time constant for V1 input	-	0 ~ 9999	10	
	I 7	V1 input Min voltage	-	0.00 ~ 10.00	0.00	V
	I 8	Corresponding frequency for V1 input Min voltage	-	0.00 ~ 400.00	0.00	Hz
	I 9	V1 input Max voltage	-	0.00 ~ 10.00	10.00	V
	I 10	Corresponding frequency for V1 input Max voltage	-	0.00 ~ 400.00	60.00	Hz

Set Frq code of Drive group to 3.
Monitor the frequency setting value in the target frequency (0.00) of Drive group.

- ▶ Apply 0 ~ +10V signal between inverter keypad terminal AI and CM. Dial J1 to V terminal.

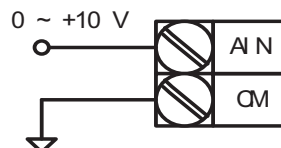

- ▶ I7 ~ I10: the input voltage range and corresponding frequency of V1 terminal can be set.
- ▶ Ex) when minimum (+) input voltage is 2V with corresponding frequency 10Hz and Max voltage is 8V with run req. 50Hz.

Set frequency

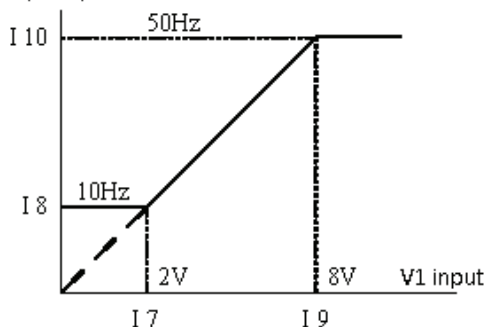

- ▶ Wire the terminals as shown below

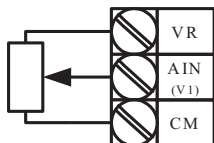

wiring diagram of potentiometer

Terminal AI setting frequency(dial J1 to terminal I): input 0 ~ 20[mA]

Group	Code	Item	Set value	Range	Initial	Unit
Drive group	0.00	Target frequency	-	0.00 ~ 400.00	0.00	Hz
	Frq	Frequency setting mode	4	0 ~ 8	0	
I/O group	I11	Filter time constant for I input	-	0 ~ 9999	10	
	I12	I input minimum current	-	0.00~ 20.00	4.00	mA
	I13	Corresponding frequency of I input minimum current	-	0.00 ~ 400.00	0.00	Hz
	I14	I input maximum current	-	0.00 ~ 20.00	20.00	mA
	I15	Corresponding frequency of I input maximum current	-	0.00 ~ 400.00	60.00	Hz
Set Frq code of Drive group to 4. Set frequency through input 0~20mA on AI terminal and CM terminal of inverter. Dial J1 to I terminal.						

Setting of keypad potentiometer V2+ terminal AI 0 ~ 20mA (dial J1 to terminal I)

Group	Code	Item	Set value	Range	Initial	Unit
Drive group	0.00	Target frequency	-	0.00 ~ 400.00	0.00	Hz
	Frq	Frequency setting mode	5	0 ~ 8	0	
<p>Set Freq code of Drive group to 5.</p> <p>The main/ auxillary speed is adopted to adjust so as to reach the override function. (Override function available using Main/Auxiliary speed adjustment)</p> <p>Relevant codes: I 2 ~ I 5 , I11 ~ I15</p>						

- ▶ Override function is to gain precise control and fast response by combining Main and Auxiliary speed input. Fast response can be achieved by Main speed and precise control can be accomplished by Aux. speed if the accuracy of Main/Aux speed is set differently.
- ▶ Follow the setting below when Main speed is given via 0 ~ 20mA with Aux. speed via keypad potentiometer (0 ~ 5V).
- ▶ When override function is used, select the Main/Aux. speed according to loads used.

Group	Code	Item	Set Value	Unit
I/O group	I 2	V2 input Min voltage	0.00	V
	I 3	Corresponding frequency of V2 input Min voltage	0.00	Hz
	I 4	V2 input Max voltage	5.00	V
	I 5	Corresponding frequency of V2 input Max voltage	5.00	Hz
	I12	I input Min voltage	4.00	mA
	I13	Corresponding frequency of I input Min current	0.00	Hz
	I14	I input Max current	20.00	mA
	I15	Corresponding frequency of I input Max current	60.00	Hz

After the setting is made as above, if 2.5V is applied to V2 terminal with 12mA given to terminal I, output frequency would be 32.5Hz. If 2.5V is applied to V2 terminal with 5V given to terminal V1, output frequency would be 32.5Hz, too.

Setting of keypad potentiometer V2+ terminal AI (dial J1 to V terminal)

Group	Code	Item	Set value	Range	Initial	Unit
Drive group	0.00	Target frequency	-	0.00 ~ 400.00	0.00	Hz
	Frq	Frequency setting mode	6	0 ~ 8	0	
<p>Set Frq code of Drive group to 6. Relevant parameters: I 2 ~ I 5 , I 6 ~ I 10 Please refer to the method and example for setting frequency through keypad potentiometer V2+ terminal AI 0 ~ 20mA (dial J1 to terminal I).</p>						

Frequency setting via RS-485 communication

Group	Code	Item	Set value	Range	Initial	Unit
Drive group	0.00	Target frequency	-	0.00~ 400.00	0.00	Hz
	Frq	Mode of frequency setting	7	0 ~ 8	0	
<p>Set Frq code of Drive group to 7. Relevant parameters: I 59, I 60, I 61. Refer to Chapter 11. Communication Function</p>						

Frequency setting via digital potentiometer (up-down)

Group	Code	Item	Set value	Range	Initial	Unit
Drive group	0.00	Target frequency	-	0.00~ 400.00	0.00	Hz
	Frq	Frequency setting mode	8	0 ~ 8	0	
<p>Set Freq. code of Drive group to 8. Relevant parameters: I 17 ~ I 21 Refer to Up-Down Function in Chapter 8. Application Function.</p>						

Chapter 7 Basic Functions

Analog frequency hold

Group	Code	Item	Set value	Range	Initial	Unit
Drive group	Frq	Frequency mode	2 ~ 7	0 ~ 8	0	
I/O group	I17	Multi-function input terminal P1 function selection	-	0 ~ 27	0	
	~	~				
	I21	Multi-function input terminal P5 function selection	23		7	
<p>It is available when Freq. code setting is 2 ~ 7. Select one terminal to use for Analog frequency hold command among Multi-function input terminal (P1 ~ P5).</p>						

When P5 terminal is selected, the following action:

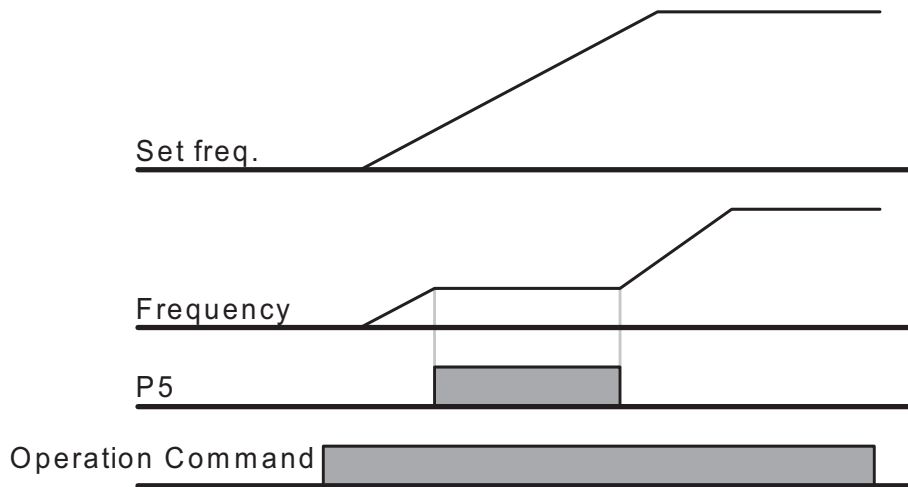

7.2 Method of multi-step frequency setting

Group	Code	Item	Set value	Range	Initial	Unit
Drive group	0.00	Target frequency	-	0.00~ 400.00	0.00	Hz
	Frq	Frequency setting mode	0	0 ~ 8	0	-
	St1	Multi-step frequency 1	-	0.00~ 400.00	0.00	Hz
	St2	Multi-Step frequency 2	-		0.00	
	St3	Multi-Step frequency 3	-		0.00	
I/O group	I19	Multi-function input terminal P3 function selection	5	0 ~ 27	2	-
	I20	Multi-function input terminal P4 function selection	6		3	-
	I21	Multi-function input terminal P5 function selection	7		4	-
	I30	Multi-step frequency 4	-	0.00~ 400.00	0.00	Hz
	I31	Multi-step frequency 5	-		0.00	
	I32	Multi-step frequency 6	-		0.00	
	I33	Multi-step frequency 7	-		0.00	

Select a terminal to give Multi-step frequency setting among P1-P5 terminals.
 If terminals P3-P5 are selected, set I19-I21 of I/O group to 5 ~ 7 respectively.
 Multi-step frequency 0 is set by frequency setting mode (Frq) and target frequency (0.00) in driving group.
 Multi-step frequency 1 ~ 3 are set at St1~ St3 in driving group, and multi-step frequency 4 ~ 7 are set at I30 ~ I33.

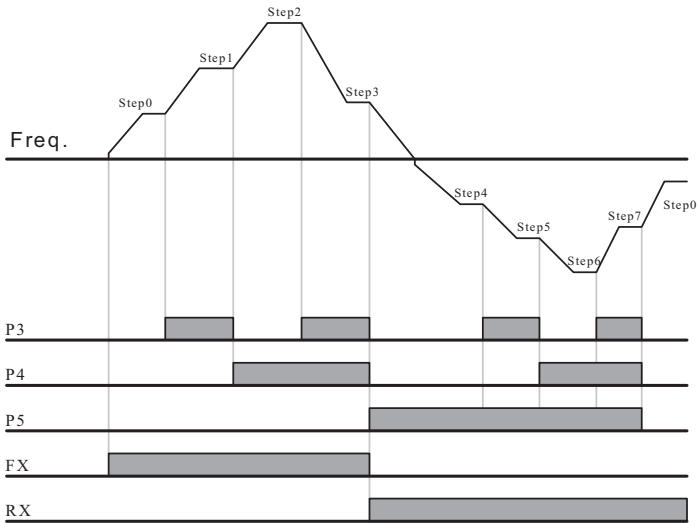

Step freq	FX or RX	P5	P4	P3
0	✓	-	-	-
1	✓	-	-	✓
2	✓	-	✓	-
3	✓	-	✓	✓
4	✓	✓	-	-
5	✓	✓	-	✓
6	✓	✓	✓	-
7	✓	✓	✓	✓

7.3 Operating command setting method

Operation via keypad RUN key and STOP/RST key

Group	Code	Item	Set value	Range	Initial	Unit
Drive group	drv	Drive mode	0	0 ~ 3	1	
	drC	Selection of motor rotation direction	-	F,r	F	

It is used only when the inverter uses the keypad control.

Set drv code of Drive group to 0.

Acceleration is started upon pressing the Run key while operating frequency is set. Motor decelerates to stop by pressing the STOP/RST key.

Selecting the rotation direction of motor is available at drC - [Selection of motor rotation direction] when operating command is issued via keypad.

drC	Operating direction of motor	F	Forward
		r	Reverse

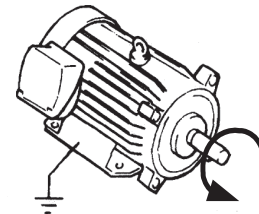

Counter-clockwise direction

Operating command 1 via FX, RX terminals of inverter

Group	Code	Item	Setting	Range	Initial	Unit
Drive group	drv	Drive mode	1	0 ~ 3	1	
I/O group	I17	Multi-function input terminal P1 function selection	0	0 ~ 27	0	
	I18	Multi-function input terminal P2 function selection	1	0 ~ 27	1	

Set drv of Drive group to 1.

When the multi-function input terminals P1 and P2 are used for FX and RX, I17 and I18 in I/O group are set to 0 and 1 respectively.

“FX” is forward run command and “RX” reverse run.

Motor is stopped when FX/RX terminal is ON/OFF at the same time.

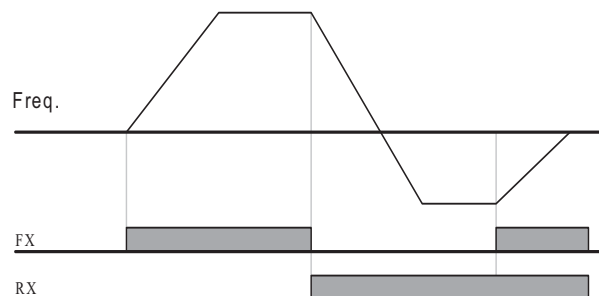

Operating command 2 via FX, RX terminal

Group	Code	Item	Set value	Range	Initial	Unit
Drive group	drv	Drive mode	2	0 ~ 3	1	
I/O group	I17	Multi-function input terminal P1 function selection	0	0 ~ 27	0	
	I18	Multi-function input terminal P2 function selection	1	0 ~ 27	1	

Set drv of Drive group to 2.

When the multi-function terminals P1 and P2 are used for FX and RX, I17 and I18 in I/O group are set to 0 and 1 respectively.

FX: Operating command setting. Motor runs in forward direction when RX terminal (P2) is OFF.

RX: Direction of motor rotation select. Motor runs in reverse direction when RX terminal (P2) is ON.

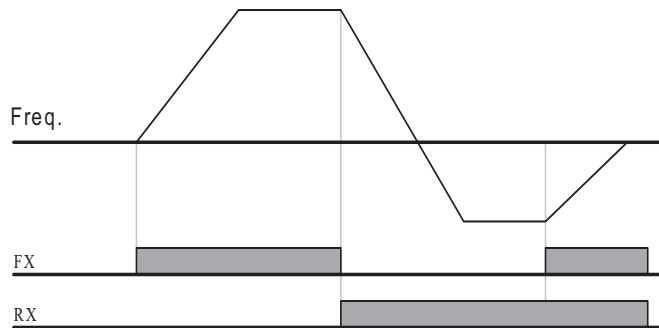

Communication operation

Group	Code	Item	Set value	Range	Initial	Unit
Drive group	drv	Drive mode	3	0 ~ 3	1	
I/O group	I59	Communication protocol select	-	0 ~ 1	0	
	I60	Inverter number]	-	1 ~ 250	1	
	I61	Baud rate	-	0 ~ 5	3	

Set drv of Drive group to 3.

Set I59, I60 and I61.

Inverter operation is performed via RS485 communication.

Refer to Chapter 11. Communication Function.

Chapter 7 Basic Functions

FX/RX operation disables

Group	Code	Item	Set value	Range	Initial	Unit
Drive group	drC	Selection of motor rotation direction	-	F,r	F	
Function group1	F1	Forward/ Reverse disable	-	0 ~ 2	0	
<p>Select the direction of motor rotation.</p> <p>0: Forward and Reverse run enable.</p> <p>1: Forward run disable</p> <p>2: Reverse run disable</p>						

Power on Start select

Group	Code	Item	Set value	Range	Initial	Unit
Drive group	drv	Drive mode	1,2	0 ~ 3	1	
Function group 2	H20	Power On Start select	1	0 ~ 1	0	
<p>H20 is set to 1.</p> <p>Setting drv to 1 or 2 (Run via control terminal) with FX or RX closed (ON), when input power is applied to inverter, the motor starts acceleration.</p> <p>When drv is set to 0 (keyboard runs) or 3 (communication operation), this parameter is inactive.</p> <p style="text-align: center;">⚠ warning</p> <p>When this function is used, the motor runs suddenly after power on. Please be careful.</p>						

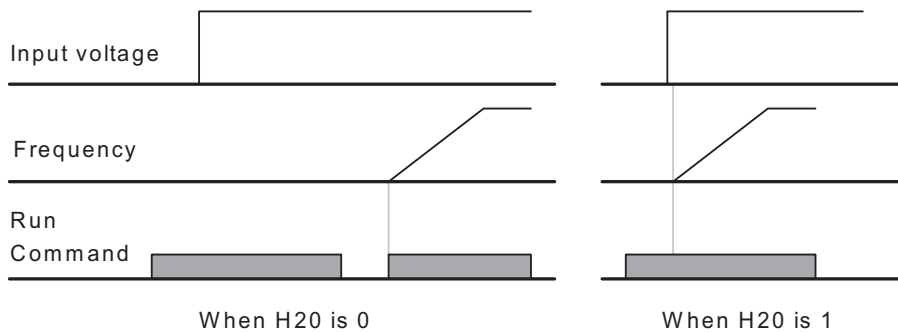

Restart after fault reset

Group	Code	Item	Set value	Range	Initial	Unit
Drive group	drv	Drive mode	1,2	0 ~ 3	1	
Function group 2	H21	Restart after fault reset selection	1	0 ~ 1	0	
<p>Set H21 to 1.</p> <p>When drv is set to terminal operation (1 or 2) with FX or RX ON, the motor starts acceleration after the fault is reset.</p> <p>This parameter is inactive when drv is set to 0 {Run via keypad} or 3 {RS-485 Communication operation}.</p>						
<p>⚠ Warning</p>						
<p>When this function is used, fault is reset via terminal or keypad, the motor starts immediately. Particular attentions shall be directed to this function due to potential hazard.</p>						

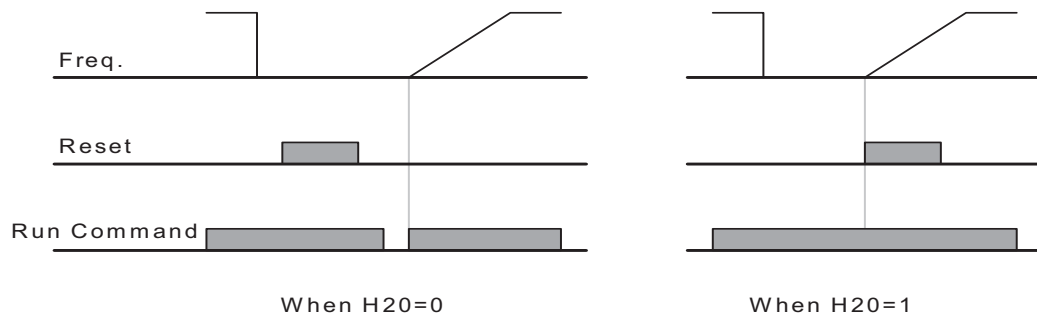

7.4 Accel/Decel time and pattern setting

Accel/Decel time setting based on Max frequency

Group	Code	Item	Set value	Range	Initial	Unit
Drive group	ACC	Accel time	-	0.0 ~ 6000.0	20.0	Sec
	dEC	Decel time	-	0.0 ~ 6000.0	20.0	Sec
Function group1	F21	Max Frequency	-	40.00~ 400.00	50.00	Hz
Function group2	H70	Frequency reference for Accel/Decel	0	0 ~ 1	0	
	H71	Accel/Decel time scale	-	0 ~ 2	1	

Set the desired Accel/Decel time at ACC/dEC in Drive group.
 If H70 in function group 2 is set to 0 (Max frequency), Accel/Decel time is the time that takes to reach the max freq from 0 Hz, it does not relate with the operation frequency.
 Desired Accel/Decel time unit is settable at the H71.

- ▶ Frequency reference for Accel/Decel (H70) is set to 0 (Max frequency), if Max frequency(F21) is set to 60Hz, Accel/Decel time 5 sec, when run frequency is set to 30Hz, time to reach 30Hz would be 2.5 sec.

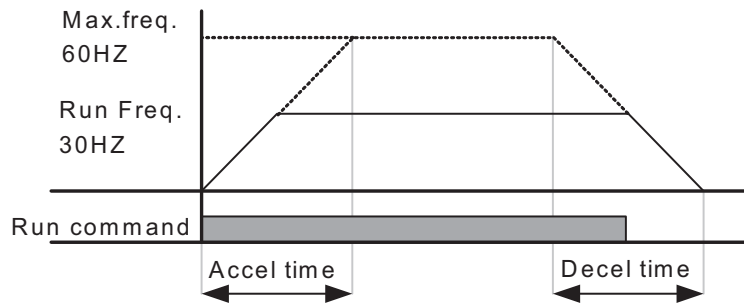

- ▶ Corresponding to load property, when more precious Accel/Decel time is desired, the setting unit can be changed as follows.

In LTVF-Cx2000, number display is available up to 5. Therefore, if time unit is set to 0.01 sec, Max Accel/Decel time would be 600.00 sec., with changes as follows:

Code	Item	Set value	Setting range for Accel/Decel time	Setting content
H71	Setting unit for Accel/Decel time	0	0.01~600.00	Unit: 0.01sec
		1	0.1~6000.0	Unit: 0. 1sec
		2	1~60000	Unit: 1sec

Accel/Decel time setting based on Operating Frequency

Group	Code	Item	Set value	Range	Initial	Unit
Drive group	ACC	Accel time	-	0.0~ 6000.0	5.0	Sec
	dEC	Decel time	-	0.0~ 6000.0	10.0	Sec
Function group 2	H70	Frequency reference for Accel / Decel time	1	0 ~ 1	0	

Desired Accel/Decel time is set at the **ACC/dEC**.
 If H70 in function group 2 is set to 1 (target frequency), Accel/Decel time is the time that takes to reach a target freq from constant run freq (Current operating freq.).

- ▶ As below: the frequency reference for Accel / Decel time (H70) is set to 1(target frequency), Accel time is set to 5 sec.
- ▶ The below graph in Section A shows the change in operating frequency when target frequency is set to 10Hz at first and then changed to 30Hz.

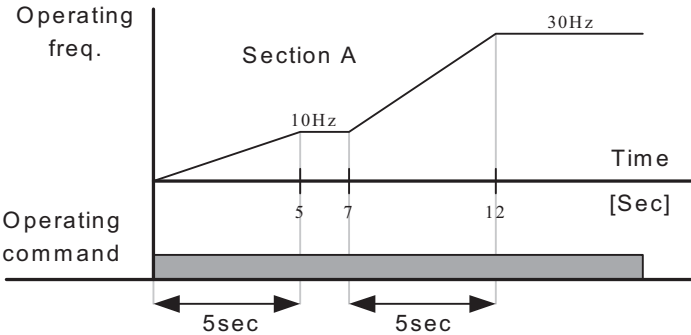

Chapter 7 Basic Functions

Multi-Accel/Decel time setting via Multi-function terminals

Group	Code	Item	Set value	Range	Initial	Unit
Drive group	ACC	Accel time	-	0.0~ 6000.0	20.0	Sec
	dEC	Decel time	-	0.0~ 6000.0	20.0	Sec
I/O group	I17	Multi-function input terminal P1 function selection	0	0 ~ 27	0	
	I18	Multi-function input terminal P2 function selection	1		1	
	I19	Multi-function input terminal P3 function selection	8		2	
	I20	Multi-function input terminal P4 function selection	9		3	
	I21	Multi-function input terminal P5 function selection	10		4	
	I34	Multi-step Accel time 1	-	0.0~ 6000.0	3.0	Sec
	~	~				
	I47	Multi-step Decel time 7	-		9.0	

Select terminals for Accel/Decel time command signal from multi-function input terminals (P1 ~ P5).
 If Accel/Decel time is set via P3 ~ P5 terminals, I19 ~ I21 codes are set to 8,9,10.
 Multi-step Accel/Decel time 0 is set at ACC, dEC in Drive group.
 Multi-step Accel/Decel time 1 ~ 7 is set at I34 ~ I47.

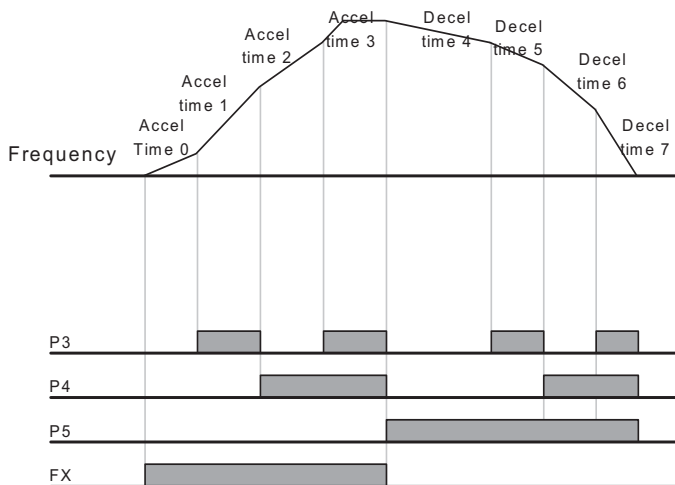

Accel / Decel time	P5	P4	P3
0	-	-	-
1	-	-	✓
2	-	✓	-
3	-	✓	✓
4	✓	-	-
5	✓	-	✓
6	✓	✓	-
7	✓	✓	✓

Accel/Decel curve setting

Group	Code	Item	Range		Initial	Unit
Function group 1	F 2	Accel pattern	0	Linear curve operation	0	
	F 3	Decel pattern	1	S curve operation		
Function group 2	H17	S-Curve Accel/Decel start curve	0 ~ 100		40	%
	H18	S-Curve Accel/Decel end curve			40	%

Accel pattern and Decel pattern can be settable at F2, F3 in function group 1.
 Linear curve operation: output frequency increases or decreases linearly according to a certain amount. It is usually used for constant torque.
 S curve operation: This curve allows the motor to accelerate and decelerate smoothly. And it is applied to application occasion such as lifting load or elevator.

⚠ Warning

When S-curve is used, the actual Accel/ Decel time is longer than the value set by user.

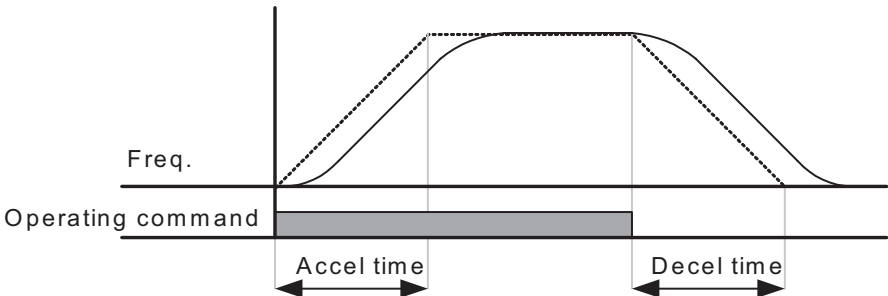

- ▶ H17 sets the starting ratio between S-curve and Linear in 1/2 of Accel/Decel Ref. Frequency, for smooth Accel/Decel starting, increase H17 to extend S-curve ratio.
- ▶ H18 sets the ending ratio between S-curve and Linear in 1/2 of Accel/Decel Ref. Frequency. For smooth and accurate speed arrival and stopping, increase H18 to extend S-curve ratio.

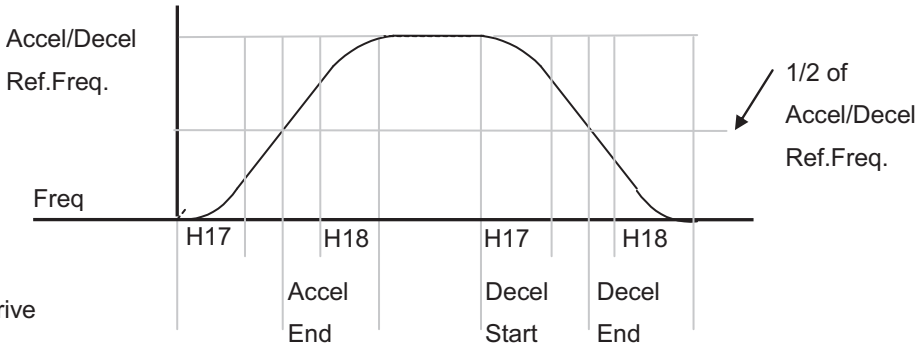

- ▶ Note that setting Frequency ^{Accel} Ref. for Accel/Decel (H70) is set to Max Freq and target freq is set below Max freq. the shape of S-curve may be distorted.

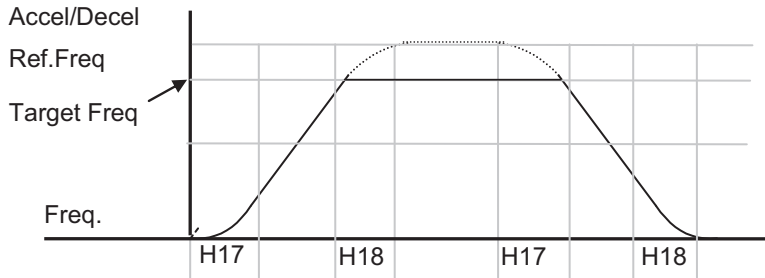

⚠ CAUTION

If Target Frequency is lower than the Max Frequency, the waveform will be shown with the top portion cut out.

- ▶ Accel time for S-curve setting = $ACC + ACC \times \frac{H17}{2} + ACC \times \frac{H18}{2}$
- ▶ Decel time for S-curve setting = $dEC + dEC \times \frac{H17}{2} + dEC \times \frac{H18}{2}$
- ▶ ACC, dEC mentioned above indicate the Accel/Decel time set in Drive group.

Accel/Decel Disable

Group	Code	Item	Set value	Range	Initial	Unit
I/O group	I17	Multi-function input terminal P1 function selection	-	0 ~ 27	0	
	~	~				
	I21	Multi-function input terminal P5 function selection	24		4	

Select one terminal among Multi-function input terminals (P1~P5) to define Accel/Decel disable.
If P5 is selected, set I21 to 24.

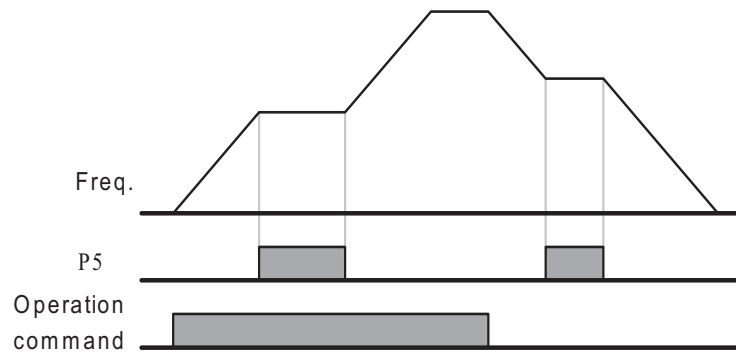

7.5 V/F control

Linear V/F pattern operation

Group	Code	Item	Set value	Range	Initial	Unit
Function group 1	F22	Base frequency	-	30.00 ~ 400.00	50.00	Hz
	F23	Start frequency	-	0.10~10.00	0.50	Hz
	F30	V/F pattern	0	0 ~ 2	0	
Function group 2	H40	Control mode select	-	0 ~ 3	0	
Set F30 to 0 (linear) This pattern maintains a linear Volts/frequency ratio from F23 (Start frequency) to F22 (Base frequency).						

- ▶ Base Frequency: Inverter outputs its rated voltage frequency. Refer to the motor nameplate Data.
- ▶ Start Frequency: Inverter starts to output its voltage frequency.

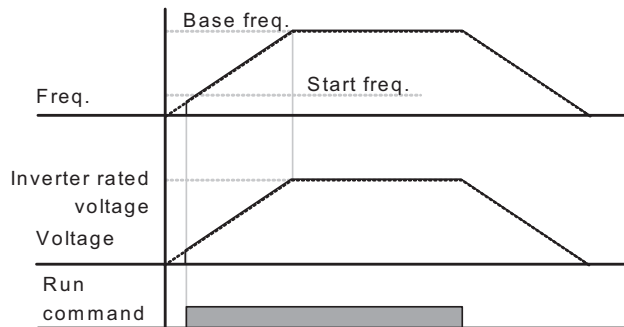

Square V/F pattern

Group	Code	Item	Set value	Range	Initial	Unit
Function group 1	F30	V/F pattern	1	0 ~ 2	0	
Set F30 to 1(square). This pattern maintains squared volts/hertz ratio. Appropriate applications are fans, pumps, etc.						

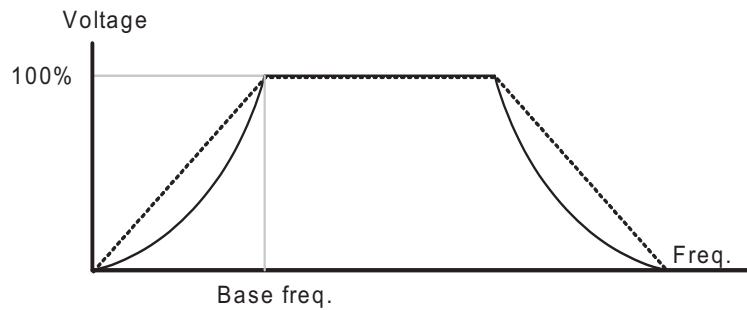

Chapter 7 Basic Functions

User V/F pattern operation

Group	Code	Item	Set value	Range	Initial	Unit
Function group 1	F30	V/F pattern	2	0 ~ 2	0	
	F31	User V/F frequency 1	-	0.00~ 400.00	12.50	Hz
	~	~				
	F38	User V/F voltage 4	-	0 ~ 100	100	%

Set F30 to 2 (user V/F).

User can adjust the Volt/Frequency ratio according to V/F pattern of specialized motors and load characteristics.

⚠ Caution

In case of using a standard induction motor, if this value is set much higher than linear V/F pattern, it could result in torque shortage or motor overheating due to over-energizing.

When User V/F curve is active, F28 - [Torque Boost in forward direction] and F29 - [Torque Boost in reverse direction] are deactivated.

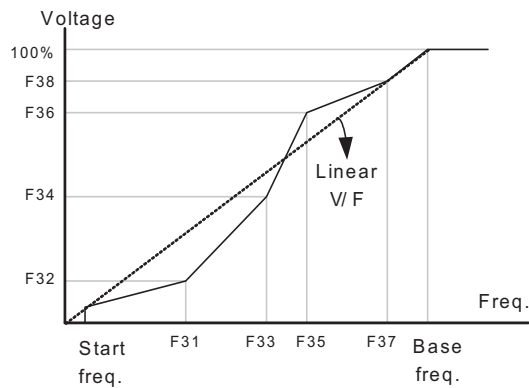

Output voltage adjustment

Group	Code	Item	Set value	Range	Initial	Unit
Function group 1	F39	Output voltage adjustment	-	40 ~ 110	100	%

This function is used to adjust the output voltage of the inverter. This is useful when the rated voltage of the motor is different from the input voltage of the inverter.

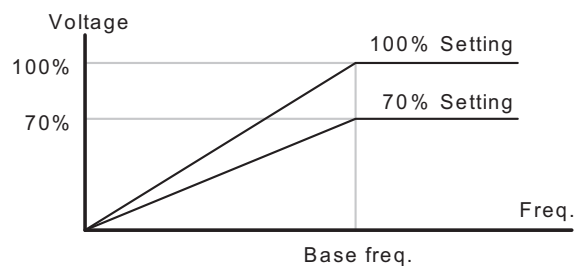

Manual torque boost

Group	Code	Item	Set value	Range	Initial	Unit
Function group 1	F27	Torque boost selection	0	0 ~ 1	0	
	F28	Forward torque boost	-	0 ~ 15	2	%
	F29	Reverse torque boost				
Set F27 to 0 (Manual torque boost) Forward/ reverse torque boost are set at F28 and F29 respectively.						
⚠ Caution						
If the boost value is set much higher than required, it may cause motor overheating due to over-energizing.						

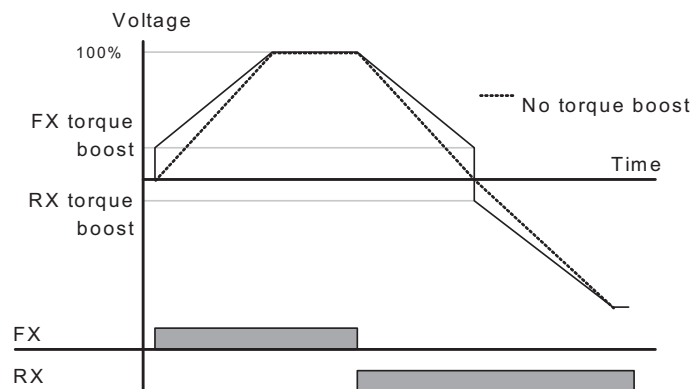

Automatic torque boost

Group	Code	Item	Set value	Range	Initial	Unit
Function group 1	F27	Torque boost selection	1	0 ~ 1	0	
Function group 2	H34	No Load Motor Current	-	0.1 ~ 50	-	A
	H41	Auto-turning	0	0 ~ 1	0	
	H42	Stator resistance (Rs)	-	0 ~ 56	-	Ω
Before the auto-torque boost setting, stator resistance (H42) and no-load current (H34) of motor shall be set correctly. (Refer to page 8-15).						
Set F27 to 1 (automatic torque boost). The inverter automatically calculates torque compensation according motor parameters and outputs the corresponding voltage.						

7.6 Stop mode select

Decel to stop

Group	Code	Item	Set value	Range	Initial	Unit
Function group 1	F4	Stop mode selection	0	0 ~ 3	0	
Set F4 to 0 (Decel to stop). Motor decelerates to 0 Hz and stops during the setting time.						

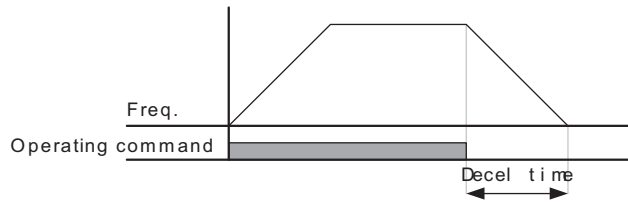

DC braking to stop

Group	Code	Item	Set value	Range	Initial	Unit
Function group 1	F4	Stop mode selection	1	0 ~ 3	0	
Set F4 to 1 (DC braking stop). Refer to page 8-1.						

Free run to stop

Group	Code	Item	Set value	Range	Initial	Unit
Function group 1	F4	Stop mode selection	2	0 ~ 3	0	
Set F4 to 2 (Free run stop). When operating command is turned OFF, the inverter turn off the output frequency and voltage, then the motor stops in the matter of mechanical inertia.						

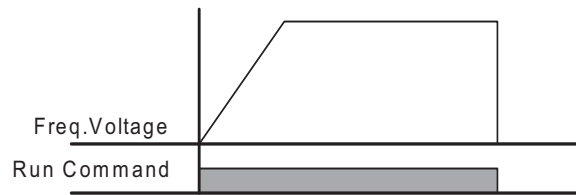

Electric braking

Group	Code	Item	Set value	Range	Initial	Unit
Function group 1	F4	Stop mode selection	3	0 ~ 3	0	
Set F4 to 3 (electric braking)						
When operating command is turned off, the motor stops at the rapidest speed. Refer to page 8-25.						

7.7 Frequency limit

Frequency limit using Max Frequency and Start Frequency

Group	Code	Item	Set value	Range	Initial	Unit
Function group 1	F21	Max frequency	-	0.00~ 400.00	6 50.00	Hz
	F23	Start frequency	-	0.10 ~ 10.00	0.50	Hz
Max Frequency: Frequency highest limit. Any frequency cannot be set above [Max frequency] except for F22 [Base frequency].						
Start Frequency: Frequency lowest limit. If a frequency is set lower than this, 0.00 is automatically set.						

Frequency limit using High/Low frequency limit

Group	Code	Item	Set value	Range	Initial	Unit
Function group 1	F24	Frequency high/low limit select	1	0 ~ 1	0	
	F25	Frequency high limit	-	0.00~ 400.00	50.00	Hz
	F26	Frequency low limit	-	0.00~ 400.00	0.50	Hz
Set F24 to 1 (High/low setting of operating frequency)						
The target frequency can be set within the range of F25 and F26.						

- ▶ When frequency setting is done via Analog input (voltage or current input), the inverter operates within the range of high and low limit frequency as shown below.
- ▶ This setting is also valid when frequency setting is done via keypad.

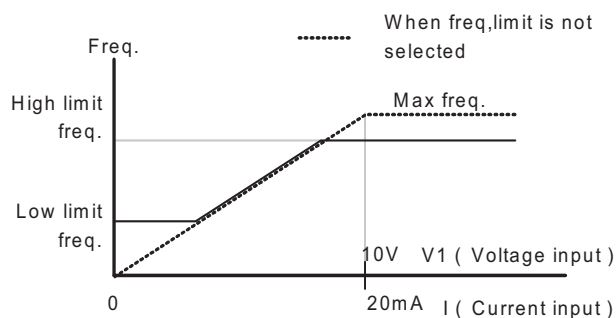

Skip frequency operation

Group	Code	Item	Set value	Range	Initial	Unit
Function group 2	H10	Skip frequency selection	1	0 ~ 1	0	
	H11	Skip frequency low limit 1	-	0.10 ~ 400.00	10.00	Hz
	~	~				
	H16	Skip frequency high limit 3	-	0.10 ~ 400.00	35.00	Hz

Set H10 to 1 (using skip frequency function).

The operating frequency can't be set at H11~H16. The frequency value of low-number parameter can not be higher than that of high-number parameter.

Skip frequency is settable within max frequency (F21) and start frequency (F23).

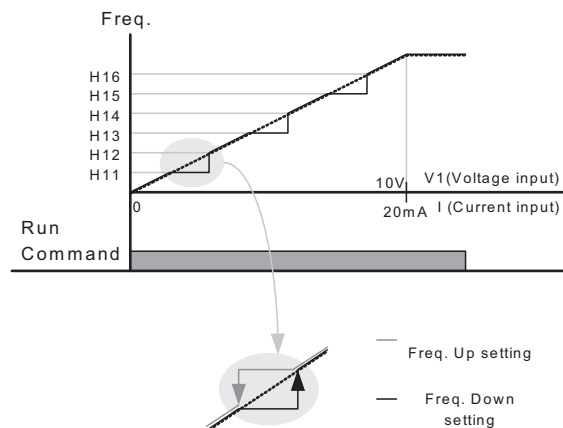

- ▶ The skip-frequency function is to prevent that motor operates in the range of resonance frequency in the mechanical system. However, during acceleration or deceleration the motor can run through the skip-frequency range but can't run at a certain speed.
- ▶ When Accel is made, if the frequency setting value (setting via voltage, current, RS-485 communication or keypad) is within the skip-frequency range, the frequency setting shall maintain at the skip-frequency low limit, it starts to be increased beyond the range.
- ▶ When Decel is made, if the frequency setting value (setting via voltage, current, RS-485 communication or keypad) is within the skip-frequency range, the frequency setting shall maintain at the skip-frequency low limit, it starts to be decreased beyond the range.

8. Application

8.1 DC brake

- Measures to stop motor through DC brake

Group	Code	Item	Set Value	Setting Range	Initial	Unit
Function	F 4	Stop mode select	1	0 ~ 3	0	
Group 1	F 8	DC Brake start frequency	-	0.10 ~ 60.00	5.00	Hz
	F 9	DC Brake wait time	-	0.00 ~ 60.00	0.10	Second
	F10	DC Brake voltage	-	0 ~ 200	50	%
	F11	DC Brake time	-	0.0 ~ 60.0	1.0	Second
<ul style="list-style-type: none"> ▪ Function group 1: Select 1 (DC brake to stop) in F4 code ▪ F8: Initial frequency for DC brake ▪ F9: Waiting time of inverter before DC brake ▪ F10: Set as per the rated current of motor (based on H33) ▪ F11: The time set shall be the time for work of DC braking voltage 						
 Caution						
The over-voltage or overlong time in DC brake will cause overheat or damage of motor.						

- ▶ Setting F10 or F11 to 0 will disable DC brake.
- ▶ Waiting time of DC brake: When load inertia is large or DC Brake Start Frequency is high, over current trip may occur. It can be prevented using F9.
- ▶ In case of DC brake at high load inertia and frequency, change the DC brake controller gain according to H37 set value.

H37	Load inertia ratio	0	Less than 10 times
		1	About 10 times
		2	More than 10 times

Chapter 8 Application

● Starting DC brake

Group	Code	Item	Set Value	Setting Range	Initial	Unit
Function Group 1	F12	DC Brake start voltage	-	0 ~ 200	50	%
	F13	DC Brake start time	-	0.0 ~ 60.0	0.0	sec

- F12: Set on the basis of rated current of motor—H33
- F13: Motor starts to accelerate after DC voltage is applied for the set time—F13

⚠ Caution

If excessive DC Brake voltage is set or DC Brake time is set too long, it may cause motor overheating and damage to the motor.

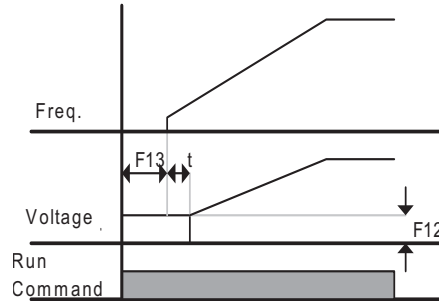

- ▶ Setting F12 or F13 to 0 will disable Starting DC brake.
- ▶ t: The inverter starts to accelerate after the time set in F13 ends.

● DC brake at a stop

Group	Code	Item	Set Value	Setting Range	Initial	Unit
Function Group 1	F12	DC Brake start voltage	-	0 ~ 200	50	%
I/O Group	I19	Multi-function input terminal P3 function selection	11	0 ~ 25	2	

- F12: Set on the basis of rated current of motor—H33
- One of the multi-function input terminal (P1~P5) may be selected to set as signal to stop DC brake
- If P3 terminal is set for this function, set I19 in I/O group to 11 (stop of DC brake)

⚠ Caution

If excessive DC Brake voltage is set or DC Brake time is set too long, it may cause motor overheating and damage to the motor.

Voltage

P3

8.2 Jog control

Run command

● Jog Operation

Group	Code	Item	Set Value	Setting Range	Initial	Unit
Function Group 1	F20	Jog frequency	-	0.00~ 400.00	10.00	Hz
I/O Group	I21	Multi-function input terminal P5 function selection	4	0 ~ 27	4	

- Function group 1: set the jog frequency in F20.
- Select a terminal to use for jog operation from multi-function input terminals (P1~P8)
- If P5 is set for jog operation, set I21 to 4 (jog)
- Jog frequency can be set within the range of F21 [Max frequency] and F23 [Start frequency].

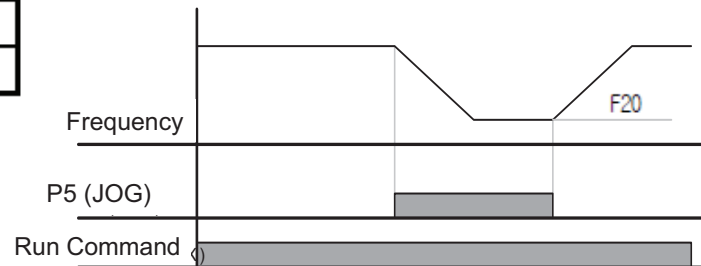
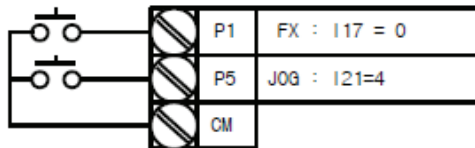

- ▶ Jog operation overrides all other operations except Dwell operation. Therefore, if Jog frequency command is entered in the middle of Multi-Step, Up-Down or 3-wire operation, operation is executed at Jog frequency.

● JOG FX/RX Operation

Group	Code	Item	Set Value	Setting Range	Initial	Unit
Function Group 1	F20	Jog frequency	-	0.00~ 400.00	10.00	Hz
I/O Group	I20	Multi-function input terminal P4 function selection	26	0 ~ 27	3	
	I21	Multi-function input terminal P5 function selection	27	0 ~ 27	4	

Chapter 8 Application

- Function group 1: set the jog frequency in F20.
- Select a terminal to use for the Jog-FX from multi-function input terminals (P1~P5)
- If P4 is set for jog FX, set I20 to 26 (jog-FX) in I/O group.

- ▶ Jog frequency can be set within the range of F21 (Max frequency) and F23 (Start frequency).
- ▶ The following diagram is an example when target frequency is 30Hz and Jog frequency is 10 Hz.

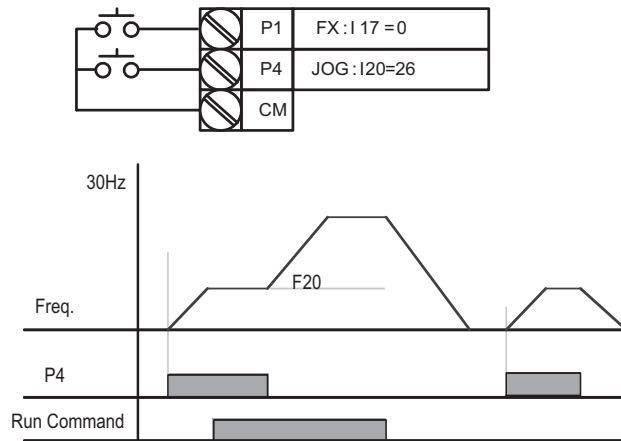

8.3 UP/Down operation

- UP/Down storage function

Group	Code	Item	Set Value	Setting Range	Initial	Unit
Drive group	Frq	Frequency setting mode	8	0 ~ 8	0	
I/O group	I17	Multi-function input terminal P1 selection	0	0 ~ 27	0	
	I19	Multi-function input terminal P3 selection	25		2	
	I20	Multi-function input terminal P4 selection	15		3	
	I21	Multi-function input terminal P5 selection	16		4	
Function group 1	F63	Up-Down frequency save select	-	0 ~ 1	0	
	F64	Up-Down frequency storage	-		0.00	

- Select 8 in Frq code of drive group
- Select the terminal which uses as a up-down drive among multi-function input terminals(P1~P5)

- If you select P4 and P5 as an up-down drive terminal, select each 15 (frequency increase command) and 16 (frequency decrease command) in the I20 and I21 of I/O group.
- If you select P3 terminal as an up-down save initial terminal, select 25 (up-down save initialization) in the I19 of I/O group.
- Up/down Save function: If F63, 'Save up/down frequency', is set to 1, the frequency before the inverter was stopped or decelerated is saved in F64.

- ▶ While up-down save operates, the user can initialize the saved up-down frequency by setting multi-function input terminal as a up-down frequency save initialization.

F63	Save up/down frequency select	0 (Initial)	Remove 'save up/down frequency'
		1	Set 'save up/down frequency'
F64	Save up/down frequency	Up/down frequency saved	

- ▶ If 'Up/Down Save Frequency Initialization' signal is input while the multi-function input 'Up' or 'Down' function is applied, this signal is ignored.

● Up-down mode select

Group	Code	Item	Set Value	Setting Range	Initial	Unit
Drive group	Frq	Frequency setting mode	8	0 ~ 8	0	
I/O group	I17	Multi-function input terminal P1 selection	0	0 ~ 27	0	
	I20	Multi-function input terminal P4 selection	15		3	
	I21	Multi-function input terminal P5 selection	16		4	
Function group 1	F65	Up-down mode select	-	0 ~ 2	0	
	F66	Up-Down step frequency	-	0.00~ 400.00	0.00	Hz

- Select 8 in Frq code of drive group
- Select the terminal which uses as a up-down drive from multi-function input terminals(P1~P5)
- Operates in selected mode as a step frequency set in F66.

- ▶ The up-down mode is Select as follows

F65	Up/down select	0	The reference frequency is increased according to base of Max/Min frequency. (Initial value)
		1	Increased as many as step frequency (F66) according to edge input
		2	Combination of 0 and 1
F66	Step frequency	Frequency increased according to edge input	

- ▶ When F65 is 0: If you press UP, it is increased up to Max. Frequency as a speed set in the above. (If frequency limit exist, speed is increased up to upper limit.) If press DOWN, It is decreased as a speed

set in the above regardless of stop method. (If frequency limit exist, speed is decreased up to lower limit.)

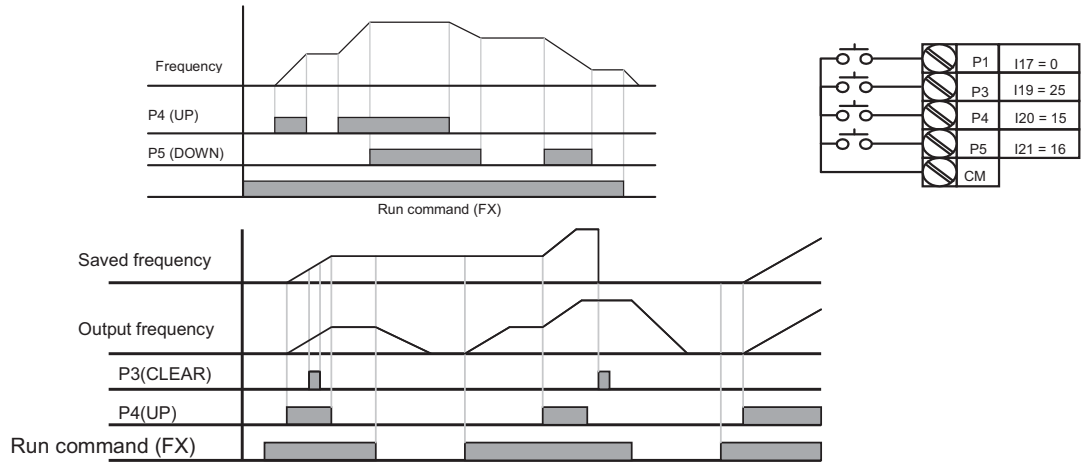

Run command (FX)

- ▶ When F65 is 1: It is increased as many as step frequency set as F66 at the rising edge of multifunction input set as UP and when up-down is defined, it saves frequency at the falling edge. It is decreased as many as step frequency set as F66 at the falling edge of rising edge of multifunction input set as DOWN and when up-down is defined, it saves frequency as the falling edge. In this case, while multifunction input set as UP or DOWN is defined, if stop command is inputted, previous falling edge value is saved and if multi-function input is not defined, present frequency is not saved. The accel/decel time is same with when stted as "0".
- ▶ When F65 is 2: It is increased as many as step frequency set as F66 at the rising edge of multifunction input set as UP and if it is activated for 3 second, it operates like something set as "0". It is decreased as many as step frequency set as F66 at the rising edge of multi-function input set as DOWN and if it is activated for 3 second, it operates like something set as "0" and the accel/decel time is same with when stted as "0".

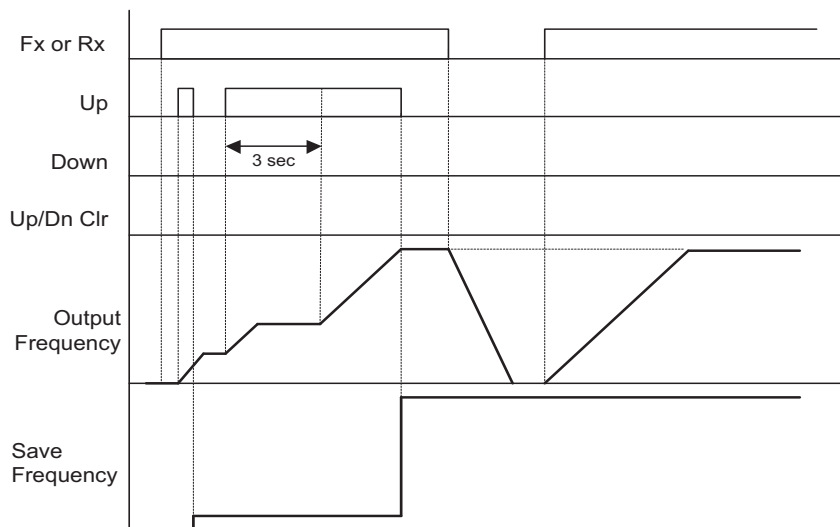

⚠ Caution

Because of UP or DOWN, when the input is entered again before it is increased as many as 1 step frequency, the input is ignored and the saved frequency is also frequency of the inactivated moment

8.4 3-Wire

Group	Code	Item	Set Value	Setting range	Initial	Unit
I/O group	I17	Multi-function Input terminal P1 select	0	0 ~ 27	0	
	~	~				
	I21	Multi-function Input terminal P5 select	17		4	

- Select the terminal from P1-P5 for use as 3-Wire operation
- If P5 is selected, set I21 to 17 (3-Wire operation) in the I/O group.

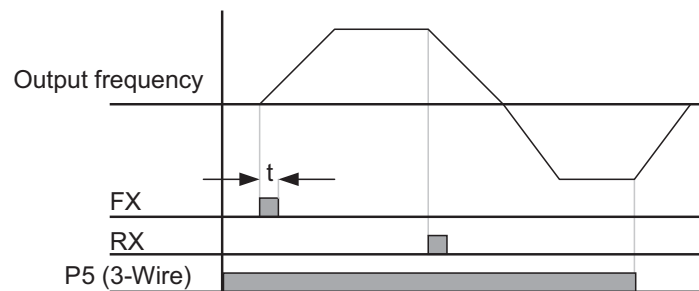
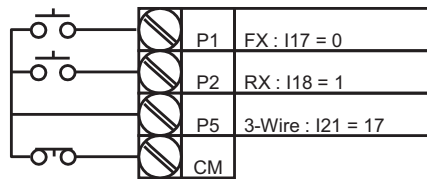

- ▶ Input signal is latched (saved) in 3-Wire operation. Therefore, inverter can be operated by Push-button switch.
- ▶ The bandwidth of pulse (t) should not be less than 50msec.

8.5 Dwell operation

Group	Code	Item	Set Value	Setting Range	Initial	Unit
Function group 2	H 7	Dwell frequency	-	0.10 ~ 400.00	5.00	Hz

Chapter 8 Application

	H 8	Dwell time	-	0.0 ~ 10.0	0.0	sec
<ul style="list-style-type: none"> In this setting, motor begins to accelerate after dwell operation is executed for dwell time at the dwell frequency. It is mainly used to release mechanical brake in elevators after operating at dwell frequency. 						

- ▶ Dwell frequency: This function is used to output torque in an intended direction. It is useful in hoisting applications to get enough torque before releasing a mechanical brake. Rated Slip frequency is calculated by the formula shown below.

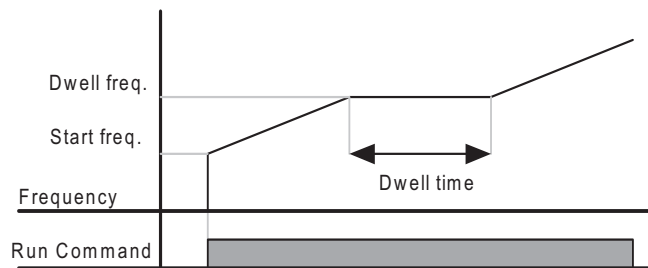

8.6 Slip compensation

Group	Code	Item	Set Value	Setting Range	Initial	Unit
Function group 2	H30	Motor type select	-	0.1 ~ 11.00	0.75	
	H31	Number of motor poles	-	2 ~ 12	4	
	H32	Rated slip frequency	-	0.00 ~ 10.00	2.33	Hz
	H33	Motor rated current	-	0.5 ~ 150.0	26.3	A
	H34	Motor No Load Current	-	0.1 ~ 50.0	11.0	A
	H36	Motor efficiency	-	50 ~ 100	87	%
	H37	Load inertia rate	-	0 ~ 2	0	
	H40	Control mode select	1	0 ~ 3	0	
<ul style="list-style-type: none"> Set H40 – [Control mode select] to 1 (Slip compensation) in the function group 2 This function enables the motor to run in constant speed by compensating inherent slip in an induction motor. 						

- ▶ H30: Set the motor type

H30	Motor type select	0.1	0.1kW
		~	
		11.0	11.0kW

- ▶ H31: Enter the pole number on the Motor nameplate.
- ▶ H32: Enter the slip frequency in accordance with the following formula and motor nameplate.

$$f_s = f_r - \left(\frac{rpm \times P}{120} \right)$$

Where,

f_s = Rated slip frequency

f_r = Rated frequency

rpm = Motor rated RPM

P = Motor pole number

Ex) Rated freq.: 60Hz, Rated RPM: 1740rpm, Poles: 4,

$$f_s = 60 - \left(\frac{1740 \times 4}{120} \right) = 2 Hz$$

- ▶ H33: Enter the motor nameplate rated current.
- ▶ H34: Enter the measured current when the motor is running at rated frequency after the load is removed. Enter 50% of the rated motor current when it is difficult to measure the motor no load current.
- ▶ H36: Enter motor efficiency on the nameplate.
- ▶ H37: Select load inertia based on motor inertia as shown below.

H37	Load inertia rate	0	Less than 10 times motor inertia
		1	About 10 times motor inertia
		2	Greater than 10 times motor inertia

- ▶ As the loads are heavier, the speed gap between rated RPM and synchronous speed is widening (see the figure below). This function compensates for this inherent slip.

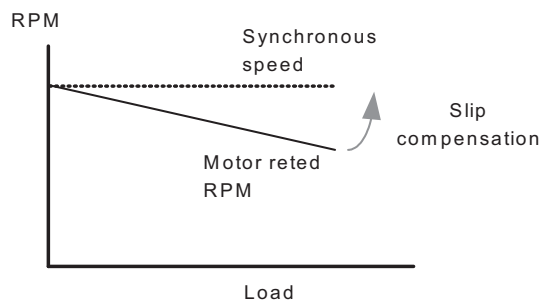

8.7 PID control

Group	Code	Item	Set Value	Setting Range	Initial	Unit
Function group 2	H49	PID Operation selection	1	0 ~ 1	0	-
	H50	PID Feedback selection	-	0 ~ 2	0	-
	H51	P gain for PID controller	-	0.0~ 999.9	300.0	%
	H52	Integral time for PID controller (I gain)	-	0.1~ 32.0	1.0	sec
	H53	Differential time for PID controller (D gain)	-	0.0~30.0	0	sec
	H54	PID mode select	-	0 ~ 1	0	-
	H55	PID output frequency high limit	-	0.1 ~ 400.0	60.0	Hz
	H56	PID output frequency low limit	-	0.10 ~ 400.00	0.50	Hz
	H57	PID reference select	-	0 ~ 4	0	-
	H58	PID unit select	-	0 ~ 1	0	-
	H61	Sleep delay time	-	0.0~2000.0	60.0	sec
	H62	Sleep frequency	-	0.00 ~ 400.00	0.00	Hz
	H63	Wake-up level	-	0.0 ~ 100.0	35.0	%
I/O group	I17	Multi-function input terminal selection	21	0 ~ 27	-	-
Drive group	rEF	PID reference	-	0.00 ~ 400.00 / 0.0 ~ 100.0	0.00 / 0.0	Hz / %
	FbK	PID feedback	-	0.00~ 400.00 / 0.0 ~ 100.0	0.00 / 0.0	Hz / %
<ul style="list-style-type: none"> ▪ In order to control the amount of following water, pressure and temperature, do PID control to inverter output frequency. ▪ Select H49 of function group 2 as a 1 (PID drive select). Then REF and FBK category show. Set PID reference value in REF and real PID feedback amount is monitored at the FBK ▪ PID drive is classified as two which are Normal PID mode and Process PID mode. It can be set in the H54 (PID mode select) 						

▶ H50: Select the feedback type of PID controller.

H50	PID Feedback select	0	Terminal I input (0 ~ 20[mA])
		1	Terminal AI(V input) (0 ~ 10[V])
		2	Communication RS-485

- ▶ H51: Set the percentage of output to error. If P Gain is set to 50%, 50% of the error value will be output. Higher value can reach the target control value faster but it may cause oscillation.
- ▶ H52: Set the time to output the accumulated error value. Set the time required to output 100% when the error value is 100%. If H52 - [Integral time for PID controller (I gain)] is set to 1 sec and the error becomes 100%, 100% will be output in 1 sec. Adjusting the value may reduce the nominal error. If the value is reduced, response will be faster but setting too low may lead to controller oscillation.
- ▶ H53: Set the output value to the variation of the error. The error is detected by 0.01 sec. If differential time is set to 0.01 sec and the percentage variation of error per 1 sec is 100%, 1% per 10msec is output.
- ▶ H55, H56: It limits the output of the PID controller.
- ▶ H57: selects PID Reference
- ▶ H58: PID Reference and PID feedback's units are classified as two which is [Hz] and [%].
- ▶ H58=0: [Hz], H58=1: [%]
- ▶ I17 ~ I21: To exchange PID to V/FI operation, set one of P1-P5 terminal to 21 (switch between PID mode and V/F mode).

- ▶ rPM : Calculates the feedback from H50 into motor frequency and displays it.
- ▶ rEF: indicates PID controller's command value.
- ▶ Fbk: converts feedback amount set in H50 to motor frequency.

Chapter 8 Application

► Normal PID drive (H54=0)

PID control diagram

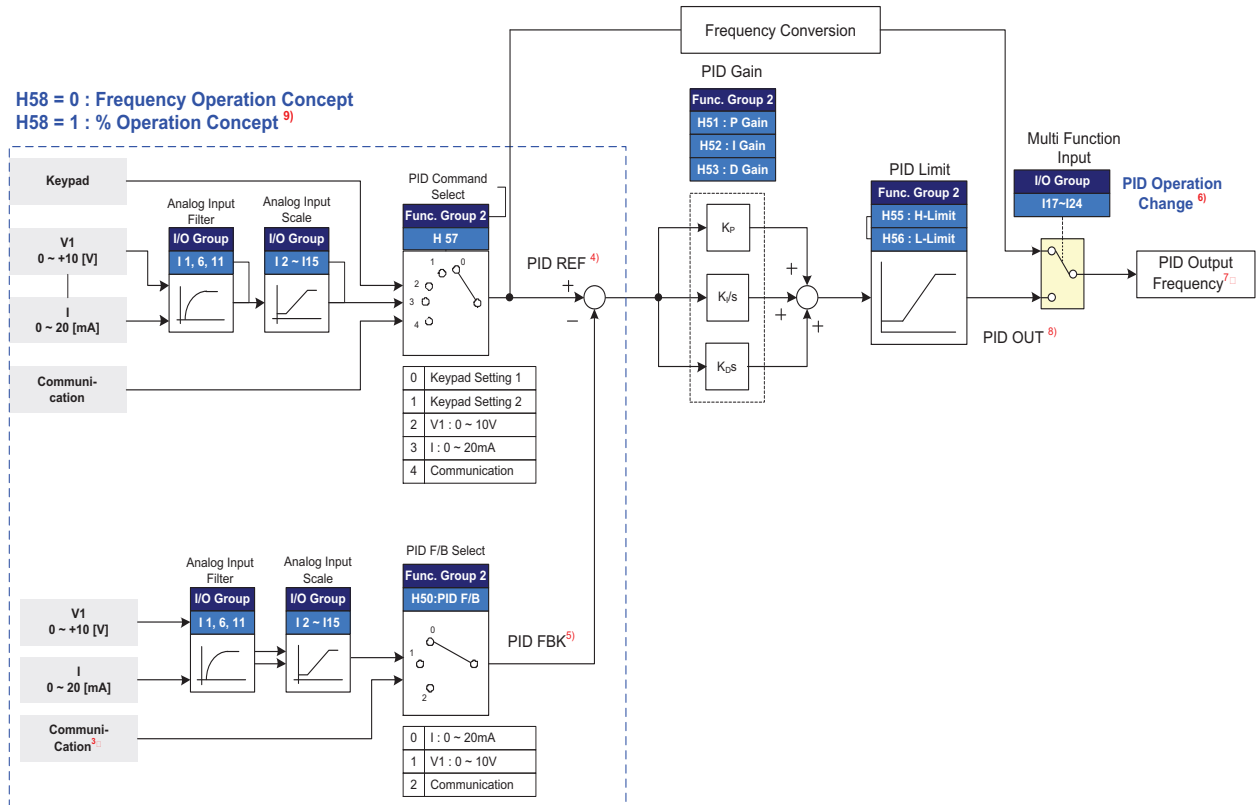

Note 3) Adds RS-485 communications to PID Feedback category.

Note 4) PID REF value can be changed and checked in the “rEF” of the DRV group.

Unit is [Hz] when H58=0 and [%] when H58=1

Note 5) PID FBK value can be checked in the “Fbk” of the DRV group. Unit is same with the “rEF”

Note 6) If PID switching is inputted to the multi-input (P1~P8), though H58 is 1, [%] is converted into [Hz].

Note 7) Output frequency is displayed in the “SPD” of DRV group.

Note 8) PID OUT of Normal PID is single polarity and it is limited by H55 (H-Limit) and H56 (L-Limit).

Note 9) 100% is F21 (Max. frequency)

- Process PID drive (H54=1)

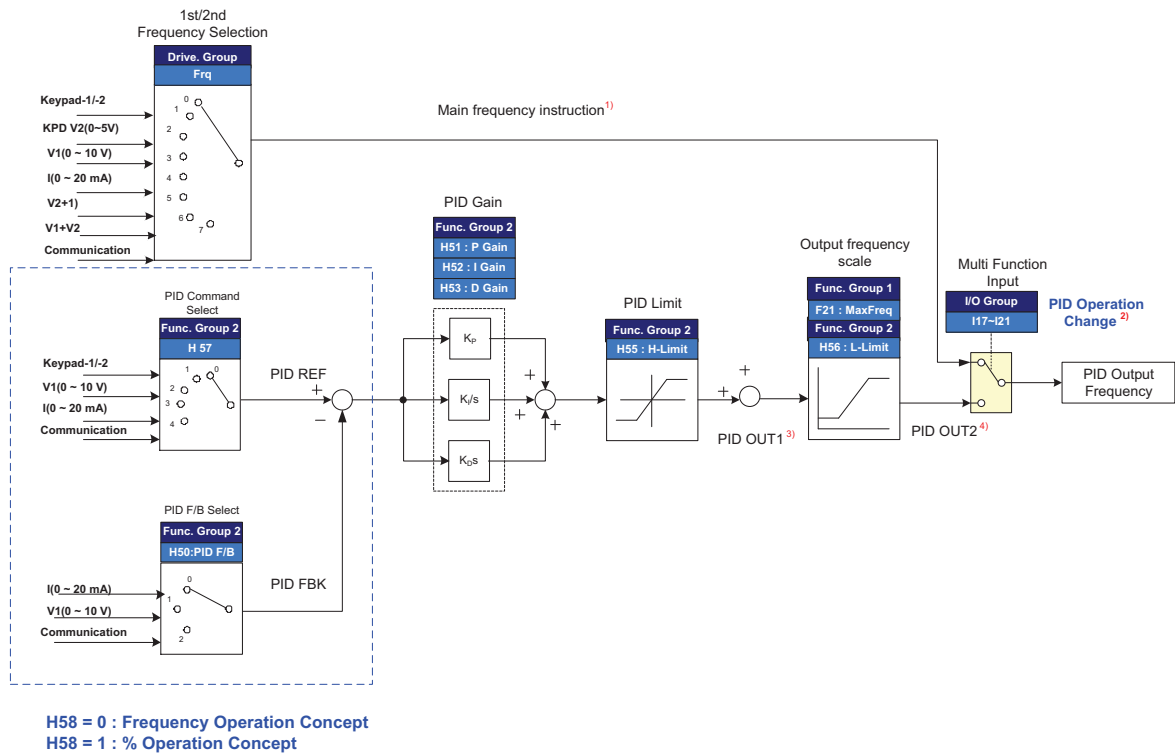

H58=0: Frequency Operation Concept

H58=1:% Operation Concept

Note 1) Speed command is the frequency (FRQ=8, except Up/Down) set by FRQ/FRQ2 and real output frequency is sum of speed command, PID OUT1 and PID OUT2.

Note 2) If PID switching drive is selected; the actual output frequency shall be speed.

Note 3) Differing with Normal PID, PID OUT1's polarity is double in the module, and it is limited H55 (PID upper Limit).

Note 4) Real output frequency PID OUT2 is limited by F21 (Max. Freq) and H56 (PID lower Limit)
 Other operation is same with the Normal PID.

- Sleep & Wake-up
 - ▶ Sleep function means if output frequency of PID control is maintained at the set sleep frequency (H62) over sleep delay time (H61) due to not enough flux, Sleep function becomes sleep mode automatically and inverter is stop. Under sleep mode, if error of PID Reference and Feedback is over H63 (Wake up Level), Sleep mode is released and the inverter restarts.
 - ▶ If stop command is input, Sleep mode is released

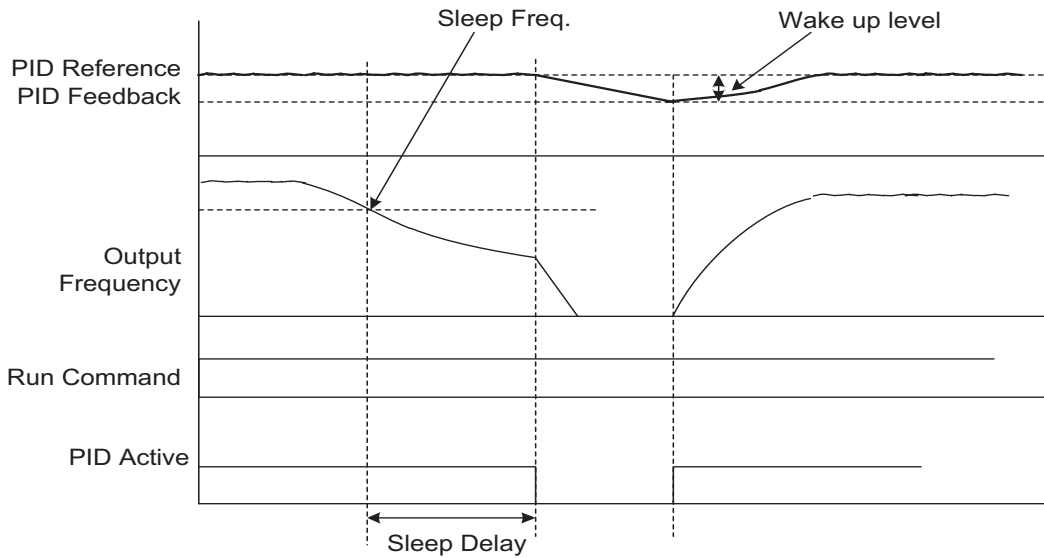

8.8 Auto-tuning

Group	Code	Item	Set Value	Setting Range	Initial	Unit
Function group 2	H41	Auto turning	1	0 ~ 1	0	-
	H42	Stator resistance (Rs)	-	0 ~ 56	-	Ω
	H44	Leakage inductance (Lσ)	-	0.00 ~ 600.00	-	mH

- Automatic measuring of the motor parameters is provided.
- The measured motor parameters in H41 can be used in Auto Torque Boost and sensorless Vector Control.
- Press the "STOP" key for 5 seconds on the panel to start the automatic turning

⚠ Caution

Auto tuning should be executed after stopping the motor. Motor shaft must not run by the load during H41 – [Auto tuning].

- ▶ H41: When H41 is set to 1 and press the Enter key, Auto tuning is activated and “tUn” will appear on the LED keypad. When finished, “H41” will be displayed.
- ▶ H42, H44: The values of motor stator resistance and leakage inductance detected in H41 are displayed, respectively. When Auto tuning is skipped or H93 (Parameter initialize) is done, the default value corresponding to motor type (H30) will be displayed.
- ▶ Press the STOP key on the keypad or turn on the EST terminal to stop the Auto Tuning.
- ▶ If Auto tuning is interrupted, the default value will be set. If auto-tuning of leakage inductance is interrupted, the measured value is used and the default of leakage inductance is set.
- ▶ See page 8-16 for motor parameter default values.

 Caution

Do not enter any incorrect value as stator resistance and leakage inductance. Otherwise, the function of Sensorless vector control and Auto torque boost could be deteriorated.

8.9 Sensorless Vector Control

Group	Code	Item	Set Value	Setting Range	Initial	Unit
Function group 2	H40	Control mode select	3	0 ~ 3	0	-
	H30	Motor type select	-	0.1 ~ 11.0	-	kW
	H32	Rated slip frequency	-	0~ 10	-	Hz
	H33	Motor rated current	-	0.5 ~ 150	-	A
	H34	Motor No Load Current	-	0.1 ~ 50	-	A
	H42	Stator resistance (Rs)	-	0 ~ 56	-	Ω
	H44	Leakage inductance (L σ)	-	0 ~ 600.0	-	mH
Function Group 1	F14	Time for energizing a motor	-	0.0~60.0	0.5	Sec
<ul style="list-style-type: none"> ▪ If H40 – [Control mode select] is set to 3, Sensorless vector control will become active. 						
 Caution						
Motor parameters should be set for high performance. It is highly recommended Auto tuning be done prior to proceeding operation via Sensorless vector control.						

- ▶ Ensure that the following parameters are entered correctly for high performance in Sensorless vector control.
- ▶ H30: Select motor type connected to inverter output.
- ▶ H32: Enter rated slip frequency based on motor nameplate RPM and rated frequency (See 8-8).
- ▶ H33: Enter motor nameplate rated current.
- ▶ H34: After removing the load, select H40 – [Control mode select] to 0 9V/F control) and run the motor at 60Hz. Enter the current displayed in Cur-[Output current] as motor no load current. If it is difficult to

Chapter 8 Application

remove the load from the motor shaft, enter the value either 40 to 50% of the H33 – [Motor rated current] or the factory default.

- ▶ In case that occur torque ruffle while high speed driving, lower H34-[No load current] to 30%.
- ▶ H42, H44: Enter the value of the parameter measured during H41 – [Auto tuning] or the factory default.
- ▶ F14: This parameter accelerates the motor after pre-exciting the motor for the set time. The amount of the pre-exciting current is set in H34- [Motor no load current].
- ▶ Directly enter the motor nameplate value except motor rating when 0.2kW is used.
- Factory default by motor ratings

Input voltage	Motor rating [kW]	Current rating [A]	No-load Current [A]	Rated slip freq [Hz]	Stator Resistance [Ω]	Leakage inductance [mH]
230	0.1	0.6	0.4	2.00	30.00	240.00
	0.2	1.1	0.6	2.33	14.00	122.00
	0.4	1.8	1.2	3.00	6.7	61.00
	0.75	3.5	2.1	2.33	2.46	28.14
	1.1	4.8	2.1	2.33	2.46	28.14
	1.5	6.5	3.0	2.33	1.13	14.75
	2.2	8.8	4.4	2.00	0.869	11.31
	3.0	11.6	4.4	2.00	0.869	11.31
	3.7	12.9	4.9	2.33	0.5	5.41
	4.0	14.6	4.9	2.33	0.5	5.41
	5.5	19.7	6.6	2.33	0.314	3.6
	7.5	26.3	11.0	2.33	0.196	2.89
11.0	37.0	12.5	1.33	0.120	2.47	
415	0.1	0.4	0.3	2.00	56.00	600.00
	0.2	0.7	0.4	2.33	28.00	300.00
	0.4	1.1	0.7	3.00	14.00	177.86
	0.75	2.0	1.3	2.33	7.38	88.44
	1.1	2.4	1.3	2.33	7.38	88.44
	1.5	3.7	2.1	2.33	3.39	44.31
	2.2	5.1	2.6	2.00	2.607	34.21
	3.0	5.8	2.6	2.00	2.607	34.21
	3.7	6.5	3.3	2.33	1.5	16.23
	4.0	8.4	3.3	2.33	1.5	16.23
	5.5	11.3	3.9	2.33	0.94	10.74
	7.5	15.2	5.7	2.33	0.52	8.80
11.0	22.6	7.5	1.33	0.36	7.67	

8.10 Energy-saving operation

Group	Code	Item	Set Value	Setting Range	Initial	Unit
Function Group 1	F40	Energy-saving level]	-	0 ~ 30	0	%
<ul style="list-style-type: none"> ▪ Set the amount of output voltage to be reduced in F40. ▪ Set as the percent of Max output voltage. ▪ For fan or pump applications, energy consumption can be dramatically reduced by decreasing the output voltage when light or no load is connected. 						

Output

F40

Output

8.11 Speed search

Group	Code	Item	Set Value	Setting Range	Initial	Unit
Function group 2	H22	Speed search select	-	0 ~ 15	0	
	H23	Current level	-	80 ~ 200	150	%
	H24	Speed search P gain	-	0 ~ 9999	100	
	H25	Speed search I gain	-		200	
I/O Group	I55	Multi-function relay select]	15	0 ~ 19	17	
<ul style="list-style-type: none"> ■ This is used to prevent possible fault from occurring if the inverter outputs the voltage during operation after the load is removed. ■ The inverter estimates the motor rpm based on output current. Therefore, detecting exact speed is difficult. 						

▶ The following table shows 4 types of Speed search selection.

H22	Speed search select	Set Value	Speed search during H20 – [Power ON start]	Speed search during Instant Power Failure restart	Speed search during H21- [Restart after fault reset]	Speed search during Acceleration
			Bit 3	Bit 2	Bit 1	Bit 0
	0		-	-	-	-
	1		-	-	-	✓
	2		-	-	✓	-
	3		-	-	✓	✓
	4		-	✓	-	-
	5		-	✓	-	✓
	6		-	✓	✓	-
	7		-	✓	✓	✓
	8		✓	-	-	-
	9		✓	-	-	✓
	10		✓	-	✓	-
	11		✓	-	✓	✓
	12		✓	✓	-	-
	13		✓	✓	-	✓
	14		✓	✓	✓	-
	15		✓	✓	✓	✓

- ▶ H23: Limits current during Speed search. Set as the percent of H33.
 - ▶ H24, H25: Speed search is activated via PI control. Adjust P gain and I gain corresponding to the load characteristics.
 - ▶ I55: Signal of active Speed search is given to external sequence via Multi-function relay output (3ABC).
- EX) Speed search during Instant Power Failure restart

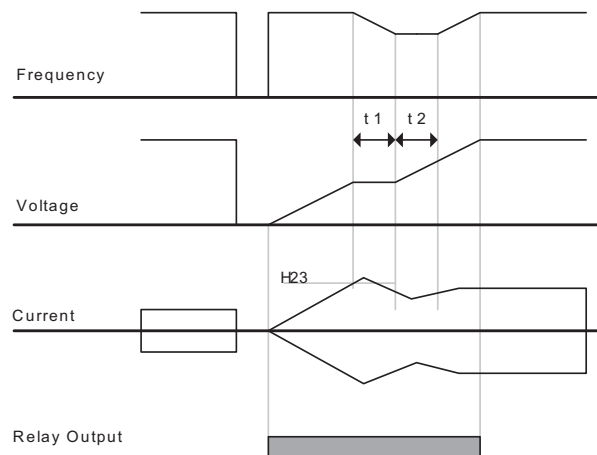

- When the input power is cut off due to instant power failure, the inverter outputs Low voltage trip (LV) to hold the output.
 - When the power is restored, the inverter outputs the frequency before the low voltage trip and the voltage is increased due to PI control.
 - t1: If current is increasing over the preset level in H23, the rise in voltage will stop and the frequency is decreased.
 - t2: If the opposite of t1 occurs, the increase in voltage starts again and the decrease in frequency stops.
 - When the frequency and voltage are restored back to the nominal level, acceleration will continue at the frequency before trip.
- ▶ Speed search operation is suitable for loads with high inertia. Stop the motor and restart when friction in load is high.
 - ▶ LTVF-Cx100 keeps normal operation when instant power failure occurs and power is restored in 15 msec for the use of its inverter rating.
 - ▶ Inverter DC link voltage can vary depending on output load quantity. Therefore, Low Voltage trip may occur when instant power failure is maintained over 15msec or output is higher than its rating.
 - ▶ Instant power failure specification is applied when input voltage to Inverter is 200~230V AC for 230V class, or 380~480V AC for 415V class.

8.12 Auto restart try

Group	Code	Item	Set Value	Setting Range	Initial	Unit
Function group 2	H26	Number of Auto Restart try	-	0 ~ 10	0	
	H27	Auto Restart time	-	0.0~ 60.0	1.0	sec
<ul style="list-style-type: none"> ▪ This parameter (H26) sets the number of times of auto restart. ▪ It is used to prevent the system down caused by internal protection function activated by the causes such as noise. 						

- ▶ H26: Auto restart will become active after the time set in H27. H26 – [Number of Auto restart try] is reduced by 1 when it is active. If the trip outnumbers the preset restart try, auto restart function is deactivated. If the setting is reset via the control terminal or the STOP/RST key on the keypad, the number of auto restart try set by user is automatically entered Set Value.
- ▶ If there is no more trip occurring for 30 sec after Auto restart operation, the H26 is restored to the preset value.
- ▶ When operation is stopped due to Low voltage (Lvt) or Emergency stop (EST), Inverter Overheat (Oht), and Hardware Trip (HWt), Auto restart will be deactivated.
- ▶ After the H27- [Auto Restart time], the motor starts acceleration automatically via speed search (H22-25).
- ▶ The following pattern is shown when the H26 – [Number of auto restart try] is set to 2.

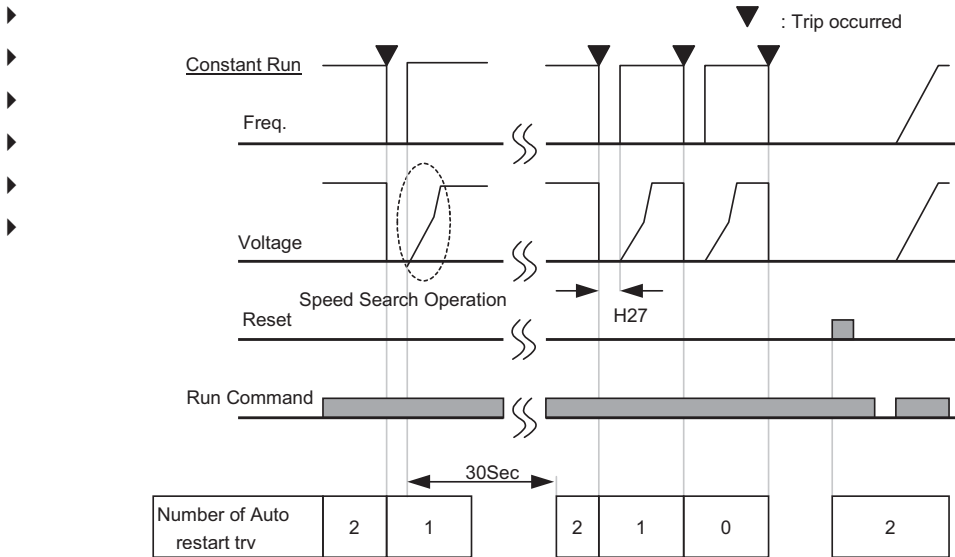

8.13 Carrier frequency select

Group	Code	Item	Set Value	Setting Range	Initial	Unit
Function group 2	H39	Carrier frequency select	-	1 ~ 15	(0.1~3.7KW)5 (5.5~7.5KW)3	kHz

The carrier frequency select can adjust the noise of motor during operation
 When F72=0, the inverter is used for HD, H39 default value is 5kHz(default value of 5.5/7.5KW is 3KHz), max value is set to be 15kHz
 When F72=1, the inverter is used for ND, H39 default value is 2kHz, max value is set to be 5kHz.

H39	When setting carrier frequency high,	Motor sound reduced
		Inverter heat loss increased
		Inverter noise increased
		Inverter leakage current increased

8.14 2nd motor operation

Group	Code	Item	Set Value	Setting Range	Initial	Unit
Function group 2	H81	2nd motor accel time	-	0.0 ~ 6000.0	5.0	Second
	H82	2nd motor decel time	-	0.0 ~ 6000.0	10.0	Second
	H83	2nd motor base freq.	-	30.00~ 400.00	60.00	Hz
	H84	2nd motor V/F pattern	-	0 ~ 2	0	
	H85	2nd motor Positive torque boost	-	0 ~ 15	5	%
	H86	2nd motor Negative torque boost	-	0 ~ 15	5	%
	H87	2nd motor stall prevention level	-	30 ~ 150	150	%
	H88	2nd motor electronic thermal level for 1 min	-	50 ~ 200	150	%
	H89	2nd motor electronic thermal level for continuous operation	-	50 ~ 150	100	%
	H90	2nd motor rated current	-	0.1~ 100.0	26.3	A
I/O Group	I17	Multi-function Input terminal P1Function select	-	0 ~ 27	0	
	~	~				
	I21	Multi-function Input terminal P5Function select	12		4	

■ Set the terminal among Multi-function input terminals (P1~ P5) for second motor operation.
 ■ To define the terminal P5 as second motor operation, set I21 to 12 in the I/O group.

- ▶ Used when an inverter operates 2 motors connected to two different types of the loads.
- ▶ 2nd motor operation does not drive 2 motors at the same time.
- ▶ As the figure below, when using two motors with an inverter by exchanging them, select one motor from 2 motors connected. When 1stselected motor operation is stopped, select a terminal for 2nd motor and define H81-H90 parameters to drive the 2nd motor.
- ▶ Define the 2nd motor select when a motor is stopped.
- ▶ H81 ~ H90 parameters function the same as 1st motor.

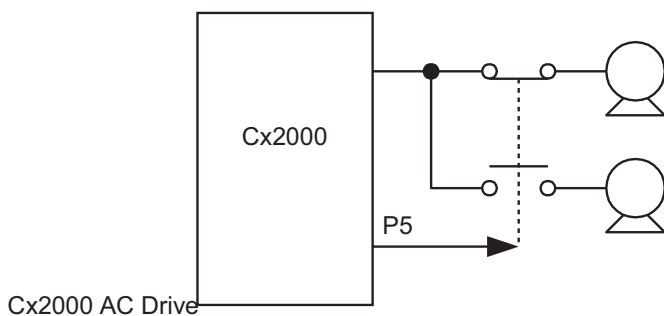

8.15 HD/ND select

Group	Code	Item	Set Value	Setting Range	Initial	Unit
Function Group 1	F72	HD/ND Select	-	0 ~ 1	0	-
<ul style="list-style-type: none"> ▪ Select rated capacity of inverter. ▪ 0: used for HD for constant torque application 1: used for ND for decreasing torque application Rated current and applicable motors of inverter HD/ND refer to page 13-1, 13-2. 						
 Caution						
<p>Rated current of three-phase inverter will be changed if F72 changes. And overload capacity of the inverter is also different.</p> <p>Single-phase inverter is applicable for HD occasion only.</p>						

8.16 Frequency setting and 2nd drive method select

Group	Code	Item	Set Value	Setting range	Initial	Unit
Drive group	drv	Drive mode 1	-	0 ~ 3	1	
	Frq	Frequency mode 1	-	0 ~ 8	0	
	drv2	Drive mode 2	-	0 ~ 3	1	
	Frq2	Frequency mode 2	-	0 ~ 7	0	
I/O group	I17~21	Multi-function input terminal P1 select	22	0 ~ 27		
<ul style="list-style-type: none"> ▪ Drive mode 1 is used when the input set as 2nd source is not entered into multi-input (I17~I21) ▪ Drive mode 2 can input frequency setting and drive command as a 2nd setting value by using multi-input terminal. In case of driving away from inverter by communication, it is used when quit the communication and operate by inverter. ▪ The switching method for Drive mode 1 and Drive mode 2 is as follows ▪ If multi-input terminal set as Drive mode 2 is off, it used as Drive mode 1 and frequency mode 1. If multi-input terminal set as Drive mode 2 is on, it used as Drive mode 2 and frequency mode 2. 						

- ▶ Selects the self drive in the 2nd switching of drv2 among the followings

drv2	Drive mode 2	0	Operation via Run/Stop key on the Keypad	
		1	Terminal operation	FX: Forward run command
				RX: Reverse run command
		2		FX: Run/Stop command
				RX: Forward/Reverse Command
3	Operation via communication RS-485			

- ▶ Selects the self drive in the 2nd switching of Frq2 among the followings

Frq2	Frequency mode2	0	Digital	Keypad digital frequency mode1
		1		Keypad digital frequency mode2
		2	Analog	V2 potentiometer: 0~ 5V
		3		AI terminal (J1 to V): 0 ~ +10V
		4		AI terminal (J1 to I): 0 ~ 20mA
		5		V2 potentiometer + AI terminal (J1 to I) set
		6		V2 potentiometer + AI terminal (J1 to V) set
		7	Operation via communication RS-485	

- ▶ The following is example for switching of drv1 and drv2.

Group	Code	Item	Set Value	Setting Range	Initial	Unit
Drive group	drv	Drive mode 1	3	0 ~ 3	1	
	Frq	Frequency mode 1	0	0 ~ 8	0	
	drv2	Drive mode 2	1	0 ~ 3	1	
	Frq2	Frequency mode 2	0	0 ~ 7	0	
I/O group	I 21	Multi-function input terminal P5 input terminal	22	0 ~ 27	7	

- ▶ The following figure is drawn when setting is like the above and command frequency is 30 [Hz], F4 [stop method]=0

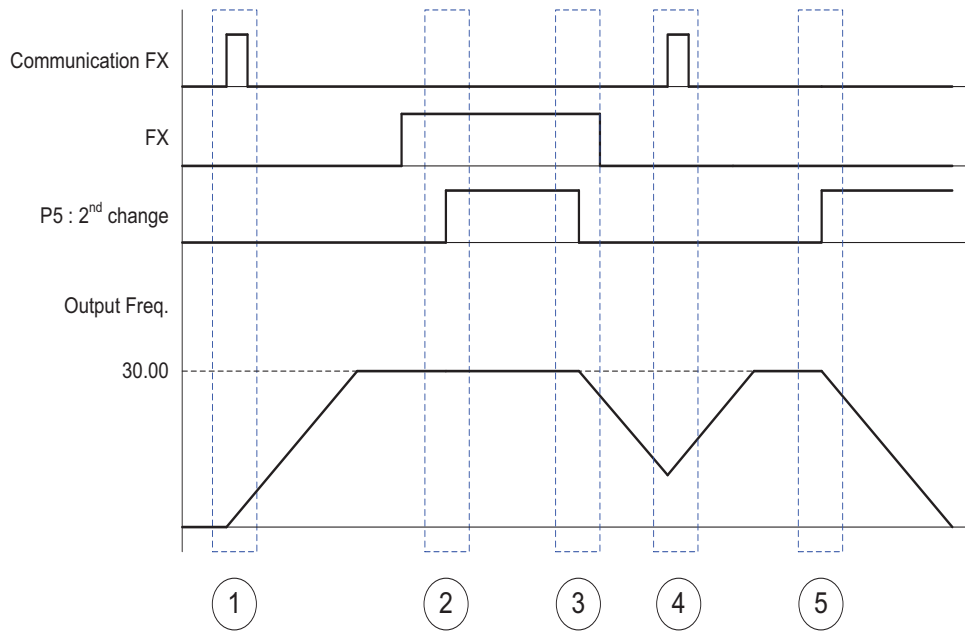

- ▶ ① Accelerate for accel time up to setting frequency by Drive 1 mode, FX signal.
- ▶ ② Drive continuously under FX is ON because DRV2 is 1 when P5 terminal input is ON and changes into 2nd.
- ▶ ③ Stop gradually as stop command because DRV is communication drive when P5 terminal input is OFF and changes into 1st.
- ▶ ④ Accelerate up to setting frequency for Drive 1 mode, FX signal is ON.
- ▶ ⑤ Stop gradually under FX is OFF because DRV2 is 1 when P8 terminal input is ON and changes into 2nd.

⚠ Caution

If you press ON while multi-function input terminal (P1 ~ P5) is set to 2nd Source, frequency command and drive command is changed to Drive mode 2. So you should check Drive mode 2 before input multi-function terminal.

8.17 Over voltage trip prevention during deceleration and Power Braking

Group	Code	Item	Set Value	Setting range	Initial	Unit
Function	F 4	Select stop method	3	0 ~ 3	0	
Group 1	F59	BIT 0: stall prevention under Accel	-	0 ~ 7	0	
		BIT 1: stall prevention under constant speed				
BIT 2: stall prevention under Decel						
	F61	Select voltage limit under Decel	-	0 ~ 1	0	

- To prevent overvoltage trip when reducing speed, set BIT2 of F59 to 1 and set 3 of F4 for Power Braking.

- ▶ Overvoltage trip prevention when reducing speed: a function preventing overvoltage trip when reducing speed or at stop by using the regeneration braking power.
- ▶ Power Braking: Adjusting the deceleration slope or accelerate again, when inverter's DC voltage rises above a certain level by the electric motor's regeneration energy. It can be used when short deceleration time without braking resistance is needed. However, be aware that the deceleration time can get longer than the set one and when it's used at a load that frequently decelerates, be cautious of damage caused by the motor's over heating.

⚠ Caution

Stall prevention and Power Braking only operate when decelerating, and Power Braking has the precedence. That is, when BIT2 of F59 and Power Braking of F4 are both set, Power Braking operates.

F61(selecting voltage restriction when decelerating) is visible when BIT2 of F59 is set. Overvoltage trip may occur, if the deceleration time is too short or the inertia too big.

8.18 External brake control

Group	Code	Item	Set Value	Setting Range	Initial	Unit
Function group 2	H40	Controlling method select	0	0~3	0	
I/O group	I 82	Brake open current	-	0.0~180.0	50.0	%
	I 83	Brake open delay time	-	0.00~10.00	1.00	sec
	I 84	Brake open CW Freq.	-	0.00~400.00	1.00	Hz
	I 85	Brake open CCW Freq.	-	0.00~400.00	1.00	Hz
	I 86	Brake close delay time	-	0.00~10.00	1.00	sec
	I 87	Brake close Freq.	-	0.00~400.00	2.00	Hz
	I 55	Multi-function relay select	19	0~ 19	17	
<ul style="list-style-type: none"> I 82~87 is visible only when I55 is set to 19. 						

- ▶ The function will be used to control ON/OFF of brake in the load system, in addition the Set Value shall be 0 (V/F control) for the control pattern (H40). The control pattern and order shall be confirmed before use.
- ▶ After brake control starts, prevent DC brake and frequency protection
- Brake open order
Input motor operation command, the inverter accelerates to forward/reverse start frequency (I84, I85), and the motor current reaches the start current (I82), the output relay will release bake start signal, maintain the start delay time of brake before acceleration.
- Brake close order
Input Stop command in operation, the motor will decelerate, and stop deceleration after the output frequency reaches the brake close frequency (I87), the output relay will release bake close signal, maintain the close delay time of brake (I86), and the output frequency will be "0".

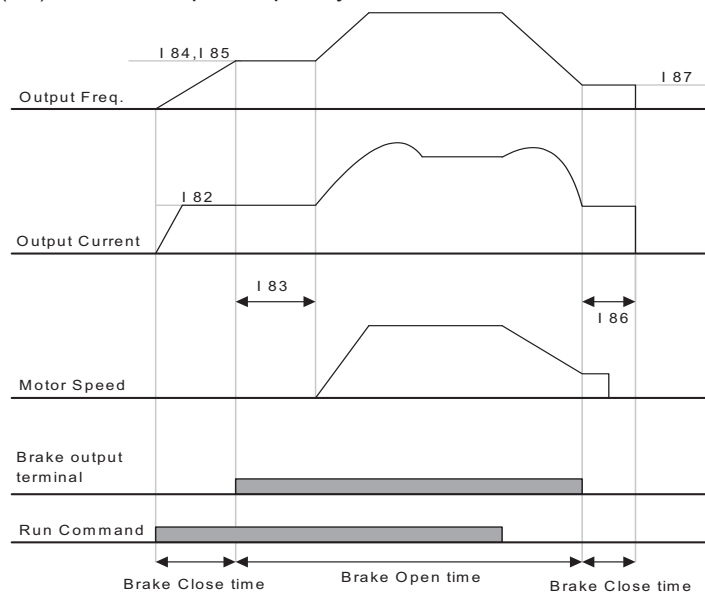

⚠ Caution

External brake control is applicable for V/F control only, and the brake open frequency is lower than close.
--

8.19 Kinetic energy buffering

Group	Code	Item	Set Value	Setting Range	Initial	Unit
Function group 2	H64	KEB operation select	1	0~1	0	
	H65	KEB operation start level	-	110.0 ~ 140.0	125.0	-
	H66	KEB operation stop level	-	110.0 ~ 145.0	130.0	%
	H67	KEB operation gain	-	1 ~ 20000	50	-
	H37	Load inertia	0	0~2	0	-

- ▶ When power failure occurs in the input power, DC link voltage of the inverter gets low and low voltage defect occurs resulting a cut of the output. Its function is to maintain the voltage of DC link by controlling output frequency of the inverter during the time of power failure. That is, it can keep the time from the point of power failure to low voltage defect long.
- ▶ H64 (KEB Select): Selects energy buffering operation when input power is cut. If H64 is set to 0, it operates normal deceleration run until low voltage occurs. When H64 is set to 1, it controls the inverter output frequency and charges the energy occurred from the motor to the inverter DC.
- ▶ H 65(KEB operation start level), H 66(KEB operation stop level) : Selects starting and stopping point of the energy buffering operation. Set the stop level(H65) higher than the start level(H 66) setting the low voltage defect level as standard.
- ▶ H 37(Load inertia) : Uses the momentum amount of the load inertia to control energy buffering operation. If the inertia ratio is set high, the frequency change range gets small when running energy buffering.

8.20 DRAW drive

Group	Code	Item	Set Value	Setting Range	Initial	Unit
Function	F70	DRAW mode select	-	0 ~ 3	0	-
Group 1	F71	DRAW ratio	-	0.0 ~ 100.0	0.0	%

- ▶ It's a kind of open loop tension control that uses the speed difference of motor running under main frequency command to keep material's tension in between steady.
- ▶ The output frequency selected according to the F70(DRAW mode select)

F70	Draw Operation	0	Draw not operated
		1	AI V (0~10V) terminal input draw operation
		2	AI I (0~20mA) terminal input draw operation
		3	Potentiometer V2 (0~50V) input draw operation

Chapter 8 Application

▶ Select 1, 2 and 3 for F70

The center value of analogue input (selected by the set value of I6~I15) as standard, if the input is bigger than the standard (center value of analogue input), the frequency increases. If the input is smaller than the standard (center value of analogue input), the frequency decreases. And the frequency will increase or decrease according to draw ratio set in F71.

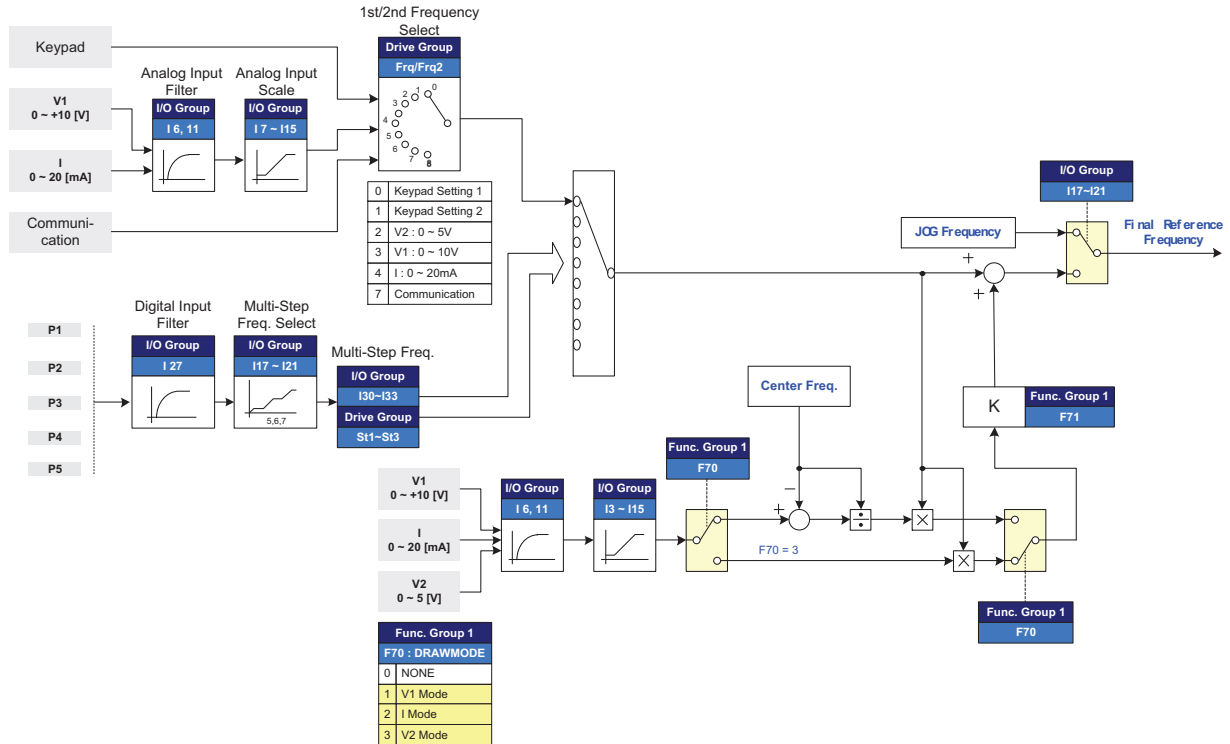

▶ DRAW operation example

If draw operation is set to 30Hz, F70=1(V1: 0V ~10V), F71=10.0% selected, (I7~I10 = initial), Frequency that gets changed by DRAW operation is 27Hz(V1=0V) ~33Hz(V1=10V).

⚠ Caution

- When operating DRAW, command frequency set in FRQ/FRQ2 can't be selected in F70 (DRAW mode select).
- For example, if FRQ=3(V1) and F70=1(V1), it does not operate.

8.21 2 Phase PWM drive

Group	Code	Item	Set Value	Setting Range	Initial	Unit
Function group 2	H48	PWM controlling mode 0: NORMAL PWM 1: 2 phase PWM	1	0 ~ 1	0	

- ▶ Heat loss and leakage current from inverter can be reduced when H48 is set to 1(2 phase PWM) according to the ratio of load, but the motor noise will increase.

8.22 Cooling fan control

Group	Code	Item	Set Value	Setting Range	Initial	Unit
Function group 2	H77	Cooling fan control	1	0 ~ 1	0	
<ul style="list-style-type: none"> ▪ Control the On/ Off of the cooling fan to cool the Inverter heat sink. 						

- ▶ When it is set to 0:
 - . Cooling fan begins to operate when power ON.
 - . Cooling fan is stopped when inverter main circuit voltage becomes low voltage due to power off.
- ▶ When it is set to 1:
 - . Cooling fan begins to operate when power is turned ON with operating command ON.
 - . Cooling fan is stopped when operating command is turned Off with inverter output shut off.
 - . Cooling fan keeps operating when heat sink temperature exceeds a certain limit regardless of operating command.
 - . Make the inverter power off, and cooling fan will stop when the voltage of main loop inside the inverter is under low voltage.
 - . Used when frequent Run/Stop or quite stop is required. This may make the cooling fan life longer.

8.23 Operating mode select when cooling fan trip occurs

Group	Code	Item	Set Value	Setting Range	Initial	Unit
Function group 2	H78	Operating mode when cooling fan trip occurs	-	0 ~ 1	1	-
I/O group	I55	Multi-function relay select	18	0 ~ 19	17	-
<ul style="list-style-type: none"> ▪ Select 0 or 1 in H78 code. ▪ If H78 code is set to 0 (continuous operation), alarm can be output in I54 when cooling fan trip occurs. 						

Chapter 8 Application

- ▶ 0: continuous operation when cooling fan trip occurs.
 - . Operation is not stopped regardless of cooling fan trip.
 - . When I55 is set to 18 (cooling fan fault alarm), fault alarm signal can be output using Multi-function relay.

⚠ Caution

If operation is continued after cooling fan trip occurs, Overheat trip may happen and protective function be activated. It also reduces the life of main components due to rise in inverter inner temperature.

- ▶ 1: operation stopped at cooling fan fault
 - . when cooling fan fault occurs,  message is displayed on the LED and operation is stopped.
 - . If I55 is set to 17(Fault output), fault message is displayed.

8.24 Input voltage set of inverter

Group	Code	Item	Set Value	Setting Range	Initial	Unit
Function Group 1	F67	Input voltage for 230V inverter		170~240	220	
Function Group 1	F68	Input voltage for 415V inverter		320~480	380	
<ul style="list-style-type: none"> ▪ F67 set input voltage of 230V level inverter ▪ F68 set input voltage of 415V level inverter <p>The adjustment of input voltage will influence the voltage level when failure of inverter occurs under low voltage</p>						

8.25 Parameter Initialize / Lock

- Parameter initialize

Group	Code	Item	Setting Range		Initial
Function group 2	H93	Parameter initialize	0	-	0
			1	All groups initialize	
			2	Drive group initialize	
			3	Function group 1 initialize	
			4	Function group 2 initialize	
			5	I/O group initialize	
<ul style="list-style-type: none"> ▪ Select the group to be initialized and perform it in H93 code. 					

- ▶ Press Enter (●) key after setting in H93. H93 will be displayed again after initialization is complete.
- Password register

Group	Code	Item	Set Value	Setting Range	Initial	Unit
Function group 2	H94	Password register	-	0 ~ FFFF	0	
	H95	Parameter lock	-	0 ~ FFFF	0	
<ul style="list-style-type: none"> ▪ Register password for Parameter lock (H95). ▪ Password should be Hex decimal. (0 ~ 9, A, B, C, D, E, F) 						
 Caution						
After setting modification lock function of H95, Do not forget the registered password. If you try to release lock, you need the registered password.						

- ▶ Factory default password is 0. Enter the new password except 0.
- ▶ Follow the steps below when you register the password for the first time.

No	Note	Keypad display
1	Move to H94 code	H94
2	Press Enter (●) key twice.	0
3	Register password. (Ex: 123)	123
4	123 will blink when Enter (●) key is pressed.	123
5	Press Enter (●) key.	H94

- ▶ Follow the table below to change the password. (Current PW: 123 -> New PW: 456)

No	Note	Keypad display
1	Move to H94 code.	H94
2	Press Enter (●) key.	0
3	Enter any number (e.g.: 122).	122
4	Press the Enter (●) key. 0 is displayed because wrong value was entered. Password cannot be changed in this status.	0
5	Enter the right password.	123
6	Press Enter (●) key.	123
7	Enter the new password.	456
8	Press the Enter (●) key. Then "456" will blink.	456
9	Press Enter (●) key.	H94

Chapter 8 Application

- Parameter lock

Group	Code	Item	Set Value	Setting Range	Initial	Unit
Function group 2	H95	Parameter lock	-	0 ~ FFFF	0	
	H94	Input password	-	0 ~ FFFF	0	
Use password to protect parameters set by users						

- ▶ Use password registered in H94 to lock parameter

No	Note	Keypad Display
1	Move to H95 code	H95
2	Press Enter (●) key.	UL
3	UL(Unlock) means unlock	UL
4	Press Enter (●) key.	0
5	Input the value registered in H94 (e.g.: 123)	123
6	Press Enter (●) key.	L
7	L(lock)means lock	L
8	Press Enter (●) key.	H95

- ▶ Use password registered in H94 to unlock the parameters

No	Note	Keypad Display
1	Move to H95 code	H95
2	Press Enter (●) key.	L
3	L(lock) means lock	L
4	Press Enter (●) key.	0
5	Input the value registered in H94 (e.g.: 123)	123
6	Press Enter (●) key.	UL
7	UL(Unlock) means unlock	UL
8	Press Enter (●) key.	H95

8.26 Voltage for DB start

Group	Code	Item	Setting value	Setting Range	Initial	Unit
Function group 1	F73	Start voltage for 230V inverter	-	300~400	390	V
Function group 1	F74	Start voltage for 415V inverter	-	600~800	780	V
<ul style="list-style-type: none"> ▪ F73 sets DB start voltage for 230V inverter ▪ F74 sets DB start voltage for 415V inverter ▪ F73 / F74 is set to improve braking performance. 						

9 Monitoring

9.1 Operating status monitoring

- Output current

Group	Code	Name	Set Value	Range	Default	Unit
Drive group	CUr	Output current	-			
Inverter output current can be monitored in Cur.						

- Motor RPM

Group	Code	Name	Set Value	Range	Default	Unit
Drive group	rPM	Motor RPM	-			
Function group 2	H31	Number of motor poles	-	2 ~ 12	4	
	H49	PID control select	-	0 ~ 1	0	
	H74	Gain for Motor rpm display	-	1 ~ 1000	100	%
<ul style="list-style-type: none"> ■ Motor rpm can be monitored in rPM,. This rpm is the synchronous one imposed on the motor. 						

- ▶ When H40 is set to 0 (V/F control), the Inverter output frequency (f) is displayed in rPM using the formula below. Motor slip is not considered.

$$RPM = \left(\frac{120 \times f}{H\ 31} \right) \times \frac{H\ 74}{100}$$

- ▶ In case that H49 code is 1 (PID control), Feed back amount is converted into frequency.
- ▶ H31: Enter the number of rated motor poles on the nameplate.
- ▶ H74: This parameter is used to change the motor speed display to mechanical speed.

- Inverter DC Link Voltage

Group	Code	Name	Set Value	Range	Default	Unit
Drive group	dCL	Inverter DC Link Voltage	-			
<ul style="list-style-type: none"> ■ Inverter DC link voltage can be monitored in dCL. 						

- ▶ $\sqrt{2}$ times the value of input voltage is displayed while motor is at a stop.



Chapter 9 Monitoring

- User display select

Group	Code	Name	Set Value	Range	Default	Unit
Drive group	vOL	User display select	-			
Function group 2	H73	Monitoring item select	-	0 ~ 2	0	

- The selected item in H73 can be monitored in vOL.
- If output power or torque is selected, Por or tOr will be displayed by vOL code.

▶ H73: Select one of the desired item numbers.

H73	Monitoring item select	0	Output voltage [V]	
		1	Output power [kW]	
		2	Torque [kgf · m]	

▶ Enter motor efficiency indicated on motor nameplate to H36 to display correct torque.

- Power on display

Group	Code	Name	Setting Range		Default
Function group 2	H72	Power on display	0	Target frequency	0
			1	Accel time (ACC)	
			2	Decel time (DEC)	
			3	Drive mode (drv)	
			4	Frequency mode (Frq)	
			5	Multi-step frequency 1 (St1)	
			6	Multi-step frequency 2 (St2)	
			7	Multi-step frequency 3 (St3)	
			8	Output current (CUr)	
			9	Motor rpm (rPM)	
			10	Inverter DC link voltage (dCL)	
			11	User display select (vOL)	
			12	Fault display 1(nOn)	
			13	Operating direction select (drC)	
			14	Output current 2	
			15	Motor rpm 2	
			16	Inverter DC link voltage 2	
17	User display select 2				

- Select the parameter set in H72 to be displayed when Power ON.

■ The output current, motor rpm, DC link voltage and User display select are displayed directly when 14~17 are set in H72.

9.2 Monitoring the I/O terminal

- Input terminal status monitoring

Group	Code	Name	Set Value	Range	Default	Unit
I/O group	I25	Input terminals status display	-	-	-	
<p>■ Input terminal status (ON/Off) can be monitored in I25.</p>						

The following is displayed when P1, P3, P4 are ON and P2, P5 are OFF.

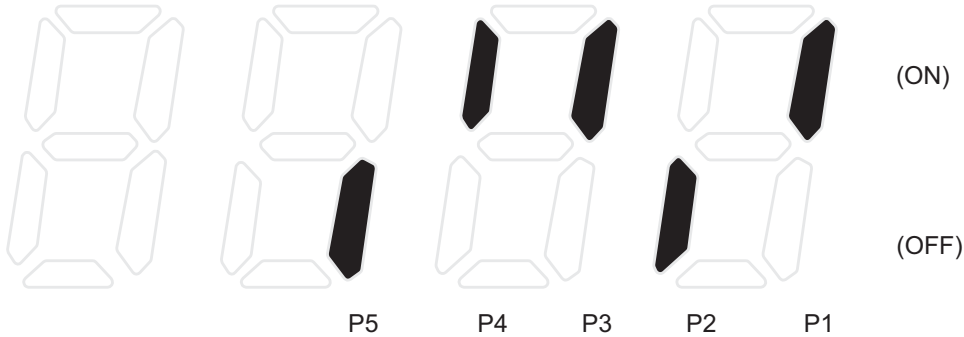

- Output terminal status monitoring

Group	Code	Name	Set Value	Range	Default	Unit
I/O group	I26	Output terminals status display	-	-	-	
<p>■ Multi-function relays status (ON/Off) can be monitored in I26.</p>						

The followings are displayed when Multi-function relay is ON.

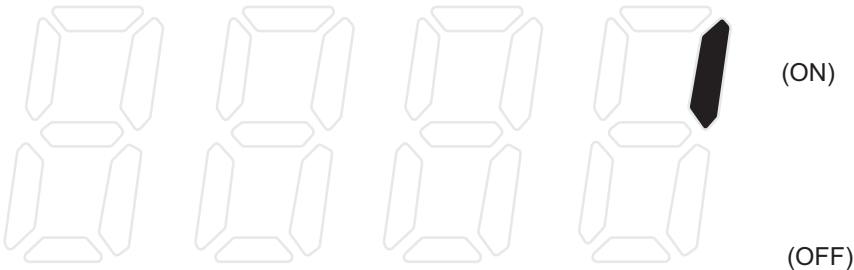

9.3 Monitoring fault condition

- Monitoring current fault status

Group	Code	Name	Set Value	Range	Default	Unit
Drive group	nOn	Current Fault Display	-			
<ul style="list-style-type: none"> ■ Fault occurred during operation is displayed in nOn. ■ Up to 3 kinds of faults can be monitored. 						

This parameter gives information including frequency-->current-->accel/decel time on fault types and the operating status at the time of the fault. Refer to Page 4-11 or 9-5 for keypad setting.

Fault types	Frequency		
	Current		
	Accel/Decel Information		Fault during Accel
			Fault during Decel
			Fault during constant run

Refer to Page 12-1 on fault types.

- Fault History Monitoring

Group	Code	Name	Set Value	Range	Default	Unit
Function group 2	H 1	Fault history 1	-			
	~	~				
	H 5	Fault history 5	-			
	H 6	Reset fault history	-	0 ~ 1	0	
<ul style="list-style-type: none"> ■ H 1 ~ H 5: Up to 5 faults information is stored. ■ H 6: Previous fault information stored in the code H1 thru H5 is all cleared. 						

- ▶ When a fault occurs during operation, it can be monitored in the **nOn**.

- ▶ When the fault condition is reset via the STOP/RST key or multi-function terminal, information displayed in the **nOn** will be moved to H1. In addition, the previous fault info stored in H1 will be automatically moved to H2. Therefore, the updated fault info will be stored in the H1.
- ▶ When more than 1 fault occurred at the same time, faults will be stored in one code.
- ▶ Data in H1~H5 will be initialized during the initialization of parameters. When H6 is set to 1, the data in H1~H5 will be initialized as well.
- ▶ After confirmation, the fault will be moved to other codes as follows:

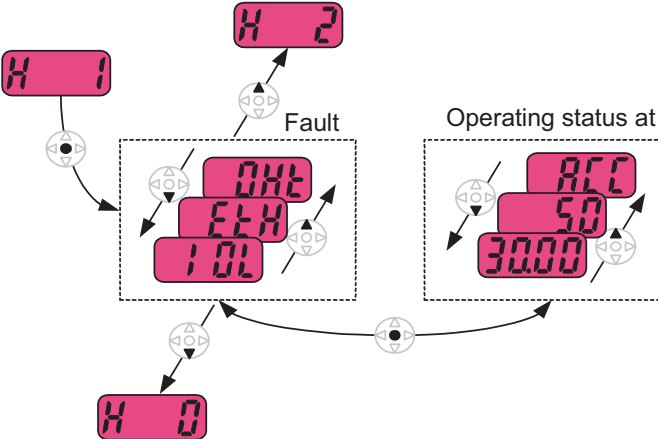

9.4 Analog Output

Group	Code	Name	Set Value	Range	Default	Unit
I/O Group	I50	Analog output item select	-	0 ~ 3	0	
	I51	Analog output level adjustment	-	10 ~ 200	100	%

■ Output item and the level from the AM terminal are selectable and adjustable.

- ▶ I50: The selected item will be output to Analog output terminal (AM).

I50	Analog output item select	Item corresponding to 10V	
		200V	400V
0	Output frequency.	Max Frequency (F21)	
1	Output current	150% of Inverter rated current	
2	Output voltage	282Vac	564Vac
3	Inverter DC link voltage	410Vdc	820Vdc

- ▶ I51: If you want to use Analog output value as a gauge input, the value can be adjustable according to various gauge specifications.

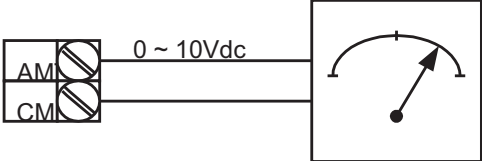

9.5 Multi-function relay output select I55

Group	Code	Name	Setting Range			Initial	
I/O Group	I55	Multi-function Relay select	0	FDT-1			17
			1	FDT-2			
			2	FDT-3			
			3	FDT-4			
			4	FDT-5			
			5	Overload (OL)			
			6	Inverter Overload (IOL)			
			7	Motor stall (STALL)			
			8	Over voltage trip (Ovt)			
			9	Low voltage trip(Lvt)			
			10	Inverter overheat(OHt)			
			11	Command loss			
			12	During run			
			13	During stop			
			14	During constant run			
			15	During speed searching			
			16	Wait time for run signal input			
			17	Fault output			
			18	Cooling fan trip alarm			
			19	Brake control signal			
I/O Group	I56	Fault output select		When setting Number of auto restart tries (H26) bit 2	When the trip other than low voltage trip occurs bit 1	When the Low voltage trip occurs bit 0	2
			0	-	-	-	
			1	-	-	✓	
			2	-	✓	-	
			3	-	✓	✓	
			4	✓	-	-	
			5	✓	-	✓	
			6	✓	✓	-	
			7	✓	✓	✓	

Select the desired item to be output via the keypad of relay.

- ▶ I56: When 17 (Fault output) is selected in I55, Multi-function output terminal and relay will be activated with the value in I56.

0 : FDT-1

- ▶ Check whether the output frequency matches the user-setting frequency.
- ▶ Active condition: Absolute value (preset frequency - output frequency) \leq Frequency Detection Bandwidth/2

Group	Code	Name	Set Value	Range	Initial	Unit
I/O Group	I53	Detected Frequency Bandwidth	-	0.00~ 400.00	10.00	Hz
Cannot be set above Max frequency (F21).						

- ▶ When setting I53 to 10.0:

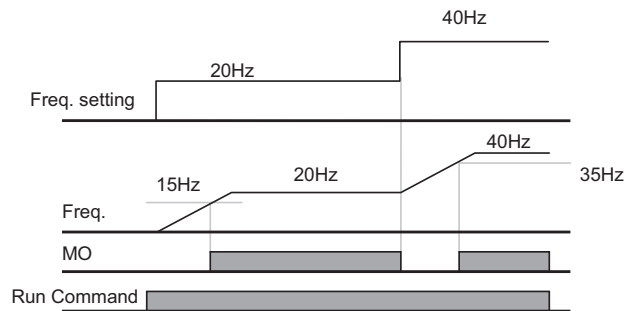

1 : FDT-2

- ▶ Activated when the preset frequency matches frequency detection level (I52) and FDT-1 condition is met.
- ▶ Active condition: (Preset frequency = FDT level) & FDT-1

Group	Code	Name	Set Value	Range	Default	Unit
I/O Group	I52	Detected Frequency level	-	0.00 ~ 400.00	30.00	Hz
	I53	Detected Frequency Bandwidth	-		10.00	
Cannot be set above Max frequency (F21).						

- ▶ When setting I52 and I53 to 30.00 Hz and 10.00 Hz, respectively

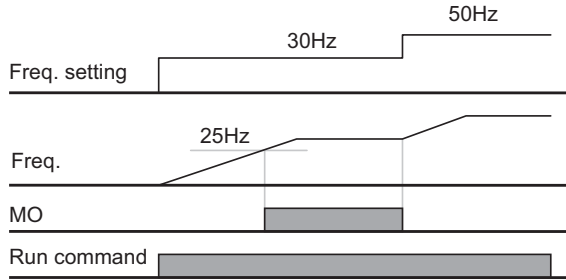

2 : FDT-3

- ▶ Activated when run frequency meets the following condition
- ▶ Active condition: $\text{Absolute value (FDT level - run frequency)} \leq \text{FDT Bandwidth}/2$

Group	Code	Name	Set Value	Range	Default	Unit
I/O Group	I52	Detected Frequency level	-	0.00 ~ 400.00	30.00	Hz
	I53	Detected Frequency Bandwidth	-		10.00	
Cannot be set above Max frequency (F21).						

- ▶ When setting I52 and I53 to 30.0Hz and 10.0 Hz, respectively

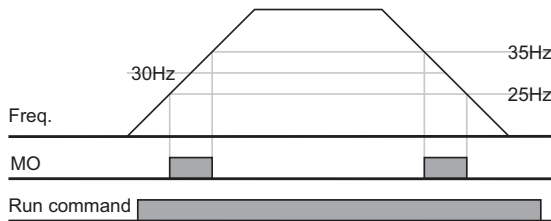

3 : FDT-4

- ▶ Activated when run frequency meets the following condition
- ▶ Accel time: Run Frequency \geq FDT Level
- ▶ Decel time: Run Frequency $>$ (FDT Level – FDT Bandwidth/2)

Group	Code	Name	Set Value	Range	Default	Unit
I/O Group	I52	Detected Frequency level	-	0.00 ~ 400.00	30.00	Hz
	I53	Detected Frequency Bandwidth	-		10.00	
Cannot be set above Max frequency (F21).						

- ▶ When setting I52 and I53 to 30.00Hz and 10.00 Hz, respectively

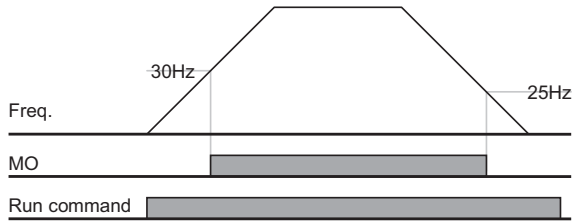

4 : FDT-5

- ▶ Activated contact contrast to FDT-4.
- ▶ Active condition:
 Accel time: Run Frequency \geq FDT Level
 Decel time: Run Frequency $>$ (FDT Level – FDT Bandwidth/2)

Group	Code	Name	Set Value	Range	Default	Unit
I/O Group	I52	Detected Frequency level	-	0.00 ~ 400.00	30.00	Hz
	I53	Detected Frequency Bandwidth	-		10.00	
Cannot be set above Max frequency (F21).						

Chapter 9 Monitoring

- ▶ When setting I52 and I53 to 30.00Hz and 10.00 Hz, respectively

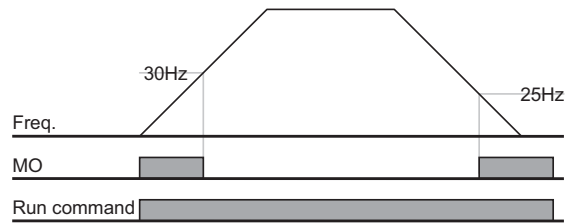

5 : Overload (OLt)

- ▶ Refer to page 10-2.

6 : Inverter Overload (IOLt)

- ▶ Refer to page 10-5

7 : Motor stall (STALL)

- ▶ Refer to page 10-3.

8 : Over voltage trip (Ovt)

- ▶ Activated when over voltage trip occurs due to DC link voltage exceeded 400Vdc for 230V class and 820Vdc for 415V class.

9: Low voltage trip (Lvt)

- ▶ Activated when low voltage trip occurs due to DC link voltage under 180Vdc for 230V class and 360Vdc for 415V class

10: Inverter heatsink overheat (Oht)

- ▶ Activated when the heatsink is overheated

11: Command loss

- ▶ Activated when Analog (V1,I) and RS485 communication commands are lost.

12: During operation

- ▶ Activated when run command is input and inverter outputs its voltage.

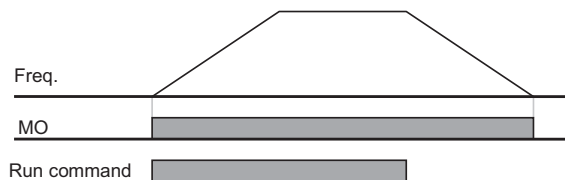

13 : During stop

- ▶ Activated during stop without active command

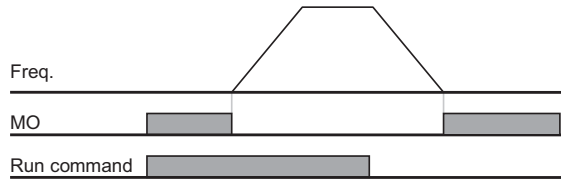

14 : During constant run

- ▶ Activated during constant speed operation

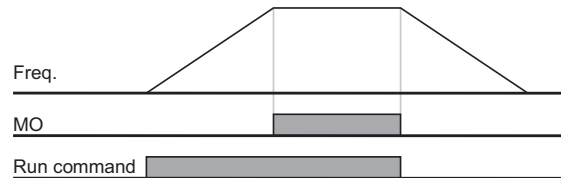

15: During speed searching

- ▶ Refer to page 8-17.

16: Wait time for run signal input

- ▶ This function becomes active during normal operation and that the inverter waits for active run command from external sequence.

17: Fault output

- ▶ The parameter set in I56 is activated.
- ▶ For example, if setting I55, I56 to 17 and 2, respectively, Multi-function output relay will become active when trip other than “Low voltage trip” occurred.

18: Cooling fan trip alarm

- ▶ Used to output alarm signal when H78 is set to 0(constant operation at cooling fan trip). Refer to page 8-29.

19: Brake signal

- ▶ It is used for signal output when set for use of external brake signal. Refer to the page 8-26.

10. Protective Functions

10.1 Electronic Thermal

Group	Code	Parameter	Set Value	Range	Initial	Unit
Function group 1	F50	ETH (Electronic thermal) select	1	0 ~ 1	0	
	F51	Electronic thermal level for 1 minute	-	50 ~ 200	150	%
	F52	Electronic thermal level for continuous	-	50 ~ 150	100	%
	F53	Motor cooling type	-	0 ~ 1	0	

Select F50 – [Electronic thermal select] to 1.
It activates when the motor is overheated (time-inverse). If current is greater than that set in F51, inverter output is turned off for the preset time in F51.

- ▶ F51: Enter the value of max current that is capable of flowing to the motor continuously for one minute. It is set in percent of motor rated current. The value cannot be set lower than F52.
- ▶ F52: Enter the amount of current for continuous operation. Normally motor rated current is used. It cannot be set greater than F51.
- ▶ F53: For a standard motor, cooling fans are equipped; however, cooling effects can be achieved when a motor is running at low speed. A separately powered cooling fan is used.

F53	Motor cooling type	0	Standard motors having a cooling fan directly connected to the shaft
		1	Special motor that uses a separately powered cooling fan.

Current for continuous operation [%]

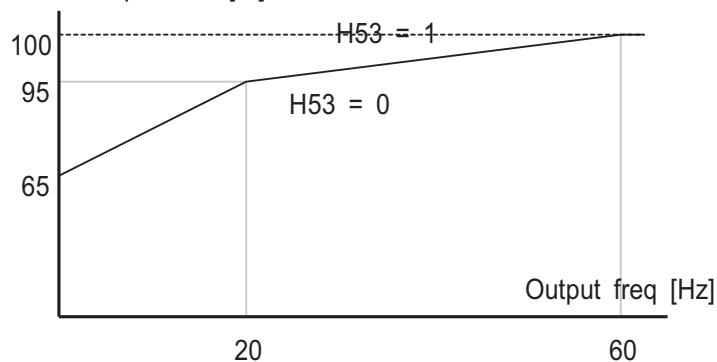

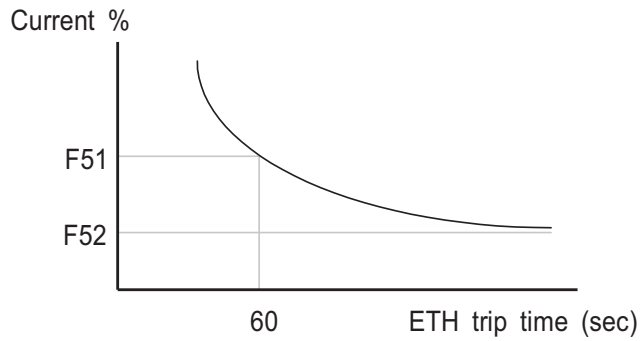

10.2 Overload warning and trip

Overload warning

Group	Code	Parameter	Set Value	Range	Initial	Unit
Function	F54	Overload warning level	-	30 ~ 150	150	%
Group 1	F55	Overload warning time	-	0.0 ~ 30.0	10.0	Sec
I/O Group	I55	Multi-function relay function select	5	0 ~ 19	17	
Set I55 (multi-function relay select) to 5 (Overload: OL)						

▶ F54: Set the value as a percent of motor rated current.

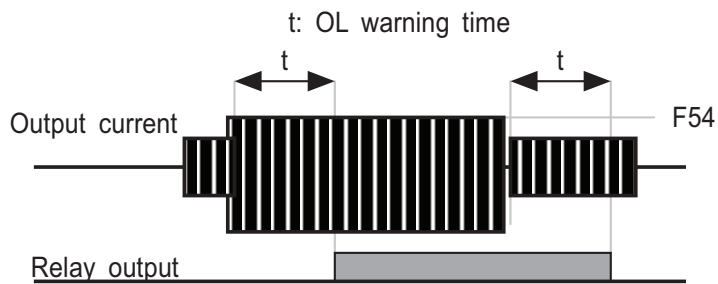

● Overload trip

Group	Code	Parameter	Set Value	Range	Initial	Unit
Function group 1	F56	Overload trip select	1	0 ~ 1	1	
	F57	Overload trip level	-	30 ~ 200	180	%
	F58	Overload trip time	-	0.0~ 60.0	60.0	sec
<ul style="list-style-type: none"> ■ Set F56 to 1 in the function group 1 ■ Inverter output is turned off when motor is overloaded. ■ Inverter output is turned off when motor current reaches to over trip level (F57) for overload trip time (F58). 						

10.3 Stall prevention

Group	Code	Parameter	Set Value	Range	Initial	Unit
Function group 1	F59	Stall prevention select	-	0 ~ 7	0	
	F60	Stall prevention level	-	30 ~ 200	150	%
I/O Group	I55	Multi-function relay function select	7	0 ~ 19	17	
<ul style="list-style-type: none"> ■ During acceleration: Motor starts deceleration when current exceeding the value set in F60 flows. ■ During constant run: Motor decelerates when current exceeding the value set in F60. ■ During deceleration: Motor deceleration is stopped when inverter DC link voltage rises above a certain voltage level. ■ F60: The value is set as the percent of motor rated current (H33). ■ I55: Multi-function relay can transmit the stall status to the parts outside. The output can be achieved if the motor is connected though F59 is not selected for stall prevention. 						

▶ F59: Stall prevention can be set as the table below.

F59	Stall prevention	Set Value	During Deceleration	During constant speed	During Accel-eration
			BIT 2	BIT 1	BIT 0
		0	-	-	-
		1	-	-	✓
		2	-	✓	-
		3	-	✓	✓
		4	✓	-	-
		5	✓	-	✓
		6	✓	✓	-
		7	✓	✓	✓

- ▶ For example, set F59 to 3 to make stall prevention active during Acceleration and constant run.
- ▶ When stall prevention is executed during acceleration or deceleration, Accel/Decel time may take longer than the user-setting time.
- ▶ When stall prevention is activated during constant run, t1, t2 executed in accordance with the value set in ACC - [Accel time] and dEC - [Decel time].

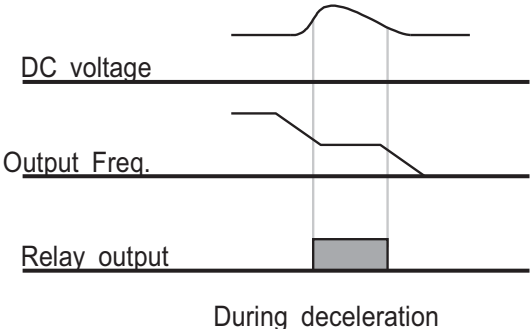
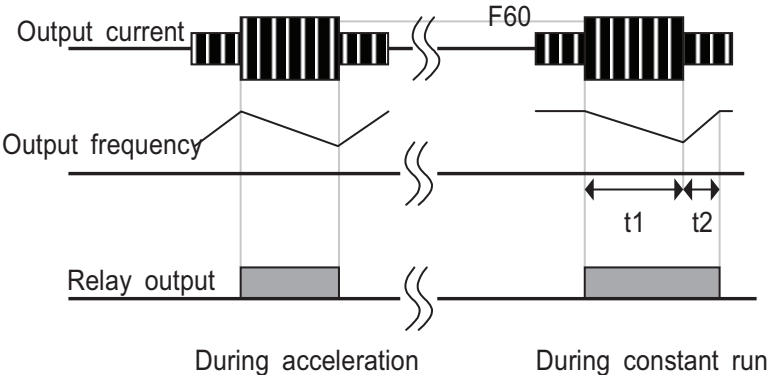

10.4 Output phase loss protection

Group	Code	Parameter	Set Value	Range	Initial	Unit
Function group 2	H19	Input/Output phase loss protection select	1	0 ~ 3	3	
<ul style="list-style-type: none"> ■ Set H19 value to 3 in the function group 2. ■ Output phase loss: Inverter output is shut off at the event of more than one phase loss among 3 phase output (U, V and W). ■ Input phase loss: Inverter output is blocked at the event of more than one phase loss among R, S and T. 						
 Warning						
Set H33 [Motor rated current] correctly. If the actual motor rated current and the value of H33 are different, output phase loss protection function could not be activated.						

H19	Input/Output phase loss protection select	Input loss phase protection		Output loss phase protection	
		Bit 1		Bit 0	
	0				
	1			✓	
	2	✓			
	3	✓			✓

10.5 External trip signal

Group	Code	Parameter	Set Value	Range	Initial	Unit
I/O Group	I17	Multi-function input terminal P1 define		0 ~ 27	0	
	~	~				
	I20	Multi-function input terminal P4 define	18		3	
	I21	Multi-function input terminal P5 define	19		4	
<ul style="list-style-type: none"> ■ Select a terminal among P1 thru P5 to output external trip signal. ■ Set I20 to 18 and I21 to 19 to define P4 and P5 as External A contact and B contact. 						

- ▶ External trip signal input A contact (N.O.): Normal open contact input. When P4 terminal set to “Ext trip-A” is ON (Closed), inverter displays the fault and turns off its output.
- ▶ External trip signal input B contact (N.C.): Normal close contact input. When P5 terminal set to “Ext trip-B” is OFF (Open), inverter displays the fault and turns off its output.

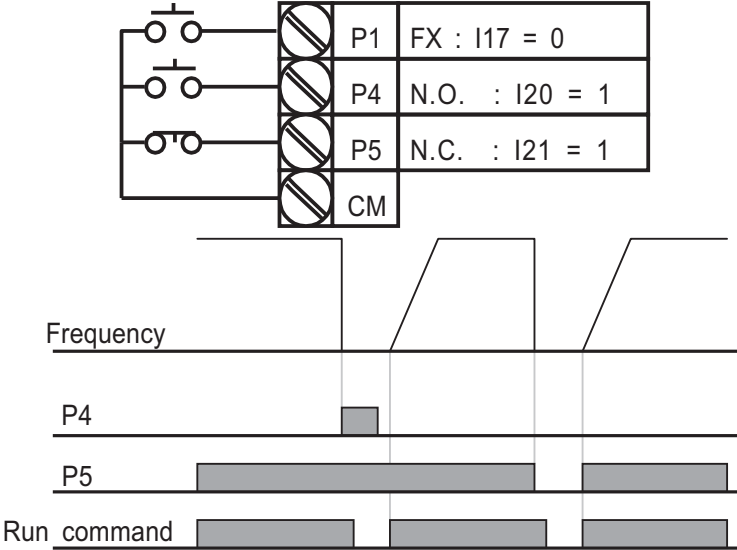

10.6 Inverter Overload

Group	Code	Parameter	Set Value	Range	Initial	Unit
I/O group	I55	Multi-function relay function select	6	0 ~ 19	17	

- ▶ Inverter overload prevention function is activated when the current above inverter rated current according to the inverse time
- ▶ Multi-function relay prevention is used to transmit the relay signal to external parts during inverter overload trip.

10.7 Speed command loss

Group	Code	Parameter	Set Value	Range	Initial	Unit
I/O Group	I16	Select criteria for analog speed command loss	0	0 ~ 2	0	
	I62	Drive mode select at loss of speed command	-	0 ~ 2	0	
	I63	Wait time after loss of speed Command	-	0.1 ~ 120.0	1.0	Sec
	I55	Multi-function relay select	11	0 ~ 19	17	

- Select the Drive mode when frequency reference set via Analog (V, I) input terminal or communication option is lost.

▶ I16 Select criteria for analog speed command loss

I16	Select criteria for analog speed command loss	0	Not used
		1	When half the value set in I2, I7, I12 is Entered
		2	When less than the value set in I2, I7, I12 is entered

Ex 1) The inverter determines the freq reference is lost when DRV- Frq is set to 3 (Analog V input), I 16 to 1 and analog input signal is less than half the value set in I 7.

Ex 2) The inverter determines the freq reference is lost when DRV- Frq is set to 5 (V2+I), I16 to 2 and V2 input signal is either below the value set in I2 or I input value is less than the I 12 value.

- ▶ I62: When no frequency command is given for the time set in I63, set the drive mode as the table below.

I62	Drive mode select after loss of frequency command	0	Continuous operation with the frequency before command loss occurs
		1	Free run stop (output cut off)
		2	Decel to stop

- ▶ I55: Multi-function relay is used to output information on loss of frequency command to external sequence.

Ex) when I16 is set to 2, I62 to 2, I63 to 5.0 sec and I55 to 11, respectively

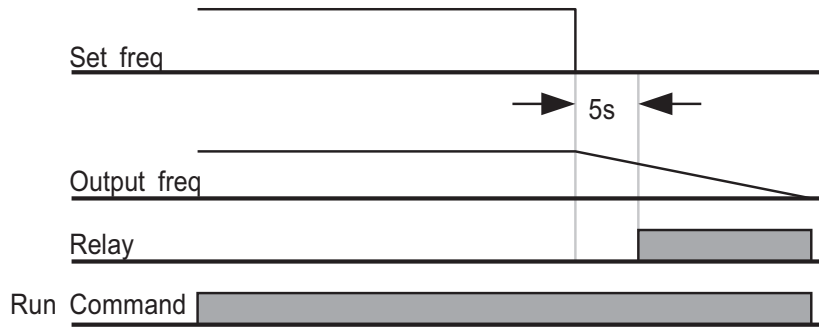

10.8 DB Resistor Enable Duty setting

Group	Code	Parameter	Set Value	Range	Initial	Unit
Function	H75	Enable duty limit	1	0 ~ 1	1	
group 2	H76	Enable duty	-	0 ~ 30	10	%

- Set H75 to 1.
- Set %ED (Enable Duty) in H76.

▶

▶ H75: DB resistor ED limit setting

0	Not limit for use of DB resistor
	⚠ Warning
	Take caution when DB resistor is used over its Watt rating. Fire may result from resistor overheat. When resistor having heat detection sensor is used, sensor output can be used as external trip signal in multifunction input.
1	ED is limited as the setting in H76.

- ▶ H76: set the resistor operating rate (%ED) in one sequence of operation. Continuous usage rate is Max 15 sec and usage signal is not issued over 15 seconds.
- ▶ The inverter capacity varies with DB resistor; please refer to Page 13-5.
- ▶ For 230V inverter, when DC link voltage rises to the value set in F73, the DB resistor is activated.

Chapter 10 Protective Functions

- ▶ For 415V inverter, when DC link voltage rises to the value set in F74, the DB resistor is activated.

$$\text{EX1) } H_{76} = \frac{T_{_dec}}{T_{_acc} + T_{_steady} + T_{_dec} + T_{_stop}} \times 100 [\%]$$

Where,

T_acc: Acceleration time to reach a setting freq.

T_steady: Time for constant speed operation at setting freq.

T_dec: Time to decelerate to lower freq. than that in constant speed or time to stop from freq. in constant speed.

T_stop: waiting time at a stop before operation is resumed.

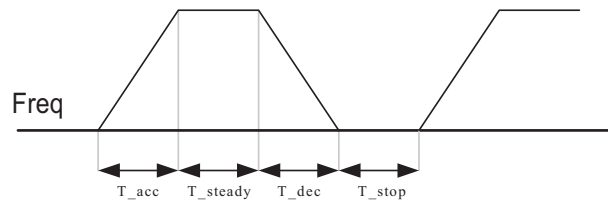

$$\text{EX2) } H_{76} = \frac{T_{_dec}}{T_{_dec} + T_{_steady 1} + T_{_acc} + T_{_steady 2}} \times 100 [\%]$$

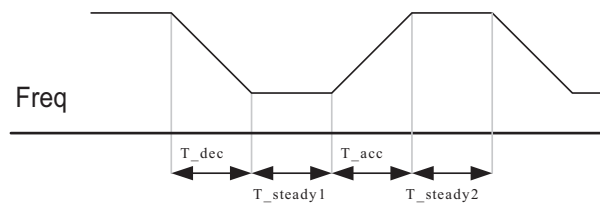

11. Communication

11.1 Introduction

This chapter describes specification, installation and operation instruction for communication between inverter and PC or FA computer. The communication of LTVF-Cx2000 inverter makes use of PC or F A computer (hereinafter called computer) remote operation or monitoring LTVF-Cx2000 inverters.

Features:

Inverter can be easily applied for factory automation because operation and monitoring is available by User-program

Parameter change and monitoring is available via computer. (Ex: Accel/Decel time, Freq. Command etc.)

Interface type of RS485 reference:

- 1) Allows the inverters to communicate with any other computers
- 2) Allows connection of up to 16 inverters with multi-drop link system
- 3) Noise-resistant interface

Through RS232-485 converters in market, communication can be achieved between inverters and computer inside RS-485, and the specifications and performances of converters may vary with manufacturers. However, the basic functions are the same; refer to the converter manual for detailed specifications from manufacturers.

Note

Before installation and operation, this should be read thoroughly. If not, it can cause personal injury or damage to other equipment.

11.2 Specification

Item	Specification	Item	Specification
Communication type	RS-485	Control type	Asynchronous communication system
Transmission type	Bus type, multi-drop	Communication pattern	Half-duplex system
Inverter type	LTVF-Cx2000 inverter	Symbol system	ASCII (8 bit)
Converter	RS-485 converter	Sum check	2 bits
Connection number	Up to 16 sets	Parity check	None/Even/Odd
Transmission distance	Max 1200 (recommended 700m or less)		
Communication speed	Option: 38400/19200/9600/4800/2400/1200 bps		
Stop bit length	Modbus-RTU : 2 bit		
Installation type	Connection to special terminal (S+, S-) on the keypad.		
Power supply	Separated from the inverter		

11.3 Installation

1) Connecting the communication line

Connect the RS-485 communication line to the inverter's (S+), (S-) terminals of the control terminals
Check the connection and turn ON the inverter.

If the communication line is connected correctly set the communication-related parameters as the following:

Relevant functions:

drv [Drive mode] : 3 (Communication run)

Frq [Freq. mode] : 7 (Communication run)

I 60 [Inverter Number] : 1~250 (Do not repeat, if more than 1 inverters are connected)

I 61 [Baud-rate] : 3 (9,600 bps as Factory default)

I 62 [Lost Mode] : 0 - (continue the frequency run before lost)

I 63 [Wait Time for Command Lost]: 1.0 sec

I 59 [Comm. Prot]: 0 – (Modbus-RTU)

2) Computer and inverter connection

System Configuration

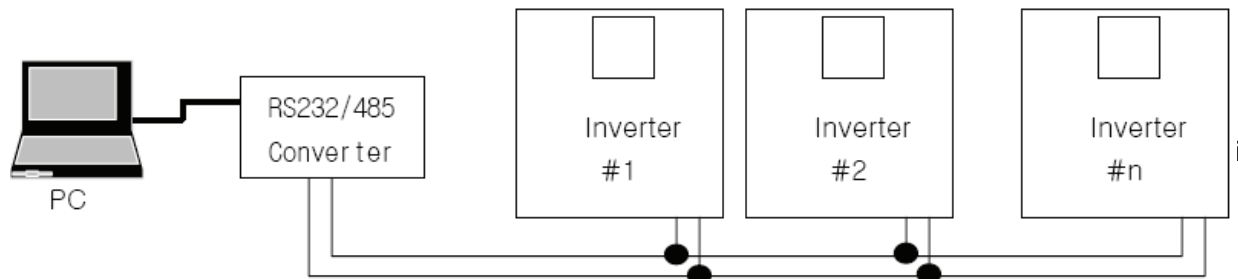

11.4 operation

1) Operation steps

Check whether the computer and the inverter are connected correctly.

Turn ON the inverter. But do not connect the load until stable communication between the computer and the inverter is verified.

Start the operating program for the inverter from the computer (Operate the inverter using the operating program for the inverter).

Refer to "Troubleshooting" if the communication is not operating normally.

*User program or the "DriveConnect" program supplied from LT Industrial Systems can be used as

the operating program for the inverter.

11.5 Communication protocol (MODBUS-RTU)

Use Modbus-RTU protocol (Open protocol).

Computer or other hosts can be Master and inverters Slave.

Inverter responds to Read/Write command from Master.

Code		Description
Function Code	0x03	Read Hold Register
	0x04	Read Input Register
	0x06	Preset Single Register
	0x10	Preset Multiple Register
Exception Code	0x01	ILLEGAL FUNCTION
	0x02	ILLEGAL DATA ADDRESS
	0x03	ILLEGAL DATA VALUE
	0x06	SLAVE DEVICE BUSY
	User define	0x14

11.6 Parameter code list <Common area> (note 1)

Address	Parameter	Scale	Unit	R/W	Allotment for Bits					
0x0000	INV model			R	C: LTVF-Cx2000					
0x0001	INV capacity			R	0000:0.1kW-1	0001:0.2kW-1	0002:0.4kW-1			
					0003:0.8kW-1	0004:1.5kW-1	0005:2.2kW-1			
					0006:0.1kW-2	0007:0.2kW-2	0008:0.4kW-2			
					0009:0.8kW-2	000A:1.5kW-2	000B:2.2kW-2			
					000C:3.7kW-2	000D:5.5kW-2	000E:7.5kW-2			
					000F:0.4kW-4	0010:0.8kW-4	0011:1.5kW-4			
					0012:2.2kW-4	0013:3.7kW-4	0014:5.5kW-4			
					0015:7.5kW-4					
0x0002	Inverter input voltage	-	-	R	0 : 1P 220V, 1 :3P 220V, 2 : 3P 440V					
0x0003	Version	-	-	R	(Ex) 0x0010 : Version 1.0					
0x0004	Parameter Lock	-	-	R/W	0 : Lock(default), 1: Unlock					
0x0005	Freq. Reference	0.01	Hz	R/W	Starting freq. ~ Max. freq.					
0x0006	Run Command B7, B6: drive type			R	B15, B14, B13 : Reserved					
					B12, B11, B10, B9, B8 : Freq. command					
					0 :	DRV-00	1 :	Reserved	2 :	Multi-step speed 1
					3 :	Multi-step speed 2	4 :	Multi-step speed 3	5 :	Multi-step speed 4
					6 :	Multi-step speed 5	7 :	Multi-step speed 6	8 :	Multi-step speed 7
					9 :	UP	10 :	DN	11 :	Up/Dn stop
				R/W	12 :	V2 (knob)	13 :	V1	14 :	I
					15 :	V2+I	16 :	V2+V1	17 :	JOG
					18 :	PID	19 :	Commu.		
					0 :	Terminal	1 :	Keypad	3 :	Commu.
					B5 :	Reversed	B4 :	Emergency Stop	B3 :	Reset
					B2 :	Reverse	B1 :	Forward	B0 :	Stop
0x0007	Acceleration Time	0.1	sec	R/W	See Function List					
0x0008	Deceleration	0.1	sec	R/W	See Function List					

	Time									
0x0009	Output Current	0.1	A	R	See Function List					
0x000A	Output Frequency	0.01	Hz	R	See Function List					
Address	Parameter	Scale	Unit	R/W	Allotment for Bits					
0x000B	Output voltage	0.1	V	R	See Function List					
0x000C	DC Link Voltage	0.1	V	R	See Function List					
0x000D	Output Power	0.1	kW	R	See Function List					
0x000E	Inverter Status			R	B15	Reserved	B14	REM. Freq.		
					B13	REM. R/S	B12	Reverse run command		
					B11	Forward run command	B10	Brake open		
					B9	Not Used	B8	Stopping		
					B7	DC Braking	B6	Speed arrived		
					B5	Deceleration	B4	Acceleration		
					B3	Fault (Trip)	B2	Reverse running		
					B1	Forward running	B0	Stop		
0x000F	Trip information -A			R	B15	LVT	B14	IOLT	B13	POT
					B12	FAN	B11	EET	B10	EXT-B
					B9	Reserved	B8	OLT	B7	ETH
					B6	OHT	B5	GFT	B4	COL
					B3	EST	B2	EXT-A	B1	OVT
					B0	OCT				
0x0010	Input terminal status			R	B15~B5 : Reserved					
					B4	P5	B3	P4	B2	P3
					B1	P2	B0	P1		
0x0011	Output terminal status			R	B4	3ABC				
					Other: Reserved					
0x0012	V1			R	0~10 keypad terminal AIN V(0x0000 ~ 0x03FF)					
0x0013	V2			R	0~5V keypad potentiometer (0x0000 ~ 0x03FF)					
0x0014	I			R	0~20mA keypad terminal AIN I (0x0000 ~ 0x03FF)					
0x0015	RPM			R	Motor synchronous speed					
0x001A	Unit display			R	Not used					
0x001B	Pole number			R	Not used					

Chapter 11 Communication

0x001C	User version			R	Not used
--------	--------------	--	--	---	----------

Address	Parameter	Scale	Unit	R/W	Allotment for Bits					
					B5	NBR	B4	OC2	B3	REEP
0x001D	Trip information-B			R	B7	SAFB	B6	SAFA		
					B2	NTC	B1	Reserved	B0	COM
0x001E	PID feedback	0.1	%	W	PID Feedback is set by communication					
0x0100 ~ 0x0107	Read address register (Note 3)				0x0100 : I66		0x0101 : I67		0x0102 : I68	
							0x0103 : I69		0x0104 : I70	
							0x0105 : I71		0x0106 : I72	
							0x0107 : I73			
0x0108 ~ 0x010F	Write address register (Note 3)			W	0x0108 : I74		0x0109 : I75		0x010A : I76	
							0x010B : I77		0x010C : I78	
							0x010D : I79		0x010E : I80	
							0x010F : I81			

Note 1) the changed value in Common area affects the current setting but returns to the previous setting when power is cycled or Inverter is reset. However, changing value is immediately reflected in other parameter groups even in the case of Reset or Power On/Off.

Note 2) S/W version of Common area is displayed in Hexadecimal, while that of parameter area is displayed in decimal.

11.7 Troubleshooting

Refer to Troubleshooting when RS-485 communication error occurs.

Check points	Corrective measures
Is the power provided to the RS-485?	Provide electric power to the converter.
Are the connections between converter and computer correct?	Refer to converter manual.
Does the Drive start communication?	Start communication
Is baud rate of inverter correctly set?	Set the correct value in accordance with "11-3 Installation"

Is the data format of user program* right?	Revise User Program (Note 1)
Is the connection between converter and communication card right?	Refer to the correct wiring in accordance with“11.3 Installation”.

Note 1) User program is User-made S/W for PC.

11.8 The (ASCII Code List)

Character	Hex	Character	Hex	Character	Hex	Character	Hex	Character	Hex
A	41	a	61	0	30	:	3A	DLE	10
B	42	b	62	1	31	;	3B	EM	19
C	43	c	63	2	32	<	3C	ACK	06
D	44	d	64	3	33	=	3D	ENQ	05
E	45	e	65	4	34	>	3E	EOT	04
F	46	f	66	5	35	?	3F	ESC	1B
G	47	g	67	6	36	@	40	ETB	17
H	48	h	68	7	37	[5B	ETX	03
I	49	i	69	8	38	\	5C	FF	0C
J	4A	J	6A	9	39]	5D	FS	1C
K	4B	k	6B	space	20	^	5E	GS	1D
L	4C	l	6C	!	21	_	5F	HT	09
M	4D	m	6D	"	22	`	60	LF	0A
N	4E	n	6E	#	23	{	7B	NAK	15
O	4F	o	6F	\$	24		7C	NUL	00
P	50	p	70	%	25	}	7D	RS	1E
Q	51	q	71	&	26	~	7E	SI	0F
R	52	r	72	'	27	BEL	07	SO	0E
S	53	s	73	(28	BS	08	SOH	01
T	54	t	74)	29	CAN	18	STX	02
U	55	u	75	*	2A	CR	0D	SUB	1A
V	56	v	76	+	2B	DC1	11	SYN	16
W	57	w	77	,	2C	DC2	12	US	1F
X	58	x	78	-	2D	DC3	13	VT	0B
Y	59	y	79	.	2E	DC4	14		
Z	5A	z	7A	/	2F	DEL	7F		









12. Troubleshoot and maintenance

12.1 Protective functions



 **Warning!**











When a fault occurs, the protective function will be activated, and the fault (shown as the below table) displays on keypad. The cause must be corrected before the fault can be cleared. If the protective function keeps active, it could lead to the reduction of inverter lifetime and damage to the equipment.



Protection on output current and input voltage of the inverter

Fault display	Protective function	Description
	Over current	The inverter turns off its output when the output current of the inverter flows more than the inverter rated current.
	Short circuit	When IGBT's Arm is short and output short occurs, the inverter turns off its output
	Ground fault	The inverter turns off its output when a ground fault occurs and the ground fault current is more than the internal setting value of the inverter.
	Inverter overload	The inverter turns off its output when the output current of the inverter flows more than the rated level (150% for 1 minute).
	Overload protection	The inverter turns off its output if the output current of the inverter flows at 150% of the inverter rated current for more than the current limit time (1 min).
	Overheating	The inverter turns off its output if the heat sink overheats due to a damaged cooling fan or an alien substance in the cooling fan by detecting the temperature of the heat sink.
	Output phase loss	The inverter turns off its output when the one or more of the output (U, V, W) phase is open. The inverter detects the output current to check the phase loss of the output.
	Over voltage	The inverter turns off its output if the DC voltage of the main circuit increases higher than 400 V when the motor decelerates. This fault can also occur due to a surge voltage generated at the power supply system.
	Low voltage	The inverter turns off its output if the DC voltage is below 180V because insufficient torque or overheating of the motor can occur when the input voltage of the inverter drops.





Chapter 12 Troubleshoot and maintenance



	Electronic thermal protection	The internal electronic thermal of the inverter determines the overheating of the motor. If the motor is overloaded the inverter turns off the output. The inverter cannot protect the motor when driving a motor having more than 4 poles or multi motors..
	Input phase loss	Inverter output is blocked when one of R, S, T is open or the electrolytic capacitor needs to be replaced.

● Internal loop and external fault terminal of inverter		
Fault display	Protective function	Description
	Parameter save Abnormity	It occurs when the parameters changed by user fail to be saved in the internal inverter and the power is applied.
	Hardware Abnormity	It occurs when the software is abnormal. If the faults can not be cleared by STOP/RESET key or reset terminal on the panel. The input power supply of the inverter is cut off and the power is not applied again until the panel power disappears completely.
	Panel communication abnormity	When the communication between inverter and panel are abnormal, If the faults can not be cleared by STOP/RESET key or reset terminal on the panel. The input power supply of the inverter is cut off and the power is not applied until the panel power disappears completely.
	Panel abnormity	It occurs when the inverter panel is abnormal, which lasts a certain amount of time.
	Cool fan abnormity	It occurs when the cool fan of the inverter is abnormal. The cool fan can run consecutively or stop (refer to page 8-28).
	Emergency stop	When the emergency stop (EST) terminal closes, the inverter output is turned off. <div style="border: 1px solid black; padding: 5px; margin-top: 10px;"> <p style="text-align: center;">⚠Caution:</p> <p>In case that the operation command signal (FX or RX) of the terminal closes, it can run again through shutoff of EST terminal.</p> </div>
	Contract A Fault signal	As for the function (117-121) of the multi-function output terminal of group I/O, when the terminal set with 18 (external fault signal input: contact A) closes, the inverter output is turned off.
	Contract B Fault signal	As for the function (117-121) of the multi-function output terminal of group I/O, when the terminal set with 19 (external fault signal input: contact B) closes, the inverter output is turned off.
	Frequency command loss	As for the abnormity of the frequency command, when the inverter runs through analog input (0~10V or 0~20V) or RS-485 communications, the signals can not be input, while, the operation method set is chosen according to operation method when the speed command is lost.
	NTC disconnection	The output is turned off when NTC is disconnected.





	Brake control abnormality	When the brake control is used, the output current is lower than the rated current value of the motor set (I82) and lasts for over 10s, then the inverter output is turned off and the brake is not opened.
	Safe stop Terminal A disconnection	If safe stop is required, cut off panel SA and SC and turn off the inverter output.
	Safe stop Terminal B disconnection	If safe stop is required, cut off panel SA and SC and turn off the inverter output.

12.2 Fault remedy

Protective function	Abnormal cause	Countermeasures
 Over current	 Caution	
	When an over current fault occurs, operation must be started after the cause is removed to avoid damage to IGBT inside the inverter.	
	<ul style="list-style-type: none"> ☞ Accel/Decel time is too short compared to the GD₂ of the load. ☞ The inverter load is greater the rated value. ☞ Inverter output is uploaded when the motor is free running. ☞ Occurrence of output short circuit and ground fault ☞ Mechanical brake of the motor is operating too fast. 	<ul style="list-style-type: none"> ☞ Increase the Accel/Decel time. ☞ Replace the inverter with greater capacity. ☞ Resume operation after stopping the motor or use H22. ☞ Check the output wiring. ☞ Check the mechanical brake.
 Short circuit	<ul style="list-style-type: none"> ☞ Occurrence of short circuit between upper and lower IGBT arms ☞ Output short circuit of the inverter occurs ☞ Accel/Decel time is too short comparing the load inertia GD₂. 	<ul style="list-style-type: none"> ☞ Check IGBT. ☞ Check the output wiring of the inverter. ☞ Increase the Accel/Decel time.
 Ground fault	<ul style="list-style-type: none"> ☞ The ground fault of the output wiring for the inverter occurs ☞ The motor insulation is damaged due to overheating. 	<ul style="list-style-type: none"> ☞ Check the output wiring of the inverter. ☞ Please replace the motor.

 Inverter overload	<ul style="list-style-type: none"> ☞ The load of the inverter exceeds its rated value. ☞ Torque compensation is oversize. 	<ul style="list-style-type: none"> ☞ Increase the capacity of motor and inverter. ☞ Decrease torque compensation.
 Overload protection		



Fault remedy

Protective functions	Abnormal causes	Countermeasures
 Inverter Overheat	<ul style="list-style-type: none"> ☞ The cooling system is abnormal. ☞ The service time of the inverter exceeds the replacement period of the cool fan. ☞ The environmental temperature is too high. 	<ul style="list-style-type: none"> ☞ Check the air inlet and outlet and so on, to see if there is any foreign substance available. ☞ Replace the cool fan of the inverter. ☞ The environmental temperature of the inverter shall keep under 50°C.
 Output phase loss	<ul style="list-style-type: none"> ☞ Output electromagnetic contactor has a bad contact. ☞ Bad output wiring 	<ul style="list-style-type: none"> ☞ Check the output electromagnetic contactor of the inverter. ☞ Check the output wiring.
 Cool fan abnormality	<ul style="list-style-type: none"> ☞ There are some foreign substances inhaled into the inverter intake. ☞ The service time of the inverter exceeds the replacement period of the inverter. 	<ul style="list-style-type: none"> ☞ Check the air inlet and outlet. ☞ Replace the cool fan of the inverter.
 Over voltage	<ul style="list-style-type: none"> ☞ Accel/Decel time is too short compared to the load inertia GD2. ☞ Regenerative load is available at the output end of the inverter. ☞ Supply voltage is too high. 	<ul style="list-style-type: none"> ☞ Increase Decel time. ☞ Use brake resistance. ☞ Check if the supply voltage exceeds the value specified.
 Low voltage	<ul style="list-style-type: none"> ☞ The supply voltage is too low. ☞ The low exceeds the power capacity. ☞ The power electromagnetic contactor has a bad contract. 	<ul style="list-style-type: none"> ☞ Check if the supply voltage is lower than the value specified. ☞ Increase the capacity of the power supply. ☞ Replace the electromagnetic contractor.

Chapter 12 Troubleshoot and maintenance

 <p>Electronic thermal protection</p>	<ul style="list-style-type: none"> ☞ Motor is overheated. ☞ The inverter load is greater than the rated value. ☞ The electric thermal protection is set too low. ☞ The inverter capacity is set incorrectly. ☞ Long operation at low speed. 	<ul style="list-style-type: none"> ☞ Reduce the load or running frequency. ☞ Increase the inverter capacity. ☞ The electronic thermal protection rating is set correctly. ☞ Set the inverter capacity correctly. ☞ Choose a cool fan with a separate power supply.
--	--	---

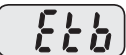
Fault remedy

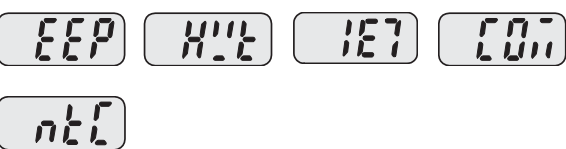
Protective functions	Abnormal causes	Countermeasures
 <p>Contract A Fault signal input</p>	<ul style="list-style-type: none"> ☞ The terminal with the function choice (117 ~ 121) of multi-function input terminal set with 18 is closed. 	<ul style="list-style-type: none"> ☞ Remove the abnormality of the loop connected on the external fault terminal and check the causes for external faults.
 <p>Contract B Fault signal input</p>	<ul style="list-style-type: none"> ☞ The terminal with the function choice (117 ~ 121) of multi-function input terminal set with 19 is opened. 	
 <p>Frequency command loss</p>	<ul style="list-style-type: none"> ☞ Inverter terminal V1 and I has no frequency commands. 	<ul style="list-style-type: none"> ☞ Check the connection wiring of AIN terminal and command grade.
 <p>Brake control Abnormity</p>	<ul style="list-style-type: none"> ☞ Operation is not available if there is no brake open current. 	<ul style="list-style-type: none"> ☞ Check the capacity and wiring of motor.
 <p>EEP: Parameter save error HWT: Hardware fault iE7: Communication error between panel and inverter. COM: Keypad error NTC: NTC error</p>		<ul style="list-style-type: none"> ☞ Contact your local LT Branch.

☞ Overload protection:

IOLT: When HD is used, IOLT (inverter Overload) protection is activated at 150% of the inverter rated current for 1 minute and greater.

While ND is used, IOLT (inverter overload) is activated at 110% of the inverter rated current for 1 minute.

OLT: OLT parameter F56 is set to 1, the output current exceeds the set value of F57 and lasts the setting time of F58.

☞ The inverter is not provided with “Over speed Protection”.

12.3 Precautions for maintenance



Warning

Ensure to cut off the power supply before maintenance.
Make sure to perform maintenance after checking the DC link capacitor has discharged.
LTVF-Cx2000 series uses many semiconductor components. Take correct measures against electrostatic damage while installing or inspecting it.
Do not change various apparatuses and connectors inside the inverter.

12.4 Inspection points

Daily inspection

Inspect if the installation environment is suitable or not.
Inspect if there is any abnormality about the cooling system.
Inspect if there is any vibration or noise.
Inspect if there is any overheating or discoloration.

Periodic inspection

Inspect if screws and bolts may become loose or rust due to influences from external environment, do retighten or replace them.

Check if there is any foreign substance in the inverter or radiator , please remove it with an air blower if possible

Check if there are such abnormalities, for example, the cool fan runs abnormally, the outside change a nd capacity of the electrolytic capacitor reduce and the electromagnetic contractor has a bad contact, etc , do replace them if possible.

12.5 Part replacement

The inverter consists of electronic parts with semiconductor apparatuses. Due to service limit of parts about structures or properties, the inverter has worse performance or any fault occurs, so the parts shall be replaced periodically.

Part name	Change period	Method of replacement
Cool fan	3	New part
DC link capacitor	4	New part
Electrolytic capacitor on control board	4	New part
Relay	-	Decide after investigation

13 Product specifications and options

13.1 Basic specifications

- Input and output specifications: single-phase input voltage (230V)

LTVF -C1■■■■BAA		0001	0002	0003	0005	0008	0011
Applicable motor	[HP]	1/8	1/4	1/2	1	2	3
	[kW]	0.1	0.2	0.4	0.75	1.5	2.2
Output ratings	Rated capacity [kVA] ²⁾	0.3	0.5	1.0	1.9	3.0	4.2
	Rated current[A] ³⁾	0.8	1.4	2.5	5.0	8.0	11
	Max. output frequency	400 [Hz] ⁴⁾					
	Max. output voltage [V]	Three phase 200 ~ 240V ⁵⁾					
Input ratings	Rated voltage [V]	Single phase 200 ~ 240 VAC (+10%, -15%)					
	Rated frequency	50 ~ 60 [Hz] ($\pm 5\%$)					
	Rated current[A]	1.4	2.8	5.5	11	14.1	24
Cooling type		Natural cooling			Forced cooling		
Weight of inverter [kg]		0.55	0.55	0.8	1.22	1.42	1.97

- Input and output specifications: three-phase input voltage (230V)

LTVF -C2■■■■BAA			0001	0002	0003	0006	0010	0012	0018	0030	0040
Applicable motor ¹⁾	HD	[HP]	1/8	1/4	1/2	1	2	3	5	7.5	10
		[kW]	0.1	0.2	0.4	0.75	1.5	2.2	3.7	5.5	7.5
	ND	[HP]	1/4	1/2	1	1.5	3	4	5.4	10	15
		[kW]	0.2	0.4	0.75	1.1	2.2	3.0	4.0	7.5	11.0
Output ratings	Rated capacity [kVA] ²⁾	HD	0.3	0.5	1.0	1.9	3.0	4.2	6.1	9.1	12.2
		ND	0.4	0.7	1.3	2.4	3.8	5.2	7.6	12.1	16.3
	Rated current [A] ³⁾	HD	0.8	1.4	2.5	5.0	8.0	11.0	16.0	24.0	32.0
		ND	1.1	1.8	3.1	6.3	10.0	12.0	18.0	30.0	40.0
	Max. output frequency	400 [Hz] ⁴⁾									
Max. output voltage [V]	Three phase 200 ~ 240V ⁵⁾										
Input ratings	Rated voltage [V]		Three phase 200 ~ 240 VAC (+10%, -15%)								
	Rated current[A]	HD	0.7	1.5	2	5.8	7.5	11	18.9	22.1	28.6
		ND	1.1	1.9	3.9	7.3	10.8	13.9	24	28.6	41.2
Rated frequency		50 ~ 60 [Hz] ($\pm 5\%$)									
Cooling type			Natural cooling				Forced cooling				
Weight of inverter [kg]			0.55	0.55	0.8	0.8	1.22	1.42	1.97	3.3	3.3

Chapter 13 Product specifications and options

- Input and output specifications: three phase input voltage 415V class

LTVF -C4■■■■BAA			0002	0003	0005	0007	0010	0016	0023
Applicable motor ¹⁾	HD	[HP]	1/2	1	2	3	5	7.5	10
		[kW]	0.4	0.75	1.5	2.2	3.7	5.5	7.5
	ND	[HP]	1	1.5	3	4	5.4	10	15
		[kW]	0.75	1.1	2.2	3.0	4.0	7.5	11.0
Output ratings	Rated capacity[kVA] ²⁾	HD	1.0	1.9	3.0	4.2	6.1	9.1	12.2
		ND	1.2	2.4	3.8	5.2	7.6	12.1	16.3
	Rated current [A] ³⁾	HD	1.25	2.5	4.0	5.5	8.0	12.0	16.0
		ND	2.0	3.1	5.1	6.9	10.0	16.0	23.0
	Max. output frequency		400 [Hz] ⁴⁾						
Max. output voltage [V]		Three phase 380 ~ 480V ⁵⁾							
Input ratings	Rated voltage [V]		Three phase 380 ~ 480 VAC (+10%, -15%)						
	Rated frequency		50 ~ 60 [Hz] (±5%)						
	Rated current[A]	HD	1.8	3.2	4.4	6	10.4	11	14.4
ND		2.1	4.3	5.9	8.1	14	14.7	21.9	
Cooling type			Natural cooling	Forced cooling					
Weight of inverter [kg]			0.8	0.8	1.22	1.42	1.97	3.3	3.4

Note 1) indicates the maximum applicable motor capacity when using a 4-pole standard motor of HIGEN.

Note 2) Rated capacity is based on 220V for 230V class and 440V for 415V class.

Note 3) Refer to 13-2 when Carrier frequency setting (H39) is above 6kHz.

Note 4) The max. Frequency setting range can be extended to 120Hz when H40 is set to 3 (sensorless vector control)..

Note 5) the maximum output voltage cannot be higher than the input voltage and it can be programmable below input voltage.

● Control

Control type		V/F control, sensorless vector control
Frequency precision setting		Digital command: 0.01Hz Analog command: 0.03Hz (Max. frequency: 60Hz)
Frequency precision		Operation by digital command: 0.01% of max. output frequency. Analog command operation: 0.1% of max. output frequency.
V/F pattern		Linear, squared, user V/F
Overload capacity		HD: 150%/ 1min; ND: 110%/ 1min
Torque compensation		Manual/auto torque compensation
Dynamic torque 20% Braking	Max. brake torque	20% ¹⁾
	Time/%ED	150% ²⁾ when using optional DB resistor

Note 1) Means average braking torque from deceleration to stop of a motor.

Note 2) Refer to page 13-6 for DB resistor specification.

● Operation

Operation mode		Keypad / Terminal / Communication operation	
Frequency setting		Analog type: 0 ~ 10[V], 0 ~ 20[mA] Digital type: Keypad Panel potentiometer	
Operational functions		PID control, Up-Down operation, 3-wiring operation Optional NPN / PNP (refer to page 2-12)	
Input	P1 ~ P5 Multi-function terminals (5 pcs) P1 ~ P5	Functions: Forward/Reverse operation, emergency stop, fault reset, Jog operation, multi-step frequency – high, mid and low, multi-step Accel/ Decel- High, Mid, Low, DC braking at stop, 2 nd motor select, Up/Down operation function (Increase/Decrease of frequency), 3-wire operation, External fault signal input (contract A/B), General operation switched during PID operation, 2 nd Source, Analog hold, Accel/Decel stop, Up/Down Save Freq, jog forwards/reverse operation.	
Output	Multi-function relay	Fault output and inverter status output	Less than (N.O., N.C.) AC250V 1A, Less than DC 30V 1A
	Analog output	0 ~ 10Vdc (less than 10mA): choose among Output Freq, Output Current, Output Voltage, DC link selectable.	

Chapter 13 Product specifications and options

Protective function

Faults	Over voltage, low voltage, over current, short circuit, ground current detection, inverter overheat, motor overheat, input and output phase loss, overload protection, communication error, loss of frequency command, hardware fault, cool fan trip, brake error.
Alarm	Stall prevention, overload
Momentary Power Loss ¹⁾	Below 16 msec: Continuous operation Above 16 msec: Auto restarting.

Note 1): the rated input voltage is 220V for 230V class, 440V for 415V class, and the rated input is subject to HD.

● Structure and application environment

Protection degree	Opening (IP00), IP40 (Ambient Temperature 40°C) ²⁾
Application temperature	HD operation: -10 ~ 50°C (no freezing) ND operation: -10 ~ 40°C (no freezing)
Storage temperature	-20°C ~ 65°C
Application humidity	Below relative humidity 90% RH (no condensation)
Altitude/Vibration	Below 1000m, 5.9/sec ² (0.6G)
Atmospheric pressure	70~106 kPa
Installation environment	There shall not be corrosive air, combustible gas, oil mist, dust and so on.

Note 2) under development

13.2 Rated current of inverter decreasing

13.2.1 Influence of carrier frequency on rated current decreasing

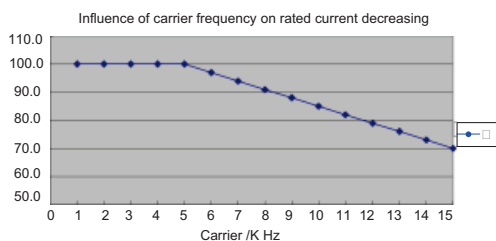

Figure 13-1 operating as CT

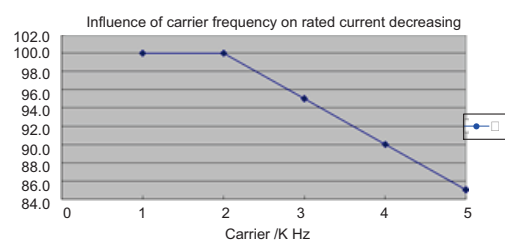

Figure 13-2 operating as VT

Caution

1) The above graph is only applied when the inverter is operated in the allowable temperature. Pay attention to the air cooling when the inverter is installed in a panel box, and the inside temperature should be within an allowable temperature range.

2) The output current value on the above graph is the proportion of inverter's rated current; it is applied to relative rated motor of the inverter.

13.2.2 Influence of input voltage on rated current decreasing

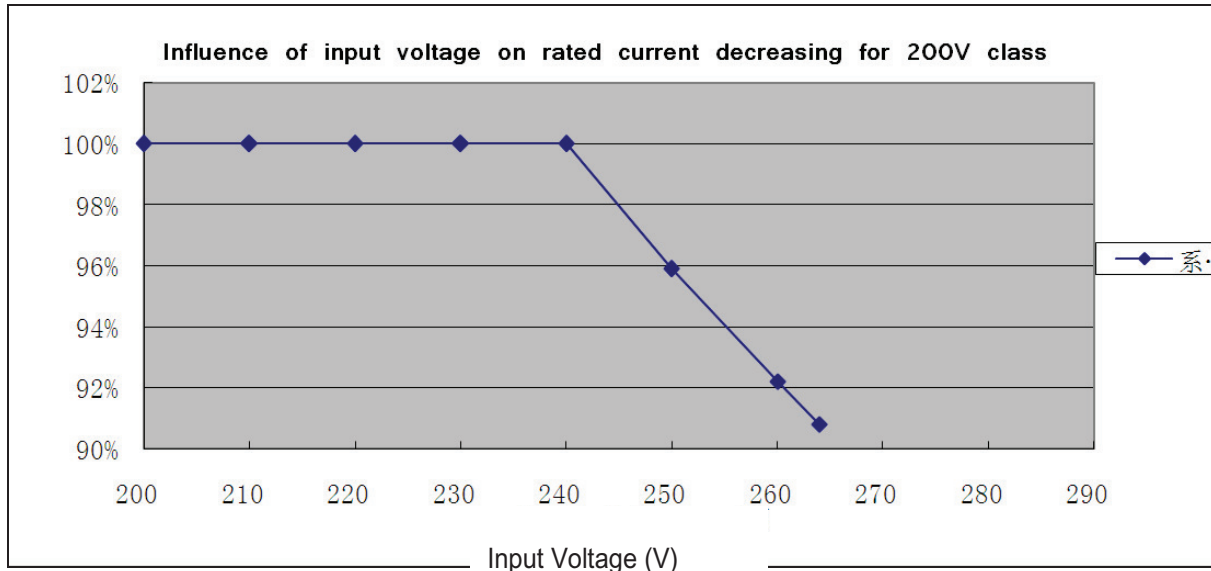

Figure 13-3 current decreasing for 230V class inverter

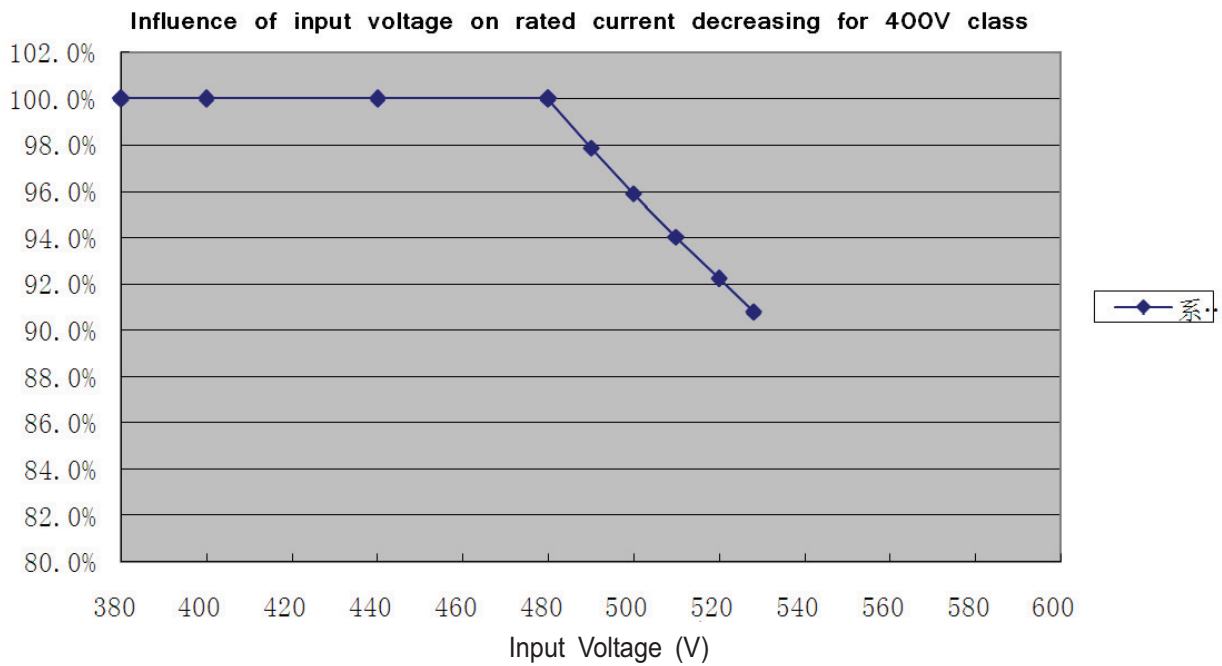
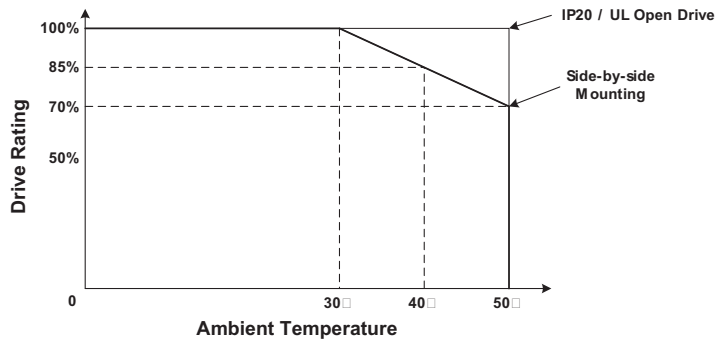

Figure 13-4 current decreasing for 415V class inverter

13.3 drive rating decreasing vs. ambient temperature curve for side-by-side mounting



Note : Above graph is for HD models. If ND models to be used for 50 deg C, deration of 2% per deg rise shall be considered above 40 deg C upto 50 deg C.

13.4 Braking resistor

Power Supply & Voltage	Inverter capacity [kW]	100% braking		150% braking	
		Resistance value [Ω]	Power ^{*)} [W]	Resistance value [Ω]	Power ^{*)} [W]
230V	0.1	1200	20	1000	20
	0.2	700	25	500	35
	0.4	400	50	300	100
	0.75	200	100	150	150
	1.5	100	200	60	300
	2.2	60	300	50	400
	3.7	40	500	33	600
	5.5	30	700	20	800
	7.5	20	1000	15	1200
415V	0.4	1800	50	1200	100
	0.75	900	100	600	150
	1.5	450	200	300	300
	2.2	300	300	200	400
	3.7	200	500	130	600
	5.5	120	700	85	1000
	7.5	90	1000	60	1200

* The above power efficiency (%ED) totals 5%, and its continuous operation time total 15s.

13.5 Remote option

- Option“Cx2000 Remote KPD”



Display: 7-segment LED SET/RUN/REV/FWD LED
Key: RUN STOP/RESET Enter Up/Down Right/Left
Knob: Volume

Display		
7 segment LED	Operation data and parameter information are displayed.	
SET	Lit during parameter setting	Blinks when a fault occurs
RUN	Lit during operation	
REW	Lit during reverse run	
FWD	Lit during forward run	
Key		
RUN	Run command	
STOP/RESET	STOP: Stop command during operation , RESET: Reset command when fault occurs	

Chapter 13 Product specifications and options

▲	UP	Used to move parameter codes or increase parameter values
▼	DOWM	Used to move parameter codes or increase parameter values
◀	LEFT	Used to switch parameter groups or move the cursor to the left when the parameters are written
▶	RIGHT	Used to switch parameter groups or move the cursor to the right when the parameters are written
ENT	ENT	Used to read, write and keep the parameter values
Knob		
Volume	The keypad potentiometer V2 is used for frequency setting	

- Specification (mm)

Remote control option set includes one remote keypad (①), one connection cable (③) and one installation panel for remote keypad (②).

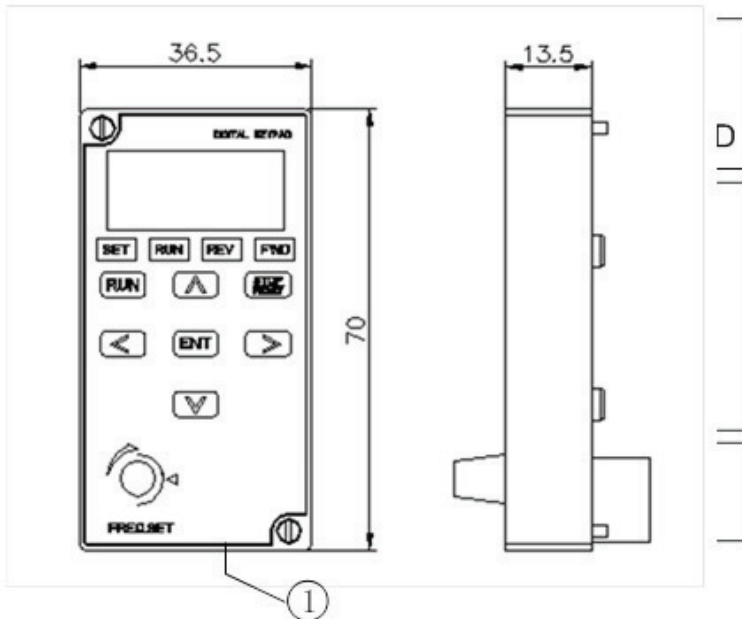

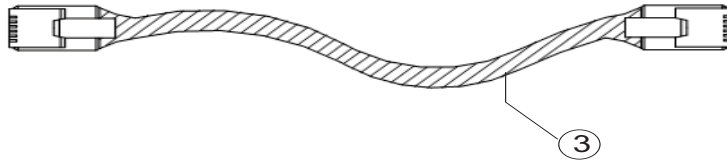
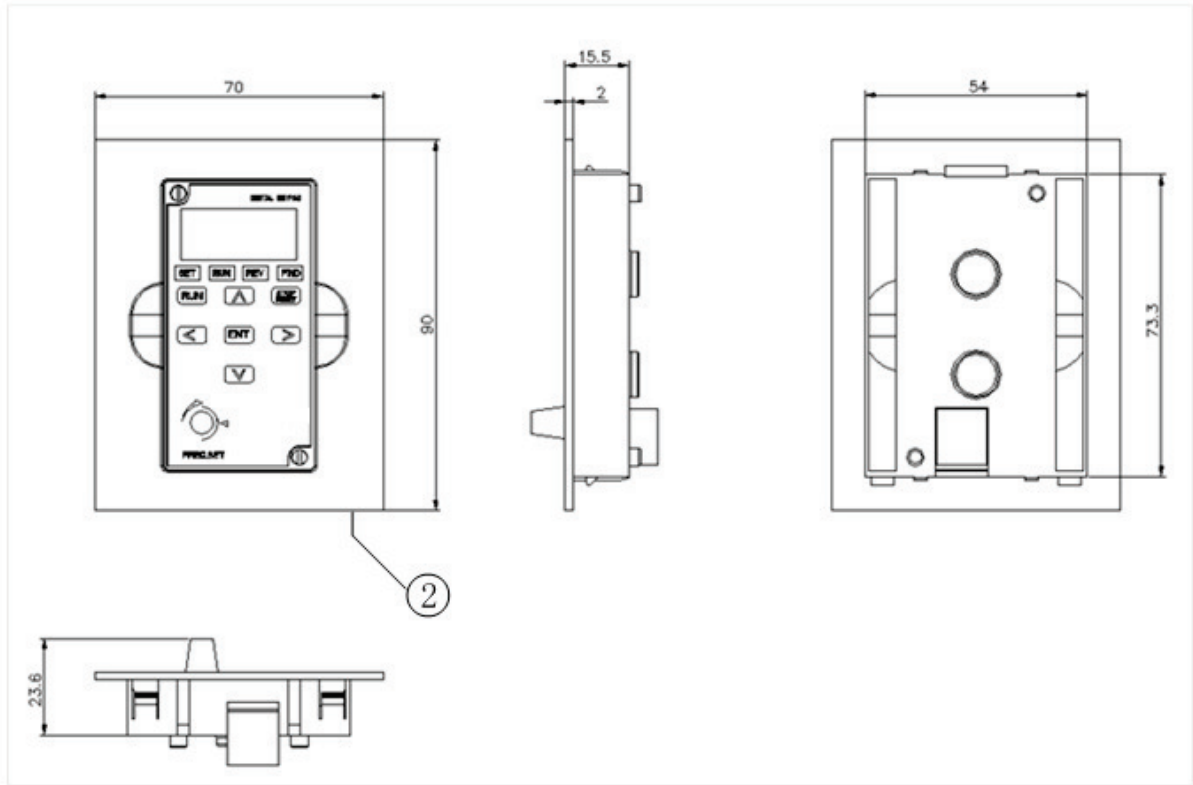

NO.	Description	note
①	remote keypad	
②	installation panel for remote keypad	
③	connection cable	refer to the below table

Remote control option set item

ITEM	Description
60210147W0	Remote 2m,SV-Cx2000[①+②+③connection cable 2m]
60210145W0	Remote 3m,SV-Cx2000[①+②+③connection cable 3m]
60210146W0	Remote 5m,SV-Cx2000[①+②+③connection cable 5m]

Attention : It is strongly recommended to use the above remote cable to prevent malfunction due to voltage drop or noise.

- installation

1) remove the front cover ;

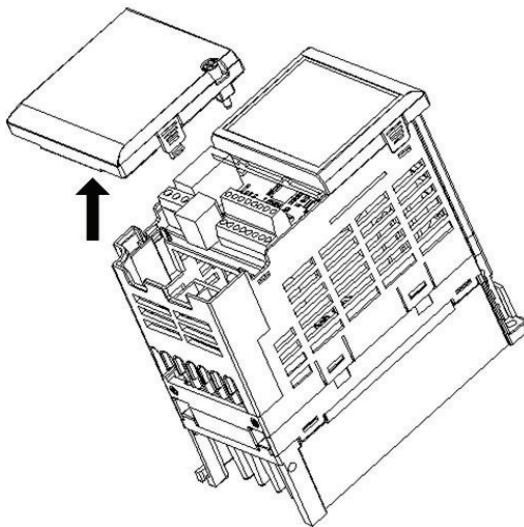

2) shown as below, connect I/O PCB to remote keypad by connection cable.

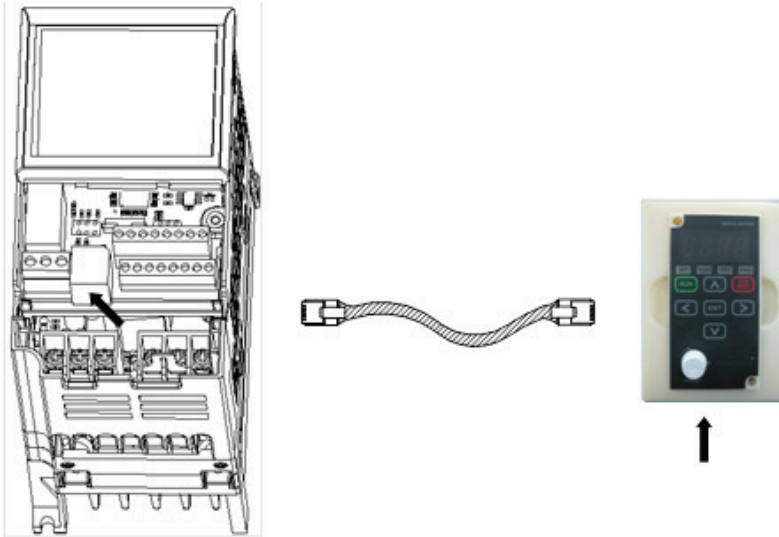

Attention

- Do not use the remote cable other than standard L&T'. Otherwise, malfunction may occur due to noise input or voltage drop in the keypad.
- Check for disconnection of the communication cable and/or poor cable connection if "----" is displayed on the 7-segment display of the Remote keypad.