



# 8400

E84AVBCxxxxx...

Inverter Drives 8400 BaseLine C \_\_\_\_\_

Reference manual

EN



13295753

# Overview of technical documentation for Inverter Drives 8400

---

## Project planning, selection & ordering

- Hardware manual 8400 BaseLine C/D
- Catalogue

## Mounting & wiring

- MA 8400 BaseLine C
- MA for the accessories

## Parameterisation

- SW 8400 BaseLine C

← This documentation

## Drive commissioning

- SW 8400 BaseLine C
  - Chapter "Commissioning"
  - Chapter "Diagnostics & error management"
- Remote maintenance manual

← This documentation

## Networking

- KHB for the communication medium used
- MA for the accessories

### Legend:

- Printed documentation
- Online documentation (PDF/Engineer online help)

### Abbreviations used:

- BA Operating Instructions
- KHB Communication manual
- MA Mounting instructions
- SW Software/reference manual

# Contents

---

<b>1</b>	<b>About this documentation</b>	<b>8</b>
1.1	Document history	8
1.2	Conventions used	9
1.3	Terminology used	10
1.4	Definition of the notes used	11
<b>2</b>	<b>Introduction: Parameterising the controller</b>	<b>12</b>
2.1	General notes on parameters	13
2.2	Handling the memory module	14
2.3	Internal Keypad	17
2.3.1	Display elements and control panel	17
2.3.2	LED status display	18
2.3.3	Display messages	19
2.3.4	Menu structure	21
2.3.5	User menu	22
2.3.6	Quick saving of all parameters at the push of a button	23
2.3.7	Password protection	23
<b>3</b>	<b>Commissioning</b>	<b>25</b>
3.1	Safety instructions with regard to commissioning	25
3.2	Preparing the 8400 BaseLine for commissioning	26
3.3	Commissioning with integrated keypad	27
3.3.1	Load Lenze setting	27
3.3.2	Parameterise drive/application	28
3.3.3	Save parameter settings safe against mains failure	29
3.3.4	Enable controller and select speed	30
3.4	Commissioning with the »Engineer«	31
3.4.1	Preconditions for commissioning with the »Engineer«	31
3.4.2	Creating an »Engineer« project & going online	32
3.4.3	Parameterise drive/application	33
3.4.4	Save parameter settings safe against mains failure	37
3.4.5	Enable controller and select speed	37
3.5	PC manual control	39
3.5.1	Activating PC manual control	39
3.5.2	Speed control	42
<b>4</b>	<b>Device control (DCTRL)</b>	<b>44</b>
4.1	Device commands	46
4.1.1	Load Lenze setting	48
4.1.2	Loading parameter settings	48
4.1.3	Save parameter settings	49
4.1.4	Import EPM data	50
4.1.5	Enable/Inhibit controller	50
4.1.6	Activate/Deactivate quick stop	50
4.1.7	Reset error	51
4.1.8	Delete logbook	51
4.1.9	Identify motor parameters	51
4.1.10	CAN reset node	52
4.2	Device states	53
4.2.1	Init	55
4.2.2	MotorIdent	56
4.2.3	SafeTorqueOff	56
4.2.4	ReadyToSwitchON	57
4.2.5	SwitchedON	58
4.2.6	OperationEnabled	59

# Contents

---

4.2.7	Trouble	60
4.2.8	Fault	61
4.3	"Inhibit at power-on" auto-start option	62
<b>5</b>	<b>Motor control (MCTRL)</b>	<b>64</b>
5.1	Motor selection/Motor data	65
5.1.1	Selecting a motor from the motor catalogue in the »Engineer«	68
5.1.2	Automatic motor data identification	70
5.2	Selecting the control mode	73
5.2.1	Selection help	75
5.3	Defining current and speed limits	76
5.4	V/f characteristic control (VFCplus)	78
5.4.1	Parameterisation dialog/signal flow	78
5.4.2	Basic settings	80
5.4.2.1	Defining the V/f characteristic shape	80
5.4.2.2	Defining current limits (I <sub>max</sub> controller)	81
5.4.3	Optimise control behaviour	82
5.4.3.1	Adapting the V/f base frequency	83
5.4.3.2	Adapting the V <sub>min</sub> boost	84
5.4.3.3	Optimising the I <sub>max</sub> controller	85
5.4.3.4	Torque limitation	85
5.4.4	Remedies for undesired drive behaviour	86
5.5	Sensorless vector control (SLVC)	87
5.5.1	Parameterisation dialog	88
5.5.2	Speed control with torque limitation	89
5.5.3	Basic settings	90
5.5.4	Optimise control behaviour	90
5.5.4.1	Optimising the starting performance after a controller enable	90
5.5.5	Remedies for undesired drive behaviour	91
5.6	Parameterisable additional functions	92
5.6.1	Selection of switching frequency	92
5.6.2	Flying restart function	94
5.6.3	DC-injection braking	96
5.6.3.1	Manual DC-injection braking (DCB)	97
5.6.3.2	Automatic DC-injection braking (Auto-DCB)	97
5.6.4	Slip compensation	99
5.6.5	Oscillation damping	100
5.7	Braking operation/braking energy management	101
5.7.1	Setting the voltage source for braking operation	102
5.7.2	Avoiding thermal overload of the brake resistor	102
5.8	Monitoring	103
5.8.1	Device overload monitoring (I <sub>xt</sub> )	103
5.8.2	Motor load monitoring (I <sub>2xt</sub> )	104
5.8.3	Brake resistor monitoring (I <sub>2xt</sub> )	106
5.8.4	Mains phase failure monitoring	107
<b>6</b>	<b>I/O terminals</b>	<b>108</b>
6.1	Digital terminals	109
6.2	Analog terminals	111
6.2.1	Parameterising analog input	112
6.3	User-defined terminal assignment	114
6.3.1	Source-destination principle	115
6.3.2	Changing the terminal assignment with the »Engineer«	116
6.3.3	Changing the terminal assignment via configuration parameters	117
6.4	Electrical data	119

# Contents

---

<b>7</b>	<b>Drive application</b>	121
7.1	Parameterisation dialog	122
7.1.1	Signal flow	124
7.1.1.1	Selection of the main speed setpoint	126
7.1.1.2	Motor potentiometer function	126
7.1.1.3	Process controller	126
7.2	Interface description	127
7.3	Setting parameters (short overview)	132
7.4	Pre-assignment of the drive application	133
7.4.1	Input connections	133
7.4.2	Output connections	134
7.4.3	Internal signal flow for control via terminals	135
7.4.4	Internal signal flow for control via CAN	136
7.4.5	Process data assignment for control via CAN	137
7.5	Terminal assignment of the control modes	139
7.5.1	Terminals 0	140
7.5.2	Terminals 2	140
7.5.3	Terminals 11	141
7.5.4	Terminals 16	141
7.5.5	Keypad	142
7.5.6	PC	143
7.5.7	CAN	144
<b>8</b>	<b>Diagnostics &amp; error management</b>	145
8.1	Basics on error handling in the controller	145
8.2	Drive diagnostics with the »Engineer«	146
8.3	Drive diagnostics via bus system	148
8.4	Logbook	149
8.4.1	Functional description	149
8.4.2	Reading out logbook entries	150
8.4.3	Exporting logbook entries to a file	150
8.5	Monitoring	151
8.5.1	Monitoring configuration	152
8.5.2	Setting the error response	153
8.6	Maloperation of the drive	154
8.7	Error messages of the operating system	156
8.7.1	Structure of the error number (bit coding)	156
8.7.1.1	Error type	156
8.7.1.2	Error subject area	157
8.7.1.3	Error ID	157
8.7.1.4	Example for bit coding of the error number	158
8.7.2	Reset of error message	158
8.7.3	Short overview (A-Z)	159
8.7.4	Cause & possible remedies	161

# Contents

---

<b>9</b>	<b>System bus "CAN on board"</b>	<b>169</b>
9.1	General information	170
9.1.1	General data and application conditions	171
9.1.2	Supported protocols	171
9.1.3	Communication time	172
9.1.4	Activating the bus terminating resistor	173
9.1.5	Setting baud rate & node address	173
9.2	LED status displays for the system bus	174
9.3	Going online via system bus (CAN on board)	175
9.4	Structure of the CAN data telegram	176
9.4.1	Identifier	176
9.4.2	User data	178
9.5	Communication phases/network management	179
9.5.1	Status transitions	180
9.5.2	Network management telegram (NMT)	181
9.5.3	Parameterising the controller as CAN master	182
9.6	Process data transfer	183
9.6.1	Available process data objects	184
9.6.1.1	RPDO1   Port block "LP_CanIn1"	185
9.6.1.2	RPDO2   Port block "LP_CanIn2"	186
9.6.1.3	TPDO1   Port block "LP_CanOut1"	187
9.6.1.4	TPDO2   Port block "LP_CanOut2"	188
9.6.2	Identifiers of the process data objects	189
9.6.3	Transmission type	190
9.6.4	PDO synchronisation via sync telegram	192
9.6.5	Monitoring of the RPDOs for data reception	193
9.7	Parameter data transfer	194
9.7.1	Identifiers of the parameter data objects	195
9.7.2	User data	195
9.7.2.1	Command	196
9.7.2.2	Addressing by means of index and subindex	197
9.7.2.3	Data 1 ... Data 4	198
9.7.2.4	Error messages	199
9.7.3	Parameter data telegram examples	201
9.7.3.1	Read parameters	201
9.7.3.2	Write parameters	202
9.7.3.3	Read block parameters	203
9.8	Monitoring	206
9.8.1	Integrated error detection	206
9.8.2	Heartbeat protocol	207
9.8.2.1	Telegram structure	207
9.8.2.2	Parameter setting	208
9.8.2.3	Commissioning example	209
9.8.3	Emergency telegram	210
9.9	Implemented CANopen objects	211

# Contents

---

<b>10</b>	<b>Parameter reference</b>	228
10.1	Structure of the parameter descriptions	229
10.1.1	Data type	230
10.1.2	Parameters with read-only access	230
10.1.3	Parameters with write access	231
10.1.3.1	Parameters with setting range	231
10.1.3.2	Parameters with selection list	231
10.1.3.3	Parameters with bit-coded setting	232
10.1.3.4	Parameters with subcodes	233
10.1.4	Parameter attributes	234
10.2	Parameter list	235
10.2.1	Selection lists for configuration parameters	298
10.2.1.1	Selection list - analog signals	298
10.2.1.2	Selection list - digital signals	299
10.3	Table of attributes	300
<b>11</b>	<b>Function library</b>	304
11.1	L_MPot_1	305
11.1.1	Activate & control motor potentiometer	307
11.1.2	Deactivate motor potentiometer	308
11.2	L_NSet_1	309
11.2.1	Main setpoint path	310
11.2.2	JOG setpoints	310
11.2.3	Setpoint inversion	311
11.2.4	Ramp function generator for the main setpoint	311
11.2.5	S-shaped ramp	311
11.3	L_PCTRL_1	312
11.3.1	Control characteristic	315
11.3.2	Ramp function generator	316
11.3.3	Operating range of the PID process controller	316
11.3.4	Evaluation of the output signal	316
11.4	L_RLO_1	317
11.5	LS_AnalogInput	319
11.6	LS_DigitalInput	320
11.7	LS_DigitalOutput	321
11.8	LS_DisFree	322
11.9	LS_DisFree_a	323
11.10	LS_DisFree_b	324
11.11	LS_DriveInterface	325
11.12	LS_Keypad	328
11.13	LS_ParFix	329
11.14	LS_ParFree_a	330
11.15	LS_ParFree_b	331
11.16	LS_SetError_1	332
	<b>Index</b>	333
	Your opinion is important to us	340

# 1 About this documentation

## 1.1 Document history

---

# 1 About this documentation



### Danger!

The controller is a source of danger which may lead to death or severe injury of persons.

To protect yourself and others against these dangers, observe the safety instructions before switching on the controller.

Please read the safety instructions in the mounting instructions and the hardware manual of the 8400 BaseLine C controller. Both documents are supplied with the controller.

This documentation contains information on the parameterisation of the 8400 BaseLine C controller using the integrated keypad and the L-force »Engineer«.

The information in this documentation is valid for the 8400 BaseLine C controller with the following nameplate data:

Product series	Type designation	From software version
8400 BaseLine C	E84AVBCxxxxxxxx	01.00

Depending on the software version of the controller and the version of the installed »Engineer« software, the screenshots in this documentation may differ from the representation in the »Engineer«.



### Tip!

Information and tools around the Lenze products can be found in the Download area on

<http://www.Lenze.com>

## 1.1 Document history



Version			Description
1.6	01/2014	TD05	Error corrections & supplements and converted to new layout
1.5	04/2013	TD05	Error corrections & supplements, parameter reference V03.04.00
1.4	04/2011	TD05	Error corrections & supplements, parameter reference V03.03.00
1.3	09/2010	TD05	Restructuring of some chapters, error corrections & supplements
1.2	11/2009	TD06	Error corrections
1.1	05/2009	TD06	Error corrections
1.0	04/2009	TD06	First edition



# 1 About this documentation

## 1.2 Conventions used

This documentation uses the following conventions to distinguish between different types of information:

Type of information	Writing	Examples/notes
Spelling of numbers		
Decimal separator	Point	The decimal point is generally used. For example: 1234.56
Text		
Version info	Blue text colour	All information that only applies to a certain controller software version or higher is identified accordingly in this documentation. Example: <a href="#">This function extension is available from software version V3.0!</a>
Program name	» «	The Lenze »Engineer« PC software ...
Window	<i>italics</i>	The <i>Message</i> window ... / The <i>Options</i> dialog box...
Variable identifier		By setting <i>bEnable</i> to TRUE...
Control element	<b>bold</b>	The <b>OK</b> button... / The <b>Copy</b> command... / The <b>Properties</b> tab... / The <b>Name</b> input field...
Sequence of menu commands		If the execution of a function requires several commands, the individual commands are separated by an arrow: Select <b>File→Open</b> to...
Shortcut	< <b>bold</b> >	Press < <b>F1</b> > to open the online help. If a command requires a combination of keys, a "+" is placed between the key symbols: Use < <b>Shift</b> >+< <b>ESC</b> > to...
Hyperlink	<u>Underlined</u>	Optically highlighted reference to another topic. In this documentation activated by mouse-click.
DIP switch	\ ("Backslash")	For separating the data of the DIP-Schalterbank from the switch number, the Backslash" is used. For instance, S2\8 indicates bank S2 and switch 8 (on the far right).
Icons		
Page reference	 9	Optically highlighted reference to another page. In this documentation activated by mouse-click.
Step-by-step instructions		Step-by-step instructions are indicated by a pictograph.

Information that is only valid for or as from a certain software version of the controller are marked accordingly in this documentation.

# 1 About this documentation

## 1.3 Terminology used

### 1.3 Terminology used

Term	Meaning
»Engineer«	Lenze PC software which supports you in "engineering" (parameterisation, diagnostics and configuration) throughout the whole life cycle, i.e. from planning to maintenance of the commissioned machine.
Application	A technology application is a drive solution equipped with Lenze's experience and know-how in which function and system blocks interconnected to a signal flow are the basis for implementing typical drive tasks.
ASM	Asynchronous motor
CINH	Abbreviation: Controller <b>in</b> hibit (pulse inhibit)
Code	Parameter used for controller parameterisation or monitoring. The term is usually called "index".
DC-injection braking	DC injection braking is to brake and/or hold the motor. For this purpose, the 8400 BaseLine C creates a quasi DC field at the stator of the asynchronous machine. The energy to be dissipated is converted into heat in the rotor.
DCTRL	Abbreviation: Drive control (device control)
Display code	Parameter that displays the current state or value of an input/output of a system block.
EPM	Memory module on which all parameters of the drive system are saved non-volatily. These include the parameters of the controller and communication-relevant parameters for the communication unit used.
Function block	A function block can be compared with an integrated circuit that contains a certain control logic and delivers one or several values when being executed. <ul style="list-style-type: none"><li>• Each function block has a unique identifier, e.g. "L_MPot_1" (motor potentiometer function)</li></ul>
Holding brake	The holding brake serves to hold the rotor by means of a mechanical unit.
LA	Abbreviation: Lenze Application block <ul style="list-style-type: none"><li>• Example: "LA_NCtrl" – block for the "actuating drive speed" application.</li></ul>
Lenze setting	This setting is the default factory setting of the device.
LP	Abbreviation: Lenze Port block <ul style="list-style-type: none"><li>• Example: "LP_Network_In" – port block for fieldbus communication.</li></ul>
LS	Abbreviation: Lenze System block <ul style="list-style-type: none"><li>• Example: "LS_DigitalInput" – system block for digital input signals.</li></ul>
MCTRL	Abbreviation: <b>M</b> otor control
Port block	Block for implementing the process data transfer via a fieldbus
QSP	Quick stop ("Quick stop): The motor control is decoupled from the setpoint selection and within a parameterisable deceleration time, the motor is brought to a standstill ( $n_{act} = 0$ ).
Service brake	The service brake serves to shutdown rotary or translatory masses in motion in a controlled manner. The energy to be dissipated in this process is converted into heat in the form of friction energy. This process is a regular and recurring operating mode.
SLVC	Motor control: Sensorless vector control ("SensorLess Vector Control")
SM	Synchronous motor
Subcode	If a code contains several parameters, the individual parameters are stored under "subcodes". This manual uses a slash "/" as a separator between code and subcode (e.g. "C118/3"). The term is usually called "subindex".
System block	In the application, system blocks provide interfaces to basic functions and to the hardware of the controller (e.g. to the digital inputs).

# 1 About this documentation

## 1.4 Definition of the notes used

---

Term	Meaning
USB diagnostic adapter	The USB diagnostic adapter is used for the operation, parameterisation, and diagnostics of the controller. Data are exchanged between the PC (USB connection) and the controller (diagnostic interface on the front) via the diagnostic adapter. <ul style="list-style-type: none"><li>• Order designation: E94AZCUS</li></ul>
VFCplus	Motor control: V/f characteristic control ("Voltage Frequency Control")

## 1.4 Definition of the notes used

The following signal words and symbols are used in this documentation to indicate dangers and important information:

### Safety instructions

Layout of the safety instructions:



#### **Pictograph and signal word!**

(characterise the type and severity of danger)

#### **Note**

(describes the danger and informs how to prevent dangerous situations)

Pictograph	Signal word	Meaning
	<b>Danger!</b>	<b>Danger of personal injury through dangerous electrical voltage</b> Reference to an imminent danger that may result in death or serious personal injury if the corresponding measures are not taken.
	<b>Danger!</b>	<b>Danger of personal injury through a general source of danger</b> Reference to an imminent danger that may result in death or serious personal injury if the corresponding measures are not taken.
	<b>Stop!</b>	<b>Danger of property damage</b> Reference to a possible danger that may result in property damage if the corresponding measures are not taken.

### Application notes

Pictograph	Signal word	Meaning
	<b>Note!</b>	Important note to ensure trouble-free operation
	<b>Tip!</b>	Useful tip for easy handling

## 2 Introduction: Parameterising the controller

---

## 2 Introduction: Parameterising the controller

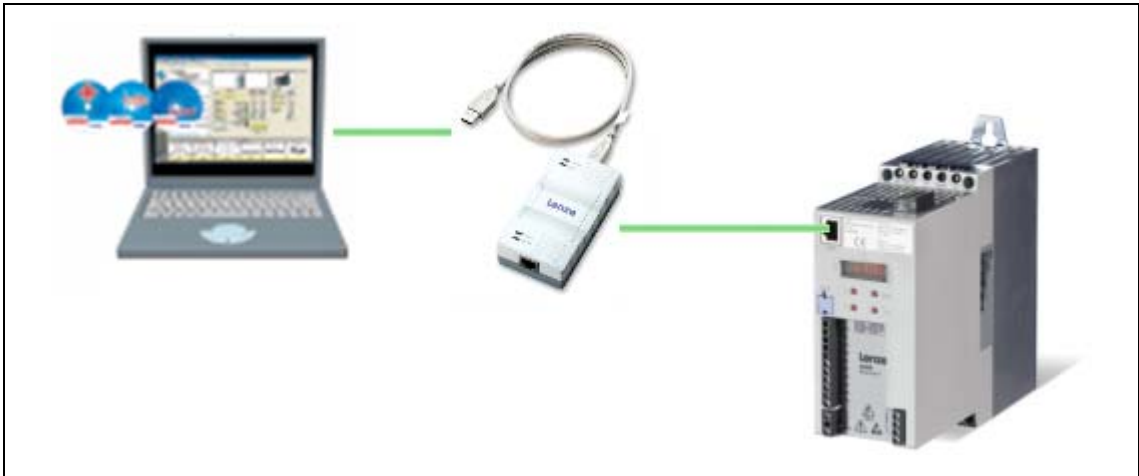

[2-1] Example configuration for parameterising the controller (here: BaseLine D)

Being a component of a machine which includes a speed-variable drive system, the controller needs to be adjusted to its drive task and the motor. The controller is adjusted by changing parameters which are saved in the memory module.



### Danger!

In general, changing a parameter causes an immediate response in the controller!

- This may lead to undesirable behaviour on the motor shaft if the controller has been enabled!
- Setpoint sources, for instance, may switch over all of a sudden (e.g. when configuring the signal source for the main setpoint).

Certain device commands or settings which may cause critical states of drive behaviour constitute exceptions. Such parameter changes are only possible if the controller is inhibited. Otherwise, a corresponding error message will be issued.

The parameters can optionally be accessed from the integrated keypad, or the L-force »Engineer«, or a master control via fieldbus communication:

- The USB diagnostic adapter, for instance, can be used for the communication between the PC (including the L-force »Engineer« software) and the controller, see illustration. The USB diagnostic adapter is the connection between the PC (free USB port) and the controller (diagnostic interface).
- For fieldbus communication, the 8400 BaseLine C controller is provided with a CANopen interface.

## 2 Introduction: Parameterising the controller

### 2.1 General notes on parameters

#### 2.1 General notes on parameters

All parameters for controller parameterising or monitoring are saved as so-called "codes".

- The codes are numbered and designated by a "C" in front of the code, e.g. "C002" in the documentation and the keypad display.
- In addition, every code has a name and specific attributes:
  - Access type (read, write)
  - Data type
  - Limit values
  - Lenze setting (factory-set scaling)
- For the sake of clarity, some codes contain "subcodes" for saving parameters.
  - This manual uses a slash "/" as a separator between code and subcode (e.g. "C115/1").
  - In the keypad display, the subcodes are designated by a small "c", e.g. "c001".
- According to their functionality, the parameters are divided into three groups:

Parameter group	Examples
<b>Setting parameters</b> Parameters for specifying setpoints and for setting device / monitoring functions.	<a href="#">C007</a> : Selection of control mode <a href="#">C012</a> : Acceleration time - main setpoint <a href="#">C039</a> : Fixed setpoints
<b>Configuration parameters</b> Parameters for configuring signal connections within the device, e.g. assignment of the digital input terminals to the control inputs of the application.	<a href="#">C620</a> : System connection list: 16-bit <a href="#">C621</a> : System connection list: Bool <a href="#">C700</a> : LA_NCtrl: Analog connection list <a href="#">C701</a> : LA_NCtrl: Digital connection list
<b>Diagnostic/Display parameters</b> Parameters for displaying device-internal process factors, current actual values, and status messages, e.g. for diagnostic purposes. These are read-only parameters.	<a href="#">C052</a> : Motor voltage <a href="#">C137</a> : Device status <a href="#">C150</a> : Status word <a href="#">C165</a> : Error info



#### Tip!

The terms "code" and "subcode" generally correspond to the terms "index" and "subindex" and "parameter" and "subparameter".

### 2.2 Handling the memory module



#### Danger!

After power-off, wait at least three minutes before working on the controller. When removing the memory module, ensure that the controller is deenergised.

If the memory module has been removed and the device is switched on, the connector pins are live and thus dangerous since the protection against contact is missing.

All parameters of the drive system are saved non-volatily in the memory module of the controller. This includes the parameters of the controller and parameters relevant for communication.

The plug-in version is especially suited for

- restoring an application after replacing a device.
- duplicating identical drive tasks within the 8400 Baseline frequency inverter series, e.g. by using the optionally available EPM Programmer.



#### Note!

- When the device is switched on, all parameters are automatically loaded from the memory module to the main memory of the controller.
- The 8400 Baseline and 8400 motec controllers use the same (grey) memory module. The memory module can be shifted between these controllers but the controller must be reparameterised afterwards.
- The memory module is not compatible with the memory modules of the 8400 StateLine and 8400 HighLine controllers.
- If the memory module has been removed, the "PS01" error message appears.

When handling the memory module, a distinction is drawn between the following scenarios:

#### Delivery status



- The memory module is plugged into the EPM slot at the front of the controller.
- The Lenze setting of the parameters is stored in the memory module.
- The memory module can be preconfigured with customer-specific data.
- The memory module is available as a spare part - without any data.

---

### During operation



#### Stop!

The memory module must not be plugged in or unplugged during operation.

- The memory module (EPM) is required for operation.
- Full functionality of the memory module is even provided if the power supply has been switched off and only the electronic components of the controller are externally supplied by a 24 V DC voltage, e.g. via the X4/24E terminal.
- Parameter settings can be saved manually.
- Parameter settings can be loaded manually.
- Parameter changes can be saved automatically.

### Replacing the controller

- In the event of a device replacement, the entire parameter data of an axis can be copied to the replacement device by "taking along" the memory module, so that additional PC or diagnosis terminal operations are not required.
- When replacing the controller, the versions of the old device and the new device are of importance. Before data are actually transferred, the versions are internally checked. Basically, the following applies:
  - Parameter sets of old devices with V 1.0 can be processed on new devices  $\geq$  V 1.0 (downward compatibility).
  - Parameters of devices with higher versions are not supported on devices with lower versions. An error message (PS02/PS03) occurs if the parameter set versions of the two devices are not compatible.

### Saving the parameters in the memory module safe against mains failure

Controller parameter changes via the »Engineer«, the integrated keypad, or a master control via fieldbus communication will be lost after mains switching of the controller unless the settings have been explicitly saved.



You have various opportunities to prevent a data loss by saving the parameter settings in the memory module:

- [Quick saving of all parameters at the push of a button](#) (📖 23)
- [Automatic saving of parameter changes](#) (📖 49)
- [Manual saving of parameter settings](#) (📖 49)

---

### Parameter set transfer using the »Engineer«

When an online connection to the controller has been established, the following transfer functions can directly be executed via the *Toolbar* or the **Online** menu using the L-force »Engineer«:

Symbol	Menu command	Shortcut
	Download parameter set	<F5>
	Read parameter set from device	<F7>
	Save parameter set	

**Tip!**

Detailed information on parameter set transfers using the »Engineer« can be found in the »Engineer« online help.



## 2.3

## Internal Keypad

The controller front is provided with an integrated keypad. Use the keypad for quick and simple parameter setting and for displaying current actual values and device states via the respective display parameters.

**Note!**

After switching on the controller, the internal keypad performs a quick self-test. All segments of the display flash. After the self-test, the keypad shows "rdy" for a short time and then changes to the display of the setpoint speed of the motor. The keypad is now ready for operation.

## 2.3.1

## Display elements and control panel

Important status information of the controller is displayed optically by LEDs. The positions of the coloured LEDs are marked on the housing by letters.

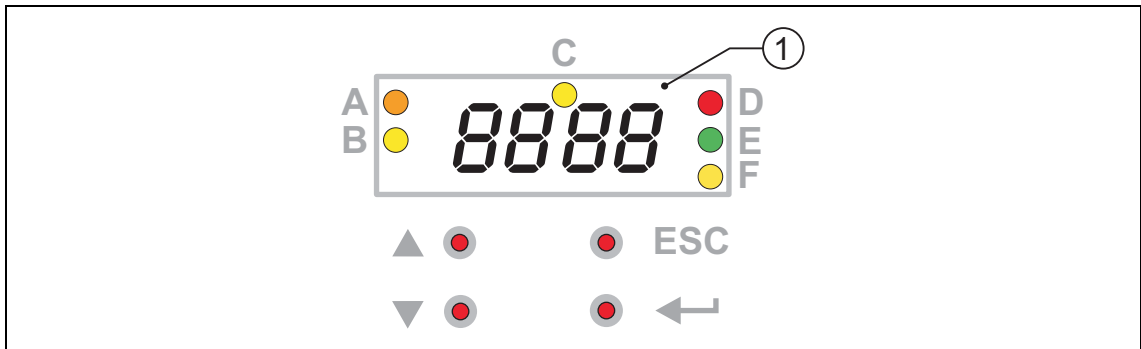

Symbol	Information	Meaning
①	4-character display with LEDs (A ... F)	
A	orange	Set current/torque limit is reached
B	yellow	Minus sign for identifying the negative numbers bigger than 4 characters when the rotational direction has been reversed.
C	yellow	User LED <ul style="list-style-type: none"> <li>• configurable via <a href="#">C621/42</a></li> <li>• user-defined LED status</li> </ul>
D	red	DRIVE ERROR / DRIVE READY
E	green	▶ <a href="#">LED status display</a> (□ 18)
F	yellow	Direction of rotation: CCW rotation
	Off	Direction of rotation: CW rotation
	blinking	Commanded direction is not equal to actual direction (e.g. during reversing)

## Control elements

Key	Name	Function
ESC	Escape key	On menu and parameter level: Back In case of parameter processing: Abort (discard changed setting)
↵	Enter key	On menu and parameter level: Next (confirm selection) In case of parameter processing: OK (accept changed setting) Long pressing (3 seconds): Saving of all parameters ▶ <a href="#">Quick saving of all parameters at the push of a button</a> (📖 23)
▲	Navigation key upwards	On menu and parameter level: Navigation In case of parameter processing: Set parameter value
▼	Navigation key downwards	Long pressing (> 2 seconds): Quick scroll function

## 2.3.2 LED status display

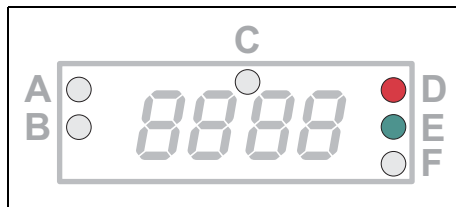

Information on some operating states can quickly be obtained via the front D and E LEDs:

The meaning can be seen from the table below.

E "DRIVE READY"	D "DRIVE ERROR"	Description	Device state (Display in <a href="#">C137</a> )
OFF	OFF	OFF or initialisation active	<a href="#">Init</a>
	OFF	Safe torque off is active	<a href="#">SafeTorqueOff</a>
	OFF	Device is ready to start	<a href="#">ReadyToSwitchON</a>
	OFF	Device is switched on	<a href="#">SwitchedON</a>
	OFF	Motor data identification/operation	<a href="#">OperationEnabled</a>
		The controller is ready to switch on, switched on or the operation is enabled and a warning is indicated.	
OFF		Trouble is active	<a href="#">Trouble</a>
OFF		Fault is active	<a href="#">Fault</a>
<b>Legend</b>			
The symbols used for indicating the LED states have the following meaning:			
	LED is flashing once approx. every 3 seconds ( <i>slow flash</i> )		
	LED is flashing once approx. every 1.25 seconds ( <i>flash</i> )		
	LED is flashing twice approx. every 1.25 seconds ( <i>double flash</i> )		
	LED is blinking every second		
	LED is permanently on		

## 2.3.3 Display messages

Display		Meaning
<i>RnD1</i>	constant	Analog input 1: Current < 4 mA
<i>bF</i>	blinking	Identification error. • Drive ID stored in EMP does not match the drive ID stored in the controller.
<i>br</i>	flashes during the hold time of DC braking	DC braking is executed.
<i>CR06</i>	constant	CAN CRC error
<i>CR07</i>	constant	CAN Bus Warn
<i>CR08</i>	constant	CAN Bus Stopped
<i>CR0b</i>	constant	CAN Bus Live Time
<i>CR0F</i>	constant	CAN: Bit 14 ("SetFail") in the control word is set.
<i>CAL</i>	blinking	Identification is executed. The operation is not yet enabled.
<i>CAL / Err</i>	alternatively blinking	Identification is not ready to start. • <a href="#">C088</a> , <a href="#">C089</a> or <a href="#">C090</a> is 0.
<i>CAL / StOP</i>	alternatively blinking	Identification is ready to start.
<i>CE1</i>	constant	CAN: Time monitoring for RPDO1 has tripped.
<i>CE2</i>	constant	CAN: Time monitoring for RPDO2 has tripped.
<i>CE4</i>	constant	CAN Bus Off
<i>CL</i>	constant	Clamp: The current limit value selected in <a href="#">C022</a> has been reached.
<i>dEc</i>	constant	Deceleration is temporarily suspended because of higher bus voltage
<i>dFD1 ... dFI0</i>	constant	Internal error
<i>dH69</i>	constant	Adjustment data error
<i>Err</i>	blinking	A wrong password has been entered.
<i>FCL</i>	constant	The current limit value selected in <a href="#">C022</a> has been exceeded.
<i>FSt</i>	constant	"Flying restart" function is executed.
<i>ID1</i>	constant	Motor data identification error
<i>LU</i>	constant	DC bus undervoltage
<i>OC1</i>	constant	Power section - short circuit
<i>OC12</i>	constant	I2xt brake resistor overload
<i>OC2</i>	constant	Power section - earth fault
<i>OC5</i>	constant	Ixt overload
<i>OC6</i>	constant	I2xt motor overload
<i>OC9</i>	constant	Ixt overload - shutdown limit
<i>OH</i>	constant	Heatsink overtemperature
<i>OU</i>	constant	DC bus overvoltage
<i>PR55</i>	0.5 seconds on	Password protection is active
<i>PS01</i>	constant	No memory module inserted
<i>PS02</i>	constant	Parameter set is invalid
<i>PS03</i>	constant	Parameter set device invalid
<i>PS31</i>	constant	Incompatible or unknown HW components have been found.
<i>Su02</i>	constant	One mains phase is missing

---

Display		Meaning
<i>USD1</i>	constant	User error 1
<i>USD2</i>	constant	User error 2



Detailed information on diagnostics using the »Engineer« and a description of possible error messages can be found in the chapter entitled "[Diagnostics & error management](#)".

( 145)

## 2.3.4 Menu structure

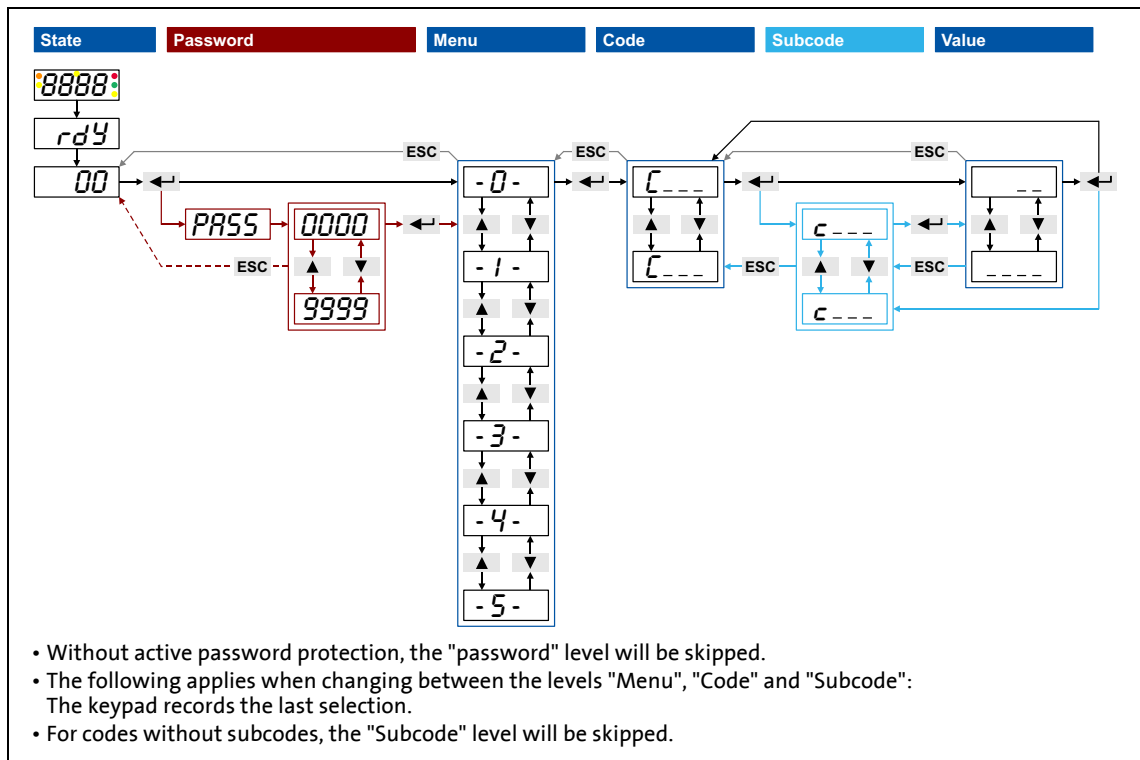

Menu	Info
-0-	Access to the parameters of the user menu. <ul style="list-style-type: none"> <li>The user menu of a device serves to create a selection of frequently used parameters to be able to access and change these parameters quickly. <a href="#">▶ User menu (22)</a></li> </ul>
-1-	Access to all drive parameters.
-2-	Access to parameters for quick commissioning with terminal control.
-3-	Access to parameters for quick commissioning with the integrated keypad.
-4-	Access to motor control parameters.
-5-	Access to diagnostic/display parameters.

**Note!**

When the password protection is activated and no password or a wrong password is entered, only the parameters of the user menu can be accessed using the integrated keypad. All other menus/parameters require the correct password.

[▶ Password protection \(23\)](#)

### 2.3.5 User menu

The user menu (menu -0-) contains a selection of frequently used parameters to be able to access and change these parameters quickly.

- The integrated keypad serves to change the preset parameter selection in [C517](#): Enter the codes the user menu is to contain into the subcodes c001 ...c020. When "0" is set, no entry is displayed in the user menu.
- The »Engineer« serves to configure the user menu on the **User menu** tab of the controller. Here, additional functions are available for loading and saving the parameter selection.

The user menu contains the following parameters:

Code	Subcode	Info	Lenze setting	
			Value	Unit
<a href="#">C051</a>	-	Display of actual speed value	-	rpm
<a href="#">C053</a>	-	Display of DC-bus voltage	-	V
<a href="#">C054</a>	-	Display of motor current	-	A
<a href="#">C061</a>	-	Display of heatsink temperature	-	°C
<a href="#">C137</a>	-	Display of device status	-	-
<a href="#">C011</a>	-	Reference speed	1500	rpm
<a href="#">C039</a>	c001	Fixed setpoint 1	40.0	%
	c002	Fixed setpoint 2	60.0	%
	c003	Fixed setpoint 3	80.0	%
<a href="#">C012</a>	-	Acceleration time - main setpoint	2.0	s
<a href="#">C013</a>	-	Deceleration time - main setpoint	2.0	s
<a href="#">C015</a>	-	V/f base frequency	50.0	Hz
<a href="#">C016</a>	-	Vmin boost	0.0	%
<a href="#">C022</a>	-	I <sub>max</sub> in motor mode	47.00	A
<a href="#">C120</a>	-	Motor overload threshold (I <sup>2</sup> xt)	100	%
<a href="#">C087</a>	-	Rated motor speed	1460	rpm
<a href="#">C099</a>	-	Display of firmware version	-	-

Highlighted in grey = display parameter



#### Note!

If the password protection is activated and no password or a wrong password is entered, only these parameters can be accessed with the integrated keypad.

▶ [Password protection](#) (📖 23)

### 2.3.6 Quick saving of all parameters at the push of a button

Keep the entry button pressed for 3 seconds to save all parameter settings safe against mains failure.

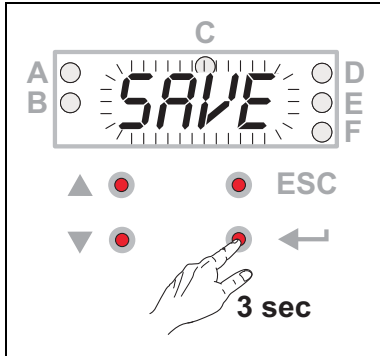

- During the saving process, "SAVE" is blinking in the display.
- After approximately 2 seconds, "SAVE" will disappear from the display and you can continue your work.

#### Related topics:

▶ [Save parameter settings](#) (49)

### 2.3.7 Password protection

The controller offers the option to protect the unauthorised access to the menu level by assigning a password. The following sections describe how to create, change, or delete the password protection and how to access the menu level via the password.

#### Enter password and confirm it

Carry out the steps if you want to create the password protection for the first time for e.g. a controller in default status:

Step		Info
1.	Mains on	After the mains has been switched on and the keypad self test has been completed, "00" is displayed
2.	↵	After pressing the enter key: Without password protection you have free access from here to all menus (and thus all parameters).
3.	▲	Select menu -1- (all parameters).
4.	↵	Confirm selection.
5.	▲	Select code <a href="#">C094</a> ("password").
6.	↵	Confirm selection. ("00" is now blinking, i.e. entry is possible.)
7.	▲	Set the desired password ("01" ... "9999").
8.	↵	Accept password.
9.	↵ (3 seconds)	Keep the entry button pressed for 3 seconds in order to save the parameter settings safe against mains failure.

### Change the existing password or deactivate the password protection

Step		Info
1.	Mains on	After the mains has been switched on and the keypad self test has been completed, "00" is displayed
2.	↵	After pressing the enter key and with existing password protection: "PASS" is displayed for a short time, then "0000".
3.	▲	Enter password.
4.	↵	Confirm entry.
5.	▲	Select menu -1- (all parameters).
6.	↵	Confirm selection.
7.	▲	Select code <a href="#">C094</a> ("password").
8.	↵	Confirm selection. (The existing password is now blinking, i.e. a change is possible.)
9.	▲ ▼	Change password: Set new password ("01" ... "9999"). Deactivate password protection: Set "00".
10.	↵	Accept setting.
11.	↵ (3 seconds)	Keep the entry button pressed for 3 seconds in order to save the parameter settings safe against mains failure.

### Access password-protected controller without knowing the password

When the password protection is activated and no password or a wrong password is entered, only the max. 20 parameters of the [user menu](#) can be accessed.

Step		Info
1.	Mains on	After the mains has been switched on and the keypad self test has been completed, "00" is displayed
2.	↵	After pressing the enter key and with existing password protection: "PASS" is displayed for a short time, then "0000".
3.	↵ or ▲ ↵	After direct confirmation of the value "0000": <ul style="list-style-type: none"> <li>Only the parameters of the <a href="#">user menu</a> can be selected.</li> </ul> When the wrong password has been entered and confirmed: <ul style="list-style-type: none"> <li>"Err" is displayed for a short time, then only the parameters of the <a href="#">User menu</a> can be selected.</li> </ul>

### Reach password-protected menu level with knowing the password

Step		Info
1.	Mains on	After the mains has been switched on and the keypad self test has been completed, "00" is displayed
2.	↵	After pressing the enter key and with existing password protection: "PASS" is displayed for a short time, then "0000".
3.	▲	Enter password.
4.	↵	When the correct password has been confirmed: You have free access from here to all menus (and thus all parameters).



# 3 Commissioning

## 3.1 Safety instructions with regard to commissioning

---

# 3 Commissioning

The 8400 BaseLine C controller is commissioned in one of the following ways:

- Commissioning with integrated keypad
  - If only a few parameters have to be adapted.
  - For test/demonstration purposes.
- Commissioning with PC/»Engineer«
  - The »Engineer« provides a comfortable access to all parameters of the 8400 BaseLine C controller and hence full flexibility in the commissioning process.

## 3.1 Safety instructions with regard to commissioning

### General safety instructions

In order to prevent injury to persons or damage to material assets

- before connecting the mains voltage, check
  - The wiring for completeness, short circuit, and earth fault
  - The "emergency stop" function of the entire system
  - The motor circuit configuration (star/delta) must be adapted to the output voltage of the controller
  - The in-phase connection of the motor
- Check the setting of the most important drive parameters before enabling the controller:
  - The V/f rated frequency must be adapted to the motor circuit configuration!
  - The drive parameters relevant for your application must be set correctly!
  - The configuration of the I/O terminals must be adapted to the wiring!
- Make sure that no speed setpoint is applied before controller enable.

### Safety instructions with regard to motor operation



#### **Danger!**

- For thermal reasons, continuous operation of self-ventilated motors at a low field frequency and rated motor current is not permissible!
  - If required, activate the [Brake resistor monitoring \(l2xt\)](#). (□ 106)
- With regard to the V/f base frequency ([C015](#)), observe the following difference to the controllers 8400 StateLine/HighLine/TopLine:  
For the 8400 BaseLine, the reference voltage for the V/f base frequency is the rated motor voltage ([C090](#)) according to motor nameplate (independent of the mains voltage on the supply side).

## 3.2

## Preparing the 8400 BaseLine for commissioning

**Danger!**

Take all the necessary safety precautions before you carry out the following commissioning steps and switch the device on!

▶ [Safety instructions with regard to commissioning](#) (📖 25)

## 1. Wiring the power connections

- Refer to the mounting instructions supplied with the drive controller to find help on how to correctly design the power connections to match the requirements of your device.

## 2. Wire the control connections

- The following shows the wiring for the Lenze setting.

Terminal	Function
<b>Analog input at X4</b> 	
<b>A1U</b>	Setpoint selection • Scaling: 10 V $\equiv$ 100 % $\equiv$ 1500 rpm (for 4-pole motor)

Terminal	Function
<b>Digital inputs at X4</b> 	
<b>RFR</b>	Controller enable: HIGH level Error reset: HIGH-LOW edge
<b>DI1</b>	Selection fixed setpoint 1 ... 3
<b>DI2</b>	
<b>DI3</b>	Request DC-injection braking (DCB)
<b>DI4</b>	Request change of direction of rotation

## 3. Inhibit the controller:

Set terminal X4/RFR to LOW level or open contact to terminal X4/12I .

## 4. Switch on voltage supply of the controller.

- Information on some operating states can be quickly obtained via the LED display of the integrated keypad. ▶ [LED status display](#) (📖 18)

When the green LED is blinking and the red LED is off, the controller is ready to start and you can continue with commissioning as required:

▶ [Commissioning with integrated keypad](#) (📖 27)

or

▶ [Commissioning with the »Engineer«](#) (📖 31)

### 3.3 Commissioning with integrated keypad

Only a few parameters need to be adapted for the drive. Afterwards, the drive application can be immediately controlled via the digital and analog inputs of the controller in the preset control mode "Terminals 0".



Information on how to use the integrated keypad can be found in the chapter entitled "[Internal Keypad](#)". (☞ 17)

#### Commissioning steps

In the following, commissioning of the controller using the integrated keypad is described step by step. Please process the chapters consecutively and execute all steps carefully. This procedure will help you to commission the controller quickly and as safe as possible:

- ▶ [Load Lenze setting](#)
- ▶ [Parameterise drive/application](#) (☞ 28)
- ▶ [Save parameter settings safe against mains failure](#) (☞ 29)
- ▶ [Enable controller and select speed](#) (☞ 30)

#### 3.3.1 Load Lenze setting

In order to achieve a defined device configuration, it is advisable to make sure that the device is in its original delivery state. For this purpose, the "Load Lenze setting" device command is available.

Step		Info
1.	Mains on	After the mains has been switched on and the keypad self test has been completed, "00" is displayed
2.	↵	After pressing the enter key: Without password protection you have free access from here to all menus (and thus all parameters).
3.	▲	Select menu -2-. • The menu -2- contains parameters for quick commissioning with terminal control.
4.	↵	Confirm selection.
5.	↵	Confirm first code <a href="#">C002</a> ("device commands") of the menu -2-.
6.	↵	Confirm subcode c001 ("load Lenze setting").
7.	▲	Set value "01" (≡ "Start").
8.	↵	Accept parameter setting to execute the "Load Lenze setting" device command.

### 3.3.2 Parameterise drive/application

The menu -2- of the integrated keypad contains all basic parameters to commission the drive/application "actuating drive speed" quickly and easily for a terminal control. When you set these parameters to suitable and sensible values, the controller can be operated properly.

Parameter	Lenze setting		Info
	Value	Unit	
<a href="#">C002/1</a> Load Lenze setting	0: Off / ready		Reset all parameters to the Lenze setting which are saved in the controller firmware.
<a href="#">C007</a> Select control mode	10: Terminals 0		▶ <a href="#">Terminal assignment of the control modes</a> (☞ 139)
<a href="#">C011</a> Reference speed	1500	rpm	All speed setpoint selections are provided in % and always refer to the reference speed set in <a href="#">C011</a> . The motor reference speed is given on the motor nameplate.
<a href="#">C012</a> Acceleration time - main setpoint	2.0	s	The setpoint is led via a ramp function generator with linear characteristic. The ramp function generator converts setpoint step-changes at the input into a ramp. ▶ <a href="#">L_NSet_1</a> (☞ 309)
<a href="#">C013</a> Deceleration time - main setpoint	2.0	s	
<a href="#">C015</a> V/f base frequency	50.0	Hz	▶ <a href="#">Adapting the V/f base frequency</a> (☞ 83)
<a href="#">C016</a> Vmin boost	0.0	%	▶ <a href="#">Adapting the Vmin boost</a> (☞ 84)
<a href="#">C022</a> Current limit (in motor mode)	47.00	A	▶ <a href="#">Optimising the I<sub>max</sub> controller</a> (☞ 85)
<a href="#">C087</a> Rated motor speed	1460	rpm	▶ <a href="#">Motor selection/Motor data</a> (☞ 65)
<a href="#">C089</a> Rated motor frequency	50	Hz	
<a href="#">C039/1</a> Fixed setpoint 1	40.0	%	A fixed setpoint for the setpoint generator can be activated instead of the main setpoint via the digital inputs DI1 and DI2. • The fixed setpoints are selected in [%] based on the reference speed ( <a href="#">C011</a> ). ▶ <a href="#">L_NSet_1</a> (☞ 309)
<a href="#">C039/2</a> Fixed setpoint 2	60.0	%	
<a href="#">C039/3</a> Fixed setpoint 3	80.0	%	
<a href="#">C051</a> Actual speed value	-	rpm	
<a href="#">C054</a> Current motor current	-	A	

Highlighted in grey = display parameter

#### More detailed information on the drive application:

- ▶ [Drive application](#) (☞ 121)
- ▶ [Interface description](#) (☞ 127)
- ▶ [Setting parameters \(short overview\)](#) (☞ 132)
- ▶ [Pre-assignment of the drive application](#) (☞ 133)
- ▶ [Terminal assignment of the control modes](#) (☞ 139)

### 3.3.3 Save parameter settings safe against mains failure

If parameter settings are changed in the controller, those changes will be lost after mains switching of the controller unless the settings have been saved explicitly.

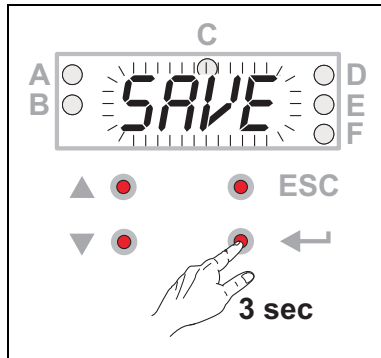

- Keep the entry button pressed for 3 seconds in order to save the parameter settings safe against mains failure.

 **Tip!**

In [C141](#), an automatic saving can be activated.  
▶ [Automatic saving of parameter changes](#) (49)

### 3.3.4 Enable controller and select speed



#### Note!

If the controller is enabled at power-on and the auto-start option is activated in [C142](#) "Inhibit at power-on" (Lenze setting), the controller remains in the "[ReadyToSwitchON](#)" state.

For changing to the "[SwitchedON](#)" state, first deactivate the controller enable: Set terminal X4/RFR to LOW level or open contact to terminal X4/12I.

When the controller is in the "[SwitchedON](#)" state:

1. Enable controller:  
Set terminal X4/RFR to HIGH level or close contact to terminal X4/12I n.
2. Select speed:
  - In the "Terminals 0" by selecting a voltage at the analog input or by selecting a fixed setpoint via the digital inputs DI1/DI2.

DI1	DI2	Speed selection
LOW	LOW	The setpoint speed is selected via the analog input 1 • Scaling: 10 V $\equiv$ 100 % $\equiv$ reference speed ( <a href="#">C011</a> )
HIGH	LOW	The fixed setpoint 1 ( <a href="#">C039/1</a> ) is used as setpoint speed. • Lenze setting: 40 % of the reference speed ( <a href="#">C011</a> )
LOW	HIGH	The fixed setpoint 2 ( <a href="#">C039/2</a> ) is used as setpoint speed. • Lenze setting: 60 % of the reference speed ( <a href="#">C011</a> )
HIGH	HIGH	The fixed setpoint 3 ( <a href="#">C039/3</a> ) is used as setpoint speed. • Lenze setting: 80 % of the reference speed ( <a href="#">C011</a> )



#### Note!

Observe the actual speed value (display in [C051](#)) as well as the [LED status display](#) and [Display messages](#) indicated in the integrated keypad.



#### Tip!

More control functions in the "Terminals 0" control mode:

- DI3: HIGH level  $\equiv$  request DC-injection braking
- DI4: HIGH level  $\equiv$  request change of direction of rotation

### 3.4 Commissioning with the »Engineer«

Commissioning with the »Engineer« is suited for every drive task and in particular for drive tasks with more demanding requirements/more comprehensive parameter setting.

In the following, commissioning of the controller is described step by step. Please process the chapters consecutively and execute all steps carefully. This procedure will help you to commission the controller quickly and as safe as possible:

- ▶ [Preconditions for commissioning with the »Engineer«](#)
- ▶ [Creating an »Engineer« project & going online](#)
- ▶ [Parameterise drive/application](#)
- ▶ [Save parameter settings safe against mains failure](#)
- ▶ [Enable controller and select speed](#)

#### 3.4.1 Preconditions for commissioning with the »Engineer«

For commissioning, you need

- a PC that satisfies the following requirements:
  - processor with 1.4 GHz or higher
  - at least 512 MB RAM and 650 MB free hard disc space
  - Microsoft® Windows® 2000 operating system (from service pack 2 onwards) or Windows® XP
- the Lenze »Engineer« PC software
- a connection to the controller, e.g. via USB diagnostic adapter:
  - Connect the USB diagnostic adapter to the diagnostic interface X6.
  - Connect the USB diagnostic adapter to the PC via a free USB port.



#### Tip!

How to obtain/update the L-force »Engineer« software:

- **Download from the Internet:**  
The full version of the »Engineer StateLevel« is provided free of charge. Current software can be found on the Internet in the "Services & Downloads" area under <http://www.Lenze.com>.
- **Requesting the CD**  
You can also request the L-force »Engineer« separately on CD free of charge at your Lenze representative. See the "About Lenze" area on our homepage for e.g. the corresponding German address.

---

### 3.4.2 Creating an »Engineer« project & going online



You can find detailed information on the general use of the »Engineer« in the online help which you can call with **[F1]**.

- In the "Working with projects" chapter, all options of the *start-up wizard* are described to create a new »Engineer« project.

The following steps describe the standard procedure of creating a project using the **Select component from catalogue** option. Here, you select the single components (controller, motor, etc.) from selection lists.

1. Start the »Engineer«.
2. Create a new project by means of the *Start-up wizard* and the **Select component from catalogue** option:
  - In the **Component** dialog step, select the 8400 BaseLine C controller.
  - Select the other components (motor/gearbox) to be added to the project in the **Other components** dialog step.
3. Go online.
  - After a successful connection to the controller, the following status is displayed in the *Status line*:



4. Download parameter set.
  - This command serves to overwrite the current parameter settings in the controller by parameter settings of the »Engineer« project.



### 3.4.3 Parameterise drive/application

Go to *Workspace* and change to the **Application parameters** tab.

#### Parameterising the motor control

On the left, the parameters of the motor control are arranged:

1. Go to the **1 Motor control (C006)** list field and select the required motor control.



#### Note!

In the Lenze setting, the V/f characteristic control (VFCplus) with linear characteristic is set in [C006](#) as motor control.

- The V/f characteristic control (VFCplus) is an motor control for standard frequency inverter applications based on a simple and robust control process which is suitable for the operation of machines with linear or square-law load torque characteristic (e.g. fans).
- The parameter settings have been set in advance in such a way that, if the drive controller and 50 Hz asynchronous machine match each other in terms of performance, the drive controller is immediately ready for operation without any further parameter setting work and the motor works satisfactorily.

## 2. Adapting the parameters of the motor control:

Parameter	Lenze setting		Info
	Value	Unit	
<b>2</b> V/f base frequency (C015)	50.0	Hz	▶ <a href="#">Adapting the V/f base frequency</a> (📖 83)
<b>3</b> I <sub>max</sub> in motor mode (C022)	47.00	A	▶ <a href="#">Optimising the I<sub>max</sub> controller</a> (📖 85)
<b>4</b> V <sub>min</sub> boost (C016)	0.0	%	▶ <a href="#">Adapting the V<sub>min</sub> boost</a> (📖 84)

**Tip!**

Also check the other information on the nameplate against the motor data set in the drive controller. You can find further information in the chapter entitled "[Motor selection/Motor data](#)". (📖 65)

**Recommendations for the following application cases:**

- If the controller and motor differ greatly from each other in terms of performance: Set the I<sub>max</sub> limit (in motor mode) in [C022](#) to double the rated motor current.
- If a higher starting torque is required:  
In idle state of the motor, set the V<sub>min</sub> boost in [C016](#) in such a way that the rated motor current flows at a field frequency of f = 3 Hz (display in [C058](#)).
- If a high torque is to be available at low speed and without a feedback: Select the "sensorless vector control" (SLVC) in [C006](#) as motor control.

### Parameterise application

On the right of the **Application parameters** tab, the parameters of the application are arranged:

1. Select the required control mode in the **1 Control mode (C007)** list field.
  - The corresponding wiring diagram is displayed in a pop-up window if you click the **?** button right to the list field.
  - For a detailed description, see chapter entitled "[Terminal assignment of the control modes](#)". ([□ 139](#))
2. Optional: Use process controller.
  - For this purpose select the required operating mode in the **2 L\_PCTRL\_1: Operating mode (C242)** list field.
  - For a detailed description see the function block [L\\_PCTRL\\_1](#). ([□ 312](#))
  - The parameterisation dialog of the process controller can be accessed via the **Process controller** button.
3. Optional: Use motor potentiometer.
  - For this purpose, select "1: On" in the **3 L\_MPot\_1: Use (C806)** list field.
  - For a detailed description see the function block [L\\_MPot\\_1](#). ([□ 305](#))
  - The parameterisation dialog of the process controller can be accessed via the **Motor potentiometer** button.

## 4. Adapt parameters of the application:

Parameter	Lenze setting		Info
	Value	Unit	
<b>4</b> Accel. time - main setpoint (C012)	2.0	s	The setpoint is led via a ramp function generator with linear characteristic. The ramp function generator converts setpoint step-changes at the input into a ramp. ▶ <a href="#">L_NSet_1</a> (📖 309)
<b>5</b> Decel. time - main setpoint (C013)	2.0	s	
<b>6</b> Reference speed (C011)	1500	rpm	All speed setpoint selections are provided in % and always refer to the reference speed set in <a href="#">C011</a> . The motor reference speed is given on the motor name-plate.
<b>7</b> Deceleration time - quick stop (C105)	5.0	s	When "quick stop" is requested, the motor control is decoupled from the setpoint selection and within the deceleration time parameterised in <a href="#">C105</a> , the motor is brought to a standstill in ( $n_{act} = 0$ ). ▶ <a href="#">Activate/Deactivate quick stop</a> (📖 50)
<b>8</b> Fixed setpoint 1 (C039/1)	40.0	%	A fixed setpoint for the setpoint generator can be activated instead of the main setpoint via the digital inputs DI1 and DI2. • The fixed setpoints are selected in [%] based on the reference speed ( <a href="#">C011</a> ). ▶ <a href="#">L_NSet_1</a> (📖 309)
<b>9</b> Fixed setpoint 2 (C039/2)	60.0	%	
<b>10</b> Fixed setpoint 3 (C039/3)	80.0	%	

**Tip!**

- Via the **Signal flow** button, you get one dialog level lower to the signal flow of the application with further parameterisation opportunities. See chapter entitled "[Parameterisation dialog](#)". (📖 122)
- The preconfigured I/O connection in the selected control mode can be changed via configuration parameters. See chapter entitled "[User-defined terminal assignment](#)". (📖 114)

**More detailed information on the drive application:**

- ▶ [Drive application](#) (📖 121)
- ▶ [Interface description](#) (📖 127)
- ▶ [Setting parameters \(short overview\)](#) (📖 132)
- ▶ [Pre-assignment of the drive application](#) (📖 133)
- ▶ [Terminal assignment of the control modes](#) (📖 139)

### 3.4.4 Save parameter settings safe against mains failure

In order that parameter settings made in the device do not get lost by means of mains switching, you must save the parameter set explicitly safe against mains failure in the device.

-  Save parameter set

### 3.4.5 Enable controller and select speed



#### Note!

If the controller is enabled at power-on and the auto-start option is activated in [C142](#) (Lenze setting), the controller remains in the "[ReadyToSwitchON](#)" state (display in [C137](#)).

For changing to the "[SwitchedON](#)" state, first deactivate the controller enable: Set terminal X4/RFR to LOW level or open contact to terminal X4/12I.

When the controller is in the "[SwitchedON](#)" state:

1. Enable controller:  
Set terminal X4/RFR to HIGH level or close contact to terminal X4/12I n.
2. Select speed:
  - In the "Terminals 0" by selecting a voltage at the analog input or by selecting a fixed setpoint via the digital inputs DI1/DI2.

DI1	DI2	Speed selection
LOW	LOW	The setpoint speed is selected via the analog input 1 • Scaling: 10 V $\equiv$ 100 % $\equiv$ reference speed ( <a href="#">C011</a> )
HIGH	LOW	The fixed setpoint 1 ( <a href="#">C039/1</a> ) is used as setpoint speed. • Lenze setting: 40 % of the reference speed ( <a href="#">C011</a> )
LOW	HIGH	The fixed setpoint 2 ( <a href="#">C039/2</a> ) is used as setpoint speed. • Lenze setting: 60 % of the reference speed ( <a href="#">C011</a> )
HIGH	HIGH	The fixed setpoint 3 ( <a href="#">C039/3</a> ) is used as setpoint speed. • Lenze setting: 80 % of the reference speed ( <a href="#">C011</a> )



#### Note!

Observe the actual speed value (display in [C051](#)) as well as the [LED status display](#) and [Display messages](#) indicated in the keypad.



#### Tip!

More control functions in the "Terminals 0" control mode:

- DI3: HIGH level  $\equiv$  request DC-injection braking
- DI4: HIGH level  $\equiv$  request change of direction of rotation

### Diagnostics options

When the »Engineer« is used, trouble during commissioning can be detected and eliminated conveniently. Proceed as follows:

- Check whether error messages appear in the »Engineer«.
  - You can find a description of each possible message in the chapter entitled "[Diagnostics & error management](#)". (□ 145)
- Check the input terminals for their corresponding setpoints.
  - The **Terminal assignment** tab displays the current input/output signals.
- Check the signal flow of the application.
  - To do this, open the **Application Parameters** tab and click on the **Signal flow** button. The signal flow which is then shown enables a view of the setpoints being applied and their processing.

### 3.5 PC manual control

This function extension is available as of version 03.03.00 and is supported by the »Engineer« as of version 2.14!

For test and demonstration purposes, PC manual control can be used to manually control various drive functions via the »Engineer« when an online connection has been established.

#### Supported drive functions:

- Speed control (follow a speed setpoint)
- Activate/Deactivate quick stop

#### More control functions:

- Reset of error message
- Set digital/analog outputs (in preparation)

#### Diagnostic functions:

- Display of the actual speed value and motor current (in a temporal characteristic)
- Display of the current device state
- Display of the status determining error
- Display of the status of the digital/analog inputs (in preparation)

#### 3.5.1 Activating PC manual control



#### Stop!

PC manual control must be explicitly activated by the user.

If PC manual control is activated, the controller is inhibited via device command ([C002/16](#)) first.



#### Note!

##### For activated PC manual control:

The online connection between the PC and the controller is monitored by the controller.

- If the online connection is interrupted for longer than 2 s, error response "Fault" is triggered, i.e. the motor becomes torqueless and is coasting unless it already is at standstill.

PC manual control transmits all required control and setpoint signals to the motor interface.

- The application is now decoupled from these interfaces, but will be processed as before and remains unchanged.
- It does not matter what type of motor control is set in [C006](#).

**How to activate PC manual control:**

1. If an online connection to the controller has not been established yet:
  -  Go online.
2. Go to *Workspace* and change to the **Application parameters** tab.
3. Go to the *Overview* dialog level and click the **PC manual control** button.
  - The following safety note is displayed first:

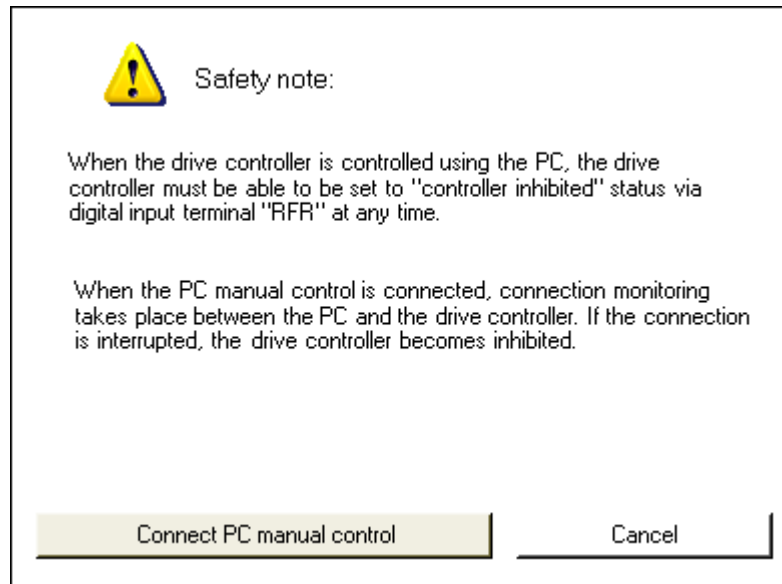

- Click the **Cancel** button to abort the action and close the dialog box.
4. To acknowledge the note and activate PC manual control:
    - Click the **Connect PC manual control** button.
    - The controller is inhibited via device command ([C002/16](#)).
    - The *PC manual control* operator dialog is displayed.



### PC manual control operator dialog

On the left-hand side, the *PC manual control* operator dialog includes control elements which serve to select various control functions. On the right-hand side, setpoint and status displays are provided for diagnostic purposes:

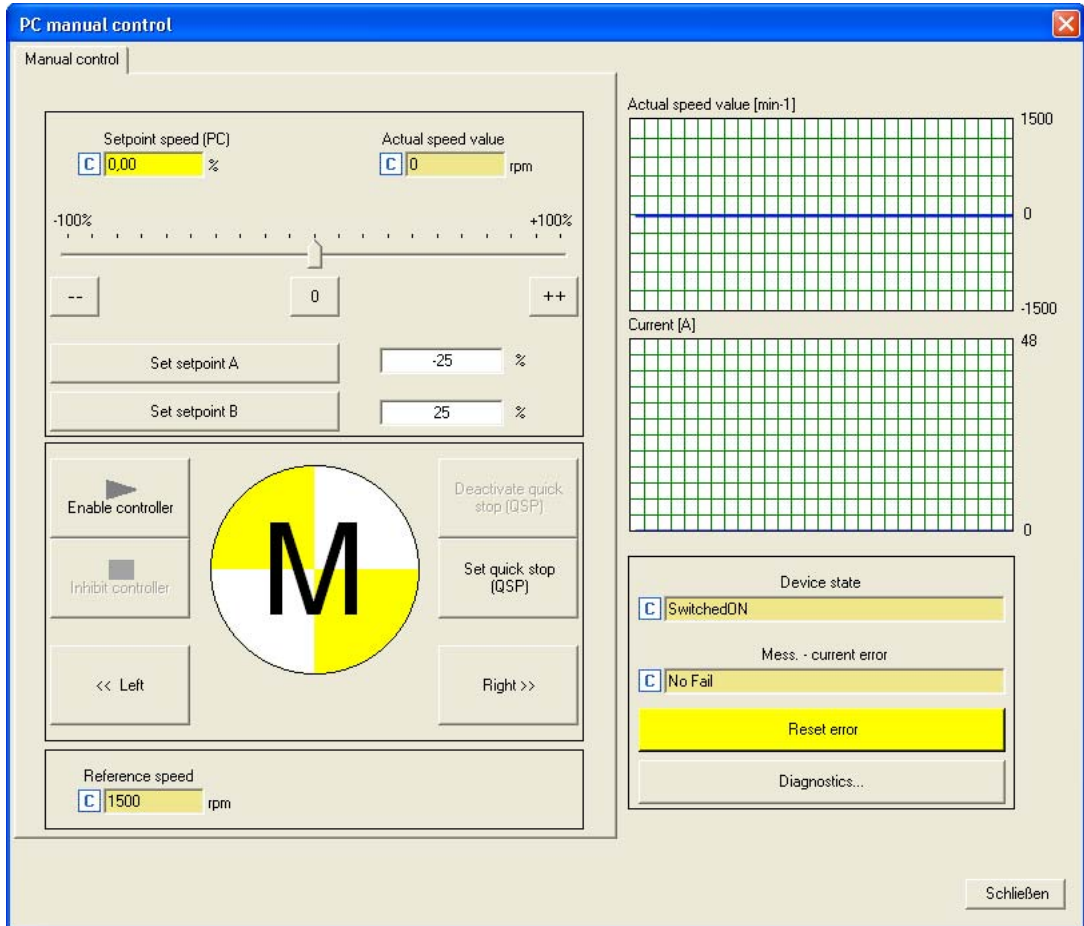

### Note!

PC manual control can be exited any time by clicking the **Close** button.

If you exit PC manual control or change to another tab, the controller is inhibited via device command ([C002/16](#)), i.e. the motor becomes torqueless and is coasting unless it already is at standstill.

The execution of the various functions is described in the following chapters.

## 3.5.2 Speed control

Via the **Speed control** tab, simply make the drive rotate in the "Speed follower" operating mode without the need to set control parameters or feedback systems:

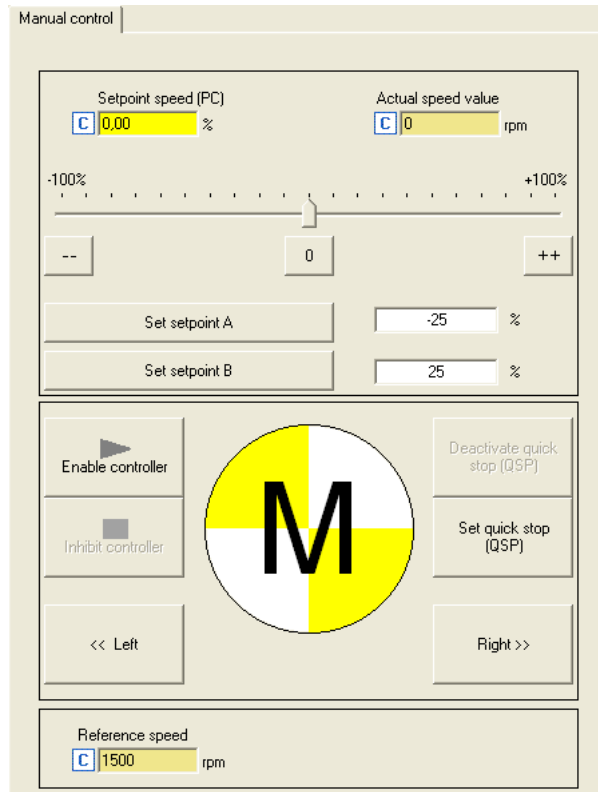

#### How to make the motor rotate in its most basic way:

- Set the desired speed setpoint in [%] based on the reference speed, e.g. directly in the **Setpoint PC** input field or via the slider.
  - Via the -- / 0 / ++ buttons, the currently set speed setpoint can be reduced/increased in steps of 10 percent or set to zero.
  - Via the **Set setpoint A/B** buttons, the speed setpoint can be set to a previously set constant value A/B.
- To start the speed follower:

Enable the controller via the **Enable controller** button.

  - Please observe that the controller will not be enabled if other sources of controller inhibit (e.g. terminal RFR) are active.
  - The enabled controller is now following the selected speed setpoint.
  - To avoid shocks or overload in case of great setpoint changes, the speed setpoint follows a linear ramp generator with adjustable acceleration/deceleration time.
  - Via the **Inhibit controller** button, the controller can be inhibited again, i.e. the motor becomes torqueless and is coasting unless it already is at standstill.

**Further functions:**

- If the **Set quick stop (QSP)** button is clicked, the motor is braked to a standstill within the deceleration time parameterised in [C105](#).
  - Via the **Deactivate quick stop (QSP)** button, the quick stop can be deactivated.
- Via the << **Left** and **Right** >> buttons, the direction of rotation can be changed.

### 4 Device control (DCTRL)

This chapter provides information on the internal device control as well as the device commands which can be executed via the subcodes of [C002](#).

- The device control causes the controller to take defined device states.
- The device control provides a multitude of status information in many ways:
  - Optically via the [LED status display](#) of the integrated keypad. ([18](#))
  - As text messages in the [Logbook](#). ([149](#))
  - As process signals via the outputs of the [LS\\_DriveInterface](#) system block. ([325](#))
  - Via diagnostic / display parameters which are included in the »Engineer« parameter list as well as in the **Diagnostics** category in the keypad.



#### Note!

The device states of the controller are based on the operating states of the CiA402 standard. ▶ [Device states](#) ([53](#))



### How to get to the parameterisation dialog of the device control:

1. »Engineer« Go to the *Project view* and select the 8400 BaseLine C controller.
2. Go to *Workspace* and change to the **Application parameters** tab.
3. Go to the *Overview* dialog level and click the **Drive interface** button.

### Parameterisation dialog in the »Engineer«

The parameterisation dialog shows the input / output signals and the internal signal flow of the [LS\\_DriveInterface](#) system block which displays the device control in the application:

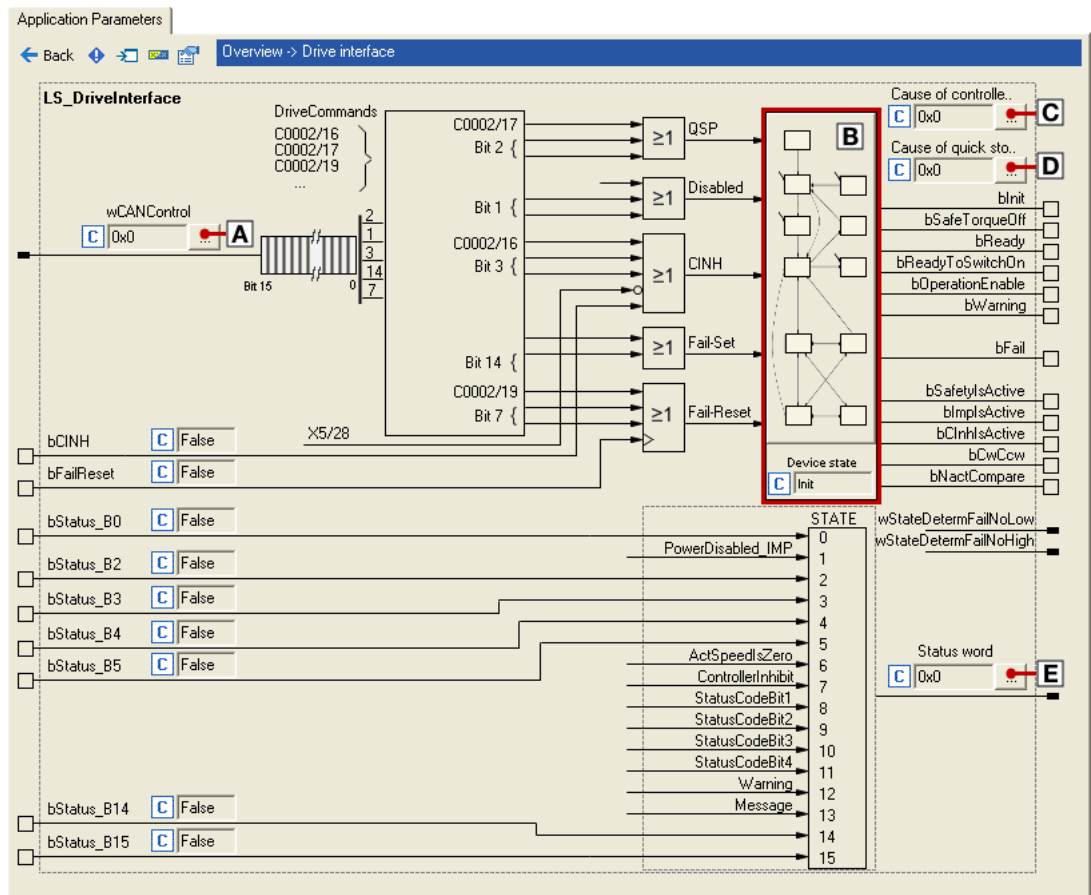

Range / Meaning	Display parameter
<b>A</b> Display of the CAN control word	<a href="#">C136/2</a>
<b>B</b> Display of the internal state machine and the current device state	<a href="#">C137</a>
<b>C</b> Display of all active sources of a controller inhibit	<a href="#">C158</a>
<b>D</b> Display of all active sources of a quick stop	<a href="#">C159</a>
<b>E</b> Display of the status word of the device control	<a href="#">C150</a>

# 4 Device control (DCTRL)

## 4.1 Device commands

---

### 4.1 Device commands

The following subchapters describe the device commands which are provided in the subcodes of [C002](#) 002 and can be carried out using the keypad or, alternatively, the »Engineer« when an online connection has been established.

The device commands serve to directly control the controller, to organise parameter sets, and to call diagnostic services.

Regarding the execution of the device commands, a distinction is drawn between:

- Device commands which have an immediate effect on control (e.g. "Activate quick stop")
  - After being called in [C002/x](#), these device commands provide static status information ("On" or "Off").
- Device commands with longer execution durations (several seconds)
  - After being called in [C002/x](#), these device commands provide the status information "Work in progress".
  - The execution of the device command has not finished successfully until the "Off / ready" status information is provided in [C002/x](#).
  - In the event of an error, the "Action cancelled" status information is provided in [C002/x](#). In this case, further details can be obtained from the status of the device command executed last which is displayed in [C003](#).



#### Note!

- Before activating the device commands through a master control, please wait for the "ready" message of the controller.
- The device will reject a write process to [C002/x](#) if the value is >1 and issue an error message.
- [C003](#) displays the status of the device command executed last..



Detailed information on the various device commands can be found in the following subchapters.

- Before you follow the instructions given therein, ensure that you have selected the controller in the *Project view*.

### Device commands - short overview



C00002 Subcode:	Device command	Controller inhibit required	Status information
1	<a href="#">Load Lenze setting</a>	●	dynamic
2	<a href="#">Loading parameter settings</a>	●	dynamic
7	<a href="#">Save parameter settings</a>		dynamic
12	<a href="#">Import EPM data</a>		static
16	<a href="#">Enable/Inhibit controller</a>		static
17	<a href="#">Activate/Deactivate quick stop</a>		static
19	<a href="#">Reset error</a>		static
21	<a href="#">Delete logbook</a>		static
23	<a href="#">Identify motor parameters</a>	●	dynamic
26	<a href="#">CAN reset node</a>		static

\* Subcodes which are not listed are reserved for future extensions.

### Activate device command

When an online connection has been established, you can simply use the »Engineer« to activate a device command by selecting the corresponding option from the **Parameter** tab in [C002/x](#) ("0: Off" or "1: On / start").

- Alternatively, the device command can also be activated via e.g. keypad or through a master control by writing to [C002/x](#).
- Some of the frequently used device commands (such as "Save parameter settings") can also be executed via *toolbar* icons of the »Engineer« when an online connection has been established:

Symbol	Function
	Enable controller
	Inhibit controller
	Save parameter settings



### Note!

Device commands that can be executed via the *toolbar* of the »Engineers« always affect the element currently selected in the *Project view* including all subelements!

- If no controller, but e.g. a system module is selected in the *Project view*, the corresponding device command will be activated in all lower-level controllers having an online connection with the »Engineer«.

Before the desired action is carried out, a confirmation prompt appears first, asking whether the action is really to be carried out.

## 4 Device control (DCTRL)

### 4.1 Device commands

---

#### 4.1.1 Load Lenze setting

The [C002/1](#) = "1: : On / start" device command resets the parameters to the Lenze setting which are saved in the controller firmware.

- Can only be executed if the controller is inhibited; otherwise, the feedback [C002/1](#) = "6: No access - controller inhibit" will be returned.
- All parameter changes which have been carried out after the last time the parameter settings were saved will be lost!
- This device command has an effect on the settings of the parameters of the operating system, application and module.



##### How to load the Lenze setting:

1. If the controller is enabled, it must be inhibited, e.g. by executing the "Enable/Inhibit controller" device command" ([C002/16](#) = "0: Off / ready").
2. Execute the "Load Lenze setting" device command  
[C002/1](#) = "1: On / start"

The load process may take a couple of seconds. After the device command has been called in [C002/1](#) a dynamic status information ("Work in progress" → "Off / ready") is returned.

#### 4.1.2 Loading parameter settings

The [C002/2](#) = "1: On / start" device command reloads all parameters from the memory module to the controller.

- Can only be executed if the controller is inhibited; otherwise, the feedback [C002/2](#) = "6: No access - controller inhibit" will be returned.
- All parameter changes which have been carried out after the last time the parameter settings were saved will be lost!
- This device command has an effect on the settings of the parameters of the operating system, application and module.



##### Note!

When the device is switched on, all parameters are automatically loaded from the memory module to the main memory of the controller.



##### How to reload the starting parameter settings from the memory module:

1. If the controller is enabled, it must be inhibited, e.g. by executing the "Enable/Inhibit controller" device command ([C002/16](#) = "0: Off / ready").
2. Execute the "Load Lenze setting" device command:  
[C002/2](#) = "1: On / start"

The load process may take a couple of seconds. After the device command has been called in [C002/2](#) a dynamic status information ("Work in progress" → "Off / ready") is returned.



### 4.1.3 Save parameter settings

If parameter settings are changed in the controller, those changes will be lost after mains switching of the controller unless the settings have been saved explicitly.

You have various opportunities to prevent a data loss by saving the parameter settings in the memory module:

- [Quick saving of all parameters at the push of a button](#) (📄 23)
- [Automatic saving of parameter changes](#)
- [Manual saving of parameter settings](#)



#### Note!

How to prevent a data loss:

- Do not switch off the supply voltage during the saving process.
- Only unplug the memory module if the device is switched off.

#### Automatic saving of parameter changes



#### Stop!

Activating this function is not permissible if parameters are changed very frequently (e.g. in case of cyclic writing of parameters via a bus system).

The maximum service life of the memory module amounts to one million writing cycles. Make sure that this value will not be reached.

When you set the selection "1: Active" in [C141/1](#), the automatic saving function is activated and every parameter change is automatically saved in the memory module. Thus, manual saving of parameter settings is not required anymore.

#### Manual saving of parameter settings

The [C002/7](#) = "1: On / start" device command saves the current parameter settings safe against mains failure to the memory module of the controller.

## 4 Device control (DCTRL)

### 4.1 Device commands

---

#### 4.1.4 Import EPM data

The [C002/12](#) = "1: On / start" device command activates the automatic import of parameters from the memory module after the error message "PS04: Par.set incompatible".

#### 4.1.5 Enable/Inhibit controller



The [C002/16](#) = "1: On / start" device command enables the controller, provided that no other source of a controller inhibit is active.

The [C002/16](#) = "0: : On / start" device command enables the controller, provided that no other source of a controller inhibit is active.

- The motor becomes torqueless and coasts down.
- When the controller is inhibited, the status output *bClnhActive* of the [LS\\_DriveInterface](#) system block is set to TRUE.
- When the controller inhibit request is reset, the drive synchronises to the actual speed. For this purpose,
  - If the flying restart circuit is activated in [C990](#), the flying restart function parameterised in [C991](#) is used for the synchronisation to the rotary or standing drive. ▶ [Flying restart function](#) (94)



#### Tip!

- The controller can also be enabled or inhibited via the  and  toolbar icons.
- [C158](#) provides a bit coded representation of all active sources/triggers of a controller inhibit.

#### 4.1.6 Activate/Deactivate quick stop

The [C002/17](#) = "1: On / start" device command activates the quick stop function, i.e. the motor control is separated from the setpoint selection, and within the deceleration time parameterised in [C105](#) the motor is brought to a standstill ( $n_{act} = 0$ ).

Parameter	Info	Lenze setting	
		Value	Unit
<a href="#">C105</a>	Deceleration time - quick stop	2.000	s

- A pulse inhibit (CINH) is set if the "Auto-DCB" function has been activated via [C019](#).

The [C002/17](#) = "0: Off / ready" device command deactivates the quick stop again, provided that no other source of a quick stop is active.



#### Tip!

[C159](#) provides a bit coded representation of all active sources/triggers of a quick stop.

## 4 Device control (DCTRL)

### 4.1 Device commands

---

#### 4.1.7 Reset error

The [C002/19](#) = "1: On / start" device command acknowledges an existing error message if the error cause has been eliminated and thus the error is not pending anymore.

- After resetting the current error, further errors may be pending which must be reset as well.
- The last 8 errors are displayed in [C168](#).



#### Tip!

An error message can also be acknowledged by activating the **Reset error** button in the **Diagnostics** tab.

In the Lenze setting, switching RFR also causes an error acknowledgement (see configuration parameter [C701/2](#)).

Detailed information on error messages can be found in the chapter entitled "[Diagnostics & error management](#)". ([📖 145](#))

#### 4.1.8 Delete logbook

The [C002/21](#) = "1: On / start" device command deletes all logbook entries.



#### Tip!

Click the **Logbook** button in the **Diagnostics** tab to display the logbook in the »Engineer«.

In the *Logbook* dialog box, it is also possible to delete all logbook entries by clicking the **Delete** button.

Detailed information on the logbook can be found in the chapter entitled "[Diagnostics & error management](#)". ([📖 145](#))

#### 4.1.9 Identify motor parameters

The [C002/23](#) = "1: On / start" device command performs automatic identification of the motor parameters.

- The device command is only executed when the drive controller is in the "[SwitchedON](#)" state.
- In order to identify the motor parameters, the controller must be enabled after this device command.
  - After that it changes to the "[MotorIdent](#)" device state.
  - After the execution of the identification, it changes back to the "[SwitchedON](#)" device state.



#### Tip!

Detailed information on automatic identification of motor parameters can be found in the "[Automatic motor data identification](#)" subchapter on motor control (MCTRL). ([📖 70](#))

## 4 Device control (DCTRL)

### 4.1 Device commands

---

#### 4.1.10 CAN reset node

The [C002/26](#) = "1: On / start" device command reinitialises the CAN interface which is required after e.g. changing the data transfer rate, the node address, or identifiers..



General information on the CAN interface can be found in the chapter entitled "[System bus "CAN on board"](#)". ([169](#))

# 4 Device control (DCTRL)

## 4.2 Device states

### 4.2 Device states

The state machine causes the controller to take defined states:

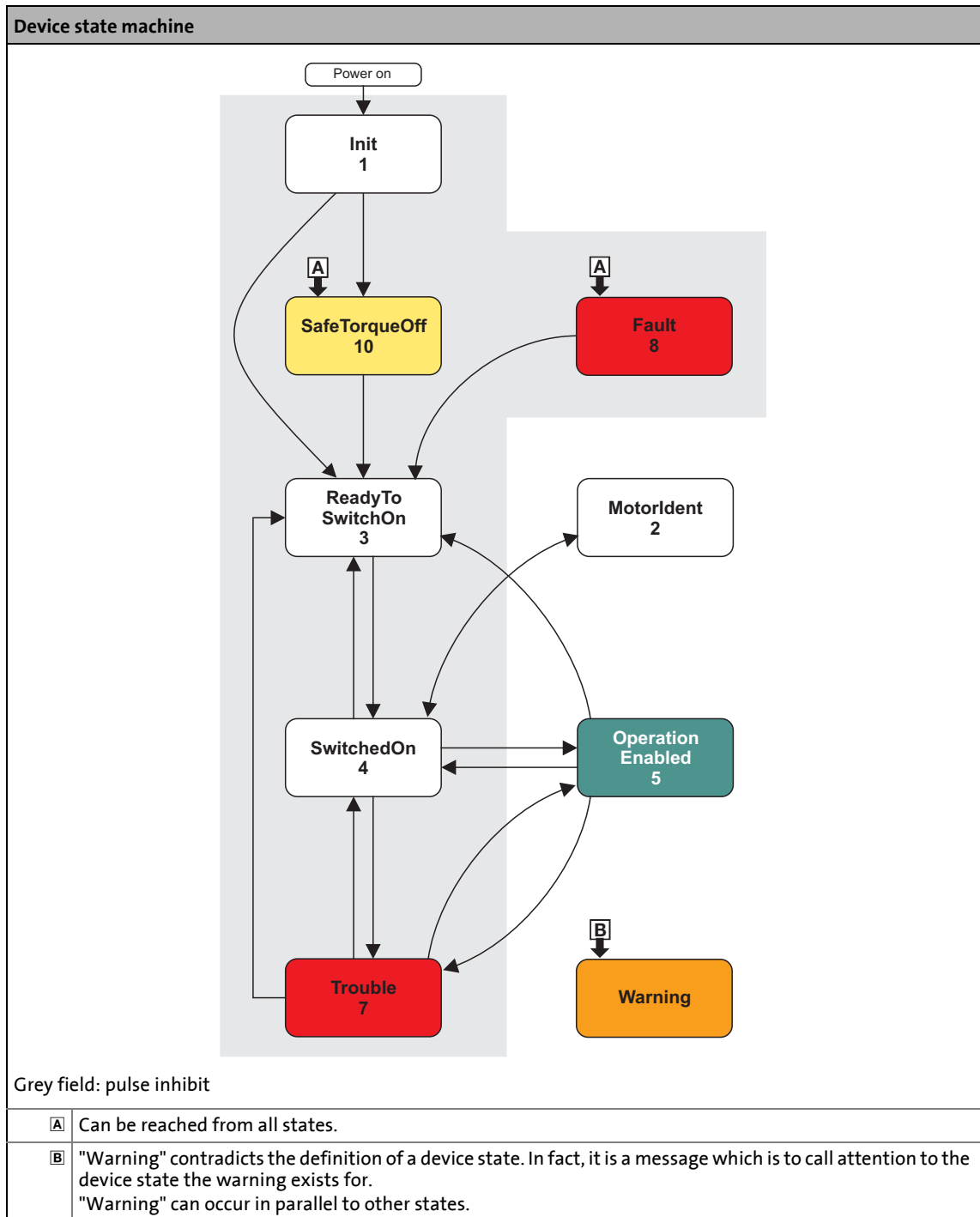

- The arrows between the device states mark the points where the possible device states begin and end.
- The digits stand for the state ID (see table below).

# 4 Device control (DCTRL)

## 4.2 Device states

- The change from one state to another is done in a 1 ms cycle. If, at the same time, several state change requests exist, the state with the higher priority is processed first (see the following table).
- [C137](#) displays the current device state.
- [C150](#)(status word) provides a bit coded representation of the current device state via bits 8 ... 11 (see table below).

ID	Device state (Display in <a href="#">C137</a> )	Priority	Status bits (display in <a href="#">C150</a> )				Meaning
			Bit 11	Bit 10	Bit 9	Bit 8	
0	-(reserved)	-	0	0	0	0	-
1	<a href="#">Init</a>	-	0	0	0	1	Initialisation is active
2	<a href="#">MotorIdent</a>	-	0	0	1	0	Motor parameter identification is active
3	<a href="#">ReadyToSwitchON</a>	Prio 4	0	0	1	1	Device is ready to start
4	<a href="#">SwitchedON</a>	Prio 3	0	1	0	0	Device is switched on
5	<a href="#">OperationEnabled</a>	Prio 1	0	1	0	1	Operation
6	-(reserved)	-	0	1	1	0	-
7	<a href="#">Trouble</a>	Prio 2	0	1	1	1	Trouble is active
8	<a href="#">Fault</a>	Prio 6	1	0	0	0	Fault is active
9	-(reserved)	-	1	0	0	1	-
10	<a href="#">SafeTorqueOff</a>	Prio 5	1	0	1	0	Safe torque off is active
11	-(reserved)	-	1	0	1	1	-
...	...	...	...				...
15	-(reserved)	-	1	1	1	1	-

[4-1] Device states, priorities, and meaning of the status bits in the status word

# 4 Device control (DCTRL)

## 4.2 Device states

---

### 4.2.1 Init

LED DRIVE READY	LED DRIVE ERROR	Display in <a href="#">C137</a>	Display in status word 1 ( <a href="#">C150</a> )			
			Bit 11	Bit 10	Bit 9	Bit 8
OFF	OFF	Init	0	0	0	1

In the "Init" device status

- is the controller directly after the supply voltage is switched on.
- the operating system is initialised.
- all device components (memory module, power section, etc.) are identified.
- the parameters are read out of the memory module.
- it is checked whether the DC-bus voltage is within the tolerance zone and the precharge relay is closed.
- the inverter is inhibited, i.e., there is no voltage output at the motor terminals.
- the communication via CAN and diagnostic interface does not work yet.
- the application is not yet processed.
- the monitoring mode is not yet active.
- the controller cannot be parameterised yet and no device commands can be carried out yet.



#### Note!

If the initialisation is completed, it changes automatically to the "[ReadyToSwitchON](#)" device state.

# 4 Device control (DCTRL)

## 4.2 Device states

### 4.2.2 MotorIdent

LED DRIVE READY	LED DRIVE ERROR	Display in <a href="#">C137</a>	Display in status word 1 ( <a href="#">C150</a> )			
			Bit 11	Bit 10	Bit 9	Bit 8
	OFF	MotorIdent	0	0	1	0

In the "MotorIdent" device state

- is the controller when being in the "[SwitchedON](#)" state and having activated the "[Identify motor parameters](#)" device command and being enabled.
- the application remains active.
- all system interfaces (IO, bus systems, etc.) remain active.
- error monitoring remains active
- the inverter is controlled independently of the setpoint sources.



#### Stop!

During motor parameter identification, the controller does not respond to setpoint changes or control processes, (e.g. speed setpoints, quick stop, torque limitations).

After the motor parameter identification is completed, the state changes back to "[SwitchedON](#)".



#### Tip!

Detailed information on motor parameter identification can be found in the "[Automatic motor data identification](#)" subchapter on motor control. ([70](#))

### 4.2.3 SafeTorqueOff

LED DRIVE READY	LED DRIVE ERROR	Display in <a href="#">C137</a>	Display in status word 1 ( <a href="#">C150</a> )			
			Bit 11	Bit 10	Bit 9	Bit 8
	OFF	SafeTorqueOff	1	0	1	0

In the "SafeTorqueOff" device state

- the controller can only be if a safety module is connected and the power section is supplied and at least one of the two safe inputs SI1/SI2 is set to LOW level.
- the next transaction to the "[ReadyToSwitchON](#)" state takes place.



Detailed and important information on the integrated safety system can be found in the hardware manual!



# 4 Device control (DCTRL)

## 4.2 Device states

### 4.2.4 ReadyToSwitchON

LED DRIVE READY	LED DRIVE ERROR	Display in <a href="#">C137</a>	Display in status word 1 ( <a href="#">C150</a> )			
			Bit 11	Bit 10	Bit 9	Bit 8
	OFF	ReadyToSwitchON	0	0	1	1

In the "ReadyToSwitchOn" device state

- is the controller after the initialisation has been completed successfully.
- is the controller even after cancelling "[Trouble](#)", "[Fault](#)" or "[SafeTorqueOff](#)".
- I/O signalare evaluated.
- the monitoring modes are active.
- the controller can be parameterised.
- the application is basically executable.
- prevents in the Lenze setting the auto-start option "Inhibit at power-on" activated in [C142](#) from changing to the "[SwitchedON](#)" state.



#### **Danger!**

If the "Inhibit at power-on" auto-start option has been deactivated in [C142](#) the "Ready-ToSwitchOn" state directly switches to the "[SwitchedON](#)" state.

▶ "[Inhibit at power-on](#)" auto-start option ([□ 62](#))

# 4 Device control (DCTRL)

## 4.2 Device states

### 4.2.5 SwitchedON

LED DRIVE READY	LED DRIVE ERROR	Display in <a href="#">C137</a>	Display in status word 1 ( <a href="#">C150</a> )			
			Bit 11	Bit 10	Bit 9	Bit 8
	OFF	SwitchedON	0	1	0	0

In the "SwitchedOn" device state

- is the controller if the user has inhibited the controller (and no error is pending).
- I/O signalare evaluated.
- the monitoring modes are active.
- the controller can be parameterised.
- the application is basically executable.
- it can be changed to the "[OperationEnabled](#)" state by deactivating the controller inhibit.



**Tip!**

[C158](#) provides a bit coded representation of all active sources/triggers of a controller inhibit.

Depending on certain conditions, a state change takes place based on the "SwitchedOn" device state:

Change condition	Changeover to the device state
Control bit "EnableOperation" in control word <i>wCANControl</i> = "1" <b>AND</b> terminal RFR = HIGH level (controller enable)	<a href="#">OperationEnabled</a>
Control bit "SwitchOn" = "0".	<a href="#">ReadyToSwitchON</a>
Motor parameter identification requested.	<a href="#">MotorIdent</a>
Undervoltage in the DC bus.	<a href="#">Trouble/Fault</a> (dependent on <a href="#">C600/1</a> )
Error with error response "Trouble" occurs.	<a href="#">Trouble</a>

#### Related topics:

- ▶ [Process data assignment for control via CAN](#) (📖 137)

# 4 Device control (DCTRL)

## 4.2 Device states

### 4.2.6 OperationEnabled

LED DRIVE READY	LED DRIVE ERROR	Display in <a href="#">C137</a>	Display in status word 1 ( <a href="#">C150</a> )			
			Bit 11	Bit 10	Bit 9	Bit 8
	OFF	OperationEnabled	0	1	0	1

In the "OperationEnabled" state

- is the controller if the controller inhibit is deactivated and no trouble ("Trouble") and fault ("Fault") are existent.
- the operation is enabled and the motor follows the setpoint defined by the active application (in case of sensorless vector control only after the magnetisation process is completed).

Depending on certain conditions, a state change takes place based on the "OperationEnabled" device state.

Change condition	Changeover to the device state
Control bit "EnableOperation" in control word $wCANControl = "0"$ OR terminal RFR = LOW level (controller inhibit).	<a href="#">SwitchedON</a>
Control bit "SwitchOn" = "0".	<a href="#">ReadyToSwitchON</a>
Undervoltage in the DC bus.	<a href="#">Trouble/Fault</a> (dependent on <a href="#">C600/1</a> )
Error with error response "Trouble" occurs.	<a href="#">Trouble</a>

#### Related topics:

- ▶ [Process data assignment for control via CAN](#) ([📖 137](#))

### 4.2.7 Trouble

LED DRIVE READY	LED DRIVE ERROR	Display in <a href="#">C137</a>	Display in status word 1 ( <a href="#">C150</a> )			
			Bit 11	Bit 10	Bit 9	Bit 8
OFF		Trouble	0	1	1	1

In the "Trouble" device state

- is the controller if monitoring has caused a "Trouble" error response.
- the motor has no torque (is coasting) due to the inhibit of the inverter.



#### Note!

The "Trouble" device state is automatically abandoned if the error cause has been removed.

If in [C142](#) the "Inhibit at trouble" auto-start option is activated, an explicit deactivation of the controller inhibit is required for leaving the state.

Depending on certain conditions a state change takes place based on the "Trouble" device state.

Change condition	Changeover to the device state
The error cause is no longer active.	<a href="#">ReadyToSwitchON</a>
Control bit "EnableOperation" in control word $wCANControl = "1"$ AND terminal RFR = HIGH level (controller enable) AND the message has been cancelled.	<a href="#">OperationEnabled</a>
Control bit "EnableOperation" in control word $wCANControl = "0"$ OR terminal RFR = LOW level (controller inhibit) AND the message has been cancelled.	<a href="#">SwitchedON</a>

#### Related topics:

- ▶ [Process data assignment for control via CAN](#) (📖 137)
- ▶ [Basics on error handling in the controller](#) (📖 145)
- ▶ [Error messages of the operating system](#) (📖 156)

### 4.2.8 Fault

LED DRIVE READY	LED DRIVE ERROR	Display in <a href="#">C137</a>	Display in status word 1 ( <a href="#">C150</a> )			
			Bit 11	Bit 10	Bit 9	Bit 8
OFF		Fault	1	0	0	0

In the "Fault" device state

- is the controller if monitoring has caused a "Fault" error response.
- the motor has no torque (is coasting) due to the inhibit of the inverter.

The error must explicitly be reset ("acknowledged") in order to exit the device state, e.g. by the device command "[Reset error](#)" or via the control bit "ResetFault" in the control word *wCANControl*.



#### Note!

If an undervoltage in the DC bus of the drive controller occurs (error message "LU"), the device changes to the "[Trouble](#)" state.

An additional error of higher priority leads the device into the "[Fault](#)" state.

According to the [Device state machine](#), the device changes to the "[ReadyToSwitchON](#)" state after acknowledging the error although the undervoltage is still available!

If in [C142](#) the "Inhibit at fault" auto-start option "is activated, an explicit deactivation of the controller inhibit is required for leaving the state.

#### Related topics:

- ▶ [Process data assignment for control via CAN](#) (📖 137)
- ▶ [Basics on error handling in the controller](#) (📖 145)
- ▶ [Error messages of the operating system](#) (📖 156)

### 4.3 "Inhibit at power-on" auto-start option

In the Lenze setting in [C142](#) the auto-start option "Inhibit at power-on" is activated. This setting prevents a change to the "[SwitchedON](#)" state if the controller is already enabled at mains power-up.



#### **Danger!**

When the auto-start option "Inhibit at power-on" is deactivated, the motor can directly start after power-on if the controller is enabled!

The following three cases describe the controller behaviour as a function of controller enable and set auto-start option. Here, we assume that no fault and trouble exist in the controller after power-on and the control bit "EnableOperation" in the control word *wCANControl* is set to "1".

**Case 1: No controller enable at power-on**

If there is no controller enable at power-on, the controller remains in the "[SwitchedON](#)" state. Only with controller enable it is changed to the "[OperationEnabled](#)" state, independent of the setting of the auto-start option:

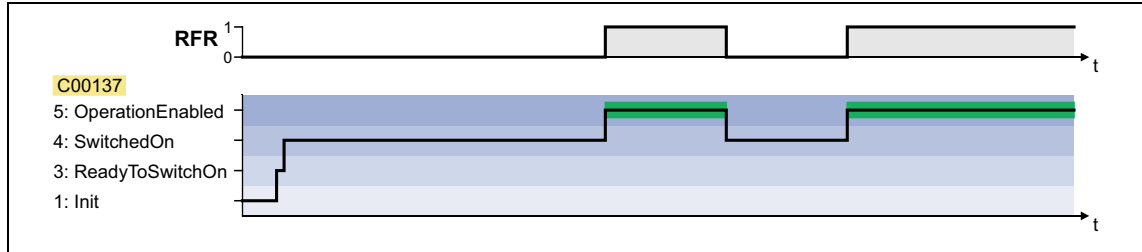
**Case 2: Controller enable at power-on and "Inhibit at power-on" activated**

If the controller is enabled at power-on and the auto-start option "Inhibit at power-on" is active, the controller remains in the "[ReadyToSwitchON](#)" state. In order to change to the "[SwitchedON](#)" state, the controller enable must first be deactivated. When the controller enable is then activated, it is changed to the "[OperationEnabled](#)" state:

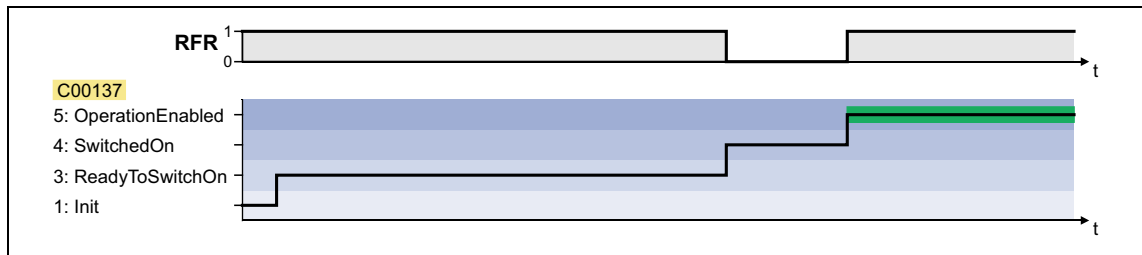
**Case 3: Controller enable at power-on and "Inhibit at power-on" deactivated**

If in [C142](#) the auto-start option "option "Inhibit at power-on" is deactivated (bit 0 = 0) and the controller is enabled, the "[ReadyToSwitchON](#)" state switches directly to the "[SwitchedON](#)" state and afterwards to the "[OperationEnabled](#)" state:

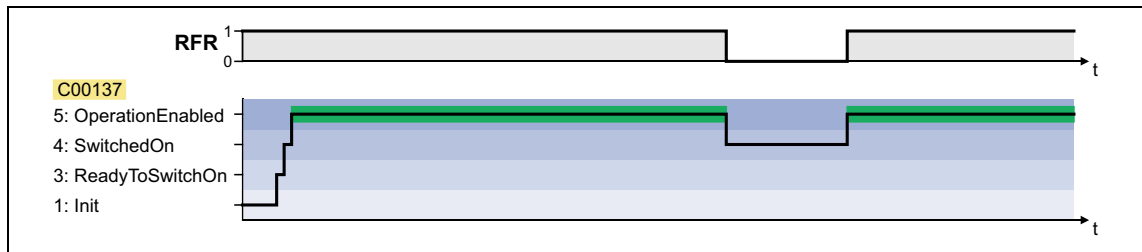

## 5 Motor control (MCTRL)

---

### 5 Motor control (MCTRL)

This chapter provides information on the parameter setting of the controller's internal motor control.

**Topics:**

- ▶ [Motor selection/Motor data](#)
- ▶ [Selecting the control mode](#)
- ▶ [Defining current and speed limits](#)
- ▶ [V/f characteristic control \(VFCplus\)](#)
- ▶ [Sensorless vector control \(SLVC\)](#)
- ▶ [Parameterisable additional functions](#)
- ▶ [Braking operation/braking energy management](#)
- ▶ [Monitoring](#)



# 5 Motor control (MCTRL)

## 5.1 Motor selection/Motor data

### 5.1 Motor selection/Motor data

The motor data term comprises all parameters that only depend on the motor and that only characterise the electrical behaviour of the machine. The motor data are independent of the application in which the controller and the motor are used.



Proceed as follows to open the dialog for parameterising the motor data:

1. »Engineer« Go to the *Project* view and select the 8400 BaseLine C controller.
2. Go to *Workspace* and change to the **Application parameters** tab.
3. Go to the *Overview* dialog level and click the following button:



#### Parameterisation dialog in the »Engineer«

Motor selection	
Selected motor:	SDSGA047-22, 100 (Y)

Motor data		Actual values	
Rated motor power	0,08 kW	Actual speed value	0 rpm
Rated motor speed	2700 rpm	Motor voltage	0 V
Rated motor current	0,54 A	DC-bus voltage	0 V
Rated motor frequency	100 Hz	Motor current	0,00 A
Rated motor voltage	390 V	Thermal motor load (Fxt)	0 %
Motor cosine phi	0,50		

- Via the **from Motor Catalogue** button, the motor catalogue can be opened to select another motor. ▶ [Selecting a motor from the motor catalogue in the »Engineer«](#) (68)
- Via the **From drive...** button, the motor data set in the controller can be copied to the »Engineer« when an online connection has been established.

**Note!**

Sensorless vector control in particular requires the motor data parameters to be set. The motor data comprise the data of the motor nameplate and the data of the motor equivalent circuit.

If the motor has been selected via the motor catalogue of the »Engineer« or the motor data have been adapted offline using the »Engineer«, all motor data must then be copied to the controller and saved power-failure-proof to the memory module (device command: [C002/11](#)) when an online connection has been established.

**Motor data**

In the parameterisation dialog, the data of the motor nameplate for the selected motor are displayed under "Motor data".

Parameter	Info
<a href="#">C081</a>	Rated motor power
<a href="#">C087</a>	Rated motor speed
<a href="#">C088</a>	Rated motor current
<a href="#">C089</a>	Rated motor frequency
<a href="#">C090</a>	Rated motor voltage
<a href="#">C091</a>	Motor cos $\varphi$

**Actual values**

When an online connection to the controller has been established, the following actual values are displayed in the parameterisation dialog under "Actual values":

Parameter	Info
<a href="#">C051</a>	Actual speed value
<a href="#">C052</a>	Motor voltage
<a href="#">C053</a>	DC-bus voltage
<a href="#">C054</a>	Motor current
<a href="#">C066</a>	Thermal motor load (I2xt)
Highlighted in grey = display parameter	

# 5 Motor control (MCTRL)

## 5.1 Motor selection/Motor data

### Adapting motor data manually

If a third party manufacturer's motor is used, the displayed motor data can exactly be adapted to the real motor by clicking the **From project...** button and selecting the "Own motor settings" entry from the **Motor selection** dialog box afterwards. For this purpose, the data of the motor nameplate and the equivalent circuit diagram must be available.



#### Tip!

For a better concentricity factor, we recommend to perform motor parameter identification of the third party manufacturer's motor first. The motor parameters can be manually adapted afterwards.

Improving the concentricity factor includes

- the adjustment of the inverter error characteristic to the drive system and
- the knowledge of the motor cable resistance.

Both factors are determined in the course of motor parameter identification.

▶ [Automatic motor data identification](#) (□ 70)

### Other motor data

Click the **Other motor data...** button and go to the *Other motor data* dialog box including the motor equivalent circuit:

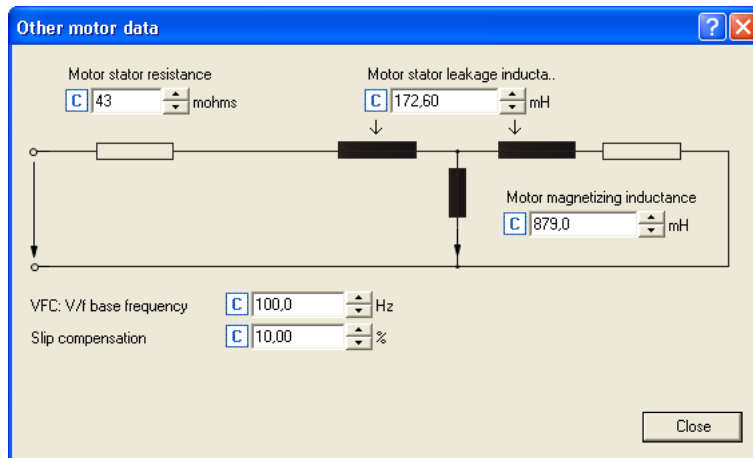

Parameter	Info
<a href="#">C084</a>	Motor stator resistance
<a href="#">C085</a>	Motor stator leakage inductance
<a href="#">C092</a>	Motor magnetising inductance
<a href="#">C015</a>	VFCplus: V/f base frequency
<a href="#">C021</a>	Slip compensation

# 5 Motor control (MCTRL)

## 5.1 Motor selection/Motor data

### 5.1.1 Selecting a motor from the motor catalogue in the »Engineer«

If a checkmark is set in the **Motor** control field in the "Other components" dialog when the controller is inserted into the project, the motor for the controller can be selected from the motor catalogue in another dialog:

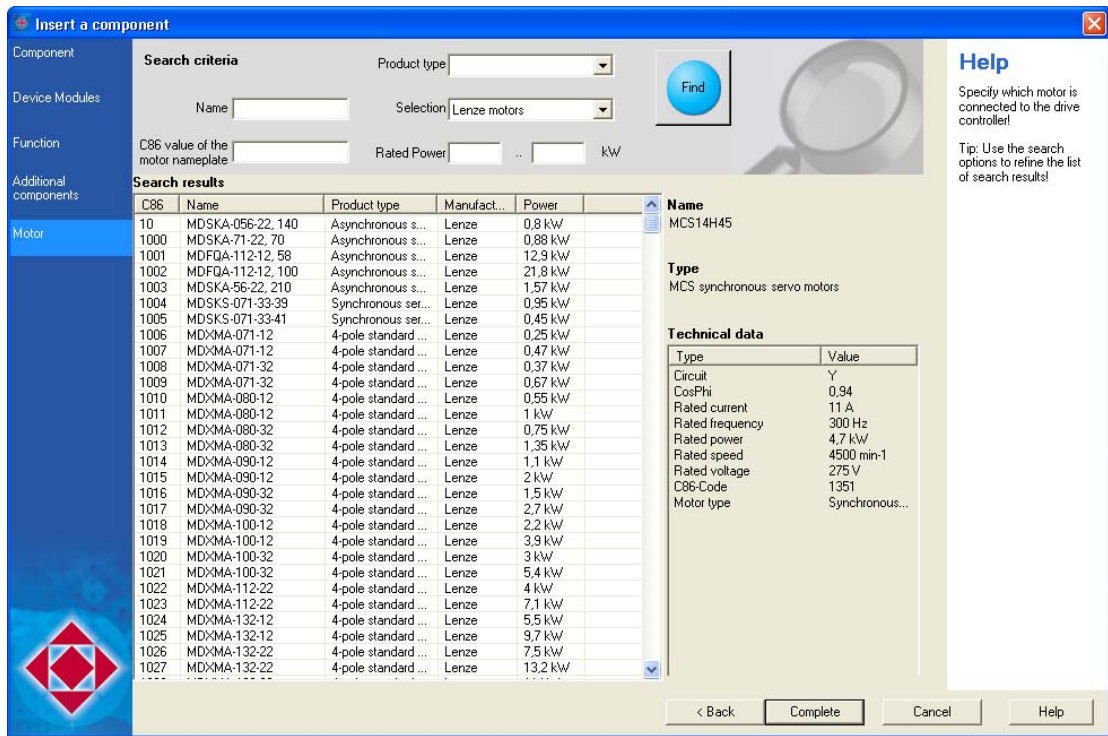

- Alternatively, the motor can be inserted into the project at a later time via the **Insert a component** command.
- Go to the **Application parameters** tab in the *Overview → Motor data* dialog level and click the **From motor catalogue...** button to also reach the motor catalogue for the selection of another motor.

# 5 Motor control (MCTRL)

## 5.1 Motor selection/Motor data

### Accepting the default values of the motor

If a motor is selected from the motor catalogue at a later time, the *Use motor's default values* dialog box is displayed afterwards which includes all motor data of the selected motor. Please select here which of the default values are to be copied to the controller:

Controller:

Motor:

Motor parameter

Use selection of motor controller in C0006: No default value available for this motor

Use following values in drive controller:

Code	Subcode	Name	Value	Unit
0015	000	VFC: V/f base frequency	100	Hz
0021	000	Slip compensation	10	%
0081	000	Rated motor power	0.08	kW
0084	000	Motor stator resistance	43	mohms
0085	000	Motor stator leakage inductance	172.6	mH
0087	000	Rated motor speed	2700	rpm
0088	000	Rated motor current	0.54	A
0089	000	Rated motor frequency	100	Hz
0090	000	Rated motor voltage	390	V
0091	000	Motor cosine phi	0.5	
0092	000	Motor magnetizing inductance	879	mH

Path parameters for operation with zero load

Use following values in drive controller:

Code	Subcode	Name	Value	Unit

Ok



**Tip!** If a third party manufacturer's motor is used, select a Lenze motor from the motor catalogue first which is similar in terms of current, voltage and speed rating. Adapt the preselected motor data exactly to the real motor afterwards.

# 5 Motor control (MCTRL)

## 5.1 Motor selection/Motor data

---

### 5.1.2 Automatic motor data identification

Via the "Identify motor parameters" device command " ([C002/23](#)), the inverter characteristic, the influences of the motor cable, and the motor parameters listed in the table below can be identified automatically:

Parameter	Info
<a href="#">C015</a>	V/f base frequency
<a href="#">C016</a>	V <sub>min</sub> boost
<a href="#">C021</a>	Slip compensation
<a href="#">C084</a>	Motor stator resistance
<a href="#">C085</a>	Motor stator leakage inductance
<a href="#">C092</a>	Motor magnetising inductance
<a href="#">C095</a>	Motor magnetising current



#### Danger!

During motor parameter identification, the motor is energised via the outputs U, V and W of the controller!

Observe the corresponding safety instructions!



#### Stop!

If motor parameter identification is aborted, unstable drive behaviour may be the result!



#### Note!

- We strongly recommend motor parameter identification before the initial commissioning of the sensorless vector control (SLVC).
- The motor parameter identification must be carried out when the motor is cold!
- The load machine may remain connected. Holding brakes, if present, may remain in the braking position.
- With an idling motor, a small angular offset may occur at the motor shaft.
- The amplitude of the rated motor current ([C088](#)) is injected to identify the stator resistance. If the rated motor current amounts to less than 60 % of the rated inverter current, at least 60 % of the rated inverter current will be injected to ensure sufficient motor parameter identification accuracy.

### Preconditions

The motor parameters listed in the table below are excluded from automatic identification and must therefore be adapted to the used motor before motor parameter identification is carried out (see motor nameplate).

Parameter	Info
<a href="#">C081</a>	Rated motor power
<a href="#">C087</a>	Rated motor speed
<a href="#">C088</a>	Rated motor current
<a href="#">C089</a>	Rated motor frequency
<a href="#">C090</a>	Rated motor voltage
<a href="#">C091</a>	Motor cos $\varphi$

### Duration & sequence of the motor parameter identification

The duration of the motor parameter identification is approx. 30 s. The following steps are carried out during this time:

1. The motor stator resistance ([C084](#)) is measured.
2. The inverter error characteristic is measured.
3. The motor stator leakage inductance ([C085](#)) is measured
4. The motor magnetising inductance ([C092](#)) is measured
5. The motor magnetising current ([C095](#)) is measured.
6. The V/f base frequency ([C015](#)) is calculated.
7. The slip compensation ([C021](#)) is calculated.
8. The  $V_{\min}$  boost ([C016](#)) is detected.



### Note!

Motor parameter identification may be aborted if a special motor (e.g. mid-frequency motor) is used or if there is a large deviation between inverter and motor power.

Another cause for the abort of the motor parameter identification could be the implausibility of the entered nameplate data, e.g. the entry  $P = 0$  kW for the motor power.

**How to carry out automatic motor parameter identification:**

1. Inhibit the controller if it is enabled, e.g. via the [C002/16](#) device command or a LOW signal at the X4/RFR terminal.
2. Wait until the drive is at standstill.
3. Transfer the nameplate data to the following codes:
  - [C081](#): Rated motor power
  - [C087](#): Rated motor speed
  - [C088](#): Rated motor current (according to the connection method  $\Upsilon/\Delta$ )
  - [C089](#): Rated motor frequency (according to the connection method  $\Upsilon/\Delta$ )
  - [C090](#): Rated motor voltage (according to the connection method  $\Upsilon/\Delta$ )
  - [C091](#): Motor  $\cos \varphi$
4. Start motor parameter identification via the [C002/23](#) device command.
5. Enable the controller again.
  - Motor parameter identification starts.
  - The progress of the identification can be seen in [C002/23](#).
  - The identification is completed if the "0: Off / ready" message is displayed in [C002/23](#).
6. Inhibit controller again.



# 5 Motor control (MCTRL)

## 5.2 Selecting the control mode

### 5.2 Selecting the control mode

The 8400 BaseLine C controller supports various modes for motor control (open loop or closed loop).

- V/f characteristic control (VFCplus) with linear characteristic is preset.
- The control mode can be selected in the »Engineer« on the **Application parameter** tab via the **Motor control (C006)** list field:

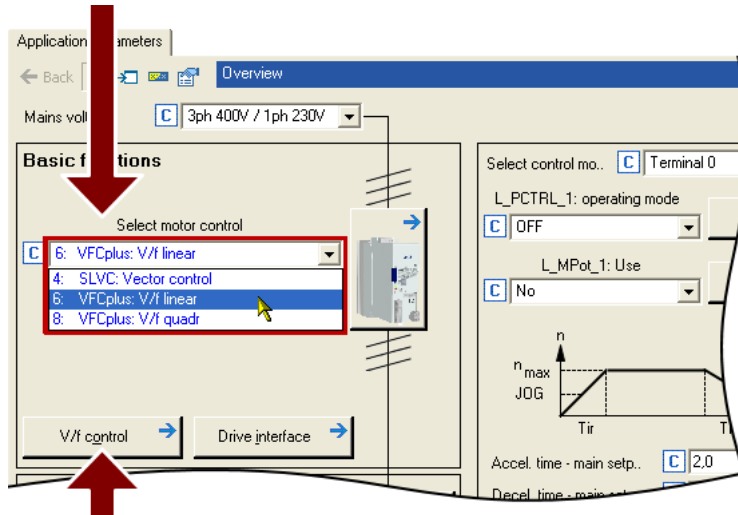

- A click on the **Motor control...** button leads you to the parameterisation dialog of the selected motor control. (The button is labelled according to the selected motor control.)



#### Tip!

In order to make the selection of the motor control easier, we provide a selection help with recommendations and alternatives for standard applications in the subchapter entitled "[Selection help](#)". (📖 75)

The following section briefly describe the control modes. A reference to more details can be found at the end of each section.

### V/f characteristic control (VFCplus)

The V/f characteristic control (VFCplus) is a motor control mode for standard frequency inverter applications based on a simple and robust control process which is suitable for the operation of machines with linear or square-law load torque characteristic (e.g. fans). Furthermore, this motor control mode is also suitable for group drives and special motors. Due to the low parameterisation effort, commissioning of such applications is fast and easy.

The  $V_{\min}$  boost (C016) and slip compensation (C021) required for optimising the drive behaviour are dimensioned for machines with power adaptations to the inverter in the Lenze setting.

▶ [V/f characteristic control \(VFCplus\)](#) (📖 78)

### Sensorless vector control (SLVC)

Sensorless (field-oriented) vector control is based on a decoupled, separate control for the torque-producing and the field-producing current component. In addition, the actual speed is reconstructed by means of a motor model so that a speed sensor is not required.

▶ [Sensorless vector control \(SLVC\)](#) (📖 87)

In comparison to the V/f characteristic control without feedback, the following can be achieved by means of sensorless vector control SLVC:

- A higher maximum torque throughout the entire speed range
- A higher speed accuracy
- A higher concentricity factor
- A higher level of efficiency
- The implementation of torque-actuated operation with speed limitation
- The limitation of the maximum torque in motor and generator mode for speed-actuated operation

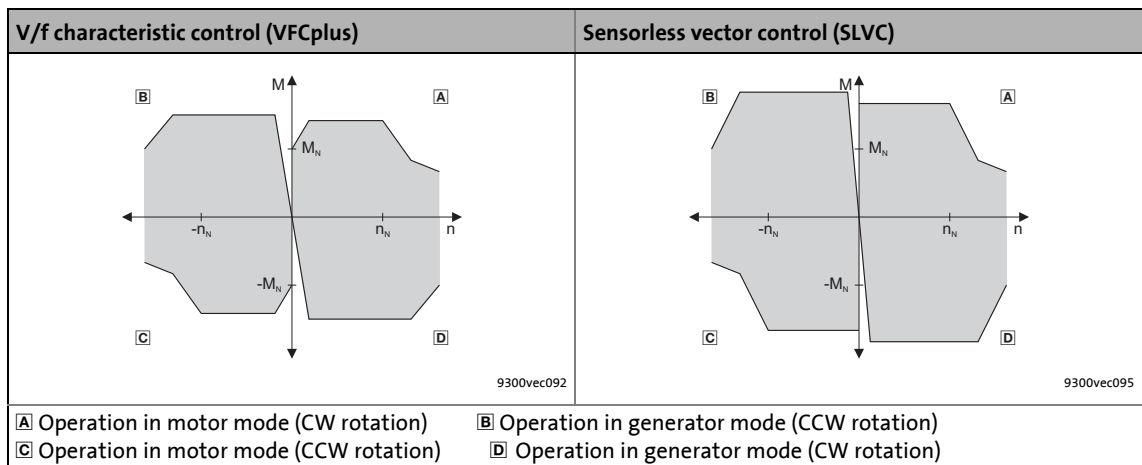

**Tip!**

If a high torque without feedback is to be provided at small speeds, we recommend the "Sensorless vector control" motor control mode.

# 5 Motor control (MCTRL)

## 5.2 Selecting the control mode

### 5.2.1 Selection help

To ease the selection of the motor control mode, the two following tables contain recommendations and alternatives to standard applications.

Application	Recommended	Alternatively
<b>Single drives</b>		
With constant load	VFCplus: V/f linear	SLVC
With extremely alternating loads	VFCplus: V/f linear	SLVC
With high starting duty	SLVC	VFCplus: V/f linear
Torque limitation	SLVC	-
With torque limitation (power control)	VFCplus: V/f linear	SLVC
Three-phase reluctance motor	VFCplus: V/f linear	-
Three-phase sliding rotor motor	VFCplus: V/f linear	-
Three-phase AC motors with permanently assigned frequency/voltage characteristic	VFCplus: V/f linear	-
Pump and fan drives with quadratic load characteristic	VFCplus: V/f quadratic	VFCplus or SLVC
Simple hoists	VFCplus: V/f linear	-
<b>Group drives</b> ( <i>several motors connected to controller</i> )		
Identical motors and loads	VFCplus: V/f linear	-
Different motors and/or alternating loads	VFCplus: V/f linear	-

[5-1] Standard applications without speed feedback

### 5.3 Defining current and speed limits

#### Limitation of the speed setpoint

Parameterising the reference speed in [C011](#) means that the drive must rotate at the set speed if a speed setpoint of 100% is specified

All speed setpoint selections are provided in % and always refer to the reference speed set in [C011](#).



#### Tip!

For reasons of achievable resolution and the accuracy involved, the reference speed should be geared to the speed range required for the respective application.

Lenze recommendation: Reference speed ([C011](#)) = 1500 ... 3000 rpm

Irrespective of the selected motor control, there are more limitation options:

Parameter	Info	Lenze setting	
		Value	Unit
<a href="#">C909/1</a>	Max. positive speed	120	%
<a href="#">C909/2</a>	Max. negative speed	120	%
<a href="#">C910/1</a>	Max. positive output frequency	1000	Hz
<a href="#">C910/2</a>	Max. negative output frequency	1000	Hz

#### Current limitation in motor and generator mode

In the various motor control modes, the controller is provided with functions which determine the dynamic behaviour under load and counteract exceedance of the maximum current in motor or generator mode.

Parameter	Info	Lenze setting	
		Value	Unit
<a href="#">C022</a>	I <sub>max</sub> in motor mode	47.00	A
<a href="#">C023</a>	I <sub>max</sub> in generator mode • 100 % ≙ I <sub>max</sub> in motor mode ( <a href="#">C022</a> )	100	%

The current limits must be selected depending on

- the permissible maximum current of the motor → recommendation:  $I(\text{Mot})_N < 1.5 \dots 2.0$
- the permissible maximum current of the inverter
- the torque in motor/generator mode required for the application



### Note!

#### Highly dynamic applications

(that have e.g. too short acceleration/deceleration times or excessively changing loads)

The overcurrent disconnection may respond (fault message OC1), if the setting of the maximum current in motor mode in [C022](#) approximately corresponds to the maximum permissible value of the respective inverter.

#### Remedies:

- Increase of the acceleration and deceleration ramp times
- Reduction of the maximum current in motor mode ([C022](#))
- Reduction of the maximum current in generator mode ([C023](#))
- Adaptation of the indirect peak current limitation (procedure depends on the selected motor control mode, see below)
- Reduction of the reset time of the current limiting controller ([C074/1](#))

#### Influencing the torque in motor/generator mode

The torque in motor and generator mode can be limited via the *nTorqueMotLim* and *nTorqueGenLim* process signal inputs.

- If V/f characteristic control (VFCplus) is selected, limitation is indirectly performed via a so-called  $I_{max}$  controller.
- If sensorless vector control (SLVC) is selected, the limitation has a direct effect on the torque-producing current component.

If keypad control is selected, the *nTorqueMotLim* and *nTorqueGenLim* process signals can be parameterised via [C728/1...2](#).



#### How to adapt the peak current limitation:

V/f characteristic control (VFCplus):

- Reduce the slip compensation with [C021](#).

V/f control (VFCplus + encoder):

- Reduce  $V_{min}$  boost in [C016](#).

Sensorless vector control (SLVC):

- Reduce the slip compensation with [C021](#).
- Reduce the limitation of the torque in motor mode via *nTorqueMotLimit\_a* ([C728/1](#)) and the limitation of the torque in generator mode via *nTorqueGenLimit\_a* ([C728/2](#)).

## 5.4 V/f characteristic control (VFCplus)

In case of the V/f characteristic control (VFCplus), the motor voltage of the inverter is determined by means of a linear or quadratic characteristic depending on the field frequency or motor speed to be generated. The voltage follows a preselected characteristic.



### Stop!

- The following must be observed when operating drives with quadratic V/f characteristic:
  - Please always check whether the corresponding drive is suitable for operation with a quadratic V/f characteristic!
  - If your pump drive or fan drive is not suitable for operation with a quadratic V/f characteristic, you must use either use the V/f characteristic control function with a linear V/f characteristic or the sensorless vector control (SLVC).
- For adjustment, observe the thermal performance of the connected asynchronous motor at low output frequencies.
  - Usually, standard asynchronous motors with insulation class B can be operated for a short time with their rated current in the frequency range  $0 \text{ Hz} \leq f \leq 25 \text{ Hz}$ .
  - Contact the motor manufacturer to get the exact setting values for the max. permissible motor current of self-ventilated motors in the lower speed range.
  - If you select the quadratic V/f characteristic, we recommend to set a lower  $V_{\min}$ .
- The nameplate data of the motor (at least rated speed and rated frequency) must be entered if, instead of a standard motor, an asynchronous motor is used with the following values:
  - rated frequency  $\neq 50 \text{ Hz}$  (star) or
  - rated frequency  $\neq 87 \text{ Hz}$  (delta) or
  - number of pole pairs  $\neq 2$



### Note!

When the auto DCB threshold is set ([C019](#))  $> 0$  rpm, there is no torque at the motor shaft in the lower speed range!

▶ [Automatic DC-injection braking \(Auto-DCB\)](#) (97)

### 5.4.1 Parameterisation dialog/signal flow



Proceed as follows to open the dialog for parameterising the motor control:

1. »Engineer« Go to the *Project view* and select the 8400 BaseLine C controller.
2. Go to *Workspace* and change to the **Application parameters** tab.
3. Select the motor control from the *Overview* dialog level in the **Motor control** list field:
  - "6: VFCplus: V/f linear" for linear characteristic or
  - "8: VFCplus: V/f quadr" for square-law characteristic
4. Click the **Motor control V/f** button to change to the *Overview* → *Motor control V/f* dialog box.

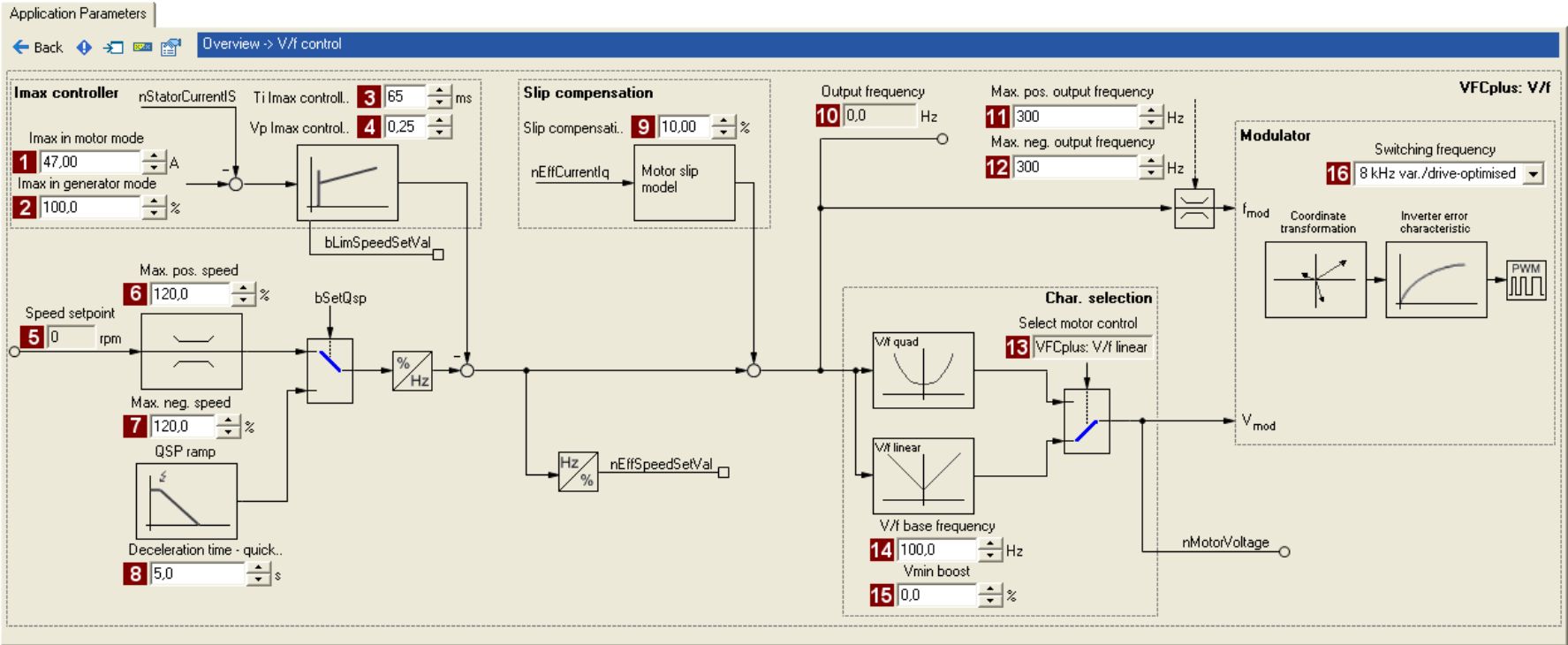

Parameter	Info	Parameter	Info	Parameter	Info
1	<a href="#">C022</a> I <sub>max</sub> in motor mode	9	<a href="#">C021</a> <a href="#">Slip compensation</a>	13	<a href="#">C006</a> Motor control
2	<a href="#">C023</a> I <sub>max</sub> in generator mode	10	<a href="#">C058</a> Output frequency	14	<a href="#">C015</a> V/f base frequency
3	<a href="#">C074</a> Ti I <sub>max</sub> controller	11	<a href="#">C910/1</a> Max. pos. output frequency	15	<a href="#">C016</a> V <sub>min</sub> boost
4	<a href="#">C073</a> Vp I <sub>max</sub> controller	12	<a href="#">C910/2</a> Max. neg. output frequency	16	<a href="#">C018</a> Switching frequency
5	<a href="#">C050</a> Speed setpoint				
6	<a href="#">C909/1</a> Max. pos. speed				
7	<a href="#">C909/2</a> Max. neg. speed				
8	<a href="#">C105</a> Deceleration time - quick stop				

### 5.4.2 Basic settings

The "Initial commissioning steps" listed in the table below are sufficient for a simple characteristic control.

- Detailed information on the individual steps can be found in the following subchapters.

Initial commissioning steps	
1.	<a href="#">Defining the V/f characteristic shape.</a> (☞ 80)
2.	<a href="#">Defining current limits (I<sub>max</sub> controller).</a> (☞ 81)



#### Tip!

Information on the optimisation of the control mode and the adaptation to the real application is provided in the "[Optimise control behaviour](#)" chapter. (☞ 82)

Parameterisable additional functions are described correspondingly in the "[Parameterisable additional functions](#)" chapter. (☞ 92)

#### 5.4.2.1 Defining the V/f characteristic shape

Generally, two different characteristic shapes can be defined:

- 1. Linear V/f characteristic:**  
For drives for a constant, speed-independent load torque.
- 2. Quadratic V/f characteristic:**  
For drives with a load torque curve which is quadratic or in relation to speed. Quadratic V/f characteristics are preferred in the case of centrifugal pumps and fan drives.

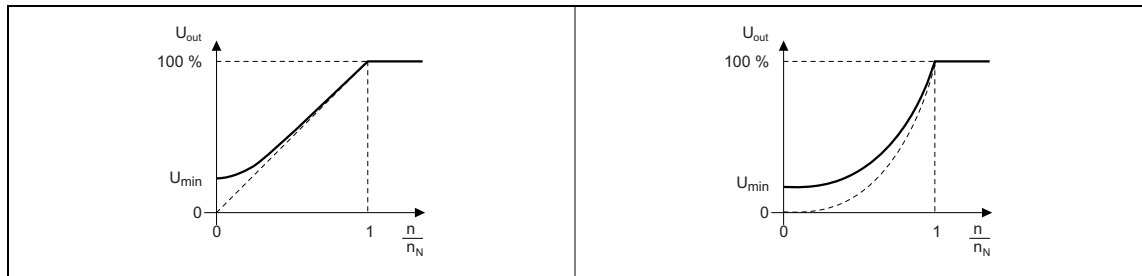

[5-2] Principle of a linear and quadratic V/f characteristic

The V/f characteristic shape is defined by selecting the corresponding motor control mode in [C006](#):

- "6: VFCplus: V/f linear" for linear characteristic
- "8: VFCplus: V/f quadr" for square-law characteristic



### 5.4.2.2 Defining current limits (I<sub>max</sub> controller)

The V/f characteristic control (VFCplus) is provided with a current limitation control which is decisive for the dynamic behaviour under load and counteracts exceedance of the maximum current in motor or generator mode. This current limitation control is called I<sub>max</sub> control.

- The efficiency (motor current) measured by the I<sub>max</sub> control is compared with the current limit value for motor load set in [C022](#) and the current limit value for generator mode set in [C023](#).
- If the current limit values are exceeded, the controller changes its dynamic behaviour.

#### Motor overload during acceleration

The controller prolongs the acceleration ramp to keep the current on or below the current limit.

#### Generator overload during deceleration

The controller prolongs the deceleration ramp to keep the current on or below the current limit.

#### Increasing load with constant speed

- If the motor current limit value is reached:
  - The controller reduces the effective speed setpoint until a stable working point is set or an effective speed setpoint of 0 rpm is reached.
  - If the load is reduced, the controller increases the effective speed setpoint until the setpoint speed is reached or the load reaches the current limit value again.
- When the generator current limit value is reached:
  - The controller increases the effective speed setpoint until a stable working point is set or the maximally permissible speed ([C909](#)) or output frequency ([C910](#)).
  - If the load is reduced, the controller reduces the effective speed setpoint until the setpoint speed is reached or the load reaches the current limit value again.
- If a sudden load is built up at the motor shaft (e.g. drive is blocked), the overcurrent disconnection may respond (fault message OC1).

### 5.4.3 Optimise control behaviour

The V/f characteristic control (VFCplus) is generally ready for operation. It can be adapted subsequently by adapting the characteristic and/or the drive behaviour.

#### Adapting characteristic

For the linear and quadratic characteristic, it is also possible to match its curve to different load profiles or motors by adapting the V/f base frequency ([C015](#)) and the  $V_{\min}$ -boost ([C016](#)).

▶ [Adapting the V/f base frequency](#) (📖 83)

▶ [Adapting the  \$V\_{\min}\$  boost](#) (📖 84)

#### Adapting drive behaviour

- Limitation of the maximum current by a current limitation controller (e.g. to prevent the motor from stalling or to limit to the maximally permissible motor current). ▶ [Optimising the  \$I\_{\max}\$  controller](#) (📖 85)
- Adaptation of the field frequency by a load-dependent slip compensation (improved speed accuracy for systems without feedback)

### 5.4.3.1 Adapting the V/f base frequency

The V/f base frequency ([C015](#)) determines the slope of the V/f characteristic and has considerable influence on the current, torque, and power performance of the motor.

- The setting in [C015](#) applies to all permitted mains voltages.
- Mains fluctuations or fluctuations of the DC-bus voltage (operation in generator mode) do not need to be considered when the V/f base frequency is set. They are automatically compensated for by the internal mains voltage compensation of the device.
- Depending on the setting in [C015](#), it may be required to adapt the reference speed ([C011](#)) to traverse the entire speed range of the motor.
- In standard applications, the V/f base frequency ([C015](#)) is set to the value of the rated motor frequency ([C089](#)) as a typical value and corresponds to the data of the motor nameplate.
- Reference voltage for the V/f base frequency is the rated motor voltage ([C090](#)) according to motor nameplate.



#### Note!

##### 87-Hz operation

4-pole asynchronous motors which are designed for a rated frequency of  $f = 50$  Hz in star connection can be operated in delta connection when being constantly excited up to  $f = 87$  Hz.

- Advantages:
  - Higher speed-setting range
  - 73% higher power output in case of standard motors
- Motor current and motor power increase by the factor  $\sqrt{3}$ .
- The field weakening range starts above 87 Hz.
- Generally, this process can also be used with motors which have different numbers of pole pairs. In case of 2-pole asynchronous motors, the mechanical limit speed must be maintained.

### 5.4.3.2 Adapting the V<sub>min</sub> boost

The V<sub>min</sub> boost (C016) of the motor voltage serves to select a load independent magnetising current which is required for asynchronous motors. The torque behaviour of the motor can be optimised by adapting the setting in C016.



#### Note!

The V<sub>min</sub> boost has an effect on output frequencies below the V/f base frequency (C015).

The general linear and quadratic V/f characteristics are shown in the illustrations below. The illustrations show the impacts of the parameters used to adapt the characteristic shape.

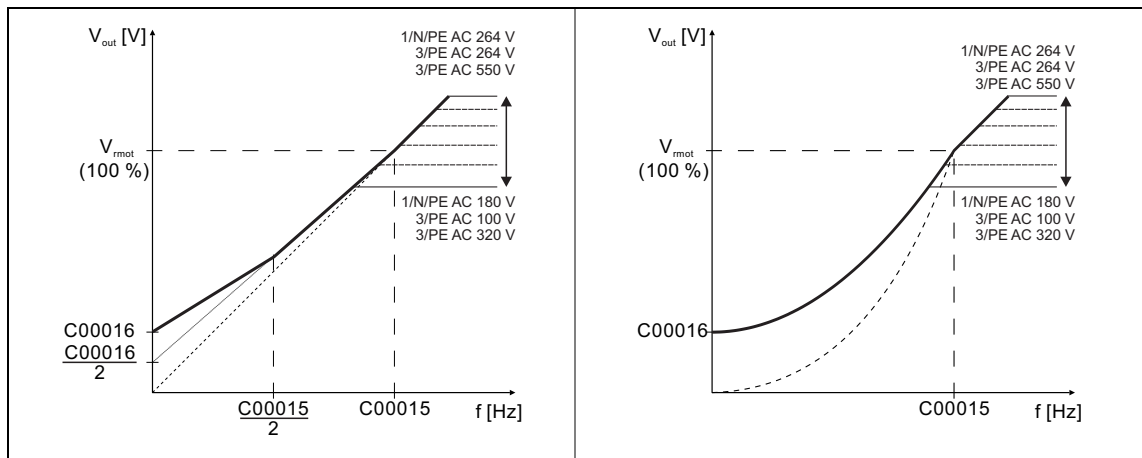

[5-3] Representation of the linear V/f characteristic (on the left) and quadratic V/f characteristic (on the right)



#### To set the V<sub>min</sub> boost, proceed as follows:

1. Operate motor in idle state at approx. 6 % of the rated motor speed.
2. Increase V<sub>min</sub> boost (C016) until the following motor current is reached:

Motor in short-time operation up to 0.5 n<sub>N</sub>

- for self-ventilated motors:  $I_{\text{Motor}} \approx I_{\text{N Motor}}$
- for forced ventilated motors:  $I_{\text{Motor}} \approx I_{\text{N Motor}}$

Motor in continuous operation up to 0.5 n<sub>N</sub>

- for self-ventilated motors:  $I_{\text{Motor}} \approx 0.8 I_{\text{N Motor}}$
- for forced ventilated motors:  $I_{\text{Motor}} \approx I_{\text{N Motor}}$



#### Note!

V<sub>min</sub> boost is automatically calculated by the motor parameter identification using the data specified on the motor nameplate so that a no-load current of approx. 0.8 I<sub>rated motor</sub> results at the slip frequency of the machine.

### 5.4.3.3 Optimising the I<sub>max</sub> controller

Using the Lenze setting of the current limitation controller, the drive is stable:

Parameter	Info	Lenze setting	
		Value	Unit
<a href="#">C073</a>	VFC: Vp I <sub>max</sub> controller	0.25	
<a href="#">C074</a>	VFC: Ti I <sub>max</sub> controller	65	ms

Most applications do not require optimisation.

The setting of the current limitation controller must be adapted if

- power control including great moments of inertia is performed.
  - Recommendation: Increase of the reset time Ti ([C074](#)) of the I<sub>max</sub> controller.
- overcurrent errors occur due to load impulses or too high acceleration ramps.
  - Recommendation: Reduction of the gain Vp ([C073](#)) and reset time Ti ([C074](#)) of the I<sub>max</sub> controller.

### 5.4.3.4 Torque limitation

The previous chapter, "[Optimising the I<sub>max</sub> controller](#)", describes how the drive can be protected from overload. During commissioning, these settings are carried out once and remain unchanged afterwards. However, it is often necessary to limit the torque to a lower value for plant or process reasons.

- To avoid overload in the drive train, the torque in motor mode can be limited via the *nTorqueMotLimit\_a* process input signal, and the torque in generator mode can be limited via the *nTorqueGenLimit\_a* process input signal:

Identifier <small>DIS code   data type</small>	Information/possible settings
nTorqueMotLimit_a <a href="#">C830/4</a>   INT	Torque limitation in motor mode <ul style="list-style-type: none"> <li>• Scaling: 16384 ≙ 100 % M<sub>max</sub> (<a href="#">C057</a>)</li> <li>• Setting range: 0 ... +199.9 %</li> <li>• If keypad control is performed: Parameterisable via <a href="#">C728/1</a>.</li> </ul>
nTorqueGenLimit_a <a href="#">C830/5</a>   INT	Torque limitation in generator mode <ul style="list-style-type: none"> <li>• Scaling: 16384 ≙ 100 % M<sub>max</sub> (<a href="#">C057</a>)</li> <li>• Setting range: -199.9 ... 0 %</li> <li>• If keypad control is performed: Parameterisable via <a href="#">C728/2</a>.</li> </ul>



#### Note!

- The accuracy of the torque limitation is limited because the actual torque ([C056/2](#)) is only calculated from the slip speed measured indirectly via the motor current. For this purpose, the correct entry of the motor data is required. ▶ [Motor selection/Motor data](#) (□ 65)
- To avoid instabilities during operation with active slip compensation, the torque limit values are internally processed as absolute values.
- If slip compensation is deactivated ([C021](#) = 0) indirect torque limitation is executed (differential signal between apparent motor current and *nTorqueMotLimit\_a* or *nTorqueGenLimit\_a*). Above the no-load current of the motor, the accuracy of the indirect torque limitation is limited.

# 5 Motor control (MCTRL)

## 5.4 V/f characteristic control (VFCplus)

### 5.4.4 Remedies for undesired drive behaviour

Drive behaviour	Remedy
Inadequately smooth running at low speeds, especially in the case of operation with a long motor cable	▶ <a href="#">Automatic motor data identification</a> (📖 70)
Problems in case of high starting duty (great mass inertia)	▶ <a href="#">Adapting the Vmin boost</a> (📖 84)
Drive does not follow the speed setpoint.	<p>The current controller intervenes in the set field frequency to limit the controller output current to the maximum current (C0022, C0023). Therefore:</p> <ul style="list-style-type: none"> <li>• Prolong acceleration/deceleration time:           <ul style="list-style-type: none"> <li><a href="#">C012</a>: Acceleration time - main setpoint</li> <li><a href="#">C013</a>: Deceleration time - main setpoint</li> </ul> </li> <li>• Consider a sufficient magnetising time of the motor. Depending on the motor power, the magnetising time amounts to 0.1 ... 0.2 s.</li> <li>• Increase permissible maximum current:           <ul style="list-style-type: none"> <li><a href="#">C022</a>: I<sub>max</sub> in motor mode</li> <li><a href="#">C023</a>: I<sub>max</sub> in generator mode)</li> </ul> </li> </ul>
Insufficient speed constancy at high load (setpoint and motor speed are not proportional anymore)	<ul style="list-style-type: none"> <li>• Increase slip compensation (<a href="#">C021</a>). Important: Unstable drive due to overcompensation!</li> <li>• With cyclic load impulses (e. g. centrifugal pump), a smooth motor characteristic is achieved by smaller values in <a href="#">C021</a> (possibly negative values).</li> </ul>
Controller cannot follow dynamic processes, i.e. too short acceleration/deceleration times in terms of load ratios.	<ul style="list-style-type: none"> <li>• Increase the gain of the I<sub>max</sub> controller (<a href="#">C073</a>)</li> <li>• Reduce the reset time of the I<sub>max</sub> controller(<a href="#">C074</a>)</li> <li>• Increase acceleration time (<a href="#">C012</a>)</li> <li>• Increase deceleration time (<a href="#">C013</a>)</li> </ul>

### 5.5 Sensorless vector control (SLVC)

Sensorless vector control (SLVC) is based on a better motor current control according to the Lenze FTC process.



#### Stop!

- The connected motor must not be more than two power classes smaller than the motor assigned to the controller.
- Operation of the sensorless vector control (SLVC) is only permissible for one single drive!
- Operation of the sensorless vector control (SLVC) is not permissible for hoists!
- The Lenze setting permits the operation of a power-adapted motor. Optimal operation is only possible if either:
  - the motor is selected via the Lenze motor catalogue
  - the motor nameplate data are entered and motor parameter identification is carried out afterwards
  - or -
  - the nameplate data and equivalent circuit data of the motor (motor leakage inductance and mutual motor inductance, slip compensation and motor stator resistance) are entered manually.
- When you enter the motor nameplate data, take into account the phase connection implemented for the motor (star or delta connection). Only enter the data applying to the selected connection type.
  - In this context, also observe the instructions in the chapter entitled "[Adapting the V/f base frequency](#)" relating to V/f characteristic control. (83)



#### Note!

Optimal operation of the sensorless vector control (SLVC) can be achieved from a minimum speed of approx. 0.5-fold slip speed. At lower speed values below the 0.5-fold slip speed, the maximum torque is reduced.

The maximum field frequency with this motor control mode is 650 Hz.

In comparison to the V/f characteristic control without feedback, the following can be achieved by means of sensorless vector control SLVC:

- A higher maximum torque throughout the entire speed range
- A higher speed accuracy
- A higher concentricity factor
- A higher level of efficiency
- The limitation of the maximum torque in motor and generator mode for speed-actuated operation

### 5.5.1 Parameterisation dialog



Proceed as follows to open the dialog for parameterising the motor control:

1. »Engineer« Go to the *Project view* and select the 8400 Baseline C controller.
2. Go to *Workspace* and change to the **Application parameters** tab.
3. Select the motor control "4: SLVC: Vector control" from the *Overview* dialog level in the **Motor control** (C006) list field.
4. Click the **Motor control vector** button to change to the *Overview* → *Motor control vector* dialog box.
  - This dialog level lists shows all relevant parameters in a parameter list.

Short overview of the relevant parameters:

Parameter	Info
<a href="#">C006</a>	Selection of the motor control → "4: SLVC: Vector control"
<a href="#">C011</a>	Reference speed
<a href="#">C018</a>	Switching frequency
<a href="#">C021</a>	Slip compensation
<a href="#">C022</a>	I <sub>max</sub> in motor mode
<a href="#">C023</a>	I <sub>max</sub> in generator mode
<a href="#">C050</a>	Speed setpoint
<a href="#">C057</a>	Maximum torque
<a href="#">C058</a>	Output frequency
<a href="#">C081</a>	Rated motor power
<a href="#">C084</a>	Motor stator resistance
<a href="#">C085</a>	Motor stator leakage inductance
<a href="#">C087</a>	Rated motor speed
<a href="#">C088</a>	Rated motor current
<a href="#">C089</a>	Rated motor frequency
<a href="#">C090</a>	Rated motor voltage
<a href="#">C091</a>	Motor cosine phi
<a href="#">C092</a>	Motor magnetising inductance
<a href="#">C095</a>	Motor magnetising current
<a href="#">C097</a>	Rated motor torque
<a href="#">C105</a>	Deceleration time - quick stop
<a href="#">C909/1</a>	Max. pos. speed
<a href="#">C909/2</a>	Max. neg. speed
<a href="#">C910/1</a>	Max. pos. output frequency
<a href="#">C910/2</a>	Max. neg. output frequency
Highlighted in grey = display parameter	



### 5.5.2 Speed control with torque limitation

A speed setpoint is selected and the drive system is operated in a speed-controlled manner.

The operational performance can be adapted in the following ways:

- Overload limitation in the drive train
  - The torque is limited via the torque setpoint.
  - The torque setpoint is identical to the value at the output of the speed controller, *nOutputSpeedCtrl*.
  - To avoid overload in the drive train, the torque in motor mode can be limited via the *nTorqueMotLimit\_a* process input signal, and the torque in generator mode can be limited via the *nTorqueGenLimit\_a* process input signal:

Identifier <small>DIS code   data type</small>	Information/possible settings
nTorqueMotLimit_a <small>C830/4   INT</small>	Torque limitation in motor mode <ul style="list-style-type: none"> <li>• Scaling: 16384 <math>\equiv</math> 100 % <math>M_{\max}</math> (C057)</li> <li>• Setting range: 0 ... +199.9 %</li> <li>• If keypad control is performed: Parameterisable via C728/1.</li> </ul>
nTorqueGenLimit_a <small>C830/5   INT</small>	Torque limitation in generator mode <ul style="list-style-type: none"> <li>• Scaling: 16384 <math>\equiv</math> 100 % <math>M_{\max}</math> (C057)</li> <li>• Setting range: -199.9 ... 0 %</li> <li>• If keypad control is performed: Parameterisable via C728/2.</li> </ul>



#### Note!

To avoid instabilities during operation, the torque limit values are internally processed as absolute values.

- Motor current limitation
  - A cross current setpoint is calculated from the torque setpoint which is limited depending on the magnetising current, the max. current in motor mode (C022) and the max. current in generator mode (C023).
  - Here, the total current injected into the motor does not exceed the max. currents in motor and generator mode.
- [Slip compensation](#) (99)
  - Using a slip model, the slip of the machine is reconstructed.
  - The slip compensation (C021) acts as the influencing parameter.

# 5 Motor control (MCTRL)

## 5.5 Sensorless vector control (SLVC)

### 5.5.3 Basic settings

The following "Initial commissioning steps" must be performed to commission the sensorless vector control:

Initial commissioning steps					
1.	<p>Set the motor selection/motor data</p> <ul style="list-style-type: none"><li>When selecting and parameterising the motor, the motor nameplate data and the equivalent circuit diagram data are relevant. Detailed information can be found in the "<a href="#">Motor selection/Motor data</a>" chapter. (📖 65)</li></ul> <p>Depending on the motor manufacturer, proceed as follows:</p> <table border="1"><thead><tr><th>Lenze motor:</th><th>Third party manufacturer's motor:</th></tr></thead><tbody><tr><td><p><a href="#">Selecting a motor from the motor catalogue in the »Engineer«</a></p><p>- or -</p><ol style="list-style-type: none"><li>Set the motor nameplate data</li><li><a href="#">Automatic motor data identification</a></li></ol></td><td><ol style="list-style-type: none"><li>Set the motor nameplate data</li><li><a href="#">Automatic motor data identification</a> or set known data of the equivalent circuit diagram manually: <a href="#">C084</a>: Motor stator resistance <a href="#">C085</a>: Motor stator leakage inductance <a href="#">C092</a>: Motor magnetising inductance <a href="#">C095</a>: Motor magnetising current</li></ol></td></tr></tbody></table>	Lenze motor:	Third party manufacturer's motor:	<p><a href="#">Selecting a motor from the motor catalogue in the »Engineer«</a></p> <p>- or -</p> <ol style="list-style-type: none"><li>Set the motor nameplate data</li><li><a href="#">Automatic motor data identification</a></li></ol>	<ol style="list-style-type: none"><li>Set the motor nameplate data</li><li><a href="#">Automatic motor data identification</a> or set known data of the equivalent circuit diagram manually: <a href="#">C084</a>: Motor stator resistance <a href="#">C085</a>: Motor stator leakage inductance <a href="#">C092</a>: Motor magnetising inductance <a href="#">C095</a>: Motor magnetising current</li></ol>
Lenze motor:	Third party manufacturer's motor:				
<p><a href="#">Selecting a motor from the motor catalogue in the »Engineer«</a></p> <p>- or -</p> <ol style="list-style-type: none"><li>Set the motor nameplate data</li><li><a href="#">Automatic motor data identification</a></li></ol>	<ol style="list-style-type: none"><li>Set the motor nameplate data</li><li><a href="#">Automatic motor data identification</a> or set known data of the equivalent circuit diagram manually: <a href="#">C084</a>: Motor stator resistance <a href="#">C085</a>: Motor stator leakage inductance <a href="#">C092</a>: Motor magnetising inductance <a href="#">C095</a>: Motor magnetising current</li></ol>				
2.	Determine the motor control: <a href="#">C006</a> = "4: SLVC: Vector control"				
3.	Set slip compensation ( <a href="#">C021</a> ). ▶ <a href="#">Slip compensation</a> (📖 99)				



#### Tip!

We recommend to use the flying restart function for connecting/synchronising the inverter to an already rotating drive system. ▶ [Flying restart function](#) (📖 94)

Parameterisable additional functions are described correspondingly in the "[Parameterisable additional functions](#)" chapter. (📖 92)

### 5.5.4 Optimise control behaviour

#### 5.5.4.1 Optimising the starting performance after a controller enable

After the controller is enabled, a time delay is caused during the start due to the magnetisation of the motor. If this delay cannot be tolerated for specific applications, the motor must always be operated in an energised condition.

##### Procedure without setting a controller inhibit

- Deactivate the auto-DCB function with [C019](#) = 0.
- Do not activate the controller inhibit. Instead, stop the drive by selecting a setpoint of 0 or by activating the quick stop function.

### 5.5.5 Remedies for undesired drive behaviour

Drive behaviour	Remedy
Deviation between no-load current and magnetising current or bad speed or torque accuracy.	<p>Adapt the motor magnetising inductance (<a href="#">C092</a>) for no-load operation.</p> <ul style="list-style-type: none"> <li>• If the no-load current is greater than the magnetising current (<a href="#">C095</a>) at 0.5-fold rated motor speed, the magnetising inductance must be reduced until the no-load current and the magnetising current have the same values.</li> <li>• Otherwise, the magnetising inductance must be increased.</li> </ul> <p>Tendency of the correction of <a href="#">C092</a>:</p> <p style="text-align: center;">PN: Rated motor power</p>
Insufficient speed constancy at high load: Setpoint and motor speed are not proportional anymore. <b>Caution:</b> Overcompensation of the settings mentioned under "Remedy" may result in unstable behaviour!	<p>Via the slip compensation (<a href="#">C021</a>, the speed stability under high loads can be affected:</p> <ul style="list-style-type: none"> <li>• If <math>n_{act} &gt; n_{slip}</math>, reduce the value in <a href="#">C021</a></li> <li>• If <math>n_{act} &lt; n_{slip}</math>, increase the value in <a href="#">C021</a></li> </ul>
Unstable control with higher speeds.	<ul style="list-style-type: none"> <li>• Check the setting of the magnetising inductance (<a href="#">C092</a>) by comparing the current consumption in no-load operation with the rated magnetising current (<a href="#">C095</a>)</li> <li>• Optimise oscillation damping (<a href="#">C234</a>).</li> </ul>
"Short circuit" (OC1) error messages at short acceleration time ( <a href="#">C012</a> ) in proportion to the load (controller cannot follow the dynamic processes).	Increase acceleration time ( <a href="#">C012</a> )/deceleration time ( <a href="#">C013</a> ).
Mechanical resonance at certain speeds.	The <a href="#">L_NSet 1</a> function block masks out those speed ranges that include resonance.
Speed variations in no-load operation for speeds > 1/3 rated speed.	Minimise speed oscillations with oscillation damping ( <a href="#">C234</a> ).
Drive runs unstable.	Check set motor data (nameplate data and equivalent circuit diagram data).
Setpoint speed and actual speed differ strongly.	<ul style="list-style-type: none"> <li>▶ <a href="#">Motor selection/Motor data</a> (<a href="#">65</a>)</li> </ul>

## 5.6 Parameterisable additional functions

### 5.6.1 Selection of switching frequency

The switching frequency of the inverter that can be selected in [C018](#) influences the smooth running performance and the noise generation in the connected motor as well as the power losses in the controller.

The lower the switching frequency the higher the concentricity factor, the smaller the losses, and the higher the noise generation.



#### Stop!

If operated at a switching frequency of 16 kHz, the output current of the controller must not exceed the current limit values specified in the technical data!

▶ [Defining current and speed limits](#) (□ 76)



#### Note!

- Operate mid-frequency motors only at a switching frequency of 8 kHz or 16 kHz (var./drive-opt.).
- If operated at a switching frequency of 16 kHz, the I<sub>xt</sub> evaluation ([C064](#)) is considered including the required derating to 67 % of the rated device current at switching frequencies of 2.4 and 8 kHz.

### Settable switching frequencies

Selection in <a href="#">C018</a>	Info
1 4 kHz var./drive-optimised	<ul style="list-style-type: none"> <li>• "var.": Adaptation of the switching frequency depending on the current</li> <li>• "drive-opt.": drive-optimised modulation ("sine/delta modulation")</li> <li>• "fixed": fixed switching frequencies</li> </ul>
<b>2 8 kHz var./drive-optimised</b>	
3 16 kHz var./drive-optimised	
5 2 kHz constant/drive-optimised	
6 4 kHz constant/drive-optimised	
7 8 kHz constant/drive-optimised	
8 16 kHz constant/drive-optimised	
21 8 kHz var./drive-opt./4 kHz min	
22 16 kHz var./drive-opt./4 kHz min	
23 16 kHz var./drive-opt./8 kHz min	



#### Tip!

The Lenze setting [C018](#) = 2 (8 kHz var./drive-opt.) is the optimal value for standard applications.

### Lowering the switching frequency due to high heatsink temperatures

Exceeding the maximally permissible heatsink temperature would lead to an inhibited drive due to the "Overtemperature" error and a torquelessly coasting motor. Therefore, if the Lenze setting is selected, the switching frequency is reduced to the next frequency below when the heatsink temperature has risen to 5 °C below the maximally permissible temperature. After the heatsink has cooled down, the controller automatically switches to the next frequency above until the set switching frequency is reached.

Switching frequency reduction due to high heatsink temperature can be deactivated via [C144](#). If the switching frequency reduction is deactivated, the "OH1: Heatsink overtemperature" error message will be issued when the maximally permissible heatsink temperature is reached. An "Error" response is the result and the motor is coasting.

Parameter	Info	Lenze setting
<a href="#">C144</a>	Switching frequency reduction (temp.)	1: On

### Lowering of the switching frequency depending on the output current

"Variable" switching frequencies can be selected for the controller in [C018](#), where the controller automatically lowers the switching frequency depending on the controller output current. The modulation mode will not be changed. The changeover thresholds are included in the rated data of the Hardware Manual (the Hardware Manual is available on the CD included in the scope of supply).

When a "fixed" switching frequency is selected, no switching frequency changeover takes place. In case of fixed frequencies, the controller output current is limited to the permissible value of the corresponding switching frequency. In case of larger load impulses, the overcurrent interruption may be activated, to which the controller responds with "Error".

### Limiting the maximum output frequency

The maximum output frequency ([C910](#)) of the controller is not limited depending on the switching frequency. Therefore, adapt the maximum output frequency according to our recommendation:

$$\text{Maximum output frequency} \leq \frac{1}{8} \text{ Switching frequency}$$

- At a switching frequency of 4 kHz, for instance, 500 Hz for the maximum output frequency should not be exceeded.

Carry out further measures:

- If required, deactivate the switching frequency changeover by the heatsink temperature via [C144](#).
- If required, ensure that the changeover threshold of the controller output current to the next switching frequency below will not be exceeded. If required, select a constant switching frequency in [C018](#).

### Display of the current switching frequency

The current switching frequency applied in the controller is displayed in [C725](#).

### Operation at an ambient temperature of 45°C

The controller is designed so that operation at an ambient temperature of 45° C without derating is permissible at a switching frequency of 4 kHz.

### 5.6.2 Flying restart function

The flying restart circuit uses a simple model of an asynchronous motor which requires knowledge of the motor stator resistance  $R_S$  and the rated motor current.



#### Note!

- For a correct functioning of the flying restart circuit, we recommend to perform a parameter identification first. ▶ [Automatic motor data identification](#) (☞ 70)
- The flying restart function works safely and reliably for drives with great centrifugal masses.
- Do not use the flying restart function if several motors with different centrifugal masses are connected to a controller.
- After the controller is enabled, the motor can start for a short time or reverse when machines with low friction and low mass inertia are used.
- The flying restart function serves to identify max. field frequencies up to  $\pm 200$  Hz.
- When power-adapted standard asynchronous motors are used (rated motor power approximately corresponds to the rated inverter power), a motor parameter identification is not required.



#### Tip!

In association with the flying restart function, we recommend to read the information provided in this documentation on the following topic:

- ▶ [Automatic DC-injection braking \(Auto-DCB\)](#) (☞ 97)

#### General information

This function serves to activate a mode which is used to "catch" a coasting motor during operation without speed feedback. This means that the synchronicity between controller and motor is to be adjusted in such a way that a jerk-free transition to the rotating machines is achieved in the instant of connection.

The drive controller determines the synchronicity by identifying the synchronous field frequency.

#### Duration

The "catching" process is completed after approx. 1 ... 2 seconds. The duration is influenced by the starting value. If the field frequency is not known, we recommend the preset starting value of 10 Hz.

#### Short overview of the relevant parameters:

Parameter	Info	Lenze setting	
		Value	Unit
<a href="#">C990</a>	Flying restart fct.: Activation	Off	
<a href="#">C991</a>	Flying restart fct.: Process	-n...+n   Last output frequency	
<a href="#">C992</a>	Flying restart: Start frequency	10	Hz
<a href="#">C994</a>	Flying restart fct.: Current	25.00	%

**How to parameterise the flying restart function:**

1. Activate the flying restart circuit by selecting "1: On" in [C990](#).
  - Every time the controller is enabled, a synchronisation to the rotating or standing drive is carried out.

When the Lenze setting is used, most applications do not require additional controller settings.

If additional settings are necessary, proceed as follows:

2. Define the process and hence the speed range/rotational frequency range in [C991](#) which is to be examined by the flying restart circuit.
  - We recommend the Lenze setting "5: -n...+n | Last output frequency"
3. Adjust setting in [C992](#) if required.

The preset starting frequency which defines the starting point of the flying restart function is optimised for standard motors.

- We recommend to define a starting frequency of approximately 20 % of the rated motor frequency to enable a safe and fast connection to standing drive systems.
4. Set the flying restart current in [C994](#).

We recommend setting a flying restart current of 10 % ... 25 % of the rated motor current.

- During a flying restart process, a current is injected into the motor to identify the speed.
- Reducing the current causes a reduction of the motor torque during the flying restart process. A short-time starting action or reversing of the motor is prevented with low flying restart currents.
- An increase of the current improves the robustness of the flying restart function.

## 5.6.3 DC-injection braking

**Danger!**

Holding braking is not possible when this braking mode is used!

DC-injection braking allows the drive to be quickly braked to a standstill without the need to use an external brake resistor.

- The braking current is set in [C036](#).
- The maximum braking torque to be generated by the DC braking current is approx. 20 ... 30 % of the rated motor torque. It is lower than that for braking in generator mode with an external brake resistor.
- Automatic DC-injection braking (Auto-DCB) improves the starting performance of the motor when operated without speed feedback.

**Tip!**

DC-injection braking has the advantage that it is possible to influence the braking time by changing the motor current or the braking torque..

**Short overview of the relevant parameters:**

Parameter	Info	Lenze setting	
		Value	Unit
<a href="#">C019</a>	Auto-DCB: Threshold • Operating threshold for activating DC-injection braking	3	rpm
<a href="#">C036</a>	DCB: Current • Braking current in [%] based on $I_{max}$ ( <a href="#">C022</a> )	50	%
<a href="#">C106</a>	Auto-DCB: Hold time	0.5	s
<a href="#">C107</a>	DCB: Hold time	999.0	s
<a href="#">C701/4</a>	LA_NCtrl: bSetDCBrake • Selection of the signal source for activating DC-injection braking	Dependent on the selected control mode	

**Method**

DC-injection braking can be carried out in two ways with different types of activation:

- ▶ [Manual DC-injection braking \(DCB\)](#) (📖 97)
- ▶ [Automatic DC-injection braking \(Auto-DCB\)](#) (📖 97)



### 5.6.3.1 Manual DC-injection braking (DCB)

DC-injection braking can be manually activated via the *bSetDCBrake* process input.

- For HIGH-active inputs, DC-injection braking is active as long as the signal is at HIGH level.
- After the hold time ([C107](#)) has expired, the controller sets the pulse inhibit (CINH).



#### Tip!

- In the preset "Terminals 0" control mode, DC-injection braking can be manually activated via the digital input DI3.
- In the preset "Terminals 11" control mode, DC-injection braking can be manually activated via the digital input DI2.

### 5.6.3.2 Automatic DC-injection braking (Auto-DCB)

"Automatic DC-injection braking" (referred to in the following as "Auto-DCB") can be used if there is a requirement that the drive be isolated from the supply at  $n \approx 0$ .

#### Function

For understanding the auto-DCB function, it is necessary to distinguish between three different types of operation:

- The drive has been enabled and, in the course of operation, the speed setpoint falls below the Auto-DCB threshold.
  - In case of operation without speed feedback, a braking current ([C036](#)) is injected. After the auto-DCB hold time ([C106](#)) has expired, the motor is deenergised via the auto-DCB function, i.e. a controller inhibit (CINH) is set.
- When the controller is enabled, the drive is at standstill ( $n = 0$ ).  
If the enabled drive is to start, the speed setpoint passed via the acceleration ramp must exceed the auto-DCB threshold ([C019](#)). Below this threshold, the motor will not be energised.
- When the controller is enabled, the motor (still) rotates at a speed which is above the auto DCB threshold. If the speed setpoint reached via the acceleration ramp exceeds the auto DCB threshold ([C019](#)), the motor will be energised and the drive will be "caught". ▶ [Flying restart function](#) ([94](#))



#### How to set the automatic DC-injection braking

- Set a hold time in [C106](#) > 0 s.
  - Automatic DC-injection braking is active for the time set.
  - In case of operation without speed feedback, the braking current set in [C036](#) is injected
  - After the set hold time has expired, the controller sets a pulse inhibit.
- Set the operating threshold in [C019](#).
  - The operating threshold can serve to set a dead band in the setpoint. If DC-injection braking is not to be active then, [C106](#) must be set to a value of "0".

### Explanation of the automatic DC-injection braking function by means of an example

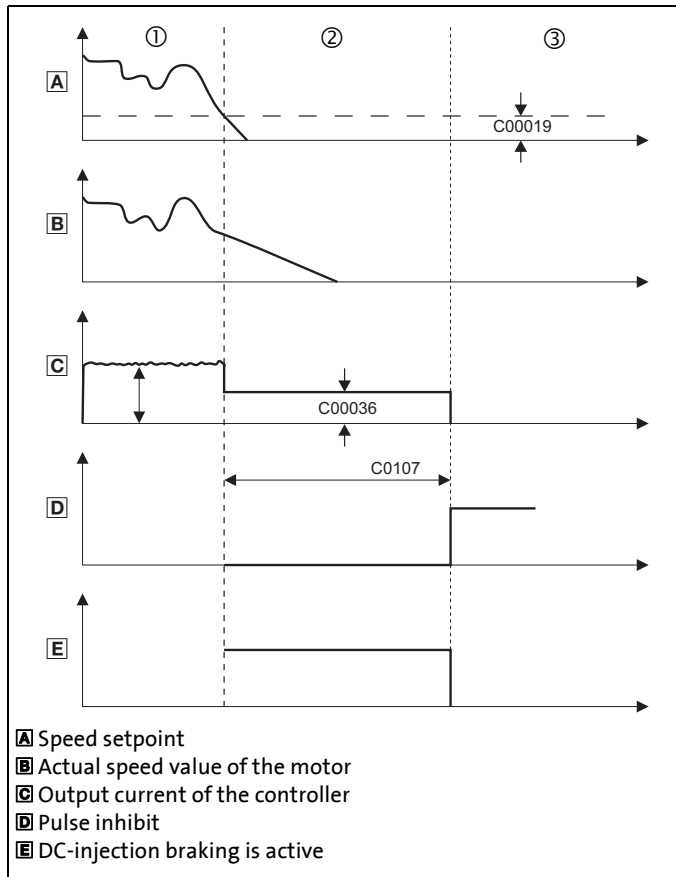

① The motor rotates at a specified speed. The current adjusts itself to the load, see [C](#).

② The DC braking current set in [C036](#) is injected.

③ After the hold time ([C106](#)) has expired, a pulse inhibit is set.

[5-4] Example 1: Signal characteristic for automatic DC-injection braking of a drive without speed feedback

### 5.6.4 Slip compensation

Under load, the speed of an asynchronous machine decreases. This load-dependent speed drop is called slip. The slip can partly be compensated for by the setting in [C021](#).

Parameter	Info	Lenze setting	
		Value	Unit
<a href="#">C021</a>	Slip compensation	0.00	%

- The setting of [C021](#) can be done automatically in the course of motor parameter identification.
  - ▶ [Automatic motor data identification](#) (70)
- The setting must be made manually if the motor parameter identification cannot be called up.



#### How to set the slip compensation manually:

1. Calculate the slip compensation according to motor nameplate data:

$$s = \frac{n_{rsyn} - n_r}{n_{rsyn}} \cdot 100\%$$

$$n_{rsyn} = \frac{f_r \cdot 60}{p}$$

- s Slip constant ([C021](#)) [%]
- $n_{rsyn}$  Synchronous motor speed [rpm]
- $n_r$  Rated motor speed according to the motor nameplate [rpm]
- $f_r$  Rated motor frequency according to the motor nameplate [Hz]
- p Number of motor pole pairs (1, 2, 3 ...)

2. Transfer the calculated slip constant s in [C021](#).
3. Correct the setting in [C021](#) while the drive is running until the load-dependent speed drop does not occur anymore between idling and maximum load of the motor in the desired speed range.



#### Tip!

The following guide value applies to a correctly set slip compensation:

- Deviation from the rated motor speed  $\leq 1\%$  for the speed range of 10 % ... 100 % of the rated motor speed and loads  $\leq$  rated motor torque.
- Greater deviations are possible in the field weakening range.
- [C021](#) is set too high, the drive may get unstable.
- Negative slip ([C021](#) < 0) with V/f characteristic control results in "smoother" drive behaviour at heavy load impulses or applications requiring a significant speed drop under load.

### 5.6.5 Oscillation damping

Mechanical oscillations are undesirable effects in every process and they may have an adverse effect on the single system components and/or the production output.

Mechanical oscillations in the form of speed oscillations are suppressed by the oscillation damping function.

Parameter	Info	Lenze setting	
		Value	Unit
<a href="#">C234</a>	Oscillation damping influence	5.00	%

Oscillation damping is successfully used with

- unloaded motors (no-load oscillations)
- motors whose rated power deviates from the rated power of the controller.
  - e.g. during operation at high switching frequency including the power derating involved.
- operation with higher-pole motors
- operation with special motors
- compensation of resonance in the drive
  - At an output frequency of approx. 20 ... 40 Hz, some asynchronous motors can show resonance which causes current and speed variations and thus destabilise the running operation.



#### How to eliminate speed oscillations:

1. Approach the area where the speed oscillations occur.
2. Reduce the speed oscillations by changing [C234](#) step by step.
3. These can be indicators for smooth running:
  - Constant motor current characteristic
  - Reduction of the mechanical oscillations in the bearing seat

## 5.7 Braking operation/braking energy management

When electric motors are braked, the kinetic energy of the drive train is fed back into the DC circuit regeneratively. This energy leads to an increase in the DC bus voltage. In order to avoid overvoltage in the DC bus, several different strategies can be used:

- Use of an external brake resistor
- Use of an external brake module (only for inverters with single phase supply)
- Coupling of the inverters in a DC-bus connection (only for inverters with three-phase supply)
- Recovery of regenerative energy with a regenerative module (only for inverters with three-phase supply)



### Stop!

If the connected brake resistor is smaller than required, the brake chopper can be destroyed!

- For rated data see hardware manual.
- Appropriate protective measures are provided in the "[Avoiding thermal overload of the brake resistor](#)" subchapter. (102)



### Note!

- We recommend to use the brake chopper (brake transistor) which is integrated into the controller for the braking operation, regardless of the selected motor control.
- For a DC-bus connection with other devices, we recommend to connect the regenerative power supply module to terminals +UG and –UG.
- If none of these measures is taken, e.g. the overvoltage deactivation ("OU") may respond in case of low deceleration times during regenerative operation. ▶ [Error messages of the operating system](#) (156)



Observe the notes on braking operation in the hardware manual! (see "braking operation" chapter).

All the necessary instructions for the drive controller are stored in electronic form on the data carrier supplied with the 8400 drive controller.

### Short overview of the relevant parameters:

Parameter	Info	Lenze setting	
		Value	Unit
<a href="#">C173</a>	Mains voltage	3ph 400 V / 1ph 230 V	
<a href="#">C174</a>	Reduced brake chopper threshold	0	V
<a href="#">C574</a>	Resp. to brake resist. overtemp.	No response	

### 5.7.1 Setting the voltage source for braking operation

The voltage threshold for braking operation is set via the mains voltage (C173) and the reduced brake chopper threshold (C174). When this "brake chopper threshold" is exceeded in the DC bus, the energy is dissipated in the DC bus via the brake resistor and the DC-bus voltage is reduced.

- The brake chopper threshold is preset as follows so that it is higher than the specified mains (C173):

C173	Mains voltage		Brake chopper threshold	
	1-phase	3-phase	1-phase	3-phase
0	1ph 230V	3ph 400V	380V DC	725V DC
1	1ph 230V	3ph 440V	380V DC	35V DC
2	1ph 230V	3ph 480V	380V DC	775V DC
3	1ph 230V	3ph 500V	380V DC	790V DC

- This brake chopper threshold can be reduced by 0 ... 150 V via C174.



#### Stop!

The brake chopper threshold resulting from C173 and C174 must not exceed the stationary DC-bus voltage!

#### Example:

- A 400 V device has a maximum mains voltage of 420 V AC.
  - Maximum stationary DC-bus voltage:  $420 \text{ V AC} \cdot 1.414 = 594 \text{ V DC}$
  - C173 has been set with the selection "0" for 400 V AC mains.
- This means that C174 can be set to a maximum of 131 V DC ( $725 \text{ V DC} - 594 \text{ V DC}$ ).

### 5.7.2 Avoiding thermal overload of the brake resistor

- Parameterisation of an error response in C574 and evaluation of the parameterised error message within the application or within the machine control system.
  - See chapter entitled "[Brake resistor monitoring \(l2xt\)](#)". (106)
- External interconnection using the thermal contact on the brake resistor (e.g. supply interruption via the mains contactor and activation of the mechanical brakes).

### 5.8 Monitoring

Many monitoring functions that are integrated into the controller can detect errors and thus protect the device/motor from damage or overload.

- Detailed information on the individual monitoring functions can be found in the following sub-chapters.

Monitoring	Response (Lenze setting)	Parameter
<a href="#">Device overload monitoring (Ixt)</a>	Warning	<a href="#">C604</a>
<a href="#">Motor load monitoring (I2xt)</a>	Warning	<a href="#">C606</a>
<a href="#">Brake resistor monitoring (I2xt)</a>	No Reaction	<a href="#">C574</a>
<a href="#">Mains phase failure monitoring</a>	Warning	<a href="#">C565</a>

#### Parameterisable responses

If a monitoring function trips, the response set via the corresponding parameter is carried out. The following responses can be selected:

- "No response": Response/monitoring is deactivated.
- "Fault": Change of the operating status by a pulse inhibit of the power output stage.
- "Warning": Operating status of the controller remains unchanged. Only a message is entered into the logbook of the controller.

#### Related topics:

- ▶ [Device states](#) (📖 53)
- ▶ [Diagnostics & error management](#) (📖 145)
- ▶ [Basics on error handling in the controller](#) (📖 145)
- ▶ [Error messages of the operating system](#) (📖 156)

#### 5.8.1 Device overload monitoring (Ixt)

In [C064/1...3](#) displays the device utilisation (ixt) in [%] in different time intervals:

Parameter	Info
<a href="#">C064/1</a>	Device utilisation (Ixt) <ul style="list-style-type: none"> <li>• Maximum value of the pulse utilisation (<a href="#">C064/2</a>) and permanent utilisation (<a href="#">C064/3</a>).</li> </ul>
<a href="#">C064/2</a>	Device utilisation (Ixt) 15s <ul style="list-style-type: none"> <li>• Pulse utilisation over the last 15 seconds (only for loads &gt;160 %).</li> </ul>
<a href="#">C064/3</a>	Device utilisation (Ixt) 3 min <ul style="list-style-type: none"> <li>• Permanent utilisation over the last 3 minutes.</li> </ul>
Highlighted in grey = display parameter	

- If the device utilisation reaches the switch-off threshold set in [C123](#):
  - The error response set in [C604](#) will be carried out (Lenze setting: "Warning").
  - The "[OC5: Ixt overload](#)" error message will be entered into the logbook.
- A setting of [C604](#) = "0: No Reaction" deactivates the monitoring.

### 5.8.2 Motor load monitoring (I<sup>2</sup>xt)

The Inverter Drives 8400 are provided with a simple, sensorless, thermal I<sup>2</sup>xt motor monitoring of self-ventilated standard motors which is based on a mathematical model.

- In [C066](#) displays the calculated motor load in [%].
- If the motor load reaches the switch-off threshold set in [C120](#):
  - The error response set in [C606](#) will be carried out (Lenze setting: "Warning").
  - The "[OC6: I<sup>2</sup>xt motor overload](#)" error message will be entered into the logbook.
- A setting of [C606](#) = "0: No Reaction" deactivates the monitoring.



#### Stop!

The I<sup>2</sup>xt motor monitoring does not present full motor protection! As the motor utilisation calculated in the thermal motor model is lost after mains switching, for instance the following operating states cannot be measured correctly:

- Restarting (after mains switching) of a motor that is already very hot.
- Change of the cooling conditions (e.g. cooling air flow interrupted or too warm).

A full motor protection requires additional measures as e.g. the evaluation of temperature sensors that are located directly in the winding or the use of thermal contacts.



#### Note!

From version 03.04.00, the thermal motor load displayed in [C066](#) can be pre-initialised when the device is connected to the mains, optionally using a fixed value or the value used last at the time when the device was switched off. The desired initialisation is selected in [C122](#). In the Lenze setting of [C122](#), the behaviour remains unchanged (no initialisation).

#### Adjustment of the motor utilisation meter

The motor utilisation meter for indicating the motor load in [C066](#) begins to count when the apparent motor current ([C054](#)) is greater than the set overload threshold ([C120](#)).

The overload threshold ([C120](#)) is to be set as follows:

$$C00120 = \frac{I_r}{I_N} \cdot 100\%$$

$I_r$  : Rated motor current (see nameplate of motor)

$I_N$  : Rated controller current at a switching frequency of  $f = 8$  kHz

- If you reduce [C120](#) starting from the calculated value, the motor utilisation meter will already be counted up before the rated overload threshold is reached.
- If you reduce [C120](#) starting from the calculated value, the motor utilisation meter will already be counted up before the rated overload threshold is reached.



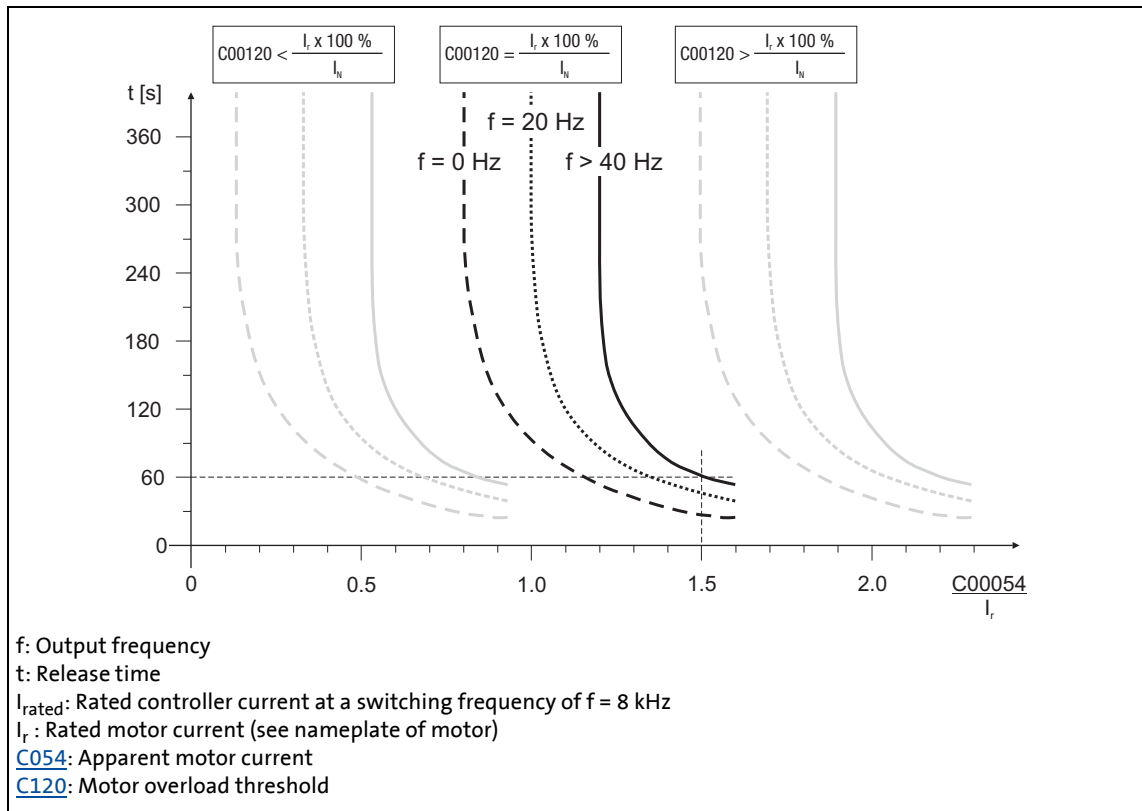

[5-5] Tripping characteristic of the  $I^2xt$  monitoring

### Example:

$$C120 = I_r / I_{rated} \times 100\%$$

$$C054 = 150\% \text{ rated motor current}$$

- After approx. 60 seconds, [C066](#) has reached the final value 100% at output frequencies  $f > 40 \text{ Hz}$ .
- The controller outputs the "[OC6: I²xt overload motor](#)" error message and triggers the response set in [C606](#) (default setting: "Warning").



### Tip!

- If forced ventilated motors are used, a premature response of the overload threshold can be avoided by deactivating this function if necessary ([C606](#) = "0: No Reaction").
- The current limits set in [C022](#) and [C023](#) influence the  $I^2xt$  calculation only in an indirect way. However, the operation of the motor at maximum possible load can be averted.
  - ▶ [Defining current and speed limits](#) (76)

### 5.8.3 Brake resistor monitoring (I<sup>2</sup>xt)

Due to the converted braking power, the brake resistor is thermally stressed and can even be thermally destroyed by excessive braking power.

The monitoring of the I<sup>2</sup>xt utilisation of the controller serves to protect the brake resistor. It acts in proportion to the converted braking power.



#### Danger!

In the Lenze setting (([C574](#) = "0: No Reaction") the response of the monitoring function does not stop the braking operation!

In particular for applications such as hoists or applications with a DC-bus connection, it must be checked if a stopping of the braking operation due to the setting of [C574](#) = "1: Fault" is permissible.



#### Stop!

Implement appropriate protective measures against thermal overload of the brake resistor!

##### Examples:

- Parameterisation of an error response in [C574](#) and evaluation of the parameterised error message within the application or within the machine control system.
  - Interruption of the mains supply by means of the temperature contact at the brake resistor and a simultaneous activation of the mechanical brake.
- If the I<sup>2</sup>xt utilisation reaches a permanently set switch-off threshold:
    - The error response set in [C574](#) takes place.
    - The "[OC12: I<sup>2</sup>xt brake resistor overload](#)" error message is entered into the logbook.
  - If the system is dimensioned correctly, the monitoring mode should not respond.
  - If the DC-bus voltage exceeds the overvoltage threshold due to a braking energy that is too high, the monitoring for overvoltage in the DC bus is activated ("OU: DC-bus overvoltage" error message).

#### Related topics:

- ▶ [Braking operation/braking energy management](#) (📖 101)

### 5.8.4 Mains phase failure monitoring



#### Stop!

Under load, the mains input of a three-phase controller can be destroyed if the device is only supplied by two phases (e.g. if a mains phase fails).

The drive controller has a simple mains-phase failure detection function with which a mains phase failure can be detected under load.

- In the case of power-adapted machines, approx. 50 % of the rated motor power must be exceeded so that a main-phase failure can be detected.
- If the mains phase failure monitoring is tripped:
  - The error response set in [C565](#) will be carried out (Lenze setting: "Warning").
  - The "[Su02: Mains voltage switched-off](#)" error message is entered into the logbook.

## 6 I/O terminals

This chapter provides information on the function, possible parameter settings, and technical data of the input/output terminals of the controller.

In the »Engineer«, the digital and analog input and output terminals are parameterised on the **Terminal assignment** tab. To do this, go to the **Control terminals** list field and select the terminals that you wish to parameterise:

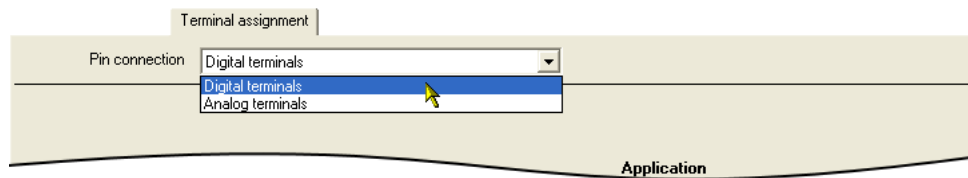

You can find further information in the respective subchapter:

▶ [Digital terminals](#) (📖 109)

▶ [Analog terminals](#) (📖 111)



### Note!

The input and output terminals of the controller are already functionally assigned in the default setting ("Lenze setting"). The preconfigured assignment depends on the control mode selected in [C007](#).

▶ [Terminal assignment of the control modes](#) (📖 139)



### Tip!

How you can alter the preconfigured assignment of the input and output terminals is described in the chapter entitled "[User-defined terminal assignment](#)". (📖 114)

---

## 6.1 Digital terminals

### Digital input terminals

The drive controller has

- four parameterisable input terminals (DI1 ... DI4) for detecting digital signals.
- one RFR control input for controller enable.

### Digital output terminals

The drive controller has

- a parameterisable output terminal (DO1) for outputting digital signals,
- a relay output (NO/COM).



### Note!

Initialisation behaviour:

- After mains switching up to the start of the application
  - the digital output remains set to FALSE.
  - the switching contact of the relay (NO/COM) remains open.

Exception handling:

- In the event of a critical exception in the application (e.g. reset), the digital output is set to FALSE.

Switching cycle diagnostics of the relay:

- A reference for evaluating the wear limit can be obtained via the number of switching cycles of the relay displayed in [C177/2](#).

**Parameterisation dialog in the »Engineer«**

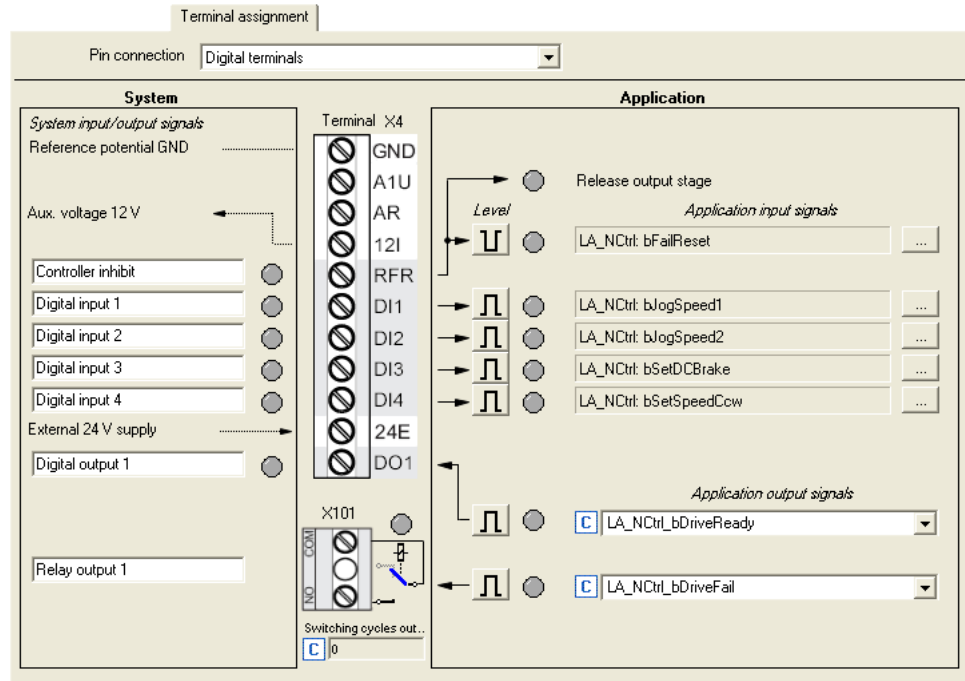

Button	Function
	Indicates the polarity of the input is HIGH active. The polarity can be changed from HIGH active to LOW active by clicking on this button.
	Indicates that the polarity of the input is LOW active. The polarity can be changed from LOW active to HIGH active by clicking on this button.
	Open the parameterising dialog for assigning application inputs to the digital input. ▶ <a href="#">Changing the terminal assignment with the »Engineer«</a> (116)

**Short overview of parameters for the digital terminals:**

Parameter	Info	Lenze setting	
		Value	Unit
<b>Digital inputs DI1 ... DI5</b>			
<a href="#">C114</a>	DIx: Polarity	Bit coded	
<a href="#">C443/1</a>	DIx: Terminal level	-	
<a href="#">C443/2</a>	DIx: Output level (to the application)	-	
<b>Digital output DO1 / relay output</b>			
<a href="#">C118</a>	DOx: Inversion	Bit coded	
<a href="#">C444/1</a>	DOx: Input level (from the application)	-	
<a href="#">C444/2</a>	DOx: Terminal level	-	
<b>Digital outputs - terminal configuration</b>			
<a href="#">C621/1</a>	LS_DigitalOutput:bRelay	50: LA_nCtrl_bDriveFail	
<a href="#">C621/2</a>	LS_DigitalOutput:bOut1	51: LA_nCtrl_bDriveReady	
Highlighted in grey = display parameter			

### 6.2 Analog terminals

The controller is provided with an analog input for detecting a voltage signal. The voltage signal can be e.g. an analog speed setpoint selection or the signal of an external sensor (temperature, pressure, etc.).

- Possible voltage ranges:
  - 0 ... +10 V (Lenze setting)
  - 0 ... +5 V
  - 1 ... +5 V
- An external 250-Ω load resistor and a respective parameter setting allow to implement a current loop:
  - 0 ... 20 mA, without open-circuit monitoring
  - 4 ... 20 mA, with open-circuit monitoring



#### Note!

To avoid undefined states, free input terminals of the controller must be assigned as well, e.g. by applying 0 V to the terminal.

#### Parameterisation dialog in the »Engineer«:

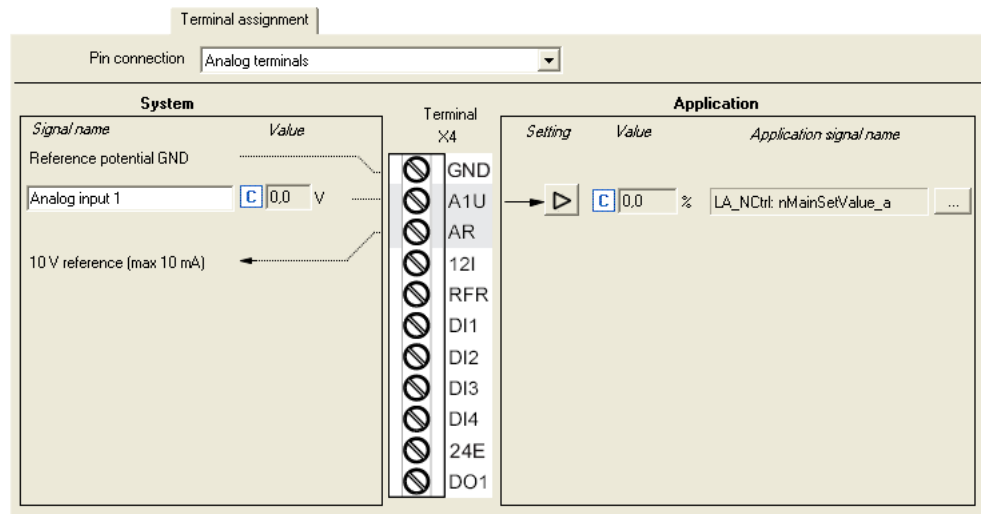

Button	Function
	<a href="#">Parameterising analog input</a> (📖 112)
	Open the parameterising dialog for assigning application inputs to the analog input. ▶ <a href="#">Changing the terminal assignment with the »Engineer«</a> (📖 116)

6.2.1 Parameterising analog input

By clicking  on the **Terminal assignment** tab, you reach the parameterising dialog for the analog input:

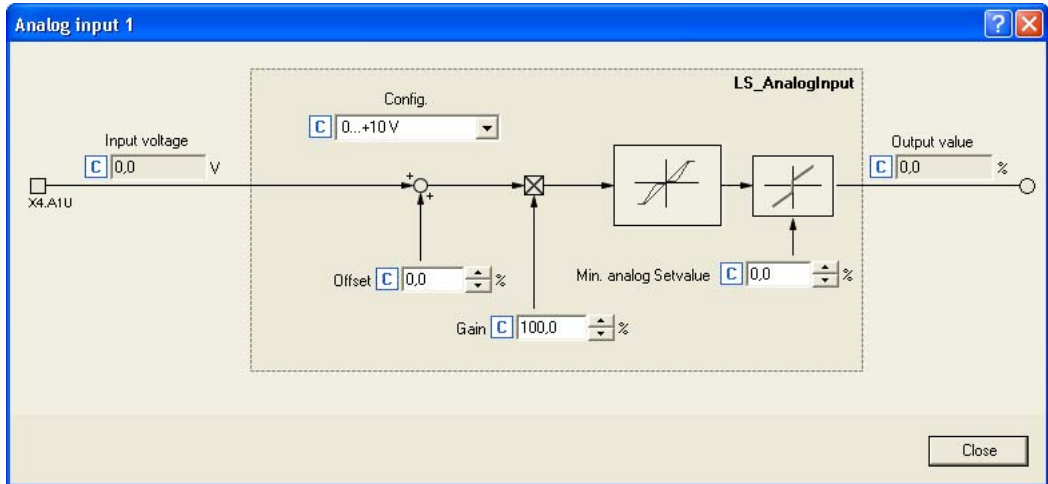

Short overview of parameters for the analog input:

Parameter	Info	Lenze setting	
		Value	Unit
<a href="#">C034/1</a>	AIN1: Config.	0: 0 ... +10 V	
<a href="#">C026/1</a>	AIN1: Offset	0.0	%
<a href="#">C027/1</a>	AIN1: Gain	100.0	%
<a href="#">C010/1</a>	AIN1: Minimum analog setpoint	0.0	%
<a href="#">C028/1</a>	AIN1: Input voltage	-	V
<a href="#">C033/1</a>	AIN1: Output value (to application)	-	%
<a href="#">C598/1</a>	Resp. to open circuit AIN1	1: Fault	

Highlighted in grey = display parameter

Using the analog input as current input

In the Lenze setting, a voltage signal in the range 0 ... +10 V is evaluated via the analog input terminal A1U.

For evaluating a current signal:

1. Connect external 250-Ω load resistor.
2. Make the following setting in [C034/1](#):
  - Selection "1: 0 ... +5 V" for 0 ... 20 mA current loop.
  - Selection "2: +1 ... +5 V" for 4 ... 20 mA current loop ("life zero", with open-circuit monitoring).
3. With a configuration as 4 ... 20 mA current loop in [C598/1](#), set the desired error response in the event of open circuit (Lenze setting: "Fault").



### Minimum and maximum output speed

The speed range required for the application results from the selected reference speed ([C011](#)) and the minimum analog setpoint ([C010](#)):

- The reference speed set in [C011](#) is reached at a speed setpoint selection of 100 %.
- All speed setpoint selections are provided in % and always refer to the reference speed set in [C011](#) (independent of the setpoint source).
- The speed set in [C010](#) corresponds to the minimum speed if the speed setpoint has been selected via the analog input (Lenze setting) and a voltage of 0 V is applied to the X4/A1U input terminal.

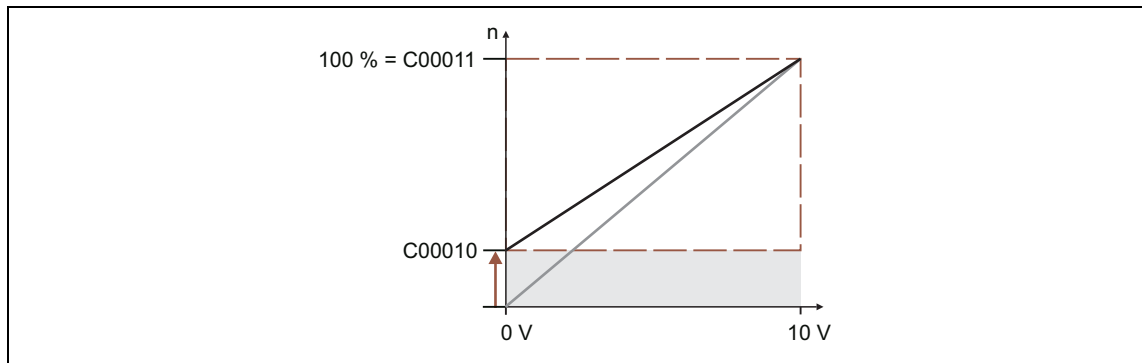

[6-1] Relation between the selected setpoint and minimum and maximum output speed

---

### 6.3 User-defined terminal assignment

In order to individually adapt the preconfigured assignment of the input/output terminals to your application, you can choose one of the following procedures:

- A. In the »Engineer«:
  - Change the terminal assignment on the **Terminal assignment** tab.
  - Change the signal assignment on the **Application Parameters** tab, on the dialog level *Overview* → *Signal flow*.
- B. In the »Engineer« or with the keypad:
  - Change the parameters for signal configuration in the parameters list.



#### Note!

If you change the preconfigured assignment of the input/output terminals, the terminal assignment will be a user-defined one. In [C007](#), control mode "0: Interconnection changed" will be shown.



#### Tip!

First set a suitable Lenze configuration by selecting a corresponding control mode in [C007](#). We recommend using the »Engineer« for the implementation of comprehensive user-defined drive solutions.

### 6.3.1 Source-destination principle

The I/O configuration of the input and output signals is carried out according to the source/destination principle:

- A connection always has a direction and therefore always has a source and a target.
- The input signals of the application are logically linked via configuration parameters to the output signals of system blocks which represent the device input terminals.
- The inputs of system blocks that represent the device output terminals are logically linked to output signals of the application via configuration parameters.

The following graphic illustrates the source/destination principle:

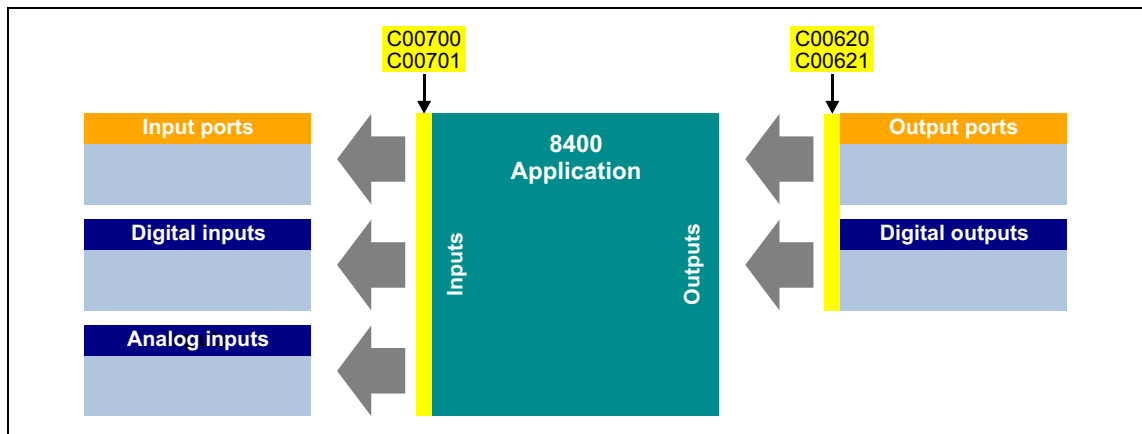

[6-2] Source-destination principle

Note the following:

- A device input terminal can be logically linked to several inputs of the application.
- Each input of the application can only be logically linked to one input signal.
- An output of the application can be logically linked to several device output terminals.

### 6.3.2 Changing the terminal assignment with the »Engineer«

The »Engineer« serves to easily change the preconfigured terminal assignment via corresponding dialogs. The following task serves to describe the respective procedure.

**Task:** Based on the preset control mode "Terminals 0", the digital input DI2 is used for activating the quick stop instead of selecting the fixed setpoint 2/3. For this purpose, the digital input DI2 must not be linked to the *bJogSpeed2* input but to the *bSetQuickstop* input of the application.

#### Possibility 1: Change terminal assignment by means of the Terminal Assignment tab

##### Procedure:

1. Select the "Digital terminals" entry on the **Terminal assignment** tab in the **Control terminals** list field:



2. Click the **...** button for the DI2 terminal in order to open the dialog box *Assignment Terminal* --> *Function block*.
  - In the list field, all block inputs that are currently logically linked to digital input DI2 are marked with a checkmark:

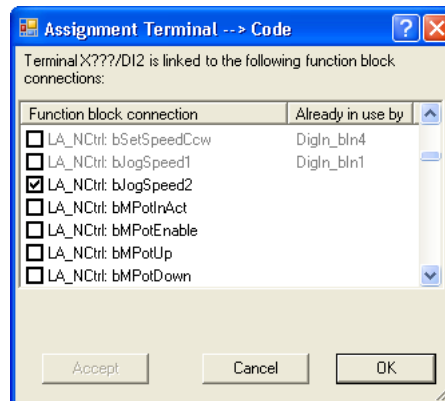

3. Remove checkmark for the connection **LA\_NCtrl: bJogSpeed2** in order to cancel the existing logical link.
4. Set checkmark for connection **LA\_NCtrl: bSetQuickstop** in order to logically link this application input to digital input DI2.
5. Click the **OK** button to close the dialog box again.

### Possibility 2: Change terminal assignment by means of the signal flow shown

#### Procedure:

1. Go to the **Application parameters** tab.
2. Go to the **Application Parameters** tab and click on the **Signal flow** button in order to change to the dialog level *Overview* → *Signal flow*.
3. In the **bJogSpeed2** list field, set the selection "0: Not interconnected".
4. In the **bSetQuickstop** list field, set the "12: DigIn\_bIn2" selection.

### 6.3.3 Changing the terminal assignment via configuration parameters

The preconfigured terminal assignment can be reconfigured via a bus system, with the keypad or with the »Engineer« by means of configuration parameters.

- Each configuration parameter represents a signal input of a function block, a system block or an application block.
- Each configuration parameter contains a selection list with output signals of the same type of data.
- Logical linking is thus carried out by selecting the output signal for the corresponding signal input.

In the following example, digital output 1 (**LS\_DigitalOutput.bOut1** input) is logically linked to the status signal "Drive ready" (**LA\_nCtrl\_bDriveReady** output signal):

	C...	Name	Value	Unit
621	1	LS_DigitalOutput: bRelay	LA_NCtrl_bDriveFail	
621	2	LS_DigitalOutput: bOut1	51: LA_NCtrl_bDriveReady	
621	3	Reserved	51: LA_NCtrl_bDriveReady	
621	4	Reserved	52: LA_NCtrl_bClnhActive	
621	5	Reserved	53: LA_NCtrl_bQSPisActive	
621	6	USER LED	54: LA_NCtrl_bSafeTorqueOff	
621	7	LA_NCtrl: bStatusBit0	55: LA_NCtrl_bSafetyIsActive	
621	8	LA_NCtrl: bStatusBit2	60: LA_NCtrl_bSpeedCow	
621	9	LA_NCtrl: bStatusBit3	61: LA_NCtrl_bActSpeedEqZero	
621	10	LA_NCtrl: bStatusBit4	62: LA_NCtrl_bSpeedSetReached	
			63: LA_NCtrl_bSpeedActEqSet	
			64: LA_NCtrl_bNActCompare	



#### Tip!

An overview of all configuration parameters and their Lenze setting in the different control modes is provided in the chapter "[Pre-assignment of the drive application](#)". (133)

**Example**

**Task:** Based on the preset control mode "Terminals 0", the digital input DI2 is used for activating the quick stop instead of selecting the fixed setpoint 2/3. For this purpose, the digital input DI2 must not be linked to the *bJogSpeed2* input but to the *bSetQuickstop* input of the application.

**Procedure:**

1. Change the setting of the configuration parameter LA\_NCtrl: bSetQuickstop (C701/3) which represents the logical link of the *bSetQuickstop* application input: "0: Not connected" → "12: DigIn\_bln2"
2. Change the setting of the configuration parameter LA\_NCtrl: bJogSpeed2 (C701/7) which represents the logical link of the *bJogSpeed2* application input: "12: DigIn\_bln2" → "0: Not connected"

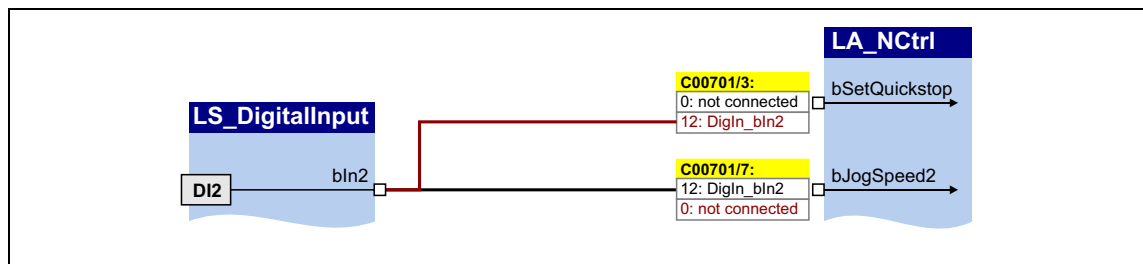

[6-3] Example: Changing the terminal assignment via configuration parameters

**Tip!**

The example shows, for each input of the application, the associated configuration parameter (C700/x or C701/x) is only allowed to contain one source that you enter.

**Related topics:**

- ▶ [Pre-assignment of the drive application](#) (133)

## 6.4

## Electrical data

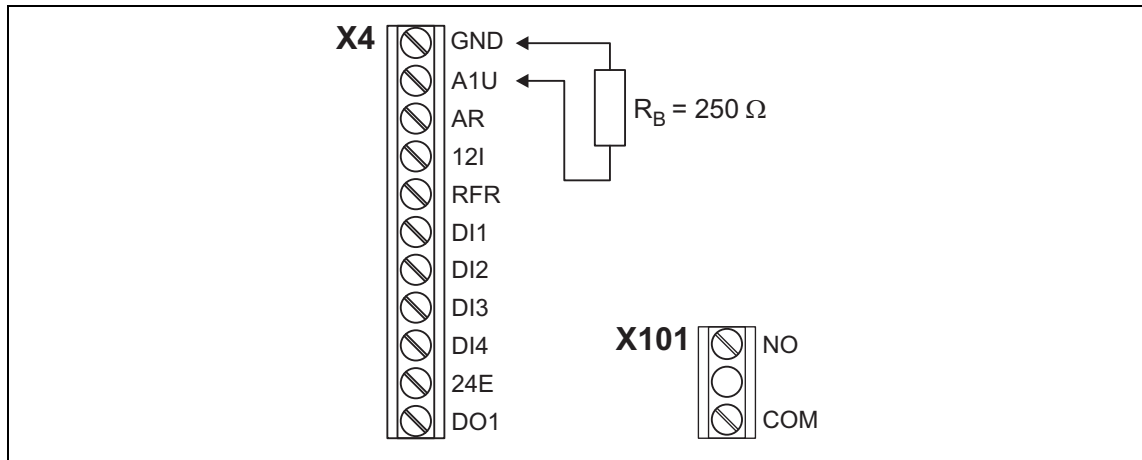

Terminal	Application / electrical data
GND	Reference potential
A1U	Voltage or current input
	General data:
	Resolution: 10 bits (Error: 1 digit $\equiv$ 0.1 %, in relation to the final value)
	Conversion rate: 1 kHz In order to filter short-time faults in the analog signal characteristic, the analog input value is led via a digital lag filter with a time constant of 5 ms.
	Processing cycle: 1 kHz (1 ms)
	Electric strength of external voltage: $\pm 15$ V, permanent
	If used as voltage input:
	Level/scaling: When <a href="#">C034/1</a> = "0": 0 ... +10 V $\equiv$ 0 ... +2 <sup>14</sup> $\equiv$ 0 ... +16384 $\equiv$ 0 ... +100 % When <a href="#">C034/1</a> = "1" or "2": 0 ... +5 V $\equiv$ 0 ... +2 <sup>14</sup> $\equiv$ 0 ... +16384 $\equiv$ 0 ... +100 %
	Input resistance: > 50 k $\Omega$
	Input voltage in case of open circuit: Display "0" (V < 0.2 V, absolute)
	Accuracy: $\pm 0.1$ V
	If used as current input (with external 250- $\Omega$ load resistor; see illustration):
	Level/scaling: 0 ... +20 mA $\equiv$ 0 ... +2 <sup>14</sup> $\equiv$ 0 ... +16384 $\equiv$ 0 ... +100 %
	Input resistance: 250 $\Omega$ (external)
AR	10-V reference voltage for analog input
	maximum output current: 10 mA
12I	12 V voltage for connecting the digital inputs via potential-free contacts
	• Internal supply: DC
	maximum output current: 50 mA
	Electric strength of external voltage: +30 V
	Overcurrent protection: Automatic reset
RFR	Controller enable
	• Electrical data as in digital inputs

Terminal	Application / electrical data
DI1 ... DI4	Digital inputs (according to IEC 61131-2, type 1)
	LOW level: 0 ... +2.5 V
	HIGH level: +10 ... +30 V
	Input current: 4 mA per input (at 12 V supply of terminal 12I)
	Electric strength of external voltage: $\pm 30$ V, permanent
	Input impedance: 3.3 k $\Omega$ (2.0 k $\Omega$ ... 5.0 k $\Omega$ )
	Processing cycle: 1 kHz (1 ms)
24E	External 24-V voltage supply
	Input voltage: 24 V according to IEC 61131-2 DC 15.0 ... 30.0 V Max. residual ripple $\pm 5$ % SELV/PELV
	Polarity reversal protection: In case of polarity reversal, the internal 12-V supply is active; no destruction.
	Current consumption: $\approx 50$ mA during operation
DO1	Digital output (according to IEC 61131-2, type 1)
	LOW level: 0 ... +5 V
	HIGH level: +15 ... +30 V (independent of voltage at X4/24E)
	Output current: max. 50 mA (external resistance > 480 $\Omega$ at 24 V)
	Electric strength of external voltage: +30 V Integrated polarity reversal protection diode for switching inductive loads
	Processing cycle: 1 kHz (1 ms)
	Behaviour in case of overload: Reduced voltage or periodical connection/disconnection
NO / COM	Relay output <ul style="list-style-type: none"> <li>• Potential-free contact (NO contact)</li> <li>• AC 250 V / 3 A</li> <li>• DC 24 V / 2 A ... 240 V / 0.22 A (with suppressor circuit)</li> </ul> Important: The minimum load must not fall below 12 V and 5 mA.



## 7 Drive application

The "actuating drive speed" application provided in the 8400 BaseLine C controller is a drive solution equipped with Lenze's experience and know-how in which function and system blocks interconnected to a signal flow clearly show the basis for implementing typical drive tasks.

The application serves to solve speed-controlled drive tasks, e.g. conveyor drives (interconnected), extruders, test benches, vibrators, travelling drives, presses, machining tools, dosing systems.

### Brief description of the features

- Pre-configured control modes for terminals and bus control (with predefined process data connection to the fieldbus)
- Free configuration of input and output signals
- Offset and gain of the main setpoint (if defined via analog input)
- Up to 3 fixed setpoints for speed
- Adjustable setpoint ramp times
- Linear or S-shaped ramp
- Quick stop (QSP) with adjustable ramp time
- Connectable motor potentiometer function (as alternative setpoint source)
- Connectable process controller (PID controller) with various operating modes
- Load monitoring

### Input/output interface

The application features an input interface for the connection of the signal sources (e.g. main setpoint) as well as an output interface for the control of output terminals and output ports.

### Parameter

The setting/parameterisation of internal functions, the selection of setpoints and the display of actual values is executed via parameters. A re-configuration of the interfaces is also possible via the corresponding configuration parameters.

### Related topics:

- ▶ [Introduction: Parameterising the controller](#) (12)
- ▶ [Commissioning with integrated keypad](#) (27)
- ▶ [Commissioning with the »Engineer«](#) (31)

# 7 Drive application

## 7.1 Parameterisation dialog

### 7.1 Parameterisation dialog

Go to the **Application parameter** tab to change the most important settings for the application in the top dialog level *Overview* :

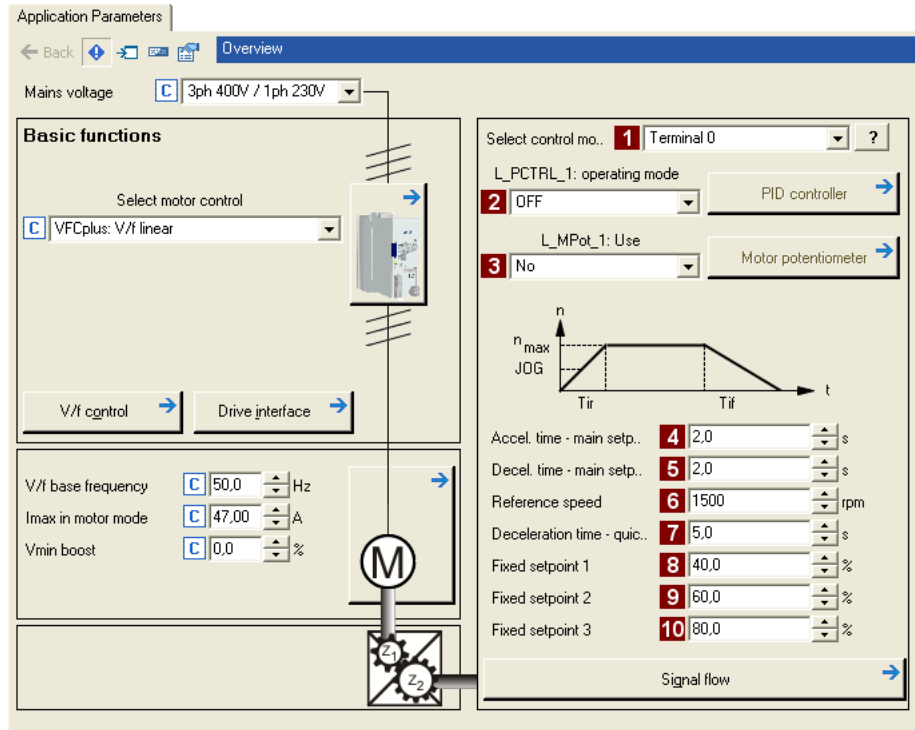

Short overview of the relevant parameters:

Parameter	Lenze setting		Info
	Value	Unit	
<b>1</b> <b>Control mode</b> (C007)	10: Terminals 0		<p>Various control modes can be selected for the application. The selection of the control mode determines the way the application is controlled, e.g. via terminals or via a fieldbus.</p> <ul style="list-style-type: none"> <li>The preconfigured assignment of the input/output terminals and ports in the respective control mode is described in the chapter entitled "<a href="#">Terminal assignment of the control modes</a>". (139)</li> <li>Detailed information on the individual configuration of the input/output terminals can be found in the description of the I/O terminals in the subchapter "<a href="#">User-defined terminal assignment</a>". (114)</li> </ul>
<b>2</b> <b>L_PCTRL_1: Operating mode</b> (C242)	0: Off		<p>A process controller (PID controller) is connected downstream of the setpoint generator.</p> <ul style="list-style-type: none"> <li>In the Lenze setting, the process controller is deactivated.</li> <li>The activation is executed by selecting the operating mode in <a href="#">C242</a>.</li> <li>For a detailed functional description see <a href="#">FB L_PCTRL_1</a>. (312)</li> </ul>

Parameter	Lenze setting		Info
	Value	Unit	
<b>3</b> <b>L_MPot_1: Use</b> (C806)	0: No		Alternatively, the main speed setpoint can be generated via a motor potentiometer function. <ul style="list-style-type: none"> <li>In the Lenze setting, the motor potentiometer function is deactivated.</li> <li>Activation is possible via <a href="#">C806</a> or via the <i>bMPotEnable</i> input.</li> <li>The behaviour of the motor potentiometer during switch-on of the drive system can be selected in <a href="#">C805</a>.</li> <li>For a detailed functional description see <a href="#">FB L_MPot_1</a>. (□ 305)</li> </ul>
<b>4</b> <b>Accel. time - main setpoint</b> (C012)	2.0	s	The setpoint is led via a ramp function generator with linear characteristic. The ramp function generator converts setpoint step-changes at the input into a ramp. <ul style="list-style-type: none"> <li>For a detailed functional description see <a href="#">FB L_NSet_1</a>. (□ 309)</li> </ul>
<b>5</b> <b>Decel. time - main setpoint</b> (C013)	2.0	s	
<b>6</b> <b>Reference speed</b> (C011)	1500	rpm	All speed setpoint selections are provided in % and always refer to the reference speed set in <a href="#">C011</a> . The motor reference speed is given on the motor nameplate.
<b>7</b> <b>Deceleration time - quick stop</b> (C105)	5.0	s	When "quick stop" is requested, the motor control is decoupled from the setpoint selection and within the deceleration time parameterised in <a href="#">C105</a> , the motor is brought to a standstill ( $n_{act} = 0$ ). <p>▶ <a href="#">Activate/Deactivate quick stop</a> (□ 50)</p>
<b>8</b> <b>Fixed setpoint 1</b> (C039/1)	40.0	%	A fixed setpoint for the setpoint generator can be activated instead of the main setpoint via the selection inputs <i>blogSpeed1</i> and <i>blogSpeed2</i> . <ul style="list-style-type: none"> <li>The fixed setpoints are selected in [%] based on the reference speed (<a href="#">C011</a>).</li> <li>For a detailed functional description see <a href="#">FB L_NSet_1</a>. (□ 309)</li> </ul>
<b>9</b> <b>Fixed setpoint 2</b> (C039/2)	60.0	%	
<b>10</b> <b>Fixed setpoint 3</b> (C039/3)	80.0	%	

**Tip!**

When you click the **Signal flow** button, you will get one dialog level down to the signal flow of the application.

# 7 Drive application

## 7.1 Parameterisation dialog

### 7.1.1 Signal flow

When you go to the **Application parameters** tab to the top dialog level *Overview* and click the **Signal flow** button, you will get one dialog level down to the signal flow of the application (here displayed with the preset control mode "Terminals 0"):

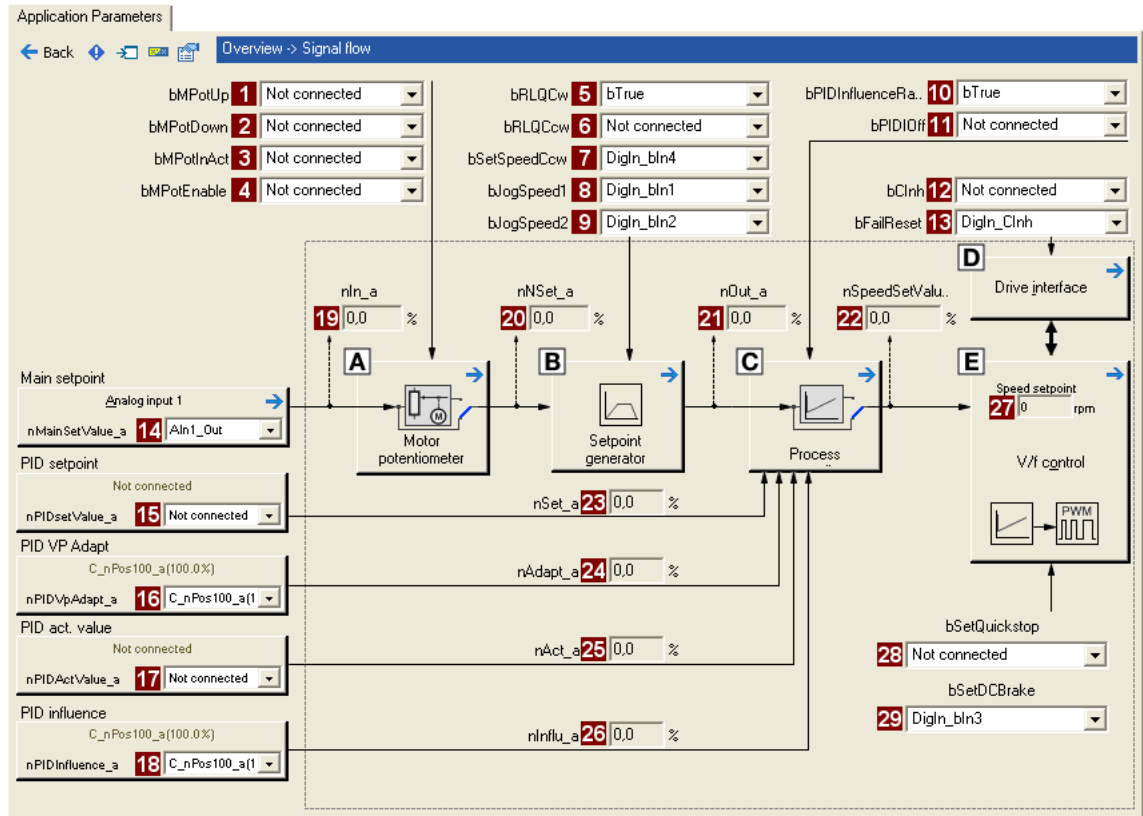

- A** Motor potentiometer ([L\\_MPot\\_1](#))
- B** Setpoint generator ([L\\_NSet\\_1](#))
- C** Process controller ([L\\_PCTRL\\_1](#))
- D** Device control ([LS\\_DriveInterface](#))
- E** [Motor control \(MCTRL\)](#)



All input and output interfaces of the application are described in the chapter entitled "[Interface description](#)". (127)

#### Configuration parameters for digital control signals:

Parameter	Selection of signal source (Lenze setting)	for control signal:
<b>1</b> <b>bMPotUp</b> ( <a href="#">C701/8</a> )	0: Not connected	<a href="#">L_MPot_1</a> : Increase speed setpoint
<b>2</b> <b>bMPotDown</b> ( <a href="#">C701/9</a> )	0: Not connected	<a href="#">L_MPot_1</a> : Decrease speed setpoint
<b>3</b> <b>bMPotInAct</b> ( <a href="#">C701/10</a> )	0: Not connected	<a href="#">L_MPot_1</a> : Activate inactive function
<b>4</b> <b>bMPotEnable</b> ( <a href="#">C701/11</a> )	0: Not connected	<a href="#">L_MPot_1</a> : Activate motor potentiometer function
<b>5</b> <b>bRLQCw</b> ( <a href="#">C701/17</a> )	1: C_bTrue	Activate clockwise rotation (fail-safe)

Parameter	Selection of signal source (Lenze setting)	for control signal:
<b>6</b> <b>bRLQCcw</b> (C701/18)	0: Not connected	Activate counter-clockwise rotation (fail-safe)
<b>7</b> <b>bSetSpeedCcw</b> (C701/5)	14: DigIn_bln4 (DI4)	Change of direction of rotation
<b>8</b> <b>bJogSpeed1</b> (C701/6)	11: DigIn_bln1 (DI1)	Selection of fixed setpoints (JOG setpoints)
<b>9</b> <b>bJogSpeed2</b> (C701/7)	12: DigIn_bln2 (DI2)	
<b>10</b> <b>bPIDEnableInfluenceRamp</b> (C701/15)	1: C_bTrue	<a href="#">L_PCTRL_1</a> : Activate ramp for influencing factor
<b>11</b> <b>bPIDOff</b> (C701/16)	0: Not connected	<a href="#">L_PCTRL_1</a> : Switch off I component
<b>12</b> <b>bCInh</b> (C701/1)	1: C_bTrue	<a href="#">Enable/Inhibit controller</a>
<b>13</b> <b>bFailReset</b> (C701/2)	15: DigIn_Clnh (RFR)	<a href="#">Reset of error message</a>
<b>28</b> <b>bSetQuickstop</b> (C701/3)	0: Not connected	Enable quick stop (QSP)
<b>29</b> <b>bSetDCBrake</b> (C701/3)	13: DigIn_bln3 (DI3)	Manual DC-injection braking (DCB)

#### Configuration parameters for analog setpoints:

Parameter	Selection of signal source (Lenze setting)	for setpoint selection:
<b>14</b> <b>nMainSetValue_a</b> (C700/1)	10: AI1_Out (Analog input 1)	Main setpoint • 100 % ≙ reference speed (C011)
<b>15</b> <b>nPIDSetValue_a</b> (C700/9)	0: Not connected	<a href="#">L_PCTRL_1</a> : Sensor setpoint or process setpoint for operating mode 2
<b>16</b> <b>nPIDVpAdapt_a</b> (C700/6)	1: C_nPos100_a (100%)	<a href="#">L_PCTRL_1</a> : Adaptation of the gain Vp set in <a href="#">C222</a> in percent
<b>17</b> <b>nPIDActValue_a</b> (C700/7)	0: Not connected	<a href="#">L_PCTRL_1</a> : Actual speed value or actual sensor value (actual process value)
<b>18</b> <b>nPIDInfluence_a</b> (C700/8)	1: C_nPos100_a (100%)	<a href="#">L_PCTRL_1</a> : Limitation of the influencing factor in percent

#### Display parameter

Parameter	Info
<b>19</b> <b>nIn_a</b> (C830/11)	Input value of motor potentiometer
<b>20</b> <b>nNSet_a</b> (C830/1)	Input value of setpoint generator
<b>21</b> <b>nOut_a</b> (C830/2)	Output value of setpoint generator
<b>22</b> <b>nSpeedSetValue_a</b> (C830/2)	Speed setpoint for motor control
<b>23</b> <b>nSet_a</b> (C830/8)	Sensor setpoint or process setpoint for operating mode 2
<b>24</b> <b>nAdapt_a</b> (C830/7)	Adaptation of the gain Vp set in <a href="#">C222</a> in percent
<b>25</b> <b>nAct_a</b> (C830/6)	Speed or actual sensor value (actual process value)

# 7 Drive application

## 7.1 Parameterisation dialog

---

Parameter	Info
<b>26</b> nInflu_a (C830/9)	Limitation of the influencing factor in percent
<b>27</b> Speed setpoint (C050)	Speed setpoint

### 7.1.1.1 Selection of the main speed setpoint

The main speed setpoint is selected in the Lenze setting via the analog input 1.

- Scaling: 10 V  $\equiv$  100 % reference speed ([C011](#))
- The main setpoint is transformed to a speed setpoint in the setpoint encoder via a ramp function generator with linear or S-shaped ramps.
- For a detailed functional description see FB [L\\_NSet\\_1](#). ([309](#))

#### Related topics:

- ▶ [Analog terminals](#) ([111](#))
- ▶ [Parameterising analog input](#) ([112](#))

### 7.1.1.2 Motor potentiometer function

Alternatively, the main speed setpoint can be generated via a motor potentiometer function.

- In the Lenze setting, the motor potentiometer function is deactivated.
- Activation is possible via [C806](#) or via the *bMPotEnable* input.
- The behaviour of the motor potentiometer during switch-on of the drive system can be selected in [C805](#).
- For a detailed functional description see FB [L\\_MPot\\_1](#). ([305](#))

### 7.1.1.3 Process controller

A process controller (PID controller) is connected downstream of the setpoint generator.

- In the Lenze setting, the process controller is deactivated.
- The activation is executed by selecting the operating mode in [C242](#).
- For a detailed functional description see FB [L\\_PCTRL\\_1](#). ([312](#))

### 7.2 Interface description



#### Tip!

You can change the preconfigured assignment of the respective input via the configuration parameters given in the first column.

▶ [User-defined terminal assignment](#) (114)

#### Inputs

Identifier	Data type Configuration parameters	Information/possible settings
nMainSetValue_a	INT <a href="#">C700/1</a>	<p>Main speed setpoint</p> <ul style="list-style-type: none"> <li>• Scaling: <math>16384 \equiv 100\%</math> reference speed (<a href="#">C011</a>)</li> <li>• The main setpoint is transformed to a speed setpoint in the setpoint encoder via a ramp function generator with linear or S-shaped ramps.</li> <li>• Upstream to the ramp function generator, a blocking speed masking function and a setpoint MinMax limitation are effective.</li> <li>• For a detailed functional description see FB <a href="#">L_NSet</a>.</li> </ul>
nTorqueMotLim_a nTorqueGenLim_a	INT <a href="#">C700/2...3</a>	<p>Torque limitation in motor mode and in generator mode</p> <ul style="list-style-type: none"> <li>• These input signals are directly transferred to the motor control to limit the controller's maximum torque in motor and generator mode.</li> <li>• The drive cannot output a higher torque in motor/generator mode than set here.</li> <li>• The applied values (any polarity) are internally interpreted as absolute values.</li> <li>• If sensorless vector control (SLVC) is selected, the limitation has a <u>direct</u> effect on the torque-producing current component.</li> <li>• Scaling: <math>16384 \equiv 100\% M_{max}</math> (<a href="#">C057</a>)</li> </ul> <p>Torque limits in motor and generator mode:</p>
<b>Device control</b>		
wCANControl	WORD	<p>Control word via system bus (CAN)</p> <ul style="list-style-type: none"> <li>• In the control mode "30: CAN", the controller controlled by a master control (e.g. IPC) receives its control word by the CANopen system bus interface. The process data word is provided at this input by the upstream port block <a href="#">LP_CanIn1</a>.</li> <li>• See the "<a href="#">Process data assignment for control via CAN</a>" subchapter for a detailed description of the individual control bits.</li> <li>• Display parameter: <a href="#">C136/2</a></li> </ul>
bCInh	BOOL <a href="#">C701/1</a>	<p><a href="#">Enable/Inhibit controller</a></p> <p>FALSE</p> <p>Enable controller: The controller switches to the "<a href="#">OperationEnabled</a>" device state, if no other source of a controller inhibit is active.</p> <ul style="list-style-type: none"> <li>• <a href="#">C158</a> provides a bit coded representation of all active sources/triggers of a controller inhibit.</li> </ul>
		<p>TRUE</p> <p>Inhibit controller (controller inhibit): The controller switches to the "<a href="#">SwitchedON</a>" device state.</p>

Identifier	Information/possible settings
bFailReset Data type Configuration parameters BOOL <a href="#">C701/2</a>	<a href="#">Reset of error message</a> In the Lenze setting this input is connected to the digital input controller enable so that a possibly existing error message is reset together with the controller enable (if the cause for the fault is eliminated). TRUE The current fault is reset, if the cause for the fault is eliminated. • If the fault still exists, the error status remains unchanged.
bSetQuickstop BOOL <a href="#">C701/3</a>	Enable quick stop (QSP) • Also see device command " <a href="#">Activate/Deactivate quick stop</a> ". TRUE Activate quick stop • The motor control is decoupled from the setpoint selection and within the deceleration time parameterised in <a href="#">C105</a> the motor is brought to a standstill ( $n_{ist} = 0$ ). • The motor is kept at a standstill during closed-loop operation. • A pulse inhibit (CINH) is set if the "Auto-DCB" function has been activated via <a href="#">C019</a> . FALSE Deactivate quick stop • The quick stop is deactivated if no other source for the quick stop is active. • <a href="#">C159</a> provides a bit coded representation of all active sources/ triggers of a quick stop.
bSetDCBrake BOOL <a href="#">C701/4</a>	Manual DC-injection braking (DCB) • Detailed information on DC-injection braking is provided in the motor control, subchapter " <a href="#">DC-injection braking</a> ".  <b>Note!</b> Holding braking is not possible when this braking mode is used! FALSE Deactivate DC-injection braking. TRUE Activate DC-injection braking, i.e. the drive is brought to a standstill by means of DC-injection braking. • The braking effect stops when the rotor is at standstill. • After the hold time (( <a href="#">C107</a> ) has expired, the controller sets the pulse inhibit (CINH).
<b>Fail-safe selection of the direction of rotation in connection with quick stop</b> • In control mode "Terminals 16", both inputs are connected to the digital terminals DI3 and DI4. • For a detailed functional description see FB <a href="#">L_RLO</a> .	
bRLQCw BOOL <a href="#">C701/17</a>	Activate clockwise rotation (fail-safe) FALSE Quick stop TRUE Clockwise rotation
bRLQCcw BOOL <a href="#">C701/18</a>	Activate counter-clockwise rotation (fail-safe) FALSE Quick stop TRUE Counter-clockwise rotation



Identifier Data type Configuration parameters	Information/possible settings				
<b>Setpoint generator</b> • For a detailed functional description see FB <a href="#">L_NSet</a> .					
bSetSpeedCcw  BOOL <a href="#">C701/5</a>	Change of direction of rotation • For instance if a motor or gearbox is fixed laterally reversed to a machine part, but the setpoint selection should still be executed for the positive direction of rotation.  <table border="1" data-bbox="608 533 1441 607"> <tr> <td>FALSE</td> <td>Clockwise rotation (Cw)</td> </tr> <tr> <td>TRUE</td> <td>Counter-clockwise rotation (Ccw)</td> </tr> </table>	FALSE	Clockwise rotation (Cw)	TRUE	Counter-clockwise rotation (Ccw)
FALSE	Clockwise rotation (Cw)				
TRUE	Counter-clockwise rotation (Ccw)				
bJogSpeed1 bJogSpeed2  BOOL <a href="#">C701/6</a> <a href="#">C701/7</a>	Selection inputs for fixed changeover setpoints (JOG setpoints) for the main setpoint • A fixed setpoint for the setpoint generator can be activated instead of the main setpoint via these selection inputs. • The two selection inputs are binary coded, therefore you can select three fixed setpoints. • In the case of binary coded selection "0" (all inputs = FALSE or not assigned), main setpoint <i>nMainSetValue_a</i> is active. • The fixed setpoints are selected in <a href="#">C039/1...3</a> in [%] based on the reference speed ( <a href="#">C011</a> ). • For a detailed functional description see FB <a href="#">L_NSet</a> .				
bRFG_0  BOOL <a href="#">C701/12</a>	Ramp function generator: Lead the main setpoint integrator to "0" within the current <i>Ti</i> times • For a detailed functional description see FB <a href="#">L_NSet</a> .  <table border="1" data-bbox="608 981 1441 1043"> <tr> <td>TRUE</td> <td>The current value of the main setpoint integrator is led to "0" within the <i>Ti</i> time set.</td> </tr> </table>	TRUE	The current value of the main setpoint integrator is led to "0" within the <i>Ti</i> time set.		
TRUE	The current value of the main setpoint integrator is led to "0" within the <i>Ti</i> time set.				
<b>Motor potentiometer</b> Alternatively to the input signal <i>nMainSetValue_a</i> , the main setpoint can also be generated by a motor potentiometer function. • In the Lenze setting, the motor potentiometer function is deactivated. • Activation is possible via <a href="#">C806</a> or via the <i>bMPotEnable</i> input. • The behaviour of the motor potentiometer during switch-on of the drive system can be selected in <a href="#">C805</a> . • For a detailed functional description see FB <a href="#">L_MPot</a> .					
bMPotUp  BOOL <a href="#">C701/8</a>	Increasing the speed setpoint  <table border="1" data-bbox="608 1283 1441 1350"> <tr> <td>TRUE</td> <td>Approach the upper speed value set in <a href="#">C800</a> with the acceleration time set in <a href="#">C802</a>.</td> </tr> </table>	TRUE	Approach the upper speed value set in <a href="#">C800</a> with the acceleration time set in <a href="#">C802</a> .		
TRUE	Approach the upper speed value set in <a href="#">C800</a> with the acceleration time set in <a href="#">C802</a> .				
bMPotDown  BOOL <a href="#">C701/9</a>	Decreasing the speed setpoint  <table border="1" data-bbox="608 1384 1441 1451"> <tr> <td>TRUE</td> <td>Approach the lower speed limit value set in <a href="#">C801</a> with the deceleration time set in <a href="#">C803</a>.</td> </tr> </table>	TRUE	Approach the lower speed limit value set in <a href="#">C801</a> with the deceleration time set in <a href="#">C803</a> .		
TRUE	Approach the lower speed limit value set in <a href="#">C801</a> with the deceleration time set in <a href="#">C803</a> .				
bMPotInAct  BOOL <a href="#">C701/10</a>	Activating the inactive function  <table border="1" data-bbox="608 1485 1441 1581"> <tr> <td>TRUE</td> <td>The speed setpoint behaves according to the inactive function set in <a href="#">C804</a>. • In the Lenze setting, the speed setpoint is maintained.</td> </tr> </table>	TRUE	The speed setpoint behaves according to the inactive function set in <a href="#">C804</a> . • In the Lenze setting, the speed setpoint is maintained.		
TRUE	The speed setpoint behaves according to the inactive function set in <a href="#">C804</a> . • In the Lenze setting, the speed setpoint is maintained.				
bMPotEnable  BOOL <a href="#">C701/11</a>	Activating the motor potentiometer function • This input and <a href="#">C806</a> are OR'd.  <table border="1" data-bbox="608 1648 1441 1709"> <tr> <td>TRUE</td> <td>The motor potentiometer function is active; the speed setpoint can be changed via the <i>bMPotUp</i> and <i>bMPotDown</i> control inputs.</td> </tr> </table>	TRUE	The motor potentiometer function is active; the speed setpoint can be changed via the <i>bMPotUp</i> and <i>bMPotDown</i> control inputs.		
TRUE	The motor potentiometer function is active; the speed setpoint can be changed via the <i>bMPotUp</i> and <i>bMPotDown</i> control inputs.				

Identifier	Data type Configuration parameters	Information/possible settings	
<b>Process controller</b>			
<ul style="list-style-type: none"> <li>In the Lenze setting, the process controller is deactivated.</li> <li>The activation is executed by selecting the operating mode in <a href="#">C242</a>.</li> <li>For a detailed functional description see FB <a href="#">L_PCTRL</a>.</li> </ul>			
bPIDEnableInfluenceRamp	BOOL <a href="#">C701/15</a>	Activate ramp for influencing factor	
		FALSE	Influencing factor of the PID controller is ramped down to "0".
		TRUE	Influencing factor of the PID controller is ramped up to the value <i>nPIDInfluence_a</i> .
bPIDOff	BOOL <a href="#">C701/16</a>	Switch off I-component of the process controller	
		TRUE	I-component of the process controller is switched off.
nPIDVpAdapt_a	INT <a href="#">C700/6</a>	Adaptation of the gain Vp set in <a href="#">C222</a> in percent <ul style="list-style-type: none"> <li>Scaling: 16384 <math>\equiv</math> 100 %</li> <li>Internal limitation to <math>\pm 199.9</math> %</li> <li>Changes can be done online.</li> </ul>	
nPIDActValue_a	INT <a href="#">C700/7</a>	Speed or actual sensor value (actual process value) <ul style="list-style-type: none"> <li>Scaling: 16384 <math>\equiv</math> 100 %</li> <li>Internal limitation to <math>\pm 199.9</math> %</li> </ul>	
nPIDInfluence_a	INT <a href="#">C700/8</a>	Limitation of the influencing factor in percent <ul style="list-style-type: none"> <li>The influence factor of the PID controller can be limited to a certain value (-199.9% ... +199.9%) via <i>nPIDInfluence_a</i>.</li> <li>Scaling: 16384 <math>\equiv</math> 100 %</li> <li>Internal limitation to <math>\pm 199.9</math> %</li> </ul>	
nPIDSetValue_a	INT <a href="#">C700/9</a>	Sensor setpoint or process setpoint for operating mode 2 <ul style="list-style-type: none"> <li>Scaling: 16384 <math>\equiv</math> 100 %</li> <li>Internal limitation to <math>\pm 199.9</math> %</li> </ul>	

## Outputs

Identifier	Data type	Value/meaning
<b>Device control</b>		
wDeviceStateWord	WORD	Status word of the controller (based on DSP-402) <ul style="list-style-type: none"> <li>The status word contains information on the currents status of the drive controller.</li> <li>In control mode "30: CAN", the status word is transmitted to the master control as process data word via the <a href="#">LP_CanOut1</a> port block.</li> <li>For a detailed description of the individual status bits, see subchapter entitled "<a href="#">Process data assignment for control via CAN</a>".</li> <li>Display parameter: <a href="#">C150</a></li> </ul>
wDeviceAuxStateWord	WORD	Extended status word of the controller
wDetermFailNoLow	WORD	Display of the current error (Low-Word)
wDetermFailNoHigh	WORD	Display of the current error (High-Word)
bDriveFail	BOOL	TRUE Controller in error status <ul style="list-style-type: none"> <li>"<a href="#">Fault</a>" device state is active.</li> </ul>
bDriveReady	BOOL	TRUE Controller is ready for operation. <ul style="list-style-type: none"> <li>"<a href="#">SwitchedON</a>" device state is active.</li> <li>The drive is in this device state if the DC bus voltage is applied and the controller is still inhibited by the user (controller inhibit).</li> </ul>

Identifier	Data type	Value/meaning	
bCInhActive	BOOL	TRUE	Controller inhibit is active
bQSPisActive	BOOL	TRUE	Quick stop is active
bSafeTorqueOff	BOOL	TRUE	" <a href="#">SafeTorqueOff</a> " device state is active
bSafetyIsActive	BOOL	TRUE	In preparation
bSpeedCcw	BOOL	FALSE	Clockwise rotation (Cw)
		TRUE	Counter-clockwise rotation (Ccw)
bActSpeedEqZero	BOOL	TRUE	Current speed is 0
bSpeedSetReached	BOOL	TRUE	Speed setpoint reached
bSpeedActEqSet	BOOL	TRUE	Actual speed value has reached the setpoint within one hysteresis band
bNactCompare	BOOL	TRUE	During open-loop operation: Speed setpoint < comparison value ( <a href="#">C024</a> )
		TRUE	During closed-loop operation: Actual speed value < comparison value ( <a href="#">C024</a> )
bImaxActive	BOOL	TRUE	The current setpoint is limited internally (the controller operates at the maximum current limit)
<b>Motor control</b>			
bHeatSinkWarning	BOOL	TRUE	Heatsink overtemperature detected
bOVDetected	BOOL	TRUE	Overvoltage detected
bDcBrakeOn	BOOL	TRUE	<a href="#">DC-injection braking</a> active
bFlyingSyncActive	BOOL	TRUE	<a href="#">Flying restart function</a> is executed
nMotorFreqAct_a	<a href="#">C058</a>   INT	Current field frequency	
nOutputSpeedCtrl_a	INT	Speed or slip controller output • Scaling: 16384 $\equiv$ 100 % reference speed ( <a href="#">C011</a> )	
nMotorSpeedAct_a	<a href="#">C051</a>   INT	Actual speed value • Scaling: 16384 $\equiv$ 100 % reference speed ( <a href="#">C011</a> )	
nMotorVoltage_a	INT	Current motor voltage/inverter output voltage • Scaling: 16384 $\equiv$ 1000 V	
nDCVoltage_a	INT	Actual DC-bus voltage • Scaling: 16384 $\equiv$ 1000 V	
nMotorCurrent_a	INT	Current motor current • Scaling: 16384 $\equiv$ 100 % $I_{\max\_mot}$ ( <a href="#">C022</a> )	
nMotorTorqueAct_a	<a href="#">C056/2</a>   INT	Actual torque • With "VFC (+encoder)" motor control, this value is determined from the current motor current and corresponds to the actual torque only by approximation. • Scaling: 16384 $\equiv$ 100 % $M_{\max}$ ( <a href="#">C057</a> )	
nHeatsinktemperature_a	INT	Heatsink temperature	

## 7.3

## Setting parameters (short overview)

Parameter	Info	Lenze setting	
		Value	Unit
<a href="#">C012</a>	Accel. time - main setpoint	2.0	s
<a href="#">C013</a>	Decel. time - main setpoint	2.0	s
<a href="#">C182</a>	S-ramp time PT1	20.00	s
<a href="#">C134</a>	Ramp smoothing - main setpoint	0: Off	
<a href="#">C019</a>	Auto-DCB: Threshold	3	rpm
<a href="#">C036</a>	DCB: Current	50.0	%
<a href="#">C039/1</a>	Fixed setpoint 1	40.0	%
<a href="#">C039/2</a>	Fixed setpoint 2	60.0	%
<a href="#">C039/3</a>	Fixed setpoint 3	80.0	%
<a href="#">C105</a>	Deceleration time - quick stop	5.0	s
<a href="#">C106</a>	Auto-DCB: Hold time	0.5	s
<a href="#">C107</a>	DCB: Hold time	999.0	s
<a href="#">C222</a>	L_PCTRL_1: Vp	1.0	
<a href="#">C223</a>	L_PCTRL_1: Tn	400	ms
<a href="#">C224</a>	L_PCTRL_1: Kd	0.0	
<a href="#">C225</a>	L_PCTRL_1: MaxLimit	199.9	%
<a href="#">C226</a>	L_PCTRL_1: MinLimit	-199.9	%
<a href="#">C227</a>	L_PCTRL_1: Acceleration time	0.1	s
<a href="#">C228</a>	L_PCTRL_1: Deceleration time	0.1	s
<a href="#">C231/1</a>	L_PCTRL_1: Pos. maximum	199.9	%
<a href="#">C231/2</a>	L_PCTRL_1: Pos. minimum	0.0	%
<a href="#">C231/3</a>	L_PCTRL_1: Neg. minimum	0.0	%
<a href="#">C231/4</a>	L_PCTRL_1: Neg. maximum	199.9	%
<a href="#">C242</a>	L_PCTRL_1: Operating mode	0: Off	
<a href="#">C243</a>	L_PCTRL_1: Acceleration time influence	5.0	s
<a href="#">C244</a>	L_PCTRL_1: Deceleration time influence	5.0	s
<a href="#">C245</a>	L_PCTRL_1: PID output value	-	%
<a href="#">C800</a>	L_MPot_1: Upper limit	100.0	%
<a href="#">C801</a>	L_MPot_1: Lower limit	-100.0	%
<a href="#">C802</a>	L_MPot_1: Acceleration time	10.0	s
<a href="#">C803</a>	L_MPot_1: Deceleration time	10.0	s
<a href="#">C804</a>	L_MPot_1: Inactive function	0: Retain value	
<a href="#">C805</a>	L_MPot_1: Init function	0: Load last value	
<a href="#">C806</a>	L_MPot_1: Use	0: No	

## 7.4 Pre-assignment of the drive application

### 7.4.1 Input connections

Configuration parameters	Identifier	Control mode						
		10 (terminals 0) See fig. <a href="#">[7-1]</a>	12 (Terminal 2)	14 (terminals 11)	16 (terminals 16)	20 (keypad)	21 (PC)	30 (CAN) See fig. <a href="#">[7-2]</a>
<a href="#">C700/1</a>	nMainSetValue_a	X4/A1U	X4/A1U	X4/A1U	X4/A1U	<a href="#">C728/3</a>	<a href="#">C472/1</a>	PDO1/word 2
<a href="#">C700/2</a>	nTorqueMotLim_a	<a href="#">C472/3</a>	<a href="#">C472/3</a>	<a href="#">C472/3</a>	<a href="#">C472/3</a>	<a href="#">C728/1</a>	<a href="#">C472/3</a>	<a href="#">C472/3</a>
<a href="#">C700/3</a>	nTorqueGenLim_a	<a href="#">C472/3</a>	<a href="#">C472/3</a>	<a href="#">C472/3</a>	<a href="#">C472/3</a>	<a href="#">C728/2</a>	<a href="#">C472/3</a>	<a href="#">C472/3</a>
<a href="#">C700/5</a>	wCANDriveControl	0x0009	0x0009	0x0009	0x0009	0x0009	0x0009	PDO1/word 1
<a href="#">C700/6</a>	nPIDVpAdapt_a	100 %	100 %	100 %	100 %	100 %	100 %	100 %
<a href="#">C700/7</a>	nPIDActValue_a	-	-	-	-	-	-	-
<a href="#">C700/8</a>	nPIDInfluence_a	100 %	100 %	100 %	100 %	100 %	100 %	100 %
<a href="#">C700/9</a>	nPIDSetValue_a	-	-	-	-	-	-	-
<a href="#">C701/1</a>	bCInh	-	-	-	-	-	-	-
<a href="#">C701/2</a>	bFailReset	X4/RFR	X4/RFR	X4/RFR	X4/RFR	X4/RFR	X4/RFR	X4/RFR
<a href="#">C701/3</a>	bSetQuickstop	-	X4/DI3	-	-	<a href="#">C727/1</a>	-	X4/DI3
<a href="#">C701/4</a>	bSetDCBrake	X4/DI3	-	X4/DI2	-	<a href="#">C727/2</a>	<a href="#">C470/3</a>	PDO1/bit 11
<a href="#">C701/5</a>	bSetSpeedCcw	X4/DI4	X4/DI4	X4/DI1	-	<a href="#">C727/3</a>	<a href="#">C470/4</a>	PDO1/bit 15
<a href="#">C701/6</a>	blogSpeed1	X4/DI1	X4/DI1	-	X4/DI1	<a href="#">C727/4</a>	<a href="#">C470/1</a>	PDO1/bit 12
<a href="#">C701/7</a>	blogSpeed2	X4/DI2	X4/DI2	-	X4/DI2	<a href="#">C727/5</a>	<a href="#">C470/2</a>	PDO1/bit 13
<a href="#">C701/8</a>	bMPotUp	-	-	X4/DI3	-	-	-	-
<a href="#">C701/9</a>	bMPotDown	-	-	X4/DI4	-	-	-	-
<a href="#">C701/10</a>	bMPotInAct	-	-	-	-	-	-	-
<a href="#">C701/11</a>	bMPotEnable	-	-	TRUE	-	-	-	-
<a href="#">C701/12</a>	bRFG_0	-	-	-	-	-	-	PDO1/bit 8
<a href="#">C701/13</a>	bSetError1	-	-	-	-	-	-	-
<a href="#">C701/14</a>	bSetError2	-	-	-	-	-	-	-
<a href="#">C701/15</a>	bPIDInfluenceRamp	TRUE	TRUE	TRUE	TRUE	TRUE	TRUE	TRUE
<a href="#">C701/16</a>	bPIDIOff	-	-	-	-	-	-	-
<a href="#">C701/17</a>	bRLQCw	TRUE	TRUE	TRUE	X4/DI3	TRUE	TRUE	TRUE
<a href="#">C701/18</a>	bRLQCcw	-	-	-	X4/DI4	-	-	-

7.4.2 Output connections

Configuration parameters	Identifier	Control mode						
		10 (terminals 0) See fig. <a href="#">[7-1]</a>	12 (Terminal 2)	14 (terminals 11)	16 (terminals 16)	20 (keypad)	21 (PC)	30 (CAN) See fig. <a href="#">[7-2]</a>
<a href="#">C620/5</a>	<a href="#">LS_DisFree</a> : wDis1 (→C481/1)	-	-	-	-	wDeviceStateWord		-
<a href="#">C620/6</a>	<a href="#">LS_DisFree</a> : wDis2 (→C481/2)	-	-	-	-	-	-	-
<a href="#">C620/7</a>	<a href="#">LS_DisFree</a> : wDis3 (→C481/3)	-	-	-	-	-	-	-
<a href="#">C620/8</a>	<a href="#">LS_DisFree</a> : wDis4 (→C481/4)	-	-	-	-	-	-	-
<a href="#">C620/9</a>	<a href="#">LS_DisFree_a</a> : nDis1_a (→C482/1)	-	-	-	-	nMotorSpeedAct_a		-
<a href="#">C620/10</a>	<a href="#">LS_DisFree_a</a> : nDis2_a (→C482/2)	-	-	-	-	nOutputSpeedCtrl_a		-
<a href="#">C620/11</a>	<a href="#">LS_DisFree_a</a> : nDis3_a (→C482/3)	-	-	-	-	-	-	-
<a href="#">C620/12</a>	<a href="#">LS_DisFree_a</a> : nDis4_a (→C482/4)	-	-	-	-	-	-	-
<a href="#">C620/20</a>	<a href="#">LP_CanOut1</a> : wState	-	-	-	-	-	-	wDeviceStateWord
<a href="#">C620/21</a>	<a href="#">LP_CanOut1</a> : wOut2	-	-	-	-	-	-	nMotorSpeedAct_a
<a href="#">C620/22</a>	<a href="#">LP_CanOut1</a> : wOut3	-	-	-	-	-	-	nOutputSpeedCtrl_a
<a href="#">C620/23</a>	<a href="#">LP_CanOut1</a> : wOut4	-	-	-	-	-	-	-
<a href="#">C620/24</a>	<a href="#">LP_CanOut2</a> : wOut1	-	-	-	-	-	-	-
<a href="#">C620/25</a>	<a href="#">LP_CanOut2</a> : wOut2	-	-	-	-	-	-	-
<a href="#">C620/26</a>	<a href="#">LP_CanOut2</a> : wOut3	-	-	-	-	-	-	-
<a href="#">C620/27</a>	<a href="#">LP_CanOut2</a> : wOut4	-	-	-	-	-	-	-
<a href="#">C621/1</a>	<a href="#">LS_DigitalOutput</a> : bRelay (X101)	bDriveFail	bDriveFail					
<a href="#">C621/2</a>	<a href="#">LS_DigitalOutput</a> : bOut1 (X4/DO1)	bDriveReady	bDriveReady					
<a href="#">C621/6</a>	USER-LED	bNactCompare	bNactCompare					
<a href="#">C621/7</a>	LA_NCtrl: bStatusBit0	-	-	-	-	-	-	-
<a href="#">C621/8</a>	LA_NCtrl: bStatusBit2	bImaxActive	bImaxActive					
<a href="#">C621/9</a>	LA_NCtrl: bStatusBit3	bSpeedSetReached	bSpeedSetReached					
<a href="#">C621/10</a>	LA_NCtrl: bStatusBit4	bSpeedActEqSet	bSpeedActEqSet					
<a href="#">C621/11</a>	LA_NCtrl: bStatusBit5	bNactCompare	bNactCompare					
<a href="#">C621/12</a>	LA_NCtrl: bStatusBit14	bSpeedCcw	bSpeedCcw					
<a href="#">C621/13</a>	LA_NCtrl: bStatusBit15	bDriveReady	bDriveReady					
<a href="#">C621/16</a>	<a href="#">LS_DisFree_b</a> : bDis1 (→C480/Bit0)	-	-	-	-	bDriveReady		-
<a href="#">C621/17</a>	<a href="#">LS_DisFree_b</a> : bDis2 (→C480/Bit1)	-	-	-	-	bDriveFail		-
<a href="#">C621/18</a>	<a href="#">LS_DisFree_b</a> : bDis3 (→C480/Bit2)	-	-	-	-	-	-	-
...	...	-	-	-	-	-	-	-
<a href="#">C621/23</a>	<a href="#">LS_DisFree_b</a> : bDis8 (→C480/Bit7)	-	-	-	-	-	-	-
<a href="#">C621/30...45</a>	<a href="#">LP_CanOut1</a> : bState_BO ... B15	-	-	-	-	-	-	-
<a href="#">C621/46...61</a>	<a href="#">LP_CanOut2</a> : bOut1_BO ... B15	-	-	-	-	-	-	-

### 7.4.3 Internal signal flow for control via terminals

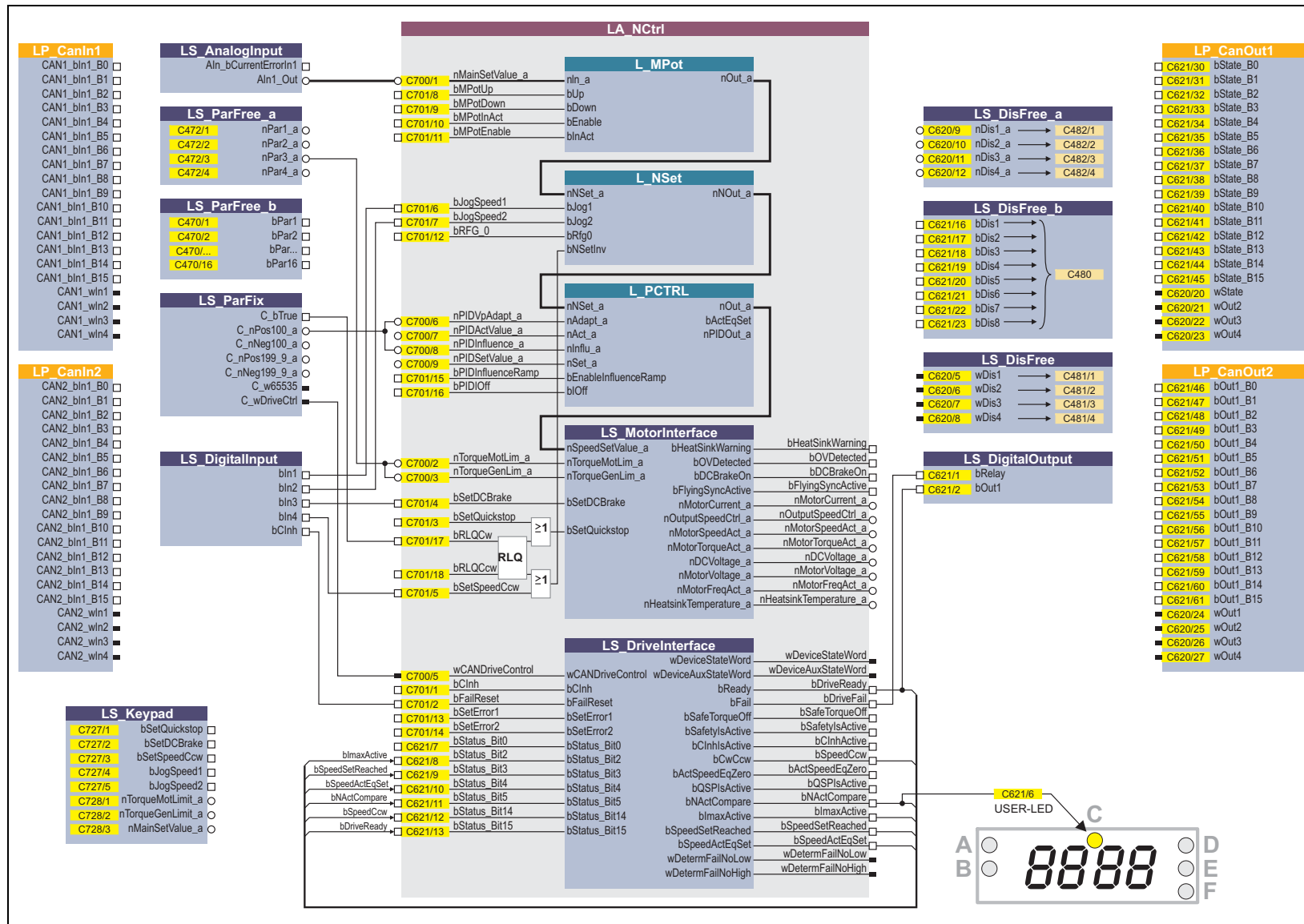

[7-1] Interconnection of the internal interfaces in the Lenze setting (control mode "terminals 0")

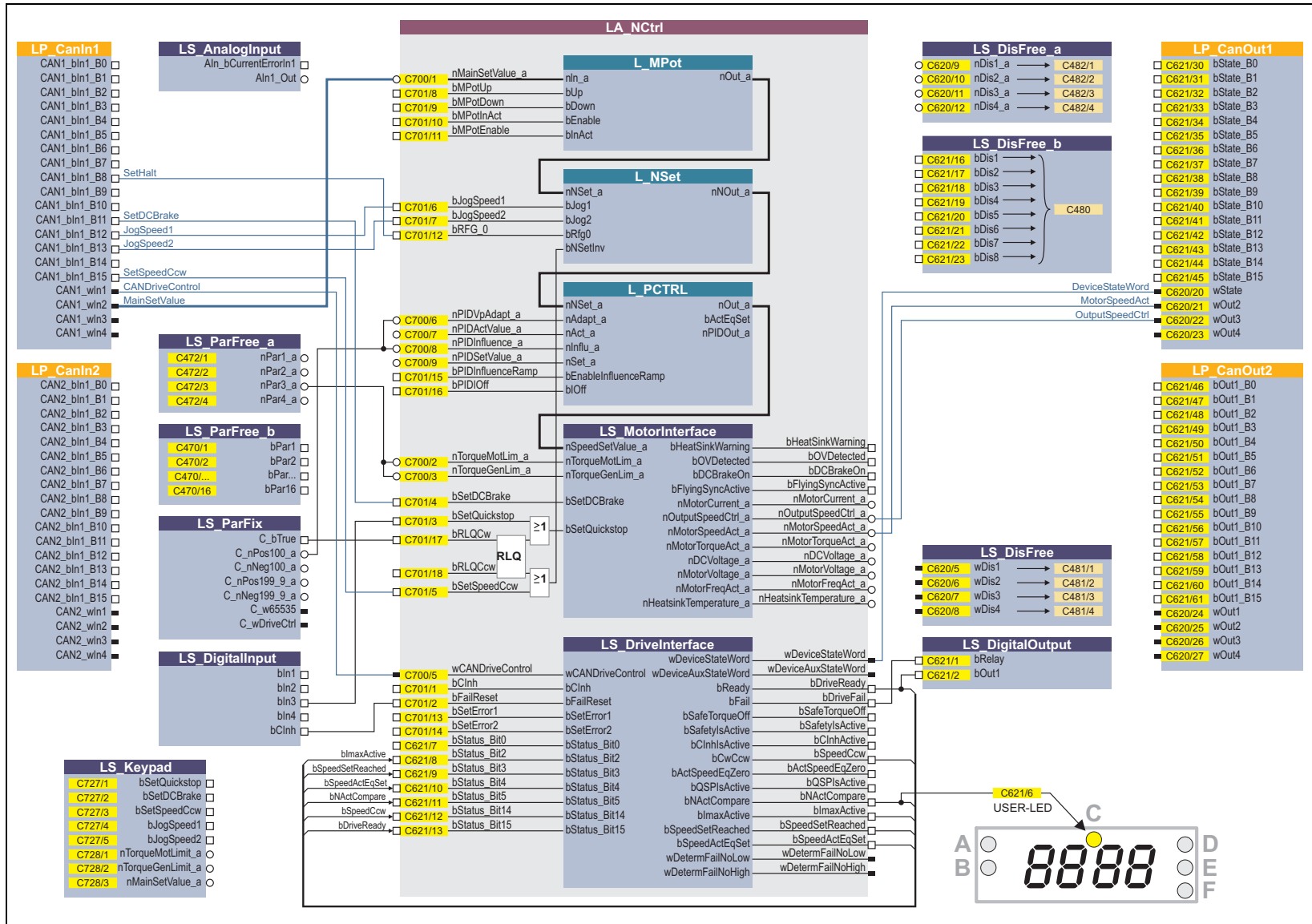

[7-2] Interconnection of the internal interfaces for control via system bus (control mode "CAN")

7.4.4 Internal signal flow for control via CAN



### 7.4.5 Process data assignment for control via CAN

The CAN communication (preconfiguration) is connected to the technology application by selecting the control mode "30: [CAN](#)" in [C007](#).

The assignment of the process data words only depends on the application, not on the system bus:

Input words	Name	Assignment
Word 1	DriveControl	Control word • For bit assignment, see table below.
Word 2	MainSetValue	Speed setpoint • Scaling: 16384 ≙ 100 % reference speed ( <a href="#">C011</a> )
Word 3	-	Not preconfigured
Word 4	-	Not preconfigured

Control word	Name	Function
Bit 0	SwitchOn	1 ≙ Change to the " <a href="#">SwitchedON</a> " device state • This bit must be set in the control word to ensure that the device changes to the " <a href="#">SwitchedON</a> " device state after mains connection without the need for a master control specifying this bit via fieldbus.
Bit 1	DisableVoltage	1 ≙ Inhibit inverter control (IMP - pulse inhibit)
Bit 2	SetQuickStop	1 ≙ Activate quick stop (QSP). ▶ <a href="#">Activate/Deactivate quick stop</a> ( <a href="#">□ 50</a> )
Bit 3	EnableOperation	1 ≙ Enable controller (RFR) • If control via terminals is performed, this bit must be set in the control word. Otherwise the controller is inhibited. ▶ <a href="#">Enable/Inhibit controller</a> ( <a href="#">□ 50</a> )
Bit 4	ModeSpecific_1	Reserved (currently not assigned)
Bit 5	ModeSpecific_2	
Bit 6	ModeSpecific_3	
Bit 7	ResetFault	1 ≙ Reset fault (trip reset) • Acknowledge fault message (if the error cause has been eliminated). ▶ <a href="#">Reset error</a> ( <a href="#">□ 51</a> )
Bit 8	SetHalt	1 ≙ Activate stop function • Stop drive via stopping ramp (in preparation).
Bit 9	reserved_1	Reserved (currently not assigned)
Bit 10	reserved_2	
Bit 11	SetDCBrake	1 ≙ activate DC-injection braking ▶ <a href="#">Manual DC-injection braking (DCB)</a> ( <a href="#">□ 97</a> )
Bit 12	JogSpeed1	Activation of fixed speed 1 ... 3
Bit 13	JogSpeed2	
Bit 14	SetFail	1 ≙ Set error (trip set)
Bit 15	SetSpeedCcw	0 ≙ Direction of rotation to the right (Cw) 1 ≙ Direction of rotation to the left (Ccw)



#### Tip!

Bit 11, 12, 13 and 15 of the control word can also be assigned with other control functions via configuration parameters, see figure [\[7-2\]](#). ([□ 136](#))

Output words	Name	Assignment
Word 1	DriveControlStatus	Status word • For bit assignment, see table below.
Word 2	MotorSpeedAct	Actual speed value • Scaling: 16384 $\equiv$ 100 % reference speed ( <a href="#">C011</a> )
Word 3	MotorSpeedSet	Resulting overall setpoint • Scaling: 16384 $\equiv$ 100 % reference speed ( <a href="#">C011</a> )
Word 4	-	Not preconfigured

Status word	Name	Status
Bit 0	FreeStatusBit0	Free status bit 0 (configurable in <a href="#">C621/7</a> ) Not assigned in Lenze setting.
Bit 1	PowerDisabled	1 $\equiv$ Inverter control inhibited (pulse inhibit is active)
Bit 2	FreeStatusBit2	Free status bit 2 (configurable in <a href="#">C621/8</a> ) In Lenze setting pre-assigned with <i>LA_NCtrl_bImaxActive</i> signal: 1 $\equiv$ The current setpoint is internally limited (the controller operates at the maximum current limit)
Bit 3	FreeStatusBit3	Free status bit 3 (configurable in <a href="#">C621/9</a> ) In the Lenze setting pre-assigned with <i>LA_NCtrl_bSpeedSetReached</i> signal: 1 $\equiv$ Speed setpoint reached
Bit 4	FreeStatusBit4	Free status bit 4 (configurable in <a href="#">C621/10</a> ) In the Lenze setting pre-assigned with <i>LA_NCtrl_bSpeedActEqSet</i> signal: 1 $\equiv$ Actual speed value has reached the setpoint within one hysteresis band
Bit 5	FreeStatusBit5	Free status bit 5 (configurable in <a href="#">C621/11</a> ) In the Lenze setting pre-assigned with <i>LA_NCtrl_bNActCompare</i> signal: • In case of "open loop" operation: 1 $\equiv$ speed setpoint < comparison value ( <a href="#">C024</a> ) • In case of "open loop" operation 1 $\equiv$ actual speed value < comparison value ( <a href="#">C024</a> )
Bit 6	ActSpeedIsZero	1 $\equiv$ current speed is 0
Bit 7	ControllerInhibit	1 $\equiv$ Controller inhibited (controller inhibit is active)
Bit 8	StatusCodeBit0	Bit coded display of the active device state ▶ <a href="#">Device states</a> (see table <a href="#">[4-1]</a> )
Bit 9	StatusCodeBit1	
Bit 10	StatusCodeBit2	
Bit 11	StatusCodeBit3	
Bit 12	Warning	1 $\equiv$ A warning exists.
Bit 13	Trouble	1 $\equiv$ Controller is in the "Trouble" device state • E.g. if an overvoltage has occurred.
Bit 14	FreeStatusBit14	Free status bit 14 (configurable in <a href="#">C621/12</a> ) In the Lenze setting pre-assigned with <i>LA_NCtrl_bSpeedCcw</i> signal: 0 $\equiv$ Clockwise direction of rotation (Cw), 1 $\equiv$ Counter-clockwise direction of rotation (Ccw)
Bit 15	FreeStatusBit15	Free status bit 15 (configurable in <a href="#">C621/13</a> ) In Lenze setting pre-assigned with <i>LA_NCtrl_bDriveReady</i> signal: 1 $\equiv$ Drive controller is ready for operation

## 7.5 Terminal assignment of the control modes

The following table shows which functions are assigned to the digital terminals in the different control modes.

Control mode	Analog input A1U	Assignment of the digital terminals				DO1	Relay output NO / COM
		DI1	DI2	DI3	DI4		
<a href="#">Terminals 0</a>	Setpoint selection 10 V ≙ 100 % reference speed ( <a href="#">C011</a> )	JOG 1/3	JOG 2/3	DCB	Cw/Ccw	Status "Drive is ready to start"	Status "An error occurred"
<a href="#">Terminals 2</a>		JOG 1/3	JOG 2/3	QSP	Cw/Ccw		
<a href="#">Terminals 11</a>		Cw/Ccw	DCB	MPotUp	MPotDown		
<a href="#">Terminals 16</a>		JOG 1/3	JOG 2/3	Cw/QSP	Ccw/QSP		
<a href="#">Keypad</a>	-	-	-	-	-		
<a href="#">PC</a>	-	-	-	-	-		
<a href="#">CAN</a>	-	QSP	-	-	-		
<b>Abbreviations used:</b>							
JOG	Selection of the fixed setpoints 1 ... 3 in <a href="#">C039/1...3</a>						
DCB	Manual DC-injection braking						
Cw/Ccw	CW/CCW rotation						
QSP	Quick stop						
MPotUp	Motor potentiometer: Increase speed						
MPotDown	Motor potentiometer: Decrease speed						
Cw/QSP	Fail-safe selection of the direction of rotation in connection with quick stop						
Ccw/QSP							

### Related topics:

- ▶ [User-defined terminal assignment](#) (📖 114)
- ▶ [Pre-assignment of the drive application](#) (📖 133)

7.5.1 Terminals 0

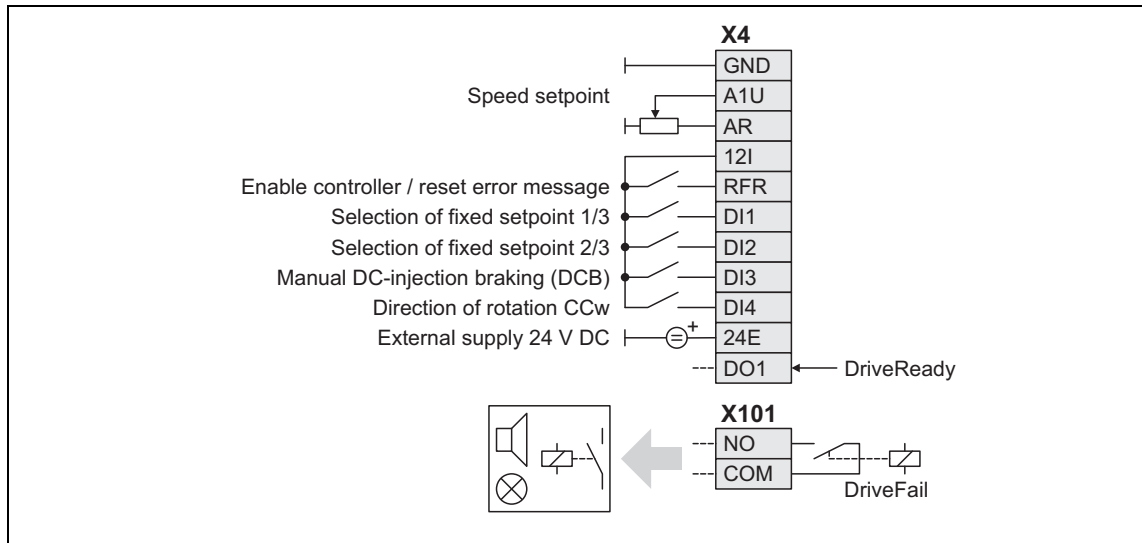

Connection	Assignment	Connection	Assignment
RFR	LA_NCtrl.bFailReset	A1U	LA_NCtrl.nMainSetValue_a 10 V ≙ 100 % reference speed (C011)
DI1	LA_NCtrl.bJogSpeed1	NO, COM	LA_NCtrl.bDriveFail
DI2	LA_NCtrl.bJogSpeed2	DO1	LA_NCtrl.bDriveReady
DI3	LA_NCtrl.bSetDCBrake		
DI4	LA_NCtrl.bSetSpeedCcw		

7.5.2 Terminals 2

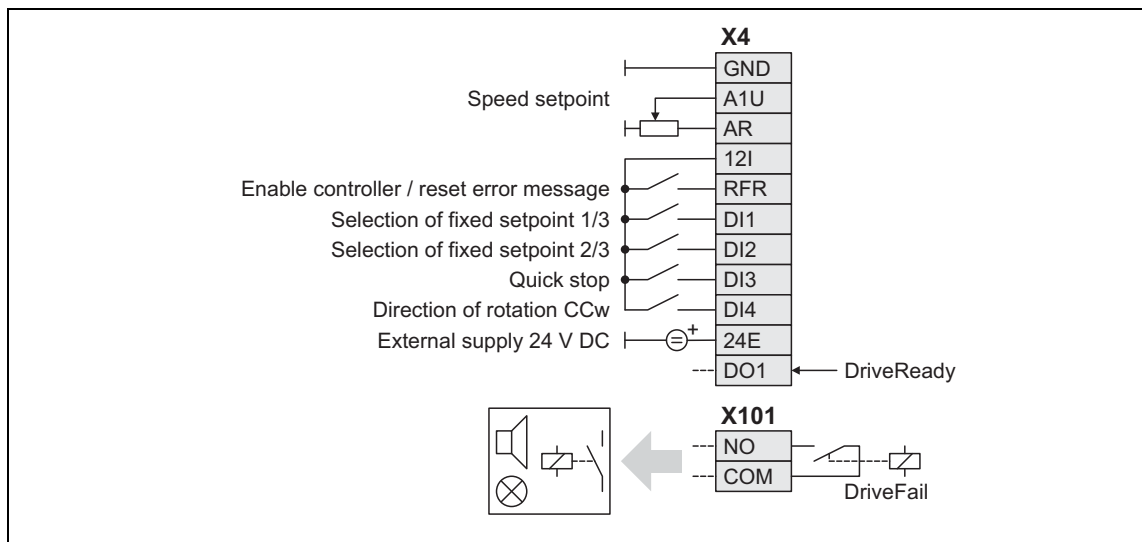

Connection	Assignment	Connection	Assignment
RFR	LA_NCtrl.bFailReset	A1U	LA_NCtrl.nMainSetValue_a 10 V ≙ 100 % reference speed (C011)
DI1	LA_NCtrl.bJogSpeed1	NO, COM	LA_NCtrl.bDriveFail
DI2	LA_NCtrl.bJogSpeed2	DO1	LA_NCtrl.bDriveReady
DI3	LA_NCtrl.bSetQuickstop		
DI5	LA_NCtrl.bBrkRelease		

7.5.3 Terminals 11

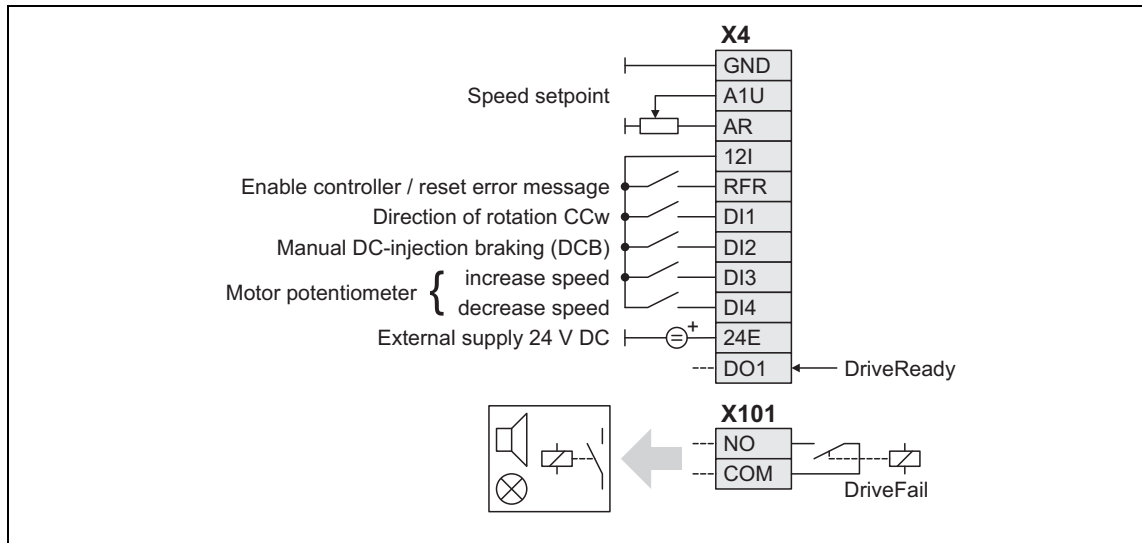

Connection	Assignment	Connection	Assignment
RFR	LA_NCtrl.bFailReset	A1U	LA_NCtrl.nMainSetValue_a 10 V ≙ 100 % reference speed (C011)
DI1	LA_NCtrl.bSetSpeedCcw	NO, COM	LA_NCtrl.bDriveFail
DI2	LA_NCtrl.bSetDCBrake	DO1	LA_NCtrl.bDriveReady
DI3	LA_NCtrl.bMPotUp		
DI4	LA_NCtrl.bMPotDown		

7.5.4 Terminals 16

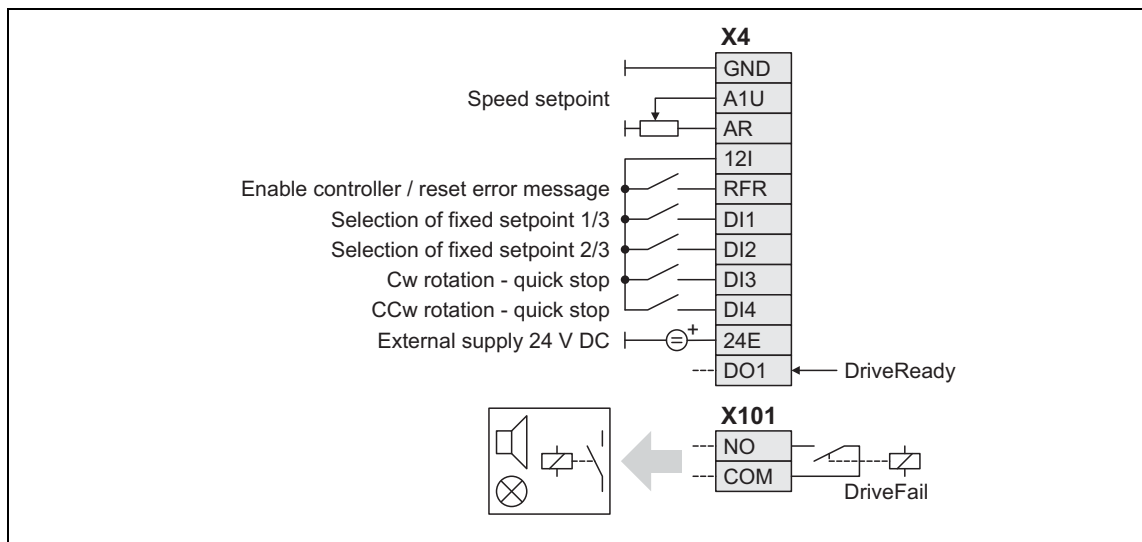

Connection	Assignment	Connection	Assignment
RFR	LA_NCtrl.bFailReset	A1U	LA_NCtrl.nMainSetValue_a 10 V ≙ 100 % reference speed (C011)
DI1	LA_NCtrl.bJogSpeed1	NO, COM	LA_NCtrl.bDriveFail
DI2	LA_NCtrl.bJogSpeed2	DO1	LA_NCtrl.bDriveReady
DI3	LA_NCtrl.bRLQCw		
DI4	LA_NCtrl.bRLQCcw		

7.5.5

Keypad

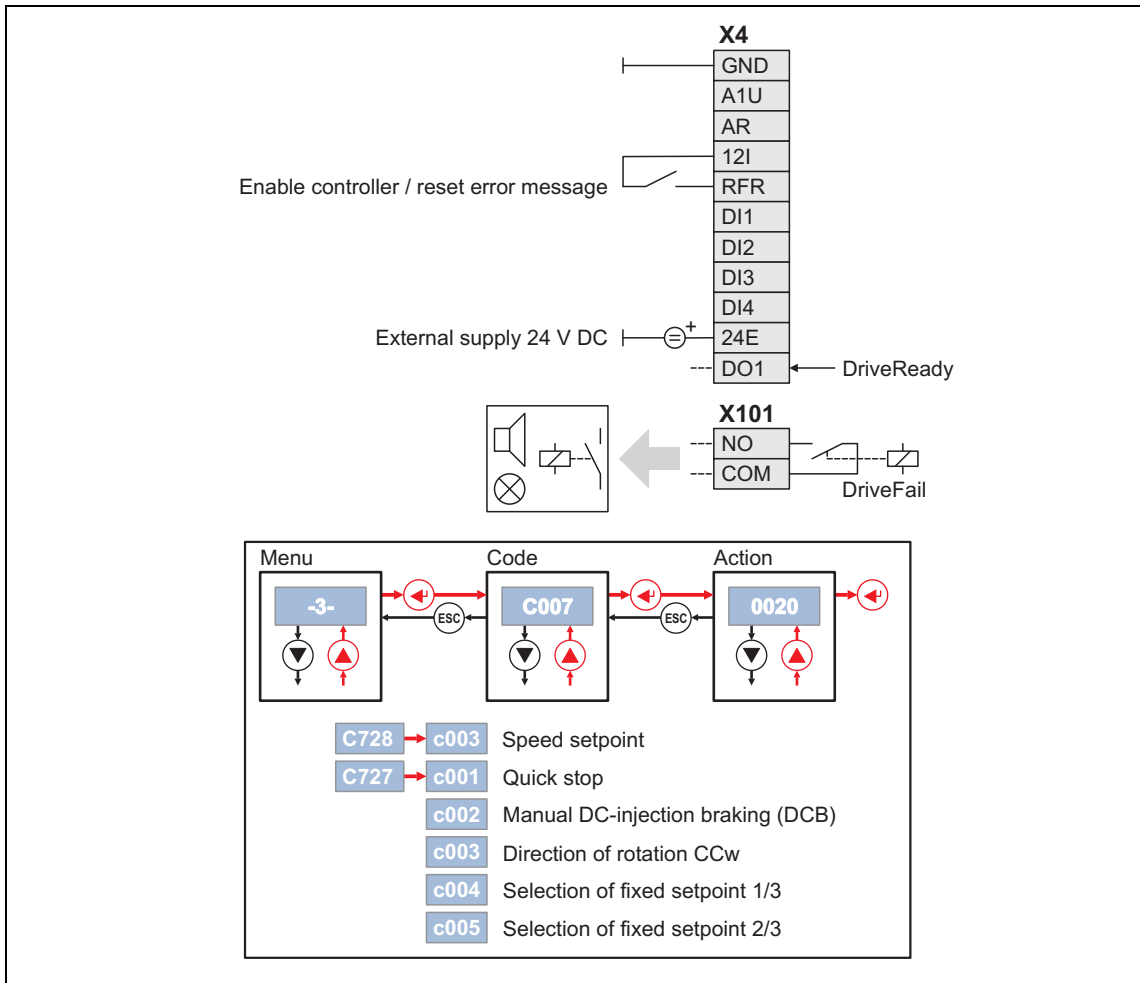

Connection	Assignment	Connection	Assignment
RFR	LA_NCtrl.bFailReset	A1U	-
DI1	-		
DI2	-		
DI3	-	NO, COM	LA_NCtrl.bDriveFail
DI4	-	DO1	LA_NCtrl.bDriveReady

7.5.6

PC

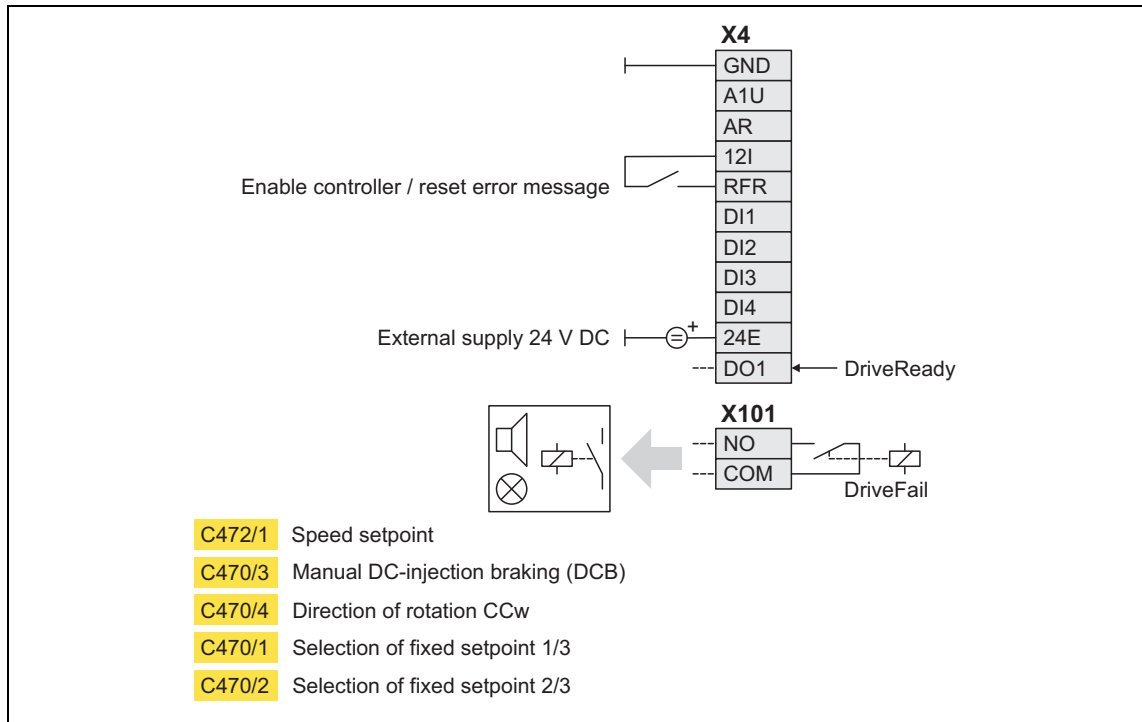

Connection	Assignment	Connection	Assignment
RFR	LA_NCtrl.bFailReset	A1U	-
DI1	-	NO, COM	LA_NCtrl.bDriveFail
DI2	-	DO1	LA_NCtrl.bDriveReady
DI3	-		
DI4	-		

In this control mode, the control is executed via "free" parameters. The connection to inputs/outputs of the application takes place via the following system blocks:

System block	Function
<a href="#">LS_DisFree</a>	Any four 16-bit signals of the application can be displayed on display codes
<a href="#">LS_DisFree a</a>	Any four analog signals of the application can be displayed on display codes
<a href="#">LS_DisFree b</a>	Any eight digital signals of the application can be displayed on a bit-coded display code
<a href="#">LS_ParFree a</a>	Output of 4 parameterisable analog signals
<a href="#">LS_ParFree b</a>	Output of 16 parameterisable digital signals

7.5.7

CAN

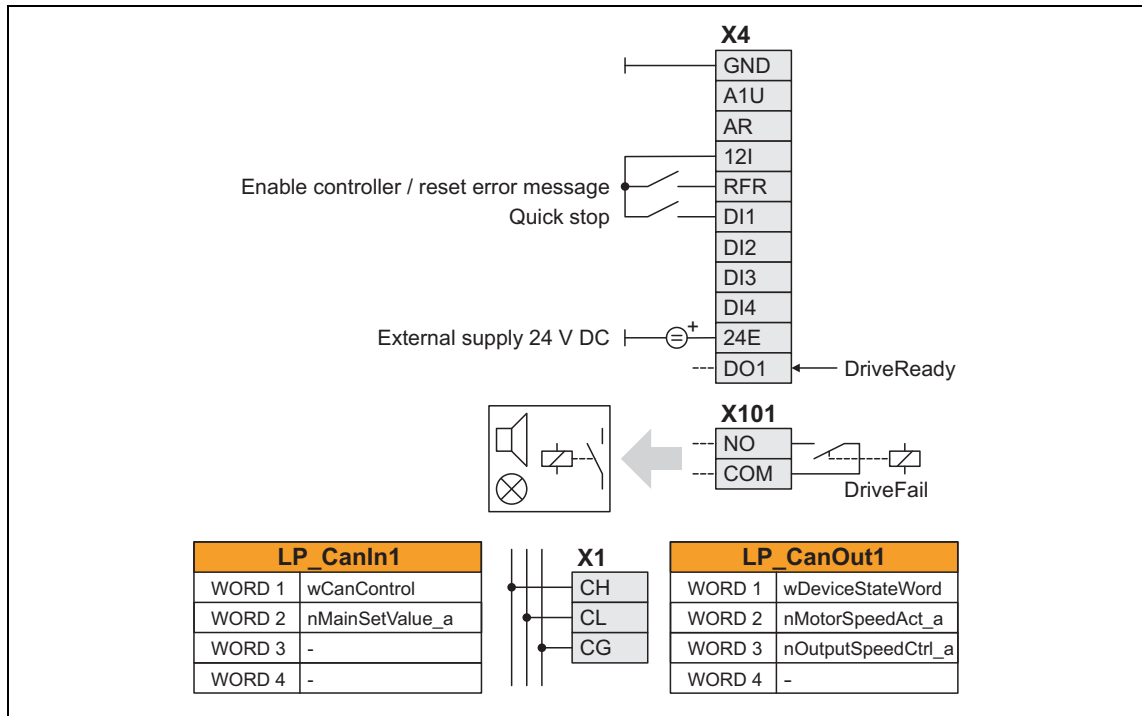

Connection	Assignment	Connection	Assignment
RFR	LA_NCtrl.bFailReset	A1U	-
DI1	LA_NCtrl.SetQuickstop	NO, COM	LA_NCtrl.bDriveFail
DI2	-	DO1	LA_NCtrl.bDriveReady
DI3	-		
DI4	-		



The preconfigured interconnection of the internal interfaces in control mode "CAN" is shown in figure [7-2]. (📖 136)

Related topics:

- ▶ [Process data assignment for control via CAN](#) (📖 137)
- ▶ [System bus "CAN on board"](#) (📖 169)
- ▶ [RPDO1 | Port block "LP\\_CanIn1"](#) (📖 185)
- ▶ [TPDO1 | Port block "LP\\_CanOut1"](#) (📖 187)



# 8 Diagnostics & error management

## 8.1 Basics on error handling in the controller

---

## 8 Diagnostics & error management

This chapter provides information on error handling, drive diagnostics, and fault analysis.

### 8.1 Basics on error handling in the controller

Many of the functions integrated into the controller can

- detect errors and thus protect the device from damage or overload, e.g. short-circuit detection, Ixt overload detection, overtemperature detection, etc.
- detect operating errors by the user, e.g. a missing memory module,
- output warning signals, e.g. if the speed is too high or too low, etc.

Depending on the importance, the error detection in the device responds very fast (e.g. short-circuit detection < 1 ms) or in a slower cycle (e.g. temperature monitoring approx. 100 ms).

All functions provided with an error detection (e.g. the motor control) supply information to a so-called error handler. The error handler is processed every 1 ms and evaluates all information.

In this evaluation, the current error (display in [C165](#)) is generated and the controller is caused to take the respective error status (e.g. trouble).

The error information in [C166/1..3](#) is used for error diagnosis and contains the following information:

1. Error type (e.g. "Warning")
2. Error subject area (e.g. "motor management/encoder")
3. The error ID within the error subject area

Together all types of information form the real error number which is unique in the whole device system. ▶ [Structure of the error number \(bit coding\)](#) ([📖 156](#))

In addition to the control of the device state by the error handler, a logbook function records the errors and their histories. ▶ [Logbook](#) ([📖 149](#))



#### Tip!

For many device errors, the error type and hence the response of the controller to the error can be parameterised. ▶ [Setting the error response](#) ([📖 153](#))

### 8.2 Drive diagnostics with the »Engineer«





Information on the drive diagnostics with the integrated keypad can be found in the chapter "Introduction" in the subchapter "[Internal Keypad](#)":

▶ [LED status display](#) (18)

▶ [Display messages](#) (19)

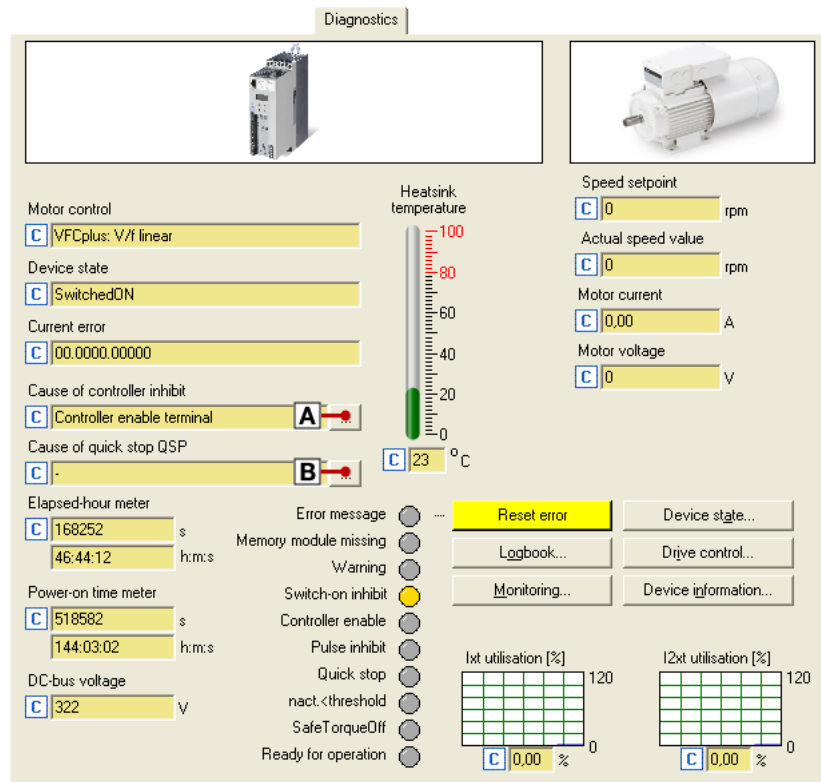
When an online connection to the controller has been established, the connected controller can be diagnosed and relevant actual controller states can be displayed in a clearly arranged visualisation using the »Engineer« :



Button	Function
	<ul style="list-style-type: none"> <li>[A] Display all active sources of a controller inhibit.</li> <li>[B] Display all active sources of a quick stop.</li> </ul>
<b>Resetting an error</b>	Acknowledge fault message (if the error cause has been eliminated).
<b>Logbook...</b>	<a href="#">Display the Logbook</a> of the controller. (149)
<b>Monitoring...</b>	<a href="#">Configure the Monitoring</a> . (151)
<b>Device state...</b>	Display the internal state machine including the current device state.
<b>Drive control...</b>	Display the bit assignment of the following control-related words: <ul style="list-style-type: none"> <li>• CAN control word (136/2)</li> <li>• Cause of controller inhibit (158)</li> <li>• Cause of quick stop QSP(159)</li> <li>• Status word (150)</li> <li>• Extended status word (155)</li> </ul>
<b>Device information...</b>	Display identification data, e.g. information on firmware version.

**How to diagnose a drive with the »Engineer«:**

1. Go to the *Project view* and select the 8400 BaseLine C controller.
2. Click the  icon or execute the **Online→Go online** command to establish an online connection to the controller.
3. Select the **Diagnostics** tab.
  - With an online connection, the **Diagnostics** tab displays current status information about the controller.

**Related topics:**

- ▶ [Device control \(DCTRL\)](#) (📖 44)
- ▶ [Device states](#) (📖 53)

# 8 Diagnostics & error management

## 8.3 Drive diagnostics via bus system

### 8.3 Drive diagnostics via bus system

The following display parameters contain actual values, states, and error messages.

- These parameters are listed in the »Engineer« parameter list in the **Diagnostics** category.
- A detailed description of these parameters can be found in the chapter "[Parameter reference](#)" ([□ 228](#)).

Parameter	Display
<a href="#">C051</a>	MCTRL: Actual speed value
<a href="#">C052</a>	Motor voltage
<a href="#">C053</a>	DC-bus voltage
<a href="#">C054</a>	Motor current
<a href="#">C056/1</a>	Torque setpoint
<a href="#">C056/2</a>	Actual torque
<a href="#">C058</a>	Output frequency
<a href="#">C059</a>	Appl.: Reference frequency C11
<a href="#">C061</a>	Heatsink temperature
<a href="#">C064/1</a>	Device utilisation (lxt)
<a href="#">C064/2</a>	Device utilisation (lxt) 15s
<a href="#">C064/3</a>	Device utilisation (lxt) 3 min
<a href="#">C136/2</a>	CAN control word
<a href="#">C137</a>	Device state
<a href="#">C150</a>	Status word
<a href="#">C155</a>	Status word 2
<a href="#">C158</a>	Cause of controller inhibit
<a href="#">C159</a>	Cause of quick stop QSP
<a href="#">C165/1</a>	Current error
<a href="#">C166/1</a>	Error type, current
<a href="#">C166/2</a>	Error subject area, current
<a href="#">C166/3</a>	Error ID, current
<a href="#">C168/1...8</a>	Error ID, history 1 ... 8
<a href="#">C169/1...8</a>	Time of error, history 1 ... 8
<a href="#">C170/1...8</a>	Error counter, history 1 ... 8
<a href="#">C177/1</a>	Switching cycles mains switching
<a href="#">C177/2</a>	Switching cycles output relay
<a href="#">C178</a>	Time the controller was enabled (elapsed-hour meter)
<a href="#">C179</a>	Power-up time (power-on time meter)

### 8.4 Logbook

The integrated logbook function of the controller chronologically logs important events within the system. The logbook is intended to support you in troubleshooting and controller diagnostics.

#### Events that can be logged

The following events can be logged in the logbook:

- [Error messages of the operating system](#) (📖 156)
- Error messages generated by the application (via [LS\\_SetError 1](#))

#### Information saved

For each event, the following information is saved in the logbook:

- Type of response to the event (e.g. "Warning")
- Subject area that activated the event (e.g. "motor management/encoder").
- Event
- Value of power-on time meter

#### Memory depth

Maximum number of logbook entries: 8

#### 8.4.1 Functional description

The structure of the logbook corresponds to a ring buffer:

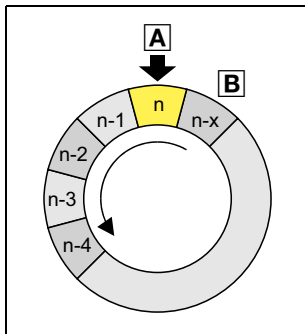

- As long as free logbook memory locations are available, the entries will be saved to the next free memory location (A).
- If all memory locations are occupied, the oldest entry (B) will be deleted in favour of a new entry.
- The newest entries will always remain available.



#### Note!

In the event of a supply voltage failure, the logbook is saved and reloaded automatically when the controller is switched on. This ensures that the error history of the device does not get lost. For this reason it is very important to act with caution when deleting the logbook entries.

### 8.4.2 Reading out logbook entries

We recommend to read out logbook entries with the »Engineer«, since the »Engineer« shows the entries clearly arranged and enables them to be exported into a log file. Alternatively, the corresponding parameters can be read out using the keypad or via the fieldbus.



#### How to display logbook entries in the »Engineer«:

1. Go to the *Project view* and select the 8400 BaseLine C controller.
2. Click the  icon or execute the **Online→Go online** command to establish an online connection to the controller.
3. Select the **Diagnostics** tab from the *Workspace*.
4. Click **Logbook**.
  - The *Logbook* dialog box with logbook entries is displayed.
  - Click **Delete** to delete an entry from the logbook.
  - Click **Export** to export the entries from the logbook into a \*.log file. ▶ [Exporting logbook entries to a file](#) (150)
5. Click the **Close** button to close the *Logbook* dialog box again.

### 8.4.3 Exporting logbook entries to a file



#### How to export the logbook entries to a file:

1. Go to the *Logbook* dialog box and click the **Export...** button.
  - The *Export logbook* dialog box is displayed.
2. Specify the folder, file name, and file type for the file.
3. Click the **Save** button to export the logbook entries to the specified file.
  - Hidden logbook entries are not exported, i.e. the filter criteria specified are accounted for during the export.
  - The logbook entries are written to the file in the form of a semicolon separated list.

### 8.5 Monitoring

The controller is provided with various monitoring functions which protect the drive against impermissible operating conditions.

- If a monitoring function responds,
  - an entry will be made into the [Logbook](#) of the controller,
  - the response (Trouble, Fault, etc.) set for this monitoring function will be triggered,
  - the status of the internal device control changes according to the selected response, controller inhibit is set, and the front "DRIVE ERROR" LED D ("DRIVE ERROR") goes on:

Response	Entry in the logbook	Display in <a href="#">C168</a>	Pulse inhibit	Controller inhibit	Acknowledgement required	LED D "DRIVE ERROR"
None						OFF
Fault	☑	☑	☑	☑	☑	■ ■ ■
Trouble	☑	☑	☑	☑ (after 0.5 s)		▬ ▬ ▬
WarningLocked	☑	☑			☑	▬

#### Related topics:

- ▶ [LED status display](#) (18)
- ▶ [Device states](#) (53)
- ▶ [Device overload monitoring \(lxt\)](#) (103)
- ▶ [Motor load monitoring \(l2xt\)](#) (104)
- ▶ [Brake resistor monitoring \(l2xt\)](#) (106)
- ▶ [Mains phase failure monitoring](#) (107)

### 8.5.1 Monitoring configuration



How to configure the monitoring functions using the »Engineer«:

1. Go to the *Project view* and select the 8400 BaseLine C controller.
2. Select the **Diagnostics** tab from the *Workspace*.
3. Click the **Monitoring...** button.
  - The *8400 monitoring configuration* dialog box is displayed via which the desired settings can be made:

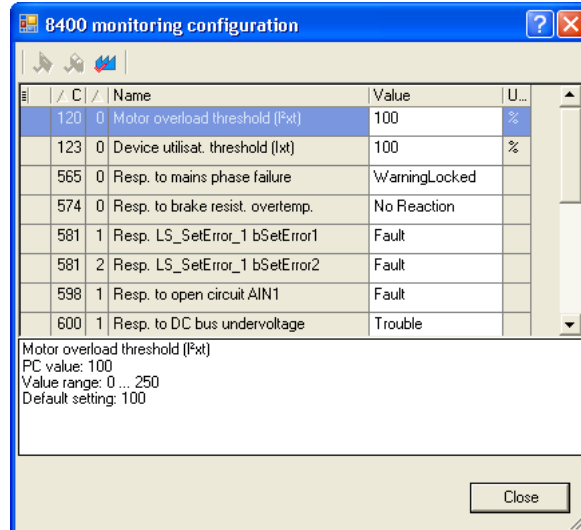

#### Related topics:

- ▶ [Setting the error response](#) (153)



### 8.5.2 Setting the error response

When a monitoring function responds, the response set for this monitoring function (Trouble, Fault, etc.) will be triggered.

- For many monitoring functions the response can be individually parameterised via parameters.

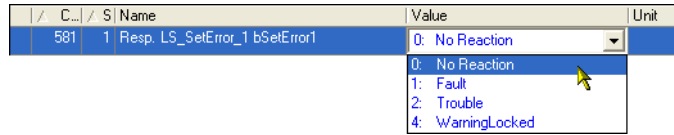

**Tip!**

The table in chapter "[Short overview \(A-Z\)](#)" contains the error messages for which the response can be set. ([159](#))

### Warning thresholds

Some of the monitoring functions are activated if a defined warning threshold has been exceeded.

- The corresponding preset threshold values can be changed via the following parameters:

Parameter	Info	Lenze setting	
		Value	Unit
<a href="#">C120</a>	Motor overload threshold (I <sup>2</sup> xt)	100	%
<a href="#">C123</a>	Device utilisat. threshold (Ixt)	100	%
<a href="#">C909/1</a>	Max. positive speed	120	%
<a href="#">C909/2</a>	Max. negative speed	120	%
<a href="#">C910/1</a>	Max. positive output frequency	300	Hz
<a href="#">C910/2</a>	Max. negative output frequency	300	Hz

## 8.6 Maloperation of the drive

Maloperation	Cause	Remedy
Motor does not rotate	DC-bus voltage is too low • Red LED is blinking every 1 s	Check mains voltage
	Controller is inhibited • Green LED is blinking	Deactivate controller inhibit • Note: Controller inhibit can be set via several sources! • <a href="#">C158</a> displays all active sources for controller inhibit.
	Automatic start is inhibited	LOW/HIGH edge at RFR If required, correct auto-start option in <a href="#">C142</a> . ▶ <a href="#">"Inhibit at power-on" auto-start option</a>
	DC-injection braking (DCB) is active	Deactivate <a href="#">DC-injection braking</a>
	Mechanical motor brake is not released	Release mechanical motor brake manually or electrically
	Quick stop (QSP) active	Deactivate quick stop • Note: Quick stop can be set via several sources! • <a href="#">C159</a> displays all active sources for quick stop.
	Setpoint = 0	Select setpoint
	Setpoint = 0 with activated fixed setpoint	Set fixed setpoint in <a href="#">C039/1...3</a>
	Trouble is active	Clear fault
	With <a href="#">C006</a> = 4 zwar "SLVC: Vector control" has been set, but no motor parameter identification has been carried out.	Carry out automatic motor parameter identification with the <a href="#">C002/23</a> device command. ▶ <a href="#">Automatic motor data identification</a>
Assignment of several mutually exclusive functions with a signal source in <a href="#">C701</a>	Correct configuration in <a href="#">C701</a> .	
Motor rotates irregularly	Motor cable is defective	Check motor cable
	Maximum motor current in motor or generator mode is set too low	Adjust settings to the application: <a href="#">C022</a> : I <sub>max</sub> in motor mode <a href="#">C023</a> : I <sub>max</sub> in generator mode
	Motor is underexcited or overexcited	Check parameterisation: <a href="#">C006</a> : Motor control <a href="#">C015</a> : VFC: V/f base frequency <a href="#">C016</a> : VFC: V <sub>min</sub> boost
	Rated motor data (stator resistance, speed, current, frequency, voltage) and cos φ and/or magnetising inductance is not adapted to the motor data	Carry out automatic motor parameter identification with the <a href="#">C002/23</a> device command - or - Adjust motor parameters manually: <a href="#">C084</a> : Motor stator resistance <a href="#">C087</a> : Rated motor speed <a href="#">C088</a> : Rated motor current <a href="#">C089</a> : Rated motor frequency <a href="#">C090</a> : Rated motor voltage <a href="#">C091</a> : Motor cosine phi <a href="#">C092</a> : Motor magnetising inductance
	Motor windings are wired incorrectly	Reverse from star connection to delta connection

Maloperation	Cause	Remedy
Motor consumes too much current	$U_{\min}$ boost has been selected too high	Correct setting with <a href="#">C016</a>
	V/f base frequency has been selected too low	Correct setting with <a href="#">C015</a>
	Rated motor data (stator resistance, speed, current, frequency, voltage) and $\cos \varphi$ and/or magnetising inductance is not adapted to the motor data	Carry out automatic motor parameter identification with the <a href="#">C002/23</a> device command - or - Adjust motor parameters manually: <a href="#">C084</a> : Motor stator resistance <a href="#">C087</a> : Rated motor speed <a href="#">C088</a> : Rated motor current <a href="#">C089</a> : Rated motor frequency <a href="#">C090</a> : Rated motor voltage <a href="#">C091</a> : Motor cosine phi <a href="#">C092</a> : Motor magnetising inductance
Motor parameter identification is aborted with error LP1	Motor is too small compared to the rated device power (>1 : 3)	Use device with lower rated power
	DC injection braking (DCB) is active via terminal	Deactivate <a href="#">DC-injection braking</a>
Drive behaviour with vector control is not satisfactory	different	Optimise or manually adapt vector control ▶ <a href="#">Sensorless vector control (SLVC)</a>
		Carry out automatic motor parameter identification with the <a href="#">C002/23</a> device command ▶ <a href="#">Automatic motor data identification</a>
Torque dip in field weakening range or motor stalling when being operated in the field weakening range	Motor is overloaded	Check motor load
	Motor windings are wired incorrectly	Reverse from star connection to delta connection
	V/f base frequency is set too high	Correct setting with <a href="#">C015</a>
	Mains voltage is too low	Increase mains voltage

# 8 Diagnostics & error management

## 8.7 Error messages of the operating system

### 8.7 Error messages of the operating system

This chapter describes all error messages of the controller operating system and possible causes & remedies.



**Tip!**

Each error message is also saved in the logbook in chronological order. ▶ [Logbook](#) (📖 149)

#### 8.7.1 Structure of the error number (bit coding)

If an error occurs in the controller, the internal fault memory saves a 32-bit value which contains the following information:

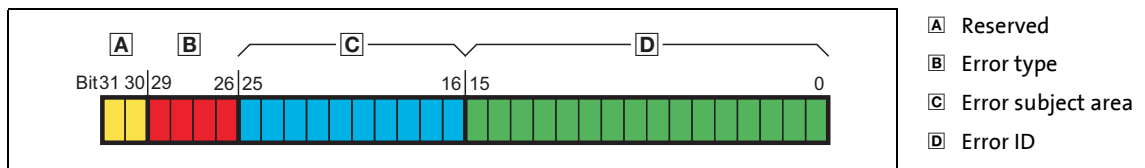

[8-1] Structure of the error number

For the sake of legibility, the error number in the logbook is displayed with the following syntax: **[Error type].[Error subject area no.].[Error ID]**

##### 8.7.1.1 Error type



The error type gives information about the behaviour/response of the controller to the error. The error type for some device errors can also be parameterised.

Bit 29	Bit 28	Bit 27	Bit 26	Meaning
0	0	0	0	0: No response
0	0	0	1	1: Fault
0	0	1	0	2: Trouble
0	1	0	0	4: WarningLocked

# 8 Diagnostics & error management

## 8.7 Error messages of the operating system

### 8.7.1.2 Error subject area

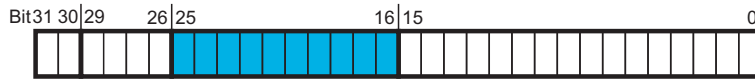

The error subject area indicates the internal "function unit" of the controller in which the error has occurred:

Error subject area		Assigned errors	Remedy possible by user?
No.	Name		
111	Supply voltage	Errors that occur in connection with the supply voltage of the device.	Yes
119	Temperature	Errors that occur for temperature reasons.	Yes
123	Motor management / encoder	Errors that occur within the motor control or encoder evaluation.	Yes
125	Analog I/O	Errors that occur in connection with the analog inputs and outputs.	Yes
131	CAN general	Errors related to general CAN functions.	Yes
135	CAN PDO	Errors that are explicitly only related to the CAN-PDO (process data objects).	Yes
144	Parameter set	Errors that occur in connection with the parameter set or the parameter set memory (memory module).	Yes if the error relates to a missing or incompatible memory module.
145	Device firmware (internal error)	Internal error of the device firmware.	No
400	Device hardware defective	Errors that occur due to defective device hardware.	No
980	US01: User error 1	Errors generated by the user (by the application) via the <a href="#">LS_SetError_1</a> system block.	Yes
981	US02: User error 2		

### 8.7.1.3 Error ID

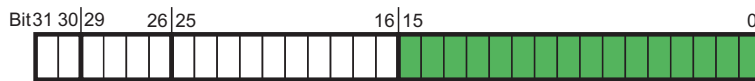

16-bit value (0 ... 65535) for error identification within the error subject area.

### 8.7.1.4 Example for bit coding of the error number

In [C168](#) displays the internal error number "75169803".

- This decimal value corresponds to the following bit sequence:

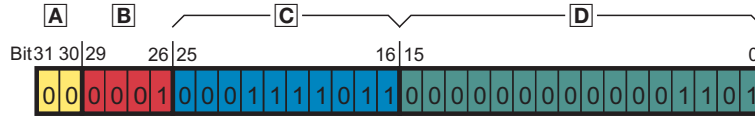

Assignment	Information	Meaning in the example
	Reserved	-
	Error type	1: Fault (pulse inhibit)
	Error subject area	123: Motor management / encoder
	Error ID	13: " <a href="#">LU: DC bus undervoltage</a> "

- Thus, error number "75169803" means:  
An overcurrent has been detected in the "Motor management/encoder" subject area. A pulse inhibit is set as error response. The error message must be acknowledged after the error has been eliminated.

### 8.7.2 Reset of error message

An error message with the response "Fault", "Trouble", or "Warning locked" must be explicitly reset (acknowledged) after the cause of the error has been eliminated.



To reset (acknowledge) a pending error message, execute the device command [C002/19](#) = "1".



#### Tip!

With an online connection to the controller, use the **Diagnostics** tab of the »Engineer« and click **Error message reset** to reset a pending error message.

### 8.7.3 Short overview (A-Z)

The table below contains all error messages of the controller operating system in alphabetical order.



#### Note!

For the sake of legibility, the [Logbook](#) and [C165](#) display the error number with the following syntax:

**[Error type].[Error subject area no.].[.].[Error ID]**

In this documentation, "xx", a wildcard, stands for the error type since it is configurable for many error messages.



#### Tip!

If you click the cross-reference in the first column, "Error number", you get to the detailed description of the respective error message in the subsequent "[Cause & possible remedies](#)" chapter . ([161](#))

Error number	Error message	Response (Lenze setting)	can be set in	CAN Emergency Error Code
▶ <a href="#">xx.0125.00001</a>	An01: AIN1_I < 4 mA	Fault	<a href="#">C598/1</a>	0xF000
▶ <a href="#">xx.0131.00006</a>	CA06: CAN CRC error	No response	<a href="#">C592/1</a>	0x8000
▶ <a href="#">xx.0131.00007</a>	CA07: CAN Bus Warn	No response	<a href="#">C592/3</a>	0x8000
▶ <a href="#">xx.0131.00008</a>	CA08: CAN Bus Stopped	No response	<a href="#">C592/4</a>	0x8000
▶ <a href="#">xx.0131.00011</a>	CA0b: CAN Bus Live Time	No response	<a href="#">C592/5</a>	0x8130
▶ <a href="#">xx.0131.00015</a>	CA0F: CAN control word	No response	<a href="#">C594/2</a>	0xF000
▶ <a href="#">xx.0135.00001</a>	CE1: CAN RPDO1	No response	<a href="#">C593/1</a>	0x8100
▶ <a href="#">xx.0135.00002</a>	CE2: CAN RPDO2	No response	<a href="#">C593/2</a>	0x8100
▶ <a href="#">xx.0131.00000</a>	CE4: CAN Bus Off	No response	<a href="#">C592/2</a>	0x8000
▶ <a href="#">xx.0145.00001</a>	dF01: Internal error 01	Fault	-	
▶ <a href="#">xx.0145.00002</a>	dF02: Internal error 02	Fault	-	
▶ <a href="#">xx.0145.00003</a>	dF03: Internal error 03	Fault	-	
▶ <a href="#">xx.0145.00004</a>	dF04: Internal error 04	Fault	-	
▶ <a href="#">xx.0145.00005</a>	dF05: Internal error 05	Fault	-	
▶ <a href="#">xx.0145.00006</a>	dF06: Internal error 06	Fault	-	
▶ <a href="#">xx.0145.00007</a>	dF07: Internal error 07	Fault	-	
▶ <a href="#">xx.0145.00008</a>	dF08: Internal error 08	Fault	-	
▶ <a href="#">xx.0145.00009</a>	dF09: Internal error 09	Fault	-	
▶ <a href="#">xx.0145.00010</a>	dF10: Internal error 10	Fault	-	
▶ <a href="#">xx.0400.00105</a>	dH69: Adjustment data error	Fault	-	0x5530
▶ <a href="#">xx.0123.00057</a>	ID1: Motor data identification error	WarningLocked	-	0xF000
▶ <a href="#">xx.0123.00015</a>	LU: DC bus undervoltage	Trouble	<a href="#">C600/1</a>	0x3100
▶ <a href="#">xx.0123.00016</a>	OC1: Power section - short circuit	Fault	-	0x2000
▶ <a href="#">xx.0123.00017</a>	OC2: Power section - earth fault	Fault	-	0x2000
▶ <a href="#">xx.0119.00050</a>	OC5: Ixt overload	WarningLocked	<a href="#">C604</a>	0x2000
▶ <a href="#">xx.0123.00105</a>	OC6: I2xt motor overload	WarningLocked	<a href="#">C606</a>	0x2000
▶ <a href="#">xx.0119.00052</a>	OC9: Ixt overload - shutdown limit	Fault	-	0x2000
▶ <a href="#">xx.0123.00065</a>	OC12: I2xt brake resistance overload	Fault	-	0xF000
▶ <a href="#">xx.0119.00001</a>	OH: Heatsink overtemperature	Fault	-	0x4000
▶ <a href="#">xx.0123.00014</a>	OU: DC bus overvoltage	Trouble	-	0x3100
▶ <a href="#">xx.0144.00001</a>	PS01: No memory module	Warning	-	0x6300
▶ <a href="#">xx.0144.00002</a>	PS02: Par. set invalid	Fault	-	0x6300

# 8 Diagnostics & error management

## 8.7 Error messages of the operating system

---

Error number	Error message	Response (Lenze setting)	can be set in	CAN Emergency Error Code
▶ <a href="#">xx.0144.00003</a>	PS03: Par. set device invalid	Fault	-	0x6300
▶ <a href="#">xx.0144.00004</a>	PS04: Par. set device incompatible	Fault	-	0x6300
▶ <a href="#">xx.0144.00031</a>	PS31: Ident. error	Fault	-	0x6300
▶ <a href="#">xx.0111.00002</a>	Su02: One mains phase is missing	WarningLocked	<a href="#">C565</a>	0x3000
▶ <a href="#">xx.0980.00000</a>	US01: User error 1	Fault	<a href="#">C581/1</a>	0x6200
▶ <a href="#">xx.0981.00000</a>	US02: User error 2	Fault	<a href="#">C581/2</a>	0x6200



### 8.7.4 Cause & possible remedies

This chapter contains all error messages of the controller operating system in numerical order of the error numbers. The list provides detailed information on the response to the error message as well as information on the cause & possible remedies.



#### Note!

For the sake of legibility, the [Logbook](#) and [C165](#) display the error number with the following syntax:

**[Error type].[Error subject area no.].[Error ID]**

In this documentation, "xx", a wildcard, stands for the error type since it is configurable for many error messages.



#### Tip!

A list of all error messages of the controller operating system in alphabetical order can be found in the previous chapter "[Short overview \(A-Z\)](#)" ([□ 159](#)).

#### Su02: One mains phase is missing [xx.0111.00002]

<b>Response</b> (Lenze setting printed in bold)		<b>Setting:</b> <a href="#">C565</a> ( <input checked="" type="checkbox"/> Adjustable response)
<input checked="" type="checkbox"/> None <input checked="" type="checkbox"/> Fault <input type="checkbox"/> Trouble <input checked="" type="checkbox"/> WarningLocked		
<b>Cause</b>	<b>Remedy</b>	
One mains phase of a three-phase supply has failed.	Check mains connection (terminal X100).	

#### OH: Heatsink overtemperature [xx.0119.00001]

<b>Response</b> (Lenze setting printed in bold)	
<input type="checkbox"/> None <input checked="" type="checkbox"/> Fault <input type="checkbox"/> Trouble <input type="checkbox"/> WarningLocked	
<b>Cause</b>	<b>Remedy</b>
The heatsink temperature is higher than the fixed limit temperature (90 °C). Maybe the ambient temperature of the controller is too high or the fan or its ventilation slots are dirty.	<ul style="list-style-type: none"> <li>• Check control cabinet temperature.</li> <li>• Clean filter.</li> <li>• Clean controller.</li> <li>• If required, clean or replace the fan.</li> <li>• Provide for sufficient cooling of the device.</li> </ul>

#### OC5: Ixt overload [xx.0119.00050]

<b>Response</b> (Lenze setting printed in bold)		<b>Setting:</b> <a href="#">C604</a> ( <input checked="" type="checkbox"/> Adjustable response)
<input checked="" type="checkbox"/> None <input checked="" type="checkbox"/> Fault <input type="checkbox"/> Trouble <input checked="" type="checkbox"/> WarningLocked		
<b>Cause</b>	<b>Remedy</b>	
The Ixt overload check has tripped. <ul style="list-style-type: none"> <li>• Operating threshold = 100 % Ixt (adjustable in <a href="#">C123</a>)</li> </ul> Possible causes: <ul style="list-style-type: none"> <li>• Wrong dimensioning of the device with regard to its motor load.</li> <li>• Load cycles are not complied with.</li> </ul>	<ul style="list-style-type: none"> <li>• Check and, if required, correct dimensioning of the device and the motor load with regard to technical data.</li> <li>• Reduce motor load cycles (observe load cycles according to documentation).</li> </ul>	

# 8 Diagnostics & error management

## 8.7 Error messages of the operating system

### OC9: Ixt overload - shutdown limit [xx.0119.00052]

Response (Lenze setting printed in bold)	
<input type="checkbox"/> None <input checked="" type="checkbox"/> <b>Fault</b> <input checked="" type="checkbox"/> <b>Trouble</b> <input type="checkbox"/> WarningLocked	
Cause	Remedy
<p>The Ixt overload check has tripped.</p> <ul style="list-style-type: none"> <li>• Operating threshold = 110 % Ixt (fixed)</li> </ul> <p>Possible causes:</p> <ul style="list-style-type: none"> <li>• Wrong dimensioning of the device with regard to its motor load.</li> <li>• Load cycles are not complied with.</li> </ul>	<ul style="list-style-type: none"> <li>• Check and, if required, correct dimensioning of the device and the motor load with regard to technical data.</li> <li>• Reduce motor load cycles (observe load cycles according to documentation).</li> </ul>

### OU: DC bus overvoltage [xx.0123.00014]

Response (Lenze setting printed in bold)	
<input type="checkbox"/> None <input checked="" type="checkbox"/> <b>Fault</b> <input checked="" type="checkbox"/> <b>Trouble</b> <input type="checkbox"/> WarningLocked	
Cause	Remedy
<p>The device has detected an overvoltage in the DC bus. To protect the device hardware, the inverter control is switched off.</p> <ul style="list-style-type: none"> <li>• Depending on the configuration of the auto-start lock function, <a href="#">C142</a> serves to set that, if this error has been tripped, the controller only starts after the controller inhibit is switched.</li> <li>• If this error message remains active longer than the time set in <a href="#">C601</a> a "Fault" is tripped.</li> </ul>	<ul style="list-style-type: none"> <li>• Reduce load in generator mode.</li> <li>• Use a brake resistor.</li> <li>• Use a regenerative power supply unit.</li> <li>• Establish a DC-bus connection.</li> </ul>

### LU: DC bus undervoltage [xx.0123.00015]

Response (Lenze setting printed in bold)		Setting: <a href="#">C600/1</a> <input checked="" type="checkbox"/> Adjustable response
<input type="checkbox"/> None <input checked="" type="checkbox"/> <b>Fault</b> <input checked="" type="checkbox"/> <b>Trouble</b> <input type="checkbox"/> WarningLocked		
Cause	Remedy	
<p>The device has detected a DC bus undervoltage. The inverter control is switched off because the drive properties of the motor control cannot be provided anymore due to the DC bus undervoltage.</p> <ul style="list-style-type: none"> <li>• Depending on the configuration of the auto-start lock function, <a href="#">C142</a> serves to set that, if this error has been tripped, the controller only starts after the controller inhibit is switched.</li> </ul>	<ul style="list-style-type: none"> <li>• Switch on mains supply or ensure sufficient supply via DC bus.</li> <li>• Adjust setting in <a href="#">C142</a> if required.</li> </ul>	

### OC1: Power section - short circuit [xx.0123.00016]

Response (Lenze setting printed in bold)	
<input type="checkbox"/> None <input checked="" type="checkbox"/> <b>Fault</b> <input type="checkbox"/> Trouble <input type="checkbox"/> WarningLocked	
Cause	Remedy
<p>The device has recognised a short circuit of the motor phases. To protect the device electronics, the inverter control is switched off.</p> <ul style="list-style-type: none"> <li>• Mostly, incorrectly executed motor connections are the cause.</li> <li>• If the device is inappropriately dimensioned with regard to the motor load and the current limitation in the controller (Imax controller) is set incorrectly, this error message may also occur.</li> </ul> <p>► <a href="#">Motor control: Defining current limits</a></p>	<ul style="list-style-type: none"> <li>• Check motor connections and the corresponding plug connector on the device.</li> <li>• Only use permissible combinations of device power and motor power.</li> <li>• Do not set the dynamics of the current limitation controller too high.</li> </ul>

# 8 Diagnostics & error management

## 8.7 Error messages of the operating system

### OC2: Power section - earth fault [xx.0123.00017]

<b>Response</b> (Lenze setting printed in bold)	
<input type="checkbox"/> None <input checked="" type="checkbox"/> <b>Fault</b> <input type="checkbox"/> Trouble <input type="checkbox"/> WarningLocked	
<b>Cause</b>	<b>Remedy</b>
<p>The device has recognised an earth fault at one of the motor phases. To protect the device electronics, the inverter control is switched off.</p> <ul style="list-style-type: none"> <li>• Mostly, incorrectly executed motor connections are the cause.</li> <li>• If motor filter, motor cable length, and cable type (shielding capacity) are dimensioned incorrectly, this error message may occur due to leakage currents to PE.</li> </ul>	<ul style="list-style-type: none"> <li>• Check motor connections and the corresponding plug connector on the device.</li> <li>• Use motor filters, cable lengths, and cable types recommended by Lenze.</li> </ul>

### ID1: Motor data identification error [xx.0123.00057]

<b>Response</b> (Lenze setting printed in bold)	
<input type="checkbox"/> None <input type="checkbox"/> Fault <input type="checkbox"/> Trouble <input checked="" type="checkbox"/> <b>WarningLocked</b>	
<b>Cause</b>	<b>Remedy</b>
<p>The device has detected an error during the motor data identification.</p> <p>Possible causes:</p> <ul style="list-style-type: none"> <li>• Interrupted motor cable.</li> <li>• Switched-off power section during the identification.</li> <li>• Implausible start parameter settings.</li> </ul>	<ul style="list-style-type: none"> <li>• Check the motor connections and the corresponding plug connector on the device and, if necessary, the motor terminal box.</li> <li>• Correct start parameters for the motor parameter identification (motor nameplate data).</li> <li>• Stable power supply of the device.</li> </ul>

### OC12: I2xt overload - brake resistor [xx.0123.00065]

<b>Response</b> (Lenze setting printed in bold)	
<input type="checkbox"/> None <input checked="" type="checkbox"/> <b>Fault</b> <input type="checkbox"/> Trouble <input type="checkbox"/> WarningLocked	
<b>Cause</b>	<b>Remedy</b>
Too frequent and too long braking processes.	Check drive dimensioning.

### OC6: I2xt overload - motor [xx.0123.00105]

<b>Response</b> (Lenze setting printed in bold)		<b>Setting:</b> <a href="#">C606</a> <input checked="" type="checkbox"/> Adjustable response)
<input checked="" type="checkbox"/> None <input checked="" type="checkbox"/> <b>Fault</b> <input type="checkbox"/> Trouble <input checked="" type="checkbox"/> <b>WarningLocked</b>		
<b>Cause</b>	<b>Remedy</b>	
Thermal overload of the motor.	<ul style="list-style-type: none"> <li>• Observe load requirements.</li> <li>• Correct dimensioning if necessary.</li> <li>• In case of VFCplus operation: Check Vmin boost (<a href="#">C016</a>).</li> <li>▶ <a href="#">Set Vmin boost</a></li> </ul>	

### An01: AIN1\_I < 4 mA [xx.0125.00001]

<b>Response</b> (Lenze setting printed in bold)		<b>Setting:</b> <a href="#">C598/1</a> <input checked="" type="checkbox"/> Adjustable response)
<input checked="" type="checkbox"/> None <input checked="" type="checkbox"/> <b>Fault</b> <input checked="" type="checkbox"/> Trouble <input checked="" type="checkbox"/> <b>WarningLocked</b>		
<b>Cause</b>	<b>Remedy</b>	
<p>Open-circuit monitoring for analog input has tripped.</p> <ul style="list-style-type: none"> <li>• Only if the analog input has been configured as a current loop of 4 ... 20 (<a href="#">C034/1</a> = 2).</li> </ul>	<ul style="list-style-type: none"> <li>• Check wiring of the analog X4/A1U input terminal for open circuit.</li> <li>• Check connection of the external 250-Ω load resistor between the terminals A1U and GND.</li> <li>• Check minimum current values of the signal sources.</li> </ul>	

# 8 Diagnostics & error management

## 8.7 Error messages of the operating system

### CE4: CAN bus off [xx.0131.00000]

<b>Response</b> (Lenze setting printed in bold)		<b>Setting:</b> <a href="#">C592/2</a> (☑ Adjustable response)
☑ <b>None</b> ☑ Fault ☑ Trouble ☑ WarningLocked		
<b>Cause</b>		<b>Remedy</b>
<p><a href="#">CAN on board</a>: "Bus off" status</p> <ul style="list-style-type: none"> <li>Received too many faulty telegrams.</li> <li>Damaged cable (e.g. loose contact).</li> <li>Two nodes have the same ID.</li> </ul>		<ul style="list-style-type: none"> <li>Check wiring and bus terminating resistor.</li> <li>Set identical baud rate for each bus node.</li> <li>Assign different IDs to nodes.</li> <li>Eliminate electrical interference (e.g. EMC).</li> </ul>

### CA06: CAN CRC error [xx.0131.00006]

<b>Response</b> (Lenze setting printed in bold)		<b>Setting:</b> <a href="#">C592/1</a> (☑ Adjustable response)
☑ <b>None</b> ☑ Fault ☑ Trouble ☑ WarningLocked		
<b>Cause</b>		<b>Remedy</b>
<p><a href="#">CAN on board</a>: A faulty CAN telegram has been detected.</p>		<ul style="list-style-type: none"> <li>Check wiring and bus terminating resistor.</li> <li>Eliminate electrical interference (e.g. EMC).</li> </ul>

### CA07: CAN bus warning [xx.0131.00007]

<b>Response</b> (Lenze setting printed in bold)		<b>Setting:</b> <a href="#">C592/3</a> (☑ Adjustable response)
☑ <b>None</b> ☑ Fault ☑ Trouble ☑ WarningLocked		
<b>Cause</b>		<b>Remedy</b>
<p><a href="#">CAN on board</a>: Incorrect transmission or reception of more than 96 CAN telegrams.</p> <ul style="list-style-type: none"> <li>The current number of incorrectly transmitted CAN telegrams is displayed in <a href="#">C372/1</a>.</li> <li>The current number of incorrectly received CAN telegrams is displayed in <a href="#">C372/2</a>.</li> <li>The current CAN error status is displayed in <a href="#">C345</a>.</li> </ul>		<ul style="list-style-type: none"> <li>Check wiring and bus terminating resistor.</li> <li>Set identical baud rate for each bus node.</li> <li>Assign different IDs to nodes.</li> <li>Eliminate electrical interference (e.g. EMC).</li> </ul>

### CA08: CAN bus stopped [xx.0131.00008]

<b>Response</b> (Lenze setting printed in bold)		<b>Setting:</b> <a href="#">C592/4</a> (☑ Adjustable response)
☑ <b>None</b> ☑ Fault ☑ Trouble ☑ WarningLocked		
<b>Cause</b>		<b>Remedy</b>
<p><a href="#">CAN on board</a>: The device has received the "Stop Remote Node" NMT telegram.</p>		Check CAN master (NMT master).

### CA0b: CAN bus live time [xx.0131.00011]

<b>Response</b> (Lenze setting printed in bold)		<b>Setting:</b> <a href="#">C592/5</a> (☑ Adjustable response)
☑ <b>None</b> ☑ Fault ☑ Trouble ☑ WarningLocked		
<b>Cause</b>		<b>Remedy</b>
<p><a href="#">CAN on board</a>: Cyclic node monitoring</p> <ul style="list-style-type: none"> <li>Being a Heartbeat consumer, the device has not received a Heartbeat telegram from Heartbeat producer 1 ... 7 within the defined time.</li> <li>The current states of the Heartbeat producers are displayed in <a href="#">C347/1...7</a>.</li> </ul>		<ul style="list-style-type: none"> <li>Reactivate Heartbeat producers by mains switching, restarting the controller, or a CAN Reset Node.</li> <li>Reparameterise CAN Heartbeat producer time or switch off consumer monitoring and reset error status if latched.</li> <li>▶ <a href="#">System bus "CAN on board": Heartbeat protocol</a></li> </ul>

# 8 Diagnostics & error management

## 8.7 Error messages of the operating system

### CA0F: CAN control word [xx.0131.00015]

<b>Response</b> (Lenze setting printed in bold)		<b>Setting:</b> <a href="#">C594/2</a> (☑ Adjustable response)
☑ None ☑ Fault ☑ Trouble ☑ WarningLocked		
<b>Cause</b>		<b>Remedy</b>
Bit 14 ("SetFail") in the wCANControl control word of the system block <a href="#">LS_DriveInterface</a> has been set.		Trace back signal source on the CAN bus that sets bit 14 ("SetFail").

### CE1: CAN RPDO1 [xx.0135.00001]

<b>Response</b> (Lenze setting printed in bold)		<b>Setting:</b> <a href="#">C593/1</a> (☑ Adjustable response)
☑ None ☑ Fault ☑ Trouble ☑ WarningLocked		
<b>Cause</b>		<b>Remedy</b>
<p><a href="#">CAN on board</a>: Time monitoring for RPDO1 has tripped.</p> <ul style="list-style-type: none"> <li>RPDO1 has not been received within the monitoring time set in <a href="#">C357/1</a> or was faulty.</li> </ul>		<ul style="list-style-type: none"> <li>Set the correct telegram length at the CAN master (transmitter).</li> <li>Eliminate electrical interference (e.g. EMC).</li> <li>Adjust monitoring time in <a href="#">C357/1</a> or switch off time monitoring.</li> </ul>

### CE2: CAN RPDO2 [xx.0135.00002]

<b>Response</b> (Lenze setting printed in bold)		<b>Setting:</b> <a href="#">C593/2</a> (☑ Adjustable response)
☑ None ☑ Fault ☑ Trouble ☑ WarningLocked		
<b>Cause</b>		<b>Remedy</b>
<p><a href="#">CAN on board</a>: Time monitoring for RPDO2 has tripped.</p> <ul style="list-style-type: none"> <li>RPDO2 has not been received within the monitoring time set in <a href="#">C357/2</a> or was faulty.</li> </ul>		<ul style="list-style-type: none"> <li>Set the correct telegram length at the CAN master (transmitter).</li> <li>Eliminate electrical interference (e.g. EMC).</li> <li>Adjust monitoring time in <a href="#">C357/2</a> or switch off time monitoring.</li> </ul>

### PS01: No memory module [xx.0144.00001]

<b>Response</b> (Lenze setting printed in bold)		
☐ None ☐ Fault ☐ Trouble ☐ WarningLocked		
<b>Cause</b>		<b>Remedy</b>
Memory module is either not available or not snapped into place correctly.		<ul style="list-style-type: none"> <li>If a memory module has been provided: Plug the memory module into the slot of the standard device intended for this purpose.</li> <li>If a memory module has been provided: Check if the memory module has been plugged-in correctly.</li> </ul>

### PS02: Par. set invalid [xx.0144.00002]

<b>Response</b> (Lenze setting printed in bold)		
☐ None ☑ Fault ☐ Trouble ☐ WarningLocked		
<b>Cause</b>		<b>Remedy</b>
<p>The parameter set saved to the memory module is invalid because it has not been saved completely.</p> <ul style="list-style-type: none"> <li>This can be due to voltage failure or caused by removing the memory module while saving the parameter set.</li> </ul>		Ensure voltage supply during the storage process and that the module remains plugged into the slot.

# 8 Diagnostics & error management

## 8.7 Error messages of the operating system

### PS03: Par. set device invalid [xx.0144.00003]

<b>Response</b> (Lenze setting printed in bold)	
<input type="checkbox"/> None <input checked="" type="checkbox"/> <b>Fault</b> <input type="checkbox"/> Trouble <input type="checkbox"/> WarningLocked	
<b>Cause</b>	<b>Remedy</b>
The parameter set in the device is invalid.	Consultation with Lenze required.

### PS04: Par. set device incompatible [xx.0144.00004]

<b>Response</b> (Lenze setting printed in bold)	
<input type="checkbox"/> No Reaction <input checked="" type="checkbox"/> <b>Fault</b> <input type="checkbox"/> Trouble <input type="checkbox"/> Warning	
<b>Cause</b>	<b>Remedy</b>
The parameter set saved to the memory module is incompatible to the standard device. <ul style="list-style-type: none"><li>An incompatibility of the parameter set is caused e.g. when the memory module of an 8400 StateLine is plugged into an 8400 BaseLine or the parameter set in the memory module has a higher version than expected by the standard device.</li></ul>	When the memory modules are exchanged, observe the downward compatibility: <ul style="list-style-type: none"><li>OK: BaseLine V2.0 to BaseLine V3.0</li><li>Not OK: StateLine Vx.x to BaseLine Vx.x</li><li>Not OK: BaseLine V3.0 to BaseLine &lt; V3.0</li></ul>

### PS31: Ident. error [xx.0144.00031]

<b>Response</b> (Lenze setting printed in bold)	
<input type="checkbox"/> None <input checked="" type="checkbox"/> <b>Fault</b> <input type="checkbox"/> Trouble <input type="checkbox"/> WarningLocked	
<b>Cause</b>	<b>Remedy</b>
Incompatible or unknown HW components have been found.	<ul style="list-style-type: none"><li>Check which HW components are faulty (<a href="#">C203/x</a>: Product type code).</li><li>Check temperature range of the device at the start.</li><li>Check whether a software update at Lenze is possible.</li></ul>

### dF01: Internal error 01 [xx.0145.00001]

<b>Response</b> (Lenze setting printed in bold)	
<input type="checkbox"/> None <input checked="" type="checkbox"/> <b>Fault</b> <input type="checkbox"/> Trouble <input type="checkbox"/> WarningLocked	
<b>Cause</b>	<b>Remedy</b>
Device error	<ul style="list-style-type: none"><li>Reduce switching frequency (<a href="#">C018</a>) to 4 kHz.</li><li>If the problem occurs again, you need to consult Lenze.</li></ul>

### dF02: Internal error 02 [xx.0145.00002]

<b>Response</b> (Lenze setting printed in bold)	
<input type="checkbox"/> None <input checked="" type="checkbox"/> <b>Fault</b> <input type="checkbox"/> Trouble <input type="checkbox"/> WarningLocked	
<b>Cause</b>	<b>Remedy</b>
Device error	<ul style="list-style-type: none"><li>Mains switching or restart of the controller, respectively.</li><li>If the problem occurs again, you need to consult Lenze.</li></ul>

# 8 Diagnostics & error management

## 8.7 Error messages of the operating system

---

### dF03: Internal error 03 [xx.0145.00003]

<b>Response</b> (Lenze setting printed in bold)	
<input type="checkbox"/> None <input checked="" type="checkbox"/> <b>Fault</b> <input type="checkbox"/> Trouble <input type="checkbox"/> WarningLocked	
<b>Cause</b>	<b>Remedy</b>
Device error	<ul style="list-style-type: none"><li>• Mains switching or restart of the controller, respectively.</li><li>• If the problem occurs again, you needs to consult Lenze.</li></ul>

### dF04: Internal error 04 [xx.0145.00004]

<b>Response</b> (Lenze setting printed in bold)	
<input type="checkbox"/> None <input checked="" type="checkbox"/> <b>Fault</b> <input type="checkbox"/> Trouble <input type="checkbox"/> WarningLocked	
<b>Cause</b>	<b>Remedy</b>
Device error	<ul style="list-style-type: none"><li>• Mains switching or restart of the controller, respectively.</li><li>• If the problem occurs again, you needs to consult Lenze.</li></ul>

### dF05: Internal error 05 [xx.0145.00005]

<b>Response</b> (Lenze setting printed in bold)	
<input type="checkbox"/> None <input checked="" type="checkbox"/> <b>Fault</b> <input type="checkbox"/> Trouble <input type="checkbox"/> WarningLocked	
<b>Cause</b>	<b>Remedy</b>
Device error	<ul style="list-style-type: none"><li>• Mains switching or restart of the controller, respectively.</li><li>• If the problem occurs again, you needs to consult Lenze.</li></ul>

### dF06: Internal error 06 [xx.0145.00006]

<b>Response</b> (Lenze setting printed in bold)	
<input type="checkbox"/> None <input checked="" type="checkbox"/> <b>Fault</b> <input type="checkbox"/> Trouble <input type="checkbox"/> WarningLocked	
<b>Cause</b>	<b>Remedy</b>
Device error	<ul style="list-style-type: none"><li>• Mains switching or restart of the controller, respectively.</li><li>• If the problem occurs again, you needs to consult Lenze.</li></ul>

### dF07: Internal error 07 [xx.0145.00007]

<b>Response</b> (Lenze setting printed in bold)	
<input type="checkbox"/> None <input checked="" type="checkbox"/> <b>Fault</b> <input type="checkbox"/> Trouble <input type="checkbox"/> WarningLocked	
<b>Cause</b>	<b>Remedy</b>
Device error	<ul style="list-style-type: none"><li>• Mains switching or restart of the controller, respectively.</li><li>• If the problem occurs again, you needs to consult Lenze.</li></ul>

# 8 Diagnostics & error management

## 8.7 Error messages of the operating system

---

### dF08: Internal error 08 [xx.0145.00008]

<b>Response</b> (Lenze setting printed in bold)	
<input type="checkbox"/> None <input checked="" type="checkbox"/> <b>Fault</b> <input type="checkbox"/> Trouble <input type="checkbox"/> WarningLocked	
<b>Cause</b>	<b>Remedy</b>
Device error	<ul style="list-style-type: none"><li>• Mains switching or restart of the controller, respectively.</li><li>• If the problem occurs again, you need to consult Lenze.</li></ul>

### dF09: Internal error 09 [xx.0145.00009]

<b>Response</b> (Lenze setting printed in bold)	
<input type="checkbox"/> None <input checked="" type="checkbox"/> <b>Fault</b> <input type="checkbox"/> Trouble <input type="checkbox"/> WarningLocked	
<b>Cause</b>	<b>Remedy</b>
Device error	<ul style="list-style-type: none"><li>• Mains switching or restart of the controller, respectively.</li><li>• If the problem occurs again, you need to consult Lenze.</li></ul>

### dF10: Internal error 10 [xx.0145.00010]

<b>Response</b> (Lenze setting printed in bold)	
<input type="checkbox"/> None <input checked="" type="checkbox"/> <b>Fault</b> <input type="checkbox"/> Trouble <input type="checkbox"/> WarningLocked	
<b>Cause</b>	<b>Remedy</b>
Device error	<ul style="list-style-type: none"><li>• Mains switching or restart of the controller, respectively.</li><li>• If the problem occurs again, you need to consult Lenze.</li></ul>

### dH69: Adjustment fault [xx.0400.00105]

<b>Response</b> (Lenze setting printed in bold)	
<input type="checkbox"/> None <input checked="" type="checkbox"/> <b>Fault</b> <input type="checkbox"/> Trouble <input type="checkbox"/> WarningLocked	
<b>Cause</b>	<b>Remedy</b>
Device error	Consultation with Lenze required.

### US01: User error 1 [xx.0980.00000]

<b>Response</b> (Lenze setting printed in bold)	
<input checked="" type="checkbox"/> None <input checked="" type="checkbox"/> <b>Fault</b> <input checked="" type="checkbox"/> Trouble <input checked="" type="checkbox"/> WarningLocked	
Setting: <a href="#">C581/1</a> ( <input checked="" type="checkbox"/> Adjustable response)	
<b>Cause</b>	<b>Remedy</b>
User error 1 has been tripped via the <i>bSetError1</i> input of the <a href="#">LS_SetError_1</a> system block.	User-defined.

### US02: User error 2 [xx.0981.00000]

<b>Response</b> (Lenze setting printed in bold)	
<input checked="" type="checkbox"/> None <input checked="" type="checkbox"/> <b>Fault</b> <input checked="" type="checkbox"/> Trouble <input checked="" type="checkbox"/> WarningLocked	
Setting: <a href="#">C581/2</a> ( <input checked="" type="checkbox"/> Adjustable response)	
<b>Cause</b>	<b>Remedy</b>
User error 2 has been tripped via the <i>bSetError2</i> input of the <a href="#">LS_SetError_1</a> system block.	User-defined.



### 9 System bus "CAN on board"

The controller has an integrated CANopen system bus interface ("CAN on board") which is used to exchange i.a. process data and parameter values between the nodes. Furthermore, other modules can be connected via this interface such as decentralised terminals, operator and input devices (HMIs), as well as external controls and host systems.

The interface transfers CAN objects following the CANopen communication profile (CiA DS301, version 4.02) developed by the umbrella organisation of CiA (CAN in Automation) in conformity with the CAL (CAN Application Layer).



#### Tip!

- In the »Engineer« parameter list, category **CAN**, you can find the parameters relevant for the CANopen system bus interface classified in different subcategories.
- Information on CAN communication modules and CANopen system bus interfaces of other Lenze devices is provided in the "CAN" communication manual in the Lenze library.



The preconfigured interconnection of the internal interfaces for a control via CAN is shown in chapter "Drive application" in figure [\[7-2\]](#). ([□ 136](#))

## 9.1 General information

For many years, the system bus (CAN) based on the CANopen communication profile has been integrated in Lenze controllers. Due to the lower number of data objects available, the functionality and compatibility of the previous system bus are lower as compared to CANopen. For parameter setting, two parameter data channels are always available to the user while CANopen provides only one active parameter channel.

The system bus (CANopen) of the Inverter Drives 8400 is a further development of the system bus (CAN) including the following properties:

- Full compatibility according to CANopen DS301, V4.02.
- Support of the "Heartbeat" NMT slave function (DS301, V4.02).
- Number of parameterisable server SDO channels:
  - Max. 2 channels with 1 ... 8 bytes
  - Due to the 2 server SDO channels, an address range of 1 ... 63 is provided.
- Number of parameterisable PDO channels:
  - For device version "BaseLine C":
    - max. 2 Transmit-PDOs (TPDOs) with 1 ... 8 bytes (adjustable)
    - max. 2 Receive-PDOs (RPDOs) with 1 ... 8 bytes (adjustable)
  - From device version "StateLine" onwards:
    - max. 3 Transmit-PDOs (TPDOs) with 1 ... 8 bytes (adjustable)
    - max. 3 Receive-PDOs (RPDOs) with 1 ... 8 bytes (adjustable)
- All PDO channels are functionally equivalent.
- Monitoring of the RPDOs for data reception
- Adjustable error response to ...
  - physical CAN errors (frame, bit, ACK error)
  - bus-stop, bus working
  - absent PDOs
- Telegram counters for SDOs and PDOs
- Bus status diagnostics
- Boot-up telegram generation
- Emergency telegram generation
- Reset node telegram generation (in case of master configuration)
- Sync telegram generation and response to sync telegrams:
  - Data transmission/reception
  - Device-internal time base synchronisation
- Abort codes
- All CAN on board functions can be parameterised via codes
- Object directory (all mandatory functions, optional functions, indexes)

### 9.1.1 General data and application conditions

Range	Values
Communication profile	CANopen, DS301 V4.02
Communication medium	DIN ISO 11898
Network topology	Line terminated at both ends
Adjustable node addresses	1 ... 63 <ul style="list-style-type: none"> <li>adjustable per code <a href="#">C350</a></li> <li>from "StateLine" device version onwards also adjustable via DIP switches.</li> </ul>
Max. number of nodes	63
Adjustable baud rates	20, 50, 125, 250, 500, 1000 kbps <ul style="list-style-type: none"> <li>adjustable per code <a href="#">C351</a></li> <li>from "StateLine" device version onwards also adjustable via DIP switches.</li> <li>20 kbps and 1000 kbps: Not in case of "StateLine" device version.</li> </ul>
Process data	For "BaseLine C" version: <ul style="list-style-type: none"> <li>Max. 2 transmit PDOs (TPDOs) with 1 ... 8 bytes (adjustable)</li> <li>Max. 2 receive PDOs (RPDOs) with 1 ... 8 bytes (adjustable)</li> </ul>
	For "StateLine" version: <ul style="list-style-type: none"> <li>Max. 3 transmit PDOs (TPDOs) with 1 ... 8 bytes (adjustable)</li> <li>Max. 3 receive PDOs (RPDOs) with 1 ... 8 bytes (adjustable)</li> </ul>
Parameter data	Max. 2 server SDO channels with 1 ... 8 bytes
Transfer mode for TPDOs	<ul style="list-style-type: none"> <li>With change of data</li> <li>Time-controlled, 1 to x ms</li> <li>After the reception of 1 to 240 sync telegrams</li> </ul>

### 9.1.2 Supported protocols

Protocols	
Standard PDO protocols	PDO write PDO read
SDO protocols	SDO download SDO download initiate SDO download segment
	SDO upload SDO upload initiate SDO upload segment
	SDO abort transfer
	SDO block download SDO block download initiate SDO block download end
	SDO block upload SDO block upload initiate SDO block upload end
NMT protocols	Start remote node (master and slave)
	Stop remote node (slave)
	Enter pre-operational (slave)
	Reset node (slave and local device)
	Reset communication protocol (slave)

Protocols	
Monitoring protocols	Heartbeat (heartbeat producer and heartbeat consumer) <ul style="list-style-type: none"> <li>• "BaseLine C" version: 1 Heartbeat Producer can be monitored.</li> <li>• "StateLine" version: Up to 7 Heartbeat Producers can be monitored.</li> <li>• "HighLine" version: Up to 15 Heartbeat Producers can be monitored.</li> </ul>
	Emergency telegram (to master)

### 9.1.3 Communication time

The communication time is the time between the start of a request and the arrival of the corresponding response.



#### Tip!

The communication times in the CAN network depend on:

- the processing time in the device
- the telegram runtime (baud rate/telegram length)
- the bus load (especially if the bus is charged with PDOs and SDOs at a low baud rate)

#### Processing time in the 8400 controller

No dependencies exist between parameter data and process data.

- Parameter data: approx. 5 ms (typical value)
  - For parameters concerning the motor control (e.g. C011), the processing time may be longer (up to 30 ms).
- Process data: 1 ms

# 9 System bus "CAN on board"

## 9.1 General information

### 9.1.4 Activating the bus terminating resistor

The CAN bus has to be terminated at the first and last physical node each by a resistor (120 Ω) between CAN low and CAN high:

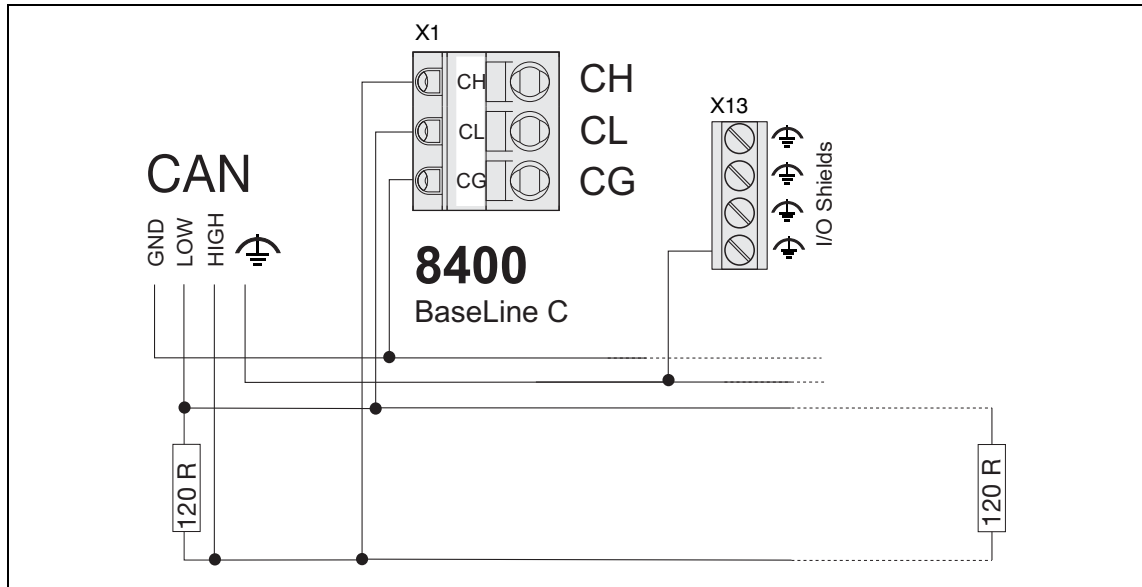

[9-1] Terminations at the beginning and end of the CAN bus

### 9.1.5 Setting baud rate & node address

The baud rate is set via code [C351](#).

- Options: 20, 50, 125, 250, 500, 1000 kbps
- Lenze setting: 500 kbps

The node address is set via code [C350](#).

- Valid address range: 1 to 63



#### Note!

The addresses of the nodes must differ from each other.

9.2

LED status displays for the system bus

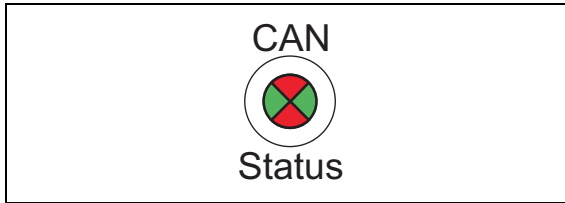

- CAN-Run (green): Signals the CANopen status
- CAN-Error (red): Signals a CANopen error

Frequency of the display	CAN signalling and meaning
Permanently red	CAN-Run: -, CAN-Error: <b>Bus Off</b> 
Flashes	Automatic detection of baud rate is active 
Green is blinking every 0.2 s	CAN-Run: <b>Pre-Operational</b> , CAN-Error: - 
Green is blinking every 0.2 s Red is blinking 1 time, 1 s off	CAN-Run: <b>Pre-Operational</b> , CAN-Error: <b>Warning Limit reached</b> 
Green is blinking every 0.2 s Red is blinking 2 times, 1 s off	CAN-Run: <b>Pre-Operational</b> , CAN-Error: <b>Node Guard Event</b> 
Permanently green	CAN-Run: <b>Operational</b> , CAN-Error: - 
Permanently green Red is blinking 1 time, 1 s off	CAN-Run: <b>Operational</b> , Fault: <b>Warning Limit reached</b> 
Permanently green Red is blinking 2 times, 1 s off	CAN-Run: <b>Operational</b> , CAN-Error: <b>Node Guard Event</b> 
Permanently green Red is blinking 3 times, 1 s off	CAN-Run: <b>Operational</b> , CAN-Error: <b>Sync Message Error</b> 
Green is blinking every second	CAN-Run: <b>Stopped</b> , CAN-Error: - 
Green is blinking every second Red is blinking 1 time, 1 s off	CAN-Run: <b>Stopped</b> , CAN-Error: <b>Warning Limit reached</b> 
Green is blinking every second Red is blinking 2 times, 1 s off	CAN-Run: <b>Stopped</b> , CAN-Error: <b>Node Guard Event</b> 

# 9 System bus "CAN on board"

## 9.3 Going online via system bus (CAN on board)

### 9.3 Going online via system bus (CAN on board)

The integrated system bus interface (CAN on board, X1 terminal) can also be used for the communication between the »Engineer« and the controller, alternatively to the USB diagnostic adapter.

- Lenze offers the following communication accessories for connection to the PC:

Communication accessories	PC interface
<b>PC system bus adapter 2173</b> incl. connection cable and voltage supply adapter <ul style="list-style-type: none"><li>• for DIN keyboard connection (EMF2173IB)</li><li>• for PS/2 keyboard connection (EMF2173IBV002)</li><li>• for PS/2 keyboard connection with electrical isolation (EMF2173IBV003)</li></ul>	Parallel interface (LPT port)
<b>PC system bus adapter 2177</b> incl. connection cable (EMF2177IB)	USB (Universal Serial Bus)



#### Note!

- For detailed information about the PC system bus adapter, please see the "CAN Communication Manual".
- Please observe the documentation for the PC system bus adapter!
- In the »Engineer«, go to the *Device assignment offline devices* dialog box and select the "System bus CAN" entry from the **Bus connection** list field to establish an online connection.

# 9 System bus "CAN on board"

## 9.4 Structure of the CAN data telegram

### 9.4 Structure of the CAN data telegram

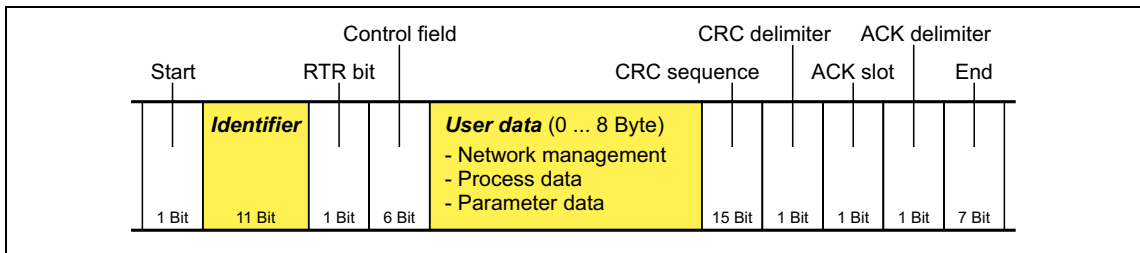

[9-2] Basic structure of the CAN telegram

The following subchapters provide a detailed description of the identifier and the user data. The other signals refer to the transfer characteristics of the CAN telegram whose description is not included in the scope of this documentation.



#### Tip!

Please visit the homepage of the CAN user organisation CiA (CAN in automation) for further information:

<http://www.can-cia.org>

#### 9.4.1 Identifier

The principle of the CAN communication is based on a message-oriented data exchange between a transmitter and many receivers. All nodes can transmit and receive quasi-simultaneously.

The identifier, also called COB-ID (abbr. for communication object identifier), is used to control which node is to receive a transmitted message. In addition to the addressing, the identifier contains information on the priority of the message and the type of user data.

The identifier consists of a basic identifier and the node address of the node to be addressed:

**Identifier (COB-ID) = basic identifier + node address (node ID)**

Exception: The identifier for process data/heartbeat/emergency objects as well as network management and sync telegrams is freely assigned by the user (either manually or automatically by the network configurator), or is permanently assigned.

#### Node address (node ID)

Every node of the system bus network must be assigned to a node address (also called node ID) within the valid address range (1 ... 63) for unambiguous identification.

- Assigning a node address more than once within a network is impermissible.
- The own node address is configured via code [C350](#).



### Identifier assignment

The system bus is message-oriented instead of node-oriented. Every message has an unambiguous identification, the identifier. For CANopen, node-oriented transfer is achieved by the fact that every message has only one transmitter.

- The basic identifiers for network management (NMT) and sync as well as the basic SDO channel (SDO1) are defined in the CANopen protocol and cannot be changed.
- In the Lenze setting, the basic identifiers of the PDOs are preset according to the "Predefined connection set" of DS301, V4.02 and can be changed via parameters/indexes if required.
  - ▶ [Identifiers of the process data objects](#) (📖 189)

Object		Direction		Lenze-Base-ID		CANopen-Base-ID	
		from device	to device	dec	hex	dec	hex
Network management (NMT)				0	0	0	0
Sync <sup>1)</sup>				128	80	128	80
Emergency <sup>1)</sup>		●		128	80	128	80
PDO1 (Process data channel 1)	TPDO1	●		384	180	384	180
	RPDO1		●	512	200	512	200
PDO2 (Process data channel 2)	TPDO2	●		640	280	640	280
	RPDO2		●	641	281	768	300
SDO1 (Parameter data channel 1)	TSDO1	●		1408	580	1408	580
	RSDO1		●	1536	600	1536	600
SDO2 (Parameter data channel 2)	TSDO2	●		1472	5C0	1472	5C0
	RSDO2		●	1600	640	1600	640
Heartbeat		●		1792	700	1792	700
Boot-up		●		1792	700	1792	700

1) If you set the sync transmit/receive identifier manually, observe the use of the emergency telegram, since it has the same COB-ID.

### 9.4.2 User data

All nodes communicate by exchanging data telegrams via the system bus. The user data area of the CAN telegram either contains network management data or parameter data or process data:

#### Networkmanagement data

(NMT data)

- Control information on start, stop, reset, etc. of communication to specific nodes or to all nodes of the CAN network.

#### Process data

(PDOs – process data objects)

- Process data are transferred via the process data channel.
- Process data can be used to control the controller.
- Process data are not saved to the controller.
- Process data are transmitted between host system and nodes to ensure continuous exchange of current input and output data.
- Process data usually are unscaled/scalable raw data.
- Process data are, for instance, setpoints and actual values.
- The exact meaning of the PDO file contents is determined via the function block editor (FB Editor) in the I/O level or via the PDO mapping.

#### Parameter data

(SDOs – service data objects)

- Parameter data are the CANopen indexes or, in case of Lenze devices, the codes.
- Parameters are, for instance, used for one-off plant setting during commissioning or when the material is changed on a production machine.
- Parameter data are transmitted as SDOs via the parameter data channel. They are acknowledged by the receiver, i.e. the transmitter gets a feedback about the transmission being successful or not.
- The parameter data channel enables access to all Lenze codes and CANopen indexes.
- Parameter changes are automatically saved to the controller until mains switching.
- In general, the parameter transfer is not time-critical.
- Parameter data are, for instance, operating parameters, diagnostic information and motor data as well as control information on the interconnection of function blocks in the I/O level of the FB Editor.

## 9.5 Communication phases/network management

Regarding communication via the system bus, the controller distinguishes between the following statuses:

Status	Explanation
"Initialisation" (Initialisation)	After switch-on, an initialisation run is carried out. <ul style="list-style-type: none"> <li>• During this phase, the controller is not involved in the data exchange via the bus.</li> <li>• The standard values are re-written to all CAN-relevant parameters.</li> <li>• After initialisation is completed, the controller is automatically set to the "Pre-Operational" status.</li> </ul>
"Pre-Operational" (before being ready for operation)	Parameter data can be received, process data are ignored.
"Operational" (ready for operation)	Parameter data and process data can be received!
"Stopped" (stopped)	Only network management telegrams can be received.

Communication object	Initialisation	Pre-Operational	Operational	Stopped
PDO			●	
SDO		●	●	
Sync		●	●	
Emergency		●	●	
Boot-up	●			
Network management (NMT)		●	●	●





### Tip!

Part of the initialisation or the entire initialisation can be carried out anew in every status by transferring the corresponding network management telegrams.

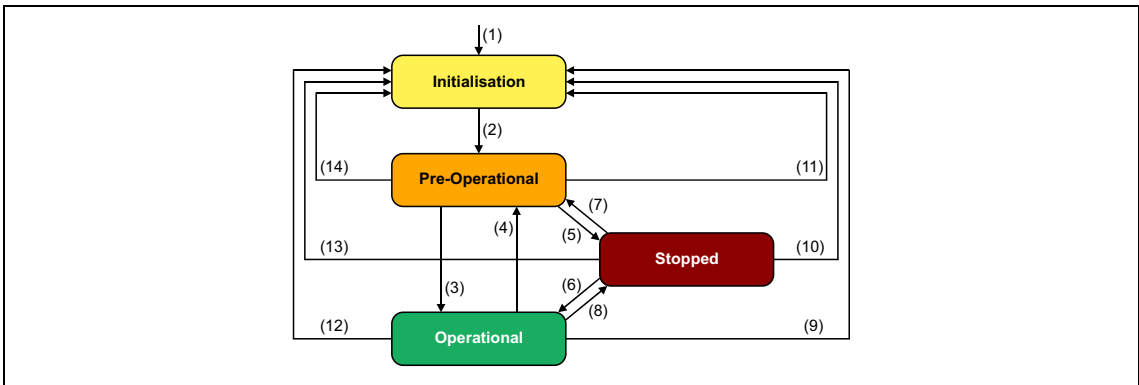
9.5.1 Status transitions



[9-3] NMT status transitions in the CAN network

Transition	NMT command	Status after change	Effects on process/parameter data after status change
(1)	-	Initialisation	Initialisation starts automatically when the mains is switched on. • During initialisation, the controller is not involved in the data exchange. • After the initialisation is completed, the node sends a boot-up message with an individual identifier and automatically changes to the "pre-operational" status.
(2)	-	Pre-Operational	In this phase, the master determines the way in which the node(s) takes/take part in communication.
	From here, the master changes the statuses for the entire network. • A target address included in the NMT command defines the receiver(s). • If the 8400 controller is configured as CAN master, the status is automatically changed to "Operational" after a waiting time has expired ( <a href="#">C356/1</a> ) and the 0x0100 ("Start remote node") NMT command is transmitted to all nodes. • Data can only be exchanged via process data objects if the status is "Operational"!		
(3), (6)	0x01 xx Start remote node	Operational	Network management/sync/emergency telegrams as well as process data (PDO) and parameter data (SDO) are active. Optional: When the status is changed, event and time-controlled process data (PDOs) are transmitted once.
(4), (7)	0x80 xx Enter Pre-Operational	Pre-Operational	Network management/sync/emergency telegrams and parameter data (SDO) are active.
(5), (8)	0x02 xx Stop remote node	Stopped	Only network management telegrams can be received.
(9), (10), (11)	0x81 xx Reset node	Initialisation	All CAN-relevant parameters (CiA DS 301) are initialised with the saved values.
(12), (13), (14)	0x82 xx Reset communication		All CAN-relevant parameters (CiA DS 301) are initialised with the saved values.
	Meaning of the node address in the NMT command: • xx = 0x00: If this assignment is selected, the telegram addresses all nodes (broadcast telegram). The status of all nodes can be changed at the same time. • xx = Node ID: If a node address is specified, only the status of the node with the corresponding address changes.		

### 9.5.2 Network management telegram (NMT)

The telegram for the network management contains identifier "0" and the command included in the user data which consists of the command byte and the node address:

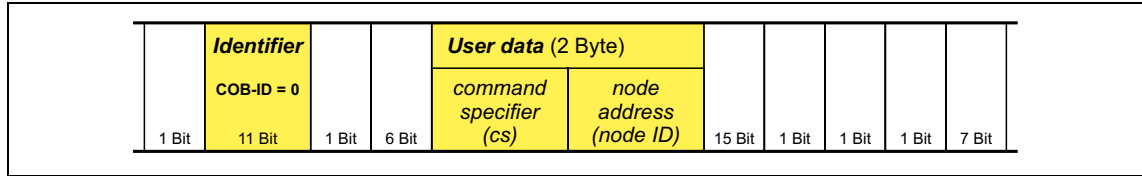

[9-4] Network management telegram for changing over the communication phases

Command specifier (cs)		NMT command
dec	hex	
1	0x01	Start remote node
2	0x02	Stop remote node
128	0x80	Enter Pre-Operational
129	0x81	Reset node
130	0x82	Reset communication

The change-over of the communication phases for the entire network is carried out by one node, the CAN master. The function of the CAN master can also be carried out by the controller.

▶ [Parameterising the controller as CAN master \(182\)](#)

#### Example:

Data can only be exchanged via process data objects if the status is "Operational". If the CAN master is supposed to switch all nodes connected to the bus from the "Pre-Operational" communication status to the "Operational" communication status, the identifier and user data in the transmission telegram must be set as follows:

- Identifier: 0x00 (network management)
- User data: 0x0100 ("Start remote node" NMT command to all nodes)

### 9.5.3 Parameterising the controller as CAN master

If the initialisation of the system bus and the associated status change from "Pre-Operational" to "Operational" is not effected by a superimposed host system, the controller can instead be defined to be a "quasi" master to execute this task.

The controller is configured as CAN master in [C352](#).

- Being the CAN master, the controller sets all nodes connected to the bus (broadcast telegram) to the "Operational" communication status with the "Start remote node" NMT telegram. Only in this communication status, data can be exchanged via process data objects.
- A delay time can be set in [C356/1](#) which must expire after mains switching before the controller transmits the "Start remote node" NMT telegram.

Parameter	Info	Lenze setting	
		Value	Unit
<a href="#">C352</a>	CAN slave/master	Slave	
<a href="#">C356/1</a>	CAN delay boot-up - Operational	3000	ms



#### Note!

A change in master/slave operation in [C352](#) will only become effective by

- renewed mains switching of the controller

or

- the "Reset node" or "Reset communication" NMT telegram has been transmitted to the controller.

The "CAN reset node" device command ([C002/26](#)) is provided as an alternative to the "Reset node" NMT telegram for the reinitialisation of the CAN-specific device parameters.



#### Tip!

Master functionality is only required during the initialisation phase of the drive system.

### 9.6 Process data transfer

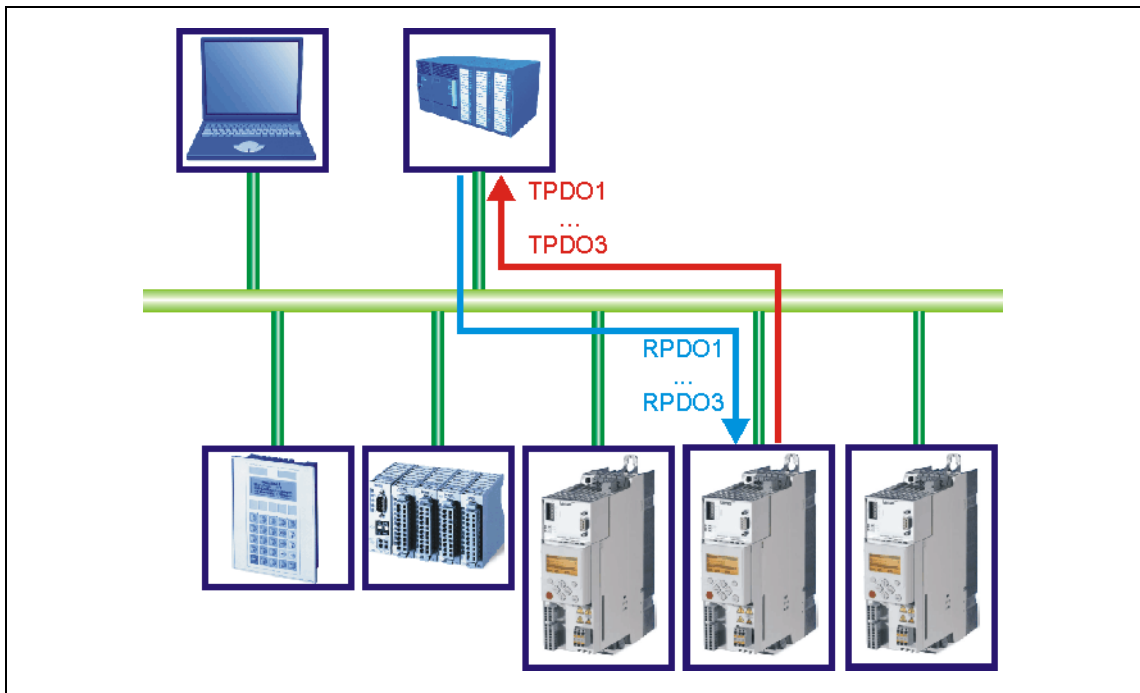

[9-5] PDO data transfer from / to the higher-level host system

"BaseLine C" versions have two separate process channels (PDO1 and PDO2) and from the "Stateline" version three separate process data channels (PDO1 ... PDO3) for process data transfer.

#### Definitions

- Process data telegrams between the host system and the devices are distinguished in terms of direction as follows:
  - Process data telegrams to the device (RPDO)
  - Process data telegrams from the device (TPDO)
- The CANopen process data objects are designated as seen from the node's view:
  - Receive PDOs (RPDOx): Process data object received by a node
  - Transmit PDOs (TPDOx): Process data object sent by a node



#### Note!

Data can only be exchanged via process data objects if the status is "Operational"!

▶ [Communication phases/network management](#) (179)

### 9.6.1 Available process data objects

8400 BaseLine C controllers have a maximum number of 2 receive PDOs (RPDOs) and 2 transmit PDOs (TPDOs).

#### Receive PDOs (RPDOs)

The process data objects transmitted from the CAN bus to the drive are processed via the [LP\\_CanIn1](#) and [LP\\_CanIn2](#) port blocks.

- Every port block provides 4 words (2 bytes/word). The data of every first word are provided in a bit decoded manner (bit 0 ... 15).
- The first word of the [LP\\_CanIn1](#) port block is defined as control word.
  - For the predefined assignment, see the "[Process data assignment for control via CAN](#)" sub-chapter for drive application.

#### Transmit PDOs (TPDOs)

The process data objects transmitted from the drive to the CAN bus are processed via the [LP\\_CanOut1](#) and [LP\\_CanOut2](#) port blocks.

- Every port block receives 4 words (2 bytes/word). The data of every first word are transmitted bit by bit (bit 0 ... 15).
- The first word of the [LP\\_CanOut1](#) port block is defined as status word.
  - For the predefined assignment, see the "[Process data assignment for control via CAN](#)" sub-chapter for drive application.



The preconfigured interconnection of the internal interfaces for a control via CAN is shown in chapter "Drive application" in figure [\[7-2\]](#). ([□ 136](#))



### 9.6.1.1 RPDO1 | Port block "LP\_CanIn1"

The LP\_CanIn1 port block maps process data object RPDO1.

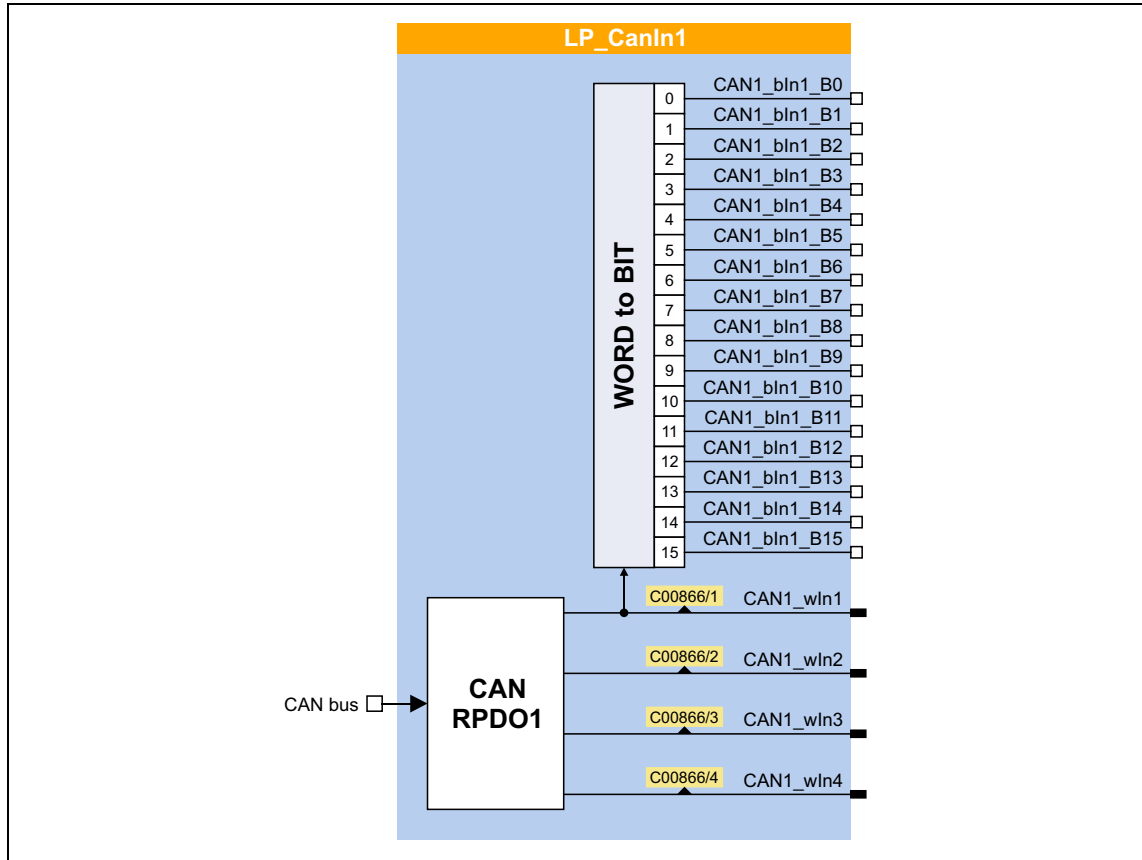

Short overview of the parameters for LP\_CanIn1:

Parameter	Info	Lenze setting	
<a href="#">C866/1</a>	LP_CanIn1: wln1	-	
<a href="#">C866/2</a>	LP_CanIn1: wln2	-	
<a href="#">C866/3</a>	LP_CanIn1: wln3	-	
<a href="#">C866/4</a>	LP_CanIn1: wln4	-	
Highlighted in grey = display parameter			

### 9.6.1.2 RPDO2 | Port block "LP\_CanIn2"

The LP\_CanIn2 port block maps process data object RPDO2.

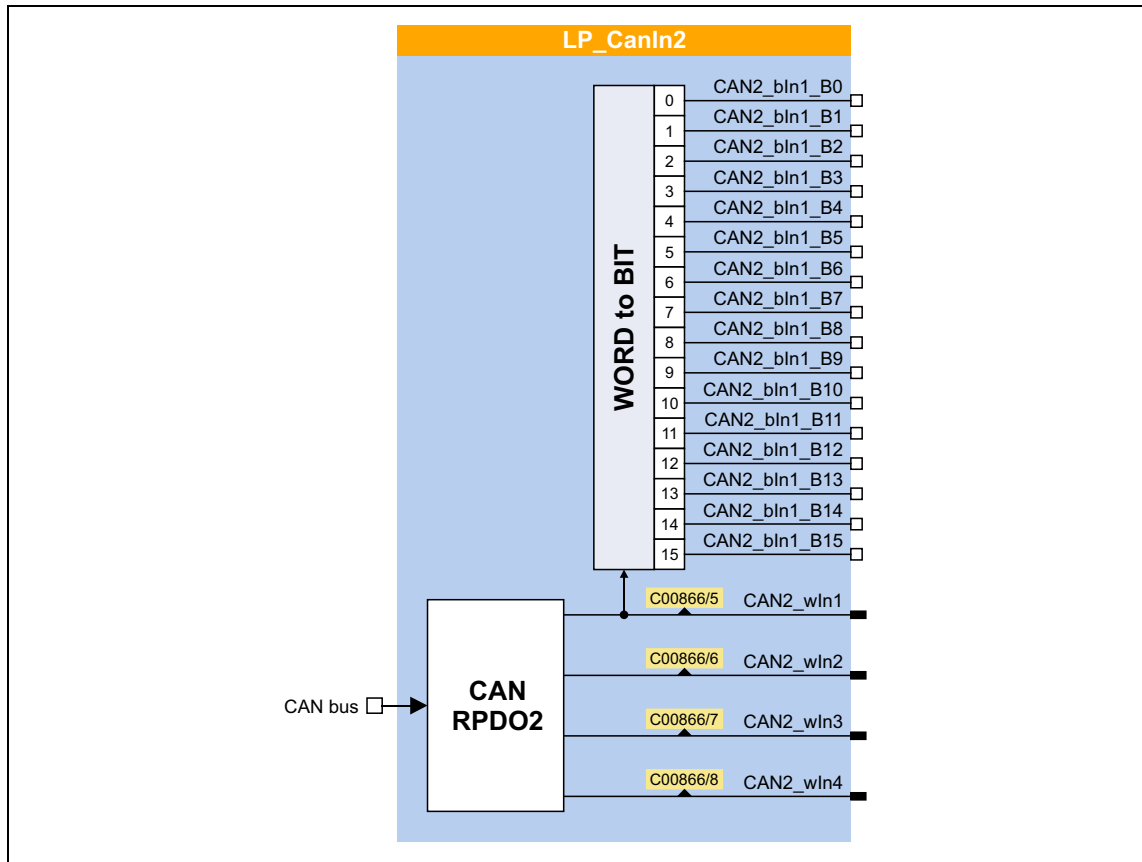

Short overview of the parameters for LP\_CanIn2:

Parameter	Info	Lenze setting
<a href="#">C866/5</a>	LP_CanIn2: wIn1	-
<a href="#">C866/6</a>	LP_CanIn2: wIn2	-
<a href="#">C866/7</a>	LP_CanIn2: wIn3	-
<a href="#">C866/8</a>	LP_CanIn2: wIn4	-
Highlighted in grey = display parameter		

### 9.6.1.3 TPDO1 | Port block "LP\_CanOut1"

The LP\_CanOut1 port block maps process data object TPDO1.

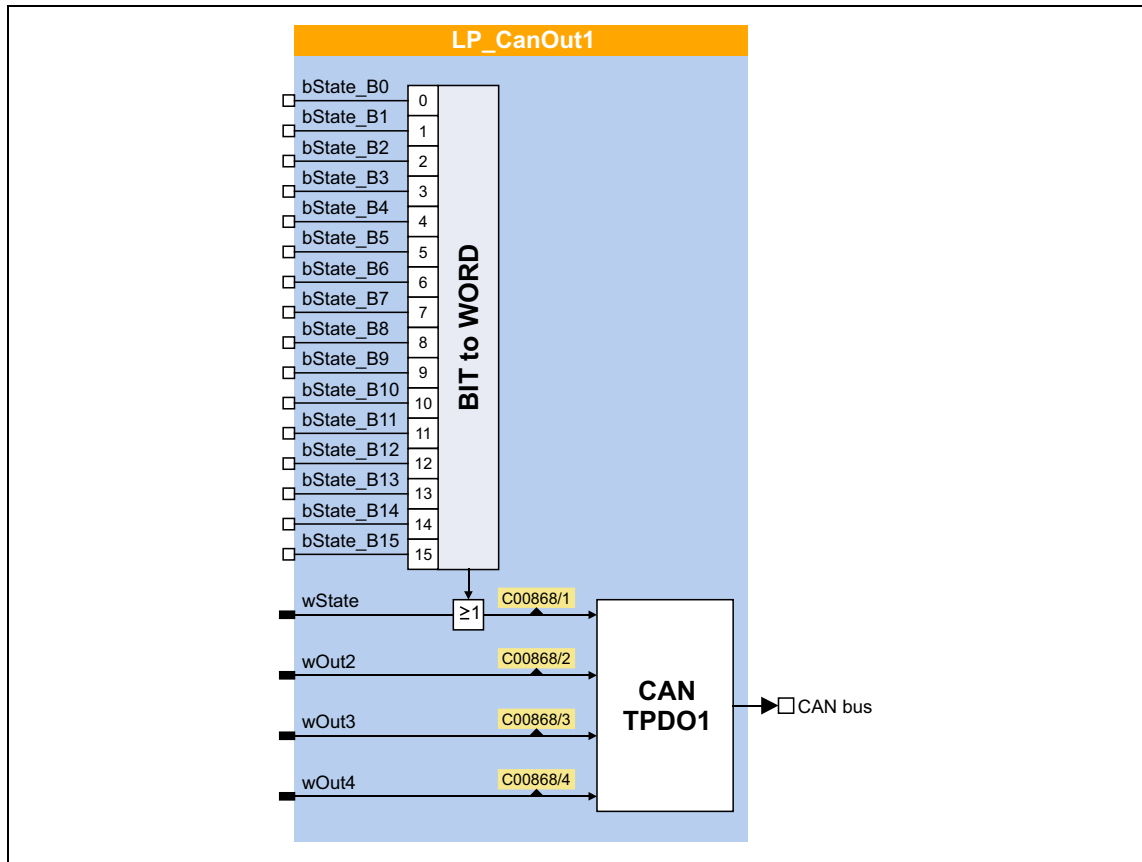

Short overview of the parameters for LP\_CanOut1:

Parameter	Info	Lenze setting
<a href="#">C868/1</a>	LP_CanOut1:wState	-
<a href="#">C868/2</a>	LP_CanOut1:wOut2	-
<a href="#">C868/3</a>	LP_CanOut1:wOut3	-
<a href="#">C868/4</a>	LP_CanOut1: wOut4	-
Highlighted in grey = display parameter		

# 9 System bus "CAN on board"

## 9.6 Process data transfer

### 9.6.1.4 TPDO2 | Port block "LP\_CanOut2"

The LP\_CanOut2 port block maps process data object TPDO2.

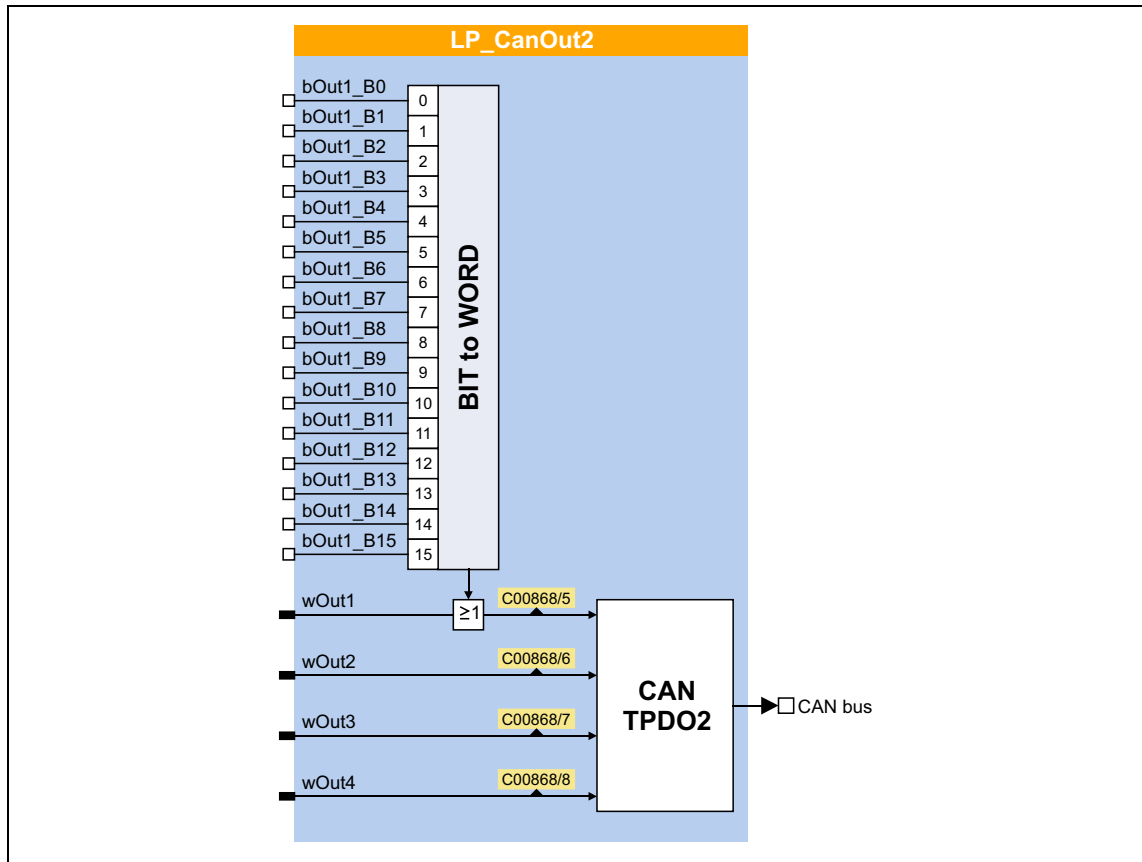

Short overview of the parameters for LP\_CanOut2:

Parameter	Info	Lenze setting
<a href="#">C868/5</a>	LP_CanOut2: wOut1	-
<a href="#">C868/6</a>	LP_CanOut2: wOut2	-
<a href="#">C868/7</a>	LP_CanOut2: wOut3	-
<a href="#">C868/8</a>	LP_CanOut2: wOut4	-
Highlighted in grey = display parameter		

### 9.6.2 Identifiers of the process data objects

In the Lenze setting, the identifier for process data objects PDO1 ... PDO2 consists of a so-called basic identifier (CANBaseID) and the node address set in [C350](#):

**Identifier (COB-ID) = basic identifier + node address (node ID)**

- The basic identifiers of the PDOs comply with the "Predefined connection set" of DS301, V4.02.
- Alternatively, you can define via code [C353](#) that the identifiers of the PDOs are to be assigned according to Lenze definition or that individual settings are to be made.
  - If [C353](#) = "2: COBID = C0354/x" the identifiers of the PDOs can be individually set via the Lenze codes and CANopen indexes listed in the table below. That way, identifiers independent of the node address can be set for specific PDOs.
- If identifiers are assigned individually, all PDOs must have basic identifier values in the range of 385 ... 1407.

Process data object	Basic identifier		Individual setting	
	dec	hex	Lenze code	CANopen index
PDO1				
RPDO1	512	0x200	<a href="#">C354/1</a>	<a href="#">I-1400/1</a>
TPDO1	384	0x180	<a href="#">C354/2</a>	<a href="#">I-1800/1</a>
PDO2				
RPDO2	768	0x300	<a href="#">C354/3</a>	<a href="#">I-1401/1</a>
TPDO2	640	0x280	<a href="#">C354/4</a>	<a href="#">I-1801/1</a>



#### Note!

After a node address change ([C350](#)) and a CAN reset node afterwards, the subcodes of [C354](#) automatically resume the values which result from the respective basic identifier and the set node address.

#### Short overview: Parameters for setting the identifiers

Parameter	Info	Lenze setting	
		Value	Unit
<a href="#">C353/1</a>	COBID source CAN1_IN/OUT	0: COBID = C0350 + CANBaseID	
<a href="#">C353/2</a>	COBID source CAN2_IN/OUT	0: COBID = C0350 + CANBaseID	
<a href="#">C354/1</a>	COBID CAN1_IN	0x00000201	
<a href="#">C354/2</a>	COBID CAN1_OUT	0x00000181	
<a href="#">C354/3</a>	COBID CAN2_IN	0x00000301	
<a href="#">C354/4</a>	COBID CAN2_OUT	0x00000281	

### 9.6.3 Transmission type

Process data objects can be transmitted in an event-controlled or time-controlled manner. The below table shows that it is possible to combine the different methods by means of logic operations (AND, OR):

- Event-controlled  
The PDO is sent when a special device-internal event has occurred, e.g. when the data contents of the TPDO have changed or when a transmission cycle time has elapsed
- Synchronous transmission  
A TPDO (or RPDO) is transmitted (or received) after the device has received a sync telegram (COB-ID 0x80).
- Cyclic transmission  
The cyclic transmission of PDOs takes place when the transmission cycle time has elapsed.
- Polled via RTR  
A TPDO is transmitted when another device requests it by means of a data request telegram (RTR remote transmit request). For this purpose, the data requester (e.g. the master) sends the data request telegram with the COB-ID of the TPDO requested to be sent. The receiver recognises the RTR and transmits the corresponding PDO.

Transmission type	PDO transmission			Logic combination of different transmission types
	cyclic	synchronous	event-controlled	
0		●	●	AND
1 ... 240		●		-
254, 255	●		●	OR

Transmission type	Description
0	Synchronous and acyclic: The PDO is transmitted on an event-controlled basis with every sync (e.g. when a bit change occurs in the PDO).
1 ... 240	Synchronous and cyclic (sync-controlled with response): <ul style="list-style-type: none"> <li>• Selection <math>n = 1</math>: The PDO is transmitted with <u>every</u> sync.</li> <li>• Selection <math>1 &lt; n \leq 240</math>: The PDO is transmitted with <u>every n-th</u> sync.</li> </ul>
241 ... 251	Reserved
252	Synchronous - only RTR
253	Asynchronous - only RTR
254, 255	Asynchronous - manufacturer-specific/device profile specific: If this value is entered, the PDO transmission is event-controlled <u>or</u> cyclic. (Note: The values "254" and "255" have the same meaning). For a cyclic transmission, a cycle time must be entered for the respective PDO. In this case, cyclic transmission takes place in addition to event-controlled transmission.

The communication parameters such as the transmission mode and cycle time can be set freely for every PDO and independently of the settings of other PDOs:

Parameter	Info	Lenze setting	
		Value	Unit
<b>CAN1_OUT</b>			
<a href="#">C00322/1</a>	Transmission mode	254	
<a href="#">C00324/2</a>	Blocking time	0	ms
<a href="#">C00356/5</a>	Cycle time	0	ms
<b>CAN2_OUT</b>			
<a href="#">C00322/2</a>	Transmission mode	254	
<a href="#">C00324/3</a>	Blocking time	0	ms
<a href="#">C00356/2</a>	Cycle time	0	ms
<b>CAN1_IN ... CAN2_IN</b>			
<a href="#">C00323/1...2</a>	Transmission mode CAN1_IN ... CAN2_IN • For RPDO, it serves as monitoring setting in the case of sync-controlled PDOs.	254	

### Blocking time

In [C00324/x](#), an "inhibit time" can be set that defines the shortest transmission cycle for the "asynchronous - manufacturer-specific/device-profile specific" transmission type.

Example: Cycle time = 500 ms, blocking time = 100 ms, sporadic data change:

- In case of a sporadic data change < 500 ms, fastest transmission is every 100 ms (event-controlled transmission). The transmission cycle timer is reset to 0 if the transmission has been triggered in an event-controlled manner.
- In case of a sporadic data change > 500 ms, fastest transmission is every 500 ms due to the set blocking time (cyclic transmission).



### Tip!

The setting can also be carried out via the following CANopen objects:

- [I-1400](#) ... [I-1401](#): Communication parameters for RPDO1 ... RPDO2
- [I-1800](#) ... [I-1801](#): Communication parameters for TPDO1 ... TPDO2

### 9.6.4 PDO synchronisation via sync telegram

During cyclic transmission, one or more PDOs are transmitted/received in fixed time intervals. An additional specific telegram, the so-called sync telegram, is used for synchronising cyclic process data.

- The sync telegram is the trigger point for the transmission of process data from the slaves to the master and for the acceptance of process data from the master in the slaves.
- For sync-controlled process data processing, the sync telegram must be generated accordingly.
- The response to a sync telegram is determined by the selected transmission type. ▶ [Transmission type](#) (190)

#### Basic workflow

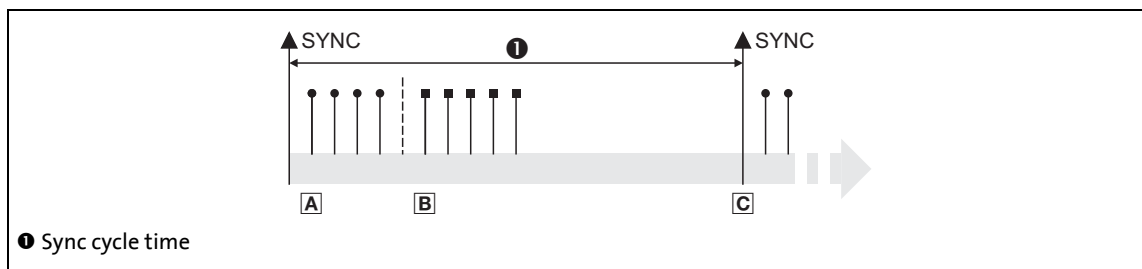

[9-6] Sync telegram

- After the sync telegram has been received, the slaves transmit the synchronous process data to the master (TPDOs). The master reads them as process input data.
- When the transmission process is completed, the slaves receive (RPDOs) the process output data (of the master).
  - All other telegrams (e.g. parameters or event-controlled process data) are accepted acyclically by the slaves after the transmission is completed.
  - Illustration [9-6] does not include acyclic data. However, they need to be considered when dimensioning the cycle time.
- The data are accepted in the slave with the next sync telegram if the Rx mode is set to 1 ... 240. If the Rx mode is 254 or 255, the data are accepted in the next device cycle, irrespective of the sync telegram.

#### Short overview: Parameters for the synchronisation via sync telegram

Parameter	Info	Lenze setting		Assignment	
		Value	Unit	Sync master	Sync slave
<a href="#">C367</a>	CAN Sync-Rx identifier	128			●
<a href="#">C368</a>	CAN Sync-Tx-Identifier	128		●	
<a href="#">C369</a>	CAN Sync transmission cycle time	0	ms	●	



### 9.6.5 Monitoring of the RPDOs for data reception

Every RPDO1 ... RPDO2 has a parameterisable monitoring time in which the RPDO must arrive. If the RPDO is not received within the monitoring time or with the configured sync, the response parameterised for the respective RPDO is activated.

#### Short overview: Parameters for RPDO monitoring

Parameter	Info	Lenze setting	
		Value	Unit
<a href="#">C357/1</a>	CAN1_IN monitoring time	3000	ms
<a href="#">C357/2</a>	CAN2_IN monitoring time	3000	ms
<a href="#">C593/1</a>	Resp. to CAN1_IN monitoring	No response	
<a href="#">C593/2</a>	Resp. to CAN2_IN monitoring	No response	

### 9.7 Parameter data transfer

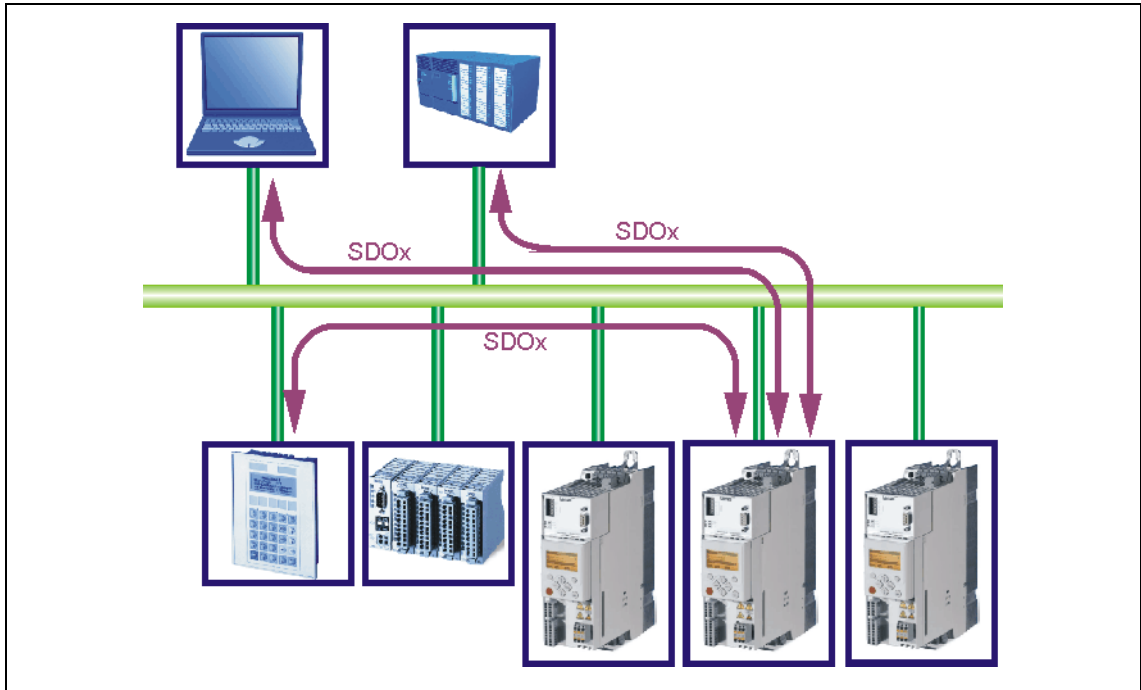

[9-7] Parameter data transfer via the available parameter data channels

Parameters are values stored in codes on Lenze controllers.

Two parameter data channels are available for parameter setting, enabling the simultaneous connection of different devices for configuration purposes.

Parameter data are transmitted via the system bus as SDOs (*Service Data Objects*) and acknowledged by the receiver. The SDO enables read and write access to all device parameters and to the CANopen object directory integrated in the device. Indices (e.g. 0x1000) ensure access to device parameters and functions included in the object directory. To transfer SDOs, the information contained in the user data must comply with the CAN SDO protocol.



#### Note!

Up to and including version 03.00.00, the parameter data channels 1 and 2 are activated.

As of version 03.02.00, only the parameter data channel 1 is activated in the Lenze setting according to CANopen.

- In order to activate both parameter data channels according to the previous behaviour, set "2 SDO Lenze" in [C00366](#).

### 9.7.1 Identifiers of the parameter data objects

In the Lenze setting, the basic identifiers of the SDOs are preset according to the "Predefined Connection Set".

The identifiers of the parameter data objects SDO1 and SDO2 result from the basic identifier and the node address set under code [C350](#):

**Identifier = basic identifier + node address**

Object		Direction		Lenze-Base-ID		CANopen-Base-ID	
		from device	to device	dec	hex	dec	hex
SDO1 (Parameter data channel 1)	TSDO1	●		1408	580	1408	580
	RSDO1		●	1536	600	1536	600
SDO2 (Parameter data channel 2)	TSDO2	●		1472	5C0	1472	5C0
	RSDO2		●	1600	640	1600	640
Heartbeat		●		1792	700	1792	700
Boot-up		●		1792	700	1792	700

### 9.7.2 User data

Structure of the user data of the parameter data telegram

1st byte	2nd byte	3rd byte	4th byte	5th byte	6th byte	7th byte	8th byte
Command	Index		Subindex	Data 1	Data 2	Data 3	Data 4
	Low byte	High byte		Low word		High word	
				Low byte	High byte	Low byte	High byte



#### Note!

The user data are presented in the Motorola format.

▶ [Parameter data telegram examples](#) (📖 201)

The following subchapters provide detailed information on user data.

## 9.7.2.1 Command

1st byte	2nd byte	3rd byte	4th byte	5th byte	6th byte	7th byte	8th byte
<b>Command</b>	<b>Index</b>		<b>Subindex</b>	<b>Data 1</b>	<b>Data 2</b>	<b>Data 3</b>	<b>Data 4</b>
	Low byte	High byte		Low word		High word	
				Low byte	High byte	Low byte	High byte

The following commands can be transmitted or received for writing and reading the parameters:

Command	1st byte		Data length	Info
	hex	dec		
Write request	0x23	35	4 bytes	Writing of a parameter to the controller.
	0x2B	43	2 bytes	
	0x2F	47	1 byte	
	0x21	33	Block	
Write response	0x60	96	4 bytes	Controller acknowledges a write request.
Read request	0x40	64	4 bytes	Reading of a parameter from the controller.
Read response	0x43	67	4 bytes	Controller's response to a read request with the current parameter value.
	0x4B	75	2 bytes	
	0x4F	79	1 byte	
	0x41	65	Block	
Error response	0x80	128	4 bytes	Controller's response if the write/read request could not be executed correctly. ▶ <a href="#">Error messages</a> (199)

More precisely, the command byte comprises the following information:

Command	1st byte							
	Command specifier (cs)			Toggle (t)	Length*		e	s
	Bit 7	Bit 6	Bit 5	Bit 4	Bit 3	Bit 2	Bit 1	Bit 0
Write request	0	0	1	0	0/1	0/1	1	1
Write response	0	1	1	0	0	0	0	0
Read request	0	1	0	0	0	0	0	0
Read response	0	1	0	0	0/1	0/1	1	1
Error response	1	0	0	0	0	0	0	0

\*Bit coding of the length: 00 = 4 bytes, 01 = 3 bytes, 10 = 2 bytes, 11 = 1 byte  
e: expedited (shortened block service)  
s: segmented (normal block service)

**Tip!**

More commands are defined in CANopen specification DS301, V4.02 (e.g. segmented transfer).

# 9 System bus "CAN on board"

## 9.7 Parameter data transfer

### 9.7.2.2 Addressing by means of index and subindex

1st byte	2nd byte	3rd byte	4th byte	5th byte	6th byte	7th byte	8th byte
Command	Index		Subindex	Data 1	Data 2	Data 3	Data 4
	Low byte	High byte		Low word		High word	
				Low byte	High byte	Low byte	High byte

A parameter (a Lenze code) is addressed as per the following formula:  
**Index = 24575 - (Lenze code number)**

#### Example

C011 parameter (motor reference speed) is to be addressed.

Calculation:

- Index:
  - Decimal:  $24575 - 11 = 24564$
  - Hexadecimal:  $0x5FFF - 0xB = 0x5FF4$
- Subindex: 0x00 (subindex 0 since the parameter does not have any subcodes)

Entries:

1st byte	2nd byte	3rd byte	4th byte	5th byte	6th byte	7th byte	8th byte
Command	Index		Subindex	Data 1	Data 2	Data 3	Data 4
	0xF4	0x5F	0x00				

# 9 System bus "CAN on board"

## 9.7 Parameter data transfer

### 9.7.2.3 Data 1 ... Data 4

1st byte	2nd byte	3rd byte	4th byte	5th byte	6th byte	7th byte	8th byte
Command	Index		Subindex	Data 1	Data 2	Data 3	Data 4
	Low byte	High byte		Low word		High word	
				Low byte	High byte	Low byte	High byte

Maximally 4 bytes are available for parameter value entries. Depending on the data format, they are assigned as follows:

5th byte	6th byte	7th byte	8th byte
Parameter value (1 byte)	0x00	0x00	0x00
Parameter value (2 bytes)		0x00	0x00
Low byte	High byte		
Parameter value (4 bytes)			
Low word		High word	
Low byte	High byte	Low byte	High byte



#### Note!

The "Factor" column of the [Table of attributes](#) contains a so-called scaling factor for all Lenze parameters. The scaling factor is relevant to the transfer of parameter values which have one or more decimal positions in the parameter list.

If the scaling factor is > 1, the value must be multiplied by the indicated scaling factor prior to transmission to be able to transfer the value as an integer. At the SDO client end, the integer must be divided by the scaling factor to obtain the original value including decimal positions again.

#### Example

A value of "123.45" is to be transmitted for a code, unit: "%" (e.g. C039/1: "Fixed setpoint-JOG1").

In controllers of the 8400 series, parameters with the "%" unit have two decimal positions and hence a scaling factor of "100".

Calculation:

- Value to be transmitted = scaling factor x value
- Data (1...4) = 100 x 123.45 = 12345 (0x00 00 30 39)

Entries:

1st byte	2nd byte	3rd byte	4th byte	5th byte	6th byte	7th byte	8th byte
Command	Index		Subindex	Data 1	Data 2	Data 3	Data 4
				0x39	0x30	0x00	0x00

# 9 System bus "CAN on board"

## 9.7 Parameter data transfer

### 9.7.2.4 Error messages

1st byte	2nd byte	3rd byte	4th byte	5th byte	6th byte	7th byte	8th byte
<b>Command</b>	<b>Index</b>		<b>Subindex</b>	<b>Error code</b>			
0x80 (128)	Low byte	High byte		Low word		High word	
				Low byte	High byte	Low byte	High byte

In the event of an error, the addressed node generates a telegram with the "Error response" (0x80) command.

- The telegram includes the index and subindex of the code where the error occurred.
- The error code is entered in bytes 5 ... 8.
  - The error codes are standardised according to DS301, V4.02.
  - The representation of the error codes is provided in reverse read direction (see example below).

#### Example

Representation of error code "0x06 04 00 41" in bytes 5 ... 8:

1st byte	2nd byte	3rd byte	4th byte	5th byte	6th byte	7th byte	8th byte
<b>Command</b>	<b>Index</b>		<b>Subindex</b>	<b>Error code</b>			
				0x41	0x00	0x04	0x06

### Meaning of the error codes

The error codes are standardised acc. to DS301, V4.02.

Error code	Explanation
0x0503 0000	Toggle bit not changed
0x0504 0000	SDO protocol expired
0x0504 0001	Invalid or unknown client/server command specifier
0x0504 0002	Invalid block size (only block mode)
0x0504 0003	Invalid sequence number (only block mode)
0x0504 0004	CRC error (only block mode)
0x0504 0005	Not sufficient memory
0x0601 0000	Object access not supported
0x0601 0001	Attempt to read a write-only object
0x0601 0002	Attempt to write to a read-only object
0x0602 0000	Object not listed in object directory
0x0604 0041	Object not mapped to PDO
0x0604 0042	Number and length of the objects to be transferred exceed the PDP length.
0x0604 0043	General parameter incompatibility
0x0604 0047	General internal device incompatibility
0x0606 0000	Access denied because of hardware error
0x0607 0010	Unsuitable data type, unsuitable service parameter length
0x0607 0012	Unsuitable data type, service parameter length exceeded
0x0607 0013	Unsuitable data type, service parameter length not long enough
0x0609 0011	Subindex does not exist
0x0609 0030	Parameter value range exceeded
0x0609 0031	Parameter values too high
0x0609 0032	Parameter values too low
0x0609 0036	Maximum value falls below minimum value
0x0800 0000	General error
0x0800 0020	Data cannot be transferred/saved for application.
0x0800 0021	Data cannot be transferred/saved for application due to local control.
0x0800 0022	Data cannot be transferred/saved for application due to current device status.
0x0800 0023	Dynamic generation of object directory failed or no object directory available (e.g. object directory generated from file, generation not possible because of a file error).



# 9 System bus "CAN on board"

## 9.7 Parameter data transfer

### 9.7.3 Parameter data telegram examples

#### 9.7.3.1 Read parameters

**Task:** The heatsink temperature of 43 °C (code [C061](#), data format INTEGER16, scaling factor 1) of the controller with node address "5" is to be read.

#### Telegram to drive

Identifier	User data							
	1st byte	2nd byte	3rd byte	4th byte	5th byte	6th byte	7th byte	8th byte
	Command	Index		Subindex	Data 1	Data 2	Data 3	Data 4
0x0605	0x40	0xC2	0x5F	0x00	0x00	0x00	0x00	0x00

Explanations on the telegram to the drive	
Identifier	= 1536 + node address = 1536 + 5 = 1541 = 0x0605 (1536 = SDO1 basic identifier to the controller)
Command	= 0x40 = "Read request" (request to read a parameter from the controller)
Index	= 24575 - code number = 24575 - 61 = 24514 = 0x5FC2
Subindex	= 0 (code <a href="#">C061</a> has no subcodes)

#### Response telegram from drive (if data have been correctly transmitted)

Identifier	User data							
	1st byte	2nd byte	3rd byte	4th byte	5th byte	6th byte	7th byte	8th byte
	Command	Index		Subindex	Data 1	Data 2	-	-
0x0585	0x4B	0xC2	0x5F	0x00	0x2B	0x00	-	-

Explanations on the telegram from the drive	
Identifier	= 1408 + node address = 1408 + 5 = 1413 = 0x0585 (1408 = SDO1 basic identifier from the controller)
Command	= 0x4B = "Read response" (response to the read request with current value)
Index	as in telegram to the drive
Subindex	
Data 1 ... 2	= 0x002B = 43 [°C]

### 9.7.3.2 Write parameters

**Task:** The rated current of the connected motor is to be entered with  $I_{rated} = 10.20$  A (code [C088](#)) into the controller with node address "2".

Data 1 ... 4	Calculation
Value for motor current, (data type U16; display factor 1/100)	$10.20 \times 100 = 1020$ (0x03 FC)

#### Telegram to drive

Identifier	User data							
	1st byte	2nd byte	3rd byte	4th byte	5th byte	6th byte	7th byte	8th byte
	Command	Index		Subindex	Data 1	Data 2	Data 3	Data 4
0x0602	0x23	0xA7	0x5F	0x00	0xFC	0x03	0x00	0x00

Explanations on the telegram to the drive	
Identifier	= $1536 + \text{node address} = 1536 + 2 = 1538 = 0x0602$ (1536 = SDO1 basic identifier to the controller)
Command	= 0x23 = "Write request" (request to write a parameter to the controller)
Index	= $24575 - \text{code number} = 24575 - 88 = 24487 = 0x5FA7$
Subindex	= 0 (code <a href="#">C088</a> has no subcodes)
Data 1 ... 4	= $10.20 \times 100 = 1020 = 0x000003FC$ (motor current value; data type U32; display factor 1/100)

#### Response telegram from drive (if data have been correctly transmitted)

Identifier	User data							
	1st byte	2nd byte	3rd byte	4th byte	5th byte	6th byte	7th byte	8th byte
	Command	Index		Subindex	Data 1	Data 2	Data 3	Data 4
0x0582	0x60	0xA7	0x5F	0x00	0x00	0x00	0x00	0x00

Explanations on the telegram from the drive	
Identifier	= $1408 + \text{node address} = 1408 + 2 = 1410 = 0x0582$ (1408 = SDO1 basic identifier from the controller)
Command	= 0x60 = "Write response" (acknowledgement of the write access from the controller)
Index	as in telegram to the drive
Subindex	

### 9.7.3.3 Read block parameters

**Task:** The firmware version (code [C099](#)) to be read from the parameter set of the controller with node address "12". The firmware version has a length of 11 ASCII characters which are transmitted as a block parameter. Depending on the block, the data width from the 2nd to 8th byte is assigned within the user data.

#### Telegram 1 to the drive: Read request

Identifier	User data							
	1st byte	2nd byte	3rd byte	4th byte	5th byte	6th byte	7th byte	8th byte
	Command	Index		Subindex	Data 1	Data 2	Data 3	Data 4
0x060C	0x40	0x9C	0x5F	0x00	0x00	0x00	0x00	0x00

Explanations on the telegram to the drive	
Identifier	= 1536 + node address = 1536 + 12 = 1548 = 0x060C (1536 = SDO1 basic identifier to the controller)
Command	= 0x40 = "Read request" (request to read a parameter from the controller)
Index	= 24575 - code number = 24575 - 99 = 24476 = 0x5F9C
Subindex	= 0 (code <a href="#">C099</a> has no subcodes)

#### Response telegram 1 from the drive: Indication of the block length (11 characters)

Identifier	User data							
	1st byte	2nd byte	3rd byte	4th byte	5th byte	6th byte	7th byte	8th byte
	Command	Index		Subindex	Data 1	Data 2	Data 3	Data 4
0x058C	0x41	0x9C	0x5F	0x00	0x0B	0x00	0x00	0x00

Explanations on the telegram from the drive	
Identifier	= 1408 + node address = 1408 + 12 = 1420 = 0x058C (1408 = SDO1 basic identifier from the controller)
Command	= 0x41 = "Read response" (response is block telegram)
Index	as in telegram to the drive
Subindex	
Data 1 ... 4	= 0x0000000B = data length of 11 characters in the ASCII format

### Telegram 2 to the drive: Request of the 1st data block

Identifier	User data							
	1st byte	2nd byte	3rd byte	4th byte	5th byte	6th byte	7th byte	8th byte
	Command	Data 1	Data 2	Data 3	Data 4	Data 5	Data 6	Data 7
0x060C	0x60	0x00	0x00	0x00	0x00	0x00	0x00	0x00

Explanations on the telegram to the drive	
Command	= 0x60 = "Read segment request" (request: read data block) • Bit 4 = 0 (toggle bit)  <b>Influence of the toggle bit on the request command</b> The blocks are toggled one after another, i.e. the request is made with the "0x60" (= 0110*0000 <sub>bin</sub> ) command, then with the "0x70" (= 0111*0000 <sub>bin</sub> ) command, and then again with the "0x60" command, etc. * Toggle bit

### Response telegram 2 from the drive: Transmission of the 1st data block

Identifier	User data							
	1st byte	2nd byte	3rd byte	4th byte	5th byte	6th byte	7th byte	8th byte
	Command	Data 1	Data 2	Data 3	Data 4	Data 5	Data 6	Data 7
0x058C	0x00	0x30	0x31	0x2E	0x30	0x30	0x2E	0x30
		0 <sub>asc</sub>	1 <sub>asc</sub>	·asc	0 <sub>asc</sub>	0 <sub>asc</sub>	·asc	0 <sub>asc</sub>

Explanations on the telegram to the drive	
Command	= 0x00 = 00000000 <sub>bin</sub> • Bit 4 = 0 (toggle bit)  <b>Influence of the toggle bit on the transmission command</b> • The 1st response of the controller in the command byte is "0x0000*0000 <sub>bin</sub> " if bytes 2 ... 8 are completely filled with data and other telegrams are following. • The 2nd response of the controller in the command byte is "0x0001*0000 <sub>bin</sub> " if bytes 2 ... 8 are completely filled with data and other telegrams are following, etc. * Toggle bit
Data 1 ... 7	= "01.00.0" (ASCII representation)

### Telegram 3 to the drive: Request of the 2nd data block

Identifier	User data							
	1st byte	2nd byte	3rd byte	4th byte	5th byte	6th byte	7th byte	8th byte
	Command	Data 1	Data 2	Data 3	Data 4	Data 5	Data 6	Data 7
0x060C	0x70	0x00	0x00	0x00	0x00	0x00	0x00	0x00

Explanations on telegram 3 to the drive	
Command	= 0x70 = "Read segment request" (request: read data block) • Bit 4 = 1 (toggle bit)

### Response telegram 3 from the drive: Transmission of the 2nd data block including end identifier

Identifier	User data							
	1st byte	2nd byte	3rd byte	4th byte	5th byte	6th byte	7th byte	8th byte
	Command	Data 1	Data 2	Data 3	Data 4	Data 5	Data 6	Data 7
0x058C	0x17	0x30	0x2E	0x30	0x30	0x00	0x00	0x00
		0 <sub>asc</sub>	·asc	0 <sub>asc</sub>	0 <sub>asc</sub>	-	-	-

Explanations on telegram 3 from the drive	
Command	= 0x17 = 00010111 <sub>bin</sub> : • Bit 0 = 1 (end of transmission) • Bit 1 ... bit 3 = 011 <sub>bin</sub> (3 bytes do not contain any data) • Bit 4 = 1 (toggle bit)
	<b>Influence of the final bit and the residual data length on the transmission command</b> • The end of transmission is signalled via the set final bit 0. • Bits 1 ... 3 reveal the number of bytes that do not contain any data anymore. * Toggle bit
Data 1 ... 7	= "0.00" (ASCII representation) The result of the data block transmission is: "01.00.00.00"

### 9.8 Monitoring

#### 9.8.1 Integrated error detection

If a node detects an error, it rejects the CAN telegram bits received so far and transmits an error flag. The error flag consists of 6 consecutive bits with the same logic value.

The following errors are detected:

##### **Bit error**

The sending node follows the transmission on the bus and interrupts the transmission if it receives a different logic value than the value transmitted. With the next bit, the sending node starts the transmission of an error flag.

In the arbitration phase, the transmitter only detects a bit error if a dominantly sent bit is received as recessive bit. In the ACK slot as well, the dominant overwriting of a recessive bit is not indicated as a bit error.

##### **Stuff-bit error**

If more than 5 consecutive bits have the same logic value before the ACK delimiter in the CAN telegram, the previously transmitted telegram will be rejected and an error flag will be sent with the next bit.

##### **CRC error**

If the received CRC checksum does not correspond to the checksum calculated in the CAN chip, the CAN controller will send an error flag after the ACK delimiter and the previously transmitted telegram will be annulled.

##### **Acknowledgement error**

If the sent ACK slot recessively sent by the transmitting node is not dominantly overwritten by a receiver, the transmitting node will cancel the transmission. The transmitting node will annul the transmitted telegram and will send an error flags with the next bit.

##### **Format error**

If a dominant bit is detected in the CRC delimiter, in the ACK delimiter or in the first 6 bits of the EOF field, the received telegram will be rejected and an error flag will be sent with the next bit.

9.8.2 Heartbeat protocol

The heartbeat protocol can be used for node monitoring purposes within a CAN network.

Basic workflow

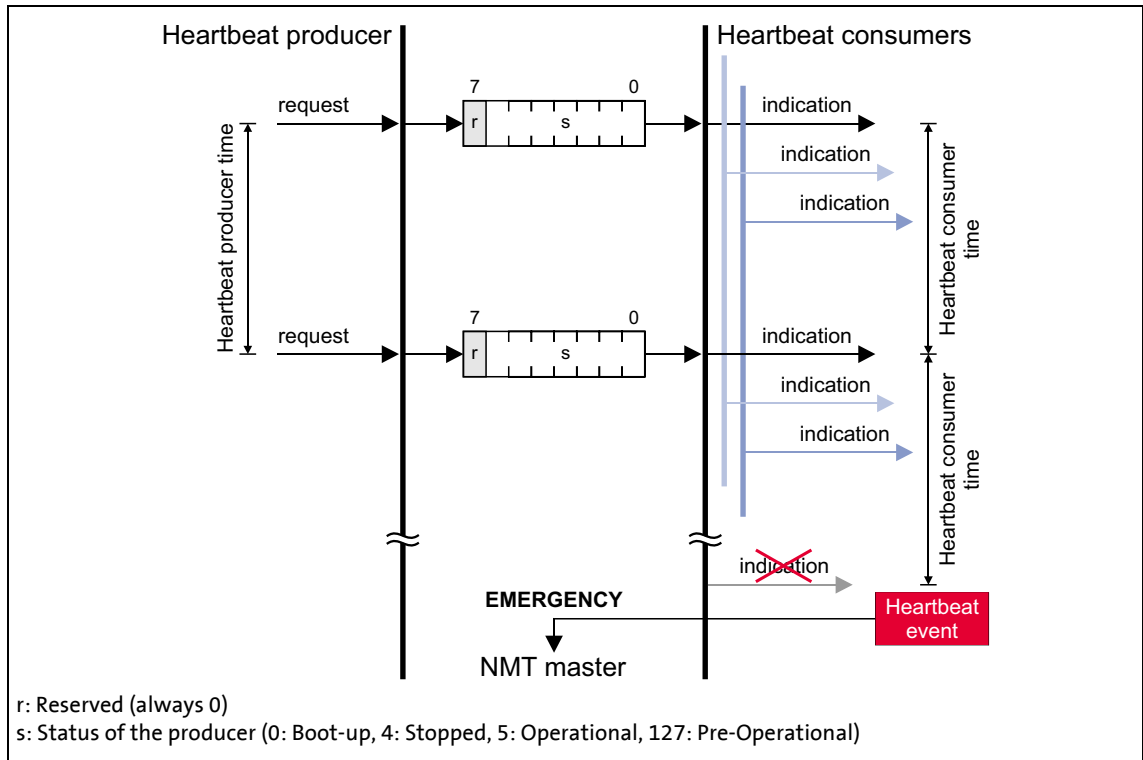

[9-8] Heartbeat protocol

1. A heartbeat producer cyclically transmits a so-called heartbeat telegram to one or more consumers.
2. The consumer(s) monitor the heartbeat telegram for arrival on a regular basis.

9.8.2.1 Telegram structure

- The heartbeat telegram of the producer has the following identifier:  
Identifier (COB-ID) = 1792 + producer's node address
- The user data (1 byte) contain the status (s) of the producer:

Heartbeat producer status		Data								
Communication status	Decimal value (s)	(r)	Producer status (s)							
		Bit 7	Bit 6	Bit 5	Bit 4	Bit 3	Bit 2	Bit 1	Bit 0	
Boot-up	0	0	0	0	0	0	0	0	0	
Stopped	4	0	0	0	0	0	1	0	0	
Operational	5	0	0	0	0	0	1	0	1	
Pre-Operational	127	0	1	1	1	1	1	1	1	

### 9.8.2.2 Parameter setting

Short overview of the parameters for the "Heartbeat" monitoring function:

Parameter	Info	Lenze setting		Assignment	
		Value	Unit	Consumer	Producer
<a href="#">C347/1...n</a>	CAN status of the heartbeat producer 1 ... n	-		●	
<a href="#">C381</a>	Heartbeat producer time	0	ms		●
<a href="#">C385/1...n</a>	CAN node address of the heartbeat producer 1 ... n	0		●	
<a href="#">C386/1...n</a>	Heartbeat consumer time for the heartbeat producer 1 ... n	0	ms	●	
<a href="#">C592/5</a>	Resp. to heartbeat event	No response		●	
Highlighted in grey = display parameter					

#### Heartbeat producer time

Time interval for the transmission of the heartbeat telegram to the consumer(s).

- Parameterisable in [C381](#) or via object [I-1017](#). The parameterised time is rounded down to an integer multiple of 5 ms.
- The heartbeat telegram is sent automatically as soon as a time > 0 ms is set.

#### Heartbeat consumer time

Monitoring time for the nodes (producers) to be monitored.

- Parameterisable in [C386/1...n](#) or via object [I-1016](#).
- The parameterised time is rounded down to an integer multiple of 5 ms and must have a greater value than the heartbeat producer time of the node to be monitored.
- The maximum number of the nodes to be monitored depends on the device version:
  - "Baseline C": 1 Heartbeat Producer can be monitored.
  - "StateLine C": Up to 7 Heartbeat Producers can be monitored.
  - "HighLine C": Up to 15 Heartbeat Producers can be monitored.
  - "TopLine C": Up to 15 Heartbeat Producers can be monitored.
- The node address(es) of the nodes to be monitored is/are set in [C385/1...n](#) or via object [I-1016](#).

#### Heartbeat event

The "Heartbeat event" is activated in the consumer if it does not receive any heartbeat telegram from the producer within the heartbeat consumer time:

- The consumer changes from the "Operational" communication status to the "Pre-Operational" communication status.
- The NMT master receives an emergency telegram containing emergency error code 0x8130.
- The response parameterised in [C592/5](#) is activated (Lenze setting: "No response").



**Note!**

The heartbeat monitoring will not start until the first heartbeat telegram of a monitored producer has been received successfully and the "Pre-Operational" NMT status has been assumed.

The boot-up telegram counts as the first heartbeat telegram.

**9.8.2.3 Commissioning example****Task**

An 8400 controller (node 2) which is configured as heartbeat consumer is to monitor another 8400 controller (heartbeat producer, node 1).

- The heartbeat producer is to transmit a heartbeat telegram to the heartbeat consumer every 10 ms.
- The heartbeat consumer monitors the heartbeat telegram for arrival. A response is to be activated in the event of an error.

**Parameterising the heartbeat producer (node 1)**

1. Set the heartbeat producer time ([C381](#)) to 10 ms.

**Parameterising the heartbeat consumer (node 2)**

1. Set the CAN node address of the producer in [C385/1](#).
2. Set the heartbeat consumer time in [C386/1](#).
  - Note: The heartbeat consumer time must be greater than the heartbeat producer time of the node to be monitored set in [C381](#).
3. Set the desired response in [C592/5](#) which is to be activated should a heartbeat event in the consumer occur.

**Tip!**

In [C347/1...n](#) displays the heartbeat status of the monitored nodes.

**Heartbeat telegram**

- The heartbeat telegram of the producer has the following identifier:  
Identifier (COB-ID) = 1792 + producer's node address = 1792 + 1 = 1793 = 0x701

### 9.8.3 Emergency telegram

If the error status changes because an internal device error occurs or has been eliminated, the NMT master receives an emergency telegram once with the following structure:

1st byte	2nd byte	3rd byte	4th byte	5th byte	6th byte	7th byte	8th byte
Emergency error codes		Error register	Manufacturer-specific error message				
Low byte	High byte	<a href="#">I-1001</a>	0x00 (reserved)	Low word		High word	
See table below				Low byte	High byte	Low byte	High byte
			<ul style="list-style-type: none"> <li>• For emergency error code 0xF000: Lenze error number (value displayed in <a href="#">C168</a>)</li> <li>• All other emergency error codes have a value of "0" here.</li> </ul>				

Emergency error codes	Error register	Cause
0x0000	0xXX	One of several errors eliminated
	0x00	One error has been eliminated (error-free status afterwards)
0x3100	0x01	Supply voltage of standard device faulty or failed
0x8100	0x11	Communication error (warning)
0x8130	0x11	Life guarding error or heartbeat error
0x8150	0x11	Collision of identifiers (COB-IDs): An identifier parameterised for reception is also used for transmission.
0x8210	0x11	PDO length shorter than expected
0x8220	0x11	PDO length greater than expected
0x8700	0x11	Monitoring of the sync telegram
0xF000	0x01	Generic error <ul style="list-style-type: none"> <li>• An error with a "Fault", "Trouble", "TroubleQSP", "Warning", or "SystemFault" error response occurred in the standard device.</li> <li>• Error message is the Lenze error number (<a href="#">C168</a>).</li> </ul>

The [Short overview \(A-Z\)](#) of error messages of the operating system includes a list of more emergency error codes. ([📖 159](#))

#### Example

1st byte	2nd byte	3rd byte	4th byte	5th byte	6th byte	7th byte	8th byte
Emergency error codes		Error register	Manufacturer-specific error message				
0x00	0xF0	0x01	0x00 (reserved)	Lenze error number			
Generic error				<a href="#">▶ Error messages of the operating system</a> Corresponding error-free message: Value "0x00000000"			



**Tip!**

A detailed description can be found in CAN specification DS301, V4.02.

# 9 System bus "CAN on board"

## 9.9 Implemented CANopen objects

### 9.9 Implemented CANopen objects

Lenze devices can both be parameterised with Lenze codes and manufacturer-independent "CANopen objects". A completely CANopen-compliant communication can only be achieved by using CANopen objects for parameter setting. The CANopen objects described in this chapter are defined in the CAN specification DS301 V4.02.

Many CANopen objects can be mapped on Lenze codes. In the following table, the corresponding Lenze codes are listed in the column "Relationship to Lenze codes".



#### Note!

Some of the terms used here derive from the CANopen protocol.

#### Overview of CANopen indices and their relationship to Lenze codes

CANopen object			Relationship to Lenze code
Index	Subindex	Name	
<a href="#">I-1000</a>	0	Device type	-
<a href="#">I-1001</a>	0	Error register	-
<a href="#">I-1003</a>	Predefined error field		
	0	Number of errors	-
	1 ... 10	Standard error field	-
<a href="#">I-1005</a>	0	COB-ID SYNC message	<a href="#">C367</a>
			<a href="#">C368</a>
<a href="#">I-1006</a>	0	Communication cycle period	<a href="#">C369</a>
<a href="#">I-1014</a>	0	COB-ID EMCY	-
<a href="#">I-1016</a>	Consumer heartbeat time		
	0	Highest subindex supported	-
	1 ... n	Consumer heartbeat time <ul style="list-style-type: none"> <li>• "BaseLine C" version: n = 1</li> <li>• "StateLine C" version: n = 7</li> <li>• "HighLine C" version: n = 15</li> <li>• "TopLine C" version: n = 15</li> </ul>	<a href="#">C385/1...n</a> <a href="#">C386/1...n</a>
<a href="#">I-1017</a>	0	Producer heartbeat time	<a href="#">C381</a>
<a href="#">I-1018</a>	Identity object		
	0	Highest subindex supported	-
	1	Vendor ID	-
	2	Product code	-
	3	Revision number	-
<a href="#">I-1200</a>	SDO1 server parameter		
	0	Highest subindex supported	-
	1	COB-ID client → server (rx)	-
	2	COB-ID server → client (tx)	-
<a href="#">I-1201</a>	SDO2 server parameter		
	0	Highest subindex supported	-
	1	COB-ID client → server (rx)	-
	2	COB-ID server → client (tx)	-

CANopen object			Relationship to Lenze code
Index	Subindex	Name	
<a href="#">I-1400</a>	RPDO1 communication parameter		
	0	Highest subindex supported	-
	1	COB-ID used by RPDO	<a href="#">C355/1</a>
	2	Transmission type	<a href="#">C323/1</a>
<a href="#">I-1401</a>	RPDO2 communication parameter		
	0	Highest subindex supported	-
	1	COB-ID used by RPDO	<a href="#">C355/3</a>
	2	Transmission type	<a href="#">C323/2</a>
<a href="#">I-1600</a>	RPDO1 mapping parameter		
	0	Number of mapped application objects in PDO	-
	1 ... 4	Application object 1 ... 4	-
<a href="#">I-1601</a>	RPDO2 mapping parameter		
	0	Number of mapped application objects in PDO	-
	1 ... 4	Application object 1 ... 4	-
<a href="#">I-1800</a>	TPDO1 communication parameter		
	0	Highest subindex supported	-
	1	COB-ID used by TPDO	<a href="#">C355/2</a>
	2	Transmission type	<a href="#">C322/1</a>
	3	Inhibit time	-
	5	Event timer	<a href="#">C356/5</a> <a href="#">C369</a>
<a href="#">I-1801</a>	TPDO2 communication parameter		
	0	Highest subindex supported	-
	1	COB-ID used by TPDO	<a href="#">C355/4</a>
	2	Transmission type	<a href="#">C322/2</a>
	3	Inhibit time	-
	5	Event timer	<a href="#">C356/2</a> <a href="#">C369</a>
<a href="#">I-1A00</a>	TPDO1 mapping parameter		
	0	Number of mapped application objects in PDO	-
	1 ... 4	Application object 1 ... 4	-
<a href="#">I-1A01</a>	TPDO2 mapping parameter		
	0	Number of mapped application objects in PDO	-
	1 ... 4	Application object 1 ... 4	-

## I-1000

Index <b>I-1000</b>	Name: <b>Device type</b>				
Subindex	Default setting	Display range (min. value   unit   max. value)		Access	Data type
0: Device type	0	0		4294967295	ro U32

The CANopen index I-1000 specifies the profile for this device. Furthermore, additional information defined in the device profile itself can be stored here.

8th byte	7th byte	6th byte	5th byte
Data 4	Data 3	Data 2	Data 1
High word		Low word	
High byte	Low byte	High byte	Low byte
Additional information		Device profile number	

[9-9] Data telegram assignment

In case of 8400 series controllers, the four bytes contain the following values:

- 5th and 6th byte: The data content is 0x0000, i.e. no profile definition.
- 7th byte: The data content specifies the device type: Here the value is 0x00 for controllers.
- 8th byte: The data content is 0x00.

The data content for the 8400 controller thus is: 00 00 00 00

## I-1001

Index: <b>I-1001</b>	Name: <b>Error register</b>				
Subindex	Default setting	Display range (min. value   unit   max. value)		Access	Data type
0: Error register	-	0		255	ro U8

Error register

The error status in the data byte (U8) is bit coded. The following error states are coded in the data byte (U8):

Bit 7	Bit 6	Bit 5	Bit 4	Bit 3	Bit 2	Bit 1	Bit 0	Error status
0	0	0	0	0	0	0	0	No error
0	0	0	0	0	0	0	1	Device error message
0	0	0	1	0	0	0	1	Communication error

## I-1003

Index: I-1003	Name: Predefined error field					
Subindex	Default setting	Display range (min. value   unit   max. value)			Access	Data type
0: Number of errors	0	0		255	rw	U8
1 ... 10: Standard error field	-	0		4294967295	ro	U32

## Error history

This object indicates that an error has occurred in the module and in the standard device.

Subindex	Meaning
0	Number of saved error messages
1 ... 10	Display of the error list The error messages (U32) consist of a 16-bit error code and a manufacturer-specific information field comprising 16 bits.

**Note!**

The values in the "standard error field" under subindex 1 ... 10 will be deleted if the sub-index "number of recorded errors" is overwritten with the value "0".

Emergency error codes	Cause	Entry in the error register (I-1001)
0x0000	One of several errors eliminated	0xXX
	Elimination of one single error (afterwards no more errors)	0x00
0x1000	Standard device is in error status (error response "fault", "message", "warning", "error", "quick stop by trouble", or "system error")	0x01
0x3100	Supply voltage of standard device faulty or failed	0x01
0x8100	Communication error (warning)	0x11
0x8130	Life guard error or heartbeat error	0x11
0x8150	Collision of COB-IDs: An ID parameterised for reception is also used for transmission.	0x11
0x8210	PDO length shorter than expected	0x11
0x8220	PDO length greater than expected	0x11
0x8700	Monitoring of the sync telegram	0x11

## I-1005

Index: I-1005	Name: COB-ID SYNC message					
Subindex	Default setting	Display range (min. value   unit   max. value)		Access	Data type	
0: COB-ID SYNC message	0x0000 0080 or 0x8000 0080	0		4294967295	rw	U32

This object can be used to activate the generation of sync telegrams and to write the identifier value.

- This object relates to codes [C367](#) and [C368](#).

### Creating sync telegrams

Sync telegrams are created by setting bit 30 (see below) to "1". The time between the sync telegrams can be set using the object [I-1006](#).

### Writing identifiers

To receive PDOs, the value 0x80 must be entered in the 11-bit identifier in the Lenze setting (and according to CANopen specification) . This means that all modules are by default set to the same sync telegram.

- If sync telegrams are only to be received by certain communication modules, their identifiers can be entered with values up to and including 0x07FF.
- The identifier can only be changed if the communication module does not send any sync telegrams (bit 30 = "0").
- How to change the identifier:
  - Deactivate identifier (set bit 30 to "0").
  - Change identifier.
  - Activate identifier (set bit 30 to "1").

8th byte		7th byte		6th byte		5th byte	
Data 4		Data 3		Data 2		Data 1	
Bit 31	Bit 30	Bit 29 ... bit 11				Bit 10 ... bit 0	
<b>X</b>	<b>0/1</b>	<b>Extended identifier*</b>				<b>11-bit identifier</b>	

\* The extended identifier is not supported. Bit 11 ... bit 29 must be set to "0".

[9-10] Data telegram assignment

## I-1006

Index: <b>I-1006</b>	Name: <b>Communication cycle period</b>				
Subindex	Default setting	Display range (min. value   unit   max. value)		Access	Data type
0: Communication cycle period	0 µs	0	µs	65535000	rw U32

Setting the sync telegram cycle time.

- The cycle time can be selected as "1000" or as an integer multiple of it.
- If "0 µs" is set (Lenze setting), no sync telegrams are created.
- This object relates to code [C369](#).

## I-1014

Index: <b>I-1014</b>	Name: <b>COB-ID EMCY</b>				
Subindex	Default setting	Display range (min. value   unit   max. value)		Access	Data type
0: COB-ID EMCY	0x80 + node ID	0		4294967295	rw U32

When communication errors occur and are acknowledged or when internal errors occur in the communication module or controller (e.g. "fault"), the system bus sends an error message. The telegram is sent once for every error. This function can be activated or deactivated with bit 31.

8th byte		7th byte		6th byte		5th byte	
Data 4		Data 3		Data 2		Data 1	
Bit 31	Bit 30	Bit 29 ... bit 11				Bit 10 ... bit 0	
0/1	0	Extended identifier*				11-bit identifier	
* The extended identifier is not supported. Bit 11 ... bit 29 must be set to "0".							

[9-11] Data telegram assignment

Bit	Setting	
Bit 31	0	Emergency object is valid.
	1	Emergency object is invalid.

**Note!**

The identifier can only be changed in the "emergency object invalid" status (bit 31 = 1).



# 9 System bus "CAN on board"

## 9.9 Implemented CANopen objects | I-1016

### I-1016

Index: <b>I-1016</b>	Name: <b>Consumer heartbeat time</b>				
Subindex	Default setting	Display range (min. value   unit   max. value)		Access	Data type
0: Highest subindex supported	BaseLine C: 1 StateLine C: 7 HighLine C: 15 TopLine C: 15	- (read access only)		ro	U16
1 ... n: Consumer heartbeat time	0	0		65535 rw	U16

Monitoring time for the nodes to be monitored via heartbeat. ▶ [Heartbeat protocol](#) (□ 207)

- The parameterised time is rounded down to an integer multiple of 5 ms and must have a greater value than the heartbeat producer time of the node to be monitored.

Subindex	Meaning	Lenze code
0	Number of nodes to be monitored	
1 ... n	Node ID and heartbeat time of the node to be monitored	Node ID: <a href="#">C385/x</a> Heartbeat time: <a href="#">C386/x</a>

8th byte	7th byte	6th byte	5th byte
Data 4	Data 3	Data 2	Data 1
Bit 31 ... bit 24	Bit 23 ... bit 16	Bit 15 ... bit 0	
<b>0</b> (reserved)	<b>Node ID</b>	<b>Heartbeat time</b> in [ms]	

[9-12] Data telegram assignment

### I-1017

Index: <b>I-1017</b>	Name: <b>Producer heartbeat time</b>				
Subindex	Default setting	Display range (min. value   unit   max. value)		Access	Data type
0: Producer heartbeat time	0	0	ms	65535 rw	U16

Time interval for sending the heartbeat telegram to the consumer(s). ▶ [Heartbeat protocol](#) (□ 207)

- The parameterised time is rounded down to an integer multiple of 5 ms.
- The heartbeat telegram is automatically sent as soon as a time > 0 ms is entered. In this case, the "node guarding" monitoring function is deactivated.
- This object relates to code [C381](#).

## I-1018

Index: <b>I-1018</b>		Name: <b>Identity object</b>				
Subindex	Default setting	Display range (min. value   unit   max. value)			Access	Data type
0: Highest subindex supported	see below	0		4294967295	ro	U32
1: Vendor ID						
2: Product code						
3: Revision number						
4: Serial number						

Subindex	Meaning
1	Manufacturer's identification number <ul style="list-style-type: none"> <li>The identification number allocated to Lenze by the organisation "CAN in Automation e. V." is "0x0000003B".</li> </ul>
2	Product code
	0x84001 8400 BaseLine C
	0x84002 8400 StateLine C
	0x84003 8400 HighLine C
	0x84004 8400 TopLine C
3	Main and subversion of firmware
4	Serial number

## I-1200

Index: <b>I-1200</b>		Name: <b>SDO1 server parameter</b>				
Subindex	Default setting	Display range (min. value   unit   max. value)			Access	Data type
0: Highest subindex supported	2	2		2	ro	U8
1: COB-ID client -> server (rx)	node ID + 0x600	0		4294967295	ro	U32
2: COB-ID server -> client (tx)	node ID + 0x580	0		4294967295	ro	U32

Identifiers for SDO server channel 1 (basic SDO channel).

- According to DS301 V4.02, the basic SDO channel can neither be changed nor deactivated.

Subindex	Meaning
1	Specification of receive identifier <ul style="list-style-type: none"> <li>For SDO server channel 1: node address (C350) + 0x580</li> </ul>
2	Specification of send identifier <ul style="list-style-type: none"> <li>For SDO server channel 1: Node address (C350) + 0x580</li> </ul>

8th byte		7th byte		6th byte		5th byte	
Data 4		Data 3		Data 2		Data 1	
Bit 31	Bit 30	Bit 29 ... bit 11				Bit 10 ... bit 0	
0	0	Extended identifier*				11-bit identifier	

\* The extended identifier is not supported. Bit 11 ... bit 29 must be set to "0".

[9-13] Data telegram assignment

## I-1201

Index: <b>I-1201</b>	Name: <b>SDO2 server parameter</b>					
Subindex	Default setting	Display range (min. value   unit   max. value)		Access	Data type	
0: Highest subindex supported	3	- (read access only)		ro	U8	
1: COB-ID client -> server (rx)	0x80000000	0		4294967295	rw	U32
2: COB-ID server -> client (tx)	0x80000000	0		4294967295	rw	U32

Identifiers for SDO server channel 2.

- The SDO server parameter is only valid, if bit 31 is set to "0" for both transmission directions (subindex 1 and 2).
- In the Lenze setting, the SDO server channels 2 are deactivated (bit 31 = "1").
- The identifier can only be changed if the SDO is invalid (bit 31 = "1").

Subindex	Meaning
1	Specification of receive identifier
2	Specification of send identifier

8th byte		7th byte		6th byte		5th byte	
Data 4		Data 3		Data 2		Data 1	
Bit 31	Bit 30	Bit 29 ... bit 11				Bit 10 ... bit 0	
<b>0/1</b>	<b>0</b>	<b>Extended identifier*</b>				<b>11-bit identifier</b>	

\* The extended identifier is not supported. Bit 11 ... bit 29 must be set to "0".

[9-14] Data telegram assignment

Bit	Setting
Bit 31	0 SDO is valid.
	1 SDO is invalid.

How to change the identifier:

1. Deactivate identifier (set bit 31 to "1").
2. Change identifier.
3. Activate identifier (set bit 31 to "0").

**Example**

Parameter data channel 2 of the controller with node address 4 shall be activated.

- For this, bit 31 must be set to "0" (≡ "SDO is valid") in subindices 1 and 2 of the object [I-1201](#).
- The master must send the two "write request" commands to the nodes via the basic SDO channel.

**Identifier calculation**

- Identifier (COB-ID) = basic identifier + node address (node ID)
- Basic identifier SDO2 from master to drive: 1600 (0x640)  
→ Identifier = 0x640 + 0x4 = 0x644
- Basic identifier SDO2 from drive to master: 1472 (0x5C0)  
→ Identifier = 0x5C0 + 0x4 = 0x5C4

**Resulting data (data 1 ... data 4)**

8th byte		7th byte		6th byte		5th byte	
Data 4		Data 3		Data 2		Data 1	
Bit 31	Bit 30	Bit 29 ... bit 11				Bit 10 ... bit 0	
0	0	Extended identifier = 0				11-bit identifier = 0x644	
0x00		0x00		0x06		0x44	

[9-15] Data telegram assignment for subindex 1

8th byte		7th byte		6th byte		5th byte	
Data 4		Data 3		Data 2		Data 1	
Bit 31	Bit 30	Bit 29 ... bit 11				Bit 10 ... bit 0	
0	0	Extended identifier = 0				11-bit identifier = 0x5C4	
0x00		0x00		0x05		0xC4	

[9-16] Data telegram assignment for subindex 2

**User data assignment**

1st byte	2nd byte	3rd byte	4th byte	5th byte	6th byte	7th byte	8th byte
Command	Index		Subindex	Data 1	Data 2	Data 3	Data 4
0x23	0x01	0x12	0x01	0x44	0x06	0x00	0x00

[9-17] User data assignment for writing to subindex 1

1st byte	2nd byte	3rd byte	4th byte	5th byte	6th byte	7th byte	8th byte
Command	Index		Subindex	Data 1	Data 2	Data 3	Data 4
0x23	0x01	0x12	0x02	0xC4	0x05	0x00	0x00

[9-18] User data assignment for writing to subindex 2

## I-1400

Index: <b>I-1400</b>		Name: <b>RPDO1 communication parameter</b>			
Subindex	Default setting	Display range (min. value   unit   max. value)		Access	Data type
0: Highest subindex supported	5	- (read access only)		ro	U8
1: COB-ID used by RPDO	0x200 + node ID	0		4294967295	rw U32
2: Transmission type	254	0		255	rw U8
3: Inhibit time	-	- (not used for RPDOs)		rw	U16
4: Compatibility entry	-	- (reserved, read or write access leads to error message 0x06090011)		rw	U8
5: Event timer	-	- (not used for RPDOs)		rw	U16

Communication parameter for receiving process data via RPDO1

Subindex	Meaning	Code
0	"5" is permanently set. • Max. 5 subindices are supported.	-
1	RPDO1 identifier • According to the "Predefined Connection Set", the basic setting is: Identifier = 0x200 + node ID	<a href="#">C354/1</a>
2	RPDO transmission type according to DS301 V4.02 ▶ <a href="#">Transmission type</a> (☞ 190)	<a href="#">C323/1</a>

8th byte		7th byte		6th byte		5th byte	
Data 4		Data 3		Data 2		Data 1	
Bit 31	Bit 30	Bit 29 ... bit 11				Bit 10 ... bit 0	
0/1	0/1	Extended identifier*				11-bit identifier	

\* The extended identifier is not supported. Bit 11 ... bit 29 must be set to "0".

[9-19] Data telegram assignment

How to change the identifier:

1. Deactivate identifier (set bit 31 to "1").
2. Change identifier.
3. Activate identifier (set bit 31 to "0").

Description of subindex 1

Bit no.	Value	Explanation
0 ... 10	0/1	11-bit identifier
(11 ... 28)*	0	*) The extended identifier (29 bits) is not supported. Any of these bits must be "0".
29*	0	
30	0	RTR to this PDO possible (cannot be set)
	1	RTR to this PDO not possible (Lenze)
31	0	PDO active
	1	PDO not active

[9-20] I-1400 ... I-1402, subindex 1

## Description of subindex 2

	PDO transmission		Transmission type	Explanation
	cyclic	synchronous		
X	X		n = 1 ... 240	When a value n is entered, this PDO will be accepted with every nth SYNC.
		X	n = 254	PDO will be accepted immediately.

[9-21] I-1400 ... I-1402, subindex 2

## I-1401

Index: I-1401	Name: RPDO2 communication parameter				
Subindex	Default setting	Display range (min. value   unit   max. value)		Access	Data type
0: Highest subindex supported	5	- (read access only)		ro	U8
1: COB-ID used by RPDO	0x300 + node ID	0	4294967295	rw	U32
2: Transmission type	254	0	255	rw	U8
3: Inhibit time	-	- (not used for RPDOs)		rw	U16
4: Compatibility entry	-	- (reserved, read or write access leads to error message 0x06090011)		rw	U8
5: Event timer	-	- (not used for RPDOs)		rw	U16

## Communication parameter for receiving process data via RPDO2

Subindex	Meaning	Code
0	"5" is permanently set. • Max. 5 subindices are supported.	-
1	RPDO2 identifier • According to the "Predefined Connection Set", the basic setting is: Identifier = 0x300 + node ID	<a href="#">C354/3</a>
2	RPDO transmission type according to DS301 V4.02 ▶ <a href="#">Transmission type</a> (□ 190)	<a href="#">C323/2</a>

- For data telegram assignment and description of subindices 1 and 2, see object [I-1400](#).

## How to change the identifier:

1. Deactivate identifier (set bit 31 to "1").
2. Change identifier.
3. Activate identifier (set bit 31 to "0").

## I-1600

Index: I-1600	Name: RPDO1 mapping parameter					
Subindex	Default setting	Display range (min. value   unit   max. value)			Access	Data type
0: Number of mapped application objects in PDO	0	0		8	rw	U8
1 ... 4: Application object 1 ... 4	0	0		4294967295	rw	U32

The object I-1600 serves to receive parameter data as RPDO1.

- This object relates to codes [C409/1...4](#) and [C866/1...4](#).

Subindex	Meaning
0	Number of mapped objects
1 ... 4	Mapping entries 1 ... 4 for RPDO1 <ul style="list-style-type: none"> <li>• The 4th mapping entry is used for the statistic mapping. For this, there is no value available.</li> </ul>

8th byte	7th byte	6th byte	5th byte
Data 4	Data 3	Data 2	Data 1
Bit 31 ... bit 16		Bit 15 ... bit 8	Bit 7 ... bit 0
Index		Subindex	Length

[9-22] Data telegram assignment

IEC 61131 process data words are mapped. Only whole bytes can be mapped (1-byte/mapping entry).

#### Related topics:

- ▶ [RPDO1 | Port block "LP\\_CanIn1"](#) (📖 185)

## I-1601

Index: I-1601	Name: RPDO2 mapping parameter					
Subindex	Default setting	Display range (min. value   unit   max. value)			Access	Data type
0: Number of mapped application objects in PDO	0	0		8	rw	U8
1 ... 4: Application object 1 ... 4	0	0		4294967295	rw	U32

The object I-1601 serves to receive parameter data as RPDO2.

- This object relates to codes [C409/5...8](#) and [C866/5...8](#).

Subindex	Meaning
0	Number of mapped objects
1 ... 4	Mapping entries 1 ... 4 for RPDO2 <ul style="list-style-type: none"> <li>• The 4th mapping entry is used for the statistic mapping. For this, there is no value available.</li> </ul>

- For data telegram assignment, see object [I-1600](#).

#### Related topics:

- ▶ [RPDO2 | Port block "LP\\_CanIn2"](#) (📖 186)

## I-1800

Index: <b>I-1800</b>		Name: <b>TPDO1 communication parameter</b>				
Subindex	Default setting	Display range (min. value   unit   max. value)			Access	Data type
0: Highest subindex supported	5	- (read access only)			ro	U8
1: COB-ID used by TPDO	0x180 + node ID	0		4294967295	rw	U32
2: Transmission type	254	0		255	rw	U8
3: Inhibit time	0 ms	0	0.1 ms	65535	rw	U16
4: Reserved	-	- (reserved, read or write access leads to error message 0x06090011)			rw	U8
5: Event timer	0 ms	0	ms	65535	rw	U16

Communication parameter for sending process data via TPDO1

Subindex	Meaning	Code
0	"5" is permanently set. • Max. 5 subindices are supported.	-
1	TPDO1 identifier • According to the "Predefined Connection Set", the basic setting is: Identifier = 0x180 + node ID	<a href="#">C354/2</a>
2	TPDO transmission type according to DS301 V4.02 ▶ <a href="#">Transmission type</a> (□ 190)	<a href="#">C322/1</a>
3	Minimum time between sending two identical TPDOs (see DS301 V4.02).	-
5	Cycle time for PDO transmission with transmission type "254".	<a href="#">C356/5</a> <a href="#">C369</a>

8th byte		7th byte		6th byte		5th byte	
Data 4		Data 3		Data 2		Data 1	
Bit 31	Bit 30	Bit 29 ... bit 11				Bit 10 ... bit 0	
<b>0/1</b>	<b>0/1</b>	<b>Extended identifier*</b>				<b>11-bit identifier</b>	

\* The extended identifier is not supported. Bit 11 ... bit 29 must be set to "0".

[9-23] Data telegram assignment

Bit	Setting	
Bit 30	0	RTR to this PDO possible (Lenze).
	1	RTR to this PDO not possible (not adjustable)
Bit 31	0	PDO active
	1	PDO inactive

How to change the identifier:

1. Deactivate identifier (set bit 31 to "1").
2. Change identifier.
3. Activate identifier (set bit 31 to "0").



**Subindex 2 - transmission type**

PDO transmission			Transmission type	Explanation
cyclic	synchronous	event-controlled		
●	●		n = 1 ... 240	When a value n is entered, this PDO will be accepted with every nth SYNC.
	●		n = 252	On sync, the PDO is filled with new data, but only sent on RTR.
		●	n = 254, 255	Event-controlled or cyclic

**Subindex 3 - inhibit time****Note!**

The delay time can only be changed when the PDO is not active (see subindex 1, bit 31 = 1).

The entered value multiplied by 0.1 gives the delay time in [ms]. Only integers will be considered, i.e. fractional numbers will be **rounded down** to integers.

Example:

- Entered value: 26
- Calculated time =  $26 \times 0.1$  [ms] = 2.6 [ms] → delay time = 2 [ms]

**Subindex 5 - event timer**

For cyclic operation (transmission type 254), the cycle time for sending the process data object on the CAN bus can be set under subindex 5:

The entered value corresponds to the time in [ms].

## I-1801

Index: I-1801	Name: TPDO2 communication parameter					
Subindex	Default setting	Display range (min. value   unit   max. value)			Access	Data type
0: Highest subindex supported	5	- (read access only)			ro	U8
1: COB-ID used by TPDO	0x280 + node ID	0		4294967295	rw	U32
2: Transmission type	254	0		255	rw	U8
3: Inhibit time	0 ms	0	0.1 ms	65535	rw	U16
4: Reserved	-	- (reserved, read or write access leads to error message 0x06090011)			rw	U8
5: Event timer	0 ms	0	ms	65535	rw	U16

Communication parameter for sending process data via TPDO2

Subindex	Meaning	Code
0	"5" is permanently set. • Max. 5 subindices are supported.	-
1	TPDO2 identifier • According to the "Predefined Connection Set", the basic setting is: Identifier = 0x280 + node ID	<a href="#">C354/4</a>
2	TPDO transmission type according to DS301 V4.02 ▶ <a href="#">Transmission type</a> (☰ 190)	<a href="#">C322/2</a>
3	Minimum time between sending two identical TPDOs (see DS301 V4.02).	-
5	Cycle time for PDO transmission with transmission type "254".	<a href="#">C356/2</a> <a href="#">C369</a>

- For data telegram assignment and description of subindices, see object [I-1800](#).

How to change the identifier:

1. Deactivate identifier (set bit 31 to "1").
2. Change identifier.
3. Activate identifier (set bit 31 to "0").

## I-1A00

Index: I-1A00	Name: TPDO1 mapping parameter					
Subindex	Default setting	Display range (min. value   unit   max. value)			Access	Data type
0: Number of mapped application objects in PDO	0	0		8	rw	U8
1 ... 4: Application object 1 ... 4	0	0		4294967295	rw	U32

The object I-1A00 serves to send parameter data as TPDO1.

- This object relates to code [C868/1...4](#).

Subindex	Meaning
0	Number of mapped objects
1 ... 4	Mapping entries 1 ... 4 for TPDO1 <ul style="list-style-type: none"> <li>• The 4th mapping entry is used for the statistic mapping. For this, there is no value available.</li> </ul>

8th byte	7th byte	6th byte	5th byte
Data 4	Data 3	Data 2	Data 1
Bit 31 ... bit 16		Bit 15 ... bit 8	Bit 7 ... bit 0
Index		Subindex	Length

[9-24] Data telegram assignment

IEC 61131 process data words are mapped. Only whole bytes can be mapped (1-byte/mapping entry).

#### Related topics:

- ▶ [TPDO1 | Port block "LP\\_CanOut1"](#) (📖 187)

## I-1A01

Index: I-1A01	Name: TPDO2 mapping parameter					
Subindex	Default setting	Display range (min. value   unit   max. value)			Access	Data type
0: Number of mapped application objects in PDO	0	0		8	rw	U8
1 ... 4: Application object 1 ... 4	0	0		4294967295	rw	U32

The object I-1A01 serves to send parameter data as TPDO2.

- This object relates to code [C868/5...8](#).

Subindex	Meaning
0	Number of mapped objects
1 ... 4	Mapping entries 1 ... 4 for TPDO2 <ul style="list-style-type: none"> <li>• The 4th mapping entry is used for the statistic mapping. For this, there is no value available.</li> </ul>

- For data telegram assignment, see object [I-1A00](#).

#### Related topics:

- ▶ [TPDO2 | Port block "LP\\_CanOut2"](#) (📖 188)

### 10 Parameter reference

This chapter describes all parameters which can be used for parameterising and monitoring the controller.

---

Parameters which are only available in the controller from a certain software version onwards are marked with a corresponding note in the parameter description ("from version xx.xx.xx").

The parameter descriptions are based on the software version V03.04.00

---



#### Tip!

For quick reference of a parameter with a certain name, simply use the **index** of the online documentation. The index always contains the corresponding code in parentheses after the name.

General information on parameter setting can be found in the chapter entitled "[Introduction: Parameterising the controller](#)". (□ 12)

For general information on how to read and change parameters, please see the online documentation for the »Engineer«.

## 10.1 Structure of the parameter descriptions

Each parameter is described in the [Parameter list](#) in the form of a table which consists of the following three areas:

### Table header

The table header contains the following general information:

- Parameter number (Cxxxxx)
- Parameter name (display text in the »Engineer« and keypad)
- [Data type](#)
- Parameter index in decimal and hexadecimal notation for access via a fieldbus (e.g. CAN system bus).



### Tip!

The parameter index is calculated as follows:

- Index [dec] = 24575 - code
- Index [hex] = 0x5FFF - code

Example for code C00005:

- Index [dec] = 24575 - 5 = 24570
- Index [hex] = 0x5FFF - 0x{5} = 0x5FFA

### Table contents

The table contains further general explanations & notes on the parameter and the possible settings, which are represented in different ways depending on the parameter type:

- [Parameters with read-only access](#)
- [Parameters with write access](#)

### Table footer

The table footer contains the [Parameter attributes](#).

**10.1.1 Data type**

The parameters can be of the following data types:

Data type	Meaning
INTEGER_16	16-bit value with sign
INTEGER_32	32-bit value with sign
UNSIGNED_8	8-bit value without sign
UNSIGNED_16	16-bit value without sign
UNSIGNED_32	32-bit value without sign
VISIBLE_STRING	String of characters from printable characters

**10.1.2 Parameters with read-only access**

Parameters for which the "write access" attribute has not been set, can only be read. They cannot be changed by the user.

**Description structure**

Parameter Name: <b>Cxxxxx</b>   _____	Data type: _____ Index: _____
Description	
<b>Display range (min. value   unit   max. value)</b>	
_____	
<input checked="" type="checkbox"/> Read access <input type="checkbox"/> Write access <input type="checkbox"/> CINH <input type="checkbox"/> PLC STOP <input type="checkbox"/> No transfer <input type="checkbox"/> COM <input type="checkbox"/> MOT                   Scaling factor: 1	

**Representation in the »Engineer«**

The »Engineer« displays these parameters with a grey background or, with an online connection, with a pale-yellow background:

№	C...	S	Name	Value	Unit
3	0		Status of last device command	Successful	

# 10 Parameter reference

## 10.1 Structure of the parameter descriptions

### 10.1.3 Parameters with write access

Only parameters with a check mark (☑) in front of the "write access" attribute can be changed by the user. The Lenze setting for these parameters is **printed in bold**.

- The settings can either be selected from a selection list or the values can be entered directly.
- Values outside the valid setting range are represented in red in the »Engineer«.

#### 10.1.3.1 Parameters with setting range

##### Description structure

Parameter   Name: Cxxxxx   _____	Data type: _____ Index: _____
Description	
<b>Setting range (min. value   unit   max. value)</b>	<b>Lenze setting</b>
☑ Read access ☑ Write access ☐ CINH ☐ PLC STOP ☐ No transfer ☐ COM ☐ MOT Scaling factor: 1	

##### Parameter setting in the »Engineer«

In the »Engineer«, parameters are set by entering the desired value into the input field:

C... / S	Name	Value	Unit
11 0	Appl.: Reference speed	1500	rpm

#### 10.1.3.2 Parameters with selection list

##### Description structure

Parameter   Name: Cxxxxx   _____	Data type: _____ Index: _____
Description	
<b>Selection list (Lenze setting printed in bold)</b>	
<b>1</b>	
2	
3	
☑ Read access ☑ Write access ☐ CINH ☐ PLC STOP ☐ No transfer ☐ COM ☐ MOT Scaling factor: 1	

### Parameter setting in the »Engineer«

In the »Engineer«, a list field is used for parameter setting:

SI Name	Value	Unit
173 0 Mains voltage	0: 3ph 400V	
	0: 3ph 400V	
	1: 3ph 440V	
	2: 3ph 480V	

### 10.1.3.3 Parameters with bit-coded setting

#### Description structure

Parameter   Name: Cxxxxx   _____	Data type: _____ Index: _____
Description	
<b>Value is bit-coded:</b>	
Bit 0	
...	
Bit 31	
<input checked="" type="checkbox"/> Read access <input checked="" type="checkbox"/> Write access <input type="checkbox"/> CINH <input type="checkbox"/> PLC STOP <input type="checkbox"/> No transfer <input type="checkbox"/> COM <input type="checkbox"/> MOT           Scaling factor: 1	

### Parameter setting in the »Engineer«

The »Engineer« uses a dialog box for parameter setting in which the individual bits can be set or reset. Alternatively, the value can be entered as a decimal or hexadecimal value:

**DOx inversion** [Close]

Value

Decimal: 0      Hexadecimal: 0x0

Bit	Comment
<input type="checkbox"/> 0	Relay inverted
<input type="checkbox"/> 1	DO1 inverted
<input type="checkbox"/> 2	Reserved
<input type="checkbox"/> 3	Reserved
<input type="checkbox"/> 4	Reserved
<input type="checkbox"/> 5	Reserved
<input type="checkbox"/> 6	Reserved
<input type="checkbox"/> 7	Reserved

OK      Cancel



10.1.3.4 Parameters with subcodes

Description structure

Parameter   Name: Cxxxxx   _____		Data type: _____ Index: _____
Description		
Setting range (min. value   unit   max. value)		
<b>Subcodes</b>	<b>Lenze setting</b>	
Cxxxxx/1		
Cxxxxx/2		
Cxxxxx/3		
<input checked="" type="checkbox"/> Read access <input checked="" type="checkbox"/> Write access <input type="checkbox"/> CINH <input type="checkbox"/> PLC STOP <input type="checkbox"/> No transfer <input type="checkbox"/> COM <input type="checkbox"/> MOT                   Scaling factor: 1		

Parameter setting in the »Engineer«

The »Engineer« parameter list displays each subcode individually. The parameters are set as described in the previous chapters.

		C...	S	Name	Value	Unit
		39	1	Fixed setpoint 1	40.00	%
		39	2	Fixed setpoint 2	60.00	%
		39	3	Fixed setpoint 3	80.00	%

### 10.1.4 Parameter attributes

The table footers contain the parameter attributes:

Read access  Write access  CINH  PLC STOP  No transfer  COM  MOT    Scaling factor: 1

Attribute	Meaning	
<input checked="" type="checkbox"/> Read access	Read access to parameter possible.	
<input checked="" type="checkbox"/> Write access	Write access to parameter possible. • Please also observe the following attributes:	
	<input checked="" type="checkbox"/> CINH	Parameter value can only be changed when the controller is inhibited.
	<input checked="" type="checkbox"/> PLC STOP	Parameter value can only be changed when the application is stopped.
<input checked="" type="checkbox"/> No transfer	Parameter is <b>not</b> transferred to controller when the command <u>Download parameter set</u> is executed.	
<input checked="" type="checkbox"/> COM	Communication-relevant parameter • This parameter is relevant for parameter data transfer via the (CAN) system bus.	
<input checked="" type="checkbox"/> MOT	Motor control parameters	

#### Scaling factor

The "scaling factor" is important for parameter access via a bus system.

Signal type	Scaling factor	Resolution	Value range
Analog (scaled)	100	16 bits signed	± 199.9 %
Angular velocity	1	16 bits signed	± 32767 incr./ms
Position in [units]	10000	32 bits signed	± 214748.3647 [units]
Digital (BOOL)	1	8 bits unsigned	0 ≡ FALSE; 1 ≡ TRUE
Time	1000	16 bits unsigned	0 ... 999.000 s
Selection value	1	16 bits unsigned	0 ... 65535

**Example 1:** The value "654" of the parameter [C00028/1](#) (AIN1: input voltage) read via a bus system must be divided by the corresponding scaling factor "100" to obtain the actual display value "6.54 V".

$$\frac{\text{Read value (via bus system)}}{\text{Scaling factor}} = \text{Indicated value (Engineer)}$$

[10-1] Conversion formula for read access via bus system

**Example 2:** In order to set the parameter [C00012](#) (acceleration time main setpoint) to the value "123.45 %" via a bus system, the integer value "12345" must be transferred, i.e. the value to be set must be multiplied by the corresponding scaling factor "100".

$$\text{Value to be written (via bus system)} = \text{Value to be set} \cdot \text{Scaling factor}$$

[10-2] Conversion formula for write access via bus system

### 10.2 Parameter list

This chapter lists all parameters of the operating system in numerically ascending order.



#### Note!

The parameter descriptions are based on the software version V03.04.00.

#### C00002

Parameter   Name: C00002   Device commands		Data type: UNSIGNED 8 Index: 24573 <sub>d</sub> = 5FFD <sub>h</sub>
<b>Note:</b> <ul style="list-style-type: none"> <li>• Before switching off the supply voltage after carrying out a device command, check whether the device command has been carried out successfully via the status display under <a href="#">C00003!</a></li> <li>• Before activating the device commands through a master control, please wait for the "ready" message of the controller.</li> <li>• The device will reject a write process to C00002/x if the value is &gt;1 and issue an error message.                             <ul style="list-style-type: none"> <li>▶ <a href="#">Drive control (DCTRL): Device commands</a></li> </ul> </li> </ul>		
Selection list		
	0	Off / ready
	1	On / start
	2	Work in progress
	4	Action cancelled
	5	No access
	6	No access controller inhibit
Subcodes	Lenze setting	Info
C00002/1	0: Off / ready	Load Lenze setting <ul style="list-style-type: none"> <li>• All parameters are reset to the Lenze setting.</li> <li>• Only possible when the controller is inhibited.</li> </ul>
C00002/2	0: Off / ready	Load parameter set 1 <ul style="list-style-type: none"> <li>• Load parameter set 1 from the memory module.</li> </ul>
C00002/3	0: Off / ready	Reserved
C00002/4	0: Off / ready	Reserved
C00002/5	0: Off / ready	Reserved
C00002/6	0: Off / ready	Reserved
C00002/7	0: Off / ready	Save parameter set 1 <ul style="list-style-type: none"> <li>• Saving parameter set 1 in the memory module safe against mains failure.</li> </ul>
C00002/8	0: Off / ready	Reserved
C00002/9	0: Off / ready	Reserved
C00002/10	0: Off / ready	Reserved
C00002/11	0: Off / ready	Save all parameter sets <ul style="list-style-type: none"> <li>• All parameter sets are saved in the memory module with mains failure protection.</li> </ul>
C00002/12	0: Off / ready	Import EPM data <ul style="list-style-type: none"> <li>• Setting "1: On / start" activates the automatic import of parameters of the memory module after the error message "PS04".</li> </ul>

Parameter   Name: <b>C00002   Device commands</b>		Data type: UNSIGNED 8 Index: 24573 <sub>d</sub> = 5FFD <sub>h</sub>
C00002/13	0: Off / ready	Reserved
C00002/14	0: Off / ready	Reserved
C00002/15	0: Off / ready	Reserved
C00002/16	1: On / start	Enable controller "1" ≡ Enable controller "0" ≡ Inhibit controller
C00002/17	0: Off / ready	Activate quick stop "1" ≡ Activate quick stop "0" ≡ Deactivate quick stop
C00002/18	0: Off / ready	Reserved
C00002/19	0: Off / ready	Reset error <ul style="list-style-type: none"> <li>• After resetting the current error, further errors may be pending which must be reset as well.</li> <li>• Details of the currently pending error are displayed in <a href="#">C00166</a>.</li> </ul>
C00002/20	0: Off / ready	Reserved
C00002/21	0: Off / ready	Delete logbook <ul style="list-style-type: none"> <li>• All entries in the controller logbook will be deleted.</li> <li>• In the logbook, information on the error history is saved.</li> </ul>
C00002/22	0: Off / ready	Reserved
C00002/23	0: Off / ready	Identify motor parameters <ul style="list-style-type: none"> <li>• This device command serves to carry out an automatic identification of the motor parameters.</li> <li>• The device command is only executed when the controller is in the "SwitchedOn" state.</li> <li>• In order to identify the motor parameters, the controller must be enabled after this device command.</li> </ul> ▶ <a href="#">Identifying motor parameters automatically</a>
C00002/24	0: Off / ready	Reserved
C00002/25	0: Off / ready	Reserved
C00002/26	0: Off / ready	CAN reset node <ul style="list-style-type: none"> <li>• Reinitialise "CAN on board" interface.</li> <li>• Required when changing the baud rate, node address, or identifiers.</li> </ul> ▶ <a href="#">System bus "CAN on board"</a>
C00002/27	0: Off / ready	Reserved
C00002/28	0: Off / ready	Reserved
C00002/29	0: Off / ready	Reserved
C00002/30	0: Off / ready	Reserved
C00002/31	0: Off / ready	Reserved
C00002/32	0: Off / ready	Reserved
<input checked="" type="checkbox"/> Read access <input checked="" type="checkbox"/> Write access <input type="checkbox"/> CINH <input type="checkbox"/> PLC STOP <input checked="" type="checkbox"/> No transfer <input type="checkbox"/> COM <input type="checkbox"/> MOT   Scaling factor: 1		

## C00003

Parameter   Name: <b>C00003   Status of last device command</b>		Data type: UNSIGNED_8 Index: 24572 <sub>d</sub> = 5FFC <sub>h</sub>
Status of the device command carried out last ( <a href="#">C00002</a> ).		
<b>Note:</b> Before switching off the supply voltage after carrying out a device command, check whether the device command has been carried out successfully via the status display! <a href="#">▶ Drive control (DCTRL): Device commands</a>		
Selection list (read only)		Info
0	Successful	Device command has been carried out successfully.
1	Command unknown	Device command is implausible or not known in the system.
2	No access	Access for requested device command is not approved.
3	Time-out	Device command could not be processed in the defined time (time-out).
<input checked="" type="checkbox"/> Read access <input type="checkbox"/> Write access <input type="checkbox"/> CINH <input type="checkbox"/> PLC STOP <input checked="" type="checkbox"/> No transfer <input type="checkbox"/> COM <input type="checkbox"/> MOT             Scaling factor: 1		

## C00006

Parameter   Name: <b>C00006   Motor control</b>		Data type: UNSIGNED_8 Index: 24569 <sub>d</sub> = 5FF9 <sub>h</sub>
Selection of the motor control mode <a href="#">▶ Motor control (MCTRL): Select control mode</a>		
Selection list (Lenze setting printed in bold)		Info
4	SLVC: Vector control	This control type is used for sensorless vector control of an asynchronous motor. • The control type requires motor parameters to be set as exactly as possible! <a href="#">▶ Sensorless vector control</a>
6	<b>VFCplus: V/f linear</b>	This control type is used for the speed control of an asynchronous motor via a linear V/f characteristic and is the simplest control type. • For setting the V/f characteristic, only the rated frequency ( <a href="#">C00089</a> ) and the rated voltage ( <a href="#">C00090</a> ) of the motor have to be entered. <a href="#">▶ V/f characteristic control</a>
8	VFCplus: V/f quadr	This control type is used for speed control of an asynchronous motor via a square-law V/f characteristic. • For setting the V/f characteristic, only the rated frequency ( <a href="#">C00089</a> ) and the rated voltage ( <a href="#">C00090</a> ) of the motor have to be entered. <a href="#">▶ V/f characteristic control</a>
<input checked="" type="checkbox"/> Read access <input checked="" type="checkbox"/> Write access <input type="checkbox"/> CINH <input type="checkbox"/> PLC STOP <input type="checkbox"/> No transfer <input type="checkbox"/> COM <input type="checkbox"/> MOT             Scaling factor: 1		

## C00007

Parameter   Name: <b>C00007   Control mode</b>		Data type: UNSIGNED_16 Index: 24568 <sub>d</sub> = 5FF8 <sub>h</sub>
Selection of how the application is to be controlled.		
Selection list (Lenze setting printed in bold)		Info
0	Wiring has changed	This display appears when the preset configuration has been reparameterised via the connection parameters.
<b>10</b>	<b>Terminals 0</b>	The technology application is controlled via the digital input terminals of the controller: <ul style="list-style-type: none"> <li>• DI1 = fixed setpoint 1/3</li> <li>• DI2 = fixed setpoint 2/3</li> <li>• DI3 = activate DC injection braking</li> <li>• DI4 = change of direction of rotation</li> </ul>
12	Terminals 2	The technology application is controlled via the digital input terminals of the controller: <ul style="list-style-type: none"> <li>• DI1 = fixed setpoint 1/3</li> <li>• DI2 = fixed setpoint 2/3</li> <li>• DI3 = quick stop</li> <li>• DI4 = change of direction of rotation</li> </ul>
14	Terminals 11	The technology application is controlled via the digital input terminals of the controller: <ul style="list-style-type: none"> <li>• DI1 = change of direction of rotation</li> <li>• DI2 = activate DC injection braking</li> <li>• DI3 = motor potentiometer: Higher speed</li> <li>• DI4 = motor potentiometer: Lower speed</li> </ul>
16	Terminals 16	The technology application is controlled via the digital input terminals of the controller: <ul style="list-style-type: none"> <li>• DI1 = fixed setpoint 1/3</li> <li>• DI2 = fixed setpoint 2/3</li> <li>• DI3 = CW rotation/quick stop</li> <li>• DI4 = CCW rotation/quick stop</li> </ul>
20	Keypad	The technology application is controlled via the keypad: <ul style="list-style-type: none"> <li>→ <a href="#">C00002</a>: Device commands</li> <li>→ <a href="#">C00003</a>: Status of last device command</li> <li>→ <a href="#">C00727</a>: Executing control commands</li> <li>→ <a href="#">C00728</a>: Selecting analog setpoints</li> <li>▲ Increase speed</li> <li>▼ Reduce speed</li> </ul>
21	PC	The technology application is controlled via the "Free parameters" of the controller (PC control).
30	CAN	The technology application is controlled by means of CAN-PDOs via the system bus "CAN on board". <ul style="list-style-type: none"> <li>▶ <a href="#">System bus "CAN on board"</a></li> </ul>
<input checked="" type="checkbox"/> Read access <input checked="" type="checkbox"/> Write access <input type="checkbox"/> CINH <input type="checkbox"/> PLC STOP <input type="checkbox"/> No transfer <input type="checkbox"/> COM <input type="checkbox"/> MOT   Scaling factor: 1		

## C00010

Parameter   Name: <b>C00010   Minimum analog setpoint</b>		Data type: INTEGER_16 Index: 24565 <sub>d</sub> = 5FF5 <sub>h</sub>
As of version 03.00.00 Lower limit for analog input		
<a href="#">▶ Analog terminals</a>		
<b>Setting range (min. value   unit   max. value)</b>		
0.0	%	100.0
<b>Subcodes</b>	<b>Lenze setting</b>	<b>Info</b>
C00010/1	0.0 %	Min. analog setpoint
<input checked="" type="checkbox"/> Read access <input checked="" type="checkbox"/> Write access <input type="checkbox"/> CINH <input type="checkbox"/> PLC STOP <input type="checkbox"/> No transfer <input type="checkbox"/> COM <input type="checkbox"/> MOT   Scaling factor: 100		

## C00011

Parameter   Name: <b>C00011   Appl.: Reference speed</b>		Data type: UNSIGNED_16 Index: 24564 <sub>d</sub> = 5FF4 <sub>h</sub>
Setting the reference speed		
<ul style="list-style-type: none"> <li>• In the controller, all speed-related signals are processed to one reference variable in percent.</li> <li>• Set a reference speed here that corresponds to 100 %.</li> <li>• The frequency of the set reference speed is displayed in <a href="#">C00059</a>.</li> </ul>		
<b>Note:</b>		
This is not a maximum limitation!		
All values in percent in the controller may be in the range of 0 ... 199.99 %.		
<b>Setting range (min. value   unit   max. value)</b>		<b>Lenze setting</b>
50	rpm	9999 <b>1500 rpm</b>
<input checked="" type="checkbox"/> Read access <input checked="" type="checkbox"/> Write access <input type="checkbox"/> CINH <input type="checkbox"/> PLC STOP <input type="checkbox"/> No transfer <input type="checkbox"/> COM <input type="checkbox"/> MOT   Scaling factor: 1		

## C00012

Parameter   Name: <b>C00012   Acceleration time main setpoint</b>		Data type: UNSIGNED_32 Index: 24563 <sub>d</sub> = 5FF3 <sub>h</sub>
FB <a href="#">L_NSet_1</a> : Acceleration time of the ramp generator for the main speed setpoint		
<b>Setting range (min. value   unit   max. value)</b>		<b>Lenze setting</b>
0.0	s	999.9 <b>2.0 s</b>
<input checked="" type="checkbox"/> Read access <input checked="" type="checkbox"/> Write access <input type="checkbox"/> CINH <input type="checkbox"/> PLC STOP <input type="checkbox"/> No transfer <input type="checkbox"/> COM <input type="checkbox"/> MOT   Scaling factor: 1000		

## C00013

Parameter   Name: <b>C00013   Deceleration time main setpoint</b>		Data type: UNSIGNED_32 Index: 24562 <sub>d</sub> = 5FF2 <sub>h</sub>
FB <a href="#">L_NSet_1</a> : Deceleration time of the ramp generator for the main speed setpoint		
<b>Setting range (min. value   unit   max. value)</b>		<b>Lenze setting</b>
0.0	s	999.9 <b>2.0 s</b>
<input checked="" type="checkbox"/> Read access <input checked="" type="checkbox"/> Write access <input type="checkbox"/> CINH <input type="checkbox"/> PLC STOP <input type="checkbox"/> No transfer <input type="checkbox"/> COM <input type="checkbox"/> MOT   Scaling factor: 1000		

## C00015

Parameter   Name: <b>C00015   VFC: V/f base frequency</b>			Data type: UNSIGNED_16 Index: 24560 <sub>d</sub> = 5FF0 <sub>h</sub>	
V/f base frequency for V/f characteristic control ( <a href="#">VFCplus</a> )				
<ul style="list-style-type: none"> <li>The motor voltage increases linearly with the frequency until the base frequency is reached. From this value on, the motor voltage remains constant, the speed increases and the maximum torque decreases.</li> <li>After the motor to be used has been selected from the motor catalogue, the suitable value can be entered automatically. An automatic detection via the motor parameter identification is possible as well.</li> </ul>				
<b>Setting range (min. value   unit   max. value)</b>			<b>Lenze setting</b>	
7.5	Hz	999.9	<b>50.0 Hz</b>	
<input checked="" type="checkbox"/> Read access <input checked="" type="checkbox"/> Write access <input type="checkbox"/> CINH <input type="checkbox"/> PLC STOP <input type="checkbox"/> No transfer <input type="checkbox"/> COM <input checked="" type="checkbox"/> MOT   Scaling factor: 10				

## C00016

Parameter   Name: <b>C00016   VFC: Vmin boost</b>			Data type: UNSIGNED_16 Index: 24559 <sub>d</sub> = 5FEF <sub>h</sub>	
Boost of the V/f voltage characteristic within the range of low speed or frequency values for the ( <a href="#">VFCplus</a> ) V/f characteristic control.				
<ul style="list-style-type: none"> <li>This may increase the starting torque.</li> <li>After the motor to be used has been selected from the motor catalogue, the suitable value can be entered automatically. An automatic detection via the motor parameter identification is possible as well.</li> </ul>				
▶ <a href="#">Motor control (MCTRL): Setting Vmin boost</a>				
<b>Setting range (min. value   unit   max. value)</b>			<b>Lenze setting</b>	
0.0	%	100.0	<b>0.0 %</b>	
<input checked="" type="checkbox"/> Read access <input checked="" type="checkbox"/> Write access <input type="checkbox"/> CINH <input type="checkbox"/> PLC STOP <input type="checkbox"/> No transfer <input type="checkbox"/> COM <input type="checkbox"/> MOT   Scaling factor: 100				

## C00018

Parameter   Name: <b>C00018   Switching frequency</b>			Data type: UNSIGNED_8 Index: 24557 <sub>d</sub> = 5FED <sub>h</sub>	
Selection of the pulse width modulated switching frequency transferred from the inverter to the motor				
<ul style="list-style-type: none"> <li>When a variable switching frequency is selected, the switching frequency may change as a function of the load and rotational frequency.</li> </ul>				
▶ <a href="#">Selection of the switching frequency</a>				
<b>Selection list (Lenze setting printed in bold)</b>				
1	4 kHz var./drive-optimised			
2	<b>8 kHz var./drive-optimised</b>			
3	16 kHz var./drive-optimised			
5	2 kHz constant/drive-optimised			
6	4 kHz constant/drive-optimised			
7	8 kHz constant/drive-optimised			
8	16 kHz constant/drive-optimised			
21	8 kHz var/4 kHz min.			
22	16 kHz var/4 kHz min.			
23	16 kHz var/8 kHz min.			
<input checked="" type="checkbox"/> Read access <input checked="" type="checkbox"/> Write access <input type="checkbox"/> CINH <input type="checkbox"/> PLC STOP <input type="checkbox"/> No transfer <input type="checkbox"/> COM <input type="checkbox"/> MOT   Scaling factor: 1				



## C00019

Parameter   Name: <b>C00019   Auto DCB: Threshold</b>		Data type: UNSIGNED_16 Index: 24556 <sub>d</sub> = 5FEC <sub>h</sub>	
Setpoint speed threshold for automatic DC injection braking <ul style="list-style-type: none"> <li>For speed setpoints with values below the thresholds a DC current is injected or the motor is not supplied with current, depending on the setting.</li> </ul> <p style="text-align: right;"><a href="#">▶ DC injection braking</a></p>			
<b>Setting range</b> (min. value   unit   max. value)		<b>Lenze setting</b>	
0	rpm	9999	<b>3 rpm</b>
<input checked="" type="checkbox"/> Read access <input checked="" type="checkbox"/> Write access <input type="checkbox"/> CINH <input type="checkbox"/> PLC STOP <input type="checkbox"/> No transfer <input type="checkbox"/> COM <input type="checkbox"/> MOT   Scaling factor: 1			

## C00021

Parameter   Name: <b>C00021   Slip comp.</b>		Data type: INTEGER_16 Index: 24554 <sub>d</sub> = 5FEA <sub>h</sub>	
Slip compensation for V/f characteristic control ( <a href="#">VFCplus</a> ) and sensorless vector control ( <a href="#">SLVC</a> ) <ul style="list-style-type: none"> <li>An increase of the slip compensation causes a greater frequency and voltage increase when the machine is loaded.</li> <li>After the motor to be used has been selected from the motor catalogue, the suitable value can be entered automatically. An automatic detection via the motor parameter identification is possible as well.</li> </ul> <p style="text-align: right;"><a href="#">▶ Motor control (MCTRL): Optimising the operational performance by slip compensation</a></p>			
<b>Setting range</b> (min. value   unit   max. value)		<b>Lenze setting</b>	
-50.00	%	50.00	<b>0.00 %</b>
<input checked="" type="checkbox"/> Read access <input checked="" type="checkbox"/> Write access <input type="checkbox"/> CINH <input type="checkbox"/> PLC STOP <input type="checkbox"/> No transfer <input type="checkbox"/> COM <input type="checkbox"/> MOT   Scaling factor: 100			

## C00022

Parameter   Name: <b>C00022   I<sub>max</sub> in motor mode</b>		Data type: UNSIGNED_16 Index: 24553 <sub>d</sub> = 5FE9 <sub>h</sub>	
Maximum current in motor mode for all motor control modes			
<b>Setting range</b> (min. value   unit   max. value)		<b>Lenze setting</b>	
0.00	A	99.99	<b>47.00 A</b>
<input checked="" type="checkbox"/> Read access <input checked="" type="checkbox"/> Write access <input type="checkbox"/> CINH <input type="checkbox"/> PLC STOP <input type="checkbox"/> No transfer <input type="checkbox"/> COM <input type="checkbox"/> MOT   Scaling factor: 100			

## C00023

Parameter   Name: <b>C00023   I<sub>max</sub> in generator mode</b>		Data type: INTEGER_16 Index: 24552 <sub>d</sub> = 5FE8 <sub>h</sub>	
Maximum current in generator mode for all motor control modes <ul style="list-style-type: none"> <li>100 % ≡ I<sub>max</sub> in motor mode (<a href="#">C00022</a>)</li> </ul>			
<b>Setting range</b> (min. value   unit   max. value)		<b>Lenze setting</b>	
0.0	%	100.0	<b>100.0 %</b>
<input checked="" type="checkbox"/> Read access <input checked="" type="checkbox"/> Write access <input type="checkbox"/> CINH <input type="checkbox"/> PLC STOP <input type="checkbox"/> No transfer <input type="checkbox"/> COM <input type="checkbox"/> MOT   Scaling factor: 100			

## C00024

Parameter   Name: <b>C00024   Comparison value N_Act</b>		Data type: INTEGER_16 Index: 24551 <sub>d</sub> = 5FE7 <sub>h</sub>
Threshold for the actual speed comparison <ul style="list-style-type: none"> <li>• This parameter serves to set a threshold that is compared with the actual speed value.</li> <li>• When the value falls below this threshold, the <i>bNactCompare</i> output of the SB <a href="#">LS_DriveInterface</a> switches to TRUE.</li> <li>• Switching hysteresis = +1 %</li> </ul>		
<b>Setting range (min. value   unit   max. value)</b>		<b>Lenze setting</b>
0.0	%	199.9 <b>0.0 %</b>
<input checked="" type="checkbox"/> Read access <input checked="" type="checkbox"/> Write access <input type="checkbox"/> CINH <input type="checkbox"/> PLC STOP <input type="checkbox"/> No transfer <input type="checkbox"/> COM <input type="checkbox"/> MOT   Scaling factor: 100		

## C00026

Parameter   Name: <b>C00026   AINx: Offset</b>		Data type: INTEGER_16 Index: 24549 <sub>d</sub> = 5FE5 <sub>h</sub>
Offset for analog input <a href="#">▶ Analog terminals</a>		
<b>Setting range (min. value   unit   max. value)</b>		
-199.9	%	199.9
<b>Subcodes</b>	<b>Lenze setting</b>	<b>Info</b>
C00026/1	0.0 %	AIN1: Offset
<input checked="" type="checkbox"/> Read access <input checked="" type="checkbox"/> Write access <input type="checkbox"/> CINH <input type="checkbox"/> PLC STOP <input type="checkbox"/> No transfer <input type="checkbox"/> COM <input type="checkbox"/> MOT   Scaling factor: 100		

## C00027

Parameter   Name: <b>C00027   AINx: Gain</b>		Data type: INTEGER_32 Index: 24548 <sub>d</sub> = 5FE4 <sub>h</sub>
Gain for analog input <a href="#">▶ Analog terminals</a>		
<b>Setting range (min. value   unit   max. value)</b>		
-199.9	%	199.9
<b>Subcodes</b>	<b>Lenze setting</b>	<b>Info</b>
C00027/1	100.0 %	AIN1: Gain
<input checked="" type="checkbox"/> Read access <input checked="" type="checkbox"/> Write access <input type="checkbox"/> CINH <input type="checkbox"/> PLC STOP <input type="checkbox"/> No transfer <input type="checkbox"/> COM <input type="checkbox"/> MOT   Scaling factor: 100		

## C00028

Parameter   Name: <b>C00028   AINx: Input voltage</b>		Data type: INTEGER_16 Index: 24547 <sub>d</sub> = 5FE3 <sub>h</sub>
Display of the input voltage at the analog input <a href="#">▶ Analog terminals</a>		
<b>Display range (min. value   unit   max. value)</b>		
-10.0	V	10.0
<b>Subcodes</b>	<b>Lenze setting</b>	<b>Info</b>
C00028/1		AIN1: Input voltage
<input checked="" type="checkbox"/> Read access <input type="checkbox"/> Write access <input type="checkbox"/> CINH <input type="checkbox"/> PLC STOP <input checked="" type="checkbox"/> No transfer <input type="checkbox"/> COM <input type="checkbox"/> MOT   Scaling factor: 100		

## C00029

Parameter   Name: <b>C00029   AINx: Input current</b>		Data type: INTEGER_16 Index: 24546 <sub>d</sub> = 5FE2 <sub>h</sub>
Display of the input current at the analog input <ul style="list-style-type: none"> <li>• When the analog input has been configured for current measurement (<a href="#">C00034/1</a> = 1 or 2).</li> <li>• When <a href="#">C00034/1</a> is set = 2 (4 ... 20 mA), 0 ... 16 mA is displayed.</li> </ul> <p style="text-align: right;"><a href="#">▶ Analog terminals</a></p>		
<b>Display range (min. value   unit   max. value)</b>		
0.0	mA	20.0
<b>Subcodes</b>		<b>Info</b>
C00029/1		AIN1: Input current
<input checked="" type="checkbox"/> Read access <input type="checkbox"/> Write access <input type="checkbox"/> CINH <input type="checkbox"/> PLC STOP <input checked="" type="checkbox"/> No transfer <input type="checkbox"/> COM <input type="checkbox"/> MOT   Scaling factor: 100		

## C00033

Parameter   Name: <b>C00033   AINx: Output value</b>		Data type: INTEGER_16 Index: 24542 <sub>d</sub> = 5FDE <sub>h</sub>
Display of the output value in percent of the analog input amplifier <ul style="list-style-type: none"> <li>• 100 % <math>\equiv</math> 16384 <math>\equiv</math> +10 V / +20 mA</li> </ul> <p style="text-align: right;"><a href="#">▶ Analog terminals</a></p>		
<b>Display range (min. value   unit   max. value)</b>		
-199.9	%	199.9
<b>Subcodes</b>		<b>Info</b>
C00033/1		AIN1: Output value
<input checked="" type="checkbox"/> Read access <input type="checkbox"/> Write access <input type="checkbox"/> CINH <input type="checkbox"/> PLC STOP <input checked="" type="checkbox"/> No transfer <input type="checkbox"/> COM <input type="checkbox"/> MOT   Scaling factor: 100		

## C00034

Parameter   Name: <b>C00034   AINx: Configuration</b>		Data type: UNSIGNED_8 Index: 24541 <sub>d</sub> = 5FDD <sub>h</sub>
Configuration of the analog input for current or voltage measurement <p style="text-align: right;"><a href="#">▶ Analog terminals</a></p>		
<b>Selection list</b>		<b>Info</b>
0	0...+10 V	Input signal is voltage signal 0 V ... +10 V <ul style="list-style-type: none"> <li>• 0 V ... +10 V <math>\equiv</math> 0 % ... +100 %</li> </ul>
1	0...+5V	With external load resistor (250 Ohms): Input signal is the current signal 0 mA ... 20 mA <ul style="list-style-type: none"> <li>• 0 mA ... 20 mA <math>\equiv</math> 0 % ... +100 %</li> </ul>
2	1...+5V (4...20mA)	With external load resistor (250 Ohms): Input signal is the current signal 4 mA ... 20 mA <ul style="list-style-type: none"> <li>• 4 mA ... 20 mA <math>\equiv</math> 0 % ... +100 %</li> <li>• The current loop is monitored for open circuit (I &lt; 4 mA) by the device.</li> </ul>
<b>Subcodes</b>		<b>Info</b>
C00034/1		AIN1: Config.
<input checked="" type="checkbox"/> Read access <input checked="" type="checkbox"/> Write access <input type="checkbox"/> CINH <input type="checkbox"/> PLC STOP <input type="checkbox"/> No transfer <input type="checkbox"/> COM <input type="checkbox"/> MOT   Scaling factor: 1		

## C00036

Parameter   Name: <b>C00036   DCB: Current</b>		Data type: INTEGER_16 Index: 24539 <sub>d</sub> = 5FDB <sub>h</sub>
Current value in [%] for DC-injection braking • 100 % ≡ I <sub>max</sub> in motor mode ( <a href="#">C00022</a> )		
<a href="#">▶ DC injection braking</a>		
<b>Setting range (min. value   unit   max. value)</b>		<b>Lenze setting</b>
0.0	%	150.0
		<b>50.0 %</b>
<input checked="" type="checkbox"/> Read access <input checked="" type="checkbox"/> Write access <input type="checkbox"/> CINH <input type="checkbox"/> PLC STOP <input type="checkbox"/> No transfer <input type="checkbox"/> COM <input type="checkbox"/> MOT   Scaling factor: 100		

## C00039

Parameter   Name: <b>C00039   Fixed setpoint x (L_NSet_1 n-Fix)</b>		Data type: INTEGER_16 Index: 24536 <sub>d</sub> = 5FD8 <sub>h</sub>
FB <a href="#">L_NSet_1</a> : Fixed speed setpoints (JOG values) for the setpoint generator		
<b>Setting range (min. value   unit   max. value)</b>		
-199.9	%	199.9
<b>Subcodes</b>	<b>Lenze setting</b>	<b>Info</b>
C00039/1	40.0 %	Fixed setpoint 1
C00039/2	60.0 %	Fixed setpoint 2
C00039/3	80.0 %	Fixed setpoint 3
<input checked="" type="checkbox"/> Read access <input checked="" type="checkbox"/> Write access <input type="checkbox"/> CINH <input type="checkbox"/> PLC STOP <input type="checkbox"/> No transfer <input type="checkbox"/> COM <input type="checkbox"/> MOT   Scaling factor: 100		

## C00050

Parameter   Name: <b>C00050   MCTRL: Speed setpoint</b>		Data type: INTEGER_32 Index: 24525 <sub>d</sub> = 5FCD <sub>h</sub>
Display of the speed setpoint at the speed setpoint input of the motor control		
<b>Display range (min. value   unit   max. value)</b>		
-9999	rpm	9999
<input checked="" type="checkbox"/> Read access <input type="checkbox"/> Write access <input type="checkbox"/> CINH <input type="checkbox"/> PLC STOP <input checked="" type="checkbox"/> No transfer <input type="checkbox"/> COM <input type="checkbox"/> MOT   Scaling factor: 1		

## C00051

Parameter   Name: <b>C00051   MCTRL: Actual speed value</b>		Data type: INTEGER_32 Index: 24524 <sub>d</sub> = 5FCC <sub>h</sub>
Display of the actual speed value of the motor shaft		
<b>Note:</b>		
The displayed value only corresponds to the real actual speed value of the motor shaft if an encoder is connected to the motor and the evaluation of the feedback signal has been set correctly ("Closed loop" operation). In case of operation without speed feedback, the signal is calculated from the motor control and thus may not correspond to the real actual speed.		
<b>Display range (min. value   unit   max. value)</b>		
-9999	rpm	9999
<input checked="" type="checkbox"/> Read access <input type="checkbox"/> Write access <input type="checkbox"/> CINH <input type="checkbox"/> PLC STOP <input checked="" type="checkbox"/> No transfer <input type="checkbox"/> COM <input type="checkbox"/> MOT   Scaling factor: 1		

## C00052

Parameter   Name: <b>C00052   Motor voltage</b>		Data type: UNSIGNED_16 Index: 24523 <sub>d</sub> = 5FCB <sub>h</sub>
Display of the current motor voltage/output voltage of the inverter		
<b>Display range (min. value   unit   max. value)</b>		
0	V	1000
<input checked="" type="checkbox"/> Read access <input type="checkbox"/> Write access <input type="checkbox"/> CINH <input type="checkbox"/> PLC STOP <input checked="" type="checkbox"/> No transfer <input type="checkbox"/> COM <input type="checkbox"/> MOT           Scaling factor: 1		

## C00053

Parameter   Name: <b>C00053   DC-bus voltage</b>		Data type: UNSIGNED_16 Index: 24522 <sub>d</sub> = 5FCB <sub>h</sub>
Display of the current DC-bus voltage		
<b>Display range (min. value   unit   max. value)</b>		
0	V	1000
<input checked="" type="checkbox"/> Read access <input type="checkbox"/> Write access <input type="checkbox"/> CINH <input type="checkbox"/> PLC STOP <input checked="" type="checkbox"/> No transfer <input type="checkbox"/> COM <input type="checkbox"/> MOT           Scaling factor: 1		

## C00054

Parameter   Name: <b>C00054   Motor current</b>		Data type: UNSIGNED_16 Index: 24521 <sub>d</sub> = 5FC9 <sub>h</sub>
Display of the current motor current/output current of the inverter		
<b>Display range (min. value   unit   max. value)</b>		
0.00	A	300.00
<input checked="" type="checkbox"/> Read access <input type="checkbox"/> Write access <input type="checkbox"/> CINH <input type="checkbox"/> PLC STOP <input checked="" type="checkbox"/> No transfer <input type="checkbox"/> COM <input type="checkbox"/> MOT           Scaling factor: 100		

## C00056

Parameter   Name: <b>C00056   Torque</b>		Data type: INTEGER_32 Index: 24519 <sub>d</sub> = 5FC7 <sub>h</sub>
Display of the current torque		
<b>Display range (min. value   unit   max. value)</b>		
-99.00	Nm	99.00
<b>Subcodes</b>		<b>Info</b>
C00056/1		Torque setpoint • Only with sensorless vector control ( <a href="#">SLVC</a> ).
C00056/2		Actual torque • Estimated actual torque for all motor control modes.
<input checked="" type="checkbox"/> Read access <input type="checkbox"/> Write access <input type="checkbox"/> CINH <input type="checkbox"/> PLC STOP <input checked="" type="checkbox"/> No transfer <input type="checkbox"/> COM <input type="checkbox"/> MOT           Scaling factor: 100		

## C00057

Parameter   Name: <b>C00057   Maximum torque</b>		Data type: UNSIGNED_32 Index: 24518 <sub>d</sub> = 5FC6 <sub>h</sub>
Display of the maximum torque to be generated by the motor • The maximum torque to be generated by the motor depends on various factors, e.g. on I <sub>max</sub> in motor mode ( <a href="#">C00022</a> ) and the motor type used.		
<b>Display range (min. value   unit   max. value)</b>		
0.0	Nm	999.9
<input checked="" type="checkbox"/> Read access <input type="checkbox"/> Write access <input type="checkbox"/> CINH <input type="checkbox"/> PLC STOP <input checked="" type="checkbox"/> No transfer <input type="checkbox"/> COM <input type="checkbox"/> MOT           Scaling factor: 100		

## C00058

Parameter   Name: <b>C00058   Output frequency</b>		Data type: INTEGER_32 Index: 24517 <sub>d</sub> = 5FC5 <sub>h</sub>
Display of the current output frequency		
<b>Display range (min. value   unit   max. value)</b>		
-655.0	Hz	655.0
<input checked="" type="checkbox"/> Read access <input type="checkbox"/> Write access <input type="checkbox"/> CINH <input type="checkbox"/> PLC STOP <input checked="" type="checkbox"/> No transfer <input type="checkbox"/> COM <input type="checkbox"/> MOT           Scaling factor: 100		

## C00059

Parameter   Name: <b>C00059   Appl.: Reference frequency C11</b>		Data type: UNSIGNED_32 Index: 24516 <sub>d</sub> = 5FC4 <sub>h</sub>
Display of the field frequency which corresponds to the reference speed set in <a href="#">C00011</a> .		
<b>Display range (min. value   unit   max. value)</b>		
0.0	Hz	999.9
<input checked="" type="checkbox"/> Read access <input type="checkbox"/> Write access <input type="checkbox"/> CINH <input type="checkbox"/> PLC STOP <input checked="" type="checkbox"/> No transfer <input type="checkbox"/> COM <input type="checkbox"/> MOT           Scaling factor: 100		

## C00061

Parameter   Name: <b>C00061   Heatsink temperature</b>		Data type: INTEGER_16 Index: 24514 <sub>d</sub> = 5FC2 <sub>h</sub>
Display of the current heatsink temperature		
<b>Display range (min. value   unit   max. value)</b>		
-50	°C	150
<input checked="" type="checkbox"/> Read access <input type="checkbox"/> Write access <input type="checkbox"/> CINH <input type="checkbox"/> PLC STOP <input checked="" type="checkbox"/> No transfer <input type="checkbox"/> COM <input type="checkbox"/> MOT           Scaling factor: 1		

## C00064

Parameter   Name: <b>C00064   Device utilisation (lxt)</b>		Data type: INTEGER_16 Index: 24511 <sub>d</sub> = 5FBF <sub>h</sub>
Display of the device utilisation lxt in different time resolutions		
<ul style="list-style-type: none"> <li>If the value displayed here exceeds the threshold set in <a href="#">C00123</a>, the fault message "OC5: Device overload (lxt)" is output and the fault response set in <a href="#">C00604</a> is executed (default setting: "Warning").</li> </ul>		
<b>Display range (min. value   unit   max. value)</b>		
0	%	250
<b>Subcodes</b>	<b>Info</b>	
C00064/1	Device utilisation (lxt) <ul style="list-style-type: none"> <li>Maximum value of the pulse utilisation (C00064/2) and permanent utilisation (C00064/3).</li> </ul>	
C00064/2	Device utilisation (lxt) 15s <ul style="list-style-type: none"> <li>Pulse utilisation over the last 15 seconds (only for loads &gt;160 %).</li> </ul>	
C00064/3	Device utilisation (lxt) 3 min <ul style="list-style-type: none"> <li>Permanent utilisation over the last 3 minutes.</li> </ul>	
<input checked="" type="checkbox"/> Read access <input type="checkbox"/> Write access <input type="checkbox"/> CINH <input type="checkbox"/> PLC STOP <input checked="" type="checkbox"/> No transfer <input type="checkbox"/> COM <input type="checkbox"/> MOT           Scaling factor: 100		

## C00066

Parameter   Name: <b>C00066   Thermal motor load (I<sup>2</sup>xt)</b>		Data type: INTEGER_16 Index: 24509 <sub>d</sub> = 5FB <sub>h</sub>	
Display of the thermal motor load being detected sensorless via a motor model			
<ul style="list-style-type: none"> <li>If the value displayed here exceeds the threshold set in <a href="#">C00120</a>, the fault message "OC6: Thermal motor overload (I<sup>2</sup>xt)" is output and the fault response set in <a href="#">C00606</a> is executed (default setting: "Warning").</li> </ul>			
<b>Display range (min. value   unit   max. value)</b>			
0	%	200	
<input checked="" type="checkbox"/> Read access <input type="checkbox"/> Write access <input type="checkbox"/> CINH <input type="checkbox"/> PLC STOP <input checked="" type="checkbox"/> No transfer <input type="checkbox"/> COM <input type="checkbox"/> MOT   Scaling factor: 100			

## C00073

Parameter   Name: <b>C00073   Vp I<sub>max</sub> controller</b>		Data type: UNSIGNED_16 Index: 24502 <sub>d</sub> = 5FB <sub>h</sub>	
Amplification factor Vp for I <sub>max</sub> controller			
<b>Setting range (min. value   unit   max. value)</b>		<b>Lenze setting</b>	
0.00		16.00	0.25
<input checked="" type="checkbox"/> Read access <input checked="" type="checkbox"/> Write access <input type="checkbox"/> CINH <input type="checkbox"/> PLC STOP <input type="checkbox"/> No transfer <input type="checkbox"/> COM <input checked="" type="checkbox"/> MOT   Scaling factor: 100			

## C00074

Parameter   Name: <b>C00074   Ti I<sub>max</sub> controller</b>		Data type: UNSIGNED_16 Index: 24501 <sub>d</sub> = 5FB <sub>h</sub>	
Reset time Ti for I <sub>max</sub> controller			
<b>Setting range (min. value   unit   max. value)</b>		<b>Lenze setting</b>	
12	ms	9990	65 ms
<input checked="" type="checkbox"/> Read access <input checked="" type="checkbox"/> Write access <input type="checkbox"/> CINH <input type="checkbox"/> PLC STOP <input type="checkbox"/> No transfer <input type="checkbox"/> COM <input checked="" type="checkbox"/> MOT   Scaling factor: 1			

## C00081

Parameter   Name: <b>C00081   Rated motor power</b>		Data type: UNSIGNED_16 Index: 24494 <sub>d</sub> = 5FA <sub>h</sub>	
This value can be obtained from the motor nameplate. After the motor to be used has been selected from the motor catalogue, the suitable value can be entered automatically.			
<b>Note:</b>			
It is mandatory to give the rated motor power for the sensorless vector control ( <a href="#">SLVC</a> ).			
<b>Setting range (min. value   unit   max. value)</b>		<b>Lenze setting</b>	
0.00	kW	99.00	11.00 kW
<input checked="" type="checkbox"/> Read access <input checked="" type="checkbox"/> Write access <input type="checkbox"/> CINH <input type="checkbox"/> PLC STOP <input type="checkbox"/> No transfer <input type="checkbox"/> COM <input checked="" type="checkbox"/> MOT   Scaling factor: 100			

## C00084

Parameter   Name: <b>C00084   Motor stator resistance</b>		Data type: UNSIGNED_32 Index: 24491 <sub>d</sub> = 5FA <sub>h</sub>	
After the motor to be used has been selected from the motor catalogue, the suitable value can be entered automatically. An automatic detection via the motor parameter identification is possible as well.			
<b>Setting range (min. value   unit   max. value)</b>		<b>Lenze setting</b>	
0	mohm	200000	330 mohm
<input checked="" type="checkbox"/> Read access <input checked="" type="checkbox"/> Write access <input type="checkbox"/> CINH <input type="checkbox"/> PLC STOP <input type="checkbox"/> No transfer <input type="checkbox"/> COM <input checked="" type="checkbox"/> MOT   Scaling factor: 1			

## C00085

Parameter   Name: <b>C00085   Motor stator leakage inductance</b>			Data type: UNSIGNED_16 Index: 24490 <sub>d</sub> = 5FAA <sub>h</sub>
After the motor to be used has been selected from the motor catalogue, the suitable value can be entered automatically. An automatic detection via the motor parameter identification is possible as well.			
<b>Setting range (min. value   unit   max. value)</b>			<b>Lenze setting</b>
0.00	mH	650.00	<b>0.00 mH</b>
<input checked="" type="checkbox"/> Read access <input checked="" type="checkbox"/> Write access <input type="checkbox"/> CINH <input type="checkbox"/> PLC STOP <input type="checkbox"/> No transfer <input type="checkbox"/> COM <input checked="" type="checkbox"/> MOT Scaling factor: 100			

## C00087

Parameter   Name: <b>C00087   Rated motor speed</b>			Data type: UNSIGNED_16 Index: 24488 <sub>d</sub> = 5FA8 <sub>h</sub>
This value can be obtained from the motor nameplate. After the motor to be used has been selected from the motor catalogue, the suitable value can be entered automatically.			
<b>Note:</b> It is mandatory to give the rated motor speed for the sensorless vector control ( <a href="#">SLVC</a> ).			
<b>Setting range (min. value   unit   max. value)</b>			<b>Lenze setting</b>
50	rpm	9999	<b>1460 rpm</b>
<input checked="" type="checkbox"/> Read access <input checked="" type="checkbox"/> Write access <input type="checkbox"/> CINH <input type="checkbox"/> PLC STOP <input type="checkbox"/> No transfer <input type="checkbox"/> COM <input checked="" type="checkbox"/> MOT Scaling factor: 1			

## C00088

Parameter   Name: <b>C00088   Rated motor current</b>			Data type: UNSIGNED_16 Index: 24487 <sub>d</sub> = 5FA7 <sub>h</sub>
This value can be obtained from the motor nameplate. After the motor to be used has been selected from the motor catalogue, the suitable value can be entered automatically.			
<b>Setting range (min. value   unit   max. value)</b>			<b>Lenze setting</b>
0.00	A	99.00	<b>21.00 A</b>
<input checked="" type="checkbox"/> Read access <input checked="" type="checkbox"/> Write access <input type="checkbox"/> CINH <input type="checkbox"/> PLC STOP <input type="checkbox"/> No transfer <input type="checkbox"/> COM <input checked="" type="checkbox"/> MOT Scaling factor: 100			

## C00089

Parameter   Name: <b>C00089   Rated motor frequency</b>			Data type: UNSIGNED_16 Index: 24486 <sub>d</sub> = 5FA6 <sub>h</sub>
This value can be obtained from the motor nameplate. After the motor to be used has been selected from the motor catalogue, the suitable value can be entered automatically.			
<b>Note:</b> It is mandatory to give the rated motor frequency for the sensorless vector control ( <a href="#">SLVC</a> ).			
<b>Setting range (min. value   unit   max. value)</b>			<b>Lenze setting</b>
10	Hz	1000	<b>50 Hz</b>
<input checked="" type="checkbox"/> Read access <input checked="" type="checkbox"/> Write access <input type="checkbox"/> CINH <input type="checkbox"/> PLC STOP <input type="checkbox"/> No transfer <input type="checkbox"/> COM <input checked="" type="checkbox"/> MOT Scaling factor: 1			



## C00090

Parameter   Name: <b>C00090   Rated motor voltage</b>		Data type: UNSIGNED_16 Index: 24485 <sub>d</sub> = 5FA5 <sub>h</sub>	
This value can be obtained from the motor nameplate. After the motor to be used has been selected from the motor catalogue, the suitable value can be entered automatically.			
<b>Setting range (min. value   unit   max. value)</b>		<b>Lenze setting</b>	
0	V	1000	<b>400 V</b>
<input checked="" type="checkbox"/> Read access <input checked="" type="checkbox"/> Write access <input type="checkbox"/> CINH <input type="checkbox"/> PLC STOP <input type="checkbox"/> No transfer <input type="checkbox"/> COM <input checked="" type="checkbox"/> MOT Scaling factor: 1			

## C00091

Parameter   Name: <b>C00091   Motor cosine phi</b>		Data type: UNSIGNED_8 Index: 24484 <sub>d</sub> = 5FA4 <sub>h</sub>	
This value can be obtained from the motor nameplate. After the motor to be used has been selected from the motor catalogue, the suitable value can be entered automatically.			
<b>Setting range (min. value   unit   max. value)</b>		<b>Lenze setting</b>	
0.40		1.00	<b>0.85</b>
<input checked="" type="checkbox"/> Read access <input checked="" type="checkbox"/> Write access <input type="checkbox"/> CINH <input type="checkbox"/> PLC STOP <input type="checkbox"/> No transfer <input type="checkbox"/> COM <input checked="" type="checkbox"/> MOT Scaling factor: 100			

## C00092

Parameter   Name: <b>C00092   Motor magnetising inductance</b>		Data type: UNSIGNED_16 Index: 24483 <sub>d</sub> = 5FA3 <sub>h</sub>	
After the motor to be used has been selected from the motor catalogue, the suitable value can be entered automatically. An automatic detection via the motor parameter identification is possible as well.			
<b>Setting range (min. value   unit   max. value)</b>		<b>Lenze setting</b>	
0.0	mH	6500.0	<b>0.0 mH</b>
<input checked="" type="checkbox"/> Read access <input checked="" type="checkbox"/> Write access <input type="checkbox"/> CINH <input type="checkbox"/> PLC STOP <input type="checkbox"/> No transfer <input type="checkbox"/> COM <input checked="" type="checkbox"/> MOT Scaling factor: 10			

## C00093

Parameter   Name: <b>C00093   Power section identification</b>		Data type: UNSIGNED_16 Index: 24482 <sub>d</sub> = 5FA2 <sub>h</sub>	
Display of the identification of the detected power section of the controller			
<b>Display range (min. value   unit   max. value)</b>			
0		65535	
<input checked="" type="checkbox"/> Read access <input type="checkbox"/> Write access <input type="checkbox"/> CINH <input type="checkbox"/> PLC STOP <input checked="" type="checkbox"/> No transfer <input type="checkbox"/> COM <input type="checkbox"/> MOT Scaling factor: 1			

## C00094

Parameter   Name: <b>C00094   Password</b>		Data type: INTEGER_32 Index: 24481 <sub>d</sub> = 5FA1 <sub>h</sub>	
The controller provides the opportunity to protect the menu level from unauthorised access by assigning a password.			
<a href="#">▶ Password protection</a>			
<b>Setting range (min. value   unit   max. value)</b>		<b>Lenze setting</b>	
0		9999	<b>0</b>
<input checked="" type="checkbox"/> Read access <input checked="" type="checkbox"/> Write access <input type="checkbox"/> CINH <input type="checkbox"/> PLC STOP <input type="checkbox"/> No transfer <input type="checkbox"/> COM <input type="checkbox"/> MOT Scaling factor: 1			

## C00095

Parameter   Name: <b>C00095   Motor magnetising current</b>		Data type: UNSIGNED_16 Index: 24480 <sub>d</sub> = 5FA0 <sub>h</sub>
After the motor to be used has been selected from the motor catalogue, the suitable value can be entered automatically. An automatic detection via the motor parameter identification is possible as well.		
<b>Display range (min. value   unit   max. value)</b>		
0.00	A	99.00
<input checked="" type="checkbox"/> Read access <input type="checkbox"/> Write access <input type="checkbox"/> CINH <input type="checkbox"/> PLC STOP <input type="checkbox"/> No transfer <input type="checkbox"/> COM <input checked="" type="checkbox"/> MOT Scaling factor: 100		

## C00097

Parameter   Name: <b>C00097   Rated motor torque</b>		Data type: UNSIGNED_32 Index: 24478 <sub>d</sub> = 5F9E <sub>h</sub>
Display of the rated motor torque • The value displayed here is calculated from different parameters, e.g. the maximum current set in <a href="#">C00022</a> .		
<b>Display range (min. value   unit   max. value)</b>		
0.00	Nm	99.00
<input checked="" type="checkbox"/> Read access <input type="checkbox"/> Write access <input type="checkbox"/> CINH <input type="checkbox"/> PLC STOP <input checked="" type="checkbox"/> No transfer <input type="checkbox"/> COM <input type="checkbox"/> MOT Scaling factor: 100		

## C00098

Parameter   Name: <b>C00098   Device rated current</b>		Data type: UNSIGNED_16 Index: 24477 <sub>d</sub> = 5F9D <sub>h</sub>
Display of the rated inverter current which is defined by the integrated power section.		
<b>Display range (min. value   unit   max. value)</b>		
0.0	A	999.0
<input checked="" type="checkbox"/> Read access <input type="checkbox"/> Write access <input type="checkbox"/> CINH <input type="checkbox"/> PLC STOP <input checked="" type="checkbox"/> No transfer <input type="checkbox"/> COM <input type="checkbox"/> MOT Scaling factor: 10		

## C00099

Parameter   Name: <b>C00099   Firmware version</b>		Data type: VISIBLE_STRING Index: 24476 <sub>d</sub> = 5F9C <sub>h</sub>
Display of the firmware version of the device as string		
<input checked="" type="checkbox"/> Read access <input type="checkbox"/> Write access <input type="checkbox"/> CINH <input type="checkbox"/> PLC STOP <input checked="" type="checkbox"/> No transfer <input type="checkbox"/> COM <input type="checkbox"/> MOT		

## C00100

Parameter   Name: <b>C00100   Firmware version</b>		Data type: UNSIGNED_8 Index: 24475 <sub>d</sub> = 5F9B <sub>h</sub>
Display of the firmware version of the device, divided into subsections.		
<b>Display range (min. value   unit   max. value)</b>		
0		99
<b>Subcodes</b>		<b>Info</b>
C00100/1		Firmware version - main version
C00100/2		Firmware version - subversion
C00100/3		Firmware version - release
C00100/4		Firmware version - build
<input checked="" type="checkbox"/> Read access <input type="checkbox"/> Write access <input type="checkbox"/> CINH <input type="checkbox"/> PLC STOP <input checked="" type="checkbox"/> No transfer <input type="checkbox"/> COM <input type="checkbox"/> MOT Scaling factor: 1		

## C00105

Parameter   Name: <b>C00105   Deceleration time quick stop</b>		Data type: UNSIGNED_32 Index: 24470 <sub>d</sub> = 5F96 <sub>h</sub>	
The set deceleration time determines the ramp slope at quick stop <ul style="list-style-type: none"> <li>When the output frequency falls below the threshold set in <a href="#">C00019</a>, the DC injection brake DCB is activated.</li> </ul> <p><b>Note:</b> The S-ramp time set in <a href="#">C00182</a> is also active with quick stop! In order to reach the required deceleration time for quick stop, set the time accordingly lower in this parameter.</p>			
<b>Setting range</b> (min. value   unit   max. value)		<b>Lenze setting</b>	
0.0	s	999.9	<b>5.0 s</b>
<input checked="" type="checkbox"/> Read access <input checked="" type="checkbox"/> Write access <input type="checkbox"/> CINH <input type="checkbox"/> PLC STOP <input type="checkbox"/> No transfer <input type="checkbox"/> COM <input type="checkbox"/> MOT   Scaling factor: 1000			

## C00106

Parameter   Name: <b>C00106   Auto DCB: Hold time</b>		Data type: UNSIGNED_32 Index: 24469 <sub>d</sub> = 5F95 <sub>h</sub>	
Hold time of the automatic DC injection brake <ul style="list-style-type: none"> <li>The DC injection brake is applied for the time set here if the value falls below the speed setpoint set in <a href="#">C00019</a>.</li> </ul>			
<b>Setting range</b> (min. value   unit   max. value)		<b>Lenze setting</b>	
0.0	s	999.0	<b>0.5 s</b>
<input checked="" type="checkbox"/> Read access <input checked="" type="checkbox"/> Write access <input type="checkbox"/> CINH <input type="checkbox"/> PLC STOP <input type="checkbox"/> No transfer <input type="checkbox"/> COM <input type="checkbox"/> MOT   Scaling factor: 1000			

## C00107

Parameter   Name: <b>C00107   DCB: Hold time</b>		Data type: UNSIGNED_32 Index: 24468 <sub>d</sub> = 5F94 <sub>h</sub>	
Maximum hold time of the manual DC injection brake <ul style="list-style-type: none"> <li>In order not to overload the motor thermally, a time for automatic switch-off of the DC injection brake can be set here.</li> </ul>			
<b>Setting range</b> (min. value   unit   max. value)		<b>Lenze setting</b>	
0.0	s	999.0	<b>999.0 s</b>
<input checked="" type="checkbox"/> Read access <input checked="" type="checkbox"/> Write access <input type="checkbox"/> CINH <input type="checkbox"/> PLC STOP <input type="checkbox"/> No transfer <input type="checkbox"/> COM <input type="checkbox"/> MOT   Scaling factor: 1000			

## C00114

Parameter   Name: <b>C00114   DIx inversion</b>		Data type: UNSIGNED_16 Index: 24461 <sub>d</sub> = 5F8D <sub>h</sub>
Polarity of the digital inputs <ul style="list-style-type: none"> <li>Every digital input of the device can be inverted with regard to polarity via this bit field.</li> </ul> <p style="text-align: right;"><a href="#">▶ Digital terminals</a></p>		
Setting range (min. hex value   max. hex value)		Lenze setting
0x0000	0xFFFF	<b>0x8000</b> (decimal: 32768)
Value is bit-coded: ( <input checked="" type="checkbox"/> = bit set)		Info
Bit 0 <input type="checkbox"/>	DI1 inverted	Inversion of digital input 1
Bit 1 <input type="checkbox"/>	DI2 inverted	Inversion of digital input 2
Bit 2 <input type="checkbox"/>	DI3 inverted	Inversion of digital input 3
Bit 3 <input type="checkbox"/>	DI4 inverted	Inversion of digital input 4
Bit 4 <input type="checkbox"/>	Reserved	
Bit 5 <input type="checkbox"/>	Reserved	
Bit 6 <input type="checkbox"/>	Reserved	
Bit 7 <input type="checkbox"/>	Reserved	
Bit 8 <input type="checkbox"/>	Reserved	
Bit 9 <input type="checkbox"/>	Reserved	
Bit 10 <input type="checkbox"/>	Reserved	
Bit 11 <input type="checkbox"/>	Reserved	
Bit 12 <input type="checkbox"/>	Reserved	
Bit 13 <input type="checkbox"/>	Reserved	
Bit 14 <input type="checkbox"/>	Reserved	
Bit 15 <input checked="" type="checkbox"/>	RFR inverted	Inversion of RFR digital input (controller enable)
<input checked="" type="checkbox"/> Read access <input checked="" type="checkbox"/> Write access <input type="checkbox"/> CINH <input type="checkbox"/> PLC STOP <input type="checkbox"/> No transfer <input type="checkbox"/> COM <input type="checkbox"/> MOT		

## C00118

Parameter   Name: <b>C00118   DOx inversion</b>		Data type: UNSIGNED_8 Index: 24457 <sub>d</sub> = 5F89 <sub>h</sub>
Polarity of the digital outputs <ul style="list-style-type: none"> <li>Every digital output of the device can be inverted with regard to polarity via this bit field.</li> </ul> <p style="text-align: right;"><a href="#">▶ Digital terminals</a></p>		
Setting range (min. hex value   max. hex value)		Lenze setting
0x00	0xFF	<b>0x00</b> (decimal: 0)
Value is bit-coded: ( <input checked="" type="checkbox"/> = bit set)		Info
Bit 0 <input type="checkbox"/>	Relay inverted	Relay inversion
Bit 1 <input type="checkbox"/>	DO1 inverted	Inversion of digital output 1
Bit 2 <input type="checkbox"/>	Reserved	
Bit 3 <input type="checkbox"/>	Reserved	
Bit 4 <input type="checkbox"/>	Reserved	
Bit 5 <input type="checkbox"/>	Reserved	
Bit 6 <input type="checkbox"/>	Reserved	
Bit 7 <input type="checkbox"/>	Reserved	
<input checked="" type="checkbox"/> Read access <input checked="" type="checkbox"/> Write access <input type="checkbox"/> CINH <input type="checkbox"/> PLC STOP <input type="checkbox"/> No transfer <input type="checkbox"/> COM <input type="checkbox"/> MOT		

## C00120

Parameter   Name: <b>C00120   Motor overload threshold (I<sup>2</sup>xt)</b>		Data type: INTEGER_16 Index: 24455 <sub>d</sub> = 5F87 <sub>h</sub>
Operating threshold for the error message "OC6: Motor overload (I <sup>2</sup> xt)" <ul style="list-style-type: none"> <li>• The response for reaching the threshold can be selected in <a href="#">C00606</a>.</li> <li>• The current thermal motor load is displayed in <a href="#">C00066</a>.</li> </ul> <p style="text-align: right;">▶ <a href="#">Motor overload monitoring (I2xt)</a></p>		
<b>Setting range (min. value   unit   max. value)</b>		<b>Lenze setting</b>
0	%	250 <b>100 %</b>
<input checked="" type="checkbox"/> Read access <input checked="" type="checkbox"/> Write access <input type="checkbox"/> CINH <input type="checkbox"/> PLC STOP <input type="checkbox"/> No transfer <input type="checkbox"/> COM <input type="checkbox"/> MOT             Scaling factor: 100		

## C00122

Parameter   Name: <b>C00122   Initial value motor overload (I<sup>2</sup>xt)</b>		Data type: UNSIGNED_16 Index: 24453 <sub>d</sub> = 5F85 <sub>h</sub>
From version 03.04.00 The thermal motor load displayed in <a href="#">C00066</a> is pre-initialised with the value set here when the device is connected to the mains. <ul style="list-style-type: none"> <li>• If "100.00 %" is set, the last value at switching off the device is used for the initialisation.</li> <li>• Recommended setting for operation according to UL: 50.00 %</li> </ul> <p style="text-align: right;">▶ <a href="#">Motor overload monitoring (I2xt)</a></p>		
<b>Setting range (min. value   unit   max. value)</b>		
0.00	%	100.00
<b>Subcodes</b>	<b>Lenze setting</b>	<b>Info</b>
C00122/1	0.00 %	Initial value motor overload (I <sup>2</sup> xt)
<input checked="" type="checkbox"/> Read access <input checked="" type="checkbox"/> Write access <input type="checkbox"/> CINH <input type="checkbox"/> PLC STOP <input type="checkbox"/> No transfer <input type="checkbox"/> COM <input checked="" type="checkbox"/> MOT             Scaling factor: 100		

## C00123

Parameter   Name: <b>C00123   Device utilisation threshold (Ixt)</b>		Data type: INTEGER_16 Index: 24452 <sub>d</sub> = 5F84 <sub>h</sub>
Operating threshold for the error message "OC5: Device overload (Ixt)" <ul style="list-style-type: none"> <li>• The response for reaching the threshold can be selected in <a href="#">C00604</a>.</li> <li>• The current device utilisation is displayed in <a href="#">C00064</a>.</li> </ul>		
<b>Setting range (min. value   unit   max. value)</b>		<b>Lenze setting</b>
0	%	100 <b>100 %</b>
<input checked="" type="checkbox"/> Read access <input checked="" type="checkbox"/> Write access <input type="checkbox"/> CINH <input type="checkbox"/> PLC STOP <input type="checkbox"/> No transfer <input type="checkbox"/> COM <input type="checkbox"/> MOT             Scaling factor: 100		

## C00134

Parameter   Name: <b>C00134   Ramp smoothing, main setpoint</b>		Data type: UNSIGNED_8 Index: 24441 <sub>d</sub> = 5F79 <sub>h</sub>
FB <a href="#">L_NSet_1</a> : Configuration of the ramp smoothing for the main setpoint		
<b>Selection list (Lenze setting printed in bold)</b>		<b>Info</b>
<b>0</b>	<b>Off</b>	Ramp rounding deactivated
1	PT1 behaviour	Ramp rounding with PT1 behaviour <ul style="list-style-type: none"> <li>• The corresponding S-ramp time must be set in <a href="#">C00182</a>.</li> </ul>
<input checked="" type="checkbox"/> Read access <input checked="" type="checkbox"/> Write access <input type="checkbox"/> CINH <input type="checkbox"/> PLC STOP <input type="checkbox"/> No transfer <input type="checkbox"/> COM <input type="checkbox"/> MOT             Scaling factor: 1		

C00136

Parameter   Name: <b>C00136   Communication control words</b>		Data type: UNSIGNED_16 Index: 24439 <sub>d</sub> = 5F77 <sub>h</sub>
Control words of the communication interfaces		
<b>Display area (min. hex value   max. hex value)</b>		
0x0000		0xFFFF
<b>Value is bit-coded:</b>		
Bit 0	SwitchOn	
Bit 1	IMP	
Bit 2	SetQuickStop	
Bit 3	EnableOperation	
Bit 4	Reserved	
Bit 5	Reserved	
Bit 6	Reserved	
Bit 7	ResetFault	
Bit 8	SetHalt	
Bit 9	reserved_1	
Bit 10	reserved_2	
Bit 11	LenzeSpecific_1	
Bit 12	LenzeSpecific_2	
Bit 13	LenzeSpecific_3	
Bit 14	SetFail	
Bit 15	LenzeSpecific_4	
<b>Subcodes</b>		<b>Info</b>
C00136/1		Reserved
C00136/2		CAN control word • Control word of the communication interface CAN (CAN on board)
<input checked="" type="checkbox"/> Read access <input type="checkbox"/> Write access <input type="checkbox"/> CINH <input type="checkbox"/> PLC STOP <input checked="" type="checkbox"/> No transfer <input type="checkbox"/> COM <input type="checkbox"/> MOT		

**C00137**

Parameter   Name: <b>C00137   Device state</b>		Data type: UNSIGNED_16 Index: 24438 <sub>d</sub> = 5F76 <sub>h</sub>
Display of the current device state		
<b>Selection list (read only)</b>		
0	Reserved	
1	Init	
2	MotorIdent	
3	ReadyToSwitchON	
4	SwitchedON	
5	OperationEnable	
6	Reserved	
7	Trouble	
8	Fault	
9	Reserved	
10	SafeTorqueOff	
11	Reserved	
12	Reserved	
13	Reserved	
14	Reserved	
15	Reserved	
<input checked="" type="checkbox"/> Read access <input type="checkbox"/> Write access <input type="checkbox"/> CINH <input type="checkbox"/> PLC STOP <input checked="" type="checkbox"/> No transfer <input type="checkbox"/> COM <input type="checkbox"/> MOT                   Scaling factor: 1		

**C00141**

Parameter   Name: <b>C00141   Device settings</b>		Data type: UNSIGNED_8 Index: 24434 <sub>d</sub> = 5F72 <sub>h</sub>
<i>As of version 03.00.00</i>		
<b>Selection list</b>		
0	Inactive	
1	Active	
<b>Subcodes</b>	<b>Lenze setting</b>	<b>Info</b>
C00141/1	0: Inactive	Always save parameters <ul style="list-style-type: none"> <li>• When this function is activated, every parameter change is saved in the memory module. A manual saving of parameter sets is not required anymore.</li> </ul> <b>Note:</b> Activating this function is not permissible if parameters are changed very frequently (e.g. in case of cyclic writing of parameters via a bus system).
<input checked="" type="checkbox"/> Read access <input checked="" type="checkbox"/> Write access <input type="checkbox"/> CINH <input type="checkbox"/> PLC STOP <input type="checkbox"/> No transfer <input type="checkbox"/> COM <input type="checkbox"/> MOT                   Scaling factor: 1		

C00142

Parameter   Name: <b>C00142   Auto-start option</b>		Data type: UNSIGNED_8 Index: 24433 <sub>d</sub> = 5F71 <sub>h</sub>	
Starting performance of the controller after mains connection and reset of "Trouble" or "Fault". ▶ <a href="#">"Inhibit at power-on" auto-start option</a>			
<b>Setting range</b> (min. hex value   max. hex value)		<b>Lenze setting</b>	
0x00		0xFF	<b>0x01</b> (decimal: 1)
<b>Value is bit-coded: (<input checked="" type="checkbox"/> = bit set)</b>			
Bit 0 <input checked="" type="checkbox"/>	Inhibit at mains ON		
Bit 1 <input type="checkbox"/>	Inhibit at trouble		
Bit 2 <input type="checkbox"/>	Inhibit at fault		
Bit 3 <input type="checkbox"/>	Reserved		
Bit 4 <input type="checkbox"/>	Reserved		
Bit 5 <input type="checkbox"/>	Reserved		
Bit 6 <input type="checkbox"/>	Reserved		
Bit 7 <input type="checkbox"/>	Reserved		
<input checked="" type="checkbox"/> Read access <input checked="" type="checkbox"/> Write access <input type="checkbox"/> CINH <input type="checkbox"/> PLC STOP <input type="checkbox"/> No transfer <input type="checkbox"/> COM <input type="checkbox"/> MOT			

C00144

Parameter   Name: <b>C00144   Switching frequency reduction (temp.)</b>		Data type: UNSIGNED_8 Index: 24431 <sub>d</sub> = 5F6F <sub>h</sub>	
Activation of the automatic switching frequency reduction at too high temperature			
<b>Selection list</b> (Lenze setting printed in bold)		<b>Info</b>	
0	Off	Automatic switching frequency reduction deactivated	
<b>1</b>	<b>On</b>	Automatic switching frequency reduction activated	
<input checked="" type="checkbox"/> Read access <input checked="" type="checkbox"/> Write access <input type="checkbox"/> CINH <input type="checkbox"/> PLC STOP <input type="checkbox"/> No transfer <input type="checkbox"/> COM <input type="checkbox"/> MOT                   Scaling factor: 1			



## C00150

Parameter   Name: C00150   Status word		Data type: UNSIGNED_16 Index: 24425 <sub>d</sub> = 5F69 <sub>h</sub>
Bit-coded device status word		
<b>Display area</b> (min. hex value   max. hex value)		
0x0000		0xFFFF
<b>Value is bit-coded:</b>		<b>Info</b>
Bit 0	FreeStatusBit0	Free status bit 0
Bit 1	PowerDisabled	Power switched off
Bit 2	FreeStatusBit2	Free status bit 2
Bit 3	FreeStatusBit3	Free status bit 3
Bit 4	FreeStatusBit4	Free status bit 4
Bit 5	FreeStatusBit5	Free status bit 5
Bit 6	ActSpeedIsZero	Current speed is 0
Bit 7	ControllerInhibit	Controller is inhibited
Bit 8	StatusCodeBit0	Status code bit 0
Bit 9	StatusCodeBit1	Status code bit 1
Bit 10	StatusCodeBit2	Status code bit 2
Bit 11	StatusCodeBit3	Status code bit 3
Bit 12	Warning	Warning
Bit 13	Trouble	Fault
Bit 14	FreeStatusBit14	Free status bit 14
Bit 15	FreeStatusBit15	Free status bit 15
<input checked="" type="checkbox"/> Read access <input type="checkbox"/> Write access <input type="checkbox"/> CINH <input type="checkbox"/> PLC STOP <input checked="" type="checkbox"/> No transfer <input type="checkbox"/> COM <input type="checkbox"/> MOT		

C00155

Parameter   Name: <b>C00155   Status word 2</b>		Data type: UNSIGNED_16 Index: 24420 <sub>d</sub> = 5F64 <sub>h</sub>
Bit-coded device status word 2		
<b>Display area (min. hex value   max. hex value)</b>		
0x0000		0xFFFF
<b>Value is bit-coded:</b>		<b>Info</b>
Bit 0	Fail	Error
Bit 1	M_max	Maximum torque
Bit 2	I_max	Maximum current
Bit 3	PowerDisabled	Power switched off
Bit 4	Ready	Controller is ready for operation
Bit 5	ControllerInhibit	Controller is inhibited
Bit 6	Trouble	Fault
Bit 7	InitState	Initialisation
Bit 8	CwCcw	CW/CCW rotation
Bit 9	Reserved	
Bit 10	SafeTorqueOff	Safe torque off
Bit 11	Reserved	
Bit 12	Reserved	
Bit 13	Reserved	
Bit 14	Quick stop	Quick stop is active
Bit 15	MotorIdent	Motor parameter identification active
<input checked="" type="checkbox"/> Read access <input type="checkbox"/> Write access <input type="checkbox"/> CINH <input type="checkbox"/> PLC STOP <input checked="" type="checkbox"/> No transfer <input type="checkbox"/> COM <input type="checkbox"/> MOT		

C00158

Parameter   Name: <b>C00158   Cause for controller inhibit</b>		Data type: UNSIGNED_16 Index: 24417 <sub>d</sub> = 5F61 <sub>h</sub>
Bit-coded display of the cause/source of controller inhibit		
<b>Display area (min. hex value   max. hex value)</b>		
0x0000		0xFFFF
<b>Value is bit-coded:</b>		
Bit 0	Terminal controller enable	
Bit 1	CANDriveControl	
Bit 2	Reserved	
Bit 3	SwitchOn	
Bit 4	Application	
Bit 5	Device command	
Bit 6	Error response	
Bit 7	Reserved	
Bit 8	Reserved	
Bit 9	Reserved	
Bit 10	AutoStartLock	
Bit 11	Motor parameter identification	
Bit 12	Reserved	
Bit 13	DCB-IMP	
Bit 14	Reserved	
Bit 15	Reserved	
<input checked="" type="checkbox"/> Read access <input type="checkbox"/> Write access <input type="checkbox"/> CINH <input type="checkbox"/> PLC STOP <input checked="" type="checkbox"/> No transfer <input type="checkbox"/> COM <input type="checkbox"/> MOT		

## C00159

Parameter   Name: <b>C00159   Cause for quick stop QSP</b>		Data type: UNSIGNED_16 Index: 24416 <sub>d</sub> = 5F60 <sub>h</sub>
Bit-coded display of the cause/source of quick stop		
<b>Display area (min. hex value   max. hex value)</b>		
0x0000		0xFFFF
<b>Value is bit-coded:</b>		
Bit 0	Terminal	
Bit 1	CANDriveControl	
Bit 2	Reserved	
Bit 3	SwitchOn	
Bit 4	Application	
Bit 5	Device command	
Bit 6	Reserved	
Bit 7	Reserved	
Bit 8	Reserved	
Bit 9	Reserved	
Bit 10	Reserved	
Bit 11	Reserved	
Bit 12	Reserved	
Bit 13	Reserved	
Bit 14	Reserved	
Bit 15	Reserved	
<input checked="" type="checkbox"/> Read access <input type="checkbox"/> Write access <input type="checkbox"/> CINH <input type="checkbox"/> PLC STOP <input checked="" type="checkbox"/> No transfer <input type="checkbox"/> COM <input type="checkbox"/> MOT		

## C00165

Parameter   Name: <b>C00165   Error information</b>		Data type: VISIBLE_STRING Index: 24410 <sub>d</sub> = 5F5A <sub>h</sub>
Display of the error numbers divided into sectors in the case of an error		
<b>Subcodes</b>		<b>Info</b>
C00165/1		Current error
<input checked="" type="checkbox"/> Read access <input type="checkbox"/> Write access <input type="checkbox"/> CINH <input type="checkbox"/> PLC STOP <input checked="" type="checkbox"/> No transfer <input type="checkbox"/> COM <input type="checkbox"/> MOT		

## C00166

Parameter   Name: <b>C00166   Error information text</b>		Data type: VISIBLE_STRING Index: 24409 <sub>d</sub> = 5F59 <sub>h</sub>
Display of details of the currently pending error		
<b>Subcodes</b>		<b>Info</b>
C00166/1		Resp. - current error • Response of the currently pending error
C00166/2		Subj.area curr. error • Subject area of the currently pending error
C00166/3		Mess.curr.error • Textual message of the currently pending error
<input checked="" type="checkbox"/> Read access <input type="checkbox"/> Write access <input type="checkbox"/> CINH <input type="checkbox"/> PLC STOP <input checked="" type="checkbox"/> No transfer <input type="checkbox"/> COM <input type="checkbox"/> MOT		

## C00167

Parameter   Name: <b>C00167   Logbook data</b>	Data type: OCTET_STRING Index: 24408 <sub>d</sub> = 5F58 <sub>h</sub>
<b>This code is for device-internal use only and must not be written to by the user!</b>	

## C00168

Parameter   Name: <b>C00168   Error number</b>	Data type: UNSIGNED_32 Index: 24407 <sub>d</sub> = 5F57 <sub>h</sub>
<b>Display range (min. value   unit   max. value)</b>	
0	4294967295
<b>Subcodes</b>	<b>Info</b>
C00168/1	Display of the internal error number for the last 8 occurred errors
C00168/...	
C00168/8	
<input checked="" type="checkbox"/> Read access <input type="checkbox"/> Write access <input type="checkbox"/> CINH <input type="checkbox"/> PLC STOP <input checked="" type="checkbox"/> No transfer <input type="checkbox"/> COM <input type="checkbox"/> MOT           Scaling factor: 1	

## C00169

Parameter   Name: <b>C00169   Time of error</b>	Data type: UNSIGNED_32 Index: 24406 <sub>d</sub> = 5F56 <sub>h</sub>
<b>Display range (min. value   unit   max. value)</b>	
0	4294967295
<b>Subcodes</b>	<b>Info</b>
C00169/1	Display of the time of error for the last 8 occurred errors
C00169/...	
C00169/8	
<input checked="" type="checkbox"/> Read access <input type="checkbox"/> Write access <input type="checkbox"/> CINH <input type="checkbox"/> PLC STOP <input checked="" type="checkbox"/> No transfer <input type="checkbox"/> COM <input type="checkbox"/> MOT           Scaling factor: 1	

## C00170

Parameter   Name: <b>C00170   Error counter</b>	Data type: UNSIGNED_8 Index: 24405 <sub>d</sub> = 5F55 <sub>h</sub>
<b>Display range (min. value   unit   max. value)</b>	
0	255
<b>Subcodes</b>	<b>Info</b>
C00170/1	Display of the error counter for the last 8 occurred errors
C00170/...	
C00170/8	
<input checked="" type="checkbox"/> Read access <input type="checkbox"/> Write access <input type="checkbox"/> CINH <input type="checkbox"/> PLC STOP <input checked="" type="checkbox"/> No transfer <input type="checkbox"/> COM <input type="checkbox"/> MOT           Scaling factor: 1	

## C00171

Parameter   Name: <b>C00171   Logbook access index</b>	Data type: UNSIGNED_8 Index: 24404 <sub>d</sub> = 5F54 <sub>h</sub>
<b>This code is for device-internal use only and must not be written to by the user!</b>	

## C00173

Parameter   Name: <b>C00173   Mains voltage</b>		Data type: UNSIGNED_8 Index: 24402 <sub>d</sub> = 5F52 <sub>h</sub>
Selection of the mains voltage for operating the device.		
Selection list (Lenze setting printed in bold)		Info
0	<b>3ph 400V / 1ph 230V</b>	3-phase 400 V or 1-phase 230 V
1	3ph 440V / 1ph 230V	3-phase 440 V or 1-phase 230 V
2	3ph 480V / 1ph 230V	3-phase 480 V or 1-phase 230 V
3	3ph 500V / 1ph 230V	3-phase 500 V or 1-phase 230 V
<input checked="" type="checkbox"/> Read access <input checked="" type="checkbox"/> Write access <input checked="" type="checkbox"/> CINH <input type="checkbox"/> PLC STOP <input type="checkbox"/> No transfer <input type="checkbox"/> COM <input type="checkbox"/> MOT   Scaling factor: 1		

## C00174

Parameter   Name: <b>C00174   Reduced brake chopper threshold</b>		Data type: UNSIGNED_8 Index: 24401 <sub>d</sub> = 5F51 <sub>h</sub>
The threshold from which on the brake chopper is controlled is reduced by the voltage value set here.		
Setting range (min. value   unit   max. value)		Lenze setting
0	V	150 <b>0 V</b>
<input checked="" type="checkbox"/> Read access <input checked="" type="checkbox"/> Write access <input type="checkbox"/> CINH <input type="checkbox"/> PLC STOP <input type="checkbox"/> No transfer <input type="checkbox"/> COM <input type="checkbox"/> MOT   Scaling factor: 1		

## C00177

Parameter   Name: <b>C00177   Switching cycles</b>		Data type: UNSIGNED_32 Index: 24398 <sub>d</sub> = 5F4E <sub>h</sub>
Counter of different switching cycles and stressful situations		
Display range (min. value   unit   max. value)		
0		2147483647
Subcodes		Info
C00177/1		Number of mains switching cycles
C00177/2		Number of switching cycles of the output relay
<input checked="" type="checkbox"/> Read access <input type="checkbox"/> Write access <input type="checkbox"/> CINH <input type="checkbox"/> PLC STOP <input checked="" type="checkbox"/> No transfer <input type="checkbox"/> COM <input type="checkbox"/> MOT   Scaling factor: 1		

## C00178

Parameter   Name: <b>C00178   Elapsed-hour meter</b>		Data type: UNSIGNED_32 Index: 24397 <sub>d</sub> = 5F4D <sub>h</sub>
Display of the operating hours in "seconds" unit		
Display range (min. value   unit   max. value)		
0	s	2147483647
<input checked="" type="checkbox"/> Read access <input type="checkbox"/> Write access <input type="checkbox"/> CINH <input type="checkbox"/> PLC STOP <input checked="" type="checkbox"/> No transfer <input type="checkbox"/> COM <input type="checkbox"/> MOT   Scaling factor: 1		

## C00179

Parameter   Name: <b>C00179   Power-on time meter</b>		Data type: UNSIGNED_32 Index: 24396 <sub>d</sub> = 5F4C <sub>h</sub>
Display of the power-on time in "seconds" unit		
Display range (min. value   unit   max. value)		
0	s	2147483647
<input checked="" type="checkbox"/> Read access <input type="checkbox"/> Write access <input type="checkbox"/> CINH <input type="checkbox"/> PLC STOP <input checked="" type="checkbox"/> No transfer <input type="checkbox"/> COM <input type="checkbox"/> MOT   Scaling factor: 1		

## C00182

Parameter   Name: <b>C00182   S-ramp time PT1</b>			Data type: INTEGER_16 Index: 24393 <sub>d</sub> = 5F49 <sub>h</sub>
FB <a href="#">L_NSet 1</a> : PT1 S-ramp time for the main setpoint ramp function generator • Only effective with activated ramp smoothing ( <a href="#">C00134</a> = "1").			
<b>Setting range</b> (min. value   unit   max. value)			<b>Lenze setting</b>
0.01	s	50.00	<b>20.00 s</b>
<input checked="" type="checkbox"/> Read access <input checked="" type="checkbox"/> Write access <input type="checkbox"/> CINH <input type="checkbox"/> PLC STOP <input type="checkbox"/> No transfer <input type="checkbox"/> COM <input type="checkbox"/> MOT Scaling factor: 100			

## C00200

Parameter   Name: <b>C00200   Firmware product type</b>			Data type: VISIBLE_STRING Index: 24375 <sub>d</sub> = 5F37 <sub>h</sub>
Display of the firmware product type			
<input checked="" type="checkbox"/> Read access <input type="checkbox"/> Write access <input type="checkbox"/> CINH <input type="checkbox"/> PLC STOP <input checked="" type="checkbox"/> No transfer <input type="checkbox"/> COM <input type="checkbox"/> MOT			

## C00201

Parameter   Name: <b>C00201   Firmware compile date</b>			Data type: VISIBLE_STRING Index: 24374 <sub>d</sub> = 5F36 <sub>h</sub>
Display of the firmware compilation date			
<input checked="" type="checkbox"/> Read access <input type="checkbox"/> Write access <input type="checkbox"/> CINH <input type="checkbox"/> PLC STOP <input checked="" type="checkbox"/> No transfer <input type="checkbox"/> COM <input type="checkbox"/> MOT			

## C00203

Parameter   Name: <b>C00203   Product type code</b>			Data type: VISIBLE_STRING Index: 24372 <sub>d</sub> = 5F34 <sub>h</sub>
As of version 03.00.00 Display of the single device component types			
<b>Subcodes</b>		<b>Info</b>	
C00203/1		Reserved	
C00203/2		Reserved	
C00203/3		Reserved	
C00203/4		Type: I/O micro	
C00203/5		Type: Memory module	
C00203/6		Type: Safety module	
C00203/7		Reserved	
C00203/8		Type: Complete device	
C00203/9		Reserved	
<input checked="" type="checkbox"/> Read access <input type="checkbox"/> Write access <input type="checkbox"/> CINH <input type="checkbox"/> PLC STOP <input checked="" type="checkbox"/> No transfer <input type="checkbox"/> COM <input type="checkbox"/> MOT			

## C00222

Parameter   Name: <b>C00222   L_PCTRL_1: Vp</b>			Data type: INTEGER_16 Index: 24353 <sub>d</sub> = 5F21 <sub>h</sub>
FB <a href="#">L_PCTRL 1</a> : Gain factor Vp for the PID process controller			
<b>Setting range</b> (min. value   unit   max. value)			<b>Lenze setting</b>
0.1		500.0	<b>1.0</b>
<input checked="" type="checkbox"/> Read access <input checked="" type="checkbox"/> Write access <input type="checkbox"/> CINH <input type="checkbox"/> PLC STOP <input type="checkbox"/> No transfer <input type="checkbox"/> COM <input type="checkbox"/> MOT Scaling factor: 10			

## C00223

Parameter   Name: <b>C00223   L_PCTRL_1: Tn</b>			Data type: UNSIGNED_16 Index: 24352 <sub>d</sub> = 5F20 <sub>h</sub>
FB <a href="#">L_PCTRL_1</a> : Reset time Tn for the PID process controller			
<b>Setting range</b> (min. value   unit   max. value)			<b>Lenze setting</b>
20	ms	6000	<b>400 ms</b>
<input checked="" type="checkbox"/> Read access <input checked="" type="checkbox"/> Write access <input type="checkbox"/> CINH <input type="checkbox"/> PLC STOP <input type="checkbox"/> No transfer <input type="checkbox"/> COM <input type="checkbox"/> MOT Scaling factor: 1			

## C00224

Parameter   Name: <b>C00224   L_PCTRL_1: Kd</b>			Data type: UNSIGNED_16 Index: 24351 <sub>d</sub> = 5F1F <sub>h</sub>
FB <a href="#">L_PCTRL_1</a> : Derivative-action coefficient Kd for the PID process controller			
<b>Setting range</b> (min. value   unit   max. value)			<b>Lenze setting</b>
0.0		5.0	<b>0.0</b>
<input checked="" type="checkbox"/> Read access <input checked="" type="checkbox"/> Write access <input type="checkbox"/> CINH <input type="checkbox"/> PLC STOP <input type="checkbox"/> No transfer <input type="checkbox"/> COM <input type="checkbox"/> MOT Scaling factor: 10			

## C00225

Parameter   Name: <b>C00225   L_PCTRL_1: MaxLimit</b>			Data type: INTEGER_16 Index: 24350 <sub>d</sub> = 5F1E <sub>h</sub>
FB <a href="#">L_PCTRL_1</a> : Maximum output value of the PID process controller			
<b>Setting range</b> (min. value   unit   max. value)			<b>Lenze setting</b>
-199.9	%	199.9	<b>199.9 %</b>
<input checked="" type="checkbox"/> Read access <input checked="" type="checkbox"/> Write access <input type="checkbox"/> CINH <input type="checkbox"/> PLC STOP <input type="checkbox"/> No transfer <input type="checkbox"/> COM <input type="checkbox"/> MOT Scaling factor: 100			

## C00226

Parameter   Name: <b>C00226   L_PCTRL_1: MinLimit</b>			Data type: INTEGER_16 Index: 24349 <sub>d</sub> = 5F1D <sub>h</sub>
FB <a href="#">L_PCTRL_1</a> : Minimum output value of the PID process controller			
<b>Setting range</b> (min. value   unit   max. value)			<b>Lenze setting</b>
-199.9	%	199.9	<b>-199.9 %</b>
<input checked="" type="checkbox"/> Read access <input checked="" type="checkbox"/> Write access <input type="checkbox"/> CINH <input type="checkbox"/> PLC STOP <input type="checkbox"/> No transfer <input type="checkbox"/> COM <input type="checkbox"/> MOT Scaling factor: 100			

## C00227

Parameter   Name: <b>C00227   L_PCTRL_1: Acceleration time</b>			Data type: UNSIGNED_32 Index: 24348 <sub>d</sub> = 5F1C <sub>h</sub>
FB <a href="#">L_PCTRL_1</a> : Acceleration time for the output value of the PID process controller			
<b>Setting range</b> (min. value   unit   max. value)			<b>Lenze setting</b>
0.0	s	999.9	<b>0.1 s</b>
<input checked="" type="checkbox"/> Read access <input checked="" type="checkbox"/> Write access <input type="checkbox"/> CINH <input type="checkbox"/> PLC STOP <input type="checkbox"/> No transfer <input type="checkbox"/> COM <input type="checkbox"/> MOT Scaling factor: 1000			



## C00228

Parameter   Name: <b>C00228   L_PCTRL_1: Deceleration time</b>		Data type: UNSIGNED_32 Index: 24344 <sub>d</sub> = 5F1B <sub>h</sub>	
FB <a href="#">L_PCTRL_1</a> : Deceleration time for the output value of the PID process controller			
<b>Setting range</b> (min. value   unit   max. value)		<b>Lenze setting</b>	
0.0	s	999.9	<b>0.1 s</b>
<input checked="" type="checkbox"/> Read access <input checked="" type="checkbox"/> Write access <input type="checkbox"/> CINH <input type="checkbox"/> PLC STOP <input type="checkbox"/> No transfer <input type="checkbox"/> COM <input type="checkbox"/> MOT   Scaling factor: 1000			

## C00231

Parameter   Name: <b>C00231   L_PCTRL_1: Operating range</b>		Data type: INTEGER_16 Index: 24344 <sub>d</sub> = 5F1B <sub>h</sub>	
FB <a href="#">L_PCTRL_1</a> : Operating range for the PID process controller			
<b>Setting range</b> (min. value   unit   max. value)			
0.0	%	199.9	
<b>Subcodes</b>	<b>Lenze setting</b>	<b>Info</b>	
C00231/1	199.9 %	<a href="#">L_PCTRL_1</a> : Pos. maximum	
C00231/2	0.0 %	<a href="#">L_PCTRL_1</a> : Pos. minimum	
C00231/3	0.0 %	<a href="#">L_PCTRL_1</a> : Neg. minimum	
C00231/4	199.9 %	<a href="#">L_PCTRL_1</a> : Neg. maximum	
<input checked="" type="checkbox"/> Read access <input checked="" type="checkbox"/> Write access <input type="checkbox"/> CINH <input type="checkbox"/> PLC STOP <input type="checkbox"/> No transfer <input type="checkbox"/> COM <input type="checkbox"/> MOT   Scaling factor: 100			

## C00234

Parameter   Name: <b>C00234   Oscillation damping influence</b>		Data type: UNSIGNED_16 Index: 24341 <sub>d</sub> = 5F15 <sub>h</sub>	
		▶ <a href="#">Oscillation damping</a>	
<b>Setting range</b> (min. value   unit   max. value)		<b>Lenze setting</b>	
0	%	250	<b>5 %</b>
<input checked="" type="checkbox"/> Read access <input checked="" type="checkbox"/> Write access <input type="checkbox"/> CINH <input type="checkbox"/> PLC STOP <input type="checkbox"/> No transfer <input type="checkbox"/> COM <input type="checkbox"/> MOT   Scaling factor: 100			

## C00235

Parameter   Name: <b>C00235   Filter time - oscill. damping</b>		Data type: UNSIGNED_8 Index: 24340 <sub>d</sub> = 5F14 <sub>h</sub>	
<b>This code is for device-internal use only and must not be written to by the user!</b>			

## C00236

Parameter   Name: <b>C00236   Oscillation damping - field weakening</b>		Data type: UNSIGNED_8 Index: 24339 <sub>d</sub> = 5F13 <sub>h</sub>	
<b>This code is for device-internal use only and must not be written to by the user!</b>			

## C00242

Parameter   Name: <b>C00242   L_PCTRL_1: Operating mode</b>		Data type: UNSIGNED_8 Index: 24333 <sub>d</sub> = 5F0D <sub>h</sub>
FB <a href="#">L_PCTRL_1</a> : Selection of the operating mode		
<ul style="list-style-type: none"> <li>Depending on the selection, the blue switches in the displayed signal flow are set accordingly in the Engineer on the <b>Application parameter</b> tab in the <i>Overview</i> → <i>Signal flow</i> → <i>Process controller</i> dialog level.</li> </ul>		
Selection list (Lenze setting printed in bold)		Info
0	<b>Off</b>	The input setpoint <i>nSet_a</i> is output without any changes at the output <i>nOut_a</i> .
1	Additive + feedforward control	<i>nSet_a</i> and <i>nAct_a</i> are used as PID input values. The arriving <i>nSet_a</i> is additively linked to the value output by the PID element.
2	PID as setpoint generator.	<i>nSet_a</i> and <i>nAct_a</i> are used as PID input values. The input <i>nSet_a</i> is not considered.
3	PID setpoint from L_NSet_1	<i>nSet_a</i> and <i>nAct_a</i> are used as PID input values. The input <i>nSet_a</i> is not considered.
<input checked="" type="checkbox"/> Read access <input checked="" type="checkbox"/> Write access <input type="checkbox"/> CINH <input type="checkbox"/> PLC STOP <input type="checkbox"/> No transfer <input type="checkbox"/> COM <input type="checkbox"/> MOT   Scaling factor: 1		

## C00243

Parameter   Name: <b>C00243   L_PCTRL_1: Acceleration time influence</b>		Data type: UNSIGNED_32 Index: 24332 <sub>d</sub> = 5F0C <sub>h</sub>
FB <a href="#">L_PCTRL_1</a> : Acceleration time for showing the PID output value		
Setting range (min. value   unit   max. value)		Lenze setting
0.0	s	999.9
		<b>5.0 s</b>
<input checked="" type="checkbox"/> Read access <input checked="" type="checkbox"/> Write access <input type="checkbox"/> CINH <input type="checkbox"/> PLC STOP <input type="checkbox"/> No transfer <input type="checkbox"/> COM <input type="checkbox"/> MOT   Scaling factor: 1000		

## C00244

Parameter   Name: <b>C00244   L_PCTRL_1: Deceleration time influence</b>		Data type: UNSIGNED_32 Index: 24331 <sub>d</sub> = 5F0B <sub>h</sub>
FB <a href="#">L_PCTRL_1</a> : Deceleration time for masking out the PID output value		
Setting range (min. value   unit   max. value)		Lenze setting
0.0	s	999.9
		<b>5.0 s</b>
<input checked="" type="checkbox"/> Read access <input checked="" type="checkbox"/> Write access <input type="checkbox"/> CINH <input type="checkbox"/> PLC STOP <input type="checkbox"/> No transfer <input type="checkbox"/> COM <input type="checkbox"/> MOT   Scaling factor: 1000		

## C00245

Parameter   Name: <b>C00245   L_PCTRL_1: PID output value</b>		Data type: INTEGER_16 Index: 24330 <sub>d</sub> = 5F0A <sub>h</sub>
FB <a href="#">L_PCTRL_1</a> : Display of the output value of the PID process controller		
Display range (min. value   unit   max. value)		
-199.9	%	199.9
<input checked="" type="checkbox"/> Read access <input type="checkbox"/> Write access <input type="checkbox"/> CINH <input type="checkbox"/> PLC STOP <input type="checkbox"/> No transfer <input type="checkbox"/> COM <input type="checkbox"/> MOT   Scaling factor: 100		

## C00308

Parameter   Name: <b>C00308   Activation of internal features</b>		Data type: UNSIGNED_16 Index: 24267 <sub>d</sub> = 5ECB <sub>h</sub>
<b>This code is for device-internal use only and must not be written to by the user!</b>		

## C00309

Parameter   Name: <b>C00309   Delay time</b>	Data type: UNSIGNED_16 Index: 24266 <sub>d</sub> = 5ECA <sub>h</sub>
<b>This code is for device-internal use only and must not be written to by the user!</b>	

## C00322

Parameter   Name: <b>C00322   Transmission mode CAN TxPDOs</b>	Data type: UNSIGNED_8 Index: 24253 <sub>d</sub> = 5EBD <sub>h</sub>
<p>TPDO transmission type according to DS301 V4.02</p> <ul style="list-style-type: none"> <li>The following transmission modes are supported: <ul style="list-style-type: none"> <li>0: Synchronous and acyclic</li> <li>1 ... 240: Synchronous and cyclic</li> <li>252: Synchronous - only RTR</li> <li>253: Asynchronous - only RTR</li> <li>254: Asynchronous - manufacturer-specific</li> <li>255: Asynchronous - device profile specific</li> </ul> </li> <li>The basic setting for all PDOs is the "asynchronous - manufacturer-specific" setting (254).</li> <li>Mapping of the CANopen objects <a href="#">I-1800/2</a> and <a href="#">I-1801/2</a> (see DS301 V4.02).</li> </ul> <p style="text-align: right;"><a href="#">▶ System bus "CAN on board"</a></p>	
<b>Setting range (min. value   unit   max. value)</b>	
0	255
<b>Subcodes</b>	<b>Lenze setting</b>
C00322/1	254
C00322/2	254
<b>Info</b>	
Transmission mode CAN1 OUT	
Transmission mode CAN2 OUT	
<input checked="" type="checkbox"/> Read access <input checked="" type="checkbox"/> Write access <input type="checkbox"/> CINH <input type="checkbox"/> PLC STOP <input type="checkbox"/> No transfer <input checked="" type="checkbox"/> COM <input type="checkbox"/> MOT   Scaling factor: 1	

## C00323

Parameter   Name: <b>C00323   Transmission mode CAN Rx PDOs</b>	Data type: UNSIGNED_8 Index: 24252 <sub>d</sub> = 5EBD <sub>h</sub>
<p>RPDO transmission type according to DS301 V4.02</p> <ul style="list-style-type: none"> <li>In the case of the RPDO serves as monitoring setting in the case of sync-controlled PDOs.</li> <li>The following transmission modes are supported: <ul style="list-style-type: none"> <li>0: Synchronous and acyclic</li> <li>1 ... 240: Synchronous and cyclic</li> <li>252: Synchronous - only RTR</li> <li>253: Asynchronous - only RTR</li> <li>254: Asynchronous - manufacturer-specific</li> <li>255: Asynchronous - device profile specific</li> </ul> </li> <li>The basic setting for all PDOs is the "asynchronous - manufacturer-specific" setting (254).</li> <li>Mapping of the CANopen objects <a href="#">I-1400/2</a> and <a href="#">I-1401/2</a> (see DS301 V4.02).</li> </ul> <p style="text-align: right;"><a href="#">▶ System bus "CAN on board"</a></p>	
<b>Setting range (min. value   unit   max. value)</b>	
0	255
<b>Subcodes</b>	<b>Lenze setting</b>
C00323/1	254
C00323/2	254
<b>Info</b>	
Transmission mode CAN1 IN	
Transmission mode CAN2 IN	
<input checked="" type="checkbox"/> Read access <input checked="" type="checkbox"/> Write access <input type="checkbox"/> CINH <input type="checkbox"/> PLC STOP <input type="checkbox"/> No transfer <input checked="" type="checkbox"/> COM <input type="checkbox"/> MOT   Scaling factor: 1	

## C00324

Parameter   Name: <b>C00324   CAN transmit blocking time</b>		Data type: UNSIGNED_16 Index: 24251 <sub>d</sub> = 5EBB <sub>h</sub>
As of version 03.03.00 Blocking time for transmitting the emergency telegram and the process data		
<b>Note:</b> If the "asynchronous - manufacturer-specific/device-profile specific" transmission type has been set, the transmission cycle timer is reset to 0 if transmission has been triggered in an event-controlled manner.		
Example: Cycle time ( <a href="#">C00356/x</a> ) = 500 ms, blocking time = 100 ms, sporadic data change: <ul style="list-style-type: none"> <li>• In case of a sporadic data change &lt; 500 ms, fastest transmission is every 100 ms due to the set blocking time (event-controlled transmission).</li> <li>• In case of a sporadic data change &gt; 500 ms, fastest transmission is every 500 ms due to the set blocking time (cyclic transmission).</li> </ul> <p style="text-align: right;"><a href="#">▶ System bus "CAN on board"</a></p>		
<b>Setting range (min. value   unit   max. value)</b>		
0	ms	6500
<b>Subcodes</b>	<b>Lenze setting</b>	<b>Info</b>
C00324/1	0 ms	Emergency blocking time
C00324/2	0 ms	CAN1_OUT blocking time
C00324/3	0 ms	CAN2_OUT blocking time
<input checked="" type="checkbox"/> Read access <input checked="" type="checkbox"/> Write access <input type="checkbox"/> CINH <input type="checkbox"/> PLC STOP <input type="checkbox"/> No transfer <input checked="" type="checkbox"/> COM <input type="checkbox"/> MOT   Scaling factor: 1		

## C00345

Parameter   Name: <b>C00345   CAN error status</b>		Data type: UNSIGNED_8 Index: 24230 <sub>d</sub> = 5EA6 <sub>h</sub>
<a href="#">▶ System bus "CAN on board"</a>		
<b>Selection list (read only)</b>		
0	No Error	
1	Warning ErrActive	
2	Warning ErrPassive	
3	Bus off	
4	Reserved	
5	Reserved	
<input checked="" type="checkbox"/> Read access <input type="checkbox"/> Write access <input type="checkbox"/> CINH <input type="checkbox"/> PLC STOP <input checked="" type="checkbox"/> No transfer <input type="checkbox"/> COM <input type="checkbox"/> MOT   Scaling factor: 1		

## C00347

Parameter   Name: <b>C00347   CAN status HeartBeat producer</b>		Data type: UNSIGNED_8 Index: 24228 <sub>d</sub> = 5EA4 <sub>h</sub>
▶ <a href="#">System bus "CAN on board": Heartbeat protocol</a>		
<b>Selection list (read only)</b>		
0	Boot-up	
4	Stopped	
5	Operational	
127	Pre-Operational	
250	Failed	
255	NoResponse	
<b>Subcodes</b>		<b>Info</b>
C00347/1		Status node 1
<input checked="" type="checkbox"/> Read access <input type="checkbox"/> Write access <input type="checkbox"/> CINH <input type="checkbox"/> PLC STOP <input checked="" type="checkbox"/> No transfer <input checked="" type="checkbox"/> COM <input type="checkbox"/> MOT           Scaling factor: 1		

## C00350

Parameter   Name: <b>C00350   CAN node address</b>		Data type: UNSIGNED_8 Index: 24225 <sub>d</sub> = 5EA1 <sub>h</sub>
Setting of the node address via parameters <ul style="list-style-type: none"> <li>• The node address can only be parameterised if the node address "0" is set via the DIP switches.</li> <li>• A change of the node address will only become effective after a CAN reset node.</li> </ul>		
▶ <a href="#">System bus "CAN on board"</a>		
<b>Setting range (min. value   unit   max. value)</b>		<b>Lenze setting</b>
1		63 <b>1</b>
<input checked="" type="checkbox"/> Read access <input checked="" type="checkbox"/> Write access <input type="checkbox"/> CINH <input type="checkbox"/> PLC STOP <input type="checkbox"/> No transfer <input checked="" type="checkbox"/> COM <input type="checkbox"/> MOT           Scaling factor: 1		

## C00351

Parameter   Name: <b>C00351   CAN baud rate</b>		Data type: UNSIGNED_8 Index: 24224 <sub>d</sub> = 5EA0 <sub>h</sub>
Setting of the baud rate via parameters <ul style="list-style-type: none"> <li>• The baud rate can only be parameterised if the baud rate "0" is set via the DIP switches.</li> <li>• A change of the baud rate will only become effective after a CAN reset node.</li> </ul>		
▶ <a href="#">System bus "CAN on board"</a>		
<b>Selection list (Lenze setting printed in bold)</b>		
<b>0</b>	<b>500 kbps</b>	
1	250 kbps	
2	125 kbps	
3	50 kbps	
4	1000 kbps	
5	20 kbps	
<input checked="" type="checkbox"/> Read access <input checked="" type="checkbox"/> Write access <input type="checkbox"/> CINH <input type="checkbox"/> PLC STOP <input type="checkbox"/> No transfer <input checked="" type="checkbox"/> COM <input type="checkbox"/> MOT           Scaling factor: 1		

## C00352

Parameter   Name: <b>C00352   CAN Slave/Master</b>		Data type: UNSIGNED_8 Index: 24223 <sub>d</sub> = 5E9F <sub>h</sub>
The drive starts as CAN master after mains switching if the value "1" has been entered and saved here. ▶ <a href="#">System bus "CAN on board"</a>		
<b>Selection list</b> (Lenze setting printed in bold)		
0	<b>Slave</b>	
1	Master	
<input checked="" type="checkbox"/> Read access <input checked="" type="checkbox"/> Write access <input type="checkbox"/> CINH <input type="checkbox"/> PLC STOP <input type="checkbox"/> No transfer <input checked="" type="checkbox"/> COM <input type="checkbox"/> MOT   Scaling factor: 1		

## C00353

Parameter   Name: <b>C00353   CAN IN/OUT COBID source</b>		Data type: UNSIGNED_8 Index: 24222 <sub>d</sub> = 5E9E <sub>h</sub>
Identifier allocation procedure for the CANx In/OUT process data ▶ <a href="#">System bus "CAN on board"</a>		
<b>Selection list</b>		<b>Info</b>
0	COBID = C0350 + LenzeBaseID	COBID = device address + LenzeBaseID
1	COBID = C0350 + CANBaseID	COBID = device address + CANBaseID ( <a href="#">C00354/x</a> )
2	COBID = C0354/x	COBID = <a href="#">C00354/x</a> + 384
<b>Subcodes</b>		<b>Info</b>
C00353/1	1: COBID = C0350 + CANBaseID	COBID source CAN1_IN/OUT
C00353/2	1: COBID = C0350 + CANBaseID	COBID source CAN2_IN/OUT
<input checked="" type="checkbox"/> Read access <input checked="" type="checkbox"/> Write access <input type="checkbox"/> CINH <input type="checkbox"/> PLC STOP <input type="checkbox"/> No transfer <input checked="" type="checkbox"/> COM <input type="checkbox"/> MOT   Scaling factor: 1		

## C00354

Parameter   Name: <b>C00354   COBID</b>		Data type: UNSIGNED_32 Index: 24221 <sub>d</sub> = 5E9D <sub>h</sub>
Setting of the default COBID according to CANopen • A change of the COBID will only become effective after a CAN reset node. ▶ <a href="#">System bus "CAN on board"</a>		
<b>Setting range</b> (min. hex value   max. hex value)		
0x00000000		0xFFFFFFFF
<b>Value is bit-coded:</b>		<b>Info</b>
Bit 0	COBID Bit0	<ul style="list-style-type: none"> <li>• Bit 0 ... 10: COB-ID</li> <li>• Bit 11 ... 30: Reserved</li> <li>• Bit 31: PDO invalid (is not transmitted)</li> </ul>
...	...	
Bit 31	PDO invalid	
<b>Subcodes</b>		<b>Info</b>
C00354/1	513	COBID CAN1_IN
C00354/2	385	COBID CAN1_OUT
C00354/3	769	COBID CAN2_IN
C00354/4	641	COBID CAN2_OUT
<input checked="" type="checkbox"/> Read access <input checked="" type="checkbox"/> Write access <input type="checkbox"/> CINH <input type="checkbox"/> PLC STOP <input type="checkbox"/> No transfer <input checked="" type="checkbox"/> COM <input type="checkbox"/> MOT		

## C00355

Parameter   Name: <b>C00355   Active COBID</b>		Data type: UNSIGNED_16 Index: 24220 <sub>d</sub> = 5E9C <sub>h</sub>
Display of the COBID of the PDOs that is active in the CAN stack <a href="#">▶ System bus "CAN on board"</a>		
<b>Display range (min. value   unit   max. value)</b>		
0		2047
<b>Subcodes</b>		<b>Info</b>
C00355/1		Active COBID CAN1_IN
C00355/2		Active COBID CAN1_OUT
C00355/3		Active COBID CAN2_IN
C00355/4		Active COBID CAN2_OUT
<input checked="" type="checkbox"/> Read access <input type="checkbox"/> Write access <input type="checkbox"/> CINH <input type="checkbox"/> PLC STOP <input checked="" type="checkbox"/> No transfer <input checked="" type="checkbox"/> COM <input type="checkbox"/> MOT           Scaling factor: 1		

## C00356

Parameter   Name: <b>C00356   CAN time settings</b>		Data type: UNSIGNED_16 Index: 24219 <sub>d</sub> = 5E9B <sub>h</sub>
Different time settings for the CAN interface <a href="#">▶ System bus "CAN on board"</a>		
<b>Setting range (min. value   unit   max. value)</b>		
0	ms	65000
<b>Subcodes</b>	<b>Lenze setting</b>	<b>Info</b>
C00356/1	3000 ms	CAN delay during status change from "Boot-up" to "Operational"
C00356/2	0 ms	CAN2_OUT cycle time
C00356/3	0 ms	CAN3_OUT cycle time
C00356/4	0 ms	CANx_OUT time "Operational" to "First transmission"
C00356/5	0 ms	CAN1_OUT cycle time
<input checked="" type="checkbox"/> Read access <input checked="" type="checkbox"/> Write access <input type="checkbox"/> CINH <input type="checkbox"/> PLC STOP <input type="checkbox"/> No transfer <input checked="" type="checkbox"/> COM <input type="checkbox"/> MOT           Scaling factor: 1		

## C00357

Parameter   Name: <b>C00357   CAN monitoring times</b>		Data type: UNSIGNED_16 Index: 24218 <sub>d</sub> = 5E9A <sub>h</sub>
Mapping of the RPDO event time (see DS301 V4.02) <ul style="list-style-type: none"> <li>• If a non-zero value is entered, the RPDO is expected after the time set has elapsed.</li> <li>• If the RPDO is not received within the expected time, the response set in <a href="#">C00593/1...2</a> is effected.</li> </ul> <a href="#">▶ System bus "CAN on board"</a>		
<b>Setting range (min. value   unit   max. value)</b>		
0	ms	65000
<b>Subcodes</b>	<b>Lenze setting</b>	<b>Info</b>
C00357/1	3000 ms	CAN1_IN monitoring time
C00357/2	3000 ms	CAN2_IN monitoring time
<input checked="" type="checkbox"/> Read access <input checked="" type="checkbox"/> Write access <input type="checkbox"/> CINH <input type="checkbox"/> PLC STOP <input type="checkbox"/> No transfer <input checked="" type="checkbox"/> COM <input type="checkbox"/> MOT           Scaling factor: 1		

C00359

Parameter   Name: <b>C00359   CAN status</b>		Data type: UNSIGNED_8 Index: 24216 <sub>d</sub> = 5E98 <sub>h</sub>
<a href="#">▶ System bus "CAN on board"</a>		
<b>Selection list (read only)</b>		
0	Operational	
1	Pre-Operat.	
2	Reserved	
3	Reserved	
4	BootUp	
5	Stopped	
6	Reserved	
7	Reset	
<input checked="" type="checkbox"/> Read access <input type="checkbox"/> Write access <input type="checkbox"/> CINH <input type="checkbox"/> PLC STOP <input checked="" type="checkbox"/> No transfer <input checked="" type="checkbox"/> COM <input type="checkbox"/> MOT                   Scaling factor: 1		

C00360

Parameter   Name: <b>C00360   CAN telegram counter</b>		Data type: UNSIGNED_16 Index: 24215 <sub>d</sub> = 5E97 <sub>h</sub>
<a href="#">▶ System bus "CAN on board"</a>		
<b>Display range (min. value   unit   max. value)</b>		
0		65535
<b>Subcodes</b>		<b>Info</b>
C00360/1		All PDOs/SDOs transmitted
C00360/2		All PDOs/SDOs received
C00360/3		CAN1_OUT telegram counter
C00360/4		CAN2_OUT telegram counter
C00360/5		Reserved
C00360/6		SDO1 OUT telegram counter
C00360/7		SDO2 OUT telegram counter
C00360/8		CAN1_IN telegram counter
C00360/9		CAN2_IN telegram counter
C00360/10		Reserved
C00360/11		SDO1 IN telegram counter
C00360/12		SDO2 IN telegram counter
<input checked="" type="checkbox"/> Read access <input type="checkbox"/> Write access <input type="checkbox"/> CINH <input type="checkbox"/> PLC STOP <input checked="" type="checkbox"/> No transfer <input checked="" type="checkbox"/> COM <input type="checkbox"/> MOT                   Scaling factor: 1		



## C00364

Parameter   Name: <b>C00364   CAN MessageError</b>		Data type: UNSIGNED_8 Index: 24211 <sub>d</sub> = 5E93 <sub>h</sub>
▶ <a href="#">System bus "CAN on board"</a>		
<b>Display area (min. hex value   max. hex value)</b>		
0x00		0xFF
<b>Value is bit-coded:</b>		
Bit 0	No Error	
Bit 1	StuffError	
Bit 2	FormError	
Bit 3	AckError	
Bit 4	Bit1Error	
Bit 5	Bit0Error	
Bit 6	CRCError	
Bit 7	Reserved	
<input checked="" type="checkbox"/> Read access <input type="checkbox"/> Write access <input type="checkbox"/> CINH <input type="checkbox"/> PLC STOP <input checked="" type="checkbox"/> No transfer <input checked="" type="checkbox"/> COM <input type="checkbox"/> MOT		

## C00366

Parameter   Name: <b>C00366   Number of CAN SDO channels</b>		Data type: UNSIGNED_8 Index: 24209 <sub>d</sub> = 5E91 <sub>h</sub>
<a href="#">Function change as of version 03.02.00</a> Selection of the number of active parameter data channels <ul style="list-style-type: none"> <li>• <a href="#">Up to and including version 03.00.00</a>, the parameter data channels 1 and 2 are activated.</li> <li>• <a href="#">As of version 03.02.00</a>, only the parameter data channel 1 is active in the Lenze setting according to CANopen. In order to activate both parameter channels according to the previous behaviour, set "2 SDO Lenze".</li> </ul>		
▶ <a href="#">System bus "CAN on board"</a>		
<b>Selection list (Lenze setting printed in bold)</b>		
0	<b>1 SDO CANopen</b>	
1	2 SDO Lenze	
<input checked="" type="checkbox"/> Read access <input checked="" type="checkbox"/> Write access <input type="checkbox"/> CINH <input type="checkbox"/> PLC STOP <input type="checkbox"/> No transfer <input checked="" type="checkbox"/> COM <input type="checkbox"/> MOT           Scaling factor: 1		

## C00367

Parameter   Name: <b>C00367   CAN Sync-Rx-Identifier</b>		Data type: UNSIGNED_16 Index: 24208 <sub>d</sub> = 5E90 <sub>h</sub>
Identifier by means of which the sync slave is to receive sync telegrams. <ul style="list-style-type: none"> <li>• Mapping of the CANopen object <a href="#">I-1005</a> (see DS301 V4.02).</li> </ul>		
▶ <a href="#">System bus "CAN on board"</a>		
<b>Setting range (min. value   unit   max. value)</b>		<b>Lenze setting</b>
128		255 <b>128</b>
<input checked="" type="checkbox"/> Read access <input checked="" type="checkbox"/> Write access <input type="checkbox"/> CINH <input type="checkbox"/> PLC STOP <input type="checkbox"/> No transfer <input checked="" type="checkbox"/> COM <input type="checkbox"/> MOT           Scaling factor: 1		

## C00368

Parameter   Name: <b>C00368   CAN Sync-Tx identifier</b>		Data type: UNSIGNED_16 Index: 24207 <sub>d</sub> = 5E8F <sub>h</sub>	
Identifier by means of which the sync master is to transmit sync telegrams. <ul style="list-style-type: none"> <li>• Mapping of the CANopen object <a href="#">I-1005</a> (see DS301 V4.02).</li> </ul> <p style="text-align: right;">▶ <a href="#">System bus "CAN on board"</a></p>			
<b>Setting range (min. value   unit   max. value)</b>		<b>Lenze setting</b>	
128		255	<b>128</b>
<input checked="" type="checkbox"/> Read access <input checked="" type="checkbox"/> Write access <input type="checkbox"/> CINH <input type="checkbox"/> PLC STOP <input type="checkbox"/> No transfer <input checked="" type="checkbox"/> COM <input type="checkbox"/> MOT   Scaling factor: 1			

## C00369

Parameter   Name: <b>C00369   CAN Sync transmission cycle time</b>		Data type: UNSIGNED_16 Index: 24206 <sub>d</sub> = 5E8E <sub>h</sub>	
Cycle during which the sync master is to transmit sync telegrams. <ul style="list-style-type: none"> <li>• If "0 ms" is set (Lenze setting), no sync telegrams are generated.</li> <li>• Mapping of the CANopen object <a href="#">I-1006</a> (see DS301 V4.02).</li> </ul> <p style="text-align: right;">▶ <a href="#">System bus "CAN on board"</a></p>			
<b>Setting range (min. value   unit   max. value)</b>		<b>Lenze setting</b>	
0	ms	65000	<b>0 ms</b>
<input checked="" type="checkbox"/> Read access <input checked="" type="checkbox"/> Write access <input type="checkbox"/> CINH <input type="checkbox"/> PLC STOP <input type="checkbox"/> No transfer <input checked="" type="checkbox"/> COM <input type="checkbox"/> MOT   Scaling factor: 1			

## C00372

Parameter   Name: <b>C00372   CAN_Tx_Rx_Error</b>		Data type: UNSIGNED_8 Index: 24203 <sub>d</sub> = 5E8B <sub>h</sub>	
▶ <a href="#">System bus "CAN on board"</a>			
<b>Display range (min. value   unit   max. value)</b>			
0	ms	255	
<b>Subcodes</b>		<b>Info</b>	
C00372/1		Tx_Error	
C00372/2		Rx_Error	
<input checked="" type="checkbox"/> Read access <input type="checkbox"/> Write access <input type="checkbox"/> CINH <input type="checkbox"/> PLC STOP <input checked="" type="checkbox"/> No transfer <input checked="" type="checkbox"/> COM <input type="checkbox"/> MOT   Scaling factor: 1			

## C00381

Parameter   Name: <b>C00381   CAN Heartbeat Producer Time</b>		Data type: UNSIGNED_16 Index: 24194 <sub>d</sub> = 5E82 <sub>h</sub>	
Time interval for the transmission of the heartbeat telegram to the consumer(s). <ul style="list-style-type: none"> <li>• The heartbeat telegram is sent automatically as soon as a time &gt; 0 ms is set.</li> <li>• Mapping of the CANopen object <a href="#">I-1017</a> (see DS301 V4.02).</li> </ul> <p style="text-align: right;">▶ <a href="#">System bus "CAN on board"</a></p>			
<b>Setting range (min. value   unit   max. value)</b>		<b>Lenze setting</b>	
0	ms	65535	<b>0 ms</b>
<input checked="" type="checkbox"/> Read access <input checked="" type="checkbox"/> Write access <input type="checkbox"/> CINH <input type="checkbox"/> PLC STOP <input type="checkbox"/> No transfer <input checked="" type="checkbox"/> COM <input type="checkbox"/> MOT   Scaling factor: 1			

## C00385

Parameter   Name: <b>C00385   CAN NodeID Heartbeat producer</b>		Data type: UNSIGNED_8 Index: 24190 <sub>d</sub> = 5E7E <sub>h</sub>
Address of the node which is to be monitored by heartbeat. ▶ <a href="#">System bus "CAN on board": Heartbeat protocol</a>		
<b>Setting range (min. value   unit   max. value)</b>		
0		127
<b>Subcodes</b>	<b>Lenze setting</b>	<b>Info</b>
C00385/1	0	CAN node address HeartBeat Producer 1
<input checked="" type="checkbox"/> Read access <input checked="" type="checkbox"/> Write access <input type="checkbox"/> CINH <input type="checkbox"/> PLC STOP <input checked="" type="checkbox"/> No transfer <input checked="" type="checkbox"/> COM <input type="checkbox"/> MOT   Scaling factor: 1		

## C00386

Parameter   Name: <b>C00386   ConsumerTime HeartBeat Producer</b>		Data type: UNSIGNED_16 Index: 24189 <sub>d</sub> = 5E7D <sub>h</sub>
ConsumerTime for the node which is to be monitored by heartbeat. ▶ <a href="#">System bus "CAN on board": Heartbeat protocol</a>		
<b>Setting range (min. value   unit   max. value)</b>		
0	ms	60000
<b>Subcodes</b>	<b>Lenze setting</b>	<b>Info</b>
C00386/1	0 ms	ConsumerTime HeartBeat Producer 1
<input checked="" type="checkbox"/> Read access <input checked="" type="checkbox"/> Write access <input type="checkbox"/> CINH <input type="checkbox"/> PLC STOP <input type="checkbox"/> No transfer <input checked="" type="checkbox"/> COM <input type="checkbox"/> MOT   Scaling factor: 1		

## C00389

Parameter   Name: <b>C00389   PDO valid / invalid</b>		Data type: UNSIGNED_8 Index: 24186 <sub>d</sub> = 5E7A <sub>h</sub>
As of version 03.00.00 ▶ <a href="#">System bus "CAN on board"</a>		
<b>Selection list</b>		
0	PDO available/valid	
1	PDO not available/invalid	
<b>Subcodes</b>	<b>Lenze setting</b>	<b>Info</b>
C00389/1	0: PDO available/valid	PDO valid / invalid CAN1_IN
C00389/2	0: PDO available/valid	PDO valid / invalid CAN1_OUT
C00389/3	0: PDO available/valid	PDO valid / invalid CAN2_IN
C00389/4	0: PDO available/valid	PDO valid / invalid CAN2_OUT
<input checked="" type="checkbox"/> Read access <input checked="" type="checkbox"/> Write access <input type="checkbox"/> CINH <input type="checkbox"/> PLC STOP <input type="checkbox"/> No transfer <input checked="" type="checkbox"/> COM <input type="checkbox"/> MOT   Scaling factor: 1		

## C00409

Parameter   Name: <b>C00409   LP_CanIn Mapping</b>		Data type: UNSIGNED_16 Index: 24166 <sub>d</sub> = 5E66 <sub>h</sub>
As of version 03.00.00 Mapping for port blocks LP_CanIn1 and LP_CanIn2 <a href="#">▶ System bus "CAN on board": Port blocks</a>		
<b>Setting range (min. value   unit   max. value)</b>		
0		65535
<b>Subcodes</b>	<b>Lenze setting</b>	<b>Info</b>
C00409/1	0	LP_CanIn1_wIn1(wCtrl)
C00409/2	0	LP_CanIn1_wIn2
C00409/3	0	LP_CanIn1_wIn3
C00409/4	0	LP_CanIn1_wIn4
C00409/5	0	LP_CanIn2_wIn1
C00409/6	0	LP_CanIn2_wIn2
C00409/7	0	LP_CanIn2_wIn3
C00409/8	0	LP_CanIn2_wIn4
<input checked="" type="checkbox"/> Read access <input checked="" type="checkbox"/> Write access <input type="checkbox"/> CINH <input type="checkbox"/> PLC STOP <input type="checkbox"/> No transfer <input type="checkbox"/> COM <input type="checkbox"/> MOT   Scaling factor: 1		

C00443

Parameter   Name: <b>C00443   DIx: Level</b>		Data type: UNSIGNED_16 Index: 24132 <sub>d</sub> = 5E44 <sub>h</sub>
Bit-coded display of the level of the digital inputs		
<a href="#">▶ Digital terminals</a>		
<b>Display area (min. hex value   max. hex value)</b>		
0x0000		0xFFFF
<b>Value is bit-coded:</b>		<b>Info</b>
Bit 0	DI1	Bit set = HIGH level
Bit 1	DI2	
Bit 2	DI3	
Bit 3	DI4	
Bit 4	Reserved	
Bit 5	Reserved	
Bit 6	Reserved	
Bit 7	Reserved	
Bit 8	Reserved	
Bit 9	Reserved	
Bit 10	Reserved	
Bit 11	Reserved	
Bit 12	Reserved	
Bit 13	Reserved	
Bit 14	Reserved	
Bit 15	CINH	
<b>Subcodes</b>		<b>Info</b>
C00443/1		DIx: Terminal level
C00443/2		DIx: Output level
<input checked="" type="checkbox"/> Read access <input type="checkbox"/> Write access <input type="checkbox"/> CINH <input type="checkbox"/> PLC STOP <input checked="" type="checkbox"/> No transfer <input type="checkbox"/> COM <input type="checkbox"/> MOT		

## C00444

Parameter   Name: <b>C00444   DOx: Level</b>		Data type: UNSIGNED_16 Index: 24131 <sub>d</sub> = 5E43 <sub>h</sub>
Bit-coded display of the level of the digital outputs		
<a href="#">▶ Digital terminals</a>		
<b>Display area</b> (min. hex value   max. hex value)		
0x0000		0xFFFF
<b>Value is bit-coded:</b>		<b>Info</b>
Bit 0	Relay	Bit set = HIGH level
Bit 1	DO1	
Bit 2	Reserved	
Bit 3	Reserved	
Bit 4	Reserved	
Bit 5	Reserved	
Bit 6	Reserved	
Bit 7	Reserved	
Bit 8	Reserved	
Bit 9	Reserved	
Bit 10	Reserved	
Bit 11	Reserved	
Bit 12	Reserved	
Bit 13	Reserved	
Bit 14	Reserved	
Bit 15	Reserved	
<b>Subcodes</b>		<b>Info</b>
C00444/1		DOx: Input level
C00444/2		DOx: Terminal level
<input checked="" type="checkbox"/> Read access <input type="checkbox"/> Write access <input type="checkbox"/> CINH <input type="checkbox"/> PLC STOP <input checked="" type="checkbox"/> No transfer <input type="checkbox"/> COM <input type="checkbox"/> MOT		

## C00462

Parameter   Name: <b>C00462   Keypad/PC: Setpoint control</b>		Data type: UNSIGNED_16 Index: 24113 <sub>d</sub> = 5E31 <sub>h</sub>
<b>This code is for device-internal use only and must not be written to by the user!</b>		

## C00470

Parameter   Name: <b>C00470   LS_ParFree_b</b>		Data type: UNSIGNED_8 Index: 24105 <sub>d</sub> = 5E29 <sub>h</sub>
SB <a href="#">LS_ParFree_b</a> : Setting of the signal level to be output		
<b>Selection list</b>		
0	False	
1	True	
<b>Subcodes</b>		<b>Info</b>
C00470/1	0: False	Signal level for output <i>bPar1 ... bPar16</i>
C00470/...		
C00470/16		
<input checked="" type="checkbox"/> Read access <input checked="" type="checkbox"/> Write access <input type="checkbox"/> CINH <input type="checkbox"/> PLC STOP <input type="checkbox"/> No transfer <input type="checkbox"/> COM <input type="checkbox"/> MOT           Scaling factor: 1		

## C00472

Parameter   Name: <b>C00472   LS_ParFree_a</b>		Data type: INTEGER_16 Index: 24103 <sub>d</sub> = 5E27 <sub>h</sub>
SB <a href="#">LS_ParFree_a</a> : Setting of the analog signals to be output		
<b>Setting range</b> (min. value   unit   max. value)		
-199.9	%	199.9
<b>Subcodes</b>	<b>Lenze setting</b>	<b>Info</b>
C00472/1	0.0 %	Value for output <i>nPar1_a</i>
C00472/2	0.0 %	Value for output <i>nPar2_a</i>
C00472/3	100.0 %	Value for output <i>nPar3_a</i>
C00472/4	100.0 %	Value for output <i>nPar4_a</i>
<input checked="" type="checkbox"/> Read access <input checked="" type="checkbox"/> Write access <input type="checkbox"/> CINH <input type="checkbox"/> PLC STOP <input type="checkbox"/> No transfer <input type="checkbox"/> COM <input type="checkbox"/> MOT   Scaling factor: 100		

## C00480

Parameter   Name: <b>C00480   LS_DisFree_b</b>		Data type: UNSIGNED_8 Index: 24095 <sub>d</sub> = 5E1F <sub>h</sub>
SB <a href="#">LS_DisFree_b</a> : Display of the input values		
<b>Display area</b> (min. hex value   max. hex value)		
0x00		0xFF
<b>Value is bit-coded:</b>		<b>Info</b>
Bit 0	bDis1	Signal level input <i>bDis1 ... bDis8</i>
...	...	
Bit 7	bDis8	
<input checked="" type="checkbox"/> Read access <input type="checkbox"/> Write access <input type="checkbox"/> CINH <input type="checkbox"/> PLC STOP <input type="checkbox"/> No transfer <input type="checkbox"/> COM <input type="checkbox"/> MOT		

## C00481

Parameter   Name: <b>C00481   LS_DisFree</b>		Data type: UNSIGNED_16 Index: 24094 <sub>d</sub> = 5E1E <sub>h</sub>
SB <a href="#">LS_DisFree</a> : Display of the input values		
<b>Display area</b> (min. hex value   max. hex value)		
0x0000		0xFFFF
<b>Value is bit-coded:</b>		
Bit 0	Bit0	
...	...	
Bit 15	Bit15	
<b>Subcodes</b>		<b>Info</b>
C00481/1		Input values <i>wDis1 ... wDis4</i>
C00481/...		
C00481/4		
<input checked="" type="checkbox"/> Read access <input type="checkbox"/> Write access <input type="checkbox"/> CINH <input type="checkbox"/> PLC STOP <input type="checkbox"/> No transfer <input type="checkbox"/> COM <input type="checkbox"/> MOT		

## C00482

Parameter   Name: <b>C00482   LS_DisFree_a</b>		Data type: INTEGER_16 Index: 24093 <sub>d</sub> = 5E1D <sub>h</sub>
SB <a href="#">LS_DisFree_a</a> : Display of the input values		
<b>Display range (min. value   unit   max. value)</b>		
-199.9	%	199.9
<b>Subcodes</b>		<b>Info</b>
C00482/1		Input values <i>nDis1_a</i> ... <i>nDis4_a</i>
C00482/...		
C00482/4		
<input checked="" type="checkbox"/> Read access <input type="checkbox"/> Write access <input type="checkbox"/> CINH <input type="checkbox"/> PLC STOP <input type="checkbox"/> No transfer <input type="checkbox"/> COM <input type="checkbox"/> MOT           Scaling factor: 100		

## C00516

Parameter   Name: <b>C00516   Checksums</b>		Data type: UNSIGNED_32 Index: 24059 <sub>d</sub> = 5DFB <sub>h</sub>
<b>Display range (min. value   unit   max. value)</b>		
0		255
<b>Subcodes</b>		<b>Info</b>
C00516/1		Checksum of interconnection
<input checked="" type="checkbox"/> Read access <input type="checkbox"/> Write access <input type="checkbox"/> CINH <input type="checkbox"/> PLC STOP <input checked="" type="checkbox"/> No transfer <input type="checkbox"/> COM <input type="checkbox"/> MOT           Scaling factor: 1		



## C00517

Parameter   Name: <b>C00517   User menu</b>		Data type: INTEGER_32 Index: 24058 <sub>d</sub> = 5DFA <sub>h</sub>
<p>When a system is installed, parameters must be changed time and again until the system runs satisfactorily. The user menu of a device serves to create a selection of frequently used parameters to be able to access and change these parameters quickly.</p> <ul style="list-style-type: none"> <li>For setting "0" no entry is displayed in the user menu.</li> </ul>		
Setting range (min. value   unit   max. value)		
0		994
Subcodes	Lenze setting	Info
C00517/1	51	<a href="#">C00051</a> : Display of actual speed value
C00517/2	53	<a href="#">C00053</a> : Display of DC-bus voltage
C00517/3	54	<a href="#">C00054</a> : Display of motor current
C00517/4	61	<a href="#">C00061</a> : Display of heatsink temperature
C00517/5	137	<a href="#">C00137</a> : Display of device state
C00517/6	0	User menu: entry 6
C00517/7	0	User menu: entry 7
C00517/8	11	<a href="#">C00011</a> : Reference speed
C00517/9	39	<a href="#">C00039/1</a> : Fixed setpoint 1 <a href="#">C00039/2</a> : Fixed setpoint 2 <a href="#">C00039/3</a> : Fixed setpoint 3
C00517/10	0	User menu: entry 10
C00517/11	12	<a href="#">C00012</a> : Acceleration time main setpoint
C00517/12	13	<a href="#">C00013</a> : Deceleration time main setpoint
C00517/13	15	<a href="#">C00015</a> : V/f base frequency
C00517/14	16	<a href="#">C00016</a> : Vmin boost
C00517/15	22	<a href="#">C00022</a> : I <sub>max</sub> in motor mode
C00517/16	120	<a href="#">C00120</a> : Motor overload threshold (I <sup>2</sup> xt)
C00517/17	87	<a href="#">C00087</a> : Rated motor speed
C00517/18	99	<a href="#">C00099</a> : Display of firmware version
C00517/19	0	User menu: entry 19
C00517/20	0	User menu: entry 20
<input checked="" type="checkbox"/> Read access <input checked="" type="checkbox"/> Write access <input type="checkbox"/> CINH <input type="checkbox"/> PLC STOP <input type="checkbox"/> No transfer <input type="checkbox"/> COM <input type="checkbox"/> MOT   Scaling factor: 1		

## C00565

Parameter   Name: <b>C00565   Resp. to mains phase failure</b>		Data type: UNSIGNED_8 Index: 24010 <sub>d</sub> = 5DCA <sub>h</sub>
Response to the failure of mains phases		
Selection list (Lenze setting printed in bold)		
0	No Reaction	
1	Fault	
<b>4</b>	<b>WarningLocked</b>	
<input checked="" type="checkbox"/> Read access <input checked="" type="checkbox"/> Write access <input type="checkbox"/> CINH <input type="checkbox"/> PLC STOP <input type="checkbox"/> No transfer <input type="checkbox"/> COM <input type="checkbox"/> MOT   Scaling factor: 1		

## C00574

Parameter   Name: <b>C00574   Resp. to brake resist. overtemp.</b>		Data type: UNSIGNED_8 Index: 24001 <sub>d</sub> = 5DC1 <sub>h</sub>
Response when the permanently set threshold for monitoring the brake resistor utilisation has been reached.		
<b>Selection list</b> (Lenze setting printed in bold)		
0	<b>No Reaction</b>	
1	Fault	
4	WarningLocked	
<input checked="" type="checkbox"/> Read access <input checked="" type="checkbox"/> Write access <input type="checkbox"/> CINH <input type="checkbox"/> PLC STOP <input type="checkbox"/> No transfer <input type="checkbox"/> COM <input type="checkbox"/> MOT   Scaling factor: 1		

## C00581

Parameter   Name: <b>C00581   Resp. to LS_SetError_x</b>		Data type: UNSIGNED_8 Index: 23994 <sub>d</sub> = 5DBA <sub>h</sub>
Selection of the error responses for application error messages • An application error message is tripped by a FALSE-TRUE edge at the binary inputs <i>bSetError1...2</i> .		
<b>Selection list</b>		
0	No Reaction	
1	Fault	
2	Trouble	
4	WarningLocked	
<b>Subcodes</b>	<b>Lenze setting</b>	<b>Info</b>
C00581/1	1: Fault	<a href="#">LS_SetError_1</a> : Resp. bSetError1
C00581/2	1: Fault	<a href="#">LS_SetError_1</a> : Resp. bSetError2
<input checked="" type="checkbox"/> Read access <input checked="" type="checkbox"/> Write access <input type="checkbox"/> CINH <input type="checkbox"/> PLC STOP <input type="checkbox"/> No transfer <input type="checkbox"/> COM <input type="checkbox"/> MOT   Scaling factor: 1		

## C00592

Parameter   Name: <b>C00592   Resp. to CAN bus connection</b>		Data type: UNSIGNED_8 Index: 23983 <sub>d</sub> = 5DAF <sub>h</sub>
Configuration of monitoring of the CAN interface (group 1) <span style="float: right;">▶ <a href="#">System bus "CAN on board"</a></span>		
<b>Selection list</b>		
0	No Reaction	
1	Fault	
2	Trouble	
4	WarningLocked	
<b>Subcodes</b>	<b>Lenze setting</b>	<b>Info</b>
C00592/1	0: No Reaction	Response to incorrect telegram for CAN communication
C00592/2	0: No Reaction	Response to "BusOff" (bus system switched off)
C00592/3	0: No Reaction	Response to warnings of the CAN controller
C00592/4	0: No Reaction	Response to communication stop of a CAN bus node
C00592/5	0: No Reaction	Response to an event in the case of monitoring via heart-beat protocol
<input checked="" type="checkbox"/> Read access <input checked="" type="checkbox"/> Write access <input type="checkbox"/> CINH <input type="checkbox"/> PLC STOP <input type="checkbox"/> No transfer <input type="checkbox"/> COM <input type="checkbox"/> MOT   Scaling factor: 1		

## C00593

Parameter   Name: <b>C00593   Resp. to CANx_IN monitoring</b>		Data type: UNSIGNED_8 Index: 23982 <sub>d</sub> = 5DAE <sub>h</sub>
Configuration of monitoring of the CAN interface (group 2)		
<a href="#">▶ System bus "CAN on board"</a>		
Selection list		
0	No Reaction	
1	Fault	
2	Trouble	
4	WarningLocked	
Subcodes	Lenze setting	Info
C00593/1	0: No Reaction	Response if the monitoring time set in <a href="#">C00357/1</a> for the reception of the PDO CAN1_IN is exceeded.
C00593/2	0: No Reaction	Response if the monitoring time set in <a href="#">C00357/2</a> for the reception of the PDO CAN2_IN is exceeded.
<input checked="" type="checkbox"/> Read access <input checked="" type="checkbox"/> Write access <input type="checkbox"/> CINH <input type="checkbox"/> PLC STOP <input type="checkbox"/> No transfer <input type="checkbox"/> COM <input type="checkbox"/> MOT   Scaling factor: 1		

## C00594

Parameter   Name: <b>C00594   Resp. to control word error</b>		Data type: UNSIGNED_8 Index: 23981 <sub>d</sub> = 5DAD <sub>h</sub>
<a href="#">As of version 03.00.00</a>		
Configuration of monitoring of the device control		
Selection list		
0	No Reaction	
1	Fault	
2	Trouble	
4	WarningLocked	
Subcodes	Lenze setting	Info
C00594/1	1: Fault	Response if error bit 14 in the CAN control word is set.
<input checked="" type="checkbox"/> Read access <input checked="" type="checkbox"/> Write access <input type="checkbox"/> CINH <input type="checkbox"/> PLC STOP <input type="checkbox"/> No transfer <input type="checkbox"/> COM <input type="checkbox"/> MOT   Scaling factor: 1		

## C00598

Parameter   Name: <b>C00598   Resp. to open circuit AINx</b>		Data type: UNSIGNED_8 Index: 23977 <sub>d</sub> = 5DA9 <sub>h</sub>
Configuration of monitoring the analog input		
<a href="#">▶ Analog terminals</a>		
Selection list		
0	No Reaction	
1	Fault	
2	Trouble	
4	WarningLocked	
Subcodes	Lenze setting	Info
C00598/1	1: Fault	Response to open circuit at AIN1 when being configured as 4 ... 20 mA-current loop
<input checked="" type="checkbox"/> Read access <input checked="" type="checkbox"/> Write access <input type="checkbox"/> CINH <input type="checkbox"/> PLC STOP <input type="checkbox"/> No transfer <input type="checkbox"/> COM <input type="checkbox"/> MOT   Scaling factor: 1		

## C00600

Parameter   Name: <b>C00600   Resp. to DC bus undervoltage</b>		Data type: UNSIGNED_8 Index: 23975 <sub>d</sub> = 5DA7 <sub>h</sub>
Configuration of monitoring of the motor control (group 3)		
<b>Selection list</b>		
1	Fault	
2	Trouble	
<b>Subcodes</b>	<b>Lenze setting</b>	<b>Info</b>
C00600/1	2: Trouble	Response to undervoltage in the DC bus
<input checked="" type="checkbox"/> Read access <input checked="" type="checkbox"/> Write access <input type="checkbox"/> CINH <input type="checkbox"/> PLC STOP <input type="checkbox"/> No transfer <input type="checkbox"/> COM <input type="checkbox"/> MOT   Scaling factor: 1		

## C00601

Parameter   Name: <b>C00601   Del. resp.to fault: DC bus overvoltage</b>		Data type: UNSIGNED_16 Index: 23974 <sub>d</sub> = 5DA6 <sub>h</sub>
Delay times for error responses		
<b>Setting range (min. value   unit   max. value)</b>		
0.00	s	65.00
<b>Subcodes</b>	<b>Lenze setting</b>	<b>Info</b>
C00601/1	2.00 s	Delay time for error activation "DC-bus overvoltage" • In case of DC-bus overvoltage, an error is only transmitted after this delay time has elapsed.
<input checked="" type="checkbox"/> Read access <input checked="" type="checkbox"/> Write access <input type="checkbox"/> CINH <input type="checkbox"/> PLC STOP <input type="checkbox"/> No transfer <input type="checkbox"/> COM <input type="checkbox"/> MOT   Scaling factor: 1000		

## C00604

Parameter   Name: <b>C00604   Resp. to device overload (lxt)</b>		Data type: UNSIGNED_8 Index: 23971 <sub>d</sub> = 5DA3 <sub>h</sub>
Response if the adjustable device utilisation threshold ( <a href="#">C00123</a> ) is reached. • The current device utilisation is displayed in <a href="#">C00064</a> .		
<b>Selection list (Lenze setting printed in bold)</b>		
0	No Reaction	
1	Fault	
4	<b>WarningLocked</b>	
<input checked="" type="checkbox"/> Read access <input checked="" type="checkbox"/> Write access <input type="checkbox"/> CINH <input type="checkbox"/> PLC STOP <input type="checkbox"/> No transfer <input type="checkbox"/> COM <input type="checkbox"/> MOT   Scaling factor: 1		

## C00606

Parameter   Name: <b>C00606   Resp. to motor overload (l*xt)</b>		Data type: UNSIGNED_8 Index: 23969 <sub>d</sub> = 5DA1 <sub>h</sub>
Response if the adjustable motor overload threshold ( <a href="#">C00120</a> ) is reached. • The current thermal motor load is displayed in <a href="#">C00066</a> .		
<b>Selection list (Lenze setting printed in bold)</b>		
0	No Reaction	
1	Fault	
4	<b>WarningLocked</b>	
<input checked="" type="checkbox"/> Read access <input checked="" type="checkbox"/> Write access <input type="checkbox"/> CINH <input type="checkbox"/> PLC STOP <input type="checkbox"/> No transfer <input type="checkbox"/> COM <input type="checkbox"/> MOT   Scaling factor: 1		

## C00620

Parameter   Name: <b>C00620   16-bit system connection</b>		Data type: UNSIGNED_16 Index: 23955 <sub>d</sub> = 5D93 <sub>h</sub>
Connection parameters: 16-bit inputs <ul style="list-style-type: none"> <li>• Selection of the 16-bit output signals for connection with the 16-bit input signals.</li> <li>• The selection list contains all 16-bit output signals which can be assigned to the 16-bit inputs mapped by the subcodes.</li> </ul>		
<b>Selection list</b>		
See <a href="#">selection list - analog signals</a>		
Subcodes	Lenze setting	Info
C00620/1	0: Not connected	Reserved
C00620/2	0: Not connected	Reserved
C00620/3	0: Not connected	Reserved
C00620/4	0: Not connected	Reserved
C00620/5	0: Not connected	<a href="#">LS_DisFree</a> :wDis1
C00620/6	0: Not connected	<a href="#">LS_DisFree</a> :wDis2
C00620/7	0: Not connected	<a href="#">LS_DisFree</a> :wDis3
C00620/8	0: Not connected	<a href="#">LS_DisFree</a> :wDis4
C00620/9	0: Not connected	<a href="#">LS_DisFree_a</a> :nDis1_a
C00620/10	0: Not connected	<a href="#">LS_DisFree_a</a> :nDis2_a
C00620/11	0: Not connected	<a href="#">LS_DisFree_a</a> :nDis3_a
C00620/12	0: Not connected	<a href="#">LS_DisFree_a</a> :nDis4_a
C00620/13	0: Not connected	Reserved
C00620/14	0: Not connected	Reserved
C00620/15	0: Not connected	Reserved
C00620/16	0: Not connected	Reserved
C00620/17	0: Not connected	Reserved
C00620/18	0: Not connected	Reserved
C00620/19	0: Not connected	Reserved
C00620/20	0: Not connected	<a href="#">LP_CanOut1</a> : wState
C00620/21	0: Not connected	<a href="#">LP_CanOut1</a> : wOut2
C00620/22	0: Not connected	<a href="#">LP_CanOut1</a> : wOut3
C00620/23	0: Not connected	<a href="#">LP_CanOut1</a> : wOut4
C00620/24	0: Not connected	<a href="#">LP_CanOut2</a> : wOut1
C00620/25	0: Not connected	<a href="#">LP_CanOut2</a> : wOut2
C00620/26	0: Not connected	<a href="#">LP_CanOut2</a> : wOut3
C00620/27	0: Not connected	<a href="#">LP_CanOut2</a> : wOut4
<input checked="" type="checkbox"/> Read access <input checked="" type="checkbox"/> Write access <input type="checkbox"/> CINH <input type="checkbox"/> PLC STOP <input type="checkbox"/> No transfer <input type="checkbox"/> COM <input type="checkbox"/> MOT             Scaling factor: 1		

## C00621

Parameter   Name: C00621   Bool system connection		Data type: UNSIGNED_16 Index: 23954 <sub>d</sub> = 5D92 <sub>h</sub>
Connection parameters: Binary inputs <ul style="list-style-type: none"> <li>• Selection of the binary output signals for connection with the binary input signals.</li> <li>• The selection list contains all binary output signals which can be assigned to the binary inputs mapped by the subcodes.</li> </ul>		
<b>Selection list</b>		
See <a href="#">selection list - digital signals</a>		
Subcodes	Lenze setting	Info
C00621/1	50: LA_NCtrl_bDriveFail	<a href="#">LS_DigitalOutput</a> :bRelay
C00621/2	51: LA_NCtrl_bDriveReady	<a href="#">LS_DigitalOutput</a> :bOut1
C00621/3	0: Not connected	Reserved
C00621/4	0: Not connected	Reserved
C00621/5	0: Not connected	Reserved
C00621/6	64: LA_NCtrl_bNActCompare	USER LED
C00621/7	0: Not connected	<a href="#">LA_NCtrl</a> : bStatusBit0
C00621/8	65: LA_NCtrl_bImaxActive	<a href="#">LA_NCtrl</a> : bStatusBit2
C00621/9	62: LA_NCtrl_bSpeedSetReached	<a href="#">LA_NCtrl</a> : bStatusBit3
C00621/10	63: LA_NCtrl_bSpeedActEqSet	<a href="#">LA_NCtrl</a> : bStatusBit4
C00621/11	64: LA_NCtrl_bNActCompare	<a href="#">LA_NCtrl</a> : bStatusBit5
C00621/12	60: LA_NCtrl_bSpeedCcw	<a href="#">LA_NCtrl</a> : bStatusBit14
C00621/13	51: LA_NCtrl_bDriveReady	<a href="#">LA_NCtrl</a> : bStatusBit15
C00621/14	0: Not connected	Reserved
C00621/15	0: Not connected	Reserved
C00621/16	0: Not connected	<a href="#">LS_DisFree_b</a> : bDis1
C00621/17	0: Not connected	<a href="#">LS_DisFree_b</a> : bDis2
C00621/18	0: Not connected	<a href="#">LS_DisFree_b</a> : bDis3
C00621/19	0: Not connected	<a href="#">LS_DisFree_b</a> : bDis4
C00621/20	0: Not connected	<a href="#">LS_DisFree_b</a> : bDis5
C00621/21	0: Not connected	<a href="#">LS_DisFree_b</a> : bDis6
C00621/22	0: Not connected	<a href="#">LS_DisFree_b</a> : bDis7
C00621/23	0: Not connected	<a href="#">LS_DisFree_b</a> : bDis8
C00621/24	0: Not connected	Reserved
C00621/25	0: Not connected	Reserved
C00621/26	0: Not connected	Reserved
C00621/27	0: Not connected	Reserved

Parameter   Name: <b>C00621   Bool system connection</b>		Data type: UNSIGNED_16 Index: 23954 <sub>d</sub> = 5D92 <sub>h</sub>
C00621/28	0: Not connected	Reserved
C00621/29	0: Not connected	Reserved
C00621/30	0: Not connected	<a href="#">LP_CanOut1</a> : bState_B0
C00621/31	0: Not connected	<a href="#">LP_CanOut1</a> : bState_B1
C00621/32	0: Not connected	<a href="#">LP_CanOut1</a> : bState_B2
C00621/33	0: Not connected	<a href="#">LP_CanOut1</a> : bState_B3
C00621/34	0: Not connected	<a href="#">LP_CanOut1</a> : bState_B4
C00621/35	0: Not connected	<a href="#">LP_CanOut1</a> : bState_B5
C00621/36	0: Not connected	<a href="#">LP_CanOut1</a> : bState_B6
C00621/37	0: Not connected	<a href="#">LP_CanOut1</a> : bState_B7
C00621/38	0: Not connected	<a href="#">LP_CanOut1</a> : bState_B8
C00621/39	0: Not connected	<a href="#">LP_CanOut1</a> : bState_B9
C00621/40	0: Not connected	<a href="#">LP_CanOut1</a> : bState_B10
C00621/41	0: Not connected	<a href="#">LP_CanOut1</a> : bState_B11
C00621/42	0: Not connected	<a href="#">LP_CanOut1</a> : bState_B12
C00621/43	0: Not connected	<a href="#">LP_CanOut1</a> : bState_B13
C00621/44	0: Not connected	<a href="#">LP_CanOut1</a> : bState_B14
C00621/45	0: Not connected	<a href="#">LP_CanOut1</a> : bState_B15
C00621/46	0: Not connected	<a href="#">LP_CanOut2</a> : bOut1_B0
C00621/47	0: Not connected	<a href="#">LP_CanOut2</a> : bOut1_B1
C00621/48	0: Not connected	<a href="#">LP_CanOut2</a> : bOut1_B2
C00621/49	0: Not connected	<a href="#">LP_CanOut2</a> : bOut1_B3
C00621/50	0: Not connected	<a href="#">LP_CanOut2</a> : bOut1_B4
C00621/51	0: Not connected	<a href="#">LP_CanOut2</a> : bOut1_B5
C00621/52	0: Not connected	<a href="#">LP_CanOut2</a> : bOut1_B6
C00621/53	0: Not connected	<a href="#">LP_CanOut2</a> : bOut1_B7
C00621/54	0: Not connected	<a href="#">LP_CanOut2</a> : bOut1_B8
C00621/55	0: Not connected	<a href="#">LP_CanOut2</a> : bOut1_B9
C00621/56	0: Not connected	<a href="#">LP_CanOut2</a> : bOut1_B10
C00621/57	0: Not connected	<a href="#">LP_CanOut2</a> : bOut1_B11
C00621/58	0: Not connected	<a href="#">LP_CanOut2</a> : bOut1_B12
C00621/59	0: Not connected	<a href="#">LP_CanOut2</a> : bOut1_B13
C00621/60	0: Not connected	<a href="#">LP_CanOut2</a> : bOut1_B14
C00621/61	0: Not connected	<a href="#">LP_CanOut2</a> : bOut1_B15
<input checked="" type="checkbox"/> Read access <input checked="" type="checkbox"/> Write access <input type="checkbox"/> CINH <input type="checkbox"/> PLC STOP <input type="checkbox"/> No transfer <input type="checkbox"/> COM <input type="checkbox"/> MOT   Scaling factor: 1		

## C00700

Parameter   Name: C00700   LA_NCtrl: Analog connection list		Data type: UNSIGNED_16 Index: 23875 <sub>d</sub> = 5D43 <sub>h</sub>
Connection parameters for "Actuating drive speed" application: 16-bit inputs <ul style="list-style-type: none"> <li>• Selection of the 16-bit output signals for connection with the 16-bit input signals</li> <li>• The selection list contains all 16-bit output signals which can be assigned to the 16-bit inputs mapped by the subcodes.</li> </ul>		
<b>Selection list</b>		
See <a href="#">selection list - analog signals</a>		
Subcodes	Lenze setting	Info
C00700/1	10: AIn1_Out	<a href="#">LA_NCtrl</a> : nMainSetValue_a
C00700/2	22: nPar3_a	<a href="#">LA_NCtrl</a> : nTorqueMotLim_a
C00700/3	22: nPar3_a	<a href="#">LA_NCtrl</a> : nTorqueGenLim_a
C00700/4	0: Not connected	Reserved
C00700/5	6: C_wDriveCtrl	<a href="#">LA_NCtrl</a> : wCANDriveControl
C00700/6	1: C_nPos100_a(100.0%)	<a href="#">LA_NCtrl</a> : nPIDVpAdapt_a
C00700/7	0: Not connected	<a href="#">LA_NCtrl</a> : nPIDActValue_a
C00700/8	1: C_nPos100_a(100.0%)	<a href="#">LA_NCtrl</a> : nPIDInfluence_a
C00700/9	0: Not connected	<a href="#">LA_NCtrl</a> : nPIDsetValue_a
<input checked="" type="checkbox"/> Read access <input checked="" type="checkbox"/> Write access <input type="checkbox"/> CINH <input type="checkbox"/> PLC STOP <input type="checkbox"/> No transfer <input type="checkbox"/> COM <input type="checkbox"/> MOT             Scaling factor: 1		



## C00701

Parameter   Name: <b>C00701   LA_NCtrl: digital connection list</b>		Data type: UNSIGNED_16 Index: 23874 <sub>d</sub> = 5D42 <sub>h</sub>
Connection parameters for "Actuating drive speed" application: Binary inputs <ul style="list-style-type: none"> <li>• Selection of the binary output signals for connection with the binary input signals</li> <li>• The selection list contains all binary output signals which can be assigned to the binary inputs mapped by the subcodes.</li> </ul>		
<b>Selection list</b>		
See <a href="#">selection list - digital signals</a>		
Subcodes	Lenze setting	Info
C00701/1	0: Not connected	<a href="#">LA_NCtrl</a> : bCInh
C00701/2	15: DigIn_CInh	<a href="#">LA_NCtrl</a> : bFailReset
C00701/3	0: Not connected	<a href="#">LA_NCtrl</a> : bSetQuickstop
C00701/4	13: DigIn_bIn3	<a href="#">LA_NCtrl</a> : bSetDCBrake
C00701/5	14: DigIn_bIn4	<a href="#">LA_NCtrl</a> : bSetSpeedCcw
C00701/6	11: DigIn_bIn1	<a href="#">LA_NCtrl</a> : bJogSpeed1
C00701/7	12: DigIn_bIn2	<a href="#">LA_NCtrl</a> : bJogSpeed2
C00701/8	0: Not connected	<a href="#">LA_NCtrl</a> : bMPotUp
C00701/9	0: Not connected	<a href="#">LA_NCtrl</a> : bMPotDown
C00701/10	0: Not connected	<a href="#">LA_NCtrl</a> : bMPotInAct
C00701/11	0: Not connected	<a href="#">LA_NCtrl</a> : bMPotEnable
C00701/12	0: Not connected	<a href="#">LA_NCtrl</a> : bRFG_0
C00701/13	0: Not connected	<a href="#">LA_NCtrl</a> : bSetError1
C00701/14	0: Not connected	<a href="#">LA_NCtrl</a> : bSetError2
C00701/15	1: C_bTrue	<a href="#">LA_NCtrl</a> : bPIDInfluenceRamp
C00701/16	0: Not connected	<a href="#">LA_NCtrl</a> : bPIDIOff
C00701/17	1: C_bTrue	<a href="#">LA_NCtrl</a> : bRLQCw
C00701/18	0: Not connected	<a href="#">LA_NCtrl</a> : bRLQCcw
<input checked="" type="checkbox"/> Read access <input checked="" type="checkbox"/> Write access <input type="checkbox"/> CINH <input type="checkbox"/> PLC STOP <input type="checkbox"/> No transfer <input type="checkbox"/> COM <input type="checkbox"/> MOT             Scaling factor: 1		

## C00725

Parameter   Name: <b>C00725   Current switching frequency</b>		Data type: UNSIGNED_8 Index: 23850 <sub>d</sub> = 5D2A <sub>h</sub>
Display of the current switching frequency <ul style="list-style-type: none"> <li>• When a variable switching frequency is selected in <a href="#">C00018</a>, the switching frequency may change as a function of the load and rotational frequency.</li> </ul>		
<b>Selection list (read only)</b>		
1	4 kHz var./drive-optimised	
2	8 kHz var./drive-optimised	
3	16 kHz var./drive-optimised	
5	2 kHz constant/drive-optimised	
6	4 kHz constant/drive-optimised	
7	8 kHz constant/drive-optimised	
8	16 kHz constant/drive-optimised	
<input checked="" type="checkbox"/> Read access <input type="checkbox"/> Write access <input type="checkbox"/> CINH <input type="checkbox"/> PLC STOP <input checked="" type="checkbox"/> No transfer <input type="checkbox"/> COM <input type="checkbox"/> MOT             Scaling factor: 1		

## C00727

Parameter   Name: <b>C00727   LS_Keypad: Digital values</b>		Data type: UNSIGNED_8 Index: 23848 <sub>d</sub> = 5D28 <sub>h</sub>
Executing control commands when operating via keypad		
<b>Setting range</b> (min. value   unit   max. value)		
0		1
<b>Subcodes</b>	<b>Lenze setting</b>	<b>Info</b>
C00727/1	0	"1" ≙ request quick stop
C00727/2	0	"1" ≙ request DC-injection braking
C00727/3	0	"1" ≙ request change of direction of rotation
C00727/4	0	"1" ≙ request fixed speed setpoint 1
C00727/5	0	"1" ≙ request fixed speed setpoint 2
<input checked="" type="checkbox"/> Read access <input checked="" type="checkbox"/> Write access <input type="checkbox"/> CINH <input type="checkbox"/> PLC STOP <input checked="" type="checkbox"/> No transfer <input type="checkbox"/> COM <input type="checkbox"/> MOT   Scaling factor: 1		

## C00728

Parameter   Name: <b>C00728   LS_Keypad: Keypad analog values</b>		Data type: INTEGER_16 Index: 23847 <sub>d</sub> = 5D27 <sub>h</sub>
Selection of different setpoints when operating via keypad		
<b>Setting range</b> (min. value   unit   max. value)		
-199.9	%	199.9
<b>Subcodes</b>	<b>Lenze setting</b>	<b>Info</b>
C00728/1	100.0 %	Torque limit in motor mode
C00728/2	100.0 %	Torque limit in generator mode
C00728/3	0.0 %	Setpoint speed
<input checked="" type="checkbox"/> Read access <input checked="" type="checkbox"/> Write access <input type="checkbox"/> CINH <input type="checkbox"/> PLC STOP <input type="checkbox"/> No transfer <input type="checkbox"/> COM <input type="checkbox"/> MOT   Scaling factor: 100		

## C00729

Parameter   Name: <b>C00729   Keypad/PC: Speed setpoint</b>		Data type: INTEGER_16 Index: 23846 <sub>d</sub> = 5D26 <sub>h</sub>
<b>This code is for device-internal use only and must not be written to by the user!</b>		

## C00800

Parameter   Name: <b>C00800   L_MPot_1: Upper limit</b>		Data type: INTEGER_16 Index: 23775 <sub>d</sub> = 5CDF <sub>h</sub>
FB <a href="#">L_MPot_1</a> : Upper limit of the motor potentiometer function		
<b>Setting range</b> (min. value   unit   max. value)		<b>Lenze setting</b>
-199.9	%	199.9 <b>100.0 %</b>
<input checked="" type="checkbox"/> Read access <input checked="" type="checkbox"/> Write access <input type="checkbox"/> CINH <input type="checkbox"/> PLC STOP <input type="checkbox"/> No transfer <input type="checkbox"/> COM <input type="checkbox"/> MOT   Scaling factor: 100		

## C00801

Parameter   Name: <b>C00801   L_MPot_1: Lower limit</b>		Data type: INTEGER_16 Index: 23774 <sub>d</sub> = 5CDE <sub>h</sub>
FB <a href="#">L_MPot_1</a> : Lower limit of the motor potentiometer function		
<b>Setting range</b> (min. value   unit   max. value)		<b>Lenze setting</b>
-199.9	%	199.9 <b>-100.0 %</b>
<input checked="" type="checkbox"/> Read access <input checked="" type="checkbox"/> Write access <input type="checkbox"/> CINH <input type="checkbox"/> PLC STOP <input type="checkbox"/> No transfer <input type="checkbox"/> COM <input type="checkbox"/> MOT   Scaling factor: 100		

## C00802

Parameter   Name: <b>C00802   L_MPot_1: Acceleration time</b>		Data type: UNSIGNED_16 Index: 23773 <sub>d</sub> = 5CDD <sub>h</sub>	
FB <a href="#">L_MPot_1</a> : Acceleration time of the motor potentiometer function			
<b>Setting range</b> (min. value   unit   max. value)		<b>Lenze setting</b>	
0.1	s	999.9	<b>10.0 s</b>
<input checked="" type="checkbox"/> Read access <input checked="" type="checkbox"/> Write access <input type="checkbox"/> CINH <input type="checkbox"/> PLC STOP <input type="checkbox"/> No transfer <input type="checkbox"/> COM <input type="checkbox"/> MOT   Scaling factor: 10			

## C00803

Parameter   Name: <b>C00803   L_MPot_1: Deceleration time</b>		Data type: UNSIGNED_16 Index: 23772 <sub>d</sub> = 5CDD <sub>h</sub>	
FB <a href="#">L_MPot_1</a> : Deceleration time of the motor potentiometer function			
<b>Setting range</b> (min. value   unit   max. value)		<b>Lenze setting</b>	
0.1	s	999.9	<b>10.0 s</b>
<input checked="" type="checkbox"/> Read access <input checked="" type="checkbox"/> Write access <input type="checkbox"/> CINH <input type="checkbox"/> PLC STOP <input type="checkbox"/> No transfer <input type="checkbox"/> COM <input type="checkbox"/> MOT   Scaling factor: 10			

## C00804

Parameter   Name: <b>C00804   L_MPot_1: Inactive fct.</b>		Data type: UNSIGNED_8 Index: 23771 <sub>d</sub> = 5CDA <sub>h</sub>	
FB <a href="#">L_MPot_1</a> : Selection of the response when deactivating the motor potentiometer via the <i>blnAct</i> input			
<b>Selection list</b> (Lenze setting printed in bold)		<b>Info</b>	
<b>0</b>	<b>Keep value</b>	Keep output value	
1	Deceleration to 0	Deceleration via ramp to 0	
2	Deceleration to lower limit	Deceleration via ramp to lower limit ( <a href="#">C00801</a> )	
3	Without ramp to 0	Jump to 0	
4	Without ramp to lower limit	Jump to lower limit ( <a href="#">C00800</a> )	
5	Acceleration to upper limit	Acceleration via ramp to upper limit ( <a href="#">C00800</a> )	
<input checked="" type="checkbox"/> Read access <input checked="" type="checkbox"/> Write access <input type="checkbox"/> CINH <input type="checkbox"/> PLC STOP <input type="checkbox"/> No transfer <input type="checkbox"/> COM <input type="checkbox"/> MOT   Scaling factor: 1			

## C00805

Parameter   Name: <b>C00805   L_MPot_1: Init fct.</b>		Data type: UNSIGNED_8 Index: 23770 <sub>d</sub> = 5CDA <sub>h</sub>	
FB <a href="#">L_MPot_1</a> : Selection of the response when switching on the device			
<b>Selection list</b> (Lenze setting printed in bold)			
<b>0</b>	<b>Load last value</b>		
1	Load lower limit		
2	Load 0		
<input checked="" type="checkbox"/> Read access <input checked="" type="checkbox"/> Write access <input type="checkbox"/> CINH <input type="checkbox"/> PLC STOP <input type="checkbox"/> No transfer <input type="checkbox"/> COM <input type="checkbox"/> MOT   Scaling factor: 1			

## C00806

Parameter   Name: <b>C00806   L_MPot_1: Use</b>		Data type: UNSIGNED_8 Index: 23769 <sub>d</sub> = 5CD9 <sub>h</sub>
FB <a href="#">L_MPot_1</a> : Use of the motor potentiometer		
Selection list (Lenze setting printed in bold)		Info
<b>0</b> No		The motor potentiometer is not used. • The analog value applied to the <i>nIn_a</i> input is looped through without any changes to the <i>nOut_a</i> output.
1 Yes		The motor potentiometer is used. • The analog value applied at the <i>nIn_a</i> input is led via the motor potentiometer and provided at the <i>nOut_a</i> output.
<input checked="" type="checkbox"/> Read access <input checked="" type="checkbox"/> Write access <input type="checkbox"/> CINH <input type="checkbox"/> PLC STOP <input type="checkbox"/> No transfer <input type="checkbox"/> COM <input type="checkbox"/> MOT   Scaling factor: 1		

## C00830

Parameter   Name: <b>C00830   16-bit analogue input</b>		Data type: INTEGER_16 Index: 23745 <sub>d</sub> = 5CC1 <sub>h</sub>
Display in percent of 16-bit input values of different blocks		
Display range (min. value   unit   max. value)		
-199.9	%	199.9
Subcodes		Info
C00830/1		<a href="#">L_NSet_1</a> : nNSet_a
C00830/2		<a href="#">L_NSet_1</a> : nOut_a
C00830/3		LS_MCTRL: nSpeedSetValue_a
C00830/4		LS_MCTRL: nTorqueMotLimit_a
C00830/5		LS_MCTRL: nTorqueGenLimit_a
C00830/6		<a href="#">L_PCTRL_1</a> : nAct_a
C00830/7		<a href="#">L_PCTRL_1</a> : nAdapt_a
C00830/8		<a href="#">L_PCTRL_1</a> : nSet_a
C00830/9		<a href="#">L_PCTRL_1</a> : nInflu_a
C00830/10		<a href="#">L_PCTRL_1</a> : nNSet_a
C00830/11		<a href="#">L_MPot_1</a> : nIn_a
<input checked="" type="checkbox"/> Read access <input type="checkbox"/> Write access <input type="checkbox"/> CINH <input type="checkbox"/> PLC STOP <input checked="" type="checkbox"/> No transfer <input type="checkbox"/> COM <input type="checkbox"/> MOT   Scaling factor: 100		

## C00831

Parameter   Name: <b>C00831   16-bit common input</b>		Data type: UNSIGNED_16 Index: 23744 <sub>d</sub> = 5CC0 <sub>h</sub>
Decimal/hexadecimal/bit-coded display of 16-bit input values of different blocks		
Display area (min. hex value   max. hex value)		
0x0000		0xFFFF
Value is bit-coded:		
Bit 0	Bit0	
...	...	
Bit 15	Bit15	
Subcodes		Info
C00831/1		<a href="#">LS_DCTRL</a> : wCANControl
<input checked="" type="checkbox"/> Read access <input type="checkbox"/> Write access <input type="checkbox"/> CINH <input type="checkbox"/> PLC STOP <input checked="" type="checkbox"/> No transfer <input type="checkbox"/> COM <input type="checkbox"/> MOT		

## C00833

Parameter   Name: C00833   8-bit input		Data type: UNSIGNED_8 Index: 23742 <sub>d</sub> = 5CBE <sub>h</sub>
Display of the signal status of the binary inputs of different blocks		
<b>Selection list</b>		
0	False	
1	True	
<b>Subcodes</b>		<b>Info</b>
C00833/1		<a href="#">L_NSet_1</a> : bRfg0
C00833/2		<a href="#">L_NSet_1</a> : bNSetInv
C00833/3		<a href="#">L_NSet_1</a> : bJog1
C00833/4		<a href="#">L_NSet_1</a> : bJog2
C00833/5		<a href="#">LS_SetError_1</a> : bSetError1
C00833/6		<a href="#">LS_SetError_1</a> : bSetError2
C00833/7		<a href="#">L_MPot_1</a> : bUp
C00833/8		<a href="#">L_MPot_1</a> : bInAct
C00833/9		<a href="#">L_MPot_1</a> : bDown
C00833/10		<a href="#">L_MPot_1</a> : bEnable
C00833/11		Reserved
C00833/12		<a href="#">L_PCTRL_1</a> : bIOff
C00833/13		<a href="#">L_PCTRL_1</a> : bEnableInfluenceRamp
C00833/14		<a href="#">LS_DCTRL</a> : bCINH
C00833/15		<a href="#">LS_DCTRL</a> : bFailReset
C00833/16		<a href="#">LS_DCTRL</a> : bStatus_B0
C00833/17		<a href="#">LS_DCTRL</a> : bStatus_B2
C00833/18		<a href="#">LS_DCTRL</a> : bStatus_B3
C00833/19		<a href="#">LS_DCTRL</a> : bStatus_B4
C00833/20		<a href="#">LS_DCTRL</a> : bStatus_B5
C00833/21		<a href="#">LS_DCTRL</a> : bStatus_B14
C00833/22		<a href="#">LS_DCTRL</a> : bStatus_B15
C00833/23		<a href="#">L_RLO_1</a> : bCw
C00833/24		<a href="#">L_RLO_1</a> : bCcw
<input checked="" type="checkbox"/> Read access <input type="checkbox"/> Write access <input type="checkbox"/> CINH <input type="checkbox"/> PLC STOP <input checked="" type="checkbox"/> No transfer <input type="checkbox"/> COM <input type="checkbox"/> MOT             Scaling factor: 1		

C00866

Parameter   Name: <b>C00866   CAN input words</b>		Data type: UNSIGNED_16 Index: 23709 <sub>d</sub> = 5C9D <sub>h</sub>
Display of the 16-bit input values of the CAN interface		
<a href="#">▶ System bus "CAN on board"</a>		
<b>Display area (min. hex value   max. hex value)</b>		
0x0000		0xFFFF
<b>Value is bit-coded:</b>		
Bit 0	Bit0	
...	...	
Bit 15	Bit15	
<b>Subcodes</b>		<b>Info</b>
C00866/1		<a href="#">LP_CanIn1</a> : wCtrl
C00866/2		<a href="#">LP_CanIn1</a> : wIn2
C00866/3		<a href="#">LP_CanIn1</a> : wIn3
C00866/4		<a href="#">LP_CanIn1</a> : wIn4
C00866/5		<a href="#">LP_CanIn2</a> : wIn1
C00866/6		<a href="#">LP_CanIn2</a> : wIn2
C00866/7		<a href="#">LP_CanIn2</a> : wIn3
C00866/8		<a href="#">LP_CanIn2</a> : wIn4
<input checked="" type="checkbox"/> Read access <input type="checkbox"/> Write access <input type="checkbox"/> CINH <input type="checkbox"/> PLC STOP <input checked="" type="checkbox"/> No transfer <input type="checkbox"/> COM <input type="checkbox"/> MOT		

C00868

Parameter   Name: <b>C00868   CAN output words</b>		Data type: UNSIGNED_16 Index: 23707 <sub>d</sub> = 5C9B <sub>h</sub>
Display of the 16-bit output values of the CAN interface		
<a href="#">▶ System bus "CAN on board"</a>		
<b>Display area (min. hex value   max. hex value)</b>		
0x0000		0xFFFF
<b>Value is bit-coded:</b>		
Bit 0	Bit0	
Bit 1	Bit1	
Bit 2	Bit2	
Bit 3	Bit3	
Bit 4	Bit4	
Bit 5	Bit5	
Bit 6	Bit6	
Bit 7	Bit7	
Bit 8	Bit8	
Bit 9	Bit9	
Bit 10	Bit10	
Bit 11	Bit11	
Bit 12	Bit12	
Bit 13	Bit13	
Bit 14	Bit14	
Bit 15	Bit15	
<b>Subcodes</b>		<b>Info</b>
C00868/1		<a href="#">LP_CanOut1</a> : wOut1
C00868/2		<a href="#">LP_CanOut1</a> : wOut2
C00868/3		<a href="#">LP_CanOut1</a> : wOut3
C00868/4		<a href="#">LP_CanOut1</a> : wOut4
C00868/5		<a href="#">LP_CanOut2</a> : wOut1
C00868/6		<a href="#">LP_CanOut2</a> : wOut2
C00868/7		<a href="#">LP_CanOut2</a> : wOut3
C00868/8		<a href="#">LP_CanOut2</a> : wOut4
<input checked="" type="checkbox"/> Read access <input type="checkbox"/> Write access <input type="checkbox"/> CINH <input type="checkbox"/> PLC STOP <input checked="" type="checkbox"/> No transfer <input type="checkbox"/> COM <input type="checkbox"/> MOT		

C00909

Parameter   Name: <b>C00909   Speed limitation</b>		Data type: INTEGER_16 Index: 23666 <sub>d</sub> = 5C72 <sub>h</sub>
Maximum positive/negative speed for all operating modes		
<b>Setting range (min. value   unit   max. value)</b>		
0.0	%	175.0
<b>Subcodes</b>		<b>Info</b>
C00909/1	120.0 %	Max. pos. speed
C00909/2	120.0 %	Max. neg. speed
<input checked="" type="checkbox"/> Read access <input checked="" type="checkbox"/> Write access <input type="checkbox"/> CINH <input type="checkbox"/> PLC STOP <input type="checkbox"/> No transfer <input type="checkbox"/> COM <input type="checkbox"/> MOT                   Scaling factor: 100		

## C00910

Parameter   Name: <b>C00910   Frequency limitation</b>		Data type: UNSIGNED_16 Index: 23665 <sub>d</sub> = 5C71 <sub>h</sub>
Maximum positive/negative output frequency for all operating modes		
<b>Setting range</b> (min. value   unit   max. value)		
0	Hz	300
<b>Subcodes</b>	<b>Lenze setting</b>	<b>Info</b>
C00910/1	300 Hz	Max. pos. output frequency
C00910/2	300 Hz	Max. neg. output frequency
<input checked="" type="checkbox"/> Read access <input checked="" type="checkbox"/> Write access <input type="checkbox"/> CINH <input type="checkbox"/> PLC STOP <input type="checkbox"/> No transfer <input type="checkbox"/> COM <input type="checkbox"/> MOT   Scaling factor: 1		

## C00990

Parameter   Name: <b>C00990   Flying restart fct.: Activation</b>		Data type: UNSIGNED_8 Index: 23585 <sub>d</sub> = 5C21 <sub>h</sub>
Switch on /activate flying restart circuit for non-feedback drive systems		
▶ <a href="#">Flying restart function</a>		
<b>Selection list</b> (Lenze setting printed in bold)		
<b>0</b>	<b>Off</b>	
1	On	
<input checked="" type="checkbox"/> Read access <input checked="" type="checkbox"/> Write access <input type="checkbox"/> CINH <input type="checkbox"/> PLC STOP <input type="checkbox"/> No transfer <input type="checkbox"/> COM <input type="checkbox"/> MOT   Scaling factor: 1		

## C00991

Parameter   Name: <b>C00991   Flying restart fct.: Process</b>		Data type: UNSIGNED_16 Index: 23584 <sub>d</sub> = 5C20 <sub>h</sub>
Selection of the speed search range for flying restart function		
▶ <a href="#">Flying restart function</a>		
<b>Selection list</b> (Lenze setting printed in bold)		
<b>5</b>	<b>-n...+n   Last output frequency</b>	
6	-n...+n   Actual setpoint frequency	
<input checked="" type="checkbox"/> Read access <input checked="" type="checkbox"/> Write access <input type="checkbox"/> CINH <input type="checkbox"/> PLC STOP <input type="checkbox"/> No transfer <input type="checkbox"/> COM <input type="checkbox"/> MOT   Scaling factor: 1		

## C00992

Parameter   Name: <b>C00992   Flying restart: Start frequency</b>		Data type: INTEGER_16 Index: 23583 <sub>d</sub> = 5C1F <sub>h</sub>
Selection of the starting value for the flying restart function		
▶ <a href="#">Flying restart function</a>		
<b>Setting range</b> (min. value   unit   max. value)		<b>Lenze setting</b>
-200	Hz	200 <b>10 Hz</b>
<input checked="" type="checkbox"/> Read access <input checked="" type="checkbox"/> Write access <input type="checkbox"/> CINH <input type="checkbox"/> PLC STOP <input type="checkbox"/> No transfer <input type="checkbox"/> COM <input type="checkbox"/> MOT   Scaling factor: 1		



## C00994

Parameter   Name: <b>C00994 - Flying restart fct.: Current</b>		Data type: INTEGER_16 Index: 23581 <sub>d</sub> = 5C1D <sub>h</sub>
Current to be injected during the flying restart process <ul style="list-style-type: none"> <li>• 100 % ≡ rated motor current (<a href="#">C00081</a>).</li> <li>• The flying restart current should amount to 10 ... 25 % of the rated motor current.</li> </ul> <p style="text-align: right;"><a href="#">▶ Flying restart function</a></p>		
<b>Setting range (min. value   unit   max. value)</b>		<b>Lenze setting</b>
0.0	%	100.0
		<b>25.0 %</b>
<input checked="" type="checkbox"/> Read access <input checked="" type="checkbox"/> Write access <input type="checkbox"/> CINH <input type="checkbox"/> PLC STOP <input type="checkbox"/> No transfer <input type="checkbox"/> COM <input type="checkbox"/> MOT   Scaling factor: 100		

# 10 Parameter reference

## 10.2 Parameter list

---

### 10.2.1 Selection lists for configuration parameters

#### 10.2.1.1 Selection list - analog signals

This selection list is relevant for the following parameters:

Parameter	
<a href="#">C00620</a>	16-bit system connection
<a href="#">C00700</a>	LA_NCtrl: Analog connection list

Selection list - analog signals	
0	Not connected
1	C_nPos100_a(100.0%)
2	C_nNeg100_a(-100.0%)
3	C_nPos199_9_a(199.9%)
4	C_nNeg199_9_a(-199.9%)
5	C_w65535
6	C_wDriveCtrl
10	Aln1_Out
20	nPar1_a
21	nPar2_a
22	nPar3_a
23	nPar4_a
24	LS_Keypad_nTorqueMotLim_a
25	LS_Keypad_nTorqueGenLim_a
26	LS_Keypad_nMainSetValue_a
30	CAN1_wIn1
31	CAN1_wIn2
32	CAN1_wIn3
33	CAN1_wIn4
34	CAN2_wIn1
35	CAN2_wIn2
36	CAN2_wIn3
37	CAN2_wIn4
50	LA_NCtrl_nMotorFreqAct_a
51	LA_NCtrl_nMotorSpeedSet_a
52	LA_NCtrl_nMotorSpeedAct_a
53	LA_NCtrl_nMotor Voltage_a
54	LA_NCtrl_nDCVoltage_a
55	LA_NCtrl_nMotorCurrent_a
56	LA_NCtrl_nMotorTorqueAct_a
57	LA_NCtrl_nHeatsinktemperature_a
58	LA_NCtrl_nOutputSpeedCtrl_a
70	LA_NCtrl_wDeviceStateWord
71	LA_NCtrl_wDeviceAuxStateWord
72	LA_NCtrl_wDetermFailNoLow
73	LA_NCtrl_wDetermFailNoHigh

### 10.2.1.2 Selection list - digital signals

This selection list is relevant for the following parameters:

Parameter	
<a href="#">C00621</a>	Bool system connection
<a href="#">C00701</a>	LA_NCtrl: Digital connection list

Selection list - digital signals	
0	Not connected
1	C_bTrue
11	DigIn_bln1
12	DigIn_bln2
13	DigIn_bln3
14	DigIn_bln4
15	DigIn_Clnh
20	bPar1
21	bPar2
22	bPar3
23	bPar4
24	bPar5
25	bPar6
26	bPar7
27	bPar8
28	bPar9
29	bPar10
30	bPar11
31	bPar12
32	bPar13
33	bPar14
34	bPar15
35	bPar16
36	LS_Keypad_bSetQuickstop
37	LS_Keypad_bSetDCBrake
38	LS_Keypad_bSetSpeedCcw
39	LS_Keypad_bJogSpeed1
40	LS_Keypad_bJogSpeed2
50	LA_NCtrl_bDriveFail
51	LA_NCtrl_bDriveReady
52	LA_NCtrl_bClnhActive
53	LA_NCtrl_bQSPisActive
54	LA_NCtrl_bSafeTorqueOff
60	LA_NCtrl_bSpeedCcw
61	LA_NCtrl_bActSpeedEqZero
62	LA_NCtrl_bSpeedSetReached
63	LA_NCtrl_bSpeedActEqSet
64	LA_NCtrl_bNActCompare
65	LA_NCtrl_bImaxActive
66	LA_NCtrl_bHeatSinkWarning
67	LA_NCtrl_bOVDetected

Selection list - digital signals	
68	LA_NCtrl_bDCBrakeOn
69	LA_NCtrl_bFlyingSyncActive
70	Ain_bCurrentErrorIn1
100	CAN1_bln1_B0
101	CAN1_bln1_B1
102	CAN1_bln1_B2
103	CAN1_bln1_B3
104	CAN1_bln1_B4
105	CAN1_bln1_B5
106	CAN1_bln1_B6
107	CAN1_bln1_B7
108	CAN1_bln1_B8
109	CAN1_bln1_B9
110	CAN1_bln1_B10
111	CAN1_bln1_B11
112	CAN1_bln1_B12
113	CAN1_bln1_B13
114	CAN1_bln1_B14
115	CAN1_bln1_B15
120	CAN1_bln2_B0
121	CAN1_bln2_B1
122	CAN1_bln2_B2
123	CAN1_bln2_B3
124	CAN1_bln2_B4
125	CAN1_bln2_B5
126	CAN1_bln2_B6
127	CAN1_bln2_B7
128	CAN1_bln2_B8
129	CAN1_bln2_B9
130	CAN1_bln2_B10
131	CAN1_bln2_B11
132	CAN1_bln2_B12
133	CAN1_bln2_B13
134	CAN1_bln2_B14
135	CAN1_bln2_B15

### 10.3 Table of attributes

The table of attributes contains information that is required for a communication to the controller via parameters.

#### How to read the table of attributes:

Column		Meaning	Entry	
Code		Parameter name	Cxxxxx	
Name		Parameter short text (display text)	Text	
Index	dec	Index under which the parameter is addressed. The subindex of array variables corresponds to the Lenze subcode number.	24575 - Lenze code number	Is only required for access via a bus system.
	hex		5FFF <sub>h</sub> - Lenze code number	
Data	DS	Data structure	E	Single variable (only one parameter element)
			A	Array variable (several parameter elements)
	DA	Number of array elements (subcodes)	Number	
	DT	Data type	INTEGER_16	2 bytes with sign
			INTEGER_32	4 bytes with sign
			UNSIGNED_8	1 byte without sign
			UNSIGNED_16	2 bytes without sign
UNSIGNED_32			4 bytes without sign	
Factor	Factor for data transfer via a bus system, depending on the number of decimal positions	Factor	1 = no decimal positions 10 = 1 decimal position 100 = 2 decimal positions 1000 = 3 decimal positions	
Access	R	Read access	<input checked="" type="checkbox"/> Reading permitted	
	W	Write access	<input checked="" type="checkbox"/> Writing permitted	
	CINH	Controller inhibit required	<input checked="" type="checkbox"/> Writing is only possible when the controller is inhibited	

Code	Name	Index		Data				Access		
		dec	hex	DS	DA	DT	Factor	R	W	CINH
<a href="#">C00002</a>	Device commands	24573	5FFD	A	32	UNSIGNED_8	1	<input checked="" type="checkbox"/>	<input checked="" type="checkbox"/>	
<a href="#">C00003</a>	Status of last device command	24572	5FFC	E	1	UNSIGNED_8	1	<input checked="" type="checkbox"/>		
<a href="#">C00006</a>	Motor control	24569	5FF9	E	1	UNSIGNED_8	1	<input checked="" type="checkbox"/>	<input checked="" type="checkbox"/>	
<a href="#">C00007</a>	Control mode	24568	5FF8	E	1	UNSIGNED_16	1	<input checked="" type="checkbox"/>	<input checked="" type="checkbox"/>	
<a href="#">C00010</a>	Minimum analog setpoint	24565	5FF5	A	1	INTEGER_16	100	<input checked="" type="checkbox"/>	<input checked="" type="checkbox"/>	
<a href="#">C00011</a>	Appl.: Reference speed	24564	5FF4	E	1	UNSIGNED_16	1	<input checked="" type="checkbox"/>	<input checked="" type="checkbox"/>	
<a href="#">C00012</a>	Accel. time - main setpoint	24563	5FF3	E	1	UNSIGNED_32	1000	<input checked="" type="checkbox"/>	<input checked="" type="checkbox"/>	
<a href="#">C00013</a>	Decel. time - main setpoint	24562	5FF2	E	1	UNSIGNED_32	1000	<input checked="" type="checkbox"/>	<input checked="" type="checkbox"/>	
<a href="#">C00015</a>	VFC: V/f base frequency	24560	5FF0	E	1	UNSIGNED_16	10	<input checked="" type="checkbox"/>	<input checked="" type="checkbox"/>	
<a href="#">C00016</a>	VFC: Vmin boost	24559	5FEF	E	1	UNSIGNED_16	100	<input checked="" type="checkbox"/>	<input checked="" type="checkbox"/>	
<a href="#">C00018</a>	Switching frequency	24557	5FED	E	1	UNSIGNED_8	1	<input checked="" type="checkbox"/>	<input checked="" type="checkbox"/>	
<a href="#">C00019</a>	Auto-DCB: Threshold	24556	5FEC	E	1	UNSIGNED_16	1	<input checked="" type="checkbox"/>	<input checked="" type="checkbox"/>	
<a href="#">C00021</a>	Slip comp.	24554	5FEA	E	1	INTEGER_16	100	<input checked="" type="checkbox"/>	<input checked="" type="checkbox"/>	
<a href="#">C00022</a>	I <sub>max</sub> in motor mode	24553	5FE9	E	1	UNSIGNED_16	100	<input checked="" type="checkbox"/>	<input checked="" type="checkbox"/>	
<a href="#">C00023</a>	I <sub>max</sub> in generator mode	24552	5FE8	E	1	INTEGER_16	100	<input checked="" type="checkbox"/>	<input checked="" type="checkbox"/>	
<a href="#">C00024</a>	Comparison value N_Act	24551	5FE7	E	1	INTEGER_16	100	<input checked="" type="checkbox"/>	<input checked="" type="checkbox"/>	
<a href="#">C00026</a>	AINx: Offset	24549	5FE5	A	1	INTEGER_16	100	<input checked="" type="checkbox"/>	<input checked="" type="checkbox"/>	
<a href="#">C00027</a>	AINx: Gain	24548	5FE4	A	1	INTEGER_32	100	<input checked="" type="checkbox"/>	<input checked="" type="checkbox"/>	
<a href="#">C00028</a>	AINx: Input voltage	24547	5FE3	A	1	INTEGER_16	100	<input checked="" type="checkbox"/>		
<a href="#">C00029</a>	AINx: Input current	24546	5FE2	A	1	INTEGER_16	100	<input checked="" type="checkbox"/>		
<a href="#">C00033</a>	AINx: Output value	24542	5FDE	A	1	INTEGER_16	100	<input checked="" type="checkbox"/>		
<a href="#">C00034</a>	AINx: Configuration	24541	5FDD	A	1	UNSIGNED_8	1	<input checked="" type="checkbox"/>	<input checked="" type="checkbox"/>	

Code	Name	Index		Data				Access		
		dec	hex	DS	DA	DT	Factor	R	W	CINH
<a href="#">C00036</a>	DCB: Current	24539	5FDB	E	1	INTEGER_16	100	<input checked="" type="checkbox"/>	<input checked="" type="checkbox"/>	
<a href="#">C00039</a>	Fixed setpoint x (L_NSet_1 n-Fix)	24536	5FD8	A	3	INTEGER_16	100	<input checked="" type="checkbox"/>	<input checked="" type="checkbox"/>	
<a href="#">C00050</a>	MCTRL: Speed setpoint	24525	5FCD	E	1	INTEGER_32	1	<input checked="" type="checkbox"/>		
<a href="#">C00051</a>	MCTRL: Actual speed value	24524	5FCC	E	1	INTEGER_32	1	<input checked="" type="checkbox"/>		
<a href="#">C00052</a>	Motor voltage	24523	5FCB	E	1	UNSIGNED_16	1	<input checked="" type="checkbox"/>		
<a href="#">C00053</a>	DC-bus voltage	24522	5FCA	E	1	UNSIGNED_16	1	<input checked="" type="checkbox"/>		
<a href="#">C00054</a>	Motor current	24521	5FC9	E	1	UNSIGNED_16	100	<input checked="" type="checkbox"/>		
<a href="#">C00056</a>	Torque	24519	5FC7	A	2	INTEGER_32	100	<input checked="" type="checkbox"/>		
<a href="#">C00057</a>	Maximum torque	24518	5FC6	E	1	UNSIGNED_32	100	<input checked="" type="checkbox"/>		
<a href="#">C00058</a>	Output frequency	24517	5FC5	E	1	INTEGER_32	100	<input checked="" type="checkbox"/>		
<a href="#">C00059</a>	Appl.: Reference frequency C11	24516	5FC4	E	1	UNSIGNED_32	100	<input checked="" type="checkbox"/>		
<a href="#">C00061</a>	Heatsink temperature	24514	5FC2	E	1	INTEGER_16	1	<input checked="" type="checkbox"/>		
<a href="#">C00064</a>	Device utilisation (lxt)	24511	5FBF	A	3	INTEGER_16	100	<input checked="" type="checkbox"/>		
<a href="#">C00066</a>	Thermal motor load (l <sup>xt</sup> )	24509	5FBD	E	1	INTEGER_16	100	<input checked="" type="checkbox"/>		
<a href="#">C00073</a>	Vp lmax controller	24502	5FB6	E	1	UNSIGNED_16	100	<input checked="" type="checkbox"/>	<input checked="" type="checkbox"/>	
<a href="#">C00074</a>	Ti lmax controller	24501	5FB5	E	1	UNSIGNED_16	1	<input checked="" type="checkbox"/>	<input checked="" type="checkbox"/>	
<a href="#">C00081</a>	Rated motor power	24494	5FAE	E	1	UNSIGNED_16	100	<input checked="" type="checkbox"/>	<input checked="" type="checkbox"/>	
<a href="#">C00084</a>	Motor stator resistance	24491	5FAB	E	1	UNSIGNED_32	1	<input checked="" type="checkbox"/>	<input checked="" type="checkbox"/>	
<a href="#">C00085</a>	Motor stator leakage inductance	24490	5FAA	E	1	UNSIGNED_16	100	<input checked="" type="checkbox"/>	<input checked="" type="checkbox"/>	
<a href="#">C00087</a>	Rated motor speed	24488	5FA8	E	1	UNSIGNED_16	1	<input checked="" type="checkbox"/>	<input checked="" type="checkbox"/>	
<a href="#">C00088</a>	Rated motor current	24487	5FA7	E	1	UNSIGNED_16	100	<input checked="" type="checkbox"/>	<input checked="" type="checkbox"/>	
<a href="#">C00089</a>	Rated motor frequency	24486	5FA6	E	1	UNSIGNED_16	1	<input checked="" type="checkbox"/>	<input checked="" type="checkbox"/>	
<a href="#">C00090</a>	Rated motor voltage	24485	5FA5	E	1	UNSIGNED_16	1	<input checked="" type="checkbox"/>	<input checked="" type="checkbox"/>	
<a href="#">C00091</a>	Motor cosine phi	24484	5FA4	E	1	UNSIGNED_8	100	<input checked="" type="checkbox"/>	<input checked="" type="checkbox"/>	
<a href="#">C00092</a>	Motor magnetising inductance	24483	5FA3	E	1	UNSIGNED_16	10	<input checked="" type="checkbox"/>	<input checked="" type="checkbox"/>	
<a href="#">C00093</a>	Power section identification	24482	5FA2	E	1	UNSIGNED_16	1	<input checked="" type="checkbox"/>		
<a href="#">C00094</a>	Password	24481	5FA1	E	1	INTEGER_32	1	<input checked="" type="checkbox"/>	<input checked="" type="checkbox"/>	
<a href="#">C00095</a>	Motor magnetising current	24480	5FA0	E	1	UNSIGNED_16	100	<input checked="" type="checkbox"/>		
<a href="#">C00097</a>	Rated motor torque	24478	5F9E	E	1	UNSIGNED_32	100	<input checked="" type="checkbox"/>		
<a href="#">C00098</a>	Rated device current	24477	5F9D	E	1	UNSIGNED_16	10	<input checked="" type="checkbox"/>		
<a href="#">C00099</a>	Firmware version	24476	5F9C	E	1	VISIBLE_STRING		<input checked="" type="checkbox"/>		
<a href="#">C00100</a>	Firmware version	24475	5F9B	A	4	UNSIGNED_8	1	<input checked="" type="checkbox"/>		
<a href="#">C00105</a>	Deceleration time - quick stop	24470	5F96	E	1	UNSIGNED_32	1000	<input checked="" type="checkbox"/>	<input checked="" type="checkbox"/>	
<a href="#">C00106</a>	Auto-DCB: Hold time	24469	5F95	E	1	UNSIGNED_32	1000	<input checked="" type="checkbox"/>	<input checked="" type="checkbox"/>	
<a href="#">C00107</a>	DCB: Hold time	24468	5F94	E	1	UNSIGNED_32	1000	<input checked="" type="checkbox"/>	<input checked="" type="checkbox"/>	
<a href="#">C00114</a>	Dlx inversion	24461	5F8D	E	1	UNSIGNED_16		<input checked="" type="checkbox"/>	<input checked="" type="checkbox"/>	
<a href="#">C00118</a>	DOx inversion	24457	5F89	E	1	UNSIGNED_8		<input checked="" type="checkbox"/>	<input checked="" type="checkbox"/>	
<a href="#">C00120</a>	Motor overload threshold (l <sup>xt</sup> )	24455	5F87	E	1	INTEGER_16	100	<input checked="" type="checkbox"/>	<input checked="" type="checkbox"/>	
<a href="#">C00122</a>	Initial value motor overload (l <sup>xt</sup> )	24453	5F85	A	1	UNSIGNED_16	100	<input checked="" type="checkbox"/>	<input checked="" type="checkbox"/>	
<a href="#">C00123</a>	Device utilisat. threshold (lxt)	24452	5F84	E	1	INTEGER_16	100	<input checked="" type="checkbox"/>	<input checked="" type="checkbox"/>	
<a href="#">C00134</a>	Ramp smoothing - main setpoint	24441	5F79	E	1	UNSIGNED_8	1	<input checked="" type="checkbox"/>	<input checked="" type="checkbox"/>	
<a href="#">C00136</a>	Communication control words	24439	5F77	A	2	UNSIGNED_16		<input checked="" type="checkbox"/>		
<a href="#">C00137</a>	Device state	24438	5F76	E	1	UNSIGNED_16	1	<input checked="" type="checkbox"/>		
<a href="#">C00141</a>	Device settings	24434	5F72	A	1	UNSIGNED_8	1	<input checked="" type="checkbox"/>	<input checked="" type="checkbox"/>	
<a href="#">C00142</a>	Auto-start option	24433	5F71	E	1	UNSIGNED_8		<input checked="" type="checkbox"/>	<input checked="" type="checkbox"/>	
<a href="#">C00144</a>	Switching frequency reduction (temp.)	24431	5F6F	E	1	UNSIGNED_8	1	<input checked="" type="checkbox"/>	<input checked="" type="checkbox"/>	
<a href="#">C00150</a>	Status word	24425	5F69	E	1	UNSIGNED_16		<input checked="" type="checkbox"/>		
<a href="#">C00155</a>	Status word 2	24420	5F64	E	1	UNSIGNED_16		<input checked="" type="checkbox"/>		
<a href="#">C00158</a>	Cause of controller inhibit	24417	5F61	E	1	UNSIGNED_16		<input checked="" type="checkbox"/>		
<a href="#">C00159</a>	Cause of quick stop QSP	24416	5F60	E	1	UNSIGNED_16		<input checked="" type="checkbox"/>		
<a href="#">C00165</a>	Error information	24410	5F5A	A	1	VISIBLE_STRING		<input checked="" type="checkbox"/>		

Code	Name	Index		Data				Access		
		dec	hex	DS	DA	DT	Factor	R	W	CINH
<a href="#">C00166</a>	Error information text	24409	5F59	A	3	VISIBLE_STRING		<input checked="" type="checkbox"/>		
<a href="#">C00168</a>	Error number	24407	5F57	A	8	UNSIGNED_32	1	<input checked="" type="checkbox"/>		
<a href="#">C00169</a>	Time of error	24406	5F56	A	8	UNSIGNED_32	1	<input checked="" type="checkbox"/>		
<a href="#">C00170</a>	Error counter	24405	5F55	A	8	UNSIGNED_8	1	<input checked="" type="checkbox"/>		
<a href="#">C00173</a>	Mains voltage	24402	5F52	E	1	UNSIGNED_8	1	<input checked="" type="checkbox"/>	<input checked="" type="checkbox"/>	<input checked="" type="checkbox"/>
<a href="#">C00174</a>	Reduced brake chopper threshold	24401	5F51	E	1	UNSIGNED_8	1	<input checked="" type="checkbox"/>	<input checked="" type="checkbox"/>	
<a href="#">C00177</a>	Switching cycles	24398	5F4E	A	2	UNSIGNED_32	1	<input checked="" type="checkbox"/>		
<a href="#">C00178</a>	Elapsed-hour meter	24397	5F4D	E	1	UNSIGNED_32	1	<input checked="" type="checkbox"/>		
<a href="#">C00179</a>	Power-on time meter	24396	5F4C	E	1	UNSIGNED_32	1	<input checked="" type="checkbox"/>		
<a href="#">C00182</a>	S-ramp time PT1	24393	5F49	E	1	INTEGER_16	100	<input checked="" type="checkbox"/>	<input checked="" type="checkbox"/>	
<a href="#">C00200</a>	Firmware product type	24375	5F37	E	1	VISIBLE_STRING		<input checked="" type="checkbox"/>		
<a href="#">C00201</a>	Firmware compile date	24374	5F36	E	1	VISIBLE_STRING		<input checked="" type="checkbox"/>		
<a href="#">C00203</a>	Product type code	24372	5F34	A	9	VISIBLE_STRING		<input checked="" type="checkbox"/>		
<a href="#">C00222</a>	L_PCTRL_1: Vp	24353	5F21	E	1	INTEGER_16	10	<input checked="" type="checkbox"/>	<input checked="" type="checkbox"/>	
<a href="#">C00223</a>	L_PCTRL_1: Tn	24352	5F20	E	1	UNSIGNED_16	1	<input checked="" type="checkbox"/>	<input checked="" type="checkbox"/>	
<a href="#">C00224</a>	L_PCTRL_1: Kd	24351	5F1F	E	1	UNSIGNED_16	10	<input checked="" type="checkbox"/>	<input checked="" type="checkbox"/>	
<a href="#">C00225</a>	L_PCTRL_1: MaxLimit	24350	5F1E	E	1	INTEGER_16	100	<input checked="" type="checkbox"/>	<input checked="" type="checkbox"/>	
<a href="#">C00226</a>	L_PCTRL_1: MinLimit	24349	5F1D	E	1	INTEGER_16	100	<input checked="" type="checkbox"/>	<input checked="" type="checkbox"/>	
<a href="#">C00227</a>	L_PCTRL_1: Acceleration time	24348	5F1C	E	1	UNSIGNED_32	1000	<input checked="" type="checkbox"/>	<input checked="" type="checkbox"/>	
<a href="#">C00228</a>	L_PCTRL_1: Deceleration time	24347	5F1B	E	1	UNSIGNED_32	1000	<input checked="" type="checkbox"/>	<input checked="" type="checkbox"/>	
<a href="#">C00231</a>	L_PCTRL_1: Operating range	24344	5F18	A	4	INTEGER_16	100	<input checked="" type="checkbox"/>	<input checked="" type="checkbox"/>	
<a href="#">C00234</a>	Oscillation damping influence	24341	5F15	E	1	UNSIGNED_16	100	<input checked="" type="checkbox"/>	<input checked="" type="checkbox"/>	
<a href="#">C00242</a>	L_PCTRL_1: Operating mode	24333	5F0D	E	1	UNSIGNED_8	1	<input checked="" type="checkbox"/>	<input checked="" type="checkbox"/>	
<a href="#">C00243</a>	L_PCTRL_1: Acceleration time influence	24332	5F0C	E	1	UNSIGNED_32	1000	<input checked="" type="checkbox"/>	<input checked="" type="checkbox"/>	
<a href="#">C00244</a>	L_PCTRL_1: Deceleration time influence	24331	5F0B	E	1	UNSIGNED_32	1000	<input checked="" type="checkbox"/>	<input checked="" type="checkbox"/>	
<a href="#">C00245</a>	L_PCTRL_1: PID output value	24330	5F0A	E	1	INTEGER_16	100	<input checked="" type="checkbox"/>		
<a href="#">C00322</a>	Transmission mode CAN TxPDOs	24253	5EBD	A	2	UNSIGNED_8	1	<input checked="" type="checkbox"/>	<input checked="" type="checkbox"/>	
<a href="#">C00323</a>	Transmission mode CAN Rx PDOs	24252	5EBC	A	2	UNSIGNED_8	1	<input checked="" type="checkbox"/>	<input checked="" type="checkbox"/>	
<a href="#">C00324</a>	CAN transmit blocking time	24251	5EBB	A	3	UNSIGNED_16	1	<input checked="" type="checkbox"/>	<input checked="" type="checkbox"/>	
<a href="#">C00345</a>	CAN error status	24230	5EA6	E	1	UNSIGNED_8	1	<input checked="" type="checkbox"/>		
<a href="#">C00347</a>	CAN status HeartBeat producer	24228	5EA4	A	1	UNSIGNED_8	1	<input checked="" type="checkbox"/>		
<a href="#">C00350</a>	CAN node address	24225	5EA1	E	1	UNSIGNED_8	1	<input checked="" type="checkbox"/>	<input checked="" type="checkbox"/>	
<a href="#">C00351</a>	CAN baud rate	24224	5EA0	E	1	UNSIGNED_8	1	<input checked="" type="checkbox"/>	<input checked="" type="checkbox"/>	
<a href="#">C00352</a>	CAN slave/master	24223	5E9F	E	1	UNSIGNED_8	1	<input checked="" type="checkbox"/>	<input checked="" type="checkbox"/>	
<a href="#">C00353</a>	CAN IN/OUT COBID source	24222	5E9E	A	2	UNSIGNED_8	1	<input checked="" type="checkbox"/>	<input checked="" type="checkbox"/>	
<a href="#">C00354</a>	COBID	24221	5E9D	A	4	UNSIGNED_32		<input checked="" type="checkbox"/>	<input checked="" type="checkbox"/>	
<a href="#">C00355</a>	Active COBID	24220	5E9C	A	4	UNSIGNED_16	1	<input checked="" type="checkbox"/>		
<a href="#">C00356</a>	CAN time settings	24219	5E9B	A	5	UNSIGNED_16	1	<input checked="" type="checkbox"/>	<input checked="" type="checkbox"/>	
<a href="#">C00357</a>	CAN monitoring times	24218	5E9A	A	2	UNSIGNED_16	1	<input checked="" type="checkbox"/>	<input checked="" type="checkbox"/>	
<a href="#">C00359</a>	CAN status	24216	5E98	E	1	UNSIGNED_8	1	<input checked="" type="checkbox"/>		
<a href="#">C00360</a>	CAN telegram counter	24215	5E97	A	12	UNSIGNED_16	1	<input checked="" type="checkbox"/>		
<a href="#">C00364</a>	CAN MessageError	24211	5E93	E	1	UNSIGNED_8		<input checked="" type="checkbox"/>		
<a href="#">C00366</a>	Number of CAN SDO channels	24209	5E91	E	1	UNSIGNED_8	1	<input checked="" type="checkbox"/>	<input checked="" type="checkbox"/>	
<a href="#">C00367</a>	CAN Sync-Rx identifier	24208	5E90	E	1	UNSIGNED_16	1	<input checked="" type="checkbox"/>	<input checked="" type="checkbox"/>	
<a href="#">C00368</a>	CAN Sync-Tx Identifier	24207	5E8F	E	1	UNSIGNED_16	1	<input checked="" type="checkbox"/>	<input checked="" type="checkbox"/>	
<a href="#">C00369</a>	CAN Sync transmission cycle time	24206	5E8E	E	1	UNSIGNED_16	1	<input checked="" type="checkbox"/>	<input checked="" type="checkbox"/>	
<a href="#">C00372</a>	CAN_Tx_Rx_Error	24203	5E8B	A	2	UNSIGNED_8	1	<input checked="" type="checkbox"/>		
<a href="#">C00381</a>	CAN Heartbeat Producer time	24194	5E82	E	1	UNSIGNED_16	1	<input checked="" type="checkbox"/>	<input checked="" type="checkbox"/>	
<a href="#">C00385</a>	CAN NodeID Heartbeat producer	24190	5E7E	A	1	UNSIGNED_8	1	<input checked="" type="checkbox"/>	<input checked="" type="checkbox"/>	
<a href="#">C00386</a>	ConsumerTime HeartBeat Producer	24189	5E7D	A	1	UNSIGNED_16	1	<input checked="" type="checkbox"/>	<input checked="" type="checkbox"/>	

Code	Name	Index		Data				Access		
		dec	hex	DS	DA	DT	Factor	R	W	CINH
<a href="#">C00389</a>	PDO valid / invalid	24186	5E7A	A	4	UNSIGNED_8	1	<input checked="" type="checkbox"/>	<input checked="" type="checkbox"/>	
<a href="#">C00409</a>	LP_CanIn Mapping	24166	5E66	A	8	UNSIGNED_16	1	<input checked="" type="checkbox"/>	<input checked="" type="checkbox"/>	
<a href="#">C00443</a>	DIx: Level	24132	5E44	A	2	UNSIGNED_16		<input checked="" type="checkbox"/>		
<a href="#">C00444</a>	DOx: Level	24131	5E43	A	2	UNSIGNED_16		<input checked="" type="checkbox"/>		
<a href="#">C00470</a>	LS_ParFree_b	24105	5E29	A	16	UNSIGNED_8	1	<input checked="" type="checkbox"/>	<input checked="" type="checkbox"/>	
<a href="#">C00472</a>	LS_ParFree_a	24103	5E27	A	4	INTEGER_16	100	<input checked="" type="checkbox"/>	<input checked="" type="checkbox"/>	
<a href="#">C00480</a>	LS_DisFree_b	24095	5E1F	E	1	UNSIGNED_8		<input checked="" type="checkbox"/>		
<a href="#">C00481</a>	LS_DisFree	24094	5E1E	A	4	UNSIGNED_16		<input checked="" type="checkbox"/>		
<a href="#">C00482</a>	LS_DisFree_a	24093	5E1D	A	4	INTEGER_16	100	<input checked="" type="checkbox"/>		
<a href="#">C00516</a>	Checksums	24059	5DFB	A	1	UNSIGNED_32	1	<input checked="" type="checkbox"/>		
<a href="#">C00517</a>	User menu	24058	5DFA	A	20	INTEGER_32	1	<input checked="" type="checkbox"/>	<input checked="" type="checkbox"/>	
<a href="#">C00565</a>	Resp. to mains phase failure	24010	5DCA	E	1	UNSIGNED_8	1	<input checked="" type="checkbox"/>	<input checked="" type="checkbox"/>	
<a href="#">C00574</a>	Resp. to brake resist. overtemp.	24001	5DC1	E	1	UNSIGNED_8	1	<input checked="" type="checkbox"/>	<input checked="" type="checkbox"/>	
<a href="#">C00581</a>	Resp. to LS_SetError_x	23994	5DBA	A	2	UNSIGNED_8	1	<input checked="" type="checkbox"/>	<input checked="" type="checkbox"/>	
<a href="#">C00592</a>	Resp. to CAN bus connection	23983	5DAF	A	5	UNSIGNED_8	1	<input checked="" type="checkbox"/>	<input checked="" type="checkbox"/>	
<a href="#">C00593</a>	Resp. to CANx_IN monitoring	23982	5DAE	A	2	UNSIGNED_8	1	<input checked="" type="checkbox"/>	<input checked="" type="checkbox"/>	
<a href="#">C00594</a>	Resp. to control word error	23981	5DAD	A	1	UNSIGNED_8	1	<input checked="" type="checkbox"/>	<input checked="" type="checkbox"/>	
<a href="#">C00598</a>	Resp. to open circuit AINx	23977	5DA9	A	1	UNSIGNED_8	1	<input checked="" type="checkbox"/>	<input checked="" type="checkbox"/>	
<a href="#">C00600</a>	Resp. to DC bus undervoltage	23975	5DA7	A	1	UNSIGNED_8	1	<input checked="" type="checkbox"/>	<input checked="" type="checkbox"/>	
<a href="#">C00601</a>	Del. resp.to fault: DC bus overvoltage	23974	5DA6	A	1	UNSIGNED_16	1000	<input checked="" type="checkbox"/>	<input checked="" type="checkbox"/>	
<a href="#">C00604</a>	Resp. to device overload (Ixt)	23971	5DA3	E	1	UNSIGNED_8	1	<input checked="" type="checkbox"/>	<input checked="" type="checkbox"/>	
<a href="#">C00606</a>	Resp. to motor overload (I*xt)	23969	5DA1	E	1	UNSIGNED_8	1	<input checked="" type="checkbox"/>	<input checked="" type="checkbox"/>	
<a href="#">C00620</a>	16-bit system connection	23955	5D93	A	27	UNSIGNED_16	1	<input checked="" type="checkbox"/>	<input checked="" type="checkbox"/>	
<a href="#">C00621</a>	Bool system connection	23954	5D92	A	61	UNSIGNED_16	1	<input checked="" type="checkbox"/>	<input checked="" type="checkbox"/>	
<a href="#">C00700</a>	LA_NCtrl: Analog connection list	23875	5D43	A	9	UNSIGNED_16	1	<input checked="" type="checkbox"/>	<input checked="" type="checkbox"/>	
<a href="#">C00701</a>	LA_NCtrl: Digital connection list	23874	5D42	A	18	UNSIGNED_16	1	<input checked="" type="checkbox"/>	<input checked="" type="checkbox"/>	
<a href="#">C00725</a>	Current switching frequency	23850	5D2A	E	1	UNSIGNED_8	1	<input checked="" type="checkbox"/>		
<a href="#">C00727</a>	LS_Keypad: Digital values	23848	5D28	A	5	UNSIGNED_8	1	<input checked="" type="checkbox"/>	<input checked="" type="checkbox"/>	
<a href="#">C00728</a>	LS_Keypad: Keypad analog values	23847	5D27	A	3	INTEGER_16	100	<input checked="" type="checkbox"/>	<input checked="" type="checkbox"/>	
<a href="#">C00800</a>	L_MPot_1: Upper limit	23775	5CDF	E	1	INTEGER_16	100	<input checked="" type="checkbox"/>	<input checked="" type="checkbox"/>	
<a href="#">C00801</a>	L_MPot_1: Lower limit	23774	5CDE	E	1	INTEGER_16	100	<input checked="" type="checkbox"/>	<input checked="" type="checkbox"/>	
<a href="#">C00802</a>	L_MPot_1: Acceleration time	23773	5CDD	E	1	UNSIGNED_16	10	<input checked="" type="checkbox"/>	<input checked="" type="checkbox"/>	
<a href="#">C00803</a>	L_MPot_1: Deceleration time	23772	5CDC	E	1	UNSIGNED_16	10	<input checked="" type="checkbox"/>	<input checked="" type="checkbox"/>	
<a href="#">C00804</a>	L_MPot_1: Inactive function	23771	5CDB	E	1	UNSIGNED_8	1	<input checked="" type="checkbox"/>	<input checked="" type="checkbox"/>	
<a href="#">C00805</a>	L_MPot_1: Init function	23770	5CDA	E	1	UNSIGNED_8	1	<input checked="" type="checkbox"/>	<input checked="" type="checkbox"/>	
<a href="#">C00806</a>	L_MPot_1: Use	23769	5CD9	E	1	UNSIGNED_8	1	<input checked="" type="checkbox"/>	<input checked="" type="checkbox"/>	
<a href="#">C00830</a>	16-bit analog input	23745	5CC1	A	11	INTEGER_16	100	<input checked="" type="checkbox"/>		
<a href="#">C00831</a>	16-bit common input	23744	5CC0	A	1	UNSIGNED_16		<input checked="" type="checkbox"/>		
<a href="#">C00833</a>	8-bit input	23742	5CBE	A	24	UNSIGNED_8	1	<input checked="" type="checkbox"/>		
<a href="#">C00866</a>	CAN input words	23709	5C9D	A	8	UNSIGNED_16		<input checked="" type="checkbox"/>		
<a href="#">C00868</a>	CAN output words	23707	5C9B	A	8	UNSIGNED_16		<input checked="" type="checkbox"/>		
<a href="#">C00909</a>	Speed limitation	23666	5C72	A	2	INTEGER_16	100	<input checked="" type="checkbox"/>	<input checked="" type="checkbox"/>	
<a href="#">C00910</a>	Frequency limitation	23665	5C71	A	2	UNSIGNED_16	1	<input checked="" type="checkbox"/>	<input checked="" type="checkbox"/>	
<a href="#">C00990</a>	Flying restart fct.: Activation	23585	5C21	E	1	UNSIGNED_8	1	<input checked="" type="checkbox"/>	<input checked="" type="checkbox"/>	
<a href="#">C00991</a>	Flying restart fct.: Process	23584	5C20	E	1	UNSIGNED_16	1	<input checked="" type="checkbox"/>	<input checked="" type="checkbox"/>	
<a href="#">C00992</a>	Flying restart: Start frequency	23583	5C1F	E	1	INTEGER_16	1	<input checked="" type="checkbox"/>	<input checked="" type="checkbox"/>	
<a href="#">C00994</a>	Flying restart fct.: Current	23581	5C1D	E	1	INTEGER_16	100	<input checked="" type="checkbox"/>	<input checked="" type="checkbox"/>	

## 11 Function library

This chapter describes the function and system blocks that are part of the drive application.

Function block	Function
<a href="#">L_MPot_1</a>	Motor potentiometer (as alternative setpoint source)
<a href="#">L_NSet_1</a>	Setpoint generator
<a href="#">L_PCTRL_1</a>	Process controller
<a href="#">L_RLO_1</a>	Fail-safe linking of a selected direction of rotation to the quick stop function (QSP)

System block	Function
<a href="#">LS_AnalogInput</a>	Interface to the analog input terminals ▶ <a href="#">Analog terminals</a> (☞ 111)
<a href="#">LS_DigitalInput</a>	Interface to the digital input terminals ▶ <a href="#">Digital terminals</a> (☞ 109)
<a href="#">LS_DigitalOutput</a>	Interface to the digital output terminals ▶ <a href="#">Digital terminals</a> (☞ 109)
<a href="#">LS_DisFree</a>	Any four 16-bit signals of the application can be displayed on display codes
<a href="#">LS_DisFree_a</a>	Any four analog signals of the application can be displayed on display codes
<a href="#">LS_DisFree_b</a>	Any eight digital signals of the application can be displayed on a bit-coded display code
<a href="#">LS_DriveInterface</a>	Interface for drive control (DCTRL) ▶ <a href="#">Device control (DCTRL)</a> (☞ 44)
<a href="#">LS_Keypad</a>	Keypad control
<a href="#">LS_ParFix</a>	Output of different constant values
<a href="#">LS_ParFree_a</a>	Output of 4 parameterisable analog signals
<a href="#">LS_ParFree_b</a>	Output of 16 parameterisable digital signals
<a href="#">LS_SetError_1</a>	Parameterisable responses to user-defined events are tripped



# 11 Function library

## 11.1 L\_MPot\_1

### 11.1 L\_MPot\_1

This FB replaces a hardware motor potentiometer and can be used as an alternative setpoint source which is controlled via two inputs.

- The signal is output via a ramp function generator with linear ramps.
- The acceleration and deceleration times are set via parameters.
- Constant ramping even with speed limit values changed online.
- The motor potentiometer function can be switched on/off online via parameters or a process signal.

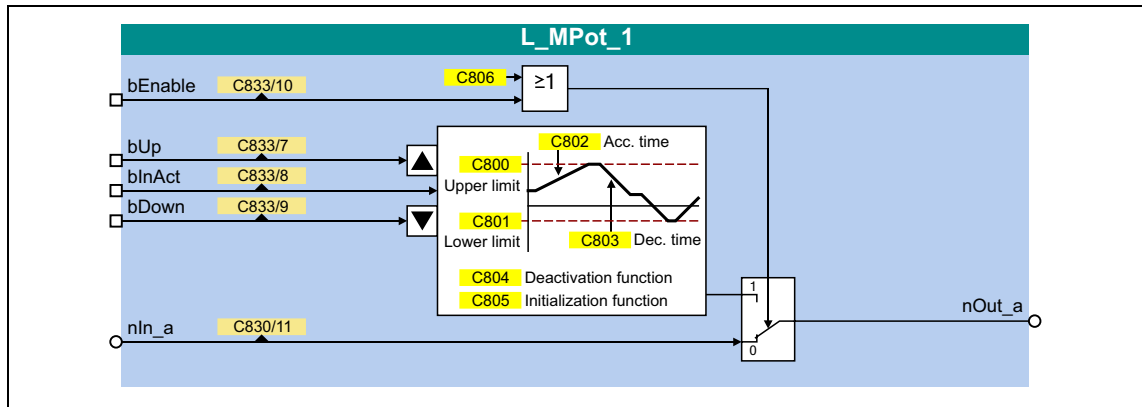

#### Inputs

Identifier	Data type	Information/possible settings
bEnable	BOOL	Switch over motor potentiometer function <i>bEnable</i> input and <a href="#">C806</a> code are OR'd.
		TRUE Motor potentiometer function is active, setpoint can be changed via <i>bUp</i> and <i>bDown</i> . • With switching to TRUE, the value applied to <i>nIn_a</i> is automatically transferred to the motor potentiometer.
		FALSE The value applied to <i>nIn_a</i> is output at <i>nOut_a</i> .
nIn_a	INT	When bEnable = FALSE, the analog input signal <i>nIn_</i> is switched to the <i>nOut_a</i> output.
bUp	BOOL	Approaching of the upper speed limit value set in <a href="#">C800</a> .
		TRUE The <i>nOut_a</i> output signal runs to its upper limit value ( <i>nHighLimit</i> ). • If the <i>bDown</i> input is simultaneously set to TRUE, the <i>nOut_a</i> output signal is not changed.
bDown	BOOL	Approaching of the lower speed limit value set in <a href="#">C801</a>
		TRUE The <i>nOut_a</i> output signal runs to its lower limit value ( <i>nLowLimit</i> ). • If the <i>bUp</i> input is simultaneously set to TRUE, the <i>nOut_a</i> output signal is not changed.
bInAct	BOOL	Deactivate motor potentiometer function • This input has the highest priority. • When the motor potentiometer is deactivated, the <i>nOut_a</i> output signal follows the function set with code <a href="#">C804</a> .
		TRUE Motor potentiometer function is deactivated.

## Outputs

Identifier	Data type	Value/meaning
nOut_a	INT	Output signal

## Parameter

Parameter	Possible settings			Info
<a href="#">C800</a>	-199.9	%	199.9	Upper limit • Lenze setting: 100.0 %
<a href="#">C801</a>	-199.9	%	199.9	Lower limit • Lenze setting: -100.0 %
<a href="#">C802</a>	0.1	s	999.9	Acceleration time • Lenze setting: 10.0 s
<a href="#">C803</a>	0.1	s	999.9	Deceleration time • Lenze setting: 10.0 s
<a href="#">C804</a>				Inactive function • Selection of response when deactivating the motor potentiometer via the input <i>blnAct</i> .
	0	Keep value (Lenze setting)		No further action; <i>nOut_a</i> retains its value.
	1	Deceleration to 0		The motor potentiometer returns to 0 % within the deceleration time $T_{if}$ .
	2	Deceleration to lower limit		The motor potentiometer runs within the deceleration time $T_{if}$ to the lower limit value ( <a href="#">C801</a> ).
	3	Without ramp to 0		<b>Important for the emergency stop function</b> The motor potentiometer output immediately changes to 0 %
	4	Without ramp to lower limit		The motor potentiometer output immediately changes to the lower limit value ( <a href="#">C801</a> ).
	5	Acceleration to upper limit		The motor potentiometer runs with the acceleration time $T_{ir}$ to the upper limit value ( <a href="#">C800</a> ).
<a href="#">C805</a>				Init function • Selection of response when switching on the device.
	0	Load last value (Lenze setting)		The output value being output during mains power-off is saved non-volatilely in the internal memory of the controller. It will be reloaded during mains power-on.
	1	Load lower limit		The lower limit value ( <a href="#">C801</a> ) is loaded during mains power-on.
	2	Load 0		An output value = 0 % is loaded during mains power-on.

Parameter	Possible settings	Info
<a href="#">C806</a>		Use of the motor potentiometer
	0 No (Lenze setting)	The motor potentiometer is not used. <ul style="list-style-type: none"> <li>The analog value applied to the <i>nIn_a</i> input is looped through without any changes to the <i>nOut_a</i> output.</li> </ul>
	1 Yes	The motor potentiometer is used. <ul style="list-style-type: none"> <li>The analog value applied at the <i>nIn_a</i> input is led via the motor potentiometer and provided at the <i>nOut_a</i> output.</li> </ul>

### 11.1.1 Activate & control motor potentiometer

When *blnAct* is set to FALSE, the motor potentiometer is activated.

- The currently active function depends on the current output signal *nOut\_a*, the limit values set and the control signals at *bUp* and *bDown*.
- When the *nOut\_a* output signal is outside the limits set, the output signal runs to the next limit with the *Ti* times set. This process is independent of the control signals at *bUp* and *bDown*.
- When the *nOut\_a* output signal is inside the limits set, the output signal changes according to the control signals at *bUp* and *bDown*.

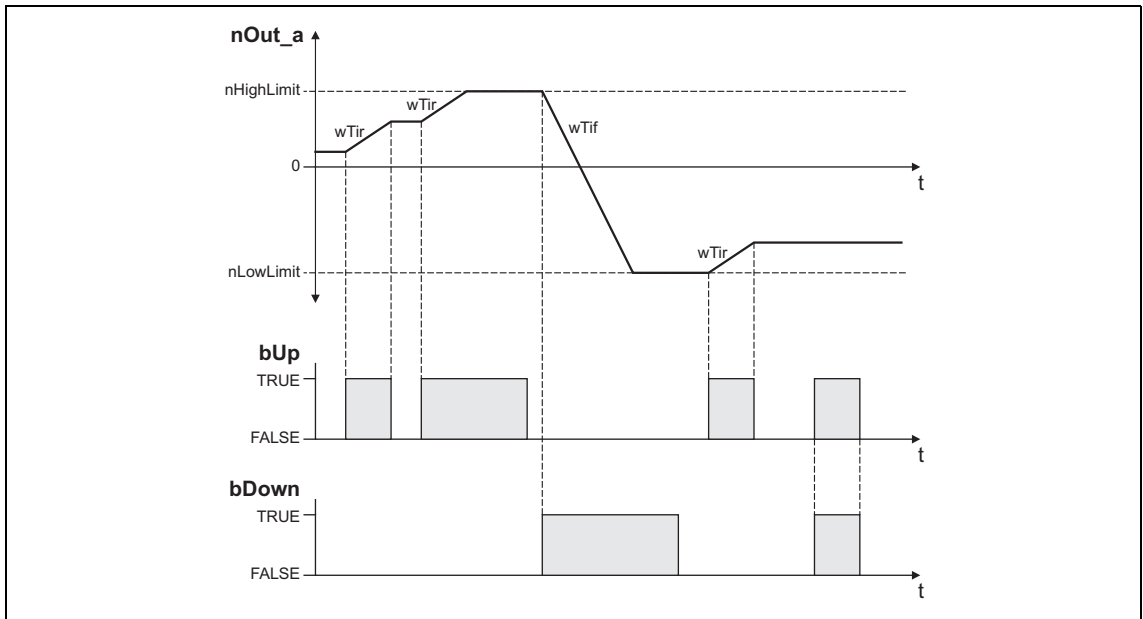

[11-1] Example: Control of the motor potentiometer

bUp	bDown	blnact	Function
FALSE	FALSE	FALSE	The <i>nOut_a</i> output signal remains unchanged.
TRUE	FALSE		The <i>nOut_a</i> output signal runs to its upper limit value ( <i>nHighLimit</i> ).
FALSE	TRUE		The <i>nOut_a</i> output signal runs to its lower limit value ( <i>nLowLimit</i> ).
TRUE	TRUE		The <i>nOut_a</i> output signal remains unchanged.
-	-	TRUE	The motor potentiometer function is deactivated. The <i>nOut_a</i> output signal responds according to the function selected via <i>Function</i> .

### 11.1.2 Deactivate motor potentiometer

When the motor potentiometer is deactivated by setting *blnAct* to TRUE the *nOut\_a* output signal responds according to the function selected in [C804](#).

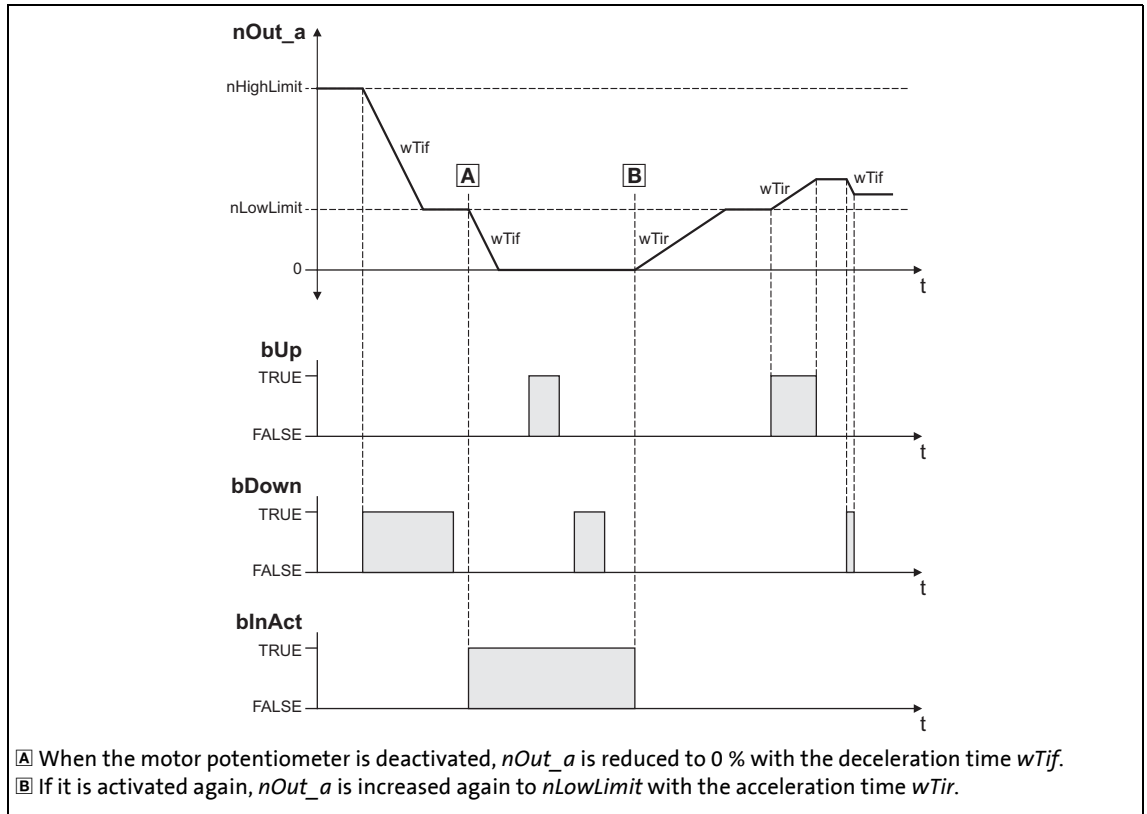

[11-2] Example: Deactivation of the motor potentiometer if [C804](#) = "1: Deceleration to 0"

# 11 Function library

## 11.2 L\_NSet\_1

### 11.2 L\_NSet\_1

This FB is used for general signal processing of process values and is provided with the following functions:

- Ramp function generator
  - With linear ramps for main setpoint path
  - With S-shaped ramp (PT1 rounding)
- Internal limitation of the input signal
- 3 fixed setpoints (JOG setpoints)

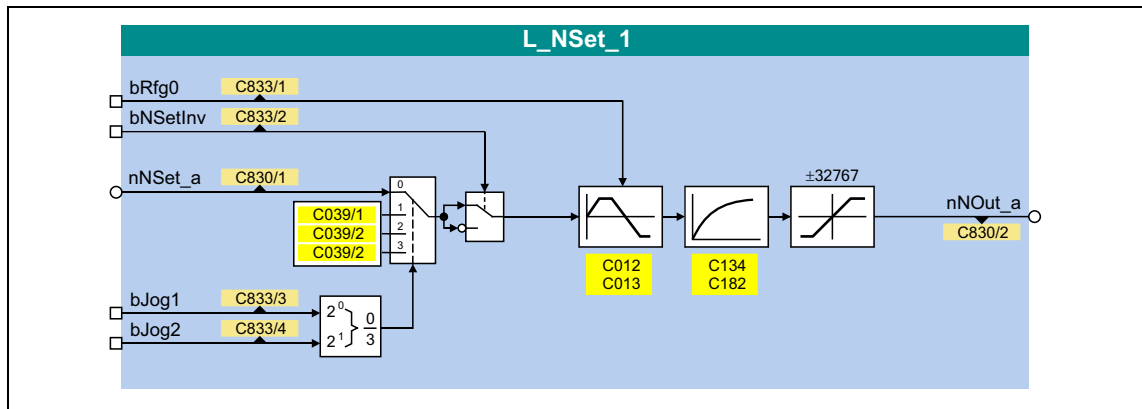

#### Inputs

Identifier	Data type	Information/possible settings
bRfg0	BOOL	Leading the main setpoint integrator to 0 within the current Ti times
		TRUE   The current value of the main setpoint integrator is led to "0" within the Ti time set.
bNSetInv	BOOL	Signal inversion for the main setpoint
		TRUE   Main setpoint signal is inverted.
nNset_a	INT	Main setpoint signal <ul style="list-style-type: none"> <li>• Scaling: 16384 ≙ 100 %</li> <li>• Other signals are also permitted</li> </ul>
bJog1 / bJog2	BOOL	Selection inputs for fixed changeover setpoints (JOG setpoints) for the main setpoint <ul style="list-style-type: none"> <li>• Selection inputs are binary coded.</li> </ul>

#### Outputs

Identifier	Data type	Value/meaning
nNOut_a	INT	Speed setpoint output signal <ul style="list-style-type: none"> <li>• Scaling: 16384 ≙ 100 %</li> </ul>

### Parameter

Parameter	Possible settings			Info
<a href="#">C012</a>	0.0	s	999.9	Acceleration time $T_{ir}$ for the main setpoint • Lenze setting: 2.0 s
<a href="#">C013</a>	0.000	s	999.9	Deceleration time $T_{if}$ for the main setpoint • Lenze setting: 2.0 s
<a href="#">C039/1</a>	-199.9	%	199.9	Fixed setpoint 1 (JOG setpoint 1) • Lenze setting: 40.0 %
<a href="#">C039/2</a>	-199.9	%	199.9	Fixed setpoint 2 (JOG setpoint 2) • Lenze setting: 60.0 %
<a href="#">C039/3</a>	-199.9	%	199.9	Fixed setpoint 3 (JOG setpoint 3) • Lenze setting: 80.0 %
<a href="#">C134</a>	0 Off			Activates ramp rounding with PT1 behaviour for the main setpoint • The corresponding S-ramp time must be set in <a href="#">C182</a> . • Lenze setting: 0 (deactivated)
	1 PT1 behaviour			
<a href="#">C182</a>	0.01	s	50.00	S-ramp time PT1 • Lenze setting: 20.00 s

### 11.2.1 Main setpoint path

- The signals in the main setpoint path are limited to a value range of  $\pm 32767$ .
- The signal at  $nNSet\_a$  is first led via the JOG selection function.
- A selected JOG value switches the  $nNSet\_a$  input inactive. Then, the subsequent signal conditioning operates with the JOG value.

### 11.2.2 JOG setpoints

In addition to the direct main setpoint selection, via the input  $nNSet\_a$  JOG setpoints can be set under [C039/1...3](#).

- The JOG setpoints are binary-coded and can be called using the  $bJog1$  and  $bJog8$  selection inputs:

Selection inputs		Used main setpoint
$bJog2$	$bJog1$	
FALSE	FALSE	$nNSet\_a$
FALSE	TRUE	<a href="#">C039/1</a>
TRUE	FALSE	<a href="#">C039/2</a>
TRUE	TRUE	<a href="#">C039/3</a>

- The number of selection inputs to be assigned depends on the number of JOG setpoints required.

# 11 Function library

## 11.2 L\_NSet\_1

### 11.2.3 Setpoint inversion

The output signal of the JOG function is led via an inverter.

The sign of the setpoint changes if *bNSetInv* is set to TRUE.

### 11.2.4 Ramp function generator for the main setpoint

The setpoint is now led via a ramp function generator with linear characteristic. The ramp function generator converts setpoint step-changes at the input into a ramp.

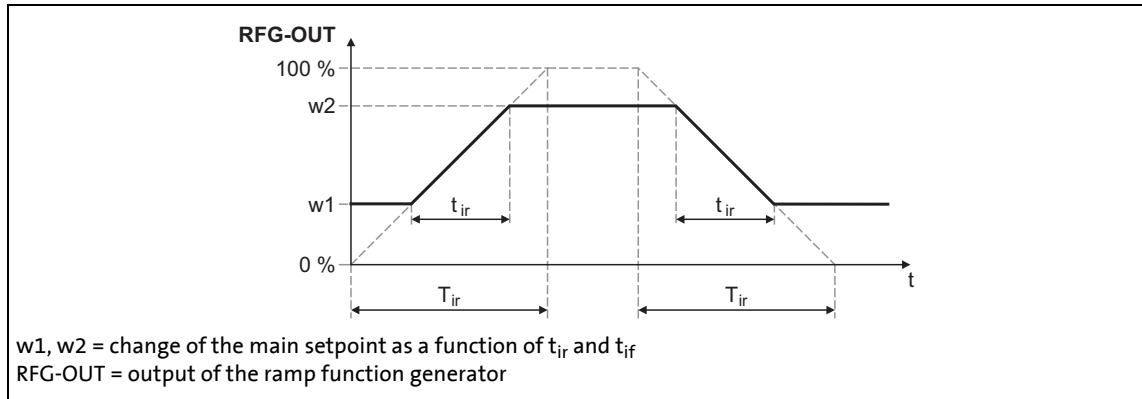

[11-3] Acceleration and deceleration times

- t<sub>ir</sub> and t<sub>if</sub> are the desired times for changing between w1 and w2.
- The ramps for acceleration and deceleration can be set individually.
  - [C012](#): Acceleration time T<sub>ir</sub>
  - [C013](#): Deceleration time T<sub>if</sub>
- The t<sub>ir</sub>/t<sub>if</sub> values are converted into the required Ti times according to the following formula:

$T_{ir} = t_{ir} \cdot \frac{100\%}{w2 - w1}$	$T_{if} = t_{if} \cdot \frac{100\%}{w2 - w1}$
-----------------------------------------------	-----------------------------------------------

- When the *bRfg0* output is set to TRUE, the ramp function generator brakes to 0 along its deceleration ramp.

### 11.2.5 S-shaped ramp

A PT1 element is connected downstream of the linear ramp function generator. This arrangement implements an S-shaped ramp for a nearly jerk-free acceleration and deceleration.

- The PT1 element can be switched on/off via [C134](#).
- The corresponding S-ramp time can be set under [C182](#).

# 11 Function library

## 11.3 L\_PCTRL\_1

### 11.3 L\_PCTRL\_1

This FB is a PID controller and can be used for various control tasks (e.g. as dancer position controller, tension controller, or pressure controller).

The FB provides with the following functions:

- Adjustable control algorithm (P, PI, PID)
- Ramp function generator for preventing setpoint step-changes at the input
- Limitation of the controller output
- Factorisation of the output signal
- Vp adaptation
- Integral action component can be switched off

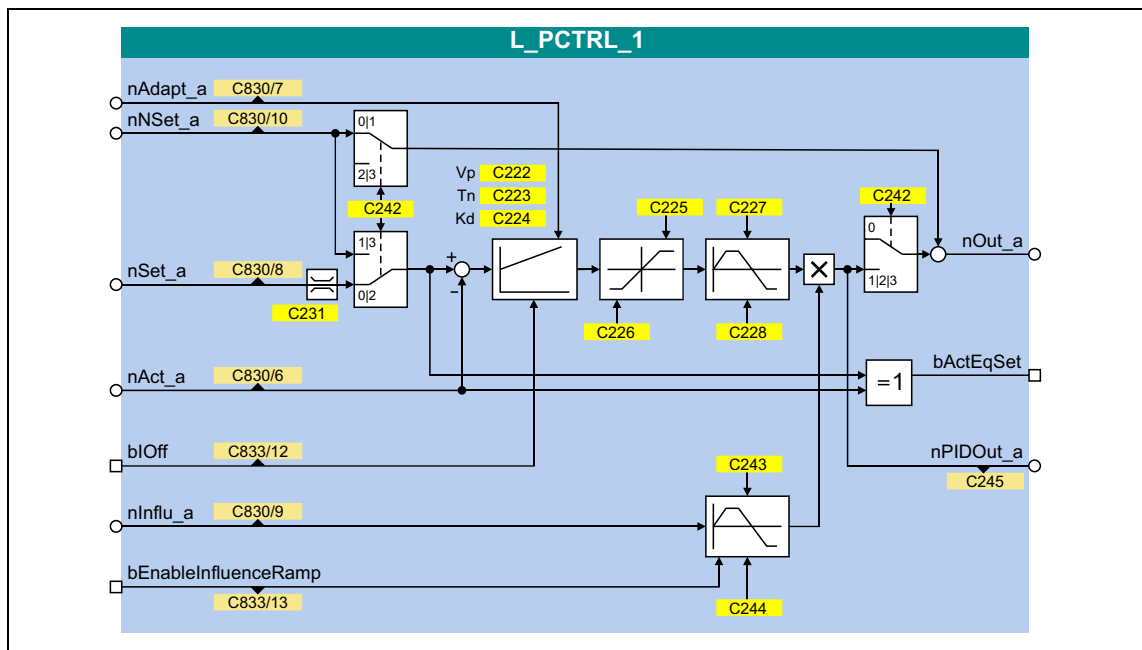

#### Inputs

Identifier	Data type	Information/possible settings
nAdapt_a	INT	Adaptation of gain Vp set in <a href="#">C222</a> in percent <ul style="list-style-type: none"> <li>• Internal limitation to <math>\pm 199.9\%</math></li> <li>• Changes can be done online.</li> <li>• Display parameter: <a href="#">C830/7</a></li> </ul>
nNSet_a	INT	Speed setpoint <ul style="list-style-type: none"> <li>• Scaling: 16384 <math>\equiv</math> 100 %</li> <li>• Internal limitation to <math>\pm 199.9\%</math></li> <li>• Display parameter: <a href="#">C830/10</a></li> </ul>
nSet_a	INT	Sensor and process setpoint for operating modes 2, 4 and 5 <ul style="list-style-type: none"> <li>• Scaling: 16384 <math>\equiv</math> 100 %</li> <li>• Internal limitation to <math>\pm 199.9\%</math></li> <li>• Display parameter: <a href="#">C830/8</a></li> </ul>
nAct_a	INT	Speed or actual sensor value (actual process value) <ul style="list-style-type: none"> <li>• Scaling: 16384 <math>\equiv</math> 100 %</li> <li>• Internal limitation to <math>\pm 199.9\%</math></li> <li>• Display parameter: <a href="#">C830/6</a></li> </ul>



Identifier	Data type	Information/possible settings
bIOff	BOOL	Switch off I-component of process controller <ul style="list-style-type: none"> <li>• Changes can be done online.</li> <li>• Display parameter: <a href="#">C833/12</a></li> </ul>
		TRUE   I-component of the process controller is switched off.
nInflu_a	INT	Limitation of the influencing factor in percent <ul style="list-style-type: none"> <li>• <i>nInflu_a</i> serves to limit the influencing factor of the PID controller contained in the FB to a required value (- 199.9 % ... + 199.9 %).</li> <li>• Scaling: 16384 <math>\equiv</math> 100 %</li> <li>• Internal limitation to <math>\pm</math> 199.9 %</li> <li>• Display parameter: <a href="#">C830/9</a></li> </ul>
bEnableInfluenceRamp	BOOL	Activate ramp for influencing factor <ul style="list-style-type: none"> <li>• Display parameter: <a href="#">C833/13</a></li> </ul>
		TRUE   Influencing factor of the PID controller is ramped up to the <i>nInflu_a</i> value.
		FALSE   Influencing factor of the PID controller is ramped down to "0".

### Outputs

Identifier	Data type	Value/meaning
nOut_a	INT	Output signal <ul style="list-style-type: none"> <li>• Internal limitation to <math>\pm</math>32767 (<math>\pm</math>199.9 %)</li> <li>• Scaling: 16384 <math>\equiv</math> 100 %</li> </ul>
bActEqSet	INT	Status output "Setpoint and actual value are identical" <ul style="list-style-type: none"> <li>TRUE   Setpoint and actual value are identical, i.e. no system deviation available.</li> </ul>
nPIDOut_a	INT	PID controller output <u>with</u> influencing factor <i>nInflu_a</i> <ul style="list-style-type: none"> <li>• There is no connection with the additive input <i>nNSet_a</i>.</li> <li>• Scaling: 16384 <math>\equiv</math> 100 %</li> <li>• Display parameter: <a href="#">C245</a></li> </ul>

### Parameter

Parameter	Possible settings			Info
<a href="#">C222</a>	0.1		500.0	Gain Vp <ul style="list-style-type: none"> <li>• Lenze setting: 1.0</li> </ul>
<a href="#">C223</a>	20	ms	6000	Reset time Tn <ul style="list-style-type: none"> <li>• Lenze setting: 400 ms</li> </ul>
<a href="#">C224</a>	0.0		5.0	Differential component Kd <ul style="list-style-type: none"> <li>• Lenze setting: 0.0</li> </ul>
<a href="#">C225</a>	-199.9	%	+199.9	Maximum value of the PID operating range <ul style="list-style-type: none"> <li>• Lenze setting: 199.9 %</li> </ul>
<a href="#">C226</a>	-199.9	%	+199.9	Minimum value of the PID operating range <ul style="list-style-type: none"> <li>• Lenze setting: -199.9 %</li> </ul>
<a href="#">C227</a>	0.0	s	999.9	Acceleration time for the ramp at the PID output (should be set as steep as possible) <ul style="list-style-type: none"> <li>• Lenze setting: 0.1 s</li> </ul>
<a href="#">C228</a>	0.0	s	999.9	Deceleration time for the ramp at the PID output <ul style="list-style-type: none"> <li>• Lenze setting: 0.1 s</li> </ul>

Parameter	Possible settings			Info
<a href="#">C231/1</a> (Pos. Maximum) <a href="#">C231/2</a> (Pos. Minimum) <a href="#">C231/3</a> (Neg. Minimum) <a href="#">C231/4</a> (Neg. Maximum)	0.0	%	199.9	Operating range <ul style="list-style-type: none"> <li>• Determination of the operating range for the PID process controller by limiting the input signal <i>nSet_a</i>.</li> <li>• Lenze setting: No limitation (-199.9 % ... +199.9 %)</li> </ul>
<a href="#">C242</a>				Operating mode
	0	Off (Lenze setting)		The input setpoint <i>nSet_a</i> is output without any changes at the output <i>nOut_a</i> .
	1	Additive + feedforward control		<i>nSet_a</i> and <i>nAct_a</i> are used as PID input values. The arriving <i>nSet_a</i> is additively linked to the value output by the PID element.
	2	PID as setpoint generator.		<i>nSet_a</i> and <i>nAct_a</i> are used as PID input values. The input <i>nSet_a</i> is not considered.
	3	PID setpoint from <a href="#">L_NSet_1</a>		<i>nSet_a</i> and <i>nAct_a</i> are used as PID input values. The input <i>nSet_a</i> is not considered.
<a href="#">C243</a>	0.0	s	999.9	Influence acceleration time <ul style="list-style-type: none"> <li>• Acceleration time <math>T_{ir}</math> for the influencing factor.</li> <li>• Lenze setting: 5.0 s</li> </ul>
<a href="#">C244</a>	0.0	s	999.9	Influence deceleration time <ul style="list-style-type: none"> <li>• Deceleration time <math>T_{if}</math> for the influencing factor.</li> <li>• Lenze setting: 5.0 s</li> </ul>
<a href="#">C245</a>	-199.9	%	+199.9	Display of PID output value <i>nPIDOut_a</i>

### 11.3.1 Control characteristic

The PI algorithm is active in the Lenze setting.

#### Gain (P component)

The input value is controlled by a linear characteristic. The slope of the characteristic is determined by the controller gain  $V_p$ .

The controller gain  $V_p$  is set under [C222](#).

- The controller gain can be adapted via the input  $nAdapt\_a$  (also possible in online mode).
- The input value  $nAdapt\_a$  has a direct effect on the controller gain:

$$P = nAdapt\_a \cdot C00222$$

Example: With the parameterised controller gain  $V_p = 2.0$  and  $nAdapt\_a = 75\%$ , the resulting gain factor is as follows:

$$P = \frac{75 [\%]}{100 [\%]} \cdot 2.0 = 1.5$$

#### Integral action component (I component)

The I component of the controller can be deactivated by setting the input  $bIOff$  to TRUE.

- Setting the reset time  $T_n$  to the maximum value of "6000 ms" also deactivates the I component.
- The I component can be switched on and off online.

#### Adjustment time

The reset time  $T_n$  is set under [C223](#).

#### Differential component $K_d$ (D component)

The differential component  $K_d$  is set under [C224](#).

- The setting "0.0" deactivates the D component (Lenze setting). In this way, the PID controller becomes a PI controller or P controller, if the I component has been deactivated as well.

### 11.3.2 Ramp function generator

The PID output is led via a ramp function generator with linear characteristic. This serves to transfer setpoint step-changes at the PID output into a ramp which should be as steep as possible.

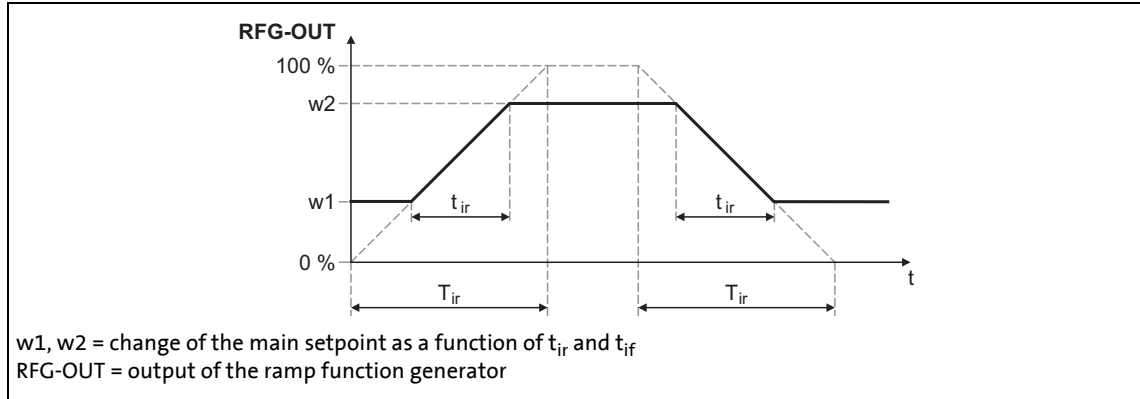

[11-4] Acceleration and deceleration times

- $t_{ir}$  and  $t_{if}$  are the desired times for changing between  $w1$  and  $w2$ .
- The ramps for acceleration and deceleration can be set individually.
  - [C227](#): Acceleration time  $T_{ir}$
  - [C228](#): Deceleration time  $T_{if}$
- The  $t_{ir}/t_{if}$  values are converted into the required  $Ti$  times according to the following formula:

$T_{ir} = t_{ir} \cdot \frac{100\%}{w2 - w1}$	$T_{if} = t_{if} \cdot \frac{100\%}{w2 - w1}$
-----------------------------------------------	-----------------------------------------------

- The ramp function generator is immediately set to "0" by setting *bInAct* to TRUE.

### 11.3.3 Operating range of the PID process controller

The value range of the input signal *nSet\_a* and thus the operating range of the PID process controller can be limited with the following parameters:

- [C231/1](#): Pos. maximum (default setting: 199.9 %)
- [C231/2](#): Pos. minimum (default setting: 0.0 %)
- [C231/3](#): Neg. minimum (default setting: 0.0 %)
- [C231/4](#): Neg. maximum (default setting: 199.9 %)

### 11.3.4 Evaluation of the output signal

After the limitation, the output signal is evaluated with the influencing factor *nInflu\_a*. The evaluation is activated/suppressed along a ramp when the input *bEnableInfluenceRamp* is set to TRUE. The ramp times are set with the parameters "Acceleration time influence" ([C243](#)) and "Deceleration time influence" ([C244](#)).

# 11 Function library

## 11.4 L\_RLO\_1

### 11.4 L\_RLO\_1

This FB links a selected direction of rotation to the quick stop function with wire-break protection.

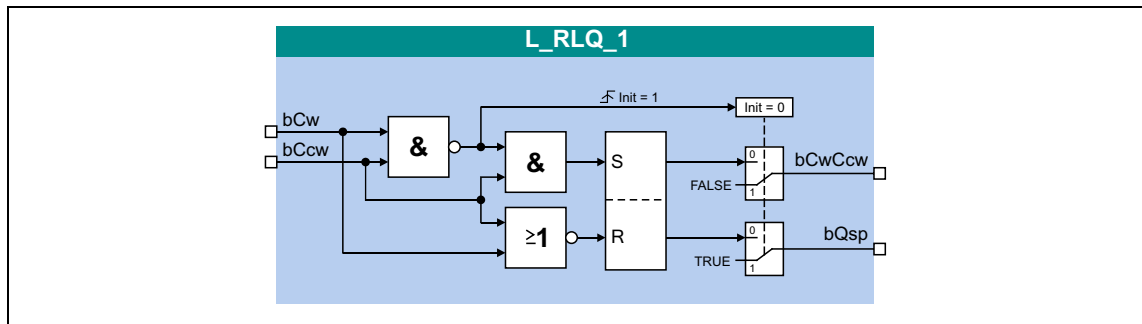

#### Inputs

Identifier	Data type	Information/possible settings
bCw	BOOL	Input • TRUE = CW rotation
bCCw	BOOL	Input • TRUE = CCW rotation

#### Outputs

Identifier	Data type	Value/meaning
bQSP	BOOL	Output signal for quick stop (QSP)
bCwCcw	BOOL	Output signal for CW/CCW rotation • TRUE = CCW rotation

#### Function

Inputs		Outputs		Notes
bCw	bCCw	bCwCcw	bQSP	
TRUE	TRUE	FALSE	TRUE	The inputs have this state only if a TRUE signal is being applied to <u>both</u> inputs at the moment of switch-on! See also FB illustration above, "Init" = 1.
If <i>one</i> of the inputs has the TRUE state, the following truth table applies:				
FALSE	FALSE	FALSE	TRUE	See also FB illustration above, "Init" = 0.
TRUE	FALSE	FALSE	FALSE	
FALSE	TRUE	TRUE	FALSE	
TRUE	TRUE	X (save)		

[11-5] Truth table of the FB L\_RLO, 0 = FALSE, 1 = TRUE

# 11 Function library

11.4 L\_RLO\_1

## Wiring in the application

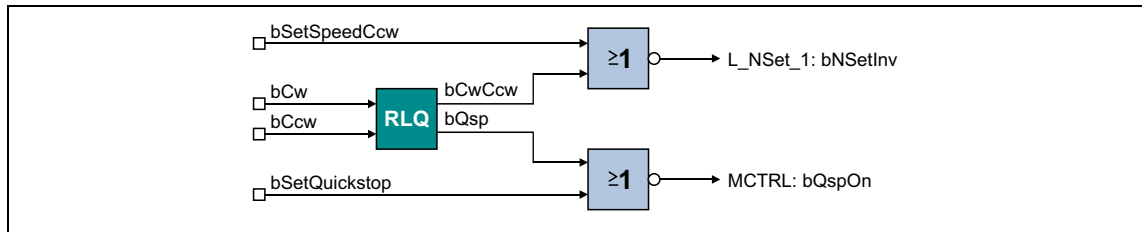

[11-6] Internal wiring

# 11 Function library

## 11.5 LS\_AnalogInput

### 11.5 LS\_AnalogInput

The **LS\_AnalogInput** system block displays the analog input in the application on I/O level.

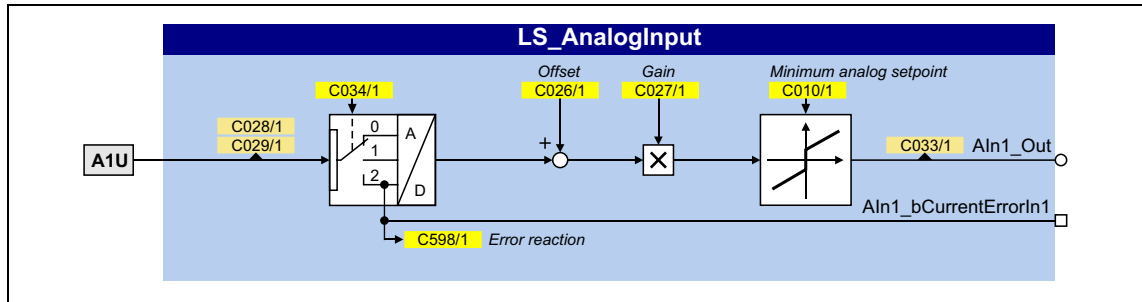

### Outputs

Identifier	Data type	Value/meaning
nIn1_a	<a href="#">C033/1</a>   INT	Analog input 1 <ul style="list-style-type: none"> <li>Scaling:               <ul style="list-style-type: none"> <li><math>\pm 2^{14} \equiv \pm 10 \text{ V}</math> for use as voltage input</li> <li><math>+2^{14} \equiv +20 \text{ mA}</math> for use as current input</li> </ul> </li> </ul>
bCurrentErrorIn1	BOOL	Status signal "Current input error" <ul style="list-style-type: none"> <li>Only when analog input 1 is used as current input.</li> <li>Application: Cable-breakage monitoring of the 4 ...20 mA circuit.</li> </ul>
		TRUE   $ I_{AIN1}  < 4 \text{ mA}$

### Related topics:

- ▶ [Analog terminals](#) (📖 111)
- ▶ [Electrical data](#) (📖 119)

# 11 Function library

## 11.6 LS\_DigitalInput

### 11.6 LS\_DigitalInput

The **LS\_DigitalInput** system block displays the digital input terminals in the application on I/O level.

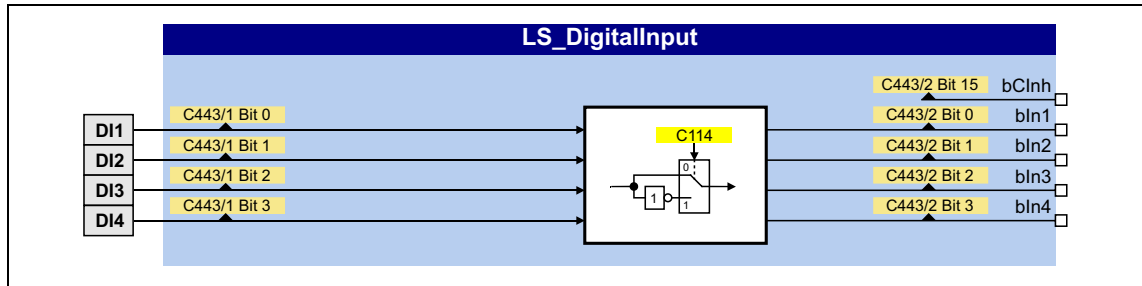

#### Outputs

Identifier	Value/meaning
<small>DIS code   data type</small> bCInh	RFR digital input (controller enable)
<small>C443/2   BOOL</small> bIn1 ... bIn4	Digital input DI1 ... DI4

#### Related topics:

- ▶ [Digital terminals](#) (109)
- ▶ [Electrical data](#) (119)



11.7 LS\_DigitalOutput

The LS\_DigitalInput system block displays the digital output terminals in the application on I/O level.

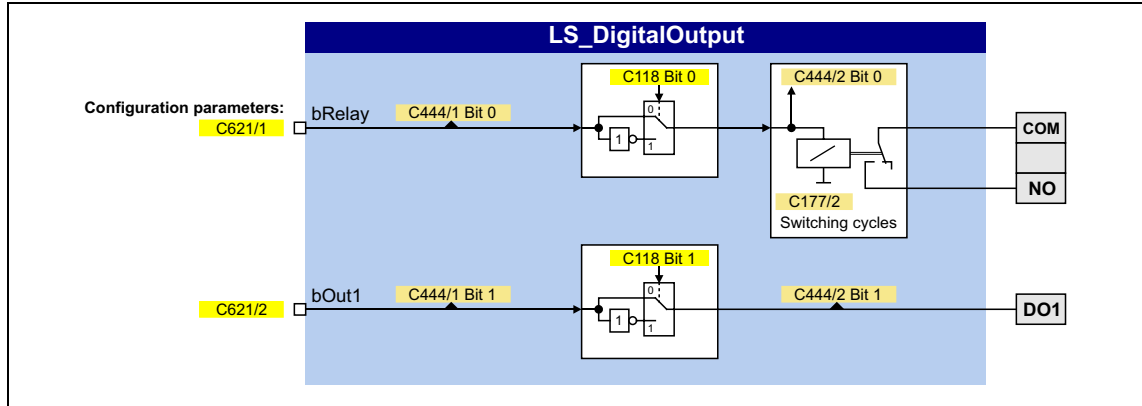

Inputs

Identifier	Information/possible settings
bRelay <small>DIS code   data type</small> <a href="#">C444/1</a>   BOOL	Relay output (potential-free two-way switch)
bOut1 <small>DIS code   data type</small> <a href="#">C444/1</a>   BOOL	Digital output DO1

Related topics:

- ▶ [Digital terminals](#) (109)
- ▶ [Electrical data](#) (119)

11.8 LS\_DisFree

This system block displays any four 16-bit signals of the application on display codes. The signals to be displayed are selected via the given configuration parameters.

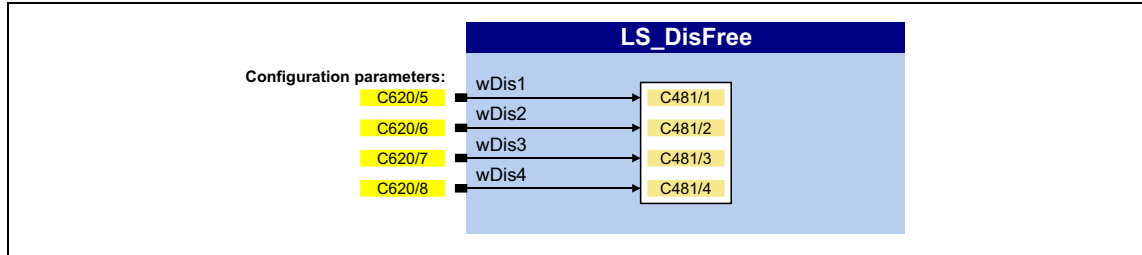

Inputs

Identifier	Data type	Information/possible settings
wDis1 ... wDis4	WORD	Inputs for any 16-bit signals of the application

Parameter

Parameter	Possible settings	Info
<a href="#">C481/1...4</a>	0x0000	0xFFFF Display of the 16-bit signals at the wDis1 ... wDis4 inputs
<a href="#">C620/5...8</a>	See <a href="#">selection list - analog signals</a> Configuration parameters for the inputs wDis1 ... wDis4	

11.9 LS\_DisFree\_a

This system block displays any four analog signals of the application on display codes. The signals to be displayed are selected via the given configuration parameters.

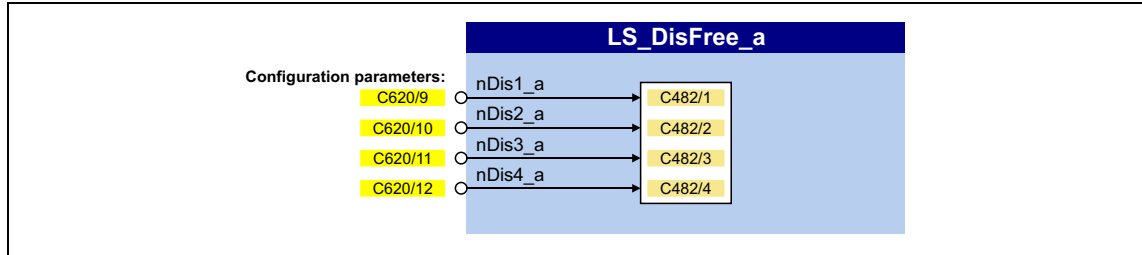

Inputs

Identifier	Data type	Information/possible settings
nDis1_a ... nDis4_a	INT	Inputs for any analog signal of the application

Parameter

Parameter	Possible settings	Info
<a href="#">C482/1...4</a>	-199.9 %	199.9 % Display of the analog signals which are applied at the <i>nDis1_a</i> ... <i>nDis4_a</i> inputs.
<a href="#">C620/9...12</a>	See <a href="#">selection list - analog signals</a>	Configuration parameters for the inputs <i>nDis1_a</i> ... <i>nDis4_a</i>

### 11.10 LS\_DisFree\_b

This system block displays any eight digital signals of the application on a bit-coded display code. The signals to be displayed are selected via the given configuration parameters.

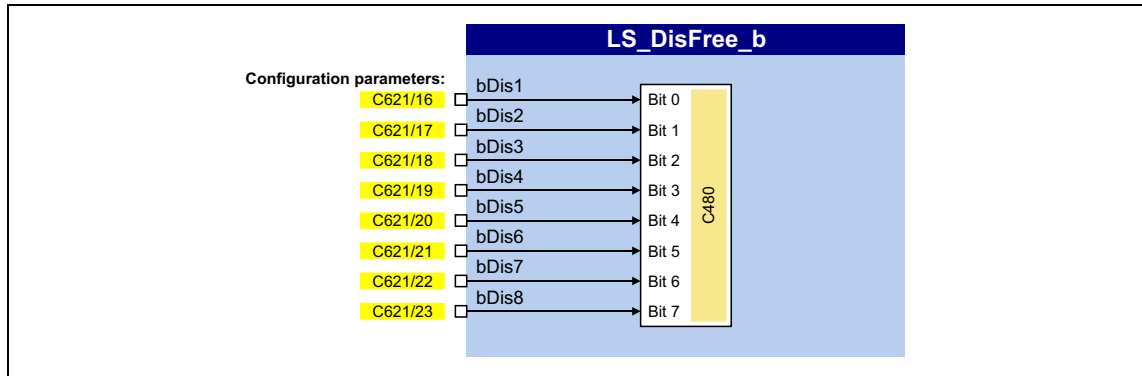

#### Inputs

Identifier	Data type	Information/possible settings
bDis1 ... bDis8	BOOL	Inputs for any digital signal of the application

#### Parameter

Parameter	Possible settings	Info
<a href="#">C480</a>	0x0000 Bit 0 Signal level at the <i>bDis1</i> input Bit 1 Signal level at the <i>bDis2</i> input Bit 2 Signal level at the <i>bDis3</i> input ... Bit 7 Signal level at the <i>bDis8</i> input	0xFFFF Display of the digital signals applied at the <i>bDis1</i> ... <i>bDis8</i> inputs in the form of hexadecimal values
<a href="#">C621/16...23</a>	See <a href="#">selection list - digital signals</a>	Configuration parameters for the inputs <i>bDis1</i> ... <i>bDis8</i>

# 11 Function library

## 11.11 LS\_DriveInterface

### 11.11 LS\_DriveInterface

The LS\_DriveInterface system block displays the device control in the application.

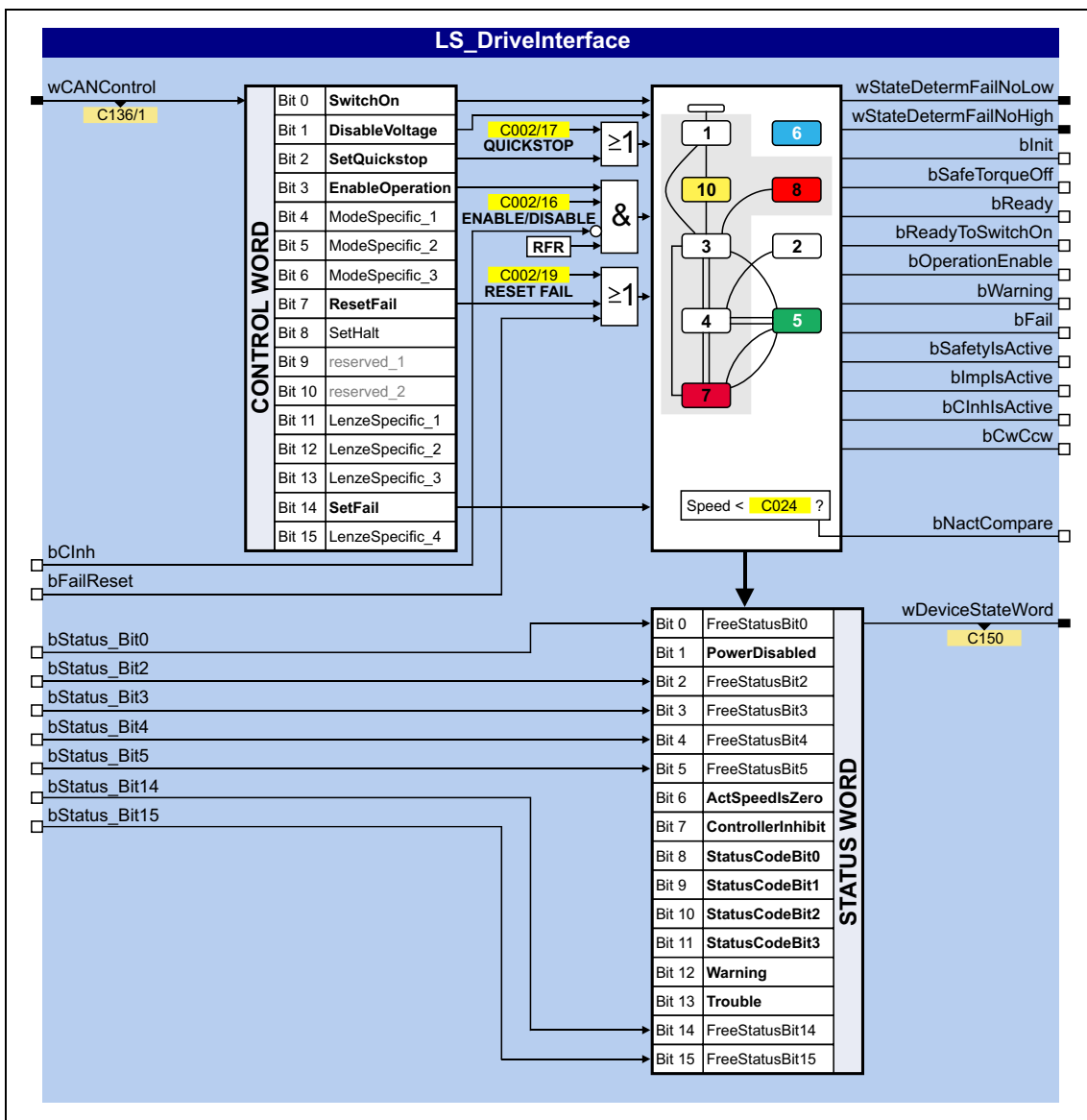

## Inputs

Identifier DIS code   data type	Information/possible settings														
wCANControl <a href="#">C136/1</a>   WORD	Control word via system bus (CAN) <ul style="list-style-type: none"> <li>In the control mode "30: CAN", the controller controlled by a master control (e.g. IPC) receives its control word by the CANopen system bus interface. The process data word is provided at this input by the upstream port block <a href="#">LP_CanIn1</a>.</li> <li>See the "<a href="#">Process data assignment for control via CAN</a>" chapter for a detailed description of the individual control bits.</li> </ul>														
bCInh <a href="#">C833/14</a>   BOOL	<a href="#">Enable/Inhibit controller</a> <table border="1" data-bbox="608 600 1441 779"> <tr> <td data-bbox="608 600 759 712">FALSE</td> <td data-bbox="759 600 1441 712">Enable controller: The controller switches to the "<a href="#">OperationEnabled</a>" device state, if no other source of a controller inhibit is active. <ul style="list-style-type: none"> <li><a href="#">C158</a> provides a bit coded representation of all active sources/triggers of a controller inhibit.</li> </ul> </td> </tr> <tr> <td data-bbox="608 712 759 779">TRUE</td> <td data-bbox="759 712 1441 779">Inhibit controller (controller inhibit): The controller switches to the "<a href="#">SwitchedON</a>" device state.</td> </tr> </table>	FALSE	Enable controller: The controller switches to the " <a href="#">OperationEnabled</a> " device state, if no other source of a controller inhibit is active. <ul style="list-style-type: none"> <li><a href="#">C158</a> provides a bit coded representation of all active sources/triggers of a controller inhibit.</li> </ul>	TRUE	Inhibit controller (controller inhibit): The controller switches to the " <a href="#">SwitchedON</a> " device state.										
FALSE	Enable controller: The controller switches to the " <a href="#">OperationEnabled</a> " device state, if no other source of a controller inhibit is active. <ul style="list-style-type: none"> <li><a href="#">C158</a> provides a bit coded representation of all active sources/triggers of a controller inhibit.</li> </ul>														
TRUE	Inhibit controller (controller inhibit): The controller switches to the " <a href="#">SwitchedON</a> " device state.														
bFailReset <a href="#">C833/15</a>   BOOL	<a href="#">Reset of error message</a> In the Lenze setting this input is connected to the digital input controller enable so that a possibly existing error message is reset together with the controller enable (if the cause for the fault is eliminated). <table border="1" data-bbox="608 898 1441 960"> <tr> <td data-bbox="608 898 759 960">TRUE</td> <td data-bbox="759 898 1441 960">The current fault is reset, if the cause for the fault is eliminated. <ul style="list-style-type: none"> <li>If the fault still exists, the error status remains unchanged.</li> </ul> </td> </tr> </table>	TRUE	The current fault is reset, if the cause for the fault is eliminated. <ul style="list-style-type: none"> <li>If the fault still exists, the error status remains unchanged.</li> </ul>												
TRUE	The current fault is reset, if the cause for the fault is eliminated. <ul style="list-style-type: none"> <li>If the fault still exists, the error status remains unchanged.</li> </ul>														
bStatus_Bit0 bStatus_Bit2 bStatus_Bit3 bStatus_Bit4 bStatus_Bit5 bStatus_Bit14 bStatus_Bit15 <a href="#">C833/16...22</a>   BOOL	Freely assignable bits in the status word of the controller. <ul style="list-style-type: none"> <li>You can use these bits for returning information to the master control (e.g. IPC).</li> </ul> Pre-assignment in the Lenze setting: <table border="1" data-bbox="608 1070 1441 1415"> <tr> <td data-bbox="608 1070 759 1104">Bit0</td> <td data-bbox="759 1070 1441 1104">- (Not connected)</td> </tr> <tr> <td data-bbox="608 1104 759 1137">Bit2</td> <td data-bbox="759 1104 1441 1137">Current setpoint in the limitation</td> </tr> <tr> <td data-bbox="608 1137 759 1171">Bit3</td> <td data-bbox="759 1137 1441 1171">Speed setpoint reached</td> </tr> <tr> <td data-bbox="608 1171 759 1249">Bit4</td> <td data-bbox="759 1171 1441 1249">Actual speed value has reached the setpoint within one hysteresis band</td> </tr> <tr> <td data-bbox="608 1249 759 1283">Bit5</td> <td data-bbox="759 1249 1441 1283">Speed setpoint &lt; comparison value (<a href="#">C024</a>)</td> </tr> <tr> <td data-bbox="608 1283 759 1384">Bit14</td> <td data-bbox="759 1283 1441 1384">Current direction of rotation: 0 ≡ Clockwise rotation (Cw) 1 ≡ Counter-clockwise rotation (Ccw)</td> </tr> <tr> <td data-bbox="608 1384 759 1415">Bit15</td> <td data-bbox="759 1384 1441 1415">Drive is ready for operation</td> </tr> </table>	Bit0	- (Not connected)	Bit2	Current setpoint in the limitation	Bit3	Speed setpoint reached	Bit4	Actual speed value has reached the setpoint within one hysteresis band	Bit5	Speed setpoint < comparison value ( <a href="#">C024</a> )	Bit14	Current direction of rotation: 0 ≡ Clockwise rotation (Cw) 1 ≡ Counter-clockwise rotation (Ccw)	Bit15	Drive is ready for operation
Bit0	- (Not connected)														
Bit2	Current setpoint in the limitation														
Bit3	Speed setpoint reached														
Bit4	Actual speed value has reached the setpoint within one hysteresis band														
Bit5	Speed setpoint < comparison value ( <a href="#">C024</a> )														
Bit14	Current direction of rotation: 0 ≡ Clockwise rotation (Cw) 1 ≡ Counter-clockwise rotation (Ccw)														
Bit15	Drive is ready for operation														

## Outputs

Identifier DIS code   data type	Value/meaning	
wDeviceStateWord <a href="#">C150</a>   WORD	Status word of the controller (based on DSP-402) <ul style="list-style-type: none"> <li>The status word contains information on the current status of the drive controller.</li> <li>In control mode "30: CAN", the status word is transmitted to the master control as process data word via the <a href="#">LP_CanOut1</a> port block.</li> <li>For a detailed description of each status bit see chapter "<a href="#">Process data assignment for control via CAN</a>".</li> </ul>	
wStateDetermFailNoLow WORD	Display of the status determining error (LOW word)	
wStateDetermFailNoHigh WORD	Display of the status determining error (HIGH word)	
bInit BOOL	TRUE	" <a href="#">Init</a> " device state is active
bSafeTorqueOff BOOL	TRUE	" <a href="#">SafeTorqueOff</a> " device state is active
bReady BOOL	TRUE	" <a href="#">SwitchedON</a> " device state is active
bReadyToSwitchOn BOOL	TRUE	" <a href="#">ReadyToSwitchON</a> " device state is active
bOperationEnable BOOL	TRUE	" <a href="#">OperationEnabled</a> " device state is active
bWarning BOOL	TRUE	A warning exists
bFail BOOL	TRUE	" <a href="#">Fault</a> " device state is active
bSafetyIsActive BOOL	TRUE	In preparation
bImplsActive BOOL	TRUE	Pulse inhibit is active
bCIhIsActive BOOL	TRUE	Controller inhibit is active
bCwCcw BOOL	FALSE	Clockwise rotation (Cw)
	TRUE	Counter-clockwise rotation (Ccw)
bNactCompare BOOL	TRUE	During open-loop operation: Speed setpoint < comparison value ( <a href="#">C024</a> )
		During closed-loop operation: Actual speed value < comparison value ( <a href="#">C024</a> )

### 11.12 LS\_Keypad

This system block is used on I/O interconnection level if the "Keypad" control mode has been selected in [C007](#).

In the "Keypad" control mode, the **LS\_Keypad** system block passes on various setpoints and control commands to the technology application which can be selected/activated via codes using the keypad.

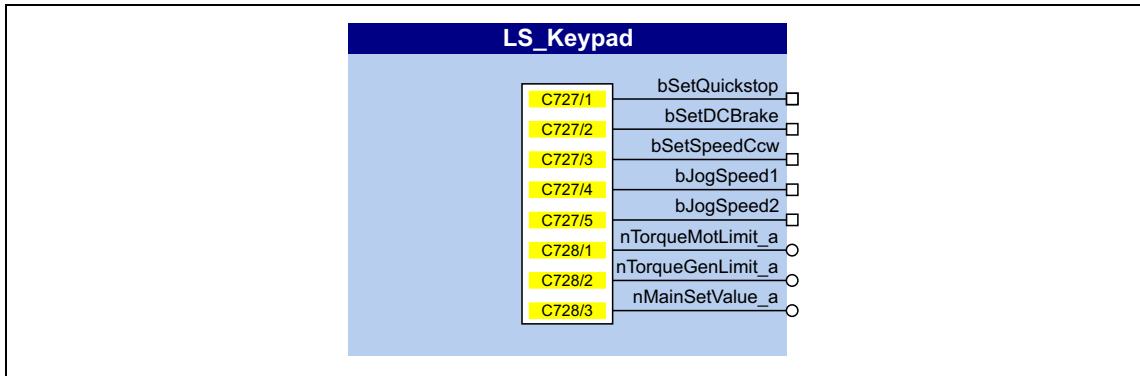

#### Outputs

Identifier	Data type	Value/meaning
bSetQuickstop	BOOL	<a href="#">C727/1</a> = "1" ≡ Request quick stop
bSetDCBrake	BOOL	<a href="#">C727/2</a> = "1" ≡ Request DC-injection braking
bSetSpeedCcw	BOOL	<a href="#">C727/3</a> = "1" ≡ Request reversal"
bJogSpeed1	BOOL	<a href="#">C727/4</a> = "1" ≡ Request fixed speed setpoint 1/2
bJogSpeed2	BOOL	<a href="#">C727/5</a> = "1" ≡ Request fixed speed setpoint 2/3
nTorqueMotLimit_a	INT	Torque limit in motor mode set in <a href="#">C728/1</a> • Lenze setting: 100.0 %
nTorqueGenLimit_a	INT	Torque limit in generator mode set in <a href="#">C728/2</a> • Lenze setting: 100.0 %
nMainSetValue_a	INT	Setpoint speed set in <a href="#">C728/3</a> • Lenze setting: 0.0 %

#### Parameter

Parameter	Possible settings			Info
<a href="#">C727/1...8</a>	0		1	Keypad digital values • Executing control commands when operating via keypad • See the "Outputs" table for the meaning of the individual sub-codes
<a href="#">C728/1...3</a>	-199.9	%	199.9	Keypad analog values • Selection of different setpoints when operating via keypad • See the "Outputs" table for the meaning of the individual sub-codes



### 11.13 LS\_ParFix

This system block outputs various fixed values (constants) to be used in the interconnection. The constants can be assigned to other inputs via configuration parameters.

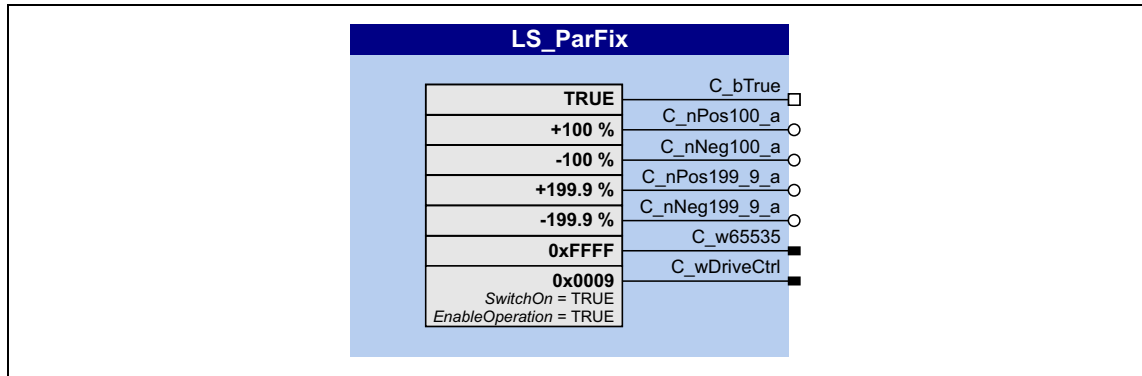

#### Outputs

Identifier	Data type	Value/meaning
C_bTrue	BOOL	1 ≙ TRUE
C_nPos100_a	INT	16384 ≙ + 100 %
C_nNeg100_a	INT	-16384 ≙ - 100 %
C_nPos199_9_a	INT	32767 ≙ + 199.9 %
C_nNeg199_9_a	INT	-32767 ≙ - 199.9 %
C_w65535	WORD	65535 ≙ 0xFFFF
C_wDriveCtrl	WORD	9 ≙ 0x0009 <ul style="list-style-type: none"> <li>• Bit 0, SwitchOn = TRUE</li> <li>• Bit 3, EnableOperation = TRUE</li> <li>• All others: FALSE</li> </ul> See also: <a href="#">▶ Process data assignment for control via CAN (137)</a>

#### Related topics:

▶ [User-defined terminal assignment \(114\)](#)

### 11.14 LS\_ParFree\_a

This system block outputs 4 parameterisable analog signals. The analog signals can be assigned to other inputs via configuration parameters.

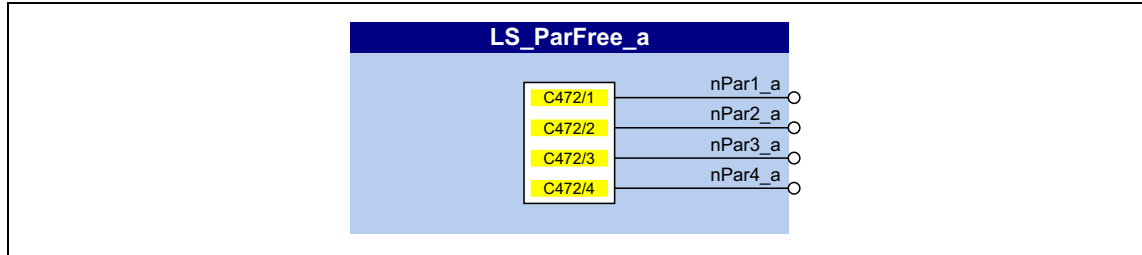

#### Outputs

Identifier	Data type	Value/meaning
nPar1_a ... nPar4_a	INT	Output of the analog signals parameterised in <a href="#">C472/1...4</a>

#### Parameter

Parameter	Possible settings			Info
<a href="#">C472/1...4</a>	-199.9	%	+199.9	Selection of analog signals to be output

#### Related topics:

- ▶ [User-defined terminal assignment](#) (📖 114)

**11.15 LS\_ParFree\_b**

This system block outputs 16 parameterisable digital signals. The digital signals can be assigned to other inputs via configuration parameters.

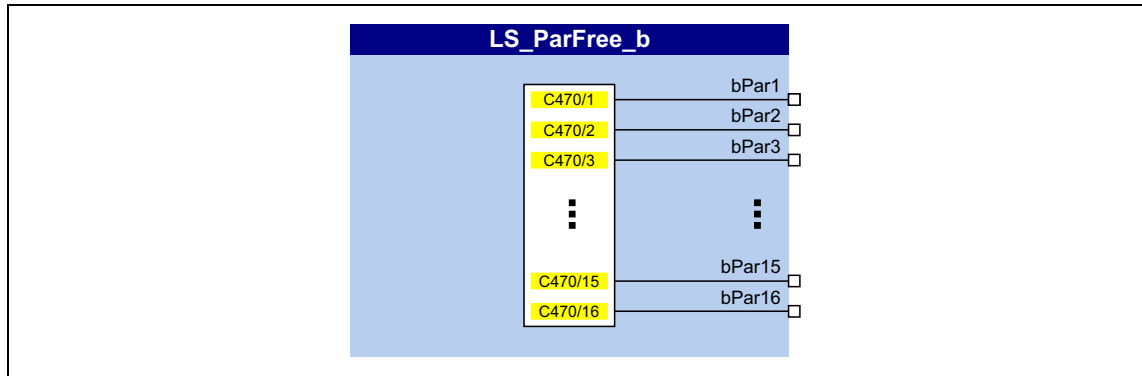

**Outputs**

Identifier	Data type	Value/meaning
bPar1 ... bPar16	BOOL	Output of the signals levels (FALSE/TRUE) parameterised in <a href="#">C470/1...16</a>

**Parameter**

Parameter	Possible settings	Info
<a href="#">C470/1...16</a>		Selection of signal levels to be output • Bit 0 ... 15 = <i>bPar1 ... bPar16</i>
	0 "FALSE" signal is output	
	1 "TRUE" signal is output	

**Related topics:**

- ▶ [User-defined terminal assignment](#) (📖 114)

# 11 Function library

## 11.16 LS\_SetError\_1

### 11.16 LS\_SetError\_1

This system block is used for error handling within the application.

- The application can trip up to two different user error messages with parameterisable error response via the two boolean inputs.
- If both inputs are set to TRUE at the same time, the *bSetError1* inputs trips the error message.

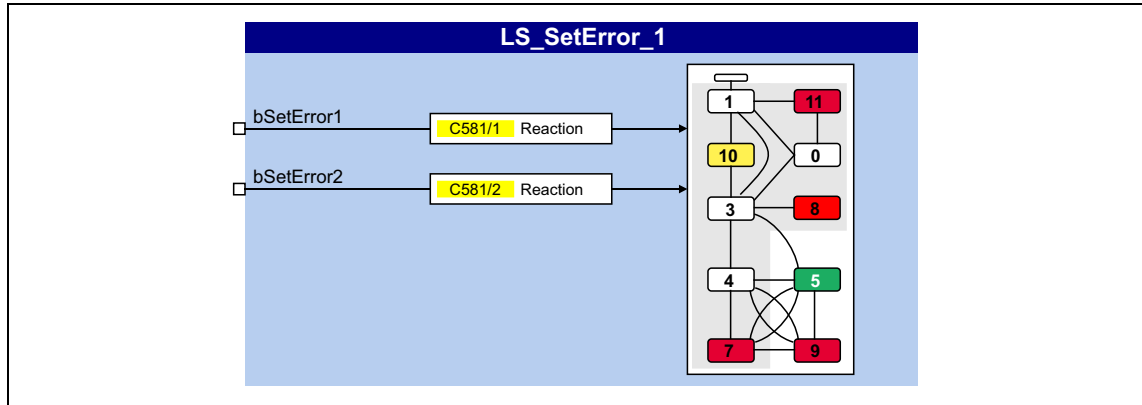

#### Inputs

Identifier	Data type	Information/possible settings
bSetError1	BOOL	Input for tripping " <a href="#">US01: User error 1</a> " <ul style="list-style-type: none"> <li>• Error subject number: 980</li> <li>• Error number: <math>(C581/1 \times 0x0400000) + (980 \times 0x10000)</math></li> </ul>
bSetError2	BOOL	Input for tripping " <a href="#">US02: User error 2</a> " <ul style="list-style-type: none"> <li>• Error subject number: 981</li> <li>• Error number: <math>(C581/2 \times 0x0400000) + (981 \times 0x10000)</math></li> </ul>

#### Parameter

Parameter	Possible settings	Info								
<a href="#">C581/1...2</a>	<table border="1"> <tr> <td>0</td> <td>No response</td> </tr> <tr> <td>1</td> <td>Fault (pulse inhibit)</td> </tr> <tr> <td>2</td> <td>Trouble</td> </tr> <tr> <td>4</td> <td>WarningLocked</td> </tr> </table>	0	No response	1	Fault (pulse inhibit)	2	Trouble	4	WarningLocked	Response for user error 1 ... 2 <ul style="list-style-type: none"> <li>• lenze setting: "Fault"</li> </ul>
0	No response									
1	Fault (pulse inhibit)									
2	Trouble									
4	WarningLocked									

# Index

---

## Numbers

- 16-bit analog input (C00830) [292](#)
- 16-bit system connection (C00620) [285](#)
- 16Bit-Input common (C00831) [292](#)
- 87-Hz operation [83](#)
- 8-bit input (C00833) [293](#)

## A

- Acceleration time main setpoint (C00012) [239](#)
- Acknowledgement error [206](#)
- Activating the bus terminating resistor [173](#)
- Active COBID (C00355) [271](#)
- AINx
  - Configuration (C00034) [243](#)
  - Gain (C00027) [242](#)
  - Input current (C00029) [243](#)
  - Input voltage (C00028) [242](#)
  - Offset (C00026) [242](#)
  - Output value (C00033) [243](#)
- An01
  - AIN1\_I < 4 mA (error message) [163](#)
- Analog inputs [111](#)
- Appl.
  - Reference frequency C11 (C00059) [246](#)
  - Reference speed (C00011) [239](#)
- Application notes [11](#)
- Assignment of the process data objects [184](#)
- Auto-DCB [97](#)
  - Hold time (C00106) [251](#)
  - Threshold (C00019) [241](#)
- Automatic DC-injection braking (Auto-DCB) [97](#)
- Automatic motor data identification [70](#)
- Automatic saving [49](#)
- Auto-start option (C00142) [256](#)

## B

- Bit error [206](#)
- Blocks [304](#)
- Bool system connection (C00621) [286](#)
- Brake chopper [101](#)
- Brake resistor [101](#)
- Brake resistor monitoring (I2xt) [106](#)
- Braking operation [101](#)

## C

- C10 [239](#)
- C100 [250](#)
- C105 [251](#)
- C106 [251](#)
- C107 [251](#)
- C11 [239](#)
- C114 [252](#)
- C118 [252](#)
- C12 [239](#), [310](#)

- C120 [253](#)
- C122 [253](#)
- C123 [253](#)
- C13 [239](#), [310](#)
- C134 [253](#), [310](#)
- C136 [254](#)
- C137 [255](#)
- C141 [255](#)
- C142 [256](#)
- C144 [256](#)
- C15 [240](#)
- C150 [257](#)
- C155 [258](#)
- C158 [259](#)
- C159 [260](#)
- C16 [240](#)
- C165 [260](#)
- C166 [260](#)
- C167 [261](#)
- C168 [261](#)
- C169 [261](#)
- C170 [261](#)
- C171 [261](#)
- C173 [262](#)
- C174 [262](#)
- C177 [262](#)
- C178 [262](#)
- C179 [262](#)
- C18 [240](#)
- C182 [263](#), [310](#)
- C19 [241](#)
- C2 [235](#)
- C200 [263](#)
- C201 [263](#)
- C203 [263](#)
- C21 [241](#)
- C22 [241](#)
- C222 [263](#), [313](#)
- C223 [264](#), [313](#)
- C224 [264](#), [313](#)
- C225 [264](#), [313](#)
- C226 [264](#), [313](#)
- C227 [264](#), [313](#)
- C228 [265](#), [313](#)
- C23 [241](#)
- C231 [265](#), [314](#)
- C234 [265](#)
- C235 [265](#)
- C236 [265](#)
- C24 [242](#)
- C242 [266](#), [314](#)
- C243 [266](#), [314](#)
- C244 [266](#), [314](#)

# Index

---

C245 [266](#), [314](#)  
C26 [242](#)  
C27 [242](#)  
C28 [242](#)  
C29 [243](#)  
C3 [237](#)  
C308 [266](#)  
C309 [267](#)  
C322 [267](#)  
C323 [267](#)  
C324 [268](#)  
C33 [243](#)  
C34 [243](#)  
C345 [268](#)  
C347 [269](#)  
C350 [269](#)  
C351 [269](#)  
C352 [270](#)  
C353 [270](#)  
C354 [270](#)  
C355 [271](#)  
C356 [271](#)  
C357 [271](#)  
C359 [272](#)  
C36 [244](#)  
C360 [272](#)  
C364 [273](#)  
C366 [273](#)  
C367 [273](#)  
C368 [274](#)  
C369 [274](#)  
C372 [274](#)  
C381 [274](#)  
C385 [275](#)  
C386 [275](#)  
C389 [275](#)  
C39 [244](#), [310](#)  
C409 [276](#)  
C443 [277](#)  
C444 [278](#)  
C462 [278](#)  
C470 [278](#), [331](#)  
C472 [279](#), [330](#)  
C480 [279](#), [324](#)  
C481 [279](#), [322](#)  
C482 [280](#), [323](#)  
C50 [244](#)  
C51 [244](#)  
C516 [280](#)  
C517 [281](#)  
C52 [245](#)  
C53 [245](#)  
C54 [245](#)  
C56 [245](#)  
C565 [281](#)  
C57 [245](#)  
C574 [282](#)  
C58 [246](#)  
C581 [282](#)  
C59 [246](#)  
C592 [282](#)  
C593 [283](#)  
C594 [283](#)  
C598 [283](#)  
C6 [237](#)  
C600 [284](#)  
C601 [284](#)  
C604 [284](#)  
C606 [284](#)  
C61 [246](#)  
C620 [285](#)  
C621 [286](#)  
C64 [246](#)  
C66 [247](#)  
C7 [238](#)  
C700 [288](#)  
C701 [289](#)  
C725 [289](#)  
C727 [290](#), [328](#)  
C728 [290](#), [328](#)  
C729 [290](#)  
C73 [247](#)  
C74 [247](#)  
C800 [290](#), [306](#)  
C801 [290](#), [306](#)  
C802 [291](#), [306](#)  
C803 [291](#), [306](#)  
C804 [291](#), [306](#), [308](#)  
C805 [291](#)  
C806 [292](#), [307](#)  
C81 [247](#)  
C830 [292](#)  
C831 [292](#)  
C833 [293](#)  
C84 [247](#)  
C85 [248](#)  
C866 [294](#)  
C868 [295](#)  
C87 [248](#)  
C88 [248](#)  
C89 [248](#)  
C90 [249](#)  
C909 [295](#)  
C91 [249](#)  
C910 [296](#)  
C92 [249](#)

- C93 [249](#)
  - C94 [249](#)
  - C95 [250](#)
  - C97 [250](#)
  - C98 [250](#)
  - C99 [250](#)
  - C990 [296](#)
  - C991 [296](#)
  - C992 [296](#)
  - C994 [297](#)
  - CA06
    - CAN CRC error (error message) [164](#)
  - CA07
    - CAN bus warning (error message) [164](#)
  - CA08
    - CAN bus stopped (error message) [164](#)
  - CA0b
    - CAN Bus Live Time (error message) [164](#)
  - CA0F
    - CAN control word (error message) [165](#)
  - CAN baud rate (C00351) [269](#)
  - CAN data telegram [176](#)
  - CAN error status (C00345) [268](#)
  - CAN Heartbeat Producer Time (C00381) [274](#)
  - CAN IN/OUT COBID source (C00353) [270](#)
  - CAN input words (C00866) [294](#)
  - CAN MessageError (C00364) [273](#)
  - CAN monitoring times (C00357) [271](#)
  - CAN node address (C00350) [269](#)
  - CAN NodeID Heartbeat producer (C00385) [275](#)
  - CAN on board [169](#)
  - CAN output words (C00868) [295](#)
  - CAN Slave/Master (C00352) [270](#)
  - CAN start remote node [182](#)
  - CAN status (C00359) [272](#)
  - CAN status HeartBeat producer (C00347) [269](#)
  - CAN Sync transmission cycle time (C00369) [274](#)
  - CAN Sync-Rx-Identifier (C00367) [273](#)
  - CAN Sync-Tx identifier (C00368) [274](#)
  - CAN telegram counter (C00360) [272](#)
  - CAN time settings (C00356) [271](#)
  - CAN transmit blocking time (C00324) [268](#)
  - CAN\_Tx\_Rx\_Error (C00372) [274](#)
  - Cause for controller inhibit (C00158) [259](#)
  - Cause for quick stop QSP (C00159) [260](#)
  - CE1
    - CAN RPDO1 (error message) [165](#)
  - CE2
    - CAN RPDO2 (error message) [165](#)
  - CE4
    - CAN bus off (error message) [164](#)
  - Checksums (C00516) [280](#)
  - COB-ID [176](#)
  - COBID (C00354) [270](#)
  - COB-ID EMCY (I-1014) [216](#)
  - COB-ID SYNC message (I-1005) [215](#)
  - Communication control words (C00136) [254](#)
  - Communication cycle period (I-1006) [216](#)
  - Communication time [172](#)
  - Comparison value N\_Act (C00024) [242](#)
  - Consumer heartbeat time (I-1016) [217](#)
  - ConsumerTime HeartBeat Producer (C00386) [275](#)
  - Control mode [73](#)
  - Control mode (C00007) [238](#)
  - Conventions used [9](#)
  - CRC error [206](#)
  - Current switching frequency (C00725) [289](#)
- ## D
- Data type [230](#)
  - DCB
    - Current (C00036) [244](#)
    - Hold time (C00107) [251](#)
  - DCB (DC-injection braking) [97](#)
  - DC-bus voltage (C00053) [245](#)
  - DC-injection braking [96](#)
  - Deceleration time main setpoint (C00013) [239](#)
  - Deceleration time quick stop (C00105) [251](#)
  - Defining current limits [76](#)
  - Defining speed limits [76](#)
  - Delayed resp. to fault
    - DC bus overvoltage (C00601) [284](#)
  - Device commands (C00002) [235](#)
  - Device overload monitoring (Ixt) [103](#)
  - Device rated current (C00098) [250](#)
  - Device settings (C00141) [255](#)
  - Device state (C00137) [255](#)
  - Device type (I-1000) [213](#)
  - Device utilisation (Ixt) (C00064) [246](#)
  - Device utilisation threshold (Ixt) (C00123) [253](#)
  - dF01
    - Internal error 01 (error message) [166](#)
  - dF02
    - Internal error 02 (error message) [166](#)
  - dF03
    - Internal error 03 (error message) [167](#)
  - dF04
    - Internal error 04 (error message) [167](#)
  - dF05
    - Internal error 05 (error message) [167](#)
  - dF06
    - Internal error 06 (error message) [167](#)
  - dF07
    - Internal error 07 (error message) [167](#)
  - dF08
    - Internal error 08 (error message) [168](#)
  - dF09
    - Internal error 09 (error message) [168](#)

- dF10
  - Internal error 10 (error message) [168](#)
- dH69
  - Adjustment fault (error message) [168](#)
- Digital input assignment [289](#)
- Digital inputs [109](#)
- Digital outputs [109](#)
- Digital terminals [109](#)
- Dlx
  - Level (C00443) [277](#)
- Dlx inversion (C00114) [252](#)
- DOx
  - Level (C00444) [278](#)
- DOx inversion (C00118) [252](#)
- Drive interface [44](#)
- E**
- Elapsed-hour meter (C00178) [262](#)
- Electrical data I/O terminals [119](#)
- E-mail to Lenze [340](#)
- Emergency [210](#)
- Error counter (C00170) [261](#)
- Error detection [206](#)
- Error ID [157](#)
- Error information (C00165) [260](#)
- Error information text (C00166) [260](#)
- Error messages [156](#)
- Error messages (short overview) [159](#)
- Error messages (system bus) [199](#)
- Error number [156](#)
  - xx.0111.00002 [161](#)
  - xx.0119.00001 [161](#)
  - xx.0119.00050 [161](#)
  - xx.0119.00052 [162](#)
  - xx.0123.00014 [162](#)
  - xx.0123.00015 [162](#)
  - xx.0123.00016 [162](#)
  - xx.0123.00017 [163](#)
  - xx.0123.00057 [163](#)
  - xx.0123.00065 [163](#)
  - xx.0123.00105 [163](#)
  - xx.0125.00001 [163](#)
  - xx.0131.00000 [164](#)
  - xx.0131.00006 [164](#)
  - xx.0131.00007 [164](#)
  - xx.0131.00008 [164](#)
  - xx.0131.00011 [164](#)
  - xx.0131.00015 [165](#)
  - xx.0135.00001 [165](#)
  - xx.0135.00002 [165](#)
  - xx.0144.00001 [165](#)
  - xx.0144.00002 [165](#)
  - xx.0144.00003 [166](#)
  - xx.0144.00004 [166](#)
  - xx.0144.00031 [166](#)
  - xx.0145.00001 [166](#)
  - xx.0145.00002 [166](#)
  - xx.0145.00003 [167](#)
  - xx.0145.00004 [167](#)
  - xx.0145.00005 [167](#)
  - xx.0145.00006 [167](#)
  - xx.0145.00007 [167](#)
  - xx.0145.00008 [168](#)
  - xx.0145.00009 [168](#)
  - xx.0145.00010 [168](#)
  - xx.0400.00105 [168](#)
  - xx.0980.00000 [168](#)
  - xx.0981.00000 [168](#)
- Error number (C00168) [261](#)
- Error register (I-1001) [213](#)
- Error subject area [157](#)
- Error type [156](#)
- Exporting logbook entries [150](#)
- F**
- Feedback to Lenze [340](#)
- Firmware compile date (C00201) [263](#)
- Firmware product type (C00200) [263](#)
- Firmware version (C00099) [250](#)
- Firmware version (C00100) [250](#)
- Fixed setpoint x (L\_NSet\_1 n-Fix) (C00039) [244](#)
- Flying restart fct. [94](#)
  - Activation (C00990) [296](#)
  - Current (C00994) [297](#)
  - Process (C00991) [296](#)
  - Start frequency (C00992) [296](#)
- Format error [206](#)
- Frequency limitation (C00910) [296](#)
- Function assignment [289](#)
- Function blocks [304](#)
- Function library [304](#)
- G**
- General data (CAN on board) [171](#)
- H**
- Heartbeat protocol [207](#)
- Heatsink temperature (C00061) [246](#)
- I**
- I-1000 [213](#)
- I-1001 [213](#)
- I-1003 [214](#)
- I-1005 [215](#)
- I-1006 [216](#)
- I-1014 [216](#)
- I-1016 [217](#)
- I-1017 [217](#)
- I-1018 [218](#)
- I-1200 [218](#)
- I-1201 [219](#)



I-1400 [221](#)  
I-1401 [222](#)  
I-1600 [223](#)  
I-1601 [223](#)  
I-1800 [224](#)  
I-1801 [226](#)  
I-1A00 [227](#)  
I-1A01 [227](#)

ID1

Motor data identification error (error message) [163](#)

Identifier (CAN) [176](#)

Identifiers of the parameter data objects [195](#)

Identifiers of the process data objects [189](#)

Identity object (I-1018) [218](#)

I<sub>max</sub> controller [81](#)

I<sub>max</sub> in generator mode (C00023) [241](#)

I<sub>max</sub> in motor mode (C00022) [241](#)

Initial value motor overload (I<sub>xt</sub>) (C00122) [253](#)

Integrated error detection [206](#)

Interconnection

"Terminals 0" control mode [135](#)

Control mode "CAN" [136](#)

Internal wiring

"Terminals 0" control mode [135](#)

Control mode "CAN" [136](#)

## L

L\_MPot [305](#)

L\_MPot\_1 [305](#)

Acceleration time (C00802) [291](#)

Deceleration time (C00803) [291](#)

Inactive fct. (C00804) [291](#)

Init fct. (C00805) [291](#)

Lower limit (C00801) [290](#)

Upper limit (C00800) [290](#)

Use (C00806) [292](#)

L\_NSet [309](#)

L\_NSet\_1 [309](#)

L\_PCTRL [312](#)

L\_PCTRL\_1 [312](#)

Acceleration time (C00227) [264](#)

Acceleration time influence (C00243) [266](#)

Deceleration time (C00228) [265](#)

Deceleration time influence (C00244) [266](#)

K<sub>d</sub> (C00224) [264](#)

MaxLimit (C00225) [264](#)

MinLimit (C00226) [264](#)

Operating mode (C00242) [266](#)

Operating range (C00231) [265](#)

PID output value (C00245) [266](#)

T<sub>n</sub> (C00223) [264](#)

V<sub>p</sub> (C00222) [263](#)

L\_RLQ [317](#)

L\_RLQ\_1 [317](#)

LA\_NCtrl

Analog connection list (C00700) [288](#)

Digital connection list (C00701) [289](#)

Layout of the safety instructions [11](#)

LED status display [18](#)

Library [304](#)

LP\_CanIn Mapping (C00409) [276](#)

LP\_CanIn1 [185](#)

LP\_CanIn2 [186](#)

LP\_CanOut1 [187](#)

LP\_CanOut2 [188](#)

LS\_AnalogInput [319](#)

LS\_DigitalInput [320](#)

LS\_DigitalOutput [321](#)

LS\_DisFree [322](#)

LS\_DisFree (C00481) [279](#)

LS\_DisFree\_a [323](#)

LS\_DisFree\_a (C00482) [280](#)

LS\_DisFree\_b [324](#)

LS\_DisFree\_b (C00480) [279](#)

LS\_DriveInterface [325](#)

LS\_Keypad [328](#)

digital values (C00727) [290](#)

Keypad analog values (C00728) [290](#)

LS\_ParFix [329](#)

LS\_ParFree\_a [330](#)

LS\_ParFree\_a (C00472) [279](#)

LS\_ParFree\_b [331](#)

LS\_ParFree\_b (C00470) [278](#)

LS\_SetError\_1 [332](#)

LU

DC bus undervoltage (error message) [162](#)

## M

Mains phase failure monitoring [107](#)

Mains voltage (C00173) [262](#)

Manual DC-injection braking (DCB) [97](#)

Master functionality (CAN) [182](#)

Maximum torque (C00057) [245](#)

MCTRL

Actual speed value (C00051) [244](#)

Speed setpoint (C00050) [244](#)

Minimum analog setpoint (C00010) [239](#)

Monitoring [103](#), [151](#)

Motor catalogue [68](#)

Motor control [64](#)

87-Hz operation [83](#)

DC-injection braking [96](#)

Flying restart fct. [94](#)

Oscillation damping [100](#)

Selection help [75](#)

Selection of switching frequency [92](#)

Selection of the control mode [73](#)

Sensorless vector control (SLVC) [87](#)

Slip compensation [99](#)

V/f characteristic control (VFCplus) [78](#)  
Motor control (C00006) [237](#)  
Motor cosine phi (C00091) [249](#)  
Motor current (C00054) [245](#)  
Motor data [65](#)  
Motor load monitoring (I2xt) [104](#)  
Motor magnetising current (C00095) [250](#)  
Motor magnetising inductance (C00092) [249](#)  
Motor overload threshold (I<sup>2</sup>xt) (C00120) [253](#)  
Motor parameter identification [70](#)  
Motor parameter identification is active [56](#)  
Motor selection [65](#)  
Motor stator leakage inductance (C00085) [248](#)  
Motor stator resistance (C00084) [247](#)  
Motor voltage (C00052) [245](#)

## N

Network management telegram (NMT) [181](#)  
NMT (network management) [181](#)  
Node address [176](#)  
Node ID [176](#)  
Number of CAN SDO channels (C00366) [273](#)

## O

OC1  
Power section - short circuit (error message) [162](#)  
OC12  
I2xt overload - brake resistor (error message) [163](#)  
OC2  
Power section - earth fault (error message) [163](#)  
OC5  
Ixt overload (error message) [161](#)  
OC6  
I2xt overload - motor (error message) [163](#)  
OC9  
Ixt overload - shutdown limit (error message) [162](#)  
OH  
Heatsink overtemperature (error message) [161](#)  
Operating conditions (CAN on board) [171](#)  
Oscillation damping [100](#)  
Oscillation damping influence (C00234) [265](#)  
OU  
DC bus overvoltage (error message) [162](#)  
Output frequency (C00058) [246](#)

## P

Password (C00094) [249](#)  
Password protection [23](#)  
PC manual control [39](#)  
PDO mapping [185](#), [186](#)  
PDO synchronisation [192](#)  
PDO valid / invalid (C00389) [275](#)  
Peak current limitation [76](#)  
Plant parameters [69](#)

Port block "LP\_CanIn1" [185](#)  
Port block "LP\_CanIn2" [186](#)  
Port block "LP\_CanOut1" [187](#)  
Port block "LP\_CanOut2" [188](#)  
Power section identification (C00093) [249](#)  
Power-on time meter (C00179) [262](#)  
Pre-defined error field (I-1003) [214](#)  
Process data objects, identifiers [189](#)  
Processing time [172](#)  
Producer heartbeat time (I-1017) [217](#)  
Product type code (C00203) [263](#)  
PS01  
No memory module (error message) [165](#)  
PS02  
Par. set invalid (error message) [165](#)  
PS03  
Par. set device invalid (error message) [166](#)  
PS04  
Par. set device incompatible (error message) [166](#)  
PS31  
Ident. error (error message) [166](#)

## R

Ramp smoothing, main setpoint (C00134) [253](#)  
Rated motor current (C00088) [248](#)  
Rated motor frequency (C00089) [248](#)  
Rated motor power (C00081) [247](#)  
Rated motor speed (C00087) [248](#)  
Rated motor torque (C00097) [250](#)  
Rated motor voltage (C00090) [249](#)  
Reduced brake chopper threshold (C00174) [262](#)  
Reset of error message [158](#)  
Resp. to brake resist. overtemp. (C00574) [282](#)  
Resp. to CAN bus connection (C00592) [282](#)  
Resp. to CANx\_IN monitoring (C00593) [283](#)  
Resp. to control word error (C00594) [283](#)  
Resp. to DC bus undervoltage (C00600) [284](#)  
Resp. to device overload (Ixt) (C00604) [284](#)  
Resp. to LS\_SetError\_x (C00581) [282](#)  
Resp. to mains phase failure (C00565) [281](#)  
Resp. to motor overload (I<sup>2</sup>xt) (C00606) [284](#)  
Resp. to open circuit AINx (C00598) [283](#)  
RPDO1 communication parameter (I-1400) [221](#)  
RPDO1 mapping parameter (I-1600) [223](#)  
RPDO2 communication parameter (I-1401) [222](#)  
RPDO2 mapping parameter (I-1601) [223](#)

## S

Safety instructions [11](#)  
Save parameter settings [49](#)  
Saving parameters automatically [49](#)  
SDO1 server parameter (I-1200) [218](#)  
SDO2 server parameter (I-1201) [219](#)  
Selection help for motor control [75](#)

# Index

---

Selection of switching frequency [92](#)  
Selection of the control mode [73](#)  
Sensorless vector control (SLVC) [74](#), [87](#)  
Setting the baud rate [173](#)  
Setting the error response [153](#)  
Setting the node address [173](#)  
Short overview of error messages [159](#)  
Signal flow  
    V/f characteristic control (VFCplus) [78](#)  
    V/f control (VFCplus + encoder) [88](#)  
Signal source assignment [289](#)  
Slip comp. (C00021) [241](#)  
Slip compensation [99](#)  
Speed control with torque limitation (SLVC) [89](#)  
Speed limitation (C00909) [295](#)  
S-ramp time PT1 (C00182) [263](#)  
Status of last device command (C00003) [237](#)  
Status word (C00150) [257](#)  
Status word 2 (C00155) [258](#)  
Stuff-bit error [206](#)  
Su02  
    One mains phase is missing (error message) [161](#)  
Switching cycles (C00177) [262](#)  
Switching frequency [92](#)  
Switching frequency (C00018) [240](#)  
Switching frequency reduction (temp.) (C00144) [256](#)  
Sync telegram [192](#)  
System blocks [304](#)  
System bus [169](#)  
System error messages [156](#)

## T

Thermal motor load (I<sup>2</sup>xt) (C00066) [247](#)  
Ti I<sub>max</sub> controller (C00074) [247](#)  
Time of error (C00169) [261](#)  
Torque (C00056) [245](#)  
Torque limitation [85](#)  
TPDO1 communication parameter (I-1800) [224](#)  
TPDO1 mapping parameter (I-1A00) [227](#)  
TPDO2 communication parameter (I-1801) [226](#)  
TPDO2 mapping parameter (I-1A01) [227](#)  
Transmission mode CAN Rx PDOs (C00323) [267](#)  
Transmission mode CAN TxPDOs (C00322) [267](#)  
Transmission type [190](#)

## U

US01  
    User error 1 (error message) [168](#)  
US02  
    User error 2 (error message) [168](#)  
User data [195](#)  
User menu [22](#)  
User menu (C00517) [281](#)

## V

V/f base frequency [83](#)  
V/f characteristic control (VFCplus) [74](#), [78](#)  
VFC  
    V/f base frequency (C00015) [240](#)  
    Vmin boost (C00016) [240](#)  
Vmin boost [84](#)  
Vp I<sub>max</sub> controller (C00073) [247](#)

# FEEDBACK



## Your opinion is important to us

These instructions were created to the best of our knowledge and belief to give you the best possible support for handling our product.

If you have suggestions for improvement, please e-mail us to:

[feedback-docu@Lenze.de](mailto:feedback-docu@Lenze.de)

Thank you for your support.

*Your Lenze documentation team*





Lenze AC Tech Corporation  
630 Douglas Street  
Uxbridge, MA 01569  
USA

☎ +1 508 / 278-9100  
📠 +1 508 / 278-7873  
✉ [info@actechdrives.com](mailto:info@actechdrives.com)  
🌐 [www.actech.com](http://www.actech.com)

#### Service

Lenze Service GmbH  
Breslauer Straße 3  
D-32699 Extertal  
Germany

☎ 00 80 00 / 24 4 68 77 (24 h helpline)  
📠 +49 (0)51 54 / 82-11 12  
✉ [Service@Lenze.de](mailto:Service@Lenze.de)



# 8400

E84AVBDxxxxx...

Inverter Drives 8400 BaseLine D\_\_\_\_\_

Reference manual

EN



13292140

# Overview of technical documentation for Inverter Drives 8400

---

## Project planning, selection & ordering

- Hardware manual 8400 BaseLine C/D
- Catalogue

## Mounting & wiring

- MA 8400 BaseLine D
- MA for the accessories

## Parameterisation

- SW 8400 BaseLine D

← This documentation

## Drive commissioning

- SW 8400 BaseLine D
  - Chapter "Commissioning"
  - Chapter "Diagnostics & error management"
- Remote maintenance manual

← This documentation

## Networking

- KHB for the communication medium used
- MA for the accessories

### Legend:

- Printed documentation
- Online documentation (PDF/Engineer online help)

### Abbreviations used:

- BA Operating Instructions
- KHB Communication manual
- MA Mounting instructions
- SW Software/reference manual



# Contents

---

<b>1</b>	<b>About this documentation</b>	<b>8</b>
1.1	Document history	8
1.2	Conventions used	9
1.3	Terminology used	10
1.4	Definition of the notes used	12
<b>2</b>	<b>Introduction: Parameterising the controller</b>	<b>13</b>
2.1	General notes on parameters	14
2.2	Handling the memory module	15
2.3	Internal Keypad	18
2.3.1	Display elements and control panel	18
2.3.2	LED status display	19
2.3.3	Display messages	20
2.3.4	Menu structure	22
2.3.5	User menu	23
2.3.6	Quick saving of all parameters at the push of a button	24
2.3.7	Password protection	24
<b>3</b>	<b>Commissioning</b>	<b>26</b>
3.1	Safety instructions with regard to commissioning	26
3.2	Preparing the 8400 BaseLine for commissioning	27
3.3	Commissioning with integrated keypad	28
3.3.1	Load Lenze setting	28
3.3.2	Parameterise drive/application	29
3.3.3	Save parameter settings safe against mains failure	30
3.3.4	Enable controller and select speed	31
3.4	Commissioning with the »Engineer«	32
3.4.1	Preconditions for commissioning with the »Engineer«	32
3.4.2	Creating an »Engineer« project & going online	33
3.4.3	Parameterise drive/application	34
3.4.4	Save parameter settings safe against mains failure	38
3.4.5	Enable controller and select speed	38
3.5	PC manual control	40
3.5.1	Activating PC manual control	40
3.5.2	Speed control	43
<b>4</b>	<b>Device control (DCTRL)</b>	<b>45</b>
4.1	Device commands	47
4.1.1	Load Lenze setting	49
4.1.2	Loading parameter settings	49
4.1.3	Save parameter settings	50
4.1.4	Import EPM data	50
4.1.5	Enable/Inhibit controller	51
4.1.6	Activate/Deactivate quick stop	51
4.1.7	Reset error	52
4.1.8	Delete logbook	52
4.1.9	Identify motor parameters	53
4.2	Device states	54
4.2.1	Init	56
4.2.2	MotorIdent	57
4.2.3	SafeTorqueOff	57
4.2.4	ReadyToSwitchON	58
4.2.5	SwitchedON	59
4.2.6	OperationEnabled	60

# Contents

---

4.2.7	Trouble	61
4.2.8	Fault	62
4.3	"Inhibit at power-on" auto-start option	63
<b>5</b>	<b>Motor control (MCTRL)</b>	<b>65</b>
5.1	Motor selection/Motor data	66
5.1.1	Selecting a motor from the motor catalogue in the »Engineer«	69
5.1.2	Automatic motor data identification	71
5.2	Selecting the control mode	74
5.2.1	Selection help	76
5.3	Defining current and speed limits	77
5.4	V/f characteristic control (VFCplus)	79
5.4.1	Parameterisation dialog/signal flow	79
5.4.2	Basic settings	81
5.4.2.1	Defining the V/f characteristic shape	81
5.4.2.2	Defining current limits (I <sub>max</sub> controller)	82
5.4.3	Optimise control behaviour	83
5.4.3.1	Adapting the V/f base frequency	84
5.4.3.2	Adapting the V <sub>min</sub> boost	85
5.4.3.3	Optimising the I <sub>max</sub> controller	86
5.4.3.4	Torque limitation	86
5.4.4	Remedies for undesired drive behaviour	87
5.5	Sensorless vector control (SLVC)	88
5.5.1	Parameterisation dialog	89
5.5.2	Speed control with torque limitation	89
5.5.3	Basic settings	91
5.5.4	Optimise control behaviour	91
5.5.4.1	Optimising the starting performance after a controller enable	91
5.5.5	Remedies for undesired drive behaviour	92
5.6	Parameterisable additional functions	93
5.6.1	Selection of switching frequency	93
5.6.2	Flying restart function	95
5.6.3	DC-injection braking	97
5.6.3.1	Manual DC-injection braking (DCB)	98
5.6.3.2	Automatic DC-injection braking (Auto-DCB)	98
5.6.4	Slip compensation	100
5.6.5	Oscillation damping	101
5.7	Braking operation/braking energy management	102
5.7.1	Setting the voltage source for braking operation	103
5.7.2	Avoiding thermal overload of the brake resistor	103
5.8	Monitoring	104
5.8.1	Device overload monitoring (I <sub>xt</sub> )	104
5.8.2	Motor load monitoring (I <sub>2xt</sub> )	105
5.8.3	Brake resistor monitoring (I <sub>2xt</sub> )	107
5.8.4	Mains phase failure monitoring	108
<b>6</b>	<b>I/O terminals</b>	<b>109</b>
6.1	Digital terminals	110
6.2	Analog terminals	112
6.2.1	Parameterising analog input	113
6.3	User-defined terminal assignment	115
6.3.1	Source-destination principle	116
6.3.2	Changing the terminal assignment with the »Engineer«	117
6.3.3	Changing the terminal assignment via configuration parameters	118
6.4	Electrical data	120

# Contents

---

<b>7</b>	<b>Drive application</b>	122
7.1	Parameterisation dialog	123
7.1.1	Signal flow	125
7.1.1.1	Selection of the main speed setpoint	127
7.1.1.2	Motor potentiometer function	127
7.1.1.3	Process controller	127
7.2	Interface description	128
7.3	Setting parameters (short overview)	133
7.4	Pre-assignment of the drive application	134
7.4.1	Input connections	134
7.4.2	Output connections	135
7.4.3	Internal signal flow for control via terminals	136
7.5	Terminal assignment of the control modes	137
7.5.1	Terminals 0	138
7.5.2	Terminals 2	138
7.5.3	Terminals 11	139
7.5.4	Terminals 16	139
7.5.5	Keypad	140
7.5.6	PC	141
<b>8</b>	<b>Diagnostics &amp; error management</b>	142
8.1	Basics on error handling in the controller	142
8.2	Drive diagnostics with the »Engineer«	143
8.3	Drive diagnostics via bus system	145
8.4	Logbook	146
8.4.1	Functional description	146
8.4.2	Reading out logbook entries	147
8.4.3	Exporting logbook entries to a file	147
8.5	Monitoring	148
8.5.1	Monitoring configuration	149
8.5.2	Setting the error response	150
8.6	Maloperation of the drive	151
8.7	Error messages of the operating system	153
8.7.1	Structure of the error number (bit coding)	153
8.7.1.1	Error type	153
8.7.1.2	Error subject area	154
8.7.1.3	Error ID	154
8.7.1.4	Example for bit coding of the error number	155
8.7.2	Reset of error message	155
8.7.3	Short overview (A-Z)	156
8.7.4	Cause & possible remedies	157

# Contents

---

<b>9</b>	<b>Parameter reference</b>	164
9.1	Structure of the parameter descriptions	165
9.1.1	Data type	166
9.1.2	Parameters with read-only access	166
9.1.3	Parameters with write access	167
9.1.3.1	Parameters with setting range	167
9.1.3.2	Parameters with selection list	167
9.1.3.3	Parameters with bit-coded setting	168
9.1.3.4	Parameters with subcodes	169
9.1.4	Parameter attributes	170
9.2	Parameter list	171
9.2.1	Selection lists for configuration parameters	219
9.2.1.1	Selection list - analog signals	219
9.2.1.2	Selection list - digital signals	220
9.3	Table of attributes	221
<b>10</b>	<b>Function library</b>	225
10.1	L_MPot_1	226
10.1.1	Activate & control motor potentiometer	228
10.1.2	Deactivate motor potentiometer	229
10.2	L_NSet_1	230
10.2.1	Main setpoint path	231
10.2.2	JOG setpoints	231
10.2.3	Setpoint inversion	232
10.2.4	Ramp function generator for the main setpoint	232
10.2.5	S-shaped ramp	232
10.3	L_PCTRL_1	233
10.3.1	Control characteristic	236
10.3.2	Ramp function generator	237
10.3.3	Operating range of the PID process controller	237
10.3.4	Evaluation of the output signal	237
10.4	L_RLO_1	238
10.5	LS_AnalogInput	240
10.6	LS_DigitalInput	241
10.7	LS_DigitalOutput	242
10.8	LS_DisFree	243
10.9	LS_DisFree_a	244
10.10	LS_DisFree_b	245
10.11	LS_DriveInterface	246
10.12	LS_Keypad	249
10.13	LS_ParFix	250
10.14	LS_ParFree_a	251
10.15	LS_ParFree_b	252
10.16	LS_SetError_1	253
	<b>Index</b>	254
	Your opinion is important to us	259

# Contents

---

# 1 About this documentation

## 1.1 Document history

# 1 About this documentation



### Danger!

The controller is a source of danger which may lead to death or severe injury of persons. To protect yourself and others against these dangers, observe the safety instructions before switching on the controller.

Please read the safety instructions in the mounting instructions and the hardware manual of the 8400 BaseLine D controller. Both documents are supplied with the controller.

This documentation contains information on the parameterisation of the 8400 BaseLine D controller using the integrated keypad and the L-force »Engineer«.

The information in this documentation is valid for the 8400 BaseLine D controller with the following nameplate data:

Type	Type designation	From software version	Important
8400 BaseLine D	E84AVBDExxxxSX0	2.1	Variant without digital output X4/DO1
8400 BaseLine D	E84AVBDExxxxSX1	2.1	Variant with digital output X4/DO1

Depending on the software version of the controller and the version of the installed »Engineer« software, the screenshots in this documentation may differ from the representation in the »Engineer«.



### Tip!

Information and tools around the Lenze products can be found in the Download area on <http://www.Lenze.com>



## 1.1 Document history

Version			Description
5.5	01/2014	TD05	Error corrections & supplements and converted to new layout
5.4	04/2013	TD05	Error corrections & supplements, parameter reference V03.04.00
5.3	04/2011	TD05	Error corrections & supplements, parameter reference V03.03.00
5.2	09/2010	TD05	Restructuring of some chapters, error corrections & supplements
5.1	11/2009	TD06	Error corrections & supplements
5.0	04/2009	TD06	Error corrections & supplements
4.0	04/2009	TD06	Error corrections & supplements
3.0	02/2009	TD06	Error corrections & supplements

# 1 About this documentation

## 1.2 Conventions used

This documentation uses the following conventions to distinguish between different types of information:

Type of information	Writing	Examples/notes
Spelling of numbers		
Decimal separator	Point	The decimal point is generally used. For example: 1234.56
Text		
Version info	Blue text colour	All information that only applies to a certain controller software version or higher is identified accordingly in this documentation. Example: <a href="#">This function extension is available from software version V3.0!</a>
Program name	» «	The Lenze »Engineer« PC software ...
Window	<i>italics</i>	The <i>Message</i> window ... / The <i>Options</i> dialog box...
Variable identifier		By setting <i>bEnable</i> to TRUE...
Control element	<b>bold</b>	The <b>OK</b> button... / The <b>Copy</b> command... / The <b>Properties</b> tab... / The <b>Name</b> input field...
Sequence of menu commands		If the execution of a function requires several commands, the individual commands are separated by an arrow: Select <b>File→Open</b> to...
Shortcut	< <b>bold</b> >	Press < <b>F1</b> > to open the online help. If a command requires a combination of keys, a "+" is placed between the key symbols: Use < <b>Shift</b> >+< <b>ESC</b> > to...
Hyperlink	<u>Underlined</u>	Optically highlighted reference to another topic. In this documentation activated by mouse-click.
DIP switch	\ ("Backslash")	For separating the data of the DIP-Schalterbank from the switch number, the Backslash" is used. For instance, S2\8 indicates bank S2 and switch 8 (on the far right).
Icons		
Page reference	 9	Optically highlighted reference to another page. In this documentation activated by mouse-click.
Step-by-step instructions		Step-by-step instructions are indicated by a pictograph.

Information that is only valid for or as from a certain software version of the controller are marked accordingly in this documentation.

# 1 About this documentation

## 1.3 Terminology used

### 1.3 Terminology used

Term	Meaning
»Engineer«	Lenze PC software which supports you in "engineering" (parameterisation, diagnostics and configuration) throughout the whole life cycle, i.e. from planning to maintenance of the commissioned machine.
Application	A technology application is a drive solution equipped with Lenze's experience and know-how in which function and system blocks interconnected to a signal flow are the basis for implementing typical drive tasks.
ASM	Asynchronous motor
CINH	Abbreviation: Controller inhibit (pulse inhibit)
Code	Parameter used for controller parameterisation or monitoring. The term is usually called "index".
DC-injection braking	DC injection braking is to brake and/or hold the motor. For this purpose, the 8400 BaseLine D creates a quasi DC field at the stator of the asynchronous machine. The energy to be dissipated is converted into heat in the rotor.
DCTRL	Abbreviation: Drive control (device control)
Display code	Parameter that displays the current state or value of an input/output of a system block.
EPM	Memory module on which all parameters of the drive system are saved non-volatily. These include the parameters of the controller and communication-relevant parameters for the communication unit used.
Function block	A function block can be compared with an integrated circuit that contains a certain control logic and delivers one or several values when being executed. <ul style="list-style-type: none"><li>• Each function block has a unique identifier, e.g. "L_MPot_1" (motor potentiometer function)</li></ul>
Holding brake	The holding brake serves to hold the rotor by means of a mechanical unit.
LA	Abbreviation: Lenze Application block <ul style="list-style-type: none"><li>• Example: "LA_NCtrl" – block for the "actuating drive speed" application.</li></ul>
Lenze setting	This setting is the default factory setting of the device.
LP	Abbreviation: Lenze Port block <ul style="list-style-type: none"><li>• Example: "LP_Network_In" – port block for fieldbus communication.</li></ul>
LS	Abbreviation: Lenze System block <ul style="list-style-type: none"><li>• Example: "LS_DigitalInput" – system block for digital input signals.</li></ul>
MCTRL	Abbreviation: Motor control
Port block	Block for implementing the process data transfer via a fieldbus
QSP	Quick stop ("Quick stop): The motor control is decoupled from the setpoint selection and within a parameterisable deceleration time, the motor is brought to a standstill ( $n_{act} = 0$ ).
Service brake	The service brake serves to shutdown rotary or translatory masses in motion in a controlled manner. The energy to be dissipated in this process is converted into heat in the form of friction energy. This process is a regular and recurring operating mode.
SLVC	Motor control: Sensorless vector control ("SensorLess Vector Control")
SM	Synchronous motor
Subcode	If a code contains several parameters, the individual parameters are stored under "subcodes". This manual uses a slash "/" as a separator between code and subcode (e.g. "C118/3"). The term is usually called "subindex".
System block	In the application, system blocks provide interfaces to basic functions and to the hardware of the controller (e.g. to the digital inputs).



# 1 About this documentation

## 1.3 Terminology used

---

Term	Meaning
USB diagnostic adapter	The USB diagnostic adapter is used for the operation, parameterisation, and diagnostics of the controller. Data are exchanged between the PC (USB connection) and the controller (diagnostic interface on the front) via the diagnostic adapter. <ul style="list-style-type: none"><li data-bbox="667 416 983 445">• Order designation: E94AZCUS</li></ul>
VFCplus	Motor control: V/f characteristic control ("Voltage Frequency Control")

# 1 About this documentation

## 1.4 Definition of the notes used

---

### 1.4 Definition of the notes used

The following signal words and symbols are used in this documentation to indicate dangers and important information:

#### Safety instructions

Layout of the safety instructions:



#### **Pictograph and signal word!**

(characterise the type and severity of danger)

#### **Note**

(describes the danger and informs how to prevent dangerous situations)

Pictograph	Signal word	Meaning
	<b>Danger!</b>	<b>Danger of personal injury through dangerous electrical voltage</b> Reference to an imminent danger that may result in death or serious personal injury if the corresponding measures are not taken.
	<b>Danger!</b>	<b>Danger of personal injury through a general source of danger</b> Reference to an imminent danger that may result in death or serious personal injury if the corresponding measures are not taken.
	<b>Stop!</b>	<b>Danger of property damage</b> Reference to a possible danger that may result in property damage if the corresponding measures are not taken.

#### Application notes

Pictograph	Signal word	Meaning
	<b>Note!</b>	Important note to ensure trouble-free operation
	<b>Tip!</b>	Useful tip for easy handling

## 2 Introduction: Parameterising the controller

---

### 2 Introduction: Parameterising the controller

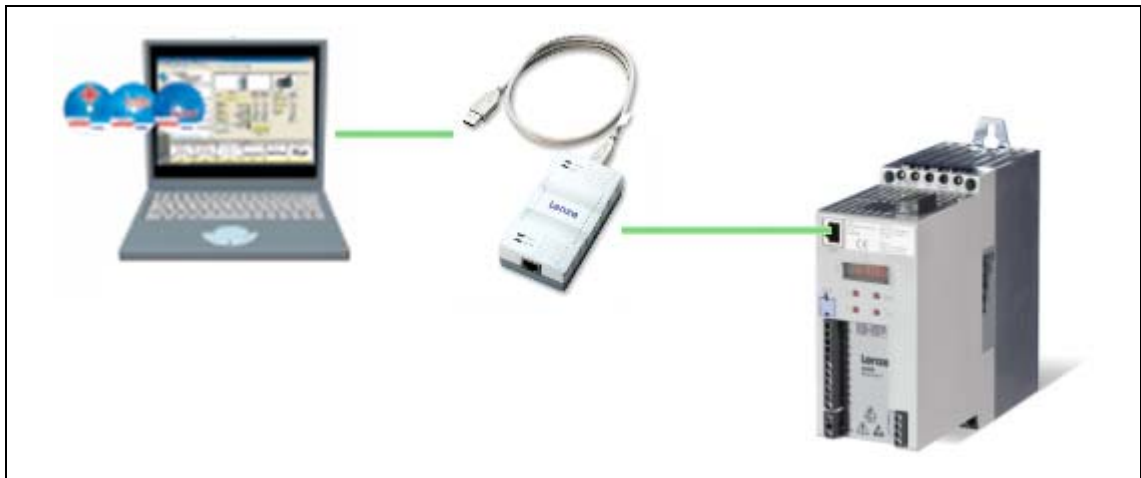

[2-1] Example configuration for parameterising the controller (here: BaseLine D)

Being a component of a machine which includes a speed-variable drive system, the controller needs to be adjusted to its drive task and the motor. The controller is adjusted by changing parameters which are saved in the memory module.



#### **Danger!**

In general, changing a parameter causes an immediate response in the controller!

- This may lead to undesirable behaviour on the motor shaft if the controller has been enabled!
- Setpoint sources, for instance, may switch over all of a sudden (e.g. when configuring the signal source for the main setpoint).

Certain device commands or settings which may cause critical states of drive behaviour constitute exceptions. Such parameter changes are only possible if the controller is inhibited. Otherwise, a corresponding error message will be issued.

The parameters can optionally be accessed from the integrated keypad, or the L-force »Engineer«.

- The USB diagnostic adapter, for instance, can be used for the communication between the PC (including the L-force »Engineer« software) and the controller, see illustration. The USB diagnostic adapter is the connection between the PC (free USB port) and the controller (diagnostic interface).

## 2 Introduction: Parameterising the controller

### 2.1 General notes on parameters

---

#### 2.1 General notes on parameters

All parameters for controller parameterising or monitoring are saved as so-called "codes".

- The codes are numbered and designated by a "C" in front of the code, e.g. "C002" in the documentation and the keypad display.
- In addition, every code has a name and specific attributes:
  - Access type (read, write)
  - Data type
  - Limit values
  - Lenze setting (factory-set scaling)
- For the sake of clarity, some codes contain "subcodes" for saving parameters.
  - This manual uses a slash "/" as a separator between code and subcode (e.g. "C115/1").
  - In the keypad display, the subcodes are designated by a small "c", e.g. "c001".
- According to their functionality, the parameters are divided into three groups:

Parameter group	Examples
<b>Setting parameters</b> Parameters for specifying setpoints and for setting device / monitoring functions.	<a href="#">C007</a> : Selection of control mode <a href="#">C012</a> : Acceleration time - main setpoint <a href="#">C039</a> : Fixed setpoints
<b>Configuration parameters</b> Parameters for configuring signal connections within the device, e.g. assignment of the digital input terminals to the control inputs of the application.	<a href="#">C620</a> : System connection list: 16-bit <a href="#">C621</a> : System connection list: Bool <a href="#">C700</a> : LA_NCtrl: Analog connection list <a href="#">C701</a> : LA_NCtrl: Digital connection list
<b>Diagnostic/Display parameters</b> Parameters for displaying device-internal process factors, current actual values, and status messages, e.g. for diagnostic purposes. These are read-only parameters.	<a href="#">C052</a> : Motor voltage <a href="#">C137</a> : Device status <a href="#">C150</a> : Status word <a href="#">C165</a> : Error info



#### Tip!

The terms "code" and "subcode" generally correspond to the terms "index" and "subindex" and "parameter" and "subparameter".

#### 2.2 Handling the memory module



#### Danger!

After power-off, wait at least three minutes before working on the controller. When removing the memory module, ensure that the controller is deenergised.

If the memory module has been removed and the device is switched on, the connector pins are live and thus dangerous since the protection against contact is missing.

All parameters of the drive system are saved non-volatily in the memory module of the controller. This includes the parameters of the controller and parameters relevant for communication.

The plug-in version is especially suited for

- restoring an application after replacing a device.
- duplicating identical drive tasks within the 8400 Baseline frequency inverter series, e.g. by using the optionally available EPM Programmer.



#### Note!

- When the device is switched on, all parameters are automatically loaded from the memory module to the main memory of the controller.
- The 8400 Baseline and 8400 motec controllers use the same (grey) memory module. The memory module can be shifted between these controllers but the controller must be reparameterised afterwards.
- The memory module is not compatible with the memory modules of the 8400 StateLine and 8400 HighLine controllers.
- If the memory module has been removed, the "PS01" error message appears.

When handling the memory module, a distinction is drawn between the following scenarios:

#### Delivery status



- The memory module is plugged into the EPM slot at the front of the controller.
- The Lenze setting of the parameters is stored in the memory module.
- The memory module can be preconfigured with customer-specific data.
- The memory module is available as a spare part - without any data.

---

### During operation



#### Stop!

The memory module must not be plugged in or unplugged during operation.

- The memory module (EPM) is required for operation.
- Full functionality of the memory module is even provided if the power supply has been switched off and only the electronic components of the controller are externally supplied by a 24 V DC voltage, e.g. via the X4/24E terminal.
- Parameter settings can be saved manually.
- Parameter settings can be loaded manually.
- Parameter changes can be saved automatically.

### Replacing the controller

- In the event of a device replacement, the entire parameter data of an axis can be copied to the replacement device by "taking along" the memory module, so that additional PC or diagnosis terminal operations are not required.
- When replacing the controller, the versions of the old device and the new device are of importance. Before data are actually transferred, the versions are internally checked. Basically, the following applies:
  - Parameter sets of old devices with V 1.0 can be processed on new devices  $\geq$  V 1.0 (downward compatibility).
  - Parameters of devices with higher versions are not supported on devices with lower versions. An error message (PS02/PS03) occurs if the parameter set versions of the two devices are not compatible.

### Saving the parameters in the memory module safe against mains failure

Controller parameter changes via the »Engineer«, the integrated keypad, or a master control via fieldbus communication will be lost after mains switching of the controller unless the settings have been explicitly saved.



You have various opportunities to prevent a data loss by saving the parameter settings in the memory module:

- [Quick saving of all parameters at the push of a button](#) (📖 24)
- [Automatic saving of parameter changes](#) (📖 50)
- [Manual saving of parameter settings](#) (📖 50)

---

### Parameter set transfer using the »Engineer«

When an online connection to the controller has been established, the following transfer functions can directly be executed via the *Toolbar* or the **Online** menu using the L-force »Engineer«:

Symbol	Menu command	Shortcut
	Download parameter set	<F5>
	Read parameter set from device	<F7>
	Save parameter set	

**Tip!**

Detailed information on parameter set transfers using the »Engineer« can be found in the »Engineer« online help.

## 2.3 Internal Keypad

The controller front is provided with an integrated keypad. Use the keypad for quick and simple parameter setting and for displaying current actual values and device states via the respective display parameters.



### Note!

After switching on the controller, the internal keypad performs a quick self-test. All segments of the display flash. After the self-test, the keypad shows "rdy" for a short time and then changes to the display of the setpoint speed of the motor. The keypad is now ready for operation.

### 2.3.1 Display elements and control panel

Important status information of the controller is displayed optically by LEDs. The positions of the coloured LEDs are marked on the housing by letters.

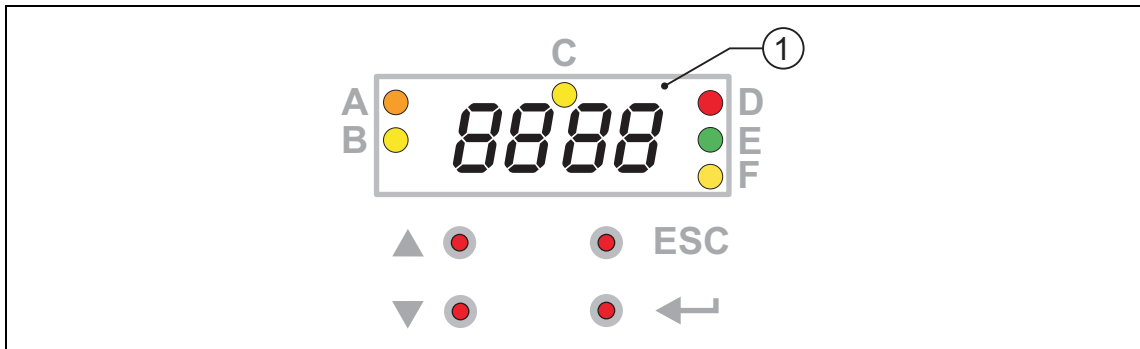

Symbol	Information	Meaning
①	4-character display with LEDs (A ... F)	
A	orange	Set current/torque limit is reached
B	yellow	Minus sign for identifying the negative numbers bigger than 4 characters when the rotational direction has been reversed.
C	yellow	User LED <ul style="list-style-type: none"> <li>• configurable via <a href="#">C621/42</a></li> <li>• user-defined LED status</li> </ul>
D	red	DRIVE ERROR / DRIVE READY
E	green	▶ <a href="#">LED status display</a> (□ 19)
F	yellow	Direction of rotation: CCW rotation
	Off	Direction of rotation: CW rotation
	blinking	Commanded direction is not equal to actual direction (e.g. during reversing)



## Control elements

Key	Name	Function
ESC	Escape key	On menu and parameter level: Back In case of parameter processing: Abort (discard changed setting)
↵	Enter key	On menu and parameter level: Next (confirm selection) In case of parameter processing: OK (accept changed setting) Long pressing (3 seconds): Saving of all parameters ▶ <a href="#">Quick saving of all parameters at the push of a button</a> (📖 24)
▲	Navigation key upwards	On menu and parameter level: Navigation In case of parameter processing: Set parameter value
▼	Navigation key downwards	Long pressing (> 2 seconds): Quick scroll function

## 2.3.2 LED status display

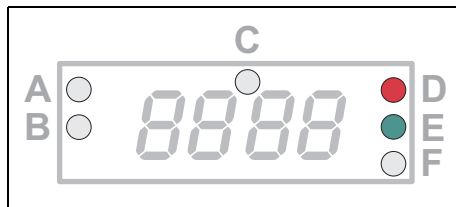

Information on some operating states can quickly be obtained via the front D and E LEDs:

The meaning can be seen from the table below.

E "DRIVE READY"	D "DRIVE ERROR"	Description	Device state (Display in <a href="#">C137</a> )
OFF	OFF	OFF or initialisation active	<a href="#">Init</a>
	OFF	Safe torque off is active	<a href="#">SafeTorqueOff</a>
	OFF	Device is ready to start	<a href="#">ReadyToSwitchON</a>
	OFF	Device is switched on	<a href="#">SwitchedON</a>
	OFF	Motor data identification/operation	<a href="#">OperationEnabled</a>
		The controller is ready to switch on, switched on or the operation is enabled and a warning is indicated.	
OFF		Trouble is active	<a href="#">Trouble</a>
OFF		Fault is active	<a href="#">Fault</a>
<b>Legend</b>			
The symbols used for indicating the LED states have the following meaning:			
	LED is flashing once approx. every 3 seconds ( <i>slow flash</i> )		
	LED is flashing once approx. every 1.25 seconds ( <i>flash</i> )		
	LED is flashing twice approx. every 1.25 seconds ( <i>double flash</i> )		
	LED is blinking every second		
	LED is permanently on		

### 2.3.3 Display messages

Display		Meaning
<i>RnD1</i>	constant	Analog input 1: Current < 4 mA
<i>bF</i>	blinking	Identification error. • Drive ID stored in EMP does not match the drive ID stored in the controller.
<i>br</i>	flashes during the hold time of DC braking	DC braking is executed.
<i>CL</i>	blinking	Identification is executed. The operation is not yet enabled.
<i>CL / Err</i>	alternatively blinking	Identification is not ready to start. • <a href="#">C088</a> , <a href="#">C089</a> or <a href="#">C090</a> is 0.
<i>CL / StOP</i>	alternatively blinking	Identification is ready to start.
<i>CL</i>	constant	Clamp: The current limit value selected in <a href="#">C022</a> has been reached.
<i>dEc</i>	constant	Deceleration is temporarily suspended because of higher bus voltage
<i>dFD1 ... dFD10</i>	constant	Internal error
<i>dHE9</i>	constant	Adjustment data error
<i>Err</i>	blinking	A wrong password has been entered.
<i>FCL</i>	constant	The current limit value selected in <a href="#">C022</a> has been exceeded.
<i>FSt</i>	constant	"Flying restart" function is executed.
<i>ID1</i>	constant	Motor data identification error
<i>LU</i>	constant	DC bus undervoltage
<i>OC1</i>	constant	Power section - short circuit
<i>OC12</i>	constant	I2xt brake resistor overload
<i>OC2</i>	constant	Power section - earth fault
<i>OC5</i>	constant	Ixt overload
<i>OC6</i>	constant	I2xt motor overload
<i>OC9</i>	constant	Ixt overload - shutdown limit
<i>OH</i>	constant	Heatsink overtemperature
<i>OU</i>	constant	DC bus overvoltage
<i>PR55</i>	0.5 seconds on	Password protection is active
<i>PS01</i>	constant	No memory module inserted
<i>PS02</i>	constant	Parameter set is invalid
<i>PS03</i>	constant	Parameter set device invalid
<i>PS31</i>	constant	Incompatible or unknown HW components have been found.
<i>Su02</i>	constant	One mains phase is missing
<i>US01 / US02</i>	constant	User error 1 / user error 2



Detailed information on diagnostics using the »Engineer« and a description of possible error messages can be found in the chapter entitled "[Diagnostics & error management](#)".

( 142)

## 2 Introduction: Parameterising the controller

### 2.3 Internal Keypad

#### 2.3.4 Menu structure

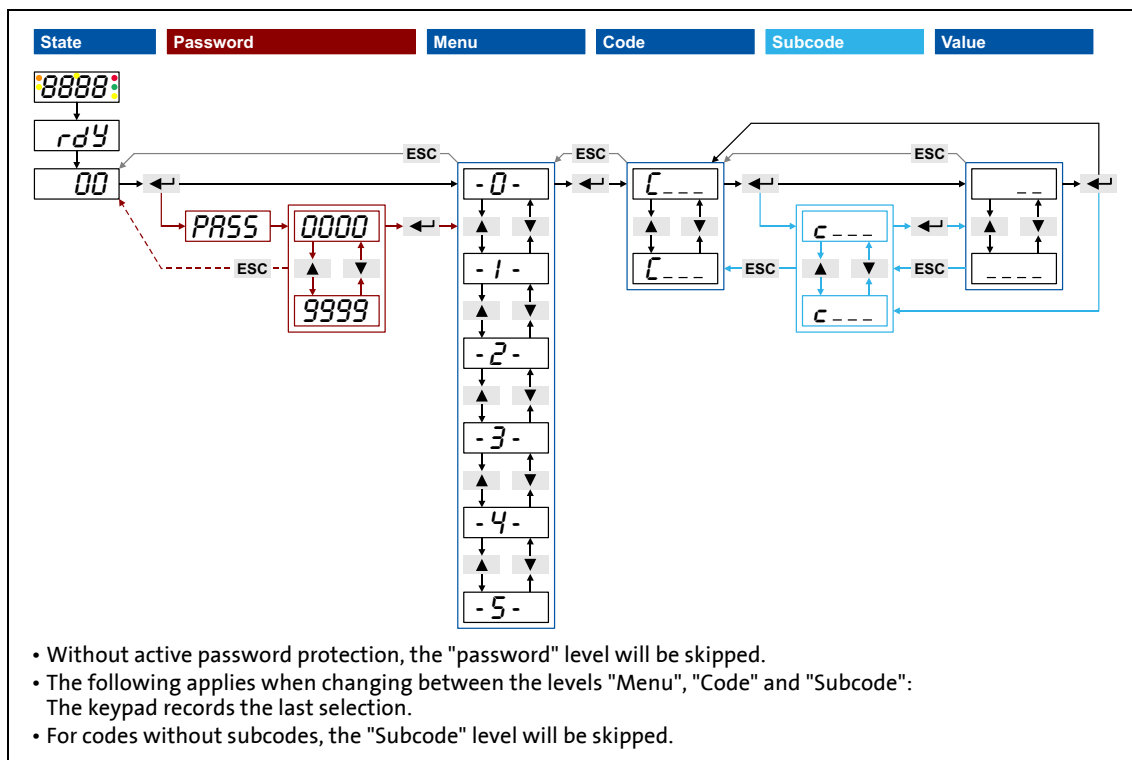

Menu	Info
-0-	Access to the parameters of the user menu. • The user menu of a device serves to create a selection of frequently used parameters to be able to access and change these parameters quickly. ▶ <a href="#">User menu</a> (23)
-1-	Access to all drive parameters.
-2-	Access to parameters for quick commissioning with terminal control.
-3-	Access to parameters for quick commissioning with the integrated keypad.
-4-	Access to motor control parameters.
-5-	Access to diagnostic/display parameters.



#### Note!

When the password protection is activated and no password or a wrong password is entered, only the parameters of the user menu can be accessed using the integrated keypad. All other menus/parameters require the correct password.

▶ [Password protection](#) (24)

### 2.3.5 User menu

The user menu (menu -0-) contains a selection of frequently used parameters to be able to access and change these parameters quickly.

- The integrated keypad serves to change the preset parameter selection in [C517](#): Enter the codes the user menu is to contain into the subcodes c001 ...c020. When "0" is set, no entry is displayed in the user menu.
- The »Engineer« serves to configure the user menu on the **User menu** tab of the controller. Here, additional functions are available for loading and saving the parameter selection.

The user menu contains the following parameters:

Code	Subcode	Info	Lenze setting	
			Value	Unit
<a href="#">C051</a>	-	Display of actual speed value	-	rpm
<a href="#">C053</a>	-	Display of DC-bus voltage	-	V
<a href="#">C054</a>	-	Display of motor current	-	A
<a href="#">C061</a>	-	Display of heatsink temperature	-	°C
<a href="#">C137</a>	-	Display of device status	-	-
<a href="#">C011</a>	-	Reference speed	1500	rpm
<a href="#">C039</a>	c001	Fixed setpoint 1	40.0	%
	c002	Fixed setpoint 2	60.0	%
	c003	Fixed setpoint 3	80.0	%
<a href="#">C012</a>	-	Acceleration time - main setpoint	2.0	s
<a href="#">C013</a>	-	Deceleration time - main setpoint	2.0	s
<a href="#">C015</a>	-	V/f base frequency	50.0	Hz
<a href="#">C016</a>	-	Vmin boost	0.0	%
<a href="#">C022</a>	-	I <sub>max</sub> in motor mode	47.00	A
<a href="#">C120</a>	-	Motor overload threshold (I <sup>2</sup> xt)	100	%
<a href="#">C087</a>	-	Rated motor speed	1460	rpm
<a href="#">C099</a>	-	Display of firmware version	-	-

Highlighted in grey = display parameter



#### Note!

If the password protection is activated and no password or a wrong password is entered, only these parameters can be accessed with the integrated keypad.

▶ [Password protection](#) (📖 24)

### 2.3.6 Quick saving of all parameters at the push of a button

Keep the entry button pressed for 3 seconds to save all parameter settings safe against mains failure.

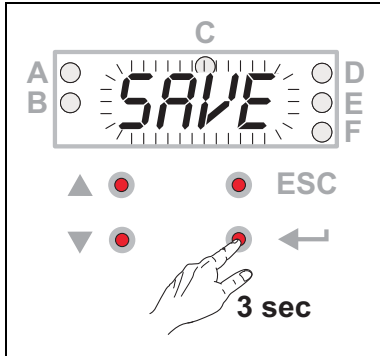

- During the saving process, "SAVE" is blinking in the display.
- After approximately 2 seconds, "SAVE" will disappear from the display and you can continue your work.

#### Related topics:

▶ [Save parameter settings](#) (450)

### 2.3.7 Password protection

The controller offers the option to protect the unauthorised access to the menu level by assigning a password. The following sections describe how to create, change, or delete the password protection and how to access the menu level via the password.

#### Enter password and confirm it

Carry out the steps if you want to create the password protection for the first time for e.g. a controller in default status:

Step		Info
1.	Mains on	After the mains has been switched on and the keypad self test has been completed, "00" is displayed
2.	↵	After pressing the enter key: Without password protection you have free access from here to all menus (and thus all parameters).
3.	▲	Select menu -1- (all parameters).
4.	↵	Confirm selection.
5.	▲	Select code <a href="#">C094</a> ("password").
6.	↵	Confirm selection. ("00" is now blinking, i.e. entry is possible.)
7.	▲	Set the desired password ("01" ... "9999").
8.	↵	Accept password.
9.	↵ (3 seconds)	Keep the entry button pressed for 3 seconds in order to save the parameter settings safe against mains failure.

**Change the existing password or deactivate the password protection**

Step		Info
1.	Mains on	After the mains has been switched on and the keypad self test has been completed, "00" is displayed
2.	↵	After pressing the enter key and with existing password protection: "PASS" is displayed for a short time, then "0000".
3.	▲	Enter password.
4.	↵	Confirm entry.
5.	▲	Select menu -1- (all parameters).
6.	↵	Confirm selection.
7.	▲	Select code <a href="#">C094</a> ("password").
8.	↵	Confirm selection. (The existing password is now blinking, i.e. a change is possible.)
9.	▲ ▼	Change password: Set new password ("01" ... "9999"). Deactivate password protection: Set "00".
10.	↵	Accept setting.
11.	↵ (3 seconds)	Keep the entry button pressed for 3 seconds in order to save the parameter settings safe against mains failure.

**Access password-protected controller without knowing the password**

When the password protection is activated and no password or a wrong password is entered, only the max. 20 parameters of the [user menu](#) can be accessed.

Step		Info
1.	Mains on	After the mains has been switched on and the keypad self test has been completed, "00" is displayed
2.	↵	After pressing the enter key and with existing password protection: "PASS" is displayed for a short time, then "0000".
3.	↵ or ▲ ↵	After direct confirmation of the value "0000": <ul style="list-style-type: none"> <li>• Only the parameters of the <a href="#">user menu</a> can be selected.</li> </ul> When the wrong password has been entered and confirmed: <ul style="list-style-type: none"> <li>• "Err" is displayed for a short time, then only the parameters of the <a href="#">User menu</a> can be selected.</li> </ul>

**Reach password-protected menu level with knowing the password**

Step		Info
1.	Mains on	After the mains has been switched on and the keypad self test has been completed, "00" is displayed
2.	↵	After pressing the enter key and with existing password protection: "PASS" is displayed for a short time, then "0000".
3.	▲	Enter password.
4.	↵	When the correct password has been confirmed: You have free access from here to all menus (and thus all parameters).

## 3

## Commissioning

The 8400 BaseLine D controller is commissioned in one of the following ways:

- Commissioning with integrated keypad
  - If only a few parameters have to be adapted.
  - For test/demonstration purposes.
- Commissioning with PC/»Engineer«
  - The »Engineer« provides a comfortable access to all parameters of the 8400 BaseLine D controller and hence full flexibility in the commissioning process.

## 3.1

## Safety instructions with regard to commissioning

## General safety instructions

In order to prevent injury to persons or damage to material assets

- before connecting the mains voltage, check
  - The wiring for completeness, short circuit, and earth fault
  - The "emergency stop" function of the entire system
  - The motor circuit configuration (star/delta) must be adapted to the output voltage of the controller
  - The in-phase connection of the motor
- Check the setting of the most important drive parameters before enabling the controller:
  - The V/f rated frequency must be adapted to the motor circuit configuration!
  - The drive parameters relevant for your application must be set correctly!
  - The configuration of the I/O terminals must be adapted to the wiring!
- Make sure that no speed setpoint is applied before controller enable.

## Safety instructions with regard to motor operation

**Danger!**

- For thermal reasons, continuous operation of self-ventilated motors at a low field frequency and rated motor current is not permissible!
  - If required, activate the [Brake resistor monitoring \(l2xt\)](#). (□ 107)
- With regard to the V/f base frequency ([C015](#)), observe the following difference to the controllers 8400 StateLine/HighLine/TopLine:  
For the 8400 BaseLine, the reference voltage for the V/f base frequency is the rated motor voltage ([C090](#)) according to motor nameplate (independent of the mains voltage on the supply side).



## 3.2

## Preparing the 8400 BaseLine for commissioning

**Danger!**

Take all the necessary safety precautions before you carry out the following commissioning steps and switch the device on!

▶ [Safety instructions with regard to commissioning](#) (📖 26)

## 1. Wiring the power connections

- Refer to the mounting instructions supplied with the drive controller to find help on how to correctly design the power connections to match the requirements of your device.

## 2. Wire the control connections

- The following shows the wiring for the Lenze setting.

Analog input at X4	Terminal	Function
	<b>A1U</b>	Setpoint selection <ul style="list-style-type: none"> <li>• Scaling: 10 V <math>\equiv</math> 100 % <math>\equiv</math> 1500 rpm (for 4-pole motor)</li> </ul>

Digital inputs at X4	Terminal	Function
	<b>RFR</b>	Controller enable: HIGH level Error reset: HIGH-LOW edge
	<b>DI1</b>	Selection fixed setpoint 1 ... 3
	<b>DI2</b>	
	<b>DI3</b>	Request DC-injection braking (DCB)
	<b>DI4</b>	Request change of direction of rotation

## 3. Inhibit the controller:

Set terminal X4/RFR to LOW level or open contact to terminal X4/12I .

## 4. Switch on voltage supply of the controller.

- Information on some operating states can be quickly obtained via the LED display of the integrated keypad. ▶ [LED status display](#) (📖 19)

When the green LED is blinking and the red LED is off, the controller is ready to start and you can continue with commissioning as required:

▶ [Commissioning with integrated keypad](#) (📖 28)

or

▶ [Commissioning with the »Engineer«](#) (📖 32)

### 3.3 Commissioning with integrated keypad

Only a few parameters need to be adapted for the drive. Afterwards, the drive application can be immediately controlled via the digital and analog inputs of the controller in the preset control mode "Terminals 0".



Information on how to use the integrated keypad can be found in the chapter entitled "[Internal Keypad](#)". (☞ 18)

#### Commissioning steps

In the following, commissioning of the controller using the integrated keypad is described step by step. Please process the chapters consecutively and execute all steps carefully. This procedure will help you to commission the controller quickly and as safe as possible:

- ▶ [Load Lenze setting](#)
- ▶ [Parameterise drive/application](#) (☞ 29)
- ▶ [Save parameter settings safe against mains failure](#) (☞ 30)
- ▶ [Enable controller and select speed](#) (☞ 31)

#### 3.3.1 Load Lenze setting

In order to achieve a defined device configuration, it is advisable to make sure that the device is in its original delivery state. For this purpose, the "Load Lenze setting" device command is available.

Step		Info
1.	Mains on	After the mains has been switched on and the keypad self test has been completed, "00" is displayed
2.	↵	After pressing the enter key: Without password protection you have free access from here to all menus (and thus all parameters).
3.	▲	Select menu -2-. • The menu -2- contains parameters for quick commissioning with terminal control.
4.	↵	Confirm selection.
5.	↵	Confirm first code <a href="#">C002</a> ("device commands") of the menu -2-.
6.	↵	Confirm subcode c001 ("load Lenze setting").
7.	▲	Set value "01" (≡ "Start").
8.	↵	Accept parameter setting to execute the "Load Lenze setting" device command.

### 3.3.2 Parameterise drive/application

The menu -2- of the integrated keypad contains all basic parameters to commission the drive/application "actuating drive speed" quickly and easily for a terminal control. When you set these parameters to suitable and sensible values, the controller can be operated properly.

Parameter	Lenze setting		Info
	Value	Unit	
<a href="#">C002/1</a> Load Lenze setting	0: Off / ready		Reset all parameters to the Lenze setting which are saved in the controller firmware.
<a href="#">C007</a> Select control mode	10: Terminals 0		▶ <a href="#">Terminal assignment of the control modes</a> (☞ 137)
<a href="#">C011</a> Reference speed	1500	rpm	All speed setpoint selections are provided in % and always refer to the reference speed set in <a href="#">C011</a> . The motor reference speed is given on the motor nameplate.
<a href="#">C012</a> Acceleration time - main setpoint	2.0	s	The setpoint is led via a ramp function generator with linear characteristic. The ramp function generator converts setpoint step-changes at the input into a ramp. ▶ <a href="#">L_NSet_1</a> (☞ 230)
<a href="#">C013</a> Deceleration time - main setpoint	2.0	s	
<a href="#">C015</a> V/f base frequency	50.0	Hz	▶ <a href="#">Adapting the V/f base frequency</a> (☞ 84)
<a href="#">C016</a> Vmin boost	0.0	%	▶ <a href="#">Adapting the Vmin boost</a> (☞ 85)
<a href="#">C022</a> Current limit (in motor mode)	47.00	A	▶ <a href="#">Optimising the I<sub>max</sub> controller</a> (☞ 86)
<a href="#">C087</a> Rated motor speed	1460	rpm	▶ <a href="#">Motor selection/Motor data</a> (☞ 66)
<a href="#">C089</a> Rated motor frequency	50	Hz	
<a href="#">C039/1</a> Fixed setpoint 1	40.0	%	A fixed setpoint for the setpoint generator can be activated instead of the main setpoint via the digital inputs DI1 and DI2. • The fixed setpoints are selected in [%] based on the reference speed ( <a href="#">C011</a> ). ▶ <a href="#">L_NSet_1</a> (☞ 230)
<a href="#">C039/2</a> Fixed setpoint 2	60.0	%	
<a href="#">C039/3</a> Fixed setpoint 3	80.0	%	
<a href="#">C051</a> Actual speed value	-	rpm	
<a href="#">C054</a> Current motor current	-	A	

Highlighted in grey = display parameter

#### More detailed information on the drive application:

- ▶ [Drive application](#) (☞ 122)
- ▶ [Interface description](#) (☞ 128)
- ▶ [Setting parameters \(short overview\)](#) (☞ 133)
- ▶ [Pre-assignment of the drive application](#) (☞ 134)
- ▶ [Terminal assignment of the control modes](#) (☞ 137)

### 3.3.3 Save parameter settings safe against mains failure

If parameter settings are changed in the controller, those changes will be lost after mains switching of the controller unless the settings have been saved explicitly.

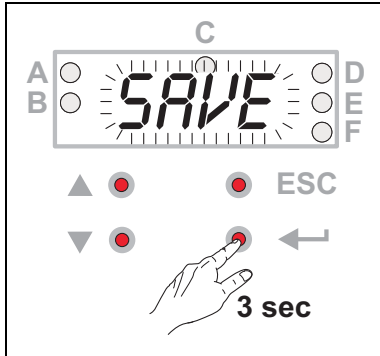

- Keep the entry button pressed for 3 seconds in order to save the parameter settings safe against mains failure.

 **Tip!**

In [C141](#), an automatic saving can be activated.  
▶ [Automatic saving of parameter changes \(p. 50\)](#)

### 3.3.4 Enable controller and select speed



#### Note!

If the controller is enabled at power-on and the auto-start option is activated in [C142](#) "Inhibit at power-on" (Lenze setting), the controller remains in the "[ReadyToSwitchON](#)" state.

For changing to the "[SwitchedON](#)" state, first deactivate the controller enable: Set terminal X4/RFR to LOW level or open contact to terminal X4/12I.

When the controller is in the "[SwitchedON](#)" state:

1. Enable controller:

Set terminal X4/RFR to HIGH level or close contact to terminal X4/12I n.

2. Select speed:

- In the "Terminals 0" by selecting a voltage at the analog input or by selecting a fixed setpoint via the digital inputs DI1/DI2.

DI1	DI2	Speed selection
LOW	LOW	The setpoint speed is selected via the analog input 1 • Scaling: 10 V $\equiv$ 100 % $\equiv$ reference speed ( <a href="#">C011</a> )
HIGH	LOW	The fixed setpoint 1 ( <a href="#">C039/1</a> ) is used as setpoint speed. • Lenze setting: 40 % of the reference speed ( <a href="#">C011</a> )
LOW	HIGH	The fixed setpoint 2 ( <a href="#">C039/2</a> ) is used as setpoint speed. • Lenze setting: 60 % of the reference speed ( <a href="#">C011</a> )
HIGH	HIGH	The fixed setpoint 3 ( <a href="#">C039/3</a> ) is used as setpoint speed. • Lenze setting: 80 % of the reference speed ( <a href="#">C011</a> )



#### Note!

Observe the actual speed value (display in [C051](#)) as well as the [LED status display](#) and [Display messages](#) indicated in the integrated keypad.



#### Tip!

More control functions in the "Terminals 0" control mode:

- DI3: HIGH level  $\equiv$  request DC-injection braking
- DI4: HIGH level  $\equiv$  request change of direction of rotation

### 3.4 Commissioning with the »Engineer«

Commissioning with the »Engineer« is suited for every drive task and in particular for drive tasks with more demanding requirements/more comprehensive parameter setting.

In the following, commissioning of the controller is described step by step. Please process the chapters consecutively and execute all steps carefully. This procedure will help you to commission the controller quickly and as safe as possible:

- ▶ [Preconditions for commissioning with the »Engineer«](#)
- ▶ [Creating an »Engineer« project & going online](#)
- ▶ [Parameterise drive/application](#)
- ▶ [Save parameter settings safe against mains failure](#)
- ▶ [Enable controller and select speed](#)

#### 3.4.1 Preconditions for commissioning with the »Engineer«

For commissioning, you need

- a PC that satisfies the following requirements:
  - processor with 1.4 GHz or higher
  - at least 512 MB RAM and 650 MB free hard disc space
  - Microsoft® Windows® 2000 operating system (from service pack 2 onwards) or Windows® XP
- the Lenze »Engineer« PC software
- a connection to the controller, e.g. via USB diagnostic adapter:
  - Connect the USB diagnostic adapter to the diagnostic interface X6.
  - Connect the USB diagnostic adapter to the PC via a free USB port.



#### Tip!

How to obtain/update the L-force »Engineer« software:

- **Download from the Internet:**  
The full version of the »Engineer StateLevel« is provided free of charge. Current software can be found on the Internet in the "Services & Downloads" area under <http://www.Lenze.com>.
- **Requesting the CD**  
You can also request the L-force »Engineer« separately on CD free of charge at your Lenze representative. See the "About Lenze" area on our homepage for e.g. the corresponding German address.

---

### 3.4.2 Creating an »Engineer« project & going online



You can find detailed information on the general use of the »Engineer« in the online help which you can call with **[F1]**.

- In the "Working with projects" chapter, all options of the *start-up wizard* are described to create a new »Engineer« project.

The following steps describe the standard procedure of creating a project using the **Select component from catalogue** option. Here, you select the single components (controller, motor, etc.) from selection lists.

1. Start the »Engineer«.
2. Create a new project by means of the *Start-up wizard* and the **Select component from catalogue** option:
  - In the **Component** dialog step, select the 8400 BaseLine D controller.
  - Select the other components (motor/gearbox) to be added to the project in the **Other components** dialog step.
3. Go online.
  - After a successful connection to the controller, the following status is displayed in the *Status line*:



4. Download parameter set.
  - This command serves to overwrite the current parameter settings in the controller by parameter settings of the »Engineer« project.

### 3.4.3 Parameterise drive/application

Go to *Workspace* and change to the **Application parameters** tab.

#### Parameterising the motor control

On the left, the parameters of the motor control are arranged:

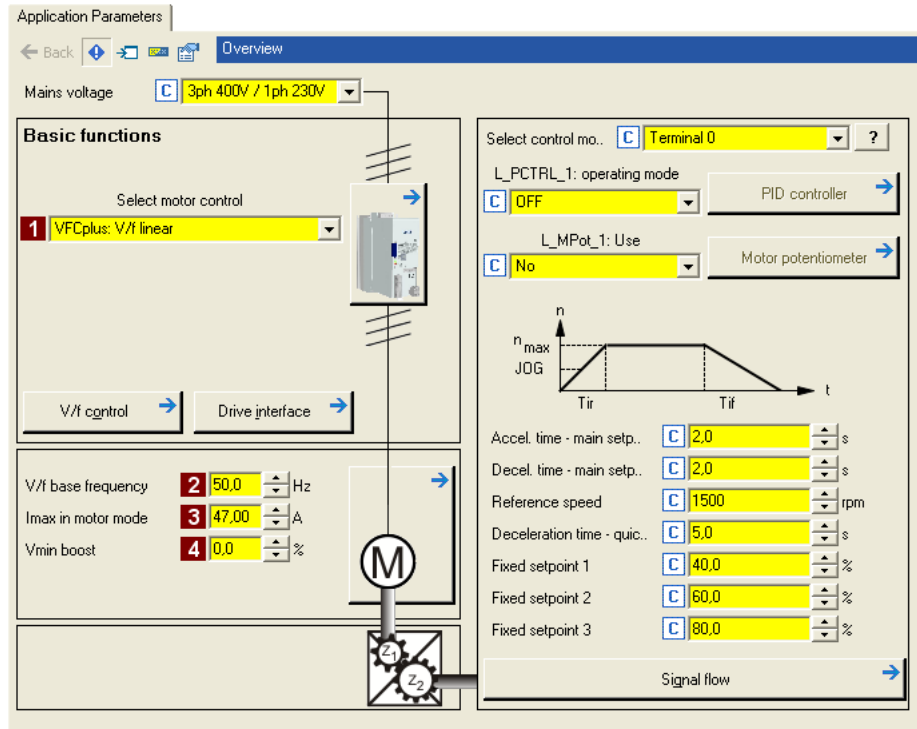

1. Go to the **1 Motor control (C006)** list field and select the required motor control.



#### Note!

In the Lenze setting, the V/f characteristic control (VFCplus) with linear characteristic is set in **C006** as motor control.

- The V/f characteristic control (VFCplus) is an motor control for standard frequency inverter applications based on a simple and robust control process which is suitable for the operation of machines with linear or square-law load torque characteristic (e.g. fans).
- The parameter settings have been set in advance in such a way that, if the drive controller and 50 Hz asynchronous machine match each other in terms of performance, the drive controller is immediately ready for operation without any further parameter setting work and the motor works satisfactorily.



## 2. Adapting the parameters of the motor control:

Parameter	Lenze setting		Info
	Value	Unit	
<b>2</b> V/f base frequency (C015)	50.0	Hz	▶ <a href="#">Adapting the V/f base frequency</a> (📖 84)
<b>3</b> I <sub>max</sub> in motor mode (C022)	47.00	A	▶ <a href="#">Optimising the I<sub>max</sub> controller</a> (📖 86)
<b>4</b> V <sub>min</sub> boost (C016)	0.0	%	▶ <a href="#">Adapting the V<sub>min</sub> boost</a> (📖 85)

**Tip!**

Also check the other information on the nameplate against the motor data set in the drive controller. You can find further information in the chapter entitled "[Motor selection/Motor data](#)". (📖 66)

**Recommendations for the following application cases:**

- If the controller and motor differ greatly from each other in terms of performance: Set the I<sub>max</sub> limit (in motor mode) in [C022](#) to double the rated motor current.
- If a higher starting torque is required:  
In idle state of the motor, set the V<sub>min</sub> boost in [C016](#) in such a way that the rated motor current flows at a field frequency of  $f = 3$  Hz (display in [C058](#)).
- If a high torque is to be available at low speed and without a feedback: Select the "sensorless vector control" (SLVC) in [C006](#) as motor control.

### Parameterise application

On the right of the **Application parameters** tab, the parameters of the application are arranged:

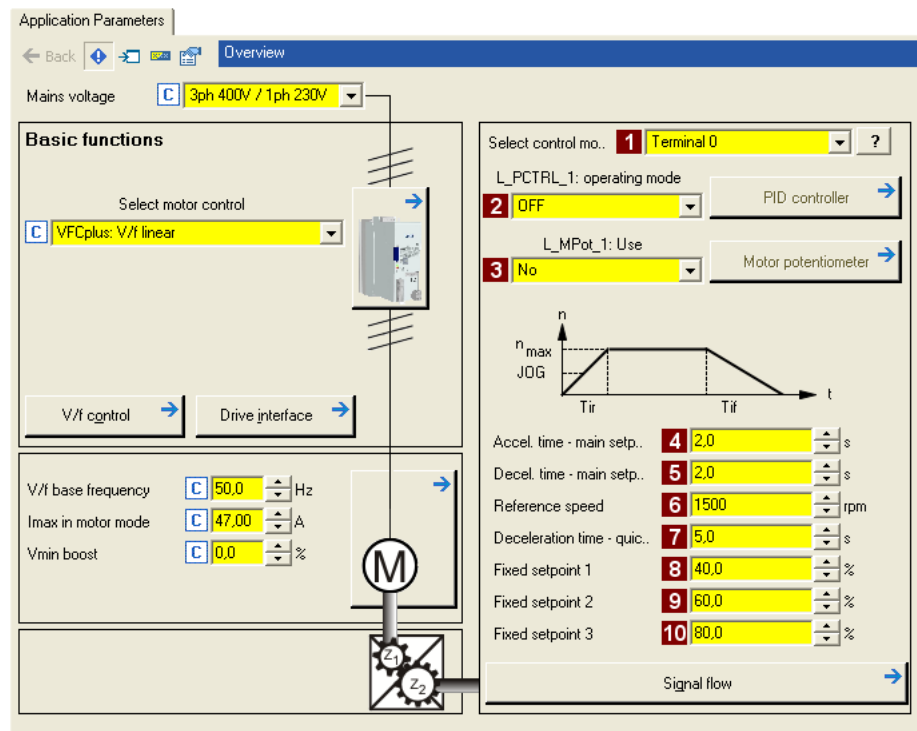

1. Select the required control mode in the **1 Control mode (C007)** list field.
  - The corresponding wiring diagram is displayed in a pop-up window if you click the **?** button right to the list field.
  - For a detailed description, see chapter entitled "[Terminal assignment of the control modes](#)". ([□ 137](#))
2. Optional: Use process controller.
  - For this purpose select the required operating mode in the **2 L\_PCTRL\_1: Operating mode (C242)** list field.
  - For a detailed description see the function block [L\\_PCTRL\\_1](#). ([□ 233](#))
  - The parameterisation dialog of the process controller can be accessed via the **Process controller** button.
3. Optional: Use motor potentiometer.
  - For this purpose, select "1: On" in the **3 L\_MPot\_1: Use (C806)** list field.
  - For a detailed description see the function block [L\\_MPot\\_1](#). ([□ 226](#))
  - The parameterisation dialog of the process controller can be accessed via the **Motor potentiometer** button.

## 4. Adapt parameters of the application:

Parameter	Lenze setting		Info
	Value	Unit	
<b>4</b> Accel. time - main setpoint ( <a href="#">C012</a> )	2.0	s	The setpoint is led via a ramp function generator with linear characteristic. The ramp function generator converts setpoint step-changes at the input into a ramp. ▶ <a href="#">L_NSet_1</a> ( <a href="#">📖 230</a> )
<b>5</b> Decel. time - main setpoint ( <a href="#">C013</a> )	2.0	s	
<b>6</b> Reference speed ( <a href="#">C011</a> )	1500	rpm	All speed setpoint selections are provided in % and always refer to the reference speed set in <a href="#">C011</a> . The motor reference speed is given on the motor name-plate.
<b>7</b> Deceleration time - quick stop ( <a href="#">C105</a> )	5.0	s	When "quick stop" is requested, the motor control is decoupled from the setpoint selection and within the deceleration time parameterised in <a href="#">C105</a> , the motor is brought to a standstill in ( $n_{act} = 0$ ). ▶ <a href="#">Activate/Deactivate quick stop</a> ( <a href="#">📖 51</a> )
<b>8</b> Fixed setpoint 1 ( <a href="#">C039/1</a> )	40.0	%	A fixed setpoint for the setpoint generator can be activated instead of the main setpoint via the digital inputs DI1 and DI2. • The fixed setpoints are selected in [%] based on the reference speed ( <a href="#">C011</a> ). ▶ <a href="#">L_NSet_1</a> ( <a href="#">📖 230</a> )
<b>9</b> Fixed setpoint 2 ( <a href="#">C039/2</a> )	60.0	%	
<b>10</b> Fixed setpoint 3 ( <a href="#">C039/3</a> )	80.0	%	

**Tip!**

- Via the **Signal flow** button, you get one dialog level lower to the signal flow of the application with further parameterisation opportunities. See chapter entitled "[Parameterisation dialog](#)". ([📖 123](#))
- The preconfigured I/O connection in the selected control mode can be changed via configuration parameters. See chapter entitled "[User-defined terminal assignment](#)". ([📖 115](#))

**More detailed information on the drive application:**

- ▶ [Drive application](#) ([📖 122](#))
- ▶ [Interface description](#) ([📖 128](#))
- ▶ [Setting parameters \(short overview\)](#) ([📖 133](#))
- ▶ [Pre-assignment of the drive application](#) ([📖 134](#))
- ▶ [Terminal assignment of the control modes](#) ([📖 137](#))

### 3.4.4 Save parameter settings safe against mains failure

In order that parameter settings made in the device do not get lost by means of mains switching, you must save the parameter set explicitly safe against mains failure in the device.

-  Save parameter set

### 3.4.5 Enable controller and select speed



#### Note!

If the controller is enabled at power-on and the auto-start option is activated in [C142](#) (Lenze setting), the controller remains in the "[ReadyToSwitchON](#)" state (display in [C137](#)).

For changing to the "[SwitchedON](#)" state, first deactivate the controller enable: Set terminal X4/RFR to LOW level or open contact to terminal X4/12I.

When the controller is in the "[SwitchedON](#)" state:

1. Enable controller:  
Set terminal X4/RFR to HIGH level or close contact to terminal X4/12I n.
2. Select speed:
  - In the "Terminals 0" by selecting a voltage at the analog input or by selecting a fixed setpoint via the digital inputs DI1/DI2.

DI1	DI2	Speed selection
LOW	LOW	The setpoint speed is selected via the analog input 1 • Scaling: 10 V $\equiv$ 100 % $\equiv$ reference speed ( <a href="#">C011</a> )
HIGH	LOW	The fixed setpoint 1 ( <a href="#">C039/1</a> ) is used as setpoint speed. • Lenze setting: 40 % of the reference speed ( <a href="#">C011</a> )
LOW	HIGH	The fixed setpoint 2 ( <a href="#">C039/2</a> ) is used as setpoint speed. • Lenze setting: 60 % of the reference speed ( <a href="#">C011</a> )
HIGH	HIGH	The fixed setpoint 3 ( <a href="#">C039/3</a> ) is used as setpoint speed. • Lenze setting: 80 % of the reference speed ( <a href="#">C011</a> )



#### Note!

Observe the actual speed value (display in [C051](#)) as well as the [LED status display](#) and [Display messages](#) indicated in the keypad.



#### Tip!

More control functions in the "Terminals 0" control mode:

- DI3: HIGH level  $\equiv$  request DC-injection braking
- DI4: HIGH level  $\equiv$  request change of direction of rotation

**Diagnostics options**

When the »Engineer« is used, trouble during commissioning can be detected and eliminated conveniently. Proceed as follows:

- Check whether error messages appear in the »Engineer«.
  - You can find a description of each possible message in the chapter entitled "[Diagnostics & error management](#)". (□ 142)
- Check the input terminals for their corresponding setpoints.
  - The **Terminal assignment** tab displays the current input/output signals.
- Check the signal flow of the application.
  - To do this, open the **Application Parameters** tab and click on the **Signal flow** button. The signal flow which is then shown enables a view of the setpoints being applied and their processing.

### 3.5 PC manual control

This function extension is available as of version 03.03.00 and is supported by the »Engineer« as of version 2.14!

For test and demonstration purposes, PC manual control can be used to manually control various drive functions via the »Engineer« when an online connection has been established.

#### Supported drive functions:

- Speed control (follow a speed setpoint)
- Activate/Deactivate quick stop

#### More control functions:

- Reset of error message
- Set digital/analog outputs (in preparation)

#### Diagnostic functions:

- Display of the actual speed value and motor current (in a temporal characteristic)
- Display of the current device state
- Display of the status determining error
- Display of the status of the digital/analog inputs (in preparation)

#### 3.5.1 Activating PC manual control



#### Stop!

PC manual control must be explicitly activated by the user.

If PC manual control is activated, the controller is inhibited via device command ([C002/16](#)) first.



#### Note!

##### For activated PC manual control:

The online connection between the PC and the controller is monitored by the controller.

- If the online connection is interrupted for longer than 2 s, error response "Fault" is triggered, i.e. the motor becomes torqueless and is coasting unless it already is at standstill.

PC manual control transmits all required control and setpoint signals to the motor interface.

- The application is now decoupled from these interfaces, but will be processed as before and remains unchanged.
- It does not matter what type of motor control is set in [C006](#).

**How to activate PC manual control:**

1. If an online connection to the controller has not been established yet:
  -  Go online.
2. Go to *Workspace* and change to the **Application parameters** tab.
3. Go to the *Overview* dialog level and click the **PC manual control** button.
  - The following safety note is displayed first:

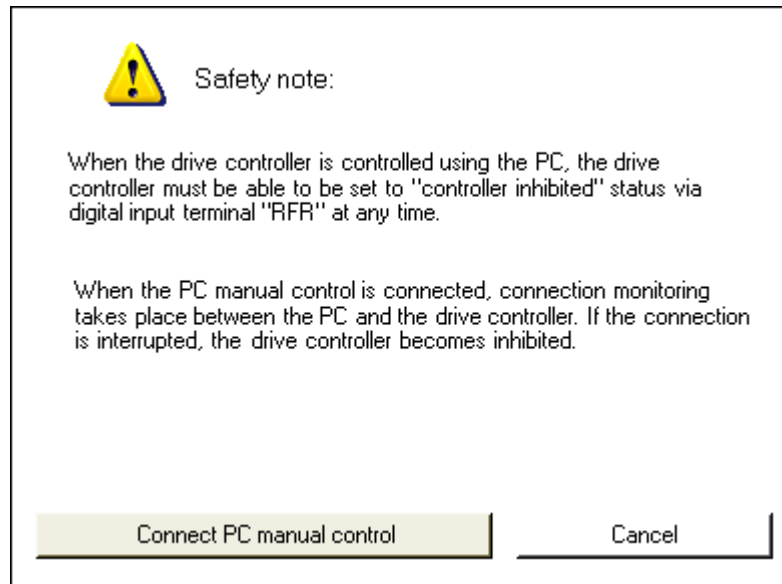

- Click the **Cancel** button to abort the action and close the dialog box.
4. To acknowledge the note and activate PC manual control:
    - Click the **Connect PC manual control** button.
    - The controller is inhibited via device command ([C002/16](#)).
    - The *PC manual control* operator dialog is displayed.

### PC manual control operator dialog

On the left-hand side, the *PC manual control* operator dialog includes control elements which serve to select various control functions. On the right-hand side, setpoint and status displays are provided for diagnostic purposes:

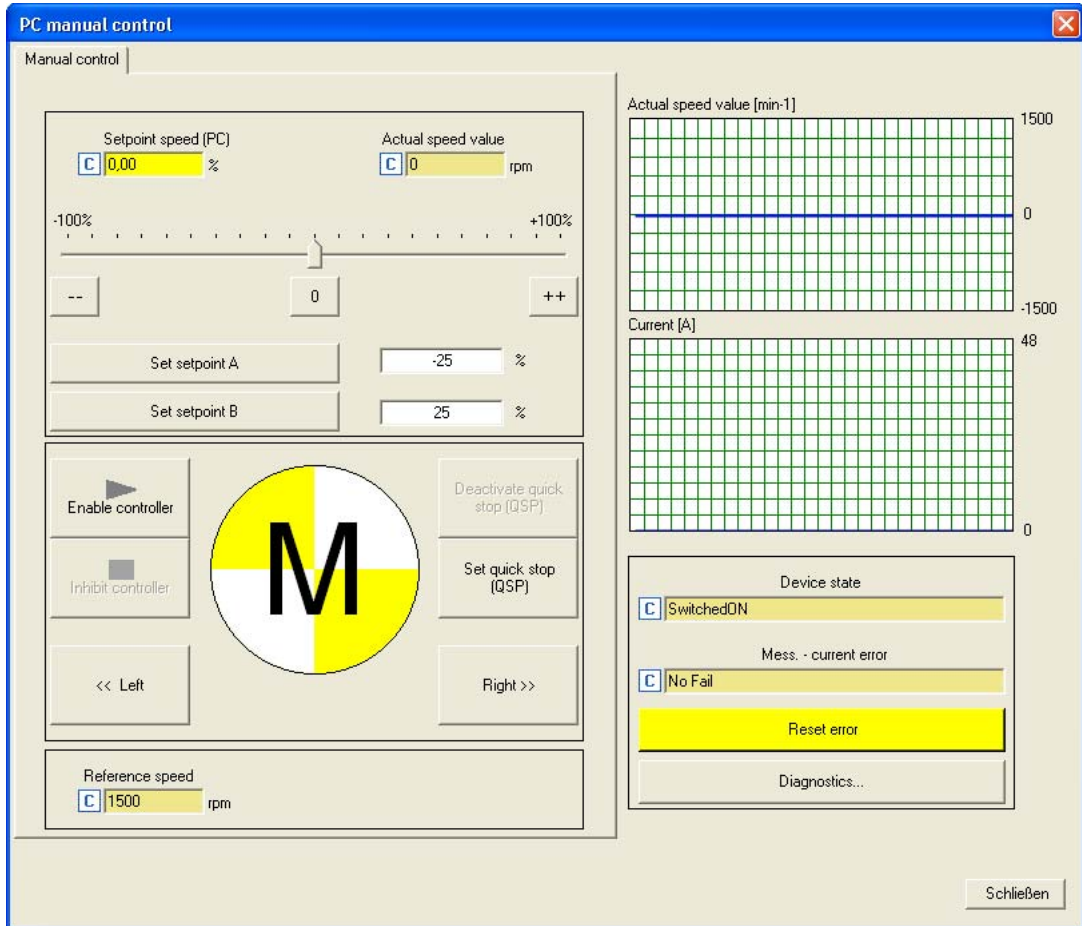

### Note!

PC manual control can be exited any time by clicking the **Close** button.

If you exit PC manual control or change to another tab, the controller is inhibited via device command ([C002/16](#)), i.e. the motor becomes torqueless and is coasting unless it already is at standstill.

The execution of the various functions is described in the following chapters.



## 3.5.2 Speed control

Via the **Speed control** tab, simply make the drive rotate in the "Speed follower" operating mode without the need to set control parameters or feedback systems:

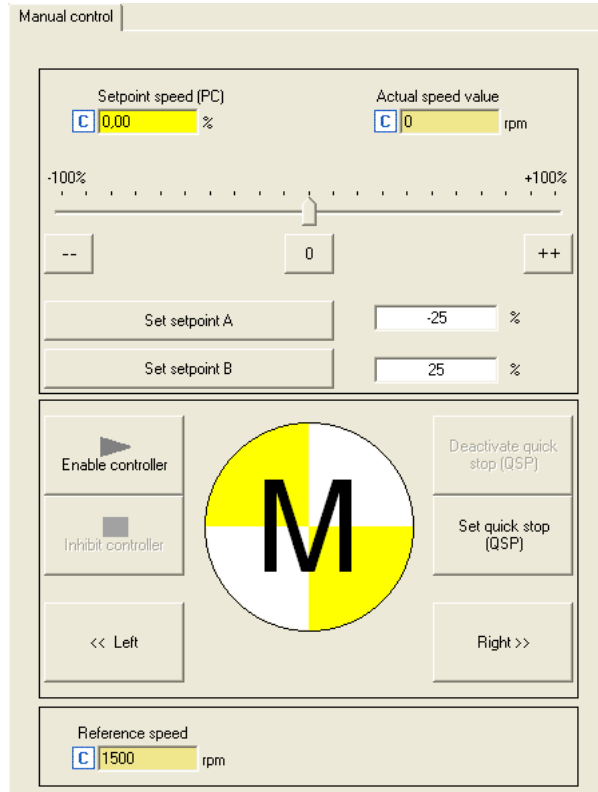

#### How to make the motor rotate in its most basic way:

1. Set the desired speed setpoint in [%] based on the reference speed, e.g. directly in the **Setpoint PC** input field or via the slider.
  - Via the -- / 0 / ++ buttons, the currently set speed setpoint can be reduced/increased in steps of 10 percent or set to zero.
  - Via the **Set setpoint A/B** buttons, the speed setpoint can be set to a previously set constant value A/B.
2. To start the speed follower:
 

Enable the controller via the **Enable controller** button.

  - Please observe that the controller will not be enabled if other sources of controller inhibit (e.g. terminal RFR) are active.
  - The enabled controller is now following the selected speed setpoint.
  - To avoid shocks or overload in case of great setpoint changes, the speed setpoint follows a linear ramp generator with adjustable acceleration/deceleration time.
  - Via the **Inhibit controller** button, the controller can be inhibited again, i.e. the motor becomes torqueless and is coasting unless it already is at standstill.

**Further functions:**

- If the **Set quick stop (QSP)** button is clicked, the motor is braked to a standstill within the deceleration time parameterised in [C105](#).
  - Via the **Deactivate quick stop (QSP)** button, the quick stop can be deactivated.
- Via the **<< Left** and **Right >>** buttons, the direction of rotation can be changed.

### 4 Device control (DCTRL)

This chapter provides information on the internal device control as well as the device commands which can be executed via the subcodes of [C002](#).

- The device control causes the controller to take defined device states.
- The device control provides a multitude of status information in many ways:
  - Optically via the [LED status display](#) of the integrated keypad. (📖 19)
  - As text messages in [Logbook](#). (📖 146)
  - As process signals via the outputs of the [LS\\_DriveInterface](#) system block. (📖 246)
  - Via diagnostic / display parameters which are included in the »Engineer« parameter list as well as in the **Diagnostics** category in the keypad.



#### Note!

The device states of the controller are based on the operating states of the CiA402 standard. ▶ [Device states](#) (📖 54)



## How to get to the parameterisation dialog of the device control:

1. »Engineer« Go to the *Project view* and select the 8400 Baseline D controller.
2. Go to *Workspace* and change to the **Application parameters** tab.
3. Go to the *Overview* dialog level and click the **Drive interface** button.

## Parameterisation dialog in the »Engineer«

The parameterisation dialog shows the input / output signals and the internal signal flow of the [LS\\_DriveInterface](#) system block which displays the device control in the application:

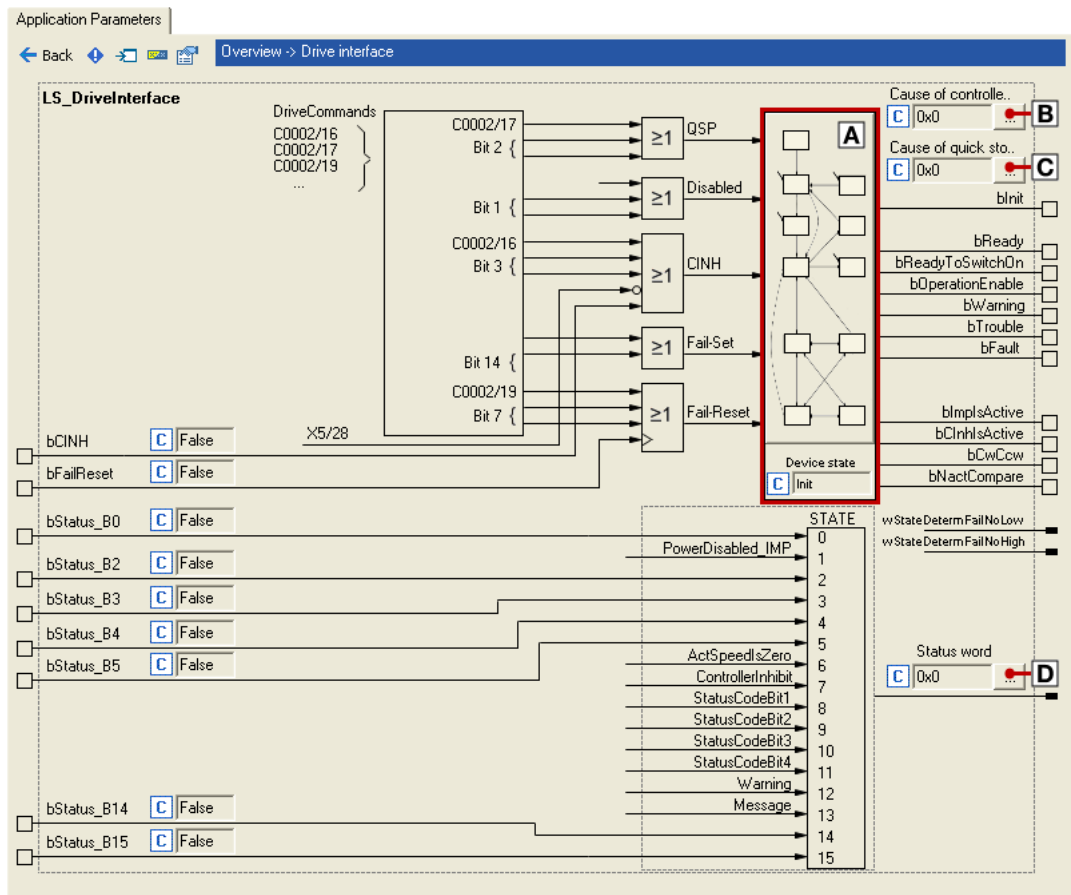

Range / Meaning	Display parameter
<b>A</b> Display of the internal state machine and the current device state	<a href="#">C137</a>
<b>B</b> Display of all active sources of a controller inhibit	<a href="#">C158</a>
<b>C</b> Display of all active sources of a quick stop	<a href="#">C159</a>
<b>D</b> Display of the status word of the device control	<a href="#">C150</a>

# 4 Device control (DCTRL)

## 4.1 Device commands

---

### 4.1 Device commands

The following subchapters describe the device commands which are provided in the subcodes of [C002](#) and can be carried out using the keypad or, alternatively, the »Engineer« when an online connection has been established.

The device commands serve to directly control the controller, to organise parameter sets, and to call diagnostic services.

Regarding the execution of the device commands, a distinction is drawn between:

- Device commands which have an immediate effect on control (e.g. "Activate quick stop")
  - After being called in [C002/x](#), these device commands provide static status information ("On" or "Off").
- Device commands with longer execution durations (several seconds)
  - After being called in [C002/x](#), these device commands provide the status information "Work in progress".
  - The execution of the device command has not finished successfully until the "Off / ready" status information is provided in [C002/x](#).
  - In the event of an error, the "Action cancelled" status information is provided in [C002/x](#). In this case, further details can be obtained from the status of the device command executed last which is displayed in [C003](#).



#### Note!

- Before activating the device commands through a master control, please wait for the "ready" message of the controller.
- The device will reject a write process to [C002/x](#) if the value is >1 and issue an error message.
- In [C003](#) displays the status of the device command executed last.



Detailed information on the various device commands can be found in the following subchapters.

- Before you follow the instructions given therein, ensure that you have selected the controller in the *Project view*.

### Device commands - short overview



C00002 Subcode:	Device command	Controller inhibit required	Status information
1	<a href="#">Load Lenze setting</a>	●	dynamic
2	<a href="#">Loading parameter settings</a>	●	dynamic
7	<a href="#">Save parameter settings</a>		dynamic
12	<a href="#">Import EPM data</a>		static
16	<a href="#">Enable/Inhibit controller</a>		static
17	<a href="#">Activate/Deactivate quick stop</a>		static
19	<a href="#">Reset error</a>		static
21	<a href="#">Delete logbook</a>		static
23	<a href="#">Identify motor parameters</a>	●	dynamic

\* Subcodes which are not listed are reserved for future extensions.

### Activate device command

When an online connection has been established, you can simply use the »Engineer« to activate a device command by selecting the corresponding option from the **Parameter** tab in [C002/x](#) ("0: Off" or "1: On / start").

- Alternatively, the device command can also be activated via keypad by writing to [C002/x](#).
- Some of the frequently used device commands (such as "Save parameter settings") can also be executed via *toolbar* icons of the »Engineer« when an online connection has been established:

Symbol	Function
	Enable controller
	Inhibit controller
	Save parameter settings



### Note!

Device commands that can be executed via the *toolbar* of the »Engineers« always affect the element currently selected in the *Project view* including all subelements!

- If no controller, but e.g. a system module is selected in the *Project view*, the corresponding device command will be activated in all lower-level controllers having an online connection with the »Engineer«.

Before the desired action is carried out, a confirmation prompt appears first, asking whether the action is really to be carried out.

## 4 Device control (DCTRL)

### 4.1 Device commands

---

#### 4.1.1 Load Lenze setting

The [C002/1](#) = "1: On / start" device command resets the parameters to the Lenze setting which are saved in the controller firmware.

- Can only be executed if the controller is inhibited; otherwise, the feedback [C002/1](#) = "6: No access - controller inhibit" will be returned".
- All parameter changes which have been carried out after the last time the parameter settings were saved will be lost!
- This device command has an effect on the settings of the parameters of the operating system, application and module.



##### How to load the Lenze setting:

1. If the controller is enabled, it must be inhibited, e.g. by executing the "Enable/Inhibit controller" device command" ([C002/16](#) = "0: Off / ready").
2. Execute the "Load Lenze setting" device command [C002/1](#) = "1: On / start"

The load process may take a couple of seconds. After the device command has been called in [C002/1](#) a dynamic status information ("Work in progress" W "Off / ready") is returned.

#### 4.1.2 Loading parameter settings

The [C002/2](#) = "1: On / start" device command reloads all parameters from the memory module to the controller.

- Can only be executed if the controller is inhibited; otherwise, the feedback [C002/2](#) = "6: No access - controller inhibit" will be returned.
- All parameter changes which have been carried out after the last time the parameter settings were saved will be lost!
- This device command has an effect on the settings of the parameters of the operating system, application and module.



##### Note!

When the device is switched on, all parameters are automatically loaded from the memory module to the main memory of the controller.



##### How to reload the starting parameter settings from the memory module:

1. If the controller is enabled, it must be inhibited, e.g. by executing the "Enable/Inhibit controller" device command ([C002/16](#) = "0: Off / ready").
2. Execute the "Load Lenze setting" device command: [C002/2](#) = "1: On / start"

The load process may take a couple of seconds. After the device command has been called in [C002/2](#) a dynamic status information ("Work in progress" W "Off / ready") is returned.

## 4 Device control (DCTRL)

### 4.1 Device commands

---

#### 4.1.3 Save parameter settings

If parameter settings are changed in the controller, those changes will be lost after mains switching of the controller unless the settings have been saved explicitly.

You have various opportunities to prevent a data loss by saving the parameter settings in the memory module:

- [Quick saving of all parameters at the push of a button](#) (☰ 24)
- [Automatic saving of parameter changes](#)
- [Manual saving of parameter settings](#)



#### Note!

How to prevent a data loss:

- Do not switch off the supply voltage during the saving process.
- Only unplug the memory module if the device is switched off.

#### Automatic saving of parameter changes



#### Stop!

Activating this function is not permissible if parameters are changed very frequently (e.g. in case of cyclic writing of parameters via a bus system).

The maximum service life of the memory module amounts to one million writing cycles. Make sure that this value will not be reached.

When you set the selection "1: Active" in [C141/1](#), the automatic saving function is activated and every parameter change is automatically saved in the memory module.

#### Manual saving of parameter settings

The [C002/7](#) = "1: On / start" device command saves the current parameter settings safe against mains failure to the memory module of the controller.

#### 4.1.4 Import EPM data

The [C002/12](#) = "1: device command activates the automatic import of parameters from the memory module after the error message "PS04: Par.set incompatible".



# 4 Device control (DCTRL)

## 4.1 Device commands

---

### 4.1.5 Enable/Inhibit controller



The [C002/16](#) = "1: : On / start" device command enables the controller, provided that no other source of a controller inhibit is active.

The [C002/16](#) = "0: Off / ready" device command serves to inhibit the controller, i.e. the power output stages in the controller are inhibited and the speed/current controller of the motor control is reset.zurückgesetzt.

- The motor becomes torqueless and coasts down.
- When the controller is inhibited, the status output *bCInhActive* of the [LS\\_DriveInterface](#) system block is set to TRUE.
- When the controller inhibit request is reset, the drive synchronises to the actual speed. For this purpose,
  - If the flying restart circuit is activated in [C990](#), the flying restart function parameterised in [C991](#) is used for the synchronisation to the rotary or standing drive. ▶ [Flying restart function](#) ([□ 95](#))



#### Tip!

- The controller can also be enabled or inhibited via the  and  toolbar icons.
- [C158](#) provides a bit coded representation of all active sources/triggers of a controller inhibit.

### 4.1.6 Activate/Deactivate quick stop

The [C002/17](#) = ""1: On / start" device command activates the quick stop function, i.e. the motor control is separated from the setpoint selection, and within the deceleration time parameterised in [C105](#) the motor is brought to a standstill ( $n_{act} = 0$ ).

Parameter	Info	Lenze setting	
		Value	Unit
<a href="#">C105</a>	Deceleration time - quick stop	2.000	s

- A pulse inhibit (CINH) is set if the "Auto-DCB" function has been activated via [C019](#).

The [C002/17](#) = "0: Off / ready" device command deactivates the quick stop again, provided that no other source of a quick stop is active.



#### Tip!

[C159](#) provides a bit coded representation of all active sources/triggers of a quick stop.

## 4 Device control (DCTRL)

### 4.1 Device commands

---

#### 4.1.7 Reset error

The [C002/19](#) = "1: On / start" device command acknowledges an existing error message if the error cause has been eliminated and thus the error is not pending anymore.

- After resetting the current error, further errors may be pending which must be reset as well.
- The last 8 errors are displayed in [C168](#).



#### Tip!

An error message can also be acknowledged by activating the **Reset error** button in the **Diagnostics** tab.

In the Lenze setting, switching RFR also causes an error acknowledgement (see configuration parameter [C701/2](#)).

Detailed information on error messages can be found in the chapter entitled "[Diagnostics & error management](#)". ([142](#))

#### 4.1.8 Delete logbook

The [C002/21](#) = "1: On / start" device command deletes all logbook entries.



#### Tip!

Click the **Logbook** button in the **Diagnostics** tab to display the logbook in the »Engineer«.

In the *Logbook* dialog box, it is also possible to delete all logbook entries by clicking the **Delete** button.

Detailed information on the logbook can be found in the chapter entitled "[Diagnostics & error management](#)". ([142](#))

## 4 Device control (DCTRL)

### 4.1 Device commands

---

#### 4.1.9 Identify motor parameters

The [C002/23](#) = "1: On / start" device command performs automatic identification of the motor parameters.

- The device command is only executed when the drive controller is in the "[SwitchedON](#)" state.
- In order to identify the motor parameters, the controller must be enabled after this device command.
  - After that it changes to the "[MotorIdent](#)" device state.
  - After the execution of the identification, it changes back to the "[SwitchedON](#)" device state.



#### Tip!

Detailed information on automatic identification of motor parameters can be found in the "[Automatic motor data identification](#)" subchapter on motor control (MCTRL). ([📖 71](#))

# 4 Device control (DCTRL)

## 4.2 Device states

### 4.2 Device states

The state machine causes the controller to take defined states:

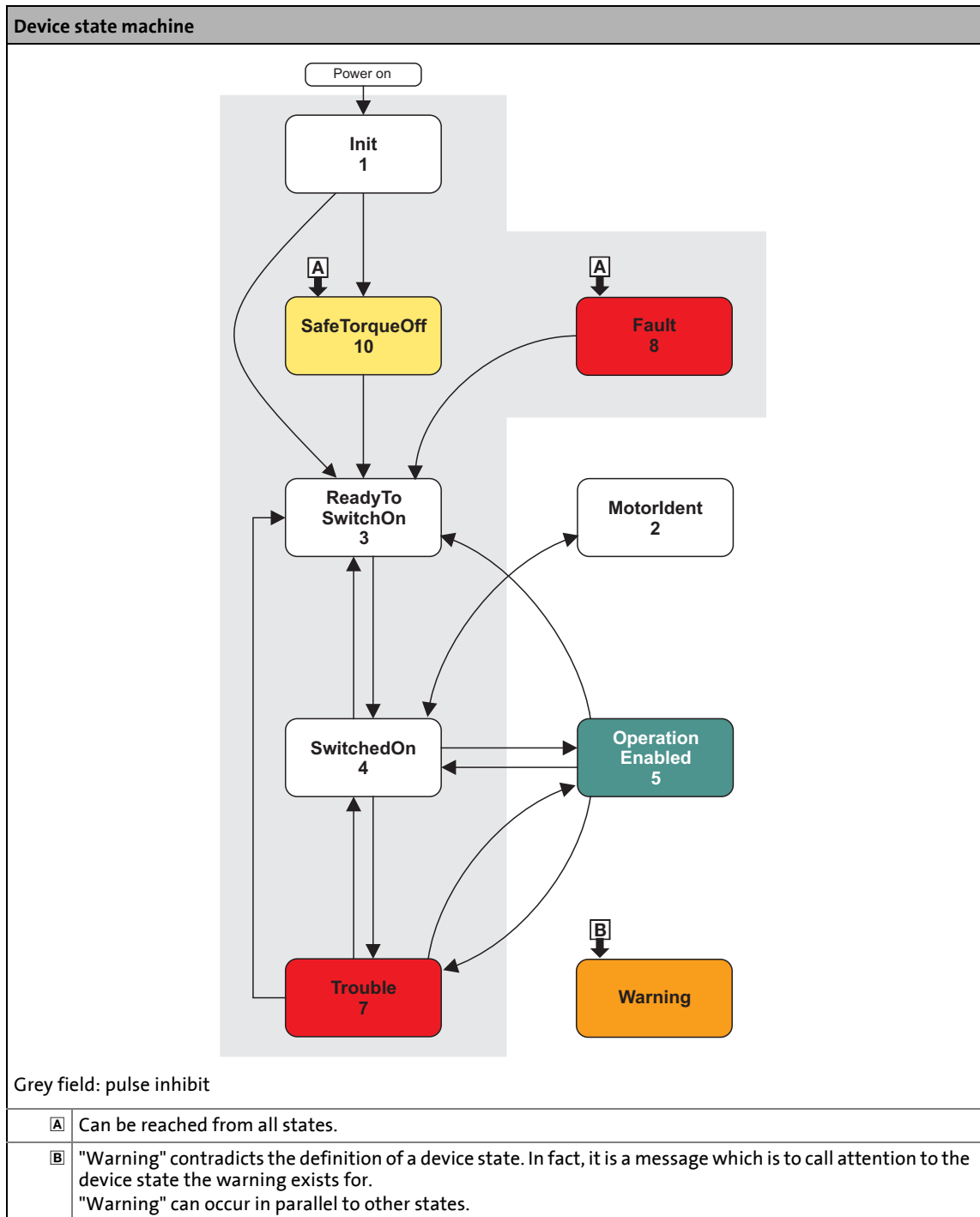

- The arrows between the device states mark the points where the possible device states begin and end.
- The digits stand for the state ID (see table below).

# 4 Device control (DCTRL)

## 4.2 Device states

- The change from one state to another is done in a 1 ms cycle. If, at the same time, several state change requests exist, the state with the higher priority is processed first (see the following table).
- In [C137](#) displays the current device state.
- In [C150](#) (status word) provides a bit coded representation of the current device state via bits 8 ... 11 (see table below).

ID	Device state (Display in <a href="#">C137</a> )	Priority	Status bits (Display in <a href="#">C150</a> )				Meaning
			Bit 11	Bit 10	Bit 9	Bit 8	
0	-(reserved)	-	0	0	0	0	-
1	<a href="#">Init</a>	-	0	0	0	1	Initialisation is active
2	<a href="#">MotorIdent</a>	-	0	0	1	0	Motor parameter identification is active
3	<a href="#">ReadyToSwitchON</a>	Prio 4	0	0	1	1	Device is ready to start
4	<a href="#">SwitchedON</a>	Prio 3	0	1	0	0	Device is switched on
5	<a href="#">OperationEnabled</a>	Prio 1	0	1	0	1	Operation
6	-(reserved)	-	0	1	1	0	-
7	<a href="#">Trouble</a>	Prio 2	0	1	1	1	Trouble is active
8	<a href="#">Fault</a>	Prio 6	1	0	0	0	Fault is active
9	-(reserved)	-	1	0	0	1	-
10	<a href="#">SafeTorqueOff</a>	Prio 5	1	0	1	0	Safe torque off is active
11	-(reserved)	-	1	0	1	1	-
...	...	...	...				...
15	-(reserved)	-	1	1	1	1	-

[4-1] Device states, priorities, and meaning of the status bits in the status word

# 4 Device control (DCTRL)

## 4.2 Device states

---

### 4.2.1 Init

LED DRIVE READY	LED DRIVE ERROR	Display in <a href="#">C137</a>	Display in status word 1 ( <a href="#">C150</a> )			
			Bit 11	Bit 10	Bit 9	Bit 8
OFF	OFF	Init	0	0	0	1

In the "Init" device status

- is the controller directly after the supply voltage is switched on.
- the operating system is initialised.
- all device components (memory module, power section, etc.) are identified.
- the parameters are read out of the memory module.
- it is checked whether the DC-bus voltage is within the tolerance zone and the precharge relay is closed.
- the inverter is inhibited, i.e., there is no voltage output at the motor terminals.
- the communication via diagnostic interface does not work yet.
- the application is not yet processed.
- the monitoring mode is not yet active.
- the controller cannot be parameterised yet and no device commands can be carried out yet.



#### Note!

If the initialisation is completed, it changes automatically to the "[ReadyToSwitchON](#)" device state.

# 4 Device control (DCTRL)

## 4.2 Device states

### 4.2.2 MotorIdent

LED DRIVE READY	LED DRIVE ERROR	Display in <a href="#">C137</a>	Display in status word 1 ( <a href="#">C150</a> )			
			Bit 11	Bit 10	Bit 9	Bit 8
	OFF	MotorIdent	0	0	1	0

In the "MotorIdent" device state

- is the controller when being in the "[SwitchedON](#)" state and having activated the "[Identify motor parameters](#)" device command and being enabled.
- the application remains active.
- all system interfaces (IO, bus systems, etc.) remain active.
- error monitoring remains active
- the inverter is controlled independently of the setpoint sources.



#### Stop!

During motor parameter identification, the controller does not respond to setpoint changes or control processes, (e.g. speed setpoints, quick stop, torque limitations).

After the motor parameter identification is completed, the state changes back to "[SwitchedON](#)".



#### Tip!

Detailed information on motor parameter identification can be found in the "[Automatic motor data identification](#)" subchapter on motor control. ([71](#))

### 4.2.3 SafeTorqueOff

LED DRIVE READY	LED DRIVE ERROR	Display in <a href="#">C137</a>	Display in status word 1 ( <a href="#">C150</a> )			
			Bit 11	Bit 10	Bit 9	Bit 8
	OFF	SafeTorqueOff	1	0	1	0

In the "SafeTorqueOff" device state

- the controller can only be if a safety module is connected and the power section is supplied and at least one of the two safe inputs SI1/SI2 is set to LOW level.
- the next transaction to the "[ReadyToSwitchON](#)" state takes place.



Detailed and important information on the integrated safety system can be found in the hardware manual!

### 4.2.4 ReadyToSwitchON

LED DRIVE READY	LED DRIVE ERROR	Display in <a href="#">C137</a>	Display in status word 1 ( <a href="#">C150</a> )			
			Bit 11	Bit 10	Bit 9	Bit 8
	OFF	ReadyToSwitchON	0	0	1	1

In the "ReadyToSwitchOn" device state

- is the controller after the initialisation has been completed successfully.
- is the controller even after cancelling "[Trouble](#)", "[Fault](#)" or "[SafeTorqueOff](#)".
- I/O signalare evaluated.
- the monitoring modes are active.
- the controller can be parameterised.
- the application is basically executable.
- prevents in the Lenze setting the auto-start option "Inhibit at power-on" activated in [c142](#) "from changing to the "[SwitchedON](#)" state.



#### Danger!

If the "Inhibit at power-on" auto-start option has been deactivated in [C142](#), the "ReadyToSwitchOn" state directly switches to the "[SwitchedON](#)" state.

▶ "[Inhibit at power-on](#)" auto-start option ([□ 63](#))



# 4 Device control (DCTRL)

## 4.2 Device states

### 4.2.5 SwitchedON

LED DRIVE READY	LED DRIVE ERROR	Display in <a href="#">C137</a>	Display in status word 1 ( <a href="#">C150</a> )			
			Bit 11	Bit 10	Bit 9	Bit 8
	OFF	SwitchedON	0	1	0	0

In the "SwitchedOn" device state

- is the controller if the user has inhibited the controller (and no error is pending).
- I/O signalare evaluated.
- the monitoring modes are active.
- the controller can be parameterised.
- the application is basically executable.
- it can be changed to the "[OperationEnabled](#)" state by deactivating the controller inhibit.



**Tip!**

[C158](#) provides a bit coded representation of all active sources/triggers of a controller inhibit.

Depending on certain conditions, a state change takes place based on the "SwitchedOn" device state:

Change condition	Changeover to the device state
Terminal RFR = HIGH level (controller enable)	<a href="#">OperationEnabled</a>
Motor parameter identification requested.	<a href="#">MotorIdent</a>
Undervoltage in the DC bus.	<a href="#">Trouble/Fault</a> (dependent on <a href="#">C600/1</a> )
Error with error response "Trouble" occurs.	<a href="#">Trouble</a>

# 4 Device control (DCTRL)

## 4.2 Device states

### 4.2.6 OperationEnabled

LED DRIVE READY	LED DRIVE ERROR	Display in <a href="#">C137</a>	Display in status word 1 ( <a href="#">C150</a> )			
			Bit 11	Bit 10	Bit 9	Bit 8
	OFF	OperationEnabled	0	1	0	1

In the "OperationEnabled" state

- is the controller if the controller inhibit is deactivated and no trouble ("Trouble") and fault ("Fault") are existent.
- the operation is enabled and the motor follows the setpoint defined by the active application (in case of sensorless vector control only after the magnetisation process is completed).

Depending on certain conditions, a state change takes place based on the "OperationEnabled" device state.

Change condition	Changeover to the device state
Terminal RFR = LOW level (controller inhibit).	<a href="#">SwitchedON</a>
Undervoltage in the DC bus.	<a href="#">Trouble/Fault</a> (dependent on <a href="#">C600/1</a> )
Error with error response "Trouble" occurs.	<a href="#">Trouble</a>

### 4.2.7 Trouble

LED DRIVE READY	LED DRIVE ERROR	Display in <a href="#">C137</a>	Display in status word 1 ( <a href="#">C150</a> )			
			Bit 11	Bit 10	Bit 9	Bit 8
OFF		Trouble	0	1	1	1

In the "Trouble" device state

- is the controller if monitoring has caused a "Trouble" error response.
- the motor has no torque (is coasting) due to the inhibit of the inverter.



#### Note!

The "Trouble" device state is automatically abandoned if the error cause has been removed.

If in [C142](#) the "Inhibit at trouble" auto-start option is activated, an explicit deactivation of the controller inhibit is required for leaving the state.

Depending on certain conditions a state change takes place based on the "Trouble" device state.

Change condition	Changeover to the device state
The error cause is no longer active.	<a href="#">ReadyToSwitchON</a>
Terminal RFR = HIGH level (controller enable) <b>AND</b> the message has been cancelled.	<a href="#">OperationEnabled</a>

#### Related topics:

- ▶ [Basics on error handling in the controller](#) (📖 142)
- ▶ [Error messages of the operating system](#) (📖 153)

### 4.2.8 Fault

LED DRIVE READY	LED DRIVE ERROR	Display in <a href="#">C137</a>	Display in status word 1 ( <a href="#">C150</a> )			
			Bit 11	Bit 10	Bit 9	Bit 8
OFF		Fault	1	0	0	0

In the "Fault" device state

- is the controller if monitoring has caused a "Fault" error response.
- the motor has no torque (is coasting) due to the inhibit of the inverter.

The error must explicitly be reset ("acknowledged") in order to exit the device state, e.g. by the device command "[Reset error](#)".



#### Note!

If an undervoltage in the DC bus of the drive controller occurs (error message "LU"), the device changes to the "[Trouble](#)" state.

An additional error of higher priority leads the device into the "[Fault](#)" state.

According to the [Device state machine](#), the device changes to the "[ReadyToSwitchON](#)" state after acknowledging the error although the undervoltage is still available!

If in [C142](#) the "Inhibit at fault" auto-start option is activated, an explicit deactivation of the controller inhibit is required for leaving the state.

#### Related topics:

- ▶ [Basics on error handling in the controller](#) ([📖 142](#))
- ▶ [Error messages of the operating system](#) ([📖 153](#))

## 4 Device control (DCTRL)

### 4.3 "Inhibit at power-on" auto-start option

---

#### 4.3 "Inhibit at power-on" auto-start option

In the Lenze setting in [C142](#) the auto-start option "Inhibit at power-on" is activated. This setting prevents a change to the "[SwitchedON](#)" state if the controller is already enabled at mains power-up.



#### **Danger!**

When the auto-start option "Inhibit at power-on" is deactivated, the motor can directly start after power-on if the controller is enabled!

The following three cases describe the controller behaviour as a function of controller enable and set auto-start option. Here, we assume that no fault and trouble exist in the controller after power-on.

**Case 1: No controller enable at power-on**

If there is no controller enable at power-on, the controller remains in the "[SwitchedON](#)" state. Only with controller enable it is changed to the "[OperationEnabled](#)" state, independent of the setting of the auto-start option:

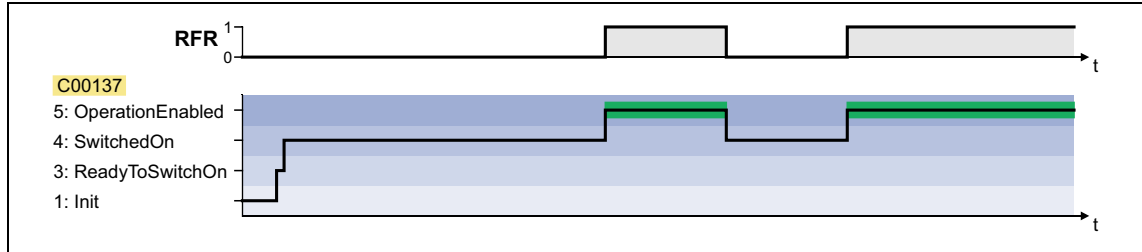
**Case 2: Controller enable at power-on and "Inhibit at power-on" activated**

If the controller is enabled at power-on and the auto-start option "Inhibit at power-on" is active, the controller remains in the "[ReadyToSwitchON](#)" state. In order to change to the "[SwitchedON](#)" state, the controller enable must first be deactivated. When the controller enable is then activated, it is changed to the "[OperationEnabled](#)" state:

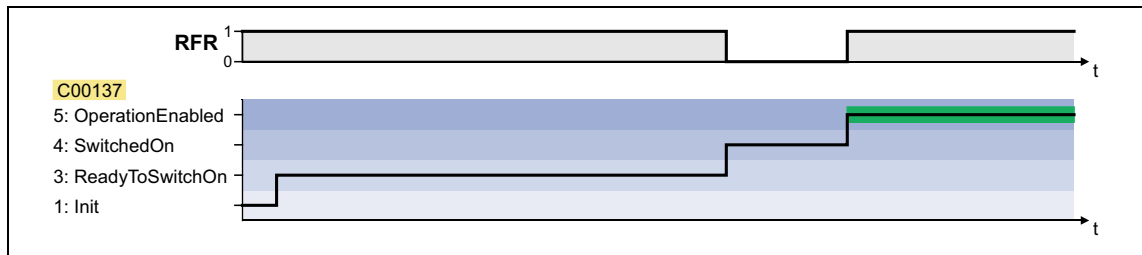
**Case 3: Controller enable at power-on and "Inhibit at power-on" deactivated**

If in [C142](#) the auto-start option "Inhibit at power-on" is deactivated (bit 0 = 0) and the controller is enabled, the "[ReadyToSwitchON](#)" state switches directly to the "[SwitchedON](#)" state and afterwards to the "[OperationEnabled](#)" state after power-on:

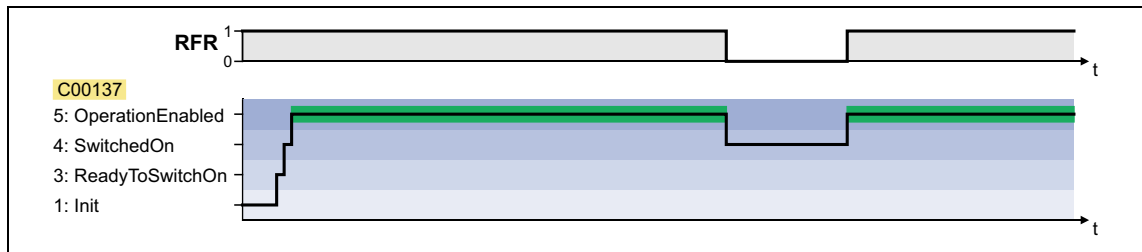

## 5 Motor control (MCTRL)

---

### 5 Motor control (MCTRL)

This chapter provides information on the parameter setting of the controller's internal motor control.

**Topics:**

- ▶ [Motor selection/Motor data](#)
- ▶ [Selecting the control mode](#)
- ▶ [Defining current and speed limits](#)
- ▶ [V/f characteristic control \(VFCplus\)](#)
- ▶ [Sensorless vector control \(SLVC\)](#)
- ▶ [Parameterisable additional functions](#)
- ▶ [Braking operation/braking energy management](#)
- ▶ [Monitoring](#)

# 5 Motor control (MCTRL)

## 5.1 Motor selection/Motor data

### 5.1 Motor selection/Motor data

The motor data term comprises all parameters that only depend on the motor and that only characterise the electrical behaviour of the machine. The motor data are independent of the application in which the controller and the motor are used.



Proceed as follows to open the dialog for parameterising the motor data:

1. »Engineer« Go to the *Project* view and select the 8400 Baseline D controller.
2. Go to *Workspace* and change to the **Application parameters** tab.
3. Go to the *Overview* dialog level and click the following button:



#### Parameterisation dialog in the »Engineer«

Motor selection	
Selected motor:	SDSGA047-22, 100 (Y)

Motor data		Actual values	
Rated motor power	0,08 kW	Actual speed value	0 rpm
Rated motor speed	2700 rpm	Motor voltage	0 V
Rated motor current	0,54 A	DC-bus voltage	0 V
Rated motor frequency	100 Hz	Motor current	0,00 A
Rated motor voltage	390 V	Thermal motor load (Fxt)	0 %
Motor cosine phi	0,50		

- Via the **from Motor Catalogue** button, the motor catalogue can be opened to select another motor. ▶ [Selecting a motor from the motor catalogue in the »Engineer«](#) (69)
- Via the **From drive...** button, the motor data set in the controller can be copied to the »Engineer« when an online connection has been established.



**Note!**

Sensorless vector control in particular requires the motor data parameters to be set. The motor data comprise the data of the motor nameplate and the data of the motor equivalent circuit.

If the motor has been selected via the motor catalogue of the »Engineer« or the motor data have been adapted offline using the »Engineer«, all motor data must then be copied to the controller and saved power-failure-proof to the memory module (device command: [C002/11](#)) when an online connection has been established.

**Motor data**

In the parameterisation dialog, the data of the motor nameplate for the selected motor are displayed under "Motor data".

Parameter	Info
<a href="#">C081</a>	Rated motor power
<a href="#">C087</a>	Rated motor speed
<a href="#">C088</a>	Rated motor current
<a href="#">C089</a>	Rated motor frequency
<a href="#">C090</a>	Rated motor voltage
<a href="#">C091</a>	Motor cos $\varphi$

**Actual values**

When an online connection to the controller has been established, the following actual values are displayed in the parameterisation dialog under "Actual values":

Parameter	Info
<a href="#">C051</a>	Actual speed value
<a href="#">C052</a>	Motor voltage
<a href="#">C053</a>	DC-bus voltage
<a href="#">C054</a>	Motor current
<a href="#">C066</a>	Thermal motor load (I2xt)
Highlighted in grey = display parameter	

# 5 Motor control (MCTRL)

## 5.1 Motor selection/Motor data

### Adapting motor data manually

If a third party manufacturer's motor is used, the displayed motor data can exactly be adapted to the real motor by clicking the **From project...** button and selecting the "Own motor settings" entry from the **Motor selection** dialog box afterwards. For this purpose, the data of the motor nameplate and the equivalent circuit diagram must be available.



#### Tip!

For a better concentricity factor, we recommend to perform motor parameter identification of the third party manufacturer's motor first. The motor parameters can be manually adapted afterwards.

Improving the concentricity factor includes

- the adjustment of the inverter error characteristic to the drive system and
- the knowledge of the motor cable resistance.

Both factors are determined in the course of motor parameter identification.

▶ [Automatic motor data identification](#) (□ 71)

### Other motor data

Click the **Other motor data...** button and go to the *Other motor data* dialog box including the motor equivalent circuit:

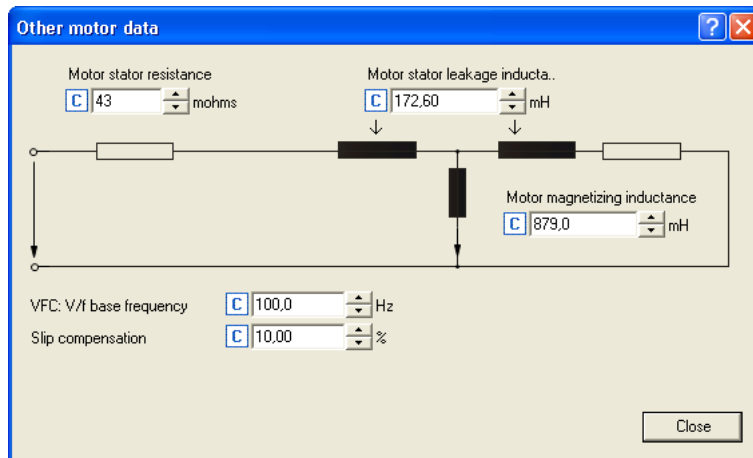

Parameter	Info
<a href="#">C084</a>	Motor stator resistance
<a href="#">C085</a>	Motor stator leakage inductance
<a href="#">C092</a>	Motor magnetising inductance
<a href="#">C015</a>	VFCplus: V/f base frequency
<a href="#">C021</a>	Slip compensation

# 5 Motor control (MCTRL)

## 5.1 Motor selection/Motor data

### 5.1.1 Selecting a motor from the motor catalogue in the »Engineer«

If a checkmark is set in the **Motor** control field in the "Other components" dialog when the controller is inserted into the project, the motor for the controller can be selected from the motor catalogue in another dialog:

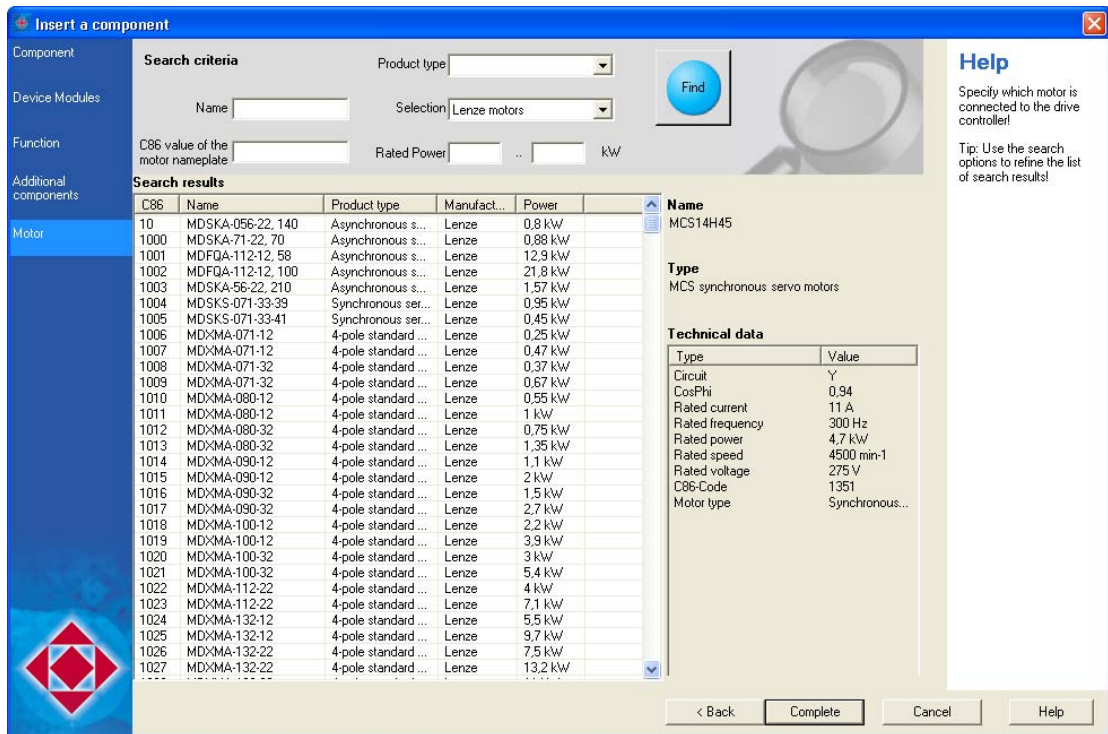

- Alternatively, the motor can be inserted into the project at a later time via the **Insert a component** command.
- Go to the **Application parameters** tab in the *Overview* → *Motor data* dialog level and click the **From motor catalogue...** button to also reach the motor catalogue for the selection of another motor.

# 5 Motor control (MCTRL)

## 5.1 Motor selection/Motor data

### Accepting the default values of the motor

If a motor is selected from the motor catalogue at a later time, the *Use motor's default values* dialog box is displayed afterwards which includes all motor data of the selected motor. Please select here which of the default values are to be copied to the controller:

Controller: [8400 BaseLine C (8400 BaseLine C)]

Motor: [SDSGA047-22, 100 (Y)]

Motor parameter

Use selection of motor controller in C0006: [No default value available for this motor]

Use following values in drive controller:

Code	Subcode	Name	Value	Unit
0015	000	VFC: V/f base frequency	100	Hz
0021	000	Slip compensation	10	%
0081	000	Rated motor power	0.08	kW
0084	000	Motor stator resistance	43	mohms
0085	000	Motor stator leakage inductance	172.6	mH
0087	000	Rated motor speed	2700	rpm
0088	000	Rated motor current	0.54	A
0089	000	Rated motor frequency	100	Hz
0090	000	Rated motor voltage	390	V
0091	000	Motor cosine phi	0.5	
0092	000	Motor magnetizing inductance	879	mH

Path parameters for operation with zero load

Use following values in drive controller:

Code	Subcode	Name	Value	Unit

Ok



#### Tip!

If a third party manufacturer's motor is used, select a Lenze motor from the motor catalogue first which is similar in terms of current, voltage and speed rating. Adapt the preselected motor data exactly to the real motor afterwards.

# 5 Motor control (MCTRL)

## 5.1 Motor selection/Motor data

---

### 5.1.2 Automatic motor data identification

Via the "Identify motor parameters" device command " ([C002/23](#)), the inverter characteristic, the influences of the motor cable, and the motor parameters listed in the table below can be identified automatically:

Parameter	Info
<a href="#">C015</a>	V/f base frequency
<a href="#">C016</a>	V <sub>min</sub> boost
<a href="#">C021</a>	Slip compensation
<a href="#">C084</a>	Motor stator resistance
<a href="#">C085</a>	Motor stator leakage inductance
<a href="#">C092</a>	Motor magnetising inductance
<a href="#">C095</a>	Motor magnetising current



#### Danger!

During motor parameter identification, the motor is energised via the outputs U, V and W of the controller!

Observe the corresponding safety instructions!



#### Stop!

If motor parameter identification is aborted, unstable drive behaviour may be the result!



#### Note!

- We strongly recommend motor parameter identification before the initial commissioning of the sensorless vector control (SLVC).
- The motor parameter identification must be carried out when the motor is cold!
- The load machine may remain connected. Holding brakes, if present, may remain in the braking position.
- With an idling motor, a small angular offset may occur at the motor shaft.
- The amplitude of the rated motor current ([C088](#)) is injected to identify the stator resistance. If the rated motor current amounts to less than 60 % of the rated inverter current, at least 60 % of the rated inverter current will be injected to ensure sufficient motor parameter identification accuracy.

### Preconditions

The motor parameters listed in the table below are excluded from automatic identification and must therefore be adapted to the used motor before motor parameter identification is carried out (see motor nameplate).

Parameter	Info
<a href="#">C081</a>	Rated motor power
<a href="#">C087</a>	Rated motor speed
<a href="#">C088</a>	Rated motor current
<a href="#">C089</a>	Rated motor frequency
<a href="#">C090</a>	Rated motor voltage
<a href="#">C091</a>	Motor cos $\varphi$

### Duration & sequence of the motor parameter identification

The duration of the motor parameter identification is approx. 30 s. The following steps are carried out during this time:

1. The motor stator resistance ([C084](#)) is measured.
2. The inverter error characteristic is measured.
3. The motor stator leakage inductance ([C085](#)) is measured
4. The motor magnetising inductance ([C092](#)) is measured
5. The motor magnetising current ([C095](#)) is measured.
6. The V/f base frequency ([C015](#)) is calculated.
7. The slip compensation ([C021](#)) is calculated.
8. The  $V_{\min}$  boost ([C016](#)) is detected.



### Note!

Motor parameter identification may be aborted if a special motor (e.g. mid-frequency motor) is used or if there is a large deviation between inverter and motor power.

Another cause for the abort of the motor parameter identification could be the implausibility of the entered nameplate data, e.g. the entry  $P = 0$  kW for the motor power.

**How to carry out automatic motor parameter identification:**

1. Inhibit the controller if it is enabled, e.g. via the [C002/16](#) device command or a LOW signal at the X4/RFR terminal.
2. Wait until the drive is at standstill.
3. Transfer the nameplate data to the following codes:
  - [C081](#): Rated motor power
  - [C087](#): Rated motor speed
  - [C088](#): Rated motor current (according to the connection method  $\Upsilon/\Delta$ )
  - [C089](#): Rated motor frequency (according to the connection method  $\Upsilon/\Delta$ )
  - [C090](#): Rated motor voltage (according to the connection method  $\Upsilon/\Delta$ )
  - [C091](#): Motor  $\cos \varphi$
4. Start motor parameter identification via the [C002/23](#) device command.
5. Enable the controller again.
  - Motor parameter identification starts.
  - The progress of the identification can be seen in [C002/23](#).
  - The identification is completed if the "0: Off / ready" message is displayed in [C002/23](#).
6. Inhibit controller again.

# 5 Motor control (MCTRL)

## 5.2 Selecting the control mode

### 5.2 Selecting the control mode

The 8400 BaseLine D controller supports various modes for motor control (open loop or closed loop).

- V/f characteristic control (VFCplus) with linear characteristic is preset.
- The control mode can be selected in the »Engineer« on the **Application parameter** tab via the **Motor control (C006)** list field:

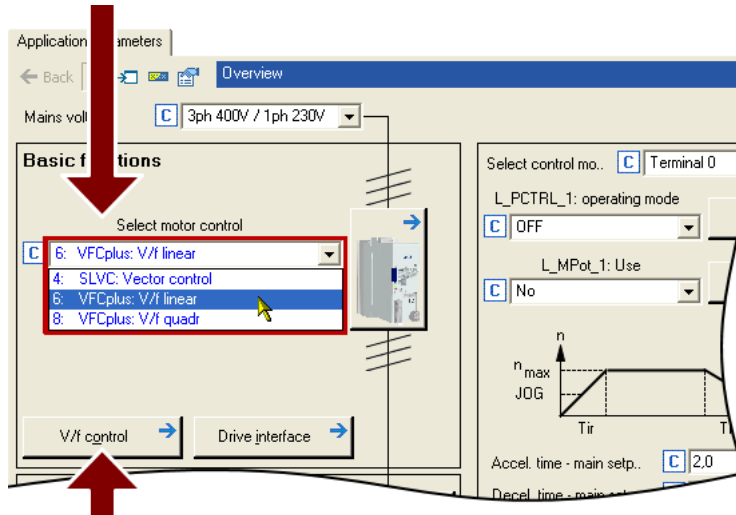

- A click on the **Motor control...** button leads you to the parameterisation dialog of the selected motor control. (The button is labelled according to the selected motor control.)



#### Tip!

In order to make the selection of the motor control easier, we provide a selection help with recommendations and alternatives for standard applications in the subchapter entitled "[Selection help](#)". (📖 76)

The following section briefly describe the control modes. A reference to more details can be found at the end of each section.



# 5 Motor control (MCTRL)

## 5.2 Selecting the control mode

### V/f characteristic control (VFCplus)

The V/f characteristic control (VFCplus) is a motor control mode for standard frequency inverter applications based on a simple and robust control process which is suitable for the operation of machines with linear or square-law load torque characteristic (e.g. fans). Furthermore, this motor control mode is also suitable for group drives and special motors. Due to the low parameterisation effort, commissioning of such applications is fast and easy.

The  $V_{\min}$  boost (C016) and slip compensation (C021) required for optimising the drive behaviour are dimensioned for machines with power adaptations to the inverter in the Lenze setting.

▶ [V/f characteristic control \(VFCplus\)](#) (📖 79)

### Sensorless vector control (SLVC)

Sensorless (field-oriented) vector control is based on a decoupled, separate control for the torque-producing and the field-producing current component. In addition, the actual speed is reconstructed by means of a motor model so that a speed sensor is not required.

▶ [Sensorless vector control \(SLVC\)](#) (📖 88)

In comparison to the V/f characteristic control without feedback, the following can be achieved by means of sensorless vector control SLVC:

- A higher maximum torque throughout the entire speed range
- A higher speed accuracy
- A higher concentricity factor
- A higher level of efficiency
- The implementation of torque-actuated operation with speed limitation
- The limitation of the maximum torque in motor and generator mode for speed-actuated operation

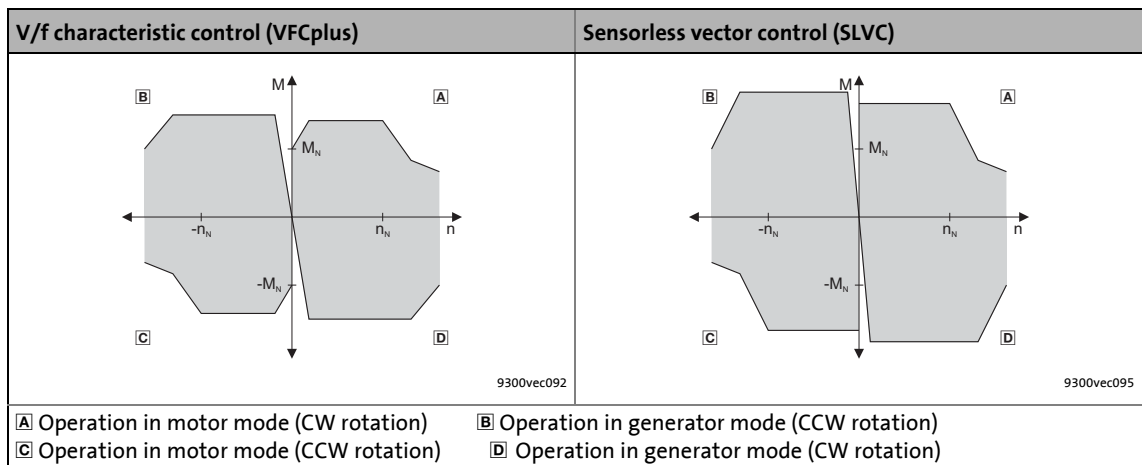

#### Tip!

If a high torque without feedback is to be provided at small speeds, we recommend the "Sensorless vector control" motor control mode.

# 5 Motor control (MCTRL)

## 5.2 Selecting the control mode

### 5.2.1 Selection help

To ease the selection of the motor control mode, the two following tables contain recommendations and alternatives to standard applications.

Application	Recommended	Alternatively
<b>Single drives</b>		
With constant load	VFCplus: V/f linear	SLVC
With extremely alternating loads	VFCplus: V/f linear	SLVC
With high starting duty	SLVC	VFCplus: V/f linear
Torque limitation	SLVC	-
With torque limitation (power control)	VFCplus: V/f linear	SLVC
Three-phase reluctance motor	VFCplus: V/f linear	-
Three-phase sliding rotor motor	VFCplus: V/f linear	-
Three-phase AC motors with permanently assigned frequency/voltage characteristic	VFCplus: V/f linear	-
Pump and fan drives with quadratic load characteristic	VFCplus: V/f quadratic	VFCplus or SLVC
Simple hoists	VFCplus: V/f linear	-
<b>Group drives</b> ( <i>several motors connected to controller</i> )		
Identical motors and loads	VFCplus: V/f linear	-
Different motors and/or alternating loads	VFCplus: V/f linear	-

[5-1] Standard applications without speed feedback

# 5 Motor control (MCTRL)

## 5.3 Defining current and speed limits

### 5.3 Defining current and speed limits

#### Limitation of the speed setpoint

Parameterising the reference speed in [C011](#) means that the drive must rotate at the set speed if a speed setpoint of 100% is specified

All speed setpoint selections are provided in % and always refer to the reference speed set in [C011](#).



#### Tip!

For reasons of achievable resolution and the accuracy involved, the reference speed should be geared to the speed range required for the respective application.

Lenze recommendation: Reference speed ([C011](#)) = 1500 ... 3000 rpm

Irrespective of the selected motor control, there are more limitation options:

Parameter	Info	Lenze setting	
		Value	Unit
<a href="#">C909/1</a>	Max. positive speed	120	%
<a href="#">C909/2</a>	Max. negative speed	120	%
<a href="#">C910/1</a>	Max. positive output frequency	1000	Hz
<a href="#">C910/2</a>	Max. negative output frequency	1000	Hz

#### Current limitation in motor and generator mode

In the various motor control modes, the controller is provided with functions which determine the dynamic behaviour under load and counteract exceedance of the maximum current in motor or generator mode.

Parameter	Info	Lenze setting	
		Value	Unit
<a href="#">C022</a>	$I_{max}$ in motor mode	47.00	A
<a href="#">C023</a>	$I_{max}$ in generator mode • 100 % $\equiv$ $I_{max}$ in motor mode ( <a href="#">C022</a> )	100	%

The current limits must be selected depending on

- the permissible maximum current of the motor  $\rightarrow$  recommendation:  $I(Mot)_N < 1.5 \dots 2.0$
- the permissible maximum current of the inverter
- the torque in motor/generator mode required for the application



## Note!

### Highly dynamic applications

(that have e.g. too short acceleration/deceleration times or excessively changing loads)

The overcurrent disconnection may respond (fault message OC1), if the setting of the maximum current in motor mode in [C022](#) approximately corresponds to the maximum permissible value of the respective inverter.

#### Remedies:

- Increase of the acceleration and deceleration ramp times
- Reduction of the maximum current in motor mode ([C022](#))
- Reduction of the maximum current in generator mode ([C023](#))
- Adaptation of the indirect peak current limitation (procedure depends on the selected motor control mode, see below)
- Reduction of the reset time of the current limiting controller ([C074/1](#))

### Influencing the torque in motor/generator mode

The torque in motor and generator mode can be limited via the *nTorqueMotLim* and *nTorqueGenLim* process signal inputs.

- If V/f characteristic control (VFCplus) is selected, limitation is indirectly performed via a so-called  $I_{max}$  controller.
- If sensorless vector control (SLVC) is selected, the limitation has a direct effect on the torque-producing current component.

If keypad control is selected, the *nTorqueMotLim* and *nTorqueGenLim* process signals can be parameterised via [C728/1...2](#).



### How to adapt the peak current limitation:

V/f characteristic control (VFCplus):

- Reduce the slip compensation with [C021](#).

V/f control (VFCplus + encoder):

- Reduce  $V_{min}$  boost in [C016](#).

Sensorless vector control (SLVC):

- Reduce the slip compensation with [C021](#).
- Reduce the limitation of the torque in motor mode via *nTorqueMotLimit\_a* ([C728/1](#)) and the limitation of the torque in generator mode via *nTorqueGenLimit\_a* ([C728/2](#)).

## 5.4 V/f characteristic control (VFCplus)

In case of the V/f characteristic control (VFCplus), the motor voltage of the inverter is determined by means of a linear or quadratic characteristic depending on the field frequency or motor speed to be generated. The voltage follows a preselected characteristic.



### Stop!

- The following must be observed when operating drives with quadratic V/f characteristic:
  - Please always check whether the corresponding drive is suitable for operation with a quadratic V/f characteristic!
  - If your pump drive or fan drive is not suitable for operation with a quadratic V/f characteristic, you must use either use the V/f characteristic control function with a linear V/f characteristic or the sensorless vector control (SLVC).
- For adjustment, observe the thermal performance of the connected asynchronous motor at low output frequencies.
  - Usually, standard asynchronous motors with insulation class B can be operated for a short time with their rated current in the frequency range  $0 \text{ Hz} \leq f \leq 25 \text{ Hz}$ .
  - Contact the motor manufacturer to get the exact setting values for the max. permissible motor current of self-ventilated motors in the lower speed range.
  - If you select the quadratic V/f characteristic, we recommend to set a lower  $V_{\min}$ .
- The nameplate data of the motor (at least rated speed and rated frequency) must be entered if, instead of a standard motor, an asynchronous motor is used with the following values:
  - rated frequency  $\neq 50 \text{ Hz}$  (star) or
  - rated frequency  $\neq 87 \text{ Hz}$  (delta) or
  - number of pole pairs  $\neq 2$



### Note!

When the auto DCB threshold is set ([C019](#))  $> 0$  rpm, there is no torque at the motor shaft in the lower speed range!

▶ [Automatic DC-injection braking \(Auto-DCB\)](#) (98)

### 5.4.1 Parameterisation dialog/signal flow



Proceed as follows to open the dialog for parameterising the motor control:

1. »Engineer« Go to the *Project view* and select the 8400 BaseLine D controller.
2. Go to *Workspace* and change to the **Application parameters** tab.
3. Select the motor control from the *Overview* dialog level in the **Motor control** list field:
  - "6: VFCplus: V/f linear" for linear characteristic or
  - "8: VFCplus: V/f quadr" for square-law characteristic
4. Click the **Motor control V/f** button to change to the *Overview* → *Motor control V/f* dialog box.

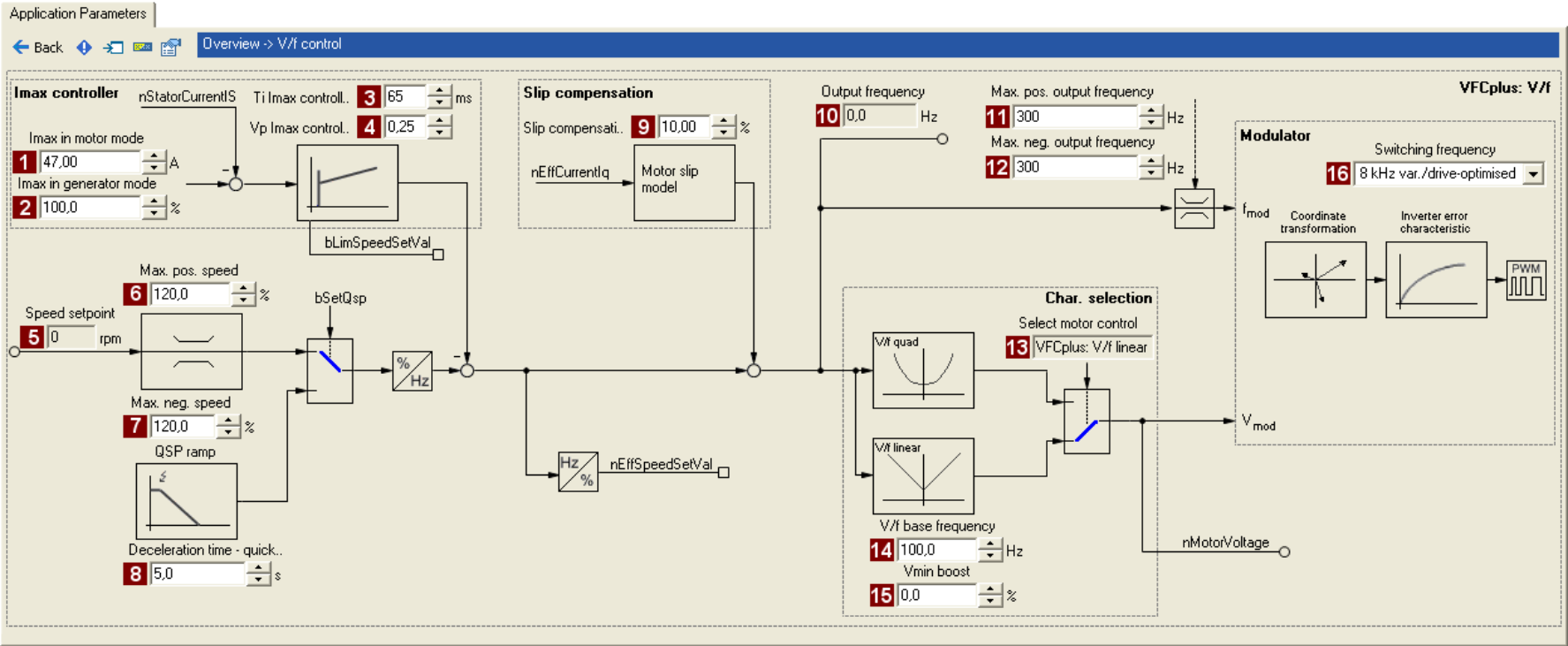

Parameter	Info	Parameter	Info	Parameter	Info
1	<a href="#">C022</a> I <sub>max</sub> in motor mode	9	<a href="#">C021</a> <a href="#">Slip compensation</a>	13	<a href="#">C006</a> Motor control
2	<a href="#">C023</a> I <sub>max</sub> in generator mode	10	<a href="#">C058</a> Output frequency	14	<a href="#">C015</a> V/f base frequency
3	<a href="#">C074</a> T <sub>i</sub> I <sub>max</sub> controller	11	<a href="#">C910/1</a> Max. pos. output frequency	15	<a href="#">C016</a> V <sub>min</sub> boost
4	<a href="#">C073</a> V <sub>p</sub> I <sub>max</sub> controller	12	<a href="#">C910/2</a> Max. neg. output frequency	16	<a href="#">C018</a> Switching frequency
5	<a href="#">C050</a> Speed setpoint				
6	<a href="#">C909/1</a> Max. pos. speed				
7	<a href="#">C909/2</a> Max. neg. speed				
8	<a href="#">C105</a> Deceleration time - quick stop				

### 5.4.2 Basic settings

The "Initial commissioning steps" listed in the table below are sufficient for a simple characteristic control.

- Detailed information on the individual steps can be found in the following subchapters.

Initial commissioning steps	
1.	<a href="#">Defining the V/f characteristic shape.</a> (81)
2.	<a href="#">Defining current limits (I<sub>max</sub> controller).</a> (82)



#### Tip!

Information on the optimisation of the control mode and the adaptation to the real application is provided in the "[Optimise control behaviour](#)" chapter. (83)

Parameterisable additional functions are described correspondingly in the "[Parameterisable additional functions](#)" chapter. (93)

#### 5.4.2.1 Defining the V/f characteristic shape

Generally, two different characteristic shapes can be defined:

- 1. Linear V/f characteristic:**  
For drives for a constant, speed-independent load torque.
- 2. Quadratic V/f characteristic:**  
For drives with a load torque curve which is quadratic or in relation to speed. Quadratic V/f characteristics are preferred in the case of centrifugal pumps and fan drives.

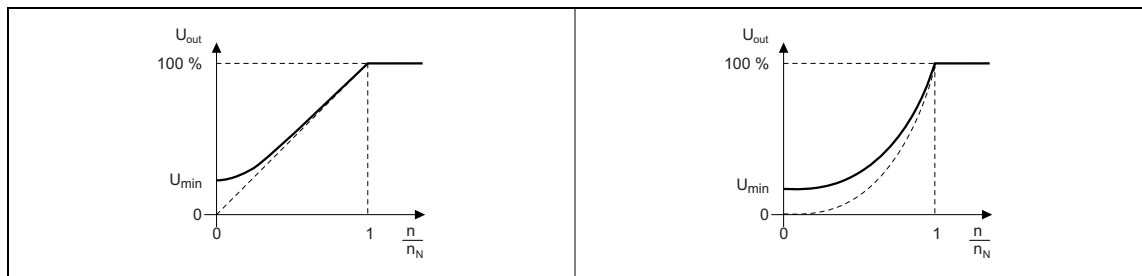

[5-2] Principle of a linear and quadratic V/f characteristic

The V/f characteristic shape is defined by selecting the corresponding motor control mode in [C006](#):

- "6: VFCplus: V/f linear" for linear characteristic
- "8: VFCplus: V/f quadr" for square-law characteristic

#### 5.4.2.2 Defining current limits (I<sub>max</sub> controller)

The V/f characteristic control (VFCplus) is provided with a current limitation control which is decisive for the dynamic behaviour under load and counteracts exceedance of the maximum current in motor or generator mode. This current limitation control is called I<sub>max</sub> control.

- The efficiency (motor current) measured by the I<sub>max</sub> control is compared with the current limit value for motor load set in [C022](#) and the current limit value for generator mode set in [C023](#).
- If the current limit values are exceeded, the controller changes its dynamic behaviour.

##### Motor overload during acceleration

The controller prolongs the acceleration ramp to keep the current on or below the current limit.

##### Generator overload during deceleration

The controller prolongs the deceleration ramp to keep the current on or below the current limit.

##### Increasing load with constant speed

- If the motor current limit value is reached:
  - The controller reduces the effective speed setpoint until a stable working point is set or an effective speed setpoint of 0 rpm is reached.
  - If the load is reduced, the controller increases the effective speed setpoint until the setpoint speed is reached or the load reaches the current limit value again.
- When the generator current limit value is reached:
  - The controller increases the effective speed setpoint until a stable working point is set or the maximally permissible speed ([C909](#)) or output frequency ([C910](#)).
  - If the load is reduced, the controller reduces the effective speed setpoint until the setpoint speed is reached or the load reaches the current limit value again.
- If a sudden load is built up at the motor shaft (e.g. drive is blocked), the overcurrent disconnection may respond (fault message OC1).



### 5.4.3 Optimise control behaviour

The V/f characteristic control (VFCplus) is generally ready for operation. It can be adapted subsequently by adapting the characteristic and/or the drive behaviour.

#### Adapting characteristic

For the linear and quadratic characteristic, it is also possible to match its curve to different load profiles or motors by adapting the V/f base frequency ([C015](#)) and the  $V_{\min}$ -boost ([C016](#)).

▶ [Adapting the V/f base frequency](#) (📖 84)

▶ [Adapting the  \$V\_{\min}\$  boost](#) (📖 85)

#### Adapting drive behaviour

- Limitation of the maximum current by a current limitation controller (e.g. to prevent the motor from stalling or to limit to the maximally permissible motor current). ▶ [Optimising the  \$I\_{\max}\$  controller](#) (📖 86)
- Adaptation of the field frequency by a load-dependent slip compensation (improved speed accuracy for systems without feedback)

### 5.4.3.1 Adapting the V/f base frequency

The V/f base frequency ([C015](#)) determines the slope of the V/f characteristic and has considerable influence on the current, torque, and power performance of the motor.

- The setting in [C015](#) applies to all permitted mains voltages.
- Mains fluctuations or fluctuations of the DC-bus voltage (operation in generator mode) do not need to be considered when the V/f base frequency is set. They are automatically compensated for by the internal mains voltage compensation of the device.
- Depending on the setting in [C015](#), it may be required to adapt the reference speed ([C011](#)) to traverse the entire speed range of the motor.
- In standard applications, the V/f base frequency ([C015](#)) is set to the value of the rated motor frequency ([C089](#)) as a typical value and corresponds to the data of the motor nameplate.
- Reference voltage for the V/f base frequency is the rated motor voltage ([C090](#)) according to motor nameplate.



#### Note!

##### 87-Hz operation

4-pole asynchronous motors which are designed for a rated frequency of  $f = 50$  Hz in star connection can be operated in delta connection when being constantly excited up to  $f = 87$  Hz.

- Advantages:
  - Higher speed-setting range
  - 73% higher power output in case of standard motors
- Motor current and motor power increase by the factor  $\sqrt{3}$ .
- The field weakening range starts above 87 Hz.
- Generally, this process can also be used with motors which have different numbers of pole pairs. In case of 2-pole asynchronous motors, the mechanical limit speed must be maintained.

### 5.4.3.2 Adapting the V<sub>min</sub> boost

The V<sub>min</sub> boost (C016) of the motor voltage serves to select a load independent magnetising current which is required for asynchronous motors. The torque behaviour of the motor can be optimised by adapting the setting in C016.



#### Note!

The V<sub>min</sub> boost has an effect on output frequencies below the V/f base frequency (C015).

The general linear and quadratic V/f characteristics are shown in the illustrations below. The illustrations show the impacts of the parameters used to adapt the characteristic shape.

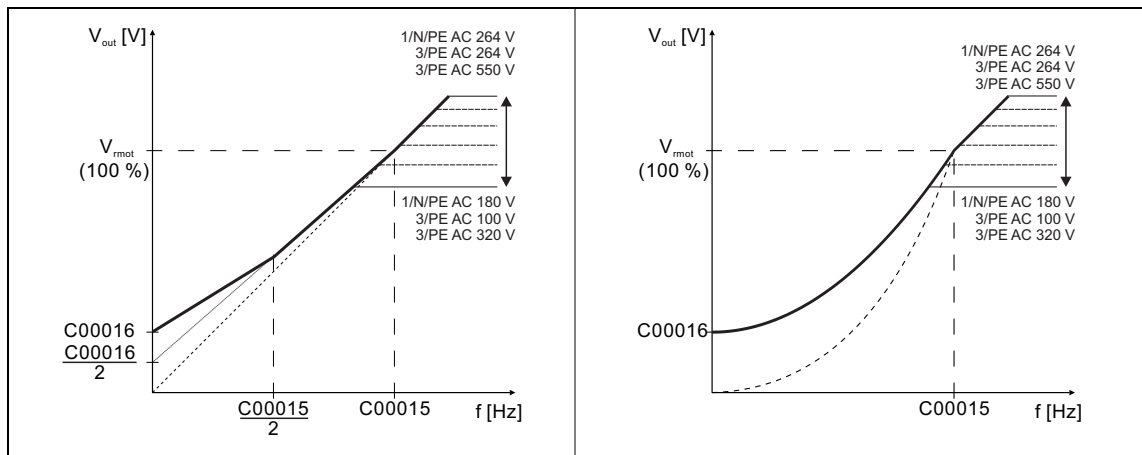

[5-3] Representation of the linear V/f characteristic (on the left) and quadratic V/f characteristic (on the right)



#### To set the V<sub>min</sub> boost, proceed as follows:

1. Operate motor in idle state at approx. 6 % of the rated motor speed.
2. Increase V<sub>min</sub> boost (C016) until the following motor current is reached:

Motor in short-time operation up to 0.5 n<sub>N</sub>

- for self-ventilated motors:  $I_{Motor} \approx I_{N Motor}$
- for forced ventilated motors:  $I_{Motor} \approx I_{N Motor}$

Motor in continuous operation up to 0.5 n<sub>N</sub>

- for self-ventilated motors:  $I_{Motor} \approx 0.8 I_{N Motor}$
- for forced ventilated motors:  $I_{Motor} \approx I_{N Motor}$



#### Note!

V<sub>min</sub> boost is automatically calculated by the motor parameter identification using the data specified on the motor nameplate so that a no-load current of approx. 0.8 I<sub>rated motor</sub> results at the slip frequency of the machine.

### 5.4.3.3 Optimising the I<sub>max</sub> controller

Using the Lenze setting of the current limitation controller, the drive is stable:

Parameter	Info	Lenze setting	
		Value	Unit
<a href="#">C073</a>	VFC: Vp I <sub>max</sub> controller	0.25	
<a href="#">C074</a>	VFC: Ti I <sub>max</sub> controller	65	ms

Most applications do not require optimisation.

The setting of the current limitation controller must be adapted if

- power control including great moments of inertia is performed.
  - Recommendation: Increase of the reset time Ti ([C074](#)) of the I<sub>max</sub> controller.
- overcurrent errors occur due to load impulses or too high acceleration ramps.
  - Recommendation: Reduction of the gain Vp ([C073](#)) and reset time Ti ([C074](#)) of the I<sub>max</sub> controller.

### 5.4.3.4 Torque limitation

The previous chapter, "[Optimising the I<sub>max</sub> controller](#)", describes how the drive can be protected from overload. During commissioning, these settings are carried out once and remain unchanged afterwards. However, it is often necessary to limit the torque to a lower value for plant or process reasons.

- To avoid overload in the drive train, the torque in motor mode can be limited via the *nTorqueMotLimit\_a* process input signal, and the torque in generator mode can be limited via the *nTorqueGenLimit\_a* process input signal:

Identifier <small>DIS code   data type</small>	Information/possible settings
nTorqueMotLimit_a <a href="#">C830/4</a>   INT	Torque limitation in motor mode <ul style="list-style-type: none"> <li>• Scaling: 16384 ≙ 100 % M<sub>max</sub> (<a href="#">C057</a>)</li> <li>• Setting range: 0 ... +199.9 %</li> <li>• If keypad control is performed: Parameterisable via <a href="#">C728/1</a>.</li> </ul>
nTorqueGenLimit_a <a href="#">C830/5</a>   INT	Torque limitation in generator mode <ul style="list-style-type: none"> <li>• Scaling: 16384 ≙ 100 % M<sub>max</sub> (<a href="#">C057</a>)</li> <li>• Setting range: -199.9 ... 0 %</li> <li>• If keypad control is performed: Parameterisable via <a href="#">C728/2</a>.</li> </ul>



#### Note!

- The accuracy of the torque limitation is limited because the actual torque ([C056/2](#)) is only calculated from the slip speed measured indirectly via the motor current. For this purpose, the correct entry of the motor data is required. ▶ [Motor selection/Motor data](#) (□ 66)
- To avoid instabilities during operation with active slip compensation, the torque limit values are internally processed as absolute values.
- If slip compensation is deactivated ([C021](#) = 0) indirect torque limitation is executed (differential signal between apparent motor current and *nTorqueMotLimit\_a* or *nTorqueGenLimit\_a*). Above the no-load current of the motor, the accuracy of the indirect torque limitation is limited.

# 5 Motor control (MCTRL)

## 5.4 V/f characteristic control (VFCplus)

### 5.4.4 Remedies for undesired drive behaviour

Drive behaviour	Remedy
Inadequately smooth running at low speeds, especially in the case of operation with a long motor cable	▶ <a href="#">Automatic motor data identification</a> (📖 71)
Problems in case of high starting duty (great mass inertia)	▶ <a href="#">Adapting the Vmin boost</a> (📖 85)
Drive does not follow the speed setpoint.	The current controller intervenes in the set field frequency to limit the controller output current to the maximum current (C0022, C0023). Therefore: <ul style="list-style-type: none"><li>• Prolong acceleration/deceleration time: <a href="#">C012</a>: Acceleration time - main setpoint <a href="#">C013</a>: Deceleration time - main setpoint</li><li>• Consider a sufficient magnetising time of the motor. Depending on the motor power, the magnetising time amounts to 0.1 ... 0.2 s.</li><li>• Increase permissible maximum current: <a href="#">C022</a>: I<sub>max</sub> in motor mode <a href="#">C023</a>: I<sub>max</sub> in generator mode)</li></ul>
Insufficient speed constancy at high load (setpoint and motor speed are not proportional anymore)	<ul style="list-style-type: none"><li>• Increase slip compensation (<a href="#">C021</a>). Important: Unstable drive due to overcompensation!</li><li>• With cyclic load impulses (e. g. centrifugal pump), a smooth motor characteristic is achieved by smaller values in <a href="#">C021</a> (possibly negative values).</li></ul>
Controller cannot follow dynamic processes, i.e. too short acceleration/deceleration times in terms of load ratios.	<ul style="list-style-type: none"><li>• Increase the gain of the I<sub>max</sub> controller (<a href="#">C073</a>)</li><li>• Reduce the reset time of the I<sub>max</sub> controller(<a href="#">C074</a>)</li><li>• Increase acceleration time (<a href="#">C012</a>)</li><li>• Increase deceleration time (<a href="#">C013</a>)</li></ul>

## 5.5 Sensorless vector control (SLVC)

Sensorless vector control (SLVC) is based on a better motor current control according to the Lenze FTC process.



### Stop!

- The connected motor must not be more than two power classes smaller than the motor assigned to the controller.
- Operation of the sensorless vector control (SLVC) is only permissible for one single drive!
- Operation of the sensorless vector control (SLVC) is not permissible for hoists!
- The Lenze setting permits the operation of a power-adapted motor. Optimal operation is only possible if either:
  - the motor is selected via the Lenze motor catalogue
  - the motor nameplate data are entered and motor parameter identification is carried out afterwards
  - or -
  - the nameplate data and equivalent circuit data of the motor (motor leakage inductance and mutual motor inductance, slip compensation and motor stator resistance) are entered manually.
- When you enter the motor nameplate data, take into account the phase connection implemented for the motor (star or delta connection). Only enter the data applying to the selected connection type.
  - In this context, also observe the instructions in the chapter entitled "[Adapting the V/f base frequency](#)" relating to V/f characteristic control. (84)



### Note!

Optimal operation of the sensorless vector control (SLVC) can be achieved from a minimum speed of approx. 0.5-fold slip speed. At lower speed values below the 0.5-fold slip speed, the maximum torque is reduced.

The maximum field frequency with this motor control mode is 650 Hz.

In comparison to the V/f characteristic control without feedback, the following can be achieved by means of sensorless vector control SLVC:

- A higher maximum torque throughout the entire speed range
- A higher speed accuracy
- A higher concentricity factor
- A higher level of efficiency
- The limitation of the maximum torque in motor and generator mode for speed-actuated operation

# 5 Motor control (MCTRL)

## 5.5 Sensorless vector control (SLVC)

### 5.5.1 Parameterisation dialog



Proceed as follows to open the dialog for parameterising the motor control:

1. »Engineer« Go to the *Project view* and select the 8400 BaseLine D controller.
2. Go to *Workspace* and change to the **Application parameters** tab.
3. Select the motor control "4: SLVC: Vector control" from the *Overview* dialog level in the **Motor control** ([C006](#)) list field.
4. Click the **Motor control vector** button to change to the *Overview* → *Motor control vector* dialog box.
  - This dialog level lists shows all relevant parameters in a parameter list.

Short overview of the relevant parameters:

Parameter	Info
<a href="#">C006</a>	Selection of the motor control → "4: SLVC: Vector control"
<a href="#">C011</a>	Reference speed
<a href="#">C018</a>	Switching frequency
<a href="#">C021</a>	Slip compensation
<a href="#">C022</a>	Imax in motor mode
<a href="#">C023</a>	Imax in generator mode
<a href="#">C050</a>	Speed setpoint
<a href="#">C057</a>	Maximum torque
<a href="#">C058</a>	Output frequency
<a href="#">C081</a>	Rated motor power
<a href="#">C084</a>	Motor stator resistance
<a href="#">C085</a>	Motor stator leakage inductance
<a href="#">C087</a>	Rated motor speed
<a href="#">C088</a>	Rated motor current
<a href="#">C089</a>	Rated motor frequency
<a href="#">C090</a>	Rated motor voltage
<a href="#">C091</a>	Motor cosine phi
<a href="#">C092</a>	Motor magnetising inductance
<a href="#">C095</a>	Motor magnetising current
<a href="#">C097</a>	Rated motor torque
<a href="#">C105</a>	Deceleration time - quick stop
<a href="#">C909/1</a>	Max. pos. speed
<a href="#">C909/2</a>	Max. neg. speed
<a href="#">C910/1</a>	Max. pos. output frequency
<a href="#">C910/2</a>	Max. neg. output frequency

Highlighted in grey = display parameter

### 5.5.2 Speed control with torque limitation

A speed setpoint is selected and the drive system is operated in a speed-controlled manner.

The operational performance can be adapted in the following ways:

- Overload limitation in the drive train
  - The torque is limited via the torque setpoint.
  - The torque setpoint is identical to the value at the output of the speed controller, *nOutputSpeedCtrl*.
  - To avoid overload in the drive train, the torque in motor mode can be limited via the *nTorqueMotLimit\_a* process input signal, and the torque in generator mode can be limited via the *nTorqueGenLimit\_a* process input signal:

Identifier <small>DIS code   data type</small>	Information/possible settings
nTorqueMotLimit_a <a href="#">C830/4</a>   INT	Torque limitation in motor mode <ul style="list-style-type: none"> <li>• Scaling: 16384 <math>\equiv</math> 100 % <math>M_{\max}</math> (<a href="#">C057</a>)</li> <li>• Setting range: 0 ... +199.9 %</li> <li>• If keypad control is performed: Parameterisable via <a href="#">C728/1</a>.</li> </ul>
nTorqueGenLimit_a <a href="#">C830/5</a>   INT	Torque limitation in generator mode <ul style="list-style-type: none"> <li>• Scaling: 16384 <math>\equiv</math> 100 % <math>M_{\max}</math> (<a href="#">C057</a>)</li> <li>• Setting range: -199.9 ... 0 %</li> <li>• If keypad control is performed: Parameterisable via <a href="#">C728/2</a>.</li> </ul>



### Note!

To avoid instabilities during operation, the torque limit values are internally processed as absolute values.

- Motor current limitation
  - A cross current setpoint is calculated from the torque setpoint which is limited depending on the magnetising current, the max. current in motor mode ([C022](#)) and the max. current in generator mode ([C023](#)).
  - Here, the total current injected into the motor does not exceed the max. currents in motor and generator mode.
- [Slip compensation](#) ([100](#))
  - Using a slip model, the slip of the machine is reconstructed.
  - The slip compensation ([C021](#)) acts as the influencing parameter.



# 5 Motor control (MCTRL)

## 5.5 Sensorless vector control (SLVC)

### 5.5.3 Basic settings

The following "Initial commissioning steps" must be performed to commission the sensorless vector control:

Initial commissioning steps					
1.	<p>Set the motor selection/motor data</p> <ul style="list-style-type: none"><li>When selecting and parameterising the motor, the motor nameplate data and the equivalent circuit diagram data are relevant. Detailed information can be found in the "<a href="#">Motor selection/Motor data</a>" chapter. (<a href="#">66</a>)</li></ul> <p>Depending on the motor manufacturer, proceed as follows:</p> <table border="1"><thead><tr><th>Lenze motor:</th><th>Third party manufacturer's motor:</th></tr></thead><tbody><tr><td><p><a href="#">Selecting a motor from the motor catalogue in the »Engineer«</a></p><p>- or -</p><ol style="list-style-type: none"><li>Set the motor nameplate data</li><li><a href="#">Automatic motor data identification</a></li></ol></td><td><ol style="list-style-type: none"><li>Set the motor nameplate data</li><li><a href="#">Automatic motor data identification</a> or set known data of the equivalent circuit diagram manually: <a href="#">C084</a>: Motor stator resistance <a href="#">C085</a>: Motor stator leakage inductance <a href="#">C092</a>: Motor magnetising inductance <a href="#">C095</a>: Motor magnetising current</li></ol></td></tr></tbody></table>	Lenze motor:	Third party manufacturer's motor:	<p><a href="#">Selecting a motor from the motor catalogue in the »Engineer«</a></p> <p>- or -</p> <ol style="list-style-type: none"><li>Set the motor nameplate data</li><li><a href="#">Automatic motor data identification</a></li></ol>	<ol style="list-style-type: none"><li>Set the motor nameplate data</li><li><a href="#">Automatic motor data identification</a> or set known data of the equivalent circuit diagram manually: <a href="#">C084</a>: Motor stator resistance <a href="#">C085</a>: Motor stator leakage inductance <a href="#">C092</a>: Motor magnetising inductance <a href="#">C095</a>: Motor magnetising current</li></ol>
Lenze motor:	Third party manufacturer's motor:				
<p><a href="#">Selecting a motor from the motor catalogue in the »Engineer«</a></p> <p>- or -</p> <ol style="list-style-type: none"><li>Set the motor nameplate data</li><li><a href="#">Automatic motor data identification</a></li></ol>	<ol style="list-style-type: none"><li>Set the motor nameplate data</li><li><a href="#">Automatic motor data identification</a> or set known data of the equivalent circuit diagram manually: <a href="#">C084</a>: Motor stator resistance <a href="#">C085</a>: Motor stator leakage inductance <a href="#">C092</a>: Motor magnetising inductance <a href="#">C095</a>: Motor magnetising current</li></ol>				
2.	<p>Determine the motor control: <a href="#">C006</a> = "4: SLVC: Vector control"</p>				
3.	<p>Set slip compensation (<a href="#">C021</a>). ▶ <a href="#">Slip compensation</a> (<a href="#">100</a>)</p>				



#### Tip!

We recommend to use the flying restart function for connecting/synchronising the inverter to an already rotating drive system. ▶ [Flying restart function](#) ([95](#))

Parameterisable additional functions are described correspondingly in the "[Parameterisable additional functions](#)" chapter. ([93](#))

### 5.5.4 Optimise control behaviour

#### 5.5.4.1 Optimising the starting performance after a controller enable

After the controller is enabled, a time delay is caused during the start due to the magnetisation of the motor. If this delay cannot be tolerated for specific applications, the motor must always be operated in an energised condition.

##### Procedure without setting a controller inhibit

- Deactivate the auto-DCB function with [C019](#) = 0.
- Do not activate the controller inhibit. Instead, stop the drive by selecting a setpoint of 0 or by activating the quick stop function.

### 5.5.5 Remedies for undesired drive behaviour

Drive behaviour	Remedy
Deviation between no-load current and magnetising current or bad speed or torque accuracy.	<p>Adapt the motor magnetising inductance (<a href="#">C092</a>) for no-load operation.</p> <ul style="list-style-type: none"> <li>• If the no-load current is greater than the magnetising current (<a href="#">C095</a>) at 0.5-fold rated motor speed, the magnetising inductance must be reduced until the no-load current and the magnetising current have the same values.</li> <li>• Otherwise, the magnetising inductance must be increased.</li> </ul> <p>Tendency of the correction of <a href="#">C092</a>:</p> <p>PN: Rated motor power</p>
Insufficient speed constancy at high load: Setpoint and motor speed are not proportional anymore. <b>Caution:</b> Overcompensation of the settings mentioned under "Remedy" may result in unstable behaviour!	<p>Via the slip compensation (<a href="#">C021</a>, the speed stability under high loads can be affected:</p> <ul style="list-style-type: none"> <li>• If <math>n_{act} &gt; n_{slip}</math>, reduce the value in <a href="#">C021</a></li> <li>• If <math>n_{act} &lt; n_{slip}</math>, increase the value in <a href="#">C021</a></li> </ul>
Unstable control with higher speeds.	<ul style="list-style-type: none"> <li>• Check the setting of the magnetising inductance (<a href="#">C092</a>) by comparing the current consumption in no-load operation with the rated magnetising current (<a href="#">C095</a>)</li> <li>• Optimise oscillation damping (<a href="#">C234</a>).</li> </ul>
"Short circuit" (OC1) error messages at short acceleration time ( <a href="#">C012</a> ) in proportion to the load (controller cannot follow the dynamic processes).	Increase acceleration time ( <a href="#">C012</a> )/deceleration time ( <a href="#">C013</a> ).
Mechanical resonance at certain speeds.	The <a href="#">L_NSet 1</a> function block masks out those speed ranges that include resonance.
Speed variations in no-load operation for speeds $> 1/3$ rated speed.	Minimise speed oscillations with oscillation damping ( <a href="#">C234</a> ).
Drive runs unstable.	Check set motor data (nameplate data and equivalent circuit diagram data).
Setpoint speed and actual speed differ strongly.	<ul style="list-style-type: none"> <li>▶ <a href="#">Motor selection/Motor data</a> (<a href="#">66</a>)</li> </ul>

## 5.6 Parameterisable additional functions

### 5.6.1 Selection of switching frequency

The switching frequency of the inverter that can be selected in [C018](#) influences the smooth running performance and the noise generation in the connected motor as well as the power losses in the controller.

The lower the switching frequency the higher the concentricity factor, the smaller the losses, and the higher the noise generation.



#### Stop!

If operated at a switching frequency of 16 kHz, the output current of the controller must not exceed the current limit values specified in the technical data!

▶ [Defining current and speed limits](#) (□ 77)



#### Note!

- Operate mid-frequency motors only at a switching frequency of 8 kHz or 16 kHz (var./drive-opt.).
- If operated at a switching frequency of 16 kHz, the Ixt evaluation ([C064](#)) is considered including the required derating to 67 % of the rated device current at switching frequencies of 2.4 and 8 kHz.

#### Settable switching frequencies

Selection in <a href="#">C018</a>	Info
1 4 kHz var./drive-optimised	<ul style="list-style-type: none"> <li>• "var.": Adaptation of the switching frequency depending on the current</li> <li>• "drive-opt.": drive-optimised modulation ("sine/delta modulation")</li> <li>• "fixed": fixed switching frequencies</li> </ul>
2 <b>8 kHz var./drive-optimised</b>	
3 16 kHz var./drive-optimised	
5 2 kHz constant/drive-optimised	
6 4 kHz constant/drive-optimised	
7 8 kHz constant/drive-optimised	
8 16 kHz constant/drive-optimised	
21 8 kHz var./drive-opt./4 kHz min	
22 16 kHz var./drive-opt./4 kHz min	
23 16 kHz var./drive-opt./8 kHz min	



#### Tip!

The Lenze setting [C018](#) = 2 (8 kHz var./drive-opt.) is the optimal value for standard applications.

### Lowering the switching frequency due to high heatsink temperatures

Exceeding the maximally permissible heatsink temperature would lead to an inhibited drive due to the "Overtemperature" error and a torquelessly coasting motor. Therefore, if the Lenze setting is selected, the switching frequency is reduced to the next frequency below when the heatsink temperature has risen to 5 °C below the maximally permissible temperature. After the heatsink has cooled down, the controller automatically switches to the next frequency above until the set switching frequency is reached.

Switching frequency reduction due to high heatsink temperature can be deactivated via [C144](#). If the switching frequency reduction is deactivated, the "OH1: Heatsink overtemperature" error message will be issued when the maximally permissible heatsink temperature is reached. An "Error" response is the result and the motor is coasting.

Parameter	Info	Lenze setting
<a href="#">C144</a>	Switching frequency reduction (temp.)	1: On

### Lowering of the switching frequency depending on the output current

"Variable" switching frequencies can be selected for the controller in [C018](#), where the controller automatically lowers the switching frequency depending on the controller output current. The modulation mode will not be changed. The changeover thresholds are included in the rated data of the Hardware Manual (the Hardware Manual is available on the CD included in the scope of supply).

When a "fixed" switching frequency is selected, no switching frequency changeover takes place. In case of fixed frequencies, the controller output current is limited to the permissible value of the corresponding switching frequency. In case of larger load impulses, the overcurrent interruption may be activated, to which the controller responds with "Error".

### Limiting the maximum output frequency

The maximum output frequency ([C910](#)) of the controller is not limited depending on the switching frequency. Therefore, adapt the maximum output frequency according to our recommendation:

$$\text{Maximum output frequency} \leq \frac{1}{8} \text{ Switching frequency}$$

- At a switching frequency of 4 kHz, for instance, 500 Hz for the maximum output frequency should not be exceeded.

Carry out further measures:

- If required, deactivate the switching frequency changeover by the heatsink temperature via [C144](#).
- If required, ensure that the changeover threshold of the controller output current to the next switching frequency below will not be exceeded. If required, select a constant switching frequency in [C018](#).

### Display of the current switching frequency

The current switching frequency applied in the controller is displayed in [C725](#).

### Operation at an ambient temperature of 45°C

The controller is designed so that operation at an ambient temperature of 45° C without derating is permissible at a switching frequency of 4 kHz.

### 5.6.2 Flying restart function

The flying restart circuit uses a simple model of an asynchronous motor which requires knowledge of the motor stator resistance  $R_S$  and the rated motor current.



#### Note!

- For a correct functioning of the flying restart circuit, we recommend to perform a parameter identification first. ▶ [Automatic motor data identification](#) (☞ 71)
- The flying restart function works safely and reliably for drives with great centrifugal masses.
- Do not use the flying restart function if several motors with different centrifugal masses are connected to a controller.
- After the controller is enabled, the motor can start for a short time or reverse when machines with low friction and low mass inertia are used.
- The flying restart function serves to identify max. field frequencies up to  $\pm 200$  Hz.
- When power-adapted standard asynchronous motors are used (rated motor power approximately corresponds to the rated inverter power), a motor parameter identification is not required.



#### Tip!

In association with the flying restart function, we recommend to read the information provided in this documentation on the following topic:

- ▶ [Automatic DC-injection braking \(Auto-DCB\)](#) (☞ 98)

#### General information

This function serves to activate a mode which is used to "catch" a coasting motor during operation without speed feedback. This means that the synchronicity between controller and motor is to be adjusted in such a way that a jerk-free transition to the rotating machines is achieved in the instant of connection.

The drive controller determines the synchronicity by identifying the synchronous field frequency.

#### Duration

The "catching" process is completed after approx. 1 ... 2 seconds. The duration is influenced by the starting value. If the field frequency is not known, we recommend the preset starting value of 10 Hz.

#### Short overview of the relevant parameters:

Parameter	Info	Lenze setting	
		Value	Unit
<a href="#">C990</a>	Flying restart fct.: Activation	Off	
<a href="#">C991</a>	Flying restart fct.: Process	-n...+n   Last output frequency	
<a href="#">C992</a>	Flying restart: Start frequency	10	Hz
<a href="#">C994</a>	Flying restart fct.: Current	25.00	%

**How to parameterise the flying restart function:**

1. Activate the flying restart circuit by selecting "1: On" in [C990](#).
  - Every time the controller is enabled, a synchronisation to the rotating or standing drive is carried out.

When the Lenze setting is used, most applications do not require additional controller settings.

If additional settings are necessary, proceed as follows:

2. Define the process and hence the speed range/rotational frequency range in [C991](#) which is to be examined by the flying restart circuit.
  - We recommend the Lenze setting "5: -n...+n | Last output frequency"
3. Adjust setting in [C992](#) if required.

The preset starting frequency which defines the starting point of the flying restart function is optimised for standard motors.

- We recommend to define a starting frequency of approximately 20 % of the rated motor frequency to enable a safe and fast connection to standing drive systems.
4. Set the flying restart current in [C994](#).

We recommend setting a flying restart current of 10 % ... 25 % of the rated motor current.

- During a flying restart process, a current is injected into the motor to identify the speed.
- Reducing the current causes a reduction of the motor torque during the flying restart process. A short-time starting action or reversing of the motor is prevented with low flying restart currents.
- An increase of the current improves the robustness of the flying restart function.

## 5.6.3 DC-injection braking

**Danger!**

Holding braking is not possible when this braking mode is used!

DC-injection braking allows the drive to be quickly braked to a standstill without the need to use an external brake resistor.

- The braking current is set in [C036](#).
- The maximum braking torque to be generated by the DC braking current is approx. 20 ... 30 % of the rated motor torque. It is lower than that for braking in generator mode with an external brake resistor.
- Automatic DC-injection braking (Auto-DCB) improves the starting performance of the motor when operated without speed feedback.

**Tip!**

DC-injection braking has the advantage that it is possible to influence the braking time by changing the motor current or the braking torque..

**Short overview of the relevant parameters:**

Parameter	Info	Lenze setting	
		Value	Unit
<a href="#">C019</a>	Auto-DCB: Threshold • Operating threshold for activating DC-injection braking	3	rpm
<a href="#">C036</a>	DCB: Current • Braking current in [%] based on $I_{max}$ ( <a href="#">C022</a> )	50	%
<a href="#">C106</a>	Auto-DCB: Hold time	0.5	s
<a href="#">C107</a>	DCB: Hold time	999.0	s
<a href="#">C701/4</a>	LA_NCtrl: bSetDCBrake • Selection of the signal source for activating DC-injection braking	Dependent on the selected control mode	

**Method**

DC-injection braking can be carried out in two ways with different types of activation:

- ▶ [Manual DC-injection braking \(DCB\)](#) (📖 98)
- ▶ [Automatic DC-injection braking \(Auto-DCB\)](#) (📖 98)

### 5.6.3.1 Manual DC-injection braking (DCB)

DC-injection braking can be manually activated via the *bSetDCBrake* process input.

- For HIGH-active inputs, DC-injection braking is active as long as the signal is at HIGH level.
- After the hold time ([C107](#)) has expired, the controller sets the pulse inhibit (CINH).



#### Tip!

- In the preset "Terminals 0" control mode, DC-injection braking can be manually activated via the digital input DI3.
- In the preset "Terminals 11" control mode, DC-injection braking can be manually activated via the digital input DI2.

### 5.6.3.2 Automatic DC-injection braking (Auto-DCB)

"Automatic DC-injection braking" (referred to in the following as "Auto-DCB") can be used if there is a requirement that the drive be isolated from the supply at  $n \approx 0$ .

#### Function

For understanding the auto-DCB function, it is necessary to distinguish between three different types of operation:

- The drive has been enabled and, in the course of operation, the speed setpoint falls below the Auto-DCB threshold.
  - In case of operation without speed feedback, a braking current ([C036](#)) is injected. After the auto-DCB hold time ([C106](#)) has expired, the motor is deenergised via the auto-DCB function, i.e. a controller inhibit (CINH) is set.
- When the controller is enabled, the drive is at standstill ( $n = 0$ ).  
If the enabled drive is to start, the speed setpoint passed via the acceleration ramp must exceed the auto-DCB threshold ([C019](#)). Below this threshold, the motor will not be energised.
- When the controller is enabled, the motor (still) rotates at a speed which is above the auto DCB threshold. If the speed setpoint reached via the acceleration ramp exceeds the auto DCB threshold ([C019](#)), the motor will be energised and the drive will be "caught". [▶ Flying restart function \(95\)](#)



#### How to set the automatic DC-injection braking

- Set a hold time in [C106](#)  $> 0$  s.
  - Automatic DC-injection braking is active for the time set.
  - In case of operation without speed feedback, the braking current set in [C036](#) is injected
  - After the set hold time has expired, the controller sets a pulse inhibit.
- Set the operating threshold in [C019](#).
  - The operating threshold can serve to set a dead band in the setpoint. If DC-injection braking is not to be active then, [C106](#) must be set to a value of "0".



### Explanation of the automatic DC-injection braking function by means of an example

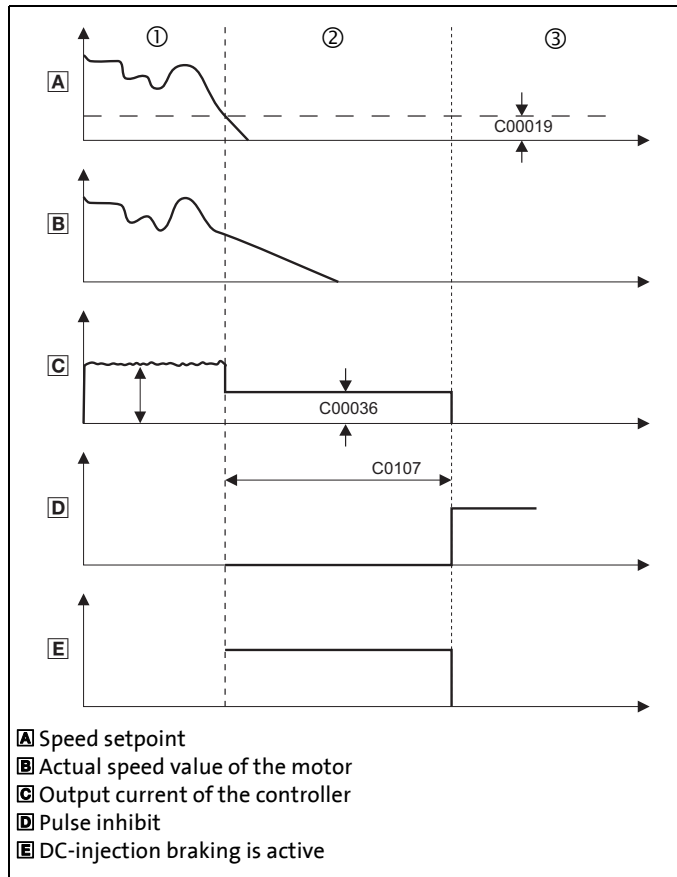

① The motor rotates at a specified speed. The current adjusts itself to the load, see **C**.

② The DC braking current set in **C036** is injected.

③ After the hold time (**C106**) has expired, a pulse inhibit is set.

[5-4] Example 1: Signal characteristic for automatic DC-injection braking of a drive without speed feedback

### 5.6.4 Slip compensation

Under load, the speed of an asynchronous machine decreases. This load-dependent speed drop is called slip. The slip can partly be compensated for by the setting in [C021](#).

Parameter	Info	Lenze setting	
		Value	Unit
<a href="#">C021</a>	Slip compensation	0.00	%

- The setting of [C021](#) can be done automatically in the course of motor parameter identification.
  - ▶ [Automatic motor data identification](#) (71)
- The setting must be made manually if the motor parameter identification cannot be called up.



#### How to set the slip compensation manually:

1. Calculate the slip compensation according to motor nameplate data:

$$s = \frac{n_{rsyn} - n_r}{n_{rsyn}} \cdot 100\%$$

$$n_{rsyn} = \frac{f_r \cdot 60}{p}$$

- s Slip constant ([C021](#)) [%]
- $n_{rsyn}$  Synchronous motor speed [rpm]
- $n_r$  Rated motor speed according to the motor nameplate [rpm]
- $f_r$  Rated motor frequency according to the motor nameplate [Hz]
- p Number of motor pole pairs (1, 2, 3 ...)

2. Transfer the calculated slip constant s in [C021](#).
3. Correct the setting in [C021](#) while the drive is running until the load-dependent speed drop does not occur anymore between idling and maximum load of the motor in the desired speed range.



#### Tip!

The following guide value applies to a correctly set slip compensation:

- Deviation from the rated motor speed  $\leq 1\%$  for the speed range of 10 % ... 100 % of the rated motor speed and loads  $\leq$  rated motor torque.
- Greater deviations are possible in the field weakening range.
- [C021](#) is set too high, the drive may get unstable.
- Negative slip ([C021](#) < 0) with V/f characteristic control results in "smoother" drive behaviour at heavy load impulses or applications requiring a significant speed drop under load.

### 5.6.5 Oscillation damping

Mechanical oscillations are undesirable effects in every process and they may have an adverse effect on the single system components and/or the production output.

Mechanical oscillations in the form of speed oscillations are suppressed by the oscillation damping function.

Parameter	Info	Lenze setting	
		Value	Unit
<a href="#">C234</a>	Oscillation damping influence	5.00	%

Oscillation damping is successfully used with

- unloaded motors (no-load oscillations)
- motors whose rated power deviates from the rated power of the controller.
  - e.g. during operation at high switching frequency including the power derating involved.
- operation with higher-pole motors
- operation with special motors
- compensation of resonance in the drive
  - At an output frequency of approx. 20 ... 40 Hz, some asynchronous motors can show resonance which causes current and speed variations and thus destabilise the running operation.



#### How to eliminate speed oscillations:

1. Approach the area where the speed oscillations occur.
2. Reduce the speed oscillations by changing [C234](#) step by step.
3. These can be indicators for smooth running:
  - Constant motor current characteristic
  - Reduction of the mechanical oscillations in the bearing seat

## 5.7 Braking operation/braking energy management

When electric motors are braked, the kinetic energy of the drive train is fed back into the DC circuit regeneratively. This energy leads to an increase in the DC bus voltage. In order to avoid overvoltage in the DC bus, several different strategies can be used:

- Use of an external brake resistor
- Use of an external brake module (only for inverters with single phase supply)
- Coupling of the inverters in a DC-bus connection (only for inverters with three-phase supply)
- Recovery of regenerative energy with a regenerative module (only for inverters with three-phase supply)



### Stop!

If the connected brake resistor is smaller than required, the brake chopper can be destroyed!

- For rated data see hardware manual.
- Appropriate protective measures are provided in the "[Avoiding thermal overload of the brake resistor](#)" subchapter. (103)



### Note!

- We recommend to use the brake chopper (brake transistor) which is integrated into the controller for the braking operation, regardless of the selected motor control.
- For a DC-bus connection with other devices, we recommend to connect the regenerative power supply module to terminals +UG and –UG.
- If none of these measures is taken, e.g. the overvoltage deactivation ("OU") may respond in case of low deceleration times during regenerative operation. ▶ [Error messages of the operating system](#) (153)



Observe the notes on braking operation in the hardware manual! (see "braking operation" chapter).

All the necessary instructions for the drive controller are stored in electronic form on the data carrier supplied with the 8400 drive controller.

### Short overview of the relevant parameters:

Parameter	Info	Lenze setting	
		Value	Unit
<a href="#">C173</a>	Mains voltage	3ph 400 V / 1ph 230 V	
<a href="#">C174</a>	Reduced brake chopper threshold	0	V
<a href="#">C574</a>	Resp. to brake resist. overtemp.	No response	

### 5.7.1 Setting the voltage source for braking operation

The voltage threshold for braking operation is set via the mains voltage (C173) and the reduced brake chopper threshold (C174). When this "brake chopper threshold" is exceeded in the DC bus, the energy is dissipated in the DC bus via the brake resistor and the DC-bus voltage is reduced.

- The brake chopper threshold is preset as follows so that it is higher than the specified mains (C173):

C173	Mains voltage		Brake chopper threshold	
	1-phase	3-phase	1-phase	3-phase
0	1ph 230V	3ph 400V	380V DC	725V DC
1	1ph 230V	3ph 440V	380V DC	35V DC
2	1ph 230V	3ph 480V	380V DC	775V DC
3	1ph 230V	3ph 500V	380V DC	790V DC

- This brake chopper threshold can be reduced by 0 ... 150 V via C174.



#### Stop!

The brake chopper threshold resulting from C173 and C174 must not exceed the stationary DC-bus voltage!

#### Example:

- A 400 V device has a maximum mains voltage of 420 V AC.
  - Maximum stationary DC-bus voltage:  $420 \text{ V AC} * 1.414 = 594 \text{ V DC}$
  - C173 has been set with the selection "0" for 400 V AC mains.
- This means that C174 can be set to a maximum of 131 V DC ( $725 \text{ V DC} - 594 \text{ V DC}$ ).

### 5.7.2 Avoiding thermal overload of the brake resistor

- Parameterisation of an error response in C574 and evaluation of the parameterised error message within the application or within the machine control system.
  - See chapter entitled "[Brake resistor monitoring \(l2xt\)](#)". (107)
- External interconnection using the thermal contact on the brake resistor (e.g. supply interruption via the mains contactor and activation of the mechanical brakes).

### 5.8 Monitoring

Many monitoring functions that are integrated into the controller can detect errors and thus protect the device/motor from damage or overload.

- Detailed information on the individual monitoring functions can be found in the following sub-chapters.

Monitoring	Response (Lenze setting)	Parameter
<a href="#">Device overload monitoring (Ixt)</a>	Warning	<a href="#">C604</a>
<a href="#">Motor load monitoring (I2xt)</a>	Warning	<a href="#">C606</a>
<a href="#">Brake resistor monitoring (I2xt)</a>	No Reaction	<a href="#">C574</a>
<a href="#">Mains phase failure monitoring</a>	Warning	<a href="#">C565</a>

#### Parameterisable responses

If a monitoring function trips, the response set via the corresponding parameter is carried out. The following responses can be selected:

- "No response": Response/monitoring is deactivated.
- "Fault": Change of the operating status by a pulse inhibit of the power output stage.
- "Warning": Operating status of the controller remains unchanged. Only a message is entered into the logbook of the controller.

#### Related topics:

- ▶ [Device states](#) (📖 54)
- ▶ [Diagnostics & error management](#) (📖 142)
- ▶ [Basics on error handling in the controller](#) (📖 142)
- ▶ [Error messages of the operating system](#) (📖 153)

#### 5.8.1 Device overload monitoring (Ixt)

In [C064/1...3](#) displays the device utilisation (ixt) in [%] in different time intervals:

Parameter	Info
<a href="#">C064/1</a>	Device utilisation (Ixt) <ul style="list-style-type: none"> <li>• Maximum value of the pulse utilisation (<a href="#">C064/2</a>) and permanent utilisation (<a href="#">C064/3</a>).</li> </ul>
<a href="#">C064/2</a>	Device utilisation (Ixt) 15s <ul style="list-style-type: none"> <li>• Pulse utilisation over the last 15 seconds (only for loads &gt;160 %).</li> </ul>
<a href="#">C064/3</a>	Device utilisation (Ixt) 3 min <ul style="list-style-type: none"> <li>• Permanent utilisation over the last 3 minutes.</li> </ul>
Highlighted in grey = display parameter	

- If the device utilisation reaches the switch-off threshold set in [C123](#):
  - The error response set in [C604](#) will be carried out (Lenze setting: "Warning").
  - The "[OC5: Ixt overload](#)" error message will be entered into the logbook.
- A setting of [C604](#) = "0: No Reaction" deactivates the monitoring.

### 5.8.2 Motor load monitoring (I<sup>2</sup>xt)

The Inverter Drives 8400 are provided with a simple, sensorless, thermal I<sup>2</sup>xt motor monitoring of self-ventilated standard motors which is based on a mathematical model.

- In [C066](#) displays the calculated motor load in [%].
- If the motor load reaches the switch-off threshold set in [C120](#):
  - The error response set in [C606](#) will be carried out (Lenze setting: "Warning").
  - The "[OC6: I<sup>2</sup>xt motor overload](#)" error message will be entered into the logbook.
- A setting of [C606](#) = "0: No Reaction" deactivates the monitoring.



#### Stop!

The I<sup>2</sup>xt motor monitoring does not present full motor protection! As the motor utilisation calculated in the thermal motor model is lost after mains switching, for instance the following operating states cannot be measured correctly:

- Restarting (after mains switching) of a motor that is already very hot.
- Change of the cooling conditions (e.g. cooling air flow interrupted or too warm).

A full motor protection requires additional measures as e.g. the evaluation of temperature sensors that are located directly in the winding or the use of thermal contacts.



#### Note!

From version 03.04.00, the thermal motor load displayed in [C066](#) can be pre-initialised when the device is connected to the mains, optionally using a fixed value or the value used last at the time when the device was switched off. The desired initialisation is selected in [C122](#). In the Lenze setting of [C122](#), the behaviour remains unchanged (no initialisation).

#### Adjustment of the motor utilisation meter

The motor utilisation meter for indicating the motor load in [C066](#) begins to count when the apparent motor current ([C054](#)) is greater than the set overload threshold ([C120](#)).

The overload threshold ([C120](#)) is to be set as follows:

$$C00120 = \frac{I_r}{I_N} \cdot 100\%$$

$I_r$  : Rated motor current (see nameplate of motor)

$I_N$  : Rated controller current at a switching frequency of  $f = 8 \text{ kHz}$

- If you reduce [C120](#) starting from the calculated value, the motor utilisation meter will already be counted up before the rated overload threshold is reached.
- If you reduce [C120](#) starting from the calculated value, the motor utilisation meter will already be counted up before the rated overload threshold is reached.

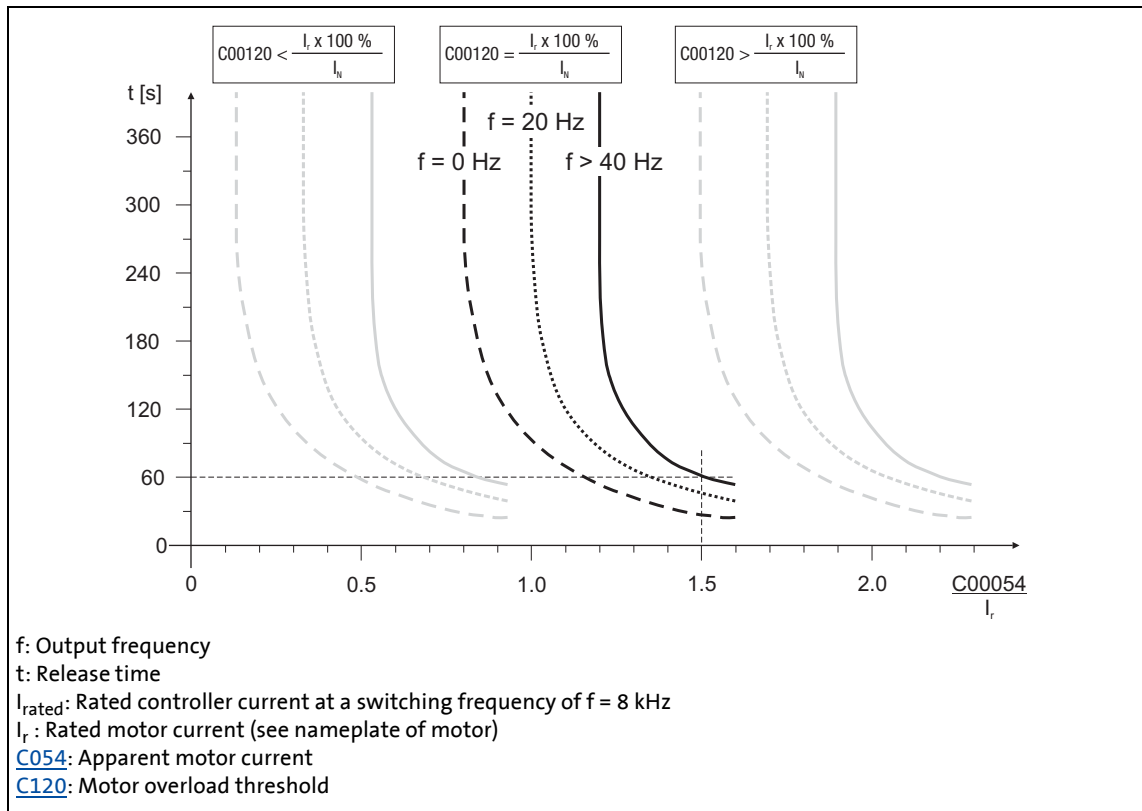

[5-5] Tripping characteristic of the  $I^2xt$  monitoring

### Example:

$$\text{C120} = I_r / I_{rated} \times 100 \%$$

$$\text{C054} = 150 \% \text{ rated motor current}$$

- After approx. 60 seconds, [C066](#) has reached the final value 100 % at output frequencies  $f > 40 \text{ Hz}$ .
- The controller outputs the "[OC6: I2xt overload motor](#)" error message and triggers the response set in [C606](#) (default setting: "Warning").



### Tip!

- If forced ventilated motors are used, a premature response of the overload threshold can be avoided by deactivating this function if necessary ([C606](#) = "0: No Reaction").
- The current limits set in [C022](#) and [C023](#) influence the  $I^2xt$  calculation only in an indirect way. However, the operation of the motor at maximum possible load can be averted.
  - ▶ [Defining current and speed limits](#) (77)



### 5.8.3 Brake resistor monitoring (I<sup>2</sup>xt)

Due to the converted braking power, the brake resistor is thermally stressed and can even be thermally destroyed by excessive braking power.

The monitoring of the I<sup>2</sup>xt utilisation of the controller serves to protect the brake resistor. It acts in proportion to the converted braking power.



#### Danger!

In the Lenze setting (([C574](#) = "0: No Reaction") the response of the monitoring function does not stop the braking operation!

In particular for applications such as hoists or applications with a DC-bus connection, it must be checked if a stopping of the braking operation due to the setting of [C574](#) = "1: Fault" is permissible.



#### Stop!

Implement appropriate protective measures against thermal overload of the brake resistor!

##### Examples:

- Parameterisation of an error response in [C574](#) and evaluation of the parameterised error message within the application or within the machine control system.
  - Interruption of the mains supply by means of the temperature contact at the brake resistor and a simultaneous activation of the mechanical brake.
- If the I<sup>2</sup>xt utilisation reaches a permanently set switch-off threshold:
    - The error response set in [C574](#) takes place.
    - The "[OC12: I<sup>2</sup>xt brake resistor overload](#)" error message is entered into the logbook.
  - If the system is dimensioned correctly, the monitoring mode should not respond.
  - If the DC-bus voltage exceeds the overvoltage threshold due to a braking energy that is too high, the monitoring for overvoltage in the DC bus is activated ("OU: DC-bus overvoltage" error message).

#### Related topics:

- ▶ [Braking operation/braking energy management](#) (📖 102)

---

#### 5.8.4 Mains phase failure monitoring



### Stop!

Under load, the mains input of a three-phase controller can be destroyed if the device is only supplied by two phases (e.g. if a mains phase fails).

The drive controller has a simple mains-phase failure detection function with which a mains phase failure can be detected under load.

- In the case of power-adapted machines, approx. 50 % of the rated motor power must be exceeded so that a main-phase failure can be detected.
- If the mains phase failure monitoring is tripped:
  - The error response set in [C565](#) will be carried out (Lenze setting: "Warning").
  - The "[Su02: Mains voltage switched-off](#)" error message is entered into the logbook.

## 6 I/O terminals

This chapter provides information on the function, possible parameter settings, and technical data of the input/output terminals of the controller.

In the »Engineer«, the digital and analog input and output terminals are parameterised on the **Terminal assignment** tab. To do this, go to the **Control terminals** list field and select the terminals that you wish to parameterise:

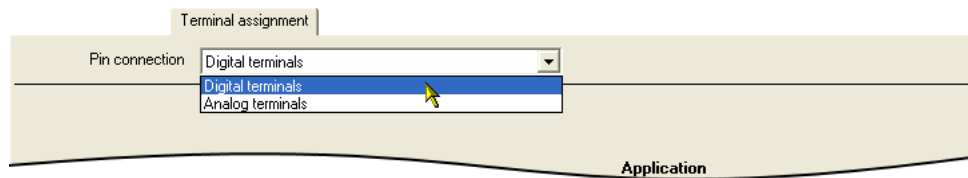

You can find further information in the respective subchapter:

- ▶ [Digital terminals](#) (📖 110)
- ▶ [Analog terminals](#) (📖 112)



### Note!

The input and output terminals of the controller are already functionally assigned in the default setting ("Lenze setting"). The preconfigured assignment depends on the control mode selected in [C007](#).

- ▶ [Terminal assignment of the control modes](#) (📖 137)



### Tip!

How you can alter the preconfigured assignment of the input and output terminals is described in the chapter entitled "[User-defined terminal assignment](#)". (📖 115)

---

## 6.1 Digital terminals

### Digital input terminals

The drive controller has

- four parameterisable input terminals (DI1 ... DI4) for detecting digital signals.
- one RFR control input for controller enable.

### Digital output terminals

The drive controller has

- a parameterisable output terminal (DO1) for outputting digital signals,
- a relay output (NO/COM).



### Note!

Initialisation behaviour:

- After mains switching up to the start of the application
  - the digital output remains set to FALSE.
  - the switching contact of the relay (NO/COM) remains open.

Exception handling:



- In the event of a critical exception in the application (e.g. reset), the digital output is set to FALSE.

Switching cycle diagnostics of the relay:

- A reference for evaluating the wear limit can be obtained via the number of switching cycles of the relay displayed in [C177/2](#).

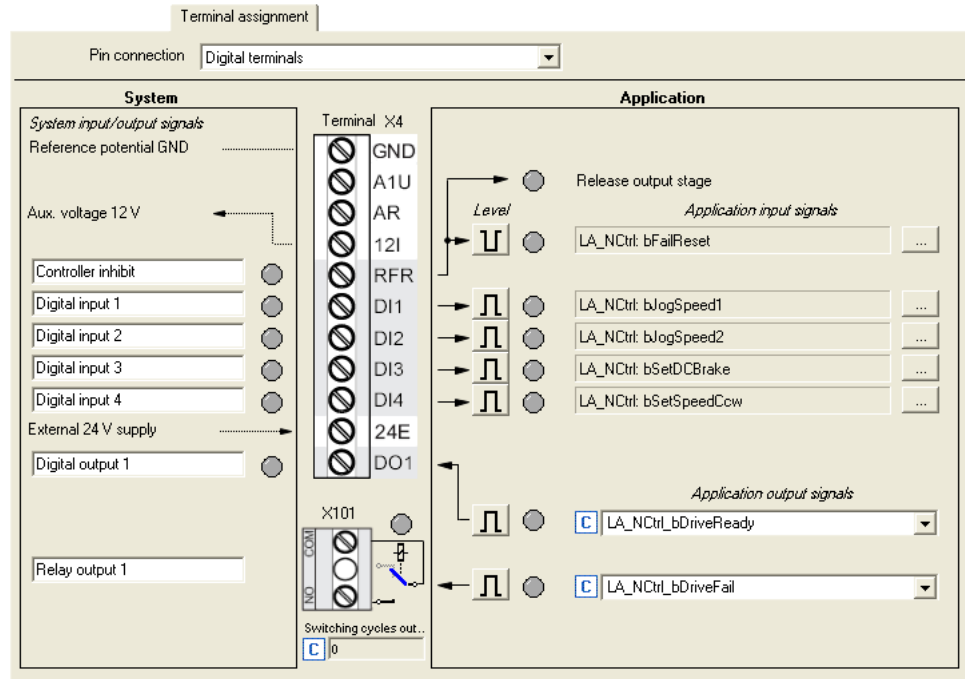
**Parameterisation dialog in the »Engineer«**



Button	Function
	Indicates the polarity of the input is HIGH active. The polarity can be changed from HIGH active to LOW active by clicking on this button.
	Indicates that the polarity of the input is LOW active. The polarity can be changed from LOW active to HIGH active by clicking on this button.
	Open the parameterising dialog for assigning application inputs to the digital input. ▶ <a href="#">Changing the terminal assignment with the »Engineer«</a> (117)

**Short overview of parameters for the digital terminals:**

Parameter	Info	Lenze setting	
		Value	Unit
<b>Digital inputs DI1 ... DI5</b>			
<a href="#">C114</a>	DIx: Polarity	Bit coded	
<a href="#">C443/1</a>	DIx: Terminal level	-	
<a href="#">C443/2</a>	DIx: Output level (to the application)	-	
<b>Digital output DO1 / relay output</b>			
<a href="#">C118</a>	DOx: Inversion	Bit coded	
<a href="#">C444/1</a>	DOx: Input level (from the application)	-	
<a href="#">C444/2</a>	DOx: Terminal level	-	
<b>Digital outputs - terminal configuration</b>			
<a href="#">C621/1</a>	LS_DigitalOutput:bRelay	50: LA_nCtrl_bDriveFail	
<a href="#">C621/2</a>	LS_DigitalOutput:bOut1	51: LA_nCtrl_bDriveReady	
Highlighted in grey = display parameter			

### 6.2 Analog terminals

The controller is provided with an analog input for detecting a voltage signal. The voltage signal can be e.g. an analog speed setpoint selection or the signal of an external sensor (temperature, pressure, etc.).

- Possible voltage ranges:
  - 0 ... +10 V (Lenze setting)
  - 0 ... +5 V
  - 1 ... +5 V
- An external 250-Ω load resistor and a respective parameter setting allow to implement a current loop:
  - 0 ... 20 mA, without open-circuit monitoring
  - 4 ... 20 mA, with open-circuit monitoring



#### Note!

To avoid undefined states, free input terminals of the controller must be assigned as well, e.g. by applying 0 V to the terminal.

#### Parameterisation dialog in the »Engineer«:

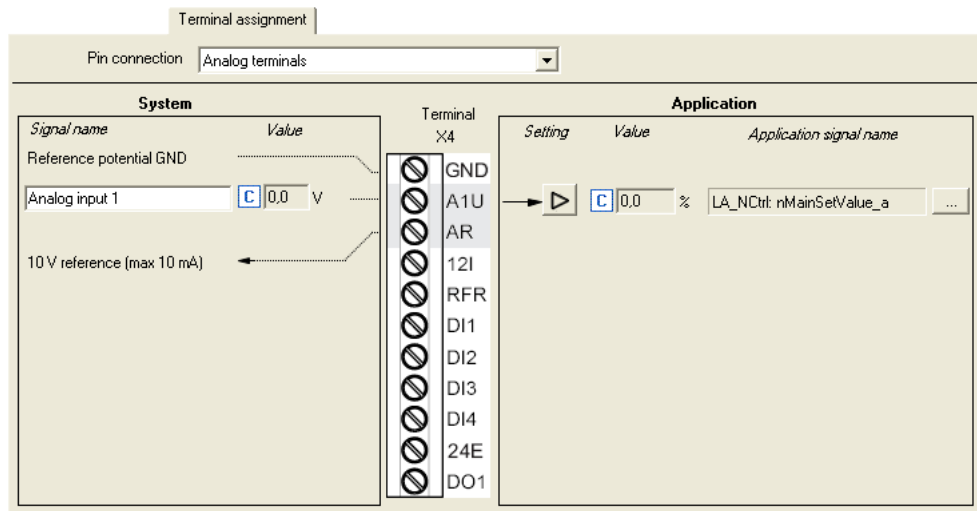

Button	Function
	<a href="#">Parameterising analog input</a> (📖 113)
	Open the parameterising dialog for assigning application inputs to the analog input. ▶ <a href="#">Changing the terminal assignment with the »Engineer«</a> (📖 117)

### 6.2.1 Parameterising analog input

By clicking  on the **Terminal assignment** tab, you reach the parameterising dialog for the analog input:

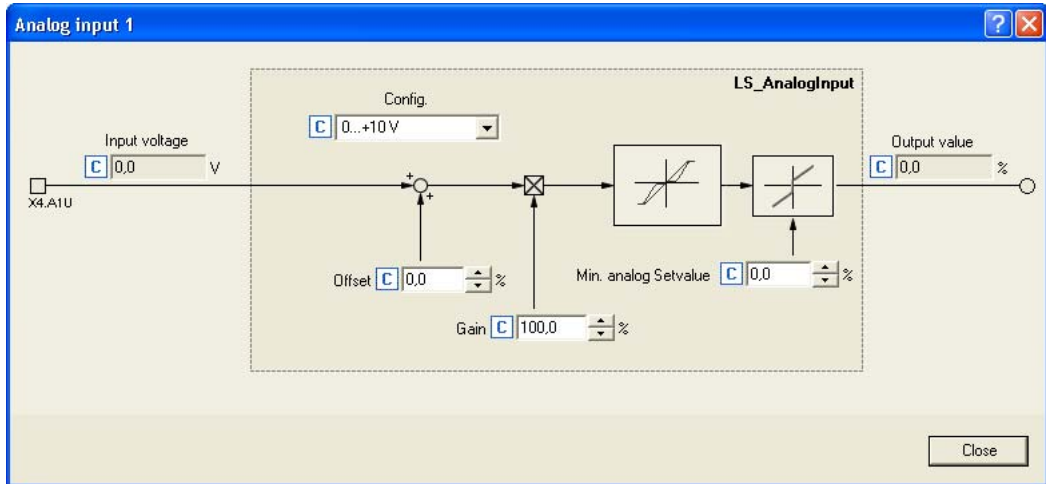

Short overview of parameters for the analog input:

Parameter	Info	Lenze setting	
		Value	Unit
<a href="#">C034/1</a>	AIN1: Config.	0: 0 ... +10 V	
<a href="#">C026/1</a>	AIN1: Offset	0.0	%
<a href="#">C027/1</a>	AIN1: Gain	100.0	%
<a href="#">C010/1</a>	AIN1: Minimum analog setpoint	0.0	%
<a href="#">C028/1</a>	AIN1: Input voltage	-	V
<a href="#">C033/1</a>	AIN1: Output value (to application)	-	%
<a href="#">C598/1</a>	Resp. to open circuit AIN1	1: Fault	

Highlighted in grey = display parameter

#### Using the analog input as current input

In the Lenze setting, a voltage signal in the range 0 ... +10 V is evaluated via the analog input terminal A1U.

For evaluating a current signal:

1. Connect external 250-Ω load resistor.
2. Make the following setting in [C034/1](#):
  - Selection "1: 0 ... +5 V" for 0 ... 20 mA current loop.
  - Selection "2: +1 ... +5 V" for 4 ... 20 mA current loop ("life zero", with open-circuit monitoring).
3. With a configuration as 4 ... 20 mA current loop in [C598/1](#), set the desired error response in the event of open circuit (Lenze setting: "Fault").

### Minimum and maximum output speed

The speed range required for the application results from the selected reference speed ([C011](#)) and the minimum analog setpoint ([C010](#)):

- The reference speed set in [C011](#) is reached at a speed setpoint selection of 100 %.
  - All speed setpoint selections are provided in % and always refer to the reference speed set in [C011](#) (independent of the setpoint source).
- The speed set in [C010](#) corresponds to the minimum speed if the speed setpoint has been selected via the analog input (Lenze setting) and a voltage of 0 V is applied to the X4/A1U input terminal.

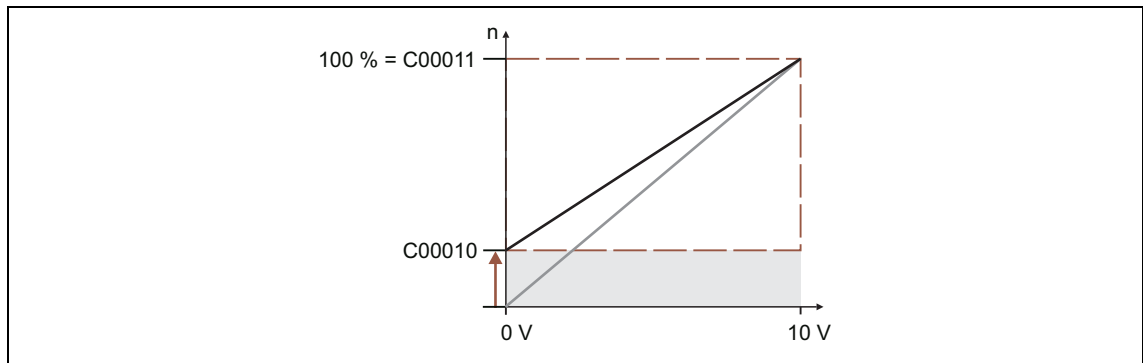

[6-1] Relation between the selected setpoint and minimum and maximum output speed



---

### 6.3 User-defined terminal assignment

In order to individually adapt the preconfigured assignment of the input/output terminals to your application, you can choose one of the following procedures:

- A. In the »Engineer«:
  - Change the terminal assignment on the **Terminal assignment** tab.
  - Change the signal assignment on the **Application Parameters** tab, on the dialog level *Overview* → *Signal flow*.
- B. In the »Engineer« or with the keypad:
  - Change the parameters for signal configuration in the parameters list.



#### Note!

If you change the preconfigured assignment of the input/output terminals, the terminal assignment will be a user-defined one. In [C007](#), control mode "0: Interconnection changed" will be shown.



#### Tip!

First set a suitable Lenze configuration by selecting a corresponding control mode in [C007](#). We recommend using the »Engineer« for the implementation of comprehensive user-defined drive solutions.

### 6.3.1 Source-destination principle

The I/O configuration of the input and output signals is carried out according to the source/destination principle:

- A connection always has a direction and therefore always has a source and a target.
- The input signals of the application are logically linked via configuration parameters to the output signals of system blocks which represent the device input terminals.
- The inputs of system blocks that represent the device output terminals are logically linked to output signals of the application via configuration parameters.

The following graphic illustrates the source/destination principle:

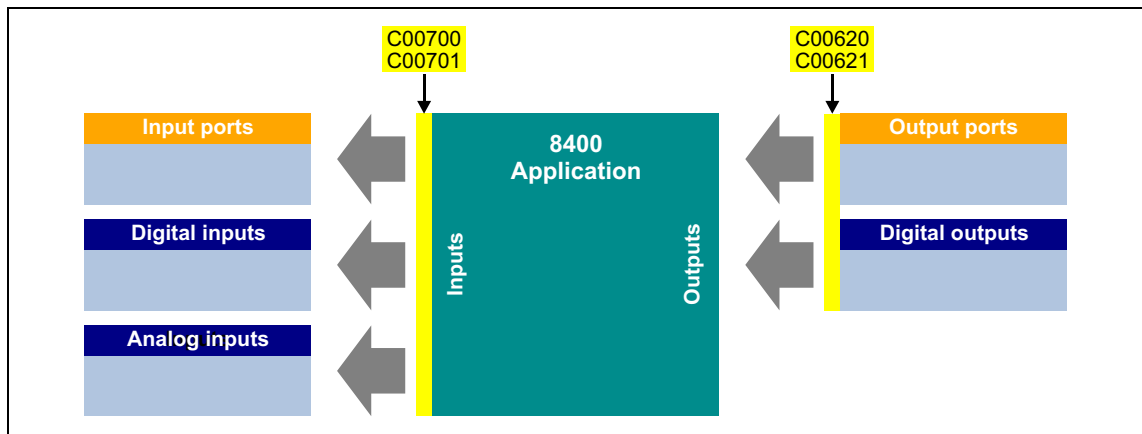

[6-2] Source-destination principle

Note the following:

- A device input terminal can be logically linked to several inputs of the application.
- Each input of the application can only be logically linked to one input signal.
- An output of the application can be logically linked to several device output terminals.

### 6.3.2 Changing the terminal assignment with the »Engineer«

The »Engineer« serves to easily change the preconfigured terminal assignment via corresponding dialogs. The following task serves to describe the respective procedure.

**Task:** Based on the preset control mode "Terminals 0", the digital input DI2 is used for activating the quick stop instead of selecting the fixed setpoint 2/3. For this purpose, the digital input DI2 must not be linked to the *bJogSpeed2* input but to the *bSetQuickstop* input of the application.

#### Possibility 1: Change terminal assignment by means of the Terminal Assignment tab

##### Procedure:

1. Select the "Digital terminals" entry on the **Terminal assignment** tab in the **Control terminals** list field:

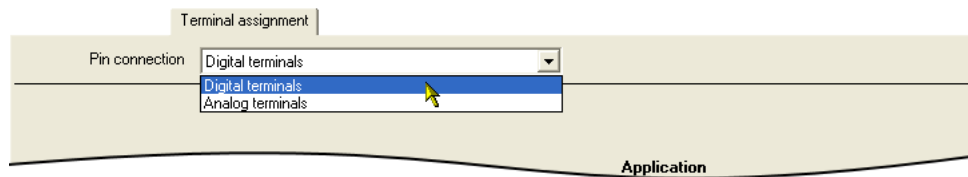

2. Click the **...** button for the DI2 terminal in order to open the dialog box *Assignment Terminal* --> *Function block*.
  - In the list field, all block inputs that are currently logically linked to digital input DI2 are marked with a checkmark:

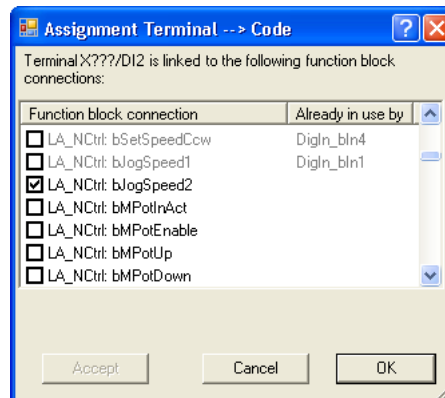

3. Remove checkmark for the connection **LA\_NCtrl: bJogSpeed2** in order to cancel the existing logical link.
4. Set checkmark for connection **LA\_NCtrl: bSetQuickstop** in order to logically link this application input to digital input DI2.
5. Click the **OK** button to close the dialog box again.

**Possibility 2: Change terminal assignment by means of the signal flow shown**Procedure:

1. Go to the **Application parameters** tab.
2. Go to the **Application Parameters** tab and click on the **Signal flow** button in order to change to the dialog level *Overview* → *Signal flow*.
3. In the **bJogSpeed2** list field, set the selection "0: Not interconnected".
4. In the **bSetQuickstop** list field, set the "12: DigIn\_bIn2" selection.

**6.3.3 Changing the terminal assignment via configuration parameters**

The preconfigured terminal assignment can be reconfigured via a bus system, with the keypad or with the »Engineer« by means of configuration parameters.

- Each configuration parameter represents a signal input of a function block, a system block or an application block.
- Each configuration parameter contains a selection list with output signals of the same type of data.
- Logical linking is thus carried out by selecting the output signal for the corresponding signal input.

In the following example, digital output 1 (**LS\_DigitalOutput.bOut1** input) is logically linked to the status signal "Drive ready" (**LA\_nCtrl\_bDriveReady** output signal):

	C...	Name	Value	Unit
621	1	LS_DigitalOutput: bRelay	LA_NCtrl_bDriveFail	
621	2	LS_DigitalOutput: bOut1	51: LA_NCtrl_bDriveReady	
621	3	Reserved	51: LA_NCtrl_bDriveReady	
621	4	Reserved	52: LA_NCtrl_bClnhActive	
621	5	Reserved	53: LA_NCtrl_bQSPisActive	
621	6	USER LED	54: LA_NCtrl_bSafeTorqueOff	
621	7	LA_NCtrl: bStatusBit0	55: LA_NCtrl_bSafetyIsActive	
621	8	LA_NCtrl: bStatusBit2	60: LA_NCtrl_bSpeedCow	
621	9	LA_NCtrl: bStatusBit3	61: LA_NCtrl_bActSpeedEqZero	
621	10	LA_NCtrl: bStatusBit4	62: LA_NCtrl_bSpeedSetReached	
			63: LA_NCtrl_bSpeedActEqSet	
			64: LA_NCtrl_bNActCompare	

**Tip!**

An overview of all configuration parameters and their Lenze setting in the different control modes is provided in the chapter "[Pre-assignment of the drive application](#)". (□ 134)

**Example**

**Task:** Based on the preset control mode "Terminals 0", the digital input DI2 is used for activating the quick stop instead of selecting the fixed setpoint 2/3. For this purpose, the digital input DI2 must not be linked to the *bJogSpeed2* input but to the *bSetQuickstop* input of the application.

**Procedure:**

1. Change the setting of the configuration parameter LA\_NCtrl: bSetQuickstop (C701/3) which represents the logical link of the *bSetQuickstop* application input: "0: Not connected" → "12: DigIn\_bln2"
2. Change the setting of the configuration parameter LA\_NCtrl: bJogSpeed2 (C701/7) which represents the logical link of the *bJogSpeed2* application input: "12: DigIn\_bln2" → "0: Not connected"

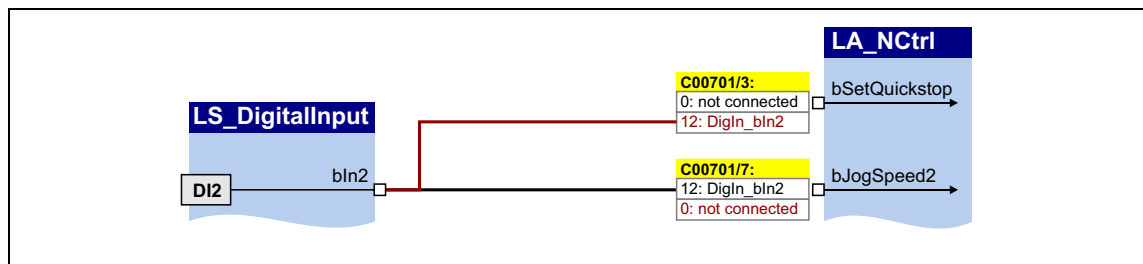

[6-3] Example: Changing the terminal assignment via configuration parameters

**Tip!**

The example shows, for each input of the application, the associated configuration parameter (C700/x or C701/x) is only allowed to contain one source that you enter.

**Related topics:**

- ▶ [Pre-assignment of the drive application](#) (134)

## 6.4

## Electrical data

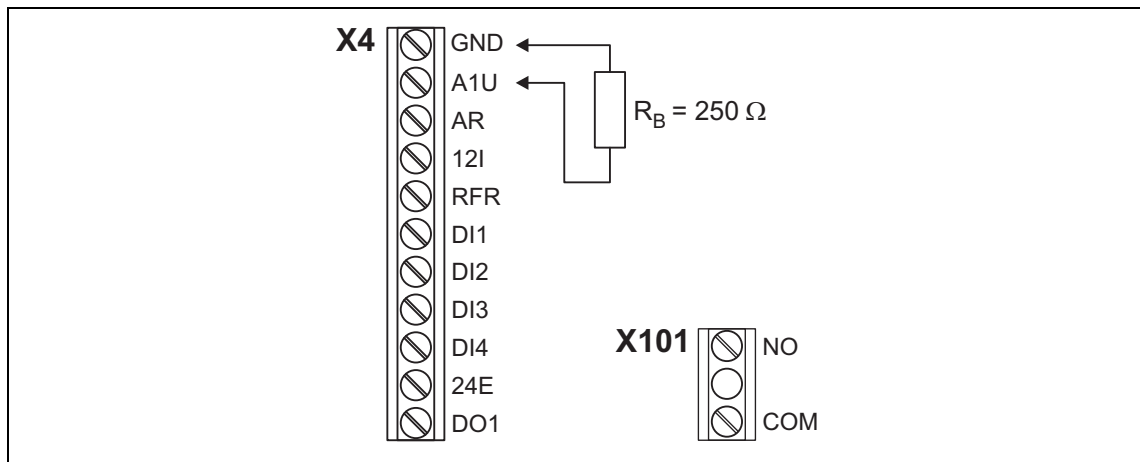

Terminal	Application / electrical data
GND	Reference potential
A1U	Voltage or current input
	General data:
	Resolution: 10 bits (Error: 1 digit $\equiv$ 0.1 %, in relation to the final value)
	Conversion rate: 1 kHz In order to filter short-time faults in the analog signal characteristic, the analog input value is led via a digital lag filter with a time constant of 5 ms.
	Processing cycle: 1 kHz (1 ms)
	Electric strength of external voltage: $\pm 15$ V, permanent
	If used as voltage input:
	Level/scaling: When <a href="#">C034/1</a> = "0": 0 ... +10 V $\equiv$ 0 ... +2 <sup>14</sup> $\equiv$ 0 ... +16384 $\equiv$ 0 ... +100 % When <a href="#">C034/1</a> = "1" or "2": 0 ... +5 V $\equiv$ 0 ... +2 <sup>14</sup> $\equiv$ 0 ... +16384 $\equiv$ 0 ... +100 %
	Input resistance: > 50 k $\Omega$
	Input voltage in case of open circuit: Display "0" (V < 0.2 V, absolute)
	Accuracy: $\pm 0.1$ V
	If used as current input (with external 250- $\Omega$ load resistor; see illustration):
	Level/scaling: 0 ... +20 mA $\equiv$ 0 ... +2 <sup>14</sup> $\equiv$ 0 ... +16384 $\equiv$ 0 ... +100 %
	Input resistance: 250 $\Omega$ (external)
AR	10-V reference voltage for analog input
	maximum output current: 10 mA
12I	12 V voltage for connecting the digital inputs via potential-free contacts
	• Internal supply: DC
	maximum output current: 50 mA
	Electric strength of external voltage: +30 V
	Overcurrent protection: Automatic reset
RFR	Controller enable
	• Electrical data as in digital inputs

Terminal	Application / electrical data
DI1 ... DI4	Digital inputs (according to IEC 61131-2, type 1)
	LOW level: 0 ... +2.5 V
	HIGH level: +10 ... +30 V
	Input current: 4 mA per input (at 12 V supply of terminal 12I)
	Electric strength of external voltage: ±30 V, permanent
	Input impedance: 3.3 kΩ (2.0 kΩ ... 5.0 kΩ)
	Processing cycle: 1 kHz (1 ms)
24E	External 24-V voltage supply
	Input voltage: 24 V according to IEC 61131-2 DC 15.0 ... 30.0 V Max. residual ripple ±5 % SELV/PELV
	Polarity reversal protection: In case of polarity reversal, the internal 12-V supply is active; no destruction.
	Current consumption: ≈ 50 mA during operation
DO1	Digital output (according to IEC 61131-2, type 1)
	LOW level: 0 ... +5 V
	HIGH level: +15 ... +30 V (independent of voltage at X4/24E)
	Output current: max. 50 mA (external resistance > 480 Ω at 24 V)
	Electric strength of external voltage: +30 V Integrated polarity reversal protection diode for switching inductive loads
	Processing cycle: 1 kHz (1 ms)
	Behaviour in case of overload: Reduced voltage or periodical connection/disconnection
NO / COM	Relay output <ul style="list-style-type: none"> <li>• Potential-free contact (NO contact)</li> <li>• AC 250 V / 3 A</li> <li>• DC 24 V / 2 A ... 240 V / 0.22 A (with suppressor circuit)</li> </ul> Important: The minimum load must not fall below 12 V and 5 mA.

## 7 Drive application

The "actuating drive speed" application provided in the 8400 Baseline D controller is a drive solution equipped with Lenze's experience and know-how in which function and system blocks interconnected to a signal flow clearly show the basis for implementing typical drive tasks.

The application serves to solve speed-controlled drive tasks, e.g. conveyor drives (interconnected), extruders, test benches, vibrators, travelling drives, presses, machining tools, dosing systems.

### Brief description of the features

- Pre-configured control modes for terminals and bus control (with predefined process data connection to the fieldbus)
- Free configuration of input and output signals
- Offset and gain of the main setpoint (if defined via analog input)
- Up to 3 fixed setpoints for speed
- Adjustable setpoint ramp times
- Linear or S-shaped ramp
- Quick stop (QSP) with adjustable ramp time
- Connectable motor potentiometer function (as alternative setpoint source)
- Connectable process controller (PID controller) with various operating modes
- Load monitoring

### Input/output interface

The application features an input interface for the connection of the signal sources (e.g. main setpoint) as well as an output interface for the control of output terminals and output ports.

### Parameter

The setting/parameterisation of internal functions, the selection of setpoints and the display of actual values is executed via parameters. A re-configuration of the interfaces is also possible via the corresponding configuration parameters.

### Related topics:

- ▶ [Introduction: Parameterising the controller](#) (13)
- ▶ [Commissioning with integrated keypad](#) (28)
- ▶ [Commissioning with the »Engineer«](#) (32)



# 7 Drive application

## 7.1 Parameterisation dialog

### 7.1 Parameterisation dialog

Go to the **Application parameter** tab to change the most important settings for the application in the top dialog level *Overview* :

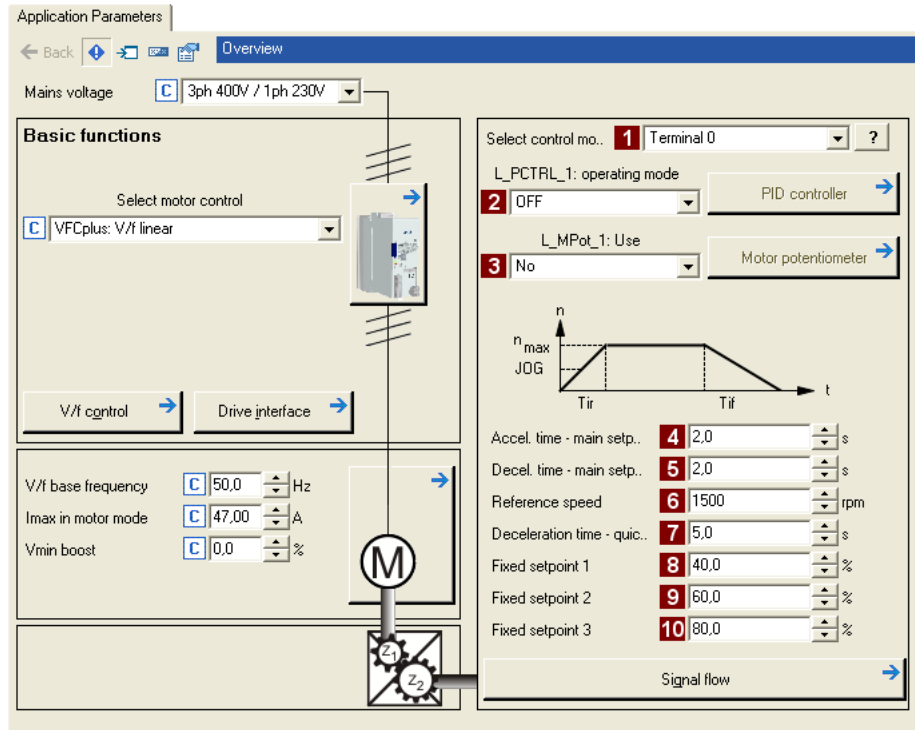

Short overview of the relevant parameters:

Parameter	Lenze setting		Info
	Value	Unit	
<b>1</b> <b>Control mode</b> (C007)	10: Terminals 0		<p>Various control modes can be selected for the application. The selection of the control mode determines the way the application is controlled, e.g. via terminals or via a fieldbus.</p> <ul style="list-style-type: none"> <li>The preconfigured assignment of the input/output terminals and ports in the respective control mode is described in the chapter entitled "<a href="#">Terminal assignment of the control modes</a>". (137)</li> <li>Detailed information on the individual configuration of the input/output terminals can be found in the description of the I/O terminals in the subchapter "<a href="#">User-defined terminal assignment</a>". (115)</li> </ul>
<b>2</b> <b>L_PCTRL_1: Operating mode</b> (C242)	0: Off		<p>A process controller (PID controller) is connected downstream of the setpoint generator.</p> <ul style="list-style-type: none"> <li>In the Lenze setting, the process controller is deactivated.</li> <li>The activation is executed by selecting the operating mode in <a href="#">C242</a>.</li> <li>For a detailed functional description see <a href="#">FB L_PCTRL_1</a>. (233)</li> </ul>

Parameter	Lenze setting		Info
	Value	Unit	
<b>3</b> <b>L_MPot_1: Use</b> (C806)	0: No		Alternatively, the main speed setpoint can be generated via a motor potentiometer function. <ul style="list-style-type: none"> <li>In the Lenze setting, the motor potentiometer function is deactivated.</li> <li>Activation is possible via <a href="#">C806</a> or via the <i>bMPotEnable</i> input.</li> <li>The behaviour of the motor potentiometer during switch-on of the drive system can be selected in <a href="#">C805</a>.</li> <li>For a detailed functional description see <a href="#">FB L_MPot_1. (□ 226)</a></li> </ul>
<b>4</b> <b>Accel. time - main setpoint</b> (C012)	2.0	s	The setpoint is led via a ramp function generator with linear characteristic. The ramp function generator converts setpoint step-changes at the input into a ramp. <ul style="list-style-type: none"> <li>For a detailed functional description see <a href="#">FB L_NSet_1. (□ 230)</a></li> </ul>
<b>5</b> <b>Decel. time - main setpoint</b> (C013)	2.0	s	
<b>6</b> <b>Reference speed</b> (C011)	1500	rpm	All speed setpoint selections are provided in % and always refer to the reference speed set in <a href="#">C011</a> . The motor reference speed is given on the motor name-plate.
<b>7</b> <b>Deceleration time - quick stop</b> (C105)	5.0	s	When "quick stop" is requested, the motor control is decoupled from the setpoint selection and within the deceleration time parameterised in <a href="#">C105</a> , the motor is brought to a standstill in ( $n_{act} = 0$ ). <p>▶ <a href="#">Activate/Deactivate quick stop (□ 51)</a></p>
<b>8</b> <b>Fixed setpoint 1</b> (C039/1)	40.0	%	A fixed setpoint for the setpoint generator can be activated instead of the main setpoint via the selection inputs <i>blogSpeed1</i> and <i>blogSpeed2</i> . <ul style="list-style-type: none"> <li>The fixed setpoints are selected in [%] based on the reference speed (<a href="#">C011</a>).</li> <li>For a detailed functional description see <a href="#">FB L_NSet_1. (□ 230)</a></li> </ul>
<b>9</b> <b>Fixed setpoint 2</b> (C039/2)	60.0	%	
<b>10</b> <b>Fixed setpoint 3</b> (C039/3)	80.0	%	

**Tip!**

When you click the **Signal flow** button, you will get one dialog level down to the signal flow of the application.

# 7 Drive application

## 7.1 Parameterisation dialog

### 7.1.1 Signal flow

When you go to the **Application parameters** tab to the top dialog level *Overview* and click the **Signal flow** button, you will get one dialog level down to the signal flow of the application (here displayed with the preset control mode "Terminals 0"):

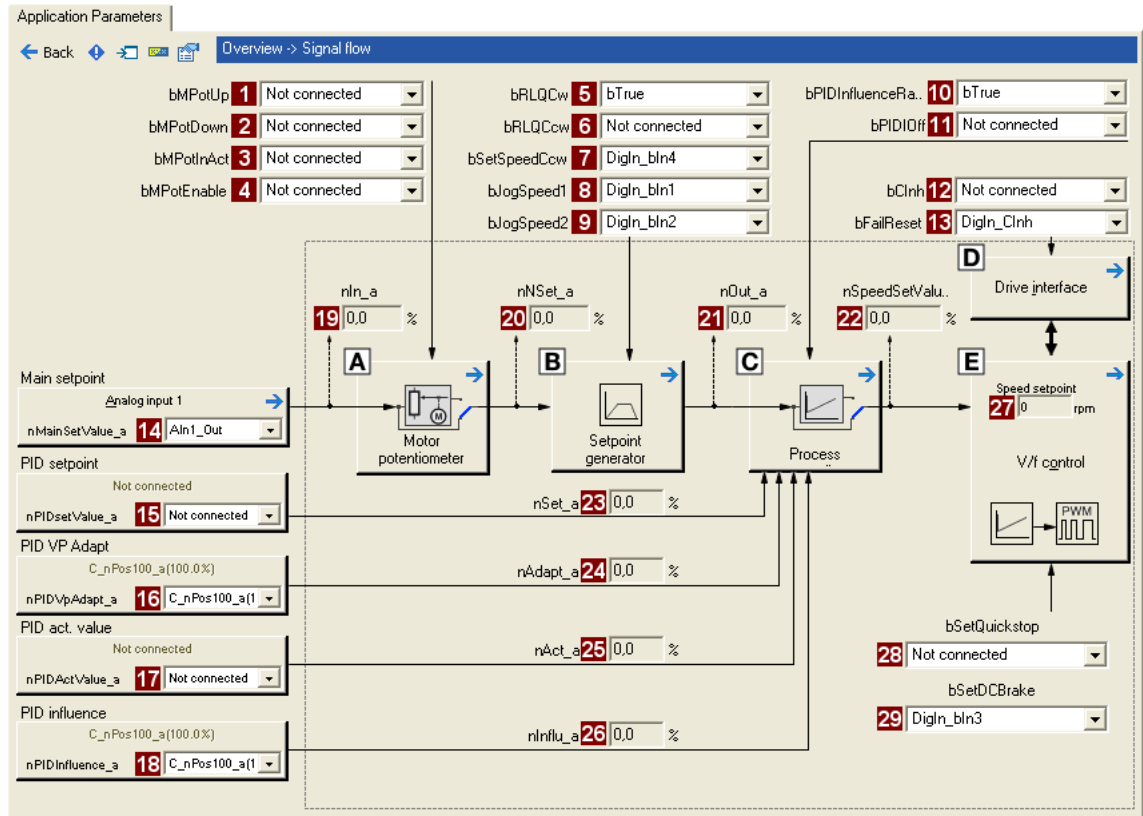

- A** Motor potentiometer ([L\\_MPot\\_1](#))
- B** Setpoint generator ([L\\_NSet\\_1](#))
- C** Process controller ([L\\_PCTRL\\_1](#))
- D** Device control ([LS\\_DriveInterface](#))
- E** [Motor control \(MCTRL\)](#)



All input and output interfaces of the application are described in the chapter entitled "[Interface description](#)". ([128](#))

#### Configuration parameters for digital control signals:

Parameter	Selection of signal source (Lenze setting)	for control signal:
<b>1</b> <b>bMPotUp</b> ( <a href="#">C701/8</a> )	0: Not connected	<a href="#">L_MPot_1</a> : Increase speed setpoint
<b>2</b> <b>bMPotDown</b> ( <a href="#">C701/9</a> )	0: Not connected	<a href="#">L_MPot_1</a> : Decrease speed setpoint
<b>3</b> <b>bMPotInAct</b> ( <a href="#">C701/10</a> )	0: Not connected	<a href="#">L_MPot_1</a> : Activate inactive function
<b>4</b> <b>bMPotEnable</b> ( <a href="#">C701/11</a> )	0: Not connected	<a href="#">L_MPot_1</a> : Activate motor potentiometer function
<b>5</b> <b>bRLQCw</b> ( <a href="#">C701/17</a> )	1: C_bTrue	Activate clockwise rotation (fail-safe)

Parameter	Selection of signal source (Lenze setting)	for control signal:
<b>6</b> <b>bRLQCcw</b> <a href="#">(C701/18)</a>	0: Not connected	Activate counter-clockwise rotation (fail-safe)
<b>7</b> <b>bSetSpeedCcw</b> <a href="#">(C701/5)</a>	14: DigIn_bln4 (DI4)	Change of direction of rotation
<b>8</b> <b>bJogSpeed1</b> <a href="#">(C701/6)</a>	11: DigIn_bln1 (DI1)	Selection of fixed setpoints (JOG setpoints)
<b>9</b> <b>bJogSpeed2</b> <a href="#">(C701/7)</a>	12: DigIn_bln2 (DI2)	
<b>10</b> <b>bPIDEnableInfluenceRamp</b> <a href="#">(C701/15)</a>	1: C_bTrue	<a href="#">L_PCTRL_1</a> : Activate ramp for influencing factor
<b>11</b> <b>bPIDOff</b> <a href="#">(C701/16)</a>	0: Not connected	<a href="#">L_PCTRL_1</a> : Switch off I component
<b>12</b> <b>bCInh</b> <a href="#">(C701/1)</a>	1: C_bTrue	<a href="#">Enable/Inhibit controller</a>
<b>13</b> <b>bFailReset</b> <a href="#">(C701/2)</a>	15: DigIn_Clnh (RFR)	<a href="#">Reset of error message</a>
<b>28</b> <b>bSetQuickstop</b> <a href="#">(C701/3)</a>	0: Not connected	Enable quick stop (QSP)
<b>29</b> <b>bSetDCBrake</b> <a href="#">(C701/3)</a>	13: DigIn_bln3 (DI3)	Manual DC-injection braking (DCB)

#### Configuration parameters for analog setpoints:

Parameter	Selection of signal source (Lenze setting)	for setpoint selection:
<b>14</b> <b>nMainSetValue_a</b> <a href="#">(C700/1)</a>	10: AI1_Out (Analog input 1)	Main setpoint • 100 % ≙ reference speed ( <a href="#">C011</a> )
<b>15</b> <b>nPIDSetValue_a</b> <a href="#">(C700/9)</a>	0: Not connected	<a href="#">L_PCTRL_1</a> : Sensor setpoint or process setpoint for operating mode 2
<b>16</b> <b>nPIDVpAdapt_a</b> <a href="#">(C700/6)</a>	1: C_nPos100_a (100%)	<a href="#">L_PCTRL_1</a> : Adaptation of the gain Vp set in <a href="#">C222</a> in percent
<b>17</b> <b>nPIDActValue_a</b> <a href="#">(C700/7)</a>	0: Not connected	<a href="#">L_PCTRL_1</a> : Actual speed value or actual sensor value (actual process value)
<b>18</b> <b>nPIDInfluence_a</b> <a href="#">(C700/8)</a>	1: C_nPos100_a (100%)	<a href="#">L_PCTRL_1</a> : Limitation of the influencing factor in percent

#### Display parameter

Parameter	Info
<b>19</b> <b>nIn_a</b> <a href="#">(C830/11)</a>	Input value of motor potentiometer
<b>20</b> <b>nNSet_a</b> <a href="#">(C830/1)</a>	Input value of setpoint generator
<b>21</b> <b>nOut_a</b> <a href="#">(C830/2)</a>	Output value of setpoint generator
<b>22</b> <b>nSpeedSetValue_a</b> <a href="#">(C830/2)</a>	Speed setpoint for motor control
<b>23</b> <b>nSet_a</b> <a href="#">(C830/8)</a>	Sensor setpoint or process setpoint for operating mode 2
<b>24</b> <b>nAdapt_a</b> <a href="#">(C830/7)</a>	Adaptation of the gain Vp set in <a href="#">C222</a> in percent
<b>25</b> <b>nAct_a</b> <a href="#">(C830/6)</a>	Speed or actual sensor value (actual process value)

# 7 Drive application

## 7.1 Parameterisation dialog

---

Parameter	Info
<b>26</b> nInflu_a (C830/9)	Limitation of the influencing factor in percent
<b>27</b> Speed setpoint (C050)	Speed setpoint

### 7.1.1.1 Selection of the main speed setpoint

The main speed setpoint is selected in the Lenze setting via the analog input 1.

- Scaling: 10 V  $\equiv$  100 % reference speed ([C011](#))
- The main setpoint is transformed to a speed setpoint in the setpoint encoder via a ramp function generator with linear or S-shaped ramps.
- For a detailed functional description see FB [L\\_NSet\\_1](#). ([230](#))

#### Related topics:

- ▶ [Analog terminals](#) ([112](#))
- ▶ [Parameterising analog input](#) ([113](#))

### 7.1.1.2 Motor potentiometer function

Alternatively, the main speed setpoint can be generated via a motor potentiometer function.

- In the Lenze setting, the motor potentiometer function is deactivated.
- Activation is possible via [C806](#) or via the *bMPotEnable* input.
- The behaviour of the motor potentiometer during switch-on of the drive system can be selected in [C805](#).
- For a detailed functional description see FB [L\\_MPot\\_1](#). ([226](#))

### 7.1.1.3 Process controller

A process controller (PID controller) is connected downstream of the setpoint generator.

- In the Lenze setting, the process controller is deactivated.
- The activation is executed by selecting the operating mode in [C242](#).
- For a detailed functional description see FB [L\\_PCTRL\\_1](#). ([233](#))

### 7.2 Interface description



**Tip!**

You can change the preconfigured assignment of the respective input via the configuration parameters given in the first column.

▶ [User-defined terminal assignment](#) (115)

#### Inputs

Identifier	Data type Configuration parameters	Information/possible settings
nMainSetValue_a	INT <a href="#">C700/1</a>	<p>Main speed setpoint</p> <ul style="list-style-type: none"> <li>• Scaling: 16384 <math>\equiv</math> 100 % reference speed (<a href="#">C011</a>)</li> <li>• The main setpoint is transformed to a speed setpoint in the setpoint encoder via a ramp function generator with linear or S-shaped ramps.</li> <li>• Upstream to the ramp function generator, a blocking speed masking function and a setpoint MinMax limitation are effective.</li> <li>• For a detailed functional description see FB <a href="#">L_NSet</a>.</li> </ul>
nTorqueMotLim_a nTorqueGenLim_a	INT <a href="#">C700/2...3</a>	<p>Torque limitation in motor mode and in generator mode</p> <ul style="list-style-type: none"> <li>• These input signals are directly transferred to the motor control to limit the controller's maximum torque in motor and generator mode.</li> <li>• The drive cannot output a higher torque in motor/generator mode than set here.</li> <li>• The applied values (any polarity) are internally interpreted as absolute values.</li> <li>• If sensorless vector control (SLVC) is selected, the limitation has a <u>direct</u> effect on the torque-producing current component.</li> <li>• Scaling: 16384 <math>\equiv</math> 100 % <math>M_{max}</math> (<a href="#">C057</a>)</li> </ul> <p>Torque limits in motor and generator mode:</p>
<b>Device control</b>		
bCInh	BOOL <a href="#">C701/1</a>	<p><a href="#">Enable/Inhibit controller</a></p> <p>FALSE Enable controller: The controller switches to the "<a href="#">OperationEnabled</a>" device state, if no other source of a controller inhibit is active.</p> <ul style="list-style-type: none"> <li>• <a href="#">C158</a> provides a bit coded representation of all active sources/ triggers of a controller inhibit..</li> </ul>
		<p>TRUE Inhibit controller (controller inhibit): The controller switches to the "<a href="#">SwitchedON</a>" device state.</p>
bFailReset	BOOL <a href="#">C701/2</a>	<p><a href="#">Reset of error message</a></p> <p>In the Lenze setting this input is connected to the digital input controller enable so that a possibly existing error message is reset together with the controller enable (if the cause for the fault is eliminated).</p>
		<p>TRUE The current fault is reset, if the cause for the fault is eliminated.</p> <ul style="list-style-type: none"> <li>• If the fault still exists, the error status remains unchanged.</li> </ul>

Identifier Data type Configuration parameters	Information/possible settings	
bSetQuickstop BOOL <a href="#">C701/3</a>	Enable quick stop (QSP) • Also see device command " <a href="#">Activate/Deactivate quick stop</a> ".	
	TRUE	Activate quick stop • The motor control is decoupled from the setpoint selection and within the deceleration time parameterised in <a href="#">C105</a> the motor is brought to a standstill ( $n_{ist} = 0$ ). • The motor is kept at a standstill during closed-loop operation. • A pulse inhibit (CINH) is set if the "Auto-DCB" function has been activated via <a href="#">C019</a> .
	FALSE	Deactivate quick stop • The quick stop is deactivated if no other source for the quick stop is active. • <a href="#">C159</a> provides a bit coded representation of all active sources/triggers of a quick stop..
bSetDCBrake BOOL <a href="#">C701/4</a>	Manual DC-injection braking (DCB) • Detailed information on DC-injection braking is provided in the motor control, subchapter " <a href="#">DC-injection braking</a> ".	
	 <b>Note!</b> Holding braking is not possible when this braking mode is used!	
	FALSE	Deactivate DC-injection braking.
TRUE	Activate DC-injection braking, i.e. the drive is brought to a standstill by means of DC-injection braking. • The braking effect stops when the rotor is at standstill. • After the hold time ( <a href="#">C107</a> ) has expired, the controller sets the pulse inhibit (CINH).	
<b>Fail-safe selection of the direction of rotation in connection with quick stop</b> • In control mode "Terminals 16", both inputs are connected to the digital terminals DI3 and DI4. • For a detailed functional description see FB <a href="#">L_RLO</a> .		
bRLQCw BOOL <a href="#">C701/17</a>	Activate clockwise rotation (fail-safe)	
	FALSE	Quick stop
TRUE	Clockwise rotation	bRLQCcw BOOL <a href="#">C701/18</a>
FALSE	Quick stop	
TRUE	Counter-clockwise rotation	

Identifier	Data type Configuration parameters	Information/possible settings		
<b>Setpoint generator</b>				
<ul style="list-style-type: none"> <li>For a detailed functional description see FB <a href="#">L_NSet</a>.</li> </ul>				
bSetSpeedCcw	BOOL <a href="#">C701/5</a>	Change of direction of rotation		
		<ul style="list-style-type: none"> <li>For instance if a motor or gearbox is fixed laterally reversed to a machine part, but the setpoint selection should still be executed for the positive direction of rotation.</li> </ul>		
		<table border="1"> <tr> <td>FALSE</td> <td>Clockwise rotation (Cw)</td> </tr> <tr> <td>TRUE</td> <td>Counter-clockwise rotation (Ccw)</td> </tr> </table>	FALSE	Clockwise rotation (Cw)
FALSE	Clockwise rotation (Cw)			
TRUE	Counter-clockwise rotation (Ccw)			
bJogSpeed1 bJogSpeed2	BOOL <a href="#">C701/6</a> <a href="#">C701/7</a>	Selection inputs for fixed changeover setpoints (JOG setpoints) for the main setpoint <ul style="list-style-type: none"> <li>A fixed setpoint for the setpoint generator can be activated instead of the main setpoint via these selection inputs.</li> <li>The two selection inputs are binary coded, therefore you can select three fixed setpoints.</li> <li>In the case of binary coded selection "0" (all inputs = FALSE or not assigned), main setpoint <i>nMainSetValue_a</i> is active.</li> <li>The fixed setpoints are selected in <a href="#">C039/1...3</a> in [%] based on the reference speed (<a href="#">C011</a>).</li> <li>For a detailed functional description see FB <a href="#">L_NSet</a>.</li> </ul>		
bRFG_0	BOOL <a href="#">C701/12</a>	Ramp function generator: Lead the main setpoint integrator to "0" within the current <i>Ti</i> times		
		<ul style="list-style-type: none"> <li>For a detailed functional description see FB <a href="#">L_NSet</a>.</li> </ul> <table border="1"> <tr> <td>TRUE</td> <td>The current value of the main setpoint integrator is led to "0" within the <i>Ti</i> time set.</td> </tr> </table>	TRUE	The current value of the main setpoint integrator is led to "0" within the <i>Ti</i> time set.
TRUE	The current value of the main setpoint integrator is led to "0" within the <i>Ti</i> time set.			
<b>Motor potentiometer</b>				
Alternatively to the input signal <i>nMainSetValue_a</i> , the main setpoint can also be generated by a motor potentiometer function. <ul style="list-style-type: none"> <li>In the Lenze setting, the motor potentiometer function is deactivated.</li> <li>Activation is possible via <a href="#">C806</a> or via the <i>bMPotEnable</i> input.</li> <li>The behaviour of the motor potentiometer during switch-on of the drive system can be selected in <a href="#">C805</a>.</li> <li>For a detailed functional description see FB <a href="#">L_MPot</a>.</li> </ul>				
bMPotUp	BOOL <a href="#">C701/8</a>	Increasing the speed setpoint		
		<table border="1"> <tr> <td>TRUE</td> <td>Approach the upper speed value set in <a href="#">C800</a> with the acceleration time set in <a href="#">C802</a>.</td> </tr> </table>	TRUE	Approach the upper speed value set in <a href="#">C800</a> with the acceleration time set in <a href="#">C802</a> .
TRUE	Approach the upper speed value set in <a href="#">C800</a> with the acceleration time set in <a href="#">C802</a> .			
bMPotDown	BOOL <a href="#">C701/9</a>	Decreasing the speed setpoint		
		<table border="1"> <tr> <td>TRUE</td> <td>Approach the lower speed limit value set in <a href="#">C801</a> with the deceleration time set in <a href="#">C803</a>.</td> </tr> </table>	TRUE	Approach the lower speed limit value set in <a href="#">C801</a> with the deceleration time set in <a href="#">C803</a> .
TRUE	Approach the lower speed limit value set in <a href="#">C801</a> with the deceleration time set in <a href="#">C803</a> .			
bMPotInAct	BOOL <a href="#">C701/10</a>	Activating the inactive function		
		<table border="1"> <tr> <td>TRUE</td> <td>The speed setpoint behaves according to the inactive function set in <a href="#">C804</a>.               <ul style="list-style-type: none"> <li>In the Lenze setting, the speed setpoint is maintained.</li> </ul> </td> </tr> </table>	TRUE	The speed setpoint behaves according to the inactive function set in <a href="#">C804</a> . <ul style="list-style-type: none"> <li>In the Lenze setting, the speed setpoint is maintained.</li> </ul>
TRUE	The speed setpoint behaves according to the inactive function set in <a href="#">C804</a> . <ul style="list-style-type: none"> <li>In the Lenze setting, the speed setpoint is maintained.</li> </ul>			
bMPotEnable	BOOL <a href="#">C701/11</a>	Activating the motor potentiometer function		
		<ul style="list-style-type: none"> <li>This input and <a href="#">C806</a> are OR'd.</li> </ul> <table border="1"> <tr> <td>TRUE</td> <td>The motor potentiometer function is active; the speed setpoint can be changed via the <i>bMPotUp</i> and <i>bMPotDown</i> control inputs.</td> </tr> </table>	TRUE	The motor potentiometer function is active; the speed setpoint can be changed via the <i>bMPotUp</i> and <i>bMPotDown</i> control inputs.
TRUE	The motor potentiometer function is active; the speed setpoint can be changed via the <i>bMPotUp</i> and <i>bMPotDown</i> control inputs.			



Identifier	Data type Configuration parameters	Information/possible settings	
<b>Process controller</b>			
<ul style="list-style-type: none"> <li>In the Lenze setting, the process controller is deactivated.</li> <li>The activation is executed by selecting the operating mode in <a href="#">C242</a>.</li> <li>For a detailed functional description see FB <a href="#">L_PCTRL</a>.</li> </ul>			
bPIDEnableInfluenceRamp	BOOL <a href="#">C701/15</a>	Activate ramp for influencing factor	
		FALSE	Influencing factor of the PID controller is ramped down to "0".
		TRUE	Influencing factor of the PID controller is ramped up to the value <i>nPIDInfluence_a</i> .
bPIDOff	BOOL <a href="#">C701/16</a>	Switch off I-component of the process controller	
		TRUE	I-component of the process controller is switched off.
nPIDVpAdapt_a	INT <a href="#">C700/6</a>	Adaptation of the gain Vp set in <a href="#">C222</a> in percent <ul style="list-style-type: none"> <li>Scaling: 16384 <math>\equiv</math> 100 %</li> <li>Internal limitation to <math>\pm 199.9</math> %</li> <li>Changes can be done online.</li> </ul>	
nPIDActValue_a	INT <a href="#">C700/7</a>	Speed or actual sensor value (actual process value) <ul style="list-style-type: none"> <li>Scaling: 16384 <math>\equiv</math> 100 %</li> <li>Internal limitation to <math>\pm 199.9</math> %</li> </ul>	
nPIDInfluence_a	INT <a href="#">C700/8</a>	Limitation of the influencing factor in percent <ul style="list-style-type: none"> <li>The influence factor of the PID controller can be limited to a certain value (-199.9% ... +199.9%) via <i>nPIDInfluence_a</i>.</li> <li>Scaling: 16384 <math>\equiv</math> 100 %</li> <li>Internal limitation to <math>\pm 199.9</math> %</li> </ul>	
nPIDSetValue_a	INT <a href="#">C700/9</a>	Sensor setpoint or process setpoint for operating mode 2 <ul style="list-style-type: none"> <li>Scaling: 16384 <math>\equiv</math> 100 %</li> <li>Internal limitation to <math>\pm 199.9</math> %</li> </ul>	

## Outputs

Identifier	Data type	Value/meaning
<b>Device control</b>		
wDeviceStateWord	WORD	Status word of the controller (based on DSP-402) <ul style="list-style-type: none"> <li>Display parameter: <a href="#">C150</a></li> </ul>
wDeviceAuxStateWord	WORD	Extended status word of the controller
wDetermFailNoLow	WORD	Display of the current error (Low-Word)
wDetermFailNoHigh	WORD	Display of the current error (High-Word)
bDriveFail	BOOL	TRUE Controller in error status <ul style="list-style-type: none"> <li>"<a href="#">Fault</a>" device state is active.</li> </ul>
bDriveReady	BOOL	TRUE Controller is ready for operation. <ul style="list-style-type: none"> <li>"<a href="#">SwitchedON</a>" device state is active.</li> <li>The drive is in this device state if the DC bus voltage is applied and the controller is still inhibited by the user (controller inhibit).</li> </ul>
bCInhActive	BOOL	TRUE Controller inhibit is active
bQSPisActive	BOOL	TRUE Quick stop is active
bSafeTorqueOff	BOOL	TRUE " <a href="#">SafeTorqueOff</a> " device state is active

Identifier	Data type	Value/meaning	
bSafetyIsActive	BOOL	TRUE	In preparation
bSpeedCcw	BOOL	FALSE	Clockwise rotation (Cw)
		TRUE	Counter-clockwise rotation (Ccw)
bActSpeedEqZero	BOOL	TRUE	Current speed is 0
bSpeedSetReached	BOOL	TRUE	Speed setpoint reached
bSpeedActEqSet	BOOL	TRUE	Actual speed value has reached the setpoint within one hysteresis band
bNactCompare	BOOL	TRUE	During open-loop operation: Speed setpoint < comparison value (C024)
			During closed-loop operation: Actual speed value < comparison value (C024)
bImaxActive	BOOL	TRUE	The current setpoint is limited internally (the controller operates at the maximum current limit)
<b>Motor control</b>			
bHeatSinkWarning	BOOL	TRUE	Heatsink overtemperature detected
bOVDetected	BOOL	TRUE	Overvoltage detected
bDcBrakeOn	BOOL	TRUE	<a href="#">DC-injection braking</a> active
bFlyingSyncActive	BOOL	TRUE	<a href="#">Flying restart function</a> is executed
nMotorFreqAct_a	<a href="#">C058</a>   INT	Current field frequency	
nOutputSpeedCtrl_a	INT	Speed or slip controller output • Scaling: 16384 ≙ 100 % reference speed (C011)	
nMotorSpeedAct_a	<a href="#">C051</a>   INT	Actual speed value • Scaling: 16384 ≙ 100 % reference speed (C011)	
nMotorVoltage_a	INT	Current motor voltage/inverter output voltage • Scaling: 16384 ≙ 1000 V	
nDCVoltage_a	INT	Actual DC-bus voltage • Scaling: 16384 ≙ 1000 V	
nMotorCurrent_a	INT	Current motor current • Scaling: 16384 ≙ 100 % $I_{\max\_mot}$ (C022)	
nMotorTorqueAct_a	<a href="#">C056/2</a>   INT	Actual torque • With "VFC (+encoder)" motor control, this value is determined from the current motor current and corresponds to the actual torque only by approximation. • Scaling: 16384 ≙ 100 % $M_{\max}$ (C057)	
nHeatsinktemperature_a	INT	Heatsink temperature	

## 7.3

## Setting parameters (short overview)

Parameter	Info	Lenze setting	
		Value	Unit
<a href="#">C012</a>	Accel. time - main setpoint	2.0	s
<a href="#">C013</a>	Decel. time - main setpoint	2.0	s
<a href="#">C182</a>	S-ramp time PT1	20.00	s
<a href="#">C134</a>	Ramp smoothing - main setpoint	0: Off	
<a href="#">C019</a>	Auto-DCB: Threshold	3	rpm
<a href="#">C036</a>	DCB: Current	50.0	%
<a href="#">C039/1</a>	Fixed setpoint 1	40.0	%
<a href="#">C039/2</a>	Fixed setpoint 2	60.0	%
<a href="#">C039/3</a>	Fixed setpoint 3	80.0	%
<a href="#">C105</a>	Deceleration time - quick stop	5.0	s
<a href="#">C106</a>	Auto-DCB: Hold time	0.5	s
<a href="#">C107</a>	DCB: Hold time	999.0	s
<a href="#">C222</a>	L_PCTRL_1: Vp	1.0	
<a href="#">C223</a>	L_PCTRL_1: Tn	400	ms
<a href="#">C224</a>	L_PCTRL_1: Kd	0.0	
<a href="#">C225</a>	L_PCTRL_1: MaxLimit	199.9	%
<a href="#">C226</a>	L_PCTRL_1: MinLimit	-199.9	%
<a href="#">C227</a>	L_PCTRL_1: Acceleration time	0.1	s
<a href="#">C228</a>	L_PCTRL_1: Deceleration time	0.1	s
<a href="#">C231/1</a>	L_PCTRL_1: Pos. maximum	199.9	%
<a href="#">C231/2</a>	L_PCTRL_1: Pos. minimum	0.0	%
<a href="#">C231/3</a>	L_PCTRL_1: Neg. minimum	0.0	%
<a href="#">C231/4</a>	L_PCTRL_1: Neg. maximum	199.9	%
<a href="#">C242</a>	L_PCTRL_1: Operating mode	0: Off	
<a href="#">C243</a>	L_PCTRL_1: Acceleration time influence	5.0	s
<a href="#">C244</a>	L_PCTRL_1: Deceleration time influence	5.0	s
<a href="#">C245</a>	L_PCTRL_1: PID output value	-	%
<a href="#">C800</a>	L_MPot_1: Upper limit	100.0	%
<a href="#">C801</a>	L_MPot_1: Lower limit	-100.0	%
<a href="#">C802</a>	L_MPot_1: Acceleration time	10.0	s
<a href="#">C803</a>	L_MPot_1: Deceleration time	10.0	s
<a href="#">C804</a>	L_MPot_1: Inactive function	0: Retain value	
<a href="#">C805</a>	L_MPot_1: Init function	0: Load last value	
<a href="#">C806</a>	L_MPot_1: Use	0: No	

## 7.4 Pre-assignment of the drive application

### 7.4.1 Input connections

Configuration parameters	Identifier	Control mode					
		10 (terminals 0)	12 (Terminal 2)	14 (terminals 11)	16 (terminals 16)	20 (keypad)	21 (PC)
<a href="#">C700/1</a>	nMainSetValue_a	X4/A1U	X4/A1U	X4/A1U	X4/A1U	<a href="#">C728/3</a>	<a href="#">C472/1</a>
<a href="#">C700/2</a>	nTorqueMotLim_a	<a href="#">C472/3</a>	<a href="#">C472/3</a>	<a href="#">C472/3</a>	<a href="#">C472/3</a>	<a href="#">C728/1</a>	<a href="#">C472/3</a>
<a href="#">C700/3</a>	nTorqueGenLim_a	<a href="#">C472/3</a>	<a href="#">C472/3</a>	<a href="#">C472/3</a>	<a href="#">C472/3</a>	<a href="#">C728/2</a>	<a href="#">C472/3</a>
<a href="#">C700/6</a>	nPIDVpAdapt_a	100 %	100 %	100 %	100 %	100 %	100 %
<a href="#">C700/7</a>	nPIDActValue_a	-	-	-	-	-	-
<a href="#">C700/8</a>	nPIDInfluence_a	100 %	100 %	100 %	100 %	100 %	100 %
<a href="#">C700/9</a>	nPIDSetValue_a	-	-	-	-	-	-
<a href="#">C701/1</a>	bCInh	-	-	-	-	-	-
<a href="#">C701/2</a>	bFailReset	X4/RFR	X4/RFR	X4/RFR	X4/RFR	X4/RFR	X4/RFR
<a href="#">C701/3</a>	bSetQuickstop	-	X4/DI3	-	-	<a href="#">C727/1</a>	-
<a href="#">C701/4</a>	bSetDCBrake	X4/DI3	-	X4/DI2	-	<a href="#">C727/2</a>	<a href="#">C470/3</a>
<a href="#">C701/5</a>	bSetSpeedCcw	X4/DI4	X4/DI4	X4/DI1	-	<a href="#">C727/3</a>	<a href="#">C470/4</a>
<a href="#">C701/6</a>	bJogSpeed1	X4/DI1	X4/DI1	-	X4/DI1	<a href="#">C727/4</a>	<a href="#">C470/1</a>
<a href="#">C701/7</a>	bJogSpeed2	X4/DI2	X4/DI2	-	X4/DI2	<a href="#">C727/5</a>	<a href="#">C470/2</a>
<a href="#">C701/8</a>	bMPotUp	-	-	X4/DI3	-	-	-
<a href="#">C701/9</a>	bMPotDown	-	-	X4/DI4	-	-	-
<a href="#">C701/10</a>	bMPotInAct	-	-	-	-	-	-
<a href="#">C701/11</a>	bMPotEnable	-	-	TRUE	-	-	-
<a href="#">C701/12</a>	bRFG_0	-	-	-	-	-	-
<a href="#">C701/13</a>	bSetError1	-	-	-	-	-	-
<a href="#">C701/14</a>	bSetError2	-	-	-	-	-	-
<a href="#">C701/15</a>	bPIDInfluenceRamp	TRUE	TRUE	TRUE	TRUE	TRUE	TRUE
<a href="#">C701/16</a>	bPIDIOff	-	-	-	-	-	-
<a href="#">C701/17</a>	bRLQCw	TRUE	TRUE	TRUE	X4/DI3	TRUE	TRUE
<a href="#">C701/18</a>	bRLQCcw	-	-	-	X4/DI4	-	-

7.4.2 Output connections

Configuration parameters	Identifier	Control mode					
		10 (terminals 0)	12 (Terminal 2)	14 (terminals 11)	16 (terminals 16)	20 (keypad)	21 (PC)
<a href="#">C620/5</a>	<a href="#">LS_DisFree</a> : wDis1 (→C481/1)	-	-	-	-	wDeviceStateWord	
<a href="#">C620/6</a>	<a href="#">LS_DisFree</a> : wDis2 (→C481/2)	-	-	-	-	-	-
<a href="#">C620/7</a>	<a href="#">LS_DisFree</a> : wDis3 (→C481/3)	-	-	-	-	-	-
<a href="#">C620/8</a>	<a href="#">LS_DisFree</a> : wDis4 (→C481/4)	-	-	-	-	-	-
<a href="#">C620/9</a>	<a href="#">LS_DisFree_a</a> : nDis1_a (→C482/1)	-	-	-	-	nMotorSpeedAct_a	
<a href="#">C620/10</a>	<a href="#">LS_DisFree_a</a> : nDis2_a (→C482/2)	-	-	-	-	nOutputSpeedCtrl_a	
<a href="#">C620/11</a>	<a href="#">LS_DisFree_a</a> : nDis3_a (→C482/3)	-	-	-	-	-	-
<a href="#">C620/12</a>	<a href="#">LS_DisFree_a</a> : nDis4_a (→C482/4)	-	-	-	-	-	-
<a href="#">C621/1</a>	<a href="#">LS_DigitalOutput</a> :bRelay (X101)	bDriveFail			bDriveFail		
<a href="#">C621/2</a>	<a href="#">LS_DigitalOutput</a> :bOut1 (X4/DO1)	bDriveReady			bDriveReady		
<a href="#">C621/6</a>	USER-LED	bNactCompare			bNactCompare		
<a href="#">C621/7</a>	LA_NCtrl: bStatusBit0	-	-	-	-	-	-
<a href="#">C621/8</a>	LA_NCtrl: bStatusBit2	bImaxActive			bImaxActive		
<a href="#">C621/9</a>	LA_NCtrl: bStatusBit3	bSpeedSetReached			bSpeedSetReached		
<a href="#">C621/10</a>	LA_NCtrl: bStatusBit4	bSpeedActEqSet			bSpeedActEqSet		
<a href="#">C621/11</a>	LA_NCtrl: bStatusBit5	bNactCompare			bNactCompare		
<a href="#">C621/12</a>	LA_NCtrl: bStatusBit14	bSpeedCcw			bSpeedCcw		
<a href="#">C621/13</a>	LA_NCtrl: bStatusBit15	bDriveReady			bDriveReady		
<a href="#">C621/16</a>	<a href="#">LS_DisFree_b</a> : bDis1 (→C480/Bit0)	-	-	-	-	bDriveReady	
<a href="#">C621/17</a>	<a href="#">LS_DisFree_b</a> : bDis2 (→C480/Bit1)	-	-	-	-	bDriveFail	
<a href="#">C621/18</a>	<a href="#">LS_DisFree_b</a> : bDis3 (→C480/Bit2)	-	-	-	-	-	-
...	...						
<a href="#">C621/23</a>	<a href="#">LS_DisFree_b</a> : bDis8 (→C480/Bit7)						

### 7.4.3 Internal signal flow for control via terminals

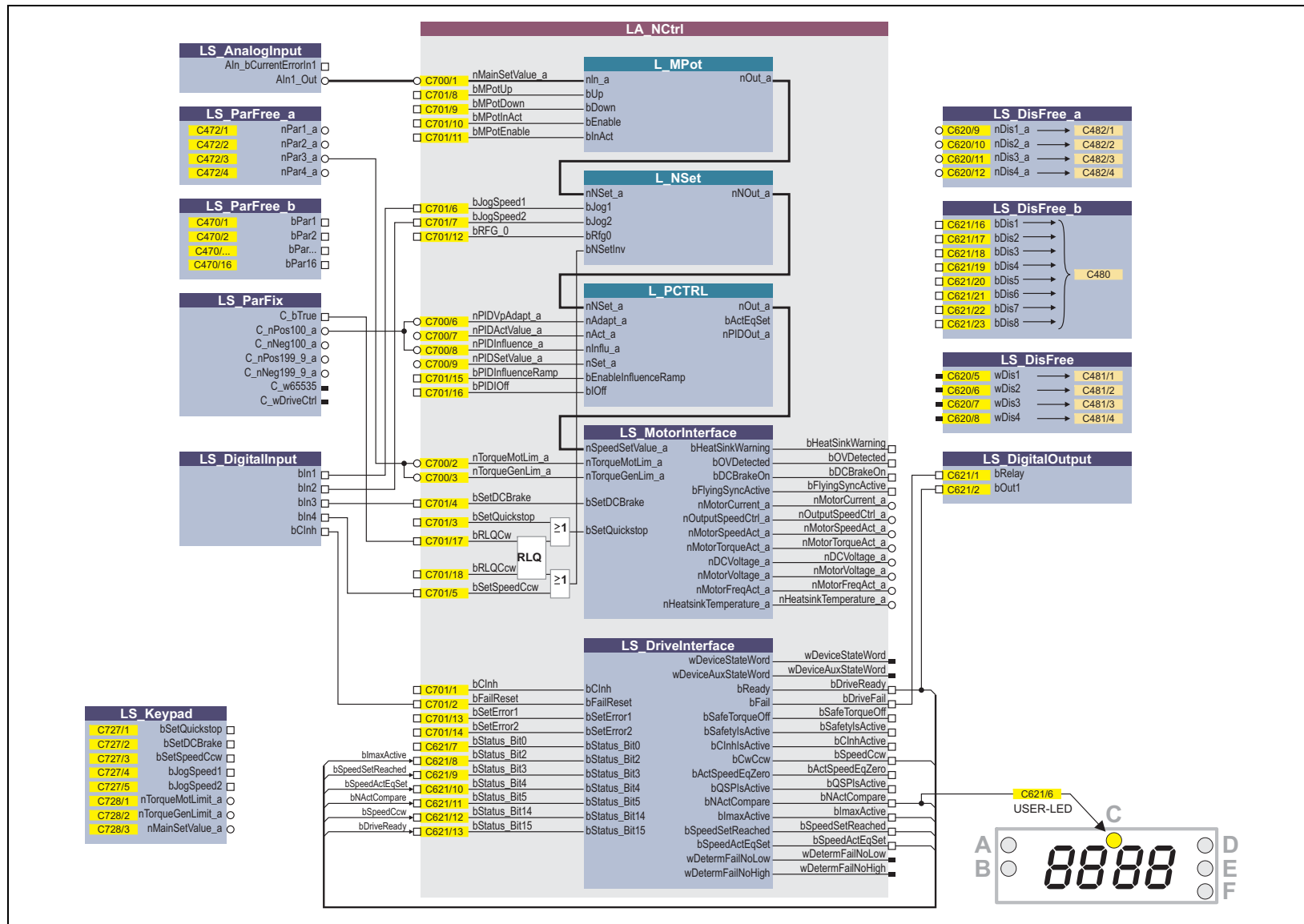

[7-1] Interconnection of the internal interfaces in the Lenze setting (control mode "terminals 0")

## 7.5 Terminal assignment of the control modes

The following table shows which functions are assigned to the digital terminals in the different control modes.

Control mode	Analog input A1U	Assignment of the digital terminals				DO1	Relay output NO / COM
		DI1	DI2	DI3	DI4		
<a href="#">Terminals 0</a>	Setpoint selection 10 V ≙ 100 % reference speed ( <a href="#">C011</a> )	JOG 1/3	JOG 2/3	DCB	Cw/Ccw	Status "Drive is ready to start"	Status "An error occurred"
<a href="#">Terminals 2</a>		JOG 1/3	JOG 2/3	QSP	Cw/Ccw		
<a href="#">Terminals 11</a>		Cw/Ccw	DCB	MPotUp	MPotDown		
<a href="#">Terminals 16</a>		JOG 1/3	JOG 2/3	Cw/QSP	Ccw/QSP		
<a href="#">Keypad</a>	-	-	-	-	-		
<a href="#">PC</a>	-	-	-	-	-		
<b>Abbreviations used:</b>							
JOG	Selection of the fixed setpoints 1 ... 3 in <a href="#">C039/1...3</a>						
DCB	Manual DC-injection braking						
Cw/Ccw	CW/CCW rotation						
QSP	Quick stop						
MPotUp	Motor potentiometer: Increase speed						
MPotDown	Motor potentiometer: Decrease speed						
Cw/QSP	Fail-safe selection of the direction of rotation in connection with quick stop						
Ccw/QSP							

### Related topics:

- ▶ [User-defined terminal assignment](#) (📖 115)
- ▶ [Pre-assignment of the drive application](#) (📖 134)

7.5.1 Terminals 0

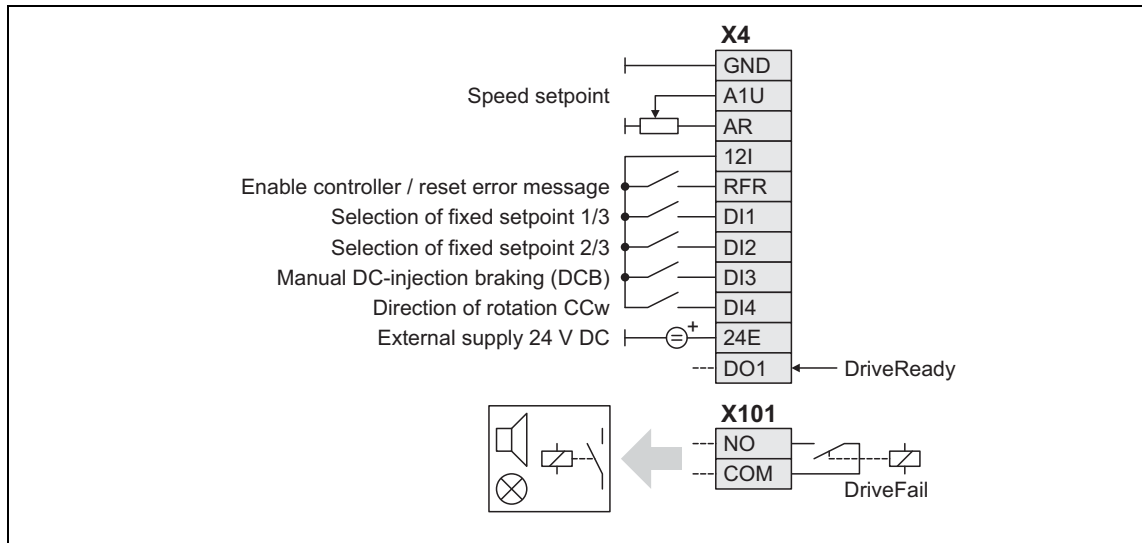

Connection	Assignment	Connection	Assignment
RFR	LA_NCtrl.bFailReset	A1U	LA_NCtrl.nMainSetValue_a 10 V ≙ 100 % reference speed (C011)
DI1	LA_NCtrl.bJogSpeed1	NO, COM	LA_NCtrl.bDriveFail
DI2	LA_NCtrl.bJogSpeed2	DO1	LA_NCtrl.bDriveReady
DI3	LA_NCtrl.bSetDCBrake		
DI4	LA_NCtrl.bSetSpeedCcw		

7.5.2 Terminals 2

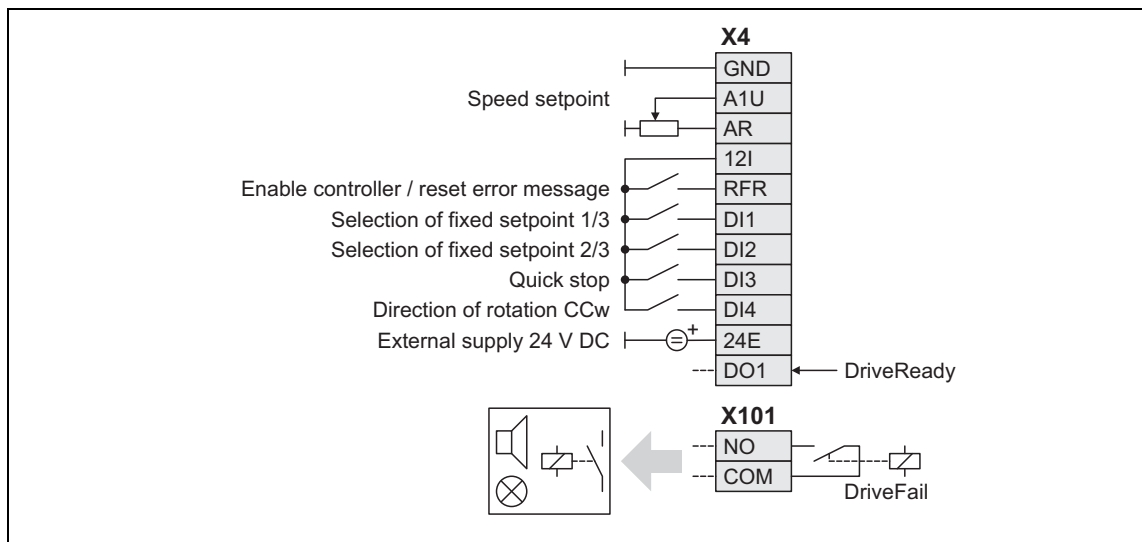

Connection	Assignment	Connection	Assignment
RFR	LA_NCtrl.bFailReset	A1U	LA_NCtrl.nMainSetValue_a 10 V ≙ 100 % reference speed (C011)
DI1	LA_NCtrl.bJogSpeed1	NO, COM	LA_NCtrl.bDriveFail
DI2	LA_NCtrl.bJogSpeed2	DO1	LA_NCtrl.bDriveReady
DI3	LA_NCtrl.bSetQuickstop		
DI5	LA_NCtrl.bBrkRelease		



7.5.3 Terminals 11

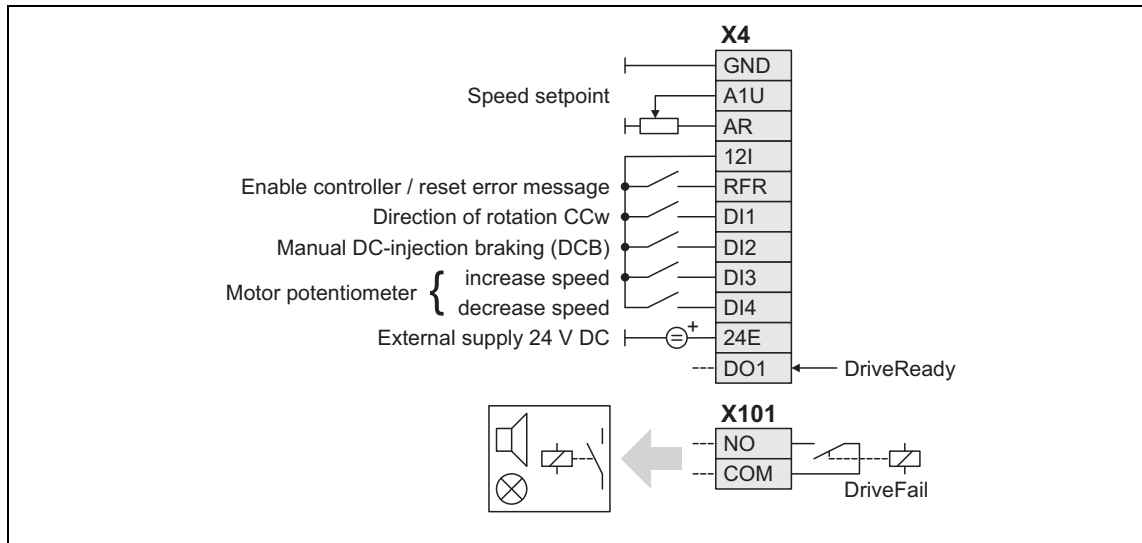

Connection	Assignment	Connection	Assignment
RFR	LA_NCtrl.bFailReset	A1U	LA_NCtrl.nMainSetValue_a 10 V ≙ 100 % reference speed (C011)
DI1	LA_NCtrl.bSetSpeedCcw	NO, COM	LA_NCtrl.bDriveFail
DI2	LA_NCtrl.bSetDCBrake	DO1	LA_NCtrl.bDriveReady
DI3	LA_NCtrl.bMPotUp		
DI4	LA_NCtrl.bMPotDown		

7.5.4 Terminals 16

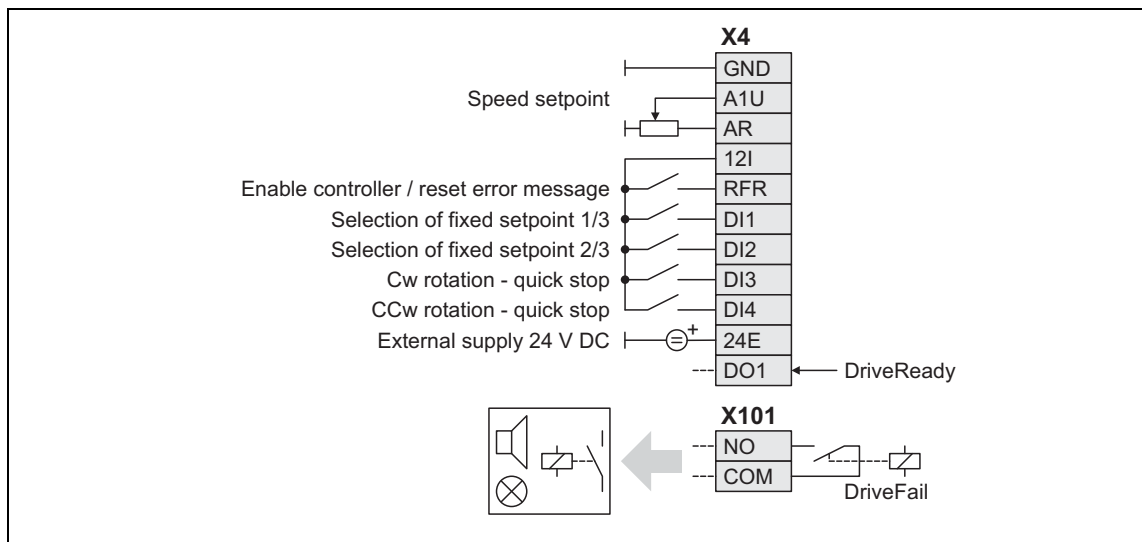

Connection	Assignment	Connection	Assignment
RFR	LA_NCtrl.bFailReset	A1U	LA_NCtrl.nMainSetValue_a 10 V ≙ 100 % reference speed (C011)
DI1	LA_NCtrl.bJogSpeed1	NO, COM	LA_NCtrl.bDriveFail
DI2	LA_NCtrl.bJogSpeed2	DO1	LA_NCtrl.bDriveReady
DI3	LA_NCtrl.bRLQCw		
DI4	LA_NCtrl.bRLQCcw		

7.5.5

Keypad

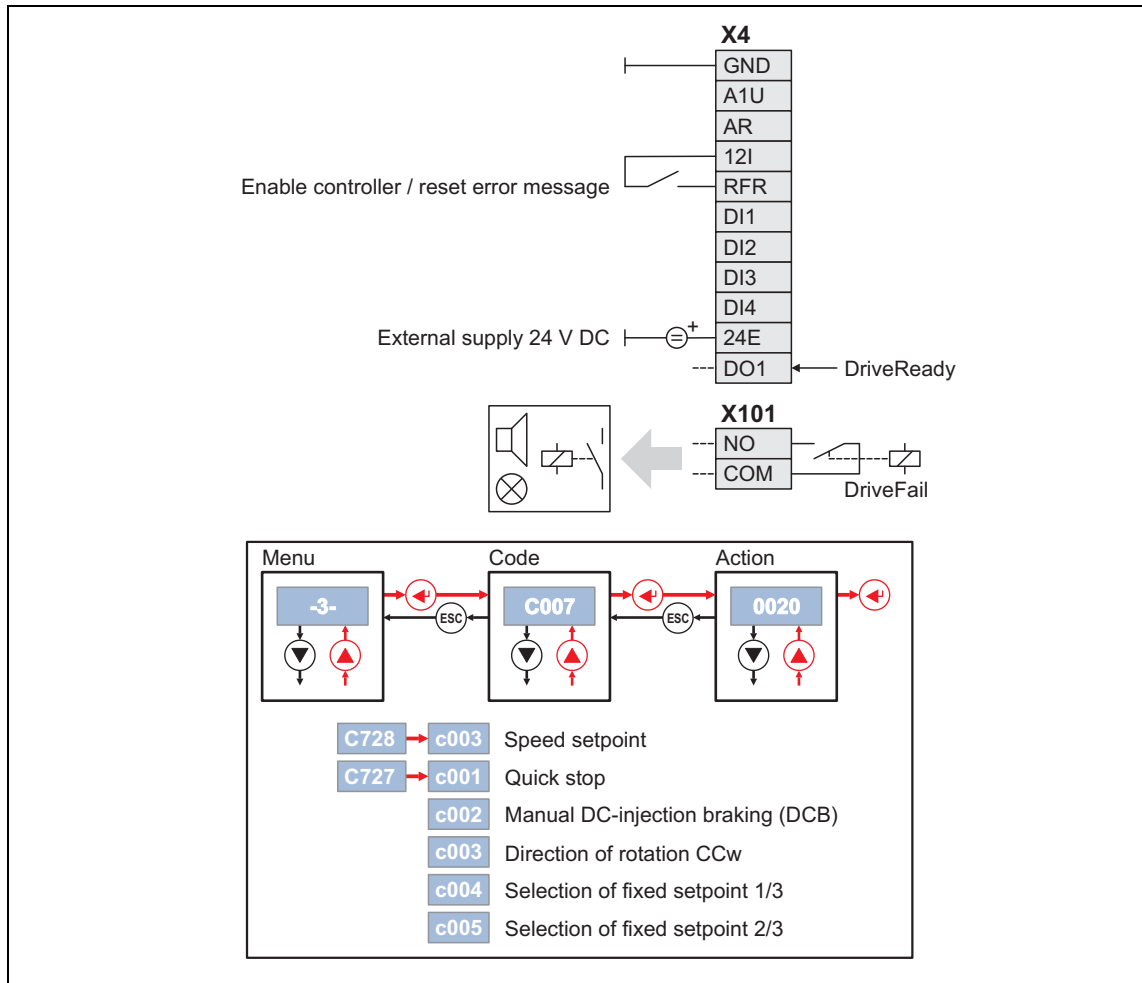

Connection	Assignment	Connection	Assignment
RFR	LA_NCtrl.bFailReset	A1U	-
DI1	-		
DI2	-		
DI3	-	NO, COM	LA_NCtrl.bDriveFail
DI4	-	DO1	LA_NCtrl.bDriveReady

7.5.6

PC

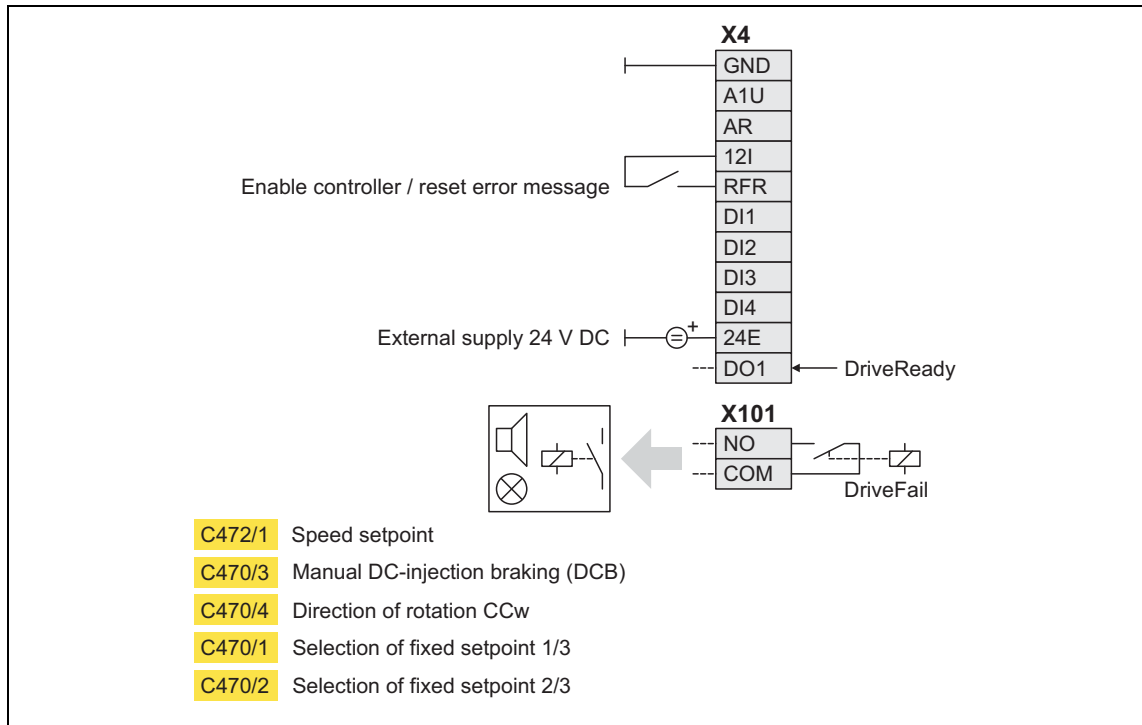

Connection	Assignment	Connection	Assignment
RFR	LA_NCtrl.bFailReset	A1U	-
DI1	-	NO, COM	LA_NCtrl.bDriveFail
DI2	-	DO1	LA_NCtrl.bDriveReady
DI3	-		
DI4	-		

In this control mode, the control is executed via "free" parameters. The connection to inputs/outputs of the application takes place via the following system blocks:

System block	Function
<a href="#">LS_DisFree</a>	Any four 16-bit signals of the application can be displayed on display codes
<a href="#">LS_DisFree a</a>	Any four analog signals of the application can be displayed on display codes
<a href="#">LS_DisFree b</a>	Any eight digital signals of the application can be displayed on a bit-coded display code
<a href="#">LS_ParFree a</a>	Output of 4 parameterisable analog signals
<a href="#">LS_ParFree b</a>	Output of 16 parameterisable digital signals

# 8 Diagnostics & error management

## 8.1 Basics on error handling in the controller

---

## 8 Diagnostics & error management

This chapter provides information on error handling, drive diagnostics, and fault analysis.

### 8.1 Basics on error handling in the controller

Many of the functions integrated into the controller can

- detect errors and thus protect the device from damage or overload, e.g. short-circuit detection, Ixt overload detection, overtemperature detection, etc.
- detect operating errors by the user, e.g. a missing memory module,
- output warning signals, e.g. if the speed is too high or too low, etc.

Depending on the importance, the error detection in the device responds very fast (e.g. short-circuit detection < 1 ms) or in a slower cycle (e.g. temperature monitoring approx. 100 ms).

All functions provided with an error detection (e.g. the motor control) supply information to a so-called error handler. The error handler is processed every 1 ms and evaluates all information.

In this evaluation, the current error (display in [C165](#)) is generated and the controller is caused to take the respective error status (e.g. trouble).

The error information in [C166/1..3](#) is used for error diagnosis and contains the following information:

1. Error type (e.g. "Warning")
2. Error subject area (e.g. "motor management/encoder")
3. The error ID within the error subject area

Together all types of information form the real error number which is unique in the whole device system. ▶ [Structure of the error number \(bit coding\)](#) ([📖 153](#))

In addition to the control of the device state by the error handler, a logbook function records the errors and their histories. ▶ [Logbook](#) ([📖 146](#))



#### Tip!

For many device errors, the error type and hence the response of the controller to the error can be parameterised. ▶ [Setting the error response](#) ([📖 150](#))

### 8.2 Drive diagnostics with the »Engineer«



Information on the drive diagnostics with the integrated keypad can be found in the chapter "Introduction" in the subchapter "[Internal Keypad](#)":

- ▶ [LED status display](#) (19)
- ▶ [Display messages](#) (20)

When an online connection to the controller has been established, the connected controller can be diagnosed and relevant actual controller states can be displayed in a clearly arranged visualisation using the »Engineer« :

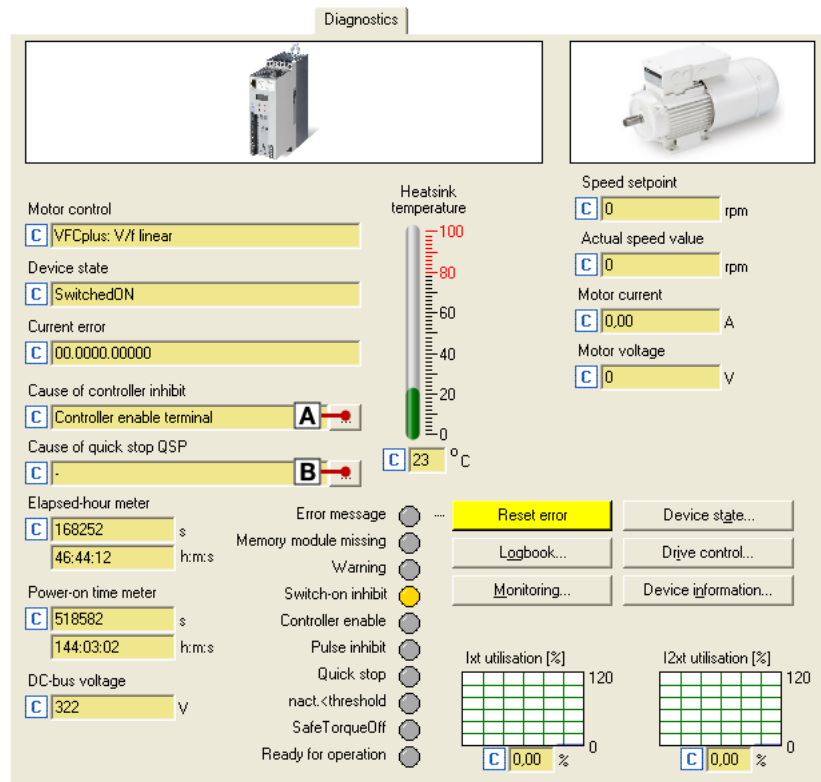

Button	Function
	<ul style="list-style-type: none"> <li>[A] Display all active sources of a controller inhibit.</li> <li>[B] Display all active sources of a quick stop.</li> </ul>
Resetting an error	Acknowledge fault message (if the error cause has been eliminated).
Logbook...	<a href="#">Display the Logbook</a> of the controller. (146)
Monitoring...	<a href="#">Configure the Monitoring</a> . (148)
Device state...	Display the internal state machine including the current device state.
Drive control...	Display the bit assignment of the following control-related words: <ul style="list-style-type: none"> <li>• Cause of controller inhibit (C158)</li> <li>• Cause of quick stop QSP (C159)</li> <li>• Status word (C150)</li> <li>• Extended status word (C155)</li> </ul>
Device information...	Display identification data, e.g. information on firmware version.

# 8 Diagnostics & error management

## 8.2 Drive diagnostics with the »Engineer«

---



### How to diagnose a drive with the »Engineer«:

1. Go to the *Project view* and select the 8400 BaseLine D controller.
2. Click the  icon or execute the **Online→Go online** command to establish an online connection to the controller.
3. Select the **Diagnostics** tab.
  - With an online connection, the **Diagnostics** tab displays current status information about the controller.

### Related topics:

- ▶ [Device control \(DCTRL\)](#) (📖 45)
- ▶ [Device states](#) (📖 54)

# 8 Diagnostics & error management

## 8.3 Drive diagnostics via bus system

### 8.3 Drive diagnostics via bus system

The following display parameters contain actual values, states, and error messages.

- These parameters are listed in the »Engineer« parameter list in the **Diagnostics** category.
- A detailed description of these parameters can be found in the chapter "[Parameter reference](#)" ([□ 164](#)).

Parameter	Display
<a href="#">C051</a>	MCTRL: Actual speed value
<a href="#">C052</a>	Motor voltage
<a href="#">C053</a>	DC-bus voltage
<a href="#">C054</a>	Motor current
<a href="#">C056/1</a>	Torque setpoint
<a href="#">C056/2</a>	Actual torque
<a href="#">C058</a>	Output frequency
<a href="#">C059</a>	Appl.: Reference frequency C11
<a href="#">C061</a>	Heatsink temperature
<a href="#">C064/1</a>	Device utilisation (lxt)
<a href="#">C064/2</a>	Device utilisation (lxt) 15s
<a href="#">C064/3</a>	Device utilisation (lxt) 3 min
<a href="#">C137</a>	Device state
<a href="#">C150</a>	Status word
<a href="#">C155</a>	Status word 2
<a href="#">C158</a>	Cause of controller inhibit
<a href="#">C159</a>	Cause of quick stop QSP
<a href="#">C165/1</a>	Current error
<a href="#">C166/1</a>	Error type, current
<a href="#">C166/2</a>	Error subject area, current
<a href="#">C166/3</a>	Error ID, current
<a href="#">C168/1...8</a>	Error ID, history 1 ... 8
<a href="#">C169/1...8</a>	Time of error, history 1 ... 8
<a href="#">C170/1...8</a>	Error counter, history 1 ... 8
<a href="#">C177/1</a>	Switching cycles mains switching
<a href="#">C177/2</a>	Switching cycles output relay
<a href="#">C178</a>	Time the controller was enabled (elapsed-hour meter)
<a href="#">C179</a>	Power-up time (power-on time meter)

### 8.4 Logbook

The integrated logbook function of the controller chronologically logs important events within the system. The logbook is intended to support you in troubleshooting and controller diagnostics.

#### Events that can be logged

The following events can be logged in the logbook:

- [Error messages of the operating system](#) (📖 153)
- Error messages generated by the application (via [LS\\_SetError 1](#))

#### Information saved

For each event, the following information is saved in the logbook:

- Type of response to the event (e.g. "Warning")
- Subject area that activated the event (e.g. "motor management/encoder").
- Event
- Value of power-on time meter

#### Memory depth

Maximum number of logbook entries: 8

#### 8.4.1 Functional description

The structure of the logbook corresponds to a ring buffer:

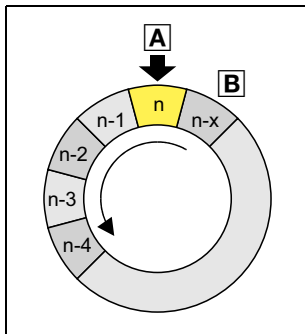

- As long as free logbook memory locations are available, the entries will be saved to the next free memory location (A).
- If all memory locations are occupied, the oldest entry (B) will be deleted in favour of a new entry.
- The newest entries will always remain available.



#### Note!

In the event of a supply voltage failure, the logbook is saved and reloaded automatically when the controller is switched on. This ensures that the error history of the device does not get lost. For this reason it is very important to act with caution when deleting the logbook entries.



### 8.4.2 Reading out logbook entries

We recommend to read out logbook entries with the »Engineer«, since the »Engineer« shows the entries clearly arranged and enables them to be exported into a log file. Alternatively, the corresponding parameters can be read out using the keypad or via the fieldbus.



#### How to display logbook entries in the »Engineer«:

1. Go to the *Project view* and select the 8400 BaseLine D controller.
2. Click the  icon or execute the **Online→Go online** command to establish an online connection to the controller.
3. Select the **Diagnostics** tab from the *Workspace*.
4. Click **Logbook**.
  - The *Logbook* dialog box with logbook entries is displayed.
  - Click **Delete** to delete an entry from the logbook.
  - Click **Export** to export the entries from the logbook into a \*.log file. ▶ [Exporting logbook entries to a file](#) (147)
5. Click the **Close** button to close the *Logbook* dialog box again.

### 8.4.3 Exporting logbook entries to a file



#### How to export the logbook entries to a file:

1. Go to the *Logbook* dialog box and click the **Export...** button.
  - The *Export logbook* dialog box is displayed.
2. Specify the folder, file name, and file type for the file.
3. Click the **Save** button to export the logbook entries to the specified file.
  - Hidden logbook entries are not exported, i.e. the filter criteria specified are accounted for during the export.
  - The logbook entries are written to the file in the form of a semicolon separated list.

### 8.5 Monitoring

The controller is provided with various monitoring functions which protect the drive against impermissible operating conditions.

- If a monitoring function responds,
  - an entry will be made into the [Logbook](#) of the controller,
  - the response (Trouble, Fault, etc.) set for this monitoring function will be triggered,
  - the status of the internal device control changes according to the selected response, controller inhibit is set, and the front "DRIVE ERROR" LED D ("DRIVE ERROR") goes on:

Response	Entry in the logbook	Display in <a href="#">C168</a>	Pulse inhibit	Controller inhibit	Acknowledgement required	LED D "DRIVE ERROR"
None						OFF
Fault	☑	☑	☑	☑	☑	■ ■ ■
Trouble	☑	☑	☑	☑ (after 0.5 s)		▬ ▬ ▬
WarningLocked	☑	☑			☑	▬

#### Related topics:

- ▶ [LED status display](#) (📖 19)
- ▶ [Device states](#) (📖 54)
- ▶ [Device overload monitoring \(lxt\)](#) (📖 104)
- ▶ [Motor load monitoring \(l2xt\)](#) (📖 105)
- ▶ [Brake resistor monitoring \(l2xt\)](#) (📖 107)
- ▶ [Mains phase failure monitoring](#) (📖 108)

### 8.5.1 Monitoring configuration



How to configure the monitoring functions using the »Engineer«:

1. Go to the *Project view* and select the 8400 BaseLine D controller.
2. Select the **Diagnostics** tab from the *Workspace*.
3. Click the **Monitoring...** button.
  - The *8400 monitoring configuration* dialog box is displayed via which the desired settings can be made:

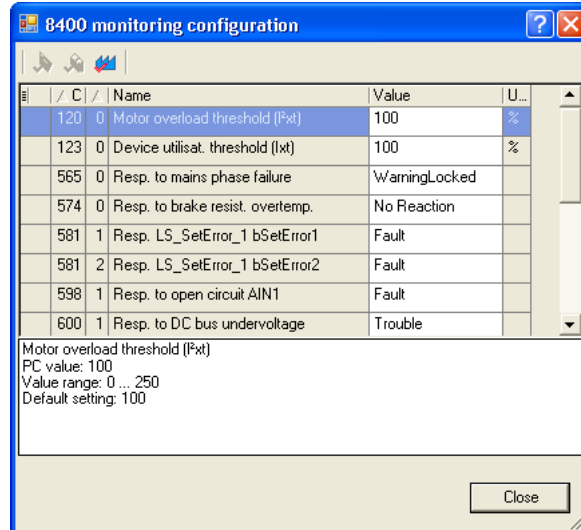

#### Related topics:

- ▶ [Setting the error response](#) (150)

### 8.5.2 Setting the error response

When a monitoring function responds, the response set for this monitoring function (Trouble, Fault, etc.) will be triggered.

- For many monitoring functions the response can be individually parameterised via parameters.

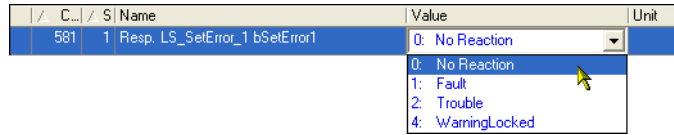

**Tip!**

The table in chapter "[Short overview \(A-Z\)](#)" contains the error messages for which the response can be set. ([📖 156](#))

### Warning thresholds

Some of the monitoring functions are activated if a defined warning threshold has been exceeded.

- The corresponding preset threshold values can be changed via the following parameters:

Parameter	Info	Lenze setting	
		Value	Unit
<a href="#">C120</a>	Motor overload threshold (I <sup>2</sup> xt)	100	%
<a href="#">C123</a>	Device utilisat. threshold (Ixt)	100	%
<a href="#">C909/1</a>	Max. positive speed	120	%
<a href="#">C909/2</a>	Max. negative speed	120	%
<a href="#">C910/1</a>	Max. positive output frequency	300	Hz
<a href="#">C910/2</a>	Max. negative output frequency	300	Hz

### 8.6 Maloperation of the drive

Maloperation	Cause	Remedy
Motor does not rotate	DC-bus voltage is too low • Red LED is blinking every 1 s	Check mains voltage
	Controller is inhibited • Green LED is blinking	Deactivate controller inhibit • Note: Controller inhibit can be set via several sources ! • <a href="#">C158</a> displays all active sources for controller inhibit.
	Automatic start is inhibited	LOW/HIGH edge at RFR If required, correct auto-start option in <a href="#">C142</a> . ▶ <a href="#">"Inhibit at power-on" auto-start option</a>
	DC-injection braking (DCB) is active	Deactivate <a href="#">DC-injection braking</a>
	Mechanical motor brake is not released	Release mechanical motor brake manually or electrically
	Quick stop (QSP) active	Deactivate quick stop • Note: Quick stop can be set via several sources! • <a href="#">C159</a> displays all active sources for quick stop.
	Setpoint = 0	Select setpoint
	Setpoint = 0 with activated fixed setpoint	Set fixed setpoint in <a href="#">C039/1...3</a>
	Trouble is active	Clear fault
	<a href="#">C006</a> = 4 "SLVC: Vector control" has been set, but no motor parameter identification has been carried out.	Carry out automatic motor parameter identification with the <a href="#">C002/23</a> device command ▶ <a href="#">Automatic motor data identification</a>
Assignment of several mutually exclusive functions with a signal source in <a href="#">C701</a>	Correct configuration in <a href="#">C701</a>	
Motor rotates irregularly	Motor cable is defective	Check motor cable
	Maximum motor current in motor or generator mode is set too low	Adjust settings to the application: <a href="#">C022</a> : I <sub>max</sub> in motor mode <a href="#">C023</a> : I <sub>max</sub> in generator mode
	Motor is underexcited or overexcited	Check parameterisation: <a href="#">C006</a> : Motor control <a href="#">C015</a> : VFC: V/f base frequency <a href="#">C016</a> : VFC: V <sub>min</sub> boost
	Rated motor data (stator resistance, speed, current, frequency, voltage) and cos φ and/or magnetising inductance is not adapted to the motor data	Carry out automatic motor parameter identification with the <a href="#">C002/23</a> device command - or - Adjust motor parameters manually: <a href="#">C084</a> : Motor stator resistance <a href="#">C087</a> : Rated motor speed <a href="#">C088</a> : Rated motor current <a href="#">C089</a> : Rated motor frequency <a href="#">C090</a> : Rated motor voltage <a href="#">C091</a> : Motor cosine phi <a href="#">C092</a> : Motor magnetising inductance
	Motor windings are wired incorrectly	Reverse from star connection to delta connection

Maloperation	Cause	Remedy
Motor consumes too much current	$U_{\min}$ boost has been selected too high	Correct setting with <a href="#">C016</a>
	V/f base frequency has been selected too low	Correct setting with <a href="#">C015</a>
	Rated motor data (stator resistance, speed, current, frequency, voltage) and $\cos \varphi$ and/or magnetising inductance is not adapted to the motor data	Carry out automatic motor parameter identification with the <a href="#">C002/23</a> device command - or - Adjust motor parameters manually: <a href="#">C084</a> : Motor stator resistance <a href="#">C087</a> : Rated motor speed <a href="#">C088</a> : Rated motor current <a href="#">C089</a> : Rated motor frequency <a href="#">C090</a> : Rated motor voltage <a href="#">C091</a> : Motor cosine phi <a href="#">C092</a> : Motor magnetising inductance
Motor parameter identification is aborted with error LP1	Motor is too small compared to the rated device power (>1 : 3)	Use device with lower rated power
	DC injection braking (DCB) is active via terminal	Deactivate <a href="#">DC-injection braking</a>
Drive behaviour with vector control is not satisfactory	different	Optimise or manually adapt vector control ▶ <a href="#">Sensorless vector control (SLVC)</a>
		Carry out automatic motor parameter identification with the <a href="#">C002/23</a> device command ▶ <a href="#">Automatic motor data identification</a>
Torque dip in field weakening range or motor stalling when being operated in the field weakening range	Motor is overloaded	Check motor load
	Motor windings are wired incorrectly	Reverse from star connection to delta connection
	V/f base frequency is set too high	Correct setting with <a href="#">C015</a>
	Mains voltage is too low	Increase mains voltage

# 8 Diagnostics & error management

## 8.7 Error messages of the operating system

### 8.7 Error messages of the operating system

This chapter describes all error messages of the controller operating system and possible causes & remedies.



**Tip!**

Each error message is also saved in the logbook in chronological order. ▶ [Logbook](#) (□ 146)

#### 8.7.1 Structure of the error number (bit coding)

If an error occurs in the controller, the internal fault memory saves a 32-bit value which contains the following information:

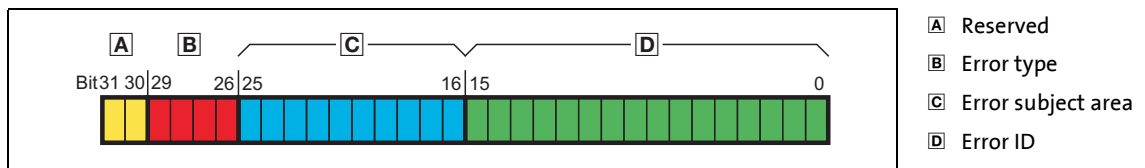

[8-1] Structure of the error number

For the sake of legibility, the error number in the logbook is displayed with the following syntax: **[Error type].[Error subject area no.].[Error ID]**

##### 8.7.1.1 Error type



The error type gives information about the behaviour/response of the controller to the error. The error type for some device errors can also be parameterised.

Bit 29	Bit 28	Bit 27	Bit 26	Meaning
0	0	0	0	0: No response
0	0	0	1	1: Fault
0	0	1	0	2: Trouble
0	1	0	0	4: WarningLocked

# 8 Diagnostics & error management

## 8.7 Error messages of the operating system

### 8.7.1.2 Error subject area

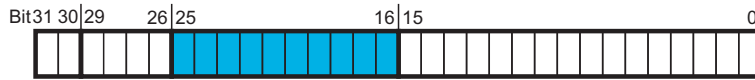

The error subject area indicates the internal "function unit" of the controller in which the error has occurred:

Error subject area		Assigned errors	Remedy possible by user?
No.	Name		
111	Supply voltage	Errors that occur in connection with the supply voltage of the device.	Yes
119	Temperature	Errors that occur for temperature reasons.	Yes
123	Motor management / encoder	Errors that occur within the motor control or encoder evaluation.	Yes
125	Analog I/O	Errors that occur in connection with the analog inputs and outputs.	Yes
144	Parameter set	Errors that occur in connection with the parameter set or the parameter set memory (memory module).	Yes if the error relates to a missing or incompatible memory module.
145	Device firmware (internal error)	Internal error of the device firmware.	No
400	Device hardware defective	Errors that occur due to defective device hardware.	No
980	US01: User error 1	Errors generated by the user (by the application) via the <a href="#">LS_SetError_1</a> system block.	Yes
981	US02: User error 2		

### 8.7.1.3 Error ID

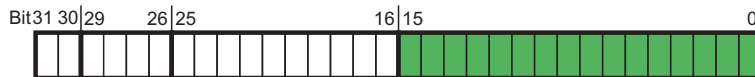

16-bit value (0 ... 65535) for error identification within the error subject area.



### 8.7.1.4 Example for bit coding of the error number

In [C168](#) displays the internal error number "75169803".

- This decimal value corresponds to the following bit sequence:

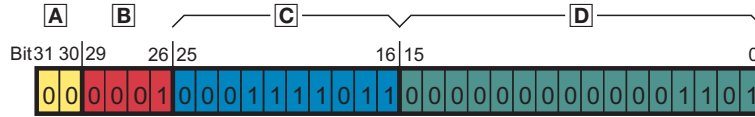

Assignment	Information	Meaning in the example
	Reserved	-
	Error type	1: Fault (pulse inhibit)
	Error subject area	123: Motor management / encoder
	Error ID	13: " <a href="#">LU: DC bus undervoltage</a> "

- Thus, error number "75169803" means:  
An overcurrent has been detected in the "Motor management/encoder" subject area. A pulse inhibit is set as error response. The error message must be acknowledged after the error has been eliminated.

### 8.7.2 Reset of error message

An error message with the response "Fault", "Trouble", or "Warning locked" must be explicitly reset (acknowledged) after the cause of the error has been eliminated.



To reset (acknowledge) a pending error message, execute the device command [C002/19](#) = "1".



#### Tip!

With an online connection to the controller, use the **Diagnostics** tab of the »Engineer« and click **Error message reset** to reset a pending error message.

### 8.7.3 Short overview (A-Z)

The table below contains all error messages of the controller operating system in alphabetical order.



#### Note!

For the sake of legibility, the [Logbook](#) and [C165](#) display the error number with the following syntax:

**[Error type].[Error subject area no.].[.].[Error ID]**

In this documentation, "xx", a wildcard, stands for the error type since it is configurable for many error messages.



#### Tip!

If you click the cross-reference in the first column, "Error number", you get to the detailed description of the respective error message in the subsequent "[Cause & possible remedies](#)" chapter. ([157](#))

Error number	Error message	Response (Lenze setting)	can be set in	CAN Emergency Error Code
▶ <a href="#">xx.0125.00001</a>	An01: AIN1_I < 4 mA	Fault	<a href="#">C598/1</a>	0xF000
▶ <a href="#">xx.0145.00001</a>	dF01: Internal error 01	Fault	-	
▶ <a href="#">xx.0145.00002</a>	dF02: Internal error 02	Fault	-	
▶ <a href="#">xx.0145.00003</a>	dF03: Internal error 03	Fault	-	
▶ <a href="#">xx.0145.00004</a>	dF04: Internal error 04	Fault	-	
▶ <a href="#">xx.0145.00005</a>	dF05: Internal error 05	Fault	-	
▶ <a href="#">xx.0145.00006</a>	dF06: Internal error 06	Fault	-	
▶ <a href="#">xx.0145.00007</a>	dF07: Internal error 07	Fault	-	
▶ <a href="#">xx.0145.00008</a>	dF08: Internal error 08	Fault	-	
▶ <a href="#">xx.0145.00009</a>	dF09: Internal error 09	Fault	-	
▶ <a href="#">xx.0145.00010</a>	dF10: Internal error 10	Fault	-	
▶ <a href="#">xx.0400.00105</a>	dH69: Adjustment data error	Fault	-	0x5530
▶ <a href="#">xx.0123.00057</a>	ID1: Motor data identification error	WarningLocked	-	0xF000
▶ <a href="#">xx.0123.00015</a>	LU: DC bus undervoltage	Trouble	<a href="#">C600/1</a>	0x3100
▶ <a href="#">xx.0123.00016</a>	OC1: Power section - short circuit	Fault	-	0x2000
▶ <a href="#">xx.0123.00017</a>	OC2: Power section - earth fault	Fault	-	0x2000
▶ <a href="#">xx.0119.00050</a>	OC5: Ixt overload	WarningLocked	<a href="#">C604</a>	0x2000
▶ <a href="#">xx.0123.00105</a>	OC6: I2xt motor overload	WarningLocked	<a href="#">C606</a>	0x2000
▶ <a href="#">xx.0119.00052</a>	OC9: Ixt overload - shutdown limit	Fault	-	0x2000
▶ <a href="#">xx.0123.00065</a>	OC12: I2xt brake resistance overload	Fault	-	0xF000
▶ <a href="#">xx.0119.00001</a>	OH: Heatsink overtemperature	Fault	-	0x4000
▶ <a href="#">xx.0123.00014</a>	OU: DC bus overvoltage	Trouble	-	0x3100
▶ <a href="#">xx.0144.00001</a>	PS01: No memory module	Warning	-	0x6300
▶ <a href="#">xx.0144.00002</a>	PS02: Par. set invalid	Fault	-	0x6300
▶ <a href="#">xx.0144.00003</a>	PS03: Par. set device invalid	Fault	-	0x6300
▶ <a href="#">xx.0144.00004</a>	PS04: Par. set device incompatible	Fault	-	0x6300
▶ <a href="#">xx.0144.00031</a>	PS31: Ident. error	Fault	-	0x6300
▶ <a href="#">xx.0111.00002</a>	Su02: One mains phase is missing	WarningLocked	<a href="#">C565</a>	0x3000
▶ <a href="#">xx.0980.00000</a>	US01: User error 1	Fault	<a href="#">C581/1</a>	0x6200
▶ <a href="#">xx.0981.00000</a>	US02: User error 2	Fault	<a href="#">C581/2</a>	0x6200

### 8.7.4 Cause & possible remedies

This chapter contains all error messages of the controller operating system in numerical order of the error numbers. The list provides detailed information on the response to the error message as well as information on the cause & possible remedies.



#### Note!

For the sake of legibility, the [Logbook](#) and [C165](#) display the error number with the following syntax:

**[Error type].[Error subject area no.].[Error ID]**

In this documentation, "xx", a wildcard, stands for the error type since it is configurable for many error messages.



#### Tip!

A list of all error messages of the controller operating system in alphabetical order can be found in the previous chapter "[Short overview \(A-Z\)](#)" ([□ 156](#)).

#### Su02: One mains phase is missing [xx.0111.00002]

<b>Response</b> (Lenze setting printed in bold)		<b>Setting:</b> <a href="#">C565</a> ( <input checked="" type="checkbox"/> Adjustable response)
<input checked="" type="checkbox"/> None <input checked="" type="checkbox"/> Fault <input type="checkbox"/> Trouble <input checked="" type="checkbox"/> WarningLocked		
<b>Cause</b>	<b>Remedy</b>	
One mains phase of a three-phase supply has failed.	Check mains connection (terminal X100).	

#### OH: Heatsink overtemperature [xx.0119.00001]

<b>Response</b> (Lenze setting printed in bold)	
<input type="checkbox"/> None <input checked="" type="checkbox"/> Fault <input type="checkbox"/> Trouble <input type="checkbox"/> WarningLocked	
<b>Cause</b>	<b>Remedy</b>
The heatsink temperature is higher than the fixed limit temperature (90 °C). Maybe the ambient temperature of the controller is too high or the fan or its ventilation slots are dirty.	<ul style="list-style-type: none"> <li>• Check control cabinet temperature.</li> <li>• Clean filter.</li> <li>• Clean controller.</li> <li>• If required, clean or replace the fan.</li> <li>• Provide for sufficient cooling of the device.</li> </ul>

#### OC5: Ixt overload [xx.0119.00050]

<b>Response</b> (Lenze setting printed in bold)		<b>Setting:</b> <a href="#">C604</a> ( <input checked="" type="checkbox"/> Adjustable response)
<input checked="" type="checkbox"/> None <input checked="" type="checkbox"/> Fault <input type="checkbox"/> Trouble <input checked="" type="checkbox"/> WarningLocked		
<b>Cause</b>	<b>Remedy</b>	
The Ixt overload check has tripped. <ul style="list-style-type: none"> <li>• Operating threshold = 100 % Ixt (adjustable in <a href="#">C123</a>)</li> </ul> Possible causes: <ul style="list-style-type: none"> <li>• Wrong dimensioning of the device with regard to its motor load.</li> <li>• Load cycles are not complied with.</li> </ul>	<ul style="list-style-type: none"> <li>• Check and, if required, correct dimensioning of the device and the motor load with regard to technical data.</li> <li>• Reduce motor load cycles (observe load cycles according to documentation).</li> </ul>	

# 8 Diagnostics & error management

## 8.7 Error messages of the operating system

### OC9: Ixt overload - shutdown limit [xx.0119.00052]

Response (Lenze setting printed in bold)	
<input type="checkbox"/> None <input checked="" type="checkbox"/> <b>Fault</b> <input checked="" type="checkbox"/> <b>Trouble</b> <input type="checkbox"/> WarningLocked	
Cause	Remedy
<p>The Ixt overload check has tripped.</p> <ul style="list-style-type: none"> <li>Operating threshold = 110 % Ixt (fixed)</li> </ul> <p>Possible causes:</p> <ul style="list-style-type: none"> <li>Wrong dimensioning of the device with regard to its motor load.</li> <li>Load cycles are not complied with.</li> </ul>	<ul style="list-style-type: none"> <li>Check and, if required, correct dimensioning of the device and the motor load with regard to technical data.</li> <li>Reduce motor load cycles (observe load cycles according to documentation).</li> </ul>

### OU: DC bus overvoltage [xx.0123.00014]

Response (Lenze setting printed in bold)	
<input type="checkbox"/> None <input checked="" type="checkbox"/> <b>Fault</b> <input checked="" type="checkbox"/> <b>Trouble</b> <input type="checkbox"/> WarningLocked	
Cause	Remedy
<p>The device has detected an overvoltage in the DC bus. To protect the device hardware, the inverter control is switched off.</p> <ul style="list-style-type: none"> <li>Depending on the configuration of the auto-start lock function, <a href="#">C142</a> serves to set that, if this error has been tripped, the controller only starts after the controller inhibit is switched.</li> <li>If this error message remains active longer than the time set in <a href="#">C601</a> a "Fault" is tripped.</li> </ul>	<ul style="list-style-type: none"> <li>Reduce load in generator mode.</li> <li>Use a brake resistor.</li> <li>Use a regenerative power supply unit.</li> <li>Establish a DC-bus connection.</li> </ul>

### LU: DC bus undervoltage [xx.0123.00015]

Response (Lenze setting printed in bold)		Setting: <a href="#">C600/1</a> <input checked="" type="checkbox"/> Adjustable response
<input type="checkbox"/> None <input checked="" type="checkbox"/> <b>Fault</b> <input checked="" type="checkbox"/> <b>Trouble</b> <input type="checkbox"/> WarningLocked		
Cause	Remedy	
<p>The device has detected a DC bus undervoltage. The inverter control is switched off because the drive properties of the motor control cannot be provided anymore due to the DC bus undervoltage.</p> <ul style="list-style-type: none"> <li>Depending on the configuration of the auto-start lock function, <a href="#">C142</a> serves to set that, if this error has been tripped, the controller only starts after the controller inhibit is switched.</li> </ul>	<ul style="list-style-type: none"> <li>Switch on mains supply or ensure sufficient supply via DC bus.</li> <li>Adjust setting in <a href="#">C142</a> if required.</li> </ul>	

### OC1: Power section - short circuit [xx.0123.00016]

Response (Lenze setting printed in bold)	
<input type="checkbox"/> None <input checked="" type="checkbox"/> <b>Fault</b> <input type="checkbox"/> <b>Trouble</b> <input type="checkbox"/> WarningLocked	
Cause	Remedy
<p>The device has recognised a short circuit of the motor phases. To protect the device electronics, the inverter control is switched off.</p> <ul style="list-style-type: none"> <li>Mostly, incorrectly executed motor connections are the cause.</li> <li>If the device is inappropriately dimensioned with regard to the motor load and the current limitation in the controller (I<sub>max</sub> controller) is set incorrectly, this error message may also occur.</li> </ul> <p>► <a href="#">Motor control: Defining current limits</a></p>	<ul style="list-style-type: none"> <li>Check motor connections and the corresponding plug connector on the device.</li> <li>Only use permissible combinations of device power and motor power.</li> <li>Do not set the dynamics of the current limitation controller too high.</li> </ul>

# 8 Diagnostics & error management

## 8.7 Error messages of the operating system

### OC2: Power section - earth fault [xx.0123.00017]

<b>Response</b> (Lenze setting printed in bold)	
<input type="checkbox"/> None <input checked="" type="checkbox"/> <b>Fault</b> <input type="checkbox"/> Trouble <input type="checkbox"/> WarningLocked	
<b>Cause</b>	<b>Remedy</b>
<p>The device has recognised an earth fault at one of the motor phases. To protect the device electronics, the inverter control is switched off.</p> <ul style="list-style-type: none"> <li>• Mostly, incorrectly executed motor connections are the cause.</li> <li>• If motor filter, motor cable length, and cable type (shielding capacity) are dimensioned incorrectly, this error message may occur due to leakage currents to PE.</li> </ul>	<ul style="list-style-type: none"> <li>• Check motor connections and the corresponding plug connector on the device.</li> <li>• Use motor filters, cable lengths, and cable types recommended by Lenze.</li> </ul>

### ID1: Motor data identification error [xx.0123.00057]

<b>Response</b> (Lenze setting printed in bold)	
<input type="checkbox"/> None <input type="checkbox"/> Fault <input type="checkbox"/> Trouble <input checked="" type="checkbox"/> <b>WarningLocked</b>	
<b>Cause</b>	<b>Remedy</b>
<p>The device has detected an error during the motor data identification.</p> <p>Possible causes:</p> <ul style="list-style-type: none"> <li>• Interrupted motor cable.</li> <li>• Switched-off power section during the identification.</li> <li>• Implausible start parameter settings.</li> </ul>	<ul style="list-style-type: none"> <li>• Check the motor connections and the corresponding plug connector on the device and, if necessary, the motor terminal box.</li> <li>• Correct start parameters for the motor parameter identification (motor nameplate data).</li> <li>• Stable power supply of the device.</li> </ul>

### OC12: I2xt overload - brake resistor [xx.0123.00065]

<b>Response</b> (Lenze setting printed in bold)	
<input type="checkbox"/> None <input checked="" type="checkbox"/> <b>Fault</b> <input type="checkbox"/> Trouble <input type="checkbox"/> WarningLocked	
<b>Cause</b>	<b>Remedy</b>
Too frequent and too long braking processes.	Check drive dimensioning.

### OC6: I2xt overload - motor [xx.0123.00105]

<b>Response</b> (Lenze setting printed in bold)	<b>Setting:</b> <a href="#">C606</a> ( <input checked="" type="checkbox"/> Adjustable response)
<input checked="" type="checkbox"/> None <input checked="" type="checkbox"/> <b>Fault</b> <input type="checkbox"/> Trouble <input checked="" type="checkbox"/> <b>WarningLocked</b>	
<b>Cause</b>	<b>Remedy</b>
Thermal overload of the motor.	<ul style="list-style-type: none"> <li>• Observe load requirements.</li> <li>• Correct dimensioning if necessary.</li> <li>• In case of VFCplus operation: Check Vmin boost (<a href="#">C016</a>).</li> <li>▶ <a href="#">Set Vmin boost</a></li> </ul>

### An01: AIN1\_I < 4 mA [xx.0125.00001]

<b>Response</b> (Lenze setting printed in bold)	<b>Setting:</b> <a href="#">C598/1</a> ( <input checked="" type="checkbox"/> Adjustable response)
<input checked="" type="checkbox"/> None <input checked="" type="checkbox"/> <b>Fault</b> <input checked="" type="checkbox"/> Trouble <input checked="" type="checkbox"/> <b>WarningLocked</b>	
<b>Cause</b>	<b>Remedy</b>
<p>Open-circuit monitoring for analog input has tripped.</p> <ul style="list-style-type: none"> <li>• Only if the analog input has been configured as a current loop of 4 ... 20 (<a href="#">C034/1</a> = 2).</li> </ul>	<ul style="list-style-type: none"> <li>• Check wiring of the analog X4/A1U input terminal for open circuit.</li> <li>• Check connection of the external 250-Ω load resistor between the terminals A1U and GND.</li> <li>• Check minimum current values of the signal sources.</li> </ul>

# 8 Diagnostics & error management

## 8.7 Error messages of the operating system

### PS01: No memory module [xx.0144.00001]

<b>Response</b> (Lenze setting printed in bold)	
<input type="checkbox"/> None <input type="checkbox"/> Fault <input type="checkbox"/> Trouble <input type="checkbox"/> WarningLocked	
<b>Cause</b>	<b>Remedy</b>
Memory module is either not available or not snapped into place correctly.	<ul style="list-style-type: none"><li>• If a memory module has been provided: Plug the memory module into the slot of the standard device intended for this purpose.</li><li>• If a memory module has been provided: Check if the memory module has been plugged-in correctly.</li></ul>

### PS02: Par. set invalid [xx.0144.00002]

<b>Response</b> (Lenze setting printed in bold)	
<input type="checkbox"/> None <input checked="" type="checkbox"/> Fault <input type="checkbox"/> Trouble <input type="checkbox"/> WarningLocked	
<b>Cause</b>	<b>Remedy</b>
The parameter set saved to the memory module is invalid because it has not been saved completely. <ul style="list-style-type: none"><li>• This can be due to voltage failure or caused by removing the memory module while saving the parameter set.</li></ul>	Ensure voltage supply during the storage process and that the module remains plugged into the slot.

### PS03: Par. set device invalid [xx.0144.00003]

<b>Response</b> (Lenze setting printed in bold)	
<input type="checkbox"/> None <input checked="" type="checkbox"/> Fault <input type="checkbox"/> Trouble <input type="checkbox"/> WarningLocked	
<b>Cause</b>	<b>Remedy</b>
The parameter set in the device is invalid.	Consultation with Lenze required.

### PS04: Par. set device incompatible [xx.0144.00004]

<b>Response</b> (Lenze setting printed in bold)	
<input type="checkbox"/> No Reaction <input checked="" type="checkbox"/> Fault <input type="checkbox"/> Trouble <input type="checkbox"/> Warning	
<b>Cause</b>	<b>Remedy</b>
The parameter set saved to the memory module is incompatible to the standard device. <ul style="list-style-type: none"><li>• An incompatibility of the parameter set is caused e.g. when the memory module of an 8400 StateLine is plugged into an 8400 BaseLine or the parameter set in the memory module has a higher version than expected by the standard device.</li></ul>	When the memory modules are exchanged, observe the downward compatibility: <ul style="list-style-type: none"><li>• OK: BaseLine V2.0 to BaseLine V3.0</li><li>• Not OK: StateLine Vx.x to BaseLine Vx.x</li><li>• Not OK: BaseLine V3.0 to BaseLine &lt; V3.0</li></ul>

### PS31: Ident. error [xx.0144.00031]

<b>Response</b> (Lenze setting printed in bold)	
<input type="checkbox"/> None <input checked="" type="checkbox"/> Fault <input type="checkbox"/> Trouble <input type="checkbox"/> WarningLocked	
<b>Cause</b>	<b>Remedy</b>
Incompatible or unknown HW components have been found.	<ul style="list-style-type: none"><li>• Check which HW components are faulty (<a href="#">C203/x</a>: Product type code).</li><li>• Check temperature range of the device at the start.</li><li>• Check whether a software update at Lenze is possible.</li></ul>

# 8 Diagnostics & error management

## 8.7 Error messages of the operating system

---

### dF01: Internal error 01 [xx.0145.00001]

<b>Response</b> (Lenze setting printed in bold)	
<input type="checkbox"/> None <input checked="" type="checkbox"/> <b>Fault</b> <input type="checkbox"/> Trouble <input type="checkbox"/> WarningLocked	
<b>Cause</b>	<b>Remedy</b>
Device error	<ul style="list-style-type: none"><li>• Reduce switching frequency (<a href="#">C018</a>) to 4 kHz.</li><li>• If the problem occurs again, you need to consult Lenze.</li></ul>

### dF02: Internal error 02 [xx.0145.00002]

<b>Response</b> (Lenze setting printed in bold)	
<input type="checkbox"/> None <input checked="" type="checkbox"/> <b>Fault</b> <input type="checkbox"/> Trouble <input type="checkbox"/> WarningLocked	
<b>Cause</b>	<b>Remedy</b>
Device error	<ul style="list-style-type: none"><li>• Mains switching or restart of the controller, respectively.</li><li>• If the problem occurs again, you need to consult Lenze.</li></ul>

### dF03: Internal error 03 [xx.0145.00003]

<b>Response</b> (Lenze setting printed in bold)	
<input type="checkbox"/> None <input checked="" type="checkbox"/> <b>Fault</b> <input type="checkbox"/> Trouble <input type="checkbox"/> WarningLocked	
<b>Cause</b>	<b>Remedy</b>
Device error	<ul style="list-style-type: none"><li>• Mains switching or restart of the controller, respectively.</li><li>• If the problem occurs again, you need to consult Lenze.</li></ul>

### dF04: Internal error 04 [xx.0145.00004]

<b>Response</b> (Lenze setting printed in bold)	
<input type="checkbox"/> None <input checked="" type="checkbox"/> <b>Fault</b> <input type="checkbox"/> Trouble <input type="checkbox"/> WarningLocked	
<b>Cause</b>	<b>Remedy</b>
Device error	<ul style="list-style-type: none"><li>• Mains switching or restart of the controller, respectively.</li><li>• If the problem occurs again, you need to consult Lenze.</li></ul>

### dF05: Internal error 05 [xx.0145.00005]

<b>Response</b> (Lenze setting printed in bold)	
<input type="checkbox"/> None <input checked="" type="checkbox"/> <b>Fault</b> <input type="checkbox"/> Trouble <input type="checkbox"/> WarningLocked	
<b>Cause</b>	<b>Remedy</b>
Device error	<ul style="list-style-type: none"><li>• Mains switching or restart of the controller, respectively.</li><li>• If the problem occurs again, you need to consult Lenze.</li></ul>

# 8 Diagnostics & error management

## 8.7 Error messages of the operating system

---

### dF06: Internal error 06 [xx.0145.00006]

<b>Response</b> (Lenze setting printed in bold)	
<input type="checkbox"/> None <input checked="" type="checkbox"/> <b>Fault</b> <input type="checkbox"/> Trouble <input type="checkbox"/> WarningLocked	
<b>Cause</b>	<b>Remedy</b>
Device error	<ul style="list-style-type: none"><li>• Mains switching or restart of the controller, respectively.</li><li>• If the problem occurs again, you needs to consult Lenze.</li></ul>

### dF07: Internal error 07 [xx.0145.00007]

<b>Response</b> (Lenze setting printed in bold)	
<input type="checkbox"/> None <input checked="" type="checkbox"/> <b>Fault</b> <input type="checkbox"/> Trouble <input type="checkbox"/> WarningLocked	
<b>Cause</b>	<b>Remedy</b>
Device error	<ul style="list-style-type: none"><li>• Mains switching or restart of the controller, respectively.</li><li>• If the problem occurs again, you needs to consult Lenze.</li></ul>

### dF08: Internal error 08 [xx.0145.00008]

<b>Response</b> (Lenze setting printed in bold)	
<input type="checkbox"/> None <input checked="" type="checkbox"/> <b>Fault</b> <input type="checkbox"/> Trouble <input type="checkbox"/> WarningLocked	
<b>Cause</b>	<b>Remedy</b>
Device error	<ul style="list-style-type: none"><li>• Mains switching or restart of the controller, respectively.</li><li>• If the problem occurs again, you needs to consult Lenze.</li></ul>

### dF09: Internal error 09 [xx.0145.00009]

<b>Response</b> (Lenze setting printed in bold)	
<input type="checkbox"/> None <input checked="" type="checkbox"/> <b>Fault</b> <input type="checkbox"/> Trouble <input type="checkbox"/> WarningLocked	
<b>Cause</b>	<b>Remedy</b>
Device error	<ul style="list-style-type: none"><li>• Mains switching or restart of the controller, respectively.</li><li>• If the problem occurs again, you needs to consult Lenze.</li></ul>

### dF10: Internal error 10 [xx.0145.00010]

<b>Response</b> (Lenze setting printed in bold)	
<input type="checkbox"/> None <input checked="" type="checkbox"/> <b>Fault</b> <input type="checkbox"/> Trouble <input type="checkbox"/> WarningLocked	
<b>Cause</b>	<b>Remedy</b>
Device error	<ul style="list-style-type: none"><li>• Mains switching or restart of the controller, respectively.</li><li>• If the problem occurs again, you needs to consult Lenze.</li></ul>



# 8 Diagnostics & error management

## 8.7 Error messages of the operating system

---

### dH69: Adjustment fault [xx.0400.00105]

<b>Response</b> (Lenze setting printed in bold)	
<input type="checkbox"/> None <input checked="" type="checkbox"/> <b>Fault</b> <input type="checkbox"/> Trouble <input type="checkbox"/> WarningLocked	
<b>Cause</b>	<b>Remedy</b>
Device error	Consultation with Lenze required.

### US01: User error 1 [xx.0980.00000]

<b>Response</b> (Lenze setting printed in bold)		<b>Setting:</b> <a href="#">C581/1</a> <input checked="" type="checkbox"/> Adjustable response
<input checked="" type="checkbox"/> None <input checked="" type="checkbox"/> <b>Fault</b> <input checked="" type="checkbox"/> Trouble <input checked="" type="checkbox"/> WarningLocked		
<b>Cause</b>	<b>Remedy</b>	
User error 1 has been tripped via the <i>bSetError1</i> input of the <a href="#">LS_SetError_1</a> system block.	User-defined.	

### US02: User error 2 [xx.0981.00000]

<b>Response</b> (Lenze setting printed in bold)		<b>Setting:</b> <a href="#">C581/2</a> <input checked="" type="checkbox"/> Adjustable response
<input checked="" type="checkbox"/> None <input checked="" type="checkbox"/> <b>Fault</b> <input checked="" type="checkbox"/> Trouble <input checked="" type="checkbox"/> WarningLocked		
<b>Cause</b>	<b>Remedy</b>	
User error 2 has been tripped via the <i>bSetError2</i> input of the <a href="#">LS_SetError_1</a> system block.	User-defined.	

### 9 Parameter reference

This chapter describes all parameters which can be used for parameterising and monitoring the controller.

---

Parameters which are only available in the controller from a certain software version onwards are marked with a corresponding note in the parameter description ("from version xx.xx.xx").

The parameter descriptions are based on the software version V03.04.00

---



#### Tip!

For quick reference of a parameter with a certain name, simply use the **index** of the online documentation. The index always contains the corresponding code in parentheses after the name.

General information on parameter setting can be found in the chapter entitled "[Introduction: Parameterising the controller](#)". (13)

For general information on how to read and change parameters, please see the online documentation for the »Engineer«.

# 9 Parameter reference

## 9.1 Structure of the parameter descriptions

---

### 9.1 Structure of the parameter descriptions

Each parameter is described in the [Parameter list](#) in the form of a table which consists of the following three areas:

#### Table header

The table header contains the following general information:

- Parameter number (Cxxxxx)
- Parameter name (display text in the »Engineer« and keypad)
- [Data type](#)
- Parameter index in decimal and hexadecimal notation for access via a fieldbus (e.g. CAN system bus).



#### Tip!

The parameter index is calculated as follows:

- Index [dec] = 24575 - code
- Index [hex] = 0x5FFF - code

Example for code C00005:

- Index [dec] = 24575 - 5 = 24570
- Index [hex] = 0x5FFF - 0x{5} = 0x5FFA

#### Table contents

The table contains further general explanations & notes on the parameter and the possible settings, which are represented in different ways depending on the parameter type:

- [Parameters with read-only access](#)
- [Parameters with write access](#)

#### Table footer

The table footer contains the [Parameter attributes](#).

# 9 Parameter reference

## 9.1 Structure of the parameter descriptions

### 9.1.1 Data type

The parameters can be of the following data types:

Data type	Meaning
INTEGER_16	16-bit value with sign
INTEGER_32	32-bit value with sign
UNSIGNED_8	8-bit value without sign
UNSIGNED_16	16-bit value without sign
UNSIGNED_32	32-bit value without sign
VISIBLE_STRING	String of characters from printable characters

### 9.1.2 Parameters with read-only access

Parameters for which the "write access" attribute has not been set, can only be read. They cannot be changed by the user.

#### Description structure

Parameter Name: Cxxxxx   _____	Data type: _____ Index: _____
Description	
Display range (min. value   unit   max. value)	
<input checked="" type="checkbox"/> Read access <input type="checkbox"/> Write access <input type="checkbox"/> CINH <input type="checkbox"/> PLC STOP <input type="checkbox"/> No transfer <input type="checkbox"/> COM <input type="checkbox"/> MOT    Scaling factor: 1	

#### Representation in the »Engineer«

The »Engineer« displays these parameters with a grey background or, with an online connection, with a pale-yellow background:

	C...	S	Name	Value	Unit
	3	0	Status of last device command	Successful	

# 9 Parameter reference

## 9.1 Structure of the parameter descriptions

### 9.1.3 Parameters with write access

Only parameters with a check mark (☑) in front of the "write access" attribute can be changed by the user. The Lenze setting for these parameters is **printed in bold**.

- The settings can either be selected from a selection list or the values can be entered directly.
- Values outside the valid setting range are represented in red in the »Engineer«.

#### 9.1.3.1 Parameters with setting range

##### Description structure

Parameter   Name: Cxxxxx   _____		Data type: _____ Index: _____	
Description			
<b>Setting range</b> (min. value   unit   max. value)		<b>Lenze setting</b>	
☑ Read access ☑ Write access ☐ CINH ☐ PLC STOP ☐ No transfer ☐ COM ☐ MOT Scaling factor: 1			

##### Parameter setting in the »Engineer«

In the »Engineer«, parameters are set by entering the desired value into the input field:

C...	S	Name	Value	Unit
11	0	Appl.: Reference speed	1500	rpm

#### 9.1.3.2 Parameters with selection list

##### Description structure

Parameter   Name: Cxxxxx   _____		Data type: _____ Index: _____	
Description			
<b>Selection list</b> (Lenze setting printed in bold)			
<b>1</b>			
2			
3			
☑ Read access ☑ Write access ☐ CINH ☐ PLC STOP ☐ No transfer ☐ COM ☐ MOT Scaling factor: 1			

**Parameter setting in the »Engineer«**

In the »Engineer«, a list field is used for parameter setting:

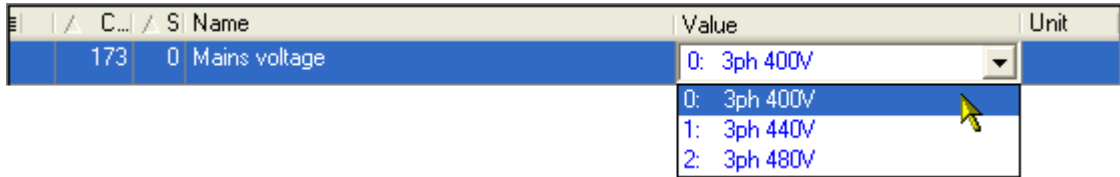

**9.1.3.3 Parameters with bit-coded setting**

**Description structure**

Parameter   Name: Cxxxxx   _____	Data type: _____ Index: _____
Description	
<b>Value is bit-coded:</b>	
Bit 0	
...	
Bit 31	
<input checked="" type="checkbox"/> Read access <input checked="" type="checkbox"/> Write access <input type="checkbox"/> CINH <input type="checkbox"/> PLC STOP <input type="checkbox"/> No transfer <input type="checkbox"/> COM <input type="checkbox"/> MOT                   Scaling factor: 1	

**Parameter setting in the »Engineer«**

The »Engineer« uses a dialog box for parameter setting in which the individual bits can be set or reset. Alternatively, the value can be entered as a decimal or hexadecimal value:

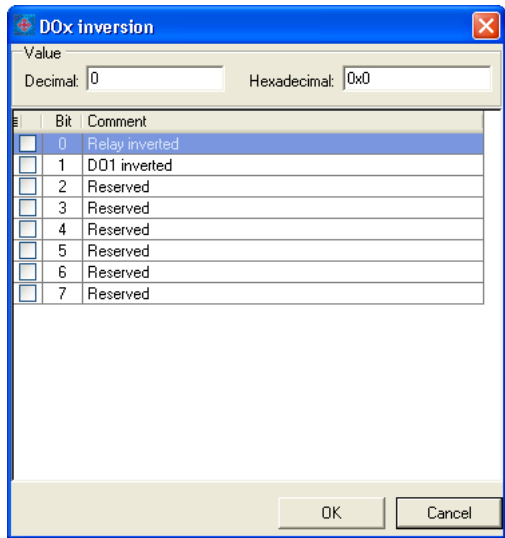

9.1.3.4 Parameters with subcodes

Description structure

Parameter   Name: Cxxxxx   _____		Data type: _____ Index: _____
Description		
Setting range (min. value   unit   max. value)		
<b>Subcodes</b>	<b>Lenze setting</b>	
Cxxxxx/1		
Cxxxxx/2		
Cxxxxx/3		
<input checked="" type="checkbox"/> Read access <input checked="" type="checkbox"/> Write access <input type="checkbox"/> CINH <input type="checkbox"/> PLC STOP <input type="checkbox"/> No transfer <input type="checkbox"/> COM <input type="checkbox"/> MOT                   Scaling factor: 1		

Parameter setting in the »Engineer«

The »Engineer« parameter list displays each subcode individually. The parameters are set as described in the previous chapters.

	C...	S	Name	Value	Unit
	39	1	Fixed setpoint 1	40.00	%
	39	2	Fixed setpoint 2	60.00	%
	39	3	Fixed setpoint 3	80.00	%

9.1.4 Parameter attributes

The table footers contain the parameter attributes:

Read access  Write access  CINH  PLC STOP  No transfer  COM  MOT    Scaling factor: 1

Attribute	Meaning
<input checked="" type="checkbox"/> Read access	Read access to parameter possible.
<input checked="" type="checkbox"/> Write access	Write access to parameter possible. • Please also observe the following attributes:
	<input checked="" type="checkbox"/> CINH      Parameter value can only be changed when the controller is inhibited.
	<input checked="" type="checkbox"/> PLC STOP      Parameter value can only be changed when the application is stopped.
<input checked="" type="checkbox"/> No transfer	Parameter is <b>not</b> transferred to controller when the command <u>Download parameter set</u> is executed.
<input checked="" type="checkbox"/> COM	Communication-relevant parameter • This parameter is relevant for parameter data transfer via the (CAN) system bus.
<input checked="" type="checkbox"/> MOT	Motor control parameters

**Scaling factor**

The "scaling factor" is important for parameter access via a bus system.

Signal type	Scaling factor	Resolution	Value range
Analog (scaled)	100	16 bits signed	± 199.9 %
Angular velocity	1	16 bits signed	± 32767 increments/ms
Position in [units]	10000	32 bits signed	± 214748.3647 [units]
Digital (BOOL)	1	8 bits unsigned	0 ≡ FALSE; 1 ≡ TRUE
Time	1000	16 bits unsigned	0 ... 999.000 s
Selection value	1	16 bits unsigned	0 ... 65535

**Example 1:** The value "654" of the parameter [C00028/1](#) (AIN1: input voltage) read via a bus system must be divided by the corresponding scaling factor "100" to obtain the actual display value "6.54 V".

$$\frac{\text{Read value (via bus system)}}{\text{Scaling factor}} = \text{Indicated value (Engineer)}$$

[9-1] Conversion formula for read access via bus system

**Example 2:** In order to set the parameter [C00012](#) (acceleration time main setpoint) to the value "123.45 %" via a bus system, the integer value "12345" must be transferred, i.e. the value to be set must be multiplied by the corresponding scaling factor "100".

$$\text{Value to be written (via bus system)} = \text{Value to be set} \cdot \text{Scaling factor}$$

[9-2] Conversion formula for write access via bus system



# 9 Parameter reference

## 9.2 Parameter list

### 9.2 Parameter list

This chapter lists all parameters of the operating system in numerically ascending order.



#### Note!

The parameter descriptions are based on the software version V03.04.00.

#### C00002

Parameter   Name: C00002   Device commands		Data type: UNSIGNED_8 Index: 24573 <sub>d</sub> = 5FFD <sub>h</sub>
<b>Note:</b> <ul style="list-style-type: none"><li>• Before switching off the supply voltage after carrying out a device command, check whether the device command has been carried out successfully via the status display under <a href="#">C00003!</a></li><li>• Before activating the device commands through a master control, please wait for the "ready" message of the controller.</li><li>• The device will reject a write process to C00002/x if the value is &gt;1 and issue an error message. ▶ <a href="#">Drive control (DCTRL): Device commands</a></li></ul>		
<b>Selection list</b>		
0	Off / ready	
1	On / start	
2	Work in progress	
4	Action cancelled	
5	No access	
6	No access controller inhibit	
Subcodes	Lenze setting	Info
C00002/1	0: Off / ready	Load Lenze setting <ul style="list-style-type: none"><li>• All parameters are reset to the Lenze setting.</li><li>• Only possible when the controller is inhibited.</li></ul>
C00002/2	0: Off / ready	Load parameter set 1 <ul style="list-style-type: none"><li>• Load parameter set 1 from the memory module.</li></ul>
C00002/3	0: Off / ready	Reserved
C00002/4	0: Off / ready	Reserved
C00002/5	0: Off / ready	Reserved
C00002/6	0: Off / ready	Reserved
C00002/7	0: Off / ready	Save parameter set 1 <ul style="list-style-type: none"><li>• Saving parameter set 1 in the memory module safe against mains failure.</li></ul>
C00002/8	0: Off / ready	Reserved
C00002/9	0: Off / ready	Reserved
C00002/10	0: Off / ready	Reserved
C00002/11	0: Off / ready	Save all parameter sets <ul style="list-style-type: none"><li>• All parameter sets are saved in the memory module with mains failure protection.</li></ul>
C00002/12	0: Off / ready	Import EPM data <ul style="list-style-type: none"><li>• Setting "1: On / start" activates the automatic import of parameters of the memory module after the error message "PS04".</li></ul>

Parameter   Name: <b>C00002   Device commands</b>		Data type: UNSIGNED 8 Index: 24573 <sub>d</sub> = 5FFD <sub>h</sub>
C00002/13	0: Off / ready	Reserved
C00002/14	0: Off / ready	Reserved
C00002/15	0: Off / ready	Reserved
C00002/16	1: On / start	Enable controller "1" ≡ Enable controller "0" ≡ Inhibit controller
C00002/17	0: Off / ready	Activate quick stop "1" ≡ Activate quick stop "0" ≡ Deactivate quick stop
C00002/18	0: Off / ready	Reserved
C00002/19	0: Off / ready	Reset error <ul style="list-style-type: none"> <li>• After resetting the current error, further errors may be pending which must be reset as well.</li> <li>• Details of the currently pending error are displayed in <a href="#">C00166</a>.</li> </ul>
C00002/20	0: Off / ready	Reserved
C00002/21	0: Off / ready	Delete logbook <ul style="list-style-type: none"> <li>• All entries in the controller logbook will be deleted.</li> <li>• In the logbook, information on the error history is saved.</li> </ul>
C00002/22	0: Off / ready	Reserved
C00002/23	0: Off / ready	Identify motor parameters <ul style="list-style-type: none"> <li>• This device command serves to carry out an automatic identification of the motor parameters.</li> <li>• The device command is only executed when the controller is in the "SwitchedOn" state.</li> <li>• In order to identify the motor parameters, the controller must be enabled after this device command.</li> </ul> ▶ <a href="#">Identifying motor parameters automatically</a>
C00002/24	0: Off / ready	Reserved
C00002/25	0: Off / ready	Reserved
C00002/26	0: Off / ready	Reserved
C00002/27	0: Off / ready	Reserved
C00002/28	0: Off / ready	Reserved
C00002/29	0: Off / ready	Reserved
C00002/30	0: Off / ready	Reserved
C00002/31	0: Off / ready	Reserved
C00002/32	0: Off / ready	Reserved
<input checked="" type="checkbox"/> Read access <input checked="" type="checkbox"/> Write access <input type="checkbox"/> CINH <input type="checkbox"/> PLC STOP <input checked="" type="checkbox"/> No transfer <input type="checkbox"/> COM <input type="checkbox"/> MOT   Scaling factor: 1		

# 9 Parameter reference

## 9.2 Parameter list | C00003

### C00003

Parameter   Name: <b>C00003   Status of last device command</b>		Data type: UNSIGNED_8 Index: 24572 <sub>d</sub> = 5FFC <sub>h</sub>
Status of the device command carried out last ( <a href="#">C00002</a> ).		
<p><b>Note:</b> Before switching off the supply voltage after carrying out a device command, check whether the device command has been carried out successfully via the status display!</p> <p style="text-align: right;">▶ <a href="#">Drive control (DCTRL): Device commands</a></p>		
Selection list (read only)		Info
0	Successful	Device command has been carried out successfully.
1	Command unknown	Device command is implausible or not known in the system.
2	No access	Access for requested device command is not approved.
3	Time-out	Device command could not be processed in the defined time (time-out).
<input checked="" type="checkbox"/> Read access <input type="checkbox"/> Write access <input type="checkbox"/> CINH <input type="checkbox"/> PLC STOP <input checked="" type="checkbox"/> No transfer <input type="checkbox"/> COM <input type="checkbox"/> MOT           Scaling factor: 1		

### C00006

Parameter   Name: <b>C00006   Motor control</b>		Data type: UNSIGNED_8 Index: 24569 <sub>d</sub> = 5FF9 <sub>h</sub>
Selection of the motor control mode		
▶ <a href="#">Motor control (MCTRL): Select control mode</a>		
Selection list (Lenze setting printed in bold)		Info
4	SLVC: Vector control	<p>This control type is used for sensorless vector control of an asynchronous motor.</p> <ul style="list-style-type: none"> <li>The control type requires motor parameters to be set as exactly as possible!</li> </ul> <p>▶ <a href="#">Sensorless vector control</a></p>
6	<b>VFCplus: V/f linear</b>	<p>This control type is used for the speed control of an asynchronous motor via a linear V/f characteristic and is the simplest control type.</p> <ul style="list-style-type: none"> <li>For setting the V/f characteristic, only the rated frequency (<a href="#">C00089</a>) and the rated voltage (<a href="#">C00090</a>) of the motor have to be entered.</li> </ul> <p>▶ <a href="#">V/f characteristic control</a></p>
8	VFCplus: V/f quadr	<p>This control type is used for speed control of an asynchronous motor via a square-law V/f characteristic.</p> <ul style="list-style-type: none"> <li>For setting the V/f characteristic, only the rated frequency (<a href="#">C00089</a>) and the rated voltage (<a href="#">C00090</a>) of the motor have to be entered.</li> </ul> <p>▶ <a href="#">V/f characteristic control</a></p>
<input checked="" type="checkbox"/> Read access <input checked="" type="checkbox"/> Write access <input type="checkbox"/> CINH <input type="checkbox"/> PLC STOP <input type="checkbox"/> No transfer <input type="checkbox"/> COM <input type="checkbox"/> MOT           Scaling factor: 1		

# 9 Parameter reference

## 9.2 Parameter list | C00007

### C00007

Parameter   Name: <b>C00007   Control mode</b>		Data type: UNSIGNED_16 Index: 24568 <sub>d</sub> = 5FF8 <sub>h</sub>
Selection of how the application is to be controlled.		
Selection list (Lenze setting printed in bold)		Info
0	Wiring has changed	This display appears when the preset configuration has been reparameterised via the connection parameters.
<b>10</b>	<b>Terminals 0</b>	The technology application is controlled via the digital input terminals of the controller: <ul style="list-style-type: none"> <li>• DI1 = fixed setpoint 1/3</li> <li>• DI2 = fixed setpoint 2/3</li> <li>• DI3 = activate DC injection braking</li> <li>• DI4 = change of direction of rotation</li> </ul>
12	Terminals 2	The technology application is controlled via the digital input terminals of the controller: <ul style="list-style-type: none"> <li>• DI1 = fixed setpoint 1/3</li> <li>• DI2 = fixed setpoint 2/3</li> <li>• DI3 = quick stop</li> <li>• DI4 = change of direction of rotation</li> </ul>
14	Terminals 11	The technology application is controlled via the digital input terminals of the controller: <ul style="list-style-type: none"> <li>• DI1 = change of direction of rotation</li> <li>• DI2 = activate DC injection braking</li> <li>• DI3 = motor potentiometer: Higher speed</li> <li>• DI4 = motor potentiometer: Lower speed</li> </ul>
16	Terminals 16	The technology application is controlled via the digital input terminals of the controller: <ul style="list-style-type: none"> <li>• DI1 = fixed setpoint 1/3</li> <li>• DI2 = fixed setpoint 2/3</li> <li>• DI3 = CW rotation/quick stop</li> <li>• DI4 = CCW rotation/quick stop</li> </ul>
20	Keypad	The technology application is controlled via the keypad: <ul style="list-style-type: none"> <li>→ <a href="#">C00002</a>: Device commands</li> <li>→ <a href="#">C00003</a>: Status of last device command</li> <li>→ <a href="#">C00727</a>: Executing control commands</li> <li>→ <a href="#">C00728</a>: Selecting analog setpoints</li> <li>▲ Increase speed</li> <li>▼ Reduce speed</li> </ul>
21	PC	The technology application is controlled via the "Free parameters" of the controller (PC control).
<input checked="" type="checkbox"/> Read access <input checked="" type="checkbox"/> Write access <input type="checkbox"/> CINH <input type="checkbox"/> PLC STOP <input type="checkbox"/> No transfer <input type="checkbox"/> COM <input type="checkbox"/> MOT             Scaling factor: 1		

### C00010

Parameter   Name: <b>C00010   Minimum analog setpoint</b>		Data type: INTEGER_16 Index: 24565 <sub>d</sub> = 5FF5 <sub>h</sub>
As of version 03.00.00 Lower limit for analog input <div style="text-align: right;"><a href="#">▶ Analog terminals</a></div>		
Setting range (min. value   unit   max. value)		
0.0	%	100.0
Subcodes	Lenze setting	Info
C00010/1	0.0 %	Min. analog setpoint
<input checked="" type="checkbox"/> Read access <input checked="" type="checkbox"/> Write access <input type="checkbox"/> CINH <input type="checkbox"/> PLC STOP <input type="checkbox"/> No transfer <input type="checkbox"/> COM <input type="checkbox"/> MOT             Scaling factor: 100		

# 9 Parameter reference

## 9.2 Parameter list | C00011

### C00011

Parameter   Name: <b>C00011   Appl.: Reference speed</b>		Data type: UNSIGNED_16 Index: 24564 <sub>d</sub> = 5FF4 <sub>h</sub>	
Setting the reference speed <ul style="list-style-type: none"> <li>In the controller, all speed-related signals are processed to one reference variable in percent.</li> <li>Set a reference speed here that corresponds to 100 %.</li> <li>The frequency of the set reference speed is displayed in <a href="#">C00059</a>.</li> </ul>			
<b>Note:</b> This is not a maximum limitation! All values in percent in the controller may be in the range of 0 ... 199.99 %.			
<b>Setting range (min. value   unit   max. value)</b>		<b>Lenze setting</b>	
50	rpm	9999	<b>1500 rpm</b>
<input checked="" type="checkbox"/> Read access <input checked="" type="checkbox"/> Write access <input type="checkbox"/> CINH <input type="checkbox"/> PLC STOP <input type="checkbox"/> No transfer <input type="checkbox"/> COM <input type="checkbox"/> MOT   Scaling factor: 1			

### C00012

Parameter   Name: <b>C00012   Acceleration time main setpoint</b>		Data type: UNSIGNED_32 Index: 24563 <sub>d</sub> = 5FF3 <sub>h</sub>	
FB <a href="#">L_NSet_1</a> : Acceleration time of the ramp generator for the main speed setpoint			
<b>Setting range (min. value   unit   max. value)</b>		<b>Lenze setting</b>	
0.0	s	999.9	<b>2.0 s</b>
<input checked="" type="checkbox"/> Read access <input checked="" type="checkbox"/> Write access <input type="checkbox"/> CINH <input type="checkbox"/> PLC STOP <input type="checkbox"/> No transfer <input type="checkbox"/> COM <input type="checkbox"/> MOT   Scaling factor: 1000			

### C00013

Parameter   Name: <b>C00013   Deceleration time main setpoint</b>		Data type: UNSIGNED_32 Index: 24562 <sub>d</sub> = 5FF2 <sub>h</sub>	
FB <a href="#">L_NSet_1</a> : Deceleration time of the ramp generator for the main speed setpoint			
<b>Setting range (min. value   unit   max. value)</b>		<b>Lenze setting</b>	
0.0	s	999.9	<b>2.0 s</b>
<input checked="" type="checkbox"/> Read access <input checked="" type="checkbox"/> Write access <input type="checkbox"/> CINH <input type="checkbox"/> PLC STOP <input type="checkbox"/> No transfer <input type="checkbox"/> COM <input type="checkbox"/> MOT   Scaling factor: 1000			

### C00015

Parameter   Name: <b>C00015   VFC: V/f base frequency</b>		Data type: UNSIGNED_16 Index: 24560 <sub>d</sub> = 5FF0 <sub>h</sub>	
V/f base frequency for V/f characteristic control ( <a href="#">VFCplus</a> ) <ul style="list-style-type: none"> <li>The motor voltage increases linearly with the frequency until the base frequency is reached. From this value on, the motor voltage remains constant, the speed increases and the maximum torque decreases.</li> <li>After the motor to be used has been selected from the motor catalogue, the suitable value can be entered automatically. An automatic detection via the motor parameter identification is possible as well.</li> </ul>			
<b>Setting range (min. value   unit   max. value)</b>		<b>Lenze setting</b>	
7.5	Hz	999.9	<b>50.0 Hz</b>
<input checked="" type="checkbox"/> Read access <input checked="" type="checkbox"/> Write access <input type="checkbox"/> CINH <input type="checkbox"/> PLC STOP <input type="checkbox"/> No transfer <input type="checkbox"/> COM <input checked="" type="checkbox"/> MOT   Scaling factor: 10			

# 9 Parameter reference

## 9.2 Parameter list | C00016

### C00016

Parameter   Name: <b>C00016   VFC: Vmin boost</b>		Data type: UNSIGNED_16 Index: 24559 <sub>d</sub> = 5FEF <sub>h</sub>
Boost of the V/f voltage characteristic within the range of low speed or frequency values for the ( <a href="#">VFCplus</a> ) V/f characteristic control. <ul style="list-style-type: none"> <li>• This may increase the starting torque.</li> <li>• After the motor to be used has been selected from the motor catalogue, the suitable value can be entered automatically. An automatic detection via the motor parameter identification is possible as well.</li> </ul> <p style="text-align: right;">▶ <a href="#">Motor control (MCTRL): Setting Vmin boost</a></p>		
<b>Setting range (min. value   unit   max. value)</b>		<b>Lenze setting</b>
0.0	%	100.0 <b>0.0 %</b>
<input checked="" type="checkbox"/> Read access <input checked="" type="checkbox"/> Write access <input type="checkbox"/> CINH <input type="checkbox"/> PLC STOP <input type="checkbox"/> No transfer <input type="checkbox"/> COM <input type="checkbox"/> MOT                   Scaling factor: 100		

### C00018

Parameter   Name: <b>C00018   Switching frequency</b>		Data type: UNSIGNED_8 Index: 24557 <sub>d</sub> = 5FED <sub>h</sub>
Selection of the pulse width modulated switching frequency transferred from the inverter to the motor <ul style="list-style-type: none"> <li>• When a variable switching frequency is selected, the switching frequency may change as a function of the load and rotational frequency.</li> </ul> <p style="text-align: right;">▶ <a href="#">Selection of the switching frequency</a></p>		
<b>Selection list (Lenze setting printed in bold)</b>		
1	4 kHz var./drive-optimised	
2	<b>8 kHz var./drive-optimised</b>	
3	16 kHz var./drive-optimised	
5	2 kHz constant/drive-optimised	
6	4 kHz constant/drive-optimised	
7	8 kHz constant/drive-optimised	
8	16 kHz constant/drive-optimised	
21	8 kHz var/4 kHz min.	
22	16 kHz var/4 kHz min.	
23	16 kHz var/8 kHz min	
<input checked="" type="checkbox"/> Read access <input checked="" type="checkbox"/> Write access <input type="checkbox"/> CINH <input type="checkbox"/> PLC STOP <input type="checkbox"/> No transfer <input type="checkbox"/> COM <input type="checkbox"/> MOT                   Scaling factor: 1		

### C00019

Parameter   Name: <b>C00019   Auto DCB: Threshold</b>		Data type: UNSIGNED_16 Index: 24556 <sub>d</sub> = 5FEC <sub>h</sub>
Setpoint speed threshold for automatic DC injection braking <ul style="list-style-type: none"> <li>• For speed setpoints with values below the thresholds a DC current is injected or the motor is not supplied with current, depending on the setting.</li> </ul> <p style="text-align: right;">▶ <a href="#">DC injection braking</a></p>		
<b>Setting range (min. value   unit   max. value)</b>		<b>Lenze setting</b>
0	rpm	9999 <b>3 rpm</b>
<input checked="" type="checkbox"/> Read access <input checked="" type="checkbox"/> Write access <input type="checkbox"/> CINH <input type="checkbox"/> PLC STOP <input type="checkbox"/> No transfer <input type="checkbox"/> COM <input type="checkbox"/> MOT                   Scaling factor: 1		

# 9 Parameter reference

## 9.2 Parameter list | C00021

### C00021

Parameter   Name: <b>C00021   Slip comp.</b>			Data type: INTEGER_16 Index: 24554 <sub>d</sub> = 5FEA <sub>h</sub>
Slip compensation for V/f characteristic control ( <a href="#">VFCplus</a> ) and sensorless vector control ( <a href="#">SLVC</a> )			
<ul style="list-style-type: none"> <li>An increase of the slip compensation causes a greater frequency and voltage increase when the machine is loaded.</li> <li>After the motor to be used has been selected from the motor catalogue, the suitable value can be entered automatically. An automatic detection via the motor parameter identification is possible as well. <ul style="list-style-type: none"> <li>▶ <a href="#">Motor control (MCTRL): Optimising the operational performance by slip compensation</a></li> </ul> </li> </ul>			
<b>Setting range (min. value   unit   max. value)</b>			<b>Lenze setting</b>
-50.00	%	50.00	<b>0.00 %</b>
<input checked="" type="checkbox"/> Read access <input checked="" type="checkbox"/> Write access <input type="checkbox"/> CINH <input type="checkbox"/> PLC STOP <input type="checkbox"/> No transfer <input type="checkbox"/> COM <input type="checkbox"/> MOT   Scaling factor: 100			

### C00022

Parameter   Name: <b>C00022   I<sub>max</sub> in motor mode</b>			Data type: UNSIGNED_16 Index: 24553 <sub>d</sub> = 5FE9 <sub>h</sub>
Maximum current in motor mode for all motor control modes			
<b>Setting range (min. value   unit   max. value)</b>			<b>Lenze setting</b>
0.00	A	99.99	<b>47.00 A</b>
<input checked="" type="checkbox"/> Read access <input checked="" type="checkbox"/> Write access <input type="checkbox"/> CINH <input type="checkbox"/> PLC STOP <input type="checkbox"/> No transfer <input type="checkbox"/> COM <input type="checkbox"/> MOT   Scaling factor: 100			

### C00023

Parameter   Name: <b>C00023   I<sub>max</sub> in generator mode</b>			Data type: INTEGER_16 Index: 24552 <sub>d</sub> = 5FE8 <sub>h</sub>
Maximum current in generator mode for all motor control modes			
<ul style="list-style-type: none"> <li>100 % ≡ I<sub>max</sub> in motor mode (<a href="#">C00022</a>)</li> </ul>			
<b>Setting range (min. value   unit   max. value)</b>			<b>Lenze setting</b>
0.0	%	100.0	<b>100.0 %</b>
<input checked="" type="checkbox"/> Read access <input checked="" type="checkbox"/> Write access <input type="checkbox"/> CINH <input type="checkbox"/> PLC STOP <input type="checkbox"/> No transfer <input type="checkbox"/> COM <input type="checkbox"/> MOT   Scaling factor: 100			

### C00024

Parameter   Name: <b>C00024   Comparison value N_Act</b>			Data type: INTEGER_16 Index: 24551 <sub>d</sub> = 5FE7 <sub>h</sub>
Threshold for the actual speed comparison			
<ul style="list-style-type: none"> <li>This parameter serves to set a threshold that is compared with the actual speed value.</li> <li>When the value falls below this threshold, the <i>bNactCompare</i> output of the SB <a href="#">LS_DriveInterface</a> switches to TRUE.</li> <li>Switching hysteresis = +1 %</li> </ul>			
<b>Setting range (min. value   unit   max. value)</b>			<b>Lenze setting</b>
0.0	%	199.9	<b>0.0 %</b>
<input checked="" type="checkbox"/> Read access <input checked="" type="checkbox"/> Write access <input type="checkbox"/> CINH <input type="checkbox"/> PLC STOP <input type="checkbox"/> No transfer <input type="checkbox"/> COM <input type="checkbox"/> MOT   Scaling factor: 100			

# 9 Parameter reference

## 9.2 Parameter list | C00026

### C00026

Parameter   Name: <b>C00026   AINx: Offset</b>		Data type: INTEGER_16 Index: 24549 <sub>d</sub> = 5FE5 <sub>h</sub>
Offset for analog input		<a href="#">▶ Analog terminals</a>
<b>Setting range (min. value   unit   max. value)</b>		
-199.9	%	199.9
<b>Subcodes</b>	<b>Lenze setting</b>	<b>Info</b>
C00026/1	0.0 %	AIN1: Offset
<input checked="" type="checkbox"/> Read access <input checked="" type="checkbox"/> Write access <input type="checkbox"/> CINH <input type="checkbox"/> PLC STOP <input type="checkbox"/> No transfer <input type="checkbox"/> COM <input type="checkbox"/> MOT                   Scaling factor: 100		

### C00027

Parameter   Name: <b>C00027   AINx: Gain</b>		Data type: INTEGER_32 Index: 24548 <sub>d</sub> = 5FE4 <sub>h</sub>
Gain for analog input		<a href="#">▶ Analog terminals</a>
<b>Setting range (min. value   unit   max. value)</b>		
-199.9	%	199.9
<b>Subcodes</b>	<b>Lenze setting</b>	<b>Info</b>
C00027/1	100.0 %	AIN1: Gain
<input checked="" type="checkbox"/> Read access <input checked="" type="checkbox"/> Write access <input type="checkbox"/> CINH <input type="checkbox"/> PLC STOP <input type="checkbox"/> No transfer <input type="checkbox"/> COM <input type="checkbox"/> MOT                   Scaling factor: 100		

### C00028

Parameter   Name: <b>C00028   AINx: Input voltage</b>		Data type: INTEGER_16 Index: 24547 <sub>d</sub> = 5FE3 <sub>h</sub>
Display of the input voltage at the analog input		<a href="#">▶ Analog terminals</a>
<b>Display range (min. value   unit   max. value)</b>		
-10.0	V	10.0
<b>Subcodes</b>	<b>Info</b>	
C00028/1	AIN1: Input voltage	
<input checked="" type="checkbox"/> Read access <input type="checkbox"/> Write access <input type="checkbox"/> CINH <input type="checkbox"/> PLC STOP <input checked="" type="checkbox"/> No transfer <input type="checkbox"/> COM <input type="checkbox"/> MOT                   Scaling factor: 100		

### C00029

Parameter   Name: <b>C00029   AINx: Input current</b>		Data type: INTEGER_16 Index: 24546 <sub>d</sub> = 5FE2 <sub>h</sub>
Display of the input current at the analog input <ul style="list-style-type: none"> <li>• When the analog input has been configured for current measurement (<a href="#">C00034/1</a> = 1 or 2).</li> <li>• When <a href="#">C00034/1</a> is set = 2 (4 ... 20 mA), 0 ... 16 mA is displayed.</li> </ul>		<a href="#">▶ Analog terminals</a>
<b>Display range (min. value   unit   max. value)</b>		
0.0	mA	20.0
<b>Subcodes</b>	<b>Info</b>	
C00029/1	AIN1: Input current	
<input checked="" type="checkbox"/> Read access <input type="checkbox"/> Write access <input type="checkbox"/> CINH <input type="checkbox"/> PLC STOP <input checked="" type="checkbox"/> No transfer <input type="checkbox"/> COM <input type="checkbox"/> MOT                   Scaling factor: 100		



# 9 Parameter reference

## 9.2 Parameter list | C00033

### C00033

Parameter   Name: <b>C00033   AINx: Output value</b>		Data type: INTEGER_16 Index: 24542 <sub>d</sub> = 5FDE <sub>h</sub>
Display of the output value in percent of the analog input amplifier • 100 % ≙ 16384 ≙ +10 V / +20 mA		
<a href="#">▶ Analog terminals</a>		
<b>Display range (min. value   unit   max. value)</b>		
-199.9	%	199.9
<b>Subcodes</b>		<b>Info</b>
C00033/1		AIN1: Output value
<input checked="" type="checkbox"/> Read access <input type="checkbox"/> Write access <input type="checkbox"/> CINH <input type="checkbox"/> PLC STOP <input checked="" type="checkbox"/> No transfer <input type="checkbox"/> COM <input type="checkbox"/> MOT                   Scaling factor: 100		

### C00034

Parameter   Name: <b>C00034   AINx: Configuration</b>		Data type: UNSIGNED_8 Index: 24541 <sub>d</sub> = 5FDD <sub>h</sub>
Configuration of the analog input for current or voltage measurement		
<a href="#">▶ Analog terminals</a>		
<b>Selection list</b>		<b>Info</b>
0	0...+10 V	Input signal is voltage signal 0 V ... +10 V • 0 V ... +10 V ≙ 0 % ... +100 %
1	0...+5V	With external load resistor (250 Ohms): Input signal is the current signal 0 mA ... 20 mA • 0 mA ... 20 mA ≙ 0 % ... +100 %
2	1...+5V (4...20mA)	With external load resistor (250 Ohms): Input signal is the current signal 4 mA ... 20 mA • 4 mA ... 20 mA ≙ 0 % ... +100 % • The current loop is monitored for open circuit (I < 4 mA) by the device.
<b>Subcodes</b>		<b>Info</b>
C00034/1		0: 0...+10 V AIN1: Config.
<input checked="" type="checkbox"/> Read access <input checked="" type="checkbox"/> Write access <input type="checkbox"/> CINH <input type="checkbox"/> PLC STOP <input type="checkbox"/> No transfer <input type="checkbox"/> COM <input type="checkbox"/> MOT                   Scaling factor: 1		

### C00036

Parameter   Name: <b>C00036   DCB: Current</b>		Data type: INTEGER_16 Index: 24539 <sub>d</sub> = 5FDB <sub>h</sub>
Current value in [%] for DC-injection braking • 100 % ≙ I <sub>max</sub> in motor mode ( <a href="#">C00022</a> )		
<a href="#">▶ DC injection braking</a>		
<b>Setting range (min. value   unit   max. value)</b>		<b>Lenze setting</b>
0.0	%	150.0
		<b>50.0 %</b>
<input checked="" type="checkbox"/> Read access <input checked="" type="checkbox"/> Write access <input type="checkbox"/> CINH <input type="checkbox"/> PLC STOP <input type="checkbox"/> No transfer <input type="checkbox"/> COM <input type="checkbox"/> MOT                   Scaling factor: 100		

# 9 Parameter reference

## 9.2 Parameter list | C00039

### C00039

Parameter   Name: <b>C00039   Fixed setpoint x (L_NSet_1 n-Fix)</b>		Data type: INTEGER_16 Index: 24536 <sub>d</sub> = 5FD8 <sub>h</sub>
FB <u>L_NSet_1</u> : Fixed speed setpoints (JOG values) for the setpoint generator		
<b>Setting range</b> (min. value   unit   max. value)		
-199.9	%	199.9
<b>Subcodes</b>	<b>Lenze setting</b>	<b>Info</b>
C00039/1	40.0 %	Fixed setpoint 1
C00039/2	60.0 %	Fixed setpoint 2
C00039/3	80.0 %	Fixed setpoint 3
<input checked="" type="checkbox"/> Read access <input checked="" type="checkbox"/> Write access <input type="checkbox"/> CINH <input type="checkbox"/> PLC STOP <input type="checkbox"/> No transfer <input type="checkbox"/> COM <input type="checkbox"/> MOT                   Scaling factor: 100		

### C00050

Parameter   Name: <b>C00050   MCTRL: Speed setpoint</b>		Data type: INTEGER_32 Index: 24525 <sub>d</sub> = 5FCD <sub>h</sub>
Display of the speed setpoint at the speed setpoint input of the motor control		
<b>Display range</b> (min. value   unit   max. value)		
-9999	rpm	9999
<input checked="" type="checkbox"/> Read access <input type="checkbox"/> Write access <input type="checkbox"/> CINH <input type="checkbox"/> PLC STOP <input checked="" type="checkbox"/> No transfer <input type="checkbox"/> COM <input type="checkbox"/> MOT                   Scaling factor: 1		

### C00051

Parameter   Name: <b>C00051   MCTRL: Actual speed value</b>		Data type: INTEGER_32 Index: 24524 <sub>d</sub> = 5FCC <sub>h</sub>
Display of the actual speed value of the motor shaft		
<b>Note:</b> The displayed value only corresponds to the real actual speed value of the motor shaft if an encoder is connected to the motor and the evaluation of the feedback signal has been set correctly ("Closed loop" operation). In case of operation without speed feedback, the signal is calculated from the motor control and thus may not correspond to the real actual speed.		
<b>Display range</b> (min. value   unit   max. value)		
-9999	rpm	9999
<input checked="" type="checkbox"/> Read access <input type="checkbox"/> Write access <input type="checkbox"/> CINH <input type="checkbox"/> PLC STOP <input checked="" type="checkbox"/> No transfer <input type="checkbox"/> COM <input type="checkbox"/> MOT                   Scaling factor: 1		

### C00052

Parameter   Name: <b>C00052   Motor voltage</b>		Data type: UNSIGNED_16 Index: 24523 <sub>d</sub> = 5FCB <sub>h</sub>
Display of the current motor voltage/output voltage of the inverter		
<b>Display range</b> (min. value   unit   max. value)		
0	V	1000
<input checked="" type="checkbox"/> Read access <input type="checkbox"/> Write access <input type="checkbox"/> CINH <input type="checkbox"/> PLC STOP <input checked="" type="checkbox"/> No transfer <input type="checkbox"/> COM <input type="checkbox"/> MOT                   Scaling factor: 1		

# 9 Parameter reference

## 9.2 Parameter list | C00053

### C00053

Parameter   Name: <b>C00053   DC-bus voltage</b>		Data type: UNSIGNED_16 Index: 24522 <sub>d</sub> = 5FCA <sub>h</sub>
Display of the current DC-bus voltage		
<b>Display range (min. value   unit   max. value)</b>		
0	V	1000
<input checked="" type="checkbox"/> Read access <input type="checkbox"/> Write access <input type="checkbox"/> CINH <input type="checkbox"/> PLC STOP <input checked="" type="checkbox"/> No transfer <input type="checkbox"/> COM <input type="checkbox"/> MOT                   Scaling factor: 1		

### C00054

Parameter   Name: <b>C00054   Motor current</b>		Data type: UNSIGNED_16 Index: 24521 <sub>d</sub> = 5FC9 <sub>h</sub>
Display of the current motor current/output current of the inverter		
<b>Display range (min. value   unit   max. value)</b>		
0.00	A	300.00
<input checked="" type="checkbox"/> Read access <input type="checkbox"/> Write access <input type="checkbox"/> CINH <input type="checkbox"/> PLC STOP <input checked="" type="checkbox"/> No transfer <input type="checkbox"/> COM <input type="checkbox"/> MOT                   Scaling factor: 100		

### C00056

Parameter   Name: <b>C00056   Torque</b>		Data type: INTEGER_32 Index: 24519 <sub>d</sub> = 5FC7 <sub>h</sub>
Display of the current torque		
<b>Display range (min. value   unit   max. value)</b>		
-99.00	Nm	99.00
<b>Subcodes</b>		<b>Info</b>
C00056/1		Torque setpoint • Only with sensorless vector control ( <a href="#">SLVC</a> ).
C00056/2		Actual torque • Estimated actual torque for all motor control modes.
<input checked="" type="checkbox"/> Read access <input type="checkbox"/> Write access <input type="checkbox"/> CINH <input type="checkbox"/> PLC STOP <input checked="" type="checkbox"/> No transfer <input type="checkbox"/> COM <input type="checkbox"/> MOT                   Scaling factor: 100		

### C00057

Parameter   Name: <b>C00057   Maximum torque</b>		Data type: UNSIGNED_32 Index: 24518 <sub>d</sub> = 5FC6 <sub>h</sub>
Display of the maximum torque to be generated by the motor • The maximum torque to be generated by the motor depends on various factors, e.g. on I <sub>max</sub> in motor mode ( <a href="#">C00022</a> ) and the motor type used.		
<b>Display range (min. value   unit   max. value)</b>		
0.0	Nm	999.9
<input checked="" type="checkbox"/> Read access <input type="checkbox"/> Write access <input type="checkbox"/> CINH <input type="checkbox"/> PLC STOP <input checked="" type="checkbox"/> No transfer <input type="checkbox"/> COM <input type="checkbox"/> MOT                   Scaling factor: 100		

### C00058

Parameter   Name: <b>C00058   Output frequency</b>		Data type: INTEGER_32 Index: 24517 <sub>d</sub> = 5FC5 <sub>h</sub>
Display of the current output frequency		
<b>Display range (min. value   unit   max. value)</b>		
-655.0	Hz	655.0
<input checked="" type="checkbox"/> Read access <input type="checkbox"/> Write access <input type="checkbox"/> CINH <input type="checkbox"/> PLC STOP <input checked="" type="checkbox"/> No transfer <input type="checkbox"/> COM <input type="checkbox"/> MOT                   Scaling factor: 100		

# 9 Parameter reference

## 9.2 Parameter list | C00059

### C00059

Parameter   Name: <b>C00059   Appl.: Reference frequency C11</b>		Data type: UNSIGNED_32 Index: 24516 <sub>d</sub> = 5FC4 <sub>h</sub>
Display of the field frequency which corresponds to the reference speed set in <a href="#">C00011</a> .		
<b>Display range (min. value   unit   max. value)</b>		
0.0	Hz	999.9
<input checked="" type="checkbox"/> Read access <input type="checkbox"/> Write access <input type="checkbox"/> CINH <input type="checkbox"/> PLC STOP <input checked="" type="checkbox"/> No transfer <input type="checkbox"/> COM <input type="checkbox"/> MOT                   Scaling factor: 100		

### C00061

Parameter   Name: <b>C00061   Heatsink temperature</b>		Data type: INTEGER_16 Index: 24514 <sub>d</sub> = 5FC2 <sub>h</sub>
Display of the current heatsink temperature		
<b>Display range (min. value   unit   max. value)</b>		
-50	°C	150
<input checked="" type="checkbox"/> Read access <input type="checkbox"/> Write access <input type="checkbox"/> CINH <input type="checkbox"/> PLC STOP <input checked="" type="checkbox"/> No transfer <input type="checkbox"/> COM <input type="checkbox"/> MOT                   Scaling factor: 1		

### C00064

Parameter   Name: <b>C00064   Device utilisation (lxt)</b>		Data type: INTEGER_16 Index: 24511 <sub>d</sub> = 5FBF <sub>h</sub>
Display of the device utilisation lxt in different time resolutions <ul style="list-style-type: none"> <li>If the value displayed here exceeds the threshold set in <a href="#">C00123</a>, the fault message "OC5: Device overload (lxt)" is output and the fault response set in <a href="#">C00604</a> is executed (default setting: "Warning").</li> </ul>		
<b>Display range (min. value   unit   max. value)</b>		
0	%	250
<b>Subcodes</b>	<b>Info</b>	
C00064/1	Device utilisation (lxt) <ul style="list-style-type: none"> <li>Maximum value of the pulse utilisation (C00064/2) and permanent utilisation (C00064/3).</li> </ul>	
C00064/2	Device utilisation (lxt) 15s <ul style="list-style-type: none"> <li>Pulse utilisation over the last 15 seconds (only for loads &gt;160 %).</li> </ul>	
C00064/3	Device utilisation (lxt) 3 min <ul style="list-style-type: none"> <li>Permanent utilisation over the last 3 minutes.</li> </ul>	
<input checked="" type="checkbox"/> Read access <input type="checkbox"/> Write access <input type="checkbox"/> CINH <input type="checkbox"/> PLC STOP <input checked="" type="checkbox"/> No transfer <input type="checkbox"/> COM <input type="checkbox"/> MOT                   Scaling factor: 100		

### C00066

Parameter   Name: <b>C00066   Thermal motor load (l²xt)</b>		Data type: INTEGER_16 Index: 24509 <sub>d</sub> = 5FBD <sub>h</sub>
Display of the thermal motor load being detected sensorless via a motor model <ul style="list-style-type: none"> <li>If the value displayed here exceeds the threshold set in <a href="#">C00120</a>, the fault message "OC6: Thermal motor overload (l²xt)" is output and the fault response set in <a href="#">C00606</a> is executed (default setting: "Warning").</li> </ul>		
<b>Display range (min. value   unit   max. value)</b>		
0	%	200
<input checked="" type="checkbox"/> Read access <input type="checkbox"/> Write access <input type="checkbox"/> CINH <input type="checkbox"/> PLC STOP <input checked="" type="checkbox"/> No transfer <input type="checkbox"/> COM <input type="checkbox"/> MOT                   Scaling factor: 100		

# 9 Parameter reference

## 9.2 Parameter list | C00073

### C00073

Parameter   Name: <b>C00073   Vp I<sub>max</sub> controller</b>		Data type: UNSIGNED_16 Index: 24502 <sub>d</sub> = 5FB6 <sub>h</sub>	
Amplification factor V <sub>p</sub> for I <sub>max</sub> controller			
<b>Setting range</b> (min. value   unit   max. value)		<b>Lenze setting</b>	
0.00		16.00	<b>0.25</b>
<input checked="" type="checkbox"/> Read access <input checked="" type="checkbox"/> Write access <input type="checkbox"/> CINH <input type="checkbox"/> PLC STOP <input type="checkbox"/> No transfer <input type="checkbox"/> COM <input checked="" type="checkbox"/> MOT                   Scaling factor: 100			

### C00074

Parameter   Name: <b>C00074   T<sub>i</sub> I<sub>max</sub> controller</b>		Data type: UNSIGNED_16 Index: 24501 <sub>d</sub> = 5FB5 <sub>h</sub>	
Reset time T <sub>i</sub> for I <sub>max</sub> controller			
<b>Setting range</b> (min. value   unit   max. value)		<b>Lenze setting</b>	
12	ms	9990	<b>65 ms</b>
<input checked="" type="checkbox"/> Read access <input checked="" type="checkbox"/> Write access <input type="checkbox"/> CINH <input type="checkbox"/> PLC STOP <input type="checkbox"/> No transfer <input type="checkbox"/> COM <input checked="" type="checkbox"/> MOT                   Scaling factor: 1			

### C00081

Parameter   Name: <b>C00081   Rated motor power</b>		Data type: UNSIGNED_16 Index: 24494 <sub>d</sub> = 5FAE <sub>h</sub>	
This value can be obtained from the motor nameplate. After the motor to be used has been selected from the motor catalogue, the suitable value can be entered automatically.			
<b>Note:</b> It is mandatory to give the rated motor power for the sensorless vector control ( <a href="#">SLVC</a> ).			
<b>Setting range</b> (min. value   unit   max. value)		<b>Lenze setting</b>	
0.00	kW	99.00	<b>11.00 kW</b>
<input checked="" type="checkbox"/> Read access <input checked="" type="checkbox"/> Write access <input type="checkbox"/> CINH <input type="checkbox"/> PLC STOP <input type="checkbox"/> No transfer <input type="checkbox"/> COM <input checked="" type="checkbox"/> MOT                   Scaling factor: 100			

### C00084

Parameter   Name: <b>C00084   Motor stator resistance</b>		Data type: UNSIGNED_32 Index: 24491 <sub>d</sub> = 5FAB <sub>h</sub>	
After the motor to be used has been selected from the motor catalogue, the suitable value can be entered automatically. An automatic detection via the motor parameter identification is possible as well.			
<b>Setting range</b> (min. value   unit   max. value)		<b>Lenze setting</b>	
0	mohm	200000	<b>330 mohm</b>
<input checked="" type="checkbox"/> Read access <input checked="" type="checkbox"/> Write access <input type="checkbox"/> CINH <input type="checkbox"/> PLC STOP <input type="checkbox"/> No transfer <input type="checkbox"/> COM <input checked="" type="checkbox"/> MOT                   Scaling factor: 1			

### C00085

Parameter   Name: <b>C00085   Motor stator leakage inductance</b>		Data type: UNSIGNED_16 Index: 24490 <sub>d</sub> = 5FAA <sub>h</sub>	
After the motor to be used has been selected from the motor catalogue, the suitable value can be entered automatically. An automatic detection via the motor parameter identification is possible as well.			
<b>Setting range</b> (min. value   unit   max. value)		<b>Lenze setting</b>	
0.00	mH	650.00	<b>0.00 mH</b>
<input checked="" type="checkbox"/> Read access <input checked="" type="checkbox"/> Write access <input type="checkbox"/> CINH <input type="checkbox"/> PLC STOP <input type="checkbox"/> No transfer <input type="checkbox"/> COM <input checked="" type="checkbox"/> MOT                   Scaling factor: 100			

# 9 Parameter reference

## 9.2 Parameter list | C00087

### C00087

Parameter   Name: <b>C00087   Rated motor speed</b>		Data type: UNSIGNED_16 Index: 24488 <sub>d</sub> = 5FA8 <sub>h</sub>	
This value can be obtained from the motor nameplate. After the motor to be used has been selected from the motor catalogue, the suitable value can be entered automatically.			
<b>Note:</b> It is mandatory to give the rated motor speed for the sensorless vector control ( <a href="#">SLVC</a> ).			
<b>Setting range (min. value   unit   max. value)</b>		<b>Lenze setting</b>	
50	rpm	9999	<b>1460 rpm</b>
<input checked="" type="checkbox"/> Read access <input checked="" type="checkbox"/> Write access <input type="checkbox"/> CINH <input type="checkbox"/> PLC STOP <input type="checkbox"/> No transfer <input type="checkbox"/> COM <input checked="" type="checkbox"/> MOT Scaling factor: 1			

### C00088

Parameter   Name: <b>C00088   Rated motor current</b>		Data type: UNSIGNED_16 Index: 24487 <sub>d</sub> = 5FA7 <sub>h</sub>	
This value can be obtained from the motor nameplate. After the motor to be used has been selected from the motor catalogue, the suitable value can be entered automatically.			
<b>Note:</b> It is mandatory to give the rated motor current for the sensorless vector control ( <a href="#">SLVC</a> ).			
<b>Setting range (min. value   unit   max. value)</b>		<b>Lenze setting</b>	
0.00	A	99.00	<b>21.00 A</b>
<input checked="" type="checkbox"/> Read access <input checked="" type="checkbox"/> Write access <input type="checkbox"/> CINH <input type="checkbox"/> PLC STOP <input type="checkbox"/> No transfer <input type="checkbox"/> COM <input checked="" type="checkbox"/> MOT Scaling factor: 100			

### C00089

Parameter   Name: <b>C00089   Rated motor frequency</b>		Data type: UNSIGNED_16 Index: 24486 <sub>d</sub> = 5FA6 <sub>h</sub>	
This value can be obtained from the motor nameplate. After the motor to be used has been selected from the motor catalogue, the suitable value can be entered automatically.			
<b>Note:</b> It is mandatory to give the rated motor frequency for the sensorless vector control ( <a href="#">SLVC</a> ).			
<b>Setting range (min. value   unit   max. value)</b>		<b>Lenze setting</b>	
10	Hz	1000	<b>50 Hz</b>
<input checked="" type="checkbox"/> Read access <input checked="" type="checkbox"/> Write access <input type="checkbox"/> CINH <input type="checkbox"/> PLC STOP <input type="checkbox"/> No transfer <input type="checkbox"/> COM <input checked="" type="checkbox"/> MOT Scaling factor: 1			

### C00090

Parameter   Name: <b>C00090   Rated motor voltage</b>		Data type: UNSIGNED_16 Index: 24485 <sub>d</sub> = 5FA5 <sub>h</sub>	
This value can be obtained from the motor nameplate. After the motor to be used has been selected from the motor catalogue, the suitable value can be entered automatically.			
<b>Setting range (min. value   unit   max. value)</b>		<b>Lenze setting</b>	
0	V	1000	<b>400 V</b>
<input checked="" type="checkbox"/> Read access <input checked="" type="checkbox"/> Write access <input type="checkbox"/> CINH <input type="checkbox"/> PLC STOP <input type="checkbox"/> No transfer <input type="checkbox"/> COM <input checked="" type="checkbox"/> MOT Scaling factor: 1			

# 9 Parameter reference

## 9.2 Parameter list | C00091

### C00091

Parameter   Name: <b>C00091   Motor cosine phi</b>		Data type: UNSIGNED_8 Index: 24484 <sub>d</sub> = 5FA4 <sub>h</sub>	
This value can be obtained from the motor nameplate. After the motor to be used has been selected from the motor catalogue, the suitable value can be entered automatically.			
<b>Setting range (min. value   unit   max. value)</b>		<b>Lenze setting</b>	
0.40		1.00	<b>0.85</b>
<input checked="" type="checkbox"/> Read access <input checked="" type="checkbox"/> Write access <input type="checkbox"/> CINH <input type="checkbox"/> PLC STOP <input type="checkbox"/> No transfer <input type="checkbox"/> COM <input checked="" type="checkbox"/> MOT                 Scaling factor: 100			

### C00092

Parameter   Name: <b>C00092   Motor magnetising inductance</b>		Data type: UNSIGNED_16 Index: 24483 <sub>d</sub> = 5FA3 <sub>h</sub>	
After the motor to be used has been selected from the motor catalogue, the suitable value can be entered automatically. An automatic detection via the motor parameter identification is possible as well.			
<b>Setting range (min. value   unit   max. value)</b>		<b>Lenze setting</b>	
0.0	mH	6500.0	<b>0.0 mH</b>
<input checked="" type="checkbox"/> Read access <input checked="" type="checkbox"/> Write access <input type="checkbox"/> CINH <input type="checkbox"/> PLC STOP <input type="checkbox"/> No transfer <input type="checkbox"/> COM <input checked="" type="checkbox"/> MOT                 Scaling factor: 10			

### C00093

Parameter   Name: <b>C00093   Power section identification</b>		Data type: UNSIGNED_16 Index: 24482 <sub>d</sub> = 5FA2 <sub>h</sub>	
Display of the identification of the detected power section of the controller			
<b>Display range (min. value   unit   max. value)</b>			
0		65535	
<input checked="" type="checkbox"/> Read access <input type="checkbox"/> Write access <input type="checkbox"/> CINH <input type="checkbox"/> PLC STOP <input checked="" type="checkbox"/> No transfer <input type="checkbox"/> COM <input type="checkbox"/> MOT                 Scaling factor: 1			

### C00094

Parameter   Name: <b>C00094   Password</b>		Data type: INTEGER_32 Index: 24481 <sub>d</sub> = 5FA1 <sub>h</sub>	
The controller provides the opportunity to protect the menu level from unauthorised access by assigning a password.			
<a href="#">▶ Password protection</a>			
<b>Setting range (min. value   unit   max. value)</b>		<b>Lenze setting</b>	
0		9999	<b>0</b>
<input checked="" type="checkbox"/> Read access <input checked="" type="checkbox"/> Write access <input type="checkbox"/> CINH <input type="checkbox"/> PLC STOP <input type="checkbox"/> No transfer <input type="checkbox"/> COM <input type="checkbox"/> MOT                 Scaling factor: 1			

### C00095

Parameter   Name: <b>C00095   Motor magnetising current</b>		Data type: UNSIGNED_16 Index: 24480 <sub>d</sub> = 5FA0 <sub>h</sub>	
<b>As of version 03.00.00</b>			
After the motor to be used has been selected from the motor catalogue, the suitable value can be entered automatically. An automatic detection via the motor parameter identification is possible as well.			
<b>Display range (min. value   unit   max. value)</b>			
0.00	A	99.00	
<input checked="" type="checkbox"/> Read access <input type="checkbox"/> Write access <input type="checkbox"/> CINH <input type="checkbox"/> PLC STOP <input type="checkbox"/> No transfer <input type="checkbox"/> COM <input checked="" type="checkbox"/> MOT                 Scaling factor: 100			

# 9 Parameter reference

## 9.2 Parameter list | C00097

### C00097

Parameter   Name: <b>C00097   Rated motor torque</b>		Data type: UNSIGNED_32 Index: 24478 <sub>d</sub> = 5F9E <sub>h</sub>
Display of the rated motor torque <ul style="list-style-type: none"> <li>The value displayed here is calculated from different parameters, e.g. the maximum current set in <a href="#">C00022</a>.</li> </ul>		
<b>Display range (min. value   unit   max. value)</b>		
0.00	Nm	99.00
<input checked="" type="checkbox"/> Read access <input type="checkbox"/> Write access <input type="checkbox"/> CINH <input type="checkbox"/> PLC STOP <input checked="" type="checkbox"/> No transfer <input type="checkbox"/> COM <input type="checkbox"/> MOT         Scaling factor: 100		

### C00098

Parameter   Name: <b>C00098   Device rated current</b>		Data type: UNSIGNED_16 Index: 24477 <sub>d</sub> = 5F9D <sub>h</sub>
Display of the rated inverter current which is defined by the integrated power section.		
<b>Display range (min. value   unit   max. value)</b>		
0.0	A	999.0
<input checked="" type="checkbox"/> Read access <input type="checkbox"/> Write access <input type="checkbox"/> CINH <input type="checkbox"/> PLC STOP <input checked="" type="checkbox"/> No transfer <input type="checkbox"/> COM <input type="checkbox"/> MOT         Scaling factor: 10		

### C00099

Parameter   Name: <b>C00099   Firmware version</b>		Data type: VISIBLE_STRING Index: 24476 <sub>d</sub> = 5F9C <sub>h</sub>
Display of the firmware version of the device as string		
<input checked="" type="checkbox"/> Read access <input type="checkbox"/> Write access <input type="checkbox"/> CINH <input type="checkbox"/> PLC STOP <input checked="" type="checkbox"/> No transfer <input type="checkbox"/> COM <input type="checkbox"/> MOT		

### C00100

Parameter   Name: <b>C00100   Firmware version</b>		Data type: UNSIGNED_8 Index: 24475 <sub>d</sub> = 5F9B <sub>h</sub>
Display of the firmware version of the device, divided into subsections.		
<b>Display range (min. value   unit   max. value)</b>		
0		99
<b>Subcodes</b>		<b>Info</b>
C00100/1		Firmware version - main version
C00100/2		Firmware version - subversion
C00100/3		Firmware version - release
C00100/4		Firmware version - build
<input checked="" type="checkbox"/> Read access <input type="checkbox"/> Write access <input type="checkbox"/> CINH <input type="checkbox"/> PLC STOP <input checked="" type="checkbox"/> No transfer <input type="checkbox"/> COM <input type="checkbox"/> MOT         Scaling factor: 1		



# 9 Parameter reference

## 9.2 Parameter list | C00105

### C00105

Parameter   Name: <b>C00105   Deceleration time quick stop</b>		Data type: UNSIGNED_32 Index: 24470 <sub>d</sub> = 5F96 <sub>h</sub>	
The set deceleration time determines the ramp slope at quick stop <ul style="list-style-type: none"><li>When the output frequency falls below the threshold set in <a href="#">C00019</a>, the DC injection brake DCB is activated.</li></ul>			
<b>Note:</b> The S-ramp time set in <a href="#">C00182</a> is also active with quick stop! In order to reach the required deceleration time for quick stop, set the time accordingly lower in this parameter.			
<b>Setting range (min. value   unit   max. value)</b>		<b>Lenze setting</b>	
0.0	s	999.9	<b>5.0 s</b>
<input checked="" type="checkbox"/> Read access <input checked="" type="checkbox"/> Write access <input type="checkbox"/> CINH <input type="checkbox"/> PLC STOP <input type="checkbox"/> No transfer <input type="checkbox"/> COM <input type="checkbox"/> MOT			Scaling factor: 1000

### C00106

Parameter   Name: <b>C00106   Auto DCB: Hold time</b>		Data type: UNSIGNED_32 Index: 24469 <sub>d</sub> = 5F95 <sub>h</sub>	
Hold time of the automatic DC injection brake <ul style="list-style-type: none"><li>The DC injection brake is applied for the time set here if the value falls below the speed setpoint set in <a href="#">C00019</a>.</li></ul>			
<b>Setting range (min. value   unit   max. value)</b>		<b>Lenze setting</b>	
0.0	s	999.0	<b>0.5 s</b>
<input checked="" type="checkbox"/> Read access <input checked="" type="checkbox"/> Write access <input type="checkbox"/> CINH <input type="checkbox"/> PLC STOP <input type="checkbox"/> No transfer <input type="checkbox"/> COM <input type="checkbox"/> MOT			Scaling factor: 1000

### C00107

Parameter   Name: <b>C00107   DCB: Hold time</b>		Data type: UNSIGNED_32 Index: 24468 <sub>d</sub> = 5F94 <sub>h</sub>	
Maximum hold time of the manual DC injection brake <ul style="list-style-type: none"><li>In order not to overload the motor thermally, a time for automatic switch-off of the DC injection brake can be set here.</li></ul>			
<b>Setting range (min. value   unit   max. value)</b>		<b>Lenze setting</b>	
0.0	s	999.0	<b>999.0 s</b>
<input checked="" type="checkbox"/> Read access <input checked="" type="checkbox"/> Write access <input type="checkbox"/> CINH <input type="checkbox"/> PLC STOP <input type="checkbox"/> No transfer <input type="checkbox"/> COM <input type="checkbox"/> MOT			Scaling factor: 1000

## C00114

Parameter   Name: <b>C00114   DIx inversion</b>		Data type: UNSIGNED_16 Index: 24461 <sub>d</sub> = 5F8D <sub>h</sub>	
Polarity of the digital inputs <ul style="list-style-type: none"> <li>Every digital input of the device can be inverted with regard to polarity via this bit field.</li> </ul> <p style="text-align: right;"><a href="#">▶ Digital terminals</a></p>			
Setting range (min. hex value   max. hex value)		Lenze setting	
0x0000		0xFFFF	<b>0x8000</b> (decimal: 32768)
Value is bit-coded: ( <input checked="" type="checkbox"/> = bit set)		Info	
Bit 0 <input type="checkbox"/>	DI1 inverted	Inversion of digital input 1	
Bit 1 <input type="checkbox"/>	DI2 inverted	Inversion of digital input 2	
Bit 2 <input type="checkbox"/>	DI3 inverted	Inversion of digital input 3	
Bit 3 <input type="checkbox"/>	DI4 inverted	Inversion of digital input 4	
Bit 4 <input type="checkbox"/>	Reserved		
Bit 5 <input type="checkbox"/>	Reserved		
Bit 6 <input type="checkbox"/>	Reserved		
Bit 7 <input type="checkbox"/>	Reserved		
Bit 8 <input type="checkbox"/>	Reserved		
Bit 9 <input type="checkbox"/>	Reserved		
Bit 10 <input type="checkbox"/>	Reserved		
Bit 11 <input type="checkbox"/>	Reserved		
Bit 12 <input type="checkbox"/>	Reserved		
Bit 13 <input type="checkbox"/>	Reserved		
Bit 14 <input type="checkbox"/>	Reserved		
Bit 15 <input checked="" type="checkbox"/>	RFR inverted	Inversion of RFR digital input (controller enable)	
<input checked="" type="checkbox"/> Read access <input checked="" type="checkbox"/> Write access <input type="checkbox"/> CINH <input type="checkbox"/> PLC STOP <input type="checkbox"/> No transfer <input type="checkbox"/> COM <input type="checkbox"/> MOT			

## C00118

Parameter   Name: <b>C00118   DOx inversion</b>		Data type: UNSIGNED_8 Index: 24457 <sub>d</sub> = 5F89 <sub>h</sub>	
Polarity of the digital outputs <ul style="list-style-type: none"> <li>Every digital output of the device can be inverted with regard to polarity via this bit field.</li> </ul> <p style="text-align: right;"><a href="#">▶ Digital terminals</a></p>			
Setting range (min. hex value   max. hex value)		Lenze setting	
0x00		0xFF	<b>0x00</b> (decimal: 0)
Value is bit-coded: ( <input checked="" type="checkbox"/> = bit set)		Info	
Bit 0 <input type="checkbox"/>	Relay inverted	Relay inversion	
Bit 1 <input type="checkbox"/>	DO1 inverted	Inversion of digital output 1	
Bit 2 <input type="checkbox"/>	Reserved		
Bit 3 <input type="checkbox"/>	Reserved		
Bit 4 <input type="checkbox"/>	Reserved		
Bit 5 <input type="checkbox"/>	Reserved		
Bit 6 <input type="checkbox"/>	Reserved		
Bit 7 <input type="checkbox"/>	Reserved		
<input checked="" type="checkbox"/> Read access <input checked="" type="checkbox"/> Write access <input type="checkbox"/> CINH <input type="checkbox"/> PLC STOP <input type="checkbox"/> No transfer <input type="checkbox"/> COM <input type="checkbox"/> MOT			

# 9 Parameter reference

## 9.2 Parameter list | C00120

### C00120

Parameter   Name: <b>C00120   Motor overload threshold (I²xt)</b>		Data type: INTEGER_16 Index: 24455 <sub>d</sub> = 5F87 <sub>h</sub>
Operating threshold for the error message "OC6: Motor overload (I²xt)" <ul style="list-style-type: none"> <li>• The response for reaching the threshold can be selected in <a href="#">C00606</a>.</li> <li>• The current thermal motor load is displayed in <a href="#">C00066</a>.</li> </ul> <p style="text-align: right;">▶ <a href="#">Motor overload monitoring (I2xt)</a></p>		
<b>Setting range (min. value   unit   max. value)</b>		<b>Lenze setting</b>
0	%	250 <b>100 %</b>
<input checked="" type="checkbox"/> Read access <input checked="" type="checkbox"/> Write access <input type="checkbox"/> CINH <input type="checkbox"/> PLC STOP <input type="checkbox"/> No transfer <input type="checkbox"/> COM <input type="checkbox"/> MOT                   Scaling factor: 100		

### C00122

Parameter   Name: <b>C00122   Initial value motor overload (I²xt)</b>		Data type: UNSIGNED_16 Index: 24453 <sub>d</sub> = 5F85 <sub>h</sub>
From version 03.04.00 The thermal motor load displayed in <a href="#">C00066</a> is pre-initialised with the value set here when the device is connected to the mains. <ul style="list-style-type: none"> <li>• If "100.00 %" is set, the last value at switching off the device is used for the initialisation.</li> <li>• Recommended setting for operation according to UL: 50.00 %</li> </ul> <p style="text-align: right;">▶ <a href="#">Motor overload monitoring (I2xt)</a></p>		
<b>Setting range (min. value   unit   max. value)</b>		
0.00	%	100.00
<b>Subcodes</b>	<b>Lenze setting</b>	<b>Info</b>
C00122/1	0.00 %	Initial value motor overload (I²xt)
<input checked="" type="checkbox"/> Read access <input checked="" type="checkbox"/> Write access <input type="checkbox"/> CINH <input type="checkbox"/> PLC STOP <input type="checkbox"/> No transfer <input type="checkbox"/> COM <input checked="" type="checkbox"/> MOT                   Scaling factor: 100		

### C00123

Parameter   Name: <b>C00123   Device utilisation threshold (Ixt)</b>		Data type: INTEGER_16 Index: 24452 <sub>d</sub> = 5F84 <sub>h</sub>
Operating threshold for the error message "OC5: Device overload (Ixt)" <ul style="list-style-type: none"> <li>• The response for reaching the threshold can be selected in <a href="#">C00604</a>.</li> <li>• The current device utilisation is displayed in <a href="#">C00064</a>.</li> </ul>		
<b>Setting range (min. value   unit   max. value)</b>		<b>Lenze setting</b>
0	%	100 <b>100 %</b>
<input checked="" type="checkbox"/> Read access <input checked="" type="checkbox"/> Write access <input type="checkbox"/> CINH <input type="checkbox"/> PLC STOP <input type="checkbox"/> No transfer <input type="checkbox"/> COM <input type="checkbox"/> MOT                   Scaling factor: 100		

### C00134

Parameter   Name: <b>C00134   Ramp smoothing, main setpoint</b>		Data type: UNSIGNED_8 Index: 24441 <sub>d</sub> = 5F79 <sub>h</sub>
FB <a href="#">L_NSet_1</a> : Configuration of the ramp smoothing for the main setpoint		
<b>Selection list (Lenze setting printed in bold)</b>		<b>Info</b>
<b>0</b>	<b>Off</b>	Ramp rounding deactivated
1	PT1 behaviour	Ramp rounding with PT1 behaviour <ul style="list-style-type: none"> <li>• The corresponding S-ramp time must be set in <a href="#">C00182</a>.</li> </ul>
<input checked="" type="checkbox"/> Read access <input checked="" type="checkbox"/> Write access <input type="checkbox"/> CINH <input type="checkbox"/> PLC STOP <input type="checkbox"/> No transfer <input type="checkbox"/> COM <input type="checkbox"/> MOT                   Scaling factor: 1		

# 9 Parameter reference

## 9.2 Parameter list | C00137

### C00137

Parameter   Name: <b>C00137   Device state</b>		Data type: UNSIGNED_16 Index: 24438 <sub>d</sub> = 5F76 <sub>h</sub>
Display of the current device state		
<b>Selection list (read only)</b>		
0	Reserved	
1	Init	
2	MotorIdent	
3	ReadyToSwitchON	
4	SwitchedON	
5	OperationEnable	
6	Reserved	
7	Trouble	
8	Fault	
9	Reserved	
10	SafeTorqueOff	
11	Reserved	
12	Reserved	
13	Reserved	
14	Reserved	
15	Reserved	
<input checked="" type="checkbox"/> Read access <input type="checkbox"/> Write access <input type="checkbox"/> CINH <input type="checkbox"/> PLC STOP <input checked="" type="checkbox"/> No transfer <input type="checkbox"/> COM <input type="checkbox"/> MOT                   Scaling factor: 1		

### C00141

Parameter   Name: <b>C00141   Device settings</b>		Data type: UNSIGNED_8 Index: 24434 <sub>d</sub> = 5F72 <sub>h</sub>
As of version 03.00.00		
<b>Selection list</b>		
0	Inactive	
1	Active	
<b>Subcodes</b>	<b>Lenze setting</b>	<b>Info</b>
C00141/1	0: Inactive	Always save parameters <ul style="list-style-type: none"> <li>When this function is activated, every parameter change is saved in the memory module. A manual saving of parameter sets is not required anymore.</li> </ul> <b>Note:</b> Activating this function is not permissible if parameters are changed very frequently (e.g. in case of cyclic writing of parameters via a bus system).
<input checked="" type="checkbox"/> Read access <input checked="" type="checkbox"/> Write access <input type="checkbox"/> CINH <input type="checkbox"/> PLC STOP <input type="checkbox"/> No transfer <input type="checkbox"/> COM <input type="checkbox"/> MOT                   Scaling factor: 1		

# 9 Parameter reference

## 9.2 Parameter list | C00142

### C00142

Parameter   Name: <b>C00142   Auto-start option</b>		Data type: UNSIGNED_8 Index: 24433 <sub>d</sub> = 5F71 <sub>h</sub>	
Starting performance of the controller after mains connection and reset of "Trouble" or "Fault". ▶ <a href="#">"Inhibit at power-on" auto-start option</a>			
<b>Setting range</b> (min. hex value   max. hex value)		<b>Lenze setting</b>	
0x00		0xFF	<b>0x01</b> (decimal: 1)
<b>Value is bit-coded: (<input checked="" type="checkbox"/> = bit set)</b>			
Bit 0 <input checked="" type="checkbox"/>	Inhibit at mains ON		
Bit 1 <input type="checkbox"/>	Inhibit at trouble		
Bit 2 <input type="checkbox"/>	Inhibit at fault		
Bit 3 <input type="checkbox"/>	Reserved		
Bit 4 <input type="checkbox"/>	Reserved		
Bit 5 <input type="checkbox"/>	Reserved		
Bit 6 <input type="checkbox"/>	Reserved		
Bit 7 <input type="checkbox"/>	Reserved		
<input checked="" type="checkbox"/> Read access <input checked="" type="checkbox"/> Write access <input type="checkbox"/> CINH <input type="checkbox"/> PLC STOP <input type="checkbox"/> No transfer <input type="checkbox"/> COM <input type="checkbox"/> MOT			

### C00144

Parameter   Name: <b>C00144   Switching frequency reduction (temp.)</b>		Data type: UNSIGNED_8 Index: 24431 <sub>d</sub> = 5F6F <sub>h</sub>	
Activation of the automatic switching frequency reduction at too high temperature			
<b>Selection list</b> (Lenze setting printed in bold)		<b>Info</b>	
0	Off	Automatic switching frequency reduction deactivated	
<b>1</b>	<b>On</b>	Automatic switching frequency reduction activated	
<input checked="" type="checkbox"/> Read access <input checked="" type="checkbox"/> Write access <input type="checkbox"/> CINH <input type="checkbox"/> PLC STOP <input type="checkbox"/> No transfer <input type="checkbox"/> COM <input type="checkbox"/> MOT                   Scaling factor: 1			

## C00150

Parameter   Name: <b>C00150   Status word</b>		Data type: UNSIGNED_16 Index: 24425 <sub>d</sub> = 5F69 <sub>h</sub>
Bit-coded device status word		
<b>Display area (min. hex value   max. hex value)</b>		
0x0000		0xFFFF
<b>Value is bit-coded:</b>		<b>Info</b>
Bit 0	FreeStatusBit0	Free status bit 0
Bit 1	PowerDisabled	Power switched off
Bit 2	FreeStatusBit2	Free status bit 2
Bit 3	FreeStatusBit3	Free status bit 3
Bit 4	FreeStatusBit4	Free status bit 4
Bit 5	FreeStatusBit5	Free status bit 5
Bit 6	ActSpeedIsZero	Current speed is 0
Bit 7	ControllerInhibit	Controller is inhibited
Bit 8	StatusCodeBit0	Status code bit 0
Bit 9	StatusCodeBit1	Status code bit 1
Bit 10	StatusCodeBit2	Status code bit 2
Bit 11	StatusCodeBit3	Status code bit 3
Bit 12	Warning	Warning
Bit 13	Trouble	Fault
Bit 14	FreeStatusBit14	Free status bit 14
Bit 15	FreeStatusBit15	Free status bit 15
<input checked="" type="checkbox"/> Read access <input type="checkbox"/> Write access <input type="checkbox"/> CINH <input type="checkbox"/> PLC STOP <input checked="" type="checkbox"/> No transfer <input type="checkbox"/> COM <input type="checkbox"/> MOT		

## C00155

Parameter   Name: <b>C00155   Status word 2</b>		Data type: UNSIGNED_16 Index: 24420 <sub>d</sub> = 5F64 <sub>h</sub>
Bit-coded device status word 2		
<b>Display area (min. hex value   max. hex value)</b>		
0x0000		0xFFFF
<b>Value is bit-coded:</b>		<b>Info</b>
Bit 0	Fail	Error
Bit 1	M_max	Maximum torque
Bit 2	I_max	Maximum current
Bit 3	PowerDisabled	Power switched off
Bit 4	Ready	Controller is ready for operation
Bit 5	ControllerInhibit	Controller is inhibited
Bit 6	Trouble	Fault
Bit 7	InitState	Initialisation
Bit 8	CwCcw	CW/CCW rotation
Bit 9	Reserved	
Bit 10	SafeTorqueOff	Safe torque off
Bit 11	Reserved	
Bit 12	Reserved	
Bit 13	Reserved	
Bit 14	Quick stop	Quick stop is active
Bit 15	MotorIdent	Motor parameter identification active
<input checked="" type="checkbox"/> Read access <input type="checkbox"/> Write access <input type="checkbox"/> CINH <input type="checkbox"/> PLC STOP <input checked="" type="checkbox"/> No transfer <input type="checkbox"/> COM <input type="checkbox"/> MOT		

# 9 Parameter reference

## 9.2 Parameter list | C00158

### C00158

Parameter   Name: <b>C00158   Cause for controller inhibit</b>		Data type: UNSIGNED_16 Index: 24417 <sub>d</sub> = 5F61 <sub>h</sub>
Bit-coded display of the cause/source of controller inhibit		
<b>Display area (min. hex value   max. hex value)</b>		
0x0000		0xFFFF
<b>Value is bit-coded:</b>		
Bit 0	Terminal controller enable	
Bit 1	Reserved	
Bit 2	Reserved	
Bit 3	Reserved	
Bit 4	Application	
Bit 5	Device command	
Bit 6	Error response	
Bit 7	Reserved	
Bit 8	Reserved	
Bit 9	Reserved	
Bit 10	AutoStartLock	
Bit 11	Motor parameter identification	
Bit 12	Reserved	
Bit 13	DCB-IMP	
Bit 14	Reserved	
Bit 15	Reserved	
<input checked="" type="checkbox"/> Read access <input type="checkbox"/> Write access <input type="checkbox"/> CINH <input type="checkbox"/> PLC STOP <input checked="" type="checkbox"/> No transfer <input type="checkbox"/> COM <input type="checkbox"/> MOT		



## C00159

Parameter   Name: <b>C00159   Cause for quick stop QSP</b>		Data type: UNSIGNED_16 Index: 24416 <sub>d</sub> = 5F60 <sub>h</sub>
Bit-coded display of the cause/source of quick stop		
<b>Display area (min. hex value   max. hex value)</b>		
0x0000		0xFFFF
<b>Value is bit-coded:</b>		
Bit 0	Terminal	
Bit 1	Reserved	
Bit 2	Reserved	
Bit 3	Reserved	
Bit 4	Application	
Bit 5	Device command	
Bit 6	Reserved	
Bit 7	Reserved	
Bit 8	Reserved	
Bit 9	Reserved	
Bit 10	Reserved	
Bit 11	Reserved	
Bit 12	Reserved	
Bit 13	Reserved	
Bit 14	Reserved	
Bit 15	Reserved	
<input checked="" type="checkbox"/> Read access <input type="checkbox"/> Write access <input type="checkbox"/> CINH <input type="checkbox"/> PLC STOP <input checked="" type="checkbox"/> No transfer <input type="checkbox"/> COM <input type="checkbox"/> MOT		

## C00165

Parameter   Name: <b>C00165   Error information</b>		Data type: VISIBLE_STRING Index: 24410 <sub>d</sub> = 5F5A <sub>h</sub>
Display of the error numbers divided into sectors in the case of an error		
<b>Subcodes</b>		<b>Info</b>
C00165/1		Current error
<input checked="" type="checkbox"/> Read access <input type="checkbox"/> Write access <input type="checkbox"/> CINH <input type="checkbox"/> PLC STOP <input checked="" type="checkbox"/> No transfer <input type="checkbox"/> COM <input type="checkbox"/> MOT		

## C00166

Parameter   Name: <b>C00166   Error information text</b>		Data type: VISIBLE_STRING Index: 24409 <sub>d</sub> = 5F59 <sub>h</sub>
Display of details of the currently pending error		
<b>Subcodes</b>		<b>Info</b>
C00166/1		Resp. - current error • Response of the currently pending error
C00166/2		Subj.area curr. error • Subject area of the currently pending error
C00166/3		Mess.curr.error • Textual message of the currently pending error
<input checked="" type="checkbox"/> Read access <input type="checkbox"/> Write access <input type="checkbox"/> CINH <input type="checkbox"/> PLC STOP <input checked="" type="checkbox"/> No transfer <input type="checkbox"/> COM <input type="checkbox"/> MOT		

# 9 Parameter reference

## 9.2 Parameter list | C00167

### C00167

Parameter   Name: <b>C00167   Logbook data</b>	Data type: OCTET_STRING Index: 24408 <sub>d</sub> = 5F58 <sub>h</sub>
<b>This code is for device-internal use only and must not be written to by the user!</b>	

### C00168

Parameter   Name: <b>C00168   Error number</b>	Data type: UNSIGNED_32 Index: 24407 <sub>d</sub> = 5F57 <sub>h</sub>
<b>Display range (min. value   unit   max. value)</b>	
0	4294967295
<b>Subcodes</b>	<b>Info</b>
C00168/1	Display of the internal error number for the last 8 occurred errors
C00168/...	
C00168/8	
<input checked="" type="checkbox"/> Read access <input type="checkbox"/> Write access <input type="checkbox"/> CINH <input type="checkbox"/> PLC STOP <input checked="" type="checkbox"/> No transfer <input type="checkbox"/> COM <input type="checkbox"/> MOT           Scaling factor: 1	

### C00169

Parameter   Name: <b>C00169   Time of error</b>	Data type: UNSIGNED_32 Index: 24406 <sub>d</sub> = 5F56 <sub>h</sub>
<b>Display range (min. value   unit   max. value)</b>	
0	4294967295
<b>Subcodes</b>	<b>Info</b>
C00169/1	Display of the time of error for the last 8 occurred errors
C00169/...	
C00169/8	
<input checked="" type="checkbox"/> Read access <input type="checkbox"/> Write access <input type="checkbox"/> CINH <input type="checkbox"/> PLC STOP <input checked="" type="checkbox"/> No transfer <input type="checkbox"/> COM <input type="checkbox"/> MOT           Scaling factor: 1	

### C00170

Parameter   Name: <b>C00170   Error counter</b>	Data type: UNSIGNED_8 Index: 24405 <sub>d</sub> = 5F55 <sub>h</sub>
<b>Display range (min. value   unit   max. value)</b>	
0	255
<b>Subcodes</b>	<b>Info</b>
C00170/1	Display of the error counter for the last 8 occurred errors
C00170/...	
C00170/8	
<input checked="" type="checkbox"/> Read access <input type="checkbox"/> Write access <input type="checkbox"/> CINH <input type="checkbox"/> PLC STOP <input checked="" type="checkbox"/> No transfer <input type="checkbox"/> COM <input type="checkbox"/> MOT           Scaling factor: 1	

### C00171

Parameter   Name: <b>C00171   Logbook access index</b>	Data type: UNSIGNED_8 Index: 24404 <sub>d</sub> = 5F54 <sub>h</sub>
<b>This code is for device-internal use only and must not be written to by the user!</b>	

# 9 Parameter reference

## 9.2 Parameter list | C00173

### C00173

Parameter   Name: <b>C00173   Mains voltage</b>		Data type: UNSIGNED_8 Index: 24402 <sub>d</sub> = 5F52 <sub>h</sub>
Selection of the mains voltage for operating the device.		
Selection list (Lenze setting printed in bold)		Info
0	<b>3ph 400V / 1ph 230V</b>	3-phase 400 V or 1-phase 230 V
1	3ph 440V / 1ph 230V	3-phase 440 V or 1-phase 230 V
2	3ph 480V / 1ph 230V	3-phase 480 V or 1-phase 230 V
3	3ph 500V / 1ph 230V	3-phase 500 V or 1-phase 230 V
<input checked="" type="checkbox"/> Read access <input checked="" type="checkbox"/> Write access <input checked="" type="checkbox"/> CINH <input type="checkbox"/> PLC STOP <input type="checkbox"/> No transfer <input type="checkbox"/> COM <input type="checkbox"/> MOT                   Scaling factor: 1		

### C00174

Parameter   Name: <b>C00174   Reduced brake chopper threshold</b>		Data type: UNSIGNED_8 Index: 24401 <sub>d</sub> = 5F51 <sub>h</sub>
The threshold from which on the brake chopper is controlled is reduced by the voltage value set here.		
Setting range (min. value   unit   max. value)		Lenze setting
0	V	150 <b>0 V</b>
<input checked="" type="checkbox"/> Read access <input checked="" type="checkbox"/> Write access <input type="checkbox"/> CINH <input type="checkbox"/> PLC STOP <input type="checkbox"/> No transfer <input type="checkbox"/> COM <input type="checkbox"/> MOT                   Scaling factor: 1		

### C00177

Parameter   Name: <b>C00177   Switching cycles</b>		Data type: UNSIGNED_32 Index: 24398 <sub>d</sub> = 5F4E <sub>h</sub>
Counter of different switching cycles and stressful situations		
Display range (min. value   unit   max. value)		
0		2147483647
Subcodes		Info
C00177/1		Number of mains switching cycles
C00177/2		Number of switching cycles of the output relay
<input checked="" type="checkbox"/> Read access <input type="checkbox"/> Write access <input type="checkbox"/> CINH <input type="checkbox"/> PLC STOP <input checked="" type="checkbox"/> No transfer <input type="checkbox"/> COM <input type="checkbox"/> MOT                   Scaling factor: 1		

### C00178

Parameter   Name: <b>C00178   Elapsed-hour meter</b>		Data type: UNSIGNED_32 Index: 24397 <sub>d</sub> = 5F4D <sub>h</sub>
Display of the operating hours in "seconds" unit		
Display range (min. value   unit   max. value)		
0	s	2147483647
<input checked="" type="checkbox"/> Read access <input type="checkbox"/> Write access <input type="checkbox"/> CINH <input type="checkbox"/> PLC STOP <input checked="" type="checkbox"/> No transfer <input type="checkbox"/> COM <input type="checkbox"/> MOT                   Scaling factor: 1		

### C00179

Parameter   Name: <b>C00179   Power-on time meter</b>		Data type: UNSIGNED_32 Index: 24396 <sub>d</sub> = 5F4C <sub>h</sub>
Display of the power-on time in "seconds" unit		
Display range (min. value   unit   max. value)		
0	s	2147483647
<input checked="" type="checkbox"/> Read access <input type="checkbox"/> Write access <input type="checkbox"/> CINH <input type="checkbox"/> PLC STOP <input checked="" type="checkbox"/> No transfer <input type="checkbox"/> COM <input type="checkbox"/> MOT                   Scaling factor: 1		

# 9 Parameter reference

## 9.2 Parameter list | C00182

### C00182

Parameter   Name: <b>C00182   S-ramp time PT1</b>		Data type: INTEGER_16 Index: 24393 <sub>d</sub> = 5F49 <sub>h</sub>
FB <a href="#">L_NSet_1</a> : PT1 S-ramp time for the main setpoint ramp function generator • Only effective with activated ramp smoothing ( <a href="#">C00134</a> = "1").		
<b>Setting range</b> (min. value   unit   max. value)		<b>Lenze setting</b>
0.01	s	50.00 <b>20.00 s</b>
<input checked="" type="checkbox"/> Read access <input checked="" type="checkbox"/> Write access <input type="checkbox"/> CINH <input type="checkbox"/> PLC STOP <input type="checkbox"/> No transfer <input type="checkbox"/> COM <input type="checkbox"/> MOT         Scaling factor: 100		

### C00200

Parameter   Name: <b>C00200   Firmware product type</b>		Data type: VISIBLE_STRING Index: 24375 <sub>d</sub> = 5F37 <sub>h</sub>
Display of the firmware product type		
<input checked="" type="checkbox"/> Read access <input type="checkbox"/> Write access <input type="checkbox"/> CINH <input type="checkbox"/> PLC STOP <input checked="" type="checkbox"/> No transfer <input type="checkbox"/> COM <input type="checkbox"/> MOT		

### C00201

Parameter   Name: <b>C00201   Firmware compile date</b>		Data type: VISIBLE_STRING Index: 24374 <sub>d</sub> = 5F36 <sub>h</sub>
Display of the firmware compilation date		
<input checked="" type="checkbox"/> Read access <input type="checkbox"/> Write access <input type="checkbox"/> CINH <input type="checkbox"/> PLC STOP <input checked="" type="checkbox"/> No transfer <input type="checkbox"/> COM <input type="checkbox"/> MOT		

### C00203

Parameter   Name: <b>C00203   Product type code</b>		Data type: VISIBLE_STRING Index: 24372 <sub>d</sub> = 5F34 <sub>h</sub>
As of version 03.00.00		
Display of the single device component types		
<b>Subcodes</b>	<b>Info</b>	
C00203/1	Reserved	
C00203/2	Reserved	
C00203/3	Reserved	
C00203/4	Type: I/O micro	
C00203/5	Type: Memory module	
C00203/6	Type: Safety module	
C00203/7	Reserved	
C00203/8	Type: Complete device	
C00203/9	Reserved	
<input checked="" type="checkbox"/> Read access <input type="checkbox"/> Write access <input type="checkbox"/> CINH <input type="checkbox"/> PLC STOP <input checked="" type="checkbox"/> No transfer <input type="checkbox"/> COM <input type="checkbox"/> MOT		

### C00222

Parameter   Name: <b>C00222   L_PCTRL_1: Vp</b>		Data type: INTEGER_16 Index: 24353 <sub>d</sub> = 5F21 <sub>h</sub>
As of version 03.00.00		
FB <a href="#">L_PCTRL_1</a> : Gain factor Vp for the PID process controller		
<b>Setting range</b> (min. value   unit   max. value)		<b>Lenze setting</b>
0.1		500.0 <b>1.0</b>
<input checked="" type="checkbox"/> Read access <input checked="" type="checkbox"/> Write access <input type="checkbox"/> CINH <input type="checkbox"/> PLC STOP <input type="checkbox"/> No transfer <input type="checkbox"/> COM <input type="checkbox"/> MOT         Scaling factor: 10		

# 9 Parameter reference

## 9.2 Parameter list | C00223

### C00223

Parameter   Name: <b>C00223   L_PCTRL_1: Tn</b>			Data type: UNSIGNED_16 Index: 24352 <sub>d</sub> = 5F20 <sub>h</sub>
As of version 03.00.00 FB <a href="#">L_PCTRL_1</a> : Reset time Tn for the PID process controller			
<b>Setting range (min. value   unit   max. value)</b>			<b>Lenze setting</b>
20	ms	6000	<b>400 ms</b>
<input checked="" type="checkbox"/> Read access <input checked="" type="checkbox"/> Write access <input type="checkbox"/> CINH <input type="checkbox"/> PLC STOP <input type="checkbox"/> No transfer <input type="checkbox"/> COM <input type="checkbox"/> MOT                 Scaling factor: 1			

### C00224

Parameter   Name: <b>C00224   L_PCTRL_1: Kd</b>			Data type: UNSIGNED_16 Index: 24351 <sub>d</sub> = 5F1F <sub>h</sub>
As of version 03.00.00 FB <a href="#">L_PCTRL_1</a> : Derivative-action coefficient Kd for the PID process controller			
<b>Setting range (min. value   unit   max. value)</b>			<b>Lenze setting</b>
0.0		5.0	<b>0.0</b>
<input checked="" type="checkbox"/> Read access <input checked="" type="checkbox"/> Write access <input type="checkbox"/> CINH <input type="checkbox"/> PLC STOP <input type="checkbox"/> No transfer <input type="checkbox"/> COM <input type="checkbox"/> MOT                 Scaling factor: 10			

### C00225

Parameter   Name: <b>C00225   L_PCTRL_1: MaxLimit</b>			Data type: INTEGER_16 Index: 24350 <sub>d</sub> = 5F1E <sub>h</sub>
As of version 03.00.00 FB <a href="#">L_PCTRL_1</a> : Maximum output value of the PID process controller			
<b>Setting range (min. value   unit   max. value)</b>			<b>Lenze setting</b>
-199.9	%	199.9	<b>199.9 %</b>
<input checked="" type="checkbox"/> Read access <input checked="" type="checkbox"/> Write access <input type="checkbox"/> CINH <input type="checkbox"/> PLC STOP <input type="checkbox"/> No transfer <input type="checkbox"/> COM <input type="checkbox"/> MOT                 Scaling factor: 100			

### C00226

Parameter   Name: <b>C00226   L_PCTRL_1: MinLimit</b>			Data type: INTEGER_16 Index: 24349 <sub>d</sub> = 5F1D <sub>h</sub>
As of version 03.00.00 FB <a href="#">L_PCTRL_1</a> : Minimum output value of the PID process controller			
<b>Setting range (min. value   unit   max. value)</b>			<b>Lenze setting</b>
-199.9	%	199.9	<b>-199.9 %</b>
<input checked="" type="checkbox"/> Read access <input checked="" type="checkbox"/> Write access <input type="checkbox"/> CINH <input type="checkbox"/> PLC STOP <input type="checkbox"/> No transfer <input type="checkbox"/> COM <input type="checkbox"/> MOT                 Scaling factor: 100			

### C00227

Parameter   Name: <b>C00227   L_PCTRL_1: Acceleration time</b>			Data type: UNSIGNED_32 Index: 24348 <sub>d</sub> = 5F1C <sub>h</sub>
As of version 03.00.00 FB <a href="#">L_PCTRL_1</a> : Acceleration time for the output value of the PID process controller			
<b>Setting range (min. value   unit   max. value)</b>			<b>Lenze setting</b>
0.0	s	999.9	<b>0.1 s</b>
<input checked="" type="checkbox"/> Read access <input checked="" type="checkbox"/> Write access <input type="checkbox"/> CINH <input type="checkbox"/> PLC STOP <input type="checkbox"/> No transfer <input type="checkbox"/> COM <input type="checkbox"/> MOT                 Scaling factor: 1000			

# 9 Parameter reference

## 9.2 Parameter list | C00228

### C00228

Parameter   Name: <b>C00228   L_PCTRL_1: Deceleration time</b>		Data type: UNSIGNED_32 Index: 24347 <sub>d</sub> = 5F1B <sub>h</sub>	
As of version 03.00.00 FB <a href="#">L_PCTRL_1</a> : Deceleration time for the output value of the PID process controller			
Setting range (min. value   unit   max. value)		Lenze setting	
0.0	s	999.9	<b>0.1 s</b>
<input checked="" type="checkbox"/> Read access <input checked="" type="checkbox"/> Write access <input type="checkbox"/> CINH <input type="checkbox"/> PLC STOP <input type="checkbox"/> No transfer <input type="checkbox"/> COM <input type="checkbox"/> MOT                 Scaling factor: 1000			

### C00231

Parameter   Name: <b>C00231   L_PCTRL_1: Operating range</b>		Data type: INTEGER_16 Index: 24344 <sub>d</sub> = 5F18 <sub>h</sub>	
As of version 03.00.00 FB <a href="#">L_PCTRL_1</a> : Operating range for the PID process controller			
Setting range (min. value   unit   max. value)			
0.0	%	199.9	
Subcodes	Lenze setting	Info	
C00231/1	199.9 %	<a href="#">L_PCTRL_1</a> : Pos. maximum	
C00231/2	0.0 %	<a href="#">L_PCTRL_1</a> : Pos. minimum	
C00231/3	0.0 %	<a href="#">L_PCTRL_1</a> : Neg. minimum	
C00231/4	199.9 %	<a href="#">L_PCTRL_1</a> : Neg. maximum	
<input checked="" type="checkbox"/> Read access <input checked="" type="checkbox"/> Write access <input type="checkbox"/> CINH <input type="checkbox"/> PLC STOP <input type="checkbox"/> No transfer <input type="checkbox"/> COM <input type="checkbox"/> MOT                 Scaling factor: 100			

### C00234

Parameter   Name: <b>C00234   Oscillation damping influence</b>		Data type: UNSIGNED_16 Index: 24341 <sub>d</sub> = 5F15 <sub>h</sub>	
<a href="#">Oscillation damping</a>			
Setting range (min. value   unit   max. value)		Lenze setting	
0	%	250	<b>5 %</b>
<input checked="" type="checkbox"/> Read access <input checked="" type="checkbox"/> Write access <input type="checkbox"/> CINH <input type="checkbox"/> PLC STOP <input type="checkbox"/> No transfer <input type="checkbox"/> COM <input type="checkbox"/> MOT                 Scaling factor: 100			

### C00235

Parameter   Name: <b>C00235   Filter time - oscill. damping</b>		Data type: UNSIGNED_8 Index: 24340 <sub>d</sub> = 5F14 <sub>h</sub>	
<b>This code is for device-internal use only and must not be written to by the user!</b>			

### C00236

Parameter   Name: <b>C00236   Oscillation damping - field weakening</b>		Data type: UNSIGNED_8 Index: 24339 <sub>d</sub> = 5F13 <sub>h</sub>	
<b>This code is for device-internal use only and must not be written to by the user!</b>			

# 9 Parameter reference

## 9.2 Parameter list | C00242

### C00242

Parameter   Name: <b>C00242   L_PCTRL_1: Operating mode</b>		Data type: UNSIGNED_8 Index: 24333 <sub>d</sub> = 5F0D <sub>h</sub>
As of version 03.00.00 FB <a href="#">L_PCTRL_1</a> : Selection of the operating mode <ul style="list-style-type: none"> <li>Depending on the selection, the blue switches in the displayed signal flow are set accordingly in the Engineer on the <b>Application</b> parameter tab in the <i>Overview</i> → <i>Signal flow</i> → <i>Process controller</i> dialog level.</li> </ul>		
Selection list (Lenze setting printed in bold)		Info
0	<b>Off</b>	The input setpoint <i>nNSet_a</i> is output without any changes at the output <i>nOut_a</i> .
1	Additive + feedforward control	<i>nNSet_a</i> and <i>nAct_a</i> are used as PID input values. The arriving <i>nNSet_a</i> is additively linked to the value output by the PID element.
2	PID as setpoint generator.	<i>nSet_a</i> and <i>nAct_a</i> are used as PID input values. The input <i>nNSet_a</i> is not considered.
3	PID setpoint from L_NSet_1	<i>nNSet_a</i> and <i>nAct_a</i> are used as PID input values. The input <i>nSet_a</i> is not considered.
<input checked="" type="checkbox"/> Read access <input checked="" type="checkbox"/> Write access <input type="checkbox"/> CINH <input type="checkbox"/> PLC STOP <input type="checkbox"/> No transfer <input type="checkbox"/> COM <input type="checkbox"/> MOT           Scaling factor: 1		

### C00243

Parameter   Name: <b>C00243   L_PCTRL_1: Acceleration time influence</b>		Data type: UNSIGNED_32 Index: 24332 <sub>d</sub> = 5F0C <sub>h</sub>
As of version 03.00.00 FB <a href="#">L_PCTRL_1</a> : Acceleration time for showing the PID output value		
Setting range (min. value   unit   max. value)		Lenze setting
0.0	s	999.9 <b>5.0 s</b>
<input checked="" type="checkbox"/> Read access <input checked="" type="checkbox"/> Write access <input type="checkbox"/> CINH <input type="checkbox"/> PLC STOP <input type="checkbox"/> No transfer <input type="checkbox"/> COM <input type="checkbox"/> MOT           Scaling factor: 1000		

### C00244

Parameter   Name: <b>C00244   L_PCTRL_1: Deceleration time influence</b>		Data type: UNSIGNED_32 Index: 24331 <sub>d</sub> = 5F0B <sub>h</sub>
As of version 03.00.00 FB <a href="#">L_PCTRL_1</a> : Deceleration time for masking out the PID output value		
Setting range (min. value   unit   max. value)		Lenze setting
0.0	s	999.9 <b>5.0 s</b>
<input checked="" type="checkbox"/> Read access <input checked="" type="checkbox"/> Write access <input type="checkbox"/> CINH <input type="checkbox"/> PLC STOP <input type="checkbox"/> No transfer <input type="checkbox"/> COM <input type="checkbox"/> MOT           Scaling factor: 1000		

### C00245

Parameter   Name: <b>C00245   L_PCTRL_1: PID output value</b>		Data type: INTEGER_16 Index: 24330 <sub>d</sub> = 5F0A <sub>h</sub>
As of version 03.00.00 FB <a href="#">L_PCTRL_1</a> : Display of the output value of the PID process controller		
Display range (min. value   unit   max. value)		
-199.9	%	199.9
<input checked="" type="checkbox"/> Read access <input type="checkbox"/> Write access <input type="checkbox"/> CINH <input type="checkbox"/> PLC STOP <input type="checkbox"/> No transfer <input type="checkbox"/> COM <input type="checkbox"/> MOT           Scaling factor: 100		

# 9 Parameter reference

## 9.2 Parameter list | C00308

### C00308

Parameter   Name: <b>C00308   Activation of internal features</b>	Data type: UNSIGNED_16 Index: 24267 <sub>d</sub> = 5ECB <sub>h</sub>
<b>This code is for device-internal use only and must not be written to by the user!</b>	

### C00309

Parameter   Name: <b>C00309   Delay time</b>	Data type: UNSIGNED_16 Index: 24266 <sub>d</sub> = 5ECA <sub>h</sub>
<b>This code is for device-internal use only and must not be written to by the user!</b>	

### C00443

Parameter   Name: <b>C00443   DIx: Level</b>	Data type: UNSIGNED_16 Index: 24132 <sub>d</sub> = 5E44 <sub>h</sub>
Bit-coded display of the level of the digital inputs	
<a href="#">▶ Digital terminals</a>	
<b>Display area (min. hex value   max. hex value)</b>	
0x0000	0xFFFF
<b>Value is bit-coded:</b>	
Bit 0	DI1
Bit 1	DI2
Bit 2	DI3
Bit 3	DI4
Bit 4	Reserved
Bit 5	Reserved
Bit 6	Reserved
Bit 7	Reserved
Bit 8	Reserved
Bit 9	Reserved
Bit 10	Reserved
Bit 11	Reserved
Bit 12	Reserved
Bit 13	Reserved
Bit 14	Reserved
Bit 15	CINH
<b>Info</b> Bit set = HIGH level	
<b>Subcodes</b>	
C00443/1	DIx: Terminal level
C00443/2	DIx: Output level
<input checked="" type="checkbox"/> Read access <input type="checkbox"/> Write access <input type="checkbox"/> CINH <input type="checkbox"/> PLC STOP <input checked="" type="checkbox"/> No transfer <input type="checkbox"/> COM <input type="checkbox"/> MOT	



# 9 Parameter reference

## 9.2 Parameter list | C00444

### C00444

Parameter   Name: <b>C00444   DOx: Level</b>		Data type: UNSIGNED_16 Index: 24131 <sub>d</sub> = 5E43 <sub>h</sub>
Bit-coded display of the level of the digital outputs		
<a href="#">▶ Digital terminals</a>		
<b>Display area</b> (min. hex value   max. hex value)		
0x0000		0xFFFF
<b>Value is bit-coded:</b>		<b>Info</b>
Bit 0	Relay	Bit set = HIGH level
Bit 1	DO1	
Bit 2	Reserved	
Bit 3	Reserved	
Bit 4	Reserved	
Bit 5	Reserved	
Bit 6	Reserved	
Bit 7	Reserved	
Bit 8	Reserved	
Bit 9	Reserved	
Bit 10	Reserved	
Bit 11	Reserved	
Bit 12	Reserved	
Bit 13	Reserved	
Bit 14	Reserved	
Bit 15	Reserved	
<b>Subcodes</b>		<b>Info</b>
C00444/1		DOx: Input level
C00444/2		DOx: Terminal level
<input checked="" type="checkbox"/> Read access <input type="checkbox"/> Write access <input type="checkbox"/> CINH <input type="checkbox"/> PLC STOP <input checked="" type="checkbox"/> No transfer <input type="checkbox"/> COM <input type="checkbox"/> MOT		

### C00462

Parameter   Name: <b>C00462   Keypad/PC: Setpoint control</b>		Data type: UNSIGNED_16 Index: 24113 <sub>d</sub> = 5E31 <sub>h</sub>
<b>This code is for device-internal use only and must not be written to by the user!</b>		

### C00470

Parameter   Name: <b>C00470   LS_ParFree_b</b>		Data type: UNSIGNED_8 Index: 24105 <sub>d</sub> = 5E29 <sub>h</sub>
SB <a href="#">LS_ParFree_b</a> : Setting of the signal level to be output		
<b>Selection list</b>		
0	False	
1	True	
<b>Subcodes</b>		<b>Info</b>
C00470/1	0: False	Signal level for output <i>bPar1 ... bPar16</i>
C00470/...		
C00470/16		
<input checked="" type="checkbox"/> Read access <input checked="" type="checkbox"/> Write access <input type="checkbox"/> CINH <input type="checkbox"/> PLC STOP <input type="checkbox"/> No transfer <input type="checkbox"/> COM <input type="checkbox"/> MOT                   Scaling factor: 1		

# 9 Parameter reference

## 9.2 Parameter list | C00472

### C00472

Parameter   Name: <b>C00472   LS_ParFree_a</b>		Data type: INTEGER_16 Index: 24103 <sub>d</sub> = 5E27 <sub>h</sub>
SB <a href="#">LS_ParFree_a</a> : Setting of the analog signals to be output		
<b>Setting range</b> (min. value   unit   max. value)		
-199.9	%	199.9
<b>Subcodes</b>	<b>Lenze setting</b>	<b>Info</b>
C00472/1	0.0 %	Value for output <i>nPar1_a</i>
C00472/2	0.0 %	Value for output <i>nPar2_a</i>
C00472/3	100.0 %	Value for output <i>nPar3_a</i>
C00472/4	100.0 %	Value for output <i>nPar4_a</i>
<input checked="" type="checkbox"/> Read access <input checked="" type="checkbox"/> Write access <input type="checkbox"/> CINH <input type="checkbox"/> PLC STOP <input type="checkbox"/> No transfer <input type="checkbox"/> COM <input type="checkbox"/> MOT                   Scaling factor: 100		

### C00480

Parameter   Name: <b>C00480   LS_DisFree_b</b>		Data type: UNSIGNED_8 Index: 24095 <sub>d</sub> = 5E1F <sub>h</sub>
SB <a href="#">LS_DisFree_b</a> : Display of the input values		
<b>Display area</b> (min. hex value   max. hex value)		
0x00		0xFF
<b>Value is bit-coded:</b>		<b>Info</b>
Bit 0	bDis1	Signal level input <i>bDis1 ... bDis8</i>
...	...	
Bit 7	bDis8	
<input checked="" type="checkbox"/> Read access <input type="checkbox"/> Write access <input type="checkbox"/> CINH <input type="checkbox"/> PLC STOP <input type="checkbox"/> No transfer <input type="checkbox"/> COM <input type="checkbox"/> MOT		

### C00481

Parameter   Name: <b>C00481   LS_DisFree</b>		Data type: UNSIGNED_16 Index: 24094 <sub>d</sub> = 5E1E <sub>h</sub>
SB <a href="#">LS_DisFree</a> : Display of the input values		
<b>Display area</b> (min. hex value   max. hex value)		
0x0000		0xFFFF
<b>Value is bit-coded:</b>		
Bit 0	Bit0	
...	...	
Bit 15	Bit15	
<b>Subcodes</b>		<b>Info</b>
C00481/1		Input values <i>wDis1 ... wDis4</i>
C00481/...		
C00481/4		
<input checked="" type="checkbox"/> Read access <input type="checkbox"/> Write access <input type="checkbox"/> CINH <input type="checkbox"/> PLC STOP <input type="checkbox"/> No transfer <input type="checkbox"/> COM <input type="checkbox"/> MOT		

# 9 Parameter reference

## 9.2 Parameter list | C00482

### C00482

Parameter   Name: <b>C00482   LS_DisFree_a</b>		Data type: INTEGER_16 Index: 24093 <sub>d</sub> = 5E1D <sub>h</sub>
SB <a href="#">LS_DisFree_a</a> : Display of the input values		
<b>Display range (min. value   unit   max. value)</b>		
-199.9	%	199.9
<b>Subcodes</b>		<b>Info</b>
C00482/1		Input values <i>nDis1_a</i> ... <i>nDis4_a</i>
C00482/...		
C00482/4		
<input checked="" type="checkbox"/> Read access <input type="checkbox"/> Write access <input type="checkbox"/> CINH <input type="checkbox"/> PLC STOP <input type="checkbox"/> No transfer <input type="checkbox"/> COM <input type="checkbox"/> MOT           Scaling factor: 100		

### C00516

Parameter   Name: <b>C00516   Checksums</b>		Data type: UNSIGNED_32 Index: 24059 <sub>d</sub> = 5DFB <sub>h</sub>
<b>Display range (min. value   unit   max. value)</b>		
0		255
<b>Subcodes</b>		<b>Info</b>
C00516/1		Checksum of interconnection
<input checked="" type="checkbox"/> Read access <input type="checkbox"/> Write access <input type="checkbox"/> CINH <input type="checkbox"/> PLC STOP <input checked="" type="checkbox"/> No transfer <input type="checkbox"/> COM <input type="checkbox"/> MOT           Scaling factor: 1		

# 9 Parameter reference

## 9.2 Parameter list | C00517

### C00517

Parameter   Name: <b>C00517   User menu</b>		Data type: INTEGER_32 Index: 24058 <sub>d</sub> = 5DFA <sub>h</sub>
<p>When a system is installed, parameters must be changed time and again until the system runs satisfactorily. The user menu of a device serves to create a selection of frequently used parameters to be able to access and change these parameters quickly.</p> <ul style="list-style-type: none"> <li>For setting "0" no entry is displayed in the user menu.</li> </ul>		
<b>Setting range (min. value   unit   max. value)</b>		
0		994
Subcodes	Lenze setting	Info
C00517/1	51	<a href="#">C00051</a> : Display of actual speed value
C00517/2	53	<a href="#">C00053</a> : Display of DC-bus voltage
C00517/3	54	<a href="#">C00054</a> : Display of motor current
C00517/4	61	<a href="#">C00061</a> : Display of heatsink temperature
C00517/5	137	<a href="#">C00137</a> : Display of device state
C00517/6	0	User menu: entry 6
C00517/7	0	User menu: entry 7
C00517/8	11	<a href="#">C00011</a> : Reference speed
C00517/9	39	<a href="#">C00039/1</a> : Fixed setpoint 1 <a href="#">C00039/2</a> : Fixed setpoint 2 <a href="#">C00039/3</a> : Fixed setpoint 3
C00517/10	0	User menu: entry 10
C00517/11	12	<a href="#">C00012</a> : Acceleration time main setpoint
C00517/12	13	<a href="#">C00013</a> : Deceleration time main setpoint
C00517/13	15	<a href="#">C00015</a> : V/f base frequency
C00517/14	16	<a href="#">C00016</a> : Vmin boost
C00517/15	22	<a href="#">C00022</a> : I <sub>max</sub> in motor mode
C00517/16	120	<a href="#">C00120</a> : Motor overload threshold (I <sup>2</sup> xt)
C00517/17	87	<a href="#">C00087</a> : Rated motor speed
C00517/18	99	<a href="#">C00099</a> : Display of firmware version
C00517/19	0	User menu: entry 19
C00517/20	0	User menu: entry 20
<input checked="" type="checkbox"/> Read access <input checked="" type="checkbox"/> Write access <input type="checkbox"/> CINH <input type="checkbox"/> PLC STOP <input type="checkbox"/> No transfer <input type="checkbox"/> COM <input type="checkbox"/> MOT                   Scaling factor: 1		

### C00565

Parameter   Name: <b>C00565   Resp. to mains phase failure</b>		Data type: UNSIGNED_8 Index: 24010 <sub>d</sub> = 5DCA <sub>h</sub>
Response to the failure of mains phases		
<b>Selection list (Lenze setting printed in bold)</b>		
0	No Reaction	
1	Fault	
<b>4</b>	<b>WarningLocked</b>	
<input checked="" type="checkbox"/> Read access <input checked="" type="checkbox"/> Write access <input type="checkbox"/> CINH <input type="checkbox"/> PLC STOP <input type="checkbox"/> No transfer <input type="checkbox"/> COM <input type="checkbox"/> MOT                   Scaling factor: 1		

# 9 Parameter reference

## 9.2 Parameter list | C00574

### C00574

Parameter   Name: <b>C00574   Resp. to brake resist. overtemp.</b>		Data type: UNSIGNED_8 Index: 24001 <sub>d</sub> = 5DC1 <sub>h</sub>
Response when the permanently set threshold for monitoring the brake resistor utilisation has been reached.		
<b>Selection list</b> (Lenze setting printed in bold)		
0	<b>No Reaction</b>	
1	Fault	
4	WarningLocked	
<input checked="" type="checkbox"/> Read access <input checked="" type="checkbox"/> Write access <input type="checkbox"/> CINH <input type="checkbox"/> PLC STOP <input type="checkbox"/> No transfer <input type="checkbox"/> COM <input type="checkbox"/> MOT                   Scaling factor: 1		

### C00581

Parameter   Name: <b>C00581   Resp. to LS_SetError_x</b>		Data type: UNSIGNED_8 Index: 23994 <sub>d</sub> = 5DBA <sub>h</sub>
Selection of the error responses for application error messages		
<ul style="list-style-type: none"> <li>An application error message is tripped by a FALSE-TRUE edge at the binary inputs <i>bSetError1...2</i>.</li> </ul>		
<b>Selection list</b>		
0	No Reaction	
1	Fault	
2	Trouble	
4	WarningLocked	
<b>Subcodes</b>	<b>Lenze setting</b>	<b>Info</b>
C00581/1	1: Fault	<a href="#">LS_SetError_1</a> : Resp. bSetError1
C00581/2	1: Fault	<a href="#">LS_SetError_1</a> : Resp. bSetError2
<input checked="" type="checkbox"/> Read access <input checked="" type="checkbox"/> Write access <input type="checkbox"/> CINH <input type="checkbox"/> PLC STOP <input type="checkbox"/> No transfer <input type="checkbox"/> COM <input type="checkbox"/> MOT                   Scaling factor: 1		

### C00598

Parameter   Name: <b>C00598   Resp. to open circuit AINx</b>		Data type: UNSIGNED_8 Index: 23977 <sub>d</sub> = 5DA9 <sub>h</sub>
Configuration of monitoring the analog input		
<a href="#">▶ Analog terminals</a>		
<b>Selection list</b>		
0	No Reaction	
1	Fault	
2	Trouble	
4	WarningLocked	
<b>Subcodes</b>	<b>Lenze setting</b>	<b>Info</b>
C00598/1	1: Fault	Response to open circuit at AIN1 when being configured as 4 ... 20 mA-current loop
<input checked="" type="checkbox"/> Read access <input checked="" type="checkbox"/> Write access <input type="checkbox"/> CINH <input type="checkbox"/> PLC STOP <input type="checkbox"/> No transfer <input type="checkbox"/> COM <input type="checkbox"/> MOT                   Scaling factor: 1		

# 9 Parameter reference

## 9.2 Parameter list | C00600

### C00600

Parameter   Name: <b>C00600   Resp. to DC bus undervoltage</b>		Data type: UNSIGNED_8 Index: 23975 <sub>d</sub> = 5DA7 <sub>h</sub>
Configuration of monitoring of the motor control (group 3)		
<b>Selection list</b>		
1	Fault	
2	Trouble	
<b>Subcodes</b>	<b>Lenze setting</b>	<b>Info</b>
C00600/1	2: Trouble	Response to undervoltage in the DC bus
<input checked="" type="checkbox"/> Read access <input checked="" type="checkbox"/> Write access <input type="checkbox"/> CINH <input type="checkbox"/> PLC STOP <input type="checkbox"/> No transfer <input type="checkbox"/> COM <input type="checkbox"/> MOT                   Scaling factor: 1		

### C00601

Parameter   Name: <b>C00601   Del. resp.to fault: DC bus overvoltage</b>		Data type: UNSIGNED_16 Index: 23974 <sub>d</sub> = 5DA6 <sub>h</sub>
Delay times for error responses		
<b>Setting range (min. value   unit   max. value)</b>		
0.00	s	65.00
<b>Subcodes</b>	<b>Lenze setting</b>	<b>Info</b>
C00601/1	2.00 s	Delay time for error activation "DC-bus overvoltage" • In case of DC-bus overvoltage, an error is only transmitted after this delay time has elapsed.
<input checked="" type="checkbox"/> Read access <input checked="" type="checkbox"/> Write access <input type="checkbox"/> CINH <input type="checkbox"/> PLC STOP <input type="checkbox"/> No transfer <input type="checkbox"/> COM <input type="checkbox"/> MOT                   Scaling factor: 1000		

### C00604

Parameter   Name: <b>C00604   Resp. to device overload (lxt)</b>		Data type: UNSIGNED_8 Index: 23971 <sub>d</sub> = 5DA3 <sub>h</sub>
Response if the adjustable device utilisation threshold ( <a href="#">C00123</a> ) is reached. • The current device utilisation is displayed in <a href="#">C00064</a> .		
<b>Selection list (Lenze setting printed in bold)</b>		
0	No Reaction	
1	Fault	
4	<b>WarningLocked</b>	
<input checked="" type="checkbox"/> Read access <input checked="" type="checkbox"/> Write access <input type="checkbox"/> CINH <input type="checkbox"/> PLC STOP <input type="checkbox"/> No transfer <input type="checkbox"/> COM <input type="checkbox"/> MOT                   Scaling factor: 1		

### C00606

Parameter   Name: <b>C00606   Resp. to motor overload (l*xt)</b>		Data type: UNSIGNED_8 Index: 23969 <sub>d</sub> = 5DA1 <sub>h</sub>
Response if the adjustable motor overload threshold ( <a href="#">C00120</a> ) is reached. • The current thermal motor load is displayed in <a href="#">C00066</a> .		
<b>Selection list (Lenze setting printed in bold)</b>		
0	No Reaction	
1	Fault	
4	<b>WarningLocked</b>	
<input checked="" type="checkbox"/> Read access <input checked="" type="checkbox"/> Write access <input type="checkbox"/> CINH <input type="checkbox"/> PLC STOP <input type="checkbox"/> No transfer <input type="checkbox"/> COM <input type="checkbox"/> MOT                   Scaling factor: 1		

# 9 Parameter reference

## 9.2 Parameter list | C00620

### C00620

Parameter   Name: <b>C00620   16-bit system connection</b>		Data type: UNSIGNED_16 Index: 23955 <sub>d</sub> = 5D93 <sub>h</sub>
Connection parameters: 16-bit inputs <ul style="list-style-type: none"> <li>• Selection of the 16-bit output signals for connection with the 16-bit input signals.</li> <li>• The selection list contains all 16-bit output signals which can be assigned to the 16-bit inputs mapped by the subcodes.</li> </ul>		
<b>Selection list</b>		
See <a href="#">selection list - analog signals</a>		
Subcodes	Lenze setting	Info
C00620/1	0: Not connected	Reserved
C00620/2	0: Not connected	Reserved
C00620/3	0: Not connected	Reserved
C00620/4	0: Not connected	Reserved
C00620/5	0: Not connected	<a href="#">LS_DisFree:wDis1</a>
C00620/6	0: Not connected	<a href="#">LS_DisFree:wDis2</a>
C00620/7	0: Not connected	<a href="#">LS_DisFree:wDis3</a>
C00620/8	0: Not connected	<a href="#">LS_DisFree:wDis4</a>
C00620/9	0: Not connected	<a href="#">LS_DisFree_a:nDis1_a</a>
C00620/10	0: Not connected	<a href="#">LS_DisFree_a:nDis2_a</a>
C00620/11	0: Not connected	<a href="#">LS_DisFree_a:nDis3_a</a>
C00620/12	0: Not connected	<a href="#">LS_DisFree_a:nDis4_a</a>
<input checked="" type="checkbox"/> Read access <input checked="" type="checkbox"/> Write access <input type="checkbox"/> CINH <input type="checkbox"/> PLC STOP <input type="checkbox"/> No transfer <input type="checkbox"/> COM <input type="checkbox"/> MOT             Scaling factor: 1		

## C00621

Parameter   Name: C00621   Bool system connection		Data type: UNSIGNED_16 Index: 23954 <sub>d</sub> = 5D92 <sub>h</sub>
Connection parameters: Binary inputs <ul style="list-style-type: none"> <li>• Selection of the binary output signals for connection with the binary input signals.</li> <li>• The selection list contains all binary output signals which can be assigned to the binary inputs mapped by the subcodes.</li> </ul>		
<b>Selection list</b>		
See <a href="#">selection list - digital signals</a>		
Subcodes	Lenze setting	Info
C00621/1	50: LA_NCtrl_bDriveFail	<a href="#">LS_DigitalOutput</a> :bRelay
C00621/2	51: LA_NCtrl_bDriveReady	<a href="#">LS_DigitalOutput</a> :bOut1
C00621/3	0: Not connected	Reserved
C00621/4	0: Not connected	Reserved
C00621/5	0: Not connected	Reserved
C00621/6	64: LA_NCtrl_bNActCompare	USER LED
C00621/7	0: Not connected	<a href="#">LA_NCtrl</a> : bStatusBit0
C00621/8	65: LA_NCtrl_bImaxActive	<a href="#">LA_NCtrl</a> : bStatusBit2
C00621/9	62: LA_NCtrl_bSpeedSetReached	<a href="#">LA_NCtrl</a> : bStatusBit3
C00621/10	63: LA_NCtrl_bSpeedActEqSet	<a href="#">LA_NCtrl</a> : bStatusBit4
C00621/11	64: LA_NCtrl_bNActCompare	<a href="#">LA_NCtrl</a> : bStatusBit5
C00621/12	60: LA_NCtrl_bSpeedCcw	<a href="#">LA_NCtrl</a> : bStatusBit14
C00621/13	51: LA_NCtrl_bDriveReady	<a href="#">LA_NCtrl</a> : bStatusBit15
C00621/14	0: Not connected	Reserved
C00621/15	0: Not connected	Reserved
C00621/16	0: Not connected	<a href="#">LS_DisFree_b</a> : bDis1
C00621/17	0: Not connected	<a href="#">LS_DisFree_b</a> : bDis2
C00621/18	0: Not connected	<a href="#">LS_DisFree_b</a> : bDis3
C00621/19	0: Not connected	<a href="#">LS_DisFree_b</a> : bDis4
C00621/20	0: Not connected	<a href="#">LS_DisFree_b</a> : bDis5
C00621/21	0: Not connected	<a href="#">LS_DisFree_b</a> : bDis6
C00621/22	0: Not connected	<a href="#">LS_DisFree_b</a> : bDis7
C00621/23	0: Not connected	<a href="#">LS_DisFree_b</a> : bDis8
<input checked="" type="checkbox"/> Read access <input checked="" type="checkbox"/> Write access <input type="checkbox"/> CINH <input type="checkbox"/> PLC STOP <input type="checkbox"/> No transfer <input type="checkbox"/> COM <input type="checkbox"/> MOT             Scaling factor: 1		



## C00700

Parameter   Name: <b>C00700   LA_NCtrl: Analog connection list</b>		Data type: UNSIGNED_16 Index: 23875 <sub>d</sub> = 5D43 <sub>h</sub>
Connection parameters for "Actuating drive speed" application: 16-bit inputs <ul style="list-style-type: none"> <li>• Selection of the 16-bit output signals for connection with the 16-bit input signals</li> <li>• The selection list contains all 16-bit output signals which can be assigned to the 16-bit inputs mapped by the subcodes.</li> </ul>		
<b>Selection list</b>		
See <a href="#">selection list - analog signals</a>		
<b>Subcodes</b>	<b>Lenze setting</b>	<b>Info</b>
C00700/1	10: AIn1_Out	<a href="#">LA_NCtrl</a> : nMainSetValue_a
C00700/2	22: nPar3_a	<a href="#">LA_NCtrl</a> : nTorqueMotLim_a
C00700/3	22: nPar3_a	<a href="#">LA_NCtrl</a> : nTorqueGenLim_a
C00700/4	0: Not connected	Reserved
C00700/5	0: Not connected	Reserved
C00700/6	1: C_nPos100_a(100.0%)	<a href="#">LA_NCtrl</a> : nPIDVpAdapt_a
C00700/7	0: Not connected	<a href="#">LA_NCtrl</a> : nPIDActValue_a
C00700/8	1: C_nPos100_a(100.0%)	<a href="#">LA_NCtrl</a> : nPIDInfluence_a
C00700/9	0: Not connected	<a href="#">LA_NCtrl</a> : nPIDSetValue_a
<input checked="" type="checkbox"/> Read access <input checked="" type="checkbox"/> Write access <input type="checkbox"/> CINH <input type="checkbox"/> PLC STOP <input type="checkbox"/> No transfer <input type="checkbox"/> COM <input type="checkbox"/> MOT             Scaling factor: 1		

## C00701

Parameter   Name: C00701   LA_NCtrl: digital connection list		Data type: UNSIGNED_16 Index: 23874 <sub>d</sub> = 5D42 <sub>h</sub>
Connection parameters for "Actuating drive speed" application: Binary inputs <ul style="list-style-type: none"> <li>• Selection of the binary output signals for connection with the binary input signals</li> <li>• The selection list contains all binary output signals which can be assigned to the binary inputs mapped by the subcodes.</li> </ul>		
<b>Selection list</b>		
See <a href="#">selection list - digital signals</a>		
Subcodes	Lenze setting	Info
C00701/1	0: Not connected	<a href="#">LA_NCtrl</a> : bCInh
C00701/2	15: DigIn_CInh	<a href="#">LA_NCtrl</a> : bFailReset
C00701/3	0: Not connected	<a href="#">LA_NCtrl</a> : bSetQuickstop
C00701/4	13: DigIn_bIn3	<a href="#">LA_NCtrl</a> : bSetDCBrake
C00701/5	14: DigIn_bIn4	<a href="#">LA_NCtrl</a> : bSetSpeedCcw
C00701/6	11: DigIn_bIn1	<a href="#">LA_NCtrl</a> : bJogSpeed1
C00701/7	12: DigIn_bIn2	<a href="#">LA_NCtrl</a> : bJogSpeed2
C00701/8	0: Not connected	<a href="#">LA_NCtrl</a> : bMPotUp
C00701/9	0: Not connected	<a href="#">LA_NCtrl</a> : bMPotDown
C00701/10	0: Not connected	<a href="#">LA_NCtrl</a> : bMPotInAct
C00701/11	0: Not connected	<a href="#">LA_NCtrl</a> : bMPotEnable
C00701/12	0: Not connected	<a href="#">LA_NCtrl</a> : bRFG_0
C00701/13	0: Not connected	<a href="#">LA_NCtrl</a> : bSetError1
C00701/14	0: Not connected	<a href="#">LA_NCtrl</a> : bSetError2
C00701/15	1: C_bTrue	<a href="#">LA_NCtrl</a> : bPIDInfluenceRamp
C00701/16	0: Not connected	<a href="#">LA_NCtrl</a> : bPIDIOff
C00701/17	1: C_bTrue	<a href="#">LA_NCtrl</a> : bRLQCw
C00701/18	0: Not connected	<a href="#">LA_NCtrl</a> : bRLQCcw
<input checked="" type="checkbox"/> Read access <input checked="" type="checkbox"/> Write access <input type="checkbox"/> CINH <input type="checkbox"/> PLC STOP <input type="checkbox"/> No transfer <input type="checkbox"/> COM <input type="checkbox"/> MOT             Scaling factor: 1		

## C00725

Parameter   Name: C00725   Current switching frequency		Data type: UNSIGNED_8 Index: 23850 <sub>d</sub> = 5D2A <sub>h</sub>
As of version 03.00.00 Display of the current switching frequency <ul style="list-style-type: none"> <li>• When a variable switching frequency is selected in <a href="#">C00018</a>, the switching frequency may change as a function of the load and rotational frequency.</li> </ul>		
<b>Selection list (read only)</b>		
1	4 kHz var./drive-optimised	
2	8 kHz var./drive-optimised	
3	16 kHz var./drive-optimised	
5	2 kHz constant/drive-optimised	
6	4 kHz constant/drive-optimised	
7	8 kHz constant/drive-optimised	
8	16 kHz constant/drive-optimised	
<input checked="" type="checkbox"/> Read access <input type="checkbox"/> Write access <input type="checkbox"/> CINH <input type="checkbox"/> PLC STOP <input checked="" type="checkbox"/> No transfer <input type="checkbox"/> COM <input type="checkbox"/> MOT             Scaling factor: 1		

# 9 Parameter reference

## 9.2 Parameter list | C00727

### C00727

Parameter   Name: <b>C00727   LS_Keypad: Digital values</b>		Data type: UNSIGNED_8 Index: 23848 <sub>d</sub> = 5D28 <sub>h</sub>
Executing control commands when operating via keypad		
<b>Setting range</b> (min. value   unit   max. value)		
0		1
<b>Subcodes</b>	<b>Lenze setting</b>	<b>Info</b>
C00727/1	0	"1" ≙ request quick stop
C00727/2	0	"1" ≙ request DC-injection braking
C00727/3	0	"1" ≙ request change of direction of rotation
C00727/4	0	"1" ≙ request fixed speed setpoint 1
C00727/5	0	"1" ≙ request fixed speed setpoint 2
<input checked="" type="checkbox"/> Read access <input checked="" type="checkbox"/> Write access <input type="checkbox"/> CINH <input type="checkbox"/> PLC STOP <input checked="" type="checkbox"/> No transfer <input type="checkbox"/> COM <input type="checkbox"/> MOT                   Scaling factor: 1		

### C00728

Parameter   Name: <b>C00728   LS_Keypad: Keypad analog values</b>		Data type: INTEGER_16 Index: 23847 <sub>d</sub> = 5D27 <sub>h</sub>
Selection of different setpoints when operating via keypad		
<b>Setting range</b> (min. value   unit   max. value)		
-199.9	%	199.9
<b>Subcodes</b>	<b>Lenze setting</b>	<b>Info</b>
C00728/1	100.0 %	Torque limit in motor mode
C00728/2	100.0 %	Torque limit in generator mode
C00728/3	0.0 %	Setpoint speed
<input checked="" type="checkbox"/> Read access <input checked="" type="checkbox"/> Write access <input type="checkbox"/> CINH <input type="checkbox"/> PLC STOP <input type="checkbox"/> No transfer <input type="checkbox"/> COM <input type="checkbox"/> MOT                   Scaling factor: 100		

### C00729

Parameter   Name: <b>C00729   Keypad/PC: Speed setpoint</b>		Data type: INTEGER_16 Index: 23846 <sub>d</sub> = 5D26 <sub>h</sub>
<b>This code is for device-internal use only and must not be written to by the user!</b>		

### C00800

Parameter   Name: <b>C00800   L_MPot_1: Upper limit</b>		Data type: INTEGER_16 Index: 23775 <sub>d</sub> = 5CDF <sub>h</sub>
FB <a href="#">L_MPot_1</a> : Upper limit of the motor potentiometer function		
<b>Setting range</b> (min. value   unit   max. value)		<b>Lenze setting</b>
-199.9	%	199.9 <b>100.0 %</b>
<input checked="" type="checkbox"/> Read access <input checked="" type="checkbox"/> Write access <input type="checkbox"/> CINH <input type="checkbox"/> PLC STOP <input type="checkbox"/> No transfer <input type="checkbox"/> COM <input type="checkbox"/> MOT                   Scaling factor: 100		

### C00801

Parameter   Name: <b>C00801   L_MPot_1: Lower limit</b>		Data type: INTEGER_16 Index: 23774 <sub>d</sub> = 5CDE <sub>h</sub>
FB <a href="#">L_MPot_1</a> : Lower limit of the motor potentiometer function		
<b>Setting range</b> (min. value   unit   max. value)		<b>Lenze setting</b>
-199.9	%	199.9 <b>-100.0 %</b>
<input checked="" type="checkbox"/> Read access <input checked="" type="checkbox"/> Write access <input type="checkbox"/> CINH <input type="checkbox"/> PLC STOP <input type="checkbox"/> No transfer <input type="checkbox"/> COM <input type="checkbox"/> MOT                   Scaling factor: 100		

# 9 Parameter reference

## 9.2 Parameter list | C00802

### C00802

Parameter   Name: <b>C00802   L_MPot_1: Acceleration time</b>			Data type: UNSIGNED_16 Index: 23773 <sub>d</sub> = 5CDD <sub>h</sub>
FB <a href="#">L_MPot_1</a> : Acceleration time of the motor potentiometer function			
<b>Setting range</b> (min. value   unit   max. value)			<b>Lenze setting</b>
0.1	s	999.9	<b>10.0 s</b>
<input checked="" type="checkbox"/> Read access <input checked="" type="checkbox"/> Write access <input type="checkbox"/> CINH <input type="checkbox"/> PLC STOP <input type="checkbox"/> No transfer <input type="checkbox"/> COM <input type="checkbox"/> MOT                   Scaling factor: 10			

### C00803

Parameter   Name: <b>C00803   L_MPot_1: Deceleration time</b>			Data type: UNSIGNED_16 Index: 23772 <sub>d</sub> = 5CDD <sub>h</sub>
FB <a href="#">L_MPot_1</a> : Deceleration time of the motor potentiometer function			
<b>Setting range</b> (min. value   unit   max. value)			<b>Lenze setting</b>
0.1	s	999.9	<b>10.0 s</b>
<input checked="" type="checkbox"/> Read access <input checked="" type="checkbox"/> Write access <input type="checkbox"/> CINH <input type="checkbox"/> PLC STOP <input type="checkbox"/> No transfer <input type="checkbox"/> COM <input type="checkbox"/> MOT                   Scaling factor: 10			

### C00804

Parameter   Name: <b>C00804   L_MPot_1: Inactive fct.</b>			Data type: UNSIGNED_8 Index: 23771 <sub>d</sub> = 5CDA <sub>h</sub>
FB <a href="#">L_MPot_1</a> : Selection of the response when deactivating the motor potentiometer via the <i>blnAct</i> input			
<b>Selection list</b> (Lenze setting printed in bold)		<b>Info</b>	
<b>0</b>	<b>Keep value</b>	Keep output value	
1	Deceleration to 0	Deceleration via ramp to 0	
2	Deceleration to lower limit	Deceleration via ramp to lower limit ( <a href="#">C00801</a> )	
3	Without ramp to 0	Jump to 0	
4	Without ramp to lower limit	Jump to lower limit ( <a href="#">C00800</a> )	
5	Acceleration to upper limit	Acceleration via ramp to upper limit ( <a href="#">C00800</a> )	
<input checked="" type="checkbox"/> Read access <input checked="" type="checkbox"/> Write access <input type="checkbox"/> CINH <input type="checkbox"/> PLC STOP <input type="checkbox"/> No transfer <input type="checkbox"/> COM <input type="checkbox"/> MOT                   Scaling factor: 1			

### C00805

Parameter   Name: <b>C00805   L_MPot_1: Init fct.</b>			Data type: UNSIGNED_8 Index: 23770 <sub>d</sub> = 5CDA <sub>h</sub>
FB <a href="#">L_MPot_1</a> : Selection of the response when switching on the device			
<b>Selection list</b> (Lenze setting printed in bold)			
<b>0</b>	<b>Load last value</b>		
1	Load lower limit		
2	Load 0		
<input checked="" type="checkbox"/> Read access <input checked="" type="checkbox"/> Write access <input type="checkbox"/> CINH <input type="checkbox"/> PLC STOP <input type="checkbox"/> No transfer <input type="checkbox"/> COM <input type="checkbox"/> MOT                   Scaling factor: 1			

# 9 Parameter reference

## 9.2 Parameter list | C00806

### C00806

Parameter   Name: <b>C00806   L_MPot_1: Use</b>		Data type: UNSIGNED_8 Index: 23769 <sub>d</sub> = 5CD9 <sub>h</sub>
FB <a href="#">L_MPot_1</a> : Use of the motor potentiometer		
Selection list (Lenze setting printed in bold)		Info
<b>0</b> No		The motor potentiometer is not used. • The analog value applied to the <i>nIn_a</i> input is looped through without any changes to the <i>nOut_a</i> output.
1 Yes		The motor potentiometer is used. • The analog value applied at the <i>nIn_a</i> input is led via the motor potentiometer and provided at the <i>nOut_a</i> output.
<input checked="" type="checkbox"/> Read access <input checked="" type="checkbox"/> Write access <input type="checkbox"/> CINH <input type="checkbox"/> PLC STOP <input type="checkbox"/> No transfer <input type="checkbox"/> COM <input type="checkbox"/> MOT                   Scaling factor: 1		

### C00830

Parameter   Name: <b>C00830   16-bit analogue input</b>		Data type: INTEGER_16 Index: 23745 <sub>d</sub> = 5CC1 <sub>h</sub>
Display in percent of 16-bit input values of different blocks		
Display range (min. value   unit   max. value)		
-199.9	%	199.9
Subcodes		Info
C00830/1		<a href="#">L_NSet_1</a> : nNSet_a
C00830/2		<a href="#">L_NSet_1</a> : nOut_a
C00830/3		LS_MCTRL: nSpeedSetValue_a
C00830/4		LS_MCTRL: nTorqueMotLimit_a
C00830/5		LS_MCTRL: nTorqueGenLimit_a
C00830/6		<a href="#">L_PCTRL_1</a> : nAct_a
C00830/7		<a href="#">L_PCTRL_1</a> : nAdapt_a
C00830/8		<a href="#">L_PCTRL_1</a> : nSet_a
C00830/9		<a href="#">L_PCTRL_1</a> : nInflu_a
C00830/10		<a href="#">L_PCTRL_1</a> : nNSet_a
C00830/11		<a href="#">L_MPot_1</a> : nIn_a
<input checked="" type="checkbox"/> Read access <input type="checkbox"/> Write access <input type="checkbox"/> CINH <input type="checkbox"/> PLC STOP <input checked="" type="checkbox"/> No transfer <input type="checkbox"/> COM <input type="checkbox"/> MOT                   Scaling factor: 100		

### C00831

Parameter   Name: <b>C00831   16-bit common input</b>		Data type: UNSIGNED_16 Index: 23744 <sub>d</sub> = 5CC0 <sub>h</sub>
As of version 03.00.00		
Decimal/hexadecimal/bit-coded display of 16-bit input values of different blocks		
Display area (min. hex value   max. hex value)		
0x0000		0xFFFF
Value is bit-coded:		
Bit 0	Bit0	
...	...	
Bit 15	Bit15	
Subcodes		Info
C00831/1		<a href="#">LS_DCTRL</a> : wCANControl
<input checked="" type="checkbox"/> Read access <input type="checkbox"/> Write access <input type="checkbox"/> CINH <input type="checkbox"/> PLC STOP <input checked="" type="checkbox"/> No transfer <input type="checkbox"/> COM <input type="checkbox"/> MOT		

# 9 Parameter reference

## 9.2 Parameter list | C00833

### C00833

Parameter   Name: <b>C00833   8-bit input</b>		Data type: UNSIGNED_8 Index: 23742 <sub>d</sub> = 5CB <sub>Eh</sub>
As of version 03.00.00		
Display of the signal status of the binary inputs of different blocks		
Selection list		
0	False	
1	True	
Subcodes	Info	
C00833/1	<a href="#">L_NSet_1</a> : bRfg0	
C00833/2	<a href="#">L_NSet_1</a> : bNSetInv	
C00833/3	<a href="#">L_NSet_1</a> : bJog1	
C00833/4	<a href="#">L_NSet_1</a> : bJog2	
C00833/5	<a href="#">LS_SetError_1</a> : bSetError1	
C00833/6	<a href="#">LS_SetError_1</a> : bSetError2	
C00833/7	<a href="#">L_MPot_1</a> : bUp	
C00833/8	<a href="#">L_MPot_1</a> : bInAct	
C00833/9	<a href="#">L_MPot_1</a> : bDown	
C00833/10	<a href="#">L_MPot_1</a> : bEnable	
C00833/11	Reserved	
C00833/12	<a href="#">L_PCTRL_1</a> : bOff	
C00833/13	<a href="#">L_PCTRL_1</a> : bEnableInfluenceRamp	
C00833/14	<a href="#">LS_DCTRL</a> : bCINH	
C00833/15	<a href="#">LS_DCTRL</a> : bFailReset	
C00833/16	<a href="#">LS_DCTRL</a> : bStatus_B0	
C00833/17	<a href="#">LS_DCTRL</a> : bStatus_B2	
C00833/18	<a href="#">LS_DCTRL</a> : bStatus_B3	
C00833/19	<a href="#">LS_DCTRL</a> : bStatus_B4	
C00833/20	<a href="#">LS_DCTRL</a> : bStatus_B5	
C00833/21	<a href="#">LS_DCTRL</a> : bStatus_B14	
C00833/22	<a href="#">LS_DCTRL</a> : bStatus_B15	
C00833/23	<a href="#">L_RLO_1</a> : bCw	
C00833/24	<a href="#">L_RLO_1</a> : bCcw	
<input checked="" type="checkbox"/> Read access <input type="checkbox"/> Write access <input type="checkbox"/> CINH <input type="checkbox"/> PLC STOP <input checked="" type="checkbox"/> No transfer <input type="checkbox"/> COM <input type="checkbox"/> MOT                   Scaling factor: 1		

### C00909

Parameter   Name: <b>C00909   Speed limitation</b>		Data type: INTEGER_16 Index: 23666 <sub>d</sub> = 5C72 <sub>h</sub>
Maximum positive/negative speed for all operating modes		
Setting range (min. value   unit   max. value)		
0.0	%	175.0
Subcodes	Lenze setting	Info
C00909/1	120.0 %	Max. pos. speed
C00909/2	120.0 %	Max. neg. speed
<input checked="" type="checkbox"/> Read access <input checked="" type="checkbox"/> Write access <input type="checkbox"/> CINH <input type="checkbox"/> PLC STOP <input type="checkbox"/> No transfer <input type="checkbox"/> COM <input type="checkbox"/> MOT                   Scaling factor: 100		

# 9 Parameter reference

## 9.2 Parameter list | C00910

### C00910

Parameter   Name: <b>C00910   Frequency limitation</b>		Data type: UNSIGNED_16 Index: 23665 <sub>d</sub> = 5C71 <sub>h</sub>
Maximum positive/negative output frequency for all operating modes		
<b>Setting range</b> (min. value   unit   max. value)		
0	Hz	300
<b>Subcodes</b>	<b>Lenze setting</b>	<b>Info</b>
C00910/1	300 Hz	Max. pos. output frequency
C00910/2	300 Hz	Max. neg. output frequency
<input checked="" type="checkbox"/> Read access <input checked="" type="checkbox"/> Write access <input type="checkbox"/> CINH <input type="checkbox"/> PLC STOP <input type="checkbox"/> No transfer <input type="checkbox"/> COM <input type="checkbox"/> MOT                   Scaling factor: 1		

### C00990

Parameter   Name: <b>C00990   Flying restart fct.: Activation</b>		Data type: UNSIGNED_8 Index: 23585 <sub>d</sub> = 5C21 <sub>h</sub>
Switch on /activate flying restart circuit for non-feedback drive systems		
▶ <a href="#">Flying restart function</a>		
<b>Selection list</b> (Lenze setting printed in bold)		
<b>0</b>	<b>Off</b>	
1	On	
<input checked="" type="checkbox"/> Read access <input checked="" type="checkbox"/> Write access <input type="checkbox"/> CINH <input type="checkbox"/> PLC STOP <input type="checkbox"/> No transfer <input type="checkbox"/> COM <input type="checkbox"/> MOT                   Scaling factor: 1		

### C00991

Parameter   Name: <b>C00991   Flying restart fct.: Process</b>		Data type: UNSIGNED_16 Index: 23584 <sub>d</sub> = 5C20 <sub>h</sub>
Selection of the speed search range for flying restart function		
▶ <a href="#">Flying restart function</a>		
<b>Selection list</b> (Lenze setting printed in bold)		
<b>5</b>	<b>-n...+n   Last output frequency</b>	
6	-n...+n   Actual setpoint frequency	
<input checked="" type="checkbox"/> Read access <input checked="" type="checkbox"/> Write access <input type="checkbox"/> CINH <input type="checkbox"/> PLC STOP <input type="checkbox"/> No transfer <input type="checkbox"/> COM <input type="checkbox"/> MOT                   Scaling factor: 1		

### C00992

Parameter   Name: <b>C00992   Flying restart: Start frequency</b>		Data type: INTEGER_16 Index: 23583 <sub>d</sub> = 5C1F <sub>h</sub>
Selection of the starting value for the flying restart function		
▶ <a href="#">Flying restart function</a>		
<b>Setting range</b> (min. value   unit   max. value)		<b>Lenze setting</b>
-200	Hz	200 <b>10 Hz</b>
<input checked="" type="checkbox"/> Read access <input checked="" type="checkbox"/> Write access <input type="checkbox"/> CINH <input type="checkbox"/> PLC STOP <input type="checkbox"/> No transfer <input type="checkbox"/> COM <input type="checkbox"/> MOT                   Scaling factor: 1		

# 9 Parameter reference

## 9.2 Parameter list | C00994

C00994

Parameter   Name: <b>C00994 - Flying restart fct.: Current</b>		Data type: INTEGER_16 Index: 23581 <sub>d</sub> = 5C1D <sub>h</sub>	
Current to be injected during the flying restart process <ul style="list-style-type: none"><li>• 100 % ≡ rated motor current (<a href="#">C00081</a>).</li><li>• The flying restart current should amount to 10 ... 25 % of the rated motor current.</li></ul> <p style="text-align: right;">▶ <a href="#">Flying restart function</a></p>			
<b>Setting range (min. value   unit   max. value)</b>		<b>Lenze setting</b>	
0.0	%	100.0	<b>25.0 %</b>
<input checked="" type="checkbox"/> Read access <input checked="" type="checkbox"/> Write access <input type="checkbox"/> CINH <input type="checkbox"/> PLC STOP <input type="checkbox"/> No transfer <input type="checkbox"/> COM <input type="checkbox"/> MOT    Scaling factor: 100			



# 9 Parameter reference

## 9.2 Parameter list

---

### 9.2.1 Selection lists for configuration parameters

#### 9.2.1.1 Selection list - analog signals

This selection list is relevant for the following parameters:

Parameter	
<a href="#">C00620</a>	16-bit system connection
<a href="#">C00700</a>	LA_NCtrl: Analog connection list

Selection list - analog signals	
0	Not connected
1	C_nPos100_a(100.0%)
2	C_nNeg100_a(-100.0%)
3	C_nPos199_9_a(199.9%)
4	C_nNeg199_9_a(-199.9%)
5	C_w65535
6	C_wDriveCtrl
10	Aln1_Out
20	nPar1_a
21	nPar2_a
22	nPar3_a
23	nPar4_a
24	LS_Keypad_nTorqueMotLim_a
25	LS_Keypad_nTorqueGenLim_a
26	LS_Keypad_nMainSetValue_a
50	LA_NCtrl_nMotorFreqAct_a
51	LA_NCtrl_nMotorSpeedSet_a
52	LA_NCtrl_nMotorSpeedAct_a
53	LA_NCtrl_nMotor Voltage_a
54	LA_NCtrl_nDCVoltage_a
55	LA_NCtrl_nMotorCurrent_a
56	LA_NCtrl_nMotorTorqueAct_a
57	LA_NCtrl_nHeatsinktemperature_a
58	LA_NCtrl_nOutputSpeedCtrl_a
70	LA_NCtrl_wDeviceStateWord
71	LA_NCtrl_wDeviceAuxStateWord
72	LA_NCtrl_wDetermFailNoLow
73	LA_NCtrl_wDetermFailNoHigh

### 9.2.1.2 Selection list - digital signals

This selection list is relevant for the following parameters:

Parameter	
<a href="#">C00621</a>	Bool system connection
<a href="#">C00701</a>	LA_NCtrl: Digital connection list

Selection list - digital signals	
0	Not connected
1	C_bTrue
11	DigIn_bIn1
12	DigIn_bIn2
13	DigIn_bIn3
14	DigIn_bIn4
15	DigIn_CInh
20	bPar1
21	bPar2
22	bPar3
23	bPar4
24	bPar5
25	bPar6
26	bPar7
27	bPar8
28	bPar9
29	bPar10
30	bPar11
31	bPar12
32	bPar13
33	bPar14
34	bPar15
35	bPar16
36	LS_Keypad_bSetQuickstop
37	LS_Keypad_bSetDCBrake
38	LS_Keypad_bSetSpeedCcw
39	LS_Keypad_bJogSpeed1
40	LS_Keypad_bJogSpeed2
50	LA_NCtrl_bDriveFail
51	LA_NCtrl_bDriveReady
52	LA_NCtrl_bCInhActive
53	LA_NCtrl_bQSPisActive
54	LA_NCtrl_bSafeTorqueOff
60	LA_NCtrl_bSpeedCcw
61	LA_NCtrl_bActSpeedEqZero
62	LA_NCtrl_bSpeedSetReached
63	LA_NCtrl_bSpeedActEqSet
64	LA_NCtrl_bNActCompare
65	LA_NCtrl_bImaxActive
66	LA_NCtrl_bHeatSinkWarning
67	LA_NCtrl_bOVDetected
68	LA_NCtrl_bDCBrakeOn
69	LA_NCtrl_bFlyingSyncActive
70	Ain_bCurrentErrorIn1

# 9 Parameter reference

## 9.3 Table of attributes

### 9.3 Table of attributes

The table of attributes contains information that is required for a communication to the controller via parameters.

#### How to read the table of attributes:

Column		Meaning	Entry	
Code		Parameter name	Cxxxxx	
Name		Parameter short text (display text)	Text	
Index	dec	Index under which the parameter is addressed. The subindex of array variables corresponds to the Lenze subcode number.	24575 - Lenze code number	Is only required for access via a bus system.
	hex		5FFF <sub>h</sub> - Lenze code number	
Data	DS	Data structure	E	Single variable (only one parameter element)
			A	Array variable (several parameter elements)
	DA	Number of array elements (subcodes)	Number	
	DT	Data type	INTEGER_16	2 bytes with sign
			INTEGER_32	4 bytes with sign
			UNSIGNED_8	1 byte without sign
			UNSIGNED_16	2 bytes without sign
UNSIGNED_32			4 bytes without sign	
Factor	Factor for data transfer via a bus system, depending on the number of decimal positions	Factor	1 = no decimal positions 10 = 1 decimal position 100 = 2 decimal positions 1000 = 3 decimal positions	
Access	R	Read access	<input checked="" type="checkbox"/> Reading permitted	
	W	Write access	<input checked="" type="checkbox"/> Writing permitted	
	CINH	Controller inhibit required	<input checked="" type="checkbox"/> Writing is only possible when the controller is inhibited	

Code	Name	Index		Data				Access		
		dec	hex	DS	DA	DT	Factor	R	W	CINH
<a href="#">C00002</a>	Device commands	24573	5FFD	A	32	UNSIGNED_8	1	<input checked="" type="checkbox"/>	<input checked="" type="checkbox"/>	
<a href="#">C00003</a>	Status of last device command	24572	5FFC	E	1	UNSIGNED_8	1	<input checked="" type="checkbox"/>		
<a href="#">C00006</a>	Motor control	24569	5FF9	E	1	UNSIGNED_8	1	<input checked="" type="checkbox"/>	<input checked="" type="checkbox"/>	
<a href="#">C00007</a>	Control mode	24568	5FF8	E	1	UNSIGNED_16	1	<input checked="" type="checkbox"/>	<input checked="" type="checkbox"/>	
<a href="#">C00010</a>	Minimum analog setpoint	24565	5FF5	A	1	INTEGER_16	100	<input checked="" type="checkbox"/>	<input checked="" type="checkbox"/>	
<a href="#">C00011</a>	Appl.: Reference speed	24564	5FF4	E	1	UNSIGNED_16	1	<input checked="" type="checkbox"/>	<input checked="" type="checkbox"/>	
<a href="#">C00012</a>	Accel. time - main setpoint	24563	5FF3	E	1	UNSIGNED_32	1000	<input checked="" type="checkbox"/>	<input checked="" type="checkbox"/>	
<a href="#">C00013</a>	Decel. time - main setpoint	24562	5FF2	E	1	UNSIGNED_32	1000	<input checked="" type="checkbox"/>	<input checked="" type="checkbox"/>	
<a href="#">C00015</a>	VFC: V/f base frequency	24560	5FF0	E	1	UNSIGNED_16	10	<input checked="" type="checkbox"/>	<input checked="" type="checkbox"/>	
<a href="#">C00016</a>	VFC: Vmin boost	24559	5FEF	E	1	UNSIGNED_16	100	<input checked="" type="checkbox"/>	<input checked="" type="checkbox"/>	
<a href="#">C00018</a>	Switching frequency	24557	5FED	E	1	UNSIGNED_8	1	<input checked="" type="checkbox"/>	<input checked="" type="checkbox"/>	
<a href="#">C00019</a>	Auto-DCB: Threshold	24556	5FEC	E	1	UNSIGNED_16	1	<input checked="" type="checkbox"/>	<input checked="" type="checkbox"/>	
<a href="#">C00021</a>	Slip comp.	24554	5FEA	E	1	INTEGER_16	100	<input checked="" type="checkbox"/>	<input checked="" type="checkbox"/>	
<a href="#">C00022</a>	Imax in motor mode	24553	5FE9	E	1	UNSIGNED_16	100	<input checked="" type="checkbox"/>	<input checked="" type="checkbox"/>	
<a href="#">C00023</a>	Imax in generator mode	24552	5FE8	E	1	INTEGER_16	100	<input checked="" type="checkbox"/>	<input checked="" type="checkbox"/>	
<a href="#">C00024</a>	Comparison value N_Act	24551	5FE7	E	1	INTEGER_16	100	<input checked="" type="checkbox"/>	<input checked="" type="checkbox"/>	
<a href="#">C00026</a>	AINx: Offset	24549	5FE5	A	1	INTEGER_16	100	<input checked="" type="checkbox"/>	<input checked="" type="checkbox"/>	
<a href="#">C00027</a>	AINx: Gain	24548	5FE4	A	1	INTEGER_32	100	<input checked="" type="checkbox"/>	<input checked="" type="checkbox"/>	
<a href="#">C00028</a>	AINx: Input voltage	24547	5FE3	A	1	INTEGER_16	100	<input checked="" type="checkbox"/>		
<a href="#">C00029</a>	AINx: Input current	24546	5FE2	A	1	INTEGER_16	100	<input checked="" type="checkbox"/>		
<a href="#">C00033</a>	AINx: Output value	24542	5FDE	A	1	INTEGER_16	100	<input checked="" type="checkbox"/>		
<a href="#">C00034</a>	AINx: Configuration	24541	5FDD	A	1	UNSIGNED_8	1	<input checked="" type="checkbox"/>	<input checked="" type="checkbox"/>	

Code	Name	Index		Data				Access		
		dec	hex	DS	DA	DT	Factor	R	W	CINH
<a href="#">C00036</a>	DCB: Current	24539	5FDB	E	1	INTEGER_16	100	<input checked="" type="checkbox"/>	<input checked="" type="checkbox"/>	
<a href="#">C00039</a>	Fixed setpoint x (L_NSet_1 n-Fix)	24536	5FD8	A	3	INTEGER_16	100	<input checked="" type="checkbox"/>	<input checked="" type="checkbox"/>	
<a href="#">C00050</a>	MCTRL: Speed setpoint	24525	5FCD	E	1	INTEGER_32	1	<input checked="" type="checkbox"/>		
<a href="#">C00051</a>	MCTRL: Actual speed value	24524	5FCC	E	1	INTEGER_32	1	<input checked="" type="checkbox"/>		
<a href="#">C00052</a>	Motor voltage	24523	5FCB	E	1	UNSIGNED_16	1	<input checked="" type="checkbox"/>		
<a href="#">C00053</a>	DC-bus voltage	24522	5FCA	E	1	UNSIGNED_16	1	<input checked="" type="checkbox"/>		
<a href="#">C00054</a>	Motor current	24521	5FC9	E	1	UNSIGNED_16	100	<input checked="" type="checkbox"/>		
<a href="#">C00056</a>	Torque	24519	5FC7	A	2	INTEGER_32	100	<input checked="" type="checkbox"/>		
<a href="#">C00057</a>	Maximum torque	24518	5FC6	E	1	UNSIGNED_32	100	<input checked="" type="checkbox"/>		
<a href="#">C00058</a>	Output frequency	24517	5FC5	E	1	INTEGER_32	100	<input checked="" type="checkbox"/>		
<a href="#">C00059</a>	Appl.: Reference frequency C11	24516	5FC4	E	1	UNSIGNED_32	100	<input checked="" type="checkbox"/>		
<a href="#">C00061</a>	Heatsink temperature	24514	5FC2	E	1	INTEGER_16	1	<input checked="" type="checkbox"/>		
<a href="#">C00064</a>	Device utilisation (lxt)	24511	5FBF	A	3	INTEGER_16	100	<input checked="" type="checkbox"/>		
<a href="#">C00066</a>	Thermal motor load (l <sup>xt</sup> )	24509	5FBD	E	1	INTEGER_16	100	<input checked="" type="checkbox"/>		
<a href="#">C00073</a>	Vp lmax controller	24502	5FB6	E	1	UNSIGNED_16	100	<input checked="" type="checkbox"/>	<input checked="" type="checkbox"/>	
<a href="#">C00074</a>	Ti lmax controller	24501	5FB5	E	1	UNSIGNED_16	1	<input checked="" type="checkbox"/>	<input checked="" type="checkbox"/>	
<a href="#">C00081</a>	Rated motor power	24494	5FAE	E	1	UNSIGNED_16	100	<input checked="" type="checkbox"/>	<input checked="" type="checkbox"/>	
<a href="#">C00084</a>	Motor stator resistance	24491	5FAB	E	1	UNSIGNED_32	1	<input checked="" type="checkbox"/>	<input checked="" type="checkbox"/>	
<a href="#">C00085</a>	Motor stator leakage inductance	24490	5FAA	E	1	UNSIGNED_16	100	<input checked="" type="checkbox"/>	<input checked="" type="checkbox"/>	
<a href="#">C00087</a>	Rated motor speed	24488	5FA8	E	1	UNSIGNED_16	1	<input checked="" type="checkbox"/>	<input checked="" type="checkbox"/>	
<a href="#">C00088</a>	Rated motor current	24487	5FA7	E	1	UNSIGNED_16	100	<input checked="" type="checkbox"/>	<input checked="" type="checkbox"/>	
<a href="#">C00089</a>	Rated motor frequency	24486	5FA6	E	1	UNSIGNED_16	1	<input checked="" type="checkbox"/>	<input checked="" type="checkbox"/>	
<a href="#">C00090</a>	Rated motor voltage	24485	5FA5	E	1	UNSIGNED_16	1	<input checked="" type="checkbox"/>	<input checked="" type="checkbox"/>	
<a href="#">C00091</a>	Motor cosine phi	24484	5FA4	E	1	UNSIGNED_8	100	<input checked="" type="checkbox"/>	<input checked="" type="checkbox"/>	
<a href="#">C00092</a>	Motor magnetising inductance	24483	5FA3	E	1	UNSIGNED_16	10	<input checked="" type="checkbox"/>	<input checked="" type="checkbox"/>	
<a href="#">C00093</a>	Power section identification	24482	5FA2	E	1	UNSIGNED_16	1	<input checked="" type="checkbox"/>		
<a href="#">C00094</a>	Password	24481	5FA1	E	1	INTEGER_32	1	<input checked="" type="checkbox"/>	<input checked="" type="checkbox"/>	
<a href="#">C00095</a>	Motor magnetising current	24480	5FA0	E	1	UNSIGNED_16	100	<input checked="" type="checkbox"/>		
<a href="#">C00097</a>	Rated motor torque	24478	5F9E	E	1	UNSIGNED_32	100	<input checked="" type="checkbox"/>		
<a href="#">C00098</a>	Rated device current	24477	5F9D	E	1	UNSIGNED_16	10	<input checked="" type="checkbox"/>		
<a href="#">C00099</a>	Firmware version	24476	5F9C	E	1	VISIBLE_STRING		<input checked="" type="checkbox"/>		
<a href="#">C00100</a>	Firmware version	24475	5F9B	A	4	UNSIGNED_8	1	<input checked="" type="checkbox"/>		
<a href="#">C00105</a>	Deceleration time - quick stop	24470	5F96	E	1	UNSIGNED_32	1000	<input checked="" type="checkbox"/>	<input checked="" type="checkbox"/>	
<a href="#">C00106</a>	Auto-DCB: Hold time	24469	5F95	E	1	UNSIGNED_32	1000	<input checked="" type="checkbox"/>	<input checked="" type="checkbox"/>	
<a href="#">C00107</a>	DCB: Hold time	24468	5F94	E	1	UNSIGNED_32	1000	<input checked="" type="checkbox"/>	<input checked="" type="checkbox"/>	
<a href="#">C00114</a>	Dlx inversion	24461	5F8D	E	1	UNSIGNED_16		<input checked="" type="checkbox"/>	<input checked="" type="checkbox"/>	
<a href="#">C00118</a>	DOx inversion	24457	5F89	E	1	UNSIGNED_8		<input checked="" type="checkbox"/>	<input checked="" type="checkbox"/>	
<a href="#">C00120</a>	Motor overload threshold (l <sup>xt</sup> )	24455	5F87	E	1	INTEGER_16	100	<input checked="" type="checkbox"/>	<input checked="" type="checkbox"/>	
<a href="#">C00122</a>	Initial value motor overload (l <sup>xt</sup> )	24453	5F85	A	1	UNSIGNED_16	100	<input checked="" type="checkbox"/>	<input checked="" type="checkbox"/>	
<a href="#">C00123</a>	Device utilisat. threshold (lxt)	24452	5F84	E	1	INTEGER_16	100	<input checked="" type="checkbox"/>	<input checked="" type="checkbox"/>	
<a href="#">C00134</a>	Ramp smoothing - main setpoint	24441	5F79	E	1	UNSIGNED_8	1	<input checked="" type="checkbox"/>	<input checked="" type="checkbox"/>	
<a href="#">C00137</a>	Device state	24438	5F76	E	1	UNSIGNED_16	1	<input checked="" type="checkbox"/>		
<a href="#">C00141</a>	Device settings	24434	5F72	A	1	UNSIGNED_8	1	<input checked="" type="checkbox"/>	<input checked="" type="checkbox"/>	
<a href="#">C00142</a>	Auto-start option	24433	5F71	E	1	UNSIGNED_8		<input checked="" type="checkbox"/>	<input checked="" type="checkbox"/>	
<a href="#">C00144</a>	Switching frequency reduction (temp.)	24431	5F6F	E	1	UNSIGNED_8	1	<input checked="" type="checkbox"/>	<input checked="" type="checkbox"/>	
<a href="#">C00150</a>	Status word	24425	5F69	E	1	UNSIGNED_16		<input checked="" type="checkbox"/>		
<a href="#">C00155</a>	Status word 2	24420	5F64	E	1	UNSIGNED_16		<input checked="" type="checkbox"/>		
<a href="#">C00158</a>	Cause of controller inhibit	24417	5F61	E	1	UNSIGNED_16		<input checked="" type="checkbox"/>		
<a href="#">C00159</a>	Cause of quick stop QSP	24416	5F60	E	1	UNSIGNED_16		<input checked="" type="checkbox"/>		
<a href="#">C00165</a>	Error information	24410	5F5A	A	1	VISIBLE_STRING		<input checked="" type="checkbox"/>		
<a href="#">C00166</a>	Error information text	24409	5F59	A	3	VISIBLE_STRING		<input checked="" type="checkbox"/>		

Code	Name	Index		Data				Access		
		dec	hex	DS	DA	DT	Factor	R	W	CINH
<a href="#">C00168</a>	Error number	24407	5F57	A	8	UNSIGNED_32	1	<input checked="" type="checkbox"/>		
<a href="#">C00169</a>	Time of error	24406	5F56	A	8	UNSIGNED_32	1	<input checked="" type="checkbox"/>		
<a href="#">C00170</a>	Error counter	24405	5F55	A	8	UNSIGNED_8	1	<input checked="" type="checkbox"/>		
<a href="#">C00173</a>	Mains voltage	24402	5F52	E	1	UNSIGNED_8	1	<input checked="" type="checkbox"/>	<input checked="" type="checkbox"/>	<input checked="" type="checkbox"/>
<a href="#">C00174</a>	Reduced brake chopper threshold	24401	5F51	E	1	UNSIGNED_8	1	<input checked="" type="checkbox"/>	<input checked="" type="checkbox"/>	
<a href="#">C00177</a>	Switching cycles	24398	5F4E	A	2	UNSIGNED_32	1	<input checked="" type="checkbox"/>		
<a href="#">C00178</a>	Elapsed-hour meter	24397	5F4D	E	1	UNSIGNED_32	1	<input checked="" type="checkbox"/>		
<a href="#">C00179</a>	Power-on time meter	24396	5F4C	E	1	UNSIGNED_32	1	<input checked="" type="checkbox"/>		
<a href="#">C00182</a>	S-ramp time PT1	24393	5F49	E	1	INTEGER_16	100	<input checked="" type="checkbox"/>	<input checked="" type="checkbox"/>	
<a href="#">C00200</a>	Firmware product type	24375	5F37	E	1	VISIBLE_STRING		<input checked="" type="checkbox"/>		
<a href="#">C00201</a>	Firmware compile date	24374	5F36	E	1	VISIBLE_STRING		<input checked="" type="checkbox"/>		
<a href="#">C00203</a>	Product type code	24372	5F34	A	9	VISIBLE_STRING		<input checked="" type="checkbox"/>		
<a href="#">C00222</a>	L_PCTRL_1: Vp	24353	5F21	E	1	INTEGER_16	10	<input checked="" type="checkbox"/>	<input checked="" type="checkbox"/>	
<a href="#">C00223</a>	L_PCTRL_1: Tn	24352	5F20	E	1	UNSIGNED_16	1	<input checked="" type="checkbox"/>	<input checked="" type="checkbox"/>	
<a href="#">C00224</a>	L_PCTRL_1: Kd	24351	5F1F	E	1	UNSIGNED_16	10	<input checked="" type="checkbox"/>	<input checked="" type="checkbox"/>	
<a href="#">C00225</a>	L_PCTRL_1: MaxLimit	24350	5F1E	E	1	INTEGER_16	100	<input checked="" type="checkbox"/>	<input checked="" type="checkbox"/>	
<a href="#">C00226</a>	L_PCTRL_1: MinLimit	24349	5F1D	E	1	INTEGER_16	100	<input checked="" type="checkbox"/>	<input checked="" type="checkbox"/>	
<a href="#">C00227</a>	L_PCTRL_1: Acceleration time	24348	5F1C	E	1	UNSIGNED_32	1000	<input checked="" type="checkbox"/>	<input checked="" type="checkbox"/>	
<a href="#">C00228</a>	L_PCTRL_1: Deceleration time	24347	5F1B	E	1	UNSIGNED_32	1000	<input checked="" type="checkbox"/>	<input checked="" type="checkbox"/>	
<a href="#">C00231</a>	L_PCTRL_1: Operating range	24344	5F18	A	4	INTEGER_16	100	<input checked="" type="checkbox"/>	<input checked="" type="checkbox"/>	
<a href="#">C00234</a>	Oscillation damping influence	24341	5F15	E	1	UNSIGNED_16	100	<input checked="" type="checkbox"/>	<input checked="" type="checkbox"/>	
<a href="#">C00242</a>	L_PCTRL_1: Operating mode	24333	5F0D	E	1	UNSIGNED_8	1	<input checked="" type="checkbox"/>	<input checked="" type="checkbox"/>	
<a href="#">C00243</a>	L_PCTRL_1: Acceleration time influence	24332	5F0C	E	1	UNSIGNED_32	1000	<input checked="" type="checkbox"/>	<input checked="" type="checkbox"/>	
<a href="#">C00244</a>	L_PCTRL_1: Deceleration time influence	24331	5F0B	E	1	UNSIGNED_32	1000	<input checked="" type="checkbox"/>	<input checked="" type="checkbox"/>	
<a href="#">C00245</a>	L_PCTRL_1: PID output value	24330	5F0A	E	1	INTEGER_16	100	<input checked="" type="checkbox"/>		
<a href="#">C00443</a>	Dix: Level	24132	5E44	A	2	UNSIGNED_16		<input checked="" type="checkbox"/>		
<a href="#">C00444</a>	DOx: Level	24131	5E43	A	2	UNSIGNED_16		<input checked="" type="checkbox"/>		
<a href="#">C00470</a>	LS_ParFree_b	24105	5E29	A	16	UNSIGNED_8	1	<input checked="" type="checkbox"/>	<input checked="" type="checkbox"/>	
<a href="#">C00472</a>	LS_ParFree_a	24103	5E27	A	4	INTEGER_16	100	<input checked="" type="checkbox"/>	<input checked="" type="checkbox"/>	
<a href="#">C00480</a>	LS_DisFree_b	24095	5E1F	E	1	UNSIGNED_8		<input checked="" type="checkbox"/>		
<a href="#">C00481</a>	LS_DisFree	24094	5E1E	A	4	UNSIGNED_16		<input checked="" type="checkbox"/>		
<a href="#">C00482</a>	LS_DisFree_a	24093	5E1D	A	4	INTEGER_16	100	<input checked="" type="checkbox"/>		
<a href="#">C00516</a>	Checksums	24059	5DFB	A	1	UNSIGNED_32	1	<input checked="" type="checkbox"/>		
<a href="#">C00517</a>	User menu	24058	5DFA	A	20	INTEGER_32	1	<input checked="" type="checkbox"/>	<input checked="" type="checkbox"/>	
<a href="#">C00565</a>	Resp. to mains phase failure	24010	5DCA	E	1	UNSIGNED_8	1	<input checked="" type="checkbox"/>	<input checked="" type="checkbox"/>	
<a href="#">C00574</a>	Resp. to brake resist. overtemp.	24001	5DC1	E	1	UNSIGNED_8	1	<input checked="" type="checkbox"/>	<input checked="" type="checkbox"/>	
<a href="#">C00581</a>	Resp. to LS_SetError_x	23994	5DBA	A	2	UNSIGNED_8	1	<input checked="" type="checkbox"/>	<input checked="" type="checkbox"/>	
<a href="#">C00598</a>	Resp. to open circuit AlNx	23977	5DA9	A	1	UNSIGNED_8	1	<input checked="" type="checkbox"/>	<input checked="" type="checkbox"/>	
<a href="#">C00600</a>	Resp. to DC bus undervoltage	23975	5DA7	A	1	UNSIGNED_8	1	<input checked="" type="checkbox"/>	<input checked="" type="checkbox"/>	
<a href="#">C00601</a>	Del. resp.to fault: DC bus overvoltage	23974	5DA6	A	1	UNSIGNED_16	1000	<input checked="" type="checkbox"/>	<input checked="" type="checkbox"/>	
<a href="#">C00604</a>	Resp. to device overload (lxt)	23971	5DA3	E	1	UNSIGNED_8	1	<input checked="" type="checkbox"/>	<input checked="" type="checkbox"/>	
<a href="#">C00606</a>	Resp. to motor overload (l*xt)	23969	5DA1	E	1	UNSIGNED_8	1	<input checked="" type="checkbox"/>	<input checked="" type="checkbox"/>	
<a href="#">C00620</a>	16-bit system connection	23955	5D93	A	12	UNSIGNED_16	1	<input checked="" type="checkbox"/>	<input checked="" type="checkbox"/>	
<a href="#">C00621</a>	Bool system connection	23954	5D92	A	23	UNSIGNED_16	1	<input checked="" type="checkbox"/>	<input checked="" type="checkbox"/>	
<a href="#">C00700</a>	LA_NCtrl: Analog connection list	23875	5D43	A	9	UNSIGNED_16	1	<input checked="" type="checkbox"/>	<input checked="" type="checkbox"/>	
<a href="#">C00701</a>	LA_NCtrl: Digital connection list	23874	5D42	A	18	UNSIGNED_16	1	<input checked="" type="checkbox"/>	<input checked="" type="checkbox"/>	
<a href="#">C00725</a>	Current switching frequency	23850	5D2A	E	1	UNSIGNED_8	1	<input checked="" type="checkbox"/>		
<a href="#">C00727</a>	LS_Keypad: Digital values	23848	5D28	A	5	UNSIGNED_8	1	<input checked="" type="checkbox"/>	<input checked="" type="checkbox"/>	
<a href="#">C00728</a>	LS_Keypad: Keypad analog values	23847	5D27	A	3	INTEGER_16	100	<input checked="" type="checkbox"/>	<input checked="" type="checkbox"/>	
<a href="#">C00800</a>	L_MPot_1: Upper limit	23775	5CDF	E	1	INTEGER_16	100	<input checked="" type="checkbox"/>	<input checked="" type="checkbox"/>	

Code	Name	Index		Data				Access		
		dec	hex	DS	DA	DT	Factor	R	W	CINH
<a href="#">C00801</a>	L_MPot_1: Lower limit	23774	5CDE	E	1	INTEGER_16	100	<input checked="" type="checkbox"/>	<input checked="" type="checkbox"/>	
<a href="#">C00802</a>	L_MPot_1: Acceleration time	23773	5CDD	E	1	UNSIGNED_16	10	<input checked="" type="checkbox"/>	<input checked="" type="checkbox"/>	
<a href="#">C00803</a>	L_MPot_1: Deceleration time	23772	5CDC	E	1	UNSIGNED_16	10	<input checked="" type="checkbox"/>	<input checked="" type="checkbox"/>	
<a href="#">C00804</a>	L_MPot_1: Inactive function	23771	5CDB	E	1	UNSIGNED_8	1	<input checked="" type="checkbox"/>	<input checked="" type="checkbox"/>	
<a href="#">C00805</a>	L_MPot_1: Init function	23770	5CDA	E	1	UNSIGNED_8	1	<input checked="" type="checkbox"/>	<input checked="" type="checkbox"/>	
<a href="#">C00806</a>	L_MPot_1: Use	23769	5CD9	E	1	UNSIGNED_8	1	<input checked="" type="checkbox"/>	<input checked="" type="checkbox"/>	
<a href="#">C00830</a>	16-bit analog input	23745	5CC1	A	11	INTEGER_16	100	<input checked="" type="checkbox"/>		
<a href="#">C00831</a>	16-bit common input	23744	5CC0	A	1	UNSIGNED_16		<input checked="" type="checkbox"/>		
<a href="#">C00833</a>	8-bit input	23742	5CBE	A	24	UNSIGNED_8	1	<input checked="" type="checkbox"/>		
<a href="#">C00909</a>	Speed limitation	23666	5C72	A	2	INTEGER_16	100	<input checked="" type="checkbox"/>	<input checked="" type="checkbox"/>	
<a href="#">C00910</a>	Frequency limitation	23665	5C71	A	2	UNSIGNED_16	1	<input checked="" type="checkbox"/>	<input checked="" type="checkbox"/>	
<a href="#">C00990</a>	Flying restart fct.: Activation	23585	5C21	E	1	UNSIGNED_8	1	<input checked="" type="checkbox"/>	<input checked="" type="checkbox"/>	
<a href="#">C00991</a>	Flying restart fct.: Process	23584	5C20	E	1	UNSIGNED_16	1	<input checked="" type="checkbox"/>	<input checked="" type="checkbox"/>	
<a href="#">C00992</a>	Flying restart: Start frequency	23583	5C1F	E	1	INTEGER_16	1	<input checked="" type="checkbox"/>	<input checked="" type="checkbox"/>	
<a href="#">C00994</a>	Flying restart fct.: Current	23581	5C1D	E	1	INTEGER_16	100	<input checked="" type="checkbox"/>	<input checked="" type="checkbox"/>	

## 10 Function library

This chapter describes the function and system blocks that are part of the drive application.

Function block	Function
<a href="#">L_MPot_1</a>	Motor potentiometer (as alternative setpoint source)
<a href="#">L_NSet_1</a>	Setpoint generator
<a href="#">L_PCTRL_1</a>	Process controller
<a href="#">L_RLO_1</a>	Fail-safe linking of a selected direction of rotation to the quick stop function (QSP)

System block	Function
<a href="#">LS_AnalogInput</a>	Interface to the analog input terminals ▶ <a href="#">Analog terminals</a> (☞ 112)
<a href="#">LS_DigitalInput</a>	Interface to the digital input terminals ▶ <a href="#">Digital terminals</a> (☞ 110)
<a href="#">LS_DigitalOutput</a>	Interface to the digital output terminals ▶ <a href="#">Digital terminals</a> (☞ 110)
<a href="#">LS_DisFree</a>	Any four 16-bit signals of the application can be displayed on display codes
<a href="#">LS_DisFree_a</a>	Any four analog signals of the application can be displayed on display codes
<a href="#">LS_DisFree_b</a>	Any eight digital signals of the application can be displayed on a bit-coded display code
<a href="#">LS_DriveInterface</a>	Interface for drive control (DCTRL) ▶ <a href="#">Device control (DCTRL)</a> (☞ 45)
<a href="#">LS_Keypad</a>	Keypad control
<a href="#">LS_ParFix</a>	Output of different constant values
<a href="#">LS_ParFree_a</a>	Output of 4 parameterisable analog signals
<a href="#">LS_ParFree_b</a>	Output of 16 parameterisable digital signals
<a href="#">LS_SetError_1</a>	Parameterisable responses to user-defined events are tripped

10.1 L\_MPot\_1

This FB replaces a hardware motor potentiometer and can be used as an alternative setpoint source which is controlled via two inputs.

- The signal is output via a ramp function generator with linear ramps.
- The acceleration and deceleration times are set via parameters.
- Constant ramping even with speed limit values changed online.
- The motor potentiometer function can be switched on/off online via parameters or a process signal.

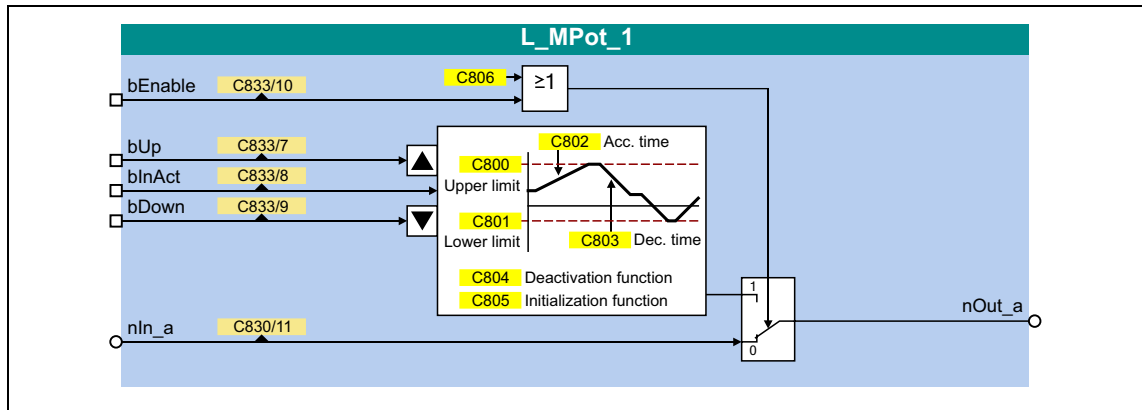

Inputs

Identifier	Data type	Information/possible settings
bEnable	BOOL	Switch over motor potentiometer function <i>bEnable</i> input and <a href="#">C806</a> code are OR'd.
		TRUE Motor potentiometer function is active, setpoint can be changed via <i>bUp</i> and <i>bDown</i> . • With switching to TRUE, the value applied to <i>nIn_a</i> is automatically transferred to the motor potentiometer.
		FALSE The value applied to <i>nIn_a</i> is output at <i>nOut_a</i> .
nIn_a	INT	When bEnable = FALSE, the analog input signal <i>nIn_</i> is switched to the <i>nOut_a</i> output.
bUp	BOOL	Approaching of the upper speed limit value set in <a href="#">C800</a>
		TRUE The <i>nOut_a</i> output signal runs to its upper limit value ( <i>nHighLimit</i> ). • If the <i>bDown</i> input is simultaneously set to TRUE, the <i>nOut_a</i> output signal is not changed.
bDown	BOOL	Approaching of the lower speed limit value set in <a href="#">C801</a>
		TRUE The <i>nOut_a</i> output signal runs to its lower limit value ( <i>nLowLimit</i> ). • If the <i>bUp</i> input is simultaneously set to TRUE, the <i>nOut_a</i> output signal is not changed.
bInAct	BOOL	Deactivate motor potentiometer function • This input has the highest priority. • When the motor potentiometer is deactivated, the <i>nOut_a</i> output signal follows the function set with code <a href="#">C804</a> .
		TRUE Motor potentiometer function is deactivated.



## Outputs

Identifier	Data type	Value/meaning
nOut_a	INT	Output signal

## Parameter

Parameter	Possible settings			Info
<a href="#">C800</a>	-199.9	%	199.9	Upper limit • Lenze setting: 100.0 %
<a href="#">C801</a>	-199.9	%	199.9	Lower limit • Lenze setting: -100.0 %
<a href="#">C802</a>	0.1	s	999.9	Acceleration time • Lenze setting: 10.0 s
<a href="#">C803</a>	0.1	s	999.9	Deceleration time • Lenze setting: 10.0 s
<a href="#">C804</a>				Inactive function • Selection of response when deactivating the motor potentiometer via the input <i>blnAct</i> .
	0	Keep value (Lenze setting)		No further action; <i>nOut_a</i> retains its value.
	1	Deceleration to 0		The motor potentiometer returns to 0 % within the deceleration time $T_{if}$ .
	2	Deceleration to lower limit		The motor potentiometer runs within the deceleration time $T_{if}$ to the lower limit value ( <a href="#">C801</a> ).
	3	Without ramp to 0		<b>Important for the emergency stop function</b> The motor potentiometer output immediately changes to 0 %
	4	Without ramp to lower limit		The motor potentiometer output immediately changes to the lower limit value ( <a href="#">C801</a> ).
	5	Acceleration to upper limit		The motor potentiometer runs with the acceleration time $T_{ir}$ to the upper limit value ( <a href="#">C800</a> ).
<a href="#">C805</a>				Init function • Selection of response when switching on the device.
	0	Load last value (Lenze setting)		The output value being output during mains power-off is saved non-volatilely in the internal memory of the controller. It will be reloaded during mains power-on.
	1	Load lower limit		The lower limit value ( <a href="#">C801</a> ) is loaded during mains power-on.
	2	Load 0		An output value = 0 % is loaded during mains power-on.

Parameter	Possible settings	Info
<a href="#">C806</a>		Use of the motor potentiometer
	0 No (Lenze setting)	The motor potentiometer is not used. <ul style="list-style-type: none"> <li>The analog value applied to the <i>nIn_a</i> input is looped through without any changes to the <i>nOut_a</i> output.</li> </ul>
	1 Yes	The motor potentiometer is used. <ul style="list-style-type: none"> <li>The analog value applied at the <i>nIn_a</i> input is led via the motor potentiometer and provided at the <i>nOut_a</i> output.</li> </ul>

### 10.1.1 Activate & control motor potentiometer

When *blnAct* is set to FALSE, the motor potentiometer is activated.

- The currently active function depends on the current output signal *nOut\_a*, the limit values set and the control signals at *bUp* and *bDown*.
- When the *nOut\_a* output signal is outside the limits set, the output signal runs to the next limit with the *Ti* times set. This process is independent of the control signals at *bUp* and *bDown*.
- When the *nOut\_a* output signal is inside the limits set, the output signal changes according to the control signals at *bUp* and *bDown*.

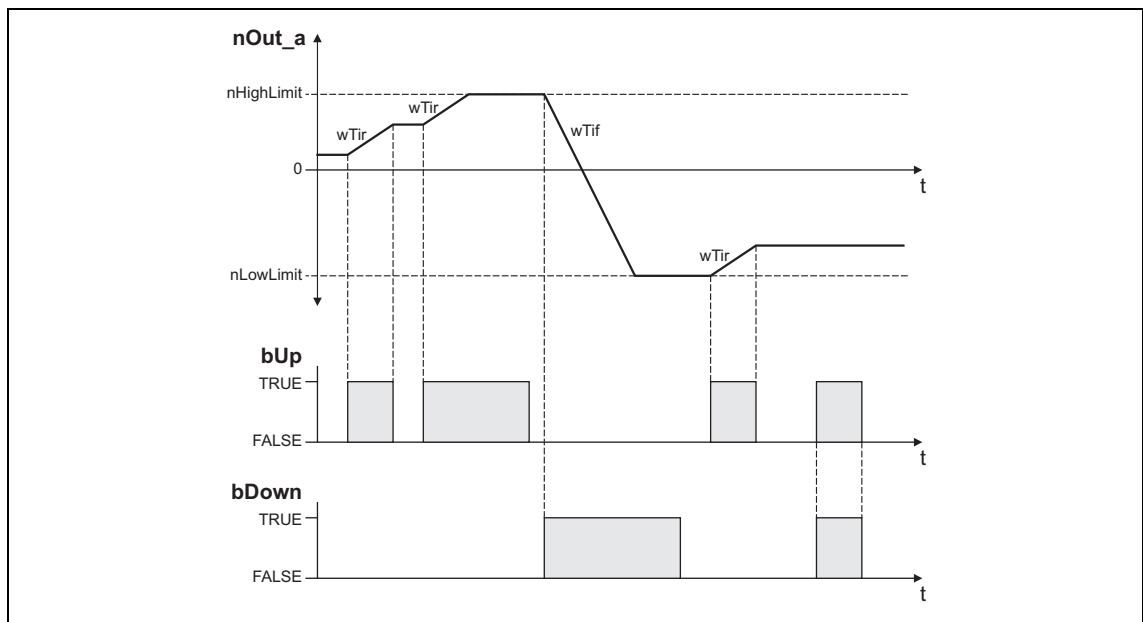

[10-1] Example: Control of the motor potentiometer

bUp	bDown	blnact	Function
FALSE	FALSE	FALSE	The <i>nOut_a</i> output signal remains unchanged.
TRUE	FALSE		The <i>nOut_a</i> output signal runs to its upper limit value ( <i>nHighLimit</i> ).
FALSE	TRUE		The <i>nOut_a</i> output signal runs to its lower limit value ( <i>nLowLimit</i> ).
TRUE	TRUE		The <i>nOut_a</i> output signal remains unchanged.
-	-	TRUE	The motor potentiometer function is deactivated. The <i>nOut_a</i> output signal responds according to the function selected via <i>Function</i> .

### 10.1.2 Deactivate motor potentiometer

When the motor potentiometer is deactivated by setting *blnAct* to TRUE, the *nOut\_a* output signal responds according to the function selected in [C804](#).

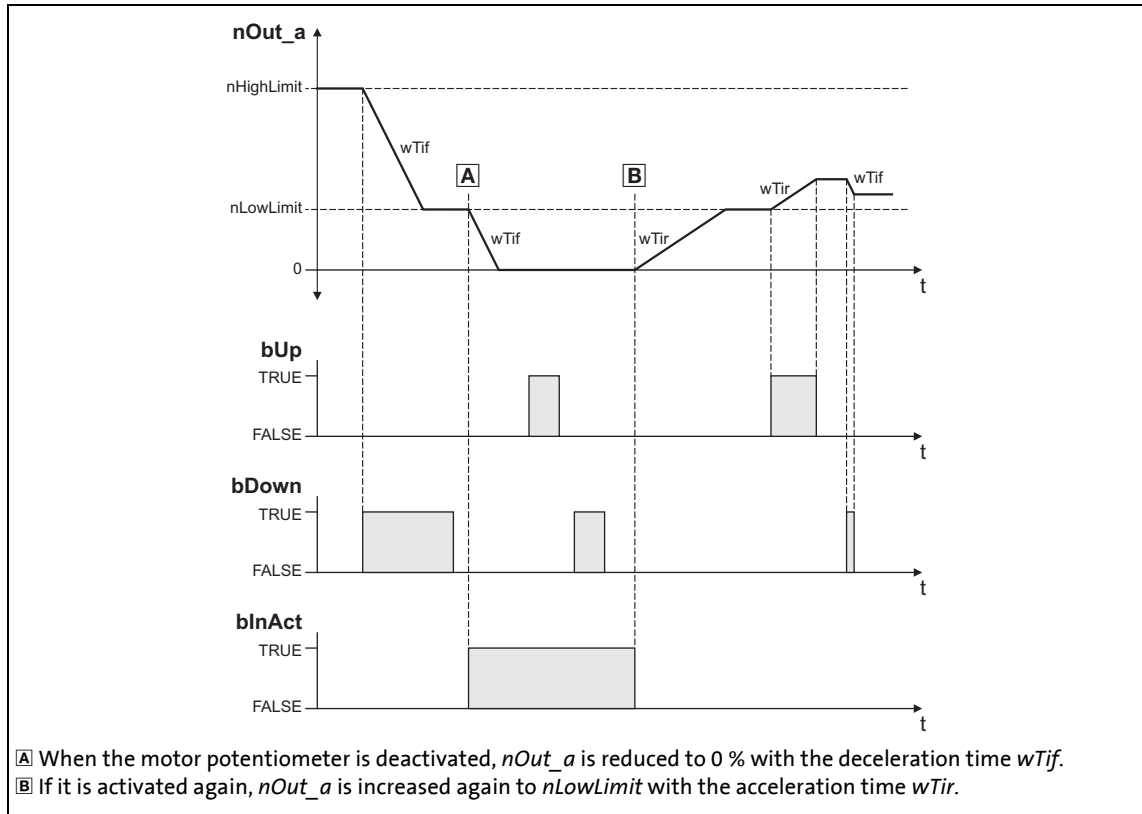

[10-2] Example: Deactivation of the motor potentiometer if [C804](#) = "1: Deceleration to 0"

# 10 Function library

## 10.2 L\_NSet\_1

### 10.2 L\_NSet\_1

This FB is used for general signal processing of process values and is provided with the following functions:

- Ramp function generator
  - With linear ramps for main setpoint path
  - With S-shaped ramp (PT1 rounding)
- Internal limitation of the input signal
- 3 fixed setpoints (JOG setpoints)

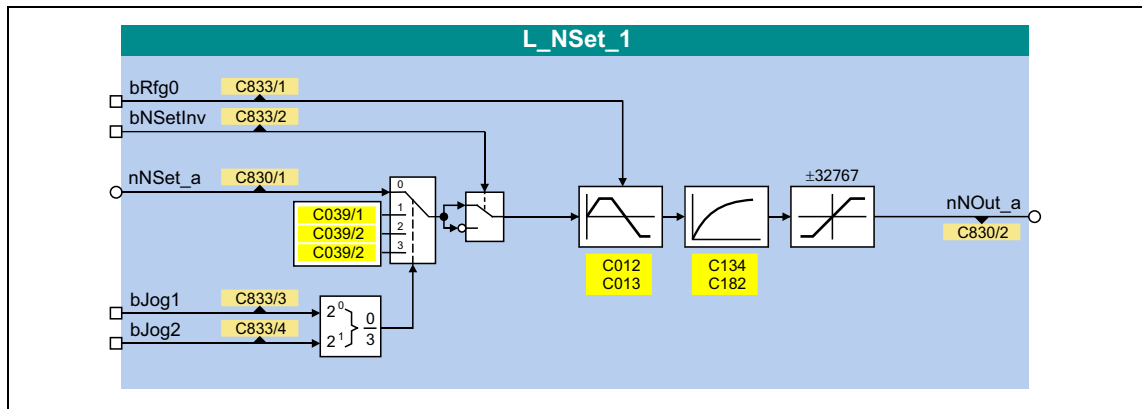

#### Inputs

Identifier	Data type	Information/possible settings
bRfg0	BOOL	Leading the main setpoint integrator to 0 within the current $T_i$ times
		TRUE   The current value of the main setpoint integrator is led to "0" within the $T_i$ time set.
bNSetInv	BOOL	Signal inversion for the main setpoint
		TRUE   Main setpoint signal is inverted.
nNset_a	INT	Main setpoint signal <ul style="list-style-type: none"> <li>• Scaling: <math>16384 \equiv 100\%</math></li> <li>• Other signals are also permitted</li> </ul>
bJog1 / bJog2	BOOL	Selection inputs for fixed changeover setpoints (JOG setpoints) for the main setpoint <ul style="list-style-type: none"> <li>• Selection inputs are binary coded.</li> </ul>

#### Outputs

Identifier	Data type	Value/meaning
nNOut_a	INT	Speed setpoint output signal <ul style="list-style-type: none"> <li>• Scaling: <math>16384 \equiv 100\%</math></li> </ul>

## Parameter

Parameter	Possible settings			Info
<a href="#">C012</a>	0.0	s	999.9	Acceleration time $T_{ir}$ for the main setpoint • Lenze setting: 2.0 s
<a href="#">C013</a>	0.000	s	999.9	Deceleration time $T_{if}$ for the main setpoint • Lenze setting: 2.0 s
<a href="#">C039/1</a>	-199.9	%	199.9	Fixed setpoint 1 (JOG setpoint 1) • Lenze setting: 40.0 %
<a href="#">C039/2</a>	-199.9	%	199.9	Fixed setpoint 2 (JOG setpoint 2) • Lenze setting: 60.0 %
<a href="#">C039/3</a>	-199.9	%	199.9	Fixed setpoint 3 (JOG setpoint 3) • Lenze setting: 80.0 %
<a href="#">C134</a>	0 Off			Activates ramp rounding with PT1 behaviour for the main setpoint • The corresponding S-ramp time must be set in <a href="#">C182</a> . • Lenze setting: 0 (deactivated)
	1 PT1 behaviour			
<a href="#">C182</a>	0.01	s	50.00	S-ramp time PT1 • Lenze setting: 20.00 s

## 10.2.1 Main setpoint path

- The signals in the main setpoint path are limited to a value range of  $\pm 32767$ .
- The signal at  $nNSet\_a$  is first led via the JOG selection function.
- A selected JOG value switches the  $nNSet\_a$  input inactive. Then, the subsequent signal conditioning operates with the JOG value.

## 10.2.2 JOG setpoints

In addition to the direct main setpoint selection, via the input  $nNSet\_a$  JOG setpoints can be set under [C039/1...3](#).

- The JOG setpoints are binary-coded and can be called using the  $bJog1$  and  $bJog8$  selection inputs:

Selection inputs		Used main setpoint
$bJog2$	$bJog1$	
FALSE	FALSE	$nNSet\_a$
FALSE	TRUE	<a href="#">C039/1</a>
TRUE	FALSE	<a href="#">C039/2</a>
TRUE	TRUE	<a href="#">C039/3</a>

- The number of selection inputs to be assigned depends on the number of JOG setpoints required.

### 10.2.3 Setpoint inversion

The output signal of the JOG function is led via an inverter.

The sign of the setpoint changes if *bNSetInv* is set to TRUE.

### 10.2.4 Ramp function generator for the main setpoint

The setpoint is now led via a ramp function generator with linear characteristic. The ramp function generator converts setpoint step-changes at the input into a ramp.

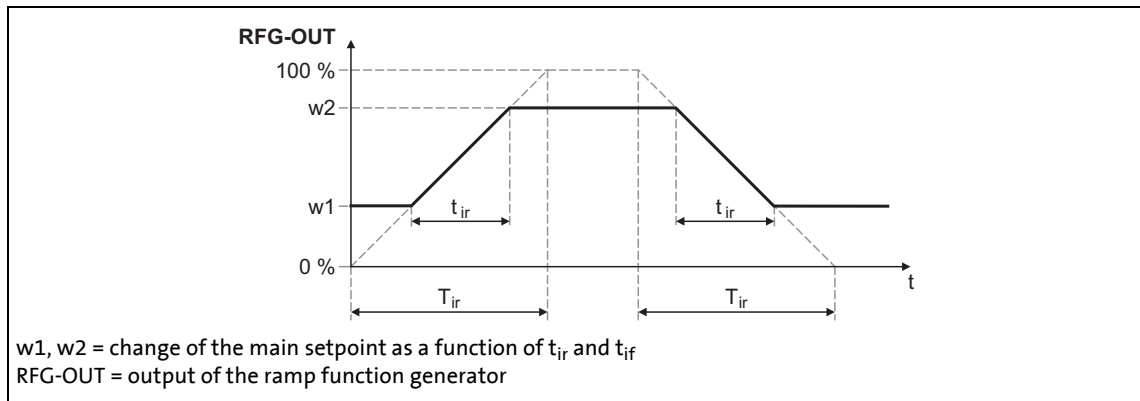

[10-3] Acceleration and deceleration times

- $t_{ir}$  and  $t_{if}$  are the desired times for changing between  $w1$  and  $w2$ .
- The ramps for acceleration and deceleration can be set individually.
  - [C012](#): Acceleration time  $T_{ir}$
  - [C013](#): Deceleration time  $T_{if}$
- The  $t_{ir}/t_{if}$  values are converted into the required  $T_i$  times according to the following formula:

$T_{ir} = t_{ir} \cdot \frac{100\%}{w2 - w1}$	$T_{if} = t_{if} \cdot \frac{100\%}{w2 - w1}$
-----------------------------------------------	-----------------------------------------------

- When the *bRfg0* output is set to TRUE, the ramp function generator brakes to 0 along its deceleration ramp.

### 10.2.5 S-shaped ramp

A PT1 element is connected downstream of the linear ramp function generator. This arrangement implements an S-shaped ramp for a nearly jerk-free acceleration and deceleration.

- The PT1 element can be switched on/off via [C134](#).
- The corresponding S-ramp time can be set under [C182](#).

### 10.3 L\_PCTRL\_1

This FB is a PID controller and can be used for various control tasks (e.g. as dancer position controller, tension controller, or pressure controller).

The FB provides with the following functions:

- Adjustable control algorithm (P, PI, PID)
- Ramp function generator for preventing setpoint step-changes at the input
- Limitation of the controller output
- Factorisation of the output signal
- Vp adaptation
- Integral action component can be switched off

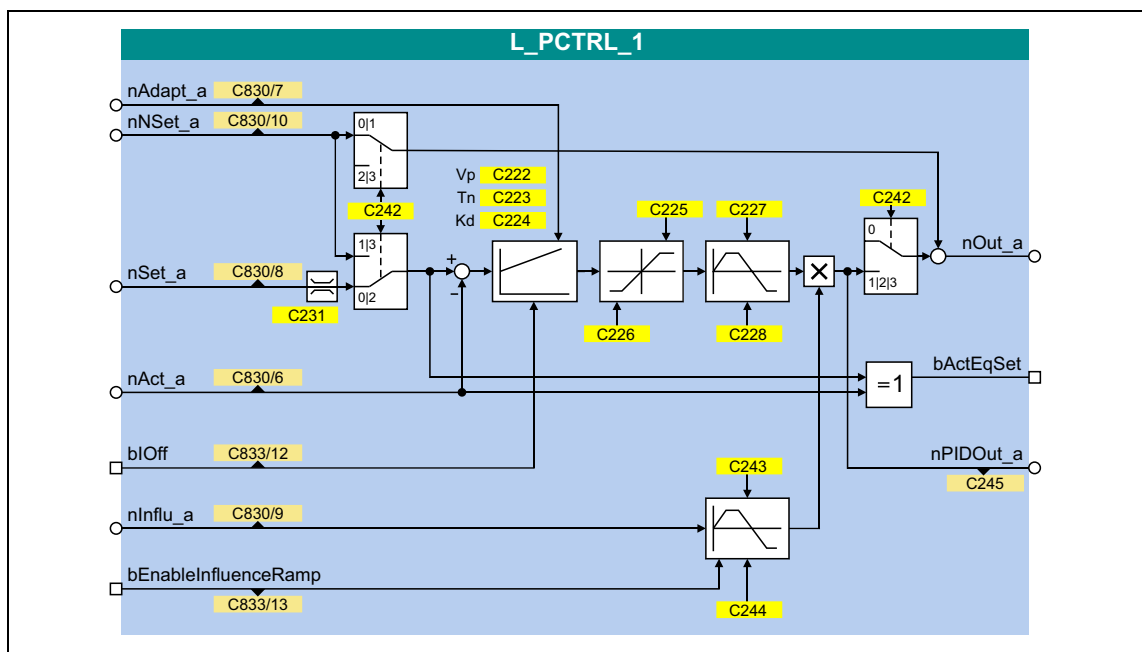

#### Inputs

Identifier	Data type	Information/possible settings
nAdapt_a	INT	Adaptation of gain Vp set in <a href="#">C222</a> in percent <ul style="list-style-type: none"> <li>• Internal limitation to <math>\pm 199.9\%</math></li> <li>• Changes can be done online.</li> <li>• Display parameter: <a href="#">C830/7</a></li> </ul>
nNSet_a	INT	Speed setpoint <ul style="list-style-type: none"> <li>• Scaling: <math>16384 \equiv 100\%</math></li> <li>• Internal limitation to <math>\pm 199.9\%</math></li> <li>• Display parameter: <a href="#">C830/10</a></li> </ul>
nSet_a	INT	Sensor and process setpoint for operating modes 2, 4 and 5 <ul style="list-style-type: none"> <li>• Scaling: <math>16384 \equiv 100\%</math></li> <li>• Internal limitation to <math>\pm 199.9\%</math></li> <li>• Display parameter: <a href="#">C830/8</a></li> </ul>
nAct_a	INT	Speed or actual sensor value (actual process value) <ul style="list-style-type: none"> <li>• Scaling: <math>16384 \equiv 100\%</math></li> <li>• Internal limitation to <math>\pm 199.9\%</math></li> <li>• Display parameter: <a href="#">C830/6</a></li> </ul>

Identifier	Data type	Information/possible settings
bIOff	BOOL	Switch off I-component of the process controller <ul style="list-style-type: none"> <li>• Changes can be done online.</li> <li>• Display parameter: <a href="#">C833/12</a></li> </ul>
		TRUE   I-component of the process controller is switched off.
nInflu_a	INT	Limitation of the influencing factor in percent <ul style="list-style-type: none"> <li>• <i>nInflu_a</i> serves to limit the influencing factor of the PID controller contained in the FB to a required value (- 199.9 % ... + 199.9 %).</li> <li>• Scaling: 16384 <math>\equiv</math> 100 %</li> <li>• Internal limitation to <math>\pm</math> 199.9 %</li> <li>• Display parameter: <a href="#">C830/9</a></li> </ul>
bEnableInfluenceRamp	BOOL	Activate ramp for influencing factor <ul style="list-style-type: none"> <li>• Display parameter: <a href="#">C833/13</a></li> </ul>
		TRUE   Influencing factor of the PID controller is ramped up to the <i>nInflu_a</i> value.
		FALSE   Influencing factor of the PID controller is ramped down to "0".

### Outputs

Identifier	Data type	Value/meaning
nOut_a	INT	Output signal <ul style="list-style-type: none"> <li>• Internal limitation to <math>\pm</math>32767 (<math>\pm</math>199.9 %)</li> <li>• Scaling: 16384 <math>\equiv</math> 100 %</li> </ul>
bActEqSet	INT	Status output "Setpoint and actual value are identical"
		TRUE   Setpoint and actual value are identical, i.e. no system deviation available.
nPIDOut_a	INT	PID controller output <u>with</u> influencing factor <i>nInflu_a</i> <ul style="list-style-type: none"> <li>• There is no connection with the additive input <i>nNSet_a</i>.</li> <li>• Scaling: 16384 <math>\equiv</math> 100 %</li> <li>• Display parameter: <a href="#">C245</a></li> </ul>

### Parameter

Parameter	Possible settings			Info
<a href="#">C222</a>	0.1		500.0	Gain Vp <ul style="list-style-type: none"> <li>• Lenze setting: 1.0</li> </ul>
<a href="#">C223</a>	20	ms	6000	Reset time Tn <ul style="list-style-type: none"> <li>• Lenze setting: 400 ms</li> </ul>
<a href="#">C224</a>	0.0		5.0	Differential component Kd <ul style="list-style-type: none"> <li>• Lenze setting: 0.0</li> </ul>
<a href="#">C225</a>	-199.9	%	+199.9	Maximum value of the PID operating range <ul style="list-style-type: none"> <li>• Lenze setting: 199.9 %</li> </ul>
<a href="#">C226</a>	-199.9	%	+199.9	Minimum value of the PID operating range <ul style="list-style-type: none"> <li>• Lenze setting: -199.9 %</li> </ul>
<a href="#">C227</a>	0.0	s	999.9	Acceleration time for the ramp at the PID output (should be set as steep as possible) <ul style="list-style-type: none"> <li>• Lenze setting: 0.1 s</li> </ul>
<a href="#">C228</a>	0.0	s	999.9	Deceleration time for the ramp at the PID output <ul style="list-style-type: none"> <li>• Lenze setting: 0.1 s</li> </ul>



Parameter	Possible settings			Info
<a href="#">C231/1</a> (Pos. Maximum) <a href="#">C231/2</a> (Pos. Minimum) <a href="#">C231/3</a> (Neg. Minimum) <a href="#">C231/4</a> (Neg. Maximum)	0.0	%	199.9	Operating range <ul style="list-style-type: none"> <li>• Determination of the operating range for the PID process controller by limiting the input signal <math>nSet_a</math>.</li> <li>• Lenze setting: No limitation (-199.9 % ... +199.9 %)</li> </ul>
<a href="#">C242</a>				Operating mode
	0	Off (Lenze setting)		The input setpoint $nNSet_a$ is output without any changes at the output $nOut_a$ .
	1	Additive + feedforward control		$nNSet_a$ and $nAct_a$ are used as PID input values. The arriving $nNSet_a$ is additively linked to the value output by the PID element.
	2	PID as setpoint generator.		$nSet_a$ and $nAct_a$ are used as PID input values. The input $nNSet_a$ is not considered.
	3	PID setpoint from <a href="#">L_NSet_1</a>		$nNSet_a$ and $nAct_a$ are used as PID input values. The input $nSet_a$ is not considered.
<a href="#">C243</a>	0.0	s	999.9	Influence acceleration time <ul style="list-style-type: none"> <li>• Acceleration time <math>T_{ir}</math> for the influencing factor.</li> <li>• Lenze setting: 5.0 s</li> </ul>
<a href="#">C244</a>	0.0	s	999.9	Influence deceleration time <ul style="list-style-type: none"> <li>• Deceleration time <math>T_{if}</math> for the influencing factor.</li> <li>• Lenze setting: 5.0 s</li> </ul>
<a href="#">C245</a>	-199.9	%	+199.9	Display of PID output value $nPIDOut_a$

### 10.3.1 Control characteristic

The PI algorithm is active in the Lenze setting.

#### Gain (P component)

The input value is controlled by a linear characteristic. The slope of the characteristic is determined by the controller gain  $V_p$ .

The controller gain  $V_p$  is set under [C222](#).

- The controller gain can be adapted via the input  $nAdapt\_a$  (also possible in online mode).
- The input value  $nAdapt\_a$  has a direct effect on the controller gain:

$$P = nAdapt\_a \cdot C00222$$

Example: With the parameterised controller gain  $V_p = 2.0$  and  $nAdapt\_a = 75\%$ , the resulting gain factor is as follows:

$$P = \frac{75 [\%]}{100 [\%]} \cdot 2.0 = 1.5$$

#### Integral action component (I component)

The I component of the controller can be deactivated by setting the input  $bIOff$  to TRUE.

- Setting the reset time  $T_n$  to the maximum value of "6000 ms" also deactivates the I component.
- The I component can be switched on and off online.

#### Adjustment time

The reset time  $T_n$  is set under [C223](#).

#### Differential component $K_d$ (D component)

The differential component  $K_d$  is set under [C224](#).

- The setting "0.0" deactivates the D component (Lenze setting). In this way, the PID controller becomes a PI controller or P controller, if the I component has been deactivated as well.

### 10.3.2 Ramp function generator

The PID output is led via a ramp function generator with linear characteristic. This serves to transfer setpoint step-changes at the PID output into a ramp which should be as steep as possible.

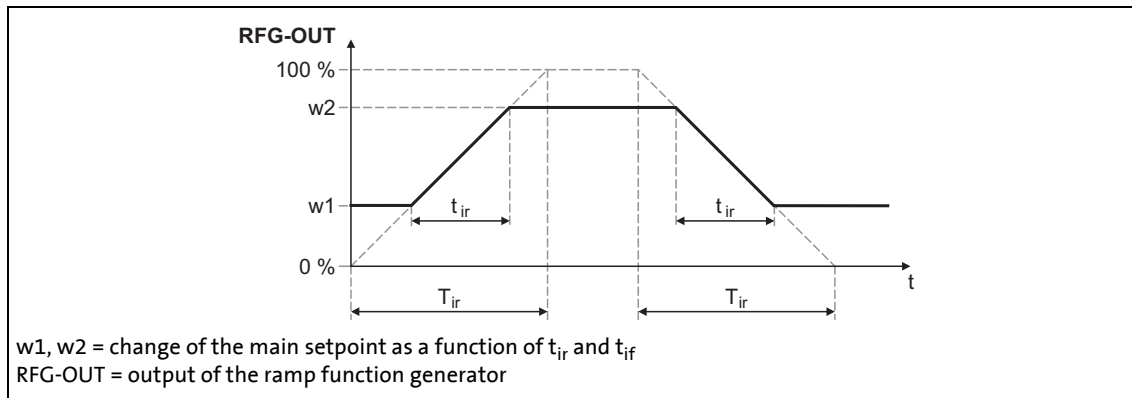

[10-4] Acceleration and deceleration times

- $t_{ir}$  and  $t_{if}$  are the desired times for changing between  $w1$  and  $w2$ .
- The ramps for acceleration and deceleration can be set individually.
  - [C227](#): Acceleration time  $T_{ir}$
  - [C228](#): Deceleration time  $T_{if}$
- The  $t_{ir}/t_{if}$  values are converted into the required  $Ti$  times according to the following formula:

$T_{ir} = t_{ir} \cdot \frac{100\%}{w2 - w1}$	$T_{if} = t_{if} \cdot \frac{100\%}{w2 - w1}$
-----------------------------------------------	-----------------------------------------------

- The ramp function generator is immediately set to "0" by setting *bInAct* to TRUE.

### 10.3.3 Operating range of the PID process controller

The value range of the input signal *nSet\_a* and thus the operating range of the PID process controller can be limited with the following parameters:

- [C231/1](#): Pos. maximum (default setting: 199.9 %)
- [C231/2](#): Pos. minimum (default setting: 0.0 %)
- [C231/3](#): Neg. minimum (default setting: 0.0 %)
- [C231/4](#): Neg. maximum (default setting: 199.9 %)

### 10.3.4 Evaluation of the output signal

After the limitation, the output signal is evaluated with the influencing factor *nInflu\_a*. The evaluation is activated/suppressed along a ramp when the input *bEnableInfluenceRamp* is set to TRUE. The ramp times are set with the parameters "Acceleration time influence" ([C243](#)) and "Deceleration time influence" ([C244](#)).

10.4

L\_RLQ\_1

This FB links a selected direction of rotation to the quick stop function with wire-break protection.

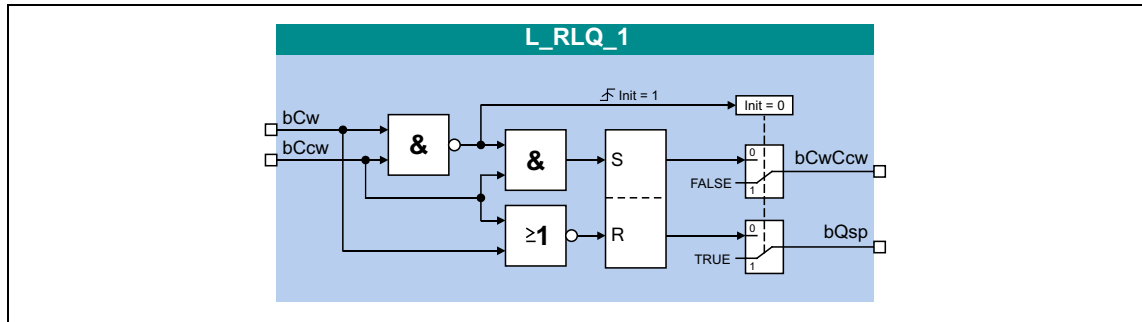

Inputs

Identifier	Data type	Information/possible settings
bCw	BOOL	Input • TRUE = CW rotation
bCCw	BOOL	Input • TRUE = CCW rotation

Outputs

Identifier	Data type	Value/meaning
bQSP	BOOL	Output signal for quick stop (QSP)
bCwCcW	BOOL	Output signal for CW/CCW rotation • TRUE = CCW rotation

Function

Inputs		Outputs		Notes
bCw	bCCw	bCwCcW	bQSP	
TRUE	TRUE	FALSE	TRUE	The inputs have this state only if a TRUE signal is being applied to <u>both</u> inputs at the moment of switch-on! See also FB illustration above, "Init" = 1.
If <i>one</i> of the inputs has the TRUE state, the following truth table applies:				
FALSE	FALSE	FALSE	TRUE	See also FB illustration above, "Init" = 0.
TRUE	FALSE	FALSE	FALSE	
FALSE	TRUE	TRUE	FALSE	
TRUE	TRUE	X (save)		

[10-5] Truth table of the FB L\_RLQ, 0 = FALSE, 1 = TRUE

Wiring in the application

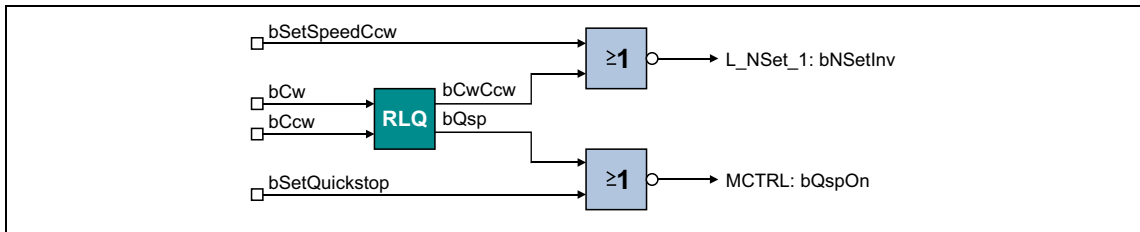

[10-6] Internal wiring

10.5

LS\_AnalogInput

The LS\_AnalogInput system block displays the analog input in the application on I/O level.

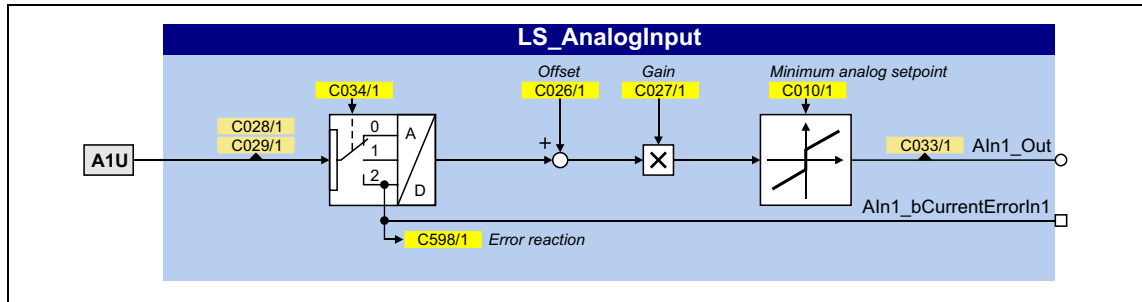

Outputs

Identifier	Data type	Value/meaning
nIn1_a	<a href="#">C033/1</a>   INT	Analog input 1 • Scaling: $\pm 2^{14} \equiv \pm 10 \text{ V}$ for use as voltage input $+ 2^{14} \equiv + 20 \text{ mA}$ for use as current input
bCurrentErrorIn1	BOOL	Status signal "Current input error" • Only when analog input 1 is used as current input. • Application: Cable-breakage monitoring of the 4 ...20 mA circuit.
		TRUE   $ I_{AIN1}  < 4 \text{ mA}$

Related topics:

- ▶ [Analog terminals](#) (112)
- ▶ [Electrical data](#) (120)

## 10.6 LS\_DigitalInput

The **LS\_DigitalInput** system block displays the digital input terminals in the application on I/O level.

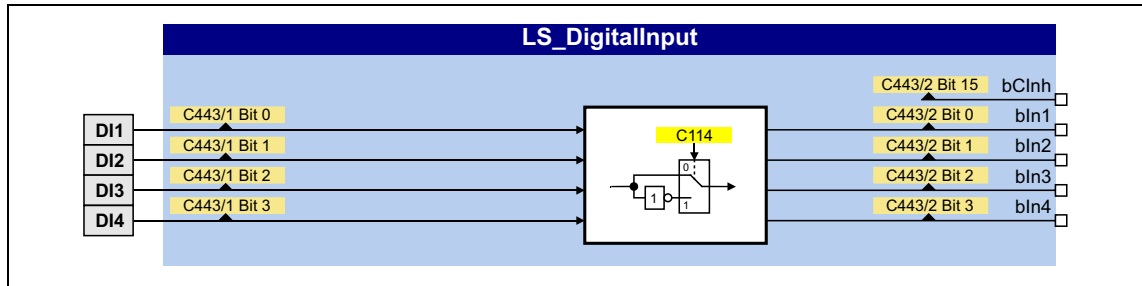

### Outputs

Identifier	Value/meaning
DIS code   data type bCInh	RFR digital input (controller enable)
<a href="#">C443/2</a>   BOOL bIn1 ... bIn4	Digital input DI1 ... DI4
<a href="#">C443/2</a>   BOOL	

### Related topics:

- ▶ [Digital terminals](#) (📖 110)
- ▶ [Electrical data](#) (📖 120)

## 10.7 LS\_DigitalOutput

The **LS\_DigitalInput** system block displays the digital output terminals in the application on I/O level.

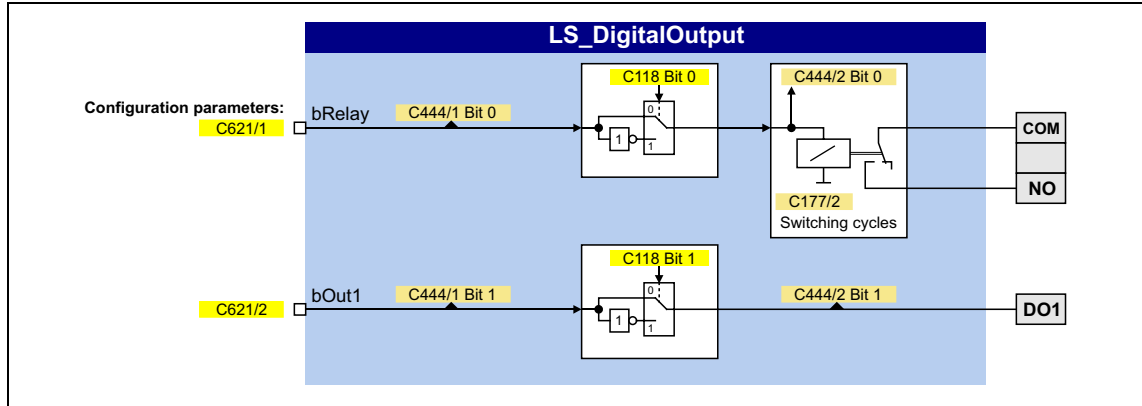

### Inputs

Identifier	Information/possible settings
bRelay <small>DIS code   data type</small> <a href="#">C444/1</a>   BOOL	Relay output (potential-free two-way switch)
bOut1 <small>DIS code   data type</small> <a href="#">C444/1</a>   BOOL	Digital output DO1

### Related topics:

- ▶ [Digital terminals](#) (110)
- ▶ [Electrical data](#) (120)



## 10.8 LS\_DisFree

This system block displays any four 16-bit signals of the application on display codes. The signals to be displayed are selected via the given configuration parameters.

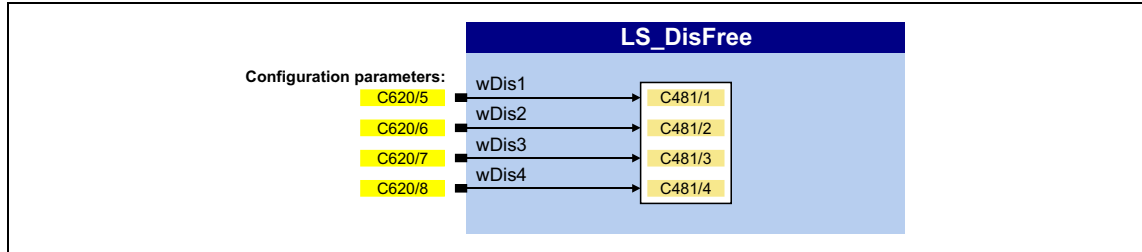

### Inputs

Identifier	Data type	Information/possible settings
wDis1 ... wDis4	WORD	Inputs for any 16-bit signals of the application

### Parameter

Parameter	Possible settings	Info
<a href="#">C481/1...4</a>	0x0000	0xFFFF Display of the 16-bit signals at the <i>wDis1 ... wDis4</i> inputs
<a href="#">C620/5...8</a>	See <a href="#">selection list - analog signals</a> Configuration parameters for the inputs <i>wDis1 ... wDis4</i>	

10.9 LS\_DisFree\_a

This system block displays any four analog signals of the application on display codes. The signals to be displayed are selected via the given configuration parameters.

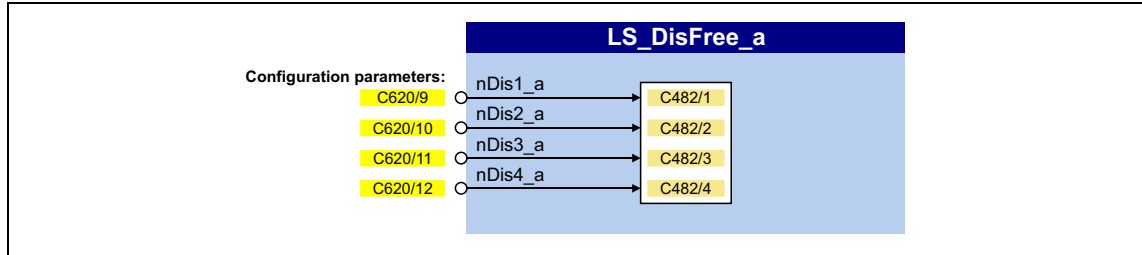

Inputs

Identifier	Data type	Information/possible settings
nDis1_a ... nDis4_a	INT	Inputs for any analog signal of the application

Parameter

Parameter	Possible settings	Info
<a href="#">C482/1...4</a>	-199.9 %      199.9 %	Display of the analog signals which are applied at the <i>nDis1_a</i> ... <i>nDis4_a</i> inputs.
<a href="#">C620/9...12</a>	See <a href="#">selection list - analog signals</a>	Configuration parameters for the inputs <i>nDis1_a</i> ... <i>nDis4_a</i>

**10.10 LS\_DisFree\_b**

This system block displays any eight digital signals of the application on a bit-coded display code. The signals to be displayed are selected via the given configuration parameters.

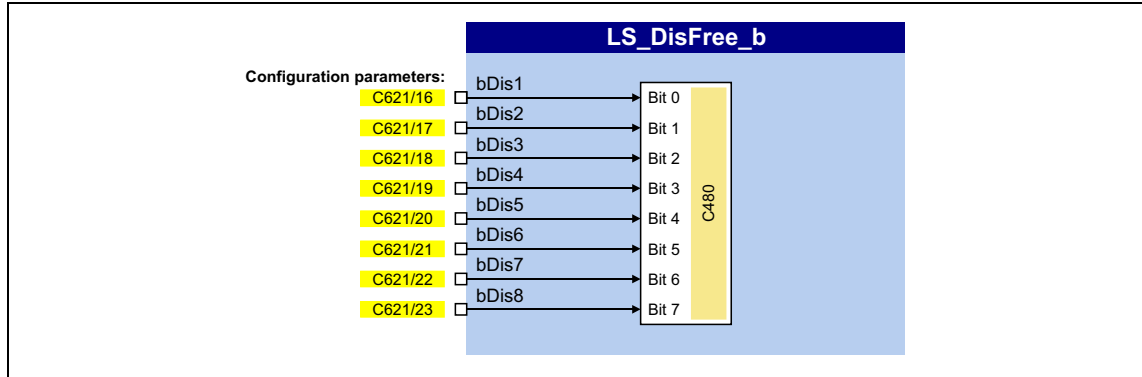

**Inputs**

Identifier	Data type	Information/possible settings
bDis1 ... bDis8	BOOL	Inputs for any digital signal of the application

**Parameter**

Parameter	Possible settings	Info																		
<a href="#">C480</a>	<table border="1" style="width: 100%;"> <tr> <td style="width: 33%;">0x0000</td> <td style="width: 33%;"></td> <td style="width: 33%;">0xFFFF</td> </tr> <tr> <td>Bit 0</td> <td colspan="2">Signal level at the <i>bDis1</i> input</td> </tr> <tr> <td>Bit 1</td> <td colspan="2">Signal level at the <i>bDis2</i> input</td> </tr> <tr> <td>Bit 2</td> <td colspan="2">Signal level at the <i>bDis3</i> input</td> </tr> <tr> <td>...</td> <td colspan="2">...</td> </tr> <tr> <td>Bit 7</td> <td colspan="2">Signal level at the <i>bDis8</i> input</td> </tr> </table>	0x0000		0xFFFF	Bit 0	Signal level at the <i>bDis1</i> input		Bit 1	Signal level at the <i>bDis2</i> input		Bit 2	Signal level at the <i>bDis3</i> input		...	...		Bit 7	Signal level at the <i>bDis8</i> input		Display of the digital signals applied at the <i>bDis1 ... bDis8</i> inputs in the form of hexadecimal values
0x0000		0xFFFF																		
Bit 0	Signal level at the <i>bDis1</i> input																			
Bit 1	Signal level at the <i>bDis2</i> input																			
Bit 2	Signal level at the <i>bDis3</i> input																			
...	...																			
Bit 7	Signal level at the <i>bDis8</i> input																			
<a href="#">C621/16...23</a>	See <a href="#">selection list - digital signals</a>	Configuration parameters for the inputs <i>bDis1 ... bDis8</i>																		

10.11 LS\_DriveInterface

The LS\_DriveInterface system block displays the device control in the application.

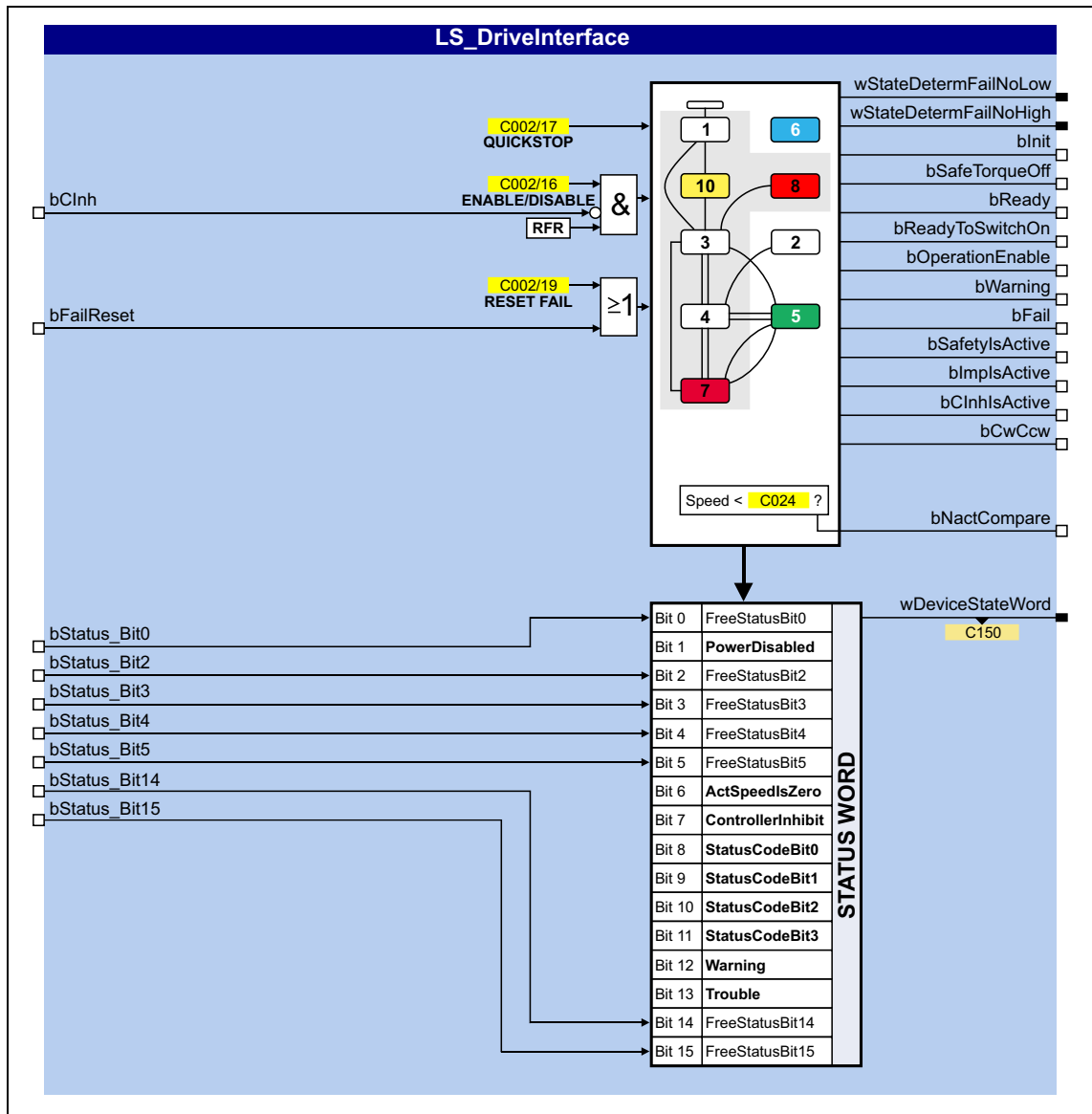

## Inputs

Identifier DIS code   data type	Information/possible settings			
bCInh <a href="#">C833/14</a>   BOOL	<a href="#">Enable/Inhibit controller</a>			
	<table border="1"> <tr> <td>FALSE</td> <td>Enable controller: The controller switches to the "<a href="#">OperationEnabled</a>" device state, if no other source of a controller inhibit is active. <ul style="list-style-type: none"> <li>• <a href="#">C158</a> provides a bit coded representation of all active sources/triggers of a controller inhibit.</li> </ul> </td> </tr> <tr> <td>TRUE</td> <td>Inhibit controller (controller inhibit): The controller switches to the "<a href="#">SwitchedON</a>" device state.</td> </tr> </table>	FALSE	Enable controller: The controller switches to the " <a href="#">OperationEnabled</a> " device state, if no other source of a controller inhibit is active. <ul style="list-style-type: none"> <li>• <a href="#">C158</a> provides a bit coded representation of all active sources/triggers of a controller inhibit.</li> </ul>	TRUE
FALSE	Enable controller: The controller switches to the " <a href="#">OperationEnabled</a> " device state, if no other source of a controller inhibit is active. <ul style="list-style-type: none"> <li>• <a href="#">C158</a> provides a bit coded representation of all active sources/triggers of a controller inhibit.</li> </ul>			
TRUE	Inhibit controller (controller inhibit): The controller switches to the " <a href="#">SwitchedON</a> " device state.			
bFailReset <a href="#">C833/15</a>   BOOL	<a href="#">Reset of error message</a> In the Lenze setting this input is connected to the digital input controller enable so that a possibly existing error message is reset together with the controller enable (if the cause for the fault is eliminated).			
	<table border="1"> <tr> <td>TRUE</td> <td>The current fault is reset, if the cause for the fault is eliminated. <ul style="list-style-type: none"> <li>• If the fault still exists, the error status remains unchanged.</li> </ul> </td> </tr> </table>	TRUE	The current fault is reset, if the cause for the fault is eliminated. <ul style="list-style-type: none"> <li>• If the fault still exists, the error status remains unchanged.</li> </ul>	
TRUE	The current fault is reset, if the cause for the fault is eliminated. <ul style="list-style-type: none"> <li>• If the fault still exists, the error status remains unchanged.</li> </ul>			
bStatus_Bit0 bStatus_Bit2 bStatus_Bit3 bStatus_Bit4 bStatus_Bit5 bStatus_Bit14 bStatus_Bit15 <a href="#">C833/16 ... 22</a>   BOOL	Freely assignable bits in the status word of the controller. Pre-assignment in the Lenze setting:			
	Bit0 - (Not connected)			
	Bit2 Current setpoint in the limitation			
	Bit3 Speed setpoint reached			
	Bit4 Actual speed value has reached the setpoint within one hysteresis band			
	Bit5 Speed setpoint < comparison value ( <a href="#">C024</a> )			
	Bit14 Current direction of rotation: 0 ≙ Clockwise rotation (Cw) 1 ≙ Counter-clockwise rotation (Ccw)			
	Bit15 Drive is ready for operation			

**Outputs**

Identifier <small>DIS code   data type</small>	Value/meaning	
wDeviceStateWord <small>C150   WORD</small>	Status word of the controller (based on DSP-402) • The status word contains information on the currents status of the drive controller.	
wStateDetermFailNoLow <small>WORD</small>	Display of the status determining error (LOW word)	
wStateDetermFailNoHigh <small>WORD</small>	Display of the status determining error (HIGH word)	
bInit <small>BOOL</small>	TRUE	" <a href="#">Init</a> " device state is active
bSafeTorqueOff <small>BOOL</small>	TRUE	" <a href="#">SafeTorqueOff</a> " device state is active
bReady <small>BOOL</small>	TRUE	" <a href="#">SwitchedON</a> " device state is active
bReadyToSwitchOn <small>BOOL</small>	TRUE	" <a href="#">ReadyToSwitchON</a> " device state is active
bOperationEnable <small>BOOL</small>	TRUE	" <a href="#">OperationEnabled</a> " device state is active
bWarning <small>BOOL</small>	TRUE	A warning exists
bFail <small>BOOL</small>	TRUE	" <a href="#">Fault</a> " device state is active
bSafetyIsActive <small>BOOL</small>	TRUE	In preparation
bImplsActive <small>BOOL</small>	TRUE	Pulse inhibit is active
bCInhIsActive <small>BOOL</small>	TRUE	Controller inhibit is active
bCwCcw <small>BOOL</small>	FALSE	Clockwise rotation (Cw)
	TRUE	Counter-clockwise rotation (Ccw)
bNactCompare <small>BOOL</small>	TRUE	During open-loop operation: Speed setpoint < comparison value ( <a href="#">C024</a> )
		During closed-loop operation: Actual speed value < comparison value ( <a href="#">C024</a> )

### 10.12 LS\_Keypad

This system block is used on I/O interconnection level if the "Keypad" control mode has been selected in [C007](#).

In the "Keypad" control mode, the **LS\_Keypad** system block passes on various setpoints and control commands to the technology application which can be selected/activated via codes using the keypad.

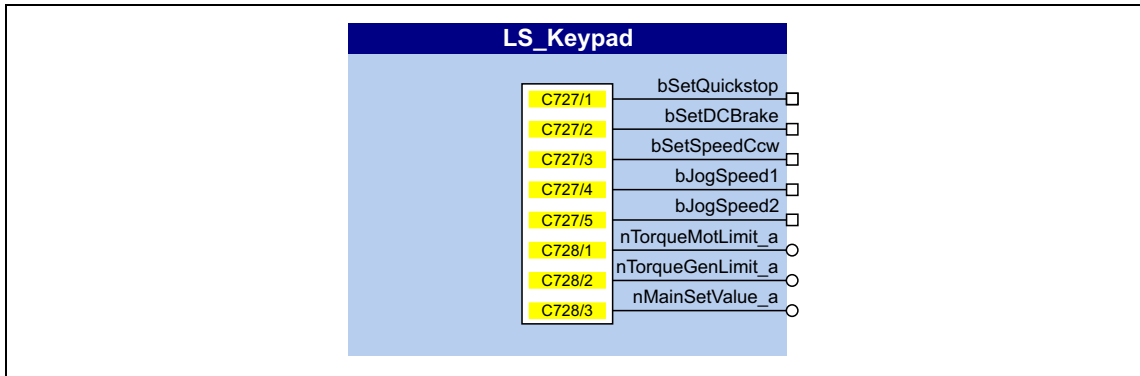

#### Outputs

Identifier	Data type	Value/meaning
bSetQuickstop	BOOL	<a href="#">C727/1</a> = "1" ≡ Request quick stop
bSetDCBrake	BOOL	<a href="#">C727/2</a> = "1" ≡ Request DC-injection braking
bSetSpeedCcw	BOOL	<a href="#">C727/3</a> = "1" ≡ Request reversal"
bJogSpeed1	BOOL	<a href="#">C727/4</a> = "1" ≡ Request fixed speed setpoint 1/2
bJogSpeed2	BOOL	<a href="#">C727/5</a> = "1" ≡ Request fixed speed setpoint 2/3
nTorqueMotLimit_a	INT	Torque limit in motor mode set in <a href="#">C728/1</a> • Lenze setting: 100.0 %
nTorqueGenLimit_a	INT	Torque limit in generator mode set in <a href="#">C728/2</a> • Lenze setting: 100.0 %
nMainSetValue_a	INT	Setpoint speed set in <a href="#">C728/3</a> • Lenze setting: 0.0 %

#### Parameter

Parameter	Possible settings			Info
<a href="#">C727/1...8</a>	0		1	Keypad digital values • Executing control commands when operating via keypad • See the "Outputs" table for the meaning of the individual sub-codes
<a href="#">C728/1...3</a>	-199.9	%	199.9	Keypad analog values • Selection of different setpoints when operating via keypad • See the "Outputs" table for the meaning of the individual sub-codes

## 10.13 LS\_ParFix

This system block outputs various fixed values (constants) to be used in the interconnection. The constants can be assigned to other inputs via configuration parameters.

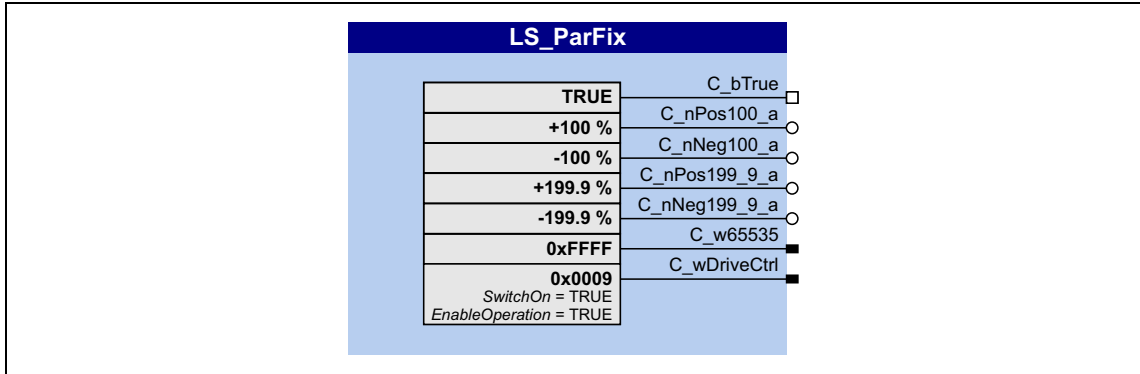

## Outputs

Identifier	Data type	Value/meaning
C_bTrue	BOOL	1 ≡ TRUE
C_nPos100_a	INT	16384 ≡ + 100 %
C_nNeg100_a	INT	-16384 ≡ - 100 %
C_nPos199_9_a	INT	32767 ≡ + 199.9 %
C_nNeg199_9_a	INT	-32767 ≡ - 199.9 %
C_w65535	WORD	65535 ≡ 0xFFFF
C_wDriveCtrl	WORD	9 ≡ 0x0009 <ul style="list-style-type: none"> <li>• Bit 0, SwitchOn = TRUE</li> <li>• Bit 3, EnableOperation = TRUE</li> <li>• All others: FALSE</li> </ul>

## Related topics:

- ▶ [User-defined terminal assignment \(115\)](#)



## 10.14 LS\_ParFree\_a

This system block outputs 4 parameterisable analog signals. The analog signals can be assigned to other inputs via configuration parameters.

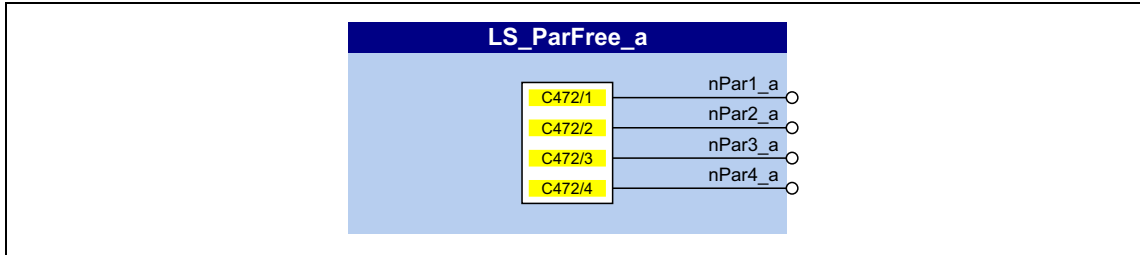

### Outputs

Identifier	Data type	Value/meaning
nPar1_a ... nPar4_a	INT	Output of the analog signals parameterised in <a href="#">C472/1...4</a>

### Parameter

Parameter	Possible settings			Info
<a href="#">C472/1...4</a>	-199.9	%	+199.9	Selection of analog signals to be output

### Related topics:

- ▶ [User-defined terminal assignment](#) (📖 115)

10.15 LS\_ParFree\_b

This system block outputs 16 parameterisable digital signals. The digital signals can be assigned to other inputs via configuration parameters.

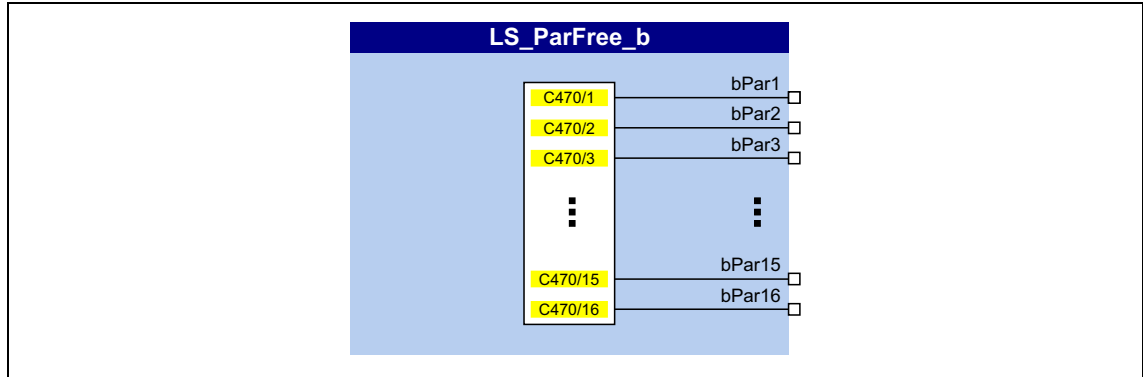

Outputs

Identifier	Data type	Value/meaning
bPar1 ... bPar16	BOOL	Output of the signals levels (FALSE/TRUE) parameterised in <a href="#">C470/1...16</a>

Parameter

Parameter	Possible settings	Info
<a href="#">C470/1...16</a>		Selection of signal levels to be output • Bit 0 ... 15 = <i>bPar1 ... bPar16</i>
	0 "FALSE" signal is output	
	1 "TRUE" signal is output	

Related topics:

- ▶ [User-defined terminal assignment](#) (📖 115)

### 10.16 LS\_SetError\_1

This system block is used for error handling within the application.

- The application can trip up to two different user error messages with parameterisable error response via the two boolean inputs.
- If both inputs are set to TRUE at the same time, the *bSetError1* inputs trips the error message.

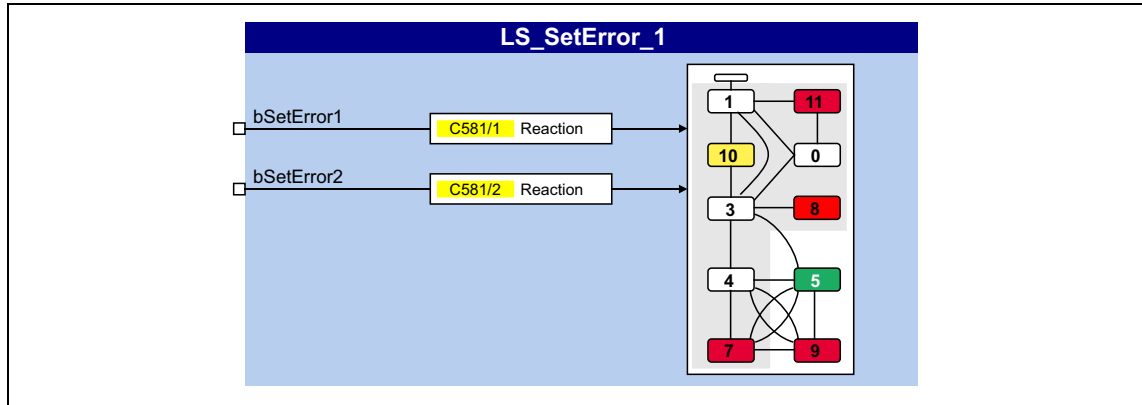

#### Inputs

Identifier	Data type	Information/possible settings
bSetError1	BOOL	Input for tripping " <a href="#">US01: User error 1</a> " <ul style="list-style-type: none"> <li>• Error subject number: 980</li> <li>• Error number: <math>(C581/1 \times 0x0400000) + (980 \times 0x10000)</math></li> </ul>
bSetError2	BOOL	Input for tripping " <a href="#">US02: User error 2</a> " <ul style="list-style-type: none"> <li>• Error subject number: 981</li> <li>• Error number: <math>(C581/2 \times 0x0400000) + (981 \times 0x10000)</math></li> </ul>

#### Parameter

Parameter	Possible settings	Info								
<a href="#">C581/1...2</a>	<table border="1"> <tr> <td>0</td> <td>No response</td> </tr> <tr> <td>1</td> <td>Fault (pulse inhibit)</td> </tr> <tr> <td>2</td> <td>Trouble</td> </tr> <tr> <td>4</td> <td>WarningLocked</td> </tr> </table>	0	No response	1	Fault (pulse inhibit)	2	Trouble	4	WarningLocked	Response for user error 1 ... 2 <ul style="list-style-type: none"> <li>• lenze setting: "Fault"</li> </ul>
0	No response									
1	Fault (pulse inhibit)									
2	Trouble									
4	WarningLocked									

# Index

---

## Numbers

- 16-bit analog input (C00830) [215](#)
- 16-bit common input (C00831) [215](#)
- 16-bit system connection (C00620) [209](#)
- 87-Hz operation [84](#)
- 8-bit input (C00833) [216](#)

## A

- Acceleration time main setpoint (C00012) [175](#)
- AINx
  - Configuration (C00034) [179](#)
  - Gain (C00027) [178](#)
  - Input current (C00029) [178](#)
  - Input voltage (C00028) [178](#)
  - Offset (C00026) [178](#)
  - Output value (C00033) [179](#)
- An01
  - AIN1\_I < 4 mA (error message) [159](#)
- Analog inputs [112](#)
- Appl.
  - Reference frequency C11 (C00059) [182](#)
  - Reference speed (C00011) [175](#)
- Application notes [12](#)
- Auto-DCB [98](#)
  - Hold time (C00106) [187](#)
  - Threshold (C00019) [176](#)
- Automatic DC-injection braking (Auto-DCB) [98](#)
- Automatic motor data identification [71](#)
- Automatic saving [50](#)
- Auto-start option (C00142) [191](#)

## B

- Blocks [225](#)
- Bool system connection (C00621) [210](#)
- Brake chopper [102](#)
- Brake resistor [102](#)
- Brake resistor monitoring (I2xt) [107](#)
- Braking operation [102](#)

## C

- C10 [174](#)
- C100 [186](#)
- C105 [187](#)
- C106 [187](#)
- C107 [187](#)
- C11 [175](#)
- C114 [188](#)
- C118 [188](#)
- C12 [175](#), [231](#)
- C120 [189](#)
- C122 [189](#)
- C123 [189](#)
- C13 [175](#), [231](#)
- C134 [189](#), [231](#)

- C137 [190](#)
- C141 [190](#)
- C142 [191](#)
- C144 [191](#)
- C15 [175](#)
- C150 [192](#)
- C155 [193](#)
- C158 [194](#)
- C159 [195](#)
- C16 [176](#)
- C165 [195](#)
- C166 [195](#)
- C167 [196](#)
- C168 [196](#)
- C169 [196](#)
- C170 [196](#)
- C171 [196](#)
- C173 [197](#)
- C174 [197](#)
- C177 [197](#)
- C178 [197](#)
- C179 [197](#)
- C18 [176](#)
- C182 [198](#), [231](#)
- C19 [176](#)
- C2 [171](#)
- C200 [198](#)
- C201 [198](#)
- C203 [198](#)
- C21 [177](#)
- C22 [177](#)
- C222 [198](#), [234](#)
- C223 [199](#), [234](#)
- C224 [199](#), [234](#)
- C225 [199](#), [234](#)
- C226 [199](#), [234](#)
- C227 [199](#), [234](#)
- C228 [200](#), [234](#)
- C23 [177](#)
- C231 [200](#), [235](#)
- C234 [200](#)
- C235 [200](#)
- C236 [200](#)
- C24 [177](#)
- C242 [201](#), [235](#)
- C243 [201](#), [235](#)
- C244 [201](#), [235](#)
- C245 [201](#), [235](#)
- C26 [178](#)
- C27 [178](#)
- C28 [178](#)
- C29 [178](#)
- C3 [173](#)

C308 [202](#)  
C309 [202](#)  
C33 [179](#)  
C34 [179](#)  
C36 [179](#)  
C39 [180](#), [231](#)  
C443 [202](#)  
C444 [203](#)  
C462 [203](#)  
C470 [203](#), [252](#)  
C472 [204](#), [251](#)  
C480 [204](#), [245](#)  
C481 [204](#), [243](#)  
C482 [205](#), [244](#)  
C50 [180](#)  
C51 [180](#)  
C516 [205](#)  
C517 [206](#)  
C52 [180](#)  
C53 [181](#)  
C54 [181](#)  
C56 [181](#)  
C565 [206](#)  
C57 [181](#)  
C574 [207](#)  
C58 [181](#)  
C581 [207](#)  
C59 [182](#)  
C598 [207](#)  
C6 [173](#)  
C600 [208](#)  
C601 [208](#)  
C604 [208](#)  
C606 [208](#)  
C61 [182](#)  
C620 [209](#)  
C621 [210](#)  
C64 [182](#)  
C66 [182](#)  
C7 [174](#)  
C700 [211](#)  
C701 [212](#)  
C725 [212](#)  
C727 [213](#), [249](#)  
C728 [213](#), [249](#)  
C729 [213](#)  
C73 [183](#)  
C74 [183](#)  
C800 [213](#), [227](#)  
C801 [213](#), [227](#)  
C802 [214](#), [227](#)  
C803 [214](#), [227](#)  
C804 [214](#), [227](#), [229](#)

C805 [214](#)  
C806 [215](#), [228](#)  
C81 [183](#)  
C830 [215](#)  
C831 [215](#)  
C833 [216](#)  
C84 [183](#)  
C85 [183](#)  
C87 [184](#)  
C88 [184](#)  
C89 [184](#)  
C90 [184](#)  
C909 [216](#)  
C91 [185](#)  
C910 [217](#)  
C92 [185](#)  
C93 [185](#)  
C94 [185](#)  
C95 [185](#)  
C97 [186](#)  
C98 [186](#)  
C99 [186](#)  
C990 [217](#)  
C991 [217](#)  
C992 [217](#)  
C994 [218](#)  
Cause for controller inhibit (C00158) [194](#)  
Cause for quick stop QSP (C00159) [195](#)  
Checksums (C00516) [205](#)  
Comparison value N\_Act (C00024) [177](#)  
Control mode [74](#)  
Control mode (C00007) [174](#)  
Conventions used [9](#)  
Current switching frequency (C00725) [212](#)

## D

Data type [166](#)  
DCB  
    Current (C00036) [179](#)  
    Hold time (C00107) [187](#)  
DCB (DC-injection braking) [98](#)  
DC-bus voltage (C00053) [181](#)  
DC-injection braking [97](#)  
Deceleration time main setpoint (C00013) [175](#)  
Deceleration time quick stop (C00105) [187](#)  
Defining current limits [77](#)  
Defining speed limits [77](#)  
Delayed resp. to fault  
    DC bus overvoltage (C00601) [208](#)  
Device commands (C00002) [171](#)  
Device overload monitoring (lxt) [104](#)  
Device rated current (C00098) [186](#)  
Device settings (C00141) [190](#)  
Device state (C00137) [190](#)

Device utilisation (lxt) (C00064) [182](#)  
Device utilisation threshold (lxt) (C00123) [189](#)  
dF01  
  Internal error 01 (error message) [161](#)  
dF02  
  Internal error 02 (error message) [161](#)  
dF03  
  Internal error 03 (error message) [161](#)  
dF04  
  Internal error 04 (error message) [161](#)  
dF05  
  Internal error 05 (error message) [161](#)  
dF06  
  Internal error 06 (error message) [162](#)  
dF07  
  Internal error 07 (error message) [162](#)  
dF08  
  Internal error 08 (error message) [162](#)  
dF09  
  Internal error 09 (error message) [162](#)  
dF10  
  Internal error 10 (error message) [162](#)  
dH69  
  Adjustment fault (error message) [163](#)  
Digital input assignment [212](#)  
Digital inputs [110](#)  
Digital outputs [110](#)  
Digital terminals [110](#)  
Dlx  
  Level (C00443) [202](#)  
Dlx inversion (C00114) [188](#)  
DOx  
  Level (C00444) [203](#)  
DOx inversion (C00118) [188](#)  
Drive interface [45](#)  
**E**  
Elapsed-hour meter (C00178) [197](#)  
Electrical data I/O terminals [120](#)  
E-mail to Lenze [259](#)  
Error counter (C00170) [196](#)  
Error ID [154](#)  
Error information (C00165) [195](#)  
Error information text (C00166) [195](#)  
Error messages [153](#)  
Error messages (short overview) [156](#)  
Error number [153](#)  
  xx.0111.00002 [157](#)  
  xx.0119.00001 [157](#)  
  xx.0119.00050 [157](#)  
  xx.0119.00052 [158](#)  
  xx.0123.00014 [158](#)  
  xx.0123.00015 [158](#)  
  xx.0123.00016 [158](#)  
  xx.0123.00017 [159](#)

  xx.0123.00057 [159](#)  
  xx.0123.00065 [159](#)  
  xx.0123.00105 [159](#)  
  xx.0125.00001 [159](#)  
  xx.0144.00001 [160](#)  
  xx.0144.00002 [160](#)  
  xx.0144.00003 [160](#)  
  xx.0144.00004 [160](#)  
  xx.0144.00031 [160](#)  
  xx.0145.00001 [161](#)  
  xx.0145.00002 [161](#)  
  xx.0145.00003 [161](#)  
  xx.0145.00004 [161](#)  
  xx.0145.00005 [161](#)  
  xx.0145.00006 [162](#)  
  xx.0145.00007 [162](#)  
  xx.0145.00008 [162](#)  
  xx.0145.00009 [162](#)  
  xx.0145.00010 [162](#)  
  xx.0400.00105 [163](#)  
  xx.0980.00000 [163](#)  
  xx.0981.00000 [163](#)  
Error number (C00168) [196](#)  
Error subject area [154](#)  
Error type [153](#)  
Exporting logbook entries [147](#)

## F

Feedback to Lenze [259](#)  
Firmware compile date (C00201) [198](#)  
Firmware product type (C00200) [198](#)  
Firmware version (C00099) [186](#)  
Firmware version (C00100) [186](#)  
Fixed setpoint x (L\_NSet\_1 n-Fix) (C00039) [180](#)  
Flying restart fct. [95](#)  
  Activation (C00990) [217](#)  
  Current (C00994) [218](#)  
  Process (C00991) [217](#)  
  Start frequency (C00992) [217](#)  
Frequency limitation (C00910) [217](#)  
Function assignment [212](#)  
Function blocks [225](#)  
Function library [225](#)

## H

Heatsink temperature (C00061) [182](#)

## I

ID1  
  Motor data identification error (error message) [159](#)  
Imax controller [82](#)  
Imax in generator mode (C00023) [177](#)  
Imax in motor mode (C00022) [177](#)  
Initial value motor overload (I<sup>2</sup>xt) (C00122) [189](#)

## Interconnection

"Terminals 0" control mode [136](#)

## Internal wiring

"Terminals 0" control mode [136](#)

## L

L\_MPot [226](#)

L\_MPot\_1 [226](#)

Acceleration time (C00802) [214](#)

Deceleration time (C00803) [214](#)

Inactive fct. (C00804) [214](#)

Init fct. (C00805) [214](#)

Lower limit (C00801) [213](#)

Upper limit (C00800) [213](#)

Use (C00806) [215](#)

L\_NSet [230](#)

L\_NSet\_1 [230](#)

L\_PCTRL [233](#)

L\_PCTRL\_1 [233](#)

Acceleration time (C00227) [199](#)

Acceleration time influence (C00243) [201](#)

Deceleration time (C00228) [200](#)

Deceleration time influence (C00244) [201](#)

Kd (C00224) [199](#)

MaxLimit (C00225) [199](#)

MinLimit (C00226) [199](#)

Operating mode (C00242) [201](#)

Operating range (C00231) [200](#)

PID output value (C00245) [201](#)

Tn (C00223) [199](#)

Vp (C00222) [198](#)

L\_RLQ [238](#)

L\_RLQ\_1 [238](#)

LA\_NCtrl

Analog connection list (C00700) [211](#)

Digital connection list (C00701) [212](#)

Layout of the safety instructions [12](#)

LED status display [19](#)

Library [225](#)

LS\_AnalogInput [240](#)

LS\_DigitalInput [241](#)

LS\_DigitalOutput [242](#)

LS\_DisFree [243](#)

LS\_DisFree (C00481) [204](#)

LS\_DisFree\_a [244](#)

LS\_DisFree\_a (C00482) [205](#)

LS\_DisFree\_b [245](#)

LS\_DisFree\_b (C00480) [204](#)

LS\_DriveInterface [246](#)

LS\_Keypad [249](#)

digital values (C00727) [213](#)

Keypad analog values (C00728) [213](#)

LS\_ParFix [250](#)

LS\_ParFree\_a [251](#)

LS\_ParFree\_a (C00472) [204](#)

LS\_ParFree\_b [252](#)

LS\_ParFree\_b (C00470) [203](#)

LS\_SetError\_1 [253](#)

LU

DC bus undervoltage (error message) [158](#)

## M

Mains phase failure monitoring [108](#)

Mains voltage (C00173) [197](#)

Manual DC-injection braking (DCB) [98](#)

Maximum torque (C00057) [181](#)

MCTRL

Actual speed value (C00051) [180](#)

Speed setpoint (C00050) [180](#)

Minimum analog setpoint (C00010) [174](#)

Monitoring [104](#), [148](#)

Motor catalogue [69](#)

Motor control [65](#)

87-Hz operation [84](#)

DC-injection braking [97](#)

Flying restart fct. [95](#)

Oscillation damping [101](#)

Selection help [76](#)

Selection of switching frequency [93](#)

Selection of the control mode [74](#)

Sensorless vector control (SLVC) [88](#)

Slip compensation [100](#)

V/f characteristic control (VFCplus) [79](#)

Motor control (C00006) [173](#)

Motor cosine phi (C00091) [185](#)

Motor current (C00054) [181](#)

Motor data [66](#)

Motor load monitoring (I2xt) [105](#)

Motor magnetising current (C00095) [185](#)

Motor magnetising inductance (C00092) [185](#)

Motor overload threshold (I<sup>3</sup>xt) (C00120) [189](#)

Motor parameter identification [71](#)

Motor parameter identification is active [57](#)

Motor selection [66](#)

Motor stator leakage inductance (C00085) [183](#)

Motor stator resistance (C00084) [183](#)

Motor voltage (C00052) [180](#)

## O

OC1

Power section - short circuit (error message) [158](#)

OC12

I2xt overload - brake resistor (error message) [159](#)

OC2

Power section - earth fault (error message) [159](#)

OC5

Ixt overload (error message) [157](#)

OC6

I2xt overload - motor (error message) [159](#)

- OC9
  - Ixt overload - shutdown limit (error message) [158](#)
- OH
  - Heatsink overtemperature (error message) [157](#)
- Oscillation damping [101](#)
- Oscillation damping influence (C00234) [200](#)
- OU
  - DC bus overvoltage (error message) [158](#)
- Output frequency (C00058) [181](#)
- P**
- Password (C00094) [185](#)
- Password protection [24](#)
- PC manual control [40](#)
- Peak current limitation [77](#)
- Plant parameters [70](#)
- Power section identification (C00093) [185](#)
- Power-on time meter (C00179) [197](#)
- Product type code (C00203) [198](#)
- PS01
  - No memory module (error message) [160](#)
- PS02
  - Par. set invalid (error message) [160](#)
- PS03
  - Par. set device invalid (error message) [160](#)
- PS04
  - Par. set device incompatible (error message) [160](#)
- PS31
  - Ident. error (error message) [160](#)
- R**
- Ramp smoothing, main setpoint (C00134) [189](#)
- Rated motor current (C00088) [184](#)
- Rated motor frequency (C00089) [184](#)
- Rated motor power (C00081) [183](#)
- Rated motor speed (C00087) [184](#)
- Rated motor torque (C00097) [186](#)
- Rated motor voltage (C00090) [184](#)
- Reduced brake chopper threshold (C00174) [197](#)
- Reset of error message [155](#)
- Resp. to brake resist. overtemp. (C00574) [207](#)
- Resp. to DC bus undervoltage (C00600) [208](#)
- Resp. to device overload (Ixt) (C00604) [208](#)
- Resp. to LS\_SetError\_x (C00581) [207](#)
- Resp. to mains phase failure (C00565) [206](#)
- Resp. to motor overload (I<sup>xt</sup>) (C00606) [208](#)
- Resp. to open circuit AINx (C00598) [207](#)
- S**
- Safety instructions [12](#)
- Save parameter settings [50](#)
- Saving parameters automatically [50](#)
- Selection help for motor control [76](#)
- Selection of switching frequency [93](#)
- Selection of the control mode [74](#)
- Sensorless vector control (SLVC) [75](#), [88](#)
- Setting the error response [150](#)
- Short overview of error messages [156](#)
- Signal flow
  - V/f characteristic control (VFCplus) [79](#)
  - V/f control (VFCplus + encoder) [89](#)
- Signal source assignment [212](#)
- Slip comp. (C00021) [177](#)
- Slip compensation [100](#)
- Speed control with torque limitation (SLVC) [89](#)
- Speed limitation (C00909) [216](#)
- S-ramp time PT1 (C00182) [198](#)
- Status of last device command (C00003) [173](#)
- Status word (C00150) [192](#)
- Status word 2 (C00155) [193](#)
- Su02
  - One mains phase is missing (error message) [157](#)
- Switching cycles (C00177) [197](#)
- Switching frequency [93](#)
- Switching frequency (C00018) [176](#)
- Switching frequency reduction (temp.) (C00144) [191](#)
- System blocks [225](#)
- System error messages [153](#)
- T**
- Thermal motor load (I<sup>xt</sup>) (C00066) [182](#)
- Ti I<sub>max</sub> controller (C00074) [183](#)
- Time of error (C00169) [196](#)
- Torque (C00056) [181](#)
- Torque limitation [86](#)
- U**
- US01
  - User error 1 (error message) [163](#)
- US02
  - User error 2 (error message) [163](#)
- User menu [23](#)
- User menu (C00517) [206](#)
- V**
- V/f base frequency [84](#)
- V/f characteristic control (VFCplus) [75](#), [79](#)
- VFC
  - V/f base frequency (C00015) [175](#)
  - V<sub>min</sub> boost (C00016) [176](#)
- V<sub>min</sub> boost [85](#)
- V<sub>p</sub> I<sub>max</sub> controller (C00073) [183](#)



# FEEDBACK



## Your opinion is important to us

These instructions were created to the best of our knowledge and belief to give you the best possible support for handling our product.

If you have suggestions for improvement, please e-mail us to:

[feedback-docu@Lenze.de](mailto:feedback-docu@Lenze.de)

Thank you for your support.

*Your Lenze documentation team*



Lenze AC Tech Corporation  
630 Douglas Street  
Uxbridge, MA 01569  
USA

☎ +1 508 / 278-9100  
📠 +1 508 / 278-7873  
✉ [info@actechdrives.com](mailto:info@actechdrives.com)  
🌐 [www.actech.com](http://www.actech.com)

#### Service

Lenze Service GmbH  
Breslauer Straße 3  
D-32699 Extertal  
Germany

☎ 00 80 00 / 24 4 68 77 (24 h helpline)  
📠 +49 (0)51 54 / 82-11 12  
✉ [Service@Lenze.de](mailto:Service@Lenze.de)