

i750 cabinet servo inverter



CiA 402

Contents

1	About this document	12
1.1	Document description.....	13
1.2	Further documents.....	14
1.3	Notations and conventions	15
2	Safety instructions	16
2.1	Basic safety instructions.....	16
2.2	Application as directed.....	17
2.3	Residual hazards	18
3	Product information	19
3.1	Features.....	19
3.1.1	Power supply.....	19
3.1.2	Single axes.....	21
3.1.3	Double axes.....	23
3.2	Identification of the products.....	25
3.2.1	Product codes.....	25
3.3	License information	26
4	Commissioning	27
4.1	Important notes.....	29
4.2	Operating interfaces	30
4.2.1	Engineering tool »EASY Starter«	30
4.2.2	Engineering tool »PLC Designer«.....	30
4.3	General information on parameter setting.....	31
4.3.1	Addressing of the parameters.....	31
4.3.2	Structure of the parameter descriptions.....	31
4.3.3	Setting and transferring safety parameters.....	32
4.3.4	Parameter overview lists	32
4.3.5	Favorites.....	32
4.3.5.1	Configuring the "Favorites".....	32
4.4	Commissioning steps	34
4.5	Saving the parameter settings.....	35
4.5.1	Save parameter settings with »EASY Starter«.....	36
4.5.2	Save parameter settings with the »PLC Designer«.....	37
5	Basic setting	39
5.1	Device name.....	40
5.2	Mains voltage	41
5.3	Function assignment of the inputs and outputs (default setting).....	42
5.4	Motor data	43
5.4.1	Select motor from motor catalog.....	44
5.4.2	Manual setting of the motor data.....	46
5.5	Motor control mode	49

Contents

6	Configure position control	50
6.1	Basic setting	51
6.1.1	Following error detection and in-position detection	52
6.1.2	Interpolation	53
6.2	Operating mode "CiA 402 cyclic sync position mode (csp)"	54
6.2.1	Default mapping	54
6.2.2	Signal flow	55
6.2.3	Control commands and status information	57
6.3	Process input data (CiA 402 objects)	58
6.4	Process output data (CiA 402 objects)	59
6.5	Monitoring the position error	60
6.6	Position detection with touch probe (TP)	62
6.6.1	Default mapping	62
6.6.2	General mode of operation	63
6.6.3	Filtering of the touch probe signal	63
6.6.4	Compensation of runtime delays	64
6.6.5	Touch probe control word	65
6.6.6	Touch probe status word	65
6.6.7	Detected time stamp and positions	66
6.7	Setpoint diagnostics	67
7	Configure speed control	68
7.1	Basic setting	69
7.2	Operating mode "CiA 402 velocity mode (vl)"	70
7.2.1	Default mapping	70
7.2.2	Signal flow (servo control)	71
7.2.3	Signal flow (V/f characteristic control)	73
7.2.4	Setpoint factor	76
7.2.5	Dimension factor	76
7.3	Operating mode "CiA 402 cyclic sync velocity mode (csv)"	77
7.3.1	Default mapping	77
7.3.2	Signal flow (servo control)	78
7.3.3	Signal flow (V/f characteristic control)	80
7.3.4	Control commands and status information	82
7.4	Process input data (CiA 402 objects)	83
7.5	Process output data (CiA 402 objects)	84
7.6	Monitoring the speed deviation	85
8	Configuring the torque control	86
8.1	Basic setting	87
8.1.1	Torque limits	88
8.1.2	Speed limitation	89
8.2	Operating mode "CiA 402 cyclic sync torque mode (cst)"	90
8.2.1	Default mapping	90
8.2.2	Signal flow	91
8.2.3	Control commands and status information	93
8.3	Process input data (CiA 402 objects)	94
8.4	Process output data (CiA 402 objects)	95
8.5	Setpoint diagnostics	96

9	Configuring the feedback system	97
9.1	Configure feedback system for motor control	98
9.1.1	General settings	99
9.1.2	Resolver settings	100
9.1.2.1	Resolver error compensation	102
9.1.3	Encoder settings	105
9.1.3.1	SinCos encoder	105
9.1.3.2	SinCos absolute value encoder with HIPERFACE® protocol	106
9.1.3.3	SSI encoder	107
9.1.3.4	One cable technology (OCT) via HIPERFACE DSL®	110
9.1.3.5	Evaluation of the signal quality	114
9.1.4	Detection of changed settings of the feedback system	115
9.1.5	Diagnostics	115
9.2	Synchronous motor: Pole position identification (PPI)	116
9.2.1	Selection of the PPI method for CiA mode	117
9.2.2	Monitoring the pole position identification	117
9.2.3	Monitoring the validity of the pole position	117
9.2.4	Pole position identification (PPI) 360°	118
9.2.5	Pole position identification (PPI) with minimum movement	122
9.2.6	Pole position identification (PPI) without movement	125
9.3	Cable check	127

10	Configuring the motor control	132
10.1	Servo control for synchronous motor (SC-PSM)	133
10.1.1	Required commissioning steps	133
10.2	Servo control for asynchronous motor (SC-ASM)	134
10.2.1	Required commissioning steps	134
10.3	Sensorless control for synchronous motor (SL-PSM)	135
10.3.1	Expert settings	135
10.4	Sensorless vector control (SLVC)	136
10.4.1	Expert settings	136
10.5	V/f characteristic control for asynchronous motor (VFC open loop)	137
10.5.1	Required commissioning steps	137
10.5.2	Basic setting	138
10.5.3	Define V/f characteristic shape	139
10.5.3.1	Linear V/f characteristic	139
10.5.3.2	Square-law V/f characteristic	139
10.5.3.3	User-definable V/f characteristic	140
10.5.4	Activate voltage vector control (I _{min} controller)	142
10.5.5	Set voltage boost	143
10.5.6	Set load adjustment	144
10.5.7	Set slip compensation	144
10.5.8	Set oscillation damping	145
10.5.9	Optimising the stalling behaviour	146
10.5.10	Flying restart circuit	147
10.6	Parameterisable motor functions	149
10.6.1	DC braking	149
10.6.2	Short-circuit braking	150
10.6.3	Holding brake control	151
10.6.3.1	Basic setting	152
10.6.3.2	Brake holding load	154
10.6.3.3	Torque feedforward control	154
10.6.3.4	Manual brake control	155
10.6.3.5	Reduction of brake supply voltage	155

10.7	Options for optimizing the control loops.....	156
10.7.1	Automatic motor identification (energized).....	156
10.7.2	Tuning of the motor and the speed controller.....	157
10.7.3	Inverter characteristic.....	159
10.7.3.1	Compensating for inverter influence.....	160
10.7.3.2	Extended settings for identification.....	161
10.7.3.3	Load standard inverter characteristic.....	161
10.7.4	Motor equivalent circuit diagram data.....	162
10.7.5	Motor control settings.....	163
10.7.5.1	Speed controller.....	163
10.7.5.2	Current controller.....	166
10.7.5.3	ASM field controller.....	169
10.7.5.4	ASM field weakening controller.....	170
10.7.5.5	ASM field weakening controller (extended).....	170
10.7.5.6	PSM operation outside the voltage range.....	171
10.7.5.7	I _{max} controller.....	172
10.7.5.8	Flying restart controller.....	172
10.7.5.9	SLVC controller.....	172
10.7.5.10	Slip controller.....	173
10.7.5.11	Position controller.....	173
10.7.5.12	PRBS excitation.....	174
10.8	Fine adjustment of the motor model.....	175
10.8.1	Correction of the stator leakage inductance (L _{ss}).....	176
10.8.2	Synchronous motor (SM): Compensate temperature and current influences.....	181
10.8.3	Asynchronous motor (ASM): Identifying L _h saturation characteristic.....	182
10.8.4	Estimate optimum magnetising current.....	184
10.9	Parameterise filter elements in the setpoint path.....	185
10.9.1	Jerk limitation.....	185
10.9.2	Notch filter (band-stop filter).....	186
10.10	Motor protection.....	189
10.10.1	Motor overload monitoring (i ² xt).....	189
10.10.1.1	Parameters for the thermal model.....	191
10.10.1.2	Speed-dependent evaluation of the motor current.....	193
10.10.1.3	UL 508-compliant motor overload monitoring.....	196
10.10.2	Motor temperature monitoring.....	197
10.10.2.1	Individual characteristic for motor temperature sensor.....	199
10.10.3	Overcurrent monitoring.....	199
10.10.4	Motor phase failure detection.....	200
10.10.5	Motor speed monitoring.....	200
10.11	Frequency and speed limitations.....	201
10.12	Testing the motor control.....	202
10.12.1	General settings for test modes.....	202
10.12.2	Manual "tension/frequency" test mode.....	204
10.12.3	Manual "current/frequency" test mode.....	205
10.12.4	Manual "current pulse" test mode.....	206
11	I/O extensions and control connections.....	208
11.1	Configure digital inputs.....	208

Contents

12	Configuring the network	210
12.1	CiA 402 device profile	211
12.1.1	Supported operating modes	211
12.1.2	Basic setting	212
12.1.3	Process input data	212
12.1.4	Process output data	212
12.1.5	Commands for device state control	213
12.1.5.1	Switch-off	215
12.1.5.2	Switch on	216
12.1.5.3	Enable operation	217
12.1.5.4	Activate quick stop	218
12.1.5.5	Disable operation	219
12.1.5.6	Pulse inhibit	220
12.1.5.7	Reset fault	221
12.1.6	Device states	222
12.1.6.1	Not ready to switch on	224
12.1.6.2	Switch-on inhibited	225
12.1.6.3	Ready to switch on	226
12.1.6.4	Switched on	227
12.1.6.5	Operation enabled	228
12.1.6.6	Quick stop active	229
12.1.6.7	Fault reaction active	230
12.1.6.8	Trouble	231
12.1.7	Operation mode "Manual Jog"	232
12.2	onboard EtherCAT - Operation as standard EtherCAT slave	233
12.2.1	Commissioning	233
12.2.2	Basic setting and options	235
12.2.2.1	Synchronisation with "distributed clocks" (DC)	235
12.2.3	Process data transfer	235
12.2.4	Parameter data transfer	236
12.2.5	Monitoring	237
12.2.6	Diagnostics	238
12.2.6.1	Status LEDs	238
12.2.6.2	Information on the network	238
12.2.6.3	Device identification	239
12.2.7	EoE communication	240

13 Device functions	241
13.1 Optical device identification.....	241
13.2 Reset parameters to default.....	242
13.3 Saving/loading the parameter settings.....	243
13.4 Enabling the device.....	244
13.5 Restart device.....	245
13.6 Restarting Safety.....	246
13.7 Export logbook.....	247
13.8 Delete logbook files.....	248
13.9 Activate loaded application.....	249
13.10 Inverter control word.....	250
13.11 Access protection.....	251
13.11.1 Write access protection.....	251
13.11.1.1 Write access protection in the »EASY Starter«.....	253
13.11.2 Brand protection.....	255
13.12 Switching frequency changeover.....	256
13.13 Device overload monitoring (ixt).....	257
13.14 Heatsink temperature monitoring.....	258
13.15 Update device firmware.....	259
13.15.1 Firmware download with »EASY Starter (firmware loader)«.....	259
13.15.1.1 Download via Ethernet connection.....	259
14 Additional functions	260
14.1 Brake energy management.....	260
14.1.1 Use of a brake resistor.....	260
14.2 Manual jog parameters.....	261
14.3 Mains failure control.....	262
14.4 Oscilloscope function.....	267

Contents

15 Functional safety	275
15.1 General information and basics.....	275
15.1.1 Stop functions.....	276
15.1.2 Prioritisation.....	276
15.1.3 Acceptance.....	276
15.1.4 Periodic inspections.....	277
15.1.5 Device exchange.....	277
15.2 Safe interfaces.....	278
15.2.1 Safe network interfaces.....	279
15.2.1.1 FSoE connection.....	280
15.3 Safe parameter setting.....	286
15.3.1 Safety address.....	287
15.3.2 Parameter set information.....	287
15.4 Safe speed and position analysis.....	289
15.4.1 Motor-encoder combinations.....	289
15.4.2 Parameter setting of the feedback system.....	290
15.5 Safety functions.....	296
15.5.1 Safe torque off (STO).....	297
15.5.1.1 Basic Safety - STO.....	298
15.5.1.2 Advanced Safety/Extended Safety.....	301
15.5.2 Safe stop 1 (SS1).....	304
15.5.2.1 Safe stop 1 time controlled (SS1-t).....	305
15.5.2.2 Safe stop 1 ramp monitored (SS1-r).....	308
15.5.3 Safe stop emergency (SSE).....	312
15.5.4 Safe stop 2 (SS2).....	314
15.5.4.1 Safe stop 2 time controlled (SS2-t).....	315
15.5.4.2 Safe stop 2 ramp monitored (SS2-r).....	318
15.5.5 Safe operating stop (SOS).....	322
15.5.6 Safe brake control (SBC).....	324
15.5.7 Safe maximum speed (SMS).....	326
15.5.8 Safely-limited speed (SLS).....	328
15.5.9 Position-dependent safe speed (PDSS).....	333
15.5.10 Safe speed monitor (SSM).....	336
15.5.11 Safely-limited position (SLP).....	338
15.5.12 Safely-limited increment (SLI).....	341
15.5.13 Safe direction (SDI).....	343
15.5.14 Safe cam (SCA).....	346
15.5.15 Safe homing (SHom).....	348
15.5.15.1 Complete homing.....	349
15.5.15.2 Mini-homing.....	353
15.5.16 Repair mode selector (RMS).....	354
15.5.17 Enable switch (ES).....	356
15.5.18 Safe Muting (MUT).....	357
15.6 Diagnostics.....	359
15.6.1 Status LEDs.....	359
15.6.1.1 Acknowledgement with confirmation button S82.....	360
15.6.2 Event history.....	361
15.6.3 Diagnostic parameters.....	362

15.7	Safety-related data.....	363
15.7.1	Safety-related characteristics Basic Safety - STO.....	363
15.7.2	Safety-related characteristics Advanced Safety.....	363
15.7.3	Safety-related characteristics Extended Safety.....	364
15.7.4	Response times of the safety unit.....	365
15.7.5	Calculation of the maximum response times.....	366
16	Diagnostics and fault elimination.....	370
16.1	Status LEDs.....	371
16.2	Logbook.....	372
16.3	Diagnostic parameters.....	374
16.3.1	Inverter diagnostics.....	376
16.3.2	Motor diagnostics.....	378
16.3.3	Network diagnostics.....	379
16.3.4	I/O diagnostics.....	379
16.3.4.1	Digital inputs and outputs.....	379
16.3.5	Safety diagnostics.....	380
16.3.6	Service life diagnostics.....	388
16.3.7	Device identification.....	388
16.4	Event handling.....	389
16.4.1	Severity.....	390
16.4.2	Configuring the severity.....	391
16.4.3	Configuring the transition response for minor faults.....	391
16.4.4	Event reset.....	392
16.5	Events, causes and remedies.....	393
16.5.1	Event ID overview.....	393
16.5.2	Causes and remedies.....	403
16.5.3	Safety - Parameter set plausibility errors.....	463
17	Technical data.....	464
18	Environmental notes and recycling.....	465
19	Appendix.....	466
19.1	Parameter attribute list.....	466
19.2	Glossary.....	492



1 About this document

WARNING!

Read this documentation carefully before starting any work.

► Please observe the safety instructions!



1.1 Document description

This documentation is valid up to firmware version:

Firmware version	Date	Internal data ID
V01.02.xx.xx	2023-12-08	V0009



1.2 Further documents

For certain tasks, information is available in further documents.

Document	Contents/topics
Planning manual	Basic information on project planning and ordering the product
Mounting and switch-on instructions	Basic information on mounting and initial switch-on of the product

More information

For certain tasks, information is available in other media.

Medium	Contents/topics
Engineering Tools	For commissioning
AKB articles	Additional technical information for users in the Application Knowledge Base
CAD data	Download in different formats from the EASY Product Finder
EPLAN macros	Project planning, documentation and management of projects for EPLAN P8.
Device descriptions	Standardized files for network configuration







Information and tools with regard to the Lenze products can be found on the Internet:

www.lenze.com → Downloads



1.3 Notations and conventions

Conventions are used in this document to distinguish between different types of information.

Numeric notation		
Decimal separator	Point	Generally shown as a decimal point. Example: 1 234.56
Warnings		
UL Warnings	UL	Are used in English and French.
UR warnings	UR	
Text		
Engineering Tools	" "	Software Example: "Engineer", "EASY Starter"
Icons		
Page reference		Reference to another page with additional information. Example:  16 = see page 16
Documentation reference		Reference to other documentation with additional information. Example:  EDKxxx = see documentation EDKxxx

Layout of the safety instructions

DANGER!

Indicates an extremely hazardous situation. Failure to comply with this instruction will result in severe irreparable injury and even death.

WARNING!

Indicates an extremely hazardous situation. Failure to comply with this instruction may result in severe irreparable injury and even death.

CAUTION!

Indicates a hazardous situation. Failure to comply with this instruction may result in slight to medium injury.

NOTICE

Indicates a material hazard. Failure to comply with this instruction may result in material damage.



2 Safety instructions

2.1 Basic safety instructions

Disregarding the following basic safety instructions and safety information may lead to severe personal injury and damage to property!

- Only use the product as directed.
- Never commission the product in the event of visible damage.
- Never modify the product technically.
- Never commission the product before assembly has been completed.
- Never operate the product without the required covers.
- Connect/disconnect all pluggable connections only in deenergized condition!
- Only remove the product from the installation in the deenergized state.
- The product can – depending on their degree of protection – have live, movable or rotating parts during or after operation. Surfaces can be hot.
- Observe the specifications of the corresponding documentation. This is the condition for safe and trouble-free operation and the achievement of the specified product features.
- The procedural notes and circuit details given in the associated documentation are suggestions and their transferability to the respective application has to be checked. The manufacturer of the product does not take responsibility for the suitability of the process and circuit proposals.
- All work with and on the product may only be carried out by qualified personnel. IEC 60364 and CENELEC HD 384 define the qualifications of these persons:
 - They are familiar with installing, mounting, commissioning, and operating the product.
 - They have the corresponding qualifications for their work.
 - They know and can apply all regulations for the prevention of accidents, directives, and laws applicable at the place of use.

Please observe the specific safety information in the other sections!



2.2 Application as directed

- The product is a professional equipment intended for use by trades, specific professions or industry and not for sale to the general public. IEC 60050 [IEV 161-05-05]
- To prevent personal injury and damage to property, higher-level safety and protection systems must be used!
- All transport locks must be removed.
- The product may only be operated under the specified operating conditions and in the specified mounting positions.
- The product is exclusively suitable for installation in control cabinets and, depending on the protection class and design, for wall and motor mounting.
- The product must only be actuated with motors that are suitable for the operation with inverters.
- The product must not be operated in private areas, in potentially explosive atmospheres and in areas with harmful gases, oils, acids and radiation.



2.3 Residual hazards

Even if notes given are taken into consideration and protective measures are implemented, the occurrence of residual risks cannot be fully prevented.

The user must take the residual hazards mentioned into consideration in the risk assessment for his/her machine/system.

If the above is disregarded, this can lead to severe injuries to persons and damage to property!

Product

Observe the warning labels on the product!



Dangerous electrical voltage:

Before working on the product, make sure there is no voltage applied to the power terminals! After mains disconnection, the power terminals will still carry the hazardous electrical voltage for the time given next to the symbol!



Electrostatic sensitive devices:

Before working on the product, the staff must ensure to be free of electrostatic charge!



High leakage current:

Carry out fixed installation and PE connection in compliance with:
EN 61800-5-1 / EN 60204-1



Hot surface:

Use personal protective equipment or wait until the device has cooled down!

Degree of protection - protection of persons and device protection

- Information applies to the mounted and ready-for-use state.
- Information does not apply to the wire range of the terminals.
 - Terminals that are not wired have low protection against physical contact.
 - Terminals for large cable cross-sections have lower classes of protection, e. g. from 15 kW IP10 only.

Device protection

- The maximum test voltage for insulation tests between a control potential of 24 V and PE must not exceed 110 V DC (EN 61800-5-1).

Motor protection

With some settings of the inverter, the connected motor can be overheated.

- E. g. by longer operation of self-ventilated motors at low speed.
- E. g. by longer operation of DC-injection braking.

Protection of the machine/system

Drives can reach dangerous overspeeds.

- E. g. by setting high output frequencies in connection with motors and machines not suitable for this purpose.
- The inverters do not provide protection against such operating conditions. For this purpose, use additional components.

Motor

If there is a short circuit of two power transistors, a residual movement of up to $180^\circ/\text{number of pole pairs}$ can occur at the motor! (e. g. 4-pole motor: residual movement max. $180^\circ/2 = 90^\circ$).



3 Product information

3.1 Features

3.1.1 Power supply

30 A

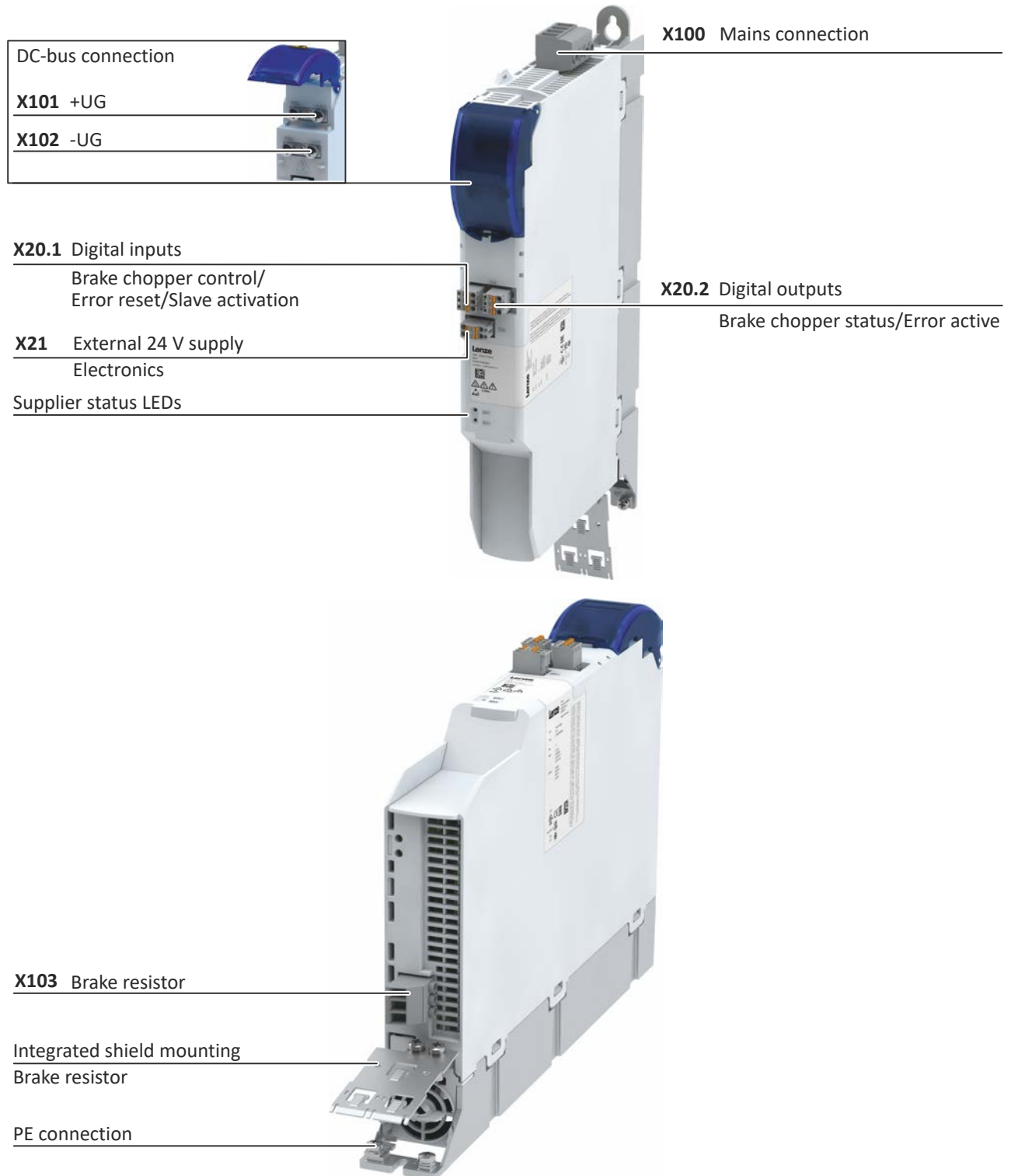

Product information

Features
Power supply



60 A

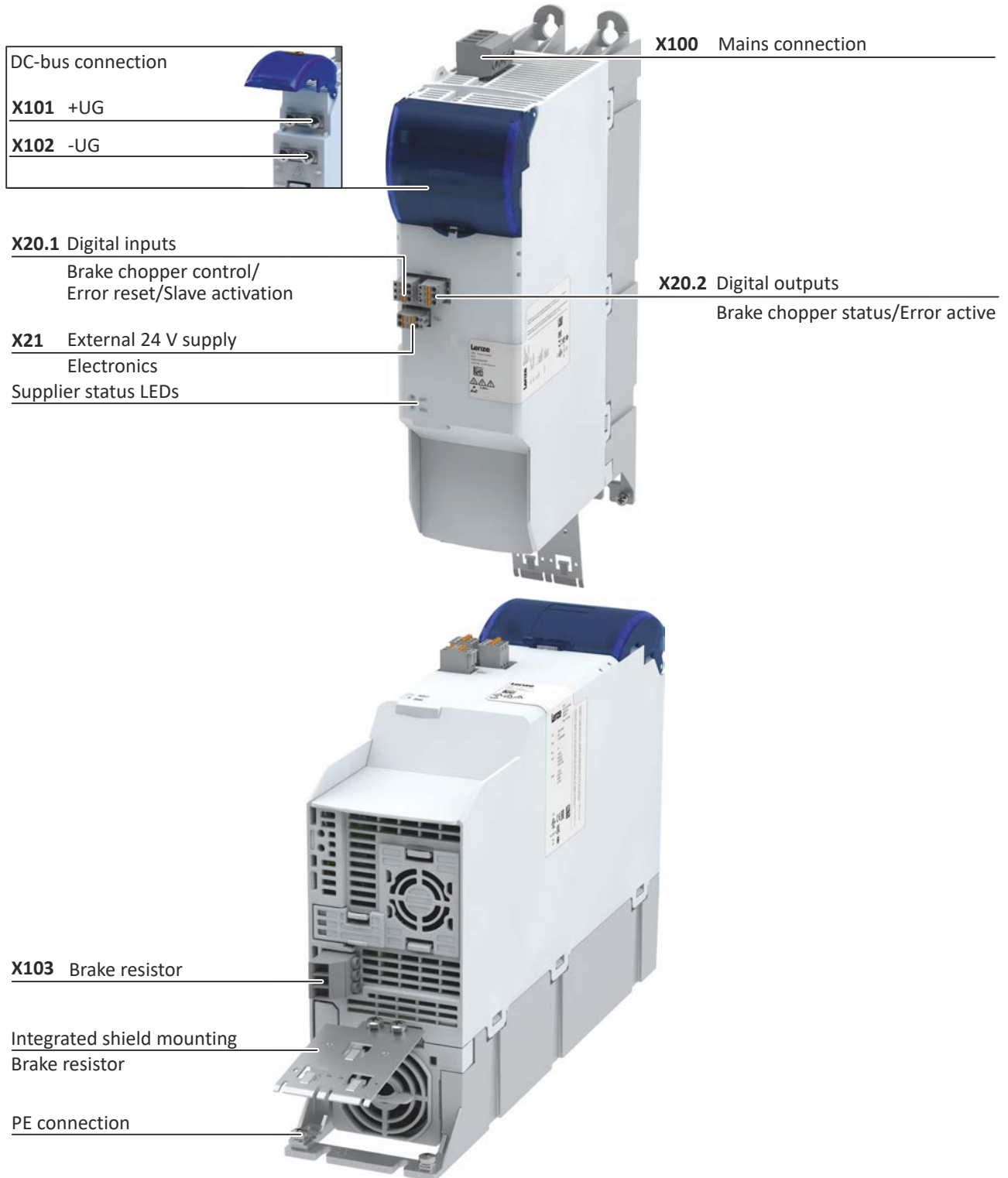



3.1.2 Single axes

1.1 kW ... 4 kW

DC-bus connection

X101 +UG

X101 -UG

Product variants safety

Advanced Safety/Extended Safety

S82 Confirmation button

Status LEDs

X3 Control terminal

X5 Control electronics
24 V supply

Basic Safety - STO

X1 STO

Product variants - feedback

Motor encoder

HIPERFACE DSL® (OCT)/PTC
(One Cable Technology)
Connection on X109

X7 Resolver
(X109 without function)

X8 Multi encoder
(X109 without function)

Inverter status LEDs

X236 onboard EtherCAT IN

X237 onboard EtherCAT OUT

EtherCAT status LEDs

EtherCAT status LEDs

X107 Motor holding brake
24 V supply

X109 Motor encoder
HIPERFACE DSL® (OCT)
PTC/thermal contact

X106 Motor holding brake

X105 Motor connection

Shielding of motor connection

PE connection

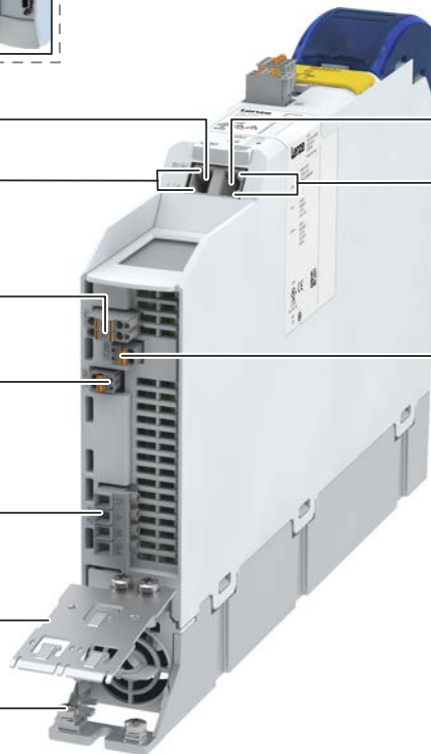

Product information

Features
Single axes



7.5 kW ... 15 kW

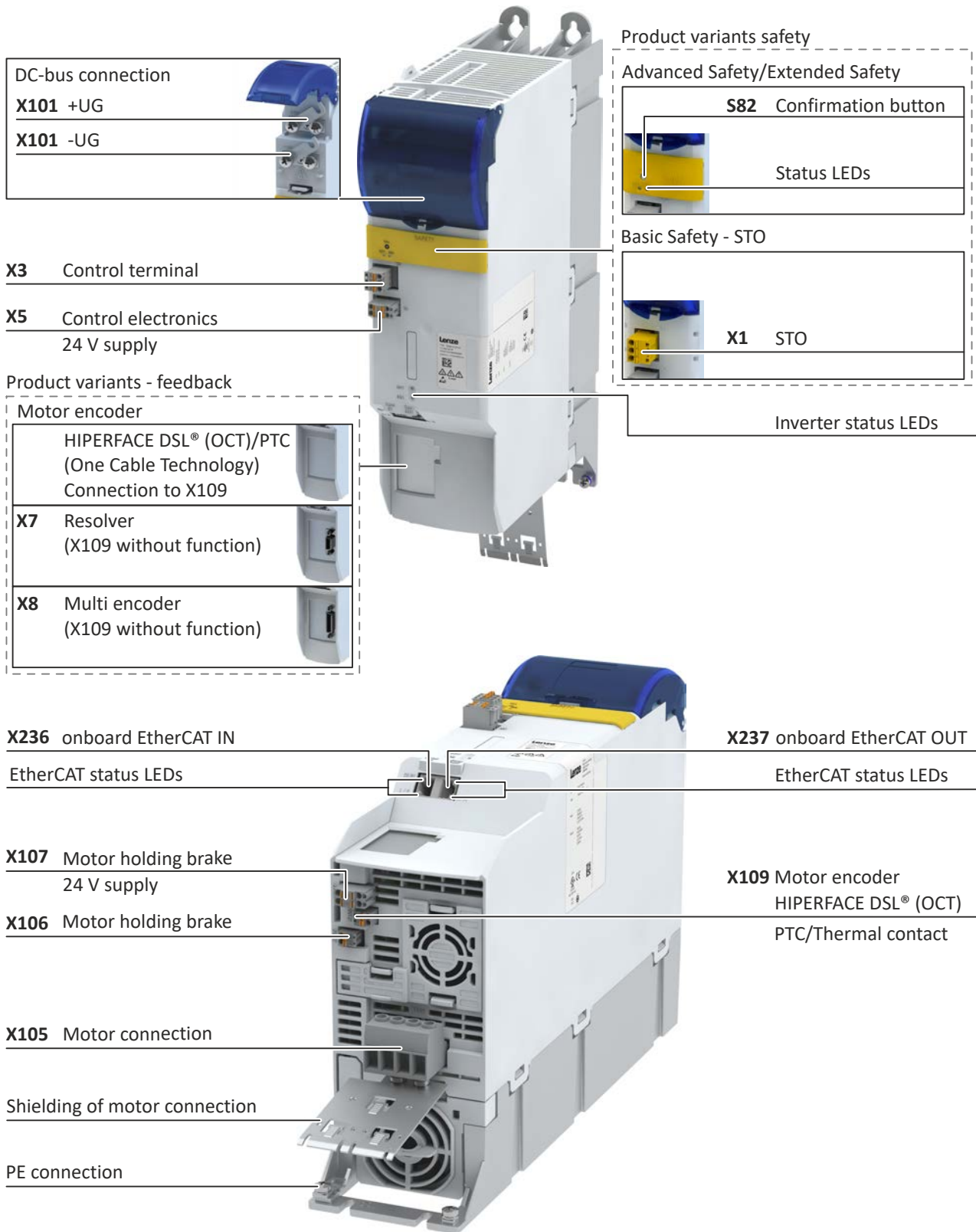



3.1.3 Double axes

2 x 1.1 kW ... 2 x 2.2 kW

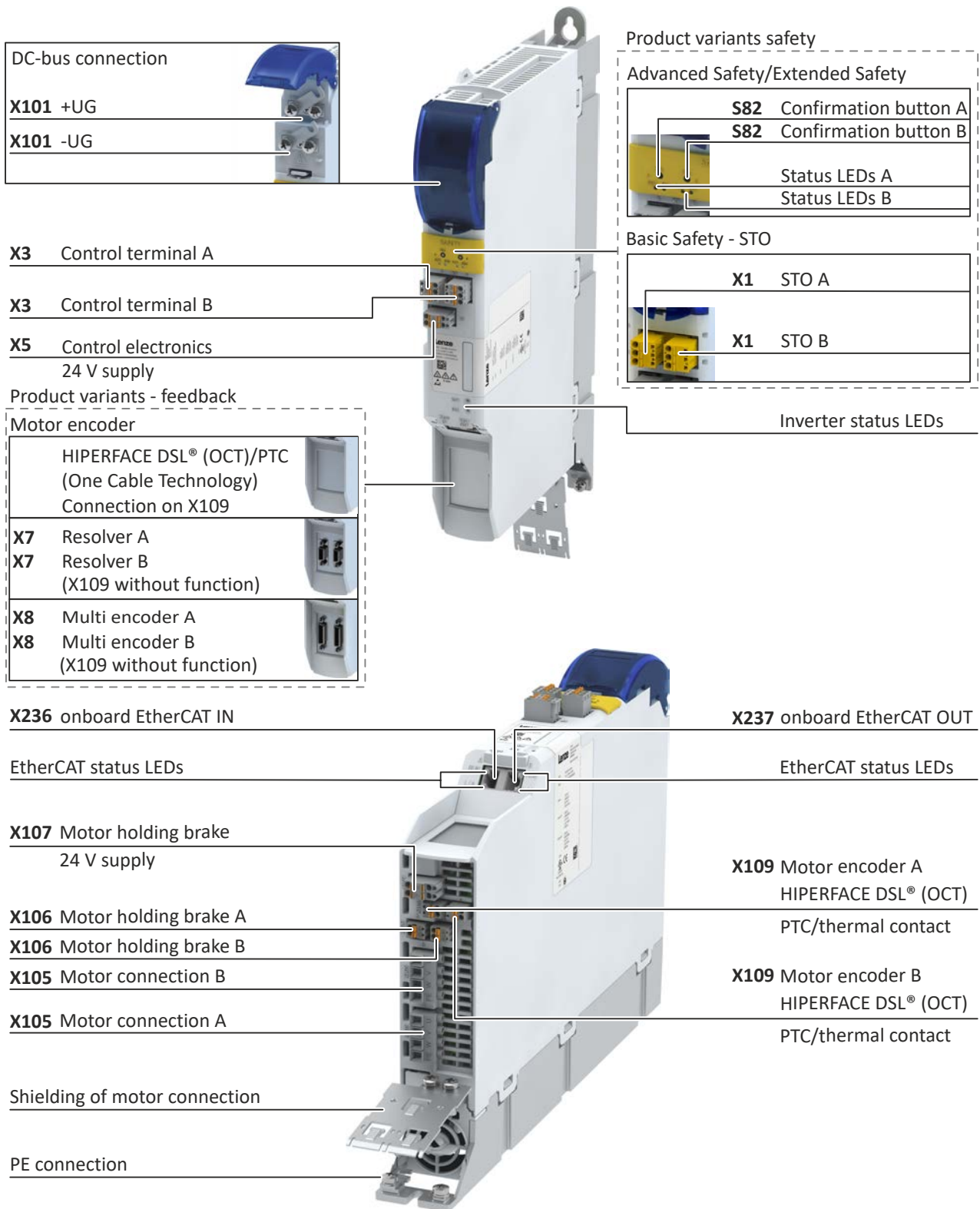

Product information

Features
Double axes



2 x 4 kW ... 2 x 7.5 kW

DC-bus connection	
X101	+UG
X101	-UG

X3 Control terminal A

X3 Control terminal B

X5 Control electronics
24 V supply

Product variants - feedback

Motor encoder	
HIPERFACE DSL® (OCT)/PTC (One Cable Technology) Connection to X109	
X7	Resolver A
X7	Resolver B (X109 without function)
X8	Multi encoder A
X8	Multi encoder B (X109 without function)

Product variants safety

Advanced Safety/Extended Safety	
S82	Confirmation button A
S82	Confirmation button B
Status LEDs A	
Status LEDs B	

Basic Safety - STO

X1	STO A
X1	STO B

Inverter status LEDs

X236 onboard EtherCAT IN

EtherCAT status LEDs

X237 onboard EtherCAT OUT

EtherCAT status LEDs

X107 Motor holding brake
24 V supply

X106 Motor holding brake A

X106 Motor holding brake B

X105 Motor connection B

X105 Motor connection A

Shielding of motor connection

PE connection

X109 Motor encoder A
HIPERFACE DSL® (OCT)
PTC/Thermal contact

X109 Motor encoder B
HIPERFACE DSL® (OCT)
PTC/Thermal contact



3.2 Identification of the products

3.2.1 Product codes

Supplier - product code

		E	7	0	A	C	P	S	E	□□□	4	□
Product type	Electronics	E										
Product family	i700		7									
Product	i700			0								
Product generation	Generation A				A							
Mounting type	Control cabinet mounting					C						
Design	Supplier						P					
Control code								S				
Rated output current	30 A DC									E	030	
	60 A DC										060	
Mains voltage	3/PE AC 400 V 3/PE AC 480 V											4
Degree of protection	IP20											S
	IP20, coated											V

Axes - product code

		I	7	5	A	E	□□□	F	□	□	V	0	0	□	□	S	
Product type	Inverter	I															
Product family	i700		7														
Product	i750			5													
Product generation	Generation A				A												
Mounting type	Control cabinet mounting					E											
Rated power (Examples)	1.1 kW															211	
	2.2 kW															222	
	7.5 kW															275	
Mains voltage	3/PE AC 400 V 3/PE AC 480 V							F									
Motor connections	Single axis															1	
	Double axis															2	
Integrated functional safety	Basic Safety - STO															A	
	Advanced Safety															F	
	Extended Safety															B	
Degree of protection	IP20, coated															V	
Interference suppression	Without															0	
Design types	Dual Use															0	
	Scope of supply	Without mounting kit														0	
		With mounting kit														K	
	Motor encoder Axis 1 and axis 2	Single axis	Resolver														20
			Encoder (SinCos/HIPERFACE®/SSI/TTL)														30
			HIPERFACE DSL®, one cable technology (OCT)														Q0
	Double axis	Resolver															22
Encoder (SinCos/HIPERFACE®/SSI/TTL)																33	
HIPERFACE DSL®, one cable technology (OCT)																QQ	
Packaging	Packed individually															S	



3.3 License information

Open Source



Lenze software may contain software components that are licensed as Free Software or Open Source. The licensing terms of the open source software components used in this product are stored in the product.

To display the license information of the open source software components, an EoE connection (Ethernet over EtherCAT) must be established between PC and product. [▶ EoE communication](#)  240

Display licence information

1. Connect product to PC via Ethernet.
2. Read out IP address of the product via »EASY Starter« engineering tool.
3. Open browser and enter **http://"**IP address of the product**"/index.html**.

The licences used are displayed in the browser.



4 Commissioning

The purpose of commissioning is to adapt the inverter as part of a machine with a variable-speed drive system to its drive task.

The i750 servo inverter is a multi-axis inverter, i.e. the axes are interconnected via an integrated DC bus. The supplier connected to the AC system feeds the DC bus.

A controller programmed according to IEC 61131 controls the axes via the CiA 402 device profile.

The Lenze engineering tool "PLC Designer" is available for programming the controller. The FAST function library enables the rapid creation of applications.

EtherCAT® is used for real-time communication.



i700/i750 tutorials are available for easy commissioning.

[i700 servo inverter - Start-up tutorials](#)

Automation with central motion control

Example: Topology for Basic Safety - STO

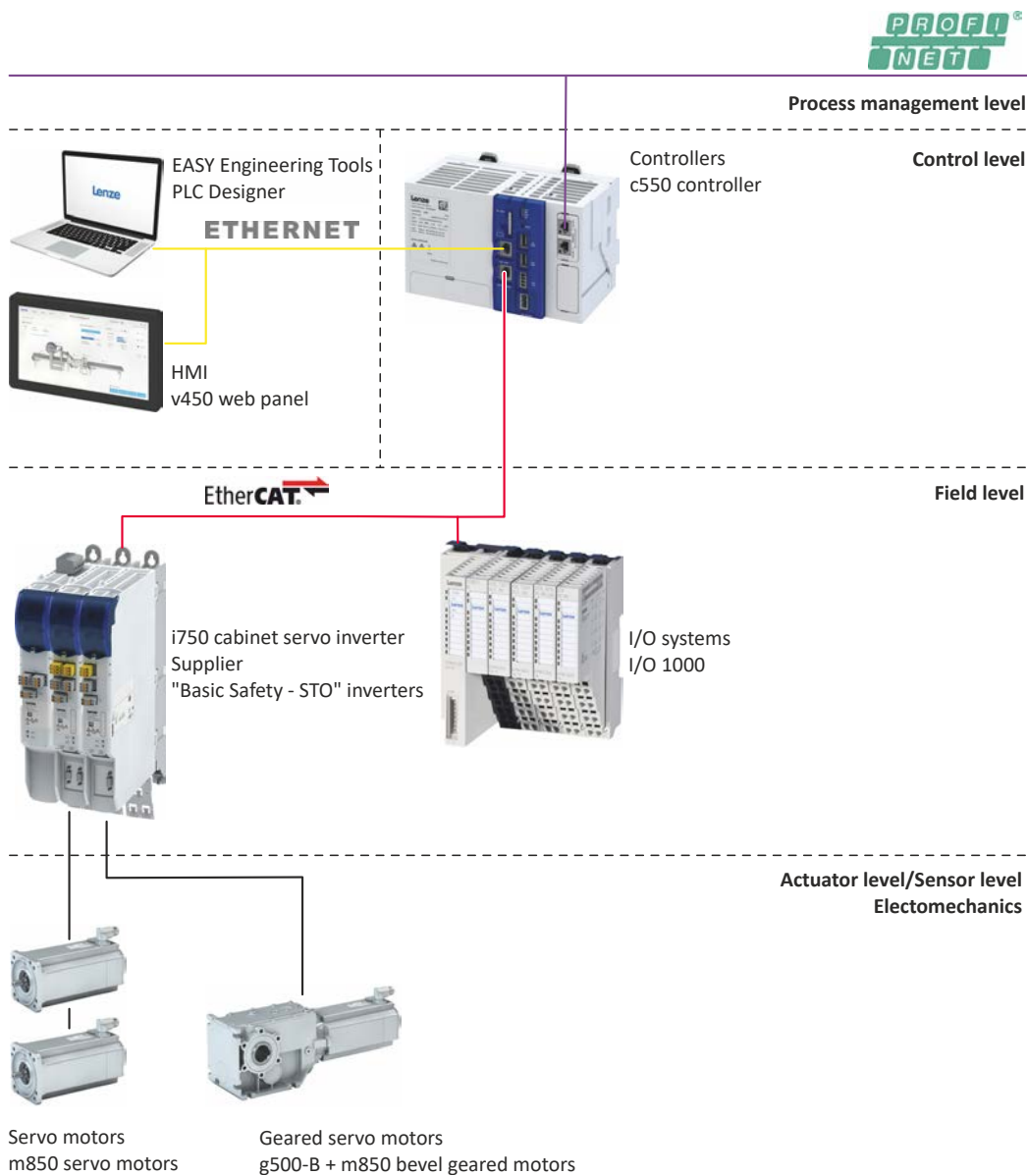

Commissioning



Automation with central motion control

Example: Topology for Advanced Safety/Extended Safety

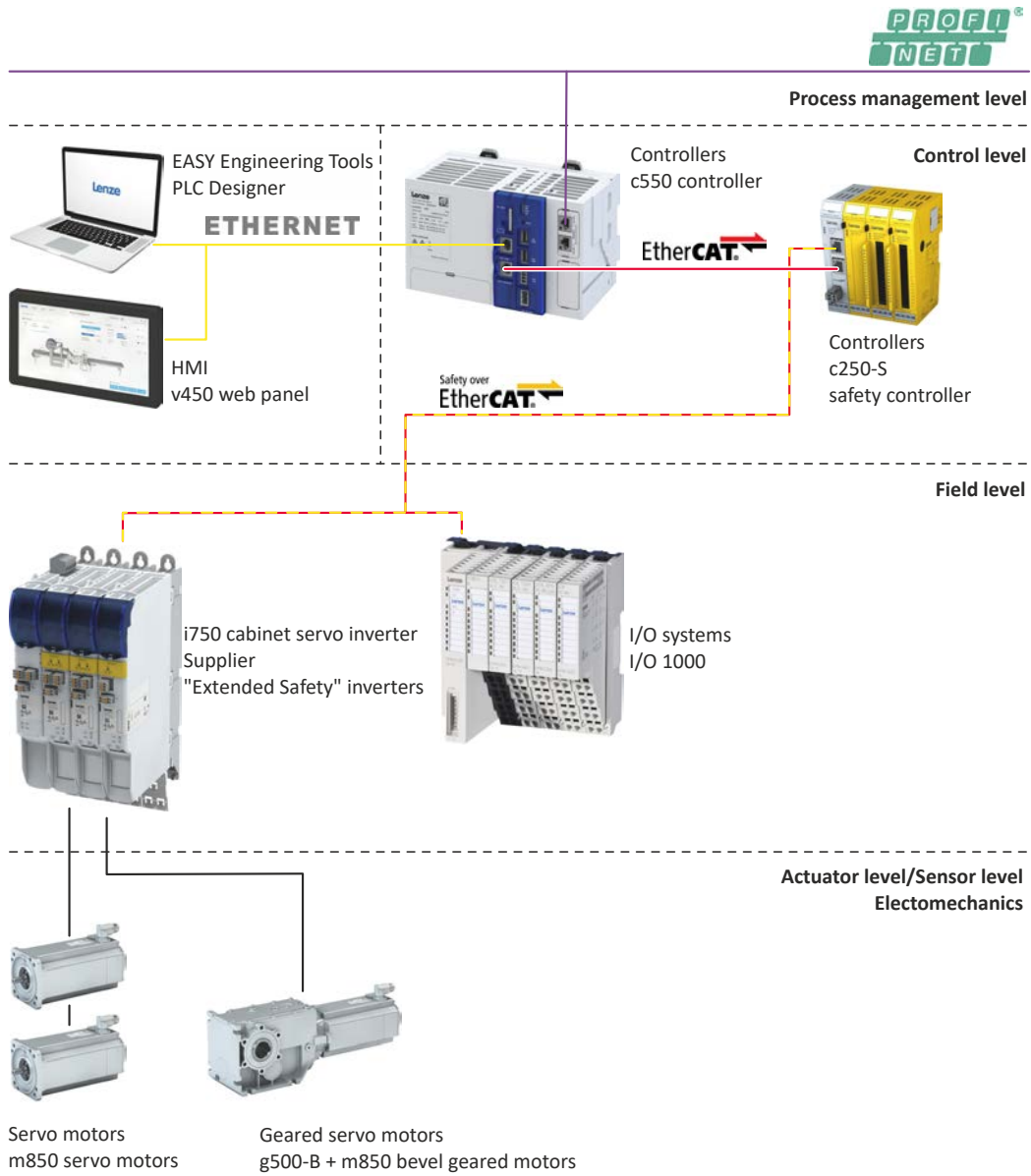



4.1 Important notes

DANGER!

Incorrect wiring can cause unexpected states during the commissioning phase.

Possible consequences: death, severe injuries or damage to property

Ensure the following before switching on the mains voltage:

- ▶ Wiring must be complete and correct.
 - ▶ Wiring must be free of short circuits and earth faults.
 - ▶ The motor circuit configuration (star/delta) must be adapted to the inverter output voltage.
 - ▶ The motor must be connected in-phase (direction of rotation).
 - ▶ The "emergency switching off" function of the overall system must operate correctly.
-

DANGER!

Incorrect settings during commissioning may cause unexpected and dangerous motor and system movements.

Possible consequences: death, severe injuries or damage to property

- ▶ Clear hazardous area.
 - ▶ Observe safety instructions and safety clearances.
-

NOTICE

The set mains voltage is lower than the actual mains voltage.

Possible consequences: Destruction of a connected brake resistor.

Due to the mains voltage being set too low, the voltage threshold for braking operation ("brake chopper threshold") is within the permissible range of the DC-bus voltage. As a result, the brake chopper is continuously in operation and the brake resistor is thermally overloaded.

- ▶ First switch on the 24 V supply and check whether the setting of the mains voltage corresponds to the supply network: ▶ [0x2540:001](#) (Rated mains voltage).
 - ▶ If it is ensured that the mains voltage is set correctly, the mains voltage can be switched on.
-

Commissioning

Operating interfaces

Engineering tool »EASY Starter«



4.2 Operating interfaces

4.2.1 Engineering tool »EASY Starter«

The »EASY Starter« is a PC software that is especially designed for the commissioning and diagnostics of the inverter.

- »EASY Starter« [Download](#)

4.2.2 Engineering tool »PLC Designer«

The "PLC Designer" is a PC software for program creation and commissioning of Lenze PLC devices according to IEC 61131-3.

In addition, the "PLC Designer" offers 6 editors, debugger, monitoring and other features.

- »PLC Designer« [Download](#)



4.3 General information on parameter setting



Certain device commands or settings which might cause a critical state of the drive behavior can only be carried out when the device is disabled.

4.3.1 Addressing of the parameters

Each parameter features a 16-bit index as its address. Under this address, the parameter is stored in the object directory of the device.

- Parameters that belong together functionally are combined in a data set. These parameters are additionally provided with an 8-bit subindex.
- The colon is used as a separator between the index and subindex Example: "0x2540:001"
- There are parameter settings that can be changed, and (diagnostic) parameters that can only be read.



The following conventions are used in this documentation for specifying the parameter address:

- The index is specified as a hexadecimal value.
- The subindex is specified as a decimal value.

4.3.2 Structure of the parameter descriptions

- The parameter descriptions in this documentation are structured in table form.
- The representation distinguishes parameters with a setting range, text, selection list, and bit-coded display.
- The default setting of parameters with a write access feature is shown in **bold**.

Example: parameters with a setting range

Address	Name / setting range / [default setting]	Information
Index:Subindex	Parameter designation Minimum value ... [default setting] ... maximum value • Optional information with regard to the parameter.	Explanations & notes with regard to the parameter.

Example: parameters with a selection list

Address	Name / setting range / [default setting]	Information
Index:Subindex	Parameter designation • Optional information with regard to the parameter.	Explanations & notes with regard to the parameter. Note: The corresponding selection number (here 0, 1, or 2) must be set. Other values are not permissible.
	0 Designation of selection 0	Optionally: Explanations & notes with regard to the corresponding selection.
	1 Designation of selection 1	The default selection is shown in bold .
	2 Designation of selection 2	

Example with bit coded display

Address	Name / setting range / [default setting]	Information
Index:Subindex	Parameter designation • Optional information with regard to the parameter.	Explanations & notes with regard to the parameter.
	Bit 0 Designation of bit 0	Optionally: Explanations & notes with regard to the corresponding bit.
	Bit 1 Designation of bit 1	
	Bit 2 Designation of bit 2	
	
	Bit 15 Designation of bit 15	

Commissioning

General information on parameter setting
Setting and transferring safety parameters
Configuring the "Favorites"



4.3.3 Setting and transferring safety parameters



Safety-relevant parameters only have to be set for devices that feature integrated safety engineering.

▶ [Safe parameter setting](#)

4.3.4 Parameter overview lists

Parameter attribute list: contains a list of all inverter parameters. This list in particular includes some information that is relevant for the reading and writing of parameters via the network.

466

4.3.5 Favorites

4.3.5.1 Configuring the "Favorites"

Parameter

Address	Name / setting range / [default setting]	Information
0x261C:001	Favorites settings: Parameter 1 0 ... [] ... 4294967295	Definition of the "Favorites" parameters. <ul style="list-style-type: none">• Format: 0xiiiiss00 (iiii = hexadecimal index, ss = hexadecimal subindex)• The lowest byte is always 0x00.• The keypad can be used to select the desired parameter from a list.
0x261C:002	Favorites settings: Parameter 2 0 ... [] ... 4294967295	
0x261C:003	Favorites settings: Parameter 3 0 ... [] ... 4294967295	
0x261C:004	Favorites settings: Parameter 4 0 ... [] ... 4294967295	
0x261C:005	Favorites settings: Parameter 5 0 ... [] ... 4294967295	
0x261C:006	Favorites settings: Parameter 6 0 ... [] ... 4294967295	
0x261C:007	Favorites settings: Parameter 7 0 ... [] ... 4294967295	
0x261C:008	Favorites settings: Parameter 8 0 ... [] ... 4294967295	
0x261C:009	Favorites settings: Parameter 9 0 ... [] ... 4294967295	
0x261C:010	Favorites settings: Parameter 10 0 ... [] ... 4294967295	
0x261C:011	Favorites settings: Parameter 11 0 ... [] ... 4294967295	
0x261C:012	Favorites settings: Parameter 12 0 ... [] ... 4294967295	
0x261C:013	Favorites settings: Parameter 13 0 ... [] ... 4294967295	
0x261C:014	Favorites settings: Parameter 14 0 ... [] ... 4294967295	
0x261C:015	Favorites settings: Parameter 15 0 ... [] ... 4294967295	
0x261C:016	Favorites settings: Parameter 16 0 ... [] ... 4294967295	
0x261C:017	Favorites settings: Parameter 17 0 ... [] ... 4294967295	
0x261C:018	Favorites settings: Parameter 18 0 ... [] ... 4294967295	
0x261C:019	Favorites settings: Parameter 19 0 ... [] ... 4294967295	
0x261C:020	Favorites settings: Parameter 20 0 ... [] ... 4294967295	
0x261C:021	Favorites settings: Parameter 21 0 ... [] ... 4294967295	



Commissioning

General information on parameter setting
 Favorites
 Configuring the "Favorites"

Address	Name / setting range / [default setting]	Information
0x261C:022	Favorites settings: Parameter 22 0 ... [] ... 4294967295	
0x261C:023	Favorites settings: Parameter 23 0 ... [] ... 4294967295	
0x261C:024	Favorites settings: Parameter 24 0 ... [] ... 4294967295	
0x261C:025	Favorites settings: Parameter 25 0 ... [] ... 4294967295	
0x261C:026	Favorites settings: Parameter 26 0 ... [] ... 4294967295	
0x261C:027	Favorites settings: Parameter 27 0 ... [] ... 4294967295	
0x261C:028	Favorites settings: Parameter 28 0 ... [] ... 4294967295	
0x261C:029	Favorites settings: Parameter 29 0 ... [] ... 4294967295	
0x261C:030	Favorites settings: Parameter 30 0 ... [] ... 4294967295	
0x261C:031	Favorites settings: Parameter 31 0 ... [] ... 4294967295	
0x261C:032	Favorites settings: Parameter 32 0 ... [] ... 4294967295	
0x261C:033	Favorites settings: Parameter 33 0 ... [] ... 4294967295	
0x261C:034	Favorites settings: Parameter 34 0 ... [] ... 4294967295	
0x261C:035	Favorites settings: Parameter 35 0 ... [] ... 4294967295	
0x261C:036	Favorites settings: Parameter 36 0 ... [] ... 4294967295	
0x261C:037	Favorites settings: Parameter 37 0 ... [] ... 4294967295	
0x261C:038	Favorites settings: Parameter 38 0 ... [] ... 4294967295	
0x261C:039	Favorites settings: Parameter 39 0 ... [] ... 4294967295	
0x261C:040	Favorites settings: Parameter 40 0 ... [] ... 4294967295	
0x261C:041	Favorites settings: Parameter 41 0 ... [] ... 4294967295	
0x261C:042	Favorites settings: Parameter 42 0 ... [] ... 4294967295	
0x261C:043	Favorites settings: Parameter 43 0 ... [] ... 4294967295	
0x261C:044	Favorites settings: Parameter 44 0 ... [] ... 4294967295	
0x261C:045	Favorites settings: Parameter 45 0 ... [] ... 4294967295	
0x261C:046	Favorites settings: Parameter 46 0 ... [] ... 4294967295	
0x261C:047	Favorites settings: Parameter 47 0 ... [] ... 4294967295	
0x261C:048	Favorites settings: Parameter 48 0 ... [] ... 4294967295	
0x261C:049	Favorites settings: Parameter 49 0 ... [] ... 4294967295	
0x261C:050	Favorites settings: Parameter 50 0 ... [] ... 4294967295	



4.4 Commissioning steps

Only a few steps are required to commission an inverter.

Preconditions:

- The complete drive system is mounted and correctly wired.
- A project and a PLC program are created in the "PLC Designer".
- All components are supplied with voltage.
- EtherCAT is configured and at least in "Pre-Operational" state.
- The »PLC Designer« is connected "online" to the inverter.

Main commissioning steps

How to quickly commission the inverter:

1. Select connected motor from the motor catalog. ▶ [Motor data](#) 143
 2. Set control mode. ▶ [Configuring the motor control](#) 132
 3. Configure feedback system:
 - a) Feedback system for motor control. ▶ [Configure feedback system for motor control](#) 98
 - b) Feedback system for Extended Safety.
 4. Check wiring (cable check). ▶ [Cable check](#) 127
If no error has occurred, the system can be tested.
 5. Log in to the Lenze controller with Online → Log in.
The EtherCAT configuration and the PLC program are loaded into the controller. Any existing data will be overwritten.
 6. Start PLC program with <F5> or the Debug → Start menu command.
 7. Execute manual jog:
 - a) Select the inverter in the device tree.
 - b) Disable inverter if necessary.
 - c) Select the "Manual jog" command in the context menu of the inverter.
The dialog box for manual control appears.
 - d) Set parameters.
 - e) Start manual jog with the "Start" button.
The "Stop" button can be used to stop manual jog at any time.
 8. Optimize control. ▶ [Options for optimizing the control loops](#) 156
- Commissioning is completed.



4.5 Saving the parameter settings



The inverter does not save parameter settings in a power-failure-proof manner.

All settings that deviate from the Lenze default setting are held centrally in the Lenze controller for all subordinate inverters and persistently stored there.

During initialization at start-up, the Lenze controller transfers the parameters to the inverters underneath.

Commissioning

Saving the parameter settings
Save parameter settings with »EASY Starter«



4.5.1 Save parameter settings with »EASY Starter«

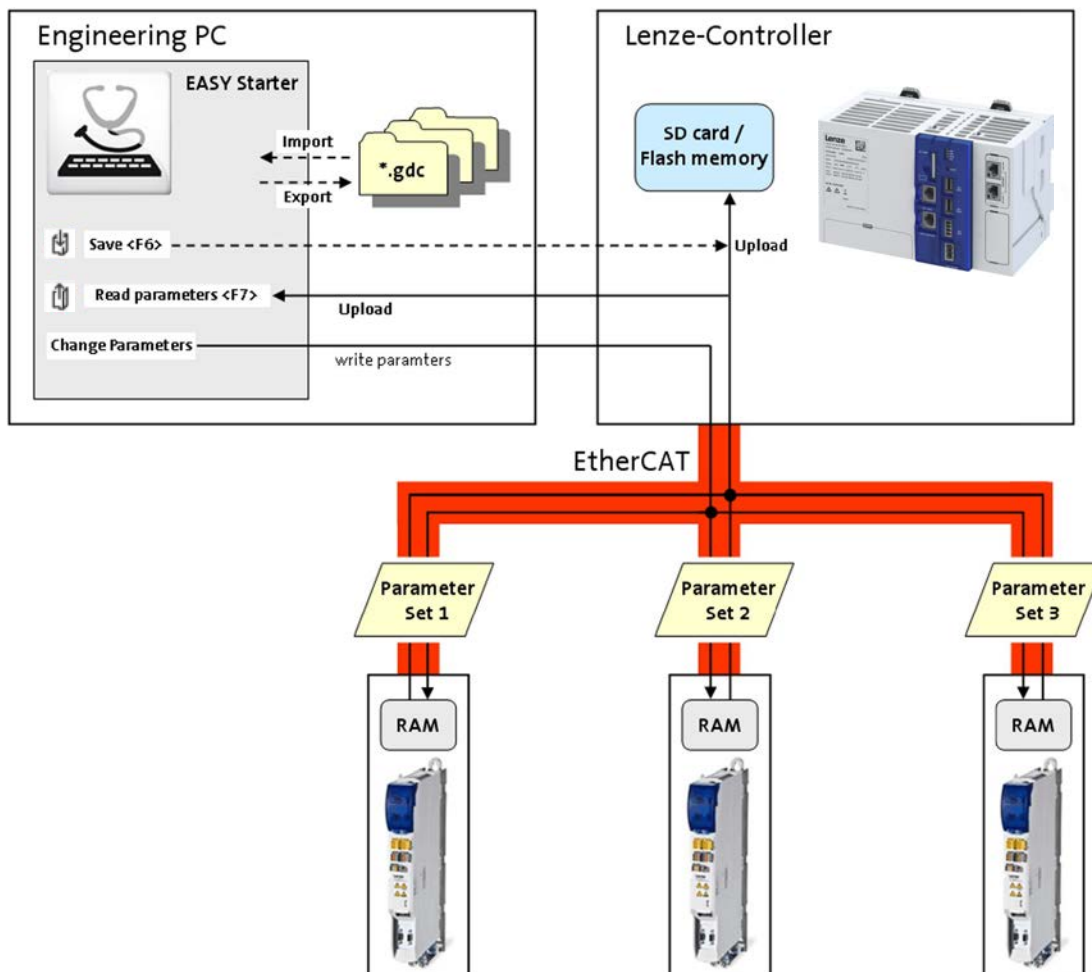



Fig. 1: Parameter management with the »EASY Starter«

Saving parameters on the engineering PC

How to save the parameter settings on the engineering PC

- The Lenze controller and the inverters must be inserted in the device list.
1. Select an inverter in the device list.
 2. Press the  button or the <F7> function key.
The parameter settings of the inverter are transferred to the "EASY Starter".
The parameter settings of the inverter are not stored in the Lenze controller.
 3. Use the "Save" button to save the parameters as a GDC file on the Engineering PC.

Saving parameters persistently in the Lenze controller

How to save the parameter settings persistently in the Lenze controller

- The Lenze controller and the inverters must be inserted in the device list.
1. Select the Lenze controller in the device list.
 2. Press the  button or the <F6> function key.
The parameter settings of all lower-level inverters are persistently stored in the Lenze controller.

After the system is switched off and on again, the Lenze controller automatically transfers the parameters to the lower-level inverters.



4.5.2 Save parameter settings with the »PLC Designer«

The parameters of the inverters are managed in the "PLC Designer" project.

With the memory function of the "PLC Designer", the "PLC Designer" project with all parameters of the lower-level inverters is saved on the Engineering PC.

The "PLC Designer" writes all parameters to the Lenze controller when logging in. This then transfers the parameters to the subordinate inverters.

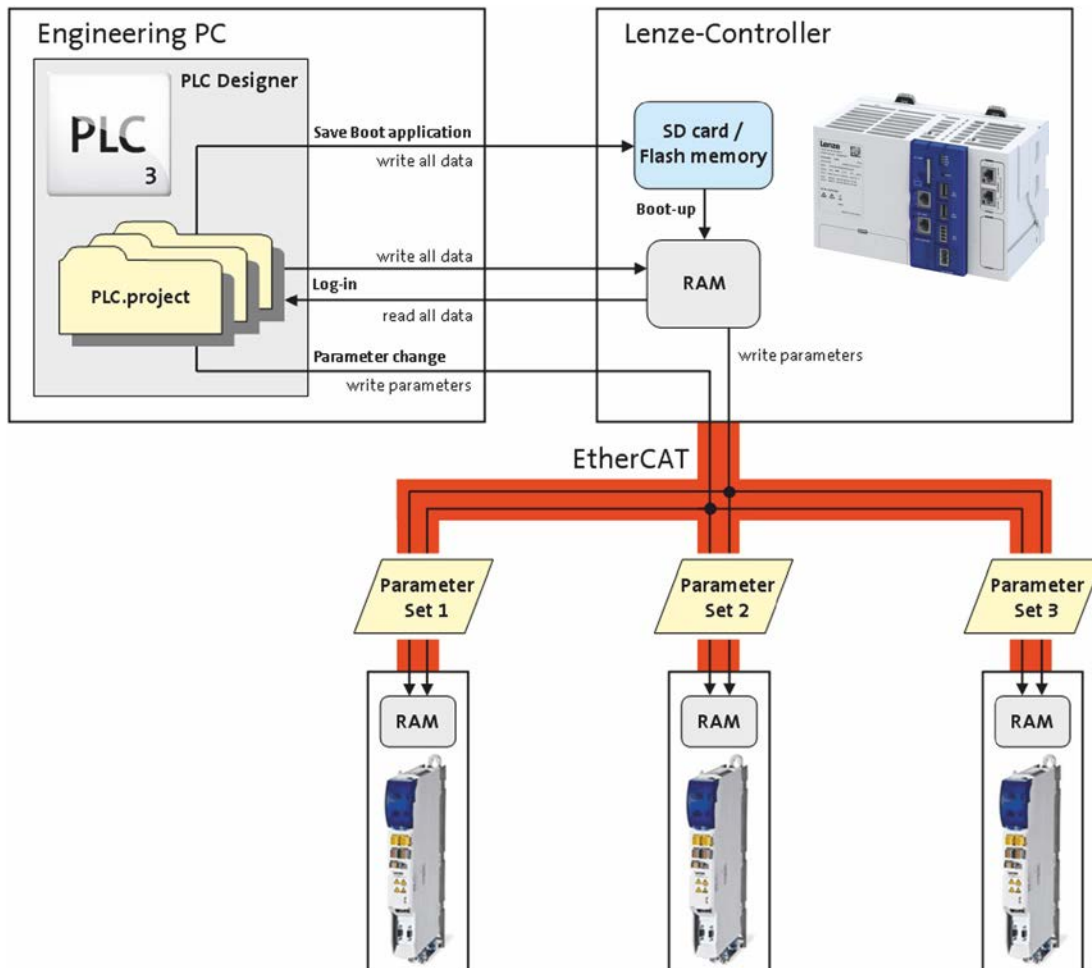

Fig. 2: Parameter management with the »PLC Designer«

Change and save parameters online

Change parameters online

- The "PLC Designer" writes the changed parameters directly to the lower-level inverter
- The "PLC Designer" changes the parameters in the »PLC Designer« project.
- The parameters are not transferred to the Lenze controller!

Transfer parameters to the Lenze controller

- Log out with the "PLC Designer" and log in again. (Menu commands: Online → Log off / Online → Log in)
- All parameters are written to the Lenze controller and transferred to the lower-level inverters.
- The parameters are not stored persistently in the Lenze controller! ▶ [Saving parameters persistently in the Lenze controller](#)

Commissioning

Saving the parameter settings

Save parameter settings with the »PLC Designer«



Change and save parameters offline

Change parameters offline

- The "PLC Designer" changes the parameters in the »PLC Designer« project.
- The parameters are not transferred to the Lenze controller!

Transfer parameters to the Lenze controller

- Log in with the »PLC Designer«. (Menu command: Online → Log in)
- All parameters are written to the Lenze controller and transferred to the lower-level inverters.
- The parameters are not stored persistently in the Lenze controller! ▶ [Saving parameters persistently in the Lenze controller](#)

Saving parameters persistently in the Lenze controller

- Execute the function "Create boot project" in the »PLC Designer«.
- The parameter settings of all lower-level inverters are persistently stored in the Lenze controller.
- After the system is switched off and on again, the Lenze controller automatically transfers the parameters to the lower-level inverters.



5 Basic setting

This chapter contains the most frequently used functions and settings to adapt the inverter to a simple application based on the default setting.

Basic setting

Device name



5.1 Device name

Parameter

Address	Name / setting range / [default setting]	Information
0x2001	Device name ["Device"]	Any device name can be set in this object for the purpose of device identification.



5.2 Mains voltage

The rated mains voltage set for the inverter has an impact on the operating range of the inverter.

Setting-up operation

For setup, the inverter can be operated with 15 V ... 60 V DC voltage.

- Setting: ▶ **0x2540:001** = [4] 60 V DC (setting-up operation).
- Supply via DC terminal X101 (+UG/-UG).

Voltage thresholds for monitoring the DC-bus voltage

- The warning thresholds for monitoring are adjustable.
- The error thresholds and reset thresholds for monitoring result from the rated mains voltage set.

Rated mains voltage	Undervoltage thresholds			Overvoltage thresholds		
	Warning threshold	Error threshold	Reset threshold	Warning threshold	Error threshold	Reset threshold
Setting in 0x2540:001	Setting in 0x2540:002	Display in 0x2540:003	Display in 0x2540:004	Setting in 0x2540:005	Display in 0x2540:006	Display in 0x2540:007

Parameter

Address	Name / setting range / [default setting]	Information
0x2540:001	Mains settings: Rated mains voltage 0 230 Veff 1 400 Veff 2 480 Veff 4 60 V DC (setting-up operation) 10 230 Veff/reduced LU level 11 400 Veff/reduced LU level 12 480 Veff/reduced LU level	Selection of the mains voltage for actuating the inverter.
0x2540:002	Mains settings: Undervoltage warning threshold 0 ... [430] ... 800 V	Monitoring for undervoltage (LU) in the DC bus: Setting of the warning threshold. • If the DC voltage in the DC bus falls below the threshold set, the inverter outputs a warning. • The warning is reset with a hysteresis of 10 V.
0x2540:003	Mains settings: Undervoltage error threshold • Read only: x V	Monitoring for undervoltage (LU) in the DC bus: Display of the fixed threshold. • If the DC voltage in the DC bus falls below the threshold displayed, the error"" response is triggered.
0x2540:004	Mains settings: Undervoltage reset threshold • Read only: x V	Display of the fixed reset threshold for monitoring DC bus undervoltage.
0x2540:005	Mains settings: Overvoltage warning threshold 0 ... [795] ... 800 V	Monitoring for overvoltage (OU) in the DC bus: Setting of the warning threshold. • If the DC bus voltage exceeds the threshold set, the inverter outputs a warning. • The warning is reset with a hysteresis of 10 V.
0x2540:006	Mains settings: Overvoltage error threshold • Read only: x V	Monitoring for overvoltage (OU) in the DC bus: Display of the fixed threshold. • If the DC-bus voltage exceeds the threshold displayed, the "Fault" response is triggered.
0x2540:007	Mains settings: Overvoltage reset threshold • Read only: x V	Display of the fixed reset threshold for monitoring DC bus overvoltage.
0x2540:008	Mains settings: DC link voltage critical • Read only	Display of value "1": the DC-bus voltage has reached a critical value.

Basic setting

Function assignment of the inputs and outputs (default setting)



5.3 Function assignment of the inputs and outputs (default setting)

"[I/O extensions and control connections](#)" describes the assignment of functions to inputs and outputs. [📖 208](#)



5.4 Motor data

The term "motor data" comprises all parameters only depending on the motor and only characterising the electrical behaviour of the motor. Motor data are independent of the application in which the inverter and the motor are used.

Preconditions

The equivalent circuit data ("Settings" tab, path: "Basic setting\motor", parameterisation dialog "Derived motor properties and equivalent circuit") apply to a motor in star connection. In case of a motor in delta connection, the delta values must be converted into equivalent star values.

Possible settings

If a Lenze motor is connected to the inverter, you can select the motor in the engineering tool from the "motor catalogue".

- For details see chapter "[Select motor from motor catalog](#)". [44](#)

Otherwise the motor data must be set manually (for details see chapter "[Manual setting of the motor data](#)"). [46](#)

Parameter

Address	Name / setting range / [default setting]	Information
0x2C08	Method for setting motor parameters	Representation of the method selected for setting the motor parameters. (Is used by the engineering tools.)
	1 Select from catalogue (Lenze motors)	
	2 Enter motor nameplate data (other motors)	
	3 Manual input (other motors)	
	4 Identification run (all motors)	

Basic setting

Motor data

Select motor from motor catalog



5.4.1 Select motor from motor catalog

The following describes how to parameterise your drive system by selecting a Lenze motor from the motor catalogue. Several processes are started invisibly in the background to load/ calculate the settings for the relevant parameters.

Preconditions

- Access to a Lenze engineering tool (e. g. »EASY Starter«).
- Parameters can be set online or offline (with or without connected motor).

Required steps

1. Open the Lenze engineering tool that provides for the functionality of a "Motor catalog".
2. Click the **Select motor...** button. In case of the »EASY Starter«, you find the **Select motor...** button on the "settings". tab.
3. Select the motor used in the "Select motor" dialog:

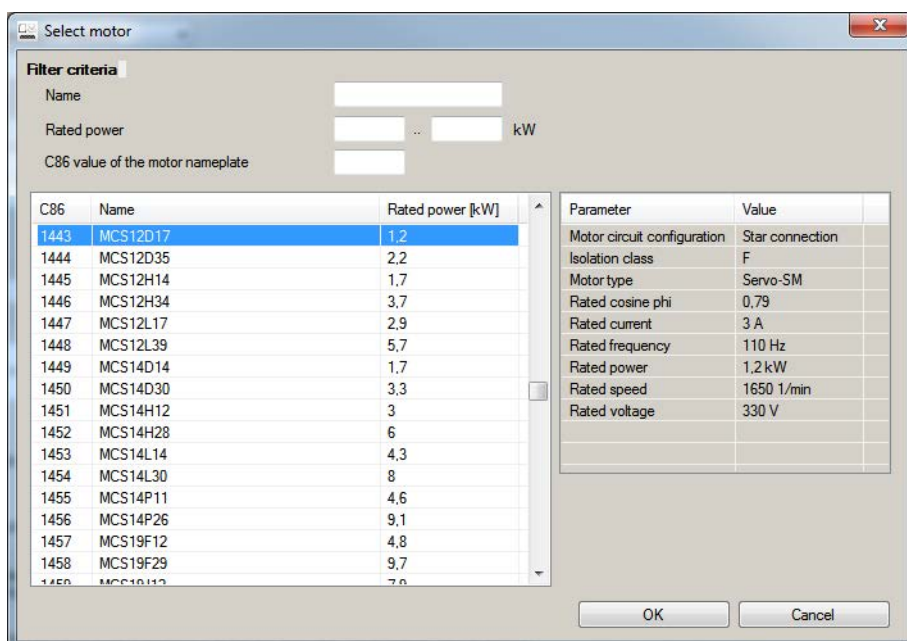

By entering filter criteria, you can restrict the selection.

Name (e. g. "MCS..."), rated power and C86 value can be found on the motor nameplate.

4. Press the **Please select** button to select the thermal sensor.

This is not required for all motors. For older motors, such as MDSKA056-22 (C86=10), a thermal sensor **CANNOT** be selected.



Observe the notes on the ? button.

5. Click the **OK** button to start the optimisation.



Parameterisation sequence

As soon as the parameterisation has been started, the following steps are initiated by the engineering tool:

1. The motor rating data and the motor equivalent circuit diagram data are loaded from the motor catalogue.
2. The motor controller settings and the speed controller settings are automatically calculated based on the previously loaded data.

Notes:

- The data involved in this parameterisation are provided by the motor catalog alone. Further user data is not required.
- The inverter characteristic is not changed by this optimisation.

Parameter

Address	Name / setting range / [default setting]	Information
0x2C01:010	Motor parameters: Motor name ["MCS06C41"]	The name (e.g. "1") can be freely selected by the user. If the motor in the engineering tool has been selected from the "motor catalog", the respective motor name is automatically entered here (example: "MDSKA080-22, 70").

Basic setting

Motor data
Manual setting of the motor data



5.4.2 Manual setting of the motor data

There are two options to parameterize a motor.

1. Enter nameplate data

Enter the following motor data:

- ▶ 0x2C01:001 Number of pole pairs
- ▶ 0x2C01:002 Stator resistance
- ▶ 0x2C01:003 Stator leakage inductance
- ▶ 0x2C01:004 Rated speed
- ▶ 0x2C01:005 Rated frequency
- ▶ 0x2C01:006 Rated power
- ▶ 0x2C01:007 Rated voltage
- ▶ 0x2C01:008 Cosine phi
- ▶ 0x2C01:009 Insulation class
- ▶ 0x6075 Rated motor current

When you touch the "Estimate" button in the engineering tool, more parameters depending on the motor are shown.

2. Enter data of the motor data sheet

The motor data and the parameters depending on the motor are entered. The parameters mentioned under 1. are the following:

- ▶ 0x2D4C:001 Thermal time constant of the winding
- ▶ 0x2D4C:002 Thermal time constant - laminated core
- ▶ 0x2D4C:003 Influence of winding
- ▶ 0x2D4C:004 Starting value
- ▶ 0x6076 Rated motor torque

Additionally for ASM:

- ▶ 0x2C02:001 Rotor resistance
- ▶ 0x2C02:002 Mutual inductance
- ▶ 0x2C02:003 Magnetizing current

Additionally for PSM:

- ▶ 0x2C03:001 EMF constant
- ▶ 0x2C03:002 Resolver pole position
- ▶ 0x2C03:003 Temperature coefficient magnets (kTN)
- ▶ 0x2C03:004 Encoder pole position

After the motor data has been parameterized via one of the two options, the following monitoring and limit values are initialized with motor-dependent preset values by touching the "Initialize" button:

- ▶ 0x2D44:001 Overspeed monitoring threshold
- ▶ 0x2D46:001 Overcurrent monitoring threshold
- ▶ 0x2D49:003 Motor temperature monitoring warning threshold
- ▶ 0x2D49:004 Motor temperature monitoring error threshold
- ▶ 0x6073 Maximum current
- ▶ 0x6075 Rated motor current



Parameter

Address	Name / setting range / [default setting]	Information
0x2822:037	Axis commands: Estimate all motor parameters based on rated data	
	0 Off/Ready	
	1 On/Start	
	2 In progress	
	3 Action cancelled	
	4 No access	
5 No access (controller inhibit)		
0x2822:038	Axis commands: HIPERFACE (A): Set position with synchronization	
	0 Off/Ready	
	1 On/Start	
	2 In progress	
	3 Action cancelled	
	4 No access	
5 No access (controller inhibit)		
0x2C01:001	Motor parameters: Number of pole pairs • Read only	Display of the number of pole pairs calculated from the rated speed and rated frequency.
0x2C01:002	Motor parameters: Stator resistance 0.0000 ... [13.5000] ... 125.0000 Ω	General motor data. Carry out settings as specified by manufacturer data/motor data sheet.
0x2C01:003	Motor parameters: Stator leakage inductance 0.000 ... [51.000] ... 500.000 mH	Note! When you enter the motor nameplate data, take into account the phase connection implemented for the motor (star or delta connection). Only enter the data applying to the connection type selected.
0x2C01:004	Motor parameters: Rated speed 0 ... [4050] ... 50000 rpm	General motor data. Carry out settings as specified by motor nameplate data.
0x2C01:005	Motor parameters: Rated frequency 0.0 ... [270.0] ... 2000.0 Hz	Note!
0x2C01:006	Motor parameters: Rated power 0.00 ... [0.25] ... 655.35 kW	When you enter the motor nameplate data, take into account the phase connection implemented for the motor (star or delta connection). Only enter the data applying to the connection type selected.
0x2C01:007	Motor parameters: Rated voltage 0 ... [225] ... 65535 V	
0x2C01:008	Motor parameters: Cosine phi 0.00 ... [0.80] ... 1.00	
0x2C01:009	Motor parameters: Insulation class	Insulation class of the motor (see motor nameplate).
	0 Y (cut-off temperature = 90 °C)	
	1 A (cut-off temperature = 105 °C)	
	2 E (cut-off temperature = 120 °C)	
	3 B (cut-off temperature = 130 °C)	
	4 F (cut-off temperature = 155 °C)	
	5 H (cut-off temperature = 180 °C)	
6 G (cut-off temperature > 180 °C)		
0x2C02:001	Motor parameter (ASM): Rotor resistance 0.0000 ... [0.0000] ... 214748.3647 Ω	Equivalent circuit data required for the motor model of the asynchronous machine.
0x2C02:002	Motor parameter (ASM): Mutual inductance 0.0 ... [0.0] ... 214748364.7 mH	
0x2C02:003	Motor parameter (ASM): Magnetising current 0.00 ... [0.00] ... 500.00 A	
0x2C03:001	Motor parameter (PSM): Back EMF constant 0.0 ... [41.8] ... 100000.0 V/1000rpm	Voltage induced by the motor (rotor voltage / 1000 rpm). For permanently excited synchronous motors, the e.m.f. constant describes the r.m.s. value of the line-to-line voltage (phase voltage) induced in idle state by the motor (reference: 1000 rpm, 20 °C). Measured: Line to Line (L - L)

Basic setting

Motor data
Manual setting of the motor data



Address	Name / setting range / [default setting]	Information
0x2C03:002	Motor parameter (PSM): Resolver pole position -179.9 ... [-90.0] ... 179.9 °	Equivalent circuit data required for the motor model of the synchronous machine.
0x2C03:003	Motor parameter (PSM): Magnets temperature coefficient (kTN) -1.000 ... [-0.110] ... 0.000 %/°C	
0x2C03:004	Motor parameter (PSM): Encoder pole position -179.9 ... [0.0] ... 179.9 °	
0x2D4C:001	Thermal model motor utilization (i ² xt): Motor utilisation (i ² xt) 1 ... [60] ... 36000 s	Setting of the time constant for the winding.
0x2D4C:002	Thermal model motor utilization (i ² xt): Thermal time constant - laminations 1 ... [852] ... 36000 s	Setting of the time constant for the laminated core.
0x2D4C:003	Thermal model motor utilization (i ² xt): Winding influence 0 ... [27] ... 100 %	Part of the thermal motor model: distribution factor of the copper winding influence.
0x6072	Max. torque 0.0 ... [250.0] ... 3276.7 %	
0x6073	Max. current 0.0 ... [150.0] ... 3276.7 %	Max. current of the inverter. Associated event ID: <ul style="list-style-type: none"> 537469829 0x20092385 - Parameterized max. motor current > max. device current
0x6075	Rated motor current 0.001 ... [1.300] ... 1000.000 A <ul style="list-style-type: none"> Setting can only be changed if the inverter is disabled. 	The rated motor current that needs to be set here serves as a reference value for different parameters that involve a setting for/display of a current value in percent. Example: <ul style="list-style-type: none"> Rated motor current = 1.7 A Max. current 0x6073 = 200 % Rated motor current = 3.4 A
0x6076	Rated motor torque 0.001 ... [0.600] ... 100000.000 Nm <ul style="list-style-type: none"> Setting can only be changed if the inverter is disabled. 	The rated motor torque to be set here serves as a reference value for different parameters with a setting/display of a torque value in percent. Example: <ul style="list-style-type: none"> Rated motor torque = 1.65 Nm Max. torque 0x6072 = 250 % Rated motor torque = 4.125 Nm
0x6080	Max. motor speed 0 ... [6075] ... 480000 rpm	Limitation of the max. motor speed. Depending on the parameter setting of 0x2D44:001 (Overspeed monitoring: threshold), the speed limitation (0x6080 / Max. motor speed) may become active before speed monitoring.



5.5 Motor control mode

The inverter supports different modes for closed-loop/open-loop motor control.

Parameter

Address	Name / setting range / [default setting]	Information
0x2C00	Motor control mode • Setting can only be changed if the inverter is disabled.	Selection of the motor control mode.
	1 Servoregelung (SC-PSM)	This control mode is used for servo control of a synchronous motor. ▶ Servo control for synchronous motor (SC-PSM) 133 A motor encoder must be connected to the inverter. This motor encoder serves as a feedback system for engine control.
	2 Servo control (SC ASM)	This control mode is used for servo control of an asynchronous motor. A motor encoder must be connected to the inverter. This motor encoder is used as a feedback system for the motor control. ▶ Servo control for asynchronous motor (SC-ASM) 134
	3 Sensorless control (SL PSM)	
	4 Sensorless vector control (SLVC)	This control type is used for sensorless vector control of an asynchronous motor. ▶ Sensorless vector control (SLVC) 136
	6 V/f characteristic control (VFC open loop)	This control mode is used for the speed control of an asynchronous motor via a V/f characteristic and is the simplest control mode. ▶ V/f characteristic control for asynchronous motor (VFC open loop) 137
	7 V/f characteristic control (VFC closed loop)	The control mode is used for speed control of an asynchronous motor via a V/f characteristic with speed feedback. A motor encoder must be connected to the inverter. This motor encoder is used as a feedback system for the motor control.

The detailed description of each motor control type can be found in the chapter "[Configuring the motor control](#)". [132](#)

Supplementary chapters:

- Chapter "[Configure feedback system for motor control](#)" describes how to set resolvers or sine/cosine encoders as motor feedback. [98](#)
- Chapter "" describes how a higher-level control loop can be used as an actual value feedback application for higher accuracy.



6 Configure position control

This operating mode provides a fast position follower with speed, torque and feed force feedforward control.

Typical applications for positioning are, for instance, transport facilities, feed drives and dosing systems.

Preconditions

A positioning control is parameterised in the servo control types to be set. ▶ [0x2C00](#)

Configure one of these motor control types:

- [0x2C00 = 1: Servo control for synchronous motor \(SC-PSM\)](#) [133](#)
- [0x2C00 = 2: Servo control for asynchronous motor \(SC-ASM\)](#) [134](#)

Further conditions are:

- The correct entry of the ▶ [Motor data](#) [43](#)
- The parameter setting of the motor control in chapter [Configuring the motor control](#) [132](#)



6.1 Basic setting

In the following, the steps required for configuring the position control are described.

1. Set the manufacturer spanning operating mode according to CiA 402.
 - **0x6060**: "CiA: Cyclic sync position (csp) [8]"
 - Detailed description in [▶ Operating mode "CiA 402 cyclic sync position mode \(csp\)"](#)
[54](#)
2. Set the maximum motor speed: **0x6080**
3. Set the rated motor torque: **0x6076**
4. Set the positive torque limit: **0x60E0**
5. Set the negative torque limit: **0x60E1**

The position control is now active and the inverter responds to the defined position setpoint.

Configure position control

Basic setting
Following error detection and in-position detection



6.1.1 Following error detection and in-position detection

The "following error detection" and "in-position detection" are functions of the position control. All parameters correspond to the CiA 402 specification.

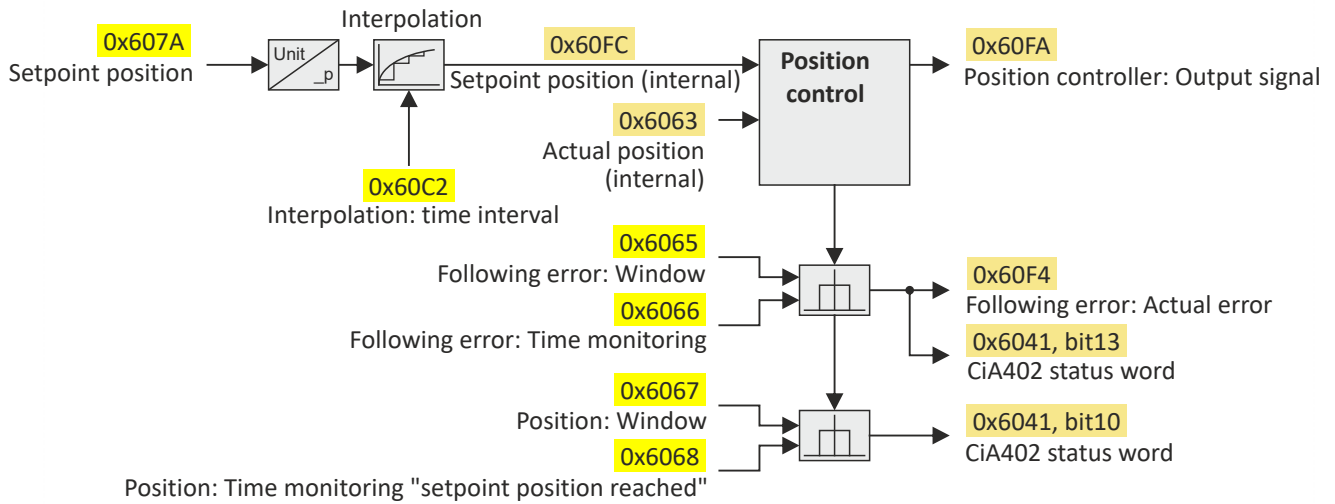

Input data

Parameter	Name	Data type
0x607A	Set position	INTEGER_32
0x60FC	Position demand internal value	INTEGER_32
0x6062	Internal set position	INTEGER_32
0x6065	Following error window	UNSDIGNED_32
0x6066	Following error delay	UNSIGNED_16
0x6067	Position reached window	UNSIGNED_32
0x6068	Position reached delay	UNSIGNED_16

Output data

Parameter	Name	Data type
0x6063	Internal actual position	INTEGER_32
0x6064	Actual position	INTEGER_32
0x60F4	Following error actual value	INTEGER_32
0x60FA	Control effort	INTEGER_32
0x6041	CiA status word	UNSIGNED_16

Parameter

Address	Name / setting range / [default setting]	Information
0x6065	Following error window 0 ... [1000] ... 4294967295	Setting of the symmetrical tolerance window around the setpoint position for following error detection. <ul style="list-style-type: none"> • 0 = following error detection deactivated. • > 0 = following error detection activated. • A following error is detected if the actual position is outside this tolerance window. • If the following error is detected longer than the time defined in 0x6066 in [ms], bit 13 ("following error") is set in the CiA status word (0x6041). • 0x60F4 displays the current deviation of the actual position from the setpoint position.
0x6066	Following error delay 0 ... [0] ... 0 ms	Setting of time delay for the following error detection. 0 = the following error is evaluated without a time delay.



Address	Name / setting range / [default setting]	Information
0x6067	Position reached window 0 ... [1000] ... 4294967295	Setting of the symmetrical tolerance window around the target position (0x607A) for the target position detection. If the actual position is within this tolerance window longer than the time defined in 0x6068 in [ms], the target position is deemed to be reached and bit 10 ("target position reached") is set in the CiA status word (0x6041).
0x6068	Position reached delay 0 ... [0] ... 0 ms	Setting of time monitoring for the target position detection. 0 = the position in the target window is evaluated without a time delay.

6.1.2 Interpolation

Parameter

Address	Name / setting range / [default setting]	Information
0x60C0	Interpolation mode	Setting of the interpolation mode.
	-1 Quadratic	
	0 Linear	
0x60C2:001	Interpolation time: Interpolation time mantissa 0 ... [1] ... 255	Basic multiplier for the interpolation time mantissa.
0x60C2:002	Interpolation time: Interpolation time exponent -128 ... [-3] ... 63	Interpolation time exponent

$$t = 0x60C2:001 \times 10^{(0x60C2:002)}$$

$$t = 1 \times 10^{(-3)} \text{ s} = 0.001 \text{ s} = 1 \text{ ms}$$

Configure position control

Operating mode "CiA 402 cyclic sync position mode (csp)"
Default mapping



6.2 Operating mode "CiA 402 cyclic sync position mode (csp)"

Subfunctions of the operating mode

- Interpolation between communication cycle and control cycle
- Position control
- Speed control
- Torque control
- Update of the actual values for position, speed and torque

6.2.1 Default mapping

The default mapping for the "cyclic sync position mode" is defined in the following parameters:

Parameter	Designation	Data type
0x1600	RPDO-->axis: cyclic sync position mode (csp)	RECORD
0x1606	RPDO-->axis: torque limit	RECORD
0x1A00	Axis-->TPDO: cyclic sync position mode (csp)	RECORD

Data received from the Controller (RPDO)

Parameter	Designation	Data type
0x6040	CiA402 control word	UNSIGNED_16
0x2830	Lenze control word	UNSIGNED_16
0x6060	Operating mode: selection	INTEGER_8
0x60B2	Torque: offset	INTEGER_16
0x607A	Position: setpoint position	INTEGER_32
0x60B1	Velocity: offset	INTEGER_32
0x2902	Speed controller: load I component	INTEGER_16
0x60E0	Torque: positive limit value	UNSIGNED_16
0x60E1	Torque: negative limit value	UNSIGNED_16

Data sent to the Controller (TPDO)

Parameter	Designation	Data type
0x6041	CiA402 status word	UNSIGNED_16
0x2831	Lenze status word	UNSIGNED_16
0x6061	Operating mode: display	INTEGER_8
0x603F	Error code	UNSIGNED_16
0x606C	Velocity: actual velocity	UNSIGNED_16
0x6077	Torque: actual torque	INTEGER_16
0x6064	Position: actual position	INTEGER_32
0x60F4	Following error: actual error	INTEGER_32



6.2.2 Signal flow

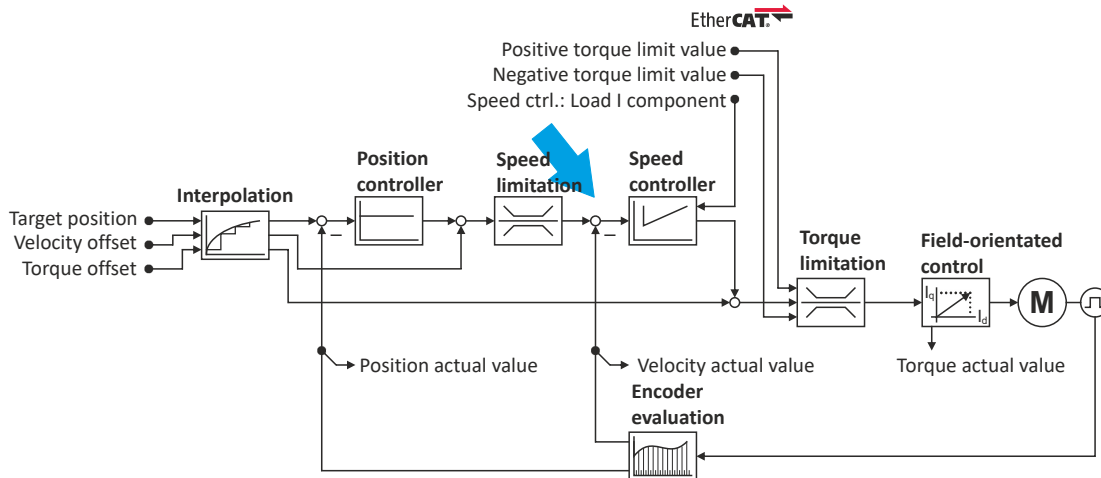

Configure position control

Operating mode "CiA 402 cyclic sync position mode (csp)"
Signal flow



Overview of the most important parameters

Function	Icon	Parameter	Name
Input data		0x6040	CiA control word
		0x2830	Inverter control word
		0x6060	CiA: Operation mode
		0x607A	Set position
		0x60B1	Offset speed
		0x60B2	Offset torque
		0x60E0	Positive torque limit
		0x60E1	Negative torque limit
		0x2902	I component load value
Output data		0x6041	CiA status word
		0x2831	Inverter status word
		0x6061	CiA: Active operation mode
		0x6064	Actual position
		0x606C	Actual speed
		0x6077	Actual torque
Interpolation		0x60C0	Interpolation mode
		0x60C2:001	Interpolation time
		0x60C2:002	Interpolation time
Position controller		0x2980	Position controller gain
		0x2981	Position controller gain adaption
		0x2982	Position controller output signal limitation
		0x2983	Actual position start value
		0x2984	Mode for setting the actual position
		0x2986	Resulting gain adaption
Speed limitation		0x6080	Max. motor speed
Speed controller		0x2900:001	Gain
		0x2900:002	Reset time
		0x2900:003	Rate time
		0x2901	Speed controller gain adaption
		0x2902	I component load value
Torque limitation		0x60E0	Positive torque limit
		0x60E1	Negative torque limit
		0x6076	Rated motor torque
		0x6072	Max. torque
Field-oriented control		0x6073	Max. current
		0x6075	Rated motor current
		0x2941	Current controller feedforward control
		0x2942:001	Current controller parameters Gain
		0x2942:002	Current controller parameters Reset time
		0x29E2	DC-bus filter time
		0x29E3	Motor voltage filter time
		0x29E0:001	Field weakening controller settings Gain (ASM)
		0x29E0:002	Field weakening controller settings Reset time (ASM)
		0x29E1	Field weakening controller Field limitation
		0x29C0:001	Field controller settings Gain
		0x29C0:002	Field controller settings Reset time
		0x2939	Switching frequency



6.2.3 Control commands and status information

The following control commands can be executed via the CiA 402 control word [0x6040](#):

Control word	State	Function
Bit 4	0	<i>reserved</i> (bit must be set to "0".)
Bit 5	0	<i>reserved</i> (bit must be set to "0".)
Bit 6	0	<i>reserved</i> (bit must be set to "0".)
Bit 8	0/1	Stop

The following status information is output via the CiA402 status word [0x6041](#):

Status word	State	Meaning
Bit 12	0	Operating mode is inactive.
	1	The drive follows the setpoint selection.



6.3 Process input data (CiA 402 objects)

Parameter

Address	Name / setting range / [default setting]	Information
0x6060	CiA: Operation mode	CiA: Operation mode
	-13 MS: Manual jog open loop (MOL)	Manufacturer-specific manual control ▶ Operation mode "Manual Jog" ☐ 232
	-12 MS: Pole position identification (PPI)	Manufacturer-specific pole position identification (PLI) ▶ Synchronous motor: Pole position identification (PPI) ☐ 116 ▶ Selection of the PPI method for CiA mode ☐ 117
	0 No selection	No selection
	2 CiA: Velocity mode (vl)	
	8 CiA: Cyclic sync position (csp)	
	9 CiA: Cyclic sync velocity mode (csv)	
10 CiA: Cyclic sync torque mode (cst)		
0x607A	Set position -2147483648 ... [0] ... 2147483647	Setting of the set position.
0x60B1	Offset speed -2147483648.00 ... [0.00] ... 2147483647.00 rpm	Additive value for setpoint velocity or velocity feedforward control - offset speed.
0x60B2	Offset torque -3276.8 ... [0.0] ... 3276.7 %	Offset torque • 100 % = rated motor power (0x6076)
0x60E0	Positive torque limit 0.0 ... [100.0] ... 3276.7 %	Positive torque limit source for speed control with torque limitation. • 100 % = Rated motor torque 0x6076
0x60E1	Negative torque limit 0.0 ... [100.0] ... 3276.7 %	Negative torque limit source for speed control with torque limitation. • 100 % = Rated motor torque 0x6076



6.4 Process output data (CiA 402 objects)

Parameter

Address	Name / setting range / [default setting]	Information
0x6064	Actual position • Read only	Display of the actual position.
0x6077	Actual torque • Read only: x.x %	Display of the actual torque. • 100 % = Rated motor torque 0x6076
0x60F4	Following error actual value • Read only	Display of the current following error.



6.5 Monitoring the position error

Position error monitoring can be used for the following control modes:

- Servo control for synchronous motor (SM), 0x2C00 = [1]
- Servo control for asynchronous motor (ASM), 0x2C00 = [2]

Following error monitoring is effective in an operating mode with position controller. The system deviation (i. e. the following error) is compared to the following error tolerance set at the input of the position controller (see red arrow in the figure below).

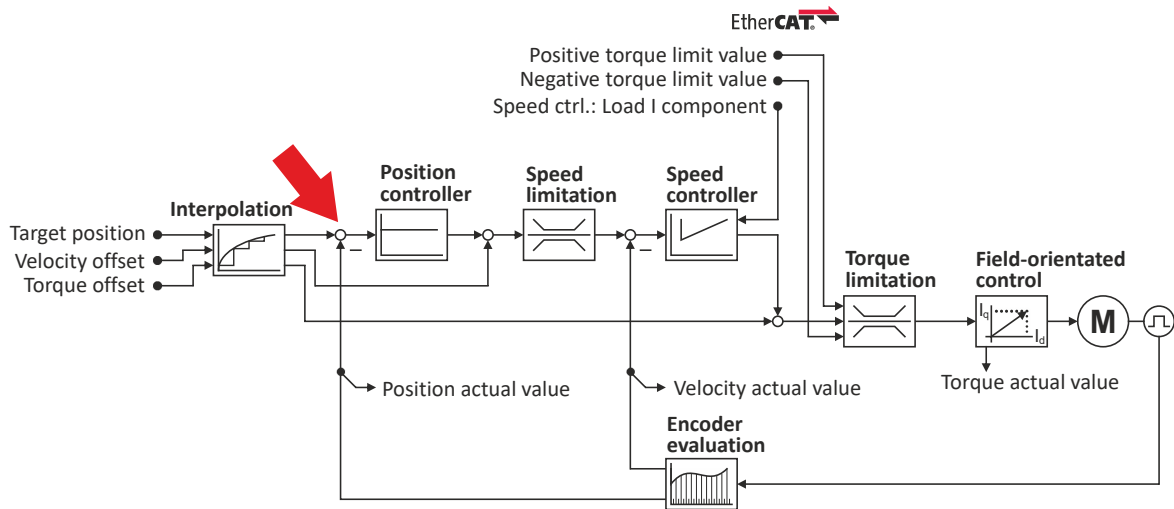

The error response set in 0x2D51:006 is executed if ...

1. the following error tolerance set in 0x2D51:004 is exceeded and ...
2. the exceedance lasts at least as long as set in 0x2D51:005.

Parameter

Address	Name / setting range / [default setting]	Information
0x2D51:004	Position error/speed error - monitoring: Position error - error threshold 1 ... [360] ... 2147483647 °	Setting of the error threshold for position error monitoring.
0x2D51:005	Position error/speed error - monitoring: Position error - min. time for error 0 ... [0] ... 50 ms	Setting of the minimum time a position error must be pending until an error/warning message is triggered.
0x2D51:006	Position error/speed error - monitoring: Position error - error response	Setting of the error response of position error monitoring.
	0 No response	
	1 Fault > CiA402	
2 Warning		
0x2922:001	Following error diagnostics: Following error (interval) - Time 10 ... [1000] ... 65535 ms	Time interval for determining the following error.
0x2922:002	Following error diagnostics: Following error (interval) - Mean value • Read only: x.xx °	Mean value in the time interval
0x2922:003	Following error diagnostics: Following error (interval) - Maximum value • Read only: x.xx °	Maximum value in the time interval
0x2922:004	Following error diagnostics: Following error (manual) - Start/Stop	Determination of the following error between manually specified start/stop command.
	0 Stop	
1 Start		



Configure position control

Monitoring the position error

Address	Name / setting range / [default setting]	Information
0x2922:005	Following error diagnostics: Following error (manual) - Mean value • Read only: x.xx °	Mean value between "start" and "stop"
0x2922:006	Following error diagnostics: Following error (manual) - Maximum value • Read only: x.xx °	Maximum value between "start" and "stop"
0x2922:007	Following error diagnostics: Following error (standstill-standstill) - Mean value • Read only: x.xx °	Mean value between "standstill" and "standstill" of the drive (< 5 rpm) The value is automatically updated when the speed drops below 5 rpm again.
0x2922:008	Following error diagnostics: Following error (standstill-standstill) - Maximum value • Read only: x.xx °	Maximum value between "standstill" and "standstill" of the drive (< 5 rev./min) The value is automatically updated when the speed drops below 5 rpm again.

Configure position control

Position detection with touch probe (TP)

Default mapping



6.6 Position detection with touch probe (TP)

A "touch probe" (short: "TP") is an event that can be triggered, for instance via a digital input in an edge-controlled manner to detect and further process an actual value (which is changing fast) at the triggering time.

- Typical applications for touch probes:
 - Homing
 - Mark synchronisation
 - Length measurements
- Up to 2 touch probe channels can be used in parallel.
- Possible touch probe sources:
 - TP1 : Zero pulse position encoder or digital input DI1
 - TP2 : Zero pulse position encoder or digital input DI2



The digital inputs DI1 and DI2 can be additionally evaluated any time as "normal" digital inputs via [0x60FD](#).

6.6.1 Default mapping

The default mapping for a touch probe detection is defined in the following parameters:

Parameter	Designation	Data type
0x1604	RPDO-->axis: touch probe (TP)	RECORD
0x1A04	Axis-->TPDO: touch probe (TP)	RECORD

Data received from the Controller (RPDO)

Parameter	Designation	Data type
0x60B8	Touch probe control word	UNSIGNED_16

Data sent to the Controller (TPDO)

Parameter	Designation	Data type
0x60B9	Touch probe status word	UNSIGNED_16
0x60BA	TP1: actual position - rising edge	INTEGER_32
0x60BB	TP1: actual position - falling edge	INTEGER_32
0x60BC	TP2: actual position - rising edge	INTEGER_32
0x60BD	TP2: actual position - falling edge	INTEGER_32



6.6.2 General mode of operation

If an event occurs at the configured touch probe source, a time stamp is detected in the servo inverter.

The detected time stamp is related to the system time and can thus be divided into two parts: One part is the control cycle in which the event occurred. The other part is the time difference starting from the detected control cycle to the real detection of the event

Thanks to a history buffer, the servo inverter knows the last n position values. Thus, the actual position is known at the start and at the end of the control cycle in which the event has occurred. A linear interpolation takes place between these two position grid points. The result is the exact position at the motor shaft at the time the event is triggered, see the schematic diagram:

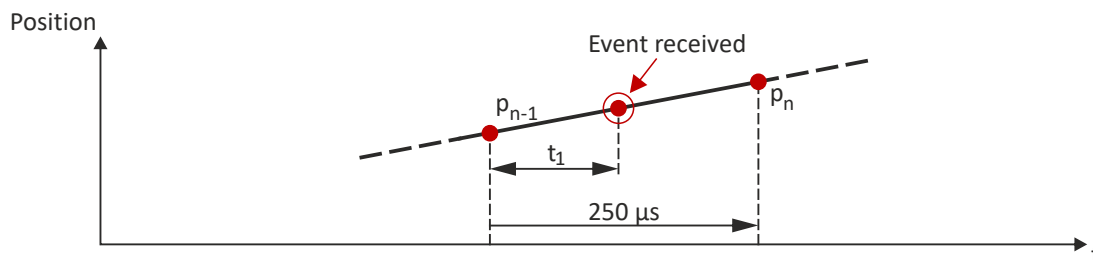

t_1 : Time difference starting from the detected control cycle to the real detection of the event

p_{n-1} : Actual position grid point 1

p_n : Actual position grid point 2

The position grid points are detected in the servo inverter in a grid of $250 \mu\text{s}$. After a touch probe has been triggered, the input is deactivated for up to $250 \mu\text{s}$ to avoid bouncing. Thus, the maximum frequency for touch probe triggering is 4 kHz.

If in contrast to the uniform movement given in the figure, an accelerated movement is taken as a basis, the $250 \mu\text{s}$ grid also allows for a very good linear position reconstruction because the speed change at the motor shaft only has a marginal impact in $250 \mu\text{s}$.

6.6.3 Filtering of the touch probe signal

For the touch probe inputs, a common filter time (debounce time) can be parameterised to debounce the TP signals so that there is no response to external interfering signals.

- The signal status of the debouncing filter is detected at the TP input and a new value is added to the filter.
- A separate setting for a touch probe is not possible. Thus, the filter time is set for all touch probe inputs.

Parameter

Address	Name / setting range / [default setting]	Information
0x2500	Touch probe filter time 0 ... [0] ... 1984	The set filter time is automatically taken into account in the touch probe calculation. The setting "0" deactivates the filter. Note! Values can be set directly. When entering a filter time between 0 ... 1984 μs , the value is automatically rounded down internally to the next value that can be set and is shown in the case of read requests.

Configure position control

Position detection with touch probe (TP)
 Compensation of runtime delays



6.6.4 Compensation of runtime delays

In reality, both the input circuit in the servo inverter and the touch probe sensor have runtime delays (latencies) themselves. These can be taken into account in the calculation of the real trigger time and thus the real position at the trigger time.

In the following figure, the event is detected in the servo inverter at the time ②. Due to the input circuit and the sensor used, the signal runtime, however, has been delayed. The real physical event has already occurred at time ①. For compensating this runtime delay, you can set a corresponding delay time for each touch probe channel that is included in the determination of the control cycle and interpolation of the position, see figure in chapter "General mode of operation". [63](#)

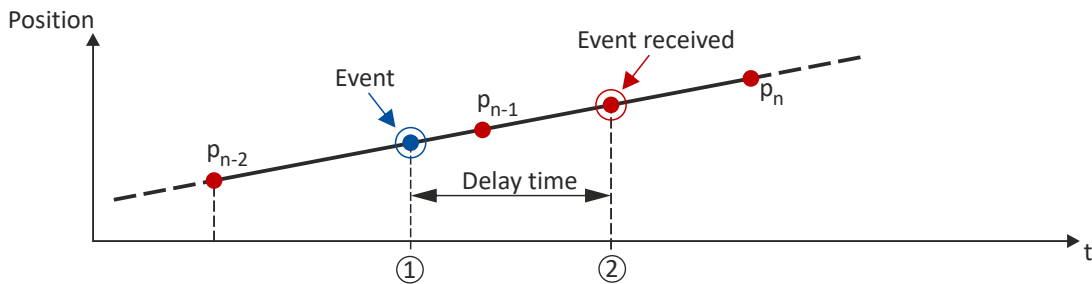

"Delay time": Delay time between the real physical event and the electrical detection.

- ① Real physical event
- ② Electrical detection of the event in the servo inverter

Delay times of the digital input and the required minimum signal duration

The following table lists the typical delay times and the required minimum signal durations for the digital inputs of the servo inverter:

Digital signal	Typical delay time	Minimum signal duration
Rising edge (HIGH pulse)	4 μ s	4 μ s
Falling edge (LOW pulse)	4 μ s	4 μ s

Parameter

Address	Name / setting range / [default setting]	Information
0x2D00:001	Touch probe (TP) delay time: Touch probe 1 delay time 0.000 ... [0.000] ... 7.000 ms	Setting of the delay time for touch probe 1.
0x2D00:002	Touch probe (TP) delay time: Touch probe 2 delay time 0.000 ... [0.000] ... 7.000 ms	Setting of the delay time for touch probe 2.



6.6.5 Touch probe control word

Control words for configuring the touch probe functionality.

- CiA control word (Touch probe 1/2): ▶ [0x60B8](#)
- Extended control word (Touch probe 3/4, manufacturer-specific): 0x2D02:001

Parameter

Address	Name / setting range / [default setting]	Information
0x60B8	Touch probe settings 0x0000 ... [0x0000] ... 0xFFFF	Control word for configuring the touch probe settings.
Bit 0	TP1 enable	0: deactivate touch probe channel 1. 1: activate touch probe channel 1.
Bit 1	TP1 continuous trigger	Event for touch probe channel 1 0: only detect the first event. 1: detect all events.
Bit 2	TP1 trigger with zero pulse	Source for touch probe channel 1 0: digital input 1 1: zero pulse position encoder
Bit 4	TP1 enable pos. edge	0: deactivate scanning.
Bit 5	TP1 enable neg. edge	1: activate scanning.
Bit 8	TP2 enable	0: deactivate touch probe channel 2. 1: activate touch probe channel 2.
Bit 9	TP2 continuous trigger	Event for touch probe channel 2 0: only detect the first event. 1: detect all events.
Bit 10	TP2 trigger with zero pulse	Source for touch probe channel 2 0: digital input 2 1: zero pulse position encoder
Bit 12	TP2 enable pos. edge	0: deactivate scanning.
Bit 13	TP2 enable neg. edge	1: activate scanning.

6.6.6 Touch probe status word

Status words of the touch probe functionality.

- CiA status word (Touch probe 1/2): ▶ [0x60B9](#)
- Extended status word (Touch probe 3/4, manufacturer-specific): 0x2D02:002

Parameter

Address	Name / setting range / [default setting]	Information
0x60B9	Touch probe status • Read only	Status of the touch probe functionality.
Bit 0	TP1 active	0: touch probe channel 1 deactivated. 1: touch probe channel 1 activated.
Bit 1	TP1 pos. edge detected	0: position not detected.
Bit 2	TP1 neg. edge detected	1: position detected.
Bit 6	TP1 level at enable start	Level for detection via touch probe channel 1 0: LOW level 1: HIGH level
Bit 8	TP2 active	0: touch probe channel 2 deactivated. 1: touch probe channel 2 activated.
Bit 9	TP2 pos. edge detected	0: position not detected.
Bit 10	TP2 neg. edge detected	1: position detected.
Bit 14	TP2 level at enable start	Level for detection via touch probe channel 2 0: LOW level 1: HIGH level

Configure position control

Position detection with touch probe (TP)
Detected time stamp and positions



6.6.7 Detected time stamp and positions



In case of the "continuous touch probe configuration", a newly detected value overwrites the previously detected value.

Parameter

Address	Name / setting range / [default setting]	Information
0x60BA	Touch probe 1: Position at pos. edge • Read only	Touch probe 1: Position at pos. edge
0x60BB	Touch probe 1: Position at neg. edge • Read only	Touch probe 1: Position at neg. edge
0x60BC	Touch probe 2: Position at pos. edge • Read only	Touch Probe 2: Position at pos. edge
0x60BD	Touch probe 2: Position at neg. edge • Read only	Touch probe 2: Position at neg. edge
0x2D01:001	Touch probe (TP) time stamp: Touch probe 1-rising edge time stamp • Read only: x ns	Display of the time stamp of the rising edge for touch probe 1.
0x2D01:002	Touch probe (TP) time stamp: Touch probe 1-falling edge time stamp • Read only: x ns	Display of the time stamp of the falling edge for touch probe 1.
0x2D01:003	Touch probe (TP) time stamp: Touch probe 2-rising edge time stamp • Read only: x ns	Display of the time stamp of the rising edge for touch probe 2.
0x2D01:004	Touch probe (TP) time stamp: Touch probe 2-falling edge time stamp • Read only: x ns	Display of the time stamp of the falling edge for touch probe 2.



6.7 Setpoint diagnostics

The following parameters provide information on the setpoints set for position control.

Parameter

Address	Name / setting range / [default setting]	Information
0x6062	Internal set position • Read only	Display of the interpolated internal set position for the position control.
0x6063	Internal actual position • Read only	Display of the actual position in the internal unit.
0x60FC	Position demand internal value • Read only	Display of the interpolated setpoint position for the position control in the internal unit.
0x60FA	Control effort • Read only; rpm	Display of the actuating signal (setpoint speed) of the position controller.



7 Configure speed control

Two operating modes are available for configuring the speed control:

- [Operating mode "CiA 402 velocity mode \(vl\)"](#)  70

Here, a speed-controlled movement of the drive is realised by defining a speed setpoint.

- [Operating mode "CiA 402 cyclic sync velocity mode \(csv\)"](#)  77

This operating mode provides a fast speed follower with torque/feed force feedforward control.

The conditions are a correct entry of the motor data ([Motor data](#)) and the parameter setting of the motor control ([Configuring the motor control](#)).



7.1 Basic setting

The following describes the steps required for configuring the speed control.

1. [0x6060](#) Set the manufacturer spanning operating mode "CiA: Velocity mode (vl) [2]" or "CiA: Cyclic sync velocity mode (csv) [9]".
 - A detailed description of the "CiA: Velocity mode (vl)" operating mode can be found in the section [Operating mode "CiA 402 velocity mode \(vl\)"](#) . [70](#)
 - A detailed description of the "CiA: Cyclic sync velocity mode (csv)" operating mode can be found in the section [Operating mode "CiA 402 cyclic sync velocity mode \(csv\)"](#) .
[77](#)
2. Set the maximum motor speed in Max. motor speed. [▶ 0x6080](#)
3. Set the rated motor torque in Rated motor torque. [▶ 0x6076](#)
4. Set the positive torque limit. [▶ 0x60E0](#)
5. Set the negative torque limit. [▶ 0x60E1](#)

The speed control is now active and the inverter responds to the speed setpoint.

Configure speed control

Operating mode "CiA 402 velocity mode (vl)"
Default mapping



7.2 Operating mode "CiA 402 velocity mode (vl)"

Selection of the operating mode

The "speed" operating mode is selected with the setting "2" in [0x6060](#).

7.2.1 Default mapping

The default mapping for the "Speed" operating mode is defined in the following parameters.

Parameter	Designation	Data type
0x1603	RPDO-->axis: Velocity mode (vl)	RECORD
0x1A03	Axis-->TPDO: Velocity mode (vl)	RECORD

Data received from the Controller (RPDO)

Parameter	Designation	Data type
0x6040	CiA402 control word	UNSIGNED_16
0x2830	Lenze control word	UNSIGNED_16
0x6060	Operating mode: selection	INTEGER_8
0x6042	Velocity: setpoint velocity vl	INTEGER_8

Data sent to the Controller (TPDO)

Parameter	Designation	Data type
0x6041	CiA402 control word	UNSIGNED_16
0x2831	Lenze control word	UNSIGNED_16
0x6061	Operating mode: display	INTEGER_8
0x603F	Error code	UNSIGNED_16
0x6044	Velocity: actual velocity vl	INTEGER_8



7.2.2 Signal flow (servo control)

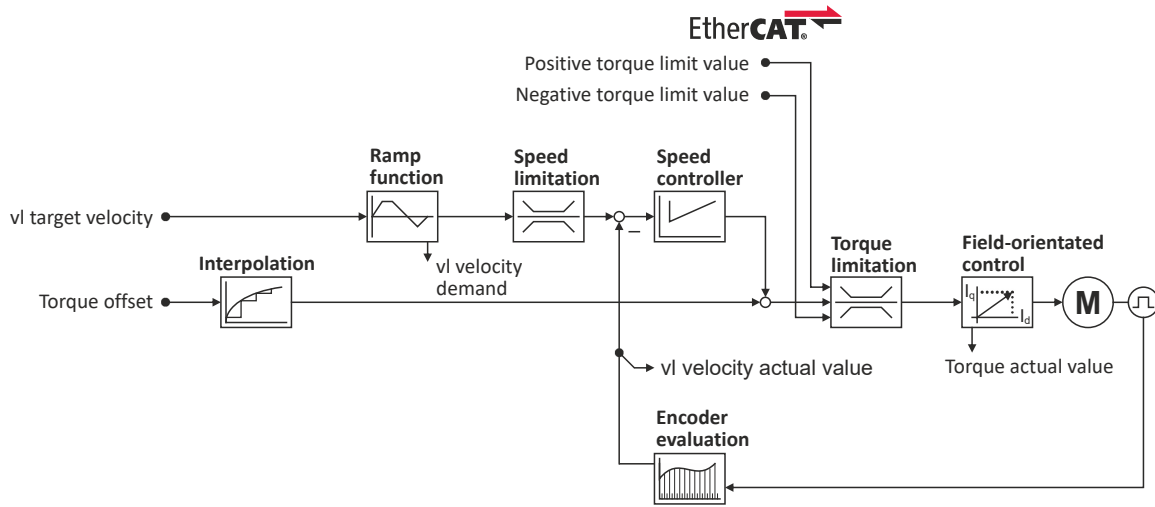

Configure speed control

Operating mode "CiA 402 velocity mode (vI)"
Signal flow (servo control)



Overview of the most important parameters

Function	Icon	Parameter	Name
Input data		0x6040	CiA control word
		0x2830	Inverter control word
		0x6060	CiA: Operation mode
		0x6042	Set speed
		0x60B2	Offset torque
		0x60E0	Positive torque limit
		0x60E1	Negative torque limit
Output data		0x6041	CiA status word
		0x2831	Inverter status word
		0x6061	CiA: Active operation mode
		0x6043	Internal set speed
		0x606C	Actual speed
		0x6077	Actual torque
Interpolation		0x60C0	Interpolation mode
		0x60C2:001	Interpolation time
		0x60C2:002	Interpolation time
Ramp function		0x6048:001	CiA acceleration: Delta speed
		0x6048:002	CiA acceleration: Delta time
		0x6049:001	CiA deceleration: Delta speed
		0x6049:002	CiA deceleration: Delta time
Speed limitation		0x6080	Max. motor speed
Speed controller		0x2900:001	Gain
		0x2900:002	Reset time
		0x2900:003	Rate time
		0x2901	Speed controller gain adaption
		0x2902	I component load value
Torque limitation		0x60E0	Positive torque limit
		0x60E1	Negative torque limit
		0x6076	Rated motor torque
		0x6072	Max. torque
Field-oriented control		0x6073	Max. current
		0x6075	Rated motor current
		0x2941	Current controller feedforward control
		0x2942:001	Current controller parameters Gain
		0x2942:002	Current controller parameters Reset time
		0x29E2	DC-bus filter time
		0x29E3	Motor voltage filter time
		0x29E0:001	Field weakening controller settings Gain (ASM)
		0x29E0:002	Field weakening controller settings Reset time (ASM)
		0x29E1	Field weakening controller Field limitation
		0x29C0:001	Field controller settings Gain
		0x29C0:002	Field controller settings Reset time
		0x2939	Switching frequency



7.2.3 Signal flow (V/f characteristic control)

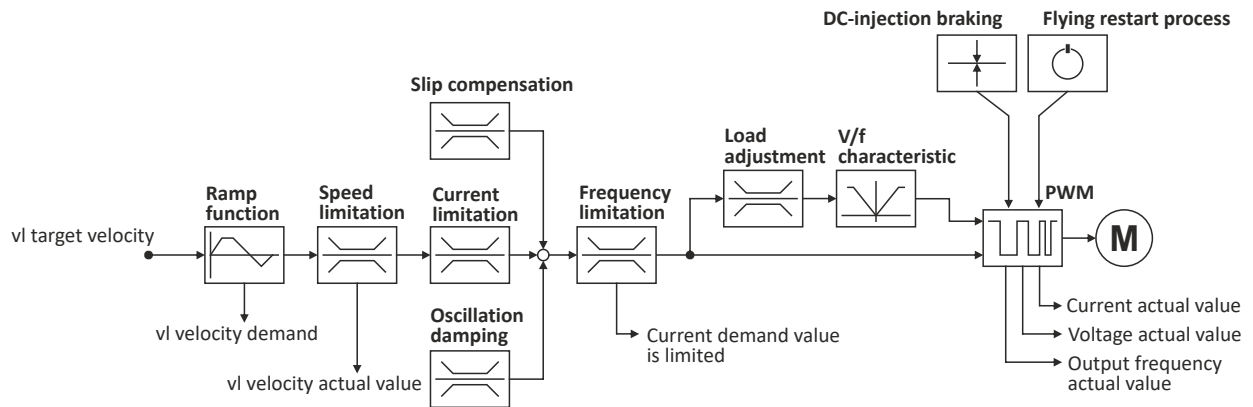





Configure speed control

Operating mode "CiA 402 velocity mode (vI)"
Signal flow (V/f characteristic control)



Short overview of the most important parameters

Function	Parameter	Designation
Input data 	0x6040	CiA402 control word
	0x2830	Lenze control word
	0x6060	Operating mode: selection
	0x6042	Velocity: setpoint velocity vI
Output data 	0x6041	CiA402 control word
	0x2831	Lenze status word
	0x6061	Operating mode: display
	0x6043	Velocity: interpolated setpoint velocity vI
	0x606C	Velocity: actual velocity
	0x6078	Motor: actual current
	0x2D82	Motor: actual voltage - Vrms, phase-phase
	0x2DDD	Device: actual output frequency
Ramp function 	0x6048:001	Ramp: speed interval (for acceleration)
	0x6048:002	Ramp: time interval (for acceleration)
	0x6049:001	Ramp: speed interval (for deceleration)
	0x6049:002	Ramp: time interval (for deceleration)
Speed limitation 	0x6080	Motor: max. speed
Slip compensation 	0x2B09:001	VFC: slip compensation - influence
	0x2B09:002	VFC: slip compensation - filter time
Current limitation 	0x2B08:001	Gain
	0x2B08:002	Reset time
	0x6073	Max. current
Oscillation damping 	0x2B0A:001	VFC: oscillation damping - gain
	0x2B0A:002	VFC: oscillation damping - filter time
	0x2B0A:003	VFC: oscillation damping - limitation
	0x2B0A:004	VFC: oscillation damping - ramp end frequency
Load adjustment 	0x2B07:001	VFC: load adjustment - direction of rotation
	0x2B07:002	VFC: load adjustment - value
V/f characteristic 	0x2B01:001	VFC: V/f characteristic - voltage in the reference point
	0x2B01:002	VFC: V/f characteristic - frequency in the reference point
	0x2B06	VFC: voltage boost
	0x2B04	VFC: voltage vector control - setpoint current
	0x2B00	VFC: V/f characteristic - form
	0x2B02:001	VFC: user-definable V/f characteristic
	...	• Frequency grid points (x1 ... x11)
	0x2B02:011	VFC: user-definable V/f characteristic
	...	• Voltage grid points (y1 ... y11)
0x2B03:011	VFC: user-definable V/f characteristic	
DC-injection braking 	0x2B80	DC-injection braking: current



A more detailed representation of the signal flow with all relevant parameters can be found in the »PLC Designer« on the signal flow tab for the servo inverter.



Configure speed control

Operating mode "CiA 402 velocity mode (vI)"
Signal flow (V/f characteristic control)

Overview of the most important parameters

Function	Icon	Parameter	Name
Input data		0x6040	CiA control word
		0x2830	Inverter control word
		0x6060	CiA: Operation mode
		0x6042	Set speed
Output data		0x6041	CiA status word
		0x2831	Inverter status word
		0x6061	CiA: Active operation mode
		0x6043	Internal set speed
		0x606C	Actual speed
		0x6078	Actual current
		0x2D82	Motor actual voltage (Veff)
		0x2DDD	Output frequency
Ramp function		0x6048:001	Acceleration ramp CiA acceleration: Delta speed
		0x6048:002	Acceleration ramp CiA acceleration: Delta time
		0x6049:001	Deceleration ramp CiA deceleration: Delta speed
		0x6049:002	Deceleration ramp CiA deceleration: Delta time
Speed limitation		0x6080	Max. motor speed
Slip compensation		0x2B09:001	Slip compensation Gain
		0x2B09:002	Slip compensation Filter time
Current limitation		0x2B08:001	V/f I _{max} controller Gain
		0x2B08:002	V/f I _{max} controller Reset time
		0x6073	Max. current
Oscillation damping		0x2B0A:001	Oscillation damping Gain
		0x2B0A:002	Oscillation damping Filter time
		0x2B0A:003	Oscillation damping Limitation
		0x2B0A:004	Oscillation damping Final ramp frequency
Load adaptation		0x2B07:001	Load adaption Direction of rotation
		0x2B07:002	Load adaption Load adaption value
V/f characteristic		0x2B01:001	V/f shape data Base voltage
		0x2B01:002	V/f shape data Base frequency
		0x2B06	Voltage boost
		0x2B04	V/f boost controller - current setpoint
		0x2B00	V/f characteristic shape
		0x2B02:001	Frequency grid points (x) user V/f characteristic x1 = f01
	
		0x2B02:011	x11 = f11
		0x2B03:001	Voltage grid points (y) user V/f characteristic y1 = U01 (x = f01)
	
0x2B03:011	y11 = U11 (x = f11)		

Configure speed control

Operating mode "CiA 402 velocity mode (vl)"
Setpoint factor



Function	Icon	Parameter	Name
DC-injection braking		0x2B80	Current for DC-injection braking

7.2.4 Setpoint factor

Parameter

Address	Name / setting range / [default setting]	Information
0x604B:001	vl set-point factor: vl set-point factor numerator -32768 ... [1] ... 32767	
0x604B:002	vl set-point factor: vl set-point factor denominator -32768 ... [1] ... 32767	

7.2.5 Dimension factor

Parameter

Address	Name / setting range / [default setting]	Information
0x604C:001	vl dimension factor: vl dimension factor numerator -2147483648 ... [1] ... 2147483647	
0x604C:002	vl dimension factor: vl dimension factor denominator -2147483648 ... [1] ... 2147483647	



7.3 Operating mode "CiA 402 cyclic sync velocity mode (csv)"

This operating mode provides a fast velocity follower with torque/feed force feedforward control.

Subfunctions of the operating mode

- Interpolation between communication cycle and control cycle
- Speed control
- Limitation of the motor speed
- Update of the actual values for position, velocity and torque

7.3.1 Default mapping

The default mapping for the cyclic sync velocity mode (csv)" is defined in the following parameters.

Parameter	Designation	Data type
0x1602	RPDO-->axis: cyclic sync velocity mode (csv)	RECORD
0x1606	RPDO-->axis: torque limit	RECORD
0x1A02	Axis-->TPDO: cyclic sync velocity mode (csv)	RECORD

Data received from the Controller (RPDO)

Parameter	Designation	Data type
0x6040	CiA402 control word	UNSIGNED_16
0x2830	Lenze control word	UNSIGNED_16
0x6060	Operating mode: selection	INTEGER_8
0x60B2	Torque: offset	INTEGER_16
0x60FF	Velocity: setpoint velocity	INTEGER_32
0x60E0	Torque: positive limit value	UNSIGNED_16
0x60E1	Torque: negative limit value	UNSIGNED_16

Data sent to the Controller (TPDO)

Parameter	Designation	Data type
0x6041	CiA402 status word	UNSIGNED_16
0x2831	Lenze status word	UNSIGNED_16
0x6061	Operating mode: display	INTEGER_8
0x603F	Error code	UNSIGNED_16
0x606C	Velocity: actual velocity	UNSIGNED_16
0x6077	Torque: actual torque	INTEGER_16
0x6064	Position: actual position	INTEGER_32

Configure speed control

Operating mode "CiA 402 cyclic sync velocity mode (csv)"
Signal flow (servo control)



7.3.2 Signal flow (servo control)

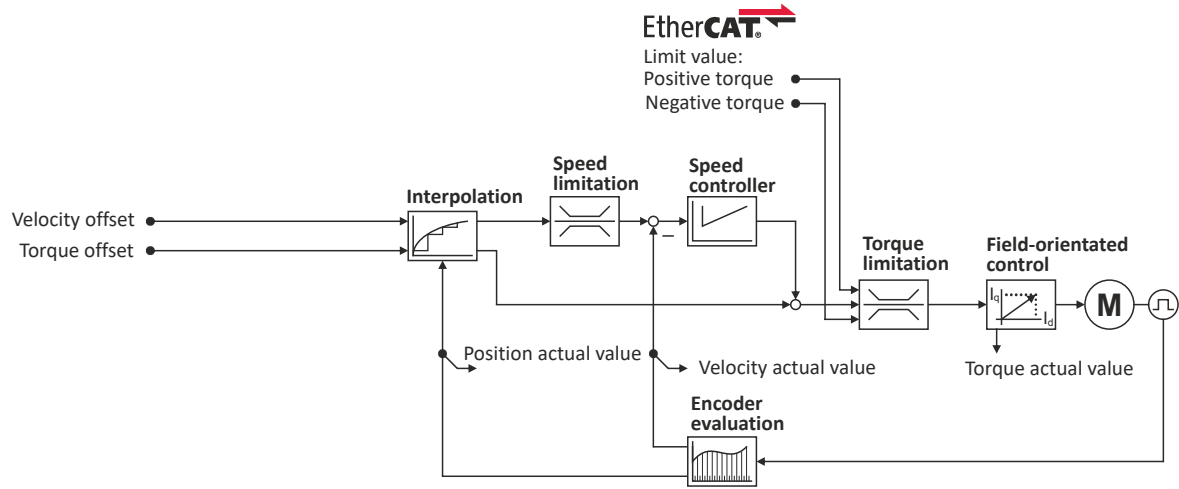



Configure speed control

Operating mode "CiA 402 cyclic sync velocity mode (csv)"
Signal flow (servo control)

Overview of the most important parameters

Function	Icon	Parameter	Name
Input data		0x6040	CiA control word
		0x2830	Inverter control word
		0x6060	CiA: Operation mode
		0x60FF	Set speed
		0x60B1	Offset speed
		0x60B2	Offset torque
		0x60E0	Positive torque limit
		0x60E1	Negative torque limit
Output data		0x6041	CiA status word
		0x2831	Inverter status word
		0x6061	CiA: Active operation mode
		0x6064	Actual position
		0x606C	Actual speed
		0x6077	Actual torque
Interpolation		0x60C0	Interpolation mode
		0x60C2:001	Interpolation time
		0x60C2:002	Interpolation time
Speed limitation		0x6080	Max. motor speed
Speed controller		0x2900:001	Gain
		0x2900:002	Reset time
		0x2900:003	Rate time
		0x2901	Speed controller gain adaption
		0x2902	I component load value
Torque limitation		0x60E0	Positive torque limit
		0x60E1	Negative torque limit
		0x6076	Rated motor torque
		0x6072	Max. torque
Field-oriented control		0x6073	Max. current
		0x6075	Rated motor current
		0x2941	Current controller feedforward control
		0x2942:001	Current controller parameters Gain
		0x2942:002	Current controller parameters Reset time
		0x29E2	DC-bus filter time
		0x29E3	Motor voltage filter time
		0x29E0:001	Field weakening controller settings Gain (ASM)
		0x29E0:002	Field weakening controller settings Reset time (ASM)
		0x29E1	Field weakening controller Field limitation
		0x29C0:001	Field controller settings Gain
		0x29C0:002	Field controller settings Reset time
		0x2939	Switching frequency

Configure speed control

Operating mode "CiA 402 cyclic sync velocity mode (csv)"
Signal flow (V/f characteristic control)



7.3.3 Signal flow (V/f characteristic control)

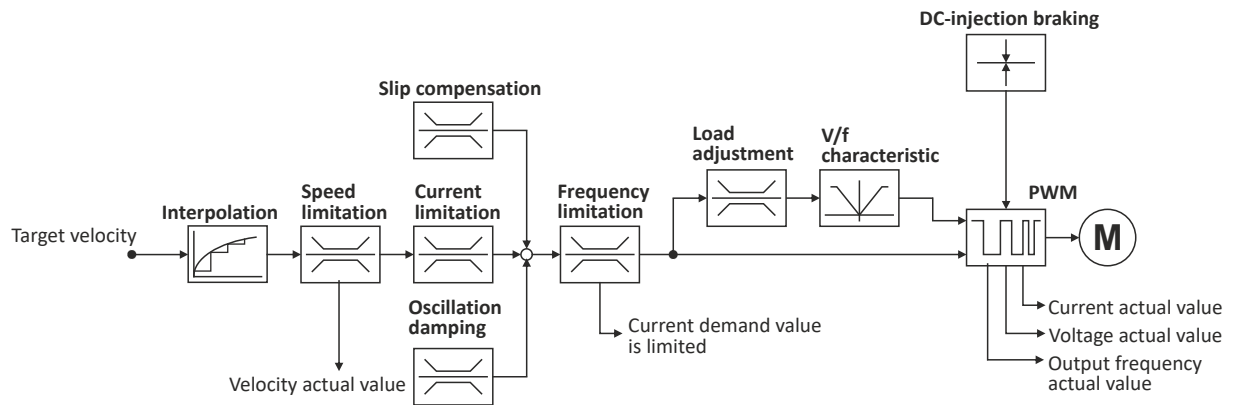



Configure speed control

Operating mode "CiA 402 cyclic sync velocity mode (csv)"
Signal flow (V/f characteristic control)

Overview of the most important parameters

Function	Icon	Parameter	Name
Input data		0x6040	CiA control word
		0x2830	Inverter control word
		0x6060	CiA: Operation mode
		0x6042	Set speed
Output data		0x6041	CiA status word
		0x2831	Inverter status word
		0x6061	CiA: Active operation mode
		0x606C	Actual speed
		0x6078	Actual current
		0x2D82	Motor actual voltage (Veff)
		0x2DDD	Output frequency
Interpolation		0x60C0	Interpolation mode
		0x60C2:001	Interpolation time
		0x60C2:002	Interpolation time
Speed limitation		0x6080	Max. motor speed
Slip compensation		0x2B09:001	Slip compensation Gain
		0x2B09:002	Slip compensation Filter time
Current limitation		0x2B08:001	V/f I _{max} controller Gain
		0x2B08:002	V/f I _{max} controller Reset time
		0x6073	Max. current
Oscillation damping		0x2B0A:001	Oscillation damping Gain
		0x2B0A:002	Oscillation damping Filter time
		0x2B0A:003	Oscillation damping Limitation
		0x2B0A:004	Oscillation damping Final ramp frequency
Load adaptation		0x2B07:001	Load adaption Direction of rotation
		0x2B07:002	Load adaption Load adaption value
V/f characteristic		0x2B01:001	V/f shape data Base voltage
		0x2B01:002	V/f shape data Base frequency
		0x2B06	Voltage boost
		0x2B04	V/f boost controller - current setpoint
		0x2B00	V/f characteristic shape
		0x2B02:001	Frequency grid points (x) user V/f characteristic x1 = f01
	
		0x2B02:011	x11 = f11
		0x2B03:001	Voltage grid points (y) user V/f characteristic y1 = U01 (x = f01)
	
0x2B03:011	y11 = U11 (x = f11)		
DC-injection braking		0x2B80	Current for DC-injection braking

Configure speed control

Operating mode "CiA 402 cyclic sync velocity mode (csv)"
Control commands and status information



7.3.4 Control commands and status information

The following control commands can be executed in the "cyclic sync velocity mode" via the CiA402 control word ([0x6040](#)):

Control word	State	Function
Bit 4	0	reserved (bit must be set to "0")
Bit 5	0	reserved (bit must be set to "0")
Bit 6	0	reserved (bit must be set to "0")
Bit 8	0 ↗ 1	Stop

The following status information are output via the CiA402 status word ([0x6041](#)) in the "cyclic sync velocity mode":

Status word	State	Meaning
Bit 12	0	"Cyclic sync velocity mode" is inactive
	1	"Cyclic sync velocity mode" is active



7.4 Process input data (CiA 402 objects)

Parameter

Address	Name / setting range / [default setting]	Information
0x6042	Set speed -32768 ... [0] ... 32767 rpm	Set speed (velocity mode).
0x6046:001	Speed limits: Min. speed 0 ... [0] ... 0 rpm	Min. speed (velocity mode).
0x6046:002	Speed limits: Max. speed 2147483647 ... [2147483647] ... 2147483647 rpm	Max. speed (velocity mode).
0x6048:001	Acceleration ramp: CiA acceleration: Delta speed 0 ... [0] ... 2147483647 rpm	CiA acceleration: Delta speed
0x6048:002	Acceleration ramp: CiA acceleration: Delta time 0 ... [10] ... 65535 s	CiA acceleration: Delta time
0x6049:001	Deceleration ramp: CiA deceleration: Delta speed 0 ... [0] ... 2147483647 rpm	CiA deceleration: Delta speed
0x6049:002	Deceleration ramp: CiA deceleration: Delta time 0 ... [10] ... 65535 s	CiA deceleration: Delta time
0x6060	CiA: Operation mode	CiA: Operation mode
	-13 MS: Manual jog open loop (MOL)	Manufacturer-specific manual control ▶ Operation mode "Manual Jog" □ 232
	-12 MS: Pole position identification (PPI)	Manufacturer-specific pole position identification (PLI) ▶ Synchronous motor: Pole position identification (PPI) □ 116 ▶ Selection of the PPI method for CiA mode □ 117
	0 No selection	No selection
	2 CiA: Velocity mode (vl)	
	8 CiA: Cyclic sync position (csp)	
	9 CiA: Cyclic sync velocity mode (csv)	
10 CiA: Cyclic sync torque mode (cst)		
0x60B1	Offset speed -2147483648.00 ... [0.00] ... 2147483647.00 rpm	Additive value for setpoint velocity or velocity feedforward control - offset speed.
0x60FF	Set speed -2147483648.00 ... [0.00] ... 2147483647.00 rpm	Setting of the set speed.



7.5 Process output data (CiA 402 objects)

Parameter

Address	Name / setting range / [default setting]	Information
0x6043	Internal set speed • Read only: x rpm	Display of the internal set speed (velocity demand).
0x6044	Actual speed • Read only: x rpm	Display of the actual speed (velocity mode).
0x606C	Actual speed • Read only: rpm	Display of the actual speed.



7.6 Monitoring the speed deviation

Monitoring of the speed deviation shall only be used in the following control modes:

- Servo control for synchronous motor (SM)
- Servo control for asynchronous motor (ASM)

Monitoring of the speed deviation is effective in the operating modes with speed controller. It monitors the system deviation at the input of the speed controller (see blue arrow):

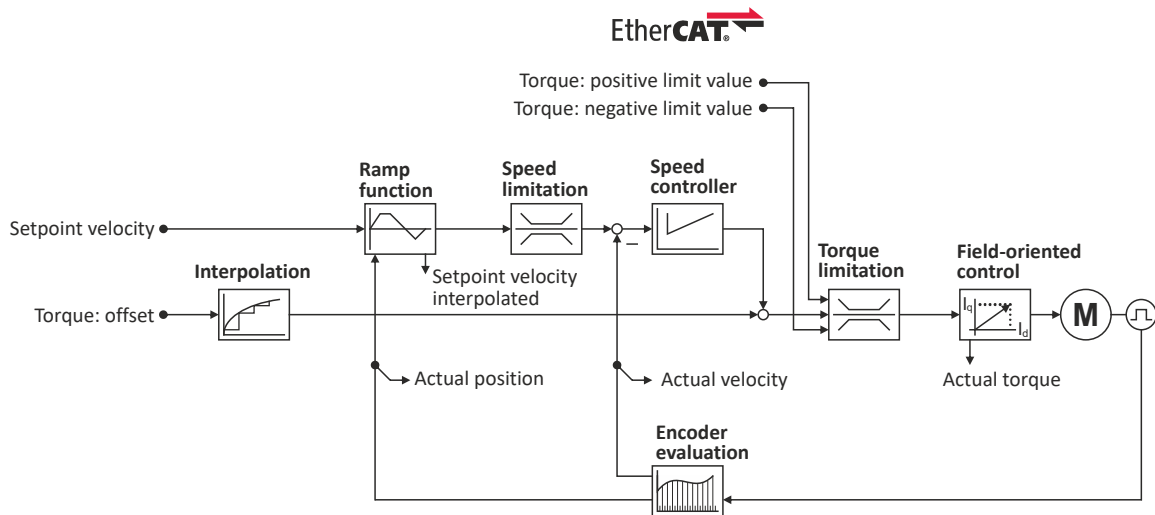

The error response set in [0x2D51:003](#) is executed if

1. the set tolerance of the speed deviation is [0x2D51:001](#) exceeded and
2. the exceedance lasts at least as long as set in [0x2D51:002](#).

Parameter

Address	Name / setting range / [default setting]	Information
0x2D51:001	Position error/speed error - monitoring: Speed error - error threshold 1 ... [50] ... 2147483647 rpm	Setting of the error threshold for speed error monitoring.
0x2D51:002	Position error/speed error - monitoring: Speed error - min. time for error 0 ... [0] ... 50 ms	Setting of the minimum time a speed error must be pending until an error/warning message is triggered.
0x2D51:003	Position error/speed error - monitoring: Speed error - error response	Setting of the error response of speed error monitoring.
	0 No response	
	1 Fault > CiA402	
	2 Warning	



8 Configuring the torque control

This operating mode provides a fast torque follower with speed limitation.

Typical applications are, for instance, winders or packaging machines.

Preconditions

The conditions are a correct entry of the motor data ([Motor data](#)) and the parameter setting of the motor control ([Configuring the motor control](#)).

A torque control can only be implemented in the motor control types to be set with `0x2C00`:

- Servoregelung (SC-PSM) [1]
- Servo control (SC ASM) [2]

Thus, first one of these motor control types must be configured.

For details see the following chapter:

- ▶ [Servo control for synchronous motor \(SC-PSM\)](#) 133
- ▶ [Servo control for asynchronous motor \(SC-ASM\)](#) 134



8.1 Basic setting

1. Set the manufacturer spanning operating mode "CiA: Cyclic sync torque mode (cst) [10]" according to CiA402.
 - A detailed description of this operating mode can be found in the "[Operating mode "CiA 402 cyclic sync torque mode \(cst\)"](#)" section. [📖 90](#)
2. Set the rated motor torque. [▶ 0x6076](#)
3. Set the permissible maximum torque. [▶ 0x6072](#)
 - The maximum torque is preset in [0x6072](#).
 - The change of the positive and negative limit of the maximum torque is described in the "[Torque limits](#)" section. [📖 88](#)
4. Parameterise speed limit. [0x2946](#)
 - The maximum speed is preset. [▶ 0x6080](#)
 - The change of the upper and lower speed limit is described in the "[Speed limitation](#)" section. [📖 89](#)
5. Define a torque setpoint for the torque control instead of a speed setpoint. The value is given in percent and based on the rated motor torque set in [0x6076](#).

The torque control with speed limitation is now active and the inverter responds to the defined torque setpoint.

Configuring the torque control

Basic setting
Torque limits



8.1.1 Torque limits

Details

The positive and negative torque limit can be set independently of each other. The torque limit must be set to the maximum torque. ▶ [0x6072](#)

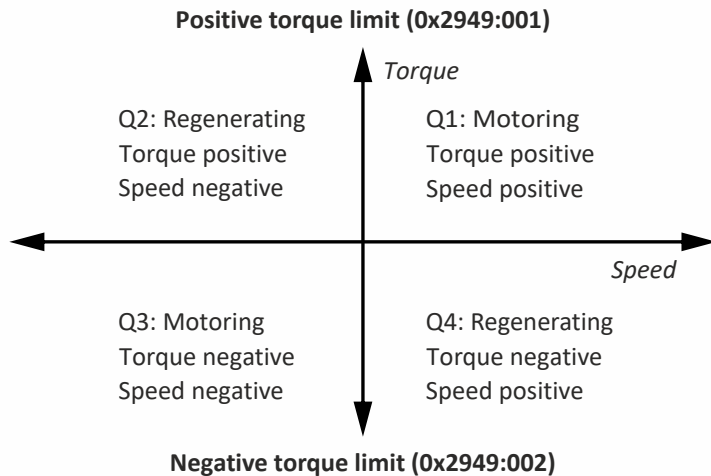

- Display of the current positive torque limit in 0x2949:004.
- Display of the current negative torque limit in 0x2949:003.

The torque limits are also active in the "Velocity Mode" with the "Servo control (SC-ASM)" motor control mode.



Regardless of the setting in 0x2949:004 and 0x2949:003, the maximum torque does not exceed the value configured in [0x6072](#).

The setting is made in percent with reference to the rated motor torque set in [0x6076](#).

Parameter

Address	Name / setting range / [default setting]	Information
0x294A:001	Torque limits offset: Torque offset -3276.7 ... [0.0] ... 3276.7 %	
0x294A:002	Torque limits offset: Resulting positive torque limit • Read only: x.x %	
0x294A:003	Torque limits offset: Resulting negative torque limit • Read only: x.x %	
0x60B2	Offset torque -3276.8 ... [0.0] ... 3276.7 %	Offset torque • 100 % = rated motor power (0x6076)
0x60E0	Positive torque limit 0.0 ... [100.0] ... 3276.7 %	Positive torque limit source for speed control with torque limitation. • 100 % = Rated motor torque 0x6076
0x60E1	Negative torque limit 0.0 ... [100.0] ... 3276.7 %	Negative torque limit source for speed control with torque limitation. • 100 % = Rated motor torque 0x6076



8.1.2 Speed limitation

The torque control controls the assigned torque setpoint within the set speed limits. The actual speed results from the load conditions of the application. For example, high speeds may occur in a torque control if no counter torque is available (load-free machine).

When the actual speed reaches the set speed limits, it is kept on the respective limit value. This function is also called "speed limitation".

Details

The lower and upper speed limit for speed limitation can be set independently of each other.

Parameter

Address	Name / setting range / [default setting]	Information
0x2946:001	Speed limitation: Upper speed limit -480000 ... [0] ... 480000 rpm	Upper limit for the speed limitation. <ul style="list-style-type: none">• Setting is only effective with the selection "Upper speed limit [5]" in .• Entry via keypad and Lenze Tools is in rpm!• Via RPDO, the unit is vel. unit. and the scaling must be taken into account.• $\pm 480000 \text{ rpm} = \pm 2^{31} [\text{n-unit}]$
0x2946:002	Speed limitation: Lower speed limit -480000 ... [0] ... 480000 rpm	Lower limit for speed limitation. <ul style="list-style-type: none">• Setting is only effective with the selection "Lower speed limit [5]" in .• Entry via keypad and Lenze Tools is in rpm!• Via RPDO, the unit is vel. unit. and the scaling must be taken into account.• $\pm 480000 \text{ rpm} = \pm 2^{31} [\text{n-unit}]$



8.2 Operating mode "CiA 402 cyclic sync torque mode (cst)"



During the quick stop, the current limit [0x6073](#) and the torque limit [0x6072](#) are active. The lower of the two limits determines the motor output torque. The torque limits from [0x60E0](#) and [0x60E1](#) are not effective during quick stop.

Subfunctions of the operating mode

- Torque control with speed limitation
- Limitation of the motor speed
- Update of the actual values for position, velocity and torque

8.2.1 Default mapping

The default mapping for the "Cyclic sync torque mode" is defined in the following parameters:

Parameter	Designation	Data type
0x1601	RPDO-->axis: cyclic sync torque mode (cst)	RECORD
0x1A01	Axis-->TPDO: cyclic sync torque mode (cst)	RECORD

Data received from the Controller (RPDO)

Parameter	Designation	Data type
0x6040	CiA402 control word	UNSIGNED_16
0x2830	Lenze control word	UNSIGNED_16
0x6060	Operating mode: selection	INTEGER_8
0x60B2	Torque: offset	INTEGER_16
0x6071	Torque: setpoint torque	INTEGER_16
0x2946:1	Speed limitation: upper speed limit	INTEGER_32
0x2946:2	Speed limitation: lower speed limit	INTEGER_32

Data sent to the Controller (TPDO)

Parameter	Designation	Data type
0x6041	CiA402 status word	UNSIGNED_16
0x2831	Lenze status word	UNSIGNED_16
0x6061	Operating mode: display	INTEGER_8
0x603F	Error code	UNSIGNED_16
0x606C	Velocity: actual velocity	UNSIGNED_16
0x6077	Torque: actual torque	INTEGER_16



8.2.2 Signal flow

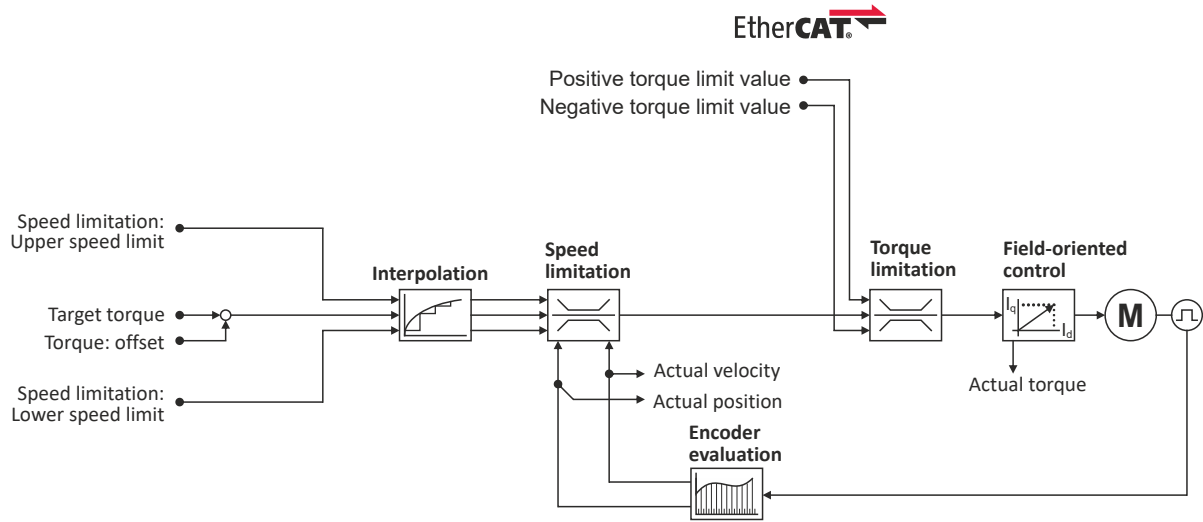

Configuring the torque control

Operating mode "CiA 402 cyclic sync torque mode (cst)"
Signal flow



Overview of the most important parameters

Function	Icon	Parameter	Name
Input data		0x6040	CiA control word
		0x2830	Inverter control word
		0x6060	CiA: Operation mode
		0x2946:001	Speed limitation Upper speed limit
		0x2946:002	Speed limitation Lower speed limit
		0x60B2	Offset torque
		0x6071	Set torque
		0x60E0	Positive torque limit
		0x60E1	Negative torque limit
Output data		0x6041	CiA status word
		0x2831	Inverter status word
		0x6061	CiA: Active operation mode
		0x606C	Actual speed
		0x6077	Actual torque
Interpolation		0x60C0	Interpolation mode
		0x60C2:001	Interpolation time
		0x60C2:002	Interpolation time
Speed limitation		0x6080	Max. motor speed
		0x2946:001	Speed limitation Upper speed limit
		0x2946:002	Speed limitation Lower speed limit
Torque limitation		0x60E0	Positive torque limit
		0x60E1	Negative torque limit
		0x6076	Rated motor torque
		0x6072	Max. torque
Field-oriented control		0x6073	Max. current
		0x6075	Rated motor current
		0x2941	Current controller feedforward control
		0x2942:001	Current controller parameters Gain
		0x2942:002	Current controller parameters Reset time
		0x29E2	DC-bus filter time
		0x29E3	Motor voltage filter time
		0x29E0:001	Field weakening controller settings Gain (ASM)
		0x29E0:002	Field weakening controller settings Reset time (ASM)
		0x29E1	Field weakening controller Field limitation
		0x29C0:001	Field controller settings Gain
		0x29C0:002	Field controller settings Reset time
		0x2939	Switching frequency



8.2.3 Control commands and status information

The following control commands can be executed in the "cyclically synchronous torque" operating mode via the CiA402 control word [0x6040](#):

Control word	State	Function
Bit 4	0	<i>reserved</i> (bit must be set to "0")
Bit 5	0	<i>reserved</i> (bit must be set to "0")
Bit 6	0	<i>reserved</i> (bit must be set to "0")
Bit 8	0/1	Stop

The following status information are output via the CiA402 status word [0x6041](#) in the "cyclic sync torque mode":

Status word	State	Meaning
Bit 12	0	"Cyclic sync torque mode" is inactive
	1	"Cyclic sync torque mode" is active



8.3 Process input data (CiA 402 objects)

Parameter

Address	Name / setting range / [default setting]	Information
0x6060	CiA: Operation mode	CiA: Operation mode
	-13 MS: Manual jog open loop (MOL)	Manufacturer-specific manual control ▶ Operation mode "Manual Jog" □ 232
	-12 MS: Pole position identification (PPI)	Manufacturer-specific pole position identification (PLI) ▶ Synchronous motor: Pole position identification (PPI) □ 116 ▶ Selection of the PPI method for CiA mode □ 117
	0 No selection	No selection
	2 CiA: Velocity mode (vl)	
	8 CiA: Cyclic sync position (csp)	
	9 CiA: Cyclic sync velocity mode (csv)	
	10 CiA: Cyclic sync torque mode (cst)	
0x6071	Set torque -3276.8 ... [0.0] ... 3276.7 %	



8.4 Process output data (CiA 402 objects)

Parameter

Address	Name / setting range / [default setting]	Information
0x6074	Internal set torque • Read only: x.x %	Display of the internal set torque. • 100 % = Rated motor torque 0x6076
0x6077	Actual torque • Read only: x.x %	Display of the actual torque. • 100 % = Rated motor torque 0x6076



8.5 Setpoint diagnostics

The following parameters provide information on the setpoints set for torque control.

Parameter

Address	Name / setting range / [default setting]	Information
0x2DD5	Torque setpoint • Read only: x.xx Nm	Display of the current torque setpoint.



9 Configuring the feedback system

This chapter provides information on how to use feedback systems.

The axes are available in 3 versions for the evaluation of a motor encoder:

- Design i750 "Hiperface DSL® (OCT)/PTC"
- Design i750 "Resolver"
- Design i750 "Multi-Encoder"
 - Supported incremental encoders: SinCos, TTL
 - Supported absolute value encoders: HIPERFACE®, SSI, SinCos+SSI

Example: Single axes and double axes 1.1 kW ... 4 kW



Design i750 "Hiperface DSL® (OCT)/PTC"



Design i750 "Resolver"



Design i750 "Multi-Encoder"



Please note that either the parameters for resolver evaluation or the parameters for encoder evaluation will be effective depending on the feedback system selected.

Configuring the feedback system

Configure feedback system for motor control



9.1 Configure feedback system for motor control

The parameter settings for the motor feedback system are accessed in »EASY Starter« via the following path:

- **Settings** tab
 - Basic setting \ Motor feedback (A)

Here, you have the choice of using the following feedback systems:

- Resolver
- Encoder

You can select the feedback system that you wish to use by pressing the correspondingly named button.



9.1.1 General settings

This chapter provides information on general settings of feedback systems for the motor control.

Pressing the **Select resolver** or **Select encoder** button displays a list of resolvers or encoders.

If the displayed list contains the feedback system used, the data is applied automatically.

Otherwise, you must enter the data of the feedback system manually.

Monitoring of the encoder cable for wire breakage

The resolver or encoder cable can be monitored for wire breakage in the default settings of parameter [0x2C45](#).

DANGER!

When the encoder / resolver is used as a motor encoder, safe motor operation is not possible in the event of an error.

Destruction of system parts

- ▶ **Fault** should always be used as a response for resolver/encoder wire breakage monitoring.
- ▶ To prevent interference injections when using an encoder, only use shielded motor and encoder cables.

Wire breakage monitoring trips in the following cases:

- Resolver
 - Wire breakage in the encoder cable
 - When the resolver impedance is too great
 - In the event of interference injections (EMC interference)
- Encoder
 - Wire breakage in the encoder cable

Sensitivity of wire breakage monitoring

The sensitivity of wire breakage monitoring can be set as a percentage using the [0x2C47](#) parameter.

Reducing the monitoring sensitivity is advantageous in environments that are severely affected by EMC problems.



If the sensitivity is not reduced (100 %), the software response time of monitoring in case of an encoder is approx. 3.5 ms and in case of a resolver 0.3 ms.

Halving the sensitivity means doubling the response time.

NOTICE

A reduced sensitivity delays the response in case of wire breakage!

Destruction of system parts by reduced sensitivity of the open-circuit monitoring.

- ▶ Increase the sensitivity to reduce the monitoring response time.

Parameter

Address	Name / setting range / [default setting]	Information
0x2C45	Motor feedback error response	
	0 No response	▶ Severity □ 390
	1 Warning	
	2 Trouble	

Configuring the feedback system

Configure feedback system for motor control
Resolver settings



Address	Name / setting range / [default setting]	Information
0x2C46	Number of the absolute ascertainable revolutions of motor encoder • Read only	Is set by the firmware according to the available version: • 0: no absolute value encoder (sin/cos encoder) or resolver with number of pole pairs > 1 • 1: Single-turn absolute value encoder or resolver with number of pole pairs = 1 • >1: Multi-turn absolute value encoder
0x2C47	Open circuit detection sensitivity of motor encoder 1 ... [100] ... 100 %	The sensitivity can be reduced by percentage, e. g. in case of EMC interferences.
0x608F:001	Position encoder resolution: Encoder increments • Setting can only be changed if the inverter is disabled.	Position encoder resolution: Encoder increments Setting the number of bits to be used for resolving a mechanical motor revolution.
	65536 16 bit	
	262144 18 bit	
	1048576 20 bit	
	4194304 22 bit	
	16777216 24 bit	
	67108864 26 bit	
	268435456 28 bit	
1073741824 30 bit		
0x608F:002	Position encoder resolution: Motor revolutions 1 ... [1] ... 1 • Setting can only be changed if the inverter is disabled.	Denominator of the position resolution: Number of motor revolutions. Only setting "1" is accepted.
0x6090:001	Velocity encoder resolution: Encoder increments/s 0 ... [33554432] ... 2147483647 • Setting can only be changed if the inverter is disabled.	Setting of the encoder increments/s.
0x6090:002	Velocity encoder resolution: Motor revolutions/s 0 ... [125] ... 2147483647 • Setting can only be changed if the inverter is disabled.	Setting of the motor revolutions/s.

9.1.2 Resolver settings



Resolvers with a number of pole pairs > 1 are not absolute value encoders.

Bit 4 in 0x2833 (Lenze status word 2) therefore remains set to "0".

The "distinguishable revolutions" specification in 0x2C46 is also set to "0".

The following applies to synchronous motors:

- When the number of motor pole pairs to the number of resolver pole pairs is an integer ratio (0x2C01:001), the pole position only has to be identified once.
- When the number of motor pole pairs to the number of resolver pole pairs is a non-integer ratio (0x2C01:001), the pole position must be identified every time the inverter is connected to 24 V. ▶ [Synchronous motor: Pole position identification \(PPI\)](#) 116

Parameter

Address	Name / setting range / [default setting]	Information
0x2822:025	Axis commands: Get motor encoder characteristic (resolver)	Values determined in order to compensate for resolver faults.
	0 Off/Ready	
	1 On/Start	
	2 In progress	
	3 Action cancelled	
	4 No access	
5 No access (Device disabled)		



Configuring the feedback system

Configure feedback system for motor control
Resolver settings

Address	Name / setting range / [default setting]	Information
0x2C43	Motor encoder resolver number of pole pairs 1 ... [1] ... 10 <ul style="list-style-type: none">Setting can only be changed if the inverter is disabled.	Setting of the number of pole pairs.

Configuring the feedback system

Configure feedback system for motor control
Resolver settings
Resolver error compensation



9.1.2.1 Resolver error compensation

The actual position detected by the resolver is not exactly the same as the real physical position. There are always more or less substantial deviations.

An identification run of the resolver automatically determines the adjustment values required to compensate for the resolver error.

The determined values have a corrective effect on the cause of occurrence in the following parameters:

Cause	Remedy
Sine and cosine track do not magnetize orthogonally to each other.	0x2C44:001 Correction of the angle by means of which the two resolver tracks are supplied in a manner relative to one another.
The inductances of the sine and cosine track of the resolver have slightly different values.	0x2C44:002 and 0x2C44:003 Adjusting the gains of the digital-analog converters which feed the resolver tracks.

Conditions for executing the identification run

- Motor
 - If possible, execute the identification run before the motor is installed in the machine. Bigger load changes at the motor may have a negative impact on the identification result.
 - The motor and resolver must be properly connected to the inverter.
 - The motor must rotate freely.
- Inverter
 - The inverter must be supplied with mains voltage. Check: [0x6041](#), bit 4 = TRUE.
 - The control electronics must be supplied with voltage. For some designs, an external voltage source is required for this purpose.
 - The inverter must be connected "online" to the Engineering Tool.
- Correct parameterization:
 - Number of resolver pole pairs ([0x2C43](#))
 - Motor speed-controlled or position-controlled in servo control mode



Configuring the feedback system

Configure feedback system for motor control
Resolver settings
Resolver error compensation

How to run an identification

1. Initiate identification run with parameter [0x2822:025](#).
2. Enable inverter.
The identification run is in standby mode.
3. Approach a constant speed between $n = 500$ rpm and $n = 3000$ rpm.
The identification run is started automatically after the drive has reached a constant speed and maintained this speed for the time defined in [.](#)
This speed is saved for the identification run. In order that the identification run can be continued again, e.g. after an interruption, the drive must be operated again with this speed.

End of identification run

After the resolver error identification has been executed successfully, the parameters [0x2C44:001](#) ... [0x2C44:003](#) are written automatically. The resolver now works with these settings.

Brief interruption of the identification run

A short-time interruption, e.g. by removing the controller enable, does not stop the measurement. It is continued after the controller is enabled anew. For the duration of the interruption, the following status message is displayed: "Identification interrupted temporarily".

Cancelling the identification run

The measurement is canceled in case the inverter disable lasts longer or after the timeout time has elapsed. A timeout error is displayed for the identification run, see error messages in the logbook.

4. If the measurement was successful, the motor can be stopped
5. After the process has been completed, save the changed parameters [0x2C44:001](#) ... [0x2C44:003](#) in the inverter.

The »EASY Starter« serves to save the parameter setting of the inverter, see [▶ Saving the parameter settings](#). [□ 35](#)

Possible responses during the execution

- Motor running may appear somewhat uneven during identification.
- The direction of rotation can change.
This has no negative impact on the quality of the identification. In this case, the inverter automatically interrupts the identification run and automatically continues it if a constant speed is reached again.
- If the motor already installed in the machine does not have sufficient range in one direction for executing the identification run, you can also reverse the driving direction while the identification is active. In this case, the identification automatically switches to the "Identification temporarily interrupted ". The status is deactivated as soon as a constant speed has been reached again.



In the event of an interruption, the identification run is stopped. An error message is displayed.

If 0 % is set, the gain of the respective resolver track is only 95 % of the Lenze setting.

The detected gain can assume values in the range of 0 ... 100 %.

In case of a successful resolver error compensation, only one of the two gains is adjusted. The other value remains at 100 %.

Deactivating the resolver error compensation

For deactivating the resolver error compensation, the respective parameters must be reset again to the Lenze setting.

Configuring the feedback system

Configure feedback system for motor control
 Resolver settings
 Resolver error compensation



Parameter

Address	Name / setting range / [default setting]	Information
0x2C44:001	Motor encoder identification (Resolver): Angle -100 ... [0] ... 100	Setting of the angle to the resolver error compensation.
0x2C44:002	Motor encoder identification (Resolver): Cosine track gain 0 ... [100] ... 100 %	Setting of the gain of the cosine track to the resolver error compensation.
0x2C44:003	Motor encoder identification (Resolver): Sine track gain 0 ... [100] ... 100 %	Setting of the gain of the sine track to the resolver error compensation.
0x2C44:006	Motor encoder identification (Resolver): Identification status • Read only	Display of the resolver identification status.
	Bit 0 Identification activated	TRUE if: <ul style="list-style-type: none"> • Identification has been started. • Controller enable is active. FALSE if: <ul style="list-style-type: none"> • Identification has been aborted or completed successfully. • A timeout error is active. • The 24V supply has been switched on and default settings are loaded.
	Bit 2 Identification is running	TRUE if: <ul style="list-style-type: none"> • Identification is running. FALSE if: <ul style="list-style-type: none"> • The motor speed has fallen below the minimum speed of 500 rpm. • The identification process has been aborted temporarily and is on standby.
	Bit 3 Identification successful	TRUE if: <ul style="list-style-type: none"> • Identification has been completed successfully. FALSE if: <ul style="list-style-type: none"> • The identification is not completed yet after default settings were loaded.
	Bit 4 Identification failed	TRUE if: <ul style="list-style-type: none"> • A timeout error has occurred. FALSE if: <ul style="list-style-type: none"> • Identification has been completed successfully.
0x2C44:008	Motor encoder identification (Resolver): Cosine track offset -100.000 ... [0.000] ... 100.000 %	
0x2C44:009	Motor encoder identification (Resolver): Sine track offset -100.000 ... [0.000] ... 100.000 %	
0x2C44:011	Motor encoder identification (Resolver): Cyclic online compensation 0 Off 1 On	
0x2C44:012	Motor encoder identification (Resolver): Harmonic for cyclic online compensation 10 ... [22] ... 99	
0x2C44:013	Motor encoder identification (Resolver): Dead time compensation resolver evaluation 0.0 ... [100.0] ... 500.0 %	



Configuring the feedback system

Configure feedback system for motor control
Encoder settings
SinCos encoder

9.1.3 Encoder settings

In general, an encoder is a measuring system which serves to detect the velocity/speed and the position of a kinematics or motor.

Details



If a resolver variant is to be plugged into the respective slot of the inverter as a feedback system, the parameters in this section have no function.

Parameter

Address	Name / setting range / [default setting]	Information
0x2C40	Motor encoder type • Setting can only be changed if the inverter is disabled.	Selection of the encoder type.
	1 SinCos encoder	
	2 HIPERFACE® SinCos absolute value encoder	
	3 TTL encoder	
	4 EnDat SinCos absolute value encoder	
	5 SSI absolute value encoder	
	6 SSI SinCos absolute value encoder	
7 HIPERFACE DSL® (OCT)		
0x2C42:001	Encoder settings: Increments/revolution 1 ... [1024] ... 262143 • Setting can only be changed if the inverter is disabled.	Setting of the encoder number of increments per revolution (according to manufacturer data/encoder data sheet).
0x2C42:002	Encoder settings: Supply voltage 5.0 ... [5.0] ... 12.0 V • Setting can only be changed if the inverter is disabled.	Setting of the supply voltage.

9.1.3.1 SinCos encoder

The following SinCos encoder types without HIPERFACE® protocol are supported by the inverter:

Type	Increments/revolution	Absolute revolutions
IG1024-5V-V3 (RVS58S)	1024	0
IG2048-5V-S (ITD22)	2048	0
IG2048-5V-S	2048	0

Configuring the feedback system

Configure feedback system for motor control
Encoder settings
SinCos absolute value encoder with HIPERFACE® protocol



9.1.3.2 SinCos absolute value encoder with HIPERFACE® protocol

The following SinCos encoder types with HIPERFACE® protocol are supported by the inverter:

Type	Increments/revolution	Absolute revolutions	Type code 0x2C41:001
AM1024-8V-H (SRM50)	1024	4096 (Multiturn)	39
AM1024-8V-H (SFM60)	1024		39
AM1024-8V-K2 (SRM50S)	1024		39
AM128-8V-H (SKM36)	128		55
AM16-8V-H (SEL37)	16		71
AM16-8V-H (SEL52)	16		71
AM512-8V-H (SCM70)	512		7
AS1024-8V-H (SR550)	1024	4096 (Single-turn)	34
AS1024-8V-K2 (SR550S)	1024		34
AS16-8V-H (SEK37)	16		66
AS16-8V-H (SEK52)	16		66
AS512-8V-H (SCS70)	512		2

Use of non-supported encoder types

If the type code of the encoder used is not listed in the table of supported encoder types, this encoder can be introduced to the inverter via the [0x2C41:002](#) and [0x2C41:003](#) parameters.



In this context, please also observe the information provided in the parameter description [0x2C41:008](#).

Parameter

Address	Name / setting range / [default setting]	Information
0x2822:026	Axis commands: Get motor encoder information (HIPERFACE®)	Command for reading out data from the connected motor encoder.
	0 Off/Ready	
	1 On/Start	
	2 In progress	
	3 Action cancelled	
	4 No access	
5 No access (Device disabled)		
0x2C41:001	Motor encoder settings (HIPERFACE®): Type code detected • Read only	Type code read out of the encoder. This value is "0" if ... • a sin/cos encoder is set (0x2C40 = 2); • a communication error has occurred.
0x2C41:002	Motor encoder settings (HIPERFACE®): Type code manual input 0 ... [0] ... 255 • Setting can only be changed if the inverter is disabled.	Manual setting of the encoder type code (display in 0x2C41:001).
0x2C41:003	Motor encoder settings (HIPERFACE®): Manual input - Number of detectable motor encoder revolutions 1 ... [1] ... 65535 • Setting can only be changed if the inverter is disabled.	Manual setting of the number of distinguishable revolutions.
0x2C41:004	Motor encoder settings (HIPERFACE®): Error response	Selection of the response for communication errors or in the event of an unknown encoder.
	0 No response	
	1 Fault > CiA402	
2 Warning		
0x2C41:005	Motor encoder settings (HIPERFACE®): Serial number • Read only	The displayed serial number can be used for identifying an encoder change.
0x2C41:006	Motor encoder settings (HIPERFACE®): Actual position (raw data) • Read only	The encoder-internal position value is output without being converted.



Configuring the feedback system

Configure feedback system for motor control
Encoder settings
SSI encoder

Address	Name / setting range / [default setting]	Information
0x2C41:007	Motor encoder settings (HIPERFACE®): No. of periods detected • Read only	Display of the encoder increment according to encoder nameplate or type code.
0x2C41:008	Motor encoder settings (HIPERFACE®): Type code verification • Read only	If an encoder is connected that is not supported by the firmware, it will be displayed here. In this case, the same response takes place as in case of a communication error. The error can be removed by manually setting the type code in 0x2C41:002 . This serves to signalise to the firmware that the number of distinguishable revolutions is as well set correctly in 0x2C41:003 by the user.
	0 Unknown - manual data input	If an encoder is connected that is not supported by the firmware, it will be displayed here.
	1 Known - parameterisation ok	
0x2C41:009	Motor encoder settings (HIPERFACE®): Encoder type • Read only	Display of the detected encoder type (rotary/linear).
	0 Rotative encoder	
	1 Linear encoder	
0x2C41:010	Motor encoder settings (HIPERFACE®): Period length of linear encoder • Read only: x nm	Display of the period length of the linear encoder.

9.1.3.3 SSI encoder

SSI absolute value encoder (**S**ynchronous **S**erial **I**nterface) generate the angle information by optically scanning a code disc (e.g. as Gray Code). Each (absolute) angular position of the encoder corresponds to a code pattern that can be uniquely assigned.

All encoders that use the Stegmann SSI protocol are supported:

- Supported bit rates for SSI communication: 150 ... 1000 kbits
- Supported data word widths: 1 ... 31 bits (effective)
- Supported output code of the SSI encoder: Gray or Binary
- Cycle time: 62.5 µs, 125 µs and 250 µs .
- Encoder supply: $U < 12\text{ V}$, $I \leq 0.25\text{ A}$

How to parameterise the SSI encoder:

1. Set the supply voltage of the SSI encoder used in [0x2C42:002](#).
2. Set selection "5: SSI encoder" as the encoder type in [0x2C40](#).
3. Set the transmission rate for SSI communication in [0x2C4A:001](#).

With the SSI protocol, the permissible transmission rate decreases as the cable lengths increase. A safe transmission rate must be set according to the length of the encoder cable used and the electromagnetic interference level.

4. Set the telegram length in [0x2C4A:002](#).

The telegram length reflects the number of data bits used for transmission of a complete SSI data packet.

5. Break the received SSI data word down into partwords and, if necessary, activate data conversion of Gray into binary code.

Parameter

Address	Name / setting range / [default setting]	Information
0x2C4A:001	Motor encoder (SSI) protocol parameters: Bit rate 150 ... [300] ... 1000 kbps • Setting can only be changed if the inverter is disabled.	To enable a stable transmission rate, the length of the encoder cable used and any electromagnetic interference levels must be taken into account when setting the value.
0x2C4A:002	Motor encoder (SSI) protocol parameters: Telegram length 1 ... [25] ... 31 • Setting can only be changed if the inverter is disabled.	The set value specifies the number of data bits which are transmitted as a complete SSI data packet.

Configuring the feedback system

Configure feedback system for motor control
Encoder settings
SSI encoder



Address	Name / setting range / [default setting]	Information				
0x2C4A:003	Motor encoder (SSI) protocol parameters: Bits/revolution 1 ... [13] ... 31 • Setting can only be changed if the inverter is disabled.	Resolution of the encoder. For example, the resolution for the preset value is "13": $2^{13} = 8196$ (bits/revolution).				
0x2C4A:004	Motor encoder (SSI) protocol parameters: Position data start bit 0 ... [0] ... 30 • Setting can only be changed if the inverter is disabled.	Indicates the position in the telegram where the position data word begins.				
0x2C4A:005	Motor encoder (SSI) protocol parameters: Data package 1 start bit 0 ... [0] ... 30 • Setting can only be changed if the inverter is disabled.	Indicates the position in the telegram where data packet 1 begins.				
0x2C4A:006	Motor encoder (SSI) protocol parameters: Data package 2 start bit 0 ... [0] ... 30 • Setting can only be changed if the inverter is disabled.	Indicates the position in the telegram where data packet 2 begins.				
0x2C4A:007	Motor encoder (SSI) protocol parameters: Data package 3 start bit 0 ... [0] ... 30 • Setting can only be changed if the inverter is disabled.	Indicates the position in the telegram where data packet 3 begins.				
0x2C4A:008	Motor encoder (SSI) protocol parameters: Position data length 0 ... [0] ... 30 • Setting can only be changed if the inverter is disabled.	SSI position data length				
0x2C4A:009	Motor encoder (SSI) protocol parameters: Data package 1 length 0 ... [0] ... 30 • Setting can only be changed if the inverter is disabled.	Length of data packet 1.				
0x2C4A:010	Motor encoder (SSI) protocol parameters: Data package 2 length 0 ... [0] ... 30 • Setting can only be changed if the inverter is disabled.	Length of data packet 2.				
0x2C4A:011	Motor encoder (SSI) protocol parameters: Data package 3 length 0 ... [0] ... 30 • Setting can only be changed if the inverter is disabled.	Length of data packet 3.				
0x2C4A:012	Motor encoder (SSI) protocol parameters: Position data coding • Setting can only be changed if the inverter is disabled. <table border="1" data-bbox="316 1697 794 1765"> <tr> <td>0</td> <td>Binary</td> </tr> <tr> <td>1</td> <td>Gray</td> </tr> </table>	0	Binary	1	Gray	Coding of position data word (read only). If a value of "0" is set for the position data length in 0x2C4A:008 , then the value displayed for this parameter is also "0".
0	Binary					
1	Gray					
0x2C4A:013	Motor encoder (SSI) protocol parameters: Data package 1 coding • Setting can only be changed if the inverter is disabled. <table border="1" data-bbox="316 1883 794 1939"> <tr> <td>0</td> <td>Binary</td> </tr> <tr> <td>1</td> <td>Gray</td> </tr> </table>	0	Binary	1	Gray	Coding of data packet 1
0	Binary					
1	Gray					



Configuring the feedback system

Configure feedback system for motor control
Encoder settings
SSI encoder

Address	Name / setting range / [default setting]	Information
0x2C4A:014	Motor encoder (SSI) protocol parameters: Data package 2 coding <ul style="list-style-type: none"> Setting can only be changed if the inverter is disabled. 	Coding of data packet 2
	0 Binary	
	1 Gray	
0x2C4A:015	Motor encoder (SSI) protocol parameters: Data package 3 coding <ul style="list-style-type: none"> Setting can only be changed if the inverter is disabled. 	Coding of data packet 3
	0 Binary	
	1 Gray	
0x2C4A:016	Motor encoder (SSI) protocol parameters: Position raw data <ul style="list-style-type: none"> Read only 	Raw value of position data word (read only). If a value of "0" is set for the position data length in 0x2C4A:008 , then the value displayed for this parameter is also "0".
0x2C4A:017	Motor encoder (SSI) protocol parameters: Data package 1 raw data <ul style="list-style-type: none"> Read only 	Raw value of data packet 1 (read only). If a value of "0" is set for the data packet length 1 in 0x2C4A:013 , then the value displayed for this parameter is also "0".
0x2C4A:018	Motor encoder (SSI) protocol parameters: Data package 2 raw data <ul style="list-style-type: none"> Read only 	Raw value of data packet 2 (read only). If a value of "0" is set for the data packet length 2 in 0x2C4A:014 , then the value displayed for this parameter is also "0".
0x2C4A:019	Motor encoder (SSI) protocol parameters: Data package 3 raw data <ul style="list-style-type: none"> Read only 	Raw value of data packet 3 (read only). If a value of "0" is set for the data packet length 3 in 0x2C4A:015 , then the value displayed for this parameter is also "0".
0x2C4A:020	Motor encoder (SSI) protocol parameters: Encoder type <ul style="list-style-type: none"> Setting can only be changed if the inverter is disabled. 	
	0 Rotative encoder	
	1 Linear encoder	
0x2C4A:021	Motor encoder (SSI) protocol parameters: Position raw data scaled by 0x608F <ul style="list-style-type: none"> Read only 	
0x2C4A:022	Motor encoder (SSI) protocol parameters: Monoflop time 0 ... [0] ... 500 <ul style="list-style-type: none"> Setting can only be changed if the inverter is disabled. 	
0x2C4A:023	Motor encoder (SSI) protocol parameters: Resulting SSI-telegram cycle time <ul style="list-style-type: none"> Read only 	

Configuring the feedback system

Configure feedback system for motor control
Encoder settings
One cable technology (OCT) via HIPERFACE DSL®



9.1.3.4 One cable technology (OCT) via HIPERFACE DSL®

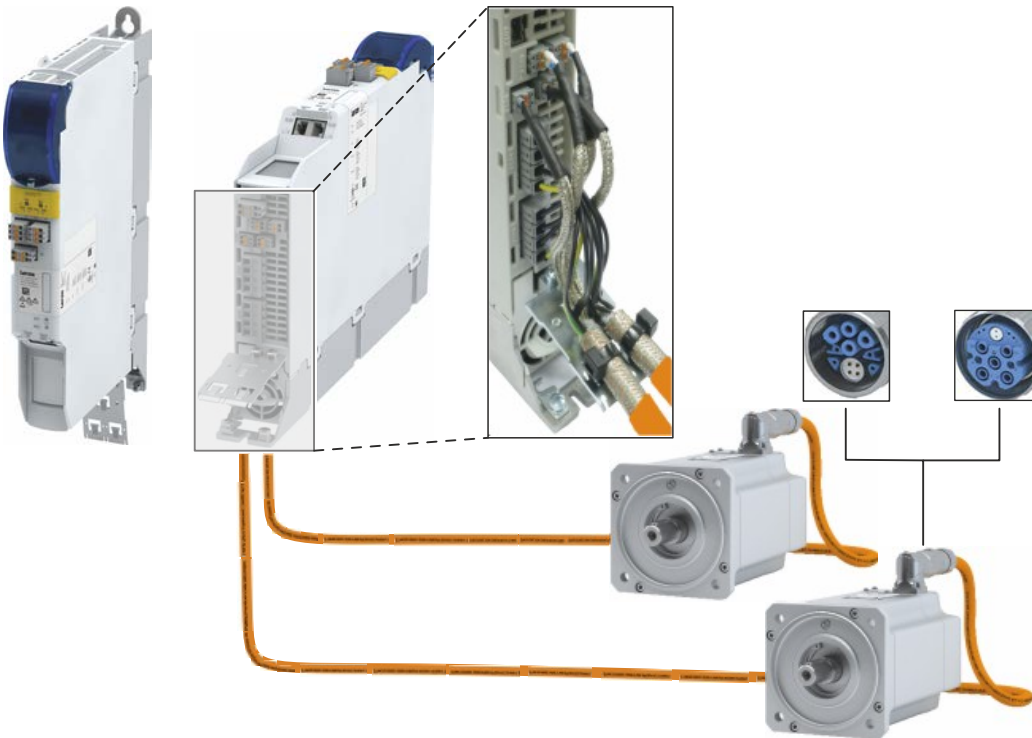

Fig. 3: Example setup HIPERFACE DSL® (OCT) for a double axis

Parameterize HIPERFACE DSL® (OCT)

Parameter **Axis settings: Function X109** = 10 to activate HIPERFACE DSL® (OCT). ▶ [0x2DE1:001](#)

Parameter

Address	Name / setting range / [default setting]	Information
0x2DE1:001	Axis settings: Function of X109	
	0 None	
	10 HIPERFACE DSL® (OCT)	
	20 PTC	
0x2C4B:001	Release version • Read only	
0x2C4B:002	Release Date • Read only	
0x2C4B:003	Encoder ID • Read only	
0x2C4B:004	Type of encoder • Read only	
0x2C4B:005	Resolution • Read only	
0x2C4B:006	Measurement range • Read only	
0x2C4B:007	Type name • Read only	
0x2C4B:008	Serial number • Read only	
0x2C4B:009	Device version • Read only	
0x2C4B:010	Firmware date • Read only	



Configuring the feedback system

Configure feedback system for motor control

Encoder settings

One cable technology (OCT) via HIPERFACE DSL®

Address	Name / setting range / [default setting]	Information	
0x2C4B:011	EEPROM size • Read only		
0x2C4B:012	Safe Channel 2 Resolution • Read only		
0x2C4B:020	Delay / RSSI • Read only		
	Bit 0	Cable delay, bit 0	
	Bit 1	Cable delay, bit 1	
	Bit 2	Cable delay, bit 2	
	Bit 3	Cable delay, bit 3	
	Bit 4	RSSI, bit 0	
	Bit 5	RSSI, bit 1	
	Bit 6	RSSI, bit 2	
0x2C4B:021	Quality monitoring • Read only		
	Bit 0	QM, bit 0	
	Bit 1	QM, bit 1	
	Bit 2	QM, bit 2	
	Bit 3	QM, bit 3	
0x2C4B:022	Slave RSSI • Read only		
	Bit 0	SRSSI, bit 0	
	Bit 1	SRSSI, bit 1	
	Bit 2	SRSSI, bit 2	
0x2C4B:023	Supply voltage • Read only: x.xxx V		
0x2C4B:024	Rotation speed range • Read only: x rpm		
0x2C4B:025	Auswahl		
	0	No value	
	1	Lifetime	
	2	Sensor monitor	
	3	Rotation speed	
0x2C4B:026	Value • Read only		
	4	Temperature	
	0x2C4B:040	Events • Read only	
	Bit 1	FREL: Channel free for "long message"	
	Bit 2	QMLW: Quality monitoring low value warning	
Bit 4	ANS: Erroneous answer to "long message"		
Bit 5	MIN: Message initialization		
Bit 8	PRST: Protocol reset warning		
Bit 9	DTE: Estimator Deviation Threshold Error		
Bit 11	POS: Estimator turned on		
Bit 14	SUM: Remote event monitoring		
Bit 15	INT: Interrupt status		

Configuring the feedback system

Configure feedback system for motor control

Encoder settings

One cable technology (OCT) via HIPERFACE DSL®



Address	Name / setting range / [default setting]	Information
0x2C4B:041	Status summaries	
	• Read only	
	Bit 0 SUM0	
	Bit 1 SUM1	
	Bit 2 SUM2	
	Bit 3 SUM3	
	Bit 4 SUM4	
	Bit 5 SUM5	
0x2C4B:042	Encoder status, byte 0	
	• Read only	
	Bit 0 Encoder status bit 0	
	Bit 1 Encoder status bit 1	
	Bit 2 Encoder status bit 2	
	Bit 3 Encoder status bit 3	
	Bit 4 Encoder status bit 4	
	Bit 5 Encoder status bit 5	
0x2C4B:043	Encoder status, byte 1	
	• Read only	
	Bit 0 Encoder status bit 8	
	Bit 1 Encoder status bit 9	
	Bit 2 Encoder status bit 10	
	Bit 3 Encoder status bit 11	
	Bit 4 Encoder status bit 12	
	Bit 5 Encoder status bit 13	
0x2C4B:044	Encoder status, byte 2	
	• Read only	
	Bit 0 Encoder status bit 16	
	Bit 1 Encoder status bit 17	
	Bit 2 Encoder status bit 18	
	Bit 3 Encoder status bit 19	
	Bit 4 Encoder status bit 20	
	Bit 5 Encoder status bit 21	
0x2C4B:045	Encoder status, byte 3	
	• Read only	
	Bit 0 Encoder status bit 24	
	Bit 1 Encoder status bit 25	
	Bit 2 Encoder status bit 26	
	Bit 3 Encoder status bit 27	
	Bit 4 Encoder status bit 28	
	Bit 5 Encoder status bit 29	
Bit 6 Encoder status bit 30		
Bit 7 Encoder status bit 31		



Configuring the feedback system

Configure feedback system for motor control

Encoder settings

One cable technology (OCT) via HIPERFACE DSL®

Address	Name / setting range / [default setting]	Information
0x2C4B:046	Encoder status, byte 4 • Read only	
	Bit 0 Encoder status bit 32	
	Bit 1 Encoder status bit 33	
	Bit 2 Encoder status bit 34	
	Bit 3 Encoder status bit 35	
	Bit 4 Encoder status bit 36	
	Bit 5 Encoder status bit 37	
	Bit 6 Encoder status bit 38	
0x2C4B:047	Encoder status, byte 5 • Read only	
	Bit 0 Encoder status bit 40	
	Bit 1 Encoder status bit 41	
	Bit 2 Encoder status bit 42	
	Bit 3 Encoder status bit 43	
	Bit 4 Encoder status bit 44	
	Bit 5 Encoder status bit 45	
	Bit 6 Encoder status bit 46	
0x2C4B:048	Encoder status, byte 6 • Read only	
	Bit 0 Encoder status bit 48	
	Bit 1 Encoder status bit 49	
	Bit 2 Encoder status bit 50	
	Bit 3 Encoder status bit 51	
	Bit 4 Encoder status bit 52	
	Bit 5 Encoder status bit 53	
	Bit 6 Encoder status bit 54	
0x2C4B:049	Encoder status, byte 7 • Read only	
	Bit 0 Encoder status bit 56	
	Bit 1 Encoder status bit 57	
	Bit 2 Encoder status bit 58	
	Bit 3 Encoder status bit 59	
	Bit 4 Encoder status bit 60	
	Bit 5 Encoder status bit 61	
	Bit 6 Encoder status bit 62	
0x2C4B:050	Fast position • Read only	

Configuring the feedback system

Configure feedback system for motor control
Encoder settings
Evaluation of the signal quality



9.1.3.5 Evaluation of the signal quality

Signal quality

The signal quality is evaluated by the [0x2C42:004](#) parameter, which is used to monitor the initial read-out and setting of the position.

If a transmission error should occur:

- The current angular drift is marked as invalid in parameter [0x2833](#), bit 7
- The inverter maintains its operating status

Angular drift



Communication with the encoder is no longer monitored during angular drift determination.

The value displayed in [0x2C42:003](#) is determined in different ways depending on the type of encoder:

• Determination of the current angular drift for the SinCos encoder

In the case of an incremental SinCos encoder, the pulses between two zero pulse events of the Z-track are counted. Assuming that there are no faults, this value corresponds to the set number of increments. The accuracy of this process corresponds to ± 1 increment graduation of the encoder, with the difference between the set number of increments and the counted pulses being converted to an angle with an accuracy of $\pm 0.1^\circ$. The disadvantage is that an updated angular drift value only become available at the end of a complete encoder revolution. In turn, this means that the update rate depends on the speed.

• Determination of the current angular drift for the SinCos Hiperface® absolute value encoder

In the case of a SinCos absolute value encoder with HIPERFACE® protocol, no Z-track is available; instead, the position is regularly read out of the encoder. When the first encoder read-out operation is performed (after power-up or elimination of wire breakage), the encoder position is used to initialise the internal device counter unit and to set an internal device position. All other read-out processes from the encoder are used to generate a difference between the internal device position and the encoder position. Assuming that there are no faults, the difference is zero. However, the dead time of the communication with the encoder means that the accuracy of the process is dependent on the speed and therefore restricted compared to the zero pulse process. However, the advantage is that the update rate does not depend on the speed, but is instead only determined by the communication rate. The update rate is encoder-specific and is generally in the range between 30 ... 50 ms.

Parameter

Address	Name / setting range / [default setting]	Information
0x2C42:003	Encoder settings: Angle drift <ul style="list-style-type: none">• Read only: x.x °	Display of the angular drift of the current angle error. This indicates whether too many or too few pulses have been detected by the internal device counter unit for EMC-related reasons.
0x2C42:004	Encoder settings: Actual amplitude signal quality <ul style="list-style-type: none">• Read only: x %	The signal quality indicates the actual amplitude of the SinCos analog signals with regard to $1 V_{ss} = 100\%$. <ul style="list-style-type: none">• The signal quality should be between 95 ... 105 %.• There is no need for optimisation if the signal quality is within the tolerance zone for the analog encoder signals given in the data sheet of the encoder manufacturer.



9.1.4 Detection of changed settings of the feedback system

Bit 0 of status word 2 indicates whether the settings of the feedback system have been changed since leaving the **Not ready to start** state. If a change has been made, bit 0 is set to value "1". ▶ [0x2833](#)

During the transition to the **Operation enabled** state, bit 0 is reset to value "0".

In all device states, changes to the following parameters continue to be monitored.

Relevant parameters of other functions

Address	Name	Default setting	Setting range
0x2C40	Motor encoder type	SinCos encoder [1]	Selection list
0x2C41:002	Motor encoder settings (HIPERFACE®): Type code manual input	0	0 ... 255
0x2C41:003	Motor encoder settings (HIPERFACE®): Manual input - Number of detectable motor encoder revolutions	1	1 ... 65535
0x2C41:005	Motor encoder settings (HIPERFACE®): Serial number	- (Read only)	
0x2C42:001	Encoder settings: Increments/revolution	1024	1 ... 262143
0x608F:001	Position encoder resolution: Encoder increments	16 bit [65536]	Selection list
0x608F:002	Position encoder resolution: Motor revolutions	1	1 ... 1

9.1.5 Diagnostics

Parameter

Address	Name / setting range / [default setting]	Information
0x2C4F	Parameter CRC of motor encoder • Read only	Display of the cyclic redundancy check (CRC) of selected encoder parameters to detect changes in the feedback settings.
0x2DDF:005	Axis information: Detected module in slot A • Read only	Display of supported feedback system for the motor.
	0 Product defined	
	1 No module	
	2 Resolver	
	3 SinCos/HIPERFACE®/SSI	
	4 SinCos/HIPERFACE®/SSI/TTL	
	5 I/O extension	
	6 SinCos/HIPERFACE®/SSI/TTL/EnDat®	
7 I/O + HTL extension		



9.2 Synchronous motor: Pole position identification (PPI)

For controlling a permanent-magnet synchronous motor, the pole position - the angle between the motor phase U and the field axis of the rotor - must be known.

- For Lenze motors with absolute value encoder or resolver, the pole position has already been set correctly.
- When incremental encoders are used (TTL or sin/cos encoders without absolute position information), a pole position identification (PPI) is always required. This also applies to Lenze motors.

NOTICE

The pole position identification (PPI) must only be executed

- ▶ for servo control with a synchronous motor of an original equipment manufacturer.
- ▶ for servo control with a synchronous motor and incremental encoders (TTL or sin/cos encoder).
- ▶ after changes to the motor feedback system, e.g. feedback replacement.

The parameter settings for pole position identification are accessed in »EASY Starter« via the following path:

- **Settings** tab
 - Basic setting \ Motor feedback (A)

Three different identification methods are offered here:

- 360° electrical
- With min. movement
- Without movement

The criteria for selecting the most suitable identification method are presented below.

Selection criteria for using the suitable pole position identification

For identifying the pole position for the currently activated feedback, the following functions are available which all provide almost the same result. Due to e.g. friction, bearing forces and a trapezoidal field pattern, the results may differ from each other.

▶ Pole position identification (PPI) 360° [118](#)

- The motor must not be braked, blocked or mechanically driven during the pole position identification! This function must not be used for hanging loads!
- Especially in case of idling drives or drives with a low load (inertia / friction), this function delivers the most accurate results.

▶ Pole position identification (PPI) with minimum movement [122](#)

- The motor must not be braked, blocked or driven during the pole position identification! Thus, this function must not be used for hanging loads!
- Regarding the accuracy, this function is in the middle range. A percentage increase of the current amplitude can enhance the accuracy of the results if required.

▶ Pole position identification (PPI) without movement [125](#)

- In case of stalled motors (e.g. with hanging loads), only this function shall be used!
- This function was developed for a wide range of motor characteristics. In case of some motor types, however, the identified pole position angle may differ considerably from the real pole position angle, so that a considerable loss in torque and greater motor losses may occur. Thus, especially when using third-party motors, we recommend the execution of a reference identification with an idling motor ▶ Pole position identification (PPI) 360° . [118](#)

If the identified values of both processes differ from each other by more than 20°, please contact Lenze.



Detailed information on the respective function can be found in the following subchapters.

9.2.1 Selection of the PPI method for CiA mode

Parameter

Address	Name / setting range / [default setting]	Information
0x2C66:001	PPI mode for 0x6060: Selection • Setting can only be changed if the inverter is disabled.	Selection of the identification method for the CiA operating mode "pole position identification (PLI)(0x6060 = -12) ▶ CiA 402 device profile 211
	1 PPI 360°	▶ Pole position identification (PPI) 360° 118
	2 PPI min. movement	▶ Pole position identification (PPI) with minimum movement 122
	3 PPI without movement	▶ Pole position identification (PPI) without movement 125

9.2.2 Monitoring the pole position identification

If an error occurs during the pole position identification or if the pulse inhibit gets active (e.g. due to a short-time undervoltage), the process is stopped with disabling the inverter without the settings being changed.

If the motor was braked or blocked during the process, this will be detected at the end of the measurement and no change will be made (exception: "pole position identification PLI (without movement)").

The error response can be parameterised:

If an error occurs during the pole position identification,

- the procedure is stopped without the settings being changed.
- the response set in [0x2C60](#) is effected.

Parameter

Address	Name / setting range / [default setting]	Information
0x2C60	PPI monitoring: Response	Selection of the response triggered by the occurrence of an error during the pole position identification (PLI).
	0 No response	
	1 Fault	
	2 Warning	

9.2.3 Monitoring the validity of the pole position

Parameter

Address	Name / setting range / [default setting]	Information
0x2C65:001	PPI validation: Activation • Setting can only be changed if the inverter is disabled.	
	0 Off	
	1 On	
0x2C65:002	PPI validation: Settings	
	0 No action	
	1 Reset PPI validation bit	
	2 Set PPI validation bit	
0x2C65:003	PPI validation: Status • Read only	
	Bit 0 Pole position is valid	
0x2C65:004	PPI validation: Pole position set value -179.9 ... [0.0] ... 179.9 °	

Configuring the feedback system

Synchronous motor: Pole position identification (PPI)
Pole position identification (PPI) 360°



9.2.4 Pole position identification (PPI) 360°

NOTICE

Mechanical damage of the motor caused by hanging loads!

Possible consequences: Irreversible damage of the motor.

- ▶ The motor must not be braked or blocked during the pole position identification. Thus, this function must not be used for hanging loads!

NOTICE

Thermal overload of the motor!

The motor may be permanently damaged.

- ▶ Before executing the pole position identification, check that the following monitoring systems are parameterised correctly.
- ▶ [Motor overload monitoring \(\$i^2xt\$ \)](#)
- ▶ [Overcurrent monitoring](#)

NOTICE

- ▶ Please observe the following: [Synchronous motor: Pole position identification \(PPI\)](#)

Functional description

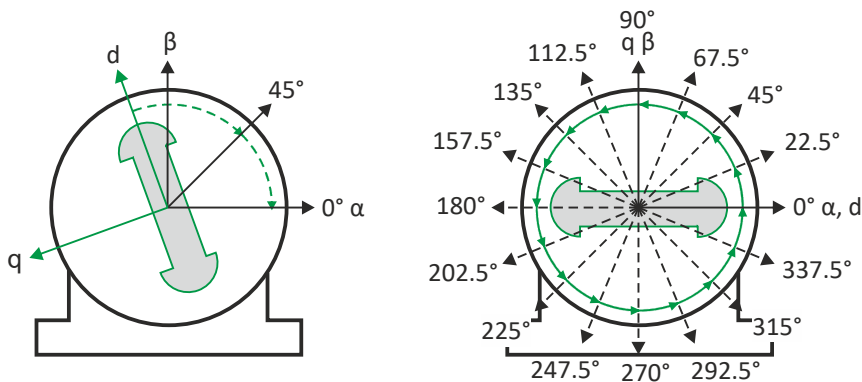



Configuring the feedback system

Synchronous motor: Pole position identification (PPI)
Pole position identification (PPI) 360°

If the servo control is set for synchronous motor and no error is pending, the current is first raised in a ramp-shaped manner to 141 % of the rated motor current after the inverter is enabled.

Left image

First, the rotor is moved from any position of rest to the 0° angle.

- For this purpose, the amplitude of the d current vector is created in the stator coordinate system at a starting angle of 45° and then turned to 0°.
- A sufficiently high amplitude of the d current vector and its rotary motion result in a magnetic force that moves the rotor to the angle 0°.

Right image

Afterwards, the d current vector is turned further in 15 steps by 22.5° each starting at the angle 0°.

- Due to the magnetic forces, the rotor adjusts to the respective angle.
- After 16 steps, the rotor has moved by absolute electrical 360°.

Result

For determining the pole position, a mean value is calculated from all 16 messages. The rotor displacement angle can be recorded via the [0x2DDE](#) parameter (actual motor rotor angle position). The detected pole position is stored in the inverter parameters, [0x2C03:0020x2C03:004](#). The detected pole position must then be saved.

Abort of the pole position identification

The pole position identification is aborted if the deviations between the rotary motion of the current vector and the rotor exceed the fault tolerance set in [0x2C41:004](#) ([check if parameter is available](#)).

Preconditions for the performance

- The motor must not be braked or blocked during the pole position identification.
- The servo inverter is error-free and in [Switched on](#) device state.

Response of the motor during performance

The rotor aligns during the pole position identification. The motor shaft moves by max. one electrical revolution which causes a corresponding movement of the connected mechanics!

How to execute the pole position identification PPI (360°):

1. If the servo inverter is enabled, disable it. [Enable operation](#)
2. Set the object [0x2825](#) to "5" to change to the "pole position identification PPI (360°)" operating mode.
3. Before the PPI can be started, the works mentioned below must be completed.
4. Enable the servo inverter to start the pole position identification (360°). Note: Inhibiting the controller serves to abort the started procedure any time if required without changing the settings.

After the pole position identification has been completed successfully...

...the controller is inhibited automatically and the pole position determined for the activated feedback system is set in the [0x2C03:002](#) object.

- Save the changed settings.
The »EASY Starter« serves to save the parameter settings of the servo inverter as parameter file (*.gdc). [Saving the parameter settings](#)
- The inverter disable set automatically by the procedure can be deactivated again via the CiA402 control word [0x6040](#). [Enable operation](#)

Configuring the feedback system

Synchronous motor: Pole position identification (PPI)
Pole position identification (PPI) 360°



Adapt pole position identification PLI (360°)

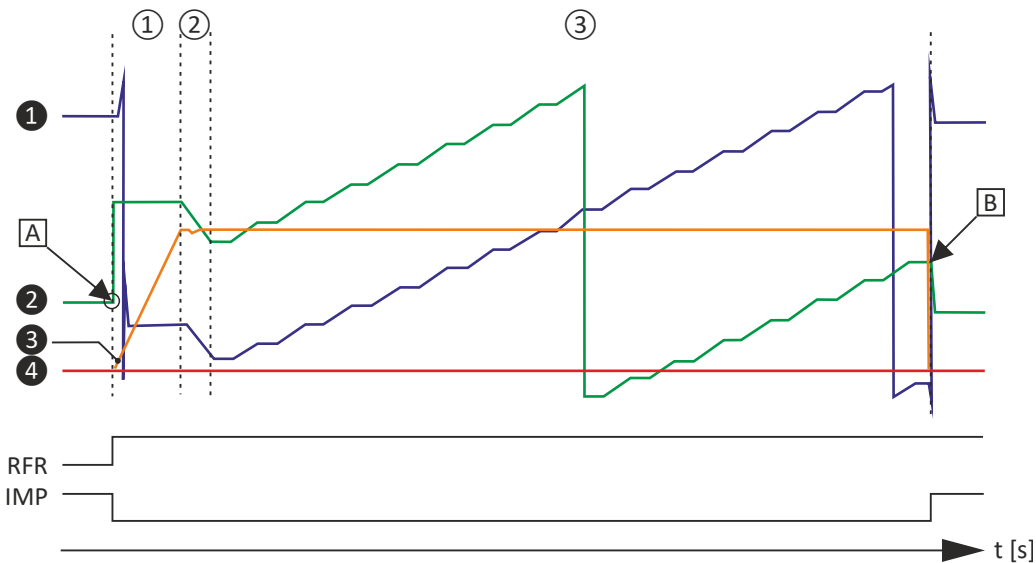

Fig. 4: Chronological sequence of the pole position identification

In case of drives with a high static friction, mass inertia or alternating load, an optimisation may be necessary:

- The amplitude of the current vector must be set so high that the motor with a high mass inertia can be accelerated.
- The cyclic continued rotation of the current vector by 22.5° has to cause an equivalent angular rotation of the motor shaft (rotor). A step function has to be achieved. Here, actual positions with very low overshoots are visible.

NOTICE

Thermal overload of the motor!

The motor may be permanently damaged.

- ▶ If no temperature monitoring is available in the motor, and/or the I^2xt motor monitoring and the maximum current monitoring are not parameterised correctly, the motor can be permanently damaged if the current amplitude is set too high!
- ▶ [Motor overload monitoring \(\$i^2xt\$ \)](#)
- ▶ [Overcurrent monitoring](#)

Overview of more objects available for

- Identification
- Triggering
- Diagnostics

Tip!

An oscilloscope serves to execute the optimisation



Configuring the feedback system

Synchronous motor: Pole position identification (PPI)

Pole position identification (PPI) 360°

Parameter	Subindex	Value/unit	INFO
0x2825	0	CiA402 mode active [0]	Operating modes [5] for PLI 360°
0x2824	0	Off [0], On [1]	
0x6040	0	0x0000	Simulation of the CiA state machine
0x2823	0	100	Progress bar
0x2C61:001	1	100 %	PLI(360°) current amplitude
0x2C61:002	2	40 s	PLI(360°) ramp time
0x2C61:003	3	Field: clockwise [0]	PLI(360°) direction of rotation
0x2C61:004	4	20°	PLI(360°) fault tolerance
0x2C61:005	5	4.81 A	Display
0x2C03:002	2	-90.0°	Detected pole position values
0x2C03:004	4	0.0°	
0x2DDE	0	1850	current rotor angle
0x2D83:002	2	0.03 A	Phase U current
0x2D83:003	3	0.04 A	Phase V current
0x2D83:004	4	-0.01 A	Phase W current
0x2DD1:003	3	0.00 A	Setpoint D current
0x2DD1:001	1	0.01 A	Current D current
0x6073	0	150.0 %	Max current
0x6075	0	3.400 A	Motor rated current, reference for 0x2C61:1
0x2D46:001	1	16.5 A	Overcurrent monitoring: threshold
0x2DDF:001	1	5.00 A	User info regarding rated current
0x2DDF:002	2	10.00 A	User info regarding maximum current

Parameter

Address	Name / setting range / [default setting]	Information								
0x2C61:001	Pole position identification (360°) settings: Current amplitude 1 ... [71] ... 1000 % <ul style="list-style-type: none"> Setting can only be changed if the inverter is disabled. 	Percentage adaptation of the current amplitude. <ul style="list-style-type: none"> For large machines and high mass inertia values or for linear direct drives, the current amplitude usually must be increased. Default setting 100 % \cong 141 % of Rated motor current (0x6075) <p>Note!</p> <p>If the current amplitude is set to > 100 %, the device utilisation (Ixt) monitoring and/or one of the motor monitoring functions may respond and cause the abort of the pole position identification.</p>								
0x2C61:002	Pole position identification (360°) settings: Ramp time 1 ... [40] ... 600 s <ul style="list-style-type: none"> Setting can only be changed if the inverter is disabled. 	Percentage adaptation of the ramp time. <ul style="list-style-type: none"> For large machines and high mass inertia values, the ramp time must be increased. For small machines, however, the pole position identification can be accelerated by reducing the ramp time. 								
0x2C61:003	Pole position identification (360°) settings: Direction of rotation <ul style="list-style-type: none"> Setting can only be changed if the inverter is disabled. <table border="1" style="margin-left: 20px;"> <tr> <td>0</td> <td>CW</td> </tr> <tr> <td>1</td> <td>CCW</td> </tr> <tr> <td>2</td> <td>CW + CCW</td> </tr> <tr> <td>3</td> <td>CCW + CW</td> </tr> </table>	0	CW	1	CCW	2	CW + CCW	3	CCW + CW	Selection of travel direction. In some situations, it may be helpful to reverse the travel direction for the pole position identification (e. g. for linear motor at the end stop).
0	CW									
1	CCW									
2	CW + CCW									
3	CCW + CW									
0x2C61:004	Pole position identification (360°) settings: Error tolerance 15 ... [20] ... 50 °	Setting of the fault tolerance for the plausibility check. <ul style="list-style-type: none"> If the rotor position detected via the encoder system is not within the tolerance zone around the position that is output in a controlled manner, the pole position identification is aborted and the parameterised error response is tripped. 								
0x2C61:005	Pole position identification (360°) settings: Absolute current amplitude <ul style="list-style-type: none"> Read only: x.xx A 	Display of the absolute current amplitude.								

Configuring the feedback system

Synchronous motor: Pole position identification (PPI)
Pole position identification (PPI) with minimum movement



9.2.5 Pole position identification (PPI) with minimum movement

NOTICE

Mechanical damage of the motor caused by hanging loads!

Possible consequences: Irreversible damage of the motor.

- ▶ The motor must not be braked or blocked during the pole position identification. Thus, this function must not be used for hanging loads!

NOTICE

Thermal overload of the motor!

The motor may be permanently damaged.

- ▶ Before executing the pole position identification, check that the following monitoring systems are parameterised correctly in order to prevent a permanent damage of the motor in the event of an error:

- ▶ ▶ [Motor overload monitoring \(i²xt\)](#)  189

- ▶ [Overcurrent monitoring](#)

Functional description

If servo control for synchronous motor is set and if no error is pending, the current position is memorised after controller enable, and the current is increased along a ramp for 10 s to 35 % of the rated motor current. This will cause the rotor to align, which, however, is compensated by a position control. If the rotor makes an electrical movement of more than 20°, an error message is output, and the value measured is discarded. This might occur in the case of motors with considerable detent torques.

If the current has reached its final value, a plausibility check is executed after a short interval: in order to detect a non-permissible blocking of the motor, a positive and a negative test angle ($\pm 20^\circ$) relative to the current position are defined after the identification. The motor must align itself to these two test angles within a tolerance of 25 %.

Conditions for the execution

- The motor must not be braked or blocked during the pole position identification.
- The servo inverter is error-free and in [Switched on](#) device state.

Response of the motor during performance

The motion of the motor will maximally correspond to the set "Max. permissible motion" (Lenze setting: 20°). If a greater motion is detected via the encoder system, the pole position identification is cancelled and the parameterised error response (Lenze setting: Fault) is triggered.

How to execute the pole position identification PLI (min. movement):

1. If the servo inverter is enabled, disable it. [Enable operation](#)
2. Set the object `0x2825` to "6" to change to the "pole position identification PLI (min. movement)" operating mode.
3. Enable the servo inverter to start the process.

Note: Inhibiting the controller serves to abort the started procedure any time if required without changing the settings.



After the pole position identification has been completed successfully...

...the controller is inhibited automatically and the pole position determined for the activated feedback system is set in the [0x2C03:002](#) object.

- Save the changed settings.
The »EASY Starter« serves to save the parameter settings of the servo inverter as parameter file (*.gdc). This file can then be imported in the »PLC Designer«. [Saving the parameter settings](#)
- The inverter disable set automatically by the procedure can be deactivated again via the CiA402 control word [0x6040](#). [Enable operation](#)

Adapt pole position identification PLI (min. movement)

The process of pole position identification described above can be adapted to the respective machine and the existing moments of inertia by using the parameters described in the following.

NOTICE

Thermal overload of the motor!

The motor may be permanently damaged.

- ▶ If no temperature monitoring is available in the motor, and/or the I^2xt motor monitoring and the maximum current monitoring are not parameterised correctly, the motor can be permanently damaged if the current amplitude is set too high!
- ▶ [Motor overload monitoring \(\$i^2xt\$ \)](#)
- ▶ [Overcurrent monitoring](#)

Parameter

Address	Name / setting range / [default setting]	Information
0x2C62:001	Pole position identification (min. movement) settings: Current amplitude 1 ... [25] ... 1000 % • Setting can only be changed if the inverter is disabled.	Percentage adaptation of the current amplitude. • For large machines, high mass inertia values or for linear direct drives, the current amplitude usually must be increased. • Default setting 25 % \equiv 35 % of Rated motor current (0x6075) Note! If the current amplitude is set to > 100 %, the device utilisation (Ixt) monitoring and/or one of the motor monitoring functions may respond and cause the abort of the pole position identification.
0x2C62:002	Pole position identification (min. movement) settings: Ramp time 1 ... [10] ... 600 s • Setting can only be changed if the inverter is disabled.	Percentage adaptation of the rate of current rise.
0x2C62:003	Pole position identification (min. movement) settings: Gain 0 ... [0] ... 1000 %	Adaptation of the proportional PI controller gain. With the Lenze setting "0 %", the PI controller works as an I controller.
0x2C62:004	Pole position identification (min. movement) settings: Reset time 0.1 ... [62.5] ... 6000.0 ms	Adaptation of the reset time of the PI controller. • In order to be able to compensate a positional variation faster, first the reset time should be reduced. If this does not result in the desired behaviour, the proportional gain can be increased. • Ensure that the position control does not get unstable. We therefore recommend you to use an I controller.

Configuring the feedback system

Synchronous motor: Pole position identification (PPI)

Pole position identification (PPI) with minimum movement



Address	Name / setting range / [default setting]	Information
0x2C62:005	Pole position identification (min. movement) settings: Max. move permitted 1 ... [20] ... 90 °	Adaptation of the permitted movement. <ul style="list-style-type: none">• The pole position identification comprises a monitoring function for the follow-up control. If a movement greater than the permissible movement set is detected by the encoder system, the pole position identification is aborted and the error response parameterised is tripped:• In order to detect a non-permissible blocking of the machine, a positive and negative test angle relative to the current position are defined after the identification. The machine must align itself to these two test angles within a tolerance of 25 %. The size of the test angle corresponds to the max. move permitted set here.
0x2C62:006	Pole position identification (min. movement) settings: Absolute current amplitude <ul style="list-style-type: none">• Read only: x.xx A	Display of the absolute current amplitude.



9.2.6 Pole position identification (PPI) without movement

The "Pole position identification (PLI) without movement" function can also be used if no motor revolution is possible (holding brake active).

NOTICE

With an incorrect parameter setting and dimensioning of the inverter, the maximum permissible motor current may be exceeded during the pole position identification.

Possible consequences: Irreversible damage of the motor

- ▶ Set the motor data correctly. ▶ [Motor data](#) 43
- ▶ Only use an inverter that is performance-matched to the motor.

DANGER!

Uncontrolled acceleration of the motor!

Undefined state of the feedback system, caused by wire breakage!

- ▶ Each pole position identification causes an update of the pole position set in the device! Therefore, ensure that the response to open circuit in the feedback system is set to Lenze setting "1: Fault" in [0x2C45](#)! Otherwise, the status of the feedback system in case of open circuit is undefined and the pole position can assume any value. There is a danger that the machine accelerates in an uncontrolled way after pole position identification!

NOTICE

Device state "switched-on"/"operation"

- ▶ The process of the pole position identification only lasts some milliseconds. During the pole position identification, the device status does not change. Only after the pole position identification, the [Operation enabled](#) device status changes to the [Operation enabled](#) device status.
- ▶ If pole position identification is started via parameter [0x2825](#), the inverter is automatically disabled at the end of the pole position identification process.

Conditions

- The wiring of the three motor phases and the motor encoder must be carried out according to the specifications from the mounting instructions.
- The inverter is ready for operation (no fault active).
- For the pole position identification (PPI) without movement, the motor must be at standstill.

NOTICE

- ▶ During the pole position identification, the error [0xFF13](#) ("identification cancelled") may occur. This may be an indication that the motor features are not suitable for this PLI process.

Functional description

After inverter enable, a defined pulse pattern is output that provides currents up to approx. maximum motor current. The respective currents are measured. Based on these currents, the field distribution can be detected so that the pole position can be calculated. Then, the inverter is automatically disabled.

The pole position identification PLI (without movement) does not need any parameterisation.

Configuring the feedback system

Synchronous motor: Pole position identification (PPI)
 Pole position identification (PPI) without movement



Preconditions for the performance

- The wiring of the three motor phases and the feedback must be carried out in accordance with the specifications from the hardware manual.
- The motor may be stalled.
- The servo inverter is error-free and in [Switched on](#) device state.
- Please observe the notes in the [Synchronous motor: Pole position identification \(PPI\)](#) section.

Response of the motor during performance

The current test pulses cause audible engine noises that may be increased by the machine mechanics depending on the mechanical coupling!

How to execute the pole position identification PLI (without movement):

1. If the servo inverter is enabled, disable it. [Enable operation](#)
2. Set the object `0x2825` to "7" to change to the "pole position identification PLI (without movement)" operating mode.
3. Enable the servo inverter to start the process.

Note: Inhibiting the controller serves to abort the started procedure any time if required without changing the settings.

After the pole position identification has been completed successfully...

...the controller is inhibited automatically and the pole position determined for the activated feedback system is set in the `0x2C03:002` object.

- For permanent storage, the changed settings from the servo inverter must be uploaded in the Controller.

The »EASY Starter« serves to save the parameter settings of the servo inverter as parameter file (*.gdc). [Saving the parameter settings](#)

- The inverter disable set automatically by the procedure can be deactivated again via the CiA402 control word `0x6040`. [Enable operation](#)

Optional settings (starting performance)

Optionally, a pole position identification without motion can be activated after switching on the servo inverter.

Parameter

Address	Name / setting range / [default setting]	Information
0x2C63:001	PPI without movement: Execution <ul style="list-style-type: none"> • Setting can only be changed if the inverter is disabled. 	Start behavior (with or without pole position identification before the start).
	0 Disabled	No pole position is identified.
	1 Only after 1st enable/encoder error	After the first controller enable and after each encoder wire breakage, a PLI without movement takes place. ⚠ CAUTION! After an encoder wire breakage, the drive may accelerate in an uncontrolled manner subsequent to the pole position identification. <ul style="list-style-type: none"> • Cause: In case of a wire breakage, the feedback system state is undefined and the pole position assumes any value. • Remedy: Set the error response "Trouble" (<code>0x2C450x2C45 = 2</code>) for an encoder wire breakage in order that the pole position will be identified after a wire breakage.
2 After each enable	After every inverter release, the pole position is identified without any movement.	
0x2C63:002	PPI without movement: Current adjust factor 50 ... [100] ... 500 % <ul style="list-style-type: none"> • Setting can only be changed if the inverter is disabled. 	



9.3 Cable check

This function serves to detect wiring errors or cable damage which can cause uncontrolled movements of the machine during the commissioning phase or during operation. The function therefore helps to prevent machine damage and serves to correct these errors as quickly as possible.

The **Cable Check** function should be executed manually by the user while the machine is commissioned, in order to identify typical errors that may occur during the machine installation.

Typical errors

- The motor encoders are connected to the wrong device before initial switch-on, whereas the motor is connected to the right device. If the motor encoders that are incorrectly connected are of the same type, the motor encoder monitoring does not detect any error.
- The motor encoders are connected to the right device, however, the motor is connected to the wrong device.
- The connection of the motor phases to the device is reversed.
- Individual wires of the rotary transducer are connected incorrectly.

Configuring the feedback system

Cable check



How to manually execute the Cable Check function:

Preconditions

- The motor can remain coupled to the kinematics.
 - In the case of drives without a motor holding brake, the rotor must be able to move by 20 ° (electrically). This makes it necessary to set the operating mode of the motor holding brake to "No brake connected". `0x2820:001 ▶ 0x2820:001 = 2`
 - In the case of drives with a motor holding brake, the test is performed against the closed motor holding brake. In the following parameter, the operating mode must be set to 0 or 1. `0x2820:001 ▶ 0x2820:001`
- The device must not be in the Fault state.
- 24 V supply voltage must be available.
- The display on the front of the blue LED shows ON or is blinking.
- The device must be supplied with mains voltage. Parameter status `0x6041, Bit 4` `0x6041, Bit 4 = TRUE`
- The device must not be in the STO state. The safety functions must be parameterized. Parameter status: `0x6041, Bit 15` `0x6041, Bit 15 = FALSE`
- The motor data must be set correctly.
- No error message must be active. Parameter status: `0x6041, Bit 3` `0x6041, Bit 3 = FALSE`. If an error message is active, first remove these errors and reset the error message.
- The motor control must be set to:
 - Servo control - synchronous motor (SM) or
 - Servo control - asynchronous motor (ASM)The function only supports these two motor controls.
- The behavior after switch-on must be set. `0x2C64 = 0`.

1. Open the »EASY Starter« engineering tool.
2. Establish an online connection to the device.
3. Call the **Motor commissioning** tab in the workspace of the »EASY Starter«.
4. Call the **Feedback** tab there.
5. In the jalousie **Cable check: Motor and motor encoder**, execute the **Cable Check** function. The Cable Check function is now activated.
6. Activate the device via the CiA402 control word `0x6040 ▶ 0x6040` or `0x6048` `0x6048` for axis B

Execution of the function is indicated as completed in the »EASY Starter« after approx. one second. Additionally, the »EASY Starter« indicates whether an error has occurred during the check:



The **Cable Check** function can always be started via the **Execute Cable Check** button if the preconditions for this are met.

No error detected by the Cable Check function

The device changes to the "**Operation enabled**" state.

- Deactivate the device. e.g. via the control word. You can do this using keys F8 / F9 in the »EASY Starter«.
- Deactivate the Cable Check function via the parameter and set a selection other than 15. `0x2825` `0x2825`

Error detected by the Cable Check function

If the Cable Check function detects an error, the i700 servo inverter automatically changes to the Fault status.



How to remove errors:

1. Consult the logbook to identify the error causes.
2. Switch off the power supply and 24 V supply of the device.
3. Check the wiring and correct it, if necessary.
4. Execute the test again.



The "Identification" status word is also used by other functions. The display is therefore only valid as long as no other function using this status word is active.
0x28320x2832

During operation, the Cable Check function can be automatically executed by the device itself, in order to detect damage on the motor or motor encoder already when the machines are switched on.

Damage during operation

Typical damage that may occur during operation

- Wire breakage on the motor encoder and/or motor cable
- Whole motor encoder cable and/or motor cable torn off
- Screwed connections that are loosening
- Loose contacts

Starting condition for the Cable Check

The following starting conditions can be set for the automatic Cable Check function:

- Check only at initial switch-on or after motor encoder error 0x2641:001 0x2641:001 = 1
- Check after every switch-on 0x2641:0010x2641:001 = 2



Observe the line diagrams for configuring the controller.

Configuring the feedback system

Cable check



How to carry out the Cable check automatically

Preconditions

- The motor can remain coupled to the kinematics.
 - In the case of drives without a motor holding brake, the rotor must be able to move by 20 ° (electrically). This makes it necessary to set the operating mode of the motor holding brake to "No brake connected". `0x2820:001 ▶ 0x2820:001 = 2`
 - In the case of drives with a motor holding brake, the test is performed against the closed motor holding brake. In the following parameter, the operating mode must be set to 0 or 1. `0x2820:001 ▶ 0x2820:001`
 - The device must not be in the Fault state.
 - 24 V supply voltage must be available.
 - The display on the front of the blue LED shows ON or is blinking.
 - The device must be supplied with mains voltage. Parameter status `0x6041, Bit 4` `0x6041, Bit 4 = TRUE`
 - The device must not be in the STO state. The safety functions must be parameterized. Parameter status: `0x6041, Bit 15` `0x6041, Bit 15 = FALSE`
 - The motor data must be set correctly.
 - No error message must be active. Parameter status: `0x6041, Bit 3` `0x6041, Bit 3 = FALSE`. If an error message is active, first remove these errors and reset the error message.
 - The motor control must be set to:
 - Servo control - synchronous motor (SM) or
 - Servo control - asynchronous motor (ASM)The function only supports these two motor controls.
 - The behavior after switch-on must be set. `0x2C64 = 0`.
1. Open the »EASY Starter« engineering tool.
 2. Establish an online connection to the device.
 3. Call the **Motor commissioning** tab in the workspace of the »EASY Starter«.
 4. Call the **Feedback** tab there.
 5. In the jalousie **Cable check: Motor and motor encoder**, execute the **Cable Check** function. The Cable Check function is now activated.
 6. In a last step, changed settings must be saved with mains failure protection.



When the pole position identification is set after every switch-on and Cable Check, the pole position identification is carried out first, followed by the Cable Check.

Depending on the parameter setting in `0x2C64:1`, the Cable Check starts automatically if the controller activates operation of the device via the CiA402 control word. The check takes approx. one second. During this time, `0x2C64, bit 1` is = TRUE. A possibly available motor holding brake remains closed. In this case, the rotor is moved against the closed motor holding brake. If no motor holding brake is available, the rotor of the motor is moved electrically by approx. 20 °. The device remains in the switched-on state until the cable check has been completed.



The Cable Check function can always be started via the Execute Cable Check button if the preconditions for this are met.

Possible error sources

- Failure of a motor phase
- Incorrect direction of rotation detected.



Parameter

Address	Name / setting range / [default setting]	Information
0x2C64:001	Cable Check: Behavior after switch on <ul style="list-style-type: none">Setting can only be changed if the inverter is disabled.	
	0 No action	
	1 Check at first switch on/after feedback error	
	2 Check at every switch on	
0x2C64:002	Cable Check: Status word <ul style="list-style-type: none">Read only	
	Bit 0 Cable check enabled	
	Bit 1 Cable check running	
	Bit 2 Cable check completed	
	Bit 3 Cable check failed	



10 Configuring the motor control

This chapter contains all functions and settings relevant for the motor control.

Basic procedure of commissioning the motor control

In the first step, the rated data of the motor must be set. The other steps depend on the respective application case.

There are several options for setting the motor data and optimising the control loops. Basically, you can select between a manual and an automatic process. Whether a setting can be applied or not depends on the motor (Lenze motor yes/no) and the application. If possible, use the possible setting listed first in the following diagram since this one leads to the most accurate results.

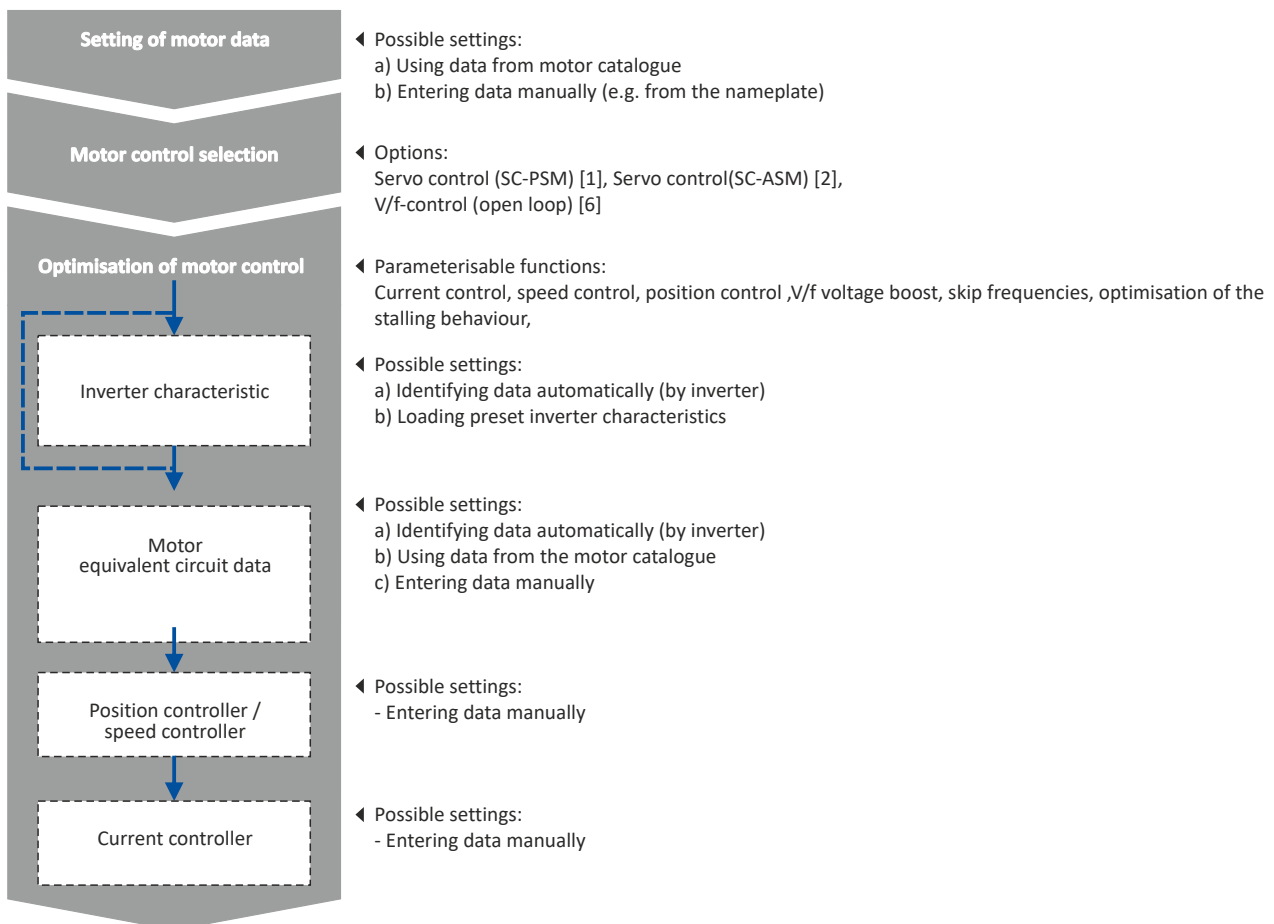



10.1 Servo control for synchronous motor (SC-PSM)

The motor control is based on a feedback, field-oriented and cascaded controller structure and enables a dynamic and stable operation in all four quadrants.

Preconditions

- The servo control (SC-PSM) is only suitable for synchronous motors.
- The servo control (SC-PSM) requires a feedback of the position.

10.1.1 Required commissioning steps

1. Check wiring by means of manual test modes: [Testing the motor control](#) 📖 202
2. Activate motor control type: `0x2C00` = "Servoregelung (SC-PSM) [1]".
3. Set motor data: [Motor data](#) 📖 43
4. Set motor monitoring:
 - [Motor temperature monitoring](#) 📖 197
5. [Configuring the feedback system](#) 📖 97
6. Only required for motors of other manufacturers:
 - Set and optimise current controller: [Current controller](#) 📖 166
 - [Correction of the stator leakage inductance \(Lss\)...](#) 📖 176
 - [Synchronous motor: Pole position identification \(PPI\)](#) 📖 116
7. Only required for an automatic calculation of the speed controller parameters:
 - Define total moment of inertia: [Tuning of the motor and the speed controller](#) 📖 157
8. Set speed controller: [Speed controller](#) 📖 163.
9. Set position controller: [Position controller](#) 📖 173
10. Optional: [Synchronous motor \(SM\): Compensate temperature and current influences](#) 📖 181
11. Optional: [Jerk limitation](#) 📖 185
12. Optional: [Notch filter \(band-stop filter\)](#) 📖 186
13. Optional: [Short-circuit braking](#) 📖 150

Configuring the motor control

Servo control for asynchronous motor (SC-ASM)
Required commissioning steps



10.2 Servo control for asynchronous motor (SC-ASM)

The motor control is based on a feedback, field-oriented and cascaded controller structure and enables a dynamic and stable operation in all four quadrants.

Preconditions

- The servo control (SC ASM) is only suitable for asynchronous motors.
- The servo control (SC ASM) requires a feedback of the position.

10.2.1 Required commissioning steps

1. Check wiring by means of manual test modes: [Testing the motor control](#) 1202
2. Activate motor control type: `0x2C00` = "Servo control (SC ASM) [2]".
3. Set motor data: [Motor data](#) 43
4. [Configuring the feedback system](#) 97
5. Only required for motors of other manufacturers:
 - Set and optimise current controller: [Current controller](#) 166
 - [Correction of the stator leakage inductance \(Lss\)...](#) 176
6. Only required for an automatic calculation of the speed controller parameters:
 - Define total moment of inertia: [Tuning of the motor and the speed controller](#) 157
7. Set speed controller: [Speed controller](#) 163.
8. Set position controller: [Position controller](#) 173
9. Only required for motors of other manufacturers:
 - Set field controller: [ASM field controller](#) 169
 - Set field weakening controller: [ASM field weakening controller](#) 170
10. Optional: [Correction of the stator leakage inductance \(Lss\)...](#) 176
11. Optional: [Asynchronous motor \(ASM\): Identifying Lh saturation characteristic](#) 182
12. Optional: [Estimate optimum magnetising current](#) 184
13. Optional: [Jerk limitation](#) 185
14. Optional: [Notch filter \(band-stop filter\)](#) 186
15. Optional: [DC braking](#) 149



10.3 Sensorless control for synchronous motor (SL-PSM)

10.3.1 Expert settings

Parameter

Address	Name / setting range / [default setting]	Information
0x2C11:001	High speed range: Lower limit 10 ... [20] ... 100 %	Definition of the lower limit of the high speed range. <ul style="list-style-type: none"> The lower limit has a permanent hysteresis of 5 %.
0x2C11:002	High speed range: Tracking controller gain 0 ... [250] ... 65535 %	Gain factor for tracking the rotor position in the motor model.
0x2C11:003	High speed range: Tracking controller reset time 0.00 ... [6.00] ... 655.35 ms	Reset time for tracking the rotor position in the motor model.
0x2C11:004	High speed range: Tracking controller decouple time 0.00 ... [0.00] ... 655.35 ms	Temporal hysteresis for the switching back and forth from the open-loop controlled to the closed-loop controlled operation.
0x2C12:001	SM low speed range: Acceleration current 0 ... [100] ... 400 %	R.m.s. current value for acceleration processes in the lower velocity range. <ul style="list-style-type: none"> 100 % = Rated motor current (0x6075) In the lower speed range and during the acceleration phase, the current setpoints of 0x2C12:001 and 0x2C12:002 are added and injected to the motor.
0x2C12:002	SM low speed range: Standstill current 0 ... [20] ... 400 %	R.m.s. current value for processes without acceleration (for instance standstill or constant setpoint speed) in the lower velocity range. <ul style="list-style-type: none"> 100 % = Rated motor current (0x6075) In the lower speed range and during the acceleration phase, the current setpoints of 0x2C12:001 and 0x2C12:002 are added and injected to the motor. <p>Note! At the "100 %" setting, a motor current flows at standstill and at constant speed. The r.m.s. value of this motor current is greater than the rated motor current by a factor of $\sqrt{2}$ at standstill. The reason for this is that a DC current is injected into the synchronous motor at a standstill. The correct rated motor current flows when the motor turns.</p>

Configuring the motor control

Sensorless vector control (SLVC)
Expert settings



10.4 Sensorless vector control (SLVC)

10.4.1 Expert settings

Parameter

Address	Name / setting range / [default setting]	Information
0x2B40:003	SLVC: Q-Feedforward 0.00 ... [0.00] ... 10000.00	Feedforward control for the SLVC Q controller.
0x2B40:004	SLVC: D-Feedforward 0.00 ... [0.00] ... 10000.00	Feedforward control of the SLVC-D controller.



10.5 V/f characteristic control for asynchronous motor (VFC open loop)

The V/f characteristic control is a motor control for conventional frequency inverter applications. It is based on a simple and robust control mode for the operation of asynchronous motors with a linear or square-law load torque characteristic (e.g. fan). Because of the minimal parameterisation effort, such applications can be commissioned easily and quickly.

Preconditions

- The V/f characteristic control is only suitable for asynchronous motors.
- If you want to actuate a drive with a square-law V/f characteristic: Please always check whether the corresponding application is suitable for operation with a square-law V/f characteristic!
- Set the motor data according to the information on the nameplate of the motor. ▶ [Motor data](#) 43

10.5.1 Required commissioning steps

1. Check wiring by means of manual test modes. ▶ [Testing the motor control](#) 202
2. Activate motor control type: `0x2C00` = "V/f characteristic control (VFC open loop) [6]".
3. Set limiting factors for the V/f characteristic:
 1. `0x2540:001`, Rated mains voltage
 2. `0x2B01:001`, Base voltage
 3. `0x2B01:002`, Base frequency
4. Set and optimise current controller ▶ [Current controller](#). 166
Setting and optimising the current controller is only required if at least one of the following functions is active:
 - Voltage vector control ▶ [Activate voltage vector control \(Imin controller\)](#) 142
 - DC braking ▶ [DC braking](#) 149
 - Flying restart function ▶ [Flying restart circuit](#) 147
5. Select a characteristic shape suitable for the application ▶ [Define V/f characteristic shape](#). 139
6. [Set voltage boost](#) 143
7. [Activate voltage vector control \(Imin controller\)](#) 142
8. [I_{max} controller](#) 172
9. Optional ▶ [Set load adjustment](#) 144
10. Optional ▶ [Flying restart circuit](#) 147
11. Optional ▶ [Set slip compensation](#) 144
12. Optional ▶ [Set oscillation damping](#) 145

Configuring the motor control

V/f characteristic control for asynchronous motor (VFC open loop)
Basic setting



10.5.2 Basic setting

The base voltage and the base frequency define the ratio of the two variables and thus the gradient of the V/f characteristic.

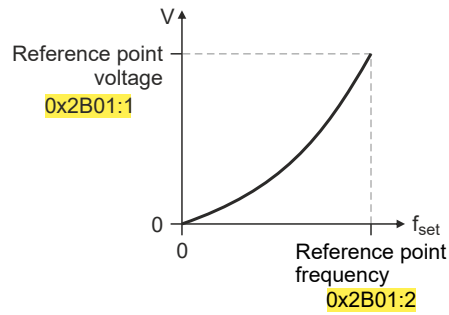
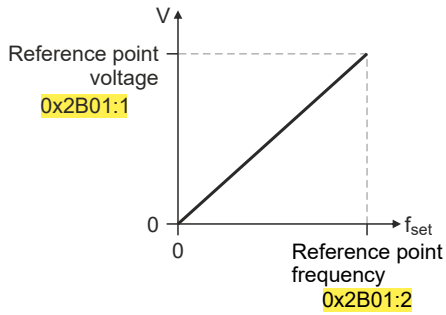

Parameter

Address	Name / setting range / [default setting]	Information
0x2B01:001	V/f shape data: Base voltage 0 ... [225] ... 5000 V	Base voltage and base frequency define the V/f ratio and thus the gradient of the V/f characteristic.
0x2B01:002	V/f shape data: Base frequency 0 ... [270] ... 5000 Hz	<ul style="list-style-type: none">The V/f base voltage is usually set to the rated motor voltage 0x2C01:007.The V/f base frequency is usually set to the rated motor frequency 0x2C01:005.



10.5.3 Define V/f characteristic shape

For adaptation purposes to different load profiles, you can select the shape of the characteristic:

Parameter

Address	Name / setting range / [default setting]	Information
0x2B00	V/f characteristic shape <ul style="list-style-type: none"> Setting can only be changed if the inverter is disabled. 	Selection of the V/f characteristic shape for the adaptation to different load profiles.
	0 Linear	Linear characteristic for drives with constant load torque over the speed. ▶ Linear V/f characteristic □ 139
	1 Quadratic	Square-law characteristic for drives with a square-law load torque over the speed. <ul style="list-style-type: none"> Square-law V/f characteristics are preferably used for centrifugal pumps and fan drives. Please always check whether the corresponding application is suitable for operation with a square-law V/f characteristic! If your pump drive or fan drive is not suitable for operation with a square-law V/f characteristic, use the linear V/f characteristic instead. ▶ Square-law V/f characteristic □ 139
	2 Adaptive	User-definable characteristic with 3 grid points.
	3 Eco	Linear characteristic with energy optimisation in the partial load operational range.

10.5.3.1 Linear V/f characteristic

The linear V/f characteristic leads to a constant torque.

10.5.3.2 Square-law V/f characteristic

The square-law V/f characteristic is typically used in heating, ventilation and climate applications to control the speed of fans and centrifugal pumps.

Configuring the motor control

V/f characteristic control for asynchronous motor (VFC open loop)
 Define V/f characteristic shape
 User-definable V/f characteristic



10.5.3.3 User-definable V/f characteristic

The "user-definable V/f characteristic" is provided for the individual adjustment of the motor magnetisation to the actual application if linear and square-law characteristics are not suitable.

- The characteristic is defined by means of 11 parameterisable grid points (voltage/frequency values).
- In the Lenze setting the 11 grid points represent a linear characteristic:

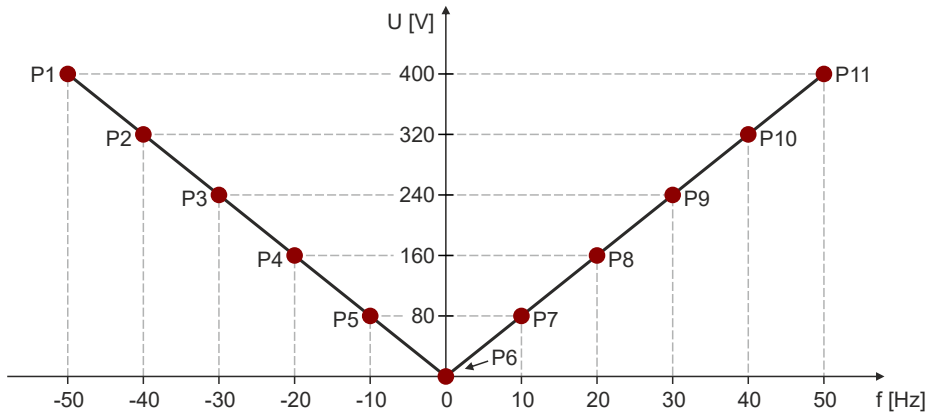

	P1	P2	P3	P4	P5	P6	P7	P8	P9	P10	P11
V	400 V	320 V	240 V	160 V	80 V	0 V	80 V	160 V	240 V	320 V	400 V
f	-50 Hz	-40 Hz	-30 Hz	-20 Hz	-10 Hz	0 Hz	10 Hz	20 Hz	30 Hz	40 Hz	50 Hz

Parameter

Address	Name / setting range / [default setting]	Information
0x2B02:001	Frequency grid points (x) user V/f characteristic: x1 = f01 -5000 ... [-50] ... 5000 Hz	Freely parameterizable V/f characteristic (values for X axis). These settings define the adaptive frequency values.
0x2B02:002	Frequency grid points (x) user V/f characteristic: x2 = f02 -5000 ... [-40] ... 5000 Hz	
0x2B02:003	Frequency grid points (x) user V/f characteristic: x3 = f03 -5000 ... [-30] ... 5000 Hz	
0x2B02:004	Frequency grid points (x) user V/f characteristic: x4 = f04 -5000 ... [-20] ... 5000 Hz	
0x2B02:005	Frequency grid points (x) user V/f characteristic: x5 = f05 -5000 ... [-10] ... 5000 Hz	
0x2B02:006	Frequency grid points (x) user V/f characteristic: x6 = f06 -5000 ... [0] ... 5000 Hz	
0x2B02:007	Frequency grid points (x) user V/f characteristic: x7 = f07 -5000 ... [10] ... 5000 Hz	
0x2B02:008	Frequency grid points (x) user V/f characteristic: x8 = f08 -5000 ... [20] ... 5000 Hz	
0x2B02:009	Frequency grid points (x) user V/f characteristic: x9 = f09 -5000 ... [30] ... 5000 Hz	
0x2B02:010	Frequency grid points (x) user V/f characteristic: x10 = f10 -5000 ... [40] ... 5000 Hz	
0x2B02:011	Frequency grid points (x) user V/f characteristic: x11 = f11 -5000 ... [50] ... 5000 Hz	



Configuring the motor control

V/f characteristic control for asynchronous motor (VFC open loop)
 Define V/f characteristic shape
 User-definable V/f characteristic

Address	Name / setting range / [default setting]	Information
0x2B03:001	Voltage grid points (y) user V/f characteristic: y1 = U01 (x = f01) 0.00 ... [400.00] ... 1000.00 V	Freely parameterizable V/f characteristic (values for Y axis). These settings define the adaptive voltage values.
0x2B03:002	Voltage grid points (y) user V/f characteristic: y2 = U02 (x = f02) 0.00 ... [320.00] ... 1000.00 V	
0x2B03:003	Voltage grid points (y) user V/f characteristic: y3 = U03 (x = f03) 0.00 ... [240.00] ... 1000.00 V	
0x2B03:004	Voltage grid points (y) user V/f characteristic: y4 = U04 (x = f04) 0.00 ... [160.00] ... 1000.00 V	
0x2B03:005	Voltage grid points (y) user V/f characteristic: y5 = U05 (x = f05) 0.00 ... [80.00] ... 1000.00 V	
0x2B03:006	Voltage grid points (y) user V/f characteristic: y6 = U06 (x = f06) 0.00 ... [0.00] ... 1000.00 V	
0x2B03:007	Voltage grid points (y) user V/f characteristic: y7 = U07 (x = f07) 0.00 ... [80.00] ... 1000.00 V	
0x2B03:008	Voltage grid points (y) user V/f characteristic: y8 = U08 (x = f08) 0.00 ... [160.00] ... 1000.00 V	
0x2B03:009	Voltage grid points (y) user V/f characteristic: y9 = U09 (x = f09) 0.00 ... [240.00] ... 1000.00 V	
0x2B03:010	Voltage grid points (y) user V/f characteristic: y10 = U10 (x = f10) 0.00 ... [320.00] ... 1000.00 V	
0x2B03:011	Voltage grid points (y) user V/f characteristic: y11 = U11 (x = f11) 0.00 ... [400.00] ... 1000.00 V	

Configuring the motor control

V/f characteristic control for asynchronous motor (VFC open loop)
Activate voltage vector control (Imin controller)



10.5.4 Activate voltage vector control (Imin controller)

The voltage vector control is used if a comparatively high starting torque must be provided. This function ensures that the required motor current is maintained in the lower speed range.

NOTICE

The boost function described here adds to the [▶ Set voltage boost function](#). [143](#)

Only set one of the two "boost" functions.

- ▶ Recommendation: torque increase in the lower speed range
- ▶ Take into consideration that the increased current at low speeds also entails higher heat losses of the motor.

- The voltage vector control is activated by defining a current setpoint.
- For the automatic calculation of the control parameters, the "Calculate Imin controller" function is provided via parameter .

Parameter

Address	Name / setting range / [default setting]	Information
0x2822:018	Axis commands: Calculate Imin controller parameter	V/f operation: Calculate minimum current controller parameters.
	0 Off/Ready	
	1 On/Start	
	2 In progress	
	3 Action cancelled	
	4 No access	
5 No access (Device disabled)		
0x2B04	V/f boost controller - current setpoint 0.00 ... [0.00] ... 500.00 A	Setting of the current setpoint for the voltage vector control. <ul style="list-style-type: none">• The setting "0.00 A" deactivates the voltage vector control.• When defining the current setpoint, we recommend you to provide a reserve of 20 % in order to largely exclude a "stalling" of the motor caused by unexpected additional loads.• Example for starting torque = rated motor torque: Set the current setpoint to approx. 120 % of the load current.
0x2B05:001	V/f boost controller settings: Gain 0.00 ... [148.21] ... 750.00 V/A	Setting of the gain for the voltage vector control.
0x2B05:002	V/f boost controller settings: Reset time 0.01 ... [3.77] ... 2000.00 ms	Setting of the reset time for the voltage vector control.
0x2B05:003	V/f boost controller settings: Dynamic current setpoint 0.00 ... [0.00] ... 500.00 A	



10.5.5 Set voltage boost

As an alternative for the “[Activate voltage vector control \(I_{min} controller\)](#)” function, a constant, load-independent voltage boost can be specified for low speeds (below the V/f rated frequency) or for a motor standstill in order to optimize the starting performance.

⚠ WARNING!

Insufficient cooling of the motor due to longer operation at standstill.

If the motor is operated at standstill for a longer time - especially in case of smaller motors - the motor can be destroyed by overtemperature!

- ▶ Connect the PTC thermistor (single sensor according to DIN 44081 or triple sensor according to DIN 44082) or thermal contact (normally-closed contact) ▶ [Motor temperature monitoring](#). 📄 197
- ▶ Parameterise and activate the ▶ [Motor overload monitoring \(i²xt\)](#). 📄 189

NOTICE

The voltage boost is added to the function ▶ [Activate voltage vector control \(I_{min} controller\)](#). 📄 142

Only set one of the two "boost" functions.

Recommendation: voltage vector control



For magnetising the motor, consider a sufficient time from the controller enable to the start of the speed ramp function generator. The bigger the motor the longer the time required for magnetisation. A motor with a power of 90 kW requires up to 2 seconds.

Depending on the required starting torque, the voltage boost must be set so that the required motor current will be available after controller enable.

- The voltage boost can be calculated by multiplying the stator resistance by the rated magnetising current:

$$\text{Starting current} \sim V_{\text{Boost}} = R_s \times I_{\text{mN}}$$

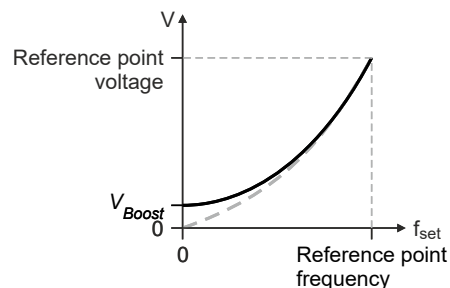
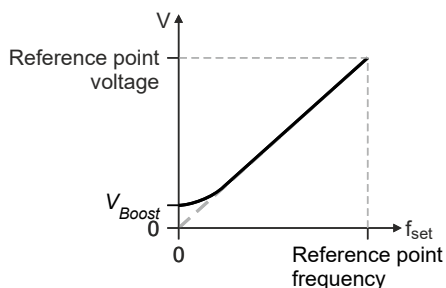

- Optionally, the voltage boost can be determined empirically by increasing the setting until the rated magnetising current flows.
- The voltage boost is added geometrically to the voltage of the characteristic:

$$V = \sqrt{V_{\text{characteristic}}^2 + V_{\text{Boost}}^2}$$

Parameter

Address	Name / setting range / [default setting]	Information
0x2B06	Voltage boost 0.0 ... [0.0] ... 100.0 V	Setting of the voltage boost for the voltage vector control.

Configuring the motor control

V/f characteristic control for asynchronous motor (VFC open loop)
Set load adjustment



10.5.6 Set load adjustment

CAUTION!

If the load adjustment is too high, the motor current may increase in idle state and the motor may overheat!

Parameter

Address	Name / setting range / [default setting]	Information
0x2B07:001	Load adaption: Direction of rotation • Setting can only be changed if the inverter is disabled.	Selection for adapting the characteristic as a function of the load in case of CW and CCW rotation.
	0 Passive load	
	1 Active load CCW	
	2 Active load CW	
0x2B07:002	Load adaption: Load adaption value 0.00 ... [20.00] ... 200.00 %	Setting of the load adaptation in [%] proportionally to the rated motor torque to obtain an appropriately "rigid" drive behavior even after start-up. • For starting torque = rated motor torque, a load adaptation of 50 % is suitable for most applications.

10.5.7 Set slip compensation

The speed of an asynchronous motor decreases as load is applied. This load-dependent speed drop is called "slip". The slip compensation serves to counteract the load-dependent speed loss.



Observe correct parameterisation of the rated motor frequency [0x2C01:005](#) and the rated motor speed [0x2C01:004](#). Both parameters serve to calculate the rated motor slip.

Parameter

Address	Name / setting range / [default setting]	Information
0x2B09:001	Slip compensation: Gain -200.00 ... [0.00] ... 200.00 %	Adjustment in percent of the slip calculated. • For instance required for deviations of the real motor data from the nameplate data. • A setting of 100 % corresponds to the rated slip of the machine in the nominal operating point.
0x2B09:002	Slip compensation: Filter time 1 ... [2000] ... 6000 ms	Filter time for the slip compensation.



10.5.8 Set oscillation damping

The oscillation damping serves to reduce the oscillations during no-load operation which are caused by energy oscillating between the mechanical system (mass inertia) and the electrical system (DC bus). Furthermore, the oscillation damping can also be used to compensate for resonances.



Damping is possible only for constant oscillations at a steady-state operating point.

Oscillations occurring sporadically cannot be damped.

Oscillation damping is not suitable for oscillations occurring during dynamic processes (e.g. accelerations or load changes). Oscillation damping is only active if the setpoint speed is greater than 10 rpm and the DC-bus voltage exceeds a value of 100 V.

The determination of the oscillation is based on the active current. In order to obtain the alternating component of the active current, this current is differentiated. This signal is then passed through a PT1 filter.

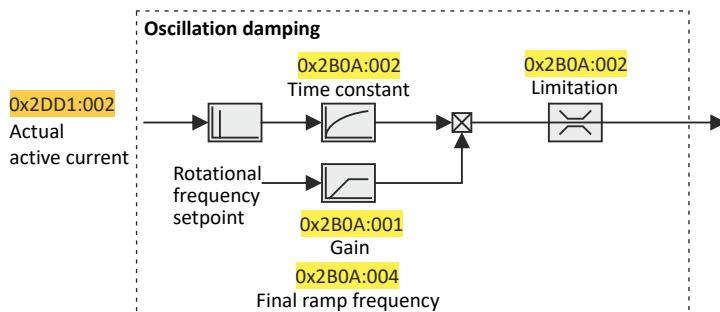

Identification of the oscillation

Before the oscillation damping can be parameterised, the oscillation must be identified. One option is to look at the motor current when the oscillation damping is switched off (gain = 0 %). The oscilloscope function of the »PLC Designer« enables to record the following currents:

- Q current 0x2DD1:002
- Total current 0x2DD1:005

A passive load and continuous operation with constant speed (steady-state operation) result in a constant current. If the drive oscillates, the motor current oscillates as well. This makes it possible to detect the frequency and amplitude of the oscillation by means of the AC component in the motor current. Hereinafter this AC component will be referred to as "current oscillation".

Configuring the motor control

V/f characteristic control for asynchronous motor (VFC open loop)
Optimising the stalling behaviour



Parameter setting

The gain of the oscillation damping is to be set according to the following equation:

$$\text{oscillation damping gain} = \frac{\text{current amplitude}}{\sqrt{2} \times \text{max. device current}} \times 100\%$$

The time constant must be set so that the oscillation can be dampened, but that higher-frequency components are filtered from the signal. The time constant is determined from the reciprocal value of the double current oscillation frequency:

$$\text{time constant} = \frac{1}{2 \times \text{oscillation frequency}}$$

The calculated oscillation frequency can be limited before being added to the rotating field frequency. The maximum frequency can be derived from the amplitude of the current oscillation, the rated motor current and the slip frequency of the connected motor:

$$\text{max. frequency} = \frac{2 \times \text{current oscillation amplitude}}{\text{rated motor current}} \times \text{rated slip frequency}$$

Parameter

Address	Name / setting range / [default setting]	Information
0x2B0A:001	Oscillation damping: Gain -100 ... [20] ... 100 %	Gain of the oscillation signal. <ul style="list-style-type: none">With the setting 0, oscillation damping is deactivated.
0x2B0A:002	Oscillation damping: Filter time 1 ... [5] ... 600 ms	Time constant of the PT1 filter.
0x2B0A:003	Oscillation damping: Limitation 0.1 ... [0.2] ... 20.0 Hz	Limitation of the calculated oscillation frequency.
0x2B0A:004	Oscillation damping: Final ramp frequency 0 ... [0] ... 100 %	Ramp end frequency from which the gain factor is expected to have reached its rated value. <ul style="list-style-type: none">By setting a ramp end frequency, a possible negative impact of the oscillation damping on the concentricity factor in the lower speed range can be reduced.The ramp end frequency refers to the rated motor frequency in percentage terms.

10.5.9 Optimising the stalling behaviour

The stalling protection function or the maximum permissible motor current in the field weakening range can be adapted.

- If the motor stalls in the field weakening range, the override point can be shifted by reducing the set value so that the motor stalling can be prevented.
- If the motor does not provide enough torque in the field weakening range, the set value must be increased.

Parameter

Address	Name / setting range / [default setting]	Information
0x2B0C	Override field weakening -500.0 ... [0.0] ... 500.0 Hz	Offset of the override point for field weakening.



10.5.10 Flying restart circuit

The "flying restart" function serves as a protective function against high compensation currents. High compensation currents can occur in the V/f characteristic control if the drive is not at standstill at the time the inverter is enabled. The "flying restart" function detects the motor speed by means of a test current and uses this information to define the frequency setpoint.

⚠ CAUTION!

If the "flying restart" function is deactivated and the inverter is not enabled at standstill, the output voltage and the output frequency do not match the current motor speed.

High compensation currents may flow! First the drive is braked towards 0 Hz to be then accelerated again!

► Ensure that the drive is at standstill before the inverter is enabled.

Flying restart process

If this function is active, the flying restart process starts after the inverter is enabled.

1. The inverter reports the started flying restart process to the Controller via bit 8 in the Lenze status word **0x2831**.
2. If a speed is found, it is reported to the Controller via bit 9 in the Lenze status word.
3. The Controller reports to the inverter via bit 0 in the Lenze control word **0x2830** that the detected speed has been accepted. As long as this is not the case, no further flying restart process is possible.

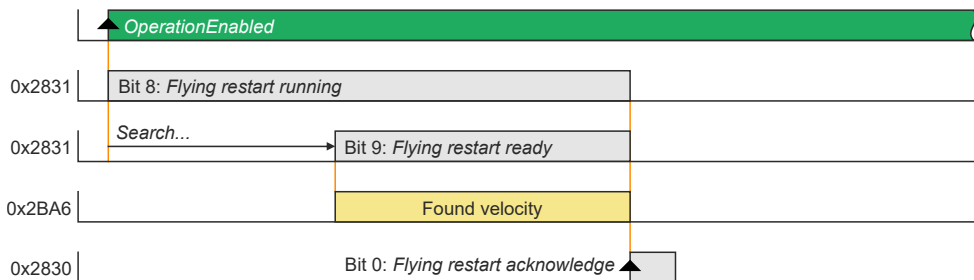

Parameter setting



The flying restart algorithm needs a motor voltage as exact as possible. Thus, a previous detection of the inverter error characteristic is absolutely necessary. **Compensate inverter influence to output voltage** In addition to the exact motor voltage, a detailed knowledge of the stator resistance is required. If the flying restart process does not work as desired, slightly adapt the setting of the stator resistance in the **0x2C01:002** object. Bit 1 in the Lenze control word **0x2830** serves to block a flying restart process.

The flying restart process involves a control loop, the controller parameter **0x2BA3** of which must be adapted to the motor. The automatic calculation is made with the parameter **0x2822:022**.

The actual flying restart process can be adjusted via the following parameters:

Configuring the motor control

V/f characteristic control for asynchronous motor (VFC open loop)
Flying restart circuit



Parameter

Address	Name / setting range / [default setting]	Information
0x2BA0	Activate flying restart	<p>Activation of the additional "flying restart" function.</p> <p>If the "flying restart" function is activated ("1: on") and the inverter disable is deactivated, a flying restart process is automatically started for determining the current motor speed if the following conditions are met:</p> <ul style="list-style-type: none"> • The V/f characteristic control is set as motor control. • The CiA402 mode is selected as drive mode. • The "flying restart" function is not blocked via bit 2 in the Inverter control word (0x2830). • No DC-injection braking is active. • No motor phase failure has been identified.
	0 Off	
	1 On	
	2 Without acknowledge or blocking	
0x2BA1	Flying restart circuit 0 ... [15] ... 100 %	
0x2BA2	Start frequency -600.0 ... [20.0] ... 600.0 Hz	<p>Start frequency of flying restart algorithm</p> <ul style="list-style-type: none"> • If it is foreseeable at which frequency the motor can be restarted on the fly, set the frequency here.
0x2BA3	Integration time 1 ... [600] ... 60000 ms	<p>Integration time of the angle controller</p> <ul style="list-style-type: none"> • The default setting is adapted for medium-power machines. • A guide value for the integration time can be calculated as a function of the motor power with the following equation: $T_i = 1.1 \mu/W * \text{Rated power (0x2C01:006)} + 9.4 \text{ ms}$ • For accelerating the search process, this guide value can be reduced. • If the flying restart frequency oscillates too much, increase the integration time again. • A longer integration time extends the time for a flying restart of the drive.
0x2BA4	Minimum deviation 0.00 ... [5.00] ... 90.00 °	Setting of the minimum permissible deviation.
0x2BA5	Delay time 0 ... [0] ... 10000 ms	In order to prevent the start of a flying restart process if the controller inhibit time is too short, a minimum active time for the inverter disable can be set here in order that a flying restart process will be started. As a pulse inhibit > 500 ms causes a controller inhibit, this also applies to pulse inhibit.
0x2BA6:001	Result: Determined speed [rpm] • Read only: x rpm	Display of the determined speed in [rpm].
0x2BA6:002	Result: Determined speed [n unit] • Read only: rpm	Display of the determined speed in [n unit].



10.6 Parameterisable motor functions

10.6.1 DC braking

The control modes for asynchronous motors provide the opportunity to use the "DC-braking" function (DC-injection braking) for braking. In this case, the motor control injects a DC current the amplitude of which is adjustable.

Preconditions

Using the "DC braking" function, the motor control injects a DC current, the amplitude of which is adjustable in the [0x2B80](#) parameter. To this end, it is necessary that the current control is adapted to the corresponding motor. For setting and optimising the current controller, see [Current controller](#). [166](#)

Details

The function can be used as follows:

1. "DC braking" can be parameterised via bit 6 in the Lenze control word [0x2830](#).

In this case, the motor system itself can be used as an energy converter.

This option is useful if

- the system is not provided with a brake resistor required for absorbing the braking energy. This method requires that a sufficient braking torque can be achieved with "DC braking".
 - the power of the brake chopper to be transformed is limited and thus must be exclusively used for the main drives of the DC network. The quality of the deceleration ramp via "DC braking" is sufficient for auxiliary drives and unburdens the brake chopper.
 - a fan drive is to be braked in the V/f characteristic operation.
2. "DC braking" can be parameterised as a response to minor faults.

An example of a minor fault is the error of an encoder of an asynchronous machine. Due to the error, the quick stop function cannot be executed anymore. An alternative is provided by the guided shutdown with a minor deceleration via the "DC braking" function.

Parameter

Address	Name / setting range / [default setting]	Information
0x2B80	Current for DC-injection braking 0.00 ... [0.00] ... 500.00 A	Braking current for DC-injection braking

Configuring the motor control

Parameterisable motor functions
Short-circuit braking



10.6.2 Short-circuit braking

The control modes for synchronous motors provide the opportunity to use "short-circuit braking" for braking.

The effect of short-circuit braking on the deceleration behaviour depends on the motor properties, the effective cable length, the load inertia and the initial speed value (starting point). Primarily, short-circuit braking serves to transform a part of the kinetic energy into heat energy which unburdens external brake assemblies and limit position dampers.



In some constellations it is not possible to decelerate the speed of a synchronous motor to zero by means of "short-circuit braking"!

Compared to the "quick stop" function, the braking effect is considerably lower.

Preconditions

If short-circuit braking shall be used as the only deceleration means, it is recommended that the feasibility is previously verified by means of tests. For this purpose, short-circuit braking can be triggered in the application via bit 6 in the Lenze control word [0x2830](#). The oscilloscope function of the engineering tool (e.g. »EASY Starter«) serves to record the following important parameters:

- Actual velocity [0x606C](#)
- Phase current U, V, W [0x2D83:002 ... 0x2D83:004](#)

Details



The short-circuit current adjusts itself freely in accordance with the motor voltage ($kE \cdot \text{speed}$) and the internal resistance of the system. Thus, it is absolutely necessary that the ampacity of the servo inverter is based on the maximum expected short-circuit current. Guide value: $I_{\text{max_device}} (3 \text{ s}) \geq 1.5 \cdot I_{\text{max_motor}}$ (according to data sheet / catalog) In case the assignment differs, a rating based on the currently possible parameters (max. speed, max. motor current, field weakening, etc.) is required!

The function can be used as follows:

1. "Short-circuit braking" can be parameterised via bit 6 in the Lenze control word [0x2830](#) if
 - the braking energy cannot be converted into heat in a brake resistor.
 - e.g. an error has been detected in the encoder system which does not permit a braking via quick stop.
2. "Short-circuit braking" can be parameterised as a response to minor faults.
 - Due to an encoder error, for instance, a quick stop might not be possible anymore.



10.6.3 Holding brake control

This device function is used for low-wear control of the motor holding brake connected to the inverter with a supply voltage of 24 V.

The motor holding brake is connected to X106. It is supplied with 24 V via X107.

Configuring the motor control

Parameterisable motor functions
Holding brake control
Basic setting



10.6.3.1 Basic setting

The following parameters must be set for the activation and basic configuration of the holding brake control.

Details

The following settings are possible:

- Brake mode ①
- For the automatic operation: ②
 - Brake release time and brake application time
 - Torque feedforward control
- Test Brake control ③
- Brake polarity ④

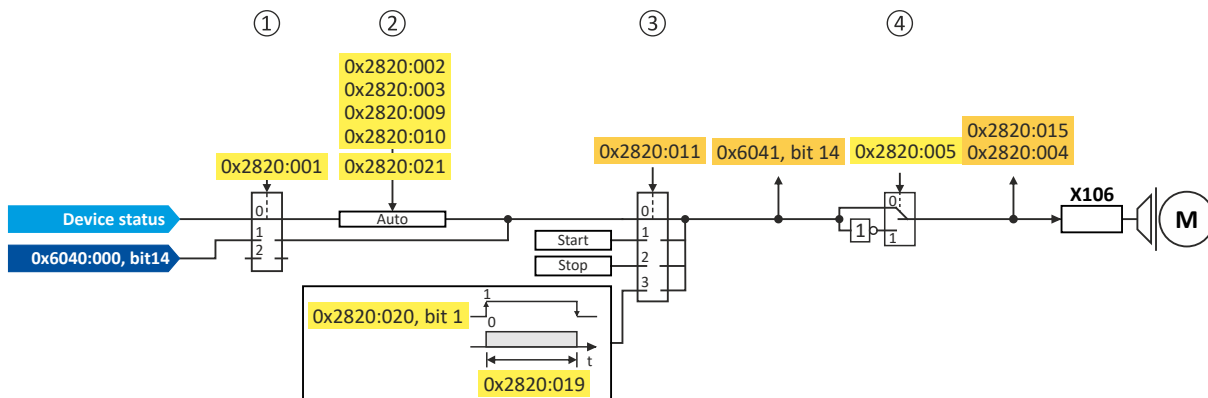

Diagnostic parameters:

- Display status of the automatic brake identification: [0x2820:004](#)
- Display signal of the brake logic before the inversion: [0x6041](#)
- Display status of the holding brake: [0x2820:015](#)



Brake mode

Possible settings: [0x2820:001](#)

- Manual control via the control word. Das control word depends on the technology application :
 - Technology application CiA 402: [0x6040](#) Bit 14
 - Speed Control technology application: [0x5030:010](#) Bit 14
 - 0: Close holding brake
 - 1: Release holding brake
- Control via device state machine (automatic operation):
 - The holding brake is controlled as a function of the device state.
 - A torque feedforward control is possible.



The torque is precontrolled for one second. During this time, the actual torque must have reached 90 % of the setpoint torque, otherwise an error is triggered.

- Response times of the holding brake during release and application can be compensated for.



In the event of an error or when STO ("SafeTorqueOff") is activated, the brake is applied immediately without considering the set brake application time. The inverter immediately changes to the switch-on disabled state.

- No brake connected (off):
 - holding brake control, automatic brake identification and brake monitoring are deactivated.

Brake polarity

The control logic of the holding brake can be inverted.

Parameter

Address	Name / setting range / [default setting]	Information
0x2820:001	Holding brake control: Brake mode	Selecting how the "Release holding brake" command is to be triggered.
	0 Automatically (via device state)	
	1 Manually	
	2 Off	The holding brake is deactivated.
0x2820:002	Holding brake control: Brake closing time 0 ... [100] ... 10000 ms	Application time (engagement time) of the holding brake. • Only effective in automatic operation.
0x2820:003	Holding brake control: Brake opening time 0 ... [100] ... 10000 ms	Release time (disengagement time) of the holding brake. • Only effective in automatic operation.
0x2820:004	Holding brake control: Brake detection • Read only	When 0x2825 = 4 (Manual control mode) and the device state changes from "switched-on" to "operation enabled", it is detected automatically whether a holding brake is connected. The brake identification is repeated after every controller enable.
	0 Detection not started	
	1 Detection running	
	2 No brake detected	
	3 Brake detected	
	4 Detection not possible	The holding brake control is switched off.
0x2820:005	Holding brake control: Brake polarity	The control logic of the holding brake can be inverted.
	0 Normal	
	1 Inverted	

Configuring the motor control

Parameterisable motor functions
Holding brake control
Brake holding load



Address	Name / setting range / [default setting]	Information
0x2820:006	Holding brake control: Brake error response	Selection of the response for holding brake monitoring. In the triggered state, the holding brake is monitored cyclically for the presence of brake current. After the brake is connected, the establishment of the brake current is subject to a time delay in accordance with the inductance. Consequently, there is a slight delay in detecting wire breakage, a terminal short-circuit or a missing brake supply. The response set here occurs when monitoring is triggered. Note: The brake is not monitored unless it is triggered. Associated event ID: <ul style="list-style-type: none"> 537526018 0x2009FF02 - Fault - Motor holding brake
	0 No fault	
	1 Fault	
	2 Warning	
0x2820:015	Holding brake control: Brake status <ul style="list-style-type: none"> Read only 	
	0 Brake closed	Holding brake is applied.
	1 Brake released	Holding brake is released.
0x2820:019	Holding brake control: Brake opening time test signal 0 ... [500] ... 10000 ms	Setting of the brake opening time when the test signal is transmitted (Brake control word bit 0 = 1).
0x2820:023	Holding brake control: Control configuration	Selection of which output signal is to be used to control the holding brake.
	0 Via internal brake module	The holding brake is controlled via the internal brake module and the brake output X106. <ul style="list-style-type: none"> The presence of the external 24 V supply for the brake output is monitored. An open-circuit detection is active. A parameterized voltage reduction is active.
	1 Via external module at X106	The brake output X106 controls a relay or power contactor which switches the brake supply.
	2 Via external module at DIx	The holding brake is controlled via the trigger "Release holding brake [115]". <ul style="list-style-type: none"> This trigger must be assigned to a digital output. The digital output in turn controls a relay or power contactor which switches the brake supply. The digital output is not suitable for direct control of a holding brake! If, instead of an electrically releasing (self-holding) holding brake, an electrically holding (self-releasing) holding brake is to be controlled, a signal inversion must be set for the digital output used!

Further setting options:

- Manual brake control [155](#)

10.6.3.2 Brake holding load

Parameter

Address	Name / setting range / [default setting]	Information
0x2820:013	Holding brake control: Holding load ramp time 0 ... [0] ... 1000 ms	By setting a ramp time, a vibration stimulation can be reduced that might be caused by the brake holding load .

10.6.3.3 Torque feedforward control

Parameter

Address	Name / setting range / [default setting]	Information
0x2820:009	Holding brake control: Starting torque source	Setting of the source for the holding brake starting torque.
	0 Last torque saved	The stopping value saved automatically during the last closing operation is used as starting torque.
	1 Torque in 0x2820:010	The parameterised starting torque is used (0x2820:010).



Configuring the motor control

Parameterisable motor functions
 Holding brake control
 Manual brake control

Address	Name / setting range / [default setting]	Information
0x2820:010	Holding brake control: Starting torque -3276.8 ... [0.0] ... 3276.7 %	Setting of the feedforward control value for the automatic operation (0x2820:009 = 1).
0x2820:021	Holding brake control: Detected actual torque • Read only: x.x %	Display of the torque actual value that is used for the feedforward control. 0x2820:009 = 0

10.6.3.4 Manual brake control

The holding brake can be opened or closed manually regardless of its operating status and the operating state of the inverter. This function can be used, for example, to move the axis manually in the event of an error.



Note for inverters with Extended Safety:

Manual brake control is only possible if no error is active in the Extended Safety.

Details

The following settings are possible:

- Open the holding brake:
 - The holding brake remains open until it closed again manually.
- Close the holding brake.
- Release the holding brake for a fixed time by a start signal and then apply it automatically:
 - Time for "Brake released": 0x2820:019
 - Start signal: 0x2820:020, bit 0 = 1
 - After the time has elapsed → bit 0 = 0

Parameter

Address	Name / setting range / [default setting]	Information
0x2820:011	Holding brake control: Override of the brake control	Mode for override or forced opening/closing of the holding brake irrespective of the operating mode. In the event of an error and activated function for forced opening, the brake is not applied.
	0 No override active	Mode for override or forced opening/closing of the holding brake irrespective of the operating mode.
	1 Open brake	• In the event of an error and activated function for forced opening, the brake is not applied.
	2 Close brake	
	3 Test pulse	
0x2820:020	Holding brake control: Brake control word 0x00 ... [0x00] ... 0xFF	Control word for the holding brake.
	Bit 0 Transmit test signal	

10.6.3.5 Reduction of brake supply voltage

Parameter

Address	Name / setting range / [default setting]	Information
0x2820:022	Holding brake control: Holding brake supply voltage	
	75 Reduction on	
	100 No reduction	

Configuring the motor control

Options for optimizing the control loops
Automatic motor identification (energized)



10.7 Options for optimizing the control loops

The option to be selected depends on the respective application. Depending on the selected option, different procedures become active and thus different parameter groups are influenced:

- Rated motor data
- Inverter characteristic
- Motor equivalent circuit diagram data
- Motor controller settings
- Speed controller settings
- Position controller settings

10.7.1 Automatic motor identification (energized)

Parameter

Address	Name / setting range / [default setting]	Information	
0x2832	Identification status	Display of the status for the automatic identification of the motor parameters.	
	• Read only		
	Bit 0 Identification enabled		Parameters for interaction with engineering tools.
	Bit 1 Identification active		
	Bit 2 Identification completed		
Bit 3 Identification failed			
0x2DE0:009	Service settings: Motor identification settings	Setting for motor identification.	
	• Read only		



Configuring the motor control

Options for optimizing the control loops
Tuning of the motor and the speed controller

10.7.2 Tuning of the motor and the speed controller

The following describes in general how to optimize the speed controller. This may be required if some parameters on the load side of the drive system have changed or have not been set yet, such as:

- Motor moment of inertia
- Load moment of inertia
- Type of coupling between motor moment of inertia and load moment of inertia

Preconditions

All rated motor data is known and set in the inverter, either by selecting the motor from the motor catalogue or manually.

- ▶ [Select motor from motor catalog](#) 44
- ▶ [Manual setting of the motor data](#) 46

Required steps

Adapt the following parameters to your drive system using the engineering tool. Since this only changes load-dependent data, the other parameter groups do not need to be calculated again.

In the engineering tool, the speed control settings can be confirmed via the **Initialise** button.

Parameter

Address	Name / setting range / [default setting]	Information
0x2910:001	Inertia settings: Motor moment of inertia 0.00 ... [0.14] ... 20000000.00 kg cm ²	Setting of the moment of inertia of the motor, relating to the motor.

Configuring the motor control

Options for optimizing the control loops
Tuning of the motor and the speed controller



Address	Name / setting range / [default setting]	Information
0x2910:002	Inertia settings: Scaled load inertia 0.00 ... [0.00] ... 20000000.00 kg cm ²	Setting of the moment of inertia of the load. <ul style="list-style-type: none">Always adjust the setting to the current load, otherwise the optimisation process for the speed controller cannot be executed successfully.
0x2910:003	Inertia settings: Coupling 0 Stiff	Selection of the type of coupling between the moment of inertia of the motor and that of the load.
0x2910:004	Inertia settings: Mechanical natural frequency 0.0 ... [0.0] ... 250.0 Hz	Setting of the mechanical natural frequency.
0x2910:005	Inertia settings: Load moment of inertia (elastic coupled) 0.00 ... [0.00] ... 20000000.00 kg cm ²	Setting of the load moment of inertia with elastic coupling (0x2910:003 = 1).

For further details on the speed controller, see chapter "[Speed controller](#)". [163](#)



10.7.3 Inverter characteristic



The settings made can be seen if required, but should not be changed. A wrong setting may influence the control negatively!

Configuring the motor control

Options for optimizing the control loops
Inverter characteristic
Compensating for inverter influence



10.7.3.1 Compensating for inverter influence

Conditions for the execution

- The motor may be stalled.
- The inverter is switched on and error-free.

Response of the motor during performance

If the motor is not braked, the motor will move slightly



Disabling the inverter serves to abort the started procedure any time if required. Already determined characteristic values are rejected in this case.

How to detect the inverter characteristic:

1. Disable the servo inverter.
2. Change to the "inverter characteristic: identification" operating mode. ▶ `0x2825 = 8`
3. Enable the servo inverter.

The procedure starts.

After the successful completion, the inverter is automatically disabled and the points of the detected inverter characteristic are set in parameter `0x2947t`.

1. Save the changed settings.
2. The inverter characteristic must only be detected again if the servo inverter, the motor or the motor cable have been replaced.
3. The inverter disable set by the procedure can be deactivated via the control word.
▶ `0x6040 = 7`

Parameter

Address	Name / setting range / [default setting]	Information
0x2947:001	Inverter characteristic: Value y1 0.00 ... [0.00] ... 20.00 V	The inverter characteristic (consisting of 17 values) is calculated and set in the course of the automatic inverter characteristic identification. Note! Changing these values is not recommended by the manufacturer.
0x2947:002	Inverter characteristic: Value y2 0.00 ... [0.00] ... 20.00 V	
0x2947:003	Inverter characteristic: Value y3 0.00 ... [0.00] ... 20.00 V	
0x2947:004	Inverter characteristic: Value y4 0.00 ... [0.00] ... 20.00 V	
0x2947:005	Inverter characteristic: Value y5 0.00 ... [0.00] ... 20.00 V	
0x2947:006	Inverter characteristic: Value y6 0.00 ... [0.00] ... 20.00 V	
0x2947:007	Inverter characteristic: Value y7 0.00 ... [0.00] ... 20.00 V	
0x2947:008	Inverter characteristic: Value y8 0.00 ... [0.00] ... 20.00 V	
0x2947:009	Inverter characteristic: Value y9 0.00 ... [0.00] ... 20.00 V	
0x2947:010	Inverter characteristic: Value y10 0.00 ... [0.00] ... 20.00 V	
0x2947:011	Inverter characteristic: Value y11 0.00 ... [0.00] ... 20.00 V	
0x2947:012	Inverter characteristic: Value y12 0.00 ... [0.00] ... 20.00 V	
0x2947:013	Inverter characteristic: Value y13 0.00 ... [0.00] ... 20.00 V	
0x2947:014	Inverter characteristic: Value y14 0.00 ... [0.00] ... 20.00 V	
0x2947:015	Inverter characteristic: Value y15 0.00 ... [0.00] ... 20.00 V	



Configuring the motor control

Options for optimizing the control loops
 Inverter characteristic
 Extended settings for identification

Address	Name / setting range / [default setting]	Information
0x2947:016	Inverter characteristic: Value y16 0.00 ... [0.00] ... 20.00 V	
0x2947:017	Inverter characteristic: Value y17 0.00 ... [0.00] ... 20.00 V	

In the event of an error

If an error occurs during the procedure or the pulse inhibit gets active (e.g. due to short-time undervoltage), the procedure is terminated with inverter disable without the settings being changed.

10.7.3.2 Extended settings for identification

For determining the characteristic, the current controller is automatically parameterised at the start of the identification process. In case of motors with a very low stator leakage inductance (< 1 mH), the automatic parameterisation can fail and the actual identification process is aborted with an error message such as "short circuit".

- For this case, it is possible to set the current controller manually via the [0x2942](#) parameter.
- The [0x2DE0:001](#) parameter serves to select whether the current controller should be calculated automatically or the values in [0x2942](#) are effective.

Parameter

Address	Name / setting range / [default setting]	Information						
0x2DE0:001	Service settings: Current controller identification settings	Whether the current controller shall be adapted automatically for the identification or set manually, is selected via: <ul style="list-style-type: none"> • 0x2942:001 (Gain) • 0x2942:002 (Reset time) 						
	<table border="1"> <tr> <td>0</td> <td>Automatic</td> </tr> <tr> <td>1</td> <td>Manuell (0x2942)</td> </tr> </table>		0	Automatic	1	Manuell (0x2942)		
0	Automatic							
1	Manuell (0x2942)							
0x2DE0:003	Service settings: Resolver - position detection dynamics 20 ... [100] ... 100 %	Setting of the dynamics for the resolver evaluation. <ul style="list-style-type: none"> • 100% ≙ max. dynamics • <100% ≙ reduced dynamics 						
0x2DE0:004	Service settings: Resolver - 8 kHz safety signal	Usually, the Der 8-kHz carrier frequency is only activated for the safety version. This parameter can also be used to switch it on and off.						
	<table border="1"> <tr> <td>0</td> <td>Automatisch durch Gerätetyp</td> </tr> <tr> <td>1</td> <td>On</td> </tr> <tr> <td>2</td> <td>Aus</td> </tr> </table>		0	Automatisch durch Gerätetyp	1	On	2	Aus
	0		Automatisch durch Gerätetyp					
1	On							
2	Aus							
0x2DE0:007	Service settings: Use measured voltage	Activation of voltage measurement. Only for devices for which voltage measurement is possible.						
	<table border="1"> <tr> <td>0</td> <td>Aus</td> </tr> <tr> <td>1</td> <td>On</td> </tr> </table>		0	Aus	1	On		
0	Aus							
1	On							

10.7.3.3 Load standard inverter characteristic

If none or only one faulty inverter characteristic could be determined, a device-typical standard inverter characteristic can be loaded.

How to load the standard inverter characteristic:

1. **Axis commands: load standard-Lh saturation characteristic** [0x2822:022](#) = start 1.
2. After completing the procedure, save the inverter characteristic set in in the inverter.

The »EASY Starter« serves to save the parameter setting of the inverter as parameter file (*.gdc). ▶ [Saving the parameter settings](#)

Parameter

Address	Name / setting range / [default setting]	Information												
0x2822:022	Axis commands: Load default inverter characteristic	Parameters for interaction with engineering tools.												
	<table border="1"> <tr> <td>0</td> <td>Off/Ready</td> </tr> <tr> <td>1</td> <td>On/Start</td> </tr> <tr> <td>2</td> <td>In progress</td> </tr> <tr> <td>3</td> <td>Action cancelled</td> </tr> <tr> <td>4</td> <td>No access</td> </tr> <tr> <td>5</td> <td>No access (Device disabled)</td> </tr> </table>		0	Off/Ready	1	On/Start	2	In progress	3	Action cancelled	4	No access	5	No access (Device disabled)
	0		Off/Ready											
	1		On/Start											
	2		In progress											
	3		Action cancelled											
	4		No access											
5	No access (Device disabled)													

Configuring the motor control

Options for optimizing the control loops
Motor equivalent circuit diagram data



10.7.4 Motor equivalent circuit diagram data

The motor equivalent circuit diagram data is automatically set when the motor is selected from the motor catalogue:

▶ [Select motor from motor catalog](#) 44

If you use a motor of a different manufacturer, you must adapt the data, e. g. from the motor data sheet according to the sizes and units mentioned if required.

Parameter

Address	Name / setting range / [default setting]	Information
0x2C01:002	Motor parameters: Stator resistance 0.0000 ... [13.5000] ... 125.0000 Ω	General motor data. Carry out settings as specified by manufacturer data/motor data sheet.
0x2C01:003	Motor parameters: Stator leakage inductance 0.000 ... [51.000] ... 500.000 mH	Note! When you enter the motor nameplate data, take into account the phase connection implemented for the motor (star or delta connection). Only enter the data applying to the connection type selected.
0x2C01:009	Motor parameters: Insulation class	Insulation class of the motor (see motor nameplate).
	0 Y (cut-off temperature = 90 °C)	
	1 A (cut-off temperature = 105 °C)	
	2 E (cut-off temperature = 120 °C)	
	3 B (cut-off temperature = 130 °C)	
	4 F (cut-off temperature = 155 °C)	
	5 H (cut-off temperature = 180 °C)	
6 G (cut-off temperature > 180 °C)		
0x2C02:001	Motor parameter (ASM): Rotor resistance 0.0000 ... [0.0000] ... 214748.3647 Ω	Equivalent circuit data required for the motor model of the asynchronous machine.
0x2C02:002	Motor parameter (ASM): Mutual inductance 0.0 ... [0.0] ... 214748364.7 mH	
0x2C02:003	Motor parameter (ASM): Magnetising current 0.00 ... [0.00] ... 500.00 A	
0x2C03:001	Motor parameter (PSM): Back EMF constant 0.0 ... [41.8] ... 100000.0 V/1000rpm	Voltage induced by the motor (rotor voltage / 1000 rpm). For permanently excited synchronous motors, the e.m.f. constant describes the r.m.s. value of the line-to-line voltage (phase voltage) induced in idle state by the motor (reference: 1000 rpm, 20 °C). Measured: Line to Line (L - L)
0x2C03:002	Motor parameter (PSM): Resolver pole position -179.9 ... [-90.0] ... 179.9 °	Equivalent circuit data required for the motor model of the synchronous machine.
0x2C03:003	Motor parameter (PSM): Magnets temperature coefficient (kTN) -1.000 ... [-0.110] ... 0.000 %/°C	
0x2C03:004	Motor parameter (PSM): Encoder pole position -179.9 ... [0.0] ... 179.9 °	



10.7.5 Motor control settings

10.7.5.1 Speed controller

The speed controller is automatically set when the motor has been selected from the motor catalogue:

▶ [Select motor from motor catalog](#) 44

The automatically calculated settings for the speed controller enable an optimal control behaviour for typical load requirements.

Manual post-optimisation of the speed controller

1. Setting of the gain

Set the proportional gain V_p in parameter [0x2900:001](#).

- Specify speed setpoint.
- Increase parameter until the drive gets unstable (observe engine noise). ▶ [0x2900:001](#)
- Reduce parameter until the drive runs stable again. ▶ [0x2900:001](#)
- Reduce the parameter to approx. half the value. ▶ [0x2900:001](#)

2. Setting of the reset time

Set the reset time T_n in parameter [0x2900:002](#).

- Reduce parameter until the drive gets unstable (observe engine noise). ▶ [0x2900:002](#)
- Increase parameter until the drive runs stable again. ▶ [0x2900:002](#)
- Increase parameter to approx. double the value. ▶ [0x2900:002](#)

3. Setting of the rate time

Set the rate time T_d in parameter [0x2900:003](#).

- Increase parameter during operation until an optimal control mode is achieved.
▶ [0x2900:003](#)

Automatically calculated settings for the speed controller



We recommend a manual post-optimisation for the optimal operation.

The function for automatically calculating the gain and reset time is executed via the parameter [0x2822:014](#).

The following equations apply to a "rigid" system.

- For elastic systems and systems with batches, the determined gain must be reduced.
- The moment of inertia required for the calculation is the sum of the moment of inertia of the motor and the load mass inertias transformed to the motor side.

Equation for calculating the gain

$$V_p = \frac{J}{a \times (T_{\text{filter}} + T_{\text{current controller}})} \times \frac{2\pi}{60}$$

Configuring the motor control

Options for optimizing the control loops
 Motor control settings
 Speed controller



Equation for calculating the reset time

$$T_n = a^2 \times (T_{\text{filter}} + T_{\text{current controller}})$$

rotating field frequencyrotating field frequencyrotating field frequencyParameter	Symbol	Description	Dimension unit
0x2900:001	V_p	Speed controller gain	Nm / rpm
-	J	Moment of inertia = $J_{\text{motor}} + \text{sum}(J_{\text{load}})$	kgm ²
-	a	Measure for the phase reserve (recommendation: $a = 4 \equiv 60^\circ$ phase reserve)	
0x2904	T_{Filter}	Filter time constant - actual speed value	s
-	$T_{\text{current controller}}$	Equivalent time constant of the current control loop = 0.0005 s	s
0x2900:002	T_n	Reset time - speed controller	s

Special case of the linear motor

In this case, a re-calculation from a linear system to a rotary system must be made. Therefore, via the feedback system a degree of freedom results for the determination of the number of pole pairs. For a rotary system, the number of pole pairs specifies the ratio of electrical and mechanical revolution, the number of encoder increments being defined via one mechanical revolution. In the case of a linear system, the user is free to decide for which length he or she wants to specify the number of encoder increments. Usually, the number of increments is given for a pole distance or for the total length of the linear scale. If the number of increments = "number of increments for one pole distance" is selected, a motor with the number of pole pairs $z_p = 1$ is created. The effective moment of inertia for a linear motor can be calculated according to the following equations. With this J value, the equations shown above can be used to calculate the speed controller gain and reset time.

Equation for calculating the effective moment of inertia

$$J = m \times \left(\frac{z_p \times 2 \times \tau_{\text{pole pair}}}{2\pi} \right)^2$$

$$z_p = \text{integer} \times \frac{s}{2 \times \tau_{\text{pole pair}}}$$

Parameter	Symbol	Description	Dimension unit
-	s	Length on which the specification for the number of encoder increments is based (e.g. per pole distance or total length).	m
-	$2 \tau_{\text{pole pair}}$	Pole distance of the permanent magnets, pole pair width	m
-	J	Moment of inertia = $J_{\text{Forcer}} + J_{\text{Slide}} + J_{\text{Load}}$	kgm ²
-	m	Moving mass = $m_{\text{Forcer}} + m_{\text{Slide}} + m_{\text{Load}}$	kg

Parameter

Address	Name / setting range / [default setting]	Information
0x2900:001	Speed controller settings: Gain 0.00000 ... [0.00033] ... 20000.00000 Nm/rpm	Gain factor V_p of the speed controller.
0x2900:002	Speed controller settings: Reset time 1.0 ... [17.6] ... 6000.0 ms	Reset time T_i of the speed controller.
0x2900:003	Speed controller settings: Rate time 0.00 ... [0.00] ... 3.00 ms	Setting of the rate time for the speed controller.
0x2901	Speed controller gain adaption 0.00 ... [100.00] ... 200.00 %	Mappable parameter for adaptive adjustment of the speed controller gain.
0x2902	I component load value -1000.0 ... [0.0] ... 1000.0 %	Setting of the load value.



Configuring the motor control

Options for optimizing the control loops

Motor control settings

Speed controller

Address	Name / setting range / [default setting]	Information
0x2903	Speed setpoint filter time 0.0 ... [0.0] ... 50.0 ms	Time constant for the speed setpoint filter.
0x2904	Actual speed filter time 0.0 ... [0.3] ... 50.0 ms	Time constant for the actual speed value filter.

Configuring the motor control

Options for optimizing the control loops
Motor control settings
Current controller



10.7.5.2 Current controller

The current controller consists of a direct-axis current controller and a cross current controller which are both parameterised identically. The direct-axis current controller controls the field-producing current (D current). The cross current controller controls the torque-producing current (Q current).

Description of the function

The function controls the control cycle. The following model parameters are improved.

- Inductance of the saturation characteristic
- Setpoint step-change in the small signal behavior

This correspond to the maximum possible dynamics of the current controller and increases the stability limit of the higher-level control loops. The higher-level control loops are the position control and the speed control. The setpoint step-changes are compensated within half a PWM cycle.

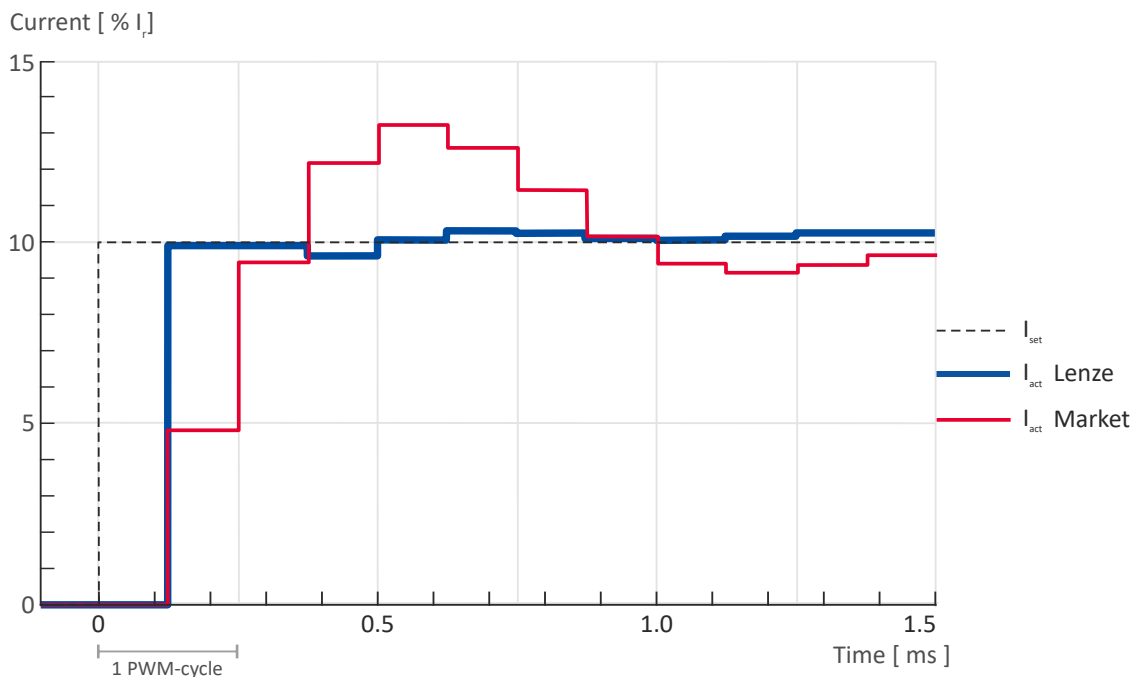

Fig. 5: Characteristic with and without torque control

Activation of the function

The function is activated via a parameter. [0x2941](#) ▶ [0x2941](#)

In case of synchronous machines, this parameter is set by default to Enable [1] and in case of asynchronous machines to Disable [0].

How to activate the function

1. Set parameter to [2].

The function is activated.



For a servo control, the current controller should always be optimized if a motor of another manufacturer with unknown motor data is used! For a V/f characteristic control, the current controller only has to be optimized if voltage vector control [Activate voltage vector control \(Imin controller\)](#) is used, or if the motor functions “DC braking” or “flying restart process” are activated.



Automatically calculated settings for the current controller



If one of the values calculated exceeds the upper object limit, the value is limited to the limit value.

There is a coupling between the two control loops (direct-axis current controller, cross current controller) which makes every actuation of a controller occur as fault in the control loop of the other controller. This coupling can be compensated by activating the current controller feedforward control via object [0x2941](#).

For the automatic calculation of the two controller parameters (gain and reset time), the "Calc. current contr. param." function is provided via object [0x2822:013](#). The calculation function is based on the stator resistance [0x2C01:002](#) and the stator leakage inductance [0x2C01:003](#). Thus, these motor parameters must be parameterized before, e. g. by the manual entry of data sheet values. The calculated controller parameters can be optimized by means of an experimental adjustment subsequently. The procedure is described in section [Manual "current pulse" test mode](#) [□ 206](#)

Equations for calculating the gain and reset time of the synchronous motor

Gain	Reset time
$V_p = \frac{L_{ss}}{T_{\text{dead time}}}$	$T_n = \frac{L_{ss}}{R_s}$

Parameter	Symbol	Description	Dimension unit
0x2942:001	V_p	Current controller gain	V/A
0x2C01:003	L_{ss}	Stator leakage inductance	H
-	$T_{\text{Dead time}}$	Equivalent time constant for the analog detection and scanning = 0.0002016 s	s
0x2942:002	T_n	Current controller reset time	s
0x2C01:002	R_s	Stator resistance (value at 20° C)	Ω

Equations for calculating the gain and reset time of the asynchronous motor

Gain	Reset time
$V_p = \frac{\sigma \times L_s}{T_{\text{dead time}}} \approx \frac{2 \times L_{ss}}{T_{\text{dead time}}}$	$\tau_n = \frac{\sigma \times L_s}{R_s} \approx \frac{2 \times L_{ss}}{R_s}$

Parameter	Symbol	Description	Dimension unit
0x2942:001	V_p	Current controller gain	V/A
-	σ	Leakage	
-	L_s	Motor stator inductance	H
0x2C01:003	L_{ss}	Motor stator leakage inductance	H
-	$T_{\text{Dead time}}$	Equivalent time constant for the analog detection and scanning = 0.0002016 s	s
0x2942:002	T_n	Current controller reset time	s
0x2C01:002	R_s	Motor stator resistance (value at 20° C)	Ω

Debugging

The function depends on the saturation characteristic of the inductances in parameter [0x2c04](#) [0x2c04](#).

For Lenze motors, this characteristic can be found in the motor table. In case of MCS motors, the characteristic values in the first 2 entries are too high. If there are any problems regarding

Configuring the motor control

Options for optimizing the control loops
Motor control settings
Current controller



the torque control, reduce these values. Lenze motors with the standard setting achieve a considerable higher performance.

In the following parameter, debugging is possible with the commissioning function **Man. Test mode curr. Imp.** [0x2825](#) ▶ [0x2825](#)

This function is documented. Here, the transient response of the current controller can be evaluated which shall considerably improve when the torque control is activated.

The following chart shows the this behavior.

- Red characteristic without torque controller
- Yellow characteristic with activated torque controller

If the course is worse with an activated torque control, the parameters of the inductance and saturation profile are faulty.

Parameter

Address	Name / setting range / [default setting]	Information
0x2941	Current controller feedforward control	Activate/deactivate feedforward control.
	0 Disable	Since the actuation of the current controller is known, they can be precontrolled to increase the actuations of the current controller.
	1 Enable	
	2 Dead-beat control	Note! For a feedforward control, the Motor equivalent circuit diagram data must be known. If only estimated values are available, we recommend you not to activate the feedforward control.
0x2942:001	Current controller parameters: Gain 0.00 ... [148.21] ... 750.00 V/A	Gain factor V_p of the current controller.
0x2942:002	Current controller parameters: Reset time 0.01 ... [3.77] ... 2000.00 ms	Reset time T_n of the current controller.
0x2943	Current setpoint filter time 0.00 ... [0.00] ... 10.00 ms	Setting of the setpoint current filter time.

Example

Applications with torque control with a switching frequency of 4 kHz reach the same dynamics as applications with 16 kHz without torque control. The stability limit of the speed controller increases depending on the switching frequency and filter setting by up to 100 %. Typical values are in the range of 30 % - 50 %. In case of applications that have already been solved with the previously found settings, an activation is not necessary.



10.7.5.3 ASM field controller

For motors with great rotor time constants or small rotor resistances, very high gain factors are calculated. Since the setting range of the field controller is limited to the double rated magnetising current, the field control loop in the case of these motors tends to a two-point response when the values calculated are entered.

The automatic calculation is made via the parameter 0x2822:016 = 1.

Starting from a calculated gain factor of approx. 1000 A/Vs, do not set the full value anymore.

Example

Calculated value: 10000 A/Vs

Setting: 3000 A/Vs

Calculation of the gain

$$V_p \approx \frac{1}{4 \times R_r \times T_{\text{current controller}}}$$

Calculation of the reset time

$$T_n = T_r = \frac{L_r}{R_r}$$

Parameter	Symbol	Description	Dimension unit
0x29C0:001	V_p	Field controller gain	A/Vs
0x29C0:002	T_n	Field controller reset time	s
0x2C02:002	L_h	Mutual motor inductance (ASM)	H
0x2C02:001	R_r	Motor rotor resistance (ASM)	Ω
-	$T_{\text{current controller}}$	Equivalent time constant of the current control loop = 0.0005 s	
-	T_r	Motor rotor time constant	
-	K_{Path}	Gain of the control path	
-	L_r	Motor rotor resistance (ASM)	H

Parameter

Address	Name / setting range / [default setting]	Information
0x29C0:001	Field controller settings: Gain 0.00 ... [165.84] ... 500000.00 A/Vs	Gain factor V_p of the field controller.
0x29C0:002	Field controller settings: Reset time 1.0 ... [15.1] ... 6000.0 ms	Reset time T_n of the field controller.

Configuring the motor control

Options for optimizing the control loops
 Motor control settings
 ASM field weakening controller



10.7.5.4 ASM field weakening controller

Since the controlled system gain changes with the speed, the field weakening controller is corrected via the speed.

The automatic calculation is made via the parameter 0x2822:017 = 1.

Calculation of the gain

$$V_p = 0, \quad V_{\text{controlled system}_{Fs}} = p \times n_{\text{eck}} \times \frac{2\pi}{60}$$

Calculation of the reset time

$$T_n = 4 \times \frac{V_{\text{controlled system}_{Fs}}}{60} \times (T_{EF} + T_{\text{filter}}), \quad T_{EF} = T_r = \frac{L_r}{R_r} \approx \frac{L_h + L_{ss}}{R_r}$$

Parameter	Symbol	Description	Dimension unit
0x29E0:001	V_p	Gain of the field weakening controller	Vs / A
-	$V_{\text{Path}_{Fs}}$	Gain of the control path	
-	P	Number of pole pairs	rpm
-	$n_{\text{transition}}$	Speed at which the field weakening is approximately initiated.	
0x29E0:002	T_n	Reset time of the field weakening controller	s
-	T_{EF}	Filter time constant of the field control loop	
0x29E3	T_{Filter}	Filter time constant for the required voltage	s
-	T_r	Motor rotor time constant	
-	L_r	Motor rotor resistance (ASM)	
0x2C02:002	L_h	Mutual motor inductance (ASM)	H
0x2C01:003	L_{ss}	Motor stator leakage inductance (ASM) or motor leakage inductance (SM)	H
0x2C02:001	R_r	Motor rotor resistance	Ω

Parameter

Address	Name / setting range / [default setting]	Information
0x29E0:001	Field weakening controller settings: Gain (ASM) 0.000 ... [0.000] ... 2147483.647 Vs/V	Gain factor V_p of the field weakening controller.
0x29E0:002	Field weakening controller settings: Reset time (ASM) 1.0 ... [2000.0] ... 240000.0 ms	Reset time T_n of the field weakening controller.
0x29E1	Field weakening controller Field limitation 5.00 ... [100.00] ... 100.00 %	Field limitation of the field weakening controller.

10.7.5.5 ASM field weakening controller (extended)

For a quick commissioning, the calculations and settings are made automatically during the optimisation.

Parameter

Address	Name / setting range / [default setting]	Information
0x29E2	DC-bus filter time 1.0 ... [25.0] ... 1000.0 ms	Filter time for the current DC-bus voltage used for field weakening.
0x29E3	Motor voltage filter time 1.0 ... [25.0] ... 1000.0 ms	Filter time for the current motor voltage used for field weakening.
0x29E4	Voltage reserve range 1 ... [5] ... 20 %	Voltage reserve at the transition point to the field weakening, with reference to the current value of the DC-bus voltage.



10.7.5.6 PSM operation outside the voltage range

The inverter control enables a synchronous motor to be operated outside the voltage range. If a motor is selected in the »EASY Starter«, the control is parameterised automatically.

Improve the transition from the base speed range to field weakening by activating the **current controller: feedforward control** parameter. ▶ [0x2941](#)

- The current controller precontrol is defined via the following parameters:
 - Motor parameter: stator resistance ▶ [0x2C01:002](#)
 - Motor parameter: stator leakage inductance ▶ [0x2C01:003](#)
 - Motor parameter (PSM): back EMF constant ▶ [0x2C03:001](#)
- If you want to operate a third-party motor in the field weakening range, you have to determine the parameters previously mentioned



Operation of synchronous motors outside the voltage range:

If pulse inhibit is set in the inverter, e.g. in case of an inverter disable or an error, the DC bus is loaded in accordance with the current speed (see equation).

- At high speed and outside the voltage range, the terminal voltage can be higher than the mains voltage!
- In order to prevent the DC bus from being loaded impermissibly high, connect a brake chopper to the DC bus!

The terminal voltage corresponds to the following equation

$$U_k = n \times \frac{U_N}{n_M}$$

V_k	Terminal voltage
n	Speed
V_{rated}	Rated mains voltage
n_m	Rated motor speed

- Mains settings: rated mains voltage ▶ [0x2540:001](#)
- Motor parameter: rated speed ▶ [0x2C01:004](#)

Delaying the buildup of field weakening

With the default setting (5 %), field weakening is initiated, thus ensuring that a punctual buildup of the field weakening current shortly before the voltage threshold is reached.

In the case of synchronous motors, setting the **Voltage reserve range** parameter may bring about a delayed start of field weakening for synchronous machines, e.g. in order to slightly reduce the thermal load of the motor. ▶ [0x29E4](#)

Configuring the motor control

Options for optimizing the control loops
Motor control settings
I_{max} controller



10.7.5.7 I_{max} controller

Defining the behaviour at the current limit (I_{max} controller)

The maximum output current or the current limit is defined by the [0x6073](#) "max. current" parameter. In case of the V/f characteristic control, an I_{max} controller is implemented for complying with this limit. If the motor current exceeds the set maximum current, the I_{max} controller is activated.

- The I_{max} controller changes the rotating field frequency so that the motor current does not exceed the current limit. In motor mode, the frequency is reduced and in generator mode it is increased.
- The gain and reset time of the I_{max} controller can be parameterised.

Optimising the I_{max} controller

The automatic calculation serves to determine starting parameters of the I_{max} controller which are sufficient for many applications. Thus, an optimisation is not required for most of the applications.

The automatic calculation is made via the parameter `0x2822:019 = 1`.

The parameters of the I_{max} controller must be adapted if

- a power control is implemented with great moments of inertia.
Recommendation:
Step 1: increase reset time in [▶ 0x2B08:002](#)
Step 2: reduce gain in [▶ 0x2B08:001](#)
- vibrations occur with V/f characteristic control during the operation of the I_{max} controller.
Recommendation:
Step 1: increase reset time in [▶ 0x2B08:002](#)
Step 2: reduce gain in [▶ 0x2B08:001](#)
- overcurrent errors occur due to load impulses or too high acceleration/deceleration ramps.
Recommendation:
Step 1: reduce reset time in [▶ 0x2B08:001](#)
Step 2: increase gain in [▶ 0x2B08:002](#)

Parameter

Address	Name / setting range / [default setting]	Information
0x2B08:001	V/f I _{max} controller: Gain 0.000 ... [0.001] ... 1000.000 Hz/A	Gain factor V _p of the I _{max} controller.
0x2B08:002	V/f I _{max} controller: Reset time 1.0 ... [100.0] ... 2000.0 ms	Reset time T _i of the I _{max} controller.

10.7.5.8 Flying restart controller

Parameter

Address	Name / setting range / [default setting]	Information
0x2BA1	Flying restart circuit 0 ... [15] ... 100 %	

10.7.5.9 SLVC controller

Parameter

Address	Name / setting range / [default setting]	Information
0x2B40:001	SLVC: Gain 0.0000 ... [0.0010] ... 1000.0000 Hz/A	Gain of the SLVC-Q controller.
0x2B40:002	SLVC: Reset time 1.0 ... [100.0] ... 2000.0 ms	Reset time of the SLVC-Q controller.



Configuring the motor control

Options for optimizing the control loops
 Motor control settings
 Slip controller

10.7.5.10 Slip controller

Parameter

Address	Name / setting range / [default setting]	Information
0x2B14:001	Gain 0.000 ... [0.100] ... 65.535	Gain of the slip controller.
0x2B14:002	Reset time 0.0 ... [100.0] ... 6553.5 ms	Reset time of the slip controller.
0x2B14:003	Frequency limitation 0.00 ... [10.00] ... 100.00 Hz	Frequency limitation of the slip controller. <ul style="list-style-type: none"> With the setting of 0 Hz, the slip controller is deactivated.

10.7.5.11 Position controller

Equation for calculating the gain

The automatic calculation is made via the parameter [0x2822:015](#) = 1.

$$V_p = \frac{1}{32 \times T_{\text{sum}}}, \quad T_{\text{sum}} = T_{\text{filter}} + T_{\text{current controller}}$$

Parameter	Symbol	Description	Dimension unit
0x2980	V_p	Position controller gain	Hz
0x2985:001 ... 0x2985:011	$V_p(n)$	Speed-dependent V_p adaptation	
0x2904	T_{Filter}	Filter time constant - actual speed value	s
-	$T_{\text{current controller}}$	Equivalent time constant of the current control loop = 0.0005 s (500 μ s)	s

Instability of the position control loop due to too high dynamic performance of the speed controller

The following countermeasure must be taken if the following error cannot be reduced to acceptable values while setting the position controller:

1. Reduce speed controller by the factor 2 and slowly increase the position controller until it gets slightly unstable again.
2. Reduce the position controller slightly and increase the speed controller until the position control loop gets slightly unstable again.
3. Repeat these steps until the following error is reduced to acceptable values.

Parameter

Address	Name / setting range / [default setting]	Information
0x2822:015	Axis commands: Calculate position controller parameter	Automatic calculation of the position controller parameters.
	0 Off/Ready	
	1 On/Start	
	2 In progress	
	3 Action cancelled	
	4 No access	
0x2980	Position controller gain 0.00 ... [28.40] ... 10000.00 1/s	Setting of the position controller gain.
0x2981	Position controller gain adaption 0.00 ... [100.00] ... 200.00 %	Setting of the percentage adaptation for the position controller gain.
0x2982	Position controller output signal limitation 0.00 ... [480000.00] ... 480000.00 rpm	Setting of the output signal limitation.
0x2983	Actual position start value -2147483647 ... [0] ... 2147483647	Specifying a new actual position.
0x2984	Mode for setting the actual position	Selection of the mode for setting or shifting the actual position.
	0 Absolute	Actual position = Actual position start value (0x2983)
	1 Relative	Actual position = actual position + Actual position start value (0x2983)

Configuring the motor control

Options for optimizing the control loops
 Motor control settings
 PRBS excitation



Address	Name / setting range / [default setting]	Information
0x2985:001	Gain characteristic adaptations: Speed setpoint 1 1 ... [10] ... 50000 rpm	Characteristic for speed-dependent adaptation of the P gain of the position controller.
0x2985:002	Gain characteristic adaptations: Gain adaption 1 1 ... [100] ... 200 %	
0x2985:003	Gain characteristic adaptations: Speed setpoint 2 1 ... [100] ... 50000 rpm	
0x2985:004	Gain characteristic adaptations: Gain adaption 2 1 ... [100] ... 200 %	
0x2985:005	Gain characteristic adaptations: Speed setpoint 3 1 ... [1000] ... 50000 rpm	
0x2985:006	Gain characteristic adaptations: Gain adaption 3 1 ... [100] ... 200 %	
0x2985:007	Gain characteristic adaptations: Speed setpoint 4 1 ... [2000] ... 50000 rpm	
0x2985:008	Gain characteristic adaptations: Gain adaption 4 1 ... [100] ... 200 %	
0x2985:009	Gain characteristic adaptations: Speed setpoint 5 1 ... [5000] ... 50000 rpm	
0x2985:010	Gain characteristic adaptations: Gain adaption 5 1 ... [100] ... 200 %	
0x2985:011	Gain characteristic adaptations: Gain characteristic adaption on/off	Switch on/off the gain characteristic adaptation. <ul style="list-style-type: none"> • 0 = off • 1 = on
	0 Off	
	1 On	
0x2986	Resulting gain adaption <ul style="list-style-type: none"> • Read only: x.xx % 	Display of the resulting gain after being adapted.

10.7.5.12 PRBS excitation

Parameter

Address	Name / setting range / [default setting]	Information
0x2837:001	Frequency analysis: Period time	
	62 62.5 μ s	
	250 250 μ s	
	1000 1 ms	
	2000 2 ms	
	3000 3 ms	
	4000 4 ms	
	5000 5 ms	
0x2837:002	Frequency analysis: Torque/current amplitude 0.0 ... [5.0] ... 100.0 %	
0x2837:003	Frequency analysis: Speed amplitude 0 ... [50] ... 1000 rpm	
0x2837:004	Frequency analysis: Position amplitude 0.0 ... [5.0] ... 100.0 °	



10.8 Fine adjustment of the motor model

The further commissioning steps are only required for servo controls if more stringent requirements with regard to the torque linearity have to be met. During the commissioning process of Lenze motors, typical values for the relevant parameters are provided. For motors of other manufacturers, these values are to be requested from the motor manufacturer, or they have to be estimated.

Configuring the motor control

Fine adjustment of the motor model
Correction of the stator leakage inductance (Lss)...



10.8.1 Correction of the stator leakage inductance (Lss)...

...and the current controller parameters by means of the saturation characteristic

For the most part, the electrical characteristics of the motor are the relevant factors for an optimal current controller setting (V_p , T_i), especially the stator resistance and the stator leakage inductance (L_{ss}). However, modern motors have their stator leakage inductance changed along with the current level so that it is impossible to have an optimal current controller setting for all working points at all times.

For applications with operating phases that involve very different current and torque requirements and, at the same time, high requirements on dynamic drive behaviour, the i700 servo inverter provides the possibility of the correction of the stator leakage inductance and the current controller settings by means of the adjustable saturation characteristic.

The saturation characteristic is a typical characteristic of motors of one type/size. It does not depend on the maximum process current of the motor in the prevailing application. Thus the defined values should be based on the key data of the motors. These are rated motor current, peak motor current for a limited time and the ultimate motor current.

NOTICE

Impact of the saturation characteristic on the current controller feedforward control

- The saturation characteristic is not only used to correct the current controller, but it also influences the current controller feedforward control (can be activated via parameter [0x2941](#)).

The following picture shows a typical saturation characteristic of an MCS motor:

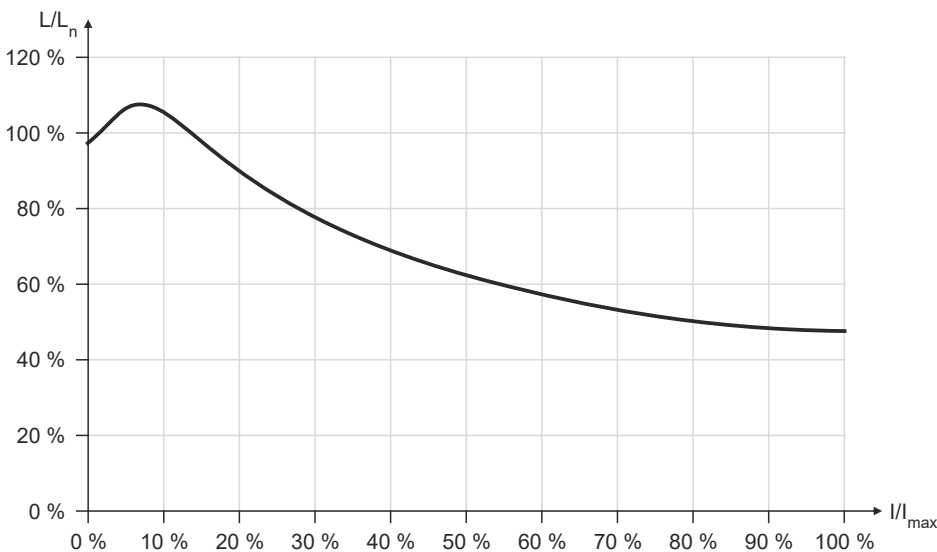

The saturation characteristic represents the change in inductance (L/L_n) as a function of the motor current (I/I_{max}). The variables of both axes which were scaled to a reference value are represented as percentages.

- When a Lenze motor is selected, the saturation characteristic is already filled with values typical of the series.



Configuring the motor control

Fine adjustment of the motor model
Correction of the stator leakage inductance (Lss)...

Distribution of the grid points

- The saturation characteristic is represented by 17 grid points.
- The 17 grid points are spaced on the X axis at equal intervals (equidistantly) in a range of 0 ... 100 %. The 100% value of the X axis refers to the current value (max. motor current in the process) set in parameter [0x2C05](#).
- The y values for the grid points can be accessed via the subindices of parameter .

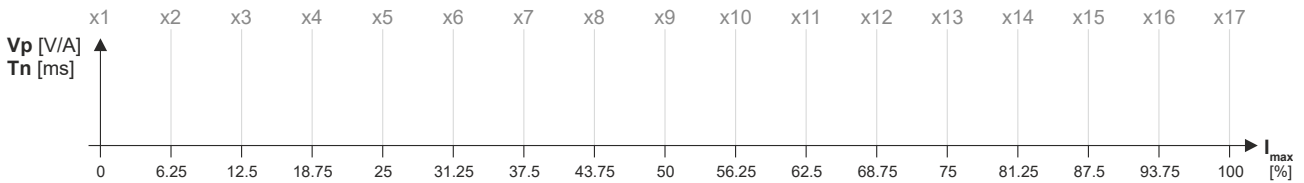

- The 100 % value of a grid point refers to
 - the set motor stator leakage inductance [0x2C01:003](#) and
 - the set current controller gain V_p [0x2942:001](#).
- Preferably select a display area of the grid points which includes at least the ultimate motor current. The current controller step response is then recorded actively only until the grid point with peak motor current. In order to prevent the motor winding from being overloaded, use the manual test mode "current pulse" for recording: [▶ Manual "current pulse" test mode.](#) [□ 206](#)
- The grid points with current setpoints above the peak motor current are determined through interpolation.
- When the saturation characteristics for motor types are determined, it makes sense in some cases to select a scaled representation of the grid point distribution. This requires to know the highest value of the quotient from "ultimate motor current / rated motor current" of the motor series.

Example of determining the saturation characteristic

Given values:

- Rated motor current: 5 A
- Maximum motor current: 20 A
- Maximum process current: 15 A

Configuring the motor control

Fine adjustment of the motor model
Correction of the stator leakage inductance (L_{ss})...



Proceeding

1. Deactivate correction: Set all subindices (0x2C04:001 ... 0x2C04:017) to 100 %.
2. Use 0x2C05 to set the maximum current up to which the motor is to be operated in the process (in this example "15 A").
3. Adjust the current controller with different current setpoints by means of the manual test mode **Manual "current pulse" test mode** and take down the corresponding settings for V_p and T_n.
 - The procedure is described in section **Manual "current pulse" test mode**.
 - The current setpoints to be set for the corresponding adjustment in object 0x2835:001 result from the scaling of the maximum process current to the X axis of the saturation characteristic.
 - The grid points which are required to define the saturation characteristic with a sufficient quality varies from motor to motor and thus has to be determined individually.
 - For this example, currents that are part of the grid points 5, 9, 13, and 15 have been selected, and a measurement at rated motor current was carried out additionally:

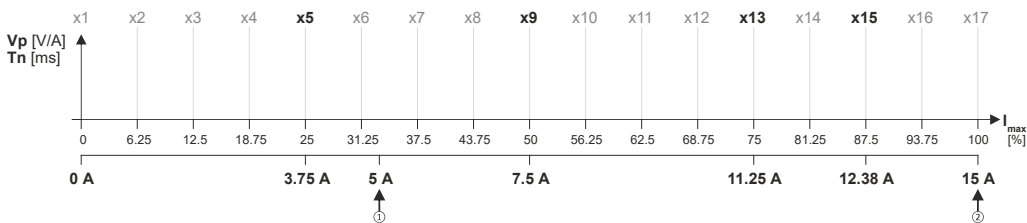

See table "Specifications for adjustment / measured values" after this listing

4. Create a characteristic based on the detected values for V_p (but do not enter any values in yet).
 - Determine the values of the grid points that have not been adjusted by interpolation between two values.
 - **Note:** This example assumes that the inductance does not change considerably below 3.75 A. For this reason, the same V_p value that resulted from the measurement with a motor current of 3.75 A was used for all grid points below 3.75 A.

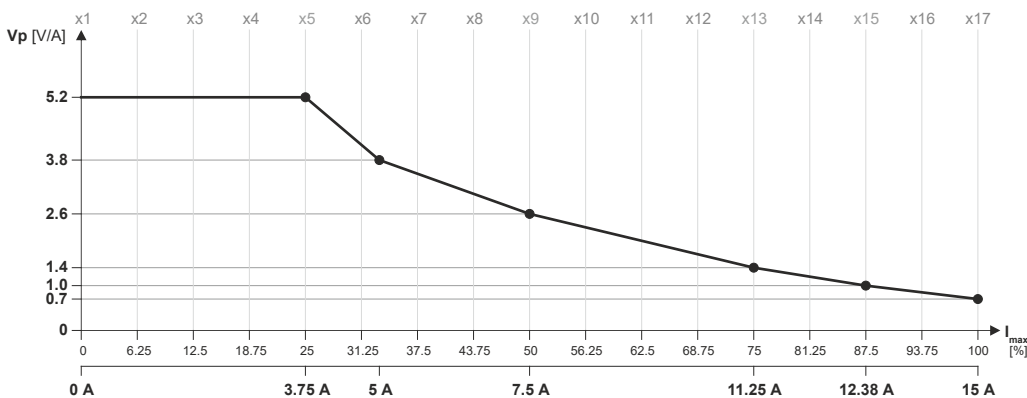

5. Set gain V_p and reset time T_n to the values that were determined during the adjustment with the rated motor current (in this example "5 A"):
 - 0x2942:001 is set to "3.8 V/A".
 - 0x2942:002 is set to "5 ms".
6. Scale V_p values on the Y axis of the characteristic to the V_p setting "3.8 V/A":



Configuring the motor control

Fine adjustment of the motor model
Correction of the stator leakage inductance (L_{ss})...

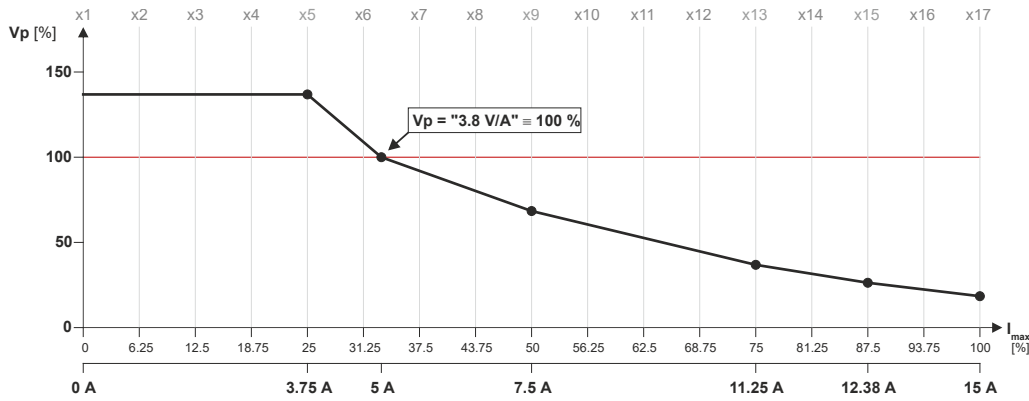

7. Enter the percentage V_p values of the grid points into the subindices (0x2C04:001 ... 0x2C04:017):

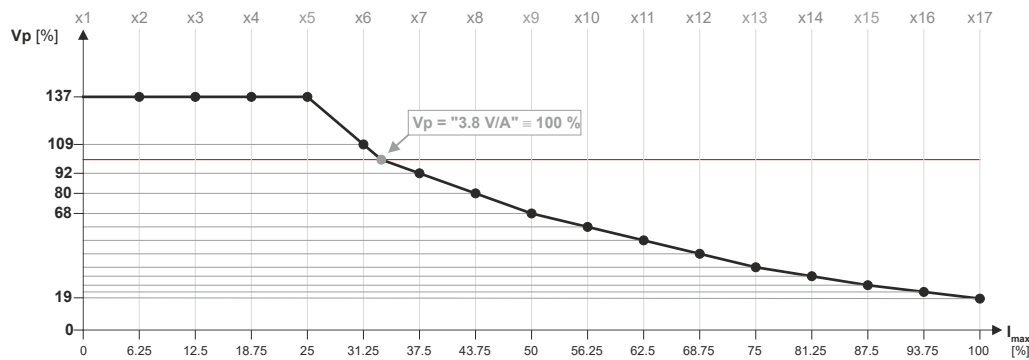

See table "Setting of grid point 1 ... 17 in [%]" after this listing

- Enter the maximum process current ("15 A") in 0x6073 as the maximum current.
 - The settings made should now cause the same basic current characteristic irrespective of the current level.
 - Now that the current controller gain is actively corrected, the step responses may slightly differ from the previous measurements. In this case, the current controller parameters must be post-optimised for the last time.
- For permanent storage: save the characteristic determined.

The »EASY Starter« serves to save the parameter settings of the inverter as parameter file (*.gdc). [Saving the parameter settings](#)

Specifications for adjustment			Measured values	
Grid point	Scaling	Current setpoint	V _p [V/A]	T _n [ms]
5	0.25 * 15 A =	3.75 A	5.2	6.5
9	0.5 * 15 A =	7.5 A	2.6	4
13	0.75 * 15 A =	11.25 A	1.4	2.5
15	0.875 * 15 A =	12.38 A	1.0	2
17	1.0 * 15 A =	15 A	0.7	1.7
Rated motor current=		5 A	3.8	5

Setting of grid point 1 ... 17 in [%]																
y1	y2	y3	y4	y5	y6	y7	y8	y9	y10	y11	y12	y13	y14	y15y	y16	y17
137	137	137	137	137	109	92	80	68	61	53	45	37	32	26	22	19

Configuring the motor control

Fine adjustment of the motor model

Correction of the stator leakage inductance (Lss)...



Parameter

Address	Name / setting range / [default setting]	Information
0x2C04:001	d-axis Lss saturation characteristic: $y_1 = L01$ ($x = 0.00$ %) 0 ... [165] ... 400 %	Saturation characteristic of the leakage inductance. The linear distribution via the current results from the maximum motor current (0x2C05).
0x2C04:002	d-axis Lss saturation characteristic: $y_2 = L02$ ($x = 6.25$ %) 0 ... [200] ... 400 %	
0x2C04:003	d-axis Lss saturation characteristic: $y_3 = L03$ ($x = 12.50$ %) 0 ... [146] ... 400 %	
0x2C04:004	d-axis Lss saturation characteristic: $y_4 = L04$ ($x = 18.75$ %) 0 ... [117] ... 400 %	
0x2C04:005	d-axis Lss saturation characteristic: $y_5 = L05$ ($x = 25.00$ %) 0 ... [97] ... 400 %	
0x2C04:006	d-axis Lss saturation characteristic: $y_6 = L06$ ($x = 31.25$ %) 0 ... [82] ... 400 %	
0x2C04:007	d-axis Lss saturation characteristic: $y_7 = L07$ ($x = 37.50$ %) 0 ... [71] ... 400 %	
0x2C04:008	d-axis Lss saturation characteristic: $y_8 = L08$ ($x = 42.75$ %) 0 ... [62] ... 400 %	
0x2C04:009	d-axis Lss saturation characteristic: $y_9 = L09$ ($x = 50.00$ %) 0 ... [55] ... 400 %	
0x2C04:010	d-axis Lss saturation characteristic: $y_{10} = L10$ ($x = 56.25$ %) 0 ... [50] ... 400 %	
0x2C04:011	d-axis Lss saturation characteristic: $y_{11} = L11$ ($x = 62.50$ %) 0 ... [46] ... 400 %	
0x2C04:012	d-axis Lss saturation characteristic: $y_{12} = L12$ ($x = 68.75$ %) 0 ... [43] ... 400 %	
0x2C04:013	d-axis Lss saturation characteristic: $y_{13} = L13$ ($x = 75.00$ %) 0 ... [42] ... 400 %	
0x2C04:014	d-axis Lss saturation characteristic: $y_{14} = L14$ ($x = 81.25$ %) 0 ... [41] ... 400 %	
0x2C04:015	d-axis Lss saturation characteristic: $y_{15} = L15$ ($x = 87.50$ %) 0 ... [41] ... 400 %	
0x2C04:016	d-axis Lss saturation characteristic: $y_{16} = L16$ ($x = 93.25$ %) 0 ... [41] ... 400 %	
0x2C04:017	d-axis Lss saturation characteristic: $y_{17} = L17$ ($x = 100.00$ %) 0 ... [41] ... 400 %	
0x2C04:018	d-axis Lss saturation characteristic: Activation Lss saturation characteristic 0 Adjustment off 1 Adjustment on	Switch on/off the correction by means of saturation characteristic.
0x2C05	Reference for current grid points (x) Lss saturation characteristic 0.0 ... [5.4] ... 2500.0 A	Setting of the maximum motor current. Serves as reference value for the scaled current data of the X axis of the saturation characteristic.



10.8.2 Synchronous motor (SM): Compensate temperature and current influences

The properties of the permanent magnets of permanently excited synchronous motors depend on the temperature and the amperage. The relationship between motor current and resulting torque changes correspondingly.

The influences of the temperature and the amperage on the magnetisation can be taken into account by the motor control and hence be compensated for.

- To compensate for the temperature dependence of the magnets, the temperature coefficient (kT) of the permanent magnet must be entered in object [0x2C03:003](#) (linear characteristic).
- To compensate for the current dependence of the magnets, multiple grid points of a characteristic must be entered in the following object (non-linear characteristic):

Parameter

Address	Name / setting range / [default setting]	Information
0x2C06:001	Grid points for magnet characteristic (current): x1 = i01/iN 0 ... [0] ... 1000 %	Characteristic for the dependency of the magnetic flux on the active motor current.
0x2C06:002	Grid points for magnet characteristic (current): y1 = kT01/kTN 0 ... [100] ... 1000 %	
0x2C06:003	Grid points for magnet characteristic (current): x2 = i02/iN 0 ... [100] ... 1000 %	
0x2C06:004	Grid points for magnet characteristic (current): y2 = kT02/kTN 0 ... [100] ... 1000 %	
0x2C06:005	Grid points for magnet characteristic (current): x3 = i03/iN 0 ... [200] ... 1000 %	
0x2C06:006	Grid points for magnet characteristic (current): y3 = kT03/kTN 0 ... [100] ... 1000 %	
0x2C06:007	Grid points for magnet characteristic (current): x4 = i04/iN 0 ... [415] ... 1000 %	
0x2C06:008	Grid points for magnet characteristic (current): y4 = kT04/kTN 0 ... [72] ... 1000 %	

Configuring the motor control

Fine adjustment of the motor model

Asynchronous motor (ASM): Identifying L_h saturation characteristic



10.8.3 Asynchronous motor (ASM): Identifying L_h saturation characteristic

In case of an asynchronous motor, the relationship between current and torque is basically determined by the saturation behaviour of the mutual inductance. If the achieved torque accuracy, especially in the field weakening range should not be sufficient, the accuracy can be increased by the individual identification of the saturation characteristic. This behaviour can be measured by the servo inverter.

Conditions for the execution

- Before this commissioning function is executed, the inverter characteristic and the motor parameters must be identified ▶ [Motor equivalent circuit diagram data](#). [□ 162](#)
- The motor may be stalled.
- The inverter is error-free and in "Switched on" device state.

Response of the motor during "standstill" performance

How to identify the L_h saturation characteristic:



The identification of the L_h saturation characteristic can take up to 11 minutes.

1. If the servo inverter enabled, disable it ▶ [Disable operation](#). [□ 219](#)
2. Select the drive mode [10] in parameter [0x2825](#): L_h saturation characteristic identification
3. Enable the inverter to start the process.
 - Check the progress in [0x2823:002](#).
 - Disabling the inverter serves to abort the started procedure any time if required. Already determined characteristic values are rejected in this case.

After successful completion...

...the inverter will be disabled automatically and the points of the determined L_h saturation characteristic are set in the parameters [0x2C07:001](#) ... [0x2C07:017](#).

- Save the changed settings.

The »EASY Starter« serves to save the parameter settings of the servo inverter as parameter file (*.gdc). ▶ [Saving the parameter settings](#) [□ 35](#)
- The inverter disable set automatically by the procedure can be deactivated again via the CiA402 control word [0x6040](#) (setting = 7, 15).

In the event of an error

If an error occurs during the procedure or the pulse inhibit gets active (e.g. due to short-time undervoltage), the procedure is terminated with inverter disable without the settings being changed.

Load standard L_h saturation characteristic

If an incorrect L_h saturation characteristic has been determined or none at all, it is possible to load a standard L_h characteristic.

How to load the standard L_h saturation characteristic:

1. The start is made via the parameter [0x2822:021](#) = 1.
2. For permanent storage: after the process has been completed, save the L_h saturation characteristic set in .

The »EASY Starter« serves to save the parameter settings of the inverter as parameter file (*.gdc). [Saving the parameter settings](#)



Configuring the motor control

Fine adjustment of the motor model
Asynchronous motor (ASM): Identifying Lh saturation characteristic

Parameter

Address	Name / setting range / [default setting]	Information
0x2822:021	Axis commands: Load default Lh saturation characteristic 0 Off/Ready 1 On/Start 2 In progress 3 Action cancelled 4 No access 5 No access (Device disabled)	Parameters for interaction with engineering tools.
0x2C07:001	Inductance grid points (y) Lh saturation characteristic: y1 = L01 (x = 0.00 %) 0 ... [118] ... 400 %	Saturation characteristic of the mutual inductance of an asynchronous machine as a function of the magnetising current.
0x2C07:002	Inductance grid points (y) Lh saturation characteristic: y2 = L02 (x = 6.25 %) 0 ... [118] ... 400 %	
0x2C07:003	Inductance grid points (y) Lh saturation characteristic: y3 = L03 (x = 12.50 %) 0 ... [118] ... 400 %	
0x2C07:004	Inductance grid points (y) Lh saturation characteristic: y4 = L04 (x = 18.75 %) 0 ... [117] ... 400 %	
0x2C07:005	Inductance grid points (y) Lh saturation characteristic: y5 = L05 (x = 25.00 %) 0 ... [116] ... 400 %	
0x2C07:006	Inductance grid points (y) Lh saturation characteristic: y6 = L06 (x = 31.25 %) 0 ... [114] ... 400 %	
0x2C07:007	Inductance grid points (y) Lh saturation characteristic: y7 = L07 (x = 37.50 %) 0 ... [111] ... 400 %	
0x2C07:008	Inductance grid points (y) Lh saturation characteristic: y8 = L08 (x = 43.75 %) 0 ... [107] ... 400 %	
0x2C07:009	Inductance grid points (y) Lh saturation characteristic: y9 = L09 (x = 50.00 %) 0 ... [100] ... 400 %	
0x2C07:010	Inductance grid points (y) Lh saturation characteristic: y10 = L10 (x = 56.25 %) 0 ... [93] ... 400 %	
0x2C07:011	Inductance grid points (y) Lh saturation characteristic: y11 = L11 (x = 62.50 %) 0 ... [86] ... 400 %	
0x2C07:012	Inductance grid points (y) Lh saturation characteristic: y12 = L12 (x = 68.75 %) 0 ... [78] ... 400 %	
0x2C07:013	Inductance grid points (y) Lh saturation characteristic: y13 = L13 (x = 75.00 %) 0 ... [71] ... 400 %	
0x2C07:014	Inductance grid points (y) Lh saturation characteristic: y14 = L14 (x = 81.25 %) 0 ... [64] ... 400 %	
0x2C07:015	Inductance grid points (y) Lh saturation characteristic: y15 = L15 (x = 87.50 %) 0 ... [57] ... 400 %	
0x2C07:016	Inductance grid points (y) Lh saturation characteristic: y16 = L16 (x = 93.75 %) 0 ... [50] ... 400 %	
0x2C07:017	Inductance grid points (y) Lh saturation characteristic: y17 = L17 (x = 100.00 %) 0 ... [42] ... 400 %	

Configuring the motor control

Fine adjustment of the motor model
Estimate optimum magnetising current



10.8.4 Estimate optimum magnetising current

In case of the given L_h saturation behaviour, there is (usually) a magnetising current where the torque efficiency is highest. This magnetising current can be determined by the servo inverter.

- Executing this function also compresses or extends the L_h saturation characteristic (interpolation points [0x2C07:001](#) ... [0x2C07:001](#)).
- After the function has been executed, the determined magnetising current is entered in [0x2C02:003](#).

Preconditions for the performance

- Before this commissioning function is executed, the motor parameters and the L_h saturation characteristic must be identified ▶ [Motor equivalent circuit diagram data](#). [162](#)
- The motor must be stalled.

Response of the motor during "standstill" performance

How to estimate the optimal magnetising current:

1. Start **Axis commands: estimate optimum magnetizing current** parameter with = 1.
▶ [0x2822:023](#)
2. After the process has been completed, save the changed inverter parameters:
 - L_h saturation characteristic ([0x2C07:001](#) ... [0x2C07:017](#))
 - Magnetising current [0x2C02:003](#)

The »EASY Starter« serves to save the parameter settings of the inverter as parameter file (*.gdc). ▶ [Saving the parameter settings](#)

Parameter

Address	Name / setting range / [default setting]	Information
0x2822:023	Axis commands: Estimate optimum magnetizing current	Parameters for interaction with engineering tools.
	0 Off/Ready	
	1 On/Start	
	2 In progress	
	3 Action cancelled	
	4 No access	
5 No access (Device disabled)		



10.9 Parameterise filter elements in the setpoint path

10.9.1 Jerk limitation

Via the max. acceleration change that can be set in parameter [0x2945 C00274](#), the change of the setpoint torque can be limited for jerk limitation. Hence, sudden torque step changes can be avoided. The entire speed characteristic is smoothed.

Parameter

Address	Name / setting range / [default setting]	Information
0x2945	Torque setpoint jerk limitation 0.1 ... [400.0] ... 400.0	Setting of the maximum acceleration change.

Configuring the motor control

Parameterise filter elements in the setpoint path
Notch filter (band-stop filter)



10.9.2 Notch filter (band-stop filter)

Due to the high dynamic performance or limit frequency of the closed current control loop, mechanical natural frequencies can be activated which may lead to an unstable speed control loop in the case of resonance.

To mask out or at least damp these resonant frequencies, two notch filters are integrated in the speed control loop of the inverter. In the Lenze setting, these filters are switched off:

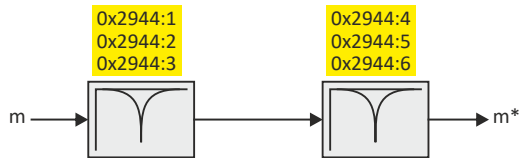

Use of the notch filters depending on the resonant frequency

⚠ WARNING!

Improperly set notch filters have a negative impact on the response and disturbance behaviour of the speed control: increased overshoot of the motor speed in case of response behaviour and / or higher speed deviations (extreme case: complete instability of the drive)

In the case of impairment,

- ▶ the drive that is still running must either be coasted down by activating the inverter disable or immediately be brought to a standstill via a brake.
- ▶ the speed controller must be optimised again afterwards.
- ▶ the test procedure must be repeated.

Output frequency	Use of notch filters
$0 \dots 1/2 f_{\text{limit_speed_controller}}$	No
$1/2 f_{\text{limit_speed_controller}} \dots f_{\text{limit_speed_Controller}}$	yes, with restriction
$< f_{\text{limit_speed_controller}}$	yes, without restriction

- The notch filters are suitable for use with resonant frequencies equal to or higher than the limit frequency of the speed controller:
 - Resonant frequencies $\geq f_{\text{limit_speed_controller}} = 70 \text{ Hz} \dots 110 \text{ Hz}$
- For resonant frequencies lower than the limit frequency of the speed controller, the use of suitable speed profiles with an S-shaped ramp is recommended.



Setting the notch filters

Since the exact frequency response of the speed control path in most cases is not known beforehand, an experimental procedure for setting the notch filters is described in the following.

How to set the notch filters:

1. Set and optimise current controller, see section [Current controller](#) . [166](#)
 2. Adapt the speed controller reset time to the filter time constant of the actual speed filter time and the equivalent time constant of the current control loop:
 - The following applies: $0x2900:002 = 16 * (0x2904 + 500 \mu s)$
- Note:** The setting of the reset time includes the equivalent time constant of the current control loop. The 500 μs indicated are typical in a power range of up to 50 kW. Above this value, greater time constants may occur.
3. Slowly increase the proportional gain of the speed controller in [0x2900:001](#) until the speed control loop starts to be unstable (acoustic determination, measurement of the motor current or recording of the speed output signal).
 4. Measure the oscillation frequency using an oscilloscope:
 - Assessing the motor current via [0x2DD1:004](#).
 - Assessing the motor speed via [0x6044](#).
 5. Set the oscillation frequency determined as filter frequency in [0x2944:001](#).
 6. Set the filter width to 40 % of the filter frequency in [0x2944:002](#).
 7. Set the filter depth to 40 dB in [0x2944:003](#).
 - If "0 dB" is set (default setting), the filter is not effective.
 8. Further increase the proportional gain of the speed controller in [0x2900:001](#) until the speed control loop starts to be unstable again.
 - If the oscillation frequency has changed now, readjust the filter frequency by trimming. The use of a second filter is ineffective here.
 - If the oscillation frequency remains the same, readjust the filter depth and/or the filter width by trimming (the first reduces the amplitude, the second lets the phase rotate faster).
 - Repeat step 8 until the desired behaviour or the limit of a sensible speed controller gain has been reached.
 9. Check the drive behaviour in case of quick stop (QSP)
 - Accelerate drive
 - Then, brake with quick stop (QSP) and check whether a reduced drive dynamics can be detected.
 - If so, reduce the influence of the filters until the reachable dynamics corresponds to the requirements.

NOTICE

- Readjust the speed controller after setting the notch filters (see section "Speed controller").
[163](#)
- Save the changed settings.
- The »EASY Starter« serves to save the parameter settings of the servo inverter as parameter file (*.gdc), see section [Saving the parameter settings](#) . [35](#)

Parameter

Address	Name / setting range / [default setting]	Information
0x2944:001	Torque setpoint notch filter: Frequency notch filter 1 1.0 ... [200.0] ... 2000.0 Hz	Setting of the frequency for notch filter 1.
0x2944:002	Torque setpoint notch filter: Bandwidth notch filter 1 0.0 ... [20.0] ... 1000.0 Hz	Setting of the bandwidth for notch filter 1.

Configuring the motor control

Parameterise filter elements in the setpoint path
Notch filter (band-stop filter)



Address	Name / setting range / [default setting]	Information
0x2944:003	Torque setpoint notch filter: Damping notch filter 1 0 ... [0] ... 100 dB	Setting of the damping for notch filter 1.
0x2944:004	Torque setpoint notch filter: Frequency notch filter 2 1.0 ... [400.0] ... 2000.0 Hz	Setting of the frequency for notch filter 2.
0x2944:005	Torque setpoint notch filter: Bandwidth notch filter 2 0.0 ... [40.0] ... 1000.0 Hz	Setting of the bandwidth for notch filter 2.
0x2944:006	Torque setpoint notch filter: Damping notch filter 2 0 ... [0] ... 100 dB	Setting of the damping for notch filter 2.



10.10 Motor protection

Many monitoring functions integrated in the inverter can detect errors and thus protect the device or motor from being destroyed or overloaded.

10.10.1 Motor overload monitoring (i^2xt)

This function monitors the thermal overload of the motor, taking the motor currents recorded and a mathematical model as a basis.

DANGER!

Fire hazard by overheating of the motor.

Possible consequences: Death or severe injuries

- ▶ Since the motor utilisation calculated in the thermal model gets lost after mains switching, the following operating states cannot be determined correctly: 1.) Restarting (after mains switching) of a motor that is already very hot and 2.) Change of the cooling conditions (e.g. cooling air flow interrupted or too warm).
- ▶ To achieve full motor protection, an additional temperature monitoring function with a separate evaluation must be installed.
- ▶ When actuating motors that are equipped with PTC thermistors or thermal contacts, always activate the PTC input.



Motor overload monitoring is important for motors without thermal sensor.

Details

During the calculation of the parameters [0x2D4D:001 ...0x2D4D:008](#), the speed dependence of the permissible motor load and thus of the permissible current (difference between the standstill current and rated current is taken into consideration.

In case of permanent overload and excess of the warning threshold set in parameter [0x2D4E](#), a warning is output in order that the higher-level Controller is still able to respond and reduce the motor load or interrupt the operation.

The calculated thermal motor utilisation is displayed in parameter [0x2D4F](#).

Parameter

Address	Name / setting range / [default setting]	Information
0x2D4F	Motor utilisation (i^2xt) • Read only: x %	Display of the current thermal motor utilisation.
0x2D4E	Motor utilisation (i^2xt) - warning threshold 0 ... [100] ... 250 %	Setting of the warning threshold for motor overload monitoring.
0x2D50:001	Motor utilisation (i^2xt) - monitoring: Error response	For displaying the motor utilisation error response (I^2xt).
	0 No response 1 Fehler > CiA402	

Configuring the motor control

Motor protection

Motor overload monitoring (i^2xt)



Address	Name / setting range / [default setting]	Information
0x2D50:002	Motor utilisation (i^2xt) - monitoring: Error threshold 0 ... [105] ... 250 %	Setting of the error threshold for motor overload monitoring.



Configuring the motor control

Motor protection
 Motor overload monitoring (i²xt)
 Parameters for the thermal model

10.10.1.1 Parameters for the thermal model

The introduction of a two-component model with two time constants (one for the winding and the other for the housing/laminated core) serves to display the thermal behaviour of the motors up to 500% of the rated current.

Structure of the monitoring

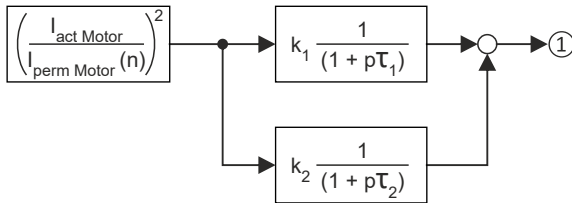

① Thermal utilisation of the motor in [%]

Parameter	Symbol	Description	Dimension unit
-	I _{actMotor}	Actual motor current	A
-	I _{permMotor}	Permissible motor current (speed-dependent)	A
0x2D4C:001	τ ₁	Therm. time constant of winding	s
0x2D4C:002	τ ₂	Therm. time constant of laminated core	s
0x2D4C:003	k ₁	Percentage of the winding in the final temperature	%
-	k ₂	Percentage of the laminated core in the final temperature: k ₂ = 100 % - k ₁	%

Calculation with only one time constant

If k₁ = "0 %" is set, the part of the winding is not taken into consideration and the thermal model is only calculated using the time constant set for the housing/laminated core. This setting is e.g. required if only the time constant of the laminated core (T₂) is known.

Parameter setting of the time constant and the influence of the winding on motors of other manufacturers

When the influence of the winding is activated, the i²xt monitoring becomes more sensible as if only the influence of the laminated core would be used for monitoring purposes.

The necessity to activate the influence of the winding rises with the increasing utilisation of the motor overload capacity. It also rises with applications where the motor is at standstill for longer periods or cyclically and a load ≥ permanent standstill current is applied.

For determining the values for the thermal time constant, try to get the data from the motor manufacturer. If this is not possible, you can use the data of a comparable Lenze motor.

Conditions for comparability are similar values in case of the following motor features:

- Square dimensions of the motor (active part)
- Length of the active part (if available)
- Permanent standstill current I₀ [A_{RMS}]
- Peak current/overload capacity [A_{RMS}]
- Copper resistance of the winding at 20 °C [R_{phase}]

Example:

Motor features	Data of the third-party motor	Description
Square dimension	95 mm	MCS09xxx = 89 mm
Standstill current	2.2 A	MCS09F38 = 3.0 A
Peak current	7.3 A	MCS09F38 = 15 A
Phase resistance	5.1 Ohms	MCS09F38 = 5.2 Ohms

Configuring the motor control

Motor protection

Motor overload monitoring (i^2xt)

Parameters for the thermal model



Parameter

Address	Name / setting range / [default setting]	Information
0x2D4C:001	Thermal model motor utilization (i^2xt): Motor utilisation (i^2xt) 1 ... [60] ... 36000 s	Setting of the time constant for the winding.
0x2D4C:002	Thermal model motor utilization (i^2xt): Thermal time constant - laminations 1 ... [852] ... 36000 s	Setting of the time constant for the laminated core.
0x2D4C:003	Thermal model motor utilization (i^2xt): Winding influence 0 ... [27] ... 100 %	Part of the thermal motor model: distribution factor of the copper winding influence.
0x2D4C:004	Thermal model motor utilization (i^2xt): Starting value 0 ... [0] ... 250 %	Value for initialising the filters for the thermal motor overload monitoring (setting in % of the permissible full load).



10.10.1.2 Speed-dependent evaluation of the motor current

WARNING!

Fire hazard by overheating of the self-ventilated standard motor

Possible consequences: Destruction of system parts

- Protect self-ventilated standard motors especially at low speeds by sufficient cooling or from impermissibly high motor currents. Carry out a speed-dependent evaluation of the permissible motor current.

WARNING!

Fire hazard by overheating of PM synchronous motors

Possible consequences: Destruction of system parts

- Please check for every individual case which r.m.s. value can be used to permanently operate the motor at standstill. In case of some motors, a derating $I_1/I_n < 100\%$ is required when $n_1/n_n = 0\%$. This serves to prevent an overload of individual motor phases as their power loss doubles with continuous DC current load. (It is called DC current load as the field frequency amounts to 0 Hz at standstill.)



When you select a Lenze motor from the catalogue and transfer its parameters into the i700 servo inverter a typical characteristic is automatically set for the selected motor. A deviating parameterisation is only required if the motor is operated in ambient conditions which demand a general derating. Example: use in site altitudes > 1000 m. In case of motors of other manufacturers, the operating points have to be parameterised based on the data sheet information.

By selecting a characteristic, the permissible motor current is evaluated depending on speed for calculating the thermal motor utilisation. For this purpose, up to four operating points on the S1 characteristic of a motor can be used.

- The S1 characteristic can be found in the technical data sheet/catalogue of the respective motor.
- The representation in the objects /characteristic is carried out as relative values with reference to rated values.

The speed-dependent evaluation of the permissible motor current can actually be switched off by parameterising all 8 characteristic points to "100 %".

Operating points		
①	Standstill n01-I01	For motors, this operating point is often described with the no-Io values.
②	Reference point n02-I02	If the value falls below the speed n02, a derating in the current is required because: <ul style="list-style-type: none"> • the motor cooling of self-ventilated motors deteriorates considerably. • a DC current load causes an increased power loss in a winding. • For motors, this operating point is also described with the no-Io values.
③	Rated point (n03=nN)-(I03=IN)	Rated values of the motor are the reference for all operating points of the i ² xt monitoring.
④	Field weakening n04-I04	This operating point should be parameterised irrespective of the use in the current application.

Configuring the motor control

Motor protection
 Motor overload monitoring (i^2xt)
 Speed-dependent evaluation of the motor current



Example of how to enter the characteristic for standard and servo motors

The required data of the operating points result from the S1 characteristic of the prevailing motor:

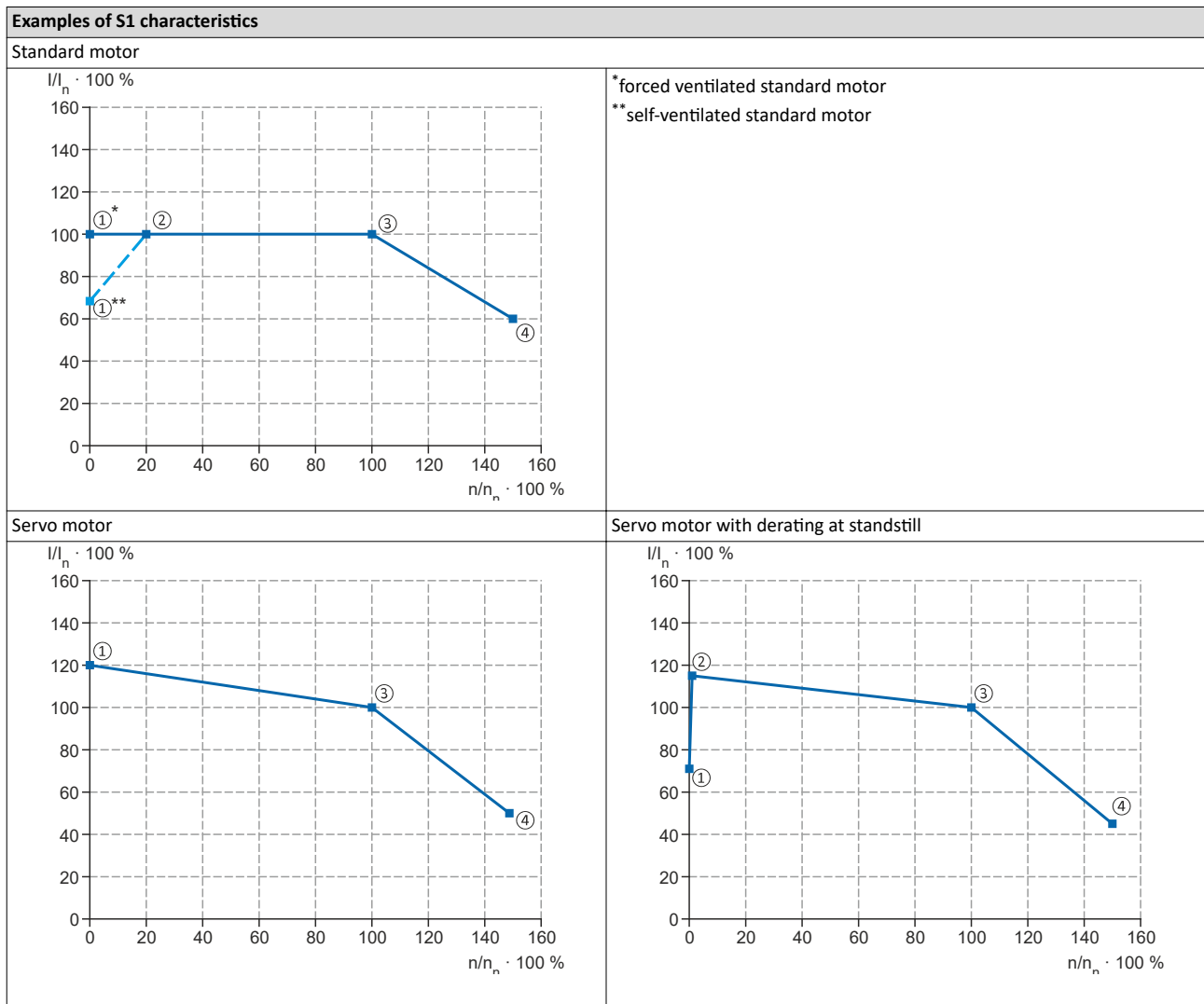

Parameter	Characteristic points	Info
0x2D4D:001	①	$n_1/n_n * 100\%$
0x2D4D:002		$I_1/I_n * 100\%$
0x2D4D:003	②	$n_2/n_n * 100\%$
0x2D4D:004		$I_2/I_n * 100\%$
0x2D4D:005	③	$n_3/n_n * 100\%$
0x2D4D:006		$I_3/I_n * 100\%$
0x2D4D:007	④	$n_4/n_n * 100\%$
0x2D4D:008		$I_4/I_n * 100\%$



Configuring the motor control

Motor protection
 Motor overload monitoring (i^2xt)
 Speed-dependent evaluation of the motor current

Parameter

Address	Name / setting range / [default setting]	Information
0x2D4D:001	Motor utilisation (i^2xt) - specific characteristic: x1 = n01/nN (n01 ~ 0) 0 ... [0] ... 600 %	User-definable characteristic for speed-dependent evaluation of the motor current.
0x2D4D:002	Motor utilisation (i^2xt) - specific characteristic: y1 = i01/iN (x1) 0 ... [100] ... 600 %	
0x2D4D:003	Motor utilisation (i^2xt) - specific characteristic: x2 = n02/nN (n02 = limit reduced cooling) 0 ... [0] ... 600 %	
0x2D4D:004	Motor utilisation (i^2xt) - specific characteristic: y2 = i02/iN (x2) 0 ... [100] ... 600 %	
0x2D4D:005	Motor utilisation (i^2xt) - specific characteristic: x3 = n03/nN (n03 = rated speed) 0 ... [100] ... 600 %	
0x2D4D:006	Motor utilisation (i^2xt) - specific characteristic: y3 = i03/iN (x3) 0 ... [100] ... 600 %	
0x2D4D:007	Motor utilisation (i^2xt) - specific characteristic: x4 = n04/nN (n04 = limit field weakening) 0 ... [100] ... 600 %	
0x2D4D:008	Motor utilisation (i^2xt) - specific characteristic: y4 = i04/iN (x4) 0 ... [100] ... 600 %	

Configuring the motor control

Motor protection

Motor overload monitoring (I^2xt)

UL 508-compliant motor overload monitoring



10.10.1.3 UL 508-compliant motor overload monitoring

If the operation of the motor requires the compliance with the UL Standard 508, and the UL 508-compliant motor overload monitoring is realised by the mathematical model of the I^2xt monitoring, the following conditions must be observed.

UL 508 condition 1:

In case of a motor load of 600 %, the I^2xt warning must be output within 20 seconds.

- A motor load of 600 % exists if the r.m.s. value of the total motor current displayed in parameter [0x2DD1:005](#) corresponds to 600% of the rated motor current [0x6075](#).

This condition can be fulfilled by setting the following parameters:

- Motor utilisation (I^2xt): thermal time constant - laminated core ▶ [0x2D4C:002](#)
- Motor utilisation (I^2xt): influence winding ▶ [0x2D4C:003](#)
- Motor utilisation (I^2xt): motor overload warning threshold ▶ [0x2D4E](#)
- Motor utilisation (I^2xt): response ▶ [0x2D50:001](#)
- Motor utilisation (I^2xt): error threshold ▶ [0x2D50:002](#)

UL 508 condition 2:

In case of a motor load of 110 %, the I^2xt warning at a motor rotating field frequency of 10 Hz must be output faster than at a motor rotating field frequency of 20 Hz.

- The current motor rotating field frequency is displayed in parameter [0x2DDD](#).
- A motor load of 110 % exists if the r.m.s. value of the total motor current displayed in parameter [0x2DD1:005](#) corresponds to 110 % of the rated motor current [0x6075](#).

This condition can be fulfilled by setting the following parameters:

- I^2xt : $x1 = n01/nN$ ($n01 \sim 0$) ▶ [0x2D4D:001](#)
- I^2xt : $y1 = i01/iN$ ($x = n01 \sim 0$) ▶ [0x2D4D:002](#)
- I^2xt : $x2 = n02/nN$ ($n02 =$ reduced cooling limit) ▶ [0x2D4D:003](#)
- I^2xt : $y2 = i02/iN$ ($x = n02 =$ reduced cooling limit) ▶ [0x2D4D:004](#)

UL 508 condition 3:

After mains switching and a motor load > 100 %, the I^2xt warning must be output faster than in the same overload case before mains switching.

- A motor load > 100 % exists if the r.m.s. value of the total motor current displayed in parameter [0x2DD1:005](#) is higher than the rated motor current [0x6075](#).

This condition can be fulfilled by setting the following parameters:

- Motor utilisation (I^2xt): starting value ▶ [0x2D4C:004](#)



10.10.2 Motor temperature monitoring

In order to record and monitor the motor temperature, a PTC thermistor (single sensor according to DIN 44081 or triple sensor according to DIN 44082) or thermal contact (normally-closed contact) can be connected to the terminals T1 and T2. This measure helps to prevent the motor from being destroyed by overheating.

Preconditions

- The inverter can only evaluate one PTC thermistor! Do not connect several PTC thermistors in series or parallel.
- If several motors are actuated on one inverter, thermal contacts (NC contacts) (TCO) connected in series are to be used.
- To achieve full motor protection, an additional temperature monitoring function with a separate evaluation must be installed.
- By default, a wire jumper is installed between terminals X109/T1 and X109/T2, which must be removed when the PTC thermistor or thermal contact (TCO) is connected.

Details

If $1.6\text{ k}\Omega < R < 4\text{ k}\Omega$ at terminals X109/T1 and X109/T2, the monitoring function will be activated; see functional test below.

- If the monitoring function is activated, the response set in [0x2D49:002](#) will be effected.
- The setting [0x2D49:002](#) = 0 deactivates the monitoring function.



If a suitable motor temperature sensor is connected to the terminals X109/T1 and X109/T2 and the response in [0x2D49:002](#) is set to "Fault [3]", the response of the motor overload monitoring may be set other than "Fault [3]" in .

▶ [Motor overload monitoring \(i²xt\)](#) 189

Functional test

Connect a fixed resistor to the PTC input:

- $R > 4\text{ k}\Omega$: The monitoring function must be activated.
- $R < 1\text{ k}\Omega$: The monitoring function must not be activated.

Details

If $1.6\text{ k}\Omega < R < 4\text{ k}\Omega$ at terminals X109/T1 and X109/T2, the monitoring function will be activated; see functional test below.

- If the monitoring function is activated, the response set in [0x2D48:002](#) will be effected.
- The setting [0x2D48:002](#) = 0 deactivates the monitoring function.



If a suitable motor temperature sensor is connected to the terminals X109/T1 and X109/T2 and the response in [0x2D48:002](#) is set to "Fault [3]", the response of the motor overload monitoring may be set other than "Fault [3]" in [0x2D4B:003](#).

▶ [Motor overload monitoring \(i²xt\)](#) 189

Functional test

Connect a fixed resistor to the PTC input (T1/T2):

- $R > 4\text{ k}\Omega$: The monitoring function must be activated.
- $R < 1\text{ k}\Omega$: The monitoring function must not be activated.

Parameter

Address	Name / setting range / [default setting]	Information
0x2D48:002	PTC temperature sensor monitoring: Error response	Setting of a response for PTC temperature monitoring.
	0 No response	
	1 Fault > CiA402	
	2 Warning	

Configuring the motor control

Motor protection

Motor temperature monitoring



Address	Name / setting range / [default setting]	Information
0x2D49:001	Motor temperature monitoring: Temperature sensor type	Selection of the motor temperature sensor used.
	0 KTY83-110	
	1 KTY83-110+2xPTC 150 °C	
	2 KTY84-130	
	3 Specific characteristic	
	4 Reserved	
	5 PT1000	
6 PT1000+2xPTC 150 °C		
0x2D49:002	Motor temperature monitoring: Response	Selection of the response to the triggering of the motor temperature monitoring. Associated event IDs: <ul style="list-style-type: none"> • 537477904 0x20094310 - Motor overtemperature • 537478016 0x20094380 - Fault - Motor temperature sensor
	0 No response	
	1 Warning	
0x2D49:003	Motor temperature monitoring: Warning threshold -3276.8 ... [145.0] ... 3276.7 °C	Setting of the warning threshold for motor temperature monitoring. The warning threshold is reset with a hysteresis of 5 °C. Associated event ID: <ul style="list-style-type: none"> • 537478016 0x20094380 - Fault - Motor temperature sensor
0x2D49:004	Motor temperature monitoring: Error threshold -3276.8 ... [155.0] ... 3276.7 °C	Setting of the error threshold for motor temperature monitoring The warning threshold is reset with a hysteresis of 5 °C. Associated event ID: <ul style="list-style-type: none"> • 537478016 0x20094380 - Fault - Motor temperature sensor
0x2D49:005	Motor temperature monitoring: Actual motor temperature <ul style="list-style-type: none"> • Read only: x.x °C 	Display of the current motor temperature.
0x2D49:006	Motor temperature monitoring: Spec. characteristic temperature grid point 1 0.0 ... [25.0] ... 255.0 °C	Parameter for the specific thermal sensor characteristic (0x2D49:001 = 3).
0x2D49:007	Motor temperature monitoring: Spec. characteristic temperature grid point 2 0.0 ... [150.0] ... 255.0 °C	
0x2D49:008	Motor temperature monitoring: Spec. characteristic resistance grid point 1 0 ... [1000] ... 30000 Ω	
0x2D49:009	Motor temperature monitoring: Spec. characteristic resistance grid point 2 0 ... [2225] ... 30000 Ω	
0x2DDF:007	Axis information: Function of X109 <ul style="list-style-type: none"> • Read only 	
0	None	
10	HIPERFACE DSL® (OCT)	
20	PTC	



10.10.2.1 Individual characteristic for motor temperature sensor



The setting of a characteristic for the motor temperature sensor is not suitable as an adequate replacement of a tripping unit for the thermal protection of rotating electrical machines (EN 60947- 8:2013)!

If required, you can define and activate a special characteristic for the motor temperature sensor.

- The special characteristic is activated via the setting [0x2D49:001](#) = 3
- The special characteristic is defined based on two parameterisable grid points. The two grid points define a line that is extrapolated to the left and to the right.

This default setting can be changed by the following parameters:

- Thermal sensor characteristic: Grid point 1 - temperature ▶ [0x2D49:006](#)
- Thermal sensor characteristic: Grid point 1 - resistance ▶ [0x2D49:008](#)
- Thermal sensor characteristic: Grid point 2 - temperature ▶ [0x2D49:007](#)
- Thermal sensor characteristic: Grid point 2 - resistance ▶ [0x2D49:009](#)



Selecting a motor from the motor catalogue overwrites the parameters of the special characteristic!

10.10.3 Overcurrent monitoring

This function monitors the instantaneous value of the motor current and serves to protect the motor from irreversible damage. Overcurrent monitoring is effective for all motor control modes.

NOTICE

With an incorrect parameterization, the maximum permissible motor current may be exceeded in the process.

Possible consequences: Irreversible damage of the motor

Avoid motor damages by using the overcurrent monitoring function as follows:

- ▶ The setting of the threshold for the overcurrent monitoring in [0x2D46:001](#) must be adapted to the connected motor.
- ▶ Set the maximum current of the inverter in [0x6073](#) much lower than the threshold for overcurrent monitoring for a dynamic limitation of the motor current.

Parameter

Address	Name / setting range / [default setting]	Information
0x2D46:001	Overcurrent monitoring: Threshold 0.0 ... [5.4] ... 3000.0 A	Associated event ID: • 537469828 0x20092384 - Ultimate motor current reached
0x2D46:002	Overcurrent monitoring: Response	Selection of the response to the triggering of motor current monitoring. Associated event ID: • 537469828 0x20092384 - Ultimate motor current reached
	0 No response	
	1 Warning	
	2 Trouble	

Configuring the motor control

Motor protection
Motor phase failure detection



10.10.4 Motor phase failure detection

The motor phase failure detection function can be activated for both synchronous and asynchronous motors.



In the Lenze setting, monitoring is not activated!

Preconditions

Motor phase failure detection during operation is suitable for applications which are operated with a constant load and speed. In other cases, transient processes or unfavourable operating points can cause erroneous triggering to occur.

Parameter

Address	Name / setting range / [default setting]	Information
0x2D45:001	Motor phase failure detection: Response - Motor phase 1	Selection of the response following the detection of a motor phase failure during operation. Associated event IDs: <ul style="list-style-type: none"> 537526025 0x2009FF09 - Motor phase missing 537526026 0x2009FF0A - Motor phase failure phase U 537526027 0x2009FF0B - Motor phase failure phase V 537526028 0x2009FF0C - Motor phase failure phase W
	0 No response	▶ Severity □ 390
	1 Warning	
	2 Trouble	
0x2D45:002	Motor phase failure detection: Current threshold 1.0 ... [5.0] ... 10.0 %	
0x2D45:003	Motor phase failure detection: Voltage threshold 0.0 ... [10.0] ... 100.0 V	Voltage threshold for motor phase monitoring for the VFC control mode (0x2C00 = 6). <ul style="list-style-type: none"> The monitoring function is triggered if the motor current exceeds the rated motor current-dependent current threshold for longer than 20 ms. Rated motor current 0x6075 In case of the V/f characteristic control, the voltage threshold is considered additionally for the motor phase failure detection. If the motor voltage is higher than the voltage threshold, monitoring is combined with the motor current.
0x2D45:004	Motor phase failure detection: Response - Motor phase 2	Selection of the response following the detection of a motor phase failure directly after controller enable.
	0 No response	▶ Severity □ 390
	1 Fault > CIA402	
	2 Trouble	

10.10.5 Motor speed monitoring

This function monitors the motor speed during operation.

Parameter

Address	Name / setting range / [default setting]	Information
0x2D44:001	Overspeed monitoring: Threshold 5 ... [8000] ... 50000 rpm	
0x2D44:002	Overspeed monitoring: Response	Selection of the response to the triggering of motor speed monitoring. Associated event ID: <ul style="list-style-type: none"> 537526022 0x2009FF06 - Motor overspeed
	0 No response	▶ Severity □ 390
	1 Warning	
	2 Trouble	



10.11 Frequency and speed limitations



By limiting the maximum output frequency to ± 599 Hz, the devices are not subject to the export restrictions of the "EC-Dual-Use Regulation" (EC 428/2009).

Output frequency

The output frequency of the servo inverter is limited to a maximum value, the amount of which corresponds to the lower of the two following values:

$$f_{lim} = \frac{f_{chop}}{8} \quad \text{or} \quad f_{lim} = f_{max_device}$$

- f_{lim} Maximum output frequency
 f_{chop} Switching frequency [0x2939](#)
 f_{max_de} Maximum device output frequency: ± 599 Hz
vice

Due to the limitation of the "Dual-Use Regulation" (EC 428/2009), values > 599 Hz do not lead to an increase of the output frequency. Please note the dead band that occurs in this case.

Speed setpoint

If servo control is used, the speed setpoint is limited depending on the number of motor pole pairs:

$$n_{lim} = \frac{f_{lim} \times 60}{z_p}$$

- n_{lim} Speed limit value
 f_{lim} Maximum output frequency (± 599 Hz)
 z_p Number of motor pole pairs

- If the speed setpoint is limited, bit 1 ("Speed: Setpoint 1 limited") or bit 5 ("Speed: Setpoint 2 limited") is set in the Lenze status word [0x2831](#).
- The behavior corresponds to the behavior which is shown when the set maximum speed [0x6080](#) is reached.
- The sequence is as follows: First limit the speed to [0x6080](#), then limit to speed limit value n_{lim} .

Frequency setpoint

If V/f characteristic control is used, the frequency setpoint is limited in addition to the speed setpoint.

- If the frequency setpoint is limited, bit 10 ("Output frequency limited") is set in the Lenze status word [0x2831](#).

Configuring the motor control

Testing the motor control
General settings for test modes



10.12 Testing the motor control

Parameter

Address	Name / setting range / [default setting]	Information
0x2825	Drive mode selection	
	<ul style="list-style-type: none"> Setting can only be changed if the inverter is disabled. 	
	0 CiA402 operating modes	
	1 Manual "voltage/frequency" test mode	
	2 Manual "current/frequency" test mode	
	3 Manual "current pulse" test mode	
	4 Manual control mode	
	5 Pole position identification (360°)	
	6 Pole position identification (min. movement)	
	7 Pole position identification (without movement)	
	8 Inverter characteristic identification	
	9 Motor parameters identification	
	10 Lh saturation characteristic identification	
	11 PRBS excitation - mechanical plant	
	12 PRBS excitation - current control loop	
	13 PRBS excitation - speed control loop	
	14 PRBS excitation - position control loop	
	15 Cable check	
16 Leakage inductance identification		
17 Manual "position" test mode		

10.12.1 General settings for test modes

Wiring check by means of manual test modes

Before starting the parameter setting of the inverter, check the motor wiring (motor connection / feedback connection) for errors and function and correct them if required:

1. Provided that the motor is connected in correct phase relation and the rotating field frequency [0x2DDD](#) is positive, the motor shaft rotates clockwise.
2. An existing speed feedback in the rotor position ([0x2DDE](#)) generates a numerical value with positive counting direction. If required, take corrective measures: see the table at the end of the list.
3. After the controller inhibit ([0x6040](#)) has been activated, the following manual test modes are available via the parameter [0x2825](#):

- [Manual "tension/frequency" test mode](#)
- [Manual "current/frequency" test mode](#)

The parameters for the test modes can be adapted via the parameter . Please observe the notes in the description of the respective test mode.

Rotating field frequency 0x2DDD	Display 0x2DDE	Measure
CW	0...2047	None
	2047...0	Correct motor connection / feedback connection
CCW	2047...0	None
	0...2047	Correct motor connection / feedback connection

Parameter

Address	Name / setting range / [default setting]	Information
0x2835:001	Manual test mode: Current setpoint -1000 ... [0] ... 1000 %	Setting of the r.m.s. value of a phase current for the test mode. <ul style="list-style-type: none"> 100 %: Rated motor current (0x6075)



Configuring the motor control

Testing the motor control
General settings for test modes

Address	Name / setting range / [default setting]	Information
0x2835:002	Manual test mode: Frequency -1000.0 ... [0.0] ... 1000.0 Hz	Setting of the frequency for the test mode.
0x2835:003	Manual test mode: Starting angle -1000.0 ... [0.0] ... 1000.0 °	Setting of the starting angle for the test mode. Note! After the inverter has been enabled, the synchronous motor makes a jerky compensating movement if its pole position does not correspond to the starting angle.

Configuring the motor control

Testing the motor control
Manual "tension/frequency" test mode



10.12.2 Manual "tension/frequency" test mode

Functional description



In case of devices that correspond to the "dual use regulation" (EC 428/2009), values higher than + 599 Hz up to lower than - 599 Hz do not increase the output frequency. Please observe the deadband occurring in this case.

Further information can be found in the section "[Frequency and speed limitations](#)".

[201](#)

After the controller is enabled in this test mode, a rotary field voltage is output at the motor terminals with the set output frequency f_{out} .

- If the selected frequency is positive, the motor should rotate clockwise when looking at the A side of the motor. If this is not the case, the motor phases are connected incorrectly.
- The output voltage level is determined by the following equation

Equation for calculating the output voltage			
$U_{out} = f_{out} \times \frac{U_{rated}}{f_{rated}}$			
Parameter	Symbol	Description	Dimension unit
0x2D82	V_{out}	Current output voltage	V
0x2835:002	f_{out}	Output frequency for test mode Please observe the notes in the section " Frequency and speed limitations ". 201	Hz
0x2B01:001	V_{rated}	Base voltage	V
0x2B01:002	f_{rated}	Base frequency	Hz

The manual "voltage / frequency" test mode also serves to check the wiring of the feedback system.

- If the feedback system of a synchronous motor is set correctly, an actual speed should be displayed that can be calculated with the following equation (if the feedback system of an asynchronous motor is set correctly, the actual speed is a bit lower due to the slip):

Equation for calculating the actual speed			
$n_{act} = \frac{f_{out}}{zP_{motor}} \times 60$			
Parameter	Symbol	Description	Dimension unit
0x606C	n_{act}	Actual speed	rpm
0x2835:002	f_{out}	Output frequency for test mode	Hz
0x2C01:001	zP_{Motor}	Number of motor pole pairs	

Conditions for the execution

- The motor must rotate freely.
- The servo inverter is error-free and in the "switched-on" device state.

Response of the motor during performance

The motor moves as a function of the set output frequency.



How to activate the manual "voltage/frequency" test mode:

1. Disable the inverter ▶ [Enable operation](#). [📄 217](#)
2. Change to the "voltage/frequency" test mode. ▶ $0x2825 = 1$
3. Enable the inverter to start the test mode.
4. To stop the test mode again:
 - Disable inverter.
 - Change back to the "CiA402 operating mode". ▶ $0x2825 = 0$

10.12.3 Manual "current/frequency" test mode

Preconditions for the performance

- The motor must rotate freely.
- The inverter is error-free and in "Switched on" device state.

Functional description

In this test mode, three phase currents are injected into the connected motor after the inverter is enabled.

- Adaptation of the phase currents:

Parameter	Info	Data type
0x2835:001	R.m.s. value of a phase current <ul style="list-style-type: none">• Selected in [%] based on the rated motor current.	INTEGER_16
0x2835:002	Frequency	INTEGER_16
0x2835:003	Starting angle	INTEGER_16

- Reading out the present phase currents:

Parameter	Info	Data type
0x2D83:002	Motor current phase U	INTEGER_32
0x2D83:003	Motor current phase V	INTEGER_32
0x2D83:004	Motor current phase W	INTEGER_32

Advantages compared to the manual "voltage/frequency" test mode

- The current cannot be set freely but is adjusted to a defined value.
- If a synchronous motor is connected, it is possible to predict the torque.

Response of the motor during performance

- The motor moves as a function of the set output frequency.



After the inverter has been enabled, the synchronous motor makes a jerky compensating movement if its pole position does not correspond to the starting angle.

How to activate the manual "current/frequency" test mode:

1. Disable inverter ▶ [Enable operation](#). [📄 217](#)
2. Change to the "current/frequency" test mode. ▶ $0x2825 = 2$
3. Enable the inverter to start the test mode.
4. To stop the test mode again:
 - Disable inverter.
 - Change back to the CiA402 operating mode. ▶ $0x2825 = 0$

Configuring the motor control

Testing the motor control
Manual "current pulse" test mode



10.12.4 Manual "current pulse" test mode

The stator resistance and the stator inductance of the inverter must be adapted to the electrical characteristics of the motor. For an experimental adjustment, the manual "Current pulse" test mode can be used.



This test mode is provided for adjusting the current controller in the "Servo control for synchronous motor/asynchronous motor" operating mode and is not suitable for adjusting the I_{max} controller in the "V/f characteristic control (VFC)" operating mode!

In the manual "Current pulse" test mode, setpoint step-changes are applied to the current controller input subsequent to controller enable. The step responses must then either be recorded using an oscilloscope and a clamp-on ammeter, or using the oscilloscope function of the inverter. It is the objective to optimise the two "Gain" and "Reset time" current controller parameters by evaluating the step responses so that a speedy current characteristic is achieved, which, if possible, is free of harmonics.

In the case of motors with single pole windings, satisfactory results are possibly only achieved with a current-dependent correction of the current controller parameters. For this purpose, a characteristic is stored in the inverter, which describes the current dependence of the stator leakage inductance and which tracks the current controller gain.



After the inverter has been enabled, the synchronous motor makes a jerky compensating movement if its pole position does not correspond to the starting angle.

The motor phase U is energized with a DC current the level of which is determined via the following equation.

$$I_{\text{phase_U}} = \sqrt{2} \times I_{\text{test}} [\%] \times \frac{I_{\text{rated}}}{100\%}$$

In motor phases V and W, half of this DC current flows (negative; from the motor).

$$I_{\text{phase_V_W}} = -0.5 \times \sqrt{2} \times I_{\text{test}} [\%] \times \frac{I_{\text{rated}}}{100\%}$$

The following parameters are relevant to the calculation:

- Manual test mode: setpoint current ▶ [0x2835:001](#)
- Motor rated current ▶ [0x6075](#)
- Read only: current phase U ▶ [0x2D83:002](#)
- Read only: current phase V ▶ [0x2D83:003](#)
- Read only: current phase W ▶ [0x2D83:004](#)

Conditions for the execution

- The motor must be parameterised completely.
- The motor utilisation (I^2xt) monitoring must be parameterised and switched to active. ▶ [Motor overload monitoring \(\$I^2xt\$ \)](#) [189](#)
- The motor must rotate freely.
- The inverter is error-free and switched on.
- The rotor of synchronous motors must be in the pole centre during the test. For some synchronous motors, it might be required to align and lock the rotor in the pole centre.
 - Using the manual test mode "current/frequency" is useful for a one-time alignment of the rotor with the following settings:
R.m.s. value = 70 ... 100 %; frequency = 0 Hz; starting angle = 0°
▶ [Manual "current/frequency" test mode](#) [205](#)
 - Fixation by means of the holding brake or the use of external fixation aids



Responses of the motor during performance



Remove the mechanical fixation after the current controller has been adjusted!

The motor usually aligns itself only once with the first controller enable.

How to adjust the current controller by means of the manual test mode "current pulse":

- Disable inverter.
- Calculate start parameters for the inverter based on the parameterised motor data.
 - The automatic calculation is made via the parameter 0x2822:013.
 - You can determine the start parameter manually.
- Change to the "current pulse" test mode. ▶ 0x2825 = 3
- Set the setpoint current for the manual test mode. ▶ 0x2835:001
- Enable the inverter for a short while to start the test mode.
- Measure the step response of the motor current in the motor phase U by means of an oscilloscope and a clamp-on ammeter.
- Evaluate the step response.
- Adjust the gain and the reset time of the inverter.
- Repeat steps 1 ... 6 until the optimum step response of the motor current has been reached.
- Exit the test mode:
 - Disable the inverter.
 - Change to the CiA402 mode. ▶ 0x2825 = 0
- For permanent saving: save changed current controller parameters.



11 I/O extensions and control connections

11.1 Configure digital inputs



The digital inputs 1 ... 2 are located onboard on terminal X3.

Details

The digital inputs are used for control tasks. For this purpose, the digital inputs are available as selectable triggers for functions.

The following settings are possible for the digital inputs:

- Debounce time ①
- Inversion ②
- Manual I/O control ③

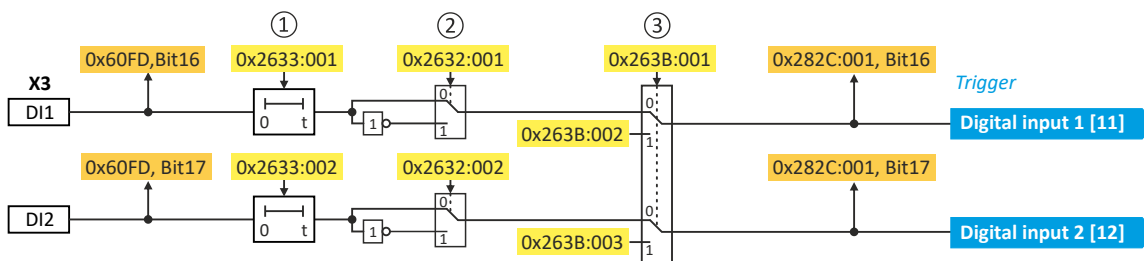

Diagnostic parameters

Display of the logic state of the digital inputs: [0x60FD](#).

Debounce time

The debounce time can be used to prevent short disturbances from being erroneously recognized as signals.

Inversion

Each digital input can be configured in such a way that the state pending at the terminal is logically inverted internally. This way, a closed contact, for instance, serves to deactivate an assigned function instead of activating it.

Manual I/O control

Each digital input can be manually overridden. After the function is activated, the actual values are "frozen". Afterwards, each digital input can be overwritten manually.

Setting:

- Activation for all digital inputs: [0x263B:001](#)
- Entry of the individual manual values: [0x263B:002](#) ... [0x263B:003](#)

Parameter

Address	Name / setting range / [default setting]	Information
0x2632:001	Inversion of digital inputs: Digital input 1	Inversion of digital input 1
	0 Not inverted	
	1 Inverted	
0x2632:002	Inversion of digital inputs: Digital input 2	Inversion of digital input 2
	0 Not inverted	
	1 Inverted	
0x2633:001	Digital input debounce time: Digital input 1 0 ... [0] ... 50 ms	Debounce time of digital input 1



I/O extensions and control connections

Configure digital inputs

Address	Name / setting range / [default setting]	Information
0x2633:002	Digital input debounce time: Digital input 2 0 ... [0] ... 50 ms	Debounce time of digital input 2
0x263B:001	Digital inputs internal control: Activation	Activation of the internal control for all available digital inputs.
	0 Off	
	1 On	
0x263B:002	Digital inputs internal control: DI1 internal control	Input of the manual value for the digital inputs.
	0 Off	
	1 On	
0x263B:003	Digital inputs internal control: DI2 internal control	
	0 Off	
	1 On	



12 Configuring the network



The following conventions are used in this documentation for specifying the parameter address:

- The index is specified as a hexadecimal value.
 - The subindex is specified as a decimal value.
-



12.1 CiA 402 device profile

The CiA[®] 402 device profile defines the functional behaviour of stepping motors, servo drives, and frequency inverters. In order to be able to describe the different drive types, various operating modes and device parameters are specified in the device profile. Each operating mode provides objects (e.g. for the setpoint speed, acceleration and deceleration) to generate the desired drive behaviour.

- CiA[®] is a registered community trademark of the CAN in Automation e. V user organization.
- More information can be found in the CiA 402 specification (CANopen device profile for drives and Motion Control) of the CAN in Automation (CiA) user organization:
<http://www.can-cia.org>

12.1.1 Supported operating modes

The inverter supports the following CiA 402 operating modes:

CiA 402 operating modes	Can be used with	
	Servo control	V/f characteristic control
Operating mode "CiA 402 cyclic sync position mode (csp)" □ 54	●	-
Operating mode "CiA 402 velocity mode (vl)" □ 70	●	●
Operating mode "CiA 402 cyclic sync velocity mode (csv)" □ 77	●	●
Operating mode "CiA 402 cyclic sync torque mode (cst)" □ 90	●	-

A CiA 402 operating mode can be activated via [0x6060](#).

Parameter

Address	Name / setting range / [default setting]	Information
0x6060	CiA: Operation mode	CiA: Operation mode
	-13 MS: Manual jog open loop (MOL)	Manufacturer-specific manual control ▶ Operation mode "Manual Jog" □ 232
	-12 MS: Pole position identification (PPI)	Manufacturer-specific pole position identification (PLI) ▶ Synchronous motor: Pole position identification (PPI) □ 116 ▶ Selection of the PPI method for CiA mode □ 117
	0 No selection	No selection
	2 CiA: Velocity mode (vl)	
	8 CiA: Cyclic sync position (csp)	
	9 CiA: Cyclic sync velocity mode (csv)	
0x6061	CiA: Active operation mode • Read only	CiA: Active operation mode
	-13 MS: Manual jog open loop (MOL)	Manufacturer-specific manual control
	-12 MS: Pole position identification (PPI)	Manufacturer-specific pole position identification (PLI)
	-11 Identification	
	-10 Test mode	
	0 No selection	No selection
	2 CiA: Velocity mode (vl)	
	8 CiA: Cyclic sync position (csp)	
0x6502	Supported drive modes • Read only	Bit coded display of the operating modes supported.
	Bit 1 CiA: Velocity mode	1 = CiA: velocity mode is supported.
	Bit 7 Cyclic sync position mode	
	Bit 8 Cyclic sync velocity mode	
	Bit 9 Cyclic sync torque mode	

Configuring the network

CiA 402 device profile
Basic setting



12.1.2 Basic setting

Set the following parameters.

Parameter

Address	Name / setting range / [default setting]	Information
0x605A	CiA: Quick stop mode	Device status after exiting the quick stop ramp.
	2 Ramp > switch on disabled	Automatic change to the "Switch-on inhibited" device state. <ul style="list-style-type: none">The "Quick stop active [54]" status is reset to FALSE after ramp-down to standstill.
	6 Ramp > quick stop active	The inverter remains in the "Quick stop active" device state. <ul style="list-style-type: none">The "Quick stop active [54]" status remains TRUE until the "Quick stop" function is activated.
0x605B	Shutdown option code	Defines the transition from the status "Operation enabled" to "Ready to start".
	0 Disable drive function	0: Immediate inverter disable (standard setting)
	1 Slow down on quick stop ramp and disable drive function	1: "Quick stop" with subsequent inverter disable.
0x605E	CiA: Response to minor faults	Set the transition response for slight errors. List of minor faults: ▶ Configuring the transition response for minor faults
	-3 Advanced quick stop (hoist)	
	-2 Advanced quick stop	If possible, the motor is brought to a standstill with the "quick stop" function. If this is not possible (e.g. in the event of an encoder error), a braking torque is generated with reverse current braking or short-circuit braking.
	0 No transition response	The motor is no longer energized.
	2 Quick stop	The motor is brought to a standstill with the "quick stop" function.
0x2826	Timeout for error response 0 ... [4] ... 100 s	If the transition reaction specified in CiA: Response to minor faults is not completed within this time, the inverter changes to the "Error" state. The motor is no longer energized. When the automatic brake is activated, a brake controlled by the inverter is applied. ▶ 0x2820:001
0x607E	Polarity 0 ... [0] ... 0 <ul style="list-style-type: none">Setting can only be changed if the inverter is disabled.	Setting of the polarity of the position setpoint. 0 ≡ the position setpoint is interpreted as entered in 0x607A (Set position).
0x6085	Quick stop deceleration 0 ... [2147483647] ... 2147483647	Change in velocity used for deceleration to a standstill if quick stop is activated.

12.1.3 Process input data

Information on the CiA 402 process input data can be found in the following sections:

- Configure position control [▶ Process input data \(CiA 402 objects\)](#) [📖 58](#)
- Configure speed control [▶ Process input data \(CiA 402 objects\)](#) [📖 83](#)
- Configure torque control [▶ Process input data \(CiA 402 objects\)](#) [📖 94](#)

12.1.4 Process output data

Information on the CiA 402 process output data can be found in the following sections:

- Configure position control [▶ Process output data \(CiA 402 objects\)](#) [📖 59](#)
- Configure speed control [▶ Process output data \(CiA 402 objects\)](#) [📖 84](#)
- Configure torque control [▶ Process output data \(CiA 402 objects\)](#) [📖 95](#)



12.1.5 Commands for device state control

0x6040 (CiA control word) can be used to trigger commands to put the inverter into a certain device state.

Command	Bit pattern in the CiA control word (0x6040)							
	Bit 7	Bit 6	Bit 5	Bit 4	Bit 3	Bit 2	Bit 1	Bit 0
	Reset fault	Dependent on the operating mode			Operation enable	Activating quick stop	Establish readiness for operation	Switch-on
Switch-off □ 215	0	X	X	X	X	1	1	0
Switch on □ 216	0	X	X	X	0	1	1	1
Enable operation □ 217	0	X	X	X	1	1	1	1
Activate quick stop □ 218	0	X	X	X	X	0	1	X
Disable operation □ 219	0	X	X	X	0	1	1	1
Pulse inhibit □ 220	0	X	X	X	X	X	0	X
Reset fault □ 221	0/1	X	X	X	X	X	X	X

X = state is not relevant

More Lenze-specific control bits (bit 8 ... 15)

Command	Bit pattern in the CiA control word (0x6040)							
	Bit 15	Bit 14	Bit 13	Bit 12	Bit 11	Bit 10	Bit 9	Bit 8
	Reserved	Release brake	Reserved	Dependent on the operating mode				Stop motor
Apply brake	X	0	X	X	X	X	X	X
Release brake	X	1	X	X	X	X	X	X
Stop motor	X	X	X	X	X	X	X	1

X = state is not relevant

Detailed information on the various commands can be found in the following sections.

Parameter

Address	Name / setting range / [default setting]	Information
0x6040	CiA control word 0x0000 ... [0x0000] ... 0xFFFF	Mappable CiA control word with bit assignment according to device profile CiA 402.
	Bit 0	Switch on 1 = switch-on
	Bit 1	Enable voltage 1 = Enable voltage
	Bit 2	Disable quick stop 0 = activate quick stop
	Bit 3	Enable operation 1 = Enable operation
	Bit 4	Operation mode specific
	Bit 5	Operation mode specific
	Bit 6	Operation mode specific
	Bit 7	Fault reset 0-1 edge = fault reset
	Bit 8	Halt 1 = stop motor (ramping down to frequency setpoint 0 Hz)
	Bit 9	Operation mode specific Operating mode specific
Bit 14	Release holding brake 1 = release holding brake ⚠ CAUTION! <ul style="list-style-type: none"> The manually triggered "Release holding brake" command has a direct impact on the "Release holding brake [115]" trigger. Thus, the holding brake can be manually released if the power section is switched off. The responsibility for a manual opening of the holding brake lies with the user of the external trigger source for the "Release holding brake" command. ▶ Holding brake control □ 151	
0x2DE0:014	Service settings: Overwrite bit 4 of CiA control word	
	0 No overwrite	
	1 Overwrite with FALSE	
	2 Overwrite with TRUE	

Configuring the network

CiA 402 device profile

Commands for device state control



Example

A PLC program of a PLCopen control can, for instance, trigger several commands for state changes in a row by the level change at the *bRegulatorOn* input of the "MC_Power" block.

In the mentioned example, these device commands are "Switch-off" and "Switch on" in this order.



12.1.5.1 Switch-off

This command serves to change the "Switch-on inhibited" device state to the "Ready to switch on" device state.

If the pulse inhibit has already been deactivated and the device status of the inverter is "Operation enabled", this command sets the pulse inhibit again.

- If automatic brake operation is activated, the parameterized Brake closing time (0x2820:002) is observed: The system waits until the brake is applied before the pulse inhibit is set. In the CiA 402 "CiA: Velocity mode", the Brake closing time is not observed.
- The motor has no torque.
- The device state "Switched on" or "Operation enabled" changes back to the "Ready to switch on" state.

⚠ DANGER!

Uncontrolled motor movements by pulse inhibit.

If the motor has no torque, a load that is connected to motors without a holding brake may cause uncontrolled movements! Without a load, the motor will coast.

Possible consequences: Death or severe injuries

► Only operate the inverter under permissible load conditions.

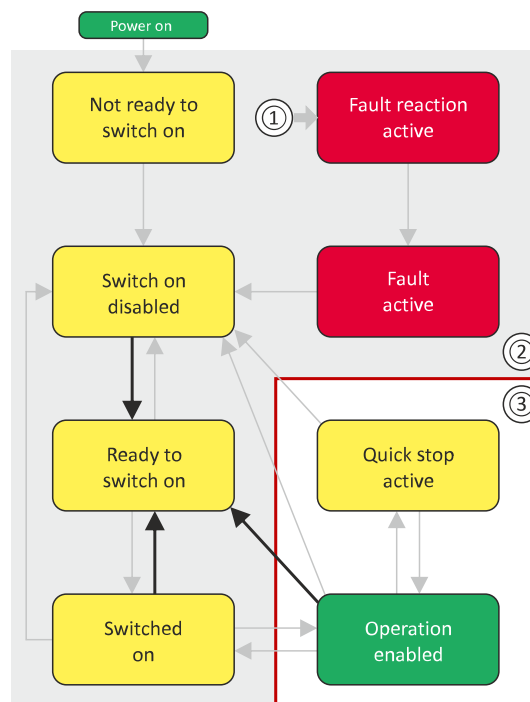

- 1 From all states
- 2 Power section disabled (pulse inhibit)
- 3 Power section enabled

Bit pattern in the CiA control word (0x6040)								
Bit 15 ... 8	Bit 7	Bit 6	Bit 5	Bit 4	Bit 3	Bit 2	Bit 1	Bit 0
Reserved (specific)	Reset fault	Operating mode dependent			Operation enabled	Activate quick stop	Establish readiness for operation	Switch-on
X	0	X	X	X	X	1	1	0

X = state is not relevant

Configuring the network

CiA 402 device profile
 Commands for device state control
 Switch on



12.1.5.2 Switch on

This command serves to deactivate the switch on inhibit which is active after switch on or after the reset (acknowledgement) of an error.

A changeover to the "Switched on" device status takes place.

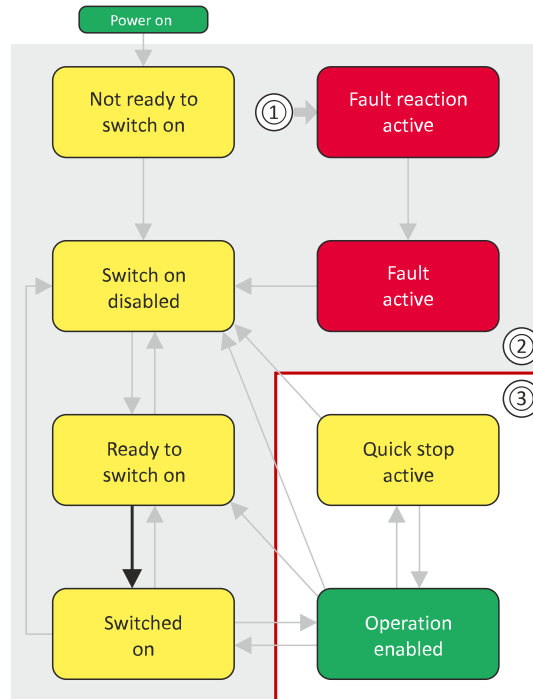

- 1 From all states
- 2 Power section inhibited (pulse inhibit)
- 3 Power section enabled

Bit pattern in the CiA control word (0x6040)								
Bit 15 ... 8	Bit 7	Bit 6	Bit 5	Bit 4	Bit 3	Bit 2	Bit 1	Bit 0
Reserved (specific)	Reset fault	Operating mode-dependent			Operation enabled	Activate quick stop	Establish readiness for operation	Switch-on
X	0	X	X	X	0	1	1	1

X = state is not relevant



12.1.1.5.3 Enable operation

This command enables the operation and stop an active quick stop again.

- A changeover to the "Operation enabled" device status takes place.
- The output stages of the inverter become active.

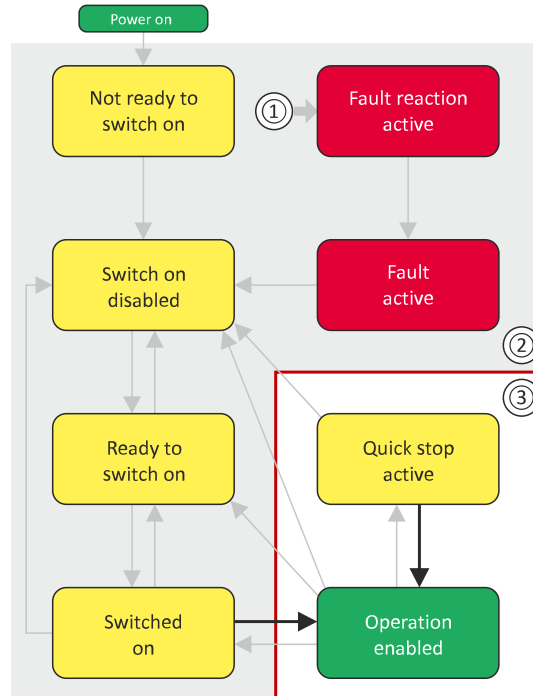

- 1 From all states
- 2 Power section inhibited (pulse inhibit)
- 3 Power section enabled

Bit pattern in the CiA control word (0x6040)								
Bit 15 ... 8	Bit 7	Bit 6	Bit 5	Bit 4	Bit 3	Bit 2	Bit 1	Bit 0
Reserved (specific)	Reset fault	Operating mode dependent			Operation enabled	Activate quick stop	Establish readiness for operation	Switch-on
X	0	X	X	X	1	1	1	1

X = state is not relevant

Configuring the network

CiA 402 device profile
 Commands for device state control
 Activate quick stop



12.1.5.4 Activate quick stop

This command activates quick stop when the operation is enabled.

- The drive is brought to a standstill irrespective of the setpoint specified with the deceleration (0x6085) set for quick stop.
- A changeover to the "Quick stop active" device status takes place.
- Then, state change to "Switch-on inhibited" parameter 0x605A "CiA: Quick stop mode".

If the operation is not enabled (device state "Ready to switch on" or "Switched on"), this command changes the state to "operation disabled".

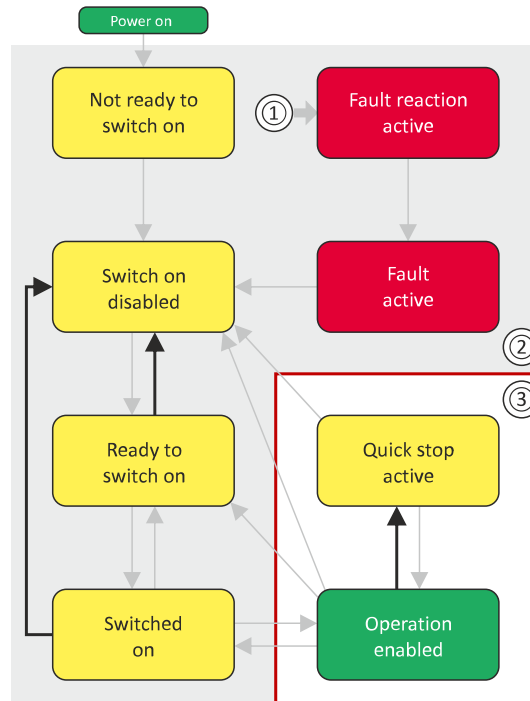

- 1 From all states
- 2 Power section disabled (pulse inhibit)
- 3 Power section enabled

Bit pattern in the CiA control word (0x6040)								
Bit 15 ... 8	Bit 7	Bit 6	Bit 5	Bit 4	Bit 3	Bit 2	Bit 1	Bit 0
Reserved (specific)	Reset fault	Operating mode dependent			Operation enabled	Activate quick stop	Establish readiness for operation	Switch-on
X	0	X	X	X	X	0	1	X

X = state is not relevant

- During quick stop, the inverter executes the setpoint generation and no longer follows the setpoint defined by the network master.
- If several inverters execute a chained synchronous motion, the quick stop function has to be coordinated by the network master by means of a quick stop profile (master function). In this case, quick stop cannot be activated via the control bit 2.
- During the quick stop, the maximum current (0x6073) and the maximum torque (0x6072) are active. The lower of the two limits determines the motor torque output. The torque limits from 0x60E0 and 0x60E1 are not effective during the quick stop.



12.1.5.5 Disable operation

This command disables the enabled operation again.

- The pulse inhibit is set (pulses of the inverter are inhibited).
- If automatic brake operation is activated, the parameterized Brake closing time (0x2820:002) is observed: The system waits until the brake is applied before the pulse inhibit is set. In the CiA 402 "CiA: Velocity mode", the Brake closing time is not observed.
- A changeover to the "Switched on" device state takes place.

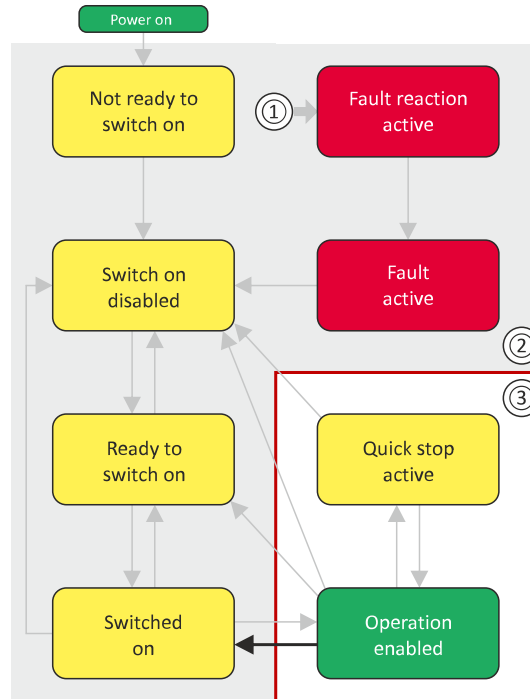

- 1 From all states
- 2 Power section disabled (pulse inhibit)
- 3 Power section enabled

Bit pattern in the CiA control word (0x6040)								
Bit 15 ... 8	Bit 7	Bit 6	Bit 5	Bit 4	Bit 3	Bit 2	Bit 1	Bit 0
Reserved (specific)	Reset fault	Operating mode dependent			Operation enabled	Activate quick stop	Establish readiness for operation	Switch-on
X	0	X	X	X	0	1	1	1

X = state is not relevant

Configuring the network

CiA 402 device profile
 Commands for device state control
 Pulse inhibit



12.1.5.6 Pulse inhibit

This command disables the output stages of the inverter.

- The pulse inhibit is activated (pulses of the inverter are inhibited) if not already active.
- The motor has no torque.
- A changeover to the "Switch-on inhibited" device state takes place.

⚠ DANGER!

Uncontrolled motor movements by pulse inhibit.

If the motor has no torque, a load that is connected to motors without a holding brake may cause uncontrolled movements! Without a load, the motor will coast.

Possible consequences: Death or severe injuries

► Only operate the inverter under permissible load conditions.

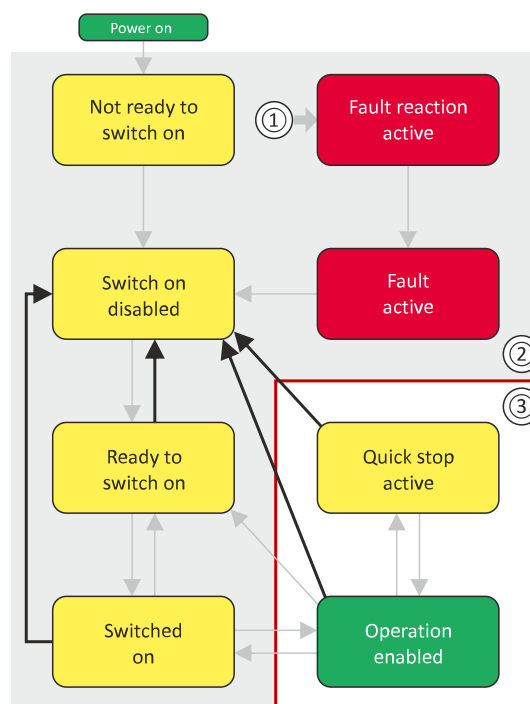

- 1 From all states
- 2 Power section inhibited (pulse inhibit)
- 3 Power section enabled

Bit pattern in the CiA control word (0x6040)

Bit 15 ... 8	Bit 7	Bit 6	Bit 5	Bit 4	Bit 3	Bit 2	Bit 1	Bit 0
Reserved (specific)	Reset fault	Operating mode dependent			Operation enabled	Activate quick stop	Establish readiness for operation	Switch-on
X	0	X	X	X	X	X	0	X

X = state is not relevant



12.1.5.7 Reset fault

This command resets a pending fault if the cause of the fault has been eliminated.

- The pulse inhibit remains active (pulses of the inverter are inhibited).
- A changeover to the "Switch-on inhibited" device status takes place (switch-on inhibit remains active).

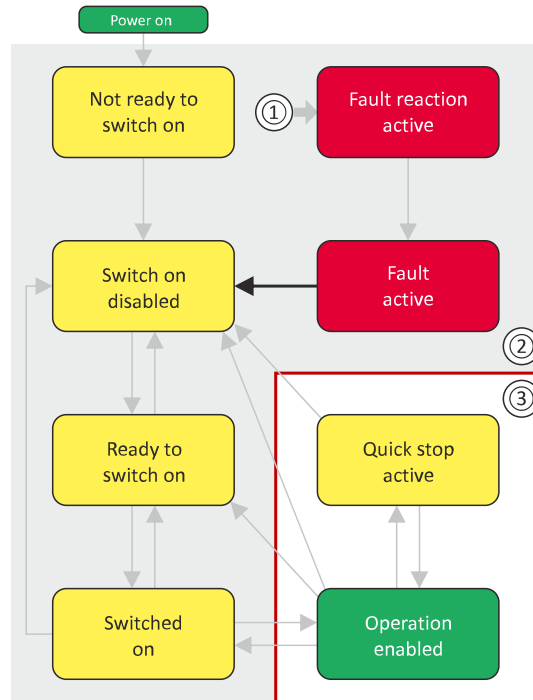

- 1 From all states
- 2 Power section inhibited (pulse inhibit)
- 3 Power section enabled

Bit pattern in the CiA control word (0x6040)								
Bit 15 ... 8	Bit 7	Bit 6	Bit 5	Bit 4	Bit 3	Bit 2	Bit 1	Bit 0
Reserved (specific)	Reset fault	Operating mode dependent			Operation enabled	Activating quick stop	Establish readiness for operation	Switch-on
X	0/1	X	X	X	X	X	X	X

X = state is not relevant

Configuring the network

CiA 402 device profile
Device states



12.1.6 Device states

0x6041 (CiA status word) displays the current device status of the inverter.

Device status	Bit pattern in the CiA 402 status word (0x6041)							
	Bit 7	Bit 6	Bit 5	Bit 4	Bit 3	Bit 2	Bit 1	Bit 0
	Warning is active	Operation inhibited	Quick stop active	DC bus ready for operation	Fault active	Operation enabled	Switched on	Ready to switch on
Not ready to switch on □ 224	X	1	X	X	0	0	0	0
Switch-on inhibited □ 225	X	1	X	X	0	0	0	0
Ready to switch on □ 226	X	1	1	X	0	0	0	1
Switched on □ 227	X	1	1	X	0	0	1	1
Operation enabled □ 228	X	0	0	X	0	1	1	1
Quick stop active □ 229	X	0	1	X	0	1	1	1
Fault reaction active □ 230	X	0	X	X	1	1	1	1
Trouble □ 231	X	1	X	X	1	0	0	0
X = state is not relevant								

Status bit 7: "Warning active"

Status bit 7 indicates a warning.

- A warning does **not** cause a state change.
- Warnings do not need to be reset.

More Lenze-specific status bits (bit 8 ... 15)

Device status	Bit pattern in the CiA 402 status word (0x6041)							
	Bit 15	Bit 14	Bit 13	Bit 12	Bit 11	Bit 10	Bit 9	Bit 8
	Not active	Brake released	Following error is active	Drive follows setpoint selection	Internal limitation is active	Target position reached	Control word processed successfully	RPDOs deactivated
Brake applied	X	0	X	X	X	X	X	X
Brake released	X	1	X	X	X	X	X	X
Active	0	X	X	X	X	X	X	X
not active	1	X	X	X	X	X	X	X
X = state is not relevant								

Detailed information on the various device states can be found in the following sections.



Parameter

Address	Name / setting range / [default setting]	Information
0x6041	CiA status word • Read only	Mappable CiA status word with bit assignment according to device profile CiA 402.
	Bit 0 Ready to switch on	1 = drive ready to start
	Bit 1 Switched on	1 = drive switched-on
	Bit 2 Operation enabled	1 = operation enabled
	Bit 3 Fault	1 = fault or trouble active
	Bit 4 Voltage enabled	1 = DC bus ready for operation
	Bit 5 Quick stop disabled	0 = quick stop active
	Bit 6 Switch on disabled	1 = operation inhibited
	Bit 7 Warning	1 = warning active
	Bit 8 RPDOs disabled	1 = cyclic PDOs have been deactivated
	Bit 9 CiA control enabled	1 = inverter can receive commands via network. • Bit is not set in the operating mode 0x6060 = "MS: Velocity mode [-2]".
	Bit 10 Setpoint reached	1 = the actual speed is in the window.
	Bit 11 Internal limit active	1 = internal limitation of a setpoint active
	Bit 12 Operation mode specific	1 = operation enabled and no test mode activated. (no internal setpoint generation active.)
	Bit 13 Operation mode specific	1 ≙ following error active
	Bit 14 Holding brake released	1 = holding brake released
Bit 15 STO not active	0 = STO is active or impermissible state at the safe inputs SIA and SIB (inverter disabled) 1 = STO is not active (inverter enabled)	

Configuring the network

CiA 402 device profile
 Device states
 Not ready to switch on



12.1.6.1 Not ready to switch on

This is the device state of the inverter directly after switching on the supply voltage.

- In this device status, the device is initialised.
- Communication is not possible yet.
- The inverter cannot be parameterised yet and no device commands can be carried out yet.
- The motor brake, if available, is closed.
- Operation is inhibited.

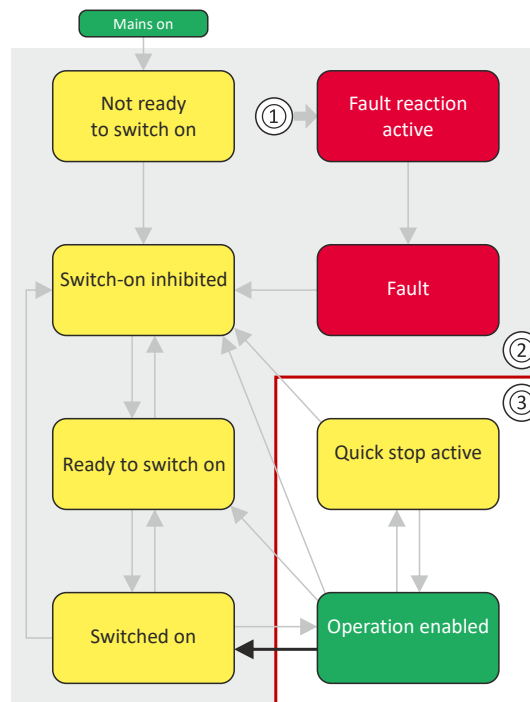

- 1 From all states
- 2 Power section inhibited (pulse inhibit)
- 3 Power section enabled

Bit pattern in the CiA status word (0x6041)								
Bit 15 ... 8	Bit 7	Bit 6	Bit 5	Bit 4	Bit 3	Bit 2	Bit 1	Bit 0
Reserved (specific)	Warning active	Operation inhibited	Quick stop active	DC bus ready for operation	Fault active	Operation enabled	Switched on	Ready to switch on
X	X	0	X	X	0	0	0	0

X = state is not relevant



12.1.6.2 Switch-on inhibited

This is the device state of the inverter after the device has been initialised successfully.

A change to this state also takes place when the EtherCAT bus is in "Operational" state or the PDO communication via (Control selection) is deactivated.

- Process data monitoring is active.
- Communication is possible.
- The DC-bus voltage can be present.
- The inverter can be parameterised.
- If the internal holding brake control (0x2820:001) is active in the inverter, the motor brake is closed.
- Operation is inhibited.

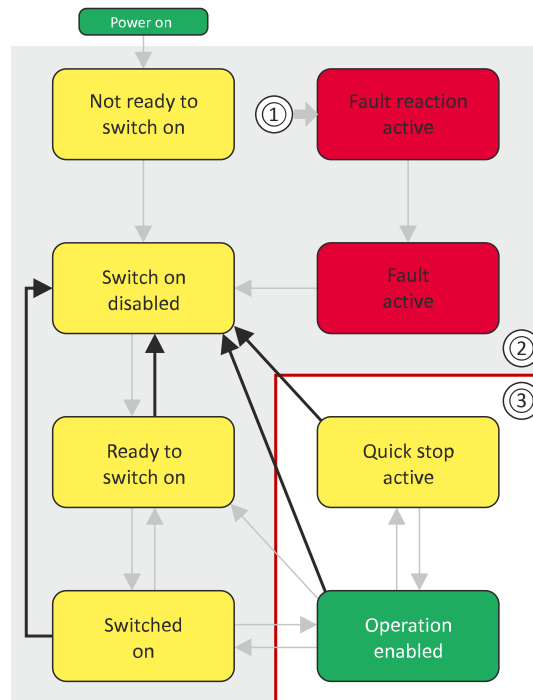

- 1 From all states
- 2 Power section inhibited (pulse inhibit)
- 3 Power section enabled

Bit pattern in the CiA status word (0x6041)								
Bit 15 ... 8	Bit 7	Bit 6	Bit 5	Bit 4	Bit 3	Bit 2	Bit 1	Bit 0
Reserved (specific)	Warning active	Operation inhibited	Quick stop active	DC bus ready for operation	Fault active	Operation enabled	Switched on	Ready to switch on
X	X	1	X	X	0	0	0	0

X = state is not relevant

Configuring the network

CiA 402 device profile
 Device states
 Ready to switch on



12.1.6.3 Ready to switch on

This is the device state of the inverter after the device has been initialised successfully and after the **Switch-off** command has been triggered.

A change to this device state also takes place if the "Switch-off" command was triggered in the states "Switched on" or "Enable operation".

- Process data monitoring is active.
- Communication is possible.
- The DC-bus voltage is available.
- The inverter can be parameterised.
- If the internal holding brake control (0x2820:001) is active in the inverter, the motor brake is closed.
- Operation is inhibited.

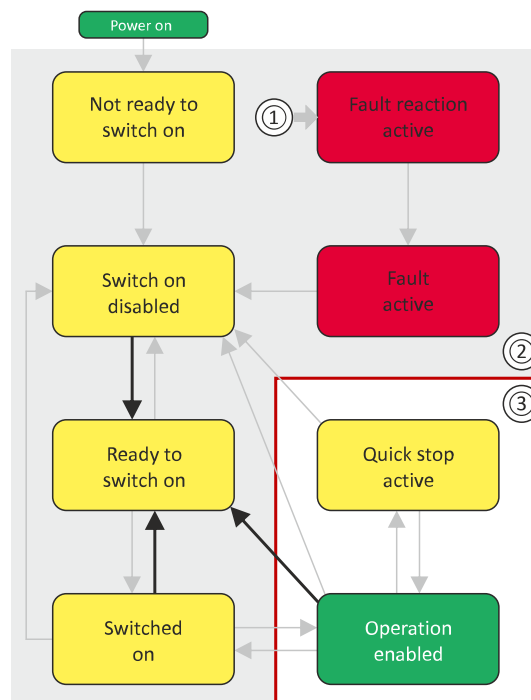

- 1 From all states
- 2 Power section inhibited (pulse inhibit)
- 3 Power section enabled

Bit pattern in the CiA status word (0x6041)								
Bit 15 ... 8	Bit 7	Bit 6	Bit 5	Bit 4	Bit 3	Bit 2	Bit 1	Bit 0
Reserved (specific)	Warning active	Operation inhibited	Quick stop active	DC bus ready for operation	Fault active	Operation enabled	Switched on	Ready to switch on
X	X	0	1	X	0	0	0	1

X = state is not relevant



12.1.6.4 Switched on

This is the device state of the inverter after the "Switch on" command has been triggered in the "Ready to switch on" device state.

- Process data monitoring is active.
- Communication is possible.
- The DC-bus voltage is available.
- The inverter can be parameterized.
- If the internal holding brake control (0x2820:001) is active in the inverter, the motor brake is closed.
- Operation is disabled.

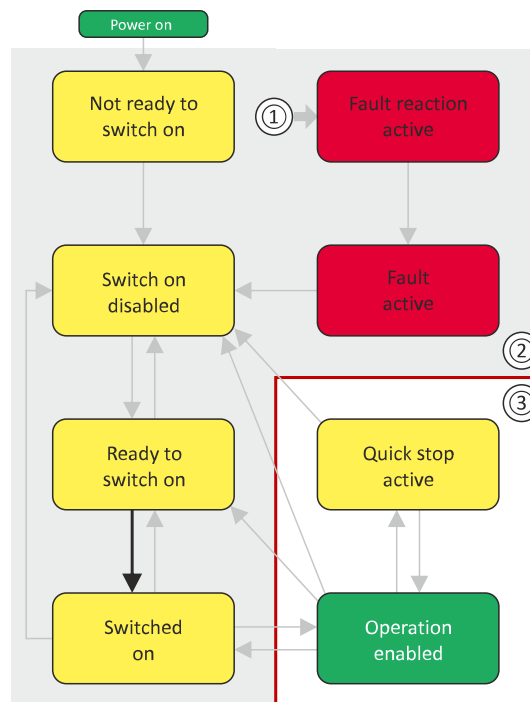

- 1 From all states
- 2 Power section disabled (pulse inhibit)
- 3 Power section enabled

Bit pattern in the CiA status word (0x6041)								
Bit 15 ... 8	Bit 7	Bit 6	Bit 5	Bit 4	Bit 3	Bit 2	Bit 1	Bit 0
Reserved (specific)	Warning active	Operation disabled	Quick stop active	DC bus ready for operation	Fault active	Operation enabled	Switched on	Ready to switch on
X	X	0	1	X	0	0	1	1

X = state is not relevant

Configuring the network

CiA 402 device profile
 Device states
 Operation enabled



12.1.6.5 Operation enabled

This device state represents normal operation. Operation in the selected operating mode is enabled and no errors have occurred.

- Only the parameters of the inverter can be changed that do not require an inverter disable.
- A motor brake, if any, is open if the automatic operation of the holding brake control is activated (`0x2820:001 = 0`).
- The drive control is active.

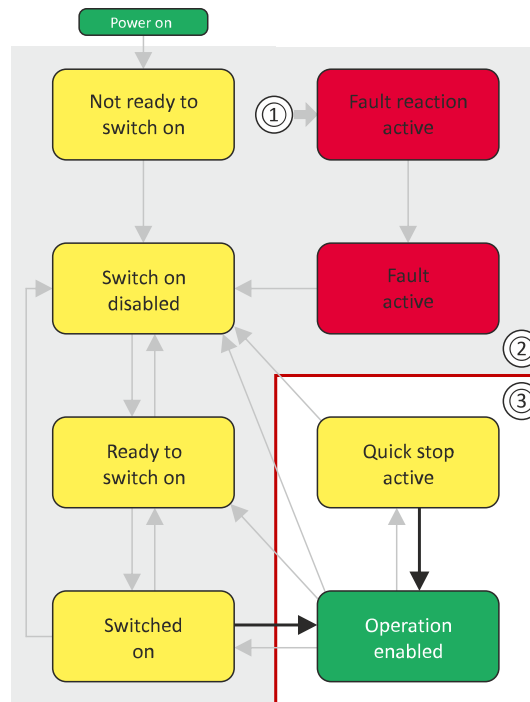

- 1 From all states
- 2 Power section inhibited (pulse inhibit)
- 3 Power section enabled

Bit pattern in the CiA status word (<code>0x6041</code>)								
Bit 15 ... 8	Bit 7	Bit 6	Bit 5	Bit 4	Bit 3	Bit 2	Bit 1	Bit 0
Reserved (specific)	Warning active	Operation inhibited	Quick stop active	DC bus ready for operation	Fault active	Operation enabled	Switched on	Ready to switch on
X	X	0	1	X	0	1	1	1

X = state is not relevant



12.1.6.6 Quick stop active

This device state is active if quick stop is executed or active.

- Only the parameters of the inverter can be changed that do not require an inverter disable.
- If the internal holding brake control (0x2820:001) is active in the inverter, the motor brake is closed.
- The drive control is active.

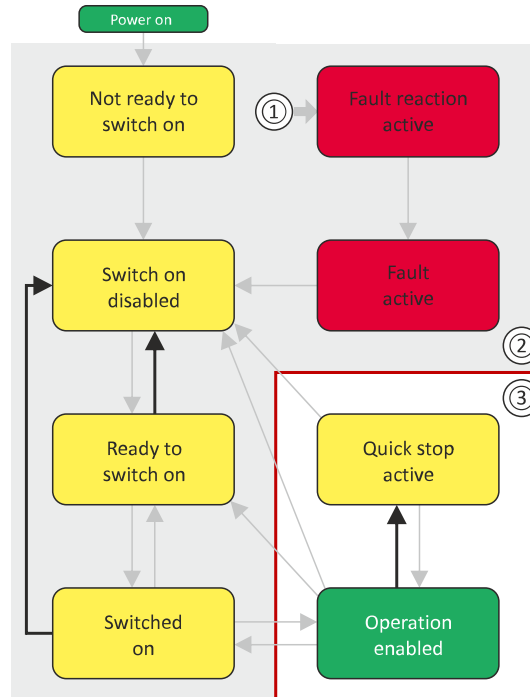

- 1 From all states
- 2 Power section inhibited (pulse inhibit)
- 3 Power section enabled

Bit pattern in the CiA status word (0x6041)								
Bit 15 ... 8	Bit 7	Bit 6	Bit 5	Bit 4	Bit 3	Bit 2	Bit 1	Bit 0
Reserved (specific)	Warning active	Operation inhibited	Quick stop active	DC bus ready for operation	Fault active	Operation enabled	Switched on	Ready to switch on
X	X	0	0	X	0	1	1	1

X = state is not relevant

The "Enable operation" command stops an active quick stop.

Configuring the network

CiA 402 device profile
 Device states
 Fault reaction active



12.1.6.7 Fault reaction active

This device state becomes active if a minor fault occurs. This means that the inverter is still able to drive the motor in a controlled way.

- The inverter is brought to a standstill irrespective of the setpoint specified with the deceleration (0x6085) set for quick stop.

If the inverter is at standstill, a change to the "Trouble" device state take place automatically.

- Only the parameters of the inverter can be changed that do not require an inverter disable.
- If the internal holding brake control (0x2820:001) is active in the inverter, the motor brake is closed.
- The drive control is active.

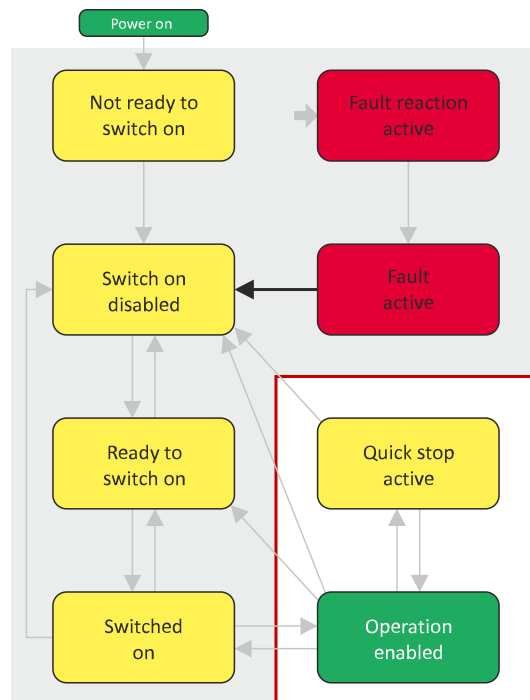

- 1 From all states
- 2 Power section inhibited (pulse inhibit)
- 3 Power section enabled

Bit pattern in the CiA status word (0x6041)								
Bit 15 ... 8	Bit 7	Bit 6	Bit 5	Bit 4	Bit 3	Bit 2	Bit 1	Bit 0
Reserved (specific)	Warning active	Operation inhibited	Quick stop active	DC bus ready for operation	Fault active	Operation enabled	Switched on	Ready to switch on
X	X	0	X	X	1	1	1	1

X = state is not relevant



12.1.6.8 Trouble

This device state becomes active if a serious system fault occurs. This means that the inverter is no longer able to drive the motor in a controlled way. The inverter is switched off immediately.

- The pulse inhibit is active (pulses of the inverter are inhibited).
- The motor is torqueless.
- The motor brake, if available, is closed.
- Operation is inhibited.
- The inverter can be parameterised.

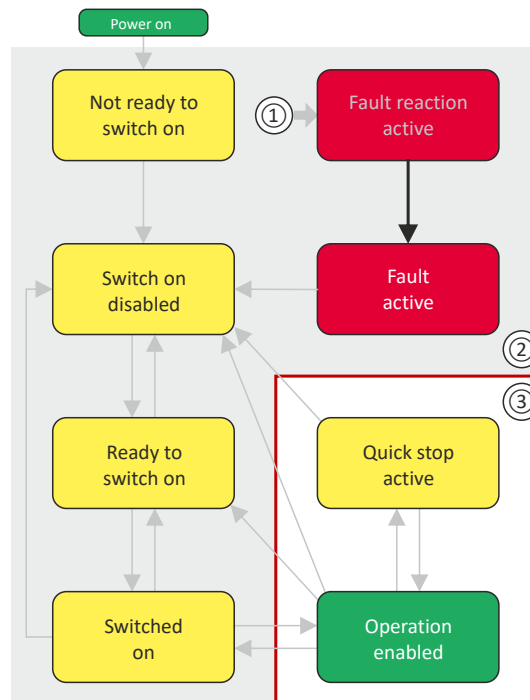

- 1 From all states
- 2 Power section inhibited (pulse inhibit)
- 3 Power section enabled

Bit pattern in the CiA status word (0x6041)								
Bit 15 ... 8	Bit 7	Bit 6	Bit 5	Bit 4	Bit 3	Bit 2	Bit 1	Bit 0
Reserved (specific)	Warning active	Operation inhibited	Quick stop active	DC bus ready for operation	Fault active	Operation enabled	Switched on	Ready to switch on
X	X	0	X	X	1	0	0	0

X = state is not relevant

This device state can only be left with the "Reset fault" command if the cause of the fault has been removed.

Configuring the network

CiA 402 device profile

Operation mode "Manual Jog"



12.1.7 Operation mode "Manual Jog"

Parameter

Address	Name / setting range / [default setting]	Information
0x2C67:001	MOL settings for 0x6060: Current setpoint 1 0 ... [71] ... 200 %	
0x2C67:002	MOL settings for 0x6060: Frequency 1 -500.0 ... [1.0] ... 500.0 Hz	
0x2C67:003	MOL settings for 0x6060: Current 1 - ramp time 10 ... [10] ... 1000 ms	
0x2C67:004	MOL settings for 0x6060: Frequency 1 - ramp time 0 ... [200] ... 10000 ms	
0x2C67:005	MOL settings for 0x6060: Starting angle 1 -179.9 ... [0.0] ... 179.9 °	
0x2C67:006	MOL settings for 0x6060: Stopping time 1 0.0 ... [10000.0] ... 10000.0 s <ul style="list-style-type: none">Setting can only be changed if the inverter is disabled.	
0x2C67:011	MOL settings for 0x6060: Current setpoint 2 0 ... [71] ... 200 %	
0x2C67:012	MOL settings for 0x6060: Frequency 2 -500.0 ... [5.0] ... 500.0 Hz	
0x2C67:013	MOL settings for 0x6060: Current 2 - ramp time 10 ... [10] ... 1000 ms	
0x2C67:014	MOL settings for 0x6060: Frequency 2 - ramp time 0 ... [1000] ... 10000 ms	
0x2C67:015	MOL settings for 0x6060: Starting angle 2 -179.9 ... [0.0] ... 179.9 °	
0x2C67:016	MOL settings for 0x6060: Stopping time 2 0.0 ... [10000.0] ... 10000.0 s <ul style="list-style-type: none">Setting can only be changed if the inverter is disabled.	



12.2 onboard EtherCAT - Operation as standard EtherCAT slave

12.2.1 Commissioning

Preconditions:

- The inverter is networked as an EtherCAT slave with an EtherCAT master and, if necessary, further EtherCAT devices.
- The entire wiring has already been checked for completeness, short circuit and earth fault.
- All EtherCAT devices are supplied with voltage and are switched on.
- The inverter is commissioned with the "EASY Starter" or the "PLC Designer".
 - [Download »EASY Starter«](#)
 - [Download »PLC Designer«](#)
- The EtherCAT master is commissioned with a manufacturer-specific engineering tool.
Examples:
 - Lenze Controller with »PLC Designer«
 - Beckhoff PLC with TwinCAT
- The device description file required for project engineering of the inverter is installed.
 - The "PLC Designer" receives these files via the Lenze EASY Package Manager.
 - Third party engineering tools require an ESI device description file.
[Download XML/ESI files for Lenze devices](#)
 - We always recommend the use of the current device description.

Parameterization required

The EtherCAT device must be configured as slave.



By default, the slave functionality is activated. = 0

How to activate the slave functionality:

1. Setting: = 0
2. Save parameter settings.
 - ▶ [Saving the parameter settings](#) 35
3. Restart inverter.

Device command: `0x2022:035 = 1`

The inverter is now configured as a slave.

Configuring the network

onboard EtherCAT - Operation as standard EtherCAT slave
Commissioning



Commissioning steps

How to configure the network:

1. Configure gateway function of the master

1. Start »PLC Designer«.
2. Open or recreate a »PLC Designer« project.
3. Open the "Communication settings" tab of the master.
4. Click "Add gateway".

Do the following in the appearing dialog box:

- a) Enter the IP address of the master.
 - b) Confirm the entry with "OK".
5. Click "Search network".
 6. Select the corresponding master for the previously entered IP address.
 7. Click "Set active path".
 8. Log into the master using the "Online → Log in" menu command or with <Alt>+<F8>. Now you can access the slaves from the Engineering PC via the EtherCAT master as gateway.

2. Carry out network scan.

1. Execute the "Start Search" command in the context menu of the master.
The appearing dialog box lists all available EtherCAT devices according to the physical order in the network.
2. Click "Copy all devices into the project".
The physical network structure is reproduced in the »PLC Designer« project.



A proper operation requires that the network topology generated in the project corresponds to the physical order of the EtherCAT devices in the network. Otherwise, an error message displays which slave (product code) is to be expected at which position.

3. Adapt EtherCAT device to the application

1. Adapt parameter values of the inverter.
2. Set the PDO-Mapping.
3. The selected parameters must be set as shown above.

4. Load the network configuration into the master

1. Log off: Menu command "Online → Log off" or <Ctrl>+<F8>.
2. Compiling: Menu command "Build → Build" or <F11>.
3. Log in: Menu command "Online → Log in" or <Alt>+<F8>.

The configuration, the parameter settings and the PLC program are loaded into the master. Afterwards, all EtherCAT slaves are initialized.



These steps must be carried out after every change within the »PLC Designer« project. An already existing configuration and an existing PLC program in the master are overwritten.



12.2.2 Basic setting and options

12.2.2.1 Synchronisation with "distributed clocks" (DC)

The **Distributed Clocks** (DC) functionality enables an exact time leveling for applications, in which several axes execute simultaneous, coordinated movements. The data is accepted synchronously with the PLC program. For DC synchronization, all slaves are synchronized with a reference clock, the so-called "DC master".

Parameter

Address	Name / setting range / [default setting]	Information
0x2580:001	Distributed Clocks: Real time status • Read only	Since its switch-on, the inverter has not yet received any real time information from outside. The inverter still works with a time based on the time of the last switch-off or the time stamp of the firmware.
	0 Not adjusted	Since its switch-on, the inverter has not yet received any real time information from outside.
	1 Adjusted once	
	2 Adjusted cyclically	
0x2580:002	Distributed Clocks: First setting time • Read only: x ns	Display of the time when the inverter has received a real time information from outside for the first time after its switch-on. In the "No real time information received yet", the value "0" is displayed.
0x2580:003	Distributed Clocks: Newest setting time • Read only: x ns	Display of the time when the inverter has most recently received a real time information from outside.
0x2580:004	Distributed Clocks: Current time • Read only: x ns	Display of the time information currently used by the inverter (device time).

12.2.3 Process data transfer

- Process data is cyclically transferred between the EtherCAT master and the slaves (permanent exchange of current input and output data).
- The transfer of process data is time-critical.
- Supported cycle times:
 - 0.250 ms
 - 0.500 ms
 - 1,000 ms ... integer multiples of 1,000 ms ... max. 10,000 ms
- The process data serve to control the EtherCAT slaves.
- The process data can be directly accessed by the master. The data in the PLC, for instance, are directly stored in the I/O area.
- The contents of the process data are defined via I/O data mapping. This defines which EtherCAT objects are to be transmitted cyclically. The mapping of the process data depends on the technology application used.
- Process data is not saved in the device.
- Process data is, e.g. setpoints, actual values, control and status words.

Configuring the network

onboard EtherCAT - Operation as standard EtherCAT slave
Parameter data transfer



12.2.4 Parameter data transfer

- For configuring and diagnosing the EtherCAT devices, the parameters are accessed by means of acyclic communication.
- Parameter data are transferred as SDOs (Service Data Objects).
- The SDO services enable the writing and reading access to parameters and EtherCAT objects.
- The transfer of parameter data is usually not time-critical.
- Parameter data is, for instance, operating parameters, motor data and diagnostic information.

SDO return values

If an SDO request is evaluated negatively, a corresponding error code is output:

Index	Description
0x00000000	No fault.
0x05030000	The state of the toggle bit has not changed.
0x05040000	SDO protocol time-out.
0x05040001	Invalid or unknown specification symbol for the client/server command.
0x05040005	The space in the main memory is not sufficient.
0x06010000	Unsupported access to an object.
0x06010001	Read access to a write-only object.
0x06010002	Write access to a read-only object.
0x06020000	An object is not available in the object directory.
0x06040041	An object cannot be mapped into the PDO.
0x06040042	The number and/or length of the mapped objects would exceed the PDO length.
0x06040043	General parameter incompatibility.
0x06040047	General internal incompatibility in the device.
0x06060000	The access has failed due to errors in the hardware.
0x06070010	The data type or the parameter length do not match.
0x06070012	Wrong data type: The parameter length is too big.
0x06070013	Wrong data type: The parameter length is too small.
0x06090011	A subindex is not available.
0x06090030	The value range for parameters is too big (only in case of write access).
0x06090031	The parameter value is too high.
0x06090032	The parameter value is too low.
0x06090036	The maximum value is smaller than the minimum value.
0x08000000	General fault.
0x08000020	Data cannot be transferred to the application or saved in the application.
0x08000021	Due to local control, the data cannot be transferred to the application or saved in the application.
0x08000022	Due to the current device state, the data cannot be transferred to the application or saved in the application.
0x08000023	The dynamic object directory generation has failed or no object directory is available.



12.2.5 Monitoring

Three different EtherCAT monitoring systems are available.

- Monitoring for cable interruption
- For distributed clocks (DC):
 - Sync0 monitoring
 - PDO telegram failure detection

Monitoring for cable interruption

This monitoring generally checks whether the EtherCAT cable is interrupted. Monitoring is not configurable and works with and without distributed clocks".

Behavior in the event of a cable interruption:

- The inverter changes to the "Safe-Operational" state.
- The inverter triggers a parameterizable error response.
 - Error response: ▶ [0x605E](#)
 - Error code: ▶ [0x30018181](#)

Sync0 monitoring for DC

This monitoring checks whether the Sync0 signals are generated correctly in time in the inverter when the inverter is in the "Operational" state.

The following is monitored:

- After "Pre-Operational" has changed to "Safe-Operational", the generation of Sync0 pulses has to be started within 5 seconds.
- The change from "Safe-Operational" to "Operational" without Sync0 signals being generated.
- No more Sync0 signals are detected for the duration of the double Sync0 cycle time.

Error behavior:

- The inverter changes to the "Safe-Operational" state.
- The inverter triggers a parameterizable error response.
 - Error response: ▶ [0x605E](#)
 - Error code: ▶ [0x30018700](#)
 - AL status code: 0x32

PDO telegram failure detection for DC

This monitoring checks whether an EtherCAT PDO telegram has arrived between two Sync0 signals (Sync Manager 2 Event).

For this purpose, the inverter has an internal error counter for PDO telegram failures:

- Each failed PDO telegram increases the counter by the value "3".
- Each correctly received PDO telegram decreases the counter by the value "1".
- Monitoring is configurable. ▶ [0x10F1:002](#)

Error behavior:

- The inverter changes to the "Safe-Operational" state.
- The inverter triggers a parameterizable error response.
 - Error response: ▶ [0x605E](#)
 - Error code: ▶ [0x30018701](#)



Recommendation: Set [0x10F1:002](#) ≥ 4.

Thus one failed PDO telegram is tolerated, two PDO telegram failures in a row are forbidden.

Configuring the network

onboard EtherCAT - Operation as standard EtherCAT slave
 Diagnostics
 Status LEDs



Parameter



Address	Name / setting range / [default setting]	Information
0x10F1:001	Error settings: Local error reaction	An error response takes place exclusively via the inverter.
	2 Device specific state	
0x10F1:002	Error settings: Sync error counter limit 0 ... [20] ... 100	Setting for PDO frame failure detection. When the internal telegram failure error counter reaches the value set here, the inverter changes to the "Safe-Operational" state and causes an error (CiA402 error code 0x8700).

12.2.6 Diagnostics



12.2.6.1 Status LEDs

The meaning of the "RUN" and "ERR" LEDs can be obtained from the following two tables.



LED "RUN" (green)

Blinking pattern	EtherCAT status	Status/meaning
off	off / Init	The network option is not active at the network or is in the "Init" status.
 blinking	Pre-Operational	Access to parameters and objects is possible. No process data exchange.
	Safe-Operational	The data is not active yet in the standard device.
 on	"Operational"	Valid process data is exchanged cyclically.

"ERR" LED (red)

Blinking pattern	Status/meaning
off	No fault
 flickers	Local error. The network option changes automatically to the "Safe-Operational" status.
 on (red)	A "Sync Manager Watchdog Timeout" has occurred.
 blinking	The configuration is invalid/incorrect.

"L/A" LED (green)

Blinking pattern	State	Meaning
off	Not connected	Network not available
 on	Connected	Network available No data transfer
 blinking	Traffic	Data transfer

12.2.6.2 Information on the network

Parameter

Address	Name / setting range / [default setting]	Information
0x2378	onboard EtherCAT - status • Read only	Display of the active network status.
	1 Initialisation	
	2 Pre-Operational	
	3 Bootstrap	
	4 Safe-Operational	
	8 Operational	
0x2379	onboard EtherCAT - Error • Read only	Display of the active network error.



Address	Name / setting range / [default setting]	Information
0x2372:009	onboard EtherCAT - Information: Active interface mode • Read only	Display of the active EtherCAT master/slave functionality for the system bus interface.
	0 Slave	Slave functionality is active.
	1 Master	Master functionality is active.

12.2.6.3 Device identification

Parameter

Address	Name / setting range / [default setting]	Information
0x1000	Device type • Read only	CANopen device profile according CANopen specification CiA 301/ CiA 402.
0x1008	Manufacturer device name • Read only	Display of the manufacturer device name.
0x1009	Manufacturer hardware version • Read only	Display of the manufacturer hardware version.
0x100A	Manufacturer software version • Read only	Display of the manufacturer software version.
0x1018:001	Identity object: Vendor ID • Read only	Display of the manufacturer's identification number.
0x1018:002	Identity object: Product Code • Read only	Display of the product code of the inverter.
0x1018:003	Identity object: Revision number • Read only	Display of the main and subversion of the firmware.
0x1018:004	Identity object: Serial number • Read only	Display of the serial number of the inverter.

Configuring the network

onboard EtherCAT - Operation as standard EtherCAT slave
EoE communication



12.2.7 EoE communication

With the protocol "Ethernet over EtherCAT (EoE)" normal standard Ethernet telegrams can be sent via the EtherCAT network without affecting the real-time communication of the EtherCAT process data.

The protocol enables the establishment of a parameter communication (SDO communication) to devices on the EtherCAT bus via a standard Ethernet connection.

Preconditions:

EoE communication

- A MAC address must be transmitted in the EoE initialization telegram.
- IP address assignment
 - With static IP address assignment, an IP different from 0.0.0.0, subnet mask and gateway IP must also be transmitted.
 - With dynamic IP address assignment, the transmission of the IP address, subnet mask and gateway IP can be omitted in the EoE initialization telegram.

System architecture

- The IP address assignment in the network can be done statically by the EtherCAT master via configuration or via a higher-level infrastructure that can be connected to the Ethernet switch port terminal.
- The PC used can obtain the IP address via the Ethernet switch port terminal if this supports a DHCP server or BOOTP mechanisms, or it must itself have a statically assigned IP in the same subnet.

Supported protocols and services

- ARP
- DHCP-Client
- ESDCP
- ICMP (ping)
- UDP/TCP
- GCI-SDO communication (TCP-Port 9410)

Parameter

Address	Name / setting range / [default setting]	Information
0x2020:001	EoE information: Virtual MAC address • Read only	Display of the virtual MAC address.
0x2020:002	EoE information: IP address • Read only	Display of the IP address.
0x2020:003	EoE information: Subnet mask • Read only	Display of the subnet mask.
0x2020:004	EoE information: Standard gateway • Read only	Display of the standard gateway.
0x2020:005	EoE information: DNS server • Read only	Display of the DNS server.
0x2020:006	EoE information: DNS name • Read only	Display of the DNS name.
0x2020:007	EoE information: Received packages 0 ... [] ... 4294967295	Display of the packages received during the EoE transmission.
0x2020:008	EoE information: Transmitted packages 0 ... [] ... 4294967295	Display of the packages sent during the EoE transmission.



13 Device functions

13.1 Optical device identification

For applications including several interconnected inverters it may be difficult to locate a device that has been connected online. The "Optical device identification" function serves to locate the inverter by means of blinking LEDs.

Details

In order to start the visual tracking,

- click the button in the toolbar of the »EASY Starter«  or
- set `0x2021:001` = "Start [1]".

After the start, both LEDs "RDY" and "ERR" on the front of the inverter synchronously blink very fast.

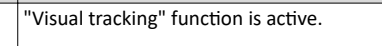
"RDY" LED (blue)	"ERR" LED (red)	Status/meaning
		"Visual tracking" function is active.
Both LEDs are blinking in a very rapidly synchronous mode		

The blinking duration can be set in `0x2021:002` or selected in the »EASY Starter« in the dropdown list field:

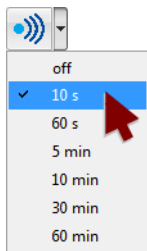

Parameter

Address	Name / setting range / [default setting]	Information
0x2021:001	Optical tracking: Start detection	1 = start optical device identification. <ul style="list-style-type: none"> • After the start, the two LEDs "RDY" and "ERR" on the front of the inverter are blinking with a blinking frequency of 20 Hz for the blinking duration set in <code>0x2021:002</code>. The setting is then automatically reset to "0" again. • If the function is reactivated within the blinking time set, the time is extended correspondingly. • A manual reset to "0" makes it possible to stop the function prematurely.
	0 Stop 1 Start	
0x2021:002	Optical tracking: Blinking duration 0 ... [5] ... 6000 s	Setting of the blinking duration for the visual tracking.



13.2 Reset parameters to default

Parameter

Address	Name / setting range / [default setting]	Information
0x2022:001	Device commands: Load default settings <ul style="list-style-type: none"> Setting can only be changed if the inverter is disabled. 	1 = reset all parameters in the RAM memory of the inverter to the default setting that is stored in the inverter firmware. <ul style="list-style-type: none"> All parameter changes made by the user are lost during this process! It may take some seconds to execute the task. When the task has been executed successfully, the value 0 is shown. Loading parameters has a direct effect on the cyclic communication: The data exchange for control is interrupted and a communication error is generated.
	0 Off / ready	Only status feedback
	1 On / start	Execute device command
	2 In progress	Only status feedback
	3 Action cancelled	
	4 No access	
5 No access (Device disabled)		



13.3 Saving/loading the parameter settings

If parameter settings of the inverter are changed, these changes at first are only made in the RAM memory of the inverter. In order to save the parameter settings with mains failure protection, the inverter is provided with the corresponding device command in the parameter.

Device functions

Enabling the device



13.4 Enabling the device

Parameter

Address	Name / setting range / [default setting]	Information
0x2822:001	Axis commands: Enable inverter	Parameters for interaction with engineering tools.
	0 Inverter inhibited	
	1 Inverter enabled	



13.5 Restart device



If the inverter communicates with the master as network node via EtherCAT: executing the device command may cause an interruption of the EtherCAT communication with the master and a standstill of the drive.

Parameter

Address	Name / setting range / [default setting]	Information
0x2022:035	Device commands: Restart Device	Parameter for interaction with engineering tools.
	0 Off / ready	Only status feedback
	1 On / start	Execute device command
	2 In progress	Only status feedback
	3 Action cancelled	
	4 No access	
	5 No access (Device disabled)	



13.6 Restarting Safety

Parameter

Address	Name / setting range / [default setting]	Information
0x2022:041	Device commands: Restart extended safety	
	0 Off / ready	Only status feedback
	1 On / start	Execute device command
	2 In progress	Only status feedback
	3 Action cancelled	
	4 No access	
	5 No access (Device disabled)	



13.7 Export logbook

The export of the complete logbook can be started with the [0x2022:036](#) parameter.

Parameter

Address	Name / setting range / [default setting]	Information
0x2022:036	Device commands: Export Logbook	Exports the logbook for the upload into the engineering tools.
	0 Off / ready	Only status feedback
	1 On / start	Execute device command
	2 In progress	Only status feedback
	3 Action cancelled	
	4 No access	
5 No access (Device disabled)		



13.8 Delete logbook files

The logbook files can be deleted with the [0x2022:015](#) parameter.

Parameter

Address	Name / setting range / [default setting]	Information
0x2022:037	Device commands: Delete Logfiles	Deletion of log files on the device that were exported in an earlier step via 0x2022:036 (Export Logbook).
	0 Off / ready	Only status feedback
	1 On / start	Execute device command
	2 In progress	Only status feedback
	3 Action cancelled	
	4 No access	
	5 No access (Device disabled)	



13.9 Activate loaded application

The loaded application can be activated with the parameter.



13.10 Inverter control word

Parameter

Address	Name / setting range / [default setting]	Information
0x2830	Inverter control word 0x0000 ... [0x0000] ... 0xFFFF	The control word serves to influence the control functions.
	Bit 0 Flying restart completed	This bit enables the control to report the acceptance of the recorded speed to the "flying restart" function. Thus, the flying restart process is completed.
	Bit 1 Block flying restart	TRUE: the flying restart process is blocked.
	Bit 4 Set load value	TRUE: set load value.
	Bit 5 Select new actual position	TRUE: define new actual position. <ul style="list-style-type: none"> Setting/shifting of Actual position (0x6064) to Actual position start value (0x2983) considering the set resolution (0x608F:001, 0x608F:002). Mode for setting the actual position: 0x2984)
	Bit 6 Activate DC-injection braking or short-circuit braking	DC-injection braking or short-circuit braking is activated via this bit.
	Bit 7 Disable speed and position monitoring	
	Bit 8 Disable VFC-Eco	
	Bit 9 Brake status override	
	Bit 10 Activate SLS	
Bit 11 Stop mains failure control		



13.11 Access protection

13.11.1 Write access protection

Optionally a write access protection can be installed for the inverter parameters.



Write access protection via network is not restricted. Irrespective of the write access protection that is currently set, a higher-level controller, OPC-UA server, or any other communication partner connected to the inverter is always provided with full read/write access to all parameters of the inverter.



After activating the write access protection, you have to enter a valid PIN to remove the write access protection. Note down the defined PIN(s) and keep this information in a safe place! If you lose the PIN(s), the inverter can only be disabled by resetting it to the delivery status. This means, all parameter settings made by the user get lost! ▶ [Reset parameters to default](#) 242

Details

Usually the write access protection function is implemented by the engineer/OEM, for example to protect the inverter against incorrect parameterization by non-authorized persons. For diagnostic purposes, a read access to all parameters is always possible.

The write access protection allows for the following configurations:

- Full write access
- Write access only to favorites or (when knowing PIN1) to all parameters
- No write access or (when knowing PIN2) full write access
- No write access or (when knowing PIN1) write access only to favorites or (when knowing PIN2) to all parameters

The following table compares the four possible configurations:

PIN1 setting	PIN2 setting	Log-in	Status display after log-in	Active write access protection (via keypad/»EASY Starter«)
0x203D	0x203E	0x203F	0x2040	
0	0	-	0	No access protection configured.
		Access →		
		Diagnostics (read access)	Favorites	All parameters
> 0	0	0 or wrong PIN	2	Write access only possible to favorites.
		Correct PIN1	0	Write access to all parameters possible.
		Access →		
		Diagnostics (read access)	Favorites	PIN1 All parameters
0	> 0	0 or wrong PIN	1	No write access.
		Correct PIN2	0	Write access to all parameters possible.
		Access →		
		Diagnostics (read access)	PIN2 Favorites	All parameters
> 0	> 0	0 or wrong PIN	1	No write access.
		Correct PIN1	2	Write access only possible to favorites.
		Correct PIN2	0	Write access to all parameters possible.
		Access →		
		Diagnostics (read access)	PIN1 Favorites	PIN2 All parameters
If PIN1 and PIN2 are set identically, a write access to all parameters is possible after the PIN has been entered correctly.				

Device functions

Access protection
Write access protection





Parameter

Address	Name / setting range / [default setting]	Information
0x203D	PIN1 access protection -1 ... [0] ... 9999	PIN definition for write access protection. <ul style="list-style-type: none">• 1 ... 9999 = set/change PIN.
0x203E	PIN2 access protection -1 ... [0] ... 9999	<ul style="list-style-type: none">• 0 = delete PIN (deactivate access protection).• When the PIN has been set successfully, the value -1 is shown; otherwise 0.• Setting/changing the PIN via keypad/»EASY Starter« only possible if no write access protection is active.• Settings/changes via »EASY Starter« become effective immediately; via keypad they only become effective when the parameter group has been exited.
0x203F	PIN1/PIN2 log-in -32768 ... [0] ... 32767	Parameter for PIN entry for the purpose of deactivating an active access protection temporarily. <ul style="list-style-type: none">• 1 ... 9999 = log-in (deactivate access protection temporarily).• 0 = logout (reactivate access protection).• After having logged in successfully, the value -1 is shown; otherwise 0.• After 10 invalid entries, the log-in function is inhibited. In order to remove the log-in inhibit, the inverter must be switched off and on again.



13.11.1.1 Write access protection in the »EASY Starter«

If a write access protection is active for the online connected inverter, it is displayed in the status bar of the »EASY Starter«:

Display	Representation of the parameters in the »EASY Starter«
 No write access	All parameters in all dialogs are displayed as read-only parameters.
 Only favorites	Except for the favorites, all parameters in all dialogs are displayed as read-only parameters.

An active write access protection can be removed when the PIN is known.

How to remove an active write access protection temporarily:

1. Click the symbol  in the toolbar.

The "Log in / Log off" dialog box is displayed:

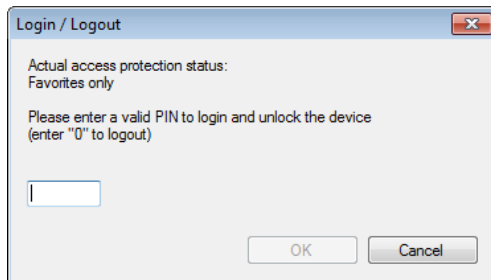

2. Enter the valid PIN and confirm with **OK**.



After 10 invalid entries, the log-in function is inhibited. In order to remove the log-in inhibit, the inverter must be switched off and on again.

The write access protection gets active again:

- Automatically 10 minutes after the last login or after the last active write access. It takes max. 10 minutes to be automatically logged out again after each write access.
- Automatically after the mains voltage is switched on again.
- Manually by entering a "0" in the dialog box "Log in / Log off" (see above).

Device functions

Access protection
Write access protection
Write access protection in the »EASY Starter«



Configuring the write access protection with »EASY Starter«

The write access protection is activated by specifying PIN1 and/or PIN2 (depending on the desired configuration of the write access protection).

How to activate the write access protection:

1. Go to the "Settings" tab and navigate to the "Access protection" parameterisation dialog:

The write access to the parameter set in the inverter can be fully or partially protected.
If a configuration with write access protection is selected, the inverter starts with protection immediately. It can be temporarily canceled by using the login button from toolbar and enter a valid PIN.

 10 min after login, logout or after a restart of the inverter the maximum configured access protection is activated again.

There are 4 different configurations available: (Can only be changed online)

<input type="radio"/> Full write access			
<input type="radio"/> Favorites only or full write access	Power ON Login with PIN1	➔	Favorites only Full write access
<input type="radio"/> No or full write access	Power ON Login with PIN2	➔	No write access Full write access
<input type="radio"/> No, favorites only or full write access	Power ON Login with PIN1 Login with PIN2	➔	No write access Favorites only Full write access

2. Select the desired configuration of the write access protection.

The "PIN definition" dialog box is displayed. The possible entries depend on the selected configuration.

PIN Definition

Define PIN1 (1..9999) for future login to have full write access.

PIN1

Repeat PIN1



OK Cancel

3. Enter the desired PIN(s) and confirm with **OK**.



After successful execution, the write access protection is immediately effective and is displayed in the »EASY Starter« status bar.

4. For a permanent acceptance of the configuration:  Save parameter settings in the device.

How to change already defined PIN(s):

1.  Remove the active write access protection temporarily (see above).
2. Select the "Full write access" configuration in the "Access protection" parameterisation dialog.
3. Select again the desired configuration of the write access protection.
4. Enter new PIN(s) and confirm with **OK**.
5.  Save parameter settings in the device.

How to remove a configured write access protection permanently:

1.  Remove the active write access protection temporarily (see above).
2. Select the "Full write access" configuration in the "Access protection" parameterisation dialog.
3.  Save parameter settings in the device.



Impact of the write access protection on »EASY Starter« functions

The following »EASY Starter« functions are not supported when write access protection is active:

- Parameter set download
- Definition of the "Favorites" parameters.
- Definition of the parameters for the "Parameter change-over" function

The following »EASY Starter« functions are supported irrespective of whether write access protection is active:

- Optical device identification [0x2021:001](#)
- Enable/inhibit inverter [0x2822:001](#)
- Resetting parameters to default [0x2022:001](#)
- Save parameter set
- Load user parameter
- Load OEM parameter
- Error reset

13.11.2 Brand protection

Parameter

Address	Name / setting range / [default setting]	Information
0x2100:001	Brand protection: PIN set -1 ... [0] ... 9999999	<ul style="list-style-type: none">• 0: no brand protection.• 1 ... 9999999: possible pins.• -1: brand protection is active.
0x2100:002	Brand protection: PIN input -2 ... [0] ... 9999999	<ul style="list-style-type: none">• 0: not checked.• 1 ... 9999999: possible pins.• -1: check was successful.• -2: check was not successful.
0x2100:003	Brand protection: Encryption 0 ... [0] ... 9	Encryption for brand protection.



13.12 Switching frequency changeover

The output voltage of the inverter is a DC voltage with sine-coded pulse width modulation (PWM). This corresponds by approximation to a AC voltage with variable frequency. The frequency of the PWM pulses is adjustable and is called "switching frequency".

Details

The switching frequency has an impact on the smooth running performance and the noise generation in the motor connected as well as on the power loss in the inverter. The lower the switching frequency, the better the concentricity factor, the smaller the power loss and the higher the noise generation.

Parameter

Address	Name / setting range / [default setting]	Information
0x2939	Switching frequency	Selection of the inverter switching frequency.
	2 8 kHz variable / drive-optimised	Abbreviations used: <ul style="list-style-type: none"> • "Variable": Adaptation of the switching frequency as a function of the current. The carrier frequency is reduced depending on the heat sink temperature and the ixt load. • "Fixed": The carrier frequency is fixed, no frequency reduction. • "Drive-optimised": reduces the capacitive currents from the motor to the earth. • "Min. P_v": reduces the capacitive currents from the motor to the earth and optimizes power dissipation.
	3 16 kHz variable / drive-optimised	
	6 4 kHz fixed / drive-optimised	
	7 8 kHz fixed / drive-optimised	
8 16 kHz fixed / drive-optimised		



13.13 Device overload monitoring (ixt)

The inverter calculates the ixt utilization in order to protect itself against thermal overload. In simple terms: a higher current or an overcurrent that continues for a longer time causes a higher ixt utilization.

DANGER!

Uncontrolled motor movements by pulse inhibit.

When the device overload monitoring function is activated, pulse inhibit is set and the motor has no torque. A load that is connected to motors without a holding brake may therefore cause uncontrolled movements! Without a load, the motor will coast.

Possible consequences: Death or severe injuries

► Only operate the inverter under permissible load conditions.

Details

The device overload monitoring function primarily offers protection to the power section. Indirectly, also other components such as filter chokes, circuit-board conductors, and terminals are protected against overheating. Short-time overload currents followed by recovery periods of smaller current utilisation are permissible. The monitoring function during operation checks whether these conditions are met, taking into consideration that higher switching frequencies and lower stator frequencies as well as higher DC currents cause a greater device utilization.

- If the total utilization exceeds the total warning threshold set in (default setting: 95 %), the inverter outputs a warning.
- If the device utilization exceeds the permanent error threshold 100 %, the inverter is disabled immediately and generates an error message.
- The device overload can be obtained from the planning manual.



The total utilization is determined via various timers that become active at different high currents. As a result, it can happen that individual timers still display 0% utilization, although the total utilization is already significantly higher.

Parameter

Address	Name / setting range / [default setting]	Information
0x2D40:001	Device utilisation ixt: Power unit actual utilisation • Read only: x %	Display of the power module utilisation.
0x2D40:002	Device utilisation ixt: Power unit warning threshold 0 ... [95] ... 101 %	If the device utilisation exceeds the threshold set, the inverter outputs a warning.
0x2D40:003	Device utilisation ixt: Power unit error threshold • Read only: x %	If the power module utilisation exceeds the displayed threshold, the inverter outputs a warning.
0x2D40:004	Device utilisation ixt: Device actual utilisation • Read only: x %	Display of the current device utilisation.
0x2D40:005	Device utilisation ixt: Device warning threshold 0 ... [95] ... 101 %	
0x2D40:006	Device utilisation ixt: Device error threshold • Read only: x %	If the device utilisation exceeds the displayed threshold, the device outputs an error.



13.14 Heatsink temperature monitoring

In order to avoid an impermissible heating of the servo inverter, the temperature of the heatsink is detected and monitored.



The temperature of the heatsink is measured in the temperature range of 0 ... 80 °C with a tolerance of -2 ... +4 °C. Beyond this temperature range, the measuring accuracy decreases faster.

Parameter

Address	Name / setting range / [default setting]	Information
0x2D84:001	Heatsink temperature: Heatsink temperature • Read only: x.x °C	Display of the current heatsink temperature.
0x2D84:002	Heatsink temperature: Warning threshold 50.0 ... [90.0] ... 100.0 °C	Warning threshold for temperature monitoring. <ul style="list-style-type: none"> • If the heatsink temperature exceeds the threshold set here, the inverter outputs a warning. • The warning is reset with a hysteresis of approx. 5 °C. • If the heatsink temperature increases further and exceeds the non-adjustable error threshold (100 °C), the inverter changes to the "Fault" device status. The inverter is disabled and thus any further operation is stopped.



Device functions

Update device firmware
Firmware download with »EASY Starter (firmware loader)«
Download via Ethernet connection

13.15 Update device firmware

13.15.1 Firmware download with »EASY Starter (firmware loader)«

13.15.1.1 Download via Ethernet connection

Parameter

Address	Name / setting range / [default setting]	Information
0x243C:001	Device: Ethernet commands: Device: Start firmware update <ul style="list-style-type: none">Setting can only be changed if the inverter is disabled.	
	0 Off / ready	
	1 On / start	
	4 No access	
	20 20%	Only status feedback
	40 40%	
	60 60%	
	80 80%	

Additional functions

Brake energy management
Use of a brake resistor



14 Additional functions

14.1 Brake energy management

When braking electrical motors, the kinetic energy of the drive train is fed back regeneratively to the DC bus. This energy causes a DC-bus voltage boost. If the energy fed back is too high, the inverter reports an error.

Several different strategies can serve to avoid DC-bus overvoltage:

- Stopping the deceleration ramp function generator when the active voltage threshold for the brake operation is exceeded
- Use of the "Inverter motor brake" function
- Combination of the above named options

Details

The voltage threshold for braking operation results on the basis of the rated mains voltage set:

Rated mains voltage (0x2540:001)	Voltage thresholds for braking operation	
	Braking operation on	Braking operation off
230 V	390 V DC	380 V DC
400 V	725 V DC	710 V DC
480 V	780 V DC	765 V DC

14.1.1 Use of a brake resistor

For braking operation, optionally the brake chopper integrated in the inverter (brake transistor) can be used.

NOTICE

Incorrect dimensioning of the brake resistor may result in the destruction of the integrated brake chopper (brake transistor).

- ▶ Only connect a brake resistor complying in terms of performance to terminals R_{B1} and R_{B2} of the inverter.
- ▶ Avoiding thermal overload of the brake resistor.



14.2 Manual jog parameters

Parameter

Address	Name / setting range / [default setting]	Information
0x2836:001	Manual control mode: Current setpoint 0 ... [30] ... 200 %	Setting of the current setpoint value for manual control. <ul style="list-style-type: none"> 100 % \equiv Rated current (0x2DDF:001)
0x2836:002	Manual control mode: Frequency -1000.0 ... [0.0] ... 1000.0 Hz	Setting of the frequency for manual control.
0x2836:003	Manual control mode: Ramp time (current) 0 ... [0] ... 1000 ms	Setting of the period of time during which the current setpoint value is achieved from zero onwards.
0x2836:004	Manual control mode: Ramp time (frequency) 0 ... [500] ... 10000 ms	Setting of the period of time during which the frequency is achieved from zero onwards. The frequency ramp only starts up when the current ramp has reached the value configured in 0x2836:001 (Current setpoint).
0x2836:005	Manual control mode: Time monitoring (frequency) 0 ... [2500] ... 100000 ms	Setting of the time period for time monitoring. <ul style="list-style-type: none"> The manual control features a time monitoring function which is coupled to a write access to 0x2836:002 (Frequency). If no write access to 0x2836:002 takes place within the time period set here, the frequency is moved to zero via the parameterised ramp. When the 0 Hz have been reached, the inverter changes to the error status and is inhibited. After acknowledging the error, the CiA402 state machine must be switched from "Switch-on inhibited" back to the "Operation enabled" state before proceeding with manual control.
0x2836:006	Manual control mode: Current controller gain 0.00 ... [20.00] ... 750.00 V/A	Setting of the current controller gain.
0x2836:007	Manual control mode: Current controller reset time 0.01 ... [20.00] ... 2000.00 ms	Setting of the current controller reset time.



14.3 Mains failure control

This function can decelerate the drive in the event of a mains voltage failure and use its kinetic energy to maintain the DC-bus voltage for a certain period of time. This makes it possible to keep the drive running during a brief failure of the mains voltage or, in the event of a longer failure, to run it to a standstill in a guided manner.

Details

The mains failure control is activated when the mains failure monitoring has detected a mains failure.

In the default setting, the mains failure control is switched off. ▶ [Activate mains failure control](#) 265



Controlled regenerative operation raises the DC-bus voltage. This can trigger an overvoltage fault. If an overvoltage fault is to be reliably excluded, the excess energy must be dissipated by a brake resistor.

Functional description of the mains failure monitoring

The mains failure monitoring compares the currently measured DC-bus voltage with the filtered DC-bus voltage.

If the measured DC-bus voltage `0x6079` is smaller than the filtered DC-bus voltage `0x2D66:014` and smaller than 90 % of the nominal DC-bus voltage, a mains failure is detected.

The mains failure is signaled in status word 2 of the inverter: `0x2833`, bit 14 (Mains failure detected)



If a lot of kinetic energy is fed back into the DC bus during a mains failure, the mains failure monitoring will only respond with a delay or possibly not at all due to the DC-bus voltage not dropping.

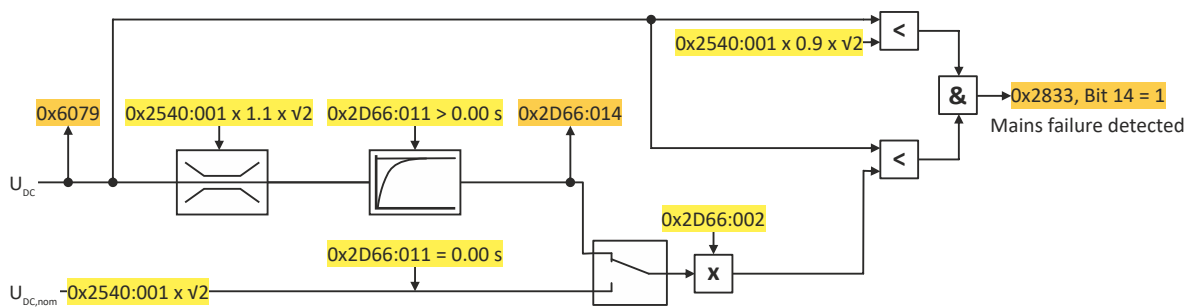

Fig. 6: Function of the mains failure monitoring



Functional description of the mains failure control

Setting [0x2833](#), bit 14 (Mains failure detected) activates the mains failure control if it is enabled. ([0x2D66:001](#) = 2):

- The motor control switches to speed control with setpoint 0 rpm.
- The deceleration torque ramps up from a starting value to the parameterized maximum value.
 - Maximum value: [0x2D66:012](#)
 - Ramp time: [0x2D66:013](#)
 - The ramp time determines the jerk of the deceleration.
- The starting value depends on the current operating mode of the drive:
 - Operation in motor mode: Starting torque = 0 Nm.
 - Operation in generator mode: Starting torque = [0x6077](#) (Actual torque)
- After the drive has come to a standstill, the [0x3181](#) (Mains failure) error message is output.
- The original motor control is reactivated with the parameterized values.



If undervoltage occurs during mains failure control, the controller is disabled.

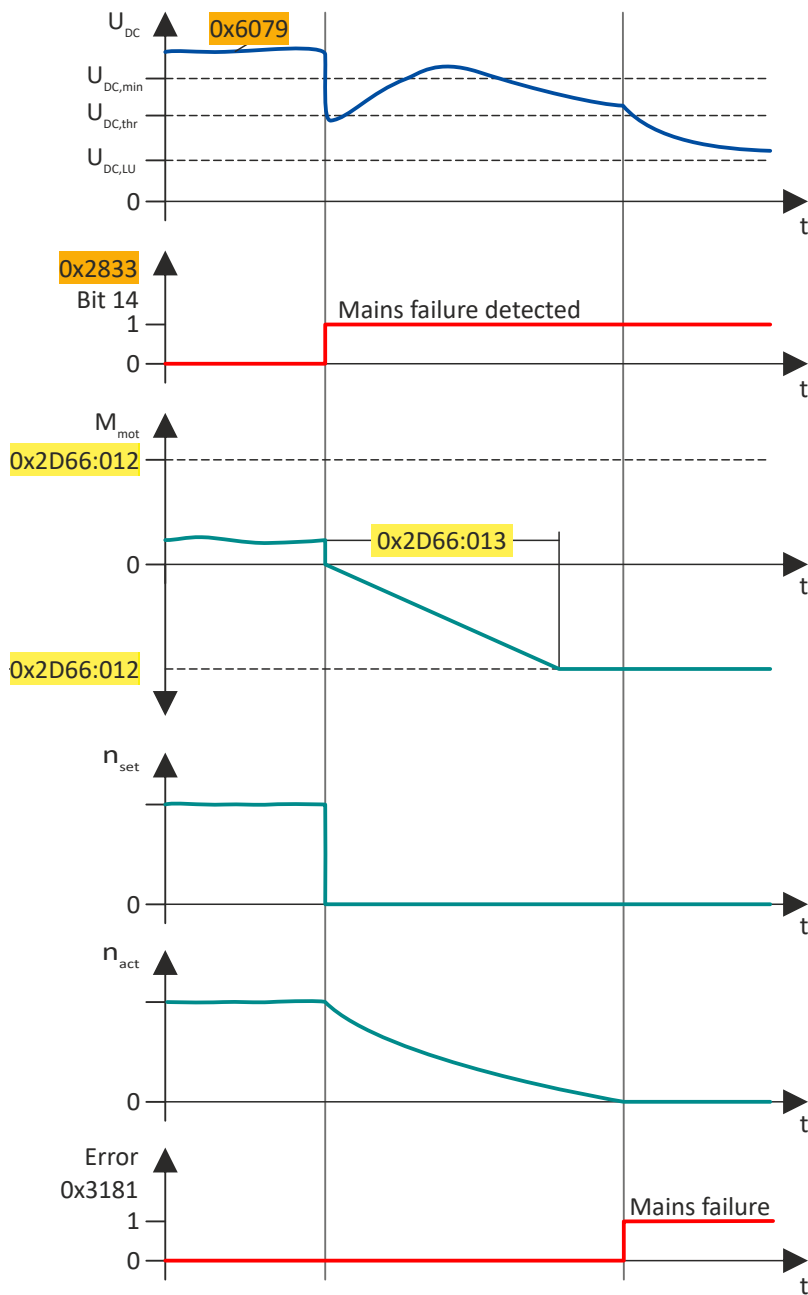

Fig. 7: Sequence of mains failure control in motor operation



Activate mains failure control

How to set up the mains failure control:

1. Define filter time for the DC-bus voltage:

a) **0x2D66:011** = 0.00 s (no filtering):

The current DC-bus voltage is compared with the nominal DC-bus voltage Rated mains voltage (**0x2540:001**) x $\sqrt{2}$.



Note the following when making this setting:

The usual short-term fluctuations of the mains voltage can already trigger the mains failure control.

b) **0x2D66:011** > 0.00 s (filtering active):

The current DC-bus voltage is compared with the filtered DC-bus voltage **0x2D66:014** weighted with factor **0x2D66:002**.



Note the following when making this setting:

The usual short-term fluctuations of the mains voltage cannot trigger the mains failure control.

2. Set the activation threshold: ▶ **0x2D66:002** (= weighting for forming the comparison value).

Recommended setting: 75%

With the setting 75 %, the mains failure control is activated if the current DC-bus voltage is more than 25 % below the comparison value.



For high values for the activation threshold, note the following:

The higher the value, the sooner a mains failure is detected due to a sudden drop in DC-bus voltage.

The higher the value, the more energy reserve is available for the guided shutdown in the DC bus.

If the value is too high, there is a risk of false tripping.

For low values for the activation threshold, note the following:

If the value is too low, the energy reserve in the DC bus may be too low.

An undervoltage fault would interrupt the guided shutdown.

3. Activate mains failure control: **0x2D66:001** = 2 (Enabled).

The mains failure control becomes active with these settings when the DC-bus voltage falls below the comparison values.

Behavior in case of mains recovery



The mains failure control is not terminated when the mains returns.

To switch to normal operation immediately, the mains failure control must be terminated via the control word:

Inverter control word ▶ **0x2830**, bit 11 = 1 (Stop mains failure control)

Deactivate mains failure control

These events terminate the mains failure control:

- Lock mains failure control ▶ **0x2D66:001** = 0 (Disabled)
- Exit via Inverter control word ▶ **0x2830**, bit 11 = 1 (Stop mains failure control)
- Inverter disable
- Inverter disable due to an error (e.g. undervoltage)

Additional functions

Mains failure control



Parameter

Address	Name / setting range / [default setting]	Information
0x2D66:001	Mains failure control: Enable function	Enable mains failure control.
	0 Disabled	Operation without mains failure control.
	2 Enabled	Operation with mains failure control.
0x2D66:002	Mains failure control: DC-bus activation level 60 ... [75] ... 90 %	Weighting of the source of the comparison value Recommended setting: 75% If the DC-bus voltage falls below the comparison value, the mains failure control is triggered: <ul style="list-style-type: none"> • 0x2D66:011 = 0.00 s (no filtering): Comparison value = nominal DC-bus voltage (0x2540:001 x √2) x 0x2D66:002. • 0x2D66:011 > 0.00 s (filtering active): Comparison value = filtered DC-bus voltage (0x2D66:014) x 0x2D66:002.
0x2D66:011	Mains failure control: Filter time 0.00 ... [0.00] ... 60.00 s	Filter time for filtering the measured DC-bus voltage. 0x6079 0.00 s = no filtering The setting also determines the source of the comparison value for detecting the mains failure: <ul style="list-style-type: none"> • 0x2D66:011 = 0.00 s (no filtering): Source = nominal DC-bus voltage (0x2540:001 x √2). • 0x2D66:011 > 0.00 s (filtering active): Source = filtered DC-bus voltage (0x2D66:014).
0x2D66:012	Mains failure control: Ramp max. torque 0.0 ... [30.0] ... 3276.7 %	Maximum torque of the torque ramp for braking the drive to standstill. Reference: Rated motor torque (0x6076)
0x2D66:013	Mains failure control: Ramp time 0.00 ... [1.00] ... 5.00 s	Ramp time for reaching the maximum torque. Reference: Torque change 0 Nm → maximum torque
0x2D66:014	Mains failure control: Actual DC bus voltage (filtered) <ul style="list-style-type: none"> • Read only: x.xxx V 	Display of the filtered DC-bus voltage.



14.4 Oscilloscope function

The oscilloscope function is operated via the separate "Oscilloscope" tab of the »EASY Starter« engineering tool. Here, you can find the user interface with all the relevant dialogs and setting options.

Preconditions

Configuring the oscilloscope and starting the recording is only possible when an online connection to the inverter has been established.

User interface

In the Lenze engineering tool used, set the trigger condition and the sample rate via the oscilloscope user interface when an online connection to the inverter has been established and select the parameters to be recorded.

The configuration is transferred into the inverter and checked each time it changes. Should the check identify invalid settings, the oscilloscope triggers an error message.

After the measurement is completed and when an online connection has been established, the measured data in the inverter is transmitted to the engineering tool and represented graphically on the oscilloscope user interface.

Ch	On	Inv	Name	yPos I	yPos II	ΔyPos	Unit	AS	1/Div	Offset	Position
1	<input checked="" type="checkbox"/>	<input type="checkbox"/>	0x2836.002 Manual ctrlmode: Freque...				Hz	<input checked="" type="checkbox"/>	100	0	0
2	<input checked="" type="checkbox"/>	<input type="checkbox"/>	0x2946.001 T-node: Upper speed limit				rpm	<input checked="" type="checkbox"/>	100	0	0
3	<input checked="" type="checkbox"/>	<input type="checkbox"/>	0x2946.002 T-node: Lower speed limit				rpm	<input checked="" type="checkbox"/>	100	0	0
4	<input checked="" type="checkbox"/>	<input checked="" type="checkbox"/>	0x2C42.004 Encoder: Signal quality ...				%	<input checked="" type="checkbox"/>	100	0	0
5	<input type="checkbox"/>	<input type="checkbox"/>						<input type="checkbox"/>			
6	<input type="checkbox"/>	<input type="checkbox"/>						<input type="checkbox"/>			
7	<input type="checkbox"/>	<input type="checkbox"/>						<input type="checkbox"/>			
8	<input type="checkbox"/>	<input type="checkbox"/>						<input type="checkbox"/>			

- A Oscilloscope toolbar
- B Oscillogram field
- C Channel list field
- D Status line

- E Set trigger conditions
- F Set sample rate and time base
- G Start / stop of recording
- H Comment input field and error message

Additional functions

Oscilloscope function



Toolbar

Icon	Function
	Load oscillogram / configuration from file
	Load recorded oscillogram from the device
	Save oscillogram in file
	Copy oscillogram to the clipboard
	Print oscillogram
	Display cursor
	Center cursor
	Scale curve automatically
	Activate zoom function
"Time base:"	Display of the set time base
	Tool settings (right-hand side of the toolbar)

Technical data	
Number of channels	1 ... 8
Data memory depth	Maximally 65535 measured values for each channel
Data width of a channel	Maximally 64 bits, according to the data type of the parameter to be recorded
Sample rate	62.5 μ s or a multiple thereof, max. 100 ms
Recording duration at lowest sampe rate	4.1 s (62.5 μ s * 65535 measured values)
Recording duration at highest sample rate	6553,5 s (100 ms * 65535 measured values)
Maximum time base	655,35 s
Trigger level	According to the value range of the parameter to be triggered
Trigger delay	-100 % ... +400 %
Trigger source	Channel 1 ... 8

Selecting parameters to be recorded

The oscilloscope supports up to eight channels, thus maximally eight parameters can be recorded in an oscillogram. The **Channels** list field serves to configure the parameters to be recorded as signal sources:

Column	Name	Meaning
1	-	Curve colour for the representation in the oscillogram
2	Ch	Channel number
3	On	on / off
4	Inv	Inversion on / off
5	Name	Selection of the parameter to be recorded
6	yPos I	Value at cursor I in vertical direction
7	yPos II	Value at cursor II in vertical direction
8	Δ yPos	Difference between the two values of yPos I and yPos II (displayed as amount)
9	Unit	Scaling
10	AS	Activation / deactivation of the autoscaling function
11	1 / Div	
12	Offset	The offset value is subtracted from the recorded raw value before the scaling is executed. This serves to, e. g., make very small value fluctuations visible within one consistently very high recording value (e. g. harmonics with a low amplitude).
13	Position	Regarding the vertical curve scale -5 ... 5, the position value determines the vertical position of the zero point of the Y axis of a curve.



How to select a parameter for recording:

1. Double-click the "Name" column in the **Channel** list field to open the "Selection of signal sources" dialog box.
 2. Select the parameters to be recorded in the dialog box.
 3. Press the "Ok" button. This closes the dialog box and the selection is accepted.
 4. Repeat the steps 1 ... 3 to select up to seven further parameters to be recorded.
- The selected parameters are recorded when the oscilloscope is started.

How to change a parameter for recording:

1. Double-click the parameter to be changed in the **Channels** list field in the "Name" column.
 2. Make a new selection in the "Selection of signal sources" dialog box.
 3. Press the "Ok" button. This closes the dialog box and the selection is accepted.
- The changed parameters are recorded when the oscilloscope is started.

How to cancel a selection again:

1. Right-click the parameter to be removed in the **Channels** list field in the "Name" column to open the context menu.
2. Select the "Remove signal source" command in the context menu.

Defining the recording time / sample rate

How to define the duration and sample rate for recording:

1. Select the desired time base in the time base list field.
 - a) The current setting of the time base multiplied by 10 results in the recording time.
 - b) As the size of the measured data memory in the inverter is limited, a compromise is usually made between sample rate and recording time.
2. Either enter the desired sample rate in [ms] in the sample rate input field or open the "Sample rate selection" dialog by clicking the "Sample rate" button and select a sample rate < 1 ms.
 - a) The sample rate in the inverter is automatically corrected to integer multiples of 62.5 μ s.

Thus, the duration and sample rate are defined for recording.

Additional functions

Oscilloscope function



Defining the trigger condition

Based on the trigger condition, define the starting time of recording in the inverter. The oscilloscope offers various trigger conditions which serve to control the recording of the measured values.

The trigger threshold can be changed in the "Value" input field on the "Settings" tab if the channel is selected in "Signal source" that contains the corresponding parameter.

Setting	Function
Signal source	Selection of the trigger source:
Channel	Triggering takes place on a channel configured in the "vertical channel settings" list field.
immediate trigger	No trigger condition, recording takes place immediately after the start.
Value	Value, from which onwards triggering is caused.
Deceleration	Time delay of recording with regard to the trigger event.
Pre-trigger	When entering a negative delay time, you can detect signals that occur before the trigger event. <div style="text-align: center;"> </div> <p>The trigger time is marked with a dashed line in the oscillogram. If it is triggered on the occurrence of an event, values caused by the event can be detected in this way.</p>
Post-trigger	When entering a positive delay time, you can detect signals that occur a certain time after the trigger event. <div style="text-align: center;"> </div>
Edge	Two trigger types are available:
increasing	First, the value must fall below the defined trigger value and then exceed it in order that triggering is activated.
decreasing	First, the value must exceed the defined trigger value and then fall below it in order that triggering is activated.

Starting recording

Press the button , "Start recording"

In order to obtain a sample rate as high as possible when the parameter values are recorded, the data is first saved in the measured data memory of the inverter and then transmitted to the Engineering PC as oscillogram. The current recording status is displayed in the status bar.



Adjusting the representation



As soon as the diagram does not show the complete measurement anymore, a scrollbar appears below the time axis. You can use the scrollbar to move the visible section horizontally. The time-axis inscription and the position indicator are automatically corrected during scrolling.

After recording and subsequent transmission of the online oscillogram to the Engineering PC, it is visualised in the oscilloscope. If required, you can now adjust the representation using the zoom function or the automatic scaling function.







Change time base subsequently

A measurement already carried out can be extended or compressed by changing the time base.

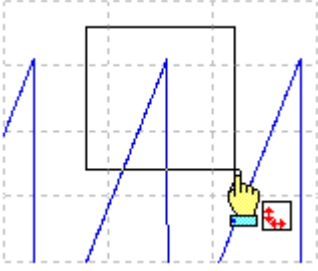
For this purpose, change the setting of the time base via the toolbar (on top).

Zoom function

The zoom function will be activated by selecting the  in the toolbar. When the function is activated, the button is highlighted.

Zoom function	Proceeding
Zoom selection	<p>Hold down the left mouse button and draw the section to be zoomed:</p>  <ul style="list-style-type: none"> • The selection is shown with a frame. • When the left mouse button is released, the selection is zoomed in the oscillogram.
Horizontal stretching	<p>On the horizontal scale:</p>  Hold down the left mouse button and move the mouse pointer to the left to stretch the shown selection from the right edge.  Hold down the right mouse button and move the mouse pointer to the right to stretch the shown selection from the left edge. <p>Moving the mouse pointer in opposite direction continuously reduces the stretching.</p>
Vertical stretching	<p>On the vertical scale:</p>  Hold down the left mouse button and move the mouse pointer to the bottom to stretch the shown selection from the top.  Hold down the right mouse button and move the mouse pointer to the top to stretch the shown selection from the bottom. <p>Moving the mouse pointer in opposite direction continuously reduces the stretching.</p>
Return to original representation	 Click the right mouse button in the diagram to return step by step to the original representation.

Additional functions

Oscilloscope function



Automatic scaling function

Use the automatic scaling function to automatically scale and reposition the representation of selectable signal characteristics in the oscillograph and reset the offset to "0".

How to execute automatic scaling

1. Select the channels and parameters for automatic scaling in the **Channels** dialog box.
2. Click the corresponding symbol in the oscilloscope toolbar to activate the automatic scaling function.

The cursor function

In addition to the zoom and scaling function, there is the cursor function which is called by double-clicking the **Channels** list field.

The double-click opens a list of all signal sources with the following options:

- Display of individual measured values of a selectable channel
- Addition, subtraction or multiplication of any two measured values
- Square-law mean value of any two measured values

How to use the cursor function:

1. Go to the oscilloscope toolbar and click the "Cursor" button to activate the cursor function.
 - a) Two movable vertical measuring lines are displayed in the oscillogram.
2. Select the channel for which individual measuring lines are to be displayed from the **Channels** list field.
3. Hold down the left mouse button and drag the red vertical measuring line to the desired position.
 - a) The active measuring line is represented by a continuous line, the inactive measuring line is represented by a dotted line.
 - b) If you position the mouse pointer over the inactive measuring line, the measuring line automatically becomes active.
 - c) The columns **yPos I** and **yPos II** in the **Channels** list field display the values measured at the measuring lines. The column **ΔyPos** or **QWM** displays the cursor differential value or square-law mean value of all values between both cursors.
 - d) The sum value to be displayed can be defined in the "tool settings" dialog. This dialog can be set via the "Tool settings" dialog on the right in the toolbar.
 - e) Comparing peak values: Several values displayed in the oscillogram can be compared to each other using a horizontal measuring line. The measuring line is automatically created based on the current cursor point and thus cannot be shifted.



Managing oscillograms

If several data records are loaded in the oscilloscope at the same time, the measured data to be displayed is selected via the respective tab above the displayed oscillogram. There are three types of oscillograms:

- **Device oscillogram**

The device oscillogram is the only oscillogram to establish a connection to the target system in order to carry out an oscilloscope measurement. It is always displayed as the first "Device on the left" tab.

- **Offline oscillogram**

The offline oscillogram is an oscillogram already saved in the Engineering PC.

- The configuration of the offline oscillogram can be reused for future recordings.
- The offline oscillogram is displayed as a tab with the file name that was allocated for this oscillogram while being saved.

- **Merge oscillogram**

The merge oscillogram ("Merge" tab) is automatically available if two or more oscillograms are loaded in the oscilloscope at the same time.

- In the merge oscillogram, several characteristics from the currently loaded oscillograms can be overlaid, e. g. to compare signal characteristics from different recordings.

Commenting oscillograms

You can add a comment on the selected oscillogram into the comment input field.

- When you execute the "Save oscillogram" command, the comment is saved together with the oscillogram in the file.
- When you select an oscillogram with a comment to be loaded in the "Load oscillogram" dialog box, this comment is displayed in the dialog box.

Saving oscillogram in file

After selecting the parameters to be recorded from the selection list of the signal sources and making any further necessary settings, you can save this configuration and the recording if already carried out on the Engineering PC for a later reuse.

How to save the oscillogram:

1. Click the symbol in the toolbar. the "Save oscillogram" dialog box is displayed.
2. Define a name in the Name input field of the oscillogram to be saved.
3. Click the "Export to file" button.
4. Specify the folder and file name for the oscillogram be stored in the Save as dialog box.
5. Click the Save button. The dialog box is closed.

The current oscillogram is saved.

Additional functions

Oscilloscope function



Loading oscillogram / configuration from file



The reuse of a saved configuration is only reasonable for inverters of the same type, as otherwise due to a scaling of the oscilloscope channels that is not adapted, incorrect values are displayed!

Data sets/configurations which have already been saved can be reloaded into the oscilloscope any time, e.g. for the overlay function.

How to load an oscillogram or a configuration:

1. Click the symbol in the oscilloscope toolbar. The "Load oscillogram" dialog box is displayed.
2. Press the Search... button.
3. Select the file to be imported within the desktop environment from the Open dialog box.
4. If the oscillogram is to be used as configuration, select the As configuration... option.
5. Click the Open button. The dialog box is closed.

The selected oscillogram or configuration is imported.

Closing the oscillogram

You can close an open OFFLINE oscillogram again any time.

- After an oscillogram is closed, it is no longer available in the oscillogram list field. The oscilloscope changes automatically to the display of the ONLINE oscillogram.
- If the closed oscillogram was included in the MERGE oscillogram, its channels will be removed from the MERGE oscillogram.
- Go to the oscilloscope toolbar and click the symbol to close the currently displayed OFFLINE oscillogram.

Overlay function

The overlay function serves to overlay several characteristics from the currently loaded data sets, e.g. to compare signal characteristics from different recordings.

- If two or more oscillograms are loaded in the oscilloscope, e.g. the ONLINE oscillogram and an oscillogram that was previously loaded into a file, a "MERGE" oscillogram will be automatically available in the "Oscillogram" list field.
- If the merge oscillogram is selected, the desired characteristics to be overlaid or compared can be selected from the loaded oscillograms in the Vertical channel settings group field.
- If an ONLINE oscillogram is used in the MERGE oscillogram, an update is carried out in the MERGE oscillogram in the case of a renewed recording.
- Removing variables from an OFFLINE or ONLINE oscillogram causes the characteristics in the MERGE oscillogram to be deleted.

Copying an oscillogram to the clipboard

For documentation purposes, it is possible to copy the measured data of an oscillogram as a table or, alternatively, the oscilloscope user interface as a picture, to the clipboard for use in other programs.

How to copy the oscillogram to the clipboard:

1. Click the symbol in the oscilloscope toolbar. The "Copy oscillogram" dialog box is displayed.
2. Select the desired option:
 - a) Curve points: the measured data is copied to the clipboard as a table.
 - b) Screenshot: the oscilloscope user interface is copied to the clipboard as a picture.
3. Press the OK button. The dialog box is closed and the selected option is copied to the clipboard.



15 Functional safety

15.1 General information and basics

Safety component

The safety component in the inverter provides the safe interfaces (e.g. safe inputs or safe network interfaces). If the STO safety function is requested, the safety component immediately brings about the torque-free state according to EN 61800-5-2.

In the "Advanced Safety" or "Extended Safety" version, the safety component also monitors safe compliance with the limit values. If monitored limit values are exceeded, the safety component reacts with safety functions according to EN 61800-5-2.

Identification of the components

The functional safety components and the associated connections are usually marked in yellow. Since the functional safety standards do not prescribe color coding, the components and terminals can also be designed in other colors.

Standards

Safety regulations are confirmed by laws and other governmental guidelines and measures and the prevailing opinion among experts, e.g. by technical regulations.

The regulations and rules to be applied must be observed in accordance with the application.

Risk assessment

This documentation can only accentuate the need for a risk assessment. The user of the integrated functional safety must read up on standards and the legal situation.

Before a machine can be put into circulation, the manufacturer of the machine has to conduct a risk assessment according to the 2006/42/EC: Machinery Directive [UKCA: S.I. 2008/1597 - The Supply of Machinery (Safety) Regulations 2008] to determine the hazards associated with the use of the machine.

The Machinery Directive refers to three basic principles for the highest possible level of safety:

- Hazard elimination / minimisation by the construction itself.
- Taking the protective measures required against hazards that cannot be removed.
- Existing residual hazards must be documented and the user must be informed of them.

Detailed information on the risk assessment is provided in the DIN EN ISO 12100:2013-08: Safety of machinery – General principles for design – Risk assessment and risk reduction. The result of the risk assessment determines the category for safety-related control systems according to EN ISO 13849-1. Safety-oriented parts of the machine control must be compliant.

Mission time

The mission time of the used components must be complied with.

In case of a defect or when the mission time of a component has expired, the complete component must be replaced. Continued operation is not permitted!



The mission time for the safety functions cannot be reset by a special proof test.

The specified mission time starts at the date of manufacture.

Mission time ▶ [Safety-related data](#) 363

Functional safety

General information and basics
Stop functions



15.1.1 Stop functions

The stop functions differ according to how they are triggered:

- Normal stop (simple stop)
 - Triggering via a safe input (if available) with the parameterized stop function (e.g. STO or SS1).
 - Triggering via a safety bus by activating the corresponding bit (e.g. STO or SS1) in the control data.
- Emergency stop
 - Triggering via a safe input (if available) with the parameterized SSE function.
 - Triggering via a safety bus by activating the corresponding SSE bit in the control data.
 - STO or SS1 can be configured as the function to be executed via the parameter "SSE: Emergency stop function".
- Error stop
 - Triggered as a response to an error.

15.1.2 Prioritisation

Stop functions with higher priority influence the flow of lower-order functions which have already been initiated.

Hierarchy:

1. Safe torque off (STO)
 - STO has the highest priority and hence precedence over all other functions.
 - Functions that have already been initiated (e.g. SS1 or SS2) are canceled and the drive is switched off.
2. Safe stop 1 (SS1)
 - SS1 has priority over SS2.
 - Observing the defined stop time for SS1 and SS2 as well as the SS1 mode, the drive is rendered torqueless.

The monitoring functions have equal priorities and can be executed simultaneously with the stop function.

15.1.3 Acceptance

The machine manufacturer must check and prove the operability of the safety functions used.

- The machine manufacturer must authorize a person with expertise and knowledge of the safety functions to carry out the test.
- The test result of every safety function must be documented and signed by the inspector.

A complete test comprises the following:

- Documenting the plant including the safety functions:
 - Creating an overview screen of the plant.
 - Describing the plant.
 - Describing the safety equipment.
 - Documenting the safety functions used.
 - Checking the function of the safety functions used.
- Preparing the test report:
 - Documenting the functional test.
 - Checking the parameters.
 - Signing the test report.
- Preparing the appendix with test records:
 - Protocols for the plant
 - External recording



15.1.4 Periodic inspections

Check the operational flow of the safety-related functions at regular intervals. The risk assessment or prevailing regulations determine the time intervals between the inspections.

15.1.5 Device exchange

Exchange a maximum of one safe device before recommissioning.

How to replace a safe device:

1. Check the compatibility of the devices.
2. Set the safety address.
3. Carry out a functional test.



For double axes, ensure that the safe parameter sets are assigned to the correct axes.



15.2 Safe interfaces

Overview: Safe interfaces in Lenze inverters

Functional safety design	Products	Safe inputs	Safe output	Safe network interfaces		
				PROFIsafe	FSoE	CIP Safety™
Basic Safety - STO	i550, i750, i950	1 (STO)				
Advanced Safety - L	i750 cabinet				•	
Extended Safety - L	i750 cabinet				•	
Extended Safety - LT	i950 cabinet	4	•	•	•	•

Abbreviations used:

CIP	Common Industrial Protocol	-
FSoE	FailSafe over EtherCAT	280
PROFIsafe	Process field safety	-
STO	Safe torque off (STO)	297



15.2.1 Safe network interfaces

Parameter

Address	Name / setting range / [default setting]	Information
0x2128	S-Bus configuration	Changes only possible in the +Safety parameter list+.
	• Safety parameter (+Safety parameter list+)	
	11 FSoE/onboard EtherCAT	

Functional safety

Safe interfaces
Safe network interfaces
FSoE connection



15.2.1.1 FSoE connection



Fail-safe-over-EtherCAT (FSoE) enables the transmission of safe information via FSoE protocol according to ETG.5100 S specification, version 1.2.0 of the EtherCAT user organisation (ETG).

Safety over EtherCAT® is a registered trademark and patented technology, licensed by Beckhoff Automation GmbH, Germany.

Preconditions

ESI file

The ESI file can be used to integrate Lenze EtherCAT devices into the EtherCAT configuration software of PLC manufacturers.

The ESI file is NOT required for Lenze controllers with EtherCAT master functionality. For Lenze controllers, all device description files are installed with Lenze PLC Designer and Lenze Package Manager.



Download of the current ESI file → www.lenze.com

Addressing

A definite FsoE address ensures that a data frame reaches the correct node. If "FSoE" has been selected as safety bus, the safety address is at the same time accepted as the FSoE target address. This address must match the corresponding configuration of the safety PLC.



The checksums (CRC) of a parameter set are calculated via the set safety parameters. The calculated checksums of the safety parameter set must match the corresponding configuration of the safety PLC.



Advanced Safety

FSoE output data

The safety controller transmits FSoE output data (control commands) to the inverter:

- Data length: 11 bytes
- Control commands are LOW-active, the bit state "0" activates the function.
- Exceptions: See details in the table.

Byte-Offset	Bit-Offset							
	Bit 7	Bit 6	Bit 5	Bit 4	Bit 3	Bit 2	Bit 1	Bit 0
Byte 0	Command (CMD)							
Byte 1	AIE (0/1)	-	-	-	-	-	SS1	STO
Byte 2	-	-	-	-	-	-	-	AIS (0/1)
Byte 3	CRC_0 (low-byte)							
Byte 4	CRC_0 (high-byte)							
Byte 5	-	-	-	-	-	-	-	-
Byte 6	-	-	-	-	-	SBC	-	-
Byte 7	CRC_1 (low-byte)							
Byte 8	CRC_1 (high-byte)							
Byte 9	Connection-ID (low-byte)							
Byte 10	Connection-ID (high-byte)							

FSoE input data

The inverter transmits FSoE input data (status information) to the safety controller:

- Data length: 19 bytes
- Status information is HIGH-active, the bit status "1" indicates the active status information.

Byte offset	Bit offset							
	Bit 7	Bit 6	Bit 5	Bit 4	Bit 3	Bit 2	Bit 1	Bit 0
Byte 0	Command (CMD)							
Byte 1	Error active	-	-	-	-	-	-	STO active
Byte 2	-	-	-	-	-	-	-	SS1 active
Byte 3	CRC_0 (low-byte)							
Byte 4	CRC_0 (high-byte)							
Byte 5	-	-	-	-	-	-	-	-
Byte 6	-	-	-	-	-	-	-	-
Byte 7	CRC_1 (low-byte)							
Byte 8	CRC_1 (high-byte)							
Byte 9	-	-	-	-	-	-	-	-
Byte 10	-	-	-	-	MUT active	-	-	-
Byte 11	CRC_2 (low-byte)							
Byte 12	CRC_2 (high-byte)							
Byte 13	-	-	-	-	-	-	-	-
Byte 14	-	-	-	-	-	SBC activated	SBC active	-
Byte 15	CRC_3 (low-byte)							
Byte 16	CRC_3 (high-byte)							
Byte 17	Connection-ID (low-byte)							
Byte 18	Connection-ID (high-byte)							

Functional safety

Safe interfaces
 Safe network interfaces
 FSoE connection



Extended Safety

FSoE output data

The safety controller transmits FSoE output data (control commands) to the inverter:

- Data length: 11 bytes
- Control commands are LOW-active, the bit state "0" activates the function.
- Exceptions: See details in the table.

Byte offset	Bit offset							
	Bit 7	Bit 6	Bit 5	Bit 4	Bit 3	Bit 2	Bit 1	Bit 0
Byte 0	Command (CMD)							
Byte 1	AIE (0/1)	SDIneg	SDIpos	-	SOS	SS2	SS1	STO
Byte 2	SSE	SLI	ES (HIGH-active)	RMS (HIGH-active)	-	SHom load (0/1)	SHom start (0/1)	AIS (0/1)
Byte 3	CRC_0 (low-byte)							
Byte 4	CRC_0 (high-byte)							
Byte 5	SLP4	SLP3	SLP2	SLP1	SLS4	SLS3	SLS2	SLS1
Byte 6	-	-	-	-	-	SBC	-	PDSS
Byte 7	CRC_1 (low-byte)							
Byte 8	CRC_1 (high-byte)							
Byte 9	Connection-ID (low-byte)							
Byte 10	Connection-ID (high-byte)							



FSOE input data

The inverter transmits FSOE input data (status information) to the safety controller:

- Data length: 31 bytes
- Status information is HIGH-active, the bit status "1" indicates the active status information.

Byte offset	Bit offset							
	Bit 7	Bit 6	Bit 5	Bit 4	Bit 3	Bit 2	Bit 1	Bit 0
Byte 0	Command (CMD)							
Byte 1	Error active	SDIneg active	SDIpos active	-	SOS active	-	-	STO active
Byte 2	SSE active	SLI active	ES active	RMS active	-	SOS observed	SS2 active	SS1 active
Byte 3	CRC_0 (low-byte)							
Byte 4	CRC_0 (high-byte)							
Byte 5	SLS4 observed	SLS3 observed	SLS2 observed	SLS1 observed	SLS4 active	SLS3 active	SLS2 active	SLS1 active
Byte 6	SCA4 within limits	SCA3 within limits	SCA2 within limits	SCA1 within limits	SLP4 observed	SLP3 observed	SLP2 observed	SLP1 observed
Byte 7	CRC_1 (low-byte)							
Byte 8	CRC_1 (high-byte)							
Byte 9	SSM within limits	SMS observed	PDSSneg observed	PDSSpos observed	SDIneg observed	SDIpos observed	SHom available	SHom active
Byte 10	-	-	-	-	MUT active	Positive direction	n=0	Safe speed OK
Byte 11	CRC_2 (low-byte)							
Byte 12	CRC_2 (high-byte)							
Byte 13	-	-	-	-	-	-	-	-
Byte 14	-	-	-	-	-	SBC activated	SBC active	-
Byte 15	CRC_3 (low-byte)							
Byte 16	CRC_3 (high-byte)							
Byte 17	Actual speed n_safe, byte 0							
Byte 18	Actual speed n_safe, byte 1							
Byte 19	CRC_4 (low-byte)							
Byte 20	CRC_4 (high-byte)							
Byte 21	Actual position p_safe, byte 0							
Byte 22	Actual position p_safe, byte 1							
Byte 23	CRC_5 (low-byte)							
Byte 24	CRC_5 (high-byte)							
Byte 25	Actual position p_safe, byte 2							
Byte 26	Actual position p_safe, byte 3							
Byte 27	CRC_6 (low-byte)							
Byte 28	CRC_6 (high-byte)							
Byte 29	Connection-ID (low-byte)							
Byte 30	Connection-ID (high-byte)							

Parameter

Address	Name / setting range / [default setting]	Information
0x212A:001	FSOE project CRC 0 ... [] ... 4294967295 • Safety parameter (+Safety parameter list+)	
0xE600:001	FSOE Slave Frame Elements: Command • Read only • Safety parameter (+Safety parameter list+)	
0xE600:002	FSOE Slave Frame Elements: Connection ID • Read only • Safety parameter (+Safety parameter list+)	
0xE600:003	FSOE Slave Frame Elements: CRC_0 • Read only • Safety parameter (+Safety parameter list+)	
0xE600:004	FSOE Slave Frame Elements: CRC_1 • Read only • Safety parameter (+Safety parameter list+)	

Functional safety

Safe interfaces
 Safe network interfaces
 FSoE connection



Address	Name / setting range / [default setting]	Information				
0xE600:005	FSoE Slave Frame Elements: CRC_2 <ul style="list-style-type: none"> • Read only • Safety parameter (+Safety parameter list+) 					
0xE600:006	FSoE Slave Frame Elements: CRC_3 <ul style="list-style-type: none"> • Read only • Safety parameter (+Safety parameter list+) 					
0xE600:007	FSoE Slave Frame Elements: CRC_4 <ul style="list-style-type: none"> • Read only • Safety parameter (+Safety parameter list+) 					
0xE600:008	FSoE Slave Frame Elements: CRC_5 <ul style="list-style-type: none"> • Read only • Safety parameter (+Safety parameter list+) 					
0xE600:009	FSoE Slave Frame Elements: CRC_6 <ul style="list-style-type: none"> • Read only • Safety parameter (+Safety parameter list+) 					
0xE700:001	FSoE Master Frame Elements: Command <ul style="list-style-type: none"> • Read only • Safety parameter (+Safety parameter list+) 					
0xE700:002	FSoE Master Frame Elements: Connection ID <ul style="list-style-type: none"> • Read only • Safety parameter (+Safety parameter list+) 					
0xE700:003	FSoE Master Frame Elements: CRC_0 <ul style="list-style-type: none"> • Read only • Safety parameter (+Safety parameter list+) 					
0xE700:004	FSoE Master Frame Elements: CRC_1 <ul style="list-style-type: none"> • Read only • Safety parameter (+Safety parameter list+) 					
0xE901:001	FSoE Connection Communication Parameter: Version <ul style="list-style-type: none"> • Read only • Safety parameter (+Safety parameter list+) 					
0xE901:002	FSoE Connection Communication Parameter: Safety address <ul style="list-style-type: none"> • Read only • Safety parameter (+Safety parameter list+) 					
0xE901:003	FSoE Connection Communication Parameter: Connection ID <ul style="list-style-type: none"> • Read only • Safety parameter (+Safety parameter list+) 					
0xE901:004	FSoE Connection Communication Parameter: Watchdog Time <ul style="list-style-type: none"> • Read only • Safety parameter (+Safety parameter list+) 					
0xE901:006	FSoE Connection Communication Parameter: Connection Type <ul style="list-style-type: none"> • Read only • Safety parameter (+Safety parameter list+) <table border="1" style="margin-left: 20px;"> <tr> <td>0</td> <td>Master</td> </tr> <tr> <td>1</td> <td>Slave</td> </tr> </table>	0	Master	1	Slave	
0	Master					
1	Slave					
0xE901:007	FSoE Connection Communication Parameter: Communication Parameter Length <ul style="list-style-type: none"> • Read only • Safety parameter (+Safety parameter list+) 					
0xE901:008	FSoE Connection Communication Parameter: Application Parameter Length <ul style="list-style-type: none"> • Read only • Safety parameter (+Safety parameter list+) 					



Functional safety

Safe interfaces
Safe network interfaces
FSOE connection

Address	Name / setting range / [default setting]	Information
0xEA00:001	FSOE Connection Diagnosis: Connection State <ul style="list-style-type: none">• Read only• Safety parameter (+Safety parameter list+)	
	0 Reset	
	1 Session	
	2 Connection	
	3 Parameter	
	4 Data	
5 Failsafe		



15.3 Safe parameter setting

In »EASY Starter« and »PLC Designer«, safety parameters can only be set and transferred using the **+safety parameter list+**. When a device featuring integrated safety technology or a safety module is selected in the device list, the **+safety parameter list+** becomes available in the form of an additional tab.



The safe parameterization is checked for plausibility.

The plausibility check rejects ambiguous or contradictory settings until they have been parameterized correctly. Only then can the parameters be saved.

Safe parameter setting



When using online communication via a bus system, several users can access the same drive simultaneously and process the safe parameter set. After transferring the safe parameters, check the checksums (CRC) in the **safety parameter list** dialog. The checksums of the project must correspond to the checksums of the safety option.

The consistency of the safe parameters must be ensured by organisational measures because there are no technical means to avoid multiple users accessing parameter sets at the same time.

Parameter setting

Safety-relevant parameters can only be transmitted to the safety option by safe parameter setting. The parameter set is saved on the SD card and in the safety option with a unique safety address.

Safe parameter setting can only be performed in the service status. The service status means:

- Stop is active and the drive is switched to torqueless operation (STO).
- Communication via the safety bus is active but passivated.

The service status can be activated using the »Easy Starter«. Initializing the safety option serves to deactivate the service status.



The service status is activated when a deviation is detected in the safe parameter set on the safety option.

Parameter setting using the Easy Starter

From »Easy Starter« version 01.11 onwards, a safe parameter setting is supported. The functions of the **Safety parameter list** are documented in the online help.

Password

To save a safe parameter set, a password is required. The preset password is "Lenze Safety". The password can be changed and must have at least six characters.

The command **Reset safe parameter set in the device** serves to delete the safe parameter set. The safety functions must be re-parameterized after the reset. The password is reset to the preset password "Lenze Safety".

Acknowledge parameter set or safety address



▶ [Acknowledgement with confirmation button S82](#)  360



Parameter sets and axes

The unambiguousness of an axis with safety functions in a drive system can be achieved by means of the safety address. When a safety option is initialized, e.g. when loading the safe parameter set, the compliance of the safety address will be checked. If no compliance exists, an initialization error is reported.



Clearly define the safety address in a drive system or plant.

Document the address in circuit diagrams and labels.

In drive systems with an activated safety bus, the safety address is also used as the safety bus target address. The clear assignment of the safety address must be configured in the safety PLC.

In drive systems without activated safety bus, unambiguousness and correct assignment of the safety address must be checked. For this purpose, use the »Easy Starter« or the »PLC Designer«.

15.3.1 Safety address

The safety address is set using the 0xF980 parameter.

Parameter

Address	Name / setting range / [default setting]	Information
0xF980:001	Safety addresses: FSoE address • Read only • Safety parameter (+Safety parameter list+)	Display of the safe address set in the device.
0xF980:002	Safety addresses: Safety address 1 ... [1] ... 65534 • Safety parameter (+Safety parameter list+)	Setting of the safe address. Permitted value range: 1 ... 65534 Changes only possible in the +Safety parameter list+.

15.3.2 Parameter set information

Parameter

Address	Name / setting range / [default setting]	Information
0x2114:001	Parameter set: Version • Safety parameter (+Safety parameter list+)	Display of the version of the safe parameter set.
	10301 i750 ES V1.3	
0x2114:002	Parameter set: Project CRC 0 ... [0] ... 4294967295 • Safety parameter (+Safety parameter list+)	Project CRC of the safe parameter set.
0x2115:001	Parameter set: Status • Read only • Safety parameter (+Safety parameter list+)	
	0 No parameter set	
	1 Valid parameter set	
	4 CRC error	
	5 Version error	
	7 Plausibility error	
	8 Assignment error	
	9 Local read error	
	10 Communication error with basic device	
	11 Faulty release	
	12 Different CRCs	
	13 Changed parameter set	
	14 Parameter set checked	
	15 Parameter set check active	
0x2115:002	Parameter set: Current CRC • Read only • Safety parameter (+Safety parameter list+)	Display of the current parameter CRC from the safe parameter set.

Functional safety

Safe parameter setting
Parameter set information



Address	Name / setting range / [default setting]	Information
0x2115:003	Parameter set: Last valid CRC • Read only • Safety parameter (+Safety parameter list+)	Display of the last valid parameter set CRC.
0x2115:004	Parameter set: Parameter setting time stamp • Read only: x s • Safety parameter (+Safety parameter list+)	Time when the parameter set is taken over from the device as the value of the power-on time meter.
0x2115:005	Parameter set: Error information 1 • Read only • Safety parameter (+Safety parameter list+)	Error number in case of a plausibility error. 0x2115:001 = 7 Details: ▶ Safety - Parameter set plausibility errors □ 463
0x2115:006	Parameter set: Error information 2 • Read only • Safety parameter (+Safety parameter list+)	Reserved
0x2115:007	Parameter set: Error information 3 • Read only • Safety parameter (+Safety parameter list+)	
0x2115:008	Parameter set: Current CRC without safety address • Read only • Safety parameter (+Safety parameter list+)	Display of the current parameter CRC from the safe parameter set without safety address.



15.4 Safe speed and position analysis

Function included in variant:			Extended Safety
-------------------------------	--	--	-----------------

15.4.1 Motor-encoder combinations



The achievable risk reductions (PL/SIL) also depend on the safety function used.

Match the values specified here with the values for the safety functions:

▶ [Safety-related characteristics Extended Safety](#) 364



Also observe the supplied documentation of the encoder manufacturer.

Permissible motor-encoder combinations for safe speed and position monitoring

Synchronous servo motors

Synchronous servo motor	Safety-rated encoder			
Type	Encoder type	Encoder product code	Max. Speed [rpm]	Risk reduction
MCS 06 ... 19 MDXKS 56 / 71	SinCos absolute value, single-turn	AS1024-8V-K2	±16000	PL d / SIL 2
	SinCos absolute value, multi-turn	AM1024-8V-K2		
MCS 06 ... 19 m850S120 ... m850S190	SinCos absolute value, multi-turn	AM128-8V-K2	±15000	
	HIPERFACE DSL® (OCT)	AM20-8V-D2		
MCS 06 ... 19 MDXKS 56 / 71 m850S120 ... m850S190	Resolver	RV03	±10000/number of pole pairs	PL e / SIL 3

Asynchronous servo motors

Asynchronous servo motor	Safety-rated encoder			
Type	Encoder type	Encoder product code	Max. Speed [rpm]	Risk reduction
MCA 10 ... 26 MQA 20 ... 26	SinCos incremental	IG1024-5V-V3	±16000	PL e / SIL 3
MCA 10 ... 26 MQA 20 ... 26	Resolver	RV03	±10000/number of pole pairs	PL e / SIL 3

Three-phase AC motors

Three-phase AC motor	Safety-rated encoder			
Type	Encoder type	Encoder product code	Max. Speed [rpm]	Risk reduction
MDxMA063 ... MDxMA225 MHxMA063 ... MHxMA225 MFxMA063 ... MFxMA132 m550P080 ... m550P225	SinCos incremental	IG2048-5V-V2	±16000	PL d / SIL 2
		IG1024-5V-V2		PL e / SIL 3
		IG2048-5V-V3		



15.4.2 Parameter setting of the feedback system



The standardization for functional safety requires separate parameterization of the connected encoder system for the safety module.

Note the parameter settings required for this.

The plausibility check rejects ambiguous settings until they are correctly parameterized.

Parameter setting of the motor encoder

Standard device "Base Drive"				Safety module "Safe Drive"	
Encoder system		Parameter	Setting	Parameter	Setting
Resolver at X7	Selection		automatic recognition	0x2878:001	2 = resolver
	Number of pole pairs	0x2C43	encoder-dependent	0x2878:003	0x2878:003 = 0x2C43
Encoder at X8	Selection	0x2C40	1 = SinCos encoder	0x2878:001	1 = SinCos encoder
		0x2C40	2 = HIPERFACE® SinCos absolute value encoder		
		0x2C40	6 = SSI SinCos absolute value encoder		
	Number of increments	0x2C42:001	encoder-dependent	0x2878:002	0x2878:002 = 0x2C42:001
HIPERFACE DSL® (OCT) at X109	Selection	0x2DE1:001	10 = HIPERFACE DSL® (OCT)	0x2878:001	3 = HIPERFACE DSL® (OCT)

Scaling of the encoder values

All encoder values are managed in the safety module as 32-bit values. The lower 16 bits contain the part of one motor revolution and the higher 16 bits contain the multiple of one motor revolution.

Examples

Encoder value	Calculation	Result (hex)
¼ motor revolution	$65536/4 = 16384$	0x0000'4000
½ motor revolution	$65536/2 = 32768$	0x0000'8000
1 motor revolution	$1 * 65536 = 65536$	0x0001'0000
2 motor revolutions	$2 * 65536 = 131072$	0x0002'0000
2½ motor revolutions	$2 * 65536 + 65536/2 = 163840$	0x0002'8000



All incremental position values always refer to the motor encoder.



Commissioning of HIPERFACE DSL® encoder

During operation with HIPERFACE DSL® encoders, it is checked whether the physical encoder on the motor communicates with the correct axis. For this purpose an encoder ID is used, which is assigned and checked during initialization.

Test routine

- The following encoder IDs are expected:
 - 0 = single axis
 - 1 = double axis, axis A
 - 2 = double axis, axis B
 - Display of the current encoder ID: **0x2878:063**
 - Behavior in case of incorrectly assigned encoder ID:
 - Error message: **0x2A00FFB6**
 - The red LED of the Extended Safety module flashes: ▶ [Acknowledgement with confirmation button S82](#) [□ 360](#)
 - The user must confirm the correct axis assignment via the S82 module switch or the safe parameter list.
- Acknowledgement via S82: ▶ [Acknowledgement with confirmation button S82](#) [□ 360](#)



The encoder ID is not checked for single axes. The encoder ID is automatically set to 0.

Parameter

Address	Name / setting range / [default setting]	Information	
0x2878:001	System	Setting of the motor encoder. Changes only possible in the +Safety parameter list+.	
	• Safety parameter (+Safety parameter list+)		
	0 No motor encoder		
	1 SinCos encoder		
	2 Resolver		
0x2878:002	3 HIPERFACE DSL® (OCT)	Changes only possible in the +Safety parameter list+.	
	SinCos encoder PPR		
	1 ... [1] ... 16384		
	• Safety parameter (+Safety parameter list+)		
0x2878:003	Number of resolver pole pairs	Changes only possible in the +Safety parameter list+.	
	1 ... [1] ... 10		
0x2878:050	• Safety parameter (+Safety parameter list+)	Changes only possible in the +Safety parameter list+.	
	Safety-HDSL driver state		
	• Read only		
	Bit 0		State - bit 0
	Bit 1		State - bit 1
	Bit 2		State - bit 2
	Bit 3		State - bit 3
	Bit 4		Encoder error
	Bit 5		Encoder warning
	Bit 6		"Stuck-at" error
	Bit 7		Position CRC error
	Bit 8		Communication error
	Bit 9		Encoder type not supported
	Bit 10		Diagnostic error
	Bit 11		Self-test missing
	Bit 12		Supply voltage error
	Bit 13		Different encoder ID
Bit 14	Status bit 14 (reserved)		
Bit 15	Status bit 15 (reserved)		

Functional safety

Safe speed and position analysis
Parameter setting of the feedback system



Address	Name / setting range / [default setting]	Information
0x2878:051	Safety HDSL online status 1	
	• Read only	
	• Safety parameter (+Safety parameter list+)	
	Bit 0 FRES	
	Bit 1 FIX0	
	Bit 2 QMLW	
	Bit 3 FIX0	
	Bit 4 FIX0	
	Bit 5 MIN	
	Bit 6 POSTX0	
	Bit 7 POSTX1	
	Bit 8 PRST	
	Bit 9 FIX0	
	Bit 10 VPOS	
	Bit 11 FIX0	
	Bit 12 FIX1	
Bit 13 SCE		
Bit 14 SSUM		
Bit 15 SINT		
0x2878:052	Safety HDSL online status 2	
	• Read only	
	• Safety parameter (+Safety parameter list+)	
	Bit 0 FIX0	
	Bit 1 FIX0	
	Bit 2 QMLW	
	Bit 3 FIX0	
	Bit 4 FIX0	
	Bit 5 FIX0	
	Bit 6 POSTX0	
	Bit 7 POSTX1	
	Bit 8 PRST	
	Bit 9 FIX0	
	Bit 10 VPOS2	
	Bit 11 FIX0	
	Bit 12 FIX1	
Bit 13 SCE2		
Bit 14 SUM2		
Bit 15 FIX0		
0x2878:053	Safety HDSL Safe summary	
	• Read only	
	• Safety parameter (+Safety parameter list+)	
	Bit 0 SSUM0	
	Bit 1 SSUM1	
	Bit 2 SSUM2	
	Bit 3 SSUM3	
	Bit 4 SSUM4	
	Bit 5 SSUM5	
Bit 6 SSUM6		
Bit 7 SSUM7		



Address	Name / setting range / [default setting]	Information
0x2878:054	Safety HDSL Safe Channel 2 status	
	• Read only	
	• Safety parameter (+Safety parameter list+)	
	Bit 0 FIX2	
	Bit 1 FIX2	
	Bit 2 FIX2	
	Bit 3 FIX2	
	Bit 4 FIX2	
0x2878:055	Safety HDSL encoder status ENC_ST0	
	• Read only	
	• Safety parameter (+Safety parameter list+)	
	Bit 0 Encoder status bit 0	
	Bit 1 Encoder status bit 1	
	Bit 2 Encoder status bit 2	
	Bit 3 Encoder status bit 3	
	Bit 4 Encoder status bit 4	
0x2878:056	Safety HDSL encoder status ENC_ST1	
	• Read only	
	• Safety parameter (+Safety parameter list+)	
	Bit 0 Encoder status bit 8	
	Bit 1 Encoder status bit 9	
	Bit 2 Encoder status bit 10	
	Bit 3 Encoder status bit 11	
	Bit 4 Encoder status bit 12	
0x2878:057	Safety HDSL encoder status ENC_ST2	
	• Read only	
	• Safety parameter (+Safety parameter list+)	
	Bit 0 Encoder status bit 16	
	Bit 1 Encoder status bit 17	
	Bit 2 Encoder status bit 18	
	Bit 3 Encoder status bit 19	
	Bit 4 Encoder status bit 20	
0x2878:058	Safety HDSL encoder status ENC_ST3	
	• Read only	
	• Safety parameter (+Safety parameter list+)	
	Bit 0 Encoder status bit 24	
	Bit 1 Encoder status bit 25	
	Bit 2 Encoder status bit 26	
	Bit 3 Encoder status bit 27	
	Bit 4 Encoder status bit 28	
Bit 5 Encoder status bit 29		
Bit 6 Encoder status bit 30		
Bit 7 Encoder status bit 31		

Functional safety

Safe speed and position analysis
Parameter setting of the feedback system



Address	Name / setting range / [default setting]	Information
0x2878:059	Safety HDSL encoder status ENC_ST4	
	• Read only	
	• Safety parameter (+Safety parameter list+)	
	Bit 0 Encoder status bit 32	
	Bit 1 Encoder status bit 33	
	Bit 2 Encoder status bit 34	
	Bit 3 Encoder status bit 35	
	Bit 4 Encoder status bit 36	
0x2878:060	Safety HDSL encoder status ENC_ST5	
	• Read only	
	• Safety parameter (+Safety parameter list+)	
	Bit 0 Encoder status bit 40	
	Bit 1 Encoder status bit 41	
	Bit 2 Encoder status bit 42	
	Bit 3 Encoder status bit 43	
	Bit 4 Encoder status bit 44	
0x2878:061	Safety HDSL encoder status ENC_ST6	
	• Read only	
	• Safety parameter (+Safety parameter list+)	
	Bit 0 Encoder status bit 48	
	Bit 1 Encoder status bit 49	
	Bit 2 Encoder status bit 50	
	Bit 3 Encoder status bit 51	
	Bit 4 Encoder status bit 52	
0x2878:062	Safety HDSL encoder status ENC_ST7	
	• Read only	
	• Safety parameter (+Safety parameter list+)	
	Bit 0 Encoder status bit 56	
	Bit 1 Encoder status bit 57	
	Bit 2 Encoder status bit 58	
	Bit 3 Encoder status bit 59	
	Bit 4 Encoder status bit 60	
0x2878:063	Safety HDSL encoder ID	Display of the currently assigned encoder ID in the motor encoder. 0 = single axis 1 = double axis, axis A 2 = double axis, axis B
	• Read only	
0x2879:001	Mechanical data: Motor mounting direction	Setting of the motor mounting direction.
	• Safety parameter (+Safety parameter list+)	
	0 Motor rotating CW	
	1 Motor rotating CCW	
0x287B:001	Speed: Tolerance window (n=0) 0 ... [5] ... 16000 rpm	If the speed is within the tolerance window, the status "n = 0 rpm" is valid. Changes only possible in the +Safety parameter list+.
	• Safety parameter (+Safety parameter list+)	



Functional safety

Safe speed and position analysis

Parameter setting of the feedback system

Address	Name / setting range / [default setting]	Information
0x287B:002	Speed: Tolerance speed comparison 1 ... [20] ... 16000 rpm • Safety parameter (+Safety parameter list+)	Changes only possible in the +Safety parameter list+.
0x287B:003	Speed: Current speed n_safe • Read only: x rpm • Safety parameter (+Safety parameter list+)	Ist-Drehzahl, ermittelt aus der Validierung von nBD und nSD. Geht in die weitere Verarbeitung der geschwindigkeitsabhängigen Sicherheitsfunktionen ein.
0x287B:004	Speed: Internal current speed nSD • Read only: x rpm • Safety parameter (+Safety parameter list+)	Drehzahlwert Safe-Drive, intern ermittelte Ist-Geschwindigkeit aus der Safety-Applikation
0x287B:005	Speed: Internal current speed nBD • Read only: x rpm • Safety parameter (+Safety parameter list+)	Drehzahlwert Base-Drive, intern ermittelte Ist-Geschwindigkeit aus der Standardapplikation
0x287B:006	Speed: Current speed difference nSD-nBD • Read only: x rpm • Safety parameter (+Safety parameter list+)	
0x287C:001	Position: Tolerance position comparison 1 ... [8192] ... 1024000 incr. • Safety parameter (+Safety parameter list+)	Changes only possible in the +Safety parameter list+.
0x287C:002	Position: Current position p_safe • Read only: x incr. • Safety parameter (+Safety parameter list+)	Ist-Position, ermittelt aus der Validierung von pBD und pSD. Geht in die weitere Verarbeitung der positionsabhängigen Sicherheitsfunktionen ein. 1-Geber-System: Der inkrementelle Positionswert hat Bezug zum Motorgeber. 2-Geber-System: Der inkrementelle Positionswert hat Bezug zum Lastgeber.
0x287C:003	Position: Internal current position pSD • Read only: x incr. • Safety parameter (+Safety parameter list+)	Positionswert Safe-Drive, intern ermittelte Ist-Position aus der Safety-Applikation 1-Geber-System: Der inkrementelle Positionswert hat Bezug zum Motorgeber. 2-Geber-System: Die eingestellten Getriebefaktoren werden bei der Berechnung der Positionswerte berücksichtigt.
0x287C:004	Position: Internal current position pBD • Read only: x incr. • Safety parameter (+Safety parameter list+)	Positionswert Base-Drive, intern ermittelte Ist-Position aus der Standard-Applikation 1-Geber-System: Der inkrementelle Positionswert hat Bezug zum Motorgeber. 2-Geber-System: Der inkrementelle Positionswert hat Bezug zum Lastgeber.
0x287C:005	Position: Current position difference pSD-pBD • Read only: x incr. • Safety parameter (+Safety parameter list+)	



15.5 Safety functions

Overview: Safety functions in Lenze inverters

Functional safety design	Products	Stop functions							Monitoring functions							Operation and diagnostics				
		Without feedback					With feedback		Without feedback			With feedback				MUT	Safety bus	I/Os		
		STO	SS1	SSE	SBC	CAS	SS2	SOS	SMS	SLS	SSM	SDI	SLI	PDSS	SLP				SCA	
Basic Safety - STO	i550, i750, i950	•																		•
Advanced Safety - L	i750 cabinet	•	•		•													•	•	
Extended Safety - L	i750 cabinet	•	•	•	•		•	•	•	•	•	•	•	•	•	•	•	•	•	
Extended Safety - LT	i950 cabinet	•	•	•	•	•	•	•	•	•	•	•	•	•	•	•	•	•	•	•

Abbreviations used:

STO	Safe torque off (STO)	297
SS1	Safe stop 1 (SS1)	304
SSE	Safe stop emergency (SSE)	312
SBC	Safe brake control (SBC)	324
CAS	STO cascading (CAS)	-
SS2	Safe stop 2 (SS2)	314
SOS	Safe operating stop (SOS)	322
SMS	Safe maximum speed (SMS)	326
SLS	Safely-limited speed (SLS)	328
SSM	Safe speed monitor (SSM)	336
SDI	Safe direction (SDI)	343
SLI	Safely-limited increment (SLI)	341
PDSS	Position-dependent safe speed (PDSS)	333
SLP	Safely-limited position (SLP)	338
SCA	Safe cam (SCA)	346
MUT	Safe Muting (MUT)	357
I/Os	Safe inputs	-
	Safe output	-



15.5.1 Safe torque off (STO)

The "Safe Torque Off (STO)" safety function safely switches off the drive. The drive coasts down.

STO corresponds to an uncontrolled shutdown according to EN 60204-1, category 0.

With STO, additional measures are required for an "emergency switching off" according to EN 60204-1.

Functional safety

Safety functions
Safe torque off (STO)
Basic Safety - STO



15.5.1.1 Basic Safety - STO

Function included in variant:	Basic Safety - STO		
-------------------------------	--------------------	--	--

Preconditions

- Additional measures are required to prevent movement caused by external forces.
- When assessing risk, also take into account overtravel distances.

Important notes

DANGER!

No "emergency switching off" in terms with EN 60204-1

With the "Safe torque off" (STO) function, no "emergency switching off" in terms with EN 60204-1 can be executed without additional measures. There is no electrical isolation between the motor and inverter and no service switch or maintenance switch!

Possible consequences: Death or severe injuries

- ▶ "Emergency switching off" requires electrical isolation, e. g. by a central mains contactor.

DANGER!

The power supply is not safely disconnected.

Possible consequences: Death or severe injuries due to electrical voltage.

- ▶ Turn off the power supply.

DANGER!

Uncontrolled rotation of the motor possible.

Possible consequences: Death or severe injuries

- ▶ Set the motor to standstill mechanically.

DANGER!

Automatic restart can occur if the request of the safety function is deactivated.

Possible consequences: Death or severe injuries

- ▶ You must provide external measures according to EN ISO 13849-1 which ensure that the drive only restarts after a confirmation.



Functional description

STO

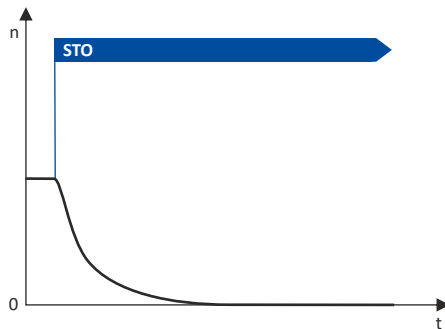

- The transmission of the pulse width modulation is safely switched off by STO. The power drivers do not generate a rotating field anymore.
- The motor is safely switched to torqueless operation.

Activation

STO is activated via the safe input X1 with the channels SIA and SIB:

Safe input X1		Inverter device state
SIA	SIB	
LOW	LOW	STO active
LOW	HIGH	Impermissible state (drive disabled)
HIGH	LOW	
HIGH	HIGH	Drive enabled



If the GS connection is interrupted, or in case of a short circuit/cross-circuit of GS to SIA/SIB, STO is active.

Status messages



The status feedback described below takes place via **non-secure** interfaces. The status feedback must not be used to control other safety functions!

Status feedback via network

The CiA status word (**0x6041**) contains the status of the STO function according to the following truth table. This parameter object can be read via non-secure network interfaces.

Status			Status feedback
Safe input X1		Inverter device state	CiA status word (Object 0x6041)
SIA	SIB		Bit 15
LOW	LOW	STO active	0
LOW	HIGH	Impermissible state (drive disabled)	0
HIGH	LOW		0
HIGH	HIGH	Drive enabled	1

Setting

Functional sequence and error response have no adjustable parameters.

Functional safety

Safety functions
Safe torque off (STO)
Basic Safety - STO



Diagnostics

Diagnostic parameter

Address	Name / setting range / [default setting]	Information
0x6041	CiA status word • Read only	Mappable CiA status word with bit assignment according to device profile CiA 402.
	Bit 0 Ready to switch on	1 = drive ready to start
	Bit 1 Switched on	1 = drive switched-on
	Bit 2 Operation enabled	1 = operation enabled
	Bit 3 Fault	1 = fault or trouble active
	Bit 4 Voltage enabled	1 = DC bus ready for operation
	Bit 5 Quick stop disabled	0 = quick stop active
	Bit 6 Switch on disabled	1 = operation inhibited
	Bit 7 Warning	1 = warning active
	Bit 8 RPDOs disabled	1 = cyclic PDOs have been deactivated
	Bit 9 CiA control enabled	1 = inverter can receive commands via network. • Bit is not set in the operating mode 0x6060 = "MS: Velocity mode [-2]".
	Bit 10 Setpoint reached	1 = the actual speed is in the window.
	Bit 11 Internal limit active	1 = internal limitation of a setpoint active
	Bit 12 Operation mode specific	1 = operation enabled and no test mode activated. (no internal setpoint generation active.)
	Bit 13 Operation mode specific	1 ≙ following error active
Bit 14 Holding brake released	1 = holding brake released	
Bit 15 STO not active	0 = STO is active or impermissible state at the safe inputs SIA and SIB (inverter disabled) 1 = STO is not active (inverter enabled)	



15.5.1.2 Advanced Safety/Extended Safety

Function included in variant:		Advanced Safety	Extended Safety
-------------------------------	--	-----------------	-----------------

Preconditions

- Additional measures are required to prevent movement caused by external forces.
- When assessing risk, also take into account overtravel distances.

Important notes

DANGER!

No "emergency switching off" in terms with EN 60204-1

With the "Safe torque off" (STO) function, no "emergency switching off" in terms with EN 60204-1 can be executed without additional measures. There is no electrical isolation between the motor and inverter and no service switch or maintenance switch!

Possible consequences: Death or severe injuries

- ▶ "Emergency switching off" requires electrical isolation, e. g. by a central mains contactor.

DANGER!

The power supply is not safely disconnected.

Possible consequences: Death or severe injuries due to electrical voltage.

- ▶ Turn off the power supply.

DANGER!

Uncontrolled rotation of the motor possible.

Possible consequences: Death or severe injuries

- ▶ Set the motor to standstill mechanically.

DANGER!

Automatic restart can occur if the request of the safety function is deactivated.

Possible consequences: Death or severe injuries

- ▶ You must provide external measures according to EN ISO 13849-1 which ensure that the drive only restarts after a confirmation.

Functional safety

Safety functions
Safe torque off (STO)
Advanced Safety/Extended Safety



Functional description

STO

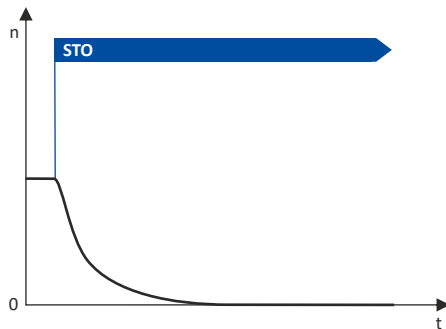

- The transmission of the pulse width modulation is safely switched off by STO. The power drivers do not generate a rotating field anymore.
- The motor is safely switched to torqueless operation.

Activation

Directly:

- Via a safety bus

Automatically by activating the safety functions:

- Safe stop emergency (SSE)

Automatically after the safety functions have expired:

- Safe stop 1 (SS1)

As a result of errors in the stop functions:

- Safe Operating Stop (SOS)

As a result of errors in the safety functions for speed monitoring:

- Safe maximum speed (SMS)
- Safely limited speed (SLS)
- Safe position-dependent speed (PDSS)

As a result of errors in the safety functions for position monitoring:

- Safely limited increment (SLI)
- Safe direction (SDI)
- Safely limited position (SLP)

Restart

- The restart sets the drive in motion after it was previously brought to a standstill via a stop function.
- Whether the restart needs to be acknowledged or if it launches automatically can be parameterized in a manner dependent on the preceding stop function.



Setting

Functional sequence and error response have no adjustable parameters.



Adapt the restart to your application.

Parameter

Address	Name / setting range / [default setting]	Information
0x2891	STO Source S-Bus • Safety parameter (+Safety parameter list+)	Changes only possible in the +Safety parameter list+.
	0 Disabled	
	1 Activated	
0x2892:001	STO: Restart • Safety parameter (+Safety parameter list+)	Changes only possible in the +Safety parameter list+.
	0 Acknowledged restart	
	1 Automatic restart	

Functional safety

Safety functions
Safe stop 1 (SS1)



15.5.2 Safe stop 1 (SS1)

The "Safe Stop 1 (SS1)" safety function monitors whether a deceleration ramp in the application causes the drive to come to a standstill.

SS1 corresponds to a controlled stop according to EN 60204-1, stop category 1.



15.5.2.1 Safe stop 1 time controlled (SS1-t)

Function included in variant:		Advanced Safety	Extended Safety
-------------------------------	--	-----------------	-----------------

SS1-t triggers the normal stop STO after the stop time has elapsed or after reaching standstill.

Preconditions

- A deceleration ramp in the application guides the drive to standstill.
- Additional measures are required to prevent movement caused by external forces.

Important notes

DANGER!

The power supply is not safely disconnected.

Possible consequences: Death or severe injuries due to electrical voltage.

- ▶ Turn off the power supply.

DANGER!

Uncontrolled rotation of the motor possible.

Possible consequences: Death or severe injuries

- ▶ Set the motor to standstill mechanically.

DANGER!

Automatic restart can occur if the request of the safety function is deactivated.

Possible consequences: Death or severe injuries

- ▶ You must provide external measures according to EN ISO 13849-1 which ensure that the drive only restarts after a confirmation.

Functional safety

Safety functions

Safe stop 1 (SS1)

Safe stop 1 time controlled (SS1-t)



Functional description

SS1-t (STO after stop time)

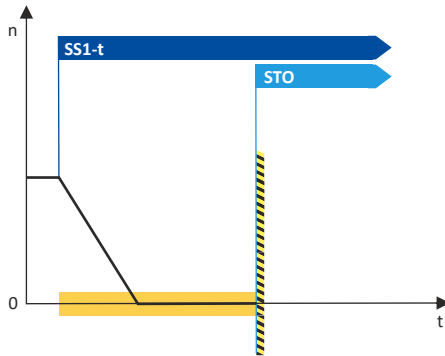

- SS1-t activates the normal stop STO when the parameterized stop time has elapsed.
- If standstill has not yet been reached, the motor coasts down.

SS1-t (STO at standstill)

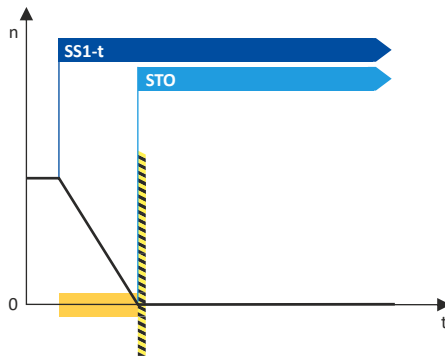

- SS1-t activates the normal stop STO when standstill is detected.
- A waiting time can also be parameterized.
 - The waiting time starts when the standstill is detected.
 - SS1-t activates the normal stop STO when the waiting time has elapsed.
- Detection of standstill:
 - For applications without encoder: $n \leq 5$ rpm
 - For applications with encoder: n is within the parameterized tolerance window

Activation

Directly:

- Via a safety bus

Automatically by activating the safety functions:

- Safe stop emergency (SSE)

As a result of errors in the safety functions for speed monitoring:

- Safe maximum speed (SMS)
- Safely limited speed (SLS)
- Safe position-dependent speed (PDSS)

As a result of errors in the safety functions for position monitoring:

- Safely limited increment (SLI)
- Safe direction (SDI)
- Safely limited position (SLP)



Functional safety

Safety functions
 Safe stop 1 (SS1)
 Safe stop 1 time controlled (SS1-t)

Restart

- The restart sets the drive in motion after it was previously brought to a standstill via a stop function.
- Restarting is only possible after the stop time has elapsed completely.
- Whether the restart needs to be acknowledged or if it launches automatically can be parameterized in a manner dependent on the preceding stop function.

Error behavior

States that trigger an event and an error stop:

- The drive does not stop after the stop time has elapsed.
 - Event: SS1/SS2 - Stop time exceeded (0x2A00FF88)
 - Error stop STO

Setting

Please note when setting the parameters:

- Defining the stop time:
 - Consider the closing time of the brake.
 - For applications without an encoder, the stop time must be 0.5 s longer than the deceleration time parameterized in the inverter.



The mode of action of the parameters can be found in the dialog box for the function in the "+Safety parameter list+" in the engineering tool used.

Parameter

Address	Name / setting range / [default setting]	Information
0x2894:001	SS1, SS2: Stopping time 0 ... [0] ... 30000 ms • Safety parameter (+Safety parameter list+)	Monitored stopping time for SS1 and SS2. Changes only possible in the +Safety parameter list+.
0x2896	SS1 Source S-Bus • Safety parameter (+Safety parameter list+)	Changes only possible in the +Safety parameter list+.
	0 Disabled 1 Activated	
0x2897:001	SS1: Mode • Safety parameter (+Safety parameter list+)	Condition at which STO is triggered. Changes only possible in the +Safety parameter list+.
	0 STO after stopping time 1 STO at n=0	STO is only processed after the parameterized stopping time has elapsed. STO is already triggered after reaching n=0.
0x2897:002	SS1: Delay STO after n=0 0 ... [0] ... 30000 ms • Safety parameter (+Safety parameter list+)	Delay time after detection of n = 0 until triggering of STO Only relevant if "SS1 mode" = "STO with n=0" and operation with encoder system. Changes only possible in the +Safety parameter list+.

Functional safety

Safety functions

Safe stop 1 (SS1)

Safe stop 1 ramp monitored (SS1-r)



15.5.2.2 Safe stop 1 ramp monitored (SS1-r)

Function included in variant:			Extended Safety
-------------------------------	--	--	-----------------

SS1-r triggers the normal stop STO after the stop time has elapsed or after reaching standstill.

SS1-r also monitors the deceleration ramp of the application.

Preconditions

- A deceleration ramp in the application guides the drive to standstill.
- Additional measures are required to prevent movement caused by external forces.
- A safety-rated encoder system records the speed.
- Ramp monitoring is activated.

Important notes

DANGER!

Uncontrolled rotation of the motor possible if no safety-rated encoder system is used.

Possible consequences: Death or severe injuries

- ▶ Use a safety-rated encoder system to use this function.

DANGER!

The power supply is not safely disconnected.

Possible consequences: Death or severe injuries due to electrical voltage.

- ▶ Turn off the power supply.

DANGER!

Uncontrolled rotation of the motor possible.

Possible consequences: Death or severe injuries

- ▶ Set the motor to standstill mechanically.

DANGER!

Automatic restart can occur if the request of the safety function is deactivated.

Possible consequences: Death or severe injuries

- ▶ You must provide external measures according to EN ISO 13849-1 which ensure that the drive only restarts after a confirmation.



Functional description

SS1-r (STO after stop time)

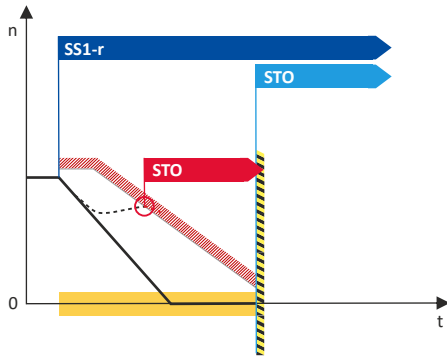

- If the SS1-r stop function is activated, a monitoring ramp is calculated and placed over the deceleration ramp in the application.
- SS1-r activates the normal stop STO when the parameterized stop time has elapsed and the monitoring ramp has not been exceeded.
- If standstill has not yet been reached, the motor coasts down.

SS1-r (STO at standstill)

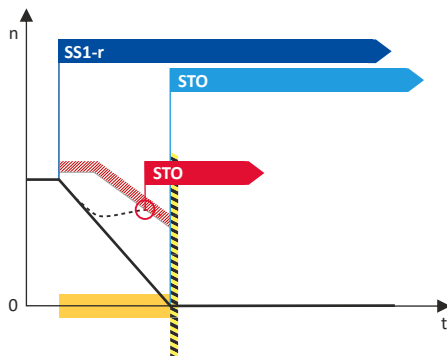

- If the SS1-r stop function is activated, a monitoring ramp is calculated and placed over the deceleration ramp in the application.
- SS1-r activates the normal stop STO when standstill is detected and the monitoring ramp has not been exceeded.
- Detection of standstill:
 - For applications without encoder: $n \leq 5$ rpm
 - For applications with encoder: n is within the parameterized tolerance window

Functional safety

Safety functions
Safe stop 1 (SS1)
Safe stop 1 ramp monitored (SS1-r)



Activation

Directly:

- Via a safety bus

Automatically by activating the safety functions:

- Safe stop emergency (SSE)

As a result of errors in the safety functions for speed monitoring:

- Safe maximum speed (SMS)
- Safely limited speed (SLS)
- Safe position-dependent speed (PDSS)

As a result of errors in the safety functions for position monitoring:

- Safely limited increment (SLI)
- Safe direction (SDI)
- Safely limited position (SLP)

Restart

- The restart sets the drive in motion after it was previously brought to a standstill via a stop function.
- Restarting is only possible after the stop time has elapsed completely.
- Whether the restart needs to be acknowledged or if it launches automatically can be parameterized in a manner dependent on the preceding stop function.

Error behavior

States that trigger an event and an error stop:

- The drive does not stop after the stop time has elapsed.
 - Event: SS1/SS2 - Stop time exceeded (0x2A00FF88)
 - Error stop STO
- The speed of the drive exceeds the monitoring ramp within the stop time.
 - Event: SS1/SS2 - Speed ramp exceeded (0x2A00FF95)
 - Error stop STO

Setting

Please note when setting the parameters:

- Defining the stop time:
 - Consider the closing time of the brake.
- Activate ramp monitoring.
- Define the monitoring ramp:
 - Set the relative or absolute start offset of the ramp.
 - Set the smoothing time of the ramp.

The monitoring ramp is calculated from the start offset, smoothing time and stop time.



The mode of action of the parameters can be found in the dialog box for the function in the "+Safety parameter list+" in the engineering tool used.

Parameter

Address	Name / setting range / [default setting]	Information
0x2894:001	SS1, SS2: Stopping time 0 ... [0] ... 30000 ms • Safety parameter (+Safety parameter list+)	Monitored stopping time for SS1 and SS2. Changes only possible in the +Safety parameter list+.



Functional safety

Safety functions
 Safe stop 1 (SS1)
 Safe stop 1 ramp monitored (SS1-r)

Address	Name / setting range / [default setting]	Information
0x2894:002	SS1, SS2: Ramp monitoring <ul style="list-style-type: none"> Safety parameter (+Safety parameter list+) 	Changes only possible in the +Safety parameter list+.
	0 Disabled	
	1 Activated	
0x2894:003	SS1, SS2: Ramp - Smoothing time 0 ... [0] ... 100 % <ul style="list-style-type: none"> Safety parameter (+Safety parameter list+) 	S-ramp time of the deceleration ramp for SS1 and SS2. 0 % = linear ramp Changes only possible in the +Safety parameter list+.
0x2894:004	SS1, SS2: Ramp - Offset mode <ul style="list-style-type: none"> Safety parameter (+Safety parameter list+) 	Changes only possible in the +Safety parameter list+.
	0 Relativ	
	1 Absolute	
0x2894:005	SS1, SS2: Ramp - Start-offset relative 0 ... [5] ... 100 % <ul style="list-style-type: none"> Safety parameter (+Safety parameter list+) 	Changes only possible in the +Safety parameter list+.
0x2894:006	SS1, SS2: Ramp - Start-offset absolute 0 ... [0] ... 16000 rpm <ul style="list-style-type: none"> Safety parameter (+Safety parameter list+) 	
0x2894:007	SS1, SS2: Ramp - Currently monitored speed <ul style="list-style-type: none"> Read only: x rpm Safety parameter (+Safety parameter list+) 	Currently monitored speed value with active ramp monitoring.
0x2894:008	SS1, SS2: Ramp - Minimum difference <ul style="list-style-type: none"> Read only: x rpm Safety parameter (+Safety parameter list+) 	Minimum difference between actual speed and monitored ramp.
0x2896	SS1 Source S-Bus <ul style="list-style-type: none"> Safety parameter (+Safety parameter list+) 	Changes only possible in the +Safety parameter list+.
	0 Disabled	
	1 Activated	
0x2897:001	SS1: Mode <ul style="list-style-type: none"> Safety parameter (+Safety parameter list+) 	Condition at which STO is triggered. Changes only possible in the +Safety parameter list+.
	0 STO after stopping time	STO is only processed after the parameterized stopping time has elapsed.
	1 STO at n=0	STO is already triggered after reaching n=0.
0x2897:002	SS1: Delay STO after n=0 0 ... [0] ... 30000 ms <ul style="list-style-type: none"> Safety parameter (+Safety parameter list+) 	Delay time after detection of n = 0 until triggering of STO Only relevant if "SS1 mode" = "STO with n=0" and operation with encoder system. Changes only possible in the +Safety parameter list+.

Functional safety

Safety functions
Safe stop emergency (SSE)
Preconditions



15.5.3 Safe stop emergency (SSE)

Function included in variant:			Extended Safety
-------------------------------	--	--	-----------------

The "Safe emergency stop (SSE)" safety function has a higher priority for triggering the "Safe torque off (STO)" or "Safe stop 1 (SS1)" stop functions.

SSE is primarily controlled from all states, operating modes or safety functions.

SSE immediately triggers the assigned stop function.

Preconditions

- The requirements for the triggered stop function must be met.

Important notes



Connect the emergency stop button, which must not be overridden by the safe repair mode (RMS), to the SSE function via the safety controller and the safety bus.

Functional description

SSE (STO)

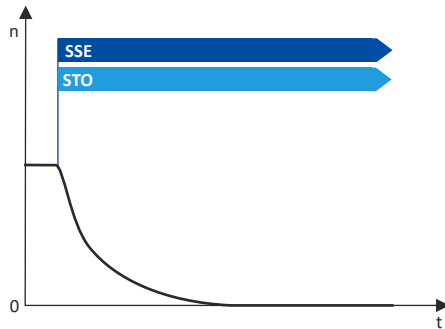

SSE (SS1-t)

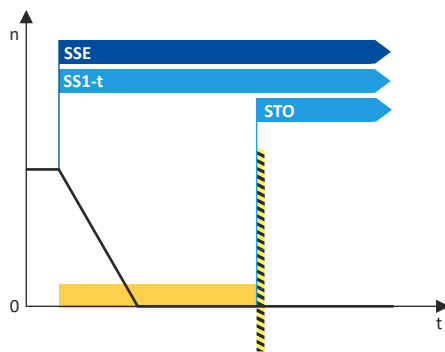

The SSE safety function initiates the parameterized stop function with the highest priority.

Activation

Directly:

- Via a safety bus



Setting



The mode of action of the parameters can be found in the dialog box for the function in the "+Safety parameter list+" in the engineering tool used.

Parameter

Address	Name / setting range / [default setting]	Information
0x28A2	SSE Source S-Bus • Safety parameter (+Safety parameter list+)	Changes only possible in the +Safety parameter list+.
	0 Disabled	
	1 Activated	
0x28A3:001	SSE: Emergency stop function • Safety parameter (+Safety parameter list+)	Changes only possible in the +Safety parameter list+.
	0 STO	
	1 SS1	

Functional safety

Safety functions
Safe stop 2 (SS2)



15.5.4 Safe stop 2 (SS2)

The "Safe Stop 2 (SS2)" safety function monitors whether a deceleration ramp in the application causes the drive to come to a standstill.

SS2 corresponds to a controlled stop according to EN 60204-1, stop category 2.



15.5.4.1 Safe stop 2 time controlled (SS2-t)

Function included in variant:			Extended Safety
-------------------------------	--	--	-----------------

SS2-t triggers the normal stop SOS after the stop time has elapsed or after reaching speed 0. The reached position is actively held and monitored.

Preconditions

- A deceleration ramp in the application guides the drive to standstill.
- A safety-rated encoder system records the speed.

Important notes

DANGER!

Uncontrolled rotation of the motor possible if no safety-rated encoder system is used.

Possible consequences: Death or severe injuries

- ▶ Use a safety-rated encoder system to use this function.

DANGER!

Automatic restart can occur if the request of the safety function is deactivated.

Possible consequences: Death or severe injuries

- ▶ You must provide external measures according to EN ISO 13849-1 which ensure that the drive only restarts after a confirmation.

Functional safety

Safety functions
Safe stop 2 (SS2)
Safe stop 2 time controlled (SS2-t)



Functional description

SS2-t (SOS after stop time)

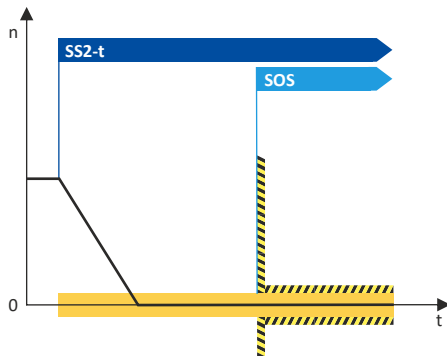

- SS2-t activates the normal stop SOS when the parameterized stop time has elapsed and the speed $n = 0$ has been detected.

SS2-t (SOS at $n = 0$)

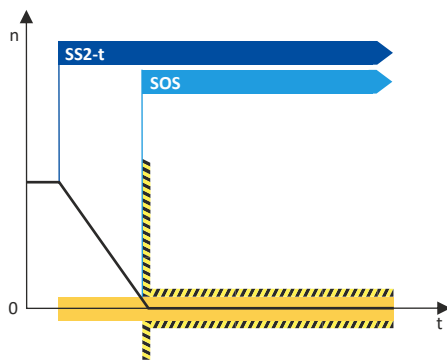

- SS2-t activates the normal stop SOS when the speed $n = 0$ is detected.
- Restarting is only possible after the stop time has elapsed completely.

Activation

As a result of errors in the safety functions for speed monitoring:

- Safe maximum speed (SMS)
- Safely limited speed (SLS)
- Safe position-dependent speed (PDSS)

As a result of errors in the safety functions for position monitoring:

- Safely limited increment (SLI)
- Safe direction (SDI)
- Safely limited position (SLP)

Error behavior

States that trigger an event and an error stop:

- The drive does not stop after the stop time has elapsed.
 - Event: SS1/SS2 - Stop time exceeded (0x2A00FF88)
 - Error stop STO



Setting

Please note when setting the parameters:

- Defining the stop time:
 - Consider the closing time of the brake.



The mode of action of the parameters can be found in the dialog box for the function in the "+Safety parameter list+" in the engineering tool used.

Parameter

Address	Name / setting range / [default setting]	Information
0x2894:001	SS1, SS2: Stopping time 0 ... [0] ... 30000 ms • Safety parameter (+Safety parameter list+)	Monitored stopping time for SS1 and SS2. Changes only possible in the +Safety parameter list+.
0x289A	SS2 Source S-Bus • Safety parameter (+Safety parameter list+)	Changes only possible in the +Safety parameter list+.
	0 Disabled 1 Activated	
0x289B:001	SS2: Mode • Safety parameter (+Safety parameter list+)	Condition at which SOS is triggered. Changes only possible in the +Safety parameter list+.
	0 SOS after stopping time	SOS is only processed after the parameterized stopping time has elapsed.
	1 SOS at n=0	SOS is already triggered after reaching n=0.

Functional safety

Safety functions

Safe stop 2 (SS2)

Safe stop 2 ramp monitored (SS2-r)



15.5.4.2 Safe stop 2 ramp monitored (SS2-r)

Function included in variant:			Extended Safety
-------------------------------	--	--	-----------------

SS2-r triggers the normal stop SOS after the stop time has elapsed or after reaching speed 0. The reached position is actively held and monitored.

SS2-r-r also monitors the deceleration ramp of the application.

Preconditions

- A deceleration ramp in the application guides the drive to standstill.
- A safety-rated encoder system records the speed.
- Ramp monitoring is activated.

Important notes

DANGER!

Uncontrolled rotation of the motor possible if no safety-rated encoder system is used.

Possible consequences: Death or severe injuries

- ▶ Use a safety-rated encoder system to use this function.

DANGER!

Automatic restart can occur if the request of the safety function is deactivated.

Possible consequences: Death or severe injuries

- ▶ You must provide external measures according to EN ISO 13849-1 which ensure that the drive only restarts after a confirmation.



Functional description

SS2-r (SOS after stop time)

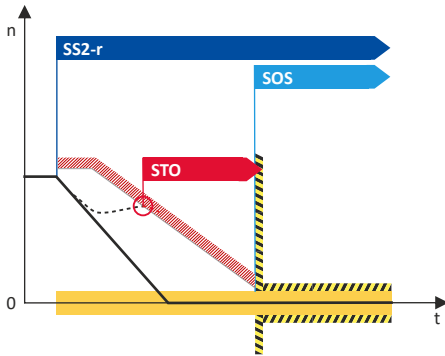

- If the SS2-r-r stop function is activated, a monitoring ramp is calculated and placed over the deceleration ramp in the application.
- SS2-r activates the normal stop SOS when the parameterized stop time has elapsed and the monitoring ramp has not been exceeded.

SS2-r (SOS at $n = 0$)

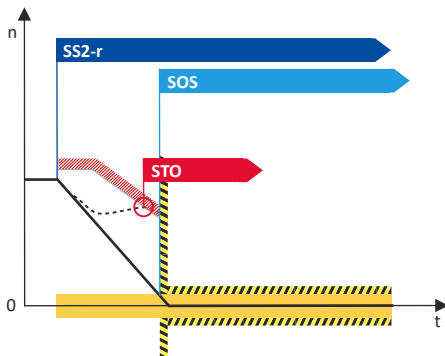

- If the SS2-r-r stop function is activated, a monitoring ramp is calculated and placed over the deceleration ramp in the application.
- SS2-r activates the normal stop SOS if the speed $n = 0$ is detected and the monitoring ramp has not been exceeded.

Activation

As a result of errors in the safety functions for speed monitoring:

- Safe maximum speed (SMS)
- Safely limited speed (SLS)
- Safe position-dependent speed (PDSS)

As a result of errors in the safety functions for position monitoring:

- Safely limited increment (SLI)
- Safe direction (SDI)
- Safely limited position (SLP)

Functional safety

Safety functions
 Safe stop 2 (SS2)
 Safe stop 2 ramp monitored (SS2-r)



Error behavior

States that trigger an event and an error stop:

- The drive does not stop after the stop time has elapsed.
 - Event: SS1/SS2 - Stop time exceeded (0x2A00FF88)
 - Error stop STO
- The speed of the drive exceeds the monitoring ramp within the stop time.
 - Event: SS1/SS2 - Speed ramp exceeded (0x2A00FF95)
 - Error stop STO

Setting

Please note when setting the parameters:

- Activate ramp monitoring.
- Define the monitoring ramp:
 - Set the relative or absolute start offset of the ramp.
 - Set the smoothing time of the ramp.

The monitoring ramp is calculated from the start offset, smoothing time and stop time.



The mode of action of the parameters can be found in the dialog box for the function in the "+Safety parameter list+" in the engineering tool used.

Parameter

Address	Name / setting range / [default setting]	Information
0x2894:001	SS1, SS2: Stopping time 0 ... [0] ... 30000 ms • Safety parameter (+Safety parameter list+)	Monitored stopping time for SS1 and SS2. Changes only possible in the +Safety parameter list+.
0x2894:002	SS1, SS2: Ramp monitoring • Safety parameter (+Safety parameter list+)	Changes only possible in the +Safety parameter list+.
	0 Disabled	
	1 Activated	
0x2894:003	SS1, SS2: Ramp - Smoothing time 0 ... [0] ... 100 % • Safety parameter (+Safety parameter list+)	S-ramp time of the deceleration ramp for SS1 and SS2. 0 % = linear ramp Changes only possible in the +Safety parameter list+.
0x2894:004	SS1, SS2: Ramp - Offset mode • Safety parameter (+Safety parameter list+)	Changes only possible in the +Safety parameter list+.
	0 Relativ	
	1 Absolute	
0x2894:005	SS1, SS2: Ramp - Start-offset relative 0 ... [5] ... 100 % • Safety parameter (+Safety parameter list+)	Changes only possible in the +Safety parameter list+.
0x2894:006	SS1, SS2: Ramp - Start-offset absolute 0 ... [0] ... 16000 rpm • Safety parameter (+Safety parameter list+)	
0x2894:007	SS1, SS2: Ramp - Currently monitored speed • Read only: x rpm • Safety parameter (+Safety parameter list+)	Currently monitored speed value with active ramp monitoring.
0x2894:008	SS1, SS2: Ramp - Minimum difference • Read only: x rpm • Safety parameter (+Safety parameter list+)	Minimum difference between actual speed and monitored ramp.
0x289A	SS2 Source S-Bus • Safety parameter (+Safety parameter list+)	Changes only possible in the +Safety parameter list+.
	0 Disabled	
	1 Activated	



Functional safety

Safety functions

Safe stop 2 (SS2)

Safe stop 2 ramp monitored (SS2-r)

Address	Name / setting range / [default setting]	Information
0x289B:001	SS2: Mode	Condition at which SOS is triggered.
	<ul style="list-style-type: none">Safety parameter (+Safety parameter list+)	Changes only possible in the +Safety parameter list+.
	0 SOS after stopping time	SOS is only processed after the parameterized stopping time has elapsed.
	1 SOS at n=0	SOS is already triggered after reaching n=0.

Functional safety

Safety functions
Safe operating stop (SOS)
Preconditions



15.5.5 Safe operating stop (SOS)

Function included in variant:			Extended Safety
-------------------------------	--	--	-----------------

The "Safe Operating Stop (SOS)" safety function monitors the standstill of the drive. The reached position is actively held and monitored.

Preconditions

- A deceleration ramp in the application guides the drive to standstill.
- A safety-rated encoder system records speed and position.

Important notes

⚠ DANGER!

Uncontrolled rotation of the motor possible if no safety-rated encoder system is used.

Possible consequences: Death or severe injuries

- ▶ Use a safety-rated encoder system to use this function.

⚠ DANGER!

Automatic restart can occur if the request of the safety function is deactivated.

Possible consequences: Death or severe injuries

- ▶ Parameterize the acknowledged restart.
- ▶ Take external measures according to EN ISO 13849-1 to ensure that the drive only restarts after confirmation.

Functional description

SOS

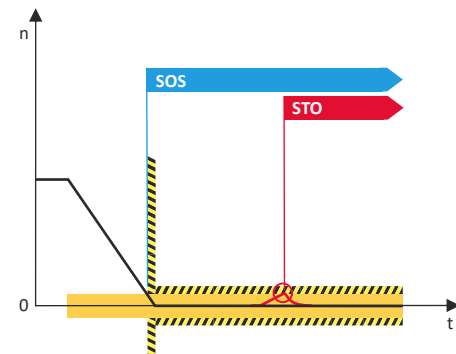

- SOS is activated when the speed $n = 0$ is detected. The reached position is actively held and monitored.
- Relative position changes are added and saved. The value is continuously compared with the tolerance window for the position deviation.
- When the SOS state is requested again, the sum of the last position changes is reset.

Activation

Directly:

- Via a safety bus

Automatically after the safety functions have expired:

- Safe stop 2 (SS2)



Error behavior

States that trigger an event and an error stop:

- The position change has exceeded the tolerance window $p = 0$.
 - Event: SOS - Tolerance limit exceeded (0x2A00FF91)
 - Error stop STO

Setting



The mode of action of the parameters can be found in the dialog box for the function in the "+Safety parameter list+" in the engineering tool used.

Parameter

Address	Name / setting range / [default setting]	Information		
0x289E	SOS Source S-Bus • Safety parameter (+Safety parameter list+)	Changes only possible in the +Safety parameter list+.		
	<table border="1"> <tr> <td>0</td> <td>Disabled</td> </tr> <tr> <td>1</td> <td>Activated</td> </tr> </table>		0	Disabled
0	Disabled			
1	Activated			
0x289F:001	SOS: Tolerance window (Delta p=0) 0 ... [8192] ... 327680 incr. • Safety parameter (+Safety parameter list+)	If the position change is within the tolerance window, the status " $\Delta p = 0$ " is valid. Changes only possible in the +Safety parameter list+.		
0x289F:002	SOS: Restart • Safety parameter (+Safety parameter list+)	Changes only possible in the +Safety parameter list+.		
	<table border="1"> <tr> <td>0</td> <td>Acknowledged restart</td> </tr> <tr> <td>1</td> <td>Automatic restart</td> </tr> </table>		0	Acknowledged restart
0	Acknowledged restart			
1	Automatic restart			
0x289F:003	SOS: Maximum change of position • Read only: x incr. • Safety parameter (+Safety parameter list+)	Value of the maximum position change while SOS has been active. The incremental position value is related to the motor encoder.		

Functional safety

Safety functions
Safe brake control (SBC)
Preconditions



15.5.6 Safe brake control (SBC)

Function included in variant:		Advanced Safety	Extended Safety
-------------------------------	--	-----------------	-----------------

The "Safe Brake Control (SBC)" safety function enables the safe control of a brake of the drive that is active at standstill, i.e. the brake closes when the brake voltage is switched off. To prevent the motor from working against the closed brake, STO can be activated simultaneously or with a time delay.

Preconditions

- SBC can only control spring-applied brakes.
- Only use safety-rated brakes.
- The brake is connected to X106.
- Brake function and brake control monitoring are controlled via X106.

Important notes



Use of non-safety-rated brakes

Possible consequences: Death or severe injuries

- Only use safety-rated brakes with suitable safety-related parameters according to EN ISO 13849-1 and/or EN 62061 or EN IEC 61508.



The internal test rate of the brake output (X106) restricts the request rate to max. 1 brake request/10 seconds.

Depending on the application test rate of the connected brake to be released you must reduce the request rate accordingly.

Functional description

SBC

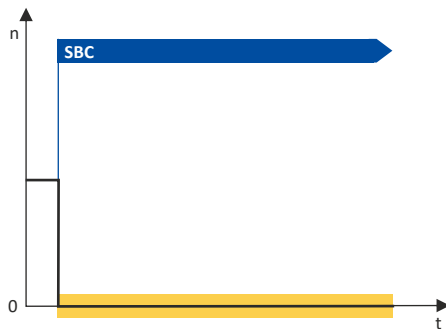

SBC (STO)

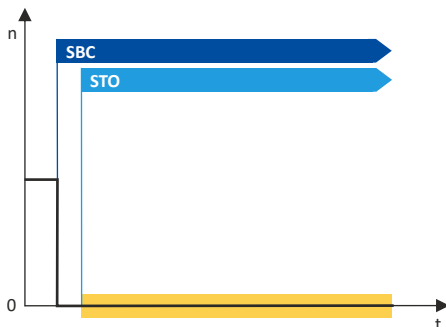



Activation

Directly:

- Via a safety bus

Error behavior

The brake is applied when any error is detected.

States that trigger an event and an error stop:

- Incompatible configuration of the brake control
 - Event: SBC - Device configuration incompatible (0x2A006187)
 - Error stop STO
- Faulty test of the brake control
 - Event: SBC - Test pulse error (0x2A00508E)
 - Error stop STO
- The brake control supply is switched off.
 - Event: SBC - Remains stuck at LOW (0x2A00508F)
 - Error stop STO

Setting

Please note when setting the parameters:

- The internal brake module must control the holding brake.
- "Normal" must be parameterized for the brake polarity.
- Other settings are not compatible with the SBC function.



The mode of action of the parameters can be found in the dialog box for the function in the "+Safety parameter list+" in the engineering tool used.

Parameter

Address	Name / setting range / [default setting]	Information
0x28E5	SBC Source S-Bus • Safety parameter (+Safety parameter list+)	Changes only possible in the +Safety parameter list+.
	0 Disabled	
	1 Activated	
0x28E6:001	SBC: Brake mode • Safety parameter (+Safety parameter list+)	Changes only possible in the +Safety parameter list+.
	1 SBC without STO	
	2 Automatic with STO	
0x28E6:002	SBC: Delay SBC 0 ... [0] ... 30000 ms • Safety parameter (+Safety parameter list+)	Time between SBC request and activation of the brake output. Changes only possible in the +Safety parameter list+.
0x28E6:003	SBC: Delay STO 0 ... [0] ... 30000 ms • Safety parameter (+Safety parameter list+)	Time between SBC request and activation of STO in automatic mode. Changes only possible in the +Safety parameter list+.
0x28E6:004	SBC: Brake open delay 0 ... [0] ... 30000 ms • Safety parameter (+Safety parameter list+)	Time between SBC deactivation and brake opening. Changes only possible in the +Safety parameter list+.

Functional safety

Safety functions
Safe maximum speed (SMS)
Preconditions



15.5.7 Safe maximum speed (SMS)

Function included in variant:			Extended Safety
-------------------------------	--	--	-----------------

The "Safe maximum speed (SMS)" safety function monitors the maximum speed of the drive.

Preconditions

- A safety-rated encoder system records speed and position.

Important notes



Uncontrolled rotation of the motor possible if no safety-rated encoder system is used.

Possible consequences: Death or severe injuries

- Use a safety-rated encoder system to use this function.

Functional description

SMS

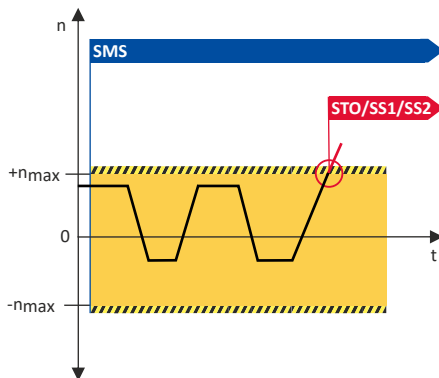

This function monitors the amount of the set maximum speed of the drive.

Activation

Via parameterization:

- Maximum speed > 0 activates the function.

Status messages

If the actual speed of the drive is within the monitoring limits:

- Output of the status message: SMS observed
 - In status word bit 4

Error behavior

States that trigger an event and an error stop:

- The actual speed has exceeded the maximum speed.
 - Event: SMS - Nmax exceeded (0x2A00FF90)
 - Error stop Parameterizable



Setting



The mode of action of the parameters can be found in the dialog box for the function in the "+Safety parameter list+" in the engineering tool used.

Parameter

Address	Name / setting range / [default setting]	Information
0x28B0:001	SMS: Maximum speed Nmax 0 ... [0] ... 16000 rpm • Safety parameter (+Safety parameter list+)	Activation of the SMS function and selection of the maximum speed. Nmax = 0 rpm deactivates the function. Changes only possible in the +Safety parameter list+.
0x28B0:002	SMS: Response (n>Nmax) • Safety parameter (+Safety parameter list+)	Changes only possible in the +Safety parameter list+.
	0 STO	
	1 SS1	
	2 SS2	

Functional safety

Safety functions
Safely-limited speed (SLS)
Preconditions



15.5.8 Safely-limited speed (SLS)

Function included in variant:			Extended Safety
-------------------------------	--	--	-----------------

The "Safely limited speed (SLS)" safety function monitors up to 4 arbitrary operating speeds of the drive.

Preconditions

- A deceleration ramp in the application decelerates the drive.
- A safety-rated encoder system records speed and position.

Important notes



Uncontrolled rotation of the motor possible if no safety-rated encoder system is used.

Possible consequences: Death or severe injuries

► Use a safety-rated encoder system to use this function.

Functional description

SLS

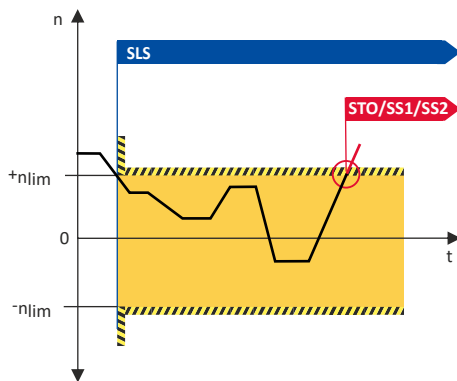

The function monitors up to 4 speed limits of the drive.

- Monitoring is activated when the set start delay has elapsed or the actual speed is within the set monitoring limits.
- In addition, the permissible direction of movement can be monitored within the monitoring limits.

Activation

Directly:

- Via a safety bus
- Via an internal status signal

Status messages

If the actual speed of the drive is within the monitoring limits:

- Output of the status message: SLS1 observed ... SLS4 observed
 - In status word bit 0 ... Bit 3



Error behavior

States that trigger an event and an error stop:

- The actual speed has exceeded a speed limit.
 - Event: SLS1 - Nlim1 exceeded (0x2A00FF89)
 - Event: SLS2 - Nlim2 exceeded (0x2A00FF8A)
 - Event: SLS3 - Nlim3 exceeded (0x2A00FF8B)
 - Event: SLS4 - Nlim4 exceeded (0x2A00FF8C)
 - Error stop Parameterizable
- The drive is moving in the wrong direction.
 - Event: SDIpos - Wrong direction (0x2A00FF8E)
 - Event: SDIneg - Wrong direction (0x2A00FF8F)
 - Error stop Parameterizable

Setting

Please note when combining the [Safely-limited speed \(SLS\)](#) and [Safe direction \(SDI\)](#) functions:

- The parameterized directions of movement must be coordinated.
- The start delays for SLS and SDI must be coordinated:
- SLS and SDI are requested at the same time.



The mode of action of the parameters can be found in the dialog box for the function in the "+Safety parameter list+" in the engineering tool used.

Parameter

Address	Name / setting range / [default setting]	Information
0x28BF:001	SLS: SLS1 - Internal source	Selection of an internal status bit as trigger source for the function. Changes only possible in the +Safety parameter list+.
	• Safety parameter (+Safety parameter list+)	
	0 Disabled	
	678496513 SDIpos active	
	678496769 SDIneg active	
	678497025 SLP active	
	678503937 SSM within limits	
	678504193 SDIpos observed	
	678504449 SDIneg observed	
	678504705 SLP1 observed	
	678504961 SLP2 observed	
	678505217 SLP3 observed	
	678505473 SLP4 observed	
	678505729 SCA1 within limits	
	678505985 SCA2 within limits	
	678506241 SCA3 within limits	
	678506497 SCA4 within limits	
678506753 PDSSpos observed		
678507009 PDSSneg observed		
678508801 Positive direction of movement		
0x28BF:002	SLS: SLS1 - Internal source inversion	Inverted evaluation of the selected internal status bit. Changes only possible in the +Safety parameter list+.
	• Safety parameter (+Safety parameter list+)	
	0 Not inverted	
	1 Invert	

Functional safety

Safety functions
Safely-limited speed (SLS)
Setting



Address	Name / setting range / [default setting]	Information
0x28BF:003	SLS: SLS2 - Internal source • Safety parameter (+Safety parameter list+)	Selection of an internal status bit as trigger source for the function. Changes only possible in the +Safety parameter list+.
	0 Disabled	
	678496513 SDIpos active	
	678496769 SDIneg active	
	678497025 SLI active	
	678503937 SSM within limits	
	678504193 SDIpos observed	
	678504449 SDIneg observed	
	678504705 SLP1 observed	
	678504961 SLP2 observed	
	678505217 SLP3 observed	
	678505473 SLP4 observed	
	678505729 SCA1 within limits	
	678505985 SCA2 within limits	
	678506241 SCA3 within limits	
	678506497 SCA4 within limits	
	678506753 PDSSpos observed	
678507009 PDSSneg observed		
678508801 Positive direction of movement		
0x28BF:004	SLS: SLS2 - Internal source inversion • Safety parameter (+Safety parameter list+)	Inverted evaluation of the selected internal status bit. Changes only possible in the +Safety parameter list+.
	0 Not inverted	
	1 Invert	
0x28BF:005	SLS: SLS3 - Internal source • Safety parameter (+Safety parameter list+)	Selection of an internal status bit as trigger source for the function. Changes only possible in the +Safety parameter list+.
	0 Disabled	
	678496513 SDIpos active	
	678496769 SDIneg active	
	678497025 SLI active	
	678503937 SSM within limits	
	678504193 SDIpos observed	
	678504449 SDIneg observed	
	678504705 SLP1 observed	
	678504961 SLP2 observed	
	678505217 SLP3 observed	
	678505473 SLP4 observed	
	678505729 SCA1 within limits	
	678505985 SCA2 within limits	
	678506241 SCA3 within limits	
	678506497 SCA4 within limits	
	678506753 PDSSpos observed	
678507009 PDSSneg observed		
678508801 Positive direction of movement		
0x28BF:006	SLS: SLS3 - Internal source inversion • Safety parameter (+Safety parameter list+)	Inverted evaluation of the selected internal status bit. Changes only possible in the +Safety parameter list+.
	0 Not inverted	
	1 Invert	



Functional safety

Safety functions
Safely-limited speed (SLS)
Setting

Address	Name / setting range / [default setting]	Information
0x28BF:007	SLS: SLS4 - Internal source • Safety parameter (+Safety parameter list+)	Selection of an internal status bit as trigger source for the function. Changes only possible in the +Safety parameter list+.
	0 Disabled	
	678496513 SDIpos active	
	678496769 SDIneg active	
	678497025 SLI active	
	678503937 SSM within limits	
	678504193 SDIpos observed	
	678504449 SDIneg observed	
	678504705 SLP1 observed	
	678504961 SLP2 observed	
	678505217 SLP3 observed	
	678505473 SLP4 observed	
	678505729 SCA1 within limits	
	678505985 SCA2 within limits	
	678506241 SCA3 within limits	
	678506497 SCA4 within limits	
	678506753 PDSSpos observed	
678507009 PDSSneg observed		
678508801 Positive direction of movement		
0x28BF:008	SLS: SLS4 - Internal source inversion • Safety parameter (+Safety parameter list+)	Inverted evaluation of the selected internal status bit. Changes only possible in the +Safety parameter list+.
	0 Not inverted	
	1 Invert	
0x28C1:001	SLS: SLS1 - Source S-Bus • Safety parameter (+Safety parameter list+)	Changes only possible in the +Safety parameter list+.
	0 Disabled	
	1 Activated	
0x28C1:002	SLS: SLS2 - Source S-Bus • Safety parameter (+Safety parameter list+)	Changes only possible in the +Safety parameter list+.
	0 Disabled	
	1 Activated	
0x28C1:003	SLS: SLS3 - Source S-Bus • Safety parameter (+Safety parameter list+)	Changes only possible in the +Safety parameter list+.
	0 Disabled	
	1 Activated	
0x28C1:004	SLS: SLS4 - Source S-Bus • Safety parameter (+Safety parameter list+)	Changes only possible in the +Safety parameter list+.
	0 Disabled	
	1 Activated	
0x28C2:001	SLS: SLS1 - Limited speed Nlim1 0 ... [0] ... 16000 rpm • Safety parameter (+Safety parameter list+)	Setting of the safely limited speed. Changes only possible in the +Safety parameter list+.
0x28C2:002	SLS: SLS2 - Limited speed Nlim2 0 ... [0] ... 16000 rpm • Safety parameter (+Safety parameter list+)	
0x28C2:003	SLS: SLS3 - Limited speed Nlim3 0 ... [0] ... 16000 rpm • Safety parameter (+Safety parameter list+)	
0x28C2:004	SLS: SLS4 - Limited speed Nlim4 0 ... [0] ... 16000 rpm • Safety parameter (+Safety parameter list+)	

Functional safety

Safety functions
Safely-limited speed (SLS)
Setting



Address	Name / setting range / [default setting]	Information
0x28C3:001	SLS: SLS1 - Braking time Nlim1 0 ... [0] ... 30000 ms • Safety parameter (+Safety parameter list+)	Safely monitored time to decelerate the drive below the set limited speed. Changes only possible in the +Safety parameter list+.
0x28C3:002	SLS: SLS2 - Braking time Nlim2 0 ... [0] ... 30000 ms • Safety parameter (+Safety parameter list+)	
0x28C3:003	SLS: SLS3 - Braking time Nlim3 0 ... [0] ... 30000 ms • Safety parameter (+Safety parameter list+)	
0x28C3:004	SLS: SLS4 - Braking time Nlim4 0 ... [0] ... 30000 ms • Safety parameter (+Safety parameter list+)	
0x28C4:001	SLS: SLS1 - Permitted direction • Safety parameter (+Safety parameter list+)	Changes only possible in the +Safety parameter list+.
	0 Both directions enabled	
	1 Positive direction enabled 2 Negative direction enabled	
0x28C4:002	SLS: SLS2 - Permitted direction • Safety parameter (+Safety parameter list+)	Changes only possible in the +Safety parameter list+.
	0 Enable both directions	
	1 Positive direction enabled 2 Negative direction enabled	
0x28C4:003	SLS: SLS3 - Permitted direction • Safety parameter (+Safety parameter list+)	Changes only possible in the +Safety parameter list+.
	0 Enable both directions	
	1 Positive direction enabled 2 Negative direction enabled	
0x28C4:004	SLS: SLS4 - Permitted direction • Safety parameter (+Safety parameter list+)	Changes only possible in the +Safety parameter list+.
	0 Enable both directions	
	1 Positive direction enabled 2 Negative direction enabled	
0x28C5:001	SLS: SLS1 - Response (n>Nlim1) • Safety parameter (+Safety parameter list+)	Changes only possible in the +Safety parameter list+.
	0 STO	
	1 SS1 2 SS2	
0x28C5:002	SLS: SLS2 - Response (n>Nlim2) • Safety parameter (+Safety parameter list+)	Changes only possible in the +Safety parameter list+.
	0 STO	
	1 SS1 2 SS2	
0x28C5:003	SLS: SLS3 - Response (n>Nlim3) • Safety parameter (+Safety parameter list+)	Changes only possible in the +Safety parameter list+.
	0 STO	
	1 SS1 2 SS2	
0x28C5:004	SLS: SLS4 - Response (n>Nlim4) • Safety parameter (+Safety parameter list+)	Changes only possible in the +Safety parameter list+.
	0 STO	
	1 SS1 2 SS2	
0x2907:001	Additional speed limitation 0 ... [0] ... 480000 rpm	



15.5.9 Position-dependent safe speed (PDSS)

Function included in variant:			Extended Safety
-------------------------------	--	--	-----------------

The safety function "Safe position-dependent speed (PDSS) monitors the speed of a drive depending on the absolute position along a limited movement range in order to ensure timely standstill at the position limits.

As a result, mechanical buffers can be dimensioned smaller or mechanical buffers and limit switches can be dispensed with altogether. A suitable safety-rated mechanical braking system may be required.

Application examples:

- Monitoring a storage and retrieval unit between the end positions

Preconditions

- The reference run must be executed.
- A safety-rated encoder system records speed and position.

Important notes



Uncontrolled rotation of the motor possible if no safety-rated encoder system is used.

Possible consequences: Death or severe injuries

- ▶ Use a safety-rated encoder system to use this function.

Functional description

PDSS

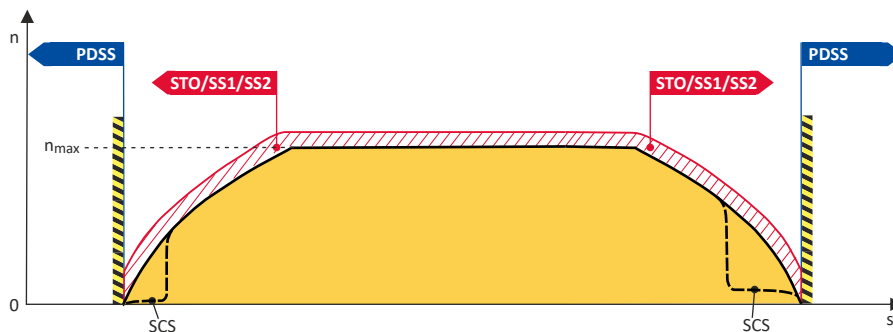

- PDSS uses the parameterized values for the maximum speed, for the decelerations and for the absolute end positions to calculate the maximum speed at each position in order to ensure timely standstill at the position limits.
- In addition, two creep speeds (SCS) can be parameterized to approach the position limits more slowly.
- From the end positions, the drive can travel with maximum acceleration.

Activation

Directly:

- Via a safety bus

Via parameterization:

- Function permanently active

Functional safety

Safety functions
Position-dependent safe speed (PDSS)
Status messages



Status messages

If the actual speed of the drive is within the monitoring limits:

- Output of the status message: PDSS positive observed
 - In status word bit 16
- Output of the status message: PDSS negative observed
 - In status word bit 17

Error behavior

States that trigger an event and an error stop:

- The actual speed has exceeded the speed limit.
 - Event: PDSS - Velocity exceeded (0x2A00FF9D)
 - Error stop Parameterizable
- The actual creep speed has exceeded the speed limit.
 - Event: PDSS - Creep velocity SCS exceeded (0x2A00FF9E)
 - Error stop Parameterizable

Setting

Please note when setting the upper and lower position limits:

- The distance between the position limits and the prohibited zones must be set so large, taking into account all parameterized tolerances, that the drive cannot collide with the prohibited zones under any circumstances.



The mode of action of the parameters can be found in the dialog box for the function in the "+Safety parameter list+" in the engineering tool used.

Parameter

Address	Name / setting range / [default setting]	Information
0x28DD	PDSS Source S-Bus • Safety parameter (+Safety parameter list+)	Changes only possible in the +Safety parameter list+.
	0 Disabled 1 Activated	
0x28DE:001	PDSS: Permanent activation • Safety parameter (+Safety parameter list+)	Selection of how the function is activated. Changes only possible in the +Safety parameter list+.
	0 On demand 1 Activated	On request via defined source. Permanent activation
0x28DE:002	PDSS: Lower position limit -2147483648 ... [0] ... 2147483647 incr. • Safety parameter (+Safety parameter list+)	Definition of the lower position limit for the function. 1-encoder system The incremental position value is related to the motor encoder. 2-encoder system The incremental position value is related to the load encoder. Changes only possible in the +Safety parameter list+.
0x28DE:003	PDSS: Upper position limit -2147483648 ... [0] ... 2147483647 incr. • Safety parameter (+Safety parameter list+)	Definition of the upper position limit for the function. 1-encoder system The incremental position value is related to the motor encoder. 2-encoder system The incremental position value is related to the load encoder. Changes only possible in the +Safety parameter list+.
0x28DE:004	PDSS: Lower SCS limit -2147483648 ... [0] ... 2147483647 incr. • Safety parameter (+Safety parameter list+)	Lower SCS limit for PDSS. Value less than or equal to the lower position limit deactivates the function. 1-encoder system The incremental position value is related to the motor encoder. 2-encoder system The incremental position value is related to the load encoder. Changes only possible in the +Safety parameter list+.



Functional safety

Safety functions
Position-dependent safe speed (PDSS)
Setting

Address	Name / setting range / [default setting]	Information
0x28DE:005	PDSS: Upper SCS limit -2147483648 ... [0] ... 2147483647 incr. • Safety parameter (+Safety parameter list+)	Upper SCS limit for PDSS. Value less than or equal to the upper position limit deactivates the function. 1-encoder system The incremental position value is related to the motor encoder. 2-encoder system The incremental position value is related to the load encoder. Changes only possible in the +Safety parameter list+.
0x28DE:006	PDSS: SCS from lower limit 0 ... [0] ... 16000 rpm • Safety parameter (+Safety parameter list+)	Safe creeping speed from the lower SCS limit onwards in the direction of the lower position limit. Changes only possible in the +Safety parameter list+.
0x28DE:007	PDSS: SCS from upper limit 0 ... [0] ... 16000 rpm • Safety parameter (+Safety parameter list+)	Safe creeping speed from the upper SCS limit onwards in the direction of the upper position limit. Changes only possible in the +Safety parameter list+.
0x28DE:008	PDSS: Maximum speed 0 ... [0] ... 16000 rpm • Safety parameter (+Safety parameter list+)	Value of the maximum permissible speed for the function. Changes only possible in the +Safety parameter list+.
0x28DE:009	PDSS: Maximum deceleration lower limit 0 ... [0] ... 32000 • Safety parameter (+Safety parameter list+)	Amount of the maximum deceleration in the direction of the lower position limit. Changes only possible in the +Safety parameter list+.
0x28DE:010	PDSS: Maximum deceleration upper limit 0 ... [0] ... 32000 • Safety parameter (+Safety parameter list+)	Amount of the maximum deceleration in the direction of the upper position limit. Changes only possible in the +Safety parameter list+.
0x28DE:011	PDSS: Error response • Safety parameter (+Safety parameter list+)	Changes only possible in the +Safety parameter list+.
	0 STO	
	1 SS1	
	2 SS2	
0x28DE:012	PDSS: Currently monitored speed • Read only: x rpm • Safety parameter (+Safety parameter list+)	Display of the currently monitored speed.
0x28DE:013	PDSS: Minimum difference monitored speed • Read only: x rpm • Safety parameter (+Safety parameter list+)	Minimum difference between actual speed and monitored envelope curve.

Functional safety

Safety functions
Safe speed monitor (SSM)
Preconditions



15.5.10 Safe speed monitor (SSM)

Function included in variant:			Extended Safety
-------------------------------	--	--	-----------------

The "Safe speed monitoring (SSM)" safety function monitors the amount of any operating speed of the drive.

A status message indicates compliance with the monitoring limits.

Application examples:

- Safe standstill monitoring
- Despite excessive speed, no immediate machine standstill may occur. The operating personnel is only informed safely.

Preconditions

- A safety-rated encoder system records speed and position.

Important notes



Uncontrolled rotation of the motor possible if no safety-rated encoder system is used.

Possible consequences: Death or severe injuries

► Use a safety-rated encoder system to use this function.

Functional description

SSM

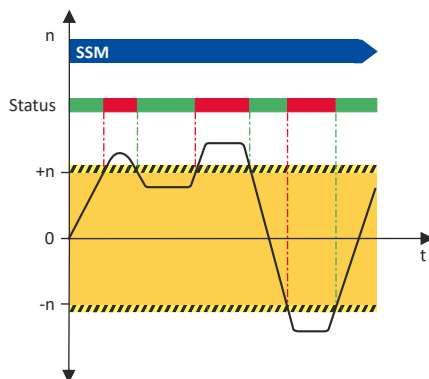

The function compares the actual speed with the parameterized speed limits.

Activation

Via parameterization:

- Monitored speed > 0 activates the function.

Status messages

If the actual speed of the drive is within the monitoring limits:

- Output of the status message: SSM within limits
 - In status word bit 5

Error behavior

If the monitoring limits are exceeded, no error message is output and no error stop is triggered.

Only the "SSM within limits" status is reset.



Functional safety

Safety functions
Safe speed monitor (SSM)
Setting

Setting



The mode of action of the parameters can be found in the dialog box for the function in the "+Safety parameter list+" in the engineering tool used.

Parameter

Address	Name / setting range / [default setting]	Information
0x28B2:001	SSM: Monitored speed 0 ... [0] ... 16000 rpm • Safety parameter (+Safety parameter list+)	Amount of the monitored speed. Value = 0 rpm deactivates the function. Changes only possible in the +Safety parameter list+.

Functional safety

Safety functions
Safely-limited position (SLP)
Preconditions



15.5.11 Safely-limited position (SLP)

Function included in variant:			Extended Safety
-------------------------------	--	--	-----------------

The "Safely limited position (SLP)" safety function monitors up to 4 absolute position limits of a permissible movement range.

Preconditions

- The reference run must be executed.
- A safety-rated encoder system records speed and position.

Important notes



Uncontrolled rotation of the motor possible if no safety-rated encoder system is used.

Possible consequences: Death or severe injuries

► Use a safety-rated encoder system to use this function.

Functional description

SLP

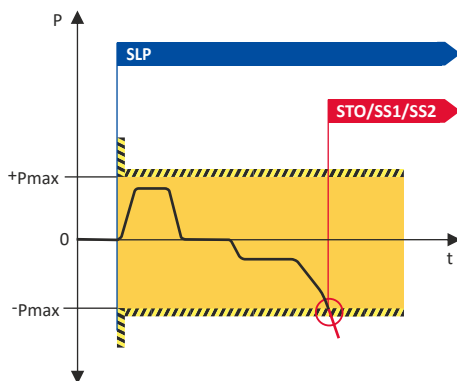

The function monitors up to 4 upper and lower position limits of the drive.

- After requesting the function, the monitoring is active immediately.

Activation

Directly:

- Via a safety bus

Status messages

If the actual position of the drive is within the monitoring limits:

- Output of the status message: SLP1 observed ... SLP4 observed
 - In status word Bit 8 ... Bit 11

Error behavior

States that trigger an event and an error stop:

- The actual position has exceeded a position limit.
 - Event: SLP1 - Position limits exceeded (0x2A00FF97)
 - Event: SLP2 - Position limits exceeded (0x2A00FF98)
 - Event: SLP3 - Position limits exceeded (0x2A00FF99)
 - Event: SLP4 - Position limits exceeded (0x2A00FF9A)
 - Error stop Parameterizable



Setting



The mode of action of the parameters can be found in the dialog box for the function in the "+Safety parameter list+" in the engineering tool used.

Parameter

Address	Name / setting range / [default setting]	Information
0x28D1:001	SLP: SLP1 - Source S-Bus • Safety parameter (+Safety parameter list+)	Changes only possible in the +Safety parameter list+.
	0 Disabled	
	1 Activated	
0x28D1:002	SLP: SLP2 - Source S-Bus • Safety parameter (+Safety parameter list+)	Changes only possible in the +Safety parameter list+.
	0 Disabled	
	1 Activated	
0x28D1:003	SLP: SLP3 - Source S-Bus • Safety parameter (+Safety parameter list+)	Changes only possible in the +Safety parameter list+.
	0 Disabled	
	1 Activated	
0x28D1:004	SLP: SLP4 - Source S-Bus • Safety parameter (+Safety parameter list+)	Changes only possible in the +Safety parameter list+.
	0 Disabled	
	1 Activated	
0x28D2:001	SLP: SLP1 - Lower position limit -2147483648 ... [0] ... 2147483647 incr. • Safety parameter (+Safety parameter list+)	Definition of the lower position limit for monitoring. 1-encoder system The incremental position value is related to the motor encoder. 2-encoder system The incremental position value is related to the load encoder. Changes only possible in the +Safety parameter list+.
0x28D2:002	SLP: SLP2 - Lower position limit -2147483648 ... [0] ... 2147483647 incr. • Safety parameter (+Safety parameter list+)	
0x28D2:003	SLP: SLP3 - Lower position limit -2147483648 ... [0] ... 2147483647 incr. • Safety parameter (+Safety parameter list+)	
0x28D2:004	SLP: SLP4 - Lower position limit -2147483648 ... [0] ... 2147483647 incr. • Safety parameter (+Safety parameter list+)	
0x28D3:001	SLP: SLP1 - Upper position limit -2147483648 ... [0] ... 2147483647 incr. • Safety parameter (+Safety parameter list+)	Definition of the upper position limit for monitoring. 1-encoder system The incremental position value is related to the motor encoder. 2-encoder system The incremental position value is related to the load encoder. Changes only possible in the +Safety parameter list+.
0x28D3:002	SLP: SLP2 - Upper position limit -2147483648 ... [0] ... 2147483647 incr. • Safety parameter (+Safety parameter list+)	
0x28D3:003	SLP: SLP3 - Upper position limit -2147483648 ... [0] ... 2147483647 incr. • Safety parameter (+Safety parameter list+)	
0x28D3:004	SLP: SLP4 - Upper position limit -2147483648 ... [0] ... 2147483647 incr. • Safety parameter (+Safety parameter list+)	
0x28D4:001	SLP: SLP1 - Error response • Safety parameter (+Safety parameter list+)	Changes only possible in the +Safety parameter list+.
	0 STO	
	1 SS1	
	2 SS2	
0x28D4:002	SLP: SLP2 - Error response • Safety parameter (+Safety parameter list+)	Changes only possible in the +Safety parameter list+.
	0 STO	
	1 SS1	
	2 SS2	

Functional safety

Safety functions
Safely-limited position (SLP)
Setting



Address	Name / setting range / [default setting]	Information
0x28D4:003	SLP: SLP3 - Error response • Safety parameter (+Safety parameter list+)	Changes only possible in the +Safety parameter list+.
	0 STO	
	1 SS1	
	2 SS2	
0x28D4:004	SLP: SLP4 - Error response • Safety parameter (+Safety parameter list+)	Changes only possible in the +Safety parameter list+.
	0 STO	
	1 SS1	
	2 SS2	



15.5.12 Safely-limited increment (SLI)

Function included in variant:			Extended Safety
-------------------------------	--	--	-----------------

The "Safely limited increment (SLI)" safety function monitors the amount of a maximum permissible position change.

Preconditions

- A safety-rated encoder system records speed and position.

Important notes



Uncontrolled rotation of the motor possible if no safety-rated encoder system is used.

Possible consequences: Death or severe injuries

- Use a safety-rated encoder system to use this function.

Functional description

SLI

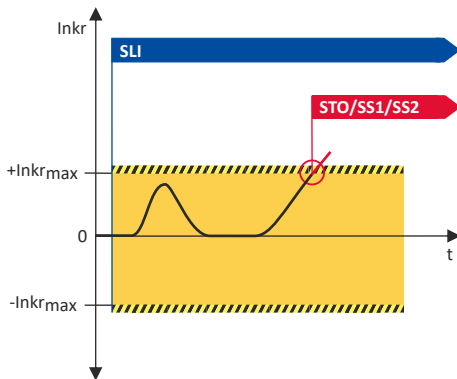

The function monitors the parameterized maximum position change.

- After requesting the function, the monitoring is active immediately.

Activation



The function cannot be activated if the drive is in the "Safe operating stop (SOS)" state.

Directly:

- Via a safety bus

Directly:

- Via a safety bus

Error behavior

States that trigger an event and an error stop:

- The position change has exceeded the monitoring limit.
 - Event: SLI - Safely limited increment exceeded (0x2A00FF96)
 - Error stop Parameterizable

Functional safety

Safety functions
Safely-limited increment (SLI)
Setting



Setting



The mode of action of the parameters can be found in the dialog box for the function in the "+Safety parameter list+" in the engineering tool used.

Parameter

Address	Name / setting range / [default setting]	Information
0x28C9	SLI Source S-Bus • Safety parameter (+Safety parameter list+)	Changes only possible in the +Safety parameter list+.
	0 Disabled	
	1 Activated	
0x28CA:001	SLI: Increment size standard operation 0 ... [0] ... 2147483647 incr. • Safety parameter (+Safety parameter list+)	Number of increments for a safely limited increment in normal operation. Changes only possible in the +Safety parameter list+.
0x28CA:002	SLI: Error response standard operation • Safety parameter (+Safety parameter list+)	Changes only possible in the +Safety parameter list+.
	0 STO	
	1 SS1	
	2 SS2	
0x28CA:004	SLI: Maximum change of position • Read only: x incr. • Safety parameter (+Safety parameter list+)	Value of the position change while SLI has been active. The incremental position value is related to the motor encoder.



15.5.13 Safe direction (SDI)

Function included in variant:			Extended Safety
-------------------------------	--	--	-----------------

The "Safe direction (SDI)" safety function monitors the direction of rotation of the drive.

A tolerance window can be used to define the number of increments that the drive may move in the blocked direction.

Preconditions

- The application guides the drive in the permitted direction of movement.
- A safety-rated encoder system records speed and position.

Important notes

DANGER!

Uncontrolled rotation of the motor possible if no safety-rated encoder system is used.

Possible consequences: Death or severe injuries

- ▶ Use a safety-rated encoder system to use this function.

NOTICE

The start delay is activated.

Machine and system parts can be destroyed if this setting is not taken into account when calculating the safety distance.

- ▶ Only use this function if the safety distance has been calculated beforehand, taking the set delay into account.
- ▶ Evaluate the feedback: "SDIpos - Wrong direction" or "SDIpos - Wrong direction".

Functional safety

Safety functions
Safe direction (SDI)
Functional description



Functional description

SDI (SDIpos)

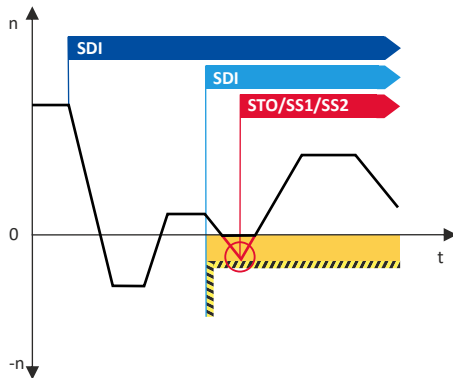

SDI (SDIneg)

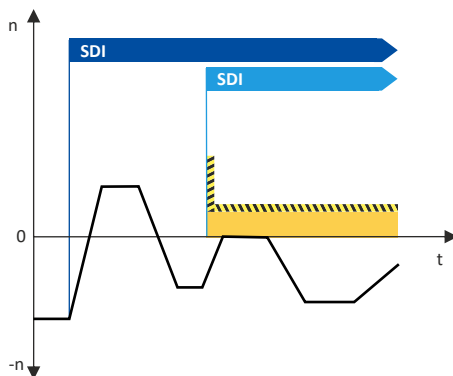

The function monitors the permissible direction of movement of the drive.

- Monitoring becomes active when the set start delay has expired.
- In addition, the number of increments that the drive may move in the blocked direction without triggering an error stop can be defined within the monitoring limits.

Activation

Directly:

- Via a safety bus

Status messages

If the direction of movement of the drive is within the monitoring limits:

- Output of the status message: SDIpos observed
 - In status word bit 6
- Output of the status message: SDIneg observed
 - In status word bit 7

Error behavior

States that trigger an event and an error stop:

- The drive is moving in the wrong direction.
 - Event: SDIpos - Wrong direction (0x2A00FF8E)
 - Event: SDIneg - Wrong direction (0x2A00FF8F)
 - Error stop Parameterizable



Setting

Please note when combining the [Safely-limited speed \(SLS\)](#) and [Safe direction \(SDI\)](#) functions:

- The parameterized directions of movement must be coordinated.
- The start delays for SLS and SDI must be coordinated:
- SLS and SDI are requested at the same time.



The mode of action of the parameters can be found in the dialog box for the function in the "+Safety parameter list+" in the engineering tool used.

Parameter

Address	Name / setting range / [default setting]	Information
0x28B9:001	SDI: SDIpos - Source S-Bus • Safety parameter (+Safety parameter list+)	Changes only possible in the +Safety parameter list+.
	0 Disabled	
	1 Activated	
0x28B9:002	SDI: SDIneg - Source S-Bus • Safety parameter (+Safety parameter list+)	Changes only possible in the +Safety parameter list+.
	0 Disabled	
	1 Activated	
0x28BA:001	SDI: Monitoring standard operation • Safety parameter (+Safety parameter list+)	Changes only possible in the +Safety parameter list+.
	0 Both directions enabled	
	1 Positive direction enabled	
	2 Negative direction enabled	
0x28BA:002	SDI: Delay time 0 ... [0] ... 30000 ms • Safety parameter (+Safety parameter list+)	Safe monitored time from activation to switching on the monitoring SDIpos or SDIneg. Changes only possible in the +Safety parameter list+.
0x28BA:003	SDI: Tolerance threshold 0 ... [8192] ... 327680 incr. • Safety parameter (+Safety parameter list+)	Setting of the tolerance threshold specifying by how many increments the motor may move in the direction locked by SDI. The incremental position value is related to the motor encoder. Changes only possible in the +Safety parameter list+.
0x28BA:004	SDI: Error response • Safety parameter (+Safety parameter list+)	Changes only possible in the +Safety parameter list+.
	0 STO	
	1 SS1	
	2 SS2	
0x28BA:005	SDI: Maximum change of position • Read only: x incr. • Safety parameter (+Safety parameter list+)	Maximum occurred position change in the not allowed direction when SDI is active.

Functional safety

Safety functions
Safe cam (SCA)
Preconditions



15.5.14 Safe cam (SCA)

Function included in variant:			Extended Safety
-------------------------------	--	--	-----------------

The "Safe cam (SCA)" safety function monitors up to 4 arbitrary absolute lower and upper position limits.

A status message indicates compliance with the monitoring limits.

Application examples:

- Monitoring the parking position of a storage and retrieval machine.
- Collision avoidance for an X-Y-Z gantry when there is a fixed obstacle in the travel range.

Preconditions

- The reference run must be executed.
- A safety-rated encoder system records speed and position.

Important notes



Uncontrolled rotation of the motor possible if no safety-rated encoder system is used.

Possible consequences: Death or severe injuries

► Use a safety-rated encoder system to use this function.

Functional description

SCA

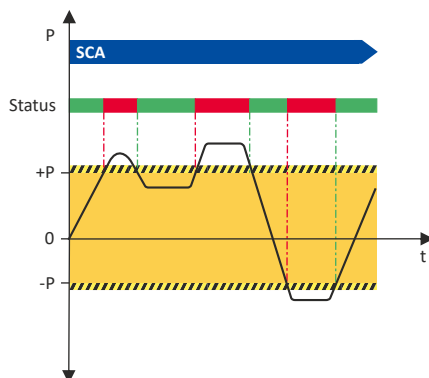

The function compares the absolute actual position with the parameterized position limits.

Activation

Via parameterization:

- Lower and upper position limits > 0 activate the function.

Status messages

If the actual position of the drive is within the monitoring limits:

- Output of the status message: SCA1 within limits ... SCA4 within limits
 - In status word bit 12 ... bit 15

Error behavior

If the monitoring limits are exceeded, no error message is output and no error stop is triggered.

Only the "SCA1 within limits" ... "SCA4 within limits" status is reset.



Setting



The mode of action of the parameters can be found in the dialog box for the function in the "+Safety parameter list+" in the engineering tool used.

Parameter

Address	Name / setting range / [default setting]	Information
0x28D8:001	SCA: SCA1 - Lower position limit -2147483648 ... [0] ... 2147483647 incr. • Safety parameter (+Safety parameter list+)	Definition of the lower position limit for the function. 1-encoder system The incremental position value is related to the motor encoder. 2-encoder system The incremental position value is related to the load encoder. Changes only possible in the +Safety parameter list+.
0x28D8:002	SCA: SCA2 - Lower position limit -2147483648 ... [0] ... 2147483647 incr. • Safety parameter (+Safety parameter list+)	
0x28D8:003	SCA: SCA3 - Lower position limit -2147483648 ... [0] ... 2147483647 incr. • Safety parameter (+Safety parameter list+)	
0x28D8:004	SCA: SCA4 - Lower position limit -2147483648 ... [0] ... 2147483647 incr. • Safety parameter (+Safety parameter list+)	
0x28D9:001	SCA: SCA1 - Upper position limit -2147483648 ... [0] ... 2147483647 incr. • Safety parameter (+Safety parameter list+)	Definition of the upper position limit for the function. 1-encoder system The incremental position value is related to the motor encoder. 2-encoder system The incremental position value is related to the load encoder. Changes only possible in the +Safety parameter list+.
0x28D9:002	SCA: SCA2 - Upper position limit -2147483648 ... [0] ... 2147483647 incr. • Safety parameter (+Safety parameter list+)	
0x28D9:003	SCA: SCA3 - Upper position limit -2147483648 ... [0] ... 2147483647 incr. • Safety parameter (+Safety parameter list+)	
0x28D9:004	SCA: SCA4 - Upper position limit -2147483648 ... [0] ... 2147483647 incr. • Safety parameter (+Safety parameter list+)	

Functional safety

Safety functions
Safe homing (SHom)



15.5.15 Safe homing (SHom)

Function included in variant:			Extended Safety
-------------------------------	--	--	-----------------

Safety functions based on absolute positions require an absolute reference point to calculate and monitor the position.

- This reference point is defined with the complete reference run.
- The mini reference run can replace the complete reference run in certain operating states.



15.5.15.1 Complete homing

The reference position determined with the reference run is the absolute reference point for the safety functions:

- Safely-limited position (SLP)
- Position-dependent safe speed (PDSS)
- Safe cam (SCA)

Important notes

DANGER!

When switched off, the motor position must not be changed by external forces.

Possible consequences: Death or severe injuries

- ▶ Make sure that the motor position does not change.
-

NOTICE

Undetected local change of the home position.

An unrecognized local change of the home position leads to incorrect values of the absolute position.

- ▶ Mount the components for detecting the reference position mechanically so that the home position cannot change due to external influences.
-

Functional safety

Safety functions
Safe homing (SHom)
Complete homing



Functional description

SHom

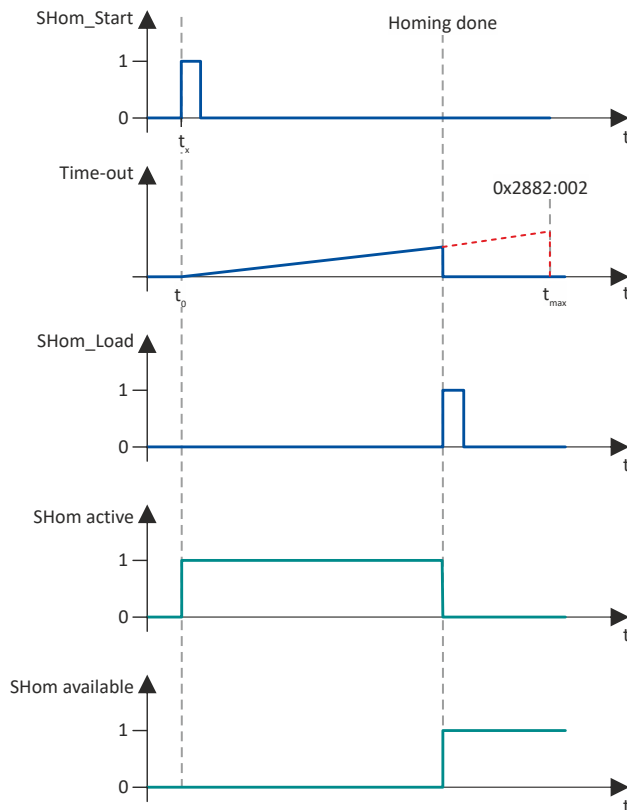

Sequence of the reference run

1. The reference run process is started via the defined input source.
2. The superimposed application must start the reference run. The drive independently takes over the motion control.
3. The reference run is performed with the set safely limited speed (SLS).
4. The reference signal "SHom_Load" is expected within the defined "Timeout" period, which adopts the parameterized position value as the "Home Position" when the reference position is passed.
5. Once the reference point is set, the reference run is ended.
6. The drive changes to normal operation.

By parameterization it can be set whether the current position is stored non-volatilely when the voltage supply is switched off. If the restart conditions are fulfilled after the voltage supply is switched on again and after a mini reference run, no new reference run is performed.

Activation

Directly:

- Via a safety bus

Status messages

If the reference run is active:

- Output of the status message: SHom activated
 - In status word bit 20

If the reference point is successfully accepted:

- Output of the status message: SHom available
 - In status word bit 21



Error behavior

States that trigger an event and an error stop:

- The reference run is faulty.
 - Event: SHom - Time-out (0x2A00FFA6)
 - Event: SHom - Home position deleted (0x2A00FFA7)
 - Event: SHom - Maximum slip value exceeded (0x2A00FFA8)
 - Event: SHom - Tolerance of start position exceeded (0x2A00FFA9)
 - Event: SHom - Tolerance of position comparison exceeded (0x2A00FFAA)
 - Error stop STO

Setting



The mode of action of the parameters can be found in the dialog box for the function in the "+Safety parameter list+" in the engineering tool used.

Parameter

Address	Name / setting range / [default setting]	Information
0x2110:014	Delete home position • Safety parameter (+Safety parameter list+)	
	0 Ready	
	1 Start	
	2 In progress	
	3 Action cancelled	
	4 No access	
0x2880:001	SHom_Start: Source • Safety parameter (+Safety parameter list+)	Changes only possible in the +Safety parameter list+.
	0 Disabled	
	13 S-Bus	
0x2881:001	SHom_Load: Source • Safety parameter (+Safety parameter list+)	Changes only possible in the +Safety parameter list+.
	13 S-Bus	
0x2882:001	SHom: Home position -2147483648 ... [0] ... 2147483647 incr. • Safety parameter (+Safety parameter list+)	Setting of the safe home position, which is taken over at SHOM_Load. It is the absolute reference point for the SLP, SCA and PDSS safety functions. 1-encoder system The incremental position value is related to the motor encoder. 2-encoder system The incremental position value is related to the load encoder. Changes only possible in the +Safety parameter list+.
0x2882:002	SHom: Timeout 0 ... [0] ... 30000 ms • Safety parameter (+Safety parameter list+)	The parameterized home mark must be detected within this monitoring time after SHom_Start. Changes only possible in the +Safety parameter list+.
0x2882:003	SHom: SLS for homing • Safety parameter (+Safety parameter list+)	Changes only possible in the +Safety parameter list+.
	3 SLS1	
	4 SLS2	
	5 SLS3	
	6 SLS4	
0x2882:004	SHom: Restart condition • Safety parameter (+Safety parameter list+)	Changes only possible in the +Safety parameter list+.
	0 Homing required	
	1 Load saved reference	

Functional safety

Safety functions
 Safe homing (SHom)
 Complete homing



Address	Name / setting range / [default setting]	Information
0x2882:005	SHom: Starting position tolerance 0 ... [0] ... 327680 incr. • Safety parameter (+Safety parameter list+)	Permitted tolerance between the safe position that is saved and the current safe position after restarting. 1-encoder system The incremental position value is related to the motor encoder. 2-encoder system The incremental position value is related to the load encoder. Changes only possible in the +Safety parameter list+.
0x2882:006	SHom: Status • Read only • Safety parameter (+Safety parameter list+)	
	0 No reference	
	1 SHom active	
	2 SHom available	
0x2882:007	SHom: Saved position • Read only: x incr. • Safety parameter (+Safety parameter list+)	Safe position saved at the last switch-off. 1-encoder system The incremental position value is related to the motor encoder. 2-encoder system The incremental position value is related to the load encoder.



15.5.15.2 Mini-homing

The mini reference run can replace the complete reference run in certain operating states.

The mini reference run is a minimum movement to check the plausibility of absolute position values.

After the reference run has been completed successfully, the drive switches to normal operation.

Preconditions

- A complete reference run was carried out before the first call.
- "Load saved reference" is set as a restart condition.

Functional description

- The drive moves at the parameterized safely limited speed SLS.
- The minimum distance for the mini reference run is calculated automatically:
 - Minimum distance $\geq 4 \times$ tolerance window for the position comparison
- Sequence of the plausibility check during the mini reference run:
 1. Are the saved position and the current position within the parameterized tolerance window for the starting position?
 2. Are the position value currently received from the inverter and the internal position value within the parameterized tolerance window for the position comparison?
 3. If the plausibility check is successful, the status bit "SHom present" is set.
 4. The drive changes to normal operation.



If complete homing is to be performed via the home position switch despite the "SHom present" status bit being set, the status bit must be reset with the "Clear home position" command.

Only the status bit is reset via this path. The superimposed application must start the complete reference run.

Activation

Automatically in the operating states:

- After mains switching
- After acknowledgement of an SSI encoder error
- After returning from the repair mode select (RMS)

Error behavior

States that trigger an event and an error stop:

- The mini reference run is faulty.
 - Event: SHom - Tolerance of start position exceeded (0x2A00FFA9)
 - Event: SHom - Tolerance of position comparison exceeded (0x2A00FFAA)
 - Error stop STO

A complete reference run is required.

Functional safety

Safety functions
Repair mode selector (RMS)
Preconditions



15.5.16 Repair mode selector (RMS)

Function included in variant:			Extended Safety
-------------------------------	--	--	-----------------

This function moves the drive from a situation that is blocking it ("Deadlock").

Application examples

- If an encoder fails, the drive must be moved to a position in which it can be repaired.



The connected encoders are not evaluated safety-related.

Only the stop functions configurable for RMS and the enable switch ES are enabled.
All other safety functions are disabled.

Preconditions

- A source for the ES enable switch must be configured.
- A stop function for RMS must be configured.

Important notes

DANGER!

Unexpected motions with unexpected speed.

Violation of the permissible movement limits.

Possible consequences: Death or severe injuries

- ▶ Use RMS exclusively to free an axis from a "deadlock".
 - ▶ If necessary, take additional safety measures to ensure that no persons can be endangered, since all monitoring functions are deactivated except for the ES enable switch.
 - ▶ Use other functions to move the drive when it is not in a "deadlock"!
-

DANGER!

When returning to normal operation, the automatic restart is not permissible.

Possible consequences: Death or severe injuries

- ▶ Parameterize the acknowledged restart.
-



Functional description

RMS

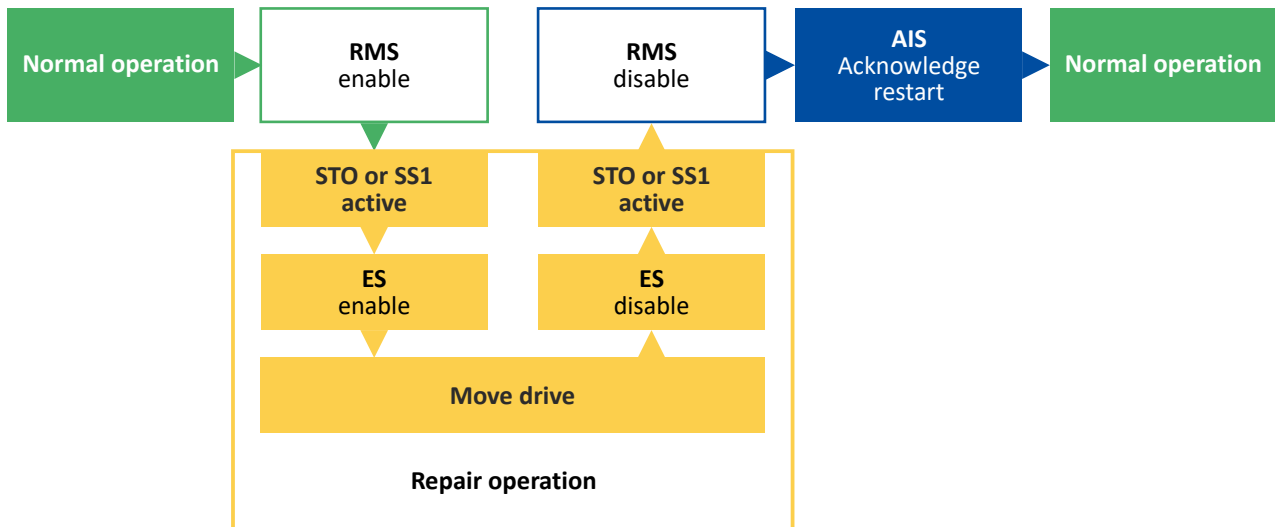

Repair operation procedure

1. Activate RMS via the configured trigger source.
The stop function configured for RMS is activated.
Speed functions and absolute position functions are deactivated.
The SHom status is reset.
2. Activate the enable switch ES via the configured trigger source.
The stop function is now overruled.
3. The drive can now be released from the "deadlock".
4. When the action is complete, deactivate the ES enable switch.
The drive can no longer be moved.
The stop function configured for RMS is activated.
5. Deactivate the trigger source for RMS.
The encoder evaluation is switched active again.
The repair mode is finished.
6. The minireference run starts automatically.
7. After a successful minireference run, the drive waits for the restart to be acknowledged.
8. Acknowledge the restart with the signal AIS.
The drive changes to normal operation.

Activation

Directly:

- Via a safety bus

Error behavior

States that trigger an event and an error stop:

- The mini reference run is faulty.
 - Event: SHom - Tolerance of start position exceeded (0x2A00FFA9)
 - Event: SHom - Tolerance of position comparison exceeded (0x2A00FFAA)
 - Error stop STO

A complete reference run is required.

After completion of the complete reference run, the drive switches to normal operation.

Functional safety

Safety functions
Enable switch (ES)
Setting



Setting

Parameter

Address	Name / setting range / [default setting]	Information
0x28AB	RMS Source • Safety parameter (+Safety parameter list+)	Changes only possible in the +Safety parameter list+.
	0 Disabled	
	13 S-Bus	
0x28AC:001	RMS: Stop function • Safety parameter (+Safety parameter list+)	Changes only possible in the +Safety parameter list+.
	0 STO	
	1 SS1	

15.5.17 Enable switch (ES)

Function included in variant:			Extended Safety
-------------------------------	--	--	-----------------

This function makes it possible to override the normal stop functions in special operation.

Preconditions

Special operation must be configured and activated.

Functional description

- The enable switch overrides the stop function active in special mode. The stop function is deactivated without delay.
- The drive can then be moved freely as long as the enable switch is active.
- If the enable switch is deactivated, the stop function for special operation is activated again without delay.

Activation

Directly:

- Via a safety bus

Setting

Parameter

Address	Name / setting range / [default setting]	Information
0x28AE	ES Source • Safety parameter (+Safety parameter list+)	Changes only possible in the +Safety parameter list+.
	0 Disabled	
	13 S-Bus	



15.5.18 Safe Muting (MUT)

Function included in variant:		Advanced Safety	Extended Safety
-------------------------------	--	-----------------	-----------------

This function deactivates all functions of the safety bus.

"Safe Muting" is used to move the drive even if the inverter is in a safety state.

- The function may only be used during commissioning or for maintenance work.
- The function is active for a maximum of 30 minutes.
- It can be ended at any time.

Preconditions

To activate the Safe Muting function, you need:

- A PC with »EASY Starter« (1.16 or higher) or »PLC Designer« with LSPE (Lenze Safety Parameter Editor).
- A permanent communication link between LSPE and inverter.
- In a network, the Safe Muting function can only be activated for one inverter at a time.
- The muting password was assigned via the password dialog in the LSPE.
- The active safe parameter set in the inverter must contain the settings for safe muting:
 - The sources to be hidden.
 - The muting password.

Important notes



Activating the Safe Muting function deactivates safety functions!

Possible consequences: Death or severe injuries

- ▶ Only authorized personnel may activate the Safe Muting function.
- ▶ An emergency stop switch-off must be present that cannot be deactivated by Safe Muting.

Activation

How to activate and deactivate Safe Muting:

1. Open LSPE:
 - a) »EASY Starter«: Open the **+Safety parameter list+** tab.
 - b) »PLC Designer«: Open the **Safe parameter set** object under the axis in the device tree.
2. Click muting dialog.
The password dialog opens.
3. Enter muting password.
The muting dialog opens.
4. Use the displayed data to ensure that the correct inverter has been selected.
Optical device identification is activated automatically. The two LEDs "RDY" and "ERR" on the front of the selected inverter flash quickly.
5. **Start** activates the function.
The function is now active for a maximum of 30 minutes. The remaining time is displayed.
6. End function
 - a) The function is automatically ended after 30 minutes.
 - b) **Stop** ends the function manually.
 - c) If the connection between LSPE and inverter is disconnected, the function is aborted immediately with an error message.
Monitored operation is reactivated immediately.
All previously deactivated safety functions are active again.

Functional safety

Safety functions
Safe Muting (MUT)
Setting



Setting

Reset muting password

The muting password can be reset in the LSPE: [0x213B:001](#) (MUT: Password) = 0

Parameter

Address	Name / setting range / [default setting]	Information
0x213A:001	MUT: Mute S-Bus • Safety parameter (+Safety parameter list+)	Changes only possible in the +Safety parameter list+.
	0 No muting	
	3 Mute completely	
0x213B:001	MUT: Password 0 ... [0] ... 4294967295 • Safety parameter (+Safety parameter list+)	Password to activate the function. Enter "0" to reset the password. Changes only possible in the +Safety parameter list+.
0x213B:002	MUT: Remaining time • Read only: x s • Safety parameter (+Safety parameter list+)	Remaining time until the function is automatically terminated. The function is active for a maximum of 30 minutes.



15.6 Diagnostics

15.6.1 Status LEDs

The LEDs "RDY" and "ERR" show the current safety status:

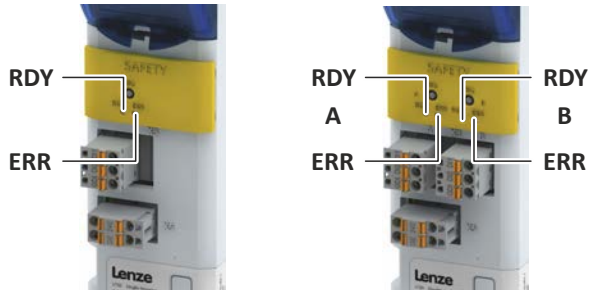

Fig. 8: Position of the RDY and ERR LEDs



⚠ DANGER!

Inaccurate status information possible due to LEDs.





LEDs are not reliable status displays.

Possible consequences: Death or severe injuries



- ▶ Only use LEDs for general diagnostics during commissioning or troubleshooting.
- ▶ Do not use LEDs as status displays.

LED "RDY" (yellow)	Status	Meaning
off	-	No status message active.
 blinking yellow 2 Hz	SOS active	
 blinking yellow 1 Hz	Service status	Transfer of parameter set requested.

Display for requested acknowledgement

LED "RDY" (yellow)	LED "ERR" (red)	Status	Meaning
 on	 blinking red 1 Hz	Restart acknowledgement requested	During startup, a modified parameter set was detected in the "Init" state. ▶ Acknowledgement with confirmation button S82 □ 360
	 blinking red 2 Hz		During startup, a changed safety address was detected in the "Init" state. ▶ Acknowledgement with confirmation button S82 □ 360
	 blinking red		During startup, a changed assignment between OCT encoder and inverter was detected in the "Init" state. ▶ Acknowledgement with confirmation button S82 □ 360

Display in the event of errors

LED "ERR" (red)	Status	Meaning
off	-	The device is working correctly.
 blinking red 2 Hz	Safety bus error	Communication via the safety bus is not established: <ul style="list-style-type: none"> • There is no valid configuration. • The start-up has not been completed yet.
 blinking red 1 Hz	Safety technology error	One of the following errors has been detected: <ul style="list-style-type: none"> • A monitoring device has been activated. • An acknowledgeable error is active.

Functional safety

Diagnostics
 Status LEDs
 Acknowledgement with confirmation button S82



Display for critical device errors

LED "RDY" (yellow)	LED "ERR" (red)	Status	Meaning
 blinking yellow	 blinking red	Critical system error	<ul style="list-style-type: none"> "Lock-out" (CPU stopped) STO is active. If the system error occurs again after switching the 24 V supply, the device is defective. It must be replaced.

15.6.1.1 Acknowledgement with confirmation button S82



All requests are acknowledged with the same steps.

The acknowledgement procedure is aborted if the reaction time of 2.5 seconds is exceeded. The acknowledgement procedure must be repeated.

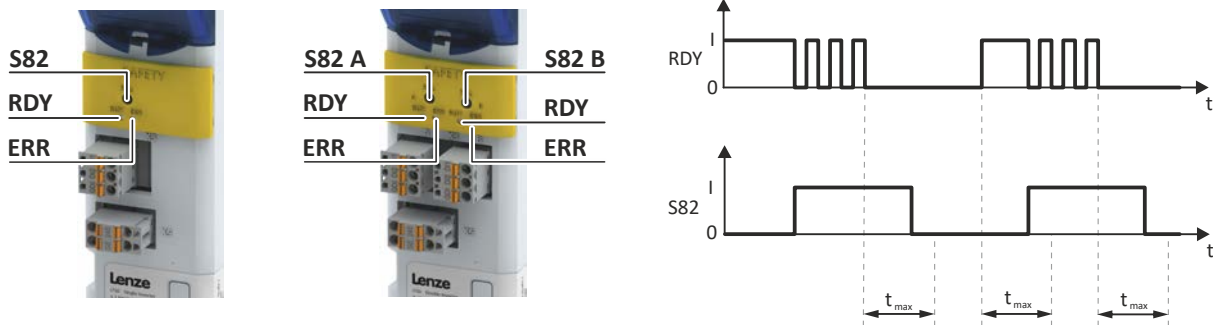

Fig. 9: Sequence of the acknowledgement procedure

RDY LED "RDY" t_{max} Maximum permissible response time
 S82 Confirmation button S82
 t Time axis

To acknowledge the request with the S82 confirmation button:

Precondition:

- The "RDY" LED is lit.
- The "ERR" LED is blinking.

- Press and hold the S82 button.
The "RDY" LED starts blinking.
- The "RDY" LED goes off after 3 seconds.
- Release the S82 button after a maximum of 2.5 seconds.
The "RDY" LED is lit.
- Press and hold the S82 button after a maximum of 2.5 seconds.
The "RDY" LED starts blinking.
- The "RDY" LED goes off after 3 seconds.
- Release the S82 button after a maximum of 2.5 seconds.
The acknowledgement is successfully completed.
The action is recorded in the inverter logbook.
- Use a function test to ensure that the acknowledgement has led to the correct result.



If the parameter set is invalid, an error is reported and the "ERR" LED starts blinking.



15.6.2 Event history

Extended Safety error messages are entered in [0x603F](#) and in the logbook of the inverter.

The meaning of the error messages is described in chapter [Events, causes and remedies](#).

If the operating status cannot be adequately diagnosed via the logbook, the event history provides Lenze Service with further diagnostic information.

Forward the event history to Lenze Service on request. E.g. screenshot of the "Logbook" blind under the "Safety Diagnostics" tab in the »EASY Starter«.



The event history must not be evaluated automatically because it contains internal debug information that may change from version to version.

Parameter

Address	Name / setting range / [default setting]	Information
0x2130:001	Safety event history: Current severity	Severity of the current event in 0x2130:002
	• Read only	
	• Safety parameter (+Safety parameter list+)	
	0 No error	
	1 Warning	
	2 Trouble	
0x2130:002	Safety event history: Internal event 1	Currently active event
	• Read only	
	• Safety parameter (+Safety parameter list+)	
0x2130:003	Safety event history: Internal event 2	Second most recent stored event
	• Read only	
	• Safety parameter (+Safety parameter list+)	

Functional safety

Diagnostics
Diagnostic parameters



Address	Name / setting range / [default setting]	Information
0x2130:004	Safety event history: Internal event 3 • Read only • Safety parameter (+Safety parameter list+)	...
0x2130:005	Safety event history: Internal event 4 • Read only • Safety parameter (+Safety parameter list+)	
0x2130:006	Safety event history: Internal event 5 • Read only • Safety parameter (+Safety parameter list+)	
0x2130:007	Safety event history: Internal event 6 • Read only • Safety parameter (+Safety parameter list+)	
0x2130:008	Safety event history: Internal event 7 • Read only • Safety parameter (+Safety parameter list+)	
0x2130:009	Safety event history: Internal event 8 • Read only • Safety parameter (+Safety parameter list+)	
0x2130:010	Safety event history: Internal event 9 • Read only • Safety parameter (+Safety parameter list+)	
0x2130:011	Safety event history: Internal event 10 • Read only • Safety parameter (+Safety parameter list+)	
0x2130:012	Safety event history: Internal event 11 • Read only • Safety parameter (+Safety parameter list+)	
0x2130:013	Safety event history: Internal event 12 • Read only • Safety parameter (+Safety parameter list+)	
0x2130:014	Safety event history: Internal event 13 • Read only • Safety parameter (+Safety parameter list+)	
0x2130:015	Safety event history: Internal event 14 • Read only • Safety parameter (+Safety parameter list+)	
0x2130:016	Safety event history: Internal event 15 • Read only • Safety parameter (+Safety parameter list+)	
0x2130:017	Safety event history: Internal event 16 • Read only • Safety parameter (+Safety parameter list+)	Oldest stored event

15.6.3 Diagnostic parameters



The diagnostic parameters for the safety functions can be found in the "Diagnostics and fault elimination" chapter.

▶ [Safety diagnostics](#) 380



15.7 Safety-related data

15.7.1 Safety-related characteristics Basic Safety - STO

Basics of the safety-related characteristics			
	Source of failure rates	SN 29500	When no values from the component manufacturers were available.
	Average max. ambient temperature	60 °C	
Basic Safety - STO			
EN IEC 61508, part 1-7 EN 62061	SFF	99 %	
	Safety Integrity Level	SIL 3	
	PFH [1/h]	< 1 E-09	< 1 % of SIL 3
	PFD _{avg} (T)	< 1 E-04	< 10 % of SIL 3 after T = 20 years
	Proof test interval T	20 years	Mission time
EN ISO 13849-1	Category	4	
	Performance Level	e	
	MTTF _d	High	> 100 years
	Mean diagnostic coverage DC _{avg}		99 %

15.7.2 Safety-related characteristics Advanced Safety

Basics of the safety-related characteristics			
	Source of failure rates	SN 29500	When no values from the component manufacturers were available.
	Average max. ambient temperature	60 °C	
Safety-related characteristic values for all safety functions except Safe Brake Control (SBC)			
EN IEC 61508, part 1-7 EN 62061	Safety Integrity Level	SIL 3	
	PFH [1/h]	< 1 E-09	< 1 % of SIL 3
	PFD _{avg} (T)	< 1 E-04	< 10 % of SIL 3 after T = 20 years
	SFF	99 %	
	Proof test interval T	20 years	Mission time
EN ISO 13849-1	Performance Level	e	
	Category	4	
	MTTF _d	High	> 250 years
	Mean diagnostic coverage DC _{avg}		95 %
Safety-related characteristic values for the Safe Brake Control (SBC) safety function			
EN IEC 61508, part 1-7 EN 62061	Safety Integrity Level	SIL 2	
	PFH [1/h]	< 1 E-08	< 1 % of SIL 2
	PFD _{avg} (T)	< 1 E-03	< 10 % of SIL 2 after T = 20 years
	SFF	99 %	
	Proof test interval T	20 years	Mission time
EN ISO 13849-1	Performance Level	d	
	Category	2	
	MTTF _d	High	> 230 years
	Mean diagnostic coverage DC _{avg}		95 %

Functional safety

Safety-related data

Safety-related characteristics Extended Safety



15.7.3 Safety-related characteristics Extended Safety

Basics of the safety-related characteristics			
	Source of failure rates	SN 29500	When no values from the component manufacturers were available.
	Average max. ambient temperature	60 °C	
All safety functions except Safe Brake Control (SBC) for drive systems with motors with resolvers and SinCos encoders			
EN IEC 61508, part 1-7 EN 62061	Safety Integrity Level	SIL 3	
	PFH [1/h]	< 1 E-09	< 1 % of SIL 3
	PFD _{avg} (T)	< 1 E-04	< 10 % of SIL 3 after T = 20 years
	SFF	99 %	
	Proof test interval T	20 years	Mission time
EN ISO 13849-1	Performance Level	e	
	Category	4	
	MTTF _d	High	> 250 years
	Mean diagnostic coverage DC _{avg}		95 %
All safety functions except Safe Brake Control (SBC) for drive systems with motors with HIPERFACE DSL® encoders (OCT)			
EN IEC 61508, part 1-7 EN 62061	Safety Integrity Level	SIL 2	
	PFH [1/h]	< 5 E-09	< 0.5 % of SIL 2
	PFD _{avg} (T)	< 5 E-04	< 5 % of SIL 2 after T = 20 years
	SFF	> 90 %	
	Proof test interval T	20 years	Mission time
EN ISO 13849-1	Performance Level	d	
	Category	3	
	MTTF _d	High	> 300 years
	Mean diagnostic coverage DC _{avg}	Medium	> 90 %
Safe Brake Control (SBC) safety function independent of the parameterized motor encoder system			
EN IEC 61508, part 1-7 EN 62061	Safety Integrity Level	SIL 2	
	PFH [1/h]	< 1 E-08	< 1 % of SIL 2
	PFD _{avg} (T)	< 1 E-03	< 10 % of SIL 2 after T = 20 years
	SFF	99 %	
	Proof test interval T	20 years	Mission time
EN ISO 13849-1	Performance Level	d	
	Category	2	
	MTTF _d	High	> 230 years
	Mean diagnostic coverage DC _{avg}		95 %



15.7.4 Response times of the safety unit

The overall system must be taken into account when determining the response time following a safety function request.

Response time of encoder monitoring

Time required to detect faults caused by continuous signal errors at the encoder interface.		[ms]
	Default setting	50
	Parameterizable via: 0x2878:004	12/50/100



It must be evaluated for each application what minimum response time is possible.

The longer the reaction time, the more the safe speed is filtered.

During dynamic processes (acceleration, deceleration), the safely evaluated speed (nSD) lags behind the actual speed of the drive (nBD) (displayed in [0x287B:006](#)).

This time offset must be taken into account when reaching limit values.

Response times of safe SBC brake control

Response time from the detection of the SBC safety function to the switch-off of the safe brake control		[ms]
t_{br}	Delay time between request and activation of the brake control	
	Parameterizable via: 0x28E6:002	0 ... 30000
t_i	Processing time in drive-based safety sensor technology	4
	Control X106 starts after	$t_{br} + t_i$
Test pulse interval and error response time		[ms]
	Test pulse interval, brake control	100
	Error response time, min. time for error detection and error triggering	200

FSoE communication response times

Information on how to calculate the processing time and transmission time of the safety bus can be found in the documentation of the safety PLC used.

Response time to a status word from the safety module (input data)		[ms]
T_{Input} T_I	Internal transfer time of the FSoE data from the safety module to the safe control system	8

Tab. 1: Response time to status word

Response time to a control word (output data)		[ms]
T_{Output} T_O	Internal transfer time of the FSoE data from the safe control to the safety module	16

Tab. 2: Response time to a control word



If safety bus communication is disturbed, the system switches to the fail-safe state after the safety bus monitoring time (T_{WD}) has elapsed. Communication via the safety bus is deactivated.

Functional safety

Safety-related data
Calculation of the maximum response times



15.7.5 Calculation of the maximum response times

For the calculation of the response time to the request of a safety function, the overall system must be taken into account:

- Response time of the connected safety sensors.
- Input delay of the safety inputs.
- Internal processing time.
- Deceleration times, braking times, and stopping times from the parameterized safety functions.
- When using a feedback system, the response time of encoder monitoring 0x2878:004
- Safety bus:
 - Monitoring time for cyclic services.
 - Monitoring time in the safety PLC.
 - Processing time in the safety PLC
- Delay times due to further components.

The ETG FSoE protocol specification contains formulas for calculating the maximum response time in fault-free operation and in the event of a fault.



In the "Application Knowledge Base", Lenze provides an Excel table as a calculation aid. This can be used to easily calculate the reaction times.

[Link to "Application Knowledge Base"](#)

Please note the following:

The variables for the individual response times are named differently in the documentation for the c250-S safety controller than in the FSoE protocol specification of the ETG.

In the following graphics, the differences are marked with "Lenze" and "ETG".

Definition of the single response times

Name Lenze	Name ETG	Description	Comment
T_Sensor	T_S	Processing time of the sensor until the signal is available at the interface.	See technical data of the sensor
T_InputFilter		Parameterized filter time of the safe input.	
T_Input	T_I	Processing time of the safe input.	E.g. safety I/O module, FSoE sensor or inverter. See technical data
T_WDInput	T_WD_In	Monitoring time parameterized in the safety PLC (c250-S) for the safe input module.	E.g. safety I/O module, FSoE sensor or inverter.
T_EtherCAT	T_Com	EtherCAT cycle time	
T_FSoE		Processing time of the communication, depending on the EtherCAT cycle time	The documentation of the c250-S specifies max. 3 x T_EtherCAT. The ETG FSoE protocol specification specifies max. 2 x T_Com. It depends on the application which factor can be used. Factor 3 means improved availability of secure communications.
T_SafetyPLC	T_L	Processing time of the safety PLC (c250-S).	Corresponds to the set cycle time of the safety application.
T_Output	T_O	Processing time of the safe output.	E.g. safety I/O module or inverter. See technical data
T_WDOutput	T_WD_Out	Monitoring time parameterized in the safety PLC (c250-S) for the safe output module.	E.g. safety I/O module or inverter.
T_Aktor	T_A	Processing time of the actuator.	See technical data of the actuator



Maximum response time with error-free communication



Note the different factors for calculating the processing time of the communication:

The documentation of the c250-S specifies max. $3 \times T_{\text{EtherCAT}}$.

The ETG FSoE protocol specification specifies max. $2 \times T_{\text{Com}}$.

It depends on the application which factor can be used. Factor 3 means improved availability of secure communications.

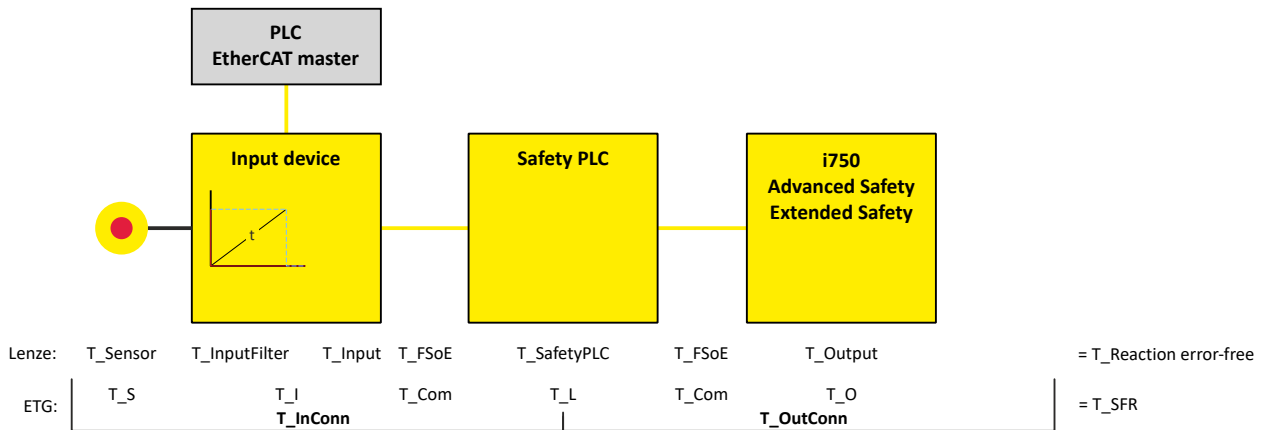

Fig. 10: Maximum response time with error-free communication **without** Safe Brake Control (SBC)

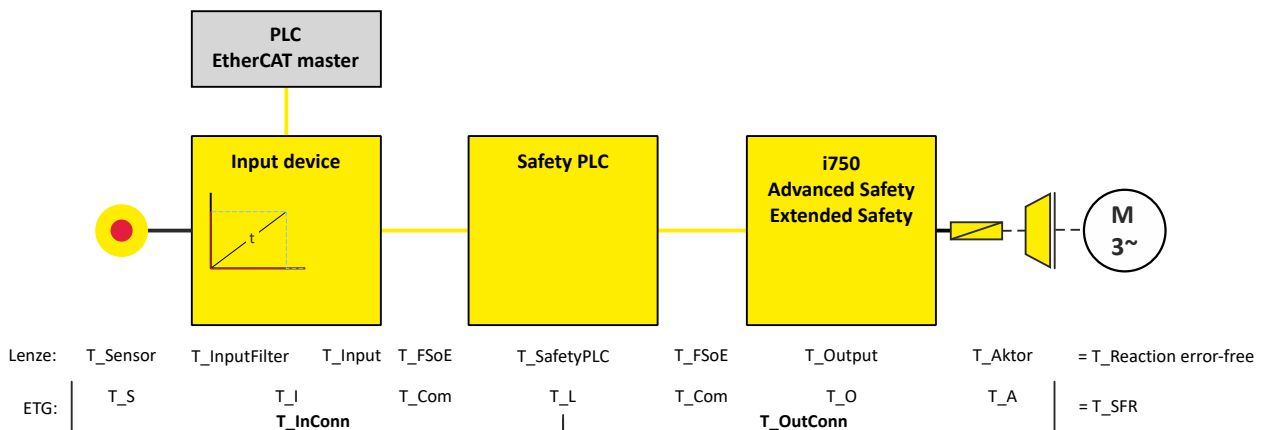

Fig. 11: Maximum response time with error-free communication **with** Safe Brake Control (SBC)

Calculation of the maximum response time with error-free communication

	Max. response time without SBC	Max. response time with SBC
T_{InConn}	$2 \times T_{\text{S}}$ $+ 2 \times T_{\text{I}}$ $+ 2 \times T_{\text{Com}} (3 \times T_{\text{Com}})$ $+ 2 \times T_{\text{L}}$	$2 \times T_{\text{S}}$ $+ 2 \times T_{\text{I}}$ $+ 2 \times T_{\text{Com}} (3 \times T_{\text{Com}})$ $+ 2 \times T_{\text{L}}$
T_{OutConn}	$+ 2 \times T_{\text{L}}$ $+ 2 \times T_{\text{Com}} (3 \times T_{\text{Com}})$ $+ 2 \times T_{\text{O}}$	$+ 2 \times T_{\text{L}}$ $+ 2 \times T_{\text{Com}} (3 \times T_{\text{Com}})$ $+ 2 \times T_{\text{O}}$ $+ 2 \times T_{\text{A}}$
	= T_{SFR}	= T_{SFR}

Functional safety

Safety-related data
Calculation of the maximum response times



Response time in case of communication interruption

The FSoE watchdog time T_{WD} is included in the calculation of the maximum response time in case of communication interruption.

The FSoE watchdog time T_{WD} can be calculated according to the formula in the ETG FSoE protocol specification.

The processing times in the individual subsystems and the processing time of the communication are included in this calculation. In addition, a reserve of 20% is added.

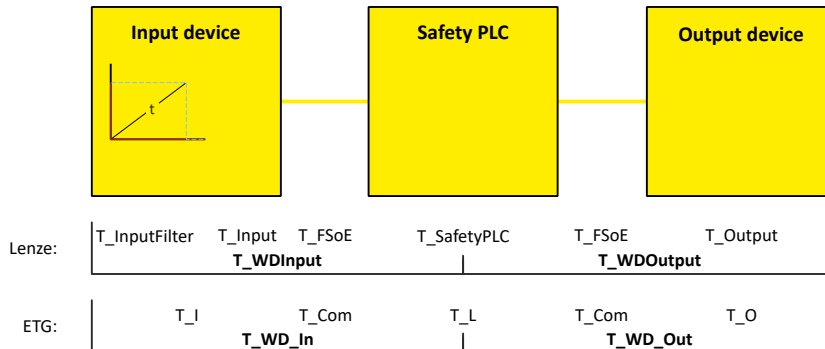

Fig. 12: FSoE watchdog time



Depending on the input module and the output module used, the calculation may result in different values.

The higher value must always be used for further calculation to improve the availability of secure communication.

Calculation of the FSoE watchdog time

	Input module		Output module
	$2 \times T_I$ $+ 4 \times T_{Com} (6 \times T_{Com})$ $+ 2 \times T_L$ $+ \Delta T (20 \%)$		$+ 4 \times T_{Com} (6 \times T_{Com})$ $+ 2 \times T_L$ $+ 2 \times T_O$ $+ \Delta T (20 \%)$
	= T_{WD_In}		= T_{WD_Out}



Calculation of the maximum response time in case of communication interruption in the input module

	Max. response time without SBC		Max. response time with SBC
T_InConn_wc	$2 \times T_S$ + T_{WD_In}		$2 \times T_S$ + T_{WD_In}
T_OutConn	+ $2 \times T_L$ + $2 \times T_{Com} (3 \times T_{Com})$ + $2 \times T_O$		+ $2 \times T_L$ + $2 \times T_{Com} (3 \times T_{Com})$ + $2 \times T_O$ + $2 \times T_A$
	= $T_{SFR_wc} (In)$		= $T_{SFR_wc} (In)$

Calculation of the maximum response time in case of communication interruption in the output module

	Max. response time without SBC		Max. response time with SBC
T_InConn	$2 \times T_S$ + $2 \times T_I$ + $2 \times T_{Com} (3 \times T_{Com})$ + $2 \times T_L$		$2 \times T_S$ + $2 \times T_I$ + $2 \times T_{Com} (3 \times T_{Com})$ + $2 \times T_L$
T_OutConn_wc	$2 \times T_L$ + T_{WD_Out}		$2 \times T_L$ + T_{WD_Out} + $2 \times T_A$
	= $T_{SFR_wc} (Out)$		= $T_{SFR_wc} (Out)$

Calculation of the maximum response time in case of communication interruption for the entire system

	Max. response time without SBC		Max. response time with SBC
T_SFR_wc	= $\max \{T_{SFR_wc} (In); T_{SFR_wc} (Out)\}$		= $\max \{T_{SFR_wc} (In); T_{SFR_wc} (Out)\}$







16 Diagnostics and fault elimination

This section contains information on error handling, drive diagnostics and fault analysis.

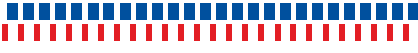

16.1 Status LEDs

The "RDY" and "ERR" LED status displays on the front of the inverter provide some quick information about certain operating states.

"RDY" LED (blue)	"ERR" LED (red)	Status/meaning
Off	Off	Supply voltage not available.
On	On	Initialisation in progress (inverter is being started.)
 Blinks (1 Hz)	Off	Safe torque off (STO) active. The inverter has been inhibited by the integrated safety system. ▶ Safe torque off (STO) □ 297
 Blinks (1 Hz)	On	Inverter inhibited, error active. ▶ Event handling □ 389
On	Off	Inverter enabled. Motor rotates according to the specified setpoint or quick stop is active.
 Both LEDs are blinking in a rapidly alternating mode		Firmware update active. ▶ Update device firmware □ 259
 Both LEDs are blinking in a very rapidly synchronous mode		"Visual tracking" function is active. ▶ Optical device identification □ 241

The description of the network-specific "BUS RDY" and "BUS ERR" LEDs can be found in chapters



16.2 Logbook

With the logbook, the controller has access to the last 32 messages of the inverter.

- The logbook is saved persistently in the inverter.
- The logbook has a ring buffer structure:
 - As long as free memory is available in the logbook, a message is entered following the next free memory unit.
 - When all memory units are occupied, the oldest message is deleted for a new message.
 - Always the most recent messages remain available.
- On the basis of the "Diag code" (32-bit word) of each individual message it can be seen which axis the message refers to.

Preconditions

The logbook can only be accessed

- via the user interface of »EASY Starter« ("Diagnostics" tab) or
- via network.

Details

In contrast to the error history buffer, the logbook additionally protocols the following events:

- Fault messages
- Change-over from normal to setup mode (and vice versa)
- Execution of device commands
- Avoidance of safety functions

The logbook entries are saved persistently in the inverter. If all 32 memory units are occupied, the oldest entry is deleted for a new entry. By means of the "Delete logbook" device command, all logbook entries can be deleted.



The logbook always displays only one active safety event.

Only when the cause of the safety event has been eliminated and the safety event has been acknowledged, the logbook will display the next safety event that is still active.

Accessing the logbook with »EASY Starter«

1. Select the inverter on the left side in the »EASY Starter« device list.
2. Change to the "Diagnostics" tab.
3. Click the icon  to open the logbook.

Observe that the logbook only presents a snapshot at the time the data is read out. If a new event occurs, the logbook must be read out again so that the new event becomes visible.

Accessing the logbook via network

The logbook can also be accessed via network from a higher-level controller or a visualisation. The structure of the diagnostic messages complies with the "ETG.1020" standard of the EtherCAT Technology Group (ETG).



See chapter 13.3 of document "ETG.1020 Protocol Enhancements" provided by the EtherCAT Technology Group (ETG) for detailed information on the structure of the diagnostic messages.



Parameter

Address	Name / setting range / [default setting]	Information
0x2022:015	Device commands: Delete logbook	<ul style="list-style-type: none">• When the device command has been executed successfully, the value 0 is shown.• Do not switch off the supply voltage during the deletion process and do not unplug the memory module!
	0 Off / ready	Only status feedback
	1 On / start	Execute device command
	2 In progress	Only status feedback
	3 Action cancelled	
	4 No access	
	5 No access (Device disabled)	



16.3 Diagnostic parameters

The inverter provides many diagnostic parameters which are helpful for operation, maintenance, error diagnosis, error correction, etc.

- The following overview lists the most common diagnostic parameters.
- Further parameters for more specific diagnostic purposes are described in the following subchapters.
- The diagnostic parameters can only be read and cannot be written to.

Parameter

Address	Name / setting range / [default setting]	Information
0x2030	CRC parameter set • Read only	
0x2B0B	Ramp generator frequency • Read only: x.x Hz	Display of the current frequency setpoint. The frequency setpoint is internally transferred to the motor control (based on scaling and ramp generator).
0x2D4F	Motor utilisation (i ² xt) • Read only: x %	Display of the current thermal motor utilisation.
0x2DA2:001	Output power: Effective power • Read only: x.xxx kW	Display of the active output power for an energy analysis in the respective application.
0x2DA3:003	Output energy: Overall energy -21474836.47 ... [0.00] ... 21474836.47 kWh	Display of the energy balance: • Positive values: Energy consumed • Negative values: Generated energy 0x2DA3:003 = 0 resets the energy balance. When replacing a device, the value of the old device can be adopted as the starting value for the new device.
0x2DD0:001	Field values: Actual value • Read only: x %	Display of the actual current flow value.
0x2DD0:002	Field values: Setpoint value • Read only: x %	Display of the setpoint flow value.
0x2DD1:001	Motor currents: Actual D-current (id) • Read only: x.xx A	Display of the actual D current.
0x2DD1:002	Motor currents: Actual Q-current (iq) • Read only: x.xx A	Display of the actual Q current.
0x2DD1:003	Motor currents: Setpoint D-current (id) • Read only: x.xx A	Display of the setpoint D current.
0x2DD1:004	Motor currents: Setpoint Q-current (iq) • Read only: x.xx A	Display of the setpoint Q current.
0x2DD1:005	Motor currents: Motor current (I _{eff}) • Read only: x.xx A	Display of the effective motor current.
0x2DD2	Target position interpolated • Read only	Display of the interpolated position setpoint.
0x2DD3:001	Speed setpoints: Speed setpoint • Read only: x rpm	Display of the speed setpoint value 1.
0x2DD3:002	Speed setpoints: Speed setpoint 2 • Read only: x rpm	Display of the speed setpoint value 2.
0x2DD3:003	Speed setpoints: Speed setpoint limited • Read only: x rpm	Display of the limited speed setpoint.
0x2DD4:001	Speed controller output signals: Output signal 1 • Read only: x.x %	Display of the output signal 1 from the speed controller.
0x2DD4:002	Speed controller output signals: Output signal 2 • Read only: x.x %	Display of the output signal 2 from the speed controller.
0x2DD6:001	Torque filter cascade: Starting value • Read only: x.x %	Display of the start value.
0x2DD6:002	Torque filter cascade: Notch filter 1 input value • Read only: x.x %	Display of the input value for notch filter 1.



Address	Name / setting range / [default setting]	Information
0x2DD6:003	Torque filter cascade: Notch filter 2 input value • Read only: x.x %	Display of the input value for notch filter 2.
0x2DD6:004	Torque filter cascade: Torque setpoint filtered • Read only: x.x %	Display of the filtered torque setpoint value.
0x2DD7:001	Voltage values: Actual voltage (motor voltage limit) • Read only: x.x V	Display of the current motor voltage limit.
0x2DD7:002	Voltage values: Output signal D current controller • Read only: x.x V	Display of the output voltage of the D-current controller.
0x2DD7:003	Voltage values: Output signal Q current controller • Read only: x.x V	Display of the output voltage of the Q-current controller.
0x2DD7:004	Voltage values: D voltage (magnetisation) • Read only: x.x V	Display of the D-voltage (magnetisation).
0x2DD7:005	Voltage values: Q voltage (torque) • Read only: x.x V	Display of the Q-voltage (torque).
0x2DD7:006	Voltage values: Phases U-V • Read only: x.x V	Display of the actual voltage phase U - phase V.
0x2DD7:007	Voltage values: Phases V-W • Read only: x.x V	Display of the actual voltage phase V - phase W.
0x2DD7:008	Voltage values: Phases W-U • Read only: x.x V	Display of the actual voltage phase W - phase U.
0x2DD7:009	Voltage values: Phase U • Read only: x.x V	Display of the actual voltage of phase U.
0x2DD7:010	Voltage values: Phase V • Read only: x.x V	Display of the actual voltage of phase V.
0x2DD7:011	Voltage values: Phase W • Read only: x.x V	Display of the actual voltage of phase W.
0x2DDC	Actual slip value • Read only: x.x Hz	Display of the actual slip.
0x2DDD	Output frequency • Read only: x.x Hz	Display of the current output frequency of the inverter.
0x2DDE	Actual rotor angle position • Read only	Display of the actual position of the rotor angle.
0x2DDF:001	Axis information: Rated current • Read only: x.xx A	Display of the rated current of the axis.
0x2DDF:002	Axis information: Maximum current • Read only: x.xx A	Display of the maximum current of the axis. Associated event ID: • 537469829 0x20092385 - Parameterized max. motor current > max. device current
0x2DE0:006	Service settings: OEM service Data - SN • Read only	Display of OEM service data.
0x6077	Actual torque • Read only: x.x %	Display of the actual torque. • 100 % = Rated motor torque 0x6076
0x6078	Actual current • Read only: x.x %	Display of the motor actual current. • 100 % = Rated motor current 0x6075
0x6079	DC-bus voltage • Read only: x.xxx V	Display of the current DC-bus voltage.

Diagnostics and fault elimination

Diagnostic parameters
Inverter diagnostics



16.3.1 Inverter diagnostics

The following parameters supply some information about the current operating status of the inverter.

This includes the following information:

- Active access protection after log-in by means of PIN1/PIN2
- Currently loaded parameter settings
- Cause(s) for disable, quick stop and stop.
- Active control source and active setpoint source
- Active operating mode
- Status of the internal motor control

Parameter

Address	Name / setting range / [default setting]	Information
0x2010:001	Device event monitor: EreignisortEvent location • Read only	Display of the event location for the currently pending event.
	0 No error	
	1 Functional safety	
	4 Basic settings	
	5 Communication	
	6 Kinematics	
	7 Motion	
	8 Technology application	
0x2010:002	Device event monitor: Severity • Read only	Display of the severity level for the currently active event.
	0 No response	
	1 Fault > CiA402	
	2 Warning	
	11 Information	
	13 Warning locked	
	15 Trouble > logbook only	
	16 Trouble	
	18 Fault > logbook only	
	19 Fault > Application quick stop > Quick stop	
	20 Fault > inverter quick stop > quick stop	
	21 Fault > inverter quick stop > inverter disabled	
	23 Fault > inverter disabled	
0x2010:003	Device event monitor: Event status • Read only	Display of the event status for the currently pending event.
	0 No event active	
	1 Reset possible	
	2 Reset not possible	
0x2010:005	Device event monitor: Number of current event • Read only	Display of the event ID for the currently pending event.
0x2010:006	Device event monitor: Time stamp of current event • Read only: x ns	Display of the time stamp for the current upcoming event.
0x2040	Access protection status • Read only	Bit-coded display of the active access protection after login by PIN1/ PIN2.
	Bit 0 No write access	
	Bit 1 Only favorites changeable	



Diagnostics and fault elimination

Diagnostic parameters
Inverter diagnostics

Address	Name / setting range / [default setting]	Information
0x2539:001	Hardware-Diagnose: External supply voltage • Read only: x.x V	
0x2539:002	Hardware-Diagnose: Control board temperature • Read only: x.x °C	
0x2823	Status of axis commands • Read only: x %	
0x282A:001	Status words: Cause of disable • Read only	Bit-coded display of the cause(s) for disabled inverter.
	Bit 2 Axis command	1 = the inverter was disabled via axis command 0x2822:001 .
	Bit 7 Drive not ready	1 = the inverter was disabled internally since the drive was not ready for operation. Possible causes: • Under/overvoltage in the DC bus • Defective device hardware
	Bit 12 CiA402 Inverter disabled	1 = the inverter was disabled by the internal state machine. The bit is only set if • Operating mode 0x6060 = "CiA: Velocity mode (vl) [2]" and • state machine in the "Switch on disabled" state and • the state change has not been carried out via the "Disable operation" command.
	Bit 14 Safety	
Bit 16 PROFINET energy pause active	-	
0x282A:004	Status words: Extended status word • Read only	Bit-coded status word.
	Bit 0 Brake is opened	-
	Bit 1 Reserved	
	Bit 2 Reserved	
0x2831	Inverter status word • Read only	Bit coded status word of the internal motor control.
	Bit 0 Position controller in limitation	-
	Bit 1 Speed setpoint 1 limited	1 = input of speed controller 1 in limitation.
	Bit 2 Speed controller in limitation	1 = output of speed controller 1 in limitation.
	Bit 3 Torque setpoint limited	1 = setpoint torque in limitation.
	Bit 4 Q-current setpoint limited	1 = setpoint current in limitation.
	Bit 5 Speed setpoint 2 limited	1 = input of speed controller 2 in "torque mode" in limitation.
	Bit 6 Upper speed limit active	1 = in "torque mode", the speed is limited to upper speed limit 0x2946:001 .
	Bit 7 Lower speed limit active	1 = in "torque mode", the speed is limited to lower speed limit 0x2946:002 .
	Bit 8 Flying restart active	-
	Bit 9 Flying restart completed	
	Bit 10 Output frequency limited	1 = setpoint frequency with V/f operation in limitation.
	Bit 11 Magnetization completed	1 = Magnetisation completed during V/f operation. Otherwise 0.
	Bit 12 Motor phase error	1 = motor phase failure detection active.
	Bit 13 Feedback open circuit	-
Bit 14 Error reset blocking time active	1 = the error can only be reset when the blocking time has elapsed.	
Bit 15 Clamp active	-	

Diagnostics and fault elimination

Diagnostic parameters

Motor diagnostics



Address	Name / setting range / [default setting]	Information
0x2833	Inverter status word 2 • Read only	Bit-coded status word 2 of the inverter.
	Bit 0 Motor encoder modified	
	Bit 1 Manual test mode active	1 = manual test mode active.
	Bit 2 Manual control active	1 = manual control active.
	Bit 4 Motor encoder = absolute value encoder	-
	Bit 5 Motor encoder absolute position available	
	Bit 6 DC braking active	1 = DC braking active.
	Bit 7 Motor encoder angle drift invalid	-
	Bit 8 Load encoder modified	
	Bit 9 Load encoder angle drift invalid	
	Bit 10 Load encoder = absolute value encoder	
	Bit 11 Load encoder absolute position available	
	Bit 12 Brake open	
	Bit 13 Cable check active	
	Bit 14 Mains failure detected	
0x284F	Current error • Read only	Test display of the current error. • This object contains a reference for the text to be displayed from the ESI file as well as the substitution values for all wildcards in this text. • The text has the same structure as the diagnostic messages in the history buffer.
0x603F	Error code • Read only	Error message
0x6061	CiA: Active operation mode • Read only	CiA: Active operation mode
	-13 MS: Manual jog open loop (MOL)	Manufacturer-specific manual control
	-12 MS: Pole position identification (PPI)	Manufacturer-specific pole position identification (PLI)
	-11 Identification	
	-10 Test mode	
	0 No selection	No selection
	2 CiA: Velocity mode (vl)	
	8 CiA: Cyclic sync position (csp)	
	9 CiA: Cyclic sync velocity mode (csv)	
	10 CiA: Cyclic sync torque mode (cst)	

16.3.2 Motor diagnostics

The following parameters supply some information about the current operating status of the motor.

Parameter

Address	Name / setting range / [default setting]	Information
0x2832	Identification status • Read only	Display of the status for the automatic identification of the motor parameters.
	Bit 0 Identification enabled	Parameters for interaction with engineering tools.
	Bit 1 Identification active	
	Bit 2 Identification completed	
	Bit 3 Identification failed	
0x2D82	Motor actual voltage (Veff) • Read only: x.x V	Display of the current motor voltage.
0x2D83:001	Motor-Phasenströme: Zero system current • Read only: x.xx A	Display of the zero current.
0x2D83:002	Motor-Phasenströme: Phase U current • Read only: x.xx A	Display of the current of phase U.
0x2D83:003	Motor-Phasenströme: Phase V current • Read only: x.xx A	Display of the current of phase V.



Address	Name / setting range / [default setting]	Information
0x2D83:004	Motor-Phasenströme: Phase W current • Read only: x.xx A	Display of the current of phase W.
0x2D8A	Actual speed error • Read only: x rpm	Display of the speed error.
0x6404	Motor manufacturer ["Lenze"]	Setting of the motor manufacturer.

16.3.3 Network diagnostics

The following parameters show some general information with regard to the network option available and the network.

Related topics

▶ [Configuring the network](#) 210

16.3.4 I/O diagnostics

This section describes the diagnostics of the analog and digital inputs and outputs that can be found on the control terminal X3.

16.3.4.1 Digital inputs and outputs

The following parameters serve to diagnose the digital inputs and outputs of the inverter.

Parameter

Address	Name / setting range / [default setting]	Information	
0x282C:001	I/O diagnostic: Application level of the digital inputs • Read only	This parameter indicates the bit coded state or the digital inputs contain the setting of 0x2632:001 (Digital input 1).	
	Bit 16		Digital input 1
	Bit 17		Digital input 2
	Bit 18		Digital input 3
	Bit 19		Digital input 4
	Bit 20		Digital input 5
	Bit 21		Digital input 6
	Bit 22		Digital input 7
	Bit 23		Digital input 8
	Bit 24		Digital input 9
	Bit 25		Reserved
	Bit 26		Reserved
	Bit 27		Reserved
	Bit 28		Reserved
	Bit 29		Reserved
	Bit 30		Reserved
	Bit 31		Reserved

Diagnostics and fault elimination

Diagnostic parameters
Safety diagnostics
Digital inputs and outputs



Address	Name / setting range / [default setting]	Information	
0x60FD	Digital input status • Read only	Bit coded display of the current status of the digital inputs	
	Bit 0	Reserved	-
	Bit 1	Reserved	-
	Bit 2	Reserved	-
	Bit 3	Reserved	-
	Bit 16	Digital input 1	
	Bit 17	Digital input 2	
	Bit 18	Digital input 3	
	Bit 19	Digital input 4	
	Bit 20	Digital input 5	
	Bit 21	Digital input 6	
	Bit 22	Digital input 7	
	Bit 23	Digital input 8	
	Bit 24	Digital input 9	
	Bit 25	Internal interconnection of digital inputs	0 = digital inputs are internally set to HIGH (NPN) level via pull-up resistors. 1 = digital inputs are internally set to LOW (PNP) level via pull-down resistors.
	Bit 26	Reserved	-
	Bit 27	Reserved	-
Bit 28	Reserved	-	
Bit 29	Reserved	-	
Bit 30	Reserved	-	
Bit 31	Reserved	-	

Related topics

► [Configure digital inputs](#) 208

16.3.5 Safety diagnostics

Parameter

Address	Name / setting range / [default setting]	Information
0x212C:001	Safety software: Firmware version • Read only • Safety parameter (+Safety parameter list+)	Identification data of the safety software
0x212C:002	Safety software: Bootloader version • Read only • Safety parameter (+Safety parameter list+)	
0x212D:001	Safety hardware: Hardware version • Read only • Safety parameter (+Safety parameter list+)	Identification data of the safety hardware
0x212D:003	Safety hardware: Serial number • Read only • Safety parameter (+Safety parameter list+)	
0x212D:004	Safety hardware: Production date • Read only • Safety parameter (+Safety parameter list+)	
0x2131:001	Safety hardware: Power-on time • Read only: x s • Safety parameter (+Safety parameter list+)	Operating data of the safety hardware
0x2132	Safety status • Read only • Safety parameter (+Safety parameter list+)	Display of the internal safety states



Diagnostics and fault elimination

Diagnostic parameters
Safety diagnostics

Address	Name / setting range / [default setting]	Information		
0x2870:001	Safety interface: Control data	Bit-coded control word of the safety functions.		
	<ul style="list-style-type: none"> • Read only • Safety parameter (+Safety parameter list+) 			
	Bit 0 STO active			
	Bit 1 SS1 active			
	Bit 2 SS2 active			
	Bit 3 SOS active			
	Bit 4 SLS1 active			
	Bit 5 SLS2 active			
	Bit 6 SLS3 active			
	Bit 7 SLS4 active			
	Bit 8 SDIpos active			
	Bit 9 SDIneg active			
	Bit 10 SLI active			
	Bit 11 SSE active			
	Bit 12 ES active			
	Bit 14 RMS active			
	Bit 15 SBC active			
Bit 16 MUT active				
0x2870:002	Safety interface: Status data	Bit-coded status word of the safety functions		
	<ul style="list-style-type: none"> • Read only • Safety parameter (+Safety parameter list+) 			
	Bit 0 SLS1 observed			
	Bit 1 SLS2 observed			
	Bit 2 SLS3 observed			
	Bit 3 SLS4 observed			
	Bit 4 SMS observed			
	Bit 5 SSM within limits			
	Bit 6 SDIpos observed			
	Bit 7 SDIneg observed			
	Bit 8 SLP1 observed			
	Bit 9 SLP2 observed			
	Bit 10 SLP3 observed			
	Bit 11 SLP4 observed			
	Bit 12 SCA1 within limits			
	Bit 13 SCA2 within limits			
	Bit 14 SCA3 within limits			
	Bit 15 SCA4 within limits			
	Bit 16 PDSS positive observed			
	Bit 17 PDSS negative observed			
	Bit 18 SOS observed			
	Bit 19 SBC activated			
	Bit 20 SHom activated			
	Bit 21 SHom available			
	Bit 22 Safe speed OK			
	Bit 23 n=0			
	Bit 24 Positive travel direction			
	Bit 31 Fault active			
	0x2870:003		Safety interface: I/O status	Bit-coded I/O status word of the inputs.
			<ul style="list-style-type: none"> • Read only • Safety parameter (+Safety parameter list+) 	
			Bit 8 AIS S-Bus	
			Bit 9 AIE S-Bus	
			Bit 10 SHom_Start S-Bus	
Bit 11 SHom_Load S-Bus				

Diagnostics and fault elimination

Diagnostic parameters
Safety diagnostics



Address	Name / setting range / [default setting]	Information
0x2871:001	Safety interface bits: STO active <ul style="list-style-type: none"> • Read only • Safety parameter (+Safety parameter list+) 	Display of the individual bits from the control word of the safety functions 0x2870:001 Logic: 1 = function active
0x2871:002	Safety interface bits: SS1 active <ul style="list-style-type: none"> • Read only • Safety parameter (+Safety parameter list+) 	
0x2871:003	Safety interface bits: SS2 active <ul style="list-style-type: none"> • Read only • Safety parameter (+Safety parameter list+) 	
0x2871:004	Safety interface bits: SOS active <ul style="list-style-type: none"> • Read only • Safety parameter (+Safety parameter list+) 	
0x2871:005	Safety interface bits: SLS1 active <ul style="list-style-type: none"> • Read only • Safety parameter (+Safety parameter list+) 	
0x2871:006	Safety interface bits: SLS2 active <ul style="list-style-type: none"> • Read only • Safety parameter (+Safety parameter list+) 	
0x2871:007	Safety interface bits: SLS3 active <ul style="list-style-type: none"> • Read only • Safety parameter (+Safety parameter list+) 	
0x2871:008	Safety interface bits: SLS4 active <ul style="list-style-type: none"> • Read only • Safety parameter (+Safety parameter list+) 	
0x2871:009	Safety interface bits: SDIpos active <ul style="list-style-type: none"> • Read only • Safety parameter (+Safety parameter list+) 	
0x2871:010	Safety interface bits: SDIneg active <ul style="list-style-type: none"> • Read only • Safety parameter (+Safety parameter list+) 	
0x2871:011	Safety interface bits: SLI active <ul style="list-style-type: none"> • Read only • Safety parameter (+Safety parameter list+) 	
0x2871:012	Safety interface bits: SSE active <ul style="list-style-type: none"> • Read only • Safety parameter (+Safety parameter list+) 	
0x2871:013	Safety interface bits: ES active <ul style="list-style-type: none"> • Read only • Safety parameter (+Safety parameter list+) 	
0x2871:015	Safety interface bits: RMS active <ul style="list-style-type: none"> • Read only • Safety parameter (+Safety parameter list+) 	
0x2871:016	Safety interface bits: SBC active <ul style="list-style-type: none"> • Read only • Safety parameter (+Safety parameter list+) 	
0x2871:017	Safety interface bits: MUT active <ul style="list-style-type: none"> • Read only • Safety parameter (+Safety parameter list+) 	



Diagnostics and fault elimination

Diagnostic parameters
Safety diagnostics

Address	Name / setting range / [default setting]	Information
0x2871:033	Safety interface bits: SLS1 observed <ul style="list-style-type: none"> • Read only • Safety parameter (+Safety parameter list+) 	Display of the individual bits from the status word of the safety functions. 0x2870:002 Logic: 1 = function active
0x2871:034	Safety interface bits: SLS2 observed <ul style="list-style-type: none"> • Read only • Safety parameter (+Safety parameter list+) 	
0x2871:035	Safety interface bits: SLS3 observed <ul style="list-style-type: none"> • Read only • Safety parameter (+Safety parameter list+) 	
0x2871:036	Safety interface bits: SLS4 observed <ul style="list-style-type: none"> • Read only • Safety parameter (+Safety parameter list+) 	
0x2871:037	Safety interface bits: SMS observed <ul style="list-style-type: none"> • Read only • Safety parameter (+Safety parameter list+) 	
0x2871:038	Safety interface bits: SSM within limits <ul style="list-style-type: none"> • Read only • Safety parameter (+Safety parameter list+) 	
0x2871:039	Safety interface bits: SDIpos observed <ul style="list-style-type: none"> • Read only • Safety parameter (+Safety parameter list+) 	
0x2871:040	Safety interface bits: SDIneg observed <ul style="list-style-type: none"> • Read only • Safety parameter (+Safety parameter list+) 	
0x2871:041	Safety interface bits: SLP1 observed <ul style="list-style-type: none"> • Read only • Safety parameter (+Safety parameter list+) 	
0x2871:042	Safety interface bits: SLP2 observed <ul style="list-style-type: none"> • Read only • Safety parameter (+Safety parameter list+) 	
0x2871:043	Safety interface bits: SLP3 observed <ul style="list-style-type: none"> • Read only • Safety parameter (+Safety parameter list+) 	
0x2871:044	Safety interface bits: SLP4 observed <ul style="list-style-type: none"> • Read only • Safety parameter (+Safety parameter list+) 	
0x2871:045	Safety interface bits: SCA1 within limits <ul style="list-style-type: none"> • Read only • Safety parameter (+Safety parameter list+) 	
0x2871:046	Safety interface bits: SCA2 within limits <ul style="list-style-type: none"> • Read only • Safety parameter (+Safety parameter list+) 	
0x2871:047	Safety interface bits: SCA3 within limits <ul style="list-style-type: none"> • Read only • Safety parameter (+Safety parameter list+) 	
0x2871:048	Safety interface bits: SCA4 within limits <ul style="list-style-type: none"> • Read only • Safety parameter (+Safety parameter list+) 	
0x2871:049	Safety interface bits: PDSSpos observed <ul style="list-style-type: none"> • Read only • Safety parameter (+Safety parameter list+) 	
0x2871:050	Safety interface bits: PDSSneg observed <ul style="list-style-type: none"> • Read only • Safety parameter (+Safety parameter list+) 	

Diagnostics and fault elimination

Diagnostic parameters
Safety diagnostics



Address	Name / setting range / [default setting]	Information
0x2871:051	Safety interface bits: SOS observed <ul style="list-style-type: none"> • Read only • Safety parameter (+Safety parameter list+) 	
0x2871:052	Safety interface bits: SBC activated <ul style="list-style-type: none"> • Read only • Safety parameter (+Safety parameter list+) 	
0x2871:053	Safety interface bits: SHom active <ul style="list-style-type: none"> • Read only • Safety parameter (+Safety parameter list+) 	
0x2871:054	Safety interface bits: SHom available <ul style="list-style-type: none"> • Read only • Safety parameter (+Safety parameter list+) 	
0x2871:055	Safety interface bits: Safe speed OK <ul style="list-style-type: none"> • Read only • Safety parameter (+Safety parameter list+) 	
0x2871:056	Safety interface bits: n=0 <ul style="list-style-type: none"> • Read only • Safety parameter (+Safety parameter list+) 	
0x2871:057	Safety interface bits: Positive direction <ul style="list-style-type: none"> • Read only • Safety parameter (+Safety parameter list+) 	
0x2871:064	Safety interface bits: Error active <ul style="list-style-type: none"> • Read only • Safety parameter (+Safety parameter list+) 	
0x2871:073	Safety interface bits: AIS S-Bus <ul style="list-style-type: none"> • Read only • Safety parameter (+Safety parameter list+) 	Display of individual bits from the I/O status word of the inputs. 0x2870:003 Logic: 1 = function active
0x2871:074	Safety interface bits: AIE S-Bus <ul style="list-style-type: none"> • Read only • Safety parameter (+Safety parameter list+) 	
0x2871:075	Safety interface bits: SHom_Start S-Bus <ul style="list-style-type: none"> • Read only • Safety parameter (+Safety parameter list+) 	
0x2871:076	Safety interface bits: SHom_Load S-Bus <ul style="list-style-type: none"> • Read only • Safety parameter (+Safety parameter list+) 	



Diagnostics and fault elimination

Diagnostic parameters
Safety diagnostics

Address	Name / setting range / [default setting]	Information	
0x2874	S-Bus control data	Display of the control data from the safety bus, filtered with the functions parameterized via S-Bus. Logic: 1 = Function requested	
	<ul style="list-style-type: none"> • Read only • Safety parameter (+Safety parameter list+) 		
	Bit 0		STO
	Bit 1		SS1
	Bit 2		SS2
	Bit 3		SLS1
	Bit 4		SLS2
	Bit 5		SLS3
	Bit 6		SLS4
	Bit 7		SDIpos
	Bit 8		SDIneg
	Bit 9		ES
	Bit 10		SLI
	Bit 12		SLP1
	Bit 13		SLP2
	Bit 14		SLP3
	Bit 15		SLP4
	Bit 16		AIS
	Bit 17		AIE
	Bit 18		SOS
	Bit 19		RMS
	Bit 20		SHom_Start
	Bit 21		SHom_Load
	Bit 22		PDSS
	Bit 23		SSE
Bit 25	SBC		

Diagnostics and fault elimination

Diagnostic parameters
Safety diagnostics



Address	Name / setting range / [default setting]	Information
0x2875:001	S-Bus control bits: STO • Read only • Safety parameter (+Safety parameter list+)	Display of the control bit status from the safety bus without filtering and changing the logic.
0x2875:002	S-Bus control bits: SS1 • Read only • Safety parameter (+Safety parameter list+)	
0x2875:003	S-Bus control bits: SS2 • Read only • Safety parameter (+Safety parameter list+)	
0x2875:004	S-Bus control bits: SLS1 • Read only • Safety parameter (+Safety parameter list+)	
0x2875:005	S-Bus control bits: SLS2 • Read only • Safety parameter (+Safety parameter list+)	
0x2875:006	S-Bus control bits: SLS3 • Read only • Safety parameter (+Safety parameter list+)	
0x2875:007	S-Bus control bits: SLS4 • Read only • Safety parameter (+Safety parameter list+)	
0x2875:008	S-Bus control bits: SDIpos • Read only • Safety parameter (+Safety parameter list+)	
0x2875:009	S-Bus control bits: SDIneg • Read only • Safety parameter (+Safety parameter list+)	
0x2875:010	S-Bus control bits: ES • Read only • Safety parameter (+Safety parameter list+)	
0x2875:011	S-Bus control bits: SLI • Read only • Safety parameter (+Safety parameter list+)	
0x2875:013	S-Bus control bits: SLP1 • Read only • Safety parameter (+Safety parameter list+)	
0x2875:014	S-Bus control bits: SLP2 • Read only • Safety parameter (+Safety parameter list+)	
0x2875:015	S-Bus control bits: SLP3 • Read only • Safety parameter (+Safety parameter list+)	
0x2875:016	S-Bus control bits: SLP4 • Read only • Safety parameter (+Safety parameter list+)	
0x2875:017	S-Bus control bits: AIS • Read only • Safety parameter (+Safety parameter list+)	
0x2875:018	S-Bus control bits: AIE • Read only • Safety parameter (+Safety parameter list+)	
0x2875:019	S-Bus control bits: SOS • Read only • Safety parameter (+Safety parameter list+)	



Diagnostics and fault elimination

Diagnostic parameters
Safety diagnostics

Address	Name / setting range / [default setting]	Information
0x2875:020	S-Bus control bits: RMS • Read only • Safety parameter (+Safety parameter list+)	
0x2875:021	S-Bus control bits: SHom_Start • Read only • Safety parameter (+Safety parameter list+)	
0x2875:022	S-Bus control bits: SHom_Load • Read only • Safety parameter (+Safety parameter list+)	
0x2875:023	S-Bus control bits: PDSS • Read only • Safety parameter (+Safety parameter list+)	
0x2875:024	S-Bus control bits: SSE • Read only • Safety parameter (+Safety parameter list+)	
0x2875:026	S-Bus control bits: SBC • Read only • Safety parameter (+Safety parameter list+)	
0x28E8:001	Diagnostic: Configuration diagnostic value 1 • Safety parameter (+Safety parameter list+)	"Diagnostic value 1" configuration • Display in 0x28E9:001 . • The configured value can be recorded via the oscilloscope function integrated in the Lenze tool.
	0 Not used	Default setting for Advanced Safety
	1 PDSS - Current monitored speed	Current PDSS speed Default setting for Extended Safety
	2 SS1, SS2 - Current speed ramp	Deceleration ramp for safety functions SS1 and SS2
	10 Internal actual speed nSD	Speed value Safe-Drive, internally determined actual speed from the safety application
	11 Internal actual speed nBD	Speed value Base-Drive, internally determined actual speed from standard application
	23 FSoE - Slave Command	FSoE command from safety slave
	24 FSoE - Master Command	FSoE command from safety master
	25 FSoE - Slave SafeData 0	FSoE data, byte 0 from safety slave
	26 FSoE - Master SafeData 0	FSoE data, byte 0 from safety master
30 Internal event 1	Currently active event from the event history 0x2130:002	
0x28E8:002	Diagnostic: Configuration diagnostic value 2 • Safety parameter (+Safety parameter list+)	"Diagnostic value 2" configuration • Display in 0x28E9:002 . • The configured value can be recorded via the oscilloscope function integrated in the Lenze tool.
	0 Not used	Default setting for Advanced Safety
	1 PDSS - Current monitored speed	Current PDSS speed
	2 SS1, SS2 - Current speed ramp	Deceleration ramp for safety functions SS1 and SS2 Default setting for Extended Safety
	10 Internal actual speed nSD	Speed value Safe-Drive, internally determined actual speed from the safety application
	11 Internal actual speed nBD	Speed value Base-Drive, internally determined actual speed from standard application
	23 FSoE - Slave Command	FSoE command from safety slave
	24 FSoE - Master Command	FSoE command from safety master
	25 FSoE - Slave SafeData 0	FSoE data, byte 0 from safety slave
	26 FSoE - Master SafeData 0	FSoE data, byte 0 from safety master
30 Internal event 1	Currently active event from the event history 0x2130:002	
0x28E9:001	Diagnostic: Diagnostic value 1 • Read only • Safety parameter (+Safety parameter list+)	Display of the value selected in 0x28E8:001 .

Diagnostics and fault elimination

Diagnostic parameters
Service life diagnostics



Address	Name / setting range / [default setting]	Information
0x28E9:002	Diagnostic: Diagnostic value 2 • Read only • Safety parameter (+Safety parameter list+)	Display of the value selected in 0x28E8:002.

16.3.6 Service life diagnostics

The following parameters provide some information about the use of the inverter.

This includes the following information:

- Operating and power-on time of the inverter/control unit
- Operating time of the internal fan
- Number of switching cycles of the mains voltage
- Number of switching cycles of the relay
- Number of short-circuits and earth faults that have occurred
- Display of the number of "Clamp responded too often" errors that have occurred.

Parameter

Address	Name / setting range / [default setting]	Information
0x2D81:001	Life-diagnosis: Operating time • Read only: x s	Display showing for how long the device has been running so far (device status "operation enabled").
0x2D81:002	Life-diagnosis: Power-on time • Read only: x s	Display showing for how long the device has been supplied with line voltage so far.
0x2D81:004	Life-diagnosis: Main switching cycles • Read only	Display of the number of switching cycles of the mains voltage.
0x2D81:006	Life-diagnosis: Short-circuit counter • Read only	Display of the number of short circuits that have occurred.
0x2D81:007	Life-diagnosis: Earth fault counter • Read only	Display of the number of earth faults that have occurred.
0x2D81:009	Life-diagnosis: Fan operating time • Read only: x s	Display showing for how long the internal fan has been running so far.

16.3.7 Device identification

The following parameters show some general information about the inverter.

Parameter

Address	Name / setting range / [default setting]	Information
0x2000:001	Device data: Product code • Read only	Product code of the complete device.
0x2000:002	Device data: Serial number • Read only	Serial number of the complete device. Example: "0000000000000000XYZXYZ"
0x2000:003	Device data: Production date • Read only	The date of manufacture and the time of the device, e. g. "2013-03-13 11: 59: 04".
0x2000:004	Device data: CU firmware version • Read only	Firmware version of the control unit. Example: "01.00.01.00"
0x2000:006	Device data: CU bootloader version • Read only	Bootloader version of the control unit. Example: "2015.10-20180517"
0x2000:008	Device data: Object directory version • Read only	Example: "108478"
0x2000:019	Device data: Safety module version • Read only	
0x2002:006	Device module: CU serial number • Read only	Serial number of the control unit.
0x2002:007	Device module: PU serial number • Read only	Serial number of the power unit.
0x67FF	Device profile number • Read only	



16.4 Event handling

The inverter has various monitoring functions that protect the drive against impermissible operating conditions.

If monitoring functions respond, events with different levels of severity are triggered.

Diagnostics and fault elimination

Event handling
Severity



16.4.1 Severity

The severity of an event determines the response of the inverter.

The events are logged in different places.

Severity	Response	Reset required
No response	<ul style="list-style-type: none"> The event does not trigger a response in the inverter. The running process is not affected. 	-
Information	<ul style="list-style-type: none"> The event does not trigger a response in the inverter. The running process is not affected. Logbook entry only. 	-
Warning	<ul style="list-style-type: none"> The 'Warning' status is set. The running process is not affected. If the event is no longer active, the warning is automatically reset. 	-
Warning locked	<ul style="list-style-type: none"> The 'Warning' status is set. The running process is not affected. If the event is no longer active, the warning must be actively reset. 	•
Error > logbook entry only	<ul style="list-style-type: none"> The 'Error' status is set. The running process is not affected. Logbook entry only. Response by external devices possible. 	•
Error > application quick stop > quick stop	<ul style="list-style-type: none"> The 'Error' status is set. The drive is brought to a standstill with the quick stop ramp of the application. The inverter remains enabled during standstill. 	•
Error > inverter quick stop > quick stop	<ul style="list-style-type: none"> The 'Error' status is set. The drive is brought to a standstill with the quick stop ramp of the inverter. The inverter remains enabled during standstill. 	•
Error > inverter quick stop > inverter disabled	<ul style="list-style-type: none"> The 'Error' status is set. The drive is brought to a standstill with the quick stop ramp of the inverter. The inverter is disabled during standstill. The motor has no torque. When the automatic brake is activated, a brake controlled by the inverter is applied. 	•
Error > CiA402	<p>In case of serious errors:</p> <ul style="list-style-type: none"> The 'Error' status is set. The inverter is disabled immediately. The motor has no torque. When the automatic brake is activated, a brake controlled by the inverter is applied. 	•
	<p>In case of slight errors:</p> <ul style="list-style-type: none"> In 0x605E a transition response can be set. The 'Fault reaction active' status is set as long as the transition response is active. <p>When the standstill is reached or the timeout time has expired:</p> <ul style="list-style-type: none"> The 'Error' status is set. The inverter is disabled immediately. The motor has no torque. When the automatic brake is activated, a brake controlled by the inverter is applied. 	•
Error > inverter disabled	<ul style="list-style-type: none"> The 'Error' status is set. The inverter is disabled immediately. The motor has no torque. When the automatic brake is activated, a brake controlled by the inverter is applied. 	•



Logging

Severity	Display in CiA status word 0x6041	Display in event monitor 0x2010:002	Display in Engineering Tool	Logbook entry
No response	-	0	-	-
Information	-	11	•	•
Warning	Bit 7 = 1	2	•	•
Warning locked	Bit 7 = 1	13	•	•
Error > logbook entry only	Bit 3 = 1	18	•	•
Error > application quick stop > quick stop	Bit 3 = 1	19	•	•
Error > inverter quick stop > quick stop	Bit 3 = 1	20	•	•
Error > inverter quick stop > inverter disabled	Bit 3 = 1	21	•	•
Error > CiA402	Bit 3 = 1	1	•	•
Error > inverter disabled	Bit 3 = 1	23	•	•

16.4.2 Configuring the severity

For certain events, the severity level can be configured via parameters. This allows the response to be adapted to the application.

In the overview of event IDs you will find the preset for each event and, if necessary, the parameter with which you can adjust the severity.

► [Event ID overview](#) 393

16.4.3 Configuring the transition response for minor faults

For slight errors, a transition response can be set before the 'Error' status is set.

Slight errors are predefined and cannot be changed by the user.

The transition response is active until standstill is reached or the timeout time has elapsed.

The inverter can still control the motor in a controlled manner.

List of defined slight errors

Event ID	Event	Severity	Configurable in
537478016	0x20094380 Fault - Motor temperature sensor	Warning	0x2D49:002 0x2D49:003 0x2D49:004
537490179	0x20097303 Fault - Motor feedback		-
537490304	0x20097380 Motor encoder - Communication error		-
537526018	0x2009FF02 Fault - Motor holding brake	Fault	0x2820:006
805405057	0x30018181 EtherCAT - Communication error		-
805406464	0x30018700 EtherCAT - Sync error		-
805406465	0x30018701 Sync PLL - Time-out	Fault	-

Parameter

Address	Name / setting range / [default setting]	Information
0x605E	CiA: Response to minor faults	Set the transition response for slight errors. List of minor faults: ► Configuring the transition response for minor faults
	-3 Advanced quick stop (hoist)	
	-2 Advanced quick stop	If possible, the motor is brought to a standstill with the "quick stop" function. If this is not possible (e.g. in the event of an encoder error), a braking torque is generated with reverse current braking or short-circuit braking.
	0 No transition response	The motor is no longer energized.
	2 Quick stop	The motor is brought to a standstill with the "quick stop" function.

Diagnostics and fault elimination

Event handling
Event reset



Address	Name / setting range / [default setting]	Information
0x2826	Timeout for error response 0 ... [4] ... 100 s	If the transition reaction specified in CiA: Response to minor faults is not completed within this time, the inverter changes to the 'Error' state. The motor is no longer energized. When the automatic brake is activated, a brake controlled by the inverter is applied. ▶ 0x2820:001

16.4.4 Event reset

Depending on the severity of the event, the event must be reset so that inverter operation can continue.

Resetting is possible only when the cause of triggering the event has been eliminated.

Options to reset events:

- Via buttons in the Engineering Tools in the "Diagnostics" tab
- Via network with bit 7 in CiA 402 control word [0x6040](#)
- Via parameter [0x2841](#)

Notes:

- Certain events can only be reset by mains switching.
- Certain events (e. g. earth fault or short circuit of the motor phases) may cause a blocking time.
 - The error can be reset only after the blocking time has elapsed.
 - An active blocking time is displayed via bit 14 in the inverter status word. [0x2831](#).
- Details: ▶ [Causes and remedies](#)

Parameter

Address	Name / setting range / [default setting]	Information
0x2840	Error reset time • Read only: x ms	Display of the remaining blocking time until the event can be reset.
0x2841	Reset error 0 ... [0] ... 1	1 = reset error
0x2022:035	Device commands: Restart Device	Parameter for interaction with engineering tools.
	0 Off / ready	Only status feedback
	1 On / start	Execute device command
	2 In progress	Only status feedback
	3 Action cancelled	
	4 No access	
5 No access (Device disabled)		



16.5 Events, causes and remedies

16.5.1 Event ID overview

The following table contains the most important event IDs of the device in ascending order.

- Clicking the event ID shows you a detailed description of the event.
- If the device displays an "internal event" that is not listed here, restart the device. If the event persists, make a note of the event ID and contact the manufacturer.

Event ID	Event	Severity	Configurable in
537469728	0x20092320 Short circuit or earth leakage at the motor end	Fault	-
537469760	0x20092340 Short circuit at the motor end	Fault	-
537469777	0x20092351 Motor utilization too high (i ² t)		-
537469824	0x20092380 Trouble - utilization of the power section (ixt) too high	Fault	-
537469825	0x20092381 Warning - Utilization of the power section (ixt) too high	Warning	-
537469826	0x20092382 Fault - Device utilization (ixt) too high		-
537469827	0x20092383 Warning - Device utilization (ixt) too high	Warning	-
537469828	0x20092384 Ultimate motor current reached		0x2D46:001 0x2D46:002
537469829	0x20092385 Parameterized max. motor current > max. device current	Warning	-
537469830	0x20092386 Clamp is active	Warning	-
537469831	0x20092387 Clamp responded too often	Fault	-
537469833	0x20092389 Warning - device utilization (ixt) too high	Warning	-
537469835	0x2009238B Trouble - Device utilization (ixt) too high	Fault	-
537473552	0x20093210 Fault - DC bus overvoltage	Fault	-
537473568	0x20093220 Fault - DC bus undervoltage	Trouble	-
537477648	0x20094210 Fault - Power unit overtemperature	Fault	-
537477760	0x20094280 Fault - Heat sink temperature sensor	Fault	-
537477761	0x20094281 Heat sink fan warning	Fault	-
537477762	0x20094282 Thermal overload of control unit	Fault	-
537477904	0x20094310 Motor overtemperature	Warning	0x2D49:002
537478016	0x20094380 Fault - Motor temperature sensor	Warning	0x2D49:002 0x2D49:003 0x2D49:004
537478017	0x20094381 Error - Motor temperature monitoring (PTC)		-
537478018	0x20094382 Motor overtemperature (load encoder/master encoder)		-
537478019	0x20094383 Motor temperature sensor error (load encoder/master encoder)		-
537481490	0x20095112 External supply voltage critical	Warning	-
537485706	0x2009618A Warning - Internal fan	Warning	-
537486096	0x20096310 Incorrect parameter set download	Warning	-
537486112	0x20096320 Parameter error in object	Warning	-
537486248	0x200963A8 Persistent data not saved correctly.	Fault	-
537489537	0x20097081 Fault - Analog input 1		-
537489538	0x20097082 Analog input 2 fault		-
537489697	0x20097121 Fault - Pole position identification	Fault	-
537490179	0x20097303 Fault - Motor feedback		-
537490180	0x20097304 Error - Load encoder/master encoder		-
537490304	0x20097380 Motor encoder - Communication error		-
537490305	0x20097381 Motor encoder - wrong absolute value because motor speed is too high		-
537490306	0x20097382 Load encoder/master encoder - Communication error		-
537490307	0x20097383 Load encoder/master encoder - wrong absolute value because motor speed is too high		-
537490308	0x20097384 Motor encoder (EnDat) - Communication error	Fault	-
537490310	0x20097386 Load encoder (EnDat) - Communication error	Fault	-
537526016	0x2009FF00 Fatal internal error	Fault	-
537526017	0x2009FF01 Fatal internal communication error	Fault	-
537526018	0x2009FF02 Fault - Motor holding brake	Fault	0x2820:006

Diagnostics and fault elimination

Events, causes and remedies

Event ID overview



Event ID	Event	Severity	Configurable in
537526019	0x2009FF03 Fatal internal error - task overflow	Fault	-
537526020	0x2009FF04 PPI - Motor movement too large		-
537526021	0x2009FF05 Safe torque off (STO) activated	Warning	-
537526022	0x2009FF06 Motor overspeed	Warning	0x2D44:002
537526023	0x2009FF07 Not permitted during identification or in test mode	Warning	-
537526024	0x2009FF08 Not permitted during identification	Warning	-
537526025	0x2009FF09 Motor phase missing	No response	0x2D45:001
537526026	0x2009FF0A Motor phase failure phase U	No response	0x2D45:001
537526027	0x2009FF0B Motor phase failure phase V	No response	0x2D45:001
537526028	0x2009FF0C Motor phase failure phase W	No response	0x2D45:001
537526029	0x2009FF0D No resolver connected - command cannot be executed	Warning	-
537526030	0x2009FF0E Speed too low - command cannot be executed	Warning	-
537526031	0x2009FF0F No resolver as motor encoder connected - command cannot be executed	Warning	-
537526032	0x2009FF10 Time-out during resolver identification	Warning	-
537526033	0x2009FF11 Numeric problem during resolver identification	Warning	-
537526034	0x2009FF12 Inverter error too large	Warning	-
537526035	0x2009FF13 Identification aborted		-
537526036	0x2009FF14 Not permitted in state 'operation enabled' or 'quick stop active'	Warning	-
537526037	0x2009FF15 No HIPERFACE® absolute value encoder as motor encoder connected - command cannot be executed	Warning	-
537526038	0x2009FF16 Connected HIPERFACE® motor encoder is not supported		-
537526039	0x2009FF17 Connected HIPERFACE® motor encoder is not supported - command cannot be executed	Warning	-
537526040	0x2009FF18 Communication time-out in manual control mode	Fault	-
537526041	0x2009FF19 Motor parameter identification fault	Fault	-
537526042	0x2009FF1A Connected HIPERFACE® load encoder/master encoder is not supported		-
537526043	0x2009FF1B Connected HIPERFACE® load encoder/master encoder is not supported - command cannot be executed	Warning	-
537526044	0x2009FF1C No resolver as load encoder/master encoder connected - command cannot be executed	Warning	-
537526045	0x2009FF1D No HIPERFACE® absolute value encoder as load encoder/master encoder connected - command cannot be executed	Warning	-
537526046	0x2009FF1E FIQ runtime error	Fault	-
537526048	0x2009FF20 Brand protection - check failed	Warning	-
537526049	0x2009FF21 Time-out holding brake feedforward control	Fault	-
537526050	0x2009FF22 Velocity error	Fault	-
537526051	0x2009FF23 Position error	Fault	-
537526054	0x2009FF26 Cable check - Motor movement too large	Fault	-
537526055	0x2009FF27 Cable check - Wrong motor angle detected	Fault	-
537526062	0x2009FF2E Connected motor encoder is not supported	Fault	-
537526063	0x2009FF2F Connected load encoder/master encoder is not supported	Fault	-
537526070	0x2009FF36 Warning - Brake resistor overload		-
537526071	0x2009FF37 Automatic start disabled	Fault	-
537526076	0x2009FF3C Backup created via device command	Information	-
537526077	0x2009FF3D Backup restored via device command	Information	-
537526080	0x2009FF40 Error - Brake transistor	Fault	-
537526081	0x2009FF41 Error - Charging circuit	Fault	-
537526082	0x2009FF42 Mains phase failure	Fault	-
537526083	0x2009FF43 Motor encoder requires restart of the device	Fault	-
537526084	0x2009FF44 Load encoder requires restart of the device	Fault	-
537526097	0x2009FF51 Internal communication to PLC failed	Fault	-
537526110	0x2009FF5E Invalid module combination in slot A and slot B	Fault	-
671158529	0x28011101 Initialization - Parameter value could not be written	Information	-
671158530	0x28011102 Load default setting - Parameter value could not be written	Warning	-



Diagnostics and fault elimination

Events, causes and remedies

Event ID overview

Event ID	Event	Severity	Configurable in
671158785	0x28011201 Parameters - Initialization failed	Warning	-
671158786	0x28011202 Parameters - Loading default values failed	Warning	-
671158787	0x28011203 Parameters - Loading TA default values failed	Warning	-
671159298	0x28011402 Opening the parameter description failed	Fault	-
671159299	0x28011403 Opening the parameter set failed	Fault	-
671219713	0x28020001 Logbook: Corrupt restore data	Information	-
671219773	0x2802003D Logbook cleared	Information	-
671219776	0x28020040 Logbook: Timeout restoring data	Information	-
671219777	0x28020041 Logbook: Error restoring data	Information	-
671219778	0x28020042 First boot with this firmware version	Information	-
671219779	0x28020043 Logbook was restored.	Information	-
671219780	0x28020044 Logbook: Error reading persistent data.	Information	-
671263317	0x2802AA55 The chronology of the logbook is not consistent	Information	-
671354881	0x28041001 CmpLenzeErrorManagementAccess loaded without errors	Information	-
671420673	0x28051101 Test-Mode - More Application Credit required, application is starting delayed	Warning	-
671420674	0x28051102 Application-Credit - Invalid license data	Warning	-
671420675	0x28051103 Application-Credit - License data missing	Warning	-
671421185	0x28051301 Boot application - More Application Credit required	Warning	-
704663682	0x2A005082 Internal error - Button S82	Warning	-
704663692	0x2A00508C Internal switch-off path - Error	Warning	-
704663693	0x2A00508D Internal switch-off path - Test pulse error	Warning	-
704663694	0x2A00508E SBC - Test pulse error	Warning	-
704663695	0x2A00508F SBC - Remains stuck at LOW	Warning	-
704663696	0x2A005090 Faulty internal adjustment data	Warning	-
704663828	0x2A005114 Reference voltage error	Warning	-
704663829	0x2A005115 6 V voltage error	Warning	-
704663830	0x2A005116 5 V voltage error	Warning	-
704663831	0x2A005117 3.3 V voltage error	Warning	-
704668032	0x2A006180 Internal error - STO activated	Warning	-
704668037	0x2A006185 Communication error - Basic device	Warning	-
704668038	0x2A006186 Synchronization error - Basic device	Information	-
704668039	0x2A006187 SBC - Device configuration incompatible	Warning	-
704668043	0x2A00618B HDSL - Device configuration incompatible	Warning	-
704668553	0x2A006389 New safety parameter set deleted	Information	-
704668554	0x2A00638A New safety parameter set loaded	Information	-
704668555	0x2A00638B Memory module - Access error	Warning	-
704668556	0x2A00638C Different safety parameter sets	Warning	-
704668557	0x2A00638D Extended Safety - No safety parameter set	Warning	-
704668558	0x2A00638E Extended Safety - Safety parameter set defect	Warning	-
704668559	0x2A00638F Safety parameter set - Format error	Warning	-
704668560	0x2A006390 Safety parameter set - Plausibility error	Warning	-
704668561	0x2A006391 Safety parameter set - Communication error	Warning	-
704668562	0x2A006392 Different safety addresses detected	Warning	-
704668563	0x2A006393 SSM - Wrong PDO version	Warning	-
704668565	0x2A006395 Internal limitation active	Warning	-
704676245	0x2A008195 FSoE - Unexpected command	Information	-
704676246	0x2A008196 FSoE - Unknown command	Information	-
704676247	0x2A008197 FSoE - Invalid connection ID	Information	-
704676248	0x2A008198 FSoE - CRC error	Information	-
704676249	0x2A008199 FSoE - Watchdog expired	Information	-
704676252	0x2A00819C FSoE - Invalid communication parameter data	Information	-
704676253	0x2A00819D FSoE - Invalid application parameter length	Information	-
704676254	0x2A00819E FSoE - Invalid application parameter data	Information	-
704676255	0x2A00819F FSoE - Passivated	Information	-

Diagnostics and fault elimination

Events, causes and remedies

Event ID overview



Event ID		Event	Severity	Configurable in
704676264	0x2A0081A8	FSoE - Invalid slave address	Information	-
704676265	0x2A0081A9	FSoE - Invalid communication parameter length	Information	-
704676266	0x2A0081AA	FSoE - Data exchange left	Information	-
704708488	0x2A00FF88	SS1/SS2 - Stop time exceeded	Warning	-
704708489	0x2A00FF89	SLS1 - Nlim1 exceeded	Warning	-
704708490	0x2A00FF8A	SLS2 - Nlim2 exceeded	Warning	-
704708491	0x2A00FF8B	SLS3 - Nlim3 exceeded	Warning	-
704708492	0x2A00FF8C	SLS4 - Nlim4 exceeded	Warning	-
704708493	0x2A00FF8D	SLS/SMS - Error stop not executed	Warning	-
704708494	0x2A00FF8E	SDIpos - Wrong direction	Warning	-
704708495	0x2A00FF8F	SDIneg - Wrong direction	Warning	-
704708496	0x2A00FF90	SMS - Nmax exceeded	Warning	-
704708497	0x2A00FF91	SOS - Tolerance limit exceeded	Warning	-
704708498	0x2A00FF92	No feedback system configured	Warning	-
704708501	0x2A00FF95	SS1/SS2 - Speed ramp exceeded	Warning	-
704708502	0x2A00FF96	SLI - Safely limited increment exceeded	Warning	-
704708503	0x2A00FF97	SLP1 - Position limits exceeded	Warning	-
704708504	0x2A00FF98	SLP2 - Position limits exceeded	Warning	-
704708505	0x2A00FF99	SLP3 - Position limits exceeded	Warning	-
704708506	0x2A00FF9A	SLP4 - Position limits exceeded	Warning	-
704708507	0x2A00FF9B	SLP - No home position	Warning	-
704708509	0x2A00FF9D	PDSS - Velocity exceeded	Warning	-
704708510	0x2A00FF9E	PDSS - Creep velocity SCS exceeded	Warning	-
704708518	0x2A00FFA6	SHom - Time-out	Warning	-
704708519	0x2A00FFA7	SHom - Home position deleted	Information	-
704708520	0x2A00FFA8	SHom - Maximum slip value exceeded	Warning	-
704708521	0x2A00FFA9	SHom - Tolerance of start position exceeded	Warning	-
704708522	0x2A00FFAA	SHom - Tolerance of position comparison exceeded	Warning	-
704708523	0x2A00FFAB	SSM - Invalid safe velocity	Warning	-
704708524	0x2A00FFAC	SSM - Encoder error	Warning	-
704708525	0x2A00FFAD	SSM - Resolver error	Warning	-
704708526	0x2A00FFAE	SSM - Error in standard device data	Warning	-
704708527	0x2A00FFAF	SSM - Speed deviation too high	Warning	-
704708528	0x2A00FFB0	SSM - Synchronization error	Warning	-
704708529	0x2A00FFB1	MUT - Muting function active	Information	-
704708530	0x2A00FFB2	MUT - Muting function completed	Information	-
704708531	0x2A00FFB3	MUT - Muting function aborted	Information	-
704708532	0x2A00FFB4	HDSL - Error encoder supply	Warning	-
704708533	0x2A00FFB5	HDSL - Encoder error detected	Warning	-
704708534	0x2A00FFB6	HDSL - Encoder error	Warning	-
704708535	0x2A00FFB7	SSM - HDSL encoder error	Warning	-
704708536	0x2A00FFB8	HDSL encoder - ID was set	Information	-
704708537	0x2A00FFB9	Internal product code incompatible	Warning	-
805306384	0x30000010	Internal error	Warning	-
805306385	0x30000011	Internal error	Warning	-
805306386	0x30000012	Internal error	Warning	-
805306387	0x30000013	Internal error	Warning	-
805306570	0x300000CA	Internal error	Warning	-
805306571	0x300000CB	Internal error	Warning	-
805311368	0x30001388	Internal error	Warning	-
805311369	0x30001389	CTRL - Feature not supported	Fault	-
805311370	0x3000138A	CTRL - Invalid index	Fault	-
805311371	0x3000138B	ISW - Invalid offset	Fault	-
805311373	0x3000138D	CTRL - Invalid size	Fault	-
805311374	0x3000138E	ISW - Invalid data	Fault	-



Diagnostics and fault elimination

Events, causes and remedies

Event ID overview

Event ID	Event	Severity	Configurable in
805311375	0x3000138F ISW - Not ready	Fault	-
805311376	0x30001390 CTRL - Busy	Fault	-
805311377	0x30001391 ISW - Cannot queue acyclic EtherCAT command	Warning	-
805311378	0x30001392 CFG - No memory left	Fault	-
805311379	0x30001393 CTRL - Invalid parameter	Fault	-
805311380	0x30001394 CTRL - Not found	Fault	-
805311382	0x30001396 ISW - Invalid state	Fault	-
805311383	0x30001397 ISW - Cannot add slave to timer list	Fault	-
805311384	0x30001398 SLV - Time-out	Fault	-
805311385	0x30001399 ISW - Open failed	Fault	-
805311386	0x3000139A LLA - Send failed	Fault	-
805311387	0x3000139B CFG - Error when queuing a mailbox command	Fault	-
805311388	0x3000139C ISW - Invalid mailbox command	Fault	-
805311389	0x3000139D ISW - Unknown mailbox protocol command	Fault	-
805311390	0x3000139E ISW - Access denied	Fault	-
805311394	0x300013A2 CFG - Invalid product key	Fault	-
805311395	0x300013A3 PRJ - Wrong format of master XML file	Fault	-
805311396	0x300013A4 CTRL - Function disabled	Fault	-
805311398	0x300013A6 PRJ - Mismatch of bus configuration and number of connected slaves	Fault	-
805311399	0x300013A7 PRJ - Error reading master XML file	Fault	-
805311401	0x300013A9 PRJ - Configurator error - cyclic commands are missing in master XML file	Fault	-
805311402	0x300013AA PRJ - AL_STATUS register read command is missing in master XML file	Fault	-
805311403	0x300013AB ISW - Fatal internal McSm error	Fault	-
805311404	0x300013AC SLV - Slave error	Fault	-
805311405	0x300013AD SLV - Frame lost, IDX mismatch	Fault	-
805311406	0x300013AE SLV - At least one EtherCAT command is missing in the received frame	Fault	-
805311408	0x300013B0 CTRL - IOCTL_EC_IOCTL_DC_LATCH_REQ_LTIMVALS not possible in DC Latching auto read mode	Fault	-
805311409	0x300013B1 SLV - Auto increment address - increment mismatch (slave missing)	Fault	-
805311410	0x300013B2 CTRL - Slave in invalid state, e.g. not in OP (API not callable in this state)	Fault	-
805311411	0x300013B3 SLV - Fixed station address lost or slave missing - FPRD to AL_STATUS failed	Fault	-
805311412	0x300013B4 PRJ - Too many cyclic commands in XML configuration file	Fault	-
805311414	0x300013B6 RAP - Master core not accessible	Fault	-
805311415	0x300013B7 SLV - COE mailbox send - WKC error	Fault	-
805311416	0x300013B8 SLV - COE mailbox receive - WKC error	Fault	-
805311417	0x300013B9 CTRL - No mailbox support	Fault	-
805311418	0x300013BA CoE - Protocol not supported	Fault	-
805311419	0x300013BB PRJ - EoE protocol not supported	Fault	-
805311420	0x300013BC FoE . Protocol not supported	Fault	-
805311421	0x300013BD PRJ - SoE protocol not supported	Fault	-
805311422	0x300013BE PRJ - VoE protocol not supported	Fault	-
805311423	0x300013BF PRJ - Configuration violates evaluation limits	Fault	-
805311424	0x300013C0 CFG - Evaluation time expired	Fault	-
805311431	0x300013C7 COE - invalid slave state	Fault	-
805311432	0x300013C8 CoE - SDO Abort 'Toggle bit not alternated (0x05030000)'	Information	-
805311433	0x300013C9 CoE - SDO Abort 'SDO protocol time-out (0x05040000)'	Warning	-
805311434	0x300013CA CoE - SDO Abort 'Client/server command specifier not valid or unknown (0x05040001)'	Information	-
805311435	0x300013CB CoE - SDO Abort 'Invalid block size (block mode only) (0x05040002)'	Information	-
805311436	0x300013CC CoE - SDO Abort 'Invalid sequence number (block mode only) (0x05040003)'	Information	-

Diagnostics and fault elimination

Events, causes and remedies
Event ID overview



Event ID		Event	Severity	Configurable in
805311437	0x300013CD	CoE - SDO Abort 'CRC error (block mode only) (0x05040004)'	Information	-
805311438	0x300013CE	CoE - SDO Abort 'Out of memory (0x05040005)'	Information	-
805311439	0x300013CF	CoE - SDO Abort 'Unsupported access to an object (0x06010000)'	Information	-
805311440	0x300013D0	CoE - SDO Abort 'Attempt to read a write only object (0x06010001)'	Information	-
805311441	0x300013D1	CoE - SDO Abort 'Attempt to write a read only object (0x06010002)'	Information	-
805311442	0x300013D2	CoE - SDO-Abort 'Object does not exist in the object dictionary (0x06020000)'	Information	-
805311443	0x300013D3	CoE - SDO Abort 'Object cannot be mapped to the PDO (0x06040041)'	Information	-
805311444	0x300013D4	CoE - SDO Abort 'Number and length of objects to be mapped exceed PDO length (0x06040042)'	Information	-
805311445	0x300013D5	CoE - SDO Abort 'General parameter incompatibility (0x06040043)'	Information	-
805311446	0x300013D6	CoE - SDO Abort 'General internal incompatibility in the device (0x06040047)'	Information	-
805311447	0x300013D7	CoE - SDO Abort 'Access failed due to a hardware error (0x06060000)'	Information	-
805311448	0x300013D8	CoE - SDO Abort 'Data type or length of service parameters do not match (0x06070010)'	Information	-
805311449	0x300013D9	CoE - SDO Abort 'Data type does not match, service parameter too high (0x06070012)'	Information	-
805311450	0x300013DA	CoE - SDO Abort 'Data type does not match, service parameter too low (0x06070013)'	Information	-
805311451	0x300013DB	CoE - SDO Abort 'Subindex does not exist (0x06090011)'	Information	-
805311452	0x300013DC	CoE - SDO Abort 'Write access - Parameter value exceeds limits (0x06090030)'	Information	-
805311453	0x300013DD	CoE - SDO Abort 'Write access - Parameter value too high (0x06090031)'	Information	-
805311454	0x300013DE	CoE - SDO Abort 'Write access - Parameter value too low (0x06090032)'	Information	-
805311455	0x300013DF	CoE - SDO Abort 'Maximum value less than minimum value (0x06090036)'	Information	-
805311456	0x300013E0	CoE - SDO Abort 'General error (0x08000000)'	Information	-
805311457	0x300013E1	CoE - SDO Abort 'Data cannot be transferred/stored in application (0x08000020)'	Information	-
805311458	0x300013E2	CoE - SDO Abort 'Local control - Data cannot be transferred/stored in application (0x08000021)'	Information	-
805311459	0x300013E3	CoE - SDO Abort 'Actual device state - Data cannot be transferred/stored in application (0x08000022)'	Information	-
805311460	0x300013E4	CoE - SDO Abort 'Object dictionary - Dynamic generation fails or object dictionary is missing (0x08000023)'	Information	-
805311461	0x300013E5	CoE - SDO Abort 'Unknown abort code'	Information	-
805311462	0x300013E6	CoE - Invalid parameter	Information	-
805311463	0x300013E7	CoE - CoE protocol not supported	Information	-
805311464	0x300013E8	CoE - Unknown FoE error	Information	-
805311465	0x300013E9	CoE - FoE error 'Not found'	Information	-
805311466	0x300013EA	CoE - FoE error 'Access denied'	Information	-
805311467	0x300013EB	CoE - FoE error 'Disk full'	Information	-
805311468	0x300013EC	CoE - FoE error 'Illegal'	Information	-
805311469	0x300013ED	CoE - FoE error 'Wrong packet number'	Information	-
805311470	0x300013EE	CoE - FoE error 'Already existing'	Information	-
805311471	0x300013EF	CoE - FoE error 'User missing'	Information	-
805311472	0x300013F0	CoE - FoE error 'Only possible in bootstrap'	Information	-
805311473	0x300013F1	CoE - FoE error 'No bootstrap'	Information	-
805311474	0x300013F2	CoE - FoE error 'No access rights'	Information	-
805311475	0x300013F3	CoE - FoE error 'Program error'	Information	-
805311476	0x300013F4	CoE - FoE error 'Invalid parameter'	Information	-
805311480	0x300013F8	CTRL - Master configuration not found	Fault	-
805311481	0x300013F9	SLV - Command error while EEPROM upload	Fault	-



Diagnostics and fault elimination

Events, causes and remedies

Event ID overview

Event ID	Event	Severity	Configurable in
805311482	0x300013FA SLV - Command error while EEPROM download	Fault	-
805311483	0x300013FB PRJ - Cyclic command too long	Fault	-
805311484	0x300013FC PRJ - Invalid input offset in cyc cmd, please check InputOffs	Fault	-
805311485	0x300013FD PRJ - Invalid output offset in cyc cmd, please check OutputOffs	Fault	-
805311753	0x30001509 RAP - Invalid cookie	Fault	-
805311754	0x3000150A RAP - Watchdog expired	Fault	-
805311755	0x3000150B RAP - Connecting 2nd server denied, multi server support is disabled	Fault	-
805311756	0x3000150C RAP - Logon aborted	Fault	-
805311757	0x3000150D RAP - Invalid version	Fault	-
805311769	0x30001519 RAP - Server stopped	Fault	-
805311770	0x3000151A RAP - Watchdog expired	Fault	-
805311771	0x3000151B RAP - Reconnect time expired	Fault	-
805311772	0x3000151C RAP - Client logged on	Fault	-
805311773	0x3000151D RAP - Client reconnected	Fault	-
805311774	0x3000151E RAP - Socket changed after reconnect	Fault	-
805311817	0x30001549 DCM - Init function not called or call not successful	Fault	-
805311818	0x3000154A DCM - Controller error - synchronization out of limit	Fault	-
805311819	0x3000154B DCM - Not enough memory	Fault	-
805311820	0x3000154C DCM - Hardware layer - (BSP) invalid	Fault	-
805311821	0x3000154D DCM - Hardware layer - Error while modifying the timer	Fault	-
805311822	0x3000154E DCM - Hardware layer - Timer is not running	Fault	-
805311823	0x3000154F DCM - Hardware layer - Function is called on wrong CPU	Fault	-
805311881	0x30001589 EtherCAT - State change of master successful	Fault	-
805311882	0x3000158A EtherCAT - Bus scan successful	Fault	-
805311883	0x3000158B EtherCAT - Bus scan error	Fault	-
805311884	0x3000158C EtherCAT - Distributed clocks state	Fault	-
805311885	0x3000158D EtherCAT - Distributed clocks - Latching state	Fault	-
805311886	0x3000158E CoE - SDO download failure	Information	-
805311887	0x3000158F CoE - SDO upload failure	Information	-
805311888	0x30001590 CoE - OD-list upload failure	Information	-
805311889	0x30001591 CoE - Object description upload failure	Information	-
805311890	0x30001592 CoE - Object entry description upload failure	Information	-
805311891	0x30001593 CoE - Emergency transfer failure	Information	-
805311892	0x30001594 CoE - Emergency request	Information	-
805311893	0x30001595 Cyclic command WKC error	Fault	-
805311894	0x30001596 Master init command WKC error	Warning	-
805311895	0x30001597 Slave init command WKC error	Warning	-
805311896	0x30001598 EoE receive WKC error	Warning	-
805311897	0x30001599 CoE receive WKC error	Warning	-
805311898	0x3000159A FoE receive WKC error	Fault	-
805311899	0x3000159B SoE receive - WKC error	Warning	-
805311900	0x3000159C EoE send WKC error	Warning	-
805311901	0x3000159D CoE send WKC error	Warning	-
805311902	0x3000159E FoE send WKC error	Warning	-
805311903	0x3000159F SoE send - WKC error	Warning	-
805311904	0x300015A0 Retry sending a frame	Fault	-
805311905	0x300015A1 Response on Ethernet frame	Fault	-
805311906	0x300015A2 Additional error information	Fault	-
805311907	0x300015A3 EtherCAT command - IDX actual value	Fault	-
805311908	0x300015A4 EtherCAT command - IDX set value	Fault	-
805311909	0x300015A5 Init command response error - No response	Warning	-
805311910	0x300015A6 Init command response error - Validation error	Warning	-
805311911	0x300015A7 Init command response error - Failed	Warning	-
805311912	0x300015A8 Master init command response error - No response	Warning	-

Diagnostics and fault elimination

Events, causes and remedies
Event ID overview



Event ID		Event	Severity	Configurable in
805311913	0x300015A9	Master init command response error - Validation error	Warning	-
805311914	0x300015AA	Missing EtherCAT command in Ethernet frame	Fault	-
805311915	0x300015AB	Mailbox init command timeout	Warning	-
805311916	0x300015AC	At least one EtherCAT slave not in 'Operational'	Warning	-
805311917	0x300015AD	EtherCAT cable connected	Information	-
805311918	0x300015AE	EtherCAT cable not connected	Information	-
805311919	0x300015AF	Cyclic commands - Time-out	Fault	-
805311920	0x300015B0	Redundant operation - Ethernet cable is missing at 2nd EtherCAT interface	Warning	-
805311921	0x300015B1	At least one slave is in state 'Error'	Warning	-
805311922	0x300015B2	Slave error	Warning	-
805311923	0x300015B3	Communication to device interrupted	Warning	-
805311924	0x300015B4	SDO abort	Warning	-
805311925	0x300015B5	DC slaves are 'in-sync'	Information	-
805311926	0x300015B6	DC slaves are 'out-of-sync'	Warning	-
805311927	0x300015B7	DC single latch on slave	Fault	-
805311928	0x300015B8	MbxTferRcv - file upload failure	Fault	-
805311929	0x300015B9	MbxTferRcv - file download failure	Fault	-
805311930	0x300015BA	Client registration lost	Fault	-
805311931	0x300015BB	Redundant operation - Ethernet cable connected	Information	-
805311932	0x300015BC	SoE write error init command mbox	Warning	-
805311960	0x300015D8	Hot Connect - all groups detected	Information	-
805311961	0x300015D9	Hot Connect - all group errors detected	Warning	-
805311962	0x300015DA	Slave removed from bus	Warning	-
805311963	0x300015DB	Slave added to bus	Information	-
805311964	0x300015DC	Topology was changed	Information	-
805311965	0x300015DD	Port closed	Information	-
805311966	0x300015DE	MbxTferRcv - Write IDN failure	Information	-
805311967	0x300015DF	MbxTferRcv - Read IDN failure	Information	-
805311968	0x300015E0	SoE - Emergency transfer failure	Information	-
805311969	0x300015E1	SoE - Emergency request	Information	-
805311970	0x300015E2	SoE - Notification transfer failure	Information	-
805311971	0x300015E3	SoE - Notification request	Information	-
805311972	0x300015E4	FoE abort	Information	-
805312069	0x30001645	Bus scan state	Information	-
805312070	0x30001646	Latch/Edge	Information	-
805312071	0x30001647	Latch/Edge - No edge	Information	-
805312072	0x30001648	Remote API diagnosis port - Connection established	Information	-
805312073	0x30001649	Remote API diagnosis port - Connection disconnected	Information	-
805312074	0x3000164A	Client registered from cookie	Information	-
805312075	0x3000164B	Client unregistered from cookie	Information	-
805312076	0x3000164C	Unknown notification	Information	-
805312077	0x3000164D	Slave latched	Information	-
805312078	0x3000164E	Bus scan - Error	Information	-
805312079	0x3000164F	Invalid number of slaves	Information	-
805312080	0x30001650	Cannot get SlaveInfo	Information	-
805312081	0x30001651	Deviation of slave	Information	-
805312082	0x30001652	Slave is not configured	Information	-
805312083	0x30001653	SlaveInfo	Information	-
805312084	0x30001654	SLV - Error retrieving configuration data	Information	-
805312085	0x30001655	Bus scan - Deviation	Information	-
805312086	0x30001656	Communication to device interrupted	Information	-
805312087	0x30001657	Slave is not in expected status	Warning	-
805312090	0x3000165A	Wrong response on 'configured fix address request' for slave	Information	-
805312091	0x3000165B	Wrong response on 'alias address' request for slave	Information	-



Diagnostics and fault elimination

Events, causes and remedies

Event ID overview

Event ID	Event	Severity	Configurable in
805312092	0x3000165C Cannot execute EC_IOCTL_DC_SLV_SYNC_DEVLIMIT_GET	Information	-
805312093	0x3000165D Cannot read latch timer	Information	-
805312094	0x3000165E Cannot execute EC_IOCTL_DC_SLV_SYNC_RESTART	Information	-
805312097	0x30001661 RAP - Invalid parameter size	Information	-
805312098	0x30001662 RAP - Marshaling error	Information	-
805312099	0x30001663 Unable to enqueue (missing calls to ProcessNotificationJobs)	Fault	-
805312100	0x30001664 No connection to slaves	Information	-
805312101	0x30001665 ecatSetTargetState cannot set EtherCAT master into target state, master is busy (time-out)	Information	-
805312102	0x30001666 ecatStop() returns 'Busy', retry...	Information	-
805312103	0x30001667 Mailbox transfer request - Error	Information	-
805312104	0x30001668 Mailbox transfer	Information	-
805312105	0x30001669 Waiting for mailbox transfer from master...	Information	-
805312106	0x3000166A Mailbox transfer - Fatal time-out error	Information	-
805312107	0x3000166B Bus cycle and Sync period are different	Information	-
805312108	0x3000166C Error getting the bus scan state	Fault	-
805312109	0x3000166D Wrong response on DC supported request or slave	Information	-
805312110	0x3000166E Unable to set 'DC slave sync disable'	Fault	-
805312111	0x3000166F Error when restarting bus scan	Warning	-
805312112	0x30001670 Bus scan timeout	Warning	-
805312568	0x30001838 Configuration error - Check of VendorID failed	Warning	-
805312569	0x30001839 Configuration error - Check of ProductCode failed	Information	-
805312570	0x3000183A Configuration error - Check of Revision failed	Information	-
805312571	0x3000183B Configuration error - Check of VendorID failed	Information	-
805312572	0x3000183C Configuration error - Odd device at bus end	Information	-
805312578	0x30001842 Internal error counter resetted	Information	-
805312580	0x30001844 All slaves 'Operational' again	Information	-
805312581	0x30001845 Cyclic command WKC error	Warning	-
805312582	0x30001846 Frame response error	Warning	-
805312583	0x30001847 Not all slaves are 'Operational'	Information	-
805312584	0x30001848 Emergency message - Overflow, further messages blocked	Warning	-
805312588	0x3000184C New configuration loaded	Information	-
805312589	0x3000184D New configuration loaded, no slaves defined	Information	-
805312590	0x3000184E Master - Start failed, configuration error	Information	-
805312591	0x3000184F New configuration loaded from slaves EEPROM	Information	-
805312598	0x30001856 Master - Start failed	Warning	-
805312599	0x30001857 Master - Start failed, bus configuration error	Warning	-
805312600	0x30001858 Master - Start failed, EtherCAT cable disconnected	Warning	-
805312601	0x30001859 Master - Start failed, DC/DCM configuration	Warning	-
805312602	0x3000185A Master - Start failed, cannot set slaves to 'Pre-Operational'	Warning	-
805312608	0x30001860 Master - Set 'Operational' failed	Warning	-
805312609	0x30001861 Master - Set 'Operational' failed, Master not initialized	Warning	-
805312610	0x30001862 Master - Set 'Operational' failed, EtherCAT cable disconnected	Warning	-
805312611	0x30001863 Master - Set 'Operational' failed, DCM not in-sync	Warning	-
805312612	0x30001864 Master - Set 'Operational' failed, bus cycle and DC different	Warning	-
805312613	0x30001865 Master - Set 'Operational' takes some time...	Warning	-
805312614	0x30001866 Master - Set 'Operational' failed, time-out	Warning	-
805312615	0x30001867 Master - Set 'Operational' failed, slave error	Warning	-
805312616	0x30001868 Master - Set 'Operational' aborted by reset command	Warning	-
805312618	0x3000186A Master - Stopping failed	Warning	-
805312619	0x3000186B Master - Stopping failed, cannot set Slaves 'Pre-Operational'	Warning	-
805312628	0x30001874 Master - Shutdown failed	Warning	-
805312638	0x3000187E Remote API Server - Start failed	Warning	-
805312648	0x30001888 Start Download Service	Information	-
805312649	0x30001889 Download Service_DONE	Information	-

Diagnostics and fault elimination

Events, causes and remedies

Event ID overview



Event ID	Event	Severity	Configurable in
805312668	0x3000189C MMC - Internal error	Warning	-
805312669	0x3000189D MMC - 'Modular Machine Configuration' is active	Information	-
805312670	0x3000189E MMC - Service started	Information	-
805312671	0x3000189F MMC - Service stopped	Information	-
805312672	0x300018A0 MMC - Error in configuration files	Warning	-
805312673	0x300018A1 MMC - File does not exist	Warning	-
805312674	0x300018A2 MMC - Parsing error	Warning	-
805312675	0x300018A3 MMC - parsing of file successful	Warning	-
805312676	0x300018A4 MMC - Devices not sorted in ascending order or devices missing	Warning	-
805312677	0x300018A5 MMC - Number of devices in device tree differs	Warning	-
805312678	0x300018A6 MMC - Device type mismatch for Alias Address	Warning	-
805312679	0x300018A7 MMC - Invalid Alias Address	Warning	-
805312680	0x300018A8 MMC - Duplicated Alias Address	Warning	-
805312681	0x300018A9 MMC - No configuration checks	Information	-
805312682	0x300018AA MMC - Invalid configuration	Warning	-
805312683	0x300018AB MMC - Mandatory slave missing	Warning	-
805312684	0x300018AC MMC - Optional slave is present, but not allowed	Warning	-
805312685	0x300018AD MMC - No valid service active	Warning	-
805312686	0x300018AE MMC - Address assignment error, less slaves connected than configured	Warning	-
805312687	0x300018AF MMC - Address assignment error, more slaves connected than configured	Fault	-
805312688	0x300018B0 MMC - Address assignment error, invalid device	Fault	-
805312689	0x300018B1 MMC - Address assignment successful	Information	-
805312690	0x300018B2 MMC - Address assignment failed	Information	-
805312691	0x300018B3 MMC - Address assignment done	Information	-
805312692	0x300018B4 MMC - Address assignment error, writing address by CoE	Warning	-
805312693	0x300018B5 MMC - Slave identification error	Warning	-
805312694	0x300018B6 MMC - Slave identification error, slave ident data failed	Warning	-
805312695	0x300018B7 MMC - Service state cannot be changed, set bus to 'INIT' first	Information	-
805312867	0x30001963 Last ETC message	Information	-
805405056	0x30018180 EtherCAT - DC synchronization required	Warning	-
805405057	0x30018181 EtherCAT - Communication error		-
805405312	0x30018280 EtherCAT - Wrong sync manager address	Fault	-
805405313	0x30018281 EtherCAT - Wrong sync manager size	Fault	-
805405314	0x30018282 EtherCAT - Wrong sync manager settings	Fault	-
805405315	0x30018283 PDO mapping: Unknown object	Fault	-
805405316	0x30018284 No PDO mapping object	Fault	-
805405317	0x30018285 Too many objects mapped	Fault	-
805405318	0x30018286 PDO mapping error	Fault	-
805405320	0x30018288 PDO mapping object is already used by PLC.	Fault	-
805406464	0x30018700 EtherCAT - Sync error		-
805406465	0x30018701 Sync PLL - Time-out	Fault	-
805437220	0x3001FF24 Invalid Sync0 cycle time	Fault	-
822313234	0x31038112 Network - Time-out explicit message		-
822313236	0x31038114 Network - Overall communication time-out		-
822313360	0x31038190 Network - Watchdog time-out		-
822313361	0x31038191 Network - Disruption of cyclic data exchange		-
822313362	0x31038192 Network - Initialization error		-
822313363	0x31038193 Network - Invalid cyclic process data		-
822313370	0x3103819A Network - Initialization with safety option failed	Information	-
822313371	0x3103819B Network - Communication time-out with safety option	Information	-
822313607	0x31038287 Network - Invalid configuration		-



16.5.2 Causes and remedies

537469728 | 0x20092320 **Short circuit or earth leakage at the motor end**

Cause	Remedy	Severity/response
<ul style="list-style-type: none"> Short circuit/earth fault of motor cable Capacitive charging current of the motor cable too high. 	<ul style="list-style-type: none"> Check motor cable. Check length of the motor cable. Use shorter or lower-capacitance motor cable. 	Fault <ul style="list-style-type: none"> The event can only be reset after a blocking time.
		Blocking time: 5 s

537469760 | 0x20092340 **Short circuit at the motor end**

Cause	Remedy	Severity/response
Short circuit of motor cable	Check motor cable for short circuit.	Fault <ul style="list-style-type: none"> The event can only be reset after a blocking time.
		Blocking time: 5 s

537469777 | 0x20092351 **Motor utilization too high ($i^2 \cdot t$)**

Cause	Remedy	Severity/response
Motor thermally overloaded, e.g. by an impermissible continuous current or by frequent or too long acceleration processes.	Check drive sizing. Check the setting in the warning threshold or error threshold.	(configurable) Setting parameters:

537469824 | 0x20092380 **Trouble - utilization of the power section (ixt) too high**

Cause	Remedy	Severity/response
Power section overloaded.	Check drive sizing.	Fault

537469825 | 0x20092381 **Warning - Utilization of the power section (ixt) too high**

Cause	Remedy	Severity/response
Power section overloaded.	Check drive sizing.	Warning

537469826 | 0x20092382 **Fault - Device utilization (ixt) too high**

Cause	Remedy	Severity/response
Device utilisation (ixt) too high by frequent and too long acceleration processes.	Check drive sizing. <ul style="list-style-type: none"> Reduce the maximum current of the inverter 0x6073. In case of high mass inertias, reduce maximum current of the inverter 0x6073 to 150 %. 	(configurable) <ul style="list-style-type: none"> The event can only be reset after a blocking time.
		Blocking time: 3 s
		Setting parameters:

Related topics

▶ [Device overload monitoring \(ixt\)](#) 257

537469827 | 0x20092383 **Warning - Device utilization (ixt) too high**

Cause	Remedy	Severity/response
Device utilisation (ixt) too high by frequent and too long acceleration processes.	Check drive dimensioning.	Warning

Related topics

▶ [Device overload monitoring \(ixt\)](#) 257

Diagnostics and fault elimination

Events, causes and remedies
Causes and remedies



537469828 | 0x20092384 Ultimate motor current reached

Cause	Remedy	Severity/response
Ultimate motor current reached.	<ul style="list-style-type: none"> Reduce the maximum current of the inverter. 0x6073 Optimize the current controller. 0x2942 	(configurable) Setting parameters: 0x2D46:001 0x2D46:002

537469829 | 0x20092385 Parameterized max. motor current > max. device current

Cause	Remedy	Severity/response
Parameterized max. motor current 0x6073 > max. device current 0x2DDF:002	Reduce max. motor current. 0x6073	Warning

537469830 | 0x20092386 Clamp is active

Cause	Remedy	Severity/response
Max. device current has been reached. (Display in 0x2DDF:002)	<ul style="list-style-type: none"> Select a flatter speed ramp. Reduce the load. Set I_{max} controller more dynamically. 0x2B08 	Warning

537469831 | 0x20092387 Clamp responded too often

Cause	Remedy	Severity/response
Maximum current of the axis (display in 0x2DDF:002) has been reached too often in succession.	<ul style="list-style-type: none"> Select a flatter speed ramp. Reduce the load. Set I_{max} controller more dynamically. 	Fault

Related topics

▶ [I_{max} controller](#) [172](#)

537469833 | 0x20092389 Warning - device utilization (ixt) too high

Cause	Remedy	Severity/response
Frequent and too long acceleration processes with overcurrent.	Check drive sizing.	Warning

537469835 | 0x2009238B Trouble - Device utilization (ixt) too high

Cause	Remedy	Severity/response
Frequent and too long acceleration processes with overcurrent.	Check drive sizing.	Fault

537473552 | 0x20093210 Fault - DC bus overvoltage

Cause	Remedy	Severity/response
DC-bus voltage has exceeded the error threshold for overvoltage due to a too high braking energy or a too high mains voltage. The error threshold (display in 0x2540:006) results from the setting of the rated mains voltage in 0x2540:001 .		Fault

Related topics

▶ [Mains voltage](#) [41](#)

▶ [Brake energy management](#) [260](#)



537473568 | 0x20093220 **Fault - DC bus undervoltage**

Cause	Remedy	Severity/response
DC-bus voltage has fallen below the error threshold for undervoltage. The error threshold (display in 0x2540:003) results from the setting of the rated mains voltage in 0x2540:001 .	<ul style="list-style-type: none"> • Check mains voltage. • Check DC-bus voltage. • Check mains settings. • Check fuses. 	Trouble <ul style="list-style-type: none"> • The event can only be reset after a blocking time.
		Blocking time: 5 s

Related topics

▶ [Mains voltage](#) 41

537477648 | 0x20094210 **Fault - Power unit overtemperature**

Cause	Remedy	Severity/response
The heatsink temperature of the power unit (display in 0x2D84:001) has exceeded the fixed error threshold (100 °C). <ul style="list-style-type: none"> • Ambient temperature too high. • Fan or ventilation slots are polluted. • Fan is defective. 	<ul style="list-style-type: none"> • Check mains voltage. • Provide for a sufficient cooling of the device. In case of a 100 % load, 60 C to +70°C are normal. Display of the heatsink temperature in 0x2D84:001. • Clean fan and ventilation slots. If required, replace fan. • Reduce switching frequency 0x2939 	Fault

537477760 | 0x20094280 **Fault - Heat sink temperature sensor**

Cause	Remedy	Severity/response
Sensor for the temperature monitoring of the power unit is defective. The failure of the temperature monitoring function poses the risk of overheating!	Hardware error: it is necessary to contact the manufacturer, since the device must be replaced.	Fault

537477761 | 0x20094281 **Heat sink fan warning**

Cause	Remedy	Severity/response
Warning of the heatsink fan.	Clean fan and ventilation slots. If required, replace fan. The fans can be unlocked via locking hooks and can then be removed.	Fault

537477762 | 0x20094282 **Thermal overload of control unit**

Cause	Remedy	Severity/response
<ul style="list-style-type: none"> • Control card temperature > 100 °C • Ambient temperature too high 	<ul style="list-style-type: none"> • Provide for better cooling. • Reduce ambient temperature. 	Fault

537477904 | 0x20094310 **Motor overtemperature**

Cause	Remedy	Severity/response
The motor temperature sensor connected to terminals X109/T1 and X109/T2 measures a too high motor temperature. <ul style="list-style-type: none"> • Motor too hot by impermissibly high currents. • Motor too hot by frequent and too long acceleration processes. 	<ul style="list-style-type: none"> • Check drive dimensioning. • Check motor temperature sensor and wiring. 	Warning (configurable) <ul style="list-style-type: none"> • The event can only be reset after a blocking time.
		Blocking time: 5 s
		Setting parameters: 0x2D49:002

Related topics

▶ [Motor temperature monitoring](#) 197

Diagnostics and fault elimination

Events, causes and remedies
Causes and remedies



537478016 | 0x20094380 **Fault - Motor temperature sensor**

Cause	Remedy	Severity/response
Motor PTC error.	Connect PTC or switch off monitoring.	Warning (configurable) Setting parameters: 0x2D49:002 0x2D49:003 0x2D49:004

537478017 | 0x20094381 **Error - Motor temperature monitoring (PTC)**

Cause	Remedy	Severity/response
Motor PTC error.	Connect PTC or switch off monitoring.	(configurable) Setting parameters:

537478018 | 0x20094382 **Motor overtemperature (load encoder/master encoder)**

Cause	Remedy	Severity/response
Motor temperature via load encoder higher than variable temperature limit.	Connect PTC or switch off monitoring. Set a higher warning threshold (0x2D49:003) and/or error threshold (0x2D49:004).	(configurable) Setting parameters:

537478019 | 0x20094383 **Motor temperature sensor error (load encoder/master encoder)**

Cause	Remedy	Severity/response
Motor PTC error.	Connect PTC or switch off monitoring.	(configurable) Setting parameters:

537481490 | 0x20095112 **External supply voltage critical**

Cause	Remedy	Severity/response
External supply voltage failed or too low.	<ul style="list-style-type: none"> Check external 24V voltage supply (terminal X5/24E). Check mains voltage. 	Warning

537485706 | 0x2009618A **Warning - Internal fan**

Cause	Remedy	Severity/response
Warning of the internal fan.	Check/replace internal fan.	Warning

537486096 | 0x20096310 **Incorrect parameter set download**

Cause	Remedy	Severity/response
CRC error in the parameter set detected. Vendor, product code or OBD revision are different. The parameter set is unknown.	Recreate parameter set. Repeat parameter set download.	Warning

537486112 | 0x20096320 **Parameter error in object**

Cause	Remedy	Severity/response
Unknown index in the parameter set.	Recreate parameter set.	Warning



Diagnostics and fault elimination

Events, causes and remedies
Causes and remedies

537486248 | 0x200963A8 **Persistent data not saved correctly.**

Cause	Remedy	Severity/response
		Fault

537489537 | 0x20097081 **Fault - Analog input 1**

Cause	Remedy	Severity/response
The monitoring function of the input signal configured for analog input 1 in and has been triggered.	<ul style="list-style-type: none"> Check input signal at analog input 1. Check configuration of the monitoring function. 	(configurable) Setting parameters:

Related topics

537489538 | 0x20097082 **Analog input 2 fault**

Cause	Remedy	Severity/response
The monitoring function of the input signal configured for analog input 2 in and has been triggered.	<ul style="list-style-type: none"> Check input signal at analog input 2. Check configuration of the monitoring function. 	(configurable) Setting parameters:

Related topics

537489697 | 0x20097121 **Fault - Pole position identification**

Cause	Remedy	Severity/response
<ul style="list-style-type: none"> Too many deviations during the pole position identification. Compared to the inverter, the rated motor current is too high or too low. 	<ul style="list-style-type: none"> Check setting of the motor data. Ensure that the motor is at a standstill during the pole position identification process. Ensure that the motor and inverter match each other in terms of power. 	Fault

537490179 | 0x20097303 **Fault - Motor feedback**

Cause	Remedy	Severity/response
Defective encoder cable. Defective encoder.	Check encoder cable. Check encoder. Switch off monitoring if no encoder is used.	(configurable) Setting parameters:

537490180 | 0x20097304 **Error - Load encoder/master encoder**

Cause	Remedy	Severity/response
Defective encoder cable. Defective encoder.	Check encoder cable. Check encoder. Switch off monitoring if no encoder is used.	(configurable) Setting parameters:

537490304 | 0x20097380 **Motor encoder - Communication error**

Cause	Remedy	Severity/response
The communication to an encoder is disturbed.	Check the supply voltage of the encoder. (0x2C42:002) Check encoder cable.	(configurable) Setting parameters:

Diagnostics and fault elimination

Events, causes and remedies
Causes and remedies



537490305 | 0x20097381 **Motor encoder - wrong absolute value because motor speed is too high**

Cause	Remedy	Severity/response
The absolute encoder position cannot be accepted as the motor rotates too fast.	Let the motor coast.	(configurable)
		Setting parameters:

537490306 | 0x20097382 **Load encoder/master encoder - Communication error**

Cause	Remedy	Severity/response
The communication to an encoder is disturbed.	Check the supply voltage of the encoder. (0x2C42:002) Check encoder cable.	(configurable)
		Setting parameters:

537490307 | 0x20097383 **Load encoder/master encoder - wrong absolute value because motor speed is too high**

Cause	Remedy	Severity/response
The absolute encoder position cannot be accepted as the motor rotates too fast.	Let the motor coast.	(configurable)
		Setting parameters:

537490308 | 0x20097384 **Motor encoder (EnDat) - Communication error**

Cause	Remedy	Severity/response
		Fault

537490310 | 0x20097386 **Load encoder (EnDat) - Communication error**

Cause	Remedy	Severity/response
		Fault

537526016 | 0x2009FF00 **Fatal internal error**

Cause	Remedy	Severity/response
Internal error	Restart the device. If the error persists, contact the manufacturer.	Fault

537526017 | 0x2009FF01 **Fatal internal communication error**

Cause	Remedy	Severity/response
Internal error	Restart the device. If the error persists, contact the manufacturer.	Fault

537526018 | 0x2009FF02 **Fault - Motor holding brake**

Cause	Remedy	Severity/response
Brake fault due to short circuit or cable break.	Check brake. Check wiring.	Fault (configurable)
		Setting parameters: 0x2820:006

537526019 | 0x2009FF03 **Fatal internal error - task overflow**

Cause	Remedy	Severity/response
Internal error	Restart the device. If the error persists, contact the manufacturer.	Fault



Diagnostics and fault elimination

Events, causes and remedies
Causes and remedies

537526020 | 0x2009FF04 **PPI - Motor movement too large**

Cause	Remedy	Severity/response
Motor moved too much during pole position identification.	Check controller settings in 0x2C62.	(configurable) Setting parameters:

537526021 | 0x2009FF05 **Safe torque off (STO) activated**

Cause	Remedy	Severity/response
"Safe Torque Off (STO)" has been activated via Safety. The movement is interrupted although the controller is still enabled.	Enable "Safe Torque Off (STO)" again or disable controller. In the event of false tripping, check the wiring at terminal X1.	Warning

537526022 | 0x2009FF06 **Motor overspeed**

Cause	Remedy	Severity/response
The motor speed has reached the error threshold for overspeed set in 0x2D44:001.	Adapt the maximum motor speed 0x6080 and the warning threshold or error threshold 0x2D44:001.	Warning (configurable) • The event can only be reset after a blocking time.
		Blocking time: 1 s
		Setting parameters: 0x2D44:002

Related topics

▶ [Motor speed monitoring](#) 200

537526023 | 0x2009FF07 **Not permitted during identification or in test mode**

Cause	Remedy	Severity/response
An attempt was made to write a parameter that has an influence on a currently running identification or the currently activated test mode.	Do not change parameters until identification is complete or test mode is deactivated again.	Warning

537526024 | 0x2009FF08 **Not permitted during identification**

Cause	Remedy	Severity/response
An attempt was made to write a parameter that has an influence on a currently running identification.	Do not change parameters until identification is complete.	Warning

537526025 | 0x2009FF09 **Motor phase missing**

Cause	Remedy	Severity/response
A failure of several motor phases has been detected.	<ul style="list-style-type: none"> Check wiring between inverter and motor. In case of a false tripping, adapt the settings for the motor phase failure detection. 	No response (configurable) • The event can only be reset after a blocking time.
		Blocking time: 2 s
		Setting parameters: 0x2D45:001

Related topics

▶ [Motor phase failure detection](#) 200

Diagnostics and fault elimination

Events, causes and remedies
Causes and remedies



537526026 | 0x2009FF0A Motor phase failure phase U

Cause	Remedy	Severity/response
A failure of the motor phase U has been detected.	<ul style="list-style-type: none"> Check wiring between inverter and motor. In case of a false tripping, adapt the settings for the motor phase failure detection. <ul style="list-style-type: none"> 0x2D45:002 (Current threshold) 0x2D45:003 (Voltage threshold) 	No response (configurable)
		<ul style="list-style-type: none"> The event can only be reset after a blocking time.
		Blocking time: 2 s
		Setting parameters: 0x2D45:001

Related topics

▶ [Motor phase failure detection](#) 200

537526027 | 0x2009FF0B Motor phase failure phase V

Cause	Remedy	Severity/response
A failure of the motor phase V has been detected.	<ul style="list-style-type: none"> Check wiring between inverter and motor. In case of a false tripping, adapt the settings for the motor phase failure detection. <ul style="list-style-type: none"> 0x2D45:002 (Current threshold) 0x2D45:003 (Voltage threshold) 	No response (configurable)
		<ul style="list-style-type: none"> The event can only be reset after a blocking time.
		Blocking time: 2 s
		Setting parameters: 0x2D45:001

Related topics

▶ [Motor phase failure detection](#) 200

537526028 | 0x2009FF0C Motor phase failure phase W

Cause	Remedy	Severity/response
A failure of the motor phase W has been detected.	<ul style="list-style-type: none"> Check wiring between inverter and motor. In case of a false tripping, adapt the settings for the motor phase failure detection. <ul style="list-style-type: none"> 0x2D45:002 (Current threshold) 0x2D45:003 (Voltage threshold) 	No response (configurable)
		<ul style="list-style-type: none"> The event can only be reset after a blocking time.
		Blocking time: 2 s
		Setting parameters: 0x2D45:001

537526029 | 0x2009FF0D No resolver connected - command cannot be executed

Cause	Remedy	Severity/response
An attempt was made to identify a resolver fault. But the V/f control without feedback system is selected as the control mode.	The resolver error can only be identified if a resolver is used as a feedback system. (0x2C00 = 1 or 2)	Warning

537526030 | 0x2009FF0E Speed too low - command cannot be executed

Cause	Remedy	Severity/response
The current speed is too low to identify the resolver error.	Repeat identification at higher speed.	Warning

537526031 | 0x2009FF0F No resolver as motor encoder connected - command cannot be executed

Cause	Remedy	Severity/response
An attempt was made to identify a resolver fault. But there is an encoder available as a feedback system.	The resolver error can only be identified if a resolver is used as a feedback system.	Warning



537526032 | 0x2009FF10 **Time-out during resolver identification**

Cause	Remedy	Severity/response
The current speed is too low to identify the resolver error.	Repeat identification at higher speed.	Warning

537526033 | 0x2009FF11 **Numeric problem during resolver identification**

Cause	Remedy	Severity/response
The current speed is too low to identify the resolver error.	Repeat identification at higher speed.	Warning

537526034 | 0x2009FF12 **Inverter error too large**

Cause	Remedy	Severity/response
The results of the inverter error identification are not plausible.	Check shielding of the motor cable. Connect the shield with a surface as large as possible.	Warning

537526035 | 0x2009FF13 **Identification aborted**

Cause	Remedy	Severity/response
Pole position identification has been aborted. An error has occurred during identification or the controller has been disabled.	Repeat pole position identification.	(configurable) Setting parameters:

537526036 | 0x2009FF14 **Not permitted in state 'operation enabled' or 'quick stop active'**

Cause	Remedy	Severity/response
Reading out and accepting the HIPERFACE® data is only permitted when the controller is inhibited.	Disable controller before reading out.	Warning

537526037 | 0x2009FF15 **No HIPERFACE® absolute value encoder as motor encoder connected - command cannot be executed**

Cause	Remedy	Severity/response
An attempt was made to read out HIPERFACE® data although no HIPERFACE® encoder is connected. No HIPERFACE® encoder is selected in 0x2C40.	Connect HIPERFACE® encoder. A HIPERFACE® encoder must be selected in 0x2C40.	Warning

537526038 | 0x2009FF16 **Connected HIPERFACE® motor encoder is not supported**

Cause	Remedy	Severity/response
The HIPERFACE® encoder has a type code that is neither stored in the firmware nor corresponds to the type code set under 0x2C41:002.	Enter correct type code under 0x2C41:002.	(configurable) Setting parameters:

537526039 | 0x2009FF17 **Connected HIPERFACE® motor encoder is not supported - command cannot be executed**

Cause	Remedy	Severity/response
The HIPERFACE® encoder has a type code that is not stored in the firmware. Hence, no data can be detected.	Connect an encoder with a supported type code.	Warning

Diagnostics and fault elimination

Events, causes and remedies
Causes and remedies



537526040 | 0x2009FF18 Communication time-out in manual control mode

Cause	Remedy	Severity/response
The writing of the target data has failed during operation for manual wiring control longer than the time-out time. (0x2836:005)	Increase timeout. (0x2836:005) Restart manual jog dialog.	Fault

537526041 | 0x2009FF19 Motor parameter identification fault

Cause	Remedy	Severity/response
During the automatic identification of the motor, an error has occurred.	<ul style="list-style-type: none"> Set motor data so that they comply with the data on the motor nameplate. Check wiring of the motor. 	Fault

537526042 | 0x2009FF1A Connected HIPERFACE® load encoder/master encoder is not supported

Cause	Remedy	Severity/response
The HIPERFACE® encoder has a type code that is neither stored in the firmware nor corresponds to the type code set under 0x2C41:002.	Enter correct type code under 0x2C41:002.	(configurable) Setting parameters:

537526043 | 0x2009FF1B Connected HIPERFACE® load encoder/master encoder is not supported - command cannot be executed

Cause	Remedy	Severity/response
The HIPERFACE® encoder has a type code that is not stored in the firmware. Hence, no data can be detected.	Connect an encoder with a supported type code.	Warning

537526044 | 0x2009FF1C No resolver as load encoder/master encoder connected - command cannot be executed

Cause	Remedy	Severity/response
An attempt was made to identify a resolver fault. But there is an encoder available as a feedback system.	The resolver error can only be identified if a resolver is used as a feedback system.	Warning

537526045 | 0x2009FF1D No HIPERFACE® absolute value encoder as load encoder/master encoder connected - command cannot be executed

Cause	Remedy	Severity/response
An attempt was made to read out HIPERFACE® data although no HIPERFACE® encoder is connected. No HIPERFACE® encoder is selected in 0x2C50.	Connect HIPERFACE® encoder. A HIPERFACE® encoder must be selected in 0x2C50.	Warning

537526046 | 0x2009FF1E FIQ runtime error

Cause	Remedy	Severity/response
The monitoring of the FIQ by the FPGA has triggered.	Connect an encoder with a supported type code.	Fault



537526048 | 0x2009FF20 **Brand protection - check failed**

Cause	Remedy	Severity/response
The review of brand protection has failed.	Enter correct pin. Replace device with OEM device and reprogram pin.	Warning

537526049 | 0x2009FF21 **Time-out holding brake feedforward control**

Cause	Remedy	Severity/response
The specified feedforward control torque could not be built up within one second.	<ul style="list-style-type: none"> • 0x2820:009 (Starting torque source) = [0] (Last torque saved): <ul style="list-style-type: none"> - The load to be braked is too large. - Control the stored torque. ▶ 0x2820:021 • 0x2820:009 (Starting torque source) = [1] (Torque in 0x2820:010): <ul style="list-style-type: none"> - The set torque is too high. - Reduce torque. 	Fault

Related topics

▶ [Holding brake control](#) □ 151

537526050 | 0x2009FF22 **Velocity error**

Cause	Remedy	Severity/response
The speed error exceeds the limit from 0x2D51:001 for a time duration > 0x2D51:002.	Increase timeout in 0x2D51:002. Increase limit in 0x2D51:001. Increase gain of the speed controller. Increase torque limit and/or current limit.	Fault

537526051 | 0x2009FF23 **Position error**

Cause	Remedy	Severity/response
The following error exceeds the limit from 0x2D51:004 for a time duration > 0x2D51:005.	Increase timeout in 0x2D51:005. Increase limit in 0x2D51:004. Increase gain of the position controller.	Fault

537526054 | 0x2009FF26 **Cable check - Motor movement too large**

Cause	Remedy	Severity/response
Phases in the motor cable reversed. The axis was moved manually. Motor parameters are set incorrectly. For synchronous motors: The pole position is set incorrectly. For motors with holding brake: The brake was opened prematurely by an external source.	Check motor cabling. Avoid manual movement. Check number of pole pairs and motor type. Carry out the pole position identification Do not open the brake until you have checked the wiring.	Fault

537526055 | 0x2009FF27 **Cable check - Wrong motor angle detected**

Cause	Remedy	Severity/response
The determined angle between rotor and resolver differs from the setting in 0x2C03:002. The determined angle between rotor and encoder differs from the setting in 0x2C03:004.	Check encoder cabling. Check motor cabling. If appropriate, Carry out the pole position identification	Fault

Diagnostics and fault elimination

Events, causes and remedies
Causes and remedies



537526062 | 0x2009FF2E **Connected motor encoder is not supported**

Cause	Remedy	Severity/response
		Fault

537526063 | 0x2009FF2F **Connected load encoder/master encoder is not supported**

Cause	Remedy	Severity/response
		Fault

537526070 | 0x2009FF36 **Warning - Brake resistor overload**

Cause	Remedy	Severity/response
		(configurable)
		Setting parameters:

537526071 | 0x2009FF37 **Automatic start disabled**

Cause	Remedy	Severity/response
At mains connection, a start command was already available and the automatic start at power-up is set in to "Off [0]".	Deactivate starting command and reset error.	Fault

537526076 | 0x2009FF3C **Backup created via device command**

Cause	Remedy	Severity/response
Backup created via device command	For information only. No remedy necessary.	Information

537526077 | 0x2009FF3D **Backup restored via device command**

Cause	Remedy	Severity/response
Backup restored via device command	For information only. No remedy necessary.	Information

537526080 | 0x2009FF40 **Error - Brake transistor**

Cause	Remedy	Severity/response
The short-circuit monitoring of the brake transistor has triggered.	Use brake resistor with a greater resistance value. Use external brake chopper. Use regenerative module.	Fault

537526081 | 0x2009FF41 **Error - Charging circuit**

Cause	Remedy	Severity/response
The monitoring of the charge relay has responded.	Acknowledge error. If the error persists, contact the manufacturer.	Fault

537526082 | 0x2009FF42 **Mains phase failure**

Cause	Remedy	Severity/response
The mains phase monitoring has triggered.	Check mains connection.	Fault



Diagnostics and fault elimination

Events, causes and remedies
Causes and remedies

537526083 | 0x2009FF43 **Motor encoder requires restart of the device**

Cause	Remedy	Severity/response
		Fault

537526084 | 0x2009FF44 **Load encoder requires restart of the device**

Cause	Remedy	Severity/response
		Fault

537526097 | 0x2009FF51 **Internal communication to PLC failed**

Cause	Remedy	Severity/response
The internal communication between the application and the base firmware is disturbed.	Restart device.	Fault

537526110 | 0x2009FF5E **Invalid module combination in slot A and slot B**

Cause	Remedy	Severity/response
The modules in slot A and slot B cannot be combined.	Remove a module. Plug a valid module combination.	Fault • The event can only be reset by mains switching.

671158529 | 0x28011101 **Initialization - Parameter value could not be written**

Cause	Remedy	Severity/response
Initialization - Parameter value could not be written	For information only. No remedy necessary.	Information

671158530 | 0x28011102 **Load default setting - Parameter value could not be written**

Cause	Remedy	Severity/response
Write access denied with corresponding error message.	Evaluate parameter value based on the error message in the logbook. Correct parameter value accordingly.	Warning

671158785 | 0x28011201 **Parameters - Initialization failed**

Cause	Remedy	Severity/response
Not all parameters could be initialized.	See related entries in the logbook.	Warning

671158786 | 0x28011202 **Parameters - Loading default values failed**

Cause	Remedy	Severity/response
Not all presets could be written.	See related entries in the logbook.	Warning

671158787 | 0x28011203 **Parameters - Loading TA default values failed**

Cause	Remedy	Severity/response
Not all presets of the technology application could be written.	See related entries in the logbook.	Warning

Diagnostics and fault elimination

Events, causes and remedies
Causes and remedies



671159298 | 0x28011402 **Opening the parameter description failed**

Cause	Remedy	Severity/response
Parameter description is missing or faulty.	Update boot project or device firmware.	Fault

671159299 | 0x28011403 **Opening the parameter set failed**

Cause	Remedy	Severity/response
Parameter set file is missing or faulty.	Update boot project or restart device.	Fault

671219713 | 0x28020001 **Logbook: Corrupt restore data**

Cause	Remedy	Severity/response
Logbook: Corrupt restore data	For information only. No remedy necessary.	Information

671219773 | 0x2802003D **Logbook cleared**

Cause	Remedy	Severity/response
Logbook cleared	For information only. No remedy necessary.	Information

671219776 | 0x28020040 **Logbook: Timeout restoring data**

Cause	Remedy	Severity/response
Logbook: Timeout restoring data	For information only. No remedy necessary.	Information

671219777 | 0x28020041 **Logbook: Error restoring data**

Cause	Remedy	Severity/response
Logbook: Error restoring data	For information only. No remedy necessary.	Information

671219778 | 0x28020042 **First boot with this firmware version**

Cause	Remedy	Severity/response
First boot with this firmware version	For information only. No remedy necessary.	Information

671219779 | 0x28020043 **Logbook was restored.**

Cause	Remedy	Severity/response
Logbook was restored.	For information only. No remedy necessary.	Information

671219780 | 0x28020044 **Logbook: Error reading persistent data.**

Cause	Remedy	Severity/response
Logbook: Error reading persistent data.	For information only. No remedy necessary.	Information

671263317 | 0x2802AA55 **The chronology of the logbook is not consistent**

Cause	Remedy	Severity/response
The chronology of the logbook is not consistent	For information only. No remedy necessary.	Information



671354881 | 0x28041001 **CmpLenzeErrorManagementAccess loaded without errors**

Cause	Remedy	Severity/response
CmpLenzeErrorManagementAccess loaded without errors	For information only. No remedy necessary.	Information

671420673 | 0x28051101 **Test-Mode - More Application Credit required, application is starting delayed**

Cause	Remedy	Severity/response
The "Application-Credit" is not sufficient for the application. The start of the application is delayed.	Use SD card with sufficient "Application-Credit".	Warning

671420674 | 0x28051102 **Application-Credit - Invalid license data**

Cause	Remedy	Severity/response
Faulty license data was detected when the "Application-Credit" was loaded.	Use SD card with valid license data.	Warning

671420675 | 0x28051103 **Application-Credit - License data missing**

Cause	Remedy	Severity/response
No license data was found on the SD card when then the "Application-Credit" was loaded.	Use SD card with valid license data.	Warning

671421185 | 0x28051301 **Boot application - More Application Credit required**

Cause	Remedy	Severity/response
The "Application-Credit" is not sufficient for the boot application. Bootling is delayed.	Use SD card with sufficient "Application-Credit".	Warning

704663682 | 0x2A005082 **Internal error - Button S82**

Cause	Remedy	Severity/response
Internal error	Restart the device. If the error persists, replace the device.	Warning

704663692 | 0x2A00508C **Internal switch-off path - Error**

Cause	Remedy	Severity/response
Internal error	Restart the device. If the error persists, replace the device.	Warning

704663693 | 0x2A00508D **Internal switch-off path - Test pulse error**

Cause	Remedy	Severity/response
Internal error	Restart the device. If the error persists, replace the device.	Warning

Diagnostics and fault elimination

Events, causes and remedies
Causes and remedies



704663694 | 0x2A00508E **SBC - Test pulse error**

Cause	Remedy	Severity/response
Internal error	Restart the device. If the error persists, replace the device.	Warning

704663695 | 0x2A00508F **SBC - Remains stuck at LOW**

Cause	Remedy	Severity/response
Error in the safe brake control	Check the supply voltage of the brake. Check the wiring of the brake.	Warning

704663696 | 0x2A005090 **Faulty internal adjustment data**

Cause	Remedy	Severity/response
Internal error	Restart the device. If the error persists, replace the device.	Warning

704663828 | 0x2A005114 **Reference voltage error**

Cause	Remedy	Severity/response
Internal error	Restart the device. If the error persists, replace the device.	Warning

704663829 | 0x2A005115 **6 V voltage error**

Cause	Remedy	Severity/response
Internal error	Restart the device. If the error persists, replace the device.	Warning

704663830 | 0x2A005116 **5 V voltage error**

Cause	Remedy	Severity/response
Internal error	Restart the device. If the error persists, replace the device.	Warning

704663831 | 0x2A005117 **3.3 V voltage error**

Cause	Remedy	Severity/response
Internal error	Restart the device. If the error persists, replace the device.	Warning

704668032 | 0x2A006180 **Internal error - STO activated**

Cause	Remedy	Severity/response
Internal error	Restart the device. If the error persists, replace the device.	Warning

704668037 | 0x2A006185 **Communication error - Basic device**

Cause	Remedy	Severity/response
Internal error	Restart the device. If the error persists, replace the device.	Warning



704668038 | 0x2A006186 **Synchronization error - Basic device**

Cause	Remedy	Severity/response
Internal error	Restart the device. If the error persists, contact the manufacturer.	Information

704668039 | 0x2A006187 **SBC - Device configuration incompatible**

Cause	Remedy	Severity/response
		Warning

704668043 | 0x2A00618B **HDSL - Device configuration incompatible**

Cause	Remedy	Severity/response
		Warning

704668553 | 0x2A006389 **New safety parameter set deleted**

Cause	Remedy	Severity/response
New safety parameter set deleted	For information only. No remedy necessary.	Information

704668554 | 0x2A00638A **New safety parameter set loaded**

Cause	Remedy	Severity/response
New safety parameter set loaded	For information only. No remedy necessary.	Information

704668555 | 0x2A00638B **Memory module - Access error**

Cause	Remedy	Severity/response
Error accessing the safe parameter set on the SD card.	Reset safe parameter set in the device. Reload safe parameter set.	Warning

704668556 | 0x2A00638C **Different safety parameter sets**

Cause	Remedy	Severity/response
The safe parameter sets on the SD card and in the device are different.	Load a safe parameter set from the SD card into the device.	Warning

704668557 | 0x2A00638D **Extended Safety - No safety parameter set**

Cause	Remedy	Severity/response
No safe parameter set was found in the device.	Load safe parameter set into the device.	Warning

704668558 | 0x2A00638E **Extended Safety - Safety parameter set defect**

Cause	Remedy	Severity/response
The safe parameter set in the device is faulty.	Load safe parameter set into the device.	Warning

Diagnostics and fault elimination

Events, causes and remedies
Causes and remedies



704668559 | 0x2A00638F Safety parameter set - Format error

Cause	Remedy	Severity/response
Format error in the safe parameter set	Reset the safe parameter set in the device and load it again.	Warning

704668560 | 0x2A006390 Safety parameter set - Plausibility error

Cause	Remedy	Severity/response
The set safety parameters are not plausible.	Determine error number in 0x2115:005 and analyze it using the plausibility error table. Eliminate error Reload safe parameter set.	Warning

704668561 | 0x2A006391 Safety parameter set - Communication error

Cause	Remedy	Severity/response
A communication error has occurred while loading the safe parameter set.	Check communication settings. Check SD card. Reload safe parameter set.	Warning

704668562 | 0x2A006392 Different safety addresses detected

Cause	Remedy	Severity/response
The safety addresses in the device and on the SD card are different.	Adapt safety addresses. Load and save the safe parameter set again.	Warning

704668563 | 0x2A006393 SSM - Wrong PDO version

Cause	Remedy	Severity/response
Safe speed monitoring is faulty because the PDO version of the data protocol is incompatible.	Only devices with firmware > V1.0 support Extended Safety.	Warning

704668565 | 0x2A006395 Internal limitation active

Cause	Remedy	Severity/response
		Warning

704676245 | 0x2A008195 FSoE - Unexpected command

Cause	Remedy	Severity/response
Unexpected FSoE command received.	Check FSoE configuration. Restart communication.	Information

704676246 | 0x2A008196 FSoE - Unknown command

Cause	Remedy	Severity/response
Unknown FSoE command received.	Check FSoE configuration. Restart communication.	Information



Diagnostics and fault elimination

Events, causes and remedies
Causes and remedies

704676247 | 0x2A008197 FSoE - Invalid connection ID

Cause	Remedy	Severity/response
FSoE frame with invalid connection ID received.	Check FSoE configuration. Restart communication.	Information

704676248 | 0x2A008198 FSoE - CRC error

Cause	Remedy	Severity/response
The check of the CRC in the FSoE frames reports errors.	Check FSoE configuration. Restart communication.	Information

704676249 | 0x2A008199 FSoE - Watchdog expired

Cause	Remedy	Severity/response
FSoE watchdog elapsed.	Check set watchdog time in FSoE master and adapt if necessary.	Information

704676252 | 0x2A00819C FSoE - Invalid communication parameter data

Cause	Remedy	Severity/response
Invalid communication parameter data received.	Check setting of the communication parameters.	Information

704676253 | 0x2A00819D FSoE - Invalid application parameter length

Cause	Remedy	Severity/response
The length of the application parameters transmitted by the FSoE master differs from the expected length.	Check setting of the communication parameters.	Information

704676254 | 0x2A00819E FSoE - Invalid application parameter data

Cause	Remedy	Severity/response
Invalid application parameter data received.	Check setting of the communication parameters.	Information

704676255 | 0x2A00819F FSoE - Passivated

Cause	Remedy	Severity/response
Due to an error, FSoE was passivated.	Check FSoE configuration. Reset error.	Information

704676264 | 0x2A0081A8 FSoE - Invalid slave address

Cause	Remedy	Severity/response
The slave address transmitted by the FSoE master differs from the slave address set in the device.	Check slave address in the FSoE master. Check parameter setting in the device.	Information

Diagnostics and fault elimination

Events, causes and remedies

Causes and remedies



704676265 | 0x2A0081A9 FSoE - Invalid communication parameter length

Cause	Remedy	Severity/response
The length of the communication parameter transmitted by the FSoE master differs from the expected length.	Check setting of the communication parameters.	Information

704676266 | 0x2A0081AA FSoE - Data exchange left

Cause	Remedy	Severity/response
Due to an error FSoE has left the data exchange.	Check FSoE configuration. Reset error.	Information

704708488 | 0x2A00FF88 SS1/SS2 - Stop time exceeded

Cause	Remedy	Severity/response
The speed threshold "n = 0" was not reached within the stopping time.	Increase SS1/SS2- stopping time. Reduce delay time in drive.	Warning

704708489 | 0x2A00FF89 SLS1 - Nlim1 exceeded

Cause	Remedy	Severity/response
The safely limited speed SLS1 has been exceeded.	Adapt the speed-dependent parameters in the drive. Increase safely limited speed.	Warning

704708490 | 0x2A00FF8A SLS2 - Nlim2 exceeded

Cause	Remedy	Severity/response
The safely limited speed SLS2 has been exceeded.	Adapt the speed-dependent parameters in the drive. Increase safely limited speed.	Warning

704708491 | 0x2A00FF8B SLS3 - Nlim3 exceeded

Cause	Remedy	Severity/response
The safely limited speed SLS3 has been exceeded.	Adapt the speed-dependent parameters in the drive. Increase safely limited speed.	Warning

704708492 | 0x2A00FF8C SLS4 - Nlim4 exceeded

Cause	Remedy	Severity/response
The safely limited speed SLS4 has been exceeded.	Adapt the speed-dependent parameters in the drive. Increase safely limited speed.	Warning

704708493 | 0x2A00FF8D SLS/SMS - Error stop not executed

Cause	Remedy	Severity/response
A safely limited speed (SLS1-SLS4) or the maximum speed (SMS) has been exceeded. The error was not reported within the parameterized response time.	Adapt the speed-dependent parameters in the drive. Increase response time.	Warning



704708494 | 0x2A00FF8E **SDIpos - Wrong direction**

Cause	Remedy	Severity/response
The drive has moved too far in the wrong direction.	Adapt the parameterization of the higher-level controller. Increase 0x28BA:003 tolerance threshold	Warning

704708495 | 0x2A00FF8F **SDIneg - Wrong direction**

Cause	Remedy	Severity/response
The drive has moved too far in the wrong direction.	Adapt the parameterization of the higher-level controller. Increase 0x28BA:003 tolerance threshold	Warning

704708496 | 0x2A00FF90 **SMS - Nmax exceeded**

Cause	Remedy	Severity/response
The drive has exceeded the parameterized safe maximum speed (SMS).	Adapt the maximum speed in the drive.	Warning

704708497 | 0x2A00FF91 **SOS - Tolerance limit exceeded**

Cause	Remedy	Severity/response
The position change during SOS is greater than the parameterized tolerance window 0x289F:001.	Increase tolerance window Adapt response time of encoder monitoring.	Warning

704708498 | 0x2A00FF92 **No feedback system configured**

Cause	Remedy	Severity/response
An attempt was made to call up a speed-based or position-based safety function although no feedback is configured.	Configure suitable feedback.	Warning

704708501 | 0x2A00FF95 **SS1/SS2 - Speed ramp exceeded**

Cause	Remedy	Severity/response
Ramp monitoring has responded because monitoring limits have been exceeded.	Adapt parameters for ramp monitoring. (0x2894) Deactivate ramp monitoring.	Warning

704708502 | 0x2A00FF96 **SLI - Safely limited increment exceeded**

Cause	Remedy	Severity/response
The maximum permissible position change (0x28CA:001, 0x28CA:003) was exceeded.	Adapt parameters for SLI.	Warning

704708503 | 0x2A00FF97 **SLP1 - Position limits exceeded**

Cause	Remedy	Severity/response
The upper or lower position limit of SLP1 has been exceeded.	Adapt parameters for SLP1. Increase the distance to the position limits in the application.	Warning

Diagnostics and fault elimination

Events, causes and remedies
Causes and remedies



704708504 | 0x2A00FF98 **SLP2 - Position limits exceeded**

Cause	Remedy	Severity/response
The upper or lower position limit of SLP2 has been exceeded.	Adapt parameters for SLP2. Increase the distance to the position limits in the application.	Warning

704708505 | 0x2A00FF99 **SLP3 - Position limits exceeded**

Cause	Remedy	Severity/response
The upper or lower position limit of SLP3 has been exceeded.	Adapt parameters for SLP3. Increase the distance to the position limits in the application.	Warning

704708506 | 0x2A00FF9A **SLP4 - Position limits exceeded**

Cause	Remedy	Severity/response
The upper or lower position limit of SLP4 has been exceeded.	Adapt parameters for SLP4. Increase the distance to the position limits in the application.	Warning

704708507 | 0x2A00FF9B **SLP - No home position**

Cause	Remedy	Severity/response
SLP has been commissioned, but the home position is unknown.	Check status of the safe reference. (0x2882:006)	Warning

704708509 | 0x2A00FF9D **PDSS - Velocity exceeded**

Cause	Remedy	Severity/response
The drive has exceeded the current allowed speed for PDSS.	Check parameters for PDSS. Reduce speeds in the application. Increase distance to PDSS limit values.	Warning

704708510 | 0x2A00FF9E **PDSS - Creep velocity SCS exceeded**

Cause	Remedy	Severity/response
The drive has exceeded the currently permitted SCS creeping speed.	Check parameters for PDSS. Reduce speeds in the application. Increase distance to PDSS limit values.	Warning

704708518 | 0x2A00FFA6 **SHom - Time-out**

Cause	Remedy	Severity/response
After SHom_Start, the home position was not detected within the timeout set in 0x2882:002.	Adapt timeout. Check configuration of triggers for SHom_Start and SHom_Load.	Warning

704708519 | 0x2A00FFA7 **SHom - Home position deleted**

Cause	Remedy	Severity/response
The home position was deleted by acknowledging a position error or manually via 0x2114:014.	Execute SHom again.	Information



Diagnostics and fault elimination

Events, causes and remedies
Causes and remedies

704708520 | 0x2A00FFA8 SHom - Maximum slip value exceeded

Cause	Remedy	Severity/response
The maximum permissible slip has been exceeded.	Evaluate slip monitoring in 0x2870:2. Check the wear-prone drive components and replace then if necessary.	Warning

704708521 | 0x2A00FFA9 SHom - Tolerance of start position exceeded

Cause	Remedy	Severity/response
The tolerance for the starting position has been exceeded.	Do not move drive components while the mains voltage is switched off. Execute SHom again.	Warning

704708522 | 0x2A00FFAA SHom - Tolerance of position comparison exceeded

Cause	Remedy	Severity/response
The tolerance for the position comparison has been exceeded.	Check gearbox factor and mounting direction. Check the wear-prone drive components and replace then if necessary. Execute SHom again.	Warning

704708523 | 0x2A00FFAB SSM - Invalid safe velocity

Cause	Remedy	Severity/response
No safe speed could be determined. The encoder is not initialized or the status transmitted by the encoder is invalid.	Check encoder. A certified motor/encoder combination must be used.	Warning

704708524 | 0x2A00FFAC SSM - Encoder error

Cause	Remedy	Severity/response
The monitoring of the safe speed via encoder is faulty.	Check encoder. Check configuration of the encoder.	Warning

704708525 | 0x2A00FFAD SSM - Resolver error

Cause	Remedy	Severity/response
The monitoring of the safe speed via resolver is faulty.	Check encoder. Check configuration of the encoder.	Warning

704708526 | 0x2A00FFAE SSM - Error in standard device data

Cause	Remedy	Severity/response
Safe speed monitoring is faulty because the device is transmitting incorrect data.	Check encoder. Check configuration of the encoder.	Warning

704708527 | 0x2A00FFAF SSM - Speed deviation too high

Cause	Remedy	Severity/response
The difference between the internally calculated speed and the speed transmitted by the encoder is too large.	Check configuration of the encoder. Check gearbox factor. Check tolerance for the deviation.	Warning

Diagnostics and fault elimination

Events, causes and remedies
Causes and remedies



704708528 | 0x2A00FFB0 **SSM - Synchronization error**

Cause	Remedy	Severity/response
Internal error	Restart the device. If the error persists, contact the manufacturer.	Warning

704708529 | 0x2A00FFB1 **MUT - Muting function active**

Cause	Remedy	Severity/response
MUT - Muting function active	For information only. No remedy necessary.	Information

704708530 | 0x2A00FFB2 **MUT - Muting function completed**

Cause	Remedy	Severity/response
MUT - Muting function completed	For information only. No remedy necessary.	Information

704708531 | 0x2A00FFB3 **MUT - Muting function aborted**

Cause	Remedy	Severity/response
Communication error. The muting function was canceled.	Reconnect to the device. Restart the muting function.	Information

704708532 | 0x2A00FFB4 **HDSL - Error encoder supply**

Cause	Remedy	Severity/response
The supply voltage for the HIPERFACE DSL® encoder is outside the permitted range.	Check the length of the system cable. The max. permitted length must not be exceeded. Check the connections of the system cable. Check specification of the system cable.	Warning

704708533 | 0x2A00FFB5 **HDSL - Encoder error detected**

Cause	Remedy	Severity/response
HIPERFACE DSL® encoder error	Check the connections of the system cable. Check details of the error in the status parameters: 0x2878:050 ... 0x2878:062 (For the meaning of the individual bits, see the documentation of the encoder manufacturer).	Warning

704708534 | 0x2A00FFB6 **HDSL - Encoder error**

Cause	Remedy	Severity/response
HIPERFACE DSL® communication error	Check the connections of the system cable. Check details of the error in the status parameters: 0x2878:050	Warning

704708535 | 0x2A00FFB7 **SSM - HDSL encoder error**

Cause	Remedy	Severity/response
Errors in safe speed monitoring (SSM) with HIPERFACE DSL® encoder	Check encoder configuration. Check the connections of the system cable.	Warning



Diagnostics and fault elimination

Events, causes and remedies
Causes and remedies

704708536 | 0x2A00FFB8 **HDSL encoder - ID was set**

Cause	Remedy	Severity/response
The encoder ID of the connected HIPERFACE DSL® encoder has been set to the correct value. The error Different encoder ID has been fixed. The status bit has been reset: 0x2878:050, bit 13	Check whether the encoder-axis assignment is now correct.	Information

704708537 | 0x2A00FFB9 **Internal product code incompatible**

Cause	Remedy	Severity/response
		Warning

805306384 | 0x30000010 **Internal error**

Cause	Remedy	Severity/response
Internal error	Restart the device. If the error persists, contact the manufacturer.	Warning

805306385 | 0x30000011 **Internal error**

Cause	Remedy	Severity/response
Internal error	Restart the device. If the error persists, contact the manufacturer.	Warning

805306386 | 0x30000012 **Internal error**

Cause	Remedy	Severity/response
Internal error	Restart the device. If the error persists, contact the manufacturer.	Warning

805306387 | 0x30000013 **Internal error**

Cause	Remedy	Severity/response
Internal error	Restart the device. If the error persists, contact the manufacturer.	Warning

805306570 | 0x300000CA **Internal error**

Cause	Remedy	Severity/response
Internal error	Restart the device. If the error persists, contact the manufacturer.	Warning

805306571 | 0x300000CB **Internal error**

Cause	Remedy	Severity/response
Internal error	Restart the device. If the error persists, contact the manufacturer.	Warning

Diagnostics and fault elimination

Events, causes and remedies

Causes and remedies



805311368 | 0x30001388 **Internal error**

Cause	Remedy	Severity/response
Internal error	Restart the device. If the error persists, contact the manufacturer.	Warning

805311369 | 0x30001389 **CTRL - Feature not supported**

Cause	Remedy	Severity/response
Internal error	Restart the device. If the error persists, contact the manufacturer.	Fault

805311370 | 0x3000138A **CTRL - Invalid index**

Cause	Remedy	Severity/response
Internal error	Restart the device. If the error persists, contact the manufacturer.	Fault

805311371 | 0x3000138B **ISW - Invalid offset**

Cause	Remedy	Severity/response
Internal error	Restart the device. If the error persists, contact the manufacturer.	Fault

805311373 | 0x3000138D **CTRL - Invalid size**

Cause	Remedy	Severity/response
Internal error	Restart the device. If the error persists, contact the manufacturer.	Fault

805311374 | 0x3000138E **ISW - Invalid data**

Cause	Remedy	Severity/response
Internal error	Restart the device. If the error persists, contact the manufacturer.	Fault

805311375 | 0x3000138F **ISW - Not ready**

Cause	Remedy	Severity/response
Internal error	Restart the device. If the error persists, contact the manufacturer.	Fault

805311376 | 0x30001390 **CTRL - Busy**

Cause	Remedy	Severity/response
Internal error	Restart the device. If the error persists, contact the manufacturer.	Fault

805311377 | 0x30001391 **ISW - Cannot queue acyclic EtherCAT command**

Cause	Remedy	Severity/response
Internal error	Restart the device. If the error persists, contact the manufacturer.	Warning



Diagnostics and fault elimination

Events, causes and remedies
Causes and remedies

805311378 | 0x30001392 **CFG - No memory left**

Cause	Remedy	Severity/response
Internal error	Restart the device. If the error persists, contact the manufacturer.	Fault

805311379 | 0x30001393 **CTRL - Invalid parameter**

Cause	Remedy	Severity/response
Internal error	Restart the device. If the error persists, contact the manufacturer.	Fault

805311380 | 0x30001394 **CTRL - Not found**

Cause	Remedy	Severity/response
Internal error	Restart the device. If the error persists, contact the manufacturer.	Fault

805311382 | 0x30001396 **ISW - Invalid state**

Cause	Remedy	Severity/response
Internal error	Restart the device. If the error persists, contact the manufacturer.	Fault

805311383 | 0x30001397 **ISW - Cannot add slave to timer list**

Cause	Remedy	Severity/response
Internal error	Restart the device. If the error persists, contact the manufacturer.	Fault

805311384 | 0x30001398 **SLV - Time-out**

Cause	Remedy	Severity/response
Internal error	Restart the device. If the error persists, contact the manufacturer.	Fault

805311385 | 0x30001399 **ISW - Open failed**

Cause	Remedy	Severity/response
Internal error	Restart the device. If the error persists, contact the manufacturer.	Fault

805311386 | 0x3000139A **LLA - Send failed**

Cause	Remedy	Severity/response
Internal error	Restart the device. If the error persists, contact the manufacturer.	Fault

805311387 | 0x3000139B **CFG - Error when queuing a mailbox command**

Cause	Remedy	Severity/response
Internal error	Restart the device. If the error persists, contact the manufacturer.	Fault

Diagnostics and fault elimination

Events, causes and remedies

Causes and remedies



805311388 | 0x3000139C **ISW - Invalid mailbox command**

Cause	Remedy	Severity/response
Internal error	Restart the device. If the error persists, contact the manufacturer.	Fault

805311389 | 0x3000139D **ISW - Unknown mailbox protocol command**

Cause	Remedy	Severity/response
Internal error	Restart the device. If the error persists, contact the manufacturer.	Fault

805311390 | 0x3000139E **ISW - Access denied**

Cause	Remedy	Severity/response
Internal error	Restart the device. If the error persists, contact the manufacturer.	Fault

805311394 | 0x300013A2 **CFG - Invalid product key**

Cause	Remedy	Severity/response
Internal error	Restart the device. If the error persists, contact the manufacturer.	Fault

805311395 | 0x300013A3 **PRJ - Wrong format of master XML file**

Cause	Remedy	Severity/response
Internal error	Restart the device. If the error persists, contact the manufacturer.	Fault

805311396 | 0x300013A4 **CTRL - Function disabled**

Cause	Remedy	Severity/response
Internal error	Restart the device. If the error persists, contact the manufacturer.	Fault

805311398 | 0x300013A6 **PRJ - Mismatch of bus configuration and number of connected slaves**

Cause	Remedy	Severity/response
Internal error	Restart the device. If the error persists, contact the manufacturer.	Fault

805311399 | 0x300013A7 **PRJ - Error reading master XML file**

Cause	Remedy	Severity/response
Internal error	Restart the device. If the error persists, contact the manufacturer.	Fault

805311401 | 0x300013A9 **PRJ - Configurator error - cyclic commands are missing in master XML file**

Cause	Remedy	Severity/response
Internal error	Restart the device. If the error persists, contact the manufacturer.	Fault



Diagnostics and fault elimination

Events, causes and remedies
Causes and remedies

805311402 | 0x300013AA **PRJ - AL_STATUS register read command is missing in master XML file**

Cause	Remedy	Severity/response
Internal error	Restart the device. If the error persists, contact the manufacturer.	Fault

805311403 | 0x300013AB **ISW - Fatal internal McSm error**

Cause	Remedy	Severity/response
Internal error	Restart the device. If the error persists, contact the manufacturer.	Fault

805311404 | 0x300013AC **SLV - Slave error**

Cause	Remedy	Severity/response
Internal error	Restart the device. If the error persists, contact the manufacturer.	Fault

805311405 | 0x300013AD **SLV - Frame lost, IDX mismatch**

Cause	Remedy	Severity/response
Internal error	Restart the device. If the error persists, contact the manufacturer.	Fault

805311406 | 0x300013AE **SLV - At least one EtherCAT command is missing in the received frame**

Cause	Remedy	Severity/response
Internal error	Restart the device. If the error persists, contact the manufacturer.	Fault

805311408 | 0x300013B0 **CTRL - IOCTL_EC_IOCTL_DC_LATCH_REQ_LTIMVALS not possible in DC Latching auto read mode**

Cause	Remedy	Severity/response
Internal error	Restart the device. If the error persists, contact the manufacturer.	Fault

805311409 | 0x300013B1 **SLV - Auto increment address - increment mismatch (slave missing)**

Cause	Remedy	Severity/response
Internal error	Restart the device. If the error persists, contact the manufacturer.	Fault

805311410 | 0x300013B2 **CTRL - Slave in invalid state, e.g. not in OP (API not callable in this state)**

Cause	Remedy	Severity/response
Internal error	Restart the device. If the error persists, contact the manufacturer.	Fault

805311411 | 0x300013B3 **SLV - Fixed station address lost or slave missing - FPRD to AL_STATUS failed**

Cause	Remedy	Severity/response
Internal error	Restart the device. If the error persists, contact the manufacturer.	Fault

Diagnostics and fault elimination

Events, causes and remedies

Causes and remedies



805311412 | 0x300013B4 **PRJ - Too many cyclic commands in XML configuration file**

Cause	Remedy	Severity/response
Internal error	Restart the device. If the error persists, contact the manufacturer.	Fault

805311414 | 0x300013B6 **RAP - Master core not accessible**

Cause	Remedy	Severity/response
Internal error	Restart the device. If the error persists, contact the manufacturer.	Fault

805311415 | 0x300013B7 **SLV - COE mailbox send - WKC error**

Cause	Remedy	Severity/response
Internal error	Restart the device. If the error persists, contact the manufacturer.	Fault

805311416 | 0x300013B8 **SLV - COE mailbox receive - WKC error**

Cause	Remedy	Severity/response
Internal error	Restart the device. If the error persists, contact the manufacturer.	Fault

805311417 | 0x300013B9 **CTRL - No mailbox support**

Cause	Remedy	Severity/response
Internal error	Restart the device. If the error persists, contact the manufacturer.	Fault

805311418 | 0x300013BA **CoE - Protocol not supported**

Cause	Remedy	Severity/response
Slave does not support CoE.	Use slave that supports CoE.	Fault

805311419 | 0x300013BB **PRJ - EoE protocol not supported**

Cause	Remedy	Severity/response
Slave does not support EoE.	Use slave that supports EoE.	Fault

805311420 | 0x300013BC **FoE . Protocol not supported**

Cause	Remedy	Severity/response
Slave does not support FoE.	Use slave that supports FoE.	Fault

805311421 | 0x300013BD **PRJ - SoE protocol not supported**

Cause	Remedy	Severity/response
Slave does not support SoE.	Use slave that supports SoE.	Fault



Diagnostics and fault elimination

Events, causes and remedies
Causes and remedies

805311422 | 0x300013BE PRJ - VoE protocol not supported

Cause	Remedy	Severity/response
Slave does not support VoE.	Use slave that supports VoE.	Fault

805311423 | 0x300013BF PRJ - Configuration violates evaluation limits

Cause	Remedy	Severity/response
		Fault

805311424 | 0x300013C0 CFG - Evaluation time expired

Cause	Remedy	Severity/response
		Fault

805311431 | 0x300013C7 CoE - invalid slave state

Cause	Remedy	Severity/response
The slave status is invalid.	Check if slave is at least PreOperational. Check other access rights.	Fault

805311432 | 0x300013C8 CoE - SDO Abort 'Toggle bit not alternated (0x05030000)'

Cause	Remedy	Severity/response
Internal error	Restart the device. If the error persists, contact the manufacturer.	Information

805311433 | 0x300013C9 CoE - SDO Abort 'SDO protocol time-out (0x05040000)'

Cause	Remedy	Severity/response
SDO protocol timeout	Check if timeout is set too low.	Warning

805311434 | 0x300013CA CoE - SDO Abort 'Client/server command specifier not valid or unknown (0x05040001)'

Cause	Remedy	Severity/response
Internal error	Restart the device. If the error persists, contact the manufacturer.	Information

805311435 | 0x300013CB CoE - SDO Abort 'Invalid block size (block mode only) (0x05040002)'

Cause	Remedy	Severity/response
Internal error	Restart the device. If the error persists, contact the manufacturer.	Information

805311436 | 0x300013CC CoE - SDO Abort 'Invalid sequence number (block mode only) (0x05040003)'

Cause	Remedy	Severity/response
Internal error	Restart the device. If the error persists, contact the manufacturer.	Information

Diagnostics and fault elimination

Events, causes and remedies
Causes and remedies



805311437 | 0x300013CD CoE - SDO Abort 'CRC error (block mode only) (0x05040004)'

Cause	Remedy	Severity/response
Internal error	Restart the device. If the error persists, contact the manufacturer.	Information

805311438 | 0x300013CE CoE - SDO Abort 'Out of memory (0x05040005)'

Cause	Remedy	Severity/response
Internal error	Restart the device. If the error persists, contact the manufacturer.	Information

805311439 | 0x300013CF CoE - SDO Abort 'Unsupported access to an object (0x06010000)'

Cause	Remedy	Severity/response
Access denied.	Check access authorization.	Information

805311440 | 0x300013D0 CoE - SDO Abort 'Attempt to read a write only object (0x06010001)'

Cause	Remedy	Severity/response
Access denied.	Check access authorization.	Information

805311441 | 0x300013D1 CoE - SDO Abort 'Attempt to write a read only object (0x06010002)'

Cause	Remedy	Severity/response
Access denied.	Check access authorization.	Information

805311442 | 0x300013D2 CoE - SDO-Abort 'Object does not exist in the object dictionary (0x06020000)'

Cause	Remedy	Severity/response
Access denied.	Check access authorization. Check if object exists.	Information

805311443 | 0x300013D3 CoE - SDO Abort 'Object cannot be mapped to the PDO (0x06040041)'

Cause	Remedy	Severity/response
Access denied.	Check access authorization. Check if object exists.	Information

805311444 | 0x300013D4 CoE - SDO Abort 'Number and length of objects to be mapped exceed PDO length (0x06040042)'

Cause	Remedy	Severity/response
Access denied.	Check the length of the objects to be mapped.	Information

805311445 | 0x300013D5 CoE - SDO Abort 'General parameter incompatibility (0x06040043)'

Cause	Remedy	Severity/response
Access denied.	Check access authorization.	Information



Diagnostics and fault elimination

Events, causes and remedies
Causes and remedies

805311446 | 0x300013D6 CoE - SDO Abort 'General internal incompatibility in the device (0x06040047)'

Cause	Remedy	Severity/response
Access denied.	Check access authorization.	Information

805311447 | 0x300013D7 CoE - SDO Abort 'Access failed due to an hardware error (0x06060000)'

Cause	Remedy	Severity/response
Access denied.	Check access authorization. Check object properties.	Information

805311448 | 0x300013D8 CoE - SDO Abort 'Data type or length of service parameters do not match (0x06070010)'

Cause	Remedy	Severity/response
Access denied.	Check access authorization. Check object properties.	Information

805311449 | 0x300013D9 CoE - SDO Abort 'Data type does not match, service parameter too high (0x06070012)'

Cause	Remedy	Severity/response
Access denied.	Check access authorization. Check object properties.	Information

805311450 | 0x300013DA CoE - SDO Abort 'Data type does not match, service parameter too low (0x06070013)'

Cause	Remedy	Severity/response
Access denied.	Check access authorization. Check object properties.	Information

805311451 | 0x300013DB CoE - SDO Abort 'Subindex does not exist (0x06090011)'

Cause	Remedy	Severity/response
Access denied.	Check access authorization. Check object properties.	Information

805311452 | 0x300013DC CoE - SDO Abort 'Write access - Parameter value exceeds limits (0x06090030)'

Cause	Remedy	Severity/response
Access denied.	Check access authorization. Check object properties.	Information

805311453 | 0x300013DD CoE - SDO Abort 'Write access - Parameter value too high (0x06090031)'

Cause	Remedy	Severity/response
Access denied.	Check access authorization. Check object properties.	Information

805311454 | 0x300013DE CoE - SDO Abort 'Write access - Parameter value too low (0x06090032)'

Cause	Remedy	Severity/response
Access denied.	Check access authorization. Check object properties.	Information

Diagnostics and fault elimination

Events, causes and remedies
Causes and remedies



805311455 | 0x300013DF CoE - SDO Abort 'Maximum value less than minimum value (0x06090036)'

Cause	Remedy	Severity/response
Access denied.	Check access authorization. Check object properties.	Information

805311456 | 0x300013E0 CoE - SDO Abort 'General error (0x08000000)'

Cause	Remedy	Severity/response
Access denied.	Check access authorization. Check object properties.	Information

805311457 | 0x300013E1 CoE - SDO Abort 'Data cannot be transferred/stored in application (0x08000020)'

Cause	Remedy	Severity/response
Access denied.	Check access authorization. Check object properties.	Information

805311458 | 0x300013E2 CoE - SDO Abort 'Local control - Data cannot be transferred/stored in application (0x08000021)'

Cause	Remedy	Severity/response
Access denied.	Check access authorization. Check object properties.	Information

805311459 | 0x300013E3 CoE - SDO Abort 'Actual device state - Data cannot be transferred/stored in application (0x08000022)'

Cause	Remedy	Severity/response
Access denied.	Check access authorization. Check object properties.	Information

805311460 | 0x300013E4 CoE - SDO Abort 'Object dictionary - Dynamic generation fails or object dictionary is missing (0x08000023)'

Cause	Remedy	Severity/response
Access denied.	Check access authorization. Check object properties.	Information

805311461 | 0x300013E5 CoE - SDO Abort 'Unknown abort code'

Cause	Remedy	Severity/response
Access denied.	Check access authorization. Check object properties.	Information

805311462 | 0x300013E6 CoE - Invalid parameter

Cause	Remedy	Severity/response
Access denied.	Check access authorization. Check object properties. Check transfer properties.	Information



Diagnostics and fault elimination

Events, causes and remedies
Causes and remedies

805311463 | 0x300013E7 **CoE - CoE protocol not supported**

Cause	Remedy	Severity/response
Access denied.	Check access authorization. Check object properties. Check transfer properties.	Information

805311464 | 0x300013E8 **CoE - Unknown FoE error**

Cause	Remedy	Severity/response
Access denied.	Check access authorization. Check file. Check transfer properties.	Information

805311465 | 0x300013E9 **CoE - FoE error 'Not found'**

Cause	Remedy	Severity/response
Access denied.	Check access authorization. Check file. Check transfer properties.	Information

805311466 | 0x300013EA **CoE - FoE error 'Access denied'**

Cause	Remedy	Severity/response
Access denied.	Check access authorization. Check file. Check transfer properties.	Information

805311467 | 0x300013EB **CoE - FoE error 'Disk full'**

Cause	Remedy	Severity/response
Access denied.	Check access authorization. Check file. Check transfer properties.	Information

805311468 | 0x300013EC **CoE - FoE error 'Illegal'**

Cause	Remedy	Severity/response
Access denied.	Check access authorization. Check file. Check transfer properties.	Information

805311469 | 0x300013ED **CoE - FoE error 'Wrong packet number'**

Cause	Remedy	Severity/response
Internal error	Restart the device. If the error persists, contact the manufacturer.	Information

805311470 | 0x300013EE **CoE - FoE error 'Already existing'**

Cause	Remedy	Severity/response
Access denied.	Check access authorization. Check file. Check transfer properties.	Information

Diagnostics and fault elimination

Events, causes and remedies

Causes and remedies



805311471 | 0x300013EF **CoE - FoE error 'User missing'**

Cause	Remedy	Severity/response
Access denied.	Check access authorization. Check file. Check transfer properties.	Information

805311472 | 0x300013F0 **CoE - FoE error 'Only possible in bootstrap'**

Cause	Remedy	Severity/response
Access denied.	Check access authorization. Check file. Check transfer properties.	Information

805311473 | 0x300013F1 **CoE - FoE error 'No bootstrap'**

Cause	Remedy	Severity/response
Access denied.	Check access authorization. Check file. Check transfer properties.	Information

805311474 | 0x300013F2 **CoE - FoE error 'No access rights'**

Cause	Remedy	Severity/response
Access denied.	Check access authorization. Check file. Check transfer properties.	Information

805311475 | 0x300013F3 **CoE - FoE error 'Program error'**

Cause	Remedy	Severity/response
Access denied.	Check access authorization. Check object properties.	Information

805311476 | 0x300013F4 **CoE - FoE error 'Invalid parameter'**

Cause	Remedy	Severity/response
Access denied.	Check access authorization. Check file. Check transfer properties.	Information

805311480 | 0x300013F8 **CTRL - Master configuration not found**

Cause	Remedy	Severity/response
Internal error	Restart the device. If the error persists, contact the manufacturer.	Fault

805311481 | 0x300013F9 **SLV - Command error while EEPROM upload**

Cause	Remedy	Severity/response
Internal error	Restart the device. If the error persists, contact the manufacturer.	Fault



Diagnostics and fault elimination

Events, causes and remedies
Causes and remedies

805311482 | 0x300013FA **SLV - Command error while EEPROM download**

Cause	Remedy	Severity/response
Internal error	Restart the device. If the error persists, contact the manufacturer.	Fault

805311483 | 0x300013FB **PRJ - Cyclic command too long**

Cause	Remedy	Severity/response
Internal error	Restart the device. If the error persists, contact the manufacturer.	Fault

805311484 | 0x300013FC **PRJ - Invalid input offset in cyc cmd, please check InputOffs**

Cause	Remedy	Severity/response
Internal error	Restart the device. If the error persists, contact the manufacturer.	Fault

805311485 | 0x300013FD **PRJ - Invalid output offset in cyc cmd, please check OutputOffs**

Cause	Remedy	Severity/response
Internal error	Restart the device. If the error persists, contact the manufacturer.	Fault

805311753 | 0x30001509 **RAP - Invalid cookie**

Cause	Remedy	Severity/response
		Fault

805311754 | 0x3000150A **RAP - Watchdog expired**

Cause	Remedy	Severity/response
		Fault

805311755 | 0x3000150B **RAP - Connecting 2nd server denied, multi server support is disabled**

Cause	Remedy	Severity/response
		Fault

805311756 | 0x3000150C **RAP - Logon aborted**

Cause	Remedy	Severity/response
		Fault

805311757 | 0x3000150D **RAP - Invalid version**

Cause	Remedy	Severity/response
		Fault

Diagnostics and fault elimination

Events, causes and remedies
Causes and remedies



805311769 | 0x30001519 **RAP - Server stopped**

Cause	Remedy	Severity/response
		Fault

805311770 | 0x3000151A **RAP - Watchdog expired**

Cause	Remedy	Severity/response
		Fault

805311771 | 0x3000151B **RAP - Reconnect time expired**

Cause	Remedy	Severity/response
		Fault

805311772 | 0x3000151C **RAP - Client logged on**

Cause	Remedy	Severity/response
		Fault

805311773 | 0x3000151D **RAP - Client reconnected**

Cause	Remedy	Severity/response
		Fault

805311774 | 0x3000151E **RAP - Socket changed after reconnect**

Cause	Remedy	Severity/response
		Fault

805311817 | 0x30001549 **DCM - Init function not called or call not successful**

Cause	Remedy	Severity/response
		Fault

805311818 | 0x3000154A **DCM - Controller error - synchronization out of limit**

Cause	Remedy	Severity/response
		Fault

805311819 | 0x3000154B **DCM - Not enough memory**

Cause	Remedy	Severity/response
		Fault

805311820 | 0x3000154C **DCM - Hardware layer - (BSP) invalid**

Cause	Remedy	Severity/response
		Fault



Diagnostics and fault elimination

Events, causes and remedies
Causes and remedies

805311821 | 0x3000154D **DCM - Hardware layer - Error while modifying the timer**

Cause	Remedy	Severity/response
		Fault

805311822 | 0x3000154E **DCM - Hardware layer - Timer is not running**

Cause	Remedy	Severity/response
		Fault

805311823 | 0x3000154F **DCM - Hardware layer - Function is called on wrong CPU**

Cause	Remedy	Severity/response
		Fault

805311881 | 0x30001589 **EtherCAT - State change of master successful**

Cause	Remedy	Severity/response
EtherCAT - State change of master successful	For information only. No remedy necessary.	Fault

805311882 | 0x3000158A **EtherCAT - Bus scan successful**

Cause	Remedy	Severity/response
EtherCAT - Bus scan successful	For information only. No remedy necessary.	Fault

805311883 | 0x3000158B **EtherCAT - Bus scan error**

Cause	Remedy	Severity/response
Error in the network topology	Check network topology.	Fault

805311884 | 0x3000158C **EtherCAT - Distributed clocks state**

Cause	Remedy	Severity/response
		Fault

805311885 | 0x3000158D **EtherCAT - Distributed clocks - Latching state**

Cause	Remedy	Severity/response
		Fault

805311886 | 0x3000158E **CoE - SDO download failure**

Cause	Remedy	Severity/response
Internal error	Restart the device. If the error persists, contact the manufacturer.	Information

805311887 | 0x3000158F **CoE - SDO upload failure**

Cause	Remedy	Severity/response
Internal error	Restart the device. If the error persists, contact the manufacturer.	Information

Diagnostics and fault elimination

Events, causes and remedies
Causes and remedies



805311888 | 0x30001590 **CoE - OD-list upload failure**

Cause	Remedy	Severity/response
Internal error	Restart the device. If the error persists, contact the manufacturer.	Information

805311889 | 0x30001591 **CoE - Object description upload failure**

Cause	Remedy	Severity/response
Internal error	Restart the device. If the error persists, contact the manufacturer.	Information

805311890 | 0x30001592 **CoE - Object entry description upload failure**

Cause	Remedy	Severity/response
Internal error	Restart the device. If the error persists, contact the manufacturer.	Information

805311891 | 0x30001593 **CoE - Emergency transfer failure**

Cause	Remedy	Severity/response
Internal error	Restart the device. If the error persists, contact the manufacturer.	Information

805311892 | 0x30001594 **CoE - Emergency request**

Cause	Remedy	Severity/response
Internal error during transmission of emergency messages.	Check the documentation of the slave device for this emergency message. Note: "data: ..." shows by codes which error has occurred in which slave device/module. Detailed information about the coding of error messages can be found in the documentation of the corresponding slave device/module.	Information

805311893 | 0x30001595 **Cyclic command WKC error**

Cause	Remedy	Severity/response
WKC error	Check slave status. Check network topology.	Fault

805311894 | 0x30001596 **Master init command WKC error**

Cause	Remedy	Severity/response
WKC error	Check slave status. Check network topology.	Warning

805311895 | 0x30001597 **Slave init command WKC error**

Cause	Remedy	Severity/response
WKC error	Check slave status. Check network topology.	Warning



Diagnostics and fault elimination

Events, causes and remedies
Causes and remedies

805311896 | 0x30001598 **EoE receive WKC error**

Cause	Remedy	Severity/response
WKC error	Check slave status. Check network topology.	Warning

805311897 | 0x30001599 **CoE receive WKC error**

Cause	Remedy	Severity/response
WKC error	Check slave status. Check network topology.	Warning

805311898 | 0x3000159A **FoE receive WKC error**

Cause	Remedy	Severity/response
WKC error	Check slave status. Check network topology.	Fault

805311899 | 0x3000159B **SoE receive - WKC error**

Cause	Remedy	Severity/response
WKC error	Check slave status. Check network topology.	Warning

805311900 | 0x3000159C **EoE send WKC error**

Cause	Remedy	Severity/response
WKC error	Check slave status. Check network topology.	Warning

805311901 | 0x3000159D **CoE send WKC error**

Cause	Remedy	Severity/response
WKC error	Check slave status. Check network topology.	Warning

805311902 | 0x3000159E **FoE send WKC error**

Cause	Remedy	Severity/response
WKC error	Check slave status. Check network topology.	Warning

805311903 | 0x3000159F **SoE send - WKC error**

Cause	Remedy	Severity/response
WKC error	Check slave status. Check network topology.	Warning

805311904 | 0x300015A0 **Retry sending a frame**

Cause	Remedy	Severity/response
		Fault

Diagnostics and fault elimination

Events, causes and remedies
Causes and remedies



805311905 | 0x300015A1 Response on Ethernet frame

Cause	Remedy	Severity/response
		Fault

805311906 | 0x300015A2 Additional error information

Cause	Remedy	Severity/response
Internal error	Restart the device. If the error persists, contact the manufacturer.	Fault

805311907 | 0x300015A3 EtherCAT command - IDX actual value

Cause	Remedy	Severity/response
Internal error	Restart the device. If the error persists, contact the manufacturer.	Fault

805311908 | 0x300015A4 EtherCAT command - IDX set value

Cause	Remedy	Severity/response
Internal error	Restart the device. If the error persists, contact the manufacturer.	Fault

805311909 | 0x300015A5 Init command response error - No response

Cause	Remedy	Severity/response
Internal error	Restart the device. If the error persists, contact the manufacturer.	Warning

805311910 | 0x300015A6 Init command response error - Validation error

Cause	Remedy	Severity/response
Internal error	Restart the device. If the error persists, contact the manufacturer.	Warning

805311911 | 0x300015A7 Init command response error - Failed

Cause	Remedy	Severity/response
Internal error	Restart the device. If the error persists, contact the manufacturer.	Warning

805311912 | 0x300015A8 Master init command response error - No response

Cause	Remedy	Severity/response
Internal error	Restart the device. If the error persists, contact the manufacturer.	Warning

805311913 | 0x300015A9 Master init command response error - Validation error

Cause	Remedy	Severity/response
Internal error	Restart the device. If the error persists, contact the manufacturer.	Warning



Diagnostics and fault elimination

Events, causes and remedies
Causes and remedies

805311914 | 0x300015AA Missing EtherCAT command in Ethernet frame

Cause	Remedy	Severity/response
Internal error	Restart the device. If the error persists, contact the manufacturer.	Fault

805311915 | 0x300015AB Mailbox init command timeout

Cause	Remedy	Severity/response
Internal error	Restart the device. If the error persists, contact the manufacturer.	Warning

805311916 | 0x300015AC At least one EtherCAT slave not in 'Operational'

Cause	Remedy	Severity/response
Master is "Operational". At least one slave is not "Operational".	Check slave status. Check network topology.	Warning

805311917 | 0x300015AD EtherCAT cable connected

Cause	Remedy	Severity/response
EtherCAT cable connected	For information only. No remedy necessary.	Information

805311918 | 0x300015AE EtherCAT cable not connected

Cause	Remedy	Severity/response
Network cabling is faulty.	Check network cabling.	Information

805311919 | 0x300015AF Cyclic commands - Time-out

Cause	Remedy	Severity/response
Internal error	Restart the device. If the error persists, contact the manufacturer.	Fault

805311920 | 0x300015B0 Redundant operation - Ethernet cable is missing at 2nd EtherCAT interface

Cause	Remedy	Severity/response
Network cabling is faulty.	Check network cabling.	Warning

805311921 | 0x300015B1 At least one slave is in state 'Error'

Cause	Remedy	Severity/response
At least one slave is in the "Error" state.	Check slave status. Check network topology.	Warning

805311922 | 0x300015B2 Slave error

Cause	Remedy	Severity/response
A slave reports an error.	Analyze detailed error message in the logbook. Check slave status. Check network topology.	Warning

Diagnostics and fault elimination

Events, causes and remedies

Causes and remedies



805311923 | 0x300015B3 Communication to device interrupted

Cause	Remedy	Severity/response
The connection to the slave is interrupted. The slave does not respond. The slave is no longer available.	Check slave status. Check network topology.	Warning

805311924 | 0x300015B4 SDO abort

Cause	Remedy	Severity/response
CoE access denied.	Analyze detailed error message in the logbook. Check object properties. Check transfer properties.	Warning

805311925 | 0x300015B5 DC slaves are 'in-sync'

Cause	Remedy	Severity/response
DC slaves are 'in-sync'	For information only. No remedy necessary.	Information

805311926 | 0x300015B6 DC slaves are 'out-of-sync'

Cause	Remedy	Severity/response
The DC deviation is outside the permissible limits.	Check slave status. Check slave properties. Check network topology.	Warning

805311927 | 0x300015B7 DC single latch on slave

Cause	Remedy	Severity/response
Internal message	For information only. No remedy necessary.	Fault

805311928 | 0x300015B8 MbxTferRcv - file upload failure

Cause	Remedy	Severity/response
Internal error	Restart the device. If the error persists, contact the manufacturer.	Fault

805311929 | 0x300015B9 MbxTferRcv - file download failure

Cause	Remedy	Severity/response
Internal error	Restart the device. If the error persists, contact the manufacturer.	Fault

805311930 | 0x300015BA Client registration lost

Cause	Remedy	Severity/response
Internal error	Restart the device. If the error persists, contact the manufacturer.	Fault

805311931 | 0x300015BB Redundant operation - Ethernet cable connected

Cause	Remedy	Severity/response
		Information



Diagnostics and fault elimination

Events, causes and remedies
Causes and remedies

805311932 | 0x300015BC **SoE write error init command mbox**

Cause	Remedy	Severity/response
		Warning

805311960 | 0x300015D8 **Hot Connect - all groups detected**

Cause	Remedy	Severity/response
		Information

805311961 | 0x300015D9 **Hot Connect - all group errors detected**

Cause	Remedy	Severity/response
		Warning

805311962 | 0x300015DA **Slave removed from bus**

Cause	Remedy	Severity/response
A slave has been removed from the network topology.	For information only. No remedy necessary.	Warning

805311963 | 0x300015DB **Slave added to bus**

Cause	Remedy	Severity/response
A slave has been added to the network topology.	For information only. No remedy necessary.	Information

805311964 | 0x300015DC **Topology was changed**

Cause	Remedy	Severity/response
The network topology has been changed.	For information only. No remedy necessary.	Information

805311965 | 0x300015DD **Port closed**

Cause	Remedy	Severity/response
"Border Close" has been executed on the port.	Analyze detailed error message in the logbook.	Information

805311966 | 0x300015DE **MbxTferRcv - Write IDN failure**

Cause	Remedy	Severity/response
IDN - Write error.	Analyze detailed error message in the logbook.	Information

805311967 | 0x300015DF **MbxTferRcv - Read IDN failure**

Cause	Remedy	Severity/response
IDN - read error.	Analyze detailed error message in the logbook.	Information

805311968 | 0x300015E0 **SoE - Emergency transfer failure**

Cause	Remedy	Severity/response
SoE - emergency transfer error.	Analyze detailed error message in the logbook.	Information

Diagnostics and fault elimination

Events, causes and remedies

Causes and remedies



805311969 | 0x300015E1 **SoE - Emergency request**

Cause	Remedy	Severity/response
SoE - emergency request.	Analyze detailed error message in the logbook.	Information

805311970 | 0x300015E2 **SoE - Notification transfer failure**

Cause	Remedy	Severity/response
SoE - transfer error during a notification.	Analyze detailed error message in the logbook.	Information

805311971 | 0x300015E3 **SoE - Notification request**

Cause	Remedy	Severity/response
SoE - notification has been requested.	Analyze detailed error message in the logbook.	Information

805311972 | 0x300015E4 **FoE abort**

Cause	Remedy	Severity/response
FoE has been aborted.	Check file. Check transfer properties. Analyze detailed error message in the logbook.	Information

805312069 | 0x30001645 **Bus scan state**

Cause	Remedy	Severity/response
Bus scan state	For information only. No remedy necessary.	Information

805312070 | 0x30001646 **Latch/Edge**

Cause	Remedy	Severity/response
		Information

805312071 | 0x30001647 **Latch/Edge - No edge**

Cause	Remedy	Severity/response
No edge.	Analyze detailed error message in the logbook.	Information

805312072 | 0x30001648 **Remote API diagnosis port - Connection established**

Cause	Remedy	Severity/response
Remote API diagnosis port - Connection established	For information only. No remedy necessary.	Information

805312073 | 0x30001649 **Remote API diagnosis port - Connection disconnected**

Cause	Remedy	Severity/response
Remote API diagnosis port - Connection disconnected	For information only. No remedy necessary.	Information



Diagnostics and fault elimination

Events, causes and remedies
Causes and remedies

805312074 | 0x3000164A **Client registered from cookie**

Cause	Remedy	Severity/response
Client has registered with cookie.	Analyze detailed error message in the logbook.	Information

805312075 | 0x3000164B **Client unregistered from cookie**

Cause	Remedy	Severity/response
Client logged out from cookie.	Analyze detailed error message in the logbook.	Information

805312076 | 0x3000164C **Unknown notification**

Cause	Remedy	Severity/response
Internal error	Restart the device. If the error persists, contact the manufacturer.	Information

805312077 | 0x3000164D **Slave latched**

Cause	Remedy	Severity/response
Internal error	Restart the device. If the error persists, contact the manufacturer.	Information

805312078 | 0x3000164E **Bus scan - Error**

Cause	Remedy	Severity/response
Internal error	Restart the device. If the error persists, contact the manufacturer.	Information

805312079 | 0x3000164F **Invalid number of slaves**

Cause	Remedy	Severity/response
The number of detected slaves differs from the number of expected slaves.	Analyze detailed error message in the logbook. Check network topology.	Information

805312080 | 0x30001650 **Cannot get SlaveInfo**

Cause	Remedy	Severity/response
Internal error	Restart the device. If the error persists, contact the manufacturer.	Information

805312081 | 0x30001651 **Deviation of slave**

Cause	Remedy	Severity/response
Internal error	Restart the device. If the error persists, contact the manufacturer.	Information

805312082 | 0x30001652 **Slave is not configured**

Cause	Remedy	Severity/response
The slave is not configured	Check slave status. Check network topology.	Information

Diagnostics and fault elimination

Events, causes and remedies
Causes and remedies



805312083 | 0x30001653 **SlaveInfo**

Cause	Remedy	Severity/response
Internal error	Restart the device. If the error persists, contact the manufacturer.	Information

805312084 | 0x30001654 **SLV - Error retrieving configuration data**

Cause	Remedy	Severity/response
Internal error	Restart the device. If the error persists, contact the manufacturer.	Information

805312085 | 0x30001655 **Bus scan - Deviation**

Cause	Remedy	Severity/response
Internal error	Restart the device. If the error persists, contact the manufacturer.	Information

805312086 | 0x30001656 **Communication to device interrupted**

Cause	Remedy	Severity/response
Communication interruption	Check slave status. Check network topology.	Information

805312087 | 0x30001657 **Slave is not in expected status**

Cause	Remedy	Severity/response
Detected slave status differs from expected slave status.	Analyze detailed error message in the logbook. Check slave status. Check network topology.	Warning

805312090 | 0x3000165A **Wrong response on 'configured fix address request' for slave**

Cause	Remedy	Severity/response
Wrong response to the request.	Check slave status. Check network topology.	Information

805312091 | 0x3000165B **Wrong response on 'alias address' request for slave**

Cause	Remedy	Severity/response
Wrong response to the request.	Check slave status. Check network topology.	Information

805312092 | 0x3000165C **Cannot execute EC_IOCTL_DC_SLV_SYNC_DEVLIMIT_GET**

Cause	Remedy	Severity/response
The command cannot be executed	Analyze detailed error message in the logbook.	Information

805312093 | 0x3000165D **Cannot read latch timer**

Cause	Remedy	Severity/response
Read error	Analyze detailed error message in the logbook.	Information



Diagnostics and fault elimination

Events, causes and remedies
Causes and remedies

805312094 | 0x3000165E **Cannot execute EC_IOCTL_DC_SLV_SYNC_RESTART**

Cause	Remedy	Severity/response
The command cannot be executed	Analyze detailed error message in the logbook.	Information

805312097 | 0x30001661 **RAP - Invalid parameter size**

Cause	Remedy	Severity/response
RAP - Invalid parameter size	For information only. No remedy necessary.	Information

805312098 | 0x30001662 **RAP - Marshaling error**

Cause	Remedy	Severity/response
Order error	Analyze detailed error message in the logbook.	Information

805312099 | 0x30001663 **Unable to enqueue (missing calls to ProcessNotificationJobs)**

Cause	Remedy	Severity/response
		Fault

805312100 | 0x30001664 **No connection to slaves**

Cause	Remedy	Severity/response
Possibly the network cable is missing.	Check slave status. Check network topology.	Information

805312101 | 0x30001665 **ecatSetTargetState cannot set EtherCAT master into target state, master is busy (time-out)**

Cause	Remedy	Severity/response
Internal error	Restart the device. If the error persists, contact the manufacturer.	Information

805312102 | 0x30001666 **ecatStop() returns 'Busy', retry...**

Cause	Remedy	Severity/response
Internal error	Restart the device. If the error persists, contact the manufacturer.	Information

805312103 | 0x30001667 **Mailbox transfer request - Error**

Cause	Remedy	Severity/response
Internal error	Restart the device. If the error persists, contact the manufacturer.	Information

805312104 | 0x30001668 **Mailbox transfer**

Cause	Remedy	Severity/response
Internal error	Restart the device. If the error persists, contact the manufacturer.	Information

Diagnostics and fault elimination

Events, causes and remedies
Causes and remedies



805312105 | 0x30001669 **Waiting for mailbox transfer from master...**

Cause	Remedy	Severity/response
Internal error	Restart the device. If the error persists, contact the manufacturer.	Information

805312106 | 0x3000166A **Mailbox transfer - Fatal time-out error**

Cause	Remedy	Severity/response
Internal error	Restart the device. If the error persists, contact the manufacturer.	Information

805312107 | 0x3000166B **Bus cycle and Sync period are different**

Cause	Remedy	Severity/response
Incorrect setting.	Check bus cycle. Check sync period.	Information

805312108 | 0x3000166C **Error getting the bus scan state**

Cause	Remedy	Severity/response
Internal error	Restart the device. If the error persists, contact the manufacturer.	Fault

805312109 | 0x3000166D **Wrong response on DC supported request or slave**

Cause	Remedy	Severity/response
Internal error	Restart the device. If the error persists, contact the manufacturer.	Information

805312110 | 0x3000166E **Unable to set 'DC slave sync disable'**

Cause	Remedy	Severity/response
Internal error	Restart the device. If the error persists, contact the manufacturer.	Fault

805312111 | 0x3000166F **Error when restarting bus scan**

Cause	Remedy	Severity/response
Internal error	Restart the device. If the error persists, contact the manufacturer.	Warning

805312112 | 0x30001670 **Bus scan timeout**

Cause	Remedy	Severity/response
The bus scan was aborted due to timeout.	Analyze detailed error message in the logbook. Check network topology.	Warning

805312568 | 0x30001838 **Configuration error - Check of VendorID failed**

Cause	Remedy	Severity/response
The vendor ID could not be checked.	Analyze detailed error message in the logbook. Check network topology.	Warning



Diagnostics and fault elimination

Events, causes and remedies
Causes and remedies

805312569 | 0x30001839 Configuration error - Check of ProductCode failed

Cause	Remedy	Severity/response
The product code could not be checked.	Analyze detailed error message in the logbook. Check network topology.	Information

805312570 | 0x3000183A Configuration error - Check of Revision failed

Cause	Remedy	Severity/response
The revision could not be checked.	Analyze detailed error message in the logbook. Check network topology.	Information

805312571 | 0x3000183B Configuration error - Check of VendorID failed

Cause	Remedy	Severity/response
The vendor ID could not be checked.	Analyze detailed error message in the logbook. Check network topology.	Information

805312572 | 0x3000183C Configuration error - Odd device at bus end

Cause	Remedy	Severity/response
A surplus device was detected at the end of the bus.	Analyze detailed error message in the logbook. Check network topology.	Information

805312578 | 0x30001842 Internal error counter resetted

Cause	Remedy	Severity/response
Internal error counter resetted	For information only. No remedy necessary.	Information

805312580 | 0x30001844 All slaves 'Operational' again

Cause	Remedy	Severity/response
All slaves 'Operational' again	For information only. No remedy necessary.	Information

805312581 | 0x30001845 Cyclic command WKC error

Cause	Remedy	Severity/response
WKC error	Analyze detailed error message in the logbook. Check slave status. Check network topology.	Warning

805312582 | 0x30001846 Frame response error

Cause	Remedy	Severity/response
Frame response error	Analyze detailed error message in the logbook. Check slave status. Check network topology.	Warning

805312583 | 0x30001847 Not all slaves are 'Operational'

Cause	Remedy	Severity/response
Not all slaves have been set to 'Operational'.	Analyze detailed error message in the logbook. Check slave status. Check network topology.	Information

Diagnostics and fault elimination

Events, causes and remedies
Causes and remedies



805312584 | 0x30001848 Emergency message - Overflow, further messages blocked

Cause	Remedy	Severity/response
Too many emergency messages.	Check if slave sends too many emergency messages. Eliminate cause.	Warning

805312588 | 0x3000184C New configuration loaded

Cause	Remedy	Severity/response
New configuration loaded	For information only. No remedy necessary.	Information

805312589 | 0x3000184D New configuration loaded, no slaves defined

Cause	Remedy	Severity/response
New configuration loaded, no slaves defined	For information only. No remedy necessary.	Information

805312590 | 0x3000184E Master - Start failed, configuration error

Cause	Remedy	Severity/response
Internal error	See related entries in the logbook.	Information

805312591 | 0x3000184F New configuration loaded from slaves EEPROM

Cause	Remedy	Severity/response
New configuration loaded from slaves EEPROM	For information only. No remedy necessary.	Information

805312598 | 0x30001856 Master - Start failed

Cause	Remedy	Severity/response
Internal error	See related entries in the logbook.	Warning

805312599 | 0x30001857 Master - Start failed, bus configuration error

Cause	Remedy	Severity/response
Bus configuration error	Check network topology.	Warning

805312600 | 0x30001858 Master - Start failed, EtherCAT cable disconnected

Cause	Remedy	Severity/response
Network cabling is faulty.	Check network cabling.	Warning

805312601 | 0x30001859 Master - Start failed, DC/DCM configuration

Cause	Remedy	Severity/response
Internal error	Restart the device. If the error persists, contact the manufacturer.	Warning

805312602 | 0x3000185A Master - Start failed, cannot set slaves to 'Pre-Operational'

Cause	Remedy	Severity/response
Slaves cannot be set to 'Pre-Operational'.	See related entries in the logbook.	Warning



Diagnostics and fault elimination

Events, causes and remedies
Causes and remedies

805312608 | 0x30001860 **Master - Set 'Operational' failed**

Cause	Remedy	Severity/response
Operational' could not be set.	See related entries in the logbook.	Warning

805312609 | 0x30001861 **Master - Set 'Operational' failed, Master not initialized**

Cause	Remedy	Severity/response
Master not initialized.	See related entries in the logbook.	Warning

805312610 | 0x30001862 **Master - Set 'Operational' failed, EtherCAT cable disconnected**

Cause	Remedy	Severity/response
Network cabling is faulty.	Check network cabling.	Warning

805312611 | 0x30001863 **Master - Set 'Operational' failed, DCM not in-sync**

Cause	Remedy	Severity/response
Internal error	See related entries in the logbook.	Warning

805312612 | 0x30001864 **Master - Set 'Operational' failed, bus cycle and DC different**

Cause	Remedy	Severity/response
Incorrect setting.	Check bus cycle. Check sync period.	Warning

805312613 | 0x30001865 **Master - Set 'Operational' takes some time...**

Cause	Remedy	Severity/response
Master - Set 'Operational' takes some time...	For information only. No remedy necessary.	Warning

805312614 | 0x30001866 **Master - Set 'Operational' failed, time-out**

Cause	Remedy	Severity/response
	See related entries in the logbook. Check slave status. Check network topology.	Warning

805312615 | 0x30001867 **Master - Set 'Operational' failed, slave error**

Cause	Remedy	Severity/response
Slave error	See related entries in the logbook.	Warning

805312616 | 0x30001868 **Master - Set 'Operational' aborted by reset command**

Cause	Remedy	Severity/response
Master - Set 'Operational' aborted by reset command	For information only. No remedy necessary.	Warning

Diagnostics and fault elimination

Events, causes and remedies
Causes and remedies



805312618 | 0x3000186A **Master - Stopping failed**

Cause	Remedy	Severity/response
Master cannot be stopped.	See related entries in the logbook.	Warning

805312619 | 0x3000186B **Master - Stopping failed, cannot set Slaves 'Pre-Operational'**

Cause	Remedy	Severity/response
Slave error	See related entries in the logbook.	Warning

805312628 | 0x30001874 **Master - Shutdown failed**

Cause	Remedy	Severity/response
Master - Shutdown failed	For information only. No remedy necessary.	Warning

805312638 | 0x3000187E **Remote API Server - Start failed**

Cause	Remedy	Severity/response
Internal error	Restart the device. If the error persists, contact the manufacturer.	Warning

805312648 | 0x30001888 **Start Download Service**

Cause	Remedy	Severity/response
Start Download Service	For information only. No remedy necessary.	Information

805312649 | 0x30001889 **Download Service done**

Cause	Remedy	Severity/response
Download Service done	For information only. No remedy necessary.	Information

805312668 | 0x3000189C **MMC - Internal error**

Cause	Remedy	Severity/response
Internal error	Restart the device. If the error persists, contact the manufacturer.	Warning

805312669 | 0x3000189D **MMC - 'Modular Machine Configuration' is active**

Cause	Remedy	Severity/response
MMC - "Modular Machine Configuration" is active.	For information only. No remedy necessary.	Information

805312670 | 0x3000189E **MMC - Service started**

Cause	Remedy	Severity/response
MMC - Service started	For information only. No remedy necessary.	Information

805312671 | 0x3000189F **MMC - Service stopped**

Cause	Remedy	Severity/response
MMC - Service stopped	For information only. No remedy necessary.	Information



805312672 | 0x300018A0 **MMC - Error in configuration files**

Cause	Remedy	Severity/response
MMC configuration file is faulty.	Check MMC configuration file.	Warning

805312673 | 0x300018A1 **MMC - File does not exist**

Cause	Remedy	Severity/response
MMC - File does not exist	For information only. No remedy necessary.	Warning

805312674 | 0x300018A2 **MMC - Parsing error**

Cause	Remedy	Severity/response
MMC configuration file is faulty.	Check MMC configuration file.	Warning

805312675 | 0x300018A3 **MMC - parsing of file successful**

Cause	Remedy	Severity/response
MMC - parsing of file successful	For information only. No remedy necessary.	Warning

805312676 | 0x300018A4 **MMC - Devices not sorted in ascending order or devices missing**

Cause	Remedy	Severity/response
MMC configuration file is faulty.	Check MMC configuration file.	Warning

805312677 | 0x300018A5 **MMC - Number of devices in device tree differs**

Cause	Remedy	Severity/response
MMC configuration file is faulty.	Check MMC configuration file. Check network topology.	Warning

805312678 | 0x300018A6 **MMC - Device type mismatch for Alias Address**

Cause	Remedy	Severity/response
MMC configuration file is faulty.	Check MMC configuration file. Analyze detailed error message in the logbook.	Warning

805312679 | 0x300018A7 **MMC - Invalid Alias Address**

Cause	Remedy	Severity/response
Incorrect alias address.	Check SSA addresses of the slaves. Analyze detailed error message in the logbook.	Warning

805312680 | 0x300018A8 **MMC - Duplicated Alias Address**

Cause	Remedy	Severity/response
Double alias address.	Check SSA addresses of the slaves. Analyze detailed error message in the logbook.	Warning

Diagnostics and fault elimination

Events, causes and remedies

Causes and remedies



805312681 | 0x300018A9 MMC - No configuration checks

Cause	Remedy	Severity/response
MMC - No configuration checks	For information only. No remedy necessary.	Information

805312682 | 0x300018AA MMC - Invalid configuration

Cause	Remedy	Severity/response
Internal error	Restart the device. If the error persists, contact the manufacturer.	Warning

805312683 | 0x300018AB MMC - Mandatory slave missing

Cause	Remedy	Severity/response
MMC configuration file is faulty. Network topology is faulty.	Check MMC configuration file. Check network topology.	Warning

805312684 | 0x300018AC MMC - Optional slave is present, but not allowed

Cause	Remedy	Severity/response
MMC configuration file is faulty. Network topology is faulty.	Check MMC configuration file. Check network topology.	Warning

805312685 | 0x300018AD MMC - No valid service active

Cause	Remedy	Severity/response
MMC - No valid service active	For information only. No remedy necessary.	Warning

805312686 | 0x300018AE MMC - Address assignment error, less slaves connected than configured

Cause	Remedy	Severity/response
MMC configuration file is faulty. Network topology is faulty.	Analyze detailed error message in the logbook. Check MMC configuration file. Check network topology.	Warning

805312687 | 0x300018AF MMC - Address assignment error, more slaves connected than configured

Cause	Remedy	Severity/response
MMC configuration file is faulty. Network topology is faulty.	Analyze detailed error message in the logbook. Check MMC configuration file. Check network topology.	Fault

805312688 | 0x300018B0 MMC - Address assignment error, invalid device

Cause	Remedy	Severity/response
MMC configuration file is faulty. Network topology is faulty.	Analyze detailed error message in the logbook. Check MMC configuration file. Check network topology.	Fault

805312689 | 0x300018B1 MMC - Address assignment successful

Cause	Remedy	Severity/response
MMC - Address assignment successful	For information only. No remedy necessary.	Information



Diagnostics and fault elimination

Events, causes and remedies
Causes and remedies

805312690 | 0x300018B2 **MMC - Address assignment failed**

Cause	Remedy	Severity/response
MMC configuration file is faulty. Network topology is faulty.	Analyze detailed error message in the logbook. Check MMC configuration file. Check network topology.	Information

805312691 | 0x300018B3 **MMC - Address assignment done**

Cause	Remedy	Severity/response
MMC - Address assignment done	For information only. No remedy necessary.	Information

805312692 | 0x300018B4 **MMC - Address assignment error, writing address by CoE**

Cause	Remedy	Severity/response
MMC - Address assignment error, writing address by CoE	For information only. No remedy necessary.	Warning

805312693 | 0x300018B5 **MMC - Slave identification error**

Cause	Remedy	Severity/response
MMC configuration file is faulty. Network topology is faulty.	Analyze detailed error message in the logbook. Check MMC configuration file. Check network topology.	Warning

805312694 | 0x300018B6 **MMC - Slave identification error, slave ident data failed**

Cause	Remedy	Severity/response
MMC configuration file is faulty. Network topology is faulty.	Analyze detailed error message in the logbook. Check MMC configuration file. Check network topology.	Warning

805312695 | 0x300018B7 **MMC - Service state cannot be changed, set bus to 'INIT' first**

Cause	Remedy	Severity/response
Service request rejected because master not in "Init" status	Check status of the master. Set status of the master to "Init".	Information

805312867 | 0x30001963 **Last ETC message**

Cause	Remedy	Severity/response
		Information

805405056 | 0x30018180 **EtherCAT - DC synchronization required**

Cause	Remedy	Severity/response
EtherCAT Distributed Clock (DC) not activated.	Activate DC mode.	Warning

805405057 | 0x30018181 **EtherCAT - Communication error**

Cause	Remedy	Severity/response
EtherCAT communication interrupted.	<ul style="list-style-type: none"> Check bus cable. Increase watchdog time. 	(configurable) Setting parameters:

Diagnostics and fault elimination

Events, causes and remedies
Causes and remedies



805405312 | 0x30018280 EtherCAT - Wrong sync manager address

Cause	Remedy	Severity/response
Wrong Sync Manager setting from EtherCAT master	<ul style="list-style-type: none">• Check node.• Check the sequence of the nodes.• Check bus cable.	Fault

805405313 | 0x30018281 EtherCAT - Wrong sync manager size

Cause	Remedy	Severity/response
Wrong Sync Manager setting from EtherCAT master	<ul style="list-style-type: none">• Check node.• Check the sequence of the nodes.• Check bus cable.	Fault

805405314 | 0x30018282 EtherCAT - Wrong sync manager settings

Cause	Remedy	Severity/response
Wrong Sync Manager setting from EtherCAT master	<ul style="list-style-type: none">• Check node.• Check the sequence of the nodes.• Check bus cable.	Fault

805405315 | 0x30018283 PDO mapping: Unknown object

Cause	Remedy	Severity/response
Unknown index in the PDO mapping	Correct PDO mapping.	Fault

805405316 | 0x30018284 No PDO mapping object

Cause	Remedy	Severity/response
The index cannot be mapped as PDO.	Correct PDO mapping.	Fault

805405317 | 0x30018285 Too many objects mapped

Cause	Remedy	Severity/response
More than 64 objects are mapped.	Reduce number of objects in PDO mapping.	Fault

805405318 | 0x30018286 PDO mapping error

Cause	Remedy	Severity/response
PDO mapping is faulty.	Check PDO mapping.	Fault

805405320 | 0x30018288 PDO mapping object is already used by PLC.

Cause	Remedy	Severity/response
The object to be mapped is already used by the PLC.	Remove object from mapping.	Fault



Diagnostics and fault elimination

Events, causes and remedies
Causes and remedies

805406464 | 0x30018700 EtherCAT - Sync error

Cause	Remedy	Severity/response
<ul style="list-style-type: none"> EtherCAT Sync0 has failed. PDO was sent or received too late. 	<ul style="list-style-type: none"> Check in the EtherCAT master configuration whether Distributed Clock is activated. Restart EtherCAT configuration. Shift PDO reception time via user shift time. Increase telegram failure error counter: ▶ 0x10F1:002 	(configurable) Setting parameters:

805406465 | 0x30018701 Sync PLL - Time-out

Cause	Remedy	Severity/response
Error during state change Pre-Operational → Safe-Operational: <ul style="list-style-type: none"> EtherCAT Sync0 has failed. The Sync0 jitter is too high. 	<ul style="list-style-type: none"> Check DC deviation in EtherCAT master. Restart EtherCAT configuration. 	Fault

805437220 | 0x3001FF24 Invalid Sync0 cycle time

Cause	Remedy	Severity/response
The requested Sync0 cycle is outside the supported limits.	Correct Sync0 cycle.	Fault

822313234 | 0x31038112 Network - Time-out explicit message

Cause	Remedy	Severity/response
<ul style="list-style-type: none"> Within the time-out period for explicit messages, which has been parameterised by the scanner, no "explicit message" was received. The connection to the scanner has been interrupted. Failure of an explicit connection. 	<ul style="list-style-type: none"> Check cables and terminals. Plug network cables into the Ethernet port. Check the requested package interval (RPI) of the explicit connection. Increase time limit for explicit messages in the scanner. 	(configurable) Setting parameters:

822313236 | 0x31038114 Network - Overall communication time-out

Cause	Remedy	Severity/response
<ul style="list-style-type: none"> EtherNet/IP: the maximum permissible time-out period for the CIP communication set in has been exceeded. Modbus TCP/IP: the maximum permissible time-out period for the TCP communication set in has been exceeded. 	<ul style="list-style-type: none"> Check cables and terminals. Connect network cable. 	(configurable) Setting parameters:

822313360 | 0x31038190 Network - Watchdog time-out

Cause	Remedy	Severity/response
Time-out during cyclic data reception, e.g. due to an interrupted communication link to the master or missing cyclic data.	<ul style="list-style-type: none"> Check wiring of the network. Eliminate EMC interferences. 	(configurable) Setting parameters:

Diagnostics and fault elimination

Events, causes and remedies
Causes and remedies



822313361 | 0x31038191 Network - Disruption of cyclic data exchange

Cause	Remedy	Severity/response
The communication partner has interrupted the cyclic data exchange.	<ul style="list-style-type: none">• Check wiring of the network.• The slave must receive new parameterisation and configuration files by the master, in order to be able to exchange data again.	(configurable) Setting parameters:

822313362 | 0x31038192 Network - Initialization error

Cause	Remedy	Severity/response
The initialisation of the communication stack has been interrupted due to an incorrect address setting or communication configuration.	Check master/slave configuration and restart the devices.	(configurable) Setting parameters:

822313363 | 0x31038193 Network - Invalid cyclic process data

Cause	Remedy	Severity/response
The cyclic process data received are invalid.	Check cyclic process data sent by the master.	(configurable) Setting parameters:

822313370 | 0x3103819A Network - Initialization with safety option failed

Cause	Remedy	Severity/response
Communication with the safety option could not be initialized correctly.	Check safe parameter set.	Information

822313371 | 0x3103819B Network - Communication time-out with safety option

Cause	Remedy	Severity/response
Communication with the safety option is disturbed.	Check status of the safety option.	Information

822313607 | 0x31038287 Network - Invalid configuration

Cause	Remedy	Severity/response
Network configuration is faulty.	Check network configuration.	(configurable) Setting parameters:



16.5.3 Safety - Parameter set plausibility errors

The following table contains the detailed information about the possible plausibility errors.

The error code corresponds to the entry in [0x2115:005](#).

Error information 1 0x2115:005	Error in the setting of the safe parameterization
12	If SS1 is parameterized so that STO is triggered after reaching $n = 0$, the delay time "STO after $n = 0$ " must be zero.
27	If muting (MUT) is parameterized, a password must be assigned.
29	If the S-Bus is to be hidden via muting (MUT), an S-Bus must also be parameterized.

Error information 1 0x2115:005	Error in the setting of the safe parameterization
6	If no motor encoder is parameterized, no function requiring an encoder may be parameterized.
8	If a resolver is parameterized as motor encoder, max. 10000 rpm divided by the number of pole pairs of the resolver may be set as speed value due to the system.
9	If SS1 is parameterized so that STO is triggered after reaching $n = 0$, the delay time "STO after $n = 0$ " must be less than or equal to the stopping time.
12	If no motor encoder system is parameterized, the delay time "STO after $n = 0$ " must be zero.
13	The lower position limit for PDSS must be less than or equal to the upper position limit for PDSS.
14	The lower SCS limit for PDSS must be less than or equal to the upper SCS limit.
15	The lower position limit for SLP must be less than or equal to the upper position limit for SLP.
16	The lower position limit for SCA must be less than or equal to the upper position limit for SCA.
19	If the input source for SHom_Start is deactivated, no function based on an absolute position may be parameterized.
27	If muting (MUT) is parameterized, a password must be assigned. Valid from safety parameter set V1.1.
29	If the S-Bus is to be hidden via muting (MUT), an S-Bus must also be parameterized. Valid from safety parameter set V1.1.



17 Technical data



The technical data for the device (dimensions, rated data, standards and operating conditions) can be found in the associated project planning document.



18 Environmental notes and recycling

Lenze has been certified to the worldwide environmental management standard for many years (DIN EN ISO 14001). As part of our environmental policy and the associated climate responsibility, please note the following information on hazardous ingredients and the recycling of Lenze products and their packaging:



Lenze products are partly subject to the EU Directive on the restriction of certain hazardous substances in electrical and electronic equipment 2011/65/EU: RoHS Directive [UKCA: S.I. 2012/3032 - The Restriction of the Use of Certain Hazardous Substances in Electrical and Electronic Equipment Regulations 2012] . This is documented accordingly in the EU declaration of conformity and with the CE mark.



Lenze products are not subject to EU Directive 2012/19/EU: Directive on waste electrical and electronic equipment (WEEE) [UKCA: S.I. 2013/3113 - The Waste Electrical and Electronic Equipment Regulations 2013] , but some contain batteries/rechargeable batteries in accordance with EU Directive 2006/66/EC: Battery Directive [UKCA: S.I. 2009/890 - The Waste Batteries and Accumulators Regulations 2009] . The disposal route, which is separate from household waste, is indicated by corresponding labels with the "crossed-out trash can".

Any batteries/rechargeable batteries included are designed to last the life of the product and do not need to be replaced or otherwise removed by the end user.



Lenze products are usually sold with cardboard or plastic packaging. This packaging complies with EU Directive 94/62/EC: Directive on packaging and packaging waste [UKCA: S.I. 1997/648 - The Producer Responsibility Obligations (Packaging Waste) Regulations 1997] . The required disposal route is indicated by material-specific labels with the "recycling triangle".

Example: "21 - other cardboard"

REACH

Lenze products are subject to REGULATION (EC) No 1907/2006: REACH Regulation [UKCA: S.I. 2008/2852 - The REACH Enforcement Regulations 2008] . When used as intended, exposure of substances to humans, animals and the environment is excluded.

Lenze products are industrial electrical and electronic products and are disposed of professionally. Both the mechanical and electrical components such as electric motors, gearboxes or inverters contain valuable raw materials that can be recycled and reused. Proper recycling and thus maintaining the highest possible level of recyclability is therefore important and sensible from an economic and ecological point of view.

- Coordinate professional disposal with your waste disposal company.
- Separate mechanical and electrical components, packaging, hazardous waste (e.g. gear oils) and batteries/rechargeable batteries wherever possible.
- Dispose of the separated waste in an environmentally sound and proper manner (no household waste or municipal bulky waste).

What?	Material	Disposal instructions
Pallets	Wood	Return to manufacturers, freight forwarders or reusable materials collection system
Packaging material	Paper, cardboard, pasteboard, plastics	Collect and dispose of separately
Products		
Electronic devices	Metal, plastics, circuit boards, heatsinks	As electronic waste give to professional disposer for recycling
Gearbox	Oil	Drain oil and dispose of separately
	Casting, steel, aluminium	Dispose as metal scrap
Motors	Casting, copper, rotors, magnets, potting compound	As engine scrap give to professional disposer for recycling
Dry-cell batteries/rechargeable batteries		As used batteries give to professional disposer for recycling



Further information on Lenze's environmental and climate responsibility and on the topic of energy efficiency can be found on the Internet:

www.Lenze.com → search word: "Sustainability"



19 Appendix

19.1 Parameter attribute list

The parameter attribute list in particular contains some information required for reading and writing parameters via network.



Note the special features for writing the safe parameters of the Extended Safety:

»EASY Starter« or »PLC-Designer«: Writing the safe parameters is only possible via the "+Safe parameter list+" tab. The safe parameters can only be read via the "Parameter list" tab.

Higher-level controller: Writing of the safe parameters is possible by the parameter set transfer.



The following conventions are used in this documentation for specifying the parameter address:

- The index is specified as a hexadecimal value.
- The subindex is specified as a decimal value.

- The parameter attribute list contains all parameters of the inverter.
- The parameter attribute list is sorted by addresses (index:subindex) in ascending order.

How to read the parameter attribute list:

Column	Meaning
Address	Address of the parameter in the object directory. Format: Index:Subindex
Name	Parameter name
Default setting	Default setting of the parameter
Data type	Data type of the parameter:
	I8 INTEGER_8 1 byte, with sign
	I16 INTEGER_16 2 bytes with sign
	I32 INTEGER_32 4 bytes with sign
	I64 INTEGER_64 8 bytes with sign
	U8 UNSIGNED_8 1 byte without sign
	U16 UNSIGNED_16 2 bytes without sign
	U32 UNSIGNED_32 4 bytes without sign
	U64 UNSIGNED_64 8 bytes without sign
	STRING[xx] VISIBLE_STRING ASCII string (with character length xx)
	OCTET[xx] OCTET_STRING OCTET string (with xx bytes)
	IDX 4 bytes without sign. Is used specially for addressing parameters.
Factor	Factor for data transmission via network, depending on the number of decimal positions:
	1 no decimal positions
	10 1 decimal position
	100 2 decimal positions
	1000 3 decimal positions
	10000 4 decimal positions
A	Attributes (combinations of several attributes also possible):
	C Setting can only be changed if the inverter is disabled.
	E Value is displayed as IP address.
	H Value is displayed in hexadecimal form.
	T Value is displayed as time.
M	Mapping:
	• Mapping permitted.
	Mapping not permissible.



Parameter attribute list (short overview of all parameter indexes)

Address	Name	Default setting	Data type	Factor	A	M
0x1000	Device type	- (Read only)	U32	1	-	
0x1001	Error register	- (Read only)	U8	1	-	•
0x1008	Manufacturer device name	- (Read only)	STRING[50]		-	
0x1009	Manufacturer hardware version	- (Read only)	STRING[50]		-	
0x100A	Manufacturer software version	- (Read only)	STRING[50]		-	
0x1018:001	Identity object: Vendor ID	- (Read only)	U32	1	-	
0x1018:002	Identity object: Product Code	- (Read only)	U32		-	
0x1018:003	Identity object: Revision number	- (Read only)	U32	1	-	
0x1018:004	Identity object: Serial number	- (Read only)	U32	1	-	
0x10F1:001	Error settings: Local error reaction	Device specific state [2]	U32		-	
0x10F1:002	Error settings: Sync error counter limit	20	U16	1	-	
0x2000:001	Device data: Product code	- (Read only)	STRING[50]		-	
0x2000:002	Device data: Serial number	- (Read only)	STRING[50]		-	
0x2000:003	Device data: Production date	- (Read only)	STRING[50]		-	
0x2000:004	Device data: CU firmware version	- (Read only)	STRING[50]		-	
0x2000:006	Device data: CU bootloader version	- (Read only)	STRING[50]		-	
0x2000:008	Device data: Object directory version	- (Read only)	U32	1	-	
0x2000:019	Device data: Safety module version	- (Read only)	STRING[50]		-	
0x2001	Device name	"Device"	STRING[128]		-	
0x2002:006	Device module: CU serial number	- (Read only)	STRING[50]		-	
0x2002:007	Device module: PU serial number	- (Read only)	STRING[50]		-	
0x2010:001	Device event monitor: EreignisortEvent location	- (Read only)	U8		-	
0x2010:002	Device event monitor: Severity	- (Read only)	U8		-	
0x2010:003	Device event monitor: Event status	- (Read only)	U8		-	
0x2010:005	Device event monitor: Number of current event	- (Read only)	U32			H
0x2010:006	Device event monitor: Time stamp of current event	x ns (Read only)	U64	1		T
0x2020:001	EoE information: Virtual MAC address	- (Read only)	STRING[32]		-	
0x2020:002	EoE information: IP address	- (Read only)	STRING[32]		-	
0x2020:003	EoE information: Subnet mask	- (Read only)	STRING[32]		-	
0x2020:004	EoE information: Standard gateway	- (Read only)	STRING[32]		-	
0x2020:005	EoE information: DNS server	- (Read only)	STRING[32]		-	
0x2020:006	EoE information: DNS name	- (Read only)	STRING[50]		-	
0x2020:007	EoE information: Received packages		U32	1	-	
0x2020:008	EoE information: Transmitted packages		U32	1	-	
0x2021:001	Optical tracking: Start detection	Stop [0]	U8		-	
0x2021:002	Optical tracking: Blinking duration	5 s	U16	1	-	
0x2022:001	Device commands: Load default settings	Off / ready [0]	U8			C
0x2022:015	Device commands: Delete logbook	Off / ready [0]	U8		-	
0x2022:035	Device commands: Restart Device	Off / ready [0]	U8		-	
0x2022:036	Device commands: Export Logbook	Off / ready [0]	U8		-	
0x2022:037	Device commands: Delete Logfiles	Off / ready [0]	U8		-	
0x2022:041	Device commands: Restart extended safety	Off / ready [0]	U8		-	
0x2030	CRC parameter set	- (Read only)	U32	1	-	
0x203D	PIN1 access protection	0	I16	1	-	
0x203E	PIN2 access protection	0	I16	1	-	
0x203F	PIN1/PIN2 log-in	0	I16	1	-	
0x2040	Access protection status	- (Read only)	U16			H
0x2100:001	Brand protection: PIN set	0	I32	1	-	
0x2100:002	Brand protection: PIN input	0	I32	1	-	
0x2100:003	Brand protection: Encryption	0	U8	1	-	
0x2110:014	Delete home position	Ready [0]	U8		-	
0x2110:015	Activate muting	Ready [0]	U8		-	
0x2110:016	Reset error	Off / ready [0]	U8		-	
0x2110:017	Acknowledge restart	Off / ready [0]	U8		-	

Appendix

Parameter attribute list



Address	Name	Default setting	Data type	Factor	A	M
0x2110:018	Acknowledge motor encoder	Off / ready [0]	U8		-	
0x2114:001	Parameter set: Version	i750 ES V1.3 [10301]	U16		-	
0x2114:002	Parameter set: Project CRC	0	U32	1	-	
0x2115:001	Parameter set: Status	- (Read only)	U8		-	
0x2115:002	Parameter set: Current CRC	- (Read only)	U32	1	-	
0x2115:003	Parameter set: Last valid CRC	- (Read only)	U32	1	-	
0x2115:004	Parameter set: Parameter setting time stamp	x s (Read only)	U32	1	-	
0x2115:005	Parameter set: Error information 1	- (Read only)	U32	1	-	
0x2115:006	Parameter set: Error information 2	- (Read only)	U32	1	-	
0x2115:007	Parameter set: Error information 3	- (Read only)	U32	1	-	
0x2115:008	Parameter set: Current CRC without safety address	- (Read only)	U32	1	-	
0x2128	S-Bus configuration	FSoE/onboard EtherCAT [11]	U8		-	
0x212A:001	FSoE project CRC		U32	1	-	
0x212C:001	Safety software: Firmware version	- (Read only)	STRING[50]		-	
0x212C:002	Safety software: Bootloader version	- (Read only)	STRING[50]		-	
0x212D:001	Safety hardware: Hardware version	- (Read only)	STRING[50]		-	
0x212D:003	Safety hardware: Serial number	- (Read only)	STRING[50]		-	
0x212D:004	Safety hardware: Production date	- (Read only)	STRING[50]		-	
0x2130:001	Safety event history: Current severity	- (Read only)	U8		-	
0x2130:002	Safety event history: Internal event 1	- (Read only)	U16		H	
0x2130:003	Safety event history: Internal event 2	- (Read only)	U16		H	
0x2130:004	Safety event history: Internal event 3	- (Read only)	U16		H	
0x2130:005	Safety event history: Internal event 4	- (Read only)	U16		H	
0x2130:006	Safety event history: Internal event 5	- (Read only)	U16		H	
0x2130:007	Safety event history: Internal event 6	- (Read only)	U16		H	
0x2130:008	Safety event history: Internal event 7	- (Read only)	U16		H	
0x2130:009	Safety event history: Internal event 8	- (Read only)	U16		H	
0x2130:010	Safety event history: Internal event 9	- (Read only)	U16		H	
0x2130:011	Safety event history: Internal event 10	- (Read only)	U16		H	
0x2130:012	Safety event history: Internal event 11	- (Read only)	U16		H	
0x2130:013	Safety event history: Internal event 12	- (Read only)	U16		H	
0x2130:014	Safety event history: Internal event 13	- (Read only)	U16		H	
0x2130:015	Safety event history: Internal event 14	- (Read only)	U16		H	
0x2130:016	Safety event history: Internal event 15	- (Read only)	U16		H	
0x2130:017	Safety event history: Internal event 16	- (Read only)	U16		H	
0x2131:001	Safety hardware: Power-on time	x s (Read only)	U32	1	-	
0x2132	Safety status	- (Read only)	U16	1	-	
0x213A:001	MUT: Mute S-Bus	No muting [0]	U8		-	
0x213B:001	MUT: Password	0	U32	1	-	
0x213B:002	MUT: Remaining time	x s (Read only)	U32	1	-	
0x2371:009	onboard EtherCAT: Interface mode	Slave [0]	U8		C	
0x2372:009	onboard EtherCAT - Information: Active interface mode	- (Read only)	U8		-	
0x2378	onboard EtherCAT - status	- (Read only)	U16		-	•
0x2379	onboard EtherCAT - Error	- (Read only)	U16	1	-	
0x243C:001	Device: Ethernet commands: Device: Start firmware update	Off / ready [0]	U8		C	
0x2450	Engineering port control	No action/No error [0]	U8		-	
0x2451:001	Engineering port settings: IP address	0.0.0.0	U32		E	
0x2451:002	Engineering port settings: Subnet	0.0.0.0	U32		E	
0x2451:003	Engineering port settings: Gateway	0.0.0.0	U32		E	
0x2451:004	Engineering port settings: DHCP	Enabled [1]	U8		-	
0x2451:007	Engineering port settings: DNS server address	0.0.0.0	U32		E	
0x2452:001	Active engineering port settings: IP address	- (Read only)	U32		E	
0x2452:002	Active engineering port settings: Subnet	- (Read only)	U32		E	



Address	Name	Default setting	Data type	Factor	A	M
0x2452:003	Active engineering port settings: Gateway	- (Read only)	U32		E	
0x2452:004	Active engineering port settings: DHCP	- (Read only)	U8		-	
0x2452:005	Active engineering port settings: MAC address	- (Read only)	OCTET[6]		-	
0x2452:006	Active engineering port settings: Link status	- (Read only)	U8		-	
0x2452:007	Active engineering port settings: DNS server address	- (Read only)	U32		E	
0x245A:001	NTP server addresses: Activate NTP server addresses	No action/no error [0]	U8		-	
0x245A:002	NTP server addresses: NTP server address 1	0.0.0.0	U32		E	
0x245A:003	NTP server addresses: NTP server address 2	0.0.0.0	U32		E	
0x245A:004	NTP server addresses: NTP server address 3	0.0.0.0	U32		E	
0x245A:005	NTP server addresses: NTP server address 4	0.0.0.0	U32		E	
0x245A:006	NTP server addresses: NTP server name 1		STRING[253]		-	
0x245A:007	NTP server addresses: NTP server name 2		STRING[253]		-	
0x245A:008	NTP server addresses: NTP server name 3		STRING[253]		-	
0x245A:009	NTP server addresses: NTP server name 4		STRING[253]		-	
0x245B:001	System time: Setting method	NTP server [0]	U8		-	
0x245B:002	System time: Current time	ns	U64	1	T	
0x2500	Touch probe filter time	0	U16	1	-	
0x2539:001	Hardware-Diagnose: External supply voltage	x.x V (Read only)	U16	10	-	
0x2539:002	Hardware-Diagnose: Control board temperature	x.x °C (Read only)	I16	10	-	
0x2540:001	Mains settings: Rated mains voltage	400 Veff [1]	U8		-	
0x2540:002	Mains settings: Undervoltage warning threshold	430 V	U16	1	-	
0x2540:003	Mains settings: Undervoltage error threshold	x V (Read only)	U16	1	-	
0x2540:004	Mains settings: Undervoltage reset threshold	x V (Read only)	U16	1	-	
0x2540:005	Mains settings: Overvoltage warning threshold	795 V	U16	1	-	
0x2540:006	Mains settings: Overvoltage error threshold	x V (Read only)	U16	1	-	
0x2540:007	Mains settings: Overvoltage reset threshold	x V (Read only)	U16	1	-	
0x2540:008	Mains settings: DC link voltage critical	- (Read only)	U8	1	-	●
0x2580:001	Distributed Clocks: Real time status	- (Read only)	U8		-	
0x2580:002	Distributed Clocks: First setting time	x ns (Read only)	U64	1	T	
0x2580:003	Distributed Clocks: Newest setting time	x ns (Read only)	U64	1	T	
0x2580:004	Distributed Clocks: Current time	x ns (Read only)	U64	1	T	
0x2581:001	Application synchronization: Sync - Source	onboard EtherCAT [1]	U8		-	
0x2581:002	Application synchronization: Sync - Status	- (Read only)	U8		-	
0x2581:005	Application synchronization: Sync - Active cycle time	- (Read only)	U32	1	-	
0x2590:003	Energy saving: State of actual energy saving mode	- (Read only)	U8		H	
0x261C:001	Favorites settings: Parameter 1		U32	1	-	
0x261C:002	Favorites settings: Parameter 2		U32	1	-	
0x261C:003	Favorites settings: Parameter 3		U32	1	-	
0x261C:004	Favorites settings: Parameter 4		U32	1	-	
0x261C:005	Favorites settings: Parameter 5		U32	1	-	
0x261C:006	Favorites settings: Parameter 6		U32	1	-	
0x261C:007	Favorites settings: Parameter 7		U32	1	-	
0x261C:008	Favorites settings: Parameter 8		U32	1	-	
0x261C:009	Favorites settings: Parameter 9		U32	1	-	
0x261C:010	Favorites settings: Parameter 10		U32	1	-	
0x261C:011	Favorites settings: Parameter 11		U32	1	-	
0x261C:012	Favorites settings: Parameter 12		U32	1	-	
0x261C:013	Favorites settings: Parameter 13		U32	1	-	
0x261C:014	Favorites settings: Parameter 14		U32	1	-	
0x261C:015	Favorites settings: Parameter 15		U32	1	-	
0x261C:016	Favorites settings: Parameter 16		U32	1	-	
0x261C:017	Favorites settings: Parameter 17		U32	1	-	
0x261C:018	Favorites settings: Parameter 18		U32	1	-	
0x261C:019	Favorites settings: Parameter 19		U32	1	-	

Appendix

Parameter attribute list



Address	Name	Default setting	Data type	Factor	A	M
0x261C:020	Favorites settings: Parameter 20		U32	1	-	
0x261C:021	Favorites settings: Parameter 21		U32	1	-	
0x261C:022	Favorites settings: Parameter 22		U32	1	-	
0x261C:023	Favorites settings: Parameter 23		U32	1	-	
0x261C:024	Favorites settings: Parameter 24		U32	1	-	
0x261C:025	Favorites settings: Parameter 25		U32	1	-	
0x261C:026	Favorites settings: Parameter 26		U32	1	-	
0x261C:027	Favorites settings: Parameter 27		U32	1	-	
0x261C:028	Favorites settings: Parameter 28		U32	1	-	
0x261C:029	Favorites settings: Parameter 29		U32	1	-	
0x261C:030	Favorites settings: Parameter 30		U32	1	-	
0x261C:031	Favorites settings: Parameter 31		U32	1	-	
0x261C:032	Favorites settings: Parameter 32		U32	1	-	
0x261C:033	Favorites settings: Parameter 33		U32	1	-	
0x261C:034	Favorites settings: Parameter 34		U32	1	-	
0x261C:035	Favorites settings: Parameter 35		U32	1	-	
0x261C:036	Favorites settings: Parameter 36		U32	1	-	
0x261C:037	Favorites settings: Parameter 37		U32	1	-	
0x261C:038	Favorites settings: Parameter 38		U32	1	-	
0x261C:039	Favorites settings: Parameter 39		U32	1	-	
0x261C:040	Favorites settings: Parameter 40		U32	1	-	
0x261C:041	Favorites settings: Parameter 41		U32	1	-	
0x261C:042	Favorites settings: Parameter 42		U32	1	-	
0x261C:043	Favorites settings: Parameter 43		U32	1	-	
0x261C:044	Favorites settings: Parameter 44		U32	1	-	
0x261C:045	Favorites settings: Parameter 45		U32	1	-	
0x261C:046	Favorites settings: Parameter 46		U32	1	-	
0x261C:047	Favorites settings: Parameter 47		U32	1	-	
0x261C:048	Favorites settings: Parameter 48		U32	1	-	
0x261C:049	Favorites settings: Parameter 49		U32	1	-	
0x261C:050	Favorites settings: Parameter 50		U32	1	-	
0x2632:001	Inversion of digital inputs: Digital input 1	Not inverted [0]	U8		-	
0x2632:002	Inversion of digital inputs: Digital input 2	Not inverted [0]	U8		-	
0x2633:001	Digital input debounce time: Digital input 1	0 ms	U8	1	-	
0x2633:002	Digital input debounce time: Digital input 2	0 ms	U8	1	-	
0x263B:001	Digital inputs internal control: Activation	Off [0]	U8		-	
0x263B:002	Digital inputs internal control: DI1 internal control	Off [0]	U8		-	
0x263B:003	Digital inputs internal control: DI2 internal control	Off [0]	U8		-	
0x2820:001	Holding brake control: Brake mode	Off [2]	U8		-	•
0x2820:002	Holding brake control: Brake closing time	100 ms	U16	1	-	
0x2820:003	Holding brake control: Brake opening time	100 ms	U16	1	-	
0x2820:004	Holding brake control: Brake detection	- (Read only)	U16		-	
0x2820:005	Holding brake control: Brake polarity	Normal [0]	U8		-	
0x2820:006	Holding brake control: Brake error response	Fault [1]	U8		-	
0x2820:009	Holding brake control: Starting torque source	Torque in 0x2820:010 [1]	U16		-	
0x2820:010	Holding brake control: Starting torque	0.0 %	I16	10	-	•
0x2820:011	Holding brake control: Override of the brake control	No override active [0]	U8		-	•
0x2820:013	Holding brake control: Holding load ramp time	0 ms	U16	1	-	
0x2820:015	Holding brake control: Brake status	- (Read only)	U8		-	
0x2820:019	Holding brake control: Brake opening time test signal	500 ms	U16	1	-	
0x2820:020	Holding brake control: Brake control word	0x00	U8		H	
0x2820:021	Holding brake control: Detected actual torque	x.x % (Read only)	I16	10	-	
0x2820:022	Holding brake control: Holding brake supply voltage	No reduction [100]	U8		-	
0x2820:023	Holding brake control: Control configuration	Via internal brake module [0]	U8		-	



Address	Name	Default setting	Data type	Factor	A	M
0x2822:001	Axis commands: Enable inverter	Inverter enabled [1]	U8		-	
0x2822:003	Axis commands: Reset error	Off/Ready [0]	U8		-	
0x2822:013	Axis commands: Calculate current controller parameter	Off/Ready [0]	U8		-	
0x2822:014	Axis commands: Calculate speed controller parameter	Off/Ready [0]	U8		-	
0x2822:015	Axis commands: Calculate position controller parameter	Off/Ready [0]	U8		-	
0x2822:016	Axis commands: Calculate field controller parameter	Off/Ready [0]	U8		-	
0x2822:017	Axis commands: Calculate field weakening controller parameter	Off/Ready [0]	U8		-	
0x2822:018	Axis commands: Calculate Imin controller parameter	Off/Ready [0]	U8		-	
0x2822:019	Axis commands: Calculate Imax controller parameter	Off/Ready [0]	U8		-	
0x2822:020	Axis commands: Calculate flying restart circuit controller parameter	Off/Ready [0]	U8		-	
0x2822:021	Axis commands: Load default Lh saturation characteristic	Off/Ready [0]	U8		-	
0x2822:022	Axis commands: Load default inverter characteristic	Off/Ready [0]	U8		-	
0x2822:023	Axis commands: Estimate optimum magnetizing current	Off/Ready [0]	U8		-	
0x2822:024	Axis commands: Estimate basic motor parameters based on rated data	Off/Ready [0]	U8		-	
0x2822:025	Axis commands: Get motor encoder characteristic (resolver)	Off/Ready [0]	U8		-	
0x2822:026	Axis commands: Get motor encoder information (HIPERFACE®)	Off/Ready [0]	U8		-	
0x2822:027	Axis commands: Calculate SLVC controller parameter	Off/Ready [0]	U8		-	
0x2822:037	Axis commands: Estimate all motor parameters based on rated data	Off/Ready [0]	U8		-	
0x2822:038	Axis commands: HIPERFACE (A): Set position with synchronization	Off/Ready [0]	U8		-	
0x2822:042	Axis commands: Calculate speed filter time constant	Off/Ready [0]	U8		-	
0x2822:043	Axis commands: Load power dependent motor parameters	Off/Ready [0]	U8		-	
0x2822:044	Axis commands: Cogging torque compensation	Off/Ready [0]	U8		-	
0x2823	Status of axis commands	x % (Read only)	U8	1	-	
0x2824	Control selection	Keypad [1]	U8		C	
0x2825	Drive mode selection	CiA402 operating modes [0]	U8		C	
0x2826	Timeout for error response	4 s	U32	1	-	
0x282A:001	Status words: Cause of disable	- (Read only)	U32		H	●
0x282A:004	Status words: Extended status word	- (Read only)	U16		H	●
0x282C:001	I/O diagnostic: Application level of the digital inputs	- (Read only)	U32		H	●
0x2830	Inverter control word	0x0000	U16		H	●
0x2831	Inverter status word	- (Read only)	U16		H	●
0x2832	Identification status	- (Read only)	U16		H	
0x2833	Inverter status word 2	- (Read only)	U16		H	●
0x2835:001	Manual test mode: Current setpoint	0 %	I16	1	-	●
0x2835:002	Manual test mode: Frequency	0.0 Hz	I16	10	-	●
0x2835:003	Manual test mode: Starting angle	0.0 °	I16	10	-	
0x2836:001	Manual control mode: Current setpoint	30 %	U16	1	-	●
0x2836:002	Manual control mode: Frequency	0.0 Hz	I16	10	-	●
0x2836:003	Manual control mode: Ramp time (current)	0 ms	U16	1	-	
0x2836:004	Manual control mode: Ramp time (frequency)	500 ms	U16	1	-	
0x2836:005	Manual control mode: Time monitoring (frequency)	2500 ms	U32	1	-	
0x2836:006	Manual control mode: Current controller gain	20.00 V/A	U32	100	-	
0x2836:007	Manual control mode: Current controller reset time	20.00 ms	U32	100	-	



Address	Name	Default setting	Data type	Factor	A	M
0x2837:001	Frequency analysis: Period time	1 ms [1000]	U16		-	
0x2837:002	Frequency analysis: Torque/current amplitude	5.0 %	U16	10	-	
0x2837:003	Frequency analysis: Speed amplitude	50 rpm	U16	1	-	
0x2837:004	Frequency analysis: Position amplitude	5.0 °	U16	10	-	
0x2837:005	Frequency analysis: Type of excitation	PRBS [0]	U8		C	
0x2837:006	Frequency analysis: Velocity offset for 0x2825=11	0 rpm	I16	1	C	
0x2840	Error reset time	x ms (Read only)	I32	1	-	
0x2841	Reset error	0	U8	1	-	
0x284E:001	Additional error information: Component ID	- (Read only)	U16	1	-	●
0x284F	Current error	- (Read only)	OCTET[64]		-	
0x285A:001	Diagnostic configuration: Alarm suppression	0x0000	U16		H	
0x285B:001	onboard EtherCAT monitoring: Watchdog elapsed	Fault > CiA402 [1]	U8		-	
0x285B:002	onboard EtherCAT monitoring: EtherCAT role check	Warning [2]	U8		-	
0x2870:001	Safety interface: Control data	- (Read only)	U32		H	●
0x2870:002	Safety interface: Status data	- (Read only)	U32		H	●
0x2870:003	Safety interface: I/O status	- (Read only)	U32		H	●
0x2871:001	Safety interface bits: STO active	- (Read only)	BOOLEAN	1	-	●
0x2871:002	Safety interface bits: SS1 active	- (Read only)	BOOLEAN	1	-	●
0x2871:003	Safety interface bits: SS2 active	- (Read only)	BOOLEAN	1	-	●
0x2871:004	Safety interface bits: SOS active	- (Read only)	BOOLEAN	1	-	●
0x2871:005	Safety interface bits: SLS1 active	- (Read only)	BOOLEAN	1	-	●
0x2871:006	Safety interface bits: SLS2 active	- (Read only)	BOOLEAN	1	-	●
0x2871:007	Safety interface bits: SLS3 active	- (Read only)	BOOLEAN	1	-	●
0x2871:008	Safety interface bits: SLS4 active	- (Read only)	BOOLEAN	1	-	●
0x2871:009	Safety interface bits: SDIpos active	- (Read only)	BOOLEAN	1	-	●
0x2871:010	Safety interface bits: SDIneg active	- (Read only)	BOOLEAN	1	-	●
0x2871:011	Safety interface bits: SLI active	- (Read only)	BOOLEAN	1	-	●
0x2871:012	Safety interface bits: SSE active	- (Read only)	BOOLEAN	1	-	●
0x2871:013	Safety interface bits: ES active	- (Read only)	BOOLEAN	1	-	●
0x2871:015	Safety interface bits: RMS active	- (Read only)	BOOLEAN	1	-	●
0x2871:016	Safety interface bits: SBC active	- (Read only)	BOOLEAN	1	-	●
0x2871:017	Safety interface bits: MUT active	- (Read only)	BOOLEAN	1	-	●
0x2871:033	Safety interface bits: SLS1 observed	- (Read only)	BOOLEAN	1	-	●
0x2871:034	Safety interface bits: SLS2 observed	- (Read only)	BOOLEAN	1	-	●
0x2871:035	Safety interface bits: SLS3 observed	- (Read only)	BOOLEAN	1	-	●
0x2871:036	Safety interface bits: SLS4 observed	- (Read only)	BOOLEAN	1	-	●
0x2871:037	Safety interface bits: SMS observed	- (Read only)	BOOLEAN	1	-	●
0x2871:038	Safety interface bits: SSM within limits	- (Read only)	BOOLEAN	1	-	●
0x2871:039	Safety interface bits: SDIpos observed	- (Read only)	BOOLEAN	1	-	●
0x2871:040	Safety interface bits: SDIneg observed	- (Read only)	BOOLEAN	1	-	●
0x2871:041	Safety interface bits: SLP1 observed	- (Read only)	BOOLEAN	1	-	●
0x2871:042	Safety interface bits: SLP2 observed	- (Read only)	BOOLEAN	1	-	●
0x2871:043	Safety interface bits: SLP3 observed	- (Read only)	BOOLEAN	1	-	●
0x2871:044	Safety interface bits: SLP4 observed	- (Read only)	BOOLEAN	1	-	●
0x2871:045	Safety interface bits: SCA1 within limits	- (Read only)	BOOLEAN	1	-	●
0x2871:046	Safety interface bits: SCA2 within limits	- (Read only)	BOOLEAN	1	-	●
0x2871:047	Safety interface bits: SCA3 within limits	- (Read only)	BOOLEAN	1	-	●
0x2871:048	Safety interface bits: SCA4 within limits	- (Read only)	BOOLEAN	1	-	●
0x2871:049	Safety interface bits: PDSSpos observed	- (Read only)	BOOLEAN	1	-	●
0x2871:050	Safety interface bits: PDSSneg observed	- (Read only)	BOOLEAN	1	-	●
0x2871:051	Safety interface bits: SOS observed	- (Read only)	BOOLEAN	1	-	●
0x2871:052	Safety interface bits: SBC activated	- (Read only)	BOOLEAN	1	-	●
0x2871:053	Safety interface bits: SHom active	- (Read only)	BOOLEAN	1	-	●
0x2871:054	Safety interface bits: SHom available	- (Read only)	BOOLEAN	1	-	●
0x2871:055	Safety interface bits: Safe speed OK	- (Read only)	BOOLEAN	1	-	●



Address	Name	Default setting	Data type	Factor	A	M
0x2871:056	Safety interface bits: n=0	- (Read only)	BOOLEAN	1	-	●
0x2871:057	Safety interface bits: Positive direction	- (Read only)	BOOLEAN	1	-	●
0x2871:064	Safety interface bits: Error active	- (Read only)	BOOLEAN	1	-	●
0x2871:073	Safety interface bits: AIS S-Bus	- (Read only)	BOOLEAN	1	-	
0x2871:074	Safety interface bits: AIE S-Bus	- (Read only)	BOOLEAN	1	-	
0x2871:075	Safety interface bits: SHom_Start S-Bus	- (Read only)	BOOLEAN	1	-	
0x2871:076	Safety interface bits: SHom_Load S-Bus	- (Read only)	BOOLEAN	1	-	
0x2874	S-Bus control data	- (Read only)	U32		H	
0x2875:001	S-Bus control bits: STO	- (Read only)	BOOLEAN	1	-	●
0x2875:002	S-Bus control bits: SS1	- (Read only)	BOOLEAN	1	-	●
0x2875:003	S-Bus control bits: SS2	- (Read only)	BOOLEAN	1	-	●
0x2875:004	S-Bus control bits: SLS1	- (Read only)	BOOLEAN	1	-	●
0x2875:005	S-Bus control bits: SLS2	- (Read only)	BOOLEAN	1	-	●
0x2875:006	S-Bus control bits: SLS3	- (Read only)	BOOLEAN	1	-	●
0x2875:007	S-Bus control bits: SLS4	- (Read only)	BOOLEAN	1	-	●
0x2875:008	S-Bus control bits: SDIpos	- (Read only)	BOOLEAN	1	-	●
0x2875:009	S-Bus control bits: SDIneg	- (Read only)	BOOLEAN	1	-	●
0x2875:010	S-Bus control bits: ES	- (Read only)	BOOLEAN	1	-	●
0x2875:011	S-Bus control bits: SLI	- (Read only)	BOOLEAN	1	-	●
0x2875:013	S-Bus control bits: SLP1	- (Read only)	BOOLEAN	1	-	●
0x2875:014	S-Bus control bits: SLP2	- (Read only)	BOOLEAN	1	-	●
0x2875:015	S-Bus control bits: SLP3	- (Read only)	BOOLEAN	1	-	●
0x2875:016	S-Bus control bits: SLP4	- (Read only)	BOOLEAN	1	-	●
0x2875:017	S-Bus control bits: AIS	- (Read only)	BOOLEAN	1	-	●
0x2875:018	S-Bus control bits: AIE	- (Read only)	BOOLEAN	1	-	●
0x2875:019	S-Bus control bits: SOS	- (Read only)	BOOLEAN	1	-	●
0x2875:020	S-Bus control bits: RMS	- (Read only)	BOOLEAN	1	-	●
0x2875:021	S-Bus control bits: SHom_Start	- (Read only)	BOOLEAN	1	-	●
0x2875:022	S-Bus control bits: SHom_Load	- (Read only)	BOOLEAN	1	-	●
0x2875:023	S-Bus control bits: PDSS	- (Read only)	BOOLEAN	1	-	●
0x2875:024	S-Bus control bits: SSE	- (Read only)	BOOLEAN	1	-	●
0x2875:026	S-Bus control bits: SBC	- (Read only)	BOOLEAN	1	-	●
0x2878:001	System	No motor encoder [0]	U8		-	
0x2878:002	SinCos encoder PPR	1	U16	1	-	
0x2878:003	Number of resolver pole pairs	1	U8	1	-	
0x2878:004	Response time encoder monitoring	50 [50]	U8		-	
0x2878:050	Safety-HDSL driver state	- (Read only)	U16		H	
0x2878:051	Safety HDSL online status 1	- (Read only)	U16		H	
0x2878:052	Safety HDSL online status 2	- (Read only)	U16		H	
0x2878:053	Safety HDSL Safe summary	- (Read only)	U8		H	
0x2878:054	Safety HDSL Safe Channel 2 status	- (Read only)	U8		H	
0x2878:055	Safety HDSL encoder status ENC_ST0	- (Read only)	U8		H	
0x2878:056	Safety HDSL encoder status ENC_ST1	- (Read only)	U8		H	
0x2878:057	Safety HDSL encoder status ENC_ST2	- (Read only)	U8		H	
0x2878:058	Safety HDSL encoder status ENC_ST3	- (Read only)	U8		H	
0x2878:059	Safety HDSL encoder status ENC_ST4	- (Read only)	U8		H	
0x2878:060	Safety HDSL encoder status ENC_ST5	- (Read only)	U8		H	
0x2878:061	Safety HDSL encoder status ENC_ST6	- (Read only)	U8		H	
0x2878:062	Safety HDSL encoder status ENC_ST7	- (Read only)	U8		H	
0x2878:063	Safety HDSL encoder ID	- (Read only)	U8	1	-	
0x2879:001	Mechanical data: Motor mounting direction	Motor rotating CW [0]	U8		-	
0x287B:001	Speed: Tolerance window (n=0)	5 rpm	U16	1	-	
0x287B:002	Speed: Tolerance speed comparison	20 rpm	U16	1	-	
0x287B:003	Speed: Current speed n_safe	x rpm (Read only)	I16	1	-	●
0x287B:004	Speed: Internal current speed nSD	x rpm (Read only)	I16	1	-	



Address	Name	Default setting	Data type	Factor	A	M
0x287B:005	Speed: Internal current speed nBD	x rpm (Read only)	I16	1	-	
0x287B:006	Speed: Current speed difference nSD-nBD	x rpm (Read only)	I16	1	-	
0x287C:001	Position: Tolerance position comparison	8192 incr.	I32	1	-	
0x287C:002	Position: Current position p_safe	x incr. (Read only)	I32	1	-	•
0x287C:003	Position: Internal current position pSD	x incr. (Read only)	I32	1	-	
0x287C:004	Position: Internal current position pBD	x incr. (Read only)	I32	1	-	
0x287C:005	Position: Current position difference pSD-pBD	x incr. (Read only)	I32	1	-	
0x2880:001	SHom_Start: Source	Disabled [0]	U8		-	
0x2881:001	SHom_Load: Source	S-Bus [13]	U8		-	
0x2882:001	SHom: Home position	0 incr.	I32	1	-	
0x2882:002	SHom: Timeout	0 ms	U16	1	-	
0x2882:003	SHom: SLS for homing	SLS1 [3]	U8		-	
0x2882:004	SHom: Restart condition	Homing required [0]	U8		-	
0x2882:005	SHom: Starting position tolerance	0 incr.	I32	1	-	
0x2882:006	SHom: Status	- (Read only)	U8		-	
0x2882:007	SHom: Saved position	x incr. (Read only)	I32	1	-	
0x2891	STO Source S-Bus	Disabled [0]	U8		-	
0x2892:001	STO: Restart	Automatic restart [1]	U8		-	
0x2894:001	SS1, SS2: Stopping time	0 ms	U16	1	-	
0x2894:002	SS1, SS2: Ramp monitoring	Disabled [0]	U8		-	
0x2894:003	SS1, SS2: Ramp - Smoothing time	0 %	U8	1	-	
0x2894:004	SS1, SS2: Ramp - Offset mode	Relativ [0]	U8		-	
0x2894:005	SS1, SS2: Ramp - Start-offset relative	5 %	U8	1	-	
0x2894:006	SS1, SS2: Ramp - Start-offset absolute	0 rpm	U16	1	-	
0x2894:007	SS1, SS2: Ramp - Currently monitored speed	x rpm (Read only)	U16	1	-	
0x2894:008	SS1, SS2: Ramp - Minimum difference	x rpm (Read only)	I16	1	-	
0x2896	SS1 Source S-Bus	Disabled [0]	U8		-	
0x2897:001	SS1: Mode	STO after stopping time [0]	U8		-	
0x2897:002	SS1: Delay STO after n=0	0 ms	U16	1	-	
0x289A	SS2 Source S-Bus	Disabled [0]	U8		-	
0x289B:001	SS2: Mode	SOS after stopping time [0]	U8		-	
0x289E	SOS Source S-Bus	Disabled [0]	U8		-	
0x289F:001	SOS: Tolerance window (Delta p=0)	8192 incr.	I32	1	-	
0x289F:002	SOS: Restart	Acknowledged restart [0]	U8		-	
0x289F:003	SOS: Maximum change of position	x incr. (Read only)	I32	1	-	
0x28A2	SSE Source S-Bus	Disabled [0]	U8		-	
0x28A3:001	SSE: Emergency stop function	STO [0]	U8		-	
0x28AB	RMS Source	Disabled [0]	U8		-	
0x28AC:001	RMS: Stop function	STO [0]	U8		-	
0x28AE	ES Source	Disabled [0]	U8		-	
0x28B0:001	SMS: Maximum speed Nmax	0 rpm	U16	1	-	
0x28B0:002	SMS: Response (n>Nmax)	STO [0]	U8		-	
0x28B2:001	SSM: Monitored speed	0 rpm	U16	1	-	
0x28B9:001	SDI: SDIpos - Source S-Bus	Disabled [0]	U8		-	
0x28B9:002	SDI: SDIneg - Source S-Bus	Disabled [0]	U8		-	
0x28BA:001	SDI: Monitoring standard operation	Both directions enabled [0]	U8		-	
0x28BA:002	SDI: Delay time	0 ms	U16	1	-	
0x28BA:003	SDI: Tolerance threshold	8192 incr.	I32	1	-	
0x28BA:004	SDI: Error response	STO [0]	U8		-	
0x28BA:005	SDI: Maximum change of position	x incr. (Read only)	I32	1	-	
0x28BF:001	SLS: SLS1 - Internal source	Disabled [0]	U32		-	
0x28BF:002	SLS: SLS1 - Internal source inversion	Not inverted [0]	U8		-	
0x28BF:003	SLS: SLS2 - Internal source	Disabled [0]	U32		-	
0x28BF:004	SLS: SLS2 - Internal source inversion	Not inverted [0]	U8		-	
0x28BF:005	SLS: SLS3 - Internal source	Disabled [0]	U32		-	



Address	Name	Default setting	Data type	Factor	A	M
0x28BF:006	SLS: SLS3 - Internal source inversion	Not inverted [0]	U8		-	
0x28BF:007	SLS: SLS4 - Internal source	Disabled [0]	U32		-	
0x28BF:008	SLS: SLS4 - Internal source inversion	Not inverted [0]	U8		-	
0x28C1:001	SLS: SLS1 - Source S-Bus	Disabled [0]	U8		-	
0x28C1:002	SLS: SLS2 - Source S-Bus	Disabled [0]	U8		-	
0x28C1:003	SLS: SLS3 - Source S-Bus	Disabled [0]	U8		-	
0x28C1:004	SLS: SLS4 - Source S-Bus	Disabled [0]	U8		-	
0x28C2:001	SLS: SLS1 - Limited speed Nlim1	0 rpm	U16	1	-	
0x28C2:002	SLS: SLS2 - Limited speed Nlim2	0 rpm	U16	1	-	
0x28C2:003	SLS: SLS3 - Limited speed Nlim3	0 rpm	U16	1	-	
0x28C2:004	SLS: SLS4 - Limited speed Nlim4	0 rpm	U16	1	-	
0x28C3:001	SLS: SLS1 - Braking time Nlim1	0 ms	U16	1	-	
0x28C3:002	SLS: SLS2 - Braking time Nlim2	0 ms	U16	1	-	
0x28C3:003	SLS: SLS3 - Braking time Nlim3	0 ms	U16	1	-	
0x28C3:004	SLS: SLS4 - Braking time Nlim4	0 ms	U16	1	-	
0x28C4:001	SLS: SLS1 - Permitted direction	Both directions enabled [0]	U8		-	
0x28C4:002	SLS: SLS2 - Permitted direction	Enable both directions [0]	U8		-	
0x28C4:003	SLS: SLS3 - Permitted direction	Enable both directions [0]	U8		-	
0x28C4:004	SLS: SLS4 - Permitted direction	Enable both directions [0]	U8		-	
0x28C5:001	SLS: SLS1 - Response (n>Nlim1)	STO [0]	U8		-	
0x28C5:002	SLS: SLS2 - Response (n>Nlim2)	STO [0]	U8		-	
0x28C5:003	SLS: SLS3 - Response (n>Nlim3)	STO [0]	U8		-	
0x28C5:004	SLS: SLS4 - Response (n>Nlim4)	STO [0]	U8		-	
0x28C9	SLI Source S-Bus	Disabled [0]	U8		-	
0x28CA:001	SLI: Increment size standard operation	0 incr.	I32	1	-	
0x28CA:002	SLI: Error response standard operation	STO [0]	U8		-	
0x28CA:004	SLI: Maximum change of position	x incr. (Read only)	I32	1	-	
0x28D1:001	SLP: SLP1 - Source S-Bus	Disabled [0]	U8		-	
0x28D1:002	SLP: SLP2 - Source S-Bus	Disabled [0]	U8		-	
0x28D1:003	SLP: SLP3 - Source S-Bus	Disabled [0]	U8		-	
0x28D1:004	SLP: SLP4 - Source S-Bus	Disabled [0]	U8		-	
0x28D2:001	SLP: SLP1 - Lower position limit	0 incr.	I32	1	-	
0x28D2:002	SLP: SLP2 - Lower position limit	0 incr.	I32	1	-	
0x28D2:003	SLP: SLP3 - Lower position limit	0 incr.	I32	1	-	
0x28D2:004	SLP: SLP4 - Lower position limit	0 incr.	I32	1	-	
0x28D3:001	SLP: SLP1 - Upper position limit	0 incr.	I32	1	-	
0x28D3:002	SLP: SLP2 - Upper position limit	0 incr.	I32	1	-	
0x28D3:003	SLP: SLP3 - Upper position limit	0 incr.	I32	1	-	
0x28D3:004	SLP: SLP4 - Upper position limit	0 incr.	I32	1	-	
0x28D4:001	SLP: SLP1 - Error response	STO [0]	U8		-	
0x28D4:002	SLP: SLP2 - Error response	STO [0]	U8		-	
0x28D4:003	SLP: SLP3 - Error response	STO [0]	U8		-	
0x28D4:004	SLP: SLP4 - Error response	STO [0]	U8		-	
0x28D8:001	SCA: SCA1 - Lower position limit	0 incr.	I32	1	-	
0x28D8:002	SCA: SCA2 - Lower position limit	0 incr.	I32	1	-	
0x28D8:003	SCA: SCA3 - Lower position limit	0 incr.	I32	1	-	
0x28D8:004	SCA: SCA4 - Lower position limit	0 incr.	I32	1	-	
0x28D9:001	SCA: SCA1 - Upper position limit	0 incr.	I32	1	-	
0x28D9:002	SCA: SCA2 - Upper position limit	0 incr.	I32	1	-	
0x28D9:003	SCA: SCA3 - Upper position limit	0 incr.	I32	1	-	
0x28D9:004	SCA: SCA4 - Upper position limit	0 incr.	I32	1	-	
0x28DD	PDSS Source S-Bus	Disabled [0]	U8		-	
0x28DE:001	PDSS: Permanent activation	On demand [0]	U8		-	
0x28DE:002	PDSS: Lower position limit	0 incr.	I32	1	-	
0x28DE:003	PDSS: Upper position limit	0 incr.	I32	1	-	

Appendix

Parameter attribute list



Address	Name	Default setting	Data type	Factor	A	M
0x28DE:004	PDSS: Lower SCS limit	0 incr.	I32	1	-	
0x28DE:005	PDSS: Upper SCS limit	0 incr.	I32	1	-	
0x28DE:006	PDSS: SCS from lower limit	0 rpm	U16	1	-	
0x28DE:007	PDSS: SCS from upper limit	0 rpm	U16	1	-	
0x28DE:008	PDSS: Maximum speed	0 rpm	U16	1	-	
0x28DE:009	PDSS: Maximum deceleration lower limit	0	U16	1	-	
0x28DE:010	PDSS: Maximum deceleration upper limit	0	U16	1	-	
0x28DE:011	PDSS: Error response	STO [0]	U8		-	
0x28DE:012	PDSS: Currently monitored speed	x rpm (Read only)	U16	1	-	
0x28DE:013	PDSS: Minimum difference monitored speed	x rpm (Read only)	I16	1	-	
0x28E5	SBC Source S-Bus	Disabled [0]	U8		-	
0x28E6:001	SBC: Brake mode	SBC without STO [1]	U8		-	
0x28E6:002	SBC: Delay SBC	0 ms	U16	1	-	
0x28E6:003	SBC: Delay STO	0 ms	U16	1	-	
0x28E6:004	SBC: Brake open delay	0 ms	U16	1	-	
0x28E8:001	Diagnostic: Configuration diagnostic value 1	PDSS - Current monitored speed [1]	U16		-	
0x28E8:002	Diagnostic: Configuration diagnostic value 2	SS1, SS2 - Current speed ramp [2]	U16		-	
0x28E9:001	Diagnostic: Diagnostic value 1	- (Read only)	I16	1	-	●
0x28E9:002	Diagnostic: Diagnostic value 2	- (Read only)	I16	1	-	●
0x2900:001	Speed controller settings: Gain	0.00033 Nm/rpm	U32	100000	-	
0x2900:002	Speed controller settings: Reset time	17.6 ms	U16	10	-	
0x2900:003	Speed controller settings: Rate time	0.00 ms	U16	100	-	
0x2901	Speed controller gain adaption	100.00 %	U16	100	-	●
0x2902	I component load value	0.0 %	I16	10	-	●
0x2903	Speed setpoint filter time	0.0 ms	U16	10	-	
0x2904	Actual speed filter time	0.3 ms	U16	10	-	
0x2907:001	Additional speed limitation	0 rpm	U32	1	-	●
0x2910:001	Inertia settings: Motor moment of inertia	0.14 kg cm ²	U32	100	-	
0x2910:002	Inertia settings: Scaled load inertia	0.00 kg cm ²	U32	100	-	
0x2910:003	Inertia settings: Coupling	Stiff [0]	U8		-	
0x2910:004	Inertia settings: Mechanical natural frequency	0.0 Hz	U16	10	-	
0x2910:005	Inertia settings: Load moment of inertia (elastic coupled)	0.00 kg cm ²	U32	100	-	
0x2922:001	Following error diagnostics: Following error (interval) - Time	1000 ms	U16	1	-	
0x2922:002	Following error diagnostics: Following error (interval) - Mean value	x.xx ° (Read only)	U32	100	-	
0x2922:003	Following error diagnostics: Following error (interval) - Maximum value	x.xx ° (Read only)	U32	100	-	
0x2922:004	Following error diagnostics: Following error (manual) - Start/Stop	Stop [0]	U8		-	
0x2922:005	Following error diagnostics: Following error (manual) - Mean value	x.xx ° (Read only)	U32	100	-	
0x2922:006	Following error diagnostics: Following error (manual) - Maximum value	x.xx ° (Read only)	U32	100	-	
0x2922:007	Following error diagnostics: Following error (standstill-standstill) - Mean value	x.xx ° (Read only)	U32	100	-	
0x2922:008	Following error diagnostics: Following error (standstill-standstill) - Maximum value	x.xx ° (Read only)	U32	100	-	
0x2923:001	Activation	Off [0]	U8		C	
0x2923:002	Type of load	Simple speed load [0]	U8		-	
0x2923:003	Set load torque	0.0 %	I16	10	-	●
0x2923:004	Set load speed	0 rpm	I32	480000 / 214748 3647	-	●
0x2923:005	Load moment of inertia	0.00 kg cm ²	U32	100	-	



Address	Name	Default setting	Data type	Factor	A	M
0x2923:006	Friction coefficient	1.0 %	U32	10	-	
0x2923:010	Identified total ramp-up time	0.000 ms	U32	1000	-	
0x2923:011	Identified factor	1.000000	I32	100000 0	-	
0x2923:012	Identified current control - delay time	0.0	I32	10	-	
0x2923:013	Identified current control - T1	0.0	I32	10	-	
0x2923:014	Identified current control - T2	0.0	I32	10	-	
0x2923:017	Identified root 1 - real part	0.000 1/s	I32	1000	-	
0x2923:018	Identified root 1 - imaginary part	0.000 1/s	I32	1000	-	
0x2923:019	Identified root 2 - real part	0.000 1/s	I32	1000	-	
0x2923:020	Identified root 2 - imaginary part	0.000 1/s	I32	1000	-	
0x2923:021	Identified root 3 - real part	0.000 1/s	I32	1000	-	
0x2923:022	Identified root 3 - imaginary part	0.000 1/s	I32	1000	-	
0x2923:023	Identified root 4 - real part	0.000 1/s	I32	1000	-	
0x2923:024	Identified root 4 - imaginary part	0.000 1/s	I32	1000	-	
0x2923:029	Identified pole 1 - real part	0.000 1/s	I32	1000	-	
0x2923:030	Identified pole 1 - imaginary part	0.000 1/s	I32	1000	-	
0x2923:031	Identified pole 2 - real part	0.000 1/s	I32	1000	-	
0x2923:032	Identified pole 2 - imaginary part	0.000 1/s	I32	1000	-	
0x2923:033	Identified pole 3 - real part	0.000 1/s	I32	1000	-	
0x2923:034	Identified pole 3 - imaginary part	0.000 1/s	I32	1000	-	
0x2923:035	Identified pole 4 - real part	0.000 1/s	I32	1000	-	
0x2923:036	Identified pole 4 - imaginary part	0.000 1/s	I32	1000	-	
0x2923:050	Identified result - motor moment of inertia	0.00 kg cm ²	U32	100	-	
0x2923:051	Identified result - load 1 moment of inertia	0.00 kg cm ²	U32	100	-	
0x2923:052	Identified result - load 2 moment of inertia	0.00 kg cm ²	U32	100	-	
0x2923:054	Identified result - coupling between motor and load 1	0.00	U32	100	-	
0x2923:055	Identified result - coupling between load 1 and load 2	0.00	U32	100	-	
0x2923:057	Identified result - damping between motor and load 1	0.00	U32	100	-	
0x2923:058	Identified result - damping between load 1 and load 2	0.00	U32	100	-	
0x2939	Switching frequency	4 kHz fixed / drive-optimised [6]	U8		-	
0x2941	Current controller feedforward control	Disable [0]	U8		-	
0x2942:001	Current controller parameters: Gain	148.21 V/A	U32	100	-	
0x2942:002	Current controller parameters: Reset time	3.77 ms	U32	100	-	
0x2943	Current setpoint filter time	0.00 ms	U16	100	-	
0x2944:001	Torque setpoint notch filter: Frequency notch filter 1	200.0 Hz	U16	10	-	
0x2944:002	Torque setpoint notch filter: Bandwidth notch filter 1	20.0 Hz	U16	10	-	
0x2944:003	Torque setpoint notch filter: Damping notch filter 1	0 dB	U8	1	-	
0x2944:004	Torque setpoint notch filter: Frequency notch filter 2	400.0 Hz	U16	10	-	
0x2944:005	Torque setpoint notch filter: Bandwidth notch filter 2	40.0 Hz	U16	10	-	
0x2944:006	Torque setpoint notch filter: Damping notch filter 2	0 dB	U8	1	-	
0x2945	Torque setpoint jerk limitation	400.0	U16	10	-	
0x2946:001	Speed limitation: Upper speed limit	0 rpm	I32	480000 / 214748 3647	-	●
0x2946:002	Speed limitation: Lower speed limit	0 rpm	I32	480000 / 214748 3647	-	●
0x2947:001	Inverter characteristic: Value y1	0.00 V	U16	100	-	
0x2947:002	Inverter characteristic: Value y2	0.00 V	U16	100	-	

Appendix

Parameter attribute list



Address	Name	Default setting	Data type	Factor	A	M
0x2947:003	Inverter characteristic: Value y3	0.00 V	U16	100	-	
0x2947:004	Inverter characteristic: Value y4	0.00 V	U16	100	-	
0x2947:005	Inverter characteristic: Value y5	0.00 V	U16	100	-	
0x2947:006	Inverter characteristic: Value y6	0.00 V	U16	100	-	
0x2947:007	Inverter characteristic: Value y7	0.00 V	U16	100	-	
0x2947:008	Inverter characteristic: Value y8	0.00 V	U16	100	-	
0x2947:009	Inverter characteristic: Value y9	0.00 V	U16	100	-	
0x2947:010	Inverter characteristic: Value y10	0.00 V	U16	100	-	
0x2947:011	Inverter characteristic: Value y11	0.00 V	U16	100	-	
0x2947:012	Inverter characteristic: Value y12	0.00 V	U16	100	-	
0x2947:013	Inverter characteristic: Value y13	0.00 V	U16	100	-	
0x2947:014	Inverter characteristic: Value y14	0.00 V	U16	100	-	
0x2947:015	Inverter characteristic: Value y15	0.00 V	U16	100	-	
0x2947:016	Inverter characteristic: Value y16	0.00 V	U16	100	-	
0x2947:017	Inverter characteristic: Value y17	0.00 V	U16	100	-	
0x294A:001	Torque limits offset: Torque offset	0.0 %	I16	10	-	
0x294A:002	Torque limits offset: Resulting positive torque limit	x.x % (Read only)	I16	10	-	
0x294A:003	Torque limits offset: Resulting negative torque limit	x.x % (Read only)	I16	10	-	
0x2980	Position controller gain	28.40 1/s	U32	100	-	
0x2981	Position controller gain adaption	100.00 %	U16	100	-	●
0x2982	Position controller output signal limitation	480000.00 rpm	U32	480000 / 214748 3647	-	●
0x2983	Actual position start value	0	I32	1	-	●
0x2984	Mode for setting the actual position	Absolute [0]	U8		-	
0x2985:001	Gain characteristic adaptations: Speed setpoint 1	10 rpm	U16	1	-	
0x2985:002	Gain characteristic adaptations: Gain adaption 1	100 %	U16	1	-	
0x2985:003	Gain characteristic adaptations: Speed setpoint 2	100 rpm	U16	1	-	
0x2985:004	Gain characteristic adaptations: Gain adaption 2	100 %	U16	1	-	
0x2985:005	Gain characteristic adaptations: Speed setpoint 3	1000 rpm	U16	1	-	
0x2985:006	Gain characteristic adaptations: Gain adaption 3	100 %	U16	1	-	
0x2985:007	Gain characteristic adaptations: Speed setpoint 4	2000 rpm	U16	1	-	
0x2985:008	Gain characteristic adaptations: Gain adaption 4	100 %	U16	1	-	
0x2985:009	Gain characteristic adaptations: Speed setpoint 5	5000 rpm	U16	1	-	
0x2985:010	Gain characteristic adaptations: Gain adaption 5	100 %	U16	1	-	
0x2985:011	Gain characteristic adaptations: Gain characteristic adaption on/off	Off [0]	U8		-	
0x2986	Resulting gain adaption	x.xx % (Read only)	U32	100	-	
0x29C0:001	Field controller settings: Gain	165.84 A/Vs	U32	100	-	
0x29C0:002	Field controller settings: Reset time	15.1 ms	U16	10	-	
0x29E0:001	Field weakening controller settings: Gain (ASM)	0.000 Vs/V	U32	1000	-	
0x29E0:002	Field weakening controller settings: Reset time (ASM)	2000.0 ms	U32	10	-	
0x29E1	Field weakening controller Field limitation	100.00 %	U16	100	-	●
0x29E2	DC-bus filter time	25.0 ms	U16	10	-	
0x29E3	Motor voltage filter time	25.0 ms	U16	10	-	
0x29E4	Voltage reserve range	5 %	U8	1	-	
0x2B00	V/f characteristic shape	Linear [0]	U8		-	C
0x2B01:001	V/f shape data: Base voltage	225 V	U16	1	-	
0x2B01:002	V/f shape data: Base frequency	270 Hz	U16	1	-	
0x2B02:001	Frequency grid points (x) user V/f characteristic: x1 = f01	-50 Hz	I16	1	-	
0x2B02:002	Frequency grid points (x) user V/f characteristic: x2 = f02	-40 Hz	I16	1	-	
0x2B02:003	Frequency grid points (x) user V/f characteristic: x3 = f03	-30 Hz	I16	1	-	



Address	Name	Default setting	Data type	Factor	A	M
0x2B02:004	Frequency grid points (x) user V/f characteristic: x4 = f04	-20 Hz	I16	1	-	
0x2B02:005	Frequency grid points (x) user V/f characteristic: x5 = f05	-10 Hz	I16	1	-	
0x2B02:006	Frequency grid points (x) user V/f characteristic: x6 = f06	0 Hz	I16	1	-	
0x2B02:007	Frequency grid points (x) user V/f characteristic: x7 = f07	10 Hz	I16	1	-	
0x2B02:008	Frequency grid points (x) user V/f characteristic: x8 = f08	20 Hz	I16	1	-	
0x2B02:009	Frequency grid points (x) user V/f characteristic: x9 = f09	30 Hz	I16	1	-	
0x2B02:010	Frequency grid points (x) user V/f characteristic: x10 = f10	40 Hz	I16	1	-	
0x2B02:011	Frequency grid points (x) user V/f characteristic: x11 = f11	50 Hz	I16	1	-	
0x2B03:001	Voltage grid points (y) user V/f characteristic: y1 = U01 (x = f01)	400.00 V	U32	100	-	
0x2B03:002	Voltage grid points (y) user V/f characteristic: y2 = U02 (x = f02)	320.00 V	U32	100	-	
0x2B03:003	Voltage grid points (y) user V/f characteristic: y3 = U03 (x = f03)	240.00 V	U32	100	-	
0x2B03:004	Voltage grid points (y) user V/f characteristic: y4 = U04 (x = f04)	160.00 V	U32	100	-	
0x2B03:005	Voltage grid points (y) user V/f characteristic: y5 = U05 (x = f05)	80.00 V	U32	100	-	
0x2B03:006	Voltage grid points (y) user V/f characteristic: y6 = U06 (x = f06)	0.00 V	U32	100	-	
0x2B03:007	Voltage grid points (y) user V/f characteristic: y7 = U07 (x = f07)	80.00 V	U32	100	-	
0x2B03:008	Voltage grid points (y) user V/f characteristic: y8 = U08 (x = f08)	160.00 V	U32	100	-	
0x2B03:009	Voltage grid points (y) user V/f characteristic: y9 = U09 (x = f09)	240.00 V	U32	100	-	
0x2B03:010	Voltage grid points (y) user V/f characteristic: y10 = U10 (x = f10)	320.00 V	U32	100	-	
0x2B03:011	Voltage grid points (y) user V/f characteristic: y11 = U11 (x = f11)	400.00 V	U32	100	-	
0x2B04	V/f boost controller - current setpoint	0.00 A	U32	100	-	
0x2B05:001	V/f boost controller settings: Gain	148.21 V/A	U32	100	-	
0x2B05:002	V/f boost controller settings: Reset time	3.77 ms	U32	100	-	
0x2B05:003	V/f boost controller settings: Dynamic current setpoint	0.00 A	U32	100	-	
0x2B06	Voltage boost	0.0 V	U16	10	-	
0x2B07:001	Load adaption: Direction of rotation	Passive load [0]	U8		C	
0x2B07:002	Load adaption: Load adaption value	20.00 %	U32	100	-	
0x2B08:001	V/f Imax controller: Gain	0.001 Hz/A	U32	1000	-	
0x2B08:002	V/f Imax controller: Reset time	100.0 ms	U32	10	-	
0x2B09:001	Slip compensation: Gain	0.00 %	I16	100	-	
0x2B09:002	Slip compensation: Filter time	2000 ms	U16	1	-	
0x2B0A:001	Oscillation damping: Gain	20 %	I16	1	-	
0x2B0A:002	Oscillation damping: Filter time	5 ms	U16	1	-	
0x2B0A:003	Oscillation damping: Limitation	0.2 Hz	U16	10	-	
0x2B0A:004	Oscillation damping: Final ramp frequency	0 %	U8	1	-	
0x2B0B	Ramp generator frequency	x.x Hz (Read only)	I16	10	-	•
0x2B0C	Override field weakening	0.0 Hz	I16	10	-	
0x2B14:001	Gain	0.100	U16	1000	-	
0x2B14:002	Reset time	100.0 ms	U16	10	-	
0x2B14:003	Frequency limitation	10.00 Hz	U16	100	-	

Appendix

Parameter attribute list



Address	Name	Default setting	Data type	Factor	A	M
0x2B40:001	SLVC: Gain	0.0010 Hz/A	U32	10000	-	
0x2B40:002	SLVC: Reset time	100.0 ms	U32	10	-	
0x2B40:003	SLVC: Q-Feedforward	0.00	U32	100	-	
0x2B40:004	SLVC: D-Feedforward	0.00	U32	100	-	
0x2B80	Current for DC-injection braking	0.00 A	U16	100	-	
0x2BA0	Activate flying restart	Off [0]	U8		-	
0x2BA1	Flying restart circuit	15 %	U16	1	-	
0x2BA2	Start frequency	20.0 Hz	I16	10	-	
0x2BA3	Integration time	600 ms	U16	1	-	
0x2BA4	Minimum deviation	5.00 °	U16	100	-	
0x2BA5	Delay time	0 ms	U16	1	-	
0x2BA6:001	Result: Determined speed [rpm]	x rpm (Read only)	I16	1	-	•
0x2BA6:002	Result: Determined speed [n unit]	rpm (Read only)	I32	480000 / 214748 3647	-	•
0x2C00	Motor control mode	Servoregelung (SC-PSM) [1]	U8		C	
0x2C01:001	Motor parameters: Number of pole pairs	- (Read only)	U8	1	-	
0x2C01:002	Motor parameters: Stator resistance	13.5000 Ω	U32	10000	-	
0x2C01:003	Motor parameters: Stator leakage inductance	51.000 mH	U32	1000	-	
0x2C01:004	Motor parameters: Rated speed	4050 rpm	U16	1	-	
0x2C01:005	Motor parameters: Rated frequency	270.0 Hz	U16	10	-	
0x2C01:006	Motor parameters: Rated power	0.25 kW	U16	100	-	
0x2C01:007	Motor parameters: Rated voltage	225 V	U16	1	-	
0x2C01:008	Motor parameters: Cosine phi	0.80	U16	100	-	
0x2C01:009	Motor parameters: Insulation class	F (cut-off temperature = 155 °C) [4]	U8		-	
0x2C01:010	Motor parameters: Motor name	"MCS06C41"	STRING[50]		-	
0x2C02:001	Motor parameter (ASM): Rotor resistance	0.0000 Ω	U32	10000	-	
0x2C02:002	Motor parameter (ASM): Mutual inductance	0.0 mH	U32	10	-	
0x2C02:003	Motor parameter (ASM): Magnetising current	0.00 A	U16	100	-	
0x2C03:001	Motor parameter (PSM): Back EMF constant	41.8 V/1000rpm	U32	10	-	
0x2C03:002	Motor parameter (PSM): Resolver pole position	-90.0 °	I16	10	-	
0x2C03:003	Motor parameter (PSM): Magnets temperature coefficient (kTN)	-0.110 %/°C	I16	1000	-	
0x2C03:004	Motor parameter (PSM): Encoder pole position	0.0 °	I16	10	-	
0x2C04:001	d-axis Lss saturation characteristic: y1 = L01 (x = 0.00 %)	165 %	U16	1	-	
0x2C04:002	d-axis Lss saturation characteristic: y2 = L02 (x = 6.25 %)	200 %	U16	1	-	
0x2C04:003	d-axis Lss saturation characteristic: y3 = L03 (x = 12.50 %)	146 %	U16	1	-	
0x2C04:004	d-axis Lss saturation characteristic: y4 = L04 (x = 18.75 %)	117 %	U16	1	-	
0x2C04:005	d-axis Lss saturation characteristic: y5 = L05 (x = 25.00 %)	97 %	U16	1	-	
0x2C04:006	d-axis Lss saturation characteristic: y6 = L06 (x = 31.25 %)	82 %	U16	1	-	
0x2C04:007	d-axis Lss saturation characteristic: y7 = L07 (x = 37.50 %)	71 %	U16	1	-	
0x2C04:008	d-axis Lss saturation characteristic: y8 = L08 (x = 42.75 %)	62 %	U16	1	-	
0x2C04:009	d-axis Lss saturation characteristic: y9 = L09 (x = 50.00 %)	55 %	U16	1	-	
0x2C04:010	d-axis Lss saturation characteristic: y10 = L10 (x = 56.25 %)	50 %	U16	1	-	
0x2C04:011	d-axis Lss saturation characteristic: y11 = L11 (x = 62.50 %)	46 %	U16	1	-	



Address	Name	Default setting	Data type	Factor	A	M
0x2C04:012	d-axis Lss saturation characteristic: $y_{12} = L_{12}$ ($x = 68.75\%$)	43 %	U16	1	-	
0x2C04:013	d-axis Lss saturation characteristic: $y_{13} = L_{13}$ ($x = 75.00\%$)	42 %	U16	1	-	
0x2C04:014	d-axis Lss saturation characteristic: $y_{14} = L_{14}$ ($x = 81.25\%$)	41 %	U16	1	-	
0x2C04:015	d-axis Lss saturation characteristic: $y_{15} = L_{15}$ ($x = 87.50\%$)	41 %	U16	1	-	
0x2C04:016	d-axis Lss saturation characteristic: $y_{16} = L_{16}$ ($x = 93.25\%$)	41 %	U16	1	-	
0x2C04:017	d-axis Lss saturation characteristic: $y_{17} = L_{17}$ ($x = 100.00\%$)	41 %	U16	1	-	
0x2C04:018	d-axis Lss saturation characteristic: Activation Lss saturation characteristic	Adjustment on [1]	U16		-	
0x2C04:019	d-axis Lss saturation characteristic: Cross saturation factor	0 %	U16	1	-	
0x2C05	Reference for current grid points (x) Lss saturation characteristic	5.4 A	U16	10	-	
0x2C06:001	Grid points for magnet characteristic (current): $x_1 = i_{01}/i_N$	0 %	U16	1	-	
0x2C06:002	Grid points for magnet characteristic (current): $y_1 = k_{T01}/k_{TN}$	100 %	U16	1	-	
0x2C06:003	Grid points for magnet characteristic (current): $x_2 = i_{02}/i_N$	100 %	U16	1	-	
0x2C06:004	Grid points for magnet characteristic (current): $y_2 = k_{T02}/k_{TN}$	100 %	U16	1	-	
0x2C06:005	Grid points for magnet characteristic (current): $x_3 = i_{03}/i_N$	200 %	U16	1	-	
0x2C06:006	Grid points for magnet characteristic (current): $y_3 = k_{T03}/k_{TN}$	100 %	U16	1	-	
0x2C06:007	Grid points for magnet characteristic (current): $x_4 = i_{04}/i_N$	415 %	U16	1	-	
0x2C06:008	Grid points for magnet characteristic (current): $y_4 = k_{T04}/k_{TN}$	72 %	U16	1	-	
0x2C07:001	Inductance grid points (y) Lh saturation characteristic: $y_1 = L_{01}$ ($x = 0.00\%$)	118 %	U16	1	-	
0x2C07:002	Inductance grid points (y) Lh saturation characteristic: $y_2 = L_{02}$ ($x = 6.25\%$)	118 %	U16	1	-	
0x2C07:003	Inductance grid points (y) Lh saturation characteristic: $y_3 = L_{03}$ ($x = 12.50\%$)	118 %	U16	1	-	
0x2C07:004	Inductance grid points (y) Lh saturation characteristic: $y_4 = L_{04}$ ($x = 18.75\%$)	117 %	U16	1	-	
0x2C07:005	Inductance grid points (y) Lh saturation characteristic: $y_5 = L_{05}$ ($x = 25.00\%$)	116 %	U16	1	-	
0x2C07:006	Inductance grid points (y) Lh saturation characteristic: $y_6 = L_{06}$ ($x = 31.25\%$)	114 %	U16	1	-	
0x2C07:007	Inductance grid points (y) Lh saturation characteristic: $y_7 = L_{07}$ ($x = 37.50\%$)	111 %	U16	1	-	
0x2C07:008	Inductance grid points (y) Lh saturation characteristic: $y_8 = L_{08}$ ($x = 43.75\%$)	107 %	U16	1	-	
0x2C07:009	Inductance grid points (y) Lh saturation characteristic: $y_9 = L_{09}$ ($x = 50.00\%$)	100 %	U16	1	-	
0x2C07:010	Inductance grid points (y) Lh saturation characteristic: $y_{10} = L_{10}$ ($x = 56.25\%$)	93 %	U16	1	-	
0x2C07:011	Inductance grid points (y) Lh saturation characteristic: $y_{11} = L_{11}$ ($x = 62.50\%$)	86 %	U16	1	-	
0x2C07:012	Inductance grid points (y) Lh saturation characteristic: $y_{12} = L_{12}$ ($x = 68.75\%$)	78 %	U16	1	-	
0x2C07:013	Inductance grid points (y) Lh saturation characteristic: $y_{13} = L_{13}$ ($x = 75.00\%$)	71 %	U16	1	-	

Appendix

Parameter attribute list



Address	Name	Default setting	Data type	Factor	A	M
0x2C07:014	Inductance grid points (y) Lh saturation characteristic: y14 = L14 (x = 81.25 %)	64 %	U16	1	-	
0x2C07:015	Inductance grid points (y) Lh saturation characteristic: y15 = L15 (x = 87.50 %)	57 %	U16	1	-	
0x2C07:016	Inductance grid points (y) Lh saturation characteristic: y16 = L16 (x = 93.75 %)	50 %	U16	1	-	
0x2C07:017	Inductance grid points (y) Lh saturation characteristic: y17 = L17 (x = 100.00 %)	42 %	U16	1	-	
0x2C08	Method for setting motor parameters	Select from catalogue (Lenze motors) [1]	U8		-	
0x2C09:001	q-axis Lss saturation characteristic: y1 = L01 (x = 0.00 %)	165 %	U16	1	-	
0x2C09:002	q-axis Lss saturation characteristic: y2 = L02 (x = 6.25 %)	200 %	U16	1	-	
0x2C09:003	q-axis Lss saturation characteristic: y3 = L03 (x = 12.50 %)	146 %	U16	1	-	
0x2C09:004	q-axis Lss saturation characteristic: y4 = L04 (x = 18.75 %)	117 %	U16	1	-	
0x2C09:005	q-axis Lss saturation characteristic: y5 = L05 (x = 25.00 %)	97 %	U16	1	-	
0x2C09:006	q-axis Lss saturation characteristic: y6 = L06 (x = 31.25 %)	82 %	U16	1	-	
0x2C09:007	q-axis Lss saturation characteristic: y7 = L07 (x = 37.50 %)	71 %	U16	1	-	
0x2C09:008	q-axis Lss saturation characteristic: y8 = L08 (x = 42.75 %)	62 %	U16	1	-	
0x2C09:009	q-axis Lss saturation characteristic: y9 = L09 (x = 50.00 %)	55 %	U16	1	-	
0x2C09:010	q-axis Lss saturation characteristic: y10 = L10 (x = 56.25 %)	50 %	U16	1	-	
0x2C09:011	q-axis Lss saturation characteristic: y11 = L11 (x = 62.50 %)	46 %	U16	1	-	
0x2C09:012	q-axis Lss saturation characteristic: y12 = L12 (x = 68.75 %)	43 %	U16	1	-	
0x2C09:013	q-axis Lss saturation characteristic: y13 = L13 (x = 75.00 %)	42 %	U16	1	-	
0x2C09:014	q-axis Lss saturation characteristic: y14 = L14 (x = 81.25 %)	41 %	U16	1	-	
0x2C09:015	q-axis Lss saturation characteristic: y15 = L15 (x = 87.50 %)	41 %	U16	1	-	
0x2C09:016	q-axis Lss saturation characteristic: y16 = L16 (x = 93.25 %)	41 %	U16	1	-	
0x2C09:017	q-axis Lss saturation characteristic: y17 = L17 (x = 100.00 %)	41 %	U16	1	-	
0x2C09:018	q-axis Lss saturation characteristic: Table source	Identical to d-axis (0x2C04) [0]	U16		-	
0x2C11:001	High speed range: Lower limit	20 %	U16	1	-	
0x2C11:002	High speed range: Tracking controller gain	250 %	U16	1	-	
0x2C11:003	High speed range: Tracking controller reset time	6.00 ms	U16	100	-	
0x2C11:004	High speed range: Tracking controller decouple time	0.00 ms	U16	100	-	
0x2C12:001	SM low speed range: Acceleration current	100 %	U16	1	-	
0x2C12:002	SM low speed range: Standstill current	20 %	U16	1	-	
0x2C16:001	Cogging torque compensation: Enable compensation	On [1]	U8		-	
0x2C16:002	Cogging torque compensation: Commutation turns	1	U8	1	-	
0x2C16:003	Cogging torque compensation: Max. recommended identification speed	x rpm (Read only)	U16	1	-	
0x2C16:005	Cogging torque compensation: Identification state	- (Read only)	U16		H	
0x2C16:006	Cogging torque compensation: Amplitude 1	0.000 %	I16	1000	C	
0x2C16:007	Cogging torque compensation: Phase 1	0.0 °	I16	10	C	
0x2C16:008	Cogging torque compensation: Amplitude 2	0.000 %	I16	1000	C	



Address	Name	Default setting	Data type	Factor	A	M
0x2C16:009	Cogging torque compensation: Phase 2	0.0 °	I16	10	C	
0x2C16:010	Cogging torque compensation: Amplitude 3	0.000 %	I16	1000	C	
0x2C16:011	Cogging torque compensation: Phase 3	0.0 °	I16	10	C	
0x2C16:012	Cogging torque compensation: Amplitude 4	0.000 %	I16	1000	C	
0x2C16:013	Cogging torque compensation: Phase 4	0.0 °	I16	10	C	
0x2C16:014	Cogging torque compensation: Amplitude 5	0.000 %	I16	1000	C	
0x2C16:015	Cogging torque compensation: Phase 5	0.0 °	I16	10	C	
0x2C16:016	Cogging torque compensation: Amplitude 6	0.000 %	I16	1000	C	
0x2C16:017	Cogging torque compensation: Phase 6	0.0 °	I16	10	C	
0x2C16:018	Cogging torque compensation: Amplitude 7	0.000 %	I16	1000	C	
0x2C16:019	Cogging torque compensation: Phase 7	0.0 °	I16	10	C	
0x2C16:020	Cogging torque compensation: Amplitude 8	0.000 %	I16	1000	C	
0x2C16:021	Cogging torque compensation: Phase 8	0.0 °	I16	10	C	
0x2C16:022	Cogging torque compensation: Amplitude 9	0.000 %	I16	1000	C	
0x2C16:023	Cogging torque compensation: Phase 9	0.0 °	I16	10	C	
0x2C16:024	Cogging torque compensation: Amplitude 10	0.000 %	I16	1000	C	
0x2C16:025	Cogging torque compensation: Phase 10	0.0 °	I16	10	C	
0x2C40	Motor encoder type	SinCos encoder [1]	U8		C	
0x2C41:001	Motor encoder settings (HIPERFACE®): Type code detected	- (Read only)	U8	1	-	
0x2C41:002	Motor encoder settings (HIPERFACE®): Type code manual input	0	U8	1	C	
0x2C41:003	Motor encoder settings (HIPERFACE®): Manual input - Number of detectable motor encoder revolutions	1	U16	1	C	
0x2C41:004	Motor encoder settings (HIPERFACE®): Error response	Fault > CiA402 [1]	U8		-	
0x2C41:005	Motor encoder settings (HIPERFACE®): Serial number	- (Read only)	STRING[50]		-	
0x2C41:006	Motor encoder settings (HIPERFACE®): Actual position (raw data)	- (Read only)	U32	1	-	•
0x2C41:007	Motor encoder settings (HIPERFACE®): No. of periods detected	- (Read only)	U16	1	-	•
0x2C41:008	Motor encoder settings (HIPERFACE®): Type code verification	- (Read only)	U8		-	•
0x2C41:009	Motor encoder settings (HIPERFACE®): Encoder type	- (Read only)	U8		-	•
0x2C41:010	Motor encoder settings (HIPERFACE®): Period length of linear encoder	x nm (Read only)	U32	1	-	•
0x2C42:001	Encoder settings: Increments/revolution	1024	U32	1	C	
0x2C42:002	Encoder settings: Supply voltage	5.0 V	U8	10	C	
0x2C42:003	Encoder settings: Angle drift	x.x ° (Read only)	I16	10	-	•
0x2C42:004	Encoder settings: Actual amplitude signal quality	x % (Read only)	U8	1	-	
0x2C42:008	Encoder settings: Encoder voltage cos track	x.xxx V (Read only)	I16	1000	-	
0x2C42:009	Encoder settings: Encoder voltage sin track	x.xxx V (Read only)	I16	1000	-	
0x2C43	Motor encoder resolver number of pole pairs	1	U8	1	C	
0x2C44:001	Motor encoder identification (Resolver): Angle	0	I16	1	-	
0x2C44:002	Motor encoder identification (Resolver): Cosine track gain	100 %	U16	1	-	
0x2C44:003	Motor encoder identification (Resolver): Sine track gain	100 %	U16	1	-	
0x2C44:006	Motor encoder identification (Resolver): Identification status	- (Read only)	U16		H	
0x2C44:008	Motor encoder identification (Resolver): Cosine track offset	0.000 %	I32	1000	-	
0x2C44:009	Motor encoder identification (Resolver): Sine track offset	0.000 %	I32	1000	-	
0x2C44:011	Motor encoder identification (Resolver): Cyclic online compensation	On [1]	U8		-	



Address	Name	Default setting	Data type	Factor	A	M
0x2C44:012	Motor encoder identification (Resolver): Harmonic for cyclic online compensation	22	U16	1	-	
0x2C44:013	Motor encoder identification (Resolver): Dead time compensation resolver evaluation	100.0 %	I16	10	-	
0x2C45	Motor feedback error response	Warning [1]	U8		-	
0x2C46	Number of the absolute ascertainable revolutions of motor encoder	-(Read only)	U16	1	-	
0x2C47	Open circuit detection sensitivity of motor encoder	100 %	U8	1	-	
0x2C48:001	Motor encoder (EnDat): Response communication error	Warning [1]	U8		-	
0x2C48:002	Motor encoder (EnDat): Actual position (raw data)	-(Read only)	U32	1	-	•
0x2C48:003	Motor encoder (EnDat): Serial number	-(Read only)	STRING[50]		-	
0x2C48:004	Motor encoder (EnDat): ID number	-(Read only)	STRING[50]		-	
0x2C48:005	Motor encoder (EnDat): Encoder designation	-(Read only)	STRING[50]		-	
0x2C48:006	Motor encoder (EnDat): EnDat ordering designation	-(Read only)	STRING[50]		-	
0x2C48:007	Motor encoder (EnDat): EnDat command set	-(Read only)	STRING[50]		-	
0x2C48:008	Motor encoder (EnDat): Encoder type	-(Read only)	U8	1	-	
0x2C48:009	Motor encoder (EnDat): Signal periods per revolution/Length of signal period	-(Read only)	U32	1	-	
0x2C48:010	Motor encoder (EnDat): Distinguishable revolutions	-(Read only)	U16	1	-	
0x2C48:011	Motor encoder (EnDat): Max. clock frequency	x kHz (Read only)	U16	1	-	
0x2C48:012	Motor encoder (EnDat): Measuring step or measuring steps/rev for serial data transmission	-(Read only)	U32	1	-	
0x2C48:013	Motor encoder (EnDat): Scaling factor for resolution	-(Read only)	U16	1	-	
0x2C48:014	Motor encoder (EnDat): Measuring step, or measuring steps/rev or subdivision values of a grating period	-(Read only)	U32	1	-	
0x2C4A:001	Motor encoder (SSI) protocol parameters: Bit rate	300 kbps	U16	1	C	
0x2C4A:002	Motor encoder (SSI) protocol parameters: Telegram length	25	U8	1	C	
0x2C4A:003	Motor encoder (SSI) protocol parameters: Bits/revolution	13	U8	1	C	
0x2C4A:004	Motor encoder (SSI) protocol parameters: Position data start bit	0	U8	1	C	
0x2C4A:005	Motor encoder (SSI) protocol parameters: Data package 1 start bit	0	U8	1	C	
0x2C4A:006	Motor encoder (SSI) protocol parameters: Data package 2 start bit	0	U8	1	C	
0x2C4A:007	Motor encoder (SSI) protocol parameters: Data package 3 start bit	0	U8	1	C	
0x2C4A:008	Motor encoder (SSI) protocol parameters: Position data length	0	U8	1	C	
0x2C4A:009	Motor encoder (SSI) protocol parameters: Data package 1 length	0	U8	1	C	
0x2C4A:010	Motor encoder (SSI) protocol parameters: Data package 2 length	0	U8	1	C	
0x2C4A:011	Motor encoder (SSI) protocol parameters: Data package 3 length	0	U8	1	C	
0x2C4A:012	Motor encoder (SSI) protocol parameters: Position data coding	Binary [0]	U8		C	
0x2C4A:013	Motor encoder (SSI) protocol parameters: Data package 1 coding	Binary [0]	U8		C	
0x2C4A:014	Motor encoder (SSI) protocol parameters: Data package 2 coding	Binary [0]	U8		C	
0x2C4A:015	Motor encoder (SSI) protocol parameters: Data package 3 coding	Binary [0]	U8		C	
0x2C4A:016	Motor encoder (SSI) protocol parameters: Position raw data	-(Read only)	U32	1	-	•
0x2C4A:017	Motor encoder (SSI) protocol parameters: Data package 1 raw data	-(Read only)	U32	1	-	•



Address	Name	Default setting	Data type	Factor	A	M
0x2C4A:018	Motor encoder (SSI) protocol parameters: Data package 2 raw data	- (Read only)	U32	1	-	●
0x2C4A:019	Motor encoder (SSI) protocol parameters: Data package 3 raw data	- (Read only)	U32	1	-	●
0x2C4A:020	Motor encoder (SSI) protocol parameters: Encoder type	Rotative encoder [0]	U8		C	
0x2C4A:021	Motor encoder (SSI) protocol parameters: Position raw data scaled by 0x608F	- (Read only)	I32	1	-	●
0x2C4A:022	Motor encoder (SSI) protocol parameters: Monoflop time	0	U16	1	C	
0x2C4A:023	Motor encoder (SSI) protocol parameters: Resulting SSI-telegram cycle time	- (Read only)	U16	10	-	
0x2C4B:001	Release version	- (Read only)	U8	1	-	
0x2C4B:002	Release Date	- (Read only)	U32	1	-	
0x2C4B:003	Encoder ID	- (Read only)	U32	1	-	
0x2C4B:004	Type of encoder	- (Read only)	U16	1	-	
0x2C4B:005	Resolution	- (Read only)	U32	1	-	
0x2C4B:006	Measurement range	- (Read only)	U32	1	-	
0x2C4B:007	Type name	- (Read only)	STRING[50]		-	
0x2C4B:008	Serial number	- (Read only)	STRING[50]		-	
0x2C4B:009	Device version	- (Read only)	STRING[50]		-	
0x2C4B:010	Firmware date	- (Read only)	STRING[50]		-	
0x2C4B:011	EEPROM size	- (Read only)	U16	1	-	
0x2C4B:012	Safe Channel 2 Resolution	- (Read only)	U32	1	-	
0x2C4B:020	Delay / RSSI	- (Read only)	U8		H	
0x2C4B:021	Quality monitoring	- (Read only)	U8		H	
0x2C4B:022	Slave RSSI	- (Read only)	U8		H	
0x2C4B:023	Supply voltage	x.xxx V (Read only)	U16	1000	-	
0x2C4B:024	Rotation speed range	x rpm (Read only)	U16	1	-	
0x2C4B:025	Auswahl	No value [0]	U16		-	
0x2C4B:026	Value	- (Read only)	I64	1	-	
0x2C4B:027	Communication error counter	- (Read only)	U32	1	-	
0x2C4B:040	Events	- (Read only)	U16		H	
0x2C4B:041	Status summaries	- (Read only)	U8		H	
0x2C4B:042	Encoder status, byte 0	- (Read only)	U8		H	
0x2C4B:043	Encoder status, byte 1	- (Read only)	U8		H	
0x2C4B:044	Encoder status, byte 2	- (Read only)	U8		H	
0x2C4B:045	Encoder status, byte 3	- (Read only)	U8		H	
0x2C4B:046	Encoder status, byte 4	- (Read only)	U8		H	
0x2C4B:047	Encoder status, byte 5	- (Read only)	U8		H	
0x2C4B:048	Encoder status, byte 6	- (Read only)	U8		H	
0x2C4B:049	Encoder status, byte 7	- (Read only)	U8		H	
0x2C4B:050	Fast position	- (Read only)	I64	1	-	
0x2C4F	Parameter CRC of motor encoder	- (Read only)	U32	1	-	
0x2C60	PPI monitoring: Response	Fault [1]	U8		-	
0x2C61:001	Pole position identification (360°) settings: Current amplitude	71 %	U16	1	C	
0x2C61:002	Pole position identification (360°) settings: Ramp time	40 s	U16	1	C	
0x2C61:003	Pole position identification (360°) settings: Direction of rotation	CW [0]	U8		C	
0x2C61:004	Pole position identification (360°) settings: Error tolerance	20 °	U8	1	-	
0x2C61:005	Pole position identification (360°) settings: Absolute current amplitude	x.xx A (Read only)	U32	100	-	
0x2C61:006	Pole position identification (360°) settings: ixt threshold for reversal of rotating direction	30 %	U8	1	-	



Address	Name	Default setting	Data type	Factor	A	M
0x2C61:010	Pole position identification (360°) settings: Actual commutation angle	x.xxx ° (Read only)	U32	1000	-	
0x2C62:001	Pole position identification (min. movement) settings: Current amplitude	25 %	U16	1	C	
0x2C62:002	Pole position identification (min. movement) settings: Ramp time	10 s	U16	1	C	
0x2C62:003	Pole position identification (min. movement) settings: Gain	0 %	U16	1	-	
0x2C62:004	Pole position identification (min. movement) settings: Reset time	62.5 ms	U16	10	-	
0x2C62:005	Pole position identification (min. movement) settings: Max. move permitted	20 °	U8	1	-	
0x2C62:006	Pole position identification (min. movement) settings: Absolute current amplitude	x.xx A (Read only)	U32	100	-	
0x2C63:001	PPI without movement: Execution	Disabled [0]	U8		C	
0x2C63:002	PPI without movement: Current adjust factor	100 %	U16	1	C	
0x2C64:001	Cable Check: Behavior after switch on	No action [0]	U8		C	
0x2C64:002	Cable Check: Status word	- (Read only)	U16		H	
0x2C65:001	PPI validation: Activation	Off [0]	U8		C	
0x2C65:002	PPI validation: Settings	No action [0]	U8		-	
0x2C65:003	PPI validation: Status	- (Read only)	U16		H	•
0x2C65:004	PPI validation: Pole position set value	0.0 °	I16	10	-	
0x2C66:001	PPI mode for 0x6060: Selection	PPI 360° [1]	U8		C	
0x2C67:001	MOL settings for 0x6060: Current setpoint 1	71 %	U16	1	-	
0x2C67:002	MOL settings for 0x6060: Frequency 1	1.0 Hz	I16	10	-	
0x2C67:003	MOL settings for 0x6060: Current 1 - ramp time	10 ms	U16	1	-	
0x2C67:004	MOL settings for 0x6060: Frequency 1 - ramp time	200 ms	U16	1	-	
0x2C67:005	MOL settings for 0x6060: Starting angle 1	0.0 °	I16	10	-	
0x2C67:006	MOL settings for 0x6060: Stopping time 1	10000.0 s	U32	10	C	
0x2C67:011	MOL settings for 0x6060: Current setpoint 2	71 %	U16	1	-	
0x2C67:012	MOL settings for 0x6060: Frequency 2	5.0 Hz	I16	10	-	
0x2C67:013	MOL settings for 0x6060: Current 2 - ramp time	10 ms	U16	1	-	
0x2C67:014	MOL settings for 0x6060: Frequency 2 - ramp time	1000 ms	U16	1	-	
0x2C67:015	MOL settings for 0x6060: Starting angle 2	0.0 °	I16	10	-	
0x2C67:016	MOL settings for 0x6060: Stopping time 2	10000.0 s	U32	10	C	
0x2D00:001	Touch probe (TP) delay time: Touch probe 1 delay time	0.000 ms	U16	1000	-	
0x2D00:002	Touch probe (TP) delay time: Touch probe 2 delay time	0.000 ms	U16	1000	-	
0x2D01:001	Touch probe (TP) time stamp: Touch probe 1-rising edge time stamp	x ns (Read only)	U32	1	-	•
0x2D01:002	Touch probe (TP) time stamp: Touch probe 1-falling edge time stamp	x ns (Read only)	U32	1	-	•
0x2D01:003	Touch probe (TP) time stamp: Touch probe 2-rising edge time stamp	x ns (Read only)	U32	1	-	•
0x2D01:004	Touch probe (TP) time stamp: Touch probe 2-falling edge time stamp	x ns (Read only)	U32	1	-	•
0x2D40:001	Device utilisation ixt: Power unit actual utilisation	x % (Read only)	U16	1	-	•
0x2D40:002	Device utilisation ixt: Power unit warning threshold	95 %	U16	1	-	
0x2D40:003	Device utilisation ixt: Power unit error threshold	x % (Read only)	U16	1	-	
0x2D40:004	Device utilisation ixt: Device actual utilisation	x % (Read only)	U16	1	-	•
0x2D40:005	Device utilisation ixt: Device warning threshold	95 %	U16	1	-	
0x2D40:006	Device utilisation ixt: Device error threshold	x % (Read only)	U16	1	-	
0x2D44:001	Overspeed monitoring: Threshold	8000 rpm	U16	1	-	
0x2D44:002	Overspeed monitoring: Response	Warning [1]	U8		-	
0x2D45:001	Motor phase failure detection: Response - Motor phase 1	No response [0]	U8		-	
0x2D45:002	Motor phase failure detection: Current threshold	5.0 %	U8	10	-	



Address	Name	Default setting	Data type	Factor	A	M
0x2D45:003	Motor phase failure detection: Voltage threshold	10.0 V	U16	10	-	
0x2D45:004	Motor phase failure detection: Response - Motor phase 2	No response [0]	U8		-	
0x2D46:001	Overcurrent monitoring: Threshold	5.4 A	U16	10	-	
0x2D46:002	Overcurrent monitoring: Response	Warning [1]	U8		-	
0x2D48:002	PTC temperature sensor monitoring: Error response	Fault > CiA402 [1]	U8		-	
0x2D49:001	Motor temperature monitoring: Temperature sensor type	PT1000 [5]	U8		-	
0x2D49:002	Motor temperature monitoring: Response	Warning [1]	U8		-	
0x2D49:003	Motor temperature monitoring: Warning threshold	145.0 °C	I16	10	-	
0x2D49:004	Motor temperature monitoring: Error threshold	155.0 °C	I16	10	-	
0x2D49:005	Motor temperature monitoring: Actual motor temperature	x.x °C (Read only)	I16	10	-	●
0x2D49:006	Motor temperature monitoring: Spec. characteristic temperature grid point 1	25.0 °C	I16	10	-	
0x2D49:007	Motor temperature monitoring: Spec. characteristic temperature grid point 2	150.0 °C	I16	10	-	
0x2D49:008	Motor temperature monitoring: Spec. characteristic resistance grid point 1	1000 Ω	I16	1	-	
0x2D49:009	Motor temperature monitoring: Spec. characteristic resistance grid point 2	2225 Ω	I16	1	-	
0x2D4C:001	Thermal model motor utilization (i ² xt): Motor utilisation (i ² xt)	60 s	U16	1	-	
0x2D4C:002	Thermal model motor utilization (i ² xt): Thermal time constant - laminations	852 s	U16	1	-	
0x2D4C:003	Thermal model motor utilization (i ² xt): Winding influence	27 %	U8	1	-	
0x2D4C:004	Thermal model motor utilization (i ² xt): Starting value	0 %	U16	1	-	
0x2D4D:001	Motor utilisation (i ² xt) - specific characteristic: x1 = n01/nN (n01 ~ 0)	0 %	U16	1	-	
0x2D4D:002	Motor utilisation (i ² xt) - specific characteristic: y1 = i01/iN (x1)	100 %	U16	1	-	
0x2D4D:003	Motor utilisation (i ² xt) - specific characteristic: x2 = n02/nN (n02 = limit reduced cooling)	0 %	U16	1	-	
0x2D4D:004	Motor utilisation (i ² xt) - specific characteristic: y2 = i02/iN (x2)	100 %	U16	1	-	
0x2D4D:005	Motor utilisation (i ² xt) - specific characteristic: x3 = n03/nN (n03 = rated speed)	100 %	U16	1	-	
0x2D4D:006	Motor utilisation (i ² xt) - specific characteristic: y3 = i03/iN (x3)	100 %	U16	1	-	
0x2D4D:007	Motor utilisation (i ² xt) - specific characteristic: x4 = n04/nN (n04 = limit field weakening)	100 %	U16	1	-	
0x2D4D:008	Motor utilisation (i ² xt) - specific characteristic: y4 = i04/iN (x4)	100 %	U16	1	-	
0x2D4E	Motor utilisation (i ² xt) - warning threshold	100 %	U16	1	-	
0x2D4F	Motor utilisation (i ² xt)	x % (Read only)	U16	1	-	●
0x2D50:001	Motor utilisation (i ² xt) - monitoring: Error response	Fehler > CiA402 [1]	U8		-	
0x2D50:002	Motor utilisation (i ² xt) - monitoring: Error threshold	105 %	U16	1	-	
0x2D51:001	Position error/speed error - monitoring: Speed error - error threshold	50 rpm	U32	1	-	
0x2D51:002	Position error/speed error - monitoring: Speed error - min. time for error	0 ms	U16	1	-	
0x2D51:003	Position error/speed error - monitoring: Speed error - error response	No response [0]	U8		-	
0x2D51:004	Position error/speed error - monitoring: Position error - error threshold	360 °	U32	1	-	
0x2D51:005	Position error/speed error - monitoring: Position error - min. time for error	0 ms	U16	1	-	



Address	Name	Default setting	Data type	Factor	A	M
0x2D51:006	Position error/speed error - monitoring: Position error - error response	No response [0]	U8		-	
0x2D66:001	Mains failure control: Enable function	Disabled [0]	U8		-	
0x2D66:002	Mains failure control: DC-bus activation level	75 %	U8	1	-	
0x2D66:011	Mains failure control: Filter time	0.00 s	U16	100	-	
0x2D66:012	Mains failure control: Ramp max. torque	30.0 %	U16	10	-	
0x2D66:013	Mains failure control: Ramp time	1.00 s	U16	100	-	
0x2D66:014	Mains failure control: Actual DC bus voltage (filtered)	x.xxx V (Read only)	U32	1000	-	
0x2D81:001	Life-diagnosis: Operating time	x s (Read only)	U32	1	-	
0x2D81:002	Life-diagnosis: Power-on time	x s (Read only)	U32	1	-	
0x2D81:004	Life-diagnosis: Main switching cycles	- (Read only)	U32	1	-	
0x2D81:006	Life-diagnosis: Short-circuit counter	- (Read only)	U32	1	-	
0x2D81:007	Life-diagnosis: Earth fault counter	- (Read only)	U32	1	-	
0x2D81:009	Life-diagnosis: Fan operating time	x s (Read only)	U32	1	-	
0x2D82	Motor actual voltage (Veff)	x.x V (Read only)	U32	10	-	●
0x2D83:001	Motor-Phasenströme: Zero system current	x.xx A (Read only)	I32	100	-	●
0x2D83:002	Motor-Phasenströme: Phase U current	x.xx A (Read only)	I32	100	-	●
0x2D83:003	Motor-Phasenströme: Phase V current	x.xx A (Read only)	I32	100	-	●
0x2D83:004	Motor-Phasenströme: Phase W current	x.xx A (Read only)	I32	100	-	●
0x2D84:001	Heatsink temperature: Heatsink temperature	x.x °C (Read only)	I16	10	-	
0x2D84:002	Heatsink temperature: Warning threshold	90.0 °C	I16	10	-	
0x2D8A	Actual speed error	x rpm (Read only)	I32	1	-	●
0x2DA2:001	Output power: Effective power	x.xxx kW (Read only)	I32	1000	-	●
0x2DA3:003	Output energy: Overall energy	0.00 kWh	I32	100	-	
0x2DD0:001	Field values: Actual value	x % (Read only)	U16	1	-	●
0x2DD0:002	Field values: Setpoint value	x % (Read only)	U16	1	-	●
0x2DD1:001	Motor currents: Actual D-current (id)	x.xx A (Read only)	I32	100	-	●
0x2DD1:002	Motor currents: Actual Q-current (iq)	x.xx A (Read only)	I32	100	-	●
0x2DD1:003	Motor currents: Setpoint D-current (id)	x.xx A (Read only)	I32	100	-	●
0x2DD1:004	Motor currents: Setpoint Q-current (iq)	x.xx A (Read only)	I32	100	-	●
0x2DD1:005	Motor currents: Motor current (Ieff)	x.xx A (Read only)	I32	100	-	●
0x2DD2	Target position interpolated	- (Read only)	I32	1	-	●
0x2DD3:001	Speed setpoints: Speed setpoint	x rpm (Read only)	I32	1	-	●
0x2DD3:002	Speed setpoints: Speed setpoint 2	x rpm (Read only)	I32	1	-	●
0x2DD3:003	Speed setpoints: Speed setpoint limited	x rpm (Read only)	I32	1	-	●
0x2DD4:001	Speed controller output signals: Output signal 1	x.x % (Read only)	I16	10	-	●
0x2DD4:002	Speed controller output signals: Output signal 2	x.x % (Read only)	I16	10	-	●
0x2DD5	Torque setpoint	x.xx Nm (Read only)	I32	100	-	●
0x2DD6:001	Torque filter cascade: Starting value	x.x % (Read only)	I16	10	-	●
0x2DD6:002	Torque filter cascade: Notch filter 1 input value	x.x % (Read only)	I16	10	-	●
0x2DD6:003	Torque filter cascade: Notch filter 2 input value	x.x % (Read only)	I16	10	-	●
0x2DD6:004	Torque filter cascade: Torque setpoint filtered	x.x % (Read only)	I16	10	-	●
0x2DD7:001	Voltage values: Actual voltage (motor voltage limit)	x.x V (Read only)	I16	10	-	●
0x2DD7:002	Voltage values: Output signal D current controller	x.x V (Read only)	I16	10	-	●
0x2DD7:003	Voltage values: Output signal Q current controller	x.x V (Read only)	I16	10	-	●
0x2DD7:004	Voltage values: D voltage (magnetisation)	x.x V (Read only)	I16	10	-	●
0x2DD7:005	Voltage values: Q voltage (torque)	x.x V (Read only)	I16	10	-	●
0x2DD7:006	Voltage values: Phases U-V	x.x V (Read only)	I16	10	-	●
0x2DD7:007	Voltage values: Phases V-W	x.x V (Read only)	I16	10	-	●
0x2DD7:008	Voltage values: Phases W-U	x.x V (Read only)	I16	10	-	●
0x2DD7:009	Voltage values: Phase U	x.x V (Read only)	I16	10	-	●
0x2DD7:010	Voltage values: Phase V	x.x V (Read only)	I16	10	-	●
0x2DD7:011	Voltage values: Phase W	x.x V (Read only)	I16	10	-	●
0x2DDC	Actual slip value	x.x Hz (Read only)	I16	10	-	●



Address	Name	Default setting	Data type	Factor	A	M
0x2DDD	Output frequency	x.x Hz (Read only)	I16	10	-	●
0x2DDE	Actual rotor angle position	- (Read only)	I16	1	-	●
0x2DDF:001	Axis information: Rated current	x.xx A (Read only)	U16	100	-	●
0x2DDF:002	Axis information: Maximum current	x.xx A (Read only)	U16	100	-	●
0x2DDF:005	Axis information: Detected module in slot A	- (Read only)	U8		-	●
0x2DDF:007	Axis information: Function of X109	- (Read only)	U8		-	●
0x2DE0:001	Service settings: Current controller identification settings	Automatic [0]	U8		-	
0x2DE0:003	Service settings: Resolver - position detection dynamics	100 %	U16	1	-	
0x2DE0:004	Service settings: Resolver - 8 kHz safety signal	Automatisch durch Gerätetyp [0]	U8		-	
0x2DE0:006	Service settings: OEM service Data - SN	- (Read only)	U32	1	-	
0x2DE0:007	Service settings: Use measured voltage	On [1]	U8		-	
0x2DE0:009	Service settings: Motor identification settings	- (Read only)	U32	1	-	
0x2DE0:014	Service settings: Overwrite bit 4 of CiA control word	No overwrite [0]	U8		-	
0x2DE0:026	Service settings: Actual speed filter time	10.0 ms	U16	10	-	
0x2DE1:001	Axis settings: Function of X109	HIPERFACE DSL® (OCT) [10]	U8		-	
0x603F	Error code	- (Read only)	U16		H	●
0x6040	CiA control word	0x0000	U16		H	●
0x6041	CiA status word	- (Read only)	U16		H	●
0x6042	Set speed	0 rpm	I16	1	-	●
0x6043	Internal set speed	x rpm (Read only)	I16	1	-	●
0x6044	Actual speed	x rpm (Read only)	I16	1	-	●
0x6046:001	Speed limits: Min. speed	0 rpm	U32	1	-	●
0x6046:002	Speed limits: Max. speed	2147483647 rpm	U32	1	-	●
0x6048:001	Acceleration ramp: CiA acceleration: Delta speed	0 rpm	U32	1	-	●
0x6048:002	Acceleration ramp: CiA acceleration: Delta time	10 s	U16	1	-	●
0x6049:001	Deceleration ramp: CiA deceleration: Delta speed	0 rpm	U32	1	-	●
0x6049:002	Deceleration ramp: CiA deceleration: Delta time	10 s	U16	1	-	●
0x604B:001	vl set-point factor: vl set-point factor numerator	1	I16	1	-	●
0x604B:002	vl set-point factor: vl set-point factor denominator	1	I16	1	-	●
0x604C:001	vl dimension factor: vl dimension factor numerator	1	I32	1	-	●
0x604C:002	vl dimension factor: vl dimension factor denominator	1	I32	1	-	●
0x605A	CiA: Quick stop mode	Ramp > switch on disabled [2]	I16		-	
0x605B	Shutdown option code	Disable drive function [0]	I16		-	
0x605E	CiA: Response to minor faults	Advanced quick stop [-2]	I16		-	
0x6060	CiA: Operation mode	No selection [0]	I8		-	●
0x6061	CiA: Active operation mode	- (Read only)	I8		-	●
0x6062	Internal set position	- (Read only)	I32	1	-	
0x6063	Internal actual position	- (Read only)	I32	1	-	●
0x6064	Actual position	- (Read only)	I32	1	-	●
0x6065	Following error window	1000	U32	1	-	●
0x6066	Following error delay	0 ms	U16	1	-	●
0x6067	Position reached window	1000	U32	1	-	
0x6068	Position reached delay	0 ms	U16	1	-	
0x606C	Actual speed	rpm (Read only)	I32	480000 / 2147483647	-	●
0x6071	Set torque	0.0 %	I16	10	-	●
0x6072	Max. torque	250.0 %	U16	10	-	●
0x6073	Max. current	150.0 %	U16	10	-	
0x6074	Internal set torque	x.x % (Read only)	I16	10	-	
0x6075	Rated motor current	1.300 A	U32	1000	C	
0x6076	Rated motor torque	0.600 Nm	U32	1000	C	

Appendix

Parameter attribute list



Address	Name	Default setting	Data type	Factor	A	M
0x6077	Actual torque	x.x % (Read only)	I16	10	-	●
0x6078	Actual current	x.x % (Read only)	I16	10	-	●
0x6079	DC-bus voltage	x.xxx V (Read only)	U32	1000	-	●
0x607A	Set position	0	I32	1	-	●
0x607E	Polarity	0	U8	1	C	
0x6080	Max. motor speed	6075 rpm	U32	1	-	●
0x6085	Quick stop deceleration	2147483647	U32	1	-	
0x608F:001	Position encoder resolution: Encoder increments	16 bit [65536]	U32		C	
0x608F:002	Position encoder resolution: Motor revolutions	1	U32	1	C	
0x6090:001	Velocity encoder resolution: Encoder increments/s	33554432	U32	1	C	
0x6090:002	Velocity encoder resolution: Motor revolutions/s	125	U32	1	C	
0x60B1	Offset speed	0.00 rpm	I32	480000 / 214748 3647	-	●
0x60B2	Offset torque	0.0 %	I16	10	-	●
0x60B8	Touch probe settings	0x0000	U16		H	●
0x60B9	Touch probe status	- (Read only)	U16		H	●
0x60BA	Touch probe 1: Position at pos. edge	- (Read only)	I32	1	-	●
0x60BB	Touch probe 1: Position at neg. edge	- (Read only)	I32	1	-	●
0x60BC	Touch probe 2: Position at pos. edge	- (Read only)	I32	1	-	●
0x60BD	Touch probe 2: Position at neg. edge	- (Read only)	I32	1	-	●
0x60C0	Interpolation mode	Quadratic [-1]	I16		-	●
0x60C2:001	Interpolation time: Interpolation time mantissa	1	U8	1	-	
0x60C2:002	Interpolation time: Interpolation time exponent	-3	I8	1	-	
0x60E0	Positive torque limit	100.0 %	U16	10	-	●
0x60E1	Negative torque limit	100.0 %	U16	10	-	●
0x60F4	Following error actual value	- (Read only)	I32	1	-	●
0x60FA	Control effort	rpm (Read only)	I32	480000 / 214748 3647	-	●
0x60FC	Position demand internal value	- (Read only)	I32	1	-	
0x60FD	Digital input status	- (Read only)	U32		H	●
0x60FF	Set speed	0.00 rpm	I32	480000 / 214748 3647	-	●
0x6404	Motor manufacturer	"Lenze"	STRING[50]		-	
0x6502	Supported drive modes	- (Read only)	U32		H	
0x67FF	Device profile number	- (Read only)	U32	1	-	
0xE600:001	FSoE Slave Frame Elements: Command	- (Read only)	U8	1	-	●
0xE600:002	FSoE Slave Frame Elements: Connection ID	- (Read only)	U16	1	-	●
0xE600:003	FSoE Slave Frame Elements: CRC_0	- (Read only)	U16	1	-	●
0xE600:004	FSoE Slave Frame Elements: CRC_1	- (Read only)	U16	1	-	●
0xE600:005	FSoE Slave Frame Elements: CRC_2	- (Read only)	U16	1	-	●
0xE600:006	FSoE Slave Frame Elements: CRC_3	- (Read only)	U16	1	-	●
0xE600:007	FSoE Slave Frame Elements: CRC_4	- (Read only)	U16	1	-	●
0xE600:008	FSoE Slave Frame Elements: CRC_5	- (Read only)	U16	1	-	●
0xE600:009	FSoE Slave Frame Elements: CRC_6	- (Read only)	U16	1	-	●
0xE700:001	FSoE Master Frame Elements: Command	- (Read only)	U8	1	-	●
0xE700:002	FSoE Master Frame Elements: Connection ID	- (Read only)	U16	1	-	●
0xE700:003	FSoE Master Frame Elements: CRC_0	- (Read only)	U16	1	-	●
0xE700:004	FSoE Master Frame Elements: CRC_1	- (Read only)	U16	1	-	●
0xE901:001	FSoE Connection Communication Parameter: Version	- (Read only)	STRING[2]		-	



Address	Name	Default setting	Data type	Factor	A	M
0xE901:002	FSoE Connection Communication Parameter: Safety address	- (Read only)	U16	1	-	
0xE901:003	FSoE Connection Communication Parameter: Connection ID	- (Read only)	U16	1	-	
0xE901:004	FSoE Connection Communication Parameter: Watchdog Time	- (Read only)	U16	1	-	
0xE901:006	FSoE Connection Communication Parameter: Connection Type	- (Read only)	U16		-	
0xE901:007	FSoE Connection Communication Parameter: Communication Parameter Length	- (Read only)	U16	1	-	
0xE901:008	FSoE Connection Communication Parameter: Application Parameter Length	- (Read only)	U16	1	-	
0xEA00:001	FSoE Connection Diagnosis: Connection State	- (Read only)	U16		-	
0xF980:001	Safety addresses: FSoE address	- (Read only)	U16	1	-	
0xF980:002	Safety addresses: Safety address	1	U16	1	-	



19.2 Glossary

Definitions in functional safety

Abbreviation	Meaning
AIE	Acknowledge In Error, error acknowledgement
AIS	Acknowledge In Stop, restart acknowledgement
OFF state	Triggered signal status of the safety sensors
CCF	Common Cause Error (also β -value)
EC_FS	Error Class Fail Safe
EC_SS1	Error Class Safe Stop 1
EC_SS2	Error Class Safe Stop 2
EC_STO	Error Class Safe Torque Off Stop 0
ON state	Signal status of the safety sensors in normal operation
FIT	Failure In Time, 1 FIT = 10^{-9} Error/h
FMEA	Failure Mode and Effect Analysis
FSoE	FailSafe over EtherCAT
GSDML	Device description file with PROFINET-specific data to integrate the configuring software of a PROFINET controller.
HFT	Hardware Failure Tolerance
Cat.	Category according to EN ISO 13849-1
nBD	Speed value Base-Drive, internally determined actual speed from standard application
nSD	Safe-Drive speed value, internally determined actual speed from the safety application
n_safe	Actual speed determined from validation of nBD and nSD. Enters the further processing of the speed-dependent safety functions.
OSSD	Output Signal Switching Device, tested signal output
pBD	Base-Drive position value, internally determined actual position from standard application
pSD	Safe-Drive position value, internally determined actual position from the safety application
p_safe	Actual position determined from validation of pBD and pSD. Enters the further processing of the position-dependent safety functions.
PELV	Protective Extra Low Voltage
PL	Performance Level according to EN ISO 13849-1
PM	Plus-Minus – switched signal paths
PP	Plus-Plus – switched signal paths
PS	PROFIsafe
PWM	Pulse Width Modulation
SCS	Safe Creeping Speed
SD-In	Safe Digital Input
SD-Out	Safe Digital Output
SELV	Safety Extra Low Voltage
SFF	Safe Failure Fraction
SIL	Safety Integrity Level according to EN IEC 61508

