



Inverter

i950 cabinet inverter 0.55 ... 110 kW

Contents

1	About this document	13
1.1	Document description	13
1.2	Further documents	13
1.3	Notations and conventions	14
2	Safety instructions	15
2.1	Basic safety instructions	15
2.2	Application as directed	16
2.3	Handling	16
2.4	Residual hazards	17
3	Product information	19
3.1	Identification of the products	19
3.1.1	Product codes	19
3.1.2	Nameplates	20
3.2	Features	21
4	Electrical installation	27
4.1	Important notes	27
4.2	Connection to the IT system	27
4.3	Networks	27
4.3.1	EtherCAT	27
4.3.2	EtherCAT system bus	27
5	Commissioning	28
5.1	Important notes	28
5.2	Operating interfaces	29
5.2.1	Engineering tool »EASY Starter«	30
5.2.1.1	Generate a connection between inverter and »EASY Starter«	31
5.3	General information on parameter setting	32
5.3.1	Addressing of the parameters	32
5.3.2	Structure of the parameter descriptions	32
5.3.3	Parameter overview lists	32
5.3.4	Favorites	33
5.3.4.1	Configuring the "Favorites"	33
5.4	Commissioning	36
5.4.1	UMCLN_SGG_001450	37
5.5	Saving the parameter settings	39
5.5.1	Save parameter settings with »EASY Starter«	39
6	Basic setting	40
6.1	Device name	40
6.2	Mains voltage	40
6.3	Function assignment of the inputs and outputs (default setting)	40
6.4	Motor data	41
6.4.1	Select motor from motor catalog	42
6.4.2	Manual setting of the motor data	44
6.5	Motor control mode	46
7	Start, stop and rotating direction commands	47
7.1	Control selection	47

Contents

8	Configure position control	48
8.1	Basic setting	49
8.1.1	Following error detection and in-position detection	50
8.1.2	Interpolation	51
8.2	Operating mode "CiA 402 cyclic sync position mode (csp)"	52
8.2.1	Default mapping	52
8.2.2	Signal flow	53
8.2.3	Control commands and status information	55
8.3	Process input data (CiA 402 objects)	55
8.4	Process output data (CiA 402 objects)	55
8.5	Monitoring the position error	56
8.6	Position detection with touch probe (TP)	57
8.6.1	Default mapping	57
8.6.2	General mode of operation	58
8.6.3	Filtering of the touch probe signal	58
8.6.4	Compensation of runtime delays	59
8.6.5	Touch probe control word	60
8.6.6	Touch probe status word	60
8.6.7	Extension for the digital inputs DI3 and DI4	61
8.6.8	Detected time stamp and positions	61
8.7	Setpoint diagnostics	62
9	Configure speed control	63
9.1	Basic setting	63
9.2	Operating mode "CiA 402 velocity mode (vl)"	64
9.2.1	Default mapping	64
9.2.2	Signal flow (servo control)	65
9.2.3	Signal flow (V/f characteristic control)	67
9.2.4	UMCLN_SGG_001435	69
9.2.5	UMCLN_SGG_001436	69
9.3	Operating mode "CiA 402 cyclic sync velocity mode (csv)"	70
9.3.1	Default mapping	70
9.3.2	Signal flow (servo control)	71
9.3.3	Signal flow (V/f characteristic control)	73
9.3.4	Control commands and status information	75
9.4	Process input data (CiA 402 objects)	75
9.5	Process output data (CiA 402 objects)	75
9.6	Monitoring the speed deviation	76
10	Configuring the torque control	77
10.1	Basic setting	78
10.1.1	Torque limits	79
10.1.2	Speed limitation	80
10.2	Operating mode "CiA 402 cyclic sync torque mode (cst)"	81
10.2.1	Default mapping	81
10.2.2	Signal flow	82
10.2.3	Control commands and status information	84
10.3	Process input data (CiA 402 objects)	84
10.4	Process output data (CiA 402 objects)	84
10.5	Setpoint diagnostics	84

11	Configuring the feedback system	85
11.1	Configure feedback system for motor control	86
11.1.1	General settings	87
11.1.2	Resolver settings	89
11.1.2.1	Resolver error compensation	90
11.1.3	Encoder settings	92
11.1.3.1	SinCos encoder	93
11.1.3.2	SinCos absolute value encoder with HIPERFACE® protocol	93
11.1.3.3	SSI encoder	95
11.1.3.4	One cable technology (OCT) via HIPERFACE DSL®	97
11.1.3.5	Evaluation of the signal quality	98
11.1.4	Detection of changed settings of the feedback system	99
11.1.5	Diagnostics	99
11.2	Second feedback system for the technology application	100
11.2.1	General settings	100
11.2.2	Resolver settings	101
11.2.2.1	Resolver error compensation	102
11.2.3	Encoder settings	104
11.2.3.1	SinCos encoder	105
11.2.3.2	SinCos absolute value encoder with HIPERFACE® protocol	105
11.2.3.3	SSI encoder	107
11.2.3.4	Evaluation of the signal quality	109
11.2.4	Detection of changed settings of the feedback system	110
11.2.5	Diagnostics	110
11.3	Encoder: Evaluation of safely speed and position	111
11.4	Synchronous motor: Pole position identification (PPI)	112
11.4.1	Monitoring the pole position identification	113
11.4.2	Pole position identification (PPI) 360°	114
11.4.3	Pole position identification (PPI) with minimum movement	118
11.4.4	Pole position identification (PPI) without movement	121
11.5	Cable check	123

Contents

12	Configuring the motor control	127
12.1	Servo control for synchronous motor (SC-PSM)	128
12.1.1	Required commissioning steps	128
12.2	Servo control for asynchronous motor (SC-ASM)	129
12.2.1	Required commissioning steps	129
12.3	Sensorless control for synchronous motor (SL-PSM)	129
12.3.1	Required commissioning steps	129
12.4	V/f characteristic control for asynchronous motor (VFC open loop)	130
12.4.1	Required commissioning steps	130
12.4.2	Basic setting	131
12.4.3	Define V/f characteristic shape	132
12.4.3.1	Linear V/f characteristic	132
12.4.3.2	Square-law V/f characteristic	132
12.4.3.3	User-definable V/f characteristic	132
12.4.4	Activate voltage vector control (I _{min} controller)	133
12.4.5	Set voltage boost	134
12.4.6	Set load adjustment	135
12.4.7	Set slip compensation	135
12.4.8	Set oscillation damping	136
12.4.9	Optimising the stalling behaviour	137
12.4.10	Flying restart circuit	138
12.5	Parameterisable motor functions	140
12.5.1	DC braking	140
12.5.2	Short-circuit braking	141
12.5.3	Holding brake control	142
12.5.3.1	Basic setting	143
12.5.3.2	Brake holding load	144
12.5.3.3	Torque feedforward control	145
12.5.3.4	Manual brake control	145
12.5.3.5	Reduction of brake supply voltage	145
12.6	Options for optimizing the control loops	146
12.6.1	Automatic motor identification (energized)	146
12.6.2	Tuning of the motor and the speed controller	147
12.6.3	Inverter characteristic	149
12.6.3.1	Compensating for inverter influence	150
12.6.3.2	Extended settings for identification	151
12.6.3.3	Load standard inverter characteristic	151
12.6.4	Motor equivalent circuit diagram data	152
12.6.5	Motor control settings	153
12.6.5.1	Speed controller	153
12.6.5.2	Current controller	156
12.6.5.3	ASM field controller	159
12.6.5.4	ASM field weakening controller	160
12.6.5.5	ASM field weakening controller (extended)	160
12.6.5.6	PSM field weakening controller	161
12.6.5.7	I _{max} controller	162
12.6.5.8	Flying restart controller	162
12.6.5.9	Position controller	163

12.7	Fine adjustment of the motor model	164
12.7.1	Correction of the stator leakage inductance (L _{ss}).....	165
12.7.2	Synchronous motor (SM): Compensate temperature and current influences	170
12.7.3	Asynchronous motor (ASM): Identify L _h saturation characteristic.....	171
12.7.4	Estimate optimum magnetising current.....	173
12.8	Parameterise filter elements in the setpoint path	174
12.8.1	Jerk limitation.....	174
12.8.2	Notch filter (band-stop filter).....	175
12.9	Motor protection	178
12.9.1	Motor overload monitoring (i ² *t)	178
12.9.1.1	Parameters for the thermal model.....	180
12.9.1.2	Speed-dependent evaluation of the motor current.....	182
12.9.1.3	UL 508-compliant motor overload monitoring.....	185
12.9.2	Motor temperature monitoring.....	186
12.9.2.1	Individual characteristic for motor temperature sensor	188
12.9.3	Overcurrent monitoring.....	188
12.9.4	Motor phase failure detection	189
12.9.5	Motor speed monitoring	189
12.10	Frequency and speed limitations.....	190
12.11	Testing the motor control.....	191
12.11.1	General settings for test modes	191
12.11.2	Manual "tension/frequency" test mode	193
12.11.3	Manual "current/frequency" test mode.....	194
12.11.4	Manual "current pulse" test mode.....	195
13	I/O extensions and control connections.....	197
13.1	Configure digital inputs.....	197
13.2	Configure analog inputs.....	200
13.2.1	Analog input 1	200
13.3	Configure digital outputs.....	202
13.3.1	Digital output 1.....	202
13.3.2	Digital output 2.....	203
13.3.3	Digital output 3.....	203
13.3.4	Digital output 4.....	203
13.3.5	Digital output 5.....	203
13.3.6	Digital output 6.....	203
14	Configure engineering port	204
14.1	Basic setting.....	205
14.2	NTP server addresses.....	206
14.3	Diagnostics	206

Contents

15	Configuring the network	207
15.1	CiA 402 device profile	208
15.1.1	Supported operating modes	208
15.1.2	Basic setting	209
15.1.3	Process input data	209
15.1.4	Process output data	209
15.1.5	Commands for device state control	210
15.1.5.1	Switch on	211
15.1.5.2	Enable operation	212
15.1.5.3	Activate quick stop	213
15.1.5.4	Pulse inhibit	214
15.1.5.5	Reset fault	215
15.1.6	Device states	216
15.1.6.1	Not ready to switch on	218
15.1.6.2	Switch-on inhibited	219
15.1.6.3	Ready to switch on	220
15.1.6.4	Switched on	221
15.1.6.5	Operation enabled	222
15.1.6.6	Quick stop active	223
15.1.6.7	Fault reaction active	224
15.1.6.8	Trouble	225
15.2	EtherCAT	226
15.2.1	Commissioning	227
15.2.2	Basic setting and options	228
15.2.2.1	Synchronisation with "distributed clocks" (DC)	228
15.2.2.2	Parameterising additional functions	228
15.2.3	Process data transfer	231
15.2.3.1	Standard mapping	231
15.2.3.2	Dynamic (free) configuration	232
15.2.3.3	Further communication objects	232
15.2.3.4	Expert settings	232
15.2.4	Parameter data transfer	233
15.2.5	Monitoring	233
15.2.6	Diagnostics	234
15.2.6.1	LED status display	234
15.2.6.2	Information on the network	234
15.2.6.3	EtherCAT master diagnostics	236
15.2.6.4	Error history buffer	245
15.2.6.5	Device identification	245
15.2.7	EoE communication	246

15.3	PROFINET.....	247
15.3.1	Commissioning.....	248
15.3.1.1	Settings in the »EASY Starter«.....	248
15.3.1.2	Restarting or stopping the communication.....	249
15.3.1.3	Settings in the Siemens »TIA Portal«.....	249
15.3.1.4	Device description file.....	250
15.3.1.5	Establishing a connection to the »EASY Starter« via PROFINET.....	250
15.3.2	Basic setting and options.....	251
15.3.2.1	Station name and IP configuration.....	251
15.3.2.2	Suppress diagnostic messages to the IO controller.....	252
15.3.3	Process data transfer.....	252
15.3.4	Parameter data transfer.....	253
15.3.5	Monitoring.....	254
15.3.6	Diagnostics.....	255
15.3.6.1	LED status display.....	255
15.3.6.2	Information on the network.....	255
15.3.7	PROFIsafe.....	257
15.3.8	PROFIenergy.....	258
15.3.8.1	Supported commands.....	258
15.3.8.2	Supported measured values.....	258
15.4	EtherCAT system bus.....	259
15.4.1	Commissioning.....	261
15.4.2	Basic setting and options.....	262
15.4.3	Process data transfer.....	263
15.4.3.1	Process output data.....	264
15.4.3.2	Process input data.....	264
15.4.4	Monitoring.....	265
15.4.5	Diagnostics.....	266
15.4.5.1	LED status displays.....	266
15.4.5.2	Information on the network.....	266
15.4.5.3	Device identification.....	268

Contents

16 Device functions	270
16.1 Optical device identification.....	270
16.2 Reset parameters to default.....	271
16.3 Saving/loading the parameter settings.....	272
16.4 Enabling the device.....	273
16.5 Restart device.....	273
16.6 Start/stop application.....	273
16.7 Restarting Extended Safety.....	274
16.8 Export logbook.....	274
16.9 Delete logbook files.....	274
16.10 Activate loaded application.....	274
16.11 Uploading the application.....	275
16.12 Inverter control word.....	275
16.13 Access protection.....	275
16.13.1 Brand protection.....	275
16.14 Switching frequency changeover.....	276
16.15 Device overload monitoring (i*t).....	277
16.16 Heatsink temperature monitoring.....	278
16.17 Update device firmware.....	278
16.17.1 Firmware download with »EASY Starter (firmware loader)«.....	278
16.17.1.1 Download via Ethernet connection.....	278
17 Additional functions	279
17.1 Brake energy management.....	279
17.1.1 Use of a brake resistor.....	279
17.2 Manual jog parameters.....	280
17.3 Mains failure control.....	281
17.4 Oscilloscope function.....	282

18 Safety functions	291
18.1 Safe torque off (STO).....	292
18.2 Safe stop emergency (SSE)	294
18.3 Safe stop 1 (SS1)	295
18.4 Safe stop 2 (SS2)	298
18.5 Ramp monitoring.....	301
18.6 Safe operating stop (SOS).....	303
18.7 Safe maximum speed (SMS).....	305
18.8 Safely-limited speed (SLS)	306
18.9 Safe speed monitor (SSM).....	312
18.10 Safely-limited increment (SLI).....	313
18.11 Safe direction (SDI).....	315
18.12 Safely-limited position (SLP).....	317
18.13 Position-dependent safe speed (PDSS).....	320
18.14 Safe homing (SHOM).....	323
18.15 Mini-homing.....	326
18.16 Safe cam (SCA).....	327
18.17 Operation mode selector (OMS)	329
18.18 Enable switch (ES).....	332
18.19 Repair mode selector (RMS).....	333
18.20 STO cascading (CAS).....	335
18.21 Safe brake control (SBC).....	336
18.22 Safe muting (MUT).....	338
18.23 Safe network interfaces	340
18.23.1 FSoE connection	341
18.24 Connection to the applications	345
18.24.1 Inputs.....	345
18.24.2 Outputs	346
18.24.3 Control signals.....	346
18.24.4 Status signals.....	348
18.25 Safe parameter setting.....	353
18.25.1 Safety address	353
18.25.2 Parameter set information.....	353
18.26 Response times.....	354
18.27 Diagnostics	358
18.27.1 LED status display.....	358
18.27.1.1 LED status during parameter set transfer	358
18.27.2 Error history buffer	358
18.27.3 Diagnostic parameters.....	360

Contents

19	Diagnostics and fault elimination	361
19.1	LED status display	361
19.2	Logbook	362
19.3	Diagnostic parameters	363
19.3.1	Inverter diagnostics	365
19.3.2	Motor diagnostics	368
19.3.3	Network diagnostics	368
19.3.4	I/O diagnostics	370
19.3.4.1	Digital inputs and outputs	370
19.3.4.2	Analog inputs and outputs	371
19.3.5	Diagnostics of the application	371
19.3.6	Service life diagnostics	371
19.3.7	Device identification	372
19.4	Error handling	373
19.4.1	Error types	373
19.4.1.1	Timeout for error response	373
19.4.2	Error configuration	373
19.4.3	Error reset	374
19.5	Error codes, causes and remedies	375
20	Technical data	436
20.1	Standards and operating conditions	436
20.1.1	Conformities and approvals	436
20.1.2	Protection of persons and device protection	436
20.1.3	EMC data	436
20.1.4	Motor connection	437
20.1.5	Environmental conditions	437
20.1.6	Electrical supply conditions	437
20.2	3-phase mains connection 400 V	438
20.2.1	Rated data	438
20.3	3-phase mains connection 480 V	440
20.3.1	Rated data	440
21	Appendix	442
21.1	Parameter attribute list	442
21.2	Glossary	472



1 About this document

WARNING!

Read this documentation carefully before starting any work.

► Please observe the safety instructions!

1.1 Document description

This documentation is valid up to firmware version:

Firmware version	Software data version	Date
V_1_3_7	V_1_3_7_001	2019-06-07

1.2 Further documents

For certain tasks, information is available in further documents.

Document	Contents/topics
Configuration document	Basic information on project planning and ordering the product
Commissioning document	Fundamental information for the installation and commissioning of the product

For certain tasks, information is available in other media.

Form	Contents/topics
Engineering Tools	For commissioning
AKB articles	Additional technical information for users in the Application Knowledge Base
CAD data	Download in different formats from the EASY Product Finder
EPLAN macros	Project planning, documentation and management of projects for EPLAN P8.

These media can be found here: Lenze.com



Information and tools with regard to the Lenze products can be found on the Internet: www.Lenze.com → Downloads





About this document

Notations and conventions



1.3 Notations and conventions

This document uses the following conventions to distinguish different types of information:

Numeric notation			
	Decimal separator	Point	The decimal point is always used. Example: 1 234.56
Warning			
	UL warning	UL	Are used in English and French.
	UR warning	UR	
Text			
	Engineering tools	» «	Software Example: »Engineer«, »EASY Starter«
Icons			
	Page reference		Reference to another page with additional information Example:  16 = see page 16
	Documentation reference		Reference to another documentation with additional information Example:  EDKxxx = see documentation EDKxxx

Layout of the safety instructions

DANGER!

Indicates an extremely hazardous situation. Failure to comply with this instruction will result in severe irreparable injury and even death.

WARNING!

Indicates an extremely hazardous situation. Failure to comply with this instruction may result in severe irreparable injury and even death.

CAUTION!

Indicates a hazardous situation. Failure to comply with this instruction may result in slight to medium injury.

NOTICE

Indicates a material hazard. Failure to comply with this instruction may result in material damage.



2 Safety instructions

Disregarding the following basic safety measures and safety information may lead to severe personal injury and damage to property!

Observe all specifications of the corresponding documentation supplied. This is the precondition for safe and trouble-free operation and for obtaining the product features specified.

Please observe the specific safety information in the other sections!

2.1 Basic safety instructions

DANGER!

Danger to life due to electrical voltage!

The product's power connections can still be carrying voltage when the mains supply has been switched off.

Possible consequences: Death, severe injury, or burns

- ▶ Do not touch the power connections immediately.
- ▶ Take note of the corresponding warning plates on the product.
- ▶ Check power terminals for isolation from supply.

DANGER!

Dangerous electrical voltage

Possible consequences: Death or severe injuries from electric shock

- ▶ Any work on the device must only be carried out in a deenergized state.
- ▶ After switching off the mains voltage, observe the signs on the product.

Personnel

The product must only be used by qualified personnel. IEC 60364 or CENELEC HD 384 define the skills of these persons:

- They are familiar with installing, mounting, commissioning, and operating the product.
- They have the corresponding qualifications for their work.
- They know and can apply all regulations for the prevention of accidents, directives, and laws applicable at the place of use.

Process engineering

The procedural notes and circuit details described are only proposals. It is up to the user to check whether they can be adapted to the particular applications. Lenze does not take any responsibility for the suitability of the procedures and circuit proposals described.

Device protection

- The maximum test voltage for insulation tests between a control potential of 24 V and PE must not exceed 110 V DC (EN 61800-5-1).

Safety instructions

Application as directed



2.2 Application as directed

- The product must only be operated under the operating conditions prescribed in this documentation.
- The product meets the protection requirements of 2014/35/EU: Low-Voltage Directive.
- Commissioning or starting the operation as directed of a machine with the product is not permitted until it has been ensured that the machine meets the regulations of the EC Directive 2006/42/EU: Machinery Directive; observe EN 60204-1.
- Commissioning or starting operation as directed is only permissible if the EMC Directive is complied with 2014/30/EU.
- Applied standards and regulations: EN 61800-5-1 and EN 61800-3 .
- The product is not a household appliance, but is only designed as a component for commercial or professional use in terms of EN 61000-3-2.
- Drive systems comply with categories according to EN 61800-3, if the product is used in accordance with the technical data.
- In residential areas, the product may cause EMC interferences. The operator is responsible for taking interference suppression measures.
- The product must only be actuated with motors that are suitable for the operation with inverters.
 - Lenze L-force motors meet the requirements
 - Exception: m240 motors are designed for mains operation only.

2.3 Handling

- Never commission the product in the event of visible damage.
- The product must never be technically modified.
- Never commission the product before assembly has been completed.
- The product must never be operated without required covers.
- Establish, separate and change all electrical connections only in deenergised state!



2.4 Residual hazards

Product

Observe the warning labels on the product!

DANGER!

Danger to life due to electrical voltage!

The product's power connections can still be carrying voltage when the mains supply has been switched off.

Possible consequences: Death, severe injury, or burns

- ▶ Do not touch the power connections immediately.
- ▶ Take note of the corresponding warning plates on the product.
- ▶ Check power terminals for isolation from supply.



Electrostatic sensitive devices:

Before working on the product, the staff must ensure to be free of electrostatic charge!

WARNING!

Dangerous electrical voltage

Device error causes an overvoltage in the system.

- ▶ For a voltage supply with 24 V DC ($\pm 25\%$), use a safely separated power supply unit according to the valid SELV/PELV requirements.

Motor protection

With some settings of the inverter, the connected motor can be overheated.

- E. g. by longer operation of self-ventilated motors at low speed.
- E. g. by longer operation of the DC-injection brake.



Dangerous electrical voltage:

Before working on the product, make sure there is no voltage applied to the power terminals!

After mains disconnection, the power terminals will still carry the hazardous electrical voltage for the time given next to the symbol!



High leakage current:

Carry out fixed installation and PE connection in compliance with:
EN 61800-5-1 / EN 60204-1

Protection of the machine/system

Drives can reach dangerous overspeeds.

- E. g. by setting high output frequencies in connection with motors and machines not suitable for this purpose.
- The inverters do not provide protection against such operating conditions. For this purpose, use additional components.

Switch contactors in the motor cable only if the controller is inhibited.

- Switching while the inverter is enabled is only permissible if no monitoring functions are activated.



Hot surface:

Use personal protective equipment or wait until the device has cooled down!

Motor

If there is a short circuit of two power transistors, a residual movement of up to $180^\circ/\text{number of pole pairs}$ can occur at the motor! (e. g. 4-pole motor: residual movement max. $180^\circ/2 = 90^\circ$).

Safety instructions

Residual hazards



NOTICE

High input voltage at the device.

Destruction of the device.

- ▶ Observe maximum permissible input voltage.
 - ▶ Fuse device at the input against too high input voltage.
-

NOTICE

Short circuit at the device due to electrostatic discharge.

Destruction of the device.

- ▶ The personnel must be free of electrostatic charge prior to working on the device.
-

Degree of protection - protection of persons and device protection

- Information applies to the mounted and ready-for-use state.
- Information does not apply to the wire range of the terminals.
 - Terminals that are not wired have low protection against physical contact.
 - Terminals for large cable cross-sections have lower classes of protection, e. g. from 15 kW IP10 only.



3 Product information

3.1 Identification of the products

In tables, the first 9 digits of the corresponding product code are used to identify the products:

3.1.1 Product codes

		I	9	5	A	E	□□□	F	1	□	□	□	0	□□□□
Product type	Inverter	I												
Product family	i900		9											
Product	i950			5										
Product generation	Generation 1				A									
Mounting type	Control cabinet mounting					E								
Rated power [W]	0.55 kW						155							
	0.75 kW						175							
	2.2 kW						222							
	4.0 kW						240							
	7,5 kW						275							
	11 kW						311							
	15 kW						315							
	22 kW						322							
	30 kW						330							
	45 kW						345							
	55 kW						355							
	75 kW						375							
	90 kW						390							
	110 kW						411							
Mains voltage and connection type	3/PE AC 400 V													
	3/PE 480 V AC							F						
Motor connections	Single axis								1					
Integrated functional safety	Basic Safety STO									A				
	Extended Safety									C				
Enclosure	IP20										0			
	IP20, coated										V			
Interference suppression	Without											0		
	Integrated RFI filter											1		
Design types	Control code											0		□□□□

Product information

Identification of the products
Nameplates



3.1.2 Nameplates

Position and meaning of the nameplates

Complete inverter	Component (options)
<p>① Nameplate at front top: Technical data, type and serial number of the inverter</p>	<p>① Type and serial number of the component</p>
<p>② Nameplate at the side: Technical data of the inverter</p>	<p>-</p>



3.2 Features

Power range 0.55 kW ... 4 kW

PE connection

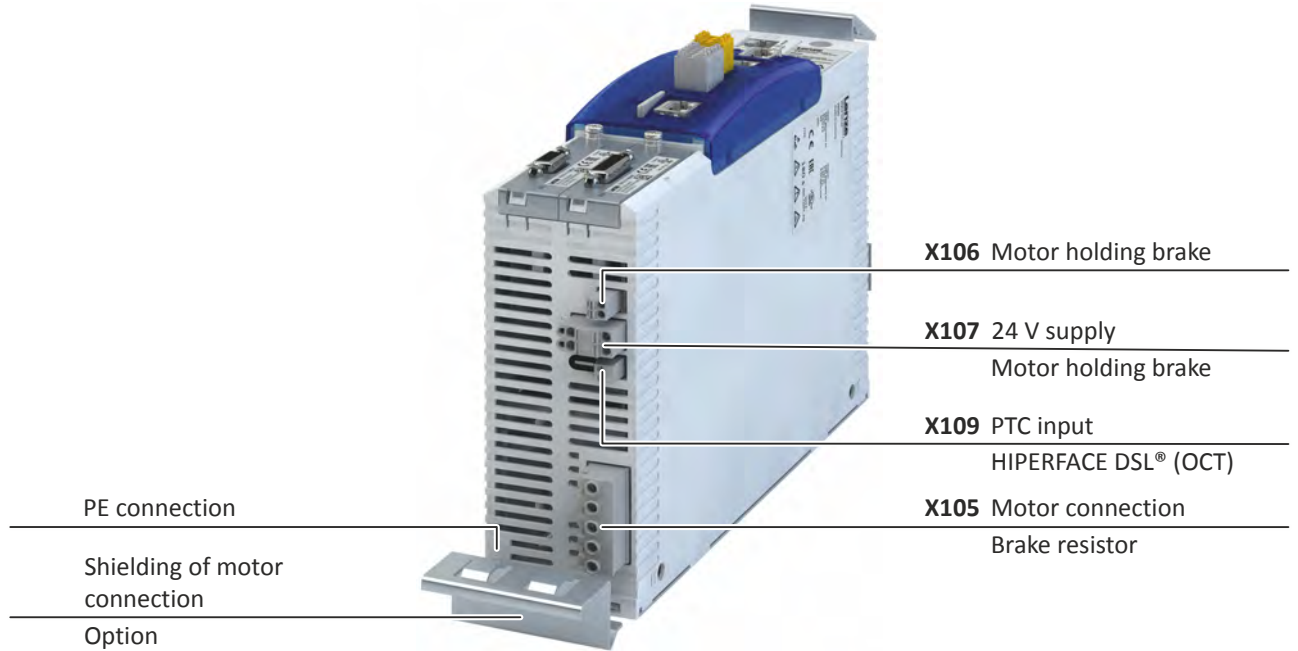
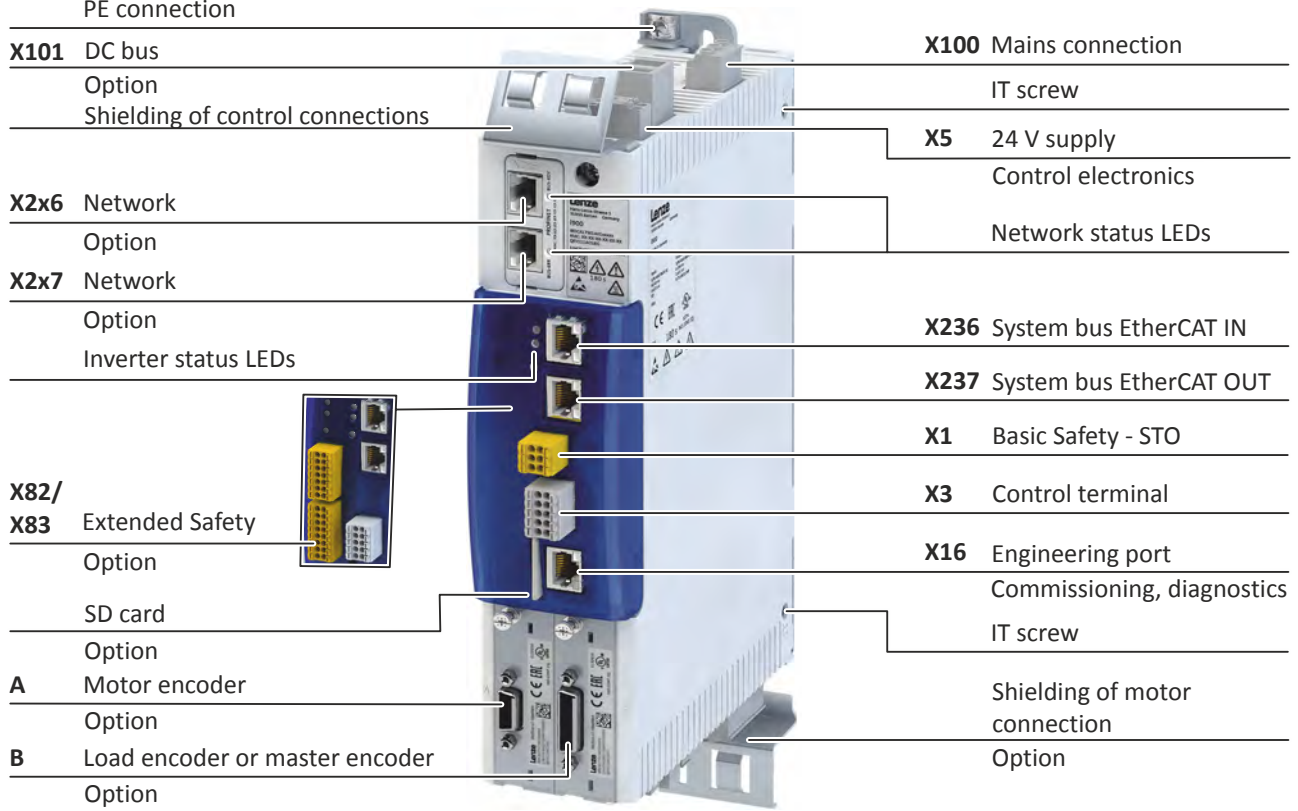

Product information

Features



Power range 7.5 kW ... 15 kW

X100 Mains connection	X101 DC bus
PE connection	Option
Shielding of control connections	X5 24 V supply
	Control electronics
	Network status LEDs
X2x6 Network	
Option	
X2x7 Network	X236 System bus EtherCAT IN
Option	
Inverter status LEDs	X237 System bus EtherCAT OUT
	X1 Basic Safety - STO
X82/ Extended Safety	X3 Control terminal
X83 Option	X16 Engineering port
	Commissioning, diagnostics
	IT screw
SD card	
Option	
A Motor encoder	
Option	
B Load encoder or master encoder	
Option	
	Shielding of motor connection
	Option
X105 Motor connection	X106 Motor holding brake
Brake resistor	
	X107 24 V supply
	Motor holding brake
PE connection	X109 PTC input
Shielding of motor connection	
Option	



Product information

Features

Power range 22 kW

X100 Mains connection/DC bus

PE connection

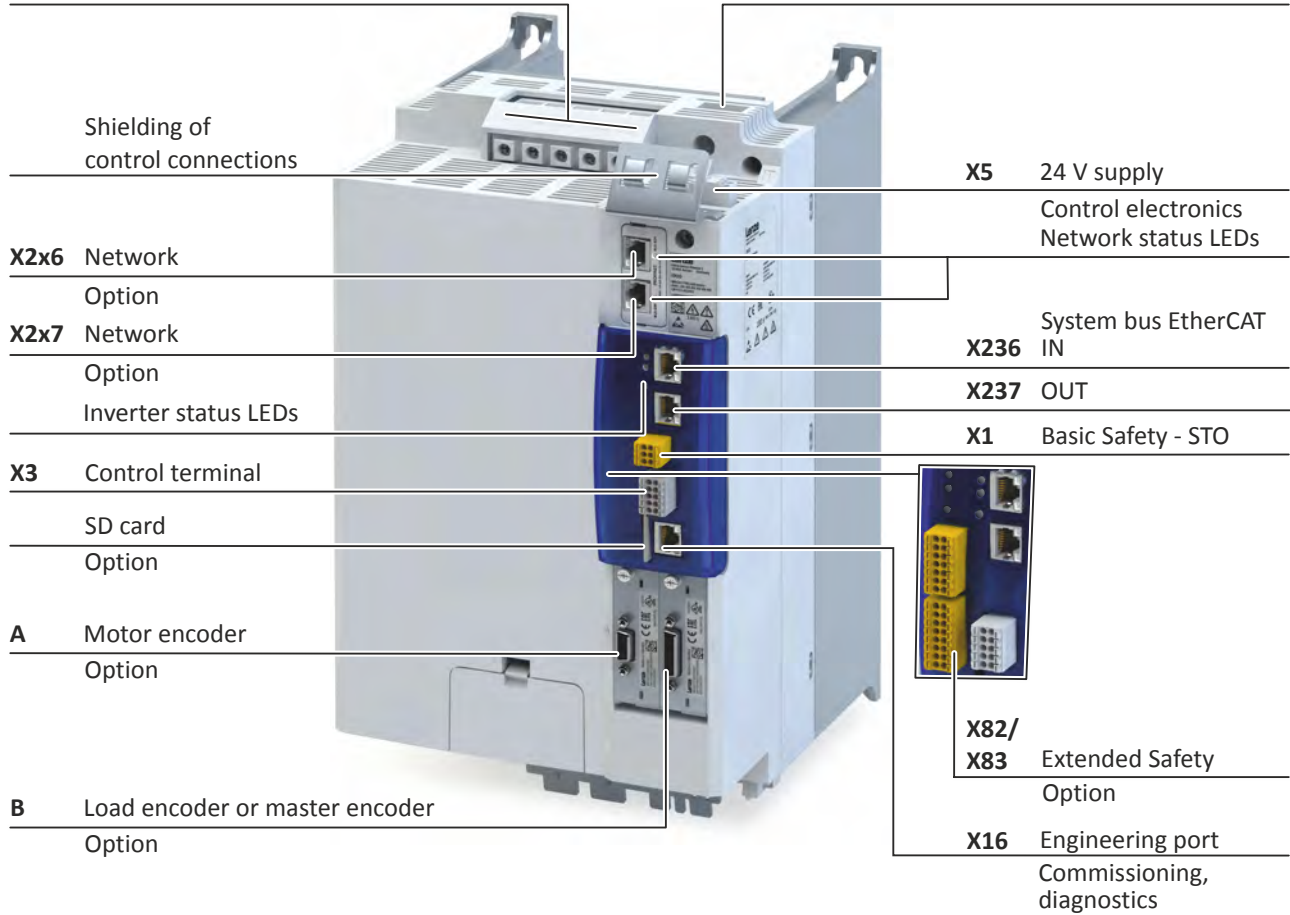

X105 Motor connection

Brake resistor

PE connection

IT screw

Shielding of motor connection

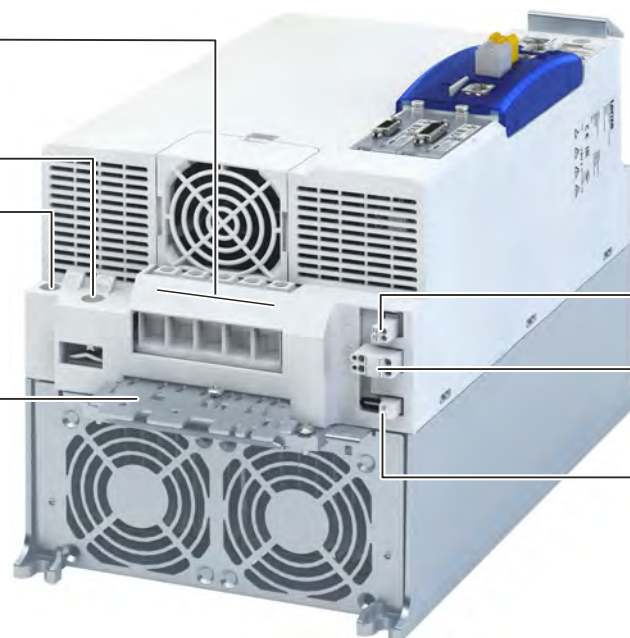

X106 Motor holding brake

X107 24 V supply
Motor holding brake

X109 PTC input

Product information

Features



Power range 30 kW ... 45 kW

X100 Mains connection

Shielding of control connections

PE connection

X5 24 V supply

Control electronics

X2x6 Network

Network status LEDs

Option

X2x7 Network

System bus EtherCAT

Option

Inverter status LEDs

X236

IN

X1 Basic Safety - STO

X237 OUT

SD card

Option

A Motor encoder

Option

B Load encoder or master encoder

Option

X82/

X83

Extended Safety

Option

X3

Control terminal

X16

Engineering port

Commissioning,
diagnostics

X105 Motor connection

Brake resistor

IT screw

PE connection

X106 Motor holding brake

X107 24 V supply

Motor holding brake

Shielding of motor connection

X109 PTC input





Product information

Features

Power range 55 kW ... 75 kW

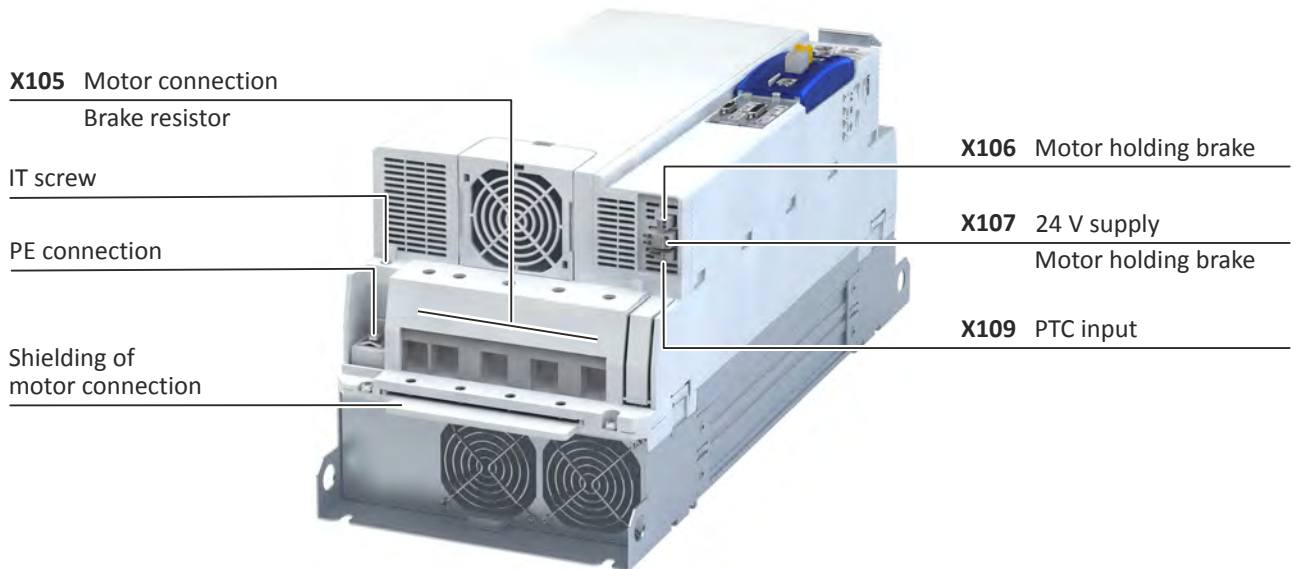
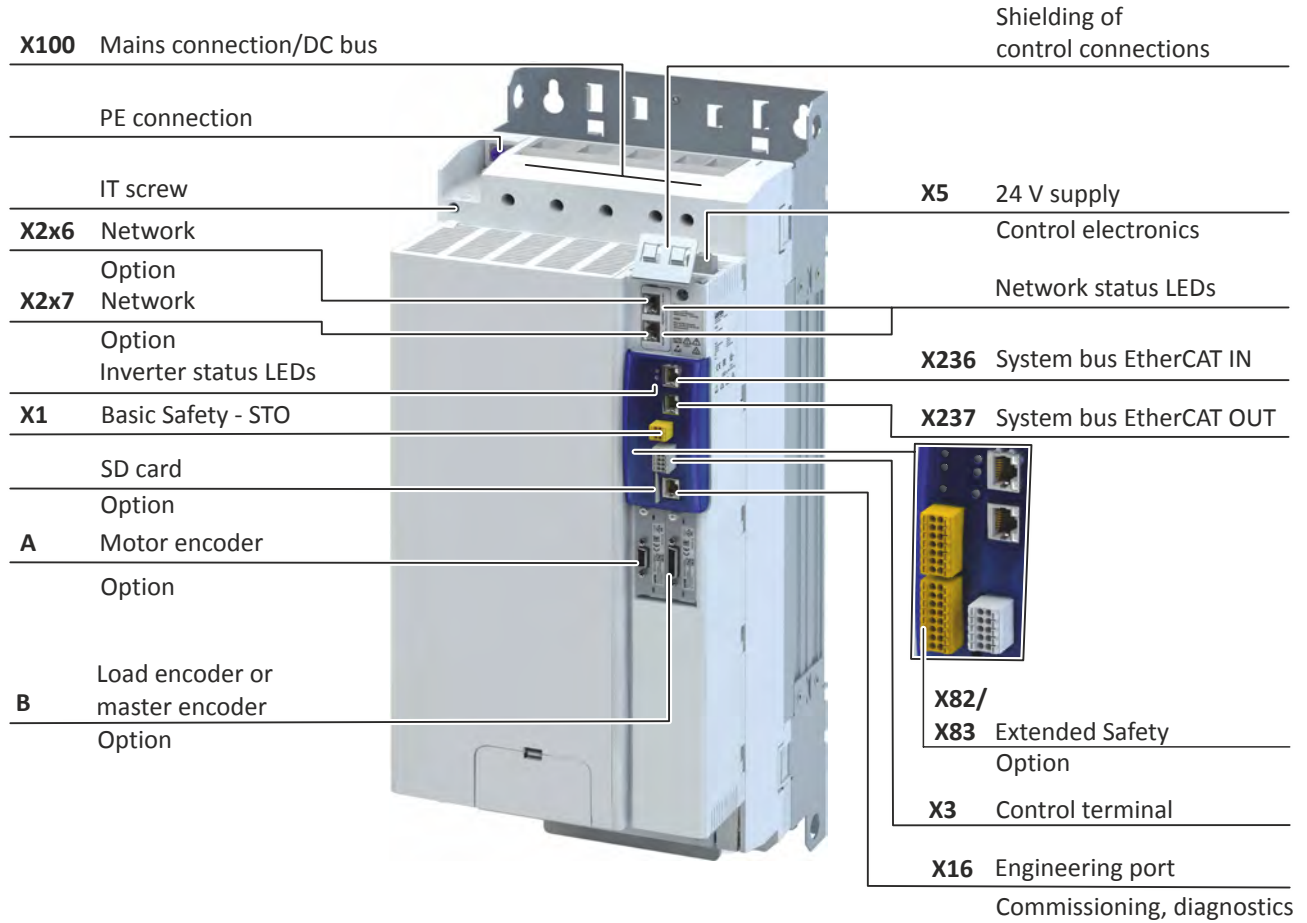

Product information

Features



Power range 90 kW ... 110 kW

X100 Mains connection/DC bus

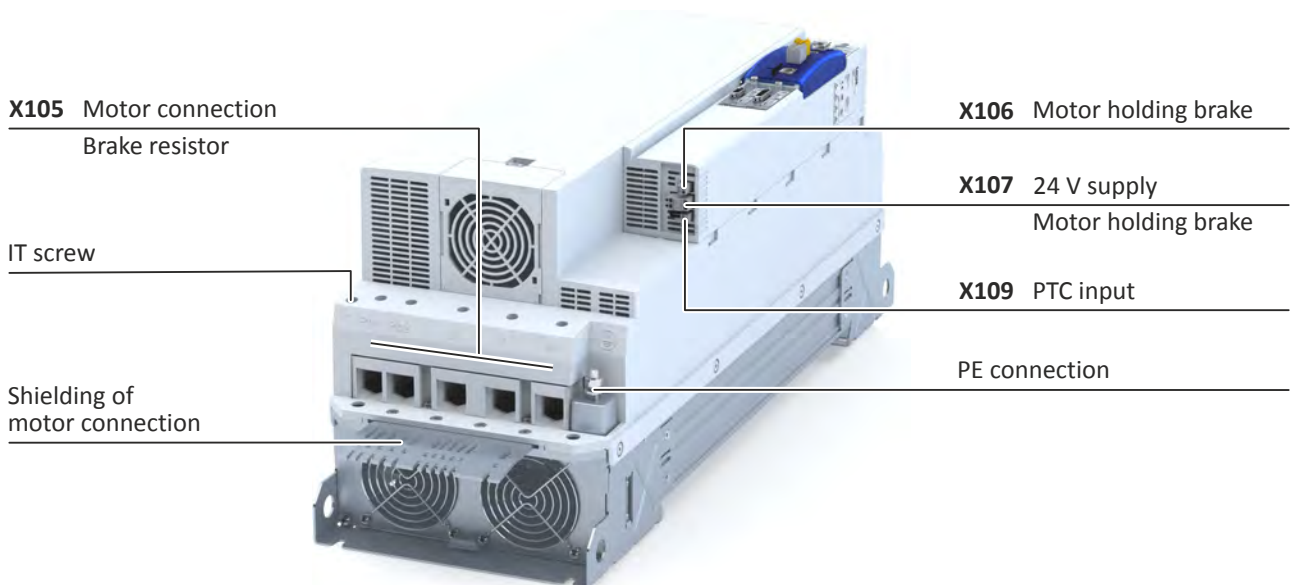
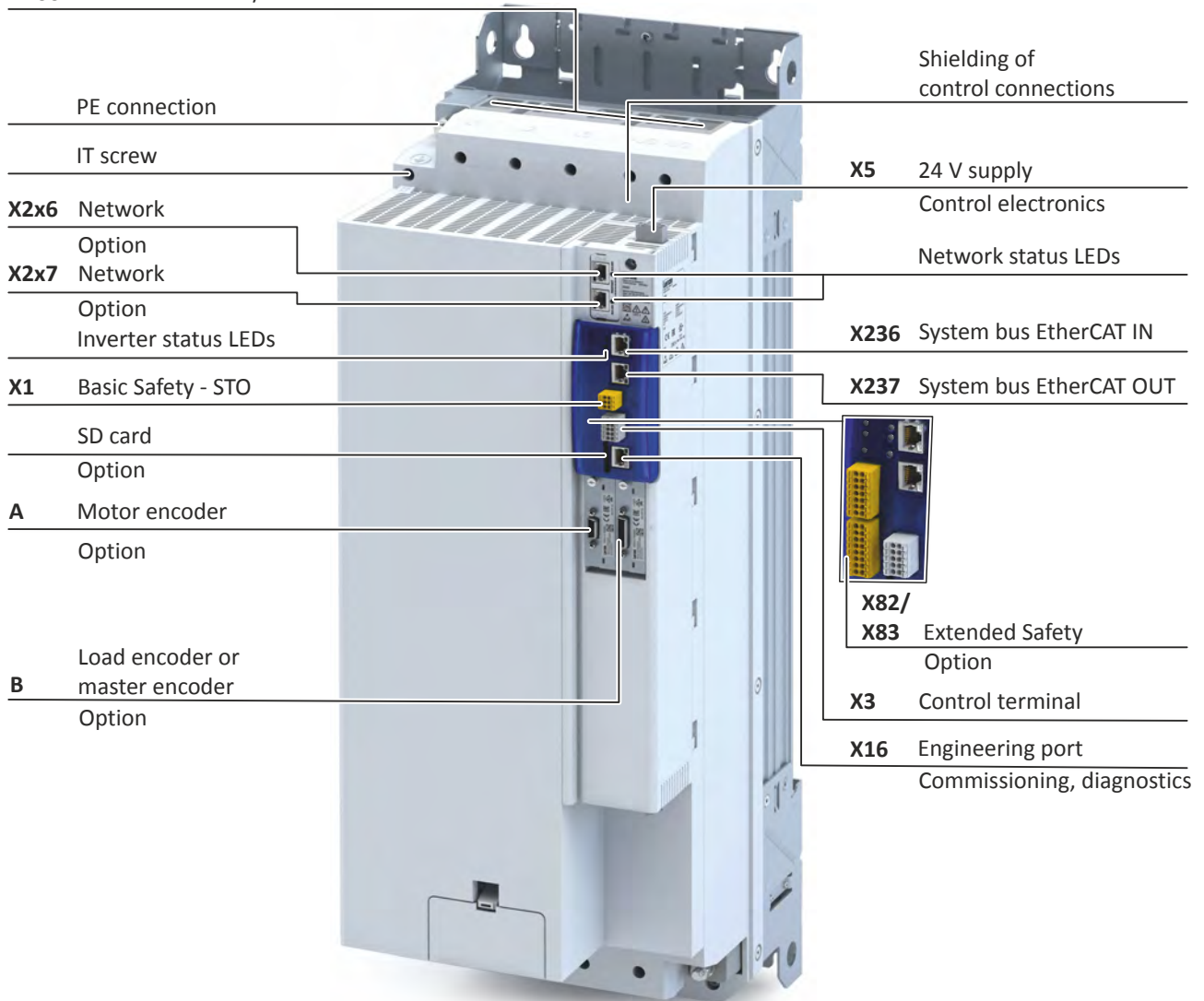



4 Electrical installation

4.1 Important notes

⚠ WARNING!

Dangerous electrical voltage

Device error causes an overvoltage in the system.

- ▶ For a voltage supply with 24 V DC ($\pm 25\%$), use a safely separated power supply unit according to the valid SELV/PELV requirements.

4.2 Connection to the IT system

NOTICE

Internal components have earth/ground potential



Possible consequence: The monitoring devices of the IT system will be triggered.

- ▶ Before connection to an IT system be absolutely sure to remove the screws labeled with "IT" on the product.

4.3 Networks

4.3.1 EtherCAT

LED "L/A"

Blinking pattern	State	Meaning
off	Not connected	Network not available
 on	Connected	Network available No data transfer
 blinking	Traffic	Data transfer

4.3.2 EtherCAT system bus

Typical topologies

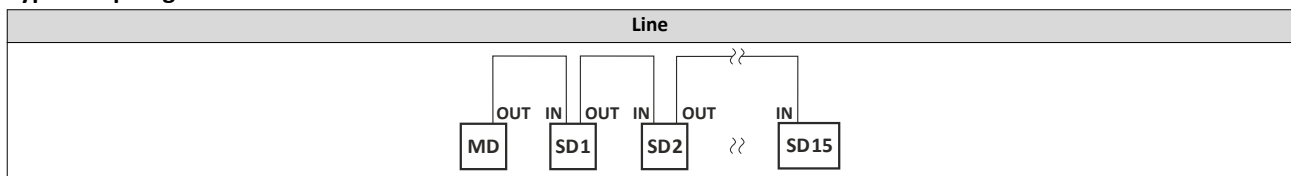

MD Master device

SD Slave Device

Bus-related information			
Name		EtherCAT system bus	
Communication medium		Ethernet 100 Mbps, full duplex	
Use		Connection of the inverter to the system bus cross communication or as standard EtherCAT slave	
Status display		1 LED (RUN)	



5 Commissioning

The purpose of commissioning is to adapt the inverter as part of a machine with a variable-speed drive system to its drive task.

5.1 Important notes

DANGER!

Incorrect wiring can cause unexpected states during the commissioning phase.

Possible consequences: death, severe injuries or damage to property

Ensure the following before switching on the mains voltage:

- ▶ Wiring must be complete and correct.
- ▶ Wiring must be free of short circuits and earth faults.
- ▶ The motor circuit configuration (star/delta) must be adapted to the inverter output voltage.
- ▶ The motor must be connected in-phase (direction of rotation).
- ▶ The "emergency off" function of the overall system must operate correctly.

DANGER!

Incorrect settings during commissioning may cause unexpected and dangerous motor and system movements.

Possible consequences: death, severe injuries or damage to property

- ▶ Clear hazardous area.
- ▶ Observe safety instructions and safety clearances.



5.2 Operating interfaces

Depending on the inverter, there are one or several options for accessing the device parameters that are available for customising the drive task.

Simple access to the device parameters is provided by the Lenze Engineering Tool »EASY Starter«. Connection **X16** is used as an interface for an engineering PC in this case.

If the inverter is equipped with the "PROFINET" network option, the terminals **X2x6** or **X2x7** can also be used.

Commissioning

Operating interfaces
Engineering tool »EASY Starter«



5.2.1 Engineering tool »EASY Starter«

The »EASY Starter« is a PC software that is especially designed for the commissioning and diagnostics of the inverter.

- »EASY Starter« Download

Sample screenshot:

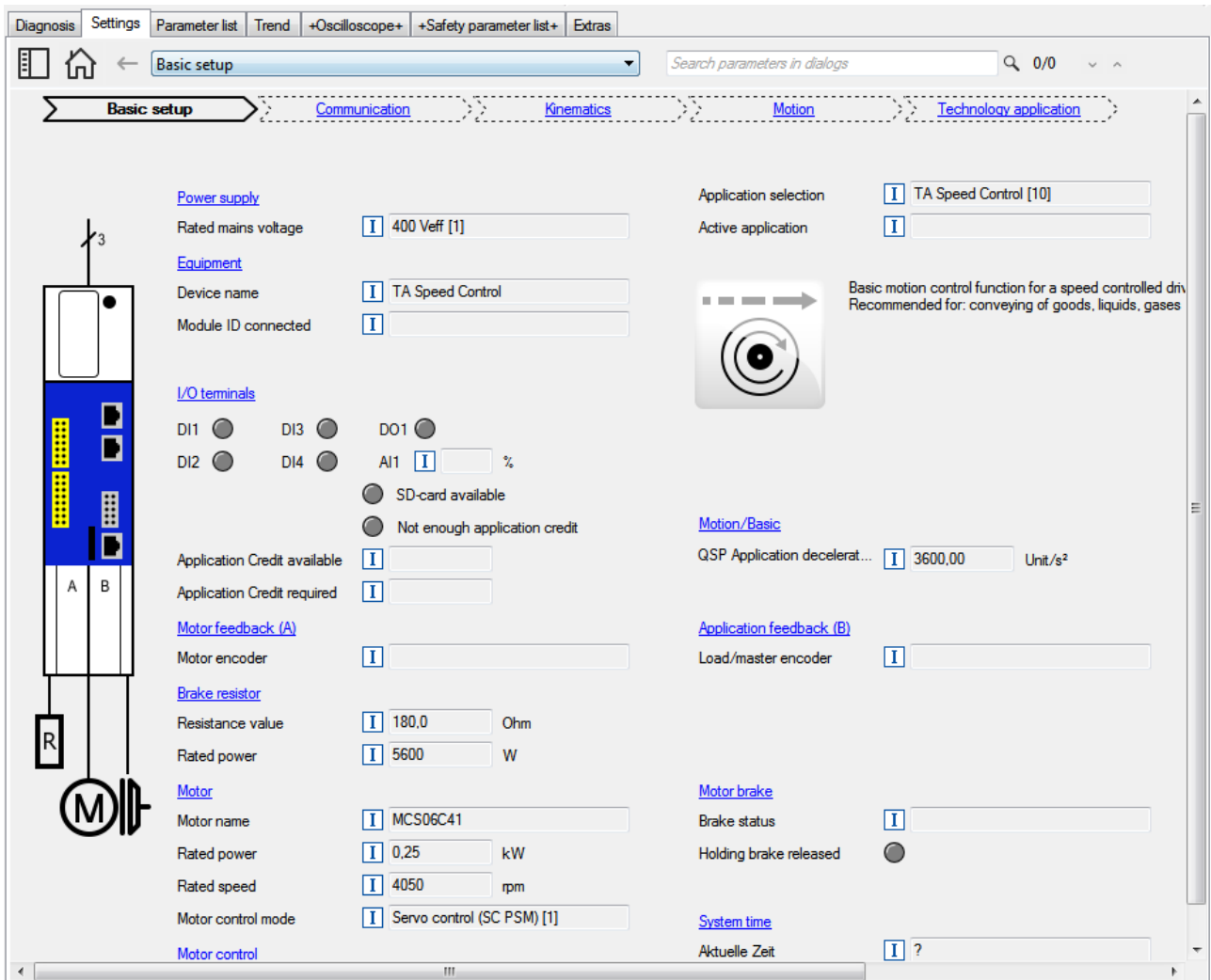

The upper part of the **Settings** tab displays the sequence of five essential commissioning steps. By clicking a link, the corresponding interface appears with the most important parameters to be set.

Commissioning step	Description of the settings
Basic setting	Settings to adapt the inverter to a simple application based on the default setting.
Communication	Settings for communication via the system bus (EtherCAT), another fieldbus and the engineering port X16 (PC interface).
Kinematics	Basic settings of the technology application serve to adapt the motor and load side (gearbox ratio, mounting direction, moment of inertia etc.)
Motion	Basic settings of the technology application for adapting the motion control.
Technology application	Settings to adapt the technology application to the application.

Parameter fields

- The parameters are sorted by topic.
- The parameter values currently set are displayed.
- Fields highlighted in yellow indicate the online connection to the device.
- Pressing the key [F1] opens the program help.



5.2.1.1 Generate a connection between inverter and »EASY Starter«

For commissioning the inverter with the »EASY Starter«, a communication link with the inverter is required. This can be established in a wired manner only.

Additional information on network configuration: [► Configure engineering port](#)  204

Further information on how to create a communication link via "PROFINET":

[► PROFINET](#)  247

How to establish a communication to the inverter via the engineering port X16:

Preconditions

- The functional test described in the mounting and switch-on instructions has been completed successfully (without any errors or faults).
- The inverter is ready for operation (mains voltage is switched on).

Required accessories

- Engineering PC with installed »EASY Starter«
- Standard network cable

1. Plug the network cable into the engineering port **X16** of the inverter.
2. Use the network cable to connect the inverter to the PC on which the »EASY Starter« is installed.
3. Start the »EASY Starter«.
The "Add devices" dialog is shown.
4. Select the "Ethernet" connection.
5. Click the **Insert** button.

The »EASY Starter« searched for connected devices via the communication path selected.

When the connection has been established successfully, the inverter is displayed in the device list. The inverter parameters can now be accessed via the tabs of the »EASY Starter«.

Commissioning

General information on parameter setting
Addressing of the parameters



5.3 General information on parameter setting

The controller can be parameterized in individual functions. The basic structure of the parameters is described in the following. The parameter list of the device is only available after the PLC program has been compiled. This list can be found as a tab under the controller in the PLC project tree of the »PLC-Designer«.



Certain device commands or settings which might cause a critical state of the drive behavior can only be carried out when the device is disabled.

5.3.1 Addressing of the parameters

Each parameter features a 16-bit index as its address. Under this address, the parameter is stored in the object directory of the device.

- Parameters that belong together functionally are combined in a data set. These parameters are additionally provided with an 8-bit subindex.
- The colon is used as a separator between the index and subindex Example: "0x2540:001"
- There are parameter settings that can be changed, and (diagnostic) parameters that can only be read.

5.3.2 Structure of the parameter descriptions

- The parameter descriptions in this documentation are structured in table form.
- The representation distinguishes parameters with a setting range, text, selection list, and bit-coded display.
- The default setting of parameters with a write access feature is shown in **bold**.

Example: parameters with a setting range

Address	Name / setting range / [default setting]	Information
Index:Subindex	Parameter designation Minimum value ... [default setting] ... maximum value • Optional information with regard to the parameter.	Explanations & notes with regard to the parameter.

Example: parameters with a selection list

Address	Name / setting range / [default setting]	Information
Index:Subindex	Parameter designation • Optional information with regard to the parameter.	Explanations & notes with regard to the parameter. Note: The corresponding selection number (here 0, 1, or 2) must be set. Other values are not permissible.
	0 Designation of selection 0	Optionally: Explanations & notes with regard to the corresponding selection.
	1 Designation of selection 1	
	2 Designation of selection 2	The default selection is shown in bold .

Example with bit coded display

Address	Name / setting range / [default setting]	Information
Index:Subindex	Parameter designation • Optional information with regard to the parameter.	Explanations & notes with regard to the parameter.
	Bit 0 Designation of bit 0	Optionally: Explanations & notes with regard to the corresponding bit.
	Bit 1 Designation of bit 1	
	Bit 2 Designation of bit 2	
	
	Bit 15 Designation of bit 15	

5.3.3 Parameter overview lists

[Parameter attribute list](#): contains a list of all inverter parameters. This list in particular includes some information that is relevant for the reading and writing of parameters via the network.

[442](#)



5.3.4 Favorites

In order to gain quick access using the »EASY Starter«, frequently used parameters of the inverter can be defined as "Favorites".

- »EASY Starter« provides quick access to the "Favorites" via the *Favorites* tab.

5.3.4.1 Configuring the "Favorites"

The "Favorites" can be configured by the user.

Details

A maximum number of 50 parameters can be defined as "Favorites".

The easiest way to process the selection of the favorites is via the parameterisation dialog in the »EASY Starter«:

1. Change to the "Parameter list" tab.
2. Select group 0 - Favorites.
3. Click the button.
4. Process favorites:

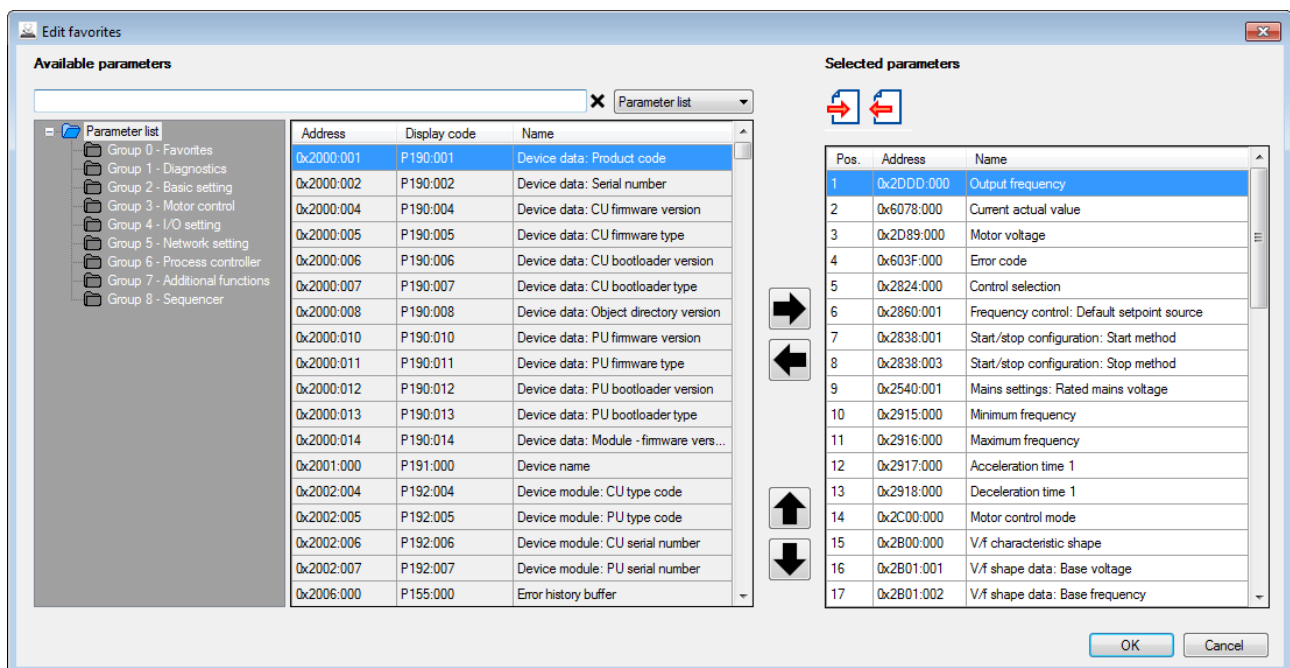

Default favorites can be changed via network using the following parameters:

Parameter

Address	Name / setting range / [default setting]	Information
0x261C:001	Favorites settings: Parameter 1 0 ... [] ... 4294967295	Definition of the "Favorites" parameters. <ul style="list-style-type: none"> • Format: 0xiiiiSS00 (iiii = hexadecimal index, SS = hexadecimal subindex) • The lowest byte is always 0x00. • The keypad can be used to select the desired parameter from a list.
0x261C:002	Favorites settings: Parameter 2 0 ... [] ... 4294967295	
0x261C:003	Favorites settings: Parameter 3 0 ... [] ... 4294967295	
0x261C:004	Favorites settings: Parameter 4 0 ... [] ... 4294967295	
0x261C:005	Favorites settings: Parameter 5 0 ... [] ... 4294967295	
0x261C:006	Favorites settings: Parameter 6 0 ... [] ... 4294967295	
0x261C:007	Favorites settings: Parameter 7 0 ... [] ... 4294967295	
0x261C:008	Favorites settings: Parameter 8 0 ... [] ... 4294967295	
0x261C:009	Favorites settings: Parameter 9 0 ... [] ... 4294967295	

Commissioning

General information on parameter setting
Favorites



Address	Name / setting range / [default setting]	Information
0x261C:010	Favorites settings: Parameter 10 0 ... [] ... 4294967295	
0x261C:011	Favorites settings: Parameter 11 0 ... [] ... 4294967295	
0x261C:012	Favorites settings: Parameter 12 0 ... [] ... 4294967295	
0x261C:013	Favorites settings: Parameter 13 0 ... [] ... 4294967295	
0x261C:014	Favorites settings: Parameter 14 0 ... [] ... 4294967295	
0x261C:015	Favorites settings: Parameter 15 0 ... [] ... 4294967295	
0x261C:016	Favorites settings: Parameter 16 0 ... [] ... 4294967295	
0x261C:017	Favorites settings: Parameter 17 0 ... [] ... 4294967295	
0x261C:018	Favorites settings: Parameter 18 0 ... [] ... 4294967295	
0x261C:019	Favorites settings: Parameter 19 0 ... [] ... 4294967295	
0x261C:020	Favorites settings: Parameter 20 0 ... [] ... 4294967295	
0x261C:021	Favorites settings: Parameter 21 0 ... [] ... 4294967295	
0x261C:022	Favorites settings: Parameter 22 0 ... [] ... 4294967295	
0x261C:023	Favorites settings: Parameter 23 0 ... [] ... 4294967295	
0x261C:024	Favorites settings: Parameter 24 0 ... [] ... 4294967295	
0x261C:025	Favorites settings: Parameter 25 0 ... [] ... 4294967295	
0x261C:026	Favorites settings: Parameter 26 0 ... [] ... 4294967295	
0x261C:027	Favorites settings: Parameter 27 0 ... [] ... 4294967295	
0x261C:028	Favorites settings: Parameter 28 0 ... [] ... 4294967295	
0x261C:029	Favorites settings: Parameter 29 0 ... [] ... 4294967295	
0x261C:030	Favorites settings: Parameter 30 0 ... [] ... 4294967295	
0x261C:031	Favorites settings: Parameter 31 0 ... [] ... 4294967295	
0x261C:032	Favorites settings: Parameter 32 0 ... [] ... 4294967295	
0x261C:033	Favorites settings: Parameter 33 0 ... [] ... 4294967295	
0x261C:034	Favorites settings: Parameter 34 0 ... [] ... 4294967295	
0x261C:035	Favorites settings: Parameter 35 0 ... [] ... 4294967295	
0x261C:036	Favorites settings: Parameter 36 0 ... [] ... 4294967295	
0x261C:037	Favorites settings: Parameter 37 0 ... [] ... 4294967295	
0x261C:038	Favorites settings: Parameter 38 0 ... [] ... 4294967295	
0x261C:039	Favorites settings: Parameter 39 0 ... [] ... 4294967295	



Commissioning

General information on parameter setting
Favorites

Address	Name / setting range / [default setting]	Information
0x261C:040	Favorites settings: Parameter 40 0 ... [] ... 4294967295	
0x261C:041	Favorites settings: Parameter 41 0 ... [] ... 4294967295	
0x261C:042	Favorites settings: Parameter 42 0 ... [] ... 4294967295	
0x261C:043	Favorites settings: Parameter 43 0 ... [] ... 4294967295	
0x261C:044	Favorites settings: Parameter 44 0 ... [] ... 4294967295	
0x261C:045	Favorites settings: Parameter 45 0 ... [] ... 4294967295	
0x261C:046	Favorites settings: Parameter 46 0 ... [] ... 4294967295	
0x261C:047	Favorites settings: Parameter 47 0 ... [] ... 4294967295	
0x261C:048	Favorites settings: Parameter 48 0 ... [] ... 4294967295	
0x261C:049	Favorites settings: Parameter 49 0 ... [] ... 4294967295	
0x261C:050	Favorites settings: Parameter 50 0 ... [] ... 4294967295	



5.4 Commissioning

Prerequisites

- The mechanical and electrical installation of the inverter is complete.
- If necessary, the motor is mechanically decoupled from the system.
 - Check whether the system can be mechanically damaged if the non-decoupled drive makes uncontrolled movements.
- The connection between the inverter and the engineering PC with installed »EASY Starter« has been established.
- The »EASY Starter« is open and connected to the inverter.
- The inverter is supplied with voltage.
 - For parameterisation purposes, it makes sense to supply the device with 24 V if the mains voltage and the motor data deviate from the default setting. ▶ [Function assignment of the inputs and outputs \(default setting\)](#) 40
 - If it has been ensured that the mains voltage and motor data settings correspond to the real conditions, the mains voltage can be connected.
- The device list of the »EASY Starter« contains the inverter with the correct device description.
 - Additional information on the device description can be found in the chapter dealing with configuration of the respective fieldbus network. ▶ [Configuring the network](#) 207
 - For an explanation of where the device list can be found, please consult the online help of the »EASY Starter«. Press the **F1** key to call up the online help.
- No fault is indicated by the inverter diagnostics.
 - Check the LED status displays. [LED status display](#) 361
 - Check the error messages. [Logbook](#) 362
 - Check available application credit on the storage medium.

Commissioning

The five main commissioning steps are shown in order towards the top of the **Settings** tab. Clicking on a link displays a corresponding interface containing the most important parameters that need to be set.

▶ [General information on parameter setting](#) 32

Commissioning step	Description of the settings
Basic settings	The basic settings are sufficient for drive rotation . <ul style="list-style-type: none"> • Check every preset parameter value to determine whether it can be retained for the application. • If a value has to be changed, click the cross-reference highlighted in blue to which the parameter is assigned. A new interface opens. Here, the relevant value can now be changed. • Once all parameters have been correctly set in the basic settings, you can allow the drive to rotate .
Communication	These commissioning steps are for adjusting the drive and only have to be adapted where necessary. <ul style="list-style-type: none"> • Basic settings of the technology application for adjusting the motor end and load side (gearbox ratio, mounting direction, moments of inertia, etc.) • Basic settings of the technology application for adjusting the motion control. • Settings for adjusting the technology application for the application.
Kinematics	
Motion	
Technology application	

After adjusting the parameters: ▶ [Saving the parameter settings](#) 39



5.4.1 UMCLN_SGG_001450

Setting and transferring safety parameters



Safety-relevant parameters only have to be set for devices that feature integrated safety engineering or safety modules.

Observe the **online help information on the safety parameter list**.

In »EASY Starter« and »PLC Designer«, safety parameters can only be set and transferred using the **safety parameter list**. When a device featuring integrated safety engineering or a safety module is selected in the device list, the **safety parameter list** becomes available in the form of an additional tab.

Safe parameter setting



When using online communication via a bus system, several users can access the same drive simultaneously and process the safe parameter set. After transferring the safe parameters, check the checksums (CRC) in the **safety parameter list** dialog. The checksums of the project must correspond to the checksums of the safety option.

The consistency of the safe parameters must be ensured by organisational measures because there are no technical means to avoid multiple users accessing parameter sets at the same time.

Parameter setting

Safety-relevant parameters can only be transmitted to the safety option by safe parameter setting. The parameter set is saved on the SD card and in the safety option with a unique safety address.

Safe parameter setting can only be performed in the service status. The service status means:

- Stop is active and the drive is switched to torqueless operation (STO).
- Communication via the safety bus is active but passivated.

The service status can be activated using the »Easy Starter«. Initializing the safety option serves to deactivate the service status.



The service status is activated if the parameter set on the SD card does not correspond to the parameter set of the safety option during the initialization.

Parameter setting using the Easy Starter

From »Easy Starter« version 01.11 onwards, a safe parameter setting is supported. The functions of the **Safety parameter list** are documented in the online help.

Password

To save a safe parameter set, a password is required. The preset password is "Lenze Safety". The password can be changed and must have at least six characters.

The command **Reset safe parameter set in the device** serves to delete the safe parameter set. The safety functions must be re-parameterized after the reset. The password is reset to the preset password "Lenze Safety".

Accept parameter set from the SD card

Safe parameter set acceptance is supported by means of a safe parameter set saved in the device.

Commissioning

Commissioning
UMCLN_SGG_001450



Acknowledge parameter set or safety address



The parameter set and the safety address are acknowledged by the same procedure.

At a response time above 2.5 seconds, the parameter set acceptance is aborted and must be repeated.

How to acknowledge the parameter set or the safety address:

- "RDY" LED is illuminated.
 - "ERR" LED is blinking.
1. Press and hold the **S82** button.
 - a) The "RDY" LED is blinking.
 - b) The "RDY" LED goes off after 3 seconds.
 2. Release the **S82** button after a maximum of 2.5 seconds.
 - a) "RDY" LED is lit.
 3. Press and hold the **S82** button after a maximum of 2.5 seconds.
 - a) The "RDY" LED is blinking.
 - b) The "RDY" LED goes off after 3 seconds.
 4. Release the **S82** button after a maximum of 2.5 seconds.

The new parameter set or new safety address has been acknowledged.



The action is recorded in the inverter logbook.

If the parameter set is invalid, an error is reported and the "ERR" LED starts blinking.

Parameter sets and axes

The unambiguousness of an axis with safety functions in a drive system can be achieved by means of the safety address. When a safety option is initialized, e.g. when loading the safe parameter set, the compliance of the safety address will be checked. If no compliance exists, an initialization error is reported.



Clearly define the safety address in a drive system or plant.

Document the address in circuit diagrams and labels.

Ensure identical settings when replacing the module.

In drive systems with an activated safety bus, the safety address is also used as the safety bus target address. The clear assignment of the safety address must be configured in the safety PLC.

In drive systems without activated safety bus, unambiguousness and correct assignment of the safety address must be checked. For this purpose, use the »Easy Starter« or the »PLC Designer«.



5.5 Saving the parameter settings

During operation with the CiA 402 device profile, no settings are saved. The settings are transmitted when the master control is started. If applications are used, the SD card with the licence data also serves as storage medium.

The active application is displayed in the parameter. ▶ [0x2013:001](#)

The application can be modified via the parameter. [0x4000](#)

Use the "Save user data" device command to save the parameter settings of the controller locally on the SD card of the device.

5.5.1 Save parameter settings with »EASY Starter«

If a parameter setting has been changed with the »EASY Starter« but not yet saved in the memory medium with mains failure protection, the status line of the »EASY Starter« displays the note "The parameter set was changed".

There are 3 options to save the parameter settings in the user memory of the storage medium:

- Click the button in the toolbar of the »EASY Starter« .
- Press the function key **F6**.
- Execute the device command "Save user data": [0x2022:003](#) = "On / start [1]".

Basic setting

Device name



6 Basic setting

This chapter contains the most frequently used functions and settings to adapt the inverter to a simple application based on the default setting.

6.1 Device name

Parameter

Address	Name / setting range / [default setting]	Information
0x2001	Device name ["Device"]	Any device name can be set in this object for the purpose of device identification.

6.2 Mains voltage

The rated mains voltage set for the inverter has an impact on the operating range of the inverter.

Parameter

Address	Name / setting range / [default setting]	Information
0x2540:001	Mains settings: Rated mains voltage	Selection of the mains voltage for actuating the inverter.
	0 230 Veff	
	1 400 Veff	
	2 480 Veff	
	4 60 V (setting-up operation)	
	10 230 Veff/reduced LU level	
	11 400 Veff/reduced LU level	
	12 480 Veff/reduced LU level	
0x2540:002	Mains settings: Undervoltage warning threshold 0 ... [430] ... 800 V	Monitoring for undervoltage (LU) in the DC bus: Setting of the warning threshold. <ul style="list-style-type: none">If the DC voltage in the DC bus falls below the threshold set, the inverter outputs a warning.The warning is reset with a hysteresis of 10 V.
0x2540:003	Mains settings: Undervoltage error threshold <ul style="list-style-type: none">Read only: x V	Monitoring for undervoltage (LU) in the DC bus: Display of the fixed threshold. <ul style="list-style-type: none">If the DC voltage in the DC bus falls below the threshold displayed, the error"" response is triggered.
0x2540:004	Mains settings: Undervoltage reset threshold <ul style="list-style-type: none">Read only: x V	Display of the fixed reset threshold for monitoring DC bus undervoltage.
0x2540:005	Mains settings: Overvoltage warning threshold 0 ... [795] ... 800 V	Monitoring for overvoltage (OU) in the DC bus: Setting of the warning threshold. <ul style="list-style-type: none">If the DC bus voltage exceeds the threshold set, the inverter outputs a warning.The warning is reset with a hysteresis of 10 V.
	Mains settings: Overvoltage error threshold <ul style="list-style-type: none">Read only: x V	
0x2540:007	Mains settings: Overvoltage reset threshold <ul style="list-style-type: none">Read only: x V	Display of the fixed reset threshold for monitoring DC bus overvoltage.
0x2540:008	Mains settings: DC link voltage critical <ul style="list-style-type: none">Read only	Display of value "1": the DC-bus voltage has reached a critical value.

6.3 Function assignment of the inputs and outputs (default setting)

"[I/O extensions and control connections](#)" describes the assignment of functions to inputs and outputs. [197](#)



6.4 Motor data

The term "motor data" comprises all parameters only depending on the motor and only characterising the electrical behaviour of the motor. Motor data are independent of the application in which the inverter and the motor are used.

Preconditions

The equivalent circuit data ("Settings" tab, path: "Basic setting\motor", parameterisation dialog "Derived motor properties and equivalent circuit") apply to a motor in star connection. In case of a motor in delta connection, the delta values must be converted into equivalent star values.

Possible settings

If a Lenze motor is connected to the inverter, you can select the motor in the engineering tool from the "motor catalogue".

- For details see chapter "[Select motor from motor catalog](#)". [42](#)

Otherwise the motor data must be set manually (for details see chapter "[Manual setting of the motor data](#)"). [44](#)

Parameter

Address	Name / setting range / [default setting]	Information
0x2C08	Method for setting motor parameters	Representation of the method selected for setting the motor parameters. (Is used by the engineering tools.)
	1 Select from catalogue (Lenze motors)	
	2 Enter motor nameplate data (other motors)	
	3 Manual input (other motors)	
	4 Identification run (all motors)	

Basic setting

Motor data

Select motor from motor catalog



6.4.1 Select motor from motor catalog

The following describes how to parameterise your drive system by selecting a Lenze motor from the motor catalogue. Several processes are started invisibly in the background to load/calculate the settings for the relevant parameters.

Preconditions

- Access to a Lenze engineering tool (e. g. »EASY Starter«).
- Parameters can be set online or offline (with or without connected motor).

Required steps

1. Open the Lenze engineering tool that provides for the functionality of a "Motor catalog".
2. Click the **Select motor...** button. In case of the »EASY Starter«, you find the **Select motor...** button on the "settings". tab.
3. Select the motor used in the "Select motor" dialog:

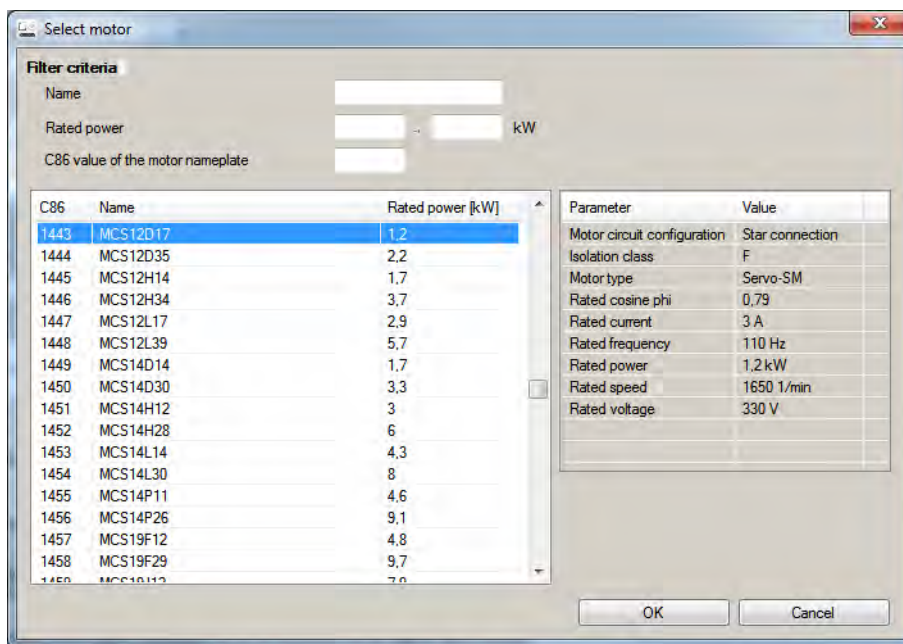

By entering filter criteria, you can restrict the selection.

Name (e. g. "MCS..."), rated power and C86 value can be found on the motor nameplate.

4. Press the **Please select** button to select the thermal sensor.

This is not required for all motors. For older motors, such as MDSKA056-22 (C86=10), a thermal sensor **CANNOT** be selected.



Observe the notes on the ? button.

5. Click the **OK** button to start the optimisation.



Parameterisation sequence

As soon as the parameterisation has been started, the following steps are initiated by the engineering tool:

1. The motor rating data and the motor equivalent circuit diagram data are loaded from the motor catalogue.
2. The motor controller settings and the speed controller settings are automatically calculated based on the previously loaded data.

Notes:

- The data involved in this parameterisation are provided by the motor catalog alone. Further user data is not required.
- The inverter characteristic is not changed by this optimisation.

Parameter

Address	Name / setting range / [default setting]	Information
0x2C01:010	Motor parameters: Motor name ["MCS06C41"]	The name (e.g. "1") can be freely selected by the user. If the motor in the engineering tool has been selected from the "motor catalog", the respective motor name is automatically entered here (example: "MDSKA080-22, 70").

Basic setting

Motor data

Manual setting of the motor data



6.4.2 Manual setting of the motor data

There are two options to parameterize a motor.

1. Enter nameplate data

Enter the following motor data:

- ▶ [0x2C01:001](#) Number of pole pairs
- ▶ [0x2C01:002](#) Stator resistance
- ▶ [0x2C01:003](#) Stator leakage inductance
- ▶ [0x2C01:004](#) Rated speed
- ▶ [0x2C01:005](#) Rated frequency
- ▶ [0x2C01:006](#) Rated power
- ▶ [0x2C01:007](#) Rated voltage
- ▶ [0x2C01:008](#) Cosine phi
- ▶ [0x2C01:009](#) Insulation class
- ▶ [0x6075](#) Rated motor current

When you touch the "Estimate" button in the engineering tool, more parameters depending on the motor are shown.

2. Enter data of the motor data sheet

The motor data and the parameters depending on the motor are entered. The parameters mentioned under 1. are the following:

- ▶ [0x2D4C:001](#) Thermal time constant of the winding
- ▶ [0x2D4C:002](#) Thermal time constant - laminated core
- ▶ [0x2D4C:003](#) Influence of winding
- ▶ [0x2D4C:004](#) Starting value
- ▶ [0x6067](#) Rated motor torque

Additionally for ASM:

- ▶ [0x2C02:001](#) Rotor resistance
- ▶ [0x2C02:002](#) Mutual inductance
- ▶ [0x2C02:003](#) Magnetizing current

Additionally for PSM:

- ▶ [0x2C03:001](#) EMF constant
- ▶ [0x2C03:002](#) Resolver pole position
- ▶ [0x2C03:003](#) Temperature coefficient magnets (kTN)
- ▶ [0x2C03:004](#) Encoder pole position

After the motor data has been parameterized via one of the two options, the following monitoring and limit values are initialized with motor-dependent preset values by touching the "Initialize" button:

- ▶ [0x2D44:001](#) Overspeed monitoring threshold
- ▶ [0x2D46:001](#) Overcurrent monitoring threshold
- ▶ [0x2D49:003](#) Motor temperature monitoring warning threshold
- ▶ [0x2D49:004](#) Motor temperature monitoring error threshold
- ▶ [0x6073](#) Maximum current
- ▶ [0x6075](#) Rated motor current



Parameter

Address	Name / setting range / [default setting]	Information
0x2822:037	Axis commands: Estimate all motor parameters based on rated data	
	0 Off/Ready	
	1 On/Start	
	2 In progress	
	3 Action cancelled	
	4 No access	
5 No access (controller inhibit)		
0x2C01:001	Motor parameters: Number of pole pairs • Read only	Display of the number of pole pairs calculated from the rated speed and rated frequency.
0x2C01:002	Motor parameters: Stator resistance 0.0000 ... [13.5000] ... 125.0000 Ω	General motor data. Carry out settings as specified by manufacturer data/motor data sheet.
0x2C01:003	Motor parameters: Stator leakage inductance 0.000 ... [51.000] ... 500.000 mH	Note! When you enter the motor nameplate data, take into account the phase connection implemented for the motor (star or delta connection). Only enter the data applying to the connection type selected.
0x2C01:004	Motor parameters: Rated speed 0 ... [4050] ... 50000 rpm	General motor data. Carry out settings as specified by motor nameplate data.
0x2C01:005	Motor parameters: Rated frequency 0.0 ... [270.0] ... 1000.0 Hz	Note!
0x2C01:006	Motor parameters: Rated power 0.00 ... [0.25] ... 655.35 kW	When you enter the motor nameplate data, take into account the phase connection implemented for the motor (star or delta connection). Only enter the data applying to the connection type selected.
0x2C01:007	Motor parameters: Rated voltage 0 ... [225] ... 65535 V	
0x2C01:008	Motor parameters: Cosine phi 0.00 ... [0.80] ... 1.00	
0x2C01:009	Motor parameters: Insulation class	Insulation class of the motor (see motor nameplate).
	0 Y (cut-off temperature = 90 °C)	
	1 A (cut-off temperature = 105 °C)	
	2 E (cut-off temperature = 120 °C)	
	3 B (cut-off temperature = 130 °C)	
	4 F (cut-off temperature = 155 °C)	
	5 H (cut-off temperature = 180 °C)	
6 G (cut-off temperature > 180 °C)		
0x2C02:001	Motor parameter (ASM): Rotor resistance 0.0000 ... [0.0000] ... 214748.3647 Ω	Equivalent circuit data required for the motor model of the asynchronous machine.
0x2C02:002	Motor parameter (ASM): Mutual inductance 0.0 ... [0.0] ... 214748364.7 mH	
0x2C02:003	Motor parameter (ASM): Magnetising current 0.00 ... [0.00] ... 500.00 A	
0x2C03:001	Motor parameter (PSM): Back EMF constant 0.0 ... [41.8] ... 100000.0 V/1000rpm	Voltage induced by the motor (rotor voltage / 1000 rpm). For permanently excited synchronous motors, the e.m.f. constant describes the r.m.s. value of the line-to-line voltage (phase voltage) induced in idle state by the motor (reference: 1000 rpm, 20 °C). Measured: Line to Line (L - L)
0x2C03:002	Motor parameter (PSM): Resolver pole position -179.9 ... [-90.0] ... 179.9 °	Equivalent circuit data required for the motor model of the synchronous machine.
0x2C03:003	Motor parameter (PSM): Magnets temperature coefficient (kTN) -1.000 ... [-0.110] ... 0.000 %/°C	
0x2C03:004	Motor parameter (PSM): Encoder pole position -179.9 ... [0.0] ... 179.9 °	
0x2D4C:001	Thermisches Modell Motorauslastung (i ² xt): Motor utilisation (i ² xt) 1 ... [60] ... 36000 s	Setting of the time constant for the winding.
0x2D4C:002	Thermisches Modell Motorauslastung (i ² xt): Thermal time constant - laminations 1 ... [852] ... 36000 s	Setting of the time constant for the laminated core.

Basic setting

Motor control mode

Manual setting of the motor data



Address	Name / setting range / [default setting]	Information
0x2D4C:003	Thermisches Modell Motorauslastung (i^2 xt): Winding influence 0 ... [27] ... 100 %	Part of the thermal motor model: distribution factor of the copper winding influence.
0x6073	Max. current 0.0 ... [150.0] ... 3276.7 %	Max. current of the inverter. <ul style="list-style-type: none"> 100 % = Rated motor current (0x6075) If the current consumption of the motor exceeds this current limit, the inverter changes its dynamic behaviour in order to counteract this exceedance. If the modified dynamic behaviour fails to eliminate the excess current consumption, the inverter outputs an error. When 0x6078 (current actual value in %) exceeds 0x6073 (max. current actual value in %) the message 0x238A is displayed. This status is also displayed in the following network status word bits: <ul style="list-style-type: none"> 0x400C:001 bit 14 0x400C:002 bit 2
0x6075	Rated motor current 0.001 ... [1.300] ... 500.000 A <ul style="list-style-type: none"> Setting can only be changed if the inverter is disabled. 	The rated motor current that needs to be set here serves as a reference value for different parameters that involve a setting for/display of a current value in percent. Example: <ul style="list-style-type: none"> Rated motor current = 1.7 A Max. current 0x6073 = 200 % Rated motor current = 3.4 A
0x6076	Rated motor torque 0.001 ... [0.600] ... 1000.000 Nm <ul style="list-style-type: none"> Setting can only be changed if the inverter is disabled. 	The rated motor torque to be set here serves as a reference value for different parameters with a setting/display of a torque value in percent. Example: <ul style="list-style-type: none"> Rated motor torque = 1.65 Nm Max. torque = 250 % Rated motor torque = 4.125 Nm
0x6080	Max. motor speed 0 ... [6075] ... 480000 rpm	Limitation of the max. motor speed. Depending on the parameter setting of 0x2D44:001 (Overspeed monitoring: threshold), the speed limitation (0x6080 / Max. motor speed) may become active before speed monitoring.

6.5 Motor control mode

The inverter supports different modes for closed-loop/open-loop motor control.

Parameter

Address	Name / setting range / [default setting]	Information
0x2C00	Motor control mode <ul style="list-style-type: none"> Setting can only be changed if the inverter is disabled. 	Selection of the motor control type.
	1 Servoregelung (SC-PSM)	This control mode is used for servo control of a synchronous motor. <ul style="list-style-type: none"> ▶ Servo control for synchronous motor (SC-PSM) 128 A motor encoder must be connected to the inverter. This motor encoder serves as a feedback system for engine control.
	2 Servo control (SC-ASM)	This control mode is used for servo control of an asynchronous motor. <ul style="list-style-type: none"> ▶ Servo control for asynchronous motor (SC-ASM) 129 A motor encoder must be connected to the inverter. This motor encoder is used as a feedback system for the motor control.
	6 V/f characteristic control (VFC open loop)	This control mode is used for the speed control of an asynchronous motor via a V/f characteristic and is the simplest control mode. <ul style="list-style-type: none"> ▶ V/f characteristic control for asynchronous motor (VFC open loop) 130

Supplementary chapters:

- Chapter "[Configure feedback system for motor control](#)" describes how to set resolvers or sine/cosine encoders as motor feedback. [86](#)
- Chapter "[Second feedback system for the technology application](#)" describes how a higher-level control loop can be used as an actual value feedback application for higher accuracy. [100](#)



The detailed description of each motor control type can be found in the chapter "[Configuring the motor control](#)". [127](#)



7 Start, stop and rotating direction commands

7.1 Control selection

Parameter

Address	Name / setting range / [default setting]	Information
0x2824	Control selection <ul style="list-style-type: none"> Setting can only be changed if the inverter is disabled. 	Selection of the type of inverter control.
	0 Flexible I/O configuration	This selection enables a flexible assignment of the start, stop, and rotating direction commands with digital signal sources. <ul style="list-style-type: none"> Digital signal sources can be digital inputs, network and keypad. The I/O configuration is made via the parameters 0x2631:xx (P400.xx).
	1 Keypad	This selection enables the motor to be started exclusively via the start key of the keypad. Other signal sources for starting the motor are ignored. <p> Start motor  Stop motor</p> <p>Note!</p> <ul style="list-style-type: none"> The functions "Enable inverter" and "Run" must be set to TRUE to start the motor. If jog operation is active, the motor cannot be stopped via the  keypad key.



8 Configure position control

This operating mode provides a fast position follower with speed, torque and feed force feedforward control.

Typical applications for positioning are, for instance, transport facilities, feed drives and dosing systems.

Preconditions

A positioning control is parameterised in the servo control types to be set. ▶ [0x2C00](#)

Configure one of these motor control types:

- [0x2C00 = 1: Servo control for synchronous motor \(SC-PSM\)](#) [📖 128](#)
- [0x2C00 = 2: Servo control for asynchronous motor \(SC-ASM\)](#) [📖 129](#)

Further conditions are:

- The correct entry of the ▶ [Motor data](#) [📖 41](#)
- The parameter setting of the motor control in chapter [Configuring the motor control](#) [📖 127](#)



8.1 Basic setting

In the following, the steps required for configuring the position control are described.

1. Set the manufacturer spanning operating mode according to CiA 402.
 - [0x6060](#): "CiA: Cyclic sync position [8]"
 - Detailed description in [▶ Operating mode "CiA 402 cyclic sync position mode \(csp\)"](#)
[📖 52](#)
2. Set the maximum motor speed: [0x6080](#)
3. Set the rated motor torque: [0x6076](#)
4. Set the positive torque limit: [0x60E0](#)
5. Set the negative torque limit: [0x60E1](#)

The position control is now active and the inverter responds to the defined position setpoint.

Configure position control

Basic setting
Following error detection and in-position detection



8.1.1 Following error detection and in-position detection

The "following error recognition" and "in-position recognition" are functions of the position control. All parameters correspond to the CiA 402 specification.

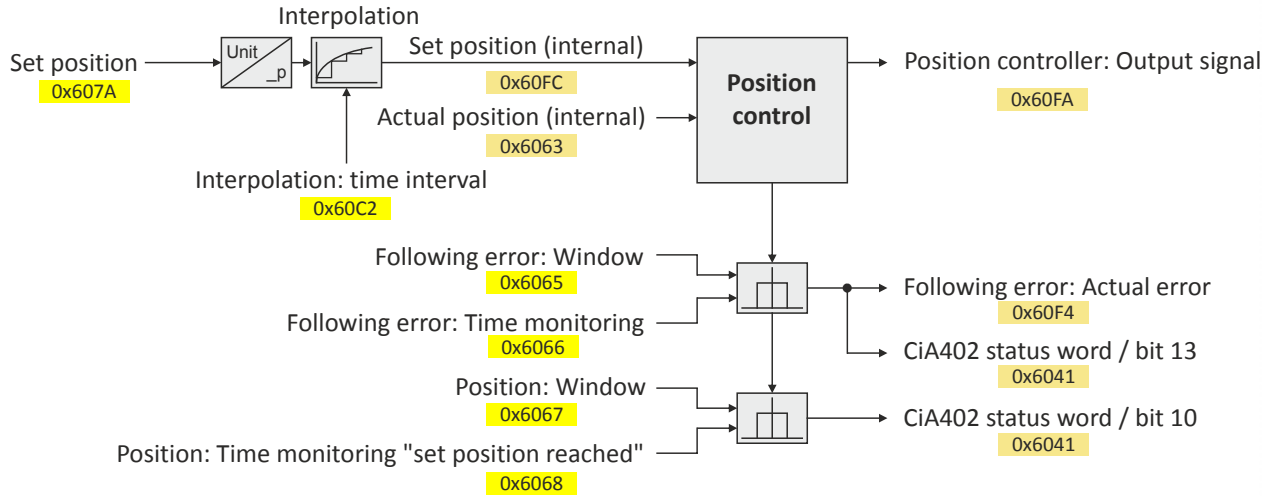

Input data

Parameter	Designation	Data type
0x607A	Set position	INTEGER_32
0x60FC	Position demand internal value	INTEGER_32
0x6062	Internal set position	INTEGER_32
0x6065	Following error window	UNSIGNED_32
0x6066	Following error delay	UNSIGNED_16
0x6067	Position reached window	UNSIGNED_32
0x6068	Position reached delay	UNSIGNED_16

Output data

Parameter	Designation	Data type
0x6063	Actual position	INTEGER_32
0x6064	Actual position	INTEGER_32
0x60F4	Following error actual value	INTEGER_32
0x60FA	Control effort	INTEGER_32
0x6041	CiA status word	UNSIGNED_16

Parameter

Address	Name / setting range / [default setting]	Information
0x6065	Following error window 0 ... [1000] ... 4294967295 pos. unit	Setting of the symmetrical tolerance window around the setpoint position for following error detection. <ul style="list-style-type: none"> • 0 = following error detection deactivated. • > 0 = following error detection activated. • A following error is detected if the actual position is outside this tolerance window. • If the following error is detected longer than the time defined in 0x6066 in [ms], bit 13 ("following error") is set in the CiA status word (0x6041). • 0x60F4 displays the current deviation of the actual position from the setpoint position.
0x6066	Following error delay 0 ... [0] ... 0 ms	Setting of time delay for the following error detection. 0 = the following error is evaluated without a time delay.



Configure position control

Basic setting
Interpolation

Address	Name / setting range / [default setting]	Information
0x6067	Position reached window 0 ... [1000] ... 4294967295 pos. unit	Setting of the symmetrical tolerance window around the target position (0x607A) for the target position detection. If the actual position is within this tolerance window longer than the time defined in 0x6068 in [ms], the target position is deemed to be reached and bit 10 ("target position reached") is set in the CiA status word (0x6041).
0x6068	Position reached delay 0 ... [0] ... 0 ms	Setting of time monitoring for the target position detection. 0 = the position in the target window is evaluated without a time delay.

8.1.2 Interpolation

When you select an operating mode with cyclic setpoint selection, all setpoints are first led via interpolators which divides down setpoint step-changes of the bus cycle to the cycle time of the control loops. All interpolators together are parameterised via 0x60C2:001 (Interpolation time mantissa).

Parameter

Address	Name / setting range / [default setting]	Information
0x60C0	Interpolation mode	Setting of the interpolation mode.
	-1 Quadratic	
	0 Linear	
0x60C2:001	Interpolation time period: Interpolation time mantissa 0 ... [1] ... 255	Basic multiplier for the interpolation time mantissa.
0x60C2:002	Interpolation time period: Interpolation time exponent -6 ... [-3] ... 0	Interpolation time exponent

$$t = 0x60C2:001 * 10^{(0x60C2:002)}$$

$$t = 1 * 10^{(-3)} s = 0.001 s = 1 ms$$

Configure position control

Operating mode "CiA 402 cyclic sync position mode (csp)"
Default mapping



8.2 Operating mode "CiA 402 cyclic sync position mode (csp)"

Subfunctions of the operating mode

- Interpolation between communication cycle and control cycle
- Position control
- Speed control
- Torque control
- Update of the actual values for position, speed and torque

8.2.1 Default mapping

The default mapping for the "cyclic sync position mode" is defined in the following parameters:

Parameter	Designation	Data type
0x1600	RPDO-->axis: cyclic sync position mode (csp)	RECORD
0x1606	RPDO-->axis: torque limit	RECORD
0x1A00	Axis-->TPDO: cyclic sync position mode (csp)	RECORD

Data received from the Controller (RPDO)

Parameter	Designation	Data type
0x6040	CiA402 control word	UNSIGNED_16
0x2830	Lenze control word	UNSIGNED_16
0x6060	Operating mode: selection	INTEGER_8
0x60B2	Torque: offset	INTEGER_16
0x607A	Position: setpoint position	INTEGER_32
0x60B1	Velocity: offset	INTEGER_32
0x2902	Speed controller: load I component	INTEGER_16
0x60E0	Torque: positive limit value	UNSIGNED_16
0x60E1	Torque: negative limit value	UNSIGNED_16

Data sent to the Controller (TPDO)

Parameter	Designation	Data type
0x6041	CiA402 status word	UNSIGNED_16
0x2831	Lenze status word	UNSIGNED_16
0x6061	Operating mode: display	INTEGER_8
0x603F	Error code	UNSIGNED_16
0x606C	Velocity: actual velocity	UNSIGNED_16
0x6077	Torque: actual torque	INTEGER_16
0x6064	Position: actual position	INTEGER_32
0x60F4	Following error: actual error	INTEGER_32



Configure position control

Operating mode "CiA 402 cyclic sync position mode (csp)"
Signal flow

8.2.2 Signal flow

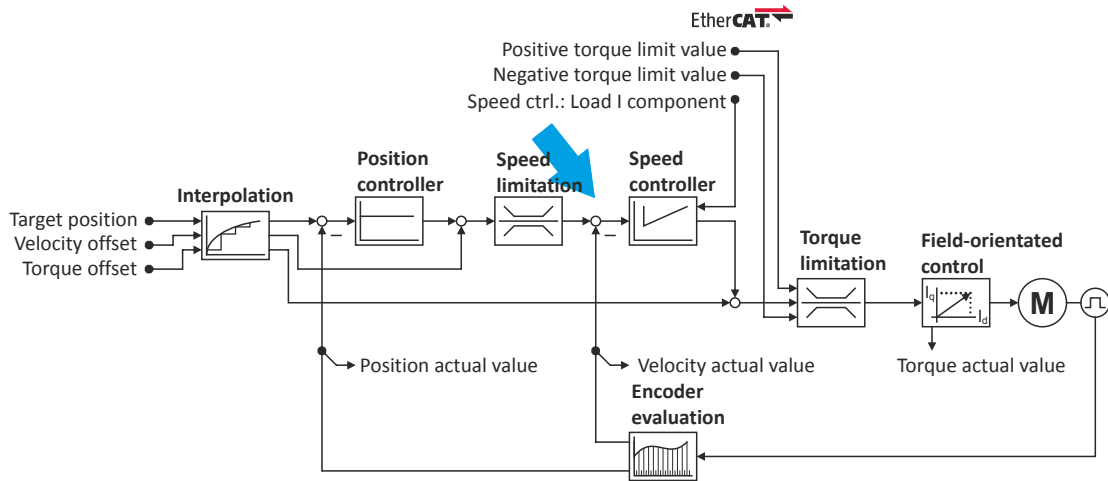

Configure position control

Operating mode "CiA 402 cyclic sync position mode (csp)"
Signal flow



Overview of the most important parameters

Function	Parameter	Designation
Input data 	0x6040	CiA control word
	0x2830	Inverter control word
	0x6060	CiA: Operation mode
	0x607A	Set position
	0x60B1	Offset speed
	0x60B2	Offset torque
	0x60E0	Positive torque limit
	0x60E1	Negative torque limit
	0x2902	I component load value
Output data 	0x6041	CiA status word
	0x2831	Inverter-Statuswort
	0x6061	CiA: Active operation mode
	0x6064	Actual position
	0x606C	Actual speed
	0x6077	Actual torque
Interpolation 	0x60C0	Interpolation mode
	0x60C2:001	Interpolation time period
	0x60C2:002	Interpolation time period
Position controller 	0x2980	Position controller gain
	0x2981	Position controller gain adaption
	0x2982	Position controller output signal limitation
	0x2983	Actual position start value
	0x2984	Mode for setting the actual position
	0x2986	Resulting gain adaption
Speed limitation 	0x6080	Max. motor speed
Speed controller 	0x2900:001	Gain
	0x2900:002	Reset time
	0x2900:003	Rate time
	0x2901	Speed controller gain adaption
	0x2902	I component load value
Torque limitation 	0x60E0	Positive torque limit
	0x60E1	Negative torque limit
	0x6076	Rated motor torque
		Max. torque
Field-oriented control 	0x6073	Device: max. current
	0x6075	Motor: rated current
	0x2941	Current controller: feedforward control
	0x2942:001	Current controller: gain
	0x2942:002	Current controller: reset time
	0x29E2	DC bus: actual voltage - filter time
	0x29E3	Motor: actual voltage - filter time
	0x29E0:001	Field weakening controller: gain
	0x29E0:002	Field weakening controller: reset time
	0x29E1	Limitation of setpoint field
	0x29C0:001	Field controller: gain
	0x29C0:002	Field controller: reset time
	0x2939	Switching frequency



Configure position control

Process input data (CiA 402 objects)
Control commands and status information

8.2.3 Control commands and status information

The following control commands can be executed via the CiA 402 control word **0x6040**:

Control word	State	Function
Bit 4	0	reserved (bit must be set to "0".)
Bit 5	0	reserved (bit must be set to "0".)
Bit 6	0	reserved (bit must be set to "0".)
Bit 8	0/1	Stop

The following status information is output via the CiA402 status word **0x6041**:

Status word	State	Meaning
Bit 12	0	Operating mode is inactive.
	1	The drive follows the setpoint selection.

8.3 Process input data (CiA 402 objects)

Parameter

Address	Name / setting range / [default setting]	Information
0x6060	CiA: Operation mode	CiA: Operation mode
	0 No selection	No selection
	2 CiA: Velocity mode	▶ Operating mode "CiA 402 velocity mode (vl)" □ 64
	8 CiA: Cyclic sync position	▶ Operating mode "CiA 402 cyclic sync position mode (csp)" □ 52
	9 Cyclic sync velocity mode	▶ Operating mode "CiA 402 cyclic sync velocity mode (csv)" □ 70
10 Cyclic sync torque mode	▶ Operating mode "CiA 402 cyclic sync torque mode (cst)" □ 81	
0x607A	Set position -2147483648 ... [0] ... 2147483647 pos. unit	Setting of the set position.
0x60B1	Offset speed -480000.00 ... [0.00] ... 480000.00 rpm	Additive value for setpoint velocity or velocity feedforward control - offset speed.
0x60B2	Offset torque -3276.8 ... [0.0] ... 3276.7 %	Offset torque • 100 % = rated motor power (0x6076)
0x60E0	Positive torque limit 0.0 ... [100.0] ... 3276.7 %	Positive torque limit source for speed control with torque limitation. • 100 % = Rated motor torque. ▶ 0x6076
0x60E1	Negative torque limit 0.0 ... [100.0] ... 3276.7 %	Code previously C3687. Negative torque limit source for speed control with torque limitation. • 100 % = Rated motor torque ▶ 0x6076

8.4 Process output data (CiA 402 objects)

Parameter

Address	Name / setting range / [default setting]	Information
0x6064	Actual position • Read only: x pos. unit	Display of the actual position.
0x6077	Actual torque • Read only: x.x %	Display of the actual torque. • 100 % = Rated motor torque. ▶ 0x6076
0x60F4	Following error actual value • Read only: x pos. unit	Display of the current following error.

Configure position control

Monitoring the position error



8.5 Monitoring the position error

Position error monitoring can be used for the following control modes:

- Servo control for synchronous motor (SM), `0x2C00` = [1]
- Servo control for asynchronous motor (ASM), `0x2C00` = [2]

Following error monitoring is effective in an operating mode with position controller. The system deviation (i. e. the following error) is compared to the following error tolerance set at the input of the position controller (see red arrow in the figure below).

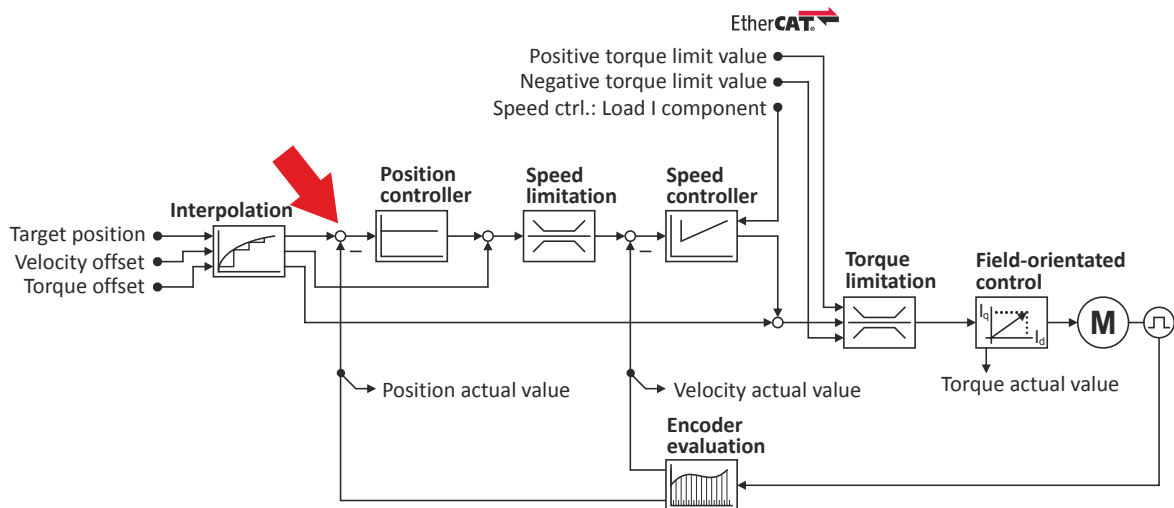

The error response set in `0x2D51:006` is executed if ...

1. the following error tolerance set in `0x2D51:004` is exceeded and ...
2. the exceedance lasts at least as long as set in `0x2D51:005`.

Parameter

Address	Name / setting range / [default setting]	Information
0x2D51:004	Position error/speed error - monitoring: Position error - error threshold 1 ... [360] ... 2147483647 °	Setting of the error threshold for position error monitoring.
0x2D51:005	Position error/speed error - monitoring: Position error - min. time for error 0 ... [0] ... 50 ms	Setting of the minimum time a position error must be pending until an error/warning message is triggered.
0x2D51:006	Position error/speed error - monitoring: Position error - error response	Setting of the error response of position error monitoring.
	0 No response	
	1 Fault > CiA402	
	2 Warning	



8.6 Position detection with touch probe (TP)

A "touch probe" (short: "TP") is an event that can be triggered, for instance via a digital input in an edge-controlled manner to detect and further process an actual value (which is changing fast) at the triggering time.

- Typical applications for touch probes:
 - Homing
 - Mark synchronisation
 - Length measurements
- Up to 2 touch probe channels can be used in parallel.
- Possible touch probe sources:
 - TP1 : Zero pulse position encoder or digital input DI1
 - TP2 : Zero pulse position encoder or digital input DI2



The digital inputs DI1 and DI2 can be additionally evaluated any time as "normal" digital inputs via [0x60FD](#).

8.6.1 Default mapping

The default mapping for a touch probe detection is defined in the following parameters:

Parameter	Designation	Data type
0x1604	RPDO-->axis: touch probe (TP)	RECORD
0x1A04	Axis-->TPDO: touch probe (TP)	RECORD

Data received from the Controller (RPDO)

Parameter	Designation	Data type
0x60B8	Touch probe control word	UNSIGNED_16

Data sent to the Controller (TPDO)

Parameter	Designation	Data type
0x60B9	Touch probe status word	UNSIGNED_16
0x60BA	TP1: actual position - rising edge	INTEGER_32
0x60BB	TP1: actual position - falling edge	INTEGER_32
0x60BC	TP2: actual position - rising edge	INTEGER_32
0x60BD	TP2: actual position - falling edge	INTEGER_32

Configure position control

Position detection with touch probe (TP)
General mode of operation



8.6.2 General mode of operation

If an event occurs at the configured touch probe source, a time stamp is detected in the servo inverter.

The detected time stamp is related to the system time and can thus be divided into two parts: One part is the control cycle in which the of the event. The other part is the time difference starting from the detected control cycle to the real detection of the event

Thanks to a history buffer, the servo inverter knows the last n position values. Thus, the actual position is known at the start and at the end of the control cycle in which the event has occurred. A linear interpolation takes place between these two position grid points. The result is the exact position at the motor shaft at the time the event is triggered, see the schematic diagram:

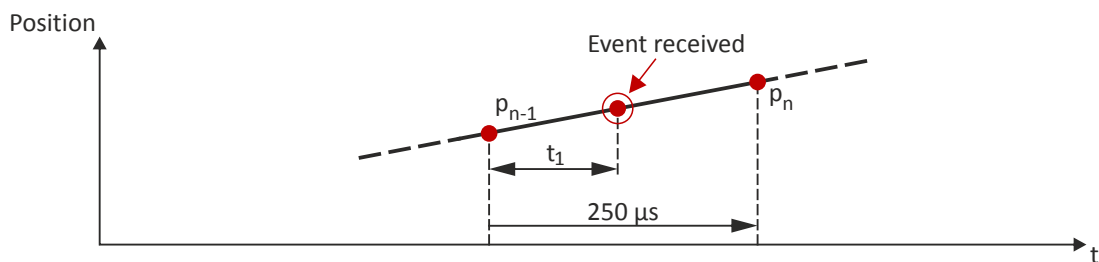

t_1 : Time difference starting from the detected control cycle to the real detection of the event

p_{n-1} : Actual position grid point 1

p_n : Actual position grid point 2

The position grid points are detected in the servo inverter in a grid of $250 \mu s$. After a touch probe has been triggered, the input is deactivated for up to $250 \mu s$ to avoid bouncing. Thus, the maximum frequency for touch probe triggering is 4 kHz.

If in contrast to the uniform movement given in the figure, an accelerated movement is taken as a basis, the $250 \mu s$ grid also allows for a very good linear position reconstruction because the speed change at the motor shaft only has a marginal impact in $250 \mu s$.

8.6.3 Filtering of the touch probe signal

For the touch probe inputs, a common filter time (debounce time) can be parameterised to debounce the TP signals so that there is no response to external interfering signals.

- The signal status of the debouncing filter is detected at the TP input and a new value is added to the filter.
- A separate setting for a touch probe is not possible. Thus, the filter time is set for all touch probe inputs.

Parameter

Address	Name / setting range / [default setting]	Information
0x2500	Touch probe filter time 0 ... [0] ... 1984 us	The set filter time is automatically taken into account in the touch probe calculation. The setting "0" deactivates the filter. Note! Values can be set directly. When entering a filter time between 0 ... 1984 μs , the value is automatically rounded down internally to the next value that can be set and is shown in the case of read requests.



Configure position control

Position detection with touch probe (TP)
 Compensation of runtime delays

8.6.4 Compensation of runtime delays

In reality, both the input circuit in the servo inverter and the touch probe sensor have runtime delays (latencies) themselves. These can be taken into account in the calculation of the real trigger time and thus the real position at the trigger time.

In the following figure, the event is detected in the servo inverter at the time ②. Due to the input circuit and the sensor used, the signal runtime, however, has been delayed. The real physical event has already occurred at time ①. For compensating this runtime delay, you can set a corresponding delay time for each touch probe channel that is included in the determination of the control cycle and interpolation of the position, see figure in chapter "General mode of operation". [58](#)

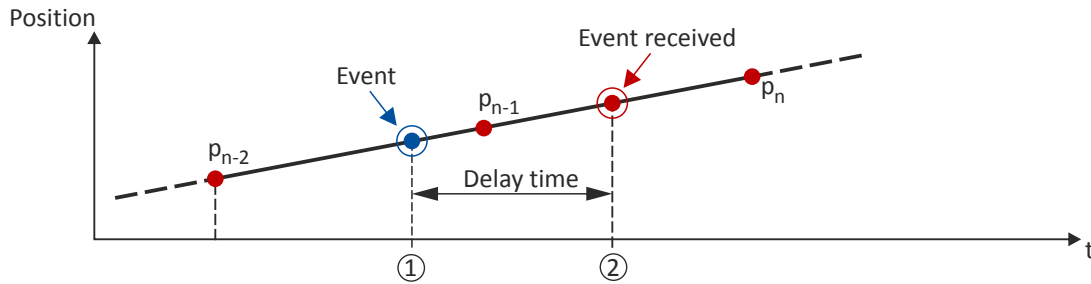

"Delay time": Delay time between the real physical event and the electrical detection.

- ① Real physical event
- ② Electrical detection of the event in the servo inverter

Delay times of the digital input and the required minimum signal duration

The following table lists the typical delay times and the required minimum signal durations for the digital inputs of the servo inverter:

Digital signal	Typical delay time	Minimum signal duration
Rising edge (HIGH pulse)	4 μ s	4 μ s
Falling edge (LOW pulse)	4 μ s	4 μ s

Parameter

Address	Name / setting range / [default setting]	Information
0x2D00:001	Touch probe (TP) delay time: Touch probe 1 delay time 0.000 ... [0.000] ... 7.000 ms	Setting of the delay time for touch probe 1.
0x2D00:002	Touch probe (TP) delay time: Touch probe 2 delay time 0.000 ... [0.000] ... 7.000 ms	Setting of the delay time for touch probe 2.
0x2D00:003	Touch probe (TP) delay time: Touch probe 3 delay time 0.000 ... [0.000] ... 7.000 ms	Setting of the delay time for touch probe 3.
0x2D00:004	Touch probe (TP) delay time: Touch probe 4 delay time 0.000 ... [0.000] ... 7.000 ms	Setting of the delay time for touch probe 4.

Configure position control

Position detection with touch probe (TP)
Touch probe control word



8.6.5 Touch probe control word

Control word for configuring the touch probe functionality.

Parameter

Address	Name / setting range / [default setting]	Information
0x60B8	Touch probe settings 0x0000 ... [0x0000] ... 0xFFFF	Control word for configuring the touch probe settings.
Bit 0	TP1 enable	0: deactivate touch probe channel 1. 1: activate touch probe channel 1.
Bit 1	TP1 continuous trigger	Event for touch probe channel 1 0: only detect the first event. 1: detect all events.
Bit 2	TP1 trigger with zero pulse	Source for touch probe channel 1 0: digital input 1 1: zero pulse position encoder
Bit 4	TP1 enable pos. edge	0: deactivate scanning.
Bit 5	TP1 enable neg. edge	1: activate scanning.
Bit 6	Reserved	
Bit 8	TP2 enable	0: deactivate touch probe channel 2. 1: activate touch probe channel 2.
Bit 9	TP2 continuous trigger	Event for touch probe channel 2 0: only detect the first event. 1: detect all events.
Bit 10	TP2 trigger with zero pulse	Source for touch probe channel 2 0: digital input 2 1: zero pulse position encoder
Bit 12	TP2 enable pos. edge	0: deactivate scanning.
Bit 13	TP2 enable neg. edge	1: activate scanning.
Bit 14	Reserved	

8.6.6 Touch probe status word

Status word of the touch probe functionality.

Parameter

Address	Name / setting range / [default setting]	Information
0x60B9	Touch probe status • Read only	Status of the touch probe functionality.
Bit 0	TP1 active	0: touch probe channel 1 deactivated. 1: touch probe channel 1 activated.
Bit 1	TP1 pos. edge detected	0: position not detected.
Bit 2	TP1 neg. edge detected	1: position detected.
Bit 6	TP1 level at enable start	Level for detection via touch probe channel 1 0: LOW level 1: HIGH level
Bit 8	TP2 active	0: touch probe channel 2 deactivated. 1: touch probe channel 2 activated.
Bit 9	TP2 pos. edge detected	0: position not detected.
Bit 10	TP2 neg. edge detected	1: position detected.
Bit 14	TP2 level at enable start	Level for detection via touch probe channel 2 0: LOW level 1: HIGH level



Configure position control

Position detection with touch probe (TP)
Extension for the digital inputs DI3 and DI4

8.6.7 Extension for the digital inputs DI3 and DI4

Parameter

Address	Name / setting range / [default setting]	Information	
0x2D02:001	Touch probe diagnostics: Touch probe 3/4 function 0x0000 ... [0x0000] ... 0xFFFF		
	Bit 0 Activate touch probe 3		
	Bit 1 Touch probe 3 trigger = 1st event/continuous		
	Bit 2 Touch probe 3 source = TP input/zero pulse		
	Bit 4 Touch probe 3 sampling = rising edge		
	Bit 5 Touch probe 3 sampling = falling edge		
	Bit 6 Position feedback source		
	Bit 8 Activate touch probe 4		
	Bit 9 Touch probe 4 trigger = 1st event/continuous		
	Bit 10 Touch probe 4 source = TP input/zero pulse		
	Bit 12 Erfassung Touch-Probe 4 = steigende Flanke		
	Bit 13 Erfassung Touch-Probe 4 = fallende Flanke		
	Bit 14 Position feedback source		
	0x2D02:002		Touch probe diagnostics: Touch-Probe 3/4 status • Read only
Bit 0 Touch-Probe 3 ist aktiviert			
Bit 1 Touch-Probe 3 - Position erfasst fallende Flanke			
Bit 2 Touch-Probe 3 - Position erfasst steigende Flanke			
Bit 6 Touch-Probe 3 - Pegel bei Zeitstempel			
Bit 8 Touch-Probe 4 ist aktiviert			
Bit 9 Touch-Probe 4 - Position erfasst fallende Flanke			
0x2D03:001	Touch probe position: Touch probe 3 position rising edge • Read only: x pos. unit		
	0x2D03:002		Touch probe position: Touch probe 3 position falling edge • Read only: x pos. unit
	0x2D03:003		Touch probe position: Touch probe 4 position rising edge • Read only: x pos. unit
	0x2D03:004		Touch probe position: Touch probe 4 position falling edge • Read only: x pos. unit

8.6.8 Detected time stamp and positions



In case of the "continuous touch probe configuration", a newly detected value overwrites the previously detected value.

Parameter

Address	Name / setting range / [default setting]	Information
0x2D01:001	Touch probe (TP) time stamp: Touch probe 1-rising edge time stamp • Read only: x ns	Display of the time stamp of the rising edge for touch probe 1.
0x2D01:002	Touch probe (TP) time stamp: Touch probe 1-falling edge time stamp • Read only: x ns	Display of the time stamp of the falling edge for touch probe 1.

Configure position control

Setpoint diagnostics

Detected time stamp and positions



Address	Name / setting range / [default setting]	Information
0x2D01:003	Touch probe (TP) time stamp: Touch probe 2-rising edge time stamp • Read only: x ns	Display of the time stamp of the rising edge for touch probe 2.
0x2D01:004	Touch probe (TP) time stamp: Touch probe 2-falling edge time stamp • Read only: x ns	Display of the time stamp of the falling edge for touch probe 2.
0x2D01:005	Touch probe (TP) time stamp: Touch probe 3-rising edge time stamp • Read only: x ns	Display of the time stamp of the rising edge for touch probe 3.
0x2D01:006	Touch probe (TP) time stamp: Touch probe 3-falling edge time stamp • Read only: x ns	Display of the time stamp of the falling edge for touch probe 3.
0x2D01:007	Touch probe (TP) time stamp: Touch probe 4-rising edge time stamp • Read only: x ns	Display of the time stamp of the rising edge for touch probe 4.
0x2D01:008	Touch probe (TP) time stamp: Touch probe 4-falling edge time stamp • Read only: x ns	Display of the time stamp of the falling edge for touch probe 4.
0x60BA	Touch probe 1: Position at pos. edge • Read only: x pos. unit	Touch probe 1: Position at pos. edge
0x60BB	Touch probe 1: Position at neg. edge • Read only: x pos. unit	Touch probe 1: Position at neg. edge
0x60BC	Touch probe 2: Position at pos. edge • Read only: x pos. unit	Touch Probe 2: Position at pos. edge
0x60BD	Touch probe 2: Position at neg. edge • Read only: x pos. unit	Touch probe 2: Position at neg. edge

8.7 Setpoint diagnostics

The following parameters provide information on the setpoints set for position control.

Parameter

Address	Name / setting range / [default setting]	Information
0x6062	Internal set position • Read only: x pos. unit	Display of the interpolated internal set position for the position control.
0x6063	Actual position • Read only: x incr.	Display of the actual position in the internal unit.
0x60FC	Position demand internal value • Read only: x incr.	Display of the interpolated setpoint position for the position control in the internal unit.
0x60FA	Control effort • Read only: rpm	Display of the actuating signal (setpoint speed) of the position controller.



9 Configure speed control

Two operating modes are available for configuring the speed control:

- [Operating mode "CiA 402 velocity mode \(vl\)"](#) 64

Here, a speed-controlled movement of the drive is realised by defining a speed setpoint.

- [Operating mode "CiA 402 cyclic sync velocity mode \(csv\)"](#) 70

This operating mode provides a fast speed follower with torque/feed force feedforward control.

The conditions are a correct entry of the motor data ([Motor data](#)) and the parameter setting of the motor control ([Configuring the motor control](#)).

9.1 Basic setting

The following describes the steps required for configuring the speed control.

1. [0x6060](#) Set the manufacturer spanning operating mode "CiA: Velocity mode [2]" or "Cyclic sync velocity mode [9]".
 - A detailed description of the "CiA: Velocity mode" operating mode can be found in the section [Operating mode "CiA 402 velocity mode \(vl\)"](#) . 64
 - A detailed description of the "Cyclic sync velocity mode" operating mode can be found in the section [Operating mode "CiA 402 cyclic sync velocity mode \(csv\)"](#) . 70
2. Set the maximum motor speed in Max. motor speed. ▶ [0x6080](#)
3. Set the rated motor torque in Rated motor torque. ▶ [0x6076](#)
4. Set the positive torque limit. ▶ [0x60E0](#)
5. Set the negative torque limit. ▶ [0x60E1](#)

The speed control is now active and the inverter responds to the speed setpoint.

Configure speed control

Operating mode "CiA 402 velocity mode (vl)"
Default mapping



9.2 Operating mode "CiA 402 velocity mode (vl)"

Selection of the operating mode

The "speed" operating mode is selected with the setting "2" in [0x6060](#).

9.2.1 Default mapping

The default mapping for the "Speed" operating mode is defined in the following parameters.

Parameter	Designation	Data type
0x1603	RPDO-->axis: Velocity mode (vl)	RECORD
0x1A03	Axis-->TPDO: Velocity mode (vl)	RECORD

Data received from the Controller (RPDO)

Parameter	Designation	Data type
0x6040	CiA402 control word	UNSIGNED_16
0x2830	Lenze control word	UNSIGNED_16
0x6060	Operating mode: selection	INTEGER_8
0x6042	Velocity: setpoint velocity vl	INTEGER_8

Data sent to the Controller (TPDO)

Parameter	Designation	Data type
0x6041	CiA402 control word	UNSIGNED_16
0x2831	Lenze control word	UNSIGNED_16
0x6061	Operating mode: display	INTEGER_8
0x603F	Error code	UNSIGNED_16
0x6044	Velocity: actual velocity vl	INTEGER_8



Configure speed control

Operating mode "CiA 402 velocity mode (v1)"
Signal flow (servo control)

9.2.2 Signal flow (servo control)

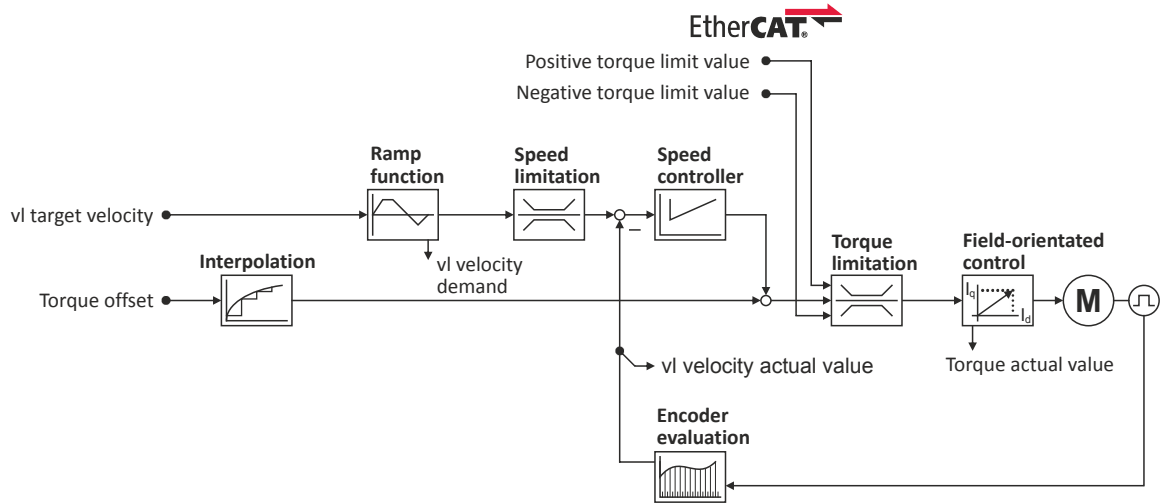





Configure speed control

Operating mode "CiA 402 velocity mode (vl)"
Signal flow (servo control)



Short overview of the most important parameters

Function	Parameter	Designation
Input data 	0x6040	CiA402 control word
	0x2830	Lenze control word
	0x6060	Operating mode: selection
	0x6042	Velocity: setpoint velocity vl
	0x60B2	Torque: offset
	0x60E0	Torque: positive limit value
	0x60E1	Torque: negative limit value
Output data 	0x6041	CiA402 control word
	0x2831	Lenze status word
	0x6061	Operating mode: display
	0x6043	Velocity: interpolated setpoint velocity vl
	0x606C	Velocity: actual velocity
	0x6077	Torque: actual torque
Interpolation 	0x60C2	Interpolation: time interval
Ramp function 	0x6048:001	Ramp: speed interval (for acceleration)
	0x6048:002	Ramp: time interval (for acceleration)
	0x6049:001	Ramp: speed interval (for deceleration)
	0x6049:002	Ramp: time interval (for deceleration)
Speed limitation 	0x6080	Motor: max. speed
Speed controller 	0x2900:001	Speed controller: gain
	0x2900:002	Speed controller: reset time
	0x2900:003	Speed controller: rate time
	0x2901	Speed controller: gain - adjustment
	0x2902	Speed controller: load I component
Torque limiter 	0x60E0	Torque: positive limit value
	0x60E1	Torque: negative limit value
	0x6076	Motor: rated torque
		Torque: max. torque
Field-oriented control 	0x6073	Device: max. current
	0x6075	Motor: rated current
	0x2941	Current controller: feedforward control
	0x2942:001	Current controller: gain
	0x2942:002	Current controller: reset time
	0x29E2	DC bus: actual voltage - filter time
	0x29E3	Motor: actual voltage - filter time (only if 0x2C00 = 2: Servo control for asynchronous motor (SC-ASM))
	0x29E0:001	Field weakening controller: gain
	0x29E0:002	Field weakening controller: reset time
	0x29E1	Limitation of setpoint field (only if 0x2C00 = 2: Servo control for asynchronous motor (SC-ASM))
	0x29C0:001	Field controller: gain
	0x29C0:002	Field controller: reset time
	0x2939	Switching frequency



Configure speed control

Operating mode "CiA 402 velocity mode (vl)"
Signal flow (V/f characteristic control)

9.2.3 Signal flow (V/f characteristic control)

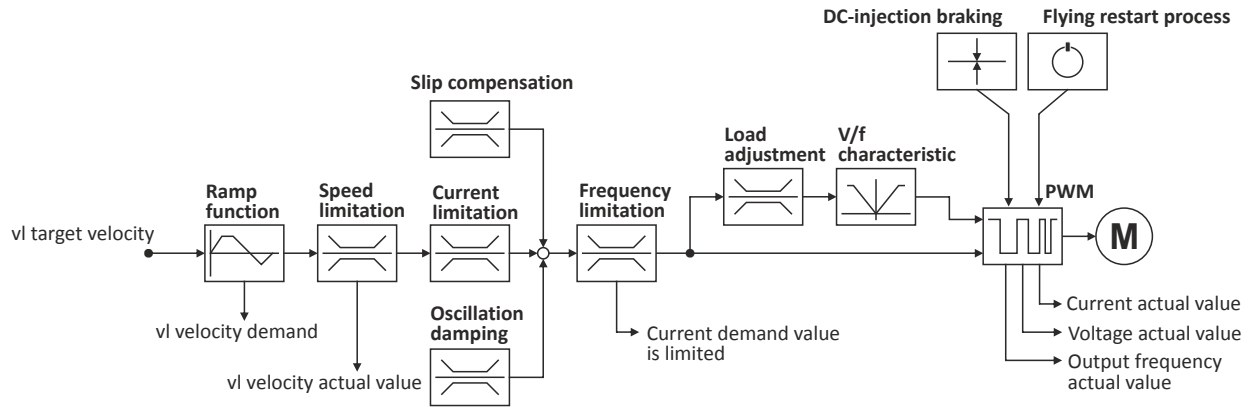

Configure speed control

Operating mode "CiA 402 velocity mode (vl)"
Signal flow (V/f characteristic control)



Short overview of the most important parameters

Function	Parameter	Designation
Input data 	0x6040	CiA402 control word
	0x2830	Lenze control word
	0x6060	Operating mode: selection
	0x6042	Velocity: setpoint velocity vl
Output data 	0x6041	CiA402 control word
	0x2831	Lenze status word
	0x6061	Operating mode: display
	0x6043	Velocity: interpolated setpoint velocity vl
	0x606C	Velocity: actual velocity
	0x6078	Motor: actual current
	0x2D82	Motor: actual voltage - Vrms, phase-phase
	0x2DDD	Device: actual output frequency
Ramp function 	0x6048:001	Ramp: speed interval (for acceleration)
	0x6048:002	Ramp: time interval (for acceleration)
	0x6049:001	Ramp: speed interval (for deceleration)
	0x6049:002	Ramp: time interval (for deceleration)
Speed limitation 	0x6080	Motor: max. speed
Slip compensation 	0x2B09:001	VFC: slip compensation - influence
	0x2B09:002	VFC: slip compensation - filter time
Current limitation 	0x2B08:001	Gain
	0x2B08:002	Reset time
	0x6073	Max. current
Oscillation damping 	0x2B0A:001	VFC: oscillation damping - gain
	0x2B0A:002	VFC: oscillation damping - filter time
	0x2B0A:003	VFC: oscillation damping - limitation
	0x2B0A:004	VFC: oscillation damping - ramp end frequency
Load adjustment 	0x2B07:001	VFC: load adjustment - direction of rotation
	0x2B07:002	VFC: load adjustment - value
V/f characteristic 	0x2B01:001	VFC: V/f characteristic - voltage in the reference point
	0x2B01:002	VFC: V/f characteristic - frequency in the reference point
	0x2B06	VFC: voltage boost
	0x2B04	VFC: voltage vector control - setpoint current
	0x2B00	VFC: V/f characteristic - form
	...	VFC: user-definable V/f characteristic • Frequency grid points (x1 ... x11)
	...	VFC: user-definable V/f characteristic • Voltage grid points (y1 ... y11)
DC-injection braking 	0x2B80	DC-injection braking: current



A more detailed representation of the signal flow with all relevant parameters can be found in the »PLC Designer« on the signal flow tab for the servo inverter.



9.2.4 UMCLN_SGG_001435

Parameter

Address	Name / setting range / [default setting]	Information
0x604B:001	vl set-point factor: vl set-point factor numerator -32768 ... [1] ... 32767	
0x604B:002	vl set-point factor: vl set-point factor denominator -32768 ... [1] ... 32767	

9.2.5 UMCLN_SGG_001436

Parameter

Address	Name / setting range / [default setting]	Information
0x604C:001	vl dimension factor: vl dimension factor numerator -2147483648 ... [1] ... 2147483647	
0x604C:002	vl dimension factor: vl dimension factor denominator -2147483648 ... [1] ... 2147483647	

Configure speed control

Operating mode "CiA 402 cyclic sync velocity mode (csv)"
Default mapping



9.3 Operating mode "CiA 402 cyclic sync velocity mode (csv)"

This operating mode provides a fast velocity follower with torque/feed force feedforward control.

Subfunctions of the operating mode

- Interpolation between communication cycle and control cycle
- Speed control
- Limitation of the motor speed
- Update of the actual values for position, velocity and torque

9.3.1 Default mapping

The default mapping for the cyclic sync velocity mode (csv)" is defined in the following parameters.

Parameter	Designation	Data type
0x1602	RPDO-->axis: cyclic sync velocity mode (csv)	RECORD
0x1606	RPDO-->axis: torque limit	RECORD
0x1A02	Axis-->TPDO: cyclic sync velocity mode (csv)	RECORD

Data received from the Controller (RPDO)

Parameter	Designation	Data type
0x6040	CiA402 control word	UNSIGNED_16
0x2830	Lenze control word	UNSIGNED_16
0x6060	Operating mode: selection	INTEGER_8
0x60B2	Torque: offset	INTEGER_16
0x60FF	Velocity: setpoint velocity	INTEGER_32
0x60E0	Torque: positive limit value	UNSIGNED_16
0x60E1	Torque: negative limit value	UNSIGNED_16

Data sent to the Controller (TPDO)

Parameter	Designation	Data type
0x6041	CiA402 status word	UNSIGNED_16
0x2831	Lenze status word	UNSIGNED_16
0x6061	Operating mode: display	INTEGER_8
0x603F	Error code	UNSIGNED_16
0x606C	Velocity: actual velocity	UNSIGNED_16
0x6077	Torque: actual torque	INTEGER_16
0x6064	Position: actual position	INTEGER_32



Configure speed control

Operating mode "CiA 402 cyclic sync velocity mode (csv)"
Signal flow (servo control)

9.3.2 Signal flow (servo control)

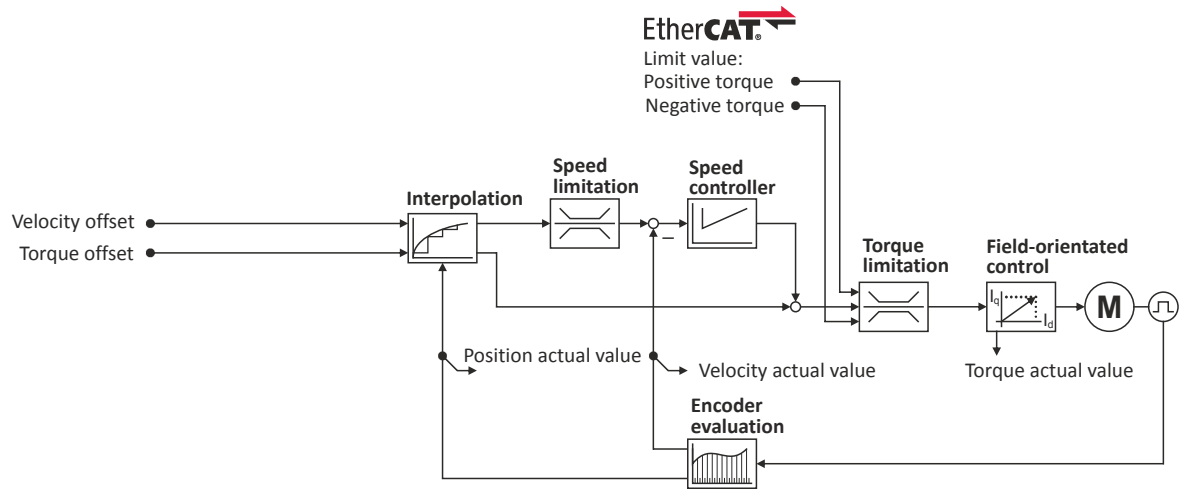







Configure speed control

Operating mode "CiA 402 cyclic sync velocity mode (csv)"
Signal flow (servo control)



Short overview of the most important parameters

Function	Parameter	Designation
Input data 	0x6040	CiA402 control word
	0x2830	Lenze control word
	0x6060	Operating mode: selection
	0x60B1	Velocity: offset
	0x60B2	Torque: offset
	0x60E0	Torque: positive limit value
	0x60E1	Torque: negative limit value
Output data 	0x6041	CiA402 status word
	0x2831	Lenze status word
	0x6061	Operating mode: display
	0x6064	Position: actual position
	0x606C	Velocity: actual velocity
	0x6077	Torque: actual torque
Interpolation 	0x60C2:001	Interpolation: time interval
Speed limitation 	0x6080	Motor: max. speed
Speed controller 	0x2900:001	Speed controller: gain
	0x2900:002	Speed controller: reset time
	0x2900:003	Speed controller: rate time
	0x2901	Speed controller: gain - adjustment
	0x2902	Speed controller: load I component
Torque limitation 	0x60E0	Positive limit value
	0x60E1	Negative limit value
	0x6076	Motor: rated torque
	0x6072	Torque: max. torque
Field-oriented control 	0x6073	Device: max. current
	0x6075	Motor: rated current
	0x2941	Current controller: feedforward control
	0x2942:001	Current controller: gain
	0x2942:002	Current controller: reset time
	0x29E2	DC bus: actual voltage - filter time
	0x29E3	Motor: actual voltage - filter time
	0x29E0:001	Field weakening controller: gain
	0x29E0:002	Field weakening controller: reset time
	0x29E1	Limitation of setpoint field
	0x29C0:001	Field controller: gain
	0x29C0:002	Field controller: reset time
	0x2939	Switching frequency



Configure speed control

Operating mode "CiA 402 cyclic sync velocity mode (csv)"
Signal flow (V/f characteristic control)

9.3.3 Signal flow (V/f characteristic control)

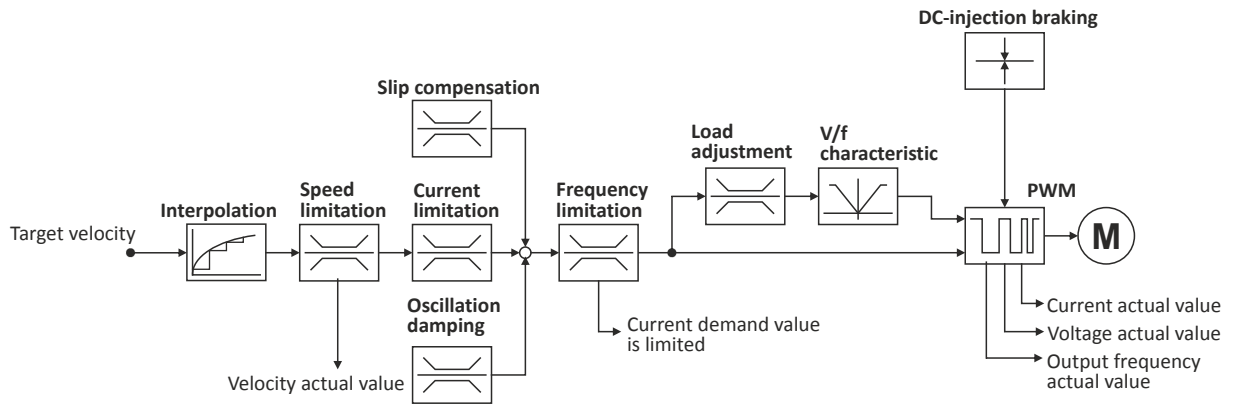





Configure speed control

Operating mode "CiA 402 cyclic sync velocity mode (csv)"
Signal flow (V/f characteristic control)



Short overview of the most important parameters

Function	Parameter	Designation
Input data 	0x6040	CiA402 control word
	0x2830	Lenze control word
	0x6060	Operating mode: selection
	0x60FF	Velocity: Setpoint velocity
Output data 	0x6041	CiA402 status word
	0x2831	Lenze status word
	0x6061	Operating mode: display
	0x606C	Velocity: actual velocity
	0x6078	Motor: actual current
	0x2D82	Motor: actual voltage - Vrms, phase-phase
	0x2DDD	Device: actual output frequency
Interpolation 	0x60C2:001 0x60C2:002	Interpolation: Time interval and interpolation time: exponent
Speed limitation 	0x6080	Motor: max. speed
Slip compensation 	0x2B09:001	VFC: Slip compensation - influence
	0x2B09:002	VFC: Slip compensation - filter time
Current limitation 	0x2B08:001	Gain
	0x2B08:002	Reset time
Oscillation damping 	0x2B0A:001	VFC: Oscillation damping - gain
	0x2B0A:002	VFC: Oscillation damping - filter time
	0x2B0A:003	VFC: Oscillation damping - limitation
	0x2B0A:004	VFC: Oscillation damping - ramp end frequency
Load adjustment 	0x2B07:001	VFC: Load adjustment - direction of rotation
	0x2B07:002	VFC: Load adjustment - value
V/f characteristic 	0x2B01:001	VFC: V/f characteristic - voltage in the reference point
	0x2B01:002	VFC: V/f characteristic - frequency in the reference point
	0x2B06	VFC: voltage boost
	0x2B04	VFC: voltage vector control - setpoint current
	0x2B00	VFC: V/f characteristic form
	...	VFC: user-definable V/f characteristic • Voltage grid points (x1 ... x11)
	...	VFC: user-definable V/f characteristic • Tension grid points (y1 ... y11) Field weakening controller: reset time
DC-injection braking 	0x2B80	DC-injection braking: current



A more detailed representation of the signal flow with all relevant parameters can be found in the »PLC Designer« on the signal flow tab for the servo inverter.



9.3.4 Control commands and status information

The following control commands can be executed in the "cyclic sync velocity mode" via the CiA402 control word (0x6040):

Control word	State	Function
Bit 4	0	reserved (bit must be set to "0")
Bit 5	0	reserved (bit must be set to "0")
Bit 6	0	reserved (bit must be set to "0")
Bit 8	0 ↗ 1	Stop

The following status information are output via the CiA402 status word (0x6041) in the "cyclic sync velocity mode":

Status word	State	Meaning
Bit 12	0	"Cyclic sync velocity mode" is inactive
	1	"Cyclic sync velocity mode" is active

9.4 Process input data (CiA 402 objects)

Parameter

Address	Name / setting range / [default setting]	Information
0x6042	Set speed -32768 ... [0] ... 32767 rpm	Set speed (velocity mode).
0x6046:001	Speed limits: Min. speed 0 ... [0] ... 0 rpm	Min. speed (velocity mode).
0x6046:002	Speed limits: Max. speed 2147483647 ... [2147483647] ... 2147483647 rpm	Max. speed (velocity mode).
0x6048:001	Acceleration ramp: CiA acceleration: Delta speed 0 ... [0] ... 2147483647 rpm	CiA acceleration: Delta speed
0x6048:002	Acceleration ramp: CiA acceleration: Delta time 0 ... [10] ... 65535 s	CiA acceleration: Delta time
0x6049:001	Deceleration ramp: CiA deceleration: Delta speed 0 ... [0] ... 2147483647 rpm	CiA deceleration: Delta speed
0x6049:002	Deceleration ramp: CiA deceleration: Delta time 0 ... [10] ... 65535 s	CiA deceleration: Delta time
0x6060	CiA: Operation mode	CiA: Operation mode
	0 No selection	No selection
	2 CiA: Velocity mode	▶ Operating mode "CiA 402 velocity mode (vl)" □ 64
	8 CiA: Cyclic sync position	▶ Operating mode "CiA 402 cyclic sync position mode (csp)" □ 52
	9 Cyclic sync velocity mode	▶ Operating mode "CiA 402 cyclic sync velocity mode (csv)" □ 70
10 Cyclic sync torque mode	▶ Operating mode "CiA 402 cyclic sync torque mode (cst)" □ 81	
0x60B1	Offset speed -480000.00 ... [0.00] ... 480000.00 rpm	Additive value for setpoint velocity or velocity feedforward control - offset speed.
0x60FF	Set speed -480000.00 ... [0.00] ... 480000.00 rpm	Setting of the set speed.

9.5 Process output data (CiA 402 objects)

Parameter

Address	Name / setting range / [default setting]	Information
0x6043	Internal set speed • Read only: x rpm	Display of the internal set speed (velocity demand).
0x6044	Actual speed • Read only: x rpm	Display of the actual speed (velocity mode).
0x606C	Actual speed • Read only: rpm	Display of the actual speed.

Configure speed control

Monitoring the speed deviation



9.6 Monitoring the speed deviation

Monitoring of the speed deviation shall only be used in the following control modes:

- Servo control for synchronous motor (SM)
- Servo control for asynchronous motor (ASM)

Monitoring of the speed deviation is effective in the operating modes with speed controller. It monitors the system deviation at the input of the speed controller (see blue arrow):

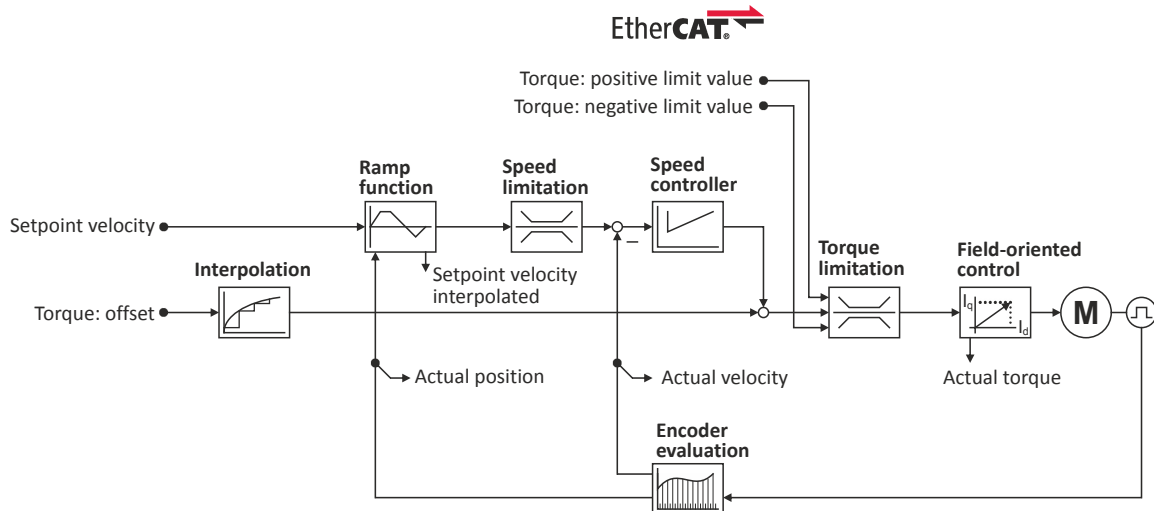

The error response set in [0x2D51:003](#) is executed if

1. the set tolerance of the speed deviation is [0x2D51:001](#) exceeded and
2. the exceedance lasts at least as long as set in [0x2D51:002](#).

Parameter

Address	Name / setting range / [default setting]	Information
0x2D51:001	Position error/speed error - monitoring: Speed error - error threshold 1 ... [50] ... 2147483647 rpm	Setting of the error threshold for speed error monitoring.
0x2D51:002	Position error/speed error - monitoring: Speed error - min. time for error 0 ... [0] ... 50 ms	Setting of the minimum time a speed error must be pending until an error/warning message is triggered.
0x2D51:003	Position error/speed error - monitoring: Speed error - error response	Setting of the error response of speed error monitoring.
	0 No response	
	1 Fault > CiA402	
	2 Warning	



10 Configuring the torque control

This operating mode provides a fast torque follower with speed limitation.

Typical applications are, for instance, winders or packaging machines.

Preconditions

The conditions are a correct entry of the motor data ([Motor data](#)) and the parameter setting of the motor control ([Configuring the motor control](#)).

A torque control can only be implemented in the motor control types to be set with `0x2C00`:

- Servoregelung (SC-PSM) [1]
- Servo control (SC ASM) [2]

Thus, first one of these motor control types must be configured.

For details see the following chapter:

- ▶ [Servo control for synchronous motor \(SC-PSM\)](#) [128](#)
- ▶ [Servo control for asynchronous motor \(SC-ASM\)](#) [129](#)

Configuring the torque control

Basic setting



10.1 Basic setting

1. Set the manufacturer spanning operating mode "Cyclic sync torque mode [10]" according to CiA402.
 - A detailed description of this operating mode can be found in the "[Operating mode "CiA 402 cyclic sync torque mode \(cst\)""](#)" section. [81](#)
2. Set the rated motor torque. [▶ 0x6076](#)
3. Set the permissible maximum torque.
 - The maximum torque is preset in .
 - The change of the positive and negative limit of the maximum torque is described in the "[Torque limits](#)" section. [79](#)
4. Parameterise speed limit. 0x2946
 - The maximum speed is preset. [▶ 0x6080](#)
 - The change of the upper and lower speed limit is described in the "[Speed limitation](#)" section. [80](#)
5. Define a torque setpoint for the torque control instead of a speed setpoint. The value is given in percent and based on the rated motor torque set in [0x6076](#).

The torque control with speed limitation is now active and the inverter responds to the defined torque setpoint.



10.1.1 Torque limits

Details

The positive and negative torque limit can be set independently of each other. The torque limit must be set to the maximum torque.

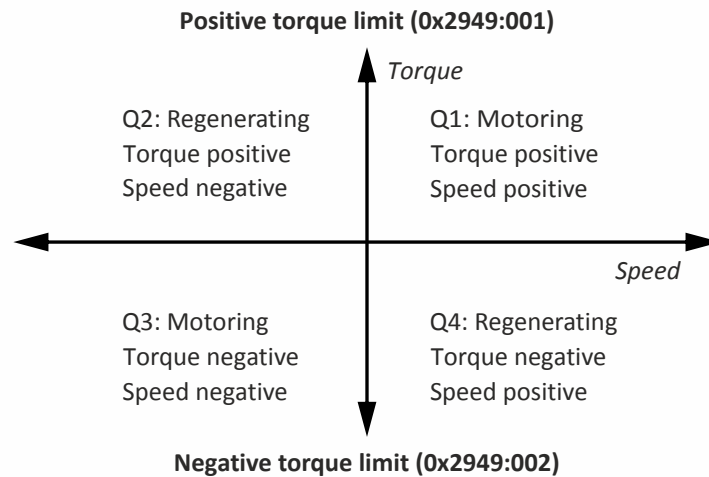

- Display of the current positive torque limit in 0x2949:004.
- Display of the current negative torque limit in 0x2949:003.

The torque limits are also active in the "Velocity Mode" with the SC/ASM control mode.



Regardless of the setting in 0x2949:004 and 0x2949:004, the maximum torque does not exceed the value configured in .

The setting is made in percent with reference to the rated motor torque set in [0x6076](#).

Parameter

Address	Name / setting range / [default setting]	Information
0x294A:001	Torque limits offset: Torque offset -3276.7 ... [0.0] ... 3276.7 %	
0x294A:002	Torque limits offset: Resulting positive torque limit • Read only: x.x %	
0x294A:003	Torque limits offset: Resulting negative torque limit • Read only: x.x %	
0x60B2	Offset torque -3276.8 ... [0.0] ... 3276.7 %	Offset torque • 100 % = rated motor power (0x6076)
0x60E0	Positive torque limit 0.0 ... [100.0] ... 3276.7 %	Positive torque limit source for speed control with torque limitation. • 100 % = Rated motor torque. ▶ 0x6076
0x60E1	Negative torque limit 0.0 ... [100.0] ... 3276.7 %	Code previously C3687. Negative torque limit source for speed control with torque limitation. • 100 % = Rated motor torque ▶ 0x6076

Configuring the torque control

Basic setting
Speed limitation



10.1.2 Speed limitation

The torque control controls the assigned torque setpoint within the set speed limits. The actual speed results from the load conditions of the application. For example, high speeds may occur in a torque control if no counter torque is available (load-free machine).

When the actual speed reaches the set speed limits, it is kept on the respective limit value. This function is also called "speed limitation".

Details

The lower and upper speed limit for speed limitation can be set independently of each other.

Parameter

Address	Name / setting range / [default setting]	Information
0x2946:001	Speed limitation: Upper speed limit -479999.999776482 ... [0] ... 479999.999776482 rpm	Upper limit for the speed limitation. <ul style="list-style-type: none">• Setting is only effective with the selection "Upper speed limit [5]" in .• Entry via keypad and Lenze Tools is in rpm!• Via RPDO, the unit is vel. unit. and the scaling must be taken into account.• $\pm 480000 \text{ rpm} = \pm 2^{31} [\text{n-unit}]$
0x2946:002	Speed limitation: Lower speed limit -479999.999776482 ... [0] ... 479999.999776482 rpm	Lower limit for speed limitation. <ul style="list-style-type: none">• Setting is only effective with the selection "Lower speed limit [5]" in .• Entry via keypad and Lenze Tools is in rpm!• Via RPDO, the unit is vel. unit. and the scaling must be taken into account.• $\pm 480000 \text{ rpm} = \pm 2^{31} [\text{n-unit}]$



10.2 Operating mode "CiA 402 cyclic sync torque mode (cst)"



During the quick stop, the current limit [0x6073](#) and the torque limit are active. The lower of the two limits determines the motor output torque. The torque limits from [0x60E0](#) and [0x60E1](#) are not effective during quick stop.

Subfunctions of the operating mode

- Torque control with speed limitation
- Limitation of the motor speed
- Update of the actual values for position, velocity and torque

10.2.1 Default mapping

The default mapping for the "Cyclic sync torque mode" is defined in the following parameters:

Parameter	Designation	Data type
0x1601	RPDO-->axis: cyclic sync torque mode (cst)	RECORD
0x1A01	Axis-->TPDO: cyclic sync torque mode (cst)	RECORD

Data received from the Controller (RPDO)

Parameter	Designation	Data type
0x6040	CiA402 control word	UNSIGNED_16
0x2830	Lenze control word	UNSIGNED_16
0x6060	Operating mode: selection	INTEGER_8
0x60B2	Torque: offset	INTEGER_16
0x6071	Torque: setpoint torque	INTEGER_16
0x2946:1	Speed limitation: upper speed limit	INTEGER_32
0x2946:2	Speed limitation: lower speed limit	INTEGER_32

Data sent to the Controller (TPDO)

Parameter	Designation	Data type
0x6041	CiA402 status word	UNSIGNED_16
0x2831	Lenze status word	UNSIGNED_16
0x6061	Operating mode: display	INTEGER_8
0x603F	Error code	UNSIGNED_16
0x606C	Velocity: actual velocity	UNSIGNED_16
0x6077	Torque: actual torque	INTEGER_16

Configuring the torque control

Operating mode "CiA 402 cyclic sync torque mode (cst)"
Signal flow



10.2.2 Signal flow

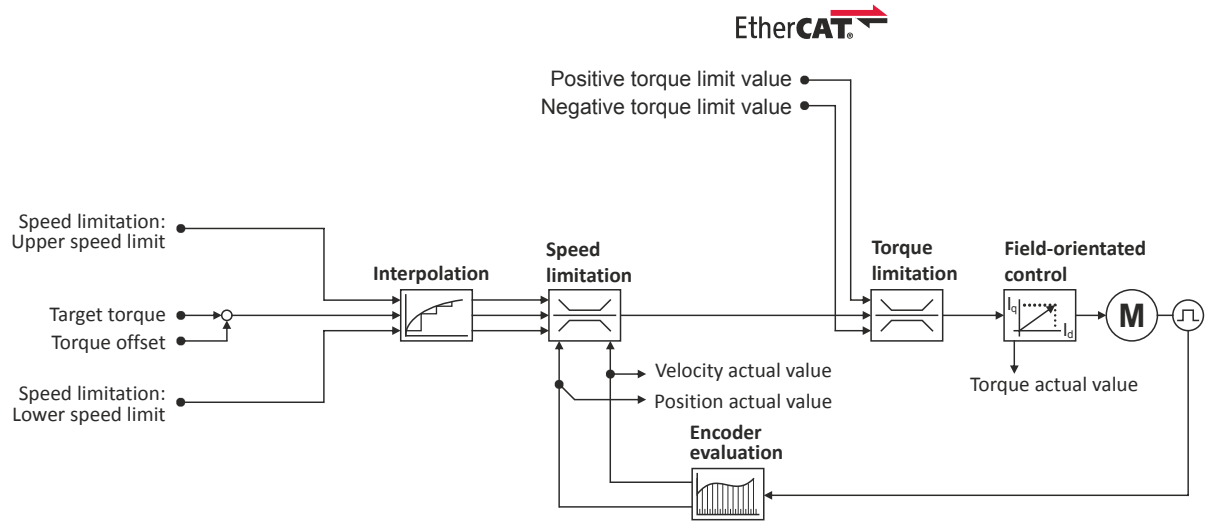









Configuring the torque control

Operating mode "CiA 402 cyclic sync torque mode (cst)"
Signal flow

Short overview of the most important parameters

Function	Parameter	Designation
Input data 	0x6040	CiA402 control word
	0x2830	Lenze control word
	0x6060	Operating mode: selection
	0x2946:001	Speed limitation: upper speed limit
	0x60B2	Torque: offset
	0x6071	Torque: setpoint torque
	0x2946:002	Speed limitation: lower speed limit
	0x60E0	Torque: positive limit value
	0x60E1	Torque: negative limit value
Output data 	0x6041	CiA402 status word
	0x2831	Lenze status word
	0x6061	Operating mode: display
	0x606C	Velocity: actual velocity
	0x6077	Torque: actual torque
Interpolation 	0x60C0	Interpolation algorithm
	0x60C2:001	Interpolation: time interval and interpolation time: Exponent
	0x60C2:002	
Speed limitation 	0x6080	Motor: max. speed
	0x2946:001	Speed limitation: upper speed limit
	0x2946:002	Speed limitation: lower speed limit
Torque limitation 	0x60E0	Torque: positive limit value
	0x60E1	Torque: negative limit value
	0x6076	Motor: rated torque
		Torque: max. torque
Field-oriented control 	0x6073	Device: max. current
	0x6075	Motor: rated current
	0x2941	Current controller: feedforward control
	0x2942:001	Current controller: gain
	0x2942:002	Current controller: reset time
	0x29E2	DC bus: actual voltage - filter time
	0x29E3	Motor: actual voltage - filter time
	0x29E0:001	Field weakening controller: gain
	0x29E0:002	Field weakening controller: reset time
	0x29E1	Field: limitation of setpoint field
	0x29C0:001	Field controller: gain
	0x29C0:002	Field controller: reset time
	0x2939	Switching frequency



A more detailed representation of the signal flow with all relevant parameters can be found in the »PLC Designer« on the signal flow tab for the inverter.

Configuring the torque control

Process input data (CiA 402 objects)
Control commands and status information



10.2.3 Control commands and status information

The following control commands can be executed in the "cyclically synchronous torque" operating mode via the CiA402 control word **0x6040**:

Control word	State	Function
Bit 4	0	<i>reserved</i> (bit must be set to "0")
Bit 5	0	<i>reserved</i> (bit must be set to "0")
Bit 6	0	<i>reserved</i> (bit must be set to "0")
Bit 8	0/1	Stop

The following status information are output via the CiA402 status word **0x6041** in the "cyclic sync torque mode":

Status word	State	Meaning
Bit 12	0	"Cyclic sync torque mode" is inactive
	1	"Cyclic sync torque mode" is active

10.3 Process input data (CiA 402 objects)

Parameter

Address	Name / setting range / [default setting]	Information
0x6060	CiA: Operation mode	CiA: Operation mode
	0 No selection	No selection
	2 CiA: Velocity mode	▶ Operating mode "CiA 402 velocity mode (vl)" ☐ 64
	8 CiA: Cyclic sync position	▶ Operating mode "CiA 402 cyclic sync position mode (csp)" ☐ 52
	9 Cyclic sync velocity mode	▶ Operating mode "CiA 402 cyclic sync velocity mode (csv)" ☐ 70
10 Cyclic sync torque mode	▶ Operating mode "CiA 402 cyclic sync torque mode (cst)" ☐ 81	
0x6071	Set torque -3276.8 ... [0.0] ... 3276.7 %	<ul style="list-style-type: none"> 100 % = Rated motor torque 0x6076 The inverter does not support the CiA 402 torque mode.

10.4 Process output data (CiA 402 objects)

Parameter

Address	Name / setting range / [default setting]	Information
0x6074	Internal set torque • Read only: x.x %	Display of the internal set torque. • 100 % = Rated motor torque 0x6076
0x6077	Actual torque • Read only: x.x %	Display of the actual torque. • 100 % = Rated motor torque. ▶ 0x6076

10.5 Setpoint diagnostics

The following parameters provide information on the setpoints set for torque control.

Parameter

Address	Name / setting range / [default setting]	Information
0x2DD5	Torque setpoint • Read only: x.xx Nm	Display of the current torque setpoint.



11 Configuring the feedback system

This chapter provides information on how to use feedback systems.

The inverter can be equipped to allow the connection of up to two independent feedback systems.

Each of the two feedback systems

- Is placed in a designated slot in the lower part of the inverter
- Has an encoder connection on its front side
- Is an optional equipment feature of the inverter

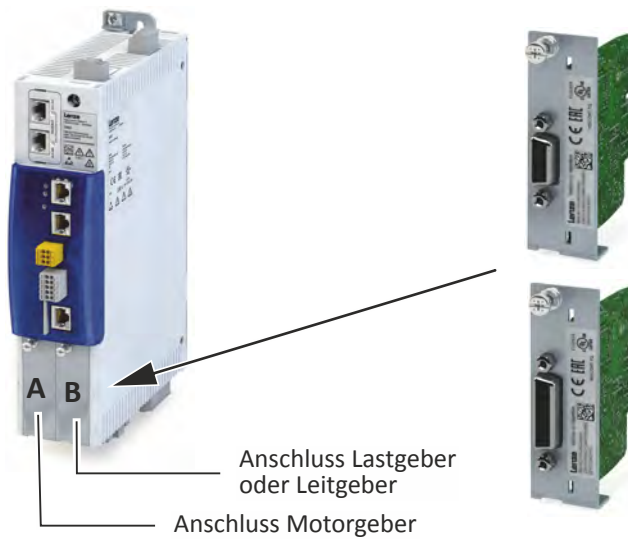

At the time of commissioning, the feedback system is already specified by the hardware of the respective device version.



Please note that one of two sets of parameters will be effective depending on which feedback system option has been selected: either the parameters for resolver evaluation or the parameters for encoder evaluation.

Configuring the feedback system

Configure feedback system for motor control



11.1 Configure feedback system for motor control

The parameter settings for the motor feedback system are accessed in »EASY Starter« via the following path:

- **Settings** tab
 - Basic setting \ Motor feedback (A)

Here, you have the choice of using the following feedback systems:

- Resolver
- Encoder

You can select the feedback system that you wish to use by pressing the correspondingly named button.



Configuring the feedback system

Configure feedback system for motor control
General settings

11.1.1 General settings

This chapter provides information on general settings of feedback systems for the motor control.

Pressing the **Select resolver** or **Select encoder** button displays a list of resolvers or encoders.

If the displayed list contains the feedback system used, the data is applied automatically.

Otherwise, you must enter the data of the feedback system manually.

Monitoring of the encoder cable for wire breakage

The resolver or encoder cable can be monitored for wire breakage in the default settings of parameter [0x2C45](#).

DANGER!

When the encoder / resolver is used as a motor encoder, safe motor operation is not possible in the event of an error.

Destruction of system parts

- ▶ **Fault** should always be used as a response for resolver/encoder wire breakage monitoring.
- ▶ To prevent interference injections when using an encoder, only use shielded motor and encoder cables.

Wire breakage monitoring trips in the following cases:

- Resolver
 - Wire breakage in the encoder cable
 - When the resolver impedance is too great
 - In the event of interference injections (EMC interference)
- Encoder
 - Wire breakage in the encoder cable

Sensitivity of wire breakage monitoring

The sensitivity of wire breakage monitoring can be set as a percentage using the [0x2C47](#) parameter.

Reducing the monitoring sensitivity is advantageous in environments that are severely affected by EMC problems.



If the sensitivity is not reduced (100 %), the software response time of monitoring in case of an encoder is approx. 3.5 ms and in case of a resolver 0.3 ms.

Halving the sensitivity means doubling the response time.

NOTICE

A reduced sensitivity delays the response in case of wire breakage!

Destruction of system parts by reduced sensitivity of the open-circuit monitoring.

- ▶ Increase the sensitivity to reduce the monitoring response time.

Configuring the feedback system

Configure feedback system for motor control
General settings



Parameter

Address	Name / setting range / [default setting]	Information
0x2C45	Encoder error response	Selection of the response to the triggering of the encoder signal loss monitoring. Only active when used as: <ul style="list-style-type: none"> Feedback system for motor control, when set Associated error code: <ul style="list-style-type: none"> 29443 0x7303 - RANLI_CIMES_1000_20870
	0 No response	
	1 Fault > CiA402	
	2 Warning	
0x2C46	Number of the absolute ascertainable revolutions of motor encoder <ul style="list-style-type: none"> Read only 	Is set by the firmware according to the available version: <ul style="list-style-type: none"> 0: no absolute value encoder (sin/cos encoder) or resolver with number of pole pairs > 1 1: Single-turn absolute value encoder or resolver with number of pole pairs = 1 >1: Multi-turn absolute value encoder
0x2C47	Open circuit detection sensitivity of motor encoder 1 ... [100] ... 100 %	The sensitivity can be reduced by percentage, e. g. in case of EMC interferences.
0x608F:001	Position encoder resolution: Encoder increments <ul style="list-style-type: none"> Setting can only be changed if the inverter is disabled. 	Setting the number of bits to be used for resolving a mechanical motor revolution. Position encoder resolution: Encoder increments
	65536 16 bit	
	262144 18 bit	
	1048576 20 bit	
	4194304 22 bit	
	16777216 24 bit	
	67108864 26 bit	
	268435456 28 bit	
	1073741824 30 bit	
0x608F:002	Position encoder resolution: Motor revolutions 1 ... [1] ... 1 <ul style="list-style-type: none"> Setting can only be changed if the inverter is disabled. 	Denominator of the position resolution: Number of motor revolutions. Only setting "1" is accepted.
0x6090:001	Velocity encoder resolution: Encoder increments/s 0 ... [33554432] ... 2147483647 <ul style="list-style-type: none"> Setting can only be changed if the inverter is disabled. 	Setting of the encoder increments/s.
0x6090:002	Velocity encoder resolution: Motor revolutions/s 0 ... [125] ... 2147483647 <ul style="list-style-type: none"> Setting can only be changed if the inverter is disabled. 	Setting of the motor revolutions/s.



Configuring the feedback system

Configure feedback system for motor control
Resolver settings

11.1.2 Resolver settings



Resolvers with a number of pole pairs > 1 are not absolute value encoders.

Bit 4 in [0x2833](#) (Lenze status word 2) therefore remains set to "0".

The "distinguishable revolutions" specification in [0x2C46](#) is also set to "0".

The following applies to synchronous motors:

- When the number of motor pole pairs to the number of resolver pole pairs is an integer ratio ([0x2C01:001](#)), the pole position only has to be identified once.
- When the number of motor pole pairs to the number of resolver pole pairs is a non-integer ratio ([0x2C01:001](#)), the pole position must be identified every time the inverter is connected to 24 V. ▶ [Synchronous motor: Pole position identification \(PPI\)](#) [112](#)

Parameter

Address	Name / setting range / [default setting]	Information
0x2822:025	Axis commands: Get motor encoder characteristic (resolver)	Values determined in order to compensate for resolver faults.
	0 Off/Ready	
	1 On/Start	
	2 In progress	
	3 Action cancelled	
	4 No access	
5 No access (Inverter disabled)		
0x2C43	Motor encoder resolver number of pole pairs 1 ... [1] ... 10 • Setting can only be changed if the inverter is disabled.	Setting of the number of pole pairs.

Configuring the feedback system

Configure feedback system for motor control
Resolver settings



11.1.2.1 Resolver error compensation

The actual position detected by the resolver is not exactly the same as the real physical position. There are always deviations to a lesser or greater extent.

An identification run of the resolver automatically generates the adjustment values required for compensation of the resolver error.

The values calculated have a counteractive corrective effect on the underlying cause in the following parameters:

Cause	Remedy
Sine and cosine track do not magnetise orthogonally to each other.	0x2C44:001 Correction of the angle by means of which the two resolver tracks are supplied in a manner relative to one another.
The inductances of the sine and cosine track of the resolver have slightly different values.	0x2C44:002 and 0x2C44:003 Adjusting the gains of the digital-analog converters which feed the resolver tracks.

Conditions for executing the identification run

- Mechanical motor / inverter connection
 - If possible, execute the identification run before the motor is installed in the machine. Bigger load changes at the motor may have a negative impact on the identification result.
 - Motor and resolver must be properly connected to the inverter.
 - The motor must rotate freely.
- Voltage supply of the inverter
 - The inverter must be supplied with mains voltage. Check: [0x6041](#), bit 4 = TRUE.
 - The control electronics must be supplied with voltage. For this purpose, some designs require an external voltage source.
- Correct setting of the following data in the »EASY Starter« engineering tool:
 - Number of resolver pole pairs ([0x2C43](#))
 - Speed-controlled or position-controlled motor in servo control
- The inverter must be connected "online" to the engineering tool.

Possible responses during the execution

- The identification method can cause an uneven motor running during the identification.
- The direction of rotation can change.

This does not have a negative impact on the quality of the identification. In this case, the inverter automatically interrupts the identification run and automatically continues it if a constant speed is reached again.
- If the motor already installed in the machine does not have sufficient range in one direction for executing the identification run, you can also reverse the driving direction while the identification is active. In this case, the identification automatically switches to the "Identification temporarily interrupted ". The status is deactivated as soon as a constant speed has been reached again.



In the event of an interruption, the identification run is stopped. An error message is displayed.

If 0 % is set, the gain of the respective resolver track is only 95 % of the Lenze setting.

The detected gain can assume values in the range of 0 ... 100 %.

In case of a successful resolver error compensation, only one of the two gains is adjusted. The other value remains at 100 %.

How to run an identification



If possible, execute the identification run before the motor is installed in the machine. If relatively big load changes occur in the kinematics to be moved, this may have a negative impact on the result of the identification run.



Configuring the feedback system

Configure feedback system for motor control
Resolver settings

1. Initiate an identification run with parameter [0x2822:025](#).
2. Enable inverter.

The identification run is in standby mode.

3. Approach a constant speed between $n = 500$ rpm and $n = 3000$ rpm.

The identification run is started automatically after the drive has reached a constant speed and maintains it over the time defined in .

This speed is saved for the identification run. In order that the identification run can be continued again, e.g. after an interruption, the drive must be operated again with this speed.

End of the identification run

After the resolver error identification has been executed successfully, the parameters [0x2C44:001](#) ... [0x2C44:003](#) are written automatically. The resolver now works with these settings.

Short-time interruption of the identification run

A short-time interruption, e.g. by removing the controller enable, does not stop the measurement. It is continued after the controller is enabled anew. For the duration of the interruption, the following status message is displayed: "Identification interrupted temporarily")

Abort of the identification run

The measurement is aborted if the controller inhibit persists or after the time-out time has elapsed. A time-out error is output for the identification run (see error messages in the logbook).

4. If the measurement was successful, the motor can be stopped
5. At the end of the procedure, save the changed parameters [0x2C44:001](#) ... [0x2C44:003](#) in the inverter.

»EASY Starter« can be used to save the inverter parameter settings, see [▶ Saving the parameter settings](#). [□ 39](#)

Deactivating the resolver error compensation

For deactivating the resolver error compensation, the respective parameters must be reset again to the Lenze setting.

Parameter

Address	Name / setting range / [default setting]	Information
0x2C44:001	Motor encoder identification (Resolver): Angle -100 ... [0] ... 100	Setting of the angle to the resolver error compensation.
0x2C44:002	Motor encoder identification (Resolver): Cosine track gain 0 ... [100] ... 100 %	Setting of the gain of the cosine track to the resolver error compensation.
0x2C44:003	Motor encoder identification (Resolver): Sine track gain 0 ... [100] ... 100 %	Setting of the gain of the sine track to the resolver error compensation.

Configuring the feedback system

Configure feedback system for motor control
Encoder settings



Address	Name / setting range / [default setting]	Information
0x2C44:006	Motor encoder identification (Resolver): Identification status • Read only	Display of the resolver identification status.
	Bit 0 Identification activated	TRUE if: • Identification has been started. • Controller enable is active. FALSE if: • Identification has been aborted or completed successfully. • A timeout error is active. • The 24V supply has been switched on and default settings are loaded.
	Bit 2 Identification is running	TRUE if: • Identification is running. FALSE if: • The motor speed has fallen below the minimum speed of 500 rpm. • The identification process has been aborted temporarily and is on standby.
	Bit 3 Identification successful	TRUE if: • Identification has been completed successfully. FALSE if: • The identification is not completed yet after default settings were loaded.
	Bit 4 Identification failed	TRUE if: • A timeout error has occurred. FALSE if: • Identification has been completed successfully.

11.1.3 Encoder settings

In general, an encoder is a measuring system which serves to detect the velocity/speed and the position of a kinematics or motor.

Details



If a resolver variant is to be plugged into the respective slot of the inverter as a feedback system, the parameters in this section have no function.

Parameter

Address	Name / setting range / [default setting]	Information
0x2C40	Motor encoder type • Setting can only be changed if the inverter is disabled.	Selection of the encoder type.
	1 SinCos encoder	
	2 Hiperface absolute value encoder	
	3 TTL	
	5 SSI encoder	
	6 SinCos + SSI absolute value encoder	
0x2C42:001	Encoder settings: Increments/revolution 1 ... [1024] ... 131072 • Setting can only be changed if the inverter is disabled.	Setting of the encoder number of increments per revolution (according to manufacturer data/encoder data sheet).



Configuring the feedback system

Configure feedback system for motor control
Encoder settings

Address	Name / setting range / [default setting]	Information
0x2C42:002	Encoder settings: Supply voltage 5.0 ... [5.0] ... 12.0 V • Setting can only be changed if the inverter is disabled.	Setting of the supply voltage.

11.1.3.1 SinCos encoder

The following SinCos encoder types without HIPERFACE® protocol are supported by the inverter:

Type	Increments/revolution	Absolute revolutions
IG1024-5V-V3 (RVS58S)	1024	0
IG2048-5V-S (ITD22)	2048	0
IG2048-5V-S	2048	0

11.1.3.2 SinCos absolute value encoder with HIPERFACE® protocol

The following SinCos encoder types with HIPERFACE® protocol are supported by the inverter:

Type	Increments/revolution	Absolute revolutions	Type code 0x2C41:001
AM1024-8V-H (SRM50)	1024	4096 (Multiturn)	39
AM1024-8V-H (SFM60)	1024		39
AM1024-8V-K2 (SRM50S)	1024		39
AM128-8V-H (SKM36)	128		55
AM16-8V-H (SEL37)	16		71
AM16-8V-H (SEL52)	16		71
AM512-8V-H (SCM70)	512		7
AS1024-8V-H (SRS50)	1024	4096 (Single-turn)	34
AS1024-8V-K2 (SRS50S)	1024		34
AS16-8V-H (SEK37)	16		66
AS16-8V-H (SEK52)	16		66
AS512-8V-H (SCS70)	512		2

Use of non-supported encoder types

If the type code of the encoder used is not listed in the table of supported encoder types, this encoder can be introduced to the inverter via the [0x2C41:002](#) and [0x2C41:003](#) parameters.



In this context, please also observe the information provided in the parameter description [0x2C41:008](#).

Parameter

Address	Name / setting range / [default setting]	Information
0x2822:026	Axis commands: Get motor encoder information (Hiperface)	Command for reading out data from the connected motor encoder.
	0 Off/Ready	
	1 On/Start	
	2 In progress	
	3 Action cancelled	
	4 No access	
5 No access (Inverter disabled)		
0x2C41:001	Motor encoder settings (Hiperface): Type code detected • Read only	Type code read out of the encoder. This value is "0" if ... • a sin/cos encoder is set (0x2C40 = 2); • a communication error has occurred.
0x2C41:002	Motor encoder settings (Hiperface): Type code manual input 0 ... [0] ... 255 • Setting can only be changed if the inverter is disabled.	Manual setting of the encoder type code (display in 0x2C41:001).

Configuring the feedback system

Configure feedback system for motor control
Encoder settings



Address	Name / setting range / [default setting]	Information
0x2C41:003	Motor encoder settings (Hiperface): No. of periods manual input 1 ... [1] ... 65535 • Setting can only be changed if the inverter is disabled.	Manual setting of the number of distinguishable revolutions.
0x2C41:004	Motor encoder settings (Hiperface): Error response	Selection of the response for communication errors or in the event of an unknown encoder. Associated error codes: • 29568 0x7380 - RANLI_CIMES_1000_20894 • 29569 0x7381 - RANLI_CIMES_1000_20900 • 65302 0xFF16 - RANLI_CIMES_1000_20897
	0 No response	
	1 Fault > CiA402	
	2 Warning	
0x2C41:005	Motor encoder settings (Hiperface): Serial number • Read only	The displayed serial number can be used for identifying an encoder change.
0x2C41:006	Motor encoder settings (Hiperface): Actual position (raw data) • Read only	The encoder-internal position value is output without being converted.
0x2C41:007	Motor encoder settings (Hiperface): No. of periods detected • Read only	Display of the encoder increment according to encoder nameplate or type code.
0x2C41:008	Motor encoder settings (Hiperface): Type code verification • Read only	If an encoder is connected that is not supported by the firmware, it will be displayed here. In this case, the same response takes place as in case of a communication error. The error can be removed by manually setting the type code in 0x2C41:002 . This serves to signalise to the firmware that the number of distinguishable revolutions is as well set correctly in 0x2C41:003 by the user.
	0 Unknown - manual data input	If an encoder is connected that is not supported by the firmware, it will be displayed here.
	1 Known - parameterisation ok	
0x2C41:009	Motor encoder settings (Hiperface): Encoder type • Read only	Display of the detected encoder type (rotary/linear).
	0 Rotative encoder	
	1 Linear encoder	
0x2C41:010	Motor encoder settings (Hiperface): No. of periods linear encoder • Read only: x nm	Display of the period length of the linear encoder.



Configuring the feedback system

Configure feedback system for motor control
Encoder settings

11.1.3.3 SSI encoder

SSI absolute value encoders (**S**ynchronous **S**erial **I**nterface) generate the angle information via optical scanning of a code disc (e.g. Gray code). Every (absolute) angle position of the encoder corresponds to a uniquely identifiable code pattern.

All encoders that use the Stegemann SSI protocol are supported:

- Supported bit rates for SSI communication: 150 ... 1000 kbits
- Supported data word widths: 1 ... 31 bits (effective)
- Supported output code of the SSI encoder: Gray or binary
- Cycle time: 62.5 µs, 125 µs and 250 µs .
- Encoder supply: $U < 12\text{ V}$, $I \leq 0.25\text{ A}$

How to parameterise the SSI encoder:

1. Set the supply voltage of the SSI encoder used in [0x2C42:002](#).
2. Set selection "5: SSI encoder" as the encoder type in [0x2C40](#).
3. Set the transmission rate for SSI communication in [0x2C4A:001](#).

With the SSI protocol, the permissible transmission rate decreases as the cable lengths increase. A safe transmission rate must be set according to the length of the encoder cable used and the electromagnetic interference level.

4. Set the telegram length in [0x2C4A:002](#).

The telegram length reflects the number of data bits used for transmission of a complete SSI data packet.

5. Break the received SSI data word down into partwords and, if necessary, activate data conversion of Gray into binary code.

Parameter

Address	Name / setting range / [default setting]	Information
0x2C4A:001	Protokoll-Parameter Motorgeber (SSI): Übertragungsrate 150 ... [300] ... 1000 kbps • Setting can only be changed if the inverter is disabled.	To enable a stable transmission rate, the length of the encoder cable used and any electromagnetic interference levels must be taken into account when setting the value.
0x2C4A:002	Protokoll-Parameter Motorgeber (SSI): Telegrammlänge 1 ... [25] ... 31 • Setting can only be changed if the inverter is disabled.	The set value specifies the number of data bits which are transmitted as a complete SSI data packet.
0x2C4A:003	Protokoll-Parameter Motorgeber (SSI): Bits/ Umdrehung 1 ... [13] ... 31 • Setting can only be changed if the inverter is disabled.	Resolution of the encoder. For example, the resolution for the preset value is "13": $2^{13} = 8196$ (bits/revolution).
0x2C4A:004	Protokoll-Parameter Motorgeber (SSI): Startbit Positionsdaten 0 ... [0] ... 30 • Setting can only be changed if the inverter is disabled.	Indicates the position in the telegram where the position data word begins.
0x2C4A:005	Protokoll-Parameter Motorgeber (SSI): Startbit Datenpaket 1 0 ... [0] ... 30 • Setting can only be changed if the inverter is disabled.	Indicates the position in the telegram where data packet 1 begins.
0x2C4A:006	Protokoll-Parameter Motorgeber (SSI): Startbit Datenpaket 2 0 ... [0] ... 30 • Setting can only be changed if the inverter is disabled.	Indicates the position in the telegram where data packet 2 begins.

Configuring the feedback system

Configure feedback system for motor control
Encoder settings



Address	Name / setting range / [default setting]	Information
0x2C4A:007	Protokoll-Parameter Motorgeber (SSI): Startbit Datenpaket 3 0 ... [0] ... 30 • Setting can only be changed if the inverter is disabled.	Indicates the position in the telegram where data packet 3 begins.
0x2C4A:008	Protokoll-Parameter Motorgeber (SSI): Länge Positionsdaten 0 ... [0] ... 30 • Setting can only be changed if the inverter is disabled.	SSI position data length
0x2C4A:009	Protokoll-Parameter Motorgeber (SSI): Länge Datenpaket 1 0 ... [0] ... 30 • Setting can only be changed if the inverter is disabled.	Length of data packet 1.
0x2C4A:010	Protokoll-Parameter Motorgeber (SSI): Länge Datenpaket 2 0 ... [0] ... 30 • Setting can only be changed if the inverter is disabled.	Length of data packet 2.
0x2C4A:011	Protokoll-Parameter Motorgeber (SSI): Länge Datenpaket 3 0 ... [0] ... 30 • Setting can only be changed if the inverter is disabled.	Length of data packet 3.
0x2C4A:012	Protokoll-Parameter Motorgeber (SSI): Codierung Positionsdaten • Setting can only be changed if the inverter is disabled.	Coding of position data word (read only). If a value of "0" is set for the position data length in 0x2C4A:008 , then the value displayed for this parameter is also "0".
	0 Binär	
	1 Gray	
0x2C4A:013	Protokoll-Parameter Motorgeber (SSI): Codierung Datenpaket 1 • Setting can only be changed if the inverter is disabled.	Coding of data packet 1
	0 Binär	
	1 Gray	
0x2C4A:014	Protokoll-Parameter Motorgeber (SSI): Codierung Datenpaket 2 • Setting can only be changed if the inverter is disabled.	Coding of data packet 2
	0 Binär	
	1 Gray	
0x2C4A:015	Protokoll-Parameter Motorgeber (SSI): Codierung Datenpaket 3 • Setting can only be changed if the inverter is disabled.	Coding of data packet 3
	0 Binär	
	1 Gray	
0x2C4A:016	Protokoll-Parameter Motorgeber (SSI): Rohdaten Position • Read only	Raw value of position data word (read only). If a value of "0" is set for the position data length in 0x2C4A:008 , then the value displayed for this parameter is also "0".
0x2C4A:017	Protokoll-Parameter Motorgeber (SSI): Rohdaten Datenpaket 1 • Read only	Raw value of data packet 1 (read only). If a value of "0" is set for the data packet length 1 in 0x2C4A:013 , then the value displayed for this parameter is also "0".
0x2C4A:018	Protokoll-Parameter Motorgeber (SSI): Rohdaten Datenpaket 2 • Read only	Raw value of data packet 2 (read only). If a value of "0" is set for the data packet length 2 in 0x2C4A:014 , then the value displayed for this parameter is also "0".
0x2C4A:019	Protokoll-Parameter Motorgeber (SSI): Rohdaten Datenpaket 3 • Read only	Raw value of data packet 3 (read only). If a value of "0" is set for the data packet length 3 in 0x2C4A:015 , then the value displayed for this parameter is also "0".



Configuring the feedback system

Configure feedback system for motor control
Encoder settings

11.1.3.4 One cable technology (OCT) via HIPERFACE DSL®

Parameterize HIPERFACE DSL® (OCT)



The one cable technology is possible with MCS and m850 servo motors. The motor must be provided with a HIPERFACE DSL® encoder.

The Lenze hybrid cable EYP0080AxxxxM11A00 must be used as a connection cable.

Make sure no encoder module is plugged in slot A.

The one cable technology cannot be used in connection with the Extended Safety option.

Install the shields of the encoder cores and the brake cores separately.

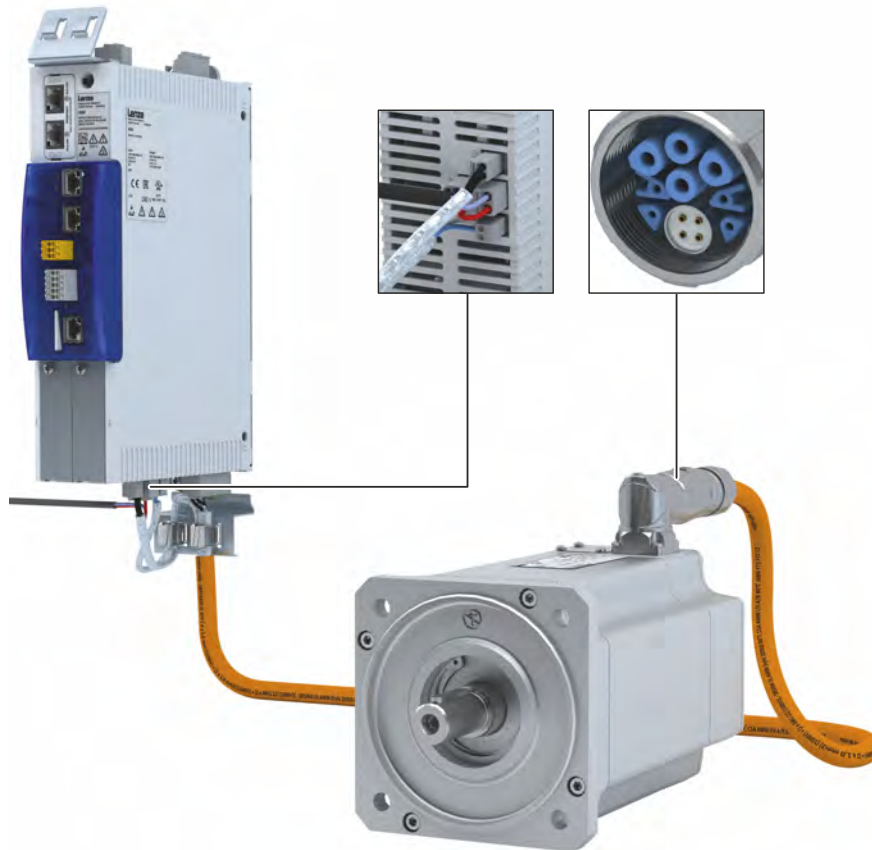

Fig. 1: HIPERFACE DSL® (OCT) connection

Parameter **Axis settings: Function X109** = 10 to activate HIPERFACE DSL® (OCT). ▶ [0x2DE1:001](#)

Parameter

Address	Name / setting range / [default setting]	Information
0x2DE1:001	Axis settings: Function of X109	
	0 None	
	10 HIPERFACE DSL® (OCT)	
	20 PTC	

Configuring the feedback system

Configure feedback system for motor control
Encoder settings



11.1.3.5 Evaluation of the signal quality

Signal quality

The signal quality is evaluated by the `0x2C42:004` parameter, which is used to monitor the initial read-out and setting of the position.

If a transmission error should occur:

- The current angular drift is marked as invalid in parameter `0x2833`, bit 7
- The inverter maintains its operating status

Angular drift



Communication with the encoder is no longer monitored during angular drift determination.

The value displayed in `0x2C42:003` is determined in different ways depending on the type of encoder:

- **Determination of the current angular drift for the SinCos encoder**

In the case of an incremental SinCos encoder, the pulses between two zero pulse events of the Z-track are counted. Assuming that there are no faults, this value corresponds to the set number of increments. The accuracy of this process corresponds to ± 1 increment graduation of the encoder, with the difference between the set number of increments and the counted pulses being converted to an angle with an accuracy of $\pm 0.1^\circ$. The disadvantage is that an updated angular drift value only become available at the end of a complete encoder revolution. In turn, this means that the update rate depends on the speed.

- **Determination of the current angular drift for the SinCos Hiperface® absolute value encoder**

In the case of a SinCos absolute value encoder with HIPERFACE® protocol, no Z-track is available; instead, the position is regularly read out of the encoder. When the first encoder read-out operation is performed (after power-up or elimination of wire breakage), the encoder position is used to initialise the internal device counter unit and to set an internal device position. All other read-out processes from the encoder are used to generate a difference between the internal device position and the encoder position. Assuming that there are no faults, the difference is zero. However, the dead time of the communication with the encoder means that the accuracy of the process is dependent on the speed and therefore restricted compared to the zero pulse process. However, the advantage is that the update rate does not depend on the speed, but is instead only determined by the communication rate. The update rate is encoder-specific and is generally in the range between 30 ... 50 ms.

Parameter

Address	Name / setting range / [default setting]	Information
0x2C42:003	Encoder settings: Angle drift <ul style="list-style-type: none">• Read only: x.x °	Display of the angular drift of the current angle error. This indicates whether too many or too few pulses have been detected by the internal device counter unit for EMC-related reasons.
0x2C42:004	Encoder settings: Actual amplitude signal quality <ul style="list-style-type: none">• Read only: x %	The signal quality indicates the actual amplitude of the SinCos analog signals with regard to $1 V_{SS} = 100\%$. <ul style="list-style-type: none">• The signal quality should be between 95 ... 105 %.• There is no need for optimisation if the signal quality is within the tolerance zone for the analog encoder signals given in the data sheet of the encoder manufacturer.



Configuring the feedback system

Configure feedback system for motor control
Detection of changed settings of the feedback system

11.1.4 Detection of changed settings of the feedback system

Bit 0 of status word 2 indicates whether the settings of the feedback system have been changed since leaving the **Not ready to start** state. If a change has been made, bit 0 is set to value "1". ▶ [0x2833](#)

During the transition to the **Operation enabled** state, bit 0 is reset to value "0".

In all device states, changes to the following parameters continue to be monitored.

Relevant parameters of other functions

Address	Name	Default setting	Setting range
0x2C40	Motor encoder type	SinCos encoder [1]	Selection list
0x2C41:002	Motor encoder settings (Hiperface): Type code manual input	0	0 ... 255
0x2C41:003	Motor encoder settings (Hiperface): No. of periods manual input	1	1 ... 65535
0x2C41:005	Motor encoder settings (Hiperface): Serial number	- (Read only)	
0x2C42:001	Encoder settings: Increments/revolution	1024	1 ... 131072
0x608F:001	Position encoder resolution: Encoder increments	16 bit [65536]	Selection list
0x608F:002	Position encoder resolution: Motor revolutions	1	1 ... 1

11.1.5 Diagnostics

Parameter

Address	Name / setting range / [default setting]	Information
0x2C4F	Parameter CRC of motor encoder • Read only	Display of the cyclic redundancy check (CRC) of selected encoder parameters to detect changes in the feedback settings.
0x2DDF:005	Axis information: Motor encoder • Read only	Display of supported feedback system for the motor.
	0 Produktdefiniert	
	1 Kein Geber	
	2 Resolver	
	3 SinCos-Geber oder Hiperface-Absolutwertgeber	
4 TTL + HTL encoder		



11.2 Second feedback system for the technology application

The parameter settings for the feedback system of the application are accessed in »EASY starter« via the following path:

- **Settings** tab
 - Basic setting \ Feedback application (B)

Here, you have the choice of using the following feedback systems:

- Resolver
- Encoder

You can select the feedback system that you wish to use by pressing the correspondingly named button.

11.2.1 General settings

This chapter provides information on general feedback system settings for the application.

Parameter

Address	Name / setting range / [default setting]	Information
0x2C55	Load encoder/master encoder error response	Via this parameter, the error response to an encoder error of application feedback B (slot B) is set. Selection of the response to the triggering of the encoder signal loss monitoring. Only active when used as: <ul style="list-style-type: none"> • Feedback system for motor control if set, • Signal source for the "position counter" function. Associated error code: <ul style="list-style-type: none"> • 29444 0x7304 - RANLI_CIMES_1000_20910
	0 No response	
	1 Fault > CiA402	
	2 Warning	
0x2C56	Number of the absolute ascertainable revolutions of load encoder/master encoder <ul style="list-style-type: none"> • Read only 	Is set by the firmware according to the available version: <ul style="list-style-type: none"> • 0: no absolute value encoder (sin/cos encoder) or resolver with number of pole pairs > 1 • 1: Hiperface encoder SingleTurn or resolver with number of pole pairs = 1 • > 1: Hiperface encoder Multi Turn
0x2C57	Open circuit detection sensitivity of load encoder/master encoder 1 ... [100] ... 100 %	The sensitivity can be reduced by percentage, e. g. in case of EMC interferences.
0x60E6:001	Additional position encoder resolution - encoder increments: Load encoder/master encoder - number of increments <ul style="list-style-type: none"> • Setting can only be changed if the inverter is disabled. 	Setting the number of bits to be used for resolving a mechanical revolution of the secondary feedback system.
	65536 16 Bit	
	262144 18 Bit	
	1048576 20 Bit	
	4194304 22 Bit	
	16777216 24 Bit	
	67108864 26 Bit	
	268435456 28 Bit	
1073741824 30 Bit		
0x60EB:001	Additional position encoder resolution - motor revolutions: Load encoder/master encoder - resolution of motor revolutions 1 ... [1] ... 1 <ul style="list-style-type: none"> • Setting can only be changed if the inverter is disabled. 	Setting of the number of revolutions of the secondary feedback system. Only setting "1" is accepted.



11.2.2 Resolver settings



Resolvers with a number of pole pairs > 1 are not absolute value encoders.

Bit 10 in [0x2833](#) (Lenze status word 2) therefore remains set to "0".

The "distinguishable revolutions" specification in [0x2C56](#) is also set to "0".

Parameter

Address	Name / setting range / [default setting]	Information
0x2822:029	Axis commands: Get load encoder/master encoder characteristic (resolver)	Definition of the resolver characteristic for application feedback.
	0 Off/Ready	
	1 On/Start	
	2 In progress	
	3 Action cancelled	
	4 No access	
5 No access (Inverter disabled)		
0x2C53	Load encoder/master encoder resolver number of pole pairs 1 ... [1] ... 1 <ul style="list-style-type: none"> Setting can only be changed if the inverter is disabled. 	Setting of the number of pole pairs.



11.2.2.1 Resolver error compensation

The actual position detected by the resolver is not exactly the same as the real physical position. There are always deviations to a lesser or greater extent.

An identification run of the resolver automatically generates the adjustment values required for compensation of the resolver error.

The values calculated have a counteractive corrective effect on the underlying cause in the following parameters:

Cause	Remedy
Sine and cosine track do not magnetise orthogonally to each other.	0x2C44:001 Correction of the angle by means of which the two resolver tracks are supplied in a manner relative to one another.
The inductances of the sine and cosine track of the resolver have slightly different values.	0x2C44:002 and 0x2C44:003 Adjusting the gains of the digital-analog converters which feed the resolver tracks.

Conditions for executing the identification run

- Mechanical motor / inverter connection
 - If possible, execute the identification run before the motor is installed in the machine. Bigger load changes at the motor may have a negative impact on the identification result.
 - Motor and resolver must be properly connected to the inverter.
 - The motor must rotate freely.
- Voltage supply of the inverter
 - The inverter must be supplied with mains voltage. Check: [0x6041](#), bit 4 = TRUE.
 - The control electronics must be supplied with voltage. For this purpose, some designs require an external voltage source.
- Correct setting of the following data in the »EASY Starter« engineering tool:
 - Number of resolver pole pairs ([0x2C43](#))
 - Speed-controlled or position-controlled motor in servo control
- The inverter must be connected "online" to the engineering tool.

Possible responses during the execution

- The identification method can cause an uneven motor running during the identification.
 - The direction of rotation can change.
- This does not have a negative impact on the quality of the identification. In this case, the inverter automatically interrupts the identification run and automatically continues it if a constant speed is reached again.
- If the motor already installed in the machine does not have sufficient range in one direction for executing the identification run, you can also reverse the driving direction while the identification is active. In this case, the identification automatically switches to the "Identification temporarily interrupted ". The status is deactivated as soon as a constant speed has been reached again.



In the event of an interruption, the identification run is stopped. An error message is displayed.

If 0 % is set, the gain of the respective resolver track is only 95 % of the Lenze setting.

The detected gain can assume values in the range of 0 ... 100 %.

In case of a successful resolver error compensation, only one of the two gains is adjusted. The other value remains at 100 %.

How to run an identification



If possible, execute the identification run before the motor is installed in the machine. If relatively big load changes occur in the kinematics to be moved, this may have a negative impact on the result of the identification run.



1. Initiate an identification run with parameter [0x2822:025](#).
2. Enable inverter.

The identification run is in standby mode.

3. Enter a constant speed between $n = 500$ rpm and $n = 3000$ rpm.

The identification run is started automatically after the drive has reached a constant speed and maintains it over the time defined in .

This speed is saved for the identification run. In order that the identification run can be continued again, e.g. after an interruption, the drive must be operated again with this speed.

End of the identification run

After the resolver error identification has been executed successfully, the parameters [0x2C44:001](#) ... [0x2C44:003](#) are written automatically. The resolver now works with these settings.

Short-time interruption of the identification run

A short-time interruption, e.g. by removing the controller enable, does not stop the measurement. It is continued after the controller is enabled anew. For the duration of the interruption, the following status message is displayed: "Identification interrupted temporarily")

Abort of the identification run

The measurement is aborted if the controller inhibit persists or after the time-out time has elapsed. A time-out error is output for the identification run (see error messages in the logbook).

4. If the measurement was successful, the motor can be stopped
5. At the end of the procedure, save the changed parameters [0x2C44:001](#) ... [0x2C44:003](#) in the inverter.

»EASY Starter« can be used to save the inverter parameter settings, see [▶ Saving the parameter settings](#). [□ 39](#)

Deactivating the resolver error compensation

For deactivating the resolver error compensation, the respective parameters must be reset again to the Lenze setting.

Parameter

Address	Name / setting range / [default setting]	Information
0x2C54:001	Load encoder/master encoder identification (Resolver): Angle -100 ... [0] ... 100	Setting of the angle to the resolver error compensation.
0x2C54:002	Load encoder/master encoder identification (Resolver): Cosine track gain 0 ... [100] ... 100 %	Setting of the gain of the cosine track to the resolver error compensation.
0x2C54:003	Load encoder/master encoder identification (Resolver): Sine track gain 0 ... [100] ... 100 %	Setting of the gain of the sine track to the resolver error compensation.

Configuring the feedback system

Second feedback system for the technology application

Encoder settings



Address	Name / setting range / [default setting]	Information
0x2C54:006	Load encoder/master encoder identification (Resolver): Identification status • Read only	Display of the resolver identification status.
	Bit 0 Identification activated	TRUE if: • Identification has been started. • Controller enable is active. FALSE if: • Identification has been aborted or completed successfully. • A timeout error is active. • The 24V supply has been switched on and default settings are loaded.
	Bit 2 Identification is running	TRUE if: • Identification is running. FALSE if: • The motor speed has fallen below the minimum speed of 500 rpm. • The identification process has been aborted temporarily and is on standby.
	Bit 3 Identification successful	TRUE if: • Identification has been completed successfully. FALSE if: • The identification is not completed yet after default settings were loaded.
	Bit 4 Identification failed	TRUE if: • A timeout error has occurred. FALSE if: • Identification has been completed successfully.

11.2.3 Encoder settings

In general, an encoder is a measuring system which serves to detect the velocity/speed and possibly the position of a kinematics or motor.

Details



If a resolver variant is to be plugged into the respective slot of the inverter as a feedback system, the parameters in this section have no function.

Generally, an encoder can be used for a variety of tasks:

- As setpoint encoder for defining a speed / frequency setpoint.
- As setpoint encoder for defining a position setpoint.
- As setpoint encoder for defining a setpoint for the process controller.
- As actual value encoder for feeding back the variable for the process controller.
- As kinematics encoder (feedback system).

Parameter

Address	Name / setting range / [default setting]	Information
0x2C50	Load encoder/master encoder type • Setting can only be changed if the inverter is disabled.	Selection of the encoder type.
	1 SinCos encoder	
	2 Hiperface absolute value encoder	
	3 TTL	
	5 SSI encoder	
	6 SinCos + SSI absolute value encoder	
0x2C52:001	Load encoder/master encoder settings (encoder): Increments/revolution 1 ... [1024] ... 131072 • Setting can only be changed if the inverter is disabled.	Setting of the encoder number of increments (according to manufacturer data/encoder data sheet).



Address	Name / setting range / [default setting]	Information
0x2C52:002	Load encoder/master encoder settings (encoder): Supply voltage 5.0 ... [5.0] ... 12.0 V • Setting can only be changed if the inverter is disabled.	Setting of the supply voltage.

11.2.3.1 SinCos encoder

The following SinCos encoder types without HIPERFACE® protocol are supported by the inverter:

Type	Increments/revolution	Absolute revolutions
IG1024-5V-V3 (RV558S)	1024	0
IG2048-5V-S (ITD22)	2048	0
IG2048-5V-S	2048	0

11.2.3.2 SinCos absolute value encoder with HIPERFACE® protocol

The following SinCos encoder types with HIPERFACE® protocol are supported by the inverter:

Type	Increments/revolution	Absolute revolutions	Type code 0x2C41:001
AM1024-8V-H (SRM50)	1024	4096 (Multiturn)	39
AM1024-8V-H (SFM60)	1024		39
AM1024-8V-K2 (SRM50S)	1024		39
AM128-8V-H (SKM36)	128		55
AM16-8V-H (SEL37)	16		71
AM16-8V-H (SEL52)	16		71
AM512-8V-H (SCM70)	512		7
AS1024-8V-H (SRS50)	1024	4096 (Single-turn)	34
AS1024-8V-K2 (SRS50S)	1024		34
AS16-8V-H (SEK37)	16		66
AS16-8V-H (SEK52)	16		66
AS512-8V-H (SCS70)	512		2

Use of non-supported encoder types

If the type code of the encoder used is not listed in the table of supported encoder types, this encoder can be introduced to the inverter via two parameters. ▶ [0x2C51:002](#) ▶ [0x2C51:003](#)



In this context, please also observe the information provided in the parameter description [0x2C41:008](#).

Parameter

Address	Name / setting range / [default setting]	Information
0x2822:030	Axis commands: Get load encoder/master encoder information (Hiperface)	Obtain Hiperface information from the encoder for application feedback.
	0 Off/Ready	
	1 On/Start	
	2 In progress	
	3 Action cancelled	
	4 No access	
5 No access (controller inhibit)		
0x2C51:001	Hiperface load encoder/master encoder settings: Type code detected • Read only	Type code read out of the encoder. This value is "0" if ... • a sin/cos encoder is set (0x2C50 = 2); • a communication error has occurred.
0x2C51:002	Hiperface load encoder/master encoder settings: Type code manual input 0 ... [0] ... 255 • Setting can only be changed if the inverter is disabled.	Manual setting of the encoder type code (display in 0x2C51:001).

Configuring the feedback system

Second feedback system for the technology application

Encoder settings



Address	Name / setting range / [default setting]	Information
0x2C51:003	Hiperface load encoder/master encoder settings: No. of periods manual input 1 ... [1] ... 65535 • Setting can only be changed if the inverter is disabled.	Manual setting of the number of distinguishable revolutions.
0x2C51:004	Hiperface load encoder/master encoder settings: Error response	Selection of the response for communication errors or in the event of an unknown encoder. Associated error codes: • 29570 0x7382 - RANLI_CIMES_1000_20911 • 29571 0x7383 - RANLI_CIMES_1000_20912 • 65306 0xFF1A - RANLI_CIMES_1000_20913
	0 No response	
	1 Fault > CiA402	
	2 Warning	
0x2C51:005	Hiperface load encoder/master encoder settings: Serial number • Read only	The displayed serial number can be used for identifying an encoder change.
0x2C51:006	Hiperface load encoder/master encoder settings: Actual position (raw data) • Read only	The encoder-internal position value is output without being converted.
0x2C51:007	Hiperface load encoder/master encoder settings: No. of periods detected • Read only	Display of the encoder increment according to encoder nameplate or type code.
0x2C51:008	Hiperface load encoder/master encoder settings: Type code verification • Read only	If an encoder is connected that is not supported by the firmware, it will be displayed here. In this case, the same response takes place as in case of a communication error. The error can be removed by manually setting the type code in 0x2C51:002 . This serves to signalise to the firmware that the number of distinguishable revolutions is as well set correctly in 0x2C51:003 by the user.
	0 Unknown - manual data input	In this case, the same response takes place as in case of a communication error. The error can be removed by manually setting the type code in 0x2C51:002 . This serves to signalise to the firmware that the number of distinguishable revolutions is as well set correctly in 0x2C51:003 by the user.
	1 Known - parameterisation ok	
0x2C51:009	Hiperface load encoder/master encoder settings: Encoder type • Read only	Display of the detected encoder type (rotary/linear).
	0 Rotative encoder	
	1 Linear encoder	
0x2C51:010	Hiperface load encoder/master encoder settings: No. of periods linear encoder • Read only: x nm	Display of the period length of the linear encoder.



11.2.3.3 SSI encoder

SSI absolute value encoders (**S**ynchronous **S**erial **I**nterface) generate the angle information via optical scanning of a code disc (e.g. Gray code). Every (absolute) angle position of the encoder corresponds to a uniquely identifiable code pattern.

All encoders that use the Stegemann SSI protocol are supported:

- Supported bit rates for SSI communication: 150 ... 1000 kbits
- Supported data word widths: 1 ... 31 bits (effective)
- Supported output code of the SSI encoder: Gray or binary
- Cycle time: 62.5 µs, 125 µs and 250 µs .
- Encoder supply: $U < 12\text{ V}$, $I \leq 0.25\text{ A}$

How to parameterise the SSI encoder:

1. Set the supply voltage of the SSI encoder used in [0x2C52:002](#).
2. Set selection "5: SSI encoder" as the encoder type in [0x2C50](#).
3. Set the transmission rate for SSI communication in [0x2C5A:001](#).

With the SSI protocol, the permissible transmission rate decreases as the cable lengths increase. A safe transmission rate must be set according to the length of the encoder cable used and the electromagnetic interference level.

4. Set the telegram length in [0x2C5A:002](#).

The telegram length reflects the number of data bits used for transmission of a complete SSI data packet.

5. Break the received SSI data word down into partwords and, if necessary, activate data conversion of Gray into binary code.

Parameter

Address	Name / setting range / [default setting]	Information
0x2C5A:001	Protokoll-Parameter Lastgeber/Leitgeber (SSI): Übertragungsrate 150 ... [300] ... 1000 kbps • Setting can only be changed if the inverter is disabled.	To enable a stable transmission rate, the length of the encoder cable used and any electromagnetic interference levels must be taken into account when setting the value.
0x2C5A:002	Protokoll-Parameter Lastgeber/Leitgeber (SSI): Telegrammlänge 1 ... [25] ... 31 • Setting can only be changed if the inverter is disabled.	The set value specifies the number of data bits which are transmitted as a complete SSI data packet.
0x2C5A:003	Protokoll-Parameter Lastgeber/Leitgeber (SSI): Bits/ Umdrehung 1 ... [13] ... 31 • Setting can only be changed if the inverter is disabled.	Resolution of the encoder. For example, the resolution for the preset value is "13": $2^{13} = 8196$ (bits/revolution).
0x2C5A:004	Protokoll-Parameter Lastgeber/Leitgeber (SSI): Startbit Positionsdaten 0 ... [0] ... 30 • Setting can only be changed if the inverter is disabled.	Indicates the position in the telegram where the position data word begins.
0x2C5A:005	Protokoll-Parameter Lastgeber/Leitgeber (SSI): Startbit Datenpaket 1 0 ... [0] ... 30 • Setting can only be changed if the inverter is disabled.	Indicates the position in the telegram where data packet 1 begins.
0x2C5A:006	Protokoll-Parameter Lastgeber/Leitgeber (SSI): Startbit Datenpaket 2 0 ... [0] ... 30 • Setting can only be changed if the inverter is disabled.	Indicates the position in the telegram where data packet 2 begins.

Configuring the feedback system

Second feedback system for the technology application

Encoder settings



Address	Name / setting range / [default setting]	Information
0x2C5A:007	Protokoll-Parameter Lastgeber/Leitgeber (SSI): Startbit Datenpaket 3 0 ... [0] ... 30 • Setting can only be changed if the inverter is disabled.	Indicates the position in the telegram where data packet 3 begins.
0x2C5A:008	Protokoll-Parameter Lastgeber/Leitgeber (SSI): Länge Positionsdaten 0 ... [25] ... 30 • Setting can only be changed if the inverter is disabled.	SSI position data length
0x2C5A:009	Protokoll-Parameter Lastgeber/Leitgeber (SSI): Länge Datenpaket 1 0 ... [0] ... 30 • Setting can only be changed if the inverter is disabled.	Length of data packet 1.
0x2C5A:010	Protokoll-Parameter Lastgeber/Leitgeber (SSI): Länge Datenpaket 2 0 ... [0] ... 30 • Setting can only be changed if the inverter is disabled.	Length of data packet 2.
0x2C5A:011	Protokoll-Parameter Lastgeber/Leitgeber (SSI): Länge Datenpaket 3 0 ... [0] ... 30 • Setting can only be changed if the inverter is disabled.	Length of data packet 3.
0x2C5A:012	Protokoll-Parameter Lastgeber/Leitgeber (SSI): Codierung Positionsdaten • Setting can only be changed if the inverter is disabled.	Coding of position data word (read only). If a value of "0" is set for the position data length in 0x2C4A:008 , then the value displayed for this parameter is also "0".
	0 Binär	
	1 Gray	
0x2C5A:013	Protokoll-Parameter Lastgeber/Leitgeber (SSI): Codierung Datenpaket 1 • Setting can only be changed if the inverter is disabled.	Coding of data packet 1
	0 Binär	
	1 Gray	
0x2C5A:014	Protokoll-Parameter Lastgeber/Leitgeber (SSI): Codierung Datenpaket 2 • Setting can only be changed if the inverter is disabled.	Coding of data packet 2
	0 Binär	
	1 Gray	
0x2C5A:015	Protokoll-Parameter Lastgeber/Leitgeber (SSI): Codierung Datenpaket 3 • Setting can only be changed if the inverter is disabled.	Coding of data packet 3
	0 Binär	
	1 Gray	
0x2C5A:016	Protokoll-Parameter Lastgeber/Leitgeber (SSI): Rohdaten Position • Read only	Raw value of position data word (read only). If a value of "0" is set for the position data length in 0x2C4A:008 , then the value displayed for this parameter is also "0".
0x2C5A:017	Protokoll-Parameter Lastgeber/Leitgeber (SSI): Rohdaten Datenpaket 1 • Read only	Raw value of data packet 1 (read only). If a value of "0" is set for the data packet length 1 in 0x2C4A:013 , then the value displayed for this parameter is also "0".
0x2C5A:018	Protokoll-Parameter Lastgeber/Leitgeber (SSI): Rohdaten Datenpaket 2 • Read only	Raw value of data packet 2 (read only). If a value of "0" is set for the data packet length 2 in 0x2C4A:014 , then the value displayed for this parameter is also "0".
0x2C5A:019	Protokoll-Parameter Lastgeber/Leitgeber (SSI): Rohdaten Datenpaket 3 • Read only	Raw value of data packet 3 (read only). If a value of "0" is set for the data packet length 3 in 0x2C4A:015 , then the value displayed for this parameter is also "0".



11.2.3.4 Evaluation of the signal quality

Signal quality

The signal quality is evaluated by the parameter [0x2C52:004](#), which serves to monitor the initial reading and setting of the position.

If a transmission error occurs

- the current angular drift is marked as invalid in the parameter [0x2833](#), bit 9.
- the inverter keeps its operating status.

Angular drift



Communication with the encoder is no longer monitored during the angular drift determination.

The value displayed in [0x2C52:003](#) is determined in different ways depending on the encoder type:

- **Determination of the current angular drift for the sin/cos encoder**

In the case of an incremental SinCos encoder, the pulses between two zero pulse events of the Z-track are counted. Assuming that there are no faults, this value corresponds to the set number of increments. The accuracy of this process corresponds to ± 1 increment graduation of the encoder, with the difference between the set number of increments and the counted pulses being converted to an angle with an accuracy of $\pm 0.1^\circ$. The disadvantage is that an updated angular drift value only becomes available at the end of a complete encoder revolution. In turn, this means that the update rate depends on the speed.

- **Determination of the current angular drift for the SinCos-Hiperface® absolute value encoder**

In the case of a SinCos absolute value encoder with HIPERFACE® protocol, no Z-track is available; instead, the position is regularly read out of the encoder. When the first encoder read-out operation is performed (after power-up or elimination of wire breakage), the encoder position is used to initialise the internal device counter unit and to set an internal device position. All other read-out processes from the encoder are used to generate a difference between the internal device position and the encoder position. Assuming that there are no faults, the difference is zero. However, the dead time of the communication with the encoder means that the accuracy of the process is dependent on the speed and therefore restricted compared to the zero pulse process. However, the advantage is that the update rate does not depend on the speed, but is instead only determined by the communication rate. The update rate is encoder-specific and is generally in the range between 30 ... 50 ms.

Parameter

Address	Name / setting range / [default setting]	Information
0x2C52:003	Load encoder/master encoder settings (encoder): Angle drift • Read only: x.x °	Display of the angular drift of the current angle error.
0x2C52:004	Load encoder/master encoder settings (encoder): Actual amplitude signal quality • Read only: x %	The signal quality indicates the actual amplitude of the SinCos analog signals with regard to $1 V_{SS} = 100\%$. • The signal quality should be between 95 ... 105 %. • There is no need for optimisation if the signal quality is within the tolerance zone for the analog encoder signals given in the data sheet of the encoder manufacturer.

Configuring the feedback system

Second feedback system for the technology application
 Detection of changed settings of the feedback system



11.2.4 Detection of changed settings of the feedback system

Bit 0 of status word 2 indicates whether the settings of the feedback system have been changed since leaving the **Not ready to start** state. If a change has been made, bit 0 is set to value "1". ▶ [0x2833](#)

During the transition to the **Operation enabled** state, bit 0 is reset to value "0".

In all device states, changes to the following parameters continue to be monitored.

Relevant parameters of other functions

Address	Name	Default setting	Setting range
0x2C50	Load encoder/master encoder type	SinCos encoder [1]	Selection list
0x2C51:002	Hiperface load encoder/master encoder settings: Type code manual input	0	0 ... 255
0x2C51:003	Hiperface load encoder/master encoder settings: No. of periods manual input	1	1 ... 65535
0x2C51:005	Hiperface load encoder/master encoder settings: Serial number	- (Read only)	
0x2C52:001	Load encoder/master encoder settings (encoder): Increments/revolution	1024	1 ... 131072
0x608F:001	Position encoder resolution: Encoder increments	16 bit [65536]	Selection list
0x608F:002	Position encoder resolution: Motor revolutions	1	1 ... 1

11.2.5 Diagnostics

Parameter

Address	Name / setting range / [default setting]	Information
0x2C56	Number of the absolute ascertainable revolutions of load encoder/master encoder • Read only	Is set by the firmware according to the available version: • 0: no absolute value encoder (sin/cos encoder) or resolver with number of pole pairs > 1 • 1: Hiperface encoder SingleTurn or resolver with number of pole pairs = 1 • > 1: Hiperface encoder Multi Turn
0x2C5F	Parameter CRC of load encoder/master encoder • Read only	Display of the cyclic redundancy check (CRC) of selected encoder parameters to detect changes in the feedback settings.
0x2DDF:006	Axis information: Load encoder/master encoder • Read only	Display of the supported feedback system for the application. Cannot be used as motor feedback.
	0 Produktdefiniert	
	1 Kein Geber	
	2 Resolver	
	3 SinCos-Geber oder Hiperface-Absolutwertgeber	
	4 TTL + HTL encoder	
0x60E4:001	Additional position actual value: Load encoder/master encoder - actual position • Read only; x pos. unit	Display of the actual position of the secondary feedback system.
0x60E5:001	Additional velocity actual value: Load encoder/master encoder - actual speed • Read only; rpm	Display of the actual velocity of the secondary feedback system.



11.3 Encoder: Evaluation of safely speed and position

Parameter

Address	Name / setting range / [default setting]	Information
0x2878:001	Motor encoder: Motor encoder system • Read only	
	0 No motor encoder	
	1 SinCos encoder	
	2 Resolver	
0x2878:002	Motor encoder: SinCos encoder increments • Read only	
0x2878:003	Motor encoder: Number of resolver pole pairs • Read only	
0x2879:001	Mechanical data: Motor mounting direction • Read only	
	0 Clockwise rotating motor	
	1 Counter-clockwise rotating motor	
0x287A:001	Load encoder: Load encoder system • Read only	
	0 No load encoder	
	1 Analog encoder	
	2 Digital encoder	
0x287A:003	Load encoder: Load encoder gearbox factor numerator • Read only	
0x287A:004	Load encoder: Load encoder gearbox factor denominator • Read only	
0x287A:005	Load encoder: Load encoder mounting direction • Read only	
	0 Same as motor encoder	
	1 Inverse to motor encoder	
0x287A:006	Load encoder: Load encoder position -2147483648 ... [0] ... 2147483647 incr.	
0x287A:007	Load encoder: Status of load encoder position	
	0 Invalid	
	1 Valid	
0x287B:001	Velocity monitoring: Tolerance window (n=0) • Read only: x rpm	
0x287B:002	Velocity monitoring: Velocity comparison tolerance • Read only: x rpm	
0x287B:003	Velocity monitoring: Actual velocity n_safe • Read only: x rpm	
0x287B:004	Velocity monitoring: Internal actual velocity nSD • Read only: x rpm	
0x287B:005	Velocity monitoring: Internal actual velocity nBD • Read only: x rpm	
0x287B:006	Velocity monitoring: Actual velocity difference nSD-nBD • Read only: x rpm	
0x287C:001	Position monitoring: Position comparison tolerance • Read only: x incr.	
0x287C:002	Position monitoring: Actual Position p_safe • Read only: x incr.	
0x287C:003	Position monitoring: Internal actual position pSD • Read only: x incr.	
0x287C:004	Position monitoring: Internal actual position pBD • Read only: x incr.	
0x287C:005	Position monitoring: Current pos. difference pSD-pBD • Read only: x incr.	

Configuring the feedback system

Synchronous motor: Pole position identification (PPI)



11.4 Synchronous motor: Pole position identification (PPI)

For controlling a permanent-magnet synchronous motor, the pole position - the angle between the motor phase U and the field axis of the rotor - must be known.

- For Lenze motors with absolute value encoder or resolver, the pole position has already been set correctly.
- When incremental encoders are used (TTL or sin/cos encoders without absolute position information), a pole position identification (PPI) is always required. This also applies to Lenze motors.

NOTICE

The pole position identification (PPI) must only be executed

- ▶ for servo control with a synchronous motor of an original equipment manufacturer.
- ▶ for servo control with a synchronous motor and incremental encoders (TTL or sin/cos encoder).
- ▶ after changes to the motor feedback system, e.g. feedback replacement.

The parameter settings for pole position identification are accessed in »EASY Starter« via the following path:

- **Settings** tab
 - Basic setting \ Motor feedback (A)

Three different identification methods are offered here:

- 360° electrical
- With min. movement
- Without movement

The criteria for selecting the most suitable identification method are presented below.

Selection criteria for using the suitable pole position identification

For identifying the pole position for the currently activated feedback, the following functions are available which all provide almost the same result. Due to e.g. friction, bearing forces and a trapezoidal field pattern, the results may differ from each other.

▶ Pole position identification (PPI) 360° [114](#)

- The motor must not be braked, blocked or mechanically driven during the pole position identification! This function must not be used for hanging loads!
- Especially in case of idling drives or drives with a low load (inertia / friction), this function delivers the most accurate results.

▶ Pole position identification (PPI) with minimum movement [118](#)

- The motor must not be braked, blocked or driven during the pole position identification! Thus, this function must not be used for hanging loads!
- Regarding the accuracy, this function is in the middle range. A percentage increase of the current amplitude can enhance the accuracy of the results if required.

▶ Pole position identification (PPI) without movement [121](#)

- In case of stalled motors (e.g. with hanging loads), only this function shall be used!
- This function was developed for a wide range of motor characteristics. In case of some motor types, however, the identified pole position angle may differ considerably from the real pole position angle, so that a considerable loss in torque and greater motor losses may occur. Thus, especially when using third-party motors, we recommend the execution of a reference identification with an idling motor ▶ Pole position identification (PPI) 360° . [114](#)

If the identified values of both processes differ from each other by more than 20°, please contact Lenze.

Detailed information on the respective function can be found in the following subchapters.



Configuring the feedback system

Synchronous motor: Pole position identification (PPI)
Monitoring the pole position identification

11.4.1 Monitoring the pole position identification

If an error occurs during the pole position identification or if the pulse inhibit gets active (e.g. due to a short-time undervoltage), the process is stopped with disabling the inverter without the settings being changed.

If the motor was braked or blocked during the process, this will be detected at the end of the measurement and no change will be made (exception: "pole position identification PLI (without movement)").

The error response can be parameterised:

If an error occurs during the pole position identification,

- the procedure is stopped without the settings being changed.
- the response set in [0x2C60](#) is effected.

Parameter

Address	Name / setting range / [default setting]	Information
0x2C60	PPI monitoring: Reaction	Selection of the response triggered by the occurrence of an error during the pole position identification (PLI). Associated error codes: <ul style="list-style-type: none"> • 65284 0xFF04 - RANLI_CIMES_1000_20880 • 65299 0xFF13 - RANLI_CIMES_1000_15967
	0 No response	
	1 Fault > CiA402	
	2 Warning	

Configuring the feedback system

Synchronous motor: Pole position identification (PPI)
Pole position identification (PPI) 360°



11.4.2 Pole position identification (PPI) 360°

DANGER!

Mechanical damage of the motor caused by hanging loads!

The motor may be permanently damaged.

- ▶ The motor must not be braked or blocked during the pole position identification. Thus, this function must not be used for hanging loads!

NOTICE

Thermal overload of the motor!

The motor may be permanently damaged.

- ▶ Before executing the pole position identification, check that the following monitoring systems are parameterised correctly.
- ▶ [Motor overload monitoring \(\$i^2 \cdot t\$ \)](#)
- ▶ [Overcurrent monitoring](#)

NOTICE

- ▶ Please observe the following: [Synchronous motor: Pole position identification \(PPI\)](#)

Functional description

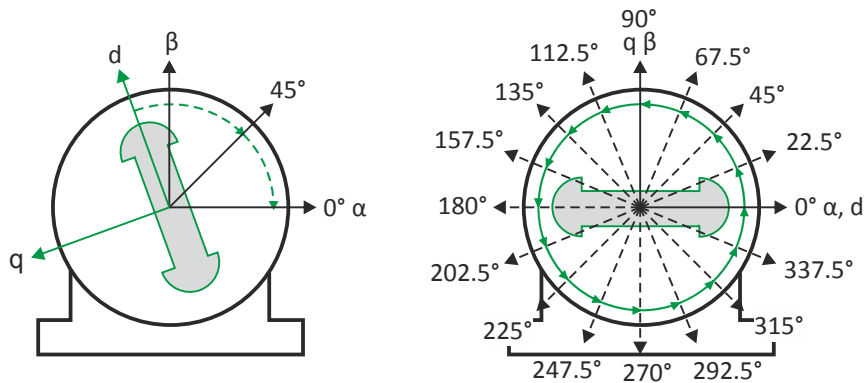



Configuring the feedback system

Synchronous motor: Pole position identification (PPI)
Pole position identification (PPI) 360°

If the servo control is set for synchronous motor and no error is pending, the current is first raised in a ramp-shaped manner to 141 % of the rated motor current after the inverter is enabled.

Left image

First, the rotor is moved from any position of rest to the 0° angle.

- For this purpose, the amplitude of the d current vector is created in the stator coordinate system at a starting angle of 45° and then turned to 0°.
- A sufficiently high amplitude of the d current vector and its rotary motion result in a magnetic force that moves the rotor to the angle 0°.

Right image

Afterwards, the d current vector is turned further in 15 steps by 22.5° each starting at the angle 0°.

- Due to the magnetic forces, the rotor adjusts to the respective angle.
- After 16 steps, the rotor has moved by absolute electrical 360°.

Result

For determining the pole position, a mean value is calculated from all 16 messages. The rotor displacement angle can be recorded via the [0x2DDE](#) parameter (actual motor rotor angle position). The detected pole position is stored in the inverter parameters, [0x2C03:0020x2C03:004](#). The detected pole position must then be saved.

Abort of the pole position identification

The pole position identification is aborted if the deviations between the rotary motion of the current vector and the rotor exceed the fault tolerance set in [0x2C41:004](#) (check if parameter is available).

Preconditions for the performance

- The motor must not be braked or blocked during the pole position identification.
- The servo inverter is error-free and in [Switched on](#) device state.

Response of the motor during performance

The rotor aligns during the pole position identification. The motor shaft moves by max. one electrical revolution which causes a corresponding movement of the connected mechanics!

How to execute the pole position identification PPI (360°):

1. If the servo inverter is enabled, disable it. [Enable operation](#)
2. Set the object [0x2825](#) to "5" to change to the "pole position identification PPI (360°)" operating mode.
3. Before the PPI can be started, the works mentioned below must be completed.
4. Enable the servo inverter to start the pole position identification (360°). Note: Inhibiting the controller serves to abort the started procedure any time if required without changing the settings.

After the pole position identification has been completed successfully...

...the controller is inhibited automatically and the pole position determined for the activated feedback system is set in the [0x2C03:002](#) object.

- Save the changed settings.

The »EASY Starter« serves to save the parameter settings of the servo inverter as parameter file (*.gdc). [Saving the parameter settings](#)

- The inverter disable set automatically by the procedure can be deactivated again via the CiA402 control word [0x6040](#). [Enable operation](#)

Configuring the feedback system

Synchronous motor: Pole position identification (PPI)
Pole position identification (PPI) 360°



Adapt pole position identification PPI (360°)

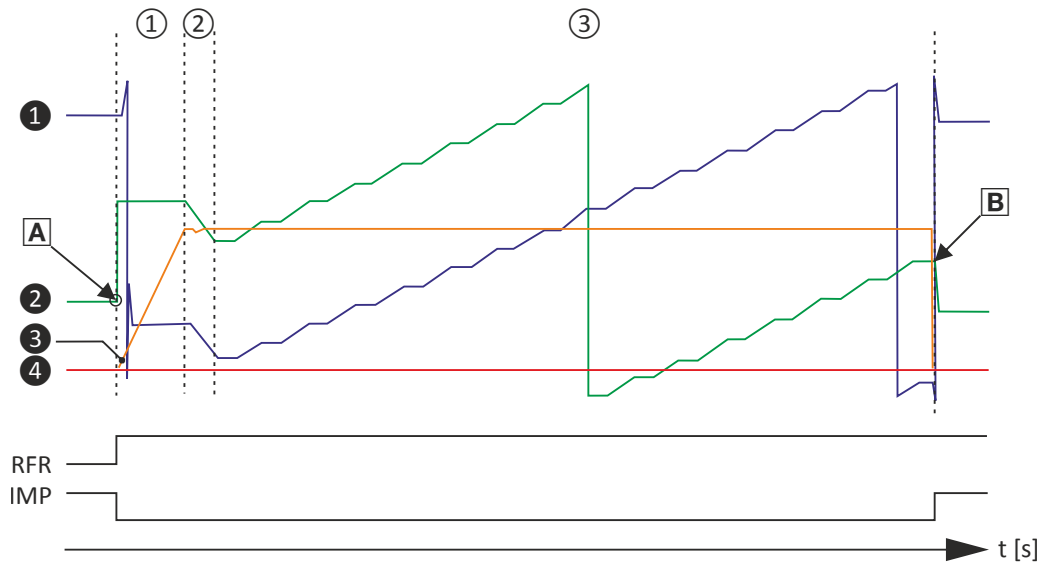

Fig. 2: Chronological sequence of the pole position identification

In case of drives with a high static friction, mass inertia or alternating load, an optimisation may be necessary:

- The amplitude of the current vector must be set so high that the motor with a high mass inertia can be accelerated.
- The cyclic continued rotation of the current vector by 22.5° has to cause an equivalent angular rotation of the motor shaft (rotor). A step function has to be achieved. Here, actual positions with very low overshoots are visible.

NOTICE

Thermal overload of the motor!

The motor may be permanently damaged.

- ▶ If no temperature monitoring is available in the motor, and/or the $I^2 \cdot t$ motor monitoring and the maximum current monitoring are not parameterised correctly, the motor can be permanently damaged if the current amplitude is set too high!
- ▶ [Motor overload monitoring \(\$i^2 \cdot t\$ \)](#)
- ▶ [Overcurrent monitoring](#)

Overview of more objects available for

- Identification
- Triggering
- Diagnostics

Tip!

An oscilloscope serves to execute the optimisation



Configuring the feedback system

Synchronous motor: Pole position identification (PPI)

Pole position identification (PPI) 360°

Parameter	Subindex	Value/unit	INFO
0x2825	0	CiA402 mode active [0]	Operating modes [5] for PLI 360°
0x2824	0	Activate [1]	
0x6040	0	0x0000	Simulation of the CiA state machine
0x2823	0	100	Progress bar
0x2C61:001	1	100 %	PLI(360°) current amplitude
0x2C61:002	2	40 s	PLI(360°) ramp time
0x2C61:003	3	Field: clockwise [0]	PLI(360°) direction of rotation
0x2C61:004	4	20°	PLI(360°) fault tolerance
0x2C61:005	5	4.81 A	Display
0x2C03:002	2	-90.0°	Detected pole position values
0x2C03:004	4	0.0°	
0x2DDE	0	1850	current rotor angle
0x2D83:002	2	0.03 A	Phase U current
0x2D83:003	3	0.04 A	Phase V current
0x2D83:004	4	-0.01 A	Phase W current
0x2DD1:003	3	0.00 A	Setpoint D current
0x2DD1:001	1	0.01 A	Current D current
0x6073	0	150.0 %	Max current
0x6075	0	3.400 A	Motor rated current, reference for 0x2C61:1
0x2D46:001	1	16.5 A	Overcurrent monitoring: threshold
0x2DDF:001	1	5.00 A	User info regarding rated current
0x2DDF:002	2	10.00 A	User info regarding maximum current

Parameter

Address	Name / setting range / [default setting]	Information
0x2C61:001	Pole position identification (360°) settings: Current amplitude 1 ... [100] ... 1000 % • Setting can only be changed if the inverter is disabled.	Percentage adaptation of the current amplitude. • For large machines and high mass inertia values or for linear direct drives, the current amplitude usually must be increased. • Default setting 100 % \cong 141 % of Rated motor current (0x6075) Note! If the current amplitude is set to > 100 %, the device utilisation (Ixt) monitoring and/or one of the motor monitoring functions may respond and cause the abort of the pole position identification.
0x2C61:002	Pole position identification (360°) settings: Ramp time 1 ... [40] ... 600 s • Setting can only be changed if the inverter is disabled.	Percentage adaptation of the ramp time. • For large machines and high mass inertia values, the ramp time must be increased. • For small machines, however, the pole position identification can be accelerated by reducing the ramp time.
0x2C61:003	Pole position identification (360°) settings: Direction of rotation • Setting can only be changed if the inverter is disabled. 0 CW 1 CCW	Selection of travel direction. In some situations, it may be helpful to reverse the travel direction for the pole position identification (e. g. for linear motor at the end stop).
0x2C61:004	Pole position identification (360°) settings: Error tolerance 15 ... [20] ... 50 °	Setting of the fault tolerance for the plausibility check. • If the rotor position detected via the encoder system is not within the tolerance zone around the position that is output in a controlled manner, the pole position identification is aborted and the parameterised error response is tripped.
0x2C61:005	Pole position identification (360°) settings: Absolute current amplitude • Read only: x.xx A	Display of the absolute current amplitude.

Configuring the feedback system

Synchronous motor: Pole position identification (PPI)
Pole position identification (PPI) with minimum movement



11.4.3 Pole position identification (PPI) with minimum movement

⚠ DANGER!

Mechanical damage of the motor caused by hanging loads!

The motor may be permanently damaged.

- ▶ The motor must not be braked or blocked during the pole position identification. Thus, this function must not be used for hanging loads!

NOTICE

Thermal overload of the motor!

The motor may be permanently damaged.

- ▶ Before executing the pole position identification, check that the following monitoring systems are parameterised correctly in order to prevent a permanent damage of the motor in the event of an error:
 - ▶ ▶ [Motor overload monitoring \(\$i^2 \cdot t\$ \)](#) 178
 - ▶ [Overcurrent monitoring](#)

Functional description

If servo control for synchronous motor is set and if no error is pending, the current position is memorised after controller enable, and the current is increased along a ramp for 10 s to 35 % of the rated motor current. This will cause the rotor to align, which, however, is compensated by a position control. If the rotor makes an electrical movement of more than 20°, an error message is output, and the value measured is discarded. This might occur in the case of motors with considerable detent torques.

If the current has reached its final value, a plausibility check is executed after a short interval: in order to detect a non-permissible blocking of the motor, a positive and a negative test angle ($\pm 20^\circ$) relative to the current position are defined after the identification. The motor must align itself to these two test angles within a tolerance of 25 %.

Conditions for the execution

- The motor must not be braked or blocked during the pole position identification.
- The servo inverter is error-free and in [Switched on](#) device state.

Response of the motor during performance

The motion of the motor will maximally correspond to the set "Max. permissible motion" (Lenze setting: 20°). If a greater motion is detected via the encoder system, the pole position identification is cancelled and the parameterised error response (Lenze setting: Fault) is triggered.

How to execute the pole position identification PLI (min. movement):

1. If the servo inverter is enabled, disable it. [Enable operation](#)
2. Set the object 0x2825 to "6" to change to the "pole position identification PLI (min. movement)" operating mode.
3. Enable the servo inverter to start the process.

Note: Inhibiting the controller serves to abort the started procedure any time if required without changing the settings.



Configuring the feedback system

Synchronous motor: Pole position identification (PPI)
Pole position identification (PPI) with minimum movement

After the pole position identification has been completed successfully...

...the controller is inhibited automatically and the pole position determined for the activated feedback system is set in the [0x2C03:002](#) object.

- Save the changed settings.
The »EASY Starter« serves to save the parameter settings of the servo inverter as parameter file (*.gdc). This file can then be imported in the »PLC Designer«. [Saving the parameter settings](#)
- The inverter disable set automatically by the procedure can be deactivated again via the CiA402 control word [0x6040](#). [Enable operation](#)

Adapt pole position identification PPI (min. movement)

The process of pole position identification described above can be adapted to the respective machine and the existing moments of inertia by using the parameters described in the following.

NOTICE

Thermal overload of the motor!

The motor may be permanently damaged.

- ▶ If no temperature monitoring is available in the motor, and/or the I^2t motor monitoring and the maximum current monitoring are not parameterised correctly, the motor can be permanently damaged if the current amplitude is set too high!
- ▶ [Motor overload monitoring \(\$i^2 \cdot t\$ \)](#)
- ▶ [Overcurrent monitoring](#)

Parameter

Address	Name / setting range / [default setting]	Information
0x2C62:001	Pole position identification (min. movement) settings: Current amplitude 1 ... [25] ... 1000 % • Setting can only be changed if the inverter is disabled.	Percentage adaptation of the current amplitude. • For large machines, high mass inertia values or for linear direct drives, the current amplitude usually must be increased. • Default setting 25 % \approx 35 % of Rated motor current (0x6075) Note! If the current amplitude is set to > 100 %, the device utilisation (Ixt) monitoring and/or one of the motor monitoring functions may respond and cause the abort of the pole position identification.
0x2C62:002	Pole position identification (min. movement) settings: Ramp time 1 ... [10] ... 600 s • Setting can only be changed if the inverter is disabled.	Percentage adaptation of the rate of current rise.
0x2C62:003	Pole position identification (min. movement) settings: Gain 0 ... [0] ... 1000 %	Adaptation of the proportional PI controller gain. With the Lenze setting "0 %", the PI controller works as an I controller.
0x2C62:004	Pole position identification (min. movement) settings: Reset time 0.1 ... [62.5] ... 6000.0 ms	Adaptation of the reset time of the PI controller. • In order to be able to compensate a positional variation faster, first the reset time should be reduced. If this does not result in the desired behaviour, the proportional gain can be increased. • Ensure that the position control does not get unstable. We therefore recommend you to use an I controller.
0x2C62:005	Pole position identification (min. movement) settings: Max. move permitted 1 ... [20] ... 90 °	Adaptation of the permitted movement. • The pole position identification comprises a monitoring function for the follow-up control. If a movement greater than the permissible movement set is detected by the encoder system, the pole position identification is aborted and the error response parameterised is tripped: • In order to detect a non-permissible blocking of the machine, a positive and negative test angle relative to the current position are defined after the identification. The machine must align itself to these two test angles within a tolerance of 25 %. The size of the test angle corresponds to the max. move permitted set here.

Configuring the feedback system

Synchronous motor: Pole position identification (PPI)

Pole position identification (PPI) with minimum movement



Address	Name / setting range / [default setting]	Information
0x2C62:006	Pole position identification (min. movement) settings: Absolute current amplitude • Read only: x.xx A	Display of the absolute current amplitude.



Configuring the feedback system

Synchronous motor: Pole position identification (PPI)
Pole position identification (PPI) without movement

11.4.4 Pole position identification (PPI) without movement

The PLI function can also be used if no motor revolution is possible (holding brake active).

NOTICE

With an incorrect parameter setting and dimensioning of the inverter, the maximum permissible motor current may be exceeded during the pole position identification.

Possible consequence: Irreversible damage of the motor.

- ▶ Set the motor data correctly. ▶ [Motor data](#) 41
- ▶ Only use an inverter that is performance-matched to the motor.

DANGER!

Uncontrolled acceleration of the motor!

Undefined state of the feedback system, caused by wire breakage!

- ▶ Each pole position identification causes an update of the pole position set in the device!
Therefore, ensure that the response to open circuit in the feedback system is set to Lenze setting "1: Fault" in [0x2C45](#)! Otherwise, the status of the feedback system in case of open circuit is undefined and the pole position can assume any value. There is a danger that the machine accelerates in an uncontrolled way after pole position identification!

NOTICE

Device state "switched-on"/"operation"

- ▶ The process of the pole position identification only lasts some milliseconds. During the pole position identification, the device status does not change. Only after the pole position identification, the [Operation enabled](#) device status changes to the [Operation enabled](#) device status.
- ▶ If pole position identification is started via parameter [0x2825](#), the inverter is automatically disabled at the end of the pole position identification process.

Conditions

- The wiring of the three motor phases and the motor encoder must be carried out according to the specifications from the mounting instructions.
- The inverter is ready for operation (no fault active).
- For the pole position identification (PPI) without movement, the motor must be at standstill.

NOTICE

- ▶ During the pole position identification, the error [0xFF13](#) ("identification cancelled") may occur. This may be an indication that the motor features are not suitable for this PLI process.

Functional description

After inverter enable, a defined pulse pattern is output that provides currents up to approx. maximum motor current. The respective currents are measured. Based on these currents, the field distribution can be detected so that the pole position can be calculated. Then, the inverter is automatically disabled.

The pole position identification PLI (without movement) does not need any parameterisation.

Configuring the feedback system

Synchronous motor: Pole position identification (PPI)
Pole position identification (PPI) without movement



Preconditions for the performance

- The wiring of the three motor phases and the feedback must be carried out in accordance with the specifications from the hardware manual.
- The motor may be stalled.
- The servo inverter is error-free and in [Switched on](#) device state.
- Please observe the notes in the [Synchronous motor: Pole position identification \(PPI\)](#) section.

Response of the motor during performance

The current test pulses cause audible engine noises that may be increased by the machine mechanics depending on the mechanical coupling!

How to execute the pole position identification PLI (without movement):

1. If the servo inverter is enabled, disable it. [Enable operation](#)
2. Set the object [0x2825](#) to "7" to change to the "pole position identification PLI (without movement)" operating mode.
3. Enable the servo inverter to start the process.

Note: Inhibiting the controller serves to abort the started procedure any time if required without changing the settings.

After the pole position identification has been completed successfully...

...the controller is inhibited automatically and the pole position determined for the activated feedback system is set in the [0x2C03:002](#) object.

- For permanent storage, the changed settings from the servo inverter must be uploaded in the Controller.

The »EASY Starter« serves to save the parameter settings of the servo inverter as parameter file (*.gdc). [Saving the parameter settings](#)

- The inverter disable set automatically by the procedure can be deactivated again via the CiA402 control word [0x6040](#). [Enable operation](#)

Optional settings (starting performance)

Optionally, a pole position identification without motion can be activated after switching on the servo inverter.

Parameter

Address	Name / setting range / [default setting]	Information
0x2C63:001	PPI without movement: Execution <ul style="list-style-type: none">• Setting can only be changed if the inverter is disabled.	Start behavior (with or without pole position identification before the start).
	0 Deactivated	No pole position is identified.
	1 Only after 1st enable/encoder error	After the first controller enable and after each encoder wire breakage, a PPI without movement takes place. ⚠ CAUTION! After an encoder wire breakage, the drive may accelerate in an uncontrolled manner subsequent to the pole position identification. <ul style="list-style-type: none">• Cause: In case of a wire breakage, the feedback system state is undefined and the pole position assumes any value.• Remedy: Set the error response "Trouble" (0x2C450x2C45 = 2) for an encoder wire breakage in order that the pole position will be identified after a wire breakage.
	2 After each enable	After every inverter release, the pole position is identified without any movement.



11.5 Cable check

This function serves to detect wiring errors or cable damage which can cause uncontrolled movements of the machine during the commissioning phase or during operation. The function therefore helps to prevent machine damage and serves to correct these errors as quickly as possible.

How to manually execute the Cable Check function:

Preconditions

- The motor can remain coupled to the kinematics.
 - In the case of drives without a motor holding brake, the rotor must be able to move by 20 ° (electrically). This makes it necessary to set the operating mode of the motor holding brake to "No brake connected". [0x2820:001](#) ▶ [0x2820:001](#) = 2
 - In the case of drives with a motor holding brake, the test is performed against the closed motor holding brake. In the following parameter, the operating mode must be set to 0 or 1. [0x2820:001](#) ▶ [0x2820:001](#)
- The device must not be in the Fault state.
- 24 V supply voltage must be available.
- The display on the front of the blue LED shows ON or is blinking.
- The device must be supplied with mains voltage. Parameter status [0x6041](#), Bit 4 [0x6041](#), Bit 4 = TRUE
- The device must not be in the STO state. The safety functions must be parameterized. Parameter status: [0x6041](#), Bit 15 [0x6041](#), Bit 15 = FALSE
- The motor data must be set correctly.
- No error message must be active. Parameter status: [0x6041](#), Bit 3 [0x6041](#), Bit 3 = FALSE. If an error message is active, first remove these errors and reset the error message.
- The motor control must be set to:
 - Servo control - synchronous motor (SM) or
 - Servo control - asynchronous motor (ASM)The function only supports these two motor controls.
- The behavior after switch-on must be set. [0x2C64](#) = 0.

1. Open the »EASY Starter« engineering tool.
2. Establish an online connection to the device.
3. Call the **Motor commissioning** tab in the workspace of the »EASY Starter«.
4. Call the **Feedback** tab there.
5. In the jalousie **Cable check: Motor and motor encoder**, execute the **Cable Check** function via
The Cable Check function is now activated.
6. Activate the device via the CiA402 control word [0x6040](#) ▶ [0x6040](#) or [0x6048](#) [0x6048](#) for axis B

Execution of the function is indicated as completed in the »EASY Starter« after approx. one second. Additionally, the »EASY Starter« indicates whether an error has occurred during the check:



The **Cable Check** function can always be started via the **Execute Cable Check** button if the preconditions for this are met.

Configuring the feedback system

Cable check



The **Cable Check** function should be executed manually by the user while the machine is commissioned, in order to identify typical errors that may occur during the machine installation.

Typical errors

- The motor encoders are connected to the wrong device before initial switch-on, whereas the motor is connected to the right device. If the motor encoders that are incorrectly connected are of the same type, the motor encoder monitoring does not detect any error.
- The motor encoders are connected to the right device, however, the motor is connected to the wrong device.
- The connection of the motor phases to the device is reversed.
- Individual wires of the rotary transducer are connected incorrectly.

Starting condition for the Cable Check

The following starting conditions can be set for the automatic Cable Check function:

- Check only at initial switch-on or after motor encoder error 0x2641:001 0x2641:001 = 1
- Check after every switch-on 0x2641:0010x2641:001 = 2



Observe the line diagrams for configuring the controller.

Damage during operation

Typical damage that may occur during operation

- Wire breakage on the motor encoder and/or motor cable
- Whole motor encoder cable and/or motor cable torn off
- Screwed connections that are loosening
- Loose contacts

Possible error sources

- Failure of a motor phase
- Incorrect direction of rotation detected.



How to carry out the Cable check automatically

Preconditions

- The motor can remain coupled to the kinematics.
 - In the case of drives without a motor holding brake, the rotor must be able to move by 20 ° (electrically). This makes it necessary to set the operating mode of the motor holding brake to "No brake connected". `0x2820:001 ▶ 0x2820:001 = 2`
 - In the case of drives with a motor holding brake, the test is performed against the closed motor holding brake. In the following parameter, the operating mode must be set to 0 or 1. `0x2820:001 ▶ 0x2820:001`
- The device must not be in the Fault state.
- 24 V supply voltage must be available.
- The display on the front of the blue LED shows ON or is blinking.
- The device must be supplied with mains voltage. Parameter status `0x6041, Bit 4` `0x6041, Bit 4 = TRUE`
- The device must not be in the STO state. The safety functions must be parameterized. Parameter status: `0x6041, Bit 15` `0x6041, Bit 15 = FALSE`
- The motor data must be set correctly.
- No error message must be active. Parameter status: `0x6041, Bit 3` `0x6041, Bit 3 = FALSE`. If an error message is active, first remove these errors and reset the error message.
- The motor control must be set to:
 - Servo control - synchronous motor (SM) or
 - Servo control - asynchronous motor (ASM)The function only supports these two motor controls.
- The behavior after switch-on must be set. `0x2C64 = 0`.

1. Open the »EASY Starter« engineering tool.
2. Establish an online connection to the device.
3. Call the **Motor commissioning** tab in the workspace of the »EASY Starter«.
4. Call the **Feedback** tab there.
5. In the jalousie **Cable check: Motor and motor encoder**, execute the **Cable Check** function via
The Cable Check function is now activated.
6. In a last step, changed settings must be saved with mains failure protection.



When the pole position identification is set after every switch-on and Cable Check, the pole position identification is carried out first, followed by the Cable Check.

Depending on the parameter setting in `0x2C64:1`, the Cable Check starts automatically if the controller activates operation of the device via the `CiA402` control word. The check takes approx. one second. During this time, `0x2C64, bit 1` is = TRUE. A possibly available motor holding brake remains closed. In this case, the rotor is moved against the closed motor holding brake. If no motor holding brake is available, the rotor of the motor is moved electrically by approx. 20 °. The device remains in the switched-on state until the cable check has been completed.



The Cable Check function can always be started via the Execute Cable Check button if the preconditions for this are met.

Error detected by the Cable Check function

If the Cable Check function detects an error, the i700 servo inverter automatically changes to the Fault status.

Configuring the feedback system

Cable check



No error detected by the Cable Check function

The device changes to the "**Operation enabled**" state.

- Deactivate the device. e.g. via the control word. You can do this using keys F8 / F9 in the »EASY Starter«.
- Deactivate the Cable Check function via the parameter and set a selection other than 15. 0x2825 0x2825

During operation, the Cable Check function can be automatically executed by the device itself, in order to detect damage on the motor or motor encoder already when the machines are switched on.

How to remove errors:

1. Consult the logbook to identify the error causes.
2. Switch off the power supply and 24 V supply of the device.
3. Check the wiring and correct it, if necessary.
4. Execute the test again.



The "Identification" status word is also used by other functions. The display is therefore only valid as long as no other function using this status word is active. 0x28320x2832

Parameter

Address	Name / setting range / [default setting]	Information
0x2C64:001	Cable Check: Behavior after switch on <ul style="list-style-type: none">• Setting can only be changed if the inverter is disabled.	
	0 No action	
	1 Check at first switch on/after feedback error	
	2 Check at every switch on	
0x2C64:002	Cable Check: Cable check: Status word <ul style="list-style-type: none">• Read only	
	Bit 0 Cable check enabled	
	Bit 1 Cable check running	
	Bit 2 Cable check finished	
	Bit 3 Cable check failed	



12 Configuring the motor control

This chapter contains all functions and settings relevant for the motor control.

Basic procedure of commissioning the motor control

In the first step, the rated data of the motor must be set. The other steps depend on the respective application case.

There are several options for setting the motor data and optimising the control loops. Basically, you can select between a manual and an automatic process. Whether a setting can be applied or not depends on the motor (Lenze motor yes/no) and the application. If possible, use the possible setting listed first in the following diagram since this one leads to the most accurate results.

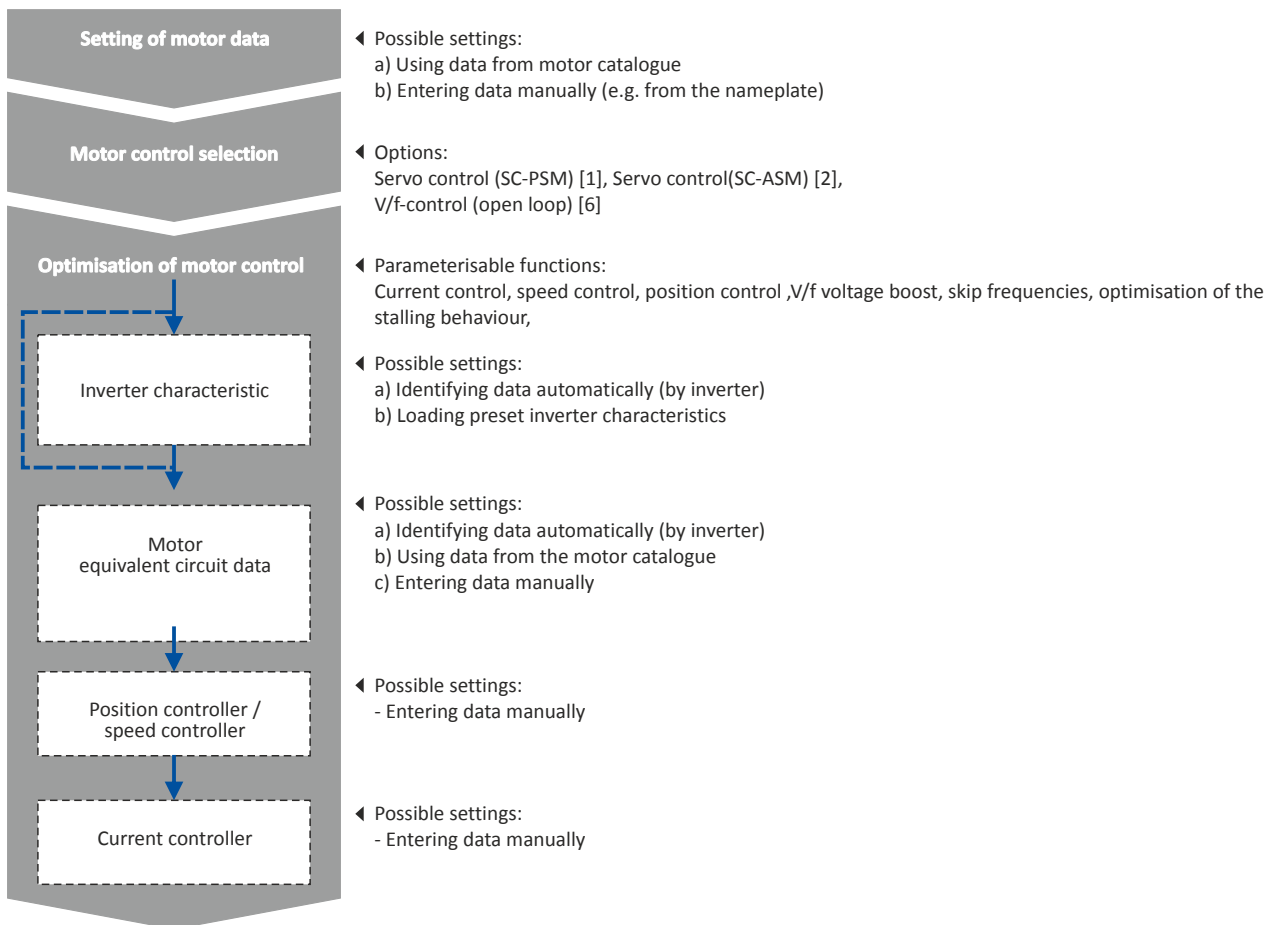

Configuring the motor control

Servo control for synchronous motor (SC-PSM)
Required commissioning steps



12.1 Servo control for synchronous motor (SC-PSM)

The motor control is based on a feedback, field-oriented and cascaded controller structure and enables a dynamic and stable operation in all four quadrants.

Preconditions

- The servo control (SC-PSM) is only suitable for synchronous motors.
- The servo control (SC-PSM) requires a feedback of the position.

12.1.1 Required commissioning steps

1. Check wiring by means of manual test modes: [Testing the motor control](#) 191
2. Activate motor control type: `0x2C00` = "Servoregelung (SC-PSM) [1]".
3. Set motor data: [Motor data](#) 41
4. Set motor monitoring:
 - [Motor temperature monitoring](#) 186
5. [Configuring the feedback system](#) 85
6. Only required for motors of other manufacturers:
 - Set and optimise current controller: [Current controller](#) 156
 - [Correction of the stator leakage inductance \(L_{ss}\)...](#) 165
 - [Synchronous motor: Pole position identification \(PPI\)](#) 112
7. Only required for an automatic calculation of the speed controller parameters:
 - Define total moment of inertia: [Tuning of the motor and the speed controller](#) 147
8. Set speed controller: [Speed controller](#) 153.
9. Set position controller: [Position controller](#) 163
10. Optional: [Synchronous motor \(SM\): Compensate temperature and current influences](#) 170
11. Optional: [Jerk limitation](#) 174
12. Optional: [Notch filter \(band-stop filter\)](#) 175
13. Optional: [Short-circuit braking](#) 141



Configuring the motor control

Servo control for asynchronous motor (SC-ASM)
Required commissioning steps

12.2 Servo control for asynchronous motor (SC-ASM)

The motor control is based on a feedback, field-oriented and cascaded controller structure and enables a dynamic and stable operation in all four quadrants.

Preconditions

- The servo control (SC ASM) is only suitable for asynchronous motors.
- The servo control (SC ASM) requires a feedback of the position.

12.2.1 Required commissioning steps

1. Check wiring by means of manual test modes: [Testing the motor control](#) [191](#)
2. Activate motor control type: `0x2C00` = "Servo control (SC ASM) [2]".
3. Set motor data: [Motor data](#) [41](#)
4. [Configuring the feedback system](#) [85](#)
5. Only required for motors of other manufacturers:
 - Set and optimise current controller: [Current controller](#) [156](#)
 - [Correction of the stator leakage inductance \(Lss\)...](#) [165](#)
6. Only required for an automatic calculation of the speed controller parameters:
 - Define total moment of inertia: [Tuning of the motor and the speed controller](#) [147](#)
7. Set speed controller: [Speed controller](#) [153](#).
8. Set position controller: [Position controller](#) [163](#)
9. Only required for motors of other manufacturers:
 - Set field controller: [ASM field controller](#) [159](#)
 - Set field weakening controller: [ASM field weakening controller](#) [160](#)
10. Optional: [Correction of the stator leakage inductance \(Lss\)...](#) [165](#)
11. Optional: [Asynchronous motor \(ASM\): Identify Lh saturation characteristic](#) [171](#)
12. Optional: [Estimate optimum magnetising current](#) [173](#)
13. Optional: [Jerk limitation](#) [174](#)
14. Optional: [Notch filter \(band-stop filter\)](#) [175](#)
15. Optional: [DC braking](#) [140](#)

12.3 Sensorless control for synchronous motor (SL-PSM)

12.3.1 Required commissioning steps

1. Optional: Activate flying restart circuit:
 - From firmware version 4 onwards, a flying restart circuit for the synchronous motor up to speeds lower than half the rated speed is supported.
 - If the flying restart circuit shall be used, set the start method "Flying restart circuit [2]" in . More settings are not required for the flying restart circuit at sensorless control of a synchronous motor.
2. Optional for a speed control with torque limitation in operating mode `0x6060` = "MS: Velocity mode [-2]":
 - Select the source in for the positive torque limit source and set it accordingly.



The torque limitation (parameter `0x2949:001/002`) can only be used for open-loop controlled operation of the SL-PSM, not for closed-loop controlled operation.

- Select the source in for the negative torque limit source and set it accordingly.

Configuring the motor control

V/f characteristic control for asynchronous motor (VFC open loop)
Required commissioning steps



12.4 V/f characteristic control for asynchronous motor (VFC open loop)

The V/f characteristic control is a motor control for conventional frequency inverter applications. It is based on a simple and robust control mode for the operation of asynchronous motors with a linear or square-law load torque characteristic (e.g. fan). Because of the minimal parameterisation effort, such applications can be commissioned easily and quickly.

Preconditions

- The V/f characteristic control is only suitable for asynchronous motors.
- If you want to actuate a drive with a square-law V/f characteristic: Please always check whether the corresponding application is suitable for operation with a square-law V/f characteristic!
- Set the motor data according to the information on the nameplate of the motor. ▶ [Motor data](#) [41](#)

12.4.1 Required commissioning steps

1. Check wiring by means of manual test modes. ▶ [Testing the motor control](#) [191](#)
2. Activate motor control type: `0x2C00` = "V/f characteristic control (VFC open loop) [6]".
3. Set limiting factors for the V/f characteristic:
 1. `0x2540:001`, Rated mains voltage
 2. `0x2B01:001`, Base voltage
 3. `0x2B01:002`, Base frequency
4. Set and optimise current controller ▶ [Current controller](#). [156](#)

Setting and optimising the current controller is only required if at least one of the following functions is active:

- Voltage vector control ▶ [Activate voltage vector control \(Imin controller\)](#) [133](#)
 - DC braking ▶ [DC braking](#) [140](#)
 - Flying restart function ▶ [Flying restart circuit](#) [138](#)
5. Select a characteristic shape suitable for the application ▶ [Define V/f characteristic shape](#). [132](#)
 6. [Set voltage boost](#) [134](#)
 7. [Activate voltage vector control \(Imin controller\)](#) [133](#)
 8. [I_{max} controller](#) [162](#)
 9. Optional ▶ [Set load adjustment](#) [135](#)
 10. Optional ▶ [Flying restart circuit](#) [138](#)
 11. Optional ▶ [Set slip compensation](#) [135](#)
 12. Optional ▶ [Set oscillation damping](#) [136](#)



Configuring the motor control

V/f characteristic control for asynchronous motor (VFC open loop)

Basic setting

12.4.2 Basic setting

The base voltage and the base frequency define the ratio of the two variables and thus the gradient of the V/f characteristic.

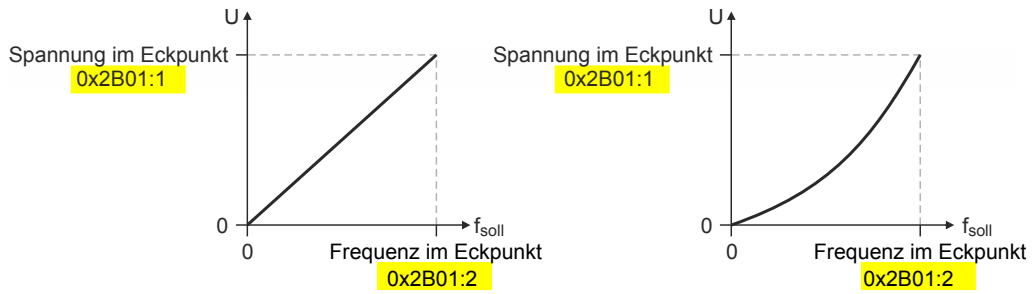

Parameter

Address	Name / setting range / [default setting]	Information
0x2B01:001	V/f shape data: Base voltage 0 ... [225] ... 5000 V	Base voltage and base frequency define the V/f ratio and thus the gradient of the V/f characteristic. <ul style="list-style-type: none"> The V/f base voltage is usually set to the rated motor voltage. 0x2C01:007 The V/f base frequency is usually set to the rated motor frequency. 0x2C01:005
0x2B01:002	V/f shape data: Base frequency 0 ... [270] ... 5000 Hz	

Configuring the motor control

V/f characteristic control for asynchronous motor (VFC open loop)
 Define V/f characteristic shape



12.4.3 Define V/f characteristic shape

For adaptation purposes to different load profiles, you can select the shape of the characteristic:

Parameter

Address	Name / setting range / [default setting]	Information
0x2B00	V/f characteristic shape • Setting can only be changed if the inverter is disabled.	Selection of the V/f characteristic shape for the adaptation to different load profiles.
	0 Linear	Linear characteristic for drives with constant load torque over the speed. ▶ Linear V/f characteristic □ 132
	1 Quadratic	Square-law characteristic for drives with a square-law load torque over the speed. • Square-law V/f characteristics are preferably used for centrifugal pumps and fan drives. • Please always check whether the corresponding application is suitable for operation with a square-law V/f characteristic! • If your pump drive or fan drive is not suitable for operation with a square-law V/f characteristic, use the linear V/f characteristic instead. ▶ Square-law V/f characteristic □ 132
	2 Adaptive	User-definable characteristic for being adapted to special load profiles.
	3 Eco	Linear characteristic with energy optimisation in the partial load operational range.

12.4.3.1 Linear V/f characteristic

The linear V/f characteristic leads to a constant torque.

12.4.3.2 Square-law V/f characteristic

The square-law V/f characteristic is typically used in heating, ventilation and climate applications to control the speed of fans and centrifugal pumps.

12.4.3.3 User-definable V/f characteristic

The "user-definable V/f characteristic" is provided for the individual adjustment of the motor magnetisation to the actual application if linear and square-law characteristics are not suitable.

- The characteristic is defined by means of 11 parameterisable grid points (voltage/frequency values).
- In the Lenze setting the 11 grid points represent a linear characteristic:

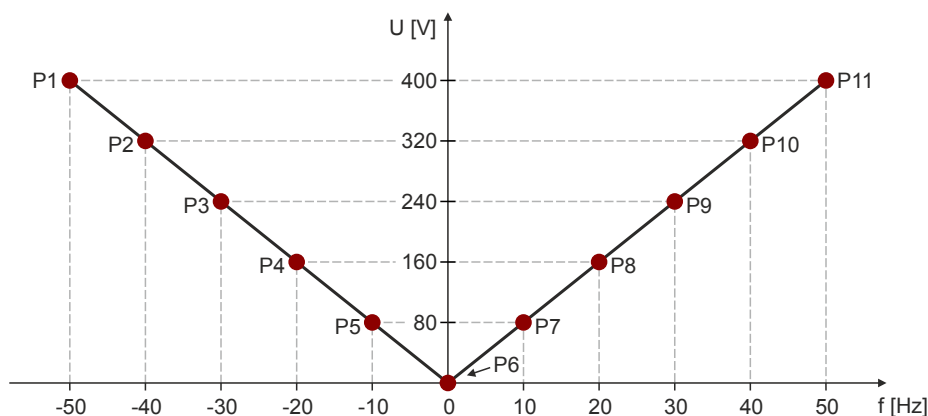

	P1	P2	P3	P4	P5	P6	P7	P8	P9	P10	P11
V	400 V	320 V	240 V	160 V	80 V	0 V	80 V	160 V	240 V	320 V	400 V
f	-50 Hz	-40 Hz	-30 Hz	-20 Hz	-10 Hz	0 Hz	10 Hz	20 Hz	30 Hz	40 Hz	50 Hz



Configuring the motor control

V/f characteristic control for asynchronous motor (VFC open loop)
 Activate voltage vector control (Imin controller)

12.4.4 Activate voltage vector control (Imin controller)

The voltage vector control is used if a comparatively high starting torque must be provided. This function ensures that the required motor current is maintained in the lower speed range.

NOTICE

The boost function described here adds to the [▶ Set voltage boost function](#). [134](#)

Only set one of the two "boost" functions.

- ▶ Recommendation: torque increase in the lower speed range
- ▶ Take into consideration that the increased current at low speeds also entails higher heat losses of the motor.

- The voltage vector control is activated by defining a current setpoint.
- For the automatic calculation of the control parameters, the "Calculate Imin controller" function is provided via parameter .

Parameter

Address	Name / setting range / [default setting]	Information
0x2B04	V/f boost controller - current setpoint 0.00 ... [0.00] ... 500.00 A	Setting of the current setpoint for the voltage vector control. <ul style="list-style-type: none"> • The setting "0.00 A" deactivates the voltage vector control. • When defining the current setpoint, we recommend you to provide a reserve of 20 % in order to largely exclude a "stalling" of the motor caused by unexpected additional loads. • Example for starting torque = rated motor torque: Set the current setpoint to approx. 120 % of the load current.
0x2B05:001	V/f boost controller settings: Gain 0.00 ... [148.21] ... 750.00 V/A	Setting of the gain for the voltage vector control.
0x2B05:002	V/f boost controller settings: Reset time 0.01 ... [3.77] ... 2000.00 ms	Setting of the reset time for the voltage vector control.

Configuring the motor control

V/f characteristic control for asynchronous motor (VFC open loop)
Set voltage boost



12.4.5 Set voltage boost

As an alternative for the “Activate voltage vector control (I_{min} controller)” function, a constant, load-independent voltage boost can be specified for low speeds (below the V/f rated frequency) or for a motor standstill in order to optimize the starting performance.

⚠ WARNING!

Insufficient cooling of the motor due to longer operation at standstill.

If the motor is operated at standstill for a longer time - especially in case of smaller motors - the motor can be destroyed by overtemperature!

- ▶ Connect the PTC thermistor (single sensor according to DIN 44081 or triple sensor according to DIN 44082) or thermal contact (normally-closed contact) ▶ [Motor temperature monitoring](#). [186](#)
- ▶ Parameterise and activate the ▶ [Motor overload monitoring \(i²*t\)](#). [178](#)

NOTICE

The voltage boost is added to the function ▶ [Activate voltage vector control \(I_{min} controller\)](#). [133](#)

Only set one of the two "boost" functions.

Recommendation: voltage vector control



For magnetising the motor, consider a sufficient time from the controller enable to the start of the speed ramp function generator. The bigger the motor the longer the time required for magnetisation. A motor with a power of 90 kW requires up to 2 seconds.

Depending on the required starting torque, the voltage boost must be set so that the required motor current will be available after controller enable.

- The voltage boost can be calculated by multiplying the stator resistance by the rated magnetising current:

$$\text{Anlaufstrom} \sim U_{\text{Boost}} = R_s \times I_{mN}$$

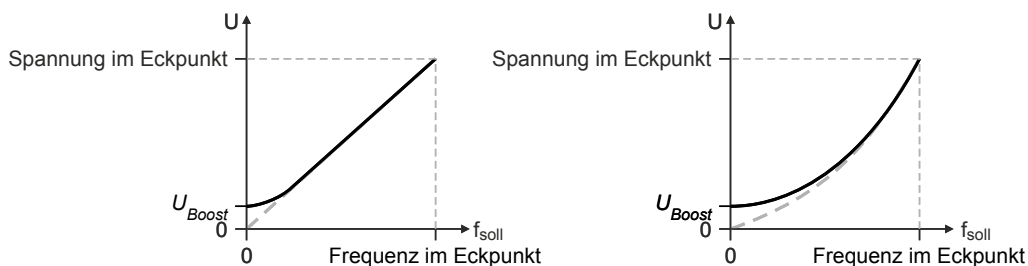

- Optionally, the voltage boost can be determined empirically by increasing the setting until the rated magnetising current flows.
- The voltage boost is added geometrically to the voltage of the characteristic:

$$U = \sqrt{U_{\text{Kennlinie}}^2 + U_{\text{Boost}}^2}$$

Parameter

Address	Name / setting range / [default setting]	Information
0x2B06	Voltage boost 0.0 ... [0.0] ... 100.0 V	Setting of the voltage boost for the voltage vector control.



12.4.6 Set load adjustment

CAUTION!

If the load adjustment is too high, the motor current may increase in idle state and the motor may overheat!

Parameter

Address	Name / setting range / [default setting]	Information
0x2B07:001	Load adaption: Direction of rotation <ul style="list-style-type: none"> Setting can only be changed if the inverter is disabled. 	Selection for adapting the characteristic as a function of the load in case of CW and CCW rotation.
	0 Passive load	
	1 Active load CCW	
	2 Active load CW	
0x2B07:002	Load adaption: Load adaption value 0.00 ... [20.00] ... 200.00 %	Setting of the load adaptation in [%] proportionally to the rated motor torque to obtain an appropriately "rigid" drive behavior even after start-up. <ul style="list-style-type: none"> For starting torque = rated motor torque, a load adaptation of 50 % is suitable for most applications.

12.4.7 Set slip compensation

The speed of an asynchronous motor decreases as load is applied. This load-dependent speed drop is called "slip". The slip compensation serves to counteract the load-dependent speed loss.



Observe correct parameterisation of the rated motor frequency [0x2C01:005](#) and the rated motor speed [0x2C01:004](#). Both parameters serve to calculate the rated motor slip.

Parameter

Address	Name / setting range / [default setting]	Information
0x2B09:001	Slip compensation: Gain -200.00 ... [0.00] ... 200.00 %	Adjustment in percent of the slip calculated. <ul style="list-style-type: none"> For instance required for deviations of the real motor data from the nameplate data. A setting of 100 % corresponds to the rated slip of the machine in the nominal operating point.
0x2B09:002	Slip compensation: Filter time 1 ... [2000] ... 6000 ms	Filter time for the slip compensation.

Configuring the motor control

V/f characteristic control for asynchronous motor (VFC open loop)
Set oscillation damping



12.4.8 Set oscillation damping

The oscillation damping serves to reduce the oscillations during no-load operation which are caused by energy oscillating between the mechanical system (mass inertia) and the electrical system (DC bus). Furthermore, the oscillation damping can also be used to compensate for resonances.



Damping is possible only for constant oscillations at a steady-state operating point.

Oscillations occurring sporadically cannot be damped.

Oscillation damping is not suitable for oscillations occurring during dynamic processes (e.g. accelerations or load changes). Oscillation damping is only active if the setpoint speed is greater than 10 rpm and the DC-bus voltage exceeds a value of 100 V.

The determination of the oscillation is based on the active current. In order to obtain the alternating component of the active current, this current is differentiated. This signal is then passed through a PT1 filter.

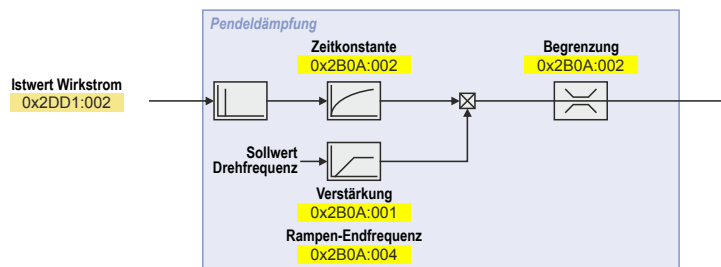

Identification of the oscillation

Before the oscillation damping can be parameterised, the oscillation must be identified. One option is to look at the motor current when the oscillation damping is switched off (gain = 0 %). The oscilloscope function of the »PLC Designer« enables to record the following currents:

- Q current 0x2DD1:002
- Total current 0x2DD1:005

A passive load and continuous operation with constant speed (steady-state operation) result in a constant current. If the drive oscillates, the motor current oscillates as well. This makes it possible to detect the frequency and amplitude of the oscillation by means of the AC component in the motor current. Hereinafter this AC component will be referred to as "current oscillation".

Parameter setting

The gain of the oscillation damping is to be set according to the following equation:

$$\text{Verstärkung der Schwingungsdämpfung} = \frac{\text{Stromamplitude}}{\sqrt{2} \cdot \text{Gerätemaximalstrom}} \cdot 100\%$$

The time constant must be set so that the oscillation can be damped, but that higher-frequency components are filtered from the signal. The time constant is determined from the reciprocal value of the double current oscillation frequency:

$$\text{Zeitkonstante} = \frac{1}{2 \cdot \text{Schwingfrequenz}}$$

The calculated oscillation frequency can be limited before being added to the rotating field frequency. The maximum frequency can be derived from the amplitude of the current oscillation, the rated motor current and the slip frequency of the connected motor:

$$\text{max. Frequenz} = \frac{2 \cdot \text{Amplitude der Stromschwingung}}{\text{Motor - Bemessungsstrom}} \cdot \text{Nennschlupffrequenz}$$



Configuring the motor control

V/f characteristic control for asynchronous motor (VFC open loop)
Optimising the stalling behaviour

Parameter

Address	Name / setting range / [default setting]	Information
0x2B0A:001	Oscillation damping: Gain -100 ... [20] ... 100 %	Gain of the oscillation signal. • With the setting 0, oscillation damping is deactivated.
0x2B0A:002	Oscillation damping: Filter time 1 ... [5] ... 600 ms	Time constant of the PT1 filter.
0x2B0A:003	Oscillation damping: Limitation 0.1 ... [0.2] ... 20.0 Hz	Limitation of the calculated oscillation frequency.
0x2B0A:004	Oscillation damping: Final ramp frequency 0 ... [0] ... 100 %	Ramp end frequency from which the gain factor is expected to have reached its rated value. • By setting a ramp end frequency, a possible negative impact of the oscillation damping on the concentricity factor in the lower speed range can be reduced. • The ramp end frequency refers to the rated motor frequency in percentage terms.

12.4.9 Optimising the stalling behaviour

The stalling protection function or the maximum permissible motor current in the field weakening range can be adapted.

- If the motor stalls in the field weakening range, the override point can be shifted by reducing the set value so that the motor stalling can be prevented.
- If the motor does not provide enough torque in the field weakening range, the set value must be increased.

Parameter

Address	Name / setting range / [default setting]	Information
0x2B0C	Override field weakening -500.0 ... [0.0] ... 500.0 Hz	Offset of the override point for field weakening.

Configuring the motor control

V/f characteristic control for asynchronous motor (VFC open loop)
Flying restart circuit



12.4.10 Flying restart circuit

The "flying restart" function serves as a protective function against high compensation currents. High compensation currents can occur in the V/f characteristic control if the drive is not at standstill at the time the inverter is enabled. The "flying restart" function detects the motor speed by means of a test current and uses this information to define the frequency setpoint.

⚠ CAUTION!

If the "flying restart" function is deactivated and the inverter is not enabled at standstill, the output voltage and the output frequency do not match the current motor speed.

High compensation currents may flow! First the drive is braked towards 0 Hz to be then accelerated again!

► Ensure that the drive is at standstill before the inverter is enabled.

Flying restart process

If this function is active, the flying restart process starts after the inverter is enabled.

1. The inverter reports the started flying restart process to the Controller via bit 8 in the Lenze status word **0x2831**.
2. If a speed is found, it is reported to the Controller via bit 9 in the Lenze status word.
3. The Controller reports to the inverter via bit 0 in the Lenze control word **0x2830** that the detected speed has been accepted. As long as this is not the case, no further flying restart process is possible.

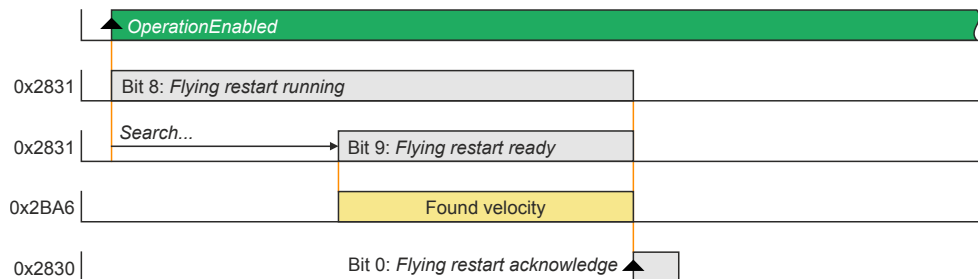

Parameter setting



The flying restart algorithm needs a motor voltage as exact as possible. Thus, a previous detection of the inverter error characteristic is absolutely necessary. **Compensate inverter influence to output voltage** In addition to the exact motor voltage, a detailed knowledge of the stator resistance is required. If the flying restart process does not work as desired, slightly adapt the setting of the stator resistance in the **0x2C01:002** object. Bit 1 in the Lenze control word **0x2830** serves to block a flying restart process.

The flying restart process involves a control loop, the controller parameter **0x2BA3** of which must be adapted to the motor. The automatic calculation is made with the parameter

► **0x2822:022**.

The actual flying restart process can be adjusted via the following parameters:



Configuring the motor control

V/f characteristic control for asynchronous motor (VFC open loop)
Flying restart circuit

Parameter

Address	Name / setting range / [default setting]	Information
0x2BA0	Activate flying restart	Activation of the additional "flying restart" function. If the "flying restart" function is activated ("1: on") and the inverter disable is deactivated, a flying restart process is automatically started for determining the current motor speed if the following conditions are met: <ul style="list-style-type: none"> • The V/f characteristic control is set as motor control. • The CiA402 mode is selected as drive mode. • The "flying restart" function is not blocked via bit 2 in the Inverter control word (0x2830). • No DC-injection braking is active. • No motor phase failure has been identified.
	0 Off	
	1 On	
0x2BA1	Flying restart circuit 0 ... [15] ... 100 %	
0x2BA2	Start frequency -600.0 ... [20.0] ... 600.0 Hz	Start frequency of flying restart algorithm <ul style="list-style-type: none"> • If it is foreseeable at which frequency the motor can be restarted on the fly, set the frequency here.
0x2BA3	Integration time 1 ... [600] ... 60000 ms	Integration time of the angle controller <ul style="list-style-type: none"> • The default setting is adapted for medium-power machines. • A guide value for the integration time can be calculated as a function of the motor power with the following equation: $T_i = 1.1 \mu/W * \text{Rated power (0x2C01:006)} + 9.4 \text{ ms}$ • For accelerating the search process, this guide value can be reduced. • If the flying restart frequency oscillates too much, increase the integration time again. • A longer integration time extends the time for a flying restart of the drive.
0x2BA4	Minimum deviation 0.00 ... [5.00] ... 90.00 °	Setting of the minimum permissible deviation.
0x2BA5	Delay time 0 ... [0] ... 10000 ms	In order to prevent the start of a flying restart process if the controller inhibit time is too short, a minimum active time for the inverter disable can be set here in order that a flying restart process will be started. As a pulse inhibit > 500 ms causes a controller inhibit, this also applies to pulse inhibit.
0x2BA6:001	Result: Determined speed [rpm] • Read only: x rpm	Display of the determined speed in [rpm].
0x2BA6:002	Result: Determined speed [n unit] • Read only: rpm	Display of the determined speed in [n unit].

Configuring the motor control

Parameterisable motor functions
DC braking



12.5 Parameterisable motor functions

12.5.1 DC braking

The control modes for asynchronous motors provide the opportunity to use the "DC-braking" function (DC-injection braking) for braking. In this case, the motor control injects a DC current the amplitude of which is adjustable.

Preconditions

Using the "DC braking" function, the motor control injects a DC current, the amplitude of which is adjustable in the [0x2B80](#) parameter. To this end, it is necessary that the current control is adapted to the corresponding motor. For setting and optimising the current controller, see [Current controller](#). [156](#)

Details

The function can be used as follows:

1. "DC braking" can be parameterised via bit 6 in the Lenze control word [0x2830](#).

In this case, the motor system itself can be used as an energy converter.

This option is useful if

- the system is not provided with a brake resistor required for absorbing the braking energy. This method requires that a sufficient braking torque can be achieved with "DC braking".
 - the power of the brake chopper to be transformed is limited and thus must be exclusively used for the main drives of the DC network. The quality of the deceleration ramp via "DC braking" is sufficient for auxiliary drives and unburdens the brake chopper.
 - a fan drive is to be braked in the V/f characteristic operation.
2. "DC braking" can be parameterised as a response to minor faults.

An example of a minor fault is the error of an encoder of an asynchronous machine. Due to the error, the quick stop function cannot be executed anymore. An alternative is provided by the guided shutdown with a minor deceleration via the "DC braking" function.

Parameter

Address	Name / setting range / [default setting]	Information
0x2B80	Current for DC-injection braking 0.00 ... [0.00] ... 500.00 A	Braking current for DC-injection braking



12.5.2 Short-circuit braking

The control modes for synchronous motors provide the opportunity to use "short-circuit braking" for braking.

The effect of short-circuit braking on the deceleration behaviour depends on the motor properties, the effective cable length, the load inertia and the initial speed value (starting point). Primarily, short-circuit braking serves to transform a part of the kinetic energy into heat energy which unburdens external brake assemblies and limit position dampers.

NOTICE

In some constellations it is not possible to decelerate the motor speed of a synchronous motor to zero by means of "short-circuit braking"!

Compared to the "quick stop" function, the braking effect is considerably lower.

► Prevention: tbd

Preconditions

If short-circuit braking shall be used as the only deceleration means, it is recommended that the feasibility is previously verified by means of tests. For this purpose, short-circuit braking can be triggered in the application via bit 6 in the Lenze control word [0x2830](#). The oscilloscope function of the engineering tool (e.g. »EASY Starter«) serves to record the following important parameters:

- Actual velocity [0x606C](#)
- Phase current U, V, W [0x2D83:002 ... 0x2D83:004](#)

Details



The short-circuit current adjusts itself freely in accordance with the motor voltage ($kE \cdot \text{speed}$) and the internal resistance of the system. Thus, it is absolutely necessary that the ampacity of the servo inverter is based on the maximum expected short-circuit current. Guide value: $I_{\text{max_device}} (3 \text{ s}) \geq 1.5 \cdot I_{\text{max_motor}}$ (according to data sheet / catalog) In case the assignment differs, a rating based on the currently possible parameters (max. speed, max. motor current, field weakening, etc.) is required!

The function can be used as follows:

1. "Short-circuit braking" can be parameterised via bit 6 in the Lenze control word [0x2830](#) if
 - the braking energy cannot be converted into heat in a brake resistor.
 - e.g. an error has been detected in the encoder system which does not permit a braking via quick stop.
2. "Short-circuit braking" can be parameterised as a response to minor faults.
 - Due to an encoder error, for instance, a quick stop might not be possible anymore.

Configuring the motor control

Parameterisable motor functions
Holding brake control



12.5.3 Holding brake control

This device function is used for low-wear control of the motor holding brake connected to the inverter with a supply voltage of 24 V.

The motor holding brake is connected to X106. It is supplied with 24 V via X107.



Configuring the motor control

Parameterisable motor functions
Holding brake control

12.5.3.1 Basic setting

The following parameters must be set for the activation and basic configuration of the holding brake control.

Details

The following settings are possible:

- Brake mode ①
- For the automatic operation: ②
 - Brake release time and brake application time
 - Torque feedforward control
- Test Brake control ③
- Brake polarity ④

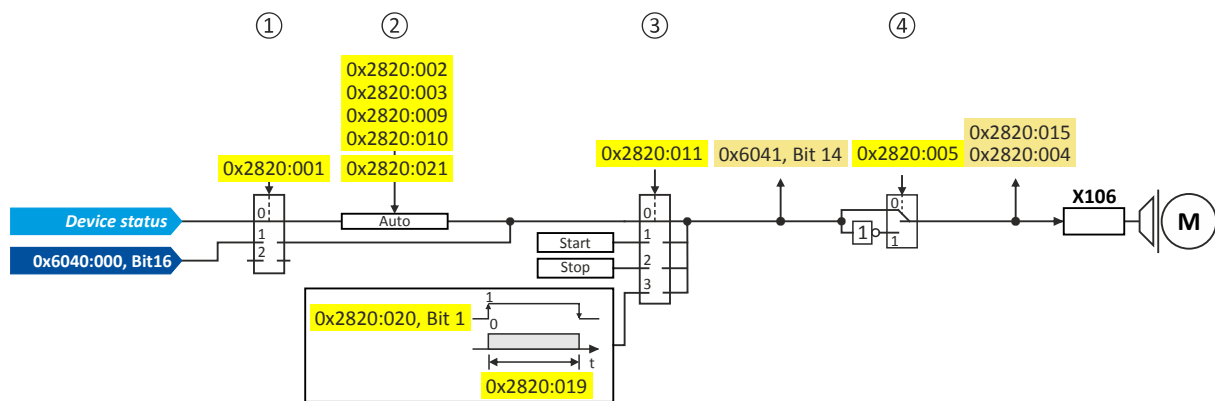

Diagnostic parameters:

- Display status of the automatic brake identification: [0x2820:004](#)
- Display signal of the brake logic before the inversion: [0x6041](#)
- Display status of the holding brake: [0x2820:015](#)

Brake mode

Possible settings: [0x2820:001](#)

- Manual control via the control word. Das control word depends on the technology application :
 - Technology application CiA 402: [0x6040](#) Bit 14
 - Speed Control technology application: [0x5030:010](#) Bit 14
 - 0: Close holding brake
 - 1: Release holding brake
- Control via device state machine (automatic operation):
 - The holding brake is controlled as a function of the device state.
 - A torque feedforward control is possible.



The torque is precontrolled for one second. During this time, the actual torque must have reached 90 % of the setpoint torque, otherwise an error is triggered.

- Response times of the holding brake during release and application can be compensated for.



In the event of an error or when STO ("SafeTorqueOff") is activated, the brake is applied immediately without considering the set brake application time. The inverter immediately changes to the switch-on disabled state.

- No brake connected (off):
 - holding brake control, automatic brake identification and brake monitoring are deactivated.

Configuring the motor control

Parameterisable motor functions
Holding brake control



Brake polarity

The control logic of the holding brake can be inverted.

Parameter

Address	Name / setting range / [default setting]	Information
0x2820:001	Holding brake control: Brake mode	Selecting how the "Release holding brake" command is to be triggered.
	0 Automatically (via device state)	Automatic operation: depending on the device state, the "Release holding brake" command is given automatically if the controller is to be enabled.
	1 Manually	Depending on the TA, the "Release holding brake" command can also be initiated by the following external triggers: TA Cia: ▶ 0x6040 bit 14 TA Speed Control: bit 10
	2 Off	The holding brake is deactivated.
0x2820:002	Holding brake control: Brake closing time 0 ... [100] ... 10000 ms	Application time (engagement time) of the holding brake. • Only effective in automatic operation.
0x2820:003	Holding brake control: Brake opening time 0 ... [100] ... 10000 ms	Release time (disengagement time) of the holding brake. • Only effective in automatic operation.
0x2820:004	Holding brake control: Brake detection • Read only	When 0x2825 = 4 (Manual control mode) and the device state changes from "switched-on" to "operation enabled", it is detected automatically whether a holding brake is connected. The brake identification is repeated after every controller enable.
	0 Detection not started	
	1 Detection running	
	2 No brake detected	
	3 Brake detected	
0x2820:005	Holding brake control: Brake polarity	The control logic of the holding brake can be inverted.
	0 Normal	
	1 Inverted	
0x2820:006	Holding brake control: Brake error response	Selection of the response for holding brake monitoring. In the triggered state, the holding brake is monitored cyclically for the presence of brake current. After the brake is connected, the establishment of the brake current is subject to a time delay in accordance with the inductance. Consequently, there is a slight delay in detecting wire breakage, a terminal short-circuit or a missing brake supply. The response set here occurs when monitoring is triggered. Note: The brake is not monitored unless it is triggered.
	0 No response	
	1 Fault > CiA402	
	2 Warning	
0x2820:015	Holding brake control: Brake status • Read only	Display of the holding brake status. • The status is also displayed via bit 14 in the CiA status word 0x6041 .
	0 Active	Holding brake is applied.
	1 Brake released	Holding brake is released.
0x2820:019	Holding brake control: Brake opening time test signal 0 ... [500] ... 10000 ms	Setting of the brake opening time when the test signal is transmitted (Brake control word bit 0 = 1).
0x2820:023	Holding brake control: Output signal configuration	
	0 Internal brake control	
	1 External component at brake output	
	2 External component at digital output	

Further setting options:

- [Manual brake control](#) [145](#)

12.5.3.2 Brake holding load

Parameter

Address	Name / setting range / [default setting]	Information
0x2820:013	Holding brake control: Holding load ramp time 0 ... [0] ... 1000 ms	By setting a ramp time, a vibration stimulation can be reduced that might be caused by the brake holding load.



Configuring the motor control

Parameterisable motor functions
Holding brake control

12.5.3.3 Torque feedforward control

Parameter

Address	Name / setting range / [default setting]	Information
0x2820:009	Holding brake control: Starting torque source	Setting of the source for the holding brake starting torque.
	0 Last torque saved	The stopping value saved automatically during the last closing operation is used as starting torque.
	1 Torque in 0x2820:010	The parameterised starting torque is used (0x2820:010).
0x2820:010	Holding brake control: Starting torque -3276.8 ... [0.0] ... 3276.7 %	Setting of the feedforward control value for the automatic operation (0x2820:009 = 1).
0x2820:021	Holding brake control: Detected actual torque • Read only: x.x %	Display of the torque actual value that is used for the feedforward control. 0x2820:009 = 0

12.5.3.4 Manual brake control

The holding brake can be released and applied manually independently of the operating mode and operating status of the inverter. This function can be used, for instance, to move the axis manually in the event of an error.

Details

The following settings are possible:

- Open the holding brake:
 - The holding brake remains open until it closed again manually.
- Close the holding brake.
- Release the holding brake for a fixed time by a start signal and then apply it automatically:
 - Time for "Brake released": 0x2820:019
 - Start signal: 0x2820:020, bit 0 = 1
 - After the time has elapsed → bit 0 = 0

Parameter

Address	Name / setting range / [default setting]	Information
0x2820:011	Holding brake control: Override of the brake control	Mode for override or forced opening/closing of the holding brake irrespective of the operating mode. In the event of an error and activated function for forced opening, the brake is not applied.
	0 No override active	Mode for override or forced opening/closing of the holding brake irrespective of the operating mode.
	1 Open brake	• In the event of an error and activated function for forced opening, the brake is not applied.
	2 Close brake	
	3 Test pulse	
0x2820:020	Holding brake control: Brake control word 0x00 ... [0x00] ... 0xFF	Control word for the holding brake.
	Bit 0 Transmit test signal	

12.5.3.5 Reduction of brake supply voltage

Parameter

Address	Name / setting range / [default setting]	Information
0x2820:022	Holding brake control: Holding brake supply voltage	
	75 Reduction on	
	100 No reduction	

Configuring the motor control

Options for optimizing the control loops
Automatic motor identification (energized)



12.6 Options for optimizing the control loops

The option to be selected depends on the respective application. Depending on the selected option, different procedures become active and thus different parameter groups are influenced:

- Rated motor data
- Inverter characteristic
- Motor equivalent circuit diagram data
- Motor controller settings
- Speed controller settings
- Position controller settings

12.6.1 Automatic motor identification (energized)

Parameter

Address	Name / setting range / [default setting]	Information
0x2832	Motor identification status <ul style="list-style-type: none">• Read only	Display of the status for the automatic identification of the motor parameters. Parameters for interaction with engineering tools.
	Bit 0 Identification enabled	Parameters for interaction with engineering tools.
	Bit 1 Identification active	
	Bit 2 Identification completed	
	Bit 3 Identification failed	
0x2DE0:009	Motor identification settings <ul style="list-style-type: none">• Read only	Setting for motor identification.



Configuring the motor control

Options for optimizing the control loops
Tuning of the motor and the speed controller

12.6.2 Tuning of the motor and the speed controller

The following describes in general how to optimize the speed controller. This may be required if some parameters on the load side of the drive system have changed or have not been set yet, such as:

- Motor moment of inertia
- Load moment of inertia
- Type of coupling between motor moment of inertia and load moment of inertia

Preconditions

All rated motor data is known and set in the inverter, either by selecting the motor from the motor catalogue or manually. ▶ [Select motor from motor catalog](#) 42 ▶ [Manual setting of the motor data](#) 44

Required steps

Adapt the following parameters to your drive system using the engineering tool. Since this only changes load-dependent data, the other parameter groups do not need to be calculated again.

In the engineering tool, the speed control settings can be confirmed via the **Initialise** button.



This function is not available via the keypad.

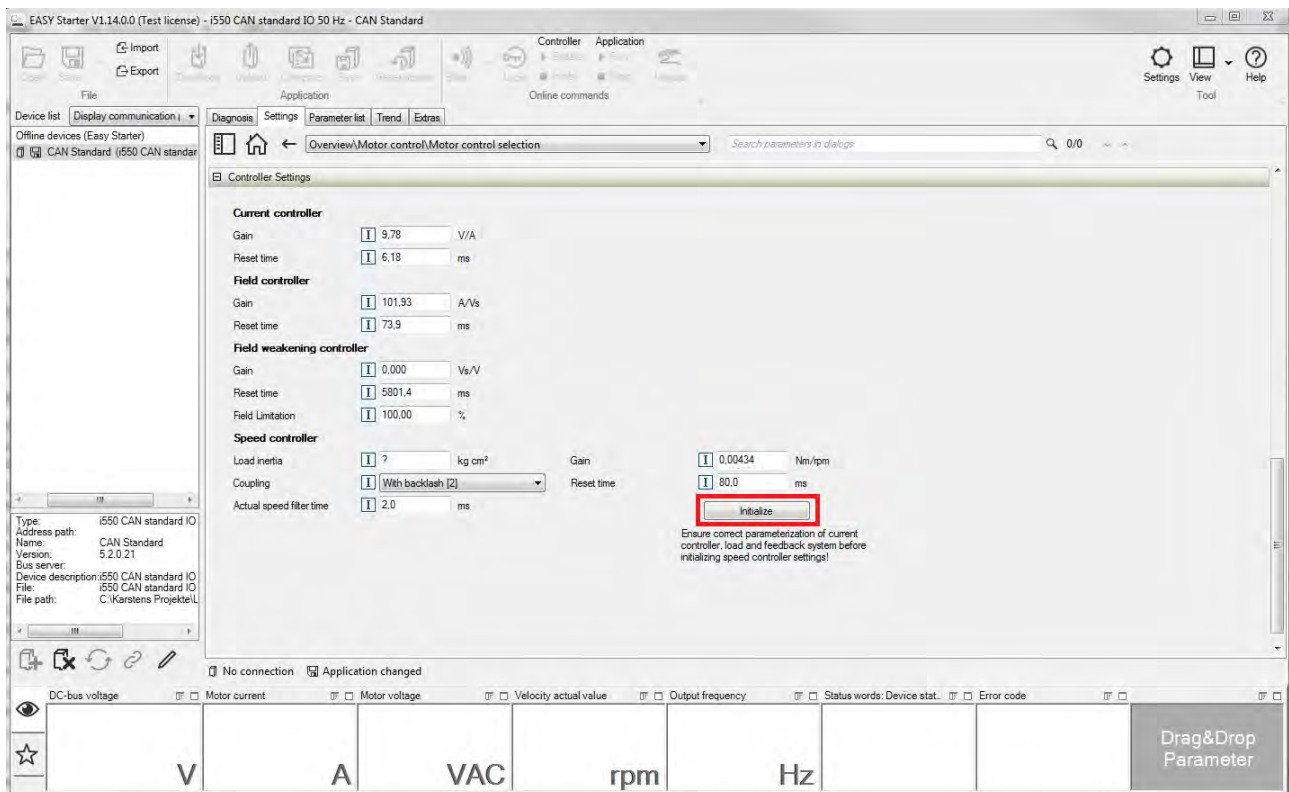

Parameter

Address	Name / setting range / [default setting]	Information
0x2910:001	Inertia settings: Motor moment of inertia 0.00 ... [0.14] ... 20000000.00 kg cm ²	Setting of the moment of inertia of the motor, relating to the motor.
0x2910:002	Inertia settings: Load moment of inertia 0.00 ... [0.00] ... 20000000.00 kg cm ²	Setting of the moment of inertia of the load. <ul style="list-style-type: none"> • Always adjust the setting to the current load, otherwise the optimisation process for the speed controller cannot be executed successfully.

Configuring the motor control

Options for optimizing the control loops

Tuning of the motor and the speed controller



Address	Name / setting range / [default setting]	Information
0x2910:003	Inertia settings: Coupling	Selection of the type of coupling between the moment of inertia of the motor and that of the load.
	0 Stiff	
0x2910:004	Inertia settings: Mechanical natural frequency 0.0 ... [0.0] ... 250.0 Hz	Setting of the mechanical natural frequency.
0x2910:005	Inertia settings: Load moment of inertia (elastic coupled) 0.00 ... [0.00] ... 20000000.00 kg cm ²	Setting of the load moment of inertia with elastic coupling (0x2910:003 = 1).

For further details on the speed controller, see chapter "[Speed controller](#)". [153](#)



Configuring the motor control

Options for optimizing the control loops
Inverter characteristic

12.6.3 Inverter characteristic



The settings made can be seen if required, but should not be changed. A wrong setting may influence the control negatively!

Configuring the motor control

Options for optimizing the control loops
Inverter characteristic



12.6.3.1 Compensating for inverter influence

Conditions for the execution

- The motor may be stalled.
- The i950 servo inverter is error-free and switched on.

Response of the motor during performance

If the motor is not braked, the motor will move slightly



Disabling the inverter serves to abort the started procedure any time if required. Already determined characteristic values are rejected in this case.

How to detect the inverter characteristic:

1. Disable the servo inverter.
2. Change to the "inverter characteristic: identification" operating mode. ▶ `0x2825 = 8`
3. Enable the servo inverter.

The procedure starts.

After the successful completion, the inverter is automatically disabled and the points of the detected inverter characteristic are set in parameter `0x2947t`.

1. Save the changed settings.
2. The inverter characteristic must only be detected again if the servo inverter, the motor or the motor cable have been replaced.
3. The inverter disable set by the procedure can be deactivated via the control word.
▶ `0x6040 = 7`

Parameter

Address	Name / setting range / [default setting]	Information
0x2947:001	Inverter characteristic: Value y1 0.00 ... [0.00] ... 20.00 V	The inverter characteristic (consisting of 17 values) is calculated and set in the course of the automatic inverter characteristic identification. Note! Changing these values is not recommended by the manufacturer.
0x2947:002	Inverter characteristic: Value y2 0.00 ... [0.00] ... 20.00 V	
0x2947:003	Inverter characteristic: Value y3 0.00 ... [0.00] ... 20.00 V	
0x2947:004	Inverter characteristic: Value y4 0.00 ... [0.00] ... 20.00 V	
0x2947:005	Inverter characteristic: Value y5 0.00 ... [0.00] ... 20.00 V	
0x2947:006	Inverter characteristic: Value y6 0.00 ... [0.00] ... 20.00 V	
0x2947:007	Inverter characteristic: Value y7 0.00 ... [0.00] ... 20.00 V	
0x2947:008	Inverter characteristic: Value y8 0.00 ... [0.00] ... 20.00 V	
0x2947:009	Inverter characteristic: Value y9 0.00 ... [0.00] ... 20.00 V	
0x2947:010	Inverter characteristic: Value y10 0.00 ... [0.00] ... 20.00 V	
0x2947:011	Inverter characteristic: Value y11 0.00 ... [0.00] ... 20.00 V	
0x2947:012	Inverter characteristic: Value y12 0.00 ... [0.00] ... 20.00 V	
0x2947:013	Inverter characteristic: Value y13 0.00 ... [0.00] ... 20.00 V	
0x2947:014	Inverter characteristic: Value y14 0.00 ... [0.00] ... 20.00 V	
0x2947:015	Inverter characteristic: Value y15 0.00 ... [0.00] ... 20.00 V	



Configuring the motor control

Options for optimizing the control loops
Inverter characteristic

Address	Name / setting range / [default setting]	Information
0x2947:016	Inverter characteristic: Value y16 0.00 ... [0.00] ... 20.00 V	
0x2947:017	Inverter characteristic: Value y17 0.00 ... [0.00] ... 20.00 V	

In the event of an error

If an error occurs during the procedure or the pulse inhibit gets active (e.g. due to short-time undervoltage), the procedure is terminated with inverter disable without the settings being changed.

12.6.3.2 Extended settings for identification

For determining the characteristic, the current controller is automatically parameterised at the start of the identification process. In case of motors with a very low stator leakage inductance (< 1 mH), the automatic parameterisation can fail and the actual identification process is aborted with an error message such as "short circuit".

- For this case, it is possible to set the current controller manually via the [0x2942](#) parameter.
- The [0x2DE0:001](#) parameter serves to select whether the current controller should be calculated automatically or the values in [0x2942](#) are effective.

Parameter

Address	Name / setting range / [default setting]	Information
0x2DE0:001	Current controller identification settings	Whether the current controller shall be adapted automatically for the identification or set manually, is selected via: <ul style="list-style-type: none"> • 0x2942:001 (Gain) • 0x2942:002 (Reset time)
	0 Automatic 1 Manuell (0x2942)	
0x2DE0:003	Resolver - position detection dynamics 20 ... [100] ... 100 %	Setting of the dynamics for the resolver evaluation. <ul style="list-style-type: none"> • 100% ≙ max. dynamics • <100% ≙ reduced dynamics
0x2DE0:004	Resolver - 8 kHz safety signal	Usually ,the Der 8-kHz carrier frequency is only activated for the safety version. This parameter can also be used to switch it on and off.
	0 Automatisch durch Gerätetyp	
	1 On 2 Aus	
0x2DE0:007	Use measured voltage	Activation of voltage measurement. Only for devices for which voltage measurement is possible.
	0 Aus 1 On	

12.6.3.3 Load standard inverter characteristic

If none or only one faulty inverter characteristic could be determined, a device-typical standard inverter characteristic can be loaded.

How to load the standard inverter characteristic:

1. **Axis commands: load standard-Lh saturation characteristic** [0x2822:022](#) = start 1.
2. After completing the procedure, save the inverter characteristic set in in the inverter.

The »EASY Starter« serves to save the parameter setting of the inverter as parameter file (*.gdc). ▶ [Saving the parameter settings](#)

Parameter

Address	Name / setting range / [default setting]	Information
0x2822:022	Axis commands: Load default inverter characteristic	Parameters for interaction with engineering tools.
	0 Off/Ready	
	1 On/Start	
	2 In progress	
	3 Action cancelled	
	4 No access 5 No access (Inverter disabled)	

Configuring the motor control

Options for optimizing the control loops
Motor equivalent circuit diagram data



12.6.4 Motor equivalent circuit diagram data

The motor equivalent circuit diagram data is automatically set when the motor is selected from the motor catalogue:

▶ [Select motor from motor catalog](#) 42

If you use a motor of a different manufacturer, you must adapt the data, e. g. from the motor data sheet according to the sizes and units mentioned if required.

Parameter

Address	Name / setting range / [default setting]	Information
0x2822:024	Axis commands: Estimate basic motor parameters based on rated data	Parameters for interaction with engineering tools.
	0 Off/Ready	
	1 On/Start	
	2 In progress	
	3 Action cancelled	
	4 No access	
5 No access (Inverter disabled)		
0x2832	Motor identification status • Read only	Display of the status for the automatic identification of the motor parameters. Parameters for interaction with engineering tools.
	Bit 0 Identification enabled	Parameters for interaction with engineering tools.
	Bit 1 Identification active	
	Bit 2 Identification completed	
Bit 3 Identification failed		
0x2C01:002	Motor parameters: Stator resistance 0.0000 ... [13.5000] ... 125.0000 Ω	General motor data. Carry out settings as specified by manufacturer data/motor data sheet.
0x2C01:003	Motor parameters: Stator leakage inductance 0.000 ... [51.000] ... 500.000 mH	Note! When you enter the motor nameplate data, take into account the phase connection implemented for the motor (star or delta connection). Only enter the data applying to the connection type selected.
0x2C01:009	Motor parameters: Insulation class	Insulation class of the motor (see motor nameplate).
	0 Y (cut-off temperature = 90 °C)	
	1 A (cut-off temperature = 105 °C)	
	2 E (cut-off temperature = 120 °C)	
	3 B (cut-off temperature = 130 °C)	
	4 F (cut-off temperature = 155 °C)	
	5 H (cut-off temperature = 180 °C)	
6 G (cut-off temperature > 180 °C)		
0x2C02:001	Motor parameter (ASM): Rotor resistance 0.0000 ... [0.0000] ... 214748.3647 Ω	Equivalent circuit data required for the motor model of the asynchronous machine.
0x2C02:002	Motor parameter (ASM): Mutual inductance 0.0 ... [0.0] ... 214748364.7 mH	
0x2C02:003	Motor parameter (ASM): Magnetising current 0.00 ... [0.00] ... 500.00 A	
0x2C03:001	Motor parameter (PSM): Back EMF constant 0.0 ... [41.8] ... 100000.0 V/1000rpm	Voltage induced by the motor (rotor voltage / 1000 rpm). For permanently excited synchronous motors, the e.m.f. constant describes the r.m.s. value of the line-to-line voltage (phase voltage) induced in idle state by the motor (reference: 1000 rpm, 20 °C). Measured: Line to Line (L - L)
0x2C03:002	Motor parameter (PSM): Resolver pole position -179.9 ... [-90.0] ... 179.9 °	Equivalent circuit data required for the motor model of the synchronous machine.
0x2C03:003	Motor parameter (PSM): Magnets temperature coefficient (kTN) -1.000 ... [-0.110] ... 0.000 %/°C	
0x2C03:004	Motor parameter (PSM): Encoder pole position -179.9 ... [0.0] ... 179.9 °	



12.6.5 Motor control settings

12.6.5.1 Speed controller

The speed controller is automatically set when the motor has been selected from the motor catalogue:

▶ [Select motor from motor catalog](#) 42

The automatically calculated settings for the speed controller enable an optimal control behaviour for typical load requirements.

Manual post-optimisation of the speed controller

1. Setting of the gain

Set the proportional gain V_p in parameter [0x2900:001](#).

- Specify speed setpoint.
- Increase parameter until the drive gets unstable (observe engine noise). ▶ [0x2900:001](#)
- Reduce parameter until the drive runs stable again. ▶ [0x2900:001](#)
- Reduce the parameter to approx. half the value. ▶ [0x2900:001](#)

2. Setting of the reset time

Set the reset time T_n in parameter [0x2900:002](#).

- Reduce parameter until the drive gets unstable (observe engine noise). ▶ [0x2900:002](#)
- Increase parameter until the drive runs stable again. ▶ [0x2900:002](#)
- Increase parameter to approx. double the value. ▶ [0x2900:002](#)

3. Setting of the rate time

Set the rate time T_d in parameter [0x2900:003](#).

- Increase parameter during operation until an optimal control mode is achieved.
▶ [0x2900:003](#)

Automatically calculated settings for the speed controller



We recommend a manual post-optimisation for the optimal operation.

The function for automatically calculating the gain and reset time is executed via the parameter [0x2822:014](#).

The following equations apply to a "rigid" system.

- For elastic systems and systems with batches, the determined gain must be reduced.
- The moment of inertia required for the calculation is the sum of the moment of inertia of the motor and the load mass inertias transformed to the motor side.

Equation for calculating the gain

$$V_p = \frac{J}{a \cdot (T_{\text{Filter}} + T_{\text{Stromregler}})} \cdot \frac{2\pi}{60}$$

Configuring the motor control

Options for optimizing the control loops
Motor control settings



Equation for calculating the reset time

$$T_n = a^2 \cdot (T_{\text{Filter}} + T_{\text{Stromregler}})$$

Parameter	Symbol	Description	Dimension unit
0x2900:001	V_p	Speed controller gain	Nm / rpm
-	J	Moment of inertia = J_{motor} + sum (J_{load})	kgm ²
-	a	Measure for the phase reserve (recommendation: $a = 4 \approx 60^\circ$ phase reserve)	
0x2904	T_{Filter}	Filter time constant - actual speed value	s
-	$T_{\text{current controller}}$	Equivalent time constant of the current control loop = 0.0005 s	s
0x2900:002	T_n	Reset time - speed controller	s

Special case of the linear motor

In this case, a re-calculation from a linear system to a rotary system must be made. Therefore, via the feedback system a degree of freedom results for the determination of the number of pole pairs. For a rotary system, the number of pole pairs specifies the ratio of electrical and mechanical revolution, the number of encoder increments being defined via one mechanical revolution. In the case of a linear system, the user is free to decide for which length he or she wants to specify the number of encoder increments. Usually, the number of increments is given for a pole distance or for the total length of the linear scale. If the number of increments = "number of increments for one pole distance" is selected, a motor with the number of pole pairs $z_p = 1$ is created. The effective moment of inertia for a linear motor can be calculated according to the following equations. With this J value, the equations shown above can be used to calculate the speed controller gain and reset time.

Equation for calculating the effective moment of inertia

$$J = m \cdot \left(\frac{z_p \cdot 2 \cdot \tau_{\text{Polpaar}}}{2\pi} \right)^2$$

$$z_p = \text{Ganzzahl} \cdot \frac{s}{2 \cdot \tau_{\text{Polpaar}}}$$

Parameter	Symbol	Description	Dimension unit
-	s	Length on which the specification for the number of encoder increments is based (e.g. per pole distance or total length).	m
-	$2 \tau_{\text{Pole pair}}$	Pole distance of the permanent magnets, pole pair width	m
-	J	Moment of inertia = $J_{\text{Forcer}} + J_{\text{Slide}} + J_{\text{Load}}$	kgm ²
-	m	Moving mass = $m_{\text{Forcer}} + m_{\text{Slide}} + m_{\text{Load}}$	kg

Parameter

Address	Name / setting range / [default setting]	Information
0x2900:001	Speed controller settings: Gain 0.00000 ... [0.00033] ... 20000.00000 Nm/rpm	Gain factor V_p of the speed controller.
0x2900:002	Speed controller settings: Reset time 1.0 ... [17.6] ... 6000.0 ms	Reset time T_i of the speed controller.
0x2900:003	Speed controller settings: Rate time 0.00 ... [0.00] ... 3.00 ms	Setting of the rate time for the speed controller.
0x2901	Speed controller gain adaption 0.00 ... [100.00] ... 200.00 %	Mappable parameter for adaptive adjustment of the speed controller gain.



Configuring the motor control

Options for optimizing the control loops
Motor control settings

Address	Name / setting range / [default setting]	Information
0x2902	I component load value -1000.0 ... [0.0] ... 1000.0 %	Setting of the load value.
0x2903	Speed setpoint filter time 0.0 ... [0.0] ... 50.0 ms	Time constant for the speed setpoint filter.
0x2904	Actual speed filter time 0.0 ... [0.3] ... 50.0 ms	Time constant for the actual speed value filter.

Configuring the motor control

Options for optimizing the control loops
Motor control settings



12.6.5.2 Current controller

This chapter contains the following topics:

- Description of the torque control
- Activation of the function
- Troubleshooting

The current controller consists of a direct-axis current controller and a cross current controller which are both parameterised identically. The direct-axis current controller controls the field-producing current (D current). The cross current controller controls the torque-producing current (Q current).

Debugging

The function depends on the saturation characteristic of the inductances in parameter `0x2c04` `0x2c04`.

For Lenze motors, this characteristic can be found in the motor table. In case of MCS motors, the characteristic values in the first 2 entries are too high. If there are any problems regarding the torque control, reduce these values. Lenze motors with the standard setting achieve a considerable higher performance.

In the following parameter, debugging is possible with the commissioning function **Man. Test mode curr. Imp.** [0x2825](#) ▶ [0x2825](#)

This function is documented. Here, the transient response of the current controller can be evaluated which shall considerably improve when the torque control is activated.

The following chart shows the this behavior.

- Red characteristic without torque controller
- Yellow characteristic with activated torque controller

If the course is worse with an activated torque control, the parameters of the inductance and saturation profile are faulty.

Activation of the function

The function is activated via a parameter. [0x2941](#) ▶ [0x2941](#)

In case of synchronous machines, this parameter is set by default to Enable [1] and in case of asynchronous machines to Disable [0].

How to activate the function

1. Set parameter to [2].

The function is activated.

Description of the function

The function controls the control cycle. The following model parameters are improved.

- Inductance of the saturation characteristic
- Setpoint step-change in the small signal behavior

This correspond to the maximum possible dynamics of the current controller and increases the stability limit of the higher-level control loops. The higher-level control loops are the



Configuring the motor control

Options for optimizing the control loops
Motor control settings

position control and the speed control. The setpoint step-changes are compensated within half a PWM cycle.

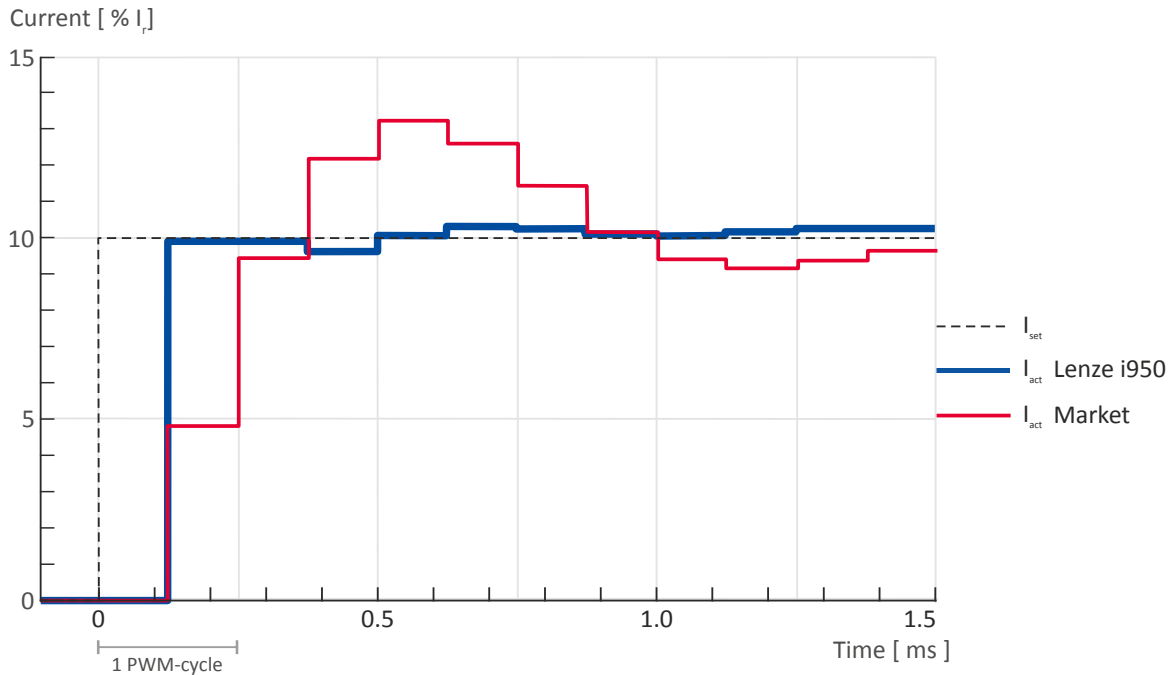

Fig. 3: Characteristic with and without torque control



For a servo control, the current controller should always be optimized if a motor of another manufacturer with unknown motor data is used! For a V/f characteristic control, the current controller only has to be optimized if voltage vector control **Activate voltage vector control (Imin controller)** is used, or if the motor functions “DC braking” or “flying restart process” are activated.

Automatically calculated settings for the current controller



If one of the values calculated exceeds the upper object limit, the value is limited to the limit value.

There is a coupling between the two control loops (direct-axis current controller, cross current controller) which makes every actuation of a controller occur as fault in the control loop of the other controller. This coupling can be compensated by activating the current controller feedforward control via object [0x2941](#).

For the automatic calculation of the two controller parameters (gain and reset time), the "Calc. current contr. param." function is provided via object [0x2822:013](#). The calculation function is based on the stator resistance [0x2C01:002](#) and the stator leakage inductance [0x2C01:003](#). Thus, these motor parameters must be parameterized before, e. g. by the manual entry of data sheet values. The calculated controller parameters can be optimized by means of an experimental adjustment subsequently. The procedure is described in section [Manual "current pulse" test mode](#) [195](#)

Equation for calculating the gain of the synchronous motor

$$V_p = \frac{L_{ss}}{T_{Totzeit}}$$

Configuring the motor control

Options for optimizing the control loops
Motor control settings



Equation for calculating the reset time of the synchronous motor

$$T_n = \frac{L_{ss}}{R_s}$$

Parameter	Symbol	Description	Dimension unit
0x2942:001	V_p	Current controller gain	V/A
0x2C01:003	L_{ss}	Stator leakage inductance	H
-	$T_{Dead\ time}$	Equivalent time constant for the analog detection and scanning = 0.0002016 s (201.6 μ s (=93.75 μ s / 0.465))	s
0x2942:002	T_{Rated}	Current controller reset time	s
0x2C01:002	R_s	Stator resistance (value at 20° C)	Ω

Equation for calculating the gain of the asynchronous motor

$$V_p = \frac{\sigma \cdot L_s}{T_{Totzeit}} \approx \frac{2 \cdot L_{ss}}{T_{Totzeit}}$$

Equation for calculating the reset time of the asynchronous motor

$$\tau_n = \frac{\sigma \cdot L_s}{R_s} \approx \frac{2 \cdot L_{ss}}{R_s}$$

Parameter	Symbol	Description	Dimension unit
0x2942:001	V_p	Current controller gain	V/A
-	σ	Leakage	
-	L_s	Motor stator inductance	H
0x2C01:003	L_{ss}	Motor stator leakage inductance	H
-	$T_{Dead\ time}$	Equivalent time constant for the analog detection and scanning = 0.00034 s	s
0x2942:002	T_{Rated}	Current controller reset time	s
0x2C01:002	R_s	Motor stator resistance (value at 20° C)	Ω

Parameter

Address	Name / setting range / [default setting]	Information
0x2941	Current controller feedforward control	Activate/deactivate feedforward control. Since the actuation of the current controller is known, they can be precontrolled to increase the actuations of the current controller. Note! For a feedforward control, the Motor equivalent circuit diagram data must be known. If only estimated values are available, we recommend you not to activate the feedforward control.
	0 Disable	
	1 Enable	
	2 Reserved	
0x2942:001	Current controller parameters: Gain 0.00 ... [148.21] ... 750.00 V/A	Gain factor V_p of the current controller.
0x2942:002	Current controller parameters: Reset time 0.01 ... [3.77] ... 2000.00 ms	Reset time T_i of the current controller.
0x2943	Current setpoint filter time 0.00 ... [0.00] ... 10.00 ms	Setting of the setpoint current filter time.

Example

Applications with torque control with a switching frequency of 4 kHz reach the same dynamics as applications with 16 kHz without torque control. The stability limit of the speed controller increases depending on the switching frequency and filter setting by up to 100 %. Typical values are in the range of 30 % - 50 %. In case of applications that have already been solved with the previously found settings, an activation is not necessary.



Configuring the motor control

Options for optimizing the control loops
Motor control settings

12.6.5.3 ASM field controller

For motors with great rotor time constants or small rotor resistances, very high gain factors are calculated. Since the setting range of the field controller is limited to the double rated magnetising current, the field control loop in the case of these motors tends to a two-point response when the values calculated are entered.

The automatic calculation is made via the parameter 0x2822:016 = 1.

Starting from a calculated gain factor of approx. 1000 A/Vs, do not set the full value anymore.

Example

Calculated value: 10000 A/Vs

Setting: 3000 A/Vs

Calculation of the gain

$$V_p \approx \frac{1}{4 \cdot R_r \cdot T_{\text{Stromregler}}}$$

Calculation of the reset time

$$T_n = T_r = \frac{L_r}{R_r}$$

Parameter	Symbol	Description	Dimension unit
0x29C0:001	V_p	Field controller gain	A/Vs
0x29C0:002	T_n	Field controller reset time	s
0x2C02:002	L_h	Mutual motor inductance (ASM)	H
0x2C02:001	R_r	Motor rotor resistance (ASM)	Ω
-	$T_{\text{current controller}}$	Equivalent time constant of the current control loop = 0.0005 s	
-	T_r	Motor rotor time constant	
-	K_{Path}	Gain of the control path	
-	L_r	Motor rotor resistance (ASM)	H

Parameter

Address	Name / setting range / [default setting]	Information
0x29C0:001	Field controller settings: Gain 0.00 ... [165.84] ... 50000.00 A/Vs	Gain factor V_p of the field controller.
0x29C0:002	Field controller settings: Reset time 1.0 ... [15.1] ... 6000.0 ms	Reset time T_n of the field controller.

Configuring the motor control

Options for optimizing the control loops
Motor control settings



12.6.5.4 ASM field weakening controller

Since the controlled system gain changes with the speed, the field weakening controller is corrected via the speed.

The automatic calculation is made via the parameter 0x2822:017 = 1.

Calculation of the gain

$$V_p = 0, \quad V_{\text{Strecke_Fs}} = p \cdot n_{\text{eck}} \cdot \frac{2\pi}{60}$$

Calculation of the reset time

$$T_n = 4 \cdot \frac{V_{\text{Strecke_Fs}}}{60} \cdot (T_{\text{EF}} + T_{\text{Filter}}), \quad T_{\text{EF}} = T_r = \frac{L_r}{R_r} \approx \frac{L_h + L_{\text{ss}}}{R_r}$$

Parameter	Symbol	Description	Dimension unit
0x29E0:001	V_p	Gain of the field weakening controller	Vs / A
-	$V_{\text{Path_Fs}}$	Gain of the control path	
-	P	Number of pole pairs	rpm
-	$n_{\text{transition}}$	Speed at which the field weakening is approximately initiated.	
0x29E0:002	T_n	Reset time of the field weakening controller	s
-	T_{EF}	Filter time constant of the field control loop	
0x29E3	T_{Filter}	Filter time constant for the required voltage	s
-	T_r	Motor rotor time constant	
-	L_r	Motor rotor resistance (ASM)	
0x2C02:002	L_h	Mutual motor inductance (ASM)	H
0x2C01:003	L_{ss}	Motor stator leakage inductance (ASM) or motor leakage inductance (SM)	H
0x2C02:001	R_r	Motor rotor resistance	Ω

Parameter

Address	Name / setting range / [default setting]	Information
0x29E0:001	Field weakening controller settings: Gain (ASM) 0.000 ... [0.000] ... 2147483.647 Vs/V	Gain factor V_p of the field weakening controller.
0x29E0:002	Field weakening controller settings: Reset time (ASM) 1.0 ... [2000.0] ... 240000.0 ms	Reset time T_n of the field weakening controller.
0x29E1	Field weakening controller Field limitation 5.00 ... [100.00] ... 100.00 %	Field limitation of the field weakening controller.

12.6.5.5 ASM field weakening controller (extended)

For a quick commissioning, the calculations and settings are made automatically during the optimisation.

Parameter

Address	Name / setting range / [default setting]	Information
0x29E2	DC-bus filter time 1.0 ... [25.0] ... 1000.0 ms	Filter time for the current DC-bus voltage used for field weakening.
0x29E3	Motor voltage filter time 1.0 ... [25.0] ... 1000.0 ms	Filter time for the current motor voltage used for field weakening.
0x29E4	Voltage reserve range 1 ... [5] ... 20 %	Voltage reserve at the transition point to the field weakening, with reference to the current value of the DC-bus voltage. Only relevant for: <ul style="list-style-type: none"> Servoregelung (SC-PSM) (0x2C00 = 1) Servo control (SC ASM) (0x2C00 = 2)



12.6.5.6 PSM field weakening controller

The inverter control enables a synchronous motor to be operated outside the voltage range. If a motor is selected in the »EASY Starter«, the control is parameterised automatically.

Improve the transition from the base speed range to field weakening by activating the **current controller: feedforward control** parameter. ▶ [0x2941](#)

- The current controller precontrol is defined via the following parameters:
 - Motor parameter: stator resistance ▶ [0x2C01:002](#)
 - Motor parameter: stator leakage inductance ▶ [0x2C01:003](#)
 - Motor parameter (PSM): back EMF constant ▶ [0x2C03:001](#)
- If you want to operate a third-party motor in the field weakening range, you have to determine the parameters previously mentioned



Operation of synchronous motors outside the voltage range:

If pulse inhibit is set in the inverter, e.g. in case of an inverter disable or an error, the DC bus is loaded in accordance with the current speed (see equation).

- At high speed and outside the voltage range, the terminal voltage can be higher than the mains voltage!
- In order to prevent the DC bus from being loaded impermissibly high, connect a brake chopper to the DC bus!

The terminal voltage corresponds to the following equation

$$U_k = n * \frac{U_N}{n_M}$$

V_k	Terminal voltage
n	Speed
V_{rated}	Rated mains voltage
n_m	Rated motor speed

- Mains settings: rated mains voltage ▶ [0x2540:001](#)
- Motor parameter: rated speed ▶ [0x2C01:004](#)

Delaying the buildup of field weakening

With the default setting (5 %), field weakening is initiated, thus ensuring that a punctual buildup of the field weakening current shortly before the voltage threshold is reached.

In the case of synchronous motors, setting the **Voltage reserve range** parameter may bring about a delayed start of field weakening for synchronous machines, e.g. in order to slightly reduce the thermal load of the motor. ▶ [0x29E4](#)

Configuring the motor control

Options for optimizing the control loops
Motor control settings



12.6.5.7 I_{max} controller

Defining the behaviour at the current limit (I_{max} controller)

The maximum output current or the current limit is defined by the [0x6073](#) "max. current" parameter. In case of the V/f characteristic control, an I_{max} controller is implemented for complying with this limit. If the motor current exceeds the set maximum current, the I_{max} controller is activated.

- The I_{max} controller changes the rotating field frequency so that the motor current does not exceed the current limit. In motor mode, the frequency is reduced and in generator mode it is increased.
- The gain and reset time of the I_{max} controller can be parameterised.

Optimising the I_{max} controller

The automatic calculation serves to determine starting parameters of the I_{max} controller which are sufficient for many applications. Thus, an optimisation is not required for most of the applications.

The automatic calculation is made via the parameter `0x2822:019 = 1`.

The parameters of the I_{max} controller must be adapted if

- a power control is implemented with great moments of inertia.

Recommendation:

Step 1: increase reset time in [▶ 0x2B08:002](#)

Step 2: reduce gain in [▶ 0x2B08:001](#)

- vibrations occur with V/f characteristic control during the operation of the I_{max} controller.

Recommendation:

Step 1: increase reset time in [▶ 0x2B08:002](#)

Step 2: reduce gain in [▶ 0x2B08:001](#)

- overcurrent errors occur due to load impulses or too high acceleration/deceleration ramps.

Recommendation:

Step 1: reduce reset time in [▶ 0x2B08:001](#)

Step 2: increase gain in [▶ 0x2B08:002](#)

Parameter

Address	Name / setting range / [default setting]	Information
0x2B08:001	V/f I _{max} controller: Gain 0.000 ... [0.001] ... 1000.000 Hz/A	Gain factor V _p of the I _{max} controller.
0x2B08:002	V/f I _{max} controller: Reset time 1.0 ... [100.0] ... 2000.0 ms	Reset time T _i of the I _{max} controller.

12.6.5.8 Flying restart controller

Parameter

Address	Name / setting range / [default setting]	Information
0x2BA1	Flying restart circuit 0 ... [15] ... 100 %	



Configuring the motor control

Options for optimizing the control loops
Motor control settings

12.6.5.9 Position controller

Equation for calculating the gain

The automatic calculation is made via the parameter 0x2822:015 = 1.

$$V_p = \frac{1}{32 \cdot T_{\text{Summe}}}, \quad T_{\text{Summe}} = T_{\text{Filter}} + T_{\text{Stromregler}}$$

Parameter	Symbol	Description	Dimension unit
0x2980	V_p	Position controller gain	Hz
0x2985:001 ... 0x2985:011	$V_p(n)$	Speed-dependent V_p adaptation	
0x2904	T_{Filter}	Filter time constant - actual speed value	s
-	$T_{\text{current controller}}$	Equivalent time constant of the current control loop = 0.0005 s (500 μ s)	s

Instability of the position control loop due to too high dynamic performance of the speed controller

The following countermeasure must be taken if the following error cannot be reduced to acceptable values while setting the position controller:

1. Reduce speed controller by the factor 2 and slowly increase the position controller until it gets slightly unstable again.
2. Reduce the position controller slightly and increase the speed controller until the position control loop gets slightly unstable again.
3. Repeat these steps until the following error is reduced to acceptable values.

Parameter

Address	Name / setting range / [default setting]	Information
0x2980	Position controller gain 0.00 ... [28.40] ... 1000.00 Hz	Setting of the position controller gain.
0x2981	Position controller gain adaption 0.00 ... [100.00] ... 200.00 %	Setting of the percentage adaptation for the position controller gain.
0x2982	Position controller output signal limitation 0.00 ... [480000.00] ... 480000.00 rpm	Setting of the output signal limitation.
0x2983	Actual position start value -2147483647 ... [0] ... 2147483647 pos. unit	Specifying a new actual position.
0x2984	Mode for setting the actual position	Selection of the mode for setting or shifting the actual position.
	0 Absolute	Actual position = Actual position start value (0x2983)
	1 Relative	Actual position = actual position + Actual position start value (0x2983)
0x2986	Resulting gain adaption • Read only: x.xx %	Display of the resulting gain after being adapted.

Configuring the motor control

Fine adjustment of the motor model



12.7 Fine adjustment of the motor model

The further commissioning steps are only required for servo controls if more stringent requirements with regard to the torque linearity have to be met. During the commissioning process of Lenze motors, typical values for the relevant parameters are provided. For motors of other manufacturers, these values are to be requested from the motor manufacturer, or they have to be estimated.



Configuring the motor control

Fine adjustment of the motor model
Correction of the stator leakage inductance (Lss)...

12.7.1 Correction of the stator leakage inductance (Lss)...

...and the current controller parameters by means of the saturation characteristic

For the most part, the electrical characteristics of the motor are the relevant factors for an optimal current controller setting (V_p , T_i), especially the stator resistance and the stator leakage inductance (Lss). However, modern motors have their stator leakage inductance changed along with the current level so that it is impossible to have an optimal current controller setting for all working points at all times.

For applications with operating phases that involve very different current and torque requirements and, at the same time, high requirements on dynamic drive behaviour, the i700 servo inverter provides the possibility of the correction of the stator leakage inductance and the current controller settings by means of the adjustable saturation characteristic.

The saturation characteristic is a typical characteristic of motors of one type/size. It does not depend on the maximum process current of the motor in the prevailing application. Thus the defined values should be based on the key data of the motors. These are rated motor current, peak motor current for a limited time and the ultimate motor current.

NOTICE

Impact of the saturation characteristic on the current controller feedforward control

- The saturation characteristic is not only used to correct the current controller, but it also influences the current controller feedforward control (can be activated via parameter [0x2941](#)).

The following picture shows a typical saturation characteristic of an MCS motor:

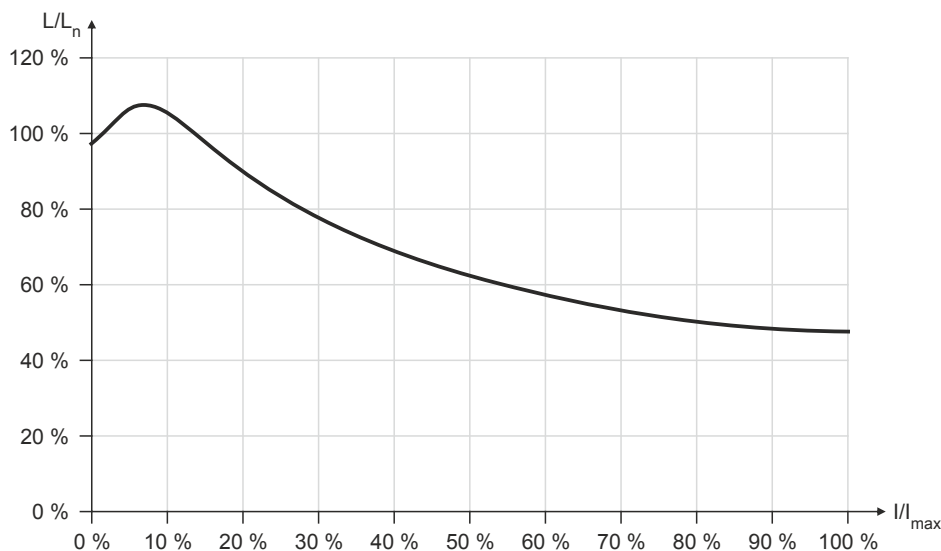

The saturation characteristic represents the change in inductance (L/L_n) as a function of the motor current (I/I_{max}). The variables of both axes which were scaled to a reference value are represented as percentages.

- When a Lenze motor is selected, the saturation characteristic is already filled with values typical of the series.

Configuring the motor control

Fine adjustment of the motor model

Correction of the stator leakage inductance (Lss)...



Distribution of the grid points

- The saturation characteristic is represented by 17 grid points.
- The 17 grid points are spaced on the X axis at equal intervals (equidistantly) in a range of 0 ... 100 %. The 100% value of the X axis refers to the current value (max. motor current in the process) set in parameter [0x2C05](#).
- The y values for the grid points can be accessed via the subindices of parameter .

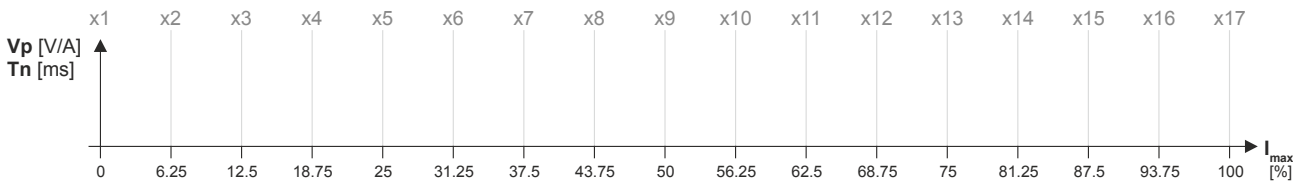

- The 100 % value of a grid point refers to
 - the set motor stator leakage inductance [0x2C01:003](#) and
 - the set current controller gain V_p [0x2942:001](#).
- Preferably select a display area of the grid points which includes at least the ultimate motor current. The current controller step response is then recorded actively only until the grid point with peak motor current. In order to prevent the motor winding from being overloaded, use the manual test mode "current pulse" for recording: [▶ Manual "current pulse" test mode.](#) [📄 195](#)
- The grid points with current setpoints above the peak motor current are determined through interpolation.
- When the saturation characteristics for motor types are determined, it makes sense in some cases to select a scaled representation of the grid point distribution. This requires to know the highest value of the quotient from "ultimate motor current / rated motor current" of the motor series.

Example of determining the saturation characteristic

Given values:

- Rated motor current: 5 A
- Maximum motor current: 20 A
- Maximum process current: 15 A



Configuring the motor control

Fine adjustment of the motor model
Correction of the stator leakage inductance (L_{ss})...

Proceeding

1. Deactivate correction: Set all subindices (0x2C04:001 ... 0x2C04:017) to 100 %.
2. Use 0x2C05 to set the maximum current up to which the motor is to be operated in the process (in this example "15 A").
3. Adjust the current controller with different current setpoints by means of the manual test mode **Manual "current pulse" test mode** and take down the corresponding settings for V_p and T_n.
 - The procedure is described in section **Manual "current pulse" test mode**.
 - The current setpoints to be set for the corresponding adjustment in object 0x2835:001 result from the scaling of the maximum process current to the X axis of the saturation characteristic.
 - The grid points which are required to define the saturation characteristic with a sufficient quality varies from motor to motor and thus has to be determined individually.
 - For this example, currents that are part of the grid points 5, 9, 13, and 15 have been selected, and a measurement at rated motor current was carried out additionally:

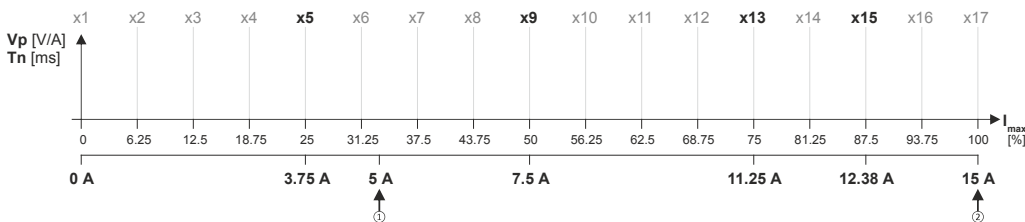

See table "Specifications for adjustment / measured values" after this listing

4. Create a characteristic based on the detected values for V_p (but do not enter any values in yet).
 - Determine the values of the grid points that have not been adjusted by interpolation between two values.
 - **Note:** This example assumes that the inductance does not change considerably below 3.75 A. For this reason, the same V_p value that resulted from the measurement with a motor current of 3.75 A was used for all grid points below 3.75 A.

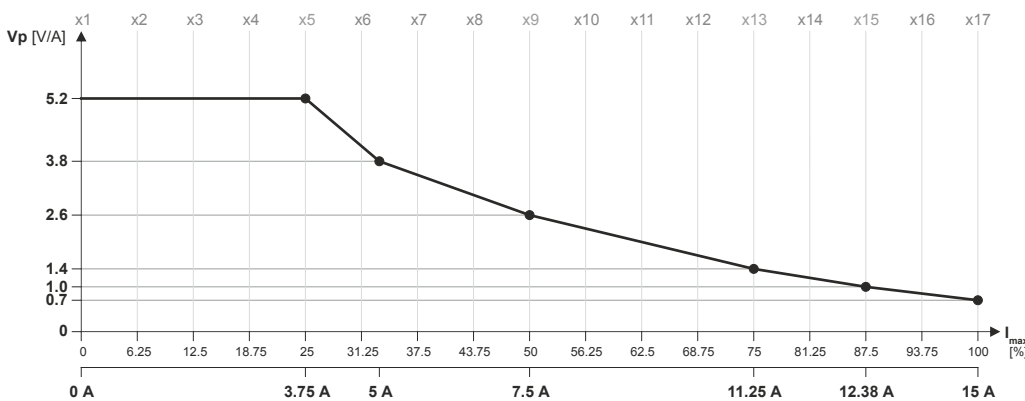

5. Set gain V_p and reset time T_n to the values that were determined during the adjustment with the rated motor current (in this example "5 A"):
 - 0x2942:001 is set to "3.8 V/A".
 - 0x2942:002 is set to "5 ms".
6. Scale V_p values on the Y axis of the characteristic to the V_p setting "3.8 V/A":

Configuring the motor control

Fine adjustment of the motor model

Correction of the stator leakage inductance (Lss)...

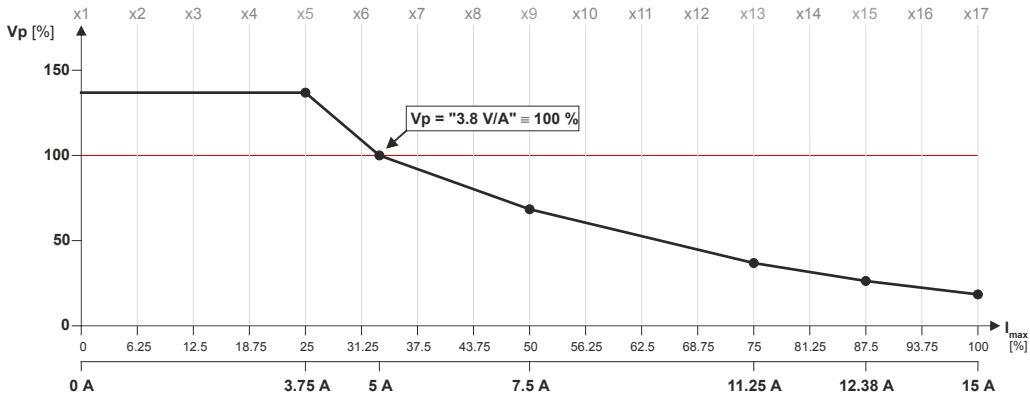

7. Enter the percentage Vp values of the grid points into the subindices

(0x2C04:001 ... 0x2C04:017):

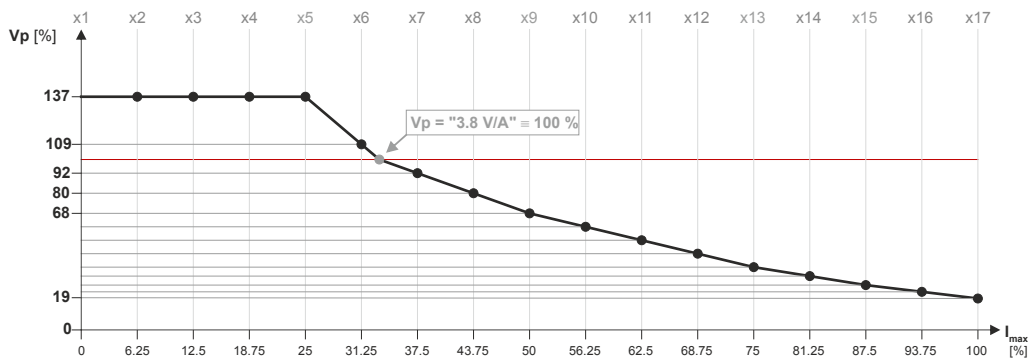

See table "Setting of grid point 1 ... 17 in [%]" after this listing

8. Enter the maximum process current ("15 A") in 0x6073 as the maximum current.

- The settings made should now cause the same basic current characteristic irrespective of the current level.
- Now that the current controller gain is actively corrected, the step responses may slightly differ from the previous measurements. In this case, the current controller parameters must be post-optimised for the last time.

9. For permanent storage: save the characteristic determined.

The »EASY Starter« serves to save the parameter settings of the inverter as parameter file (*.gdc). [Saving the parameter settings](#)

Specifications for adjustment			Measured values	
Grid point	Scaling	Current setpoint	Vp [V/A]	Tn [ms]
5	0.25 * 15 A =	3.75 A	5.2	6.5
9	0.5 * 15 A =	7.5 A	2.6	4
13	0.75 * 15 A =	11.25 A	1.4	2.5
15	0.875 * 15 A =	12.38 A	1.0	2
17	1.0 * 15 A =	15 A	0.7	1.7
Rated motor current=		5 A	3.8	5

Setting of grid point 1 ... 17 in [%]																
y1	y2	y3	y4	y5	y6	y7	y8	y9	y10	y11	y12	y13	y14	y15y	y16	y17
137	137	137	137	137	109	92	80	68	61	53	45	37	32	26	22	19



Configuring the motor control

Fine adjustment of the motor model
Correction of the stator leakage inductance (Lss)...

Parameter

Address	Name / setting range / [default setting]	Information
0x2C04:001	Inductance grid points (y) Lss saturation characteristic: y1 = L01 (x = 0.00 %) 0 ... [165] ... 400 %	Saturation characteristic of the leakage inductance. The linear distribution via the current results from the maximum motor current (0x2C05).
0x2C04:002	Inductance grid points (y) Lss saturation characteristic: y2 = L02 (x = 6.25 %) 0 ... [200] ... 400 %	
0x2C04:003	Inductance grid points (y) Lss saturation characteristic: y3 = L03 (x = 12.50 %) 0 ... [146] ... 400 %	
0x2C04:004	Inductance grid points (y) Lss saturation characteristic: y4 = L04 (x = 18.75 %) 0 ... [117] ... 400 %	
0x2C04:005	Inductance grid points (y) Lss saturation characteristic: y5 = L05 (x = 25.00 %) 0 ... [97] ... 400 %	
0x2C04:006	Inductance grid points (y) Lss saturation characteristic: y6 = L06 (x = 31.25 %) 0 ... [82] ... 400 %	
0x2C04:007	Inductance grid points (y) Lss saturation characteristic: y7 = L07 (x = 37.50 %) 0 ... [71] ... 400 %	
0x2C04:008	Inductance grid points (y) Lss saturation characteristic: y8 = L08 (x = 42.75 %) 0 ... [62] ... 400 %	
0x2C04:009	Inductance grid points (y) Lss saturation characteristic: y9 = L09 (x = 50.00 %) 0 ... [55] ... 400 %	
0x2C04:010	Inductance grid points (y) Lss saturation characteristic: y10 = L10 (x = 56.25 %) 0 ... [50] ... 400 %	
0x2C04:011	Inductance grid points (y) Lss saturation characteristic: y11 = L11 (x = 62.50 %) 0 ... [46] ... 400 %	
0x2C04:012	Inductance grid points (y) Lss saturation characteristic: y12 = L12 (x = 68.75 %) 0 ... [43] ... 400 %	
0x2C04:013	Inductance grid points (y) Lss saturation characteristic: y13 = L13 (x = 75.00 %) 0 ... [42] ... 400 %	
0x2C04:014	Inductance grid points (y) Lss saturation characteristic: y14 = L14 (x = 81.25 %) 0 ... [41] ... 400 %	
0x2C04:015	Inductance grid points (y) Lss saturation characteristic: y15 = L15 (x = 87.50 %) 0 ... [41] ... 400 %	
0x2C04:016	Inductance grid points (y) Lss saturation characteristic: y16 = L16 (x = 93.25 %) 0 ... [41] ... 400 %	
0x2C04:017	Inductance grid points (y) Lss saturation characteristic: y17 = L17 (x = 100.00 %) 0 ... [41] ... 400 %	
0x2C04:018	Inductance grid points (y) Lss saturation characteristic: Activation Lss saturation characteristic 0 Adjustment off 1 Adjustment on	Switch on/off the correction by means of saturation characteristic.
0x2C05	Reference for current grid points (x) Lss saturation characteristic 0.0 ... [5.4] ... 500.0 A	Setting of the maximum motor current. Serves as reference value for the scaled current data of the X axis of the saturation characteristic.

Configuring the motor control

Fine adjustment of the motor model

Synchronous motor (SM): Compensate temperature and current influences



12.7.2 Synchronous motor (SM): Compensate temperature and current influences

The properties of the permanent magnets of permanently excited synchronous motors depend on the temperature and the amperage. The relationship between motor current and resulting torque changes correspondingly.

The influences of the temperature and the amperage on the magnetisation can be taken into account by the motor control and hence be compensated for.

- To compensate for the temperature dependence of the magnets, the temperature coefficient (kT) of the permanent magnet must be entered in object **0x2C03:003** (linear characteristic).
- To compensate for the current dependence of the magnets, multiple grid points of a characteristic must be entered in the following object (non-linear characteristic):

Parameter

Address	Name / setting range / [default setting]	Information
0x2C06:001	Grid points for magnet characteristic (current): x1 = i01/iN 0 ... [0] ... 1000 %	Characteristic for the dependency of the magnetic flux on the active motor current.
0x2C06:002	Grid points for magnet characteristic (current): y1 = kT01/kTN 0 ... [100] ... 1000 %	
0x2C06:003	Grid points for magnet characteristic (current): x2 = i02/iN 0 ... [100] ... 1000 %	
0x2C06:004	Grid points for magnet characteristic (current): y2 = kT02/kTN 0 ... [100] ... 1000 %	
0x2C06:005	Grid points for magnet characteristic (current): x3 = i03/iN 0 ... [200] ... 1000 %	
0x2C06:006	Grid points for magnet characteristic (current): y3 = kT03/kTN 0 ... [100] ... 1000 %	
0x2C06:007	Grid points for magnet characteristic (current): x4 = i04/iN 0 ... [415] ... 1000 %	
0x2C06:008	Grid points for magnet characteristic (current): y4 = kT04/kTN 0 ... [72] ... 1000 %	



Configuring the motor control

Fine adjustment of the motor model
Asynchronous motor (ASM): Identify L_h saturation characteristic

12.7.3 Asynchronous motor (ASM): Identify L_h saturation characteristic

In case of an asynchronous motor, the relationship between current and torque is basically determined by the saturation behaviour of the mutual inductance. If the achieved torque accuracy, especially in the field weakening range should not be sufficient, the accuracy can be increased by the individual identification of the saturation characteristic. This behaviour can be measured by the servo inverter.

Conditions for the execution

- Before this commissioning function is executed, the inverter characteristic and the motor parameters must be identified ▶ [Motor equivalent circuit diagram data](#). [□ 152](#)
- The motor may be stalled.
- The inverter is error-free and in "Switched on" device state.

Response of the motor during "standstill" performance

How to identify the L_h saturation characteristic:



The identification of the L_h saturation characteristic can take up to 11 minutes.

1. If the servo inverter enabled, disable it .
2. Select the drive mode [10] in parameter [0x2825](#): L_h saturation characteristic identification
3. Enable the inverter to start the process.
 - Check the progress in [0x2823:002](#).
 - Disabling the inverter serves to abort the started procedure any time if required. Already determined characteristic values are rejected in this case.

After successful completion...

...the inverter will be disabled automatically and the points of the determined L_h saturation characteristic are set in the parameters [0x2C07:001](#) ... [0x2C07:017](#).

- Save the changed settings.
The »EASY Starter« serves to save the parameter settings of the servo inverter as parameter file (*.gdc). ▶ [Saving the parameter settings](#) [□ 39](#)
- The inverter disable set automatically by the procedure can be deactivated again via the CiA402 control word [0x6040](#) (setting = 7, 15).

In the event of an error

If an error occurs during the procedure or the pulse inhibit gets active (e.g. due to short-time undervoltage), the procedure is terminated with inverter disable without the settings being changed.

Load standard L_h saturation characteristic

If an incorrect L_h saturation characteristic has been determined or none at all, it is possible to load a standard L_h characteristic.

How to load the standard L_h saturation characteristic:

1. The start is made via the parameter [0x2822:021](#) = 1.
2. For permanent storage: after the process has been completed, save the L_h saturation characteristic set in .

The »EASY Starter« serves to save the parameter settings of the inverter as parameter file (*.gdc). [Saving the parameter settings](#)

Configuring the motor control

Fine adjustment of the motor model

Asynchronous motor (ASM): Identify Lh saturation characteristic



Parameter

Address	Name / setting range / [default setting]	Information												
0x2822:021	Axis commands: Load default Lh saturation characteristic <table border="1"> <tr> <td>0</td> <td>Off/Ready</td> </tr> <tr> <td>1</td> <td>On/Start</td> </tr> <tr> <td>2</td> <td>In progress</td> </tr> <tr> <td>3</td> <td>Action cancelled</td> </tr> <tr> <td>4</td> <td>No access</td> </tr> <tr> <td>5</td> <td>No access (Inverter disabled)</td> </tr> </table>	0	Off/Ready	1	On/Start	2	In progress	3	Action cancelled	4	No access	5	No access (Inverter disabled)	Parameters for interaction with engineering tools.
0	Off/Ready													
1	On/Start													
2	In progress													
3	Action cancelled													
4	No access													
5	No access (Inverter disabled)													
0x2C07:001	Inductance grid points (y) Lh saturation characteristic: y1 = L01 (x = 0.00 %) 0 ... [118] ... 400 %	Saturation characteristic of the mutual inductance of an asynchronous machine as a function of the magnetising current.												
0x2C07:002	Inductance grid points (y) Lh saturation characteristic: y2 = L02 (x = 6.25 %) 0 ... [118] ... 400 %													
0x2C07:003	Inductance grid points (y) Lh saturation characteristic: y3 = L03 (x = 12.50 %) 0 ... [118] ... 400 %													
0x2C07:004	Inductance grid points (y) Lh saturation characteristic: y4 = L04 (x = 18.75 %) 0 ... [117] ... 400 %													
0x2C07:005	Inductance grid points (y) Lh saturation characteristic: y5 = L05 (x = 25.00 %) 0 ... [116] ... 400 %													
0x2C07:006	Inductance grid points (y) Lh saturation characteristic: y6 = L06 (x = 31.25 %) 0 ... [114] ... 400 %													
0x2C07:007	Inductance grid points (y) Lh saturation characteristic: y7 = L07 (x = 37.50 %) 0 ... [111] ... 400 %													
0x2C07:008	Inductance grid points (y) Lh saturation characteristic: y8 = L08 (x = 43.75 %) 0 ... [107] ... 400 %													
0x2C07:009	Inductance grid points (y) Lh saturation characteristic: y9 = L09 (x = 50.00 %) 0 ... [100] ... 400 %													
0x2C07:010	Inductance grid points (y) Lh saturation characteristic: y10 = L10 (x = 56.25 %) 0 ... [93] ... 400 %													
0x2C07:011	Inductance grid points (y) Lh saturation characteristic: y11 = L11 (x = 62.50 %) 0 ... [86] ... 400 %													
0x2C07:012	Inductance grid points (y) Lh saturation characteristic: y12 = L12 (x = 68.75 %) 0 ... [78] ... 400 %													
0x2C07:013	Inductance grid points (y) Lh saturation characteristic: y13 = L13 (x = 75.00 %) 0 ... [71] ... 400 %													
0x2C07:014	Inductance grid points (y) Lh saturation characteristic: y14 = L14 (x = 81.25 %) 0 ... [64] ... 400 %													
0x2C07:015	Inductance grid points (y) Lh saturation characteristic: y15 = L15 (x = 87.50 %) 0 ... [57] ... 400 %													
0x2C07:016	Inductance grid points (y) Lh saturation characteristic: y16 = L16 (x = 93.75 %) 0 ... [50] ... 400 %													
0x2C07:017	Inductance grid points (y) Lh saturation characteristic: y17 = L17 (x = 100.00 %) 0 ... [42] ... 400 %													



Configuring the motor control

Fine adjustment of the motor model
Estimate optimum magnetising current

12.7.4 Estimate optimum magnetising current

In case of the given L_h saturation behaviour, there is (usually) a magnetising current where the torque efficiency is highest. This magnetising current can be determined by the servo inverter.

- Executing this function also compresses or extends the L_h saturation characteristic (interpolation points [0x2C07:001](#) ... [0x2C07:001](#)).
- After the function has been executed, the determined magnetising current is entered in [0x2C02:003](#).

Preconditions for the performance

- Before this commissioning function is executed, the motor parameters and the L_h saturation characteristic must be identified ▶ [Motor equivalent circuit diagram data](#). [152](#)
- The motor must be stalled.

Response of the motor during "standstill" performance

How to estimate the optimal magnetising current:

1. Start **Axis commands: estimate optimum magnetising current** parameter with = 1.
▶ [0x2822:023](#)
2. After the process has been completed, save the changed inverter parameters:
 - L_h saturation characteristic ([0x2C07:001](#) ... [0x2C07:017](#))
 - Magnetising current [0x2C02:003](#)

The »EASY Starter« serves to save the parameter settings of the inverter as parameter file (*.gdc). ▶ [Saving the parameter settings](#)

Parameter

Address	Name / setting range / [default setting]	Information
0x2822:023	Axis commands: Estimate optimum magnetizing current	Parameters for interaction with engineering tools.
	0 Off/Ready	
	1 On/Start	
	2 In progress	
	3 Action cancelled	
	4 No access	
	5 No access (Inverter disabled)	

Configuring the motor control

Parameterise filter elements in the setpoint path
Jerk limitation



12.8 Parameterise filter elements in the setpoint path

12.8.1 Jerk limitation

Via the max. acceleration change that can be set in parameter [0x2945 C00274](#), the change of the setpoint torque can be limited for jerk limitation. Hence, sudden torque step changes can be avoided. The entire speed characteristic is smoothed.

Parameter

Address	Name / setting range / [default setting]	Information
0x2945	Torque setpoint jerk limitation 0.1 ... [400.0] ... 400.0 %	Setting of the maximum acceleration change.



Configuring the motor control

Parameterise filter elements in the setpoint path
Notch filter (band-stop filter)

12.8.2 Notch filter (band-stop filter)

Due to the high dynamic performance or limit frequency of the closed current control loop, mechanical natural frequencies can be activated which may lead to an unstable speed control loop in the case of resonance.

To mask out or at least damp these resonant frequencies, two notch filters are integrated in the speed control loop of the inverter. In the Lenze setting, these filters are switched off:

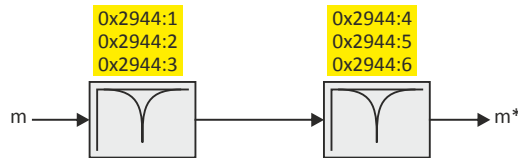

Use of the notch filters depending on the resonant frequency

⚠ WARNING!

Improperly set notch filters have a negative impact on the response and disturbance behaviour of the speed control: increased overshoot of the motor speed in case of response behaviour and / or higher speed deviations (extreme case: complete instability of the drive)

In the case of impairment,

- ▶ the drive that is still running must either be coasted down by activating the inverter disable or immediately be brought to a standstill via a brake.
- ▶ the speed controller must be optimised again afterwards.
- ▶ the test procedure must be repeated.

Output frequency	Use of notch filters
$0 \dots 1/2 f_{\text{limit_speed_controller}}$	No
$1/2 f_{\text{limit_speed_controller}} \dots f_{\text{limit_speed_Controller}}$	yes, with restriction
$< f_{\text{limit_speed_controller}}$	yes, without restriction

- The notch filters are suitable for use with resonant frequencies equal to or higher than the limit frequency of the speed controller:
 - Resonant frequencies $\geq f_{\text{limit_speed_controller}} = 70 \text{ Hz} \dots 110 \text{ Hz}$
- For resonant frequencies lower than the limit frequency of the speed controller, the use of suitable speed profiles with an S-shaped ramp is recommended.

Configuring the motor control

Parameterise filter elements in the setpoint path
Notch filter (band-stop filter)



Setting the notch filters

Since the exact frequency response of the speed control path in most cases is not known beforehand, an experimental procedure for setting the notch filters is described in the following.

How to set the notch filters:

1. Set and optimise current controller, see section [Current controller](#) . [156](#)
 2. Adapt the speed controller reset time to the filter time constant of the actual speed filter time and the equivalent time constant of the current control loop:
 - The following applies: $0x2900:002 = 16 * (0x2904 + 500 \mu s)$
- Note:** The setting of the reset time includes the equivalent time constant of the current control loop. The 500 μs indicated are typical in a power range of up to 50 kW. Above this value, greater time constants may occur.
3. Slowly increase the proportional gain of the speed controller in [0x2900:001](#) until the speed control loop starts to be unstable (acoustic determination, measurement of the motor current or recording of the speed output signal).
 4. Measure the oscillation frequency using an oscilloscope:
 - Assessing the motor current via [0x2DD1:004](#).
 - Assessing the motor speed via [0x6044](#).
 5. Set the oscillation frequency determined as filter frequency in [0x2944:001](#).
 6. Set the filter width to 40 % of the filter frequency in [0x2944:002](#).
 7. Set the filter depth to 40 dB in [0x2944:003](#).
 - If "0 dB" is set (default setting), the filter is not effective.
 8. Further increase the proportional gain of the speed controller in [0x2900:001](#) until the speed control loop starts to be unstable again.
 - If the oscillation frequency has changed now, readjust the filter frequency by trimming. The use of a second filter is ineffective here.
 - If the oscillation frequency remains the same, readjust the filter depth and/or the filter width by trimming (the first reduces the amplitude, the second lets the phase rotate faster).
 - Repeat step 8 until the desired behaviour or the limit of a sensible speed controller gain has been reached.
 9. Check the drive behaviour in case of quick stop (QSP)
 - Accelerate drive
 - Then, brake with quick stop (QSP) and check whether a reduced drive dynamics can be detected.
 - If so, reduce the influence of the filters until the reachable dynamics corresponds to the requirements.

NOTICE

- Readjust the speed controller after setting the notch filters (see section "[Speed controller](#)").
[153](#)
- Save the changed settings.
- The »EASY Starter« serves to save the parameter settings of the servo inverter as parameter file (*.gdc), see section [Saving the parameter settings](#) . [39](#)

Parameter

Address	Name / setting range / [default setting]	Information
0x2944:001	Torque setpoint notch filter: Frequency notch filter 1 1.0 ... [200.0] ... 1000.0 Hz	Setting of the frequency for notch filter 1.
0x2944:002	Torque setpoint notch filter: Bandwidth notch filter 1 0.0 ... [20.0] ... 500.0 Hz	Setting of the bandwidth for notch filter 1.
0x2944:003	Torque setpoint notch filter: Damping notch filter 1 0 ... [0] ... 100 dB	Setting of the damping for notch filter 1.
0x2944:004	Torque setpoint notch filter: Frequency notch filter 2 1.0 ... [400.0] ... 1000.0 Hz	Setting of the frequency for notch filter 2.



Configuring the motor control

Parameterise filter elements in the setpoint path
Notch filter (band-stop filter)

Address	Name / setting range / [default setting]	Information
0x2944:005	Torque setpoint notch filter: Bandwidth notch filter 2 0.0 ... [40.0] ... 500.0 Hz	Setting of the bandwidth for notch filter 2.
0x2944:006	Torque setpoint notch filter: Damping notch filter 2 0 ... [0] ... 100 dB	Setting of the damping for notch filter 2.

Configuring the motor control

Motor protection
Motor overload monitoring ($i^2 \cdot t$)



12.9 Motor protection

Many monitoring functions integrated in the inverter can detect errors and thus protect the device or motor from being destroyed or overloaded.

12.9.1 Motor overload monitoring ($i^2 \cdot t$)

This function monitors the thermal overload of the motor, taking the motor currents recorded and a mathematical model as a basis.

DANGER!

Fire hazard by overheating of the motor.

Possible consequences: Death or severe injuries

- ▶ Since the motor utilisation calculated in the thermal model gets lost after mains switching, the following operating states cannot be determined correctly: 1.) Restarting (after mains switching) of a motor that is already very hot and 2.) Change of the cooling conditions (e.g. cooling air flow interrupted or too warm).
- ▶ To achieve full motor protection, an additional temperature monitoring function with a separate evaluation must be installed.
- ▶ When actuating motors that are equipped with PTC thermistors or thermal contacts, always activate the PTC input.



Motor overload monitoring is important for motors without thermal sensor.

Details

During the calculation of the parameters [0x2D4D:001 ...0x2D4D:008](#), the speed dependence of the permissible motor load and thus of the permissible current (difference between the standstill current and rated current is taken into consideration.

In case of permanent overload and excess of the warning threshold set in parameter [0x2D4E](#), a warning is output in order that the higher-level Controller is still able to respond and reduce the motor load or interrupt the operation.

The calculated thermal motor utilisation is displayed in parameter .

Parameter

Address	Name / setting range / [default setting]	Information
0x2D4F	Motor utilisation ($i^2 \cdot t$) • Read only: x %	Display of the current thermal motor utilisation.
0x2D4E	Motor utilisation ($i^2 \cdot t$) - warning threshold 0 ... [100] ... 250 %	Setting of the warning threshold for motor overload monitoring.
0x2D50:001	Motor utilisation ($i^2 \cdot t$) - monitoring: Error response	For displaying the motor utilisation error response ($I^2 \cdot t$). Associated error code: • 9041 0x2351 - RANLI_CIMES_1000_20892
	0 Keine Reaktion	
	1 Fehler > CiA402	



Configuring the motor control

Motor protection
Motor overload monitoring ($i^2 \cdot t$)

Address	Name / setting range / [default setting]	Information
0x2D50:002	Motor utilisation ($i^2 \cdot t$) - monitoring: Error threshold 0 ... [105] ... 250 %	Setting of the error threshold for motor overload monitoring.

Configuring the motor control

Motor protection
Motor overload monitoring ($i^2 \cdot t$)



12.9.1.1 Parameters for the thermal model

The introduction of a two-component model with two time constants (one for the winding and the other for the housing/laminated core) serves to display the thermal behaviour of the motors up to 500% of the rated current.

Structure of the monitoring

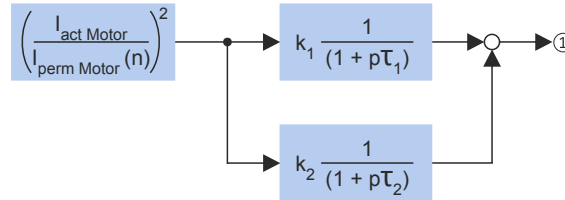

① Thermal utilisation of the motor in [%]

Parameter	Symbol	Description	Dimension unit
-	$I_{actMotor}$	Actual motor current	A
-	$I_{permMotor}$	Permissible motor current (speed-dependent)	A
0x2D4C:001	τ_1	Therm. time constant of winding	s
0x2D4C:002	τ_2	Therm. time constant of laminated core	s
0x2D4C:003	k_1	Percentage of the winding in the final temperature	%
-	k_2	Percentage of the laminated core in the final temperature: $k_2 = 100\% - k_1$	%

Calculation with only one time constant

If $k_1 = "0\%"$ is set, the part of the winding is not taken into consideration and the thermal model is only calculated using the time constant set for the housing/laminated core. This setting is e.g. required if only the time constant of the laminated core (T_2) is known.

Parameter setting of the time constant and the influence of the winding on motors of other manufacturers

When the influence of the winding is activated, the $i^2 \cdot t$ monitoring becomes more sensible as if only the influence of the laminated core would be used for monitoring purposes.

The necessity to activate the influence of the winding rises with the increasing utilisation of the motor overload capacity. It also rises with applications where the motor is at standstill for longer periods or cyclically and a load \geq permanent standstill current is applied.

For determining the values for the thermal time constant, try to get the data from the motor manufacturer. If this is not possible, you can use the data of a comparable Lenze motor.

Conditions for comparability are similar values in case of the following motor features:

- Square dimensions of the motor (active part)
- Length of the active part (if available)
- Permanent standstill current I_0 [A_RMS]
- Peak current/overload capacity [A_RMS]
- Copper resistance of the winding at 20 °C [Rphase]

Example:

Motor features	Data of the third-party motor	Description
Square dimension	95 mm	MCS09xxx = 89 mm
Standstill current	2.2 A	MCS09F38 = 3.0 A
Peak current	7.3 A	MCS09F38 = 15 A
Phase resistance	5.1 Ohms	MCS09F38 = 5.2 Ohms



Configuring the motor control

Motor protection
Motor overload monitoring ($i^2 \cdot t$)

Parameter

Address	Name / setting range / [default setting]	Information
0x2D4C:001	Thermisches Modell Motorauslastung ($i^2 \cdot t$): Motor utilisation ($i^2 \cdot t$) 1 ... [60] ... 36000 s	Setting of the time constant for the winding.
0x2D4C:002	Thermisches Modell Motorauslastung ($i^2 \cdot t$): Thermal time constant - laminations 1 ... [852] ... 36000 s	Setting of the time constant for the laminated core.
0x2D4C:003	Thermisches Modell Motorauslastung ($i^2 \cdot t$): Winding influence 0 ... [27] ... 100 %	Part of the thermal motor model: distribution factor of the copper winding influence.
0x2D4C:004	Thermisches Modell Motorauslastung ($i^2 \cdot t$): Starting value 0 ... [0] ... 250 %	Value for initialising the filters for the thermal motor overload monitoring (setting in % of the permissible full load).

Configuring the motor control

Motor protection
 Motor overload monitoring ($i^2 \cdot t$)



12.9.1.2 Speed-dependent evaluation of the motor current

WARNING!

Fire hazard by overheating of the self-ventilated standard motor

Possible consequence: destruction of system parts

- Protect self-ventilated standard motors especially at low speeds by sufficient cooling or from impermissibly high motor currents. Carry out a speed-dependent evaluation of the permissible motor current.

WARNING!

Fire hazard by overheating of PM synchronous motors

Possible consequence: destruction of system parts

- Please check for every individual case which r.m.s. value can be used to permanently operate the motor at standstill. In case of some motors, a derating $I_1/I_n < 100\%$ is required when $n_1/n_n = 0\%$. This serves to prevent an overload of individual motor phases as their power loss doubles with continuous DC current load. (It is called DC current load as the field frequency amounts to 0 Hz at standstill.)



When you select a Lenze motor from the catalogue and transfer its parameters into the i700 servo inverter a typical characteristic is automatically set for the selected motor. A deviating parameterisation is only required if the motor is operated in ambient conditions which demand a general derating. Example: use in site altitudes > 1000 m. In case of motors of other manufacturers, the operating points have to be parameterised based on the data sheet information.

By selecting a characteristic, the permissible motor current is evaluated depending on speed for calculating the thermal motor utilisation. For this purpose, up to four operating points on the S1 characteristic of a motor can be used.

- The S1 characteristic can be found in the technical data sheet/catalogue of the respective motor.
- The representation in the objects /characteristic is carried out as relative values with reference to rated values.

The speed-dependent evaluation of the permissible motor current can actually be switched off by parameterising all 8 characteristic points to "100 %".

Operating points		
①	Standstill n01-I01	For motors, this operating point is often described with the no-Io values.
②	Reference point n02-I02	If the value falls below the speed n02, a derating in the current is required because: <ul style="list-style-type: none"> • the motor cooling of self-ventilated motors deteriorates considerably. • a DC current load causes an increased power loss in a winding. • For motors, this operating point is also described with the no-Io values.
③	Rated point (n03=nN)-(I03=IN)	Rated values of the motor are the reference for all operating points of the $i^2 \cdot t$ monitoring.
④	Field weakening n04-I04	This operating point should be parameterised irrespective of the use in the current application.



Configuring the motor control

Motor protection
Motor overload monitoring ($i^2 \cdot t$)

Example of how to enter the characteristic for standard and servo motors

The required data of the operating points result from the S1 characteristic of the prevailing motor:

Examples of S1 characteristics			
Standard motor			
	<p>*forced ventilated standard motor **self-ventilated standard motor</p>		
Servo motor		Servo motor with derating at standstill	
Parameter	Characteristic points		Info
0x2D4D:001	①	$n_1/n_n * 100 \%$	Speed = "0" (standstill)
0x2D4D:002		$I_1/I_n * 100 \%$	Permissible motor current at standstill
0x2D4D:003	②	$n_2/n_n * 100 \%$	Speed from which the current must be reduced for self-ventilated motors. • Below this speed the cooling air flow of the integral fan is not sufficient anymore.
0x2D4D:004		$I_2/I_n * 100 \%$	Permissible motor current at speed n_2 (torque reduction)
0x2D4D:005	③	$n_3/n_n * 100 \%$	Rated speed
0x2D4D:006		$I_3/I_n * 100 \%$	Permissible motor current at rated speed
0x2D4D:007	④	$n_4/n_n * 100 \%$	Speed above the rated speed (in the field weakening range for asynchronous motors)
0x2D4D:008		$I_4/I_n * 100 \%$	Permissible motor current at speed n_4 (field weakening)

Configuring the motor control

Motor protection

Motor overload monitoring ($i^2 \cdot t$)



Parameter

Address	Name / setting range / [default setting]	Information
0x2D4D:001	Motor utilisation ($i^2 \cdot t$) - specific characteristic: x1 = n01/nN (n01 ~ 0) 0 ... [0] ... 600 %	User-definable characteristic for speed-dependent evaluation of the motor current.
0x2D4D:002	Motor utilisation ($i^2 \cdot t$) - specific characteristic: y1 = i01/iN (x1) 0 ... [100] ... 600 %	
0x2D4D:003	Motor utilisation ($i^2 \cdot t$) - specific characteristic: x2 = n02/nN (n02 = limit reduced cooling) 0 ... [0] ... 600 %	
0x2D4D:004	Motor utilisation ($i^2 \cdot t$) - specific characteristic: y2 = i02/iN (x2) 0 ... [100] ... 600 %	
0x2D4D:005	Motor utilisation ($i^2 \cdot t$) - specific characteristic: x3 = n03/nN (n03 = rated speed) 0 ... [100] ... 600 %	
0x2D4D:006	Motor utilisation ($i^2 \cdot t$) - specific characteristic: y3 = i03/iN (x3) 0 ... [100] ... 600 %	
0x2D4D:007	Motor utilisation ($i^2 \cdot t$) - specific characteristic: x4 = n04/nN (n04 = limit field weakening) 0 ... [100] ... 600 %	
0x2D4D:008	Motor utilisation ($i^2 \cdot t$) - specific characteristic: y4 = i04/iN (x4) 0 ... [100] ... 600 %	



12.9.1.3 UL 508-compliant motor overload monitoring

If the operation of the motor requires the compliance with the UL Standard 508, and the UL 508-compliant motor overload monitoring is realised by the mathematical model of the I^2xt monitoring, the following conditions must be observed.

UL 508 condition 3:

After mains switching and a motor load > 100 %, the I^2xt warning must be output faster than in the same overload case before mains switching.

- A motor load > 100 % exists if the r.m.s. value of the total motor current displayed in parameter [0x2DD1:005](#) is higher than the rated motor current [0x6075](#).

This condition can be fulfilled by setting the following parameters:

- Motor utilisation (I^2xt): starting value ▶ [0x2D4C:004](#)

UL 508 condition 2:

In case of a motor load of 110 %, the I^2xt warning at a motor rotating field frequency of 10 Hz must be output faster than at a motor rotating field frequency of 20 Hz.

- The current motor rotating field frequency is displayed in parameter [0x2DDD](#).
- A motor load of 110 % exists if the r.m.s. value of the total motor current displayed in parameter [0x2DD1:005](#) corresponds to 110 % of the rated motor current [0x6075](#).

This condition can be fulfilled by setting the following parameters:

- I^2xt : $x1 = n01/nN$ ($n01 \sim 0$) ▶ [0x2D4D:001](#)
- I^2xt : $y1 = i01/iN$ ($x = n01 \sim 0$) ▶ [0x2D4D:002](#)
- I^2xt : $x2 = n02/nN$ ($n02 =$ reduced cooling limit) ▶ [0x2D4D:003](#)
- I^2xt : $y2 = i02/iN$ ($x = n02 =$ reduced cooling limit) ▶ [0x2D4D:004](#)

UL 508 condition 1:

In case of a motor load of 600 %, the I^2xt warning must be output within 20 seconds.

- A motor load of 600 % exists if the r.m.s. value of the total motor current displayed in parameter [0x2DD1:005](#) corresponds to 600% of the rated motor current [0x6075](#).

This condition can be fulfilled by setting the following parameters:

- Motor utilisation (I^2xt): thermal time constant - laminated core ▶ [0x2D4C:002](#)
- Motor utilisation (I^2xt): influence winding ▶ [0x2D4C:003](#)
- Motor utilisation (I^2xt): motor overload warning threshold ▶ [0x2D4E](#)
- Motor utilisation (I^2xt): response ▶ [0x2D50:001](#)
- Motor utilisation (I^2xt): error threshold ▶ [0x2D50:002](#)

Configuring the motor control

Motor protection
Motor temperature monitoring



12.9.2 Motor temperature monitoring

In order to record and monitor the motor temperature, a PTC thermistor (single sensor according to DIN 44081 or triple sensor according to DIN 44082) or thermal contact (normally-closed contact) can be connected to the terminals T1 and T2. This measure helps to prevent the motor from being destroyed by overheating.

Preconditions

- The inverter can only evaluate one PTC thermistor! Do not connect several PTC thermistors in series or parallel.
- If several motors are actuated on one inverter, thermal contacts (NC contacts) (TCO) connected in series are to be used.
- To achieve full motor protection, an additional temperature monitoring function with a separate evaluation must be installed.
- By default, a wire jumper is installed between terminals X109/T1 and X109/T2, which must be removed when the PTC thermistor or thermal contact (TCO) is connected.

Details

If $1.6 \text{ k}\Omega < R < 4 \text{ k}\Omega$ at terminals X109/T1 and X109/T2, the monitoring function will be activated; see functional test below.

- If the monitoring function is activated, the response set in [0x2D48:002](#) will be effected.
- The setting [0x2D48:002](#) = 0 deactivates the monitoring function.



If a suitable motor temperature sensor is connected to the terminals X109/T1 and X109/T2 and the response in [0x2D48:002](#) is set to "Fault [3]", the response of the motor overload monitoring may be set other than "Fault [3]" in [0x2D4B:003](#). [▶ Motor overload monitoring \(i²*t\) 178](#)

Functional test

Connect a fixed resistor to the PTC input (T1/T2):

- $R > 4 \text{ k}\Omega$: The monitoring function must be activated.
- $R < 1 \text{ k}\Omega$: The monitoring function must not be activated.

Details

If $1.6 \text{ k}\Omega < R < 4 \text{ k}\Omega$ at terminals X109/T1 and X109/T2, the monitoring function will be activated; see functional test below.

- If the monitoring function is activated, the response set in [0x2D49:002](#) will be effected.
- The setting [0x2D49:002](#) = 0 deactivates the monitoring function.



If a suitable motor temperature sensor is connected to the terminals X109/T1 and X109/T2 and the response in [0x2D49:002](#) is set to "Fault [3]", the response of the motor overload monitoring may be set other than "Fault [3]" in . [▶ Motor overload monitoring \(i²*t\) 178](#)

Functional test

Connect a fixed resistor to the PTC input:

- $R > 4 \text{ k}\Omega$: The monitoring function must be activated.
- $R < 1 \text{ k}\Omega$: The monitoring function must not be activated.

Parameter

Address	Name / setting range / [default setting]	Information
0x2D48:002	PTC temperature sensor monitoring: Error response	Setting of a response for PTC temperature monitoring. Associated error code: <ul style="list-style-type: none">• 17281 0x4381 - RANLI_CIMES_1000_21212
	0 No response	
	1 Fault > CiA402	
	2 Warning	



Configuring the motor control

Motor protection
Motor temperature monitoring

Address	Name / setting range / [default setting]	Information
0x2D49:001	Motor temperature monitoring: Temperature sensor type	Selection of the motor temperature sensor used.
	0 KTY83-110	
	1 KTY83-110+2xPTC 150 °C	
	2 KTY84-130	
	3 Specific characteristic	
	4 Reserved	
	5 PT1000	
6 PT1000+2xPTC 150 °C		
0x2D49:002	Motor temperature monitoring: Response	Selection of the response to the triggering of the motor temperature monitoring. Associated error codes: <ul style="list-style-type: none"> • 17168 0x4310 - Motor temperature error • 17280 0x4380 - RANLI_CIMES_1000_02502 • 17282 0x4382 - RANLI_CIMES_1000_21218 • 17283 0x4383 - RANLI_CIMES_1000_21219
	0 No response	
	1 Warning	
0x2D49:003	Motor temperature monitoring: Warning threshold -3276.8 ... [145.0] ... 3276.7 °C	Setting of the warning threshold for motor temperature monitoring. The warning threshold is reset with a hysteresis of 5 °C.
0x2D49:004	Motor temperature monitoring: Error threshold -3276.8 ... [155.0] ... 3276.7 °C	Setting of the error threshold for motor temperature monitoring The warning threshold is reset with a hysteresis of 5 °C.
0x2D49:005	Motor temperature monitoring: Actual motor temperature • Read only: x.x °C	Display of the current motor temperature.
0x2D49:006	Motor temperature monitoring: Spec. characteristic temperature grid point 1 0.0 ... [25.0] ... 255.0 °C	Parameter for the specific thermal sensor characteristic (0x2D49:001 = 3).
0x2D49:007	Motor temperature monitoring: Spec. characteristic temperature grid point 2 0.0 ... [150.0] ... 255.0 °C	
0x2D49:008	Motor temperature monitoring: Spec. characteristic resistance grid point 1 0 ... [1000] ... 30000 Ω	
0x2D49:009	Motor temperature monitoring: Spec. characteristic resistance grid point 2 0 ... [2225] ... 30000 Ω	
0x2D49:010	Motor temperature monitoring: Temperature sensor feedback type	Selection of the thermal sensor relevant for temperature monitoring. Selection [3] motor and load feedback: temperature monitoring responds to the highest of both temperatures of the sensors at slot A and slot B.
	0 Motor encoder	
	3 Motor encoder and load encoder	
0x2D49:011	Motor temperature monitoring: Motor temperature (Motor encoder) • Read only: x.x °C	Display of the current motor temperature measured by motor feedback.
0x2D49:012	Motor temperature monitoring: Motor temperature (load encoder) • Read only: x.x °C	Display of the current motor temperature measured by load feedback.
0x2DDF:007	Axis information: Function of X109 • Read only	
	0 None	
	10 HIPERFACE DSL® (OCT)	
	20 PTC	

Configuring the motor control

Motor protection
Overcurrent monitoring



12.9.2.1 Individual characteristic for motor temperature sensor



The setting of a characteristic for the motor temperature sensor is not suitable as an adequate replacement of a tripping unit for the thermal protection of rotating electrical machines (EN 60947- 8:2013)!

If required, you can define and activate a special characteristic for the motor temperature sensor.

- The special characteristic is activated via the setting [0x2D49:001](#) = 3
- The special characteristic is defined based on two parameterisable grid points. The two grid points define a line that is extrapolated to the left and to the right.

This default setting can be changed by the following parameters:

- Thermal sensor characteristic: Grid point 1 - temperature ▶ [0x2D49:006](#)
- Thermal sensor characteristic: Grid point 1 - resistance ▶ [0x2D49:008](#)
- Thermal sensor characteristic: Grid point 2 - temperature ▶ [0x2D49:007](#)
- Thermal sensor characteristic: Grid point 2 - resistance ▶ [0x2D49:009](#)



Selecting a motor from the motor catalogue overwrites the parameters of the special characteristic!

12.9.3 Overcurrent monitoring

This function monitors the instantaneous value of the motor current and serves to protect the motor from irreversible damage. Overcurrent monitoring is effective for all motor control modes.

WARNING!

With an incorrect parameterization, the maximum permissible motor current may be exceeded in the process.

Possible consequence: Irreversible damage of the motor.

Avoid motor damages by using the overcurrent monitoring function as follows:

- ▶ The setting of the threshold for the overcurrent monitoring in [0x2D46:001](#) must be adapted to the connected motor.
- ▶ Set the maximum current of the inverter in [0x6073](#) much lower than the threshold for overcurrent monitoring for a dynamic limitation of the motor current.

Parameter

Address	Name / setting range / [default setting]	Information
0x2D46:001	Overcurrent monitoring: Threshold 0.0 ... [5.4] ... 3000.0 A	<ul style="list-style-type: none">• If the active motor current exceeds the set threshold, the response set in 0x2D46:002 is effected for the purpose of motor protection.• The parameter can also be set and overwritten by selecting a motor from the "motor catalog" of the engineering tool.
0x2D46:002	Overcurrent monitoring: Response	Selection of the response to the triggering of motor current monitoring. Associated error code: <ul style="list-style-type: none">• 9092 0x2384 - RANLI_CIMES_0500_03891
	0 No response	
	1 Fault > CiA402	
	2 Warning	



Configuring the motor control

Motor protection
Motor phase failure detection

12.9.4 Motor phase failure detection

The motor phase failure detection function can be activated for both synchronous and asynchronous motors.



In the Lenze setting, monitoring is not activated!

Preconditions

Motor phase failure detection during operation is suitable for applications which are operated with a constant load and speed. In other cases, transient processes or unfavourable operating points can cause erroneous triggering to occur.

Parameter

Address	Name / setting range / [default setting]	Information
0x2D45:001	Motor phase failure detection: Response - Motor phase 1	Selection of the response following the detection of a motor phase failure during operation. Associated error codes: <ul style="list-style-type: none"> 65289 0xFF09 - Motor phase missing 65290 0xFF0A - Motor phase failure phase U 65291 0xFF0B - Motor phase failure phase V 65292 0xFF0C - RANLI_CIMES_1000_20883
	0 No response	
	1 Fault > CiA402	
	2 Warning	
0x2D45:002	Motor phase failure detection: Current threshold 1.0 ... [5.0] ... 10.0 %	<ul style="list-style-type: none"> 100 % ≡ Maximum current 0x2DDF:002 Background: in order to be able to reliably detect the failure of a motor phase, first a certain must flow for the current sensor system. The detection function is therefore only activated if the motor current has exceeded the current threshold set here. Display of the present motor current: 0x6078.
0x2D45:003	Motor phase failure detection: Voltage threshold 0.0 ... [10.0] ... 100.0 V	Voltage threshold for motor phase monitoring for the VFC control mode (0x2C00 = 6). <ul style="list-style-type: none"> The monitoring function is triggered if the motor current exceeds the rated motor current-dependent current threshold for longer than 20 ms. Rated motor current 0x6075 In case of the V/f characteristic control, the voltage threshold is considered additionally for the motor phase failure detection. If the motor voltage is higher than the voltage threshold, monitoring is combined with the motor current.
0x2D45:004	Motor phase failure detection: Response - Motor phase 2	Selection of the response following the detection of a motor phase failure directly after controller enable. Associated error codes: <ul style="list-style-type: none"> 65289 0xFF09 - Motor phase missing 65290 0xFF0A - Motor phase failure phase U 65291 0xFF0B - Motor phase failure phase V 65292 0xFF0C - RANLI_CIMES_1000_20883
	0 No response	
	1 Fault > CiA402	
	2 Warning	

12.9.5 Motor speed monitoring

This function monitors the motor speed during operation.

Parameter

Address	Name / setting range / [default setting]	Information
0x2D44:001	Overspeed monitoring: Threshold 50 ... [8000] ... 50000 rpm	<ul style="list-style-type: none"> If the current motor speed reaches the threshold set, the response selected in 0x2D44:002 is effected. The parameter can also be set and overwritten by selecting a motor from the "motor catalog" of the engineering tool.

Configuring the motor control

Frequency and speed limitations
Motor speed monitoring



Address	Name / setting range / [default setting]	Information
0x2D44:002	Overspeed monitoring: Response	Selection of the response to the triggering of motor speed monitoring. Associated error code: • 65286 0xFF06 - Motor overspeed
	0 No response	
	1 Fault > CiA402	
	2 Warning	

12.10 Frequency and speed limitations



By limiting the maximum output frequency to ± 599 Hz, the devices are not subject to the export restrictions of the "EC-Dual-Use Regulation" (EC 428/2009). This applies to devices supplied from the middle of the year 2015. For certain applications, the supply of devices with the current maximum output frequency of ± 1999 Hz. If required, get in touch with your Lenze contact person.

Output frequency

The output frequency of the i700 servo inverter is limited to a maximum value, the amount of which corresponds to the lower of the two following values:

$$f_{lim} = \frac{f_{chop}}{8} \quad \text{oder} \quad f_{lim} = f_{max_Geräte}$$

f_{lim}	Maximum output frequency
f_{chop}	Switching frequency 0x2939
f_{max_device}	Maximum device output frequency 0x2835:001 , depending on the device type ± 599 Hz or ± 1999 Hz

Due to the restrictions by the "dual use regulation" (EC 428/2009), values higher than $+ 599$ Hz to $+ 1000$ Hz or $- 599$ Hz to $- 1000$ Hz do not increase the output frequency. Please observe the deadband occurring in this case.

Speed setpoint

If servo control is used, the speed setpoint is limited depending on the number of motor pole pairs:

$$n_{lim} = \frac{f_{lim}}{z_p}$$

n_{lim}	Speed limit value
f_{lim}	Maximum output frequency 0x2939
z_p	Number of motor pole pairs

- If the speed setpoint is limited, bit 1 ("Speed: Setpoint 1 limited") or bit 5 ("Speed: Setpoint 2 limited") is set in the Lenze status word [0x2831](#).
- The behaviour corresponds to the behaviour which is shown when the set maximum speed [0x6080](#) is reached.
- The sequence is: limit the speed to [0x6080](#) first, then limit it to the speed limit value n_{lim} .

Frequency setpoint

If V/f characteristic control is used, the frequency setpoint is limited in addition to the speed setpoint.

- If the frequency setpoint is limited, bit 10 ("Output frequency limited") is set in the Lenze status word [0x2831](#).



Configuring the motor control

Testing the motor control
General settings for test modes

12.11 Testing the motor control

Parameter

Address	Name / setting range / [default setting]	Information
0x2825	Drive mode selection • Setting can only be changed if the inverter is disabled.	Internal service parameter
	0 CiA402 operating modes	
	1 Manual "voltage/frequency" test mode	
	2 Manual "current/frequency" test mode	
	3 Manual "current pulse" test mode	
	4 Manual control mode	
	5 Pole position identification (360°)	
	6 Pole position identification (min. movement)	
	7 Pole position identification (without movement)	
	8 Inverter characteristic identification	
	9 Motor parameters identification	
	10 Lh saturation characteristic identification	
	11 PRBS excitation - mechanical plant	
	12 PRBS excitation - current control loop	
	13 PRBS excitation - speed control loop	
	14 PRBS excitation - position control loop	
	15 Cable check	
16 Leakage inductance identification		

12.11.1 General settings for test modes

Wiring check by means of manual test modes

Before starting the parameter setting of the inverter, check the motor wiring (motor connection / feedback connection) for errors and function and correct them if required:

1. Provided that the motor is connected in correct phase relation and the rotating field frequency **0x2DDD** is positive, the motor shaft rotates clockwise.
2. An existing speed feedback in the rotor position (**0x2DDE**) generates a numerical value with positive counting direction. If required, take corrective measures: see the table at the end of the list.
3. After the controller inhibit (**0x6040**) has been activated, the following manual test modes are available via the parameter **0x2825**:
 - Manual "tension/frequency" test mode
 - Manual "current/frequency" test mode

The parameters for the test modes can be adapted via the parameter . Please observe the notes in the description of the respective test mode.

Rotating field frequency 0x2DDD	Display 0x2DDE	Measure
CW	0...2047	None
	2047...0	Correct motor connection / feedback connection
CCW	2047...0	None
	0...2047	Correct motor connection / feedback connection

Parameter

Address	Name / setting range / [default setting]	Information
0x2835:001	Manual test mode: Current setpoint 0 ... [0] ... 1000 %	Setting of the r.m.s. value of a phase current for the test mode. • 100 %: Rated motor current (0x6075)
0x2835:002	Manual test mode: Frequency -1000.0 ... [0.0] ... 1000.0 Hz	Setting of the frequency for the test mode.

Configuring the motor control

Testing the motor control

General settings for test modes



Address	Name / setting range / [default setting]	Information
0x2835:003	Manual test mode: Starting angle -1000.0 ... [0.0] ... 1000.0 °	Setting of the starting angle for the test mode. Note! After the inverter has been enabled, the synchronous motor makes a jerky compensating movement if its pole position does not correspond to the starting angle.



12.11.2 Manual "tension/frequency" test mode

Functional description



In case of devices that correspond to the "dual use regulation" (EC 428/2009), values higher than + 599 Hz up to lower than - 599 Hz do not increase the output frequency. Please observe the deadband occurring in this case.

Further information can be found in the section "[Frequency and speed limitations](#)". [📖 190](#)

After the controller is enabled in this test mode, a rotary field voltage is output at the motor terminals with the set output frequency f_{out} .

- If the selected frequency is positive, the motor should rotate clockwise when looking at the A side of the motor. If this is not the case, the motor phases are connected incorrectly.
- The output voltage level is determined by the following equation

Equation for calculating the output voltage			
$U_{out} = f_{out} \cdot \frac{U_{rated}}{f_{rated}}$			
Parameter	Symbol	Description	Dimension unit
0x2D82	V_{out}	Current output voltage	V
0x2835:002	f_{out}	Output frequency for test mode Please observe the notes in the section " Frequency and speed limitations ". 📖 190	Hz
0x2B01:001	V_{rated}	Base voltage	V
0x2B01:002	f_{rated}	Base frequency	Hz

The manual "voltage / frequency" test mode also serves to check the wiring of the feedback system.

- If the feedback system of a synchronous motor is set correctly, an actual speed should be displayed that can be calculated with the following equation (if the feedback system of an asynchronous motor is set correctly, the actual speed is a bit lower due to the slip):

Equation for calculating the actual speed			
$n_{act} = \frac{f_{out}}{z_{p_{motor}}} \cdot 60$			
Parameter	Symbol	Description	Dimension unit
0x606C	n_{act}	Actual speed	rpm
0x2835:002	f_{out}	Output frequency for test mode	Hz
0x2C01:001	$z_{p_{Motor}}$	Number of motor pole pairs	

Conditions for the execution

- The motor must rotate freely.
- The servo inverter is error-free and in the "switched-on" device state.

Response of the motor during performance

The motor moves as a function of the set output frequency.

How to activate the manual "voltage/frequency" test mode:

1. Disable the inverter ▶ [Enable operation](#). [📖 212](#)
2. Change to the "voltage/frequency" test mode. ▶ $0x2825 = 1$
3. Enable the inverter to start the test mode.
4. To stop the test mode again:
 - Disable inverter.
 - Change back to the "CiA402 operating mode". ▶ $0x2825 = 0$

Configuring the motor control

Testing the motor control
Manual "current/frequency" test mode



12.11.3 Manual "current/frequency" test mode

Preconditions for the performance

- The motor must rotate freely.
- The inverter is error-free and in "Switched on" device state.

Functional description

In this test mode, three phase currents are injected into the connected motor after the inverter is enabled.

- Adaptation of the phase currents:

Parameter	Info	Data type
0x2835:001	R.m.s. value of a phase current <ul style="list-style-type: none">• Selected in [%] based on the rated motor current.	INTEGER_16
0x2835:002	Frequency	INTEGER_16
0x2835:003	Starting angle	INTEGER_16

- Reading out the present phase currents:

Parameter	Info	Data type
0x2D83:002	Motor current phase U	INTEGER_32
0x2D83:003	Motor current phase V	INTEGER_32
0x2D83:004	Motor current phase W	INTEGER_32

Advantages compared to the manual "voltage/frequency" test mode

- The current cannot be set freely but is adjusted to a defined value.
- If a synchronous motor is connected, it is possible to predict the torque.

Response of the motor during performance

- The motor moves as a function of the set output frequency.



After the inverter has been enabled, the synchronous motor makes a jerky compensating movement if its pole position does not correspond to the starting angle.

How to activate the manual "current/frequency" test mode:

1. Disable inverter ▶ [Enable operation.](#) [□ 212](#)
2. Change to the "current/frequency" test mode. ▶ [0x2825 = 2](#)
3. Enable the inverter to start the test mode.
4. To stop the test mode again:
 - Disable inverter.
 - Change back to the CiA402 operating mode. ▶ [0x2825 = 0](#)



12.11.4 Manual "current pulse" test mode

The stator resistance and the stator inductance of the inverter must be adapted to the electrical characteristics of the motor. For an experimental adjustment, the manual "Current pulse" test mode can be used.



This test mode is provided for adjusting the current controller in the "Servo control for synchronous motor/asynchronous motor" operating mode and is not suitable for adjusting the I_{max} controller in the "V/f characteristic control (VFC)" operating mode!

In the manual "Current pulse" test mode, setpoint step-changes are applied to the current controller input subsequent to controller enable. The step responses must then either be recorded using an oscilloscope and a clamp-on ammeter, or using the oscilloscope function of the inverter. It is the objective to optimise the two "Gain" and "Reset time" current controller parameters by evaluating the step responses so that a speedy current characteristic is achieved, which, if possible, is free of harmonics.

In the case of motors with single pole windings, satisfactory results are possibly only achieved with a current-dependent correction of the current controller parameters. For this purpose, a characteristic is stored in the inverter, which describes the current dependence of the stator leakage inductance and which tracks the current controller gain.



After the inverter has been enabled, the synchronous motor makes a jerky compensating movement if its pole position does not correspond to the starting angle.

The motor phase U is energized with a DC current the level of which is determined via the following equation.

$$I_{phase_U} = \sqrt{2} * I_{test}[\%] * \frac{I_{rated}}{100\%}$$

In motor phases V and W, half of this DC current flows (negative; from the motor).

$$I_{phase_V, _W} = -0.5 * \sqrt{2} * I_{test}[\%] * \frac{I_{rated}}{100\%}$$

The following parameters are relevant to the calculation:

- Manual test mode: setpoint current ▶ [0x2835:001](#)
- Motor rated current ▶ [0x6075](#)
- Read only: current phase U ▶ [0x2D83:002](#)
- Read only: current phase V ▶ [0x2D83:003](#)
- Read only: current phase W ▶ [0x2D83:004](#)

Conditions for the execution

- The motor must be parameterised completely.
- The motor utilisation (I^2t) monitoring must be parameterised and switched to active. ▶ [Motor overload monitoring \(\$i^2*t\$ \)](#) [178](#)
- The motor must rotate freely.
- The inverter is error-free and switched on.
- The rotor of synchronous motors must be in the pole centre during the test. For some synchronous motors, it might be required to align and lock the rotor in the pole centre.
 - Using the manual test mode "current/frequency" is useful for a one-time alignment of the rotor with the following settings:
R.m.s. value = 70 ... 100 %; frequency = 0 Hz; starting angle = 0°
▶ [Manual "current/frequency" test mode](#) [194](#)
- Fixation by means of the holding brake or the use of external fixation aids

Configuring the motor control

Testing the motor control

Manual "current pulse" test mode



Responses of the motor during performance



Remove the mechanical fixation after the current controller has been adjusted!

The motor usually aligns itself only once with the first controller enable.

How to adjust the current controller by means of the manual test mode "current pulse":

- Disable inverter.
- Calculate start parameters for the inverter based on the parameterised motor data.
 - The automatic calculation is made via the parameter 0x2822:013.
 - You can determine the start parameter manually.
- Change to the "current pulse" test mode. ▶ 0x2825 = 3
- Set the setpoint current for the manual test mode. ▶ 0x2835:001
- Enable the inverter for a short while to start the test mode.
- Measure the step response of the motor current in the motor phase U by means of an oscilloscope and a clamp-on ammeter.
- Evaluate the step response.
- Adjust the gain and the reset time of the inverter.
- Repeat steps 1 ... 6 until the optimum step response of the motor current has been reached.
- Exit the test mode:
 - Disable the inverter.
 - Change to the CiA402 mode. ▶ 0x2825 = 0
- For permanent saving: save changed current controller parameters.



13 I/O extensions and control connections

13.1 Configure digital inputs

Settings for digital input 1 ... 4.

Details

The digital inputs are used for control tasks. For this purpose, the digital inputs are available as selectable triggers for functions.

The following settings are possible for the digital inputs:

- Debounce time ①
- Inversion ②
- Manual I/O control ③

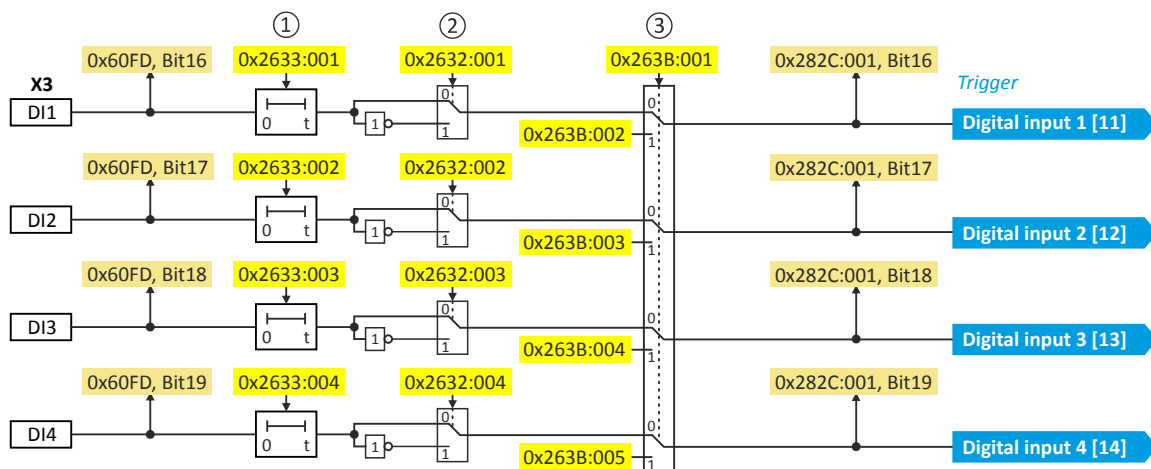

Diagnostic parameters:

- Display of the logic state of the digital inputs: **0x60FD**

Debounce time

For minimising interference pulses, a debounce time of 1 ms is set for all digital inputs.

Via »EASY Starter« (or network), the debounce time for can be increased individually for each digital input to maximally 50 ms.

Inversion

Each digital input can be configured in such a way that the status pending at the terminal is internally inverted logically. This way, a closed contact, for instance, serves to deactivate an assigned function instead of activating it. Thus, the control of the inverter can be flexibly adapted to the requirements of the actual application.

Manual I/O control

Each digital input can be overridden manually. After the function is activated, the actual values are "frozen". Afterwards, each digital input can be overwritten manually.

Setting:

- Activation for all digital inputs: **0x263B:001**
- Entering the individual manual values: **0x263B:002 ... 0x263B:005**

Parameter

Address	Name / setting range / [default setting]	Information
0x2632:001	Inversion of digital inputs: Digital input 1	Inversion of digital input 1
	0 Not inverted	
	1 Inverted	
0x2632:002	Inversion of digital inputs: Digital input 2	Inversion of digital input 2
	0 Not inverted	
	1 Inverted	

I/O extensions and control connections

Configure digital inputs



Address	Name / setting range / [default setting]	Information
0x2632:003	Inversion of digital inputs: Digital input 3	Inversion of digital input 3
	0 Not inverted	
	1 Inverted	
0x2632:004	Inversion of digital inputs: Digital input 4	Inversion of digital input 4
	0 Not inverted	
	1 Inverted	
0x2632:005	Inversion of digital inputs: Digital input 5	Inversion of digital input 5
	0 Not inverted	
	1 Inverted	
0x2632:006	Inversion of digital inputs: Digital input 6 • Only available for application I/O.	Inversion of digital input 6
	0 Not inverted	
	1 Inverted	
0x2632:007	Inversion of digital inputs: Digital input 7 • Only available for application I/O.	Inversion of digital input 7
	0 Not inverted	
	1 Inverted	
0x2632:008	Inversion of digital inputs: Digital input 8 • Only available for application I/O.	
	0 Not inverted	
	1 Inverted	
0x2632:009	Inversion of digital inputs: Digital input 9 • Only available for application I/O.	
	0 Not inverted	
	1 Inverted	
0x2633:001	Digital input debounce time: Digital input 1 0 ... [0] ... 50 ms	Debounce time of digital input 1
0x2633:002	Digital input debounce time: Digital input 2 0 ... [0] ... 50 ms	Debounce time of digital input 2
0x2633:003	Digital input debounce time: Digital input 3 0 ... [0] ... 50 ms	Debounce time of digital input 3
0x2633:004	Digital input debounce time: Digital input 4 0 ... [0] ... 50 ms	Debounce time of digital input 4
0x2633:005	Digital input debounce time: Digital input 5 0 ... [0] ... 50 ms	Debounce time of digital input 5
0x2633:006	Digital input debounce time: Digital input 6 0 ... [0] ... 50 ms • Only available for application I/O.	Debounce time of digital input 6
0x2633:007	Digital input debounce time: Digital input 7 0 ... [0] ... 50 ms • Only available for application I/O.	Debounce time of digital input 7



I/O extensions and control connections

Configure digital inputs

Address	Name / setting range / [default setting]	Information
0x2633:008	Digital input debounce time: Digital input 8 0 ... [0] ... 50 ms	
0x2633:009	Digital input debounce time: Digital input 9 0 ... [0] ... 50 ms	
0x263B:001	Digital inputs internal control: Activation	
	0 Off	
	1 On	
0x263B:002	Digital inputs internal control: DI1 internal control	
	0 Off	
	1 On	
0x263B:003	Digital inputs internal control: DI2 internal control	
	0 Off	
	1 On	
0x263B:004	Digital inputs internal control: DI3 internal control	
	0 Off	
	1 On	
0x263B:005	Digital inputs internal control: DI4 internal control	
	0 Off	
	1 On	
0x263B:006	Digital inputs internal control: DI5 internal control	
	0 Off	
	1 On	
0x263B:007	Digital inputs internal control: DI6 internal control	
	0 Off	
	1 On	
0x263B:008	Digital inputs internal control: DI7 internal control	
	0 Off	
	1 On	
0x263B:009	Digital inputs internal control: DI8 internal control	
	0 Off	
	1 On	
0x263B:010	Digital inputs internal control: DI9 internal control	
	0 Off	
	1 On	

I/O extensions and control connections

Configure analog inputs
Analog input 1



13.2 Configure analog inputs

13.2.1 Analog input 1

Settings for analog input 1.

Details

The analog input 1 can be used as setpoint source.

The following settings are possible for the analog input:

- Definition of the input range ①
- Filter time for low-pass filters ②
- Definition of the setting range (min/max range)③
- Dead band for eliminating the smallest signal levels ④
- Manual I/O control ⑤

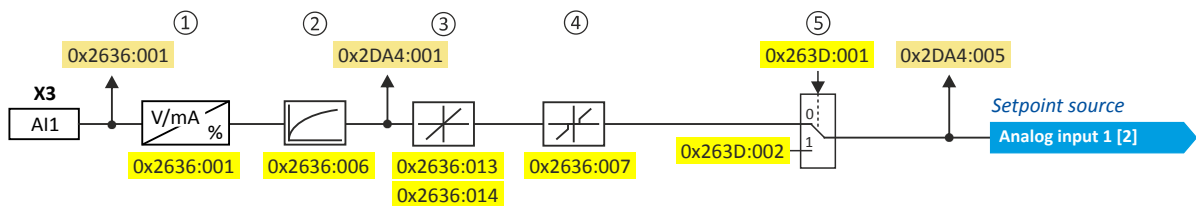

Diagnostic parameters:

- Display of the input signal status: [0x2DA4:016](#)
 - 24-V supply status
 - Calibration status
 - Input current status
 - Input voltage status
- Display of filtered input signal in %: [0x2DA4:001](#)
- Display of setpoint in %: [0x2DA4:005](#)

Definition of the input range

The analog input can be configured as voltage or current input. Internally, the signal is always converted to a value in percent.

Definition of the setting range

The setting range results from the set min and max value for the respective mode.

Manual I/O control

The analog input can be overridden manually. After the function is activated, the actual values are "frozen". Afterwards, each analog input can be overwritten manually.

Setting:

- Activation: [0x263D:001](#)
- Entering the manual value: [0x263D:002](#)

Parameter

Address	Name / setting range / [default setting]	Information
0x2636:001	Analog input 1: Input range	Definition of the input range.
	0 0 ... 10 VDC	
	3 -10 ... +10 VDC	
	4 4 ... 20 mA	
	5 0 ... 20 mA	
0x2636:006	Analog input 1: Filter time	PT1 time constant for low-pass filter. <ul style="list-style-type: none"> • By the use of a low-pass filter, the impacts of noise to an analog signal can be minimised. • For an optimum filter effect, first the noise frequency has to be determined. The time constant then has to be set so that it equals the reciprocal value of the double frequency.
	0 ... [10] ... 10000 ms	



I/O extensions and control connections

Configure analog inputs

Analog input 1

Address	Name / setting range / [default setting]	Information
0x2636:007	Analog input 1: Dead band 0.0 ... [0.0] ... 100.0 %	Optional setting of a dead band that is placed symmetrically around the frequency zero point. <ul style="list-style-type: none"> If the analog input value is within the dead band, the output value for the motor control is set to "0". 100 % = maximum value of analog input (, ,) Example: Dead band 10 % of 50 Hz: -10 V ... 10 V Dead band -5 Hz ... 5 Hz, 0 ... 10 V Dead band 0 Hz ... 5 Hz
0x2636:010	Analog input 1: Error response	Error response for analog input 1. Associated error code: <ul style="list-style-type: none"> 28801 0x7081 - Analog input 1 fault
	0 No response	
	1 Fault > CiA402	
	2 Warning	
0x2636:013	Analog input 1: Minimum value for scaling -200.0 ... [0.0] ... 200.0 %	Minimum value in percent for scaling the value at the analog input (Value in percent (0x2DA4:001)).
0x2636:014	Analog input 1: Maximum value for scaling -200.0 ... [100.0] ... 200.0 %	Maximum value in percent for scaling the value at the analog input (Value in percent (0x2DA4:001)).
0x2DA4:005	Diagnostics of analog input 1: Scaled percent value <ul style="list-style-type: none"> Read only: x.xx % 	Current value of the analog input is resolved with 2 decimal places. Display of the actual value at the analog input, scaled with the following parameters: <ul style="list-style-type: none"> Minimum value for scaling. ▶ 0x2636:013 Maximum value for scaling. ▶ 0x2636:014
0x263D:001	Analog inputs internal control: Activation	
	0 Off	
	1 On	
0x263D:002	Analog inputs internal control: AI1 internal control -200.00 ... [100.00] ... 200.00 %	

I/O extensions and control connections

Configure digital outputs
Digital output 1



13.3 Configure digital outputs

13.3.1 Digital output 1

Settings for digital output 1.

Details

The digital output 1 is controlled with the trigger selected in [0x2634:002](#).

The following settings are possible for the digital output:

- Inversion ①
- Manual I/O control ②

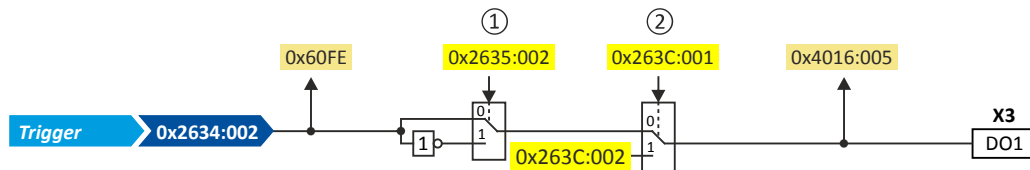

Diagnostic parameters:

- Display of the logic state of the trigger signal:
- Display of the logic state of the digital output: [0x4016:005](#)

Inversion

The trigger signal of the digital output can be internally inverted logically.

Manual I/O control

The digital output can be overridden manually. After the function is activated, the actual values are "frozen". Afterwards, each digital output can be overwritten manually.

Setting:

- Activation: [0x263C:001](#)
- Entering the manual value: [0x263C:002](#)

Parameter

Address	Name / setting range / [default setting]	Information
0x2634:002	Digital outputs function: Digital output 1	Assignment of a trigger to digital output 1. Trigger = FALSE: X3/DO1 set to LOW level. Trigger = TRUE: X3/DO1 set to HIGH level. Notes: • An inversion set in 0x2635:002 is taken into consideration here.
	10 Signal from application	
	115 Release holding brake	
0x2635:002	Inversion of digital outputs: Digital output 1	Inversion of digital output 1
	0 Not inverted	
	1 Inverted	
0x4016:005	Digital output 1: Terminal state	Display of the logic state of output terminal X3/DO1.
	• Read only	
	0 FALSE 1 TRUE	
0x263C:001	Digital outputs internal control: Activation	
	0 Off	
	1 On	
0x263C:002	Digital outputs internal control: DO1 internal control	
	0 Off	
	1 On	



I/O extensions and control connections

Configure digital outputs
Digital output 2

13.3.2 Digital output 2

Parameter

Address	Name / setting range / [default setting]	Information
0x2635:003	Inversion of digital outputs: Digital output 2 • Only available for application I/O.	Inversion of digital output 2
	0 Not inverted	
	1 Inverted	
0x263C:003	Digital outputs internal control: DO2 internal control	
	0 Off	
	1 On	

13.3.3 Digital output 3

Parameter

Address	Name / setting range / [default setting]	Information
0x2635:004	Inversion of digital outputs: Digital output 3 • Only available for application I/O.	
	0 Not inverted	
	1 Inverted	
0x263C:004	Digital outputs internal control: DO3 internal control	
	0 Off	
	1 On	

13.3.4 Digital output 4

Parameter

Address	Name / setting range / [default setting]	Information
0x2635:005	Inversion of digital outputs: Digital output 4 • Only available for application I/O.	
	0 Not inverted	
	1 Inverted	
0x263C:005	Digital outputs internal control: DO4 internal control	
	0 Off	
	1 On	

13.3.5 Digital output 5

Parameter

Address	Name / setting range / [default setting]	Information
0x2635:006	Inversion of digital outputs: Digital output 5 • Only available for application I/O.	
	0 Not inverted	
	1 Inverted	
0x263C:006	Digital outputs internal control: DO5 internal control	
	0 Off	
	1 On	

13.3.6 Digital output 6

Parameter

Address	Name / setting range / [default setting]	Information
0x2635:007	Inversion of digital outputs: Digital output 6 • Only available for application I/O.	
	0 Not inverted	
	1 Inverted	
0x263C:007	Digital outputs internal control: DO6 internal control	
	0 Off	
	1 On	

Configure engineering port



14 Configure engineering port

The given path leads you to the engineering port.

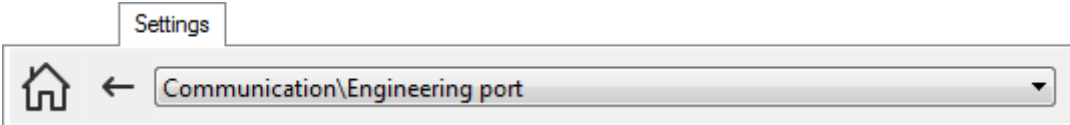



14.1 Basic setting

Preconditions

- The wired communication with the inverter has been established.
 - If this condition is not met, read more detailed notes in section "[Generate a connection between inverter and »EASY Starter«](#)". [📖 31](#)
- The PC with the installed »EASY Starter« is started.

Automatic configuration

By default, the engineering port of the inverter receives its IP address automatically from a DHCP server. By pressing the "DHCP" button, the 0x2451:004 parameter is active ("enabled").

Now, the IP configuration is completed. The inverter can be accessed via the Ethernet connection.

Manual configuration



Make sure to press the "Restart with current values" button every time you change the values.

The engineering port must be configured when a static address is to be assigned.

For this purpose, the "DHCP" button must be set to the "Disabled" state.

The following parameters can be entered in the »EASY Starter«:

- IP address
- Network mask
- Gateway address

Using a configuration file

A file named "ip.txt" can be used to reset the IP address. This file must be stored on the SD card in the root directory.

The network settings are evaluated and accepted when the inverter is started. The file is then renamed as "ip_old.txt".

The structure of the text file can look as follows:

- 192.168.101.221
- 255.255.255.0
- 192.168.101.1

If the static IP address is to be reset to DHCP, only the content of the ip.txt file must be set to "DHCP". This serves to use DHCP for a dynamic address allocation at next boot.

Parameter

Address	Name / setting range / [default setting]	Information
0x2450	Engineering port control	Activation of the engineering port settings (Ethernet).
	0 No action/No error	
	1 Restart with current values	
	10 Busy	
	11 Action cancelled	
	12 Faulted	
0x2451:001	Engineering port settings: IP address 0.0.0.0 ... [0.0.0.0] ... 255.255.255.255	Setting of the IP address. The default setting 276605120 corresponds to the IP address 192.168.124.16. • 276605120 = 0x107CA8C0 → 0xC0.0xA8.0x7C.0x10 = 192.168.124.16
0x2451:002	Engineering port settings: Subnet 0.0.0.0 ... [0.0.0.0] ... 255.255.255.255	Setting of the subnet mask. The default setting 16777215 corresponds to the following values: • 16777215 • 0xFFFFFFFF • 0xFF.0xFF.0xFF.0x00 • 255.255.255.0

Configure engineering port

NTP server addresses



Address	Name / setting range / [default setting]	Information
0x2451:003	Engineering port settings: Gateway 0.0.0.0 ... [0.0.0.0] ... 255.255.255.255	Setting of the gateway address. Example: The setting 276344004 corresponds to the gateway address 196.172.120.16. • 276344004 = 0x1078ACC4 → 0xC4.0xAC.0x78.0x10 = 196.172.120.16
0x2451:004	Engineering port settings: DHCP 0 Disabled 1 Enabled	Use (enable) of the Dynamic Host Configuration Protocol (DHCP).
0x245B:001	System time: Time base 0 NTP 1 EtherCAT distributed clock 2 Manual input	
0x245B:002	System time: Current time 0 ... [] ... 18446744073709551615 ns	

14.2 NTP server addresses

Parameter

Address	Name / setting range / [default setting]	Information
0x245A:001	NTP server addresses: Activate NTP server addresses 0 No action/no error 1 Restart with current values 10 In progress 11 Action cancelled 12 Fault	
0x245A:002	NTP server addresses: NTP server address 1 0.0.0.0 ... [0.0.0.0] ... 255.255.255.255	
0x245A:003	NTP server addresses: NTP server address 2 0.0.0.0 ... [0.0.0.0] ... 255.255.255.255	
0x245A:004	NTP server addresses: NTP server address 3 0.0.0.0 ... [0.0.0.0] ... 255.255.255.255	
0x245A:005	NTP server addresses: NTP server address 4 0.0.0.0 ... [0.0.0.0] ... 255.255.255.255	

14.3 Diagnostics

The network settings can be diagnosed as follows:

Parameter

Address	Name / setting range / [default setting]	Information
0x2452:001	Active engineering port settings: IP address • Read only	Display of the active IP address.
0x2452:002	Active engineering port settings: Subnet • Read only	Display of the active subnet mask.
0x2452:003	Active engineering port settings: Gateway • Read only	Display of the active gateway address.
0x2452:004	Active engineering port settings: Active DHCP setting • Read only 0 Disabled 1 Enabled	
0x2452:005	Active engineering port settings: MAC address • Read only	Display of the MAC-ID.



15 Configuring the network

The inverter supports the [CiA 402 device profile](#). [□ 208](#)

The following network options are available for the inverter:

- ▶ [PROFINET](#) [□ 247](#)
- ▶ [EtherCAT system bus \(on board\)](#) [□ 259](#)

Configuring the network

CiA 402 device profile
Supported operating modes



15.1 CiA 402 device profile

The CiA® 402 device profile defines the functional behaviour of stepping motors, servo drives, and frequency inverters. In order to be able to describe the different drive types, various operating modes and device parameters are specified in the device profile. Each operating mode provides objects (e.g. for the setpoint speed, acceleration and deceleration) to generate the desired drive behaviour.

- CiA® is a registered community trademark of the CAN in Automation e. V user organisation.
- More information can be found in the CiA 402 specification (CANopen device profile for drives and Motion Control) of the CAN in Automation (CiA) user organisation: <http://www.can-cia.org>

15.1.1 Supported operating modes

The inverter supports the following CiA 402 operating modes:

CiA 402 operating modes	Can be used with	
	Servo control	V/f characteristic control
Operating mode "CiA 402 cyclic sync position mode (csp)" ¶ 52	●	-
Operating mode "CiA 402 velocity mode (vl)" ¶ 64	●	●
Operating mode "CiA 402 cyclic sync velocity mode (csv)" ¶ 70	●	●
Operating mode "CiA 402 cyclic sync torque mode (cst)" ¶ 81	●	-

A CiA 402 operating mode can be activated via [0x6060](#).

Parameter

Address	Name / setting range / [default setting]	Information
0x6060	CiA: Operation mode	CiA: Operation mode
	0 No selection	No selection
	2 CiA: Velocity mode	▶ Operating mode "CiA 402 velocity mode (vl)" ¶ 64
	8 CiA: Cyclic sync position	▶ Operating mode "CiA 402 cyclic sync position mode (csp)" ¶ 52
	9 Cyclic sync velocity mode	▶ Operating mode "CiA 402 cyclic sync velocity mode (csv)" ¶ 70
	10 Cyclic sync torque mode	▶ Operating mode "CiA 402 cyclic sync torque mode (cst)" ¶ 81
0x6061	CiA: Active operation mode	CiA: Active operation mode
	• Read only	
	-11 Identification	
	-10 Test mode	
	0 No selection	No selection
	2 CiA: Velocity mode	▶ Operating mode "CiA 402 velocity mode (vl)" ¶ 64
	8 CiA: Cyclic sync position	▶ Operating mode "CiA 402 cyclic sync position mode (csp)" ¶ 52
	9 Cyclic sync velocity mode	▶ Operating mode "CiA 402 cyclic sync velocity mode (csv)" ¶ 70
10 Cyclic sync torque mode	▶ Operating mode "CiA 402 cyclic sync torque mode (cst)" ¶ 81	
0x6502	Supported drive modes	Bit coded display of the operating modes supported.
	• Read only	
	Bit 1 CiA: Velocity mode	1 = CiA: velocity mode is supported.
	Bit 7 Cyclic sync position mode	1 ≡ Cyclic sync position mode is supported.
	Bit 8 Cyclic sync velocity mode	1 ≡ Cyclic sync velocity mode is supported.
Bit 9 Cyclic sync torque mode	1 ≡ Cyclic sync torque mode is supported.	



15.1.2 Basic setting

Set the following parameters.

Parameter

Address	Name / setting range / [default setting]	Information
0x605A	CiA: Quick stop mode	Device status after exiting the quick stop ramp. <ul style="list-style-type: none"> Setting is only effective in the operating mode 0x6060 = "CiA: Velocity mode [2]".
	2 Ramp > switch on disabled	Automatic change to the "Switch-on inhibited" device state. <ul style="list-style-type: none"> The "Quick stop active [54]" status is reset to FALSE after ramp-down to standstill.
	6 Ramp > quick stop active	The inverter remains in the "Quick stop active" device state. <ul style="list-style-type: none"> The "Quick stop active [54]" status remains TRUE until the "Quick stop" function is activated.
0x605B	Shutdown option code	Defines the transition from the status "Operation enabled" to "Ready to start".
	0 Disable drive function	0: Immediate inverter disable (standard setting)
	1 Slow down on quick stop ramp and disable drive function	1: "Quick stop" with subsequent inverter disable.
0x605E	CiA: Fault reaction	Selection of the response to faults.
	-2 Advanced quick stop	If possible, the motor is braked to standstill with the "quick stop" function. If this is not possible (e. g. in case of an encoder error), reverse current braking or short-circuit braking are used for the braking process.
	0 Coast	The motor has no torque (coasts down to standstill).
	2 Quick stop	The motor is brought to a standstill with the "quick stop" function. <ul style="list-style-type: none"> In the operating mode 0x6060 = "CiA: Velocity mode [2]", the speed change set in 0x6085 is effective.
0x607E	Polarity 0 ... [0] ... 0 <ul style="list-style-type: none"> Setting can only be changed if the inverter is disabled. 	Setting of the polarity of the position setpoint. 0 ≡ the position setpoint is interpreted as entered in 0x607A (Set position).
0x6085	Quick stop deceleration 0 ... [2147483647] ... 2147483647	Change in velocity used for deceleration to a standstill if quick stop is activated. <ul style="list-style-type: none"> Setting is only effective in the operating mode 0x6060 = "CiA: Velocity mode [2]".

15.1.3 Process input data

Information on the CiA 402 process input data can be found in the following sections:

- Configure position control ▶ [Process input data \(CiA 402 objects\)](#) 55
- Configure speed control ▶ [Process input data \(CiA 402 objects\)](#) 75
- Configure torque control ▶ [Process input data \(CiA 402 objects\)](#) 84

15.1.4 Process output data

Information on the CiA 402 process output data can be found in the following sections:

- Configure position control ▶ [Process output data \(CiA 402 objects\)](#) 55
- Configure speed control ▶ [Process output data \(CiA 402 objects\)](#) 75
- Configure torque control ▶ [Process output data \(CiA 402 objects\)](#) 84

Configuring the network

CiA 402 device profile

Commands for device state control



15.1.5 Commands for device state control

0x6040 (CiA control word) can be used to trigger commands to put the inverter into a certain device state.

Command	Bit pattern in the CiA control word (0x6040)							
	Bit 7	Bit 6	Bit 5	Bit 4	Bit 3	Bit 2	Bit 1	Bit 0
	Reset fault	Dependent on the operating mode			Operation enable	Activating quick stop	Establish readiness for operation	Switch-on
	0	X	X	X	X	1	1	0
Switch on □ 211	0	X	X	X	0	1	1	1
Enable operation □ 212	0	X	X	X	1	1	1	1
Activate quick stop □ 213	0	X	X	X	X	0	1	X
	0	X	X	X	0	1	1	1
Pulse inhibit □ 214	0	X	X	X	X	X	0	X
Reset fault □ 215	0/1	X	X	X	X	X	X	X

X = state is not relevant

More Lenze-specific control bits (bit 8 ... 15)

Command	Bit pattern in the CiA control word (0x6040)							
	Bit 15	Bit 14	Bit 13	Bit 12	Bit 11	Bit 10	Bit 9	Bit 8
	Reserved	Release brake	Reserved	Dependent on the operating mode				Stop motor
Apply brake	X	0	X	X	X	X	X	X
Release brake	X	1	X	X	X	X	X	X
Stop motor	X	X	X	X	X	X	X	1

X = state is not relevant

Detailed information on the various commands can be found in the following sections.

Parameter

Address	Name / setting range / [default setting]	Information
0x6040	CiA control word 0x0000 ... 0x0000 ... 0xFFFF	Mappable CiA control word with bit assignment according to device profile CiA 402.
	Bit 0 Switch on	1 = switch-on
	Bit 1 Enable voltage	1 = Enable voltage
	Bit 2 Disable quick stop	0 = activate quick stop
	Bit 3 Enable operation	1 = Enable operation
	Bit 4 Operation mode specific	
	Bit 5 Operation mode specific	
	Bit 6 Operation mode specific	
	Bit 7 Fault reset	0-1 edge = fault reset
	Bit 8 Halt	1 = stop motor (ramping down to frequency setpoint 0 Hz)
	Bit 9 Operation mode specific	Operating mode specific
	Bit 14 Release holding brake	1 = release holding brake ⚠ CAUTION! <ul style="list-style-type: none"> The manually triggered "Release holding brake" command has a direct impact on the "Release holding brake [115]" trigger. Thus, the holding brake can be manually released if the power section is switched off. The responsibility for a manual opening of the holding brake lies with the external trigger source for the "Release holding brake" command. ▶ Holding brake control □ 142

Example

A PLC program of a PLCopen control can, for instance, trigger several commands for state changes in a row by the level change at the *bRegulatorOn* input of the "MC_Power" block.

In the mentioned example, these device commands are "" and "Switch on" in this order.



15.1.5.1 Switch on

This command serves to deactivate the switch on inhibit which is active after switch on or after the reset (acknowledgement) of an error.

A changeover to the "Switched on" device status takes place.

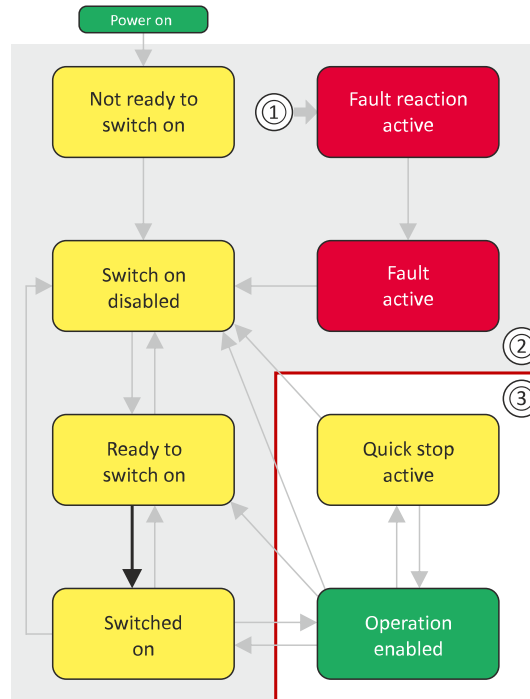

- A From all states
- B Power section inhibited (pulse inhibit)
- C Power section enabled

Bit pattern in the CiA control word (0x6040)								
Bit 15 ... 8	Bit 7	Bit 6	Bit 5	Bit 4	Bit 3	Bit 2	Bit 1	Bit 0
Reserved (specific)	Reset fault	Operating mode-dependent			Operation enabled	Activate quick stop	Establish readiness for operation	Switch-on
X	0	X	X	X	0	1	1	1

X = state is not relevant

Configuring the network

CiA 402 device profile
 Commands for device state control



15.1.5.2 Enable operation

This command enables the operation and stop an active quick stop again.

- A changeover to the "Operation enabled" device status takes place.
- The output stages of the inverter become active.

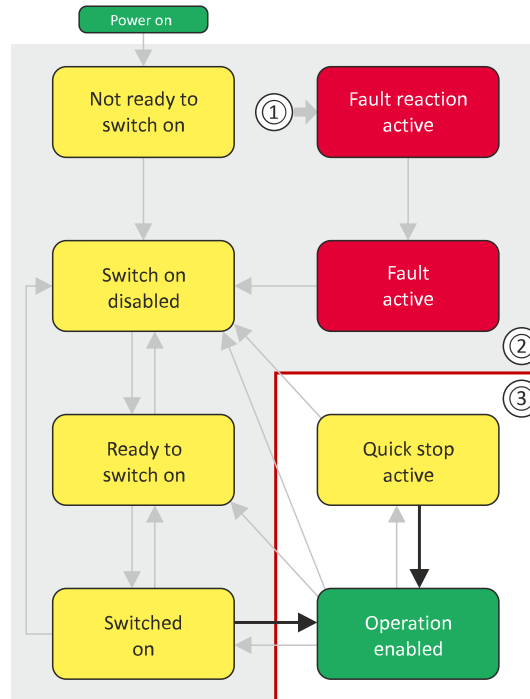

- A From all states
- B Power section inhibited (pulse inhibit)
- C Power section enabled

Bit pattern in the CiA control word (0x6040)								
Bit 15 ... 8	Bit 7	Bit 6	Bit 5	Bit 4	Bit 3	Bit 2	Bit 1	Bit 0
Reserved (specific)	Reset fault	Operating mode dependent			Operation enabled	Activate quick stop	Establish readiness for operation	Switch-on
X	0	X	X	X	1	1	1	1

X = state is not relevant



15.1.5.3 Activate quick stop

This command activates quick stop when the operation is enabled.

- The drive is brought to a standstill irrespective of the setpoint specified with the deceleration (0x6085) set for quick stop.
- A changeover to the "Quick stop active" device status takes place.
- Then, state change to "Switch-on inhibited" parameter 0x605A "CiA: Quick stop mode".

If the operation is not enabled (device state "Ready to switch on" or "Switched on"), this command changes the state to "operation disabled".

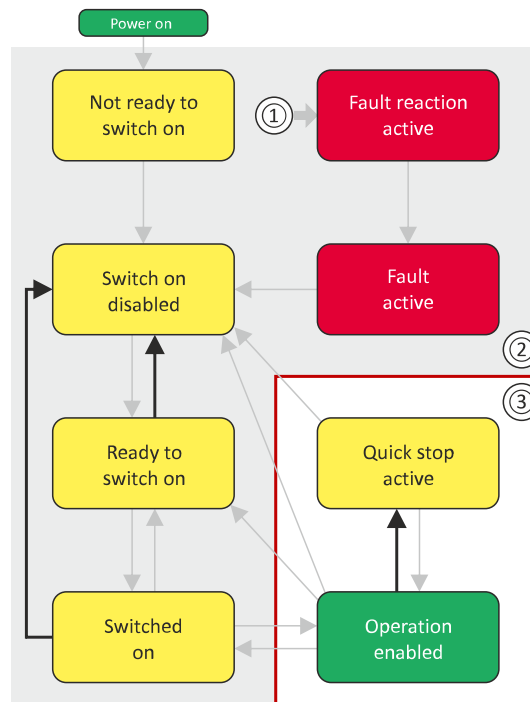

- A From all states
- B Power section disabled (pulse inhibit)
- C Power section enabled

Bit pattern in the CiA control word (0x6040)								
Bit 15 ... 8	Bit 7	Bit 6	Bit 5	Bit 4	Bit 3	Bit 2	Bit 1	Bit 0
Reserved (specific)	Reset fault	Operating mode dependent			Operation enabled	Activate quick stop	Establish readiness for operation	Switch-on
X	0	X	X	X	X	0	1	X

X = state is not relevant

- During quick stop, the inverter executes the setpoint generation and no longer follows the setpoint defined by the network master.
- If several inverters execute a chained synchronous motion, the quick stop function has to be coordinated by the network master by means of a quick stop profile (master function). In this case, quick stop cannot be activated via the control bit 2.
- During the quick stop, the max. current (0x6073) and the max. torque () are active. The lower of the two limits determines the motor output torque. The torque limits from 0x60E0 and 0x60E1 are not effective during the quick stop.

Configuring the network

CiA 402 device profile
 Commands for device state control



15.1.5.4 Pulse inhibit

This command disables the output stages of the inverter.

- The pulse inhibit is activated (pulses of the inverter are inhibited) if not already active.
- The motor has no torque.
- A changeover to the "Switch-on inhibited" device state takes place.

⚠ DANGER!

Uncontrolled movement

If the motor has no torque, a load that is connected to motors without a holding brake may cause uncontrolled movements!

► Without a load, the motor will coast.

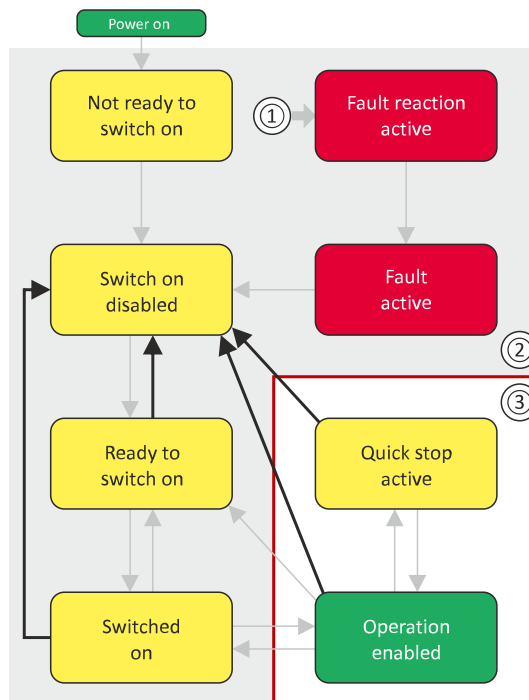

- A From all states
- B Power section inhibited (pulse inhibit)
- C Power section enabled

Bit pattern in the CiA control word (0x6040)

Bit 15 ... 8	Bit 7	Bit 6	Bit 5	Bit 4	Bit 3	Bit 2	Bit 1	Bit 0
Reserved (specific)	Reset fault	Operating mode dependent			Operation enabled	Activate quick stop	Establish readiness for operation	Switch-on
X	0	X	X	X	X	X	0	X

X = state is not relevant



15.1.5.5 Reset fault

This command resets a pending fault if the cause of the fault has been eliminated.

- The pulse inhibit remains active (pulses of the inverter are inhibited).
- A changeover to the "Switch-on inhibited" device status takes place (switch-on inhibit remains active).

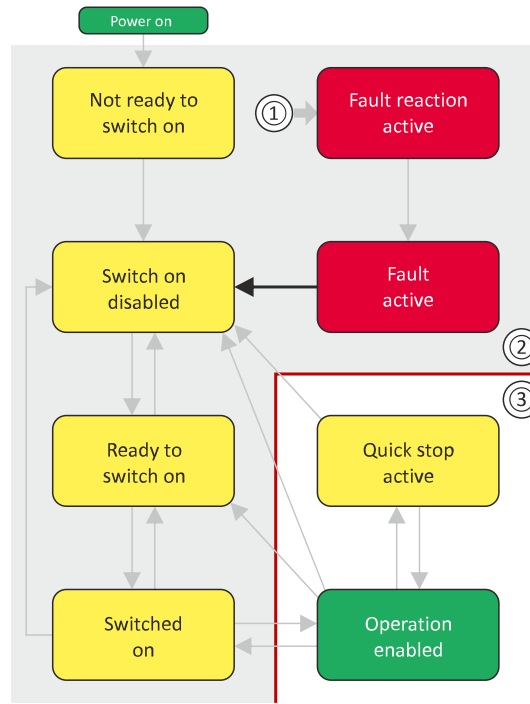

- A From all states
- B Power section inhibited (pulse inhibit)
- C Power section enabled

Bit pattern in the CiA control word (0x6040)								
Bit 15 ... 8	Bit 7	Bit 6	Bit 5	Bit 4	Bit 3	Bit 2	Bit 1	Bit 0
Reserved (specific)	Reset fault	Operating mode dependent			Operation enabled	Activating quick stop	Establish readiness for operation	Switch-on
X	0/1	X	X	X	X	X	X	X

X = state is not relevant

Configuring the network

CiA 402 device profile
Device states



15.1.6 Device states

0x6041 (CiA status word) displays the current device status of the inverter.

Device status	Bit pattern in the CiA 402 status word (0x6041)							
	Bit 7	Bit 6	Bit 5	Bit 4	Bit 3	Bit 2	Bit 1	Bit 0
	Warning is active	Operation inhibited	Quick stop active	DC bus ready for operation	Fault active	Operation enabled	Switched on	Ready to switch on
Not ready to switch on □ 218	X	1	X	X	0	0	0	0
Switch-on inhibited □ 219	X	1	X	X	0	0	0	0
Ready to switch on □ 220	X	1	1	X	0	0	0	1
Switched on □ 221	X	1	1	X	0	0	1	1
Operation enabled □ 222	X	0	0	X	0	1	1	1
Quick stop active □ 223	X	0	1	X	0	1	1	1
Fault reaction active □ 224	X	0	X	X	1	1	1	1
Trouble □ 225	X	1	X	X	1	0	0	0

X = state is not relevant

Status bit 7: "Warning active"

Status bit 7 indicates a warning.

- A warning does **not** cause a state change.
- Warnings do not need to be reset.

More Lenze-specific status bits (bit 8 ... 15)

Device status	Bit pattern in the CiA 402 status word (0x6041)							
	Bit 15	Bit 14	Bit 13	Bit 12	Bit 11	Bit 10	Bit 9	Bit 8
	Not active	Brake released	Following error is active	Drive follows setpoint selection	Internal limitation is active	Target position reached	Control word processed successfully	RPDOs deactivated
Brake applied	X	0	X	X	X	X	X	X
Brake released	X	1	X	X	X	X	X	X
Active	0	X	X	X	X	X	X	X
not active	1	X	X	X	X	X	X	X

X = state is not relevant

Detailed information on the various device states can be found in the following sections.



Configuring the network

CiA 402 device profile

Device states

Parameter

Address	Name / setting range / [default setting]	Information
0x6041	CiA status word • Read only	Mappable CiA status word with bit assignment according to device profile CiA 402.
	Bit 0 Ready to switch on	1 = drive ready to start
	Bit 1 Switched on	1 = drive switched-on
	Bit 2 Operation enabled	1 = operation enabled
	Bit 3 Fault	1 = fault or trouble active
	Bit 4 Voltage enabled	1 = DC bus ready for operation
	Bit 5 Quick stop disabled	0 = quick stop active
	Bit 6 Switch on disabled	1 = operation inhibited
	Bit 7 Warning	1 = warning active
	Bit 8 RPDOs deactivated	1 = cyclic PDOs have been deactivated.
	Bit 9 CiA control enabled	1 = inverter can receive commands via network. • Bit is not set in the operating mode 0x6060 = "MS: Velocity mode [-2]".
	Bit 10 Setpoint reached	1 = the actual speed is in the window.
	Bit 11 Internal limit active	1 = internal limitation of a setpoint active.
	Bit 12 Operation mode active	1 = operation enabled and no test mode activated. (no internal setpoint generation active.)
	Bit 13 Following error	1 ≡ following error active
Bit 14 Holding brake released	1 = holding brake released	
Bit 15 STO not active	0 = the inverter has been disabled by the integrated safety system 1 = the integrated safety system is not active Not available for i410 and i510 (always TRUE).	

Configuring the network

CiA 402 device profile
Device states



15.1.6.1 Not ready to switch on

This is the device state of the inverter directly after switching on the supply voltage.

- In this device status, the device is initialised.
- Communication is not possible yet.
- The inverter cannot be parameterised yet and no device commands can be carried out yet.
- The motor brake, if available, is closed.
- Operation is inhibited.

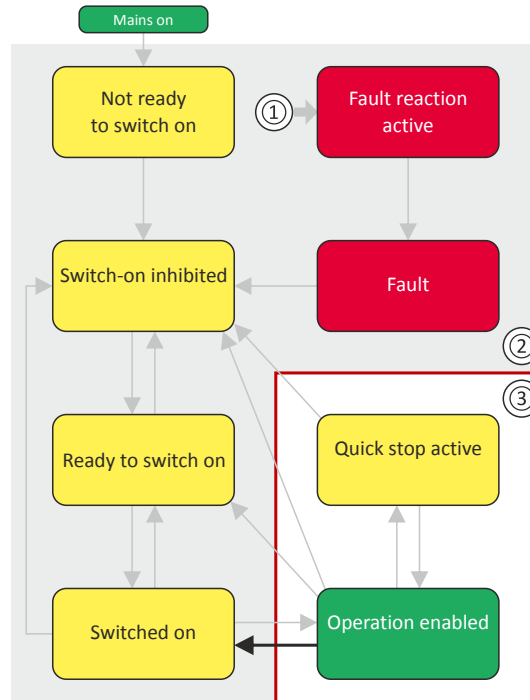

- 1 From all states
- 2 Power section inhibited (pulse inhibit)
- 3 Power section enabled

Bit pattern in the CiA status word (0x6041)								
Bit 15 ... 8	Bit 7	Bit 6	Bit 5	Bit 4	Bit 3	Bit 2	Bit 1	Bit 0
Reserved (specific)	Warning active	Operation inhibited	Quick stop active	DC bus ready for operation	Fault active	Operation enabled	Switched on	Ready to switch on
X	X	0	X	X	0	0	0	0

X = state is not relevant



15.1.6.2 Switch-on inhibited

This is the device state of the inverter after the device has been initialised successfully.

A change to this state also takes place when the EtherCAT bus is in "Operational" state or the PDO communication via **0x2824** (Control selection) is deactivated.

- Process data monitoring is active.
- Communication is possible.
- The DC-bus voltage can be present.
- The inverter can be parameterised.
- If the internal holding brake control (**0x2820:001**) is active in the inverter, the motor brake is closed.
- Operation is inhibited.

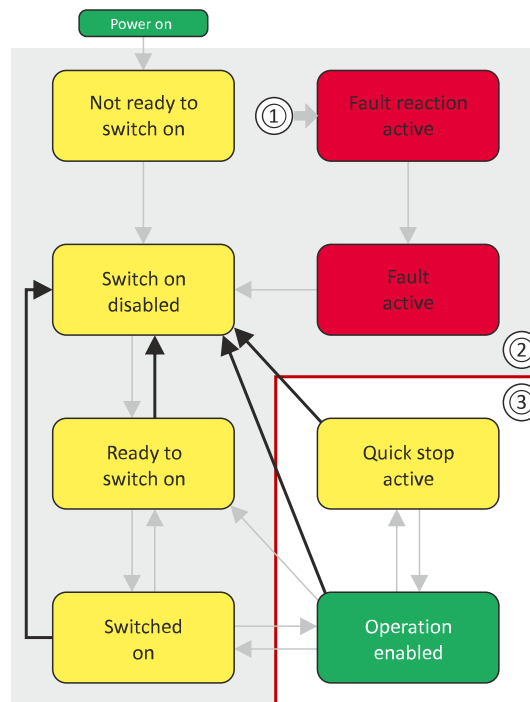

- 1 From all states
- 2 Power section inhibited (pulse inhibit)
- 3 Power section enabled

Bit pattern in the CiA status word (**0x6041**)

Bit 15 ... 8	Bit 7	Bit 6	Bit 5	Bit 4	Bit 3	Bit 2	Bit 1	Bit 0
Reserved (specific)	Warning active	Operation inhibited	Quick stop active	DC bus ready for operation	Fault active	Operation enabled	Switched on	Ready to switch on
X	X	1	X	X	0	0	0	0

X = state is not relevant

Configuring the network

CiA 402 device profile
Device states



15.1.6.3 Ready to switch on

This is the device state of the inverter after the device has been initialised successfully and after the command has been triggered.

A change to this device state also takes place if the "" command was triggered in the states "Switched on" or "Ready to switch on".

- Process data monitoring is active.
- Communication is possible.
- The DC-bus voltage is available.
- The inverter can be parameterised.
- If the internal holding brake control (0x2820:001) is active in the inverter, the motor brake is closed.
- Operation is inhibited.

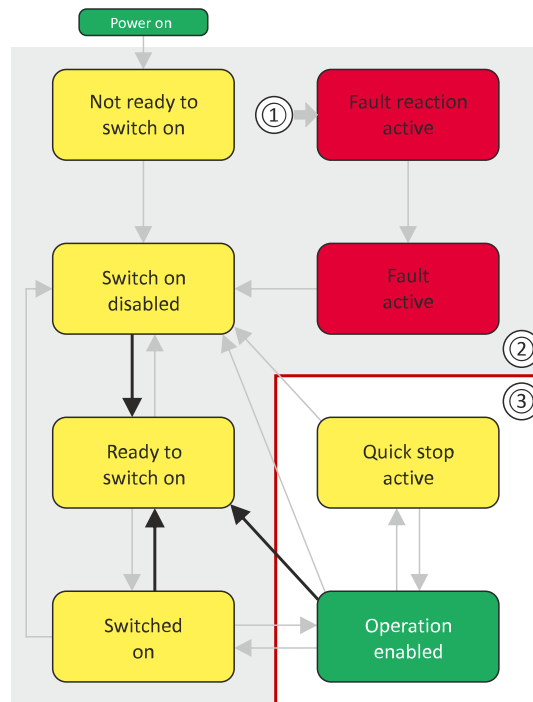

- 1 From all states
- 2 Power section inhibited (pulse inhibit)
- 3 Power section enabled

Bit pattern in the CiA status word (0x6041)								
Bit 15 ... 8	Bit 7	Bit 6	Bit 5	Bit 4	Bit 3	Bit 2	Bit 1	Bit 0
Reserved (specific)	Warning active	Operation inhibited	Quick stop active	DC bus ready for operation	Fault active	Operation enabled	Switched on	Ready to switch on
X	X	0	1	X	0	0	0	1

X = state is not relevant



15.1.6.4 Switched on

This is the device state of the inverter after the "Switch on" command has been triggered in the "Ready to switch on" device state.

- Process data monitoring is active.
- Communication is possible.
- The DC-bus voltage is available.
- The inverter can be parameterised.
- If the internal holding brake control (0x2820:001) is active in the inverter, the motor brake is closed.
- Operation is inhibited.

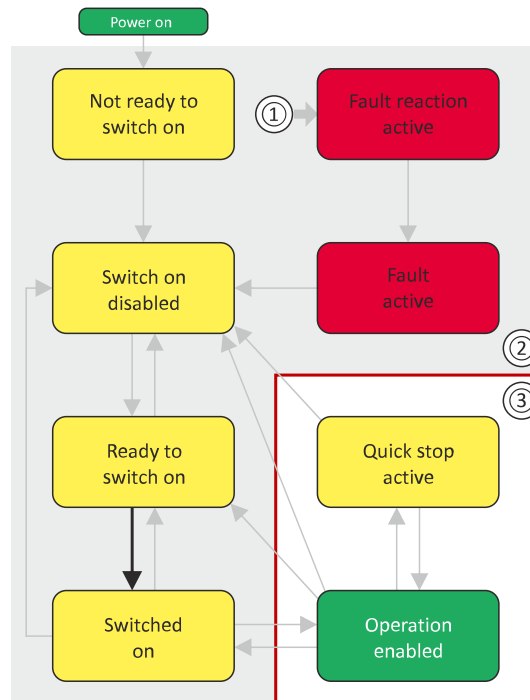

- 1 From all states
- 2 Power section inhibited (pulse inhibit)
- 3 Power section enabled

Bit pattern in the CiA status word (0x6041)								
Bit 15 ... 8	Bit 7	Bit 6	Bit 5	Bit 4	Bit 3	Bit 2	Bit 1	Bit 0
Reserved (specific)	Warning active	Operation inhibited	Quick stop active	DC bus ready for operation	Fault active	Operation enabled	Switched on	Ready to switch on
X	X	1	1	X	0	0	1	1

X = state is not relevant

Configuring the network

CiA 402 device profile
Device states



15.1.6.5 Operation enabled

This device state represents normal operation. Operation in the selected operating mode is enabled and no errors have occurred.

- Only the parameters of the inverter can be changed that do not require an inverter disable.
- A motor brake, if any, is open if the automatic operation of the holding brake control is activated (`0x2820:001 = 0`).
- The drive control is active.

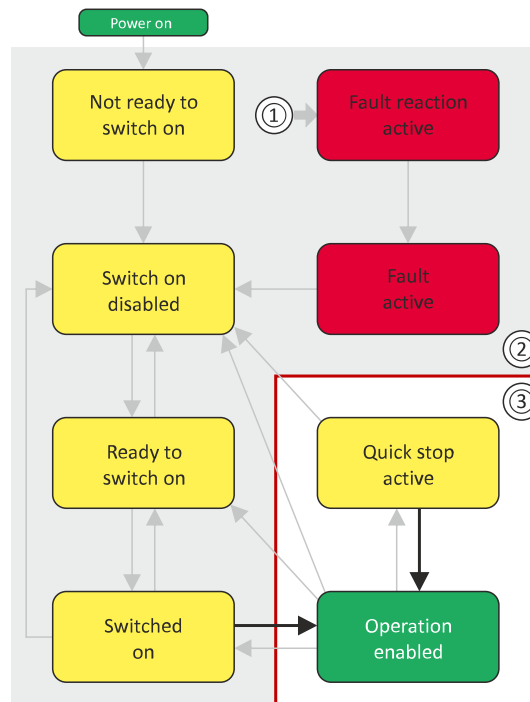

- 1 From all states
- 2 Power section inhibited (pulse inhibit)
- 3 Power section enabled

Bit pattern in the CiA status word (0x6041)

Bit 15 ... 8	Bit 7	Bit 6	Bit 5	Bit 4	Bit 3	Bit 2	Bit 1	Bit 0
Reserved (specific)	Warning active	Operation inhibited	Quick stop active	DC bus ready for operation	Fault active	Operation enabled	Switched on	Ready to switch on
X	X	0	1	X	0	1	1	1

X = state is not relevant



15.1.6.6 Quick stop active

This device state is active if quick stop is executed or active.

- Only the parameters of the inverter can be changed that do not require an inverter disable.
- If the internal holding brake control (0x2820:001) is active in the inverter, the motor brake is closed.
- The drive control is active.

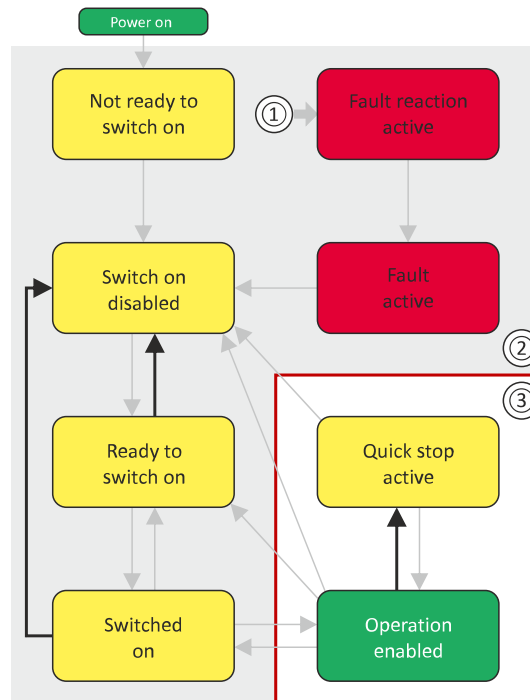

- 1 From all states
- 2 Power section inhibited (pulse inhibit)
- 3 Power section enabled

Bit pattern in the CiA status word (0x6041)								
Bit 15 ... 8	Bit 7	Bit 6	Bit 5	Bit 4	Bit 3	Bit 2	Bit 1	Bit 0
Reserved (specific)	Warning active	Operation inhibited	Quick stop active	DC bus ready for operation	Fault active	Operation enabled	Switched on	Ready to switch on
X	X	0	0	X	0	1	1	1

X = state is not relevant

The "Enable operation" command stops an active quick stop.

Configuring the network

CiA 402 device profile
Device states



15.1.6.7 Fault reaction active

This device state becomes active if a minor fault occurs. This means that the inverter is still able to drive the motor in a controlled way.

- The inverter is brought to a standstill irrespective of the setpoint specified with the deceleration (0x6085) set for quick stop.

If the inverter is at standstill, a change to the "Trouble" device state take place automatically.

- Only the parameters of the inverter can be changed that do not require an inverter disable.
- If the internal holding brake control (0x2820:001) is active in the inverter, the motor brake is closed.
- The drive control is active.

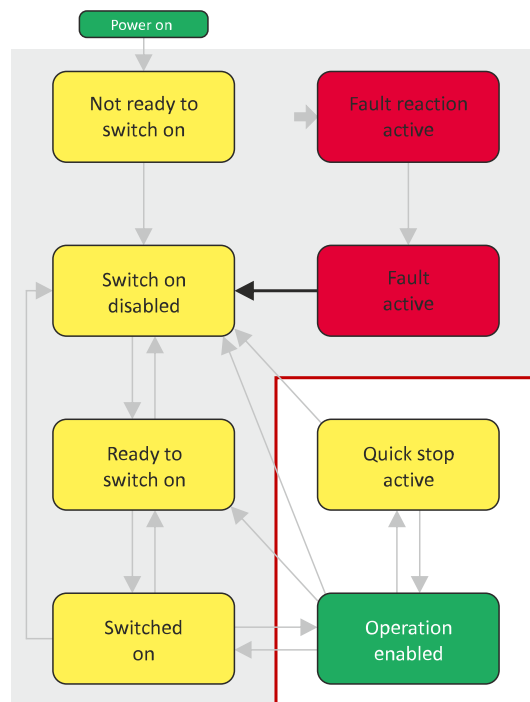

- From all states
- Power section inhibited (pulse inhibit)
- Power section enabled

Bit pattern in the CiA status word (0x6041)								
Bit 15 ... 8	Bit 7	Bit 6	Bit 5	Bit 4	Bit 3	Bit 2	Bit 1	Bit 0
Reserved (specific)	Warning active	Operation inhibited	Quick stop active	DC bus ready for operation	Fault active	Operation enabled	Switched on	Ready to switch on
X	X	0	X	X	1	1	1	1

X = state is not relevant



15.1.6.8 Trouble

This device state becomes active if a serious system fault occurs. This means that the inverter is no longer able to drive the motor in a controlled way. The inverter is switched off immediately.

- The pulse inhibit is active (pulses of the inverter are inhibited).
- The motor is torqueless.
- The motor brake, if available, is closed.
- Operation is inhibited.
- The inverter can be parameterised.

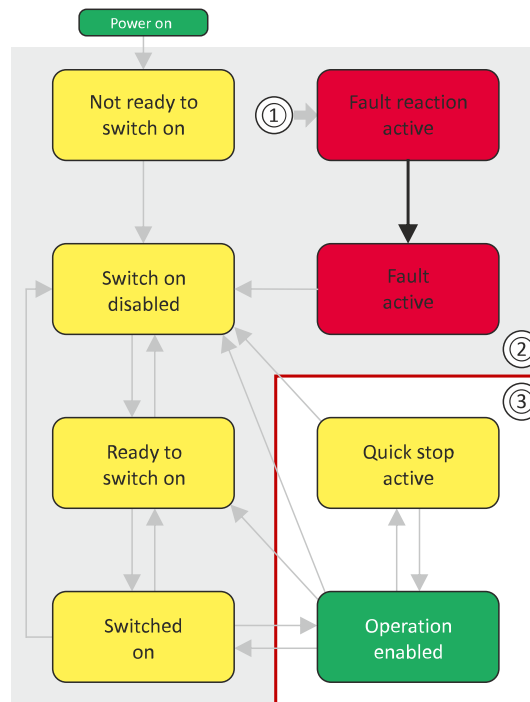

- 1 From all states
- 2 Power section inhibited (pulse inhibit)
- 3 Power section enabled

Bit pattern in the CiA status word (0x6041)								
Bit 15 ... 8	Bit 7	Bit 6	Bit 5	Bit 4	Bit 3	Bit 2	Bit 1	Bit 0
Reserved (specific)	Warning active	Operation inhibited	Quick stop active	DC bus ready for operation	Fault active	Operation enabled	Switched on	Ready to switch on
X	X	0	X	X	1	0	0	0

X = state is not relevant

This device state can only be left with the "[Reset fault](#)" command if the cause of the fault has been removed.



15.2 EtherCAT



EtherCAT® (Ethernet for Controller and Automation Technology) is an Ethernet-based fieldbus system which fulfils the application profile for industrial realtime systems.

- EtherCAT® is a registered trademark and patented technology, licensed by Beckhoff Automation GmbH, Germany.
- Detailed information on EtherCAT can be found on the web page of EtherCAT Technology Group (ETG): <http://www.ethercat.org>
- Information about the sizing of an EtherCAT network can be found in the configuration document.

Preconditions

- The inverter is equipped with the "EtherCAT" network option.
- The inverter has not been parameterized as a CiA 402 motion drive.
- For commissioning, load the current device description files for Lenze EtherCAT devices via the Package Manager to your Engineering PC.

Typical topology

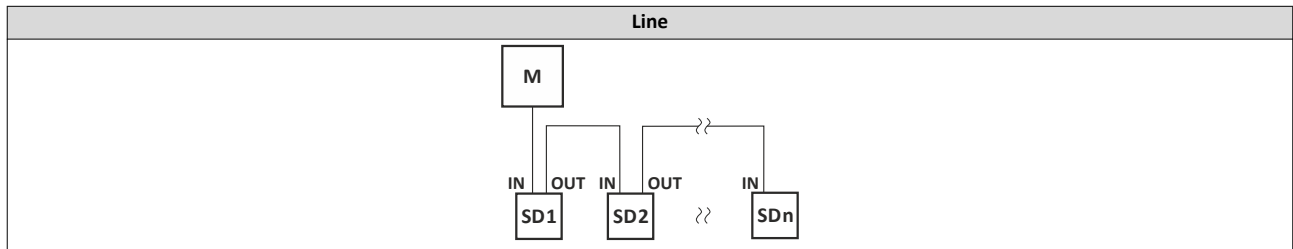

M Master
SD Slave Device

Typical topologies

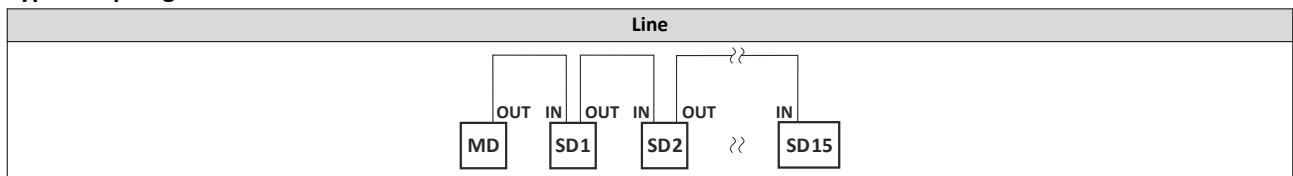

MD Master device
SD Slave Device



15.2.1 Commissioning

In the following, the required steps are described to control the device with an EtherCAT master.

During commissioning, the EtherCAT master operates as gateway to access from the Engineering PC to the slaves.

In the following, the required steps are described to control the device as EtherCAT slave.

Preconditions

- The inverter is networked as EtherCAT slave to an EtherCAT master and, if necessary, further EtherCAT devices.
 - See "Typical topologies" under: [► EtherCAT 226](#)
- The entire wiring has already been checked for completeness, short circuit and earth fault.
- All EtherCAT devices are supplied with voltage and are switched on.
- The inverter is commissioned with the »EASY Starter«.
 - Download »EASY Starter«
- The EtherCAT master is commissioned with a different engineering tool, e. g. Beckhoff TwinCAT. For this purpose, install the required ESI device description file in the engineering tool for the for the EtherCAT master. We always recommend the use of the current device description.
 - Download XML/ESI files for Lenze devices

Recommended sequence of the commissioning steps

- Use the **Online Login** menu command or the **<Alt> + <F11>** keys to log into the controller.
-
- Adapt the network configuration.
-
- Use the **Build Compile** menu command or the **<F11>** function key to compile the program code.
- Use the **Online Login** menu command or the **<Alt> + <F11>** keys to load the configuration.
- Use the **Debug Start** menu command or the **<F5>** function key to start the PLC program.

Restart of the communication

The communication needs to be restarted after the EtherCAT identifier is changed, so that the changed settings can take effect.

For restarting communication, there are two options:

- Switch inverter off and on again.
- Set **0x2360** = "Restart with current values"

Parameter

Address	Name / setting range / [default setting]	Information
0x2360	EtherCAT communication	Restart communication. <ul style="list-style-type: none"> When the device command has been executed successfully, the value 0 is shown.
	0 No action/no error	Only status feedback
	1 Restart with current values	Restart communication with the current values.
	10 In process	Only status feedback
	11 Action cancelled	
	12 Fault	
0x5850:001	Commands for EtherCAT system bus master: Kommunikation neu starten	
	0 No action/no error	Only status feedback
	1 Neustart	Only status feedback
	10 Busy	
	11 Action cancelled	
	12 Faulted	

Configuring the network

EtherCAT
Basic setting and options



15.2.2 Basic setting and options

Addressing of the EtherCAT devices

The EtherCAT devices are normally addressed via a permanent 16-bit address defined by the master. At the start, this address is assigned automatically to each node by the master, depending on the physical order in the network. The address is not saved and gets lost when the device is switched off.

"Explicit Device Identification" via rotary encoder switch or parameter

The "Explicit Device Identification" is required if the device is part of a Hot Connect group or the device is operated within a modular Lenze machine application. Each slave receives an *unambiguous* identifier for being identified by the master.

Setting	Assignment of the identifier
0x00	Identifier via the parameter .

The value set via the 2361:004 parameter is used once when the mains is switched on or after a network restart with $0x2360 = 1$. A changed value during operation will only become valid after the network has been restarted.

As an alternative, a master can also use station alias addresses of the slaves that are configured and *unambiguous* in the network. For this purpose, a station alias address must be saved in the EEPROM of the device by setting the corresponding register.

15.2.2.1 Synchronisation with "distributed clocks" (DC)

Parameter

Address	Name / setting range / [default setting]	Information
0x2580:001	Distributed Clocks: Real time status • Read only	Since its switch-on, the inverter has not yet received any real time information from outside. The inverter still works with a time based on the time of the last switch-off or the time stamp of the firmware.
	0 Not adjusted	Since its switch-on, the inverter has not yet received any real time information from outside.
	1 Adjusted once	
	2 Adjusted cyclically	
0x2580:002	Distributed Clocks: First setting time • Read only: x ns	Display of the time when the inverter has received a real time information from outside for the first time after its switch-on. In the "No real time information received yet", the value "0" is displayed.
0x2580:003	Distributed Clocks: Newest setting time • Read only: x ns	Display of the time when the inverter has most recently received a real time information from outside.
0x2580:004	Distributed Clocks: Current time • Read only: x ns	Display of the time information currently used by the inverter (device time).

15.2.2.2 Parameterising additional functions

Parameter

Address	Name / setting range / [default setting]	Information
0x2946:001	Speed limitation: Upper speed limit -479999.999776482 ... [0] ... 479999.999776482 rpm	Upper limit for the speed limitation. • Setting is only effective with the selection "Upper speed limit [5]" in . • Entry via keypad and Lenze Tools is in rpm! • Via RPDO, the unit is vel. unit. and the scaling must be taken into account. • $\pm 480000 \text{ rpm} = \pm 2^{31} [\text{n-unit}]$
0x2946:002	Speed limitation: Lower speed limit -479999.999776482 ... [0] ... 479999.999776482 rpm	Lower limit for speed limitation. • Setting is only effective with the selection "Lower speed limit [5]" in . • Entry via keypad and Lenze Tools is in rpm! • Via RPDO, the unit is vel. unit. and the scaling must be taken into account. • $\pm 480000 \text{ rpm} = \pm 2^{31} [\text{n-unit}]$
0x2DD5	Torque setpoint • Read only: x.xx Nm	Display of the current torque setpoint.



Configuring the network

EtherCAT
Basic setting and options

Address	Name / setting range / [default setting]	Information
0x6040	CiA control word 0x0000 ... [0x0000] ... 0xFFFF	Mappable CiA control word with bit assignment according to device profile CiA 402.
	Bit 0	Switch on 1 = switch-on
	Bit 1	Enable voltage 1 = Enable voltage
	Bit 2	Disable quick stop 0 = activate quick stop
	Bit 3	Enable operation 1 = Enable operation
	Bit 4	Operation mode specific
	Bit 5	Operation mode specific
	Bit 6	Operation mode specific
	Bit 7	Fault reset 0-1 edge = fault reset
	Bit 8	Halt 1 = stop motor (ramping down to frequency setpoint 0 Hz)
	Bit 9	Operation mode specific Operating mode specific
0x6041	CiA status word • Read only	Mappable CiA status word with bit assignment according to device profile CiA 402.
	Bit 0	Ready to switch on 1 = drive ready to start
	Bit 1	Switched on 1 = drive switched-on
	Bit 2	Operation enabled 1 = operation enabled
	Bit 3	Fault 1 = fault or trouble active
	Bit 4	Voltage enabled 1 = DC bus ready for operation
	Bit 5	Quick stop disabled 0 = quick stop active
	Bit 6	Switch on disabled 1 = operation inhibited
	Bit 7	Warning 1 = warning active
	Bit 8	RPDOs deactivated 1 = cyclic PDOs have been deactivated.
	Bit 9	CiA control enabled 1 = inverter can receive commands via network. • Bit is not set in the operating mode 0x6060 = "MS: Velocity mode [-2]".
	Bit 10	Setpoint reached 1 = the actual speed is in the window.
	Bit 11	Internal limit active 1 = internal limitation of a setpoint active.
	Bit 12	Operation mode active 1 = operation enabled and no test mode activated. (no internal setpoint generation active.)
	Bit 13	Following error 1 = following error active
Bit 14	Holding brake released 1 = holding brake released	
Bit 15	STO not active 0 = the inverter has been disabled by the integrated safety system 1 = the integrated safety system is not active Not available for i410 and i510 (always TRUE).	
0x6042	Set speed -32768 ... [0] ... 32767 rpm	Set speed (velocity mode).
0x6043	Internal set speed • Read only: x rpm	Display of the internal set speed (velocity demand).
0x6044	Actual speed • Read only: x rpm	Display of the actual speed (velocity mode).
0x6046:001	Speed limits: Min. speed 0 ... [0] ... 0 rpm	Min. speed (velocity mode).
0x6046:002	Speed limits: Max. speed 2147483647 ... [2147483647] ... 2147483647 rpm	Max. speed (velocity mode).
0x6048:001	Acceleration ramp: CiA acceleration: Delta speed 0 ... [0] ... 2147483647 rpm	CiA acceleration: Delta speed
0x6048:002	Acceleration ramp: CiA acceleration: Delta time 0 ... [10] ... 65535 s	CiA acceleration: Delta time

Configuring the network

EtherCAT

Basic setting and options



Address	Name / setting range / [default setting]	Information
0x6049:001	Deceleration ramp: CiA deceleration: Delta speed 0 ... [0] ... 2147483647 rpm	CiA deceleration: Delta speed
0x6049:002	Deceleration ramp: CiA deceleration: Delta time 0 ... [10] ... 65535 s	CiA deceleration: Delta time
0x605A	CiA: Quick stop mode	Device status after exiting the quick stop ramp. • Setting is only effective in the operating mode 0x6060 = "CiA: Velocity mode [2]".
	2 Ramp > switch on disabled	Automatic change to the "Switch-on inhibited" device state. • The "Quick stop active [54]" status is reset to FALSE after ramp-down to standstill.
	6 Ramp > quick stop active	The inverter remains in the "Quick stop active" device state. • The "Quick stop active [54]" status remains TRUE until the "Quick stop" function is activated.
0x605E	CiA: Fault reaction	Selection of the response to faults.
	-2 Advanced quick stop	If possible, the motor is braked to standstill with the "quick stop" function. If this is not possible (e. g. in case of an encoder error), reverse current braking or short-circuit braking are used for the braking process.
	0 Coast	The motor has no torque (coasts down to standstill).
	2 Quick stop	The motor is brought to a standstill with the "quick stop" function. • In the operating mode 0x6060 = "CiA: Velocity mode [2]", the speed change set in 0x6085 is effective.
0x6060	CiA: Operation mode	CiA: Operation mode
	0 No selection	No selection
	2 CiA: Velocity mode	▶ Operating mode "CiA 402 velocity mode (vl)" ☐ 64
	8 CiA: Cyclic sync position	▶ Operating mode "CiA 402 cyclic sync position mode (csp)" ☐ 52
	9 Cyclic sync velocity mode	▶ Operating mode "CiA 402 cyclic sync velocity mode (csv)" ☐ 70
	10 Cyclic sync torque mode	▶ Operating mode "CiA 402 cyclic sync torque mode (cst)" ☐ 81
0x6061	CiA: Active operation mode • Read only	CiA: Active operation mode
	-11 Identification	
	-10 Test mode	
	0 No selection	No selection
	2 CiA: Velocity mode	▶ Operating mode "CiA 402 velocity mode (vl)" ☐ 64
	8 CiA: Cyclic sync position	▶ Operating mode "CiA 402 cyclic sync position mode (csp)" ☐ 52
	9 Cyclic sync velocity mode	▶ Operating mode "CiA 402 cyclic sync velocity mode (csv)" ☐ 70
	10 Cyclic sync torque mode	▶ Operating mode "CiA 402 cyclic sync torque mode (cst)" ☐ 81
0x6071	Set torque -3276.8 ... [0.0] ... 3276.7 %	• 100 % = Rated motor torque 0x6076 The inverter does not support the CiA 402 torque mode.
0x6074	Internal set torque • Read only: x.x %	Display of the internal set torque. • 100 % = Rated motor torque 0x6076
0x6079	DC-bus voltage • Read only: x.xxx V	Display of the current DC-bus voltage.
0x6085	Quick stop deceleration 0 ... [2147483647] ... 2147483647	Change in velocity used for deceleration to a standstill if quick stop is activated. • Setting is only effective in the operating mode 0x6060 = "CiA: Velocity mode [2]".
0x6502	Supported drive modes • Read only	Bit coded display of the operating modes supported.
	Bit 1 CiA: Velocity mode	1 = CiA: velocity mode is supported.
	Bit 7 Cyclic sync position mode	1 ≡ Cyclic sync position mode is supported.
	Bit 8 Cyclic sync velocity mode	1 ≡ Cyclic sync velocity mode is supported.
	Bit 9 Cyclic sync torque mode	1 ≡ Cyclic sync torque mode is supported.



15.2.3 Process data transfer

- Process data is cyclically transferred between the EtherCAT master and the slaves (permanent exchange of current input and output data).
- The transfer of process data is time-critical.
- The process data serve to control the EtherCAT slaves.
- The process data can be directly accessed by the master. The data in the PLC, for instance, are directly stored in the I/O area.
- The contents of the process data are defined via I/O Data mapping (definition of the EtherCAT objects that are to be transmitted cyclically).
- Process data is not saved in the device.
- Process data is, e. g. setpoints, actual values, control and status words.

Configuration

- The available objects can be mapped in all operating modes as dynamic (free) configuration. The contents can be only be selected from the following objects.
 - Generic standard mapping objects for all operating modes: [▶ Standard mapping](#) 231
 - Mapping objects for a dynamic (free) assignment: [▶ Dynamic \(free\) configuration](#) 232
- The data format is 0xAAAABBCC (AAAA = index, BB = subindex, CC = length).

15.2.3.1 Standard mapping

Generic standard mapping of the RPDOs

Master → slave	
RPDO mapping entry 1	
RPDO mapping entry 2	
RPDO mapping entry 3	
RPDO mapping entry 4	
RPDO mapping entry 5	
RPDO mapping entry 6	
RPDO mapping entry 7	
RPDO mapping entry 8	
RPDO mapping entry 9	
RPDO mapping entry 10	
RPDO mapping entry 11	
RPDO mapping entry 12	
RPDO mapping entry 13	
RPDO mapping entry 14	
RPDO mapping entry 15	
RPDO mapping entry 16	

Generic standard mapping of the TPDOs

Slave → master	
RPDO mapping entry 1	
RPDO mapping entry 2	
RPDO mapping entry 3	
RPDO mapping entry 4	
RPDO mapping entry 5	
RPDO mapping entry 6	
RPDO mapping entry 7	
RPDO mapping entry 8	
RPDO mapping entry 9	
RPDO mapping entry 10	
RPDO mapping entry 11	
RPDO mapping entry 12	
RPDO mapping entry 13	
RPDO mapping entry 14	
RPDO mapping entry 15	
RPDO mapping entry 16	

Configuring the network

EtherCAT
Process data transfer



15.2.3.2 Dynamic (free) configuration

The freely configurable mapping objects contain an 8 bit dummy entry (0x00050008). This ensures that each object is transferred cyclically with 16 bits.



In case of the freely configurable mapping objects, it is necessary to ensure that the total size of the PDO telegrams is always a multiple of 2 bytes (i.e. 2 bytes, 4 bytes, 6 bytes, 8 bytes etc.). For this "filling up" to a 16-bit structure, an 8-bit dummy entry is available (0x00050008). An odd size of the PDO telegram does not work with the EtherCAT bus (error message in the sync master of the EtherCat master).

15.2.3.3 Further communication objects

The parameters for the implemented EtherCAT objects are described below.

15.2.3.4 Expert settings

- The sync managers are configured for the cyclic data transfer and the mailbox communication (display in ...).
- For the communication, the I/O data mapping must be configured via ... (for RPDOs) and ... (for TPDOs).



15.2.4 Parameter data transfer

- For configuring and diagnosing the EtherCAT devices, the parameters are accessed by means of acyclic communication.
- Parameter data are transferred as SDOs (Service Data Objects). SDOs (Service Data Objects)
- The SDO services enable the writing and reading access to parameters and EtherCAT objects.
 - [Process input data \(CiA 402 objects\)](#) 75
 - [Process output data \(CiA 402 objects\)](#) 75
- The transfer of parameter data is usually not time-critical.
- Parameter data is, for instance, operating parameters, motor data and diagnostic information.

SDO return values

If an SDO request is evaluated negatively, a corresponding error code is output:

Index	Description
0x00000000	No fault.
0x05030000	The state of the toggle bit has not changed.
0x05040000	SDO protocol time-out.
0x05040001	Invalid or unknown specification symbol for the client/server command.
0x05040005	The space in the main memory is not sufficient.
0x06010000	Unsupported access to an object.
0x06010001	Read access to a write-only object.
0x06010002	Write access to a read-only object.
0x06020000	An object is not available in the object directory.
0x06040041	An object cannot be mapped into the PDO.
0x06040042	The number and/or length of the mapped objects would exceed the PDO length.
0x06040043	General parameter incompatibility.
0x06040047	General internal incompatibility in the device.
0x06060000	The access has failed due to errors in the hardware.
0x06070010	The data type or the parameter length do not match.
0x06070012	Wrong data type: The parameter length is too big.
0x06070013	Wrong data type: The parameter length is too small.
0x06090011	A subindex is not available.
0x06090030	The value range for parameters is too big (only in case of write access).
0x06090031	The parameter value is too high.
0x06090032	The parameter value is too low.
0x06090036	The maximum value is smaller than the minimum value.
0x08000000	General fault.
0x08000020	Data cannot be transferred to the application or saved in the application.
0x08000021	Due to local control, the data cannot be transferred to the application or saved in the application.
0x08000022	Due to the current device state, the data cannot be transferred to the application or saved in the application.
0x08000023	The dynamic object directory generation has failed or no object directory is available.

15.2.5 Monitoring

The parameters for setting network monitoring functions are described below.

Parameter

Address	Name / setting range / [default setting]	Information
0x10F1:001	Error settings: Local error reaction	An error response takes place exclusively via the inverter.
	2 Device specific state	
0x10F1:002	Error settings: Sync error counter limit 0 ... [100] ... 100	Setting for PDO frame failure detection. When the internal telegram failure error counter reaches the value set here, the inverter changes to the "Safe-Operational" state and causes an error (CiA402 error code 0x8700).

Configuring the network

EtherCAT
Diagnostics





15.2.6 Diagnostics



15.2.6.1 LED status display

The meaning of the "RUN" and "ERR" LEDs can be obtained from the following two tables.

LED "RUN" (green)

Blinking pattern	EtherCAT status	Status/meaning
off	off / Init	The network option is not active at the network or is in the "Init" status.
 blinking	Pre-Operational	Access to parameters and objects is possible. No process data exchange.
	Safe-Operational	The data is not active yet in the standard device.
 on	"Operational"	Valid process data is exchanged cyclically.



"ERR" LED (red)

Blinking pattern	Status/meaning
off	No fault
 flickers	Local error. The network option changes automatically to the "Safe-Operational" status.
 on (red)	A "Sync Manager Watchdog Timeout" has occurred.
 blinking	The configuration is invalid/incorrect.

LED status display

Notes on the EtherCAT connection status and the data transfer can be obtained via the LED displays "RUN" and "L/A" at the RJ45 sockets.

LED "L/A"

Blinking pattern	State	Meaning
off	Not connected	Network not available
 on	Connected	Network available No data transfer
 blinking	Traffic	Data transfer

15.2.6.2 Information on the network

The following parameters show information on the network.

Parameter

Address	Name / setting range / [default setting]	Information
0x2020:001	EoE information: Virtual MAC address • Read only	Display of the virtual MAC address.
0x2020:002	EoE information: IP address • Read only	Display of the IP address.
0x2020:003	EoE information: Subnet mask • Read only	Display of the subnet mask.
0x2020:004	EoE information: Standard gateway • Read only	Display of the standard gateway.
0x2020:005	EoE information: DNS server • Read only	Display of the DNS server.
0x2020:006	EoE information: DNS name • Read only	Display of the DNS name.
0x2020:007	EoE information: Received packages 0 ... [] ... 4294967295	Display of the packages received during the EoE transmission.
0x2020:008	EoE information: Transmitted packages 0 ... [] ... 4294967295	Display of the packages sent during the EoE transmission.
0x2362:007	Active EtherCAT settings: Tx length • Read only	Display of the length of the transmitted cyclic data in bytes.
0x2362:008	Active EtherCAT settings: Rx length • Read only	Display of the length of the received cyclic data in bytes.



Configuring the network

EtherCAT
Diagnostics

Address	Name / setting range / [default setting]	Information
0x2368	EtherCAT status • Read only	Display of the current network status.
	1 Initialisation	Network initialisation is active. • No PDO/SDO transmission. • Device identification is possible by network scan.
	2 Pre-Operational	The network is active. • SDO transmission (CoE communication via mailbox) is possible. • No PDO transmission.
	3 Bootstrap	Firmware update active. • For the firmware update, the FoE protocol is used. • No PDO transmission.
	4 Safe-Operational	SDO transmission (CoE communication via mailbox) is possible. PDO transmission: • The input data in the process image are updated. • The output data from the process image are not transmitted.
	8 Operational	Normal operation • PDO/SDO transmission is possible. • Network synchronisation is successful (if used).
0x2369	EtherCAT error • Read only	Bit coded display of EtherCAT errors.
	Bit 0 Watchdog elapsed	
	Bit 2 Invalid configuration	
	Bit 3 Stack init error	
	Bit 4 Invalid process data	

Configuring the network

EtherCAT
Diagnostics



15.2.6.3 EtherCAT master diagnostics

Information is only displayed in the parameter list under **Diagnostic Master** if an online connection to the master has been established.

The following information is displayed:

- Most recent error
- Number of emergency frames
- Status information
- Information on the network topology
- Frame and error counter

In addition to the EtherCAT states, additional diagnostic information of up to 4 selected EtherCAT slaves is displayed under **Diagnostic Slaves**.

The following information is displayed:

- Slave information
- Addresses
- State
- Count values
- DC sync times

The EtherCAT slave address can be specified using the following parameters:

0x585C

0x585D

0x585E

0x585F

Parameter

Address	Name / setting range / [default setting]	Information
0x5851:001	EtherCAT master diagnosis: EtherCAT master state	Display of the EtherCAT master state.
	• Read only	
	0 Unknown	
	1 Init	
	2 Pre-Operational	
	3 Bootstrap	
	4 Safe-Operational	
8 Operational		
0x5851:002	EtherCAT master diagnosis: EtherCAT master state summary	Display of the EtherCAT master state overview.
	• Read only	
	Bit 0 Master OK	
	Bit 4 Init	
	Bit 5 Pre-Operational	
	Bit 6 Safe-Operational	
	Bit 7 Operational	
	Bit 8 Slaves in requested state	
	Bit 9 Master in requested state	
	Bit 10 Bus scan match	
	Bit 12 DC enabled	
	Bit 13 DC in sync	
	Bit 14 DC busy	
Bit 16 Link up		
0x5851:003	EtherCAT master diagnosis: EtherCAT error	Display whether an EtherCAT network error has occurred.
	• Read only	
0x5851:004	EtherCAT master diagnosis: Bus scan match	Display whether a "Bus Scan Match" exists.
	• Read only	
0x5851:005	EtherCAT master diagnosis: Configured cycle time	Display of the configured cycle time.
	• Read only: x us	
0x5851:006	EtherCAT master diagnosis: Connected slaves	Display of the number of slaves available in the network.
	• Read only	



Configuring the network

EtherCAT
Diagnostics

Address	Name / setting range / [default setting]	Information
0x5851:007	EtherCAT master diagnosis: Configured slaves • Read only	Display of the number of configured slaves.
0x5860:001	EtherCAT slaves station addresses: Station address slave 1 • Read only	Display of the slave station address.
0x5860:002	EtherCAT slaves station addresses: Station address slave 2 • Read only	
0x5860:003	EtherCAT slaves station addresses: Station address slave 3 • Read only	
0x5860:004	EtherCAT slaves station addresses: Station address slave 4 • Read only	
0x5860:005	EtherCAT slaves station addresses: Station address slave 5 • Read only	
0x5860:006	EtherCAT slaves station addresses: Station address slave 6 • Read only	
0x5860:007	EtherCAT slaves station addresses: Station address slave 7 • Read only	
0x5860:008	EtherCAT slaves station addresses: Station address slave 8 • Read only	
0x5860:009	EtherCAT slaves station addresses: Station address slave 9 • Read only	
0x5860:010	EtherCAT slaves station addresses: Station address slave 10 • Read only	
0x5860:011	EtherCAT slaves station addresses: Station address slave 11 • Read only	
0x5860:012	EtherCAT slaves station addresses: Station address slave 12 • Read only	
0x5860:013	EtherCAT slaves station addresses: Station address slave 13 • Read only	
0x5860:014	EtherCAT slaves station addresses: Station address slave 14 • Read only	
0x5860:015	EtherCAT slaves station addresses: Station address slave 15 • Read only	
0x5860:016	EtherCAT slaves station addresses: Station address slave 16 • Read only	
0x5861:001	EtherCAT slaves device names: Device name slave 1 • Read only	Display of the slave device name.

Configuring the network

EtherCAT
Diagnostics



Address	Name / setting range / [default setting]	Information
0x5861:002	EtherCAT slaves device names: Device name slave 2 • Read only	
0x5861:003	EtherCAT slaves device names: Device name slave 3 • Read only	
0x5861:004	EtherCAT slaves device names: Device name slave 4 • Read only	
0x5861:005	EtherCAT slaves device names: Device name slave 5 • Read only	
0x5861:006	EtherCAT slaves device names: Device name slave 6 • Read only	
0x5861:007	EtherCAT slaves device names: Device name slave 7 • Read only	
0x5861:008	EtherCAT slaves device names: Device name slave 8 • Read only	
0x5861:009	EtherCAT slaves device names: Device name slave 9 • Read only	
0x5861:010	EtherCAT slaves device names: Device name slave 10 • Read only	
0x5861:011	EtherCAT slaves device names: Device name slave 11 • Read only	
0x5861:012	EtherCAT slaves device names: Device name slave 12 • Read only	
0x5861:013	EtherCAT slaves device names: Device name slave 13 • Read only	
0x5861:014	EtherCAT slaves device names: Device name slave 14 • Read only	
0x5861:015	EtherCAT slaves device names: Device name slave 15 • Read only	
0x5861:016	EtherCAT slaves device names: Device name slave 16 • Read only	
0x5862:001	EtherCAT slaves device types: Device type slave 1 • Read only	
0x5862:002	EtherCAT slaves device types: Device type slave 2 • Read only	
0x5862:003	EtherCAT slaves device types: Device type slave 3 • Read only	
0x5862:004	EtherCAT slaves device types: Device type slave 4 • Read only	
0x5862:005	EtherCAT slaves device types: Device type slave 5 • Read only	
0x5862:006	EtherCAT slaves device types: Device type slave 6 • Read only	
0x5862:007	EtherCAT slaves device types: Device type slave 7 • Read only	
0x5862:008	EtherCAT slaves device types: Device type slave 8 • Read only	
0x5862:009	EtherCAT slaves device types: Device type slave 9 • Read only	
0x5862:010	EtherCAT slaves device types: Device type slave 10 • Read only	
0x5862:011	EtherCAT slaves device types: Device type slave 11 • Read only	
0x5862:012	EtherCAT slaves device types: Device type slave 12 • Read only	
0x5862:013	EtherCAT slaves device types: Device type slave 13 • Read only	
0x5862:014	EtherCAT slaves device types: Device type slave 14 • Read only	
0x5862:015	EtherCAT slaves device types: Device type slave 15 • Read only	



Configuring the network

EtherCAT
Diagnostics

Address	Name / setting range / [default setting]	Information
0x5862:016	EtherCAT slaves device types: Device type slave 16 • Read only	
0x5863:001	Mandatory EtherCAT slaves: Slave 1 is mandatory • Read only	
	0 FALSE	
	1 TRUE	
0x5863:002	Mandatory EtherCAT slaves: Slave 2 is mandatory • Read only	
	0 FALSE	
	1 TRUE	
0x5863:003	Mandatory EtherCAT slaves: Slave 3 is mandatory • Read only	
	0 FALSE	
	1 TRUE	
0x5863:004	Mandatory EtherCAT slaves: Slave 4 is mandatory • Read only	
	0 FALSE	
	1 TRUE	
0x5863:005	Mandatory EtherCAT slaves: Slave 5 is mandatory • Read only	
	0 FALSE	
	1 TRUE	
0x5863:006	Mandatory EtherCAT slaves: Slave 6 is mandatory • Read only	
	0 FALSE	
	1 TRUE	
0x5863:007	Mandatory EtherCAT slaves: Slave 7 is mandatory • Read only	
	0 FALSE	
	1 TRUE	
0x5863:008	Mandatory EtherCAT slaves: Slave 8 is mandatory • Read only	
	0 FALSE	
	1 TRUE	
0x5863:009	Mandatory EtherCAT slaves: Slave 9 is mandatory • Read only	
	0 FALSE	
	1 TRUE	
0x5863:010	Mandatory EtherCAT slaves: Slave 10 is mandatory • Read only	
	0 FALSE	
	1 TRUE	
0x5863:011	Mandatory EtherCAT slaves: Slave 11 is mandatory • Read only	
	0 FALSE	
	1 TRUE	
0x5863:012	Mandatory EtherCAT slaves: Slave 12 is mandatory • Read only	
	0 FALSE	
	1 TRUE	
0x5863:013	Mandatory EtherCAT slaves: Slave 13 is mandatory • Read only	
	0 FALSE	
	1 TRUE	

Configuring the network

EtherCAT
Diagnostics



Address	Name / setting range / [default setting]	Information
0x5863:014	Mandatory EtherCAT slaves: Slave 14 is mandatory • Read only	Display of the initialisation state of the EtherCAT slave.
	0 FALSE	
	1 TRUE	
0x5863:015	Mandatory EtherCAT slaves: Slave 15 is mandatory • Read only	
	0 FALSE	
	1 TRUE	
0x5863:016	Mandatory EtherCAT slaves: Slave 16 is mandatory • Read only	
	0 FALSE	
	1 TRUE	
0x5864:001	EtherCAT slaves initialisation status: Initalisation status slave 1 • Read only	
	0 No Error	
	1 No access	
	2 Vendor ID check failed	
	3 Product code check failed	
	4 Revision check failed	
0x5864:002	EtherCAT slaves initialisation status: Initalisation status slave 2 • Read only	
	0 No Error	
	1 No access	
	2 Vendor ID check failed	
	3 Product code check failed	
	4 Revision check failed	
0x5864:003	EtherCAT slaves initialisation status: Initalisation status slave 3 • Read only	
	0 No Error	
	1 No access	
	2 Vendor ID check failed	
	3 Product code check failed	
	4 Revision check failed	
0x5864:004	EtherCAT slaves initialisation status: Initalisation status slave 4 • Read only	
	0 No Error	
	1 No access	
	2 Vendor ID check failed	
	3 Product code check failed	
	4 Revision check failed	
0x5864:005	EtherCAT slaves initialisation status: Initalisation status slave 5 • Read only	
	0 No Error	
	1 No access	
	2 Vendor ID check failed	
	3 Product code check failed	
	4 Revision check failed	



Address	Name / setting range / [default setting]	Information
0x5864:006	EtherCAT slaves initialisation status: Initialisation status slave 6 • Read only	
	0 No Error	
	1 No access	
	2 Vendor ID check failed	
	3 Product code check failed	
	4 Revision check failed	
0x5864:007	EtherCAT slaves initialisation status: Initialisation status slave 7 • Read only	
	0 No Error	
	1 No access	
	2 Vendor ID check failed	
	3 Product code check failed	
	4 Revision check failed	
0x5864:008	EtherCAT slaves initialisation status: Initialisation status slave 8 • Read only	
	0 No Error	
	1 No access	
	2 Vendor ID check failed	
	3 Product code check failed	
	4 Revision check failed	
0x5864:009	EtherCAT slaves initialisation status: Initialisation status slave 9 • Read only	
	0 No Error	
	1 No access	
	2 Vendor ID check failed	
	3 Product code check failed	
	4 Revision check failed	
0x5864:010	EtherCAT slaves initialisation status: Initialisation status slave 10 • Read only	
	0 No Error	
	1 No access	
	2 Vendor ID check failed	
	3 Product code check failed	
	4 Revision check failed	
0x5864:011	EtherCAT slaves initialisation status: Initialisation status slave 11 • Read only	
	0 No Error	
	1 No access	
	2 Vendor ID check failed	
	3 Product code check failed	
	4 Revision check failed	
0x5864:012	EtherCAT slaves initialisation status: Initialisation status slave 12 • Read only	
	0 No Error	
	1 No access	
	2 Vendor ID check failed	
	3 Product code check failed	
	4 Revision check failed	

Configuring the network

EtherCAT
Diagnostics



Address	Name / setting range / [default setting]	Information
0x5864:013	EtherCAT slaves initialisation status: Initialisation status slave 13 • Read only	
	0 No Error	
	1 No access	
	2 Vendor ID check failed	
	3 Product code check failed	
	4 Revision check failed	
0x5864:014	EtherCAT slaves initialisation status: Initialisation status slave 14 • Read only	
	0 No Error	
	1 No access	
	2 Vendor ID check failed	
	3 Product code check failed	
	4 Revision check failed	
0x5864:015	EtherCAT slaves initialisation status: Initialisation status slave 15 • Read only	
	0 No Error	
	1 No access	
	2 Vendor ID check failed	
	3 Product code check failed	
	4 Revision check failed	
0x5864:016	EtherCAT slaves initialisation status: Initialisation status slave 16 • Read only	
	0 No Error	
	1 No access	
	2 Vendor ID check failed	
	3 Product code check failed	
	4 Revision check failed	
0x5865:001	EtherCAT slaves device status: Device status slave 1 • Read only	Display of the device status of the EtherCAT slave.
	0 Unknown	
	1 Init	
	2 Pre-Operational	
	3 Bootstrap	
	4 Safe-Operational	
	8 Operational	
	65519 Not Present	
0x5865:002	EtherCAT slaves device status: Device status slave 2 • Read only	
	0 Unknown	
	1 Init	
	2 Pre-Operational	
	3 Bootstrap	
	4 Safe-Operational	
	8 Operational	
	65519 Not Present	



Configuring the network

EtherCAT
Diagnostics

Address	Name / setting range / [default setting]	Information
0x5865:003	EtherCAT slaves device status: Device status slave 3 • Read only	
	0 Unknown	
	1 Init	
	2 Pre-Operational	
	3 Bootstrap	
	4 Safe-Operational	
	8 Operational	
65519 Not Present		
0x5865:004	EtherCAT slaves device status: Device status slave 4 • Read only	
	0 Unknown	
	1 Init	
	2 Pre-Operational	
	3 Bootstrap	
	4 Safe-Operational	
	8 Operational	
65519 Not Present		
0x5865:005	EtherCAT slaves device status: Device status slave 5 • Read only	
	0 Unknown	
	1 Init	
	2 Pre-Operational	
	3 Bootstrap	
	4 Safe-Operational	
	8 Operational	
65519 Not Present		
0x5865:006	EtherCAT slaves device status: Device status slave 6 • Read only	
	0 Unknown	
	1 Init	
	2 Pre-Operational	
	3 Bootstrap	
	4 Safe-Operational	
	8 Operational	
65519 Not Present		
0x5865:007	EtherCAT slaves device status: Device status slave 7 • Read only	
	0 Unknown	
	1 Init	
	2 Pre-Operational	
	3 Bootstrap	
	4 Safe-Operational	
	8 Operational	
65519 Not Present		
0x5865:008	EtherCAT slaves device status: Device status slave 8 • Read only	
	0 Unknown	
	1 Init	
	2 Pre-Operational	
	3 Bootstrap	
	4 Safe-Operational	
	8 Operational	
65519 Not Present		

Configuring the network

EtherCAT
Diagnostics



Address	Name / setting range / [default setting]	Information
0x5865:009	EtherCAT slaves device status: Device status slave 9 • Read only	
	0 Unknown	
	1 Init	
	2 Pre-Operational	
	3 Bootstrap	
	4 Safe-Operational	
	8 Operational	
65519 Not Present		
0x5865:010	EtherCAT slaves device status: Device status slave 10 • Read only	
	0 Unknown	
	1 Init	
	2 Pre-Operational	
	3 Bootstrap	
	4 Safe-Operational	
	8 Operational	
65519 Not Present		
0x5865:011	EtherCAT slaves device status: Device status slave 11 • Read only	
	0 Unknown	
	1 Init	
	2 Pre-Operational	
	3 Bootstrap	
	4 Safe-Operational	
	8 Operational	
65519 Not Present		
0x5865:012	EtherCAT slaves device status: Device status slave 12 • Read only	
	0 Unknown	
	1 Init	
	2 Pre-Operational	
	3 Bootstrap	
	4 Safe-Operational	
	8 Operational	
65519 Not Present		
0x5865:013	EtherCAT slaves device status: Device status slave 13 • Read only	
	0 Unknown	
	1 Init	
	2 Pre-Operational	
	3 Bootstrap	
	4 Safe-Operational	
	8 Operational	
65519 Not Present		
0x5865:014	EtherCAT slaves device status: Device status slave 14 • Read only	
	0 Unknown	
	1 Init	
	2 Pre-Operational	
	3 Bootstrap	
	4 Safe-Operational	
	8 Operational	
65519 Not Present		



Address	Name / setting range / [default setting]	Information
0x5865:015	EtherCAT slaves device status: Device status slave 15 • Read only	
	0 Unknown	
	1 Init	
	2 Pre-Operational	
	3 Bootstrap	
	4 Safe-Operational	
	8 Operational	
65519 Not Present		
0x5865:016	EtherCAT slaves device status: Device status slave 16 • Read only	
	0 Unknown	
	1 Init	
	2 Pre-Operational	
	3 Bootstrap	
	4 Safe-Operational	
	8 Operational	
65519 Not Present		

15.2.6.4 Error history buffer

Parameter

Address	Name / setting range / [default setting]	Information
0x1001	Error register • Read only	

15.2.6.5 Device identification

The EtherCAT product code in [0x1018:002](#) consists of device-specific data and the currently activated technology application (0x4000). The last three positions in the product code refer to the activated technology application.

For device identification in the network, the inverter provides the EtherCAT objects listed in the following.

The objects can only be accessed via the EtherCAT network.

Parameter

Address	Name / setting range / [default setting]	Information	
0x1000	Device type • Read only	CANopen device profile according CANopen specification CiA 301/ CiA 402.	
0x1008	Manufacturer device name • Read only	Display of the manufacturer device name.	
0x1009	Manufacturer hardware version • Read only	Display of the manufacturer hardware version.	
0x100A	Manufacturer software version • Read only	Display of the manufacturer software version.	
0x1018:001	Identity object: Vendor ID • Read only	Display of the manufacturer's identification number.	
0x1018:002	Identity object: Product Code • Read only	Display of the product code of the inverter.	
	419446784	i950 (Basic Safety - STO)	
	419450880	i950 (BS-STO) 2	
	419479552	i950 (ES)	
	419483648	i950 (ES) 4	
0x1018:003	Identity object: Revision number • Read only	Display of the main and subversion of the firmware.	
0x1018:004	Identity object: Serial number • Read only	Display of the serial number of the inverter.	

Configuring the network

EtherCAT
EoE communication



15.2.7 EoE communication

Parameter

Address	Name / setting range / [default setting]	Information
0x2362:007	Active EtherCAT settings: Tx length • Read only	Display of the length of the transmitted cyclic data in bytes.
0x2362:008	Active EtherCAT settings: Rx length • Read only	Display of the length of the received cyclic data in bytes.



15.3 PROFINET



PROFINET® (Process Field Network) is a real-time capable network based on Ethernet.

- PROFINET® is a registered trademark and patented technology licensed by the PROFIBUS & PROFINET International (PI) user organization.
- Detailed information on PROFINET can be found on the web page of the user organization: <http://www.profibus.com>
- PROFINET transmits, between the IO-Devices and a IO-Controller (PLC), parameter data, configuration data, diagnostic data, alarm messages, and process data.
- The data is transmitted as a function of its time-critical behavior via corresponding communication channels.
- The device is implemented as a PROFINET-Device in a PROFINET RT network.
- The PROFINET connections are realized as standard RJ45 sockets.
- Further information about the dimensioning of a PROFINET network can be found in the configuration document.

Preconditions

- The device is equipped with the "PROFINET" network option via slot 1. ▶ [Features](#) 21

PROFINET connection

- The PROFINET connection is established via the RJ45 sockets **X2x6** and **X2x7**.
- For establishing the connection to the network, a common standard Ethernet cable from CAT 5/5e is suitable.

Typical topologies

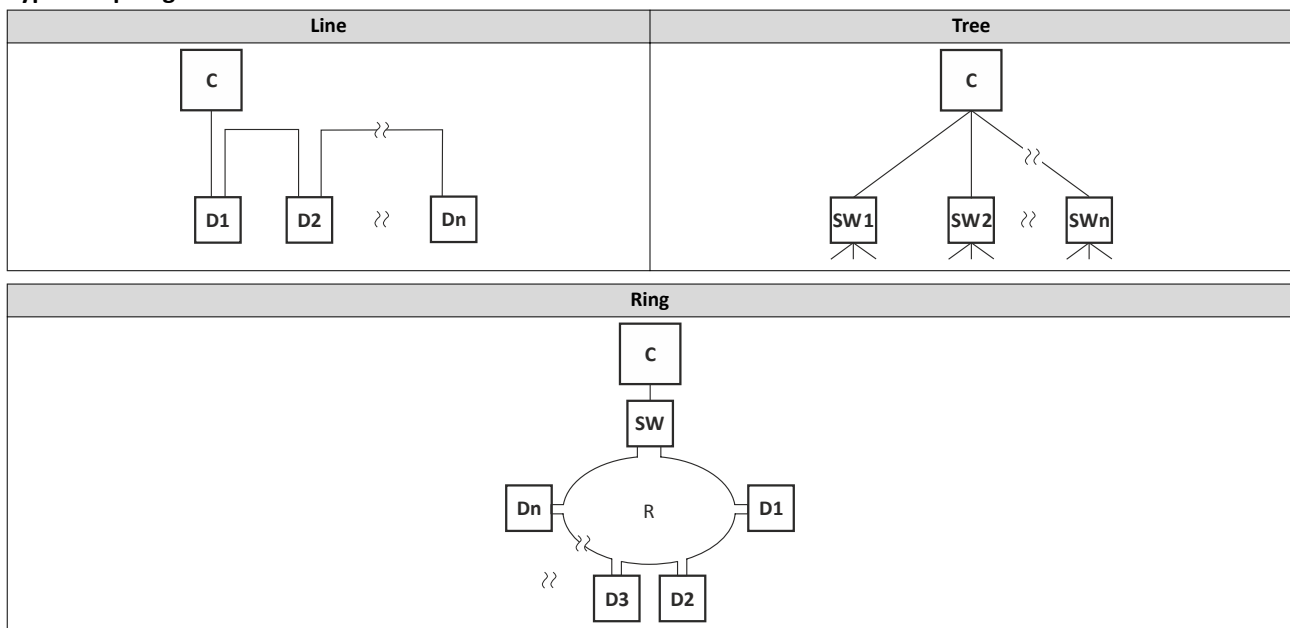

C IO controller
D IO device

SW Switch SCALANCE (MRP capable)
R Redundant domain

Configuring the network

PROFINET
Commissioning



15.3.1 Commissioning

In the following chapters, the steps required for controlling the inverter with a IO-Controller via PROFINET are described.

Preconditions

- As an IO-Device, the inverter is connected to an IO-Controller and further PROFINET nodes if required.

See "Typical topologies" under: [► PROFINET 247](#)

- The entire wiring has been checked for completeness, short circuit and earth fault.
- All PROFINET devices are supplied with voltage and are switched on.
- The functional test described in the mounting and switch-on instructions has been completed successfully (without any errors or faults).
- The inverter is commissioned with the »EASY Starter«.
 - Download »EASY Starter«
- The IO-Controller is commissioned with a different engineering tool, e. g. Siemens »TIA Portal«.

For this purpose, install the required GSDML device description file in the engineering tool for the IO-Controller for configuring the inverter.

We always recommend the use of the current device description.

- Download of GSDML files
- Please observe the necessary system requirements and the notes regarding the inverter.

[► Device description file 250](#)

15.3.1.1 Settings in the »EASY Starter«

1. Set the IP address and the station name ("PROFINET device name").

See: [► Station name and IP configuration 251](#)

2. Save the parameters in the inverter with mains failure protection. [► 0x2022:003](#)

See: [► Saving the parameter settings 39](#)

3. Restart the PROFINET communication. [► 0x2380](#)

See: [► Restarting or stopping the communication 249](#)



15.3.1.2 Restarting or stopping the communication

The communication needs to be restarted after changes to the interface configuration (e. g. station address and IP configuration) so the changed settings become effective without switching the line voltage.

▶ [Station name and IP configuration](#) 251

There are two options for restarting the communication:

- Set **0x2380** to 1 (restart with current values)
- Set **0x2380** to 2 (restart with the values saved last)

The following option can be used to stop communication:

- Set **0x2380** to 5 (stop network communication)

Parameter

Address	Name / setting range / [default setting]	Information
0x2380	PROFINET communication	Restart / stop communication <ul style="list-style-type: none"> • When the device command has been executed successfully, the value 0 is shown.
	0 No action/no error	Only status feedback
	1 Restart with current values	Restart communication with the current values.
	2 Restart with stored values	Restart communication with the values of the PROFINET parameters that have been saved last (0x2381:001 ... 0x2381:009).
	5 Stop network communication	Stop communication
	10 In progress	Only status feedback
	11 Action cancelled	
	12 Fault	

15.3.1.3 Settings in the Siemens »TIA Portal«



Here, commissioning with the Siemens »TIA Portal« is described. Please note that in the standard setting of the Siemens »TIA Portal« changes of network parameters carried out by a Lenze engineering tool (e. g. »EASY Starter«) may be overwritten.

1. Go to the device configuration and open the "net view" to drag the inverter from the catalog to the net view of the PROFINET.
2. Assign the inverter to the associated IO-Controller.
3. Mark the inverter and change to the "device view".
4. Set the IP address and the station name ("PROFINET device name") in "Properties".

See: ▶ [Station name and IP configuration](#)



In order that the inverter can be identified via Ethernet when the IO controller is switched off, the station name and the IP configuration must be saved in the inverter with mains failure protection via the separate entry with the »EASY Starter«. **0x2022:003**

See: ▶ [Saving the parameter settings](#) 39

5. Below the device name and the name of the device description file, the device view shows the pre-assignment of output and input process data words.

In slot 1, pre-assigned process data words can be changed.

When using PROFIsafe, you can add safety process data in slot 2.

▶ [PROFIsafe](#) 257

6. Save the project in the engineering tool.
7. Load the configuration into the IO-Controller.
8. Set the IO-Controller to "RUN".

Configuring the network

PROFINET
Commissioning



15.3.1.4 Device description file

The device description file must be installed in the engineering tool for configuring the network (e. g. Siemens »TIA Portal«).

- Download of GSDML files

The name of the device description file is as follows:

"GSDML-V<x>.<zz>-Lenze-I<NNN>PN<Version>-<yyyy><mm><dd>.xml".

Wildcard	Info
x	Major version of the used GSDML scheme
zz	One-digit or two-digit minor version of the used GSDML scheme
NNN	Specifying the inverter name, e. g. i<550>, i<950>, ...
Version	First software version that can be used with this GSDML.
yyyy	Year of publication
mm	Month of publication
dd	Day of publication

Define the user data length

The configuration of 1 ... 16 process data double words (4 ... 64 bytes) and 8 safety data words is supported.

Examples of selecting the device description file:

- "IEC 8 DWords I/O": 8 process data double words only in slot 1 of the PROFINET telegram)
- "Safety module 4 DWords": 4 safety double words (only in slot 2 of the PROFINET telegram when the extended safety engineering is used simultaneously)

15.3.1.5 Establishing a connection to the »EASY Starter« via PROFINET

To establish a communication link to the inverter via PROFINET ports X2x6/X2x7, proceed as follows:

Requirements:

- The network interface of the engineering PC provided for the connection is parameterised for the PROFINET IP subnetwork.
- A valid IP configuration is set in the inverter. ▶ [Station name and IP configuration](#) 251

Tools required:

- Engineering PC with installed »EASY Starter«.
- Standard Ethernet cable from CAT 5/5e

1. Plug the network cable into one of the two PROFINET ports **X2x6 / X2x7** of the inverter.
2. Use the network cable to connect the inverter to the PC on which »EASY Starter« is installed.
3. Start the »EASY Starter«.

The "Add devices" dialog is shown.

4. Select the "PROFINET " connection.
5. Enter the PROFINET IP address of the inverter.
6. Press the **Insert** button.

Once a connection has been successfully established, the inverter is displayed in the device list. The tabs in »EASY Starter« then provide access to the inverter parameters.

Configuring the network

PROFINET
Process data transfer



15.3.2.2 Suppress diagnostic messages to the IO controller

► **0x285A:001** serves to set which error response in the device suppresses the alarm message to the IO-Controller.

Parameter

Address	Name / setting range / [default setting]	Information	
0x285A:001	Diagnostic configuration: Alarm suppression 0x0000 ... [0x0000] ... 0xFFFF	Bit coded selection of error responses which suppress the alarm message to the IO controller. <ul style="list-style-type: none">• Bit x = 1 = suppress alarm message.• In the default setting "0", an alarm message is displayed for all error responses.	
	Bit 0		Information
	Bit 1		Warning
	Bit 2		Warning locked
	Bit 3		Trouble
	Bit 4		Fault > Application quick stop > Quick stop
	Bit 5		Fault > inverter quick stop > quick stop
	Bit 6		Fault > inverter quick stop > inverter disabled
	Bit 7		Fault
Bit 8	Fault > CiA402		

15.3.3 Process data transfer

Process data serve to control the device.

- The process data is transmitted cyclically between the IO-Controller and the IO-Devices participating in PROFINET.
- The process data can be directly accessed by the IO controller. In the PLC, for instance, the data is stored directly in the IO area.
- The length of the process data is 1 ... 256 bytes (max. 64 slots) per direction.
- The process data is transmitted 1 : 1 according to its sequence.



15.3.4 Parameter data transfer

Data communication with PROFINET is characterised by the simultaneous operation of cyclic and acyclic services in the network. As an optional extension, the parameter data transfer belongs to the acyclic services, which provides access to all device parameters.

Details

- The access to the device data depends on the PROFIdrive profile.
- Only one parameter request is processed at a time (no pipelining).
- No spontaneous messages are transferred.
- There are only acyclic parameter requests.

Basically, a IO-Controller can always be used to request parameters from IO-Device if the IO-Device is in the DATA_EXCHANGE state.

Transmission directions for acyclic data transfer

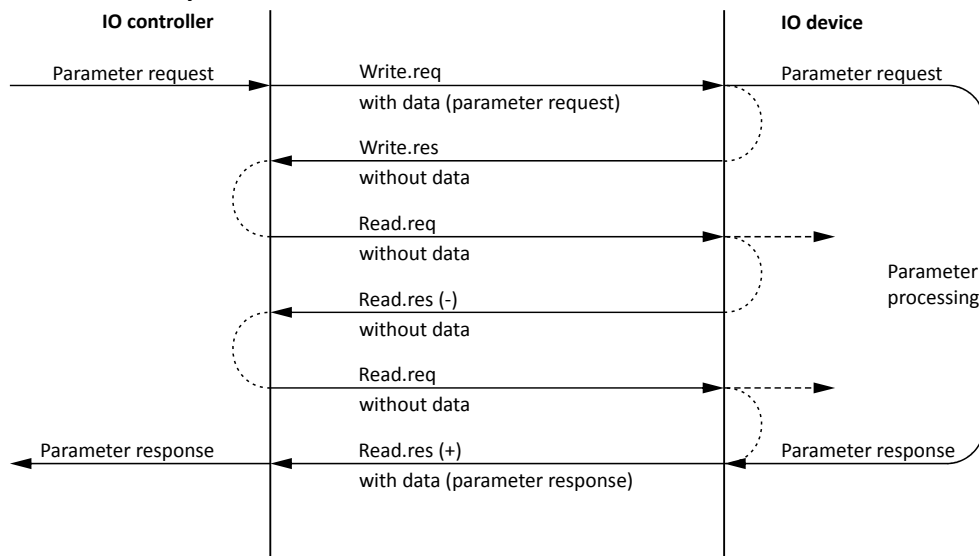

1. A "Write.req" is used to transmit the data set (DB47) as parameter request to the IO-Device.
2. "Write.res" is used to confirm the input of the message for IO-Controller.
3. With Read.req, the IO-Controller requests the response of the IO-Device
4. The IO-Device responds with a "Read.res (-)" if processing has not been completed yet.
5. After parameter processing, the parameter request is completed by transmitting the parameter response to the IO-Controller by "Read.res (+)".

Frame structure

Destr	ScrAddr	VLAN	Type 0x0800	RPC	NDR	Read/Write Block	Data	FCS
6 bytes	6 bytes	4 bytes	4 bytes	80 bytes	64 bytes	64 bytes	0 240 bytes	4 bytes

In the "Read / Write Block field", the initiator specifies the access to the "DB47" data set. The data that is written on this index or read by it, contain a header and the parameter request or the parameter response. The read data or the data to be written are contained in the "Data" field.

Configuring the network

PROFINET
Monitoring



Assignment of the user data depending on the data type

Depending on the data type used, the user data is assigned as follows:

Data type	Length	User data assignment				
		Byte 1	Byte 2	Byte 3	Byte 4	Byte ...
String	x bytes	Data (x bytes)				
U8	1 byte	Data	0x00			
U16	2 bytes	HIGH byte	LOW byte			
		Data	Data			
U32	4 bytes	HIGH word		LOW word		
		HIGH byte	LOW byte	HIGH byte	LOW byte	
		Data	Data	Data	Data	

15.3.5 Monitoring

The parameters for setting network monitoring functions are described below.

Parameter

Address	Name / setting range / [default setting]	Information
0x2859:002	Fieldbus network monitoring: Data exchange exited	Selection of the response to exiting the "Data Exchange" state. Corresponding error code: 33171 0x8191 "PROFINET: Exit Data Exchange"
	0 No response	Associated error code: • 33169 0x8191 - RANLI_CIMES_1000_21217
	1 Fault > CiA402	
	2 Warning	
0x2859:001	Fieldbus network monitoring: Watchdog elapsed	Selection of the response to a permanent interruption of the communication to the IO controller. Associated error code: 33168 0x8190 "PROFINET: Watchdog-Timeout"
	0 No response	Associated error code: • 33168 0x8190 - RANLI_CIMES_1000_20915
	1 Fault > CiA402	
	2 Warning	
0x2859:003	Fieldbus network monitoring: Invalid configuration	Selection of the response triggered by the reception of invalid configuration data. Associated error code: 33414 0x8286 "PROFINET: Configuration error"
	0 No response	Associated error code: • 33415 0x8287 - RANLI_CIMES_1000_20916
	1 Fault > CiA402	
	2 Warning	
0x2859:004	Fieldbus network monitoring: Initialisation error	Selection of the response triggered by the occurrence of an error during the initialization of the network component. Associated error code: 33170 0x8192 "PROFINET: Initialization error"
	0 No response	Associated error code: • 33170 0x8192 - RANLI_CIMES_1000_20917
	1 Fault > CiA402	
	2 Warning	



Address	Name / setting range / [default setting]	Information
0x2859:005	Fieldbus network monitoring: Invalid process data	Selection of the response triggered by the reception of invalid process data. Process data marked as invalid (IOPS is "BAD") are received by the IO Controller. Typically in case of <ul style="list-style-type: none"> • a PLC in STOP state, • alarms, • acyclic demand data. Associated error code: 33171 0x8193 "PROFINET: Invalid cyclic process data"
	0 No response	
	1 Fault > CiA402	
	2 Warning	



15.3.6 Diagnostics

15.3.6.1 LED status display



Notes on the connection status with IO-Controller can be obtained via the LEDs "BUS RDY" and "BUS ERR" of the PROFINET option (front of the device).

In addition, the LEDs "Link" and "Activity" at the RJ45 sockets indicate the connection status to the network.

LED "BUS RDY" (green)

Blinking pattern	State	Meaning
Off	Not connected	No connection to the IO-Controller
 Blinking	Connected	IO-Controller in STOP
 On	Data exchange	IO-Controller in RUN (DATA_EXCHANGE)

LED "BUS ERR" (red)

Blinking pattern	State	Meaning
Off	No fault	No fault
 flickers	IO-Device identifies (localises)	The PROFINET function "node flashing test" is triggered by IO-Controller. The flickering LED serves to identify (locate) an accessible IO-Device.
 Blinking	Impermissible settings	Impermissible settings: Stack, station name or IP parameters are invalid.
 On (red)	Fault	Communication error (e. g. Ethernet cable removed)

LED "Link" (green)

Blinking pattern	Status/meaning
off	No connection to the network.
 on	A physical connection to the network is available.

LED "Activity" (yellow)

Blinking pattern	Status/meaning
off	No data transfer.
 on or flickers	Data is exchanged via the network.

15.3.6.2 Information on the network

The following parameters show information on the network.

Parameter

Address	Name / setting range / [default setting]	Information
0x2382:001	Active PROFINET settings: IP address <ul style="list-style-type: none"> • Read only 	Display of the active IP address.

Configuring the network

PROFINET
Diagnostics



Address	Name / setting range / [default setting]	Information	
0x2382:002	Active PROFINET settings: Subnet • Read only	Display of the active subnet mask.	
0x2382:003	Active PROFINET settings: Gateway • Read only	Display of the gateway address.	
0x2382:004	Active PROFINET settings: Station name • Read only	Display of the active station name.	
0x2382:005	Active PROFINET settings: MAC Address • Read only	Display of the active MAC address.	
0x2388	PROFINET status • Read only	Bit coded display of the current Bus status.	
	Bit 0	Initialized	The network component is initialised.
	Bit 1	Online	The network component has established a cyclic I/O communication relationship to a communication partner.
	Bit 2	Connected	After initialisation, the network component waits for a communication partner and the system power-up.
	Bit 3	IP address error	The IP address is invalid. Valid IP addresses are defined according to RFC 3330.
	Bit 4	Hardware fault	
	Bit 6	Watchdog elapsed	PROFINET communication is continuously interrupted in the "Data_Exchange" state, e.g. by cable break or failure of the IO Controller. • PROFINET communication changes to the "No_Data_Exchange" state. When the watchdog monitoring time specified by the IO Controller has elapsed, the response set in is triggered in the inverter.
	Bit 7	Protocol error	
	Bit 8	PROFINET stack ok	
	Bit 9	PROFINET stack not configured	
0x2389:001	PROFINET error: Error 1 • Read only	The parameter currently contains the error detected on the network. • The error values may occur in combination with the error values from parameter 0x2389:002 .	
	0	No error	
	1	Reserved	
	2	Unit ID unknown	
	3	Max. units exceeded	
	4	Invalid size	
	5	Unit type unknown	
	6	Runtime plug error	
	7	Invalid argument	
	8	Service pending	
9	Stack not ready		
10	Command unknown		
11	Invalid address descriptor		



Address	Name / setting range / [default setting]	Information
0x2389:002	PROFINET error: Error 2 • Read only	The parameter currently contains the error detected on the network. • The error values may occur in combination with the error values from parameter 0x2389:001.
	Bit 7 IP address error	The IP address is invalid. Valid IP addresses are defined according to RFC 3330.
	Bit 8 Station name problem	The station name must be assigned according to the PROFINET specification.
	Bit 9 DataExch left	PROFINET communication is continuously interrupted in the "Data_Exchange" state, e. g. by cable break. • PROFINET communication changes to the "No_Data_Exchange" state. • When the watchdog monitoring time specified by the IO Controller has elapsed, the response set in is triggered in the inverter.
	Bit 10 Stack boot error	
	Bit 11 Stack online error	
	Bit 12 Stack state error	
	Bit 13 Stack revision error	
	Bit 14 Initialization problem	The stack cannot be initiated with the user specifications. A reason might be, e. g., a station name that does not correspond to the PROFINET specification.
Bit 15 Stack init error		

15.3.7 PROFIsafe



PROFIsafe via PROFINET enables the transfer of safe information via the PROFIsafe protocol according to the specification "PROFIsafe - Profile for Safety Technology", version 2.0.

- The PROFIsafe data is transmitted in the second slot of a PROFINET telegram.
- In the PROFIsafe data, one bit each is used to control a certain safety function.
- The structure of the PROFIsafe data is described in the PROFIsafe profile.
- The length of the PROFIsafe data (also "PROFIsafe message") is fixed at 16 bytes.
- The inverter forwards the PROFIsafe messages to the safety module (Extended Safety) for a safe evaluation.

Configuring the network

PROFINET
PROFenergy



15.3.8 PROFenergy

The device profile PROFenergy enables an energy management for systems. With the support of the "PROFenergy Class 3", the energy saving function of the inverter can be triggered and certain energy consumption values can be measured via standardised commands.

Parameter

Address	Name / setting range / [default setting]	Information
0x2590:003	Energy saving: State of actual energy saving mode <ul style="list-style-type: none">• Read only	
	Bit 0 StateOperate	
	Bit 4 StatePause	
	Bit 6 StateOperate	

15.3.8.1 Supported commands

The following PROFenergy commands are supported:

Command	Description
Start_PauseStart_Pause	Starts the energy saving function.
End_Pause	Stops the energy saving function.
Query_Mode	Requests the list of all supported energy modes.
Get_Mode	Requests the data of an energy mode.
PEM_Status	Requests the current status.
PEM_Status_with_CTTO	Requests the current status of dynamic values.
PE_Identify	Requests basic information on the modes.
Query_Version	Requests the versioning of the query.
Get_Measurement_List	Requests the list of the supported measured values.
Get_Measurement_List_with_object_number	Requests the list of supported measured values indicating the corresponding parameters.
Get_Measurement_Values	Requests the values of the measured values.
Get_Measurement_Values_with_object_number	Requests the values of the measured values indicating the corresponding parameters.
PE_Mode_ID	Manufacturer-specific energy saving mode The energy saving mode is only active if the power section is inhibited. (0x2590:003 = 1)

15.3.8.2 Supported measured values

The standardised measured values are supported:

ID	Measured value	Description
34	Active power in W	Active power
205	Active energy sum in kWh	Corresponds to the current value from parameter 0x2DA3:002. The value can be reset by writing.



15.4 EtherCAT system bus



The system bus enables the use of several inverters of the i900 series in a network.

The system bus of the inverter uses the EtherCAT® protocol.

Preconditions

- Only inverters of the i900 series are connected to the system bus.
- A maximum of 16 nodes including the master can be connected via the system bus.
- No further accessories are connected to the system bus.
- The inverters are not parameterised as CiA 402 motion drives. Selection of a technology application: 0x4000
- The »EASY Starter« does **not** allow a configuration of the system bus cross communication.



The technology application set in the inverter is not identified.

Details

- The inverter can act as a system bus master or system bus slave.
- The system bus is prepared, i. e. a configuration is not required.
- The master assigns an identical master value to all system bus nodes (slaves).
- The »EASY Starter« is sufficient ...
 - to parameterise the devices in the network;
 - to configure the process data individually.
 - Download »EASY Starter«
- If further EtherCAT-compliant devices are to be used in addition to the inverters, the bus configuration must be adapted to the »PLC Designer«.
 - Download »PLC Designer«
 - Download XML/ESI files for Lenze devices
- Detailed information regarding the adaptation of the EtherCAT configuration with the »PLC Designer« can be found here:
 - Online help »EASY Starter«/»PLC Designer«, topic "Controller-based Automation EtherCAT"
 - Communication manual "Controller-based Automation EtherCAT" (PDF)

System bus topology

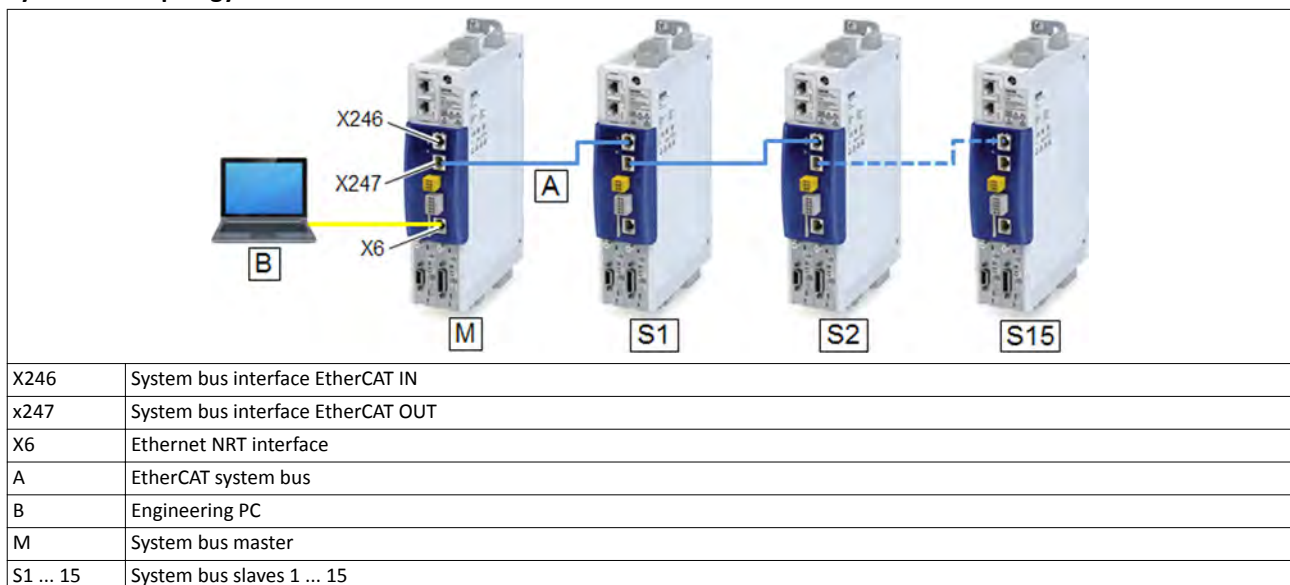

Configuring the network

EtherCAT system bus



Typical topologies

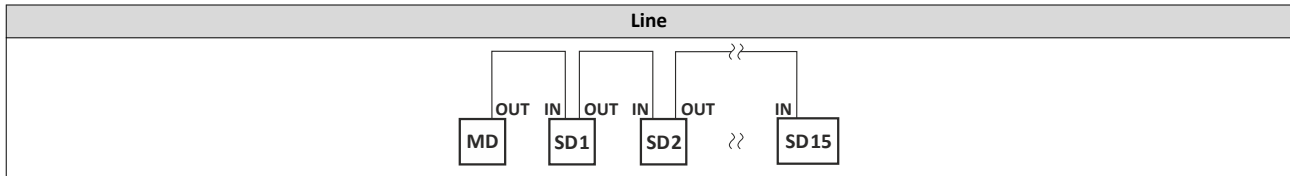

MD Master device

SD Slave Device

Bus-related information			
Name		EtherCAT system bus	
Communication medium		Ethernet 100 Mbps, full duplex	
Use		Connection of the inverter to the system bus cross communication or as standard EtherCAT slave	
Status display		1 LED (RUN)	



15.4.1 Commissioning

Commissioning can be subdivided as follows:

- Initial commissioning in which at least the system bus master must be determined.
- System bus change, in which slave devices are added or removed subsequently.

Preconditions

- The inverter is linked in the system bus network (max. 16 devices) as EtherCAT master or EtherCAT slave.

See "system bus topology" under: [▶ EtherCAT system bus](#) 259

- The entire wiring has been checked for completeness, short circuit and earth fault.
- All system bus nodes are supplied with voltage and are switched on.
- An Engineering PC with installed »EASY Starter« is connected to the master.
 - Download »EASY Starter«

Parameterisation required

Set and activate master functionality at the 1st inverter in the system bus network:

1. Setting: `0x2371:009` = 1
2. Save parameter settings.

[▶ Saving the parameter settings](#) 39

3. Restart inverter.

Device command: `0x2022:035` = 1

The master function of the 1st inverter is now activated.

The cyclic master value and the individual process data are set via the technology application (`0x4000`) of the system bus master.



The `0x2371:009` parameter does not need to be set for the slave devices. The slave functionality is already preset with the value "0".

Select and configure technology applications:

1. Select a technology application (unequal to "CiA 402").

Selection with: `0x4000`

2. Optionally set the "IO configuration" with: `0x4001`
3. Save parameter settings.

[▶ Saving the parameter settings](#) 39

The technology applications of the inverter are now set.



The technology application in the system bus master provides the master value. The slave devices are FAST slaves (process slaves) as well and follow the master value of the process master.

Start system bus:

1. Restart system bus master (1st inverter).

Device command: `0x2022:035` = 1

All devices currently found at the system are assigned and addressed to the corresponding devices in the device tree of the system bus master according to their physical order at the bus. See "Addressing of the system bus nodes under: [▶ Basic setting and options](#) 262

The number of devices at the system bus may be lower than the number of devices in the device tree of the system bus master.

All devices at the system bus are set to the "Operational" bus state when they have been identified as system bus nodes.

Configuring the network

EtherCAT system bus
Basic setting and options



15.4.2 Basic setting and options

Addressing the system bus nodes

The first device in the system bus network is always active as EtherCAT master. In addition, this device is also an internal EtherCAT slave, which e. g. provides a DC master (Distributed Clocks).

The slave devices at the system bus are addressed via their active EtherCAT station address.

This address is assigned by the master while the system bus is initialised:

- The internal slave in the master device has the address "1001".
- The first slave in the network has the address "1002".
- The second slave in the network has the address "1003" etc.

Master/slave functionality

The [0x2371:009](#) parameter is used to set the functionality of the system bus interface of the inverter (EtherCAT master/slave).

Parameter

Address	Name / setting range / [default setting]	Information
0x2371:009	EtherCAT on board: Interface mode	Selection of the master/slave functionality for the EtherCAT interface. For activating this setting, save the parameter set and restart the device.
	0 Slave	Activation of the slave functionality.
	1 Master	Activation of the master functionality.



15.4.3 Process data transfer

In the system bus network ...

- the setpoint process data (master to slave) are set via the system bus master inside the technology application;
- the actual process data (slave to master) is set via the slave device.

Data mapping

All inverter i950 slave devices have a fixed generic data mapping. This data mapping enables the use of the slave devices with an i950 inverter as system bus master and with other EtherCAT-based master control systems (PLC).

- The process data is set to 8 double words (32 bytes) for each direction.
- Output data direction: From Master to Slave.
 - Output data: **0xA200:001 ... 0xA200:008**
- Input data direction: From Slave to Master.
 - Input data: **0xA680:001 ... 0xA680:008**
- This fixed data mapping is automatically activated as master for an i950 inverter.
- The process data is transmitted cyclically in a 1 ms cycle between the master and the slaves.
- The process data transfer is synchronised by the "Distributed Clocks" EtherCAT mechanism.
 - A i950 master device provides the DC master via the internal slave.
 - The data in the slaves is accepted synchronously with the PLC program in the master.
 - All slaves are synchronised with a reference clock, the so-called "DC master".

Parameter

Address	Name / setting range / [default setting]	Information
0xA200:001	Systembus output data: Systembus data output 1 • Read only	Generic system bus output data from the PLC to the inverter.
0xA200:002	Systembus output data: Systembus data output 2 • Read only	
0xA200:003	Systembus output data: Systembus data output 3 • Read only	
0xA200:004	Systembus output data: Systembus data output 4 • Read only	
0xA200:005	Systembus output data: Systembus data output 5 • Read only	
0xA200:006	Systembus output data: Systembus data output 6 • Read only	
0xA200:007	Systembus output data: Systembus data output 7 • Read only	
0xA200:008	Systembus output data: Systembus data output 8 • Read only	
0xA680:001	Systembus input data: Systembus data input 1 0 ... [0] ... 4294967295	Generic system bus input data from the inverter to the PLC.
0xA680:002	Systembus input data: Systembus data input 2 0 ... [0] ... 4294967295	
0xA680:003	Systembus input data: Systembus data input 3 0 ... [0] ... 4294967295	
0xA680:004	Systembus input data: Systembus data input 4 0 ... [0] ... 4294967295	
0xA680:005	Systembus input data: Systembus data input 5 0 ... [0] ... 4294967295	
0xA680:006	Systembus input data: Systembus data input 6 0 ... [0] ... 4294967295	
0xA680:007	Systembus input data: Systembus data input 7 0 ... [0] ... 4294967295	
0xA680:008	Systembus input data: Systembus data input 8 0 ... [0] ... 4294967295	

Configuring the network

EtherCAT system bus
Process data transfer



15.4.3.1 Process output data

Parameter

Address	Name / setting range / [default setting]	Information
0xA200:001	Systembus output data: Systembus data output 1 • Read only	Generic system bus output data from the PLC to the inverter.
0xA200:002	Systembus output data: Systembus data output 2 • Read only	
0xA200:003	Systembus output data: Systembus data output 3 • Read only	
0xA200:004	Systembus output data: Systembus data output 4 • Read only	
0xA200:005	Systembus output data: Systembus data output 5 • Read only	
0xA200:006	Systembus output data: Systembus data output 6 • Read only	
0xA200:007	Systembus output data: Systembus data output 7 • Read only	
0xA200:008	Systembus output data: Systembus data output 8 • Read only	
0xA200:009	Systembus output data: Systembus data output 9 • Read only	
0xA200:010	Systembus output data: Systembus data output 10 • Read only	
0xA200:011	Systembus output data: Systembus data output 11 • Read only	
0xA200:012	Systembus output data: Systembus data output 12 • Read only	
0xA200:013	Systembus output data: Systembus data output 13 • Read only	
0xA200:014	Systembus output data: Systembus data output 14 • Read only	
0xA200:015	Systembus output data: Systembus data output 15 • Read only	
0xA200:016	Systembus output data: Systembus data output 16 • Read only	

15.4.3.2 Process input data

Parameter

Address	Name / setting range / [default setting]	Information
0xA680:001	Systembus input data: Systembus data input 1 0 ... [0] ... 4294967295	Generic system bus input data from the inverter to the PLC.
0xA680:002	Systembus input data: Systembus data input 2 0 ... [0] ... 4294967295	
0xA680:003	Systembus input data: Systembus data input 3 0 ... [0] ... 4294967295	
0xA680:004	Systembus input data: Systembus data input 4 0 ... [0] ... 4294967295	
0xA680:005	Systembus input data: Systembus data input 5 0 ... [0] ... 4294967295	
0xA680:006	Systembus input data: Systembus data input 6 0 ... [0] ... 4294967295	
0xA680:007	Systembus input data: Systembus data input 7 0 ... [0] ... 4294967295	
0xA680:008	Systembus input data: Systembus data input 8 0 ... [0] ... 4294967295	



Address	Name / setting range / [default setting]	Information
0xA680:009	Systembus input data: Systembus data input 9 0 ... [0] ... 4294967295	
0xA680:010	Systembus input data: Systembus data input 10 0 ... [0] ... 4294967295	
0xA680:011	Systembus input data: Systembus data input 11 0 ... [0] ... 4294967295	
0xA680:012	Systembus input data: Systembus data input 12 0 ... [0] ... 4294967295	
0xA680:013	Systembus input data: Systembus data input 13 0 ... [0] ... 4294967295	
0xA680:014	Systembus input data: Systembus data input 14 0 ... [0] ... 4294967295	
0xA680:015	Systembus input data: Systembus data input 15 0 ... [0] ... 4294967295	
0xA680:016	Systembus input data: Systembus data input 16 0 ... [0] ... 4294967295	

15.4.4 Monitoring

Monitoring of the master/slave functionality

The following scenarios are monitored:

- The inverter at position 1 is not configured as system bus master.
- Several inverters have been configured as system bus master.

Depending on the assignment of the system bus interfaces X246 (EtherCAT IN) and X247 (EtherCAT OUT) and the set interface role in [0x2371:009](#) (master/slave), a warning is output:

Network cable plugged in X246/X247	0x2371:009 = 0 (Slave)	0x2371:009 = 1 (Master)
Only X246 (EtherCAT IN) is assigned.	OK	Warning
Only X247 (EtherCAT OUT) is assigned.	Warning	OK
X246 (EtherCAT IN) and X247 (EtherCAT OUT) are assigned.	OK	Warning

The parameters for setting network monitoring functions are described below.

Parameter

Address	Name / setting range / [default setting]	Information
0x285B:001	EtherCAT system bus monitoring: Watchdog abgelaufen	
	0 No response	
	1 Fault > CiA402	
2 Warning		
0x285B:002	EtherCAT system bus monitoring: EtherCAT role check	
	0 No response	
	1 Fault > CiA402	
	2 Warning	

Configuring the network

EtherCAT system bus
Diagnostics



15.4.5 Diagnostics

For diagnostic purposes, the system bus interfaces X246 and X247 provide LED status displays and diagnostic parameters for the EtherCAT system bus.

The diagnostic parameters are divided according to the interface role (master or slave) set in [0x2371:009](#).

In the »EASY Starter«, the diagnostic parameters can be accessed in the "Diagnostics" tab via the "Network diagnostics" button:

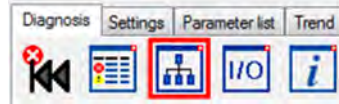

LED status display

Notes on the EtherCAT connection status and the data transfer can be obtained via the LED displays "RUN" and "L/A" at the RJ45 sockets.

15.4.5.1 LED status displays

LED status display

Notes on the EtherCAT connection status and the data transfer can be obtained via the LED displays "RUN" and "L/A" at the RJ45 sockets.

15.4.5.2 Information on the network

The following parameters show information on the network.

Parameter

Address	Name / setting range / [default setting]	Information
0x2378	Network status • Read only	Display of the active network status.
	1 Initialisation	
	2 Pre-Operational	
	3 Bootstrap	
	4 Safe-Operational	
	8 Operational	
0x2379	Network error • Read only	Display of the active network error.
0x5851:001	EtherCAT master diagnosis: EtherCAT master state • Read only	Display of the EtherCAT master state.
	0 Unknown	
	1 Init	
	2 Pre-Operational	
	3 Bootstrap	
	4 Safe-Operational	
8 Operational		
0x5851:002	EtherCAT master diagnosis: EtherCAT master state summary • Read only	Display of the EtherCAT master state overview.
	Bit 0 Master OK	
	Bit 4 Init	
	Bit 5 Pre-Operational	
	Bit 6 Safe-Operational	
	Bit 7 Operational	
	Bit 8 Slaves in requested state	
	Bit 9 Master in requested state	
	Bit 10 Bus scan match	
	Bit 12 DC enabled	
	Bit 13 DC in sync	
	Bit 14 DC busy	
	Bit 16 Link up	



Configuring the network

EtherCAT system bus
Diagnostics

Address	Name / setting range / [default setting]	Information
0x5851:003	EtherCAT master diagnosis: EtherCAT error • Read only	Display whether an EtherCAT network error has occurred.
0x5851:004	EtherCAT master diagnosis: Bus scan match • Read only	Display whether a "Bus Scan Match" exists.
0x5851:005	EtherCAT master diagnosis: Configured cycle time • Read only: x us	Display of the configured cycle time.
0x5851:006	EtherCAT master diagnosis: Connected slaves • Read only	Display of the number of slaves available in the network.
0x5851:007	EtherCAT master diagnosis: Configured slaves • Read only	Display of the number of configured slaves.
0x5860:001	EtherCAT slaves station addresses: Station address slave 1 • Read only	Display of the slave station address.
0x5861:001	EtherCAT slaves device names: Device name slave 1 • Read only	Display of the slave device name.
0x5862:001	EtherCAT slaves device types: Device type slave 1 • Read only	Display of the slave type designation.
0x5863:001	Mandatory EtherCAT slaves: Slave 1 is mandatory • Read only	
	0 FALSE	
	1 TRUE	
0x5863:002	Mandatory EtherCAT slaves: Slave 2 is mandatory • Read only	
	0 FALSE	
	1 TRUE	
0x5863:003	Mandatory EtherCAT slaves: Slave 3 is mandatory • Read only	
	0 FALSE	
	1 TRUE	
0x5863:004	Mandatory EtherCAT slaves: Slave 4 is mandatory • Read only	
	0 FALSE	
	1 TRUE	
0x5863:005	Mandatory EtherCAT slaves: Slave 5 is mandatory • Read only	
	0 FALSE	
	1 TRUE	
0x5863:006	Mandatory EtherCAT slaves: Slave 6 is mandatory • Read only	
	0 FALSE	
	1 TRUE	
0x5863:007	Mandatory EtherCAT slaves: Slave 7 is mandatory • Read only	
	0 FALSE	
	1 TRUE	
0x5863:008	Mandatory EtherCAT slaves: Slave 8 is mandatory • Read only	
	0 FALSE	
	1 TRUE	
0x5863:009	Mandatory EtherCAT slaves: Slave 9 is mandatory • Read only	
	0 FALSE	
	1 TRUE	
0x5863:010	Mandatory EtherCAT slaves: Slave 10 is mandatory • Read only	
	0 FALSE	
	1 TRUE	

Configuring the network

EtherCAT system bus
Diagnostics



Address	Name / setting range / [default setting]	Information
0x5863:011	Mandatory EtherCAT slaves: Slave 11 is mandatory • Read only	Display of the initialisation state of the EtherCAT slave.
	0 FALSE	
	1 TRUE	
0x5863:012	Mandatory EtherCAT slaves: Slave 12 is mandatory • Read only	
	0 FALSE	
	1 TRUE	
0x5863:013	Mandatory EtherCAT slaves: Slave 13 is mandatory • Read only	
	0 FALSE	
	1 TRUE	
0x5863:014	Mandatory EtherCAT slaves: Slave 14 is mandatory • Read only	
	0 FALSE	
	1 TRUE	
0x5863:015	Mandatory EtherCAT slaves: Slave 15 is mandatory • Read only	
	0 FALSE	
	1 TRUE	
0x5864:001	EtherCAT slaves initialisation status: Initalisation status slave 1 • Read only	Display of the device status of the EtherCAT slave.
	0 No Error	
	1 No access	
	2 Vendor ID check failed	
	3 Product code check failed	
	4 Revision check failed	
0x5865:001	EtherCAT slaves device status: Device status slave 1 • Read only	Display of the device status of the EtherCAT slave.
	0 Unknown	
	1 Init	
	2 Pre-Operational	
	3 Bootstrap	
	4 Safe-Operational	
	8 Operational	
	65519 Not Present	

15.4.5.3 Device identification

For device identification in the system bus network, the inverter provides the standard EtherCAT parameters [0x1018:001](#) ... [0x1018:004](#).

The EtherCAT product code in [0x1018:002](#) consists of device-specific data and the currently activated technology application (0x4000). The last three positions in the product code refer to the activated technology application.

The [0x2372:009](#) parameter indicates the functionality of the system bus interface of the inverter (EtherCAT master/slave).

Parameter

Address	Name / setting range / [default setting]	Information	
0x1018:001	Identity object: Vendor ID • Read only	Display of the manufacturer's identification number.	
0x1018:002	Identity object: Product Code • Read only	Display of the product code of the inverter.	
	419446784		i950 (Basic Safety - STO)
	419450880		i950 (BS-STO) 2
	419479552		i950 (ES)
	419483648		i950 (ES) 4



Configuring the network

EtherCAT system bus
Diagnostics

Address	Name / setting range / [default setting]	Information
0x1018:003	Identity object: Revision number • Read only	Display of the main and subversion of the firmware.
0x1018:004	Identity object: Serial number • Read only	Display of the serial number of the inverter.
0x2372:009	Systembus EtherCAT-Informationen: Active interface mode • Read only	Display of the active EtherCAT master/slave functionality for the system bus interface.
	0 Slave	Slave functionality is active.
	1 Master	Master functionality is active.



16 Device functions

16.1 Optical device identification

For applications including several interconnected inverters it may be difficult to locate a device that has been connected online. The "Optical device identification" function serves to locate the inverter by means of blinking LEDs.

Details

In order to start the visual tracking,

- click the button in the toolbar of the »EASY Starter«  or
- set `0x2021:001` = "Start [1]".

After the start, both LEDs "RDY" and "ERR" on the front of the inverter synchronously blink very fast.

"RDY" LED (blue)	"ERR" LED (red)	Status/meaning
		"Visual tracking" function is active.
Both LEDs are blinking in a very rapidly synchronous mode		

The blinking duration can be set in `0x2021:002` or selected in the »EASY Starter« in the dropdown list field:

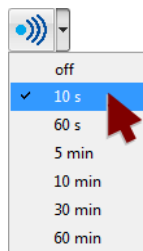

Parameter

Address	Name / setting range / [default setting]	Information		
0x2021:001	Optical tracking: Start detection	1 = start optical device identification. <ul style="list-style-type: none"> • After the start, the two LEDs "RDY" and "ERR" on the front of the inverter are blinking with a blinking frequency of 20 Hz for the blinking duration set in <code>0x2021:002</code>. The setting is then automatically reset to "0" again. • If the function is reactivated within the blinking time set, the time is extended correspondingly. • A manual reset to "0" makes it possible to stop the function prematurely. 		
	<table border="1"> <tr> <td>0</td> <td>Stop</td> </tr> <tr> <td>1</td> <td>Start</td> </tr> </table>		0	Stop
0	Stop			
1	Start			
0x2021:002	Optical tracking: Blinking duration 0 ... [5] ... 6000 s	Setting of the blinking duration for the visual tracking.		



16.2 Reset parameters to default

Parameter

Address	Name / setting range / [default setting]	Information
0x2022:001	Device commands: Load default settings	<p>1 = reset all parameters in the RAM memory of the inverter to the default setting that is stored in the inverter firmware.</p> <ul style="list-style-type: none"> All parameter changes made by the user are lost during this process! It may take some seconds to execute the task. When the task has been executed successfully, the value 0 is shown. Loading parameters has a direct effect on the cyclic communication: The data exchange for control is interrupted and a communication error is generated.
	0 Off / ready	Only status feedback
	1 On / start	Execute device command
	2 In progress	Only status feedback
	3 Action cancelled	
	4 No access	
5 No access (Inverter disabled)		
0x2022:039	Device commands: Load TA default settings	
	0 Off/Ready	Only status feedback
	1 On/Start	
	2 In progress	Only status feedback
	3 Action cancelled	
	4 No access	
5 No access (Inverter disabled)		

Device functions

Saving/loading the parameter settings



16.3 Saving/loading the parameter settings

If parameter settings of the inverter are changed, these changes at first are only made in the RAM memory of the inverter. In order to save the parameter settings with mains failure protection, the inverter is provided with the corresponding device command in the parameter. [0x2022:003](#)

Parameter

Address	Name / setting range / [default setting]	Information
0x2022:003	Device commands: Save user data	1 = save current parameter settings in the user memory of the memory module with mains failure protection. <ul style="list-style-type: none"> This process may take some seconds. When the device command has been executed successfully, the value 0 is shown. Do not switch off the supply voltage during the saving process and do not unplug the memory module from the device! When the device is switched on, all parameters are automatically loaded from the user memory of the memory module to the RAM memory of the device.
	0 Off / ready	Only status feedback
	1 On / start	Execute device command
	2 In progress	Only status feedback
	3 Action cancelled	
	4 No access	
	5 No access (Inverter disabled)	
	101 No SD card connected	
	102 SD card is write protected	
	103 SD card is full	
0x2022:040	Device commands: Parameter-Backup <ul style="list-style-type: none"> Setting can only be changed if the inverter is disabled. 	
	0 Off/Ready	
	1 On/Start	
	2 In progress	
	3 Action cancelled	
	4 No access	
	5 No access (Inverter disabled)	
	20 20%	
	40 40%	
	60 60%	
	80 80%	
	100 100%	
	101 No SD card connected	
	102 SD card is write protected	
	103 SD card is full	
0x2022:043	Device commands: Restore <ul style="list-style-type: none"> Setting can only be changed if the inverter is disabled. 	
	0 Off/Ready	
	1 On/Start	
	2 In progress	
	3 Action cancelled	
	4 No access	
	5 No access (Inverter disabled)	
	20 20%	
	40 40%	
	60 60%	
	80 80%	
	100 100%	
	101 No SD card connected	



16.4 Enabling the device

Parameter

Address	Name / setting range / [default setting]	Information
0x2822:001	Axis commands: Enable inverter	Parameters for interaction with engineering tools.
	0 Inverter inhibited	
	1 Inverter enabled	

16.5 Restart device



If the inverter communicates with the master as network node via EtherCAT: executing the device command may cause an interruption of the EtherCAT communication with the master and a standstill of the drive.

Parameter

Address	Name / setting range / [default setting]	Information
0x2022:035	Device commands: Restart Device	<ul style="list-style-type: none"> When the device command has been executed successfully, the value 0 is shown. Do not switch off the supply voltage while the device command is executed and do not unplug the memory module from the controller!
	0 Off/Ready	Only status feedback
	1 On/Start	Restart of the device.
	2 In progress	Only status feedback
	3 Action cancelled	
	4 No access	
	5 No access (Inverter disabled)	

16.6 Start/stop application

Parameter

Address	Name / setting range / [default setting]	Information	
0x2022:044	Device commands: Start application	<ul style="list-style-type: none"> When the device command has been executed successfully, the value 0 is shown. Do not switch off the supply voltage while the device command is executed and do not unplug the memory module from the controller! 	
	• Setting can only be changed if the inverter is disabled.		
	0 Off/Ready		Only status feedback
	1 On/Start		The loaded PLC application is started.
	2 In progress		Only status feedback
	3 Action cancelled		
4 No access			
0x2022:045	Device commands: Stop application	<ul style="list-style-type: none"> When the device command has been executed successfully, the value 0 is shown. Do not switch off the supply voltage while the device command is executed and do not unplug the memory module from the controller! 	
	• Setting can only be changed if the inverter is disabled.		
	0 Off/Ready		Only status feedback
	1 On/Start		
	2 In progress		Only status feedback
	3 Action cancelled		
4 No access			
	5 No access		



16.7 Restarting Extended Safety

Parameter

Address	Name / setting range / [default setting]	Information
0x2022:041	Device commands: Restart extended safety	
	0 Off/Ready	
	1 On/Start	
	2 In progress	
	3 Action cancelled	
	4 No access	
	5 No access (Inverter disabled)	

16.8 Export logbook

The export of the complete logbook can be started with the [0x2022:036](#) parameter.

Parameter

Address	Name / setting range / [default setting]	Information	
0x2022:036	Device commands: Export Logbook	<ul style="list-style-type: none"> When the device command has been executed successfully, the value 0 is shown. Do not switch off the supply voltage while the device command is executed and do not unplug the memory module from the controller! 	
	0 Off/Ready		Only status feedback
	1 On/Start		Exports the logbook for the upload into the engineering tools.
	2 In progress		Only status feedback
	3 Action cancelled		
	4 No access		
	5 No access (Inverter disabled)		

16.9 Delete logbook files

The logbook files can be deleted with the [0x2022:015](#) parameter.

Parameter

Address	Name / setting range / [default setting]	Information	
0x2022:037	Device commands: Delete Logfiles	<ul style="list-style-type: none"> When the device command has been executed successfully, the value 0 is shown. Do not switch off the supply voltage while the device command is executed and do not unplug the memory module from the controller! 	
	0 Off/Ready		Only status feedback
	1 On/Start		Deletion of log files on the device that were exported in an earlier step via 0x2022:036 (Export Logbook).
	2 In progress		Only status feedback
	3 Action cancelled		
	4 No access		
	5 No access (Inverter disabled)		

16.10 Activate loaded application

The loaded application can be activated with the [0x2022:038](#) parameter.

Parameter

Address	Name / setting range / [default setting]	Information
0x2022:038	Device commands: Activate loaded application	Start of the application that is provided/downloaded by the »Application Loader«.
	0 Off/Ready	
	1 On/Start	
	2 In progress	
	3 Action cancelled	
	4 No access	
	5 No access (Inverter disabled)	



16.11 Uploading the application

Parameter

Address	Name / setting range / [default setting]	Information
0x2022:042	Device commands: Upload application	
	0 Off/Ready	
	1 On/Start	
	2 In progress	
	3 Action cancelled	
	4 No access	
	5 No access (Inverter disabled)	
	20 20%	
	40 40%	
	60 60%	
	80 80%	
	100 100%	
	101 No SD card connected	

16.12 Inverter control word

Parameter

Address	Name / setting range / [default setting]	Information
0x2830	Inverter control word 0x0000 ... [0x0000] ... 0xFFFF	The control word serves to influence the control functions.
	Bit 0 Flying restart completed	This bit enables the control to report the acceptance of the recorded speed to the "flying restart" function. Thus, the flying restart process is completed.
	Bit 1 Block flying restart	TRUE: the flying restart process is blocked.
	Bit 4 Set load value	TRUE: set load value.
	Bit 5 Select new actual position	TRUE: define new actual position. <ul style="list-style-type: none"> Setting/shifting of Actual position (0x6064) to Actual position start value (0x2983) considering the set resolution (0x608F:001, 0x608F:002). Mode for setting the actual position: 0x2984
	Bit 6 Activate DC-injection braking or short-circuit braking	DC-injection braking or short-circuit braking is activated via this bit.
	Bit 7 Deactivate speed and position monitoring	
	Bit 8 Deactivate VFC-Eco	
	Bit 9 Brake status override	
	Bit 10 Activate SLS	
	Bit 11 Stop mains failure control	

16.13 Access protection

16.13.1 Brand protection

Parameter

Address	Name / setting range / [default setting]	Information
0x2100:001	Brand protection: PIN set -1 ... [0] ... 9999999	<ul style="list-style-type: none"> 0: no brand protection. 1 ... 9999999: possible pins. -1: brand protection is active.
0x2100:002	Brand protection: PIN input -2 ... [0] ... 9999999	<ul style="list-style-type: none"> 0: not checked. 1 ... 9999999: possible pins. -1: check was successful. -2: check was not successful.
0x2100:003	Brand protection: Encryption 0 ... [0] ... 9	Encryption for brand protection.

Device functions

Switching frequency changeover



16.14 Switching frequency changeover

The output voltage of the inverter is a DC voltage with sine-coded pulse width modulation (PWM). This corresponds by approximation to a AC voltage with variable frequency. The frequency of the PWM pulses is adjustable and is called "switching frequency".

Details

The switching frequency has an impact on the smooth running performance and the noise generation in the motor connected as well as on the power loss in the inverter. The lower the switching frequency, the better the concentricity factor, the smaller the power loss and the higher the noise generation.

Parameter

Address	Name / setting range / [default setting]	Information
0x2939	Switching frequency	Selection of the inverter switching frequency.
	1 4 kHz variable / drive-optimised	Abbreviations used: <ul style="list-style-type: none">• "Variable": adaptation of the switching frequency as a function of the current. The carrier frequency is reduced dependent on the heatsink temperature and the ixt-load.• "Fix.": the carrier frequency is fixed, no frequency reduction.• "Drive-optimized": reduces the capacitive currents from the motor to the earth.• "Min. Pv": increases the capacitive currents from the motor to the earth.
	2 8 kHz variable / drive-optimised	
	3 16 kHz variable / drive-optimised	
	5 2 kHz fixed / drive-optimised	
	6 4 kHz fixed / drive-optimised	
	7 8 kHz fixed / drive-optimised	
	8 16 kHz fixed / drive-optimised	



16.15 Device overload monitoring (i*t)

The inverter calculates the i*t utilisation in order to protect itself against thermal overload. In simple terms: a higher current or an overcurrent that continues for a longer time causes a higher i*t utilisation.

⚠ DANGER!

Uncontrolled motor movements by pulse inhibit.

When the device overload monitoring function is activated, pulse inhibit is set and the motor becomes torqueless. A load that is connected to motors without a holding brake may therefore cause uncontrolled movements! Without a load, the motor will coast.

► Only operate the inverter under permissible load conditions.

Details

The device overload monitoring function primarily offers protection to the power section. Indirectly, also other components such as filter chokes, circuit-board conductors, and terminals are protected against overheating. Short-time overload currents followed by recovery periods (times of smaller current utilisation) are permissible. The monitoring function during operation checks whether these conditions are met, taking into consideration that higher switching frequencies and lower stator frequencies as well as higher DC currents cause a greater device utilisation.

- If the total utilisation exceeds the total warning threshold set in [0x2D40:008](#) (default setting: 95 %), the inverter outputs a warning.
- If the device utilisation exceeds the permanent error threshold 100 %, the inverter is disabled immediately and generates an error message.
- The device overload can be obtained from the configuration document.

Parameter

Address	Name / setting range / [default setting]	Information
0x2D40:001	Device utilisation ixt: Power unit actual utilisation • Read only: x %	Display of the power module utilisation.
0x2D40:002	Device utilisation ixt: Power unit warning threshold 0 ... [95] ... 101 %	If the device utilisation exceeds the threshold set, the inverter outputs a warning.
0x2D40:003	Device utilisation ixt: Power unit error threshold • Read only: x %	If the power module utilisation exceeds the displayed threshold, the inverter outputs a warning.
0x2D40:004	Device utilisation ixt: Device actual utilisation • Read only: x %	Display of the current device utilisation.
0x2D40:005	Device utilisation ixt: Device warning threshold 0 ... [95] ... 101 %	
0x2D40:006	Device utilisation ixt: Device error threshold • Read only: x %	If the device utilisation exceeds the displayed threshold, the device outputs an error.
0x2D40:007	Device utilisation ixt: Actual total utilisation • Read only: x %	Display of the current total device utilisation.
0x2D40:008	Device utilisation ixt: Total utilisation warning threshold 0 ... [95] ... 101 %	If the total utilisation exceeds the set threshold, the device outputs a warning.
0x2D40:009	Device utilisation ixt: Total utilisation error threshold • Read only: x %	If the total utilisation exceeds the displayed threshold, the device outputs an error.

Device functions

Heatsink temperature monitoring
Firmware download with »EASY Starter (firmware loader)«



16.16 Heatsink temperature monitoring

In order to avoid an impermissible heating of the servo inverter, the temperature of the heatsink is detected and monitored.



The temperature of the heatsink is measured in the temperature range of 0 ... 80 °C with a tolerance of -2 ... +4 °C. Beyond this temperature range, the measuring accuracy decreases faster.

Parameter

Address	Name / setting range / [default setting]	Information
0x2D84:001, 004, 006	Heatsink temperature: Heatsink temperature • Read only: x.x °C	Display of the current heatsink temperature.
0x2D84:002	Heatsink temperature: Warning threshold 50.0 ... [90.0] ... 100.0 °C	Warning threshold for temperature monitoring. • If the heatsink temperature exceeds the threshold set here, the inverter outputs a warning. • The warning is reset with a hysteresis of approx. 5 °C. • If the heatsink temperature increases further and exceeds the non-adjustable error threshold (100 °C), the inverter changes to the "Fault" device status. The inverter is disabled and thus any further operation is stopped.

16.17 Update device firmware

16.17.1 Firmware download with »EASY Starter (firmware loader)«

16.17.1.1 Download via Ethernet connection

Parameter

Address	Name / setting range / [default setting]	Information
0x243C:001	Device: Ethernet commands: Device: Start firmware update • Setting can only be changed if the inverter is disabled.	
	0 Off/Ready	
	1 On/Start	
	4 Action cancelled	
	20 20%	
	40 40%	
	60 60%	
	80 80%	



17 Additional functions

17.1 Brake energy management

When braking electrical motors, the kinetic energy of the drive train is fed back regeneratively to the DC bus. This energy causes a DC-bus voltage boost. If the energy fed back is too high, the inverter reports an error.

Several different strategies can serve to avoid DC-bus overvoltage:

- Stopping the deceleration ramp function generator when the active voltage threshold for the brake operation is exceeded
- Use of the "Inverter motor brake" function
- Combination of the above named options

Details

The voltage threshold for braking operation results on the basis of the rated mains voltage set:

Rated mains voltage (0x2540:001)	Voltage thresholds for braking operation	
	Braking operation on	Braking operation off
230 V	390 V DC	380 V DC
400 V	725 V DC	710 V DC
480 V	780 V DC	765 V DC

Parameter

Address	Name / setting range / [default setting]	Information
0x2541:003	Brake energy management: Reduced threshold 0 ... [0] ... 100 V	The voltage threshold for the braking operation is reduced by the voltage value set here.

17.1.1 Use of a brake resistor

For braking operation, optionally the brake chopper integrated in the inverter (brake transistor) can be used.

NOTICE

Incorrect dimensioning of the brake resistor may result in the destruction of the integrated brake chopper (brake transistor).

- ▶ Only connect a brake resistor complying in terms of performance to terminals R_{B1} and R_{B2} of the inverter.
- ▶ Avoiding thermal overload of the brake resistor.

Parameter

Address	Name / setting range / [default setting]	Information
0x2550:001	Brake resistor: Minimum resistance • Read only: x.x Ω	Display of the minimum brake resistance value that can be used.
0x2550:002	Brake resistor: Resistance value 0.0 ... [180.0] ... 500.0 Ω	Resistance value of the brake resistor connected. • The value to be entered can be obtained from the brake resistor nameplate.
0x2550:003	Brake resistor: Rated power 0 ... [5600] ... 800000 W	Rated power of the brake resistor connected. • The value to be entered can be obtained from the brake resistor nameplate.
0x2550:004	Brake resistor: Maximum thermal load 0 ... [485] ... 1000000 kW	Thermal capacity of the brake resistor connected. • The value to be entered can be obtained from the brake resistor nameplate.
0x2550:006	Brake resistor: Reference resistance	Selection of the reference value for the brake resistor.
	0 Minimum resistance	
	1 Resistance value	
0x2550:007	Brake resistor: Thermal load • Read only: x.x %	Display of the utilisation of the brake resistor connected.

Additional functions

Manual jog parameters
Use of a brake resistor



Address	Name / setting range / [default setting]	Information
0x2550:008	Brake resistor: Warning threshold 50.0 ... [90.0] ... 150.0 %	Warning threshold for brake resistor monitoring. <ul style="list-style-type: none"> If the utilisation shown in reaches the threshold set, the response selected in 0x2550:010 is effected. The warning is reset with a hysteresis of 20 %.
0x2550:010	Brake resistor: Response to warning	Selection of the response that is executed when the warning threshold for brake resistor monitoring is reached.
	0 No response	
	1 Fault > CiA402	
	2 Warning	
0x2550:011	Brake resistor: Response to error	Selection of the response to be executed when the error threshold for brake resistor monitoring is reached. Associated error code: <ul style="list-style-type: none"> 65282 0xFF02 - Brake resistor: overload fault
	0 No response	
	1 Fault > CiA402	
	2 Warning	

17.2 Manual jog parameters

Parameter

Address	Name / setting range / [default setting]	Information
0x2836:001	Manual control mode: Current setpoint 0 ... [30] ... 200 %	Setting of the current setpoint value for manual control. <ul style="list-style-type: none"> 100 % ≡ Rated current (0x2DDF:001)
0x2836:002	Manual control mode: Frequency -1000.0 ... [0.0] ... 1000.0 Hz	Setting of the frequency for manual control.
0x2836:003	Manual control mode: Ramp time (current) 0 ... [0] ... 1000 ms	Setting of the period of time during which the current setpoint value is achieved from zero onwards.
0x2836:004	Manual control mode: Ramp time (frequency) 0 ... [500] ... 10000 ms	Setting of the period of time during which the frequency is achieved from zero onwards. The frequency ramp only starts up when the current ramp has reached the value configured in 0x2836:001 (Current setpoint).
0x2836:005	Manual control mode: Time monitoring (frequency) 0 ... [2500] ... 100000 ms	Setting of the time period for time monitoring. <ul style="list-style-type: none"> The manual control features a time monitoring function which is coupled to a write access to 0x2836:002 (Frequency). If no write access to 0x2836:002 takes place within the time period set here, the frequency is moved to zero via the parameterised ramp. When the 0 Hz have been reached, the inverter changes to the error status and is inhibited. After acknowledging the error, the CiA402 state machine must be switched from "Switch-on inhibited" back to the "Operation enabled" state before proceeding with manual control.
0x2836:006	Manual control mode: Current controller gain 0.00 ... [20.00] ... 750.00 V/A	Setting of the current controller gain.
0x2836:007	Manual control mode: Current controller reset time 0.01 ... [20.00] ... 2000.00 ms	Setting of the current controller reset time.



17.3 Mains failure control

Parameter

Address	Name / setting range / [default setting]	Information
0x2D66:001	Mains failure control: Enable function	1 = enable mains failure control.
	0 Disabled	
	2 Enabled	
0x2D66:002	Mains failure control: DC-bus activation level 60 ... [75] ... 90 %	Threshold below which the mains failure control is activated if it is enabled (0x2D66:001 = 1). <ul style="list-style-type: none"> • 100 % = nominal DC-bus voltage Recommended setting: <ul style="list-style-type: none"> • In general: 5 ... 10 % above the error threshold for undervoltage (display in 0x2540:003). • 230-V devices: 72 % • 400/480-V devices: 82 %
0x2D66:011	Mains failure control: Filter time 0.00 ... [0.00] ... 60.00 s	
0x2D66:012	Mains failure control: Ramp max. torque 0.0 ... [30.0] ... 3276.7 %	
0x2D66:013	Mains failure control: Ramp time 0.10 ... [1.00] ... 5.00 s	
0x2D66:014	Mains failure control: Actual DC-bus voltage <ul style="list-style-type: none"> • Read only: x.xxx V 	

Additional functions

Oscilloscope function



17.4 Oscilloscope function

The oscilloscope function is operated via the separate "Oscilloscope" tab of the »EASY Starter« engineering tool. Here, you can find the user interface with all the relevant dialogs and setting options.

Preconditions

- Configuring the oscilloscope and starting the recording is only possible when an online connection to the inverter has been established.
- The oscilloscope function enable recording of those parameters of the inverter that are marked with the "OSC" attribute. Only these parameters can be transferred into the selection list of the oscilloscope.

User interface

In the Lenze engineering tool used, set the trigger condition and the sample rate via the oscilloscope user interface when an online connection to the inverter has been established and select the parameters to be recorded.

The configuration is transferred into the inverter and checked each time it changes. Should the check identify invalid settings, the oscilloscope triggers an error message.

After the measurement is completed and when an online connection has been established, the measured data in the inverter is transmitted to the engineering tool and represented graphically on the oscilloscope user interface.

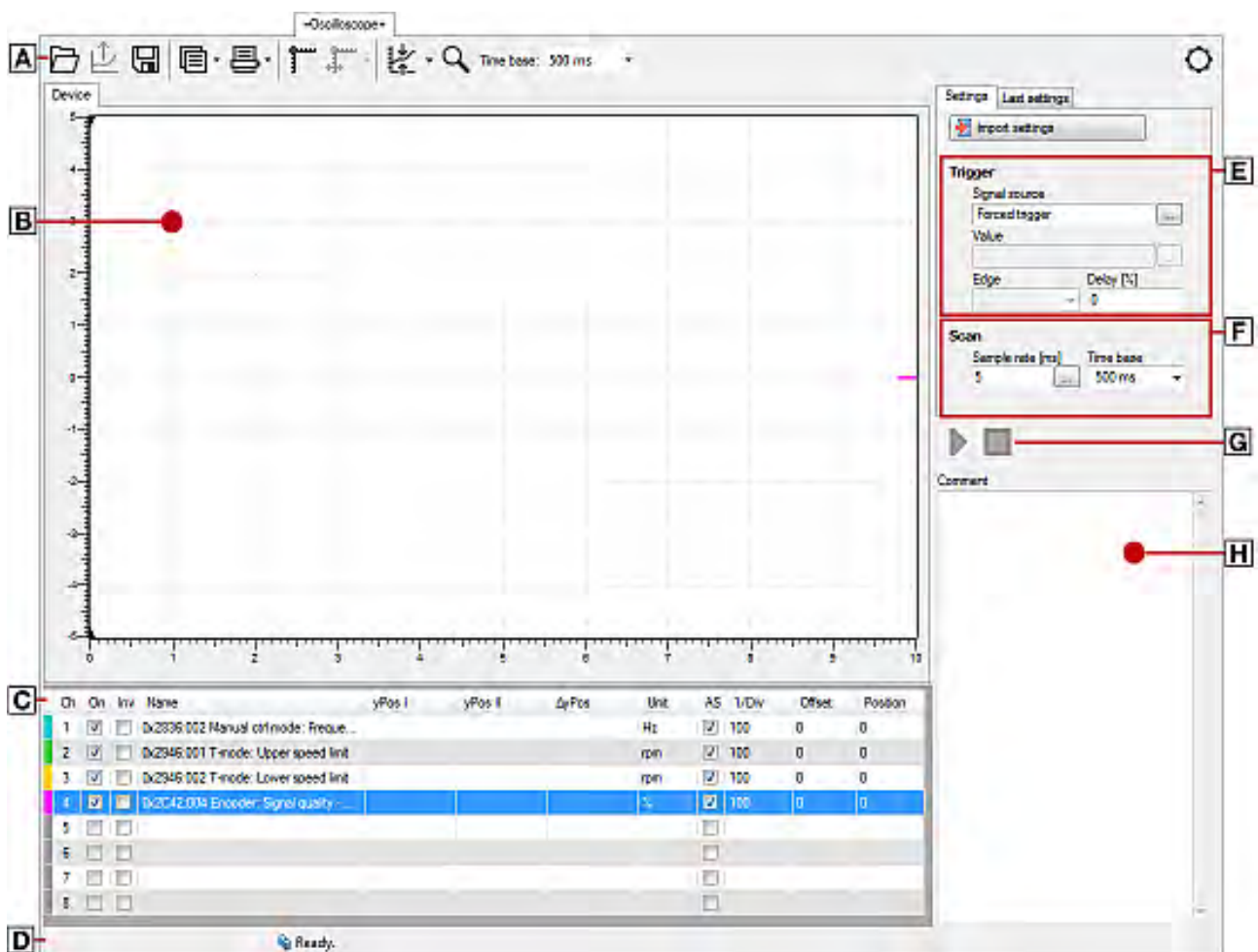











- A Oscilloscope-toolbar
- B Oscillogram field
- C Channel list field
- D Status line

- E Set trigger conditions
- F Set sample rate and time base
- G Start / stop of recording
- H Comment input field and error message



Toolbar

Icon	Function
	Load oscillogram / configuration from file
	Load recorded oscillogram from the device
	Save oscillogram in file
	Copy oscillogram to the clipboard
	Print oscillogram
	Display cursor
	Centre cursor
	Scale curve automatically
	Activate zoom function
"Time base:"	Display of the set time base
	Tool settings (right-hand side of the toolbar)

Technical data

Number of channels	1 ... 8
Data memory depth	Maximally 2048 measured values for each channel
Data width of a channel	Maximally 64 bits, according to the data type of the parameter to be recorded
Sample rate	62.5 μ s or a multiple thereof
Minimum recording time	128 ms (62.5 μ s * 2048 measured values)
Maximum time base	20.47 s
Maximum recording time	20.47 s
Trigger level	According to the value range of the parameter to be triggered
Trigger selection	
Trigger delay	-100 % ... +400 %
Trigger source	Channel 1 ... 8

Additional functions

Oscilloscope function



Selecting parameters to be recorded

The oscilloscope supports up to eight channels, thus maximally eight parameters can be recorded in an oscillogram. The **Channels** list field serves to configure the parameters to be recorded as signal sources:

Column	Name	Meaning
1	-	Curve colour for the representation in the oscillogram
2	Ch	Channel number
3	On	on / off
4	Inv	Inversion on / off
5	Name	Selection of the parameter to be recorded
6	yPos I	Value at cursor I in vertical direction
7	yPos II	Value at cursor II in vertical direction
8	ΔyPos	Difference between the two values of yPos I and yPos II (displayed as amount)
9	Unit	Scaling
10	AS	Activation / deactivation of the autoscaling function
11	1 / Div	
12	Offset	The offset value is subtracted from the recorded raw value before the scaling is executed. This serves to, e. g., make very small value fluctuations visible within one consistently very high recording value (e. g. harmonics with a low amplitude).
13	Position	Regarding the vertical curve scale -5 ... 5, the position value determines the vertical position of the zero point of the Y axis of a curve.

How to select a parameter for recording:

1. Double-click the "Name" column in the **Channel** list field to open the "Selection of signal sources" dialog box.
2. Select the parameters to be recorded in the dialog box.
3. Press the "Ok" button. This closes the dialog box and the selection is accepted.
4. Repeat the steps 1 ... 3 to select up to seven further parameters to be recorded.

The selected parameters are recorded when the oscilloscope is started.

How to change a parameter for recording:

1. Double-click the parameter to be changed in the **Channels** list field in the "Name" column.
2. Make a new selection in the "Selection of signal sources" dialog box.
3. Press the "Ok" button. This closes the dialog box and the selection is accepted.

The changed parameters are recorded when the oscilloscope is started.

How to cancel a selection again:

1. Right-click the parameter to be removed in the **Channels** list field in the "Name" column to open the context menu.
2. Select the "Remove parameter" command in the context menu.

The selected and changed parameter will not be recorded anymore when the oscilloscope is started.

Defining the recording time / sample rate



How to define the duration and sample rate for recording:

1. Select the desired time base in the time base list field.
 - a) The current setting of the time base multiplied by 10 results in the recording time.
 - b) As the size of the measured data memory in the inverter is limited, a compromise is usually made between sample rate and recording time.
 2. Either enter the desired sample rate in [ms] in the sample rate input field or open the "Sample rate selection" dialog by clicking the "Sample rate" button and select a sample rate < 1 ms.
 - a) The sample rate in the inverter is automatically corrected to integer multiples of 62.5 μ s.
- Thus, the duration and sample rate are defined for recording and are considered when the oscilloscope is started.

Defining the trigger condition

Based on the trigger condition, define the starting time of recording in the inverter. The oscilloscope offers various trigger conditions which serve to control the recording of the measured values.

The trigger threshold can be changed in the "Value" input field on the "Settings" tab if the channel is selected in "Signal source" that contains the corresponding parameter.

Setting	Function
Signal source	Selection of the trigger source:
Channel	Triggering takes place on a channel configured in the "vertical channel settings" list field.
immediate trigger	No trigger condition, recording takes place immediately after the start.
Value	Value, from which onwards triggering is caused.
Deceleration	Time delay of recording with regard to the trigger event.
Pre-trigger	When entering a negative delay time, you can detect signals that occur before the trigger event. <div style="text-align: center;"> </div> <p>The trigger time is marked with a dashed line in the oscillogram. If it is triggered on the occurrence of an event, values caused by the event can be detected in this way.</p>
Post-trigger	When entering a positive delay time, you can detect signals that occur a certain time after the trigger event. <div style="text-align: center;"> </div>
Edge	Two trigger types are available:
increasing	First, the value must fall below the defined trigger value and then exceed it in order that triggering is activated.
decreasing	First, the value must exceed the defined trigger value and then fall below it in order that triggering is activated.

Additional functions

Oscilloscope function



Starting recording

Press the button , "Start recording"

In order to obtain a sample rate as high as possible when the parameter values are recorded, the data is first saved in the measured data memory of the inverter and then transmitted to the Engineering PC as oscillogram. The current recording status is displayed in the status bar.

Adjusting the representation



As soon as the diagram does not show the complete measurement anymore, a scrollbar appears below the time axis. You can use the scrollbar to move the visible section horizontally. The time-axis inscription and the position indicator are automatically corrected during scrolling.

After recording and subsequent transmission of the online oscillogram to the Engineering PC, it is visualised in the oscilloscope. If required, you can now adjust the representation using the zoom function or the automatic scaling function.

Change time base subsequently







A measurement already carried out can be extended or compressed by changing the time base.

For this purpose, change the setting of the time base via the toolbar (on top).

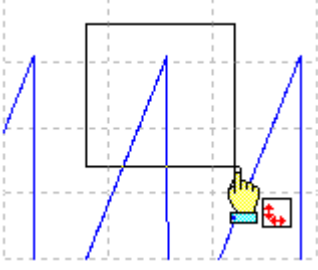

Zoom function

The zoom function will be activated by selecting the  in the toolbar. When the function is activated, the button is highlighted.

Zoom function	Proceeding	
Zoom selection		<p>Hold down the left mouse button and draw the section to be zoomed:</p>  <ul style="list-style-type: none"> • The selection is shown with a frame. • When the left mouse button is released, the selection is zoomed in the oscillogram.
Horizontal stretching	 	<p>On the horizontal scale:</p> <p>Hold down the left mouse button and move the mouse pointer to the left to stretch the shown selection from the right edge.</p> <p>Hold down the right mouse button and move the mouse pointer to the right to stretch the shown selection from the left edge.</p> <p>Moving the mouse pointer in opposite direction continuously reduces the stretching.</p>
Vertical stretching	 	<p>On the vertical scale:</p> <p>Hold down the left mouse button and move the mouse pointer to the bottom to stretch the shown selection from the top.</p> <p>Hold down the right mouse button and move the mouse pointer to the top to stretch the shown selection from the bottom.</p> <p>Moving the mouse pointer in opposite direction continuously reduces the stretching.</p>
Return to original representation		<p>Click the right mouse button in the diagram to return step by step to the original representation.</p>

Automatic scaling function

Use the automatic scaling function to automatically scale and reposition the representation of selectable signal characteristics in the oscillogram and reset the offset to "0".

How to execute automatic scaling

1. Select the channels and parameters for automatic scaling in the **Channels** dialog box.
2. Click the corresponding symbol in the oscilloscope toolbar to activate the automatic scaling function.

Additional functions

Oscilloscope function



The cursor function

In addition to the zoom and scaling function, there is the cursor function which is called by double-clicking the **Channels** list field.

The double-click opens a list of all signal sources with the following options:

- Display of individual measured values of a selectable channel
- Addition, subtraction or multiplication of any two measured values
- Square-law mean value of any two measured values

How to use the cursor function:

1. Go to the oscilloscope toolbar and click the "Cursor" button to activate the cursor function.
 - a) Two movable vertical measuring lines are displayed in the oscillogram.
2. Select the channel for which individual measuring lines are to be displayed from the **Channels** list field.
3. Hold down the left mouse button and drag the red vertical measuring line to the desired position.
 - a) The active measuring line is represented by a continuous line, the inactive measuring line is represented by a dotted line.
 - b) If you position the mouse pointer over the inactive measuring line, the measuring line automatically becomes active.
 - c) The columns **yPos I** and **yPos II** in the **Channels** list field display the values measured at the measuring lines. The column **ΔyPos** or **QWM** displays the cursor differential value or square-law mean value of all values between both cursors.
 - d) The sum value to be displayed can be defined in the "tool settings" dialog. This dialog can be set via the "Tool settings" dialog on the right in the toolbar.
 - e) Comparing peak values: Several values displayed in the oscillogram can be compared to each other using a horizontal measuring line. The measuring line is automatically created based on the current cursor point and thus cannot be shifted.

Managing oscillograms

If several data records are loaded in the oscilloscope at the same time, the measured data to be displayed is selected via the respective tab above the displayed oscillogram. There are three types of oscillograms:

- **Device oscillogram**

The device oscillogram is the only oscillogram to establish a connection to the target system in order to carry out an oscilloscope measurement. It is always displayed as the first "Device on the left" tab.

- **Offline oscillogram**

The offline oscillogram is an oscillogram already saved in the Engineering PC.

- The configuration of the offline oscillogram can be reused for future recordings.
- The offline oscillogram is displayed as a tab with the file name that was allocated for this oscillogram while being saved.

- **Merge oscillogram**

The merge oscillogram ("Merge" tab) is automatically available if two or more oscillograms are loaded in the oscilloscope at the same time.

- In the merge oscillogram, several characteristics from the currently loaded oscillograms can be overlaid, e. g. to compare signal characteristics from different recordings.

Commenting oscillograms

You can add a comment on the selected oscillogram into the comment input field.

- When you execute the "Save oscillogram" command, the comment is saved together with the oscillogram in the file.
- When you select an oscillogram with a comment to be loaded in the "Load oscillogram" dialog box, this comment is displayed in the dialog box.



Saving oscillogram in file



The reuse of a saved configuration is only reasonable for inverters of the same type (e. g. i950 inverters), as otherwise due to a scaling of the oscilloscope channels that is not adapted, incorrect values are displayed!

After selecting the parameters to be recorded from the selection list of the signal sources and making any further necessary settings, you can save this configuration and the recording if already carried out on the Engineering PC for a later reuse.

How to save the oscillogram:

1. Click the symbol in the toolbar. the "Save oscillogram" dialog box is displayed.
2. Define a name in the Name input field of the oscillogram to be saved.
3. Click the "Export to file" button.
4. Specify the folder and file name for the oscillogram be stored in the Save as dialog box.
5. Click the Save button. The dialog box is closed.

The current oscillogram is saved.

Loading oscillogram / configuration from file



The reuse of a saved configuration is only reasonable for inverters of the same type (e.g. i950 inverters), as otherwise due to a scaling of the oscilloscope channels that is not adapted, incorrect values are displayed!

Data sets/configurations which have already been saved can be reloaded into the oscilloscope any time, e.g. for the overlay function.

How to load an oscillogram or a configuration:

1. Click the symbol in the oscilloscope toolbar. The "Load oscillogram" dialog box is displayed.
2. Press the Search... button.
3. Select the file to be imported within the desktop environment from the Open dialog box.
4. If the oscillogram is to be used as configuration, select the As configuration... option.
5. Click the Open button. The dialog box is closed.

The selected oscillogram or configuration is imported.

Closing the oscillogram

You can close an open OFFLINE oscillogram again any time.

- After an oscillogram is closed, it is no longer available in the oscillogram list field. The oscilloscope changes automatically to the display of the ONLINE oscillogram.
- If the closed oscillogram was included in the MERGE oscillogram, its channels will be removed from the MERGE oscillogram.
- Go to the oscilloscope toolbar and click the symbol to close the currently displayed OFFLINE oscillogram.

Overlay function

The overlay function serves to overlay several characteristics from the currently loaded data sets, e.g. to compare signal characteristics from different recordings.

- If two or more oscillograms are loaded in the oscilloscope, e.g. the ONLINE oscillogram and an oscillogram that was previously loaded into a file, a "MERGE" oscillogram will be automatically available in the "Oscillogram" list field.
- If the merge oscillogram is selected, the desired characteristics to be overlaid or compared can be selected from the loaded oscillograms in the Vertical channel settings group field.
- If an ONLINE oscillogram is used in the MERGE oscillogram, an update is carried out in the MERGE oscillogram in the case of a renewed recording.
- Removing variables from an OFFLINE or ONLINE oscillogram causes the characteristics in the MERGE oscillogram to be deleted.

Additional functions

Oscilloscope function



Copying an oscillogram to the clipboard

For documentation purposes, it is possible to copy the measured data of an oscillogram as a table or, alternatively, the oscilloscope user interface as a picture, to the clipboard for use in other programs.

How to copy the oscillogram to the clipboard:

1. Click the symbol in the oscilloscope toolbar. The "Copy oscillogram" dialog box is displayed.
2. Select the desired option:
 - a) Curve points: the measured data is copied to the clipboard as a table.
 - b) Screenshot: the oscilloscope user interface is copied to the clipboard as a picture.
3. Press the OK button. The dialog box is closed and the selected option is copied to the clipboard.



18 Safety functions

Supported safety functions for "Basic Safety-STO"

- ▶ [Safe torque off \(STO\)](#)  292

Safety functions

Safe torque off (STO)



18.1 Safe torque off (STO)

The motor cannot generate torque and movements of the drive.

⚠ DANGER!

Automatic restart if the request of the safety function is deactivated.

Possible consequences: Death or severe injuries

- ▶ You must provide external measures according to EN ISO 13849-1 which ensure that the drive only restarts after a confirmation.

⚠ DANGER!

The power supply is not safely disconnected.

Death or serious injury due to electrical voltage.

- ▶ Turn off the power supply.

Preconditions

Motion caused by external forces must be prevented by additional measures such as mechanical braking.

The restart must be set. See chapter .

Functional description

How to safely disconnect the drive:

1. A safety sensor requests the safety function.
2. The transmission of the pulse width modulation is safely switched off by the safety unit.
The power drivers do not generate a rotating field anymore.
3. The inverter switches to the STO active device status (status word 0x6041, Bit15 = 0).
The motor is safely switched to torqueless operation (STO).

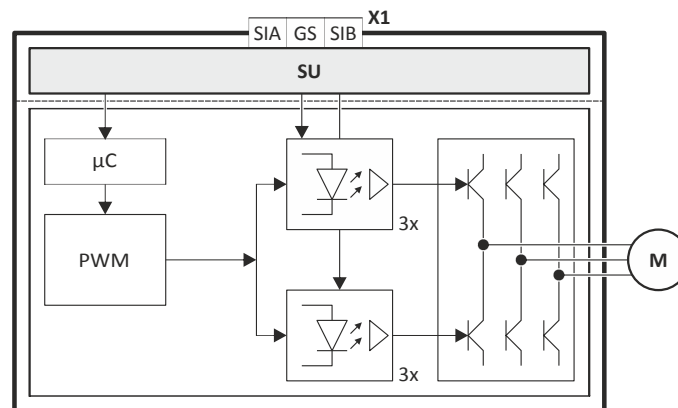

Fig. 4: Functional principle: Basic Safety - STO

X1	Control terminals of the safety unit	PWM	Pulse width modulation
SU	Hardware interface	M	Motor
µC	Microcontroller		

Functional description

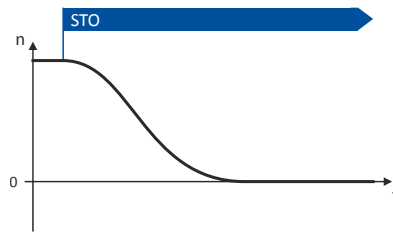

Fig. 5: Safety function STO



Functional sequence and error response have no adjustable parameters.

Activation of the function

A data telegram is sent to the inverter via the safety bus. See chapter "Sichere Netzwerkschnittstellen".

Via a safe input, if the corresponding parameter is assigned to the safe input.

In response to the error stop request.

In response to the emergency stop request.

Parameter Extended-Safety

Parameter	Source	Information
0x2890	STO: SD-In	Function source of the safe inputs for requesting the STO function
0x2891	STO: S-bus	Activation/deactivation of the STO control bit via the safety bus.
0x2893	STO active: S-bus	Influence of the status bit "STO active" on the control of existing outputs.

Parameter

Address	Name / setting range / [default setting]	Information
0x2890	STO: Source SD-In • Read only	
	0 Deactivated	
	1 SD-In1	
	2 SD-In2	
	3 SD-In3	
0x2891	STO: Source S-Bus • Read only	
	0 Deactivated	
0x2892:001	STO: STO: Restart • Read only	
	0 Acknowledged Restart	
0x2893	STO active: Output • Read only	
	0 Deactivated	
	1 SD-Out1 positive logic	
	2 SD-Out1 negative logic	

Safety functions

Safe stop emergency (SSE)



18.2 Safe stop emergency (SSE)

The safety function SSE has the highest priority. The safety function SSE is controlled primarily from all states, operating modes or safety functions. Depending on the parameter setting in [0x28A3:001](#), SSE activates one of these functions:

- ▶ Safe torque off (STO)
- ▶ Safe stop 1 (SS1)

Exception

One exception is the tripping source parameterized with SSE that can be deactivated by the "Safe Muting" function. In this case, the SSE function is not effective.

NOTICE

Emergency stop buttons must not be overruled by a special operation.

Otherwise the functional safety of the system cannot be guaranteed anymore.

- ▶ Please observe the notes in the section .
- ▶ Please observe the notes regarding the special operation (OMS) in the section ▶ [Operation mode selector \(OMS\)](#). [□ 329](#)

Preconditions

The emergency stop buttons are connected to the emergency stop function.

Activation of the function

A data telegram is sent to the inverter via the safety bus. See chapter "Sichere Netzwerkschnittstellen".

Via a safe input, if the corresponding parameter is assigned to the safe input.

Parameter

Address	Name / setting range / [default setting]	Information
0x28A1	SSE: Source SD-In • Read only	
	0 Deactivated	
	1 SD-In1	
	2 SD-In2	
	3 SD-In3	
	4 SD-In4	
0x28A2	SSE: Source S-Bus • Read only	
	0 Deactivated	
	1 Activated	
0x28A3:001	SSE: SSE: Emergency Stop function • Read only	
	0 STO	
	1 SS1	
0x28A4	SSE active: Output • Read only	
	0 Deactivated	
	1 SD-Out1 positive logic	
	2 SD-Out1 negative logic	



18.3 Safe stop 1 (SS1)

The safety function monitors the parameterized stopping time of the drive ($n = 0$).

In the SS1 function, the drive switches to torqueless state via the parameterized mode.

[0x2897:001](#)

Preconditions

The drive is brought to standstill via the application.

Movements caused by external forces require additional measures. When the stopping time is defined, the application time of the brake must be taken into consideration.

The restart is possible after the stopping time has completely elapsed. An exception from this is the special operation.

Functional description



$n = 0$ means that the motor speed is lower than the motor speed parameterized in the tolerance window. ▶ [0x287B:001](#)



The deceleration ramp can be parameterized and monitored for the SS1 stop function.

SS1-t 0x2897:001 = 0 (STO after stopping time)	SS1-t 0x2897:001 = 1 (STO at $n = 0$)
<p>The SS1 safety function switches the inverter to STO if the set stopping time has elapsed. ▶ 0x2894:001</p> <p>The switching operation is triggered irrespective of whether or not the motor is at standstill!</p>	<p>This parameter setting stops the motor.</p> <p>The deceleration $n = 0$ is parameterized in the following parameter: 0x2897:002</p>
<p>Curve (a): The motor comes to a standstill within the parameterized stopping time.</p>	<p>Curve (a): The deceleration parameterized in 0x2897:002 starts when the speed is lower than the tolerance window of the motor speed parameterized in 0x287B:001.</p> <p>After the parameterized stopping time has elapsed, the inverter switches to STO. 0x2894:001</p>
<p>Curve (b): At the moment of STO, the motor is not yet at standstill. Switching off with STO lets the motor coast down.</p>	<p>Curve (b): If the deceleration ramp is set too long, it is switched to STO after the stopping time has elapsed. In the case shown here, the motor coasts down.</p>

Notes on how the set the stopping time

Please observe the following dependency when setting der stopping time [0x2894:001](#):

- If an encoder is available:
 - The speed is calculated from the encoder data.
 - In [0x2897:001](#), selection "1": STO at $n = 0$, a waiting time [0x2897:002](#) can be set which determines when the STO status is adopted. This deceleration indicates the time between the motor standstill and the activation of STO.
- If no encoder is available:
 - The function evaluates the speed status $n = 0$ from the inverter.
 - The stopping time monitored by the safety device [0x2894:001](#) must be 0.5 s higher than the stopping time parameterized in the inverter.

Safety functions

Safe stop 1 (SS1)



Activation of the function

A data telegram is sent to the inverter via the safety bus. See chapter "Sichere Netzwerkschnittstellen".

Via a safe input, if the corresponding parameter is assigned to the safe input.

In response to the error stop request.

In response to the emergency stop request.

Parameter Extended-Safety

Parameter	Source	Information
0x2890	STO: SD-In	Function source of the safe inputs for requesting the STO function
0x2891	STO: S-bus	Activation/deactivation of the STO control bit via the safety bus.
0x2893	STO active: S-bus	Influence of the status bit "STO active" on the control of existing outputs.

Response of the function under normal circumstances

When the stopping time has elapsed (0x2894:001 or after falling below the tolerance window (0x287B:001) a standard stop is activated.

The power supply for generating the rotating field is safely interrupted (STO). The motor cannot generate torque and movements of the drive.

Response of the function in the event of an error

An error message and an error stop are triggered if:

- Standstill could not be reached when the stopping time has elapsed (0x2894:001).
- The activated ramp monitoring exceeds the parameterized deceleration ramp.

The power supply for generating the rotating field is safely interrupted (STO). The motor cannot generate any torque and movements of the drive.



A premature cancelation of the Safe Stop request does not stop the error stop function.

Parameter

Address	Name / setting range / [default setting]	Information
0x2878:004	Motor encoder: Encoder monitoring response time	
	• Read only: ms	
	12 12 ms	
	50 50 ms	
0x287B:001	Velocity monitoring: Tolerance window (n=0)	
	• Read only: x rpm	
0x2894:001	SS1, SS2: SS1, SS2: Stopping time	
• Read only: x ms		
0x2894:002	SS1, SS2: SS1, SS2: Ramp Monitoring	
	• Read only	
	0 No Ramp monitoring	
0x2894:003	SS1, SS2: SS1, SS2: Ramp smoothing time	
	• Read only: x %	
0x2894:004	SS1, SS2: SS1, SS2: Ramp Offset Mode	
	• Read only	
	0 Relative	
0x2894:005	SS1, SS2: SS1, SS2: Ramp Start Offset relative	
	• Read only: x %	
0x2894:006	SS1, SS2: SS1, SS2: Ramp Start Offset absolute	
	• Read only: x rpm	



Safety functions

Safe stop 1 (SS1)

Address	Name / setting range / [default setting]	Information
0x2894:007	SS1, SS2: SS1, SS2: Actual ramp speed • Read only: x rpm	
0x2894:008	SS1, SS2: SS1, SS2: Minimal speed difference • Read only: x rpm	
0x2895	SS1: Source SD-In • Read only	
	0 Deactivated	
	1 SD-In1	
	2 SD-In2	
	3 SD-In3	
4 SD-In4		
0x2896	SS1: Source S-Bus • Read only	
	0 Deactivated	
	1 Activated	
0x2897:001	SS1: SS1: Mode • Read only	
	0 STO after stop time	
	1 STO at n=0	
0x2897:002	SS1: SS1: Deceleration STO after n=0 • Read only: x ms	
0x2898	SS1 active: Output • Read only	
	0 Deactivated	
	1 SD-Out1 positive logic	
	2 SD-Out1 negative logic	

Safety functions

Safe stop 2 (SS2)



18.4 Safe stop 2 (SS2)

The safety function monitors whether the drive has reached the set tolerance window ($n = 0$) within the parameterised stopping time.

After the stopping time has elapsed or the value has fallen below the tolerance window, the monitoring function switches to safe operational stop (SOS) or activates the safety function (STO).

In the safe operational stop, the drive is not switched to torque-free operation. All control functions remain active for maintaining the reached position.

⚠ WARNING!

A safety-rated encoder system must be used.

Without an encoder, this safety function cannot be used.

► Apply a safety-rated encoder system to use this function.

Preconditions

The drive is brought to standstill via the application.

Movements caused by external forces require additional measures. When the stopping time is defined, the application time of the brake must be taken into consideration.

The restart is possible after the stopping time has completely elapsed. An exception from this is the special operation.

Functional description



The deceleration ramp can be parameterized and monitored for the SS2 stop function.

SS2-t 0x289B:001 = 0 (SOS after stopping time)	SS2-t 0x289B:001 = 1 (SOS at n = 0)
The safe operating stop is activated if the stopping time parameterized in 0x2894:001 has elapsed and the motor speed is lower than the value parameterized in 0x287B:001. Safe operating stop (SOS)	Curve (a): For details see Safe operating stop (SOS) . □ 303.
Curve (a): For details see Safe operating stop (SOS) . □ 303.	Curve (b): STO is also activated if, after the stopping time 0x2894:001 has elapsed, the speed is not lower than the value parameterized in 0x287B:001.
Curve (b): STO is also activated if, after the stopping time 0x2894:001 has elapsed, the speed is not lower than the value parameterized in 0x287B:001.	

Activation of the function

A data telegram is sent to the inverter via the safety bus. See chapter "Sichere Netzwerkschnittstellen".

Via a safe input, if the corresponding parameter is assigned to the safe input.

In response to the error stop request.

Response of the function under normal circumstances

When the stopping time has elapsed (0x2894:001 or after falling below the tolerance window (0x287B:001), the safety function □ 303 is activated.



Response of the function in the event of an error

An error message and an error stop are triggered if:

- Standstill could not be reached when the stopping time has elapsed ([0x2894:001](#)).
- The activated ramp monitoring exceeds the parameterized deceleration ramp.

The power supply for generating the rotating field is safely interrupted (STO). The motor cannot generate any torque and movements of the drive.



A premature cancelation of the Safe Stop request does not stop the error stop function.

Safety functions

Safe stop 2 (SS2)



Parameter

Address	Name / setting range / [default setting]	Information
0x2878:004	Motor encoder: Encoder monitoring response time	
	• Read only: ms	
	12 12 ms	
	50 50 ms	
100 100 ms		
0x287B:001	Velocity monitoring: Tolerance window (n=0)	
• Read only: x rpm		
0x2894:001	SS1, SS2: SS1, SS2: Stopping time	
• Read only: x ms		
0x2894:002	SS1, SS2: SS1, SS2: Ramp Monitoring	
	• Read only	
	0 No Ramp monitoring	
1 Ramp monitoring active		
0x2894:003	SS1, SS2: SS1, SS2: Ramp smoothing time	
	• Read only: x %	
0x2894:004	SS1, SS2: SS1, SS2: Ramp Offset Mode	
	• Read only	
	0 Relative	
1 Absolute		
0x2894:005	SS1, SS2: SS1, SS2: Ramp Start Offset relative	
• Read only: x %		
0x2894:006	SS1, SS2: SS1, SS2: Ramp Start Offset absolute	
• Read only: x rpm		
0x2894:007	SS1, SS2: SS1, SS2: Actual ramp speed	
• Read only: x rpm		
0x2894:008	SS1, SS2: SS1, SS2: Minimal speed difference	
• Read only: x rpm		
0x2899	SS2: Source SD-In	
	• Read only	
	0 Deactivated	
	1 SD-In1	
	2 SD-In2	
	3 SD-In3	
4 SD-In4		
0x289A	SS2: Source S-Bus	
	• Read only	
	0 Deactivated	
1 Activated		
0x289B:001	SS2: SS2: Mode	
	• Read only	
	0 SOS after stop time	
1 SOS at n=0		
0x289C	SS2 active: Output	
	• Read only	
	0 Deactivated	
	1 SD-Out1 positive logic	
2 SD-Out1 negative logic		



18.5 Ramp monitoring

In addition, the deceleration ramp can be parameterised and monitored for the stop functions SS1 and SS2. If the parameterised ramp is not exceeded, it is then switched to the parameterised stop function STO or SOS.

Condition

- Safe speed evaluation via the parameterised encoder system.
- Ramp monitoring is activated. ▶ [0x2894:005](#)

Functional description

Monitoring the deceleration process guarantees a higher safety level.

- The application leads the drive to a standstill.
- If the ramp monitoring is active, the starting value of the ramp and the smoothing time must be defined as percentage value.

If the speed exceeds the deceleration ramp parameterised within the stopping time or before the tolerance window ($n = 0$) is reached, an error message is triggered and an error stop is initiated.

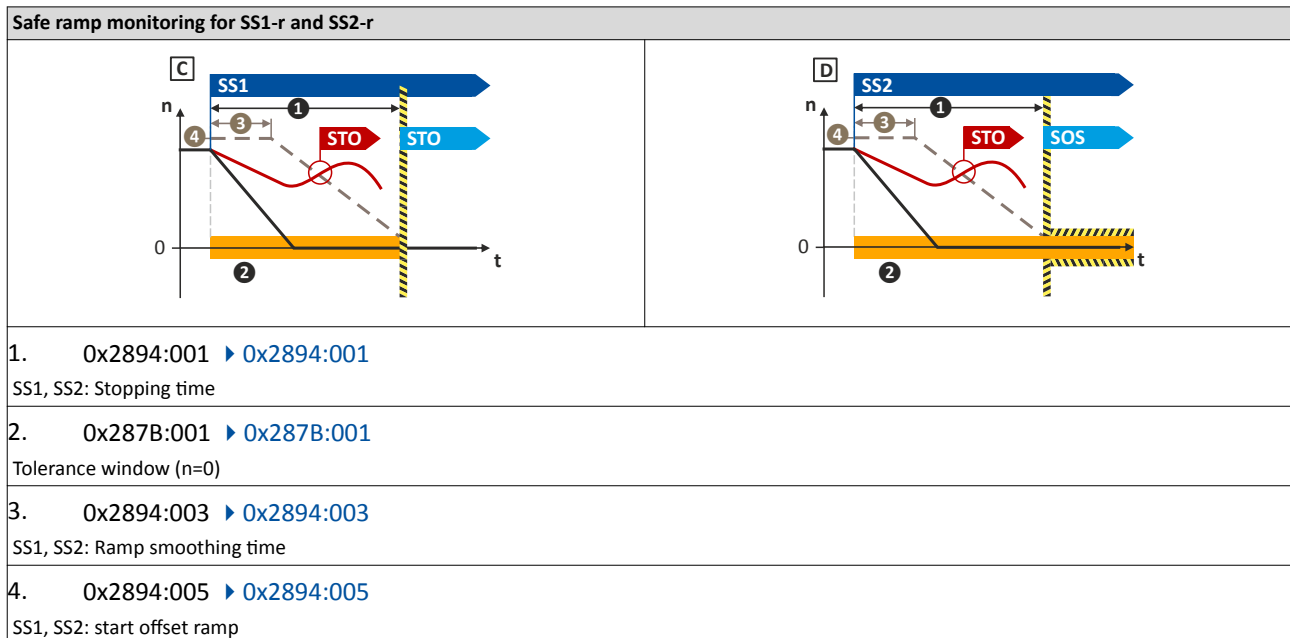

The parameterized monitoring ramp considers the parameters of the deceleration ramp in the application.



0...30 % of the actual speed are added to the actual speed as start offset. The sum is used as constant starting value.

Alternative: An absolute value can be parameterized as start offset.
▶ [0x2894:006](#).

The following parameter determines whether the relative or the absolute offset value is to be used. ▶ [0x2894:004](#)

In the Lenze setting of the start offset, the tolerance window ($n=0$) is considered as the offset. ▶ [0x2894:005](#)



The monitoring ramp starts after an internal deceleration time has elapsed. The internal deceleration time depends on “SS1, SS2”: smoothing time” and “SS1, SS2”: stopping time”.

Safety functions

Ramp monitoring



Activation

- If the stop functions SS1/SS2 are requested, a monitoring ramp is calculated and placed over the current speed characteristic.

Normal behaviour

While the stopping time elapses or before the tolerance window ($n = 0$) is reached, the parameterised speed ramp is not exceeded. When the stopping time has elapsed or the parameterised speed ramp has been exceeded, the parameterised stop function STO or SOS is activated.

Error behaviour

An error message and an error stop are triggered if:

- the current speed exceeds the stopping time of the speed ramp parameterised.
- the current speed exceeds the parameterised speed ramp before the tolerance window is reached.

The power supply for generating the rotating field is safely interrupted ▶ [Safe torque off \(STO\)](#). The motor cannot generate torques and movements of the drive.



18.6 Safe operating stop (SOS)

In the safe operational stop, the drive is not switched to torque-free operation. All control functions are maintained. The reached position remains active.

⚠ WARNING!

A safety-rated encoder system must be used.

Without an encoder, this safety function cannot be used.

► Apply a safety-rated encoder system to use this function.

Preconditions

The drive is brought to standstill via the application.

Functional description

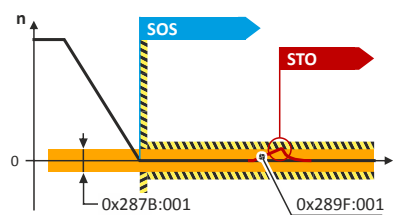

Fig. 6: SOS function

SOS is activated if the motor speed is lower than the tolerance window parameterised in [0x287B:001](#) [0x287B:001](#), tolerance window ($n=0$),.

In the SOS state, relative position changes are added and saved in [0x289F:003](#) [0x289F:003](#). The value in [0x289F:003](#) [0x289F:003](#) is continuously compared to the permissible value in [0x289F:001](#) [0x289F:001](#).

If one of the two states occurs during a safe operational stop (SOS):

- Position is outside the tolerance window safely monitored in [0x289F:001](#) [0x289F:001](#) an error message is generated and STO is activated:

When the SOS state is left, the maximum relative positioning is displayed in [0x289F:003](#) [0x289F:003](#).

The [0x289F:002](#) [0x289F:002](#) parameter defines the restart behaviour after SOS has been deactivated.

If the SOS state is requested again, the sum of the last position changes in [0x289F:003](#) [0x289F:003](#) is reset to zero.

Example: The "SS2 active" state is interrupted by an STO request. If the STO request is reset, the transition to the SOS state will follow. The position deviation is reset to $p = 0$.

Activation of the function

The following options are available to activate the function:

- The [Safe stop 2 \(SS2\) function](#) [298](#)
- The safety bus, see section "Safety bus".
- A safe input, see section "Safe inputs"

Behaviour of the function in the event of an error

In the final state "Safe operational stop (SOS)", an error message is triggered if:

- the speed exits the tolerance window set [0x287B:001](#) ($n=0$).
- the position exits the tolerance window set [0x289F:001](#) ($p=0$).

Safety functions

Safe operating stop (SOS)



Parameter

Address	Name / setting range / [default setting]	Information
0x2875:019	S bus control bits: SOS • Read only	
0x289D	SOS: Source SD-In • Read only	
	0 Deactivated	
	1 SD-In1	
	2 SD-In2	
	3 SD-In3	
0x28A0	SOS: Source SD-In4 • Read only	
	0 Deactivated	
	1 SD-Out1 positive logic	
	2 SD-Out1 negative logic	
0x289E	SOS observed: Output • Read only	
	0 Deactivated	
	1 Activated	
0x289F:001	SOS: Source S-Bus • Read only	
0x289F:002	SOS: SOS: Tolerance window (Delta p=0) • Read only: x incr.	
	0 Acknowledged Restart	
	1 Automatic Restart	
0x289F:003	SOS: SOS: Restart • Read only	
0x289F:003	SOS: SOS: Maximal Change of Position • Read only: x incr.	



18.7 Safe maximum speed (SMS)

The safety function monitors the compliance with the safe maximum motor speed set.

WARNING!

A safety-rated encoder system must be used.

Without an encoder, this safety function cannot be used.

► Apply a safety-rated encoder system to use this function.

Functional description

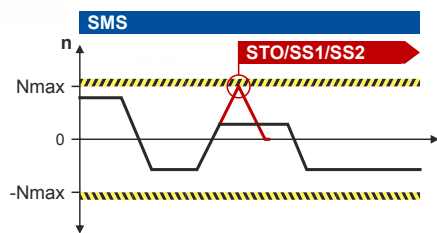

Fig. 7: SMS function

Activation of the function



The function can only be activated via parameterisation.

The function is activated by a value > 0 in `0x28B0:0010x28B0:001`.

Behaviour of the function in the event of an error

An error message is triggered if:

- The speed exceeds the maximum speed N_{max} set in `0x28B0:0010x28B0:001`.

One of the error stops parameterised in `0x28B0:002(0x28B0:002)` is initiated:

- Safe torque off (STO) [□ 292](#)
- Safe stop 1 (SS1) [□ 295](#)
- Safe stop 2 (SS2) [□ 298](#)

Parameter

Address	Name / setting range / [default setting]	Information
0x28B0:001	SMS: Maximum Speed N_{max} • Read only: x rpm	
0x28B0:002	SMS: Reaction ($n > N_{max}$) • Read only	
	0 STO	
	1 SS1	
	2 SS2	
0x28B1	SMS observed: Output • Read only	
	0 Deactivated	
	1 SD-Out1 positive logic	
	2 SD-Out1 negative logic	

Safety functions

Safely-limited speed (SLS)



18.8 Safely-limited speed (SLS)

The safety function monitors the parameterized speed N_{lim} if the following states are reached:

- The values have fallen below the parameterized speed.
- The set braking time has elapsed.

⚠ WARNING!

A safety-rated encoder system must be used.

Without an encoder, this safety function cannot be used.

► Apply a safety-rated encoder system to use this function.

Preconditions

The drive must be braked by the application.

If the SLS function is combined with the [Safe direction \(SDI\)](#) function, the values for the delay times ([0x28C4:001](#) [0x28C4:001](#) ... [0x28C4:004](#) [0x28C4:004](#)) must be coordinated. The N_{lim} braking time ([0x28C3:001](#) [0x28C3:001](#) ... [0x28C3:004](#) [0x28C3:004](#)) starts at the same time as the SDI delay time. See ► [Safe direction \(SDI\)](#) function. [315](#)

Functional description

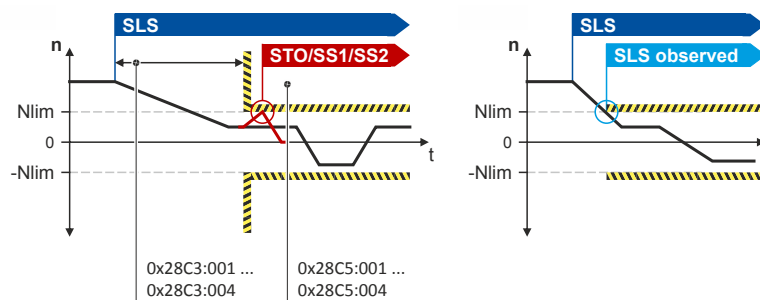

Fig. 8: SLS function

For operation within the limit values the "SLS1...4 monitored" status is set in [0x2870:002](#).

The status can be

- assigned to the safe output as a safe speed monitor.
- reported via the safety bus.

The permissible direction of movement is set via [0x28C4:001](#) ... [0x28C4:004](#).

Activation of the function

A data telegram is sent to the inverter via the safety bus. See chapter "Sichere Netzwerkschnittstellen".

Via a safe input, if the corresponding parameter is assigned to the safe input.

Via internal status signals. (From safety firmware V1.1 with parameter set version V1.1)

Behaviour of the function in the event of an error

If the speed is exceeded in the monitored state, an error message is triggered. For the SLS safety function, the following error responses can be parameterised as safe stop:

- [Safe torque off \(STO\)](#) [292](#)
- [Safe stop 1 \(SS1\)](#) [295](#)
- [Safe stop 2 \(SS2\)](#) [298](#)



Parameter

Address	Name / setting range / [default setting]	Information	
0x2870:002	SafetyInterface: SafetyInterface State		
	• Read only		
	Bit 0		SLS1 observed
	Bit 1		SLS2 observed
	Bit 2		SLS3 observed
	Bit 3		SLS4 observed
	Bit 4		SMS observed
	Bit 5		SSM within limits
	Bit 6		SDIpos observed
	Bit 7		SDIneg observed
	Bit 8		SLP1 observed
	Bit 9		SLP2 observed
	Bit 10		SLP3 observed
	Bit 11		SLP4 observed
	Bit 12		SCA1 within limits
	Bit 13		SCA2 within limits
	Bit 14		SCA3 within limits
	Bit 15		SCA4 within limits
	Bit 16		PDSS positive observed
	Bit 17		PDSS negative observed
	Bit 18		SOS observed
	Bit 19		SBC activated
	Bit 20		SHOM activated
	Bit 21		SHOM available
	Bit 22		Safe speed OK
	Bit 23		n=0
	Bit 24		Positive travel direction
	Bit 25		Slip > 25 %
Bit 26	Slip > 50 %		
Bit 27	Slip > 75%		
Bit 31	Fault active		
0x28BF:001	SLS: Internal source: SLS1: Internal source		
	• Read only		
	0		Deactivated
	678496513		SDIpos active
	678496769		SDIneg active
	678497025		SLI active
	678497793		OMS active
	678503937		SSM within limits
	678504193		SDIpos observed
	678504449		SDIneg observed
	678504705		SLP1 observed
	678504961		SLP2 observed
	678505217		SLP3 observed
	678505473		SLP4 observed
	678505729		SCA1 within limits
	678505985		SCA2 within limits
	678506241		SCA3 within limits
	678506497		SCA4 within limits
	678506753		PDSSpos observed
	678507009		PDSSneg observed
	678508801		Positive direction of movement

Safety functions

Safely-limited speed (SLS)



Address	Name / setting range / [default setting]	Information
0x28BF:002	SLS: Internal source: SLS1: Internal source inversion • Read only	
	0 Not inverted	
	1 Invert	
0x28BF:003	SLS: Internal source: SLS2: Internal source • Read only	
	0 Deactivated	
	678496513 SDIpos active	
	678496769 SDIneg active	
	678497025 SLI active	
	678497793 OMS active	
	678503937 SSM within limits	
	678504193 SDIpos observed	
	678504449 SDIneg observed	
	678504705 SLP1 observed	
	678504961 SLP2 observed	
	678505217 SLP3 observed	
	678505473 SLP4 observed	
	678505729 SCA1 within limits	
	678505985 SCA2 within limits	
	678506241 SCA3 within limits	
	678506497 SCA4 within limits	
	678506753 PDSSpos observed	
678507009 PDSSneg observed		
678508801 Positive direction of movement		
0x28BF:004	SLS: Internal source: SLS2: Internal source inversion • Read only	
	0 Not inverted	
	1 Invert	
0x28BF:005	SLS: Internal source: SLS3: Internal source • Read only	
	0 Deactivated	
	678496513 SDIpos active	
	678496769 SDIneg active	
	678497025 SLI active	
	678497793 OMS active	
	678503937 SSM within limits	
	678504193 SDIpos observed	
	678504449 SDIneg observed	
	678504705 SLP1 observed	
	678504961 SLP2 observed	
	678505217 SLP3 observed	
	678505473 SLP4 observed	
	678505729 SCA1 within limits	
	678505985 SCA2 within limits	
	678506241 SCA3 within limits	
	678506497 SCA4 within limits	
	678506753 PDSSpos observed	
678507009 PDSSneg observed		
678508801 Positive direction of movement		
0x28BF:006	SLS: Internal source: SLS3: Internal source inversion • Read only	
	0 Not inverted	
	1 Invert	



Safety functions

Safely-limited speed (SLS)

Address	Name / setting range / [default setting]	Information
0x28BF:007	SLS: Internal source: SLS4: Internal source • Read only	
	0 Deactivated	
	678496513 SDIpos active	
	678496769 SDIneg active	
	678497025 SLI active	
	678497793 OMS active	
	678503937 SSM within limits	
	678504193 SDIpos observed	
	678504449 SDIneg observed	
	678504705 SLP1 observed	
	678504961 SLP2 observed	
	678505217 SLP3 observed	
	678505473 SLP4 observed	
	678505729 SCA1 within limits	
	678505985 SCA2 within limits	
	678506241 SCA3 within limits	
	678506497 SCA4 within limits	
678506753 PDSSpos observed		
678507009 PDSSneg observed		
678508801 Positive direction of movement		
0x28BF:008	SLS: Internal source: SLS4: Internal source inversion • Read only	
	0 Not inverted	
	1 Invert	
0x28C0:001	SLS: Source SD-In: SLS1: Source SD-In • Read only	
	0 Deactivated	
	1 SD-In1	
	2 SD-In2	
	3 SD-In3	
0x28C0:002	SLS: Source SD-In: SLS2: Source SD-In • Read only	
	0 Deactivated	
	1 SD-In1	
	2 SD-In2	
	3 SD-In3	
0x28C0:003	SLS: Source SD-In: SLS3: Source SD-In • Read only	
	0 Deactivated	
	1 SD-In1	
	2 SD-In2	
	3 SD-In3	
0x28C0:004	SLS: Source SD-In: SLS4: Source SD-In • Read only	
	0 Deactivated	
	1 SD-In1	
	2 SD-In2	
	3 SD-In3	
0x28C0:004	SLS: Source SD-In: SLS4: Source SD-In • Read only	
	0 Deactivated	
	1 SD-In1	
	2 SD-In2	
	3 SD-In3	
0x28C0:004	SLS: Source SD-In: SLS4: Source SD-In • Read only	
	0 Deactivated	
	1 SD-In1	
	2 SD-In2	
	3 SD-In3	
0x28C0:004	SLS: Source SD-In: SLS4: Source SD-In • Read only	
	0 Deactivated	
	1 SD-In1	
	2 SD-In2	
	3 SD-In3	
0x28C0:004	SLS: Source SD-In: SLS4: Source SD-In • Read only	
	0 Deactivated	
	1 SD-In1	
	2 SD-In2	
	3 SD-In3	
0x28C0:004	SLS: Source SD-In: SLS4: Source SD-In • Read only	
	0 Deactivated	
	1 SD-In1	
	2 SD-In2	
	3 SD-In3	

Safety functions

Safely-limited speed (SLS)



Address	Name / setting range / [default setting]	Information
0x28C1:001	SLS: Source S-Bus: SLS1: Source S-Bus • Read only	
	0 Deactivated	
	1 Activated	
0x28C1:002	SLS: Source S-Bus: SLS2: Source S-Bus • Read only	
	0 Deactivated	
	1 Activated	
0x28C1:003	SLS: Source S-Bus: SLS3: Source S-Bus • Read only	
	0 Deactivated	
	1 Activated	
0x28C1:004	SLS: Source S-Bus: SLS4: Source S-Bus • Read only	
	0 Deactivated	
	1 Activated	
0x28C2:001	SLS: Limited Speed Nlim: SLS1: Limited Speed Nlim1 • Read only: x rpm	
0x28C2:002	SLS: Limited Speed Nlim: SLS2: Limited Speed Nlim2 • Read only: x rpm	
0x28C2:003	SLS: Limited Speed Nlim: SLS3: Limited Speed Nlim3 • Read only: x rpm	
0x28C2:004	SLS: Limited Speed Nlim: SLS4: Limited Speed Nlim4 • Read only: x rpm	
0x28C3:001	SLS: Braking time Nlim: SLS1: Braking time Nlim1 • Read only: x ms	
0x28C3:002	SLS: Braking time Nlim: SLS2: Braking time Nlim2 • Read only: x ms	
0x28C3:003	SLS: Braking time Nlim: SLS3: Braking time Nlim3 • Read only: x ms	
0x28C3:004	SLS: Braking time Nlim: SLS4: Braking time Nlim4 • Read only: x ms	
0x28C4:001	SLS: Permitted direction: SLS1: Permitted direction • Read only	
	0 Both directions enabled	
	1 Positive direction enabled	
	2 Negative direction enabled	
0x28C4:002	SLS: Permitted direction: SLS2: Permitted direction • Read only	
	0 Enable both directions	
	1 Positive direction enabled	
	2 Negative direction enabled	
0x28C4:003	SLS: Permitted direction: SLS3: Permitted direction • Read only	
	0 Enable both directions	
	1 Positive direction enabled	
	2 Negative direction enabled	
0x28C4:004	SLS: Permitted direction: SLS4: Permitted direction • Read only	
	0 Enable both directions	
	1 Positive direction enabled	
	2 Negative direction enabled	
0x28C5:001	SLS: Reaction (n>Nlim): SLS1: Reaction (n>Nlim1) • Read only	
	0 STO	
	1 SS1	
	2 SS2	



Safety functions

Safely-limited speed (SLS)

Address	Name / setting range / [default setting]	Information
0x28C5:002	SLS: Reaction (n>Nlim): SLS2: Reaction (n>Nlim2) • Read only	
	0 STO	
	1 SS1	
	2 SS2	
0x28C5:003	SLS: Reaction (n>Nlim): SLS3: Reaction (n>Nlim3) • Read only	
	0 STO	
	1 SS1	
	2 SS2	
0x28C5:004	SLS: Reaction (n>Nlim): SLS4: Reaction (n>Nlim4) • Read only	
	0 STO	
	1 SS1	
	2 SS2	
0x28C6:001	SLS active: Output: SLS1 active: Output • Read only	
	0 Deactivated	
	1 SD-Out1 positive logic	
	2 SD-Out1 negative logic	
0x28C6:002	SLS active: Output: SLS2 active: Output • Read only	
	0 Deactivated	
	1 SD-Out1 positive logic	
	2 SD-Out1 negative logic	
0x28C6:003	SLS active: Output: SLS3 active: Output • Read only	
	0 Deactivated	
	1 SD-Out1 positive logic	
	2 SD-Out1 negative logic	
0x28C6:004	SLS active: Output: SLS4 active: Output • Read only	
	0 Deactivated	
	1 SD-Out1 positive logic	
	2 SD-Out1 negative logic	
0x28C7:001	SLS observed: Output: SLS1 observed: Output • Read only	
	0 Deactivated	
	1 SD-Out1 positive logic	
	2 SD-Out1 negative logic	
0x28C7:002	SLS observed: Output: SLS2 observed: Output • Read only	
	0 Deactivated	
	1 SD-Out1 positive logic	
	2 SD-Out1 negative logic	
0x28C7:003	SLS observed: Output: SLS3 observed: Output • Read only	
	0 Deactivated	
	1 SD-Out1 positive logic	
	2 SD-Out1 negative logic	
0x28C7:004	SLS observed: Output: SLS4 observed: Output • Read only	
	0 Deactivated	
	1 SD-Out1 positive logic	
	2 SD-Out1 negative logic	
0x2907:001	Additional speed limitation 0 ... [0] ... 480000 rpm	

Safety functions

Safe speed monitor (SSM)



18.9 Safe speed monitor (SSM)

The function monitors the limited speed set.

The function is activated if:

- the monitoring limits are parameterised, or
- the values are non-zero.

WARNING!

A safety-rated encoder system must be used.

Without an encoder, this safety function cannot be used.

► Apply a safety-rated encoder system to use this function.

NOTICE

The SSM function does not feature any hysteresis.

Oscillating response of the safe output during operation in the proximity of the speed limit parameterised.

Oscillating response of the safe output when slowly passing the speed limit parameterised.

► Avoid continuous operation at the speed limit parameterised.

Functional description

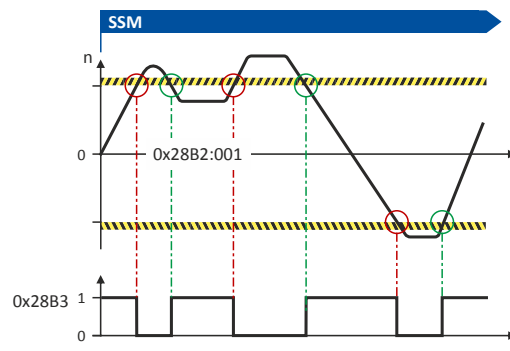

During operation within the limit values, the SSM status is set on the safety bus within the limits [0x2870:002](#)[0x2870:002](#).

The SSM status is assigned to the safe output as safe speed monitor (amount) [0x28B2:001](#)[0x28B2:001](#).

If the amount of the safe speed adopts the value "0", the SSM function is deactivated.

The status bit in [0x28B3](#)[0x28B3](#) influences the control of available outputs.

Parameter

Address	Name / setting range / [default setting]	Information
0x28B2:001	SSM parameters: SSM: Observed speed • Read only: x rpm	
0x28B3	SSM within limits • Read only	
	0 Deactivated	
	1 SD-Out1 positive logic	
	2 SD-Out1 negative logic	



18.10 Safely-limited increment (SLI)

With this function, a maximum permissible position change [incr] can be set.

Within the position window, the increments parameterised can be traversed in positive and negative directions. There is no time limit for executing this function. If the increment limits parameterised are exceeded, an error stop is initiated.

⚠ WARNING!

A safety-rated encoder system must be used.

Without an encoder, this safety function cannot be used.

► Apply a safety-rated encoder system to use this function.

Functional description

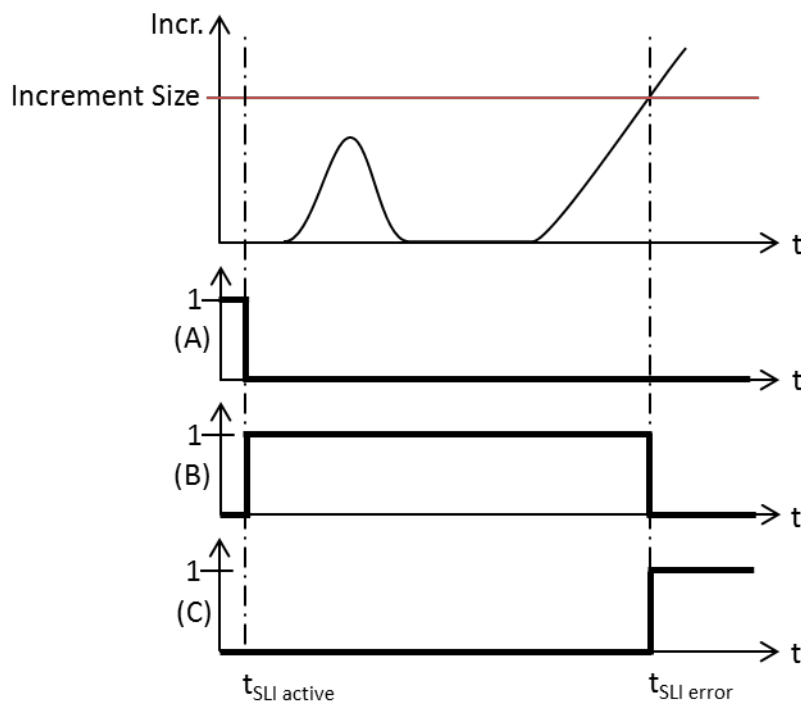

Fig. 9: SLI function

A Triggering of the function
B Monitoring active

C Error status

If the drive exceeds the increment parameterised in [0x28CA:001](#) (normal operation) or [0x28CA:003](#) (special operation), the stop function set in [0x28CA:002](#) is executed.

Activation of the function



The function cannot be activated if the drive is in [Safe operating stop \(SOS\)](#).

The function can be activated during operation.

The function is activated

- via the safety bus. For this purpose, a data telegram is sent to the inverter, [see safety bus](#).
- as a function of the operating mode changeover (OMS) by activation of the special operation, [Operation mode selector \(OMS\)](#). [329](#)
- by the OFF state on a safe input. For the OFF state, a function is parameterised. [See safe inputs](#).

Safety functions

Safely-limited increment (SLI)



Behaviour of the function in the event of an error

If the maximum permissible position change is exceeded, an error stop is initiated. The following functions can be set as safe stop:

- ▶ Safe torque off (STO) [📖 292](#)
- ▶ Safe stop 1 (SS1) [📖 295](#)
- ▶ Safe stop 2 (SS2) [📖 298](#)



When exceeding the position change in the OMS mode, the error stop set there is used. See chapter " ▶ [Operation mode selector \(OMS\)](#)". [📖 329](#)

Parameter

Address	Name / setting range / [default setting]	Information
0x28C8	SLI: Source SD-In • Read only	
	0 Deactivated	
	1 SD-In1	
	2 SD-In2	
	3 SD-In3	
0x28C9	SLI: Source S-Bus • Read only	
	0 Deactivated	
	1 Activated	
0x28CA:001	SLI: SLI: Increment size normal operation • Read only: x incr.	
0x28CA:002	SLI: SLI: Error reaction normal operation • Read only	
	0 STO	
	1 SS1	
	2 SS2	
0x28CA:003	SLI: SLI: Increment size exceptional operation • Read only: x incr.	
0x28CA:004	SLI: SLI: Maximum change of Position • Read only: x incr.	
0x28CB	SLI active: Output • Read only	
	0 Deactivated	
	1 SD-Out1 positive logic	
	2 SD-Out1 negative logic	



18.11 Safe direction (SDI)

The function monitors the direction of rotation of the motor. A parameterisable tolerance threshold ensures that the drive does not change the permissible direction of rotation. Within the limits parameterised, the drive can rotate in the impermissible direction of rotation.

NOTICE

The delay in `0x28BA:002` is parameterised with a value > 0 .

Machine parts and parts of the facility can be destroyed if this setting is not taken into consideration for the calculation of the safety distance.

- ▶ Only utilise this function if the safety distance has been calculated previously, taking the delay set into consideration.
- ▶ If necessary, the "SDIpos observed" or "SDIneg observed" feedback must be evaluated (via the [safety bus](#) or via a [safe output](#)).

⚠ WARNING!

A safety-rated encoder system must be used.

Without an encoder, this safety function cannot be used.

- ▶ Apply a safety-rated encoder system to use this function.

Condition

- The risk analysis must ensure that the deceleration presents no danger.
- The application leads the drive into the permissible direction of movement.

Conditions

- The risk analysis must ensure that the delay does not pose any hazard.
- The application leads the drive to the permissible direction of rotation.

Functional description

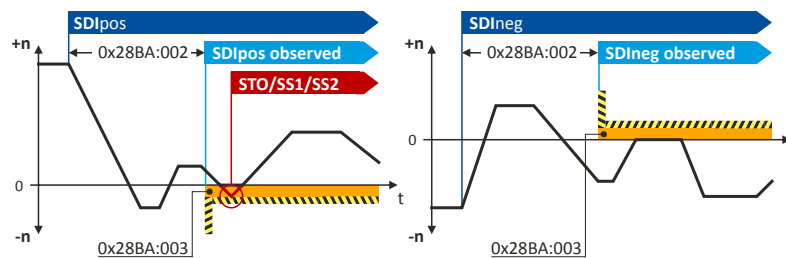

Fig. 10: SDI configuration modes

For operation within the limit values, the SDIpos observed (`0x28BB:0010x28BB:001`) or SDIneg observed (`0x28BB:0020x28BB:002`) status is set.

The status can

- be assigned to the safe output (`0x28BB:0010x28BB:001` or `0x28BB:0020x28BB:002`) or
- can be reported via the safety bus (`0x28B9:0010x28B9:001` or `0x28BB:0020x28B9:002`).

Activation of the function

A data telegram is sent to the inverter via the safety bus. See chapter "Sichere Netzwerkschnittstellen".

Via a safe input, if the corresponding parameter is assigned to the safe input.

For normal operation, the safe direction can be set via a safe parameter.

The safe direction can be combined with the [Safely-limited speed \(SLS\)](#) function. [306](#)

Safety functions

Safe direction (SDI)



If the tolerance threshold for the SDIpos or SDIneg direction set (0x28BA:0020x28BA:003) is exceeded after the delay time has elapsed (0x28BA:0030x28BA:002), an error message is triggered and the stop function set in 0x28BA:0040x28BA:S004 is activated.

Parameter

Address	Name / setting range / [default setting]	Information
0x28B8:001	SDI: Source SD-In: SDIpos: Source SD-In • Read only	
	0 Deactivated	
	1 SD-In1	
	2 SD-In2	
	3 SD-In3	
0x28B8:002	SDI: Source SD-In: SDIneg: Source SD-In • Read only	
	0 Deactivated	
	1 SD-In1	
	2 SD-In2	
	3 SD-In3	
0x28B9:001	SDI: Source S-Bus: SDIpos: Source S-Bus • Read only	
	0 Deactivated	
0x28B9:002	SDI: Source S-Bus: SDIneg: Source S-Bus • Read only	
	1 Activated	
0x28BA:001	SDI: Monitoring normal operation • Read only	
	0 Both directions enabled	
	1 Positive direction enabled	
0x28BA:002	SDI: Delay time • Read only: x ms	
	2 Negative direction enabled	
0x28BA:003	SDI: Tolerance threshold • Read only: x incr.	
0x28BA:004	SDI: Error reaction • Read only	
	0 STO	
	1 SS1	
0x28BA:005	SDI: SDI: Maximal change of Position • Read only: x incr.	
	2 SS2	
0x28BB:001	SDI observed: Output: SDIpos observed: Output • Read only	
	0 Deactivated	
	1 SD-Out1 positive logic	
0x28BB:002	SDI observed: Output: SDIneg observed: Output • Read only	
	2 SD-Out1 negative logic	
	0 Deactivated	
	1 SD-Out1 positive logic	
	2 SD-Out1 negative logic	



18.12 Safely-limited position (SLP)

The function monitors the lower and upper position limit.

Preconditions

The following function must be executed:

- Set upper position value.
- Set lower position value.
- [Safe homing \(SHOM\)](#)

Functional description

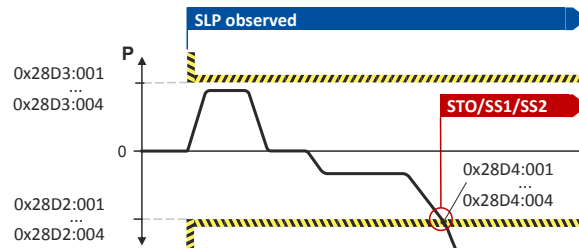

Fig. 11: SLP function

For operation within the upper limit value, the SLPpos observed status is used. 0x28D3:000

For operation within the lower limit value, the SLPneg observed status is used. 0x28D2:000

The upper and lower position limits parameterised are monitored at the time of the request, see SLPx observed status bit.

The status can

- be assigned to the safe output (0x28BB:0010x28BB:001 or 0x28BB:0020x28BB:002).
- be reported via the safety bus (0x28B9:0010x28B9:001 or 0x28BB:0020x28B9:002).

This function can be executed during normal operation and special operation. See

► [Operation mode selector \(OMS\)](#) . [329](#)

Up to four absolute position setpoint pairs can be parameterised and monitored at the same time.



In connection with this function, please also observe the information with regard to safe homing in chapter [Safe homing \(SHOM\)](#).

Activation of the function

A data telegram is sent to the inverter via the safety bus. See chapter "Sichere Netzwerkschnittstellen".

Via a safe input, if the corresponding parameter is assigned to the safe input.

Behaviour of the function in the event of an error

If the Plim position limit is exceeded during the monitoring process,

- an error message is triggered.
 - a stop function for the parameters set
 - 0x28D2:0010x28D2:001 ... 0x28D2:0040x28D2:004 the lower absolute position limit set
 - 0x28D3:0010x28D3:001 ... 0x28D3:0040x28D3:004 the upper absolute position limit set
- is triggered.

Safety functions

Safely-limited position (SLP)



Parameter

Address	Name / setting range / [default setting]	Information
0x28D0:001	SLP: Source SD-In: SLP1: Source SD-In • Read only	
	0 Deactivated	
	1 SD-In1	
	2 SD-In2	
	3 SD-In3	
	4 SD-In4	
0x28D0:002	SLP: Source SD-In: SLP2: Source SD-In • Read only	
	0 Deactivated	
	1 SD-In1	
	2 SD-In2	
	3 SD-In3	
	4 SD-In4	
0x28D0:003	SLP: Source SD-In: SLP3: Source SD-In • Read only	
	0 Deactivated	
	1 SD-In1	
	2 SD-In2	
	3 SD-In3	
	4 SD-In4	
0x28D0:004	SLP: Source SD-In: SLP4: Source SD-In • Read only	
	0 Deactivated	
	1 SD-In1	
	2 SD-In2	
	3 SD-In3	
	4 SD-In4	
0x28D1:001	SLP: Source S-Bus: SLP1: Source S-Bus • Read only	
	0 Deactivated	
	1 Activated	
0x28D1:002	SLP: Source S-Bus: SLP2: Source S-Bus • Read only	
	0 Deactivated	
	1 Activated	
0x28D1:003	SLP: Source S-Bus: SLP3: Source S-Bus • Read only	
	0 Deactivated	
	1 Activated	
0x28D1:004	SLP: Source S-Bus: SLP4: Source S-Bus • Read only	
	0 Deactivated	
	1 Activated	
0x28D2:001	SLP: Lower Postion limit: SLP1: Lower Postion limit • Read only: x incr.	
0x28D2:002	SLP: Lower Postion limit: SLP2: Lower Postion limit • Read only: x incr.	
0x28D2:003	SLP: Lower Postion limit: SLP3: Lower Postion limit • Read only: x incr.	
0x28D2:004	SLP: Lower Postion limit: SLP4: Lower Postion limit • Read only: x incr.	
0x28D3:001	SLP: Upper Postion limit: SLP1: Upper Postion limit • Read only: x incr.	
0x28D3:002	SLP: Upper Postion limit: SLP2: Upper Postion limit • Read only: x incr.	



Safety functions

Safely-limited position (SLP)

Address	Name / setting range / [default setting]	Information
0x28D3:003	SLP: Upper Position limit: SLP3: Upper Position limit • Read only: x incr.	
0x28D3:004	SLP: Upper Position limit: SLP4: Upper Position limit • Read only: x incr.	
0x28D4:001	SLP: Error reaction: SLP1: Error reaction • Read only	
	0 STO	
	1 SS1	
	2 SS2	
0x28D4:002	SLP: Error reaction: SLP2: Error reaction • Read only	
	0 STO	
	1 SS1	
	2 SS2	
0x28D4:003	SLP: Error reaction: SLP3: Error reaction • Read only	
	0 STO	
	1 SS1	
	2 SS2	
0x28D4:004	SLP: Error reaction: SLP4: Error reaction • Read only	
	0 STO	
	1 SS1	
	2 SS2	
0x28D5:001	SLP observed: Output: SLP1 observed: Output • Read only	
	0 Deactivated	
	1 SD-Out1 positive logic	
	2 SD-Out1 negative logic	
0x28D5:002	SLP observed: Output: SLP2 observed: Output • Read only	
	0 Deactivated	
	1 SD-Out1 positive logic	
	2 SD-Out1 negative logic	
0x28D5:003	SLP observed: Output: SLP3 observed: Output • Read only	
	0 Deactivated	
	1 SD-Out1 positive logic	
	2 SD-Out1 negative logic	
0x28D5:004	SLP observed: Output: SLP4 observed: Output • Read only	
	0 Deactivated	
	1 SD-Out1 positive logic	
	2 SD-Out1 negative logic	

Safety functions

Position-dependent safe speed (PDSS)



18.13 Position-dependent safe speed (PDSS)

The function

- monitors the speed of a drive as a function of the absolute position along a motion range.
- allows for the utilisation of a physically limited motion range without the use of mechanical buffers and limit switches.
- can be parameterised as permanently active.

NOTICE

If the slip compensation is used, the diagnostic marks must be overtravelled cyclically.

Machine parts and parts of the facility may be destroyed if the slip compensation described is not taken into consideration for the respective application.

- ▶ Check the slip compensation for the respective application.
- ▶ Ensure a diagnostic interval test by a higher-level control component.

Functional description

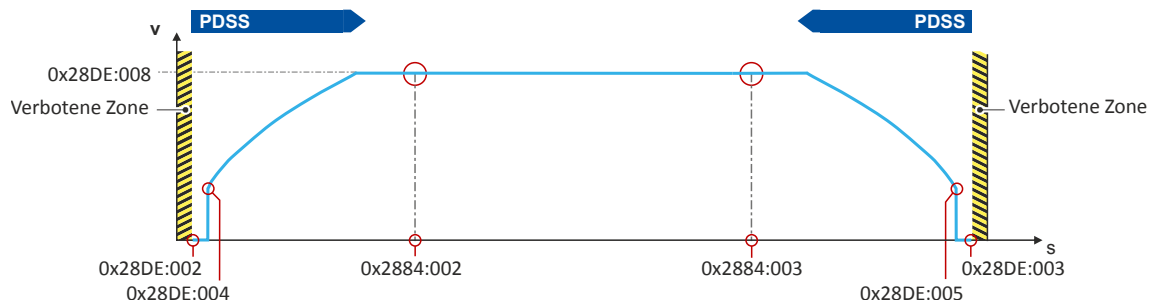

Fig. 12: PDSS function, representation of the key parameters

For this function, please also observe the description relating to the slip compensation in section .

Safe creeping speed (SCS)	
<p>It depends on the application whether the drive approaches the position limit (0x28DE:002x28DE:002) with the limited speed v_{max} (0x28DE:0080x28DE:008). The limited speed is predefined by the monitoring function.</p>	<p>By parameterising a safe creeping speed (SCS), the prohibited zone can nearly be approached. The distance to the position limit (0x28DE:002x28DE:002) and the tolerance parameterised must be selected extensively enough to rule out a collision. The speed changeover depending on the direction of rotation makes it possible for the drive to move away from the prohibited zone at maximum speed.</p>



In connection with this function, please also observe the information with regard to safe homing. See chapter [Safe homing \(SHOM\)](#). [323](#)

Activation of the function

A data telegram is sent to the inverter via the safety bus. See chapter "Sichere Netzwerkschnittstellen".



Via a safe input, if the corresponding parameter is assigned to the safe input.

Error behaviour

If the envelope curve is exceeded or when the absolute position limits are exited, an error message is triggered and an error stop with the function set in the [0x28DE:011](#) [0x28DE:011](#) parameter is initiated.

Parameter

Address	Name / setting range / [default setting]	Information
0x28DC	PDSS: Source SD-In • Read only	
	0 Deactivated	
	1 SD-In1	
	2 SD-In2	
	3 SD-In3	
0x28DD	PDSS: Source S bus • Read only	
	0 Deactivated	
0x28DE:001	PDSS parameters: PDSS: Permanent activation • Read only	
	0 On demand	
0x28DE:002	PDSS parameters: PDSS: Lower position limit • Read only: x incr.	
	1 Activated	
0x28DE:003	PDSS parameters: PDSS: Upper position limit • Read only: x incr.	
0x28DE:004	PDSS parameters: PDSS: Lower SCS limit • Read only: x incr.	
0x28DE:005	PDSS parameters: PDSS: Upper SCS limit • Read only: x incr.	
0x28DE:006	PDSS parameters: PDSS: SCS from lower limit • Read only: x rpm	
0x28DE:007	PDSS parameters: PDSS: SCS from upper limit • Read only: x rpm	
0x28DE:008	PDSS parameters: PDSS: Max. speed • Read only: x rpm	
0x28DE:009	PDSS parameters: PDSS: Max. delay - lower limit • Read only	
0x28DE:010	PDSS parameters: PDSS: Max. delay - upper limit • Read only	
0x28DE:011	PDSS parameters: PDSS: Error response • Read only	
	0 STO	
	1 SS1	
0x28DE:012	2 SS2	
	PDSS parameters: PDSS: Currently observed speed • Read only: x rpm	
0x28DE:013	PDSS parameters: PDSS: Min difference observed speed • Read only: x rpm	
0x28DF	PDSS: PDSSpos observed output • Read only	
	0 Deactivated	
	1 SD-Out1 positive logic	
	2 SD-Out1 negative logic	

Safety functions

Position-dependent safe speed (PDSS)



Address	Name / setting range / [default setting]	Information
0x28E0	PDSS: PDSSneg observed output	
	• Read only	
	0 Deactivated	
	1 SD-Out1 positive logic	
2 SD-Out1 negative logic		



18.14 Safe homing (SHOM)

This function supplements the position evaluation of the encoder systems used. See .

WARNING!

In the switched-off state, the motor position must not be changed by external forces.

A change in the motor position causes injuries and may even result in death.

► Ensure that the motor position does not change.

Preconditions

In applications with only one position switch, this switch must be connected in parallel to the inputs X82/IRS and X82/IRL.

Safety functions

Safe homing (SHOM)



Functional description



The start of the homing process does not cause the drive to execute a homing process. The initialisation and motion control are both executed autonomously by the drive.

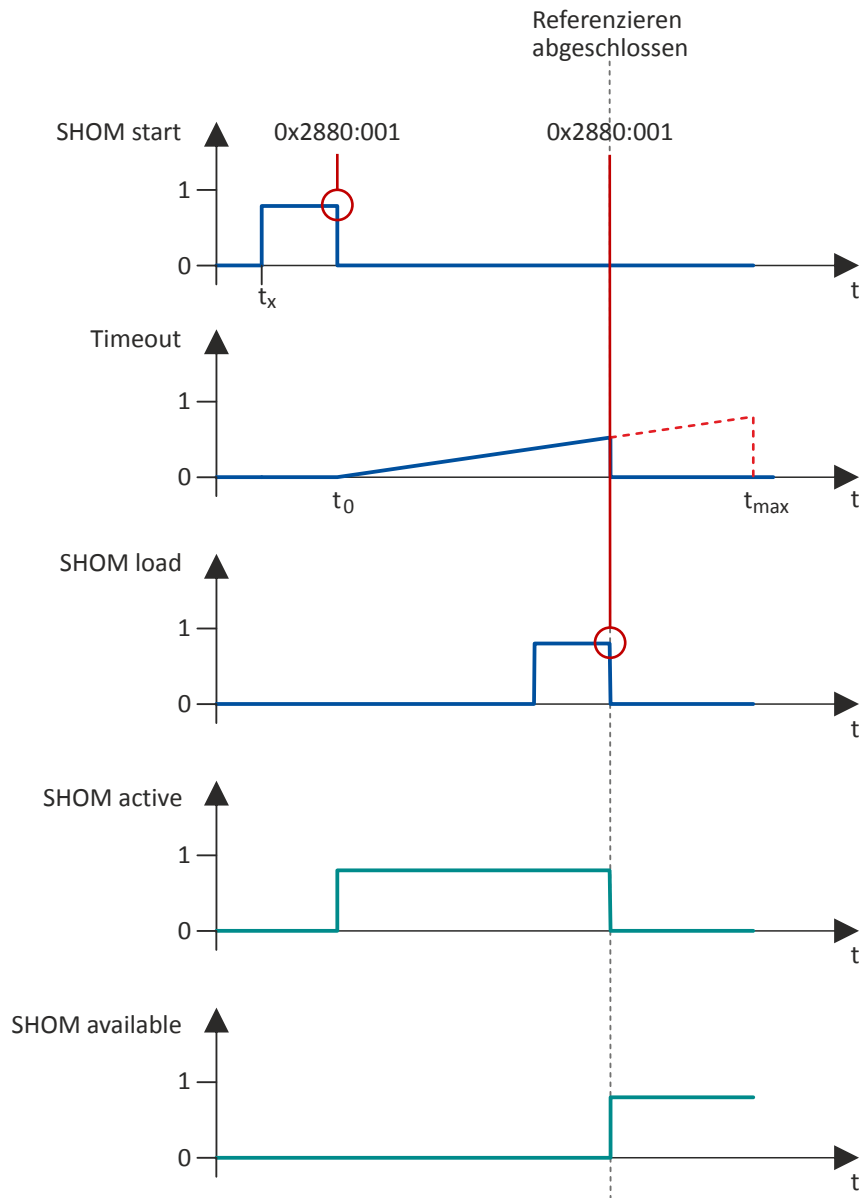

Fig. 13: Timing of the SHOM function

The homing process is for example started via the IRS signal (source can be set in [0x2880:001](#)).

The safely limited speed (SLS) is always activated. ▶ [Safely-limited speed \(SLS\)](#) 306.

Within a time period defined in [0x2882:002](#) (timeout), the [0x2881:001](#) reference signal is expected via the input X82/IRL (SHOM-Load). The reference signal defines the safe reference point [0x2882:001](#) (home position) in the absolute area.

When the reference point has been defined, homing is completed. A changeover to normal operation will follow.



The home position parameterised is the absolute reference point for these safety functions:

- Safely-limited position (SLP) [□ 317](#)
- Position-dependent safe speed (PDSS) [□ 320](#)
- Safe cam (SCA) [□ 327](#)

The following states are shown:

- The "SHOM active" state is reset (display in [0x2882:006](#)).
- The "SHOM available" state is set (display in [0x2882:006](#))

Parameter

Address	Name / setting range / [default setting]	Information
0x2110:014	SHOM: Delete home position	
	0 Ready	
	1 Start	
	2 In progress	
	3 Action cancelled	
	4 No access	
0x2880:001	SHOM_Start settings: SHOM_Start: Source	
	• Read only	
	0 Deactivated	
	13 S bus	
0x2880:002	SHOM_Start settings: SHOM_Start: Edge trigger IRS	
	• Read only	
	0 Rising edge	
0x2881:001	SHOM_Load settings: SHOM_Load: Source	
	• Read only	
	13 S bus	
0x2881:002	SHOM_Load settings: SHOM_Load: Edge trigger IRL	
	• Read only	
	0 Rising edge	
0x2882:001	Safe homing (SHOM): SHOM: Home position	
	• Read only: x incr.	
	0x2882:002	
0x2882:003	Safe homing (SHOM): SHOM: SLS homing	
	• Read only	
	3 SLS1	
	4 SLS2	
	5 SLS3	
0x2882:007	Safe homing (SHOM): SHOM: Saved position	
	• Read only: x incr.	
	0x2883	
0x2883	SHOM: Diagnostic positions source	
	• Read only	
	0 Deactivated	
	1 SD-In1	
	2 SD-In2	
	3 SD-In3	
	4 SD-In4	
	14 IRS	
15 IRL		

Safety functions

Mini-homing



Address	Name / setting range / [default setting]	Information
0x2884:001	SHOM diagnostic positions: SHOM: Detection diag position • Read only	
	0 LOW level	
	1 HIGH level	
0x2884:002	SHOM diagnostic positions: SHOM: Lower diagnostic position • Read only: x incr.	
0x2884:003	SHOM diagnostic positions: SHOM: Upper diagnostic position • Read only: x incr.	
0x2884:004	SHOM diagnostic positions: SHOM: Tolerance diag positions • Read only: x incr.	
0x2884:005	SHOM diagnostic positions: SHOM: Error response diag positions • Read only	
	0 STO	
	1 SS1	
	2 SS2	
0x2884:006	SHOM diagnostic positions: SHOM: Current difference diagnostic position • Read only: x incr.	
0x2885:001	SHOM: Slip compensation: SHOM: Maximally compensated slip • Read only: x incr.	
0x2885:002	SHOM: Slip compensation: SHOM: Slip compensation end area • Read only	
	0 Deactivated	
	1 Activated	
0x2886	SHOM: SHOM active output • Read only	
	0 Deactivated	
	1 SD-Out1 positive logic	
	2 SD-Out1 negative logic	
0x2887	SHOM: SHOM available output • Read only	
	0 Deactivated	
	1 SD-Out1 positive logic	
	2 SD-Out1 negative logic	

18.15 Mini-homing

The mini-homing process serves to reach plausibility of the safety function's absolute position values. The mini-homing process is carried out via the [Safely-limited speed \(SLS\)](#) function and is monitored by the safety function.

Prerequisites

- The safely limited speed N_{lim} must have been parameterised. [0x28C2:001](#)
- The distance of the mini reference run must \geq the 4-fold value of the parameter to be configured. [0x287C:001](#)

Completion of the mini-homing process

After the mini-homing, the status bit is set. [0x2882:006](#)

After returning from the above-mentioned states, with a parameterised safe home position, the path of motion control can generally adopt the motion in the direction of the home position.



18.16 Safe cam (SCA)

The function monitors the lower and upper position limit.

Preconditions

The following function must be executed:

- Set upper position value.
- Set lower position value.
- [Safe homing \(SHOM\)](#)

Functional description



In connection with this function, please also observe the information with regard to safe homing in chapter [Safe homing \(SHOM\)](#). [□ 323](#)

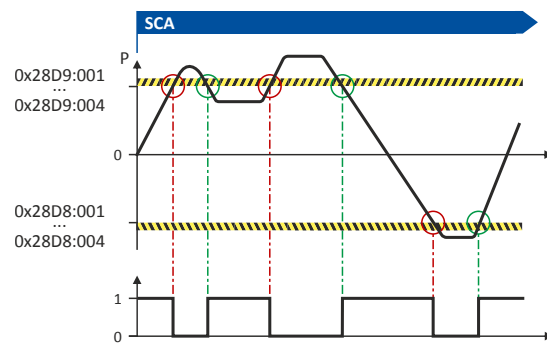

Fig. 14: SCA function

When this function is executed, the current absolute position is compared to the position limits parameterised.

- Upper position limit parameterised ([0x28D9:0010x28D9:001 ... 0x28D9:0040x28D9:004](#))
- Lower position limit parameterised ([0x28D8:0010x28D8:001 ... 0x28D8:0040x28D8:004](#))

The status of the position comparison is specified in a binary fashion in [0x2870:0020x2870:002, bit12 ... bit15](#).

The status is transmitted to the safety and standard application.

Activation of the function

The function is activated by entry of a parameter value ($\neq 0$) for the upper and lower position limit.

Safety functions

Safe cam (SCA)



Parameter

Address	Name / setting range / [default setting]	Information
0x28D8:001	SCA: Lower Postion limit: SCA1: Lower Postion limit • Read only: x incr.	
0x28D8:002	SCA: Lower Postion limit: SCA2: Lower Postion limit • Read only: x incr.	
0x28D8:003	SCA: Lower Postion limit: SCA3: Lower Postion limit • Read only: x incr.	
0x28D8:004	SCA: Lower Postion limit: SCA4: Lower Postion limit • Read only: x incr.	
0x28D9:001	SCA: Upper Postion limit: SCA1: Upper Postion limit • Read only: x incr.	
0x28D9:002	SCA: Upper Postion limit: SCA2: Upper Postion limit • Read only: x incr.	
0x28D9:003	SCA: Upper Postion limit: SCA3: Upper Postion limit • Read only: x incr.	
0x28D9:004	SCA: Upper Postion limit: SCA4: Upper Postion limit • Read only: x incr.	
0x28DA:001	SCA inbetween limits: Output: SCA1 inbetween limits: Output • Read only	
	0 Deactivated	
	1 SD-Out1 positive logic	
	2 SD-Out1 negative logic	
0x28DA:002	SCA inbetween limits: Output: SCA2 inbetween limits: Output • Read only	
	0 Deactivated	
	1 SD-Out1 positive logic	
	2 SD-Out1 negative logic	
0x28DA:003	SCA inbetween limits: Output: SCA3 inbetween limits: Output • Read only	
	0 Deactivated	
	1 SD-Out1 positive logic	
	2 SD-Out1 negative logic	
0x28DA:004	SCA inbetween limits: Output: SCA4 inbetween limits: Output • Read only	
	0 Deactivated	
	1 SD-Out1 positive logic	
	2 SD-Out1 negative logic	



18.17 Operation mode selector (OMS)

This function serves to switch between normal operation and special operation of the drive.



If the OMS safety function is requested via a HIGH signal, the safety function is switched off in the case of an open circuit. In this case, there exists no safety function in the case of an open circuit.

⚠ DANGER!

When returning to normal operation, automatic restart is not permissible.

Severe injuries and death.

► Parameterise manual restart.

⚠ WARNING!

Operating mode changeover (OMS) is activated via the safety bus.

If safe communication fails, the OMS function is deactivated.

► Configure at least one stop function (STO, SS1 or SS2).

Functional description

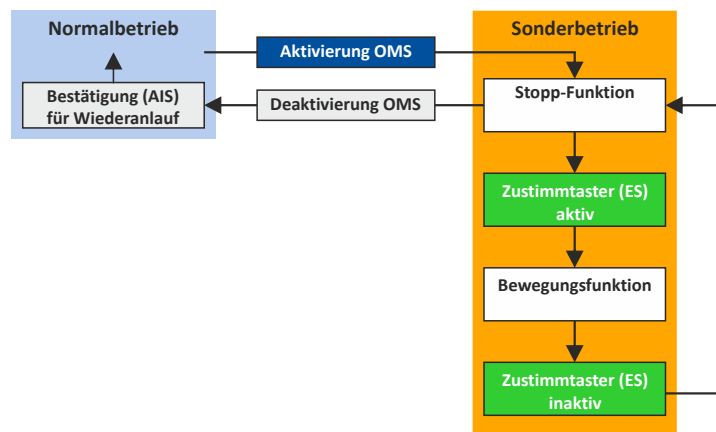

Fig. 15: OMS function

Special operation (OMS) provides for overwriting a normal stop STO, SS1 and SS2 by activating the enable switch (ES), see [Enable switch \(ES\)](#) function. [□ 332](#)

A detected error in special operation activates the stop function that is correspondingly parameterised there ([Safe torque off \(STO\)](#), [Safe stop 1 \(SS1\)](#) or [Safe stop 2 \(SS2\)](#)). The stop function can be parameterised in special operation as stop function.

If a request for special operation is pending ("OMS activation"), the stop function that is parameterised for special operation in [0x28A9:0010x28A9:001](#) ([Safe torque off \(STO\)](#), [Safe stop 1 \(SS1\)](#) or [Safe stop 2 \(SS2\)](#)) is started.

Via [Safely-limited increment \(SLI\)](#), the motion function (SLS or retracting) parameterised for special operation in [0x28A9:002 0x28A9:002](#) can be executed.

Furthermore, [0x28CA:0030x28CA:003](#) can be used to switch on the monitoring function ([Safely-limited increment \(SLI\)](#)) for the motion function parameterised.

The setting "0" deactivates the SLI monitoring function.

Safety functions

Operation mode selector (OMS)



Activation of special operation

By means of the "Operation mode selector" function, special operation is activated by an "ON state" on a safe input. The function [Enable switch \(ES\)](#) must have been assigned to the corresponding input by parameterisation.



Only if no safe input is utilised, the function can be activated via the safety bus. Via the safety bus, a data telegram with a corresponding content is sent to the inverter, see safety bus .

Deactivation of special operation

- A changeover from special operation to normal operation can only be effected when the drive is at a standstill, see [Safe torque off \(STO\)](#), [Safe stop 1 \(SS1\)](#) or [Safe stop 2 \(SS2\)](#) .
- In the case of a restart, the restart (AIS) must be acknowledged via the terminals or safety bus.
- An automatic restart is not permissible.
 - If "Automatic restart" is parameterised, this has to be prevented by special measures, e.g. programming in the master control.

Behaviour of the function in the event of an error

- The monitoring functions [Safe maximum speed \(SMS\)](#) and [Safely-limited speed \(SLS\)](#) can be activated in both operating modes (normal operation / special operation). In the event of an error, the stop function parameterised (STO, SS1 or SS2) is triggered.
- With an activated monitoring function [Safely-limited increment \(SLI\)](#), exceeding the position window triggers the stop function parameterised for special operation.



The "Emergency stop" function can be triggered in normal operation and in special operation and has the highest priority.



Safety functions

Operation mode selector (OMS)

Parameter

Address	Name / setting range / [default setting]	Information
0x2875:012	S bus control bits: OMS • Read only	
0x28A8	OMS: Source • Read only	
	0 Deactivated	
	1 SD-In1	
	2 SD-In2	
	3 SD-In3	
	4 SD-In4	
	13 S-Bus	
0x28A9:001	OMS: OMS: Stop function • Read only	
	0 STO	
	1 SS1	
	2 SS2	
0x28A9:002	OMS: OMS: Movement function • Read only	
	3 SLS1	
	4 SLS2	
	5 SLS3	
	6 SLS4	
	11 Free mode	
0x28A9:003	OMS: OMS: Function at Low Level • Read only	
	0 Normal operation	
	1 Special operation	
0x28AA	OMS active: Output • Read only	
	0 Deactivated	
	1 SD-Out1 positive logic	
	2 SD-Out1 negative logic	

Safety functions

Enable switch (ES)



18.18 Enable switch (ES)

This function makes it possible to override the normal stop functions

- [Safe torque off \(STO\)](#),
- [Safe stop 1 \(SS1\)](#) and
- [Safe stop 2 \(SS2\)](#)

in special operation.

Preconditions

A safe input or the safety bus can be used for connecting an enable switch. If the safe input is used, the **ES** bit of the safety bus must be deactivated. If no safe input is parameterised, the safety bus can be used for activation.

- Activate special operation [Operation mode selector \(OMS\)](#).
- Activate special operation [Repair mode selector \(RMS\)](#).



The plausibility check rejects ambiguous settings until they are parameterised correctly.

Functional description

The enable switch activates the motion function parameterised during special operation (OMS) and the repair mode (RMS). The drive can be traversed.

The stop times assigned to the stop functions are directly deactivated or stopped.

Activation of the function

The function is activated by the ON state of a safe input.

The function must have been assigned to the corresponding input by parameterisation.



If no safe input is utilised, the function can be activated via the safety bus. Via the safety bus, a data telegram with a corresponding content is sent to the inverter, seesafety bus.

Parameter

Address	Name / setting range / [default setting]	Information
0x2875:010	S bus control bits: ES • Read only	
0x28AE	ES: Source • Read only	
	0 Deactivated	
	1 SD-In1	
	2 SD-In2	
	3 SD-In3	
	4 SD-In4	
0x28AF	13 S-Bus	
	ES active: Output • Read only	
	0 Deactivated	
	1 SD-Out1 positive logic	
	2 SD-Out1 negative logic	



18.19 Repair mode selector (RMS)

This function moves the drive from a situation that is blocking it ("Deadlock").

In the safety concept, this state is taken into consideration as a special case for actuating an axis connected. The encoders connected are not evaluated in a safety-oriented fashion.

⚠ WARNING!

Repair mode select (RMS) is activated via the safety bus.

If the safe communication fails, the RMS function will be deactivated.

► Configure at least one stop function (STO, SS1 or SS2).

⚠ DANGER!

In the RMS operating mode unexpected movements with an unexpected speed may occur.

In the RMS operating mode, the permissible motion limits of the axis may be violated.

- The use of the RMS function is exclusively permissible to release an axis from a "deadlock". If possible, the OMS function should be used!
- In the RMS operating mode, exclusively the enable switch is effective. Ensure, if necessary by additional safety measures, that no persons can be endangered.



In the repair mode, the safety functions are solely restricted to the parameterisable STO and SS1 stop functions (without ramp monitoring) and the effectiveness of the enable switch.

⚠ DANGER!

When returning to normal operation, automatic restart is not permissible.

Severe injuries and death.

► Parameterise manual restart.

Functional description

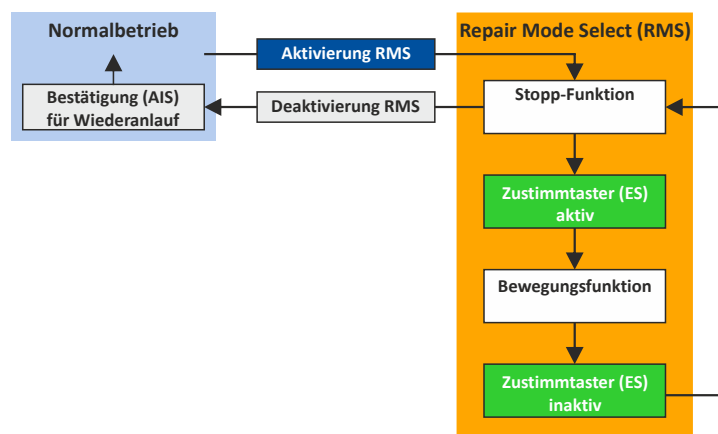

Fig. 16: RMS function

In the repair mode, speed functions and absolute position functions are deactivated. The SHOM status is reset. ► [Safe homing \(SHOM\)](#) [323](#)

Safety functions

Repair mode selector (RMS)



Request of the repair mode

The repair mode is requested by the "ON state" on a safe input. The function must have been assigned to the corresponding input by parameterisation.



Only if no safe input is utilised, the function can be activated via the safety bus. Via the safety bus, a data telegram with a corresponding content is sent to the inverter, see safety bus .

Behaviour of the function in the event of an error

If the position values of the motor encoder and the load encoder do not comply after the repair mode has been exited, the following error states are displayed if absolute position monitoring is active:

- Exit position window
- Slip error
- Deactivation of [Safe homing \(SHOM\)](#). [📖 323](#)

Parameter

Address	Name / setting range / [default setting]	Information
0x2875:020	S bus control bits: RMS • Read only	
0x28AB	RMS: Source • Read only	
	0 Deactivated	
	1 SD-In1	
	2 SD-In2	
	3 SD-In3	
	4 SD-In4	
0x28AD	RMS active: Output • Read only	
	0 Deactivated	
	1 SD-Out1 positive logic	
	2 SD-Out1 negative logic	
0x2882:004	Safe homing (SHOM): SHOM: Restart condition • Read only	
	0 Homing required	
	1 load saved reference	
0x2882:005	Safe homing (SHOM): SHOM: Tolerance - starting position • Read only: x incr.	
0x2882:006	Safe homing (SHOM): SHOM status • Read only	
	0 No reference	
	1 SHOM active	
	2 SHOM available	
	3 small referenz active	
0x28AC:001	RMS: RMS: Stop function • Read only	
	0 STO	
	1 SS1	



18.20 STO cascading (CAS)

This function allows for the synchronised shutdown of an entire drive network.

Preconditions

- As source for the cascading request, the SD-In4 input must be parameterised.
[0x21240x2124, 4: SD-In4](#)
- As an active input for the "Emergency stop" function and the input delay, a value ≤ 10 ms must be parameterised for SD-In4. [Safe inputs](#)
- As executing stop function, the "Safe torque off (STO)" function must be parameterised.
[Safe stop emergency \(SSE\) 0x28A3:001](#) [294](#)
- As restart behaviour of the drive after executing [Safe torque off \(STO\)](#), "Acknowledged restart" must be parameterised. [0x2892:0010x2892:001](#)
- The control of the SD-Out1 output via a parameterised safety bus must be inhibited. [Safety bus](#)



The plausibility check rejects other settings until the plausibility check is parameterised correctly.

- If the cascading safety function is used in connection with special operation, "SS2" must be parameterised as stop function in the operation mode selector (OMS).



The STO stop function will trigger the "Cascading" function. Activation by means of the enable switch (ES) is not possible.

Description of the principle

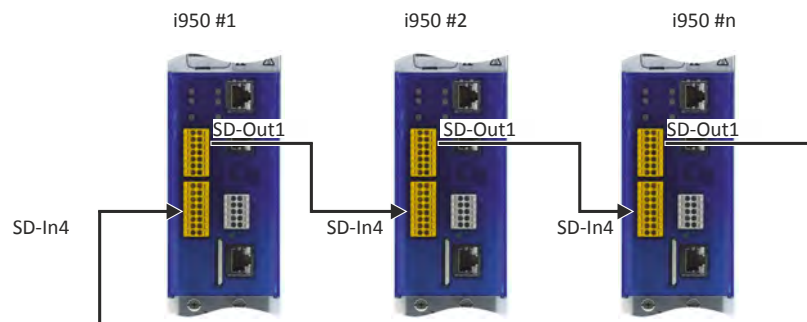

Fig. 17: CAS function

With [0x2125:0010x2125:001](#), the time period is shown, which elapses from switching the SD-Out1 output to the OFF state to recording the OFF state at the SD-In4 input.

- If, after a stop, the time period "0 ms" is shown, another safety function has triggered the stop via the cascade.
- The time period is shown until the next system acknowledgement takes place.

Activation of the function

The function is activated by parameterisation of the SD-In4 input as source for a cascading request ([0x21240x2124, 4: SD-In4](#)).

Parameter

Address	Name / setting range / [default setting]	Information
0x2124	CAS: Quelle SD-In	
	• Read only	
	0 Deactivated	
	4 SD-In4	
0x2125:001	CAS: Cascading: CAS: Stop delay	
	• Read only: x ms	

Safety functions

Safe brake control (SBC)



18.21 Safe brake control (SBC)

(From standard device firmware V1.3, safety firmware V1.1 with parameter set version V1.1)

The SBC function provides for a safe brake control by the inverter.



The internal test rate of the brake output (X106) restricts the request rate to max. 1 brake request/10 seconds.

An application-dependent test rate of the connected brake reduces the request rate accordingly.

Conditions

In order to use the SBC function, the following conditions must be fulfilled:

- The brake is connected to X106.
- Brake function and monitoring of the brake control are controlled via X106 .
- Parameter `0x2820:023` and `0x2820:005`:
 - Both parameters must be set to "0".
 - Other settings are not compatible with the SBC function.

The warning "Incompatible SBC device configuration – 0x6187" is output.

STO stop function is activated.

⚠ DANGER!

Use of non-safety-rated brakes

Severe injuries or death.

- ▶ Only use safety-rated brakes with suitable safety-related parameters according to EN ISO13849-1 and/or EN 62061 or IEC 61508.

Functional description

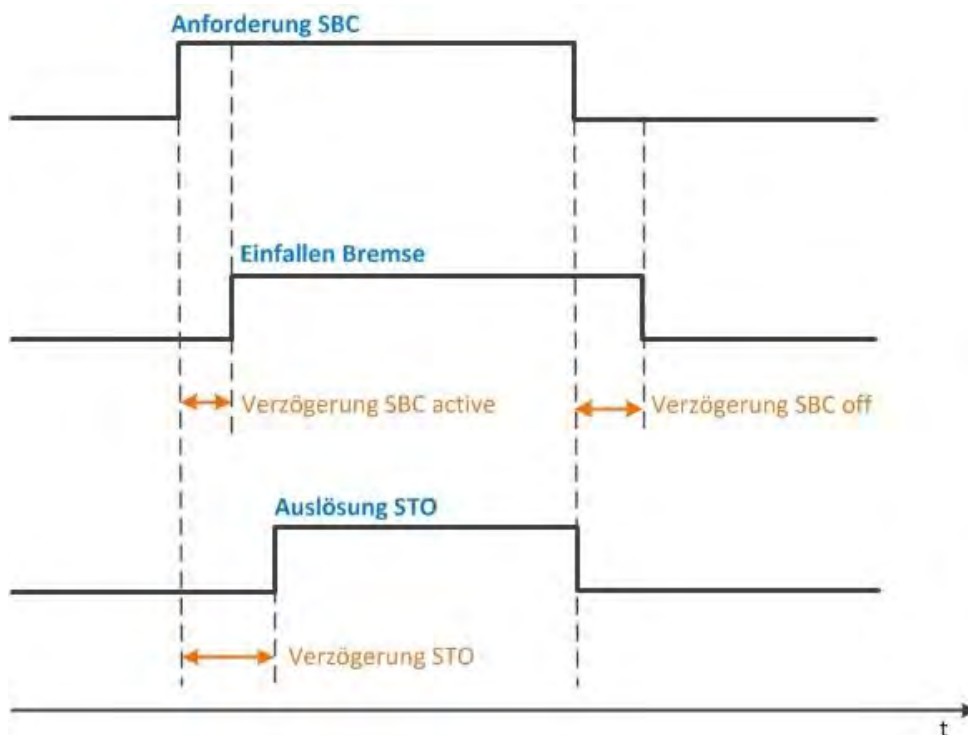

Fig. 18: SBC function



Activation of the function

A data telegram is sent to the inverter via the safety bus. See chapter "Sichere Netzwerkschnittstellen".

Via a safe input, if the corresponding parameter is assigned to the safe input.

Response of the function in the event of an error

If an error is detected, the control of the brake is switched off.



If **0x28E6:001** = 1 (SBC without STO) is parameterized, no stop function is activated in the event of an error.

Parameter

Address	Name / setting range / [default setting]	Information
0x28E4	SBC: Source SD-In • Read only	
	0 Deactivated	
	1 SD-In1	
	2 SD-In2	
	3 SD-In3	
	4 SD-In4	
0x28E5	SBC: Source S-Bus • Read only	
	0 Deactivated	
	1 Activated	
0x28E6:001	SBC settings: Brake mode • Read only	
	1 SBC without STO	
	2 Automatic with STO	
0x28E6:002	SBC settings: SBC delay • Read only: x ms	
0x28E6:003	SBC settings: STO delay • Read only: x ms	
0x28E6:004	SBC settings: Brake open delay • Read only: x ms	
0x28E7:001	SBC status outputs: "SBC active" output • Read only	
	0 Deactivated	
	1 SD-Out1 positive logic	
	2 SD-Out1 negative logic	
0x28E7:002	SBC status outputs: "SBC activated" output • Read only	
	0 Deactivated	
	1 SD-Out1 positive logic	
	2 SD-Out1 negative logic	

Safety functions

Safe muting (MUT)



18.22 Safe muting (MUT)

(From standard device firmware V1.3, safety firmware V1.1 with parameter set version V1.1)



The “safe muting” safety function may only be used during commissioning or maintenance work.

It serves to move the motor even if the inverter is in a safety state.

The safe muting function deactivates selected safe inputs and all functions of the safety bus.

The safe muting function can only be activated via the LSPE (Lenze Safety Parameter Editor). For this purpose, a special muting password must be entered.

Within a network, the safe muting function can always only be activated for one inverter.

The safe muting function is maximally active for 30 minutes. It can be interrupted or stopped anytime.



Please note the following:

If the safe muting function is stopped or interrupted by an error, the inverter automatically changes to the monitored state.

All safety functions that have been deactivated before become active again.



Activating the safe muting function deactivates safety functions!

This may result in severe injuries or death!

- ▶ Only authorized personnel is permitted to activate the safe muting function.
- ▶ One input must be parameterized as emergency stop. This input must not be deactivated by safe muting.

Conditions

In order to activate the safe muting function, you need the following:

- A PC with »Easy Starter« (1.16 or higher) or »PLC Designer« with LSPE (Lenze Safety Parameter Editor).
- A permanent communication link between LSPE and inverter.

If the connection is interrupted during safe muting, safe muting is aborted immediately with an error message. The inverter changes to the monitored operation where all safety functions are active again.

- A valid parameter set that contains the settings for safe muting:
 - The sources to be hidden. `0x213A`
 - The muting password. `0x213B:001`

Activation of the function

Activate safe muting

1. Go to the »Easy Starter« and open the **Safety parameter list** tab.
2. Select safe muting.
3. Enter password.
4. Check information in the window and ensure that the correct device has been selected.
The optical device detection is activated automatically. The blinking blue LED indicates the inverter with activated safe muting.
5. **Start** activates the safe muting function.
The safe muting function is active now.



Deactivation of the function

Deactivate safe muting

1. **Close** deactivates the safe muting function for the input.

The safe muting function is inactive now.

Parameter

Address	Name / setting range / [default setting]	Information
0x2110:015	Activate muting	
	0 Ready	
	1 Start	
	2 In progress	
	3 Action cancelled	
	4 No access	
0x213A:001	Mute sources: S-Bus • Read only	
	0 No muting	
	3 Mute completely	
0x213A:002	Mute sources: SD-In1 • Read only	
	0 No muting	
	1 Mute	
0x213A:003	Mute sources: SD-In2 • Read only	
	0 No muting	
	1 Mute	
0x213A:004	Mute sources: SD-In3 • Read only	
	0 No muting	
	1 Mute	
0x213A:005	Mute sources: SD-In4 • Read only	
	0 No muting	
	1 Mute	
0x213B:001	Muting: Password • Read only	
0x213B:002	Muting: Remaining time • Read only: x s	
0x213C	"Muting active" output • Read only	
	0 Deactivated	
	1 SD-Out1 positive logic	
	2 SD-Out1 negative logic	

Safety functions

Safe network interfaces



18.23 Safe network interfaces

Parameter

Address	Name / setting range / [default setting]	Information
0x2128	S-bus: Configuration	
	• Read only	
	0 No safety bus	
	4 PROFIsafe/PROFINET 8 words	
11 FSoE/System bus EtherCAT		



18.23.1 FSoE connection

Addressing

A definite FsoE address ensures that a data frame reaches the correct node. If "FSoE" has been selected as safety bus, the safety address is at the same time accepted as the FSoE target address. This address must match the corresponding configuration of the safety PLC.

Description

Safe transmission of information via EtherCAT.

FSoE frame

Range	Values
FSoE data	Safety outputs: 11 bytes
	Safety inputs: 31 bytes

ESI file

The ESI file contains the information required to configure the EtherCAT.

Safety functions

Safe network interfaces

FSoE connection



Parameter

Address	Name / setting range / [default setting]	Information
0x212A:001	S-Bus: Information: FSoE parameter set CRC 0 ... [] ... 4294967295	
0xE600:001	FSoE Slave Frame Elements: FSoE Slave Command • Read only	
0xE600:002	FSoE Slave Frame Elements: FSoE Slave Connection ID • Read only	
0xE600:003	FSoE Slave Frame Elements: FSoE Slave CRC_0 • Read only	
0xE600:004	FSoE Slave Frame Elements: FSoE Slave CRC_1 • Read only	
0xE600:005	FSoE Slave Frame Elements: FSoE Slave CRC_2 • Read only	
0xE600:006	FSoE Slave Frame Elements: FSoE Slave CRC_3 • Read only	
0xE600:007	FSoE Slave Frame Elements: FSoE Slave CRC_4 • Read only	
0xE600:008	FSoE Slave Frame Elements: FSoE Slave CRC_5 • Read only	
0xE600:009	FSoE Slave Frame Elements: FSoE Slave CRC_6 • Read only	
0xE700:001	FSoE Master Frame Elements: FSoE Master Command • Read only	
0xE700:002	FSoE Master Frame Elements: FSoE Master Connection ID • Read only	
0xE700:003	FSoE Master Frame Elements: FSoE Master CRC_0 • Read only	
0xE700:004	FSoE Master Frame Elements: FSoE Master CRC_1 • Read only	
0xE901:001	FSoE communication Parameters: FSoE version • Read only	
0xE901:002	FSoE communication Parameters: Safety address • Read only	
0xE901:003	FSoE communication Parameters: FSoE connection ID • Read only	
0xE901:004	FSoE communication Parameters: FSoE watchdog time • Read only	
0xE901:006	FSoE communication Parameters: FSoE connection type • Read only	
	0 Master	
	1 Slave	
0xE901:007	FSoE communication Parameters: FSoE communication parameter length • Read only	
0xE901:008	FSoE communication Parameters: FSoE application parameter length • Read only	
0xEA00:001	FSoE diagnostics: Connection state • Read only	
	0 Reset	
	1 Session	
	2 Connection	
	3 Parameter	
	4 Data	
	5 Failsafe	



Safety functions

Safe network interfaces
FSoE connection



You will find the current ESI file for this Lenze product on the Internet in the "Downloads" area under <http://www.Lenze.com>.

FSoE output data

The FSoE output data (control data) is transmitted from the control.

Byte offset	Bit offset							
	Bit 7	Bit 6	Bit 5	Bit 4	Bit 3	Bit 2	Bit 1	Bit 0
Byte 0	Command (CMD)							
Byte 1	AIE	SDIneg	SDIpos	-	SOS	SS2	SS1	STO
Byte 2	SSE	SLI	ES	RMS	OMS	SHOM load	SHOM start	AIS
Byte 3	CRC_0 (low-byte)							
Byte 4	CRC_0 (high-byte)							
Byte 5	SLP4	SLP3	SLP2	SLP1	SLS4	SLS3	SLS2	SLS1
Byte 6	-	-	-	-	-	SBC	SD-Out1	PDSS
Byte 7	CRC_1 (low-byte)							
Byte 8	CRC_1 (high-byte)							
Byte 9	Connection-ID (low-byte)							
Byte 10	Connection-ID (high-byte)							

Safety functions

Safe network interfaces
FSoE connection



FSoE input data

The FsoE input data (status information) is transmitted to the control.

	Bit offset							
Byte offset	Bit 7	Bit 6	Bit 5	Bit 4	Bit 3	Bit 2	Bit 1	Bit 0
Byte 0	Command (CMD)							
Byte 1	Error active	SDIneg active	SDIpos active	-	SOS active	-	-	STO active
Byte 2	SSE active	SLI active	ES active	RMS active	OMS active	SOS observed	SS2 active	SS1 active
Byte 3	CRC_0 (low-byte)							
Byte 4	CRC_0 (high-byte)							
Byte 5	SLS4 observed	SLS3 observed	SLS2 observed	SLS1 observed	SLS4 active	SLS3 active	SLS2 active	SLS1 active
Byte 6	SCA4 withinLimit	SCA3 withinLimit	SCA2 withinLimit	SCA1 withinLimit	SLP4 observed	SLP3 observed	SLP2 observed	SLP1 observed
Byte 7	CRC_1 (low-byte)							
Byte 8	CRC_1 (high-byte)							
Byte 9	SSM within limits	SMS observed	PDSSneg obs.	PDSSpos obs.	SDIneg observed	SDIpos observed	SHom available	SHom active
Byte 10	-	-	-	-	MUT active	Positive direction	n=0	Safe speed OK
Byte 11	CRC_2 (low-byte)							
Byte 12	CRC_2 (high-byte)							
Byte 13	-	-	-	-	SD-In4	SD-In3	SD-In2	SD-In1
Byte 14	-	-	-	-	-	SBC activated	SBC active	SD-Out1
Byte 15	CRC_3 (low-byte)							
Byte 16	CRC_3 (high-byte)							
Byte 17	Actual Speed n_safe, Byte 0							
Byte 18	Actual Speed n_safe, Byte 1							
Byte 19	CRC_4 (low-byte)							
Byte 20	CRC_4 (high-byte)							
Byte 21	Actual Position p_safe, Byte 0							
Byte 22	Actual Position p_safe, Byte 1							
Byte 23	CRC_5 (low-byte)							
Byte 24	CRC_5 (high-byte)							
Byte 25	Actual Position p_safe, Byte 2							
Byte 26	Actual Position p_safe, Byte 3							
Byte 27	CRC_6 (low-byte)							
Byte 28	CRC_6 (high-byte)							
Byte 29	Connection-ID (low-byte)							
Byte 30	Connection-ID (high-byte)							



18.24 Connection to the applications

18.24.1 Inputs

Parameter

Address	Name / setting range / [default setting]	Information
0x2118:001	SD-In: Sensor type: SD-In1: Sensor type • Read only	
	0 Input disabled	
	1 Passive sensor	
	2 Active sensor	
0x2118:002	SD-In: Sensor type: SD-In2: Sensor type • Read only	
	0 Input disabled	
	1 Passive sensor	
	2 Active sensor	
0x2118:003	SD-In: Sensor type: SD-In3: Sensor type • Read only	
	0 Input disabled	
	1 Passive sensor	
	2 Active sensor	
0x2118:004	SD-In: Sensor type: SD-In4: Sensor type • Read only	
	0 Input disabled	
	1 Passive sensor	
	2 Active sensor	
0x2119:001	SD-In: Discrepancy time: SD-In1: Discrepancy time • Read only: x ms	
0x2119:002	SD-In: Discrepancy time: SD-In2: Discrepancy time • Read only: x ms	
0x2119:003	SD-In: Discrepancy time: SD-In3: Discrepancy time • Read only: x ms	
0x2119:004	SD-In: Discrepancy time: SD-In4: Discrepancy time • Read only: x ms	
0x211A:001	SD-In: Input delay: SD-In1: Input delay • Read only: x ms	
0x211A:002	SD-In: Input delay: SD-In2: Input delay • Read only: x ms	
0x211A:003	SD-In: Input delay: SD-In3: Input delay • Read only: x ms	
0x211A:004	SD-In: Input delay: SD-In4: Input delay • Read only: x ms	
0x211B	Input image • Read only	
	Bit 0 SD-In1 channel A	
	Bit 1 SD-In1 channel B	
	Bit 2 SD-In2 channel A	
	Bit 3 SD-In2 channel B	
	Bit 4 SD-In3 channel A	
	Bit 5 SD-In3 channel B	
	Bit 6 SD-In4 channel A	
	Bit 7 SD-In4 channel B	
	Bit 16 AIE	
	Bit 17 AIS	
	Bit 24 IRS	
	Bit 25 IRL	
Bit 31 Button S82		

Safety functions

Connection to the applications
Outputs



18.24.2 Outputs

Parameter

Address	Name / setting range / [default setting]	Information
0x2120:001	SD-Out: Source S-Bus: SD-Out1: Source S-Bus • Read only	
	0 Deactivated	
	1 Activated	
0x2121:001	SD-Out logic function: SD-Out1 logic function • Read only	
	0 OR	
	1 AND	
0x2122	Output image • Read only	
	Bit 0 SD-Out1 channel A	
	Bit 1 SD-Out1 channel B	

18.24.3 Control signals

Parameter

Address	Name / setting range / [default setting]	Information
0x2129:001	S-bus: Control bits: SD-Out1 • Read only	
0x2870:001	SafetyInterface: SafetyInterface Control • Read only	
	Bit 0 STO active	
	Bit 1 SS1 active	
	Bit 2 SS2 active	
	Bit 3 SOS active	
	Bit 4 SLS1 active	
	Bit 5 SLS2 active	
	Bit 6 SLS3 active	
	Bit 7 SLS4 active	
	Bit 8 SDIpos active	
	Bit 9 SDIneg active	
	Bit 10 SLI active	
	Bit 11 SSE active	
	Bit 12 ES active	
	Bit 13 OMS active	
	Bit 14 RMS active	
	Bit 15 SBC active	
Bit 16 MUT active		



Safety functions

Connection to the applications
Control signals

Address	Name / setting range / [default setting]	Information
0x2874	S bus: Display of control data • Read only	
	Bit 0 STO	
	Bit 1 SS1	
	Bit 2 SS2	
	Bit 3 SLS1	
	Bit 4 SLS2	
	Bit 5 SLS3	
	Bit 6 SLS4	
	Bit 7 SDIpos	
	Bit 8 SDIneg	
	Bit 9 ES	
	Bit 10 SLI	
	Bit 11 OMS	
	Bit 12 SLP1	
	Bit 13 SLP2	
	Bit 14 SLP3	
	Bit 15 SLP4	
	Bit 16 AIS	
	Bit 17 AIE	
	Bit 18 SOS	
	Bit 19 RMS	
	Bit 20 SHOM_Start	
	Bit 21 SHOM_Load	
	Bit 22 PDSS	
	Bit 23 SSE	
	Bit 24 SD-Out1	
	Bit 25 SBC	
0x2875:001	S bus control bits: STO • Read only	
0x2875:002	S bus control bits: SS1 • Read only	
0x2875:003	S bus control bits: SS2 • Read only	
0x2875:004	S bus control bits: SLS1 • Read only	
0x2875:005	S bus control bits: SLS2 • Read only	
0x2875:006	S bus control bits: SLS3 • Read only	
0x2875:007	S bus control bits: SLS4 • Read only	
0x2875:008	S bus control bits: SDIpos • Read only	
0x2875:009	S bus control bits: SDIneg • Read only	
0x2875:011	S bus control bits: SLI • Read only	
0x2875:013	S bus control bits: SLP1 • Read only	
0x2875:014	S bus control bits: SLP2 • Read only	
0x2875:015	S bus control bits: SLP3 • Read only	
0x2875:016	S bus control bits: SLP4 • Read only	
0x2875:017	S bus control bits: AIS • Read only	

Safety functions

Connection to the applications

Status signals



Address	Name / setting range / [default setting]	Information
0x2875:018	S bus control bits: AIE • Read only	
0x2875:021	S bus control bits: SHOM_Start • Read only	
0x2875:022	S bus control bits: SHOM_Load • Read only	
0x2875:023	S bus control bits: PDSS • Read only	
0x2875:024	S bus control bits: SSE • Read only	
0x2875:026	S bus control bits: SBC • Read only	

18.24.4 Status signals

Parameter

Address	Name / setting range / [default setting]	Information
0x211C:001	Status bits of inputs: SD-In1 • Read only	
0x211C:002	Status bits of inputs: SD-In2 • Read only	
0x211C:003	Status bits of inputs: SD-In3 • Read only	
0x211C:004	Status bits of inputs: SD-In4 • Read only	
0x211C:005	Status bits of inputs: AIS Dig-In • Read only	
0x211C:006	Status bits of inputs: AIE Dig-In • Read only	
0x211C:007	Status bits of inputs: IRS Dig-In • Read only	
0x211C:008	Status bits of inputs: IRL Dig-In • Read only	
0x2123:001	Status bits of outputs: SD-Out1 • Read only	
0x2132	Safety module status • Read only	



Safety functions

Connection to the applications
Status signals

Address	Name / setting range / [default setting]	Information	
0x2870:002	SafetyInterface: SafetyInterface State		
	• Read only		
	Bit 0		SLS1 observed
	Bit 1		SLS2 observed
	Bit 2		SLS3 observed
	Bit 3		SLS4 observed
	Bit 4		SMS observed
	Bit 5		SSM within limits
	Bit 6		SDIpos observed
	Bit 7		SDIneg observed
	Bit 8		SLP1 observed
	Bit 9		SLP2 observed
	Bit 10		SLP3 observed
	Bit 11		SLP4 observed
	Bit 12		SCA1 within limits
	Bit 13		SCA2 within limits
	Bit 14		SCA3 within limits
	Bit 15		SCA4 within limits
	Bit 16		PDSS positive observed
	Bit 17		PDSS negative observed
	Bit 18		SOS observed
	Bit 19		SBC activated
	Bit 20		SHOM activated
	Bit 21		SHOM available
	Bit 22		Safe speed OK
	Bit 23		n=0
	Bit 24		Positive travel direction
	Bit 25		Slip > 25 %
Bit 26	Slip > 50 %		
Bit 27	Slip > 75%		
Bit 31	Fault active		

Safety functions

Connection to the applications
Status signals



Address	Name / setting range / [default setting]	Information
0x2870:003	SafetyInterface: SafetyInterface IOState	
	• Read only	
	Bit 0 SD-In1	
	Bit 1 SD-In2	
	Bit 2 SD-In3	
	Bit 3 SD-In4	
	Bit 4 AIS SD-In	
	Bit 5 AIE SD-In	
	Bit 6 IRS SD-In	
	Bit 7 IRL SD-In	
	Bit 8 AIS S-Bus	
	Bit 9 AIE S-Bus	
	Bit 10 SHOM_Start S bus	
	Bit 11 SHOM_Load S bus	
	Bit 12 SD-Out1	
	Bit 16 SD-In1 channel A	
	Bit 17 SD-In1 channel B	
	Bit 18 SD-In2 channel A	
	Bit 19 SD-In2 channel B	
	Bit 20 SD-In3 channel A	
	Bit 21 SD-In3 channel B	
	Bit 22 SD-In4 channel A	
	Bit 23 SD-In4 channel B	
	Bit 24 SD-Out1 channel A	
	Bit 25 SD-Out1 channel B	
	0x2871:001	
	• Read only	
0x2871:002	SafetyInterface bits: SS1 active	
	• Read only	
0x2871:003	SafetyInterface bits: SS2 active	
	• Read only	
0x2871:004	SafetyInterface bits: SOS active	
	• Read only	
0x2871:005	SafetyInterface bits: SLS1 active	
	• Read only	
0x2871:006	SafetyInterface bits: SLS2 active	
	• Read only	
0x2871:007	SafetyInterface bits: SLS3 active	
	• Read only	
0x2871:008	SafetyInterface bits: SLS4 active	
	• Read only	
0x2871:009	SafetyInterface bits: SDIpos active	
	• Read only	
0x2871:010	SafetyInterface bits: SDIneg active	
	• Read only	
0x2871:011	SafetyInterface bits: SLI active	
	• Read only	
0x2871:012	SafetyInterface bits: SSE active	
	• Read only	
0x2871:013	SafetyInterface bits: ES active	
	• Read only	
0x2871:014	SafetyInterface bits: OMS active	
	• Read only	
0x2871:015	SafetyInterface bits: RMS active	
	• Read only	
0x2871:016	SafetyInterface bits: SBC active	
	• Read only	



Safety functions

Connection to the applications
Status signals

Address	Name / setting range / [default setting]	Information
0x2871:017	SafetyInterface bits: MUT active • Read only	
0x2871:033	SafetyInterface bits: SLS1 observed • Read only	
0x2871:034	SafetyInterface bits: SLS2 observed • Read only	
0x2871:035	SafetyInterface bits: SLS3 observed • Read only	
0x2871:036	SafetyInterface bits: SLS4 observed • Read only	
0x2871:037	SafetyInterface bits: SMS observed • Read only	
0x2871:038	SafetyInterface bits: SSM within limits • Read only	
0x2871:039	SafetyInterface bits: SDIpos observed • Read only	
0x2871:040	SafetyInterface bits: SDIneg observed • Read only	
0x2871:041	SafetyInterface bits: SLP1 observed • Read only	
0x2871:042	SafetyInterface bits: SLP2 observed • Read only	
0x2871:043	SafetyInterface bits: SLP3 observed • Read only	
0x2871:044	SafetyInterface bits: SLP4 observed • Read only	
0x2871:045	SafetyInterface bits: SCA1 within limits • Read only	
0x2871:046	SafetyInterface bits: SCA2 within limits • Read only	
0x2871:047	SafetyInterface bits: SCA3 within limits • Read only	
0x2871:048	SafetyInterface bits: SCA4 within limits • Read only	
0x2871:049	SafetyInterface bits: PDSSpos observed • Read only	
0x2871:050	SafetyInterface bits: PDSSneg observed • Read only	
0x2871:051	SafetyInterface bits: SOS observed • Read only	
0x2871:052	SafetyInterface bits: SBC activated • Read only	
0x2871:053	SafetyInterface bits: SHOM active • Read only	
0x2871:054	SafetyInterface bits: SHOM available • Read only	
0x2871:055	SafetyInterface bits: Safe speed OK • Read only	
0x2871:056	SafetyInterface bits: n=0 • Read only	
0x2871:057	SafetyInterface bits: Positive direction • Read only	
0x2871:058	SafetyInterface bits: Slip > 25% • Read only	
0x2871:059	SafetyInterface bits: Slip > 50% • Read only	
0x2871:060	SafetyInterface bits: Slip > 75% • Read only	
0x2871:064	SafetyInterface bits: Error active • Read only	

Safety functions

Connection to the applications
Status signals



Address	Name / setting range / [default setting]	Information
0x2871:073	SafetyInterface bits: AIS S bus • Read only	
0x2871:074	SafetyInterface bits: AIE S bus • Read only	
0x2871:075	SafetyInterface bits: SHOM_Start S bus • Read only	
0x2871:076	SafetyInterface bits: SHOM_Load S bus • Read only	



18.25 Safe parameter setting

18.25.1 Safety address

The safety address is set using the 0xF980 parameter (safety address). Via the parameter, addresses in the range of 1 ... 65534 can be set.

Parameter

Address	Name / setting range / [default setting]	Information
0xF980:001	Safety address: FSoE address • Read only	
0xF980:002	Safety address: Safety address • Read only	

18.25.2 Parameter set information

Parameter

Address	Name / setting range / [default setting]	Information
0x2114:001	Parameter set Identification: Parameter set version • Read only	
	1003 i950 (Extended Safety) V1.0	
	10103 i950 (ES) V1.1	
0x2114:002	Parameter set Identification: Parameter set CRC 0 ... [0] ... 4294967295	
0x2115:001	Parameter set information: Parameter set status • Read only	
	0 No parameter set	
	1 Valid parameter set	
	4 CRC error	
	5 Version error	
	7 Plausibility error	
	8 Assignment error	
	9 Local read error	
	10 Communication error with basic device	
	11 Faulty release	
	12 Different CRCs	
	13 Changed parameter set	
	14 Parameter set checked	
	15 Parameter set check active	
0x2115:002	Parameter set information: Safety module CRC • Read only	
0x2115:003	Parameter set information: Last valid CRC • Read only	
0x2115:004	Parameter set information: Parameter setting time stamp • Read only: x s	
0x2115:005	Parameter set information: Parameter set error information 1 • Read only	
0x2115:006	Parameter set information: Parameter set error information 2 • Read only	
0x2115:007	Parameter set information: Parameter set error information 3 • Read only	

Safety functions

Response times



18.26 Response times

The overall system must be taken into account when determining the response time following a safety function request.

The following is essential for the response time:

- Response time of the connected safety sensors.
- Input delay of the safety inputs.
- Internal processing time.
- Delay times, braking times, and stopping times from the parameterized safety functions.
- When using a feedback system:
 - The response time of encoder monitoring.
- When using a safety bus:
 - Monitoring time for cyclic services.
 - Monitoring time in the safety PLC.
 - Processing time in the safety PLC.
- Delay times due to further components.

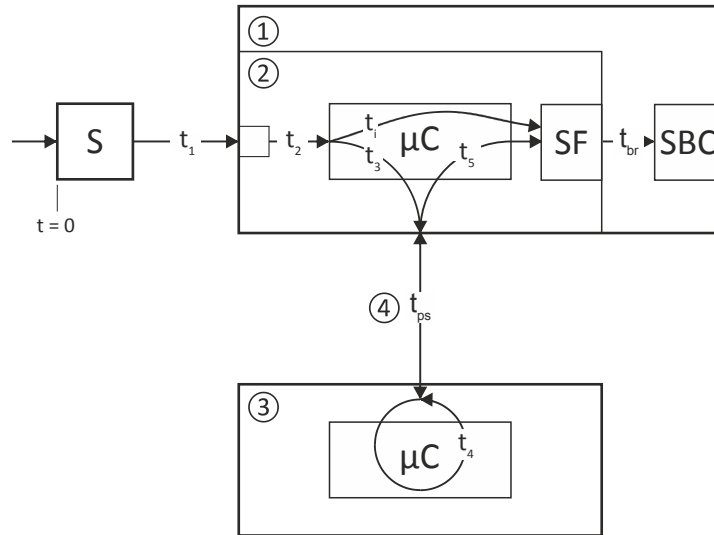

Fig. 19: Response times to the request of a safety function

- | | | | |
|---|--------------------------|-----|---------------------------|
| 1 | Standard device | μC | Microcontroller |
| 2 | Integrated safety system | S | Safety sensor technology |
| 3 | Safety PLC | SF | Activated safety function |
| 4 | Safety bus | SBC | Safe Brake Control |

Response times of safe inputs

Response time to an event in the safety sensors		[ms]
t_1	Response time of the safety sensors	according to manufacturer information
t_2	Input delay of the safe inputs	
	Parameterizable via: 0x211A:001, 0x211A:002, 0x211A:003, 0x211A:004	0...100
	Input filter	2
t_i	Processing time in drive-based safety sensor technology	4
	Safety function starts after	$t_1 + t_2 + t_i$

Tab. 1: Response time to an event in the safety sensors

Response time of the safe output

Response time of the safe output to a safety function		[ms]
	Safe output SD-Out 1 switches to	4

Tab. 2: Response time - safe output



Response times of safe SBC brake control

Response time from the detection of the SBC safety function to the switch-off of the safe brake control		[ms]
t_{br}	Delay time between request and activation of the brake control	
	Parameterizable via: 0x28E6:002	0 ... 30000
t_i	Processing time in drive-based safety sensor technology	4
	Control X106 starts after	$t_{br} + t_i$
Test pulse interval and error response time		[ms]
	Test pulse interval, brake control	100
	Error response time, min. time for error detection and error triggering	200
Response time of encoder monitoring		[ms]
	Time required to detect faults caused by continuous signal errors at the encoder interface.	
		12
	Parameterizable via: 0x2878:004	12/50/100



It is necessary to assess the minimum response time required for the respective system. A longer response time results in a higher system availability if, for instance, short-time, process-related speed steps occur at safe operational stop during setting-up operation.

Safety functions

Response times



Response times of the safety bus

Response time to an event in the safety sensors (input data)		[ms]	
t_1	Response time of the safety sensors	See manufacturer information	
t_2	Input delay of the safe inputs		
	Parameterizable via: 0x211A:001 , 0x211A:002 , 0x211A:003 , 0x211A:004 Input filter	0...100 2	
t_3	Processing time in drive-based safety system		
	Cycle time - Main Task	Technology application PLC project	
	Internal transmission time PROFIsafe	Safety: Firmware 1.0.1 Standard device: Firmware 1.2	40
		Safety: Firmware 1.1.x Standard device: Firmware 1.3	40
	Internal transmission time PROFIsafe	Safety: Firmware 1.1.x Standard device: Firmware 1.3	8
Input data ready for transmission		$t_1 + t_2 + t_3$	
t_{ps}	Cycle time PROFINET	See manufacturer information	
Input data ready for processing in the safety PLC		$t_1 + t_2 + t_3 + t_{ps}$	

Tab. 3: Response time to an event in the safety sensors

Response time to a control word (output data)		[ms]	
t_4	Processing time in the safety PLC	Calculate	
t_{ps}	Cycle time PROFINET	See manufacturer information	
t_5	Processing time in drive-based safety system		
	Cycle time - Main Task	Technology application PLC project	
	Internal transmission time PROFIsafe	Safety: Firmware 1.0.1 Standard device: Firmware 1.2	108
		Safety: Firmware 1.1.x Standard device: Firmware 1.3	108
	Internal transmission time FsoE	Safety: Firmware 1.1.x Standard device: Firmware 1.3	16
Cycle time Safety		4	
Safety function starts after		$t_4 + t_{ps} + t_5$	

Tab. 4: Response time in case of a safety bus request

Information on how to calculate the processing time and transmission time of the safety bus can be found in the documentation of the safety PLC used.



When the safety bus communication is disturbed, it is changed to the fail-safe state after the safety bus monitoring time (F_WD_Time) has elapsed. The safety bus communication is passivated.

Example

- After an event has occurred at a safe input, the message is fed back to drive-based safety via the safety PLC.
- Drive-based safety activates a safety function.
- Hence, the maximum response time to the event is calculated as follows:
 - $t_{max} = t_1 + t + t_3 + \max(F_WD_Time; t_{ps} + t_4 + t_{ps} + t_5)$
 - When calculating the maximum response time, include the times of the safety functions, e.g. in case of SS1 the stopping time until STO is active. [0x2894:001](#)

Parameter set acceptance from the SD card

Safe parameter set acceptance is supported by means of a safe parameter set saved in the device.



Acknowledging the parameter set or the safety address

The parameter set and the safety address are acknowledged by the same procedure.



The parameter set transfer is aborted if the response time of 2.5 seconds is exceeded.

The parameter set transfer must be repeated.

How to acknowledge the parameter set or the safety address.

- The "RDY" LED is lit.
 - The "ERR" LED is blinking.
1. Press and hold the S82 button.
The "RDY" LED starts blinking.
 2. The "RDY" LED goes off after 3 seconds.
 3. Release the S82 button within the space of 2.5 seconds.
The "RDY" LED is lit.
 4. Press and hold the S82 button within the space of 2.5 seconds.
The "RDY" LED starts blinking.
 5. The "RDY" LED goes off after 3 seconds.
 6. Release the S82 button within the space of 2.5 seconds.
The new parameter set or new safety address has been acknowledged.



The action is recorded in the inverter logbook.

If the parameter set is invalid, an error is reported and the "ERR" LED starts blinking.

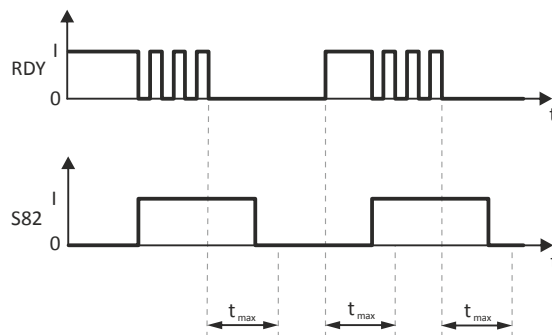

Fig. 20: Sequence of the acknowledgement procedure

RDY	"RDY" LED	t_{max}	Maximum permissible response time
S82	S82 button		
t	Time axis		

Safety functions

Diagnostics
LED status display









18.27 Diagnostics

18.27.1 LED status display





On its front, the inverter indicates the "STO active" device state via the right "RDY" LED.

You can gather the meaning of the "RDY" and "ERR" LEDs (left side) from the following two tables:

LED "RDY" (yellow)	State	Meaning
off	-	No status message active
 On (yellow)	-	Restart acknowledgement requested
 Blinking yellow 2 Hz	SOS active	
 Blinking yellow 1 Hz	Service state	Parameter set transfer requested.

"ERR" LED (red)	State	Meaning
off	-	The device is working correctly.
 on (red)	Critical device error	The device is defective and must be replaced.
 Blinking red 2 Hz	Bus error	Safety communication interrupted.
 Blinking red 1 Hz	Error detection in the safety system	One of the following errors has been detected: <ul style="list-style-type: none"> • Speed exceeded • Discrepancy of the inputs • Acknowledgable errors

18.27.1.1 LED status during parameter set transfer

LED "RDY" (yellow)	"ERR" LED (red)	Meaning
 On	 Blinking 1Hz	At start-up, a modified parameter set has been detected. Acknowledge with button S82.
 on	 Blinking 2 Hz	A modified safety address has been detected during the parameter set transfer in the "Init" state. Acknowledge with button S82.

18.27.2 Error history buffer

Parameter

Address	Name / setting range / [default setting]	Information
0x2130:001	Fault history: Actual fault type • Read only	▶ Error types □ 373
	0 No error	
	1 Warning	
	2 Trouble	
0x2130:002	Fault history: Fault history 1 • Read only	
	Bit 0	
0x2130:003	Fault history: Fault history 2 • Read only	
	Bit 0	
0x2130:004	Fault history: Fault history 3 • Read only	
	Bit 0	
0x2130:005	Fault history: Fault history 4 • Read only	
	Bit 0	
0x2130:006	Fault history: Fault history 5 • Read only	
	Bit 0	



Safety functions

Diagnostics
Error history buffer

Address	Name / setting range / [default setting]	Information
0x2130:007	Fault history: Fault history 6 • Read only	
	Bit 0	
0x2130:008	Fault history: Fault history 7 • Read only	
	Bit 0	
0x2130:009	Fault history: Fault history 8 • Read only	
	Bit 0	
0x2130:010	Fault history: Fault history 9 • Read only	
	Bit 0	
0x2130:011	Fault history: Fault history 10 • Read only	
	Bit 0	
0x2130:012	Fault history: Fault history 11 • Read only	
	Bit 0	
0x2130:013	Fault history: Fault history 12 • Read only	
	Bit 0	
0x2130:014	Fault history: Fault history 13 • Read only	
	Bit 0	
0x2130:015	Fault history: Fault history 14 • Read only	
	Bit 0	
0x2130:016	Fault history: Fault history 15 • Read only	
	Bit 0	
0x2130:017	Fault history: Fault history 16 • Read only	
	Bit 0	

Safety functions

Diagnostics

Diagnostic parameters



18.27.3 Diagnostic parameters

Parameter

Address	Name / setting range / [default setting]	Information
0x212C:001	Safety: Software: Safety: Software version • Read only	
0x212D:001	Safety: Hardware: Safety: Hardware version • Read only	
0x212D:002	Safety: Hardware: Safety: Type • Read only	
0x212D:003	Safety: Hardware: Safety: Serial number • Read only	
0x212D:004	Safety: Hardware: Safety: Production date • Read only	
0x2131:001	Safety: Operating time: Safety: Operating time • Read only: x s	
0x28E8:001	Diagnostic values configuration: Diagnostic value 1 configuration	
	0 Not used	
	1 PDSS	
	2 SS1, SS2	
	10 Internal actual speed nSD	
11 Internal actual speed nBD		
0x28E8:002	Diagnostic values configuration: Diagnostic value 2 configuration	
	0 Not used	
	1 PDSS	
	2 SS1, SS2	
	10 Internal actual speed nSD	
11 Internal actual speed nBD		
0x28E9:001	Diagnostic values: Diagnostic value 1 • Read only	
0x28E9:002	Diagnostic values: Diagnostic value 2 • Read only	



19 Diagnostics and fault elimination



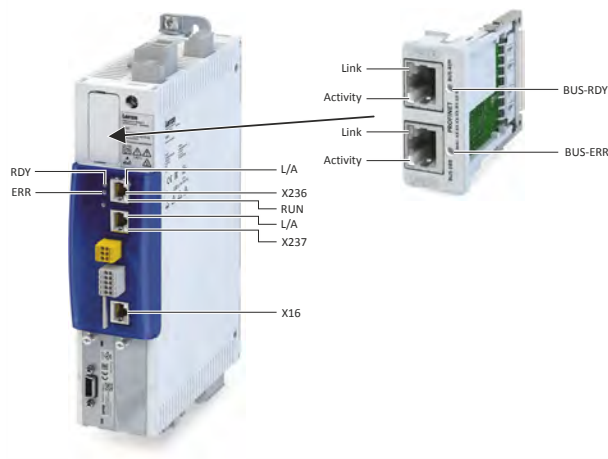

This section contains information on error handling, drive diagnostics and fault analysis.

19.1 LED status display

The "RDY" and "ERR" LED status displays on the front of the inverter provide some quick information about certain operating states.

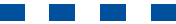

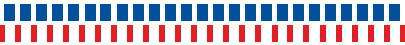
The description of the network-specific "BUS RDY" and "BUS ERR" LEDs can be found in chapters [▶ LED status display](#) [□ 255](#)

"RDY" LED (blue)	"ERR" LED (red)	Status/meaning
Off	Off	Supply voltage not available.
On	On	Initialisation in progress (inverter is being started.)
 Blinks (1 Hz)	Off	Safe torque off (STO) active. The inverter has been inhibited by the integrated safety system. ▶ Safe torque off (STO) □ 292
 Blinks (1 Hz)	On	Inverter inhibited, error active. ▶ Error handling □ 373
On	Off	Inverter enabled. Motor rotates according to the specified setpoint or quick stop is active.
 Both LEDs are blinking in a rapidly alternating mode		Firmware update active. ▶ Update device firmware □ 278
 Both LEDs are blinking in a very rapidly synchronous mode		"Visual tracking" function is active. ▶ Optical device identification □ 270



19.2 Logbook

With the logbook, the controller has access to the last 32 messages of the inverter.

- The logbook is saved persistently in the inverter.
- The logbook has a ring buffer structure:
 - As long as free memory is available in the logbook, a message is entered following the next free memory unit.
 - When all memory units are occupied, the oldest message is deleted for a new message.
 - Always the most recent messages remain available.
- On the basis of the "Diag code" (32-bit word) of each individual message it can be seen which axis the message refers to.

Preconditions

The logbook can only be accessed

- via the user interface of »EASY Starter« ("Diagnostics" tab) or
- via network.

Details

In contrast to the error history buffer, the logbook additionally protocols the following events:

- Fault messages
- Change-over from normal to setup mode (and vice versa)
- Execution of device commands
- Avoidance of safety functions

The logbook entries are saved persistently in the inverter. If all 32 memory units are occupied, the oldest entry is deleted for a new entry. By means of the "Delete logbook" device command, all logbook entries can be deleted.

Accessing the logbook with »EASY Starter«

1. Select the inverter on the left side in the »EASY Starter« device list.
2. Change to the "Diagnostics" tab.
3. Click the icon  to open the LEM logbook.

Observe that the logbook only presents a snapshot at the time the data is read out. If a new event occurs, the logbook must be read out again so that the new event becomes visible.

Accessing the logbook via network

The logbook can also be accessed via network from a higher-level controller or a visualisation. The structure of the diagnostic messages complies with the "ETG.1020" standard of the EtherCAT Technology Group (ETG).



See chapter 13.3 of document "ETG.1020 Protocol Enhancements" provided by the EtherCAT Technology Group (ETG) for detailed information on the structure of the diagnostic messages.

Parameter

Address	Name / setting range / [default setting]	Information
0x2022:015	Device commands: Delete logbook	<ul style="list-style-type: none"> • When the device command has been executed successfully, the value 0 is shown. • Do not switch off the supply voltage during the deletion process and do not unplug the memory module!
	0 Off / ready	Only status feedback
	1 On / start	
	2 In progress	Only status feedback
	3 Action cancelled	
	4 No access	
5 No access (Inverter disabled)		



19.3 Diagnostic parameters

The inverter provides many diagnostic parameters which are helpful for operation, maintenance, error diagnosis, error correction, etc.

- The following overview lists the most common diagnostic parameters.
- Further parameters for more specific diagnostic purposes are described in the following subchapters.
- The diagnostic parameters can only be read and cannot be written to.

Parameter

Address	Name / setting range / [default setting]	Information
0x2030	CRC parameter set • Read only	Display of the checksum of the parameter set. • Each parameter set has an individual checksum (CRC32) that is created from the settings of all storable indices (P-flag) of the parameter set. If a setting changes, the checksum changes as well. • Cyclic redundancy check (CRC): By comparing the checksums of parameter sets, you can check whether the parameter sets are identical or not. • If the checksum is identical with the checksum of the parameter set file saved in the Controller, the parameter set file does not need to be written into the inverter.
0x2B0B	Frequency setpoint • Read only: x.x Hz	Display of the current frequency setpoint. The frequency setpoint is internally transferred to the motor control (based on scaling and ramp generator).
0x2D4F	Motor utilisation ($i^2 \cdot t$) • Read only: x %	Display of the current thermal motor utilisation.
0x2DA2:001	Output power: Effective power • Read only: x.xxx kW	Display of the active output power for an energy analysis in the respective application.
0x2DA3:003	Output energy: Warning -21474836.47 ... [0.00] ... 21474836.47 kWh	
0x2DD0:001	Field values: Actual value • Read only: x %	Display of the actual current flow value.
0x2DD0:002	Field values: Setpoint value • Read only: x %	Display of the setpoint flow value.
0x2DD1:001	Motor currents: Actual D-current (id) • Read only: x.xx A	Display of the actual D current.
0x2DD1:002	Motor currents: Actual Q-current (iq) • Read only: x.xx A	Display of the actual Q current.
0x2DD1:003	Motor currents: Setpoint D-current (id) • Read only: x.xx A	Display of the setpoint D current.
0x2DD1:004	Motor currents: Setpoint Q-current (iq) • Read only: x.xx A	Display of the setpoint Q current.
0x2DD1:005	Motor currents: Motor current (I _{eff}) • Read only: x.xx A	Display of the effective motor current.
0x2DD2	Target position interpolated • Read only: x pos. unit	Display of the interpolated position setpoint.
0x2DD3:001	Speed setpoints: Speed setpoint • Read only: x rpm	Display of the speed setpoint value 1.
0x2DD3:002	Speed setpoints: Speed setpoint 2 • Read only: x rpm	Display of the speed setpoint value 2.
0x2DD3:003	Speed setpoints: Speed setpoint limited • Read only: x rpm	Display of the limited speed setpoint.
0x2DD4:001	Speed controller output signals: Output signal 1 • Read only: x.x %	Display of the output signal 1 from the speed controller.
0x2DD4:002	Speed controller output signals: Output signal 2 • Read only: x.x %	Display of the output signal 2 from the speed controller.
0x2DD6:001	Torque filter cascade: Starting value • Read only: x.x %	Display of the start value.
0x2DD6:002	Torque filter cascade: Notch filter 1 input value • Read only: x.x %	Display of the input value for notch filter 1.
0x2DD6:003	Torque filter cascade: Notch filter 2 input value • Read only: x.x %	Display of the input value for notch filter 2.

Diagnostics and fault elimination

Diagnostic parameters



Address	Name / setting range / [default setting]	Information
0x2DD6:004	Torque filter cascade: Torque setpoint filtered • Read only: x.x %	Display of the filtered torque setpoint value.
0x2DD7:001	Voltage values: Actual voltage (motor voltage limit) • Read only: x.x V	Display of the current motor voltage limit.
0x2DD7:002	Voltage values: Output signal D current controller • Read only: x.x V	Display of the output voltage of the D-current controller.
0x2DD7:003	Voltage values: Output signal Q current controller • Read only: x.x V	Display of the output voltage of the Q-current controller.
0x2DD7:004	Voltage values: D voltage (magnetisation) • Read only: x.x V	Display of the D-voltage (magnetisation).
0x2DD7:005	Voltage values: Q voltage (torque) • Read only: x.x V	Display of the Q-voltage (torque).
0x2DD7:006	Voltage values: Phases U-V • Read only: x.x V	Display of the actual voltage phase U - phase V.
0x2DD7:007	Voltage values: Phases V-W • Read only: x.x V	Display of the actual voltage phase V - phase W.
0x2DD7:008	Voltage values: Phases W-U • Read only: x.x V	Display of the actual voltage phase W - phase U.
0x2DD7:009	Voltage values: Phase U • Read only: x.x V	Display of the actual voltage of phase U.
0x2DD7:010	Voltage values: Phase V • Read only: x.x V	Display of the actual voltage of phase V.
0x2DD7:011	Voltage values: Phase W • Read only: x.x V	Display of the actual voltage of phase W.
0x2DDC	Actual slip value • Read only: x.x Hz	Display of the actual slip.
0x2DDD	Output frequency • Read only: x.x Hz	Display of the current output frequency of the inverter.
0x2DDE	Actual rotor angle position • Read only	Display of the actual position of the rotor angle.
0x2DDF:001	Axis information: Rated current • Read only: x.xx A	Display of the rated current of the axis.
0x2DDF:002	Axis information: Maximum current • Read only: x.xx A	Display of the maximum current of the axis.
0x2DE0:006	OEM service Data - SN • Read only	Display of OEM service data.
0x6077	Actual torque • Read only: x.x %	Display of the actual torque. • 100 % = Rated motor torque. ▶ 0x6076
0x6078	Actual current • Read only: x.x %	Display of the motor actual current. • 100 % = Rated motor current 0x6075
0x6079	DC-bus voltage • Read only: x.xxx V	Display of the current DC-bus voltage.



19.3.1 Inverter diagnostics

The following parameters supply some information about the current operating status of the inverter.

This includes the following information:

- Active access protection after log-in by means of PIN1/PIN2
- Currently loaded parameter settings
- Cause(s) for disable, quick stop and stop.
- Active control source and active setpoint source
- Active operating mode
- Status of the internal motor control

Parameter

Address	Name / setting range / [default setting]	Information
0x2010:001	Device event monitor: EreignisortEvent location • Read only	
	0 No error	
	1 Functional safety	
	4 Basic settings	
	5 Communication	
	6 Kinematics	
	7 Motion	
	8 Technology application	
0x2010:002	Device event monitor: Event type • Read only	
	0 No response	
	1 Fault > CiA402	
	2 Warning	
	11 Information	
	13 Warning locked	
	15 Trouble > logbook only	
	16 Trouble	
	18 Fault > logbook only	
	19 Fault > Application quick stop > Quick stop	
	20 Fault > inverter quick stop > quick stop	
	21 Fault > inverter quick stop > inverter disabled	
	23 Fault	
0x2010:003	Device event monitor: Event status • Read only	
	0 No event active	
	1 Reset possible	
	2 Reset not possible	
0x2010:005	Device event monitor: Number of current event • Read only	
	Bit 0	
0x2010:006	Device event monitor: Time stamp of current event • Read only: x ns	
0x2012:001	Device information: SD card status • Read only	
	0 No SD card connected	
	1 SD card connected	
0x2012:002	Device information: Application Credit available • Read only	

Diagnostics and fault elimination

Diagnostic parameters
Inverter diagnostics



Address	Name / setting range / [default setting]	Information
0x2013:001	Application information: Active application • Read only	
	0 CiA 402	
	1 "CiA 402 advanced" technology application	
	10 "Speed Control" technology application	
	20 "Table Positioning" technology application	
	40 "Electronic Gearbox" technology application	
	41 "Sync and Correction" technology application	
	50 "Winder Dancer" technology application	
	51 "Winder Tension" technology application	
100 "User" technology application		
0x2013:002	Application information: Application Credit required • Read only	
0x2539:001	Hardware-Diagnose: 24 V supply actual voltage • Read only: x.x V	
0x2539:002	Hardware-Diagnose: Control board temperature • Read only: x.x °C	
0x2823	Status of axis commands • Read only	
0x282A:001	Status words: Cause of disable • Read only	Bit-coded display of the cause(s) for disabled inverter.
	Bit 2 Axis command	1 = the inverter was disabled via axis command 0x2822:001 .
	Bit 7 Drive not ready	1 = the inverter was disabled internally since the drive was not ready for operation. Possible causes: • Under/overvoltage in the DC bus • Defective device hardware
	Bit 12 CiA402 Inverter disabled	1 = the inverter was disabled by the internal state machine. The bit is only set if • Operating mode 0x6060 = "CiA: Velocity mode [2]" and • state machine in the "Switch on disabled" state and • the state change has not been carried out via the "Disable operation" command.
	Bit 14 Safety	1 = the inverter has been disabled by the integrated safety system.
	Bit 16 PROFINET energy pause active	-



Diagnostics and fault elimination

Diagnostic parameters
Inverter diagnostics

Address	Name / setting range / [default setting]	Information	
0x2831	Inverter-Statuswort • Read only	Bit coded status word of the internal motor control.	
	Bit 0	Position controller controller in limitation	-
	Bit 1	Speed setpoint 1 limited	1 = input of speed controller 1 in limitation.
	Bit 2	Speed controller in limitation	1 = output of speed controller 1 in limitation.
	Bit 3	Torque setpoint limited	1 = setpoint torque in limitation.
	Bit 4	Soll-Q-Strom limitiert	1 = setpoint current in limitation.
	Bit 5	Speed setpoint 2 limited	1 = input of speed controller 2 in "torque mode" in limitation.
	Bit 6	Obere Drehzahlgrenze aktiv	1 = in "torque mode", the speed is limited to upper speed limit 0x2946:001 .
	Bit 7	Untere Drehzahlgrenze aktiv	1 = in "torque mode", the speed is limited to lower speed limit 0x2946:002 .
	Bit 8	Flying restart active	-
	Bit 9	Flying restart ready	-
	Bit 10	Output frequency limited	1 = setpoint frequency with V/f operation in limitation.
	Bit 11	Magnetisation completed	1 = during V/f operation, the factor 7 rotor time constant has passed (calculated from the time at which the inverter was enabled without restart on the fly and with a total motor current of 20 % rated motor current for the first time). Otherwise 0.
	Bit 12	Motorphasenfehler	1 = motor phase failure detection active.
	Bit 13	Feedback open circuit	-
Bit 14	Error reset blocking time active	1 = the error can only be reset when the blocking time has elapsed.	
Bit 15	Clamp active	-	
0x2833	Inverter status word 2 • Read only	Bit-coded status word 2 of the inverter.	
	Bit 0	Motor encoder modified	
	Bit 1	Manual test mode active	1 = manual test mode active.
	Bit 2	Manual control active	1 = manual control active.
	Bit 4	Motor encoder = absolute value encoder	-
	Bit 5	Motor encoder absolute position available	-
	Bit 6	DC braking active	1 = DC braking active.
	Bit 7	Motor encoder angle drift invalid	-
	Bit 8	Load encoder modified	-
	Bit 9	Load encoder angle drift invalid	-
	Bit 10	Load encoder = absolute value encoder	-
	Bit 11	Load encoder absolute position available	-
	Bit 12	Brake open	-
	Bit 13	Cable check active	-
	Bit 14	Mains failure detected	-
0x284F	Current error • Read only	Test display of the current error. • This object contains a reference for the text to be displayed from the ESI file as well as the substitution values for all wildcards in this text. • The text has the same structure as the diagnostic messages in the history buffer.	
0x603F	Error code • Read only	Error message	
	Bit 0		

Diagnostics and fault elimination

Diagnostic parameters
Motor diagnostics



19.3.2 Motor diagnostics

The following parameters supply some information about the current operating status of the motor.

Parameter

Address	Name / setting range / [default setting]	Information
0x2832	Motor identification status • Read only	Display of the status for the automatic identification of the motor parameters. Parameters for interaction with engineering tools.
	Bit 0 Identification enabled	Parameters for interaction with engineering tools.
	Bit 1 Identification active	
	Bit 2 Identification completed	
	Bit 3 Identification failed	
0x2D82	Motor actual voltage (Veff) • Read only: x.x V	Display of the current motor voltage.
0x2D83:001	Motor-Phasenströme: Zero system current • Read only: x.xx A	Display of the zero current.
0x2D83:002	Motor-Phasenströme: Phase U current • Read only: x.xx A	Display of the current of phase U.
0x2D83:003	Motor-Phasenströme: Phase V current • Read only: x.xx A	Display of the current of phase V.
0x2D83:004	Motor-Phasenströme: Phase W current • Read only: x.xx A	Display of the current of phase W.
0x2D8A	Actual speed error • Read only: x rpm	Display of the speed error.
0x6404	Motor manufacturer ["Lenze"]	Setting of the motor manufacturer.

19.3.3 Network diagnostics

The following parameters show some general information with regard to the network option available and the network.

Parameter

Address	Name / setting range / [default setting]	Information
0x231F:001	Communication module ID: Active module ID • Read only	Display of the network options currently configured in the device. • With the help of this module ID, the keypad only shows the communication parameters relevant to the respective network. Note! When switched on, the device checks whether the parameter settings saved in the memory module match the device hardware and firmware. In case of an incompatibility, a corresponding error message is output. For details see chapter "" (section "Hardware and firmware updates/downgrades").
	48 No network	
	82 PROFINET	
	84 EtherCAT	
0x231F:002	Communication module ID: Module ID connected • Read only	Display of the network options currently available in the device. Note! When switched on, the device checks whether the parameter settings saved in the memory module match the device hardware and firmware. In case of an incompatibility, a corresponding error message is output. For details see chapter "" (section "Hardware and firmware updates/downgrades").
	48 No network	
	82 PROFINET	
	84 EtherCAT	
0x24E7:001	EtherCAT input data: Input data 1 • Read only	
0x24E7:002	EtherCAT input data: Input data 2 • Read only	



Diagnostics and fault elimination

Diagnostic parameters
Network diagnostics

Address	Name / setting range / [default setting]	Information
0x24E7:003	EtherCAT input data: Input data 3 • Read only	
0x24E7:004	EtherCAT input data: Input data 4 • Read only	
0x24E7:005	EtherCAT input data: Input data 5 • Read only	
0x24E7:006	EtherCAT input data: Input data 6 • Read only	
0x24E7:007	EtherCAT input data: Input data 7 • Read only	
0x24E7:008	EtherCAT input data: Input data 8 • Read only	
0x24E7:009	EtherCAT input data: Input data 9 • Read only	
0x24E7:010	EtherCAT input data: Input data 10 • Read only	
0x24E7:011	EtherCAT input data: Input data 11 • Read only	
0x24E7:012	EtherCAT input data: Input data 12 • Read only	
0x24E7:013	EtherCAT input data: Input data 13 • Read only	
0x24E7:014	EtherCAT input data: Input data 14 • Read only	
0x24E7:015	EtherCAT input data: Input data 15 • Read only	
0x24E7:016	EtherCAT input data: Input data 16 • Read only	
0x24E8:001	EtherCAT output data: Output data 1 • Read only	
0x24E8:002	EtherCAT output data: Output data 2 • Read only	
0x24E8:003	EtherCAT output data: Output data 3 • Read only	
0x24E8:004	EtherCAT output data: Output data 4 • Read only	
0x24E8:005	EtherCAT output data: Output data 5 • Read only	
0x24E8:006	EtherCAT output data: Output data 6 • Read only	
0x24E8:007	EtherCAT output data: Output data 7 • Read only	
0x24E8:008	EtherCAT output data: Output data 8 • Read only	
0x24E8:009	EtherCAT output data: Output data 9 • Read only	
0x24E8:010	EtherCAT output data: Output data 10 • Read only	
0x24E8:011	EtherCAT output data: Output data 11 • Read only	
0x24E8:012	EtherCAT output data: Output data 12 • Read only	
0x24E8:013	EtherCAT output data: Output data 13 • Read only	
0x24E8:014	EtherCAT output data: Output data 14 • Read only	
0x24E8:015	EtherCAT output data: Output data 15 • Read only	
0x24E8:016	EtherCAT output data: Output data 16 • Read only	

Diagnostics and fault elimination

Diagnostic parameters
I/O diagnostics



Related topics

► [Configuring the network](#) 207

19.3.4 I/O diagnostics

This section describes the diagnostics of the analog and digital inputs and outputs that can be found on the control terminal X3.

19.3.4.1 Digital inputs and outputs

The following parameters serve to diagnose the digital inputs and outputs of the inverter.

Parameter

Address	Name / setting range / [default setting]	Information
0x282C:001	I/O diagnostic: Application level of the digital inputs • Read only	This parameter indicates the bit coded state or the digital inputs contain the setting of 0x2632:001 (Digital input 1).
	Bit 16 Digital input 1	
	Bit 17 Digital input 2	
	Bit 18 Digital input 3	
	Bit 19 Digital input 4	
	Bit 20 Digital input 5	
	Bit 21 Digital input 6	
	Bit 22 Digital input 7	
	Bit 23 Digital input 8	
	Bit 24 Digital input 9	
0x282C:002	I/O diagnostic: Digital output levels • Read only	
	Bit 16 Level of digital output 1	
	Bit 17 Level of digital output 2	
	Bit 18 Level of digital output 3	
	Bit 19 Level of digital output 4	
	Bit 20 Level of digital output 5	
0x60FD	Digital input status • Read only	Bit coded display of the current status of the digital inputs
	Bit 0 Reserved	-
	Bit 1 Reserved	-
	Bit 2 Reserved	-
	Bit 3 Reserved	-
	Bit 16 Digital input 1	0 ≡ LOW level, 1 ≡ HIGH level.
	Bit 17 Digital input 2	
	Bit 18 Digital input 3	
	Bit 19 Digital input 4	
	Bit 20 Level from digital input 5	
	Bit 21 Level from digital input 6	
	Bit 22 Level from digital input 7	
	Bit 23 Level from digital input 8	-
	Bit 24 Level from digital input 9	
0x60FE:001	Digital outputs: Digital output status 0x00000000 ... [0x00000000] ... 0xFFFFFFFF	
	Bit 0 n/a	
	Bit 16 Digital output 1	
	Bit 17 Level for digital output 2	
	Bit 18 Level for digital output 3	
	Bit 19 Level for digital output 4	
	Bit 20 Level for digital output 5	
Bit 21 Level for digital output 6		



Diagnostics and fault elimination

Diagnostic parameters
Diagnostics of the application

Address	Name / setting range / [default setting]	Information
0x4016:005	Digital output 1: Terminal state	Display of the logic state of output terminal X3/DO1.
	• Read only	
	0 FALSE	
	1 TRUE	

Related topics

▶ [Configure digital inputs](#) 197

▶ [Configure digital outputs](#) 202

19.3.4.2 Analog inputs and outputs

The following parameters serve to diagnose the analog inputs and outputs of the inverter.

Parameter

Address	Name / setting range / [default setting]	Information	
0x2DA4:001	Diagnostics of analog input 1: Value in percent	Display of the current input value at X3/AI1 scaled as value in percent.	
	• Read only: x.x %		
0x2DA4:016	Diagnostics of analog input 1: Status	Bit coded display of the status of analog input 1 (X3/AI1).	
	• Read only		
	Bit 0		Mode 0: 0 ... 10 VDC active
	Bit 3		Mode 3: -10 ... 10 VDC active
	Bit 4		Mode 4: 4 ... 20 mA active
	Bit 5		Mode 5: 0 ... 20 mA active
	Bit 6		24 V supply OK
	Bit 7		Calibration successful
	Bit 9		Input current too low (mode 4)
	Bit 10		Input voltage too low (mode 2)
	Bit 11	Input voltage too high (mode 4)	

Related topics

▶ [Configure analog inputs](#) 200

19.3.5 Diagnostics of the application

Parameter

Address	Name / setting range / [default setting]	Information	
0x5810:001	Application diagnostics: Application state	Display of the application status.	
	• Read only		
	0		Unknown/application missing
	1		Running
	2		Stopped
	3	Stopped at breakpoint	

19.3.6 Service life diagnostics

The following parameters provide some information about the use of the inverter.

This includes the following information:

- Operating and power-on time of the inverter/control unit
- Operating time of the internal fan
- Number of switching cycles of the mains voltage
- Number of switching cycles of the relay
- Number of short-circuits and earth faults that have occurred
- Display of the number of "I_{max}: Clamp responded too often" errors that have occurred.

Parameter

Address	Name / setting range / [default setting]	Information
0x2D81:001	Life-diagnosis: Operating time	Display showing for how long the device has been running so far (device status "operation enabled").
	• Read only: x s	
0x2D81:002	Life-diagnosis: Power-on time	Display showing for how long the device has been supplied with line voltage so far.
	• Read only: x s	

Diagnostics and fault elimination

Diagnostic parameters
Device identification



Address	Name / setting range / [default setting]	Information
0x2D81:004	Life-diagnosis: Main switching cycles • Read only	Display of the number of switching cycles of the mains voltage.
0x2D81:006	Life-diagnosis: Short-circuit counter • Read only	Display of the number of short circuits that have occurred.
0x2D81:007	Life-diagnosis: Earth fault counter • Read only	Display of the number of earth faults that have occurred.
0x2D81:009	Life-diagnosis: Fan operating time • Read only: x s	Display showing for how long the internal fan has been running so far.

19.3.7 Device identification

The following parameters show some general information about the inverter.

Parameter

Address	Name / setting range / [default setting]	Information
0x2000:001	Device data: Product code • Read only	Product code of the complete device.
0x2000:002	Device data: Serial number • Read only	Serial number of the complete device. Example: "0000000000000000XYZYZ"
0x2000:003	Device data: Production date • Read only	The date of manufacture and the time of the device, e. g. "2013-03-13 11: 59: 04".
0x2000:004	Device data: CU firmware version • Read only	Firmware version of the control unit. Example: "01.00.01.00"
0x2000:006	Device data: CU bootloader version • Read only	Bootloader version of the control unit. Example: "2015.10-20180517"
0x2000:008	Device data: Object directory version • Read only	Example: "108478"
0x2000:019	Device data: Safety module version • Read only	
0x2002:001	Device module: Safety module • Read only	Display of a generated string based on the connected safety module (e. g. "E50SM").
0x2002:006	Device module: CU serial number • Read only	Serial number of the control unit.
0x2002:007	Device module: PU serial number • Read only	Serial number of the power unit.
0x2002:010	Device module: Type communication module • Read only	Display of the type designation of the communication module.
0x2002:011	Device module: Serial number communication module • Read only	Display of the serial number of the communication module.
0x2002:012	Device module: Hardware version communication module • Read only	Display of the hardware version of the communication module.
0x2002:013	Device module: Type encoder 1 • Read only	Display of the type designation of the encoder 1.
0x2002:014	Device module: Serial number encoder 1 • Read only	Display of the serial number of the encoder 1.
0x2002:015	Device module: Hardware version encoder 1 • Read only	Display of the hardware version of the encoder 1.
0x2002:016	Device module: Type encoder 2 • Read only	Display of the type designation of the encoder 2.
0x2002:017	Device module: Serial number encoder 2 • Read only	Display of the serial number of the encoder 2.
0x2002:018	Device module: Hardware version encoder 2 • Read only	Display of the hardware version of the encoder 2.
0x67FF	Device profile number • Read only	



19.4 Error handling

Many functions integrated in the inverter can

- detect errors and thus protect inverter and motor from damages,
- detect an operating error of the user,
- output a warning or information if desired.

19.4.1 Error types

In the event of an error, the inverter response is determined by the error type defined for the error.

Error type "No response"

The error is completely ignored (does not affect the running process).

Error type "Warning"

A warning does not severely affect the process and may be also ignored in consideration of safety aspects.

Error type "Fault"

The motor is brought to a standstill with the quick stop ramp.

- The inverter will only be disabled after the quick stop is executed (motor at standstill) or after the time-out time set in [0x2826](#) has been elapsed. ▶ [Timeout for error response](#)
[📖 373](#)
- **Exception:** In case of a serious fault, the inverter is disabled immediately. The motor has no torque (coasts). For details see the table "[Error codes, causes and remedies](#)".

19.4.1.1 Timeout for error response

Parameter

Address	Name / setting range / [default setting]	Information
0x2826	Time-out for error response 0 ... [4] ... 100 s	<p>This timer is started when a change-over to the "Fault reaction active" device status takes place. If the motor is still rotating after the time-out time has elapsed, a change-over to the "Fault" device status takes place.</p> <ul style="list-style-type: none"> • In case of a serious error, an immediate change-over to the "Fault" device status takes place. <p>⚠ CAUTION! Changing this parameter may cause a longer ramp time in the event of an error. This must be considered when changing this parameter.</p>

19.4.2 Error configuration

The errors can be divided into two types:

- Errors with predefined error type
- Errors with configurable error type

Especially critical errors are permanently set to the "Fault" error type in order to protect inverter and motor from damages.

In case of errors with configurable error type, the default setting can be changed in consideration of safety aspects and the operational performance. The selection "No response [0]" is, however, only available for minor errors.

The "[Error codes, causes and remedies](#)" table lists the error type for each error. If the error type can be configured by the user, the "adjustable in" column displays the corresponding parameter. [📖 375](#)

Diagnostics and fault elimination

Error handling
Error reset



19.4.3 Error reset

If the error condition is not active anymore, there are several options to reset an active error and thus leave the error state again:

- Via the button  in the »EASY Starter« ("Diagnostics" tab).
- Via bit 7 in the mappable CiA 402 control word [0x6040](#).

Parameter

Address	Name / setting range / [default setting]	Information
0x2822:003	Axis commands: Reset error	Parameters for interaction with engineering tools.
	0 Off/Ready	
	1 On/Start	
	2 In progress	
	3 Action cancelled	
	4 No access	
5 No access (Inverter disabled)		
0x2840	Error reset time • Read only: x ms	Setting of the delay time for "reset error" (0x2841 = 1).
0x2841	Reset error 0 ... [0] ... 1	1 ≡ reset error (error acknowledgement)

Notes:

- Certain errors can only be reset by mains switching.
- Certain errors (e. g. earth fault or short circuit of the motor phases) may cause a blocking time. In this case, the error can be reset only after the blocking time has elapsed. An active blocking time is displayed via bit 14 in the inverter status word [0x2831](#).

The "[Error codes, causes and remedies](#)" table gives the blocking time (if available) for each error. This table also shows whether mains switching is required for the error reset. [375](#)



19.5 Error codes, causes and remedies

The following table contains the most important error codes of the device in ascending order.

- Clicking the error code shows you a detailed description of the error message.
- If the device displays an "internal error" that is not listed here, restart the device. If the error persists, make a note of the error code and contact the manufacturer.

Error code	Error message	Error type	Configurable in
0	0x0000 No error	Information	-
16	0x0010 RANLI_CIMES_1000_20919	Warning	-
17	0x0011 RANLI_CIMES_1000_20920	Warning	-
18	0x0012 RANLI_CIMES_1000_20921	Warning	-
19	0x0013 RANLI_CIMES_1000_20922	Warning	-
61	0x003D RANLI_CIMES_1000_21215	Information	-
202	0x00CA RANLI_CIMES_1000_20923	Warning	-
203	0x00CB RANLI_CIMES_1000_20924	Warning	-
4097	0x1001 RANLI_CIMES_1000_21214	Information	-
4353	0x1101 RANLI_CIMES_1000_24902	Warning	-
4354	0x1102 RANLI_CIMES_1000_24903	Warning	-
4355	0x1103 RANLI_CIMES_1000_24904	Warning	-
4865	0x1301 RANLI_CIMES_1000_24901	Warning	-
5000	0x1388 RANLI_CIMES_1000_20925	Warning	-
5001	0x1389 RANLI_CIMES_1000_20926	Warning	-
5002	0x138A RANLI_CIMES_1000_20927	Warning	-
5003	0x138B RANLI_CIMES_1000_20928	Warning	-
5005	0x138D RANLI_CIMES_1000_20929	Warning	-
5006	0x138E RANLI_CIMES_1000_20930	Warning	-
5007	0x138F RANLI_CIMES_1000_20931	Warning	-
5008	0x1390 RANLI_CIMES_1000_20932	Warning	-
5009	0x1391 RANLI_CIMES_1000_20933	Warning	-
5010	0x1392 RANLI_CIMES_1000_20934	Warning	-
5011	0x1393 RANLI_CIMES_1000_20935	Warning	-
5012	0x1394 RANLI_CIMES_1000_20936	Warning	-
5014	0x1396 RANLI_CIMES_1000_20937	Warning	-
5015	0x1397 RANLI_CIMES_1000_20938	Warning	-
5016	0x1398 RANLI_CIMES_1000_20939	Warning	-
5017	0x1399 RANLI_CIMES_1000_20940	Warning	-
5018	0x139A RANLI_CIMES_1000_20941	Warning	-
5019	0x139B RANLI_CIMES_1000_20942	Warning	-
5020	0x139C RANLI_CIMES_1000_20943	Warning	-
5021	0x139D RANLI_CIMES_1000_20944	Warning	-
5022	0x139E RANLI_CIMES_1000_20945	Warning	-
5026	0x13A2 RANLI_CIMES_1000_20946	Warning	-
5027	0x13A3 RANLI_CIMES_1000_20947	Warning	-
5028	0x13A4 RANLI_CIMES_1000_20948	Warning	-
5030	0x13A6 RANLI_CIMES_1000_20949	Warning	-
5031	0x13A7 RANLI_CIMES_1000_20950	Warning	-
5033	0x13A9 RANLI_CIMES_1000_20951	Warning	-
5034	0x13AA RANLI_CIMES_1000_20952	Warning	-
5035	0x13AB RANLI_CIMES_1000_20953	Warning	-
5036	0x13AC RANLI_CIMES_1000_20954	Warning	-
5037	0x13AD RANLI_CIMES_1000_20955	Warning	-
5038	0x13AE RANLI_CIMES_1000_20956	Warning	-
5040	0x13B0 RANLI_CIMES_1000_20957	Warning	-
5041	0x13B1 RANLI_CIMES_1000_20958	Warning	-
5042	0x13B2 RANLI_CIMES_1000_20959	Warning	-
5043	0x13B3 RANLI_CIMES_1000_20960	Warning	-

Diagnostics and fault elimination

Error codes, causes and remedies



Error code	Error message	Error type	Configurable in
5044	0x13B4 RANLI_CIMES_1000_20961	Warning	-
5046	0x13B6 RANLI_CIMES_1000_20962	Warning	-
5047	0x13B7 RANLI_CIMES_1000_20963	Warning	-
5048	0x13B8 RANLI_CIMES_1000_20964	Warning	-
5049	0x13B9 RANLI_CIMES_1000_20965	Warning	-
5050	0x13BA RANLI_CIMES_1000_20966	Warning	-
5051	0x13BB RANLI_CIMES_1000_20967	Warning	-
5052	0x13BC RANLI_CIMES_1000_20968	Warning	-
5053	0x13BD RANLI_CIMES_1000_20969	Warning	-
5054	0x13BE RANLI_CIMES_1000_20970	Warning	-
5055	0x13BF RANLI_CIMES_1000_20971	Warning	-
5056	0x13C0 RANLI_CIMES_1000_20972	Warning	-
5063	0x13C7 RANLI_CIMES_1000_20973	Warning	-
5064	0x13C8 RANLI_CIMES_1000_20974	Warning	-
5065	0x13C9 RANLI_CIMES_1000_20975	Warning	-
5066	0x13CA RANLI_CIMES_1000_20976	Warning	-
5067	0x13CB RANLI_CIMES_1000_20977	Warning	-
5068	0x13CC RANLI_CIMES_1000_20978	Warning	-
5069	0x13CD RANLI_CIMES_1000_20979	Warning	-
5070	0x13CE RANLI_CIMES_1000_20980	Warning	-
5071	0x13CF RANLI_CIMES_1000_20981	Warning	-
5072	0x13D0 RANLI_CIMES_1000_20982	Warning	-
5073	0x13D1 RANLI_CIMES_1000_20983	Warning	-
5074	0x13D2 RANLI_CIMES_1000_20984	Warning	-
5075	0x13D3 RANLI_CIMES_1000_20985	Warning	-
5076	0x13D4 RANLI_CIMES_1000_20986	Warning	-
5077	0x13D5 RANLI_CIMES_1000_20987	Warning	-
5078	0x13D6 RANLI_CIMES_1000_20988	Warning	-
5079	0x13D7 RANLI_CIMES_1000_20989	Warning	-
5080	0x13D8 RANLI_CIMES_1000_20990	Warning	-
5081	0x13D9 RANLI_CIMES_1000_20991	Warning	-
5082	0x13DA RANLI_CIMES_1000_20992	Warning	-
5083	0x13DB RANLI_CIMES_1000_20993	Warning	-
5084	0x13DC CoE: SDO abort - write access, parameter value out of range	Warning	-
5085	0x13DD RANLI_CIMES_1000_20995	Warning	-
5086	0x13DE RANLI_CIMES_1000_20996	Warning	-
5087	0x13DF CoE: SDO abort - Max. value is less than min. value. (0x06090036)	Warning	-
5088	0x13E0 RANLI_CIMES_1000_20998	Warning	-
5089	0x13E1 RANLI_CIMES_1000_20999	Warning	-
5090	0x13E2 RANLI_CIMES_1000_21000	Warning	-
5091	0x13E3 RANLI_CIMES_1000_21001	Warning	-
5092	0x13E4 RANLI_CIMES_1000_21002	Warning	-
5093	0x13E5 RANLI_CIMES_1000_21003	Warning	-
5094	0x13E6 RANLI_CIMES_1000_21004	Warning	-
5095	0x13E7 RANLI_CIMES_1000_21005	Warning	-
5096	0x13E8 RANLI_CIMES_1000_21006	Warning	-
5097	0x13E9 RANLI_CIMES_1000_21007	Warning	-
5098	0x13EA RANLI_CIMES_1000_21008	Warning	-
5099	0x13EB RANLI_CIMES_1000_21009	Warning	-
5100	0x13EC RANLI_CIMES_1000_21010	Warning	-
5101	0x13ED RANLI_CIMES_1000_21011	Warning	-
5102	0x13EE RANLI_CIMES_1000_21012	Warning	-
5103	0x13EF RANLI_CIMES_1000_21013	Warning	-
5104	0x13F0 RANLI_CIMES_1000_21014	Warning	-
5105	0x13F1 RANLI_CIMES_1000_21015	Warning	-



Diagnostics and fault elimination

Error codes, causes and remedies

Error code	Error message	Error type	Configurable in
5106	0x13F2 RANLI_CIMES_1000_21016	Warning	-
5107	0x13F3 RANLI_CIMES_1000_21017	Warning	-
5108	0x13F4 RANLI_CIMES_1000_21018	Warning	-
5112	0x13F8 RANLI_CIMES_1000_21019	Warning	-
5113	0x13F9 RANLI_CIMES_1000_21020	Warning	-
5114	0x13FA RANLI_CIMES_1000_21021	Warning	-
5115	0x13FB RANLI_CIMES_1000_21022	Warning	-
5116	0x13FC RANLI_CIMES_1000_21023	Warning	-
5117	0x13FD RANLI_CIMES_1000_21024	Warning	-
5385	0x1509 RANLI_CIMES_1000_21025	Warning	-
5386	0x150A RANLI_CIMES_1000_21026	Warning	-
5387	0x150B RANLI_CIMES_1000_21027	Warning	-
5388	0x150C RANLI_CIMES_1000_21028	Warning	-
5389	0x150D RANLI_CIMES_1000_21029	Warning	-
5401	0x1519 RANLI_CIMES_1000_21030	Warning	-
5402	0x151A RANLI_CIMES_1000_21031	Warning	-
5403	0x151B RANLI_CIMES_1000_21032	Warning	-
5404	0x151C RANLI_CIMES_1000_21033	Warning	-
5405	0x151D RANLI_CIMES_1000_21034	Warning	-
5406	0x151E RANLI_CIMES_1000_21035	Warning	-
5449	0x1549 RANLI_CIMES_1000_21036	Warning	-
5450	0x154A RANLI_CIMES_1000_21037	Warning	-
5451	0x154B RANLI_CIMES_1000_21038	Warning	-
5452	0x154C RANLI_CIMES_1000_21039	Warning	-
5453	0x154D RANLI_CIMES_1000_21040	Warning	-
5454	0x154E RANLI_CIMES_1000_21041	Warning	-
5455	0x154F RANLI_CIMES_1000_21042	Warning	-
5513	0x1589 RANLI_CIMES_1000_21043	Warning	-
5514	0x158A RANLI_CIMES_1000_21044	Warning	-
5515	0x158B RANLI_CIMES_1000_21045	Warning	-
5516	0x158C RANLI_CIMES_1000_21046	Warning	-
5517	0x158D RANLI_CIMES_1000_21047	Warning	-
5518	0x158E RANLI_CIMES_1000_21048	Warning	-
5519	0x158F RANLI_CIMES_1000_21049	Warning	-
5520	0x1590 RANLI_CIMES_1000_21050	Warning	-
5521	0x1591 RANLI_CIMES_1000_21051	Warning	-
5522	0x1592 RANLI_CIMES_1000_21052	Warning	-
5523	0x1593 RANLI_CIMES_1000_21053	Warning	-
5524	0x1594 RANLI_CIMES_1000_21054	Warning	-
5525	0x1595 RANLI_CIMES_1000_21055	Warning	-
5526	0x1596 RANLI_CIMES_1000_21056	Warning	-
5527	0x1597 RANLI_CIMES_1000_21057	Warning	-
5528	0x1598 RANLI_CIMES_1000_21058	Warning	-
5529	0x1599 RANLI_CIMES_1000_21059	Warning	-
5530	0x159A RANLI_CIMES_1000_21060	Warning	-
5531	0x159B RANLI_CIMES_1000_21061	Warning	-
5532	0x159C RANLI_CIMES_1000_21062	Warning	-
5533	0x159D RANLI_CIMES_1000_21063	Warning	-
5534	0x159E RANLI_CIMES_1000_21064	Warning	-
5535	0x159F RANLI_CIMES_1000_21065	Warning	-
5536	0x15A0 RANLI_CIMES_1000_21066	Warning	-
5537	0x15A1 RANLI_CIMES_1000_21067	Warning	-
5538	0x15A2 Internal message	Warning	-
5539	0x15A3 RANLI_CIMES_1000_21069	Warning	-
5540	0x15A4 RANLI_CIMES_1000_21070	Warning	-

Diagnostics and fault elimination

Error codes, causes and remedies



Error code	Error message	Error type	Configurable in
5541	0x15A5 RANLI_CIMES_1000_21071	Warning	-
5542	0x15A6 RANLI_CIMES_1000_21072	Warning	-
5543	0x15A7 RANLI_CIMES_1000_21073	Warning	-
5544	0x15A8 RANLI_CIMES_1000_21074	Warning	-
5545	0x15A9 RANLI_CIMES_1000_21075	Warning	-
5546	0x15AA RANLI_CIMES_1000_21076	Warning	-
5547	0x15AB RANLI_CIMES_1000_21077	Warning	-
5548	0x15AC RANLI_CIMES_1000_21078	Warning	-
5549	0x15AD RANLI_CIMES_1000_21079	Warning	-
5550	0x15AE RANLI_CIMES_1000_21080	Warning	-
5551	0x15AF RANLI_CIMES_1000_21081	Warning	-
5552	0x15B0 RANLI_CIMES_1000_21082	Warning	-
5553	0x15B1 RANLI_CIMES_1000_21083	Warning	-
5554	0x15B2 RANLI_CIMES_1000_21084	Warning	-
5555	0x15B3 RANLI_CIMES_1000_21085	Warning	-
5556	0x15B4 RANLI_CIMES_1000_21086	Warning	-
5557	0x15B5 RANLI_CIMES_1000_21087	Warning	-
5558	0x15B6 RANLI_CIMES_1000_21088	Warning	-
5559	0x15B7 RANLI_CIMES_1000_21089	Warning	-
5560	0x15B8 RANLI_CIMES_1000_21090	Warning	-
5561	0x15B9 RANLI_CIMES_1000_21091	Warning	-
5562	0x15BA RANLI_CIMES_1000_21092	Warning	-
5563	0x15BB RANLI_CIMES_1000_21093	Warning	-
5564	0x15BC RANLI_CIMES_1000_21094	Warning	-
5592	0x15D8 RANLI_CIMES_1000_21095	Warning	-
5593	0x15D9 RANLI_CIMES_1000_21096	Warning	-
5594	0x15DA RANLI_CIMES_1000_21097	Warning	-
5595	0x15DB RANLI_CIMES_1000_21098	Warning	-
5596	0x15DC RANLI_CIMES_1000_21099	Warning	-
5597	0x15DD RANLI_CIMES_1000_21100	Warning	-
5598	0x15DE RANLI_CIMES_1000_21101	Warning	-
5599	0x15DF RANLI_CIMES_1000_21102	Warning	-
5600	0x15E0 RANLI_CIMES_1000_21103	Warning	-
5601	0x15E1 RANLI_CIMES_1000_21104	Warning	-
5602	0x15E2 RANLI_CIMES_1000_21105	Warning	-
5603	0x15E3 RANLI_CIMES_1000_21106	Warning	-
5604	0x15E4 RANLI_CIMES_1000_21107	Warning	-
5701	0x1645 RANLI_CIMES_1000_21108	Warning	-
5702	0x1646 RANLI_CIMES_1000_21109	Warning	-
5703	0x1647 RANLI_CIMES_1000_21110	Warning	-
5704	0x1648 RANLI_CIMES_1000_21111	Warning	-
5705	0x1649 RANLI_CIMES_1000_21112	Warning	-
5706	0x164A RANLI_CIMES_1000_21113	Warning	-
5707	0x164B RANLI_CIMES_1000_21114	Warning	-
5708	0x164C RANLI_CIMES_1000_21115	Warning	-
5709	0x164D RANLI_CIMES_1000_21116	Warning	-
5710	0x164E RANLI_CIMES_1000_21117	Warning	-
5711	0x164F RANLI_CIMES_1000_21118	Warning	-
5712	0x1650 RANLI_CIMES_1000_21119	Warning	-
5713	0x1651 RANLI_CIMES_1000_21120	Warning	-
5714	0x1652 RANLI_CIMES_1000_21121	Warning	-
5715	0x1653 RANLI_CIMES_1000_21122	Warning	-
5716	0x1654 RANLI_CIMES_1000_21123	Warning	-
5717	0x1655 RANLI_CIMES_1000_21124	Warning	-
5718	0x1656 RANLI_CIMES_1000_21125	Warning	-



Diagnostics and fault elimination

Error codes, causes and remedies

Error code	Error message	Error type	Configurable in
5719	0x1657 RANLI_CIMES_1000_21126	Warning	-
5722	0x165A RANLI_CIMES_1000_21127	Warning	-
5723	0x165B RANLI_CIMES_1000_21128	Warning	-
5724	0x165C RANLI_CIMES_1000_21129	Warning	-
5725	0x165D RANLI_CIMES_1000_21130	Warning	-
5726	0x165E RANLI_CIMES_1000_21131	Warning	-
5729	0x1661 RANLI_CIMES_1000_21132	Warning	-
5730	0x1662 RANLI_CIMES_1000_21133	Warning	-
5731	0x1663 RANLI_CIMES_1000_21134	Warning	-
5732	0x1664 RANLI_CIMES_1000_21135	Warning	-
5733	0x1665 RANLI_CIMES_1000_21136	Warning	-
5734	0x1666 RANLI_CIMES_1000_21137	Warning	-
5735	0x1667 RANLI_CIMES_1000_21138	Warning	-
5736	0x1668 RANLI_CIMES_1000_21139	Warning	-
5737	0x1669 RANLI_CIMES_1000_21140	Warning	-
5738	0x166A RANLI_CIMES_1000_21141	Warning	-
5739	0x166B Bus cycle and Sync cycle are different	Warning	-
5740	0x166C RANLI_CIMES_1000_21143	Warning	-
5741	0x166D RANLI_CIMES_1000_21144	Warning	-
5742	0x166E RANLI_CIMES_1000_21145	Warning	-
5743	0x166F RANLI_CIMES_1000_21146	Warning	-
5744	0x1670 RANLI_CIMES_1000_21147	Warning	-
6200	0x1838 RANLI_CIMES_1000_21148	Warning	-
6201	0x1839 RANLI_CIMES_1000_21149	Warning	-
6202	0x183A RANLI_CIMES_1000_21150	Warning	-
6203	0x183B RANLI_CIMES_1000_21151	Warning	-
6204	0x183C RANLI_CIMES_1000_21152	Warning	-
6210	0x1842 RANLI_CIMES_1000_21153	Warning	-
6212	0x1844 RANLI_CIMES_1000_21154	Warning	-
6213	0x1845 RANLI_CIMES_1000_21155	Warning	-
6214	0x1846 RANLI_CIMES_1000_21156	Warning	-
6215	0x1847 RANLI_CIMES_1000_21157	Warning	-
6216	0x1848 RANLI_CIMES_1000_21158	Warning	-
6220	0x184C RANLI_CIMES_1000_21159	Warning	-
6221	0x184D RANLI_CIMES_1000_21160	Warning	-
6222	0x184E RANLI_CIMES_1000_21161	Warning	-
6223	0x184F RANLI_CIMES_1000_21162	Warning	-
6230	0x1856 RANLI_CIMES_1000_21163	Warning	-
6231	0x1857 RANLI_CIMES_1000_21164	Warning	-
6232	0x1858 RANLI_CIMES_1000_21165	Warning	-
6233	0x1859 RANLI_CIMES_1000_21166	Warning	-
6234	0x185A RANLI_CIMES_1000_21167	Warning	-
6240	0x1860 RANLI_CIMES_1000_21168	Warning	-
6241	0x1861 RANLI_CIMES_1000_21169	Warning	-
6242	0x1862 RANLI_CIMES_1000_21170	Warning	-
6243	0x1863 RANLI_CIMES_1000_21171	Warning	-
6244	0x1864 RANLI_CIMES_1000_21172	Warning	-
6245	0x1865 RANLI_CIMES_1000_21173	Warning	-
6246	0x1866 RANLI_CIMES_1000_21174	Warning	-
6247	0x1867 RANLI_CIMES_1000_21175	Warning	-
6248	0x1868 RANLI_CIMES_1000_21176	Warning	-
6250	0x186A RANLI_CIMES_1000_21177	Warning	-
6251	0x186B RANLI_CIMES_1000_21178	Warning	-
6260	0x1874 RANLI_CIMES_1000_21179	Warning	-
6270	0x187E RANLI_CIMES_1000_21180	Warning	-

Diagnostics and fault elimination

Error codes, causes and remedies



Error code	Error message	Error type	Configurable in
6280	0x1888 RANLI_CIMES_1000_21181	Warning	-
6281	0x1889 RANLI_CIMES_1000_21182	Warning	-
6300	0x189C RANLI_CIMES_1000_21183	Warning	-
6301	0x189D RANLI_CIMES_1000_21184	Warning	-
6302	0x189E RANLI_CIMES_1000_21185	Warning	-
6303	0x189F RANLI_CIMES_1000_21186	Warning	-
6304	0x18A0 RANLI_CIMES_1000_21187	Warning	-
6305	0x18A1 RANLI_CIMES_1000_21188	Warning	-
6306	0x18A2 RANLI_CIMES_1000_21189	Warning	-
6307	0x18A3 RANLI_CIMES_1000_21190	Warning	-
6308	0x18A4 RANLI_CIMES_1000_21191	Warning	-
6309	0x18A5 RANLI_CIMES_1000_21192	Warning	-
6310	0x18A6 RANLI_CIMES_1000_21193	Warning	-
6311	0x18A7 RANLI_CIMES_1000_21194	Warning	-
6312	0x18A8 RANLI_CIMES_1000_21195	Warning	-
6313	0x18A9 RANLI_CIMES_1000_21196	Warning	-
6314	0x18AA RANLI_CIMES_1000_21197	Warning	-
6315	0x18AB RANLI_CIMES_1000_21198	Warning	-
6316	0x18AC RANLI_CIMES_1000_21199	Warning	-
6317	0x18AD RANLI_CIMES_1000_21200	Warning	-
6318	0x18AE RANLI_CIMES_1000_21201	Warning	-
6319	0x18AF RANLI_CIMES_1000_21202	Warning	-
6320	0x18B0 RANLI_CIMES_1000_21203	Warning	-
6321	0x18B1 RANLI_CIMES_1000_21204	Warning	-
6322	0x18B2 RANLI_CIMES_1000_21205	Warning	-
6323	0x18B3 RANLI_CIMES_1000_21206	Warning	-
6324	0x18B4 RANLI_CIMES_1000_21207	Warning	-
6325	0x18B5 RANLI_CIMES_1000_21208	Warning	-
6326	0x18B6 RANLI_CIMES_1000_21209	Warning	-
6327	0x18B7 RANLI_CIMES_1000_21210	Warning	-
6499	0x1963 RANLI_CIMES_1000_21211	Warning	-
8992	0x2320 CiA: Short circuit/earth leakage (internal)	Fault	-
9024	0x2340 CiA: Short circuit (device internal)	Fault	-
9041	0x2351 RANLI_CIMES_1000_20892	Fehler > CiA402	0x2D50:001
9088	0x2380 RANLI_CIMES_1000_02471	Fault	-
9089	0x2381 RANLI_CIMES_1000_21879	Warning	-
9090	0x2382 I*t error	Fault	-
9091	0x2383 I*t warning	Warning	-
9092	0x2384 RANLI_CIMES_0500_03891	Fault > CiA402	0x2D46:002
9093	0x2385 Parameterized mx. motor current > max. device current - Max. output current is limited to max. device current	Warning	-
9094	0x2386 Clamp active	Warning	-
9095	0x2387 lmax: Clamp responded too often	Fault	-
9097	0x2389 Warning - drive utilisation too high	Warning	-
9099	0x238B RANLI_CIMES_1000_21886	Fault	-
12816	0x3210 DC bus overvoltage	Fault	-
12832	0x3220 DC bus undervoltage	Trouble	-
16912	0x4210 PU: overtemperature fault	Fault	-
17024	0x4280 Heat sink temperature sensor fault	Fault	-
17025	0x4281 Heat sink fan warning	Warning	-
17026	0x4282 RANLI_CIMES_1000_18284	Information	-
17168	0x4310 Motor temperature error	Warning	0x2D49:002
17280	0x4380 RANLI_CIMES_1000_02502	Warning	0x2D49:002
17281	0x4381 RANLI_CIMES_1000_21212	Fault > CiA402	0x2D48:002
17282	0x4382 RANLI_CIMES_1000_21218	Warning	0x2D49:002



Diagnostics and fault elimination

Error codes, causes and remedies

Error code	Error message	Error type	Configurable in
17283	0x4383 RANLI_CIMES_1000_21219	Warning	0x2D49:002
20608	0x5080 Internal error - AIS	Warning	-
20609	0x5081 Internal error - AIE	Warning	-
20610	0x5082 Internal error - button S82	Warning	-
20611	0x5083 Internal error - IRS	Warning	-
20619	0x508B Internal error - SD-Inx/CLx	Warning	-
20620	0x508C Internal error - internal switch-off path	Warning	-
20621	0x508D Internal error - test pulse error internal switch-off path	Warning	-
20754	0x5112 24 V supply critical	Warning	-
20756	0x5114 Reference voltage error	Warning	-
20757	0x5115 6 V voltage error	Warning	-
20758	0x5116 5 V voltage error	Warning	-
20759	0x5117 3.3 V voltage error	Warning	-
24592	0x6010 Internal error	Warning	-
24960	0x6180 Internal error - STO activated	Warning	-
24965	0x6185 Faulty communication with basic device	Warning	-
24966	0x6186 Faulty synchronization with basic device	Information	-
24970	0x618A Internal fan warning	Warning	-
25360	0x6310 RANLI_CIMES_1000_20868	Warning	-
25376	0x6320 RANLI_CIMES_1000_20869	Warning	-
25472	0x6380 F-parameter error	Information	-
25473	0x6381 F_Dest_Add unequal F-address	Information	-
25474	0x6382 F_Dest_Add = 0 or FFFFhex	Information	-
25475	0x6383 F_Source_Add = 0 or FFFFhex	Information	-
25476	0x6384 F_WD_Time = 0 ms	Information	-
25477	0x6385 F_SIL exceeds technical SIL	Information	-
25478	0x6386 F_CRC_Length error	Information	-
25479	0x6387 Wrong F-parameter version	Information	-
25481	0x6389 New safety parameter set deleted	Information	-
25482	0x638A New safety parameter set loaded	Information	-
25483	0x638B Memory module access error	Warning	-
25484	0x638C Different safety parameter sets	Warning	-
25485	0x638D No safety parameter set	Warning	-
25486	0x638E Defect safety parameter set	Warning	-
25487	0x638F Safety parameter set format error	Warning	-
25488	0x6390 Safety parameter set plausibility error	Warning	-
25489	0x6391 Safety parameter set communication error	Warning	-
25490	0x6392 Module-ID unequal effective safety address	Warning	-
25491	0x6393 SSM: Wrong PDO version	Warning	-
28801	0x7081 Analog input 1 fault	No response	0x2636:010
28961	0x7121 Pole position identification fault	Fault	-
29443	0x7303 RANLI_CIMES_1000_20870	Fault > CiA402	0x2C45
29444	0x7304 RANLI_CIMES_1000_20910	Fault > CiA402	0x2C55
29568	0x7380 RANLI_CIMES_1000_20894	Fault > CiA402	0x2C41:004
29569	0x7381 RANLI_CIMES_1000_20900	Fault > CiA402	0x2C41:004
29570	0x7382 RANLI_CIMES_1000_20911	Fault > CiA402	0x2C51:004
29571	0x7383 RANLI_CIMES_1000_20912	Fault > CiA402	0x2C51:004
33162	0x818A PROFIsafe passivated	Information	-
33163	0x818B PROFIsafe has left data exchange	Information	-
33165	0x818D PROFIsafe CRC1 error	Information	-
33168	0x8190 RANLI_CIMES_1000_20915	Warning	0x2859:001
33169	0x8191 RANLI_CIMES_1000_21217	No response	0x2859:002
33170	0x8192 RANLI_CIMES_1000_20917	Warning	0x2859:004
33171	0x8193 RANLI_CIMES_1000_20918	Warning	0x2859:005
33173	0x8195 FSoE: Unexpected command	Information	-

Diagnostics and fault elimination

Error codes, causes and remedies



Error code	Error message	Error type	Configurable in
33174	0x8196 FSoE: Unknown command	Information	-
33175	0x8197 FSoE: Invalid connection ID	Information	-
33176	0x8198 FSoE: CRC error	Information	-
33177	0x8199 FSoE: Watchdog has expired	Information	-
33180	0x819C FSoE: Invalid communication parameter data	Information	-
33181	0x819D FSoE: Invalid application parameter length	Information	-
33182	0x819E FSoE: Invalid application parameter data	Information	-
33183	0x819F FSoE passivated	Information	-
33192	0x81A8 FSoE: Invalid slave address	Information	-
33193	0x81A9 FSoE: Invalid communication parameter length	Information	-
33194	0x81AA FSoE: Data exchange left	Information	-
33411	0x8283 RANLI_CIMES_1000_02508	Fault	-
33412	0x8284 RANLI_CIMES_1000_20884	Fault	-
33413	0x8285 RANLI_CIMES_1000_02510	Fault	-
33415	0x8287 RANLI_CIMES_1000_20916	Warning	0x2859:003
36992	0x9080 Discrepancy check or function check error - SD-In1	Warning	-
36993	0x9081 Discrepancy check or function check error - SD-In2	Warning	-
36994	0x9082 Discrepancy check or function check error - SD-In3	Warning	-
36995	0x9083 Discrepancy check or function check error - SD-In4	Warning	-
36996	0x9084 Deactivated SD-In1 = HIGH	Warning	-
36997	0x9085 Deactivated SD-In2 = HIGH	Warning	-
36998	0x9086 Deactivated SD-In3 = HIGH	Warning	-
36999	0x9087 Deactivated SD-In4 = HIGH	Warning	-
37000	0x9088 SD-Out1, channel A remains stuck at HIGH	Warning	-
37001	0x9089 SD-Out1, channel A remains stuck at LOW	Warning	-
37002	0x908A SD-Out1, channel B remains stuck at HIGH	Warning	-
37003	0x908B SD-Out1, channel B remains stuck at LOW	Warning	-
37004	0x908C SD-In1, channel A remains stuck at HIGH	Warning	-
37005	0x908D SD-In1, channel B remains stuck at HIGH	Warning	-
37006	0x908E SD-In2, channel A remains stuck at HIGH	Warning	-
37007	0x908F SD-In2, channel B remains stuck at HIGH	Warning	-
37008	0x9090 SD-In3, channel A remains stuck at HIGH	Warning	-
37009	0x9091 SD-In3, channel B remains stuck at HIGH	Warning	-
37010	0x9092 SD-In4, channel A remains stuck at HIGH	Warning	-
37011	0x9093 SD-In4, channel B remains stuck at HIGH	Warning	-
37012	0x9094 Short circuit - CLA/CLB	Warning	-
65280	0xFF00 RANLI_CIMES_1000_20877	Fault	-
65281	0xFF01 RANLI_CIMES_1000_20878	Fault	-
65282	0xFF02 Brake resistor: overload fault	No response	0x2550:011
65283	0xFF03 RANLI_CIMES_1000_20879	Fault	-
65284	0xFF04 RANLI_CIMES_1000_20880	Fault > CiA402	0x2C60
65285	0xFF05 Safe Torque Off is locked	Fault	-
65286	0xFF06 Motor overspeed	Fault > CiA402	0x2D44:002
65287	0xFF07 RANLI_CIMES_1000_20881	Warning	-
65288	0xFF08 RANLI_CIMES_1000_20882	Warning	-
65289	0xFF09 Motor phase missing	No response	See details for 65289
65290	0xFF0A Motor phase failure phase U	No response	See details for 65290
65291	0xFF0B Motor phase failure phase V	No response	See details for 65291
65292	0xFF0C RANLI_CIMES_1000_20883	No response	See details for 65292
65293	0xFF0D RANLI_CIMES_1000_20886	Warning	-
65294	0xFF0E RANLI_CIMES_1000_20887	Warning	-
65295	0xFF0F RANLI_CIMES_1000_20888	Warning	-
65296	0xFF10 RANLI_CIMES_1000_20889	Warning	-
65297	0xFF11 RANLI_CIMES_1000_20890	Warning	-
65298	0xFF12 RANLI_CIMES_1000_20891	Warning	-



Diagnostics and fault elimination

Error codes, causes and remedies

Error code	Error message	Error type	Configurable in
65299	0xFF13 RANLI_CIMES_1000_15967	Fault > CiA402	0x2C60
65300	0xFF14 RANLI_CIMES_1000_20895	Warning	-
65301	0xFF15 RANLI_CIMES_1000_20896	Warning	-
65302	0xFF16 RANLI_CIMES_1000_20897	Fault > CiA402	0x2C41:004
65303	0xFF17 RANLI_CIMES_1000_20898	Warning	-
65304	0xFF18 RANLI_CIMES_1000_20899	Fault	-
65305	0xFF19 Motor parameter identification fault	Fault	-
65306	0xFF1A RANLI_CIMES_1000_20913	Fault > CiA402	0x2C51:004
65307	0xFF1B Connected Hiperface absolute value load encoder/master encoder is not supported.	Warning	-
65308	0xFF1C RANLI_CIMES_1000_21881	Warning	-
65309	0xFF1D RANLI_CIMES_1000_21882	Warning	-
65310	0xFF1E RANLI_CIMES_1000_21883	Fault	-
65312	0xFF20 RANLI_CIMES_1000_20901	Warning	-
65313	0xFF21 RANLI_CIMES_1000_20902	Fault	-
65314	0xFF22 RANLI_CIMES_1000_20903	Fault	-
65315	0xFF23 RANLI_CIMES_1000_20904	Fault	-
65319	0xFF27 RANLI_CIMES_1000_25021	Fault	-
65334	0xFF36 Brake resistor: overload warning	Warning	-
65335	0xFF37 Automatic start disabled	Fault	-
65344	0xFF40 RANLI_CIMES_1000_20906	Fault	-
65345	0xFF41 RANLI_CIMES_1000_20907	Fault	-
65346	0xFF42 RANLI_CIMES_1000_20908	Fault	-
65360	0xFF50 RANLI_CIMES_1000_21213	Fault	-
65361	0xFF51 RANLI_CIMES_1000_24900	Fault	-
65416	0xFF88 SS1/SS2: Stopping time exceeded	Warning	-
65417	0xFF89 SLS1: Nlim1 exceeded	Warning	-
65418	0xFF8A SLS2: Nlim2 exceeded	Warning	-
65419	0xFF8B SLS3: Nlim3 exceeded	Warning	-
65420	0xFF8C SLS4: Nlim4 exceeded	Warning	-
65421	0xFF8D SLS/SMS: Error stop not executed	Warning	-
65422	0xFF8E SDIpos: Wrong moving direction	Warning	-
65423	0xFF8F SDIneg: Wrong moving direction	Warning	-
65424	0xFF90 SMS: Nmax exceeded	Warning	-
65425	0xFF91 SOS: Tolerance limit exceeded	Warning	-
65426	0xFF92 Feedback not configured	Warning	-
65427	0xFF93 CAS: Round trip time exceeded	Warning	-
65428	0xFF94 CAS: Hardware error or discrepancy error	Warning	-
65429	0xFF95 SS1/SS2: Speed ramp exceeded	Warning	-
65430	0xFF96 SLI: Safely limited increment exceeded	Warning	-
65431	0xFF97 SLP1: Position limits exceeded	Warning	-
65432	0xFF98 SLP2: Position limits exceeded	Warning	-
65433	0xFF99 SLP3: Position limits exceeded	Warning	-
65434	0xFF9A SLP4: Position limits exceeded	Warning	-
65435	0xFF9B SLP: No home position	Warning	-
65437	0xFF9D PDSS: Speed exceeded	Warning	-
65438	0xFF9E PDSS: Safe creep speed SCS exceeded	Warning	-
65439	0xFF9F PDSS: No diagnostic mark detected	Warning	-
65440	0xFFA0 PDSS: Diagnostic mark detected at invalid position	Warning	-
65446	0xFFA6 SHOM: Time-out	Warning	-
65447	0xFFA7 SHOM: Home position deleted	Information	-
65448	0xFFA8 SHOM: Maximum slip value exceeded	Warning	-
65449	0xFFA9 SHOM: Tolerance of start position exceeded	Warning	-
65450	0xFFAA SHOM: Tolerance of position comparison exceeded	Warning	-
65451	0xFFAB SSM: Safe speed invalid	Warning	-

Diagnostics and fault elimination

Error codes, causes and remedies



Error code	Error message	Error type	Configurable in
65452 0xFFAC	SSM: Encoder error	Warning	-
65453 0xFFAD	SSM: Resolver error	Warning	-
65454 0xFFAE	Error in standard device data	Warning	-
65455 0xFFAF	SSM: Speed deviation too high	Warning	-
65456 0xFFB0	SSM: Synchronization error	Warning	-

0 | 0x0000 **No error**

Cause	Remedy	Error type/response
		Information

16 | 0x0010 **RANLI_CIMES_1000_20919**

Cause	Remedy	Error type/response
		Warning

17 | 0x0011 **RANLI_CIMES_1000_20920**

Cause	Remedy	Error type/response
		Warning

18 | 0x0012 **RANLI_CIMES_1000_20921**

Cause	Remedy	Error type/response
		Warning

19 | 0x0013 **RANLI_CIMES_1000_20922**

Cause	Remedy	Error type/response
		Warning

61 | 0x003D **RANLI_CIMES_1000_21215**

Cause	Remedy	Error type/response
		Information

202 | 0x00CA **RANLI_CIMES_1000_20923**

Cause	Remedy	Error type/response
		Warning

203 | 0x00CB **RANLI_CIMES_1000_20924**

Cause	Remedy	Error type/response
		Warning

4097 | 0x1001 **RANLI_CIMES_1000_21214**

Cause	Remedy	Error type/response
		Information



Diagnostics and fault elimination

Error codes, causes and remedies

4353 | 0x1101 RANLI_CIMES_1000_24902

Cause	Remedy	Error type/response
		Warning

4354 | 0x1102 RANLI_CIMES_1000_24903

Cause	Remedy	Error type/response
		Warning

4355 | 0x1103 RANLI_CIMES_1000_24904

Cause	Remedy	Error type/response
		Warning

4865 | 0x1301 RANLI_CIMES_1000_24901

Cause	Remedy	Error type/response
		Warning

5000 | 0x1388 RANLI_CIMES_1000_20925

Cause	Remedy	Error type/response
		Warning

5001 | 0x1389 RANLI_CIMES_1000_20926

Cause	Remedy	Error type/response
		Warning

5002 | 0x138A RANLI_CIMES_1000_20927

Cause	Remedy	Error type/response
		Warning

5003 | 0x138B RANLI_CIMES_1000_20928

Cause	Remedy	Error type/response
		Warning

5005 | 0x138D RANLI_CIMES_1000_20929

Cause	Remedy	Error type/response
		Warning

5006 | 0x138E RANLI_CIMES_1000_20930

Cause	Remedy	Error type/response
		Warning

Diagnostics and fault elimination

Error codes, causes and remedies



5007 | 0x138F RANLI_CIMES_1000_20931

Cause	Remedy	Error type/response
		Warning

5008 | 0x1390 RANLI_CIMES_1000_20932

Cause	Remedy	Error type/response
		Warning

5009 | 0x1391 RANLI_CIMES_1000_20933

Cause	Remedy	Error type/response
		Warning

5010 | 0x1392 RANLI_CIMES_1000_20934

Cause	Remedy	Error type/response
		Warning

5011 | 0x1393 RANLI_CIMES_1000_20935

Cause	Remedy	Error type/response
		Warning

5012 | 0x1394 RANLI_CIMES_1000_20936

Cause	Remedy	Error type/response
		Warning

5014 | 0x1396 RANLI_CIMES_1000_20937

Cause	Remedy	Error type/response
		Warning

5015 | 0x1397 RANLI_CIMES_1000_20938

Cause	Remedy	Error type/response
		Warning

5016 | 0x1398 RANLI_CIMES_1000_20939

Cause	Remedy	Error type/response
		Warning

5017 | 0x1399 RANLI_CIMES_1000_20940

Cause	Remedy	Error type/response
		Warning



Diagnostics and fault elimination

Error codes, causes and remedies

5018 | 0x139A RANLI_CIMES_1000_20941

Cause	Remedy	Error type/response
		Warning

5019 | 0x139B RANLI_CIMES_1000_20942

Cause	Remedy	Error type/response
		Warning

5020 | 0x139C RANLI_CIMES_1000_20943

Cause	Remedy	Error type/response
		Warning

5021 | 0x139D RANLI_CIMES_1000_20944

Cause	Remedy	Error type/response
		Warning

5022 | 0x139E RANLI_CIMES_1000_20945

Cause	Remedy	Error type/response
		Warning

5026 | 0x13A2 RANLI_CIMES_1000_20946

Cause	Remedy	Error type/response
		Warning

5027 | 0x13A3 RANLI_CIMES_1000_20947

Cause	Remedy	Error type/response
		Warning

5028 | 0x13A4 RANLI_CIMES_1000_20948

Cause	Remedy	Error type/response
		Warning

5030 | 0x13A6 RANLI_CIMES_1000_20949

Cause	Remedy	Error type/response
		Warning

5031 | 0x13A7 RANLI_CIMES_1000_20950

Cause	Remedy	Error type/response
		Warning

Diagnostics and fault elimination

Error codes, causes and remedies



5033 | 0x13A9 RANLI_CIMES_1000_20951

Cause	Remedy	Error type/response
		Warning

5034 | 0x13AA RANLI_CIMES_1000_20952

Cause	Remedy	Error type/response
		Warning

5035 | 0x13AB RANLI_CIMES_1000_20953

Cause	Remedy	Error type/response
		Warning

5036 | 0x13AC RANLI_CIMES_1000_20954

Cause	Remedy	Error type/response
		Warning

5037 | 0x13AD RANLI_CIMES_1000_20955

Cause	Remedy	Error type/response
		Warning

5038 | 0x13AE RANLI_CIMES_1000_20956

Cause	Remedy	Error type/response
		Warning

5040 | 0x13B0 RANLI_CIMES_1000_20957

Cause	Remedy	Error type/response
		Warning

5041 | 0x13B1 RANLI_CIMES_1000_20958

Cause	Remedy	Error type/response
		Warning

5042 | 0x13B2 RANLI_CIMES_1000_20959

Cause	Remedy	Error type/response
		Warning

5043 | 0x13B3 RANLI_CIMES_1000_20960

Cause	Remedy	Error type/response
		Warning



Diagnostics and fault elimination

Error codes, causes and remedies

5044 | 0x13B4 RANLI_CIMES_1000_20961

Cause	Remedy	Error type/response
		Warning

5046 | 0x13B6 RANLI_CIMES_1000_20962

Cause	Remedy	Error type/response
		Warning

5047 | 0x13B7 RANLI_CIMES_1000_20963

Cause	Remedy	Error type/response
		Warning

5048 | 0x13B8 RANLI_CIMES_1000_20964

Cause	Remedy	Error type/response
		Warning

5049 | 0x13B9 RANLI_CIMES_1000_20965

Cause	Remedy	Error type/response
		Warning

5050 | 0x13BA RANLI_CIMES_1000_20966

Cause	Remedy	Error type/response
		Warning

5051 | 0x13BB RANLI_CIMES_1000_20967

Cause	Remedy	Error type/response
		Warning

5052 | 0x13BC RANLI_CIMES_1000_20968

Cause	Remedy	Error type/response
		Warning

5053 | 0x13BD RANLI_CIMES_1000_20969

Cause	Remedy	Error type/response
		Warning

5054 | 0x13BE RANLI_CIMES_1000_20970

Cause	Remedy	Error type/response
		Warning

Diagnostics and fault elimination

Error codes, causes and remedies



5055 | 0x13BF RANLI_CIMES_1000_20971

Cause	Remedy	Error type/response
		Warning

5056 | 0x13C0 RANLI_CIMES_1000_20972

Cause	Remedy	Error type/response
		Warning

5063 | 0x13C7 RANLI_CIMES_1000_20973

Cause	Remedy	Error type/response
		Warning

5064 | 0x13C8 RANLI_CIMES_1000_20974

Cause	Remedy	Error type/response
		Warning

5065 | 0x13C9 RANLI_CIMES_1000_20975

Cause	Remedy	Error type/response
		Warning

5066 | 0x13CA RANLI_CIMES_1000_20976

Cause	Remedy	Error type/response
		Warning

5067 | 0x13CB RANLI_CIMES_1000_20977

Cause	Remedy	Error type/response
		Warning

5068 | 0x13CC RANLI_CIMES_1000_20978

Cause	Remedy	Error type/response
		Warning

5069 | 0x13CD RANLI_CIMES_1000_20979

Cause	Remedy	Error type/response
		Warning

5070 | 0x13CE RANLI_CIMES_1000_20980

Cause	Remedy	Error type/response
		Warning



Diagnostics and fault elimination

Error codes, causes and remedies

5071 | 0x13CF | RANLI_CIMES_1000_20981

Cause	Remedy	Error type/response
		Warning

5072 | 0x13D0 | RANLI_CIMES_1000_20982

Cause	Remedy	Error type/response
		Warning

5073 | 0x13D1 | RANLI_CIMES_1000_20983

Cause	Remedy	Error type/response
		Warning

5074 | 0x13D2 | RANLI_CIMES_1000_20984

Cause	Remedy	Error type/response
		Warning

5075 | 0x13D3 | RANLI_CIMES_1000_20985

Cause	Remedy	Error type/response
		Warning

5076 | 0x13D4 | RANLI_CIMES_1000_20986

Cause	Remedy	Error type/response
		Warning

5077 | 0x13D5 | RANLI_CIMES_1000_20987

Cause	Remedy	Error type/response
		Warning

5078 | 0x13D6 | RANLI_CIMES_1000_20988

Cause	Remedy	Error type/response
		Warning

5079 | 0x13D7 | RANLI_CIMES_1000_20989

Cause	Remedy	Error type/response
		Warning

5080 | 0x13D8 | RANLI_CIMES_1000_20990

Cause	Remedy	Error type/response
		Warning

Diagnostics and fault elimination

Error codes, causes and remedies



5081 | 0x13D9 RANLI_CIMES_1000_20991

Cause	Remedy	Error type/response
		Warning

5082 | 0x13DA RANLI_CIMES_1000_20992

Cause	Remedy	Error type/response
		Warning

5083 | 0x13DB RANLI_CIMES_1000_20993

Cause	Remedy	Error type/response
		Warning

5084 | 0x13DC CoE: SDO abort - write access, parameter value out of range

Cause	Remedy	Error type/response
		Warning

5085 | 0x13DD RANLI_CIMES_1000_20995

Cause	Remedy	Error type/response
		Warning

5086 | 0x13DE RANLI_CIMES_1000_20996

Cause	Remedy	Error type/response
		Warning

5087 | 0x13DF CoE: SDO abort - Max. value is less than min. value. (0x06090036)

Cause	Remedy	Error type/response
		Warning

5088 | 0x13E0 RANLI_CIMES_1000_20998

Cause	Remedy	Error type/response
		Warning

5089 | 0x13E1 RANLI_CIMES_1000_20999

Cause	Remedy	Error type/response
		Warning

5090 | 0x13E2 RANLI_CIMES_1000_21000

Cause	Remedy	Error type/response
		Warning



Diagnostics and fault elimination

Error codes, causes and remedies

5091 | 0x13E3 | RANLI_CIMES_1000_21001

Cause	Remedy	Error type/response
		Warning

5092 | 0x13E4 | RANLI_CIMES_1000_21002

Cause	Remedy	Error type/response
		Warning

5093 | 0x13E5 | RANLI_CIMES_1000_21003

Cause	Remedy	Error type/response
		Warning

5094 | 0x13E6 | RANLI_CIMES_1000_21004

Cause	Remedy	Error type/response
		Warning

5095 | 0x13E7 | RANLI_CIMES_1000_21005

Cause	Remedy	Error type/response
		Warning

5096 | 0x13E8 | RANLI_CIMES_1000_21006

Cause	Remedy	Error type/response
		Warning

5097 | 0x13E9 | RANLI_CIMES_1000_21007

Cause	Remedy	Error type/response
		Warning

5098 | 0x13EA | RANLI_CIMES_1000_21008

Cause	Remedy	Error type/response
		Warning

5099 | 0x13EB | RANLI_CIMES_1000_21009

Cause	Remedy	Error type/response
		Warning

5100 | 0x13EC | RANLI_CIMES_1000_21010

Cause	Remedy	Error type/response
		Warning

Diagnostics and fault elimination

Error codes, causes and remedies



5101 | 0x13ED RANLI_CIMES_1000_21011

Cause	Remedy	Error type/response
		Warning

5102 | 0x13EE RANLI_CIMES_1000_21012

Cause	Remedy	Error type/response
		Warning

5103 | 0x13EF RANLI_CIMES_1000_21013

Cause	Remedy	Error type/response
		Warning

5104 | 0x13F0 RANLI_CIMES_1000_21014

Cause	Remedy	Error type/response
		Warning

5105 | 0x13F1 RANLI_CIMES_1000_21015

Cause	Remedy	Error type/response
		Warning

5106 | 0x13F2 RANLI_CIMES_1000_21016

Cause	Remedy	Error type/response
		Warning

5107 | 0x13F3 RANLI_CIMES_1000_21017

Cause	Remedy	Error type/response
		Warning

5108 | 0x13F4 RANLI_CIMES_1000_21018

Cause	Remedy	Error type/response
		Warning

5112 | 0x13F8 RANLI_CIMES_1000_21019

Cause	Remedy	Error type/response
		Warning

5113 | 0x13F9 RANLI_CIMES_1000_21020

Cause	Remedy	Error type/response
		Warning



Diagnostics and fault elimination

Error codes, causes and remedies

5114 | 0x13FA | RANLI_CIMES_1000_21021

Cause	Remedy	Error type/response
		Warning

5115 | 0x13FB | RANLI_CIMES_1000_21022

Cause	Remedy	Error type/response
		Warning

5116 | 0x13FC | RANLI_CIMES_1000_21023

Cause	Remedy	Error type/response
		Warning

5117 | 0x13FD | RANLI_CIMES_1000_21024

Cause	Remedy	Error type/response
		Warning

5385 | 0x1509 | RANLI_CIMES_1000_21025

Cause	Remedy	Error type/response
		Warning

5386 | 0x150A | RANLI_CIMES_1000_21026

Cause	Remedy	Error type/response
		Warning

5387 | 0x150B | RANLI_CIMES_1000_21027

Cause	Remedy	Error type/response
		Warning

5388 | 0x150C | RANLI_CIMES_1000_21028

Cause	Remedy	Error type/response
		Warning

5389 | 0x150D | RANLI_CIMES_1000_21029

Cause	Remedy	Error type/response
		Warning

5401 | 0x1519 | RANLI_CIMES_1000_21030

Cause	Remedy	Error type/response
		Warning

Diagnostics and fault elimination

Error codes, causes and remedies



5402 | 0x151A RANLI_CIMES_1000_21031

Cause	Remedy	Error type/response
		Warning

5403 | 0x151B RANLI_CIMES_1000_21032

Cause	Remedy	Error type/response
		Warning

5404 | 0x151C RANLI_CIMES_1000_21033

Cause	Remedy	Error type/response
		Warning

5405 | 0x151D RANLI_CIMES_1000_21034

Cause	Remedy	Error type/response
		Warning

5406 | 0x151E RANLI_CIMES_1000_21035

Cause	Remedy	Error type/response
		Warning

5449 | 0x1549 RANLI_CIMES_1000_21036

Cause	Remedy	Error type/response
		Warning

5450 | 0x154A RANLI_CIMES_1000_21037

Cause	Remedy	Error type/response
		Warning

5451 | 0x154B RANLI_CIMES_1000_21038

Cause	Remedy	Error type/response
		Warning

5452 | 0x154C RANLI_CIMES_1000_21039

Cause	Remedy	Error type/response
		Warning

5453 | 0x154D RANLI_CIMES_1000_21040

Cause	Remedy	Error type/response
		Warning



Diagnostics and fault elimination

Error codes, causes and remedies

5454 | 0x154E | RANLI_CIMES_1000_21041

Cause	Remedy	Error type/response
		Warning

5455 | 0x154F | RANLI_CIMES_1000_21042

Cause	Remedy	Error type/response
		Warning

5513 | 0x1589 | RANLI_CIMES_1000_21043

Cause	Remedy	Error type/response
		Warning

5514 | 0x158A | RANLI_CIMES_1000_21044

Cause	Remedy	Error type/response
		Warning

5515 | 0x158B | RANLI_CIMES_1000_21045

Cause	Remedy	Error type/response
		Warning

5516 | 0x158C | RANLI_CIMES_1000_21046

Cause	Remedy	Error type/response
		Warning

5517 | 0x158D | RANLI_CIMES_1000_21047

Cause	Remedy	Error type/response
		Warning

5518 | 0x158E | RANLI_CIMES_1000_21048

Cause	Remedy	Error type/response
		Warning

5519 | 0x158F | RANLI_CIMES_1000_21049

Cause	Remedy	Error type/response
		Warning

5520 | 0x1590 | RANLI_CIMES_1000_21050

Cause	Remedy	Error type/response
		Warning

Diagnostics and fault elimination

Error codes, causes and remedies



5521 | 0x1591 RANLI_CIMES_1000_21051

Cause	Remedy	Error type/response
		Warning

5522 | 0x1592 RANLI_CIMES_1000_21052

Cause	Remedy	Error type/response
		Warning

5523 | 0x1593 RANLI_CIMES_1000_21053

Cause	Remedy	Error type/response
		Warning

5524 | 0x1594 RANLI_CIMES_1000_21054

Cause	Remedy	Error type/response
		Warning

5525 | 0x1595 RANLI_CIMES_1000_21055

Cause	Remedy	Error type/response
		Warning

5526 | 0x1596 RANLI_CIMES_1000_21056

Cause	Remedy	Error type/response
		Warning

5527 | 0x1597 RANLI_CIMES_1000_21057

Cause	Remedy	Error type/response
		Warning

5528 | 0x1598 RANLI_CIMES_1000_21058

Cause	Remedy	Error type/response
		Warning

5529 | 0x1599 RANLI_CIMES_1000_21059

Cause	Remedy	Error type/response
		Warning

5530 | 0x159A RANLI_CIMES_1000_21060

Cause	Remedy	Error type/response
		Warning



Diagnostics and fault elimination

Error codes, causes and remedies

5531 | 0x159B | RANLI_CIMES_1000_21061

Cause	Remedy	Error type/response
		Warning

5532 | 0x159C | RANLI_CIMES_1000_21062

Cause	Remedy	Error type/response
		Warning

5533 | 0x159D | RANLI_CIMES_1000_21063

Cause	Remedy	Error type/response
		Warning

5534 | 0x159E | RANLI_CIMES_1000_21064

Cause	Remedy	Error type/response
		Warning

5535 | 0x159F | RANLI_CIMES_1000_21065

Cause	Remedy	Error type/response
		Warning

5536 | 0x15A0 | RANLI_CIMES_1000_21066

Cause	Remedy	Error type/response
		Warning

5537 | 0x15A1 | RANLI_CIMES_1000_21067

Cause	Remedy	Error type/response
		Warning

5538 | 0x15A2 | Internal message

Cause	Remedy	Error type/response
		Warning

5539 | 0x15A3 | RANLI_CIMES_1000_21069

Cause	Remedy	Error type/response
		Warning

5540 | 0x15A4 | RANLI_CIMES_1000_21070

Cause	Remedy	Error type/response
		Warning

Diagnostics and fault elimination

Error codes, causes and remedies



5541 | 0x15A5 RANLI_CIMES_1000_21071

Cause	Remedy	Error type/response
		Warning

5542 | 0x15A6 RANLI_CIMES_1000_21072

Cause	Remedy	Error type/response
		Warning

5543 | 0x15A7 RANLI_CIMES_1000_21073

Cause	Remedy	Error type/response
		Warning

5544 | 0x15A8 RANLI_CIMES_1000_21074

Cause	Remedy	Error type/response
		Warning

5545 | 0x15A9 RANLI_CIMES_1000_21075

Cause	Remedy	Error type/response
		Warning

5546 | 0x15AA RANLI_CIMES_1000_21076

Cause	Remedy	Error type/response
		Warning

5547 | 0x15AB RANLI_CIMES_1000_21077

Cause	Remedy	Error type/response
		Warning

5548 | 0x15AC RANLI_CIMES_1000_21078

Cause	Remedy	Error type/response
		Warning

5549 | 0x15AD RANLI_CIMES_1000_21079

Cause	Remedy	Error type/response
		Warning

5550 | 0x15AE RANLI_CIMES_1000_21080

Cause	Remedy	Error type/response
		Warning



Diagnostics and fault elimination

Error codes, causes and remedies

5551 | 0x15AF | RANLI_CIMES_1000_21081

Cause	Remedy	Error type/response
		Warning

5552 | 0x15B0 | RANLI_CIMES_1000_21082

Cause	Remedy	Error type/response
		Warning

5553 | 0x15B1 | RANLI_CIMES_1000_21083

Cause	Remedy	Error type/response
		Warning

5554 | 0x15B2 | RANLI_CIMES_1000_21084

Cause	Remedy	Error type/response
		Warning

5555 | 0x15B3 | RANLI_CIMES_1000_21085

Cause	Remedy	Error type/response
		Warning

5556 | 0x15B4 | RANLI_CIMES_1000_21086

Cause	Remedy	Error type/response
		Warning

5557 | 0x15B5 | RANLI_CIMES_1000_21087

Cause	Remedy	Error type/response
		Warning

5558 | 0x15B6 | RANLI_CIMES_1000_21088

Cause	Remedy	Error type/response
		Warning

5559 | 0x15B7 | RANLI_CIMES_1000_21089

Cause	Remedy	Error type/response
		Warning

5560 | 0x15B8 | RANLI_CIMES_1000_21090

Cause	Remedy	Error type/response
		Warning

Diagnostics and fault elimination

Error codes, causes and remedies



5561 | 0x15B9 RANLI_CIMES_1000_21091

Cause	Remedy	Error type/response
		Warning

5562 | 0x15BA RANLI_CIMES_1000_21092

Cause	Remedy	Error type/response
		Warning

5563 | 0x15BB RANLI_CIMES_1000_21093

Cause	Remedy	Error type/response
		Warning

5564 | 0x15BC RANLI_CIMES_1000_21094

Cause	Remedy	Error type/response
		Warning

5592 | 0x15D8 RANLI_CIMES_1000_21095

Cause	Remedy	Error type/response
		Warning

5593 | 0x15D9 RANLI_CIMES_1000_21096

Cause	Remedy	Error type/response
		Warning

5594 | 0x15DA RANLI_CIMES_1000_21097

Cause	Remedy	Error type/response
		Warning

5595 | 0x15DB RANLI_CIMES_1000_21098

Cause	Remedy	Error type/response
		Warning

5596 | 0x15DC RANLI_CIMES_1000_21099

Cause	Remedy	Error type/response
		Warning

5597 | 0x15DD RANLI_CIMES_1000_21100

Cause	Remedy	Error type/response
		Warning



Diagnostics and fault elimination

Error codes, causes and remedies

5598 | 0x15DE RANLI_CIMES_1000_21101

Cause	Remedy	Error type/response
		Warning

5599 | 0x15DF RANLI_CIMES_1000_21102

Cause	Remedy	Error type/response
		Warning

5600 | 0x15E0 RANLI_CIMES_1000_21103

Cause	Remedy	Error type/response
		Warning

5601 | 0x15E1 RANLI_CIMES_1000_21104

Cause	Remedy	Error type/response
		Warning

5602 | 0x15E2 RANLI_CIMES_1000_21105

Cause	Remedy	Error type/response
		Warning

5603 | 0x15E3 RANLI_CIMES_1000_21106

Cause	Remedy	Error type/response
		Warning

5604 | 0x15E4 RANLI_CIMES_1000_21107

Cause	Remedy	Error type/response
		Warning

5701 | 0x1645 RANLI_CIMES_1000_21108

Cause	Remedy	Error type/response
		Warning

5702 | 0x1646 RANLI_CIMES_1000_21109

Cause	Remedy	Error type/response
		Warning

5703 | 0x1647 RANLI_CIMES_1000_21110

Cause	Remedy	Error type/response
		Warning

Diagnostics and fault elimination

Error codes, causes and remedies



5704 | 0x1648 RANLI_CIMES_1000_21111

Cause	Remedy	Error type/response
		Warning

5705 | 0x1649 RANLI_CIMES_1000_21112

Cause	Remedy	Error type/response
		Warning

5706 | 0x164A RANLI_CIMES_1000_21113

Cause	Remedy	Error type/response
		Warning

5707 | 0x164B RANLI_CIMES_1000_21114

Cause	Remedy	Error type/response
		Warning

5708 | 0x164C RANLI_CIMES_1000_21115

Cause	Remedy	Error type/response
		Warning

5709 | 0x164D RANLI_CIMES_1000_21116

Cause	Remedy	Error type/response
		Warning

5710 | 0x164E RANLI_CIMES_1000_21117

Cause	Remedy	Error type/response
		Warning

5711 | 0x164F RANLI_CIMES_1000_21118

Cause	Remedy	Error type/response
		Warning

5712 | 0x1650 RANLI_CIMES_1000_21119

Cause	Remedy	Error type/response
		Warning

5713 | 0x1651 RANLI_CIMES_1000_21120

Cause	Remedy	Error type/response
		Warning



Diagnostics and fault elimination

Error codes, causes and remedies

5714 | 0x1652 RANLI_CIMES_1000_21121

Cause	Remedy	Error type/response
		Warning

5715 | 0x1653 RANLI_CIMES_1000_21122

Cause	Remedy	Error type/response
		Warning

5716 | 0x1654 RANLI_CIMES_1000_21123

Cause	Remedy	Error type/response
		Warning

5717 | 0x1655 RANLI_CIMES_1000_21124

Cause	Remedy	Error type/response
		Warning

5718 | 0x1656 RANLI_CIMES_1000_21125

Cause	Remedy	Error type/response
		Warning

5719 | 0x1657 RANLI_CIMES_1000_21126

Cause	Remedy	Error type/response
		Warning

5722 | 0x165A RANLI_CIMES_1000_21127

Cause	Remedy	Error type/response
		Warning

5723 | 0x165B RANLI_CIMES_1000_21128

Cause	Remedy	Error type/response
		Warning

5724 | 0x165C RANLI_CIMES_1000_21129

Cause	Remedy	Error type/response
		Warning

5725 | 0x165D RANLI_CIMES_1000_21130

Cause	Remedy	Error type/response
		Warning

Diagnostics and fault elimination

Error codes, causes and remedies



5726 | 0x165E RANLI_CIMES_1000_21131

Cause	Remedy	Error type/response
		Warning

5729 | 0x1661 RANLI_CIMES_1000_21132

Cause	Remedy	Error type/response
		Warning

5730 | 0x1662 RANLI_CIMES_1000_21133

Cause	Remedy	Error type/response
		Warning

5731 | 0x1663 RANLI_CIMES_1000_21134

Cause	Remedy	Error type/response
		Warning

5732 | 0x1664 RANLI_CIMES_1000_21135

Cause	Remedy	Error type/response
		Warning

5733 | 0x1665 RANLI_CIMES_1000_21136

Cause	Remedy	Error type/response
		Warning

5734 | 0x1666 RANLI_CIMES_1000_21137

Cause	Remedy	Error type/response
		Warning

5735 | 0x1667 RANLI_CIMES_1000_21138

Cause	Remedy	Error type/response
		Warning

5736 | 0x1668 RANLI_CIMES_1000_21139

Cause	Remedy	Error type/response
		Warning

5737 | 0x1669 RANLI_CIMES_1000_21140

Cause	Remedy	Error type/response
		Warning



Diagnostics and fault elimination

Error codes, causes and remedies

5738 | 0x166A RANLI_CIMES_1000_21141

Cause	Remedy	Error type/response
		Warning

5739 | 0x166B Bus cycle and Sync cycle are different

Cause	Remedy	Error type/response
		Warning

5740 | 0x166C RANLI_CIMES_1000_21143

Cause	Remedy	Error type/response
		Warning

5741 | 0x166D RANLI_CIMES_1000_21144

Cause	Remedy	Error type/response
		Warning

5742 | 0x166E RANLI_CIMES_1000_21145

Cause	Remedy	Error type/response
		Warning

5743 | 0x166F RANLI_CIMES_1000_21146

Cause	Remedy	Error type/response
		Warning

5744 | 0x1670 RANLI_CIMES_1000_21147

Cause	Remedy	Error type/response
		Warning

6200 | 0x1838 RANLI_CIMES_1000_21148

Cause	Remedy	Error type/response
		Warning

6201 | 0x1839 RANLI_CIMES_1000_21149

Cause	Remedy	Error type/response
		Warning

6202 | 0x183A RANLI_CIMES_1000_21150

Cause	Remedy	Error type/response
		Warning

Diagnostics and fault elimination

Error codes, causes and remedies



6203 | 0x183B RANLI_CIMES_1000_21151

Cause	Remedy	Error type/response
		Warning

6204 | 0x183C RANLI_CIMES_1000_21152

Cause	Remedy	Error type/response
		Warning

6210 | 0x1842 RANLI_CIMES_1000_21153

Cause	Remedy	Error type/response
		Warning

6212 | 0x1844 RANLI_CIMES_1000_21154

Cause	Remedy	Error type/response
		Warning

6213 | 0x1845 RANLI_CIMES_1000_21155

Cause	Remedy	Error type/response
		Warning

6214 | 0x1846 RANLI_CIMES_1000_21156

Cause	Remedy	Error type/response
		Warning

6215 | 0x1847 RANLI_CIMES_1000_21157

Cause	Remedy	Error type/response
		Warning

6216 | 0x1848 RANLI_CIMES_1000_21158

Cause	Remedy	Error type/response
		Warning

6220 | 0x184C RANLI_CIMES_1000_21159

Cause	Remedy	Error type/response
		Warning

6221 | 0x184D RANLI_CIMES_1000_21160

Cause	Remedy	Error type/response
		Warning



Diagnostics and fault elimination

Error codes, causes and remedies

6222 | 0x184E | RANLI_CIMES_1000_21161

Cause	Remedy	Error type/response
		Warning

6223 | 0x184F | RANLI_CIMES_1000_21162

Cause	Remedy	Error type/response
		Warning

6230 | 0x1856 | RANLI_CIMES_1000_21163

Cause	Remedy	Error type/response
		Warning

6231 | 0x1857 | RANLI_CIMES_1000_21164

Cause	Remedy	Error type/response
		Warning

6232 | 0x1858 | RANLI_CIMES_1000_21165

Cause	Remedy	Error type/response
		Warning

6233 | 0x1859 | RANLI_CIMES_1000_21166

Cause	Remedy	Error type/response
		Warning

6234 | 0x185A | RANLI_CIMES_1000_21167

Cause	Remedy	Error type/response
		Warning

6240 | 0x1860 | RANLI_CIMES_1000_21168

Cause	Remedy	Error type/response
		Warning

6241 | 0x1861 | RANLI_CIMES_1000_21169

Cause	Remedy	Error type/response
		Warning

6242 | 0x1862 | RANLI_CIMES_1000_21170

Cause	Remedy	Error type/response
		Warning

Diagnostics and fault elimination

Error codes, causes and remedies



6243 | 0x1863 RANLI_CIMES_1000_21171

Cause	Remedy	Error type/response
		Warning

6244 | 0x1864 RANLI_CIMES_1000_21172

Cause	Remedy	Error type/response
		Warning

6245 | 0x1865 RANLI_CIMES_1000_21173

Cause	Remedy	Error type/response
		Warning

6246 | 0x1866 RANLI_CIMES_1000_21174

Cause	Remedy	Error type/response
		Warning

6247 | 0x1867 RANLI_CIMES_1000_21175

Cause	Remedy	Error type/response
		Warning

6248 | 0x1868 RANLI_CIMES_1000_21176

Cause	Remedy	Error type/response
		Warning

6250 | 0x186A RANLI_CIMES_1000_21177

Cause	Remedy	Error type/response
		Warning

6251 | 0x186B RANLI_CIMES_1000_21178

Cause	Remedy	Error type/response
		Warning

6260 | 0x1874 RANLI_CIMES_1000_21179

Cause	Remedy	Error type/response
		Warning

6270 | 0x187E RANLI_CIMES_1000_21180

Cause	Remedy	Error type/response
		Warning



Diagnostics and fault elimination

Error codes, causes and remedies

6280 | 0x1888 RANLI_CIMES_1000_21181

Cause	Remedy	Error type/response
		Warning

6281 | 0x1889 RANLI_CIMES_1000_21182

Cause	Remedy	Error type/response
		Warning

6300 | 0x189C RANLI_CIMES_1000_21183

Cause	Remedy	Error type/response
		Warning

6301 | 0x189D RANLI_CIMES_1000_21184

Cause	Remedy	Error type/response
		Warning

6302 | 0x189E RANLI_CIMES_1000_21185

Cause	Remedy	Error type/response
		Warning

6303 | 0x189F RANLI_CIMES_1000_21186

Cause	Remedy	Error type/response
		Warning

6304 | 0x18A0 RANLI_CIMES_1000_21187

Cause	Remedy	Error type/response
		Warning

6305 | 0x18A1 RANLI_CIMES_1000_21188

Cause	Remedy	Error type/response
		Warning

6306 | 0x18A2 RANLI_CIMES_1000_21189

Cause	Remedy	Error type/response
		Warning

6307 | 0x18A3 RANLI_CIMES_1000_21190

Cause	Remedy	Error type/response
		Warning

Diagnostics and fault elimination

Error codes, causes and remedies



6308 | 0x18A4 RANLI_CIMES_1000_21191

Cause	Remedy	Error type/response
		Warning

6309 | 0x18A5 RANLI_CIMES_1000_21192

Cause	Remedy	Error type/response
		Warning

6310 | 0x18A6 RANLI_CIMES_1000_21193

Cause	Remedy	Error type/response
		Warning

6311 | 0x18A7 RANLI_CIMES_1000_21194

Cause	Remedy	Error type/response
		Warning

6312 | 0x18A8 RANLI_CIMES_1000_21195

Cause	Remedy	Error type/response
		Warning

6313 | 0x18A9 RANLI_CIMES_1000_21196

Cause	Remedy	Error type/response
		Warning

6314 | 0x18AA RANLI_CIMES_1000_21197

Cause	Remedy	Error type/response
		Warning

6315 | 0x18AB RANLI_CIMES_1000_21198

Cause	Remedy	Error type/response
		Warning

6316 | 0x18AC RANLI_CIMES_1000_21199

Cause	Remedy	Error type/response
		Warning

6317 | 0x18AD RANLI_CIMES_1000_21200

Cause	Remedy	Error type/response
		Warning



Diagnostics and fault elimination

Error codes, causes and remedies

6318 | 0x18AE | RANLI_CIMES_1000_21201

Cause	Remedy	Error type/response
		Warning

6319 | 0x18AF | RANLI_CIMES_1000_21202

Cause	Remedy	Error type/response
		Warning

6320 | 0x18B0 | RANLI_CIMES_1000_21203

Cause	Remedy	Error type/response
		Warning

6321 | 0x18B1 | RANLI_CIMES_1000_21204

Cause	Remedy	Error type/response
		Warning

6322 | 0x18B2 | RANLI_CIMES_1000_21205

Cause	Remedy	Error type/response
		Warning

6323 | 0x18B3 | RANLI_CIMES_1000_21206

Cause	Remedy	Error type/response
		Warning

6324 | 0x18B4 | RANLI_CIMES_1000_21207

Cause	Remedy	Error type/response
		Warning

6325 | 0x18B5 | RANLI_CIMES_1000_21208

Cause	Remedy	Error type/response
		Warning

6326 | 0x18B6 | RANLI_CIMES_1000_21209

Cause	Remedy	Error type/response
		Warning

6327 | 0x18B7 | RANLI_CIMES_1000_21210

Cause	Remedy	Error type/response
		Warning

Diagnostics and fault elimination

Error codes, causes and remedies



6499 | 0x1963 RANLI_CIMES_1000_21211

Cause	Remedy	Error type/response
		Warning

8992 | 0x2320 CiA: Short circuit/earth leakage (internal)

Cause	Remedy	Error type/response
<ul style="list-style-type: none">Short circuit/earth fault of motor cableCapacitive charging current of the motor cable too high.	<ul style="list-style-type: none">Check motor cable.Check length of the motor cable.Use shorter or lower-capacitance motor cable.	Fault <ul style="list-style-type: none">The error can only be reset after a blocking time. Blocking time: 5 s

9024 | 0x2340 CiA: Short circuit (device internal)

Cause	Remedy	Error type/response
Short circuit of motor cable	Check motor cable for short circuit.	Fault <ul style="list-style-type: none">The error can only be reset after a blocking time. Blocking time: 5 s

9041 | 0x2351 RANLI_CIMES_1000_20892

Cause	Remedy	Error type/response
		Fehler > CiA402 (configurable) Setting parameters: 0x2D50:001

9088 | 0x2380 RANLI_CIMES_1000_02471

Cause	Remedy	Error type/response
		Fault

9089 | 0x2381 RANLI_CIMES_1000_21879

Cause	Remedy	Error type/response
		Warning

9090 | 0x2382 I*t error

Cause	Remedy	Error type/response
Device utilisation (I*t) too high by frequent and too long acceleration processes.	Check drive sizing. <ul style="list-style-type: none">Reduce the maximum current of the inverter 0x6073.In case of high mass inertias, reduce maximum current of the inverter 0x6073 to 150 %.	Fault <ul style="list-style-type: none">The inverter is disabled immediately. The motor has no torque (coasts).The error can only be reset after a blocking time. Blocking time: 3 s

Related topics

▶ [Device overload monitoring \(i*t\)](#) □277



9091 | 0x2383 | **I*t warning**

Cause	Remedy	Error type/response
Device utilisation (I*t) too high by frequent and too long acceleration processes.	Check drive dimensioning.	Warning

Related topics

▶ [Device overload monitoring \(i*t\)](#)  277

9092 | 0x2384 | **RANLI_CIMES_0500_03891**

Cause	Remedy	Error type/response
		Fault > CiA402 (configurable)
		Setting parameters: 0x2D46:002

9093 | 0x2385 | **Parameterized mx. motor current > max. device current - Max. output current is limited to max. device current**

Cause	Remedy	Error type/response
		Warning

9094 | 0x2386 | **Clamp active**

Cause	Remedy	Error type/response
		Warning

9095 | 0x2387 | **I_{max}: Clamp responded too often**

Cause	Remedy	Error type/response
Maximum current of the axis (display in 0x2DDF:002) has been reached too often in succession.	<ul style="list-style-type: none"> • Select a flatter speed ramp. • Reduce the load. • Set I_{max} controller more dynamically. 	Fault

Related topics

▶ [I_{max} controller](#)  162

9097 | 0x2389 | **Warning - drive utilisation too high**

Cause	Remedy	Error type/response
		Warning

9099 | 0x238B | **RANLI_CIMES_1000_21886**

Cause	Remedy	Error type/response
		Fault

Diagnostics and fault elimination

Error codes, causes and remedies



12816 | 0x3210 DC bus overvoltage

Cause	Remedy	Error type/response
DC-bus voltage has exceeded the error threshold for overvoltage due to a too high braking energy or a too high mains voltage. The error threshold (display in 0x2540:006) results from the setting of the rated mains voltage in 0x2540:001 .	<ul style="list-style-type: none">• Reduce dynamic performance of the load profile.• Check mains voltage.• Check settings for brake energy management.• = [0]: Connect brake resistor to the power unit and activate the integrated brake chopper.	Fault

Related topics

- ▶ [Mains voltage](#) [□ 40](#)
- ▶ [Brake energy management](#) [□ 279](#)

12832 | 0x3220 DC bus undervoltage

Cause	Remedy	Error type/response
DC-bus voltage has fallen below the error threshold for undervoltage. The error threshold (display in 0x2540:003) results from the setting of the rated mains voltage in 0x2540:001 .	<ul style="list-style-type: none">• Check mains voltage.• Check DC-bus voltage.• Check mains settings.• Check fuses.	Trouble
		<ul style="list-style-type: none">• The error can only be reset after a blocking time.
		Blocking time: 5 s

Related topics

- ▶ [Mains voltage](#) [□ 40](#)

16912 | 0x4210 PU: overtemperature fault

Cause	Remedy	Error type/response
The heatsink temperature of the power unit (display in 0x2D84:001 , 004 , 006) has exceeded the fixed error threshold (100 °C). <ul style="list-style-type: none">• Ambient temperature too high.• Fan or ventilation slots are polluted.• Fan is defective.	<ul style="list-style-type: none">• Check mains voltage.• Provide for a sufficient cooling of the device. In case of a 100 % load, 60 C to +70°C are normal. Display of the heatsink temperature in 0x2D84:001, 004, 006.• Clean fan and ventilation slots. If required, replace fan.• Reduce switching frequency 0x2939	Fault

17024 | 0x4280 Heat sink temperature sensor fault

Cause	Remedy	Error type/response
Sensor for the temperature monitoring of the power unit is defective. The failure of the temperature monitoring function poses the risk of overheating!	Hardware error: it is necessary to contact the manufacturer, since the device must be replaced.	Fault

17025 | 0x4281 Heat sink fan warning

Cause	Remedy	Error type/response
Warning of the heatsink fan.	Clean fan and ventilation slots. If required, replace fan. The fans can be unlocked via locking hooks and can then be removed.	Warning

17026 | 0x4282 RANLI_CIMES_1000_18284

Cause	Remedy	Error type/response
		Information



Diagnostics and fault elimination

Error codes, causes and remedies

17168 | 0x4310 Motor temperature error

Cause	Remedy	Error type/response
The motor temperature sensor connected to terminals X109/T1 and X109/T2 measures a too high motor temperature. <ul style="list-style-type: none"> Motor too hot by impermissibly high currents. Motor too hot by frequent and too long acceleration processes. 	<ul style="list-style-type: none"> Check drive dimensioning. Check motor temperature sensor and wiring. 	Warning (configurable)
		<ul style="list-style-type: none"> The error can only be reset after a blocking time.
		Blocking time: 5 s Setting parameters: 0x2D49:002

Related topics

▶ [Motor temperature monitoring](#) 186

17280 | 0x4380 RANLI_CIMES_1000_02502

Cause	Remedy	Error type/response
		Warning (configurable)
		Setting parameters: 0x2D49:002

17281 | 0x4381 RANLI_CIMES_1000_21212

Cause	Remedy	Error type/response
		Fault > CiA402 (configurable)
		Setting parameters: 0x2D48:002

17282 | 0x4382 RANLI_CIMES_1000_21218

Cause	Remedy	Error type/response
		Warning (configurable)
		Setting parameters: 0x2D49:002

17283 | 0x4383 RANLI_CIMES_1000_21219

Cause	Remedy	Error type/response
		Warning (configurable)
		Setting parameters: 0x2D49:002

20608 | 0x5080 Internal error - AIS

Cause	Remedy	Error type/response
		Warning

20609 | 0x5081 Internal error - AIE

Cause	Remedy	Error type/response
		Warning

20610 | 0x5082 Internal error - button S82

Cause	Remedy	Error type/response
		Warning

Diagnostics and fault elimination

Error codes, causes and remedies



20611 | 0x5083 Internal error - IRS

Cause	Remedy	Error type/response
		Warning

20619 | 0x508B Internal error - SD-Inx/CLx

Cause	Remedy	Error type/response
		Warning

20620 | 0x508C Internal error - internal switch-off path

Cause	Remedy	Error type/response
		Warning

20621 | 0x508D Internal error - test pulse error internal switch-off path

Cause	Remedy	Error type/response
		Warning

20754 | 0x5112 24 V supply critical

Cause	Remedy	Error type/response
24V voltage failed or too low.	<ul style="list-style-type: none">• Check optional external 24V voltage supply (terminal X3/24E), if connected.• Check mains voltage.	Warning

20756 | 0x5114 Reference voltage error

Cause	Remedy	Error type/response
		Warning

20757 | 0x5115 6 V voltage error

Cause	Remedy	Error type/response
		Warning

20758 | 0x5116 5 V voltage error

Cause	Remedy	Error type/response
		Warning

20759 | 0x5117 3.3 V voltage error

Cause	Remedy	Error type/response
		Warning

24592 | 0x6010 Internal error

Cause	Remedy	Error type/response
		Warning



Diagnostics and fault elimination

Error codes, causes and remedies

24960 | 0x6180 **Internal error - STO activated**

Cause	Remedy	Error type/response
		Warning

24965 | 0x6185 **Faulty communication with basic device**

Cause	Remedy	Error type/response
		Warning

24966 | 0x6186 **Faulty synchronization with basic device**

Cause	Remedy	Error type/response
		Information

24970 | 0x618A **Internal fan warning**

Cause	Remedy	Error type/response
Warning of the internal fan.	Check/replace internal fan.	Warning

25360 | 0x6310 **RANLI_CIMES_1000_20868**

Cause	Remedy	Error type/response
		Warning

25376 | 0x6320 **RANLI_CIMES_1000_20869**

Cause	Remedy	Error type/response
		Warning

25472 | 0x6380 **F-parameter error**

Cause	Remedy	Error type/response
		Information

25473 | 0x6381 **F_Dest_Add unequal F-address**

Cause	Remedy	Error type/response
		Information

25474 | 0x6382 **F_Dest_Add = 0 or FFFFhex**

Cause	Remedy	Error type/response
		Information

25475 | 0x6383 **F_Source_Add = 0 or FFFFhex**

Cause	Remedy	Error type/response
		Information

Diagnostics and fault elimination

Error codes, causes and remedies



25476 | 0x6384 | **F_WD_Time = 0 ms**

Cause	Remedy	Error type/response
		Information

25477 | 0x6385 | **F_SIL exceeds technical SIL**

Cause	Remedy	Error type/response
		Information

25478 | 0x6386 | **F_CRC_Length error**

Cause	Remedy	Error type/response
		Information

25479 | 0x6387 | **Wrong F-parameter version**

Cause	Remedy	Error type/response
		Information

25481 | 0x6389 | **New safety parameter set deleted**

Cause	Remedy	Error type/response
		Information

25482 | 0x638A | **New safety parameter set loaded**

Cause	Remedy	Error type/response
		Information

25483 | 0x638B | **Memory module access error**

Cause	Remedy	Error type/response
		Warning

25484 | 0x638C | **Different safety parameter sets**

Cause	Remedy	Error type/response
		Warning

25485 | 0x638D | **No safety parameter set**

Cause	Remedy	Error type/response
		Warning

25486 | 0x638E | **Defect safety parameter set**

Cause	Remedy	Error type/response
		Warning



Diagnostics and fault elimination

Error codes, causes and remedies

25487 | 0x638F | **Safety parameter set format error**

Cause	Remedy	Error type/response
		Warning

25488 | 0x6390 | **Safety parameter set plausibility error**

Cause	Remedy	Error type/response
		Warning

25489 | 0x6391 | **Safety parameter set communication error**

Cause	Remedy	Error type/response
		Warning

25490 | 0x6392 | **Module-ID unequal effective safety address**

Cause	Remedy	Error type/response
		Warning

25491 | 0x6393 | **SSM: Wrong PDO version**

Cause	Remedy	Error type/response
		Warning

28801 | 0x7081 | **Analog input 1 fault**

Cause	Remedy	Error type/response
The monitoring function of the input signal configured for analog input 1 in and has been triggered.	<ul style="list-style-type: none"> Check input signal at analog input 1. Check configuration of the monitoring function. 	No response (configurable) Setting parameters: 0x2636:010

Related topics

▶ [Analog input 1](#) [□ 200](#)

28961 | 0x7121 | **Pole position identification fault**

Cause	Remedy	Error type/response
<ul style="list-style-type: none"> Too many deviations during the pole position identification. Compared to the inverter, the rated motor current is too high or too low. 	<ul style="list-style-type: none"> Check setting of the motor data. Ensure that the motor is at a standstill during the pole position identification process. Ensure that the motor and inverter match each other in terms of power. 	Fault

29443 | 0x7303 | **RANLI_CIMES_1000_20870**

Cause	Remedy	Error type/response
		Fault > CiA402 (configurable) Setting parameters: 0x2C45

Diagnostics and fault elimination

Error codes, causes and remedies



29444 | 0x7304 RANLI_CIMES_1000_20910

Cause	Remedy	Error type/response
		Fault > CiA402 (configurable)
		Setting parameters: 0x2C55

29568 | 0x7380 RANLI_CIMES_1000_20894

Cause	Remedy	Error type/response
		Fault > CiA402 (configurable)
		Setting parameters: 0x2C41:004

29569 | 0x7381 RANLI_CIMES_1000_20900

Cause	Remedy	Error type/response
		Fault > CiA402 (configurable)
		Setting parameters: 0x2C41:004

29570 | 0x7382 RANLI_CIMES_1000_20911

Cause	Remedy	Error type/response
		Fault > CiA402 (configurable)
		Setting parameters: 0x2C51:004

29571 | 0x7383 RANLI_CIMES_1000_20912

Cause	Remedy	Error type/response
		Fault > CiA402 (configurable)
		Setting parameters: 0x2C51:004

33162 | 0x818A PROFIsafe passivated

Cause	Remedy	Error type/response
		Information

33163 | 0x818B PROFIsafe has left data exchange

Cause	Remedy	Error type/response
		Information

33165 | 0x818D PROFIsafe CRC1 error

Cause	Remedy	Error type/response
		Information

33168 | 0x8190 RANLI_CIMES_1000_20915

Cause	Remedy	Error type/response
		Warning (configurable)
		Setting parameters: 0x2859:001



Diagnostics and fault elimination

Error codes, causes and remedies

33169 | 0x8191 RANLI_CIMES_1000_21217

Cause	Remedy	Error type/response
		No response (configurable)
		Setting parameters: 0x2859:002

33170 | 0x8192 RANLI_CIMES_1000_20917

Cause	Remedy	Error type/response
		Warning (configurable)
		Setting parameters: 0x2859:004

33171 | 0x8193 RANLI_CIMES_1000_20918

Cause	Remedy	Error type/response
		Warning (configurable)
		Setting parameters: 0x2859:005

33173 | 0x8195 FSoE: Unexpected command

Cause	Remedy	Error type/response
		Information

33174 | 0x8196 FSoE: Unknown command

Cause	Remedy	Error type/response
		Information

33175 | 0x8197 FSoE: Invalid connection ID

Cause	Remedy	Error type/response
		Information

33176 | 0x8198 FSoE: CRC error

Cause	Remedy	Error type/response
		Information

33177 | 0x8199 FSoE: Watchdog has expired

Cause	Remedy	Error type/response
		Information

33180 | 0x819C FSoE: Invalid communication parameter data

Cause	Remedy	Error type/response
		Information

Diagnostics and fault elimination

Error codes, causes and remedies



33181 | 0x819D | **FSoE: Invalid application parameter length**

Cause	Remedy	Error type/response
		Information

33182 | 0x819E | **FSoE: Invalid application parameter data**

Cause	Remedy	Error type/response
		Information

33183 | 0x819F | **FSoE passivated**

Cause	Remedy	Error type/response
		Information

33192 | 0x81A8 | **FSoE: Invalid slave address**

Cause	Remedy	Error type/response
		Information

33193 | 0x81A9 | **FSoE: Invalid communication parameter length**

Cause	Remedy	Error type/response
		Information

33194 | 0x81AA | **FSoE: Data exchange left**

Cause	Remedy	Error type/response
		Information

33411 | 0x8283 | **RANLI_CIMES_1000_02508**

Cause	Remedy	Error type/response
		Fault

33412 | 0x8284 | **RANLI_CIMES_1000_20884**

Cause	Remedy	Error type/response
		Fault

33413 | 0x8285 | **RANLI_CIMES_1000_02510**

Cause	Remedy	Error type/response
		Fault

33415 | 0x8287 | **RANLI_CIMES_1000_20916**

Cause	Remedy	Error type/response
		Warning (configurable)
		Setting parameters: 0x2859:003



Diagnostics and fault elimination

Error codes, causes and remedies

36992 | 0x9080 **Discrepancy check or function check error - SD-In1**

Cause	Remedy	Error type/response
		Warning

36993 | 0x9081 **Discrepancy check or function check error - SD-In2**

Cause	Remedy	Error type/response
		Warning

36994 | 0x9082 **Discrepancy check or function check error - SD-In3**

Cause	Remedy	Error type/response
		Warning

36995 | 0x9083 **Discrepancy check or function check error - SD-In4**

Cause	Remedy	Error type/response
		Warning

36996 | 0x9084 **Deactivated SD-In1 = HIGH**

Cause	Remedy	Error type/response
		Warning

36997 | 0x9085 **Deactivated SD-In2 = HIGH**

Cause	Remedy	Error type/response
		Warning

36998 | 0x9086 **Deactivated SD-In3 = HIGH**

Cause	Remedy	Error type/response
		Warning

36999 | 0x9087 **Deactivated SD-In4 = HIGH**

Cause	Remedy	Error type/response
		Warning

37000 | 0x9088 **SD-Out1, channel A remains stuck at HIGH**

Cause	Remedy	Error type/response
		Warning

37001 | 0x9089 **SD-Out1, channel A remains stuck at LOW**

Cause	Remedy	Error type/response
		Warning

Diagnostics and fault elimination

Error codes, causes and remedies



37002 | 0x908A SD-Out1, channel B remains stuck at HIGH

Cause	Remedy	Error type/response
		Warning

37003 | 0x908B SD-Out1, channel B remains stuck at LOW

Cause	Remedy	Error type/response
		Warning

37004 | 0x908C SD-In1, channel A remains stuck at HIGH

Cause	Remedy	Error type/response
		Warning

37005 | 0x908D SD-In1, channel B remains stuck at HIGH

Cause	Remedy	Error type/response
		Warning

37006 | 0x908E SD-In2, channel A remains stuck at HIGH

Cause	Remedy	Error type/response
		Warning

37007 | 0x908F SD-In2, channel B remains stuck at HIGH

Cause	Remedy	Error type/response
		Warning

37008 | 0x9090 SD-In3, channel A remains stuck at HIGH

Cause	Remedy	Error type/response
		Warning

37009 | 0x9091 SD-In3, channel B remains stuck at HIGH

Cause	Remedy	Error type/response
		Warning

37010 | 0x9092 SD-In4, channel A remains stuck at HIGH

Cause	Remedy	Error type/response
		Warning

37011 | 0x9093 SD-In4, channel B remains stuck at HIGH

Cause	Remedy	Error type/response
		Warning



Diagnostics and fault elimination

Error codes, causes and remedies

37012 | 0x9094 **Short circuit - CLA/CLB**

Cause	Remedy	Error type/response
		Warning

65280 | 0xFF00 **RANLI_CIMES_1000_20877**

Cause	Remedy	Error type/response
		Fault

65281 | 0xFF01 **RANLI_CIMES_1000_20878**

Cause	Remedy	Error type/response
		Fault

65282 | 0xFF02 **Brake resistor: overload fault**

Cause	Remedy	Error type/response
		No response (configurable) <ul style="list-style-type: none"> The error can only be reset after a blocking time.
		Blocking time: 5 s
		Setting parameters: 0x2550:011

65283 | 0xFF03 **RANLI_CIMES_1000_20879**

Cause	Remedy	Error type/response
		Fault

65284 | 0xFF04 **RANLI_CIMES_1000_20880**

Cause	Remedy	Error type/response
		Fault > CiA402 (configurable)
		Setting parameters: 0x2C60

65285 | 0xFF05 **Safe Torque Off is locked**

Cause	Remedy	Error type/response
The safety module or safety circuit of the device was detected as being defective.	Hardware error: it is necessary to contact the manufacturer since the device must be replaced.	Fault <ul style="list-style-type: none"> The inverter is disabled immediately. The motor has no torque (coasts). The error can only be reset by mains switching.

65286 | 0xFF06 **Motor overspeed**

Cause	Remedy	Error type/response
The motor speed has reached the error threshold for overspeed set in 0x2D44:001 .	Adapt the maximum motor speed 0x6080 and the warning threshold or error threshold 0x2D44:001 .	Fault > CiA402 (configurable) <ul style="list-style-type: none"> The error can only be reset after a blocking time.
		Blocking time: 1 s
		Setting parameters: 0x2D44:002

Related topics

▶ [Motor speed monitoring](#) 189

Diagnostics and fault elimination

Error codes, causes and remedies



65287 | 0xFF07 | RANLI_CIMES_1000_20881

Cause	Remedy	Error type/response
		Warning

65288 | 0xFF08 | RANLI_CIMES_1000_20882

Cause	Remedy	Error type/response
		Warning

65289 | 0xFF09 | Motor phase missing

Cause	Remedy	Error type/response
A failure of several motor phases has been detected.	<ul style="list-style-type: none">Check wiring between inverter and motor.In case of a false tripping, adapt the settings for the motor phase failure detection.	No response (configurable) <ul style="list-style-type: none">The error can only be reset after a blocking time. Blocking time: 2 s Setting parameters: 0x2D45:004 0x2D45:001

Related topics

▶ [Motor phase failure detection](#) 📄 189

65290 | 0xFF0A | Motor phase failure phase U

Cause	Remedy	Error type/response
A failure of the motor phase U has been detected.	<ul style="list-style-type: none">Check wiring between inverter and motor.In case of a false tripping, adapt the settings for the motor phase failure detection.	No response (configurable) <ul style="list-style-type: none">The error can only be reset after a blocking time. Blocking time: 2 s Setting parameters: 0x2D45:004 0x2D45:001

Related topics

▶ [Motor phase failure detection](#) 📄 189

65291 | 0xFF0B | Motor phase failure phase V

Cause	Remedy	Error type/response
A failure of the motor phase V has been detected.	<ul style="list-style-type: none">Check wiring between inverter and motor.In case of a false tripping, adapt the settings for the motor phase failure detection.	No response (configurable) <ul style="list-style-type: none">The error can only be reset after a blocking time. Blocking time: 2 s Setting parameters: 0x2D45:004 0x2D45:001

Related topics

▶ [Motor phase failure detection](#) 📄 189

65292 | 0xFF0C | RANLI_CIMES_1000_20883

Cause	Remedy	Error type/response
		No response (configurable) Setting parameters: 0x2D45:004 0x2D45:001



Diagnostics and fault elimination

Error codes, causes and remedies

65293 | 0xFF0D | RANLI_CIMES_1000_20886

Cause	Remedy	Error type/response
		Warning

65294 | 0xFF0E | RANLI_CIMES_1000_20887

Cause	Remedy	Error type/response
		Warning

65295 | 0xFF0F | RANLI_CIMES_1000_20888

Cause	Remedy	Error type/response
		Warning

65296 | 0xFF10 | RANLI_CIMES_1000_20889

Cause	Remedy	Error type/response
		Warning

65297 | 0xFF11 | RANLI_CIMES_1000_20890

Cause	Remedy	Error type/response
		Warning

65298 | 0xFF12 | RANLI_CIMES_1000_20891

Cause	Remedy	Error type/response
		Warning

65299 | 0xFF13 | RANLI_CIMES_1000_15967

Cause	Remedy	Error type/response
		Fault > CiA402 (configurable)
		Setting parameters: 0x2C60

65300 | 0xFF14 | RANLI_CIMES_1000_20895

Cause	Remedy	Error type/response
		Warning

65301 | 0xFF15 | RANLI_CIMES_1000_20896

Cause	Remedy	Error type/response
		Warning

65302 | 0xFF16 | RANLI_CIMES_1000_20897

Cause	Remedy	Error type/response
		Fault > CiA402 (configurable)
		Setting parameters: 0x2C41:004

Diagnostics and fault elimination

Error codes, causes and remedies



65303 | 0xFF17 | RANLI_CIMES_1000_20898

Cause	Remedy	Error type/response
		Warning

65304 | 0xFF18 | RANLI_CIMES_1000_20899

Cause	Remedy	Error type/response
		Fault

65305 | 0xFF19 | Motor parameter identification fault

Cause	Remedy	Error type/response
During the automatic identification of the motor, an error has occurred.	<ul style="list-style-type: none">• Set motor data so that they comply with the data on the motor nameplate.• Check wiring of the motor.	Fault

65306 | 0xFF1A | RANLI_CIMES_1000_20913

Cause	Remedy	Error type/response
		Fault > CiA402 (configurable)
		Setting parameters: 0x2C51:004

65307 | 0xFF1B | Connected Hiperface absolute value load encoder/master encoder is not supported.

Cause	Remedy	Error type/response
		Warning

65308 | 0xFF1C | RANLI_CIMES_1000_21881

Cause	Remedy	Error type/response
		Warning

65309 | 0xFF1D | RANLI_CIMES_1000_21882

Cause	Remedy	Error type/response
		Warning

65310 | 0xFF1E | RANLI_CIMES_1000_21883

Cause	Remedy	Error type/response
		Fault

65312 | 0xFF20 | RANLI_CIMES_1000_20901

Cause	Remedy	Error type/response
		Warning

65313 | 0xFF21 | RANLI_CIMES_1000_20902

Cause	Remedy	Error type/response
		Fault



Diagnostics and fault elimination

Error codes, causes and remedies

65314 | 0xFF22 | **RANLI_CIMES_1000_20903**

Cause	Remedy	Error type/response
		Fault

65315 | 0xFF23 | **RANLI_CIMES_1000_20904**

Cause	Remedy	Error type/response
		Fault

65319 | 0xFF27 | **RANLI_CIMES_1000_25021**

Cause	Remedy	Error type/response
		Fault

65334 | 0xFF36 | **Brake resistor: overload warning**

Cause	Remedy	Error type/response
		Warning

65335 | 0xFF37 | **Automatic start disabled**

Cause	Remedy	Error type/response
At mains connection, a start command was already available and the automatic start at power-up is set in to "Off [0]".	Deactivate starting command and reset error.	Fault

65344 | 0xFF40 | **RANLI_CIMES_1000_20906**

Cause	Remedy	Error type/response
		Fault

65345 | 0xFF41 | **RANLI_CIMES_1000_20907**

Cause	Remedy	Error type/response
		Fault

65346 | 0xFF42 | **RANLI_CIMES_1000_20908**

Cause	Remedy	Error type/response
		Fault

65360 | 0xFF50 | **RANLI_CIMES_1000_21213**

Cause	Remedy	Error type/response
		Fault

65361 | 0xFF51 | **RANLI_CIMES_1000_24900**

Cause	Remedy	Error type/response
		Fault

Diagnostics and fault elimination

Error codes, causes and remedies



65416 | 0xFF88 | **SS1/SS2: Stopping time exceeded**

Cause	Remedy	Error type/response
		Warning

65417 | 0xFF89 | **SLS1: Nlim1 exceeded**

Cause	Remedy	Error type/response
		Warning

65418 | 0xFF8A | **SLS2: Nlim2 exceeded**

Cause	Remedy	Error type/response
		Warning

65419 | 0xFF8B | **SLS3: Nlim3 exceeded**

Cause	Remedy	Error type/response
		Warning

65420 | 0xFF8C | **SLS4: Nlim4 exceeded**

Cause	Remedy	Error type/response
		Warning

65421 | 0xFF8D | **SLS/SMS: Error stop not executed**

Cause	Remedy	Error type/response
		Warning

65422 | 0xFF8E | **SDIpos: Wrong moving direction**

Cause	Remedy	Error type/response
		Warning

65423 | 0xFF8F | **SDIneg: Wrong moving direction**

Cause	Remedy	Error type/response
		Warning

65424 | 0xFF90 | **SMS: Nmax exceeded**

Cause	Remedy	Error type/response
		Warning

65425 | 0xFF91 | **SOS: Tolerance limit exceeded**

Cause	Remedy	Error type/response
		Warning



Diagnostics and fault elimination

Error codes, causes and remedies

65426 | 0xFF92 | **Feedback not configured**

Cause	Remedy	Error type/response
		Warning

65427 | 0xFF93 | **CAS: Round trip time exceeded**

Cause	Remedy	Error type/response
		Warning

65428 | 0xFF94 | **CAS: Hardware error or discrepancy error**

Cause	Remedy	Error type/response
		Warning

65429 | 0xFF95 | **SS1/SS2: Speed ramp exceeded**

Cause	Remedy	Error type/response
		Warning

65430 | 0xFF96 | **SLI: Safely limited increment exceeded**

Cause	Remedy	Error type/response
		Warning

65431 | 0xFF97 | **SLP1: Position limits exceeded**

Cause	Remedy	Error type/response
		Warning

65432 | 0xFF98 | **SLP2: Position limits exceeded**

Cause	Remedy	Error type/response
		Warning

65433 | 0xFF99 | **SLP3: Position limits exceeded**

Cause	Remedy	Error type/response
		Warning

65434 | 0xFF9A | **SLP4: Position limits exceeded**

Cause	Remedy	Error type/response
		Warning

65435 | 0xFF9B | **SLP: No home position**

Cause	Remedy	Error type/response
		Warning

Diagnostics and fault elimination

Error codes, causes and remedies



65437 | 0xFF9D | **PDSS: Speed exceeded**

Cause	Remedy	Error type/response
		Warning

65438 | 0xFF9E | **PDSS: Safe creep speed SCS exceeded**

Cause	Remedy	Error type/response
		Warning

65439 | 0xFF9F | **PDSS: No diagnostic mark detected**

Cause	Remedy	Error type/response
		Warning

65440 | 0xFFA0 | **PDSS: Diagnostic mark detected at invalid position**

Cause	Remedy	Error type/response
		Warning

65446 | 0xFFA6 | **SHOM: Time-out**

Cause	Remedy	Error type/response
		Warning

65447 | 0xFFA7 | **SHOM: Home position deleted**

Cause	Remedy	Error type/response
		Information

65448 | 0xFFA8 | **SHOM: Maximum slip value exceeded**

Cause	Remedy	Error type/response
		Warning

65449 | 0xFFA9 | **SHOM: Tolerance of start position exceeded**

Cause	Remedy	Error type/response
		Warning

65450 | 0xFFAA | **SHOM: Tolerance of position comparison exceeded**

Cause	Remedy	Error type/response
		Warning

65451 | 0xFFAB | **SSM: Safe speed invalid**

Cause	Remedy	Error type/response
		Warning



Diagnostics and fault elimination

Error codes, causes and remedies

65452 | 0xFFAC | **SSM: Encoder error**

Cause	Remedy	Error type/response
		Warning

65453 | 0xFFAD | **SSM: Resolver error**

Cause	Remedy	Error type/response
		Warning

65454 | 0xFFAE | **Error in standard device data**

Cause	Remedy	Error type/response
		Warning

65455 | 0xFFAF | **SSM: Speed deviation too high**

Cause	Remedy	Error type/response
		Warning

65456 | 0xFFB0 | **SSM: Synchronization error**

Cause	Remedy	Error type/response
		Warning

Technical data

Standards and operating conditions
Conformities and approvals



20 Technical data

20.1 Standards and operating conditions

20.1.1 Conformities and approvals

Conformity		
CE	2006/42/EC	Machinery Directive
	2014/30/EU	EMC Directive (reference: CE-typical drive system)
EAC	TR CU 004/2011	Eurasian conformity: Safety of low voltage equipment
	TR CU 020/2011	Eurasian conformity: Electromagnetic compatibility of technical means
RoHS	2011/65/EU	Restrictions on the use of certain hazardous substances in electrical and electronic devices
Approval		
UL	UL 61800-5-1	for USA and Canada (requirements of the CSA 22.2 No. 274) File No. E132659

20.1.2 Protection of persons and device protection

Degree of protection		
IP20	EN 60529	Data applies to operationally ready mounted state and not in wire range of terminals
Type 1	UL 50	protection against accidental contact only
Open type	UL 61800-5-1	Only in UL-approved systems
Insulation resistance		
Overvoltage category III	EN 61800-5-1	0 ... 2000 m amsl
Overvoltage category II	EN 61800-5-1	above 2000 m a.m.s.l.
Isolation of control circuits		
Safe mains isolation via double/reinforced insulation	EN 61800-5-1	
Leakage current		
> 3.5 mA AC, > 10 mA DC	EN 61800-5-1	Please observe regulations and safety instructions!
Starting current		
≤ 3 x rated mains current		
Protective measures against		
Short circuit		
Earth fault		Earth-fault protected depending on operating status
Overtemperature of motor		PTC or thermal contact, I ² xt monitoring
Overvoltage		
Motor stalling		

20.1.3 EMC data

Noise emission		
Category C2	EN 61800-3	See rated data
Category C3	EN 61800-3	See rated data
Noise immunity		
Fulfils requirements according to	EN 61800-3	
Operation on public supply systems		
Take measures to limit the expected radio interference:		The machine or system manufacturer is responsible for compliance with the requirements for the machine/system!
< 1 kW: with mains choke	EN 61000-3-2	
> 1 kW for mains current ≤ 16 A: without additional measures		
Mains current > 16 A: With mains choke or mains filter, with dimensioning for rated power.	EN 61000-3-12	



20.1.4 Motor connection

Requirements for the shielded motor cable		
Capacitance per unit length		
C-core-core/C-core-shielding < 75/150 pF/m		≤ 2.5 mm ² / AWG 14
C-core-core/C-core-shielding < 150/300 pF/m		≥ 4 mm ² / AWG 12
Electric strength		
U ₀ /U = 0.6/1.0 kV		U ₀ = r.m.s. value external conductor to PE
U ≥ 600 V	UL	U = r.m.s. value from external conductor to external conductor

20.1.5 Environmental conditions

Energy efficiency		
Class IE2	EN 50598-2	
Climate		
1K3 (-25 ... +60°C)	EN 60721-3-1	Storage
2K3 (-25 ... +70°C)	EN 60721-3-2	Transport
3K3 (-10 ... +55°C)	EN 60721-3-3	Operation
		Operation at a switching frequency of 2 or 4 kHz Above +45°C: reduce rated output current by 2.5 %/°C
		Operation at a switching frequency of 8 or 16 kHz: Above +40°C: reduce rated output current by 2.5 %/°C
Site altitude		
0 ... 1000 m amsl		
1000 ... 4000 m amsl		Reduce rated output current by 5 %/1000 m
Pollution		
Degree of pollution 2	EN 61800-5-1 UL 61800-5-1	
Vibration resistance		
Transport		
2M2 (sine, shock)	EN 60721-3-2	In original packaging up to 45 kW
Operation		
Amplitude 1 mm		5 ... 13.2 Hz
Acceleration resistant up to 0.7 g	German Lloyd	13.2 ... 100 Hz
		up to 15 kW
Amplitude 0.075 mm		10 ... 57 Hz
Acceleration resistant up to 1 g	EN 61800-5-1	57 ... 150 Hz

20.1.6 Electrical supply conditions

Permissible power systems		
TT		Voltage to earth: max. 300 V
TN		Voltage to earth: max. 300 V
IT		Apply the measures described for IT systems!
		IT systems not relevant for UL-approved systems

Technical data

3-phase mains connection 400 V

Rated data



20.2 3-phase mains connection 400 V

20.2.1 Rated data

Inverter		I95AE155F	I95AE175F	I95AE222F	I95AE240F	I95AE275F	I95AE311F	I95AE315F
Rated power	kW	0.55	0.75	2.2	4	7.5	11	15
Rated power	hp	0.75	1	3	5	10	15	20
Mains voltage range		3/PE AC 340 V ... 528 V, 45 Hz ... 65 Hz						
Output voltage		3 AC 0-400 V						
Rated mains current								
without mains choke	A	2.5	3.3	7.8	12.5	20	28.4	-
with mains choke	A	2	2.6	5.3	9	15.7	22.3	28.8
Apparent output power	kVA	1.2	1.6	3.8	6.4	11	16	22
Rated output current								
2 kHz	A	1.8	2.4	5.6	9.5	16.5	23.5	32
4 kHz	A	1.8	2.4	5.6	9.5	16.5	23.5	32
8 kHz	A	1.8	2.4	5.6	7.1	16.5	23.5	23.5
16 kHz	A	1.2	1.6	2.6	2.9	11	12	11
Power loss								
2 kHz	W	38	44	76	116	186	256	342
4 kHz	W	39	46	80	122	197	272	363
8 kHz	W	45	54	99	154	252	351	471
16 kHz	W	45	54	99	154	252	351	471
when the controller is inhibited	W	20	20	20	20	20	20	20
Cyclic mains switching		3 times per minute						
Max. shielded motor cable length								
Category C2 (2 kHz, 4 kHz, 8 kHz)	m	20	20	20	20	20	20	20
Category C3 (2 kHz, 4 kHz, 8 kHz)	m	35	35	35	35	35	35	35
without EMC category	m	50	50	50	50	100	100	100
Weight	kg	1.6	1.6	1.6	1.6	3.9	3.9	3.9
Weight	lb	3.5	3.5	3.5	3.5	8.6	8.6	8.6



Technical data

3-phase mains connection 400 V
Rated data

Inverter		I95AE322F	I95AE330F	I95AE345F	I95AE355F	I95AE375F	I95AE390F	I95AE411F
Rated power	kW	22	30	45	55	75	90	110
Rated power	hp	30	40	60	75	100	125	150
Mains voltage range		3/PE AC 340 V ... 528 V, 45 Hz ... 65 Hz						
Output voltage		3 AC 0-400 V						
Rated mains current								
without mains choke	A	-	-	-	-	-	-	-
with mains choke	A	42	54.9	80	99	135	168	198
Apparent output power	kVA	32	41	60	75	100	121	142
Rated output current								
2 kHz	A	47	61	89	110	150	180	212
4 kHz	A	47	61	89	110	150	180	212
8 kHz	A	47	61	89	110	150	162	191
16 kHz	A	31.3	40.6	59.3	76.6	95	99	106
Power loss								
2 kHz	W	505	653	934	1151	1553	1855	2177
4 kHz	W	536	694	994	1224	1654	1975	2319
8 kHz	W	694	898	1292	1593	2157	2326	2731
16 kHz	W	694	898	1292	1593	2157	2326	2731
when the controller is inhibited	W	32	39	39	44	44	44	44
Cyclic mains switching		3 times per minute			Once per minute			
Max. shielded motor cable length								
Category C2 (2 kHz, 4 kHz, 8 kHz)	m	20	20	20	20	20	20	20
Category C3 (2 kHz, 4 kHz, 8 kHz)	m	35	35	35	100	100	100	100
without EMC category	m	100	100	100	200	200	200	200
Weight	kg	10.7	16.7	16.7	24	24	35.6	35.6
Weight	lb	23.6	37	37	53	53	78.5	78.5

Technical data

3-phase mains connection 480 V

Rated data



20.3 3-phase mains connection 480 V

20.3.1 Rated data

Inverter		I95AE155F	I95AE175F	I95AE222F	I95AE240F	I95AE275F	I95AE311F	I95AE315F
Rated power	kW	0.55	0.75	2.2	4	7.5	11	15
Rated power	hp	0.75	1	3	5	10	15	20
Mains voltage range		3/PE AC 340 V ... 528 V, 45 Hz ... 65 Hz						
Output voltage		3 AC 0-480 V						
Rated mains current								
without mains choke	A	2.1	2.8	6.5	10.5	16.6	23.7	-
with mains choke	A	1.7	2.2	4.4	7.5	13.1	18.6	24
Apparent output power	kVA	1.2	1.6	3.8	6.4	11	16	22
Rated output current								
2 kHz	A	1.6	2.1	4.8	8.2	14	21	27
4 kHz	A	1.6	2.1	4.8	8.2	14	21	27
8 kHz	A	1.6	2.1	4.8	6.2	14	21	19.8
16 kHz	A	1.1	1.4	2.2	2.5	7.8	7.8	7.2
Power loss								
2 kHz	W	38	44	76	116	186	256	342
4 kHz	W	39	46	80	122	197	272	363
8 kHz	W	45	54	99	154	252	351	471
16 kHz	W	45	54	99	154	252	351	471
when the controller is inhibited	W	20	20	20	20	20	20	20
Cyclic mains switching		3 times per minute						
Max. shielded motor cable length								
Category C2 (2 kHz, 4 kHz, 8 kHz)	m	20	20	20	20	20	20	20
Category C3 (2 kHz, 4 kHz, 8 kHz)	m	35	35	35	35	35	35	35
without EMC category	m	50	50	50	50	100	100	100
Weight	kg	1.6	1.6	1.6	1.6	3.9	3.9	3.9
Weight	lb	3.5	3.5	3.5	3.5	8.6	8.6	8.6



Technical data

3-phase mains connection 480 V
Rated data

Inverter		I95AE322F	I95AE330F	I95AE345F	I95AE355F	I95AE375F	I95AE390F	I95AE411F
Rated power	kW	22	30	45	55	75	90	110
Rated power	hp	30	40	60	75	100	125	150
Mains voltage range		3/PE AC 340 V ... 528 V, 45 Hz ... 65 Hz						
Output voltage		3 AC 0-480 V						
Rated mains current								
without mains choke	A	47.4	-	-	-	-	-	-
with mains choke	A	35.3	45.7	66.7	83	113	146	168
Apparent output power	kVA	32	41	60	75	100	121	142
Rated output current								
2 kHz	A	40.4	52	77	96	124	156	180
4 kHz	A	40.4	52	77	96	124	156	180
8 kHz	A	40.4	52	77	96	124	140	162
16 kHz	A	26.9	34.6	51.3	66.8	78.5	85.8	90
Power loss								
2 kHz	W	505	653	934	1151	1553	1855	2177
4 kHz	W	536	694	994	1224	1654	1975	2319
8 kHz	W	694	898	1292	1593	2157	2326	2731
16 kHz	W	694	898	1292	1593	2157	2326	2731
when the controller is inhibited	W	32	39	39	44	44	44	44
Cyclic mains switching		3 times per minute			Once per minute			
Max. shielded motor cable length								
Category C2 (2 kHz, 4 kHz, 8 kHz)	m	20	20	20	20	20	20	20
Category C3 (2 kHz, 4 kHz, 8 kHz)	m	35	35	35	100	100	100	100
without EMC category	m	100	100	100	200	200	200	200
Weight	kg	10.7	16.7	16.7	24	24	35.6	35.6
Weight	lb	23.6	37	37	53	53	78.5	78.5



Appendix

Parameter attribute list

Address	Name	Default setting	Data type	Factor	A	M
0x10F1:002	Error settings: Sync error counter limit	100	U32	1	-	
0x2000:001	Device data: Product code	- (Read only)	STRING[50]		X	
0x2000:002	Device data: Serial number	- (Read only)	STRING[50]		X	
0x2000:003	Device data: Production date	- (Read only)	STRING[50]		X	
0x2000:004	Device data: CU firmware version	- (Read only)	STRING[50]		X	
0x2000:006	Device data: CU bootloader version	- (Read only)	STRING[50]		X	
0x2000:008	Device data: Object directory version	- (Read only)	U32	1	X	
0x2000:019	Device data: Safety module version	- (Read only)	STRING[50]		X	
0x2001	Device name	"Device"	STRING[128]		-	
0x2002:001	Device module: Safety module	- (Read only)	STRING[50]		X	
0x2002:006	Device module: CU serial number	- (Read only)	STRING[50]		X	
0x2002:007	Device module: PU serial number	- (Read only)	STRING[50]		X	
0x2002:010	Device module: Type communication module	- (Read only)	STRING[50]		X	
0x2002:011	Device module: Serial number communication module	- (Read only)	STRING[50]		X	
0x2002:012	Device module: Hardware version communication module	- (Read only)	STRING[50]		X	
0x2002:013	Device module: Type encoder 1	- (Read only)	STRING[50]		X	
0x2002:014	Device module: Serial number encoder 1	- (Read only)	STRING[50]		X	
0x2002:015	Device module: Hardware version encoder 1	- (Read only)	STRING[50]		X	
0x2002:016	Device module: Type encoder 2	- (Read only)	STRING[50]		X	
0x2002:017	Device module: Serial number encoder 2	- (Read only)	STRING[50]		X	
0x2002:018	Device module: Hardware version encoder 2	- (Read only)	STRING[50]		X	
0x2010:001	Device event monitor: EreignisortEvent location	- (Read only)	U8		X	
0x2010:002	Device event monitor: Event type	- (Read only)	U8		X	
0x2010:003	Device event monitor: Event status	- (Read only)	U8		X	
0x2010:005	Device event monitor: Number of current event	- (Read only)	U32		HX	
0x2010:006	Device event monitor: Time stamp of current event	x ns (Read only)	U64	1	TX	
0x2012:001	Device information: SD card status	- (Read only)	U8		X	
0x2012:002	Device information: Application Credit available	- (Read only)	U16	1	X	
0x2013:001	Application information: Active application	- (Read only)	U16		X	
0x2013:002	Application information: Application Credit required	- (Read only)	U16	1	X	
0x2020:001	EoE information: Virtual MAC address	- (Read only)	STRING[32]		X	
0x2020:002	EoE information: IP adress	- (Read only)	STRING[32]		X	
0x2020:003	EoE information: Subnet mask	- (Read only)	STRING[32]		X	
0x2020:004	EoE information: Standard gateway	- (Read only)	STRING[32]		X	
0x2020:005	EoE information: DNS server	- (Read only)	STRING[32]		X	
0x2020:006	EoE information: DNS name	- (Read only)	STRING[50]		X	
0x2020:007	EoE information: Received packages		U32	1	X	
0x2020:008	EoE information: Transmitted packages		U32	1	X	
0x2021:001	Optical tracking: Start detection	Stop [0]	U8		X	
0x2021:002	Optical tracking: Blinking duration	5 s	U16	1	X	
0x2022:001	Device commands: Load default settings	Off / ready [0]	U8		X	
0x2022:003	Device commands: Save user data	Off / ready [0]	U8		X	
0x2022:015	Device commands: Delete logbook	Off / ready [0]	U8		X	
0x2022:035	Device commands: Restart Device	Off/Ready [0]	U8		X	
0x2022:036	Device commands: Export Logbook	Off/Ready [0]	U8		X	
0x2022:037	Device commands: Delete Logfiles	Off/Ready [0]	U8		X	
0x2022:038	Device commands: Activate loaded application	Off/Ready [0]	U8		X	
0x2022:039	Device commands: Load TA default settings	Off/Ready [0]	U8		X	
0x2022:040	Device commands: Parameter-Backup	Off/Ready [0]	U8		CX	
0x2022:041	Device commands: Restart extended safety	Off/Ready [0]	U8		X	
0x2022:042	Device commands: Upload application	Off/Ready [0]	U8		X	
0x2022:043	Device commands: Restore	Off/Ready [0]	U8		CX	
0x2022:044	Device commands: Start application	Off/Ready [0]	U8		CX	

Appendix

Parameter attribute list



Address	Name	Default setting	Data type	Factor	A	M
0x2022:045	Device commands: Stop application	Off/Ready [0]	U8		CX	
0x2030	CRC parameter set	- (Read only)	U32	1	X	
0x2100:001	Brand protection: PIN set	0	I32	1	X	
0x2100:002	Brand protection: PIN input	0	I32	1	X	
0x2100:003	Brand protection: Encryption	0	U8	1	X	
0x2110:014	SHOM: Delete home position	Ready [0]	U8		X	
0x2110:015	Activate muting	Ready [0]	U8		X	
0x2114:001	Parameter set Identification: Parameter set version	- (Read only)	U16		-	
0x2114:002	Parameter set Identification: Parameter set CRC	0	U32	1	-	
0x2115:001	Parameter set information: Parameter set status	- (Read only)	U8		X	
0x2115:002	Parameter set information: Safety module CRC	- (Read only)	U32	1	X	
0x2115:003	Parameter set information: Last valid CRC	- (Read only)	U32	1	X	
0x2115:004	Parameter set information: Parameter setting time stamp	x s (Read only)	U32	1	X	
0x2115:005	Parameter set information: Parameter set error information 1	- (Read only)	U32	1	X	
0x2115:006	Parameter set information: Parameter set error information 2	- (Read only)	U32	1	X	
0x2115:007	Parameter set information: Parameter set error information 3	- (Read only)	U32	1	X	
0x2118:001	SD-In: Sensor type: SD-In1: Sensor type	- (Read only)	U8		-	
0x2118:002	SD-In: Sensor type: SD-In2: Sensor type	- (Read only)	U8		-	
0x2118:003	SD-In: Sensor type: SD-In3: Sensor type	- (Read only)	U8		-	
0x2118:004	SD-In: Sensor type: SD-In4: Sensor type	- (Read only)	U8		-	
0x2119:001	SD-In: Discrepancy time: SD-In1: Discrepancy time	x ms (Read only)	U16	1	-	
0x2119:002	SD-In: Discrepancy time: SD-In2: Discrepancy time	x ms (Read only)	U16	1	-	
0x2119:003	SD-In: Discrepancy time: SD-In3: Discrepancy time	x ms (Read only)	U16	1	-	
0x2119:004	SD-In: Discrepancy time: SD-In4: Discrepancy time	x ms (Read only)	U16	1	-	
0x211A:001	SD-In: Input delay: SD-In1: Input delay	x ms (Read only)	U16	1	-	
0x211A:002	SD-In: Input delay: SD-In2: Input delay	x ms (Read only)	U16	1	-	
0x211A:003	SD-In: Input delay: SD-In3: Input delay	x ms (Read only)	U16	1	-	
0x211A:004	SD-In: Input delay: SD-In4: Input delay	x ms (Read only)	U16	1	-	
0x211B	Input image	- (Read only)	U32		HX	
0x211C:001	Status bits of inputs: SD-In1	- (Read only)	BOOLEAN	1	X	●
0x211C:002	Status bits of inputs: SD-In2	- (Read only)	BOOLEAN	1	X	●
0x211C:003	Status bits of inputs: SD-In3	- (Read only)	BOOLEAN	1	X	●
0x211C:004	Status bits of inputs: SD-In4	- (Read only)	BOOLEAN	1	X	●
0x211C:005	Status bits of inputs: AIS Dig-In	- (Read only)	BOOLEAN	1	X	
0x211C:006	Status bits of inputs: AIE Dig-In	- (Read only)	BOOLEAN	1	X	
0x211C:007	Status bits of inputs: IRS Dig-In	- (Read only)	BOOLEAN	1	X	
0x211C:008	Status bits of inputs: IRL Dig-In	- (Read only)	BOOLEAN	1	X	
0x2120:001	SD-Out: Source S-Bus: SD-Out1: Source S-Bus	- (Read only)	U8		-	
0x2121:001	SD-Out logic function: SD-Out1 logic function	- (Read only)	U8		-	
0x2122	Output image	- (Read only)	U16		HX	
0x2123:001	Status bits of outputs: SD-Out1	- (Read only)	BOOLEAN	1	X	●
0x2124	CAS: Quelle SD-In	- (Read only)	U8		-	
0x2125:001	CAS: Cascading: CAS: Stop delay	x ms (Read only)	U16	1	X	
0x2128	S-bus: Configuration	- (Read only)	U8		-	
0x2129:001	S-bus: Control bits: SD-Out1	- (Read only)	BOOLEAN	1	X	●
0x212A:001	S-Bus: Information: FSoE parameter set CRC		U32	1	X	
0x212C:001	Safety: Software: Safety: Software version	- (Read only)	STRING[50]		X	
0x212D:001	Safety: Hardware: Safety: Hardware version	- (Read only)	STRING[50]		X	
0x212D:002	Safety: Hardware: Safety: Type	- (Read only)	STRING[50]		X	
0x212D:003	Safety: Hardware: Safety: Serial number	- (Read only)	STRING[50]		X	
0x212D:004	Safety: Hardware: Safety: Production date	- (Read only)	STRING[50]		X	

Appendix

Parameter attribute list



Address	Name	Default setting	Data type	Factor	A	M
0x2382:004	Active PROFINET settings: Station name	- (Read only)	STRING[240]		X	
0x2382:005	Active PROFINET settings: MAC Address	- (Read only)	OCTET[6]		X	
0x2388	PROFINET status	- (Read only)	U16		HX	
0x2389:001	PROFINET error: Error 1	- (Read only)	U16		X	
0x2389:002	PROFINET error: Error 2	- (Read only)	U16		HX	
0x243C:001	Device: Ethernet commands: Device: Start firmware update	Off/Ready [0]	U8		CX	
0x2450	Engineering port control	No action/No error [0]	U8		X	
0x2451:001	Engineering port settings: IP address	0.0.0.0	U32		E	
0x2451:002	Engineering port settings: Subnet	0.0.0.0	U32		E	
0x2451:003	Engineering port settings: Gateway	0.0.0.0	U32		E	
0x2451:004	Engineering port settings: DHCP	Enabled [1]	U8		-	
0x2452:001	Active engineering port settings: IP address	- (Read only)	U32		EX	
0x2452:002	Active engineering port settings: Subnet	- (Read only)	U32		EX	
0x2452:003	Active engineering port settings: Gateway	- (Read only)	U32		EX	
0x2452:004	Active engineering port settings: Active DHCP setting	- (Read only)	U8		X	
0x2452:005	Active engineering port settings: MAC address	- (Read only)	OCTET[6]		X	
0x245A:001	NTP server addresses: Activate NTP server addresses	No action/no error [0]	U8		X	
0x245A:002	NTP server addresses: NTP server address 1	0.0.0.0	U32		E	
0x245A:003	NTP server addresses: NTP server address 2	0.0.0.0	U32		E	
0x245A:004	NTP server addresses: NTP server address 3	0.0.0.0	U32		E	
0x245A:005	NTP server addresses: NTP server address 4	0.0.0.0	U32		E	
0x245B:001	System time: Time base	NTP [0]	U8		X	
0x245B:002	System time: Current time	ns	U64	1	TX	
0x24E7:001	EtherCAT input data: Input data 1	- (Read only)	U32	1	X	
0x24E7:002	EtherCAT input data: Input data 2	- (Read only)	U32	1	X	
0x24E7:003	EtherCAT input data: Input data 3	- (Read only)	U32	1	X	
0x24E7:004	EtherCAT input data: Input data 4	- (Read only)	U32	1	X	
0x24E7:005	EtherCAT input data: Input data 5	- (Read only)	U32	1	X	
0x24E7:006	EtherCAT input data: Input data 6	- (Read only)	U32	1	X	
0x24E7:007	EtherCAT input data: Input data 7	- (Read only)	U32	1	X	
0x24E7:008	EtherCAT input data: Input data 8	- (Read only)	U32	1	X	
0x24E7:009	EtherCAT input data: Input data 9	- (Read only)	U32	1	X	
0x24E7:010	EtherCAT input data: Input data 10	- (Read only)	U32	1	X	
0x24E7:011	EtherCAT input data: Input data 11	- (Read only)	U32	1	X	
0x24E7:012	EtherCAT input data: Input data 12	- (Read only)	U32	1	X	
0x24E7:013	EtherCAT input data: Input data 13	- (Read only)	U32	1	X	
0x24E7:014	EtherCAT input data: Input data 14	- (Read only)	U32	1	X	
0x24E7:015	EtherCAT input data: Input data 15	- (Read only)	U32	1	X	
0x24E7:016	EtherCAT input data: Input data 16	- (Read only)	U32	1	X	
0x24E8:001	EtherCAT output data: Output data 1	- (Read only)	U32	1	X	
0x24E8:002	EtherCAT output data: Output data 2	- (Read only)	U32	1	X	
0x24E8:003	EtherCAT output data: Output data 3	- (Read only)	U32	1	X	
0x24E8:004	EtherCAT output data: Output data 4	- (Read only)	U32	1	X	
0x24E8:005	EtherCAT output data: Output data 5	- (Read only)	U32	1	X	
0x24E8:006	EtherCAT output data: Output data 6	- (Read only)	U32	1	X	
0x24E8:007	EtherCAT output data: Output data 7	- (Read only)	U32	1	X	
0x24E8:008	EtherCAT output data: Output data 8	- (Read only)	U32	1	X	
0x24E8:009	EtherCAT output data: Output data 9	- (Read only)	U32	1	X	
0x24E8:010	EtherCAT output data: Output data 10	- (Read only)	U32	1	X	
0x24E8:011	EtherCAT output data: Output data 11	- (Read only)	U32	1	X	
0x24E8:012	EtherCAT output data: Output data 12	- (Read only)	U32	1	X	
0x24E8:013	EtherCAT output data: Output data 13	- (Read only)	U32	1	X	



Appendix

Parameter attribute list

Address	Name	Default setting	Data type	Factor	A	M
0x24E8:014	EtherCAT output data: Output data 14	- (Read only)	U32	1	X	
0x24E8:015	EtherCAT output data: Output data 15	- (Read only)	U32	1	X	
0x24E8:016	EtherCAT output data: Output data 16	- (Read only)	U32	1	X	
0x2500	Touch probe filter time	0 us	U16	1	-	
0x2539:001	Hardware-Diagnose: 24 V supply actual voltage	x.x V (Read only)	U16	10	X	
0x2539:002	Hardware-Diagnose: Control board temperature	x.x °C (Read only)	I16	10	X	
0x2540:001	Mains settings: Rated mains voltage	400 Veff [1]	U8		-	
0x2540:002	Mains settings: Undervoltage warning threshold	430 V	U16	1	-	
0x2540:003	Mains settings: Undervoltage error threshold	x V (Read only)	U16	1	-	
0x2540:004	Mains settings: Undervoltage reset threshold	x V (Read only)	U16	1	-	
0x2540:005	Mains settings: Overvoltage warning threshold	795 V	U16	1	-	
0x2540:006	Mains settings: Overvoltage error threshold	x V (Read only)	U16	1	-	
0x2540:007	Mains settings: Overvoltage reset threshold	x V (Read only)	U16	1	-	
0x2540:008	Mains settings: DC link voltage critical	- (Read only)	U8	1	X	•
0x2541:003	Brake energy management: Reduced threshold	0 V	U16	1	-	
0x2550:001	Brake resistor: Minimum resistance	x.x Ω (Read only)	U16	10	X	
0x2550:002	Brake resistor: Resistance value	180.0 Ω	U16	10	-	
0x2550:003	Brake resistor: Rated power	5600 W	U32	1	-	
0x2550:004	Brake resistor: Maximum thermal load	485 kW	U32	1	-	
0x2550:006	Brake resistor: Reference resistance	Minimum resistance [0]	U8		-	
0x2550:007	Brake resistor: Thermal load	x.x % (Read only)	U16	10	X	
0x2550:008	Brake resistor: Warning threshold	90.0 %	U16	10	-	
0x2550:010	Brake resistor: Response to warning	Warning [2]	U8		-	
0x2550:011	Brake resistor: Response to error	No response [0]	U8		-	
0x2580:001	Distributed Clocks: Real time status	- (Read only)	U8		X	
0x2580:002	Distributed Clocks: First setting time	x ns (Read only)	U64	1	TX	
0x2580:003	Distributed Clocks: Newest setting time	x ns (Read only)	U64	1	TX	
0x2580:004	Distributed Clocks: Current time	x ns (Read only)	U64	1	TX	
0x2590:003	Energy saving: State of actual energy saving mode	- (Read only)	U8		HX	
0x261C:001	Favorites settings: Parameter 1		U32	1	-	
0x261C:002	Favorites settings: Parameter 2		U32	1	-	
0x261C:003	Favorites settings: Parameter 3		U32	1	-	
0x261C:004	Favorites settings: Parameter 4		U32	1	-	
0x261C:005	Favorites settings: Parameter 5		U32	1	-	
0x261C:006	Favorites settings: Parameter 6		U32	1	-	
0x261C:007	Favorites settings: Parameter 7		U32	1	-	
0x261C:008	Favorites settings: Parameter 8		U32	1	-	
0x261C:009	Favorites settings: Parameter 9		U32	1	-	
0x261C:010	Favorites settings: Parameter 10		U32	1	-	
0x261C:011	Favorites settings: Parameter 11		U32	1	-	
0x261C:012	Favorites settings: Parameter 12		U32	1	-	
0x261C:013	Favorites settings: Parameter 13		U32	1	-	
0x261C:014	Favorites settings: Parameter 14		U32	1	-	
0x261C:015	Favorites settings: Parameter 15		U32	1	-	
0x261C:016	Favorites settings: Parameter 16		U32	1	-	
0x261C:017	Favorites settings: Parameter 17		U32	1	-	
0x261C:018	Favorites settings: Parameter 18		U32	1	-	
0x261C:019	Favorites settings: Parameter 19		U32	1	-	
0x261C:020	Favorites settings: Parameter 20		U32	1	-	
0x261C:021	Favorites settings: Parameter 21		U32	1	-	
0x261C:022	Favorites settings: Parameter 22		U32	1	-	
0x261C:023	Favorites settings: Parameter 23		U32	1	-	
0x261C:024	Favorites settings: Parameter 24		U32	1	-	
0x261C:025	Favorites settings: Parameter 25		U32	1	-	
0x261C:026	Favorites settings: Parameter 26		U32	1	-	

Appendix

Parameter attribute list



Address	Name	Default setting	Data type	Factor	A	M
0x261C:027	Favorites settings: Parameter 27		U32	1	-	
0x261C:028	Favorites settings: Parameter 28		U32	1	-	
0x261C:029	Favorites settings: Parameter 29		U32	1	-	
0x261C:030	Favorites settings: Parameter 30		U32	1	-	
0x261C:031	Favorites settings: Parameter 31		U32	1	-	
0x261C:032	Favorites settings: Parameter 32		U32	1	-	
0x261C:033	Favorites settings: Parameter 33		U32	1	-	
0x261C:034	Favorites settings: Parameter 34		U32	1	-	
0x261C:035	Favorites settings: Parameter 35		U32	1	-	
0x261C:036	Favorites settings: Parameter 36		U32	1	-	
0x261C:037	Favorites settings: Parameter 37		U32	1	-	
0x261C:038	Favorites settings: Parameter 38		U32	1	-	
0x261C:039	Favorites settings: Parameter 39		U32	1	-	
0x261C:040	Favorites settings: Parameter 40		U32	1	-	
0x261C:041	Favorites settings: Parameter 41		U32	1	-	
0x261C:042	Favorites settings: Parameter 42		U32	1	-	
0x261C:043	Favorites settings: Parameter 43		U32	1	-	
0x261C:044	Favorites settings: Parameter 44		U32	1	-	
0x261C:045	Favorites settings: Parameter 45		U32	1	-	
0x261C:046	Favorites settings: Parameter 46		U32	1	-	
0x261C:047	Favorites settings: Parameter 47		U32	1	-	
0x261C:048	Favorites settings: Parameter 48		U32	1	-	
0x261C:049	Favorites settings: Parameter 49		U32	1	-	
0x261C:050	Favorites settings: Parameter 50		U32	1	-	
0x2632:001	Inversion of digital inputs: Digital input 1	Not inverted [0]	U8		-	
0x2632:002	Inversion of digital inputs: Digital input 2	Not inverted [0]	U8		-	
0x2632:003	Inversion of digital inputs: Digital input 3	Not inverted [0]	U8		-	
0x2632:004	Inversion of digital inputs: Digital input 4	Not inverted [0]	U8		-	
0x2632:005	Inversion of digital inputs: Digital input 5	Not inverted [0]	U8		-	
0x2632:006	Inversion of digital inputs: Digital input 6	Not inverted [0]	U8		-	
0x2632:007	Inversion of digital inputs: Digital input 7	Not inverted [0]	U8		-	
0x2632:008	Inversion of digital inputs: Digital input 8	Not inverted [0]	U8		-	
0x2632:009	Inversion of digital inputs: Digital input 9	Not inverted [0]	U8		-	
0x2633:001	Digital input debounce time: Digital input 1	0 ms	U8	1	-	
0x2633:002	Digital input debounce time: Digital input 2	0 ms	U8	1	-	
0x2633:003	Digital input debounce time: Digital input 3	0 ms	U8	1	-	
0x2633:004	Digital input debounce time: Digital input 4	0 ms	U8	1	-	
0x2633:005	Digital input debounce time: Digital input 5	0 ms	U8	1	-	
0x2633:006	Digital input debounce time: Digital input 6	0 ms	U8	1	-	
0x2633:007	Digital input debounce time: Digital input 7	0 ms	U8	1	-	
0x2633:008	Digital input debounce time: Digital input 8	0 ms	U8	1	-	
0x2633:009	Digital input debounce time: Digital input 9	0 ms	U8	1	-	
0x2634:002	Digital outputs function: Digital output 1	Signal from application [10]	U8		-	
0x2635:002	Inversion of digital outputs: Digital output 1	Not inverted [0]	U8		-	
0x2635:003	Inversion of digital outputs: Digital output 2	Not inverted [0]	U8		-	
0x2635:004	Inversion of digital outputs: Digital output 3	Not inverted [0]	U8		-	
0x2635:005	Inversion of digital outputs: Digital output 4	Not inverted [0]	U8		-	
0x2635:006	Inversion of digital outputs: Digital output 5	Not inverted [0]	U8		-	
0x2635:007	Inversion of digital outputs: Digital output 6	Not inverted [0]	U8		-	
0x2636:001	Analog input 1: Input range	0 ... 10 VDC [0]	U8		-	
0x2636:006	Analog input 1: Filter time	10 ms	U16	1	-	
0x2636:007	Analog input 1: Dead band	0.0 %	U16	10	-	
0x2636:010	Analog input 1: Error response	No response [0]	U8		-	
0x2636:013	Analog input 1: Minimum value for scaling	0.0 %	I16	10	-	
0x2636:014	Analog input 1: Maximum value for scaling	100.0 %	I16	10	-	



Appendix

Parameter attribute list

Address	Name	Default setting	Data type	Factor	A	M
0x263B:001	Digital inputs internal control: Activation	Off [0]	U8		X	
0x263B:002	Digital inputs internal control: DI1 internal control	Off [0]	U8		X	
0x263B:003	Digital inputs internal control: DI2 internal control	Off [0]	U8		X	
0x263B:004	Digital inputs internal control: DI3 internal control	Off [0]	U8		X	
0x263B:005	Digital inputs internal control: DI4 internal control	Off [0]	U8		X	
0x263B:006	Digital inputs internal control: DI5 internal control	Off [0]	U8		X	
0x263B:007	Digital inputs internal control: DI6 internal control	Off [0]	U8		X	
0x263B:008	Digital inputs internal control: DI7 internal control	Off [0]	U8		X	
0x263B:009	Digital inputs internal control: DI8 internal control	Off [0]	U8		X	
0x263B:010	Digital inputs internal control: DI9 internal control	Off [0]	U8		X	
0x263C:001	Digital outputs internal control: Activation	Off [0]	U8		X	
0x263C:002	Digital outputs internal control: DO1 internal control	Off [0]	U8		X	
0x263C:003	Digital outputs internal control: DO2 internal control	Off [0]	U8		X	
0x263C:004	Digital outputs internal control: DO3 internal control	Off [0]	U8		X	
0x263C:005	Digital outputs internal control: DO4 internal control	Off [0]	U8		X	
0x263C:006	Digital outputs internal control: DO5 internal control	Off [0]	U8		X	
0x263C:007	Digital outputs internal control: DO6 internal control	Off [0]	U8		X	
0x263D:001	Analog inputs internal control: Activation	Off [0]	U8		X	
0x263D:002	Analog inputs internal control: AI1 internal control	100.00 %	I16	100	X	
0x2820:001	Holding brake control: Brake mode	Off [2]	U8		-	●
0x2820:002	Holding brake control: Brake closing time	100 ms	U16	1	-	
0x2820:003	Holding brake control: Brake opening time	100 ms	U16	1	-	
0x2820:004	Holding brake control: Brake detection	- (Read only)	U16		X	
0x2820:005	Holding brake control: Brake polarity	Normal [0]	U8		-	
0x2820:006	Holding brake control: Brake error response	Fault > CiA402 [1]	U8		-	
0x2820:009	Holding brake control: Starting torque source	Torque in 0x2820:010 [1]	U16		-	
0x2820:010	Holding brake control: Starting torque	0.0 %	I16	10	-	●
0x2820:011	Holding brake control: Override of the brake control	No override active [0]	U8		X	●
0x2820:013	Holding brake control: Holding load ramptime	0 ms	U16	1	-	
0x2820:015	Holding brake control: Brake status	- (Read only)	U8		X	
0x2820:019	Holding brake control: Brake opening time test signal	500 ms	U16	1	X	
0x2820:020	Holding brake control: Brake control word	0x00	U8		HX	
0x2820:021	Holding brake control: Detected actual torque	x.x % (Read only)	I16	10	X	
0x2820:022	Holding brake control: Holding brake supply voltage	No reduction [100]	U8		-	
0x2820:023	Holding brake control: Output signal configuration	Internal brake control [0]	U8		-	
0x2822:001	Axis commands: Enable inverter	Inverter enabled [1]	U8		X	
0x2822:003	Axis commands: Reset error	Off/Ready [0]	U8		X	
0x2822:021	Axis commands: Load default Lh saturation characteristic	Off/Ready [0]	U8		X	
0x2822:022	Axis commands: Load default inverter characteristic	Off/Ready [0]	U8		X	
0x2822:023	Axis commands: Estimate optimum magnetizing current	Off/Ready [0]	U8		X	
0x2822:024	Axis commands: Estimate basic motor parameters based on rated data	Off/Ready [0]	U8		X	
0x2822:025	Axis commands: Get motor encoder characteristic (resolver)	Off/Ready [0]	U8		X	
0x2822:026	Axis commands: Get motor encoder information (Hiperface)	Off/Ready [0]	U8		X	
0x2822:029	Axis commands: Get load encoder/master encoder characteristic (resolver)	Off/Ready [0]	U8		X	
0x2822:030	Axis commands: Get load encoder/master encoder information (Hiperface)	Off/Ready [0]	U8		X	
0x2822:037	Axis commands: Estimate all motor parameters based on rated data	Off/Ready [0]	U8		X	
0x2823	Status of axis commands	- (Read only)	U8	1	X	

Appendix

Parameter attribute list



Address	Name	Default setting	Data type	Factor	A	M
0x2824	Control selection	Keypad [1]	U8		C	
0x2825	Drive mode selection	CiA402 operating modes [0]	U8		CX	
0x2826	Time-out for error response	4 s	U32	1	-	
0x282A:001	Status words: Cause of disable	- (Read only)	U32		HX	●
0x282C:001	I/O diagnostic: Application level of the digital inputs	- (Read only)	U32		HX	●
0x282C:002	I/O diagnostic: Digital output levels	- (Read only)	U32		HX	●
0x2830	Inverter control word	0x0000	U16		HX	●
0x2831	Inverter-Statuswort	- (Read only)	U16		HX	●
0x2832	Motor identification status	- (Read only)	U16		HX	
0x2833	Inverter status word 2	- (Read only)	U16		HX	●
0x2835:001	Manual test mode: Current setpoint	0 %	I16	1	X	●
0x2835:002	Manual test mode: Frequency	0.0 Hz	I16	10	X	●
0x2835:003	Manual test mode: Starting angle	0.0 °	I16	10	X	
0x2836:001	Manual control mode: Current setpoint	30 %	U16	1	X	●
0x2836:002	Manual control mode: Frequency	0.0 Hz	I16	10	X	●
0x2836:003	Manual control mode: Ramp time (current)	0 ms	U16	1	-	
0x2836:004	Manual control mode: Ramp time (frequency)	500 ms	U16	1	-	
0x2836:005	Manual control mode: Time monitoring (frequency)	2500 ms	U32	1	-	
0x2836:006	Manual control mode: Current controller gain	20.00 V/A	U32	100	-	
0x2836:007	Manual control mode: Current controller reset time	20.00 ms	U32	100	-	
0x2840	Error reset time	x ms (Read only)	I32	1	X	
0x2841	Reset error	0	U8	1	X	
0x284F	Current error	- (Read only)	OCTET[64]		X	
0x2859:001	Fieldbus network monitoring: Watchdog elapsed	Warning [2]	U8		-	
0x2859:002	Fieldbus network monitoring: Data exchange exited	No response [0]	U8		-	
0x2859:003	Fieldbus network monitoring: Invalid configuration	Warning [2]	U8		-	
0x2859:004	Fieldbus network monitoring: Initialisation error	Warning [2]	U8		-	
0x2859:005	Fieldbus network monitoring: Invalid process data	Warning [2]	U8		-	
0x285A:001	Diagnostic configuration: Alarm supression	0x0000	U16		H	
0x285B:001	EtherCAT system bus monitoring: Watchdog abgelaufen	Fault > CiA402 [1]	U8		-	
0x285B:002	EtherCAT system bus monitoring: EtherCAT role check	Warning [2]	U8		-	
0x2870:001	SafetyInterface: SafetyInterface Control	- (Read only)	U32		HX	●
0x2870:002	SafetyInterface: SafetyInterface State	- (Read only)	U32		HX	●
0x2870:003	SafetyInterface: SafetyInterface IOState	- (Read only)	U32		HX	●
0x2871:001	SafetyInterface bits: STO active	- (Read only)	BOOLEAN	1	X	●
0x2871:002	SafetyInterface bits: SS1 active	- (Read only)	BOOLEAN	1	X	●
0x2871:003	SafetyInterface bits: SS2 active	- (Read only)	BOOLEAN	1	X	●
0x2871:004	SafetyInterface bits: SOS active	- (Read only)	BOOLEAN	1	X	●
0x2871:005	SafetyInterface bits: SLS1 active	- (Read only)	BOOLEAN	1	X	●
0x2871:006	SafetyInterface bits: SLS2 active	- (Read only)	BOOLEAN	1	X	●
0x2871:007	SafetyInterface bits: SLS3 active	- (Read only)	BOOLEAN	1	X	●
0x2871:008	SafetyInterface bits: SLS4 active	- (Read only)	BOOLEAN	1	X	●
0x2871:009	SafetyInterface bits: SDIpos active	- (Read only)	BOOLEAN	1	X	●
0x2871:010	SafetyInterface bits: SDIneg active	- (Read only)	BOOLEAN	1	X	●
0x2871:011	SafetyInterface bits: SLI active	- (Read only)	BOOLEAN	1	X	●
0x2871:012	SafetyInterface bits: SSE active	- (Read only)	BOOLEAN	1	X	●
0x2871:013	SafetyInterface bits: ES active	- (Read only)	BOOLEAN	1	X	●
0x2871:014	SafetyInterface bits: OMS active	- (Read only)	BOOLEAN	1	X	●
0x2871:015	SafetyInterface bits: RMS active	- (Read only)	BOOLEAN	1	X	●
0x2871:016	SafetyInterface bits: SBC active	- (Read only)	BOOLEAN	1	X	●
0x2871:017	SafetyInterface bits: MUT active	- (Read only)	BOOLEAN	1	X	●
0x2871:033	SafetyInterface bits: SLS1 observed	- (Read only)	BOOLEAN	1	X	●
0x2871:034	SafetyInterface bits: SLS2 observed	- (Read only)	BOOLEAN	1	X	●



Appendix

Parameter attribute list

Address	Name	Default setting	Data type	Factor	A	M
0x2871:035	SafetyInterface bits: SLS3 observed	- (Read only)	BOOLEAN	1	X	●
0x2871:036	SafetyInterface bits: SLS4 observed	- (Read only)	BOOLEAN	1	X	●
0x2871:037	SafetyInterface bits: SMS observed	- (Read only)	BOOLEAN	1	X	●
0x2871:038	SafetyInterface bits: SSM within limits	- (Read only)	BOOLEAN	1	X	●
0x2871:039	SafetyInterface bits: SDIpos observed	- (Read only)	BOOLEAN	1	X	●
0x2871:040	SafetyInterface bits: SDIneg observed	- (Read only)	BOOLEAN	1	X	●
0x2871:041	SafetyInterface bits: SLP1 observed	- (Read only)	BOOLEAN	1	X	●
0x2871:042	SafetyInterface bits: SLP2 observed	- (Read only)	BOOLEAN	1	X	●
0x2871:043	SafetyInterface bits: SLP3 observed	- (Read only)	BOOLEAN	1	X	●
0x2871:044	SafetyInterface bits: SLP4 observed	- (Read only)	BOOLEAN	1	X	●
0x2871:045	SafetyInterface bits: SCA1 within limits	- (Read only)	BOOLEAN	1	X	●
0x2871:046	SafetyInterface bits: SCA2 within limits	- (Read only)	BOOLEAN	1	X	●
0x2871:047	SafetyInterface bits: SCA3 within limits	- (Read only)	BOOLEAN	1	X	●
0x2871:048	SafetyInterface bits: SCA4 within limits	- (Read only)	BOOLEAN	1	X	●
0x2871:049	SafetyInterface bits: PDSSpos observed	- (Read only)	BOOLEAN	1	X	●
0x2871:050	SafetyInterface bits: PDSSneg observed	- (Read only)	BOOLEAN	1	X	●
0x2871:051	SafetyInterface bits: SOS observed	- (Read only)	BOOLEAN	1	X	●
0x2871:052	SafetyInterface bits: SBC activated	- (Read only)	BOOLEAN	1	X	●
0x2871:053	SafetyInterface bits: SHOM active	- (Read only)	BOOLEAN	1	X	●
0x2871:054	SafetyInterface bits: SHOM available	- (Read only)	BOOLEAN	1	X	●
0x2871:055	SafetyInterface bits: Safe speed OK	- (Read only)	BOOLEAN	1	X	●
0x2871:056	SafetyInterface bits: n=0	- (Read only)	BOOLEAN	1	X	●
0x2871:057	SafetyInterface bits: Positive direction	- (Read only)	BOOLEAN	1	X	●
0x2871:058	SafetyInterface bits: Slip > 25%	- (Read only)	BOOLEAN	1	X	
0x2871:059	SafetyInterface bits: Slip > 50%	- (Read only)	BOOLEAN	1	X	
0x2871:060	SafetyInterface bits: Slip > 75%	- (Read only)	BOOLEAN	1	X	
0x2871:064	SafetyInterface bits: Error active	- (Read only)	BOOLEAN	1	X	●
0x2871:073	SafetyInterface bits: AIS S bus	- (Read only)	BOOLEAN	1	X	
0x2871:074	SafetyInterface bits: AIE S bus	- (Read only)	BOOLEAN	1	X	
0x2871:075	SafetyInterface bits: SHOM_Start S bus	- (Read only)	BOOLEAN	1	X	
0x2871:076	SafetyInterface bits: SHOM_Load S bus	- (Read only)	BOOLEAN	1	X	
0x2874	S bus: Display of control data	- (Read only)	U32		HX	
0x2875:001	S bus control bits: STO	- (Read only)	BOOLEAN	1	X	●
0x2875:002	S bus control bits: SS1	- (Read only)	BOOLEAN	1	X	●
0x2875:003	S bus control bits: SS2	- (Read only)	BOOLEAN	1	X	●
0x2875:004	S bus control bits: SLS1	- (Read only)	BOOLEAN	1	X	●
0x2875:005	S bus control bits: SLS2	- (Read only)	BOOLEAN	1	X	●
0x2875:006	S bus control bits: SLS3	- (Read only)	BOOLEAN	1	X	●
0x2875:007	S bus control bits: SLS4	- (Read only)	BOOLEAN	1	X	●
0x2875:008	S bus control bits: SDIpos	- (Read only)	BOOLEAN	1	X	●
0x2875:009	S bus control bits: SDIneg	- (Read only)	BOOLEAN	1	X	●
0x2875:010	S bus control bits: ES	- (Read only)	BOOLEAN	1	X	●
0x2875:011	S bus control bits: SLI	- (Read only)	BOOLEAN	1	X	●
0x2875:012	S bus control bits: OMS	- (Read only)	BOOLEAN	1	X	●
0x2875:013	S bus control bits: SLP1	- (Read only)	BOOLEAN	1	X	●
0x2875:014	S bus control bits: SLP2	- (Read only)	BOOLEAN	1	X	●
0x2875:015	S bus control bits: SLP3	- (Read only)	BOOLEAN	1	X	●
0x2875:016	S bus control bits: SLP4	- (Read only)	BOOLEAN	1	X	●
0x2875:017	S bus control bits: AIS	- (Read only)	BOOLEAN	1	X	●
0x2875:018	S bus control bits: AIE	- (Read only)	BOOLEAN	1	X	●
0x2875:019	S bus control bits: SOS	- (Read only)	BOOLEAN	1	X	●
0x2875:020	S bus control bits: RMS	- (Read only)	BOOLEAN	1	X	●
0x2875:021	S bus control bits: SHOM_Start	- (Read only)	BOOLEAN	1	X	●
0x2875:022	S bus control bits: SHOM_Load	- (Read only)	BOOLEAN	1	X	●
0x2875:023	S bus control bits: PDSS	- (Read only)	BOOLEAN	1	X	●

Appendix

Parameter attribute list



Address	Name	Default setting	Data type	Factor	A	M
0x2875:024	S bus control bits: SSE	- (Read only)	BOOLEAN	1	X	●
0x2875:026	S bus control bits: SBC	- (Read only)	BOOLEAN	1	X	●
0x2878:001	Motor encoder: Motor encoder system	- (Read only)	U8		-	
0x2878:002	Motor encoder: SinCos encoder increments	- (Read only)	U16	1	-	
0x2878:003	Motor encoder: Number of resolver pole pairs	- (Read only)	U8	1	-	
0x2878:004	Motor encoder: Encoder monitoring response time	ms (Read only)	U8		-	
0x2879:001	Mechanical data: Motor mounting direction	- (Read only)	U8		-	
0x287A:001	Load encoder: Load encoder system	- (Read only)	U8		-	
0x287A:003	Load encoder: Load encoder gearbox factor numerator	- (Read only)	U16	1	-	
0x287A:004	Load encoder: Load encoder gearbox factor denominator	- (Read only)	U16	1	-	
0x287A:005	Load encoder: Load encoder mounting direction	- (Read only)	U8		-	
0x287A:006	Load encoder: Load encoder position	0 incr.	I32	1	X	●
0x287A:007	Load encoder: Status of load encoder position	Invalid [0]	U8		X	●
0x287B:001	Velocity monitoring: Tolerance window (n=0)	x rpm (Read only)	U16	1	-	
0x287B:002	Velocity monitoring: Velocity comparison tolerance	x rpm (Read only)	U16	1	-	
0x287B:003	Velocity monitoring: Actual velocity n_safe	x rpm (Read only)	I16	1	X	●
0x287B:004	Velocity monitoring: Internal actual velocity nSD	x rpm (Read only)	I16	1	X	
0x287B:005	Velocity monitoring: Internal actual velocity nBD	x rpm (Read only)	I16	1	X	
0x287B:006	Velocity monitoring: Actual velocity difference nSD-nBD	x rpm (Read only)	I16	1	X	
0x287C:001	Position monitoring: Position comparison tolerance	x incr. (Read only)	I32	1	-	
0x287C:002	Position monitoring: Actual Position p_safe	x incr. (Read only)	I32	1	X	●
0x287C:003	Position monitoring: Internal actual position pSD	x incr. (Read only)	I32	1	X	
0x287C:004	Position monitoring: Internal actual position pBD	x incr. (Read only)	I32	1	X	
0x287C:005	Position monitoring: Current pos. difference pSD-pBD	x incr. (Read only)	I32	1	X	
0x2880:001	SHOM_Start settings: SHOM_Start: Source	- (Read only)	U8		-	
0x2880:002	SHOM_Start settings: SHOM_Start: Edge trigger IRS	- (Read only)	U8		-	
0x2881:001	SHOM_Load settings: SHOM_Load: Source	- (Read only)	U8		-	
0x2881:002	SHOM_Load settings: SHOM_Load: Edge trigger IRL	- (Read only)	U8		-	
0x2882:001	Safe homing (SHOM): SHOM: Home position	x incr. (Read only)	I32	1	-	
0x2882:002	Safe homing (SHOM): SHOM: Timeout	x ms (Read only)	U16	1	-	
0x2882:003	Safe homing (SHOM): SHOM: SLS homing	- (Read only)	U8		-	
0x2882:004	Safe homing (SHOM): SHOM: Restart condition	- (Read only)	U8		-	
0x2882:005	Safe homing (SHOM): SHOM: Tolerance - starting position	x incr. (Read only)	I32	1	-	
0x2882:006	Safe homing (SHOM): SHOM status	- (Read only)	U8		X	
0x2882:007	Safe homing (SHOM): SHOM: Saved position	x incr. (Read only)	I32	1	X	
0x2883	SHOM: Diagnostic positions source	- (Read only)	U8		-	
0x2884:001	SHOM diagnostic positions: SHOM: Detection diag position	- (Read only)	U8		-	
0x2884:002	SHOM diagnostic positions: SHOM: Lower diagnostic position	x incr. (Read only)	I32	1	-	
0x2884:003	SHOM diagnostic positions: SHOM: Upper diagnostic position	x incr. (Read only)	I32	1	-	
0x2884:004	SHOM diagnostic positions: SHOM: Tolerance diag positions	x incr. (Read only)	I32	1	-	
0x2884:005	SHOM diagnostic positions: SHOM: Error response diag positions	- (Read only)	U8		-	
0x2884:006	SHOM diagnostic positions: SHOM: Current difference diagnostic position	x incr. (Read only)	I32	1	X	
0x2885:001	SHOM: Slip compensation: SHOM: Maximally compensated slip	x incr. (Read only)	I32	1	-	
0x2885:002	SHOM: Slip compensation: SHOM: Slip compensation end area	- (Read only)	U8		-	



Appendix

Parameter attribute list

Address	Name	Default setting	Data type	Factor	A	M
0x2886	SHOM: SHOM active output	- (Read only)	U8		-	
0x2887	SHOM: SHOM available output	- (Read only)	U8		-	
0x2890	STO: Source SD-In	- (Read only)	U8		-	
0x2891	STO: Source S-Bus	- (Read only)	U8		-	
0x2892:001	STO: STO: Restart	- (Read only)	U8		-	
0x2893	STO active: Output	- (Read only)	U8		-	
0x2894:001	SS1, SS2: SS1, SS2: Stopping time	x ms (Read only)	U16	1	-	
0x2894:002	SS1, SS2: SS1, SS2: Ramp Monitoring	- (Read only)	U8		-	
0x2894:003	SS1, SS2: SS1, SS2: Ramp smoothing time	x % (Read only)	U8	1	-	
0x2894:004	SS1, SS2: SS1, SS2: Ramp Offset Mode	- (Read only)	U8		-	
0x2894:005	SS1, SS2: SS1, SS2: Ramp Start Offset relative	x % (Read only)	U8	1	-	
0x2894:006	SS1, SS2: SS1, SS2: Ramp Start Offset absolute	x rpm (Read only)	U16	1	-	
0x2894:007	SS1, SS2: SS1, SS2: Actual ramp speed	x rpm (Read only)	U16	1	X	
0x2894:008	SS1, SS2: SS1, SS2: Minimal speed difference	x rpm (Read only)	I16	1	X	
0x2895	SS1: Source SD-In	- (Read only)	U8		-	
0x2896	SS1: Source S-Bus	- (Read only)	U8		-	
0x2897:001	SS1: SS1: Mode	- (Read only)	U8		-	
0x2897:002	SS1: SS1: Deceleration STO after n=0	x ms (Read only)	U16	1	-	
0x2898	SS1 active: Output	- (Read only)	U8		-	
0x2899	SS2: Source SD-In	- (Read only)	U8		-	
0x289A	SS2: Source S-Bus	- (Read only)	U8		-	
0x289B:001	SS2: SS2: Mode	- (Read only)	U8		-	
0x289C	SS2 active: Output	- (Read only)	U8		-	
0x289D	SOS: Source SD-In	- (Read only)	U8		-	
0x289E	SOS: Source S-Bus	- (Read only)	U8		-	
0x289F:001	SOS: SOS: Tolerance window (Delta p=0)	x incr. (Read only)	I32	1	-	
0x289F:002	SOS: SOS: Restart	- (Read only)	U8		-	
0x289F:003	SOS: SOS: Maximal Change of Position	x incr. (Read only)	I32	1	X	
0x28A0	SOS observed: Output	- (Read only)	U8		-	
0x28A1	SSE: Source SD-In	- (Read only)	U8		-	
0x28A2	SSE: Source S-Bus	- (Read only)	U8		-	
0x28A3:001	SSE: SSE: Emergency Stop function	- (Read only)	U8		-	
0x28A4	SSE active: Output	- (Read only)	U8		-	
0x28A8	OMS: Source	- (Read only)	U8		-	
0x28A9:001	OMS: OMS: Stop function	- (Read only)	U8		-	
0x28A9:002	OMS: OMS: Movement function	- (Read only)	U8		-	
0x28A9:003	OMS: OMS: Function at Low Level	- (Read only)	U8		-	
0x28AA	OMS active: Output	- (Read only)	U8		-	
0x28AB	RMS: Source	- (Read only)	U8		-	
0x28AC:001	RMS: RMS: Stop function	- (Read only)	U8		-	
0x28AD	RMS active: Output	- (Read only)	U8		-	
0x28AE	ES: Source	- (Read only)	U8		-	
0x28AF	ES active: Output	- (Read only)	U8		-	
0x28B0:001	SMS: Maximum Speed Nmax	x rpm (Read only)	U16	1	-	
0x28B0:002	SMS: Reaction (n>Nmax)	- (Read only)	U8		-	
0x28B1	SMS observed: Output	- (Read only)	U8		-	
0x28B2:001	SSM parameters: SSM: Observed speed	x rpm (Read only)	U16	1	-	
0x28B3	SSM within limits	- (Read only)	U8		-	
0x28B8:001	SDI: Source SD-In: SDIpos: Source SD-In	- (Read only)	U8		-	
0x28B8:002	SDI: Source SD-In: SDIneg: Source SD-In	- (Read only)	U8		-	
0x28B9:001	SDI: Source S-Bus: SDIpos: Source S-Bus	- (Read only)	U8		-	
0x28B9:002	SDI: Source S-Bus: SDIneg: Source S-Bus	- (Read only)	U8		-	
0x28BA:001	SDI: Monitoring normal operation	- (Read only)	U8		-	
0x28BA:002	SDI: Delay time	x ms (Read only)	U16	1	-	
0x28BA:003	SDI: Tolerance threshold	x incr. (Read only)	I32	1	-	

Appendix

Parameter attribute list



Address	Name	Default setting	Data type	Factor	A	M
0x28BA:004	SDI: Error reaction	- (Read only)	U8		-	
0x28BA:005	SDI: SDI: Maximal change of Position	x incr. (Read only)	I32	1	X	
0x28BB:001	SDI observed: Output: SDIpos observed: Output	- (Read only)	U8		-	
0x28BB:002	SDI observed: Output: SDIneg observed: Output	- (Read only)	U8		-	
0x28BF:001	SLS: Internal source: SLS1: Internal source	- (Read only)	U32		-	
0x28BF:002	SLS: Internal source: SLS1: Internal source inversion	- (Read only)	U8		-	
0x28BF:003	SLS: Internal source: SLS2: Internal source	- (Read only)	U32		-	
0x28BF:004	SLS: Internal source: SLS2: Internal source inversion	- (Read only)	U8		-	
0x28BF:005	SLS: Internal source: SLS3: Internal source	- (Read only)	U32		-	
0x28BF:006	SLS: Internal source: SLS3: Internal source inversion	- (Read only)	U8		-	
0x28BF:007	SLS: Internal source: SLS4: Internal source	- (Read only)	U32		-	
0x28BF:008	SLS: Internal source: SLS4: Internal source inversion	- (Read only)	U8		-	
0x28C0:001	SLS: Source SD-In: SLS1: Source SD-In	- (Read only)	U8		-	
0x28C0:002	SLS: Source SD-In: SLS2: Source SD-In	- (Read only)	U8		-	
0x28C0:003	SLS: Source SD-In: SLS3: Source SD-In	- (Read only)	U8		-	
0x28C0:004	SLS: Source SD-In: SLS4: Source SD-In	- (Read only)	U8		-	
0x28C1:001	SLS: Source S-Bus: SLS1: Source S-Bus	- (Read only)	U8		-	
0x28C1:002	SLS: Source S-Bus: SLS2: Source S-Bus	- (Read only)	U8		-	
0x28C1:003	SLS: Source S-Bus: SLS3: Source S-Bus	- (Read only)	U8		-	
0x28C1:004	SLS: Source S-Bus: SLS4: Source S-Bus	- (Read only)	U8		-	
0x28C2:001	SLS: Limited Speed Nlim: SLS1: Limited Speed Nlim1	x rpm (Read only)	U16	1	-	
0x28C2:002	SLS: Limited Speed Nlim: SLS2: Limited Speed Nlim2	x rpm (Read only)	U16	1	-	
0x28C2:003	SLS: Limited Speed Nlim: SLS3: Limited Speed Nlim3	x rpm (Read only)	U16	1	-	
0x28C2:004	SLS: Limited Speed Nlim: SLS4: Limited Speed Nlim4	x rpm (Read only)	U16	1	-	
0x28C3:001	SLS: Braking time Nlim: SLS1: Braking time Nlim1	x ms (Read only)	U16	1	-	
0x28C3:002	SLS: Braking time Nlim: SLS2: Braking time Nlim2	x ms (Read only)	U16	1	-	
0x28C3:003	SLS: Braking time Nlim: SLS3: Braking time Nlim3	x ms (Read only)	U16	1	-	
0x28C3:004	SLS: Braking time Nlim: SLS4: Braking time Nlim4	x ms (Read only)	U16	1	-	
0x28C4:001	SLS: Permitted direction: SLS1: Permitted direction	- (Read only)	U8		-	
0x28C4:002	SLS: Permitted direction: SLS2: Permitted direction	- (Read only)	U8		-	
0x28C4:003	SLS: Permitted direction: SLS3: Permitted direction	- (Read only)	U8		-	
0x28C4:004	SLS: Permitted direction: SLS4: Permitted direction	- (Read only)	U8		-	
0x28C5:001	SLS: Reaction (n>Nlim): SLS1: Reaction (n>Nlim1)	- (Read only)	U8		-	
0x28C5:002	SLS: Reaction (n>Nlim): SLS2: Reaction (n>Nlim2)	- (Read only)	U8		-	
0x28C5:003	SLS: Reaction (n>Nlim): SLS3: Reaction (n>Nlim3)	- (Read only)	U8		-	
0x28C5:004	SLS: Reaction (n>Nlim): SLS4: Reaction (n>Nlim4)	- (Read only)	U8		-	
0x28C6:001	SLS active: Output: SLS1 active: Output	- (Read only)	U8		-	
0x28C6:002	SLS active: Output: SLS2 active: Output	- (Read only)	U8		-	
0x28C6:003	SLS active: Output: SLS3 active: Output	- (Read only)	U8		-	
0x28C6:004	SLS active: Output: SLS4 active: Output	- (Read only)	U8		-	
0x28C7:001	SLS observed: Output: SLS1 observed: Output	- (Read only)	U8		-	
0x28C7:002	SLS observed: Output: SLS2 observed: Output	- (Read only)	U8		-	
0x28C7:003	SLS observed: Output: SLS3 observed: Output	- (Read only)	U8		-	
0x28C7:004	SLS observed: Output: SLS4 observed: Output	- (Read only)	U8		-	
0x28C8	SLI: Source SD-In	- (Read only)	U8		-	
0x28C9	SLI: Source S-Bus	- (Read only)	U8		-	
0x28CA:001	SLI: SLI: Increment size normal operation	x incr. (Read only)	I32	1	-	
0x28CA:002	SLI: SLI: Error reaction normal operation	- (Read only)	U8		-	
0x28CA:003	SLI: SLI: Increment size exceptional operation	x incr. (Read only)	I32	1	-	
0x28CA:004	SLI: SLI: Maximum change of Position	x incr. (Read only)	I32	1	X	
0x28CB	SLI active: Output	- (Read only)	U8		-	
0x28D0:001	SLP: Source SD-In: SLP1: Source SD-In	- (Read only)	U8		-	
0x28D0:002	SLP: Source SD-In: SLP2: Source SD-In	- (Read only)	U8		-	
0x28D0:003	SLP: Source SD-In: SLP3: Source SD-In	- (Read only)	U8		-	
0x28D0:004	SLP: Source SD-In: SLP4: Source SD-In	- (Read only)	U8		-	



Appendix

Parameter attribute list

Address	Name	Default setting	Data type	Factor	A	M
0x28D1:001	SLP: Source S-Bus: SLP1: Source S-Bus	- (Read only)	U8		-	
0x28D1:002	SLP: Source S-Bus: SLP2: Source S-Bus	- (Read only)	U8		-	
0x28D1:003	SLP: Source S-Bus: SLP3: Source S-Bus	- (Read only)	U8		-	
0x28D1:004	SLP: Source S-Bus: SLP4: Source S-Bus	- (Read only)	U8		-	
0x28D2:001	SLP: Lower Postion limit: SLP1: Lower Postion limit	x incr. (Read only)	I32	1	-	
0x28D2:002	SLP: Lower Postion limit: SLP2: Lower Postion limit	x incr. (Read only)	I32	1	-	
0x28D2:003	SLP: Lower Postion limit: SLP3: Lower Postion limit	x incr. (Read only)	I32	1	-	
0x28D2:004	SLP: Lower Postion limit: SLP4: Lower Postion limit	x incr. (Read only)	I32	1	-	
0x28D3:001	SLP: Upper Postion limit: SLP1: Upper Postion limit	x incr. (Read only)	I32	1	-	
0x28D3:002	SLP: Upper Postion limit: SLP2: Upper Postion limit	x incr. (Read only)	I32	1	-	
0x28D3:003	SLP: Upper Postion limit: SLP3: Upper Postion limit	x incr. (Read only)	I32	1	-	
0x28D3:004	SLP: Upper Postion limit: SLP4: Upper Postion limit	x incr. (Read only)	I32	1	-	
0x28D4:001	SLP: Error reaction: SLP1: Error reaction	- (Read only)	U8		-	
0x28D4:002	SLP: Error reaction: SLP2: Error reaction	- (Read only)	U8		-	
0x28D4:003	SLP: Error reaction: SLP3: Error reaction	- (Read only)	U8		-	
0x28D4:004	SLP: Error reaction: SLP4: Error reaction	- (Read only)	U8		-	
0x28D5:001	SLP observed: Output: SLP1 observed: Output	- (Read only)	U8		-	
0x28D5:002	SLP observed: Output: SLP2 observed: Output	- (Read only)	U8		-	
0x28D5:003	SLP observed: Output: SLP3 observed: Output	- (Read only)	U8		-	
0x28D5:004	SLP observed: Output: SLP4 observed: Output	- (Read only)	U8		-	
0x28D8:001	SCA: Lower Postion limit: SCA1: Lower Postion limit	x incr. (Read only)	I32	1	-	
0x28D8:002	SCA: Lower Postion limit: SCA2: Lower Postion limit	x incr. (Read only)	I32	1	-	
0x28D8:003	SCA: Lower Postion limit: SCA3: Lower Postion limit	x incr. (Read only)	I32	1	-	
0x28D8:004	SCA: Lower Postion limit: SCA4: Lower Postion limit	x incr. (Read only)	I32	1	-	
0x28D9:001	SCA: Upper Postion limit: SCA1: Upper Postion limit	x incr. (Read only)	I32	1	-	
0x28D9:002	SCA: Upper Postion limit: SCA2: Upper Postion limit	x incr. (Read only)	I32	1	-	
0x28D9:003	SCA: Upper Postion limit: SCA3: Upper Postion limit	x incr. (Read only)	I32	1	-	
0x28D9:004	SCA: Upper Postion limit: SCA4: Upper Postion limit	x incr. (Read only)	I32	1	-	
0x28DA:001	SCA inbetween limits: Output: SCA1 inbetween limits: Output	- (Read only)	U8		-	
0x28DA:002	SCA inbetween limits: Output: SCA2 inbetween limits: Output	- (Read only)	U8		-	
0x28DA:003	SCA inbetween limits: Output: SCA3 inbetween limits: Output	- (Read only)	U8		-	
0x28DA:004	SCA inbetween limits: Output: SCA4 inbetween limits: Output	- (Read only)	U8		-	
0x28DC	PDSS: Source SD-In	- (Read only)	U8		-	
0x28DD	PDSS: Source S bus	- (Read only)	U8		-	
0x28DE:001	PDSS parameters: PDSS: Permanent activation	- (Read only)	U8		-	
0x28DE:002	PDSS parameters: PDSS: Lower position limit	x incr. (Read only)	I32	1	-	
0x28DE:003	PDSS parameters: PDSS: Upper position limit	x incr. (Read only)	I32	1	-	
0x28DE:004	PDSS parameters: PDSS: Lower SCS limit	x incr. (Read only)	I32	1	-	
0x28DE:005	PDSS parameters: PDSS: Upper SCS limit	x incr. (Read only)	I32	1	-	
0x28DE:006	PDSS parameters: PDSS: SCS from lower limit	x rpm (Read only)	U16	1	-	
0x28DE:007	PDSS parameters: PDSS: SCS from upper limit	x rpm (Read only)	U16	1	-	
0x28DE:008	PDSS parameters: PDSS: Max. speed	x rpm (Read only)	U16	1	-	
0x28DE:009	PDSS parameters: PDSS: Max. delay - lower limit	- (Read only)	U16	1	-	
0x28DE:010	PDSS parameters: PDSS: Max. delay - upper limit	- (Read only)	U16	1	-	
0x28DE:011	PDSS parameters: PDSS: Error response	- (Read only)	U8		-	
0x28DE:012	PDSS parameters: PDSS: Currently observed speed	x rpm (Read only)	U16	1	X	
0x28DE:013	PDSS parameters: PDSS: Min difference observed speed	x rpm (Read only)	I16	1	X	
0x28DF	PDSS: PDSSpos observed output	- (Read only)	U8		-	
0x28E0	PDSS: PDSSneg observed output	- (Read only)	U8		-	
0x28E4	SBC: Source SD-In	- (Read only)	U8		-	
0x28E5	SBC: Source S-Bus	- (Read only)	U8		-	

Appendix

Parameter attribute list



Address	Name	Default setting	Data type	Factor	A	M
0x28E6:001	SBC settings: Brake mode	- (Read only)	U8		-	
0x28E6:002	SBC settings: SBC delay	x ms (Read only)	U16	1	-	
0x28E6:003	SBC settings: STO delay	x ms (Read only)	U16	1	-	
0x28E6:004	SBC settings: Brake open delay	x ms (Read only)	U16	1	-	
0x28E7:001	SBC status outputs: "SBC active" output	- (Read only)	U8		-	
0x28E7:002	SBC status outputs: "SBC activated" output	- (Read only)	U8		-	
0x28E8:001	Diagnostic values configuration: Diagnostic value 1 configuration	PDSS [1]	U16		X	
0x28E8:002	Diagnostic values configuration: Diagnostic value 2 configuration	SS1, SS2 [2]	U16		X	
0x28E9:001	Diagnostic values: Diagnostic value 1	- (Read only)	I16	1	X	●
0x28E9:002	Diagnostic values: Diagnostic value 2	- (Read only)	I16	1	X	●
0x2900:001	Speed controller settings: Gain	0.00033 Nm/rpm	U32	100000	-	
0x2900:002	Speed controller settings: Reset time	17.6 ms	U16	10	-	
0x2900:003	Speed controller settings: Rate time	0.00 ms	U16	100	-	
0x2901	Speed controller gain adaption	100.00 %	U16	100	-	●
0x2902	I component load value	0.0 %	I16	10	-	●
0x2903	Speed setpoint filter time	0.0 ms	U16	10	-	
0x2904	Actual speed filter time	0.3 ms	U16	10	-	
0x2907:001	Additional speed limitation	0 rpm	U32	1	X	●
0x2910:001	Inertia settings: Motor moment of inertia	0.14 kg cm²	U32	100	-	
0x2910:002	Inertia settings: Load moment of inertia	0.00 kg cm²	U32	100	-	
0x2910:003	Inertia settings: Coupling	Stiff [0]	U8		-	
0x2910:004	Inertia settings: Mechanical natural frequency	0.0 Hz	U16	10	-	
0x2910:005	Inertia settings: Load moment of inertia (elastic coupled)	0.00 kg cm²	U32	100	-	
0x2939	Switching frequency	4 kHz variable / drive-optimised [1]	U8		-	
0x2941	Current controller feedforward control	Disable [0]	U8		-	
0x2942:001	Current controller parameters: Gain	148.21 V/A	U32	100	-	
0x2942:002	Current controller parameters: Reset time	3.77 ms	U32	100	-	
0x2943	Current setpoint filter time	0.00 ms	U16	100	-	
0x2944:001	Torque setpoint notch filter: Frequency notch filter 1	200.0 Hz	U16	10	-	
0x2944:002	Torque setpoint notch filter: Bandwidth notch filter 1	20.0 Hz	U16	10	-	
0x2944:003	Torque setpoint notch filter: Damping notch filter 1	0 dB	U8	1	-	
0x2944:004	Torque setpoint notch filter: Frequency notch filter 2	400.0 Hz	U16	10	-	
0x2944:005	Torque setpoint notch filter: Bandwidth notch filter 2	40.0 Hz	U16	10	-	
0x2944:006	Torque setpoint notch filter: Damping notch filter 2	0 dB	U8	1	-	
0x2945	Torque setpoint jerk limitation	400.0 %	U16	10	-	
0x2946:001	Speed limitation: Upper speed limit	0 rpm	I32	480000 / 2 ³¹	-	●
0x2946:002	Speed limitation: Lower speed limit	0 rpm	I32	480000 / 2 ³¹	-	●
0x2947:001	Inverter characteristic: Value y1	0.00 V	U16	100	-	
0x2947:002	Inverter characteristic: Value y2	0.00 V	U16	100	-	
0x2947:003	Inverter characteristic: Value y3	0.00 V	U16	100	-	
0x2947:004	Inverter characteristic: Value y4	0.00 V	U16	100	-	
0x2947:005	Inverter characteristic: Value y5	0.00 V	U16	100	-	
0x2947:006	Inverter characteristic: Value y6	0.00 V	U16	100	-	
0x2947:007	Inverter characteristic: Value y7	0.00 V	U16	100	-	
0x2947:008	Inverter characteristic: Value y8	0.00 V	U16	100	-	
0x2947:009	Inverter characteristic: Value y9	0.00 V	U16	100	-	
0x2947:010	Inverter characteristic: Value y10	0.00 V	U16	100	-	
0x2947:011	Inverter characteristic: Value y11	0.00 V	U16	100	-	
0x2947:012	Inverter characteristic: Value y12	0.00 V	U16	100	-	



Appendix

Parameter attribute list

Address	Name	Default setting	Data type	Factor	A	M
0x2947:013	Inverter characteristic: Value y13	0.00 V	U16	100	-	
0x2947:014	Inverter characteristic: Value y14	0.00 V	U16	100	-	
0x2947:015	Inverter characteristic: Value y15	0.00 V	U16	100	-	
0x2947:016	Inverter characteristic: Value y16	0.00 V	U16	100	-	
0x2947:017	Inverter characteristic: Value y17	0.00 V	U16	100	-	
0x294A:001	Torque limits offset: Torque offset	0.0 %	I16	10	-	
0x294A:002	Torque limits offset: Resulting positive torque limit	x.x % (Read only)	I16	10	X	
0x294A:003	Torque limits offset: Resulting negative torque limit	x.x % (Read only)	I16	10	X	
0x2980	Position controller gain	28.40 Hz	U32	100	-	
0x2981	Position controller gain adaption	100.00 %	U16	100	-	●
0x2982	Position controller output signal limitation	480000.00 rpm	U32	480000 /2 ³¹	-	●
0x2983	Actual position start value	0 pos. unit	I32	1	-	●
0x2984	Mode for setting the actual position	Absolute [0]	U8		-	
0x2986	Resulting gain adaption	x.xx % (Read only)	U32	100	X	
0x29C0:001	Field controller settings: Gain	165.84 A/Vs	U32	100	-	
0x29C0:002	Field controller settings: Reset time	15.1 ms	U16	10	-	
0x29E0:001	Field weakening controller settings: Gain (ASM)	0.000 Vs/V	U32	1000	-	
0x29E0:002	Field weakening controller settings: Reset time (ASM)	2000.0 ms	U32	10	-	
0x29E1	Field weakening controller Field limitation	100.00 %	U16	100	-	●
0x29E2	DC-bus filter time	25.0 ms	U16	10	-	
0x29E3	Motor voltage filter time	25.0 ms	U16	10	-	
0x29E4	Voltage reserve range	5 %	U8	1	-	
0x2B00	V/f characteristic shape	Linear [0]	U8		C	
0x2B01:001	V/f shape data: Base voltage	225 V	U16	1	-	
0x2B01:002	V/f shape data: Base frequency	270 Hz	U16	1	-	
0x2B02:001	Frequency grid points (x) user V/f characteristic: x1 = f01	-50 Hz	I16	1	-	
0x2B02:002	Frequency grid points (x) user V/f characteristic: x2 = f02	-40 Hz	I16	1	-	
0x2B02:003	Frequency grid points (x) user V/f characteristic: x3 = f03	-30 Hz	I16	1	-	
0x2B02:004	Frequency grid points (x) user V/f characteristic: x4 = f04	-20 Hz	I16	1	-	
0x2B02:005	Frequency grid points (x) user V/f characteristic: x5 = f05	-10 Hz	I16	1	-	
0x2B02:006	Frequency grid points (x) user V/f characteristic: x6 = f06	0 Hz	I16	1	-	
0x2B02:007	Frequency grid points (x) user V/f characteristic: x7 = f07	10 Hz	I16	1	-	
0x2B02:008	Frequency grid points (x) user V/f characteristic: x8 = f08	20 Hz	I16	1	-	
0x2B02:009	Frequency grid points (x) user V/f characteristic: x9 = f09	30 Hz	I16	1	-	
0x2B02:010	Frequency grid points (x) user V/f characteristic: x10 = f10	40 Hz	I16	1	-	
0x2B02:011	Frequency grid points (x) user V/f characteristic: x11 = f11	50 Hz	I16	1	-	
0x2B03:001	Voltage grid points (y) user V/f characteristic: y1 = U01 (x = f01)	400.00 V	U32	100	-	
0x2B03:002	Voltage grid points (y) user V/f characteristic: y2 = U02 (x = f02)	320.00 V	U32	100	-	
0x2B03:003	Voltage grid points (y) user V/f characteristic: y3 = U03 (x = f03)	240.00 V	U32	100	-	
0x2B03:004	Voltage grid points (y) user V/f characteristic: y4 = U04 (x = f04)	160.00 V	U32	100	-	

Appendix

Parameter attribute list



Address	Name	Default setting	Data type	Factor	A	M
0x2B03:005	Voltage grid points (y) user V/f characteristic: y5 = U05 (x = f05)	80.00 V	U32	100	-	
0x2B03:006	Voltage grid points (y) user V/f characteristic: y6 = U06 (x = f06)	0.00 V	U32	100	-	
0x2B03:007	Voltage grid points (y) user V/f characteristic: y7 = U07 (x = f07)	80.00 V	U32	100	-	
0x2B03:008	Voltage grid points (y) user V/f characteristic: y8 = U08 (x = f08)	160.00 V	U32	100	-	
0x2B03:009	Voltage grid points (y) user V/f characteristic: y9 = U09 (x = f09)	240.00 V	U32	100	-	
0x2B03:010	Voltage grid points (y) user V/f characteristic: y10 = U10 (x = f10)	320.00 V	U32	100	-	
0x2B03:011	Voltage grid points (y) user V/f characteristic: y11 = U11 (x = f11)	400.00 V	U32	100	-	
0x2B04	V/f boost controller - current setpoint	0.00 A	U32	100	-	
0x2B05:001	V/f boost controller settings: Gain	148.21 V/A	U32	100	-	
0x2B05:002	V/f boost controller settings: Reset time	3.77 ms	U32	100	-	
0x2B06	Voltage boost	0.0 V	U16	10	-	
0x2B07:001	Load adaption: Direction of rotation	Passive load [0]	U8			C
0x2B07:002	Load adaption: Load adaption value	20.00 %	U32	100	-	
0x2B08:001	V/f I _{max} controller: Gain	0.001 Hz/A	U32	1000	-	
0x2B08:002	V/f I _{max} controller: Reset time	100.0 ms	U32	10	-	
0x2B09:001	Slip compensation: Gain	0.00 %	I16	100	-	
0x2B09:002	Slip compensation: Filter time	2000 ms	U16	1	-	
0x2B0A:001	Oscillation damping: Gain	20 %	I16	1	-	
0x2B0A:002	Oscillation damping: Filter time	5 ms	U16	1	-	
0x2B0A:003	Oscillation damping: Limitation	0.2 Hz	U16	10	-	
0x2B0A:004	Oscillation damping: Final ramp frequency	0 %	U8	1	-	
0x2B0B	Frequency setpoint	x.x Hz (Read only)	I16	10	X	•
0x2B0C	Override field weakening	0.0 Hz	I16	10	-	
0x2B80	Current for DC-injection braking	0.00 A	U16	100	-	
0x2BA0	Activate flying restart	Off [0]	U8		-	
0x2BA1	Flying restart circuit	15 %	U16	1	-	
0x2BA2	Start frequency	20.0 Hz	I16	10	-	
0x2BA3	Integration time	600 ms	U16	1	-	
0x2BA4	Minimum deviation	5.00 °	U16	100	-	
0x2BA5	Delay time	0 ms	U16	1	-	
0x2BA6:001	Result: Determined speed [rpm]	x rpm (Read only)	I16	1	X	•
0x2BA6:002	Result: Determined speed [n unit]	rpm (Read only)	I32	480000 / 2 ³¹	X	•
0x2C00	Motor control mode	Servoregelung (SC-PSM) [1]	U8			C
0x2C01:001	Motor parameters: Number of pole pairs	- (Read only)	U8	1	X	
0x2C01:002	Motor parameters: Stator resistance	13.5000 Ω	U32	10000	-	
0x2C01:003	Motor parameters: Stator leakage inductance	51.0000 mH	U32	1000	-	
0x2C01:004	Motor parameters: Rated speed	4050 rpm	U16	1	-	
0x2C01:005	Motor parameters: Rated frequency	270.0 Hz	U16	10	-	
0x2C01:006	Motor parameters: Rated power	0.25 kW	U16	100	-	
0x2C01:007	Motor parameters: Rated voltage	225 V	U16	1	-	
0x2C01:008	Motor parameters: Cosine phi	0.80	U16	100	-	
0x2C01:009	Motor parameters: Insulation class	F (cut-off temperature = 155 °C) [4]	U8		-	
0x2C01:010	Motor parameters: Motor name	"MCS06C41"	STRING[50]		-	
0x2C02:001	Motor parameter (ASM): Rotor resistance	0.0000 Ω	U32	10000	-	
0x2C02:002	Motor parameter (ASM): Mutual inductance	0.0 mH	U32	10	-	
0x2C02:003	Motor parameter (ASM): Magnetising current	0.00 A	U16	100	-	
0x2C03:001	Motor parameter (PSM): Back EMF constant	41.8 V/1000rpm	U32	10	-	
0x2C03:002	Motor parameter (PSM): Resolver pole position	-90.0 °	I16	10	-	



Appendix

Parameter attribute list

Address	Name	Default setting	Data type	Factor	A	M
0x2C03:003	Motor parameter (PSM): Magnets temperature coefficient (kTN)	-0.110 %/°C	I16	1000	-	
0x2C03:004	Motor parameter (PSM): Encoder pole position	0.0 °	I16	10	-	
0x2C04:001	Inductance grid points (y) Lss saturation characteristic: y1 = L01 (x = 0.00 %)	165 %	U16	1	-	
0x2C04:002	Inductance grid points (y) Lss saturation characteristic: y2 = L02 (x = 6.25 %)	200 %	U16	1	-	
0x2C04:003	Inductance grid points (y) Lss saturation characteristic: y3 = L03 (x = 12.50 %)	146 %	U16	1	-	
0x2C04:004	Inductance grid points (y) Lss saturation characteristic: y4 = L04 (x = 18.75 %)	117 %	U16	1	-	
0x2C04:005	Inductance grid points (y) Lss saturation characteristic: y5 = L05 (x = 25.00 %)	97 %	U16	1	-	
0x2C04:006	Inductance grid points (y) Lss saturation characteristic: y6 = L06 (x = 31.25 %)	82 %	U16	1	-	
0x2C04:007	Inductance grid points (y) Lss saturation characteristic: y7 = L07 (x = 37.50 %)	71 %	U16	1	-	
0x2C04:008	Inductance grid points (y) Lss saturation characteristic: y8 = L08 (x = 42.75 %)	62 %	U16	1	-	
0x2C04:009	Inductance grid points (y) Lss saturation characteristic: y9 = L09 (x = 50.00 %)	55 %	U16	1	-	
0x2C04:010	Inductance grid points (y) Lss saturation characteristic: y10 = L10 (x = 56.25 %)	50 %	U16	1	-	
0x2C04:011	Inductance grid points (y) Lss saturation characteristic: y11 = L11 (x = 62.50 %)	46 %	U16	1	-	
0x2C04:012	Inductance grid points (y) Lss saturation characteristic: y12 = L12 (x = 68.75 %)	43 %	U16	1	-	
0x2C04:013	Inductance grid points (y) Lss saturation characteristic: y13 = L13 (x = 75.00 %)	42 %	U16	1	-	
0x2C04:014	Inductance grid points (y) Lss saturation characteristic: y14 = L14 (x = 81.25 %)	41 %	U16	1	-	
0x2C04:015	Inductance grid points (y) Lss saturation characteristic: y15 = L15 (x = 87.50 %)	41 %	U16	1	-	
0x2C04:016	Inductance grid points (y) Lss saturation characteristic: y16 = L16 (x = 93.25 %)	41 %	U16	1	-	
0x2C04:017	Inductance grid points (y) Lss saturation characteristic: y17 = L17 (x = 100.00 %)	41 %	U16	1	-	
0x2C04:018	Inductance grid points (y) Lss saturation characteristic: Activation Lss saturation characteristic	Adjustment on [1]	U16		-	
0x2C05	Reference for current grid points (x) Lss saturation characteristic	5.4 A	U16	10	-	
0x2C06:001	Grid points for magnet characteristic (current): x1 = i01/iN	0 %	U16	1	-	
0x2C06:002	Grid points for magnet characteristic (current): y1 = kT01/kTN	100 %	U16	1	-	
0x2C06:003	Grid points for magnet characteristic (current): x2 = i02/iN	100 %	U16	1	-	
0x2C06:004	Grid points for magnet characteristic (current): y2 = kT02/kTN	100 %	U16	1	-	
0x2C06:005	Grid points for magnet characteristic (current): x3 = i03/iN	200 %	U16	1	-	
0x2C06:006	Grid points for magnet characteristic (current): y3 = kT03/kTN	100 %	U16	1	-	
0x2C06:007	Grid points for magnet characteristic (current): x4 = i04/iN	415 %	U16	1	-	
0x2C06:008	Grid points for magnet characteristic (current): y4 = kT04/kTN	72 %	U16	1	-	
0x2C07:001	Inductance grid points (y) Lh saturation characteristic: y1 = L01 (x = 0.00 %)	118 %	U16	1	-	

Appendix

Parameter attribute list



Address	Name	Default setting	Data type	Factor	A	M
0x2C07:002	Inductance grid points (y) Lh saturation characteristic: y2 = L02 (x = 6.25 %)	118 %	U16	1	-	
0x2C07:003	Inductance grid points (y) Lh saturation characteristic: y3 = L03 (x = 12.50 %)	118 %	U16	1	-	
0x2C07:004	Inductance grid points (y) Lh saturation characteristic: y4 = L04 (x = 18.75 %)	117 %	U16	1	-	
0x2C07:005	Inductance grid points (y) Lh saturation characteristic: y5 = L05 (x = 25.00 %)	116 %	U16	1	-	
0x2C07:006	Inductance grid points (y) Lh saturation characteristic: y6 = L06 (x = 31.25 %)	114 %	U16	1	-	
0x2C07:007	Inductance grid points (y) Lh saturation characteristic: y7 = L07 (x = 37.50 %)	111 %	U16	1	-	
0x2C07:008	Inductance grid points (y) Lh saturation characteristic: y8 = L08 (x = 43.75 %)	107 %	U16	1	-	
0x2C07:009	Inductance grid points (y) Lh saturation characteristic: y9 = L09 (x = 50.00 %)	100 %	U16	1	-	
0x2C07:010	Inductance grid points (y) Lh saturation characteristic: y10 = L10 (x = 56.25 %)	93 %	U16	1	-	
0x2C07:011	Inductance grid points (y) Lh saturation characteristic: y11 = L11 (x = 62.50 %)	86 %	U16	1	-	
0x2C07:012	Inductance grid points (y) Lh saturation characteristic: y12 = L12 (x = 68.75 %)	78 %	U16	1	-	
0x2C07:013	Inductance grid points (y) Lh saturation characteristic: y13 = L13 (x = 75.00 %)	71 %	U16	1	-	
0x2C07:014	Inductance grid points (y) Lh saturation characteristic: y14 = L14 (x = 81.25 %)	64 %	U16	1	-	
0x2C07:015	Inductance grid points (y) Lh saturation characteristic: y15 = L15 (x = 87.50 %)	57 %	U16	1	-	
0x2C07:016	Inductance grid points (y) Lh saturation characteristic: y16 = L16 (x = 93.75 %)	50 %	U16	1	-	
0x2C07:017	Inductance grid points (y) Lh saturation characteristic: y17 = L17 (x = 100.00 %)	42 %	U16	1	-	
0x2C08	Method for setting motor parameters	Select from catalogue (Lenze motors) [1]	U8		-	
0x2C40	Motor encoder type	SinCos encoder [1]	U8		C	
0x2C41:001	Motor encoder settings (Hiperface): Type code detected	- (Read only)	U8	1	X	
0x2C41:002	Motor encoder settings (Hiperface): Type code manual input	0	U8	1	C	
0x2C41:003	Motor encoder settings (Hiperface): No. of periods manual input	1	U16	1	C	
0x2C41:004	Motor encoder settings (Hiperface): Error response	Fault > CiA402 [1]	U8		-	
0x2C41:005	Motor encoder settings (Hiperface): Serial number	- (Read only)	STRING[50]		X	
0x2C41:006	Motor encoder settings (Hiperface): Actual position (raw data)	- (Read only)	U32	1	X	●
0x2C41:007	Motor encoder settings (Hiperface): No. of periods detected	- (Read only)	U16	1	X	●
0x2C41:008	Motor encoder settings (Hiperface): Type code verification	- (Read only)	U8		X	●
0x2C41:009	Motor encoder settings (Hiperface): Encoder type	- (Read only)	U8		X	●
0x2C41:010	Motor encoder settings (Hiperface): No. of periods linear encoder	x nm (Read only)	U32	1	X	●
0x2C42:001	Encoder settings: Increments/revolution	1024	U32	1	C	
0x2C42:002	Encoder settings: Supply voltage	5.0 V	U8	10	C	
0x2C42:003	Encoder settings: Angle drift	x.x ° (Read only)	I16	10	X	●
0x2C42:004	Encoder settings: Actual amplitude signal quality	x % (Read only)	U8	1	X	
0x2C43	Motor encoder resolver number of pole pairs	1	U8	1	C	
0x2C44:001	Motor encoder identification (Resolver): Angle	0	I16	1	-	
0x2C44:002	Motor encoder identification (Resolver): Cosine track gain	100 %	U16	1	-	



Appendix

Parameter attribute list

Address	Name	Default setting	Data type	Factor	A	M
0x2C44:003	Motor encoder identification (Resolver): Sine track gain	100 %	U16	1	-	
0x2C44:006	Motor encoder identification (Resolver): Identification status	- (Read only)	U16		HX	
0x2C45	Encoder error response	Fault > CiA402 [1]	U8		-	
0x2C46	Number of the absolute ascertainable revolutions of motor encoder	- (Read only)	U16	1	X	
0x2C47	Open circuit detection sensitivity of motor encoder	100 %	U8	1	-	
0x2C4A:001	Protokoll-Parameter Motorgeber (SSI): Übertragungsrate	300 kbps	U16	1	C	
0x2C4A:002	Protokoll-Parameter Motorgeber (SSI): Telegrammlänge	25	U8	1	C	
0x2C4A:003	Protokoll-Parameter Motorgeber (SSI): Bits/ Umdrehung	13	U8	1	C	
0x2C4A:004	Protokoll-Parameter Motorgeber (SSI): Startbit Positionsdaten	0	U8	1	C	
0x2C4A:005	Protokoll-Parameter Motorgeber (SSI): Startbit Datenpaket 1	0	U8	1	C	
0x2C4A:006	Protokoll-Parameter Motorgeber (SSI): Startbit Datenpaket 2	0	U8	1	C	
0x2C4A:007	Protokoll-Parameter Motorgeber (SSI): Startbit Datenpaket 3	0	U8	1	C	
0x2C4A:008	Protokoll-Parameter Motorgeber (SSI): Länge Positionsdaten	0	U8	1	C	
0x2C4A:009	Protokoll-Parameter Motorgeber (SSI): Länge Datenpaket 1	0	U8	1	C	
0x2C4A:010	Protokoll-Parameter Motorgeber (SSI): Länge Datenpaket 2	0	U8	1	C	
0x2C4A:011	Protokoll-Parameter Motorgeber (SSI): Länge Datenpaket 3	0	U8	1	C	
0x2C4A:012	Protokoll-Parameter Motorgeber (SSI): Codierung Positionsdaten	Binär [0]	U8		C	
0x2C4A:013	Protokoll-Parameter Motorgeber (SSI): Codierung Datenpaket 1	Binär [0]	U8		C	
0x2C4A:014	Protokoll-Parameter Motorgeber (SSI): Codierung Datenpaket 2	Binär [0]	U8		C	
0x2C4A:015	Protokoll-Parameter Motorgeber (SSI): Codierung Datenpaket 3	Binär [0]	U8		C	
0x2C4A:016	Protokoll-Parameter Motorgeber (SSI): Rohdaten Position	- (Read only)	U32	1	X	•
0x2C4A:017	Protokoll-Parameter Motorgeber (SSI): Rohdaten Datenpaket 1	- (Read only)	U32	1	X	•
0x2C4A:018	Protokoll-Parameter Motorgeber (SSI): Rohdaten Datenpaket 2	- (Read only)	U32	1	X	•
0x2C4A:019	Protokoll-Parameter Motorgeber (SSI): Rohdaten Datenpaket 3	- (Read only)	U32	1	X	•
0x2C4F	Parameter CRC of motor encoder	- (Read only)	U32	1	X	
0x2C50	Load encoder/master encoder type	SinCos encoder [1]	U8		C	
0x2C51:001	Hiperface load encoder/master encoder settings: Type code detected	- (Read only)	U8	1	X	
0x2C51:002	Hiperface load encoder/master encoder settings: Type code manual input	0	U8	1	C	
0x2C51:003	Hiperface load encoder/master encoder settings: No. of periods manual input	1	U16	1	C	
0x2C51:004	Hiperface load encoder/master encoder settings: Error response	Fault > CiA402 [1]	U8		-	
0x2C51:005	Hiperface load encoder/master encoder settings: Serial number	- (Read only)	STRING[50]		X	
0x2C51:006	Hiperface load encoder/master encoder settings: Actual position (raw data)	- (Read only)	U32	1	X	•

Appendix

Parameter attribute list



Address	Name	Default setting	Data type	Factor	A	M
0x2C51:007	Hiperface load encoder/master encoder settings: No. of periods detected	- (Read only)	U16	1	X	●
0x2C51:008	Hiperface load encoder/master encoder settings: Type code verification	- (Read only)	U8		X	●
0x2C51:009	Hiperface load encoder/master encoder settings: Encoder type	- (Read only)	U8		X	●
0x2C51:010	Hiperface load encoder/master encoder settings: No. of periods linear encoder	x nm (Read only)	U32	1	X	●
0x2C52:001	Load encoder/master encoder settings (encoder): Increments/revolution	1024	U32	1	C	
0x2C52:002	Load encoder/master encoder settings (encoder): Supply voltage	5.0 V	U8	10	C	
0x2C52:003	Load encoder/master encoder settings (encoder): Angle drift	x.x ° (Read only)	I16	10	X	●
0x2C52:004	Load encoder/master encoder settings (encoder): Actual amplitude signal quality	x % (Read only)	U8	1	X	
0x2C53	Load encoder/master encoder resolver number of pole pairs	1	U8	1	C	
0x2C54:001	Load encoder/master encoder identification (Resolver): Angle	0	I16	1	-	
0x2C54:002	Load encoder/master encoder identification (Resolver): Cosine track gain	100 %	U16	1	-	
0x2C54:003	Load encoder/master encoder identification (Resolver): Sine track gain	100 %	U16	1	-	
0x2C54:006	Load encoder/master encoder identification (Resolver): Identification status	- (Read only)	U16		HX	
0x2C55	Load encoder/master encoder error response	Fault > CiA402 [1]	U8		-	
0x2C56	Number of the absolute ascertainable revolutions of load encoder/master encoder	- (Read only)	U16	1	X	
0x2C57	Open circuit detection sensitivity of load encoder/master encoder	100 %	U8	1	-	
0x2C5A:001	Protokoll-Parameter Lastgeber/Leitgeber (SSI): Übertragungsrate	300 kbps	U16	1	C	
0x2C5A:002	Protokoll-Parameter Lastgeber/Leitgeber (SSI): Telegrammlänge	25	U8	1	C	
0x2C5A:003	Protokoll-Parameter Lastgeber/Leitgeber (SSI): Bits/ Umdrehung	13	U8	1	C	
0x2C5A:004	Protokoll-Parameter Lastgeber/Leitgeber (SSI): Startbit Positionsdaten	0	U8	1	C	
0x2C5A:005	Protokoll-Parameter Lastgeber/Leitgeber (SSI): Startbit Datenpaket 1	0	U8	1	C	
0x2C5A:006	Protokoll-Parameter Lastgeber/Leitgeber (SSI): Startbit Datenpaket 2	0	U8	1	C	
0x2C5A:007	Protokoll-Parameter Lastgeber/Leitgeber (SSI): Startbit Datenpaket 3	0	U8	1	C	
0x2C5A:008	Protokoll-Parameter Lastgeber/Leitgeber (SSI): Länge Positionsdaten	25	U8	1	C	
0x2C5A:009	Protokoll-Parameter Lastgeber/Leitgeber (SSI): Länge Datenpaket 1	0	U8	1	C	
0x2C5A:010	Protokoll-Parameter Lastgeber/Leitgeber (SSI): Länge Datenpaket 2	0	U8	1	C	
0x2C5A:011	Protokoll-Parameter Lastgeber/Leitgeber (SSI): Länge Datenpaket 3	0	U8	1	C	
0x2C5A:012	Protokoll-Parameter Lastgeber/Leitgeber (SSI): Codierung Positionsdaten	Binär [0]	U8		C	
0x2C5A:013	Protokoll-Parameter Lastgeber/Leitgeber (SSI): Codierung Datenpaket 1	Binär [0]	U8		C	
0x2C5A:014	Protokoll-Parameter Lastgeber/Leitgeber (SSI): Codierung Datenpaket 2	Binär [0]	U8		C	



Appendix

Parameter attribute list

Address	Name	Default setting	Data type	Factor	A	M
0x2C5A:015	Protokoll-Parameter Lastgeber/Leitgeber (SSI): Codierung Datenpaket 3	Binär [0]	U8		C	
0x2C5A:016	Protokoll-Parameter Lastgeber/Leitgeber (SSI): Rohdaten Position	- (Read only)	U32	1	X	●
0x2C5A:017	Protokoll-Parameter Lastgeber/Leitgeber (SSI): Rohdaten Datenpaket 1	- (Read only)	U32	1	X	●
0x2C5A:018	Protokoll-Parameter Lastgeber/Leitgeber (SSI): Rohdaten Datenpaket 2	- (Read only)	U32	1	X	●
0x2C5A:019	Protokoll-Parameter Lastgeber/Leitgeber (SSI): Rohdaten Datenpaket 3	- (Read only)	U32	1	X	●
0x2C5F	Parameter CRC of load encoder/master encoder	- (Read only)	U32	1	X	
0x2C60	PPI monitoring: Reaction	Fault > CiA402 [1]	U8		-	
0x2C61:001	Pole position identification (360°) settings: Current amplitude	100 %	U16	1	C	
0x2C61:002	Pole position identification (360°) settings: Ramp time	40 s	U16	1	C	
0x2C61:003	Pole position identification (360°) settings: Direction of rotation	CW [0]	U8		C	
0x2C61:004	Pole position identification (360°) settings: Error tolerance	20 °	U8	1	-	
0x2C61:005	Pole position identification (360°) settings: Absolute current amplitude	x.xx A (Read only)	U32	100	X	
0x2C62:001	Pole position identification (min. movement) settings: Current amplitude	25 %	U16	1	C	
0x2C62:002	Pole position identification (min. movement) settings: Ramp time	10 s	U16	1	C	
0x2C62:003	Pole position identification (min. movement) settings: Gain	0 %	U16	1	-	
0x2C62:004	Pole position identification (min. movement) settings: Reset time	62.5 ms	U16	10	-	
0x2C62:005	Pole position identification (min. movement) settings: Max. move permitted	20 °	U8	1	-	
0x2C62:006	Pole position identification (min. movement) settings: Absolute current amplitude	x.xx A (Read only)	U32	100	X	
0x2C63:001	PPI without movement: Execution	Deactivated [0]	U8		C	
0x2C64:001	Cable Check: Behavior after switch on	No action [0]	U8		C	
0x2C64:002	Cable Check: Cable check: Status word	- (Read only)	U16		HX	
0x2D00:001	Touch probe (TP) delay time: Touch probe 1 delay time	0.000 ms	U16	1000	-	
0x2D00:002	Touch probe (TP) delay time: Touch probe 2 delay time	0.000 ms	U16	1000	-	
0x2D00:003	Touch probe (TP) delay time: Touch probe 3 delay time	0.000 ms	U16	1000	-	
0x2D00:004	Touch probe (TP) delay time: Touch probe 4 delay time	0.000 ms	U16	1000	-	
0x2D01:001	Touch probe (TP) time stamp: Touch probe 1-rising edge time stamp	x ns (Read only)	U32	1	X	●
0x2D01:002	Touch probe (TP) time stamp: Touch probe 1-falling edge time stamp	x ns (Read only)	U32	1	X	●
0x2D01:003	Touch probe (TP) time stamp: Touch probe 2-rising edge time stamp	x ns (Read only)	U32	1	X	●
0x2D01:004	Touch probe (TP) time stamp: Touch probe 2-falling edge time stamp	x ns (Read only)	U32	1	X	●
0x2D01:005	Touch probe (TP) time stamp: Touch probe 3-rising edge time stamp	x ns (Read only)	U32	1	X	●
0x2D01:006	Touch probe (TP) time stamp: Touch probe 3-falling edge time stamp	x ns (Read only)	U32	1	X	●
0x2D01:007	Touch probe (TP) time stamp: Touch probe 4-rising edge time stamp	x ns (Read only)	U32	1	X	●

Appendix

Parameter attribute list



Address	Name	Default setting	Data type	Factor	A	M
0x2D01:008	Touch probe (TP) time stamp: Touch probe 4-falling edge time stamp	x ns (Read only)	U32	1	X	●
0x2D02:001	Touch probe diagnostics: Touch probe 3/4 function	0x0000	U16		H	●
0x2D02:002	Touch probe diagnostics: Touch-Probe 3/4 status	- (Read only)	U16		HX	●
0x2D03:001	Touch probe position: Touch probe 3 position rising edge	x pos. unit (Read only)	I32	1	X	●
0x2D03:002	Touch probe position: Touch probe 3 position falling edge	x pos. unit (Read only)	I32	1	X	●
0x2D03:003	Touch probe position: Touch probe 4 position rising edge	x pos. unit (Read only)	I32	1	X	●
0x2D03:004	Touch probe position: Touch probe 4 position falling edge	x pos. unit (Read only)	I32	1	X	●
0x2D40:001	Device utilisation ixt: Power unit actual utilisation	x % (Read only)	U16	1	X	●
0x2D40:002	Device utilisation ixt: Power unit warning threshold	95 %	U16	1	-	
0x2D40:003	Device utilisation ixt: Power unit error threshold	x % (Read only)	U16	1	X	
0x2D40:004	Device utilisation ixt: Device actual utilisation	x % (Read only)	U16	1	X	●
0x2D40:005	Device utilisation ixt: Device warning threshold	95 %	U16	1	-	
0x2D40:006	Device utilisation ixt: Device error threshold	x % (Read only)	U16	1	X	
0x2D40:007	Device utilisation ixt: Actual total utilisation	x % (Read only)	U16	1	X	●
0x2D40:008	Device utilisation ixt: Total utilisation warning threshold	95 %	U16	1	-	
0x2D40:009	Device utilisation ixt: Total utilisation error threshold	x % (Read only)	U16	1	X	
0x2D44:001	Overspeed monitoring: Threshold	8000 rpm	U16	1	-	
0x2D44:002	Overspeed monitoring: Response	Fault > CiA402 [1]	U8		-	
0x2D45:001	Motor phase failure detection: Response - Motor phase 1	No response [0]	U8		-	
0x2D45:002	Motor phase failure detection: Current threshold	5.0 %	U8	10	-	
0x2D45:003	Motor phase failure detection: Voltage threshold	10.0 V	U16	10	-	
0x2D45:004	Motor phase failure detection: Response - Motor phase 2	No response [0]	U8		-	
0x2D46:001	Overcurrent monitoring: Threshold	5.4 A	U16	10	-	
0x2D46:002	Overcurrent monitoring: Response	Fault > CiA402 [1]	U8		-	
0x2D48:002	PTC temperature sensor monitoring: Error response	Fault > CiA402 [1]	U8		-	
0x2D49:001	Motor temperature monitoring: Temperature sensor type	PT1000 [5]	U8		-	
0x2D49:002	Motor temperature monitoring: Response	Warning [1]	U8		-	
0x2D49:003	Motor temperature monitoring: Warning threshold	145.0 °C	I16	10	-	
0x2D49:004	Motor temperature monitoring: Error threshold	155.0 °C	I16	10	-	
0x2D49:005	Motor temperature monitoring: Actual motor temperature	x.x °C (Read only)	I16	10	X	●
0x2D49:006	Motor temperature monitoring: Spec. characteristic temperature grid point 1	25.0 °C	I16	10	-	
0x2D49:007	Motor temperature monitoring: Spec. characteristic temperature grid point 2	150.0 °C	I16	10	-	
0x2D49:008	Motor temperature monitoring: Spec. characteristic resistance grid point 1	1000 Ω	I16	1	-	
0x2D49:009	Motor temperature monitoring: Spec. characteristic resistance grid point 2	2225 Ω	I16	1	-	
0x2D49:010	Motor temperature monitoring: Temperature sensor feedback type	Motor encoder [0]	U8		-	
0x2D49:011	Motor temperature monitoring: Motor temperature (Motor encoder)	x.x °C (Read only)	I16	10	X	●
0x2D49:012	Motor temperature monitoring: Motor temperature (load encoder)	x.x °C (Read only)	I16	10	X	●
0x2D4C:001	Thermisches Modell Motorauslastung (i ² xt): Motor utilisation (i ² xt)	60 s	U16	1	-	
0x2D4C:002	Thermisches Modell Motorauslastung (i ² xt): Thermal time constant - laminations	852 s	U16	1	-	



Appendix

Parameter attribute list

Address	Name	Default setting	Data type	Factor	A	M
0x2D4C:003	Thermisches Modell Motorauslastung (i ² xt): Winding influence	27 %	U8	1	-	
0x2D4C:004	Thermisches Modell Motorauslastung (i ² xt): Starting value	0 %	U16	1	-	
0x2D4D:001	Motor utilisation (i ² xt) - specific characteristic: x1 = n01/nN (n01 ~ 0)	0 %	U16	1	-	
0x2D4D:002	Motor utilisation (i ² xt) - specific characteristic: y1 = i01/iN (x1)	100 %	U16	1	-	
0x2D4D:003	Motor utilisation (i ² xt) - specific characteristic: x2 = n02/nN (n02 = limit reduced cooling)	0 %	U16	1	-	
0x2D4D:004	Motor utilisation (i ² xt) - specific characteristic: y2 = i02/iN (x2)	100 %	U16	1	-	
0x2D4D:005	Motor utilisation (i ² xt) - specific characteristic: x3 = n03/nN (n03 = rated speed)	100 %	U16	1	-	
0x2D4D:006	Motor utilisation (i ² xt) - specific characteristic: y3 = i03/iN (x3)	100 %	U16	1	-	
0x2D4D:007	Motor utilisation (i ² xt) - specific characteristic: x4 = n04/nN (n04 = limit field weakening)	100 %	U16	1	-	
0x2D4D:008	Motor utilisation (i ² xt) - specific characteristic: y4 = i04/iN (x4)	100 %	U16	1	-	
0x2D4E	Motor utilisation (i ² xt) - warning threshold	100 %	U16	1	-	
0x2D4F	Motor utilisation (i ² *t)	x % (Read only)	U16	1	X	●
0x2D50:001	Motor utilisation (i ² xt) - monitoring: Error response	Fehler > CiA402 [1]	U8		-	
0x2D50:002	Motor utilisation (i ² xt) - monitoring: Error threshold	105 %	U16	1	-	
0x2D51:001	Position error/speed error - monitoring: Speed error - error threshold	50 rpm	U32	1	-	
0x2D51:002	Position error/speed error - monitoring: Speed error - min. time for error	0 ms	U16	1	-	
0x2D51:003	Position error/speed error - monitoring: Speed error - error response	No response [0]	U8		-	
0x2D51:004	Position error/speed error - monitoring: Position error - error threshold	360 °	U32	1	-	
0x2D51:005	Position error/speed error - monitoring: Position error - min. time for error	0 ms	U16	1	-	
0x2D51:006	Position error/speed error - monitoring: Position error - error response	No response [0]	U8		-	
0x2D66:001	Mains failure control: Enable function	Disabled [0]	U8		-	
0x2D66:002	Mains failure control: DC-bus activation level	75 %	U8	1	-	
0x2D66:011	Mains failure control: Filter time	0.00 s	U16	100	-	
0x2D66:012	Mains failure control: Ramp max. torque	30.0 %	U16	10	-	
0x2D66:013	Mains failure control: Ramp time	1.00 s	U16	100	-	
0x2D66:014	Mains failure control: Actual DC-bus voltage	x.xxx V (Read only)	U32	1000	X	
0x2D81:001	Life-diagnosis: Operating time	x s (Read only)	U32	1	X	
0x2D81:002	Life-diagnosis: Power-on time	x s (Read only)	U32	1	X	
0x2D81:004	Life-diagnosis: Main switching cycles	- (Read only)	U32	1	X	
0x2D81:006	Life-diagnosis: Short-circuit counter	- (Read only)	U32	1	X	
0x2D81:007	Life-diagnosis: Earth fault counter	- (Read only)	U32	1	X	
0x2D81:009	Life-diagnosis: Fan operating time	x s (Read only)	U32	1	X	
0x2D82	Motor actual voltage (Veff)	x.x V (Read only)	U32	10	X	●
0x2D83:001	Motor-Phasenströme: Zero system current	x.xx A (Read only)	I32	100	X	●
0x2D83:002	Motor-Phasenströme: Phase U current	x.xx A (Read only)	I32	100	X	●
0x2D83:003	Motor-Phasenströme: Phase V current	x.xx A (Read only)	I32	100	X	●
0x2D83:004	Motor-Phasenströme: Phase W current	x.xx A (Read only)	I32	100	X	●
0x2D84:001, 004, 006	Heatsink temperature: Heatsink temperature	x.x °C (Read only)	I16	10	X	
0x2D84:002	Heatsink temperature: Warning threshold	90.0 °C	I16	10	-	
0x2D8A	Actual speed error	x rpm (Read only)	I32	1	X	●
0x2DA2:001	Output power: Effective power	x.xxx kW (Read only)	I32	1000	X	●

Appendix

Parameter attribute list



Address	Name	Default setting	Data type	Factor	A	M
0x2DA3:003	Output energy: Warning	0.00 kWh	I32	100	X	
0x2DA4:001	Diagnostics of analog input 1: Value in percent	x.x % (Read only)	I16	10	X	
0x2DA4:005	Diagnostics of analog input 1: Scaled percent value	x.xx % (Read only)	I16	100	X	●
0x2DA4:016	Diagnostics of analog input 1: Status	- (Read only)	U16		HX	●
0x2DD0:001	Field values: Actual value	x % (Read only)	U16	1	X	●
0x2DD0:002	Field values: Setpoint value	x % (Read only)	U16	1	X	●
0x2DD1:001	Motor currents: Actual D-current (id)	x.xx A (Read only)	I32	100	X	●
0x2DD1:002	Motor currents: Actual Q-current (iq)	x.xx A (Read only)	I32	100	X	●
0x2DD1:003	Motor currents: Setpoint D-current (id)	x.xx A (Read only)	I32	100	X	●
0x2DD1:004	Motor currents: Setpoint Q-current (iq)	x.xx A (Read only)	I32	100	X	●
0x2DD1:005	Motor currents: Motor current (Ieff)	x.xx A (Read only)	I32	100	X	●
0x2DD2	Target position interpolated	x pos. unit (Read only)	I32	1	X	●
0x2DD3:001	Speed setpoints: Speed setpoint	x rpm (Read only)	I32	1	X	●
0x2DD3:002	Speed setpoints: Speed setpoint 2	x rpm (Read only)	I32	1	X	●
0x2DD3:003	Speed setpoints: Speed setpoint limited	x rpm (Read only)	I32	1	X	●
0x2DD4:001	Speed controller output signals: Output signal 1	x.x % (Read only)	I16	10	X	●
0x2DD4:002	Speed controller output signals: Output signal 2	x.x % (Read only)	I16	10	X	●
0x2DD5	Torque setpoint	x.xx Nm (Read only)	I32	100	X	●
0x2DD6:001	Torque filter cascade: Starting value	x.x % (Read only)	I16	10	X	●
0x2DD6:002	Torque filter cascade: Notch filter 1 input value	x.x % (Read only)	I16	10	X	●
0x2DD6:003	Torque filter cascade: Notch filter 2 input value	x.x % (Read only)	I16	10	X	●
0x2DD6:004	Torque filter cascade: Torque setpoint filtered	x.x % (Read only)	I16	10	X	●
0x2DD7:001	Voltage values: Actual voltage (motor voltage limit)	x.x V (Read only)	I16	10	X	●
0x2DD7:002	Voltage values: Output signal D current controller	x.x V (Read only)	I16	10	X	●
0x2DD7:003	Voltage values: Output signal Q current controller	x.x V (Read only)	I16	10	X	●
0x2DD7:004	Voltage values: D voltage (magnetisation)	x.x V (Read only)	I16	10	X	●
0x2DD7:005	Voltage values: Q voltage (torque)	x.x V (Read only)	I16	10	X	●
0x2DD7:006	Voltage values: Phases U-V	x.x V (Read only)	I16	10	X	●
0x2DD7:007	Voltage values: Phases V-W	x.x V (Read only)	I16	10	X	●
0x2DD7:008	Voltage values: Phases W-U	x.x V (Read only)	I16	10	X	●
0x2DD7:009	Voltage values: Phase U	x.x V (Read only)	I16	10	X	●
0x2DD7:010	Voltage values: Phase V	x.x V (Read only)	I16	10	X	●
0x2DD7:011	Voltage values: Phase W	x.x V (Read only)	I16	10	X	●
0x2DDC	Actual slip value	x.x Hz (Read only)	I16	10	X	●
0x2DDD	Output frequency	x.x Hz (Read only)	I16	10	X	●
0x2DDE	Actual rotor angle position	- (Read only)	I16	1	X	●
0x2DDF:001	Axis information: Rated current	x.xx A (Read only)	U16	100	X	●
0x2DDF:002	Axis information: Maximum current	x.xx A (Read only)	U16	100	X	●
0x2DDF:005	Axis information: Motor encoder	- (Read only)	U8		X	●
0x2DDF:006	Axis information: Load encoder/master encoder	- (Read only)	U8		X	●
0x2DDF:007	Axis information: Function of X109	- (Read only)	U8		X	●
0x2DE0:001	Current controller identification settings	Automatic [0]	U8		X	
0x2DE0:003	Resolver - position detection dynamics	100 %	U16	1	-	
0x2DE0:004	Resolver - 8 kHz safety signal	Automatisch durch Gerätetyp [0]	U8		X	
0x2DE0:006	OEM service Data - SN	- (Read only)	U32	1	X	
0x2DE0:007	Use measured voltage	On [1]	U8		-	
0x2DE0:009	Motor identification settings	- (Read only)	U32	1	X	
0x2DE0:014	Overwrite bit 4 of CiA control word	No overwrite [0]	U8		-	
0x2DE1:001	Axis settings: Function of X109	PTC [20]	U8		-	
0x4000	Application selection	CiA 402 [0]	U16		C	
0x4016:005	Digital output 1: Terminal state	- (Read only)	U8		X	
0x5810:001	Application diagnostics: Application state	- (Read only)	U8		X	
0x5850:001	Commands for EtherCAT system bus master: Kommunikation neu starten	No action/no error [0]	U16		X	
0x5851:001	EtherCAT master diagnosis: EtherCAT master state	- (Read only)	U16		X	



Appendix

Parameter attribute list

Address	Name	Default setting	Data type	Factor	A	M
0x5851:002	EtherCAT master diagnosis: EtherCAT master state summary	- (Read only)	U32		HX	
0x5851:003	EtherCAT master diagnosis: EtherCAT error	- (Read only)	U16	1	X	
0x5851:004	EtherCAT master diagnosis: Bus scan match	- (Read only)	U8	1	X	
0x5851:005	EtherCAT master diagnosis: Configured cycle time	x us (Read only)	U32	1	X	
0x5851:006	EtherCAT master diagnosis: Connected slaves	- (Read only)	U16	1	X	
0x5851:007	EtherCAT master diagnosis: Configured slaves	- (Read only)	U16	1	X	
0x5860:001	EtherCAT slaves station addresses: Station address slave 1	- (Read only)	I16	1	X	
0x5860:002	EtherCAT slaves station addresses: Station address slave 2	- (Read only)	I16	1	X	
0x5860:003	EtherCAT slaves station addresses: Station address slave 3	- (Read only)	I16	1	X	
0x5860:004	EtherCAT slaves station addresses: Station address slave 4	- (Read only)	I16	1	X	
0x5860:005	EtherCAT slaves station addresses: Station address slave 5	- (Read only)	I16	1	X	
0x5860:006	EtherCAT slaves station addresses: Station address slave 6	- (Read only)	I16	1	X	
0x5860:007	EtherCAT slaves station addresses: Station address slave 7	- (Read only)	I16	1	X	
0x5860:008	EtherCAT slaves station addresses: Station address slave 8	- (Read only)	I16	1	X	
0x5860:009	EtherCAT slaves station addresses: Station address slave 9	- (Read only)	I16	1	X	
0x5860:010	EtherCAT slaves station addresses: Station address slave 10	- (Read only)	I16	1	X	
0x5860:011	EtherCAT slaves station addresses: Station address slave 11	- (Read only)	I16	1	X	
0x5860:012	EtherCAT slaves station addresses: Station address slave 12	- (Read only)	I16	1	X	
0x5860:013	EtherCAT slaves station addresses: Station address slave 13	- (Read only)	I16	1	X	
0x5860:014	EtherCAT slaves station addresses: Station address slave 14	- (Read only)	I16	1	X	
0x5860:015	EtherCAT slaves station addresses: Station address slave 15	- (Read only)	I16	1	X	
0x5860:016	EtherCAT slaves station addresses: Station address slave 16	- (Read only)	I16	1	X	
0x5861:001	EtherCAT slaves device names: Device name slave 1	- (Read only)	STRING[128]		X	
0x5861:002	EtherCAT slaves device names: Device name slave 2	- (Read only)	STRING[128]		X	
0x5861:003	EtherCAT slaves device names: Device name slave 3	- (Read only)	STRING[128]		X	
0x5861:004	EtherCAT slaves device names: Device name slave 4	- (Read only)	STRING[128]		X	
0x5861:005	EtherCAT slaves device names: Device name slave 5	- (Read only)	STRING[128]		X	
0x5861:006	EtherCAT slaves device names: Device name slave 6	- (Read only)	STRING[128]		X	
0x5861:007	EtherCAT slaves device names: Device name slave 7	- (Read only)	STRING[128]		X	
0x5861:008	EtherCAT slaves device names: Device name slave 8	- (Read only)	STRING[128]		X	
0x5861:009	EtherCAT slaves device names: Device name slave 9	- (Read only)	STRING[128]		X	
0x5861:010	EtherCAT slaves device names: Device name slave 10	- (Read only)	STRING[128]		X	
0x5861:011	EtherCAT slaves device names: Device name slave 11	- (Read only)	STRING[128]		X	
0x5861:012	EtherCAT slaves device names: Device name slave 12	- (Read only)	STRING[128]		X	
0x5861:013	EtherCAT slaves device names: Device name slave 13	- (Read only)	STRING[128]		X	
0x5861:014	EtherCAT slaves device names: Device name slave 14	- (Read only)	STRING[128]		X	

Appendix

Parameter attribute list



Address	Name	Default setting	Data type	Factor	A	M
0x5861:015	EtherCAT slaves device names: Device name slave 15	- (Read only)	STRING[128]		X	
0x5861:016	EtherCAT slaves device names: Device name slave 16	- (Read only)	STRING[128]		X	
0x5862:001	EtherCAT slaves device types: Device type slave 1	- (Read only)	STRING[50]		X	
0x5862:002	EtherCAT slaves device types: Device type slave 2	- (Read only)	STRING[50]		X	
0x5862:003	EtherCAT slaves device types: Device type slave 3	- (Read only)	STRING[50]		X	
0x5862:004	EtherCAT slaves device types: Device type slave 4	- (Read only)	STRING[50]		X	
0x5862:005	EtherCAT slaves device types: Device type slave 5	- (Read only)	STRING[50]		X	
0x5862:006	EtherCAT slaves device types: Device type slave 6	- (Read only)	STRING[50]		X	
0x5862:007	EtherCAT slaves device types: Device type slave 7	- (Read only)	STRING[50]		X	
0x5862:008	EtherCAT slaves device types: Device type slave 8	- (Read only)	STRING[50]		X	
0x5862:009	EtherCAT slaves device types: Device type slave 9	- (Read only)	STRING[50]		X	
0x5862:010	EtherCAT slaves device types: Device type slave 10	- (Read only)	STRING[50]		X	
0x5862:011	EtherCAT slaves device types: Device type slave 11	- (Read only)	STRING[50]		X	
0x5862:012	EtherCAT slaves device types: Device type slave 12	- (Read only)	STRING[50]		X	
0x5862:013	EtherCAT slaves device types: Device type slave 13	- (Read only)	STRING[50]		X	
0x5862:014	EtherCAT slaves device types: Device type slave 14	- (Read only)	STRING[50]		X	
0x5862:015	EtherCAT slaves device types: Device type slave 15	- (Read only)	STRING[50]		X	
0x5862:016	EtherCAT slaves device types: Device type slave 16	- (Read only)	STRING[50]		X	
0x5863:001	Mandatory EtherCAT slaves: Slave 1 is mandatory	- (Read only)	U8		X	
0x5863:002	Mandatory EtherCAT slaves: Slave 2 is mandatory	- (Read only)	U8		X	
0x5863:003	Mandatory EtherCAT slaves: Slave 3 is mandatory	- (Read only)	U8		X	
0x5863:004	Mandatory EtherCAT slaves: Slave 4 is mandatory	- (Read only)	U8		X	
0x5863:005	Mandatory EtherCAT slaves: Slave 5 is mandatory	- (Read only)	U8		X	
0x5863:006	Mandatory EtherCAT slaves: Slave 6 is mandatory	- (Read only)	U8		X	
0x5863:007	Mandatory EtherCAT slaves: Slave 7 is mandatory	- (Read only)	U8		X	
0x5863:008	Mandatory EtherCAT slaves: Slave 8 is mandatory	- (Read only)	U8		X	
0x5863:009	Mandatory EtherCAT slaves: Slave 9 is mandatory	- (Read only)	U8		X	
0x5863:010	Mandatory EtherCAT slaves: Slave 10 is mandatory	- (Read only)	U8		X	
0x5863:011	Mandatory EtherCAT slaves: Slave 11 is mandatory	- (Read only)	U8		X	
0x5863:012	Mandatory EtherCAT slaves: Slave 12 is mandatory	- (Read only)	U8		X	
0x5863:013	Mandatory EtherCAT slaves: Slave 13 is mandatory	- (Read only)	U8		X	
0x5863:014	Mandatory EtherCAT slaves: Slave 14 is mandatory	- (Read only)	U8		X	
0x5863:015	Mandatory EtherCAT slaves: Slave 15 is mandatory	- (Read only)	U8		X	
0x5863:016	Mandatory EtherCAT slaves: Slave 16 is mandatory	- (Read only)	U8		X	
0x5864:001	EtherCAT slaves initialisation status: Initalisation status slave 1	- (Read only)	U16		X	
0x5864:002	EtherCAT slaves initialisation status: Initalisation status slave 2	- (Read only)	U16		X	
0x5864:003	EtherCAT slaves initialisation status: Initalisation status slave 3	- (Read only)	U16		X	
0x5864:004	EtherCAT slaves initialisation status: Initalisation status slave 4	- (Read only)	U16		X	
0x5864:005	EtherCAT slaves initialisation status: Initalisation status slave 5	- (Read only)	U16		X	
0x5864:006	EtherCAT slaves initialisation status: Initalisation status slave 6	- (Read only)	U16		X	
0x5864:007	EtherCAT slaves initialisation status: Initalisation status slave 7	- (Read only)	U16		X	
0x5864:008	EtherCAT slaves initialisation status: Initalisation status slave 8	- (Read only)	U16		X	
0x5864:009	EtherCAT slaves initialisation status: Initalisation status slave 9	- (Read only)	U16		X	
0x5864:010	EtherCAT slaves initialisation status: Initalisation status slave 10	- (Read only)	U16		X	



Appendix

Parameter attribute list

Address	Name	Default setting	Data type	Factor	A	M
0x5864:011	EtherCAT slaves initialisation status: Initalisation status slave 11	- (Read only)	U16		X	
0x5864:012	EtherCAT slaves initialisation status: Initalisation status slave 12	- (Read only)	U16		X	
0x5864:013	EtherCAT slaves initialisation status: Initalisation status slave 13	- (Read only)	U16		X	
0x5864:014	EtherCAT slaves initialisation status: Initalisation status slave 14	- (Read only)	U16		X	
0x5864:015	EtherCAT slaves initialisation status: Initalisation status slave 15	- (Read only)	U16		X	
0x5864:016	EtherCAT slaves initialisation status: Initalisation status slave 16	- (Read only)	U16		X	
0x5865:001	EtherCAT slaves device status: Device status slave 1	- (Read only)	U16		X	
0x5865:002	EtherCAT slaves device status: Device status slave 2	- (Read only)	U16		X	
0x5865:003	EtherCAT slaves device status: Device status slave 3	- (Read only)	U16		X	
0x5865:004	EtherCAT slaves device status: Device status slave 4	- (Read only)	U16		X	
0x5865:005	EtherCAT slaves device status: Device status slave 5	- (Read only)	U16		X	
0x5865:006	EtherCAT slaves device status: Device status slave 6	- (Read only)	U16		X	
0x5865:007	EtherCAT slaves device status: Device status slave 7	- (Read only)	U16		X	
0x5865:008	EtherCAT slaves device status: Device status slave 8	- (Read only)	U16		X	
0x5865:009	EtherCAT slaves device status: Device status slave 9	- (Read only)	U16		X	
0x5865:010	EtherCAT slaves device status: Device status slave 10	- (Read only)	U16		X	
0x5865:011	EtherCAT slaves device status: Device status slave 11	- (Read only)	U16		X	
0x5865:012	EtherCAT slaves device status: Device status slave 12	- (Read only)	U16		X	
0x5865:013	EtherCAT slaves device status: Device status slave 13	- (Read only)	U16		X	
0x5865:014	EtherCAT slaves device status: Device status slave 14	- (Read only)	U16		X	
0x5865:015	EtherCAT slaves device status: Device status slave 15	- (Read only)	U16		X	
0x5865:016	EtherCAT slaves device status: Device status slave 16	- (Read only)	U16		X	
0x603F	Error code	- (Read only)	U16		HX	●
0x6040	CiA control word	0x0000	U16		HX	●
0x6041	CiA status word	- (Read only)	U16		HX	●
0x6042	Set speed	0 rpm	I16	1	X	●
0x6043	Internal set speed	x rpm (Read only)	I16	1	X	●
0x6044	Actual speed	x rpm (Read only)	I16	1	X	●
0x6046:001	Speed limits: Min. speed	0 rpm	U32	1	X	●
0x6046:002	Speed limits: Max. speed	2147483647 rpm	U32	1	X	●
0x6048:001	Acceleration ramp: CiA acceleration: Delta speed	0 rpm	U32	1	-	●
0x6048:002	Acceleration ramp: CiA acceleration: Delta time	10 s	U16	1	-	●
0x6049:001	Deceleration ramp: CiA deceleration: Delta speed	0 rpm	U32	1	-	●
0x6049:002	Deceleration ramp: CiA deceleration: Delta time	10 s	U16	1	-	●
0x604B:001	vl set-point factor: vl set-point factor numerator	1	I16	1	-	●
0x604B:002	vl set-point factor: vl set-point factor denominator	1	I16	1	-	●
0x604C:001	vl dimension factor: vl dimension factor numerator	1	I32	1	-	●
0x604C:002	vl dimension factor: vl dimension factor denominator	1	I32	1	-	●
0x605A	CiA: Quick stop mode	Ramp > switch on disabled [2]	I16		-	
0x605B	Shutdown option code	Disable drive function [0]	I16		-	
0x605E	CiA: Fault reaction	Advanced quick stop [-2]	I16		-	
0x6060	CiA: Operation mode	No selection [0]	I8		-	●
0x6061	CiA: Active operation mode	- (Read only)	I8		X	●
0x6062	Internal set position	x pos. unit (Read only)	I32	1	X	
0x6063	Actual position	x incr. (Read only)	I32	1	X	●
0x6064	Actual position	x pos. unit (Read only)	I32	1	X	●
0x6065	Following error window	1000 pos. unit	U32	1	-	●
0x6066	Following error delay	0 ms	U16	1	-	●
0x6067	Position reached window	1000 pos. unit	U32	1	-	

Appendix

Parameter attribute list



Address	Name	Default setting	Data type	Factor	A	M
0x6068	Position reached delay	0 ms	U16	1	-	
0x606C	Actual speed	rpm (Read only)	I32	480000 $/2^{31}$	X	●
0x6071	Set torque	0.0 %	I16	10	X	●
0x6072	Max. torque	250.0 %	U16	10	-	●
0x6073	Max. current	150.0 %	U16	10	-	
0x6074	Internal set torque	x.x % (Read only)	I16	10	X	
0x6075	Rated motor current	1.300 A	U32	1000	C	
0x6076	Rated motor torque	0.600 Nm	U32	1000	C	
0x6077	Actual torque	x.x % (Read only)	I16	10	X	●
0x6078	Actual current	x.x % (Read only)	I16	10	X	●
0x6079	DC-bus voltage	x.xxx V (Read only)	U32	1000	X	●
0x607A	Set position	0 pos. unit	I32	1	X	●
0x607E	Polarity	0	U8	1	C	
0x6080	Max. motor speed	6075 rpm	U32	1	-	●
0x6085	Quick stop deceleration	2147483647	U32	1	-	
0x608F:001	Position encoder resolution: Encoder increments	16 bit [65536]	U32		C	
0x608F:002	Position encoder resolution: Motor revolutions	1	U32	1	C	
0x6090:001	Velocity encoder resolution: Encoder increments/s	33554432	U32	1	C	
0x6090:002	Velocity encoder resolution: Motor revolutions/s	125	U32	1	C	
0x60B1	Offset speed	0.00 rpm	I32	480000 $/2^{31}$	-	●
0x60B2	Offset torque	0.0 %	I16	10	-	●
0x60B8	Touch probe settings	0x0000	U16		H	●
0x60B9	Touch probe status	- (Read only)	U16		HX	●
0x60BA	Touch probe 1: Position at pos. edge	x pos. unit (Read only)	I32	1	X	●
0x60BB	Touch probe 1: Position at neg. edge	x pos. unit (Read only)	I32	1	X	●
0x60BC	Touch probe 2: Position at pos. edge	x pos. unit (Read only)	I32	1	X	●
0x60BD	Touch probe 2: Position at neg. edge	x pos. unit (Read only)	I32	1	X	●
0x60C0	Interpolation mode	Quadratic [-1]	I16		-	●
0x60C2:001	Interpolation time period: Interpolation time mantissa	1	U8	1	-	
0x60C2:002	Interpolation time period: Interpolation time exponent	-3	I8	1	-	
0x60E0	Positive torque limit	100.0 %	U16	10	-	●
0x60E1	Negative torque limit	100.0 %	U16	10	-	●
0x60E4:001	Additional position actual value: Load encoder/ master encoder - actual position	x pos. unit (Read only)	I32	1	X	●
0x60E5:001	Additional velocity actual value: Load encoder/ master encoder - actual speed	rpm (Read only)	I32	480000 $/2^{31}$	X	●
0x60E6:001	Additional position encoder resolution - encoder increments: Load encoder/master encoder - number of increments	16 Bit [65536]	U32		C	
0x60EB:001	Additional position encoder resolution - motor revolutions: Load encoder/master encoder - resolution of motor revolutions	1	U32	1	C	
0x60F4	Following error actual value	x pos. unit (Read only)	I32	1	X	●
0x60FA	Control effort	rpm (Read only)	I32	480000 $/2^{31}$	X	●
0x60FC	Position demand internal value	x incr. (Read only)	I32	1	X	
0x60FD	Digital input status	- (Read only)	U32		HX	●
0x60FE:001	Digital outputs: Digital output status	0x00000000	U32		HX	●
0x60FF	Set speed	0.00 rpm	I32	480000 $/2^{31}$	X	●
0x6404	Motor manufacturer	"Lenze"	STRING[50]		-	
0x6502	Supported drive modes	- (Read only)	U32		HX	



Appendix

Parameter attribute list

Address	Name	Default setting	Data type	Factor	A	M
0x67FF	Device profile number	-(Read only)	U32	1	X	
0xA200:001	Systembus output data: Systembus data output 1	-(Read only)	U32	1	X	●
0xA200:002	Systembus output data: Systembus data output 2	-(Read only)	U32	1	X	●
0xA200:003	Systembus output data: Systembus data output 3	-(Read only)	U32	1	X	●
0xA200:004	Systembus output data: Systembus data output 4	-(Read only)	U32	1	X	●
0xA200:005	Systembus output data: Systembus data output 5	-(Read only)	U32	1	X	●
0xA200:006	Systembus output data: Systembus data output 6	-(Read only)	U32	1	X	●
0xA200:007	Systembus output data: Systembus data output 7	-(Read only)	U32	1	X	●
0xA200:008	Systembus output data: Systembus data output 8	-(Read only)	U32	1	X	●
0xA200:009	Systembus output data: Systembus data output 9	-(Read only)	U32	1	X	●
0xA200:010	Systembus output data: Systembus data output 10	-(Read only)	U32	1	X	●
0xA200:011	Systembus output data: Systembus data output 11	-(Read only)	U32	1	X	●
0xA200:012	Systembus output data: Systembus data output 12	-(Read only)	U32	1	X	●
0xA200:013	Systembus output data: Systembus data output 13	-(Read only)	U32	1	X	●
0xA200:014	Systembus output data: Systembus data output 14	-(Read only)	U32	1	X	●
0xA200:015	Systembus output data: Systembus data output 15	-(Read only)	U32	1	X	●
0xA200:016	Systembus output data: Systembus data output 16	-(Read only)	U32	1	X	●
0xA680:001	Systembus input data: Systembus data input 1	0	U32	1	X	●
0xA680:002	Systembus input data: Systembus data input 2	0	U32	1	X	●
0xA680:003	Systembus input data: Systembus data input 3	0	U32	1	X	●
0xA680:004	Systembus input data: Systembus data input 4	0	U32	1	X	●
0xA680:005	Systembus input data: Systembus data input 5	0	U32	1	X	●
0xA680:006	Systembus input data: Systembus data input 6	0	U32	1	X	●
0xA680:007	Systembus input data: Systembus data input 7	0	U32	1	X	●
0xA680:008	Systembus input data: Systembus data input 8	0	U32	1	X	●
0xA680:009	Systembus input data: Systembus data input 9	0	U32	1	X	●
0xA680:010	Systembus input data: Systembus data input 10	0	U32	1	X	●
0xA680:011	Systembus input data: Systembus data input 11	0	U32	1	X	●
0xA680:012	Systembus input data: Systembus data input 12	0	U32	1	X	●
0xA680:013	Systembus input data: Systembus data input 13	0	U32	1	X	●
0xA680:014	Systembus input data: Systembus data input 14	0	U32	1	X	●
0xA680:015	Systembus input data: Systembus data input 15	0	U32	1	X	●
0xA680:016	Systembus input data: Systembus data input 16	0	U32	1	X	●
0xE600:001	FSoE Slave Frame Elements: FSoE Slave Command	-(Read only)	U8	1	X	●
0xE600:002	FSoE Slave Frame Elements: FSoE Slave Connection ID	-(Read only)	U16	1	X	●
0xE600:003	FSoE Slave Frame Elements: FSoE Slave CRC_0	-(Read only)	U16	1	X	●
0xE600:004	FSoE Slave Frame Elements: FSoE Slave CRC_1	-(Read only)	U16	1	X	●
0xE600:005	FSoE Slave Frame Elements: FSoE Slave CRC_2	-(Read only)	U16	1	X	●
0xE600:006	FSoE Slave Frame Elements: FSoE Slave CRC_3	-(Read only)	U16	1	X	●
0xE600:007	FSoE Slave Frame Elements: FSoE Slave CRC_4	-(Read only)	U16	1	X	●
0xE600:008	FSoE Slave Frame Elements: FSoE Slave CRC_5	-(Read only)	U16	1	X	●
0xE600:009	FSoE Slave Frame Elements: FSoE Slave CRC_6	-(Read only)	U16	1	X	●
0xE700:001	FSoE Master Frame Elements: FSoE Master Command	-(Read only)	U8	1	X	●
0xE700:002	FSoE Master Frame Elements: FSoE Master Connection ID	-(Read only)	U16	1	X	●
0xE700:003	FSoE Master Frame Elements: FSoE Master CRC_0	-(Read only)	U16	1	X	●
0xE700:004	FSoE Master Frame Elements: FSoE Master CRC_1	-(Read only)	U16	1	X	●
0xE901:001	FSoE communication Parameters: FSoE version	-(Read only)	STRING[2]		X	
0xE901:002	FSoE communication Parameters: Safety address	-(Read only)	U16	1	X	
0xE901:003	FSoE communication Parameters: FSoE connection ID	-(Read only)	U16	1	X	
0xE901:004	FSoE communication Parameters: FSoE watchdog time	-(Read only)	U16	1	X	



Address	Name	Default setting	Data type	Factor	A	M
0xE901:006	FSoE communication Parameters: FSoE connection type	- (Read only)	U16		X	
0xE901:007	FSoE communication Parameters: FSoE communication parameter length	- (Read only)	U16	1	X	
0xE901:008	FSoE communication Parameters: FSoE application parameter length	- (Read only)	U16	1	X	
0xEA00:001	FSoE diagnostics: Connection state	- (Read only)	U16		X	
0xF980:001	Safety address: FSoE address	- (Read only)	U16	1	X	
0xF980:002	Safety address: Safety address	- (Read only)	U16	1	-	

21.2 Glossary

Abbreviation	Meaning
AIE	Acknowledge In Error, error acknowledgement
AIS	Acknowledge In Stop, restart acknowledgement
OFF state	Triggered signal status of the sensors
CCF	Common Cause Error (also β -value)
EC_FS	Error Class Fail Safe
EC_SS1	Error-Class Safe Stop 1
EC_SS2	Error-Class Safe Stop 2
EC_STO	Error-Class Safe Torque Off Stop 0
ON state	Signal status of the safety sensor in normal operation
FIT	Failure In Time, 1 FIT = 10 ⁻⁹ Error/h
FMEA	Failure Mode and Effect Analysis
FSoE	FailSafe over EtherCAT
GSDML	Device description file with PROFINET-specific data to integrate the configuring software of a PROFINET controller.
HFT	Hardware Failure Tolerance
Cat.	Category in accordance with EN ISO 13849-1
OSSD	Output Signal Switching Device, tested signal output
PELV	Protective Extra Low Voltage, extra-low voltage with safe isolation
PL	Performance Level according to EN ISO 13849-1
PM	Plus-Minus – switched signal paths
PP	Plus-Plus – switched signal paths
PS	PROFIsafe
PWM	Pulse width modulation
SCS	Safe crawling speed
SD-In	Safe Digital Input
SD-Out	Safe Digital Output
SELV	Safety Extra Low Voltage
SFF	Safe Failure Fraction
SIL	Safety Integrity Level in accordance with IEC 61508

Lenze Automation GmbH

Postfach 101352, 31763 Hameln

Hans-Lenze-Str. 1, 31855 Aerzen

GERMANY

HR Hannover B 205381

Phone +49 5154 82-0

Fax +49 5154 82-2800

sales.de@lenze.com

www.Lenze.com

Lenze Service GmbH

Breslauer Straße 3, 32699 Extertal

GERMANY

Phone 0080002446877 (24 h Helpline)

Fax +49 5154 82-1112

service.de@lenze.com