



PowerFlex 4 Adjustable Frequency AC Drive

Bulletin Number 22A

Firmware Revision 7.xxx



Allen-Bradley

by ROCKWELL AUTOMATION

User Manual

Original Instructions

Important User Information

Read this document and the documents listed in the additional resources section about installation, configuration, and operation of this equipment before you install, configure, operate, or maintain this product. Users are required to familiarize themselves with installation and wiring instructions in addition to requirements of all applicable codes, laws, and standards.

Activities including installation, adjustments, putting into service, use, assembly, disassembly, and maintenance are required to be carried out by suitably trained personnel in accordance with applicable code of practice.

If this equipment is used in a manner not specified by the manufacturer, the protection provided by the equipment may be impaired.

In no event will Rockwell Automation, Inc. be responsible or liable for indirect or consequential damages resulting from the use or application of this equipment.

The examples and diagrams in this manual are included solely for illustrative purposes. Because of the many variables and requirements associated with any particular installation, Rockwell Automation, Inc. cannot assume responsibility or liability for actual use based on the examples and diagrams.

No patent liability is assumed by Rockwell Automation, Inc. with respect to use of information, circuits, equipment, or software described in this manual.

Reproduction of the contents of this manual, in whole or in part, without written permission of Rockwell Automation, Inc., is prohibited.

Throughout this manual, when necessary, we use notes to make you aware of safety considerations.



WARNING: Identifies information about practices or circumstances that can cause an explosion in a hazardous environment, which may lead to personal injury or death, property damage, or economic loss.



ATTENTION: Identifies information about practices or circumstances that can lead to personal injury or death, property damage, or economic loss. Attentions help you identify a hazard, avoid a hazard, and recognize the consequence.

IMPORTANT Identifies information that is critical for successful application and understanding of the product.

These labels may also be on or inside the equipment to provide specific precautions.



SHOCK HAZARD: Labels may be on or inside the equipment, for example, a drive or motor, to alert people that dangerous voltage may be present.



BURN HAZARD: Labels may be on or inside the equipment, for example, a drive or motor, to alert people that surfaces may reach dangerous temperatures.



ARC FLASH HAZARD: Labels may be on or inside the equipment, for example, a motor control center, to alert people to potential Arc Flash. Arc Flash will cause severe injury or death. Wear proper Personal Protective Equipment (PPE). Follow ALL Regulatory requirements for safe work practices and for Personal Protective Equipment (PPE).

The following icon may appear in the text of this document.



Identifies information that is useful and can help to make a process easier to do or easier to understand.

Rockwell Automation recognizes that some of the terms that are currently used in our industry and in this publication are not in alignment with the movement toward inclusive language in technology. We are proactively collaborating with industry peers to find alternatives to such terms and making changes to our products and content. Please excuse the use of such terms in our content while we implement these changes.

Summary of Changes

The information below summarizes changes made for the September 2024 PowerFlex 4 Adjustable Frequency AC Drive User Manual, publication 22A-UM001L-EN-E.

Description of New or Updated Information	See Pages
Added Inclusive Language acknowledgment	Important User Info
Updated Bulletin 140M/140MT (Self-protected Combination Controller)/UL489 Circuit Breakers	16
Added 140MT motor protectors and 100-E contactors to Minimum Recommended Branch Circuit Protective Devices	17
Updated Power Terminal Block	21
Updated Programming and Parameters	39
Updated Circuit Breakers	77
Added 140MT motor protectors and 100-E contactors to Drive Ratings	78
Updated Approvals	79
Updated footnote for Specifications	79
Updated Dynamic Brake Resistors	84
Updated Communication Option Kits	86
Updated Programming Software	86

The information below summarizes changes made for the July 2017 PowerFlex 4 Adjustable Frequency AC Drive User Manual, publication 22A-UM001K-EN-E.

Description of New or Updated Information	See Pages
Line fuse footnote added to Fuse Rating column	17
Low Voltage Directive updated	31
Attention statement on Option 3 "2-W Lvl Sens" and Important statement about Option 4 "2-W Hi Speed" added to parameter P036 [Start Source]	47
Specifications table Approvals column updated	79
Sound Pressure Level specification added	80
Product Environmental Information added	81
Dynamic Brake Fuse Rating column and new footnote added	84
Network Wiring topic updated	99

The information below summarizes changes made for the June 2013 PowerFlex 4 Adjustable Frequency AC Drive User Manual, publication 22A-UM001J-EN-E.

Description of New or Updated Information	See Pages
Minimum Enclosure Volume column and new footnotes added	17 , 78
Drive, Fuse & Circuit Breaker Ratings topic updated	77
Electronic Motor Overload Protection description updated	80

Summary of Changes

The information below summarizes changes made for the September 2010 PowerFlex 4 Adjustable Frequency AC Drive User Manual, publication 22A-UM001I-EN-E.

Description of New or Updated Information	See Pages
Parameters A117 [Bus Reg Mode] and A118 [Comm Write Mode] added	51

The information below summarizes changes made for the July 2010 PowerFlex 4 Adjustable Frequency AC Drive User Manual, publication 22A-UM001H-EN-E.

Description of New or Updated Information	See Pages
Start and Speed Reference Control	29

The information below summarizes changes made for the March 2007 PowerFlex 4 Adjustable Frequency AC Drive User Manual, publication 22A-UM001G-EN-E.

Description of New or Updated Information	See Pages
Minimum Mounting Clearances clarified	12
Footnote (2) on Bulletin 140M catalog edited	17
Graphic for Analog Input, PTC wiring example corrected	25
Stop Drive icon and related warning text removed for parameter A110 [Anlg In 0-10V Lo]	64
New information on reading register address 8192 added	102
New information on reading register address 8193 adde.	103

The information below summarizes changes made for the September 2005 PowerFlex 4 Adjustable Frequency AC Drive User Manual, publication 22A-UM001F-EN-E.

Description of New or Updated Information	See Page(s)
Attention statement clarified	13
240V AC – 3-Phase 3.7 kW (5.0 Hp) drive fuse rating revised to 30 amps	17, 78
Analog Input, PTC wiring example added	25
Attention statement added to Multiple Digital Input Connections wiring example	28
Parameter P043 [Motor OL Ret] added	50
Attention statement added to parameter A082 [DB Resistor Sel]	57
External Comm Options, Compact I/O added to Table 20	86
Modbus function code 16 added	101

Table of Contents

Preface	Overview	
		Who Should Use this Manual? 7
		Reference Materials 7
		Manual Conventions 8
		Drive Frame Sizes 8
		General Precautions 9
		Catalog Number Explanation 10
Chapter 1	Installation/Wiring	
		Opening the Cover 11
		Mounting Considerations 12
		AC Supply Source Considerations 13
		General Grounding Requirements 14
		Fuses and Circuit Breakers 16
		Power Wiring 18
		I/O Wiring Recommendations 22
		Start and Speed Reference Control 29
		EMC Instructions 31
Chapter 2	Start Up	
		Prepare For Drive Start-Up 35
		Integral Keypad 36
		Viewing and Editing Parameters 37
Chapter 3	Programming and Parameters	
		About Parameters 39
		Parameter Organization 40
		Display Group 41
		Basic Program Group 46
		Advanced Program Group 51
		Parameter Cross Reference – by Name 67
Chapter 4	Troubleshooting	
		Drive Status 69
		Faults 69
		Fault Descriptions 71
		Common Symptoms and Corrective Actions 73
Appendix A	Supplemental Drive Information	
		Drive, Fuse & Circuit Breaker Ratings 77
		Specifications 78
		Product Environmental Information 81
Appendix B	Accessories and Dimensions	
		Product Selection 83
		Product Dimensions 87

Table of Contents

Appendix C	RS-485 (DSI) Protocol	
	Network Wiring	99
	Parameter Configuration	101
	Supported Modbus Function Codes	101
	Writing (06) Logic Command Data	102
	Writing (06) Reference	103
	Reading (03) Logic Status Data	103
	Reading (03) Feedback	103
	Reading (03) Drive Error Codes	104
	Reading (03) and Writing (06) Drive Parameters	104
	Additional Information	104
Appendix D	RJ45 DSI Splitter Cable	
	Connectivity Guidelines	105
	DSI Cable Accessories	106
	Connecting an RS-485 Network	107
Index	109

Overview

The purpose of this manual is to provide you with the basic information needed to install, start-up and troubleshoot the PowerFlex® 4 adjustable frequency AC drive.

Who Should Use this Manual?

This manual is intended for qualified personnel. You must be able to program and operate adjustable frequency AC drive devices. In addition, you must have an understanding of the parameter settings and functions.

Reference Materials

The following manuals are recommended for general drive information:

Resource	Description
PowerFlex AC Drive Performance Specifications per Ecodesign Regulation (EU) 2019/1781 and UK SI 2021 No. 745 Technical Data, publication PFLEX-TD003	Provides specifications per Ecodesign Regulation (EU) 2019/1781 and UK SI 2021 No. 745, including efficiency class.
Guarding Against Electrostatic Damage (ESD) Service Bulletin, publication 8000-4.5.2	Provides information on causes of ESD, and how you can guard against its effects.
Wiring and Grounding for Pulse Width Modulated (PWM) AC Drives Installation Instructions, publication DRIVES-IN001	Provides basic information that is needed to wire and ground PWM AC drives properly.
Preventive Maintenance Checklist of Industrial Control and Drive System Equipment Technical Data, publication DRIVES-TD001	Provides checklist on performing preventive maintenance for industrial control and drive system equipment.
Safety Guidelines for the Application, Installation, and Maintenance of Solid-state Control Installation Instructions, publication SGI-1.1	Provide general guidelines for the application, installation, and maintenance of solid-state control in the form of individual devices or packaged assemblies incorporating solid-state components.
Industrial Automation Wiring and Grounding Guidelines, publication 1770-4.1	Provides general guidelines for installing a Rockwell Automation industrial system.

Manual Conventions

- In this manual we refer to the PowerFlex 4 Adjustable Frequency AC Drive as: drive, PowerFlex 4 or PowerFlex 4 Drive.
- Parameter numbers and names are shown in this format:

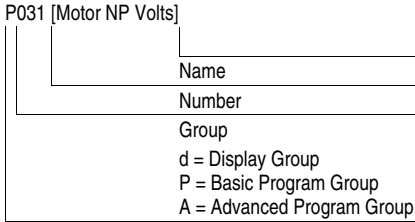

- The following words are used throughout the manual to describe an action:

Word	Meaning
Can	Possible, able to do something
Cannot	Not possible, not able to do something
May	Permitted, allowed
Must	Unavoidable, you must do this
Shall	Required and necessary
Should	Recommended
Should Not	Not Recommended

Drive Frame Sizes

Similar PowerFlex 4 drive sizes are grouped into frame sizes to simplify spare parts ordering, dimensioning, and so on. A cross reference of drive catalog numbers and their respective frame sizes is provided in [Appendix B](#).

General Precautions



ATTENTION: The drive contains high voltage capacitors which take time to discharge after removal of mains supply. Before working on drive, ensure isolation of mains supply from line inputs [R, S, T (L1, L2, L3)]. Wait three minutes for capacitors to discharge to safe voltage levels. Failure to do so may result in personal injury or death.

Darkened display LEDs is not an indication that capacitors have discharged to safe voltage levels.



ATTENTION: Only qualified personnel familiar with adjustable frequency AC drives and associated machinery should plan or implement the installation, start-up and subsequent maintenance of the system. Failure to comply may result in personal injury and/or equipment damage.



ATTENTION: This drive contains Electrostatic Discharge (ESD) sensitive parts and assemblies. Static control precautions are required when installing, testing, servicing or repairing this assembly. Component damage may result if ESD control procedures are not followed. If you are not familiar with static control procedures, reference publication [8000-4.5.2](#), “Guarding Against Electrostatic Damage” or any other applicable ESD protection handbook.



ATTENTION: An incorrectly applied or installed drive can result in component damage or a reduction in product life. Wiring or application errors, such as, undersizing the motor, incorrect or inadequate AC supply, or excessive ambient temperatures may result in malfunction of the system.



ATTENTION: The bus regulator function is extremely useful for preventing nuisance overvoltage faults resulting from aggressive decelerations, overhauling loads, and eccentric loads. However, it can also cause either of the following two conditions to occur.

1. Fast positive changes in input voltage or imbalanced input voltages can cause uncommanded positive speed changes;
2. Actual deceleration times can be longer than commanded deceleration times

However, a “Stall Fault” is generated if the drive remains in this state for 1 minute. If this condition is unacceptable, the bus regulator must be disabled (see parameter [A117](#)). In addition, installing a properly sized dynamic brake resistor will provide equal or better performance in most cases.

Catalog Number Explanation

1...3	4	5	6...8	9	10	11	12 ⁽¹⁾	13...14
22A	-	A	1P5	N	1	1	4	AA
Drive	Dash	Voltage Rating	Rating	Enclosure	HIM	Emission Class	Type	Optional

Code

22A PowerFlex 4

Code Version

3 No Brake IGBT
4 Standard

Code Voltage Phase

V 120V AC 1
A 240V AC 1
B 240V AC 3
D 480V AC 3

Code Rating

0 Not Filtered
1 Filtered

Code Interface Module

1 Fixed Keypad

Code Purpose

AA Reserved for custom firmware
...
ZZ

Code Enclosure

N Panel Mount - IP20 (NEMA Type Open)
F Flange Mount - IP20 (NEMA Type Open)
H Replacement Plate Drive - IP20 (NEMA Type Open)
- Contact factory for ordering information.

Output Current @ 100...120V Input

Code	Amps	kW (HP)
1P5	1.5	0.2 (0.25)
2P3	2.3	0.4 (0.5)
4P5	4.5	0.75 (1.0)
6P0	6.0	1.1 (1.5)

Output Current @ 200...240V Input, NO BRAKE

Code	Amps	kW (HP)
1P4	1.4	0.2 (0.25)
2P1	2.1	0.4 (0.5)
3P6	3.6	0.75 (1.0)
6P8	6.8	1.5 (2.0)
9P6	9.6	2.2 (3.0)

Output Current @ 200...240V Input

Code	Amps	kW (HP)
1P5	1.5	0.2 (0.25)
2P3	2.3	0.4 (0.5)
4P5	4.5	0.75 (1.0)
8P0	8.0	1.5 (2.0)
012	12.0	2.2 (3.0)
017	17.5	3.7 (5.0)

Output Current @ 380...480V Input

Code	Amps	kW (HP)
1P4	1.4	0.4 (0.5)
2P3	2.3	0.75 (1.0)
4P0	4.0	1.5 (2.0)
6P0	6.0	2.2 (3.0)
8P7	8.7	3.7 (5.0)

(1) Position 12 of the Catalog Number now indicates drive type. All PowerFlex 4 drives are equipped with RS-485 communication.

Installation/Wiring

This chapter provides information on mounting and wiring the PowerFlex 4 drive.

Most start-up difficulties are the result of incorrect wiring. Every precaution must be taken to assure that the wiring is done as instructed. All items must be read and understood before the actual installation begins.



ATTENTION: The following information is merely a guide for proper installation. Rockwell Automation, Inc. cannot assume responsibility for the compliance or the noncompliance to any code, national, local, or otherwise for the proper installation of this drive or associated equipment. A hazard of personal injury and/or equipment damage exists if codes are ignored during installation.

Opening the Cover

1. Press and hold in the tabs on each side of the cover.
2. Pull the cover out and up to release.

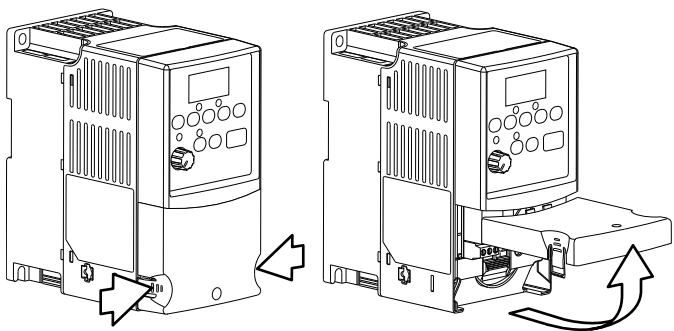

Mounting Considerations

- Mount the drive upright on a flat, vertical and level surface.
 - Install on 35 mm (1.38 in.) DIN rail.
 - or
 - Install with screws.

Table 1 – Screw Mounting Recommendations

Panel Thickness, Min	Screw Size	Mounting Torque
1.9 mm (0.0747 in.)	M4 (#8-32)	1.56...1.96 N•m (14...17 lb•in)

- Protect the cooling fan by avoiding dust or metallic particles.
- Do not expose to a corrosive atmosphere.
- Protect from moisture and direct sunlight.

Minimum Mounting Clearances

See [Appendix B](#) for mounting dimensions.

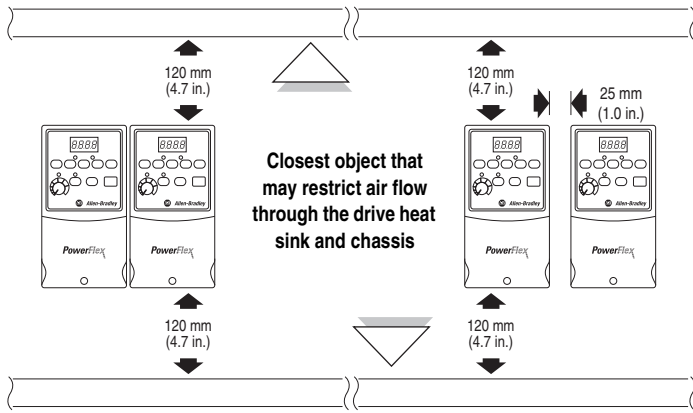

Mounting Option A

No clearance is required between drives.

Mounting Option B

Ambient Operating Temperatures

Table 2 – Enclosure and Clearance Requirements

Ambient Temperature		Enclosure Rating	Minimum Mounting Clearances
Minimum	Maximum		
-10 °C (14 °F)	40 °C (104 °F)	IP20/Open Type	Use Mounting Option A
		IP30/NEMA 1/UL Type 1 ⁽¹⁾	Use Mounting Option B
	50 °C (122 °F)	IP20/Open Type	Use Mounting Option B

⁽¹⁾ Rating requires installation of the PowerFlex 4 IP30/NEMA 1/UL Type 1 option kit.

Debris Protection

A plastic top panel is included with the drive. Install the panel to prevent debris from falling through the vents of the drive housing during installation. Remove the panel for IP20/Open Type applications.

Storage

- Store within an ambient temperature range of $-40\dots+85\text{ }^{\circ}\text{C}$ ($-40\dots+185\text{ }^{\circ}\text{F}$).
- Store within a relative humidity range of $0\dots95\%$, noncondensing.
- Do not expose to a corrosive atmosphere.

AC Supply Source Considerations

Ungrounded Distribution Systems



ATTENTION: PowerFlex 4 drives contain protective MOVs that are referenced to ground. These devices must be disconnected if the drive is installed on an ungrounded or resistive grounded distribution system.

Disconnecting MOVs

To prevent drive damage, the MOVs connected to ground shall be disconnected if the drive is installed on an ungrounded distribution system where the line-to-ground voltages on any phase could exceed 125% of the nominal line-to-line voltage. To disconnect these devices, remove the jumper shown in the [Figure 1](#) and [Figure 2](#).

1. Turn the screw counterclockwise to loosen.
2. Pull the jumper completely out of the drive chassis.
3. Tighten the screw to keep it in place.

Figure 1 – Jumper Location (A Frame Shown)

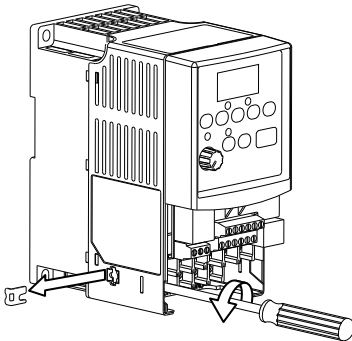

Important:
Tighten screw after
jumper removal.

Figure 2 – Phase to Ground MOV Removal

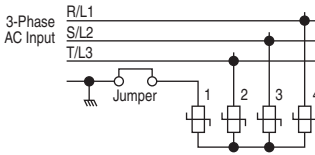

Input Power Conditioning

The drive is suitable for direct connection to input power within the rated voltage of the drive (see [Appendix A](#)). Listed in [Table 3](#) are certain input power conditions which may cause component damage or reduction in product life. If any of the conditions exist, as described in [Table 3](#), install one of the devices listed under the heading Corrective Action on the line side of the drive.

Important: Only one device per branch circuit is required. It should be mounted closest to the branch and sized to handle the total current of the branch circuit.

Table 3 – Input Power Conditions

Input Power Condition	Corrective Action
Low Line Impedance (less than 1% line reactance)	<ul style="list-style-type: none"> • Install Line Reactor⁽¹⁾ • or Isolation Transformer
Greater than 120 kVA supply transformer	
Line has power factor correction capacitors	
Line has frequent power interruptions	
Line has intermittent noise spikes in excess of 6000V (lightning)	
Phase to ground voltage exceeds 125% of normal line to line voltage	<ul style="list-style-type: none"> • Remove MOV jumper to ground. • or Install Isolation Transformer with grounded secondary if necessary.
Ungrounded distribution system	

(1) See [Appendix B](#) for accessory ordering information.

General Grounding Requirements

The drive Safety Ground - ⏏ (PE) must be connected to system ground. Ground impedance must conform to the requirements of national and local industrial safety regulations and/or electrical codes. The integrity of all ground connections should be periodically checked.

Figure 3 – Typical Grounding

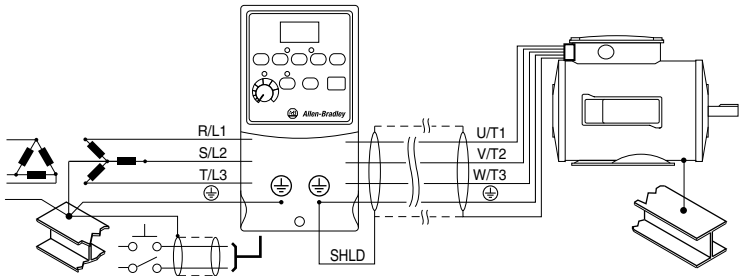

Ground Fault Monitoring

If a system ground fault monitor (RCD) is to be used, only Type B (adjustable) devices should be used to avoid nuisance tripping.

Safety Ground - \oplus (PE)

This is the safety ground for the drive that is required by code. One of these points must be connected to adjacent building steel (girder, joist), a floor ground rod or bus bar. Grounding points must comply with national and local industrial safety regulations and/or electrical codes.

Motor Ground

The motor ground must be connected to one of the ground terminals on the drive.

Shield Termination - SHLD

Either of the safety ground terminals located on the power terminal block provides a grounding point for the motor cable shield. The **motor cable** shield connected to one of these terminals (drive end) should also be connected to the motor frame (motor end). Use a shield terminating or EMI clamp to connect the shield to the safety ground terminal. The conduit box option may be used with a cable clamp for a grounding point for the cable shield.

When shielded cable is used for **control and signal wiring**, the shield should be grounded at the source end only, not at the drive end.

RFI Filter Grounding

Using single phase drives with integral filter, or an external filter with any drive rating, may result in relatively high ground leakage currents. Therefore, the **filter must only be used in installations with grounded AC supply systems and be permanently installed and solidly grounded** (bonded) to the building power distribution ground. Ensure that the incoming supply neutral is solidly connected (bonded) to the same building power distribution ground. Grounding must not rely on

flexible cables and should not include any form of plug or socket that would permit inadvertent disconnection. Some local codes may require redundant ground connections. The integrity of all connections should be periodically checked.

Fuses and Circuit Breakers

The PowerFlex 4 drive does not provide branch short circuit protection. This product should be installed with either input fuses or an input circuit breaker. National and local industrial safety regulations and/or electrical codes may determine additional requirements for these installations.



ATTENTION: To guard against personal injury and/or equipment damage caused by improper fusing or circuit breaker selection, use only the recommended line fuses/circuit breakers specified in this section.

Fusing

The PowerFlex 4 drive has been UL tested and approved for use with input fuses. The ratings in the table that follows are the minimum recommended values for use with each drive rating. The devices listed in this table are provided to serve as a guide.

■ **Bulletin 140M/140MT (Self-protected Combination Controller)/ UL489 Circuit Breakers**

■ When using Bulletin 140M/140MT or UL489 rated circuit breakers, the guidelines listed below must be followed in order to meet the NEC requirements for branch circuit protection.

- • Bulletin 140M/140MT can be used in single and group motor applications.
- • Bulletin 140M/140MT can be used up stream from the drive **without** the need for fuses.

Table 4 – Minimum Recommended Branch Circuit Protective Devices

Voltage Rating	Drive Rating kW (HP)	Fuse Rating⁽¹⁾ Amps (Line Fuse)	140M/140MT⁽²⁾⁽³⁾ Catalog Number	Recommended MCS Contactors Catalog Number	Min. Enclosure Volume⁽⁴⁾ Inches³
120V AC – 1-phase	0.2 (0.25)	10	140M-C2E-C10 140MT-C3E-C10	100-C09 100-E09	1655
	0.4 (0.5)	15	140M-C2E-C16 140MT-C3E-C16	100-C12 100-E12	1655
	0.75 (1.0)	30	140M-D8E-C20 140MT-D9E-C20	100-C23 100-E26	1655
	1.1 (1.5)	40	140M-F8E-C32	100-C37 100-E38	1655
240V AC – 1-phase NO BRAKE	0.2 (0.25)	6	140M-C2E-B40 140MT-C3E-B40	100-C09 100-E09	1655
	0.4 (0.5)	10	140M-C2E-B63 140MT-C3E-B63	100-C09 100-E09	1655
	0.75 (1.0)	15	140M-C2E-C16 140MT-C3E-C16	100-C12 100-E12	1655
	1.5 (2.0)	25	140M-C2E-C16 140MT-C3E-C16	100-C16 100-E16	1655
	2.2 (3.0)	30	140M-D8E-C25 140MT-D9E-C25	100-C23 100-E26	1655
240V AC – 1-phase	0.2 (0.25)	10	140M-C2E-B63 140MT-C3E-B63	100-C09 100-E09	1655
	0.4 (0.5)	10	140M-C2E-B63 140MT-C3E-B63	100-C09 100-E09	1655
	0.75 (1.0)	15	140M-C2E-C16 140MT-C3E-C16	100-C12 100-E12	1655
	1.5 (2.0)	30	140M-D8E-C20 140MT-D9E-C20	100-C23 100-E26	1655
240V AC – 3-phase	0.2 (0.25)	3	140M-C2E-B25 140MT-C3E-B25	100-C09 100-E09	1655
	0.4 (0.5)	6	140M-C2E-B40 140MT-C3E-B40	100-C09 100-E09	1655
	0.75 (1.0)	10	140M-C2E-C10 140MT-C3E-C10	100-C09 100-E09	1655
	1.5 (2.0)	15	140M-C2E-C16 140MT-C3E-C16	100-C12 100-E12	1655
	2.2 (3.0)	25	140M-C2E-C16 140MT-C3E-C16	100-C16 100-E16	1655
	3.7 (5.0)	30	140M-F8E-C25	100-C23 100-E26	1655

Table 4 – Minimum Recommended Branch Circuit Protective Devices (Continued)

Voltage Rating	Drive Rating kW (HP)	Fuse Rating ⁽¹⁾ Amps (Line Fuse)	140M/140MT ⁽²⁾⁽³⁾ Catalog Number	Recommended MCS Contactors Catalog Number	Min. Enclosure Volume ⁽⁴⁾ Inches ³
480V AC – 3-phase	0.4 (0.5)	3	140M-C2E-B25 140MT-C3E-B25	100-C09 100-E09	1655
	0.75 (1.0)	6	140M-C2E-B40 140MT-C3E-B40	100-C09 100-E09	1655
	1.5 (2.0)	10	140M-C2E-B63 140MT-C3E-B63	100-C09 100-E09	1655
	2.2 (3.0)	15	140M-C2E-C10 140MT-C3E-C10	100-C09 100-E09	1655
	3.7 (5.0)	15	140M-C2E-C16 140MT-C3E-C16	100-C16 100-E16	1655

- (1) Recommended Fuse Type: UL Class J, CC, T, or Type BS88; 600V (550V) or equivalent.
- (2) The AIC ratings of the Bulletin 140M/140MT devices can vary. See the Motor Protection Circuit Breaker and Motor Circuit Protector Specifications Technical Data, publication [140-TD005](#) or [140M-TD002](#).
- (3) Manual Self-protected (Type E) Combination Motor Controller, UL listed for 208 Wye or Delta, 240 Wye or Delta, 480Y/277 or 600Y/347. Not UL listed for use on 480V or 600V Delta/Delta, corner ground, or high-resistance ground systems.
- (4) When using a Manual Self-protected (Type E) Combination Motor Controller, the drive must be installed in a ventilated or non-ventilated enclosure with the minimum volume specified in this column. Application specific thermal considerations may require a larger enclosure.

Power Wiring



ATTENTION: National Codes and standards (NEC, VDE, BSI, and so on.) and local codes outline provisions for safely installing electrical equipment. Installation must comply with specifications regarding wire types, conductor sizes, branch circuit protection and disconnect devices. Failure to do so may result in personal injury and/or equipment damage.



ATTENTION: To avoid a possible shock hazard caused by induced voltages, unused wires in the conduit must be grounded at both ends. For the same reason, if a drive sharing a conduit is being serviced or installed, all drives using this conduit should be disabled. This will help minimize the possible shock hazard from “cross coupled” power leads.

Motor Cable Types Acceptable for 200...600 Volt Installations

General

A variety of cable types are acceptable for drive installations. For many installations, unshielded cable is adequate, provided it can be separated from sensitive circuits. As an approximate guide, allow a spacing of 0.3 meters (1 foot) for every 10 meters (32.8 feet) of length. In all cases, long parallel runs must be avoided. Do not use cable with an insulation thickness less than 15 mils (0.4 mm/0.015 in.). Do not route more than three sets of motor leads in a single conduit to minimize “cross talk”. If more than three drive/motor connections per conduit are required, shielded cable must be used.

UL installations in 50 °C (122 °F) ambient must use 600V, 75 °C or 90 °C (167 °F or 194 °F) wire.

UL installations in 40 °C (104 °F) ambient should use 600V, 75 °C or 90 °C (167 °F or 194 °F) wire.

Use copper wire only. Wire gauge requirements and recommendations are based on 75 °C (167 °F). Do not reduce wire gauge when using higher temperature wire.

Unshielded

THHN, THWN or similar wire is acceptable for drive installation in dry environments provided adequate free air space and/or conduit fill rates limits are provided. **Do not use THHN or similarly coated wire in wet areas.** Any wire chosen must have a minimum insulation thickness of 15 mils and should not have large variations in insulation concentricity.

Shielded

Location	Rating/Type	Description
Standard (Option 1)	600V, 75 °C or 90 °C (167 °F or 194 °F) RHH/RHW-2 Belden 29501...29507 or equivalent	<ul style="list-style-type: none"> • Four tinned copper conductors with XLPE insulation • Foil shield and tinned copper drain wire with 85% braid coverage • PVC jacket
Standard (Option 2)	Tray rated 600V, 75 °C or 90 °C (167 °F or 194 °F) RHH/RHW-2 Shawflex 2ACD/3ACD or equivalent	<ul style="list-style-type: none"> • Three tinned copper conductors with XLPE insulation • 5 mil single helical copper tape (25% overlap min) with three bare copper grounds in contact with shield • PVC jacket
Class I and II; Division I and II	Tray rated 600V, 75 °C or 90 °C (167 °F or 194 °F) RHH/RHW-2	<ul style="list-style-type: none"> • Three tinned copper conductors with XLPE insulation • 5 mil single helical copper tape (25% overlap min) with three bare copper grounds in contact with shield • PVC copper grounds on 6 mm² (10 AWG) and smaller

Reflected Wave Protection

The drive should be installed as close to the motor as possible. Installations with long motor cables may require the addition of external devices to limit voltage reflections at the motor (reflected wave phenomena). See [Table 5](#) for recommendations.

The reflected wave data applies to all frequencies 2...16 kHz.

For 240V ratings, reflected wave effects do not need to be considered.

Table 5 – Maximum Cable Length Recommendations

Reflected Wave		
380...480V Ratings	Motor Insulation Rating	Motor Cable Only⁽¹⁾
	1000 Vp-p	15 meters (49 feet)
	1200 Vp-p	40 meters (131 feet)
	1600 Vp-p	170 meters (558 feet)

⁽¹⁾ Longer cable lengths can be achieved by installing devices on the output of the drive. Consult factory for recommendations.

Output Disconnect

The drive is intended to be commanded by control input signals that will start and stop the motor. A device that routinely disconnects then reapplies output power to the motor for the purpose of starting and stopping the motor should not be used. If it is necessary to disconnect power to the motor with the drive outputting power, an auxiliary contact should be used to simultaneously disable drive control run commands.

Power Terminal Block

The drive utilizes a finger guard over the power wiring terminals. To remove:

1. Press in and hold the locking tab.
2. Slide finger guard down and out.

Replace the finger guard when wiring is complete.

Figure 4 – Power Terminal Block (A Frame Shown)

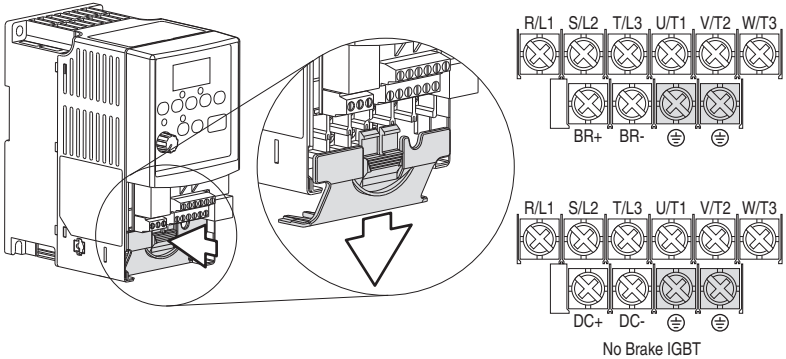

Terminal	Description
R/L1, S/L2	1-phase Input
R/L1, S/L2, T/L3	3-phase Input
U/T1	To Motor U/T1
V/T2	To Motor V/T2
W/T3	To Motor W/T3
BR+, BR-	Dynamic Brake Resistor Connection
DC+, DC-	DC Bus Connection
⊕	Safety Ground - PE

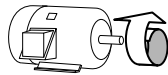

Switch any two motor leads to change forward direction.

Table 6 – Power Terminal Block Specifications

Frame	Maximum Wire Size ⁽¹⁾	Minimum Wire Size ⁽¹⁾	Torque
A	3.3 mm ² (12 AWG)	0.8 mm ² (18 AWG)	1.7...2.2 N•m (16...19 lb•in)
B	5.3 mm ² (10 AWG)	1.3 mm ² (16 AWG)	

⁽¹⁾ Maximum/Minimum sizes that the terminal block accepts. These sizes are not recommendations.

I/O Wiring Recommendations

Motor Start/Stop Precautions



ATTENTION: A contactor or other device that routinely disconnects and reapplies the AC line to the drive to start and stop the motor can cause drive hardware damage. The drive is designed to use control input signals that will start and stop the motor. If used, the input device must not exceed one operation per minute or drive damage can occur.



ATTENTION: The drive start/stop control circuitry includes solid-state components. If hazards due to accidental contact with moving machinery or unintentional flow of liquid, gas or solids exist, an additional hardwired stop circuit may be required to remove the AC line to the drive. When the AC line is removed, there will be a loss of any inherent regenerative braking effect that might be present - the motor will coast to a stop. An auxiliary braking method may be required.

Important points to remember about I/O wiring:

- Always use copper wire.
- Wire with an insulation rating of 600V or greater is recommended.
- Control and signal wires should be separated from power wires by at least 0.3 meters (1 foot).

Important: I/O terminals labeled “Common” are not referenced to the safety ground (PE) terminal and are designed to greatly reduce common mode interference.



ATTENTION: Driving the 4...20 mA analog input from a voltage source could cause component damage. Verify proper configuration prior to applying input signals.

Control Wire Types

Table 7 – Recommended Control and Signal Wire⁽¹⁾

Wire Type(s)	Description	Minimum Insulation Rating
Belden 8760/9460 (or equivalent)	0.8 mm ² (18 AWG), twisted pair, 100% shield with drain	300V 60 °C (140 °F)
Belden 8770 (or equivalent)	0.8 mm ² (18 AWG), 3 conductor, shielded for remote pot only	

⁽¹⁾ If the wires are short and contained within a cabinet which has no sensitive circuits, the use of shielded wire may not be necessary, but is always recommended.

I/O Terminal Block

Table 8 – I/O Terminal Block Specifications

Maximum Wire Size ⁽¹⁾	Minimum Wire Size ⁽¹⁾	Torque
1.3 mm ² (16 AWG)	0.13 mm ² (26 AWG)	0.5...0.8 N•m (4.4...7 lb•in)

⁽¹⁾ Maximum/Minimum sizes that the terminal block accepts. These sizes are not recommendations.

Maximum Control Wire Recommendations

Do not exceed control wiring length of 30 meters (100 feet). Control signal cable length is highly dependent on electrical environment and installation practices. To improve noise immunity, the I/O terminal block Common must be connected to ground terminal/protective earth. If using the RS-485 (DSI) port, I/O Terminal 16 should also be connected to ground terminal/protective earth.

Figure 5 – Control Wiring Block Diagram

(1) **Important:** I/O Terminal 01 is always a coast to stop input except when P036 [Start Source] is set to “3-Wire” control. In three wire control, I/O Terminal 01 is controlled by P037 [Stop Mode]. All other stop sources are controlled by P037 [Stop Mode].

Important: The drive is shipped with a jumper installed between I/O Terminals 01 and 11. Remove this jumper when using I/O Terminal 01 as a stop or enable input.

(2) Two wire control shown. For three wire control use a momentary input on I/O Terminal 02 to command a start. Use a maintained input for I/O Terminal 03 to change direction.

P036 [Start Source]	Stop	I/O Terminal 01 Stop
Keypad	Per P037	Coast
3-wire	Per P037	Per P037
2-wire	Per P037	Coast
RS-485 Port	Per P037	Coast

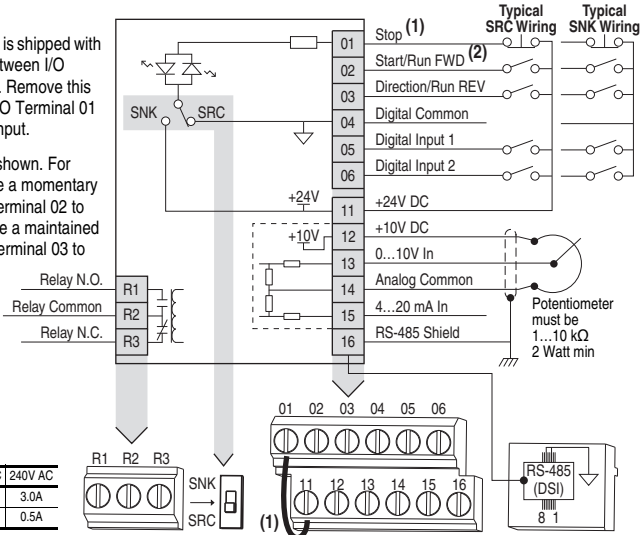

Table 9 – Control I/O Terminal Designations

No.	Signal	Default	Description	Param.
R1	Relay N.O.	Fault	Normally open contact for output relay.	A055
R2	Relay Common	–	Common for output relay.	–
R3	Relay N.C.	Fault	Normally closed contact for output relay.	A055

Sink/Source DIP Switch Source (SRC) Inputs can be wired as Sink (SNK) or Source (SRC) via DIP switch setting.

01	Stop (1)	Coast	The factory installed jumper or a normally closed input must be present for the drive to start.	P036 (1)
02	Start/Run FWD	Not Active	Command comes from the integral keypad by default. To disable reverse operation, see A095 [Reverse Disable].	P036 , P037
03	Direction/Run REV	Not Active		P036 , P037 , A095
04	Digital Common	–	For digital inputs. Electronically isolated with digital inputs from analog I/O.	–
05	Digital Input 1	Preset Freq	Program with A051 [Digital In1 Sel].	A051
06	Digital Input 2	Preset Freq	Program with A052 [Digital In2 Sel].	A052
11	+24V DC	–	Drive supplied power for digital inputs. Maximum output current is 100 mA.	–
12	+10V DC	–	Drive supplied power for 0...10V external potentiometer. Maximum output current is 15 mA.	P038
13	0...10V In (3)	Not Active	For external 0...10V input supply (input impedance = 100 kΩ) or potentiometer wiper.	P038
14	Analog Common	–	For 0...10V In or 4...20 mA In. Electronically isolated with analog inputs from digital I/O.	–

Table 9 – Control I/O Terminal Designations (Continued)

No.	Signal	Default	Description	Param.
15	4...20mA In ⁽³⁾	Not Active	For external 4...20 mA input supply (input impedance = 250 Ω).	P038
16	RS-485 (DSI) Shield	–	Terminal should be connected to safety ground - PE when using the RS-485 (DSI) communications port.	–

⁽³⁾ Only one analog frequency source may be connected at a time. If more than one reference is connected at the same time, an undetermined frequency reference will result.

I/O Wiring Examples

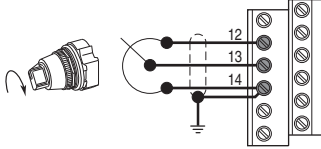
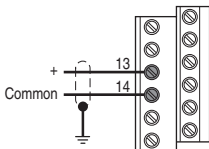
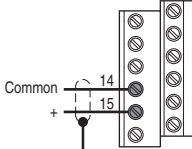
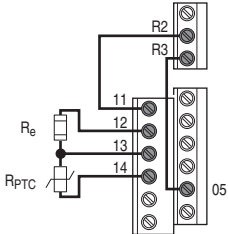
Input	Connection Example	
Potentiometer 1...10 kΩ Pot. Recommended (2 Watt minimum)	P038 [Speed Reference] = 2 "0-10V Input" 	
Analog Input 0...10V, 100 kΩ impedance 4...20 mA, 100 Ω impedance	Voltage P038 [Speed Reference] = 2 "0-10V Input" 	Current P038 [Speed Reference] = 3 "4-20mA Input" 
Analog Input, PTC For Drive Fault	Wire the PTC and External Resistor (typically matched to the PTC Hot Resistance) to I/O Terminals 12, 13, 14. Wire R2/R3 Relay Output (SRC) to I/O Terminals 5 & 11. A051 [Digital In1 Sel] = 3 "Aux Fault" A055 [Relay Out Sel] = 10 "Above Anlg V" A056 [Relay Out Level] = % Voltage Trip  <div style="border: 1px solid black; padding: 5px; width: fit-content; margin: 10px auto;"> $V_{Trip} = \frac{R_{PTC (hot)}}{R_{PTC (hot)} + R_e} \times 100$ </div>	

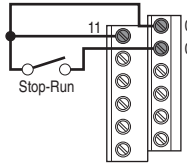
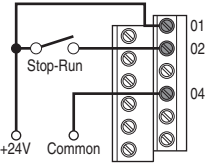
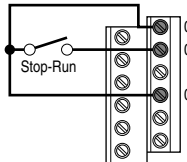
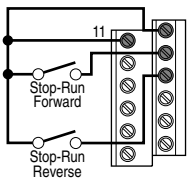
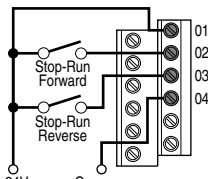
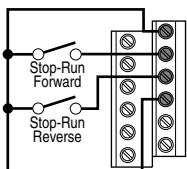
Input	Connection Example	
<p>2-wire SRC Control - Non-reversing</p> <p>P036 [Start Source] = 2, 3, or 4</p> <p>Input must be active for the drive to run. When input is opened, the drive will stop as specified by P037 [Stop Mode].</p> <p>If desired, a User Supplied 24V DC power source can be used. See the “External Supply (SRC)” example.</p>	<p>Internal supply (SRC)</p> 	<p>External supply (SRC)</p>  <p>Each digital input draws 6 mA.</p>
<p>2-wire SNK Control - Non-reversing</p>	<p>Internal supply (SNK)</p> 	
<p>2-wire SRC Control - Run FWD/Run REV</p> <p>P036 [Start Source] = 2, 3, or 4</p> <p>Input must be active for the drive to run. When input is opened, the drive will stop as specified by P037 [Stop Mode].</p> <p>If both Run Forward and Run Reverse inputs are closed at the same time, an undetermined state could occur.</p>	<p>Internal supply (SRC)</p> 	<p>External supply (SRC)</p>  <p>Each digital input draws 6 mA.</p>
<p>2-wire SNK Control - Run FWD/Run REV</p>	<p>Internal supply (SNK)</p> 	

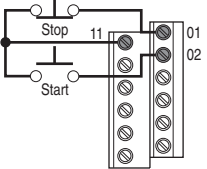
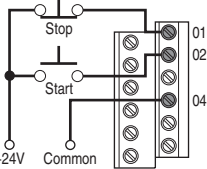
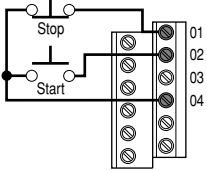
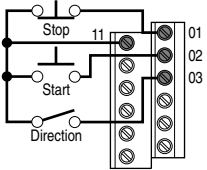
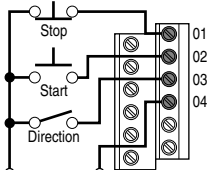
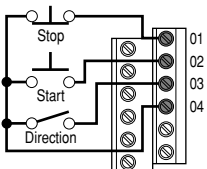
Input	Connection Example	
<p>3-wire SRC Control - Non-reversing</p> <p>P036 [Start Source] = 1</p> <p>A momentary input will start the drive. A stop input to I/O Terminal 01 will stop the drive as specified by P037 [Stop Mode].</p>	<p>Internal supply (SRC)</p> 	<p>External supply (SRC)</p>  <p>Each digital input draws 6 mA.</p>
<p>3-wire SNK Control - Non-reversing</p>	<p>Internal supply (SNK)</p> 	
<p>3-wire SRC Control - Reversing</p> <p>P036 [Start Source] = 1</p> <p>A momentary input will start the drive. A stop input to I/O Terminal 01 will stop the drive as specified by P037 [Stop Mode]. I/O Terminal 03 determines direction.</p>	<p>Internal supply (SRC)</p> 	<p>External supply (SRC)</p>  <p>Each digital input draws 6 mA.</p>
<p>3-wire SNK Control - Reversing</p>	<p>Internal supply (SNK)</p> 	

Typical Multiple Drive Connection Examples

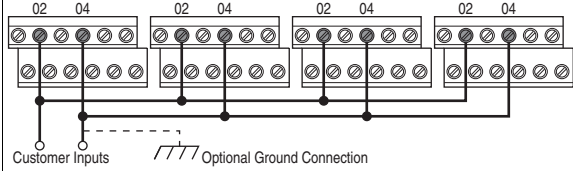
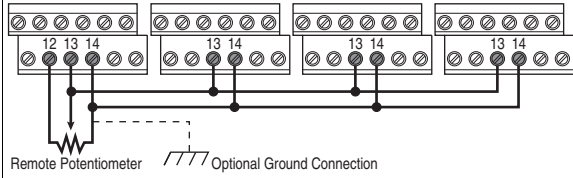
Input	Connection Example
<p>Multiple Digital Input Connections</p> <p>Customer Inputs can be wired per External supply (SRC) or Internal supply (SNK) examples on page 26.</p>	 <p>When connecting a single input such as Run, Stop, Reverse, or Preset Speeds to multiple drives, it is important to connect I/O Terminal 04 common together for all drives. If they are to be tied into another common (such as earth ground or separate apparatus ground) only one point of the daisy chain of I/O Terminal 04 should be connected.</p> <p>ATTENTION: I/O Common terminals should not be tied together when using SNK (Internal Supply) mode. In SNK mode, if power is removed from one drive, inadvertent operation of other drives that share the same I/O Common connection may occur.</p>
<p>Multiple Analog Connections</p>	 <p>When connecting a single potentiometer to multiple drives it is important to connect I/O Terminal 14 common together for all drives. I/O Terminal 14 common and I/O Terminal 13 (potentiometer wiper) should be daisy chained to each drive. All drives must be powered up for the analog signal to be read correctly.</p>

Start and Speed Reference Control

The drive speed command can be obtained from a number of different sources. The source is normally determined by P038 [Speed Reference]. However, when A051 or A052 [Digital Inx Sel] is set to option 2, 4, 5, or 6, and the digital input is active, A051 or A052 will override the speed reference commanded by P038 [Speed Reference]. See the chart below for the override priority.

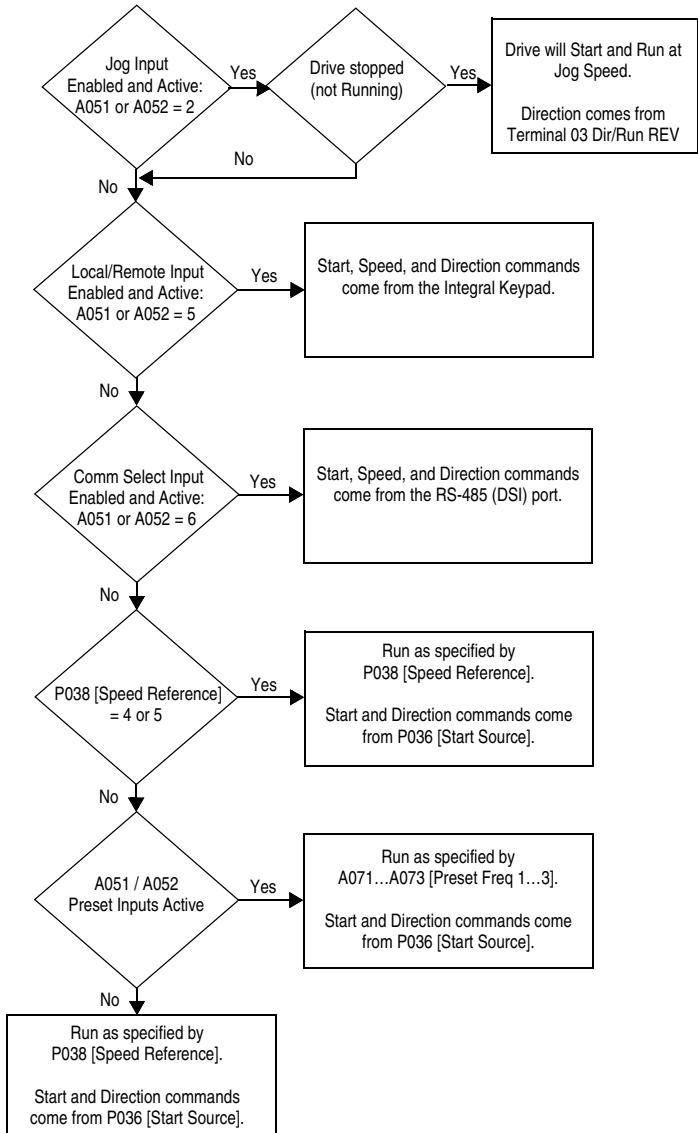

Accel/Decel Selection

The selection of Accel/Decel rates can be made through digital inputs, RS-485 (DSI) communications and/or parameters.

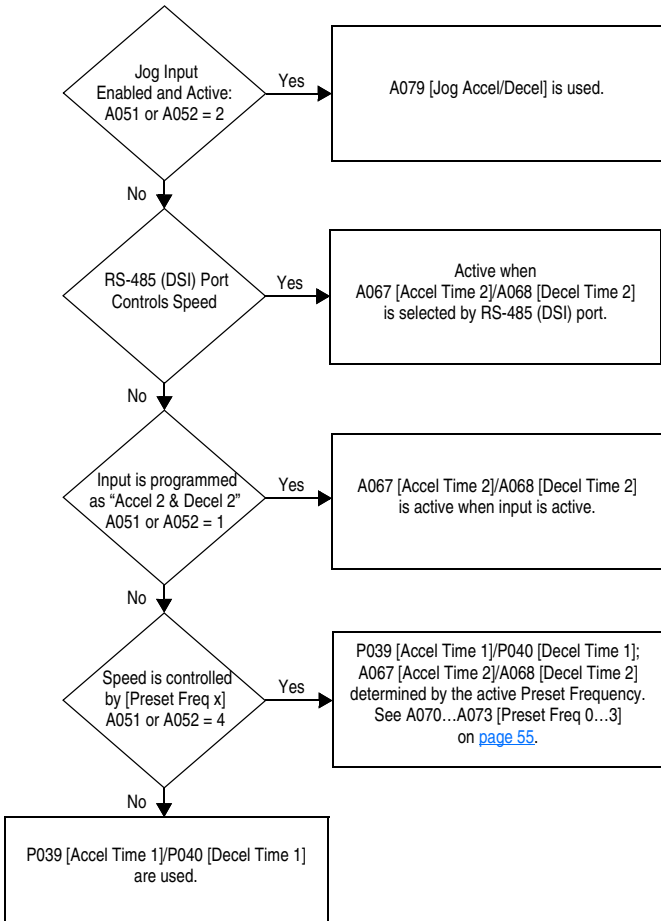

EMC Instructions

CE Conformity

Conformity with the Low Voltage (LV) Directive and Electromagnetic Compatibility (EMC) Directive has been demonstrated using harmonized European Norm (EN) standards published in the Official Journal of the European Communities. PowerFlex drives comply with the EN standards listed below when installed according to the user manual.

CE Declarations of Conformity are available online at: rok.auto/certifications.

Low Voltage Directive (2014/35/EU)

- EN 61800-5-1 Adjustable speed electrical power drive systems – Part 5-1: Safety requirements – Electrical, thermal, and energy.

Table 10 – Pollution Degree Ratings According to EN 61800-5-1

Pollution Degree	Description
1	No pollution or only dry, non-conductive pollution occurs. The pollution has no influence.
2	Normally, only non-conductive pollution occurs. Occasionally, however, a temporary conductivity caused by condensation is to be expected, when the drive is out of operation.

EMC Directive (2014/30/EU)

- EN 61800-3 Adjustable speed electrical power drive systems Part 3: EMC product standard including specific test methods.

General Notes

- If the plastic top panel is removed or the optional conduit box is not installed, the drive must be installed in an enclosure with side openings less than 12.5 mm (0.5 in.) and top openings less than 1.0 mm (0.04 in.) to maintain compliance with the LV Directive.
- The motor cable should be kept as short as possible in order to avoid electromagnetic emission as well as capacitive currents.
- Use of line filters in ungrounded systems is not recommended.
- Conformity of the drive with CE EMC requirements does not guarantee an entire machine installation complies with CE EMC requirements. Many factors can influence total machine/installation compliance.

Essential Requirements for CE Compliance

Conditions 1...3 listed below **must be** satisfied for PowerFlex drives to meet the requirements of EN 61800-3.

1. Grounding as described in [Figure 6](#). See [RFI Filter Grounding on page 15](#) for additional grounding recommendations.
2. Output power, control (I/O) and signal wiring must be braided, shielded cable with a coverage of 75% or better, metal conduit or equivalent attenuation.
3. Allowable cable length in [Table 11](#) is not exceeded.

Table 11 – Allowable Cable Length

Filter Type	EN 61800-3 First Environment Restricted Distribution or Second Environment ⁽²⁾	EN 61800-3 First Environment Unrestricted Distribution ⁽³⁾
Integral	10 meters (33 feet)	1 meter (3 feet)
External - S Type ⁽¹⁾	10 meters (33 feet)	1 meter (3 feet)
External - L Type ⁽¹⁾	100 meters (328 feet)	5 meters (16 feet)

⁽¹⁾ See [Appendix B](#) for details on optional external filters.

⁽²⁾ Equivalent to EN 55011 Class A

⁽³⁾ Equivalent to EN 55011 Class B

Figure 6 – Connections and Grounding

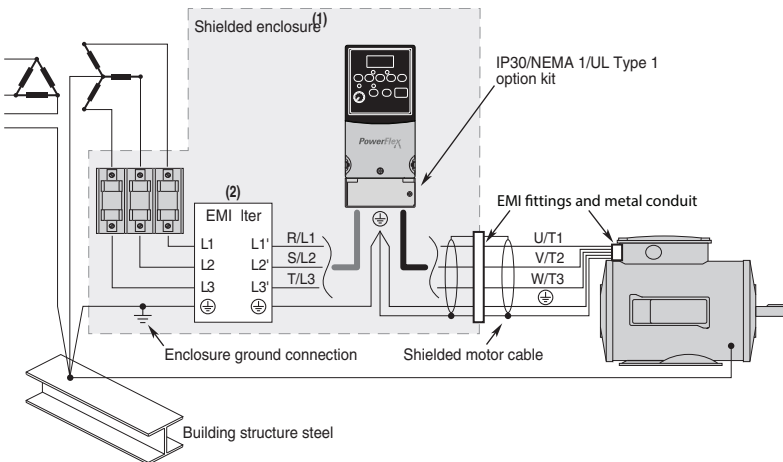

⁽¹⁾ First Environment Unrestricted Distribution installations require a shielded enclosure. Keep wire length as short as possible between the enclosure entry point and the EMI filter.

⁽²⁾ Integral EMI filters are available on 240V, 1-phase drives.

EN 61000-3-2

- 0.75 kW (1 HP) 240V 1-phase and 3-phase drives and 0.37 kW (0.5 HP) 240V 1-phase drives are suitable for installation on a private low voltage power network. Installations on a public low voltage power network may require additional external harmonic mitigation.
- Other drive ratings meet the current harmonic requirements of EN61000-3-2 without additional external mitigation.

Notes:

Start Up

This chapter describes how to start up the PowerFlex 4 drive. To simplify drive setup, the most commonly programmed parameters are organized in a single Basic Program Group.

Important: Read the [General Precautions](#) section before proceeding.



ATTENTION: Power must be applied to the drive to perform the following start-up procedures. Some of the voltages present are at incoming line potential. To avoid electric shock hazard or damage to equipment, only qualified service personnel should perform the following procedure. Thoroughly read and understand the procedure before beginning. If an event does not occur while performing this procedure, **Do Not Proceed. Remove All Power** including user supplied control voltages. User supplied voltages may exist even when main AC power is not applied to the drive. Correct the malfunction before continuing.

Prepare For Drive Start-Up

Before Applying Power to the Drive

1. Confirm that all inputs are connected to the correct terminals and are secure.
2. Verify that AC line power at the disconnect device is within the rated value of the drive.
3. Verify that any digital control power is 24 volts.
4. Verify that the Sink (SNK)/Source (SRC) Setup DIP switch is set to match your control wiring scheme. See [Figure 5](#) for location.

Important: The default control scheme is Source (SRC). The Stop terminal is jumpered (I/O Terminals 01 and 11) to allow starting from the keypad. If the control scheme is changed to Sink (SNK), the jumper must be removed from I/O Terminals 01 and 11 and installed between I/O Terminals 01 and 04.

- ❑ 5. Verify that the Stop input is present or the drive will not start.

Important: If I/O Terminal 01 is used as a stop input, the jumper between I/O Terminals 01 and 11 must be removed.

Applying Power to the Drive

- ❑ 6. Apply AC power and control voltages to the drive.
- ❑ 7. Familiarize yourself with the integral keypad features (see [Integral Keypad on page 36](#)) before setting any Program Group parameters.

Start, Stop, Direction, and Speed Control

Factory default parameter values allow the drive to be controlled from the integral keypad. No programming is required to start, stop, change direction, and control speed directly from the integral keypad.

Important: To disable reverse operation, see [A095](#) [Reverse Disable].

If a fault appears on power up, see the [Fault Descriptions on page 71](#) for an explanation of the fault code.

Variable Torque Fan/Pump Applications









For improved motor tuning performance when using a premium efficient motor on a variable torque load, set [A084](#) [Boost Select] to option 2 “35.0, VT”.

Integral Keypad

The diagram shows the integral keypad with a digital display showing 'P031'. The display is divided into 'PROGRAM' and 'FAULT' sections. The display shows 'P' in the PROGRAM section and '031' in the FAULT section. The keypad includes buttons for 'RUN', 'FWD', 'REV', 'PROGRAM', 'FAULT', 'Eco', 'Sel', and a numeric keypad. A table to the right provides a description for the fault codes displayed on the keypad.

Menu	Description
<i>d</i>	Display Group (View Only) Consists of commonly viewed drive operating conditions.
<i>P</i>	Basic Program Group Consists of most commonly used programmable functions.
<i>A</i>	Advanced Program Group Consists of remaining programmable functions.
<i>F</i>	Fault Designator Consists of list of codes for specific fault conditions. Displayed only when fault is present.









No.	LED	LED State	Description
❶	Run/Direction Status	Steady red	Indicates drive is running and commanded motor direction.
		Flashing red	Drive has been commanded to change direction. Indicates actual motor direction while decelerating to zero.
❷	Alphanumeric Display	Steady red	Indicates parameter number, parameter value, or fault code.
		Flashing red	Single digit flashing indicates that digit can be edited. All digits flashing indicates a fault condition.
❸	Displayed Units	Steady red	Indicates the units of the parameter value being displayed.
❹	Program Status	Steady red	Indicates parameter value can be changed.
❺	Fault Status	Flashing red	Indicates drive is faulted.
❻	Pot Status	Steady green	Indicates potentiometer on Integral Keypad is active.
❼	Start Key Status	Steady green	Indicates Start key on Integral Keypad is active. The Reverse key is also active unless disabled by A095 [Reverse Disable].

No.	Key	Name	Description
❸		Escape	Back one step in programming menu. Cancel a change to a parameter value and exit Program Mode.
		Select	Advance one step in programming menu. Select a digit when viewing parameter value.
		Up Arrow Down Arrow	Scroll through groups and parameters. Increase/decrease the value of a flashing digit.
		Enter	Advance one step in programming menu. Save a change to a parameter value.
❹		Potentiometer	Used to control speed of drive. Default is active. Controlled by parameter P038 [Speed Reference].
		Start	Used to start the drive. Default is active. Controlled by parameter P036 [Start Source].
		Reverse	Used to reverse direction of the drive. Default is active. Controlled by parameters P036 [Start Source] and A095 [Reverse Disable].
		Stop	Used to stop the drive or clear a fault. This key is always active. Controlled by parameter P037 [Stop Mode].

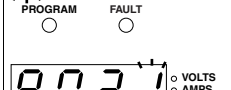
Viewing and Editing Parameters

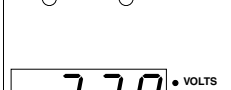
The last user-selected Display Group parameter is saved when power is removed and is displayed by default when power is reapplied.

The following is an example of basic integral keypad and display functions. This example provides basic navigation instructions and illustrates how to program the first Program Group parameter.

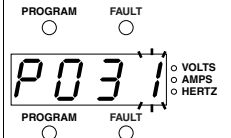
Step	Keys	Example Displays
1. When power is applied, the last user-selected Display Group parameter number is briefly displayed with flashing characters. The display then defaults to that parameter's current value (Example shows the value of d001 [Output Freq] with the drive stopped).		
2. Press Esc once to display the Display Group parameter number shown on power-up. The parameter number will flash.	Esc	
3. Press Esc again to enter the group menu. The group menu letter will flash.	Esc	
4. Press the Up Arrow or Down Arrow to scroll through the group menu (d, P, and A).	Up Arrow or Down Arrow	
5. Press Enter or Sel to enter a group. The right digit of the last viewed parameter in that group will flash.	Left Arrow or Sel	
6. Press the Up Arrow or Down Arrow to scroll through the parameters that are in the group.	Up Arrow or Down Arrow	
7. Press Enter or Sel to view the value of a parameter. If you do not want to edit the value, press Esc to return to the parameter number.	Left Arrow or Sel	
8. Press Enter or Sel to enter program mode to edit the parameter value. The right digit will flash and the Program LED will illuminate if the parameter can be edited.	Left Arrow or Sel	
9. Press the Up Arrow or Down Arrow to change the parameter value. If desired, press Sel to move from digit to digit or bit to bit. The digit or bit that you can change will flash.	Up Arrow or Down Arrow	
10. Press Esc to cancel a change. The digit will stop flashing, the previous value is restored and the Program LED will turn off. Or Press Enter to save a change. The digit will stop flashing and the Program LED will turn off.	Esc Left Arrow	
11. Press Esc to return to the parameter list. Continue to press Esc to back out of the programming menu. If pressing Esc does not change the display, then d001 [Output Frequency] is displayed. Press Enter or Sel to enter the group menu.	Esc	

The Basic Program Group ([page 46](#)) contains the most commonly changed parameters.

Programming and Parameters

Chapter 3 provides a complete listing and description of the PowerFlex 4 parameters. Parameters are programmed (viewed/edited) using the integral keypad. As an alternative, programming can also be performed using Connected Components Workbench™ or DriveExecutive™ software, a personal computer and a serial converter module. See [Appendix B](#) for catalog numbers.

About Parameters

To configure a drive to operate in a specific way, drive parameters may have to be set. Three types of parameters exist:

- **ENUM**
ENUM parameters allow a selection from 2 or more items. Each item is represented by a number.
- **Numeric Parameters**
These parameters have a single numerical value (for example, 0.1 Volts).
- **Bit Parameters**
Bit parameters have four individual bits associated with features or conditions. If the bit is 0, the feature is off or the condition is false. If the bit is 1, the feature is on or the condition is true.

Some parameters are marked as follows.

 = Stop drive before changing this parameter.

 = 32-bit parameter. Parameters marked 32-bit will have two parameter numbers when using RS-485 communications and programming software.

Parameter Organization

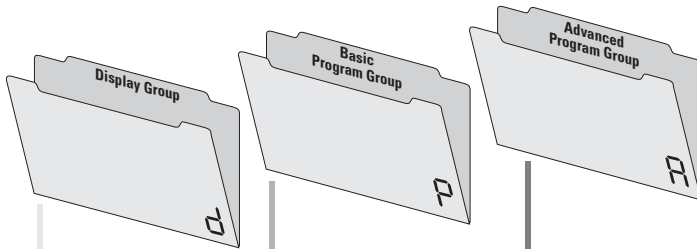

Display Group	(page 41)	Basic Program Group	(page 46)	Advanced Program Group	(page 51)
Output Freq	d001	Motor NP Volts	P031	Digital In1 Sel	A051
Commanded Freq	d002	Motor NP Hertz	P032	Digital In2 Sel	A052
Output Current	d003	Motor OL Current	P033	Relay Out Sel	A055
Output Voltage	d004	Minimum Freq	P034	Relay Out Level	A056
DC Bus Voltage	d005	Maximum Freq	P035	Accel Time 2	A067
Drive Status	d006	Start Source	P036	Decel Time 2	A068
Fault 1 Code	d007	Stop Mode	P037	Internal Freq	A069
Fault 2 Code	d008	Speed Reference	P038	Preset Freq 0	A070
Fault 3 Code	d009	Accel Time 1	P039	Preset Freq 1	A071
Process Display	d010	Decel Time 1	P040	Preset Freq 2	A072
Control Source	d012	Reset To Defaults	P041	Preset Freq 3	A073
Contrl In Status	d013	Motor OL Ret	P043	Jog Frequency	A078
Dig In Status	d014			Jog Accel/Decel	A079
Comm Status	d015			DC Brake Time	A080
Control SW Ver	d016			DC Brake Level	A081
Drive Type	d017			DB Resistor Sel	A082
Elapsed Run Time	d018			S Curve %	A083
Testpoint Data	d019			Boost Select	A084
Analog In 0-10V	d020			Maximum Voltage	A088
Analog In 4-20mA	d021			Current Limit	A089
Drive Temp	d024			Motor OL Select	A090
				PWM Frequency	A091
				Auto Rstrt Tries	A092
				Auto Rstrt Delay	A093
				Start At PowerUp	A094
				Reverse Disable	A095
				Flying Start En	A096
				Compensation	A097
				SW Current Trip	A098
				Process Factor	A099
				Fault Clear	A100
				Program Lock	A101
				Testpoint Sel	A102
				Comm Data Rate	A103
				Comm Node Addr	A104
				Comm Loss Action	A105
				Comm Loss Time	A106
				Comm Format	A107
				Anlg In 0-10V Lo	A110
				Anlg In 0-10V Hi	A111
				Anlg In 4-20mA Lo	A112
				Anlg In 4-20mA Hi	A113
				Slip Hertz @ FLA	A114
				Process Time Lo	A115
				Process Time Hi	A116
				Bus Reg Mode	A117
				Comm Write Mode	A118

Display Group

d001 [Output Freq]

Related Parameters: [d002](#), [d010](#), [P034](#), [P035](#), [P038](#)

Output frequency present at T1, T2, and T3 (U, V, and W).

Values	Default	Read Only
	Min/Max:	0.0/ P035 [Maximum Freq]
	Display:	0.1 Hz

d002 [Commanded Freq]

Related Parameters: [d001](#), [d013](#), [P034](#), [P035](#), [P038](#)

Value of the active frequency command. Displays the commanded frequency even if the drive is not running.

Important: The frequency command can come from a number of sources. See [Start and Speed Reference Control on page 29](#) for details.

Values	Default	Read Only
	Min/Max:	0.0/ P035 [Maximum Freq]
	Display:	0.1 Hz

d003 [Output Current]

The output current present at T1, T2, and T3 (U, V, and W).

Values	Default	Read Only
	Min/Max:	0.00/(Drive Rated Amps × 2)
	Display:	0.01 Amps

d004 [Output Voltage]

Related Parameters: [P031](#), [A084](#), [A088](#)

Output voltage present at terminals T1, T2, and T3 (U, V, and W).

Values	Default	Read Only
	Min/Max:	0/Drive Rated Volts
	Display:	1 VAC

d005 [DC Bus Voltage]

Present DC bus voltage level.

Values	Default	Read Only
	Min/Max:	Based on Drive Rating
	Display:	1 VDC

Display Group *(continued)*

d006 [Drive Status]

Related Parameter: [A095](#)

Present operating condition of the drive.

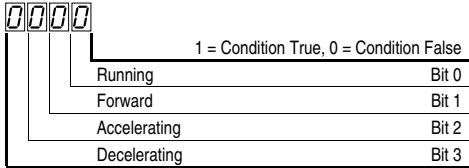

Values	Default	Read Only
	Min/Max:	0/1
	Display:	1

d007 [Fault 1 Code]

d008 [Fault 2 Code]

d009 [Fault 3 Code]

A code that represents a drive fault. The codes will appear in these parameters in the order they occur ([d007](#) [Fault 1 Code] = the most recent fault). Repetitive faults will only be recorded once.

See [Chapter 4](#) for fault code descriptions.

Values	Default	Read Only
	Min/Max:	F2/F122
	Display:	F1

d010 [Process Display]

Related Parameters: [d001](#), [A099](#), [A115](#), [A116](#)

 32-bit parameter

The output frequency scaled by [A099](#) [Process Factor] or by [A115](#) [Process Time Lo] and [A116](#) [Process Time Hi].

$$\text{Output Freq} \times \text{Process Factor} = \text{Process Display}$$

Values	Default	Read Only
	Min/Max:	0.00/9999
	Display:	0.01/1

Display Group *(continued)*

d012 [Control Source]

Related Parameters: [P036](#), [P038](#), [A051](#), [A052](#)

Displays the active source of the Start Command and Speed Command which are normally defined by the settings of [P036](#) [Start Source] and [P038](#) [Speed Reference] but may be overridden by digital inputs. See the flowcharts on [page 29](#) and [page 30](#) for details.

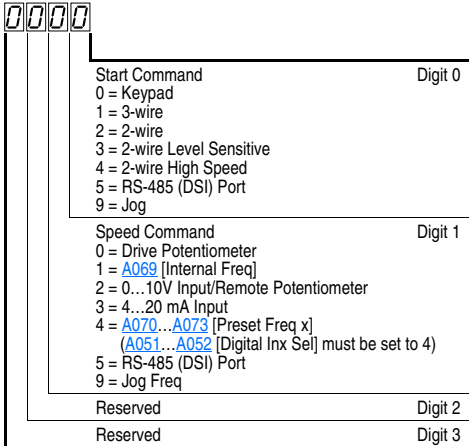

Values	Default	Read Only
Min/Max:		0/9
Display:		1

d013 [Contrl In Status]

Related Parameters: [d002](#), [P034](#), [P035](#)

Status of the control terminal block control inputs.

Important: Actual control commands may come from a source other than the control terminal block.

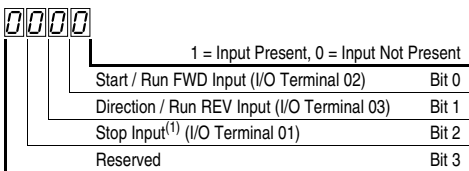

⁽¹⁾ The stop input must be present in order to start the drive. When this bit is a 1 the drive can be started. When this bit is a 0 the drive will stop.

Values	Default	Read Only
Min/Max:		0/1
Display:		1

Display Group *(continued)*

d014 [Dig In Status]

Related Parameters: [A051](#), [A052](#)

Status of the control terminal block digital inputs.

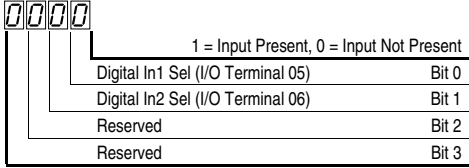

Values	Default	Read Only
	Min/Max:	0/1
	Display:	1

d015 [Comm Status]

Related Parameters: [A103](#)...[A107](#)

Status of the communications ports.

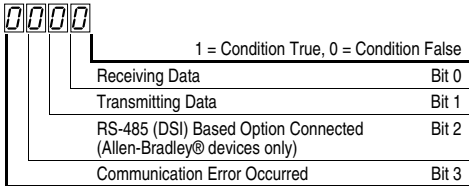

Values	Default	Read Only
	Min/Max:	0/1
	Display:	1

d016 [Control SW Ver]

Main Control Board software version.

Values	Default	Read Only
	Min/Max:	1.00/99.99
	Display:	0.01

d017 [Drive Type]

Used by Rockwell Automation field service personnel.

Values	Default	Read Only
	Min/Max:	1001/9999
	Display:	1

Display Group *(continued)*

d018 [Elapsed Run Time]

Accumulated time drive is outputting power. Time is displayed in 10 hour increments.

Values	Default	Read Only
	Min/Max:	0/9999 Hrs
	Display:	1 = 10 Hrs

d019 [Testpoint Data]

Related Parameter: [A102](#)

The present value of the function selected in [A102](#) [Testpoint Sel].

Values	Default	Read Only
	Min/Max:	0/FFFF
	Display:	1 Hex

d020 [Analog In 0-10V]

Related Parameters: [A110](#), [A111](#)

The present value of the voltage at I/O Terminal 13 (100.0% = 10 volts).

Values	Default	Read Only
	Min/Max:	0.0/100.0%
	Display:	0.1%

d021 [Analog In 4-20mA]

Related Parameters: [A112](#), [A113](#)

The present value of the current at I/O Terminal 15 (0.0% = 4mA, 100.0% = 20mA).

Values	Default	Read Only
	Min/Max:	0.0/100.0%
	Display:	0.1%

d024 [Drive Temp]

Present operating temperature of the drive power section.

Values	Default	Read Only
	Min/Max:	0/120 °C
	Display:	1 °C

Basic Program Group

P031 [Motor NP Volts]

Related Parameters: [d004](#), [A084](#)



Stop drive before changing this parameter.

Set to the motor nameplate rated volts.

Values	Default	Based on Drive Rating
	Min/Max:	20/Drive Rated Volts
	Display:	1 VAC

P032 [Motor NP Hertz]

Related Parameters: [A084](#), [A090](#)



Stop drive before changing this parameter.

Set to the motor nameplate rated frequency.

Values	Default	60 Hz
	Min/Max:	10/240 Hz
	Display:	1 Hz

P033 [Motor OL Current]

Related Parameters: [P043](#), [A055](#), [A089](#), [A090](#), [A098](#), [A114](#)

Set to the maximum allowable motor current.

The drive faults on an F7 Motor Overload if the value of this parameter is exceeded by 150% for 60 seconds.

Values	Default	Based on Drive Rating
	Min/Max:	0.0/(Drive Rated Amps × 2)
	Display:	0.1 Amps

P034 [Minimum Freq]

Related Parameters: [d001](#), [d002](#), [d013](#), [P035](#), [A110](#), [A112](#), [A115](#)

Sets the lowest frequency the drive will output continuously.

Values	Default	0.0 Hz
	Min/Max:	0.0/240.0 Hz
	Display:	0.1 Hz

P035 [Maximum Freq]

Related Parameters: [d001](#), [d002](#), [d013](#), [P034](#), [A078](#), [A111](#), [A113](#), [A115](#)



Stop drive before changing this parameter.

Sets the highest frequency the drive will output.

Values	Default	60 Hz
	Min/Max:	0/240 Hz
	Display:	1 Hz

Basic Program Group *(continued)*

P036 [Start Source]

Related Parameters: [d012](#), [P037](#)



Stop drive before changing this parameter.

See the control scheme used to start the drive.

See the [Start and Speed Reference Control on page 29](#) for details about how other drive settings can override the setting of this parameter.

Important: For all settings except option 3, the drive must receive a leading edge from the start input for the drive to start after a stop input, loss of power or fault condition.

Options	0	“Keypad” (Default)	<ul style="list-style-type: none"> Integral keypad controls drive operation. I/O Terminal 1 “Stop” = Coast-to-stop When active, the Reverse key is also active unless disabled by A095 [Reverse Disable].
	1	“3-Wire”	I/O Terminal 1 “Stop” = Stop according to the value set in P037 [Stop Mode]
	2	“2-Wire”	I/O Terminal 1 “Stop” = Coast-to-stop
	3	“2-W Lvl Sens”	Drive will restart after a “Stop” command when: <ul style="list-style-type: none"> Stop is removed and Start is held active



ATTENTION: Hazard of injury exists due to unintended operation. When P036 [Start Source] is set to option 3, and the Run input is maintained, the Run inputs do not need to be toggled after a Stop input for the drive to run again. A Stop function is provided only when the Stop input is active (open).

ATTENTION: The drive must only be controlled from the Digital Input Terminal Blocks and must NOT be used with any other DSI or Network device.

	4	“2-W Hi Speed”	<p>Important: There is greater potential voltage on the output terminals when using this option.</p> <p>Important: The drive may fault on an F5 OverVoltage if P036 [Start Source] is set to “2-W Hi Speed” and a Coast-to-stop command is given while the drive is running. For example, a Coast to Stop command is given while the drive is running when P037 [Stop Mode] = 1 “Coast, CF” or 5 “Coast” and P036 [Start Source] = 4.</p> <ul style="list-style-type: none"> Outputs are kept in a ready-to-run state. The drive responds to a “Start” command within 10 ms. I/O Terminal 1 “Stop” = Coast-to-stop
	5	“Comm Port”	<ul style="list-style-type: none"> Remote communications. See Appendix C for details. I/O Terminal 1 “Stop” = Coast-to-stop

Important: When commanding Jog via the RS-485 communications port on drives with firmware revision 1.02 or earlier, the Jog command will follow the commanded direction from I/O Terminal 03. On firmware revisions 1.03 and later, the commanded direction will be provided via the RS-485 communications port.

Important: When sending a continuous start command via the RS-485 communications port on drives with firmware revision 1.02 or earlier, a maintained stop input is required to stop the drive. Once the stop input is inactive, the drive will restart. On firmware revisions 1.03 and later, once a stop input is received, the start command must transition from high to low to high for the drive to start.

Basic Program Group *(continued)*

P037 [Stop Mode]

Related Parameters: [P036](#), [A080](#), [A081](#), [A082](#), [A105](#)

Active stop mode for all stop sources [for example, keypad, run forward (I/O Terminal 02), run reverse (I/O Terminal 03), RS-485 port] except as noted below.

Important: I/O Terminal 01 is always a coast to stop input except when [P036](#) [Start Source] is set for “3-Wire” control. When in three wire control, I/O Terminal 01 is controlled by [P037](#) [Stop Mode].

Hardware Enable Circuitry

By default, I/O Terminal 01 is a coast to stop input. The status of the input is interpreted by drive software. If the application requires the drive to be disabled without software interpretation, a “dedicated” hardware enable configuration can be utilized. This is accomplished by removing the ENBL enable jumper on the control board. In this case, the drive will always coast to a stop regardless of the settings of [P036](#) [Start Source] and [P037](#) [Stop Mode].

Options	0	“Ramp, CF ⁽¹⁾ (Default)	Ramp to Stop. “Stop” command clears active fault.
	1	“Coast, CF ⁽¹⁾	Coast-to-stop. “Stop” command clears active fault.
	2	“DC Brake, CF ⁽¹⁾	DC Injection Braking Stop. “Stop” command clears active fault.
	3	“DCBrkAuto,CF ⁽¹⁾	DC Injection Braking Stop with Auto Shutoff <ul style="list-style-type: none"> • Standard DC Injection Braking for value set in A080 [DC Brake Time] OR • Drive shuts off if the drive detects that the motor is stopped. “Stop” command clears active fault.
	4	“Ramp”	Ramp to Stop
	5	“Coast”	Coast-to-stop
	6	“DC Brake”	DC Injection Braking Stop
	7	“DC BrakeAuto”	DC Injection Braking Stop with Auto Shutoff <ul style="list-style-type: none"> • Standard DC Injection Braking for value set in A080 [DC Brake Time] OR • Drive shuts off if current limit is exceeded.

⁽¹⁾ Stop input also clears active fault.

Basic Program Group *(continued)*

P038 [Speed Reference] Related Parameters: [d001](#), [d002](#), [d012](#), [P039](#), [P040](#), [A051](#), [A052](#), [A069](#), [A070...A073](#), [A110](#), [A111](#), [A112](#), [A113](#)

Sets the source of the speed reference to the drive.

The drive speed command can be obtained from a number of different sources. The source is normally determined by [P038](#) [Speed Reference]. However, when [A051...A052](#) [Digital Inx Sel] is set to option 2, 4, 5, 6, 11, 12, 13, 14, 15, and the digital input is active, the speed reference commanded by [P038](#) [Speed Reference] will be overridden. See the flowchart on [page 29](#) for more information on speed reference control priority.

Options	0	“Drive Pot” (Default)	Internal frequency command from the potentiometer on the integral keypad
	1	“InternalFreq”	Internal frequency command from A069 [Internal Freq]
	2	“0-10V Input”	External frequency command from the 0...10V analog input or remote potentiometer
	3	“4-20mA Input”	External frequency command from the 4...20 mA analog input
	4	“Preset Freq”	External frequency command as defined by A070...A073 [Preset Freq x] when A051 and A052 [Digital Inx Sel] are programmed as “Preset Frequencies” and the digital inputs are active
	5	“Comm Port”	External frequency command from the communications port

P039 [Accel Time 1] Related Parameters: [P038](#), [P040](#), [A051](#), [A052](#), [A067](#), [A070...A073](#)

Sets the rate of acceleration for all speed increases.

$$\frac{\text{Maximum Freq}}{\text{Accel Time}} = \text{Accel Rate}$$

Values	Default	10.0 Secs
	Min/Max:	0.0/600.0 Secs
	Display:	0.1 Secs

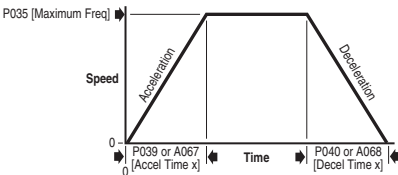

Basic Program Group *(continued)*

P040 [Decel Time 1] Related Parameters: [P038](#), [P039](#), [A051](#), [A052](#), [A068](#), [A070](#)...[A073](#)

Sets the rate of deceleration for all speed decreases.

$$\frac{\text{Maximum Freq}}{\text{Decel Time}} = \text{Decel Rate}$$

Values	Default	10.0 Secs
	Min/Max:	0.1/600.0 Secs
	Display:	0.1 Secs

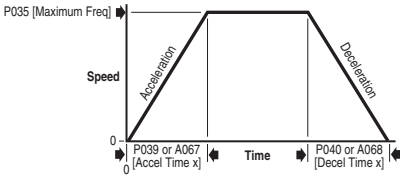

P041 [Reset To Defaults]



Stop drive before changing this parameter.

Resets all parameter values to factory defaults.

Options	0 "Idle State" (Default)	
	1 "Reset Defaults"	<ul style="list-style-type: none"> After the reset function is complete, this parameter will set itself back to "0". Causes an F48 Params Defaulted fault.

P043 [Motor OL Ret]

Related Parameter: [P033](#)

Enables/disables the Motor Overload Retention function. When Enabled, the value held in the motor overload counter is saved at power-down and restored at power-up. A change to this parameter setting resets the counter.

Options	0 "Disabled" (Default)
	1 "Enabled"

Advanced Program Group

A051 [Digital In1 Sel]

(I/O Terminal 5)

Related Parameters: [d012](#), [d014](#), [P038](#), [P039](#), [P040](#), [A067](#), [A068](#), [A070...A073](#), [A078](#), [A079](#)

A052 [Digital In2 Sel]

(I/O Terminal 6)



Stop drive before changing this parameter.

Selects the function for the digital inputs. See the flowchart on [page 29](#) for more information on speed reference control priority.

Options	0	“Not Used”	Terminal has no function but can be read over network communications via d014 [Dig In Status]
	1	“Acc 2 & Dec 2”	<ul style="list-style-type: none"> When active, A067 [Accel Time 2] and A068 [Decel Time 2] are used for all ramp rates except Jog. Can only be tied to one input <p>See the flowchart on page 30 for more information on Accel/Decel selection.</p>
	2	“Jog”	<ul style="list-style-type: none"> When input is present, drive accelerates according to the value set in A079 [Jog Accel/Decel] and ramps to the value set in A078 [Jog Frequency]. When input is removed, drive ramps to a stop according to the value set in A079 [Jog Accel/Decel]. A valid “Start” command overrides this input.
	3	“Aux Fault”	When enabled, an F2 Auxiliary Input fault will occur when the input is removed.
	4	“Preset Freq” (Default)	See A070...A073 [Preset Freq x]. Important: Digital Inputs have priority for frequency control when programmed as a Preset Speed and are active. See the flowchart on page 29 for more information on speed reference control priority.
	5	“Local”	When active, sets integral keypad as start source and potentiometer on the integral keypad as speed source.
	6	“Comm Port”	<ul style="list-style-type: none"> When active, sets communications device as default start/speed command source. Can only be tied to one input.
	7	“Clear Fault”	When active, clears an active fault.
	8	“RampStop,CF”	Causes drive to immediately ramp to a stop regardless of how P037 [Stop Mode] is set.
	9	“CoastStop,CF”	Causes drive to immediately coast to a stop regardless of how P037 [Stop Mode] is set.
	10	“DCInjStop,CF”	Causes drive to immediately begin a DC Injection stop regardless of how P037 [Stop Mode] is set.
	11	“Jog Forward”	Drive accelerates to A078 [Jog Frequency] according to A079 [Jog Accel/Decel] and ramps to stop when input becomes inactive. A valid start overrides this command.
	12	“Jog Reverse”	Drive accelerates to A078 [Jog Frequency] according to A079 [Jog Accel/Decel] and ramps to stop when input becomes inactive. A valid start overrides this command.

A051 & A052 Options (Cont.)	13	“10V In Ctrl”	Selects 0...10V or ±10V control as the frequency reference. Start source is not changed.
	14	“20mA In Ctrl”	Selects 4...20 mA control as the frequency reference. Start source is not changed.
	15...25		Reserved
	26	“Anlg Invert”	Inverts the scaling of the analog input levels set in A110 [Anlg In 0-10V Lo] and A111 [Anlg In 0-10V Hi] or A112 [Anlg In4-20mA Lo] and A113 [Anlg In4-20mA Hi].

A055 [Relay Out Sel]

Related Parameters: [P033](#), [A056](#), [A092](#)

Sets the condition that changes the state of the output relay contacts.

Options	0	“Ready/Fault” (Default)	Relay changes state when power is applied. This indicates that the drive is ready for operation. Relay returns drive to shelf state when power is removed or a fault occurs.
	1	“At Frequency”	Drive reaches commanded frequency.
	2	“MotorRunning”	Motor is receiving power from the drive.
	3	“Reverse”	Drive is commanded to run in reverse direction.
	4	“Motor Overld”	Motor overload condition exists.
	5	“Ramp Reg”	Ramp regulator is modifying the programmed accel/decel times to avoid an overcurrent or overvoltage fault from occurring.
	6	“Above Freq”	Drive exceeds the frequency (Hz) value set in A056 [Relay Out Level].
	7	“Above Cur”	Drive exceeds the current (% Amps) value set in A056 [Relay Out Level]. Important: Value for A056 [Relay Out Level] must be entered in percent of drive rated output current.
	8	“Above DCVolt”	Drive exceeds the DC bus voltage value set in A056 [Relay Out Level].
	9	“Retries Exst”	Value set in A092 [Auto Rstrt Tries] is exceeded.
	10	“Above Anlg V”	<ul style="list-style-type: none"> • Analog input voltage (I/O Terminal 13) exceeds the value set in A056 [Relay Out Level]. • This parameter setting can also be used to indicate a PTC trip point when the input (I/O Terminal 13) is wired to a PTC and external resistor. • Use A056 to set threshold.
11...19		Reserved	
20	“ParamControl”	Enables the output to be controlled over network communications by writing to A056 [Relay Out Level]. (0 = Off, 1 = On.)	
21	“NonRec Fault”	Value set in A092 [Auto Rstrt Tries] is exceeded.	

Advanced Program Group *(continued)*

A056 [Relay Out Level]

Related Parameter: [A055](#)

 32-bit parameter

Sets the trip point for the digital output relay if the value of A055 [Relay Out Sel] is 6, 7, 8, 10, or 20.

A055 Setting	A056 Min/Max
6	0/240 Hz
7	0/180%
8	0/815 Volts
10	0/100%
20	0/1

Values	Default	0.0
	Min/Max:	0.0/9999
	Display:	0.1

A067 [Accel Time 2]

Related Parameter: [P039](#)

When active, sets the rate of acceleration for all speed increases except jog. See the flowchart on [page 30](#) for details.

$$\frac{\text{Maximum Freq}}{\text{Accel Time}} = \text{Accel Rate}$$

Values	Default	20.0 Secs
	Min/Max:	0.0/600.0 Secs
	Display:	0.1 Secs

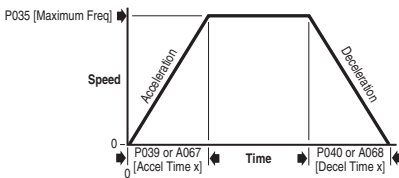

Advanced Program Group *(continued)*

A068 [Decel Time 2]

Related Parameter: [P040](#)

When active, sets the rate of deceleration for all speed decreases except jog. See the flowchart on [page 30](#) for details.

$$\frac{\text{Maximum Freq}}{\text{Decel Time}} = \text{Decel Rate}$$

Values	Default	20.0 Secs
	Min/Max:	0.1/600.0 Secs
	Display:	0.1 Secs

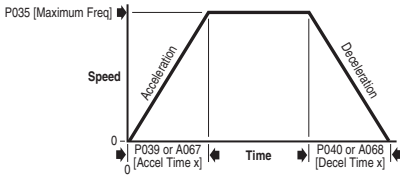

A069 [Internal Freq]

Related Parameter: [P038](#)

Provides the frequency command to the drive when P038 [Speed Reference] is set to 1 “Internal Freq”. When enabled, this parameter will change the frequency command in “real time” using the integral keypad Up Arrow or Down Arrow when in program mode.

Important: Once the desired command frequency is reached, the Enter key must be pressed to store this value to EEPROM memory. If the ESC key is used before the Enter key, the frequency will return to the original value following the normal accel/decel curve.

Values	Default	60.0 Hz
	Min/Max:	0.0/240.0 Hz
	Display:	0.1 Hz

Advanced Program Group *(continued)*

A070 [Preset Freq 0]⁽¹⁾

Related Parameters: [P038](#), [P039](#), [P040](#), [A051](#), [A052](#), [A067](#), [A068](#)

A071 [Preset Freq 1]

A072 [Preset Freq 2]

A073 [Preset Freq 3]

Values	A070 Default	0.0 Hz
	A071 Default	5.0 Hz
	A072 Default	10.0 Hz
	A073 Default	20.0 Hz
	Min/Max:	0.0/240.0 Hz
	Display:	0.1 Hz

Provides a fixed frequency command value when [A051...A052](#) [Digital Inx Sel] is set to 4 "Preset Frequencies".

An active preset input will override speed command as shown in the flowchart on [page 30](#).

⁽¹⁾ To activate A070 [Preset Freq 0] set P038 [Speed Reference] to option 4 "Preset Freq 0-3".

Input State of Digital In 1 (I/O Terminal 05)	Input State of Digital In 2 (I/O Terminal 06)	Frequency Source	Accel / Decel Parameter Used ⁽²⁾
0	0	A070 [Preset Freq 0]	[Accel Time 1] / [Decel Time 1]
1	0	A071 [Preset Freq 1]	[Accel Time 1] / [Decel Time 1]
0	1	A072 [Preset Freq 2]	[Accel Time 2] / [Decel Time 2]
1	1	A073 [Preset Freq 3]	[Accel Time 2] / [Decel Time 2]

⁽²⁾ When a Digital Input is set to "Accel 2 & Decel 2", and the input is active, that input overrides the settings in this table.

A078 [Jog Frequency]

Related Parameters: [P035](#), [A051](#), [A052](#), [A079](#)

Sets the output frequency when a jog command is issued.

Values	Default	10.0 Hz
	Min/Max:	0.0/ P035 [Maximum Freq]
	Display:	0.1 Hz

A079 [Jog Accel/Decel]

Related Parameters: [A051](#), [A052](#), [A078](#)

Sets the acceleration and deceleration time when a jog command is issued.

Values	Default	10.0 Secs
	Min/Max:	0.1/600.0 Secs
	Display:	0.1 Secs

Advanced Program Group *(continued)*

A080 [DC Brake Time]

Related Parameters: [P037](#), [A081](#)

Sets the length of time that DC brake current is “injected” into the motor. See parameter [A081](#) [DC Brake Level].

Values	Default	0.0 Secs
	Min/Max:	0.0/90.0 Secs
	Display:	0.1 Secs

A081 [DC Brake Level]

Related Parameters: [P037](#), [A080](#)

Defines the maximum DC brake current, in amps, applied to the motor when [P037](#) [Stop Mode] is set to either “Ramp” or “DC Brake”.

Values	Default	Drive Rated Amps × 0.05
	Min/Max:	0.0/(Drive Rated Amps × 1.8)
	Display:	0.1 Amps

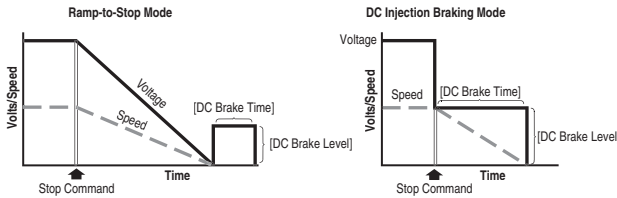

ATTENTION: If a hazard of injury due to movement of equipment or material exists, an auxiliary mechanical braking device must be used.



ATTENTION: This feature should not be used with synchronous or permanent magnet motors. Motors may be demagnetized during braking.

Advanced Program Group *(continued)*

A082 [DB Resistor Sel]



Stop drive before changing this parameter.

Enables/disables external dynamic braking.

Setting	Min/Max
0	"Disabled"
1	"Normal RA Res" (5% Duty Cycle) - See Table 15
2	"No Protection" (100% Duty Cycle)
3-99	"x%Duty Cycle" Limited (3% - 99% of Duty Cycle)

The drive is able to provide full braking indefinitely. Braking power is limited by the external DB resistor. When this parameter is set to 1 "Normal RA Res" and an appropriate RA resistor is used (see selection [Table 15](#)), the drive provides calculated resistor overload protection. However, the drive cannot protect against a brake IGBT failure.



ATTENTION: A risk of fire exists if external braking resistors are not protected. The external resistor package must be self-protected from over temperature or the protective circuit shown in [Figure 13](#), or equivalent, must be supplied.

Values	Default	0
	Min/Max:	0/99
	Display:	1

A083 [S Curve %]

Sets the percentage of acceleration or deceleration time that is applied to the ramp as S Curve. Time is added, 1/2 at the beginning and 1/2 at the end of the ramp.

Values	Default	0% (Disabled)
	Min/Max:	0/100%
	Display:	1%

Example:

Accel Time = 10 Seconds

S Curve Setting = 50%

S Curve Time = $10 \times 0.5 = 5$ Seconds

Total Time = $10 + 5 = 15$ Seconds

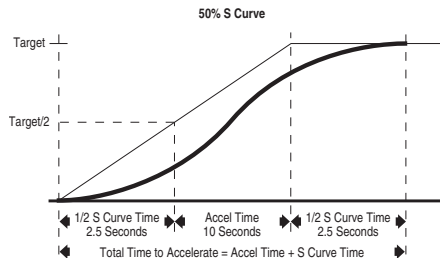

Advanced Program Group *(continued)*

A084 [Boost Select]

Related Parameters: [d004](#), [P031](#), [P032](#)

Sets the boost voltage (% of [P031](#) [Motor NP Volts]) and redefines the Volts per Hz curve.⁽¹⁾

⁽¹⁾ Drive may add additional voltage unless option 5 is selected.

Options		
1	"30.0, VT"	Variable Torque
2	"35.0, VT"	
3	"40.0, VT"	
4	"45.0, VT"	
5	"0.0 no IR"	Constant Torque
6	"0.0"	
7	"2.5, CT" [Default for 3.7kW (5HP) Drives]	
8	"5.0, CT" (Default)	
9	"7.5, CT"	
10	"10.0, CT"	
11	"12.5, CT"	
12	"15.0, CT"	
13	"17.5, CT"	
14	"20.0, CT"	

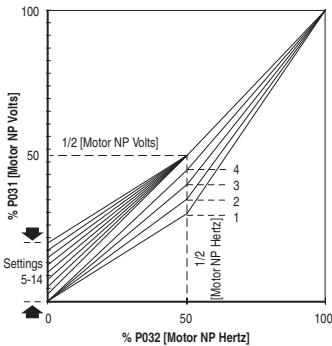

A088 [Maximum Voltage]

Sets the highest voltage the drive will output.

Values	Default	Drive Rated Volts
	Min/Max:	20/Drive Rated Volts
	Display:	1 VAC

Advanced Program Group *(continued)*

A089 [Current Limit]

Maximum output current allowed before current limiting occurs.

Values	Default	Drive Rated Amps × 1.5
	Min/Max:	0.1/(Drive Rated Amps × 1.8)
	Display:	0.1 Amps

A090 [Motor OL Select]

Related Parameter: [P032](#)

Drive provides Class 10 motor overload protection. Settings 0...2 select the derating factor for the I²t overload function.

Options	0	“No Derate” (Default)
	1	“Min Derate”
	2	“Max Derate”

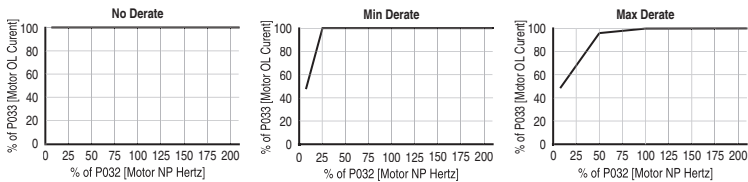

A091 [PWM Frequency]

Sets the carrier frequency for the PWM output waveform. The chart below provides derating guidelines based on the PWM frequency setting.

Important: Ignoring derating guidelines can cause reduced drive performance.

Values	Default	4.0 kHz
	Min/Max:	2.0/16.0 kHz
	Display:	0.1 kHz

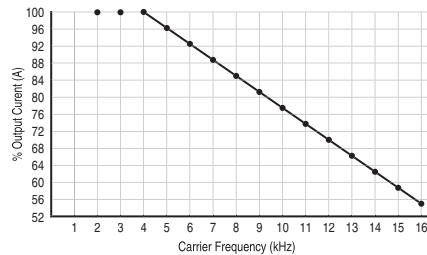

Advanced Program Group *(continued)*

A092 [Auto Rstrt Tries]

Sets the maximum number of times the drive attempts to reset a fault and restart.

Clear a Type 1 fault and restart the drive.

1. Set A092 [Auto Rstrt Tries] to a value other than “0”.
2. Set [A093](#) [Auto Rstrt Delay] to a value other than “0”.

Clear an OverVoltage, UnderVoltage, or Heatsink OvrTmp fault without restarting the drive.

1. Set A092 [Auto Rstrt Tries] to a value other than “0”.
2. Set [A093](#) [Auto Rstrt Delay] to “0”.



ATTENTION: Equipment damage and/or personal injury may result if this parameter is used in an inappropriate application. Do not use this function without considering applicable local, national and international codes, standards, regulations or industry guidelines.

Values	Default	0
	Min/Max:	0/9
	Display:	1

A093 [Auto Rstrt Delay]

Related Parameter: [A092](#)

Sets the time between restart attempts when [A092](#) [Auto Rstrt Tries] is set to a value other than zero.

Values	Default	1.0 Secs
	Min/Max:	0.0/300.0 Secs
	Display:	0.1 Secs

A094 [Start At PowerUp]



Stop drive before changing this parameter.

Enables/disables a feature that allows a Start or Run command to automatically cause the drive to resume running at commanded speed after drive input power is restored. Requires a digital input configured for Run or Start and a valid start contact.

This parameter does not function if parameter [P036](#) [Start Source] is set to 4 “2-W High Speed”.



ATTENTION: Equipment damage and/or personal injury may result if this parameter is used in an inappropriate application. Do not use this function without considering applicable local, national and international codes, standards, regulations or industry guidelines.

Options	0	“Disabled” (Default)
	1	“Enabled”

Advanced Program Group *(continued)*

A095 [Reverse Disable]

Related Parameter: [d006](#)



Stop drive before changing this parameter.

Enables/disables the function that allows the direction of motor rotation to be changed. The reverse command may come from a digital command, the keypad or a serial command. All reverse inputs including two-wire Run Reverse is ignored with reverse disabled.

Options	0	“Rev Enabled” (Default)
	1	“Rev Disabled”

A096 [Flying Start En]

Sets the condition that allows the drive to reconnect to a spinning motor at actual RPM.

Options	0	“Disabled” (Default)
	1	“Enabled”

A097 [Compensation]

Enables/disables correction options that may improve problems with motor instability.

Options	0	“Disabled”	
	1	“Electrical” (Default)	Some drive/motor combinations have inherent instabilities which are exhibited as non-sinusoidal motor currents. This setting attempts to correct this condition.
	2	“Mechanical”	Some motor/load combinations have mechanical resonances which can be excited by the drive current regulator. This setting slows down the current regulator response and attempts to correct this condition.
	3	“Both”	

A098 [SW Current Trip]

Related Parameter: [P033](#)

Enables/disables a software instantaneous (within 100 ms) current trip.

Values	Default	0.0 (Disabled)
	Min/Max:	0.0/(Drive Rated Amps × 2)
	Display:	0.1 Amps

A099 [Process Factor]

Related Parameter: [d010](#)

Scales the value displayed by [d010](#) [Process Display].

$$\text{Output Freq} \times \text{Process Factor} = \text{Process Display}$$

Values	Default	30.0
	Min/Max:	0.1/999.9
	Display:	0.1

Advanced Program Group *(continued)*

A100 [Fault Clear]



Stop drive before changing this parameter.

Resets a fault and clears the fault queue. Used primarily to clear a fault over network communications.

Options	0	“Ready/Idle” (Default)
	1	“Reset Fault”
	2	“Clear Buffer” (Parameters d007... d009 [Fault x Code])

A101 [Program Lock]

Protects parameters against change by unauthorized personnel.

Options	0	“Unlocked” (Default)
	1	“Locked”

A102 [Testpoint Sel]

Used by Rockwell Automation field service personnel.

Values	Default	400
	Min/Max:	0/FFFF
	Display:	1 Hex

A103 [Comm Data Rate]

Related Parameter: [d015](#)

Sets the serial port rate for the RS-485 (DSI) port.

Important: Power to drive must be cycled before any changes will affect drive operation.

Options	0	“1200”
	1	“2400”
	2	“4800”
	3	“9600” (Default)
	4	“19.2K”
	5	“38.4K”

A104 [Comm Node Addr]

Related Parameter: [d015](#)

Sets the drive node address for the RS-485 (DSI) port if using a network connection.

Important: Power to drive must be cycled before any changes will affect drive operation.

Values	Default	100
	Min/Max:	1/247
	Display:	1

Advanced Program Group *(continued)*

A105 [Comm Loss Action]

Related Parameters: [d015](#), [P037](#), [A106](#)

Selects the drive's response to a loss of the communication connection or excessive communication errors.

Options	0 "Fault" (Default)	Drive will fault on an F81 Comm Loss and coast to stop.
	1 "Coast to Stop"	Stops drive via coast to stop.
	2 "Stop"	Stops drive via P037 [Stop Mode] setting.
	3 "Continu Last"	Drive continues operating at communication commanded speed saved in RAM.

A106 [Comm Loss Time]

Related Parameters: [d015](#), [A105](#)

Sets the time that the drive will remain in communication loss before implementing the option selected in [A105](#) [Comm Loss Action].

Values	Default	5.0 Secs
	Min/Max:	0.1/60.0 Secs
	Display:	0.1 Secs

A107 [Comm Format]

Selects the protocol (RTU only), data bits (8 data bits only), parity (None, Even, Odd), and stop bits (1 stop bit only) used by the RS-485 port on the drive.

See [Appendix C](#) for details on using the drive communication features.

Important: Power to drive must be cycled before any changes will affect drive operation.

Options	0 "RTU 8-N-1" (Default)
	1 "RTU 8-E-1"
	2 "RTU 8-O-1"
	3 "RTU 8-N-2"
	4 "RTU 8-E-2"
	5 "RTU 8-O-2"

Advanced Program Group *(continued)*

A110 [Anlg In 0-10V Lo]

Related Parameters: [d020](#), [P034](#), [P038](#), [A051](#), [A052](#)

Sets the analog input level that corresponds to [P034](#) [Minimum Freq] if a 0-10V input is used by P038 [Speed Reference].

Analog inversion can be accomplished by setting this value larger than [A111](#) [Anlg In 0-10V Hi] or by setting [A051...A052](#) [Digital Inx Sel] to option 26 "Anlg Invert"

Values	Default	0.0%
	Min/Max:	0.0/100.0%
	Display:	0.1%

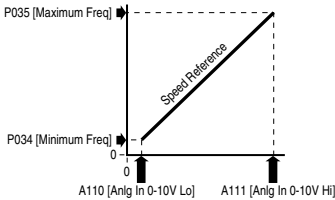

A111 [Anlg In 0-10V Hi]

Related Parameters: [d020](#), [P035](#), [P038](#), [A051](#), [A052](#)

Sets the analog input level that corresponds to [P035](#) [Maximum Freq] if a 0-10V input is used by P038 [Speed Reference].

Analog inversion can be accomplished by setting this value smaller than [A110](#) [Anlg 0-10V In Lo] or by setting [A051...A052](#) [Digital Inx Sel] to option 26 "Anlg Invert".

Values	Default	100.0%
	Min/Max:	0.0/100.0%
	Display:	0.1%

A112 [Anlg In4-20mA Lo]

Related Parameters: [d021](#), [P034](#), [P038](#), [A051](#), [A052](#)

Sets the analog input level that corresponds to [P034](#) [Minimum Freq] if a 4-20mA input is used by P038 [Speed Reference].

Analog inversion can be accomplished by setting this value larger than [A113](#) [Anlg In4-20mA Hi] or by setting [A051...A052](#) [Digital Inx Sel] to option 26 "Anlg Invert".

Values	Default	0.0%
	Min/Max:	0.0/100.0%
	Display:	0.1%

Advanced Program Group *(continued)*

A113 [Anlg In4-20mA Hi]

Related Parameters: [d021](#), [P035](#), [P038](#), [A051](#), [A052](#)

Sets the analog input level that corresponds to [P035](#) [Maximum Freq] if a 4-20mA input is used by P038 [Speed Reference].

Analog inversion can be accomplished by setting this value smaller than [A112](#) [Anlg In4-20mA Lo] or by setting [A051...A052](#) [Digital Inx Sel] to option 26 "Anlg Invert".

Values	Default	100.0%
	Min/Max:	0.0/100.0%
	Display:	0.1%

A114 [Slip Hertz @ FLA]

Related Parameter: [P033](#)

Compensates for the inherent slip in an induction motor. This frequency is added to the commanded output frequency based on motor current.

Values	Default	2.0 Hz
	Min/Max:	0.0/10.0 Hz
	Display:	0.1 Hz

A115 [Process Time Lo]

Related Parameters: [d010](#), [P034](#)

Scales the time value when the drive is running at [P034](#) [Minimum Freq]. When set to a value other than zero, [d010](#) [Process Display] indicates the duration of the process.

Values	Default	0.00
	Min/Max:	0.00/99.99
	Display:	0.01

A116 [Process Time Hi]

Related Parameters: [d010](#), [P035](#)

Scales the time value when the drive is running at [P035](#) [Maximum Freq]. When set to a value other than zero, [d010](#) [Process Display] indicates the duration of the process.

Values	Default	0.00
	Min/Max:	0.00/99.99
	Display:	0.01

A117 [Bus Reg Mode]

Controls the operation of the drive voltage regulation, which is normally operational at decel or when the bus voltage rises.

See the Attention statements on [page 9](#) for important information on bus regulation.

Options	0	"Disabled"
	1	"Enabled" (Default)

Advanced Program Group *(continued)*

A118 [Comm Write Mode]

Determines whether parameter changes made over communication port are saved and stored in Non-volatile Storage (NVS) or RAM only. If they are stored in RAM, the values will be lost at power-down.

Options	0	“Save” (Default)
	1	“RAM Only”



ATTENTION: Risk of equipment damage exists. If a controller is programmed to write parameter data to Non-volatile Storage (NVS) frequently, the NVS will quickly exceed its life cycle and cause the drive to malfunction. Do not create a program that frequently uses configurable outputs to write parameter data to NVS unless A164 [Comm Write Mode] is set to option 1.

Parameter Cross Reference – by Name

<u>Parameter Name</u>	<u>Number</u>	<u>Group</u>	<u>Parameter Name</u>	<u>Number</u>	<u>Group</u>
Accel Time 1	P039	Basic Program	Fault x Code	d007...d009	Display
Accel Time 2	A067	Advanced Program	Fault Clear	A100	Advanced Program
Analog In 0-10V	d020	Display	Flying Start En	A096	Advanced Program
Analog In 4-20mA	d021	Display	Internal Freq	A069	Advanced Program
Anlg In 0-10V Hi	A111	Advanced Program	Jog Accel/Decel	A079	Advanced Program
Anlg In 0-10V Lo	A110	Advanced Program	Jog Frequency	A078	Advanced Program
Anlg In4-20mA Hi	A113	Advanced Program	Maximum Freq	P035	Basic Program
Anlg In4-20mA Lo	A112	Advanced Program	Maximum Voltage	A088	Advanced Program
Auto Rstrt Delay	A093	Advanced Program	Minimum Freq	P034	Basic Program
Auto Rstrt Tries	A092	Advanced Program	Motor NP Hertz	P032	Basic Program
Boost Select	A084	Advanced Program	Motor NP Volts	P031	Basic Program
Bus Reg Mode	A117	Advanced Program	Motor OL Current	P033	Basic Program
Comm Data Rate	A103	Advanced Program	Motor OL Ret	P043	Basic Program
Comm Format	A107	Advanced Program	Motor OL Select	A090	Advanced Program
Comm Loss Action	A105	Advanced Program	Output Current	d003	Display
Comm Loss Time	A106	Advanced Program	Output Freq	d001	Display
Comm Node Addr	A104	Advanced Program	Output Voltage	d004	Display
Comm Status	d015	Display	Preset Freq x	A070...A073	Advanced Program
Comm Write Mode	A118	Advanced Program	Process Display	d010	Display
Commanded Freq	d002	Display	Process Factor	A099	Advanced Program
Compensation	A097	Advanced Program	Process Time Hi	A116	Advanced Program
Contrl In Status	d013	Display	Process Time Lo	A115	Advanced Program
Control Source	d012	Display	Program Lock	A101	Advanced Program
Control SW Ver	d016	Display	PWM Frequency	A091	Advanced Program
Current Limit	A089	Advanced Program	Relay Out Level	A056	Advanced Program
DB Resistor Sel	A082	Advanced Program	Relay Out Sel	A055	Advanced Program
DC Brake Level	A081	Advanced Program	Reset To Defaults	P041	Basic Program
DC Brake Time	A080	Advanced Program	Reverse Disable	A095	Advanced Program
DC Bus Voltage	d005	Display	S Curve %	A083	Advanced Program
Decel Time 1	P040	Basic Program	Slip Compensation	A114	Advanced Program
Decel Time 2	A068	Advanced Program	Speed Reference	P038	Basic Program
Dig In Status	d014	Display	Start At PowerUp	A094	Advanced Program
Digital Inx Sel	A051, A052	Advanced Program	Start Source	P036	Basic Program
Drive Status	d006	Display	Stop Mode	P037	Basic Program
Drive Temp	d024	Display	SW Current Trip	A098	Advanced Program
Drive Type	d017	Display	Testpoint Data	d019	Display
Elapsed Run Time	d018	Display	Testpoint Sel	A102	Advanced Program

Notes:

Troubleshooting

Chapter 4 provides information to guide you in troubleshooting the PowerFlex 4 drive. Included is a listing and description of drive faults (with possible solutions, when applicable).

Drive Status

The condition or state of your drive is constantly monitored. Any changes will be indicated through the integral keypad.

LED Indications

See [Integral Keypad on page 36](#) for information on drive status indicators and controls.

Faults

A fault is a condition that stops the drive. There are two fault types.

Type	Fault Description
①	<p>Auto-reset/Run</p> <p>When this type of fault occurs, and A092 [Auto Rstrt Tries] is set to a value greater than "0," a user-configurable timer, A093 [Auto Rstrt Delay], begins. When the timer reaches zero, the drive attempts to automatically reset the fault. If the condition that caused the fault is no longer present, the fault will be reset and the drive will be restarted.</p>
②	<p>Non-resettable</p> <p>This type of fault may require drive or motor repair, or is caused by wiring or programing errors. The cause of the fault must be corrected before the fault can be cleared.</p>

Fault Indication

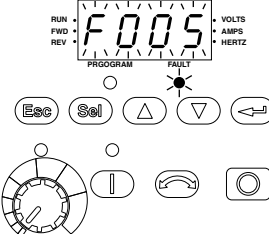
Condition	Display
<p>Drive is indicating a fault.</p> <p>The integral keypad provides visual notification of a fault condition by displaying the following.</p> <ul style="list-style-type: none"> Flashing fault number Flashing fault indicator <p>Press the Escape key to regain control of the integral keypad.</p>	

Manually Clearing Faults

Step	Key(s)
<ol style="list-style-type: none"> Press Esc to acknowledge the fault. The fault information will be removed so that you can use the integral keypad. Access d007 [Fault 1 Code] to view the most recent fault information. Address the condition that caused the fault. The cause must be corrected before the fault can be cleared. See Table 12. After corrective action has been taken, clear the fault by one of these methods. <ul style="list-style-type: none"> Press Stop if P037 [Stop Mode] is set to a value between “0” and “3”. Cycle drive power. Set A100 [Fault Clear] to “1” or “2”. Cycle digital input if A051...A052 [Digital Inx Select] is set to option 7 “Clear Fault”. 	

Automatically Clearing Faults

Option / Step
<p>Clear a Type 1 fault and restart the drive.</p> <ol style="list-style-type: none"> Set A092 [Auto Rstrt Tries] to a value other than “0”. Set A093 [Auto Rstrt Delay] to a value other than “0”. <p>Clear an OverVoltage, UnderVoltage or Heatsink OvrTmp fault without restarting the drive.</p> <ol style="list-style-type: none"> Set A092 [Auto Rstrt Tries] to a value other than “0”. Set A093 [Auto Rstrt Delay] to “0”.

Auto Restart (Reset/Run)

The Auto Restart feature provides the ability for the drive to automatically perform a fault reset followed by a start attempt without user or application intervention. This allows remote or “unattended” operation. Only certain faults are allowed to be reset. Certain faults (Type 2) that indicate possible drive component malfunction are not resettable.

Caution should be used when enabling this feature, since the drive will attempt to issue its own start command based on user selected programming.

Fault Descriptions

Table 12 – Fault Types, Descriptions, and Actions

No.	Fault	Type ⁽¹⁾	Description	Action
F2	Auxiliary Input	①	Auxiliary input interlock is open.	<ol style="list-style-type: none"> 1. Check remote wiring. 2. Verify communications programming for intentional fault.
F3	Power Loss	②	DC bus voltage remained below 85% of nominal.	<ol style="list-style-type: none"> 1. Monitor the incoming AC line for low voltage or line power interruption. 2. Check input fuses.
F4	UnderVoltage	①	DC bus voltage fell below the minimum value.	Monitor the incoming AC line for low voltage or line power interruption.
F5	OverVoltage	①	DC bus voltage exceeded maximum value.	Monitor the AC line for high line voltage or transient conditions. Bus overvoltage can also be caused by motor regeneration. Extend the decel time or install dynamic brake option.
F6	Motor Stalled	①	Drive is unable to accelerate motor.	Increase P039...A067 [Accel Time x] or reduce load so drive output current does not exceed the current set by parameter A089 [Current Limit].
F7	Motor Overload	①	Internal electronic overload trip	<ol style="list-style-type: none"> 1. An excessive motor load exists. Reduce load so drive output current does not exceed the current set by parameter P033 [Motor OL Current]. 2. Verify A084 [Boost Select] setting
F8	Heatsink OvrTmp	①	Heatsink temperature exceeds a predefined value.	<ol style="list-style-type: none"> 1. Check for blocked or dirty heat sink fins. Verify that ambient temperature has not exceeded 40 °C (104 °F) for IP30/NEMA 1/ UL Type 1 installations or 50 °C (122 °F) for IP20/Open type installations. 2. Check fan.
F12	HW OverCurrent	②	The drive output current has exceeded the hardware current limit.	Check programming. Check for excess load, improper A084 [Boost Select] setting, DC brake volts set too high or other causes of excess current.
F13	Ground Fault	②	A current path to earth ground has been detected at one or more of the drive output terminals.	Check the motor and external wiring to the drive output terminals for a grounded condition.

⁽¹⁾ See [page 69](#) for a description of fault types.

Chapter 4 Troubleshooting

No.	Fault	Type ⁽¹⁾	Description	Action
F33	Auto Rstrt Tries	②	Drive unsuccessfully attempted to reset a fault and resume running for the programmed number of A092 [Auto Rstrt Tries].	Correct the cause of the fault and manually clear.
F38	Phase U to Gnd	②	A phase to ground fault has been detected between the drive and motor in this phase.	<ol style="list-style-type: none"> 1. Check the wiring between the drive and motor. 2. Check motor for grounded phase. 3. Replace drive if fault cannot be cleared.
F39	Phase V to Gnd			
F40	Phase W to Gnd			
F41	Phase UV Short	②	Excessive current has been detected between these two output terminals.	<ol style="list-style-type: none"> 1. Check the motor and drive output terminal wiring for a shorted condition. 2. Replace drive if fault cannot be cleared.
F42	Phase UW Short			
F43	Phase VW Short			
F48	Params Defaulted		The drive was commanded to write default values to EEPROM.	<ol style="list-style-type: none"> 1. Clear the fault or cycle power to the drive. 2. Program the drive parameters as needed.
F63	SW OverCurrent	①	Programmed A098 [SW Current Trip] has been exceeded.	Check load requirements and A098 [SW Current Trip] setting.
F64	Drive Overload	②	Drive rating of 150% for 1 minute or 200% for 3 seconds has been exceeded.	Reduce load or extend Accel Time.
F70	Power Unit	②	Failure has been detected in the drive power section.	<ol style="list-style-type: none"> 1. Cycle power. 2. Replace drive if fault cannot be cleared.
F71	Net Loss		The communication network has faulted.	<ol style="list-style-type: none"> 1. Cycle power. 2. Check communications cabling. 3. Check network adapter setting. 4. Check external network status.
F81	Comm Loss	②	RS-485 (DSI) port stopped communicating.	<ol style="list-style-type: none"> 1. If adapter was not intentionally disconnected, check wiring to the port. Replace wiring, port expander, adapters or complete drive as required. 2. Check connection. 3. An adapter was intentionally disconnected. 4. Turn off using A105 [Comm Loss Action].
F100	Parameter Checksum	②	The checksum read from the board does not match the checksum calculated.	Set P041 [Reset To Defaults] to option 1 "Reset Defaults".
F122	I/O Board Fail	②	Failure has been detected in the drive control and I/O section.	<ol style="list-style-type: none"> 1. Cycle power. 2. Replace drive if fault cannot be cleared.

⁽¹⁾ See [page 69](#) for a description of fault types.

Common Symptoms and Corrective Actions

Motor does not Start.

Causes	Indication	Corrective Action
No output voltage to the motor.	None	Check the power circuit. <ul style="list-style-type: none"> • Check the supply voltage. • Check all fuses and disconnects. Check the motor. <ul style="list-style-type: none"> • Verify that the motor is connected properly. Check the control input signals. <ul style="list-style-type: none"> • Verify that a Start signal is present. If 2-wire control is used, verify that either the Run Forward or Run Reverse signal is active, but not both. • Verify that I/O Terminal 01 is active. • Verify that P036 [Start Source] matches your configuration. • Verify that A095 [Reverse Disable] is not prohibiting movement.
Improper boost setting at initial start-up.	None	Set A084 [Boost Select] to option 2 "35.0, VT".

Drive does not Start from Integral Keypad.

Causes	Indication	Corrective Action
Integral keypad is not enabled.	Green LED above Start key is not illuminated.	<ul style="list-style-type: none"> • Set parameter P036 [Start Source] to option 0 "Keypad". • Set parameter A051...A052 [Digital Inx Select] to option 5 "Local" and activate the input.
I/O Terminal 01 "Stop" input is not present.	None	Wire inputs correctly and/or install jumper.

Drive does not Start from Start or Run Inputs wired to the terminal block.

Causes	Indication	Corrective Action
Drive is Faulted	Flashing red status light	<p>Clear fault.</p> <ul style="list-style-type: none"> • Press Stop • Cycle power • Set A100 [Fault Clear] to option 1 "Clear Faults". • Cycle digital input if A051...A052 [Digital Inx Select] is set to option 7 "Clear Fault".
<p>Incorrect programming.</p> <ul style="list-style-type: none"> • P036 [Start Source] is set to option 0 "Keypad" or option 5 "RS485 (DSI) Port". • A051...A052 [Digital Inx Select] is set to option 5 "Local" and the input is active. 	None	Check parameter settings.
<p>Incorrect input wiring. See page 25 for wiring examples.</p> <ul style="list-style-type: none"> • 2-wire control requires Run Forward, Run Reverse or Jog input. • 3-wire control requires Start and Stop inputs • Stop input is always required. 	None	Wire inputs correctly and/or install jumper.
Incorrect Sink/Source DIP switch setting.	None	Set switch to match wiring scheme.

Drive does not respond to changes in speed command.

Causes	Indication	Corrective Action
No value is coming from the source of the command.	The drive "Run" indicator is lit and output is 0 Hz.	<ul style="list-style-type: none"> • Check d012 d012 [Control Source] for correct source. • If the source is an analog input, check wiring and use a meter to check for presence of signal. • Check d002 [Commanded Freq] to verify correct command.
Incorrect reference source is being selected via remote device or digital inputs.	None	<ul style="list-style-type: none"> • Check d012 [Control Source] for correct source. • Check d014 [Dig In Status] to see if inputs are selecting an alternate source. Verify settings for A051...A052 [Digital Inx Select]. • Check P038 [Speed Reference] for the source of the speed reference. Reprogram as necessary. • Review the Speed Reference Control chart on page 29.

Motor and/or drive will not accelerate to commanded speed.

Causes	Indication	Corrective Action
Acceleration time is excessive.	None	Reprogram P039 [Accel Time 1] or A067 [Accel Time 2].
Excess load or short acceleration times force the drive into current limit, slowing or stopping acceleration.	None	Compare d003 [Output Current] with A089 [Current Limit]. Remove excess load or reprogram P039 [Accel Time 1] or A067 [Accel Time 2]. Check for improper A084 [Boost Select] setting.
Speed command source or value is not as expected.	None	Verify d002 [Commanded Freq]. Check d012 [Control Source] for the proper Speed Command.
Programming is preventing the drive output from exceeding limiting values.	None	Check P035 [Maximum Freq] to insure that speed is not limited by programming.

Motor operation is unstable.

Causes	Indication	Corrective Action
Motor data was incorrectly entered.	None	<ol style="list-style-type: none"> 1. Correctly enter motor nameplate data into P031, P032, and P033. 2. Enable A097 [Compensation]. 3. Use A084 [Boost Select] to reduce boost level.

Drive will not reverse motor direction.

Causes	Indication	Corrective Action
Digital input is not selected for reversing control.	None	Check [Digital Inx Sel] See page 51 . Choose correct input and program for reversing mode.
Digital input is incorrectly wired.	None	Check input wiring. See Figure 5 .
Motor wiring is improperly phased for reverse.	None	Switch two motor leads.
Reverse is disabled.	None	Check A095 [Reverse Disable].

Notes:

Supplemental Drive Information

Drive, Fuse & Circuit Breaker Ratings

The tables on the following pages provide recommended AC line input fuse and circuit breaker information. See Fusing and Circuit Breakers below for UL and IEC requirements. Sizes listed are the recommended sizes based on 40 °C (104 °F) and the U.S. N.E.C. Other country, state or local codes may require different ratings.

Fusing

The recommended fuse types are listed below. If available current ratings do not match those listed in the tables provided, choose the next higher fuse rating.

- IEC – BS88 (British Standard) Parts 1 & 2⁽¹⁾, EN60269-1, Parts 1 & 2, type gG or equivalent should be used.
- UL – UL Class CC, T, or J must be used.⁽²⁾

Circuit Breakers

The “non-fuse” listing in the following tables include inverse time circuit breakers, instantaneous trip circuit breakers (motor circuit protectors) and 140M/140MT self-protected combination motor controllers. If one of these is chosen as the desired protection method, the following requirements apply:





- IEC – Both types of circuit breakers and 140M/140MT self-protected combination motor controllers are acceptable for IEC installations.
- UL – Only inverse time circuit breakers and the specified 140M/140MT self-protected combination motor controllers are acceptable for UL installations.

(1) Typical designations include, but may not be limited to the following; Parts 1 & 2: AC, AD, BC, BD, CD, DD, ED, EFS, EF, FF, FG, GF, GG, GH.

(2) Typical designations include; Type CC - KTK-R, FNQ-R
Type J - JKS, LPJ
Type T - JJS, JJN

Specifications

Drive Ratings									
Catalog Number	Output Ratings		Input Ratings			Branch Circuit Protection			
	kW (HP)	Amps	Voltage Range	kVA	Amps	Fuses	140M/140MT Motor Protectors ^{(2) (3)}	Contactors	Enclosure Volume, Min ⁽⁴⁾ (in. ³)
100...120V AC (±10%) – 1-phase Input, 0...230V 3-phase Output									
22A-V1P5N104	0.2 (0.25)	1.5	90...126	0.75	6.0	10	140M-C2E-C10 140MT-C3E-C10	100-C09 100-E09	1655
22A-V2P3N104	0.4 (0.5)	2.3	90...126	1.15	9.0	15	140M-C2E-C16 140MT-C3E-C16	100-C12 100-E12	1655
22A-V4P5N104	0.75 (1.0)	4.5	90...126	2.25	18.0	30	140M-D8E-C20 140MT-D9E-C20	100-C23 100-E26	1655
22A-V6P0N104	1.1 (1.5)	6.0	90...126	3.0	24.0	40	140M-F8E-C32	100-C37 100-E38	1655
200...240V AC (±10%) – 1-phase⁽¹⁾ Input, 0...230V 3-phase Output, NO BRAKE									
22A-A1P4N103	0.2 (0.25)	1.4	180...265	0.7	3.2	6	140M-C2E-B40 140MT-C3E-B40	100-C09 100-E09	1655
22A-A2P1N103	0.4 (0.5)	2.1	180...265	1.05	5.3	10	140M-C2E-B63 140MT-C3E-B63	100-C09 100-E09	1655
22A-A3P6N103	0.75 (1.0)	3.6	180...265	1.8	9.2	15	140M-C2E-C16 140MT-C3E-C16	100-C12 100-E12	1655
22A-A6P8N103	1.5 (2.0)	6.8	180...265	3.4	14.2	25	140M-C2E-C16 140MT-C3E-C16	100-C16 100-E16	1655
22A-A9P6N103	2.2 (3.0)	9.6	180...265	4.8	19.6	30	140M-D8E-C25 140MT-D9E-C25	100-C23 100-E26	1655
200...240V AC (±10%) – 1-phase⁽¹⁾ Input, 0...230V 3-phase Output									
22A-A1P5N104	0.2 (0.25)	1.5	180...265	0.75	5.0	10	140M-C2E-B63 140MT-C3E-B63	100-C09 100-E09	1655
22A-A2P3N104	0.4 (0.5)	2.3	180...265	1.15	6.0	10	140M-C2E-B63 140MT-C3E-B63	100-C09 100-E09	1655
22A-A4P5N104	0.75 (1.0)	4.5	180...265	2.25	10.0	15	140M-C2E-C16 140MT-CE3-C16	100-C12 100-E12	1655
22A-A8P0N104	1.5 (2.0)	8.0	180...265	4.0	18.0	30	140M-D8E-C20 140MT-D9E-C20	100-C23 100-E26	1655
200...240V AC (±10%) – 3-phase Input, 0...230V 3-phase Output									
22A-B1P5N104	0.2 (0.25)	1.5	180...265	0.75	1.8	3	140M-C2E-B25 140MT-C3E-B25	100-C09 100-E09	1655
22A-B2P3N104	0.4 (0.5)	2.3	180...265	1.15	2.5	6	140M-C2E-B40 140MT-C3E-B40	100-C09 100-E09	1655
22A-B4P5N104	0.75 (1.0)	4.5	180...265	2.25	5.2	10	140M-C2E-C10 140MT-C3E-C10	100-C09 100-E09	1655
22A-B8P0N104	1.5 (2.0)	8.0	180...265	4.0	9.5	15	140M-C2E-C16 140MT-C3E-C16	100-C12 100-E12	1655
22A-B012N104	2.2 (3.0)	12.0	180...265	5.5	15.5	25	140M-C2E-C16 140MT-C3E-C16	100-C16 100-E16	1655
22A-B017N104	3.7 (5.0)	17.5	180...265	8.6	21.0	30	140M-F8E-C25	100-C23 100-E26	1655
380...480V AC (±10%) – 3-phase Input, 0...460V 3-phase Output									
22A-D1P4N104	0.4 (0.5)	1.4	340...528	1.4	1.8	3	140M-C2E-B25 140MT-C3E-B25	100-C09 100-E09	1655
22A-D2P3N104	0.75 (1.0)	2.3	340...528	2.3	3.2	6	140M-C2E-B40 140MT-C3E-B40	100-C09 100-E09	1655
22A-D4P0N104	1.5 (2.0)	4.0	340...528	4.0	5.7	10	140M-C2E-B63 140MT-C3E-B63	100-C09 100-E09	1655
22A-D6P0N104	2.2 (3.0)	6.0	340...528	5.9	7.5	15	140M-C2E-C10 140MT-C3E-C10	100-C09 100-E09	1655
22A-D8P7N104	3.7 (5.0)	8.7	340...528	8.6	9.0	15	140M-C2E-C16 140MT-C3E-C16	100-C16 100-E16	1655

Input/Output Ratings		Approvals	
Output Frequency: 0...240 Hz (Programmable) Efficiency: 97.5% (Typical)		 UL508C  CSA C 22.2 No. 14  EN 61800-3  EMC Directive: 2014/30/EU: EN 61800-3 LV Directive: 2014/35/EU: EN 61800-5-1  KCC-REM-RAA-22A	
Digital Control Inputs (Input Current = 6 mA)		Analog Control Inputs	
SRC (Source) Mode: 18...24V = ON 0...6V = OFF	SNK (Sink) Mode: 0...6V = ON 18...24V = OFF	4...20 mA Analog: 250 Ω input impedance 0...10V DC Analog: 100 kΩ input impedance External Pot: 1...10 kΩ, 2 Watt minimum	
Control Output (Programmable Output, form C relay)			
Resistive Rating: 3.0 A at 30V DC, 125V AC, and 240V AC		Inductive Rating: 0.5 A at 30V DC, 125V AC, and 240V AC	
Recommended Fuses and Circuit Breakers			
Fuse: UL Class J, CC, T, or Type BS88; 600V (550V) or equivalent. Circuit Breakers: HMCP or Bulletin 140U or equivalent			
Protective Features			
Motor Protection: I ² t overload protection - 150% for 60 Secs, 200% for 3 Secs (Provides Class 10 protection)			
Overcurrent: 200% hardware limit, 300% instantaneous fault			
Over Voltage:	100...120V AC Input – Trip occurs at 405V DC bus voltage (equivalent to 150V AC incoming line) 200...240V AC Input – Trip occurs at 405V DC bus voltage (equivalent to 290V AC incoming line) 380...460V AC Input – Trip occurs at 810V DC bus voltage (equivalent to 575V AC incoming line)		
Under Voltage:	100...120V AC Input – Trip occurs at 210V DC bus voltage (equivalent to 75V AC incoming line) 200...240V AC Input – Trip occurs at 210V DC bus voltage (equivalent to 150V AC incoming line) 380...480V AC Input – Trip occurs at 390V DC bus voltage (equivalent to 275V AC incoming line)		
Control Ride-through: Minimum ride-through is 0.5 Secs - Typical value 2 Secs			
Faultless Power Ride-through: 100 milliseconds			
Dynamic Braking			
Internal brake IGBT included with all ratings except No Brake versions. See Appendix B for ordering information.			
(1)	200...240V AC — 1-phase drives are also available with an integral EMC filter. Catalog suffix changes from N103 to N113 and N104 to N114.		
(2)	The AIC ratings of the Bulletin 140M/140MT devices can vary. See the Motor Protection Circuit Breaker and Motor Circuit Protector Specifications Technical Data, publication 140-TD005 or 140M-TD002 .		
(3)	Manual Self-protected (Type E) Combination Motor Controller, UL listed for 208 Wye or Delta, 240 Wye or Delta, 480Y/277 or 600Y/347. Not UL listed for use on 480V or 600V Delta/Delta, corner ground, or high-resistance ground systems.		
(4)	When using a Manual Self-protected (Type E) Combination Motor Controller, the drive must be installed in a ventilated or non-ventilated enclosure with the minimum volume specified in this column. Application specific thermal considerations may require a larger enclosure.		

Appendix A Supplemental Drive Information

Category	Specification	
Environment	Altitude:	1000 m (3300 ft) max. without derating
	Maximum Surrounding Air Temperature without derating	
	IP20	-10...+50 °C (14...122 °F)
	NEMA 1	-10...+40 °C (14...104 °F)
	Flange Mount	Heatsink: -10...+40 °C (14...104 °F) Drive: -10...+50 °C (14...122 °F)
	Cooling Method	
	Convection	0.2 kW (0.25 HP) drives Flange Mount drives, all ratings
	Fan	All other drive ratings.
	Storage Temperature	-40...+85 °C (-40...+185 °F)
	Atmosphere	Important: Drive must not be installed in an area where the ambient atmosphere contains volatile or corrosive gas, vapors or dust. If the drive is not going to be installed for a period of time, it must be stored in an area where it will not be exposed to a corrosive atmosphere.
	Relative Humidity	0...95% noncondensing
Shock (operating)	15 g peak for 11 ms duration (±1.0 ms)	
Vibration (operating)	1 g peak, 5...2000 Hz	
Sound Pressure Level, Max (A-weighted)	Measurements are taken 1 m (3.3 ft) from the drive.	
Frame A	50 dBA	
Frame B	51 dBA	
Control	Carrier Frequency	2...16 kHz. Drive rating based on 4 kHz.
	Frequency Accuracy	
	Digital Input	Within ±0.05% of set output frequency.
	Analog Input	Within 0.5% of maximum output frequency.
	Speed Regulation - Open Loop with Slip Compensation	±2% of base speed across a 40:1 speed range.
	Stop Modes	Multiple programmable stop modes including - Ramp, Coast, DC-Brake, Ramp-to-Hold and S Curve.
	Accel/Decel	Two independently programmable accel and decel times. Each time may be programmed from 0 - 600 seconds in 0.1 second increments.
	Intermittent Overload	150% Overload capability for up to 1 minute 200% Overload capability for up to 3 seconds
Electronic Motor Overload Protection	Provides class 10 motor overload protection according to NEC article 430 and motor over-temperature protection according to NEC article 430.126 (A) (2). UL 508C File 29572.	

PowerFlex 4 Estimated Watts Loss (Rated Load, Speed, and PWM)

Voltage	kW (HP)	External Watts	Internal Watts	Total Watts Loss
100...120V	0.2 (0.25)	16	16	32
	0.4 (0.5)	22	18	40
	0.75 (1.0)	35	20	55
	1.1 (1.5)	58	22	80
200...240V	0.2 (0.25)	16	16	32
	0.4 (0.5)	22	18	40
	0.75 (1.0)	35	20	55
	1.5 (2.0)	63	22	85
	2.2 (3.0)	100	25	125
	3.7 (5.0)	150	30	180
380...480V	0.4 (0.5)	17	18	35
	0.75 (1.0)	30	20	50
	1.5 (2.0)	48	22	70
	2.2 (3.0)	75	25	100
	3.7 (5.0)	125	25	150

Product Environmental Information

Rockwell Automation maintains current product environmental information on its website at: rok.auto/certifications.

Notes:

Accessories and Dimensions

Product Selection

Table 13 – Catalog Number Description

22A	-	A	1P5	N	1	1	4
Drive	Voltage Rating	Rating	Enclosure	HIM	Emission Class	Type	

Table 14 – PowerFlex 4 Drives

Drive Ratings				Catalog Number		Frame Size
Input Voltage	kW	HP	Output Current	Panel Mount	Flange Mount ⁽¹⁾	
120V 50/60 Hz 1-phase No Filter	0.2	0.25	1.5 A	22A-V1P5N104	22A-V1P5F104	A
	0.4	0.5	2.3 A	22A-V2P3N104	22A-V2P3F104	A
	0.75	1.0	4.5 A	22A-V4P5N104	22A-V4P5F104	B
	1.1	1.5	6.0 A	22A-V6P0N104	22A-V6P0F104	B
240V 50/60 Hz 1-phase NO BRAKE With Integral "S Type" EMC Filter	0.2	0.25	1.4 A	22A-A1P4N113	–	A
	0.4	0.5	2.1 A	22A-A2P1N113	–	A
	0.75	1.0	3.6 A	22A-A3P6N113	–	A
	1.5	2.0	6.8 A	22A-A6P8N113	–	B
	2.2	3.0	9.6 A	22A-A9P6N113	–	B
240V 50/60 Hz 1-phase NO BRAKE No Filter	0.2	0.25	1.4 A	22A-A1P4N103	22A-A1P4F103	A
	0.4	0.5	2.1 A	22A-A2P1N103	22A-A2P1F103	A
	0.75	1.0	3.6 A	22A-A3P6N103	22A-A3P6F103	A
	1.5	2.0	6.8 A	22A-A6P8N103	22A-A6P8F103	B
	2.2	3.0	9.6 A	22A-A9P6N103	22A-A9P6F103	B
240V 50/60 Hz 1-phase With Integral "S Type" EMC Filter	0.2	0.25	1.5 A	22A-A1P5N114	–	A
	0.4	0.5	2.3 A	22A-A2P3N114	–	A
	0.75	1.0	4.5 A	22A-A4P5N114	–	A
	1.5	2.0	8.0 A	22A-A8P0N114	–	B
	240V 50/60 Hz 1-phase No Filter	0.2	0.25	1.5 A	22A-A1P5N104	22A-A1P5F104
0.4		0.5	2.3 A	22A-A2P3N104	22A-A2P3F104	A
0.75		1.0	4.5 A	22A-A4P5N104	22A-A4P5F104	A
1.5		2.0	8.0 A	22A-A8P0N104	22A-A8P0F104	B
240V 50/60 Hz 3-phase No Filter		0.2	0.25	1.5 A	22A-B1P5N104	22A-B1P5F104
	0.4	0.5	2.3 A	22A-B2P3N104	22A-B2P3F104	A
	0.75	1.0	4.5 A	22A-B4P5N104	22A-B4P5F104	A
	1.5	2.0	8.0 A	22A-B8P0N104	22A-B8P0F104	A
	2.2	3.0	12.0 A	22A-B012N104	22A-B012F104	B
	3.7	5.0	17.5 A	22A-B017N104	22A-B017F104	B
	480V 50/60 Hz 3-phase No Filter	0.4	0.5	1.4 A	22A-D1P4N104	22A-D1P4F104
0.75		1.0	2.3 A	22A-D2P3N104	22A-D2P3F104	A
1.5		2.0	4.0 A	22A-D4P0N104	22A-D4P0F104	A
2.2		3.0	6.0 A	22A-D6P0N104	22A-D6P0F104	A
3.7		5.0	8.7 A	22A-D8P7N104	22A-D8P7F104	B

⁽¹⁾ Replacement Plate drives are also available. Contact factory for ordering information.

Table 15 – Dynamic Brake Resistors

Drive Ratings				Catalog Number (1) (2)	Fuse Protection(3)		
Input Voltage	kW	HP	Minimum Resistance Ω		BR-	DC+/BR+	DC-
120V 50/60 Hz 1-phase	0.2	0.25	60	AK-R2-091P500	PV-10A10F	1000GH-016	1000GH-016
	0.4	0.5	60	AK-R2-091P500	PV-10A10F	1000GH-016	1000GH-016
	0.75	1.0	60	AK-R2-091P500	PV-10A10F	1000GH-016	1000GH-016
	1.1	1.5	60	AK-R2-091P500	PV-10A10F	1000GH-016	1000GH-016
240V 50/60 Hz 1-phase	0.2	0.25	60	AK-R2-091P500	PV-10A10F	1000GH-016	1000GH-016
	0.4	0.5	60	AK-R2-091P500	PV-10A10F	1000GH-016	1000GH-016
	0.75	1.0	60	AK-R2-091P500	PV-10A10F	1000GH-016	1000GH-016
	1.5	2.0	60	AK-R2-091P500	PV-10A10F	1000GH-025	1000GH-025
240V 50/60 Hz 3-phase	0.2	0.25	60	AK-R2-091P500	PV-10A10F	1000GH-016	1000GH-016
	0.4	0.5	60	AK-R2-091P500	PV-10A10F	1000GH-016	1000GH-016
	0.75	1.0	60	AK-R2-091P500	PV-10A10F	1000GH-016	1000GH-016
	1.5	2.0	60	AK-R2-091P500	PV-10A10F	1000GH-025	1000GH-025
	2.2	3.0	48	AK-R2-047P500	PV-12A10F	1000GH-032	1000GH-032
	3.7	5.0	32	AK-R2-047P500	PV-20A10F	1000GH-040	1000GH-040
480V 50/60 Hz 3-phase	0.4	0.5	121	AK-R2-091P500	PV-10A10F	1000GH-016	1000GH-016
	0.75	1.0	121	AK-R2-360P500	PV-10A10F	1000GH-016	1000GH-016
	1.5	2.0	121	AK-R2-360P500	PV-10A10F	1000GH-025	1000GH-025
	2.2	3.0	97	AK-R2-120P1K2	PV-12A10F	1000GH-025	1000GH-025
	3.7	5.0	97	AK-R2-120P1K2	PV-12A10F	1000GH-025	1000GH-025

- (1) The resistors listed in this table are rated for 5% duty cycle.
- (2) Use of Rockwell resistors is always recommended. The resistors listed have been carefully selected for optimizing performance in a variety of applications. Alternative resistors may be used, however care must be taken when making a selection. See the PowerFlex Dynamic Braking Resistor Calculator Application Technique, publication [PFLEX-AT001](#).
- (3) For IEC applications, DC Fuse is mandatory when these terminals are connected. Connect the fuse close to the terminal. Use the specified part number. PV-xxxxx fuse is from Bussman. 1000GH-xxx fuse is from Hinode.

Table 16 – Bulletin 1321-3R Series Line Reactors

Input Voltage	kW	HP	Fundamental Amps	Maximum Continuous Amps	Inductance	Watts Loss	Catalog Number (1)
240V 50/60 Hz 3-phase	0.2	0.25	2	3	12.0 mh	7.5 W	1321-3R2-A
	0.4	0.5	4	6	12.0 mh	21 W	1321-3R4-D
	0.75	1.0	8	12	3.0 mh	29 W	1321-3R8-B
	1.5	2.0	8	12	1.5 mh	19.5 W	1321-3R8-A
	2.2	3.0	12	18	1.25 mh	26 W	1321-3R12-A
	3.7	5.0	18	27	0.8 mh	36 W	1321-3R18-A
480V 50/60 Hz 3-phase	0.4	0.5	2	3	20.0 mh	11.3 W	1321-3R2-B
	0.75	1.0	4	6	9.0 mh	20 W	1321-3R4-C
	1.5	2.0	4	6	6.5 mh	20 W	1321-3R4-B
	2.2	3.0	8	12	5.0 mh	25.3 W	1321-3R8-C
	3.7	5.0	18	27	3.0 mh	29 W	1321-3R12-B

- (1) Catalog numbers listed are for 3% impedance open style units. NEMA Type 1 and 5% impedance reactor types are also available. See the 1321 Power Conditioning Products Technical Data, publication [1321-ID001](#).

Table 17 – EMC Line Filters

Drive Ratings			S Type Filter Catalog Number ⁽¹⁾	L Type Filter Catalog Number ⁽³⁾
Input Voltage	kW	HP		
120V 50/60 Hz 1-phase	0.2	0.25	–	22-RF010-AL
	0.4	0.5	–	22-RF010-AL
	0.75	1.0	–	22-RF018-BL
	1.1	1.5	–	22-RF025-CL ⁽⁴⁾
240V 50/60 Hz 1-phase	0.2	0.25	⁽²⁾	22-RF010-AL
	0.4	0.5	⁽²⁾	22-RF010-AL
	0.75	1.0	⁽²⁾	22-RF010-AL
	1.5	2.0	⁽²⁾	22-RF018-BL
240V 50/60 Hz 1-phase NO BRAKE	0.2	0.25	⁽²⁾	22-RF010-AL
	0.4	0.5	⁽²⁾	22-RF010-AL
	0.75	1.0	⁽²⁾	22-RF010-AL
	1.5	2.0	⁽²⁾	22-RF018-BL
240V 50/60 Hz 3-phase	0.2	0.25	22-RF9P5-AS	22-RF9P5-AL
	0.4	0.5	22-RF9P5-AS	22-RF9P5-AL
	0.75	1.0	22-RF9P5-AS	22-RF9P5-AL
	1.5	2.0	22-RF9P5-AS	22-RF9P5-AL
	2.2	3.0	22-RF021-BS	22-RF021-BL
	3.7	5.0	22-RF021-BS	22-RF021-BL
480V 50/60 Hz 3-phase	0.4	0.5	22-RF5P7-AS	22-RF5P7-AL
	0.75	1.0	22-RF5P7-AS	22-RF5P7-AL
	1.5	2.0	22-RF5P7-AS	22-RF5P7-AL
	2.2	3.0	22-RF012-BS	22-RF012-BL
	3.7	5.0	22-RF012-BS	22-RF012-BL

- ⁽¹⁾ This filter is suitable for use with a cable length up to 10 meters (33 feet) for Class A and 1 meter (3.3 feet) for Class B environments.
- ⁽²⁾ These ratings can be ordered with internal "S Type" filters. See the Catalog Number explanation on [page 10](#) and [Table 14](#) for details.
- ⁽³⁾ This filter is suitable for use with a cable length up to 100 meters (330 feet) for Class A and 5 meters (16.4 feet) for Class B environments.
- ⁽⁴⁾ The piggyback mounting option cannot be used with Frame B PowerFlex 4 drives and Frame C EMC Line Filters.

Table 18 – IP30/NEMA 1/UL Type 1 Kit

Item	Description	Drive Frame	Catalog Number
IP30/NEMA 1/UL Type 1 Kit	Field installed kit. Converts drive to IP30/NEMA 1/ UL Type 1 enclosure. Includes conduit box with mounting screws and plastic top panel.	A	22-JBAA
		B	22-JBAB

Table 19 – Human Interface Module (HIM) Option Kits and Accessories

Item	Description	Catalog Number
LCD Display, Remote Panel Mount	Digital speed control CopyCat capable IP66 (NEMA Type 4X/12) indoor use only 22-HIM-C2 includes 2.9 meter (9.51 feet) cable 22-HIM-C2S includes 2.0 meter (6.6 feet) cable	22-HIM-C2 22-HIM-C2S ⁽¹⁾
LCD Display, Remote Handheld	Digital speed control Full numeric keypad CopyCat capable IP30 (NEMA Type 1) Includes 1.0 meter (3.3 feet) cable Panel mount with optional bezel kit	22-HIM-A3
Bezel Kit	Panel mount for LCD display, remote handheld unit, IP30 (NEMA Type 1)	22-HIM-B1
DSI HIM Cable (DSI HIM to RJ45 cable)	1.0 meter (3.3 feet) 2.9 meter (9.51 feet)	22-HIM-H10 22-HIM-H30

⁽¹⁾ The 22-HIM-C2S is smaller than the 22-HIM-C2 and cannot be used as a direct replacement.

Table 20 – Communication Option Kits

Item	Description	Catalog Number
External DSI Communications Kit	External mounting kit for 22-COMM-C, 22-COMM-D, 22-COMM-E, and 22-COMM-P	22-XCOMM-DC-BASE
External Comms Power Supply	Optional 100...240V AC power supply for external DSI communications kit	20-XCOMM-AC-PS1
Compact I/O™ Module	3-channel	1769-SM2
DSI Cable	2.0 meter (6.6 feet) RJ45 to RJ45 cable, male to male connectors	22-RJ45CBL-C20
Splitter Cable	RJ45 one to two port splitter cable	AK-U0-RJ45-SC1
Terminating Resistors	RJ45 120 Ω resistors (2 pieces)	AK-U0-RJ45-TR1
Terminal Block	RJ45 Two-position terminal block (5 pieces)	AK-U0-RJ45-TB2P

Table 21 – Programming Software

Item	Description
Connected Components Workbench Software	Windows-based software packages for programming and configuring Allen-Bradley drives and other Rockwell Automation products. Compatibility: Microsoft Windows® Server 2012 ⁽¹⁾ , Windows Server 2012 R2, Windows Server 2016 ⁽¹⁾ , Windows Server 2019, Windows 10 IoT Enterprise 2016 LTSC 64-bit, Windows 10 IoT Enterprise 2019 LTSC, Windows 10, and Windows 11 ⁽²⁾ All supported operating systems require .NET Framework 3.5 SP1 to be installed. You can download Connected Components Workbench Standard Edition software for free at rok.auto/pcdc . To purchase Connected Components Workbench Developer Edition software, visit rok.auto/ccw .
DriveExecutive Software (Download as part of the DriveTools™ SP software package)	Windows-based software package that provides an intuitive means for monitoring or configuring Allen-Bradley drives and communications adapters online and offline. Compatibility: Microsoft Windows 7, Windows 10, and Windows Server 2019 You can download DriveTool SP software package at rok.auto/pcdc .

⁽¹⁾ Requires Connected Components Workbench software version 20.01.00 or earlier.

⁽²⁾ Requires Connected Components Workbench software version 20.01.00 or later.

Product Dimensions

Table 22 – PowerFlex 4 Panel Mount Drives

Ratings are in kW and (HP).

Frame	120V AC – 1-phase	240V AC – 1-phase, No Brake	240V AC – 1-phase	240V AC – 3-phase	480V AC – 3-phase
A	0.2 (0.25) 0.37(0.5)	0.2 (0.25) 0.37 (0.5) 0.75 (1.0)	0.2 (0.25) 0.37 (0.5) 0.75 (1.0)	0.2 (0.25) 0.37 (0.5) 0.75 (1.0) 1.5 (2.0)	0.37 (0.5) 0.75 (1.0) 1.5 (2.0)
B	0.75(1.0) 1.1 (1.5)	1.5 (2.0) 2.2 (3.0)	1.5 (2.0)	2.2 (3.0) 3.7 (5.0)	2.2 (3.0) 3.7 (5.0)

Figure 7 – PowerFlex 4 Panel Mount Drives

Dimensions are in millimeters and (inches). Weights are in kilograms and (pounds).

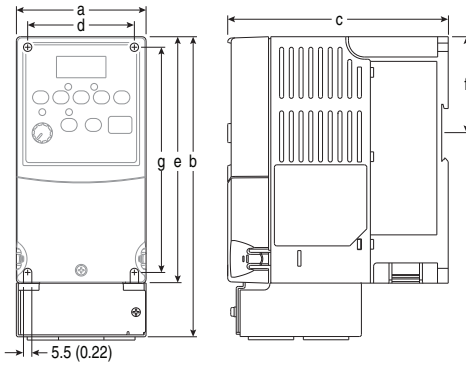

Frame	a	b ⁽¹⁾	c	d	e ⁽²⁾	f	g	Shipping Weight
A	80 (3.15)	185 (7.28)	136 (5.35)	67 (2.64)	152 (5.98)	59.3 (2.33)	140 (5.51)	1.4 (3.1)
B	100 (3.94)	213 (8.39)	136 (5.35)	87 (3.43)	180 (7.09)	87.4 (3.44)	168 (6.61)	2.2 (4.9)

⁽¹⁾ Overall height of drive with IP30/NEMA 1/UL Type 1 option kit installed

⁽²⁾ Overall height of standard IP20/Open Type drive

Figure 8 – IP30/NEMA 1/UL Type 1 Option Kit

Dimensions are in millimeters and (inches).

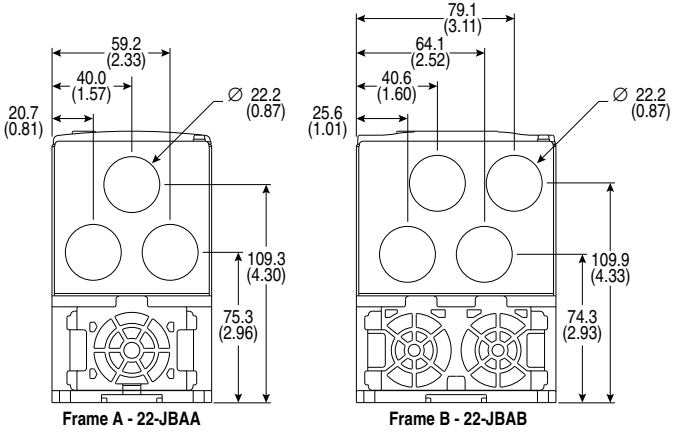

Figure 9 – PowerFlex 4 Flange Mount Drives

Dimensions are in millimeters and (inches).

Frame A**Frame B**

Figure 10 – PowerFlex 4 Cutout Dimensions

Dimensions are in millimeters and (inches).

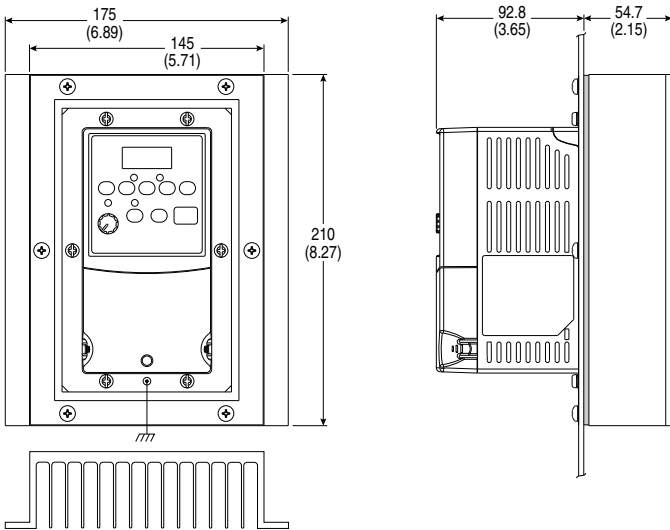
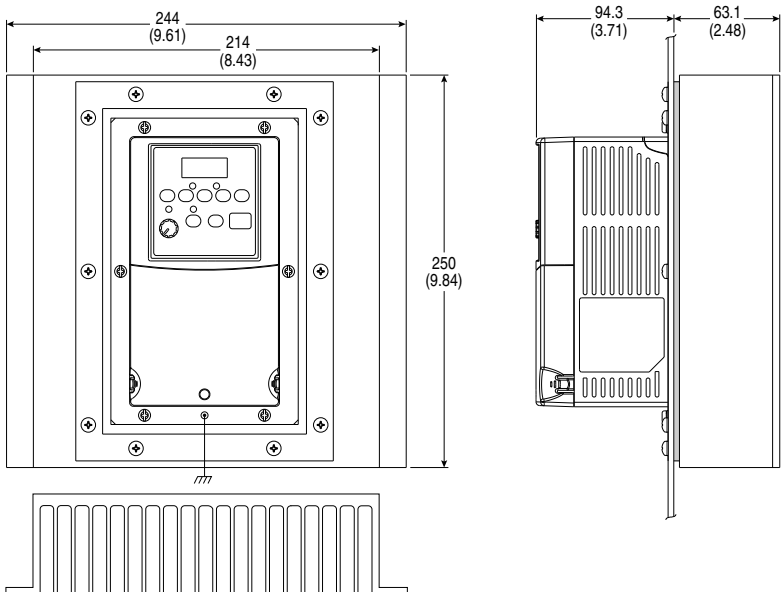
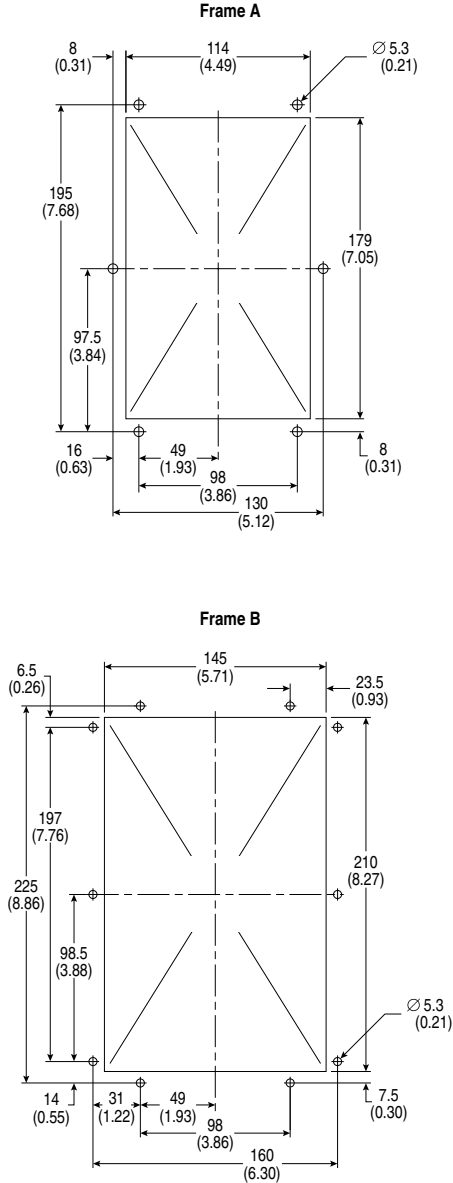
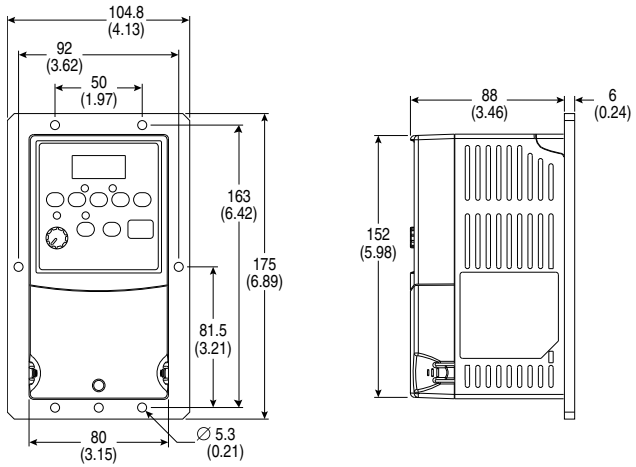

Figure 11 – PowerFlex 4 Replacement Plate Drive Dimensions

Dimensions are in millimeters and (inches).

Frame A



Frame B

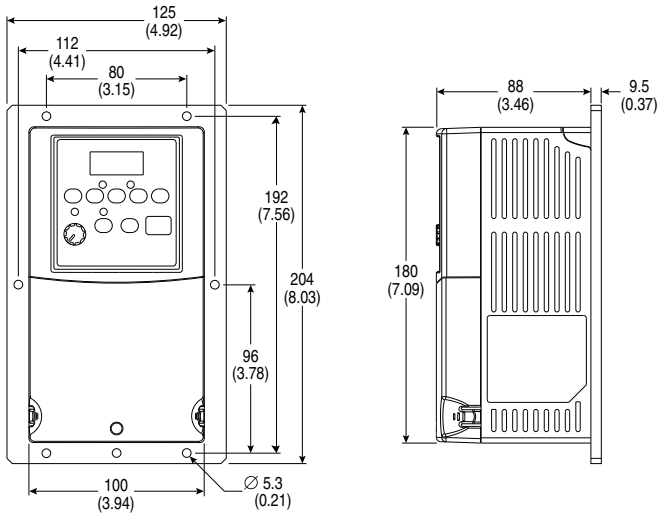
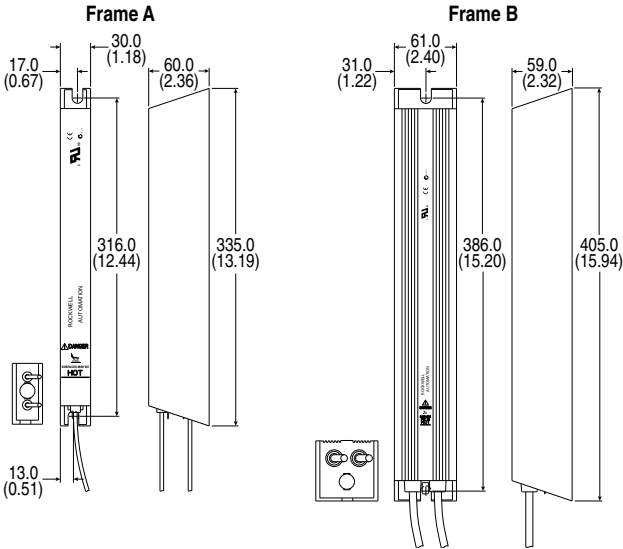

Figure 12 – Dynamic Brake Modules
 Dimensions are in millimeters and (inches).



Frame	Catalog Number
A	AK-R2-091P500, AK-R2-047P500, AK-R2-360P500
B	AK-R2-030P1K2, AK-R2-120P1K2

Figure 13 – Recommended External Brake Resistor Circuitry

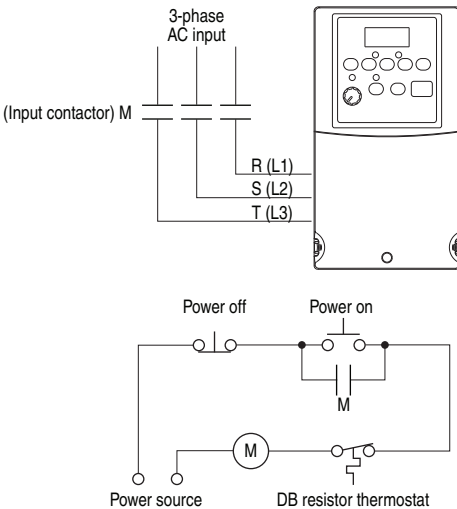
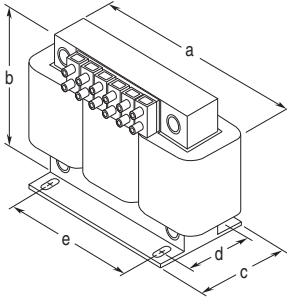

Figure 14 – Bulletin 1321-3R Series Line Reactors

Dimensions are in millimeters and (inches). Weights are in kilograms and (pounds).



Catalog Number	a	b	c	d	e	Weight
1321-3R2-A	112 (4.40)	104 (4.10)	70 (2.75)	50 (1.98)	37 (1.44)	1.8 (4)
1321-3R2-B	112 (4.40)	104 (4.10)	70 (2.75)	50 (1.98)	37 (1.44)	1.8 (4)
1321-3R4-B	112 (4.40)	104 (4.10)	76 (3.00)	50 (1.98)	37 (1.44)	1.8 (4)
1321-3R4-C	112 (4.40)	104 (4.10)	86 (3.38)	60 (2.35)	37 (1.44)	2.3 (5)
1321-3R4-D	112 (4.40)	104 (4.10)	92 (3.62)	66 (2.60)	37 (1.44)	2.7 (6)
1321-3R8-A	152 (6.00)	127 (5.00)	76 (3.00)	53 (2.10)	51 (2.00)	3.1 (7)
1321-3R8-B	152 (6.00)	127 (5.00)	76 (3.00)	53 (2.10)	51 (2.00)	3.6 (8)
1321-3R8-C	152 (6.00)	127 (5.00)	85 (3.35)	63 (2.48)	51 (2.00)	4.9 (11)
1321-3R12-A	152 (6.00)	127 (5.00)	76 (3.00)	53 (2.10)	51 (2.00)	4.1 (9)
1321-3R18-A	152 (6.00)	133 (5.25)	79 (3.10)	54 (2.13)	51 (2.00)	4.1 (9)

Figure 15 – Frame A EMC Line Filters

Dimensions are in millimeters and (inches).

Catalog Numbers: 22-RF5P7-AS, 22-RF5P7-AL; 22-RF9P5-AS, 22-RF9P5-AL; 22-RF010-AL

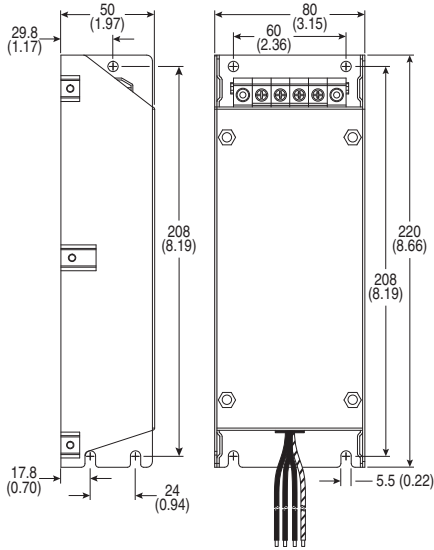

Figure 16 – Frame B EMC Line Filters

Dimensions are in millimeters and (inches).

Catalog Numbers: 22-RF012-BS, 22-RF012-BL (Series B); 22-RF018-BS; 22-RF021-BS, 22-RF012-BL

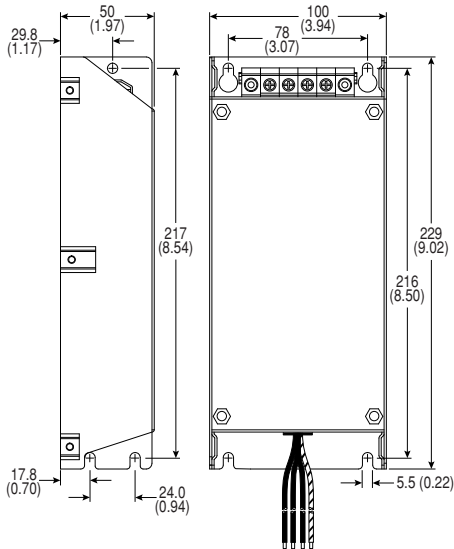
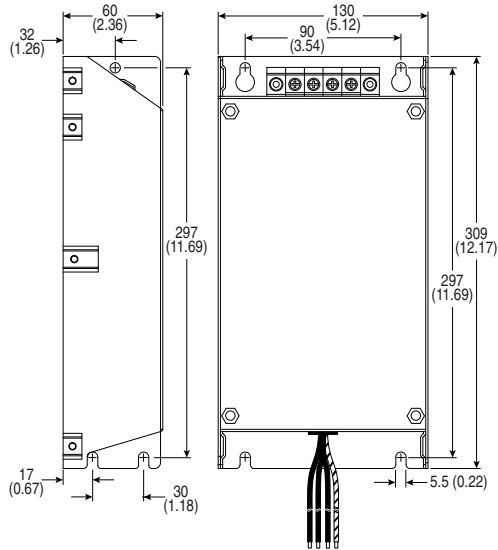

Figure 17 – Frame C EMC Line Filters

Dimensions are in millimeters and (inches).

Catalog Number: 22-RF025-CL



Important: The piggyback mounting option cannot be used with frame B PowerFlex 4 drives and frame C EMC line filters.

Figure 18 – Remote (Panel Mount) HIM
 Dimensions are in millimeters and (inches).
 Catalog Number: 22-HIM-C2

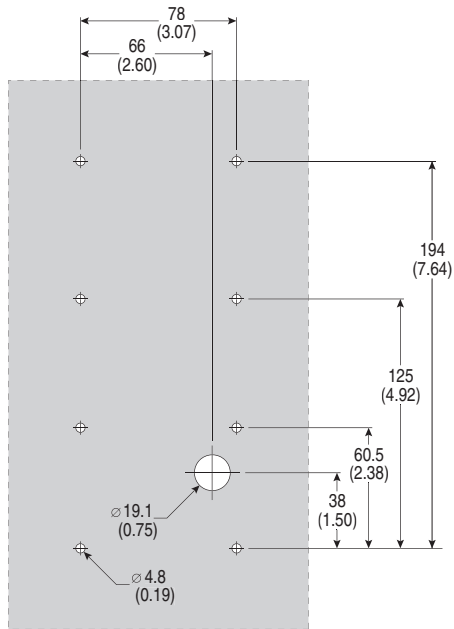
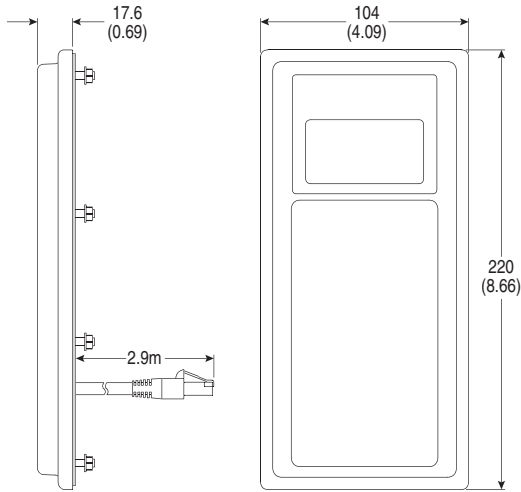
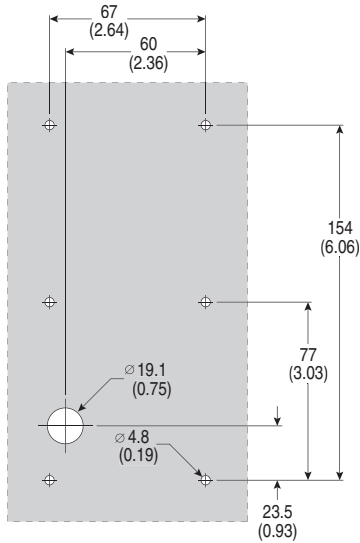
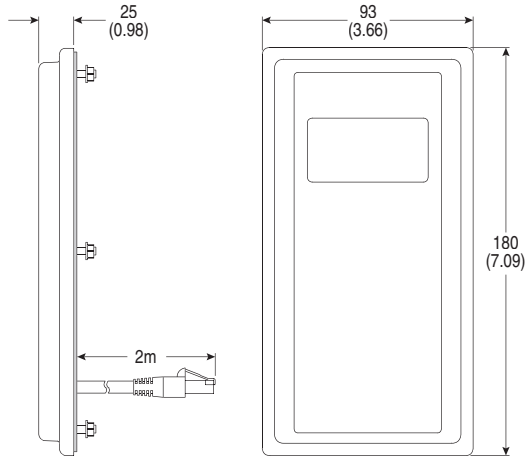

Figure 19 – Remote (Panel Mount) Small HIM

Dimensions are in millimeters and (inches).

Catalog Number: 22-HIM-C2S



Important: The 22-HIM-C2S is smaller than the 22-HIM-C2 and cannot be used as a direct replacement.

Figure 20 – NEMA Type 1 Bezel
Dimensions are in millimeters and (inches).
Catalog Number: 22-HIM-B1

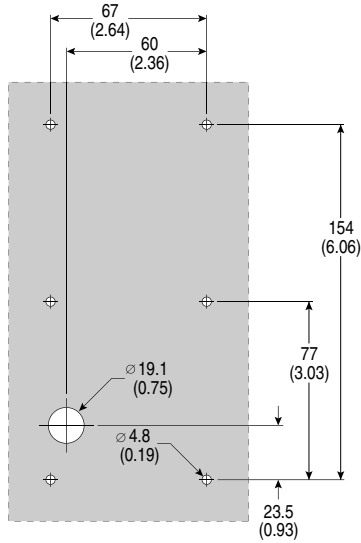
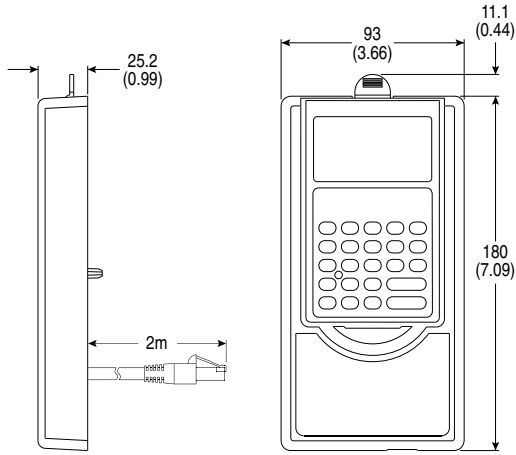

RS-485 (DSI) Protocol

PowerFlex 4 drives support the RS-485 (DSI) protocol to allow efficient operation with Rockwell Automation peripherals. In addition, some Modbus functions are supported to allow simple networking. PowerFlex 4 drives can be multi-dropped on an RS-485 network using Modbus protocol in RTU mode.

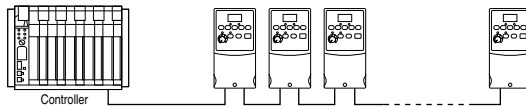

For information regarding DeviceNet® or other communication protocols, see the appropriate user manual.

Network Wiring

Network wiring consists of a shielded 2-conductor cable that is daisy chained from node to node.

Figure 21 – Network Wiring Diagram

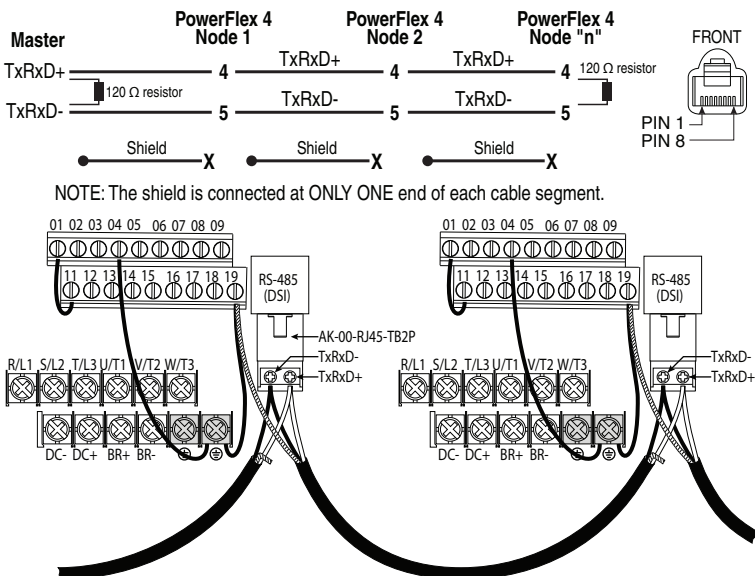

Only pins 4 and 5 on the RJ45 plug should be wired. The other pins on the PowerFlex 4 RJ45 socket must not be connected because they contain power, and so on. for other Rockwell Automation peripheral devices.

Wiring terminations on the master controller will vary depending on the master controller used and “TxRxD+” and “TxRxD-” are shown for illustration purposes only. See the master controller user manual for network terminations. Note that there is no standard for the “+” and “-” wires, and consequently Modbus device manufacturers interpret them differently. If you have problems with initially establishing communications, try swapping the two network wires at the master controller.

Standard RS-485 wiring practices apply.

- Termination resistors need to be applied at each end of the network cable.
- RS-485 repeaters may need to be used for long cable runs, or if greater than 32 nodes are needed on the network.
- Network wiring should be separated from power wires by at least 0.3 meters (1 foot).
- Network wiring should only cross power wires at a right angle.

I/O Terminal 16 (RS-485 Shield) on the PowerFlex 4 drive must also be connected to PE ground (there are two PE terminals on the drive). See [Figure 5](#) for more information.

Network Common is internally tied to I/O Terminal 04 (Digital Common). Tying I/O Terminal 04 to PE ground may improve noise immunity in some applications.

Parameter Configuration

The following PowerFlex 4 parameters are used to configure the drive to operate on a network.

Parameter	Details	Reference
P036 [Start Source]	Set to 5 "RS485 (DSI) Port" if Start is controlled from the network.	Page 47
P038 [Speed Reference]	Set to 5 "RS485 (DSI) Port" if the Speed Reference is controlled from the network.	Page 49
A103 [Comm Data Rate]	Sets the data rate for the RS-485 (DSI) port. All nodes on the network must be set to the same data rate.	Page 62
A104 [Comm Node Addr]	Sets the node address for the drive on the network. Each device on the network requires a unique node address.	Page 62
A105 [Comm Loss Action]	Selects the drive's response to communication problems.	Page 63
A106 [Comm Loss Time]	Sets the time that the drive remains in communication loss before the drive implements A105 [Comm Loss Action].	Page 63
A107 [Comm Format]	Sets the transmission mode, data bits, parity and stop bits for the RS-485 (DSI) port. All nodes on the network must be set to the same setting.	Page 63

Supported Modbus Function Codes

The peripheral interface (DSI) used on PowerFlex 4 drives supports some of the Modbus function codes.

Modbus Function Code (Decimal)	Command
03	Read Holding Registers
06	Preset (Write) Single Register
16 (10 Hexadecimal)	Preset (Write) Multiple Registers

Important: Modbus devices can be 0-based (registers are numbered starting at 0) or 1-based (registers are numbered starting at 1). Depending on the Modbus Master used, the register addresses listed on the following pages may need to be offset by +1. For example, Logic Command may be register address 8192 for some master devices (for example, ProSoft 3150-MCM SLC™ Modbus scanner) and 8193 for others (for example, PanelView™).

Writing (06) Logic Command Data

The PowerFlex 4 drive can be controlled via the network by sending Function Code 06 writes to register address 8192 (Logic Command). [P036](#) [Start Source] must be set to 5 “RS485 (DSI) Port” in order to accept the commands. In addition to being written, register address 8192 can be read using Function Code 03.

Logic Command			
Address (Decimal)	Bit(s)	Description	
8192	0	1 = Stop, 0 = Not Stop	
	1	1 = Start, 0 = Not Start	
	2	1 = Jog, 0 = No Jog	
	3	1 = Clear Faults, 0 = Not Clear Faults	
	5,4	00	No Command
		01	Forward Command
		10	Reverse Command
		11	No Command
	6	Not Used	
	7	Not Used	
	9,8	00	No Command
		01	Accel Rate 1 Enable
		10	Accel Rate 2 Enable
		11	Hold Accel Rate Selected
	11,10	00	No Command
		01	Decel Rate 1 Enable
		10	Decel Rate 2 Enable
11		Hold Decel Rate Selected	
14,13,12	000	No Command	
	001	Freq. Source = P036 [Start Source]	
	010	Freq. Source = A069 [Internal Freq]	
	011	Freq. Source = Comms (Addr 8193)	
	100	A070 [Preset Freq 0]	
	101	A071 [Preset Freq 1]	
	110	A072 [Preset Freq 2]	
111	A073 [Preset Freq 3]		
15	Not Used		

Writing (06) Reference

The Speed Reference to a PowerFlex 4 drive can be controlled via the network by sending Function Code 06 writes to register address 8193 (Reference). P038 [Speed Reference] must be set to 5 “RS485 (DSI) Port” in order to accept the Speed Reference. In addition to being written, register address 8193 can be read using Function Code 03.

Reference	
Address (Decimal)	Description
8193	A decimal value entered as xxx.x where the decimal point is fixed. For example, a decimal “100” equals 10.0 Hz and “543” equals 54.3 Hz.

Reading (03) Logic Status Data

The PowerFlex 4 Logic Status data can be read via the network by sending Function Code 03 reads to register address 8448 (Logic Status).

Logic Status		
Address (Decimal)	Bit(s)	Description
8448	0	1 = Ready, 0 = Not Ready
	1	1 = Active (Running), 0 = Not Active
	2	1 = Cmd Forward, 0 = Cmd Reverse
	3	1 = Rotating Forward, 0 = Rotating Reverse
	4	1 = Accelerating, 0 = Not Accelerating
	5	1 = Decelerating, 0 = Not Decelerating
	6	1 = Alarm, 0 = No Alarm
	7	1 = Faulted, 0 = Not Faulted
	8	1 = At Reference, 0 = Not At Reference
	9	1 = Reference Controlled by Comm
	10	1 = Operation Cmd Controlled by Comm
	11	1 = Parameters have been locked
	12	Digital Input 1 Status
	13	Digital Input 2 Status
	14	Not Used
	15	Not Used

Reading (03) Feedback

The Feedback (Output Frequency) from the PowerFlex 4 drive can be read via the network by sending Function Code 03 reads to register address 8451 (Feedback).

Feedback ⁽¹⁾	
Address (Decimal)	Description
8451	A xxx.x decimal value where the decimal point is fixed. For example, a decimal “123” equals 12.3 Hz and “300” equals 30.0 Hz.

⁽¹⁾ Returns the same data as Reading (03) Parameter d001 [Output Freq].

Reading (03) Drive Error Codes

The PowerFlex 4 Error Code data can be read via the network by sending Function Code 03 reads to register address 8449 (Drive Error Codes).

Logic Status		
Address (Decimal)	Value (Decimal)	Description
8449	0	No Fault
	2	Auxiliary Input
	3	Power Loss
	4	Undervoltage
	5	Overvoltage
	6	Motor Stalled
	7	Motor Overload
	8	Heatsink Overtemperature
	12	HW Overcurrent (300%)
	13	Ground Fault
	29	Analog Input Loss
	33	Auto Restart Tries
	38	Phase U to Ground Short
	39	Phase V to Ground Short
	40	Phase W to Ground Short
	41	Phase UV Short
	42	Phase UW Short
	43	Phase VW Short
	63	Software Overcurrent
	64	Drive Overload
70	Power Unit Fail	
80	AutoTune Fail	
81	Communication Loss	
100	Parameter Checksum Error	
122	I/O Board Fail	

Reading (03) and Writing (06) Drive Parameters

To access drive parameters, the Modbus register address equals the parameter number. For example, a decimal “1” is used to address Parameter [d001](#) [Output Freq] and decimal “39” is used to address Parameter [P039](#) [Accel Time 1].

Additional Information

Visit www.rockwellautomation.com/en-us/products/hardware/allen-bradley/vfd.html for additional information.

RJ45 DSI Splitter Cable

The PowerFlex 4 drive provides a RJ45 port to allow the connection of a single peripheral device. The RJ45 DSI splitter cable can be used to connect a second DSI peripheral device to the drive.

Connectivity Guidelines



ATTENTION: Risk of injury or equipment damage exists. The peripherals may not perform as intended if these Connectivity Guidelines are not followed. Precautions should be taken to follow these Connectivity Guidelines.

- Two peripherals maximum can be attached to a drive.
- If a single peripheral is used, it must be connected to the Master port (M) on the splitter and configured for “Auto” (default) or “Master.” Parameter 9 [Device Type] on the DSI/MDI keypads and Parameter 1 [Adapter Cfg] on the Serial Converter are used to select the type (Auto/Master/Slave).
- If two peripherals will be powered up at the same time, one must be configured as the “Master” and connected to the Master port (M) and the other must be connected as the “Slave” and connected to the Slave port (S).

RJ45 Cable Accessories

RJ45 Splitter Cable –

Catalog Number: AK-U0-RJ45-SC1

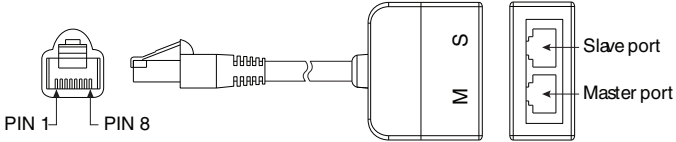

RJ45 Two-position Terminal Block Adapter –

Catalog Number: AK-U0-RJ45-TB2P

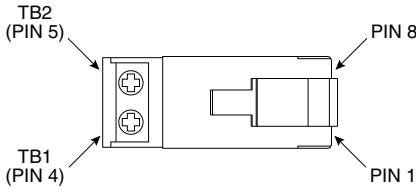

RJ45 Adapter with Integrated Termination Resistor –

Catalog Number: AK-U0-RJ45-TR1

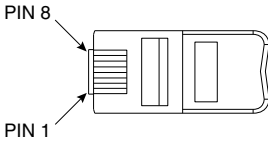

Connecting an RS-485 Network

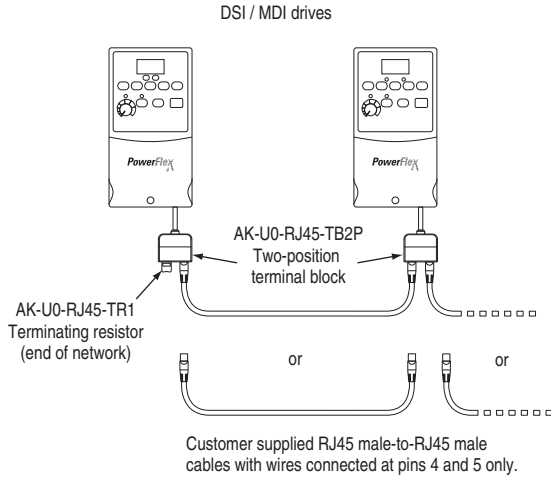

Both the master (M) and slave (S) ports on the RJ45 splitter
Cable operate as standard RS-485 ports in this configuration.

Notes:

A

AC Supply
 Ground, **14**
 Source, **13**
 Ungrounded, **13**
Advanced Program Group
 Parameters, **51**
Ambient Temperatures, **12**
Armored Cable, **19**
Auto Rstrt Tries Fault, **72**
Auxiliary Input Fault, **71**

B

Before Applying Power, **35, 36**
Bus Capacitors, Discharging, **9**

C

Cable Length, **23**
Cable, Power, **19**
Capacitors, Discharging, **9**
Catalog Number Explanation, **10**
CE Conformity, **31**
Checklist, Start-Up, **35, 36**
Circuit Breakers
 Input, **16**
Comm Loss Fault, **72**
Command Sources for Start and
 Speed, **29**
Connected Components Workbench,
 39
Contactors, Input, **22**
Control, 2 and 3 Wire, **25, 28**
Conventions, Manual, **8**
Cover, Opening, **11**
Cross Reference, Parameter
 by Name, **67**

D

Dimensions
 Drive, **87**
 Minimum Clearances, **12**
Discharging Bus Capacitors, **9**
Display, **37**

Display Group Parameters, **41**
Distribution Systems, Ungrounded,
 13
Drive Frame Size, **8, 87**
Drive Grounding, **14**
Drive Overload Fault, **72**
Drive Ratings, **10, 77**
DriveExecutive, **39**

E

Earthing, *see* *Grounding*
EMC/RFI
 Grounding, Filter, **15**
 Interference, **31**
Enclosure Rating, Changing, **12**
ESD, Static Discharge, **9**

F

Faults
 Auto Rstrt Tries, **72**
 Auxiliary Input, **71**
 Comm Loss, **72**
 Drive Overload, **72**
 Ground Fault, **71**
 Heatsink OvrTmp, **71**
 HW OverCurrent, **71**
 I/O Board Fail, **72**
 Motor Overload, **71**
 Motor Stalled, **71**
 OverVoltage, **71**
 Parameter Checksum, **72**
 Phase Short, **72**
 Phase to Ground Short, **72**
 Power Loss, **71**
 Power Unit, **72**
 SW OverCurrent, **72**
 UnderVoltage, **71**
Filter, RFI, **15**
Frame Designations, **8, 77, 87**
Fuses
 Input, **16**
 Ratings, **77**

G

- General Precautions, **9**
- Ground Fault, **71**
- Grounding
 - Filter, **15**
 - General, **14**

H

- Heatsink OvrTmp Fault, **71**
- HW OverCurrent Fault, **71**

I

- I/O
 - Wiring, **22**
 - Wiring Examples, **25, 28**
- I/O Board Fail Fault, **72**
- Input Contactor, **22**
- Input Fusing, **16**
- Input Potentiometer, **25**
- Input Power Conditioning, **14**
- Installation, **11**
- Integral Keypad, **36**
- Interference, EMC/RFI, **31**

K

- Keypad, **36**

L

- LEDs, **37**

M

- Minimum Clearances, **12**
- Motor Cable Length, **20**
- Motor Overload Fault, **71**
- Motor Stalled Fault, **71**
- motor starter, **16**
- Mounting Options and Clearances, **12**
- MOVs, **13**

O

- Opening the Cover, **11**
- Operating Temperatures, **12**
- Operator Interface, **36**
- OverVoltage Fault, **71**

P

- Parameter
 - Descriptions, **39**
 - Types, **39**
 - Viewing and Editing, **37**
- Parameter Checksum Fault, **72**
- Parameter Cross Reference
 - by Name, **67**
- Parameters
 - Advanced Program Group, **51**
 - Display Group, **41**
 - Program Group, **46**
- PE Ground, **15**
- Phase Short Fault, **72**
- Phase to Ground Fault, **72**
- Potentiometer, Wiring, **25**
- Power Cables/Wiring, **18**
- Power Conditioning, Input, **14**
- Power Loss Fault, **71**
- Power Unit Fault, **72**
- Powering Up the Drive, **35, 36**
- Precautions, General, **9**
- Product Environmental Information, **81**
- Product Selection, **83**
- Program Group Parameters, **46**
- Programming, **39**
- PTC Analog Input Wiring, **25**

R

- Ratings, **77**
- Reflective Wave Protection, **20**
- Removing Cover, **11**
- Repeated Start/Stop, **22**
- Repeated Start/Stop Precautions, **22**
- RFI, see *EMC/RFI*
- RWR (Reflective Wave Reducer), **20**

S

- Safety Ground, **15**
- Shielded Power Cables, **19**
- Short Circuit Protection, **16**
- Software, **39**

Start and Speed Reference Selection
and Control, **29, 30**

Start/Stop, Repeated, **22**

Start-Up Checklist, **35, 36**

Static Discharge, ESD, **9**

Status LEDs, **37**

Supply Source, AC, **13**

SW OverCurrent Fault, **72**

System Grounding, **14**

T

Terminal Block

I/O, **23**

Power, **21**

Three Wire Control, **25, 28**

Two Wire Control, **25, 28**

U

UnderVoltage Fault, **71**

Ungrounded Supply, **13**

Unshielded Power Cables, **19**

W

Watts Loss, **81**

Wiring, **11**

Block Diagram, **24**

I/O, **22**

I/O Examples, **25, 28**

Potentiometer, **25**

Power, **18**

PTC Example, **25**

Notes:

Rockwell Automation Support

Use these resources to access support information.

Technical Support Center	Find help with how-to videos, FAQs, chat, user forums, Knowledgebase, and product notification updates.	rok.auto/support
Local Technical Support Phone Numbers	Locate the telephone number for your country.	rok.auto/phonesupport
Technical Documentation Center	Quickly access and download technical specifications, installation instructions, and user manuals.	rok.auto/techdocs
Literature Library	Find installation instructions, manuals, brochures, and technical data publications.	rok.auto/literature
Product Compatibility and Download Center (PCDC)	Download firmware, associated files (such as AOP, EDS, and DTM), and access product release notes.	rok.auto/pcdc

Documentation Feedback

Your comments help us serve your documentation needs better. If you have any suggestions on how to improve our content, complete the form at rok.auto/docfeedback.

Waste Electrical and Electronic Equipment (WEEE)



At the end of life, this equipment should be collected separately from any unsorted municipal waste.

Rockwell Automation maintains current product environmental compliance information on its website at rok.auto/pec.





Allen-Bradley, Compact I/O, Connected Components Workbench, DriveExecutive, DriveTools, expanding human possibility, PanelView, PowerFlex, Rockwell Automation, SLC, and TechConnect are trademarks of Rockwell Automation, Inc.

DeviceNet is a trademark of ODVA, Inc.

Microsoft Windows is a trademark of Microsoft, Inc.

Trademarks not belonging to Rockwell Automation are property of their respective companies.

Rockwell Otomasyon Ticaret A.Ş. Kar Plaza İş Merkezi E Blok Kat:6 34752, İçerenköy, İstanbul, Tel: +90 (216) 5698400 EEE Yönetmeliğine Uygundur

Connect with us.    

rockwellautomation.com — expanding **human possibility**[®]

AMERICAS: Rockwell Automation, 1201 South Second Street, Milwaukee, WI 53204-2496 USA, Tel: (1) 414.382.2000

EUROPE/MIDDLE EAST/AFRICA: Rockwell Automation NV, Pegasus Park, De Kleetlaan 12a, 1831 Diegem, Belgium, Tel: (32) 2663 0600

ASIA PACIFIC: Rockwell Automation SEA Pte Ltd, 2 Corporation Road, #04-05, Main Lobby, Corporation Place, Singapore 618494, Tel: (65) 6510 6608

UNITED KINGDOM: Rockwell Automation Ltd., Pitfield, Kiln Farm, Milton Keynes, MK11 3DR, United Kingdom, Tel: (44)(1908) 838-800

Publication 22A-UM001L-EN-E - September 2024

Supersedes Publication 22A-UM001K-EN-E - August 2017

Copyright © 2024 Rockwell Automation, Inc. All rights reserved.