

PowerFlex 527 AC Drive Specifications

Bulletin Number 25C

Topic	Page
Summary of Changes	2
Product Overview	3
PowerFlex 527 AC Drives Feature	3
PowerFlex 527 AC Drive Advanced Features	4
Communications and Software	6
Catalog Number Explanation	7
Technical Specifications	8
Environmental Specifications	11
Certifications	12
Product Selection	13
Drive Dimensions and Weights	14
Design Considerations	15
Fuses and Circuit Breaker Ratings	25
Accessories	32
Safe Torque Off Function	41
Additional Resources	43



Summary of Changes

This publication contains the following new or updated information. This list includes substantive updates only and is not intended to reflect all changes.

Topic	Page
Added Inclusive Language Acknowledgment	2
Updated Certifications	12
Updated Circuit Breakers	25
Updated Fuses and Circuit Breaker tables	26...31
Updated Dynamic Brake Resistors	32

Rockwell Automation recognizes that some of the terms that are currently used in our industry and in this publication are not in alignment with the movement toward inclusive language in technology. We are proactively collaborating with industry peers to find alternatives to such terms and making changes to our products and content. Please excuse the use of such terms in our content while we implement these changes.

Product Overview

PowerFlex® 527 AC drives are designed to be used with an Allen-Bradley® Logix Programmable Automation Controller (PAC). Ideal for machines that can benefit from the same drive configuration experience for both servo and AC drives, the PowerFlex 527 drive features a built-in dual-port for EtherNet/IP™ and safety over the network. The PowerFlex 527 drive provides maximum flexibility and performance ranging up to 30 HP and 22 kW.

Designed to connect and operate only with the ControlLogix® 1756-L7x, GuardLogix® 1756-L7xS, and CompactLogix® 5370 controllers and Studio 5000 Logix Designer® application. The PowerFlex 527 is programmed with the embedded motion instructions within Studio 5000®, these are the same instructions that are used for Allen-Bradley Kinetix® servo drives. This streamlined approach provides a common user experience and just one software package to learn and use. The commonality and use of consolidated integration tools helps save valuable engineering time.

Maximize your system performance and productivity by taking advantage of the following key features that are offered in a PowerFlex 527 drive.

PowerFlex 527 AC Drives Feature

Design

- Designed to be used exclusively with Allen-Bradley Logix controllers.
- Designed for machine applications – such as pumps, fans, and in-feed and out-feed conveyors – that need speed control for induction motors.
- Logix integration helps deliver a high level of motor coordination.
- Built-in dual-port EtherNet/IP supports multiple network topologies and Device Level Ring functionality.
- Built-in hardwired Safe Torque Off. SIL 3 / PLe Cat 3.
- Integrated Safety – controller-based safety delivered via EtherNet/IP. SIL 3 / PLe Cat 3.
- Reduce your spare parts with a standard control module that can be used across the entire power range.
- Support for an incremental encoder accessory card without affecting footprint.

Packaging and Mounting

- Installation can be quick and easy using the DIN rail mounting feature on A, B, and C frame drives. Panel mounting is also available, providing added flexibility.
- Zero Stacking is allowed for ambient temperatures up to 45 °C (113 °F), saving valuable panel space.
- Integral filtering is available on all 200V and 400V ratings, providing a cost-effective means of meeting EN61800-3 Category C2 and C3 EMC requirements. External filters provide compliance to EN61800-3 Category C1, C2, and C3 EMC requirements for all PowerFlex 520-series ratings.
- An optional IP 30, NEMA/UL Type 1 conduit box is easily adapted to the standard IP 20 (NEMA Type Open) product, providing increased environmental ratings.

Optimized Performance

- Removable MOV to ground provides trouble-free operation when used on ungrounded distribution systems.
- A relay precharge limits inrush current.
- Integral brake transistor, available on all ratings, provides dynamic braking capability with simple low-cost brake resistors.
- A jumper to switch between 24V DC sink or source control for control wiring flexibility.

- Dual Overload Rating available for drives above 15 HP/11 kW. Normal duty: 110% overload for 60 seconds or 150% for 3 seconds. Heavy duty: 150% overload for 60 seconds or 180% overload (200% programmable) for 3 seconds provides robust overload protection.
- Adjustable PWM frequency up to 8 kHz delivers quiet operation.

PowerFlex 527 AC Drive Advanced Features

Control Performance

- **Frequency Control with the following options:**
 - Volts per Hertz (VHz)
 - Sensorless Vector Control (SVC)
 - Sensorless Vector Control (SVC) Economizer
- **Position Loop, including:**
 - Closed Loop Position Vector Control (with optional encoder card)
- **Velocity Loop, including:**
 - Closed Loop Velocity Vector Control (with optional encoder card)

I/O Wiring

- Two Analog Inputs (one current and one voltage) are independently isolated from the rest of the drive I/O.
- Four Digital Inputs provide application versatility.
- One Analog Output is jumper selectable between either 0...10V or 0...20 mA. This scalable, 10-bit output is suitable for metering or as a speed reference for another drive.
- Two Opto Outputs and two Relay Outputs (one form A and one form B) can be used to indicate various drive, motor, or logic conditions.

Communications

- Built-in dual-port for EtherNet/IP allows easy configuration, control, and collection of drive data over the network. It also supports Device Level Ring (DLR) topologies, providing fault-tolerant connectivity for optimum drive availability.
- Online EDS file creation with RSNetWorx™ providing ease of set-up on a network.

Common DC Bus Installations

Common DC Bus offers additional inherent braking capabilities by utilizing the drives/loads on the bus for energy absorption offering higher efficiency and cost savings. The PowerFlex 527 drive has been optimized for use in Common DC Bus or Shared DC Bus installations.

- Direct DC Bus connection to power terminal blocks.

PowerFlex 527 Control I/O Wiring Block Diagram

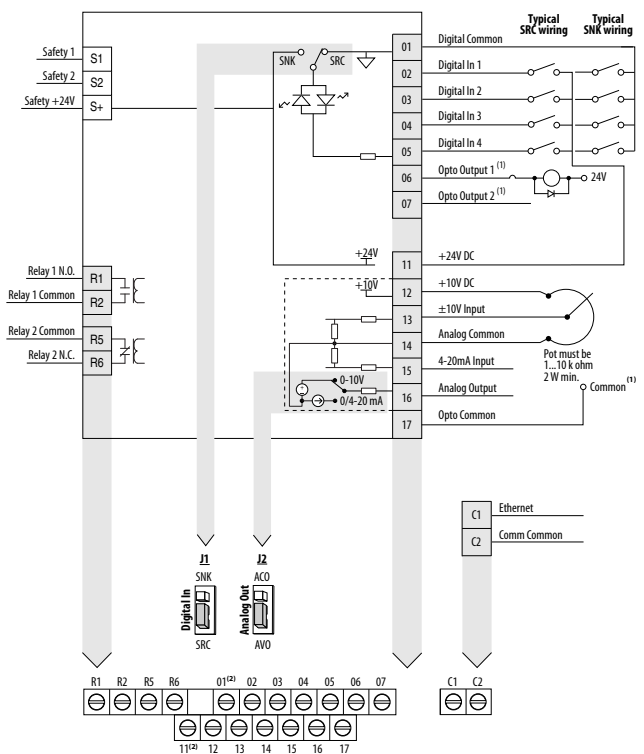

- (1) When using an opto output with an inductive load such as a relay, install a recovery diode parallel to the relay as shown, to prevent damage to the output.
- (2) Do not short across Terminals O1 and O11.

Improved Ride-through

Operation Down to 1/2 Line Voltage

The PowerFlex 527 drive allows for the selection of 1/2 DC Bus operation, for use in critical applications where continued drive output is desired even in the event of brown out or low voltage conditions. The PowerFlex 527 drive also supports enhanced inertia ride-through for additional low voltage mitigation.

- Selectable 1/2 line voltage operation
- Increased power loss ride-through

Basic Position Control

Closed loop position control using Logix motion instructions such as MAM (Motion Axis Move). For more information on Logix motion instructions, see the Logix 5000® Controllers Motion Instructions Reference Manual, publication [MOTION-RM002](#).

Closed Loop Feedback

Encoder Option Card

The PowerFlex 527 drive allows for configurable closed loop control with an optional encoder card for either speed or position feedback for improved speed regulation or basic position control.

- Improved speed regulation
- Basic position control

Feedback Details

Line Driver Type Incremental Encoder Option Card

- Quadrature (dual channel)
- 5V/12V DC supply, 10 mA min per channel
- Single-ended or Differential (A, B, and Z Channel)
- Duty Cycle of 50%, +10%
- Input Frequency up to 250 kHz
- DIP switches to select between HTL or TTL encoder signals – for 25-ENC-2/B only

Encoder Wiring Examples

I/O	Connection Example	I/O	Connection Example
Encoder Power – Internal Drive Power Internal (drive) 12V DC, 250 mA		Encoder Power – External Power Source	
Encoder Signal – Single-ended, Dual Channel		Encoder Signal – Differential, Dual Channel	

Safety Inside using Safe Torque Off Function

Safe Torque Off is a standard feature that can be applied through either hardwired safety or Integrated Safety via an EtherNet/IP network. Safe Torque Off allows you to restart your application faster after a safety-related situation.

- Safe Torque Off functionality removes rotational power without powering down the drive.
- Built-in safety reduces wiring and saves on installation space.
- Meets ISO 13849-1 standards and provides safety ratings up to and including SIL 3/PLe.

Communications and Software

Versatile Programming and Network Solutions

- A network can be configured using PowerFlex 527 drives for flexible configuration capabilities.
- Built-in dual-port for EtherNet/IP

EtherNet/IP is an established, broadly adopted network that helps simplify and enhance machine design and operation. Dual-port EtherNet/IP connectivity supports linear and ring topologies, and Device Level Ring (DLR) functionality.

The application of the CIP Safety™ protocol enables the simultaneous transmission of safety and standard control data and diagnostics information through EtherNet/IP.

PC Programming Software

Studio 5000 Logix Designer application

- PowerFlex 527 drives are used exclusively with Allen-Bradley Logix controllers.
- Drives are programmed using the motion instructions in Studio 5000 Logix Designer application.^(a)
- PowerFlex 527 drives feature drive configuration that is stored in the Logix controller, supporting fast, automatic device replacement.

Linear Topology



Star Topology

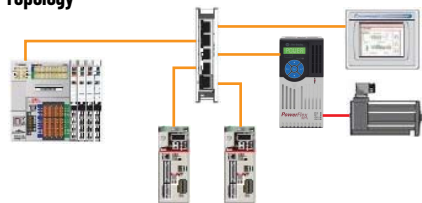

Ring Topology

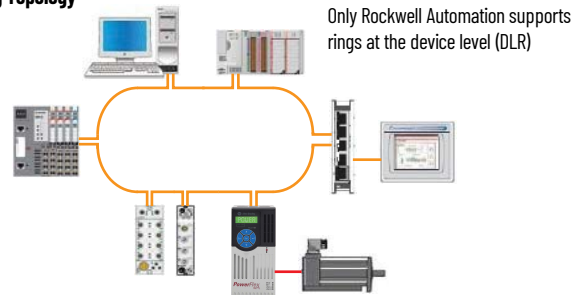

PowerFlex 527 Drive Family



^(a) Studio 5000 Logix Designer application (formerly RSLogix 5000®) version 24 or later is required.

Catalog Number Explanation

1-3	4	5	6-8	9	10	11	12	13	14
25C	-	B	2P3	N	1	1	4	-	-
Drive	Dash	Voltage Rating	Rating	Enclosure	Reserved	Emission Class	Reserved	Dash	Dash

Code	Type
25C	PowerFlex 527

Code	Voltage	Phase
V	120V AC	1
A	240V AC	1
B	240V AC	3
D	480V AC	3
E	600V AC	3

Code	EMC Filter
0	No Filter
1	Filter

Code	Braking
4	Standard

Code	Interface Module
1	Standard

Code	Enclosure
N	IP20 NEMA / Open

Code	Amps	Frame	ND		HD	
			HP	kW	HP	kW
2P5 ⁽¹⁾	2.5	A	0.5	0.4	0.5	0.4
4P8 ⁽¹⁾	4.8	B	1.0	0.75	1.0	0.75
6P0 ⁽¹⁾	6.0	B	1.5	1.1	1.5	1.1

Code	Amps	Frame	ND		HD	
			HP	kW	HP	kW
2P5 ⁽¹⁾	2.5	A	0.5	0.4	0.5	0.4
4P8 ⁽¹⁾	4.8	A	1.0	0.75	1.0	0.75
8P0 ⁽¹⁾	8.0	B	2.0	1.5	2.0	1.5
011 ⁽¹⁾	11.0	B	3.0	2.2	3.0	2.2

Code	Amps	Frame	ND		HD	
			HP	kW	HP	kW
2P5 ⁽¹⁾	2.5	A	0.5	0.4	0.5	0.4
5P0 ⁽¹⁾	5.0	A	1.0	0.75	1.0	0.75
8P0 ⁽¹⁾	8.0	A	2.0	1.5	2.0	1.5
011 ⁽¹⁾	11.0	A	3.0	2.2	3.0	2.2
017 ⁽¹⁾	17.5	B	5.0	4.0	5.0	4.0
024 ⁽¹⁾	24.0	C	7.5	5.5	7.5	5.5
032 ⁽¹⁾	32.2	D	10.0	7.5	10.0	7.5
048 ⁽²⁾	48.3	E	15.0	11.0	15.0	11.0
062 ⁽²⁾	62.1	E	20.0	15.0	15.0	11.0

Code	Amps	Frame	ND		HD	
			HP	kW	HP	kW
1P4 ⁽¹⁾	1.4	A	0.5	0.4	0.5	0.4
2P3 ⁽¹⁾	2.3	A	1.0	0.75	1.0	0.75
4P0 ⁽¹⁾	4.0	A	2.0	1.5	2.0	1.5
6P0 ⁽¹⁾	6.0	A	3.0	2.2	3.0	2.2
010 ⁽¹⁾	10.5	B	5.0	4.0	5.0	4.0
013 ⁽¹⁾	13.0	C	7.5	5.5	7.5	5.5
017 ⁽¹⁾	17.0	C	10.0	7.5	10.0	7.5
024 ⁽¹⁾	24.0	D	15.0	11.0	15.0	11.0
030 ⁽²⁾	30.0	D	20.0	15.0	15.0	11.0
037 ⁽²⁾	37.0	E	25.0	18.5	20.0	15.0
043 ⁽²⁾	43.0	E	30.0	22.0	25.0	18.5

Code	Amps	Frame	ND		HD	
			HP	kW	HP	kW
0P9 ⁽¹⁾	0.9	A	0.5	0.4	0.5	0.4
1P7 ⁽¹⁾	1.7	A	1.0	0.75	1.0	0.75
3P0 ⁽¹⁾	3.0	A	2.0	1.5	2.0	1.5
4P2 ⁽¹⁾	4.2	A	3.0	2.2	3.0	2.2
6P6 ⁽¹⁾	6.6	B	5.0	4.0	5.0	4.0
9P9 ⁽¹⁾	9.9	C	7.5	5.5	7.5	5.5
012 ⁽¹⁾	12.0	C	10.0	7.5	10.0	7.5
019 ⁽¹⁾	19.0	D	15.0	11.0	15.0	11.0
022 ⁽²⁾	22.0	D	20.0	15.0	15.0	11.0
027 ⁽²⁾	27.0	E	25.0	18.5	20.0	15.0
032 ⁽²⁾	32.0	E	30.0	22.0	25.0	18.5

(1) Normal and Heavy Duty ratings are available for drives above 15 HP / 11 kW.
 (2) 110% Overload capability for up to 60 s, 150% for up to 3 s.

Technical Specifications

Protection

Specifications	PowerFlex 527
Bus Overvoltage Trip 100...120V AC Input: 200...240V AC Input: 380...480V AC Input: 525...600V AC Input:	405V DC bus (equivalent to 150V AC incoming line) 405V DC bus (equivalent to 290V AC incoming line) 810V DC bus (equivalent to 575V AC incoming line) 1005V DC bus (equivalent to 711V AC incoming line)
Bus Undervoltage Trip 100...120V AC Input: 200...240V AC Input: 380...480V AC Input: 525...600V AC Input	190V DC bus (equivalent to 75V AC incoming line) 190V DC bus (equivalent to 150V AC incoming line) 390V DC bus (equivalent to 275V AC incoming line) 487V DC bus (equivalent to 344V AC incoming line)
Power Ride-through:	100 ms
Logic Control Ride-through:	0.5 s min, 2 s typical
Electronic Motor Overload Protection:	Provides class 10 motor overload protection according to NEC article 430 and motor over-temperature protection according to NEC article 430.126 (A) (2). UL 508C File 29572.
Overcurrent:	200% hardware limit, 300% instantaneous fault
Ground Fault Trip:	Phase-to-ground on drive output
Short Circuit Trip:	Phase-to-phase on drive output

Electrical

Specifications	PowerFlex 527
Voltage Tolerance:	-15% / +10%
Frequency Tolerance:	47...63 Hz
Input Phases:	Three-phase input provides full rating. Single-phase input provides 35% rating on three-phase drives.
Displacement Power Factor:	0.98 across entire speed range
Short Circuit Rating, max:	100,000 Amps Symmetrical
Actual Short Circuit Rating:	Determined by AIC Rating of installed fuse/circuit breaker
Transistor Type:	Insulated gate bipolar transistor (IGBT)
Internal DC Bus Choke 200...240V AC Input: 380...480V AC Input: 525...600V AC Input:	Only for Frame E drive ratings 11 kW (15 HP) 15...18.5 kW (20...25 HP) – Heavy Duty 15...18.5 kW (20...25 HP) – Heavy Duty

Control

Specifications	PowerFlex 527
Method	Frequency Control: Basic Volts/Hertz Fan/Pump Volts/Hertz Sensorless Vector Control (SVC) Sensorless Vector Control (SVC) Economizer Position Loop: Closed Loop Position Vector Control (with optional encoder card) Velocity Loop: Closed Loop Velocity Vector Control (with optional encoder card)
Carrier Frequency	2...8 kHz, Drive rating based on 4 kHz
Frequency Accuracy	Within $\pm 0.05\%$ of set output frequency
Performance VHz (Volts per Hertz): SVC (Sensorless Vector): SVC Economizer:	$\pm 1\%$ of base speed across a 60:1 speed range $\pm 0.5\%$ of base speed across a 100:1 speed range $\pm 0.5\%$ of base speed across a 100:1 speed range
Performance with Encoder Closed Loop Velocity Vector Control:	$\pm 0.1\%$ of base speed across a 100:1 speed range
Output Voltage Range:	0V to rated motor voltage
Output Frequency Range:	0...590 Hz (programmable)
Efficiency:	97.5% (typical)
Stop Modes:	Multiple programmable stop modes including – Disable and Coast, Current Decel and Disable, and Ramped Decel and Disable

Control (Continued)

Specifications		PowerFlex 527
Accel/Decel:		"REAL" tag programmable with Studio 5000 motion instructions. For more information, see the Logix 5000 Controllers Motion Instructions Reference Manual, publication MOTION-RM002 .
Intermittent Overload Normal Duty:		110% Overload capability for up to 60 s, 150% for up to 3 s Applies to the following drives: <ul style="list-style-type: none"> • 25C-B048* • 25C-B062* • 25C-D030* • 25C-D030* • 25C-D037* • 25C-D043* • 25C-E022* • 25C-E027* • 25C-E032*
Intermittent Overload Heavy Duty:		150% Overload capability for up to 60 s, 180% for up to 3 s Applies to following drives: <ul style="list-style-type: none"> • 25C-V2P5* • 25C-V4P8* • 25C-V6P0* • 25C-A2P5* • 25C-A4P8* • 25C-A8P0* • 25C-A011* • 25C-B2P5* • 25C-B5P0* • 25C-B8P0* • 25C-B011* • 25C-B017* • 25C-B024* • 25C-B032* • 25C-D1P4* • 25C-D2P3* • 25C-D4P0* • 25C-D6P0* • 25C-D010* • 25C-D013* • 25C-D017* • 25C-D024* • 25C-E0P9* • 25C-E1P7* • 25C-E3P0* • 25C-E4P2* • 25C-E6P6* • 25C-E9P9* • 25C-E012* • 25C-E019*

Control Inputs

Specifications		PowerFlex 527
Digital	Quantity:	(4) Programmable
	Current:	6 mA
	Type Source Mode (SRC): Sink Mode (SNK):	18...24V = ON, 0...6V = OFF 0...6V = ON, 18...24V = OFF
Analog	Quantity:	(2) Isolated, $\pm 10V$ and 4...20 mA
	Specification Resolution: $\pm 10V$ DC Analog: 4...20 mA Analog: External Pot:	10-bit 100 k Ω input impedance 250 Ω input impedance 1...10 k Ω , 2 W min

Control Inputs (Continued)

Specifications		PowerFlex 527
Safety (per channel)	Input Current:	<10 mA
	Input ON Voltage, max:	18...26.4V DC
	Input OFF Voltage, max:	5V DC
	Input ON Current:	10 mA
	Input OFF Current:	500 μ A
	Pulse Rejection Width:	700 μ s
	External Power Supply:	SELV/PELV
	Input Type:	Optically isolated and reverse voltage protected

Control Outputs

Specifications		PowerFlex 527
Relay	Quantity:	(2) 1 Programmable Form A and 1 Programmable Form B
	Specification Resistive Rating: Inductive Rating:	3.0 A @ 30V DC, 3.0 A @ 125V, 3.0 A @ 240V AC 0.5 A @ 30V DC, 0.5 A @ 125V, 0.5 A @ 240V AC
Opto	Quantity:	(2) Programmable
	Specification:	30V DC, 50 mA Non-inductive
Analog	Quantity:	(1) Non-isolated 0...10V or 4...20 mA
	Specification Resolution: 0...10V DC Analog: 4...20 mA Analog:	10-bit 1 k Ω min 525 Ω max





Encoder

Specifications		PowerFlex 527
Type:		Incremental, dual channel
Supply:		5V, 12V, 250 mA
Quadrature:		90 $^{\circ}$, \pm 27 $^{\circ}$ @ 25 $^{\circ}$ C (77 $^{\circ}$ F)
Duty Cycle:		50%, +10%
Requirements:		Encoders must be line driver type, quadrature (dual channel), 3.5...26V DC output, single-ended or differential, and capable of supplying a minimum of 10 mA per channel. Allowable input is DC up to a maximum frequency of 250 kHz. The encoder I/O automatically scales to allow 5V, 12V, and 24V DC nominal voltages.

Environmental Specifications

Specifications	PowerFlex 527																																		
Altitude Without derating: With derating:	See Current Derating Curves on page 16 for derating guidelines. 1000 m (3300 ft) max. Up to 4000 m (13,200 ft) max., except for 600V drives at 2000 m (6600 ft) max.																																		
Surrounding Air Temperature, max. Without derating: With derating:	See Current Derating Curves on page 16 for derating guidelines. -20...+50 °C (-4...+122 °F) -20...+60 °C (-4...+140 °F) or -20...+70 °C (-4...+158 °F) with optional Control Module Fan kit.																																		
Storage Temperature Frame A...D: Frame E:	-40...+85 °C (-40...+185 °F) -40...+70 °C (-40...+158 °F)																																		
Atmosphere:	IMPORTANT Drive must not be installed in an area where the ambient atmosphere contains volatile or corrosive gas, vapors, or dust. If the drive is not going to be installed for a period of time, it must be stored in an area where it is not exposed to a corrosive atmosphere.																																		
Relative Humidity:	0...95% noncondensing																																		
	Complies with IEC 60068-2-27 Complies with IEC 60068-2-6:2007																																		
Shock: Vibration:	<table border="1"> <thead> <tr> <th rowspan="2">Frame Size</th> <th colspan="2">Operating and Nonoperating</th> <th colspan="2">Nonoperating (Transportation)</th> </tr> <tr> <th>Force (Shock/Vibration)</th> <th>Mounting Type</th> <th>Force (Shock/Vibration)</th> <th>Mounting Type</th> </tr> </thead> <tbody> <tr> <td>A</td> <td>15 g/2 g</td> <td>DIN rail or screw</td> <td>30 g/2.5 g</td> <td>Screw only</td> </tr> <tr> <td>B</td> <td>15 g/2 g</td> <td>DIN rail or screw</td> <td>30 g/2.5 g</td> <td>Screw only</td> </tr> <tr> <td>C</td> <td>15 g/2 g</td> <td>DIN rail or screw</td> <td>30 g/2.5 g</td> <td>Screw only</td> </tr> <tr> <td>D</td> <td>15 g/2 g</td> <td>Screw only</td> <td>30 g/2.5 g</td> <td>Screw only</td> </tr> <tr> <td>E</td> <td>15 g/1.5 g</td> <td>Screw only</td> <td>30 g/2.5 g</td> <td>Screw only</td> </tr> </tbody> </table>	Frame Size	Operating and Nonoperating		Nonoperating (Transportation)		Force (Shock/Vibration)	Mounting Type	Force (Shock/Vibration)	Mounting Type	A	15 g/2 g	DIN rail or screw	30 g/2.5 g	Screw only	B	15 g/2 g	DIN rail or screw	30 g/2.5 g	Screw only	C	15 g/2 g	DIN rail or screw	30 g/2.5 g	Screw only	D	15 g/2 g	Screw only	30 g/2.5 g	Screw only	E	15 g/1.5 g	Screw only	30 g/2.5 g	Screw only
Frame Size	Operating and Nonoperating		Nonoperating (Transportation)																																
	Force (Shock/Vibration)	Mounting Type	Force (Shock/Vibration)	Mounting Type																															
A	15 g/2 g	DIN rail or screw	30 g/2.5 g	Screw only																															
B	15 g/2 g	DIN rail or screw	30 g/2.5 g	Screw only																															
C	15 g/2 g	DIN rail or screw	30 g/2.5 g	Screw only																															
D	15 g/2 g	Screw only	30 g/2.5 g	Screw only																															
E	15 g/1.5 g	Screw only	30 g/2.5 g	Screw only																															
Conformal Coating:	Complies with: IEC 60721-3-3 to level 3C2 (chemical and gases only)																																		
Surrounding Environment Pollution Degree Pollution Degree 1 and 2:	All enclosures acceptable.																																		
Sound Pressure Level (A-weighted), max Frame A and B: Frame C: Frame D: Frame E:	Measurements are taken 1 m (3.3 ft) from the drive. 53 dBA 57 dBA 64 dBA 68 dBA																																		

Certifications

Certification	PowerFlex 527
c-UL-us 	Listed to UL 508C and CSA C22.2 No. 274 Listed to UL 61800-5-1 and CSA C22.2 No. 274-17
RCM 	Australian Communications and Media Authority In conformity with the following: Radiocommunications Act: 1992 (including amendments up to 2018) Radiocommunications Standard: 2017 Radiocommunications Labelling Notice: 2017 Standards applied: EN 61800-3
	In conformity with the following European Directives: 2014/35/EU Low Voltage Directive (LVD) 2014/30/EU EMC Directive (EMC) 2006/42/EC Machinery Directive (MD) 2011/65/EU RoHS Directive (RoHS) 2009/125/EC Ecodesign Directive Standards applied: EN 61800-3 EN 61800-5-1
Functional Safety 	TÜV Rheinland Standards applied: EN ISO 13849-1 EN 61800-5-2 EN 62061 EN 60204-1 IEC 61508 Part 1-7 Certified to ISO 13849-1 SIL3/PLe with embedded Safe Torque Off function Certified to ISO 61800-5-2 and EN 62061 SIL3/PLe with Network Torque Off function Meets Functional Safety (FS) when used with embedded Safe Torque Off function
ATEX  II (2) GD TÜV 15 ATEX 7696 X TUV 21 UKEX 7033 X	Certified to ATEX Directive 2014/34/EU Group II Category (2) GD Applications with ATEX Approved Motors Certified to UK Equipment and Protective Systems Intended for Use in Potentially Explosive Atmospheres Regulations (2016 No. 1107) Group II Category (2) GD Applications with ATEX Approved Motors
KCC	Korean Registration of Broadcasting and Communications Equipment Compliant with the following standards: Article 58-2 of Radio Waves Act, Clause 3
Efficiency Class	Ecodesign regulation (EU) 2019/1781, IE2 efficiency class, see the PowerFlex AC Drive Performance Specifications per Ecodesign Regulation (EU) 2019/1781 and UK SI 2021 No. 745 Technical Data, publication PFLEX-TD003 for additional information.
AC 156	Tested by Trentec to be compliant with AC156 Acceptance Criteria for Seismic Qualification Testing of Nonstructural Components and 2003 International Building Code for worst-case seismic level for USA excluding site class F
SEMI F47	Certified compliant with the following standards: SEMI F47 IEC 61000-4-11 IEC 61000-4-34
ODVA EtherNet/IP <small>conformance tested</small>	ODVA conformance tested to EtherNet/IP specifications
Lloyd's Register	Lloyd's Register Type Approval Certificate 15/80016(E1)
IEEE P1668	Product meets the requirements of IEEE P1668
RoHS	Compliant with the European "Restriction of Hazardous Substances" 2011/65/EU Directive

The drive is also designed to meet the appropriate portions of the following specifications:

NFPA 70 - US National Electrical Code

NEMA ICS 7.1 - Safety standards for Construction and Guide for Selection, Installation, and Operation of Adjustable Speed Drive Systems.

Product Selection

Catalog Number Description

25C	-	V	2P5	N	1	0	4
Drive		Voltage Rating	Rating	Enclosure	HIM	Emission Class	Version

PowerFlex 527 Drive Ratings

Catalog Number	Output Ratings				Output Current (A)	Input Voltage Range	Total Watts Loss	Frame Size
	Normal Duty		Heavy Duty					
	HP	kW	HP	kW				
100...120V AC (-15%, +10%) - 1-phase Input, 0...230V 3-phase Output								
25C-V2P5N104	0.5	0.4	0.5	0.4	2.5	85...132	27.0	A
25C-V4P8N104	1.0	0.75	1.0	0.75	4.8	85...132	53.0	B
25C-V6PON104	1.5	1.1	1.5	1.1	6.0	85...132	67.0	B
200...240V AC (-15%, +10%) - 1-phase Input, 0...230V 3-phase Output								
25C-A2P5N104	0.5	0.4	0.5	0.4	2.5	170...264	29.0	A
25C-A4P8N104	1.0	0.75	1.0	0.75	4.8	170...264	50.0	A
25C-A8PON104	2.0	1.5	2.0	1.5	8.0	170...264	81.0	B
25C-A011N104	3.0	2.2	3.0	2.2	11.0	170...264	111.0	B
200...240V AC (-15%, +10%) - 1-phase Input with EMC Filter, 0...230V 3-phase Output								
25C-A2P5N114	0.5	0.4	0.5	0.4	2.5	170...264	29.0	A
25C-A4P8N114	1.0	0.75	1.0	0.75	4.8	170...264	53.0	A
25C-A8PON114	2.0	1.5	2.0	1.5	8.0	170...264	84.0	B
25C-A011N114	3.0	2.2	3.0	2.2	11.0	170...264	116.0	B
200...240V AC (-15%, +10%) - 3-phase Input, 0...230V 3-phase Output								
25C-B2P5N104	0.5	0.4	0.5	0.4	2.5	170...264	29.0	A
25C-B5PON104	1.0	0.75	1.0	0.75	5.0	170...264	50.0	A
25C-B8PON104	2.0	1.5	2.0	1.5	8.0	170...264	79.0	A
25C-B011N104	3.0	2.2	3.0	2.2	11.0	170...264	107.0	A
25C-B017N104	5.0	4.0	5.0	4.0	17.5	170...264	148.0	B
25C-B024N104	7.5	5.5	7.5	5.5	24.0	170...264	259.0	C
25C-B032N104	10.0	7.5	10.0	7.5	32.2	170...264	323.0	D
25C-B048N104	15.0	11.0	10.0	7.5	48.3	170...264	584.0	E
25C-B062N104	20.0	15.0	15.0	11.0	62.1	170...264	708.0	E
380...480V AC (-15%, +10%) - 3-phase Input, 0...460V 3-phase Output⁽¹⁾								
25C-D1P4N104	0.5	0.4	0.5	0.4	1.4	323...528	27.0	A
25C-D2P3N104	1.0	0.75	1.0	0.75	2.3	323...528	37.0	A
25C-D4PON104	2.0	1.5	2.0	1.5	4.0	323...528	80.0	A
25C-D6PON104	3.0	2.2	3.0	2.2	6.0	323...528	86.0	A
25C-D010N104	5.0	4.0	5.0	4.0	10.5	323...528	129.0	B
25C-D013N104	7.5	5.5	7.5	5.5	13.0	323...528	170.0	C
25C-D017N104	10.0	7.5	10.0	7.5	17.0	323...528	221.0	C
25C-D024N104	15.0	11.0	15.0	11.0	24.0	323...528	303.0	D
25C-D030N104	20.0	15.0	15.0	11.0	30.0	323...528	387.0	D
25C-D037N114 ⁽²⁾	25.0	18.5	20.0	15.0	37.0	323...528	602.0	E
25C-D043N114 ⁽²⁾	30.0	22.0	25.0	18.5	43.0	323...528	697.0	E
25C-D1P4N114	0.5	0.4	0.5	0.4	1.4	323...528	27.0	A
25C-D2P3N114	1.0	0.75	1.0	0.75	2.3	323...528	37.0	A
25C-D4PON114	2.0	1.5	2.0	1.5	4.0	323...528	81.0	A
25C-D6PON114	3.0	2.2	3.0	2.2	6.0	323...528	88.0	A
25C-D010N114	5.0	4.0	5.0	4.0	10.5	323...528	133.0	B
25C-D013N114	7.5	5.5	7.5	5.5	13.0	323...528	175.0	C

PowerFlex 527 Drive Ratings (Continued)

Catalog Number	Output Ratings				Input Voltage Range	Total Watts Loss	Frame Size	
	Normal Duty		Heavy Duty					Output Current (A)
	HP	kW	HP	kW				
25C-D017N114	10.0	7.5	10.0	7.5	17.0	323...528	230.0	C
25C-D024N114	15.0	11.0	15.0	11.0	24.0	323...528	313.0	D
25C-D030N114	20.0	15.0	15.0	11.0	30.0	323...528	402.0	D
25C-D037N114	25.0	18.5	20.0	15.0	37.0	323...528	602.0	E
25C-D043N114	30.0	22.0	25.0	18.5	43.0	323...528	697.0	E

525...600V AC (-15%, +10%) - 3-phase Input, 0...575V 3-phase Output

25C-E0P9N104	0.5	0.4	0.5	0.4	0.9	446...660	22.0	A
25C-E1P7N104	1.0	0.75	1.0	0.75	1.7	446...660	32.0	A
25C-E3P0N104	2.0	1.5	2.0	1.5	3.0	446...660	50.0	A
25C-E4P2N104	3.0	2.2	3.0	2.2	4.2	446...660	65.0	A
25C-E6P6N104	5.0	4.0	5.0	4.0	6.6	446...660	95.0	B
25C-E9P9N104	7.5	5.5	7.5	5.5	9.9	446...660	138.0	C
25C-E012N104	10.0	7.5	10.0	7.5	12.0	446...660	164.0	C
25C-E019N104	15.0	11.0	15.0	11.0	19.0	446...660	290.0	D
25C-E022N104	20.0	15.0	15.0	11.0	22.0	446...660	336.0	D
25C-E027N104	25.0	18.5	20.0	15.0	27.0	446...660	466.0	E
25C-E032N104	30.0	22.0	25.0	18.5	32.0	446...660	562.0	E

(1) A non-filtered drive is not available for 380...480V AC 25 HP (18.5 kW) and 30 HP (22.0 kW) ratings. Filtered drives are available, however you must verify that the application supports a filtered drive.
 (2) Catalogs 25C-037N114 and 25C-043N114 come with an EMC filter.

Drive Dimensions and Weights

Dimensions are in mm and (in.). Weights are in kg and (lb).

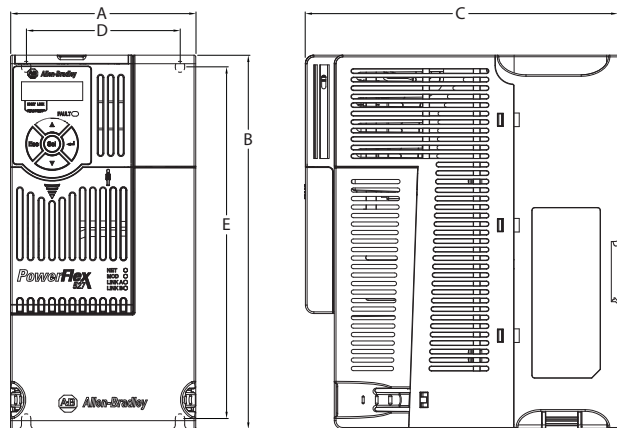

Frame Size	A	B	C	D	E	Weight
A	72.0 (2.83)	152.0 (5.98)	172.0 (6.77)	57.5 (2.26)	140.0 (5.51)	1.1 (2.4)
B	87.0 (3.43)	180.0 (7.09)	172.0 (6.77)	72.5 (2.85)	168.0 (6.61)	1.6 (3.5)
C	109.0 (4.29)	220.0 (8.66)	184.0 (7.24)	90.5 (3.56)	207.0 (8.15)	2.3 (5.0)
D	130.0 (5.12)	260.0 (10.24)	212.0 (8.35)	116.0 (4.57)	247.0 (9.72)	3.9 (8.6)
E	185.0 (7.28)	300.0 (11.81)	279.0 (10.98)	160.0 (6.30)	280.0 (11.02)	12.9 (28.4)

Design Considerations

Mounting Considerations

- Mount the drive upright on a flat, vertical, and level surface.

Frame	Screw Size	Screw Torque
A	M5 (#10...24)	1.56...1.96 N•m (14...17 lb•in)
B	M5 (#10...24)	1.56...1.96 N•m (14...17 lb•in)
C	M5 (#10...24)	1.56...1.96 N•m (14...17 lb•in)
D	M5 (#10...24)	2.45...2.94 N•m (22...26 lb•in)
E	M8 (5/16 in.)	6.0...7.4 N•m (53...65 lb•in)

- Protect the cooling fan by avoiding dust or metallic particles.
- Do not expose to a corrosive atmosphere.
- Protect from moisture and direct sunlight.

Minimum Mounting Clearances

See [Drive Dimensions and Weights on page 14](#) for mounting dimensions.

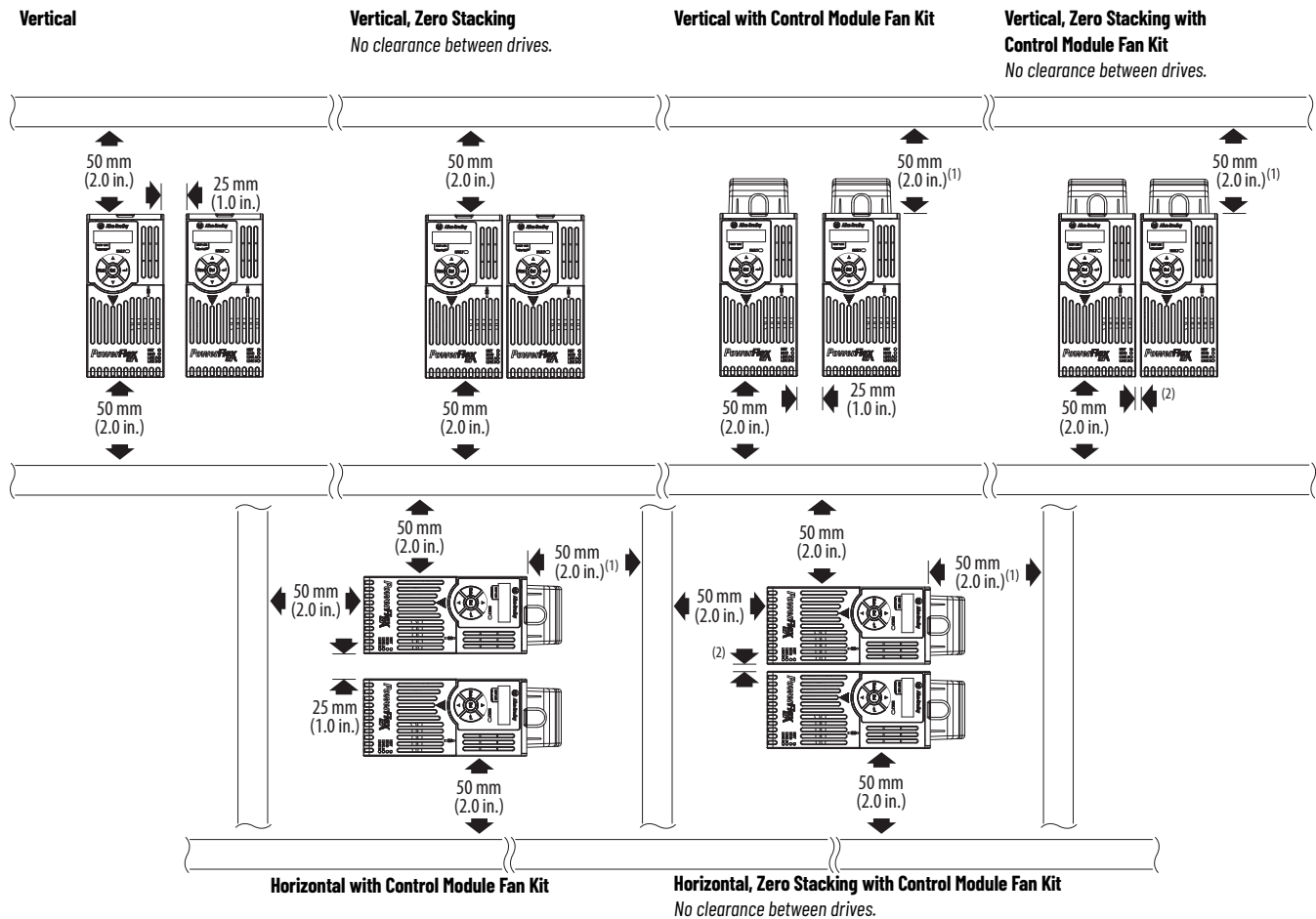

(1) For Frame E with Control Module Fan Kit only, clearance of 95 mm (3.7 in.) is required.
 (2) For Frame E with Control Module Fan Kit only, clearance of 12 mm (0.5 in.) is required.

Ambient Operating Temperatures

See [Accessories on page 32](#) for option kits.

Mounting	Enclosure Rating ⁽¹⁾	Ambient Temperature			
		Min	Max (No Derate)	Max (Derate) ⁽²⁾	Max with Control Module Fan Kit (Derate) ⁽³⁾⁽⁴⁾
Vertical	IP 20/Open Type	-20 °C (-4 °F)	50 °C (122 °F)	—	70 °C (158 °F)
	IP 30/NEMA 1/UL Type 1		45 °C (113 °F)	55 °C (131 °F)	—
Vertical, Zero Stacking	IP 20/Open Type		45 °C (113 °F)	—	65 °C (149 °F)
Horizontal with Control Module Fan Kit ⁽⁴⁾⁽⁵⁾	IP 20/Open Type		50 °C (122 °F)	—	70 °C (158 °F)
Horizontal, Zero Stacking with Control Module Fan Kit ⁽⁴⁾⁽⁵⁾	IP 20/Open Type		45 °C (113 °F)	—	65 °C (149 °F)

- (1) IP 30/NEMA 1/UL Type 1 rating requires installation of the PowerFlex 520-series IP 30/NEMA 1/UL Type 1 option kit, catalog number 25-JBAX.
- (2) For catalogs 25C-DIP4N104 and 25C-EOP9N104, the temperature that is listed under the Max (Derate) column is reduced by 5 °C (9 °F) for all mounting methods.
- (3) For catalogs 25C-DIP4N104 and 25C-EOP9N104, the temperature that is listed under the Max with Control Module Fan Kit (Derate) column is reduced by 10 °C (18 °F) for vertical and vertical with zero stacking mounting methods only.
- (4) Requires installation of the PowerFlex 520-series Control Module Fan Kit, catalog number 25-FANx-70C.
- (5) Catalogs 25C-DIP4N104 and 25C-EOP9N104 cannot be mounted using either of the horizontal mounting methods.

Current Derating Curves

Vertical Mounting

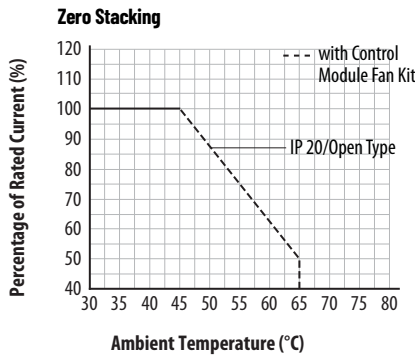
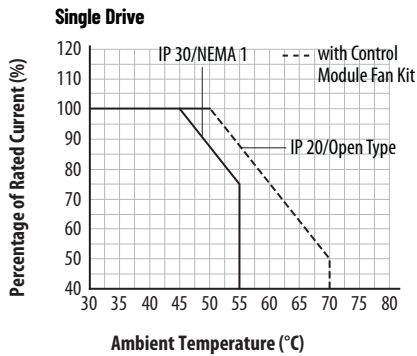

Horizontal Mounting/Floor

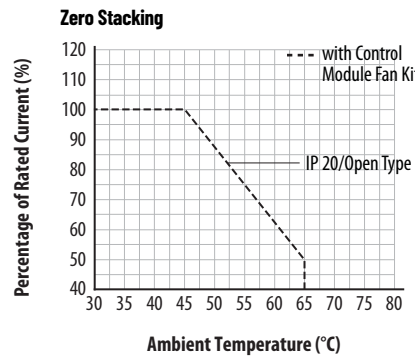
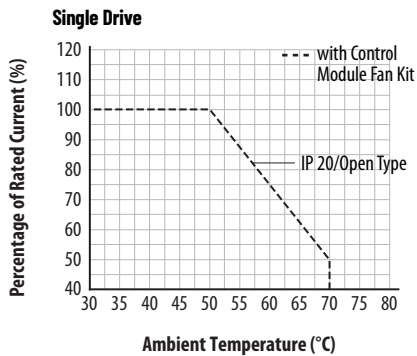

Derating Guidelines for High Altitude

The drive can be used without derating at a maximum altitude of 1000 m (3300 ft).

If the drive is used above 1000 m (3300 ft):

- Derate the maximum ambient temperature by 5 °C (41 °F) for every additional 1000 m (3300 ft), subject to limits listed in the Altitude Limit (Based on Voltage) table below.

Or

- Derate the output current by 10% for every additional 1000 m (3300 ft), subject to limits listed in the Altitude Limit (Based on Voltage) table below.

Altitude Limit (Based on Voltage)

Drive Rating	Center Ground (Wye Neutral)	Corner Ground, Impedance Ground, or Ungrounded
100...120V 1-phase	6000 m (19,685 ft)	6000 m (19,685 ft)
200...240V 1-phase	2000 m (6562 ft)	2000 m (6562 ft)
200...240V 3-phase	6000 m (19,685 ft)	2000 m (6562 ft)
380...480V 3-phase	4000 m (13,123 ft)	2000 m (6562 ft)
525...600V 3-phase	2000 m (6562 ft)	2000 m (6562 ft)

High Altitude

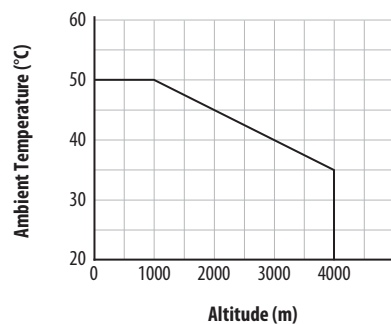
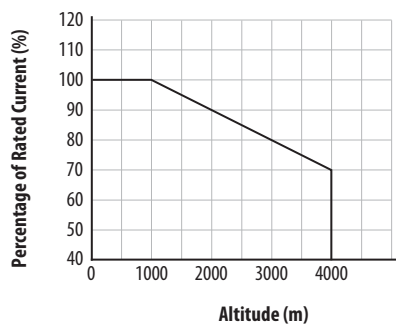

Debris Protection

Take precautions to prevent debris from falling through the vents of the drive housing during installation.

Storage

- Store within an ambient temperature range of -40...+85 °C (-40...+185 °F)^(a).
- Store within a relative humidity range of 0...95%, noncondensing.
- Do not expose to a corrosive atmosphere.

AC Supply Source Considerations

Ungrounded Distribution Systems



ATTENTION: PowerFlex 520-series drives contain protective MOVs that are referenced to ground. These devices must be disconnected if the drive is installed on an ungrounded or resistive grounded distribution system.

ATTENTION: Removing MOVs in drives with an embedded filter also disconnects the filter capacitor from earth ground.

^(a) The maximum ambient temperature for storing a Frame E drive is 70 °C (158 °F).

Disconnecting MOVs

To prevent drive damage, the MOVs connected to ground shall be disconnected if the drive is installed on an ungrounded distribution system (IT mains) where the line-to-ground voltages on any phase could exceed 125% of the nominal line-to-line voltage. To disconnect these devices, remove the jumper that is shown in the following diagrams.

1. Turn the screw counterclockwise to loosen.
2. Pull the jumper completely out of the drive chassis.
3. Tighten the screw to keep it in place.

Jumper Location (Typical)

Power Module

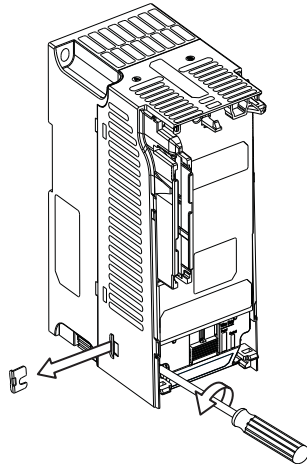

IMPORTANT Tighten screw after jumper removal.

Phase to Ground MOV Removal

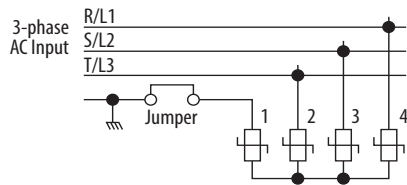

Input Power Conditioning

The drive is suitable for direct connection to input power within the rated voltage of the drive (see [Input Power Conditions on page 19](#)). Listed in the Input Power Conditions table below are certain input power conditions, which may cause component damage or reduction in product life. If any of these conditions exist, install one of the devices that are listed under the heading Corrective Action on the line side of the drive.

IMPORTANT Only one device per branch circuit is required. It should be mounted closest to the branch and sized to handle the total current of the branch circuit.

Input Power Conditions

Input Power Condition	Corrective Action
Low Line Impedance (less than 1% line reactance)	<ul style="list-style-type: none"> • Install Line Reactor⁽¹⁾ • or Isolation Transformer
Greater than 120 kVA supply transformer	
Line has power factor correction capacitors	<ul style="list-style-type: none"> • Install Line Reactor⁽¹⁾ • or Isolation Transformer
Line has frequent power interruptions	
Line has intermittent noise spikes in excess of 6000V (lightning)	
Phase to ground voltage exceeds 125% of normal line to line voltage	<ul style="list-style-type: none"> • Remove MOV jumper to ground. • or Install Isolation Transformer with grounded secondary if necessary.
Ungrounded distribution system	
240V open delta configuration (stinger leg) ⁽²⁾	<ul style="list-style-type: none"> • Install Line Reactor⁽¹⁾

⁽¹⁾ See [Accessories on page 32](#) for accessory ordering information.

⁽²⁾ For drives applied on an open delta with a middle phase grounded neutral system, the phase opposite the phase that is tapped in the middle to the neutral or earth is referred to as the "stinger leg," "high leg," "red leg," and so on. This leg should be identified throughout the system with red or orange tape on the wire at each connection point. The stinger leg should be connected to the center Phase B on the reactor. See [Bulletin 1321-3R Series Line Reactors on page 37](#) for specific line reactor part numbers.

General Grounding Requirements

The drive Safety Ground - (PE) must be connected to system ground. Ground impedance must conform to the requirements of national and local industrial safety regulations and/or electrical codes. The integrity of all ground connections should be periodically checked.

Typical Grounding

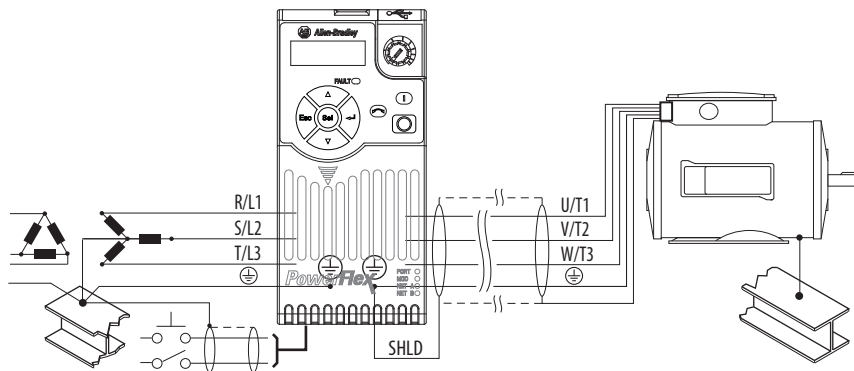

Ground Fault Monitoring

If a system ground fault monitor (RCD) is to be used, only Type B (adjustable) devices should be used to avoid nuisance tripping.

Safety Ground - (PE)

This is the safety ground for the drive that is required by code. One of these points must be connected to adjacent building steel (girder, joist), a floor ground rod or busbar. Grounding points must comply with national and local industrial safety regulations and/or electrical codes.

Motor Ground

The motor ground must be connected to one of the ground terminals on the drive.

Shield Termination - SHLD

Either of the safety ground terminals that are located on the power terminal block provides a grounding point for the motor cable shield. The **motor cable** shield connected to one of these terminals (drive end) should also be connected to the motor frame (motor end). Use a shield terminating or EMI clamp to connect the shield to the safety ground terminal. The earthing plate or conduit box option may be used with a cable clamp for a grounding point for the cable shield.

When shielded cable is used for **control and signal wiring**, the shield should be grounded at the source end only, not at the drive end.

RFI Filter Grounding

Using a drive with filter may result in relatively high ground leakage currents. Therefore, the **filter must only be used in installations with grounded AC supply systems and be permanently installed and solidly grounded** (bonded) to the building power distribution ground. Verify that the incoming supply neutral is solidly connected (bonded) to the same building power distribution ground. Grounding must not rely on flexible cables and should exclude any form of plug or socket that would permit inadvertent disconnection. Some local codes may require redundant ground connections. The integrity of all connections should be periodically checked.

Power Wiring



ATTENTION: National Codes and standards (NEC, VDE, BSI, and so on) and local codes outline provisions for safely installing electrical equipment. Installation must comply with specifications regarding wire types, conductor sizes, branch circuit protection and disconnect devices. Failure to do so may result in personal injury and/or equipment damage.

ATTENTION: To avoid a possible shock hazard that is caused by induced voltages, unused wires in the conduit must be grounded at both ends. For the same reason, if a drive sharing a conduit is being serviced or installed, all drives using this conduit should be disabled. This helps minimize the possible shock hazard from "cross coupled" power leads.

Motor Cable Types Acceptable for 100...600 Volt Installations

Various cable types are acceptable for drive installations. For many installations, unshielded cable is adequate, provided it can be separated from sensitive circuits. As an approximate guide, allow a spacing of 0.3 m (1 ft) for every 10 m (32.8 ft) of length. In all cases, long parallel runs must be avoided. Do not use cable with an insulation thickness fewer than 15 mils (0.4 mm/0.015 in.). Do not route more than three sets of motor leads in one conduit to minimize "cross talk". If more than three drive/motor connections per conduit are required, shielded cable must be used.

UL installations above 50 °C (122 °F) ambient must use 600V, 90 °C (122 °F) wire.

UL installations in 50 °C (122 °F) ambient must use 600V, 75 °C (167 °F) or 90 °C (194 °F) wire.

UL installations in 40 °C (104 °F) ambient must use 600V, 75 °C (167 °F) or 90 °C (194 °F) wire.

Use copper wire only. Wire gauge requirements and recommendations are based on 75 °C. Do not reduce wire gauge when using higher temperature wire.



ATTENTION: The distance between the drive and motor must not exceed the maximum cable length that is stated in the Motor Cable Length Restrictions Tables in "Wiring and Grounding for Pulse Width Modulated (PWM) AC Drives Installation Instructions," publication [DRIVES-IN001](#).

Unshielded Cable

THHN, THWN, or similar wire is acceptable for drive installation in dry environments provided adequate free air space and/or conduit fill rates limits are provided. Any wire that is chosen must have a minimum insulation thickness of 15 mils and should not have large variations in insulation concentricity.



ATTENTION: Do not use THHN or similarly coated wire in wet areas.

Shielded/Armored Cable

Shielded cable contains all the general benefits of multi-conductor cable with the added benefit of a copper braided shield that can contain much of the noise that is generated by a typical AC Drive. Strong consideration for shielded cable should be given in installations with sensitive equipment such as weigh scales, capacitive proximity switches and other devices that may be affected by electrical noise in the distribution system. Applications with large numbers of drives in a similar location, imposed EMC regulations or a high degree of communications / networking are also good candidates for shielded cable.

Shielded cable may also help reduce shaft voltage and induced bearing currents for some applications. In addition, the increased impedance of shielded cable may help extend the distance that the motor can be located from the drive without the addition of motor protective devices such as terminator networks. See Reflected Wave in "Wiring and Grounding for Pulse Width Modulated (PWM) AC Drives Installation Instructions," publication [DRIVES-IN001](#).

Consideration should be given to all general specifications dictated by the environment of the installation, including temperature, flexibility, moisture characteristics and chemical resistance. In addition, a braided shield should be included and be specified by the cable manufacturer as having coverage of at least 75%. An additional foil shield can greatly improve noise containment.

A good example of recommended cable is Belden 295xx (xx determines gauge). This cable has four XLPE insulated conductors with a 100% coverage foil and an 85% coverage copper braided shield (with drain wire) surrounded by a PVC jacket.

Other types of shielded cable are available, but the selection of these types may limit the allowable cable length. Particularly, some of the newer cables twist four conductors of THHN wire and wrap them tightly with a foil shield. This construction can greatly increase the cable charging current required and reduce the overall drive performance. Unless specified in the individual distance tables as tested with the drive, these cables are not recommended and their performance against the lead length limits supplied is not known.

Recommended Shielded Wire

Location	Rating/Type	Description
Standard (Option 1)	600V, 90 °C (194 °F) XHHW2/RHW-2 Anixter B209500...B209507, Belden 29501...29507, or equivalent	<ul style="list-style-type: none"> Four tinned copper conductors with XLPE insulation Copper braid/aluminum foil combination shield and tinned copper drain wire PVC jacket
Standard (Option 2)	Tray rated 600V, 90 °C (194 °F) RHH/RHW-2 Anixter 0LF-7xxxxx or equivalent	<ul style="list-style-type: none"> Three tinned copper conductors with XLPE insulation 5 mil single helical copper tape (25% overlap min) with three bare copper grounds in contact with shield PVC jacket
Class I and II; Division I and II	Tray rated 600V, 90 °C (194 °F) RHH/RHW-2 Anixter 7V-7xxxx-3G or equivalent	<ul style="list-style-type: none"> Three bare copper conductors with XLPE insulation and impervious corrugated continuously welded aluminum armor Black sunlight resistant PVC jacket overall Three copper grounds on 6 mm² (#10 AWG) and smaller.

Reflected Wave Protection

The drive should be installed as close to the motor as possible. Installations with long motor cables may require the addition of external devices to limit voltage reflections at the motor (reflected wave phenomena). See Reflected Wave in “Wiring and Grounding for Pulse Width Modulated (PWM) AC Drives Installation Instructions,” publication [DRIVES-IN001](#).

The reflected wave data applies to all carrier frequencies 2...8 kHz.

For 240V ratings and lower, reflected wave effects do not need to be considered.

Output Disconnect

The drive is intended to be commanded by control input signals that start and stop the motor. A device that routinely disconnects then reapplies output power to the motor for the purpose of starting and stopping the motor should not be used. If it is necessary to disconnect power to the motor with the drive outputting power, use Logix Designer application to disable the drive (Aux Fault or Coast-to-Stop).

Power Terminal Block Wire Specifications

Frame	Wire Size max ⁽¹⁾	Wire Size min ⁽¹⁾	Torque
A	5.3 mm ² (10 AWG)	0.8 mm ² (18 AWG)	1.76...2.16 N•m (15.6...19.1 lb•in)
B	8.4 mm ² (8 AWG)	2.1 mm ² (14 AWG)	1.76...2.16 N•m (15.6...19.1 lb•in)
C	8.4 mm ² (8 AWG)	2.1 mm ² (14 AWG)	1.76...2.16 N•m (15.6...19.1 lb•in)
D	13.3 mm ² (6 AWG)	5.3 mm ² (10 AWG)	1.76...2.16 N•m (15.6...19.1 lb•in)
E	26.7 mm ² (3 AWG)	8.4 mm ² (8 AWG)	3.09...3.77 N•m (27.3...33.4 lb•in)

⁽¹⁾ Maximum/minimum sizes that the terminal block accepts - These are not recommendations.

Common Bus/Precharge Notes

If drives are used with a disconnect switch to the common DC bus, then an auxiliary contact on the disconnect must be connected to a digital input of the drive.

I/O Wiring

Motor Start/Stop Precautions



ATTENTION: A contactor or other device that routinely disconnects and reapplies the AC line to the drive to start and stop the motor can cause drive hardware damage. The drive is designed to use control input signals that start and stop the motor. If used, the input device must not exceed one operation per minute or drive damage can occur.

Important points to remember about I/O wiring:

- Always use copper wire.
- Wire with an insulation rating of 600V or greater is recommended.
- Control and signal wires should be separated from power wires by at least 0.3 m (1 ft).

IMPORTANT I/O terminals labeled “Common” are not referenced to the safety ground (PE) terminal and are designed to greatly reduce common mode interference.



ATTENTION: Driving the 4...20 mA analog input from a voltage source could cause component damage. Verify proper configuration before applying input signals.



ATTENTION: Due to its control circuitry difference from the PowerFlex 523 and PowerFlex 525 drives, connecting Terminals 01 and 11 on the PowerFlex 527 drive causes an internal short and results in some internal components incurring damage to the control module I/O circuitry.

Signal and Control Wire Types

Recommendations are for 50 °C (122 °F) ambient temperature.
 75 °C (167 °F) wire must be used for 60 °C (140 °F) ambient temperature.
 90 °C (194 °F) wire must be used for 70 °C (158 °F) ambient temperature.

Recommended Signal Wire

Signal Type/Where Used	Belden Wire Types (or equivalent) ⁽¹⁾	Description	Insulation Rating min
Analog I/O	8760/9460	0.750 mm ² (18 AWG), twisted-pair, 100% shield with drain ⁽²⁾	300V, 60 °C (140 °F)
Remote Pot	8770	0.750 mm ² (18 AWG), 3 conductor, shielded	
Encoder	9728/9730	0.196 mm ² (24 AWG), individually shielded pairs	

⁽¹⁾ Stranded or solid wire.

⁽²⁾ If the wires are short and contained within a cabinet, which has no sensitive circuits, the use of shielded wire may not be necessary, but is always recommended.

Recommended Control Wire for Digital I/O

Type	Wire Types	Description	Insulation Rating min
Unshielded	Per US NEC or applicable national or local code	-	300V, 60 °C (140 °F)
Shielded	Multi-conductor shielded cable such as Belden 8770 (or equivalent)	0.750 mm ² (18 AWG), 3 conductor, shielded.	

Maximum Control Wire Recommendation

Do not exceed control wiring length of 30 m (100 ft). Control signal cable length is highly dependent on electrical environment and installation practices. To improve noise immunity, the I/O terminal Common may be connected to ground terminal/protective earth. When using the embedded Ethernet ports, terminal C1 is the connection for the Ethernet shield, and a ground wire must be connected to a clean ground.

Control I/O Terminal Block Wire Specifications

Frame	Wire Size max ⁽¹⁾	Wire Size min ⁽¹⁾	Torque
A...E	1.3 mm ² (16 AWG)	0.13 mm ² (26 AWG)	0.71...0.86 N•m (6.2...7.6 lb•in)

⁽¹⁾ Maximum/minimum sizes that the terminal block accepts - These are not recommendations.

Machinery Directive (2006/42/EC)

- EN ISO 13849-1:2008+AC:2009 - Safety of machinery - Safety-related parts of control systems -Part 1: General principles for design.
- EN 62061:2005+A1:2013 - Safety of machinery - Functional safety of safety-related electrical, electronic, and programmable electronic control systems.
- EN 60204-1:2006+A1:2009 - Safety of machinery - Electrical equipment of machines - Part 1: General requirements.
- EN 61800-5-2:2007 - Adjustable speed electrical power drive systems - Part 5-2: Safety requirement - Functional.

Connections and Grounding

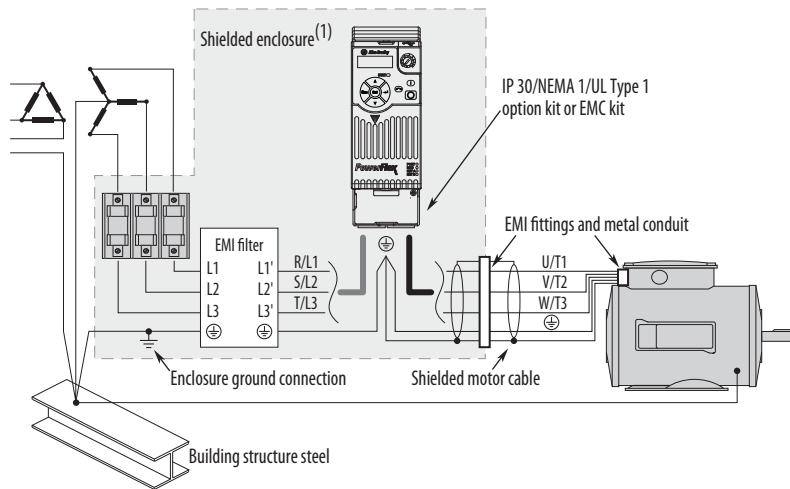

(1) Some installations require a shielded enclosure. Keep wire length as short as possible between the enclosure entry point and the EMI filter.

PowerFlex 527 RF Emission Compliance and Installation Requirements

Filter Type	Standard/Limits		
	EN61800-3 Category C1 EN61000-6-3 CISPR11 Group 1 Class B	EN61800-3 Category C2 EN61000-6-4 CISPR11 Group 1 Class A (Input power ≤ 20 kVA)	EN61800-3 Category C3 (I ≤ 100 A) CISPR11 Group 1 Class A (Input power > 20 kVA)
Internal	—	10 m (33 ft)	20 m (66 ft)
External ⁽¹⁾	30 m (16 ft)	100 m (328 ft)	100 m (328 ft)

(1) See [Accessory Dimensions on page 38](#) for more information on optional external filters.

Fuses and Circuit Breaker Ratings

The PowerFlex 527 drive does not provide branch short circuit protection. This product should be installed with either input fuses or an input circuit breaker. National and local industrial safety regulations and/or electrical codes may determine additional requirements for these installations.

The tables on pages [26...31](#) provide drive ratings and recommended AC line input fuse and circuit breaker information. Both types of short circuit protection are acceptable for UL and IEC requirements. Sizes that are listed are the recommended sizes based on 40 °C (104 °F) and the U.S. N.E.C. Other country, state, or local codes may require different ratings.

Fusing

The recommended fuse types are listed in the tables that are found on pages [26...31](#). If available current ratings do not match those listed in the tables that are provided, choose the next higher fuse rating.

- IEC – BS88 (British Standard) Parts 1 & 2^(a), EN60269-1, Parts 1 & 2, type GG or equivalent should be used.
- UL – UL Class CC, T, RK1, or J should be used.

Circuit Breakers

The “non-fuse” listings in the tables found on pages [26...31](#) include inverse time circuit breakers, instantaneous trip circuit breakers (motor circuit protectors) and 140M/140MT self-protected combination motor controllers. If one of these is chosen as the desired protection method, the following requirements apply:

- IEC – Both types of circuit breakers and 140M/140MT self-protected combination motor controllers are acceptable for IEC installations.
- UL – Only inverse time circuit breakers and the specified 140M/140MT self-protected combination motor controllers are acceptable for UL installations.

Bulletin 140M/140MT (Self-protected Combination Controller)/UL489 Circuit Breakers

When using Bulletin 140M/140MT or UL489 rated circuit breakers, the following guidelines that are listed must be followed to meet the NEC requirements for branch circuit protection.

- Bulletin 140M/140MT can be used in single motor applications.
- Bulletin 140M/140MT can be used up stream from the drive **without** the need for fuses.

If the DC Bus terminals or the Dynamic Brake terminals are used, the drive must be installed in an enclosure and fuses must be used for input protection (for CE applications only). The ventilated enclosure must be IP20 rating or higher and at least 1.5x size larger than the drive.

^(a) Typical designations include, but may not be limited to the following;
Parts 1 & 2: AC, AD, BC, BD, CD, DD, ED, EFS, EF, FF, FG, GF, GG, GH.

Fuses and Circuit Breakers for PowerFlex 527 Drives

100...120V 1-phase Input Protection Devices – Frames A...B – IEC (Non-UL) Applications

Catalog Number ⁽¹⁾	Output Ratings				Input Ratings			Frame Size	Contactor Catalog Number	IEC (Non-UL Applications)			
	ND		HD		A	kVA	Max Current A ⁽²⁾			Fuses (Rating)		Circuit Breakers	
	HP	kW	HP	kW						Min	Max	140U/140UT	140M/140MT ⁽³⁾⁽⁴⁾⁽⁵⁾
25C-V2P5N104	0.5	0.4	0.5	0.4	2.5	1.3	9.6	A	100-C12 100-E12	16	20	140U-D6D2-C12 140UT-D7D2-C12	140M-C2E-C10 140MT-C3E-C10
25C-V4P8N104	1.0	0.75	1.0	0.75	4.8	2.5	19.2	B	100-C23 100-E26	25	40	140U-D6D2-C25 140UT-D7D2-C25	140M-D8E-C20 140MT-D9E-C20
25C-V6P0N104	1.5	1.1	1.5	1.1	6.0	3.2	24.0	B	100-C23	30	50	140U-D6D2-C30 140UT-D7D2-C30	140M-F8E-C25

- ⁽¹⁾ 150% Overload capability for up to 60 s, 180% for up to 3 s.
- ⁽²⁾ When the drive is controlling motors with lower amp ratings, see the drive nameplate for drive input current rating.
- ⁽³⁾ The AIC ratings of the Bulletin 140M/140MT devices can vary. See the Motor Protection Circuit Breaker and Motor Circuit Protector Specifications Technical Data, publication [140-TD005](#) or [140M-TD002](#).
- ⁽⁴⁾ Bulletin 140M/140MT with adjustable current range should have the current trip set to the minimum range that the device does not trip.
- ⁽⁵⁾ Manual Self-protected (Type E) Combination Motor Controller, UL Listed for 480Y/277 and 600Y/347 AC input. Not UL Listed for use on 480V or 600V Delta/Delta, corner ground, or high-resistance ground systems.

100...120V 1-phase Input Protection Devices – Frames A...B – UL 61800-5-1 Applications

Catalog Number ⁽¹⁾	Output Ratings				Input Ratings			Frame Size	Contactor Catalog Number	UL Applications		
	ND		HD		A	kVA	Max Current A ⁽²⁾			Fuses (Max Rating)	Circuit Breakers	
	HP	kW	HP	kW						Class / Catalog Number	140UT	140M/140MT ⁽³⁾⁽⁴⁾⁽⁵⁾
25C-V2P5N104	0.5	0.4	0.5	0.4	2.5	1.3	9.6	A	100-C12 100-E12	CLASS CC, J, or T/20	140UT-D7D2-C12	140MT-C3E-C10 140MT-D9E-C10
25C-V4P8N104	1.0	0.75	1.0	0.75	4.8	2.5	19.2	B	100-C23 100-E26	CLASS CC, J, or T/40	— ⁽⁶⁾	140MT-D9E-C20
25C-V6P0N104	1.5	1.1	1.5	1.1	6.0	3.2	24.0	B	100-C23	CLASS CC, J, or T/50	—	140M-F8E-C25

- ⁽¹⁾ 150% Overload capability for up to 60 s, 180% for up to 3 s.
- ⁽²⁾ When the drive is controlling motors with lower amp ratings, see the drive nameplate for drive input current rating.
- ⁽³⁾ The AIC ratings of the Bulletin 140M/140MT devices can vary. See the Motor Protection Circuit Breaker and Motor Circuit Protector Specifications Technical Data, publication [140-TD005](#) or [140M-TD002](#).
- ⁽⁴⁾ Bulletin 140M/140MT with adjustable current range should have the current trip set to the minimum range that the device does not trip.
- ⁽⁵⁾ Manual Self-protected (Type E) Combination Motor Controller, UL Listed for 480Y/277 and 600Y/347 AC input. Not UL Listed for use on 480V or 600V Delta/Delta, corner ground, or high-resistance ground systems.
- ⁽⁶⁾ Circuit breaker selection is not available for this drive rating.

200...240V 1-phase Input Protection Devices – Frames A...B – IEC (Non-UL) Applications

Catalog Number ⁽¹⁾	Output Ratings				Input Ratings			Frame Size	Contactor Catalog Number	IEC (Non-UL Applications)			
	ND		HD		A	kVA	Max Current A ⁽²⁾			Fuses (Rating)		Circuit Breakers	
	HP	kW	HP	kW						Min	Max	140U/140UT/140G	140M/140MT ⁽³⁾⁽⁴⁾⁽⁵⁾
25C-A2P5N104	0.5	0.4	0.5	0.4	2.5	1.7	6.5	A	100-C09 100-E09	10	16	140U-D6D2-C10 140UT-D7D2-C10	140M-C2E-C10 140MT-C3E-C10
25C-A2P5N114	0.5	0.4	0.5	0.4	2.5	1.7	6.5	A	100-C09 100-E09	10	16	140U-D6D2-C10 140UT-D7D2-C10	140M-C2E-C10 140MT-C3E-C10
25C-A4P8N104	1.0	0.75	1.0	0.75	4.8	2.8	10.7	A	100-C12 100-E12	16	25	140U-D6D2-C15 140UT-D7D2-C15	140M-C2E-C16 140MT-C3E-C16
25C-A4P8N114	1.0	0.75	1.0	0.75	4.8	2.8	10.7	A	100-C12 100-E12	16	25	140U-D6D2-C15 140UT-D7D2-C15	140M-C2E-C16 140MT-C3E-C16
25C-A8PON104	2.0	1.5	2.0	1.5	8.0	4.8	18.0	B	100-C23	25	40	140U-D6D2-C25 140UT-D7D2-C25	140M-F8E-C25
25C-A8PON114	2.0	1.5	2.0	1.5	8.0	4.8	18.0	B	100-C23	25	40	140U-D6D2-C25 140UT-D7D2-C25	140M-F8E-C25
25C-A011N104	3.0	2.2	3.0	2.2	11.0	6.0	22.9	B	100-C37	32	50	140G-G6C3-C25	140M-F8E-C25
25C-A011N114	3.0	2.2	3.0	2.2	11.0	6.0	22.9	B	100-C37	32	50	140G-G6C3-C25	140M-F8E-C25

(1) 150% Overload capability for up to 60 s, 180% for up to 3 s.

(2) When the drive is controlling motors with lower amp ratings, see the drive nameplate for drive input current rating.

(3) The AIC ratings of the Bulletin 140M/140MT devices can vary. See the Motor Protection Circuit Breaker and Motor Circuit Protector Specifications Technical Data, publication [140-TD005](#) or [140M-TD002](#).

(4) Bulletin 140M/140MT with adjustable current range should have the current trip set to the minimum range that the device does not trip.

(5) Manual Self-protected (Type E) Combination Motor Controller, UL Listed for 480Y/277 and 600Y/347 AC input. Not UL Listed for use on 480V or 600V Delta/Delta, corner ground, or high-resistance ground systems.

200...240V 1-phase Input Protection Devices – Frames A...B – UL 61800-5-1 Applications

Catalog Number ⁽¹⁾	Output Ratings				Input Ratings			Frame Size	Contactor Catalog Number	UL Applications			
	ND		HD		A	kVA	Max Current A ⁽²⁾			Fuses (Max Rating)		Circuit Breakers	
	HP	kW	HP	kW						Class / Catalog Number	140UT	140M/140MT ⁽³⁾⁽⁴⁾⁽⁵⁾	
25C-A2P5N104	0.5	0.4	0.5	0.4	2.5	1.7	6.5	A	100-C09 100-E09	CLASS CC, J, or T/16	140U-D6D2-C10	140MT-D9E-C10	
25C-A2P5N114	0.5	0.4	0.5	0.4	2.5	1.7	6.5	A	100-C09 100-E09	CLASS CC, J, or T/16	140U-D6D2-C10	140MT-D9E-C10	
25C-A4P8N104	1.0	0.75	1.0	0.75	4.8	2.8	10.7	A	100-C12 100-E12	CLASS CC, J, or T/25	140U-D6D2-C15	140MT-D9E-C16	
25C-A4P8N114	1.0	0.75	1.0	0.75	4.8	2.8	10.7	A	100-C12 100-E12	CLASS CC, J, or T/25	140U-D6D2-C15	140MT-D9E-C16	
25C-A8PON104	2.0	1.5	2.0	1.5	8.0	4.8	18.0	B	100-C23	CLASS CC, J, or T/40	...(6)	140M-F8E-C25	
25C-A8PON114	2.0	1.5	2.0	1.5	8.0	4.8	18.0	B	100-C23	CLASS CC, J, or T/40	...(6)	140M-F8E-C25	
25C-A011N104	3.0	2.2	3.0	2.2	11.0	6.0	22.9	B	100-C37	CLASS CC, J, or T/50	...(6)	140M-F8E-C25	
25C-A011N114	3.0	2.2	3.0	2.2	11.0	6.0	22.9	B	100-C37	CLASS CC, J, or T/50	...(6)	140M-F8E-C25	

(1) 150% Overload capability for up to 60 s, 180% for up to 3 s.

(2) When the drive is controlling motors with lower amp ratings, see the drive nameplate for drive input current rating.

(3) The AIC ratings of the Bulletin 140M/140MT devices can vary. See the Motor Protection Circuit Breaker and Motor Circuit Protector Specifications Technical Data, publication [140-TD005](#) or [140M-TD002](#).

(4) Bulletin 140M/140MT with adjustable current range should have the current trip set to the minimum range that the device does not trip.

(5) Manual Self-protected (Type E) Combination Motor Controller, UL Listed for 480Y/277 and 600Y/347 AC input. Not UL Listed for use on 480V or 600V Delta/Delta, corner ground, or high-resistance ground systems.

(6) Circuit breaker selection is not available for this drive rating.

200...240V 3-phase Input Protection Devices – Frames A...E – IEC (Non-UL) Applications

Catalog Number ⁽¹⁾	Output Ratings				Input Ratings			Frame Size	Contactor Catalog Number	IEC (Non-UL Applications)			
	ND		HD		A	kVA	Max Current A ⁽²⁾			Fuses (Rating)		Circuit Breakers	
	HP	kW	HP	kW						Min	Max	140U/140UT/140G	140M/140MT ⁽³⁾⁽⁴⁾⁽⁵⁾
25C-B2P5N104	0.5	0.4	0.5	0.4	2.5	1.2	2.7	A	100-C09 100-E09	6	6	140U-D6D3-B40 140UT-D7D3-B40	140M-C2E-B40 140MT-C3E-B40
25C-B5P0N104	1.0	0.75	1.0	0.75	5.0	2.7	5.8	A	100-C09 100-E09	10	16	140U-D6D3-B80 140UT-D7D3-B80	140M-C2E-B63 140MT-C3E-B63
25C-B8P0N104	2.0	1.5	2.0	1.5	8.0	4.3	9.5	A	100-C12 100-E12	16	20	140U-D6D3-C10 140UT-D7D3-C10	140M-C2E-C10 140MT-C3E-C10
25C-B011N104	3.0	2.2	3.0	2.2	11.0	6.3	13.8	A	100-C23 100-E26	20	32	140U-D6D3-C15 140UT-D7D3-C15	140M-C2E-C16 140MT-C3E-C16
25C-B017N104	5.0	4.0	5.0	4.0	17.5	9.6	21.1	B	100-C23	32	45	140U-D6D3-C25 140UT-D7D3-C25	140M-F8E-C25
25C-B024N104	7.5	5.5	7.5	5.5	24.0	12.2	26.6	C	100-C37	35	63	140G-G6C3-C35	140M-F8E-C32
25C-B032N104	10.0	7.5	10.0	7.5	32.2	15.9	34.8	D	100-C43	45	70	140G-G6C3-C60	140M-F8E-C45
25C-B048N104 ⁽⁶⁾	15.0	11.0	15.0	11.0	48.3	20.1	44.0	E	100-C60	63	90	140G-G6C3-C70	140M-F8E-C45
25C-B062N104 ⁽⁶⁾	20.0	15.0	15.0	11.0	62.1	25.6	56.0	E	100-C72 100-E65	70	125	140G-G6C3-C90	_(7)

- (1) 150% Overload capability for up to 60 s, 180% for up to 3 s.
- (2) When the drive is controlling motors with lower amp ratings, see the drive nameplate for drive input current rating.
- (3) The AIC ratings of the Bulletin 140M/140MT devices can vary. See the Motor Protection Circuit Breaker and Motor Circuit Protector Specifications Technical Data, publication [140-TD005](#) or [140M-TD002](#).
- (4) Bulletin 140M/140MT with adjustable current range should have the current trip set to the minimum range that the device does not trip.
- (5) Manual Self-protected (Type E) Combination Motor Controller, UL Listed for 480Y/277 and 600Y/347 AC input. Not UL Listed for use on 480V or 600V Delta/Delta, corner ground, or high-resistance ground systems.
- (6) 110% Overload capability for up to 60 s, 150% for up to 3 s.
- (7) Circuit breaker selection is not available for this drive rating.

200...240V 3-phase Input Protection Devices – Frames A...E – UL 61800-5-1 Applications

Catalog Number ⁽¹⁾	Output Ratings				Input Ratings			Frame Size	Contactor Catalog Number	UL Applications			
	ND		HD		Amps	kVA	Max Amps ⁽²⁾			Fuses (Max Rating)		Circuit Breakers	
	HP	kW	HP	kW						Class / Catalog Number	140U/140UT/140G	140M/140MT ⁽³⁾⁽⁴⁾⁽⁵⁾	
25C-B2P5N104	0.5	0.4	0.5	0.4	2.5	1.2	2.7	A	100-C09 100-E09	CLASS CC, J, or T/6	140U-D6D3-B40 140UT-D7D3-B40	140M-C2E-B40 140MT-C3E-B40	
25C-B5P0N104	1.0	0.75	1.0	0.75	5.0	2.7	5.8	A	100-C09 100-E09	CLASS CC, J, or T/16	140U-D6D3-B80 140UT-D7D3-B80	140M-C2E-B63 140MT-C3E-B63	
25C-B8P0N104	2.0	1.5	2.0	1.5	8.0	4.3	9.5	A	100-C12 100-E12	CLASS CC, J, or T/20	140U-D6D3-C10 140UT-D7D3-C10	140M-C2E-C10 140MT-C3E-C10	
25C-B011N104	3.0	2.2	3.0	2.2	11.0	6.3	13.8	A	100-C23 100-E26	CLASS CC, J, or T/30	140U-D6D3-C15 140UT-D7D3-C15	140M-C2E-C16 140MT-C3E-C16	
25C-B017N104	5.0	4.0	5.0	4.0	17.5	9.6	21.1	B	100-C23	CLASS CC, J, or T/45	140U-D6D3-C25 140UT-D7D3-C25	140M-F8E-C25	
25C-B024N104	7.5	5.5	7.5	5.5	24.0	12.2	26.6	C	100-C37	CLASS CC, J, or T/60	140G-G6C3-C35	140M-F8E-C32	
25C-B032N104	10.0	7.5	10.0	7.5	32.2	15.9	34.8	D	100-C43	CLASS CC, J, or T/70	140G-G6C3-C60	140M-F8E-C45	
25C-B048N104 ⁽⁶⁾	15.0	11.0	15.0	11.0	48.3	20.1	44.0	E	100-C60	CLASS CC, J, or T/90	140G-G6C3-C70	140M-F8E-C45	
25C-B062N104 ⁽⁶⁾	20.0	15.0	15.0	11.0	62.1	25.6	56.0	E	100-C72 100-E65	CLASS CC, J, or T/125	140G-G6C3-C90	_(7)	

- (1) 150% Overload capability for up to 60 s, 180% for up to 3 s.
- (2) When the drive is controlling motors with lower amp ratings, see the drive nameplate for drive input current rating.
- (3) The AIC ratings of the Bulletin 140M/140MT devices can vary. See the Motor Protection Circuit Breaker and Motor Circuit Protector Specifications Technical Data, publication [140-TD005](#) or [140M-TD002](#).
- (4) Bulletin 140M/140MT with adjustable current range should have the current trip set to the minimum range that the device does not trip.
- (5) Manual Self-protected (Type E) Combination Motor Controller, UL Listed for 480Y/277 and 600Y/347 AC input. Not UL Listed for use on 480V or 600V Delta/Delta, corner ground, or high-resistance ground systems.
- (6) 110% Overload capability for up to 60 s, 150% for up to 3 s.
- (7) Circuit breaker selection is not available for this drive rating.

380...480V 3-phase Input Protection Devices – Frames A...E – IEC (Non-UL) Applications

Catalog Number ⁽¹⁾	Output Ratings				Input Ratings			Frame Size	Contactor Catalog Number	IEC (Non-UL Applications)			
	ND		HD		Amps	kVA	Max Amps ⁽²⁾			Fuses (Rating)		Circuit Breakers	
	HP	kW	HP	kW						Min	Max	140U/140UT/140G	140M/140MT ⁽³⁾⁽⁴⁾⁽⁵⁾
25C-D1P4N104	0.5	0.4	0.5	0.4	1.4	1.7	1.9	A	100-C09 100-E09	3	6	140U-D6D3-B30 140UT-D7D3-B30	140M-C2E-B25 140MT-C3E-B25
25C-D1P4N114	0.5	0.4	0.5	0.4	1.4	1.7	1.9	A	100-C09 100-E09	3	6	140U-D6D3-B30 140UT-D7D3-B30	140M-C2E-B25 140MT-C3E-B25
25C-D2P3N104	1.0	0.75	1.0	0.75	2.3	2.9	3.2	A	100-C09 100-E09	6	10	140U-D6D3-B60 140UT-D7D3-B60	140M-C2E-B40 140MT-C3E-B40
25C-D2P3N114	1.0	0.75	1.0	0.75	2.3	2.9	3.2	A	100-C09 100-E09	6	10	140U-D6D3-B60 140UT-D7D3-B60	140M-C2E-B40 140MT-C3E-B40
25C-D4P0N104	2.0	1.5	2.0	1.5	4.0	5.2	5.7	A	100-C09 100-E09	10	16	140U-D6D3-B60 140UT-D7D3-B60	140M-C2E-B63 140MT-C3E-B63
25C-D4P0N114	2.0	1.5	2.0	1.5	4.0	5.2	5.7	A	100-C09 100-E09	10	16	140U-D6D3-B60 140UT-D7D3-B60	140M-C2E-B63 140MT-C3E-B63
25C-D6P0N104	3.0	2.2	3.0	2.2	6.0	6.9	7.5	A	100-C09 100-E09	10	16	140U-D6D3-C10 140UT-D7D3-C10	140M-C2E-C10 140MT-C3E-C10
25C-D6P0N114	3.0	2.2	3.0	2.2	6.0	6.9	7.5	A	100-C09 100-E09	10	16	140U-D6D3-C10 140UT-D7D3-C10	140M-C2E-C10 140MT-C3E-C10
25C-D010N104	5.0	4.0	5.0	4.0	10.5	12.6	13.8	B	100-C23 100-E26	20	32	140U-D6D3-C15 140UT-D7D3-C15	140M-C2E-C16 140MT-C3E-C16
25C-D010N114	5.0	4.0	5.0	4.0	10.5	12.6	13.8	B	100-C23 100-E26	20	32	140U-D6D3-C15 140UT-D7D3-C15	140M-C2E-C16 140MT-C3E-C16
25C-D013N104	7.5	5.5	7.5	5.5	13.0	14.1	15.4	C	100-C23 100-E26	20	35	140U-D6D3-C25 140UT-D7D3-C25	140M-D8E-C20 140MT-D9E-C20
25C-D013N114	7.5	5.5	7.5	5.5	13.0	14.1	15.4	C	100-C23 100-E26	20	35	140U-D6D3-C25 140UT-D7D3-C25	140M-D8E-C20 140MT-D9E-C20
25C-D017N104	10.0	7.5	10.0	7.5	17.0	16.8	18.4	C	100-C23 100-E26	25	40	140U-D6D3-C25 140UT-D7D3-C25	140M-D8E-C20 140MT-D9E-C20
25C-D017N114	10.0	7.5	10.0	7.5	17.0	16.8	18.4	C	100-C23 100-E26	25	40	140U-D6D3-C25 140UT-D7D3-C25	140M-D8E-C20 140MT-D9E-C20
25C-D024N104	15.0	11.0	15.0	11.0	24.0	24.1	26.4	D	100-C37	35	63	140G-G6C3-C40	140M-F8E-C32
25C-D024N114	15.0	11.0	15.0	11.0	24.0	24.1	26.4	D	100-C37	35	63	140G-G6C3-C40	140M-F8E-C32
25C-D030N104 ⁽⁶⁾	20.0	15.0	15.0	11.0	30.0	30.2	33.0	D	100-C43	45	70	140G-G6C3-C50	140M-F8E-C45
25C-D030N114 ⁽⁶⁾	20.0	15.0	15.0	11.0	30.0	30.2	33.0	D	100-C43	45	70	140G-G6C3-C50	140M-F8E-C45
25C-D037N114 ⁽⁶⁾	25.0	18.5	20.0	15.0	37.0	30.8	33.7	E	100-C43	45	70	140G-G6C3-C50	140M-F8E-C45
25C-D043N114 ⁽⁶⁾	30.0	22.0	25.0	18.5	43.0	35.6	38.9	E	100-C60	50	80	140G-G6C3-C45	140M-F8E-C45

(1) 150% Overload capability for up to 60 s, 180% for up to 3 s.

(2) When the drive is controlling motors with lower amp ratings, see the drive nameplate for drive input current rating.

(3) The AIC ratings of the Bulletin 140M/140MT devices can vary. See the Motor Protection Circuit Breaker and Motor Circuit Protector Specifications Technical Data, publication [140-TD005](#) or [140M-TD002](#).

(4) Bulletin 140M/140MT with adjustable current range should have the current trip set to the minimum range that the device does not trip.

(5) Manual Self-protected (Type E) Combination Motor Controller, UL Listed for 480Y/277 and 600Y/347 AC input. Not UL Listed for use on 480V or 600V Delta/Delta, corner ground, or high-resistance ground systems.

(6) 110% Overload capability for up to 60 s, 150% for up to 3 s.

380...480V 3-phase Input Protection Devices – Frames A...E – UL 61800-5-1 Applications

Catalog Number ⁽¹⁾	Output Ratings				Input Ratings			Frame Size	Contactor Catalog Number	UL Applications		
	ND		HD		Amps	kVA	Max Amps ⁽²⁾			Fuses (Max Rating)		Circuit Breakers
	HP	kW	HP	kW						Class / Catalog Number	140U/140UT/140G	140M/140MT ⁽³⁾⁽⁴⁾⁽⁵⁾
25C-D1P4N104	0.5	0.4	0.5	0.4	1.4	1.7	1.9	A	100-C09 100-E09	CLASS CC, J, or T/6	-	140M-C2E-B25 140MT-C3E-B25
25C-D1P4N114	0.5	0.4	0.5	0.4	1.4	1.7	1.9	A	100-C09 100-E09	CLASS CC, J, or T/6	-	140M-C2E-B25 140MT-C3E-B25
25C-D2P3N104	1.0	0.75	1.0	0.75	2.3	2.9	3.2	A	100-C09 100-E09	CLASS CC, J, or T/10	-	140M-C2E-B40 140MT-C3E-B40
25C-D2P3N114	1.0	0.75	1.0	0.75	2.3	2.9	3.2	A	100-C09 100-E09	CLASS CC, J, or T/10	-	140M-C2E-B40 140MT-C3E-B40

380...480V 3-phase Input Protection Devices – Frames A...E – UL 61800-5-1 Applications (Continued)

Catalog Number ⁽¹⁾	Output Ratings				Input Ratings			Frame Size	Contactor Catalog Number	UL Applications			
	ND		HD		Amps	kVA	Max Amps ⁽²⁾			Fuses (Max Rating)		Circuit Breakers	
	HP	kW	HP	kW						Class / Catalog Number	140U/140UT/140G	140M/140MT ⁽³⁾⁽⁴⁾⁽⁵⁾	
25C-D4PON104	2.0	1.5	2.0	1.5	4.0	5.2	5.7	A	100-C09 100-E09	CLASS CC, J, or T/16	-	140M-C2E-B63 140MT-C3E-B63	
25C-D4PON114	2.0	1.5	2.0	1.5	4.0	5.2	5.7	A	100-C09 100-E09	CLASS CC, J, or T/16	-	140M-C2E-B63 140MT-C3E-B63	
25C-D6PON104	3.0	2.2	3.0	2.2	6.0	6.9	7.5	A	100-C09 100-E09	CLASS CC, J, or T/16	-	140M-C2E-C10 140MT-C3E-C10	
25C-D6PON114	3.0	2.2	3.0	2.2	6.0	6.9	7.5	A	100-C09 100-E09	CLASS CC, J, or T/16	-	140M-C2E-C10 140MT-C3E-C10	
25C-D010N104	5.0	4.0	5.0	4.0	10.5	12.6	13.8	B	100-C23 100-E26	CLASS CC, J, or T/30	-	140M-D8E-C16 140MT-C3E-C16	
25C-D010N114	5.0	4.0	5.0	4.0	10.5	12.6	13.8	B	100-C23 100-E26	CLASS CC, J, or T/30	-	140M-D8E-C16 140MT-C3E-C16	
25C-D013N104	7.5	5.5	7.5	5.5	13.0	14.1	15.4	C	100-C23 100-E26	CLASS CC, J, or T/35	-	140M-D8E-C20 140MT-D9E-C20	
25C-D013N114	7.5	5.5	7.5	5.5	13.0	14.1	15.4	C	100-C23 100-E26	CLASS CC, J, or T/35	-	140M-D8E-C20 140MT-D9E-C20	
25C-D017N104	10.0	7.5	10.0	7.5	17.0	16.8	18.4	C	100-C23 100-E26	CLASS CC, J, or T/40	-	140M-D8E-C20 140MT-D9E-C20	
25C-D017N114	10.0	7.5	10.0	7.5	17.0	16.8	18.4	C	100-C23 100-E26	CLASS CC, J, or T/40	-	140M-D8E-C20 140MT-D9E-C20	
25C-D024N104	15.0	11.0	15.0	11.0	24.0	24.1	26.4	D	100-C37	CLASS CC, J, or T/60	-	140M-F8E-C32	
25C-D024N114	15.0	11.0	15.0	11.0	24.0	24.1	26.4	D	100-C37	CLASS CC, J, or T/60	-	140M-F8E-C32	
25C-D030N104 ⁽⁶⁾	20.0	15.0	15.0	11.0	30.0	30.2	33.0	D	100-C43	CLASS CC, J, or T / 70	-	140M-F8E-C45	
25C-D030N114 ⁽⁶⁾	20.0	15.0	15.0	11.0	30.0	30.2	33.0	D	100-C43	CLASS CC, J, or T / 70	-	140M-F8E-C45	
25C-D037N114 ⁽⁶⁾	25.0	18.5	20.0	15.0	37.0	30.8	33.7	E	100-C43	CLASS CC, J, or T / 70	-	140M-F8E-C45	
25C-D043N114 ⁽⁶⁾	30.0	22.0	25.0	18.5	43.0	35.6	38.9	E	100-C60	CLASS CC, J, or T / 80	-	140M-F8E-C45	

(1) 150% Overload capability for up to 60 s, 180% for up to 3 s.
 (2) When the drive is controlling motors with lower amp ratings, see the drive nameplate for drive input current rating.
 (3) The AIC ratings of the Bulletin 140M/140MT devices can vary. See the Motor Protection Circuit Breaker and Motor Circuit Protector Specifications Technical Data, publication [140-TD005](#) or [140M-TD002](#).
 (4) Bulletin 140M/140MT with adjustable current range should have the current trip set to the minimum range that the device does not trip.
 (5) Manual Self-protected (Type E) Combination Motor Controller, UL Listed for 480Y/277 and 600Y/347 AC input. Not UL Listed for use on 480V or 600V Delta/Delta, corner ground, or high-resistance ground systems.
 (6) 110% Overload capability for up to 60 s, 150% for up to 3 s.

525...600V 3-phase Input Protection Devices – Frames A...E – IEC (Non-UL) Applications

Catalog Number ⁽¹⁾	Output Ratings				Input Ratings			Frame Size	Contactor Catalog Number	IEC (Non-UL Applications)			
	ND		HD		Amps	kVA	Max Amps ⁽²⁾			Fuses (Rating)		Circuit Breakers	
	HP	kW	HP	kW						Min	Max	140U/140UT/140G	140M/140MT ⁽³⁾⁽⁴⁾⁽⁵⁾
25C-E0P9N104	0.5	0.4	0.5	0.4	0.9	1.4	1.2	A	100-C09 100-E09	3	6	140U-D6D3-B20 140UT-D7D3-B20	140M-C2E-B25 140MT-C3E-B25
25C-E1P7N104	1.0	0.75	1.0	0.75	1.7	2.6	2.3	A	100-C09 100-E09	3	6	140U-D6D3-B30 140UT-D7D3-B20	140M-C2E-B25 140MT-C3E-B25
25C-E3PON104	2.0	1.5	2.0	1.5	3.0	4.3	3.8	A	100-C09 100-E09	6	10	140U-D6D3-B50 140UT-D7D3-B50	140M-C2E-B40 140MT-C3E-B40
25C-E4P2N104	3.0	2.2	3.0	2.2	4.2	6.1	5.3	A	100-C09 100-E09	10	16	140U-D6D3-B80 140UT-D7D3-B80	140M-C2E-B63 140MT-D9E-B63
25C-E6P6N104	5.0	4.0	5.0	4.0	6.6	9.1	8.0	B	100-C09 100-E09	10	20	140U-D6D3-C10 140UT-D7D3-C10	140M-C2E-C10 140MT-D9E-C10
25C-E9P9N104	7.5	5.5	7.5	5.5	9.9	12.8	11.2	C	100-C16 100-E16	16	25	140U-D6D3-C15 140UT-D7D3-C15	140M-C2E-C16 140MT-D9E-C16
25C-E012N104	10.0	7.5	10.0	7.5	12.0	15.4	13.5	C	100-C23 100-E26	20	32	140U-D6D3-C20	140M-C2E-C16 140MT-D9E-C16
25C-E019N104	15.0	11.0	15.0	11.0	19.0	27.4	24.0	D	100-C30	32	50	140G-G6C3-C30	140M-F8E-C25

525...600V 3-phase Input Protection Devices – Frames A...E – IEC (Non-UL) Applications (Continued)

Catalog Number ⁽¹⁾	Output Ratings				Input Ratings			Frame Size	Contactor Catalog Number	IEC (Non-UL Applications)			
	ND		HD		Amps	kVA	Max Amps ⁽²⁾			Fuses (Rating)		Circuit Breakers	
	HP	kW	HP	kW						Min	Max	140U/140UT/140G	140M/140MT ⁽³⁾⁽⁴⁾⁽⁵⁾
25C-E022N104 ⁽⁶⁾	20.0	15.0	15.0	11.0	22.0	31.2	27.3	D	100-C30	35	63	140G-G6C3-C35	140M-F8E-C32
25C-E027N104 ⁽⁶⁾	25.0	18.5	20.0	15.0	27.0	28.2	24.7	E	100-C30	35	50	140G-G6C3-C35	140M-F8E-C32
25C-E032N104 ⁽⁶⁾	30.0	22.0	25.0	18.5	32.0	33.4	29.2	E	100-C37	40	63	140G-G6C3-C50	140M-F8E-C32

⁽¹⁾ 150% Overload capability for up to 60 s, 180% for up to 3 s.

⁽²⁾ When the drive is controlling motors with lower amp ratings, see the drive nameplate for drive input current rating.

⁽³⁾ The AIC ratings of the Bulletin 140M/140MT devices can vary. See the Motor Protection Circuit Breaker and Motor Circuit Protector Specifications Technical Data, publication [140-TD005](#) or [140M-TD002](#).

⁽⁴⁾ Bulletin 140M/140MT with adjustable current range should have the current trip set to the minimum range that the device does not trip.

⁽⁵⁾ Manual Self-protected (Type E) Combination Motor Controller, UL Listed for 480Y/277 and 600Y/347 AC input. Not UL Listed for use on 480V or 600V Delta/Delta, corner ground, or high-resistance ground systems.

⁽⁶⁾  110% Overload capability for up to 60 s, 150% for up to 3 s.

525...600V 3-phase Input Protection Devices – Frames A...E – UL 61800-5-1 Applications

Catalog Number ⁽¹⁾	Output Ratings				Input Ratings			Frame Size	Contactor Catalog Number	UL Applications		
	ND		HD		Amps	kVA	Max Amps ⁽²⁾			Fuses (Max Rating)		Circuit Breakers
	HP	kW	HP	kW						Class / Catalog Number	140U/1400UT/140G	140M/140MT ⁽³⁾⁽⁴⁾⁽⁵⁾
25C-E0P9N104	0.5	0.4	0.5	0.4	0.9	1.4	1.2	A	100-C09 100-E09	CLASS CC, J, or T/6	_(6)	140M-C2E-B25 140MT-C3E-B25
25C-E1P7N104	1.0	0.75	1.0	0.75	1.7	2.6	2.3	A	100-C09 100-E09	CLASS CC, J, or T/6	_(6)	140M-C2E-B25 140MT-C3E-B25
25C-E3P0N104	2.0	1.5	2.0	1.5	3.0	4.3	3.8	A	100-C09 100-E09	CLASS CC, J, or T/10	_(6)	140M-C2E-B40 140MT-C3E-B40
25C-E4P2N104	3.0	2.2	3.0	2.2	4.2	6.1	5.3	A	100-C09 100-E09	CLASS CC, J, or T/16	_(6)	140M-D8E-B63 140MT-D9E-B63
25C-E6P6N104	5.0	4.0	5.0	4.0	6.6	9.1	8.0	B	100-C09 100-E09	CLASS CC, J, or T/20	_(6)	140M-D8E-C10 140MT-D9E-C10
25C-E9P9N104	7.5	5.5	7.5	5.5	9.9	12.8	11.2	C	100-C16 100-E16	CLASS CC, J, or T/25	_(6)	140M-D8E-C16 ⁽⁷⁾ 140MT-D9E-C16
25C-E012N104	10.0	7.5	10.0	7.5	12.0	15.4	13.5	C	100-C23 100-E26	CLASS CC, J, or T/30	_(6)	140M-D8E-C16 140MT-D9E-C16
25C-E019N104	15.0	11.0	15.0	11.0	19.0	27.4	24.0	D	100-C30	CLASS CC, J, or T/50	_(6)	140M-F8E-C25
25C-E022N104 ⁽⁸⁾	20.0	15.0	15.0	11.0	22.0	31.2	27.3	D	100-C30	CLASS CC, J, or T/60	_(6)	140M-F8E-C32
25C-E027N104 ⁽⁸⁾	25.0	18.5	20.0	15.0	27.0	28.2	24.7	E	100-C30	CLASS CC, J, or T/50	_(6)	140M-F8E-C32
25C-E032N104 ⁽⁸⁾	30.0	22.0	25.0	18.5	32.0	33.4	29.2	E	100-C37	CLASS CC, J, or T/60	_(6)	140M-F8E-C32

⁽¹⁾ 150% Overload capability for up to 60 s, 180% for up to 3 s.

⁽²⁾ When the drive is controlling motors with lower amp ratings, see the drive nameplate for drive input current rating.

⁽³⁾ The AIC ratings of the Bulletin 140M/140MT devices can vary. See the Motor Protection Circuit Breaker and Motor Circuit Protector Specifications Technical Data, publication [140-TD005](#) or [140M-TD002](#).

⁽⁴⁾ Bulletin 140M/140MT with adjustable current range should have the current trip set to the minimum range that the device does not trip.

⁽⁵⁾ Manual Self-protected (Type E) Combination Motor Controller, UL Listed for 480Y/277 and 600Y/347 AC input. Not UL Listed for use on 480V or 600V Delta/Delta, corner ground, or high-resistance ground systems.

⁽⁶⁾ Circuit breaker selection is not available for this drive rating.

⁽⁷⁾ When used with the 140M circuit breaker, the 25C-E9P9N104 must be installed in a ventilated or non-ventilated enclosure with the minimum size of 457.2 x 457.2 x 269.8 mm (18 x 18 x 10.62 in.).

⁽⁸⁾  110% Overload capability for up to 60 s, 150% for up to 3 s.

Accessories

Dynamic Brake Resistors

Drive Ratings			Resistance min $\Omega \pm 10\%$	Resistance $\Omega \pm 5\%$	Catalog Number ⁽¹⁾⁽²⁾	Fuse Protection ⁽³⁾		
Input Voltage	HP	kW				BR ⁽⁴⁾	DC+/BR+	DC-
100...120V 50/60 Hz 1-phase	0.25	0.2	56	91	AK-R2-091P500	PV-15A10F	1000GH-016	1000GH-016
	0.5	0.4	56	91	AK-R2-091P500	PV-15A10F	1000GH-016	1000GH-016
	1.0	0.75	56	91	AK-R2-091P500	PV-15A10F	1000GH-016	1000GH-016
	1.5	1.1	41	91	AK-R2-091P500	PV-15A10F	1000GH-020	1000GH-020
200...240V 50/60 Hz 1-phase	0.25	0.2	56	91	AK-R2-091P500	PV-15A10F	1000GH-016	1000GH-016
	0.5	0.4	56	91	AK-R2-091P500	PV-15A10F	1000GH-016	1000GH-016
	1.0	0.75	56	91	AK-R2-091P500	PV-15A10F	1000GH-016	1000GH-016
	2.0	1.5	41	91	AK-R2-091P500	PV-15A10F	1000GH-025	1000GH-025
200...240V 50/60 Hz 3-phase	3.0	2.2	32	47	AK-R2-047P500	PV-15A10F	1000GH-032	1000GH-032
	0.25	0.2	56	91	AK-R2-091P500	PV-20A10F	1000GH-016	1000GH-016
	0.5	0.4	56	91	AK-R2-091P500	PV-20A10F	1000GH-016	1000GH-016
	1.0	0.75	56	91	AK-R2-091P500	PV-20A10F	1000GH-016	1000GH-016
	2.0	1.5	41	91	AK-R2-091P500	PV-20A10F	1000GH-025	1000GH-025
	3.0	2.2	32	47	AK-R2-047P500	PV-20A10F	1000GH-032	1000GH-032
	5.0	4.0	18	47	AK-R2-047P500	PV-32ANH1	1000GH-050	1000GH-050
	7.5	5.5	16	30	AK-R2-030P1K2	PV-40ANH1	1000GH-063	1000GH-063
	10.0	7.5	14	30	AK-R2-030P1K2	1000GH-040	1000GH-080	1000GH-080
	15.0	11.0	14	15	AK-R2-030P1K2 ⁽⁵⁾	1000GH-050	1000GH-100	1000GH-100
380...480V 50/60 Hz 3-phase	20.0	15.0	10	15	AK-R2-030P1K2 ⁽⁵⁾	1000GH-050	1000GH-125	1000GH-125
	0.5	0.4	89	360	AK-R2-360P500	PV-10A10F	1000GH-016	1000GH-016
	1.0	0.75	89	360	AK-R2-360P500	PV-10A10F	1000GH-016	1000GH-016
	2.0	1.5	89	360	AK-R2-360P500	PV-10A10F	1000GH-016	1000GH-016
	3.0	2.2	89	120	AK-R2-120P1K2	PV-10A10F	1000GH-016	1000GH-016
	5.0	4.0	47	120	AK-R2-120P1K2	PV-20A10F	1000GH-032	1000GH-032
	7.5	5.5	47	120	AK-R2-120P1K2	PV-32ANH1	1000GH-032	1000GH-032
	10.0	7.5	47	120	AK-R2-120P1K2	PV-32ANH1	1000GH-040	1000GH-040
	15.0	11.0	43	60	AK-R2-120P1K2 ⁽⁵⁾	1000GH-025	1000GH-063	1000GH-063
	20.0	15.0	43	60	AK-R2-120P1K2 ⁽⁵⁾	1000GH-025	1000GH-080	1000GH-080
525...600V 50/60 Hz 3-phase	25.0	18.5	27	40	AK-R2-120P1K2 ⁽⁶⁾	1000GH-040	1000GH-080	1000GH-080
	30.0	22.0	27	40	AK-R2-120P1K2 ⁽⁶⁾	1000GH-040	1000GH-080	1000GH-080
	0.5	0.4	112	360	AK-R2-360P500	PV-10A10F	1000GH-016	1000GH-016
	1.0	0.75	112	360	AK-R2-360P500	PV-10A10F	1000GH-016	1000GH-016
	2.0	1.5	112	360	AK-R2-360P500	PV-10A10F	1000GH-016	1000GH-016
	3.0	2.2	112	120	AK-R2-120P1K2	PV-10A10F	1000GH-016	1000GH-016
	5.0	4.0	86	120	AK-R2-120P1K2	PV-12A10F	1000GH-025	1000GH-025
	7.5	5.5	59	120	AK-R2-120P1K2	PV-20A10F	1000GH-025	1000GH-025
	10.0	7.5	59	120	AK-R2-120P1K2	PV-20A10F	1000GH-032	1000GH-032
	15.0	11.0	59	60	AK-R2-120P1K2 ⁽⁵⁾	1000GH-025	1000GH-050	1000GH-050
	20.0	15.0	59	60	AK-R2-120P1K2 ⁽⁵⁾	1000GH-025	1000GH-063	1000GH-063
	25.0	18.5	53	60	AK-R2-120P1K2 ⁽⁵⁾	1000GH-040	1000GH-063	1000GH-063
	30.0	22.0	34	40	AK-R2-120P1K2 ⁽⁶⁾	1000GH-040	1000GH-063	1000GH-063

(1) The resistors that are listed in this table are rated for 5% duty cycle.
 (2) Use of Rockwell Automation resistors is always recommended. The resistors that are listed have been carefully selected for optimizing performance in various applications. Alternative resistors may be used, however, care must be taken when making a selection. See the PowerFlex Dynamic Braking Resistor Calculator Application Technique, publication [PFLEX-AT001](#).
 (3) For IEC applications, DC Fuse is mandatory when these terminals are connected. Connect the fuse immediate to the terminal. Use the specified part number. PV-xxxxxx fuse is from Bussman. 1000GH-xxx fuse is from Hinode.
 (4) For UL applications, DC fuse is mandatory at BR- terminal when use with a dynamic brake resistor.
 (5) Requires two resistors that are wired in parallel.
 (6) Requires three resistors that are wired in parallel.

EMC Line Filters

Drive Ratings				Frame Size	Catalog Number
Input Voltage	HP	kW	Current (A)		
100...120V 50/60 Hz 1-phase	0.5	0.4	2.5	A	25-RF011-AL
	1.0	0.75	4.8	B	25-RF023-BL
	1.5	1.1	6.0	B	25-RF023-BL
200...240V 50/60 Hz 1-phase	0.5	0.4	2.5	A	25-RF011-AL
	1.0	0.75	4.8	A	25-RF011-AL
	2.0	1.5	8.0	B	25-RF023-BL
	3.0	2.2	11.0	B	25-RF023-BL
200...240V 50/60 Hz 3-phase	0.5	0.4	2.5	A	25-RF014-AL
	1.0	0.75	5.0	A	25-RF014-AL
	2.0	1.5	8.0	A	25-RF014-AL
	3.0	2.2	11.0	A	25-RF014-AL
	5.0	4.0	17.5	B	25-RF021-BL
	7.5	5.5	24.0	C	25-RF027-CL
	10.0	7.5	32.2	D	25-RF035-DL
	15.0	11.0	48.3	E	25-RF056-EL
	20.0	15.0	62.1	E	25-RF056-EL
380...480V 50/60 Hz 3-phase	0.5	0.4	1.4	A	25-RF7P5-AL
	1.0	0.75	2.3	A	25-RF7P5-AL
	2.0	1.5	4.0	A	25-RF7P5-AL
	3.0	2.2	6.0	A	25-RF7P5-AL
	5.0	4.0	10.5	B	25-RF014-BL
	7.5	5.5	13.0	C	25-RF018-CL
	10.0	7.5	17.0	C	25-RF018-CL
	15.0	11.0	24.0	D	25-RF033-DL
	20.0	15.0	30.0	D	25-RF033-DL
	25.0	18.5	37.0	E	25-RF039-EL
	30.0	22.0	43.0	E	25-RF039-EL ⁽¹⁾
	525...600V 50/60 Hz 3-phase	0.5	0.4	0.9	A
1.0		0.75	1.7	A	25-RF8P0-BL ⁽²⁾
2.0		1.5	3.0	A	25-RF8P0-BL ⁽²⁾
3.0		2.2	4.2	A	25-RF8P0-BL ⁽²⁾
5.0		4.0	6.6	B	25-RF8P0-BL
7.5		5.5	9.9	C	25-RF014-CL
10.0		7.5	12.0	C	25-RF014-CL
15.0		11.0	18.0	D	25-RF027-DL
20.0		15.0	22.0	D	25-RF027-DL
25.0		18.5	27.0	E	25-RF029-EL
30.0		22.0	32.0	E	25-RF029-EL ⁽¹⁾

⁽¹⁾ EMC Line Filter size is based on the input current of the drive. See the tables on [page 26](#) and [page 31](#) for more information.

⁽²⁾ This 600V drive rating must be matched with a frame B EMC Line Filter.

EMC Plates

Item	Description	Frame Size	Catalog Number
EMC Plate	Optional grounding plate for shielded cables	A	25-EMC1-FA
		B	25-EMC1-FB
		C	25-EMC1-FC
		D	25-EMC1-FD
		E	25-EMC1-FE

EMC Ferrite Cores

Item	Description	Frame Size	Catalog Number
EMC Ferrite Core	For drive with internal filter	A	25-CORE-A
		B	25-CORE-B
		C	25-CORE-C
		D	25-CORE-D
		E	25-CORE-E
	For drive with external filter	A	25-CORE-RF-A
		B	25-CORE-RF-B
		C	25-CORE-RF-C
		D	25-CORE-RF-D
		E	25-CORE-RF-E

Terminators

Item	Description	Catalog Number
Terminators	For use with 3.7 kW (5 HP) and below drives	1204-TFA1
	For use with 1.5 kW (2 HP) and above drives	1204-TFB2

IP 30/NEMA 1/UL Type 1 Kit

Item	Description	Frame Size	Catalog Number
IP 30/NEMA 1/UL Type 1 Kit	Field installed kit. Converts drive to IP 30/NEMA 1/UL Type 1 enclosure. Includes conduit box with mounting screws and plastic top panel.	A	25-JBAA
		B	25-JBAB
		C	25-JBAC
		D	25-JBAD
		E	25-JBAE

Control Module Fan Kit

Item	Description	Frame Size	Catalog Number
Control Module Fan Kit	For use with drive in environments with ambient temperatures up to 70 °C or horizontal mounting.	A...D	25-FAN1-70C
		E	25-FAN2-70C

Incremental Encoder Input Option

Item	Description	Catalog Number
Incremental Encoder Board	Interface to an external incremental encoder.	25-ENC-2

Bulletin 160 to PowerFlex 520-series Mounting Adapter Plate

Item	Description	B160 Frame Size	Catalog Number
Mounting Adapter Plate	For use with drive when replacing Bulletin 160 drives in existing installations to a PowerFlex 520-series drive. Select the catalog number based on the frame size of your Bulletin 160 drive.	A	25-MAP-FA
		B	25-MAP-FB

Replacement Parts

PowerFlex 527 Power Module

Item	Description
PowerFlex 527 Power Module	Replacement power module for use with PowerFlex 527 drives. Includes: <ul style="list-style-type: none"> • Power Module • Power Module Front Cover • Power Terminal Guard • Heatsink Fan

Output Ratings				Output Current (A)	Input Voltage Range	Frame Size	Catalog Number
Normal Duty		Heavy Duty					
HP	kW	HP	kW				
100...120V AC (-15%, +10%) - 1-phase Input, 0...230V 3-phase Output							
0.5	0.4	0.5	0.4	2.5	85...132	A	25-PM1-V2P5
1.0	0.75	1.0	0.75	4.8	85...132	B	25-PM1-V4P8
1.5	1.1	1.5	1.1	6.0	85...132	B	25-PM1-V6P0
200...240V AC (-15%, +10%) - 1-phase Input, 0...230V 3-phase Output							
0.5	0.4	0.5	0.4	2.5	170...264	A	25-PM1-A2P5
1.0	0.75	1.0	0.75	4.8	170...264	A	25-PM1-A4P8
2.0	1.5	2.0	1.5	8.0	170...264	B	25-PM1-A8P0
3.0	2.2	3.0	2.2	11.0	170...264	B	25-PM1-A011
200...240V AC (-15%, +10%) - 1-phase Input with EMC Filter, 0...230V 3-phase Output							
0.5	0.4	0.5	0.4	2.5	170...264	A	25-PM2-A2P5
1.0	0.75	1.0	0.75	4.8	170...264	A	25-PM2-A4P8
2.0	1.5	2.0	1.5	8.0	170...264	B	25-PM2-A8P0
3.0	2.2	3.0	2.2	11.0	170...264	B	25-PM2-A011
200...240V AC (-15%, +10%) - 3-phase Input, 0...230V 3-phase Output							
0.5	0.4	0.5	0.4	2.5	170...264	A	25-PM1-B2P5
1.0	0.75	1.0	0.75	5.0	170...264	A	25-PM1-B5P0
2.0	1.5	2.0	1.5	8.0	170...264	A	25-PM1-B8P0
3.0	2.2	3.0	2.2	11.0	170...264	A	25-PM1-B011
5.0	4.0	5.0	4.0	17.5	170...264	B	25-PM1-B017
7.5	5.5	7.5	5.5	24.0	170...264	C	25-PM1-B024
10.0	7.5	10.0	7.5	32.2	170...264	D	25-PM1-B032
15.0	11.0	15.0	11.0	48.3	170...264	E	25-PM1-B048
20.0	15.0	15.0	11.0	62.1	170...264	E	25-PM1-B062
380...480V AC (-15%, +10%) - 3-phase Input, 0...460V 3-phase Output							
0.5	0.4	0.5	0.4	1.4	323...528	A	25-PM1-D1P4
1.0	0.75	1.0	0.75	2.3	323...528	A	25-PM1-D2P3
2.0	1.5	2.0	1.5	4.0	323...528	A	25-PM1-D4P0
3.0	2.2	3.0	2.2	6.0	323...528	A	25-PM1-D6P0
5.0	4.0	5.0	4.0	10.5	323...528	B	25-PM1-D010
7.5	5.5	7.5	5.5	13.0	323...528	C	25-PM1-D013
10.0	7.5	10.0	7.5	17.0	323...528	C	25-PM1-D017
15.0	11.0	15.0	11.0	24.0	323...528	D	25-PM1-D024
20.0	15.0	15.0	11.0	30.0	323...528	D	25-PM1-D030
380...480V AC (-15%, +10%) - 3-phase Input with EMC Filter, 0...460V 3-phase Output							
0.5	0.4	0.5	0.4	1.4	323...528	A	25-PM2-D1P4
1.0	0.75	1.0	0.75	2.3	323...528	A	25-PM2-D2P3
2.0	1.5	2.0	1.5	4.0	323...528	A	25-PM2-D4P0
3.0	2.2	3.0	2.2	6.0	323...528	A	25-PM2-D6P0
5.0	4.0	5.0	4.0	10.5	323...528	B	25-PM2-D010
7.5	5.5	7.5	5.5	13.0	323...528	C	25-PM2-D013
10.0	7.5	10.0	7.5	17.0	323...528	C	25-PM2-D017

Output Ratings (Continued)					Input Voltage Range	Frame Size	Catalog Number
Normal Duty		Heavy Duty		Output Current (A)			
HP	kW	HP	kW				
15.0	11.0	15.0	11.0	24.0	323...528	D	25-PM2-D024
20.0	15.0	15.0	11.0	30.0	323...528	D	25-PM2-D030
25.0	18.5	20.0	15.0	37.0	323...528	E	25-PM2-D037
30.0	22.0	25.0	18.5	43.0	323...528	E	25-PM2-D043
525...600V AC (-15%, +10%) – 3-phase Input, 0...575V 3-phase Output							
0.5	0.4	0.5	0.4	0.9	446...660	A	25-PM1-E0P9
1.0	0.75	1.0	0.75	1.7	446...660	A	25-PM1-E1P7
2.0	1.5	2.0	1.5	3.0	446...660	A	25-PM1-E3P0
3.0	2.2	3.0	2.2	4.2	446...660	A	25-PM1-E4P2
5.0	4.0	5.0	4.0	6.6	446...660	B	25-PM1-E6P6
7.5	5.5	7.5	5.5	9.9	446...660	C	25-PM1-E9P9
10.0	7.5	10.0	7.5	12.0	446...660	C	25-PM1-E012
15.0	11.0	15.0	11.0	19.0	446...660	D	25-PM1-E019
20.0	15.0	15.0	11.0	22.0	446...660	D	25-PM1-E022
25.0	18.5	20.0	15.0	27.0	446...660	E	25-PM1-E027
30.0	22.0	25.0	18.5	32.0	446...660	E	25-PM1-E032

PowerFlex 527 Control Module

Item	Description	Frame Size	Catalog Number
PowerFlex 527 Control Module	Replacement control module for use with PowerFlex 527 drives. Includes: <ul style="list-style-type: none"> Control module Control module front cover 	A...E	25C-CTM1

Other Parts

Item	Description	Frame Size	Catalog Number
PowerFlex 527 Control Module Front Cover	Replacement cover for the control module I/O terminals and EtherNet/IP ports.	A...E	25C-CTMFC1
PowerFlex 520-series Power Module Front Cover	Replacement cover for the PowerFlex 520-series power module.	B	25-PMFC-FB
		C	25-PMFC-FC
		D	25-PMFC-FD
		E	25-PMFC-FE
PowerFlex 520-series Power Terminal Guard	Replacement finger guard for power terminals.	A	25-PTG1-FA
		B	25-PTG1-FB
		C	25-PTG1-FC
		D	25-PTG1-FD
		E	25-PTG1-FE
PowerFlex 527 Removable Terminal Blocks Kit	Replacement terminal blocks for control wiring.	A...E	25C-RCTB
PowerFlex 527 Control Module Internal Fan Kit	Replacement internal fan for the control module.	A...E	25C-FAN2-INT
PowerFlex 520-series Heatsink Fan Kit	Replacement fan for drive power module.	A	25-FAN1-FA
		B	25-FAN1-FB
		C	25-FAN1-FC
		D	25-FAN1-FD
		E	25-FAN1-FE

Bulletin 1321-3R Series Line Reactors

Output Ratings ⁽¹⁾				Input Line Reactor ⁽²⁾⁽³⁾		Output Line Reactor ⁽²⁾⁽³⁾	
Normal Duty		Heavy Duty		IP 00 (Open Style)	IP 11 (NEMA/UL Type 1)	IP 00 (Open Style)	IP 11 (NEMA/UL Type 1)
HP	kW	HP	kW	Catalog Number	Catalog Number	Catalog Number	Catalog Number
200...240V 50/60 Hz 3-phase							
0.5	0.4	0.5	0.4	1321-3R2-D	1321-3RA2-D	1321-3R2-D	1321-3RA2-D
1.0	0.75	1.0	0.75	1321-3R4-A	1321-3RA4-A	1321-3R4-A	1321-3RA4-A
2.0	1.5	2.0	1.5	1321-3R8-A	1321-3RA8-A	1321-3R8-A	1321-3RA8-A
3.0	2.2	3.0	2.2	1321-3R12-A	1321-3RA12-A	1321-3R12-A	1321-3RA12-A
5.0	4.0	5.0	4.0	1321-3R18-A	1321-3RA18-A	1321-3R18-A	1321-3RA18-A
7.5	5.5	7.5	5.5	1321-3R25-A	1321-3RA25-A	1321-3R25-A	1321-3RA25-A
10.0	7.5	10.0	7.5	1321-3R35-A	1321-3RA35-A	1321-3R35-A	1321-3RA35-A
15.0	11.0	15.0	11.0	1321-3R45-A	1321-3RA45-A	1321-3R45-A	1321-3RA45-A
20.0	15.0	15.0	11.0	1321-3R55-A (ND) 1321-3R45-A (HD)	1321-3RA55-A (ND) 1321-3RA45-A (HD)	1321-3R55-A	1321-3RA55-A
380...480V 50/60 Hz 3-phase							
0.5	0.4	0.5	0.4	1321-3R1-C	1321-3RA1-C	1321-3R2-B	1321-3RA2-B
1.0	0.75	1.0	0.75	1321-3R2-A	1321-3RA2-A	1321-3R2-A	1321-3RA2-A
2.0	1.5	2.0	1.5	1321-3R4-B	1321-3RA4-B	1321-3R4-B	1321-3RA4-B
3.0	2.2	3.0	2.2	1321-3R8-C	1321-3RA8-C	1321-3R8-C	1321-3RA8-C
5.0	4.0	5.0	4.0	1321-3R8-B	1321-3RA8-B	1321-3R8-B	1321-3RA8-B
7.5	5.5	7.5	5.5	1321-3R12-B	1321-3RA12-B	1321-3R12-B	1321-3RA12-B
10.0	7.5	10.0	7.5	1321-3R18-B	1321-3RA18-B	1321-3R18-B	1321-3RA18-B
15.0	11.0	15.0	11.0	1321-3R25-B	1321-3RA25-B	1321-3R25-B	1321-3RA25-B
20.0	15.0	15.0	11.0	1321-3R35-B (ND) 1321-3R25-B (HD)	1321-3RA35-B (ND) 1321-3RA25-B (HD)	1321-3R25-B	1321-3RA25-B
25.0	18.5	20.0	15.0	1321-3R35-B	1321-3RA35-B	1321-3R35-B	1321-3RA35-B
30.0	22.0	25.0	18.5	1321-3R45-B (ND) 1321-3R35-B (HD)	1321-3RA45-B (ND) 1321-3RA35-B (HD)	1321-3R45-B	1321-3RA45-B
525...600V 50/60 Hz 3-phase							
0.5	0.4	0.5	0.4	1321-3R2-B	1321-3RA2-B	1321-3R2-B	1321-3RA2-B
1.0	0.75	1.0	0.75	1321-3R2-B	1321-3RA2-B	1321-3R2-B	1321-3RA2-B
2.0	1.5	2.0	1.5	1321-3R4-D	1321-3RA4-D	1321-3R4-D	1321-3RA4-D
3.0	2.2	3.0	2.2	1321-3R4-C	1321-3RA4-C	1321-3R4-C	1321-3RA4-C
5.0	4.0	5.0	4.0	1321-3R8-C	1321-3RA8-C	1321-3R8-C	1321-3RA8-C
7.5	5.5	7.5	5.5	1321-3R12-C	1321-3RA12-C	1321-3R12-C	1321-3RA12-C
10.0	7.5	10.0	7.5	1321-3R12-B	1321-3RA12-B	1321-3R12-B	1321-3RA12-B
15.0	11.0	15.0	11.0	1321-3R18-B	1321-3RA18-B	1321-3R18-B	1321-3RA18-B
20.0	15.0	15.0	11.0	1321-3R25-B (ND) 1321-3R18-B (HD)	1321-3RA25-B (ND) 1321-3RA18-B (HD)	1321-3R25-B	1321-3RA25-B
25.0	18.5	20.0	15.0	1321-3R35-C (ND) 1321-3R25-B (HD)	1321-3RA35-C (ND) 1321-3RA25-B (HD)	1321-3R35-C	1321-3RA35-C
30.0	22.0	25.0	18.5	1321-3R35-B (ND) 1321-3R35-C (HD)	1321-3RA35-B (ND) 1321-3RA35-C (HD)	1321-3R35-B	1321-3RA35-B

⁽¹⁾ Normal Duty and Heavy Duty ratings for 15 HP / 11 kW and below are identical.

⁽²⁾ Catalog numbers that are listed are for 3% impedance at 60 Hz. 5% impedance reactor types are also available. See the 1321 Power Conditioning Products Technical Data, publication [1321-TD001](#).

⁽³⁾ Input line reactors were sized based on the NEC fundamental motor amps. Output line reactors were sized based on the VFD rated output currents.

Accessory Dimensions

IP 30/NEMA 1/UL Type 1 Kit - Dimensions are in mm and (in.)

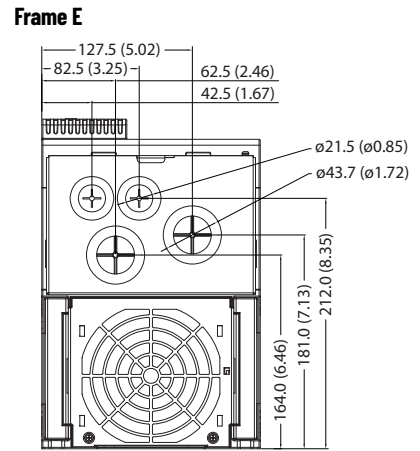
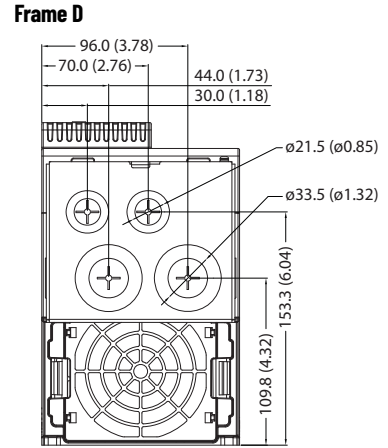
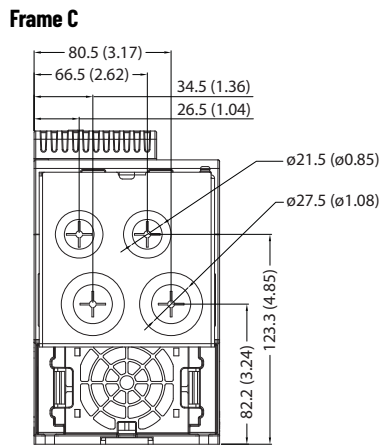
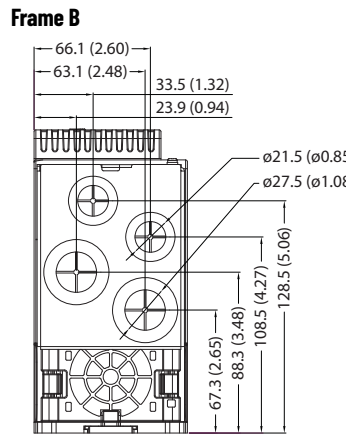
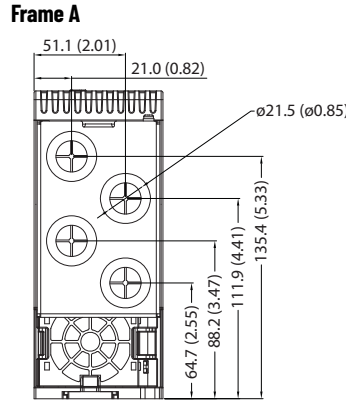
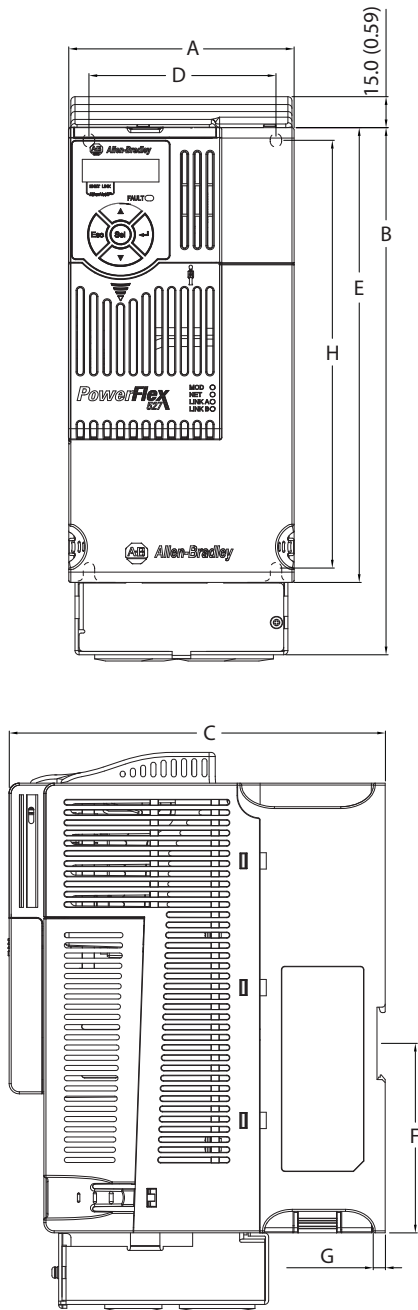

Frame Size	A	B	C	D	E	F	G	H
A	72.0 (2.83)	219.0 (8.62)	172.0 (6.77)	57.5 (2.26)	152.0 (5.98)	92.7 (3.65)	6.0 (0.24)	140.0 (5.51)
B	87.0 (3.43)	218.0 (8.58)	172.0 (6.77)	72.5 (2.85)	180.0 (7.09)	92.7 (3.65)	6.0 (0.24)	168.0 (6.61)
C	109.0 (4.29)	255.0 (10.04)	184.0 (7.24)	90.5 (3.56)	222.0 (8.66)	92.7 (3.65)	6.0 (0.24)	207.0 (8.15)
D	130.0 (5.12)	295.0 (11.61)	212.0 (8.35)	116.0 (4.57)	260.0 (10.24)	-	6.0 (0.24)	247.0 (9.74)
E	185.0 (7.28)	350.0 (13.78)	279.0 (10.98)	160.0 (6.30)	300.0 (11.81)	-	7.6 (0.30)	280.0 (11.02)

Control Module Fan Kit - Dimensions are in mm and (in.)

Frame A...D

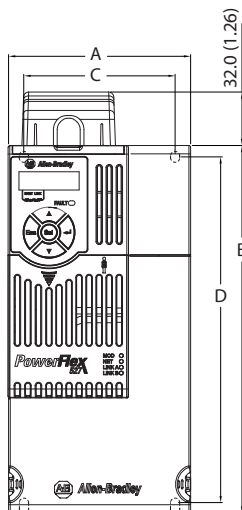

Frame E

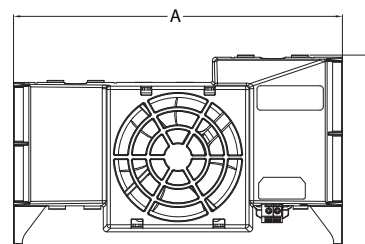
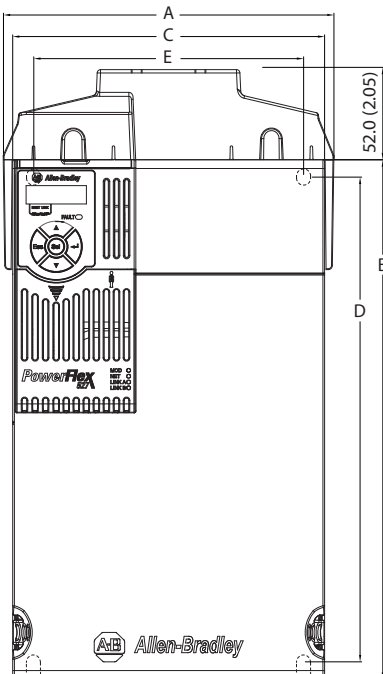

Frame Size	A	B	C	D	E	F
A	72.0 (2.83)	152.0 (5.98)	57.5 (2.26)	140.0 (5.51)	56.0 (2.20)	99.8 (3.93)
B	87.0 (3.43)	180.0 (7.09)	72.5 (2.85)	168.0 (6.61)	56.0 (2.20)	99.8 (3.93)
C	109.0 (4.29)	220.0 (8.66)	90.5 (3.56)	207.0 (8.15)	56.0 (2.20)	99.8 (3.93)
D	130.0 (5.12)	260.0 (10.24)	116.0 (4.57)	247.0 (9.72)	56.0 (2.20)	99.8 (3.93)
E	196.0 (7.72)	300.0 (11.81)	185.0 (7.28)	280.0 (11.02)	196.0 (7.72)	114.3 (4.50)

Specifications	25-FAN1-70C	25-FAN2-70C
Rated Voltage	24V DC	
Operation Voltage	14...27.6V DC	
Input Current	0.1 A	0.15 A
Speed (Reference)	7000 rpm	4500 ± 10% rpm
Air Flow max (At zero static pressure)	0.575 m ³ /min	1.574 m ³ /min
Air Pressure max (At zero airflow)	7.70 mmH ₂ O	9.598 mmH ₂ O
Acoustical Noise	40.5 dB-A	46.0 dB-A
Insulation Type	UL Class A	
Frame Size	Frame A...D	Frame E
Wire Size	0.32 mm ² (22 AWG)	
Torque	0.29...0.39 N•m (2.6...3.47 lb•in)	

EMC Line Filter - Dimensions are in mm and (in.)

Frame A...D

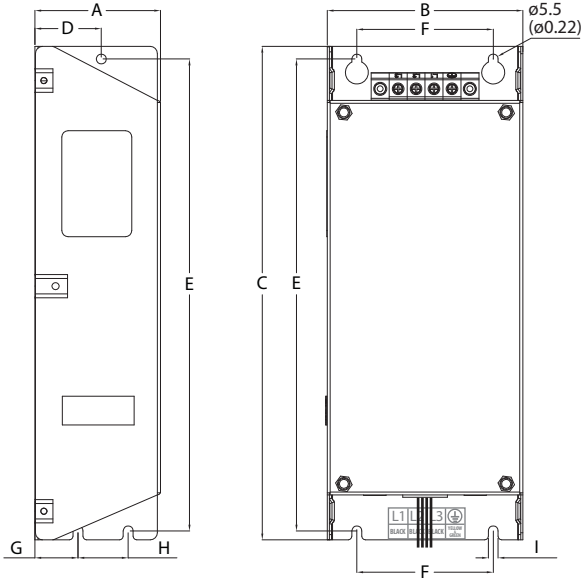

Frame E

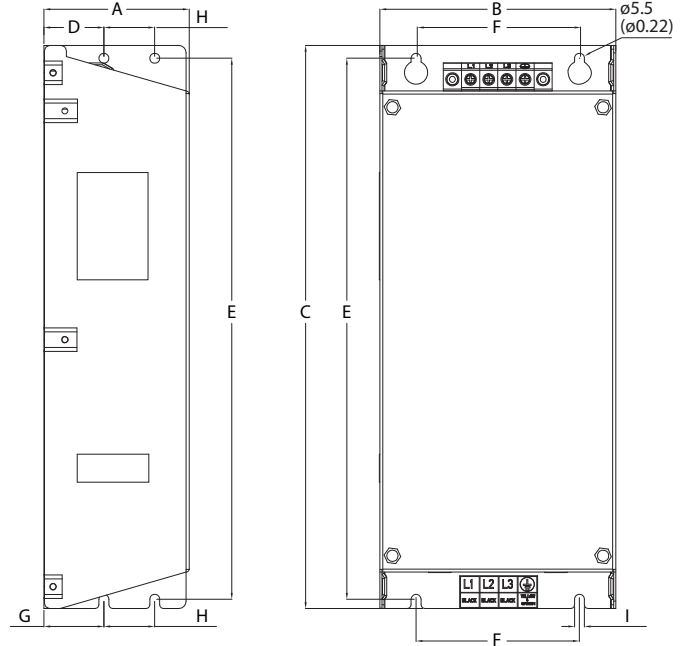

Frame Size	A	B	C	D	E	F	G	H	I
A	55.0 (2.17)	72.0 (2.83)	234.0 (9.21)	30.0 (1.18)	223.0 (8.78)	54.0 (2.13)	20.0 (0.79)	23.0 (0.91)	5.5 (0.22)
B	70.0 (2.76)	87.0 (3.43)	270.0 (10.63)	35.0 (1.38)	258.0 (10.16)	58.0 (2.28)	25.0 (0.98)	24.0 (0.94)	5.5 (0.22)
C	70.0 (2.76)	109.0 (4.29)	275.0 (10.83)	37.0 (1.46)	263.0 (10.35)	76.0 (2.99)	25.0 (0.98)	28.0 (1.10)	5.5 (0.22)
D	80.0 (3.15)	130.0 (5.12)	310.0 (12.20)	33.0 (1.30)	298.0 (11.73)	90.0 (3.54)	33.0 (1.30)	28.0 (1.10)	5.5 (0.22)
E	80.0 (3.15)	155.0 (6.10)	390.0 (15.35)	33.0 (1.30)	375.0 (14.76)	110.0 (4.33)	33.0 (1.30)	28.0 (1.10)	5.5 (0.22)

Safe Torque Off Function

The PowerFlex 527 Safe Torque Off (STO) function, when used with other safety components, helps provide protection according to EN ISO 13849 and EN62061 for STO and protection against restart. The PowerFlex 527 STO function is just one component in a safety control system. Components in the system must be chosen and applied appropriately to achieve the desired level of operator safeguarding.

PowerFlex 527 Safe Torque Off Overview

The PowerFlex 527 Safe Torque Off function:

- Provides the Safe Torque Off (STO) function that is defined in EN IEC 61800-5-2.
- Blocks gate-firing signals from reaching the insulated gate bipolar transistor (IGBT) output devices of the drive. This prevents the IGBTs from switching in the sequence necessary to generate torque in the motor.
- Can be used in combination with other safety devices to fulfill the requirements of a system "Safe Torque Off" function which satisfies Category 3 / PLe according to EN ISO 13849-1 and SIL CL 3 according to EN/IEC 62061, IEC 61508, and EN/IEC 61800-5-2.

IMPORTANT The function is suitable for performing mechanical work on the drive system or affected area of a machine only. It does not provide electrical safety.

EC Type Examination Certification

TÜV Rheinland has certified the PowerFlex 527 Safe Torque Off function compliant with the requirements for machines that are defined in Annex I of the EC Directive 2006/42/EC, and that it complies with the requirements of the relevant standards that are listed below:

- EN ISO 13849-1:2008+AC:2009 Safety of machinery – Safety-related parts of control systems – Part 1: General principles for design. (PowerFlex 527 STO achieves Category 3 / PLe)
- EN 61800-5-2:2007 Adjustable speed electrical power drive systems – Part 5-2 Safety requirements – Functional. (PowerFlex 527 STO achieves SIL CL 3)
- EN 62061:2005+A1:2013 Safety of machinery – Functional safety of safety-related electrical, electronic, and programmable electronic control systems.
- EN 60204-1:2006+A1:2009 – Safety of machinery – Electrical equipment of machines – Part 1: General requirements
- IEC 61508 Part 1-7:2010 Functional safety of electrical/electronic/programmable electronic safety-related systems – Parts 1-7.

TÜV also certifies that the PowerFlex 527 STO may be used in applications up to Category 3/ PLe according to EN ISO 13849-1 and SIL 3 according to EN 62061 / EN 61800-5-2 / IEC 61508.

The TÜV Rheinland certificate may be found at rok.auto/certifications.

Safety Concept

The PowerFlex 527 Safe Torque Off function is suitable for use in safety applications up to and including Category 3 / PLe according to EN ISO 13849-1 and SIL 3 according to EN 62061 / EN 61800-5-2 / IEC 61508.

In addition, the PowerFlex 527 STO function may be used together with other components in a safety application to achieve an overall Category 3 / PLe according to EN ISO 13849-1 and SIL 3 according to EN 62061 and IEC 61508.

Safety requirements are based on the standards current at the time of certification.

The PowerFlex 527 STO function is intended for use in safety-related applications where the de-energized state is considered to be the safe state. All examples that are shown here are based on achieving de-energization as the safe state for typical Machine Safety and Emergency Shutdown (ESD) systems.

Probability of Dangerous Failure Per Hour (PFH) Data

This PFH calculation is based on the equations from EN 61508 and show worst-case values.

Determination of safety parameters is based on the assumption that the system operates in High demand mode and that the safety function is requested at least once a year.

This table provides data for a 20-year proof test interval and demonstrates the worst-case effect of various configuration changes on the data.

IMPORTANT Determination of safety parameters is based on the assumption that the system operates in High demand mode and that the safety function is requested at least once every three months.

PFH and PFH Data

Attribute	Value
PFH (average)	1.53E-4
PFH	1.7E-9
SIL CL	3
PL	e
Category	3
MTTFd (years) 166	166
DCavg (%)	90 (medium)
HFT	1 (1002)
Mission time (years)	20

Safety Reaction Time

The safety reaction time from an input signal condition that triggers a safe stop, to the initiation of the configured Stop Type, is less than 12 ms.

Additional Resources

These documents contain additional information concerning related products from Rockwell Automation.

Resource	Description
PowerFlex 527 Adjustable Frequency AC Drive User Manual, publication 520-UM002	Describes how to configure and use the PowerFlex 527 drive in a Studio 5000 Logix Designer application.
GuardLogix 5570 Controllers User Manual, publication 1756-UM022	Describes how to configure and use the GuardLogix 5570 controller in a Studio 5000 Logix Designer application.
GuardLogix 5570 and Compact GuardLogix 5370 Reference Manual, publication 1756-RM099	Contains detailed requirements for achieving and maintaining SIL 3/PLe with the GuardLogix 5570 and Compact GuardLogix 5370 controller system, using the Studio 5000 Logix Designer application.
ControlLogix 5580 and GuardLogix 5580 Controllers User Manual, publication 1756-UM543	Describes how to configure and use the ControlLogix 5580 and GuardLogix 5580 controllers in a Studio 5000 Logix Designer application.
CompactLogix 5370 Controllers User Manual, publication 1769-UM021	Describes how to configure and use the CompactLogix 5370 controller in a Studio 5000 Logix Designer application.
Compact GuardLogix 5370 Controllers User Manual, publication 1769-UM022	Describes how to configure and use the Compact GuardLogix 5370 controller in a Studio 5000 Logix Designer application.
Wiring and Grounding for Pulse Width Modulated (PWM) AC Drives Installation Instructions, publication DRIVES-IN001	Provides basic information to install, protect, wire, and ground pulse-width modulated (PWM) AC drives
Preventive Maintenance Checklist of Industrial Control and Drive System Equipment Service Bulletin, publication DRIVES-TD001	Provides a checklist as a guide in performing preventive maintenance.
Integrated Motion on the EtherNet/IP Network: Configuration and Startup User Manual, publication MOTION-UM003	Details how to configure an Integrated Motion on EtherNet/IP networks application system.
Logix 5000 Controllers Motion Instructions Reference Manual, publication MOTION-RM002	Provides programmers with details about the motion instructions that are available for a Logix5000 controller.
Integrated Motion on the EtherNet/IP Network Reference Manual, publication MOTION-RM003	Detailed information on axis control modes and attributes for Integrated Motion on EtherNet/IP networks.
PowerFlex Dynamic Braking Resistor Calculator Application Technique, publication PFLEX-AT001	Provides information on dynamic braking and how to determine dynamic brake requirements for your drive.
Guarding Against Electrostatic Damage, publication 8000-4.5.2	Provides information on how to guard against the effects of ESD.
EtherNet/IP Network Devices User Manual, publication ENET-UM006	Describes how to configure and use EtherNet/IP devices to communicate on the EtherNet/IP network.
Ethernet Reference Manual, publication ENET-RM002	Describes basic Ethernet concepts, infrastructure components, and infrastructure features.
System Security Design Guidelines Reference Manual, publication SECURE-RM001	Provides guidance on how to conduct security assessments, implement Rockwell Automation products in a secure system, harden the control system, manage user access, and dispose of equipment.
Industrial Components Preventive Maintenance, Enclosures, and Contact Ratings Specifications, publication IC-TD002	Provides a quick reference tool for Allen-Bradley industrial automation controls and assemblies.
Safety Guidelines for the Application, Installation, and Maintenance of Solid-state Control, publication SGI-1.1	Designed to harmonize with NEMA Standards Publication No. ICS 1.1-1987 and provides general guidelines for the application, installation, and maintenance of solid-state control in the form of individual devices or packaged assemblies incorporating solid-state components.
Industrial Automation Wiring and Grounding Guidelines, publication 1770-4.1	Provides general guidelines for installing a Rockwell Automation industrial system.
Product Selection and Configuration tools, rok.auto/systemtools	Helps configure complete, valid catalog numbers and build complete quotes based on detailed product information.
Rockwell Automation Global Short-circuit Current Ratings (SCCR) Tool, rok.auto/sccr	Provides coordinated high-fault branch circuit solutions for motor starters, soft starters, and component drives.
Product Certifications website, rok.auto/certifications	Provides declarations of conformity, certificates, and other certification details.

You can view or download publications at [rok.auto/literature](#).

Rockwell Automation Support

Use these resources to access support information.

Technical Support Center	Find help with how-to videos, FAQs, chat, user forums, Knowledgebase, and product notification updates.	rok.auto/support
Local Technical Support Phone Numbers	Locate the telephone number for your country.	rok.auto/phonesupport
Technical Documentation Center	Quickly access and download technical specifications, installation instructions, and user manuals.	rok.auto/techdocs
Literature Library	Find installation instructions, manuals, brochures, and technical data publications.	rok.auto/literature
Product Compatibility and Download Center (PCDC)	Download firmware, associated files (such as AOP, EDS, and DTM), and access product release notes.	rok.auto/pcdc

Documentation Feedback

Your comments help us serve your documentation needs better. If you have any suggestions on how to improve our content, complete the form at rok.auto/docfeedback.





Allen-Bradley, CompactLogix, ControlLogix, expanding human possibility, FactoryTalk, GuardLogix, Kinetix, Logix 5000, PowerFlex, Rockwell Automation, RSLogix 5000, RSNetWorx, Studio 5000, Studio 5000 Logix Designer, and TechConnect are trademarks of Rockwell Automation, Inc.

CIP Safety and EtherNet/IP are trademarks of ODVA, Inc.

Trademarks not belonging to Rockwell Automation are property of their respective companies.

Rockwell Automation maintains current product environmental compliance information on its website at rok.auto/pec.

Rockwell Otomasyon Ticaret A.Ş. Kar Plaza İş Merkezi E Blok Kat:6 34752, İçerenköy, İstanbul, Tel: +90 (216) 5698400 EEE Yönetmeliğine Uygundur

Connect with us.    

rockwellautomation.com ————— **expanding human possibility®**

AMERICAS: Rockwell Automation, 1201 South Second Street, Milwaukee, WI 53204-2496 USA, Tel: (1) 414.382.2000

EUROPE/MIDDLE EAST/AFRICA: Rockwell Automation NV, Pegasus Park, De Kleetlaan 12a, 1831 Diegem, Belgium, Tel: (32) 2663 0600

ASIA PACIFIC: Rockwell Automation SEA Pte Ltd, 2 Corporation Road, #04-05, Main Lobby, Corporation Place, Singapore 618494, Tel: (65) 6510 6608

UNITED KINGDOM: Rockwell Automation Ltd., Pitfield, Kiln Farm, Milton Keynes, MK11 3DR, United Kingdom, Tel: (44)(1908) 838-800

Publication 520-TD002F-EN-E - September 2024

Supersedes Publication 520-TD002E-EN-E - December 2021

Copyright © 2024 Rockwell Automation, Inc. All rights reserved.