

PowerFlex 700S High Performance AC Drive Phase I Control

Firmware Versions 1.xx-2.07



Important User Information

Read this document and the documents listed in the additional resources section about installation, configuration, and operation of this equipment before you install, configure, operate, or maintain this product. Users are required to familiarize themselves with installation and wiring instructions in addition to requirements of all applicable codes, laws, and standards.

Activities including installation, adjustments, putting into service, use, assembly, disassembly, and maintenance are required to be carried out by suitably trained personnel in accordance with applicable code of practice.

If this equipment is used in a manner not specified by the manufacturer, the protection provided by the equipment may be impaired.

In no event will Rockwell Automation, Inc. be responsible or liable for indirect or consequential damages resulting from the use or application of this equipment.

The examples and diagrams in this manual are included solely for illustrative purposes. Because of the many variables and requirements associated with any particular installation, Rockwell Automation, Inc. cannot assume responsibility or liability for actual use based on the examples and diagrams.

No patent liability is assumed by Rockwell Automation, Inc. with respect to use of information, circuits, equipment, or software described in this manual.

Reproduction of the contents of this manual, in whole or in part, without written permission of Rockwell Automation, Inc., is prohibited.

Throughout this manual, when necessary, we use notes to make you aware of safety considerations.



WARNING: Identifies information about practices or circumstances that can cause an explosion in a hazardous environment, which may lead to personal injury or death, property damage, or economic loss.



ATTENTION: Identifies information about practices or circumstances that can lead to personal injury or death, property damage, or economic loss. Attentions help you identify a hazard, avoid a hazard, and recognize the consequence.

IMPORTANT

Identifies information that is critical for successful application and understanding of the product.

Labels may also be on or inside the equipment to provide specific precautions.



SHOCK HAZARD: Labels may be on or inside the equipment, for example, a drive or motor, to alert people that dangerous voltage may be present.



BURN HAZARD: Labels may be on or inside the equipment, for example, a drive or motor, to alert people that surfaces may reach dangerous temperatures.



ARC FLASH HAZARD: Labels may be on or inside the equipment, for example, a motor control center, to alert people to potential Arc Flash. Arc Flash will cause severe injury or death. Wear proper Personal Protective Equipment (PPE). Follow ALL Regulatory requirements for safe work practices and for Personal Protective Equipment (PPE).

This manual contains new and updated information.

New and Updated Information

This table contains the changes made to this revision.

Topic	Page
Updated the front and inside front covers.	–
Updated the Electronic Motor Overload Protection statement.	A-3
Updated the Drive Fusing and Circuit Breaker information and Protection Device tables.	A-6 . . . A-16
Updated the back cover.	–

Notes:

Table of Contents

	Important User Information	1-2
Summary of Changes	Manual Updates	i-1
Preface	Overview	
	Who Should Use This Manual	P-1
	What Is Not In This Manual	P-1
	Recommended Documentation	P-2
	Manual Conventions	P-3
	Drive Frame Sizes	P-3
	General Precautions	P-4
	Class 1 LED Product	P-4
	Catalog Number Explanation	P-5

Chapter 1	Installation/Wiring	
	Chapter Objectives	1-1
	Opening the Cover	1-2
	Mounting Clearances	1-2
	Operating Temperatures	1-3
	AC Supply Source Considerations	1-3
	Unbalanced or Ungrounded Distribution Systems	1-3
	Input Power Conditioning	1-4
	Grounding Requirements	1-4
	Recommended Grounding Scheme	1-4
	Shield Termination - SHLD	1-5
	RFI Filter Grounding	1-5
	Fuses and Circuit Breakers	1-5
	Power Wiring	1-6
	Power Cable Types Acceptable for 200-600 Volt Installations	1-6
	Motor Cable Lengths	1-8
	Power Terminal Block	1-8
	Cable Entry Plate Removal	1-8
	Power Wiring Access Panel Removal	1-8
	Access Panel Removal	1-8
	Replace the cover when wiring is complete.	
	AC Input Phase Selection (Frames 5 & 6 Only)	1-9
	Cooling Fan Voltage	1-9
	Selecting/Verifying Fan Voltage (Frames 5 & 6 Only)	1-9
	Dynamic Brake Resistor Considerations	1-14
	Using Input/Output Contactors	1-15
	Using PowerFlex 700S Drives with Regenerative Power Units	1-15
	Regenerative Unit to Drive Connections	1-16
	Disconnecting MOVs and Common Mode Capacitors	1-16
	I/O Wiring	1-19
	Wiring the Main Control Board I/O Terminals	1-20
	Auxiliary Power Supply	1-20
	Hard Enable Circuitry	1-21
	Main Control Board I/O Configuration Settings	1-32
	Connecting SynchLink	1-33
	Class 1 LED Product	1-33
	CE Conformity	1-35
	Low Voltage Directive (73/23/EEC)	1-35
	EMC Directive (89/336/EEC)	1-35
	General Notes	1-35
	Essential Requirements for CE Compliance	1-36
Chapter 2	Start-Up	
	Prepare for Drive Start-Up	2-1
	Before Applying Power to the Drive	2-1
	Applying Power to the Drive	2-2
	Assisted Start-Up	2-3

Chapter 3	Programming and Parameters	
	About Parameters	3-1
	How Parameters are Organized	3-3
	Parameter Data in Linear List Format	3-16
	Parameter Cross Reference By Name	3-96
Chapter 4	Troubleshooting	
	Chapter Objectives	4-1
	Faults and Alarms	4-1
	Drive Status	4-1
	LED Indications	4-2
	Precharge Board LED Indications	4-3
	HIM Indication	4-4
	Manually Clearing Faults	4-4
	Fault Descriptions	4-4
Appendix A	Supplemental Information	
	Chapter Objectives	A-1
	Specifications	A-1
	DPI Communication Configurations	A-4
	Typical Programmable Controller Configurations	A-4
	Logic Command Word	A-5
	Logic Status Word	A-6
	Output Devices	A-6
	Drive, Fuse & Circuit Breaker Ratings	A-6
	Fuse Size	A-6
	Fuse Type	A-7
	AC input Protection Devices	A-8
	List of Motors with Compatible Thermistor Ratings	A-17
	Spare Connectors	A-18
	Main Control Board	A-18
	High Resolution Encoder Interface Board	A-18
	Resolver Interface Board	A-18
	Dimensions	A-19
Appendix B	Control Block Diagrams	
	List of Control Block Diagrams	B-1
Appendix C	Application Notes	
	Input Voltage Range/Tolerance	C-1
	Motor Control Mode	C-2
	Field Oriented Control	C-2
	Permanent Magnet Control	C-3
	Motor Overload	C-3
	Mtr I2T Spd Min	C-3
	Overspeed Limit	C-4
	Stop Dwell Time	C-5
	Setpt 1 Data	C-6
	Setpt 2 Data	C-6

Appendix D	HIM Overview	
	External and Internal Connections	D-1
	LCD Display Elements	D-2
	ALT Functions	D-2
	Removing/Installing the HIM	D-3
Appendix E	PowerFlex 700S Stegmann Hi-Resolution Encoder Feedback Option	
	Chapter Objectives	E-1
	Specifications	E-1
	Stegmann Hi-Resolution Feedback Option Card Specifications	E-1
	Supported Encoders	E-1
	Wiring the Stegmann Hi-Resolution Feedback Option Card to an Encoder	E-2
	Recommended Cables	E-3
Appendix F	PowerFlex 700S Resolver Feedback Option Card	
	Chapter Objectives	F-1
	Specifications	F-1
	Resolver Feedback Option Card Specifications	F-1
	Compatible Resolvers	F-1
Appendix G	Access Procedures	
	Using this Appendix	G-1
	Removing Cover(s)	G-1
	Replacing Cover(s)	G-2
Appendix H	PowerFlex 700S Multi-Device Interface Option Card	
	Specifications	H-1
	MDI Option Card Specifications	H-1
	Supported Linear Sensors	H-1
	Supported Rotary Encoders	H-2
	Recommended Cables	H-2
	Wiring the MDI Option Card	H-3
Appendix I	PowerFlex 700S Permanent Magnet Motor Specifications	
	Compatible Permanent Magnet Motors	I-1

Index

Overview

The purpose of this manual is to provide you with the basic information needed to install, start-up and troubleshoot the PowerFlex[®] 700S Adjustable Frequency AC Drive, Frames 1-6. Refer to PFLEX-IN006 for information on installing, starting and troubleshooting the PowerFlex 700S and 700H Adjustable Frequency Drives for Frames 9 - 11.

For information on ...	See page...
Who Should Use This Manual	Preface-1
What Is Not In This Manual	Preface-1
Recommended Documentation	Preface-2
Manual Conventions	Preface-3
Drive Frame Sizes	Preface-3
General Precautions	Preface-4
Catalog Number Explanation	Preface-5

Who Should Use This Manual

This manual is intended for qualified personnel. You must be able to program and operate Adjustable Frequency AC Drive devices. In addition, you must have an understanding of the parameter settings and functions. You must also understand programmable controllers for the PowerFlex 700S with DriveLogix.

What Is Not In This Manual

Since this *User Manual* is designed to provide only basic start-up information for Frames 1 - 6, the following topics have not been included:

- Spare parts information
- Installation instructions for frames 9 - 11

For detailed drive information, please refer to publication *PowerFlex 700S with Phase I Control Reference Manual*, publication PFLEX-RM002. This publication is available online at:

www.rockwellautomation.com/literature

Recommended Documentation

The following publications provide general drive information.

Title	Publication	Available...
Wiring and Grounding for PWM AC Drives	DRIVES-IN001	www.rockwellautomation.com/literature
Safety Guidelines for the Application, Installation and Maintenance of Solid State Control	SGI-1.1	
A Global Reference Guide for Reading Schematic Diagrams	100-2.10	
Guarding Against Electrostatic Damage	8000-4.5.2	

The following publications provide specific PowerFlex drive information.

Title	Publication	Available...
Installation Instructions - Hi-Resolution Encoder Feedback Option for PowerFlex 700S Drives	20D-IN001	www.rockwellautomation.com/literature
Installation Instructions - Resolver Feedback Option for PowerFlex 700S Drives	20D-IN002	
Firmware Release Notes - PowerFlex 700S Drive (firmware revision 2.06 & 2.07)	20D-RN0016	

For detailed PowerFlex 700S information:

Title	Publication	Available...
PowerFlex Reference Manual	PFLEX-RM002	www.rockwellautomation.com/literature
PowerFlex 700S and 700H Adjustable Frequency Drives for Frames 9 - 11	PFLEX-IN006	

For Allen-Bradley Drives Technical Support:

Title	Online at...
Allen-Bradley Drives Technical Support	www.ab.com/support/abdrives

For Automation and Control Technical Support:

Title	Online at...
Rockwell Automation Technical Support	http://support.rockwellautomation.com/knowledgebase

The following publications provide necessary information when applying the DriveLogix Controller.

Title	Publication	Available...
DriveLogix Controller User Manual	20D-UM002	www.rockwellautomation.com/literature
Firmware Release Notes - DriveLogix Controller (firmware revision 10.15)	20D-RN001	
Firmware Release Notes - DriveLogix Controller (firmware revision 10.16)	20D-RN002	
Firmware Release Notes - DriveLogix Controller (firmware revision 11.14)	20D-RN003	
Logix5000 Controllers Common Procedures	1756-PM001	

Title	Publication	Available...
Installation Instructions - DriveLogix Controller for PowerFlex 700S Drives	20D-IN003	www.rockwellautomation.com/literature
Logix5000 Controllers General Instructions	1756-RM003	
ControlNet Daughtercard Installation Instructions	1788-IN002	
ControlNet Daughtercard Installation Instructions	1788-IN005	
Logix5000 Controllers Process Control and Drives Instructions	1756-RM006	
RSLogix 5000 Getting Results	9399-RLD300 GR	
RSNetwork for ControlNet Getting Results	9398-CNETGR	
RSLinx Getting Results Guide	9399-LINXGR	

The following publications provide information that is useful when planning and installing communication networks.

Title	Publication	Available...
ControlNet Coax Tap Installation Instructions	1786-5.7	www.rockwellautomation.com/literature
ControlNet Cable System Planning and Installation Manual	1786-6.2.1	
ControlNet Fiber Media Planning and Installation Guide	CNET-IN001	
SynchLink Design Guide	1756-TD008	

Manual Conventions

- In this manual we refer to the PowerFlex 700S Adjustable Frequency AC Drive as: drive, PowerFlex 700S or PowerFlex 700S Drive.
- To help differentiate parameter names and LCD display text from other text, the following conventions will be used:
 - Parameter Names will appear in [brackets] after the Parameter Number.
For example: Parameter 307 [Output Voltage].
 - Display text will appear in “quotes.” For example: “Enabled.”
- The following words are used throughout the manual to describe an action:

Word	Meaning
Can	Possible, able to do something
Cannot	Not possible, not able to do something
May	Permitted, allowed
Must	Unavoidable, you must do this
Shall	Required and necessary
Should	Recommended
Should Not	Not recommended

Drive Frame Sizes

Similar PowerFlex 700S drive sizes are grouped into frame sizes to simplify spare parts ordering, dimensioning, etc. A cross reference of drive catalog numbers and their respective frame size is provided in [Appendix A](#).

General Precautions

Class 1 LED Product



ATTENTION: Hazard of permanent eye damage exists when using optical transmission equipment. This product emits intense light and invisible radiation. Do not look into module ports or fiber optic cable connectors.



ATTENTION: This drive contains **ESD** (Electrostatic Discharge) sensitive parts and assemblies. Static control precautions are required when installing, testing, servicing or repairing this assembly. Component damage may result if ESD control procedures are not followed. If you are not familiar with static control procedures, reference A-B publication 8000-4.5.2, “Guarding Against Electrostatic Damage” or any other applicable ESD protection handbook.



ATTENTION: An incorrectly applied or installed drive can result in component damage or a reduction in product life. Wiring or application errors, such as, undersizing the motor, incorrect or inadequate AC supply, or excessive ambient temperatures may result in malfunction of the system.



ATTENTION: Only **qualified personnel** familiar with the PowerFlex 700S Drive and associated machinery should plan or implement the installation, start-up and subsequent maintenance of the system. Failure to comply may result in personal injury and/or equipment damage.



ATTENTION: To avoid an electric shock hazard, verify that the voltage on the bus capacitors has discharged before performing any work on the drive. Measure the DC bus voltage at the +DC & –DC terminals of the Power Terminal Block (refer to [Chapter 1](#) for location). The voltage must be zero.



ATTENTION: Risk of injury or equipment damage exists. DPI or SCANport host products must not be directly connected together via 1202 cables. Unpredictable behavior can result if two or more devices are connected in this manner.



ATTENTION: Risk of injury or equipment damage exists. Parameters 365 [Encdr0 Loss Cnfg] - 394 [VoltFdbkLossCnfg] let you determine the action of the drive in response to operating anomalies. Precautions should be taken to ensure that the settings of these parameters do not create hazards of injury or equipment damage.



ATTENTION: Risk of injury or equipment damage exists. Parameters 383 [SL CommLoss Data] - 392 [NetLoss DPI Cnfg] let you determine the action of the drive if communications are disrupted. You can set these parameters so that the drive continues to run. Precautions should be taken to ensure that the settings of these parameters do not create hazards of injury or equipment damage.

Catalog Number Explanation

Important: This table is not intended for ordering. For a full list of current options refer to publication 20D-PL001, *PowerFlex 700S/700S DriveLogix USA Price List*.

Position

1-3	4	5-7	8	9	10	11	12	13	14	15	16	17
20D	D	2P1	A	0	E	Y	N	A	N	N	N	N
<i>a</i>	<i>b</i>	<i>c</i>	<i>d</i>	<i>e</i>	<i>f</i>	<i>g</i>	<i>h</i>	<i>i</i>	<i>j</i>	<i>k</i>	<i>l</i>	<i>m</i>

a

Drive	
Code	Type
20D	PowerFlex 700S

b

Voltage Rating			
Code	Voltage	Ph.	Prechg.
B	240V ac	3	—
C	400V ac	3	—
D	480V ac	3	—
E	600V ac ♣	3	—
F	690V ac ➤	3	—
H	540V dc ⚡	—	N
J	650V dc ⚡	—	N
N	325V dc ➤	—	Y
P	540V dc ➤	—	Y
R	650V dc ➤	—	Y
T	810V dc ➤	—	Y
W	932V dc ➤	—	Y

♣ Note: CE Certification testing has not been performed on 600V class drives.

➤ Frames 5 & 6 Only.

⚡ Frames 5 & up.

c1

ND Rating			
208/240V, 60Hz Input			
Code	208V Amps	240V Amps	Hp
4P2	4.8	4.2	1.0
6P8	7.8	6.8	2.0
9P6	11	9.6	3.0
015	17.5	15.3	5.0
022	25.3	22	7.5
028	32.2	28	10
042	48.3	42	15
052	56	52	20
070	78.2	70	25
080	92	80	30
104	120	104	40
130	130	130	50
154	177	154	60
192	221	192	75

c2

ND Rating		
400V, 50 Hz Input		
Code	Amps	kW
2P1	2.1	0.75
3P5	3.5	1.5
5P0	5.0	2.2
8P7	8.7	4.0
011	11.5	5.5
015	15.4	7.5
022	22	11
030	30	15
037	37	18.5
043	43	22
056	56	30
072	72	37
085	85	45
105	105	55
125	125	55
140	140	75
170	170	90
205	205	110
260	260	132
261	261	132
300	300	160
385	385	200
460	460	250
500	500	250
590	590	315
650	650	355
730	730	400

c3

ND Rating		
480V, 60 Hz Input		
Code	Amps	Hp
2P1	2.1	1.0
3P4	3.4	2.0
5P0	5	3.0
8P0	8	5.0
011	11	7.5
014	14	10
022	22	15
027	27	20
034	34	25
040	40	30
052	52	40
065	65	50
077	77	60
096	96	75
125	125	100
156	156	125
180	180	150
248	248	200
261	261	200
300	300	250
385	385	300
460	460	350
500	500	450
590	590	500
650	650	500
730	730	600

c4

ND Rating		
600V, 60Hz Input ♣		
Code	Amps	Hp
022	22	20
027	27	25
032	32	30
041	41	40
052	52	50
062	62	60
077	77	75
099	99	100
125	125	125
144	144	150

♣ CE Certification testing has not been performed on 600V class drives.

Catalog Number Explanation, Cont'd

c5

ND Rating		
690V, 50 Hz Input ✦		
Code	Amps	Hp
052	52	45
060	60	55
082	82	75
098	98	90
119	119	110
142	142	132

✦ CE Certification testing has not been performed on 600V class drives.

d

Enclosure	
Code	Enclosure
A	IP20, NEMA Type 1
N	Open/IP00 ✧

✧ Frames 9 & up Only.

e

HIM	
Code	Operator Interface
0	Blank Cover
2	Digital LCD
3	Full Numeric LCD
5	Prog. Only LCD
C	Full Numeric LCD, Door Mount ✧

✧ Frames 10 & up only.

f

Documentation	
Code	Documents
E	Quick Start Guide
N	No Documentation

g

Brake	
Code	w/Brake IGBT ‡
Y	Yes
N	No

‡ Brake IGBT is standard on Frames 1-3 and optional on Frames 4-9 ONLY.

h

Brake Resistor	
Code	w/Resistor
Y	Yes ✦
N	No

✦ Not available for Frame 3 drives or larger.

i

Emission		
Code	CE Filter	CM Choke
A ✦	Yes	Yes
B ✧	Yes	No
N §	No	No

✦ Frames 1-6 Only.

✧ Frames 9 & up Only.

§ For use on ungrounded distribution systems (Frame 9 drives only).

j

Comm Slot	
Code	Version
N	None
C	DPI ControlNet (Coax)
D	DPI DeviceNet
E	DPI EtherNet/IP
Q	DPI ControlNet (Fiber)
R	DPI RIO
S	DPI RS-483 DF1
1	DriveLogix ControlNet (Coax)
2	DriveLogix ControlNet Redundant (Coax)
3	DriveLogix ControlNet (Fiber)
4	DriveLogix ControlNet Redundant (Fiber)
5	DriveLogix DeviceNet (Open Conn.)
6	DriveLogix EtherNet/IP

k

Control Options				
Code	Control Option	Logic Expansion	Synch-Link	Cassette
N	Phase I	N/A	Standard	None

l

Feedback	
Code	Option
N	None
A	Resolver
B	Stegman Hi-Resolution Encoder
C	Multi-Device Interface

m

Additional Config.	
Code	Description
N	Phase I Control
A	Phase I DriveLogix5720
B	Phase I DriveLogix5720 w/Expanded Memory

Installation/Wiring

Chapter Objectives

This chapter provides the information needed to mount and wire the PowerFlex 700S AC drive for Frames 1 - 6. For installation instructions for the PowerFlex 700S AC drive for Frames 9 - 12, refer to PFLEX-IN006.

For Information on ...	See Page...
Opening the Cover	1-2
Mounting Clearances	1-2
AC Supply Source Considerations	1-3
Grounding Requirements	1-4
Fuses and Circuit Breakers	1-5
Power Wiring	1-6
Using Input/Output Contactors	1-15
Disconnecting MOVs and Common Mode Capacitors	1-16
I/O Wiring	1-19
Connecting SynchLink	1-33
CE Conformity	1-35

Since most start-up difficulties are the result of incorrect wiring, take every precaution to assure the wiring is correct. Read and understand all items in this chapter before beginning installation.



ATTENTION: The following information is merely a guide for proper installation. Rockwell Automation, Inc. cannot assume responsibility for the compliance or the noncompliance to any code, national, local or otherwise for the proper installation of this drive or associated equipment. A hazard of personal injury and/or equipment damage exists if codes are ignored during installation.

Opening the Cover

Opening Control Assembly

Step	Description
Ⓐ	Loosen captive screw.
Ⓑ	Push down on cover.
Ⓒ	Pull cover away from assembly.

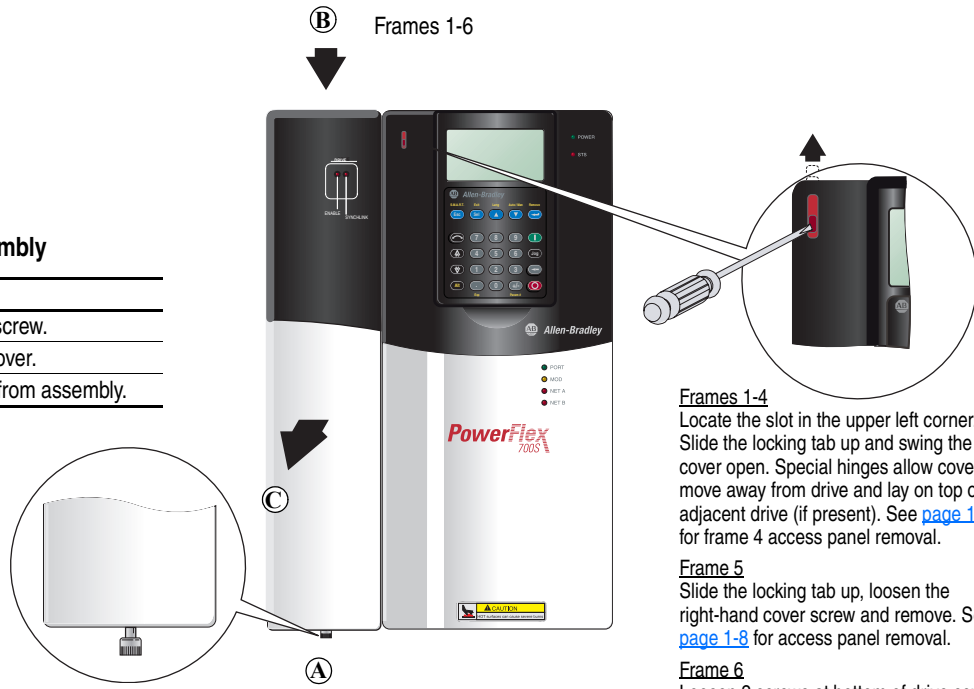

Frames 1-4
 Locate the slot in the upper left corner. Slide the locking tab up and swing the cover open. Special hinges allow cover to move away from drive and lay on top of adjacent drive (if present). See [page 1-8](#) for frame 4 access panel removal.

Frame 5
 Slide the locking tab up, loosen the right-hand cover screw and remove. See [page 1-8](#) for access panel removal.

Frame 6
 Loosen 2 screws at bottom of drive cover. Carefully slide bottom cover down and out. Loosen the 2 screws at top of cover and remove.

Mounting Clearances

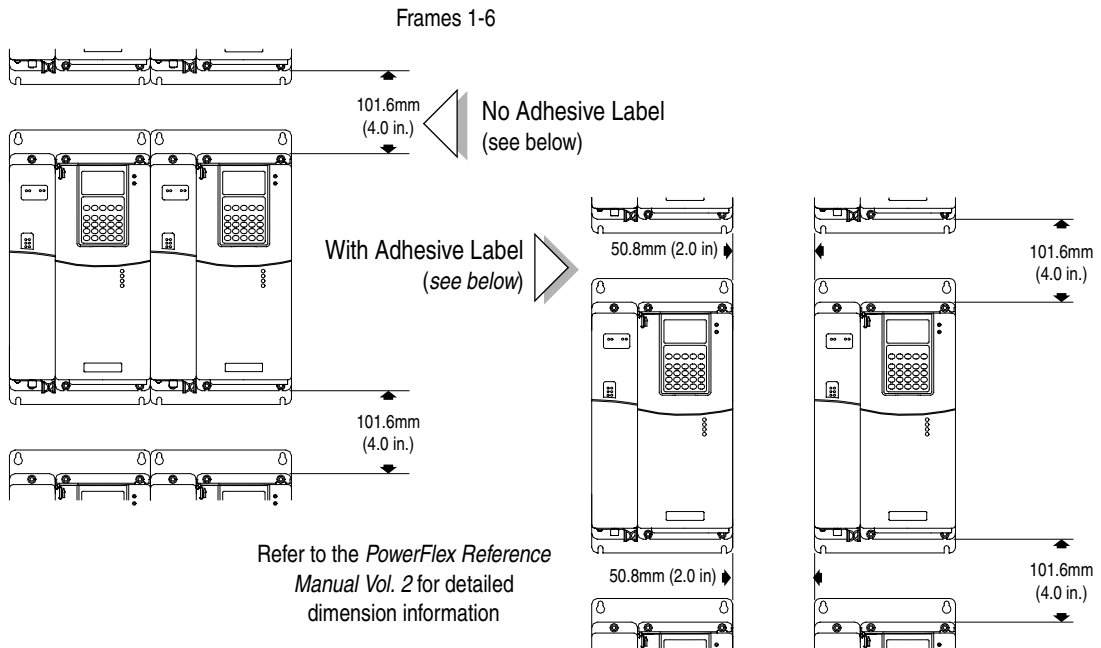

Operating Temperatures

PowerFlex 700S drives are designed to operate in surrounding air temperature of 0° to 40° C. To operate the drive in installations with surrounding air temperature between 41° and 50° C, remove the adhesive label affixed to the top of the drive enclosure.

Table 1.A Acceptable Surrounding Air Temperature & Required Actions

Drive Catalog Number	Required Action . . .		
	IP 20, NEMA Type 1	IP 20, NEMA Type Open	IP 00, NEMA Type Open
	No Action Required	Remove Top Label	Remove Top Label & Vent Plate ⁽¹⁾
All <i>Except</i> 20BC072	40° C	50° C	NA
20BC072	40° C	45° C	50° C

⁽¹⁾ To remove vent plate (see [page A-20](#) for location), lift top edge of plate from the chassis. Rotate the plate out from the back plate.

Important: Removing the adhesive label from the drive changes the NEMA enclosure rating from Type 1 to Open type.

AC Supply Source Considerations

PowerFlex drives are suitable for use on a circuit capable of delivering up to a maximum of 200,000 rms symmetrical amperes, 600 volts with recommended fuses/circuit breakers. Refer to the *PowerFlex Reference Manual Vol. 2* for actual interrupt ratings based on circuit breaker or fuse choice.



ATTENTION: To guard against personal injury and/or equipment damage caused by improper fusing or circuit breaker selection, use only the recommended line fuses/circuit breakers specified in [Appendix A](#).

If a Residual Current Detector (RCD) is used as a system ground fault monitor, only Type B (adjustable) devices should be used to avoid nuisance tripping.

Unbalanced or Ungrounded Distribution Systems

If phase to ground voltage will exceed 125% of normal or the supply system is ungrounded, refer to the *Wiring and Grounding Guidelines for PWM Drives* for more information.



ATTENTION: PowerFlex 700S drives contain protective MOVs and common mode capacitors that are referenced to ground. These devices should be disconnected if the drive is installed on an ungrounded distribution system. See [page 1-18](#) for jumper locations.

Input Power Conditioning

Certain events on the power system supplying a drive can cause component damage or shortened product life. These conditions are divided into 2 basic categories:

1. All Drives

- The power system has power factor correction capacitors switched in and out of the system, either by the user or by the power company.
- The power source has intermittent voltage spikes in excess of 6000 volts. These spikes could be caused by other equipment on the line or by events such as lightning strikes.
- The power source has frequent interruptions.

2. 5 HP or Less Drives (in addition to “1” above)

- The nearest supply transformer is larger than 100kVA or the available short circuit (fault) current is greater than 100,000A.
- The impedance in front of the drive is less than 0.5%.

If any or all of these conditions exist, it is recommended that the user install a minimum amount of impedance between the drive and the source. This impedance could come from the supply transformer itself, the cable between the transformer and drive or an additional transformer or reactor. The impedance can be calculated using the information supplied in either the *PowerFlex Reference Manual Vol. 2* or the technical document *Wiring and Grounding Guidelines*, publication DRIVES-IN001.

Grounding Requirements

The drive Safety Ground-PE must be connected to system ground.

Ground impedance must conform to the requirements of national and local industrial safety regulations and/or electrical codes. The integrity of all ground connections should be periodically checked.

Recommended Grounding Scheme

A single point (PE only) grounding scheme should be used. Some applications may require alternate grounding schemes, refer to the *Wiring and Grounding Guidelines for PWM AC Drives*, publication number DRIVES-IN001 for more information. These applications include installations with long distances between drives or drive line-ups, which could cause large potential differences between the drive or line-up grounds.

For installations within a cabinet, a single safety ground point or ground bus bar connected directly to building steel should be used. All circuits including the AC input ground conductor should be grounded independently and directly to this point/bar.

Figure 1.1 Typical Grounding

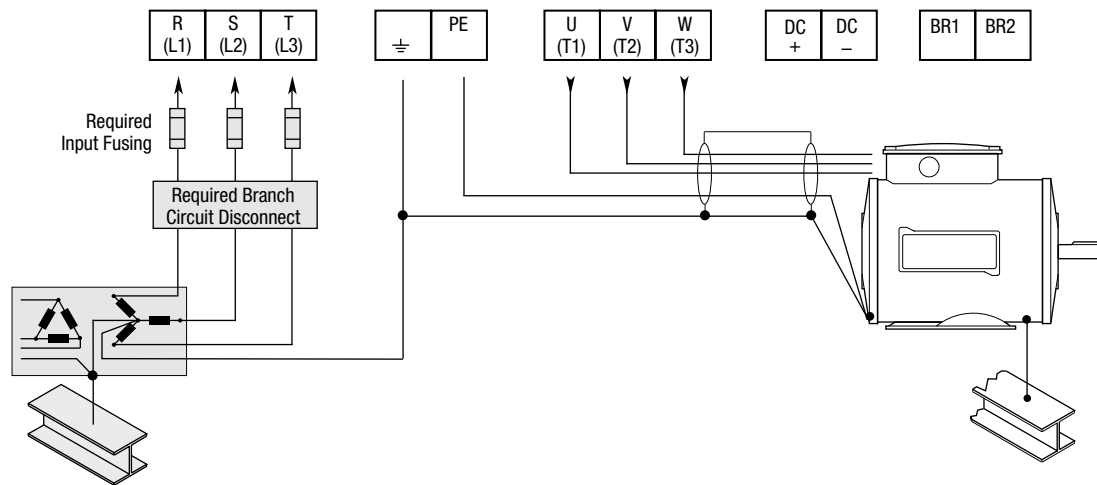

Shield Termination - SHLD

The Shield terminal (see [Figure 1.3 on page 1-12](#)) provides a grounding point for the motor cable shield. It must be connected to an earth ground by a separate continuous lead. The **motor cable** shield should be connected to this terminal on the drive (drive end) and the motor frame (motor end). Use a shield terminating or EMI clamp to connect shield to this terminal.

RFI Filter Grounding

Using an optional RFI filter may result in relatively high ground leakage currents. Therefore, the **filter must only be used in installations with grounded AC supply systems and be permanently installed and solidly grounded** (bonded) to the building power distribution ground. Ensure that the incoming supply neutral is solidly connected (bonded) to the same building power distribution ground. Grounding must not rely on flexible cables and should not include any form of plug or socket that would permit inadvertent disconnection. Some local codes may require redundant ground connections. The integrity of all connections should be periodically checked. Refer to the instructions supplied with the filter.

Fuses and Circuit Breakers

The PowerFlex 700S can be installed with either input fuses or an input circuit breaker. Local/national electrical codes may determine additional requirements for these installations. Refer to [Appendix A](#) for recommended fuses/circuit breakers.



ATTENTION: The PowerFlex 700S does not provide input power short circuit protection. Specifications for the recommended fuse or circuit breaker to provide drive input power protection against short circuits are provided in [Appendix A](#).

Power Wiring

Power Cable Types Acceptable for 200-600 Volt Installations



ATTENTION: National Codes and standards (NEC, BSI etc.) and local codes outline provisions for safely installing electrical equipment. Installation must comply with specifications regarding wire types, conductor sizes, branch circuit protection and disconnect devices. Failure to do so may result in personal injury and/or equipment damage.

A variety of cable types are acceptable for drive installations. For many installations, unshielded cable is adequate, provided it can be separated from sensitive circuits. As an approximate guide, allow a spacing of 0.3 meters (1 foot) for every 10 meters (32.8 feet) of length. In all cases, long parallel runs must be avoided. Do not use cable with an insulation thickness less than or equal to 15 mils (0.4mm/0.015 in.). Use copper wire only. Wire gauge requirements and recommendations are based on 75° C. Do not reduce wire gauge when using higher temperature wire.

Unshielded

THHN, THWN or similar wire is acceptable for drive installation in dry environments provided adequate free air space and/or conduit fill rates limits are provided. **Do not use THHN or similarly coated wire in wet areas.** Any wire chosen must have a minimum insulation thickness of 15 Mil and should not have large variations in insulation concentricity.

Shielded/Armored Cable

Shielded cable contains all of the general benefits of multi-conductor cable with the added benefit of a copper braided shield that can contain much of the noise generated by a typical AC Drive. Strong consideration for shielded cable should be given in installations with sensitive equipment such as weigh scales, capacitive proximity switches and other devices that may be affected by electrical noise in the distribution system. Applications with large numbers of drives in a similar location, imposed EMC regulations or a high degree of communications/networking are also good candidates for shielded cable.

Shielded cable may also help reduce shaft voltage and induced bearing currents for some applications. In addition, the increased impedance of shielded cable may help extend the distance the motor can be located from the drive without the addition of motor protective devices such as terminator networks. Refer to Reflected Wave in *Wiring and Grounding Guidelines for PWM AC Drives*, publication DRIVES-IN001.

Consideration should be given to all of the general specifications dictated by the environment of the installation, including temperature, flexibility, moisture characteristics and chemical resistance. In addition, a braided shield should be included and specified by the cable manufacturer as having coverage of at least 75%. An additional foil shield can be greatly improve noise containment.

A good example of recommended cable is Belden® 295xx (xx determines gauge). This cable has 4 XLPE insulated conductors with a 100% coverage foil and an 85% coverage copper braided shield (with drain wire) surrounded by a PVC jacket.

Other types of shielded cable are available, but the selection of these types may limit the allowable cable length. Particularly, some of the newer cables twist 4 conductors of THHN wire and wrap them tightly with a foil shield. This construction can greatly increase the cable charging current required and reduce the overall drive performance. Unless specified in the individual distance tables as tested with the drive, these cables are not recommended and their performance against the lead length limits supplied is not known.

Table 1.B Recommended Shielded Wire

Location	Rating/Type	Description
Standard (Option 1)	600V, 90°C (194°F) XHHW2/RHW-2 Anixter B209500-B209507, Belden 29501-29507, or equivalent	Four tinned copper conductors with XLPE insulation. Copper braid/aluminum foil combination shield and tinned copper drain wire. PVC jacket.
Standard (Option 2)	Tray rated 600V, 90°C (194°F) RHH/RHW-2 Anixter OLF-7xxxx or equivalent	Three tinned copper conductors with XLPE insulation. 5 mil single helical copper tape (25% overlap min.) with three bare copper grounds in contact with shield. PVC jacket.
Class I & II; Division I & II	Tray rated 600V, 90°C (194°F) RHH/RHW-2 Anixter 7V-7xxx-3G or equivalent	Three bare copper conductors with XLPE insulation and impervious corrugated continuously welded aluminum armor. Black sunlight resistant PVC jacket overall. Three copper grounds on #10 AWG and smaller.

EMC Compliance

Refer to [CE Conformity on page 1-35](#) for details.

Cable Trays and Conduit

If cable trays or large conduits are to be used, refer to guidelines presented in the *Wiring and Grounding Guidelines for PWM AC Drives*.



ATTENTION: To avoid a possible shock hazard caused by induced voltages, unused wires in the conduit must be grounded at both ends. For the same reason, if a drive sharing a conduit is being serviced or installed, all drives using this conduit should be disabled. This will help minimize the possible shock hazard from “cross coupled” motor leads.

Motor Cable Lengths

Typically, motor lead lengths less than 30 meters (100 feet) are acceptable. Motor lead lengths of 30 meters (100 feet) to 246 meters (800 feet) require shielded cable. If your application dictates longer lengths, refer to publication 20D-TD001, *Technical Data - PowerFlex 700S Drives*, for details.

Power Terminal Block

[Figure 1.3](#) shows the typical location of the Power Terminal Block in Frame 1 drives. The terminal block is located in the bottom section of the drive on Frame 2-5 drives.

Cable Entry Plate Removal

If additional wiring access is needed, the Cable Entry Plate on Frame 1-3 drives can be removed. Simply loosen the screws securing the plate to the chassis. The slotted mounting holes assure easy removal.

Important: Removing the Cable Entry Plate limits the maximum surrounding air temperature to 40° C (104° F).

Power Wiring Access Panel Removal

Frame	Removal Procedure <i>(Replace when wiring is complete)</i>
1, 2 & 6	Part of front cover, see page 1-2 .
3	Open front cover and gently tap/slide cover down and out.
4	Loosen the 4 screws and remove.
5	Remove front cover (see page 1-2), gently tap/slide panel up and out.

Access Panel Removal

Frame 3 drives utilize a panel/cover over the power wiring terminals. To remove, simply slide it down and out.

Replace the cover when wiring is complete.



ATTENTION: Removing the access panel/cover exposes dangerous voltages on the terminals and negates the enclosure type rating. Replace the access panel/cover when service is complete. Failure to comply may result in personal injury or equipment damage.

AC Input Phase Selection (Frames 5 & 6 Only)



ATTENTION: To avoid a shock hazard, ensure that all power to the drive has been removed before performing the following.

Moving the “Line Type” jumper shown in [Figure 1.2](#) will select single or three-phase operation. Remove plastic guard to access jumper.

Important: When selecting single-phase operation, input power must be applied to the R (L1) and S (L2) terminals only.

Cooling Fan Voltage

Common Bus drives require user supplied 120 or 240V AC to power the cooling fans. Power source is connected between “0V AC” and the terminal corresponding to your source voltage (see [Figure 1.4 on page 1-13](#)).

Table 1.C Fan VA Rating

Frame	Fan Voltage(120V or 240V)
5	100 VA
6	138 VA

Selecting/Verifying Fan Voltage (Frames 5 & 6 Only)



ATTENTION: To avoid a shock hazard, ensure that all power to the drive has been removed before performing the following.

Frames 5 & 6 utilize a transformer to match the input line voltage to the internal fan voltage. If your line voltage is different than the voltage class specified on the drive nameplate, it may be necessary to change the transformer taps. The taps are shown in the insert of frame 5 below.

Figure 1.2 Frames 5 & 6 Jumper and Transformer Locations (Frame 5 shown)

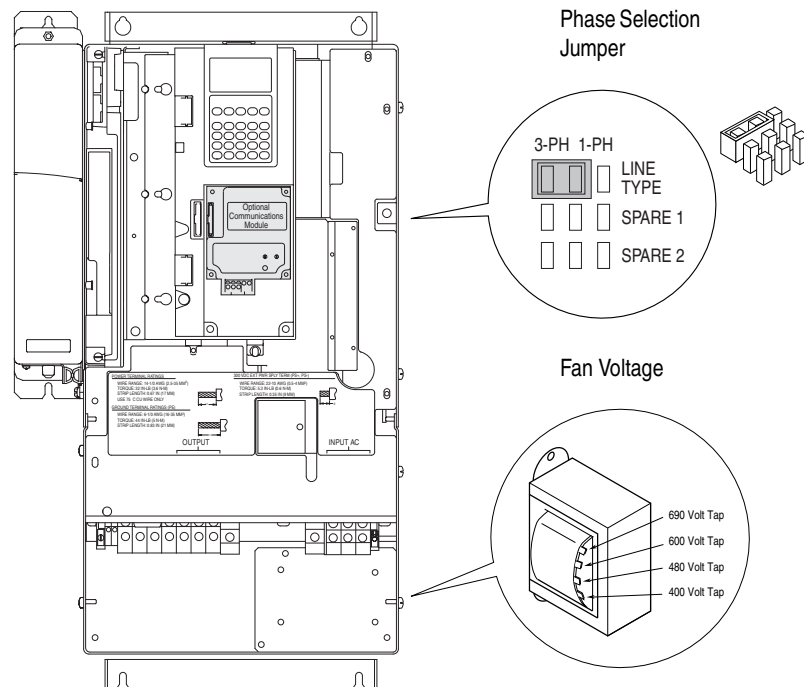

Frame 6 Transformer Tap Access

The transformer is located behind the Power Terminal Block in the area shown in [Figure 1.2](#). Gain access by releasing the terminal block from the rail. To release terminal block and change tap:

1. Locate the small metal tab at the bottom of the end block.
2. Press the tab in and pull the top of the block out. Repeat for next block if desired.
3. Select appropriate transformer tap.
4. Replace block(s) in reverse order.

Important Common Bus (DC Input) Application Notes

1. If drives without internal precharge are used (Frames 5 & 6 only), then:
 - a) precharge capability must be provided in the system to guard against possible damage, and
2. disconnect switches **Must Not** be used between the input of the drive and a common DC bus without the use of an external precharge device.

Table 1.D Power Terminal Block Specifications

No.	Name	Frame	Description	Wire Size Range ⁽¹⁾		Torque		Terminal Bolt Size ⁽²⁾		
				Maximum	Minimum	Maximum	Recommended			
①	Power Terminal Block	1	Input power and motor connections	4.0 mm ² (10 AWG)	0.5 mm ² (22 AWG)	1.7 N-m (15 lb.-in.)	0.8 N-m (7 lb.-in.)	—		
		2	Input power and motor connections	10.0 mm ² (6 AWG)	0.8 mm ² (18 AWG)	1.7 N-m (15 lb.-in.)	1.4 N-m (12 lb.-in.)	—		
		3	Input power and motor connections	25.0 mm ² (3 AWG)	2.5 mm ² (14 AWG)	3.6 N-m (32 lb.-in.)	1.8 N-m (16 lb.-in.)	—		
			BR1, BR2	10.0 mm ² (6 AWG)	0.8 mm ² (18 AWG)	1.7 N-m (15 lb.-in.)	1.4 N-m (12 lb.-in.)	—		
		4	Input power and motor connections	35.0 mm ² (1/0 AWG)	10 mm ² (8 AWG)	4.0 N-m (24 lb.-in.)	4.0 N-m (24 lb.-in.)	—		
		5 (75 HP) ⁽³⁾	R, S, T, BR1, BR2, DC+, DC-, U, V and W	50.0 mm ² (1/0 AWG)	2.5 mm ² (14 AWG)	See Note ⁽⁴⁾	See Note ⁽³⁾	—		
			PE	50.0 mm ² (1/0 AWG)	4.0 mm ² (12 AWG)			—		
		5 (100 HP) ⁽³⁾	R, S, T, DC+, DC-, U, V and W	70.0 mm ² (2/0 AWG)	16.0 mm ² (6 AWG)			—		
			BR1, BR2	50.0 mm ² (1/0 AWG)	2.5 mm ² (14 AWG)			—		
			PE	50.0 mm ² (1/0 AWG)	4.0 mm ² (12 AWG)			—		
6	Input power and motor connections	120.0 mm ² (4/0 AWG)	2.5 mm ² (14 AWG)	6 N-m (52 lb.-in.)	6 N-m (52 lb.-in.)			—		
②	SHLD Terminal	1-6	Terminating point for wiring shields	—	—			1.6 N-m (14 lb.-in.)	1.6 N-m (14 lb.-in.)	M12
③	AUX Terminal Block	1-4	Auxiliary Control Voltage ⁽⁵⁾ PS+, PS-	1.5 mm ² (16 AWG)	0.2 mm ² (24 AWG)			—	—	—
		5-6		4.0 mm ² (10 AWG)	0.5 mm ² (22 AWG)			0.6 N-m (5.3 lb.-in.)	0.6 N-m (5.3 lb.-in.)	—
④	Fan Terminal Block (Common Bus Only)	5-6	User Supplied Fan Voltage 0V AC, 120V AC, 240V AC	4.0 mm ² (10 AWG)	0.5 mm ² (22 AWG)			0.6 N-m (5.3 lb.-in.)	0.6 N-m (5.3 lb.-in.)	M10

(1) Maximum/minimum sizes that the terminal block will accept - these are not recommendations.

(2) Apply counter torque to the nut on the other side of terminations when tightening or loosening the terminal bolt in order to avoid damage to the terminal.

(3) Not all terminals present on all drives.

(4) Refer to the terminal block label inside the drive.

(5) Auxiliary power:

UL Installation - 300V DC, ±10%, Non UL Installation - 270-600V DC, ±10%.

Frame 1-6, 100 W

Figure 1.3 Typical Power Terminal Block Location

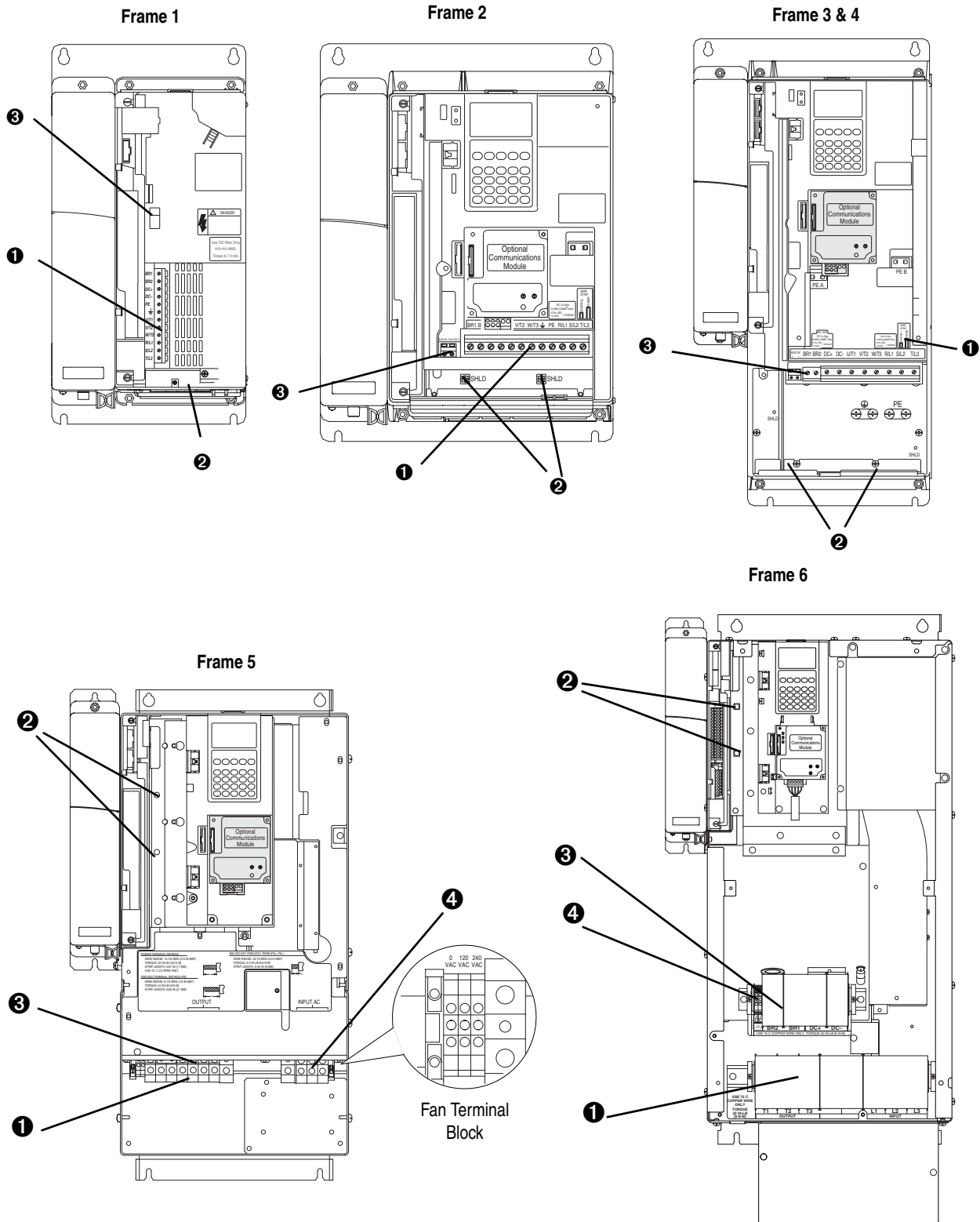
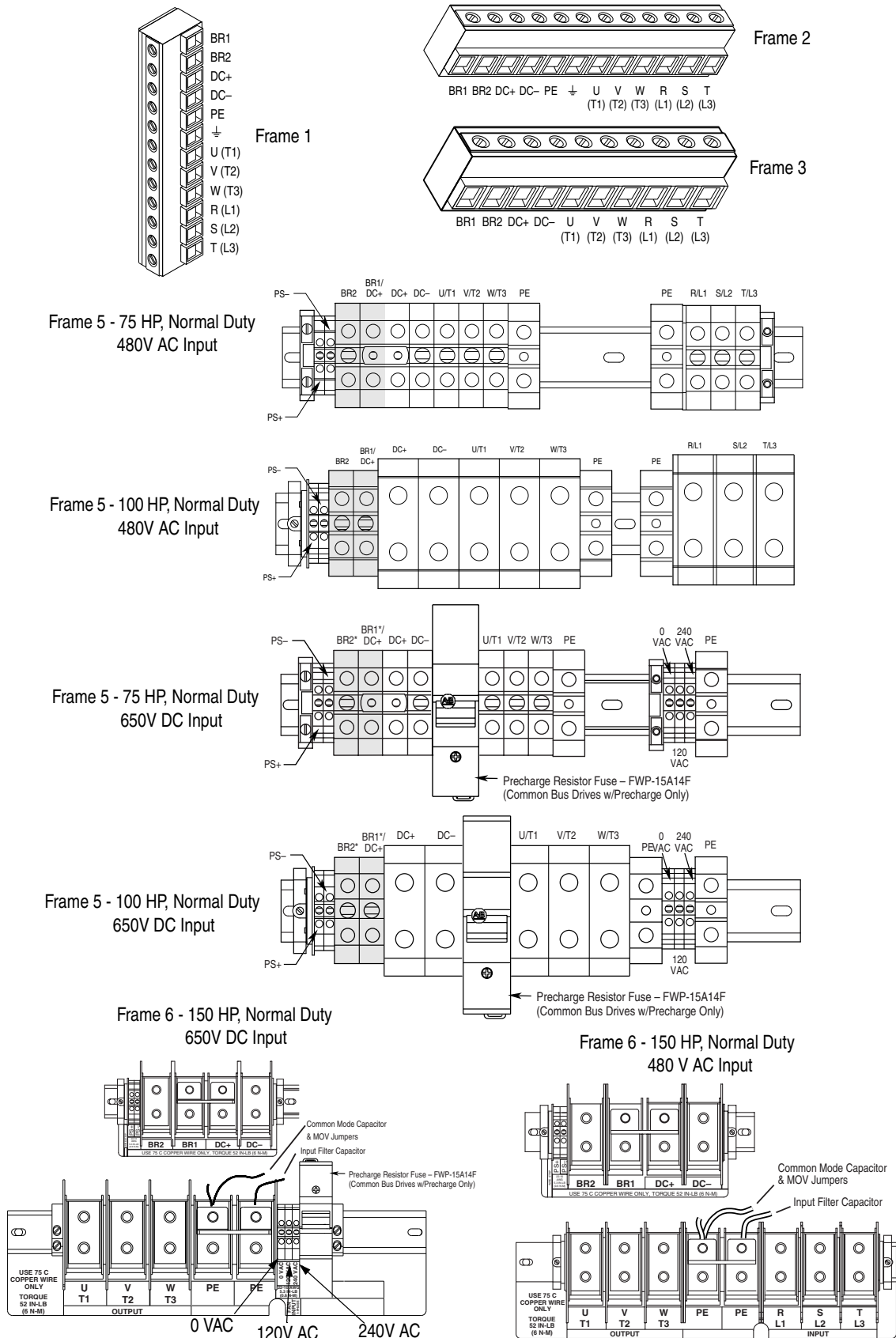

Figure 1.4 Power Terminal Block



Shaded terminals (BR1 & BR2) will only be present on drives ordered with the Brake Option.

Table 1.E Terminal Block Descriptions

Terminal	Description	Notes
BR1	DC Brake (+)	Dynamic Brake Resistor Connection (+)
BR2	DC Brake (-)	Dynamic Brake Resistor Connection (-)
DC+	DC Bus (+)	DC Input Power or Dynamic Brake Chopper
DC-	DC Bus (-)	DC Input Power or Dynamic Brake Chopper
PE	PE Ground	Refer to Figure 1.4 for location on 3 Frame drives
PS+	Aux +	Auxiliary Control Voltage. See Table 1.D on page 1-11 ⁽¹⁾
PS-	Aux -	Auxiliary Control Voltage. See Table 1.D on page 1-11 ⁽¹⁾
⊥	Motor Ground	Refer to Figure 1.3 for location on 3 Frame drives
U	U (T1)	To motor
V	V (T2)	To motor
W	W (T3)	To motor
R	R (L1)	AC Line Input Power
S	S (L2)	Three-Phase = R, S & T
T	T (L3)	Single-Phase = R & S

(1) Auxiliary power:
 UL Installation - 300V DC, ±10%, Non UL Installation - 270-600V DC, ±10%.
 1-3 Frame - 40 W, 165 mA, 5 Frame - 80 W, 90 mA

Dynamic Brake Resistor Considerations



ATTENTION: The drive does not offer protection for externally mounted brake resistors. A risk of fire exists if external braking resistors are not protected. External resistor packages must be self-protected from over temperature or a circuit equivalent to the one shown below must be supplied.

Figure 1.5 External Brake Resistor Circuitry

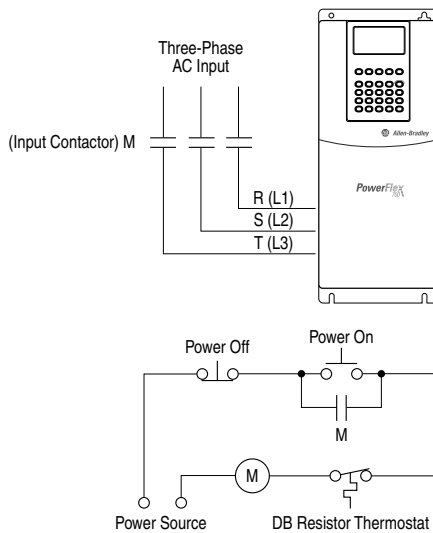

Using Input/Output Contactors



ATTENTION: A contactor or other device that routinely disconnects and reapplies the AC line to the drive to start and stop the motor can cause drive hardware damage. The drive is designed to use control input signals that will start and stop the motor. If an input device is used occasionally, an auxiliary contact on that device should also be wired to a digital input programmed as a “Enable” function. The input device must not exceed one operation per minute or drive damage will occur.



ATTENTION: The drive start/stop control circuitry includes solidstate components. If hazards due to accidental contact with moving machinery or unintentional flow of liquid, gas or solids exist, an additional hardwired stop circuit may be required to remove the AC line to the drive. When the AC line is removed, there will be a loss of any inherent regenerative braking effect that might be present - the motor will coast to a stop. An auxiliary braking method may be required.



ATTENTION: To guard against drive damage when using output contactors, the following information must be read and understood. One or more output contactors may be installed between the drive and motor(s) for the purpose of disconnecting or isolating certain motors/loads. If a contactor is opened while the drive is operating, power will be removed from the respective motor, but the drive will continue to produce voltage at the output terminals. In addition, reconnecting a motor to an active drive (by closing the contactor) could produce excessive current that may cause the drive to fault. If any of these conditions are determined to be undesirable or unsafe, an auxiliary contact on the output contactor should be wired to a drive digital input that is programmed as “Enable.” This will cause the drive to execute a coast-to-stop (cease output) whenever an output contactor is opened.

Using PowerFlex 700S Drives with Regenerative Power Units

If a Regenerative unit (i.e., 1336 REGEN) is used as a bus supply or a brake, the common mode capacitors should be disconnected (see [Table 1.F on page 1-16](#)).

Regenerative Unit to Drive Connections

Regenerative Brake Mode

Frame(s)	Terminals	
	1336 Regen	PowerFlex 700S
1 - 4	DC+ & DC-	BR1 & DC-
5 & 6	DC+ & DC-	DC+ & DC-

Regenerative Bus Supply Mode

Frame(s)	Terminals	
	1336 Regen	PowerFlex 700S
1 - 4	DC+ & DC-	DC+ & DC-
5 & 6	DC+ & DC-	DC+ & DC- of the Common Bus Drives

Disconnecting MOVs and Common Mode Capacitors

PowerFlex 700S drives contain protective MOVs and common mode capacitors that are referenced to ground. To guard against drive damage, these devices must be disconnected if the drive is installed on a resistive grounded distribution system or an ungrounded distribution system where the line-to-ground voltages on any phase could exceed 125% of the nominal line-to-line voltage. To disconnect these devices, remove the jumper(s) listed in [Table 1.F](#). Jumpers can be removed by carefully pulling the jumper straight out. See the *Wiring and Grounding Guidelines for Pulse Width Modulated (PWM) AC Drives*, publication DRIVES-IN001 for more information on ungrounded system installation.



ATTENTION: To avoid an electric shock hazard, verify that the voltage on the bus capacitors has discharged before removing/ installing jumpers. Measure the DC bus voltage at the +DC & – DC terminals of the Power Terminal Block. The voltage must be zero.

Table 1.F Jumper Removal

Frames	Jumper	Component	Jumper Location	No.
1	PEA	Common Mode Capacitors	Remove the Control Assembly and Cassette. Jumpers are located on the drive Power Board (see Figure 1.6).	①
	PEB	MOV's		②
2-4	PEA	Common Mode Capacitors	Jumpers are located above the Power Terminal Block (see Figure 1.6).	③
	PEB	MOV's		④
5	Wire	Common Mode Capacitors	Remove the I/O Cassette. The green/yellow jumper is located on the back of chassis in the area shown (see Figure 1.6). Disconnect, insulate and secure the wire to guard against unintentional contact with chassis or components.	⑤
		MOV's	Note location of green/yellow jumper wire in Figure 1.6 . Disconnect, insulate and secure the wire guard against unintentional contact with chassis or components.	⑥
		Input Filter Capacitors		

Frames	Jumper	Component	Jumper Location	No.
6	Wire	Common Mode Capacitors	Remove the wire guard from the Power Terminal Block. Disconnect the three green/yellow wires from the two "PE" terminals shown in Figure 1.4 . Insulate and secure the wires to guard against unintentional contact with chassis or components.	Please refer to Power Terminal Blocks, Frame 6 on page 1-12 .
		MOV's		
		Input Filter Capacitors		



ATTENTION: The disconnecting MOV must be used on a grounded system.

Figure 1.6 Typical Jumper Locations

Frame 1
(Control Assembly and I/O
Cassette Removed)

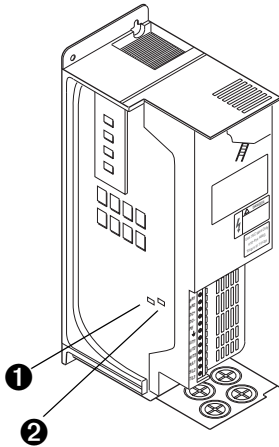

Frame 2

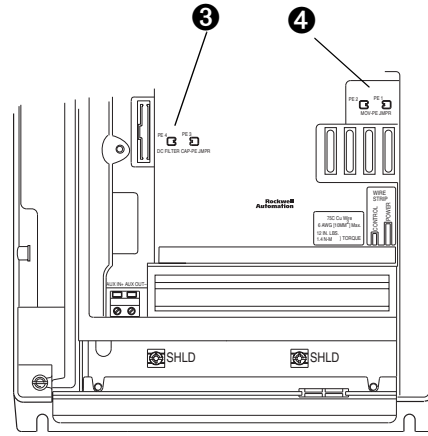

Frames 3 & 4

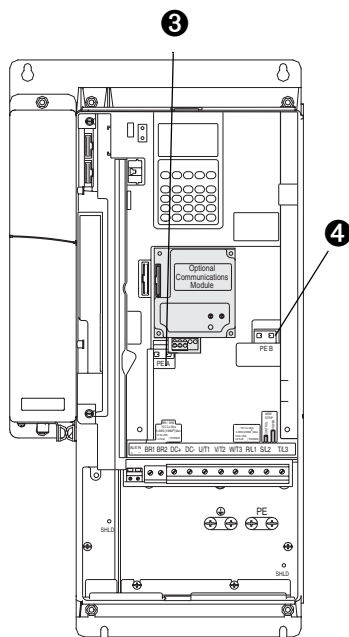

Frame 5

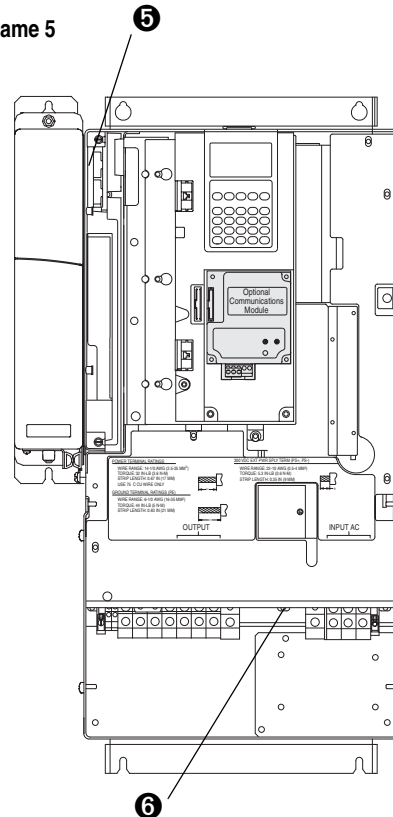

I/O Wiring

Important points to remember about I/O wiring:

- Always use tinned copper wire.
- Wire with an insulation rating of 600V or greater is recommended.
- Control and signal wires should be separated from power wires by at least 0.3 meters (1 foot).
- 4100CCF3 Flex I/O cable for use with DriveLogix is 3 ft. maximum length.

Important: I/O terminals labeled “(-)” or “Common” are not referenced to earth ground and are designed to greatly reduce common mode interference. Grounding these terminals can cause signal noise.



ATTENTION: Hazard of personal injury or equipment damage exists when using bipolar input sources. Noise and drift in sensitive input circuits can cause unpredictable changes in motor speed and direction. Use speed command parameters to help reduce input source sensitivity.

Table 1.G Recommended Control Wire

Type	Wire Type(s)	Description	Insulation Rating	
Digital I/O	Un-shielded	Per US NEC or applicable national or local code	300V, 60° C (140° F), Minimum	
	Shielded	Multi-conductor shielded cable such as Belden 8770 (or equiv.)		0.750 mm ² (18AWG), 3 conductor, shielded.
Standard Analog I/O	Belden 8760/9460 (or equiv.)	0.750 mm ² (18AWG), twisted pair, 100% shield with drain ⁽⁵⁾ .	300V, 75-90 °C (167-194 °F)	
Remote Pot	Belden 8770 (or equiv.)	0.750 mm ² (18AWG), 3 cond., shielded		
Encoder/Pulse I/O Less 30.5 m (100 ft.)	Combined: Belden 9730 (or equivalent) ⁽¹⁾	0.196 mm ² (24AWG), individually shielded.		
Encoder/Pulse I/O 30.5 m (100 ft.) to 152.4 m (500 ft.)	Signal:	Belden 9730/9728 (or equivalent) ⁽¹⁾		0.196 mm ² (24AWG), individually shielded.
	Power:	Belden 8790 ⁽²⁾		0.750 mm ² (18AWG)
	Combined:	Belden 9892 ⁽³⁾		0.330 mm ² or 0.500 mm ² ⁽³⁾
Encoder/Pulse I/O 152.4 m (500 ft.) to 259.1 m (850 ft.)	Signal:	Belden 9730/9728 (or equivalent) ⁽¹⁾		0.196 mm ² (24AWG), individually shielded.
	Power:	Belden 8790 ⁽²⁾		0.750 mm ² (18AWG)
	Combined:	Belden 9773/9774 (or equivalent) ⁽⁴⁾		0.750 mm ² (18AWG), individually shielded pair.
EMC Compliance	Refer to EMC Instructions on page 1-6 for details.			

(1) Belden 9730 is 3 individually shielded pairs (2 channel plus power). If 3 channel is required, use Belden 9728 (or equivalent).

(2) Belden 8790 is 1 shielded pair.

(3) Belden 9892 is 3 individually shielded pairs (3 channel), 0.33 mm² (22 AWG) plus 1 shielded pair 0.5 mm² (20 AWG) for power.

(4) Belden 9773 is 3 individually shielded pairs (2 channel plus power). If 3 channel is required, use Belden 9774 (or equivalent).

(5) If the wires are short and contained within a cabinet which has no sensitive circuits, the use of shielded wire may not be necessary, but is always recommended.

Wiring the Main Control Board I/O Terminals

Terminal blocks TB1 and TB2 contain connection points for all inputs, outputs and standard encoder connections. Both terminal blocks reside on the Main Control Board.

Remove the terminal block plug from the socket, and make connections.

► **TIP:** Remember to route wires through the sliding access panel at the bottom Control Assembly.

Reinstall the plug, when wiring is complete. The terminal blocks have keys, which make it difficult to insert a terminal plug into the wrong socket.

Table 1.H Main Control Board I/O Terminal Locations

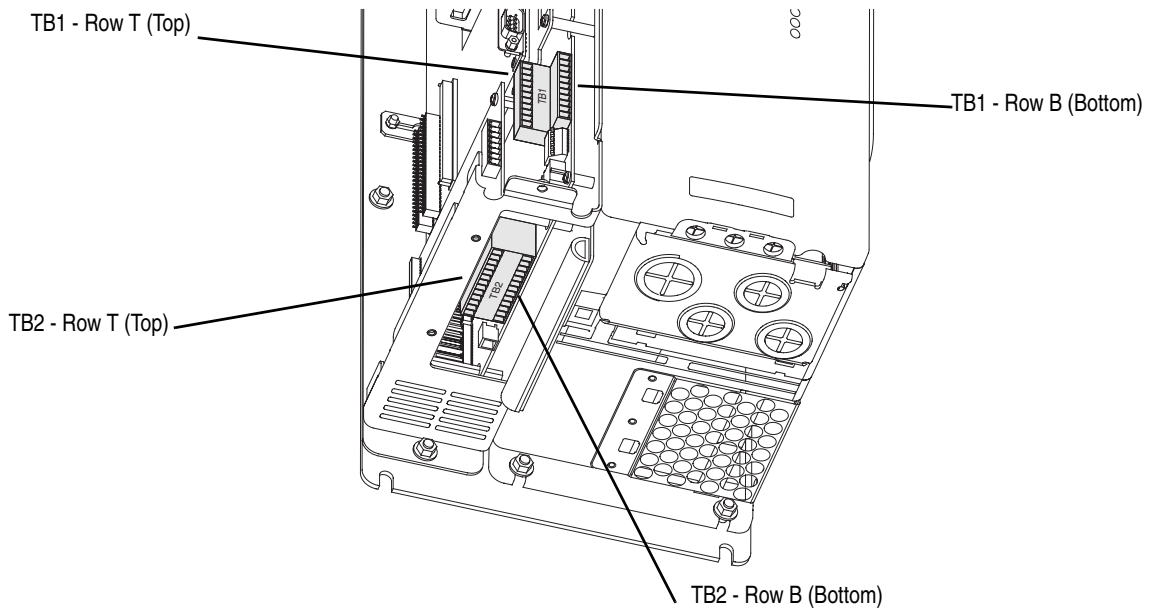

Table 1.I Main Control Board I/O Terminal Block Specifications

Name	Frame	Description	Wires Size Range ⁽¹⁾		Torque	
			Maximum	Minimum	Maximum	Recommended
I/O & Encoder Blocks	1-6	Signal & Encoder power connections	1.5 mm ² (16 AWG)	.14 mm ² (28 AWG)	.25 N-m (2.2 lb.-in.)	.22 N-m (1.9 lb.-in.)

⁽¹⁾ Maximum/minimum sizes the terminal block will accepts - these are not recommendations.

Auxiliary Power Supply

You may use an auxiliary power supply to keep the 700S Control Assembly energized when output power is de-energized. This allows the Main Control Board, DriveLogix controller and any feedback option cards to continue operation. Connect auxiliary power to terminal block. See [Table 1.D on page 1-11](#). You must set Par 153 [Control Options], bit 7 [Aux Pwr Sply] to enable this feature.

Hard Enable Circuitry

A dedicated hardware enable input is provided for applications that require the drive to be disabled without software interpretation.

Table 1.J TB1 - Row T (Top) Terminals

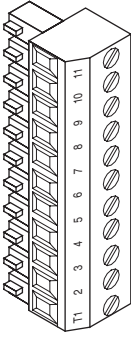

Terminal	Signal	Description	Related Parameter
T11	Power Supply 24V DC Return (-)	Power and common for pre charge and enable inputs. ⁽¹⁾ Inputs may sink or source. ⁽²⁾ Rating: 100 mA maximum.	
T10	Power Supply 24V DC (+)		
T9	Logic Common		
T8	Digital Input #1 Default = Precharge	For common DC bus drives. Must be high, for drive to complete the pre charge cycle. Load: 20 mA at 24V DC.	824, 826, 827, 828, 829, 838
T7	Enable Input	Must be high for drive to run. Load: 20 mA at 24V DC.	824, 825
T6	Digital Output #1	24V DC open collector (sinking logic) output. Rating: 25 mA maximum.	824, 843, 844
T5	Digital Output #2	24V DC open collector (sinking logic) output. Rating: 25 mA maximum.	824, 845, 846
T4	Digital Output Return	Return for Digital outputs 1 and 2.	
T3	Thermistor Input	Used only in FOC2 mode with approved motor for temperature adaptation. Refer to Appendix A, Specifications for approved motors.	485
T2	Thermistor Input Return		
T1	Thermistor Shield		

⁽¹⁾ The drive's 24V DC power supply supports only on-board digital inputs. Do not use it to power circuits outside of the drive.

⁽²⁾ Refer to wiring examples of sinking and sourcing outputs.

Table 1.K TB1 - Row T (Top) Wiring Examples

The following definitions are used throughout this section:

Source

- A. Apply positive voltage through the device to the input or output.
- B. Connect the input or output common (return) directly to the power supply common.

Sinking

- A. Apply the positive voltage directly to the input or output common (return).
- B. Connect the input or output to the power supply common through the device

Input/Output	Connection Example	Required Parameter Changes
<p>Digital Inputs used for enable and precharge control.</p> <p><i>Note:</i> 24V DC Supply - supports only on-board digital inputs. Do not use for circuits outside the drive.</p>	<p>Sourcing Precharge and Enable Inputs - using internal power supply</p>  <p>Sourcing Precharge and Enable Inputs - using external power</p> 	<p>Enable - In sourcing configuration, this circuit must connect to 24V DC power for drive to run.</p> <p>Precharge Precharge control is used in common bus configurations and is not required for AC fed drives.</p> <p>If precharge control is not required, reprogram Par 838 [DigIn1 Sel] to a value of zero or replace the contact shown with a jumper from Terminal 8 to Terminal 10.</p> <p>If precharge is needed, in sourcing configuration, this circuit must connect to 24V DC power for drive to complete the precharge cycle.</p>

Table 1.K TB1 - Row T (Top) Wiring Examples

Input/Output	Connection Example	Required Parameter Changes
	<p>Sinking Precharge and Enable Inputs - using internal power supply</p>  <p>Sinking Precharge and Enable Inputs - using external power supply</p> 	<p>Enable - In sinking configuration, this circuit must connect to 24V DC return for drive to run.</p> <p>Precharge Precharge control is used in common bus configurations and is not required for AC fed drives.</p> <p>If precharge control is not required, reprogram Par 838 [DigIn 1 Sel] to a value of zero or replace the contact shown with a jumper from Terminal 8 to Terminal 11.</p> <p>If precharge is needed, in sinking configuration, this circuit must connect to 24V DC return for drive to complete the precharge cycle.</p>
<p>Digital Outputs - 24V DC outputs 25 mA maximum per output</p>	<p>Digital Output 1 Indicating Alarm and Digital Output 2 Indicating Fault - in sourcing configuration</p> 	<ul style="list-style-type: none"> • Link Parameter 155 [Logic Status], the source, to Parameter 843 [DigOut 1 Data], the sink • Set Parameter 844 [DigOut 1 Bit] to a value of eight, so that parameter 155 [Logic Status] / bit 8 "Alarm" will control the output • Link Parameter 155 [Logic Status], the source, to Parameter 845 [DigOut 2 Data], the sink • Set Parameter 846 [DigOut 2 Bit] to a value of seven, so that Parameter 155 [Logic Status] / bit 7 [Faulted] will control the output
<p>Digital Output - 24V DC output 25 mA maximum per output.</p> <p>If one (1) output is configured in sinking, the other output is not available.</p>	<p>Digital Output 1 Indicating Alarm Fault - in sinking configuration</p> 	<ul style="list-style-type: none"> • Link Parameter 155 [Logic Status], the source, to Parameter 843 [DigOut 1 Data], the sink • Set Parameter 844 [DigOut 1 Bit] to a value of 8, so that Parameter 155 [Logic Status] / bit 8 "Alarm" will control the output

Table 1.L TB1 - Row B (Bottom) Terminals

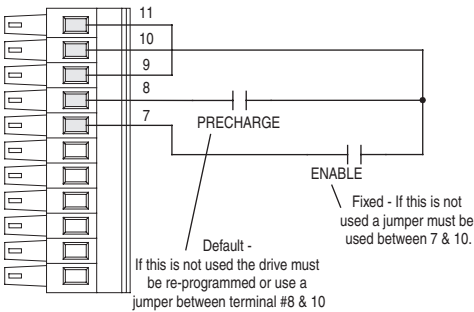
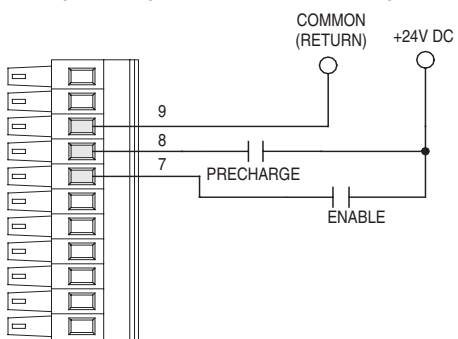

Terminal	Signal	Description	Related Parameter
B11	Analog Input #1 (-)	+/-10.0V DC or +/-1.0V DC bipolar, differential input. ⁽¹⁾ 13 bit + sign, 20k ohm input impedance	800, 802, 803, 804, 805
B10	Analog Input #1 (+)		
B9	Analog Input Shield	Optional connection point for analog input shield. ⁽²⁾	
B8	Analog Input #2 (-)	+/-10.0V DC or +/-1.0V DC bipolar, differential input. ⁽¹⁾ 13 bit + sign, 20k ohm input impedance	806, 808, 809, 810, 811
B7	Analog Input #2 (+)		
B6	Analog Output #1 (+)	+/-10.0V DCDC bipolar, differential output, 11 bit + sign, 2k ohm minimum load	812, 814, 815, 817, 818
B5	Analog Output #1 Return (-)		
B4	Analog Output Shield	Optional connection point for analog output shield. ⁽²⁾	
B3	Analog Output #2 (+)	+/-10.0V DC bipolar, differential output, 11 bit + sign, 2k ohm minimum load	813, 819, 820, 822, 823,
B2	Analog Output #2 Return (-)		
B1	Analog Output Shield	Optional connection point for analog shields.	

⁽¹⁾ Refer to [Analog Input Settings on page 1-32](#) for necessary dip switch settings.

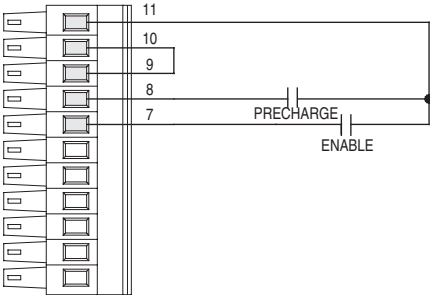
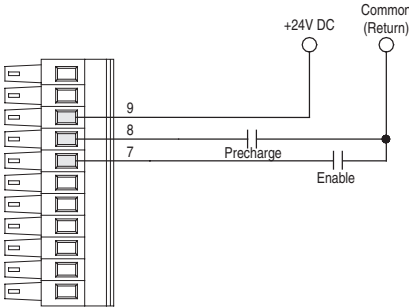
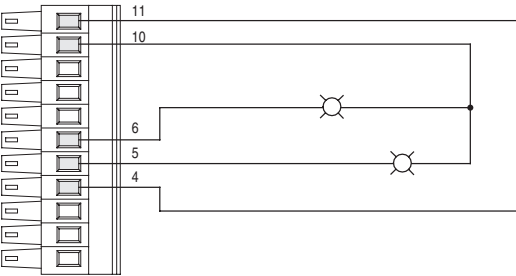
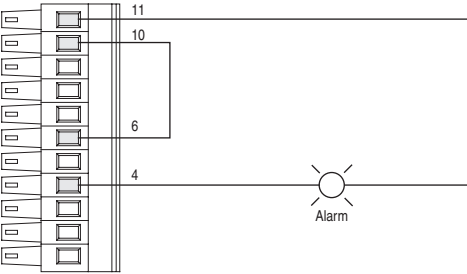
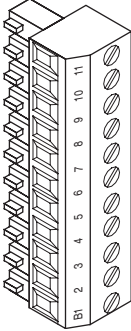
⁽²⁾ Analog shields should connect to common at the signal source, if possible. Shields for signals from ungrounded devices, such as analog tachometers, should connect to an analog shield terminal point at the drive.

Table 1.M TB1 - Row B (Bottom) Wiring Examples

Input/Output	Connection Example	Required Parameter Changes
<p>Analog Inputs +/-10V DC or +/-1.0V DC (DIP switch selectable) Terminate shields at the analog source if analog common is available</p> <p>Used for Speed Reference and Speed Trim</p>	<p>Analog Inputs for Speed Reference and Speed Trim - shield terminated at source</p> 	<p>Using Analog In1 as 0-10V speed reference</p> <ul style="list-style-type: none"> Adjust Parameter 803 [Anlg In1 Offset] so that the minimum analog signal creates the minimum speed reference (if the minimum input is 0V DC and the minimum speed reference is zero, enter a value of zero) Adjust the Parameter 802 [Anlg In1 Scale] so that the maximum analog signal creates the maximum speed reference (if the maximum input is 10V DC and the maximum speed reference is motor base speed, enter a value of 0.1) Send the data to the Speed Reference parameter Par 10 [Speed Ref 1] (the destination) linked to Par 800 [Anlg In1 Data] (the source) Select Ref 1 as the active speed ref Par 16 [Speed Ref Sel] = 1 Par 153 [Control Options], bit 0 = 0 Unipolar Speed Reference"
<p>Analog Outputs +/-10V DC or +/-1.0V DC</p> <p>Used to drive analog meters displaying speed and current</p>	<p>Analog Inputs for Speed Reference and Speed Trim - shield terminated at drive</p> 	<p>Using Analog In2 as -10 to +10V speed trim @ 10%:</p> <ul style="list-style-type: none"> Adjust Parameter 809 [Anlg In2 Offset] so that the minimum analog signal creates the minimum speed trim (if the minimum input is 0V DC and the minimum trim is zero, enter a value of zero) Adjust Parameter 808 [Anlg In2 Scale] so that the maximum analog signal creates the maximum speed trim (if the maximum input is 10V DC and the maximum speed trim is 10%, enter a value of 0.01) Send the data to the speed Reference parameter Par 12 [Speed Ref 2] (the destination) linked to Par 806 [Anlg In2 Data] (the source) Select Ref 1 as the active speed ref and Ref 2 as trim [Speed Ref Sel] = 3
<p>Analog Outputs +/-10V DC</p>	<p>Analog Outputs Indicating Motor Speed and Motor Current</p> 	<p>Using Analog Out 1, -10V to +10V to meter Motor RPM and direction:</p> <ul style="list-style-type: none"> Adjust Parameter 812 [Anlg Out1 Offset] so that minimum speed creates a minimum signal (if the minimum speed is zero and the minimum signal is zero, enter a zero) Adjust Parameter 817 [Anlg Out1 Scale] so that the maximum speed creates a maximum signal (if the maximum speed is 100% of motor base speed and the maximum signal is 10V DC, enter a value of 0.1) Send the data to the Analog Output Par 815 [Anlg Out1 Real] (the destination) linked to Par 300 [Motor Spd Fdbk] (the source) <p>Using Analog Out 2, -10V to +10V to meter Motor Current</p> <ul style="list-style-type: none"> Adjust Parameter 813 [Anlg Out2 Offset] so that minimum current creates a minimum signal (if the minimum current is zero and the minimum signal is zero, enter a zero) Adjust Parameter 822 [Anlg Out2 Scale] so that the maximum current creates a maximum signal (if the maximum current is 200% of motor NP FLA and the maximum signal is 10V DC, enter a value of 2.0) Send the data to the Analog Output Par 820 [Anlg Out2 Real] (the destination) linked to Par 308 [Output Current] (the source) Scale the Output to the source parameter Par 822 [Anlg Out2 Scale] = xx (Par2 [Motor NP FLA]/10V Output

Table 1.N TB2 - Row T (Top) Terminals



Terminal	Signal	Description	Related Parameter
T13	Encoder Signal A	Primary encoder interface. 5 or 12V DC switch selectable ⁽¹⁾ , Nominal current draw per channel @ 12V DC 45 mA, @5V DC 32 mA Maximum input frequency for Encoders 0 & 1 is 500 kHz.	222, 230, 231, 232, 233, 234, 235, 236, 237, 238
T12	Encoder Signal Not A		
T11	Encoder Signal B		
T10	Encoder Signal Not B		
T9	Encoder Signal Z		
T8	Encoder Signal Not Z		
T7	Shield	Connection point for encoder shield.	
T6	Digital Input #2	High speed 12-24V DC sinking digital input.	824, 830, 831, 832, 833, 839
T5	Digital Input #2 Return		
T4	Digital Input #3	High speed 12-24V DC sinking digital input.	824, 834, 835, 836, 837, 840
T3	Digital Input #3 Return		
T2	Power Supply +12V DC (A) (+)	5/12V DC power supply for primary encoder interface and high speed inputs. Rating 300 mA ⁽²⁾ ⁽³⁾	
T1	Power Supply +12V DC Return (A) (-)		

⁽¹⁾ Refer to [Encoder Input Settings on page 1-32](#) for necessary dip switch settings.

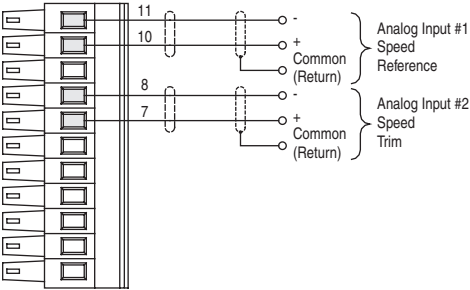
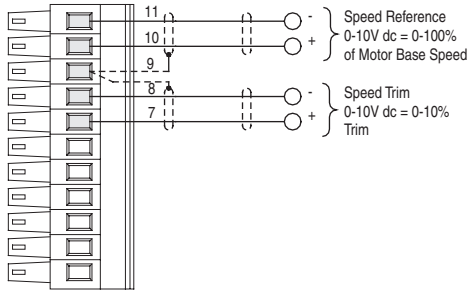
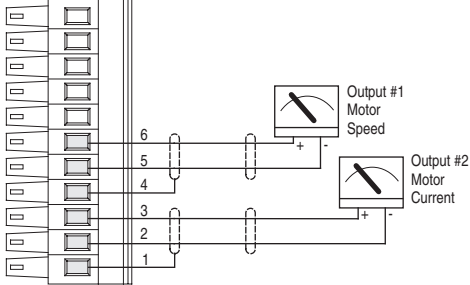
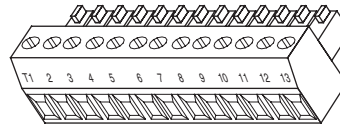
⁽²⁾ This power supply supports only the primary encoder interface and digital inputs. Do not use it to power circuits outside of the drive.

⁽³⁾ To enable 5V supply, set Jumper J6 (located in the Main Control Board) to positions T2 and T3. Default 12V supply is set to T1 and T2.

Table 1.0 TB2 - Row T (Top) Wiring Examples

Input/Output	Connection Examples	Required Parameter Changes
<p>Primary Encoder Interface - Supports 12V DC differential encoders with internal power supply.</p> <p>5V DC differential encoders may require external power supply and special jumper settings. Refer to Main Control Board I/O Configuration Settings on page 1-32 for external power supply and jumper settings.</p> <p>For 5V DC differential encoders with internal power supply, set Jumper J6 to positions T2 and T3.</p>	<p>Primary Encoder - using internal power supply</p>  <p>Primary Encoder - using external power supply</p> 	<ul style="list-style-type: none"> • Set the value of Parameter 222 [Motor Fdbk Sel] to a value of 0 - Encoder 0, so the drive will use this encoder as the primary motor speed feedback device. • Set the value of Parameter 232 [Encoder0 PPR] to match the encoder's resolution.

Table 1.0 TB2 - Row T (Top) Wiring Examples

Input/Output	Connection Examples — 3-Wire Control	Required Parameter Changes
<p>High Speed Inputs 12 or 24V DC</p>	<p>Sourcing High Speed Inputs, Used for 3 Wire Control - using the internal power supply</p> 	<ul style="list-style-type: none"> • Set the value of Parameter 839 [DigIn2 Sel] to a value of 1 - Normal Stop • Set the value of Parameter 840 [DigIn3 Sel] to a value of 2 - Start • Set Parameter 153 [Control Options] / bit 8 "3WireControl"
	<p>Sourcing High Speed Inputs, Used for 3 Wire Control - using an external power supply</p> 	<p>Note: +12V and +24V are also available from TB1 Top 10 & 11.</p>

Table 1.0 TB2 - Row T (Top) Wiring Examples

Input/Output	Connection Examples — 2-Wire Control	Required Parameter Changes
<p>High Speed Inputs 12 or 24V DC</p>	<p>Sourcing High Speed Inputs, Used for 2 Wire Control - using the internal power supply</p> 	<ul style="list-style-type: none"> • Set the value of Parameter 839 [DigIn2 Sel] to a value of 3 - Run • Set Parameter 153 [Control Options], bit 9 "2W Coast Stop" to make the drive coast stop when input 2 goes low • Reset Parameter 153 [Control Options], bit 9 "2W Coast Stop" to make the drive ramp stop when input 2 goes low • Reset Parameter 153 [Control Options], bit 8 "3Wire Control" for two wire control
	<p>Sourcing High Speed Inputs, Used for 2 Wire Control - using an external power supply</p> 	<p>Note: +12V and +24V are also available from TB1 Top 10 & 11.</p>

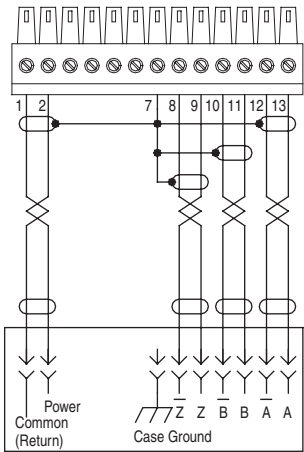
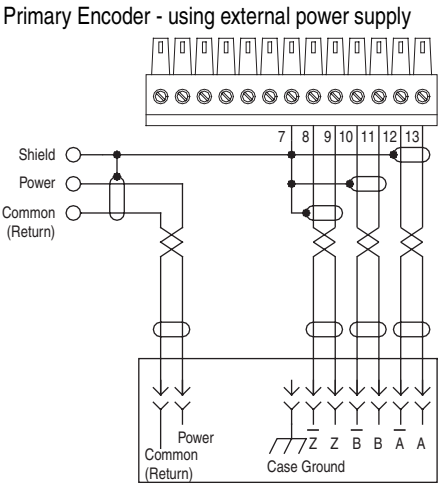
Table 1.P TB2 - Row B (Bottom) Terminals

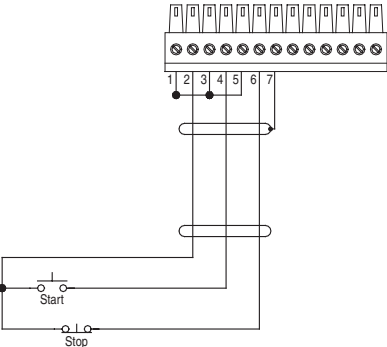
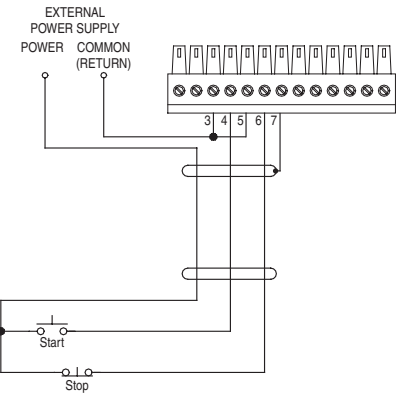

Terminal	Signal	Description	Related Parameter
B13	Encoder Signal A	Secondary encoder interface. 5 or 12V DC switch selectable ⁽¹⁾ , Nominal current draw per channel @ 12V DC 45 mA, @5V DC 32 mA Maximum input frequency for Encoders 0 & 1 is 500 kHz.	222, 240, 241, 242, 243, 244, 245, 246, 247, 248
B12	Encoder Signal Not A		
B11	Encoder Signal B		
B10	Encoder Signal Not B		
B9	Encoder Signal Z		
B8	Encoder Signal Not Z		
B7	Shield	Connection point for encoder shield.	
B6	Unused		
B5	Relay Output	Relay contact output. Rating: 5A @ 24V DC Resistive, 2A 24V DC Inductive	824, 841, 842
B4	Relay Output Return		
B3	Unused		
B2	Power Supply +12V DC (B) (+)	15/2V DC power supply for secondary encoder interface. Rating 300 mA ⁽²⁾ ⁽³⁾	
B1	Power Supply +12V DC Return (B) (-)		

⁽¹⁾ Refer to [Encoder Input Settings on page 1-32](#) for necessary dip switch settings.

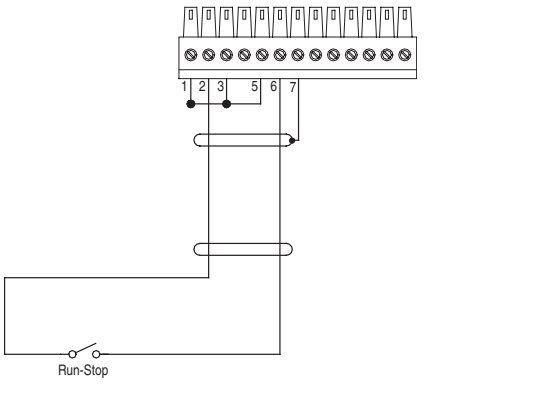
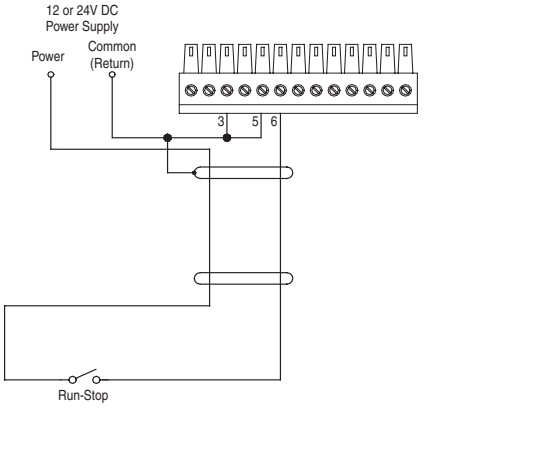
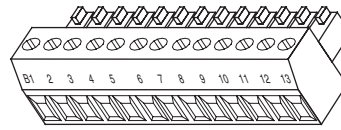
⁽²⁾ This power supply supports only the secondary encoder interface. Do not use it to power circuits outside of the drive

⁽³⁾ To enable 5V supply, set Jumper J6 (located in the Main Control Board) to positions T2 and T3. Default 12V supply is set to T1 and T2.

Table 1.Q TB2 - Row B (Bottom) Wiring Examples

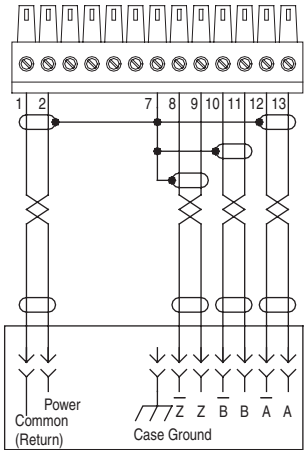
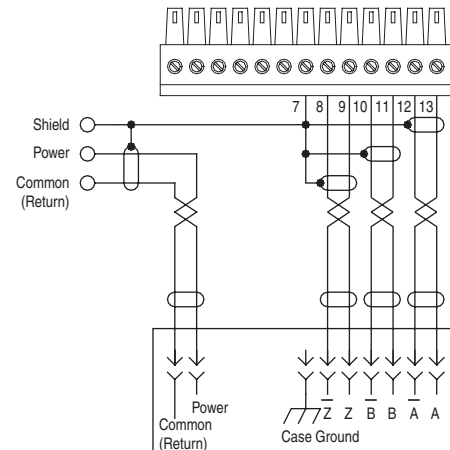
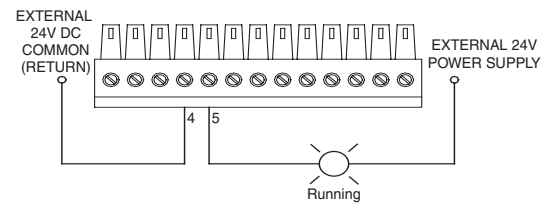
Input/Output	Connection Example	Required Parameter Changes
<p>Secondary Encoder Interface - Supports 12V DC differential encoders with internal power supply.</p> <p>5V DC differential encoders require external power supply and special jumper settings. Refer to Main Control Board I/O Configuration Settings on page 1-32 for external power supply and jumper settings.</p> <p>For 5V DC differential encoders with internal power supply, set Jumper J6 to positions T2 and T3.</p>	<p>Secondary Encoder - using internal power supply</p> 	<ul style="list-style-type: none"> • Set the value of Parameter 222 [Motor Fdbk Sel] to a value of 1 - Encoder 1, so the drive will use this encoder as the primary motor speed feedback device • Set the value of Parameter 242 [Encoder1 PPR] to match the encoder's resolution
	<p>Secondary Encoder - using external power supply</p> 	
<p>Auxiliary Output - Relay contact output</p>	<p>Auxiliary Output, Used to Indicate Running</p> 	<ul style="list-style-type: none"> • Link Parameter 155 [Logic Status], the source, to Parameter 841 [Relay Out Data], the sink • Set Parameter 842 [Relay Out Bit] to a value of one, so that Parameter 155 [Logic Status] / bit 1 "Running" will control the output.

Main Control Board I/O Configuration Settings

Figure 18 Main Control Board Dip Switches

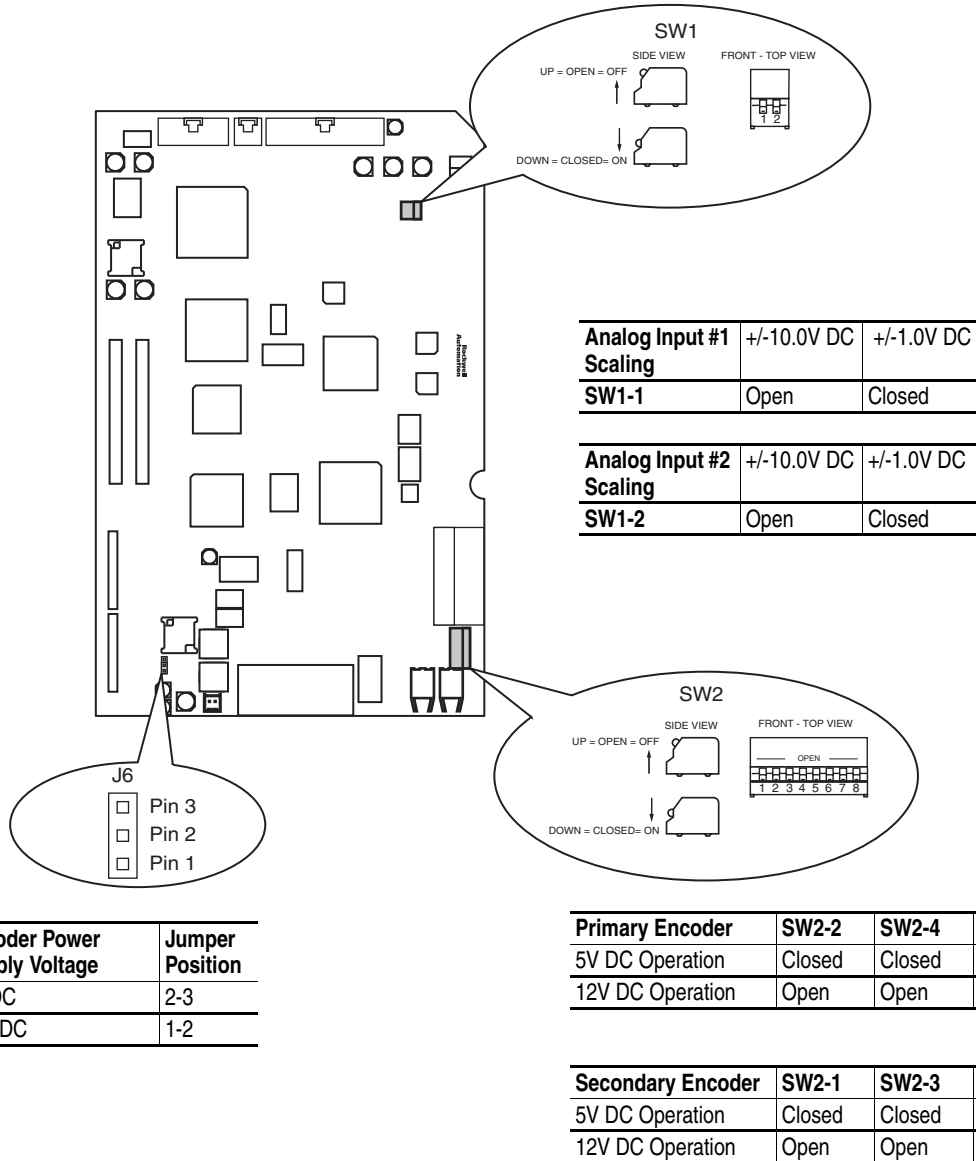

Analog Input Settings

Switch SW1-1 configures the scaling of Analog Input #1. Switch SW1-2 configures the scaling of Analog Input #2. Open the switch for +/-10.0V DC operation. Close the switch for +/-1.0V DC operation.

Encoder Input Settings

Dip switch SW2 on the main control board configures the encoder inputs for 5V DC or 12V DC operation. Switches SW2-2, 4, and 6 are for the primary encoder. Set these switches to match the encoder output specifications. Open these switches for 12V DC operation, close them for 5V DC operation.

Switches SW2-1, 3, and 5 are for the secondary encoder. Set these switches to match the encoder output specifications. Open these switches for 12V DC operation, close them for 5V DC operation.

Connecting SynchLink

SynchLink provides high-speed synchronization and communication between multiple PowerFlex 700S drives (or other products with SynchLink capability).

Refer to *The SynchLink Design Guide*, publication # 1756-TD008 when planning and connecting the SynchLink network.

Class 1 LED Product



ATTENTION: Hazard of permanent eye damage exists when using optical transmission equipment. This product emits intense light and invisible radiation. Do not look into module ports or fiber optic cable connectors.

Figure 1.1 SynchLink Connections

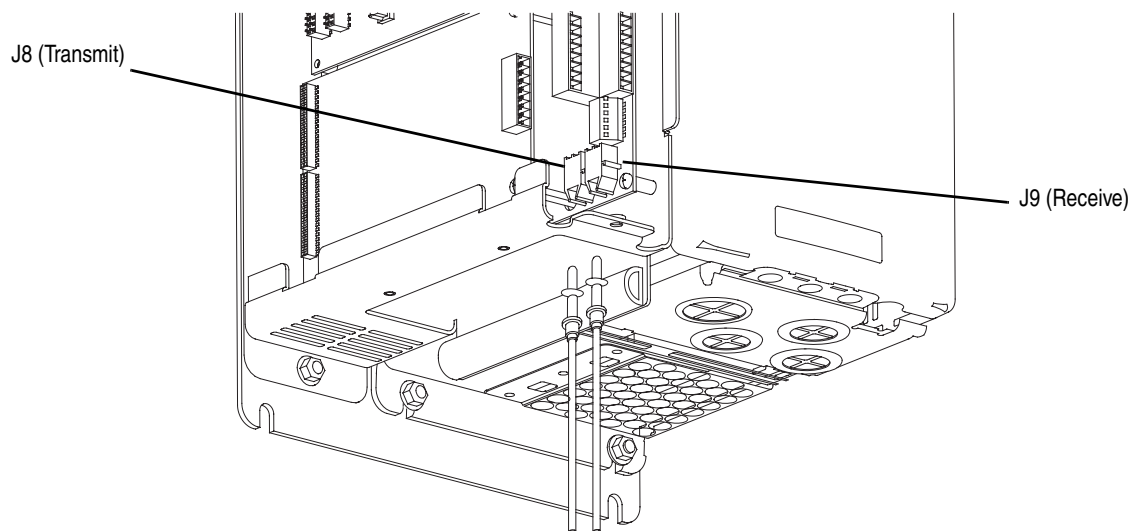

Connect cables to J9 (receive) and J8 (transmit) connectors on the bottom of the Main Control Board. Push the plug into the socket until it produces an audible click.

Important: Do not overtighten tie-wraps.

Table 1.S SynchLink Cables and Accessories

Description	Cat. No.
2 x 25 cm Fiber Optic Link	1403-CF000
2 x 1 M Fiber Optic Link	1403-CF001
2 x 3 M Fiber Optic Link	1403-CF003
2 x 5 M Fiber Optic Link	1403-CF005
10 M Fiber Optic Link	1403-CF010
20 M Fiber Optic Link	1403-CF020
50 M Fiber Optic Link	1403-CF050
100 M Fiber Optic Link	1403-CF100
250 M Fiber Optic Link	1403-CF250
500 M Fiber Optic Bulk	1403-CFBLK
SynchLink Fiber-Hub, 1 input, Base	1751-SLBA
SynchLink Fiber-Hub, 4 output, "Star" Splitter	1751-SL4SP
SynchLink Bypass Switch	1751-SLBP/A

Table 1.T Fiber Optic Cable Assembly

Specification	
Connecting Cables	200/230 micron HCS (Hard Clad Silica) <ul style="list-style-type: none"> • Versalink V-System • Lucent Technologies, • Specialty Fibers Technology Division
Maximum Cable Length	300 meters with no more than one splice or one adapter
Minimum Cable Length	1 meter
Minimum inside bend radius	25.4mm (1 in.) Any bends with a shorter inside radius can permanently damage the fiber optic cable. Signal attenuation increases with decreased inside bend radius.
Operating Wavelength	650 nm (Red)
Data Rate	5 Mbps
Maximum Node Count	<ul style="list-style-type: none"> • 10 - Daisy Chain • 256 - Star Configuration

CE Conformity

Conformity with the Low Voltage (LV) Directive and Electromagnetic Compatibility (EMC) Directive has been demonstrated using harmonized European Norm (EN) standards published in the Official Journal of the European Communities. PowerFlex Drives comply with the EN standards listed below when installed according to the User and Reference Manual.

Declarations of Conformity are available online at:
<http://www.ab.com/certification/ce/docs>.

Low Voltage Directive (73/23/EEC)

- EN50178 Electronic equipment for use in power installations.

EMC Directive (89/336/EEC)

- EN61800-3 Adjustable speed electrical power drive systems Part 3: EMC product standard including specific test methods.

General Notes

- If the adhesive label is removed from the top of the drive, the drive must be installed in an enclosure with side openings less than 12.5 mm (0.5 in.) and top openings less than 1.0 mm (0.04 in.) to maintain compliance with the LV Directive.
- The motor cable should be kept as short as possible in order to avoid electromagnetic emission as well as capacitive currents.
- Use of line filters in ungrounded systems is not recommended.
- PowerFlex drives may cause radio frequency interference if used in a residential or domestic environment. The user is required to take measures to prevent interference, in addition to the essential requirements for CE compliance listed below, if necessary.
- Conformity of the drive with CE EMC requirements does not guarantee an entire machine or installation complies with CE EMC requirements. Many factors can influence total machine/installation compliance.
- PowerFlex drives can generate conducted low frequency disturbances (harmonic emissions) on the AC supply system. More information regarding harmonic emissions can be found in the *PowerFlex Reference Manual Vol. 2*.

Essential Requirements for CE Compliance

Conditions 1-6 listed below must be satisfied for PowerFlex drives to meet the requirements of EN61800-3.

3. Standard PowerFlex 700S CE compatible Drive.
4. Review important precautions/attentions statements throughout this document before installing drive.
5. Grounding as described on [page 1-4](#).
6. Output power, control (I/O) and signal wiring must be braided, shield cable with a coverage of 75% or better, metal conduit or equivalent attenuation.
7. All shielded cables should terminate with proper shielded connector.
8. Conditions in [Table 1.U on page 36](#)

Table 1.U PowerFlex 700S EN61800-3 EMC Compatibility⁽¹⁾

Frame(s)	Second Environment		First Environment Restricted Distribution	
	<i>Restrict Motor Cable to 30 m (98 ft.)</i>		<i>Restrict Motor Cable to 150 m (492 ft.)</i>	
	<i>Any Drive and Option</i>		<i>Any Drive and Option</i>	<i>External Filter Required</i>
1 - 6	✓		✓	✓

(1) External filters for First Environment installations and increasing motor cable lengths in Second Environment installations are available. Roxburgh models KMFA (RF3 for UL installations) and MIF or Schaffner FN3258 and FN258 models are recommended. Refer to <http://www.deltron-emcon.com> and <http://www.mtecorp.com> (USA) or <http://www.schaffner.com>, respectively.

Start-Up

This chapter describes how you start-up the PowerFlex 700S Drive. Refer to [Appendix D](#) for a brief description of the HIM (Human Interface Module).

For Information on ...	See Page...
Prepare for Drive Start-Up	2-1
Assisted Start-Up	2-3



ATTENTION: Power must be applied to the drive to perform the following start-up procedure. Some of the voltages present are at incoming line potential. To avoid electric shock hazard or damage to equipment, only qualified service personnel should perform the following procedure. Thoroughly read and understand the procedure before beginning. If an event does not occur while performing this procedure, **Do Not Proceed.** **Remove Power** including user supplied control voltages. User supplied voltages may exist even when main AC power is not applied to then drive. Correct the malfunction before continuing.

Prepare for Drive Start-Up

Before Applying Power to the Drive

Important: If you have a DriveLogix application, you must first connect the battery before starting this section.

- 1. Confirm that motor wires are connected to the correct terminals and are secure. Confirm Frame 5 transformer connections (refer to [page 1-9](#)).
- 2. Confirm that encoder wires are connected to the correct terminals and are secure.
- 3. Confirm that all control inputs are connected to the correct terminals and are secure.
- 4. Verify that AC line power at the disconnect device is within the rated value of the drive.
- 5. Verify that control power voltage is correct.

The remainder of this procedure requires that a HIM be installed. If an operator interface is not available, remote devices should be used to start-up the drive.

Applying Power to the Drive

- ❑ 6. Apply AC power and control voltages to the drive. Examine the *Power (PWR)* LED.

Steady Green

Power has been applied to the drive and no faults are present.

- ❑ 7. Examine the *Status (STS)* LED. Verify that it is flashing green. If it is not in this state, check the following possible causes and take the necessary corrective action.

Flashing Yellow

A run inhibit exists in the drive. Refer to [Table 4.B on page 4-3](#) to correct the problem.

Flashing Red

A fault has occurred. Refer to [Fault Descriptions on page 4-4](#) for drive faults and actions to correct the problem.

If any digital input is configured to Stop – CF (CF = Clear Fault) or Enable, verify that signals are present or the drive will not start. Refer to [Table 4.B on page 4-3](#) for a list of potential digital input conflicts.

If a fault code appears, refer to [Fault Descriptions on page 4-4](#).

If the STS LED is not flashing green at this point, refer to the Status Indicators descriptions in [Table 4.A on page 4-2](#).



- ❑ 8. Proceed to [Assisted Start-Up on page 2-3](#).

Assisted Start-Up

This routine prompts you for information needed to start-up a drive for most applications, such as line and motor data, commonly adjusted parameters and I/O.

- ▶ **Important:** This start-up routine requires a HIM. If the drive is configured for 2-wire control, the HIM installed on the drive will also act as a 2-wire device. In 2-wire mode, the drive will start when the HIM “Start” is pressed and stop when the HIM “Start” is released. The recommended mode of use for the Start-Up Routine is 3-wire control, Parameter 153 [Control Options], Bit 8 set to “1”.

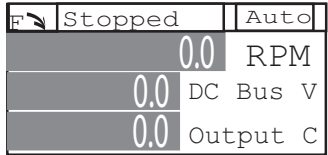
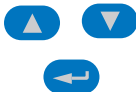
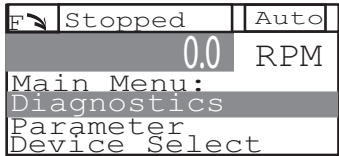
The assisted start-up routine asks simple yes or no questions and prompts you to input required information. Access Assisted Start-Up by selecting “Start-Up” from the Main Menu.

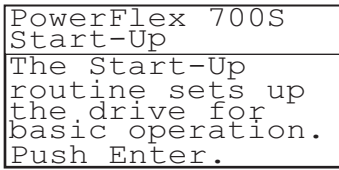
Step	Key(s)	Example LCD Displays
1. To exit the User Display screen, Press Esc.		
1. In the Main Menu, use the Down Arrow to scroll to “Start Up” 2. Press Enter.		
1. Follow the instructions on the screen to complete the Start-Up.		

- ▶ **Important:** If using a HIM the following functions are not available.
 - Alt-Man
 - Alt-Lang
 - Alt-SMART

Table 2.A Start-Up Menu

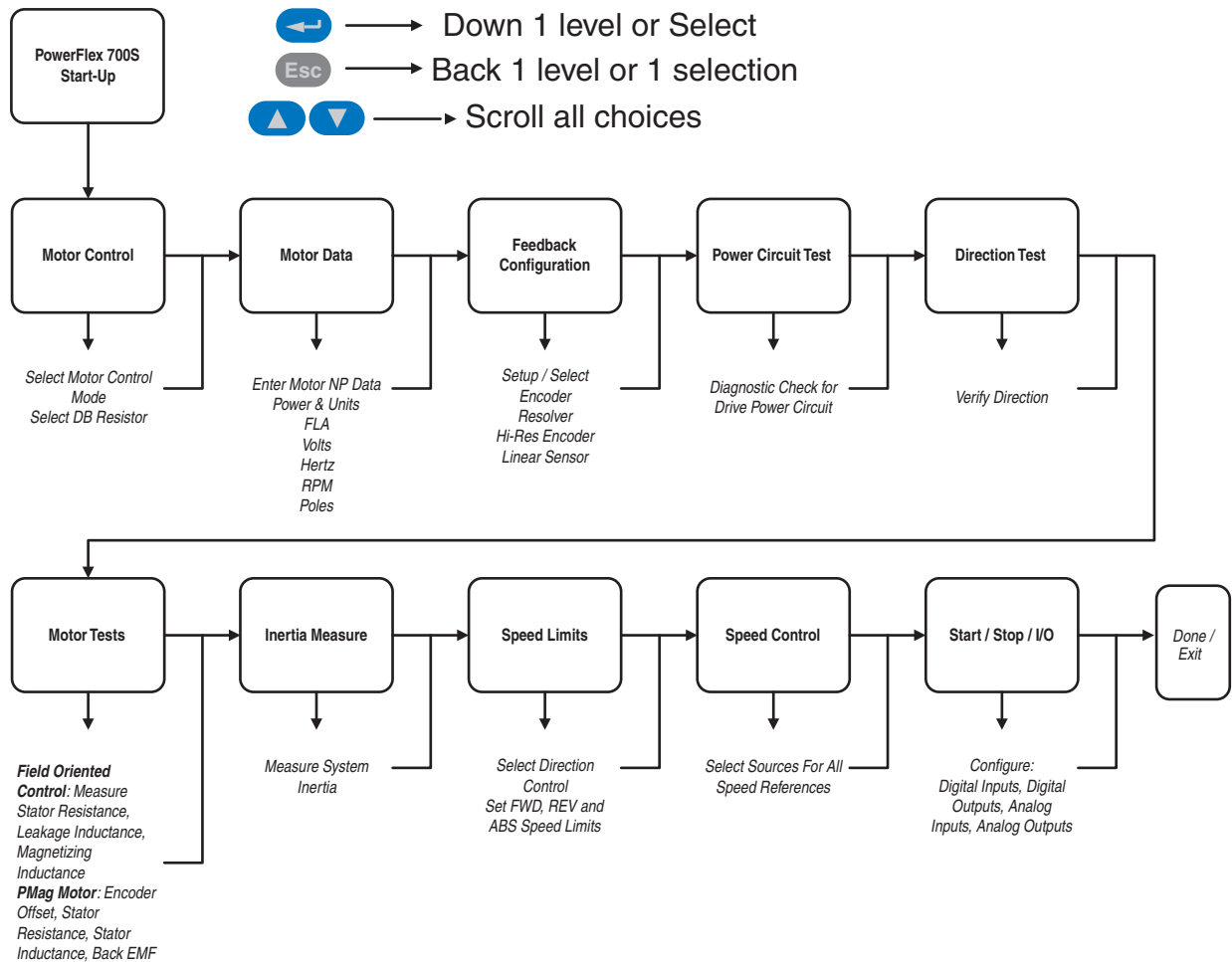

Note: In 2-wire mode, the drive will start when the HIM “Start” is pressed and stop when the HIM “Start” is released. The recommended mode of use for the Start-Up Routine is 3-wire control, Parameter 153 [Control Options], Bit 8 set to “1”.

Programming and Parameters

Chapter 3 provides a complete listing and description of the PowerFlex 700S parameters. The parameters can be programmed (viewed/edited) using a HIM (Human Interface Module). As an alternative, programming can also be performed using DriveTools™ software and a personal computer.

For information on...	See page
About Parameters	3-1
How Parameters are Organized	3-3
Parameter Data in Linear List Format	3-16
Parameter Cross Reference By Name	3-96

About Parameters

To configure a Drive module to operate in a specific way, drive parameters may have to be set. Three types of parameters exist:

- **ENUM Parameters**
These parameters allow a selection from 2 or more items
- **Bit Parameters**
These parameters have individual bits associated with features or conditions. If the bit is 0, the feature is off or the condition is false. If the bit is 1, the feature is on or the condition is true.
- **Numeric Parameters**
These parameters have a single numeric value (i.e. 0.1 Volts).

The example on the following page shows how each parameter type is presented in this manual.

1	2	3																																																			
No.	Name Description	Values																																																			
151	<p>Logic Command The controller-drive interface (as defined by the Controller Communication Format) sets bits to enable and disable various functions and algorithms. Bits that are changed here are reflected in Parameter 152 [Applied LogicCmd]. Note: Bits 4 through 9 in Logic Command are NOT recalled from Control EEPROM. They will be cleared upon drive power up or following an EEPROM recall operation.</p> <p>Options</p> <table border="1"> <thead> <tr> <th></th> <th>Reserved</th> <th>Reserved</th> <th>PositionEnbl</th> <th>ProcsTrim En</th> <th>Fric Comp</th> <th>Inertia Comp</th> <th>Sys Inert En</th> <th>Mtr Inert En</th> <th>PM Offset En</th> <th>Dir Sel En</th> <th>Pwr Diag En</th> <th>MC Atune En</th> <th>Time Axis En</th> <th>TachLoss Rst</th> <th>Spd S Crv En</th> <th>SpdRamp Dsbl</th> </tr> </thead> <tbody> <tr> <td>Default</td> <td>0</td> <td>0</td> <td>0</td> <td>0</td> <td>0</td> <td>0</td> <td>0</td> <td>0</td> <td>0</td> <td>0</td> <td>0</td> <td>0</td> <td>0</td> <td>0</td> <td>0</td> <td>0</td> </tr> <tr> <td>Bit</td> <td>15</td> <td>14</td> <td>13</td> <td>12</td> <td>11</td> <td>10</td> <td>9</td> <td>8</td> <td>7</td> <td>6</td> <td>5</td> <td>4</td> <td>3</td> <td>2</td> <td>1</td> <td>0</td> </tr> </tbody> </table> <p>0 = True 1 = False</p>		Reserved	Reserved	PositionEnbl	ProcsTrim En	Fric Comp	Inertia Comp	Sys Inert En	Mtr Inert En	PM Offset En	Dir Sel En	Pwr Diag En	MC Atune En	Time Axis En	TachLoss Rst	Spd S Crv En	SpdRamp Dsbl	Default	0	0	0	0	0	0	0	0	0	0	0	0	0	0	0	0	Bit	15	14	13	12	11	10	9	8	7	6	5	4	3	2	1	0	<p>Linkable Read-Write Data Type</p>
	Reserved	Reserved	PositionEnbl	ProcsTrim En	Fric Comp	Inertia Comp	Sys Inert En	Mtr Inert En	PM Offset En	Dir Sel En	Pwr Diag En	MC Atune En	Time Axis En	TachLoss Rst	Spd S Crv En	SpdRamp Dsbl																																					
Default	0	0	0	0	0	0	0	0	0	0	0	0	0	0	0	0																																					
Bit	15	14	13	12	11	10	9	8	7	6	5	4	3	2	1	0																																					
110	<p>Spd/Torq ModeSel Selects the source for the drive torque reference.</p>	<p>Default: 1 "Speed Reg" Options: 0 "Zero Torque" 4 "Max Spd/Torq" 1 "Speed Reg" 5 "Sum Spd/Torq" 2 "Torque Ref" 6 "AbsMn Spd/Tq" 3 "Min Spd/Torq"</p>																																																			
4	<p>Motor NP RPM Set to the motor nameplate rated RPM.</p>	<p>Units: RPM Default: Calculated Min/Max: 1/30000 Comm Scale: Parameter 4 [Motor NP RPM] = 1.0</p> <p><input checked="" type="checkbox"/> 16-bit Integer</p>																																																			

No.	Name Description																											
1	<p>No. - Parameter Number</p> <p> Parameter value cannot be changed until the drive is stopped.</p>																											
2	<p>Name - Parameter name as it appears in DriveExecutive software. Description - Brief description of parameter function.</p>																											
3	<p>Values - Define the various operating characteristics of the parameter. <i>There are 3 types of Values.</i></p> <table border="1"> <thead> <tr> <th data-bbox="240 1167 488 1194">ENUM</th> <th data-bbox="488 1167 659 1194">Default:</th> <th data-bbox="659 1167 1425 1194">Lists the value assigned at the factory.</th> </tr> </thead> <tbody> <tr> <td></td> <td data-bbox="488 1194 659 1222">Options:</td> <td data-bbox="659 1194 1425 1222">Displays the selections available.</td> </tr> <tr> <th data-bbox="240 1222 488 1249">Bit</th> <td data-bbox="488 1222 659 1249">Default:</td> <td data-bbox="659 1222 1425 1249">Lists the value assigned at the factory.</td> </tr> <tr> <td></td> <td data-bbox="488 1249 659 1276">Options:</td> <td data-bbox="659 1249 1425 1276">Displays the selections available.</td> </tr> <tr> <th data-bbox="240 1276 488 1304">Numeric</th> <td data-bbox="488 1276 659 1304">Default</td> <td data-bbox="659 1276 1425 1304">Lists the value assigned at the factory.</td> </tr> <tr> <td></td> <td data-bbox="488 1304 659 1331">Min.</td> <td data-bbox="659 1304 1425 1331">Displays lowest possible setting.</td> </tr> <tr> <td></td> <td data-bbox="488 1331 659 1358">Max.</td> <td data-bbox="659 1331 1425 1358">Displays highest possible setting.</td> </tr> <tr> <td></td> <td data-bbox="488 1358 659 1386">Type</td> <td data-bbox="659 1358 1425 1386">Indicates if parameter is linkable, read-write, read-only, and data type (i.e. integer, floating point, boolean).</td> </tr> <tr> <td></td> <td data-bbox="488 1386 659 1413">Comm Scale:</td> <td data-bbox="659 1386 1425 1413">Value sent from Controller or Comm Device = Drive Parameter Value x Comm Scale</td> </tr> </tbody> </table>	ENUM	Default:	Lists the value assigned at the factory.		Options:	Displays the selections available.	Bit	Default:	Lists the value assigned at the factory.		Options:	Displays the selections available.	Numeric	Default	Lists the value assigned at the factory.		Min.	Displays lowest possible setting.		Max.	Displays highest possible setting.		Type	Indicates if parameter is linkable, read-write, read-only, and data type (i.e. integer, floating point, boolean).		Comm Scale:	Value sent from Controller or Comm Device = Drive Parameter Value x Comm Scale
ENUM	Default:	Lists the value assigned at the factory.																										
	Options:	Displays the selections available.																										
Bit	Default:	Lists the value assigned at the factory.																										
	Options:	Displays the selections available.																										
Numeric	Default	Lists the value assigned at the factory.																										
	Min.	Displays lowest possible setting.																										
	Max.	Displays highest possible setting.																										
	Type	Indicates if parameter is linkable, read-write, read-only, and data type (i.e. integer, floating point, boolean).																										
	Comm Scale:	Value sent from Controller or Comm Device = Drive Parameter Value x Comm Scale																										

How Parameters are Organized

DriveExecutive programming software displays parameters in “Linear List” or “File Group Parameter” format. Viewing the parameters in “File Group Parameter” format simplifies programming by grouping parameters that are used for similar functions. There are twelve files. Each file is divided into multiple groups of parameters.

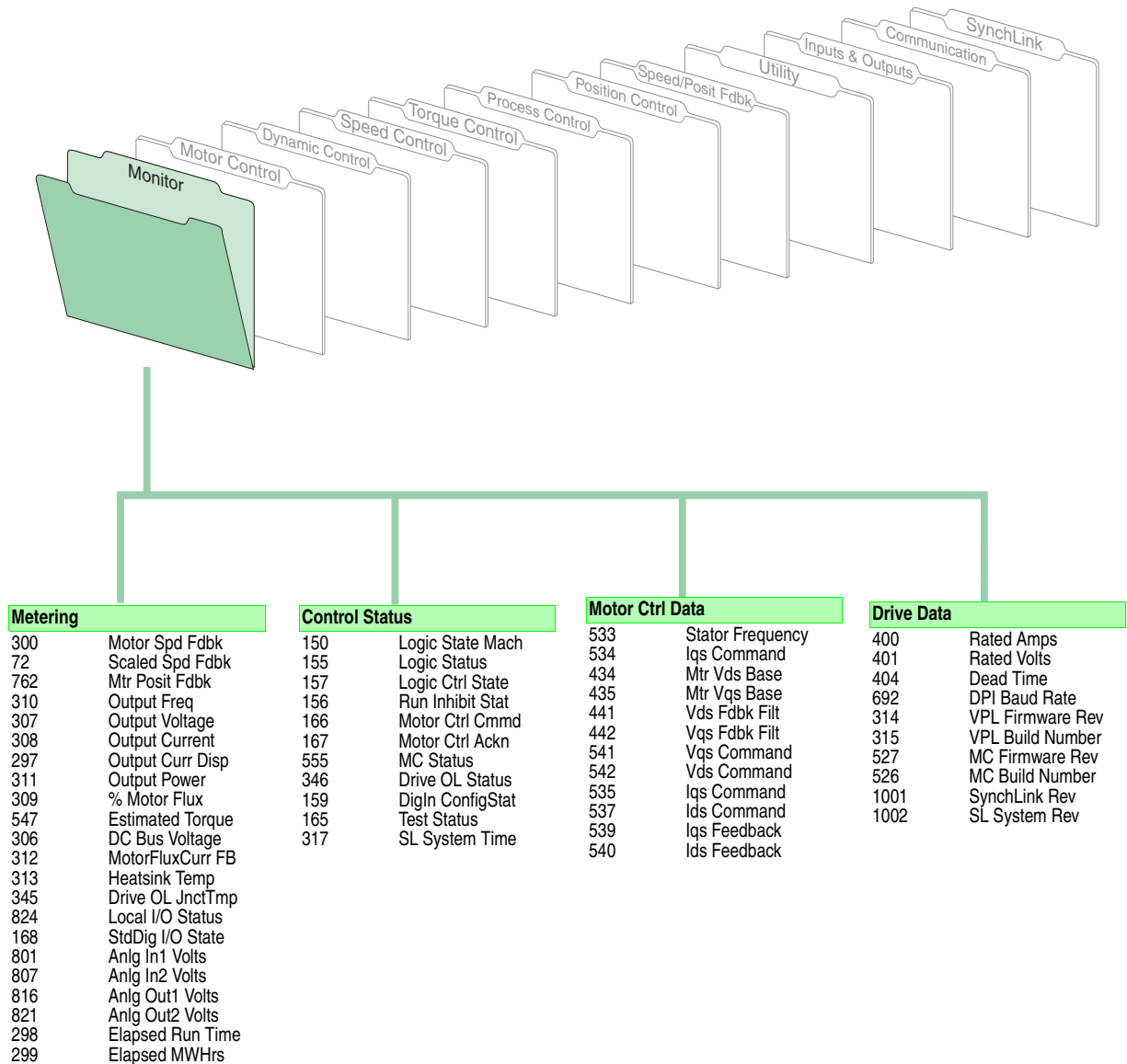

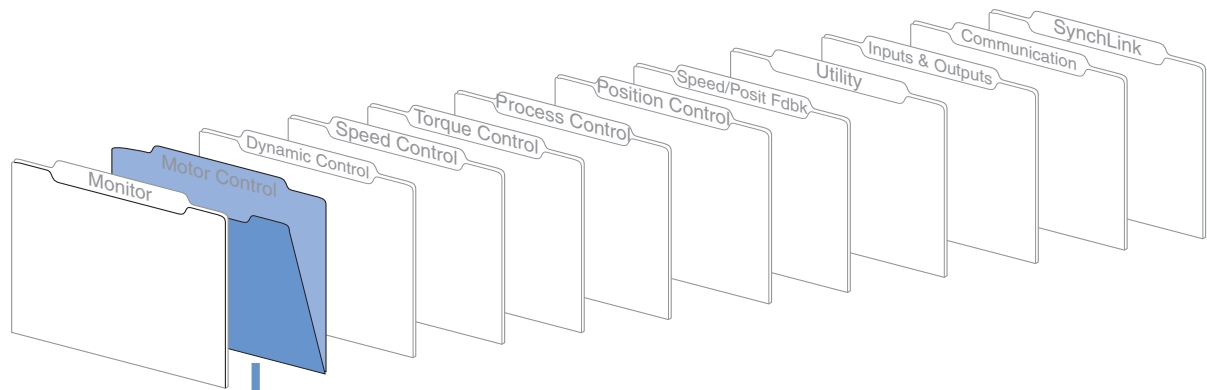

Motor Data

1	Motor NP Volts
2	Motor NP FLA
3	Motor NP Hertz
4	Motor NP RPM
5	Motor NP Power
6	Mtr NP Pwr Units
7	Motor Poles
8	Motor Inertia
9	Total Inertia
336	Service Factor

Drive Config

485	Motor Ctrl Mode
402	PWM Frequency
403	Voltage Class
405	Dead Time Comp
409	Line Undervolts
410	PreChrg TimeOut
411	PreChrg Control
510	FOC Mode Config
511	FOC2 Mode Config
514	Test Mode Config
512	PMag Mode Cnfg
505	PM TestWait Time
506	PM Test Idc Ramp
507	PM Test FreqRamp
508	PM Test Freq Ref
509	PM Test I Ref
424	Flux Ratio Ref

Tuning

423	Iqs Rate Limit
453	Iu Offset
454	Iw Offset
425	Flux Rate Limit
426	Flux Satur Coef
443	Flux Reg P Gain1
470	Flux Reg P Gain2
444	Flux Reg I Gain
500	Bus Util Limit
501	Torque En Dly
437	Vqs Max
438	Vds Max
439	Vqs Min
440	Vds Min
469	StatorInduc Gain
473	Freq Reg FF Gain
449	Freq Reg I Gain
450	Freq Reg P Gain
451	Freq Track Filt
474	Freq Reg We BW
475	Freq Reg Wr BW
447	Slip Reg P Gain
448	Slip Reg I Gain
446	Slip Gain Min
445	Slip Gain Max
476	Slip Gain Comp
472	PreCharge Delay
431	Test Current Ref
432	Test Freq Ref
433	Test Freq Rate
477	Est Theta Delay

Autotune Results

421	Iqs Integ Freq
422	Iqs Reg P Gain
429	Ids Integ Freq
430	Ids Reg P Gain
486	Rated Slip Freq
487	Motor NTC Coef
488	Flux Current
490	StatorInductance
491	StatorResistance
492	Leak Inductance
502	Rotor Resistance
503	Current Reg BW
504	PM AbsEncd Offst

PM Motor

427	PM Mtr CEMF Comp
520	PM Q Inductance
521	PM D Inductance
522	PM Stator Resist
523	PM Mtr CEMF Coef

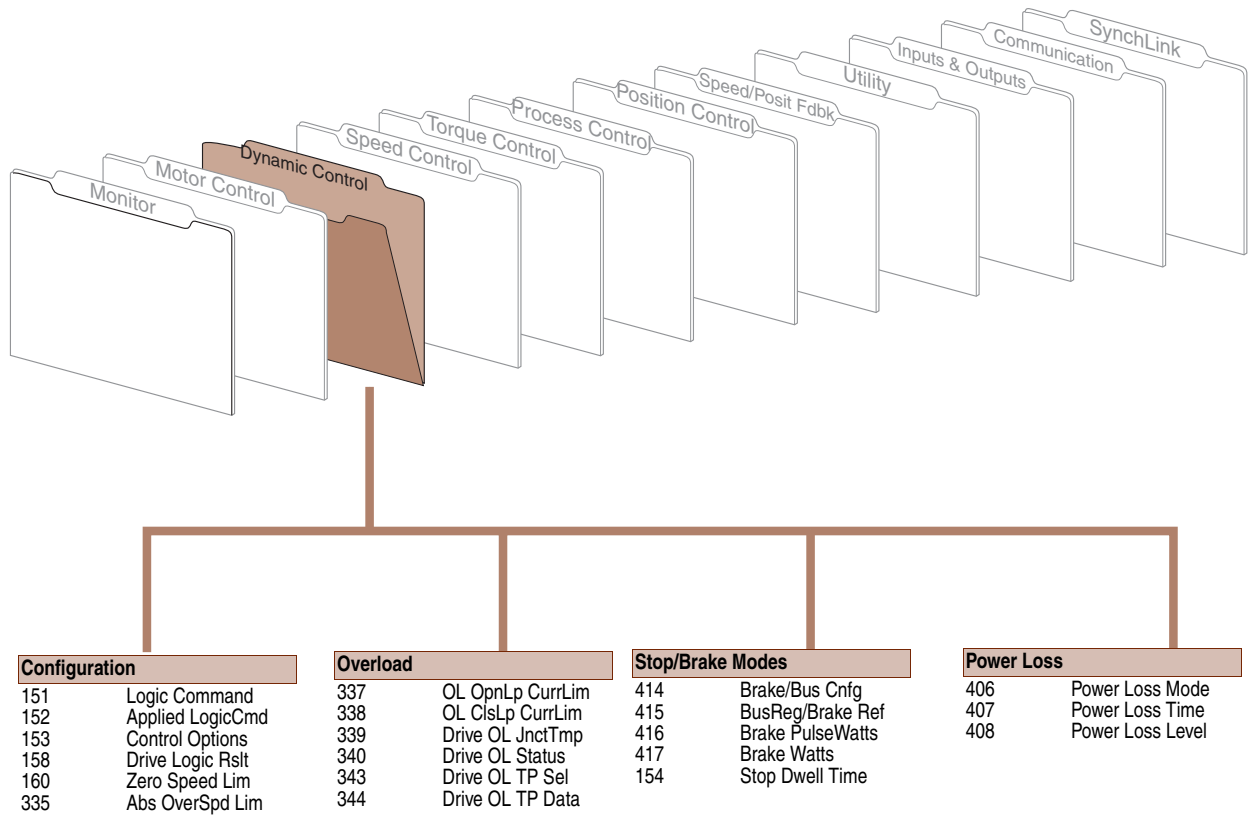

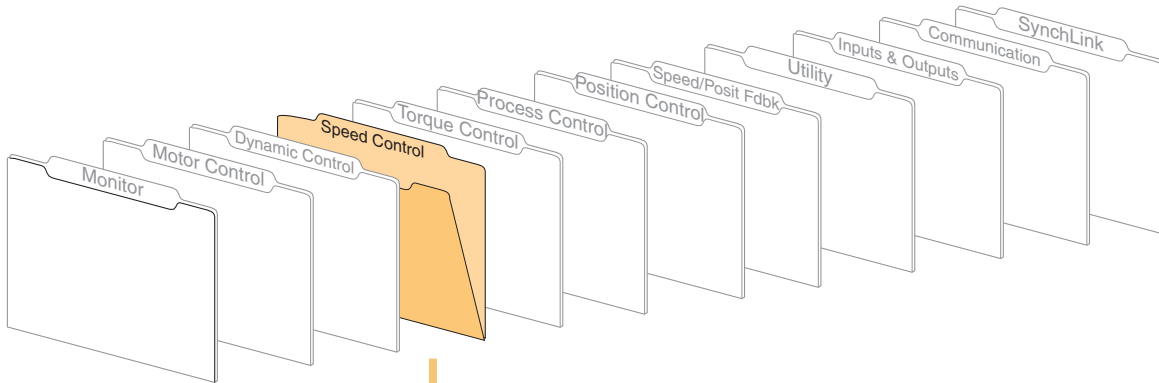

Reference		Regulator		Setpoint Monitor	
16	Speed Ref Sel	47	Spd Trim1 SpdRef	171	Set Speed Lim
10	Speed Ref 1	22	Speed Trim 2	172	Setpt 1 Data
11	Spd Ref1 Divide	25	STrim2 Filt Gain	173	Setpt1 TripPoint
12	Speed Ref 2	26	SpdTrim2 Filt BW	174	Setpt 1 Limit
13	Spd Ref2 Multi	23	Speed Trim 3	175	Setpt 2 Data
14	Speed Ref 4	24	SpdTrim 3 Scale	176	Setpt2 TripPoint
15	Speed Ref 5	19	Atune Spd Ref	177	Setpt 2 Limit
20	Speed Ref DPI	30	Rev Speed Limit		
17	Jog Speed 1	31	Fwd Speed Limit		
18	Jog Speed 2	301	Motor Speed Ref		
40	Selected Spd Ref	300	Motor Spd Fdbk		
30	Rev Speed Limit	93	SRegFB Filt Gain		
31	Fwd Speed Limit	94	SReg FB Filt BW		
41	Limited Spd Ref	71	Filtered SpdFdbk		
32	Accel Time	100	Speed Error		
33	Decel Time	89	Spd Err Filt BW		
42	Ramped Spd Ref	85	Servo Lock Gain		
34	S Curve Time	84	SpdReg AntiBckup		
43	S Curve Spd Ref	80	Speed Reg Ctrl		
37	Spd Ref Bypass	81	Spd Reg P Gain		
35	SpdRef Filt Gain	82	Spd Reg I Gain		
36	SpdRef Filt BW	87	SReg Torq Preset		
44	Filtered Spd Ref	8	Motor Inertia		
38	Speed Ref Scale	9	Total Inertia		
46	Scaled Spd Ref	90	Spd Reg BW		
21	Speed Trim 1	97	Act Spd Reg BW		
47	Spd Trim1 SpdRef	91	Spd Reg Damping		
45	Delayed Spd Ref	92	SpdReg P Gain Mx		
61	Virt Encoder EPR	101	SpdReg Integ Out		
62	Virt Encdr Posit	102	Spd Reg Pos Lim		
63	Virt Encdr Dlyed	103	Spd Reg Neg Lim		
56	Inertia SpeedRef	86	Spd Reg Droop		
55	Speed Comp	95	SRegOut FiltGain		
57	InertiaAccelGain	96	SReg Out Filt BW		
58	InertiaDecelGain	302	Spd Reg PI Out		
59	Inertia Torq Add				
60	DeltaSpeedScale				
140	FricComp Spd Ref				
141	FricComp Setup				
142	FricComp Stick				
143	FricComp Slip				
144	FricComp Rated				
145	FricComp TorqAdd				

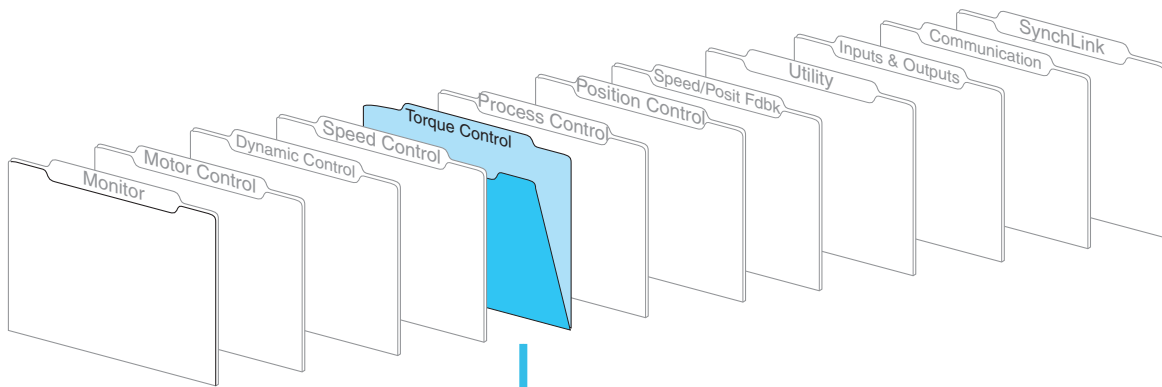

Torque		Current	
110	Spd/Torq ModeSel	309	% Motor Flux
302	Spd Reg PI Out	360	Min Flux
59	Inertia Torq Add	361	Flx LpassFilt BW
145	FricComp TorqAdd	350	Iq Actual Ref
111	Torque Ref 1	351	Iq Ref Trim
112	Torq Ref1 Div	343	OL OpnLp CurrLim
113	Torque Ref 2	356	Mtr Current Lim
114	Torq Ref2 Mult	352	Is Actual Lim
115	Torque Trim	313	Heatsink Temp
116	Torque Step	345	Drive OL JnctTmp
129	Atune Torq Ref		
117	Notch Filt Mode		
118	Notch Filt Freq		
306	DC Bus Voltage		
401	Rated Volts		
127	Mtring Power Lim		
128	Regen Power Lim		
300	Motor Spd Fdbk		
125	Torque Pos Limit		
126	Torque Neg Limit		
123	Torq PosLim Actl		
124	Torq NegLim Actl		
303	Motor Torque Ref		

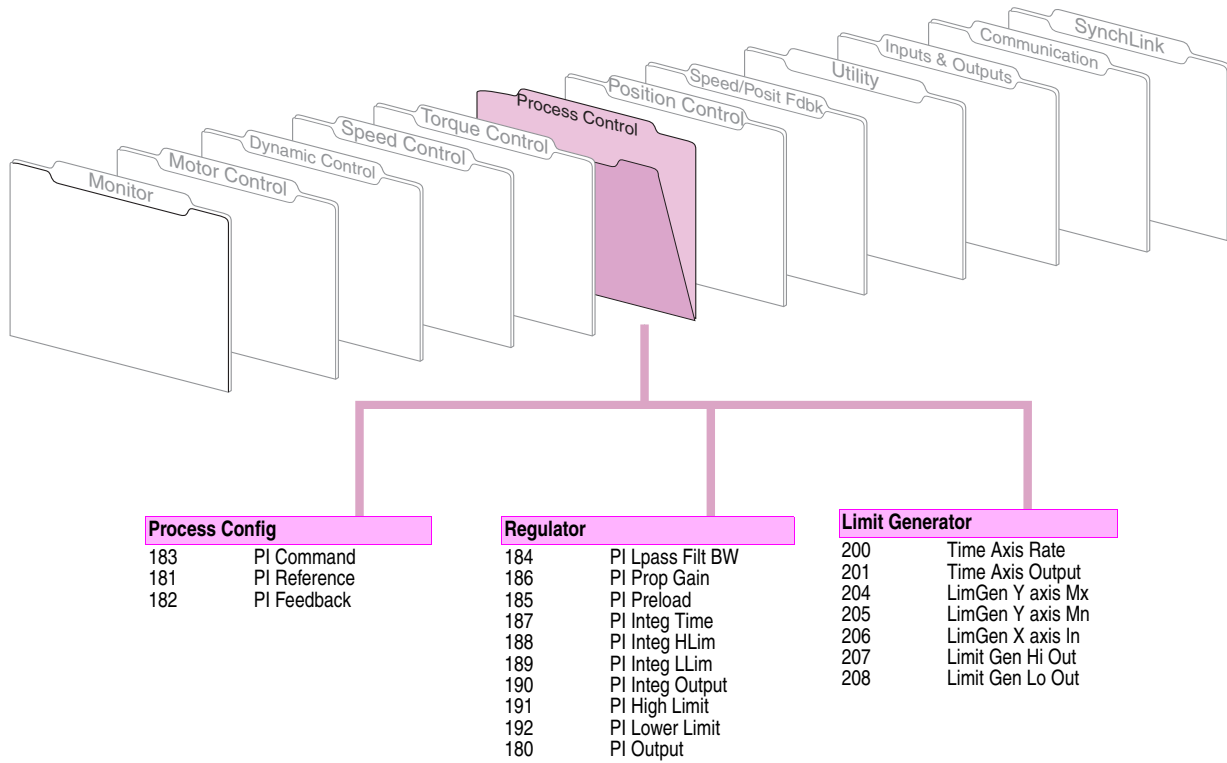

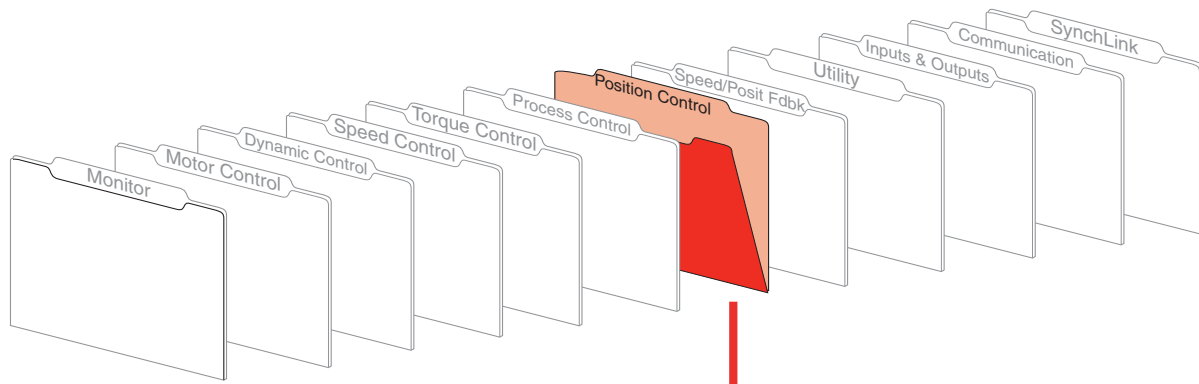

Position Config

740	Position Control
741	Position Status
742	Posit Ref Sel

Interp / Diret

743	Aux Posit Ref
745	PositRef EGR Mul
746	PositRef EGR Div
744	PositRef EGR Out
757	Abs Posit Offset
753	Posit Offset 1
754	Posit Offset 2
755	Posit Offset Spd
756	X Offst SpdFilt
747	Position Cmmd
762	Mtr Posit Fdbk
764	Posit Load Fdbk
766	Posit FB EGR Mul
767	Posit FB EGR Div
763	Act Motor Posit
765	Posit Actl Load
769	Position Error
768	PositReg P Gain
770	PositReg Integ
772	XReg Integ LoLim
773	XReg Integ HiLim
774	XReg Integ Out
771	PositReg Droop
775	XReg Spd LoLim
776	XReg Spd HiLim
318	Posit Spd Output

Point to Point

758	Pt-Pt Posit Ref
745	PositRef EGR Mul
746	PositRef EGR Div
744	PositRef EGR Out
753	Posit Offset 1
754	Posit Offset 2
755	Posit Offset Spd
756	X Offst SpdFilt
747	Position Cmmd
762	Mtr Posit Fdbk
763	Act Motor Posit
769	Position Error
768	PositReg P Gain
761	Pt-Pt Filt BW
759	Pt-Pt Accel Time
760	Pt-Pt Decel Time
775	XReg Spd LoLim
776	XReg Spd HiLim
318	Posit Spd Output

Posit Detection

784	Posit Detct1 In
785	Posit Detct2 In
780	PositDetct1 Stpt
781	PositDetct2 Stpt
769	Position Error
782	In Posit BW
783	In Posit Dwell

Sync Generator

786	Xsync Status
787	Xsync Gen Period
317	SL System Time
788	Xsync In 1
789	Xsync Out 1
790	Xsync In 2
791	Xsync Out 2
792	Xsync Out 2 Dly
793	Xsync In 3
794	Xsync Out 3

Posit Indexer

796	Posit Index Ctrl
797	Posit Index Step
798	PositIndexPreset
799	PositIndexOutput

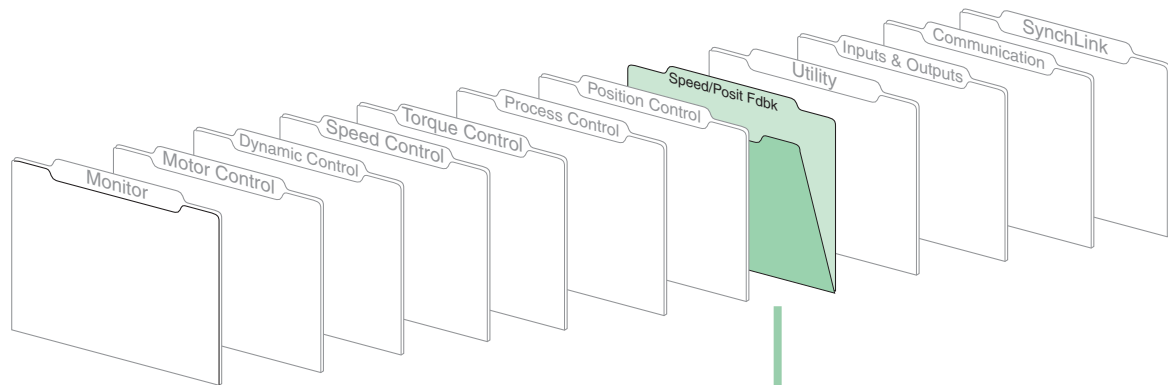

Feedback Config

- 72 Scaled Spd Fdbk
- 73 Spd Fdbk Scale
- 222 Motor Fdbk Sel
- 223 Virtual Edge/Rev
- 227 Spd Obs Trq Gain
- 220 Spd Observer BW
- 221 Load Estimate
- 300 Motor Spd Fdbk

Calculated Fdbk

- 548 Est Speed Fdbk
- 74 Motor Spd Est
- 226 Virtual Edge/Rev
- 75 MtrSpd Est Posit
- 76 MtrSpd Simulated
- 70 MtrSpd Sim Posit

Encoder Port 0

- 233 Encdr0 Config
- 234 Encdr0 Error
- 232 Encoder0 PPR
- 231 Encdr0 Spd Fdbk
- 230 Encdr0 Position
- 236 Port0 Regis Cnfg
- 237 Port0 Regis Ctrl
- 238 Port0 Regis Stat
- 235 Port0 Regis Ltch

Encoder Port 1

- 243 Encdr1 Config
- 244 Encdr1 Error
- 242 Encoder1 PPR
- 241 Encdr1 Spd Fdbk
- 240 Encdr1 Position
- 246 Port1 Regis Cnfg
- 247 Port1 Regis Ctrl
- 248 Port1 Regis Stat
- 245 Port1 Regis Ltch

Feedback Opt 0

- 249 Fdbk Option ID
- 250 FB Opt0 Posit

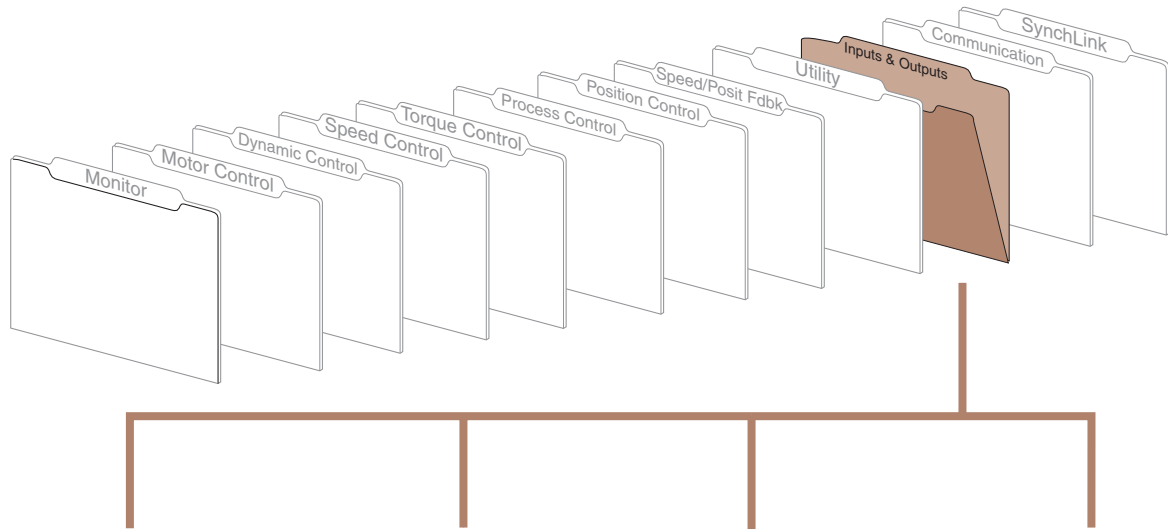

Analog Inputs		Analog Outputs		Digital Inputs		Digital Outputs	
800	Anlg In1 Data	814	AnlgOut1 Integer	825	En In Debounce	(1)	Relay Out Data
802	Anlg In1 Scale	815	Anlg Out1 Real	838	DigIn1 Sel	843	Relay Out Bit
803	Anlg In1 Offset	817	Anlg Out1 Scale	829	DigIn1 Debounce	844	Dig Out 1 Data
804	AI 1 Filt Gain	812	Anlg Out1 Offset	826	DigIn1 Data	845	Dig Out 1 Bit
805	Anlg In1 Filt BW	818	Anlg Out1 Zero	827	DigIn1 Bit	846	Dig Out 2 Data
806	Anlg In2 Data	819	AnlgOut2 Integer	828	DigIn1 User Data		Dig Out 2 Bit
808	Anlg In2 Scale	820	Anlg Out2 Real	839	DigIn2 Sel	(1)	
809	Anlg In2 Offset	822	Anlg Out2 Scale	833	DigIn2 Debounce		
810	AI 2 Filt Gain	813	Anlg Out2 Offset	830	DigIn2 Data		
811	Anlg In2 Filt BW	823	Anlg Out2 Zero	831	DigIn2 Bit		
				832	DigIn2 User Data		
				840	DigIn3 Sel		
				837	DigIn3 Debounce		
				834	DigIn3 Data		
				835	DigIn3 Bit		
				836	DigIn3 User Data		

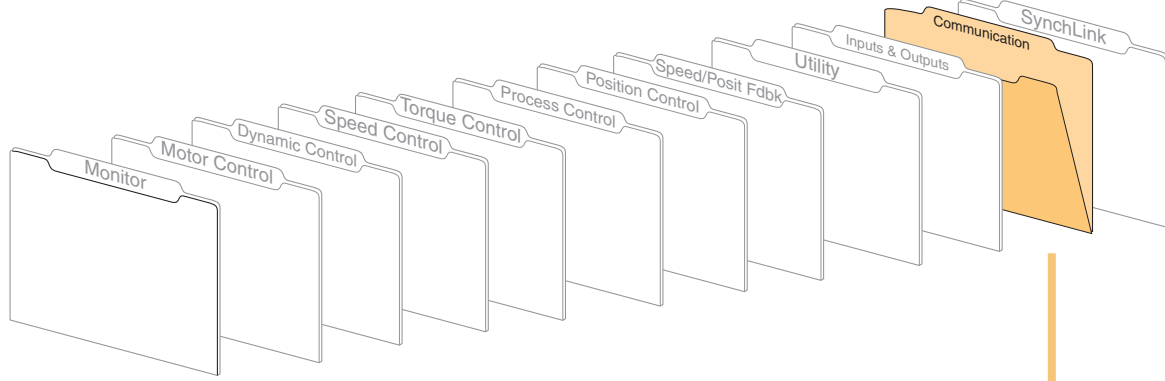

Commands	
691	DPI Ref Select
664	Lgx Comm Format

Masks & Owners	
693	Logic Mask
694	Start Mask
695	Jog Mask
696	Direction Mask
697	Fault Clr Mask
700	Stop Owner
701	Start Owner
702	Jog Owner
703	Direction Owner
704	Fault Clr Owner

DPI Data Links	
707	Data In A1 Int
708	Data In A1 Real
709	Data In A2 Int
710	Data In A2 Real
711	Data In B1 Int
712	Data In B1 Real
713	Data In B2 Int
714	Data In B2 Real
715	Data In C1 Int
716	Data In C1 Real
717	Data In C2 Int
718	Data In C2 Real
719	Data In D1 Int
720	Data In D1 Real
721	Data In D2 Int
722	Data In D2 Real
723	DLink OutDataTyp
724	Data Out A1 Int
725	Data Out A1 Real
726	Data Out A2 Int
727	Data Out A2 Real
728	Data Out B1 Int
729	Data Out B1 Real
730	Data Out B2 Int
731	Data Out B2 Real
732	Data Out C1 Int
733	Data Out C1 Real
734	Data Out C2 Int
735	Data Out C2 Real
736	Data Out D1 Int
737	Data Out D1 Real
738	Data Out D2 Int
739	Data Out D2 Real

Logix Inputs	
600	Integer In00
601	Real In00
602	Integer In01
603	Real In01
604	Integer In02
605	Real In02
606	Integer In03
607	Real In03
608	Integer In04
609	Real In04
610	Integer In05
611	Real In05
612	Integer In06
613	Real In06
614	Integer In07
615	Real In07
616	Integer In08
617	Real In08
618	Integer In09
619	Real In09
620	Integer In10
621	Real In10
622	Integer In11
623	Real In11
624	Integer In12
625	Real In12
626	Integer In13
627	Real In13
628	Integer In14
629	Real In14
630	Integer In15
631	Real In15

Logix Outputs	
632	Integer Out00
633	Real Out00
634	Integer Out01
635	Real Out01
636	Integer Out02
637	Real Out02
638	Integer Out03
639	Real Out03
640	Integer Out04
641	Real Out04
642	Integer Out05
643	Real Out05
644	Integer Out06
645	Real Out06
646	Integer Out07
647	Real Out07
648	Integer Out08
649	Real Out08
650	Integer Out09
651	Real Out09
652	Integer Out10
653	Real Out10
654	Integer Out11
655	Real Out11
656	Integer Out12
657	Real Out12
658	Integer Out13
659	Real Out13
660	Integer Out14
661	Real Out14
662	Integer Out15
663	Real Out15

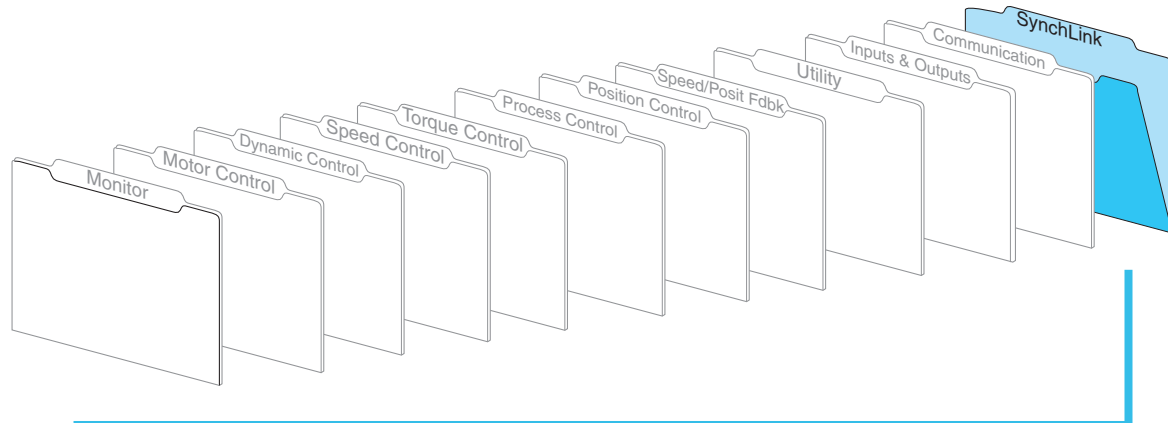

SynchLink Config	
1000	SL Node Cnfg
1010	SL Rx Comm Frmt
1011	SL Rx DirectSel0
1012	SL Rx DirectSel1
1013	SL Rx DirectSel2
1014	SL Rx DirectSel3
1020	SL Tx Comm Frmt
1021	SL Tx DirectSel0
1022	SL Tx DirectSel1
1023	SL Tx DirectSel2
1024	SL Tx DirectSel3

Multiplier	
1030	SL Mult A In
1031	SL Mult B In
1032	SL Mult Base
1033	SL Mult Out
1034	SL Mult State
1035	Real to Int In
1036	Real to Int Out

Event Data	
1040	SL Rcv Events
1049	SL Cir Events
1041	SL Rx P0 Regis
1042	SL Rx P1 Regis

Direct Data	
1054	SL Dir Int Rx0
1055	SL Dir Real Rx0
1056	SL Dir Int Rx1
1057	SL Dir Real Rx1
1058	SL Dir Int Rx2
1059	SL Dir Real Rx2
1060	SL Dir Int Rx3
1061	SL Dir Real Rx3
1140	Tx Dir Data Type
1141	SL Dir Int Tx0
1142	SL Dir Real Tx0
1143	SL Dir Int Tx1
1144	SL Dir Real Tx1
1145	SL Dir Int Tx2
1146	SL Dir Real Tx2
1147	SL Dir Int Tx3
1148	SL Dir Real Tx3

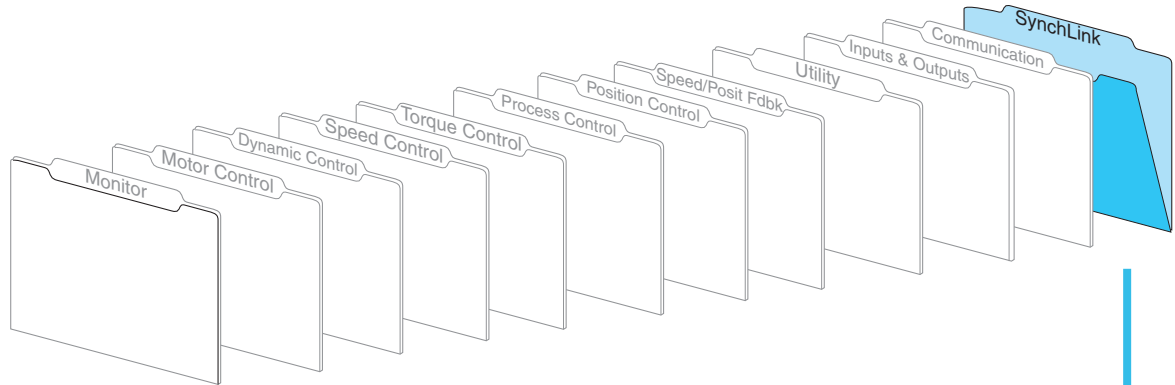









Buffered Data In

1073	SL Buf Int Rx00	1103	SL Buf Int Rx15
1074	SL Buf Real Rx00	1104	SL Buf Real Rx15
1075	SL Buf Int Rx01	1105	SL Buf Int Rx16
1076	SL Buf Real Rx01	1106	SL Buf Real Rx16
1077	SL Buf Int Rx02	1107	SL Buf Int Rx17
1078	SL Buf Real Rx02	1108	SL Buf Real Rx17
1079	SL Buf Int Rx03	1109	SL Buf Int Rx18
1080	SL Buf Real Rx03	1110	SL Buf Real Rx18
1081	SL Buf Int Rx04	1111	SL Buf Int Rx19
1082	SL Buf Real Rx04	1112	SL Buf Real Rx19
1083	SL Buf Int Rx05	1113	SL Buf Int Rx20
1084	SL Buf Real Rx05	1114	SL Buf Real Rx20
1085	SL Buf Int Rx06	1115	SL Buf Int Rx21
1086	SL Buf Real Rx06	1116	SL Buf Real Rx21
1087	SL Buf Int Rx07	1117	SL Buf Int Rx22
1088	SL Buf Real Rx07	1118	SL Buf Real Rx22
1089	SL Buf Int Rx08	1119	SL Buf Int Rx23
1090	SL Buf Real Rx08	1120	SL Buf Real Rx23
1091	SL Buf Int Rx09	1121	SL Buf Int Rx24
1092	SL Buf Real Rx09	1122	SL Buf Real Rx24
1093	SL Buf Int Rx10	1123	SL Buf Int Rx25
1094	SL Buf Real Rx10	1124	SL Buf Real Rx25
1095	SL Buf Int Rx11	1125	SL Buf Int Rx26
1096	SL Buf Real Rx11	1126	SL Buf Real Rx26
1097	SL Buf Int Rx12	1127	SL Buf Int Rx27
1098	SL Buf Real Rx12	1128	SL Buf Real Rx27
1099	SL Buf Int Rx13	1129	SL Buf Int Rx28
1100	SL Buf Real Rx13	1130	SL Buf Real Rx28
1101	SL Buf Int Rx14	1131	SL Buf Int Rx29
1102	SL Buf Real Rx14	1132	SL Buf Real Rx29

Buffered Data Out

1160	Tx Buf Data Type	1190	SL Buf Real Tx14
1161	SL Buf Int Tx00	1191	SL Buf Int Tx15
1162	SL Buf Real Tx00	1192	SL Buf Real Tx15
1163	SL Buf Int Tx01	1193	SL Buf Int Tx16
1164	SL Buf Real Tx01	1194	SL Buf Real Tx16
1165	SL Buf Int Tx02	1195	SL Buf Int Tx17
1166	SL Buf Real Tx02	1196	SL Buf Real Tx17
1167	SL Buf Int Tx03	1197	SL Buf Int Tx18
1168	SL Buf Real Tx03	1198	SL Buf Real Tx18
1169	SL Buf Int Tx04	1199	SL Buf Int Tx19
1170	SL Buf Real Tx04	1200	SL Buf Real Tx19
1171	SL Buf Int Tx05	1201	SL Buf Int Tx20
1172	SL Buf Real Tx05	1202	SL Buf Real Tx20
1173	SL Buf Int Tx06	1203	SL Buf Int Tx21
1174	SL Buf Real Tx06	1204	SL Buf Real Tx21
1175	SL Buf Int Tx07	1205	SL Buf Int Tx22
1176	SL Buf Real Tx07	1206	SL Buf Real Tx22
1177	SL Buf Int Tx08	1207	SL Buf Int Tx23
1178	SL Buf Real Tx08	1208	SL Buf Real Tx23
1179	SL Buf Int Tx09	1209	SL Buf Int Tx24
1180	SL Buf Real Tx09	1210	SL Buf Real Tx24
1181	SL Buf Int Tx10	1211	SL Buf Int Tx25
1182	SL Buf Real Tx10	1212	SL Buf Real Tx25
1183	SL Buf Int Tx11	1213	SL Buf Int Tx26
1184	SL Buf Real Tx11	1214	SL Buf Real Tx26
1185	SL Buf Int Tx12	1215	SL Buf Int Tx27
1186	SL Buf Real Tx12	1216	SL Buf Real Tx27
1187	SL Buf Int Tx13	1217	SL Buf Int Tx28
1188	SL Buf Real Tx13	1218	SL Buf Real Tx28
1189	SL Buf Int Tx14	1219	SL Buf Int Tx29
		1220	SL Buf Real Tx29

Parameter Data in Linear List Format

No.	Name Description	Values	Linkable	Read-Write	Data Type
1	 Motor NP Volts Set to the motor nameplate rated volts.	Units: Volt Default: Calculated Min/Max: 75/705		✓	16-bit Integer
2	 Motor NP FLA Set to the motor nameplate rated full load amps. Range limited by three-second inverter rating.	Units: Amps Default: Calculated Min/Max: Calculated/Calculated		✓	Real
3	 Motor NP Hertz Set to the motor nameplate rated frequency.	Units: Hz Default: Calculated Min/Max: 2.0000/500.0000		✓	Real
4	 Motor NP RPM Set to the motor nameplate rated RPM.	Units: RPM Default: Calculated Min/Max: 1/30000		✓	16-bit Integer
5	 Motor NP Power Set to the motor nameplate rated power.	Units: Hp Default: Calculated Min/Max: 0.2500/3500.0000		✓	Real
6	 Mtr NP Pwr Units The power units shown on the motor nameplate.	Default: 0 Hp Options: 0 Hp 1 W			
7	 Motor Poles Set to the number of motor poles indicated on the motor nameplate. Only even numbers are allowed.	Units: Pole Default: 4 Min/Max: 2/40		✓	16-bit Integer
8	Motor Inertia Time, in seconds, for an uncoupled motor to accelerate from zero to base speed, at rated motor torque. Calculated during autotune.	Units: Sec Default: 0.400 Min/Max: 0.0100/655.0000	✓	✓	Real
9	Total Inertia Time, in seconds, for a motor coupled to a load to accelerate from zero to base speed, at rated motor torque. Calculated during autotune.	Units: Sec Default: 2.0000 Min/Max: 0.0100/655.0000	✓	✓	Real
10	Speed Ref 1 Sets the speed reference that the drive should use when selected by Par 16 [Speed Ref Sel]. A value of 1.0 represents base speed of the motor.	Default: 0.0000 Min/Max: -/+2200000000.0000	✓	✓	Real
11	Spd Ref1 Divide Par 10 [Speed Ref 1] is divided by this number. This number can be used to scale the value of Par 10 [Speed Ref 1].	Default: 1.0000 Min/Max: -/+2200000000.0000	✓	✓	Real
12	Speed Ref 2 Sets the speed reference that the drive should use when selected by Par 16 [Speed Ref Sel]. A value of 1.0 represents base speed of the motor.	Default: 0.0000 Min/Max: -/+2200000000.0000	✓	✓	Real
13	Spd Ref2 Multi Par 12 [Speed Ref 2] is multiplied by this number. This number can be used to scale the value of Par 12 [Speed Ref 2].	Default: 1.0000 Min/Max: -/+2200000000.0000	✓	✓	Real
14	Speed Ref 4 Sets the speed reference that the drive should use when selected by Par 16 [Speed Ref Sel].	Units: RPM Default: 0.0000 Min/Max: -/+14112.0000 Comm Scale: Par 4 [Motor NP RPM] = 1.0	✓	✓	Real
15	Speed Ref 5 Sets the speed reference that the drive should use when selected by Par 16 [Speed Ref Sel].	Units: RPM Default: 0.0000 Min/Max: -/+14112.0000 Comm Scale: Par 4 [Motor NP RPM] = 1.0	✓	✓	Real
16	Speed Ref Sel Selects the source of the speed reference to the drive.	Default: 1 "Spd Ref DPI" Options: 0 "Zero Speed" 4 "Spd Ref 4" 1 "Spd Ref 1" 5 "Spd Ref 5" 2 "Spd Ref 2" 6 "Spd Ref DPI" 3 "Spd Ref 3"			
17	Jog Speed 1 Sets the speed reference that the drive should use when responding to bit 18 [Jog 1] of Par 152 [Applied LogicCmd].	Units: RPM Default: 0.0000 Min/Max: -/+14112.0000 Comm Scale: Par 4 [Motor NP RPM] = 1.0	✓	✓	Real
18	Jog Speed 2 Sets the speed reference that the drive should use when responding to bit 23 [Jog 2] of Par 152 [Applied LogicCmd].	Units: RPM Default: 0.0000 Min/Max: -/+14112.0000 Comm Scale: Par 4 [Motor NP RPM] = 1.0	✓	✓	Real
19	 Atune Spd Ref Sets the maximum speed of the motor during the Flux current and inertia tests.	Units: RPM Default: 1499.4000 Min/Max: 176.4000/1764.0000 Comm Scale: Par 4 [Motor NP RPM] = 1.0		✓	Real

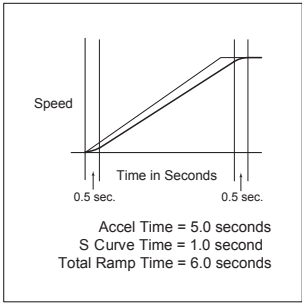
No.	Name Description	Values	Linkable	Read-Write	Data Type
20	Speed Ref DPI Sets the speed reference that the drive should use when selected in Par 16 [Speed Ref Sel]. A device communicating on a DPI port (typically a HIM) provides this value.	Units: RPM Default: 0.00000 Min/Max: -/+14112.00000 Comm Scale: Par 4 [Motor NP RPM] = 1.0			Real
21	Speed Trim 1 Provides an additive trim value to Par 46 [Scaled Spd Ref].	Units: RPM Default: 0.0000 Min/Max: -/+14112.0000 Comm Scale: Par 4 [Motor NP RPM] = 1.0	✓	✓	Real
22	Speed Trim 2 Provides an additive speed trim value to Par 47 [Spd Trim1 SpdRef] with a Lead/Lag filter. The Position regulator output is linked to this parameter by default. This speed trim value affects the speed reference input to the speed regulator.	Units: RPM Default: 0.0000 Min/Max: -/+14112.0000 Comm Scale: Par 4 [Motor NP RPM] = 1.0	✓	✓	Real
23	Speed Trim 3 Provides a scalable speed trim value that will be added to Par 47 [Spd Trim1 SpdRef]. Par 24 [SpdTrim 3 Scale] scales this value prior to the trim value affecting the speed reference.	Units: RPM Default: 0.0000 Min/Max: -/+14112.0000 Comm Scale: Par 4 [Motor NP RPM] = 1.0	✓	✓	Real
24	SpdTrim 3 Scale Par 23 [Speed Trim 3] is multiplied by this number. This number can be used to scale the value of Par 23 [Speed Trim 3].	Default: 1.0000 Min/Max: -/+1000.0000	✓	✓	Real
25	STrim2 Filt Gain Sets the lead term for the Par 22 [Speed Trim 2] filter. A value greater than 1 will result in a lead function and a value less than 1 will result in a lag function. A value of 1 will disable the filter.	Default: 1.0000 Min/Max: -/+15.0000	✓	✓	Real
26	SpdTrim2 Filt BW Sets the frequency for the Speed Trim 2 filter.	Units: R/S Default: 200.0000 Min/Max: 0.0000/1000.0000	✓	✓	Real
30	Rev Speed Limit Sets a limit on the speed reference in the negative direction. This value can be entered as a negative value or zero.	Units: RPM Default: -2205.0000 Min/Max: -14112.0000/0.0000 Comm Scale: Par 4 [Motor NP RPM] = 1.0		✓	Real
31	Fwd Speed Limit Sets a limit on the speed reference in the positive direction. This value can be entered as a positive value or zero.	Units: RPM Default: 2205.0000 Min/Max: 0.0000/14112.0000 Comm Scale: Par 4 [Motor NP RPM] = 1.0		✓	Real
32	Accel Time Sets the rate of acceleration for all speed increases, with time in seconds to base speed. Accel Rate = Par 4 [Motor NP RPM] / Par 32 [Accel Time]	Units: Sec Default: 10.0000 Min/Max: 0.0100/6553.5000	✓	✓	Real
33	Decel Time Sets the rate of deceleration for all speed decreases, with time in seconds to base speed. Decel Rate = Par 4 [Motor NP RPM] / Par 33 [Decel Time]	Units: Sec Default: 10.0000 Min/Max: 0.0100/6553.5000	✓	✓	Real
34	S Curve Time Sets the S time (Round In and Round Out) in seconds. Half of the time specified is added to the beginning and half to the end of the applied ramp. The S time is independent of speed and results in a trapezoidal torque profile. For example: 	Units: Sec Default: 0.5000 Min/Max: 0.0000/4.0000	✓	✓	Real
35	SpdRef Filt Gain Sets the lead term for the Speed Reference filter. A value greater than 1 will result in a lead function and a value less than 1 will result in a lag function. A value of 1 will disable the filter.	Default: 1.0000 Min/Max: -/+5.0000	✓	✓	Real
36	SpdRef Filt BW Sets the frequency for the Speed Reference filter.	Units: R/S Default: 0.0000 Min/Max: 0.0000/500.0000	✓	✓	Real
37	Spd Ref Bypass The speed command after the limit, ramp and s-curve blocks. Link a source directly to this parameter to bypass these blocks.	Units: RPM Default: 0.0000 Min/Max: -/+14112.0000 Comm Scale: Par 4 [Motor NP RPM] = 1.0	✓	✓	Real
38	Speed Ref Scale This parameter is multiplied with the value in Par 44 [Filtered Spd Ref] to produce the value in Par 46 [Scaled Spd Ref].	Default: 1.0000 Min/Max: -/+1000.0000 x 1	✓	✓	Real

No.	Name Description	Values	Linkable	Read-Write	Data Type
40	Selected Spd Ref Displays the speed command before the speed reference limit block.	Units: RPM Default: 0.0000 Min/Max: -/+14112.0000 Comm Scale: Par 4 [Motor NP RPM] = 1.0			Real
41	Limited Spd Ref Displays the speed command after the limit block, limited by Par 30 [Rev Speed Limit] and Par 31 [Fwd Speed Limit].	Units: RPM Default: 0.0000 Min/Max: -/+14112.0000 Comm Scale: Par 4 [Motor NP RPM] = 1.0			Real
42	Ramped Spd Ref Displays the speed command after the linear ramp block, modified by Par 32 [Accel Time] and Par 33 [Decel Time].	Units: RPM Default: 0.0000 Min/Max: -/+14112.0000 Comm Scale: Par 4 [Motor NP RPM] = 1.0			Real
43	S Curve Spd Ref Displays the speed command after the s-curve block, modified by Par 34 [S Curve Time].	Units: RPM Default: 0.0000 Min/Max: -/+14112.0000 Comm Scale: Par 4 [Motor NP RPM] = 1.0			Real
44	Filtered Spd Ref Displays the speed reference value output from the reference Lead/Lag filter.	Units: RPM Default: 0.0000 Min/Max: -/+14112.0000 Comm Scale: Par 4 [Motor NP RPM] = 1.0			Real
45	Delayed Spd Ref One sample period delayed output of Par 43 [S Curve Spd Ref]. Used in some applications to synchronize the speed reference value through SynchLink. This master drive [S Curve Spd Ref] would then be transmitted to the slave drives over SynchLink.	Units: RPM Default: 0.0000 Min/Max: -/+14112.0000 Comm Scale: Par 4 [Motor NP RPM] = 1.0			Real
46	Scaled Spd Ref Displays the speed command after scaling (the product of Par 44 [Filtered Spd Ref] and Par 38 [Speed Ref Scale]).	Units: RPM Default: 0.0000 Min/Max: -/+14112.0000 Comm Scale: Par 4 [Motor NP RPM] = 1.0			Real
47	Spd Trim1 SpdRef Displays the final speed command used by the Speed Regulator. It is the sum of the Par 46 [Scaled Spd Ref] and Par 21 [Speed Trim1].	Units: RPM Default: 0.0000 Min/Max: -/+14112.0000 Comm Scale: Par 4 [Motor NP RPM] = 1.0			Real
50	Spd Ref TP Sel Enter or write a value to select speed reference data displayed in Par 52 [Spd Ref TP Data] and Par 51 [Spd Ref TP RPM].	Default: 0 "Zero" Options: 0 "Zero" 12 "S Crv Match" 1 "User Ref" 13 "S Array Size" 2 "Logic Select" 14 "S Array Indx" 3 "Lgc Sel Ref" 15 "Reserved" 4 "Reserved" 16 "Scl Ext Trim" 5 "Logic En Ref" 17 "Trim FiltOut" 6 "Rev Spd Lim" 18 "Ref w/Trim" 7 "Fwd Spd Lim" 19 "Amp Lim2 In" 8 "Rev Lim Stat" 20 "Amp LimStat2" 9 "Fwd Lim Stat" 21 "Amp Lim2 Out" 10 "Amp Lim Stat" 22 "FTD Ramp Out" 11 "Ramp Match"			
51	Spd Ref TP RPM Displays the value selected by Par 50 [Spd Ref TP Sel] in RPM. This display should only be used if the selected value is floating point data.	Units: RPM Default: 0.0000 Min/Max: -/+14112.0000 Comm Scale: Par 4 [Motor NP RPM] = 1.0			Real
52	Spd Ref TP Data Displays the value selected by Par 50 [Spd Ref TP Sel]. A value of 1.0 represents base speed of the motor.	Default: 0 Min/Max: -/+32768			16-bit Integer
53	Drive Ramp Rslt Displays the speed reference value, after the limit function. This is the input to the error calculator and speed regulator. Available for use in peer-to-peer data links (DPI interface). This number is scaled so that rated motor speed will read 32768.	Default: 0 Min/Max: -/+262144/262144			16-bit Integer
55	 Speed Comp Displays the derivative or change in Par 56 [Inertia SpeedRef] on a per second basis. Link this parameter to Par 23 [Speed Trim 3] and set Par 24 [SpeedTrim 3 Scale] to 0.002 to reduce position error in following applications.	Default: 0.0000 Min/Max: -/+2200000000.0000			16-bit Integer
56	Inertia SpeedRef The speed input of the inertia compensator. Link this parameter to the output of an internal ramp or s-curve block. The inertia compensator generates a torque reference that is proportional to the rate of change of speed input and total inertia.	Units: RPM Default: 0.0000 Min/Max: -/+14112.0000 Comm Scale: Par 4 [Motor NP RPM] = 1.0	✓	✓	Real
57	InertiaAccelGain Sets the acceleration gain for the Inertia Compensation function. A value of 1 produces 100% compensation.	Default: 1.0000 Min/Max: 1.0000/2.0000	✓	✓	Real
58	InertiaDecelGain Sets the deceleration gain for the Inertia Compensation function. A value of 1 produces 100% compensation.	Default: 1.0000 Min/Max: 1.0000/2.0000	✓	✓	Real

No.	Name Description	Values	Linkable	Read-Write	Data Type
59	Inertia Torq Add The torque reference output generated by the inertia compensator. This torque level is modified by Par 57 [InertiaAccelGain] and Par 58 [InertiaDecelGain]. A value of 1.0 represents rated torque of the motor.	Units: P.U. Default: 1.0000 Min/Max: -/+8.0000			Real
60	DeltaSpeedScale Multiplier in the Inertia Compensation function - affects the value of Par 59 [Inertia Torq Add]. Use in center winder and unwind applications to compensate for roll diameter build-up.	Default: 1.0000 Min/Max: -/+1000.0000	✓	✓	Real
61	 Virt Encoder EPR Equivalent Edges Per Revolution (EPR) or line count of a virtual encoder. A virtual encoder is a position reference whose input comes from speed reference. It accumulates pulses at the same rate as a real encoder of identical Pulses Per Revolution (PPR). Enter the equivalent PPR. For example: Enter 1024 EPR to match an encoder with 1024 PPR.	Units: EPR Default: 4096 Min/Max: 10/67108864		✓	32-bit Integer
62	Virt Encdr Posit A 32-bit pulse accumulator of the virtual encoder. The accumulated pulse count is equivalent to the hardware accumulator of a real encoder. It accumulates at a rate of 4x the value placed in Par 61 [Virt Encoder EPR]. The accumulator starts at zero upon position enable.	Default: 0 Min/Max: -/+2147483648			32-bit Integer
63	Virt Encdr Dlyed One sample period delayed output of Par 62 [Virt Encdr Posit]. Used in some applications to phase synchronize position reference through SynchLink. The master is delayed one sample while the downstream drives update their position references – then all drives sample position simultaneously. The downstream drives do not select a delay.	Default: 0 Min/Max: -/+2147483648			32-bit Integer
70	MtrSpd Sim Posit The motor position output of the motor simulator. The simulator provides motor position information during setup and troubleshooting when actual motor control is not desired or possible. To use the motor simulator, enter a value of 4 in Par 222 [Motor Fdbk Sel].	Default: 0 Min/Max: -/+2147483648			32-bit Integer
71	Filtered SpdFdbk Displays the motor speed feedback value output from the feedback Lead/Lag filter.	Units: RPM Default: 0.0000 Min/Max: -/+14112.0000 Comm Scale: Par 4 [Motor NP RPM] = 1.0			Real
72	Scaled Spd Fdbk Displays the product of the speed feedback and Par 73 [Spd Fdbk Scale]. This parameter is for display only.	Default: 0.0000 Min/Max: -/+2200000000.0000 Comm Scale: Par 4 [Motor NP RPM] = 1.0			Real
73	Spd Fdbk Scale A user adjustable scale factor (multiplier) for speed feedback. It is multiplied with speed feedback to produce Par 72 [Scaled Spd Fdbk].	Default: 1.0000 Min/Max: -/+2200000000.0000 x 1	✓	✓	Real
74	Motor Spd Est Displays estimated motor speed, calculated when the selected feedback is sensorless or when encoderless ridethrough is enabled.	Units: RPM Default: 0.0000 Min/Max: -/+14112.0000 Comm Scale: Par 4 [Motor NP RPM] = 1.0			Real
75	MtrSpd Est Posit Summation (or integration) of Par 74 [Motor Spd Est] scaled by the value in Par 226 [Virtual Edge/Rev].	Default: 0 Min/Max: -/+2147483648			32-bit Integer
76	MtrSpd Simulated The motor speed output of the motor simulator. The simulator provides motor speed information during setup and troubleshooting when actual motor control is not desired or possible. To use the motor simulator, enter a value of 4 in Par 222 [Motor Fdbk Sel].	Units: RPM Default: 0.0000 Min/Max: -/+14112.0000 Comm Scale: Par 4 [Motor NP RPM] = 1.0			Real
77	Spd Fdbk TP Sel Enter or write a value to select the data displayed in Par 78 [Spd Fdbk TP RPM] and Par 79 [Spd Fdbk TP Data].	Default: 0 "Zero" Options: 0 "Zero" 20 "E0 dTime" 1 "Clock Time" 21 "E0 EPR" 2 "InactvFbkDev" 22 "E0 Edge Mode" 3 "ActiveFbkDev" 23 "E0 dTheta" 4 "MCP Fdbk Dev" 24 "E0 Error" 5 "Observer Err" 25 "E0 Qloss pk" 6 "UnFilt Load" 26 "E0 Ploss pk" 7 "Pri Actl Spd" 27 "E0 PlevlHist" 8 "Alt Actl Spd" 28 "E1 Edge Time" 9 "Pri Actl Pos" 29 "E1 dEdge" 10 "Alt Actl Pos" 30 "E1 dTime" 11 "Obser dp in" 31 "E1 EPR" 12 "Obser dp" 32 "E1 Edge Mode" 13 "Obser dperr" 33 "E1 dTheta" 14 "Obser accel" 34 "E1 Error" 15 "Obser K3/S" 35 "E1 Qloss pk" 16 "MCP PPR" 36 "E1 Ploss pk" 17 "MCP 2^n" 37 "E1 PlevlHist" 18 "E0 Edge Time" 38 "E0 Delta2Err" 19 "E0 dEdge" 39 "E1 Delta2Err"			Real
78	Spd Fdbk TP RPM Displays the value selected in Par 77 [Spd Fdbk TP Sel] in RPM. This display should only be used if the selected value is floating point data.	Units: RPM Default: 0.0000 Min/Max: -/+14112.0000 Comm Scale: Par 4 [Motor NP RPM] = 1.0			Real

No.	Name Description	Values	Linkable	Read-Write	Data Type																							
79	Spd Fdbk TP Data Displays the value selected in Par 77 [Spd Fdbk TP Sel]. This display should only be used if the selected value is integer data.	Default: 0 Min/Max: -/+32768			16-bit Integer																							
80	Speed Reg Ctrl Enter or write a value to configure the speed regulator integrator. Refer to Appendix B, Speed Control, on page B-4. Options <table border="1" style="margin-left: 20px;"> <tr> <td>Reserved</td> <td>Reserved</td> <td>Integ Hold</td> <td>Integ Reset</td> <td>Reserved</td> <td>Reserved</td> <td>Reserved</td> <td>Reserved</td> </tr> <tr> <td>Default</td> <td>0</td> <td>0</td> <td>0</td> <td>0</td> <td>0</td> <td>0</td> <td>0</td> </tr> <tr> <td>Bit</td> <td>0</td> <td>1</td> <td>2</td> <td>3</td> <td>4</td> <td>5</td> <td>6</td> </tr> </table> <p style="margin-left: 20px;">0 = False 1 = True</p>	Reserved	Reserved	Integ Hold	Integ Reset	Reserved	Reserved	Reserved	Reserved	Default	0	0	0	0	0	0	0	Bit	0	1	2	3	4	5	6			
Reserved	Reserved	Integ Hold	Integ Reset	Reserved	Reserved	Reserved	Reserved																					
Default	0	0	0	0	0	0	0																					
Bit	0	1	2	3	4	5	6																					
81	Spd Reg P Gain Sets the proportional gain of the speed regulator. It's value is automatically calculated based on the bandwidth setting in Par 90 [Spd Reg BW]. Proportional gain may be manually adjusted by setting Par 90 to a value of zero. Units are (per unit torque) / (per unit speed). Adjustments to Par 474 [Freq Reg We BW] and Par 475 [Freq Reg Wr BW] may be necessary when using sensorless feedback.	Default: 20.0000 Min/Max: 0.0000/600.0000	✓	✓	Real																							
82	Spd Reg I Gain Sets the integral gain of the speed regulator. It's value is automatically calculated based on the bandwidth setting in Par 90 [Spd Reg BW]. Integral gain may be manually adjusted by setting Par 90 to a value of zero. Units are (per unit torque/sec) / (per unit speed). Adjustments to Par 474 [Freq Reg We BW] and 4Par 75 [Freq Reg Wr BW] may be necessary when using sensorless feedback.	Units: /Sec Default: 50.0000 Min/Max: 0.0000/100000.0000	✓	✓	Real																							
84	SpdReg AntiBckup By setting this parameter to 0.3 the drive will not over-shoot to a step response. This parameter has no affect on the drive's response to load changes. Recommended setting is 0.1000 to 0.5000.	Default: 0.0000 Min/Max: 0.0000/0.5000	✓	✓	Real																							
85	Servo Lock Gain Sets the gain of an additional integrator in the speed regulator. The effect of Servo Lock is to increase stiffness of the speed response to a load disturbance. It behaves like a position regulator with velocity feed forward, but without the pulse accuracy of a true position regulator. The units of Servo Lock are rad/sec. Gain should normally be set to less than 1/3 speed regulator bandwidth, or for the desired response. Set to zero to disable Servo Lock.	Units: /Sec Default: 0.0000 Min/Max: 0.0000/300.0000	✓	✓	Real																							
86	Spd Reg Droop Specifies the amount of base speed that the speed reference is reduced when at full load torque. Use the droop function to cause the motor speed to decrease with an increase in load. The units are per unit speed / per unit torque.	Units: P.U. Default: 0.0000 Min/Max: 0.0000/0.2500	✓	✓	Real																							
87	SReg Torq Preset When the drive is not enabled, this parameter presets integrator output Par 101 [SpdReg Integ Out] to specified a torque level. This ensures that the torque command will be at the preset value when the drive is enabled and run. Par 80 [Speed Reg Ctrl] bit 1 [Preset Sel] = 0 enables this preset.	Units: P.U. Default: 0.0000 Min/Max: -/+8.0000	✓	✓	Real																							
89	Spd Err Filt BW Sets the bandwidth of a 2nd order Butterworth low pass filter, which reduces quantization noise. The units are rad/sec. A value of 0 will disable the filter. The value should be greater than 5 times the value of Par 90 [Spd Reg BW].	Units: R/S Default: 200.0000 Min/Max: 0.0000/2000.0000	✓	✓	Real																							

No.	Name Description	Values	Linkable	Read-Write	Data Type
90	Spd Reg BW Sets the bandwidth of the speed regulator in rad/sec. Bandwidth is also referred to as the crossover frequency. Small signal time response is approximately 1/BW and is the time to reach 63% of set point. A change to this parameter will cause an automatic update of Pars 81 [Spd Reg P Gain] and 82 [Spd Reg I Gain]. To disable the automatic gain calculation, set this parameter to a value of zero. Adjustments to Par 474 [Freq Reg We BW] and Par 475 [Freq Reg Wr BW] may be necessary when using sensorless feedback.	Units: R/S Default: 10.0000 Min/Max: 0.0000/500.0000 Min/Max limited by AutoTune calculations.	✓	✓	Real
91	Spd Reg Damping Sets the damping factor of the drive's characteristic equation and factors in the calculation of the integral gain. A damping factor of 1.0 is considered critical damp. Lowering the damping will produce faster load disturbance rejection, but may cause a more oscillatory response. When Par 90 [Spd Reg BW] is set to zero, damping factor has no effect.	Default: 1.0000 Min/Max: 0.5000/3.0000	✓	✓	Real
92	SpdReg P Gain Mx Places a limit on the maximum value of proportional gain in Par 81 [Spd Reg P Gain]. When gains are automatically calculated, this parameter is necessary to limit the amplification of noise with increased inertia.	Default: 100.0000 Min/Max: 0.0000/600.0000	✓	✓	Real
93	SRegFB Filt Gain Sets the lead term for the speed feedback filter. A value greater than 1 will result in a lead function and a value less than 1 will result in a lag function. A value of 1 will disable the filter.	Default: 1.0000 Min/Max: -5.0000/20.0000	✓	✓	Real
94	SReg FB Filt BW Sets the frequency for the Speed feedback filter.	Units: R/S Default: 35.0000 Min/Max: 0.0000/3760.0000	✓	✓	Real
95	SRegOut FiltGain Sets the lead term for the Speed Regulator output filter. A value greater than 1 will result in a lead function and a value less than 1 will result in a lag function. A value of 1 will disable the filter.	Default: 0.7000 Min/Max: -/+5.0000	✓	✓	Real
96	SReg Out Filt BW Sets the frequency for the Speed Regulator output filter.	Units: R/S Default: 30.0000 Min/Max: 0.0000/3760.0000	✓	✓	Real
97	Act Spd Reg BW Displays the actual speed regulator bandwidth or crossover frequency. The value represents the bandwidth in Par 90 [Spd Reg BW] after the maximum bandwidth limits have been applied.	Units: R/S Default: 10.0000 Min/Max: 0.0000/500.0000			Real
98	Spd Gain TP Sel Enter or write a value to select the speed gain data displayed in Par 99 [Spd Gain TP Data].	Default: 0 "Zero" Options: 0 "Zero" 12 "I Rate Limit" 1 "Iq Rate BW" 13 "I Rtlim Stat" 2 "Reserved" 14 "PGain Max" 3 "PGain Max BW" 15 "GnMx LimStat" 4 "BW Limit" 16 "Damping" 5 "InertiaMaxBW" 17 "Dmp Lim Stat" 6 "BW Lim Stat" 18 "Reserved" 7 "BW Select" 19 "Srls KpMxBW" 8 "Totl Inertia" 20 "Srls BWLimit" 9 "TI Lim Stat" 21 "SrlsInrtMxBW" 10 "Mtr Inertia" 22 "SrlsBWSelect" 11 "M InrtLStat" 23 "Srls BW Calc" 24 "Snsr BW Calc"			
99	Spd Gain TP Data Displays the value selected by Par 98 [Spd Gain TP Sel].	Default: 0.0000 Min/Max: 0.0000/500.0000			Real
100	Speed Error The error (difference) between the motor speed reference (+) and the filtered motor speed feedback (-).	Units: RPM Default: 0.0000 Min/Max: -/+14112.0000 Comm Scale: Par 4 [Motor NP RPM] = 1.0			Real
101	SpdReg Integ Out The output value of the Speed Regulator Integral channel.	Units: P.U. Default: 0.0000 Min/Max: -/+8.0000 Comm Scale: 1.0 PU Torque			Real
102	Spd Reg Pos Lim Sets the positive limit of the Speed regulator output value. The output of the Speed regulator is limited by adjustable high and low limits.	Units: P.U. Default: 3.0000 Min/Max: 0.0000/6.0000 Comm Scale: Par 4 [Motor NP RPM] = 1.0	✓	✓	Real
103	Spd Reg Neg Lim Sets the negative limit of the Speed regulator output value. The output of the Speed regulator is limited by adjustable high and low limits.	Units: P.U. Default: -3.0000 Min/Max: -6.0000/0.0000 Comm Scale: Par 4 [Motor NP RPM] = 1.0	✓	✓	Real
104	Srlss Spd Reg Kp Sets the proportional gain of the speed regulator when sensorless motor speed feedback is used. Value is automatically calculated based on the bandwidth set in Par 106 [Srlss Spd Reg BW]. Proportional gain may be manually adjusted by setting Par 106 to zero. This gain setting has no units (per unit torque) / (per unit speed error).	Default: 8.0000 Min/Max: 0.0000/200.0000		✓	Real

No.	Name Description	Values	Linkable	Read-Write	Data Type
105	SrLss Spd Reg Ki Sets the integral gain of the speed regulator when sensorless motor speed feedback is used. This value is automatically calculated based on the bandwidth set in Par 106 [SrLss Spd Reg BW]. Integral gain may be manually adjusted by setting Par 106 to zero. Units are 1/Sec (per unit torque/sec) / (per unit speed error).	Units: /Sec Default: 8.0000 Min/Max: 0.0000/4095.8000		✓	
106	SrLss Spd Reg BW Sets the bandwidth of the speed regulator when sensorless motor speed feedback is used. Units are in rad/sec. Bandwidth is also referred to as the crossover frequency. Small integral time response is approximately 1/BW and is the time to reach 63% of set point. A change to this parameter will cause an automatic update of Parameters 104 [SrLss Spd Reg Kp] and 105 [SrLss Spd Reg Ki]. To disable the automatic gain calculation, set this parameter to zero. The maximum limit for this parameter is determined by Par 354 [Iq Rate Limit], the ratio of Par 8 [Motor Inertia] to Par 9 [Total Inertia], and Par 107 [SrLss Kp Max].	Units: R/S Default: 10.0000 Min/Max: 0.0000/30.0000		✓	
107	SrLss Kp Max Places a limit on the maximum value of proportional gain in Par 104 [SrLss Spd Reg Kp], for use when sensorless motor speed feedback is used. When gains are automatically calculated, this parameter is necessary to limit the amplification of noise with increased inertia.	Default: 20.0000 Min/Max: 20.0000/35.0000			
108	Spd Reg TP Sel Enter or write a value to select speed regulator data displayed in Par 109 [Spd Reg TP Data].	Default: 0 "Zero" Options: 0 "Zero" 11 "SrLss ZeroWe" 1 "Spd FiltOut" 12 "I GainParLim" 2 "Servo Lock" 13 "P GainParLim" 3 "Spd+ServLock" 14 "SrvLck ParLm" 4 "Prop Output" 15 "AntiBkup PLm" 5 "Intg Input" 16 "Droop ParLim" 6 "Scld Int Pre" 17 "Pos Lim Stat" 7 "Sel Int Pre" 18 "Neg Lim Stat" 8 "Droop Output" 19 "Limiter Out" 9 "Out Lim Stat" 20 "Active Pgain" 10 "Intg Hold" 21 "Active Igain"			
109	Spd Reg TP Data Displays the data selected by Par 108 [Spd Reg TP Sel].	Units: P.U. Default: 0.0000 Min/Max: +/-8.0000			Real
110	Spd/Torq ModeSel Selects the source for the drive torque reference.	Default: 1 "Speed Reg" Options: 0 "Zero Torque" 4 "Max Spd/Torq" 1 "Speed Reg" 5 "Sum Spd/Torq" 2 "Torque Ref" 6 "AbsMn Spd/Tq" 3 "Min Spd/Torq"			
111	Torque Ref 1 Supplies an external motor torque reference to the drive. This parameter is divided by the value in Par 112 [Torq Ref1 Div]. A value of 1.0 represents rated torque of the motor.	Default: 0.0000 Min/Max: -/+2200000000.0000 Comm Scale: 1.0 Rated Motor Torque	✓	✓	Real
112	Torq Ref1 Div Par 111 [Torque Ref 1] is divided by this number. Use this parameter to scale the value of Par 111 [Torque Ref 1].	Default: 1.0000 Min/Max: -/+2200000000.0000		✓	Real
113	Torque Ref 2 Supplies an external motor torque reference to the drive. This parameter is multiplied by the value in Par 114 [Torq Ref2 Mult]. A value of 1.0 represents rated torque of the motor.	Default: 0.0000 Min/Max: -/+2200000000.0000 Comm Scale: 1.0 Rated Motor Torque	✓	✓	Real
114	Torq Ref2 Mult Par 113 [Torque Ref 2] is multiplied by this number. Use this parameter to scale the value of Par 113 [Torque Ref 2].	Default: 1.0000 Min/Max: -/+2200000000.0000	✓	✓	Real
115	Torque Trim The amount added to the Torque Ref 1 & 2 before the Speed/Torque Mode Selector. A value of 1.0 represents rated torque of the motor.	Units: P.U. Default: 0.0000 Min/Max: +/-8.0000 Comm Scale: 1.0 Rated Motor Torque	✓	✓	Real
116	Torque Step The amount added to the selected Torque Reference before notch filtering or limits are applied. A value of 1.0 represents rated torque of the motor.	Units: P.U. Default: 0.0000 Min/Max: +/-8.0000 Comm Scale: 1.0 Rated Motor Torque	✓	✓	Real
117	Notch Filt Mode Notch enabled.	Default: 0 "No Filter" Options: 0 "No Filter" 2 "IIR Notch" 1 "Reserved"			
118	Notch Filt Freq The center frequency for Notch filter.	Units: Hz Default: 135.0000 Min/Max: 0.0000/500.0000	✓	✓	Real
123	Torq PosLim Actl Sets the internal torque limit for positive torque reference values. The positive internal motor torque will not be allowed to exceed this value.	Units: P.U. Default: 1.0000 Min/Max: 0.0000/8.0000			Real
124	Torq NegLim Actl Sets the internal torque limit for negative torque reference values. The internal negative motor torque will not be allowed to exceed this value.	Units: P.U. Default: -1.0000 Min/Max: -8.0000/0.0000			Real

No.	Name Description	Values	Linkable	Read-Write	Data Type											
125	Torque Pos Limit Sets the external torque limit for positive torque reference values. The external positive motor torque will not be allowed to exceed this value.	Units: P.U. Default: 2.0000 Min/Max: 0.0000/8.0000	✓	✓	Real											
126	Torque Neg Limit Sets the external torque limit for negative torque reference values. The external negative motor torque will not be allowed to exceed this value.	Units: P.U. Default: -2.0000 Min/Max: -8.0000/0.0000	✓	✓	Real											
127	Mtring Power Lim Sets the maximum motoring (positive) power of the drive. This can be calculated by multiplying the desired maximum motor torque and the maximum motor speed. A value of 1.0 = nominal motor power.	Units: P.U. Default: 8.0000 Min/Max: 0.0000/8.0000	✓	✓	Real											
128	Regen Power Lim Sets the maximum regenerative (negative) power of the drive. This can be calculated by multiplying the desired maximum motor torque and the maximum motor speed. A value of 1.0 = nominal motor power.	Units: P.U. Default: -1.0000 Min/Max: -8.0000/0.0000	✓	✓	Real											
129	Atune Torq Ref Sets the motor torque that is applied to the motor during the flux current and inertia tests.	Units: P.U. Default: 0.5000 Min/Max: 0.2500/1.0000 Comm Scale: 1.0 = P.U. Motor to Torque	✓	✓	Real											
130	Torq Ref TP Sel Enter or write a value to select torque reference data displayed in Par 131 [Torq Ref TP Data].	Default: 0 "Zero" Options: 0 "Zero" 16 "Neg Lim Src" 1 "Scale Output" 17 "MPwr Par Lim" 2 "Spd Torque" 18 "RPwr Par Lim" 3 "TrqModeOut" 19 "+Torq ParLim" 4 "Actv rqMode" 20 "-Torq ParLim" 5 "Actv Mod Out" 21 "Nom Bus Volt" 6 "Torq En In" 22 "Bus Volt Hys" 7 "NotchFiltOut" 23 "Bus Reg Ref" 8 "NotchFilt In" 24 "Bus Reg Err" 9 "Torq Lim In" 25 "Bus Reg Intg" 10 "Bus Reg Out" 26 "BusReg Clamp" 11 "Pos Pwr Lim" 27 "BusRegOutput" 12 "Neg Pwr Lim" 28 "IAA Filt Out" 13 "PosAtun Torq" 29 "IAA dVf/dt" 14 "NegAtun Torq" 30 "MC Torq Lim" 15 "Pos Lim Src" 31 "Int Torq Lim"														
131	Torq Ref TP Data Displays the data selected by Par 130 [Torq Ref TP Sel].	Units: P.U. Default: 0.0000 Min/Max: +/-8.0000 Comm Scale: 1.0 = P.U. Motor to Torque			Real											
132	Inert Adapt Sel Configures the Inertia Adaptation Algorithm (IAA Function). Contains the following selections: <table border="1"> <thead> <tr> <th>Bit</th> <th>Name</th> <th>Current Function</th> </tr> </thead> <tbody> <tr> <td>0</td> <td>Inrtia Adapt</td> <td>When set to 1 (on), the IAA function will effect enhanced stability, higher bandwidths and dynamic stiffness. Useful when systems with a gear-box becomes disconnected from the load. Also used with motors that have very little inertia that otherwise lack dynamic stiffness, even at high bandwidths.</td> </tr> <tr> <td>1</td> <td>Load Est</td> <td>When set to 1 (on), the Load Estimate option removes or greatly reduces load disturbances and gives quicker system response.</td> </tr> <tr> <td>0 & 1</td> <td></td> <td>This mode enhances stability as well as removing load disturbances.</td> </tr> </tbody> </table>	Bit	Name	Current Function	0	Inrtia Adapt	When set to 1 (on), the IAA function will effect enhanced stability, higher bandwidths and dynamic stiffness. Useful when systems with a gear-box becomes disconnected from the load. Also used with motors that have very little inertia that otherwise lack dynamic stiffness, even at high bandwidths.	1	Load Est	When set to 1 (on), the Load Estimate option removes or greatly reduces load disturbances and gives quicker system response.	0 & 1		This mode enhances stability as well as removing load disturbances.	Default: 00000000 Min/Max: 00000000/00000011	✓	Real
Bit	Name	Current Function														
0	Inrtia Adapt	When set to 1 (on), the IAA function will effect enhanced stability, higher bandwidths and dynamic stiffness. Useful when systems with a gear-box becomes disconnected from the load. Also used with motors that have very little inertia that otherwise lack dynamic stiffness, even at high bandwidths.														
1	Load Est	When set to 1 (on), the Load Estimate option removes or greatly reduces load disturbances and gives quicker system response.														
0 & 1		This mode enhances stability as well as removing load disturbances.														
133	Inert Adapt BW This parameter sets the bandwidth of the Inertia Adaptation function when the IAA function is selected (Par 132 [Inert Adpt Sel], bit 0 [Inrtia Adapt]). Typical IAA bandwidths range from 70 to 150 rad/sec with 100 rad/sec nominal best. If the Load Estimate (Par 132 [Inert Adpt Sel], bit 1 [load Est]) function is selected, then this parameter sets the natural frequency of a filter in rad/sec. Typical values range from 10 to 150 rad/sec with higher values being more responsive to disturbances but with increased system noise. There is no nominal best value, but 40 rad/sec is a suggested starting point. This adjustment may not function well in 'sloppy' geared systems. If both Inertia Adaptation and Load Estimate functions are active, use a bandwidth setting of 100 rad/sec.	Units: R/S Default: 100.0000 Min/Max: 10.0000/250.0000		✓	Real											
134	Inert Adapt Gain This parameter sets a multiplier of system inertia when the Inertia Adaptation function is selected (Par 132 [Inert Adpt Sel], bit 0 [Inrtia Adapt]). Higher values may cause high frequency ringing, while smaller values may cause fundamental load instability. A typical value is 0.5 This parameter has no affect on the Load Estimate function.	Default: 0.500 Min/Max: 0.300/1.000		✓	Real											

No.	Name Description	Values	Linkable	Read-Write	Data Type																																																																																																		
140	FricComp Spd Ref Supplies a speed input to the Friction Compensation algorithm. This input is normally a speed reference from a motion planner or ramped speed reference. It will trigger a torque feed forward response depending on its value.	Units: RPM Default: 0.0000 Min/Max: -/+14112.0000 Comm Scale: Par 4 [Motor NP RPM] = 1.0	✓	✓	Real																																																																																																		
141	FricComp Setup Enter or write a value to configure the friction compensation algorithm. This is a packed word of 3 digits. Each digit has a possible selection of 10 levels. <ul style="list-style-type: none"> The least significant digit sets the speed threshold in intervals of 0.0005 pu speed. The next (middle) digit sets the hysteresis band for the "units" digit in intervals of 0.0005 pu velocity. The most significant digit sets the number of time steps from stick to slip, each step is 0.002 sec. Example: Fsetup = 524 means, 5 time steps between stick and slip, each of 0.002 sec. duration, 2 counts of hysteresis or 0.001 pu_speed (each count is 0.0005 pu speed), and 4 counts or 0.002 pu_speed is the trigger threshold (each count is 0.0005 pu speed).	Default: 325 Min/Max: 0/999Integer 		✓	16-bit Integer																																																																																																		
142	FricComp Stick The torque needed to break away from zero speed. By the nature of friction, the break away sticktion will always be greater than the running friction.	Units: P.U. Default: 0.1500 Min/Max: 0.0000/8.0000 Comm Scale: Motor P.U. Torque	✓	✓	Real																																																																																																		
143	FricComp Slip The torque level to sustain very low speed – once "break away" has been achieved. By the nature of friction, viscous friction will always be less than sticktion.	Units: P.U. Default: 0.1000 Min/Max: 0.0000/8.0000 Comm Scale: Motor P.U. Torque	✓	✓	Real																																																																																																		
144	FricComp Rated The torque needed to a base friction at base motor speed and with no process loading. The friction compensation algorithm assumes a linear or viscous component of friction between Par 143 [FricComp Slip] and Par 144 [FricComp Rated].	Units: P.U. Default: 0.2000 Min/Max: 0.0000/8.0000 Comm Scale: Motor P.U. Torque	✓	✓	Real																																																																																																		
145	FricComp TorqAdd The torque reference output of the Friction Compensation function. A value of 1.0 represents rated torque of the motor.	Units: P.U. Default: 0.0000 Min/Max: -/+8.0000 Comm Scale: Motor P.U. Torque			Real																																																																																																		
150	Logic State Mach Indicates the logical state of the drive. Value 0 - "Stopped" indicates zero speed has been detected and the speed and torque regulators are disabled.	Default: 0 "Stopped" Options: 0 "Stopped" 4 "Inertia Test" 1 "Starting" 5 "MC Diag" 2 "Running" 6 "Test Done" 3 "Stopping"																																																																																																					
151	Logic Command The controller-drive interface (as defined by the Controller Communication Format) sets bits to enable and disable various functions and algorithms. Bits that are changed here are reflected in Par 152 [Applied LogicCmd]. Note: Bits 4 through 9 in Logic Command are NOT recalled from Control EEprom. They will be cleared upon drive power up or following an EEprom recall operation.	Options																																																																																																					
		<table border="1"> <thead> <tr> <th></th> <th>Reserved</th> <th>Reserved</th> <th>PositionEnbl</th> <th>ProcsTrim En</th> <th>Fric Comp</th> <th>Inertia Comp</th> <th>Sys Inert En</th> <th>Mtr Inert En</th> <th>PW Offset En</th> <th>Dir Sel En</th> <th>Pwr Diag En</th> <th>MC Atune En</th> <th>Time Axis En</th> <th>TachLoss Rst</th> <th>Spd S Crv En</th> <th>SpdRamp Dsbl</th> </tr> </thead> <tbody> <tr> <td>Default</td> <td>0</td> <td>0</td> <td>0</td> <td>0</td> <td>0</td> <td>0</td> <td>0</td> <td>0</td> <td>0</td> <td>0</td> <td>0</td> <td>0</td> <td>0</td> <td>0</td> <td>0</td> <td>0</td> </tr> <tr> <td>Bit</td> <td>15</td> <td>14</td> <td>13</td> <td>12</td> <td>11</td> <td>10</td> <td>9</td> <td>8</td> <td>7</td> <td>6</td> <td>5</td> <td>4</td> <td>3</td> <td>2</td> <td>1</td> <td>0</td> </tr> </tbody> </table> 0 = False 1 = True		Reserved	Reserved	PositionEnbl	ProcsTrim En	Fric Comp	Inertia Comp	Sys Inert En	Mtr Inert En	PW Offset En	Dir Sel En	Pwr Diag En	MC Atune En	Time Axis En	TachLoss Rst	Spd S Crv En	SpdRamp Dsbl	Default	0	0	0	0	0	0	0	0	0	0	0	0	0	0	0	0	Bit	15	14	13	12	11	10	9	8	7	6	5	4	3	2	1	0																																																		
	Reserved	Reserved	PositionEnbl	ProcsTrim En	Fric Comp	Inertia Comp	Sys Inert En	Mtr Inert En	PW Offset En	Dir Sel En	Pwr Diag En	MC Atune En	Time Axis En	TachLoss Rst	Spd S Crv En	SpdRamp Dsbl																																																																																							
Default	0	0	0	0	0	0	0	0	0	0	0	0	0	0	0	0																																																																																							
Bit	15	14	13	12	11	10	9	8	7	6	5	4	3	2	1	0																																																																																							
152	Applied LogicCmd Displays Logic Command that is applied to the Regulators and Control Algorithms within the drive. Logic Commands come from the 32-bit Logic Command found in a connection with the Logix Controller.	Options																																																																																																					
		<table border="1"> <thead> <tr> <th></th> <th>Reserved</th> <th>Reserved</th> <th>Reserved</th> <th>Reserved</th> <th>Reserved</th> <th>Reserved</th> <th>Coast Stop</th> <th>CurrLim Stop</th> <th>Jog 2</th> <th>Reserved</th> <th>UniPol Rev</th> <th>UniPol Fwd</th> <th>Clear Fault</th> <th>Jog 1</th> <th>Start</th> <th>Normal Stop</th> <th>Reserved</th> <th>Reserved</th> <th>PositionEnbl</th> <th>ProcsTrim En</th> <th>Fric Comp</th> <th>Inertia Comp</th> <th>Sys Inert En</th> <th>Mtr Inert En</th> <th>PW Offset En</th> <th>Dir Sel En</th> <th>Pwr Diag En</th> <th>MC Atune En</th> <th>Time Axis En</th> <th>TachLoss Rst</th> <th>Spd S Crv En</th> <th>SpdRamp Dsbl</th> </tr> </thead> <tbody> <tr> <td>Default</td> <td>0</td> <td>1</td> <td>0</td> <td>1</td> <td>1</td> <td>0</td> <td>0</td> <td>0</td> <td>0</td> <td>1</td> <td>0</td> <td>0</td> <td>0</td> <td>0</td> <td>1</td> <td>0</td> <td>0</td> <td>0</td> <td>0</td> <td>0</td> <td>0</td> <td>0</td> <td>0</td> <td>0</td> <td>0</td> <td>0</td> <td>0</td> <td>0</td> <td>0</td> <td>0</td> <td>0</td> </tr> <tr> <td>Bit</td> <td>31</td> <td>30</td> <td>29</td> <td>28</td> <td>27</td> <td>26</td> <td>25</td> <td>24</td> <td>23</td> <td>22</td> <td>21</td> <td>20</td> <td>19</td> <td>18</td> <td>17</td> <td>16</td> <td>15</td> <td>14</td> <td>13</td> <td>12</td> <td>11</td> <td>10</td> <td>9</td> <td>8</td> <td>7</td> <td>6</td> <td>5</td> <td>4</td> <td>3</td> <td>2</td> <td>1</td> <td>0</td> </tr> </tbody> </table> 0 = False 1 = True		Reserved	Reserved	Reserved	Reserved	Reserved	Reserved	Coast Stop	CurrLim Stop	Jog 2	Reserved	UniPol Rev	UniPol Fwd	Clear Fault	Jog 1	Start	Normal Stop	Reserved	Reserved	PositionEnbl	ProcsTrim En	Fric Comp	Inertia Comp	Sys Inert En	Mtr Inert En	PW Offset En	Dir Sel En	Pwr Diag En	MC Atune En	Time Axis En	TachLoss Rst	Spd S Crv En	SpdRamp Dsbl	Default	0	1	0	1	1	0	0	0	0	1	0	0	0	0	1	0	0	0	0	0	0	0	0	0	0	0	0	0	0	0	0	Bit	31	30	29	28	27	26	25	24	23	22	21	20	19	18	17	16	15	14	13	12	11	10	9	8	7	6	5	4	3	2	1	0			
	Reserved	Reserved	Reserved	Reserved	Reserved	Reserved	Coast Stop	CurrLim Stop	Jog 2	Reserved	UniPol Rev	UniPol Fwd	Clear Fault	Jog 1	Start	Normal Stop	Reserved	Reserved	PositionEnbl	ProcsTrim En	Fric Comp	Inertia Comp	Sys Inert En	Mtr Inert En	PW Offset En	Dir Sel En	Pwr Diag En	MC Atune En	Time Axis En	TachLoss Rst	Spd S Crv En	SpdRamp Dsbl																																																																							
Default	0	1	0	1	1	0	0	0	0	1	0	0	0	0	1	0	0	0	0	0	0	0	0	0	0	0	0	0	0	0	0																																																																								
Bit	31	30	29	28	27	26	25	24	23	22	21	20	19	18	17	16	15	14	13	12	11	10	9	8	7	6	5	4	3	2	1	0																																																																							

No.	Name Description	Values	Linkable Read-Write Data Type																																																																																																			
153	<p>Control Options Set bits to configure the options for operating the drive.</p> <p>Options</p> <table border="1"> <tr> <td>Reserved</td><td>Reserved</td><td>Reserved</td><td>Reserved</td><td>Reserved</td><td>Reserved</td><td>Tq Trim En</td><td>Reserved</td><td>Reserved</td><td>Reserved</td><td>Reserved</td><td>Reserved</td><td>Reserved</td><td>Reserved</td><td>Reserved</td><td>Aux Pwr Sply</td><td>Auto Tach Sw</td><td>Reserved</td><td>Reserved</td><td>OL CisLpDsbl</td><td>Jog -NoInteg</td><td>Iq Delay</td><td>Motor Dir</td><td>2W CoastStop</td><td>3WireControl</td><td>Stop Cndt Tq</td><td>Stop in Torq</td><td>Jog - NoRamp</td><td>Jog in Torq</td><td>2WCurLimSip</td><td>Sreg LPF 1</td><td>SRef Filt En</td><td>BipolarSRef</td> </tr> <tr> <td>Default</td><td>0</td><td>0</td><td>0</td><td>0</td><td>0</td><td>0</td><td>0</td><td>0</td><td>0</td><td>0</td><td>0</td><td>0</td><td>0</td><td>0</td><td>0</td><td>0</td><td>0</td><td>0</td><td>0</td><td>0</td><td>0</td><td>0</td><td>0</td><td>1</td><td>0</td><td>0</td><td>0</td><td>0</td><td>0</td><td>0</td><td>0</td><td>1</td> </tr> <tr> <td>Bit</td><td>31</td><td>30</td><td>29</td><td>28</td><td>27</td><td>26</td><td>25</td><td>24</td><td>23</td><td>22</td><td>21</td><td>20</td><td>19</td><td>18</td><td>17</td><td>16</td><td>15</td><td>14</td><td>13</td><td>12</td><td>11</td><td>10</td><td>9</td><td>8</td><td>7</td><td>6</td><td>5</td><td>4</td><td>3</td><td>2</td><td>1</td><td>0</td> </tr> </table>	Reserved	Reserved	Reserved	Reserved	Reserved	Reserved	Tq Trim En	Reserved	Reserved	Reserved	Reserved	Reserved	Reserved	Reserved	Reserved	Aux Pwr Sply	Auto Tach Sw	Reserved	Reserved	OL CisLpDsbl	Jog -NoInteg	Iq Delay	Motor Dir	2W CoastStop	3WireControl	Stop Cndt Tq	Stop in Torq	Jog - NoRamp	Jog in Torq	2WCurLimSip	Sreg LPF 1	SRef Filt En	BipolarSRef	Default	0	0	0	0	0	0	0	0	0	0	0	0	0	0	0	0	0	0	0	0	0	0	0	1	0	0	0	0	0	0	0	1	Bit	31	30	29	28	27	26	25	24	23	22	21	20	19	18	17	16	15	14	13	12	11	10	9	8	7	6	5	4	3	2	1	0		0 = False 1 = True
Reserved	Reserved	Reserved	Reserved	Reserved	Reserved	Tq Trim En	Reserved	Reserved	Reserved	Reserved	Reserved	Reserved	Reserved	Reserved	Aux Pwr Sply	Auto Tach Sw	Reserved	Reserved	OL CisLpDsbl	Jog -NoInteg	Iq Delay	Motor Dir	2W CoastStop	3WireControl	Stop Cndt Tq	Stop in Torq	Jog - NoRamp	Jog in Torq	2WCurLimSip	Sreg LPF 1	SRef Filt En	BipolarSRef																																																																						
Default	0	0	0	0	0	0	0	0	0	0	0	0	0	0	0	0	0	0	0	0	0	0	0	1	0	0	0	0	0	0	0	1																																																																						
Bit	31	30	29	28	27	26	25	24	23	22	21	20	19	18	17	16	15	14	13	12	11	10	9	8	7	6	5	4	3	2	1	0																																																																						
	<table border="1"> <thead> <tr> <th>Bit</th> <th>Name</th> <th>Current Function</th> </tr> </thead> <tbody> <tr> <td>0</td> <td>Bipolar SRef</td> <td>When this bit is enabled a bipolar speed reference is used. In bipolar reference mode, Par 40 [Selected Spd Ref] indicates both the speed magnitude and the direction: Positive speed reference values (+) = forward direction and negative speed reference values (-) = reverse direction. When this bit is disabled a unipolar speed reference is used. In unipolar mode, the speed reference is limited to a minimum value of zero (0). In this case Par 40 [Selected Spd Ref] supplies only the speed magnitude. The direction is determined by Par 153 [Applied LogicCmd] bits 20 [UniPol Fwd] and 21 [UniPol Rev]. The forward/reverse direction button on the HIM is one possible source for the [Applied Logic Command] direction bits. The following chart explains the effect that the direction button on the HIM has based on the condition of the "Bipolar SRef" bit: <table border="1"> <thead> <tr> <th>Bipolar</th> <th>Reference Controlled By HIM?</th> <th>HIM Direction Button</th> </tr> </thead> <tbody> <tr> <td>Enabled</td> <td>Yes</td> <td>Changes the motor direction due to a HIM supplied (+) or (-) command signal</td> </tr> <tr> <td>Enabled</td> <td>No</td> <td>Has no effect on motor direction. Direction determined by sign of Par 40 [Selected Spd Ref].</td> </tr> <tr> <td>Disabled</td> <td>Yes</td> <td>Changes the motor direction due to a HIM supplied Forward or Reverse Logic Command bit.</td> </tr> <tr> <td>Disabled</td> <td>No</td> <td>Changes the motor direction due to a HIM supplied Forward or Reverse Logic Command bit.</td> </tr> </tbody> </table> In either Bipolar or Unipolar mode, the selected direction can be determined from the sign of Par 41 [Limited Spd Ref]. Positive values indicate forward rotation and negative values indicate reverse rotation. </td> </tr> <tr> <td>1</td> <td>SRef Filt En</td> <td>Enables Speed Reference Lead Lag Filter-reset disables</td> </tr> <tr> <td>2</td> <td>Sreg LPF 1</td> <td>Setting this bit will enable the speed regulator filter as a single order low pass filter</td> </tr> <tr> <td>4</td> <td>Jog in Torq</td> <td>Overrides Par 110 [Spd/Torq ModeSel] setting when jog command received</td> </tr> <tr> <td>5</td> <td>Jog-NoRamp</td> <td>Bypasses the Speed Reference Ramp and S-Curve</td> </tr> <tr> <td>6</td> <td>Stop in Torq</td> <td>Overrides Par 110 [Spd/Torq ModeSel] setting when stopping</td> </tr> <tr> <td>8</td> <td>3WireControl</td> <td>Configures for 3-wire control</td> </tr> <tr> <td>11</td> <td>Iq Delay</td> <td>Enables Torque Current Delay option</td> </tr> <tr> <td>12</td> <td>Jog-NoInteg</td> <td>Configures speed regulator's integrator to hold when jogging</td> </tr> <tr> <td>17</td> <td>Aux Pwr Sply</td> <td>Enables use of Aux. Power Supply. When set to 1, Main Control Board examines internal 12V DC power to see when energized. When set to 0, examines voltage of DC Bus. This bit enables Main Control Board and DriveLogix Controller to remain energized when 3-Ø voltage is de-energized.</td> </tr> </tbody> </table>	Bit	Name	Current Function	0	Bipolar SRef	When this bit is enabled a bipolar speed reference is used. In bipolar reference mode, Par 40 [Selected Spd Ref] indicates both the speed magnitude and the direction: Positive speed reference values (+) = forward direction and negative speed reference values (-) = reverse direction. When this bit is disabled a unipolar speed reference is used. In unipolar mode, the speed reference is limited to a minimum value of zero (0). In this case Par 40 [Selected Spd Ref] supplies only the speed magnitude. The direction is determined by Par 153 [Applied LogicCmd] bits 20 [UniPol Fwd] and 21 [UniPol Rev]. The forward/reverse direction button on the HIM is one possible source for the [Applied Logic Command] direction bits. The following chart explains the effect that the direction button on the HIM has based on the condition of the "Bipolar SRef" bit: <table border="1"> <thead> <tr> <th>Bipolar</th> <th>Reference Controlled By HIM?</th> <th>HIM Direction Button</th> </tr> </thead> <tbody> <tr> <td>Enabled</td> <td>Yes</td> <td>Changes the motor direction due to a HIM supplied (+) or (-) command signal</td> </tr> <tr> <td>Enabled</td> <td>No</td> <td>Has no effect on motor direction. Direction determined by sign of Par 40 [Selected Spd Ref].</td> </tr> <tr> <td>Disabled</td> <td>Yes</td> <td>Changes the motor direction due to a HIM supplied Forward or Reverse Logic Command bit.</td> </tr> <tr> <td>Disabled</td> <td>No</td> <td>Changes the motor direction due to a HIM supplied Forward or Reverse Logic Command bit.</td> </tr> </tbody> </table> In either Bipolar or Unipolar mode, the selected direction can be determined from the sign of Par 41 [Limited Spd Ref]. Positive values indicate forward rotation and negative values indicate reverse rotation.	Bipolar	Reference Controlled By HIM?	HIM Direction Button	Enabled	Yes	Changes the motor direction due to a HIM supplied (+) or (-) command signal	Enabled	No	Has no effect on motor direction. Direction determined by sign of Par 40 [Selected Spd Ref].	Disabled	Yes	Changes the motor direction due to a HIM supplied Forward or Reverse Logic Command bit.	Disabled	No	Changes the motor direction due to a HIM supplied Forward or Reverse Logic Command bit.	1	SRef Filt En	Enables Speed Reference Lead Lag Filter-reset disables	2	Sreg LPF 1	Setting this bit will enable the speed regulator filter as a single order low pass filter	4	Jog in Torq	Overrides Par 110 [Spd/Torq ModeSel] setting when jog command received	5	Jog-NoRamp	Bypasses the Speed Reference Ramp and S-Curve	6	Stop in Torq	Overrides Par 110 [Spd/Torq ModeSel] setting when stopping	8	3WireControl	Configures for 3-wire control	11	Iq Delay	Enables Torque Current Delay option	12	Jog-NoInteg	Configures speed regulator's integrator to hold when jogging	17	Aux Pwr Sply	Enables use of Aux. Power Supply. When set to 1, Main Control Board examines internal 12V DC power to see when energized. When set to 0, examines voltage of DC Bus. This bit enables Main Control Board and DriveLogix Controller to remain energized when 3-Ø voltage is de-energized.																																																					
Bit	Name	Current Function																																																																																																				
0	Bipolar SRef	When this bit is enabled a bipolar speed reference is used. In bipolar reference mode, Par 40 [Selected Spd Ref] indicates both the speed magnitude and the direction: Positive speed reference values (+) = forward direction and negative speed reference values (-) = reverse direction. When this bit is disabled a unipolar speed reference is used. In unipolar mode, the speed reference is limited to a minimum value of zero (0). In this case Par 40 [Selected Spd Ref] supplies only the speed magnitude. The direction is determined by Par 153 [Applied LogicCmd] bits 20 [UniPol Fwd] and 21 [UniPol Rev]. The forward/reverse direction button on the HIM is one possible source for the [Applied Logic Command] direction bits. The following chart explains the effect that the direction button on the HIM has based on the condition of the "Bipolar SRef" bit: <table border="1"> <thead> <tr> <th>Bipolar</th> <th>Reference Controlled By HIM?</th> <th>HIM Direction Button</th> </tr> </thead> <tbody> <tr> <td>Enabled</td> <td>Yes</td> <td>Changes the motor direction due to a HIM supplied (+) or (-) command signal</td> </tr> <tr> <td>Enabled</td> <td>No</td> <td>Has no effect on motor direction. Direction determined by sign of Par 40 [Selected Spd Ref].</td> </tr> <tr> <td>Disabled</td> <td>Yes</td> <td>Changes the motor direction due to a HIM supplied Forward or Reverse Logic Command bit.</td> </tr> <tr> <td>Disabled</td> <td>No</td> <td>Changes the motor direction due to a HIM supplied Forward or Reverse Logic Command bit.</td> </tr> </tbody> </table> In either Bipolar or Unipolar mode, the selected direction can be determined from the sign of Par 41 [Limited Spd Ref]. Positive values indicate forward rotation and negative values indicate reverse rotation.	Bipolar	Reference Controlled By HIM?	HIM Direction Button	Enabled	Yes	Changes the motor direction due to a HIM supplied (+) or (-) command signal	Enabled	No	Has no effect on motor direction. Direction determined by sign of Par 40 [Selected Spd Ref].	Disabled	Yes	Changes the motor direction due to a HIM supplied Forward or Reverse Logic Command bit.	Disabled	No	Changes the motor direction due to a HIM supplied Forward or Reverse Logic Command bit.																																																																																					
Bipolar	Reference Controlled By HIM?	HIM Direction Button																																																																																																				
Enabled	Yes	Changes the motor direction due to a HIM supplied (+) or (-) command signal																																																																																																				
Enabled	No	Has no effect on motor direction. Direction determined by sign of Par 40 [Selected Spd Ref].																																																																																																				
Disabled	Yes	Changes the motor direction due to a HIM supplied Forward or Reverse Logic Command bit.																																																																																																				
Disabled	No	Changes the motor direction due to a HIM supplied Forward or Reverse Logic Command bit.																																																																																																				
1	SRef Filt En	Enables Speed Reference Lead Lag Filter-reset disables																																																																																																				
2	Sreg LPF 1	Setting this bit will enable the speed regulator filter as a single order low pass filter																																																																																																				
4	Jog in Torq	Overrides Par 110 [Spd/Torq ModeSel] setting when jog command received																																																																																																				
5	Jog-NoRamp	Bypasses the Speed Reference Ramp and S-Curve																																																																																																				
6	Stop in Torq	Overrides Par 110 [Spd/Torq ModeSel] setting when stopping																																																																																																				
8	3WireControl	Configures for 3-wire control																																																																																																				
11	Iq Delay	Enables Torque Current Delay option																																																																																																				
12	Jog-NoInteg	Configures speed regulator's integrator to hold when jogging																																																																																																				
17	Aux Pwr Sply	Enables use of Aux. Power Supply. When set to 1, Main Control Board examines internal 12V DC power to see when energized. When set to 0, examines voltage of DC Bus. This bit enables Main Control Board and DriveLogix Controller to remain energized when 3-Ø voltage is de-energized.																																																																																																				

No.	Name Description	Values	Linkable	Read-Write	Data Type
154	Stop Dwell Time Sets an adjustable delay time between detecting zero speed and disabling the speed and torque regulators, when responding to a stop command. For more information, please see Stop Dwell Time on page C-5 . Important: Consult industry and local codes when setting the value of this parameter.	Units: Sec Default: 0.0000 Min/Max: 0.0000/10.0000	✓	✓	Real



Options		Reserved	Reserved	Reserved	Reserved	Reserved	Command Run	Start Active	Position Mode	Speed Mode	Torque Mode	Reserved	Spd Commis	MC Commis	MC En Ack	Above Setpt2	At Setpt 1	Reserved	At Setpt Spd	At Zero Spd	Tach Loss Sw	At Limit	Run Ready	Flash Mode	Alarm	Faulted	Jogging	Decelerating	Accelerating	Actual Dir	Command Dir	Running	Enabled
Default		0	0	0	0	0	0	0	0	0	0	0	0	0	0	0	0	0	0	0	0	0	0	0	0	0	0	0	0	0	0	0	
Bit		31	30	29	28	27	26	25	24	23	22	21	20	19	18	17	16	15	14	13	12	11	10	9	8	7	6	5	4	3	2	1	0
																		0 = False		1 = True													
Bit Name	Current Function	Bit	Name	Current Function																													
0	Enabled Drive is controlling motor	14	At Setpt Spd	Speed feedback is within limits defined in Par 41 [Limited Spd Ref] and 171 [Set Speed Lim]																													
1	Running Run command received & controlling motor	15	Reserved																														
2	Command Dir Commanded direction is forward	16	At Setpt 1	Par 172 [Setpt 1 Data] value is within limits defined by Par 173 [Setpt1 TripPoint] and 174 [Setpt 1 Limit]																													
3	Actual Dir Actual motor direction is forward	17	Above Setpt 2	Par 175 [Setpt 2 Data] value is within limits defined by Par 176 [Setpt2 TripPoint] and 177 [Setpt 2 Limit]																													
4	Accelerating Motor is increasing speed	18	MC En Ack	Drive is controlling motor (same as enabled)																													
5	Decelerating Motor is decreasing speed	19	MC Commis	Motor control commissioning in progress																													
6	Jogging Jog command received & controlling motor	20	Spd Commis	Speed control commissioning in progress																													
7	Faulted Exception event that causes a fault has occurred	21	Reserved																														
8	Alarm Exception event that causes an alarm has occurred	22	Torque Mode	Par 110 [Spd/Torq ModeSel] value is 2, 3, 4, 5 or 6																													
9	Flash Mode Flash upgrade in progress	23	Speed Mode	Par 110 [Spd/Torq ModeSel] value is 1 & position control is not enabled																													
10	Run Ready Enable input is high & drive is fault free	24	Position Mode	Position control active & Par 110 [Spd/Torq ModeSel] value is not 2, 3, 4, 5 or 6																													
11	At Limit Speed, Power, Current or Torque is being limited, refer to Par 304	25	Start Active	Start command received & controlling motor																													
12	Tach Loss SW Failure is detected in primary speed or position feedback device & drive has switched to secondary device	26	Command Run	Run command received																													
13	At Zero Spd Speed feedback is within limits defined in Par 160	27-31	Reserved																														



Options		Reserved	Reserved	Reserved	Reserved	Reserved	Reserved	Reserved	Reserved	Reserved	Reserved	Reserved	Reserved	Reserved	Reserved	Reserved	Reserved	Reserved	Reserved	PM Mtr Fdbk	Motin Shutdown	Dlgn Config	Bus PreChrg	Encoder PPR	Jog	Start	Flash Upgrd	Power EE	Power Loss	SW I Lim Stp	SW Coast Stp	SW Ramp Stop	No Enable	Faulted
Default		0	0	0	0	0	0	0	0	0	0	0	0	0	0	0	0	0	0	0	0	0	0	0	0	0	0	0	0	0	0	0	0	
Bit		31	30	29	28	27	26	25	24	23	22	21	20	19	18	17	16	15	14	13	12	11	10	9	8	7	6	5	4	3	2	1	0	
																		0 = False		1 = True														

Options		ProcsTrim En	Cmd Dir Upol	Lgx I/O Cnx	Lgx Run Mode	Reserved	Reserved	Reserved	Reserved	Reserved	Reserved	PM Offset Rq	Mtr Dir Req	Pwr Diag Req	MC Atune Req	FTD Ramp En	MC En Req	RThru Flux	DC Brake En	Mtr Sim Mode	RThru Coast	CurRef En	Forced Spd	Torq Ref En	Spd Reg En	SRReg IntgHld	CurLim Stop	J Tst FULSpd	Inert Tst En	PositionEnbl	SRRef SCrv En	SRRef Ramp En	Spd Ref En
Default		0	0	0	0	0	0	0	0	0	0	0	0	0	0	0	0	0	0	0	0	0	0	0	0	0	0	0	0	0	0	0	0
Bit		31	30	29	28	27	26	25	24	23	22	21	20	19	18	17	16	15	14	13	12	11	10	9	8	7	6	5	4	3	2	1	0
																		0 = False		1 = True													

No.	Name Description	Values	Linkable	Read-Write	Data Type																																																																																																		
158	Drive Logic Rslt This is the logic output of the logic parser that combines the outputs from the DPI ports and the DriveLogic controller to determine drive control based on the masks and owners. The control bits are reflected in Par 152 [Applied LogicCmd] bits 16-31. Options <table border="1"> <thead> <tr> <th></th> <th>Reserved</th> <th>Reserved</th> <th>Reserved</th> <th>Reserved</th> <th>Reserved</th> <th>Reserved</th> <th>Coast Stop</th> <th>CurrLim Stop</th> <th>Jog 2</th> <th>Reserved</th> <th>UniPol Rev</th> <th>UniPol Fwd</th> <th>Clear Fault</th> <th>Jog 1</th> <th>Start</th> <th>Normal Stop</th> <th>Reserved</th> <th>Reserved</th> <th>Reserved</th> <th>Reserved</th> <th>Reserved</th> <th>Reserved</th> <th>Coast Stop</th> <th>CurrLim Stop</th> <th>Jog 2</th> <th>Reserved</th> <th>UniPol Rev</th> <th>UniPol Fwd</th> <th>Clear Fault</th> <th>Jog 1</th> <th>Start</th> <th>Normal Stop</th> </tr> </thead> <tbody> <tr> <td>Default</td> <td>0</td><td>0</td><td>0</td><td>0</td><td>0</td><td>0</td><td>0</td><td>0</td><td>0</td><td>0</td><td>0</td><td>0</td><td>0</td><td>0</td><td>0</td><td>0</td><td>0</td><td>0</td><td>0</td><td>0</td><td>0</td><td>0</td><td>0</td><td>0</td><td>0</td><td>0</td><td>0</td><td>0</td><td>0</td><td>0</td><td>0</td><td>0</td> </tr> <tr> <td>Bit</td> <td>31</td><td>30</td><td>29</td><td>28</td><td>27</td><td>26</td><td>25</td><td>24</td><td>23</td><td>22</td><td>21</td><td>20</td><td>19</td><td>18</td><td>17</td><td>16</td><td>15</td><td>14</td><td>13</td><td>12</td><td>11</td><td>10</td><td>9</td><td>8</td><td>7</td><td>6</td><td>5</td><td>4</td><td>3</td><td>2</td><td>1</td><td>0</td> </tr> </tbody> </table> 0 = False 1 = True		Reserved	Reserved	Reserved	Reserved	Reserved	Reserved	Coast Stop	CurrLim Stop	Jog 2	Reserved	UniPol Rev	UniPol Fwd	Clear Fault	Jog 1	Start	Normal Stop	Reserved	Reserved	Reserved	Reserved	Reserved	Reserved	Coast Stop	CurrLim Stop	Jog 2	Reserved	UniPol Rev	UniPol Fwd	Clear Fault	Jog 1	Start	Normal Stop	Default	0	0	0	0	0	0	0	0	0	0	0	0	0	0	0	0	0	0	0	0	0	0	0	0	0	0	0	0	0	0	0	0	Bit	31	30	29	28	27	26	25	24	23	22	21	20	19	18	17	16	15	14	13	12	11	10	9	8	7	6	5	4	3	2	1	0			
	Reserved	Reserved	Reserved	Reserved	Reserved	Reserved	Coast Stop	CurrLim Stop	Jog 2	Reserved	UniPol Rev	UniPol Fwd	Clear Fault	Jog 1	Start	Normal Stop	Reserved	Reserved	Reserved	Reserved	Reserved	Reserved	Coast Stop	CurrLim Stop	Jog 2	Reserved	UniPol Rev	UniPol Fwd	Clear Fault	Jog 1	Start	Normal Stop																																																																							
Default	0	0	0	0	0	0	0	0	0	0	0	0	0	0	0	0	0	0	0	0	0	0	0	0	0	0	0	0	0	0	0	0																																																																							
Bit	31	30	29	28	27	26	25	24	23	22	21	20	19	18	17	16	15	14	13	12	11	10	9	8	7	6	5	4	3	2	1	0																																																																							
159	DigIn ConfigStat This parameter indicates the status of the Digital Inputs.	Default: 0 "DigIn Ok" Options: 0 "DigIn Ok" 4 "Strt+UnLatch" 1 "2 Run/Starts" 5 "2 Jog1's" 2 "Start NoStop" 6 "2 Jog2's" 3 "Run+Latched" 7 "2 FwdRevs's"																																																																																																					
160	Zero Speed Lim Establishes a band around zero speed that is used to determine when the drive considers the motor to be at zero speed.	Units: RPM Default: 17.6400 Min/Max: 0.0000/882.0000 Comm Scale: Par 4 [Motor NP RPM] = 1.0	<input checked="" type="checkbox"/>	<input checked="" type="checkbox"/>	Real																																																																																																		
161	Logic TP Sel Enter or write a value to select logic status indication displayed in Par 162 [Logic TP Data].	Default: 0 "Reserved" Options: 0 "Reserved" 15 "2ms time" 1 "Avg Spd Ref" 16 "2ms max" 2 "Avg Spd Fdbk" 17 "8ms time" 3 "LastStopMode" 18 "8ms max" 4 "Spd Ref Sel" 19 "BkGnd Time" 5 "Start State" 20 "BkGnd Max" 6 "Run State" 21 "500us %" 7 "Stop State" 22 "2ms %" 8 "PrChrg Logic" 23 "8ms %" 9 "Meas State" 24 "BkGnd %" 10 "Data State" 25 "RThru State" 11 "Diag State" 26 "RThru Timer" 12 "MC CalcState" 27 "Mtr Friction" 13 "500us time" 28 "Sys Friction" 14 "500us max" 29 "Iq proc time"																																																																																																					
162	Logic TP Data Displays the indication selected by Par 161 [Logic TP Sel].	Default: 0.0000 Min/Max: -/+2200000000.0000			Real																																																																																																		
163	Stop Oper TP Sel Enter or write a value to select data displayed in Par 164 [StpOper TPData] at the time of the last initiated stop.	Default: 0 "Zero" Options: 0 "Zero" 14 "ZM1 Spd Fdbk" 1 "Logic State" 15 "Speed Ref" 2 "Logic Input" 16 "Avg Spd Ref" 3 "Lcl In State" 17 "ZM1 Spd Ref" 4 "Logic Status" 18 "SReg PI Out" 5 "Run Inhibit" 19 "Torq Ref" 6 "Logic Ctrl" 20 "TorqRef Stat" 7 "Mtr Ctrl Cmd" 21 "DC Bus Volts" 8 "Mtr Ctrl Ack" 22 "Motor Volts" 9 "Reserved" 23 "Mtr Current" 10 "Flt Status 1" 24 "Motor Flux" 11 "Flt Status 2" 25 "Motor Freq" 12 "Motor Speed" 26 "Motor Power" 13 "Avg Spd Fdbk" 27 "Flt Status 3"																																																																																																					
164	StopOper TP Data Displays the data selected by Par 163 [Stop Oper TP Sel].	Default: 0.0000 Min/Max: -/+2200000000.0000			Real																																																																																																		
165	Test Status Indicates which test (if any) is in progress.	Default: 0 "None" Options: 0 "None" 4 "PM Offset" 1 "MC Autotune" 5 "Mtr Inertia" 2 "Power Diag" 6 "Sys Inertia" 3 "Motor Direct" 7 "Mtr+Sys J"																																																																																																					
166	Motor Ctrl Cmmnd Displays the command bits to the Motor Control Processor from the Velocity Processor.	Options <table border="1"> <thead> <tr> <th></th> <th>Reserved</th> <th>Reserved</th> <th>Reserved</th> <th>Reserved</th> <th>Reserved</th> <th>Reserved</th> <th>Reserved</th> <th>Reserved</th> <th>Reserved</th> <th>Reserved</th> <th>Reserved</th> <th>Reserved</th> <th>Reserved</th> <th>Reserved</th> <th>Reserved</th> <th>Reserved</th> <th>Reserved</th> <th>Reserved</th> <th>Reserved</th> <th>Reserved</th> <th>Reserved</th> <th>Reserved</th> <th>Reserved</th> <th>Reserved</th> <th>Reserved</th> <th>Base Block</th> <th>Reserved</th> <th>Reserved</th> <th>Torque Run</th> <th>Flux Run</th> <th>CP Enable</th> </tr> </thead> <tbody> <tr> <td>Default</td> <td>0</td><td>0</td><td>0</td><td>0</td><td>0</td><td>0</td><td>0</td><td>0</td><td>0</td><td>0</td><td>0</td><td>0</td><td>0</td><td>0</td><td>0</td><td>0</td><td>0</td><td>0</td><td>0</td><td>0</td><td>0</td><td>0</td><td>0</td><td>0</td><td>0</td><td>0</td><td>0</td><td>0</td><td>0</td><td>0</td> </tr> <tr> <td>Bit</td> <td>31</td><td>30</td><td>29</td><td>28</td><td>27</td><td>26</td><td>25</td><td>24</td><td>23</td><td>22</td><td>21</td><td>20</td><td>19</td><td>18</td><td>17</td><td>16</td><td>15</td><td>14</td><td>13</td><td>12</td><td>11</td><td>10</td><td>9</td><td>8</td><td>7</td><td>6</td><td>5</td><td>4</td><td>3</td><td>2</td><td>1</td><td>0</td> </tr> </tbody> </table> 0 = False 1 = True		Reserved	Reserved	Reserved	Reserved	Reserved	Reserved	Reserved	Reserved	Reserved	Reserved	Reserved	Reserved	Reserved	Reserved	Reserved	Reserved	Reserved	Reserved	Reserved	Reserved	Reserved	Reserved	Reserved	Reserved	Reserved	Base Block	Reserved	Reserved	Torque Run	Flux Run	CP Enable	Default	0	0	0	0	0	0	0	0	0	0	0	0	0	0	0	0	0	0	0	0	0	0	0	0	0	0	0	0	0	0	Bit	31	30	29	28	27	26	25	24	23	22	21	20	19	18	17	16	15	14	13	12	11	10	9	8	7	6	5	4	3	2	1	0					
	Reserved	Reserved	Reserved	Reserved	Reserved	Reserved	Reserved	Reserved	Reserved	Reserved	Reserved	Reserved	Reserved	Reserved	Reserved	Reserved	Reserved	Reserved	Reserved	Reserved	Reserved	Reserved	Reserved	Reserved	Reserved	Base Block	Reserved	Reserved	Torque Run	Flux Run	CP Enable																																																																								
Default	0	0	0	0	0	0	0	0	0	0	0	0	0	0	0	0	0	0	0	0	0	0	0	0	0	0	0	0	0	0																																																																									
Bit	31	30	29	28	27	26	25	24	23	22	21	20	19	18	17	16	15	14	13	12	11	10	9	8	7	6	5	4	3	2	1	0																																																																							

No.	Name Description	Values	Linkable	Read-Write	Data Type
186	PI Prop Gain Controls the proportional gain of the Process Control regulator. If the proportional gain is 1.0, the regulator output equals 1 pu for 1 pu error.	Default: 8.0000 Min/Max: 0.0000/200.0000	✓	✓	Real
187	PI Integ Time Controls the integral gain of the Process Control regulator. If the integrator time is 1.0, the regulator output equals 1 pu in 1 second for 1 pu error.	Units: /Sec Default: 8.0000 Min/Max: 0.0000/4000.0000	✓	✓	Real
188	PI Integ HLim The high limit of the integral gain channel for the Process Control regulator. A value of 1 can represent either base motor speed, motor rated torque, or 100% for some external function.	Units: P.U. Default: 0.1000 Min/Max: 0.0000/8.0000	✓	✓	Real
189	PI Integ LLim The low limit of the integral gain channel for the Process Control regulator. A value of 1 can represent either base motor speed, motor rated torque, or 100% for some external function.	Units: P.U. Default: -0.1000 Min/Max: -8.0000/0.0000	✓	✓	Real
190	PI Integ Output Displays the output value of the integral channel of the Process Control regulator. A value of 1 can represent either base motor speed, motor rated torque, or 100% for some external function.	Units: P.U. Default: 0.0000 Min/Max: +/-8.0000			Real
191	PI High Limit The high limit of the Process Control regulator output. A value of 1 can represent either base motor speed, motor rated torque, or 100% for some external function.	Units: P.U. Default: 0.1000 Min/Max: 0.0000/8.0000	✓	✓	Real
192	PI Lower Limit The low limit of the Process Control regulator output. A value of 1 can represent either base motor speed, motor rated torque, or 100% for some external function.	Units: P.U. Default: -0.1000 Min/Max: -8.0000/0.0000	✓	✓	Real
193	PI TP Sel Enter or write a value to select Process Control PI data displayed by Par 194 [PI TP Data].	Default: 0 "Zero" Options: 0 "Zero" 6 "On Out Limit" 1 "PI Error" 7 "Extern Hold" 2 "LPF Output" 8 "Hold Status" 3 "P Gain Term" 9 "Enbl Status" 4 "Reg Output" 10 "Time Axis En" 5 "On Intg Lim"			
194	PI TP Data Displays the data selected by Par 193 [PI TP Sel].	Units: P.U. Default: 0.0000 Min/Max: +/-8.0000			Real
200	Time Axis Rate Sets rate (1/sec) for the Time Function Generator to ramp from and output of 0 to 1 and from 1 to 0.	Units: /Sec Default: 1.0000 Min/Max: 0.0100/20.0000	✓	✓	Real
201	Time Axis Output The output of the Time Function Generator. When the Time Function Generator is enabled by Par 183 [PI Command] bit 1 [Enable] or Par 151 [Logic Command] bit 3 [Time Axis En], the value of this parameter ramps from 0 to 1 at a rate determined by Par 200 [Time Axis Rate]. Conversely, when the Function Generator is disabled, the value of this parameter ramps from 1 to 0.	Default: 0.0000 Min/Max: 0.0000/1.0000			Real
204	LimGen Y axis Mx Sets Par 207 [Limit Gen Hi Out] and Par 208 [Limit Gen Lo Out] when the absolute value of Par 206 [LimGen X axis In] is greater than or equal to 1.	Units: P.U. Default: 0.2500 Min/Max: 0.0000/8.0000	✓	✓	Real
205	LimGen Y axis Mn Sets Par 207 [Limit Gen Hi Out] and Par 208 [Limit Gen Lo Out] when the absolute value of Par 206 [LimGen X axis In] is equal to 0.	Units: P.U. Default: 0.0500 Min/Max: 0.0000/8.0000	✓	✓	Real
206	LimGen X axis In The X axis input to the Limit Generator. Typically this parameter is linked to a speed reference or to Par 201 [Time Axis Output].	Default: 0.0000 Min/Max: +/-8.0000	✓	✓	Real
207	Limit Gen Hi Out Displays the positive output of the Limit Generator. When Par 206 [Limit Gen X axis In] is greater than or equal to 1, this value equals Par 204 [LimGen Y axis Mx]. When Par 206 [LimGen X axis In] is equal to 0, this value equals Par 205 [LimGen Y axis Mn]. For values of X Axis input between 0 and 1, the value of this parameter is interpolated from Y axis min and max values. Typically this parameter is linked to Par 191 [PI High Limit].	Units: P.U. Default: 8.0000 Min/Max: 0.0000/8.0000			Real
208	Limit Gen Lo Out Displays the negative output of the Limit Generator. The value of this parameter is the negative of Par 207 [Limit Gen Hi Out]. Typically it is linked to Par 192 [PI Lower Limit].	Units: P.U. Default: -8.0000 Min/Max: -8.0000/0.0000			Real

No.	Name Description	Values	Linkable	Read-Write	Data Type																																																					
210	PeakDtct Ctrl In Sets the configuration of the two peak/level detectors. <ul style="list-style-type: none"> When set (in Set mode), bit 0 [Peak 1 Set] and 4 [Peak 2 Set] are level detectors that causes their output bit to match their preset bit value (Par 214 [PeakDtct1 Preset] and Par 218 [PeakDtct2 Preset], respectively). When set (in Hold mode), bit 1 [Peak 1 Hold] and 5 [Peak 2 Hold] are level detectors that cause their output to hold the present min/max. When bits 1 and 4 (Set mode) and 2 and 5 (Hold mode) are off, their output bit captures the peak min/max. Bits 2 [Peak 1 Sel] and 6 [Peak 2 Sel] determine if the peak/level detectors are positive or negative. If the bit is set the detector detects positive peaks or levels above the preset. If the bit is not set the detector detects negative peaks ("valleys") or levels below the preset. The output shows the min. or max. peak. Options <table border="1"> <tr> <td></td> <td>Reserved</td> <td>Reserved</td> <td>Reserved</td> <td>Reserved</td> <td>Reserved</td> <td>Reserved</td> <td>Reserved</td> <td>Reserved</td> <td>Reserved</td> <td>Reserved</td> <td>Peak 2 Sel</td> <td>Peak 2 Hold</td> <td>Peak 2 Set</td> <td>Reserved</td> <td>Peak 1 Sel</td> <td>Peak 1 Hold</td> <td>Peak 1 Set</td> </tr> <tr> <td>Default</td> <td>0</td> <td>0</td> <td>0</td> <td>0</td> <td>0</td> <td>0</td> <td>0</td> <td>0</td> <td>0</td> <td>0</td> <td>0</td> <td>0</td> <td>0</td> <td>0</td> <td>0</td> <td>0</td> <td>0</td> </tr> <tr> <td>Bit</td> <td>15</td> <td>14</td> <td>13</td> <td>12</td> <td>11</td> <td>10</td> <td>9</td> <td>8</td> <td>7</td> <td>6</td> <td>5</td> <td>4</td> <td>3</td> <td>2</td> <td>1</td> <td>0</td> <td></td> </tr> </table> 0 = False 1 = True		Reserved	Reserved	Reserved	Reserved	Reserved	Reserved	Reserved	Reserved	Reserved	Reserved	Peak 2 Sel	Peak 2 Hold	Peak 2 Set	Reserved	Peak 1 Sel	Peak 1 Hold	Peak 1 Set	Default	0	0	0	0	0	0	0	0	0	0	0	0	0	0	0	0	0	Bit	15	14	13	12	11	10	9	8	7	6	5	4	3	2	1	0				
	Reserved	Reserved	Reserved	Reserved	Reserved	Reserved	Reserved	Reserved	Reserved	Reserved	Peak 2 Sel	Peak 2 Hold	Peak 2 Set	Reserved	Peak 1 Sel	Peak 1 Hold	Peak 1 Set																																									
Default	0	0	0	0	0	0	0	0	0	0	0	0	0	0	0	0	0																																									
Bit	15	14	13	12	11	10	9	8	7	6	5	4	3	2	1	0																																										
211	Peak Ctrl Status Status of the peak/level detectors. A peak detector sets its bit when it detects a peak or when its input exceeds its preset - depending on the selected mode. Options <table border="1"> <tr> <td></td> <td>Reserved</td> <td>Reserved</td> <td>Reserved</td> <td>Reserved</td> <td>Reserved</td> <td>Reserved</td> <td>Reserved</td> <td>Reserved</td> <td>Reserved</td> <td>Reserved</td> <td>Reserved</td> <td>Reserved</td> <td>Reserved</td> <td>Reserved</td> <td>Peak 2 Chng</td> <td>Peak 1 Chng</td> </tr> <tr> <td>Default</td> <td>0</td> <td>0</td> <td>0</td> <td>0</td> <td>0</td> <td>0</td> <td>0</td> <td>0</td> <td>0</td> <td>0</td> <td>0</td> <td>0</td> <td>0</td> <td>0</td> <td>0</td> <td>0</td> </tr> <tr> <td>Bit</td> <td>15</td> <td>14</td> <td>13</td> <td>12</td> <td>11</td> <td>10</td> <td>9</td> <td>8</td> <td>7</td> <td>6</td> <td>5</td> <td>4</td> <td>3</td> <td>2</td> <td>1</td> <td>0</td> </tr> </table> 0 = False 1 = True		Reserved	Reserved	Reserved	Reserved	Reserved	Reserved	Reserved	Reserved	Reserved	Reserved	Reserved	Reserved	Reserved	Reserved	Peak 2 Chng	Peak 1 Chng	Default	0	0	0	0	0	0	0	0	0	0	0	0	0	0	0	0	Bit	15	14	13	12	11	10	9	8	7	6	5	4	3	2	1	0						
	Reserved	Reserved	Reserved	Reserved	Reserved	Reserved	Reserved	Reserved	Reserved	Reserved	Reserved	Reserved	Reserved	Reserved	Peak 2 Chng	Peak 1 Chng																																										
Default	0	0	0	0	0	0	0	0	0	0	0	0	0	0	0	0																																										
Bit	15	14	13	12	11	10	9	8	7	6	5	4	3	2	1	0																																										
212	PeakDtct1 In Int Integer input to the first peak/level detector.	Default: 0 Min/Max: -/+2147483648	<input checked="" type="checkbox"/>	<input checked="" type="checkbox"/>	32-bit Integer																																																					
213	PkDtct1 In Real Floating point input to the first peak/level detector.	Default: 0.0000 Min/Max: -/+2200000000.0000	<input checked="" type="checkbox"/>	<input checked="" type="checkbox"/>	Real																																																					
214	PeakDtct1 Preset The first peak/level detector (in set or hold modes) compares this value to its input (Par 212 [PeakDtct1 In Int] or 213 [PkDtct1 In Real]) for level detection. When the detector trips (in set mode) it transfers the value of this parameter to its output (Par 215 [PeakDetect1 Out]).	Default: 0.0000 Min/Max: -/+2200000000.0000	<input checked="" type="checkbox"/>	<input checked="" type="checkbox"/>	Real																																																					
215	PeakDetect1 Out Output from the first peak/level detector.	Default: 0.0000 Min/Max: -/+2200000000.0000			Real																																																					
216	PeakDtct2 In Int Integer input to second peak/level detector.	Default: 0 Min/Max: -/+2147483648	<input checked="" type="checkbox"/>	<input checked="" type="checkbox"/>	32-bit Integer																																																					
217	PkDtct2 In Real Floating point input to second peak/level detector.	Default: 0.0000 Min/Max: -/+2200000000.0000	<input checked="" type="checkbox"/>	<input checked="" type="checkbox"/>	Real																																																					
218	PeakDtct2 Preset The second detector (in set or hold modes) compares this value to its input (Par 216 [PeakDtct2 In Int] or 217 [PkDtct2 In Real]) for level detection. When the detector trips (in set mode) it transfers the value of this parameter to its output (Par 219 [PeakDetect2 Out]).	Default: 0.0000 Min/Max: -/+2200000000.0000	<input checked="" type="checkbox"/>	<input checked="" type="checkbox"/>	Real																																																					
219	PeakDetect2 Out Output from the second peak/level detector.	Default: 0.0000 Min/Max: -/+2200000000.0000			Real																																																					
220	Spd Observer BW Sets the internal bandwidth for the speed feedback observer. The setting should be as high a possible, preferably at least 6 times the value of Par 90 [Spd Reg BW]. A setting of 1000 rad/sec is reasonable for most applications. The speed observer is bypassed when set to zero.	Units: R/S Default: 0.0000 Min/Max: 0.0000/1200.0000	<input checked="" type="checkbox"/>	<input checked="" type="checkbox"/>	Real																																																					
221	Load Estimate Displays the estimated load torque, which is the side effect of the speed observer and does not include torque to accelerate or decelerate the motor if the inertia input is correct. This value is provided for display purposes.	Units: P.U. Default: 0.0000 Min/Max: -/+8.0000			Real																																																					
222	 Motor Fdbk Sel Enter or write a value to select the primary motor speed feedback device.	Default: 0 "Encoder 0" Options: 0 "Encoder 0" 4 "Motor Sim" 1 "Encoder 1" 5 "FB Opt Port0" 2 "Sensorless" 6 "FB Opt Port1" 3 "Reserved"																																																								
223	 Mtr Fdbk Alt Sel Selects the alternate feedback device if the feedback selected from Par 222 [Motor Fdbk Sel] fails.	Default: 0 "Encoder 0" Options: 0 "Encoder 0" 4 "Motor Sim" 1 "Encoder 1" 5 "FB Opt Port0" 2 "Sensorless" 6 "FB Opt Port1" 3 "Reserved"																																																								

No.	Name Description	Values	Linkable	Read-Write	Data Type
224	TachSwitch Level Sets the detection level for the automatic tach loss switchover routine. A drop in feedback speed at this percent of rated speed over 0.5 msec will cause a tach switch from the primary to alternate feedback device. This feature is enabled when bit 16 [Auto Tach Sw] in Par 153 [Control Options] is selected. Setting this level lower will make the tach switch detection more sensitive and lower the minimum speed at which a tach switch can occur. Setting this level higher will make the tach switch less sensitive and raise the minimum speed for tach switch detection.	Units: % Default: 10.0000 Min/Max: 5.0000/25.0000		✓	
226	 Virtual Edge/Rev Set the EPR (Edges Per Revolution) scaling for calculating motor position. Used in the calculation of the position feedback such as Par 70 [MtrSpd Sim Posit].	Units: EPR Default: 4096 Min/Max: 10/16777216		✓	32-bit Integer
227	Spd Obs Trq Gain Multiplication factor for the inertia input to the Speed Observer. If the specified inertia differs from actual, this value is used to fine tune the inertia value input to the observer. Normally set to 1.	Default: 1.0000 Min/Max: 0.0000/2.0000	✓	✓	Real
230	Encdr0 Position Displays the position feedback (accumulator) from encoder 0. The value changes by a value of 4 times the Pulses Per Revolution (PPR) rating of the encoder for each full revolution of the encoder shaft. Used by the Velocity Position Loop (VPL) to close the position loop if the position control is selected.	Default: 0 Min/Max: -/+2147483648			32-bit Integer
231	Encdr0 Spd Fdbk Displays the speed feedback from encoder 0. Calculated from the change of Par 230 [Encdr0 Position] and Par 232 [Encoder0 PPR].	Units: RPM Default: 0.0000 Min/Max: -/+14112.0000 Comm Scale: Par 4 [Motor NP RPM] = 1.0			Real
232	 Encoder0 PPR Sets the PPR rating of the feedback device connected to the Encoder 0 input.	Units: PPR Default: 1024 Min/Max: 10/20000		✓	16-bit Integer

No.	Name Description	Values	Linkable	Read-Write	Data Type
241	Encdr1 Spd Fdbk Displays the speed feedback from Encoder 1. Calculated from the change of Par 240 [Encdr1 Position] and Par 242 [Encoder1 PPR].	Units: RPM Default: 0 Min.Max: -/+14112.0000 Comm Scale: Par 4 [Motor NP RPM] = 1.0			Real
242	Encoder1 PPR Sets the PPR rating of the feedback device connected to the Encoder 1 input.	Units: PPR Default: 1024 Min/Max: 10/20000			16-bit Integer

243 Encdr1 Config
Specifies the configuration options for the Encoder 1.

- Bits 0 [Enc Filt bt0], 1 [Enc Filt bt1], 2 [Enc Filt bt2], and 3 [Enc Filt bt3] configure encoder input filter (see [Table 243A: Trigger Source Settings](#)). The filter requires the input signal to be stable for the specified time period. Input transitions within the filter time setting will be ignored.
- Bits 4 [Encdr 4x] and 5 [Encdr A Phs] determine how the encoder channel A and B signals will be interpreted. Typically, both encoder phases A and B are used so that direction information is available. The Par 240 [Encdr1 Position] counts up for forward rotation and down for reverse rotation. If bit 5 is set, then the B phase signal is ignored. As a result, the encoder position will only increase, regardless of rotation direction. Bits 4 and 5 together also determine the number of edges counted per encoder pulse (see [Table 243B: Encoder Sample Interval Settings](#)). "4x" sampling counts both rise and fall of both A and B encoder phases, hence 4 edges per pulse. In 4x mode, the encoder position will change by four times the encoder pulses per revolution rating (PPR) per encoder revolution (e.g., it increments the value in Par 240 [Encdr1 Position] by 4096 for one revolution of a 1024 PPR encoder).
- Bit 6 [Encdr Dir] inverts the channel A input, thus reversing the direction of the feedback.
- Bit 9 [Edge Time] configures the method of sampling used by the Velocity Position Loop (VPL). Setting the bit chooses "Edge to Edge" sampling, while resetting the bit to zero chooses "Simple Difference" sampling. "Simple Difference" sampling calculates speed by examining the difference between pulse counts over a fixed sample time. "Edge to Edge" sampling adjusts the sample time to synchronize with the position count updates from the daughter card - improving the accuracy of the speed calculation.
- Bits 12 [SmplRate bt0] through 15 [SmplRate bt3] configure the sample interval for measuring speed (see [Table 243C: Channel Interpretation Settings](#)). Increasing the encoder sample interval improves speed measurement near zero speed. Decreasing allows the speed control regulator to perform with high gains at high speeds.

Options	Reserved	Reserved	Reserved	Reserved	Reserved	Reserved	Reserved	Reserved	Reserved	Reserved	Reserved	Reserved	Reserved	Reserved	Reserved	Reserved	SmplRate bt3	SmplRate bt2	SmplRate bt1	SmplRate bt0	Reserved	Reserved	Edge Time	Reserved	Reserved	Encdr Dir	Encdr A Phs	Encdr 4x	Enc Filt bt3	Enc Filt bt2	Enc Filt bt1	Enc Filt bt0
Default	0	0	0	0	0	0	0	0	0	0	0	0	0	0	0	0	0	1	0	0	0	0	1	0	0	0	0	1	1	0	1	0
Bit	31	30	29	28	27	26	25	24	23	22	21	20	19	18	17	16	15	14	13	12	11	10	9	8	7	6	5	4	3	2	1	0

0 = False
1 = True

Table 243A: Trigger Source Settings

Bit	3	2	1	0	Input Filter Setting
0	0	0	0	0	Filter disabled
0	0	0	0	1	100 ns filter
0	0	1	0	0	200 ns filter
0	0	1	1	0	300 ns filter
0	0	1	1	1	300 ns filter
0	1	0	0	0	400 ns filter
0	1	0	1	0	500 ns filter
0	1	1	0	0	600 ns filter
0	1	1	1	0	700 ns filter
1	0	0	0	0	800 ns filter (default setting)
1	0	0	1	0	900 ns filter
1	0	1	0	0	1000 ns filter
1	0	1	1	0	1100 ns filter
1	1	0	0	0	1200 ns filter
1	1	0	1	0	1300 ns filter
1	1	1	0	0	1400 ns filter
1	1	1	1	0	1500 ns filter

Table 243C: Channel Interpretation Settings

Bit	15	14	13	12	Encoder Sample Interval Settings
0	0	0	0	0	0.5 ms
0	0	0	0	1	0.5 ms (min. setting)
0	0	1	0	0	1.0 ms
0	0	1	1	0	1.5 ms
0	1	0	0	0	2.0 ms (default setting)
0	1	0	1	0	2.5 ms
0	1	1	0	0	3.0 ms
0	1	1	1	0	3.5 ms
1	0	0	0	0	4.0 ms
1	0	0	1	0	4.5 ms
1	0	1	0	0	5.0 ms
1	0	1	1	0	5.5 ms
1	1	0	0	0	6.0 ms (max. setting)
1	1	0	1	0	6.0 ms
1	1	1	0	0	6.0 ms
1	1	1	1	0	6.0 ms

Table 243B: Encoder Sample Interval Settings

Bit	5	4	Mult.	Directions	Comments
0	0	2x	fwd/rev		Counts rise/fall of phase A, phase B only used to find direction
0	1	4x	fwd/rev		Counts rise/fall of both A and B phases (default setting)
1	0	1x	fwd only		Counts rise of phase A. Phase B ignored.
1	1	2x	fwd only		Counts rise of phase A. Phase B ignored.

No.	Name Description	Values	Linkable	Read-Write	Data Type
261	Hi Res0 TP Sel Selects data displayed by Par 262 [Hi Res0 TP Data]. <ul style="list-style-type: none"> H0 Edge Time - Latency counter value, not used for Hi-Resolution Feedback Option. H0 dEdge - Change in edge counts for one 500 microsecond update. At constant speed, this value should be constant. H0 dTime - Change in update time. This value should be constant, 500 microseconds. H0 EPR - This value should be 1,048,576 counts per revolution - this is a constant value. H0 dTheta - This is a scaled value of option 2. Ho Delta2Err - Derivative of option 2. 	Default: 0 "Zero" Options: 0 "Zero" 1 "H0 Edge Time" 2 "H0 dEdge" 3 "H0 dTime" 4 "H0 EPR" 5 "H0 Edge Mode" 6 "H0 dTheta" 7 "H0 Delta2Err"			
262	Hi Res0 TP Data Displays data selected by Par 261 [Hi Res0 TP Sel].	Default: 0 Min/Max: -/+32768			16-bit Integer

266 Reslvr0 Config
Configures options for the resolver option card at port 0.

- Setting bit 0 [Cable Tune] enables the cable tuning test, resetting the bit to zero disables the test.
- Bits 2 [Resolution 0] and 3 [Resolution 1] select the feedback resolution (see [Table 266A: Resolution Settings](#)). This determines the number of significant bits that are calculated in the value of parameter 250 [FB Opt0 Posit]. It does not affect the number of counts created per resolver revolution (see [Table 266B: Resolution Setting and Least Significant Bits Used](#)). Also, the resolution sets a limit on the maximum tracking speed (see [Table 266C: Resolution and Resolver Tracking Speed](#)).
- Setting bit 4 [Energize] energizes the resolver, resetting the bit to zero de-energizes the resolver.
- Bit 5 [Resolver Dir] determines the counting direction. If clear, the direction is forward or up. If set, the direction is reverse or down.
- Bit 9 [Edge Time] configures the method of sampling used by the Velocity Position Loop (VPL). Setting the bit chooses "Edge to Edge" sampling, while resetting the bit to zero chooses "Simple Difference" sampling. "Simple Difference" sampling calculates speed by examining the difference between pulse counts over a fixed sample time. "Edge to Edge" sampling adjusts the sample time to synchronize with the position count updates from the daughter card - improving the accuracy of the speed calculation.
- Bits 12 [SmplRate bit0] through 15 [SmplRate bit3] configure the sample interval for measuring speed (See [Table 266D: Encoder Sample Interval](#)). Increasing the encoder sample interval improves speed measurement near zero speed. Decreasing allows the speed control regulator to perform with high gains at high speeds.

Options	Reserved	Reserved	Reserved	Reserved	Reserved	Reserved	Reserved	Reserved	Reserved	Reserved	Reserved	Reserved	Reserved	Reserved	Reserved	Reserved	SmplRate bit3	SmplRate bit2	SmplRate bit1	SmplRate bit0	Reserved	Reserved	Edge Time	Reserved	Reserved	Reserved	Reserved	Resolver Dir	Energize	Resolution 1	Resolution 0	Reserved	Cable Tune
Default	0	0	0	0	0	0	0	0	0	0	0	0	0	0	0	0	1	0	0	0	0	0	1	0	0	0	0	1	0	1	0	0	
Bit	31	30	29	28	27	26	25	24	23	22	21	20	19	18	17	16	15	14	13	12	11	10	9	8	7	6	5	4	3	2	1	0	

0 = False
1 = True

Table 266A: Resolution Settings

Bit 3	2	Resolution
0	0	10 bit resolution
0	1	12 bit resolution (default setting)
1	0	14 bit resolution
1	1	16 bit resolution

Table 266B: Resolution Setting and Least Significant Bits Used





Resolution	LSB Not Used	Parameter 250 Increments by
10 bit	All bits used	1
12 bit	2 LSB not used	4
14 bit	4 LSB not used	8
16 bit	6 LSB not used	16

Table 266C: Resolution and Resolver Tracking Speed

Resolution	Tracking Speed for X1 Resolver	Tracking Speed for X2 Resolver	Tracking Speed for X5 Resolver
10 bit	55 K-rpm	27.5 K-rpm	11 K-rpm
12 bit	13.8 K-rpm	6.9 K-rpm	2.76 K-rpm
14 bit	3480 rpm	1740 rpm	696 rpm
16 bit	900 rpm	450 rpm	180 rpm





Table 266D: Encoder Sample Interval

Bit 15	14	13	12	Encoder Sample Interval Settings
0	0	0	0	0.5 ms
0	0	0	1	0.5 ms (min. setting)
0	0	1	0	1.0 ms
0	0	1	1	1.5 ms
0	1	0	0	2.0 ms (default setting)
0	1	0	1	2.5 ms
0	1	1	0	3.0 ms
0	1	1	1	3.5 ms
1	0	0	0	4.0 ms
1	0	0	1	4.5 ms
1	0	1	0	5.0 ms
1	0	1	1	5.5 ms
1	1	0	0	6.0 ms (max. setting)
1	1	0	1	6.0 ms
1	1	1	0	6.0 ms
1	1	1	1	6.0 ms

No.	Name Description	Values	Linkable	Read-Write	Data Type																																																		
267	Reslvr0 Status Indicates the status of the resolver option card port 0. <ul style="list-style-type: none"> • Bit 0 [-Cable Tune] indicates that the cable tuning test is active. • Bit 1 [-Tune Result] indicates the tuning parameter type. When set, it indicates the tuning is using the parameter database. When cleared, it indicates the tuning is using derived data. • Bit 2 [-Mtr Turning] indicates that the motor is turning. • Bit 4 [Energized] indicates the resolver is energized. • Bit 8 [Open Wire] indicates a problem with the cable (open circuit). • Bit 9 [Power Supply] indicates a problem with the option card's power supply. • Bit 10 [Diag Fail] indicates the option card has failed its power-up diagnostics. Options <table border="1" style="margin-left: 20px;"> <tr> <td></td> <td>Reserved</td> <td>Reserved</td> <td>Reserved</td> <td>Reserved</td> <td>Select OK</td> <td>Diag Fail</td> <td>Power Supply</td> <td>Open Wire</td> <td>Reserved</td> <td>Reserved</td> <td>Reserved</td> <td>Energized</td> <td>-Cable Comp</td> <td>-Mtr Turning</td> <td>-Tune Result</td> <td>-Cable Tune</td> </tr> <tr> <td>Default</td> <td>0</td> <td>0</td> <td>0</td> <td>0</td> <td>1</td> <td>1</td> <td>1</td> <td>1</td> <td>1</td> <td>1</td> <td>1</td> <td>1</td> <td>1</td> <td>1</td> <td>1</td> <td>1</td> </tr> <tr> <td>Bit</td> <td>15</td> <td>14</td> <td>13</td> <td>12</td> <td>11</td> <td>10</td> <td>9</td> <td>8</td> <td>7</td> <td>6</td> <td>5</td> <td>4</td> <td>3</td> <td>2</td> <td>1</td> <td>0</td> </tr> </table> 0 = False 1 = True		Reserved	Reserved	Reserved	Reserved	Select OK	Diag Fail	Power Supply	Open Wire	Reserved	Reserved	Reserved	Energized	-Cable Comp	-Mtr Turning	-Tune Result	-Cable Tune	Default	0	0	0	0	1	1	1	1	1	1	1	1	1	1	1	1	Bit	15	14	13	12	11	10	9	8	7	6	5	4	3	2	1	0			
	Reserved	Reserved	Reserved	Reserved	Select OK	Diag Fail	Power Supply	Open Wire	Reserved	Reserved	Reserved	Energized	-Cable Comp	-Mtr Turning	-Tune Result	-Cable Tune																																							
Default	0	0	0	0	1	1	1	1	1	1	1	1	1	1	1	1																																							
Bit	15	14	13	12	11	10	9	8	7	6	5	4	3	2	1	0																																							
268	Reslvr0 TP Sel Enter or write a value to select Fault data displayed in Par 269 [Reslvr0 TP Data].	Default: 0 "Zero" Options: 0 "Zero" 4 "R0 EPR" 1 "R0 Edge Time" 5 "R0 Edge Mode" 2 "R0 dEdge" 6 "R0 dTheta" 3 "R0 dTime" 7 "R0 Delta2Err"																																																					
269	Reslvr0 TP Data Displays the data selected by Par 268 [Reslvr0 TP Sel].	Default: 0 Min/Max: -/+2147483648			32-bit Integer																																																		
270	 Reslvr0 SpdRatio Specifies the speed ratio for the resolver option card port 0. The speed ratio comes from the following formula. Speed ratio = electrical revolutions / mechanical revolutions = pole count / 2.	Default: 1 2 poles (x1) Options: 1 2 Poles (x1) 4 8 Poles (x4) 2 4 Poles (x2) 5 10 Poles(x5) 3 6 Poles (x3)																																																					
271	 Reslvr0 Carrier Specifies the resolver carrier frequency for the resolver option card port 0.	Units: Hz Default: 0 Min/Max: 0/10000			32-bit Integer																																																		
272	 Reslvr0 In Volts Specifies the resolver input voltage for the resolver option card port 0.	Units: Volt Default: 0.0000 Min/Max: 0.0000/31.0810			Floating Point																																																		
273	 Rslvr0 XfrmRatio Specifies the resolver transform ratio for the resolver option card port 0.	Default: 0.0000 Min/Max: 0.0000/4.0950			Floating Point																																																		
274	 Reslvr0 CableBal Specifies the resolver cable balance for the resolver option card port 0.	Default: 0.0000 Min/Max: 0.0000/255.0000			Floating Point																																																		
275	Reslvr0 Type Sel Specifies the type of resolver used.	Default: 0 "Disabled" Options: 0 "Disabled" 8 "Reserved" 1 "T2014/2087x1" 9 "1326Ax 460v" 2 "T2014/2087x2" 10 "Reserved" 3 "T2014/2087x5" 11 "Reserved" 4 "MPL 460v" 12 "Reserved" 5 "Reserved" 13 "Reserved" 6 "Siemens 1FT6" 14 "AmciR11XC107" 7 "PrkrHn ZX600"																																																					
276	FB Opt1 Posit Displays the position feedback (accumulator) from port 1 of the feedback option card.	Default: 0 Min/Max: -/+2147483648			32-bit Integer																																																		
277	FB Opt1 Spd Fdbk Displays the speed feedback from port 1 of the feedback option card.	Units: RPM Default: 0.0000 Min/Max: -/+14000.0000 Comm Scale: Par 4 [Motor NP RPM] = 1.0			Floating Point																																																		
279	Opt 1 Regis Ltch Displays registration data from port 1 of the feedback option card. This data is the value of the position reference counter, latched by the external strobes. The strobe signal used to trigger the latch is configurable by Par 280 [Opt 1 Regis Cnfg].	Default: 0 Min/Max: -/+2147483648			32-bit Integer																																																		

No.	Name Description	Values	Linkable	Read-Write	Data Type
289	Lin1 Update Rate Sets the sample rate for the linear channel on the Multi Device Interface (MDI) feedback option.	Default: 2 "1.0 msec" Options: 1 "0.5 msec" 3 "1.5 msec" 2 "1.0 msec" 4 "2.0 msec"			
290	 Linear1 CPR Specifies the change in Par 276 [FB Opt1 Posit] for one revolution of the motor shaft. This value is used to scale the calculated speed, based on the change in feedback position. Units are count per motor revolution (CPR).	Units: CPR Default: 1000 Min/Max: 10/100000		✓	32-bit Integer
297	Output Curr Disp Displays measured RMS motor current with a resolution of 1/10 amperes.	Units: Amps Default: 0.0 Min/Max: 0.0/9999.9 Comm Scale: x 10			32-bit Integer
298	Elapsed Run Time Displays the total time that the drive has been running (inverter power devices active) with a resolution of 1/10 hour. This parameter is saved in power EE non-volatile memory.	Units: Hrs Default: 0.0 Min/Max: 0.0/429496736.0 Comm Scale: x 10		✓	32-bit Integer
299	Elapsed MWHrs Displays the total energy the drive has consumed or produced. Calculated from the absolute magnitude of the product of motor speed and motor torque (power), accumulated over time. This value will increase in both regen and motoring modes of operation.	Units: MWHrs Default: 0.0 Min/Max: 0.0/429496736.0 Comm Scale: x 10		✓	32-bit Integer
300	Motor Spd Fdbk Displays measured motor speed information from the selected feedback device.	Units: RPM Default: 0.0000 Min/Max: -/+14112.0000 Comm Scale: Par 4 [Motor NP RPM] = 1.0			Real
301	Motor Speed Ref Displays the speed reference value, after the limit function. This is the input to the error calculator and speed regulator.	Units: RPM Default: 0.0000 Min/Max: -/+14112.0000 Comm Scale: Par 4 [Motor NP RPM] = 1.0			Real
302	Spd Reg PI Out Displays the output of the speed regulator. This is the input to torque control. A value of 1.0 represents base torque of the motor.	Units: P.U. Default: 0.0000 Min/Max: -/+8.0000			Real
303	Motor Torque Ref Displays the reference value of motor torque. The actual value of the motor torque is within 5% of this value.	Units: P.U. Default: 0.0000 Min/Max: -/+8.0000			Real

No.	Name Description	Values	Linkable	Read-Write	Data Type																																																																																																		
304	<p>Limit Status Displays the limit status of conditions that may be limiting the current reference or torque reference.</p> <ul style="list-style-type: none"> • Bit 0 [+MCS Iq Lim] indicates that torque producing current is at its positive limit. • Bit 1 [+MCS Ws Lim] indicates that flux producing torque is at its positive limit. • Bit 2 [0 Ia from +] indicates that torque producing current is limited to zero from the positive direction - refer to Par 353 [Iq Actual Lim]. • Bit 3 [+Iq Calc] indicates the calculation for torque producing current has reached its positive limit. • Bit 4 [+Current Lim] indicates that the current reference has reached the positive Motor Current Limit set by Par 356 [Mtr Current Lim]. • Bit 5 [+DriveProtOL] indicates that the current reference has reached the positive current limit set by the Open Loop Inverter Overload, shown in Par 343 [OL OpnLp CurrLim]. • Bit 6 [+DriveProtCL] indicates that the current reference has reached the positive current limit set by the Closed Loop Inverter Overload, shown in Par 344 [OL ClsLp CurrLim]. • Bit 8 [+Torq Limit] indicates that the torque reference has reached the Positive Torque Limit set by Par 125 [Torque Pos Limit]. • Bit 9 [Mtrng PwrLim] indicates that the torque reference is being limited by the Motoring Power Limit set by Par 127 [Mtrng Power Lim]. • Bit 10 [+Torq CurLim] indicates that current reference has reached the Actual Torque Producing Current Limit set by Par 353 [Iq Actual Lim]. • Bit 11 [Atune Tq Lim] indicates that the torque reference is being limited by Par 129 [Atune Torq Ref]. • Bit 12 [+0 Torq Ena] indicates that the torque reference is limited to zero because Par 157 [Logic Ctrl State] bit 9 [Torq Ref En] is off. • Bit 13 [+0 Curr Ena] indicates that the current reference is limited to zero because Par 157 [Logic Ctrl State] bit 11 [CurrRef En] is off. • Bit 16 [-MCS Iq Lim] indicates that torque producing current is at its negative limit. • Bit 17 [-MCS Ws Lim] indicates that flux producing torque is at its negative limit. • Bit 18 [0 Iq from -] indicates that torque producing current is limited to zero from the negative direction - refer to Par 353 [Iq Actual Lim]. • Bit 19 [-Iq Calc] indicates the calculation for torque producing current has reached its negative limit. • Bit 20 [-Current Lim] indicates that the current reference has reached the negative Motor Current Limit set by Par 356 [Mtr Current Lim]. • Bit 21 [-DriveProtOL] indicates that the current reference has reached the negative current limit set by the Open Loop Inverter Overload, shown in Par 343 [OL OpnLp CurrLim]. • Bit 22 [-DriveProtCL] indicates that the current reference has reached the negative current limit set by the Closed Loop Inverter Overload, shown in Par 344 [OL ClsLp CurrLim]. • Bit 24 [-Torq Limit] indicates that the torque reference has reached the Negative Torque Limit set by Par 126 [Torque Neg Limit]. • Bit 25 [Regen PwrLim] indicates that the torque reference is being limited by the Regenerative Power Limit set by Par 128 [Regen Power Lim]. • Bit 26 [-Torq CurLim] indicates that current reference has reached the Actual Torque Producing Current Limit set by Par 353 [Iq Actual Lim]. • Bit 27 [Bus Reg Tq Lim] indicates the bus voltage regulator is active and limiting the regenerative torque. • Bit 28 [-0 Torq Ena] indicates that the torque reference is limited to zero because Par 157 [Logic Ctrl State] bit 9 [Torq Ref En] is off. • Bit 29 [-0 Curr Ena] indicates that the current reference is limited to zero because Par 157 [Logic Ctrl State] bit 11 [CurrRef En] is off. <p>Options</p> <table border="1"> <thead> <tr> <th></th> <th>Reserved</th> <th>Reserved</th> <th>-0 Curr Ena</th> <th>-0 Torq Ena</th> <th>Bus Reg Lim</th> <th>-Torq CurLim</th> <th>Regen PwrLim</th> <th>-Torq Lim</th> <th>+SpdReg Open</th> <th>+DriveProtCL</th> <th>+DriveProtOL</th> <th>-Current Lim</th> <th>-Iq Calc</th> <th>0 Iq from -</th> <th>-MCS Ws Lim</th> <th>-MCS Iq Lim</th> <th>Reserved</th> <th>Reserved</th> <th>+0 Curr Ena</th> <th>+0 Torq Ena</th> <th>Atune Tq Lim</th> <th>+Torq CurLim</th> <th>Mtrng PwrLim</th> <th>+Torq Limit</th> <th>+SpdReg Open</th> <th>+DriveProtCL</th> <th>+DriveProtOL</th> <th>+Current Lim</th> <th>+Iq Calc</th> <th>0 Iq from +</th> <th>+MCS Ws Lim</th> <th>+MCS Iq Lim</th> </tr> </thead> <tbody> <tr> <td>Default</td> <td>0</td> <td>0</td> <td>0</td> <td>0</td> <td>0</td> <td>0</td> <td>0</td> <td>0</td> <td>0</td> <td>0</td> <td>0</td> <td>0</td> <td>0</td> <td>0</td> <td>0</td> <td>0</td> <td>0</td> <td>0</td> <td>0</td> <td>0</td> <td>0</td> <td>0</td> <td>0</td> <td>0</td> <td>0</td> <td>0</td> <td>0</td> <td>0</td> <td>0</td> <td>0</td> <td>0</td> <td>0</td> </tr> <tr> <td>Bit</td> <td>31</td> <td>30</td> <td>29</td> <td>28</td> <td>27</td> <td>26</td> <td>25</td> <td>24</td> <td>23</td> <td>22</td> <td>21</td> <td>20</td> <td>19</td> <td>18</td> <td>17</td> <td>16</td> <td>15</td> <td>14</td> <td>13</td> <td>12</td> <td>11</td> <td>10</td> <td>9</td> <td>8</td> <td>7</td> <td>6</td> <td>5</td> <td>4</td> <td>3</td> <td>2</td> <td>1</td> <td>0</td> </tr> </tbody> </table> <p>0 = False 1 = True</p>		Reserved	Reserved	-0 Curr Ena	-0 Torq Ena	Bus Reg Lim	-Torq CurLim	Regen PwrLim	-Torq Lim	+SpdReg Open	+DriveProtCL	+DriveProtOL	-Current Lim	-Iq Calc	0 Iq from -	-MCS Ws Lim	-MCS Iq Lim	Reserved	Reserved	+0 Curr Ena	+0 Torq Ena	Atune Tq Lim	+Torq CurLim	Mtrng PwrLim	+Torq Limit	+SpdReg Open	+DriveProtCL	+DriveProtOL	+Current Lim	+Iq Calc	0 Iq from +	+MCS Ws Lim	+MCS Iq Lim	Default	0	0	0	0	0	0	0	0	0	0	0	0	0	0	0	0	0	0	0	0	0	0	0	0	0	0	0	0	0	0	0	0	Bit	31	30	29	28	27	26	25	24	23	22	21	20	19	18	17	16	15	14	13	12	11	10	9	8	7	6	5	4	3	2	1	0			
	Reserved	Reserved	-0 Curr Ena	-0 Torq Ena	Bus Reg Lim	-Torq CurLim	Regen PwrLim	-Torq Lim	+SpdReg Open	+DriveProtCL	+DriveProtOL	-Current Lim	-Iq Calc	0 Iq from -	-MCS Ws Lim	-MCS Iq Lim	Reserved	Reserved	+0 Curr Ena	+0 Torq Ena	Atune Tq Lim	+Torq CurLim	Mtrng PwrLim	+Torq Limit	+SpdReg Open	+DriveProtCL	+DriveProtOL	+Current Lim	+Iq Calc	0 Iq from +	+MCS Ws Lim	+MCS Iq Lim																																																																							
Default	0	0	0	0	0	0	0	0	0	0	0	0	0	0	0	0	0	0	0	0	0	0	0	0	0	0	0	0	0	0	0	0																																																																							
Bit	31	30	29	28	27	26	25	24	23	22	21	20	19	18	17	16	15	14	13	12	11	10	9	8	7	6	5	4	3	2	1	0																																																																							
305	<p>Mtr TorqCurr Ref Displays the torque current reference present at the output of the current rate limiter. 100% is equal to 1 per unit (pu) rated motor torque.</p>	<p>Units: P.U. Default: 0.0000 Min/Max: -/+8.0000</p>			Real																																																																																																		
306	<p>DC Bus Voltage Displays measured bus voltage.</p>	<p>Units: Volt Default: 0.0000 Min/Max: 0.0000/1000.0000</p>			Real																																																																																																		
307	<p>Output Voltage Displays RMS line-to-line fundamental motor voltage. This data is averaged and updated every 50 milliseconds.</p>	<p>Units: Volt Default: 0.00 Min/Max: 0.00/3000.00</p>			Real																																																																																																		
308	<p>Output Current Displays measured RMS motor current.</p>	<p>Units: Amps Default: 0.00 Min/Max: 0.00/10000.00</p>			Real																																																																																																		
309	<p>% Motor Flux Displays the motor flux in % of nominal.</p>	<p>Units: % Default: 100.0 Min/Max: 0.0/100.0 Comm Scale: 100 = 4096</p>			16-bit Integer																																																																																																		
310	<p>Output Freq Displays the motor stator frequency.</p>	<p>Units: Hz Default: 0.00 Min/Max: -/+250.00</p>			Real																																																																																																		
311	<p>Output Power Motor Power is the calculated product of the torque reference and motor speed feedback. A 125mS filter is applied to this result. Positive values indicate motoring power; negative values indicate regenerative power.</p>	<p>Units: Hp Default: 0.00 Min/Max: -/+9999.00</p>			Real																																																																																																		
312	<p>MotorFluxCurr FB Displays the measured per unit motor flux producing current.</p>	<p>Units: P.U. Default: 0.0000 Min/Max: 0.0000/1.0000</p>			Real																																																																																																		





No.	Name Description	Values	Linkable	Read-Write	Data Type
329	Fault TP Sel Enter or write a value to select Fault data displayed in Par 330 [Fault TP Data].	Default: 0 "Zero" Options: 0 "Zero" 12 "Mtr OL Input" 1 "Abs OverSpd" 13 "Mtr OL Outpt" 2 "EE Pwr State" 14 "MtrStallTime" 3 "Inv DataStat" 15 "MC Handshake" 4 "Run Time Err" 16 "VPL Handshak" 5 "LowBus Thres" 17 "MC Diag" 6 "LowBus Detct" 18 "PwrLossState" 7 "PwrLosBusVlt" 19 "12 volt loss" 8 "MCPLosBusVlt" 20 "PwrEE Chksum" 9 "MC Fit Reset" 21 "Db Read Cnt1" 10 "VPL FltReset" 22 "Db Read Cnt2" 11 "VPL TaskErr" 23 "Db Read Cnt3"			
330	Fault TP Data Displays the data selected by Par 329 [Fault TP Sel].	Default: 0 Min/Max: -/+2200000000			Real
331	Fault Stop Mode Displays the action taken by the drive during the last fault. When a fault occurs, an action is taken as a result of that fault.	Default: 0 "Ignore" Options: 0 "Ignore" 3 "Fit RampStop" 1 "Alarm" 4 "FitCurLimStop" 2 "FitCoastStop"			
335	 Abs OverSpd Lim Sets an incremental speed above Par 31 [Fwd Speed Limit] and below Par 30 [Rev Speed Limit] that is allowable before the drive indicates its speed is out of range.	Units: RPM Default: 352.8000 Min/Max: 0.0000/1750.0000 Comm Scale: Par 4 [Motor NP RPM] = 1.0		<input checked="" type="checkbox"/>	Real
336	 Service Factor Sets the minimum level of current that causes a motor overload trip under continuous operation. Current levels below this value will not result in an overload trip. For example, a service factor of 1.15 implies continuous operation up to 115% of nameplate motor current.	Units: P.U. Default: 1.1500 Min/Max: 1.0000/2.0000		<input checked="" type="checkbox"/>	Real
337	 Mtr I2T Curr Min Sets the minimum current threshold for the motor overload (I ² T) function. The value indicates the minimum current at the minimum speed, Par 338 [Mtr I2T Spd Min], and these are the first current/speed breakpoint. From this point the current threshold is linear to the value specified by Par 336 [Service Factor].	Units: P.U. Default: 0.5000 Min Max: 0.0500/2.0000		<input checked="" type="checkbox"/>	Real
338	 Mtr I2T Spd Min Sets the minimum speed for the motor overload (I ² T) function. The value indicates the minimum speed below the minimum current threshold, Par 337 [Mtr I2T Curr Min], and these are the first current/speed breakpoint. From this point the current threshold is linear to the value specified by the motor service factor Par 336 [Service Factor]. For more information, please see Motor Overload on page C-3 .	Units: P.U. Default: 1.0000 Min/Max: 0.0500/1.0000		<input checked="" type="checkbox"/>	Real
339	 Mtr I2T Calibrat Sets the current calibration level for the motor overload (I ² T) function. The value indicates the current level that the drive will fault at this current in 60 seconds.	Units: P.U. Default: 2.0000 Min/Max: 1.1000/4.0000		<input checked="" type="checkbox"/>	Real
340	Mtr I2T Trp ThrH Displays the trip threshold current for the motor overload (I ² T) function. The value depends on the motor speed, and is calculated from the minimum current, Par 337 [Mtr I2T Curr Min], the minimum speed, Par 338 [Mtr I2T Spd Min], and the motor service factor, Par 336 [Service Factor].	Units: P.U. Default: 1.1500 Min/Max: 0.0500/2.0000			Real
343	OL OpnLp CurrLim Displays the current limit set by the Open Loop Inverter Overload (OL) function. This function sets this current limit based on stator current feedback and the current ratings of the drive - continuous and short term (three-second rating). Typically the drive will have a sixty-second rating of 110% of continuous current and a three-second rating at 150% of the continuous current. Under normal operating conditions, the open loop function sets this current limit to the short term (three-second) rating. If the function detects an overload, it lowers the limit to the continuous level. After a period of time (typically one to three minutes), the function returns the limit to the short term rating.	Units: P.U. Default: 8.0000 Min/Max: 0.0000/8.0000			Real
344	OL ClsLp CurrLim Displays the current limit set by the Closed Loop Inverter Overload (OL) function. This function will set a current limit level based on the values in Par 358 [Iq Ref Limited], Par 313 [Heatsink Temp] and the thermal characteristics of the drive. Under normal operating conditions, the function typically sets the limit at 250% of the continuous drive rating. If the function determines that the power device junction temperature is approaching maximum, it will reduce this limit to the level required to prevent additional heating of the inverter. This level could be as low as the continuous rating of the drive. If the inverter temperature decreases, the function will raise the limit to a higher level. Disable this protection by setting bit 13 [OL ClsLpDsb] of Par 153 [Control Options].	Units: P.U. Default: 8.0000 Min/Max: 0.0000/8.0000			Real



No.	Name Description	Values	Linkable	Read-Write	Data Type																																																		
345	Drive OL JnctTmp Displays the calculated junction temperature of the power semiconductors in the inverter. The calculation uses the values of Par 313 [Heatsink Temp], Par 358 [Iq Ref Limited], and inverter thermal characteristics contained in the power EE memory. If this value exceeds the maximum junction temperature (visible in Par 348 [Drive OL TP Data] when Par 347 [Drive OL TP Sel] = 12 "fJunTmpMax"), two faults occur: Inverter Overtemperature Fault (fault code 15), and Junction Overtemperature Fault - indicated by bit 7 [Jnc OverTemp] of Par 346 [Drive OL Status].	Units: degC Default: 0.0000 Min/Max: -50.0000/300.0000			Real																																																		
346	Drive OL Status Indicates the status of various overload (OL) conditions. <ul style="list-style-type: none"> • Bit 0 [NTC Shorted] indicates the Negative Temperature Coefficient (NTC) device has a short circuit. • Bit 1 [NTC Open] indicates the NTC has an open circuit. • Bit 2 [HS OverTemp] indicates that the heatsink temperature is above 105C for ratings 1.1-11.0A, 115C for 14-34A, or 100C for 40-52A. • Bit 3 [HS Pending] indicates that the heatsink temperature is above 95C for ratings 1.1 -11A, 105C for 14- 34A, or 90C for 40- 52A. • Bit 4 [IT Trip] indicates the drive has exceeded the 3 second rating of either the 150% normal duty rating or 200% of the heavy duty rating. • Bit 5 [IT Pending] indicates the drive OL integrator is at 50% of the time out time. • Bit 6 [IT Foldback] indicates the drive closed loop current limit is in a fold back condition. The value of the fold back is proportional to the calculated junction temperature. • Bit 7 [Jnc Over Temp] indicates the junction temperature has exceeded the maximum temperature for the power semiconductor device. Options <table border="1"> <thead> <tr> <th></th> <th>Reserved</th> <th>Reserved</th> <th>Reserved</th> <th>Reserved</th> <th>Reserved</th> <th>Reserved</th> <th>Reserved</th> <th>Reserved</th> <th>Jnc OverTemp</th> <th>IT Foldback</th> <th>IT Pending</th> <th>IT Trip</th> <th>HS Pending</th> <th>HS OverTemp</th> <th>NTC Open</th> <th>NTC Shorted</th> </tr> </thead> <tbody> <tr> <td>Default</td> <td>0</td> <td>0</td> <td>0</td> <td>0</td> <td>0</td> <td>0</td> <td>0</td> <td>0</td> <td>0</td> <td>0</td> <td>0</td> <td>0</td> <td>0</td> <td>0</td> <td>0</td> <td>0</td> </tr> <tr> <td>Bit</td> <td>15</td> <td>14</td> <td>13</td> <td>12</td> <td>11</td> <td>10</td> <td>9</td> <td>8</td> <td>7</td> <td>6</td> <td>5</td> <td>4</td> <td>3</td> <td>2</td> <td>1</td> <td>0</td> </tr> </tbody> </table> 0 = False 1 = True		Reserved	Reserved	Reserved	Reserved	Reserved	Reserved	Reserved	Reserved	Jnc OverTemp	IT Foldback	IT Pending	IT Trip	HS Pending	HS OverTemp	NTC Open	NTC Shorted	Default	0	0	0	0	0	0	0	0	0	0	0	0	0	0	0	0	Bit	15	14	13	12	11	10	9	8	7	6	5	4	3	2	1	0			
	Reserved	Reserved	Reserved	Reserved	Reserved	Reserved	Reserved	Reserved	Jnc OverTemp	IT Foldback	IT Pending	IT Trip	HS Pending	HS OverTemp	NTC Open	NTC Shorted																																							
Default	0	0	0	0	0	0	0	0	0	0	0	0	0	0	0	0																																							
Bit	15	14	13	12	11	10	9	8	7	6	5	4	3	2	1	0																																							
347	Drive OL TP Sel Enter or write a value to select the drive overload data displayed in Par 348 [Drive OL TP Data].	Default: 0 "Zero" Options: <table border="0"> <tr> <td>0 "Zero"</td> <td>23 "flgbtJuncase"</td> </tr> <tr> <td>1 "fAbsIsCurr"</td> <td>24 "flgbtWatts"</td> </tr> <tr> <td>2 "fDelta"</td> <td>25 "ilgblPerMod"</td> </tr> <tr> <td>3 "fAbsIqCurr"</td> <td>26 "fFdThres"</td> </tr> <tr> <td>4 "fOL_l"</td> <td>27 "fFdSlope"</td> </tr> <tr> <td>5 "fOL_m"</td> <td>28 "fFdJunCase"</td> </tr> <tr> <td>6 "fOL_k"</td> <td>29 "fFdWatts"</td> </tr> <tr> <td>7 "fOL_g"</td> <td>20 "fMaxHsDegc"</td> </tr> <tr> <td>8 "fOL_intg"</td> <td>31 "fCsImp"</td> </tr> <tr> <td>9 "fCL_intg"</td> <td>32 "fCsFltr"</td> </tr> <tr> <td>10 "fInvOLClim"</td> <td>33 "fPwmHz"</td> </tr> <tr> <td>11 "fJuncDegc"</td> <td>34 "fElecHz"</td> </tr> <tr> <td>12 "fJunTmpMax"</td> <td>35 "fModIdx"</td> </tr> <tr> <td>13 "f60sPUCur"</td> <td>36 "fBoost"</td> </tr> <tr> <td>14 "f60sAmp"</td> <td>37 "fTotalWatts"</td> </tr> <tr> <td>15 "f3sPUCur"</td> <td>38 "fHSDegc"</td> </tr> <tr> <td>16 "f3sAmp"</td> <td>39 "fAdconv"</td> </tr> <tr> <td>17 "fRatioInvMtr"</td> <td>30 "Jct Temp 700S"</td> </tr> <tr> <td>18 "fRatioMtrInv"</td> <td>41 "Jct Tmp HiHp"</td> </tr> <tr> <td>19 "fConvertStat"</td> <td>42 "Jct Tmp FWD"</td> </tr> <tr> <td>20 "flgblThres"</td> <td>43 "HH Lss Intg"</td> </tr> <tr> <td>21 "flgblSlope"</td> <td>44 "HH PwrBdTemp"</td> </tr> <tr> <td>22 "flgblEnergy"</td> <td></td> </tr> </table>	0 "Zero"	23 "flgbtJuncase"	1 "fAbsIsCurr"	24 "flgbtWatts"	2 "fDelta"	25 "ilgblPerMod"	3 "fAbsIqCurr"	26 "fFdThres"	4 "fOL_l"	27 "fFdSlope"	5 "fOL_m"	28 "fFdJunCase"	6 "fOL_k"	29 "fFdWatts"	7 "fOL_g"	20 "fMaxHsDegc"	8 "fOL_intg"	31 "fCsImp"	9 "fCL_intg"	32 "fCsFltr"	10 "fInvOLClim"	33 "fPwmHz"	11 "fJuncDegc"	34 "fElecHz"	12 "fJunTmpMax"	35 "fModIdx"	13 "f60sPUCur"	36 "fBoost"	14 "f60sAmp"	37 "fTotalWatts"	15 "f3sPUCur"	38 "fHSDegc"	16 "f3sAmp"	39 "fAdconv"	17 "fRatioInvMtr"	30 "Jct Temp 700S"	18 "fRatioMtrInv"	41 "Jct Tmp HiHp"	19 "fConvertStat"	42 "Jct Tmp FWD"	20 "flgblThres"	43 "HH Lss Intg"	21 "flgblSlope"	44 "HH PwrBdTemp"	22 "flgblEnergy"								
0 "Zero"	23 "flgbtJuncase"																																																						
1 "fAbsIsCurr"	24 "flgbtWatts"																																																						
2 "fDelta"	25 "ilgblPerMod"																																																						
3 "fAbsIqCurr"	26 "fFdThres"																																																						
4 "fOL_l"	27 "fFdSlope"																																																						
5 "fOL_m"	28 "fFdJunCase"																																																						
6 "fOL_k"	29 "fFdWatts"																																																						
7 "fOL_g"	20 "fMaxHsDegc"																																																						
8 "fOL_intg"	31 "fCsImp"																																																						
9 "fCL_intg"	32 "fCsFltr"																																																						
10 "fInvOLClim"	33 "fPwmHz"																																																						
11 "fJuncDegc"	34 "fElecHz"																																																						
12 "fJunTmpMax"	35 "fModIdx"																																																						
13 "f60sPUCur"	36 "fBoost"																																																						
14 "f60sAmp"	37 "fTotalWatts"																																																						
15 "f3sPUCur"	38 "fHSDegc"																																																						
16 "f3sAmp"	39 "fAdconv"																																																						
17 "fRatioInvMtr"	30 "Jct Temp 700S"																																																						
18 "fRatioMtrInv"	41 "Jct Tmp HiHp"																																																						
19 "fConvertStat"	42 "Jct Tmp FWD"																																																						
20 "flgblThres"	43 "HH Lss Intg"																																																						
21 "flgblSlope"	44 "HH PwrBdTemp"																																																						
22 "flgblEnergy"																																																							
348	Drive OL TP Data Displays the value selected by Par 347 [Drive OL TP Sel].	Default: 0.0000 Min/Max: -/+2200000000.0000			Real																																																		
350	Iq Actual Ref Displays the value of motor current reference that is present at the output of the divide by flux calculation.	Units: P.U. Default: 0.0000 Min/Max: -/+8.0000			Real																																																		
351	Iq Ref Trim Provides an external source to command, trim or offset the internal motor current reference. This value is summed with Par 350 [Iq Actual Ref] before the current limit is applied. Scaling is in per unit motor current.	Units: P.U. Default: 0.0000 Min/Max: -/+8.0000	✓	✓	Real																																																		
352	Is Actual Lim Displays the largest allowable stator motor current. The range of allowable motor current is limited by the maximum drive current. Scaling is in per unit motor current.	Units: P.U. Default: 1.0000 Min/Max: 0.0000/8.0000			Real																																																		
353	Iq Actual Lim Displays the largest allowable torque producing (Iq) motor current. The range of allowable Iq motor current is limited by the maximum drive current and is adjusted by the motor flux current. Scaling is in per unit Iq motor current.	Units: P.U. Default: 1.0000 Min/Max: 0.0000/8.0000			Real																																																		
354	Iq Rate Limit Enter the maximum rate of change for Current Reference, in per unit current/ sec. Par 90 [Spd Reg BW] will be limited to 2/3 of this value.	Units: /Sec Default: 1000.0000 Min/Max: 5.0000/10000.0000	✓	✓	Real																																																		
355	Iq Rate Limited Displays the current reference output of the rate limiter.	Units: P.U. Default: 0.0000 Min/Max: -/+8.0000			Real																																																		



No.	Name Description	Values	Linkable	Read-Write	Data Type
356	Mtr Current Lim Sets the largest allowable motor stator current. The online maximum value of this parameter is Par 2 [Motor NP FLA]. The online minimum value is 105% of the current indicated in Par 488 [Flux Current].	Units: P.U. Default: 1.5000 Min/Max: 0.0000/24.0000	<input checked="" type="checkbox"/>	<input checked="" type="checkbox"/>	Real
358	Iq Ref Limited Sets the limit value for the motor torque producing current.	Units: P.U. Default: 0.0000 Min/Max: -/+8.0000	<input type="checkbox"/>	<input type="checkbox"/>	Real
359	Motor Flux Est Q-axis motor voltage is divided by the motor frequency while field weakening is active. This is used to convert the torque command to a motor current (Iqs) command.	Units: P.U. Default: 0.0000 Min/Max: -/+8.0000	<input type="checkbox"/>	<input type="checkbox"/>	Real
360	Min Flux Sets the smallest level of flux used to convert Par 303 [Motor Torque Ref] to a current reference above base speed.	Units: P.U. Default: 0.2500 Min/Max: 0.2500/1.0000	<input checked="" type="checkbox"/>	<input checked="" type="checkbox"/>	Real
361	Flx LpassFilt BW Sets the bandwidth of the filter that adjusts the response of the flux estimate used in the torque to current conversion. Since the field time constant varies between motors, a better control response may be obtained by adjusting the filter time constant. Normally this parameter is not changed unless a significant disturbance occurs as the motor enters field weakening AND Par 360 [Min Flux] is less than 1 per unit.	Units: R/S Default: 12.0000 Min/Max: 0.5000/100.0000	<input checked="" type="checkbox"/>	<input checked="" type="checkbox"/>	Real
363	Curr Ref TP Sel Enter or write a value to select current reference data displayed in Par 364 [Curr Ref TP Data].	Default: 0 "Zero" Options: 0 "Zero" 10 "Min Lim Stat" 1 "Iq Sum" 11 "Iq Prescale" 2 "Iq Lim In" 12 "Iqtols Stat" 3 "Iq Lim Out" 13 "Flux Status" 4 "Iq Rate Stat" 14 "Flux LPF Out" 5 "Limited Flux" 15 "Is Per Unit" 6 "MtrCrLimStat" 16 "InPos IqLim" 7 "Lim'dMtrCrLm" 17 "InNeg IqLim" 8 "Iq Act Limit" 18 "Flx Filt Hld" 9 "Iq Cal Gain"	<input type="checkbox"/>	<input type="checkbox"/>	
364	Curr Ref TP Data Displays the data selected by Par 363 [Curr Ref TP Sel].	Units: P.U. Default: 0.0000 Min/Max: -/+8.0000	<input type="checkbox"/>	<input type="checkbox"/>	Real
365	Encdr0 Loss Cnfg Enter a value to configure the drive's response to an Encoder 0 Loss exception event. <ul style="list-style-type: none"> 0 "Ignore" - Configures the drive to continue running, as normal, when this event occurs 1 "Alarm" - Configures the drive to continue running and set the appropriate alarm bit when this event occurs 2 "FitCoastStop" - configures the drive to perform a coast stop and set the appropriate fault bit, in response this event 	Default: 2 "FitCoastStop" Options: 0 "Ignore" 1 "Alarm" 2 "FitCoastStop"	<input type="checkbox"/>	<input type="checkbox"/>	
366	Encdr1 Loss Cnfg Enter a value to configure the drive's response to an Encoder 1 Loss exception event. <ul style="list-style-type: none"> 0 "Ignore" Configures the drive to continue running, as normal, when this event occurs 1 "Alarm" - Configures the drive to continue running and set the appropriate alarm bit when this event occurs 2 "FitCoastStop" - Configures the drive to perform a coast stop and set the appropriate fault bit, in response this event 	Default: 0 "FitCoastStop" Options: 0 "Ignore" 1 "Alarm" 2 "FitCoastStop"	<input type="checkbox"/>	<input type="checkbox"/>	
367	FB Opt0 LossCnfg Enter a value to configure the drive's response to a Feedback Option 0 Loss exception event. <ul style="list-style-type: none"> 0 "Ignore" Configures the drive to continue running, as normal, when this event occurs 1 "Alarm" - Configures the drive to continue running and set the appropriate alarm bit when this event occurs 2 "FitCoastStop" - Configures the drive to perform a coast stop and set the appropriate fault bit, in response this event 	Default: 0 "FitCoastStop" Options: 0 "Ignore" 1 "Alarm" 2 "FitCoastStop"	<input type="checkbox"/>	<input type="checkbox"/>	
368	FB Opt1 LossCnfg Enter a value to configure the drive's response to a Feedback Option 1 Loss exception event. <ul style="list-style-type: none"> 0 "Ignore" Configures the drive to continue running, as normal, when this event occurs 1 "Alarm" - Configures the drive to continue running and set the appropriate alarm bit when this event occurs 2 "FitCoastStop" - Configures the drive to perform a coast stop and set the appropriate fault bit, in response this event 	Default: 0 "FitCoastStop" Options: 0 "Ignore" 1 "Alarm" 2 "FitCoastStop"	<input type="checkbox"/>	<input type="checkbox"/>	





No.	Name Description	Values	Linkable	Read-Write	Data Type
369	Brake OL Cnfg Enter a value to configure the drive's response to a Brake Overload (OL) Trip exception event. This event is triggered when a Dynamic Brake (DB) overload condition occurs. <ul style="list-style-type: none"> 0 "Ignore" - Configures the drive to continue running, as normal, when this event occurs 1 "Alarm" - Configures the drive to continue running and set the appropriate alarm bit when this event occurs 2 "FitCoastStop" - Configures the drive to perform a coast stop and set the appropriate fault bit, in response this event 3 "Fit RampStop" - Configures the drive to perform a ramp stop and set the appropriate fault bit, in response this event 4 "FitCurLimStp" - Configures the drive to perform a current-limit stop and set the appropriate fault bit, in response this event 	Default: 0 "Alarm" Options: 0 "Alarm" 1 "FitCoastStop" 2 "Fit RampStop" 3 "FitCurLimStp"			
370	HiHp InPhsLs Cfg Selector for the input phase loss configuration. <ul style="list-style-type: none"> 0 "Ignore" - Configures the drive to continue running, as normal, when this event occurs 1 "Alarm" - Configures the drive to continue running and set the appropriate alarm bit when this event occurs 2 "FitCoastStop" - Configures the drive to perform a coast stop and set the appropriate fault bit, in response this event 3 "Fit RampStop" - Configures the drive to perform a ramp stop and set the appropriate fault bit, in response this event 4 "FitCurLimStp" - Configures the drive to perform a current-limit stop and set the appropriate fault bit, in response this event 	Default: 1 "Alarm" Options: 0 "Ignore" 1 "Alarm" 2 "FitCoastStop" 3 "Fit RampStop" 4 "FitCurLimStp"			
371	Mtr OL Trip Cnfg Enter a value to configure the drive's response to a Motor Overload (OL) Trip exception event. <ul style="list-style-type: none"> 0 "Ignore" - Configures the drive to continue running, as normal, when this event occurs 1 "Alarm" - Configures the drive to continue running and set the appropriate alarm bit when this event occurs 2 "FitCoastStop" - Configures the drive to perform a coast stop and set the appropriate fault bit, in response this event 3 "Fit RampStop" - Configures the drive to perform a ramp stop and set the appropriate fault bit, in response this event 4 "FitCurLimStp" - Configures the drive to perform a current-limit stop and set the appropriate fault bit, in response this event 	Default: 2 "FitCoastStop" Options: 0 "Ignore" 1 "Alarm" 2 "FitCoastStop" 3 "Fit RampStop" 4 "FitCurLimStp"			
372	Mtr OL Pend Cnfg Enter a value to configure the drive's response to a Motor Overload (OL) Pending exception event. <ul style="list-style-type: none"> 0 "Ignore" - Configures the drive to continue running, as normal, when this event occurs 1 "Alarm" - Configures the drive to continue running and set the appropriate alarm bit when this event occurs 2 "FitCoastStop" - Configures the drive to perform a coast stop and set the appropriate fault bit, in response this event 3 "Fit RampStop" - Configures the drive to perform a ramp stop and set the appropriate fault bit, in response this event 4 "FitCurLimStp" - Configures the drive to perform a current-limit stop and set the appropriate fault bit, in response this event 	Default: 1 "Alarm" Options: 0 "Ignore" 1 "Alarm" 2 "FitCoastStop" 3 "Fit RampStop" 4 "FitCurLimStp"			
373	Motor Stall Time Enter a value to specify the time delay between when the drive detects a Motor Stall condition and when it declares the exception event.	Units: Sec Default: 1.0000 Min/Max: 0.1000/3000.0000	<input checked="" type="checkbox"/>	<input checked="" type="checkbox"/>	Real
374	Motor Stall Cnfg Enter a value to configure the drive's response to a Motor Stall exception event. <ul style="list-style-type: none"> 0 "Ignore" - Configures the drive to continue running, as normal, when this event occurs 1 "Alarm" - Configures the drive to continue running and set the appropriate alarm bit when this event occurs 2 "FitCoastStop" - Configures the drive to perform a coast stop and set the appropriate fault bit, in response this event 3 "Fit RampStop" - Configures the drive to perform a ramp stop and set the appropriate fault bit, in response this event 4 "FitCurLimStp" - Configures the drive to perform a current-limit stop and set the appropriate fault bit, in response this event 	Default: 0 "Ignore" Options: 0 "Ignore" 1 "Alarm" 2 "FitCoastStop" 3 "Fit RampStop" 4 "FitCurLimStp"			

No.	Name Description	Values	Linkable	Read-Write	Data Type
375	Inv OT Pend Cnfg Enter a value to configure the drive's response to a Inverter Over-Temperature (OT) Pending exception event. This event is triggered when the Inverter NTC (Temperature protection) function detects the heat-sink temperature reaches to the overload warning level. <ul style="list-style-type: none"> 0 "Ignore" - Configures the drive to continue running, as normal, when this event occurs 1 "Alarm" - Configures the drive to continue running and set the appropriate alarm bit when this event occurs 2 "FitCoastStop" - Configures the drive to perform a coast stop and set the appropriate fault bit, in response this event 3 "Fit RampStop" - Configures the drive to perform a ramp stop and set the appropriate fault bit, in response this event 4 "FitCurLimStp" - Configures the drive to perform a current-limit stop and set the appropriate fault bit, in response this event 	Default: 1 "Alarm" Options: 0 "Ignore" 1 "Alarm" 2 "FitCoastStop" 3 "Fit RampStop" 4 "FitCurLimStp"			
376	Inv OL Pend Cnfg Enter a value to configure the drive's response to an Inverter Overload (OL) Pending exception event. This event is triggered when one of the Inverter Protection Current-Over-Time functions (Open Loop or Closed Loop) detects current and temperature at warning levels. <ul style="list-style-type: none"> 0 "Ignore" - Configures the drive to continue running, as normal, when this event occurs 1 "Alarm" - Configures the drive to continue running and set the appropriate alarm bit when this event occurs 2 "FitCoastStop" - Configures the drive to perform a coast stop and set the appropriate fault bit, in response this event 3 "Fit RampStop" - Configures the drive to perform a ramp stop and set the appropriate fault bit, in response this event 4 "FitCurLimStp" - Configures the drive to perform a current-limit stop and set the appropriate fault bit, in response this event 	Default: 1 "Alarm" Options: 0 "Ignore" 1 "Alarm" 2 "FitCoastStop" 3 "Fit RampStop" 4 "FitCurLimStp"			
377	Inv OL Trip Cnfg Enter a value to configure the drive's response to an Inverter Overload (OL) Trip exception event. This event is triggered when one of the Inverter Protection Current-Over-Time functions (Open Loop or Closed Loop) detects current and temperature at a fault level. <ul style="list-style-type: none"> 0 "Ignore" Configures the drive to continue running, as normal, when this event occurs 1 "Alarm" - Configures the drive to continue running and set the appropriate alarm bit when this event occurs 2 "FitCoastStop" - Configures the drive to perform a coast stop and set the appropriate fault bit, in response this event 	Default: 1 "Alarm" Options: 0 "Ignore" 1 "Alarm" 2 "FitCoastStop"			
378	Interp Flt Cnfg Enter a value to configure the drive's response when a Synchronization input to the Interpolator has been lost or has become excessively irregular. <ul style="list-style-type: none"> 0 "Ignore" - Configures the drive to continue running, as normal, when this event occurs 1 "Alarm" - Configures the drive to continue running and set the appropriate alarm bit when this event occurs 2 "FitCoastStop" - Configures the drive to perform a coast stop and set the appropriate fault bit, in response this event 3 "Fit RampStop" - Configures the drive to perform a ramp stop and set the appropriate fault bit, in response this event 4 "FitCurLimStp" - Configures the drive to perform a current-limit stop and set the appropriate fault bit, in response this event 	Default: 2 "FitCoastStop" Options: 0 "Ignore" 1 "Alarm" 2 "FitCoastStop" 3 "Fit RampStop" 4 "FitCurLimStp"			
379	Ext Flt/Alm Cnfg Enter a value to configure the drive's response to an External Input exception event. The event is triggered by a digital input that is configured for auxiliary fault or auxiliary aux fault by choosing option 11 "Aux Fault" or 12 "AuxFault Inv" in Pars 838 [DigIn 1 Sel], 839 [DigIn 2 Sel], or 840 [DigIn 3 Sel]. <ul style="list-style-type: none"> 0 "Ignore" - Configures the drive to continue running, as normal, when this event occurs 1 "Alarm" - Configures the drive to continue running and set the appropriate alarm bit when this event occurs 2 "FitCoastStop" - Configures the drive to perform a coast stop and set the appropriate fault bit, in response this event 3 "Fit RampStop" - Configures the drive to perform a ramp stop and set the appropriate fault bit, in response this event 4 "FitCurLimStp" - Configures the drive to perform a current-limit stop and set the appropriate fault bit, in response this event 	Default: 2 "FitCoastStop" Options: 0 "Ignore" 1 "Alarm" 2 "FitCoastStop" 3 "Fit RampStop" 4 "FitCurLimStp"			
381	PreChrg Err Cnfg Enter a value to configure the drive's response to a Precharge Error exception event. <ul style="list-style-type: none"> 0 "Ignore" Configures the drive to continue running, as normal, when this event occurs 1 "Alarm" - Configures the drive to continue running and set the appropriate alarm bit when this event occurs 2 "FitCoastStop" - Configures the drive to perform a coast stop and set the appropriate fault bit, in response this event 	Default: 2 "Alarm" Options: 0 "Ignore" 1 "Alarm" 2 "FitCoastStop"			

No.	Name Description	Values	Linkable	Read-Write	Data Type
382	MC Cmd Lim Cnfg Enter a value to configure the drive's response to a Motor-Controller (MC) Command Limitation exception event. This event is triggered when the motor-controller detects limit of the command values used in the motor-controller, and returns the exception event to the Velocity Position Loop (VPL). <ul style="list-style-type: none"> 0 "Ignore" - Configures the drive to continue running, as normal, when this event occurs 1 "Alarm" - Configures the drive to continue running and set the appropriate alarm bit when this event occurs 2 "FitCoastStop" - Configures the drive to perform a coast stop and set the appropriate fault bit, in response this event 	Default: 2 "Alarm" Options: 0 "Ignore" 1 "Alarm" 2 "FitCoastStop"			
383	SL CommLoss Data Enter a value to determine what is done with the data received from SynchLink when a communication loss occurs. <ul style="list-style-type: none"> 0 "Zero Data" - Resets data to zero 1 "Last State" - Holds data in its last state 	Default: 1 "Last State" Options: 0 "Zero Data" 1 "Last State"			
 <p>ATTENTION: Risk of injury or equipment damage exists. Parameter 383 [SL CommLoss Data] lets you determine the action of the drive if communications are disrupted. By default this parameter causes the drive to hold the data in its last state. You can set this parameter so that the drive resets the data to zero. Precautions should be taken to ensure that the setting of this parameter does not create hazards of injury or equipment damage.</p>					
384	SL CommLoss Cnfg Enter a value to configure the drive's response to SynchLink communication loss. Refer to Par 1229 [SL Error Status] for possible causes of communication loss. <ul style="list-style-type: none"> 0 "Ignore" - Configures the drive to continue running, as normal, when this event occurs 1 "Alarm" - Configures the drive to continue running and set the appropriate alarm bit when this event occurs 2 "FitCoastStop" - Configures the drive to perform a coast stop and set the appropriate fault bit, in response this event 3 "Fit RampStop" - Configures the drive to perform a ramp stop and set the appropriate fault bit, in response this event 4 "FitCurLimStp" - Configures the drive to perform a current-limit stop and set the appropriate fault bit, in response this event 	Default: 2 "FitCoastStop" Options: 0 "Ignore" 1 "Alarm" 2 "FitCoastStop" 3 "Fit RampStop" 4 "FitCurLimStp"			
 <p>ATTENTION: Risk of injury or equipment damage exists. Parameter 384 [SL CommLoss Cnfg] lets you determine the action of the drive if communications are disrupted. By default this parameter causes the drive to fault and coast to a stop. You can set this parameter so that the drive continues to run. Precautions should be taken to ensure that the setting of this parameter does not create hazards of injury or equipment damage.</p>					
385	Lgx CommLossData Enter a value to configure what drive does with the data received from the DriveLogix controller when the connection is closed or times out. <ul style="list-style-type: none"> 0 "Zero Data" - Resets data to zero 1 "Last State" - Holds data in its last state 	Default: 1 "Last State" Options: 0 "Zero Data" 1 "Last State"			
 <p>ATTENTION: Risk of injury or equipment damage exists. Parameter 385 [Lgx CommLossData] lets you determine the action of the drive if communications are disrupted. By default this parameter causes the drive to hold the data in its last state. You can set this parameter so that the drive resets the data to zero. Precautions should be taken to ensure that the setting of this parameter does not create hazards of injury or equipment damage.</p>					
386	Lgx OutOfRunCnfg Enter a value to configure the drive's response to the DriveLogix processor being in Non-Run mode. Non-Run modes include Program, Remote-Program and Faulted. <ul style="list-style-type: none"> 0 "Ignore" - Configures the drive to continue running, as normal, when this event occurs 1 "Alarm" - Configures the drive to continue running and set the appropriate alarm bit when this event occurs 2 "FitCoastStop" - Configures the drive to perform a coast stop and set the appropriate fault bit, in response this event 3 "Fit RampStop" - Configures the drive to perform a ramp stop and set the appropriate fault bit, in response this event 4 "FitCurLimStp" - Configures the drive to perform a current-limit stop and set the appropriate fault bit, in response this event 	Default: 2 "FitCoastStop" Options: 0 "Ignore" 1 "Alarm" 2 "FitCoastStop" 3 "Fit RampStop" 4 "FitCurLimStp"			
 <p>ATTENTION: Risk of injury or equipment damage exists. Parameter 386 [Lgx OutOfRunCnfg] lets you determine the action of the drive if communications are disrupted. By default this parameter causes the drive to fault and coast to a stop. You can set this parameter so that the drive continues to run. Precautions should be taken to ensure that the setting of this parameter does not create hazards of injury or equipment damage.</p>					

No.	Name Description	Values	Linkable Read-Write Data Type
387	<p>Lgx Timeout Cnfg Enter a value to configure the drive's response to a Controller to Drive connection timeout, as detected by the drive.</p> <ul style="list-style-type: none"> • 0 "Ignore" - Configures the drive to continue running, as normal, when this event occurs • 1 "Alarm" - Configures the drive to continue running and set the appropriate alarm bit when this event occurs • 2 "FitCoastStop" - Configures the drive to perform a coast stop and set the appropriate fault bit, in response this event • 3 "Fit RampStop" - Configures the drive to perform a ramp stop and set the appropriate fault bit, in response this event • 4 "FitCurLimStp" - Configures the drive to perform a current-limit stop and set the appropriate fault bit, in response this event 	<p>Default: 2 "FitCoastStop"</p> <p>Options: 0 "Ignore" 1 "Alarm" 2 "FitCoastStop" 3 "Fit RampStop" 4 "FitCurLimStp"</p>	
<div style="display: flex; align-items: center;">  <p>ATTENTION: Risk of injury or equipment damage exists. Parameter 387 [Lgx Timeout Cnfg] lets you determine the action of the drive if communications are disrupted. By default this parameter causes the drive to fault and coast to a stop. You can set this parameter so that the drive continues to run. Precautions should be taken to ensure that the setting of this parameter does not create hazards of injury or equipment damage.</p> </div>			
388	<p>Lgx Closed Cnfg Enter a value to configure the drive's response to the controller closing the Controller to Drive connection.</p> <ul style="list-style-type: none"> • 0 "Ignore" - Configures the drive to continue running, as normal, when this event occurs • 1 "Alarm" - Configures the drive to continue running and set the appropriate alarm bit when this event occurs • 2 "FitCoastStop" - Configures the drive to perform a coast stop and set the appropriate fault bit, in response this event • 3 "Fit RampStop" - Configures the drive to perform a ramp stop and set the appropriate fault bit, in response this event • 4 "FitCurLimStp" - Configures the drive to perform a current-limit stop and set the appropriate fault bit, in response this event 	<p>Default: 2 "FitCoastStop"</p> <p>Options: 0 "Ignore" 1 "Alarm" 2 "FitCoastStop" 3 "Fit RampStop" 4 "FitCurLimStp"</p>	
<div style="display: flex; align-items: center;">  <p>ATTENTION: Risk of injury or equipment damage exists. Parameter 388 [Lgx Closed Cnfg] lets you determine the action of the drive if communications are disrupted. By default this parameter causes the drive to fault and coast to a stop. You can set this parameter so that the drive continues to run. Precautions should be taken to ensure that the setting of this parameter does not create hazards of injury or equipment damage.</p> </div>			
389	<p>Lgx LinkChngCnfg Enter a value to configure the drive's response to Controller to Drive default links being removed. A default link is a link automatically set up when a communication format is selected for the Controller to Drive connection.</p> <ul style="list-style-type: none"> • 0 "Ignore" - Configures the drive to continue running, as normal, when this event occurs • 1 "Alarm" - Configures the drive to continue running and set the appropriate alarm bit when this event occurs • 2 "FitCoastStop" - Configures the drive to perform a coast stop and set the appropriate fault bit, in response this event • 3 "Fit RampStop" - Configures the drive to perform a ramp stop and set the appropriate fault bit, in response this event • 4 "FitCurLimStp" - Configures the drive to perform a current-limit stop and set the appropriate fault bit, in response this event 	<p>Default: 2 "FitCoastStop"</p> <p>Options: 0 "Ignore" 1 "Alarm" 2 "FitCoastStop" 3 "Fit RampStop" 4 "FitCurLimStp"</p>	
<div style="display: flex; align-items: center;">  <p>ATTENTION: Risk of injury or equipment damage exists. Parameter 389 [Lgx LinkChngCnfg] lets you determine the action of the drive if communications are disrupted. By default this parameter causes the drive to fault and coast to a stop. You can set this parameter so that the drive continues to run. Precautions should be taken to ensure that the setting of this parameter does not create hazards of injury or equipment damage.</p> </div>			

No.	Name Description	Values	Linkable	Read-Write	Data Type
390	<p>SL MultErr Cnfg Enter a value to configure the Drive Module's response to SynchLink Multiplier error. Refer to Par 1034 [SL Mult State] for possible causes for multiplier errors.</p> <ul style="list-style-type: none"> 0 "Ignore" - Configures the drive to continue running, as normal, when this event occurs 1 "Alarm" - Configures the drive to continue running and set the appropriate alarm bit when this event occurs 2 "FitCoastStop" - Configures the drive to perform a coast stop and set the appropriate fault bit, in response this event 3 "Fit RampStop" - Configures the drive to perform a ramp stop and set the appropriate fault bit, in response this event 4 "FitCurLimStp" - Configures the drive to perform a current-limit stop and set the appropriate fault bit, in response this event 	<p>Default: 2 "FitCoastStop"</p> <p>Options:</p> <ul style="list-style-type: none"> 0 "Ignore" 1 "Alarm" 2 "FitCoastStop" 3 "Fit RampStop" 4 "FitCurLimStp" 			
<div style="display: flex; align-items: center;">  <p>ATTENTION: Risk of injury or equipment damage exists. Parameter 390 [SL MultErr Cnfg] lets you determine the action of the drive if communications are disrupted. By default this parameter causes the drive to fault and coast to a stop. You can set this parameter so that the drive continues to run. Precautions should be taken to ensure that the setting of this parameter does not create hazards of injury or equipment damage.</p> </div>					
391	<p>DPI CommLoss Cfg Enter a value to configure the drive's response to the failure of a DPI port.</p> <ul style="list-style-type: none"> 0 "Ignore" - Configures the drive to continue running, as normal, when this event occurs 1 "Alarm" - Configures the drive to continue running and set the appropriate alarm bit when this event occurs 2 "FitCoastStop" - Configures the drive to perform a coast stop and set the appropriate fault bit, in response this event 3 "Fit RampStop" - Configures the drive to perform a ramp stop and set the appropriate fault bit, in response this event 4 "FitCurLimStp" - Configures the drive to perform a current-limit stop and set the appropriate fault bit, in response this event 	<p>Default: 2 "FitCoastStop"</p> <p>Options:</p> <ul style="list-style-type: none"> 0 "Ignore" 1 "Alarm" 2 "FitCoastStop" 3 "Fit RampStop" 4 "FitCurLimStp" 			
<div style="display: flex; align-items: center;">  <p>ATTENTION: Risk of injury or equipment damage exists. Parameter 391 [DPI CommLoss Cfg] lets you determine the action of the drive if communications are disrupted. By default this parameter causes the drive to fault and coast to a stop. You can set this parameter so that the drive continues to run. Precautions should be taken to ensure that the setting of this parameter does not create hazards of injury or equipment damage.</p> </div>					
392	<p>NetLoss DPI Cnfg Enter a value to configure the drive's response to communication fault from a network card at a DPI port.</p> <ul style="list-style-type: none"> 0 "Ignore" - Configures the drive to continue running, as normal, when this event occurs 1 "Alarm" - Configures the drive to continue running and set the appropriate alarm bit when this event occurs 2 "FitCoastStop" - Configures the drive to perform a coast stop and set the appropriate fault bit, in response this event 3 "Fit RampStop" - Configures the drive to perform a ramp stop and set the appropriate fault bit, in response this event 4 "FitCurLimStp" - Configures the drive to perform a current-limit stop and set the appropriate fault bit, in response this event 	<p>Default: 2 "FitCoastStop"</p> <p>Options:</p> <ul style="list-style-type: none"> 0 "Ignore" 1 "Alarm" 2 "FitCoastStop" 3 "Fit RampStop" 4 "FitCurLimStp" 			
<div style="display: flex; align-items: center;">  <p>ATTENTION: Risk of injury or equipment damage exists. Parameter 392 [NetLoss DPI Cnfg] lets you determine the action of the drive if communications are disrupted. By default this parameter causes the drive to fault and coast to a stop. You can set this parameter so that the drive continues to run. Precautions should be taken to ensure that the setting of this parameter does not create hazards of injury or equipment damage.</p> </div>					
393	<p>BusUndervoltCnfg Enter a value to configure the drive's response to DC Bus voltage falling below the minimum value.</p> <ul style="list-style-type: none"> 0 "Ignore" - Configures the drive to continue running, as normal, when this event occurs 1 "Alarm" - Configures the drive to continue running and set the appropriate alarm bit when this event occurs 2 "FitCoastStop" - Configures the drive to perform a coast stop and set the appropriate fault bit, in response this event 	<p>Default: 1 "Alarm"</p> <p>Options:</p> <ul style="list-style-type: none"> 0 "Ignore" 1 "Alarm" 2 "FitCoastStop" 			

No.	Name Description	Values	Linkable	Read-Write	Data Type
394	VoltFdbkLossCnfg Enter a value to configure the drive's response to a communication error between Motor Control (MC) and the motor voltage feedback board. <ul style="list-style-type: none"> 0 "Ignore" - Configures the drive to continue running, as normal, when this event occurs 1 "Alarm" - Configures the drive to continue running and set the appropriate alarm bit when this event occurs 2 "FitCoastStop" - Configures the drive to perform a coast stop and set the appropriate fault bit, in response this event 	Default: 2 "FitCoastStop" Options: 0 "Ignore" 1 "Alarm" 2 "FitCoastStop"			
396	User Data Int 01 General purpose parameter available for storage of 32-bit enumerated data by the operator. This value will be retained through a power cycle.	Default: 0 Min/Max: -/+2147483648	✓	✓	32-bit Integer
397	User Data Int 02 General purpose parameter available for storage of 32-bit enumerated data by the operator. This value will be retained through a power cycle.	Default: 0 Min/Max: -/+2147483648		✓	32-bit Integer
398	User Data Int 03 General purpose parameter available for storage of 32-bit enumerated data by the operator. This value will be retained through a power cycle.	Default: 0 Min Max: -/+2147483648		✓	32-bit Integer
399	User Data Int 04 General purpose parameter available for storage of 32-bit enumerated data by the operator. This value will be retained through a power cycle.	Default: 0 Min/Max: -/+2147483648		✓	32-bit Integer
400	Rated Amps This displays the currenting rating of the inverter. The drive automatically sets this at power up.	Units: Amps Default: 22.0000 Min/Max: 0.1000/1000.0000			Real
401	Rated Volts This displays the name plate voltage rating of the inverter. The drive automatically sets this at power up.	Units: Volt Default: 480 Min/Max: 75/690			16-bit Integer
402	PWM Frequency Sets the carrier frequency for the PWM output of the drive. Drive derating may occur at higher carrier frequencies. For derating information, refer to the <i>PowerFlex 700S Phase I Control - Reference Manual</i> , publication PFLEX-RM002. The default is dependant on the power structure of the drive.	Units: kHz Default: 2.0000 (Fr 5, 6, 9) 4.0000 (Fr 1-4) Min/Max: 1.0000/15.0000 (10.0000 Fr 5, 6, 9)			Real
403	Voltage Class Sets the drive configuration for high or low voltage class (i.e. a 400 or 480V ac drive). Allows a choice of configuration and affects many drive parameters including drive rated current, voltage, power, over loads and maximum PWM carrier frequency.	Default: 3 "High Voltage" Options: 2 "Low Voltage" 3 "High Voltage"			
404	Dead Time The time delay between turning off and turning on an upper device and a lower device in the power structure. This parameter is set at power up and is not user adjustable.	Units: μSec Default: 5.0000 Min/Max: 2.0000/100.0000			Real
405	 Dead Time Comp The amount of voltage correction used to compensate for the loss of voltage during dead time. Do not adjust. Contact factory for alternative settings.	Units: % Default: 0 Min/Max: 0/200		✓	16-bit Integer
406	 Power Loss Mode Enter a value to configure the drive's response to a loss of input power. Input voltage below the value specified in Par 408 [Power Loss Level]. Enter a value of 0 to make the drive coast (supply no current to the motor) during the power loss time (specified by Par 407 [Power Loss Time]). Enter a value of 2 to make the drive continue "normal" operation during the power loss time. Enter a value of 5 to make the drive provide only motor flux current during the power loss time.	Default: 0 "Coast" Options: 0 "Coast" 1 "Reserved" 2 "Continue" 3 "Reserved" 4 "Reserved" 5 "Flux Only"			
407	Power Loss Time Sets the time that the drive will remain in power loss mode before a fault is detected.	Units: Sec Default: 2.0000 Min/Max: 0.0000 60.0000		✓	Real
408	Power Loss Level Sets the bus voltage level at which ride-through begins and modulation ends. When bus voltage falls below this level, the drive prepares for an automatic reset. Enter a percentage of the bus voltage derived from the high voltage setting for the voltage class. For example: on a 400-480V drive. $0.221 \times 480 \text{ V ac} \times \sqrt{2} = 150 \text{ V dc}$	Units: % Default: 22.1 Min/Max: 15/95		✓	16-bit Integer
409	 Line Undervolts Controls the level of bus voltage that is needed to complete precharge and sets the level for undervoltage alarm/fault detection. Enter a percentage of the bus voltage derived from the value in Par 401 [Rated Volts]. For example: on a 480V drive. $0.615 \times 480 \text{ V ac} \times \sqrt{2} = 418 \text{ V dc}$	Units: % Default: 61.5000 Min/Max: 10.0000/90.0000		✓	Real
410	 PreChrg TimeOut Sets the time duration of precharge. If bus voltage does not stabilize within this amount of time, a Precharge Error exception event occurs.	Units: Sec Default: 30.0000 Min/Max: 10.0000 180.0000		✓	Real

No.	Name Description	Values	Linkable	Read-Write	Data Type																																																																																																
411	PreChrg Control Must equal 1 "Enbl PrChrg" to allow the drive to exit precharge and begin to run. Link this parameter to a controller output word to coordinate the precharge of multiple drives.	Default: 1 "Enbl PrChrg" Options: 0 "Hold PrChrg" 1 "Enbl PrChrg"																																																																																																			
412	Power EE TP Sel Enter or write a value to select drive power EEPROM data displayed in Par 413 [Power EE TP Data].	Default: 0 Zero																																																																																																			
Options:																																																																																																					
<table border="0"> <tr> <td>0 Zero</td><td>12 Mw Hrs Accum</td><td>24 Inv Rated Kw</td><td>36 IGBTs per Pk</td><td>48 Diode JC Tr</td><td>60 DB Ambt Tmax</td><td>72 Mtr IR Vdrop</td><td>84 Mtr IR Vdrop</td> </tr> <tr> <td>1 Volt Class</td><td>13 Inv High Vlt</td><td>25 Inv Rated V</td><td>37 GBT Rated V</td><td>49 Diode JC Tc</td><td>61 ConvT Type</td><td>73 Mtr Id Ref</td><td>85 Mtr Id Ref</td> </tr> <tr> <td>2 Assy Rev</td><td>14 Reserved</td><td>26 Inv Rated A</td><td>38 IGBT Rated A</td><td>50 GBT Tjmax</td><td>62 DC Bus Induc</td><td>74 HH Data Rev</td><td>86 HH Extr Data</td> </tr> <tr> <td>3 ASA S/N</td><td>15 Fan/Pwr Cntl</td><td>27 Inv 1min Amp</td><td>39 IGBT V Thres</td><td>51 HS Max DegC</td><td>63 AC Inp Induc</td><td>75 HH Dev Type</td><td>87 HH Volt Indx</td> </tr> <tr> <td>4 Manuf Year</td><td>16 Temp Sensor</td><td>28 inv 3sec Amp</td><td>40 IGBT Slope R</td><td>52 DB IGBT Amp</td><td>64 Precharg Res</td><td>76 HH Serial #</td><td>88 HH Size Indx</td> </tr> <tr> <td>5 Manuf Month</td><td>17 Phs AmpScale</td><td>29 SW OverC Amp</td><td>41 IGBT Sw Engy</td><td>53 DB ohms</td><td>65 PrechThrm Tc</td><td>77 HH Test Date</td><td>89 HH Option</td> </tr> <tr> <td>6 Manuf Day</td><td>18 Gnd AmpScale</td><td>30 DC Bus Cap</td><td>42 IGBT JC Tres</td><td>54 DB E Jo/degC</td><td>66 Mtr NP Units</td><td>78 HH Vcn Code</td><td>90 HH Hrd Prdct</td> </tr> <tr> <td>7 Tst ProcStat</td><td>19 Bus VltScale</td><td>31 Min PWM Khz</td><td>43 IGBT JC Tc</td><td>55 DB EB C/Wat</td><td>67 Mtr NP Power</td><td>79 HH CrsCnc ID</td><td>91 HH H/W Mdfy</td> </tr> <tr> <td>8 Life PwrCycl</td><td>20 Sml PS Watts</td><td>32 Max PWM Khz</td><td>44 IGBT CS Tres</td><td>56 DB B Jo/degC</td><td>68 Mtr NP Volts</td><td>80 HH P/B ID</td><td>92 HH 1V/Amp</td> </tr> <tr> <td>9 Life Pwrup</td><td>21 Sml PS Min V</td><td>33 Dfl PWM Khz</td><td>45 IGBT CS Tc</td><td>57 DB BA C/Watt</td><td>69 Mtr NP Amps</td><td>81 HH S/W ID</td><td>93 HH 2s/Amp</td> </tr> <tr> <td>10 Life RunTime</td><td>22 Lrg PS Watts</td><td>34 PWM Dead us</td><td>46 Diode V Thrs</td><td>58 DB Elem Tmax</td><td>70 Mtr NP Freq</td><td>82 HH P/B Rev</td><td>94 HH Scale</td> </tr> <tr> <td>11 Kw Accum</td><td>23 Lrg PS Min V</td><td>35 Drive Frame</td><td>47 Diode SlopeR</td><td>59 DB Body Tmax</td><td>71 Mtr NP RPM</td><td>83 HH S/W Rev</td><td></td> </tr> </table>						0 Zero	12 Mw Hrs Accum	24 Inv Rated Kw	36 IGBTs per Pk	48 Diode JC Tr	60 DB Ambt Tmax	72 Mtr IR Vdrop	84 Mtr IR Vdrop	1 Volt Class	13 Inv High Vlt	25 Inv Rated V	37 GBT Rated V	49 Diode JC Tc	61 ConvT Type	73 Mtr Id Ref	85 Mtr Id Ref	2 Assy Rev	14 Reserved	26 Inv Rated A	38 IGBT Rated A	50 GBT Tjmax	62 DC Bus Induc	74 HH Data Rev	86 HH Extr Data	3 ASA S/N	15 Fan/Pwr Cntl	27 Inv 1min Amp	39 IGBT V Thres	51 HS Max DegC	63 AC Inp Induc	75 HH Dev Type	87 HH Volt Indx	4 Manuf Year	16 Temp Sensor	28 inv 3sec Amp	40 IGBT Slope R	52 DB IGBT Amp	64 Precharg Res	76 HH Serial #	88 HH Size Indx	5 Manuf Month	17 Phs AmpScale	29 SW OverC Amp	41 IGBT Sw Engy	53 DB ohms	65 PrechThrm Tc	77 HH Test Date	89 HH Option	6 Manuf Day	18 Gnd AmpScale	30 DC Bus Cap	42 IGBT JC Tres	54 DB E Jo/degC	66 Mtr NP Units	78 HH Vcn Code	90 HH Hrd Prdct	7 Tst ProcStat	19 Bus VltScale	31 Min PWM Khz	43 IGBT JC Tc	55 DB EB C/Wat	67 Mtr NP Power	79 HH CrsCnc ID	91 HH H/W Mdfy	8 Life PwrCycl	20 Sml PS Watts	32 Max PWM Khz	44 IGBT CS Tres	56 DB B Jo/degC	68 Mtr NP Volts	80 HH P/B ID	92 HH 1V/Amp	9 Life Pwrup	21 Sml PS Min V	33 Dfl PWM Khz	45 IGBT CS Tc	57 DB BA C/Watt	69 Mtr NP Amps	81 HH S/W ID	93 HH 2s/Amp	10 Life RunTime	22 Lrg PS Watts	34 PWM Dead us	46 Diode V Thrs	58 DB Elem Tmax	70 Mtr NP Freq	82 HH P/B Rev	94 HH Scale	11 Kw Accum	23 Lrg PS Min V	35 Drive Frame	47 Diode SlopeR	59 DB Body Tmax	71 Mtr NP RPM	83 HH S/W Rev	
0 Zero	12 Mw Hrs Accum	24 Inv Rated Kw	36 IGBTs per Pk	48 Diode JC Tr	60 DB Ambt Tmax	72 Mtr IR Vdrop	84 Mtr IR Vdrop																																																																																														
1 Volt Class	13 Inv High Vlt	25 Inv Rated V	37 GBT Rated V	49 Diode JC Tc	61 ConvT Type	73 Mtr Id Ref	85 Mtr Id Ref																																																																																														
2 Assy Rev	14 Reserved	26 Inv Rated A	38 IGBT Rated A	50 GBT Tjmax	62 DC Bus Induc	74 HH Data Rev	86 HH Extr Data																																																																																														
3 ASA S/N	15 Fan/Pwr Cntl	27 Inv 1min Amp	39 IGBT V Thres	51 HS Max DegC	63 AC Inp Induc	75 HH Dev Type	87 HH Volt Indx																																																																																														
4 Manuf Year	16 Temp Sensor	28 inv 3sec Amp	40 IGBT Slope R	52 DB IGBT Amp	64 Precharg Res	76 HH Serial #	88 HH Size Indx																																																																																														
5 Manuf Month	17 Phs AmpScale	29 SW OverC Amp	41 IGBT Sw Engy	53 DB ohms	65 PrechThrm Tc	77 HH Test Date	89 HH Option																																																																																														
6 Manuf Day	18 Gnd AmpScale	30 DC Bus Cap	42 IGBT JC Tres	54 DB E Jo/degC	66 Mtr NP Units	78 HH Vcn Code	90 HH Hrd Prdct																																																																																														
7 Tst ProcStat	19 Bus VltScale	31 Min PWM Khz	43 IGBT JC Tc	55 DB EB C/Wat	67 Mtr NP Power	79 HH CrsCnc ID	91 HH H/W Mdfy																																																																																														
8 Life PwrCycl	20 Sml PS Watts	32 Max PWM Khz	44 IGBT CS Tres	56 DB B Jo/degC	68 Mtr NP Volts	80 HH P/B ID	92 HH 1V/Amp																																																																																														
9 Life Pwrup	21 Sml PS Min V	33 Dfl PWM Khz	45 IGBT CS Tc	57 DB BA C/Watt	69 Mtr NP Amps	81 HH S/W ID	93 HH 2s/Amp																																																																																														
10 Life RunTime	22 Lrg PS Watts	34 PWM Dead us	46 Diode V Thrs	58 DB Elem Tmax	70 Mtr NP Freq	82 HH P/B Rev	94 HH Scale																																																																																														
11 Kw Accum	23 Lrg PS Min V	35 Drive Frame	47 Diode SlopeR	59 DB Body Tmax	71 Mtr NP RPM	83 HH S/W Rev																																																																																															
413	Power EE TP Data Displays the data selected by Par 412 [Power EE TP Sel].	Default: 0 Min/Max: -/+2200000000			Real																																																																																																
414	Brake/Bus Cnfg Configures the brake and bus operation of the drive. <ul style="list-style-type: none"> Set bit 0 [Brake Enable] to enable the operation of the internal brake transistor. Set bit 1 [Brake Extern] to configure the brake to use an external resistor. Set bit 2 [BusRef High] to select the "high" voltage setting as the turn-on point for the Bus Voltage Regulator. The "high" setting brake operation starts when bus voltage reaches the value of Par 415 [BusReg/Brake Ref], and the Bus Voltage Regulator operation starts when bus voltage reaches the value of 415 [BusReg/Brake Ref] plus 4.5%. With the "low" setting both brake and regulator operation start when bus voltage reaches the value of 415 [BusReg/Brake Ref]. Set bit 3 [Bus Reg En] to enable the Bus Voltage Regulator. The output of the Bus Voltage Regulator is summed with Par 128 [Regen Power Lim] and fed into the Power Limit Calculator. It, in effect, reduces negative torque references when the bus voltage is too high. 	Options																																																																																																			
<table border="1"> <thead> <tr> <th></th> <th>Reserved</th><th>Reserved</th><th>Reserved</th><th>Reserved</th><th>Reserved</th><th>Reserved</th><th>Reserved</th><th>Reserved</th><th>Reserved</th><th>Reserved</th><th>Reserved</th><th>Reserved</th><th>Reserved</th><th>Bus Reg En</th><th>Bus Ref High</th><th>Brake Extern</th><th>Brake Enable</th> </tr> </thead> <tbody> <tr> <td>Default</td> <td>0</td><td>0</td><td>1</td><td>1</td><td>0</td><td>0</td><td>0</td><td>0</td><td>0</td><td>0</td><td>0</td><td>0</td><td>0</td><td>0</td><td>0</td><td>0</td><td>0</td> </tr> <tr> <td>Bit</td> <td>15</td><td>14</td><td>13</td><td>12</td><td>11</td><td>10</td><td>9</td><td>8</td><td>7</td><td>6</td><td>5</td><td>4</td><td>3</td><td>2</td><td>1</td><td>0</td><td></td> </tr> </tbody> </table>							Reserved	Reserved	Reserved	Reserved	Reserved	Reserved	Reserved	Reserved	Reserved	Reserved	Reserved	Reserved	Reserved	Bus Reg En	Bus Ref High	Brake Extern	Brake Enable	Default	0	0	1	1	0	0	0	0	0	0	0	0	0	0	0	0	0	Bit	15	14	13	12	11	10	9	8	7	6	5	4	3	2	1	0																																											
	Reserved	Reserved	Reserved	Reserved	Reserved	Reserved	Reserved	Reserved	Reserved	Reserved	Reserved	Reserved	Reserved	Bus Reg En	Bus Ref High	Brake Extern	Brake Enable																																																																																				
Default	0	0	1	1	0	0	0	0	0	0	0	0	0	0	0	0	0																																																																																				
Bit	15	14	13	12	11	10	9	8	7	6	5	4	3	2	1	0																																																																																					
0 = False 1 = True																																																																																																					
415	BusReg/Brake Ref Sets the "turn-on" voltage for the bus regulator and brakes. Enter a percentage of the high voltage setting for the voltage class. For example, on a 400-480V drive: $111 \times \sqrt{2} \times 480 = \text{VDC}$	Units: % Default: 111.0000 Min/Max: 110.5000117.8000		✓	Real																																																																																																
416	Brake PulseWatts Limits the power delivered to the external Dynamic Brake (DB) resistor for one second, without exceeding the rated element temperature. You may change the value of this parameter only if you have selected an external DB resistor (set bit 1 [Brake Extern] of Par 414 [Brake/Bus Cnfg]). If this rating is not available from the resistor vendor, you can approximate it with this equation: Par 416 [Brake PulseWatts] = 75,000 x Weight, where Weight equals the weight of the resistor wire element in pounds (not the entire weight of the resistor). Another equation you can use is: Par 416 [Brake PulseWatts] = Time Constant x Brake Watts; where Time Constant equals the amount of time to reach 63% of its rated temperature the maximum power applied, and Brake Watts is the maximum power rating of the resistor.	Units: Watt Default: 2000.0000 Min/Max: 1.0000/1000000.0000		✓	Real																																																																																																
417	Brake Watts Sets the maximum continuous power reference for the Dynamic Brake (DB). You may change the value of this parameter only if you have selected and external DB resistor (set bit 1 [Brake Extern] of Par 414 [Brake/Bus Cnfg]).	Units: Watt Default: 100.0000 Min/Max: 0.0000/5000.0000		✓	Real																																																																																																

No.	Name Description	Values	Linkable	Read-Write	Data Type
418	Brake TP Sel Enter or write a value to select the drive overload data displayed in Par 419 [Brake TP Data].	Default: 0 "Zero" Options: 0 "Zero" 10 "Data State" 1 "Duty Cycle" 11 "MC BrakeEnbl" 2 "Power Actual" 12 "1/rdb" 3 "Max BodyTemp" 13 "1/th_eb" 4 "Max ElemTemp" 14 "1/ce" 5 "BodyTemp Act" 15 "tamax" 6 "ElemTemp Act" 16 "1/th_ba" 7 "BTmpTripStat" 17 "1/cb" 8 "ETmpTripStat" 18 "DB IGBT Amp" 9 "Int DB Ohms"			
419	Brake TP Data Displays the data selected by Par 418 [Brake TP Sel].	Default: 0.0000 Min/Max: -/+2200000000.0000			Real
421	Iqs Integ Freq Sets the break frequency of the torque producing (q-axis) current regulator. This and Par 422 [Iqs Reg P Gain] determine the integral gain for the q-axis current regulator. Set by the autotune procedure. Do not change this value.	Units: R/S Default: 10 Min/Max: 0/32767		✓	16-bit Integer
422	Iqs Reg P Gain Sets the proportional gain of the torque producing (q-axis) current regulator. Set by the autotune procedure. Do not change this value.	Default: 1.0 Min/Max: 0.0/100.0 Comm Scale: x 10		✓	16-bit Integer
423	Iqs Rate Limit Sets the limit of the rate of change for the torque producing (q-axis) current regulator. Do not change this parameter. Use Par 355 [Iq Rate Limited] to control the q-axis current rate limit.	Units: %/mS Default: 800.0 Min/Max: 0.0/800.0 Comm Scale: x 10		✓	16-bit Integer
424	Flux Ratio Ref Active only in the Field Oriented Control (FOC) 2 control mode (when Par 485 [Motor Ctrl Mode] equals 2 "FOC 2"), when activated (Par 511 [FOC2 Mode Config], bit 28 [FlxRatRf Use] is set). Provides a scaling factor for the flux producing (d-axis) current reference. • When active (Par 511 [FOC2 Mode Config], bit 28 [FlxRatRf Use] is set), Flux Producing (d-axis) Current Reference = Par 488 [Flux Current] x Par 424 [Flux Ratio Ref]. • When inactive (Par 511 [FOC2 Mode Config], bit 28 [FlxRatRf Use] is cleared) Flux Producing (d-axis) Current Reference = Par 488 [Flux Current] below base speed and Flux Producing (d-axis) Current Reference = Par 488 [Flux Current] x motor base speed/motor speed above base speed.	Units: % Default: 99.99 Min/Max: 12.50/399.99 Comm Scale: 100 = 32767		✓	16-bit Integer
425	Flux Rate Limit Sets the limit of the rate of change for flux producing (d-axis) current.	Units: %/mS Default: 1.0 Min/Max: 0.0/195.3 Comm Scale: x 10		✓	16-bit Integer
426	Flux Satur Coef This represents the amount of flux current required to compensate for the flux saturation effect of the motor.	Units: %/ Default: 0.0 Min/Max: 0.0/51.3 Comm Scale: x 10		✓	
427	PM Mtr CEMF Comp Provides CEMF compensation for the torque producing (q-axis) current in the permanent magnet motor mode.	Units: % Default: 0 Min/Max: 0/100		✓	16-bit Integer
428	IReg IGain Fctr Adjustment for current regulator integral frequency factor (gain).	Default: 1 Min/Max: 1/20			
429	Ids Integ Freq Sets the break frequency of the flux producing (d-axis) current regulator. This and Par 430 [Ids Reg P Gain] determine the integral gain for the d-axis current regulator. Set by the autotune procedure. Do not change this value.	Units: R/S Default: 10 Min/Max: 0/32767		✓	16-bit Integer
430	Ids Reg P Gain Sets the proportional gain of the flux producing (d-axis) current regulator. Set by the autotune procedure. Do not change this value.	Default: 1.0 Min/Max: 0.0/100.0 Comm Scale: x 10		✓	16-bit Integer
431	Test Current Ref Sets the current reference used for Motor Control (MC) Test Mode.	Units: % Default: 50.0 Min/Max: 0.0/799.9 Comm Scale: x 10		✓	16-bit Integer
432	Test Freq Ref Sets the frequency reference used for Motor Control (MC) Test Mode.	Units: % Default: 10.0 Min/Max: -/+799.9 Comm Scale: x 10		✓	16-bit Integer
433	Test Freq Rate Sets the rate of change of frequency reference used for Motor Control (MC) Test Mode.	Units: %/S Default: 5.0 Min/Max: 0.0/1000.0 Comm Scale: x 10		✓	16-bit Integer
434	Mtr Vds Base Displays the motor flux producing (d-axis) voltage command when running at nameplate motor speed and load. This value is determined during the autotune procedure. Do not change this value.	Default: 0 Min/Max: -8192/0			16-bit Integer

No.	Name Description	Values	Linkable	Read-Write	Data Type
435	Mtr Vqs Base Displays the motor torque producing (q-axis) voltage command when running at nameplate motor speed and load. This value is determined during the autotune procedure. Do not change this value.	Default: 0 Min/Max: 0/8192			16-bit Integer
437	Vqs Max Displays the maximum torque producing (q-axis) voltage allowed on the motor. Adaptation is disabled below this voltage. This value is determined during the autotune procedure. Do not change this value.	Default: 7971 Min/Max: 0/32767		✓	16-bit Integer
438	Vds Max Displays the maximum flux producing (d-axis) voltage allowed on the motor. Adaptation is disabled below this voltage. This value is determined during the autotune procedure. Do not change this value.	Default: 5793 Min/Max: 0/32767		✓	16-bit Integer
439	Vqs Min Displays the minimum torque producing (q-axis) voltage required for motor control adaption. Adaptation is disabled below this voltage. This value is determined during the autotune procedure. Do not change this value.	Default: 246 Min/Max: -/+32767		✓	16-bit Integer
440	Vds Min Displays the minimum flux producing (d-axis) voltage required for motor control adaption. Adaptation is disabled below this voltage. This value is determined during the autotune procedure. Do not change this value.	Default: 246 Min/Max: -/+32767		✓	16-bit Integer
441	Vds Fdbk Filt Displays measured filtered motor flux producing (d-axis) voltage.	Default: 0 Min/Max: -/+32767			16-bit Integer
442	Vqs Fdbk Filt Displays measured filtered motor torque producing (q-axis) voltage.	Default: 0 Min/Max: -/+32767			16-bit Integer
443	Flux Reg P Gain1 Sets the Proportional (P) gain for the flux regulator. Do not change this value.	Default: 150 Min/Max: 0/32767		✓	16-bit Integer
444	Flux Reg I Gain Sets the Integral (I) gain for the flux regulator. Do not change this value.	Default: 350 Min/Max: 0/32767		✓	16-bit Integer
445	Slip Gain Max Displays the maximum slip frequency allowed in the motor control. Scaling is in hertz x 256. This value is determined during the autotune procedure. Do not change this value.	Units: % Default: 300 Min/Max: 100/10000		✓	16-bit Integer
446	Slip Gain Min Displays the minimum slip frequency allowed in the motor control. Scaling is in hertz x 256. This value is determined during the autotune procedure. Do not change this value.	Units: % Default: 50 Min/Max: 0/100		✓	16-bit Integer
447	Slip Reg P Gain Sets the Proportional (P) gain for the slip regulator. Do not change this value.	Default: 35 Min/Max: 0/32767 Comm Scale: x 1		✓	16-bit Integer
448	Slip Reg I Gain Sets the Integral (I) gain for the slip regulator. Do not change this value.	Default: 100 Min/Max: 0/32767		✓	16-bit Integer
449	Freq Reg I Gain Sets the integral gain of the Frequency Regulator, which estimates motor speed when sensorless feedback is selected. Do not change this value.	Default: 250 Min/Max: 0/32767	✓	✓	16-bit Integer
450	Freq Reg P Gain Sets the proportional gain of the Frequency Regulator, which estimates motor speed when sensorless feedback is selected. Do not change this value.	Default: 350 Min/Max: 0/32767	✓	✓	16-bit Integer
451	SrLss Preset Spd Motor speed at which to start the sensorless frequency search.	Units: RPM Default: 1750.0 Min/Max: -/+13999.6			
453	Iu Offset Sets the current offset correction for the phase U current. Value is set automatically when the drive is not running and Motor Control (MC) is not faulted. Do not change this value.	Default: 0 Min/Max: -/+32767		✓	16-bit Integer
454	Iw Offset Sets the current offset correction for the flux producing (d-axis) current regulator. This value is set automatically when the drive is not running and Motor Control (MC) is not faulted. Do not change this value.	Default: 0 Min/Max: -/+32767		✓	16-bit Integer
469	StatorInduc Gain Displays the current regulator feedforward compensation. Do not change this value.	Units: % Default: 0 Min/Max: 0/100		✓	16-bit Integer
470	Flux Reg P Gain2 Displays the additional proportional gain used at the start of Bus voltage limited field weakening. Do not change this value.	Default: 1000 Min/Max: 0/32767		✓	16-bit Integer
472	 PreCharge Delay Adjusts a delay between the time all other precharge conditions have been met and the time the drive leaves the precharge state. Can be used to control the sequence of precharge completion in a drive system. The maximum value of this parameter is calculated as follows: Par 472 [PreCharge Delay] = Par 410 [PreChrg TimeOut] - 1.0 second.	Units: Sec Default: 2.0 Min/Max: 0.0/Calculated		✓	16-bit Integer
473	Freq Reg FF Gain Provides feed forward gain to the Frequency Regulator, which estimates motor speed when sensorless feedback is selected. Higher gains make operation at low speeds smoother. However, higher gains may make operation at high speeds less stable.	Default: 300 Min/Max: 0/32767		✓	16-bit Integer

No.	Name Description	Values	Linkable	Read-Write	Data Type
474	Freq Reg We BW Sets the electrical (stator) frequency bandwidth for the Frequency Regulator, which estimates motor speed when sensorless feedback is selected. Must always be set to a value higher than Par 475 [Freq Reg Wr BW].	Default: 150 Min/Max: 0/32767		✓	16-bit Integer
475	Freq Reg Wr BW Sets the rotor (speed) frequency bandwidth for the Frequency Regulator, which estimates motor speed when sensorless feedback is selected. Must always be set to a value higher than Par 97 [Act Spd Reg BW]. Normal applications should use a value approximately 50% greater than Par 97. Applications with large dynamic ranges can use values 200-300% greater than Par 97. However large values can result in pull-outs and unstable operation.	Default: 30 Min/Max: 0/32767		✓	16-bit Integer
476	Slip Gain Comp Provides slip gain compensation for sensorless speed adjustment.	Units: % Default: 100.00 Min/Max: 0.00/400.00		✓	16-bit Integer
477	Est Theta Delay Active only in Permanent Magnet motor mode (when Par 485 [Motor Ctrl Mode] equals 2 "Pmag Motor"). Provides a delay for the function that compares the estimated rotor position and the data from the position sensor.	Units: mSec Default: 10 Min/Max: 2/1024		✓	16-bit Integer
485	Motor Ctrl Mode Enter a value to select the operating mode for the Motor Control (MC). <ul style="list-style-type: none"> 0 "FOC" - (Field Oriented Control) is induction motor control with voltage adaptation. 1 "FOC 2" (Field Oriented Control 2) is induction motor control with temperature adaptation. 2 "Pmag Motor" - (Permanent Magnet Motor Control) is permanent magnet motor operation. 4 (Test) - Is the test mode. 	Default: 0 "FOC" Options: 0 "FOC" 3 "Reserved" 1 "FOC 2" 4 "Test" 2 "Pmag Motor"			
486	Rated Slip Freq Displays the control slip frequency, determined from Par 3 [Motor NP Hertz] and Par 4 [Motor NP RPM]. Measured by the autotune procedure. Do not change this value.	Units: Hz Default: 0.470 Min/Max: 0.000/32.000 Comm Scale: x 1000		✓	16-bit Integer
487	Motor NTC Coef Defines a coefficient used to calculate the rotor temperature from the measured stator temperature. Used only in Field Oriented Control - 2 (FOC2) mode.	Units: % Default: 100 Min/Max: 50/200		✓	16-bit Integer
488	Flux Current Specifies the magnetizing current that produces rated flux in the motor in a per unit (percent representation). Measured by the autotune procedure. Do not change this value.	Units: % Default: 30.00 Min/Max: 0.00/75.00 Comm Scale: x 100		✓	16-bit Integer
490	Stator Inductance Displays the sum of the stator and cable inductances of the motor in per unit (percent representation), as determined by the autotune procedure. Scaled to percent of rated motor impedance. Do not change this value.	Units: % Default: 100.00 Min/Max: 0.00/799.99 Comm Scale: 100 = 8192\		✓	16-bit Integer
491	Stator Resistance Displays the sum of the stator and cable resistances of the motor in per unit (percent representation), as determined by the autotune procedure. Scaled to percent of rated motor impedance. Do not change this value.	Units: % Default: 1.00 Min/Max: 0.00/100.00 Comm Scale: 100 = 8192		✓	16-bit Integer
492	Leak Inductance Displays the sum of the motor stator, rotor leakage, and motor cable inductances in per unit (percent representation), as determined by the autotune procedure. Scaled to percent of rated motor impedance. Do not change this value.	Units: % Default: 20.00 Min/Max: 0.00/100.00 Comm Scale: 100 = 8192		✓	16-bit Integer
493	Leak Indc Sat 1 Displays the leakage inductance correction for the first overload level as determined by the autotune procedure.	Units: % Default: 100.00 Min/Max: 25.00/100.00			16-bit Integer
494	Leak Indc Sat 2 Displays the leakage inductance correction for the first overload level as determined by the autotune procedure.	Units: % Default: 100.00 Min/Max: 25.00/100.00			16-bit Integer
500	Bus Util Limit Sets the maximum allowed bus voltage utilization for the Motor Control. Do not change this value. Higher values may result in control instability or over-current faults.	Units: % Default: 90.0 Min/Max: 0.0/100.0 Comm Scale: 100 = 8192		✓	16-bit Integer
501	Torque En Dly Sets the delay between the time the drive is enabled and the time the Motor Control applies torque.	Units: mSec Default: 100 Min/Max: 0/32767 Comm Scale: 100 = 8192		✓	16-bit Integer
502	Rotor Resistance Displays rotor resistance, as determined by the autotune procedure. Scaled to percent of rated motor impedance. Do not change this value.	Units: % Default: 1.00 Min/Max: 0.00/100.00 Comm Scale: 100 = 8192		✓	16-bit Integer

No.	Name Description	Values	Linkable	Read-Write	Data Type																																																					
517	PMag Tune Cnfg Configures the Permanent Magnet Motor tuning mode.  ATTENTION: Do not modify this parameter. Motor/Drive instabilities and damage could result.	<table border="1"> <tr> <td>Options</td> <td>Reserved</td><td>Reserved</td><td>Reserved</td><td>Reserved</td><td>Reserved</td><td>Reserved</td><td>Reserved</td><td>Reserved</td><td>IndTestA set</td><td>Reserved</td><td>Reserved</td><td>Reserved</td><td>Reserved</td><td>Reserved</td><td>Reserved</td><td>Reserved</td><td>Reserved</td> </tr> <tr> <td>Default</td> <td>0</td><td>0</td><td>0</td><td>0</td><td>0</td><td>0</td><td>0</td><td>0</td><td>0</td><td>0</td><td>0</td><td>0</td><td>0</td><td>0</td><td>0</td><td>0</td><td>0</td> </tr> <tr> <td>Bit</td> <td>15</td><td>14</td><td>13</td><td>12</td><td>11</td><td>10</td><td>9</td><td>8</td><td>7</td><td>6</td><td>5</td><td>4</td><td>3</td><td>2</td><td>1</td><td>0</td> </tr> </table> 0 = False 1 = True	Options	Reserved	Reserved	Reserved	Reserved	Reserved	Reserved	Reserved	Reserved	IndTestA set	Reserved	Reserved	Reserved	Reserved	Reserved	Reserved	Reserved	Reserved	Default	0	0	0	0	0	0	0	0	0	0	0	0	0	0	0	0	0	Bit	15	14	13	12	11	10	9	8	7	6	5	4	3	2	1	0			
Options	Reserved	Reserved	Reserved	Reserved	Reserved	Reserved	Reserved	Reserved	IndTestA set	Reserved	Reserved	Reserved	Reserved	Reserved	Reserved	Reserved	Reserved																																									
Default	0	0	0	0	0	0	0	0	0	0	0	0	0	0	0	0	0																																									
Bit	15	14	13	12	11	10	9	8	7	6	5	4	3	2	1	0																																										
520	PM Q Inductance Indicates the percent-per unit inductance of the motor stator in the torque producing (q-axis).	Units: % Default: 20.00 Min/Max: 0.00/399.99 Comm Scale: 100 = 8192		✓	16-bit Integer																																																					
521	PM D Inductance Indicates the percent-per unit inductance of the motor stator in the flux producing (d-axis).	Units: % Default: 20.00 Min/Max: 0.00/399.99 Comm Scale: 100 = 8192		✓	16-bit Integer																																																					
522	PM Stator Resist Indicates the percent-per unit resistance of the motor stator.	Units: % Default: 1.50 Min/Max: 0.00/100.00 Comm Scale: 100 = 8192		✓	16-bit Integer																																																					
523	PM Mtr CEMF Coef Indicates the coefficient for Counter Electro Motive Force (CEMF) voltage, normalized to base motor speed.	Units: % Default: 89.99 Min/Max: 0.00/399.99 Comm Scale: 100 = 8192		✓	16-bit Integer																																																					
526	MC Build Number Displays the build number of the drive's Motor Control (MC) software.	Default: 0 Min/Max: 0/65535			16-bit Integer																																																					
527	MC Firmware Rev Displays the major and minor revision levels of the drive's Motor Control (MC) software.	Default: 0.00 Min/Max: 0.00/655.35 Comm Scale: x 10			16-bit Integer																																																					
533	Slip Ratio Used by the Field Oriented Control - 2 (FOC2) mode. Indicates the present operating slip frequency at 100% Torque Producing Current (Iqs) scaled to hertz x 100.	Units: Hz Default: 0.00 Min/Max: 0.00/327.67 Comm Scale: x 10			16-bit Integer																																																					
534	Stator Frequency Displays stator frequency as a percentage of Par 3 [Motor NP Hertz].	Units: % Default: 0.0 Min/Max: -/+800.0 Comm Scale: x 10			16-bit Integer																																																					
535	Iqs Command Displays the torque producing (q-axis) current command.	Units: % Default: 0.0 Min/Max: -/+800.0 Comm Scale: x 10			16-bit Integer																																																					
537	Ids Command Displays the flux producing (d-axis) current command.	Units: % Default: 0.0 Min/Max: -/+800.0 Comm Scale: x 10			16-bit Integer																																																					
539	Iqs Feedback Displays torque producing (q-axis) current feedback.	Units: P.U. Default: 0.0000 Min/Max: -/+8.0000			Real																																																					
540	Ids Feedback Displays flux producing (d-axis) current feedback.	Units: P.U. Default: 0.0000 Min/Max: -/+8.0000			Real																																																					
541	Vqs Command Displays the command for initiation of voltage on the torque producing axis (q-axis).	Units: % Default: 0 Min/Max: -/+200 Comm Scale: 100 = 8192			16-bit Integer																																																					
542	Vds Command Displays the command for initiation of voltage on the flux producing axis (d-axis).	Units: % Default: 0 Min/Max: -/+200 Comm Scale: 100 = 8192			16-bit Integer																																																					

No.	Name Description	Values	Linkable	Read-Write	Data Type																																																																																																																																																																																																																																																																																																																																																																																																																																																																									
544	<p>MC TP Select Enter or write a value to select Motor Control (MC) data displayed in Pars 545 [MC TP Value], and 546 [MC TP Bit], Pars 545 [MC TP Value], and 546 [MC TP Bit] are diagnostic tools you can use to view internal drive parameters.</p> <p>Options:</p> <table border="0"> <tr> <td>0</td><td>MulqsRef2</td><td>38</td><td>Wr2</td><td>76</td><td>SinThtaEcor4</td><td>114</td><td>TestMark71</td><td>152</td><td>SrLssWeEst2</td><td>190</td><td>RsEstPhi</td> </tr> <tr> <td>1</td><td>SlipRatio</td><td>39</td><td>FluxRatio1</td><td>77</td><td>MulRef2B</td><td>115</td><td>TestMark72</td><td>153</td><td>SrLssPrportl</td><td>191</td><td>RsEstSinPhi</td> </tr> <tr> <td>2</td><td>Ws</td><td>40</td><td>VbusFdbk</td><td>78</td><td>SpdFdbk</td><td>116</td><td>TestMark73</td><td>154</td><td>SrLssPI</td><td>192</td><td>RsEstVqsFbkP</td> </tr> <tr> <td>3</td><td>WrEst2</td><td>41</td><td>FluxRatio2</td><td>79</td><td>SpdIntegral</td><td>117</td><td>TestMark74</td><td>155</td><td>SrLssQAWeEst</td><td>193</td><td>RsEWeLadsCmd</td> </tr> <tr> <td>4</td><td>We</td><td>42</td><td>FluxRatio3</td><td>80</td><td>SpdPrportnal</td><td>118</td><td>TestMark75</td><td>156</td><td>SLWeGainFwk</td><td>194</td><td>REWeLadsCmdP</td> </tr> <tr> <td>5</td><td>VdsCmd</td><td>43</td><td>FluxRatio4</td><td>81</td><td>SpdPI</td><td>119</td><td>TestMark76</td><td>157</td><td>SrLssWsFf</td><td>195</td><td>RsEWeLaqsCmd</td> </tr> <tr> <td>6</td><td>VqsCmd</td><td>44</td><td>MuFlxRtioRef</td><td>82</td><td>SpdRef</td><td>120</td><td>TestMark76</td><td>158</td><td>SrLssWsEst</td><td>196</td><td>RsEstldsRat</td> </tr> <tr> <td>7</td><td>VuCmd1</td><td>45</td><td>RcpFixRatio1</td><td>83</td><td>SlipGainEst</td><td>121</td><td>TestMark78</td><td>159</td><td>SrLssWsCmd</td><td>197</td><td>RsEstlqsRat</td> </tr> <tr> <td>8</td><td>VvCmd1</td><td>46</td><td>MulfluxRef</td><td>84</td><td>SlipGainFf</td><td>122</td><td>TestMark79</td><td>160</td><td>SrLssVdsErr</td><td>198</td><td>MulqsRef2</td> </tr> <tr> <td>9</td><td>VwCmd1</td><td>47</td><td>MultestRef</td><td>85</td><td>Ws2</td><td>123</td><td>TestMark7A</td><td>161</td><td>SLVdsErrComp</td><td>199</td><td>EstThetaByMV</td> </tr> <tr> <td>10</td><td>IuFdbk</td><td>48</td><td>MotVntc</td><td>86</td><td>SlipGain</td><td>124</td><td>TestMark7B</td><td>162</td><td>SrLssStrtTmr</td><td>200</td><td>ETVdsFbkA</td> </tr> <tr> <td>11</td><td>IwFdbk</td><td>49</td><td>BaseSlip</td><td>87</td><td>SlipGainFltr</td><td>125</td><td>TestMark7C</td><td>163</td><td>SrLssWsMxLim</td><td>201</td><td>ETVqsFbkA</td> </tr> <tr> <td>12</td><td>IdsFdbk</td><td>50</td><td>VbusFdbk2</td><td>88</td><td>SlipVdsCmd</td><td>126</td><td>TestMark7D</td><td>164</td><td>SrLssWeAve</td><td>202</td><td>ETVdsFbkS</td> </tr> <tr> <td>13</td><td>IqsFdbk</td><td>51</td><td>VdsFdbk2</td><td>89</td><td>SlpVdsCmdFlt</td><td>127</td><td>TestMark7E</td><td>165</td><td>SrLssWeEst</td><td>203</td><td>ETVqsFbkS</td> </tr> <tr> <td>14</td><td>VdsFdbk</td><td>52</td><td>VqsFdbk2</td><td>90</td><td>VdsLastError</td><td>128</td><td>TestMark7F</td><td>166</td><td>SrLssKpMonit</td><td>204</td><td>ETAtanVqVd</td> </tr> <tr> <td>15</td><td>VuvFdbk</td><td>53</td><td>VdsSpdVltFit</td><td>91</td><td>VdsPrportnal</td><td>129</td><td>RWVuOut</td><td>167</td><td>SrLssKiMonit</td><td>205</td><td>ETByMtrVDfr</td> </tr> <tr> <td>16</td><td>VvwFdbk</td><td>54</td><td>WrEst1</td><td>92</td><td>VdsintMnitor</td><td>130</td><td>RWVvOut</td><td>168</td><td>SLWeKScale</td><td>206</td><td>VelRef2</td> </tr> <tr> <td>17</td><td>VqsFdbk</td><td>55</td><td>MuTestFrqRef</td><td>93</td><td>MotorVlts</td><td>131</td><td>RWVwOut</td><td>169</td><td>SrLssWrAve</td><td>207</td><td>VelOutput</td> </tr> <tr> <td>18</td><td>IdsCmd</td><td>56</td><td>TestFrqRef</td><td>94</td><td>BusUtil</td><td>132</td><td>RWuErr</td><td>170</td><td>SrLssWrCmd</td><td>208</td><td>TorqEst</td> </tr> <tr> <td>19</td><td>IqsRatio</td><td>57</td><td>FluxFltrN_1</td><td>95</td><td>FieldInitTm</td><td>133</td><td>RWvErr</td><td>171</td><td>SLWeK2Mon</td><td>209</td><td>TorqEstFltr</td> </tr> <tr> <td>20</td><td>MulqsRef</td><td>58</td><td>PrchgDlayCtr</td><td>96</td><td>IqsLimit</td><td>134</td><td>RWwErr</td><td>172</td><td>SLWrKA2Mon</td><td>210</td><td>FSLamDS</td> </tr> <tr> <td>21</td><td>IqsCmd</td><td>59</td><td>PrchTimOutCr</td><td>97</td><td>VqsCmdMotor</td><td>135</td><td>RWVuOut2</td><td>173</td><td>SrLssVdsCmd</td><td>211</td><td>FSLdsCmd</td> </tr> <tr> <td>22</td><td>We2</td><td>60</td><td>PrchPilotCtr</td><td>98</td><td>We2FieldWeak</td><td>136</td><td>RWVuOut2</td><td>174</td><td>SrLssGnMon</td><td>212</td><td>FsFluxErr</td> </tr> <tr> <td>23</td><td>VuTd</td><td>61</td><td>TrqEnableCtr</td><td>99</td><td>VqsFldWkBase</td><td>137</td><td>RWVuOut2</td><td>175</td><td>WsKff</td><td>213</td><td>FSLamDSCmd</td> </tr> <tr> <td>24</td><td>VvTd</td><td>62</td><td>MuTscan1</td><td>100</td><td>VqsldsCmd</td><td>138</td><td>RWPosState</td><td>176</td><td>WsKffBst</td><td>214</td><td>FsFluxTmr</td> </tr> <tr> <td>25</td><td>VwTd</td><td>63</td><td>ErStatFromCp</td><td>101</td><td>VqsMaxMotor</td><td>139</td><td>RWNegState</td><td>177</td><td>SLQAWeEstAve</td><td>215</td><td>SrLsVdsOff</td> </tr> <tr> <td>26</td><td>VuCmd2</td><td>64</td><td>FlxCurRteOut</td><td>102</td><td>VqsMaxVbus</td><td>140</td><td>BusDropVolts</td><td>178</td><td>SLWeEstErr</td><td>216</td><td>FSLstIntgl</td> </tr> <tr> <td>27</td><td>VvCmd2</td><td>65</td><td>ThetaE</td><td>103</td><td>CalcPUMtrFlx</td><td>141</td><td>RecoverVolts</td><td>179</td><td>SrLssIntMon</td><td>217</td><td>FSLstWe</td> </tr> <tr> <td>28</td><td>VwCmd2</td><td>66</td><td>SinThetaE1</td><td>104</td><td>FldWklnitTim</td><td>142</td><td>VdsFdbkFltr</td><td>180</td><td>SLWePosLmt</td><td>218</td><td>FSLstWr</td> </tr> <tr> <td>29</td><td>Kpwm</td><td>67</td><td>SinThetaE2</td><td>105</td><td>FluxldsFFlt</td><td>143</td><td>VqsFdbkFltr</td><td>181</td><td>SLWeNegLmt</td><td>219</td><td>PwrCalc</td> </tr> <tr> <td>30</td><td>Vds_cemf</td><td>68</td><td>SinThetaE3</td><td>106</td><td>FlxVqsCmdFlt</td><td>144</td><td>VbusFdbkFltr</td><td>182</td><td>SLWrScale</td><td>220</td><td>ThetaELin</td> </tr> <tr> <td>31</td><td>Vqs_cemf</td><td>69</td><td>SinThetaE4</td><td>107</td><td>VqsError</td><td>145</td><td>VbusMemory</td><td>183</td><td>SLErrNoCoher</td><td>221</td><td>PprCntEfcOt</td> </tr> <tr> <td>32</td><td>VdsCmd2</td><td>70</td><td>SinThetaE5</td><td>108</td><td>VqsFluxPI</td><td>146</td><td>VpEnc0VelFbk</td><td>184</td><td>SLIntLmtPosM</td><td>222</td><td>PprCntDfcTh</td> </tr> <tr> <td>33</td><td>VqsCmd2</td><td>71</td><td>SinThetaE6</td><td>109</td><td>VqsIntegral</td><td>147</td><td>VpEnc1VelFbk</td><td>185</td><td>SLIntLmtNegM</td><td>223</td><td>LinPprCnt</td> </tr> <tr> <td>34</td><td>IdsIntegral</td><td>72</td><td>ThetaEcor</td><td>110</td><td>VqsPrportl1</td><td>148</td><td>VPOpt0VelFbk</td><td>186</td><td>RsEst</td><td>224</td><td>ActiveFbk</td> </tr> <tr> <td>35</td><td>IqsIntegral</td><td>73</td><td>SinThtaEcor1</td><td>111</td><td>VqsPrportnl2</td><td>149</td><td>VPOpt1VelFbk</td><td>187</td><td>RsEstCosPhi</td><td>225</td><td>VdsCOMP</td> </tr> <tr> <td>36</td><td>DcBus</td><td>74</td><td>SinThtaEcor2</td><td>112</td><td>DbDuty</td><td>150</td><td>BitSelect1</td><td>188</td><td>RsEstFltr</td><td>226</td><td>VqsCOMP</td> </tr> <tr> <td>37</td><td>AGnd</td><td>75</td><td>SinThtaEcor3</td><td>113</td><td>TestMark70</td><td>151</td><td>BitSelect2</td><td>189</td><td>RsEstlqsCmdP</td><td>227</td><td>S4096 2.5V</td> </tr> </table>	0	MulqsRef2	38	Wr2	76	SinThtaEcor4	114	TestMark71	152	SrLssWeEst2	190	RsEstPhi	1	SlipRatio	39	FluxRatio1	77	MulRef2B	115	TestMark72	153	SrLssPrportl	191	RsEstSinPhi	2	Ws	40	VbusFdbk	78	SpdFdbk	116	TestMark73	154	SrLssPI	192	RsEstVqsFbkP	3	WrEst2	41	FluxRatio2	79	SpdIntegral	117	TestMark74	155	SrLssQAWeEst	193	RsEWeLadsCmd	4	We	42	FluxRatio3	80	SpdPrportnal	118	TestMark75	156	SLWeGainFwk	194	REWeLadsCmdP	5	VdsCmd	43	FluxRatio4	81	SpdPI	119	TestMark76	157	SrLssWsFf	195	RsEWeLaqsCmd	6	VqsCmd	44	MuFlxRtioRef	82	SpdRef	120	TestMark76	158	SrLssWsEst	196	RsEstldsRat	7	VuCmd1	45	RcpFixRatio1	83	SlipGainEst	121	TestMark78	159	SrLssWsCmd	197	RsEstlqsRat	8	VvCmd1	46	MulfluxRef	84	SlipGainFf	122	TestMark79	160	SrLssVdsErr	198	MulqsRef2	9	VwCmd1	47	MultestRef	85	Ws2	123	TestMark7A	161	SLVdsErrComp	199	EstThetaByMV	10	IuFdbk	48	MotVntc	86	SlipGain	124	TestMark7B	162	SrLssStrtTmr	200	ETVdsFbkA	11	IwFdbk	49	BaseSlip	87	SlipGainFltr	125	TestMark7C	163	SrLssWsMxLim	201	ETVqsFbkA	12	IdsFdbk	50	VbusFdbk2	88	SlipVdsCmd	126	TestMark7D	164	SrLssWeAve	202	ETVdsFbkS	13	IqsFdbk	51	VdsFdbk2	89	SlpVdsCmdFlt	127	TestMark7E	165	SrLssWeEst	203	ETVqsFbkS	14	VdsFdbk	52	VqsFdbk2	90	VdsLastError	128	TestMark7F	166	SrLssKpMonit	204	ETAtanVqVd	15	VuvFdbk	53	VdsSpdVltFit	91	VdsPrportnal	129	RWVuOut	167	SrLssKiMonit	205	ETByMtrVDfr	16	VvwFdbk	54	WrEst1	92	VdsintMnitor	130	RWVvOut	168	SLWeKScale	206	VelRef2	17	VqsFdbk	55	MuTestFrqRef	93	MotorVlts	131	RWVwOut	169	SrLssWrAve	207	VelOutput	18	IdsCmd	56	TestFrqRef	94	BusUtil	132	RWuErr	170	SrLssWrCmd	208	TorqEst	19	IqsRatio	57	FluxFltrN_1	95	FieldInitTm	133	RWvErr	171	SLWeK2Mon	209	TorqEstFltr	20	MulqsRef	58	PrchgDlayCtr	96	IqsLimit	134	RWwErr	172	SLWrKA2Mon	210	FSLamDS	21	IqsCmd	59	PrchTimOutCr	97	VqsCmdMotor	135	RWVuOut2	173	SrLssVdsCmd	211	FSLdsCmd	22	We2	60	PrchPilotCtr	98	We2FieldWeak	136	RWVuOut2	174	SrLssGnMon	212	FsFluxErr	23	VuTd	61	TrqEnableCtr	99	VqsFldWkBase	137	RWVuOut2	175	WsKff	213	FSLamDSCmd	24	VvTd	62	MuTscan1	100	VqsldsCmd	138	RWPosState	176	WsKffBst	214	FsFluxTmr	25	VwTd	63	ErStatFromCp	101	VqsMaxMotor	139	RWNegState	177	SLQAWeEstAve	215	SrLsVdsOff	26	VuCmd2	64	FlxCurRteOut	102	VqsMaxVbus	140	BusDropVolts	178	SLWeEstErr	216	FSLstIntgl	27	VvCmd2	65	ThetaE	103	CalcPUMtrFlx	141	RecoverVolts	179	SrLssIntMon	217	FSLstWe	28	VwCmd2	66	SinThetaE1	104	FldWklnitTim	142	VdsFdbkFltr	180	SLWePosLmt	218	FSLstWr	29	Kpwm	67	SinThetaE2	105	FluxldsFFlt	143	VqsFdbkFltr	181	SLWeNegLmt	219	PwrCalc	30	Vds_cemf	68	SinThetaE3	106	FlxVqsCmdFlt	144	VbusFdbkFltr	182	SLWrScale	220	ThetaELin	31	Vqs_cemf	69	SinThetaE4	107	VqsError	145	VbusMemory	183	SLErrNoCoher	221	PprCntEfcOt	32	VdsCmd2	70	SinThetaE5	108	VqsFluxPI	146	VpEnc0VelFbk	184	SLIntLmtPosM	222	PprCntDfcTh	33	VqsCmd2	71	SinThetaE6	109	VqsIntegral	147	VpEnc1VelFbk	185	SLIntLmtNegM	223	LinPprCnt	34	IdsIntegral	72	ThetaEcor	110	VqsPrportl1	148	VPOpt0VelFbk	186	RsEst	224	ActiveFbk	35	IqsIntegral	73	SinThtaEcor1	111	VqsPrportnl2	149	VPOpt1VelFbk	187	RsEstCosPhi	225	VdsCOMP	36	DcBus	74	SinThtaEcor2	112	DbDuty	150	BitSelect1	188	RsEstFltr	226	VqsCOMP	37	AGnd	75	SinThtaEcor3	113	TestMark70	151	BitSelect2	189	RsEstlqsCmdP	227	S4096 2.5V	Default: 0	MulqsRef2			
0	MulqsRef2	38	Wr2	76	SinThtaEcor4	114	TestMark71	152	SrLssWeEst2	190	RsEstPhi																																																																																																																																																																																																																																																																																																																																																																																																																																																																			
1	SlipRatio	39	FluxRatio1	77	MulRef2B	115	TestMark72	153	SrLssPrportl	191	RsEstSinPhi																																																																																																																																																																																																																																																																																																																																																																																																																																																																			
2	Ws	40	VbusFdbk	78	SpdFdbk	116	TestMark73	154	SrLssPI	192	RsEstVqsFbkP																																																																																																																																																																																																																																																																																																																																																																																																																																																																			
3	WrEst2	41	FluxRatio2	79	SpdIntegral	117	TestMark74	155	SrLssQAWeEst	193	RsEWeLadsCmd																																																																																																																																																																																																																																																																																																																																																																																																																																																																			
4	We	42	FluxRatio3	80	SpdPrportnal	118	TestMark75	156	SLWeGainFwk	194	REWeLadsCmdP																																																																																																																																																																																																																																																																																																																																																																																																																																																																			
5	VdsCmd	43	FluxRatio4	81	SpdPI	119	TestMark76	157	SrLssWsFf	195	RsEWeLaqsCmd																																																																																																																																																																																																																																																																																																																																																																																																																																																																			
6	VqsCmd	44	MuFlxRtioRef	82	SpdRef	120	TestMark76	158	SrLssWsEst	196	RsEstldsRat																																																																																																																																																																																																																																																																																																																																																																																																																																																																			
7	VuCmd1	45	RcpFixRatio1	83	SlipGainEst	121	TestMark78	159	SrLssWsCmd	197	RsEstlqsRat																																																																																																																																																																																																																																																																																																																																																																																																																																																																			
8	VvCmd1	46	MulfluxRef	84	SlipGainFf	122	TestMark79	160	SrLssVdsErr	198	MulqsRef2																																																																																																																																																																																																																																																																																																																																																																																																																																																																			
9	VwCmd1	47	MultestRef	85	Ws2	123	TestMark7A	161	SLVdsErrComp	199	EstThetaByMV																																																																																																																																																																																																																																																																																																																																																																																																																																																																			
10	IuFdbk	48	MotVntc	86	SlipGain	124	TestMark7B	162	SrLssStrtTmr	200	ETVdsFbkA																																																																																																																																																																																																																																																																																																																																																																																																																																																																			
11	IwFdbk	49	BaseSlip	87	SlipGainFltr	125	TestMark7C	163	SrLssWsMxLim	201	ETVqsFbkA																																																																																																																																																																																																																																																																																																																																																																																																																																																																			
12	IdsFdbk	50	VbusFdbk2	88	SlipVdsCmd	126	TestMark7D	164	SrLssWeAve	202	ETVdsFbkS																																																																																																																																																																																																																																																																																																																																																																																																																																																																			
13	IqsFdbk	51	VdsFdbk2	89	SlpVdsCmdFlt	127	TestMark7E	165	SrLssWeEst	203	ETVqsFbkS																																																																																																																																																																																																																																																																																																																																																																																																																																																																			
14	VdsFdbk	52	VqsFdbk2	90	VdsLastError	128	TestMark7F	166	SrLssKpMonit	204	ETAtanVqVd																																																																																																																																																																																																																																																																																																																																																																																																																																																																			
15	VuvFdbk	53	VdsSpdVltFit	91	VdsPrportnal	129	RWVuOut	167	SrLssKiMonit	205	ETByMtrVDfr																																																																																																																																																																																																																																																																																																																																																																																																																																																																			
16	VvwFdbk	54	WrEst1	92	VdsintMnitor	130	RWVvOut	168	SLWeKScale	206	VelRef2																																																																																																																																																																																																																																																																																																																																																																																																																																																																			
17	VqsFdbk	55	MuTestFrqRef	93	MotorVlts	131	RWVwOut	169	SrLssWrAve	207	VelOutput																																																																																																																																																																																																																																																																																																																																																																																																																																																																			
18	IdsCmd	56	TestFrqRef	94	BusUtil	132	RWuErr	170	SrLssWrCmd	208	TorqEst																																																																																																																																																																																																																																																																																																																																																																																																																																																																			
19	IqsRatio	57	FluxFltrN_1	95	FieldInitTm	133	RWvErr	171	SLWeK2Mon	209	TorqEstFltr																																																																																																																																																																																																																																																																																																																																																																																																																																																																			
20	MulqsRef	58	PrchgDlayCtr	96	IqsLimit	134	RWwErr	172	SLWrKA2Mon	210	FSLamDS																																																																																																																																																																																																																																																																																																																																																																																																																																																																			
21	IqsCmd	59	PrchTimOutCr	97	VqsCmdMotor	135	RWVuOut2	173	SrLssVdsCmd	211	FSLdsCmd																																																																																																																																																																																																																																																																																																																																																																																																																																																																			
22	We2	60	PrchPilotCtr	98	We2FieldWeak	136	RWVuOut2	174	SrLssGnMon	212	FsFluxErr																																																																																																																																																																																																																																																																																																																																																																																																																																																																			
23	VuTd	61	TrqEnableCtr	99	VqsFldWkBase	137	RWVuOut2	175	WsKff	213	FSLamDSCmd																																																																																																																																																																																																																																																																																																																																																																																																																																																																			
24	VvTd	62	MuTscan1	100	VqsldsCmd	138	RWPosState	176	WsKffBst	214	FsFluxTmr																																																																																																																																																																																																																																																																																																																																																																																																																																																																			
25	VwTd	63	ErStatFromCp	101	VqsMaxMotor	139	RWNegState	177	SLQAWeEstAve	215	SrLsVdsOff																																																																																																																																																																																																																																																																																																																																																																																																																																																																			
26	VuCmd2	64	FlxCurRteOut	102	VqsMaxVbus	140	BusDropVolts	178	SLWeEstErr	216	FSLstIntgl																																																																																																																																																																																																																																																																																																																																																																																																																																																																			
27	VvCmd2	65	ThetaE	103	CalcPUMtrFlx	141	RecoverVolts	179	SrLssIntMon	217	FSLstWe																																																																																																																																																																																																																																																																																																																																																																																																																																																																			
28	VwCmd2	66	SinThetaE1	104	FldWklnitTim	142	VdsFdbkFltr	180	SLWePosLmt	218	FSLstWr																																																																																																																																																																																																																																																																																																																																																																																																																																																																			
29	Kpwm	67	SinThetaE2	105	FluxldsFFlt	143	VqsFdbkFltr	181	SLWeNegLmt	219	PwrCalc																																																																																																																																																																																																																																																																																																																																																																																																																																																																			
30	Vds_cemf	68	SinThetaE3	106	FlxVqsCmdFlt	144	VbusFdbkFltr	182	SLWrScale	220	ThetaELin																																																																																																																																																																																																																																																																																																																																																																																																																																																																			
31	Vqs_cemf	69	SinThetaE4	107	VqsError	145	VbusMemory	183	SLErrNoCoher	221	PprCntEfcOt																																																																																																																																																																																																																																																																																																																																																																																																																																																																			
32	VdsCmd2	70	SinThetaE5	108	VqsFluxPI	146	VpEnc0VelFbk	184	SLIntLmtPosM	222	PprCntDfcTh																																																																																																																																																																																																																																																																																																																																																																																																																																																																			
33	VqsCmd2	71	SinThetaE6	109	VqsIntegral	147	VpEnc1VelFbk	185	SLIntLmtNegM	223	LinPprCnt																																																																																																																																																																																																																																																																																																																																																																																																																																																																			
34	IdsIntegral	72	ThetaEcor	110	VqsPrportl1	148	VPOpt0VelFbk	186	RsEst	224	ActiveFbk																																																																																																																																																																																																																																																																																																																																																																																																																																																																			
35	IqsIntegral	73	SinThtaEcor1	111	VqsPrportnl2	149	VPOpt1VelFbk	187	RsEstCosPhi	225	VdsCOMP																																																																																																																																																																																																																																																																																																																																																																																																																																																																			
36	DcBus	74	SinThtaEcor2	112	DbDuty	150	BitSelect1	188	RsEstFltr	226	VqsCOMP																																																																																																																																																																																																																																																																																																																																																																																																																																																																			
37	AGnd	75	SinThtaEcor3	113	TestMark70	151	BitSelect2	189	RsEstlqsCmdP	227	S4096 2.5V																																																																																																																																																																																																																																																																																																																																																																																																																																																																			
545	<p>MC TP Value Displays the data selected by Par 544 [MC TP Sel]. This display should only be used if the selected value is integer data. Par 545 [MC TP Value] is a diagnostic tool you can use to view internal drive parameters.</p>	Default: 0 Min/Max: -/+2147483648			32-bit Integer																																																																																																																																																																																																																																																																																																																																																																																																																																																																									
546	<p>MC TP Bit Displays the data selected by Par 544 [MC TP Sel]. This display should only be used if the selected value is bit-enumerated data. Par 546 [MC TP Bit] is a diagnostic tool you can use to view internal drive parameters.</p>	Default: 00000000000000000000000000000000 Min: 00000000000000000000000000000000 Max: 111111111111111111111111111111111111			32-bit Boolean																																																																																																																																																																																																																																																																																																																																																																																																																																																																									
548	<p>Est Speed Fdbk Displays estimated motor speed, calculated when the selected feedback is sensorless or when encoderless ridthrough is enabled. A value of 4096 indicates a motor speed equal to the value in Par 4 [Motor NP RPM].</p>	Default: 0 Min/Max: -/+32767			16-bit Integer																																																																																																																																																																																																																																																																																																																																																																																																																																																																									

No.	Name Description	Values	Linkable	Read-Write	Data Type
601	Real In00 Displays input word 00 of the controller communication format in floating point format. Paired with Par 600 [Integer In00], which displays the same data in integer format.	Default: 0.0000 Min/Max: -/+2200000000.0000			Real
602	Integer In01 Displays input word 01 of the controller communication format in integer format. Paired with Par 603 [Real In01], which displays the same data in floating point format.	Default: 0 Min/Max: -/+2147483648			32-bit Integer
603	Real In01 Displays input word 01 of the controller communication format in floating point format. Paired with Par 602 [Integer In01], which displays the same data in integer format.	Default: 0.0000 Min/Max: -/+2200000000.0000			Real
604	Integer In02 Displays input word 02 of the controller communication format in integer format. Paired with Par 605 [Real In02], which displays the same data in floating point format.	Default: 0 Min/Max: -/+2147483648			32-bit Integer
605	Real In02 Displays input word 02 of the controller communication format in floating point format. Paired with Par 604 [Integer In02], which displays the same data in integer format.	Default: 0.0000 Min/Max: -/+2200000000.0000			Real
606	Integer In03 Displays input word 03 of the controller communication format in integer format. Paired with Par 607 [Real In03], which displays the same data in floating point format.	Default: 0 Min/Max: -/+2147483648			32-bit Integer
607	Real In03 Displays input word 03 of the controller communication format in floating point format. Paired with Par 606 [Integer In03], which displays the same data in integer format.	Default: 0.0000 Min/Max: -/+2200000000.0000			Real
608	Integer In04 Displays input word 04 of the controller communication format in integer format. Paired with Par 609 [Real In04], which displays the same data in floating point format.	Default: 0 Min/Max: -/+2147483648			32-bit Integer
609	Real In04 Displays input word 04 of the controller communication format in floating point format. Paired with Par 608 [Integer In04], which displays the same data in integer format.	Default: 0.0000 Min/Max: -/+2200000000.0000			Real
610	Integer In05 Displays input word 05 of the controller communication format in integer format. Paired with Par 611 [Real In05], which displays the same data in floating point format.	Default: 0 Min/Max: -/+2147483648			32-bit Integer
611	Real In05 Displays input word 05 of the controller communication format in floating point format. Paired with Par 610 [Integer In05], which displays the same data in integer format.	Default: 0.0000 Min/Max: -/+2200000000.0000			Real
612	Integer In06 Displays input word 06 of the controller communication format in integer format. Paired with Par 613 [Real In06], which displays the same data in floating point format.	Default: 0 Min/Max: -/+2147483648			32-bit Integer
613	Real In06 Displays input word 06 of the controller communication format in floating point format. Paired with Par 612 [Integer In06], which displays the same data in integer format.	Default: 0.0000 Min/Max: -/+2200000000.0000 Comm Scale: x 1			Real
614	Integer In07 Displays input word 07 of the controller communication format in integer format. Paired with Par 615 [Real In07], which displays the same data in floating point format.	Default: 0 Min/Max: -/+2147483648 Comm Scale: x 1			32-bit Integer
615	Real In07 Displays input word 07 of the controller communication format in floating point format. Paired with Par 614 [Integer In07], which displays the same data in integer format.	Default: 0.0000 Min/Max: -/+2200000000.0000			Real
616	Integer In08 Displays input word 08 of the controller communication format in integer format. Paired with Par 617 [Real In08], which displays the same data in floating point format.	Default: 0 Min/Max: -/+2147483648			32-bit Integer
617	Real In08 Displays input word 08 of the controller communication format in floating point format. Paired with Par 616 [Integer In08], which displays the same data in integer format.	Default: 0.0000 Min/Max: -/+2200000000.0000			Real
618	Integer In09 Displays input word 09 of the controller communication format in integer format. Paired with Par 619 [Real In09], which displays the same data in floating point format.	Default: 0 Min/Max: -/+2147483648			32-bit Integer
619	Real In09 Displays input word 09 of the controller communication format in floating point format. Paired with Par 618 [Integer In09], which displays the same data in integer format.	Default: 0.0000 Min/Max: -/+2200000000.0000			Real
620	Integer In10 Displays input word 10 of the controller communication format in integer format. Paired with Par 621 [Real In10], which displays the same data in floating point format.	Default: 0 Min/Max: -/+2147483648			32-bit Integer
621	Real In10 Displays input word 10 of the controller communication format in floating point format. Paired with Par 620 [Integer In10], which displays the same data in integer format.	Default: 0.0000 Min/Max: -/+2200000000.0000			Real
622	Integer In11 Displays input word 11 of the controller communication format in integer format. Paired with Par 623 [Real In11], which displays the same data in floating point format.	Default: 0 Min/Max: -/+2147483648			32-bit Integer

No.	Name Description	Values	Linkable	Read-Write	Data Type
623	Real In11 Displays input word 11 of the controller communication format in floating point format. Paired with Par 622 [Integer In11], which displays the same data in integer format.	Default: 0.0000 Min/Max: -/+2200000000.0000			Real
624	Integer In12 Displays input word 12 of the controller communication format in integer format. Paired with Par 625 [Real In12], which displays the same data in floating point format.	Default: 0 Min/Max: -/+2147483648			32-bit Integer
625	Real In12 Displays input word 12 of the controller communication format in floating point format. Paired with Par 624 [Integer In12], which displays the same data in integer format.	Default: 0.0000 Min/Max: -/+2200000000.0000			Real
626	Integer In13 Displays input word 13 of the controller communication format in integer format. Paired with Par 627 [Real In13], which displays the same data in floating point format.	Default: 0 Min/Max: -/+2147483648			32-bit Integer
627	Real In13 Displays input word 13 of the controller communication format in floating point format. Paired with Par 626 [Integer In13], which displays the same data in integer format.	Default: 0.0000 Min/Max: -/+2200000000.0000			Real
628	Integer In14 Displays input word 14 of the controller communication format in integer format. Paired with Par 629 [Real In14], which displays the same data in floating point format.	Default: 0 Min/Max: -/+2147483648			32-bit Integer
629	Real In14 Displays input word 14 of the controller communication format in floating point format. Paired with Par 628 [Integer In14], which displays the same data in integer format.	Default: 0.0000 Min/Max: -/+2200000000.0000			Real
630	Integer In15 Displays input word 15 of the controller communication format in integer format. Paired with Par 631 [Real In15], which displays the same data in floating point format.	Default: 0 Min/Max: -/+2147483648			32-bit Integer
631	Real In15 Displays input word 15 of the controller communication format in floating point format. Paired with Par 630 [Integer In15], which displays the same data in integer format.	Default: 0.0000 Min/Max: -/+2200000000.0000			Real
632	 Integer Out00 Displays output word 00 of the controller communication format in integer format. Paired with Par 633 [Real Out00], which displays the same data in floating point format.	Default: 0 Min/Max: -/+2147483648	✓	✓	32-bit Integer
633	 Real Out00 Displays output word 00 of the controller communication format in floating point format. Paired with Par 632 [Integer Out00], which displays the same data in integer format.	Default: 0.0000 Min/Max: -/+2200000000.0000	✓	✓	Real
634	 Integer Out01 Displays output word 01 of the controller communication format in integer format. Paired with Par 635 [Real Out01], which displays the same data in floating point format.	Default: 0 Min/Max: -/+2147483648	✓	✓	32-bit Integer
635	 Real Out01 Displays output word 01 of the controller communication format in floating point format. Paired with Par 634 [Integer Out01], which displays the same data in integer format.	Default: 0.0000 Min/Max: -/+2200000000.0000	✓	✓	Real
636	 Integer Out02 Displays output word 02 of the controller communication format in integer format. Paired with Par 637 [Real Out02], which displays the same data in floating point format.	Default: 0 Min/Max: -/+2147483648	✓	✓	32-bit Integer
637	 Real Out02 Displays output word 02 of the controller communication format in floating point format. Paired with Par 636 [Integer Out02], which displays the same data in integer format.	Default: 0.0000 Min/Max: -/+2200000000.0000	✓	✓	Real
638	 Integer Out03 Displays output word 03 of the controller communication format in integer format. Paired with Par 639 [Real Out03], which displays the same data in floating point format.	Default: 0 Min/Max: -/+2147483648	✓	✓	32-bit Integer
639	 Real Out03 Displays output word 03 of the controller communication format in floating point format. Paired with Par 638 [Integer Out03], which displays the same data in integer format.	Default: 0.0000 Min/Max: -/+2200000000.0000	✓	✓	Real
640	 Integer Out04 Displays output word 04 of the controller communication format in integer format. Paired with Par 641 [Real Out04], which displays the same data in floating point format.	Default: 0 Min/Max: -/+2147483648	✓	✓	32-bit Integer
641	 Real Out04 Displays output word 04 of the controller communication format in floating point format. Paired with Par 640 [Integer Out04], which displays the same data in integer format.	Default: 0.0000 Min/Max: -/+2200000000.0000	✓	✓	Real
642	 Integer Out05 Displays output word 05 of the controller communication format in integer format. Paired with Par 643 [Real Out05], which displays the same data in floating point format.	Default: 0 Min/Max: -/+2147483648	✓	✓	32-bit Integer
643	 Real Out05 Displays output word 05 of the controller communication format in floating point format. Paired with Par 642 [Integer Out05], which displays the same data in integer format.	Default: 0.0000 Min/Max: -/+2200000000.0000	✓	✓	Real
644	 Integer Out06 Displays output word 06 of the controller communication format in integer format. Paired with Par 645 [Real Out06], which displays the same data in floating point format.	Default: 0 Min/Max: -/+2147483648	✓	✓	32-bit Integer

No.	Name Description	Values	Linkable	Read-Write	Data Type
645	Real Out06 Displays output word 06 of the controller communication format in floating point format. Paired with Par 644 [Integer Out06], which displays the same data in integer format.	Default: 0.0000 Min/Max: -/+2200000000.0000	✓	✓	Real
646	Integer Out07 Displays output word 07 of the controller communication format in integer format. Paired with Par 647 [Real Out07], which displays the same data in floating point format.	Default: 0 Min/Max: -/+2147483648	✓	✓	32-bit Integer
647	Real Out07 Displays output word 07 of the controller communication format in floating point format. Paired with Par 646 [Integer Out07], which displays the same data in integer format.	Default: 0.0000 Min/Max: -/+2200000000.0000	✓	✓	Real
648	Integer Out08 Displays output word 08 of the controller communication format in integer format. Paired with Par 649 [Real Out08], which displays the same data in floating point format.	Default: 0 Min/Max: -/+2147483648	✓	✓	32-bit Integer
649	Real Out08 Displays output word 08 of the controller communication format in floating point format. Paired with Par 648 [Integer Out08], which displays the same data in integer format.	Default: 0.0000 Min/Max: -/+2200000000.0000	✓	✓	Real
650	Integer Out09 Displays output word 09 of the controller communication format in integer format. Paired with Par 651 [Real Out09], which displays the same data in floating point format.	Default: 0 Min/Max: -/+2147483648	✓	✓	32-bit Integer
651	Real Out09 Displays output word 09 of the controller communication format in floating point format. Paired with Par 650 [Integer Out09], which displays the same data in integer format.	Default: 0.0000 Min/Max: -/+2200000000.0000	✓	✓	Real
652	Integer Out10 Displays output word 10 of the controller communication format in integer format. Paired with Par 653 [Real Out10], which displays the same data in floating point format.	Default: 0 Min/Max: -/+2147483648	✓	✓	32-bit Integer
653	Real Out10 Displays output word 10 of the controller communication format in floating point format. Paired with Par 652 [Integer Out10], which displays the same data in integer format.	Default: 0.0000 Min/Max: -/+2200000000.0000	✓	✓	Real
654	Integer Out11 Displays output word 11 of the controller communication format in integer format. Paired with Par 655 [Real Out11], which displays the same data in floating point format.	Default: 0 Min/Max: -/+2147483648 Comm Scale: x16	✓	✓	32-bit Integer
655	Real Out11 Displays output word 11 of the controller communication format in floating point format. Paired with Par 654 [Integer Out11], which displays the same data in integer format.	Default: 0.0000 Min/Max: -/+2200000000.0000	✓	✓	Real
656	Integer Out12 Displays output word 12 of the controller communication format in integer format. Paired with Par 657 [Real Out12], which displays the same data in floating point format.	Default: 0 Min/Max: -/+2147483648	✓	✓	32-bit Integer
657	Real Out12 Displays output word 12 of the controller communication format in floating point format. Paired with Par 656 [Integer Out12], which displays the same data in integer format.	Default: 0.0000 Min/Max: -/+2200000000.0000	✓	✓	Real
658	Integer Out13 Displays output word 13 of the controller communication format in integer format. Paired with Par 659 [Real Out13], which displays the same data in floating point format.	Default: 0 Min/Max: -/+2147483648	✓	✓	32-bit Integer
659	Real Out13 Displays output word 13 of the controller communication format in floating point format. Paired with Par 658 [Integer Out13], which displays the same data in integer format.	Default: 0.0000 Min/Max: -/+2200000000.0000	✓	✓	Real
660	Integer Out14 Displays output word 14 of the controller communication format in integer format. Paired with Par 661 [Real Out14], which displays the same data in floating point format.	Default: 0 Min/Max: -/+2147483648	✓	✓	32-bit Integer
661	Real Out14 Displays output word 14 of the controller communication format in floating point format. Paired with Par 660 [Integer Out14], which displays the same data in integer format.	Default: 0.0000 Min/Max: -/+2200000000.0000	✓	✓	Real
662	Integer Out15 Displays output word 15 of the controller communication format in integer format. Paired with Par 663 [Real Out15], which displays the same data in floating point format.	Default: 0 Min/Max: -/+2147483648	✓	✓	32-bit Integer
663	Real Out15 Displays output word 15 of the controller communication format in floating point format. Paired with Par 662 [Integer Out15], which displays the same data in integer format.	Default: 0.0000 Min/Max: -/+2200000000.0000	✓	✓	Real
664	Lgx Comm Format Indicates the Controller to Drive communication format. 16-Velocity Control, 0-Custom Format, 16-Position Control.	Default: 0 "Not Used" Options: 0 "Not Used" 18 "UserDefined" 16 "Velocity" 19 "Motion" 17 "Position" 32 CustmUserDef			

No.	Name Description	Values	Linkable	Read-Write	Data Type
670	Pwr Strct Mode Options Not Used Not Used Not Used Not Used Not Used Not Used Not Used Not Used Not Used Not Used Not Used Not Used Not Used Not Used Star Coupler Hi Pwr Strct Lo Pwr Strct Default 0 0 0 0 0 0 0 0 0 0 0 0 0 0 0 0 Bit 15 14 13 12 11 10 9 8 7 6 5 4 3 2 1 0 0 = False 1 = True	Bit 0: PowerFlex 700S Bit 1: Vacon HiHP			
671	HiHP Drive Fault Options Not Used Not Used Not Used Not Used Not Used EE Incompati HW Incompati Prchrg cnct uPrc Wchdng Drive OvrLd FAN Alarm VBus Wchdng VBus CRC Err VBus Lnk Lst VBus Com Dly AC Inpt Lss Default 0 0 0 0 0 0 0 0 0 0 0 0 0 0 0 0 Bit 15 14 13 12 11 10 9 8 7 6 5 4 3 2 1 0 0 = False 1 = True				
672	HiHP GndFit Cur Determines the current level for the ground fault detection. Note: The default value was changed from 125A to 13.05A and the maximum value was changed from 500A to 200A for firmware version 2.07.	Units: Amps Default: 13.0500 Min/Max: 10.0000/200.0000		<input checked="" type="checkbox"/>	
673	HiHP GndFit Dly Determines the time delay for the ground fault detection. Note: The default value for this parameter changed from 1 ms to 200 ms for firmware version 2.07.	Units: mSec Default: 200 Min/Max: 20/400		<input checked="" type="checkbox"/>	
691	DPI Ref Select Selects which DPI port can provide a reference to the drive.	Default: 1 "Local HIM" Options: 1 "Local HIM" 4 "Reserved" 2 "Ext DPI Conn" 5 "Int DPI Comm" 3 "Aux DPI Conn"			
692	DPI Baud Rate Sets the baud rate for attached drive peripherals. Reset the drive for the change to take effect.	Default: Val 0 500K Options: Val 0 500K			
693	Logic Mask Determines which adapters can control the drive. Options Undefined Undefined Undefined Undefined Undefined Undefined Undefined Undefined DriveLogix Reserved Int DPI Conn Reserved Aux DPI Conn Ext DPI Conn Local HIM Terminal Blk Default 0 0 0 0 0 0 0 0 1 1 1 1 1 1 1 1 Bit 15 14 13 12 11 10 9 8 7 6 5 4 3 2 1 0 0 = False 1 = True				
694	Start Mask Controls which adapters can issue start commands. Options Undefined Undefined Undefined Undefined Undefined Undefined Undefined Undefined DriveLogix Reserved Int DPI Conn Reserved Aux DPI Conn Ext DPI Conn Local HIM Terminal Blk Default 0 0 0 0 0 0 0 0 1 1 1 1 1 1 1 1 Bit 15 14 13 12 11 10 9 8 7 6 5 4 3 2 1 0 0 = False 1 = True				
695	Jog Mask Controls which adapters can issue jog commands. Options Undefined Undefined Undefined Undefined Undefined Undefined Undefined Undefined DriveLogix Reserved Int DPI Conn Reserved Aux DPI Conn Ext DPI Conn Local HIM Terminal Blk Default 0 0 0 0 0 0 0 0 1 1 1 1 1 1 1 1 Bit 15 14 13 12 11 10 9 8 7 6 5 4 3 2 1 0 0 = False 1 = True				

No.	Name Description	Values	Linkable	Read-Write	Data Type
696	Direction Mask Controls which adapters can issue forward/reverse direction commands.				
	Options	Undefined Undefined Undefined Undefined Undefined Undefined Undefined Undefined DriveLogix Reserved Int DPI Conn Reserved Aux DPI Conn Ext DPI Conn Local HIM Terminal Blk			
	Default	0 0 0 0 0 0 0 0 1 1 1 1 1 1 1 1			
	Bit	15 14 13 12 11 10 9 8 7 6 5 4 3 2 1 0			0 = False 1 = True
697	Fault Clr Mask Controls which adapters can clear a fault.				
	Options	Undefined Undefined Undefined Undefined Undefined Undefined Undefined Undefined DriveLogix Reserved Int DPI Conn Reserved Aux DPI Conn Ext DPI Conn Local HIM Terminal Blk			
	Default	0 0 0 0 0 0 0 0 1 1 1 1 1 1 1 1			
	Bit	15 14 13 12 11 10 9 8 7 6 5 4 3 2 1 0			0 = False 1 = True
700	Stop Owner Indicates which adapters that are presently issuing a valid stop command.				
	Options	Undefined Undefined Undefined Undefined Undefined Undefined Undefined Undefined DriveLogix Reserved Int DPI Conn Reserved Aux DPI Conn Ext DPI Conn Local HIM Terminal Blk			
	Default	0 0 0 0 0 0 0 0 0 0 0 0 0 0 0 0			
	Bit	15 14 13 12 11 10 9 8 7 6 5 4 3 2 1 0			0 = False 1 = True
701	Start Owner Indicates which adapters that are presently issuing a valid start command.				
	Options	Undefined Undefined Undefined Undefined Undefined Undefined Undefined Undefined DriveLogix Reserved Int DPI Conn Reserved Aux DPI Conn Ext DPI Conn Local HIM Terminal Blk			
	Default	0 0 0 0 0 0 0 0 0 0 0 0 0 0 0 0			
	Bit	15 14 13 12 11 10 9 8 7 6 5 4 3 2 1 0			0 = False 1 = True
702	Jog Owner Indicates which adapters that are presently issuing a valid jog command.				
	Options	Undefined Undefined Undefined Undefined Undefined Undefined Undefined Undefined DriveLogix Reserved Int DPI Conn Reserved Aux DPI Conn Ext DPI Conn Local HIM Terminal Blk			
	Default	0 0 0 0 0 0 0 0 0 0 0 0 0 0 0 0			
	Bit	15 14 13 12 11 10 9 8 7 6 5 4 3 2 1 0			0 = False 1 = True
703	Direction Owner Indicates which adapter is currently has exclusive control of direction changes.				
	Options	Undefined Undefined Undefined Undefined Undefined Undefined Undefined Undefined DriveLogix Reserved Int DPI Conn Reserved Aux DPI Conn Ext DPI Conn Local HIM Terminal Blk			
	Default	0 0 0 0 0 0 0 0 0 0 0 0 0 0 0 0			
	Bit	15 14 13 12 11 10 9 8 7 6 5 4 3 2 1 0			0 = False 1 = True

No.	Name Description	Values	Linkable	Read-Write	Data Type																																																		
704	<p>Fault Clr Owner Indicates which adapter is currently clearing a fault.</p> <p>Options</p> <table border="1"> <tr> <td></td> <td>Undefined</td> <td>Undefined</td> <td>Undefined</td> <td>Undefined</td> <td>Undefined</td> <td>Undefined</td> <td>Undefined</td> <td>Undefined</td> <td>DriveLogix</td> <td>Reserved</td> <td>Int DPI Conn</td> <td>Reserved</td> <td>Aux DPI Conn</td> <td>Ext DPI Conn</td> <td>Local HIM</td> <td>Terminal Blk</td> </tr> <tr> <td>Default</td> <td>0</td> <td>0</td> <td>0</td> <td>0</td> <td>0</td> <td>0</td> <td>0</td> <td>0</td> <td>0</td> <td>0</td> <td>0</td> <td>0</td> <td>0</td> <td>0</td> <td>0</td> <td>0</td> </tr> <tr> <td>Bit</td> <td>15</td> <td>14</td> <td>13</td> <td>12</td> <td>11</td> <td>10</td> <td>9</td> <td>8</td> <td>7</td> <td>6</td> <td>5</td> <td>4</td> <td>3</td> <td>2</td> <td>1</td> <td>0</td> </tr> </table> <p>0 = False 1 = True</p>		Undefined	Undefined	Undefined	Undefined	Undefined	Undefined	Undefined	Undefined	DriveLogix	Reserved	Int DPI Conn	Reserved	Aux DPI Conn	Ext DPI Conn	Local HIM	Terminal Blk	Default	0	0	0	0	0	0	0	0	0	0	0	0	0	0	0	0	Bit	15	14	13	12	11	10	9	8	7	6	5	4	3	2	1	0			
	Undefined	Undefined	Undefined	Undefined	Undefined	Undefined	Undefined	Undefined	DriveLogix	Reserved	Int DPI Conn	Reserved	Aux DPI Conn	Ext DPI Conn	Local HIM	Terminal Blk																																							
Default	0	0	0	0	0	0	0	0	0	0	0	0	0	0	0	0																																							
Bit	15	14	13	12	11	10	9	8	7	6	5	4	3	2	1	0																																							
707	<p>Data In A1 Int Link A Word 1 (Integer) - Parameter number whose value will be written from a communications device data table. Parameters that can only be changed while the drive is stopped cannot be used as Datalink inputs. Entering a parameter of this type will "Disable" the link. Refer to the manual that came with your communications option for datalink information.</p>	Default: 0 Min/Max: -/+2147483648			32-bit Integer																																																		
708	<p>Data In A1 Real Link A Word 1 (Real or Floating Point) - Parameters that can only be changed while the drive is stopped cannot be used as Datalink inputs. Entering a parameter of this type will "Disable" the link. Refer to the manual that came with your communications option for datalink information.</p>	Default: 0.0000 Min/Max: -/+2200000000.0000			Real																																																		
709	<p>Data In A2 Int Link A Word 2 (Integer) - Parameter number whose value will be written from a communications device data table. Parameters that can only be changed while the drive is stopped cannot be used as Datalink inputs. Entering a parameter of this type will "Disable" the link. Refer to the manual that came with your communications option for datalink information.</p>	Default: 0 Min/Max: -/+2147483648			32-bit Integer																																																		
710	<p>Data In A2 Real Link A Word 2 (Real or Floating Point) - Parameters that can only be changed while the drive is stopped cannot be used as Datalink inputs. Entering a parameter of this type will "Disable" the link. Refer to the manual that came with your communications option for datalink information.</p>	Default: 0.0000 Min/Max: -/+2200000000.0000			Real																																																		
711	<p>Data In B1 Int Link B Word 1 (Integer) - Parameter number whose value will be written from a communications device data table. Parameters that can only be changed while the drive is stopped cannot be used as Datalink inputs. Entering a parameter of this type will "Disable" the link. Refer to the manual that came with your communications option for datalink information.</p>	Default: 0 Min/Max: -/+2147483648			32-bit Integer																																																		
712	<p>Data In B1 Real Link B Word 1 (Real or Floating Point) - Parameters that can only be changed while the drive is stopped cannot be used as Datalink inputs. Entering a parameter of this type will "Disable" the link. Refer to the manual that came with your communications option for datalink information.</p>	Default: 0.0000 Min/Max: -/+2200000000.0000			Real																																																		
713	<p>Data In B2 Int Link B Word 2 (Integer) - Parameter number whose value will be written from a communications device data table. Parameters that can only be changed while the drive is stopped cannot be used as Datalink inputs. Entering a parameter of this type will "Disable" the link. Refer to the manual that came with your communications option for datalink information.</p>	Default: 0 Min/Max: -/+2147483648			32-bit Integer																																																		
714	<p>Data In B2 Real Link B Word 2 (Real or Floating Point) - Parameters that can only be changed while the drive is stopped cannot be used as Datalink inputs. Entering a parameter of this type will "Disable" the link. Refer to the manual that came with your communications option for datalink information.</p>	Default: 0.0000 Min/Max: -/+2200000000.0000			Real																																																		
715	<p>Data In C1 Int Link C Word 1 (Integer) - Parameter number whose value will be written from a communications device data table. Parameters that can only be changed while the drive is stopped cannot be used as Datalink inputs. Entering a parameter of this type will "Disable" the link. Refer to the manual that came with your communications option for datalink information.</p>	Default: 0 Min/Max: -/+2147483648			32-bit Integer																																																		
716	<p>Data In C1 Real Link C Word 1 (Real or Floating Point) - Parameters that can only be changed while the drive is stopped cannot be used as Datalink inputs. Entering a parameter of this type will "Disable" the link. Refer to the manual that came with your communications option for datalink information.</p>	Default: 0.0000 Min/Max: -/+2200000000.0000			Real																																																		

No.	Name Description	Values	Linkable	Read-Write	Data Type																																																			
717	Data In C2 Int Link C Word 2 (Integer) - Parameter number whose value will be written from a communications device data table. Parameters that can only be changed while the drive is stopped cannot be used as Datalink inputs. Entering a parameter of this type will "Disable" the link. Refer to the manual that came with your communications option for datalink information.	Default: 0 Min/Max: -/+2147483648			32-bit Integer																																																			
718	Data In C2 Real Link C Word 2 (Real or Floating Point) - Parameters that can only be changed while the drive is stopped cannot be used as Datalink inputs. Entering a parameter of this type will "Disable" the link. Refer to the manual that came with your communications option for datalink information.	Default: 0.0000 Min/Max: -/+2200000000.0000			Real																																																			
719	Data In D1 Int Link D Word 1 (Integer) - Parameter number whose value will be written from a communications device data table. Parameters that can only be changed while the drive is stopped cannot be used as Datalink inputs. Entering a parameter of this type will "Disable" the link. Refer to the manual that came with your communications option for datalink information.	Default: 0 Min/Max: -/+2147483648			32-bit Integer																																																			
720	Data In D1 Real Link D Word 1 (Real or Floating Point) - Parameters that can only be changed while the drive is stopped cannot be used as Datalink inputs. Entering a parameter of this type will "Disable" the link. Refer to the manual that came with your communications option for datalink information.	Default: 0.0000 Min/Max: -/+2200000000.0000			Real																																																			
721	Data In D2 Int Link D Word 2 (Integer) - Parameter number whose value will be written from a communications device data table. Parameters that can only be changed while the drive is stopped cannot be used as Datalink inputs. Entering a parameter of this type will "Disable" the link. Refer to the manual that came with your communications option for datalink information.	Default: 0 Min/Max: -/+2147483648			32-bit Integer																																																			
722	Data In D2 Real Link D Word 2 (Real or Floating Point) - Parameters that can only be changed while the drive is stopped cannot be used as Datalink inputs. Entering a parameter of this type will "Disable" the link. Refer to the manual that came with your communications option for datalink information.	Default: 0.0000 Min/Max: -/+2200000000.0000			Real																																																			
723	DLink OutDataTyp Set bits to configure each Datalink output word for real (floating point) data transfer. Reset bits to configure each Datalink output word for integer data transfer.																																																							
	 <table border="1" style="width: 100%; border-collapse: collapse;"> <thead> <tr> <th>Options</th> <th>Reserved</th> <th>Reserved</th> <th>Reserved</th> <th>Reserved</th> <th>Reserved</th> <th>Reserved</th> <th>Reserved</th> <th>Reserved</th> <th>D2 Out Real</th> <th>D1 Out Real</th> <th>C2 Out Real</th> <th>C1 Out Real</th> <th>B2 Out Real</th> <th>B1 Out Real</th> <th>A2 Out Real</th> <th>A1 Out Real</th> </tr> </thead> <tbody> <tr> <td>Default</td> <td>0</td> <td>0</td> <td>0</td> <td>0</td> <td>0</td> <td>0</td> <td>0</td> <td>0</td> <td>0</td> <td>0</td> <td>0</td> <td>0</td> <td>0</td> <td>0</td> <td>0</td> <td>0</td> </tr> <tr> <td>Bit</td> <td>15</td> <td>14</td> <td>13</td> <td>12</td> <td>11</td> <td>10</td> <td>9</td> <td>8</td> <td>7</td> <td>6</td> <td>5</td> <td>4</td> <td>3</td> <td>2</td> <td>1</td> <td>0</td> </tr> </tbody> </table> <p style="margin-left: 150px;">0 = False 1 = True</p>					Options	Reserved	Reserved	Reserved	Reserved	Reserved	Reserved	Reserved	Reserved	D2 Out Real	D1 Out Real	C2 Out Real	C1 Out Real	B2 Out Real	B1 Out Real	A2 Out Real	A1 Out Real	Default	0	0	0	0	0	0	0	0	0	0	0	0	0	0	0	0	Bit	15	14	13	12	11	10	9	8	7	6	5	4	3	2	1	0
Options	Reserved	Reserved	Reserved	Reserved	Reserved	Reserved	Reserved	Reserved	D2 Out Real	D1 Out Real	C2 Out Real	C1 Out Real	B2 Out Real	B1 Out Real	A2 Out Real	A1 Out Real																																								
Default	0	0	0	0	0	0	0	0	0	0	0	0	0	0	0	0																																								
Bit	15	14	13	12	11	10	9	8	7	6	5	4	3	2	1	0																																								
724	Data Out A1 Int Link A Word 1 (Integer) - Parameter number whose value will be written to a communications device data table.	Default: 0 Min/Max: -/+2147483648	✓	✓	32-bit Integer																																																			
725	Data Out A1 Real Link A Word 1 (Real or Floating Point) - Parameter number whose value will be written to a communications device data table.	Default: 0.0000 Min/Max: -/+2200000000.0000	✓	✓	Real																																																			
726	Data Out A2 Int Link A Word 2 (Integer) - Parameter number whose value will be written to a communications device data table.	Default: 0 Min/Max: -/+2147483648	✓	✓	32-bit Integer																																																			
727	Data Out A2 Real Link A Word 2 (Real or Floating Point) - Parameter number whose value will be written to a communications device data table.	Default: 0.0000 Min/Max: -/+2200000000.0000	✓	✓	Real																																																			
728	Data Out B1 Int Link B Word 1 (Integer) - Parameter number whose value will be written to a communications device data table.	Default: 0 Min/Max: -/+2147483648	✓	✓	32-bit Integer																																																			
729	Data Out B1 Real Link B Word 1 (Real or Floating Point) - Parameter number whose value will be written to a communications device data table.	Default: 0.0000 Min/Max: -/+2200000000.0000	✓	✓	Real																																																			
730	Data Out B2 Int Link B Word 2 (Integer) - Parameter number whose value will be written to a communications device data table.	Default: 0 Min/Max: -/+2147483648	✓	✓	32-bit Integer																																																			
731	Data Out B2 Real Link B Word 2 (Real or Floating Point) - Parameter number whose value will be written to a communications device data table.	Default: 0.0000 Min/Max: -/+2200000000.0000	✓	✓	Real																																																			
732	Data Out C1 Int Link C Word 1 (Integer) - Parameter number whose value will be written to a communications device data table.	Default: 0 Min/Max: -/+2147483648	✓	✓	32-bit Integer																																																			

No.	Name Description	Values	Linkable	Read-Write	Data Type
733	Data Out C1 Real Link C Word 1 (Real or Floating Point) - Parameter number whose value will be written to a communications device data table.	Default: 0.0000 Min/Max: -/+2200000000.0000	✓	✓	Real
734	Data Out C2 Int Link C Word 2 (Integer) - Parameter number whose value will be written to a communications device data table.	Default: 0 Min/Max: -/+2147483648	✓	✓	32-bit Integer
735	Data Out C2 Real Link C Word 2 (Real or Floating Point) - Parameter number whose value will be written to a communications device data table.	Default: 0.0000 Min/Max: -/+2200000000.0000	✓	✓	Real
736	Data Out D1 Int Link D Word 1 (Integer) - Parameter number whose value will be written to a communications device data table.	Default: 0 Min/Max: -/+2147483648	✓	✓	32-bit Integer
737	Data Out D1 Real Link D Word 1 (Real or Floating Point) - Parameter number whose value will be written to a communications device data table.	Default: 0.0000 Min/Max: -/+2200000000.0000	✓	✓	Real
738	Data Out D2 Int Link D Word 2 (Integer) - Parameter number whose value will be written to a communications device data table.	Default: 0 Min/Max: -/+2147483648 Comm Scale: x 1	✓	✓	32-bit Integer
739	Data Out D2 Real Link D Word 2 (Real or Floating Point) - Parameter number whose value will be written to a communications device data table.	Default: 0.0000 Min/Max: -/+2200000000.0000	✓	✓	Real

740		Position Control																																	
		Set bits to enable various position control functions.																																	
		<ul style="list-style-type: none"> Setting bit 1 [Speed Out En] enables position regulator output at Par 318 [Posit Spd Output]. Setting bit 2 [Integ En] enables integrator operation. Resetting it resets the integrator. Setting bit 3 [Integ Hold] holds the integrator in the present state. Setting bit 4 [X Offset Pol] reverses polarity of offset parameters. Setting bit 5 [XOffset ReRef] permits changing the value of position offsets without changing actual position. Resetting it makes the position offset relative to the re-referenced value or the latched value upon enable if re-reference was not performed. Bit 6 [ActPosit Rst] is only operational when Bit 8 [Xzero Preset] is off. When bit 6 [ActPosit Rst] is set, Pars 744 [PositRef EGR Out], 747 [Position Cmmnd], 763 [Act Motor Posit] and 765 [Posit Actl Load] will be set to the value of Par 762 [Mtr Posit Fdbk] upon drive enable. When bit 6 [ActPosit Rst] is cleared, the above four parameters are set to a value of the position reference selected by Par 743 [Aux Posit Ref]. Setting bit 7 [AbsoluteMode] puts the position regulator in Absolute mode. Setting bit 8 [Xzero Preset] presets Pars 744 [PositRef EGR Out], 747 [Position Cmmnd], 763 [Act Motor Posit] and 765 [Posit Actl Load] to the value in Par 762 [Mtr Posit Fdbk] minus Par 757 [Abs Posit Offset] upon drive enable. Setting bit 10 [Pt-Pt ReRef] enables setting or changing Par 758 [Pt-Pt Posit Ref] without changing actual position. Setting bit 16 [X Watch1 En] enables position Watch 1. Resetting it clears Par 741 [Position Status] bit 8 [Posit Watch1]. Setting bit 17 [X Watch1 Dir] causes Position Watch 1 output to be set when Par 763 [Act Motor Posit] is greater than Par 780 [PositDct1 Stpt]. Re-setting bit 17 [X Watch1 Dir] causes Position Watch 1 output to be set when Par 763 [Act Motor Posit] is less than Par 780 [PositDct1 Stpt]. Setting bit 18 [X Watch2 En] enables position Watch 2. Resetting it clears Par 741 [Position Status] bit 9 [Posit Watch2]. Setting bit 19 [X Watch2 Dir] causes Position Watch 2 output to be set when Par 763 [Act Motor Posit] is greater than Par 781 [PositDct2 Stpt]. Re-setting bit 19 [X Watch2 Dir] causes Position Watch 2 output to be set when Par 763 [Act Motor Posit] is less than Par 781 [PositDct2 Stpt]. 																																	
Options		Reserved	Reserved	Reserved	Reserved	Reserved	Reserved	Reserved	Reserved	Reserved	Reserved	Reserved	Reserved	Reserved	Reserved	X Watch2 Dir	X Watch2 En	X Watch1 Dir	X Watch1 En	Reserved	Reserved	Reserved	Reserved	Reserved	Pt-Pt ReRef	Reserved	Xzero Preset	AbsoluteMode	ActPosit Rst	XOffset ReRef	X Offset Pol	Integ Hold	Integ En	Speed Out En	Reserved
Default		0	0	0	0	0	0	0	0	0	0	0	0	0	0	1	0	1	0	0	0	0	0	0	0	0	1	0	0	0	0	0	0	1	0
Bit		31	30	29	28	27	26	25	24	23	22	21	20	19	18	17	16	15	14	13	12	11	10	9	8	7	6	5	4	3	2	1	0		
		0 = False 1 = True																																	

741		Position Status																																
		Indicates status of position control algorithms.																																
		<ul style="list-style-type: none"> Bit 0 [X IGain LLim] indicates the position integrator is at the lower limit. Bit 1 [X IGain HLim] indicates the position integrator is at the high limit. Bit 2 [X Spd LLim] indicates the position regulator output at the low limit. Bit 3 [X Spd HLim] indicates the position regulator output is at the high limit. Bit 4 [PtPtRRef Act] TBD. Bit 5 [XOffRRef Act] TBD. Bit 7 [Regulator On] indicates position regulator is active. Bit 8 [Posit Watch1] indicates Position Watch 1 has detected motor position equal to its setpoint, from the proper direction. Bit 9 [Posit Watch2] indicates Position Watch 2 has detected motor position equal to its setpoint, from the proper direction. Bit 10 [In Position] indicates Par 769 [Position Error] is within the position deadband specified by parameter 782 [In Posit BW]. 																																
Options		Reserved	Reserved	Reserved	Reserved	Reserved	Reserved	Reserved	Reserved	Reserved	Reserved	Reserved	Reserved	Reserved	Reserved	Reserved	Reserved	Reserved	Reserved	Reserved	Reserved	Reserved	In Position	Posit Watch2	Posit Watch1	Regulator On	Reserved	XOffRRef Act	PtPtRRef Ac	X Spd HLim	X Spd LLim	X IGain HLim	X IGain LLim	
Default		0	0	0	0	0	0	0	0	0	0	0	0	0	0	0	0	0	0	0	0	0	0	0	1	0	0	0	0	0	0	0	1	0
Bit		31	30	29	28	27	26	25	24	23	22	21	20	19	18	17	16	15	14	13	12	11	10	9	8	7	6	5	4	3	2	1	0	
		0 = False 1 = True																																

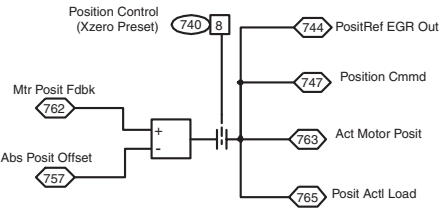

No.	Name Description	Values	Linkable	Read-Write	Data Type
742	Posit Ref Sel Enter a value to select the position mode and corresponding reference.	Default: 1 "AuxPosit Ref" Options: 0 "Interpolate" 2 "Pt to Pt" 1 "AuxPosit Ref"			
743	Aux Posit Ref Supplies position reference to the position regulator when selected by Par 742 [Posit Ref Sel]. This input is designed to be linked to a position count accumulator such as a virtual encoder or hardware accumulator.	Default: 0 Min/Max: -/+2147483648	✓	✓	32-bit Integer
744	PositRef EGR Out Accumulated output of the position reference Electronic Gear Ratio (EGR). When the position regulator is not enabled, this parameter is initialized to Par 762 [Mtr Posit Fdbk] or to the selected position reference as determined by Par 740 [Position Control] bit 6 [ActPosit Rst].	Default: 0 Min/Max: -/+2147483648			32-bit Integer
745	PositRef EGR Mul An integer value in the numerator of the EGR function that is precision multiplied by the selected position reference. A negative value will effect a change in polarity.	Default: 1 Min/Max: -/+2000000	✓	✓	32-bit Integer
746	PositRef EGR Div An integer value in the denominator of the EGR function that divides the product of the numerator of the EGR function and the selected position reference. Remainders are accumulated and not lost.	Default: 1 Min/Max: 1/2000000			32-bit Integer
747	Position Cmmd Final accumulated command to the position regulator. When the position regulator is not enabled, this parameter is initialized to Par 762 [Mtr Posit Fdbk] or to the selected position reference as determined by Par 740 [Position Control] bit 6 [ActPosit Rst]. Thereafter, its value will reflect the result of reference and offset changes.	Default: 0 Min/Max: -/+2147483648			32-bit Integer
748	CoarsePosit Trgt Input to the interpolator. This is a course position target reference.	Default: 0 Min/Max: -/+2147483648	✓		DWord
749	Interp Position Input to the interpolator. This is a course position target reference.	Default: 0 Min/Max: -/+2147483648			DWord
750	Course Spd Trgt Input to the interpolator. This is a course speed target reference.	Default: 0 Min/Max: -/+2200000000.0000		✓	Real
751	Interp Speed Output from the interpolator. This is a fine speed target reference. Interpolated value of Par 750 [Course Spd Trgt] if available, or the first derivative of Par 748 [CoursePosit Trgt] if not available.	Default: 0 Min/Max: -/+8.0000			Real
752	Interp AccelRate Output from interpolator. This is a fine acceleration rate. First derivative of Par 750 [Course Spd Trgt] if available, or zero (0) if not available.	Default: 0 Min/Max: -/+8.0000			Real
753	Posit Offset 1 Supplies a position reference offset, which is summed after the EGR and used to phase trim position reference. A step in the offset position will be internally rate limited and added to the selected reference position. The rate of correction is set by Par 755 [Posit Offset Spd]. The initial value of this parameter is latched upon position enable without causing a change in reference. Subsequent changes to the value will be relative to the latched value. See Par 740 [Position Control] bit 5 [XOffset ReRef] for re-referencing the offsets.	Default: 0 Min/Max: -/+2147483648	✓	✓	32-bit Integer
754	Posit Offset 2 Supplies another position reference offset, which is summed directly with Par 753 [Posit Offset 1]. Used to trim the phase of the selected position reference. Position offset will be internally rate limited to a velocity set by Par 755 [Posit Offset Spd].	Default: 0 Min/Max: -/+2147483648	✓	✓	32-bit Integer
755	Posit Offset Spd Sets the speed of position offset. A position offset command will not exceed this speed. The actual speed of offset is limited to a maximum value of 1/(inertia * pos gain) so as not to cause a torque pulse greater than 1 per unit. The speed will change exponentially.	Units: RPM Default: 176.4000 Min/Max: -/+14112.0000 Comm Scale: Par 4 [Motor NP RPM] = 1.0	✓	✓	Real
756	X Offst SpdFilt Displays the output of a first order filter whose time response is shaped specifically to provide an output that represents the actual speed of offset correction. It may be used as feed forward into speed reference to secure minimal position error during changes to offset.	Units: RPM Default: 0.0000 Min/Max: -/+14112.0000 Comm Scale: Par 4 [Motor NP RPM] = 1.0			Real

No.	Name Description	Values	Linkable	Read-Write	Data Type
757	Abs Posit Offset Provides an offset to absolute position. Setting Par 740 [Position Control], bit 8 [Xzero Preset] presets Pars 744 [PositRef EGR Out], 747 [Position Cmmd], 763 [Act Motor Posit] and 765 [Posit Actl Load] with the value in Par 762 [Mtr Posit Fdbk] minus Par 757 [Abs Posit Offset] upon drive enable.	Default: 0 Min/Max: -/+2147483648	✓	✓	32-bit Integer
					
758	Pt-Pt Posit Ref Provides position reference to the point to point position regulator, when the value in Par 742 [Posit Ref Sel] equals 2 "Pt to Pt". The initial value is latched upon position enable without causing movement. Subsequent changes to reference are relative to the latched position unless the position is re-referenced by Par 740 [Position Control], bit 10 [Pt-Pt ReRef]. Position moves may be made within the limits of +/- 31 bits. Point to point reference may be changed, and even reversed, during a move.	Default: 0 Min/Max: -/+2147483648	✓	✓	32-bit Integer
759	Pt-Pt Accel Time Acceleration time (sec) from zero to base speed, active only in point to point mode. Acceleration to a relatively low speed may be exponential.	Units: Sec Default: 10.0000 Min/Max: 0.1000/6553.5000	✓	✓	Real
760	Pt-Pt Decel Time Deceleration time (sec) from base speed to zero, active only in point to point mode. Some tailing can be expected at the end of a move as the drive comes into command position. It is left to the user to select a time that does not place the drive in current or torque limit. Deceleration from relatively low speed may be exponential.	Units: Sec Default: 10.0000 Min/Max: 0.1000/6553.5000	✓	✓	Real
761	Pt-Pt Filt BW Sets the bandwidth of a low pass filter which affects smoothness at the start of deceleration in the point to point mode. A high filter bandwidth will produce a more square deceleration torque, one with a higher level of jerk. Typical values range from 5 to 100 (rad/sec). A zero value will bypass the filter. Tail-out is influenced mainly by Par 768 [PositReg P Gain].	Units: R/S Default: 25.0000 Min/Max: 0.0000/500.0000	✓	✓	Real
762	Mtr Posit Fdbk Displays the accumulated pulse count of the primary feedback device as a 32 bit integer. The primary feedback device is selected by Par 222 [Motor Fdbk Sel].	Default: 0 Min/Max: -/+2147483648			32-bit Integer
763	Act Motor Posit Displays the accumulated motor position as a 32 bit integer. It tracks Par 762 [Mtr Posit Fdbk]. When the position regulator is not enabled, this parameter is initialized to Par 762 [Mtr Posit Fdbk] or to the selected position reference as determined by Par 740 [Position Control] bit 6 [ActPosit Rst].	Default: 0 Min/Max: -/+2147483648			32-bit Integer
764	Posit Load Fdbk Tracks the load position as a 32 bit integer. When a gear box connects the load to the motor, Par 766 [Posit FB EGR Mul] and Par 767 [Posit FB EGR Div] must be set to account for the gear ratio. Set Par 766 [Posit FB EGR Mul] equal to Par 767 [Posit FB EGR Div] if the load is directly connected to the motor.	Default: 0 Min/Max: -/+2147483648	✓	✓	32-bit Integer
765	Posit Actl Load Holds the accumulated output of the Load Gear Ratio as a 32 bit integer and forms the primary feedback for the position regulator integral channel. It is very important that the Load Gear Ratio be precisely set, such that the delta pulse count of one motor revolution equals the delta pulse count of this parameter. When the position regulator is not enabled, this parameter is initialized to Par 762 [Mtr Posit Fdbk] or to the selected position reference as determined by Par 740 [Position Control] bit 6 [ActPosit Rst].	Default: 0 Mi/Max: -/+2147483648			32-bit Integer
766	Posit FB EGR Mul A 32 bit integer in the numerator of the load Electronic Gear Ratio function. It is multiplied by Par 764 [Posit Load Fdbk] and divided by Par 767 [Posit FB EGR Div] to reflect the load pulse count to the motor (effectively removing the gear box ratio). The accumulated position values of Par 763 [Act Motor Posit] and Par 765 [Posit Actl Load] will be equal if the ratio is set properly. There may be some difference due to lost motion in the gear train, but there should not be an accumulated difference. It is often necessary to count gear teeth as gear box manufacturers often approximate exact ratios with decimal numbers. Enter a negative value in the numerator to account for reversed motor rotation.	Default: 1 Min/Max: -/+1000000	✓	✓	32-bit Integer
767	Posit FB EGR Div This is a 32 bit integer that forms the denominator of the load Electronic Gear Ratio function.	Default: 1 Min/Max: 1/2000000			32-bit Integer

No.	Name Description	Values	Linkable	Read-Write	Data Type
768	PositReg P Gain Sets position regulator gain as measured from position error to speed reference. The gain number is identically equal to position regulator bandwidth in rad/sec. For example: A gain of 10 means that a per unit position error of 0.1 sec. will effect a 1.0 pu speed change (1 per unit position error is the distance traveled in 1 sec. at base motor speed). The maximum value of this parameter is typically 1/3 of the speed bandwidth (rad/sec) but may be set considerably higher with careful tuning of the speed regulator output lead/lag filter.	Units: R/S Default: 4.0000 Min/Max: 0.0000/200.0000	✓	✓	Real
769	Position Error Actual position error in motor pulse counts. When the position regulator is not enabled, this 32 bit integer register is initialized to zero. When the position regulator is enabled, this parameter contains the running value of position error, often referred to as "following error".	Default: 0 Min/Max: -/+2147483648			32-bit Integer
770	PositReg Integ Sets position regulator integral gain as measured from position error to velocity reference. It has gain units of (per unit velocity/sec) / (per unit position) and is unit compatible with Par 768 [PositReg P Gain]. An integral gain of 25 means that a per unit position error of 0.1 sec will effect a 2.5 pu speed change per sec. A typical maximum value is $\frac{1}{3}$ [PositReg P Gain] ² . Note: 1 per unit position is the distance traveled in 1 sec. at base motor speed.	Units: /S ² Default: 4.0000 Min/Max: 0.0000/1000.0000 Comm Scale: x 1	✓	✓	Real
771	PositReg Droop Position Droop limits the low frequency gain of the position regulators integral channel to a value of (1/droop). It provides a means to fine tune the stability for load mounted feedback devices where lost motion may cause a problem. Typically, position droop will have a value that is less than (1/position gain), perhaps even zero for tightly coupled loads. Position droop has a gain value of (per unit position) / (per unit speed). Note: 1 per unit position is the distance traveled in 1 sec. at base motor speed.	Default: 0.0000 Min/Max: 0.0000/0.2500	✓	✓	Real
772	XReg Integ LoLim The negative limit of the position integrator.	Units: RPM Default: -176.4000 Min/Max: -14112.0000/0.0000 Comm Scale: Par 4 [Motor NP RPM] = 1.0	✓	✓	Real
773	XReg Integ HiLim The positive limit of the position integrator.	Units: RPM Default: 176.4000 Min/Max: 0.0000/14112.0000 Comm Scale: Par 4 [Motor NP RPM] = 1.0	✓	✓	Real
774	XReg Integ Out The output of the position regulator integral channel after application of the limits. This output is set to zero if the integral gain is set to zero or the integrator is not enabled.	Units: RPM Default: 0 Min/Max: -/+14112.0000 Comm Scale: Par 4 [Motor NP RPM] = 1.0			Real
775	XReg Spd LoLim The negative limit of total position regulator output. Point to point mode uses this parameter to set the reverse speed reference.	Units: RPM Default: -176.4000 Min/Max: -14112.0000/0.0000 Comm Scale: Par 4 [Motor NP RPM] = 1.0	✓	✓	Real
776	XReg Spd HiLim The positive limit of total position regulator output. Point to point mode uses this parameter to set the forward speed reference.	Units: RPM Default: 176.4000 Min/Max: 0.0000/14112.0000 Comm Scale: Par 4 [Motor NP RPM] = 1.0	✓	✓	Real
777	Posit TP Select Enter or write a value to select position regulator data displayed in Par 778 [Posit TP Data Int] and Par 779 [Posit TP DataReal].	Default: 0 "Zero" Options: 0 "Zero" 9 "Limiter Out" 1 "del Xos Vout" 10 "Ref EGR In" 2 "del Xcmd" 11 "OffsetSpdLim" 3 "del Act Load" 12 "PtoP SpdLim" 4 "del Act Mtr" 13 "Sec per Edg" 5 "Integ Error" 14 "Edge per Sec" 6 "Xprop Out" 15 "Ratio Guess" 7 "Reserved" 16 "Sync Count" 8 "PreLim Xvout"			
778	PositTP Data Int Displays the data selected by Par 777 [Posit TP Select]. This display should only be used if the selected value is integer data.	Default: 0 Min/Max: -/+2147483648			32-bit Integer
779	PositTP DataReal Displays the data selected by Par 777 [Posit TP Select] in RPM. This display should only be used if the selected value is floating point data.	Units: RPM Default: 0.0000 Min/Max: -/+3.8880799961088.0000 Comm Scale: Par 4 [Motor NP RPM] = 1.0			Real
780	PositDetct1 Stpt Provides the setpoint for Position Watch 1. Position Watch 1 is enabled and configured with Par 740 [Position Control] bits 16 & 17. Position Watch 1 compares this value with Par 784 [Posit Detct1 In] and sets bit 8 [Posit Watch1] of Par 741 [Position Status] when the appropriate condition is satisfied.	Default: 0 Min/Max: -/+2147483648			32-bit Integer
781	PositDetct2 Stpt Provides the setpoint for Position Watch 2. Position Watch 2 is enabled and configured with Par 740 [Position Control] bits 18 & 19. Position Watch 2 compares this value with Par 785 [Posit Detct2 In] and sets bit 9 [Posit Watch2] of Par 741 [Position Status] when the appropriate condition is satisfied.	Default: 0 Min/Max: -/+2147483648	✓	✓	32-bit Integer

No.	Name Description	Values	Linkable	Read-Write	Data Type																																																		
796	<p>Posit Index Ctrl Set bits to control the Position Index function.</p> <ul style="list-style-type: none"> Setting bit 0 [Enable] allows the Position Index function to run. Setting bit 1 [Step] causes Par 799 [PositIndexOutput] to change by the amount in Par 797 [Posit Index Step] if bit 0 [Enable] is on. Setting bit 2 [Reverse] causes Par 799 [PositIndexOutput] to decrement by the value in Par 797 [Posit Index Step] instead of increment if bit 0 [Enable] is on. Setting bit 3 [Preset] forces the value in Par 798 [PositIndexPreset] into Par 799 [PositIndexOutput] if bit 0 [Enable] is set. Bit 3 [Preset] overrides bits 1 [Step] and 2 [Reverse]. <p>Options</p> <table border="1"> <thead> <tr> <th></th> <th>Reserved</th> <th>Reserved</th> <th>Reserved</th> <th>Reserved</th> <th>Reserved</th> <th>Reserved</th> <th>Reserved</th> <th>Reserved</th> <th>Reserved</th> <th>Reserved</th> <th>Reserved</th> <th>Reserved</th> <th>Preset</th> <th>Reverse</th> <th>Step</th> <th>Enable</th> </tr> </thead> <tbody> <tr> <td>Default</td> <td>0</td> <td>0</td> <td>0</td> <td>0</td> <td>0</td> <td>0</td> <td>0</td> <td>0</td> <td>0</td> <td>0</td> <td>0</td> <td>0</td> <td>0</td> <td>0</td> <td>0</td> <td>0</td> </tr> <tr> <td>Bit</td> <td>15</td> <td>14</td> <td>13</td> <td>12</td> <td>11</td> <td>10</td> <td>9</td> <td>8</td> <td>7</td> <td>6</td> <td>5</td> <td>4</td> <td>3</td> <td>2</td> <td>1</td> <td>0</td> </tr> </tbody> </table> <p>0 = False 1 = True</p>		Reserved	Reserved	Reserved	Reserved	Reserved	Reserved	Reserved	Reserved	Reserved	Reserved	Reserved	Reserved	Preset	Reverse	Step	Enable	Default	0	0	0	0	0	0	0	0	0	0	0	0	0	0	0	0	Bit	15	14	13	12	11	10	9	8	7	6	5	4	3	2	1	0			
	Reserved	Reserved	Reserved	Reserved	Reserved	Reserved	Reserved	Reserved	Reserved	Reserved	Reserved	Reserved	Preset	Reverse	Step	Enable																																							
Default	0	0	0	0	0	0	0	0	0	0	0	0	0	0	0	0																																							
Bit	15	14	13	12	11	10	9	8	7	6	5	4	3	2	1	0																																							
797	<p>Posit Index Step Specifies the amount added to or subtracted from Par 799 [PositIndexOutput] on the rising edge of Par 796 [Posit Index Ctrl], bit 1 [Step]. Note that this value can be positive and negative.</p>	Default: 0 Min/Max: -/+2147483648	✓	✓	32-bit Integer																																																		
798	<p>PositIndexPreset Specifies the value to be moved into Par 799 [PositIndexOutput] when Par 796 [Posit Index Ctrl], bits 0 [Enable] and 3 [Preset] are on.</p>	Default: 0 Min/Max: -/+2147483648	✓	✓	32-bit Integer																																																		
799	<p>PositIndexOutput Displays the output of the Position Index function.</p>	Default: 0 Min/Max: -/+2147483648			32-bit Integer																																																		
800	<p>Anlg In1 Data Displays the value of Analog Input 1. This is the final value (after conversion, offsetting, scaling and filtering).</p>	Default: 0.0000 Min/Max: -/+2200000000.0000			Real																																																		
801	<p>Anlg In1 Volts Displays the sum of Par 803 [Anlg In1 Offset] and the analog to digital conversion of Analog Input 1. The display range is +/-10V. If switch SW1-1 is closed (set for +/-1.0V) the value is scaled and displayed as +/-10V.</p>	Units: Volt Default: 0.0000 Min/Max: -/+10.0000			Real																																																		
802	<p>Anlg In1 Scale Scales the range of Analog Input 1 to the range of Par 800 [Anlg In1 Data]. Par 801 [Anlg In1 Volts] is multiplied by this number to produce the input to the lead lag filter function. Par 802 = 1 and Par 800 = 10 when 10V is applied.</p>	Units: /1v Default: 0.0000 Min/Max: -/+2200000000.0000	✓	✓	Real																																																		
803	<p>Anlg In1 Offset Applies an offset to Analog Input 1. The output of the analog to digital conversion is summed with this number to produce Par 801 [Anlg In1 Volts]. This is used to zero out the analog input.</p>	Units: Volt Default: 0.0000 Min/Max: -/+20.0000	✓	✓	Real																																																		
804	<p>AI 1 Filt Gain Provides the lead term for the Analog Input 1 filter. A values greater than 1 will result in a lead function and a value less than 1 will result in a lag function.</p>	Default: 1.0000 Min/Max: -/+5.0000	✓	✓	Real																																																		
805	<p>Anlg In1 Filt BW Sets the frequency for the Analog Input 1 filter.</p>	Units: R/S Default: 0.0000 Min/Max: 0.0000/3760.0000	✓	✓	Real																																																		
806	<p>Anlg In2 Data Displays the value of Analog Input 2. This is the final value (after conversion, offsetting, scaling and filtering).</p>	Units: Volt Default: 0.0000 Min/Max: -/+2200000000.0000 Comm Scale: x 1			Real																																																		
807	<p>Anlg In2 Volts Displays sum of the Par 809 [Anlg In2 Offset] and the analog to digital conversion of Analog Input 2. The display range is +/-10V. If switch SW1-1 is closed (set for +/-1.0V) the value is scaled and displayed as +/-10V.</p>	Units: Volt Default: 0.0000 Min/Max: -/+10.0000			Real																																																		
808	<p>Anlg In2 Scale Scales the range of Analog Input 2 to the range of Par 806 [Anlg In2 Data]. Par 807 [Anlg In2 Volts] is multiplied by this number to produce the input to the lead lag filter function.</p>	Units: /1v Default: 0.0000 Min/Max: -/+2200000000.0000	✓	✓	Real																																																		
809	<p>Anlg In2 Offset Applies an offset to Analog Input 2. The output of the analog to digital conversion is summed with this number to produce Par 807 [Anlg In2 Volts].</p>	Units: Volt Default: 0.0000 Min/Max: -/+20.0000	✓	✓	Real																																																		
810	<p>AI 2 Filt Gain Provides the lead term for the Analog Input 2 filter. A values greater than 1 will result in a lead function and a value less than 1 will result in a lag function.</p>	Default: 1.0000 Min/Max: -/+5.0000	✓	✓	Real																																																		
811	<p>Anlg In2 Filt BW Sets the frequency for the Analog Input 2 filter.</p>	Units: R/S Default: 0.0000 Min/Max: 0.0000/3760.0000	✓	✓	Real																																																		
812	<p>Anlg Out1 Offset Provides an offset for Analog Output 1, before the scaling and limit blocks in the Analog Output 1 function. This parameter is summed with either Par 814 [AnlgOut1 Integer] or 815 [Anlg Out1 Real] at the beginning of the function.</p>	Default: 0.0000 Min/Max: -/+2200000000.0000	✓	✓	Real																																																		
813	<p>Anlg Out2 Offset Provides an offset for Analog Output 2, before the scaling and limit blocks in the Analog Output 2 function. This parameter is summed with either Par 819 [AnlgOut2 Integer] or 820 [Anlg Out2 Real] at the beginning of the function.</p>	Default: 0.0000 Min/Max: -/+2200000000.0000	✓	✓	Real																																																		

No.	Name Description	Values	Linkable	Read-Write	Data Type																																																																																																					
814	AnlgOut1 Integer Link this parameter to an integer source parameter and that source will control Analog Output 1.	Default: 0 Min/Max: -/+2147483648	✓	✓	32-bit Integer																																																																																																					
815	Anlg Out1 Real Link this parameter to a real (floating point) source parameter and that source will control Analog Output 1.	Default: 0.0000 Min/Max: -/+2200000000.0000.0000	✓	✓	Real																																																																																																					
816	Anlg Out1 Volts Displays the voltage reference for Analog Output 1, before the digital to analog conversion.	Units: Volt Default: 0.0000 Min/Max: -/+10.0000			Real																																																																																																					
817	Anlg Out1 Scale Scales the range of the source parameter to the range of Analog Output 1. Par 814 [AnlgOut1 Integer] or Par 815 [Anlg Out1 Real] is multiplied by this number after the limit function.	Units: /1v Default: 0.0000 Min/Max: -/+2200000000.0000	✓	✓	Real																																																																																																					
818	Anlg Out1 Zero Applies an offset to the scaled value of the Analog Output 1 function. This parameter is summed with the output of the scaling block. This sum produces Par 816 [Anlg Out1 Volts]. Typically this value corresponds to 0V for Analog Output 1.	Units: Volt Default: 0.0000 Min/Max: -/+20.0000	✓	✓	Real																																																																																																					
819	AnlgOut2 Integer Link this parameter to an integer source parameter and that source will control Analog Output 2.	Default: 0 Min/Max: -/+2147483648	✓	✓	Real																																																																																																					
820	Anlg Out2 Real Link this parameter to a real (floating point) source parameter and that source will control Analog Output 2.	Default: 0.0000 Min/Max: -/+2200000000.0000	✓	✓	Real																																																																																																					
821	Anlg Out2 Volts Displays the voltage reference for Analog Output 2, before the digital to analog conversion.	Units: Volt Default: 0.0000 Min/Max: -/+10.0000			Real																																																																																																					
822	Anlg Out2 Scale Scales the range of the source parameter to the range of Analog Output 2. Par 819 [AnlgOut2 Integer] or Par 820 [Anlg Out2 Real] is multiplied by this number after the limit function.	Units: /1v Default: 0.0000 Min/Max: -/+2200000000.0000	✓	✓	Real																																																																																																					
823	Anlg Out2 Zero Applies an offset to the scaled value of the Analog Output 2 function. This parameter is summed with the output of the scaling block. This sum produces Par 821 [Anlg Out2 Volts]. Typically this value corresponds to 0V for Analog Output 2.	Units: Volt Default: 0.0000 Min/Max: -/+20.0000	✓	✓	Real																																																																																																					
824	Local I/O Status Displays the status of the local I/O.	<table border="1"> <thead> <tr> <th>Options</th> <th>Reserved</th> <th>Reserved</th> <th>Reserved</th> <th>Reserved</th> <th>Reserved</th> <th>Reserved</th> <th>Reserved</th> <th>Reserved</th> <th>Reserved</th> <th>VPL Gate Ena</th> <th>Watch Dog</th> <th>VP TP2 Out</th> <th>VP TP1 Out</th> <th>Aux Out 2</th> <th>Aux Out 1</th> <th>Output Relay</th> <th>Reserved</th> <th>Reserved</th> <th>Reserved</th> <th>Reserved</th> <th>Reserved</th> <th>Reserved</th> <th>Reserved</th> <th>Reserved</th> <th>Reserved</th> <th>Reserved</th> <th>Reserved</th> <th>Reserved</th> <th>LogixPresent</th> <th>DigIn 3</th> <th>DigIn 2</th> <th>DigIn 1</th> <th>Enable In</th> </tr> </thead> <tbody> <tr> <td>Default</td> <td>0</td><td>0</td><td>0</td><td>0</td><td>0</td><td>0</td><td>0</td><td>0</td><td>0</td><td>0</td><td>0</td><td>0</td><td>0</td><td>0</td><td>0</td><td>0</td><td>0</td><td>0</td><td>0</td><td>0</td><td>0</td><td>0</td><td>0</td><td>0</td><td>0</td><td>0</td><td>0</td><td>0</td><td>0</td><td>0</td><td>0</td><td>0</td><td>0</td> </tr> <tr> <td>Bit</td> <td>31</td><td>30</td><td>29</td><td>28</td><td>27</td><td>26</td><td>25</td><td>24</td><td>23</td><td>22</td><td>21</td><td>20</td><td>19</td><td>18</td><td>17</td><td>16</td><td>15</td><td>14</td><td>13</td><td>12</td><td>11</td><td>10</td><td>9</td><td>8</td><td>7</td><td>6</td><td>5</td><td>4</td><td>3</td><td>2</td><td>1</td><td>0</td> </tr> </tbody> </table> <p>0 = False 1 = True</p>	Options	Reserved	Reserved	Reserved	Reserved	Reserved	Reserved	Reserved	Reserved	Reserved	VPL Gate Ena	Watch Dog	VP TP2 Out	VP TP1 Out	Aux Out 2	Aux Out 1	Output Relay	Reserved	Reserved	Reserved	Reserved	Reserved	Reserved	Reserved	Reserved	Reserved	Reserved	Reserved	Reserved	LogixPresent	DigIn 3	DigIn 2	DigIn 1	Enable In	Default	0	0	0	0	0	0	0	0	0	0	0	0	0	0	0	0	0	0	0	0	0	0	0	0	0	0	0	0	0	0	0	0	0	Bit	31	30	29	28	27	26	25	24	23	22	21	20	19	18	17	16	15	14	13	12	11	10	9	8	7	6	5	4	3	2	1	0			
Options	Reserved	Reserved	Reserved	Reserved	Reserved	Reserved	Reserved	Reserved	Reserved	VPL Gate Ena	Watch Dog	VP TP2 Out	VP TP1 Out	Aux Out 2	Aux Out 1	Output Relay	Reserved	Reserved	Reserved	Reserved	Reserved	Reserved	Reserved	Reserved	Reserved	Reserved	Reserved	Reserved	LogixPresent	DigIn 3	DigIn 2	DigIn 1	Enable In																																																																									
Default	0	0	0	0	0	0	0	0	0	0	0	0	0	0	0	0	0	0	0	0	0	0	0	0	0	0	0	0	0	0	0	0	0																																																																									
Bit	31	30	29	28	27	26	25	24	23	22	21	20	19	18	17	16	15	14	13	12	11	10	9	8	7	6	5	4	3	2	1	0																																																																										
825	En In Debounce Sets the value of the debounce filter for the Enable input. The filter requires the input signal to be stable for the specified time period. Input transitions within the filter time setting will be ignored.	Units: mSec Default: 8.0000/0.0000 Min/Max: 15.5000	✓	✓	Real																																																																																																					
826	DigIn1 Data Sets the value of Par 828 [DigIn1 User Data], except for the bit controlled by bit 1 [DigIn 1] of Par 824 [Local I/O Status].	Default: 00000000000000000000000000000000 Min: 00000000000000000000000000000000 Max: 111111111111111111111111111111111111	✓	✓	32-bit Boolean																																																																																																					
827	DigIn1 Bit Selects the bit, in Par 828 [DigIn1 User Data], which is controlled by bit controlled by bit 1 [DigIn 1] of Par 824 [Local I/O Status].	Default: 0 Min/Max: -32/31	✓	✓	16-bit Integer																																																																																																					
828	DigIn1 User Data Provides a source of data controlled by bit 1 [DigIn 1] of Par 824 [Local I/O Status]. Link to a Read-Write parameter and enter a value of 13 in Par 838 [DigIn1 Sel] to activate this function.	Default: 00000000000000000000000000000000 Min: 00000000000000000000000000000000 Max: 111111111111111111111111111111111111			32-bit Boolean																																																																																																					
829	DigIn1 Debounce Sets the value of the debounce filter for Digital Input 1. The filter requires the input signal to be stable for the specified time period. Input transitions within the filter time setting will be ignored.	Units: mSec Default: 8.0000 Min/Max: 0.0000/15.5000	✓	✓	Real																																																																																																					
830	DigIn2 Data Sets the value of Par 832 [DigIn2 User Data], except for the bit controlled by bit 2 [DigIn 2] of Par 824 [Local I/O Status].	Default: 00000000000000000000000000000000 Min: 00000000000000000000000000000000 Max: 111111111111111111111111111111111111	✓	✓	32-bit Boolean																																																																																																					
831	DigIn2 Bit Selects the bit, in Par 832 [DigIn2 User Data], which is controlled by bit controlled by bit 2 [DigIn 2] of Par 824 [Local I/O Status].	Default: 0 Min/Max: -32/31	✓	✓	16-bit Integer																																																																																																					

No.	Name Description	Values	Linkable	Read-Write	Data Type
832	DigIn2 User Data Provides a source of data controlled by bit 2 [DigIn 2] of Par 824 [Local I/O Status]. Link to a Read-Write parameter and enter a value of 13 in Par 839 [DigIn2 Sel] to activate this function.	Default: 00000000000000000000000000000000 Min: 00000000000000000000000000000000 Max: 111111111111111111111111111111111111 Comm Scale: Inputs & Outputs Digital Inputs			32-bit Boolean
833	DigIn2 Debounce Sets the value of the debounce filter for Digital Input 2. The filter requires the input signal to be stable for the specified time period. Input transitions within the filter time setting will be ignored.	Units: mSec Default: 8.0000 Min/Max: 0.0000/15.5000	✓	✓	Real
834	DigIn3 Data Sets the value of Par 836 [DigIn3 User Data], except for the bit controlled by bit 3 [DigIn 3] of Par 824 [Local I/O Status].	Default: 00000000000000000000000000000000 Min: 00000000000000000000000000000000 Max: 111111111111111111111111111111111111	✓	✓	32-bit Boolean
835	DigIn3 Bit Selects the bit, in Par 836 [DigIn 3 User Data], which is controlled by bit controlled by bit 3 [DigIn 3] of Par 824 [Local I/O Status].	Default: 0 Min/Max: -32/31	✓	✓	16-bit Integer
836	DigIn3 User Data Provides a source of data controlled by bit 3 [DigIn 3] of Par 824 [Local I/O Status]. Link to a Read-Write parameter and enter a value of 13 in Par 840 [DigIn3 Sel] to activate this function.	Default: 00000000000000000000000000000000 Min: 00000000000000000000000000000000 Max: 111111111111111111111111111111111111			32-bit Boolean
837	DigIn3 Debounce Sets the value of the debounce filter for Digital Input 3. The filter requires the input signal to be stable for the specified time period. Input transitions within the filter time setting will be ignored.	Units: mSec Default: 8.0000 Min/Max: 0.0000/15.5000	✓	✓	Real
838	DigIn1 Sel Enter or write a value to select the function of Digital Input 1. 	Default: 0 "Not Used" Options: 0 "Not Used" 8 "Fwd/Reverse" 1 "Normal Stop" 9 "CurLim Stop" 2 "Start" 10 "Coast Stop" 3 "Run" 11 "Aux Fault" 4 "Clear Faults" 12 "AuxFault Inv" 5 "Stop - CF" 13 "User Select" 6 "Jog 1" 14 "PreChrg/Disc" 7 "Jog 2"			
839	DigIn2 Sel Enter or write a value to select the function of Digital Input 2. 	Default: 4 "Not Used" Options: 0 "Not Used" 14 "Reserved" 1 "Normal Stop" 15 "Reserved" 2 "Start" 16 "Reserved" 3 "Run" 17 "Reserved" 4 "Clear Faults" 18 "Reserved" 5 "Stop - CF" 19 "Reserved" 6 "Jog 1" 20 "Reserved" 7 "Jog 2" 21 "Reserved" 8 "Fwd/Reverse" 22 "Reserved" 9 "CurLim Stop" 23 "Logix Motion" 10 "Coast Stop" 24 "+Hrd OvrTrvl" 11 "Aux Fault" 25 "-Hrd OvrTrvl" 12 "AuxFault Inv" 13 "User Select"			
840	DigIn3 Sel Enter or write a value to select the function of Digital Input 3. 	Default: 0 "Not Used" Options: 0 "Not Used" 13 "User Select" 1 "Normal Stop" 14 "Reserved" 2 "Start" 15 "Reserved" 3 "Run" 16 "Reserved" 4 "Clear Faults" 17 "Reserved" 5 "Stop-CF" 18 "Reserved" 6 "Jog 1" 19 "Reserved" 7 "Jog 2" 21 "Reserved" 8 "Fwd/Reverse" 22 "Reserved" 9 "CurLim Stop" 23 "Logix Motion" 10 "Coast Stop" 24 "+Hrd OvrTrvl" 11 "Aux Fault" 25 "-Hrd OvrTrvl" 12 "AuxFault Inv"			
841	Relay Out Data Link a word to this parameter that will control the Relay Output. The bit within the selected word that will control the Relay Output is set by Par 842 [Relay Out Bit].	Default: 00000000000000000000000000000000 Min: 00000000000000000000000000000000 Max: 111111111111111111111111111111111111	✓	✓	32-bit Boolean
842	Relay Out Bit Selects the bit, from the word linked to Par 841 [Relay Out Data] that will change the status of the Relay Output (e.g., when Par 842 [Relay Out Bit] equals 0, bit 0 of Par 841 [Relay Out Data] will control the Relay Output).	Default: 0 Min/Max: -32/31	✓	✓	16-bit Integer
843	DigOut 1 Data Link a word to this parameter that will control Digital Output 1. The bit within the selected word that will control Digital Output 1 is set by Par 844 [DigOut 1 Bit].	Default: 00000000000000000000000000000000 Min: 00000000000000000000000000000000 Max: 111111111111111111111111111111111111	✓	✓	32-bit Boolean

No.	Name Description	Values	Linkable	Read-Write	Data Type																																																																																																				
844	DigOut 1 Bit Selects the bit, from the word linked to Par 843 [DigOut 1 Data], that will change the status of Digital Output 1 (e.g., when Par 844 [DigOut 1 Bit] equals 0, bit 0 of Par 843 [DigOut 1 Data] will control Digital Output 1).	Default: 0 Min/Max: -32/31	✓	✓	16-bit Integer																																																																																																				
845	DigOut 2 Data Link a word to this parameter that will control Digital Output 2. The bit within the selected word that will control Digital Output 2 is set by Par 846 [DigOut 2 Bit].	Default: 00000000000000000000000000000000 Min: 00000000000000000000000000000000 Max: 11111111111111111111111111111111	✓	✓	32-bit Boolean																																																																																																				
846	DigOut 2 Bit Selects the bit, from the word linked to Par 845 [DigOut 2 Data], that will change the status of Digital Output 2 (e.g., when Par 846 [DigOut 2 Bit] equals 0, bit 0 of Par 845 [DigOut 2 Data] will control Digital Output 2).	Default: 0 Min/Max: -32/31	✓	✓	16-bit Integer																																																																																																				
850	ParamAccessLevel The value of this parameter establishes the level of parameter access for the Human Interface Module (HIM). • 0 "Basic" - grants access to the minimum number of parameters • 1 "Advance" - grants access to a larger group of parameters • 2 "Engineering" - grants access to all the parameters	Default: 0 "Basic" Options: 0 "Basic" 1 "Advanced" 2 "Engineering"																																																																																																							
901	MotnUpdatePeriod Servo update period for the Servo axis (drive).	Units: uSec Default: 2000 Min/Max: 1/999999			DWord																																																																																																				
902	Motion CoarseMulti Number of Par 901 [MotnUpdatePeriod] comprising one Course Update Period from the Motion Period.	Default: 4 Min/Max: 2/16			DWord																																																																																																				
903	Motn Config Configuration bits pertaining to Motion-related functions for the Servo axis.	<table border="1"> <thead> <tr> <th>Options</th> <th>Reserved</th> <th>Reserved</th> <th>Reserved</th> <th>Reserved</th> <th>Reserved</th> <th>Reserved</th> <th>Reserved</th> <th>Reserved</th> <th>Reserved</th> <th>Reserved</th> <th>Reserved</th> <th>Reserved</th> <th>Reserved</th> <th>Reserved</th> <th>Hrd Ovr Trvl</th> <th>Sft Ovr Trvl</th> <th>Polarity Neg</th> </tr> </thead> <tbody> <tr> <td>Default</td> <td>1</td> <td>1</td> <td>1</td> <td>1</td> <td>1</td> <td>1</td> <td>1</td> <td>1</td> <td>1</td> <td>1</td> <td>1</td> <td>1</td> <td>1</td> <td>1</td> <td>1</td> <td>1</td> <td>1</td> </tr> <tr> <td>Bit</td> <td>15</td> <td>14</td> <td>13</td> <td>12</td> <td>11</td> <td>10</td> <td>9</td> <td>8</td> <td>7</td> <td>6</td> <td>5</td> <td>4</td> <td>3</td> <td>2</td> <td>1</td> <td>0</td> <td></td> </tr> </tbody> </table> <p>0 = False 1 = True</p>	Options	Reserved	Reserved	Reserved	Reserved	Reserved	Reserved	Reserved	Reserved	Reserved	Reserved	Reserved	Reserved	Reserved	Reserved	Hrd Ovr Trvl	Sft Ovr Trvl	Polarity Neg	Default	1	1	1	1	1	1	1	1	1	1	1	1	1	1	1	1	1	Bit	15	14	13	12	11	10	9	8	7	6	5	4	3	2	1	0																																																		
Options	Reserved	Reserved	Reserved	Reserved	Reserved	Reserved	Reserved	Reserved	Reserved	Reserved	Reserved	Reserved	Reserved	Reserved	Hrd Ovr Trvl	Sft Ovr Trvl	Polarity Neg																																																																																								
Default	1	1	1	1	1	1	1	1	1	1	1	1	1	1	1	1	1																																																																																								
Bit	15	14	13	12	11	10	9	8	7	6	5	4	3	2	1	0																																																																																									
904	Motn Axis Status Status bits pertaining to Motion-related functions for the Servo axis.	<table border="1"> <thead> <tr> <th>Options</th> <th>Reserved</th> <th>Reserved</th> <th>Reserved</th> <th>Reserved</th> <th>Reserved</th> <th>Reserved</th> <th>Reserved</th> <th>Reserved</th> <th>Reserved</th> <th>Reserved</th> <th>Reserved</th> <th>Reserved</th> <th>Reserved</th> <th>Reserved</th> <th>AxisShdnwC1</th> <th>Reserved</th> <th>Chng Ref</th> <th>Reserved</th> <th>Reserved</th> <th>Course Updt</th> <th>CST Updt Err</th> <th>-Hrd OvrTrvl</th> <th>+Hrd OvrTrvl</th> <th>-Sft OvrTrvl</th> <th>+Sft OvrTrvl</th> <th>Reserved</th> <th>Reserved</th> <th>Reserved</th> <th>Posit Lock</th> <th>AxisShutdwn</th> <th>Drv Enable</th> <th>Main Action</th> </tr> </thead> <tbody> <tr> <td>Default</td> <td>0</td> <td>0</td> <td>0</td> <td>0</td> <td>0</td> <td>0</td> <td>0</td> <td>0</td> <td>0</td> <td>0</td> <td>0</td> <td>0</td> <td>0</td> <td>0</td> <td>0</td> <td>0</td> <td>0</td> <td>0</td> <td>0</td> <td>0</td> <td>0</td> <td>0</td> <td>0</td> <td>0</td> <td>0</td> <td>0</td> <td>0</td> <td>0</td> <td>0</td> <td>0</td> <td>0</td> <td>0</td> <td>0</td> </tr> <tr> <td>Bit</td> <td>31</td> <td>30</td> <td>29</td> <td>28</td> <td>27</td> <td>26</td> <td>25</td> <td>24</td> <td>23</td> <td>22</td> <td>21</td> <td>20</td> <td>19</td> <td>18</td> <td>17</td> <td>16</td> <td>15</td> <td>14</td> <td>13</td> <td>12</td> <td>11</td> <td>10</td> <td>9</td> <td>8</td> <td>7</td> <td>6</td> <td>5</td> <td>4</td> <td>3</td> <td>2</td> <td>1</td> <td>0</td> </tr> </tbody> </table> <p>0 = False 1 = True</p>	Options	Reserved	Reserved	Reserved	Reserved	Reserved	Reserved	Reserved	Reserved	Reserved	Reserved	Reserved	Reserved	Reserved	Reserved	AxisShdnwC1	Reserved	Chng Ref	Reserved	Reserved	Course Updt	CST Updt Err	-Hrd OvrTrvl	+Hrd OvrTrvl	-Sft OvrTrvl	+Sft OvrTrvl	Reserved	Reserved	Reserved	Posit Lock	AxisShutdwn	Drv Enable	Main Action	Default	0	0	0	0	0	0	0	0	0	0	0	0	0	0	0	0	0	0	0	0	0	0	0	0	0	0	0	0	0	0	0	0	0	Bit	31	30	29	28	27	26	25	24	23	22	21	20	19	18	17	16	15	14	13	12	11	10	9	8	7	6	5	4	3	2	1	0			
Options	Reserved	Reserved	Reserved	Reserved	Reserved	Reserved	Reserved	Reserved	Reserved	Reserved	Reserved	Reserved	Reserved	Reserved	AxisShdnwC1	Reserved	Chng Ref	Reserved	Reserved	Course Updt	CST Updt Err	-Hrd OvrTrvl	+Hrd OvrTrvl	-Sft OvrTrvl	+Sft OvrTrvl	Reserved	Reserved	Reserved	Posit Lock	AxisShutdwn	Drv Enable	Main Action																																																																									
Default	0	0	0	0	0	0	0	0	0	0	0	0	0	0	0	0	0	0	0	0	0	0	0	0	0	0	0	0	0	0	0	0	0																																																																								
Bit	31	30	29	28	27	26	25	24	23	22	21	20	19	18	17	16	15	14	13	12	11	10	9	8	7	6	5	4	3	2	1	0																																																																									
905	Motn AxisControl Command request bits from the Motion Planner to both the Servo and Feedback Only axis.	<table border="1"> <thead> <tr> <th>Options</th> <th>ChngCmdRefC1</th> <th>Reserved</th> <th>Reserved</th> <th>Reserved</th> <th>Reserved</th> <th>Reserved</th> <th>Reserved</th> <th>Reserved</th> <th>Reserved</th> <th>Reserved</th> <th>Reserved</th> <th>Reserved</th> <th>Reserved</th> <th>Reserved</th> <th>Reserved</th> <th>Reserved</th> <th>Reserved</th> <th>Reserved</th> <th>Reserved</th> <th>Reserved</th> <th>Reserved</th> <th>Reserved</th> <th>Reserved</th> <th>Reserved</th> <th>Reserved</th> <th>Reserved</th> <th>Reserved</th> <th>Reserved</th> <th>Reserved</th> <th>Reserved</th> <th>Reserved</th> <th>Reserved</th> </tr> </thead> <tbody> <tr> <td>Default</td> <td>0</td> <td>0</td> <td>0</td> <td>0</td> <td>0</td> <td>0</td> <td>0</td> <td>0</td> <td>0</td> <td>0</td> <td>0</td> <td>0</td> <td>0</td> <td>0</td> <td>0</td> <td>0</td> <td>0</td> <td>0</td> <td>0</td> <td>0</td> <td>0</td> <td>0</td> <td>0</td> <td>0</td> <td>0</td> <td>0</td> <td>0</td> <td>0</td> <td>0</td> <td>0</td> <td>0</td> <td>0</td> </tr> <tr> <td>Bit</td> <td>31</td> <td>30</td> <td>29</td> <td>28</td> <td>27</td> <td>26</td> <td>25</td> <td>24</td> <td>23</td> <td>22</td> <td>21</td> <td>20</td> <td>19</td> <td>18</td> <td>17</td> <td>16</td> <td>15</td> <td>14</td> <td>13</td> <td>12</td> <td>11</td> <td>10</td> <td>9</td> <td>8</td> <td>7</td> <td>6</td> <td>5</td> <td>4</td> <td>3</td> <td>2</td> <td>1</td> <td>0</td> </tr> </tbody> </table> <p>0 = False 1 = True</p>	Options	ChngCmdRefC1	Reserved	Reserved	Reserved	Reserved	Reserved	Reserved	Reserved	Reserved	Reserved	Reserved	Reserved	Reserved	Reserved	Reserved	Reserved	Reserved	Reserved	Reserved	Reserved	Reserved	Reserved	Reserved	Reserved	Reserved	Reserved	Reserved	Reserved	Reserved	Reserved	Reserved	Reserved	Default	0	0	0	0	0	0	0	0	0	0	0	0	0	0	0	0	0	0	0	0	0	0	0	0	0	0	0	0	0	0	0	0	Bit	31	30	29	28	27	26	25	24	23	22	21	20	19	18	17	16	15	14	13	12	11	10	9	8	7	6	5	4	3	2	1	0				
Options	ChngCmdRefC1	Reserved	Reserved	Reserved	Reserved	Reserved	Reserved	Reserved	Reserved	Reserved	Reserved	Reserved	Reserved	Reserved	Reserved	Reserved	Reserved	Reserved	Reserved	Reserved	Reserved	Reserved	Reserved	Reserved	Reserved	Reserved	Reserved	Reserved	Reserved	Reserved	Reserved	Reserved																																																																									
Default	0	0	0	0	0	0	0	0	0	0	0	0	0	0	0	0	0	0	0	0	0	0	0	0	0	0	0	0	0	0	0	0																																																																									
Bit	31	30	29	28	27	26	25	24	23	22	21	20	19	18	17	16	15	14	13	12	11	10	9	8	7	6	5	4	3	2	1	0																																																																									
906	Motn Axis Resp Command response from both the Servo and Feedback Only axis to the Motion Planner.	<table border="1"> <thead> <tr> <th>Options</th> <th>ChngCmdRefC1</th> <th>Reserved</th> <th>Reserved</th> <th>Reserved</th> <th>Reserved</th> <th>Reserved</th> <th>Reserved</th> <th>Reserved</th> <th>Reserved</th> <th>Reserved</th> <th>Reserved</th> <th>Reserved</th> <th>Reserved</th> <th>Reserved</th> <th>Reserved</th> <th>Reserved</th> <th>Reserved</th> <th>Reserved</th> <th>Reserved</th> <th>Reserved</th> <th>Reserved</th> <th>Reserved</th> <th>Reserved</th> <th>Reserved</th> <th>Reserved</th> <th>Reserved</th> <th>Reserved</th> <th>Reserved</th> <th>Reserved</th> <th>Reserved</th> <th>Reserved</th> </tr> </thead> <tbody> <tr> <td>Default</td> <td>0</td> <td>0</td> <td>0</td> <td>0</td> <td>0</td> <td>0</td> <td>0</td> <td>0</td> <td>0</td> <td>0</td> <td>0</td> <td>0</td> <td>0</td> <td>0</td> <td>0</td> <td>0</td> <td>0</td> <td>0</td> <td>0</td> <td>0</td> <td>0</td> <td>0</td> <td>0</td> <td>0</td> <td>0</td> <td>0</td> <td>0</td> <td>0</td> <td>0</td> <td>0</td> <td>0</td> </tr> <tr> <td>Bit</td> <td>31</td> <td>30</td> <td>29</td> <td>28</td> <td>27</td> <td>26</td> <td>25</td> <td>24</td> <td>23</td> <td>22</td> <td>21</td> <td>20</td> <td>19</td> <td>18</td> <td>17</td> <td>16</td> <td>15</td> <td>14</td> <td>13</td> <td>12</td> <td>11</td> <td>10</td> <td>9</td> <td>8</td> <td>7</td> <td>6</td> <td>5</td> <td>4</td> <td>3</td> <td>2</td> <td>1</td> <td>0</td> </tr> </tbody> </table> <p>0 = False 1 = True</p>	Options	ChngCmdRefC1	Reserved	Reserved	Reserved	Reserved	Reserved	Reserved	Reserved	Reserved	Reserved	Reserved	Reserved	Reserved	Reserved	Reserved	Reserved	Reserved	Reserved	Reserved	Reserved	Reserved	Reserved	Reserved	Reserved	Reserved	Reserved	Reserved	Reserved	Reserved	Reserved	Reserved	Default	0	0	0	0	0	0	0	0	0	0	0	0	0	0	0	0	0	0	0	0	0	0	0	0	0	0	0	0	0	0	0	Bit	31	30	29	28	27	26	25	24	23	22	21	20	19	18	17	16	15	14	13	12	11	10	9	8	7	6	5	4	3	2	1	0						
Options	ChngCmdRefC1	Reserved	Reserved	Reserved	Reserved	Reserved	Reserved	Reserved	Reserved	Reserved	Reserved	Reserved	Reserved	Reserved	Reserved	Reserved	Reserved	Reserved	Reserved	Reserved	Reserved	Reserved	Reserved	Reserved	Reserved	Reserved	Reserved	Reserved	Reserved	Reserved	Reserved																																																																										
Default	0	0	0	0	0	0	0	0	0	0	0	0	0	0	0	0	0	0	0	0	0	0	0	0	0	0	0	0	0	0	0																																																																										
Bit	31	30	29	28	27	26	25	24	23	22	21	20	19	18	17	16	15	14	13	12	11	10	9	8	7	6	5	4	3	2	1	0																																																																									

No.	Name Description	Values	Linkable	Read-Write	Data Type
922	Motn TP Select Selector for diagnostic testpoint relating to Motion functionality.	0 "ServoAxisCnfg" 0 "ServoAxisCnfg" 16 ""CST Upper" 1 "ServoAxisUnwd" 17 "Reserved" 2 "Marker Dist" 18 "Reserved" 3 "HomeEvent X" 19 "I/O Rx Seq#" 4 "Watch Posit" 20 "I/O Rx Msg#" 5 "Home Posit" 21 "I/O Tx Msg#" 6 "SrvoMRP Ofst" 22 "Syn Rx Seq#" 7 "SrvoAct Ofst" 23 "Syn RxMsg#" 8 "PositRegis 1" 24 "Syn Tx Msg#" 9 "PositRegis 2" 25 "Evt Rx Seq#" 10 "FdbkAxisCnfg" 26 "Evt Rx Msg#" 11 "FdbkAxisUnwd" 27 "Evt Rx Tx Msg#" 12 "FdbkMRP Ofst" 28 "Asy Rx Seq#" 13 "FdbkAct Ofst" 29 "Asy Rx Msg#" 14 "TimeEvtStat" 30 "Asy Tx Msg#" 15 "CST Lower" 31 "Reset Msg#"			
923	Motn TP Value Data for diagnostic testpoint relating to Motion functionality.	Default: 0 Min/Max: -/+2147483648			DWord
924	Motn RotaryCmmd Position command input from the Motion Planner to the Servo axis when configured in rotary mode.	Default: 0 Min/Max: -/+2147483648			DWord
925	MotnUnwdTurnCmmd Position unwind turns command input from the Motion Planner to the Servo axis when configured in rotary mode.	Default: 0 Min/Max: -/+32768			Word
926	SrvoAxis RotFdbk Position feedback output to the Motion Planner for the Servo axis when configured in rotary mode.	Default: 0 Min/Max: -/+2147483648			DWord
927	SrvoAxisUnwdFdbk Position unwind feedback output to the Motion Planner for the Servo axis when configured in rotary mode.	Default: 0 Min/Max: -/+32768			Word
928	FdbkAxis RotFdbk Position feedback output to the Motion Planner for the Feedback Only axis when configured in rotary mode.	Default: 0 Min/Max: -/+2147483648			DWord
929	FdbkAxisUnwdFdbk Position unwind feedback output to the Motion Planner for the Feedback Only axis when configured in rotary mode.	Default: 0 Min/Max: -/+32768			Word
930	MotnCnfgErrParam Indicates a parameter that is not configured properly for a motion connection to be accepted. Parameter could either have a wrong value or an incorrect link. When bit 0 [Config OK] of Par 907 [Motn Cnct Status] is set, then this parameter contains the parameter number of an incorrectly configured parameter. If more than one parameter is incorrectly configured, they are displayed after others are fixed. If there are no configuration problems relating to Motion, then this parameter contains the value of zero and bit 0 [Config OK] of Par 907 is cleared.	Default: 0 Min/Max: 0/65535			Word
940 941	+Sft OvrTrvlCnfg -Sft OvrTrvlCnfg Synchronization input to the Interpolator has been lost or has become excessively irregular. <ul style="list-style-type: none"> 0 "Ignore" - configures the drive to continue running, as normal, when this event occurs 1 "Alarm" - configures the drive to continue running and set the appropriate alarm bit when this event occurs 2 "FltCoastStop" - configures the drive to perform a coast stop and set the appropriate fault bit, in response this event. 3 "Flt RampStop" - configures the drive to perform a ramp stop and set the appropriate fault bit, in response this event. 4 "FltCurLimStp" - configures the drive to perform a current-limit stop and set the appropriate fault bit, in response this event. 	Default: 1 "Alarm" Options: 0 "Ignore" 1 "Alarm" 2 "FltCoastStop" 3 "Flt RampStop" 4 "FltCurLimStp"			
942 943	+Hrd OvrTrvlCnfg -Hrd OvrTrvlCnfg Active signal from a digital input that is configured as a positive hard overtravel input. <ul style="list-style-type: none"> 0 "Ignore" - configures the drive to continue running, as normal, when this event occurs 1 "Alarm" - configures the drive to continue running and set the appropriate alarm bit when this event occurs 2 "FltCoastStop" - configures the drive to perform a coast stop and set the appropriate fault bit, in response this event. 3 "Flt RampStop" - configures the drive to perform a ramp stop and set the appropriate fault bit, in response this event. 4 "FltCurLimStp" - configures the drive to perform a current-limit stop and set the appropriate fault bit, in response this event. 	Default: 1 "Alarm" Options: 0 "Ignore" 1 "Alarm" 2 "FltCoastStop" 3 "Flt RampStop" 4 "FltCurLimStp"			

No.	Name Description	Values	Linkable	Read-Write	Data Type	
1013	SL Rx DirectSel2 Determines the destination for the data received at word 2 of direct received data. Configure the selection by using the Peer Communication window in the DriveExecutive programming software.	Default: 0 "No Data" Options: 0 "No Data" 6 "Reserved" 1 "SL Multiply" 7 "Reserved" 2 "Event P0" 8 "Event Opt0" 3 "Reserved" 9 "Reserved" 4 "Reserved" 10 "Event Status" 5 "Reserved"				
1014	SL Rx DirectSel3 Determines the destination for the data received at word 3 of direct received data. Configure the selection by using the Peer Communication window in the DriveExecutive programming software.	Default: 0 "No Data" Options: 0 "No Data" 6 "Reserved" 1 "SL Multiply" 7 "Reserved" 2 "Event P0" 8 "Event Opt0" 3 "Reserved" 9 "Reserved" 4 "Reserved" 10 "Event Status" 5 "Reserved"				
1020	SL Tx Comm Frmt Defines the node's communication format for transmitting SynchLink data. This determines the number of axis data words, direct data words and buffered data words transmitted. Configure the format by using the Peer Communication window in the DriveExecutive programming software.	Options	Value	Axis	Direct	Buffered
			0	0	0	0
			7	0	2	18
			9	0	4	8
			17	0	4	18
1021	SL Tx DirectSel0 Determines the source type for the data transmitted by direct transmit word 0. The source type selections are: no data, event, feedback and drive parameter. If drive parameter is selected, a parameter of the appropriate data format (integer or real) must be linked to Parameter 1141 [SL Dir Int Tx0] or Parameter 1142 [SL Dir Real Tx0]. Configure the selection by using the Peer Communication window in the DriveExecutive programming software.	Default: 0 "No Data" Options: 0 "No Data" 14 "Reserved" 1 "SL Multiply" 15 "Reserved" 2 "Event P0" 16 "Reserved" 3 "Event P1" 17 "Reserved" 4 "Reserved" 18 "Reserved" 5 "Reserved" 19 "Reserved" 6 "Reserved" 20 "Reserved" 7 "Reserved" 21 "Dir Tx Data" 8 "Event Opt0" 22 "Dir Rx Data" 9 "Reserved" 23 "E0 Accum" 10 "Event Status" 24 "E1 Accum" 11 "Reserved" 25 "Opt0 Accum" 12 "Reserved" 26 "Opt1 Accum" 13 "Reserved"				
1022	SL Tx DirectSel1 Determines the source type for the data transmitted by direct transmit word 1. The source type selections are: no data, event, feedback and drive parameter. If drive parameter is selected, a parameter of the appropriate data format (integer or real) must be linked to Par 1143 [SL Dir Int Tx1] or Par 1144 [SL Dir Real Tx1]. Configure the selection by using the Peer Communication window in the DriveExecutive programming software.	Default: 0 "No Data" Options: 0 "No Data" 14 "Reserved" 1 "SL Multiply" 15 "Reserved" 2 "Event P0" 16 "Reserved" 3 "Event P1" 17 "Reserved" 4 "Reserved" 18 "Reserved" 5 "Reserved" 19 "Reserved" 6 "Reserved" 20 "Reserved" 7 "Reserved" 21 "Dir Tx Data" 8 "Event Opt0" 22 "Dir Rx Data" 9 "Reserved" 23 "E0 Accum" 10 "Event Status" 24 "E1 Accum" 11 "Reserved" 25 "Opt0 Accum" 12 "Reserved" 26 "Opt1 Accum" 13 "Reserved"				
1023	SL Tx DirectSel2 Determines the source type for the data transmitted by direct transmit word 2. The source type selections are: no data, event, feedback and drive parameter. If drive parameter is selected, a parameter of the appropriate data format (integer or real) must be linked to Parameter 1145 [SL Dir Int Tx2] or Parameter 1146 [SL Dir Real Tx2]. Configure the selection by using the Peer Communication window in the DriveExecutive programming software.	Default: 0 "No Data" Options: 0 "No Data" 14 "Reserved" 1 "SL Multiply" 15 "Reserved" 2 "Event P0" 16 "Reserved" 3 "Event P1" 17 "Reserved" 4 "Reserved" 18 "Reserved" 5 "Reserved" 19 "Reserved" 6 "Reserved" 20 "Reserved" 7 "Reserved" 21 "Dir Tx Data" 8 "Event Opt0" 22 "Dir Rx Data" 9 "Reserved" 23 "E0 Accum" 10 "Event Status" 24 "E1 Accum" 11 "Reserved" 25 "Opt0 Accum" 12 "Reserved" 26 "Opt1 Accum" 13 "Reserved"				

No.	Name Description	Values	Linkable	Read-Write	Data Type
1078	SL Buf Real Rx02 Displays the floating point (real) value of the Buffered Received Data for word 2. Data transmitted from one node to another must be the same data type. This parameter is paired with Par 1077 [SL Buf Int Rx02].	Default: 0.0000 Min/Max: -/+2200000000.0000			Real
1079	SL Buf Int Rx03 Displays the integer value of the Buffered Received Data for word 3. Data transmitted from one node to another must be the same data type. This parameter is paired with Par 1080 [SL Buf Real Rx03].	Default: 0 Min/Max: -/+2147483648			32-bit Integer
1080	SL Buf Real Rx03 Displays the floating point (real) value of the Buffered Received Data for word 3. Data transmitted from one node to another must be the same data type. This parameter is paired with Par 1079 [SL Buf Int Rx03].	Default: 0.0000 Min/Max: -/+2200000000.0000			Real
1081	SL Buf Int Rx04 Displays the integer value of the Buffered Received Data for word 4. Data transmitted from one node to another must be the same data type. This parameter is paired with Par 1082 [SL Buf Real Rx04].	Default: 0 Min/Max: -/+2147483648			32-bit Integer
1082	SL Buf Real Rx04 Displays the floating point (real) value of the Buffered Received Data for word 4. Data transmitted from one node to another must be the same data type. This parameter is paired with Par 1081 [SL Buf Int Rx04].	Default: 0.0000 Min/Max: -/+2200000000.0000			Real
1083	SL Buf Int Rx05 Displays the integer value of the Buffered Received Data for word 5. Data transmitted from one node to another must be the same data type. This parameter is paired with Par 1084 [SL Buf Real Rx05].	Default: 0 Min/Max: -/+2147483648			32-bit Integer
1084	SL Buf Real Rx05 Displays the floating point (real) value of the Buffered Received Data for word 5. Data transmitted from one node to another must be the same data type. This parameter is paired with Par 1083 [SL Buf Int Rx05].	Default: 0.0000 Min/Max: -/+2200000000.0000			Real
1085	SL Buf Int Rx06 Displays the integer value of the Buffered Received Data for word 6. Data transmitted from one node to another must be the same data type. This parameter is paired with Par 1086 [SL Buf Real Rx06].	Default: 0 Min/Max: -/+2147483648			32-bit Integer
1086	SL Buf Real Rx06 Displays the floating point (real) value of the Buffered Received Data for word 6. Data transmitted from one node to another must be the same data type. This parameter is paired with Par 1085 [SL Buf Int Rx06].	Default: 0.0000 Min/Max: -/+2200000000.0000			Real
1087	SL Buf Int Rx07 Displays the integer value of the Buffered Received Data for word 7. Data transmitted from one node to another must be the same data type. This parameter is paired with Par 1088 [SL Buf Real Rx07].	Default: 0 Min/Max: -/+2147483648			32-bit Integer
1088	SL Buf Real Rx07 Displays the floating point (real) value of the Buffered Received Data for word 7. Data transmitted from one node to another must be the same data type. This parameter is paired with Par 1087 [SL Buf Int Rx07].	Default: 0.0000 Min/Max: -/+2200000000.0000			Real
1089	SL Buf Int Rx08 Displays the integer value of the Buffered Received Data for word 8. Data transmitted from one node to another must be the same data type. This parameter is paired with Par 1090 [SL Buf Real Rx08].	Default: 0 Min/Max: -/+2147483648			32-bit Integer
1090	SL Buf Real Rx08 Displays the floating point (real) value of the Buffered Received Data for word 8. Data transmitted from one node to another must be the same data type. This parameter is paired with Par 1089 [SL Buf Int Rx08].	Default: 0.0000 Min/Max: -/+2200000000.0000			Real
1091	SL Buf Int Rx09 Displays the integer value of the Buffered Received Data for word 9. Data transmitted from one node to another must be the same data type. This parameter is paired with Par 1092 [SL Buf Real Rx09].	Default: 0 Min/Max: -/+2147483648			32-bit Integer
1092	SL Buf Real Rx09 Displays the floating point (real) value of the Buffered Received Data for word 9. Data transmitted from one node to another must be the same data type. This parameter is paired with Par 1091 [SL Buf Int Rx09].	Default: 0.0000 Min/Max: -/+2200000000.0000			Real
1093	SL Buf Int Rx10 Displays the integer value of the Buffered Received Data for word 10. Data transmitted from one node to another must be the same data type. This parameter is paired with Par 1094 [SL Buf Real Rx10].	Default: 0 Min/Max: -/+2147483648			32-bit Integer
1094	SL Buf Real Rx10 Displays the floating point (real) value of the Buffered Received Data for word 10. Data transmitted from one node to another must be the same data type. This parameter is paired with Par 1093 [SL Buf Int Rx10].	Default: 0.0000 Min/Max: -/+2200000000.0000			Real
1095	SL Buf Int Rx11 Displays the integer value of the Buffered Received Data for word 11. Data transmitted from one node to another must be the same data type. This parameter is paired with Par 1096 [SL Buf Real Rx11].	Default: 0 Min/Max: -/+2147483648			32-bit Integer

No.	Name Description	Values	Linkable	Read-Write	Data Type
1096	SL Buf Real Rx11 Displays the floating point (real) value of the Buffered Received Data for word 11. Data transmitted from one node to another must be the same data type. This parameter is paired with Par 1095 [SL Buf Int Rx11].	Default: 0.0000 Min/Max: -/+2200000000.0000			Real
1097	SL Buf Int Rx12 Displays the integer value of the Buffered Received Data for word 12. Data transmitted from one node to another must be the same data type. This parameter is paired with Par 1098 [SL Buf Real R12].	Default: 0 Min/Max: -/+2147483648			32-bit Integer
1098	SL Buf Real Rx12 Displays the floating point (real) value of the Buffered Received Data for word 12. Data transmitted from one node to another must be the same data type. This parameter is paired with Par 1097 [SL Buf Int R12].	Default: 0.0000 Min/Max: -/+2200000000.0000			Real
1099	SL Buf Int Rx13 Displays the integer value of the Buffered Received Data for word 13. Data transmitted from one node to another must be the same data type. This parameter is paired with Par 1100 [SL Buf Real R13].	Default: 0 Min/Max: -/+2147483648			32-bit Integer
1100	SL Buf Real Rx13 Displays the floating point (real) value of the Buffered Received Data for word 13. Data transmitted from one node to another must be the same data type. This parameter is paired with Par 1099 [SL Buf Int R13].	Default: 0.0000 Min/Max: -/+2200000000.0000.0000			Real
1101	SL Buf Int Rx14 Displays the integer value of the Buffered Received Data for word 14. Data transmitted from one node to another must be the same data type. his parameter is paired with Par 1102 [SL Buf Real R14].	Default: 0 Min/Max: -/+2147483648			32-bit Integer
1102	SL Buf Real Rx14 Displays the floating point (real) value of the Buffered Received Data for word 14. Data transmitted from one node to another must be the same data type. This parameter is paired with Par 1101 [SL Buf Int R14].	Default: 0.0000 Min/Max: -/+2200000000.0000			Real
1103	SL Buf Int Rx15 Displays the integer value of the Buffered Received Data for word 15. Data transmitted from one node to another must be the same data type. This parameter is paired with Par 1104 [SL Buf Real R15].	Default: 0 Min/Max: -/+2147483648			32-bit Integer
1104	SL Buf Real Rx15 Displays the floating point (real) value of the Buffered Received Data for word 15. Data transmitted from one node to another must be the same data type. This parameter is paired with Par 1103 [SL Buf Int R15].	Default: 0.0000 Min/Max: -/+2200000000.0000			Real
1105	SL Buf Int Rx16 Displays the integer value of the Buffered Received Data for word 16. Data transmitted from one node to another must be the same data type. This parameter is paired with Par 1106 [SL Buf Real Rx16].	Default: 0 Min/Max: -/+2147483648			32-bit Integer
1106	SL Buf Real Rx16 Displays the floating point (real) value of the Buffered Received Data for word 16. Data transmitted from one node to another must be the same data type. This parameter is paired with Par 1105 [SL Buf Int Rx16].	Default: 0.0000 Min/Max: -/+2200000000.0000			Real
1107	SL Buf Int Rx17 Displays the integer value of the Buffered Received Data for word 17. Data transmitted from one node to another must be the same data type. This parameter is paired with Par 1108 [SL Buf Real Rx17].	Default: 0 Min/Max: -/+2147483648			32-bit Integer
1108	SL Buf Real Rx17 Displays the floating point (real) value of the Buffered Received Data for word 17. Data transmitted from one node to another must be the same data type. This parameter is paired with Par 1107 [SL Buf Int Rx17].	Default: 0.0000 Min/Max: -/+2200000000.0000			Real
1109	SL Buf Int Rx18 Displays the integer value of the Buffered Received Data for word 18. Data transmitted from one node to another must be the same data type. This parameter is paired with Par 1110 [SL Buf Real Rx18].	Default: 0 Min/Max: -/+2147483648			32-bit Integer
1110	SL Buf Real Rx18 Displays the floating point (real) value of the Buffered Received Data for word 18. Data transmitted from one node to another must be the same data type. This parameter is paired with Par 1109 [SL Buf Int Rx18].	Default: 0.0000 Min/Max: -/+2200000000.0000			Real
1111	SL Buf Int Rx19 Displays the integer value of the Buffered Received Data for word 19. Data transmitted from one node to another must be the same data type. This parameter is paired with Par 1112 [SL Buf Real Rx19].	Default: 0 Min/Max: -/+2147483648			32-bit Integer
1112	SL Buf Real Rx19 Displays the floating point (real) value of the Buffered Received Data for word 19. Data transmitted from one node to another must be the same data type. This parameter is paired with Par 1111 [SL Buf Int Rx19].	Default: 0.0000 Min/Max: -/+2200000000.0000			Real
1113	SL Buf Int Rx20 Displays the integer value of the Buffered Received Data for word 20. Data transmitted from one node to another must be the same data type. This parameter is paired with Par 1114 [SL Buf Real Rx20].	Default: 0 Min/Max: -/+2147483648			32-bit Integer

No.	Name Description	Values	Linkable	Read-Write	Data Type
1114	SL Buf Real Rx20 Displays the floating point (real) value of the Buffered Received Data for word 20. Data transmitted from one node to another must be the same data type. This parameter is paired with Par 1113 [SL Buf Int Rx20].	Default: 0.0000 Min/Max: -/+2200000000.0000			Real
1115	SL Buf Int Rx21 Displays the integer value of the Buffered Received Data for word 21. Data transmitted from one node to another must be the same data type. This parameter is paired with Par 1116 [SL Buf Real Rx21].	Default: 0 Min/Max: -/+2147483648			32-bit Integer
1116	SL Buf Real Rx21 Displays the floating point (real) value of the Buffered Received Data for word 21. Data transmitted from one node to another must be the same data type. This parameter is paired with Par 1115 [SL Buf Int Rx21].	Default: 0.0000 Min/Max: -/+2200000000.0000			Real
1117	SL Buf Int Rx22 Displays the integer value of the Buffered Received Data for word 22. Data transmitted from one node to another must be the same data type. This parameter is paired with Par 1118 [SL Buf Real Rx22].	Default: 0 Min/Max: -/+2147483648			32-bit Integer
1118	SL Buf Real Rx22 Displays the floating point (real) value of the Buffered Received Data for word 22. Data transmitted from one node to another must be the same data type. This parameter is paired with Par 1117 [SL Buf Int Rx22].	Default: 0.0000 Min/Max: -/+2200000000.0000			Real
1119	SL Buf Int Rx23 Displays the integer value of the Buffered Received Data for word 23. Data transmitted from one node to another must be the same data type. This parameter is paired with Par 1120 [SL Buf Real Rx23].	Default: 0 Min/Max: -/+2147483648			32-bit Integer
1120	SL Buf Real Rx23 Displays the floating point (real) value of the Buffered Received Data for word 23. Data transmitted from one node to another must be the same data type. This parameter is paired with Par 1119 [SL Buf Int Rx23].	Default: 0.0000 Min/Max: -/+2200000000.0000			Real
1121	SL Buf Int Rx24 Displays the integer value of the Buffered Received Data for word 24. Data transmitted from one node to another must be the same data type. This Par is paired with Par 1122 [SL Buf Real Rx24].	Default: 0 Min/Max: -/+2147483648			32-bit Integer
1122	SL Buf Real Rx24 Displays the floating point (real) value of the Buffered Received Data for word 24. Data transmitted from one node to another must be the same data type. This parameter is paired with Par 1121 [SL Buf Int Rx24].	Default: 0.0000 Min/Max: -/+2200000000.0000			Real
1123	SL Buf Int Rx25 Displays the integer value of the Buffered Received Data for word 25. Data transmitted from one node to another must be the same data type. This parameter is paired with Par 1124 [SL Buf Real Rx25].	Default: 0 Min/Max: -/+2147483648			32-bit Integer
1124	SL Buf Real Rx25 Displays the floating point (real) value of the Buffered Received Data for word 25. Data transmitted from one node to another must be the same data type. This parameter is paired with Par 1123 [SL Buf Int Rx25].	Default: 0.0000 Min/Max: -/+2200000000.0000			Real
1125	SL Buf Int Rx26 Displays the integer value of the Buffered Received Data for word 26. Data transmitted from one node to another must be the same data type. This parameter is paired with Par 1126 [SL Buf Real Rx26].	Default: 0 Min/Max: -/+2147483648			32-bit Integer
1126	SL Buf Real Rx26 Displays the floating point (real) value of the Buffered Received Data for word 26. Data transmitted from one node to another must be the same data type. This parameter is paired with Par 1125 [SL Buf Int Rx26].	Default: 0.0000 Min/Max: -/+2200000000.0000			Real
1127	SL Buf Int Rx27 Displays the integer value of the Buffered Received Data for word 27. Data transmitted from one node to another must be the same data type. This parameter is paired with Par 1128 [SL Buf Real Rx27].	Default: 0 Min/Max: -/+2147483648			32-bit Integer
1128	SL Buf Real Rx27 Displays the floating point (real) value of the Buffered Received Data for word 27. Data transmitted from one node to another must be the same data type. This parameter is paired with Par 1127 [SL Buf Int Rx27].	Default: 0.0000 Min/Max: -/+2200000000.0000			Real
1129	SL Buf Int Rx28 Displays the integer value of the Buffered Received Data for word 28. Data transmitted from one node to another must be the same data type. This parameter is paired with Par 1130 [SL Buf Real Rx28].	Default: 0 Min/Max: -/+2147483648			32-bit Integer
1130	SL Buf Real Rx28 Displays the floating point (real) value of the Buffered Received Data for word 28. Data transmitted from one node to another must be the same data type. This parameter is paired with Par 1129 [SL Buf Int Rx28].	Default: 0.0000 Min/Max: -/+2200000000.0000			Real
1131	SL Buf Int Rx29 Displays the integer value of the Buffered Received Data for word 29. Data transmitted from one node to another must be the same data type. This parameter is paired with Par 1132 [SL Buf Real Rx29].	Default: 0 Min/Max: -/+2147483648			32-bit Integer

No.	Name Description	Value	Linkable	Read-Write	Data Type
1167	SL Buf Int Tx03 Provides integer data for Direct Transmit word 3, if the data type for word 3 indicated in Par 1160 [Tx Buf Data Type] is integer.	Default: 0 Min/Max: -/+2147483648	✓	✓	32-bit Integer
1168	SL Buf Real Tx03 Provides floating point (real) data for Direct Transmit word 3, if the data type for word 3 indicated in Par 1160 [Tx Buf Data Type] is real.	Default: 0.0000 Min/Max: -/+2200000000.0000	✓	✓	Real
1169	SL Buf Int Tx04 Provides integer data for Direct Transmit word 4, if the data type for word 4 indicated in Par 1160 [Tx Buf Data Type] is integer.	Default: 0 Min/Max: -/+2147483648	✓	✓	32-bit Integer
1170	SL Buf Real Tx04 Provides floating point (real) data for Direct Transmit word 4, if the data type for word 4 indicated in Par 1160 [Tx Buf Data Type] is real.	Default: 0.0000 Min/Max: -/+2200000000.0000	✓	✓	Real
1171	SL Buf Int Tx05 Provides integer data for Direct Transmit word 5, if the data type for word 5 indicated in Par 1160 [Tx Buf Data Type] is integer.	Default: 0 Min/Max: -/+2147483648	✓	✓	32-bit Integer
1172	SL Buf Real Tx05 Provides floating point (real) data for Direct Transmit word 5, if the data type for word 5 indicated in Par 1160 [Tx Buf Data Type] is real.	Default: 0.0000 Min/Max: -/+2200000000.0000	✓	✓	Real
1173	SL Buf Int Tx06 Provides integer data for Direct Transmit word 6, if the data type for word 6 indicated in Par 1160 [Tx Buf Data Type] is integer.	Default: 0 Min/Max: -/+2147483648	✓	✓	32-bit Integer
1174	SL Buf Real Tx06 Provides floating point (real) data for Direct Transmit word 6, if the data type for word 6 indicated in Par 1160 [Tx Buf Data Type] is real.	Default: 0.0000 Min/Max: -/+2200000000.0000	✓	✓	Real
1175	SL Buf Int Tx07 Provides integer data for Direct Transmit word 7, if the data type for word 7 indicated in Par 1160 [Tx Buf Data Type] is integer.	Default: 0 Min/Max: -/+2147483648	✓	✓	32-bit Integer
1176	SL Buf Real Tx07 Provides floating point (real) data for Direct Transmit word 7, if the data type for word 7 indicated in Par 1160 [Tx Buf Data Type] is real.	Default: 0.0000 Min/Max: -/+2200000000.0000	✓	✓	Real
1177	SL Buf Int Tx08 Provides integer data for Direct Transmit word 8, if the data type for word 8 indicated in Par 1160 [Tx Buf Data Type] is integer.	Default: 0 Min/Max: -/+2147483648	✓	✓	32-bit Integer
1178	SL Buf Real Tx08 Provides floating point (real) data for Direct Transmit word 8, if the data type for word 8 indicated in Par 1160 [Tx Buf Data Type] is real.	Default: 0.0000 Min/Max: -/+2200000000.0000	✓	✓	Real
1179	SL Buf Int Tx09 Provides integer data for Direct Transmit word 9, if the data type for word 9 indicated in Par 1160 [Tx Buf Data Type] is integer.	Default: 0 Min/Max: -/+2147483648	✓	✓	32-bit Integer
1180	SL Buf Real Tx09 Provides floating point (real) data for Direct Transmit word 9, if the data type for word 9 indicated in Par 1160 [Tx Buf Data Type] is real.	Default: 0.0000 Min/Max: -/+2200000000.0000	✓	✓	Real
1181	SL Buf Int Tx10 Provides integer data for Direct Transmit word 10, if the data type for word 10 indicated in Par 1160 [Tx Buf Data Type] is integer.	Default: 0 Min/Max: -/+2147483648	✓	✓	32-bit Integer
1182	SL Buf Real Tx10 Provides floating point (real) data for Direct Transmit word 10, if the data type for word 10 indicated in Par 1160 [Tx Buf Data Type] is real.	Default: 0.0000 Min/Max: -/+2200000000.0000	✓	✓	Real
1183	SL Buf Int Tx11 Provides integer data for Direct Transmit word 11, if the data type for word 11 indicated in Par 1160 [Tx Buf Data Type] is integer.	Default: 0 Min/Max: -/+2147483648	✓	✓	32-bit Integer
1184	SL Buf Real Tx11 Provides floating point (real) data for Direct Transmit word 11, if the data type for word 11 indicated in Par 1160 [Tx Buf Data Type] is real.	Default: 0.0000 Min/Max: -/+2200000000.0000	✓	✓	Real
1185	SL Buf Int Tx12 Provides integer data for Direct Transmit word 12, if the data type for word 12 indicated in Par 1160 [Tx Buf Data Type] is integer.	Default: 0 Min/Max: -/+2147483648	✓	✓	32-bit Integer
1186	SL Buf Real Tx12 Provides floating point (real) data for Direct Transmit word 12, if the data type for word 12 indicated in Par 1160 [Tx Buf Data Type] is real.	Default: 0.0000 Min/Max: -/+2200000000.0000	✓	✓	Real
1187	SL Buf Int Tx13 Provides integer data for Direct Transmit word 13, if the data type for word 13 indicated in Par 1160 [Tx Buf Data Type] is integer.	Default: 0 Min/Max: -/+2147483648	✓	✓	32-bit Integer
1188	SL Buf Real Tx13 Provides floating point (real) data for Direct Transmit word 13, if the data type for word 13 indicated in Par 1160 [Tx Buf Data Type] is real.	Default: 0.0000 Min/Max: -/+2200000000.0000	✓	✓	Real
1189	SL Buf Int Tx14 Provides integer data for Direct Transmit word 14, if the data type for word 14 indicated in Par 1160 [Tx Buf Data Type] is integer.	Default: 0 Min/Max: -/+2147483648	✓	✓	32-bit Integer

No.	Name Description	Value	Linkable	Read-Write	Data Type
1190	SL Buf Real Tx14 Provides floating point (real) data for Direct Transmit word 14, if the data type for word 14 indicated in Par 1160 [Tx Buf Data Type] is real.	Default: 0.0000 Min/Max: -/+2200000000.0000	✓	✓	Real
1191	SL Buf Int Tx15 Provides integer data for Direct Transmit word 15, if the data type for word 15 indicated in Par 1160 [Tx Buf Data Type] is integer.	Default: 0 Min/Max: -/+2147483648	✓	✓	32-bit Integer
1192	SL Buf Real Tx15 Provides floating point (real) data for Direct Transmit word 15, if the data type for word 15 indicated in Par 1160 [Tx Buf Data Type] is real.	Default: 0.0000 Min/Max: -/+2200000000.0000	✓	✓	Real
1193	SL Buf Int Tx16 Provides integer data for Direct Transmit word 16, if the data type for word 16 indicated in Par 1160 [Tx Buf Data Type] is integer.	Default: 0 Min/Max: -/+2147483648	✓	v	32-bit Integer
1194	SL Buf Real Tx16 Provides floating point (real) data for Direct Transmit word 16, if the data type for word 16 indicated in Par 1160 [Tx Buf Data Type] is real.	Default: 0.0000 Min/Max: -/+2200000000.0000	✓	✓	Real
1195	SL Buf Int Tx17 Provides integer data for Direct Transmit word 17, if the data type for word 17 indicated in Par 1160 [Tx Buf Data Type] is integer.	Default: 0 Min/Max: -/+2147483648	✓	✓	32-bit Integer
1196	SL Buf Real Tx17 Provides floating point (real) data for Direct Transmit word 17, if the data type for word 17 indicated in Par 1160 [Tx Buf Data Type] is real.	Default: 0.0000 Min/Max: -/+2200000000.0000	✓	✓	Real
1197	SL Buf Int Tx18 Provides integer data for Direct Transmit word 18, if the data type for word 18 indicated in Par 1160 [Tx Buf Data Type] is integer.	Default: 0 Min/Max: -/+2147483648	✓	✓	32-bit Integer
1198	SL Buf Real Tx18 Provides floating point (real) data for Direct Transmit word 18, if the data type for word 18 indicated in Par 1160 [Tx Buf Data Type] is real.	Default: 0.0000 Min/Max: -/+2200000000.0000	✓	✓	Real
1199	SL Buf Int Tx19 Provides integer data for Direct Transmit word 19, if the data type for word 19 indicated in Par 1160 [Tx Buf Data Type] is integer.	Default: 0 Min/Max: -/+2147483648	✓	✓	32-bit Integer
1200	SL Buf Real Tx19 Provides floating point (real) data for Direct Transmit word 19, if the data type for word 19 indicated in Par 1160 [Tx Buf Data Type] is real.	Default: 0.0000 Min/Max: -/+2200000000.0000	✓	✓	Real
1201	SL Buf Int Tx20 Provides integer data for Direct Transmit word 20, if the data type for word 20 indicated in Par 1160 [Tx Buf Data Type] is integer.	Default: 0 Min/Max: -/+2147483648	✓	✓	32-bit Integer
1202	SL Buf Real Tx20 Provides floating point (real) data for Direct Transmit word 20, if the data type for word 20 indicated in Par 1160 [Tx Buf Data Type] is real.	Default: 0.0000 Min/Max: -/+2200000000.0000	✓	v	Real
1203	SL Buf Int Tx21 Provides integer data for Direct Transmit word 21, if the data type for word 21 indicated in Par 1160 [Tx Buf Data Type] is integer.	Default: 0 Min/Max: -/+2147483648	✓	✓	32-bit Integer
1204	SL Buf Real Tx21 Provides floating point (real) data for Direct Transmit word 21, if the data type for word 21 indicated in Par 1160 [Tx Buf Data Type] is real.	Default: 0.0000 Min/Max: -/+2200000000.0000	✓	✓	Real
1205	SL Buf Int Tx22 Provides integer data for Direct Transmit word 22, if the data type for word 22 (indicated in Par 1160 [Tx Buf Data Type]) is integer.	Default: 0 Min/Max: -/+2147483648	✓	✓	32-bit Integer
1206	SL Buf Real Tx22 Provides floating point (real) data for Direct Transmit word 22, if the data type for word 22 (indicated in Par 1160 [Tx Buf Data Type]) is real.	Default: 0.0000 Min/Max: -/+2200000000.0000	✓	✓	Real
1207	SL Buf Int Tx23 Provides integer data for Direct Transmit word 23, if the data type for word 23 indicated in Par 1160 [Tx Buf Data Type] is integer.	Default: 0 Min/Max: -/+2147483648	✓	✓	32-bit Integer
1208	SL Buf Real Tx23 Provides floating point (real) data for Direct Transmit word 23, if the data type for word 23 indicated in Par 1160 [Tx Buf Data Type] is real.	Default: 0.0000 Min/Max: -/+2200000000.0000	✓	✓	Real
1209	SL Buf Int Tx24 Provides integer data for Direct Transmit word 24, if the data type for word 24 indicated in Par 1160 [Tx Buf Data Type] is integer.	Default: 0 Min/Max: -/+2147483648	✓	✓	32-bit Integer
1210	SL Buf Real Tx24 Provides floating point (real) data for Direct Transmit word 24, if the data type for word 24 indicated in Par 1160 [Tx Buf Data Type] is real.	Default: 0.0000 Min/Max: -/+2200000000.0000	✓	✓	Real
1211	SL Buf Int Tx25 Provides integer data for Direct Transmit word 25, if the data type for word 25 indicated in Par 1160 [Tx Buf Data Type] is integer.	Default: 0 Min/Max: -/+2147483648	✓	✓	32-bit Integer
1212	SL Buf Real Tx25 Provides floating point (real) data for Direct Transmit word 25, if the data type for word 25 indicated in Par 1160 [Tx Buf Data Type] is real.	Default: 0.0000 Min/Max: -/+2200000000.0000 Comm Scale: x 1	✓	✓	Real

No.	Name Description	Value	Linkable	Read-Write	Data Type																																																		
1229	<p>SL Error Status Indicates presence of SynchLink faults. This data is visible on the SynchLink diagnostics tab of the Peer Communication window.</p> <ul style="list-style-type: none"> • Bit 0 [Sync Loss] indicates SynchLink communication has failed, after it had been established • Bit 1 [Rx Loss] indicates the receive port is not receiving data, and the receive port configuration is set to receive data • Bit 2 [Many BOF Err] indicates the number of Beginning Of Frame (BOF) errors exceeds limit set by Par 1235 [SL BOF Err Limit] • Bit 3 [Many CRC Err] indicates the number of Cyclic Redundancy Check (CRC) errors exceeds limit set by Par 1234 [SL CRC Err Limit] • Bit 4 [Pckg Msg Err] indicates the received package sequence number has not matched for 1.0S • Bit 5 [CommForm Err] indicates the format of received data does not match the configuration of the receive port • Bit 6 [Sys Rev Err] indicates the system revision in the received data does not match the value of Par 1001 [SynchLink Rev] • Bit 7 [Mult TKeeper] indicates more than one node on the SynchLink system is configured as a time keeper <p>Options</p> <table border="1"> <thead> <tr> <th></th> <th>Reserved</th> <th>Reserved</th> <th>Reserved</th> <th>Reserved</th> <th>Reserved</th> <th>Reserved</th> <th>Reserved</th> <th>Reserved</th> <th>Mult TKeeper</th> <th>Sys Rev Err</th> <th>CommForm Err</th> <th>Pckg Msg Err</th> <th>Many CRC Err</th> <th>Many BOF Err</th> <th>Rx Loss</th> <th>Sync Loss</th> </tr> </thead> <tbody> <tr> <td>Default</td> <td>0</td> <td>0</td> <td>0</td> <td>0</td> <td>0</td> <td>0</td> <td>0</td> <td>0</td> <td>0</td> <td>0</td> <td>0</td> <td>0</td> <td>0</td> <td>0</td> <td>0</td> <td>0</td> </tr> <tr> <td>Bit</td> <td>15</td> <td>14</td> <td>13</td> <td>12</td> <td>11</td> <td>10</td> <td>9</td> <td>8</td> <td>7</td> <td>6</td> <td>5</td> <td>4</td> <td>3</td> <td>2</td> <td>1</td> <td>0</td> </tr> </tbody> </table> <p>0 = False 1 = True</p>		Reserved	Reserved	Reserved	Reserved	Reserved	Reserved	Reserved	Reserved	Mult TKeeper	Sys Rev Err	CommForm Err	Pckg Msg Err	Many CRC Err	Many BOF Err	Rx Loss	Sync Loss	Default	0	0	0	0	0	0	0	0	0	0	0	0	0	0	0	0	Bit	15	14	13	12	11	10	9	8	7	6	5	4	3	2	1	0			
	Reserved	Reserved	Reserved	Reserved	Reserved	Reserved	Reserved	Reserved	Mult TKeeper	Sys Rev Err	CommForm Err	Pckg Msg Err	Many CRC Err	Many BOF Err	Rx Loss	Sync Loss																																							
Default	0	0	0	0	0	0	0	0	0	0	0	0	0	0	0	0																																							
Bit	15	14	13	12	11	10	9	8	7	6	5	4	3	2	1	0																																							
1230	<p>SL CRC Err Accum Displays the total accumulated number of CRC errors. Clearing a CRC fault resets this accumulator. This data is visible on the SynchLink diagnostics tab of the Peer Communication window.</p>	Default: 0 Min/Max: 0/4294967296			32-bit Integer																																																		
1231	<p>SL CRC Error Displays the number of CRC errors that occurred during the last test (last 8 mS). This data is visible on the SynchLink diagnostics tab of the Peer Communication window.</p>	Default: 0 Min/Max: 0/4294967296			32-bit Integer																																																		
1232	<p>SL BOF Err Accum Displays the total accumulated number of BOF errors. Clearing a BOF fault resets this accumulator. This data is visible on the SynchLink diagnostics tab of the Peer Communication window.</p>	Default: 0 Min/Max: 0/4294967296r			32-bit Integer																																																		
1233	<p>SL BOF Error Displays the number of BOF errors that occurred during the last test (last 8 mS). This data is visible on the SynchLink diagnostics tab of the Peer Communication window.</p>	Default: 0 Min/Max: 0/4294967296			32-bit Integer																																																		
1234	<p>SL CRC Err Limit The number of CRC errors per test (per 8 mS) allowed before the drive declares a SynchLink CRC Error exception event. Set this limit on the SynchLink diagnostics tab of the Peer Communication window.</p>	Default: 2 Min/Max: 0/256			32-bit Integer																																																		
1235	<p>SL BOF Err Limit The number of BOF errors per test (per 8 mS) allowed before the drive declares a SynchLink BOF Error exception event. Set this limit on the SynchLink diagnostics tab of the Peer Communication window.</p>	Default: 2 Min/Max: 0/256			32-bit Integer																																																		
1250	<p>Trend Control Set bits to configure the Data Trend function:</p> <ul style="list-style-type: none"> • Bit 0 [Enbl Collect] - Trend data collection begins on the rising edge of this bit and continues until either this bit is set low or the trend data has been completely collected. This bit should be cleared following either the 'Triggered' status or 'Complete' status (bit 1 and 2, respectively, in Par 1251 [Trend Status]) in order to complete the trend sequence. This bit can also be cleared at any time to force the trend data sampling to stop and set the 'Complete' status bit. • Setting bit 1 [In1 Real] - specifies the Real data type for Trend Input 1. The source for Real data is Par 1265 [Trend In1 Real]. Clearing the bit specifies the Integer data type. The source for Integer data is Par 1264 [Trend In1 Int]. • Setting bit 2 [In2 Real] - specifies the Real data type for Trend Input 2. The source for Real data is Par 1267 [Trend In2 Real]. Clearing the bit specifies the Integer data type. The source for Integer data is Par 1266 [Trend In2 Int]. • Setting bit 3 [In3 Real] - specifies the Real data type for Trend Input 3. The source for Real data is Par 1269 [Trend In3 Real]. Clearing the bit specifies the Integer data type. The source for Integer data is Par 1268 [Trend In3 Int]. • Setting bit 4 [In4 Real] - specifies the Real data type for Trend Input 4. The source for Real data is Par 1271 [Trend In4 Real]. Clearing the bit specifies the Integer data type. The source for Integer data is Par 1270 [Trend In4 Int]. • Setting bit 15 [Auto Output] causes the trend output parameters to automatically cycle through the entire trend buffer at the rate specified in Par 1253 [Trend Rate]. Typically, you link the output to an analog output for display on an oscilloscope. • Auto output is accomplished by writing to Par 1283 [TrendBuffPointer]. Clearing this bit requires manual selection of Par 1283 [TrendBuffPointer] to view the trend buffer contents. <p>Options</p> <table border="1"> <thead> <tr> <th></th> <th>Auto Output</th> <th>Reserved</th> <th>Reserved</th> <th>Reserved</th> <th>Reserved</th> <th>Reserved</th> <th>Reserved</th> <th>Reserved</th> <th>Reserved</th> <th>Reserved</th> <th>Reserved</th> <th>In 4 Real</th> <th>In 3 Real</th> <th>In 2 Real</th> <th>In 1 Real</th> <th>Enbl Collect</th> </tr> </thead> <tbody> <tr> <td>Default</td> <td>0</td> <td>0</td> <td>0</td> <td>0</td> <td>0</td> <td>0</td> <td>0</td> <td>0</td> <td>0</td> <td>0</td> <td>0</td> <td>0</td> <td>0</td> <td>0</td> <td>0</td> <td>0</td> </tr> <tr> <td>Bit</td> <td>15</td> <td>14</td> <td>13</td> <td>12</td> <td>11</td> <td>10</td> <td>9</td> <td>8</td> <td>7</td> <td>6</td> <td>5</td> <td>4</td> <td>3</td> <td>2</td> <td>1</td> <td>0</td> </tr> </tbody> </table> <p>0 = False 1 = True</p>		Auto Output	Reserved	Reserved	Reserved	Reserved	Reserved	Reserved	Reserved	Reserved	Reserved	Reserved	In 4 Real	In 3 Real	In 2 Real	In 1 Real	Enbl Collect	Default	0	0	0	0	0	0	0	0	0	0	0	0	0	0	0	0	Bit	15	14	13	12	11	10	9	8	7	6	5	4	3	2	1	0			
	Auto Output	Reserved	Reserved	Reserved	Reserved	Reserved	Reserved	Reserved	Reserved	Reserved	Reserved	In 4 Real	In 3 Real	In 2 Real	In 1 Real	Enbl Collect																																							
Default	0	0	0	0	0	0	0	0	0	0	0	0	0	0	0	0																																							
Bit	15	14	13	12	11	10	9	8	7	6	5	4	3	2	1	0																																							

No.	Name Description	Value	Linkable	Read-Write	Data Type																																																			
1251	Trend Status Bits indicate the status of the Data Trend function: <ul style="list-style-type: none"> • Bit 1 [Triggered] indicates a Trend Trigger event has been detected. This bit will clear in response to the rise of Par 1250 [Trend Control], bit 0 [Enbl Collect]. • Bit 2 [Complete] indicates all the post trigger data samples have been gathered and the trend buffers are full. It will also be set if the Par 1250 [Trend Control], bit 0 [Enbl Collect] is cleared before the trigger occurs. The trend data outputs will be updated from the contents of the trend buffer data when this bit is set. Par 1250 [Trend Control], bit 0 [Enbl Collect] can be cleared after this bit is set without affecting the trend data buffer contents. This bit will clear in response to the rise of Par 1250 [Trend Control], bit 0 [Enbl Collect]. The trend outputs will be forced to zero while this bit is clear. 	Options <table border="1"> <tr> <td>Reserved</td><td>Reserved</td><td>Reserved</td><td>Reserved</td><td>Reserved</td><td>Reserved</td><td>Reserved</td><td>Reserved</td><td>Reserved</td><td>Reserved</td><td>Reserved</td><td>Reserved</td><td>Reserved</td><td>Reserved</td><td>Complete</td><td>Triggered</td><td>Reserved</td> </tr> <tr> <td>Default</td><td>0</td><td>0</td><td>0</td><td>0</td><td>0</td><td>0</td><td>0</td><td>0</td><td>0</td><td>0</td><td>0</td><td>0</td><td>0</td><td>0</td><td>0</td><td>0</td> </tr> <tr> <td>Bit</td><td>15</td><td>14</td><td>13</td><td>12</td><td>11</td><td>10</td><td>9</td><td>8</td><td>7</td><td>6</td><td>5</td><td>4</td><td>3</td><td>2</td><td>1</td><td>0</td> </tr> </table> 0 = False 1 = True	Reserved	Reserved	Reserved	Reserved	Reserved	Reserved	Reserved	Reserved	Reserved	Reserved	Reserved	Reserved	Reserved	Reserved	Complete	Triggered	Reserved	Default	0	0	0	0	0	0	0	0	0	0	0	0	0	0	0	0	Bit	15	14	13	12	11	10	9	8	7	6	5	4	3	2	1	0			
Reserved	Reserved	Reserved	Reserved	Reserved	Reserved	Reserved	Reserved	Reserved	Reserved	Reserved	Reserved	Reserved	Reserved	Complete	Triggered	Reserved																																								
Default	0	0	0	0	0	0	0	0	0	0	0	0	0	0	0	0																																								
Bit	15	14	13	12	11	10	9	8	7	6	5	4	3	2	1	0																																								
1252	Trend State Value indicates the state of the Data Trend function. <ul style="list-style-type: none"> • 0 "Wait Enable" - indicates the trend function is ready and waiting to begin data collection. Setting bit 0 [Enbl Collect] of Par1250 [Trend Control] will cause data collection to begin. In this state, Par 1283 [TrendBuffPointer] and the Trend Output parameters are active. • 1 "First Scan" - indicates the Trend function is executing the first pass through the trend sample buffer. This takes 512 ms. (0.5 ms x 1024 samples). When it enters this state, the Trend function clears bit 1 [Triggered] and bit 2 [Complete] of Par 1251 [Trend Status]. While in this state, the Trend function refreshes the data. Also while in this state, the function forces the Trend Output parameters to zero. When done, it enters the Pre-trigger state. • 2 "Pre-trigger" - indicates the Trend function is sampling the trend inputs and storing them in memory, at a rate determined by parameter 1253 [Trend Rate]. Sampling continues until either the trend trigger event occurs or bit 0 [Enbl Collect] of Par 1250 [Trend Control] is cleared. While in this state, the Trend function forces the Trend Output parameters to zero. If the trigger event occurs, the function sets bit 1 [Triggered] of Par 1251 [Trend Status] and enters the Post-trigger state. If bit 0 [Enbl Collect] of Par 1250 [Trend Control] is cleared, the function sets bit 2 [Complete] of Par 1251 [Trend Status] and returns to the Wait Enable state. • 3 "Post-trigger" indicates the Trend function is continuing to sample and save the trend inputs until the buffer is full. While in this state, the function forces the Trend Output parameters to zero. When the buffer is full, the function sets bit 2 [Complete] of Par 1251 [Trend Status] and enters the Wait Disable state. • 4 "Wait Disable" - indicates the Trend function is complete and waiting for bit 0 [Enbl Collect] of Par 1250 [Trend Control] to be cleared. When this is done, the trend function returns to the Wait Enable state. While in the Wait Disable state, Par 1283 [TrendBuffPointer] and the Trend Output Parameters are active. 	Default: 0 "Wait Enable" Options: <ul style="list-style-type: none"> 0 "Wait Enable" 1 "First Scan" 2 "Pre-trigger" 3 "Post-trigger" 4 "Wait Disable" 																																																						
1253	Trend Rate Sets the sample time for both trend input and output updates.	Units: mSec Default: 0.5000 Min/Max: 0.5000/1000.0000	✓	✓	Real																																																			
1254	Trend TrigA Int Provides the integer input for the A trigger function. This integer is converted to a real number and summed with Par 1255 [Trend TrigA Real]. The result is compared with the Trigger B sum. If the A sum exceeds the B sum, then a trend trigger will occur.	Default: 0 Min/Max: -/+2147483648	✓	✓	32-bit Integer																																																			
1255	Trend TrigA Real Provides the real input for the A trigger function. This real number is summed with Par 1254 [Trend TrigA Int]. The result is compared with the Trigger B sum. If the A sum exceeds the B sum, then a trend trigger will occur.	Default: 0.0000 Min/Max: -/+2200000000.0000	✓	✓	Real																																																			
1256	Trend TrigB Int Provides the integer input for the B trigger function. This integer is converted to a real number and summed with Par 1257 [Trend TrigB Real]. The result is compared with the Trigger A sum. If the A sum exceeds the B sum, then a trend trigger will occur.	Default: 0 Min/Max: -/+2147483648	✓	✓	32-bit Integer																																																			
1257	Trend TrigB Real Provides the real input for the B trigger function. This real number is summed with Par 1256 [Trend TrigB Int]. The result is compared with the Trigger A sum. If the A sum exceeds the B sum, then a trend trigger will occur.	Default: 0.0000 Min/Max: -/+2200000000.0000	✓	✓	Real																																																			
1258	Trend Trig Data This is the logic input for the Trend Trigger Function. A trigger will occur on the rise of the specified bit in this word. The bit will be specified by Par 1259 [Trend Trig Bit].	Default: 00000000000000000000000000000000 Min: 00000000000000000000000000000000 Max: 11111111111111111111111111111111	✓	✓	32-bit Boolean																																																			
1259	Trend Trig Bit Specifies the bit in Par 1258 [Trend Trig Data] that will cause a Trend Trigger to occur. Positive numbers specify rising edges and negative numbers specify falling edges.	Default: 0 Min/Max: -32/31	✓	✓	16-bit Integer																																																			
1260	Trend PreSamples Specifies the number of pre-trigger samples in the trend buffer. Pre-trigger samples are the samples that occur before the trigger and remain in the buffer. The remainder of the trend buffer will contain post-trigger samples.	Default: 511 Min/Max: 0/1022 j	✓	✓	16-bit Integer																																																			
1264	Trend In1 Int Provides integer input to the Trend 1 function. The Trending function samples this parameter for Trend Buffer 1, if bit 1 [In 1 Real] of Par 1250 [Trend Control] is cleared.	Default: 0 Min/Max: -/+2147483648	✓	✓	32-bit Integer																																																			

No.	Name Description	Value	Linkable	Read-Write	Data Type
1265	Trend In1 Real Provides real input to the Trend 1 function. The Trending function samples this parameter for Trend Buffer 1, if bit 1 [In 1 Real] of Par 1250 [Trend Control] is set.	Default: 0.0000 Min/Max: -/+2200000000.0000	✓	✓	Real
1266	Trend In2 Int Provides integer input to the Trend 2 function. The Trending function samples this parameter for Trend Buffer 2, if bit 2 [In 2 Real] of Par 1250 [Trend Control] is cleared.	Default: 0 Min/Max: -/+2147483648	✓	✓	32-bit Integer
1267	Trend In2 Real Provides real input to the Trend 2 function. The Trending function samples this parameter for Trend Buffer 2, if bit 2 [In 2 Real] of Par 1250 [Trend Control] is set.	Default: 0.0000 Min/Max: -/+2200000000.0000	✓	✓	Real
1268	Trend In3 Int Provides integer input to the Trend 3 function. The Trending function samples this parameter for Trend Buffer 3, if bit 3 [In 3 Real] of Par 1250 [Trend Control] is cleared.	Default: 0 Min/Max: -/+2147483648	✓	✓	32-bit Integer
1269	Trend In3 Real Provides real input to the Trend 3 function. The Trending function samples this parameter for Trend Buffer 3, if bit 3 [In 3 Real] of Par 1250 [Trend Control] is set.	Default: 0.0000 Min/Max: -/+2200000000.0000	✓	✓	Real
1270	Trend In4 Int Provides integer input to the Trend 4 function. The Trending function samples this parameter for Trend Buffer 4, if bit 4 [In 4 Real] of Par 1250 [Trend Control] is cleared.	Default: 0 Min/Max: -/+2147483648	✓	✓	32-bit Integer
1271	Trend In4 Real Provides real input to the Trend 4 function. The Trending function samples this parameter for Trend Buffer 4, if bit 4 [In 4 Real] of Par 1250 [Trend Control] is set.	Default: 0.0000 Min/Max: -/+2200000000.0000	✓	✓	Real
1280	Trend Marker Int Marks the start of data for trend buffers that are using integer data. The Trend Marker can be used to provide a scope trigger signal for the Auto Output function.	Default: 0 Min/Max: -/+2147483648	✓	✓	32-bit Integer
1281	Trend Marker Real Marks the start of data for trend buffers that are using real data. The Trend Marker can be used to provide a scope trigger signal for the Auto Output function.	Default: 0.0000 Min/Max: -/+2200000000.0000	✓	✓	Real
1283	TrendBuffPointer Selects the trend buffer element to be displayed in the Trend Output Parameters when the trend function is inactive (not collecting data samples). A zero value points to the element that corresponds to the trigger event. Negative values point to pre-trigger data. Positive values point to post-trigger data. When the Auto Output function is running, this parameter will automatically sequence through its full range, at a rate set by Par 1253 [Trend Rate].	Default: 0 Min/Max: -/+1023	✓	✓	16-bit Integer
1284	Trend Out1 Int Displays the output for Trend Buffer 1, if the buffer is using integer data. This will equal the value of the element, in Trend Buffer 1, specified by Par 1283 [TrendBuffPointer].	Default: 0 Min/Max: -/+2147483648			32-bit Integer
1285	Trend Out1 Real Displays the output for Trend Buffer 1, if the buffer is using real data. This will equal the value of the element, in Trend Buffer 1, specified by Par 1283 [TrendBuffPointer].	Default: 0.0000 Min/Max: -/+2200000000.0000			Real
1286	Trend Out2 Int Displays the output for Trend Buffer 2, if the buffer is using integer data. This will equal the value of the element, in Trend Buffer 2, specified by Par 1283 [TrendBuffPointer].	Default: 0 Min/Max: -/+2147483648			32-bit Integer
1287	Trend Out2 Real Displays the output for Trend Buffer 2, if the buffer is using real data. This will equal the value of the element, in Trend Buffer 2, specified by Par 1283 [TrendBuffPointer].	Default: 0.0000 Min/Max: -/+2200000000.0000			Real
1288	Trend Out3 Int Displays the output for Trend Buffer 3, if the buffer is using integer data. This will equal the value of the element, in Trend Buffer 3, specified by Par 1283 [TrendBuffPointer].	Default: 0 Min/Max: -/+2147483648			32-bit Integer
1289	Trend Out3 Real Displays the output for Trend Buffer 3, if the buffer is using real data. This will equal the value of the element, in Trend Buffer 3, specified by Par 1283 [TrendBuffPointer].	Default: 0.0000 Min/Max: -/+2200000000.0000			Real
1290	Trend Out4 Int Displays the output for Trend Buffer 4, if the buffer is using integer data. This will equal the value of the element, in Trend Buffer 4, specified by Par 1283 [TrendBuffPointer].	Default: 0 Min/Max: -/+2147483648			32-bit Integer
1291	Trend Out4 Real Displays the output for Trend Buffer 4, if the buffer is using real data. This will equal the value of the element, in Trend Buffer 4, specified by Par 1283 [TrendBuffPointer].	Default: 0 Min/Max: -/+2200000000.0000			Real
1300	User Data Int 05 General purpose parameter available for storage of 32-bit enumerated data by the operator. This value will be retained through a power cycle.	Default: 0 Min/Max: -/+2147483648	✓	✓	32-bit Integer
1301	User Data Int 06 General purpose parameter available for storage of 32-bit enumerated data by the operator. This value will be retained through a power cycle.	Default: 0 Min/Max: -/+2147483648	✓	✓	32-bit Integer
1315	User Data Real 01 General purpose parameter available for storage of real data by the operator. This value will be retained through a power cycle.	Default: 0.0000 Min/Max: -/+2200000000.0000			Real
1316	User Data Real 02 General purpose parameter available for storage of real data by the operator. This value will be retained through a power cycle.	Default: 0.0000 Min/Max: -/+2200000000.0000			Real

Parameter Cross Reference By Name

Name	Number
% Motor Flux	309
Abs OverSpd Lim	335
Abs Posit Offset	757
Accel Time	32
Act Motor Posit	763
Act Spd Reg BW	97
AI 1 Filt Gain	804
AI 2 Filt Gain	810
Alarm Status 1	326
Alarm Status 2	327
Anlg In1 Data	800
Anlg In1 Filt BW	805
Anlg In1 Offset	803
Anlg In1 Scale	802
Anlg In1 Volts	801
Anlg In2 Data	806
Anlg In2 Filt BW	811
Anlg In2 Offset	809
Anlg In2 Scale	808
Anlg In2 Volts	807
Anlg Out1 Offset	812
Anlg Out1 Real	815
Anlg Out1 Scale	817
Anlg Out1 Volts	816
Anlg Out1 Zero	818
Anlg Out2 Offset	813
Anlg Out2 Real	820
Anlg Out2 Scale	822
Anlg Out2 Volts	821
Anlg Out2 Zero	823
AnlgOut1 Integer	814
AnlgOut2 Integer	819
Applied LogicCmd	152
Atune Spd Ref	19
Atune Torq Ref	129
Aux Posit Ref	743
Brake OL Cnfg	369
Brake PulseWatts	416
Brake TP Data	419
Brake TP Sel	418
Brake Watts	417
Brake/Bus Cnfg	414
Bus Util Limit	500
BusReg/Brake Ref	415
BusUndervoltCnfg	393
Control Options	153
Curr Ref TP Data	364
Curr Ref TP Sel	363
Current Reg BW	503
Data In A1 Int	707
Data In A1 Real	708
Data In A2 Int	709
Data In A2 Real	710
Data In B1 Int	711
Data In B1 Real	712
Data In B2 Int	713
Data In B2 Real	714
Data In C1 Int	715
Data In C1 Real	716

Name	Number
Data In C2 Int	717
Data In C2 Real	718
Data In D1 Int	719
Data In D1 Real	720
Data In D2 Int	721
Data In D2 Real	722
Data Out A1 Int	724
Data Out A1 Real	725
Data Out A2 Int	726
Data Out A2 Real	727
Data Out B1 Int	728
Data Out B1 Real	729
Data Out B2 Int	730
Data Out B2 Real	731
Data Out C1 Int	732
Data Out C1 Real	733
Data Out C2 Int	734
Data Out C2 Real	735
Data Out D1 Int	736
Data Out D1 Real	737
Data Out D2 Int	738
Data Out D2 Real	739
DC Bus Voltage	306
Dead Time	404
Dead Time Comp	405
Decel Time	33
Delayed Spd Ref	45
DeltaSpeedScale	60
DigIn ConfigStat	159
DigIn1 Bit	827
DigIn1 Data	826
DigIn1 Debounce	829
DigIn1 Sel	838
DigIn1 User Data	828
DigIn2 Bit	831
DigIn2 Data	830
DigIn2 Debounce	833
DigIn2 Sel	839
DigIn2 User Data	832
DigIn3 Bit	835
DigIn3 Data	834
DigIn3 Debounce	837
DigIn3 Sel	840
DigIn3 User Data	836
DigOut 1 Bit	844
DigOut 1 Data	843
DigOut 2 Bit	846
DigOut 2 Data	845
Direction Mask	696
Direction Owner	703
DLink OutDataTyp	723
DPI Baud Rate	692
DPI CommLoss Cfg	391
DPI Ref Select	691
Drive Logic Rslt	158
Drive OL JnctTmp	345
Drive OL Status	346
Drive OL TP Data	348
Drive OL TP Sel	347
Elapsed MWHrs	299
Elapsed Run Time	298
En In Debounce	825

Name	Number
Encdr0 Config	233
Encdr0 Error	234
Encdr0 Loss Cnfg	365
Encdr0 Position	230
Encdr0 Spd Fdbk	231
Encdr1 Config	243
Encdr1 Error	244
Encdr1 Loss Cnfg	366
Encdr1 Position	240
Encdr1 Spd Fdbk	241
Encoder0 PPR	232
Encoder1 PPR	242
Est Speed Fdbk	548
Est Theta Delay	477
Exception Event1	320
Exception Event2	321
Ext Flt/Alm Cnfg	379
Fault Clr Mask	697
Fault Clr Owner	704
Fault Status 1	323
Fault Status 2	324
Fault TP Data	330
Fault TP Sel	329
FB Opt0 Posit	250
FB Opt0 Spd Fdbk	251
FB Opt1 LossCnfg	368
FB Opt1 Posit	276
FB Opt1 Spd Fdbk	277
Fdbk Option ID	249
Filtered Spd Ref	44
Filtered SpdFdbk	71
Flux Current	488
Flux Rate Limit	425
Flux Ratio Ref	424
Flux Reg I Gain	444
Flux Reg P Gain1	443
Flux Reg P Gain2	470
Flx LpassFilt BW	361
FOC Mode Config	510
FOC2 Mode Config	511
Freq Reg FF Gain	473
Freq Reg I Gain	449
Freq Reg P Gain	450
Freq Reg We BW	474
Freq Reg Wr BW	475
FricComp Rated	144
FricComp Setup	141
FricComp Slip	143
FricComp Spd Ref	140
FricComp Stick	142
FricComp TorqAdd	145
Fwd Speed Limit	31
Heatsink Temp	313
Hi Res0 Config	259
Hi Res0 Status	260
Hi Res0 TP Data	262
Hi Res0 TP Sel	261
Ids Command	537
Ids Feedback	540
Ids Integ Freq	429
Ids Reg P Gain	430
In Posit BW	782

Name	Number
In Posit Dwell	783
Inertia SpeedRef	56
Inertia Torq Add	59
InertiaAccelGain	57
InertiaDecelGain	58
Integer In00	600
Integer In01	602
Integer In02	604
Integer In03	606
Integer In04	608
Integer In05	610
Integer In06	612
Integer In07	614
Integer In08	616
Integer In09	618
Integer In10	620
Integer In11	622
Integer In12	624
Integer In13	626
Integer In14	628
Integer In15	630
Integer Out00	632
Integer Out01	634
Integer Out02	636
Integer Out03	638
Integer Out04	640
Integer Out05	642
Integer Out06	644
Integer Out07	646
Integer Out08	648
Integer Out09	650
Integer Out10	652
Integer Out11	654
Integer Out12	656
Integer Out13	658
Integer Out14	660
Integer Out15	662
Inv OL Pend Cnfg	376
Inv OL Trip Cnfg	377
Inv OT Pend Cnfg	375
Iq Actual Lim	353
Iq Actual Ref	350
Iq Rate Limit	354
Iq Rate Limited	355
Iq Ref Limited	358
Iq Ref Trim	351
Iqs Command	535
Iqs Feedback	539
Iqs Integ Freq	421
Iqs Rate Limit	423
Iqs Reg P Gain	422
Is Actual Lim	352
Iu Offset	453
Iw Offset	454
Jog Mask	695
Jog Owner	702
Jog Speed 1	17
Jog Speed 2	18
Leak Inductance	492
Lgx Closed Cnfg	388
Lgx Comm Format	664
Lgx CommLossData	385

Name	Number
Lgx LinkChngCnfg	389
Lgx OutOfRunCnfg	386
Lgx Timeout Cnfg	387
LimGen X axis In	206
LimGen Y axis Mn	205
LimGen Y axis Mx	204
Limit Gen Hi Out	207
Limit Gen Lo Out	208
Limit Status	304
Limited Spd Ref	41
Lin1 Update Rate	289
Line Undervolts	409
Linear1 CPR	290
Linear1 Status	286
Linear1 TP Data	288
Linear1 TP Sel	287
Load Estimate	221
Local I/O Status	824
Logic Command	151
Logic Ctrl State	157
Logic Mask	693
Logic State Mach	150
Logic Status	155
Logic TP Data	162
Logic TP Sel	161
MC Build Number	526
MC Cmd Lim Cnfg	382
MC Diag Done	551
MC Diag Error 1	552
MC Diag Error 2	553
MC Diag Error 3	554
MC Diag Status	550
MC Firmware Rev	527
MC Status	555
MC TP Bit	546
MC TP Select	544
MC TP Value	545
Min Flux	360
Motor Ctrl Ackn	167
Motor Ctrl Cmmd	166
Motor Ctrl Mode	485
Motor Fdbk Sel	222
Motor Inertia	8
Motor NP FLA	2
Motor NP Hertz	3
Motor NP Power	5
Motor NP RPM	4
Motor NP Volts	1
Motor NTC Coef	487
Motor Poles	7
Motor Spd Est	74
Motor Spd Fdbk	300
Motor Speed Ref	301
Motor Stall Cnfg	374
Motor Stall Time	373
Motor Torque Ref	303
MotorFluxCurr FB	312
Mtr Current Lim	356
Mtr I2T Calibrat	339
Mtr I2T Curr Min	337
Mtr I2T Spd Min	338
Mtr I2T Trp ThrH	340

Name	Number
Mtr NP Pwr Units	6
Mtr OL Pend Cnfg	372
Mtr OL Trip Cnfg	371
Mtr Posit Fdbk	762
Mtr TorqCurr Ref	305
Mtr Vds Base	434
Mtr Vqs Base	435
Mtring Power Lim	127
MtrSpd Est Posit	75
MtrSpd Sim Posit	70
MtrSpd Simulated	76
NetLoss DPI Cnfg	392
Notch Filt Freq	118
Notch Filt Mode	117
OL ClsLp CurrLim	344
OL OpnLp CurrLim	343
Opt 0 Regis Cnfg	254
Opt 0 Regis Ctrl	255
Opt 0 Regis Ltch	253
Opt 0 Regis Stat	256
Opt 1 Regis Cnfg	280
Opt 1 Regis Ctrl	281
Opt 1 Regis Ltch	279
Opt 1 Regis Stat	282
Output Curr Disp	297
Output Current	308
Output Freq	310
Output Power	311
Output Voltage	307
ParamAccessLevel	850
Peak Ctrl Status	211
PeakDetect1 Out	215
PeakDetect2 Out	219
PeakDtct Ctrl In	210
PeakDtct1 In Int	212
PeakDtct1 Preset	214
PeakDtct2 In Int	216
PeakDtct2 Preset	218
PI Command	183
PI Feedback	182
PI High Limit	191
PI Integ HLim	188
PI Integ LLim	189
PI Integ Output	190
PI Integ Time	187
PI Lower Limit	192
PI Lpass Filt BW	184
PI Output	180
PI Preload	185
PI Prop Gain	186
PI Reference	181
PI TP Data	194
PI TP Sel	193
PkDtct1 In Real	213
PkDtct2 In Real	217
PM AbsEncd Offst	504
PM D Inductance	521
PM Mtr CEMF Coef	523
PM Mtr CEMF Comp	427
PM Q Inductance	520
PM Stator Resist	522
PM Test Freq Ref	508

Name	Number
PM Test FreqRamp	507
PM Test I Ref	509
PM Test Idc Ramp	506
PM TestWait Time	505
PMag Mode Cnfg	512
PMag Tune Cnfg	517
Port0 Regis Cnfg	236
Port0 Regis Ctrl	237
Port0 Regis Ltch	235
Port0 Regis Stat	238
Port1 Regis Cnfg	246
Port1 Regis Ctrl	247
Port1 Regis Ltch	245
Port1 Regis Stat	248
Posit Actl Load	765
Posit Detct1 In	784
Posit Detct2 In	785
Posit FB EGR Div	767
Posit FB EGR Mul	766
Posit Index Ctrl	796
Posit Index Step	797
Posit Load Fdbk	764
Posit Offset 1	753
Posit Offset 2	754
Posit Offset Spd	755
Posit Ref Sel	742
Posit Spd Output	318
Posit TP Select	777
PositDetct1 Stpt	780
PositDetct2 Stpt	781
PositIndexOutput	799
PositIndexPreset	798
Position Cmmnd	747
Position Control	740
Position Error	769
Position Status	741
PositRef EGR Div	746
PositRef EGR Mul	745
PositRef EGR Out	744
PositReg Droop	771
PositReg Integ	770
PositReg P Gain	768
PositTP Data Int	778
PositTP DataReal	779
Power EE TP Data	413
Power EE TP Sel	412
Power Loss Level	408
Power Loss Mode	406
Power Loss Time	407
PreCharge Delay	472
PreChrg Control	411
PreChrg Err Cnfg	381
PreChrg TimeOut	410
Pt-Pt Accel Time	759
Pt-Pt Decel Time	760
Pt-Pt Filt BW	761
Pt-Pt Posit Ref	758
PWM Frequency	402
Ramped Spd Ref	42
Rated Amps	400
Rated Slip Freq	486
Rated Volts	401

Name	Number
Real In00	601
Real In01	603
Real In02	605
Real In03	607
Real In04	609
Real In05	611
Real In06	613
Real In07	615
Real In08	617
Real In09	619
Real In10	621
Real In11	623
Real In12	625
Real In13	627
Real In14	629
Real In15	631
Real Out00	633
Real Out01	635
Real Out02	637
Real Out03	639
Real Out04	641
Real Out05	643
Real Out06	645
Real Out07	647
Real Out08	649
Real Out09	651
Real Out10	653
Real Out11	655
Real Out12	657
Real Out13	659
Real Out14	661
Real Out15	663
Real to Int In	1035
Real to Int Out	1036
Regen Power Lim	128
Relay Out Bit	842
Relay Out Data	841
Reserved	1240
Reserved	1241
Reserved	1242
Reserved	1243
Reserved	1244
Reserved	1245
Reserved	1246
Reslvr0 CableBal	274
Reslvr0 Carrier	271
Reslvr0 Config	266
Reslvr0 In Volts	272
Reslvr0 SpdRatio	270
Reslvr0 Status	267
Reslvr0 TP Data	269
Reslvr0 TP Sel	268
Rev Speed Limit	30
Rotor Resistance	502
Rslvr0 XfrmRatio	273
Run Inhibit Stat	156
S Curve Spd Ref	43
S Curve Time	34
Scaled Spd Fdbk	72
Scaled Spd Ref	46
Selected Spd Ref	40
Service Factor	336

Name	Number
Servo Lock Gain	85
Set Speed Lim	171
Setpt 1 Data	172
Setpt 1 Limit	174
Setpt 2 Data	175
Setpt 2 Limit	177
Setpt1 TripPoint	173
Setpt2 TripPoint	176
SL BOF Err Accum	1232
SL BOF Err Limit	1235
SL BOF Error	1233
SL Buf Int Rx00	1073
SL Buf Int Rx01	1075
SL Buf Int Rx02	1077
SL Buf Int Rx03	1079
SL Buf Int Rx04	1081
SL Buf Int Rx05	1083
SL Buf Int Rx06	1085
SL Buf Int Rx07	1087
SL Buf Int Rx08	1089
SL Buf Int Rx09	1091
SL Buf Int Rx10	1093
SL Buf Int Rx11	1095
SL Buf Int Rx12	1097
SL Buf Int Rx13	1099
SL Buf Int Rx14	1101
SL Buf Int Rx15	1103
SL Buf Int Rx16	1105
SL Buf Int Rx17	1107
SL Buf Int Rx18	1109
SL Buf Int Rx19	1111
SL Buf Int Rx20	1113
SL Buf Int Rx21	1115
SL Buf Int Rx22	1117
SL Buf Int Rx23	1119
SL Buf Int Rx24	1121
SL Buf Int Rx25	1123
SL Buf Int Rx26	1125
SL Buf Int Rx27	1127
SL Buf Int Rx28	1129
SL Buf Int Rx29	1131
SL Buf Int Tx00	1161
SL Buf Int Tx01	1163
SL Buf Int Tx02	1165
SL Buf Int Tx03	1167
SL Buf Int Tx04	1169
SL Buf Int Tx05	1171
SL Buf Int Tx06	1173
SL Buf Int Tx07	1175
SL Buf Int Tx08	1177
SL Buf Int Tx09	1179
SL Buf Int Tx10	1181
SL Buf Int Tx11	1183
SL Buf Int Tx12	1185
SL Buf Int Tx13	1187
SL Buf Int Tx14	1189
SL Buf Int Tx15	1191
SL Buf Int Tx16	1193
SL Buf Int Tx17	1195
SL Buf Int Tx18	1197
SL Buf Int Tx19	1199
SL Buf Int Tx20	1201

Name	Number
SL Buf Int Tx21	1203
SL Buf Int Tx22	1205
SL Buf Int Tx23	1207
SL Buf Int Tx24	1209
SL Buf Int Tx25	1211
SL Buf Int Tx26	1213
SL Buf Int Tx27	1215
SL Buf Int Tx28	1217
SL Buf Int Tx29	1219
SL Buf Real Rx00	1074
SL Buf Real Rx01	1076
SL Buf Real Rx02	1078
SL Buf Real Rx03	1080
SL Buf Real Rx04	1082
SL Buf Real Rx05	1084
SL Buf Real Rx06	1086
SL Buf Real Rx07	1088
SL Buf Real Rx08	1090
SL Buf Real Rx09	1092
SL Buf Real Rx10	1094
SL Buf Real Rx11	1096
SL Buf Real Rx12	1098
SL Buf Real Rx13	1100
SL Buf Real Rx14	1102
SL Buf Real Rx15	1104
SL Buf Real Rx16	1106
SL Buf Real Rx17	1108
SL Buf Real Rx18	1110
SL Buf Real Rx19	1112
SL Buf Real Rx20	1114
SL Buf Real Rx21	1116
SL Buf Real Rx22	1118
SL Buf Real Rx23	1120
SL Buf Real Rx24	1122
SL Buf Real Rx25	1124
SL Buf Real Rx26	1126
SL Buf Real Rx27	1128
SL Buf Real Rx28	1130
SL Buf Real Rx29	1132
SL Buf Real Tx00	1162
SL Buf Real Tx01	1164
SL Buf Real Tx02	1166
SL Buf Real Tx03	1168
SL Buf Real Tx04	1170
SL Buf Real Tx05	1172
SL Buf Real Tx06	1174
SL Buf Real Tx07	1176
SL Buf Real Tx08	1178
SL Buf Real Tx09	1180
SL Buf Real Tx10	1182
SL Buf Real Tx11	1184
SL Buf Real Tx12	1186
SL Buf Real Tx13	1188
SL Buf Real Tx14	1190
SL Buf Real Tx15	1192
SL Buf Real Tx16	1194
SL Buf Real Tx17	1196
SL Buf Real Tx18	1198
SL Buf Real Tx19	1200
SL Buf Real Tx20	1202
SL Buf Real Tx21	1204
SL Buf Real Tx22	1206

Name	Number
SL Buf Real Tx23	1208
SL Buf Real Tx24	1210
SL Buf Real Tx25	1212
SL Buf Real Tx26	1214
SL Buf Real Tx27	1216
SL Buf Real Tx28	1218
SL Buf Real Tx29	1220
SL Clr Events	1049
SL Comm TP Data	1227
SL Comm TP Sel	1226
SL CommLoss Cnfg	384
SL CommLoss Data	383
SL CRC Err Accum	1230
SL CRC Err Limit	1234
SL CRC Error	1231
SL Dir Int Rx0	1054
SL Dir Int Rx1	1056
SL Dir Int Rx2	1058
SL Dir Int Rx3	1060
SL Dir Int Tx0	1141
SL Dir Int Tx1	1143
SL Dir Int Tx2	1145
SL Dir Int Tx3	1147
SL Dir Real Rx0	1055
SL Dir Real Rx1	1057
SL Dir Real Rx2	1059
SL Dir Real Rx3	1061
SL Dir Real Tx0	1142
SL Dir Real Tx1	1144
SL Dir Real Tx2	1146
SL Dir Real Tx3	1148
SL Error History	1228
SL Error Status	1229
SL Mult A In	1030
SL Mult B In	1031
SL Mult Base	1032
SL Mult Out	1033
SL Mult State	1034
SL MultErr Cnfg	390
SL Node Cnfg	1000
SL Rcv Events	1040
SL Rx Comm Frmt	1010
SL Rx DirectSel0	1011
SL Rx DirectSel1	1012
SL Rx DirectSel2	1013
SL Rx DirectSel3	1014
SL Rx Opt0 Regis	1047
SL Rx P0 Regis	1041
SL Rx P1 Regis	1042
SL System Rev	1002
SL System Time	317
SL Tx Comm Frmt	1020
SL Tx DirectSel0	1021
SL Tx DirectSel1	1022
SL Tx DirectSel2	1023
SL Tx DirectSel3	1024
Slip Gain Comp	476
Slip Gain Max	445
Slip Gain Min	446
Slip Ratio	533
Slip Reg I Gain	448
Slip Reg P Gain	447

Name	Number
Spd Err Filt BW	89
Spd Fdbk Scale	73
Spd Fdbk TP Data	79
Spd Fdbk TP RPM	78
Spd Fdbk TP Sel	77
Spd Gain TP Data	99
Spd Gain TP Sel	98
Spd Obs Trq Gain	227
Spd Observer BW	220
Spd Ref Bypass	37
Spd Ref TP Data	52
Spd Ref TP RPM	51
Spd Ref TP Sel	50
Spd Ref1 Divide	11
Spd Ref2 Multi	13
Spd Reg BW	90
Spd Reg Damping	91
Spd Reg Droop	86
Spd Reg I Gain	82
Spd Reg Neg Lim	103
Spd Reg P Gain	81
Spd Reg PI Out	302
Spd Reg Pos Lim	102
Spd Reg TP Data	109
Spd Reg TP Sel	108
Spd Trim1 SpdRef	47
Spd/Torq ModeSel	110
SpdRef Filt BW	36
SpdRef Filt Gain	35
SpdReg AntiBckup	84
SpdReg Integ Out	101
SpdReg P Gain Mx	92
SpdTrim 3 Scale	24
SpdTrim2 Filt BW	26
Speed Comp	55
Speed Error	100
Speed Ref 1	10
Speed Ref 2	12
Speed Ref 4	14
Speed Ref 5	15
Speed Ref DPI	20
Speed Ref Scale	38
Speed Ref Sel	16
Speed Reg Ctrl	80
Speed Trim 1	21
Speed Trim 2	22
Speed Trim 3	23
SReg FB Filt BW	94
SReg Out Filt BW	96
SReg Torq Preset	87
SRegFB Filt Gain	93
SRegOut FiltGain	95
Start Mask	694
Start Owner	701
Stator Frequency	534
StatorInduc Gain	469
StatorInductance	490
StatorResistance	491
Stop Dwell Time	154
Stop Oper TP Sel	163
Stop Owner	700
StopOper TP Data	164

Name	Number
STrim2 Filt Gain	25
SW Int 1 NC	1372
SW Int 1 NO	1371
SW Int 1 Output	1373
SW Real 1 NC	1375
SW Real 1 NO	1374
SW Real 1 Output	1376
Switch Control	1370
SynchLink Rev	1001
SynchLink Status	316
Test Current Ref	431
Test Freq Rate	433
Test Freq Ref	432
Test Mode Config	514
Test Status	165
Time Axis Output	201
Time Axis Rate	200
Torq NegLim Actl	124
Torq PosLim Actl	123
Torq Ref TP Data	131
Torq Ref TP Sel	130
Torq Ref1 Div	112
Torq Ref2 Mult	114
Torque En Dly	501
Torque Neg Limit	126
Torque Pos Limit	125
Torque Ref 1	111
Torque Ref 2	113
Torque Step	116
Torque Trim	115
Total Inertia	9
Trend Control	1250
Trend In1 Int	1264
Trend In1 Real	1265
Trend In2 Int	1266
Trend In2 Real	1267
Trend In3 Int	1268
Trend In3 Real	1269
Trend In4 Int	1270
Trend In4 Real	1271
Trend Mark Real	1281
Trend Marker Int	1280
Trend Out1 Int	1284
Trend Out1 Real	1285
Trend Out2 Int	1286
Trend Out2 Real	1287
Trend Out3 Int	1288
Trend Out3 Real	1289
Trend Out4 Int	1290
Trend Out4 Real	1291
Trend PreSamples	1260
Trend Rate	1253
Trend State	1252
Trend Status	1251
Trend Trig Bit	1259
Trend Trig Data	1258
Trend TrigA Int	1254
Trend TrigA Real	1255
Trend TrigB Int	1256
Trend TrigB Real	1257
TrendBuffPointer	1283
Tx Buf Data Type	1160

Name	Number
Tx Dir Data Type	1140
User Data Int 01	396
User Data Int 02	397
User Data Int 03	398
User Data Int 04	399
User Data Int 05	1300
User Data Int 06	1301
UserData Real 01	1315
UserData Real 02	1316
UserData Real 03	1317
UserData Real 04	1318
UserData Real 05	1319
UserData Real 06	1320
Vds Command	542
Vds Fdbk Filt	441
Vds Max	438
Vds Min	440
Virt Encdr Dlyed	63
Virt Encdr Posit	62
Virt Encoder EPR	61
Virtual Edge/Rev	226
Voltage Class	403
VoltFdbkLossCnfg	394
VPL Build Number	315
VPL Firmware Rev	314
Vqs Command	541
Vqs Fdbk Filt	442
Vqs Max	437
Vqs Min	439
X Offst SpdFilt	756
XReg Integ HiLim	773
XReg Integ LoLim	772
XReg Integ Out	774
XReg Spd HiLim	776
XReg Spd LoLim	775
Xsync Gen Period	787
Xsync In 1	788
Xsync In 2	790
Xsync In 3	793
Xsync Out 1	789
Xsync Out 2	791
Xsync Out 2 Dly	792
Xsync Out 3	794
Xsync Out 3 Dly	795
Xsync Status	786
Zero Speed Lim	160

Troubleshooting

Chapter Objectives

This chapter provides information to guide you in troubleshooting the PowerFlex 700S. A list and description of drive faults (with possible solutions, when applicable) and alarms is included.

For Information on...	See page...
Faults and Alarms	4-1
Drive Status	4-1
Manually Clearing Faults	4-4
Fault Descriptions	4-4

Faults and Alarms

A fault is a condition that stops the drive. There are two fault types.

Type	Fault Description
①	<p>Non-Resettable</p> <p>This type of fault normally requires drive or motor repair. The cause of the fault must be corrected before the fault can be cleared. The fault will be reset on power up after repair</p>
②	<p>User Configurable</p> <p>Programming and commissioning personnel can configure the drive's response to these exception events. Responses include:</p> <ul style="list-style-type: none"> • Ignore • Alarm • Fault Coast Stop • Fault Ramp Stop • Fault Current Limit Stop

Drive Status

The condition or state of your drive is constantly monitored. Any changes will be indicated through the front panel LEDs and/or the HIM (if present).

LED Indications

Figure 4.1 Drive Status Indicators

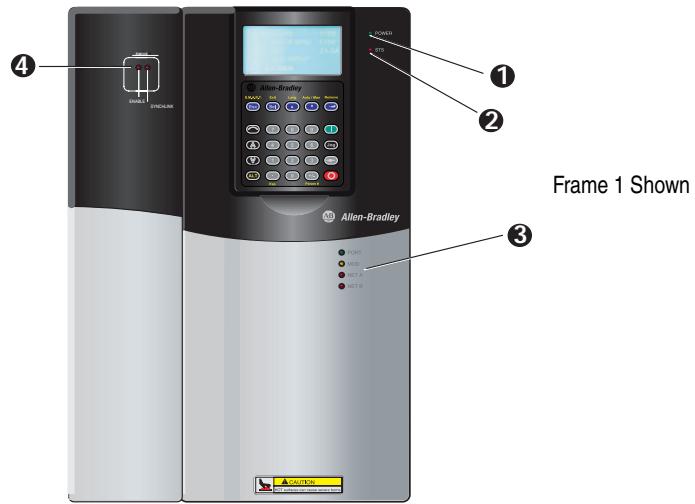

Table 4.A Drive Status Indicators

#	Name	Color	State	Description	Action		
1	PWR (Power)	Green	Steady	Illuminates when power is applied to the drive.	No action - no faults present		
		2	STS (Status)	Green	Flashing	Drive ready, but not running & no faults are present.	No action - no faults present
				Green	Steady	Drive running, no faults are present.	No action - no faults present
		Yellow	Flashing	A type 2 (non-configurable) alarm condition exists, drive continues to run.	A run inhibit exists. Refer to Table 4.B		
			Steady	A type 1 (user configurable) alarm condition exists, but drive continues to run.			
		Red	Flashing	A fault has occurred.	Refer to Table for faults.		
			Steady	A non-resettable fault has occurred.			
Red / Yellow	Flashing Alternately	The drive is in flash recovery mode. The only operation permitted is flash upgrade.	Complete Flash Upgrade				
3	PORT	Refer to the <i>Communication Adapter User Manual</i>		Status of DPI port internal communications (if present).			
				Status of communications module (when installed).			
				Status of network (if connected).			
				Status of secondary network (if connected).			
4	SYNCHLINK	Green	Steady	<ul style="list-style-type: none"> The module is configured as the time keeper or The module is configured as a follower and synchronization is complete. 			
		Green	Flashing	The follower(s) are not configured with the time keeper.			
		Red	Flashing	<ul style="list-style-type: none"> The module is configured as a time master on SynchLink and has received time information from another time master on SynchLink. 			
	ENABLE	Green	On	The drive's enable input is high.			

Precharge Board LED Indications

Precharge Board LED indicators are found on Frame 5 & 6 drives. The LEDs are located above the “Line Type” jumper shown in [Figure 1.2](#).

Name	Color	State	Description
Power	Green	Steady	Indicates when precharge board power supply is operational
Alarm	Yellow	Flashing	Number in “[]” indicates flashes and associated alarm ⁽¹⁾ :
		[1]	Low line voltage (<90%).
		[2]	Very low line voltage (<50%).
		[3]	Low phase (one phase <80% of line voltage).
		[4]	Frequency out of range or asymmetry (line sync failed).
		[5]	Low DC bus voltage (triggers ride-through operation).
		[6]	Input frequency momentarily out of range (40-65 Hz).
Fault	Red	Flashing	Number in “[]” indicates flashes and associated fault ⁽²⁾ :
		[2]	DC bus short (Udc <2% after 20 ms).
		[4]	Line sync failed or low line (Uac <50% Unom).
		[7]	DC bus short circuit detection active.

(1) An alarm condition automatically resets when the condition no longer exists

(2) A fault indicates a malfunction that must be corrected and can only be reset after cycling power.

Table 4.B Common Causes of a Pre-Start Alarm

Examine Parameter 156 [Run Inhibit Status]			
Bit	Description	Action	
1	No power is present at the Enable Terminal TB1- T7	Apply the enable	
2, 3, 4	A stop command is being issued	Close all stop inputs	
5	Power loss event is in progress, indicating a loss of the AC input voltage	Restore AC power	
6	Data supplied by the power structure EEPROM is invalid or corrupt	Cycle the power. If problem persists, replace the power structure.	
7	Flash Update in Progress	Complete Flash Procedures	
8	Drive is expecting a Start Edge and is receiving a continuous signal.	Open all start buttons and remove all start commands	
9	Drive is expecting a Jog Edge and is receiving a continuous signal.	Open all jog buttons and remove all jog commands	
10	A conflict exists between the Encoder PPR programming (Parameter 232 or 242) and the encoder configuration for edge counts (Parameter 233 or 243, bits 4 & 5).	Verify encoder data and reprogram	
11	The drive cannot precharge because a precharge input is programmed and no signal is present.	Reprogram the input or close the precharge control contact.	
12	Digital Configuration	Start input configured but stop not configured	Program Par 838-840 to include a stop button, rewire the drive
		Run input configured but control options do not match	Program Par 153, Bit 8 to “0” (2 wire control)
		Start input configured but control options do not match	Program Par 153, Bit 8 to “1” (3 wire control)
		Multiple inputs configured as Start or Run	Reprogram Par 838-840 so multiple starts, multiple runs or any combination do not exist
		Multiple inputs configured as Jog1	Reprogram Par 838-840 so only (1) is set to Jog1
		Multiple inputs configured as Jog2	Reprogram Par 838-840 so only (1) is set to Jog2
		Multiple inputs configured as Fwd/Rev	Reprogram Par 838-840 so only (1) is set to Fwd/Rev
14	Invalid Feedback Device for Permanent Magnet Motor Control	Set Par 222 to Value 5 (FB Opt Port0)	

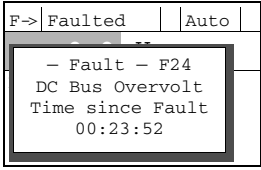

HIM Indication

The HIM also provides visual notification of a fault.

Condition	Display
<p>Drive is indicating a fault.</p> <p>The LCD HIM immediately reports the fault condition by displaying the following:</p> <ul style="list-style-type: none"> • “Faulted” appears in the status line • Fault number • Fault name • Time that has passed since the fault occurred <p>Press Esc to regain control of the HIM</p>	

Manually Clearing Faults

This section will contain a table that illustrates the HIM keystrokes necessary to clear faults.

Step	Key(s)
<p>1. Press Esc to acknowledge the fault. The fault information will be removed so that you can use the HIM.</p>	
<p>2. Address the condition that caused the fault. The cause must be corrected before the fault can be cleared.</p>	
<p>3. After corrective action has been taken, clear the fault by one of these methods.</p> <ul style="list-style-type: none"> • Press Stop • Cycle drive power • Select “Clear Faults” from Diagnostic - Faults menu 	

Fault Descriptions

Fault Descriptions and Configuration Parameters

No.	Name	Description	Action
1	Abs Ovespd Det	Motor speed has exceeded the limits set by parameter 30 [Rev Speed Limit] minus parameter 335 [Abs OverSpd Lim] or parameter 31 [Fwd Speed Limit] plus parameter 335 [Abs OverSpd Lim]	<ol style="list-style-type: none"> 1. Verify the encoder feedback is correct polarity 2. Verify drive is not in torque mode, Par 110 [Spd/Torq ModeSel], value 2, Torque Ref -If in torque mode, verify load is present. 3. Verify min/max settings Par 30 [Rev Speed Lim] and Par 31 [Fwd Speed Lim]. 4. Verify the load is not overhauling. -If the load is overhauling, turn bus regulator off, Par 414 [Brake/Bus Cnfg], bit 2 [BusRef High].
2	Vref Decel Fail	The value of parameter 301 [Motor Spd Ref] has failed to decrease during a ramp to zero speed stop. This could possibly be due to a speed trim from parameters 21 [Speed Trim 1], 22 [Speed Trim 2] or 23 [Speed Trim 3].	
3	Encoder 0 Loss	One of the following has occurred on encoder 0: <ul style="list-style-type: none"> • missing encoder (broken wire) • quadrature error • phase loss 	SynchLink report the event status to the VPL which acts according to the configuration of parameter 365 [Encdr0 Loss Cnfg]. Reconnect encoder or replace encoder.
4	Encoder 1 Loss	One of the following has occurred on encoder10: <ul style="list-style-type: none"> • missing encoder (broken wire) • quadrature error • phase loss 	SynchLink report the event status to the VPL which acts according to the configuration of parameter 366 [Encdr1 Loss Cnfg].Reconnect encoder or replace encoder.

No.	Name	Description	Action
5	Opt Port 0 Loss	<p>A fault on port 0 of the Hi-Resolution Encoder Feedback Option Card, MDI Option Card, or Resolver Feedback Option Card has occurred.</p> <p>Parameter 260 [Hi-Res0 Status] displays the fault status for port 0 of the Hi-Resolution Encoder Feedback Option Card.</p> <p>Parameter 267 [Resolver0 Status] displays the fault status for port 0 of the Resolver Feedback Option Card.</p>	
6	Opt Port 1 Loss	<p>The Linear sensor portion of the MDI feedback option card has detected a fault condition.</p> <p>Parameter 286 [Linear1 Status] displays the fault status for linear portion of the MDI feedback Option Card.</p>	
9	Slink Comm Fail	<p>A SynchLink communication fault has occurred.</p> <p>Parameter 1229 [SL Error Status] displays SynchLink errors.</p>	
10	Drive Power Loss	<p>DC Bus voltage has fallen below the minimum value</p> <ul style="list-style-type: none"> Parameter 306 [DC Bus Voltage] displays bus voltage Parameter 330 [Fault TP Data] displays the minimum value when parameter 329 [Fault TP Sel] is set to five <p>The drive must first complete precharge before this check is made</p>	
11	Motor Oload Trip	<p>A motor overload trip has occurred.</p> <p>Parameter 308 [Output Current] is squared, scaled and integrated over time. When this integrated value exceeds 1.0, this Exception Event occurs.</p> <p>The integrator's output can be viewed in Parameter 330 [Fault TP Data] when parameter 329 [Fault TP Sel] is set to 13 "Mtr OL Outpt". The overload integration rate is affected by parameters 336 [Service Factor], 337 [Mtr I2T Curr Min], 338 [Mtr I2T Spd Min] and 339 [Mtr I2T Calibrat].</p>	Reduce mechanical load
12	Motor Oload Pend	<p>A motor overload is pending.</p> <p>Parameter 308 [Output Current] is squared, scaled and integrated over time. When this integrated value exceeds 0.5, this Exception Event occurs.</p> <p>The integrator's output can be viewed in Parameter 330 [Fault TP Data] when parameter 329 [Fault TP Sel] is set to 13 "Mtr OL Outpt". The overload integration rate is affected by parameters 336 [Service Factor], 337 [Mtr I2T Curr Min], 338 [Mtr I2T Spd Min] and 339 [Mtr I2T Calibrat].</p>	Reduce mechanical load
13	Motor Stalled	<p>The motor has stalled. These three conditions have occurred at the same time for the amount of time specified in parameter 373 [Motor Stall Time]:</p> <ul style="list-style-type: none"> Drive is not stopped (parameter 150 [Logic State Mach] not equal to zero) Drive is on limit (parameter 304 [Limit Status] not equal to zero) Drive is at zero speed (parameter 155 [Logic Status], bit 13 [At Zero Spd] is set). 	<ol style="list-style-type: none"> Increase torque limit Reduce mechanical load
14	Inv Otemp Pend	<p>Parameter 313 [Heatsink Temp] is within 10° C of maximum.</p> <p>View the maximum heat sink temperature in parameter 348 [Drive OL TP Data] when parameter 347 [Drive OL TP Se] is set to 30 [fMaxHsDegc].</p>	
15	Inv Otemp Trip	<p>Parameter 313 [Heatsink Temp] is above the maximum limit or temperature sensor has failed (shorted or open).</p> <p>See parameter 346 [Drive OL Status], bit 0 [NTC Shorted] and bit 1 [NTC Open].</p>	

No.	Name	Description	Action
16	Inv OLoad Pend	<p>The drive's operating point is approaching the intermittent current rating limitation. If output current remains at or above present levels, an Inverter Overload condition will occur.</p> <p>Operation of the Inverter Overload function is configured with the following parameters:</p> <ul style="list-style-type: none"> • 336 [Service Factor] • 337 [Mtr I2T Curr Min] • 338 [Mtr I2T Spd Min] • 339 [Mtr I2T Calibrat] 	Reduce the load on the drive
17	Inv OLoad Trip	<p>The drive's operating point has exceeded the intermittent current rating and a foldback to the continuous rating in parameter 400 [Rated Amps] has occurred.</p> <p>Operation of the Inverter Overload function is configured with the following parameters:</p> <ul style="list-style-type: none"> • 336 [Service Factor] • 337 [Mtr I2T Curr Min] • 338 [Mtr I2T Spd Min] • 339 [Mtr I2T Calibrat] 	Reduce mechanical load
18	Ext Fault Input	<p>A digital input has detected an external fault.</p> <p>Enter a value of 11 "Aux Fault" or 12 "AuxFault Inv" in one of the following parameters to configure an input to detect an external fault:</p> <ul style="list-style-type: none"> • 838 [Digin 1 Sel] • 839 [Digin 2 Sel] • 840 [Digin 3 Sel] 	
19	DSP Memory Error	Flash memory does not match the SRAM memory	
20	DSP Device Error	A DSP (VPL) interrupt task has not been completed in the allotted time.	
21	Err Inertia Test	Not Used	
22	Over Frequency Fault	<p>Encoderless algorithm fails to converge on correct speed. Two possible causes:</p> <p>Velocity regulator is attempting to run below motor's slip speed</p> <p>Frequency regulator "pulls out" and commanded motor frequency slows to maximum frequency limit.</p>	
23	MC Commissn Fail	The drive has failed to complete either the Motor Autotuning procedure or the Power Circuits Diagnostics test. Parameters 552 [MC Diag Error 1], 553 [MC Diag Error 2], and 554 [MC Diag Error 3] display Motor Autotuning and Power Circuit Diagnostic faults.	
24	DC Bus Overvolt	Bus voltage has exceeded 815V dc in 400volt class drives or 405V dc for 200 volt class drives.	<ol style="list-style-type: none"> 1. Verify the AC Line. 2. Verify that either Par 414 [Brake/Bus Cnfg], the brake or bus regulator is enabled. 3. Verify that Par 128 [Regen Power Lim] is set properly. 4. If Par 414, bit 0 [Brake Enable] is set, verify braking resistor is properly sized.
26	Ground Fault	A current to earth exceeds 35% of the peak drive rating	Check the motor and external wiring to the drive output terminals for a grounded condition.
27	Inst Overcurrent	Instantaneous motor current exceeds 214% of rating	
28	VPL/MC Comm Fail	<p>A communication failure has occurred between the Velocity Position Loop (VLP) processor and the Motor Control (MC) processor on the main control board. Possible causes are:</p> <ul style="list-style-type: none"> • MC has failed to complete or pass diagnostic tests This is Indicated when Fault Test Point 16 equals 1. This test point is viewed in parameter 330 [Fault TP Data] when parameter 329 [Fault TP Sel] equals 16 "VPL Handshak". • VPL has not detected MC handshake activity for over 32 ms. This is Indicated when Fault Test Point 16 equals 1. This test point is viewed in parameter 330 [Fault TP Data] when parameter 329 [Fault TP Sel] equals 15 "MC Handshake". • MC has not detected VPL handshake activity for over 32 ms. 	

No.	Name	Description	Action
29	PWM Signal short	This fault is detected when ever the actual IGBT gate are different than the commanded IGBT states. This fault is detected by the Motor Control processor.	
30	MC Firmware	One of the following Motor Control (MC) firmware errors has occurred: <ul style="list-style-type: none"> • MC Task Over Run • Illegal Interrupt • Self Diagnostic Fault • Data Error 	
31	Precharge Error	The precharge function has failed to complete within 30 seconds of the precharge request. A precharge request is initiated when the DC Bus voltage is above the Undervoltage Trip level and the precharge input is high (the requirement for the precharge being high can be bypassed by setting parameter 838 [DigIn 1 Sel] to a value other than 14 "PreChrg/Disc").	
32	PWM Asynch	The Motor Control Processor is not synchronized with SynchLink.	
33	+/- 12volt Power	The 12V dc control voltage is outside the tolerance range. The positive voltage power must be within the band from +15.25 to +11.4V dc. The negative voltage power must be within the band from -16.6 to -10V dc.	Replace switch mode power supply. For smaller frames, replace drive.
35	Ctrl EE Checksum	The checksum read from the EEPROM does not match the checksum calculated	1. Cycle power 2. Replace MCB
38	Brake OL Trip	The calculated temperature of the dynamic braking resistor is too high. The temperature is calculated by a thermal model. <ul style="list-style-type: none"> • If the resistor is internal, the model uses resistor characteristic stored in the power structure EEPROM memory. • If the resistor is external, the model uses values of parameters 416 [Brake PulseWatts] and 417 [Brake Watts]. 	1. Verify actual temperature of brake -If hot, wait for brake to cool -If cold, cycle power to the drive 2. If cold, verify Par 416 [Brake PulseWatts] and Par 417 [Brake Watts] are correct.
39	PowerEE CRC fail	The Cycling Ring Checksum (CRC) of the data stored in the Power Board EEPROM does not match the stored CRC.	
40	Slink Mult Oflow	A SynchLink Multiplier Overflow has occurred. Parameter 1034 [SL Mult State] displays SynchLink multiplier overflow errors.	
41	Ridethru Timeout	The drive has been in a bus loss ridethrough condition for more than two seconds.	
42	DC Bus Undervolt	Bus voltage has fallen below the level configured by parameter 409 [Line Undervolts].	1. Verify the AC Line. 2. In frames 1-4, verify the precharge resistor is present. (With power off, there should be a resistance between DC+ and BR+). In frames 5 & 6, check the precharge board for errors. See the precharge board LED for fault sequence.
43	VoltageFdbk Loss	Loss of Motor or DC Bus Voltage Feedback has occurred because of a communication failure between Motor Control and Voltage Feedback board.	
44	Runtime Data Rst	Runtime data (hours, energy) has been reset to zero due to a checksum error.	
46	Interp Out Synch	Interpolator is out of synch on motion control mode.	
48	No Ctrl Device	The controlling device (HIM or controller) has been disconnected while the drive was running.	
49	DPI Loss Port 1	DPI Port 1 has stopped communicating. A SCAN port device is connected to a drive operating DPI devices at 500k Baud	Verify DPI device is present in port 1.
50	DPI Loss Port 2	DPI Port 2 has stopped communicating. A SCAN port device is connected to a drive operating DPI devices at 500k Baud	Verify DPI device is present in port 2.

No.	Name	Description	Action
51	DPI Loss Port 3	DPI Port 3 has stopped communicating. A SCAN port device is connected to a drive operating DPI devices at 500k Baud	Verify DPI device is present in port 3.
52	DPI Loss Port 4	DPI Port 4 has stopped communicating. A SCAN port device is connected to a drive operating DPI devices at 500k Baud	Verify DPI device is present in port 4.
53	DPI Loss Port 5	DPI Port 5 has stopped communicating. A SCAN port device is connected to a drive operating DPI devices at 500k Baud	Verify AC line power
54	DPI Loss Port 6	DPI Port 6 has stopped communicating. A SCAN port device is connected to a drive operating DPI devices at 500k Baud	
55	Net Loss DPI P1	A communications fault has occurred on the communication adapter at DPI port 1.	
56	Net Loss DPI P2	A communications fault has occurred on the communication adapter at DPI port 2.	
57	Net Loss DPI P3	A communications fault has occurred on the communication adapter at DPI port 3.	
58	Net Loss DPI P4	A communications fault has occurred on the communication adapter at DPI port 4.	
59	Net Loss DPI P5	A communications fault has occurred on the communication adapter at DPI port 5.	
60	Net Loss DPI P6	A communications fault has occurred on the communication adapter at DPI port 6.	
61	Logix Out of Run	The DriveLogix controller is in a Non-Run mode. Non-Run modes include program, remote-program and faulted modes.	Clear fault
62	Logix Timeout	The communication connection to the DriveLogix controller has timed out.	
63	Logix Closed	The DriveLogix controller has closed the Controller to Drive connection.	Verify drive is present in I/O
64	Logix Link Chng	A required link in the Controller to Drive Communication Format has been modified.	Clear fault
65	HiHp In PhaseLs	<i>(High Horse Power Only)</i> AC Input Phase Loss - AC voltage is not present on one or two input phases.	1. Check for voltage on each input phase. 2. Check the status of each external input fuse.
66	HiHp Bus Com Dly	<i>(High Horse Power Only)</i> Bus Communication Time Delay - the processor has not received proper periodic feedback information.	Check fiber-optic connections between the Power Interface Circuit Board and Voltage Feedback Circuit Board.
67	HiHp Bus Link Ls	<i>(High Horse Power Only)</i> Bus Communication Link Loss - bus communication between the Power Interface Circuit Board and Voltage Feedback Circuit Board has halted.	Check fiber-optic connections between the Power Interface Circuit Board and Voltage Feedback Circuit Board.
68	HiHp Bus CRC Er	<i>(High Horse Power Only)</i> Bus Communication CRC Error - too many Cycling Ring Checksum (CRC) errors have occurred in the communication bus. A fast power cycle may cause the 700S Main Control Board to attempt to communicate with the ASIC Board before the ASIC Board is energized.	Check fiber-optic connections between the Power Interface Circuit Board and Voltage Feedback Circuit Board. Wait five minutes before re-energizing the drive.
69	HiHp Bus WtchDog	<i>(High Horse Power Only)</i> Bus Communication Watchdog Error - communication has halted in the communication bus, causing the watch dog timer to expire.	1. Check fiber-optic connections between the Power Interface Circuit Board and Voltage Feedback Circuit Board. 2. Check connections between the Main Control Board and the Power Interface Circuit Board. 3. Replace the Voltage Feedback Circuit Board. 4. Replace the Power Interface Circuit Board. 5. Replace the Main Control Board.

No.	Name	Description	Action
70	HiHp Fan Fdbk Ls	<i>(High Horse Power Only)</i> Fan Feedback Loss - a fan feedback signal has been lost.	<ol style="list-style-type: none"> 1. Check the main cooling fan. 2. Check the Main Control Board cooling fan.
71	HiHp Drv OvrLoad	<i>(High Horse Power Only)</i> Drive Overload - the circuit board on the Power Module has detected an overload.	Measure output current of the drive. If the level is ever greater than the maximum drive rated output current level reduce the load. If the levels are always well below the drive rated levels, then replace the power module.
72	HiHp PwrBd PrcEr	<i>(High Horse Power Only)</i> Power Board Processor Error - a microprocessor on the Power Board has detected a communication error.	<ol style="list-style-type: none"> 1. Check fiber-optic connections between the Power Interface Circuit Board and Voltage Feedback Circuit Board. 2. Check connections between the Main Control Board and the Power Interface Circuit Board. 3. Replace the Voltage Feedback Circuit Board 4. Replace the Power Interface Circuit Board. 5. Replace the Main Control Board.
73	HiHp PrChrg Cntc	<i>(High Horse Power Only)</i> Precharge Contactor Fault - proper contactor feedback has not occurred. The precharge contactor has probably failed to pick up or the feedback signal has failed. This fault only applies to DC input drives.	<ul style="list-style-type: none"> • Check precharge circuit wiring. • Check for loose connections on X50 terminal block and/or the X9 and X15 connectors on the ASIC Board.
74	HiHp PwrEE Error	<i>(High Horse Power Only)</i> Power EEPROM Error - the rating of the drive and data in the Power EEPROM on the Power Board do not match.	Replace output power module or program a new power board.
75	HiHP PwrBd Otemp	<i>(High Horse Power Only)</i> Power Board Over-Temperature - temperature of the Power Board on has exceeded 85° C.	Check the main cooling fan and fan power supply, replace if necessary.
85	Position Error	Position feedback exceeds the position error tolerance setting, Par 913 [Motn PositErrTol].	

Notes:



Supplemental Information

Chapter Objectives

For Information on ...	See Page...
Specifications	A-1
DPI Communication Configurations	A-4
Output Devices	A-6
Drive, Fuse & Circuit Breaker Ratings	A-6
List of Motors with Compatible Thermistor Ratings	A-17
Spare Connectors	A-18
Dimensions	A-19

Specifications

Category	Specification	Frames 1-6 (690V Drive frames 5 & 6 only)						Frames 9 & up				
		200-208V Drive	240V Drive	380/400V Drive	480V Drive	600V Drive	690V Drive	380/400V Drive	480V Drive	500V Drive	600V Drive	690V Drive
Protection	AC Input Overvoltage Trip:	247VAC	285VAC	475VAC	570VAC	690VAC	863VAC	475VAC	570V AC	611V AC	690VAC	863VAC
	Bus Overvoltage Trip:	350VDC	405VDC	675VDC	810VDC	1013VDC	1164VDC	675VDC	810VDC	810VDC	1013VDC	1164VDC
	Bus Undervoltage Trip:	Adjustable						Adjustable				
	Nominal Bus Voltage:	281VDC	324VDC	540VDC	648VDC	810VDC	931VDC	540VDC	648VDC	645VDC	810VDC	931VDC
	Heat Sink Thermistor:	Monitored by microprocessor overtemp trip						Monitored by microprocessor overtemp trip				
	Drive Overcurrent Trip	Calculated value, 105% of motor rated to 200% of drive rated						Calculated value, 105% of motor rated to 200% of drive rated				
	Software Current Limit:	105% of 3 sec. rating (158%-210%)						360% of rated Heavy Duty current (typical)				
	Hardware Current Limit:	143% of 3 sec rating (215%-287%)						—				
	Instantaneous Current Limit:	—						—				
	Line Transients:	Up to 6000 volts peak per IEEE C62.41-1991						up to 6000 volts peak per IEEE C62.41-1991				
	Control Logic Noise Immunity:	Showering arc transients up to 1500V peak						Showering arc transients up to 1500V peak				
	Power Ride-Thru:	15 milliseconds at full load						15 milliseconds at full load				
Logic Control Ride-Thru	0.25 sec., drive not running						0.25 seconds, drive not running					
Ground Fault Trip:	Phase-to-ground on drive output						Phase-to-ground on drive output					
Short Circuit Trip:	Phase-to-phase on drive output						Phase-to-phase on drive output					

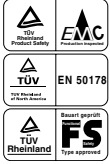
Category	Specification		
	Frames 1-6 (690V Drive frames 5 & 6 only)	Frames 9 & up	
Agency Certification		The drive is designed to meet applicable requirements of the following codes/standards: IEC 61800-2 Adjustable speed electrical power drive systems - General requirements IEC 61800-5-1 Adjustable speed electrical power drive systems - Safety requirements NFPA 70 – US National Electric Code NEMA 250 – Enclosures for Electrical Equipment	The drive is designed to meet applicable requirements of the following codes/standards: IEC 61800-2 Adjustable speed electrical power drive systems - General requirements IEC 61800-5-1 Adjustable speed electrical power drive systems - Safety requirements NFPA 70 - US National Electrical Code
		UL and cUL Listed to UL508C and CAN/CSA - 22.2 No. 14-95	UL and cUL Listed to UL508C and CAN/CSA - 22.2 No. 14-95
		Marked for all applicable European Directives EMC Directive (89/336/EEC) Emissions EN 61800-3 Adjustable Speed electrical power drive systems Part 3 Immunity EN 61800-3 Second Environment, Restricted Distribution Low Voltage Directive (73/23/EEC) EN 50178 Electronic Equipment for use in Power Installations	Marked for all applicable European Directives EMC Directive (89/336/EEC) Emissions EN 61800-3 Adjustable Speed electrical power drive systems Part 3 Low Voltage Directive (73/23/EEC) EN 50178 Electronic Equipment for use in Power Installations
		TUV Rheinland (applies to frames 1 - 6, 200/400V, and frames 5 & 6, 690V only) TUV Functional Safety Report only for frames 1 - 4, 600V (no FS mark on the label)	TUV functional safety report only (no FS mark on the label)
Environment	Altitude:	1000 m (3300 ft.) max. without derating	1000 m (3300 ft.) max. without derating
	Surrounding Air Temperature without Derating:		Based on drive rating, refer to Drive Frame chapters
	Open Type:	0 to 50° C (32 to 122° F)	
	IP20:	0 to 50° C (32 to 122° F)	
	NEMA Type 1:	0 to 40° C (32 to 104° F)	
	IP56, NEMA Type 4X:	0 to 40° C (32 to 104° F) Note: Frames 9 & 10 are rated 0 to 40° C (32 to 104° F) surrounding air.	
	Storage Temperature (all const.):	-40 to 70° C (-40 to 158° F)	-40 to 70 degrees C (-40 to 158 degrees F)
Relative Humidity:	5 to 95% non-condensing	5 to 95% non-condensing	
Shock:	10G peak for 11 ms duration (+/- 1.0 ms)	15G peak for 11ms duration (±1.0 ms)	
Vibration:	0.152 mm (0.006 in.) displacement, 1G peak, 5.5 Hz	2 mm (0.0787 in.) displacement, 1G peak EN50178 / EN60068-2-6	
Atmosphere	—	Important: Drive must not be installed in an area where the ambient atmosphere contains volatile or corrosive gas, vapors or dust. If the drive is not going to be installed for a period of time, it must be stored in an area where it will not be exposed to a corrosive atmosphere.	
Electrical	AC Input Voltage Tolerance:	See Input Voltage Range/Tolerance on page C-1 for Full Power and Operating Range	—
	Frequency Tolerance:	47-63 Hz	47-63 Hz.
	Input Phases:	Three-phase input provides full rating for all drives. Single-phase operation provides 50% of rated current.	Three-phase input provides full rating for all drives. Single-phase operation provides 50% of rated current.
	DC Input Voltage Tolerance	+/- 10% of Nominal Bus Voltage (above)	—
	Displacement Power Factor:	0.98 across speed range	0.98 across speed range
	Efficiency:	97.5% at rated amps, nominal line volts.	97.5% at rated amps, nominal line volts.
	Max. Short Circuit Current Rating: Using Recommended Fuse or Circuit Breaker Type	Maximum short circuit current rating to match specified fuse/circuit breaker capability. ≤ 200,000 Amps	≤ 200,000 Amps
	Maximum Drive to Motor Power Ratio	The drive to motor rating cannot exceed a 2:1 ratio	The drive to motor rating cannot exceed a 2:1 ratio

Category	Specification	Frames 1-6 (690V Drive frames 5 & 6 only)	Frames 9 & up	
Control	Method Induction Motor: Brushless Motor:	Sine coded PWM with programmable carrier frequency, Indirect Self-Organized, Field-Oriented Control, Current-regulated. Ratings apply to all drives. Refer to the PowerFlex® 700S - Phase I Control Reference Manual, publication PFLEX-RM002, for derating guidelines. The drive can be supplied as 6 pulse or 12 pulse in a configured package.	Sine coded PWM with programmable carrier frequency, Indirect Self-Organized, Field-Oriented Control, Current-regulated. Ratings apply to all drives. Refer to the PowerFlex® 700S - Phase I Control Reference Manual, publication PFLEX-RM002, for derating guidelines. The drive can be supplied as 6 pulse or 12 pulse in a configured package.	
	Carrier Frequency	Drive rating: 4 kHz Settings: 2, 4, 8, 10 kHz	Drive rating: 2 kHz Settings: 2, 4, 8, 10 kHz	
	Output Voltage Range:	0 to rated motor voltage	0 to rated motor voltage	
	Output Frequency Range:	0 – 320 Hz	0 – 320 Hz	
	Speed Control	Speed regulation - without feedback 0.1% of base speed across 120:1 speed range 120:1 operating range 50 rad/sec bandwidth	Speed regulation - without feedback 0.1% of base speed across 120:1 speed range 120:1 operating range 50 rad/sec bandwidth	Speed regulation - without feedback 0.1% of base speed across 120:1 speed range 120:1 operating range 50 rad/sec bandwidth
		Speed regulation - with feedback 0.001% of base speed across 120:1 speed range 1000:1 operating range 300 rad/sec bandwidth	Speed regulation - with feedback 0.001% of base speed across 120:1 speed range 1000:1 operating range 300 rad/sec bandwidth	Speed regulation - with feedback 0.001% of base speed across 120:1 speed range 1000:1 operating range 300 rad/sec bandwidth
	Torque Regulation	Torque Regulation - without feedback +/-10%, 600 rad/sec bandwidth	Torque Regulation - without feedback +/-10%, 600 rad/sec bandwidth	Torque Regulation - without feedback +/-10%, 600 rad/sec bandwidth
		Torque Regulation - with feedback +/-2%, 2500 rad/sec bandwidth	Torque Regulation - with feedback +/-2%, 2500 rad/sec bandwidth	Torque Regulation - with feedback +/-5%, 2500 rad/sec bandwidth
	Selectable Motor Control:	Field Oriented Control with and without a feedback device and permanent magnet motor control	Field Oriented Control with and without a feedback device and permanent magnet motor control	Field Oriented Control with and without a feedback device and permanent magnet motor control
	Stop Modes:	Multiple programmable stop modes including – Ramp, Coast and Current Limit	Multiple programmable stop modes including – Ramp, Coast and Current Limit	Multiple programmable stop modes including – Ramp, Coast and Current Limit
	Accel/Decel	Independently programmable accel and decel times adjustable from 0 to 6553.5 in 0.1 second increments.	Independently programmable accel and decel times adjustable from 0 to 6553.5 in 0.1 second increments.	Independently programmable accel and decel times adjustable from 0 to 6553.5 in 0.1 second increments.
	S-Curve Time	Adjustable from 0.5 to 4.0 seconds	Adjustable from 0.5 to 4.0 seconds	Adjustable from 0.5 to 4.0 seconds
	Intermittent Overload:	110% Overload capability for up to 1 minute 150% Overload capability for up to 3 seconds	110% Overload capability for up to 1 minute 150% Overload capability for up to 3 seconds	110% Overload capability for up to 1 minute 150% Overload capability for up to 3 seconds
Current Limit Capability:	Independent Motoring and Regenerative Power Limits programmable to 800% of rated output current	Independent Motoring and Regenerative Power Limits programmable to 800% of rated output current	Independent Motoring and Regenerative Power Limits programmable to 800% of rated output current	
Electronic Motor Overload Protection	Provides class 10 motor overload protection according to NEC article 430 and motor over-temperature protection according to NEC article 430.126 (A) (2). UL 508C File E59272.	Provides class 10 motor overload protection according to NEC article 430 and motor over-temperature protection according to NEC article 430.126 (A) (2). UL 508C File E59272.	Provides class 10 motor overload protection according to NEC article 430 and motor over-temperature protection according to NEC article 430.126 (A) (2). UL 508C File E59272.	

Category	Specification	Frames 1-6 (690V Drive frames 5 & 6 only)		Frames 9 & up	
Feedback	Encoder Inputs (2):	Dual Channel Plus Marker, Isolated with differential transmitter Output (Line Drive) Incremental, Dual Channel Quadrature type		Dual Channel Plus Marker, Isolated with differential transmitter Output (Line Drive) Incremental, Dual Channel Quadrature type	
	Encoder Voltage Supply:	5V DC or 12 V DC 320 mA/channel 5V DC requires an external power supply. 12 V DC minimum high state voltage of 7V DC, maximum low state voltage of 0.4V DC		5V DC or 12 V DC 320 mA/channel 5V DC requires an external power supply. 12 V DC minimum high state voltage of 7V DC, maximum low state voltage of 0.4V DC	
	Maximum Input Frequency:	400 kHz		500 kHz	
	Stegmann Option:				
	Encoder Voltage Supply:	11.5V DC @ 130 mA		11.5V DC @ 130 mA	
	Hi-Resolution Feedback:	Sine/Cosine 1V P-P Offset 2.5		Sine/Cosine 1V P-P Offset 2.5	
	Maximum Cable Length:	182 m (600 ft.)		182 m (600 ft.)	
	RS-485 Interface:	Hi-Resolution Feedback Option card obtains the following information via the Hiperface RS-485 interface shortly after power-up: Address, Command Number, Mode, Number of turns, Number of Sine/Cos cycles, Checksum		Hi-Resolution Feedback Option card obtains the following information via the Hiperface RS-485 interface shortly after power-up: Address, Command Number, Mode, Number of turns, Number of Sine/Cos cycles, Checksum	
	Customer-I/O Plug (P1) - Hi Res:	Allen-Bradley PN: S94262912 Weidmuller PN: BL3.50/90/12BK		Allen-Bradley PN: S94262912 Weidmuller PN: BL3.50/90/12BK	
	Resolver Option:				
	Excitation Frequency:	2400 Hz		2400 Hz	
	Excitation Voltage:	4.25-26 Vrms		4.25-26 Vrms	
	Operating Frequency Range:	1 - 10 kHz		1 - 10 kHz	
	Resolver Feedback Voltage:	2V ± 300 mV		2V ± 300 mV	
	Maximum Cable Length:	304.8 meters (1000 ft.)		304.8 meters (1000 ft.)	
DriveLogix	User Available MemoryBase:	256 kbytes		256 kbytes	
	With Memory Expansion Board:	768 kbytes		768 kbytes	
	Battery:	1756-BA1 (Allen-Bradley PN 94194801) 0.59g lithium		1756-BA1 (Allen-Bradley PN 94194801) 0.59g lithium	
	Serial Cable:	1761-CBLPM02 to 1761-NET-AIC		1761-CBLPM02 to 1761-NET-AIC	
		1761-CBLPA00 to 1761-NET-AIC		1761-CBLPA00 to 1761-NET-AIC	
		1756-CP3 directly to controller		1756-CP3 directly to controller	
		1747-CP3 directly to controller		1747-CP3 directly to controller	
		category 3 (2)		category 3 (2)	
Flex I/O Connection:	Up to (8) modules		Up to (8) modules		
FLEXBUS Current Output:	640 mA maximum @ 5.1V dc		640 mA maximum @ 5.1V dc		
Cable:	4100-CCF3		4100-CCF3		

DPI Communication Configurations

Typical Programmable Controller Configurations

Important: If programs are written that continuously write information to the drive, care must be taken to properly format the block transfer. If attribute 10 is selected for the block transfer, values will be written only to RAM and will not be saved by the drive. This is the preferred attribute for continuous transfers. If attribute 9 is selected, each program scan will complete a write to the drives non-volatile memory (EEPROM). Since the EEPROM has a fixed number of allowed writes, continuous block transfers will quickly damage the EEPROM. Do Not assign attribute 9 to continuous block transfers. Refer to the individual communications adapter User Manual for additional details.

Logic Status Word

Logic Bits																Status	Description
15	14	13	12	11	10	9	8	7	6	5	4	3	2	1	0		
															x	Enabled	0 = Not Enabled 1 = Enabled
															x	Running	0 = Not Running 1 = Running
															x	Command Direction	0 = Reverse 1 = Forward
															x	Actual Direction	0 = Reverse 1 = Forward
															x	Accel	0 = Not Accelerating 1 = Accelerating
															x	Decel	0 = Not Decelerating 1 = Decelerating
															x	Jogging	0 = Not Jogging 1 = Jogging
															x	Fault	0 = No Fault 1 = Fault
															x	Alarm	0 = No Alarm 1 = Alarm
															x	Flash Mode	0 = Not in Flash Mode 1 = In Flash Mode
															x	Run Ready	0 = Not Ready to Run 1 = Ready to Run
															x	At Limit ⁽¹⁾	0 = Not At Limit 1 = At Limit
															x	Tach Loss Sw	0 = Not Tach Loss Sw 1 = Tach Loss Sw
															x	At Zero Spd	0 = Not At Zero Speed 1 = At Zero Speed
															x	At Setpt Spd	0 = Not At Setpoint Speed 1 = At Setpoint Speed
															x	Reserved	

(1) See Parameter 304 - [Limit Status] in the PowerFlex 700S drive for a description of the limit status conditions.

Output Devices

Common mode cores are internal to the drive. For information on output devices such as output contactors, cable terminators and output reactors refer to the *PowerFlex Reference Manual, Vol. 2*.

Fusing and Circuit Breakers

The tables on the following pages provide recommended AC line input fuse and circuit breaker information. See Fusing and Circuit Breakers below for UL and IEC requirements. Sizes listed are the recommended sizes based on 40 °C (104 °F) and the U.S. NEC. Other country, state, or local codes can require different ratings. Tables with DC link fuse recommendations for DC input drives are also provided.

Fusing

The recommend fuse types are listed below. If available current ratings do not match those listed in the tables provided, choose the next higher fuse rating.

- IEC - BS88 (British Standard) Parts 1 & 2, EN60269-1, Parts 1 & 2, type gG or equivalent should be used.
- UL - UL requirements specify that UL Class CC, T, RK1, or J fuses must be used for all drives in this section.

Circuit Breakers

The “non-fuse” listings in the following tables include inverse time circuit breakers, instantaneous trip circuit breakers (motor circuit protectors) and 140M self-protected combination motor controllers. If one of these is chosen as the desired protection method, the following requirements apply:

- IEC - Both types of circuit breakers and 140M self-protected combination motor controllers are acceptable for IEC installations.
- UL - Only inverse time circuit breakers and the specified 140M self-protected combination motor controllers are acceptable for UL installations.

⁽¹⁾ Typical designations include, but may not be limited to the following; Parts 1 & 2: AC, AD, BC, BD, CD, DD, ED, EFS, EF, FF, FG, GF, GG, GH.

Document Update

Original Instructions



Allen-Bradley

by ROCKWELL AUTOMATION

PowerFlex 700S High Performance AC Drive

Bulletin Number 20D

Publication Reference

PowerFlex® 700S High Performance AC Drive Phase I Control, publication 20D-UM001G-EN-P - August 2013

Additional 140MT Motor Protection Circuit Breakers

Additional PowerFlex 70 AC drive circuit breakers are now available.

The following tables replace the tables that appear on pages A-8...A-16 of publication 20D-UM001G-EN-P. The following tables have Bulletin 140MT motor protection circuit breakers added to drive input protection devices.

400V AC Input Protection Devices, Frames 9...11 (see [Notes on page 9](#))

Cat. No.	Frame	HP Rating		Input Ratings		Output Current Rating [A]		Dual Element Time Delay Fuse [A]		Non-time Delay Fuse [A]		Circuit Breaker [A] (3)	Motor Circuit Protector [A] (4)	140M/MT MPCB with Adjustable Current Range (5)(6)	Power Dissipation
		MD	HD	A	KVA	Cont.	60 s	3 s	Min (1)	Max (2)	Min (1)				
400V AC Input															
200C261	9	132	—	256	171	261	287	410	325	500	325	700	400	—	—
		—	110	201	139	205	308	410	250	400	250	550	400	—	—
200C300	9	160	—	294	204	300	330	500	375	675	375	800	400	—	—
		—	132	240	166	245	368	490	325	500	325	650	400	—	—
200C385	10	200	—	377	261	385	424	600	500	800	500	1000	800	—	—
		—	160	294	204	300	450	600	375	675	375	800	600	—	—
200C460	10	250	—	451	312	460	506	770	575	900	575	1200	800	—	—
		—	200	377	261	385	578	770	500	800	500	1000	800	—	—
200C500	10	250	—	490	339	500	550	750	625	1100	625	1400	800	—	—
		—	200	411	285	420	630	840	525	1000	525	1000	800	—	—
200C590	11	315	—	590	408	590	649	956	750 (1 per phs) 375 (2 per phs)	1300 (1 per phs) 600 (2 per phs)	750 (1 per phs) 375 (2 per phs)	1700 (1 per phs) 850 (2 per phs)	1200	—	—
		—	250	520	360	520	780	956	650 (1 per phs) 325 (2 per phs)	1100 (1 per phs) 550 (2 per phs)	650 (1 per phs) 325 (2 per phs)	1500 (1 per phs) 750 (2 per phs)	800	—	—
200C650	11	355	—	650	450	650	715	1062	900 (1 per phs) 450 (2 per phs)	1300 (1 per phs) 650 (2 per phs)	900 (1 per phs) 450 (2 per phs)	1700 (1 per phs) 850 (2 per phs)	1200	—	—
		—	315	590	408	590	885	1062	750 (1 per phs) 375 (2 per phs)	1300 (1 per phs) 650 (2 per phs)	750 (1 per phs) 375 (2 per phs)	1700 (1 per phs) 850 (2 per phs)	1200	—	—
200C730	11	400	—	730	506	730	803	1095	1000 (1 per phs) 500 (2 per phs)	1500 (1 per phs) 750 (2 per phs)	1000 (1 per phs) 500 (2 per phs)	2000 (1 per phs) 1000 (2 per phs)	2000	—	—
		—	355	650	450	650	975	1170	900 (1 per phs) 450 (2 per phs)	1300 (1 per phs) 650 (2 per phs)	900 (1 per phs) 450 (2 per phs)	1700 (1 per phs) 850 (2 per phs)	1200	—	—

480V AC Input Protection Devices, Frames 1...6 (see [Notes on page 9](#))

Cat. No.	Frame	HP Rating		Input Ratings		Output Current Rating		Dual Element Time Delay Fuse [A]		Non-time Delay Fuse [A]		Circuit Breaker [A] (3)	Motor Circuit Protector [A] (4)	140M/MT MPCB with Adjustable Current Range (5)(6)		Power Dissipation Watts	
		ND	HD	A	KVA	Cont.	60 s	3 s	Min (1)	Max (2)	Min (1)			Max (2)	Available Catalog Numbers (7)		
480V AC Input																	
200D02P1	1	1	0.75	1.6	1.4	2.1	2.4	3.2	3	6	3	8	15	3	140M-C2E-B25 140MT-C3E-B25	—	103
200D03P4	1	2	1.5	2.6	2.2	3.4	4.5	6.0	4	8	4	12	15	7	140M-C2E-B40 140MT-C3E-B40	140M-D8E-B40 140MT-D9E-B40	117
200D06P0	1	3	2	3.9	3.2	5.0	5.5	7.5	6	10	6	20	20	7	140M-C2E-B63 140MT-C3E-B63	140M-D8E-B63 140MT-D9E-B63	135
200D08P0	1	5	3	6.9	5.7	8.0	8.8	12	10	15	10	30	30	15	140M-C2E-C10 140MT-C3E-C10	140M-D8E-C10 140MT-D9E-C10	210
200D00T1	1	7.5	5	9.5	7.9	11	12.1	16.5	15	20	15	40	40	15	140M-C2E-C16 140MT-C3E-C16	140M-D8E-C16 140MT-D9E-C16	243
200D00I4	1	10	7.5	12.5	10.4	14	16.5	22	17.5	30	17.5	50	50	20	140M-C2E-C16 140MT-C3E-C16	140M-D8E-C16 140MT-D9E-C16	271
200D00Z2	1	15	10	19.9	16.6	22	24.2	33	25	50	25	80	80	30	140M-C2E-C25 140MT-C3E-C25	140M-D8E-C25 140MT-D9E-C25	389
200D00Z7	2	20	15	24.8	20.6	27	33	44	35	60	35	100	100	50	—	140M-F8E-C32	467
200D00Z34	2	25	20	31.2	25.9	34	40.5	54	40	70	40	125	125	50	—	140M-F8E-C45	519
200D00A40	3	30	25	36.7	30.5	40	51	68	50	90	50	150	150	50	—	140M-F8E-C45	543
200D00E52	3	40	30	47.7	39.7	52	60	80	60	110	60	200	200	70	—	140M-CMN-6300	708
200D00E65	3	50	40	59.6	49.6	65	78	104	80	125	80	250	250	100	—	140M-CMN-9000	—
200D00T77	4	—	—	72.3	60.1	77	85	116	100	170	100	300	300	100	—	140M-CMN-9000	—
—	—	—	—	59.6	49.6	65	98	130	80	125	80	250	250	100	—	140M-CMN-9000	—
200D00E96	5	75	—	90.1	74.9	96	106	144	125	200	125	350	350	125	—	140M-CMN-9000	—
—	—	—	—	72.3	60.1	77	116	154	100	170	100	300	300	100	—	140M-CMN-9000	—
200D01Z5	5	100	—	117	97.6	125	138	163	150	250	150	500	375	150	—	140M-CMN-9000	—
—	—	—	—	90.1	74.9	96	144	168	125	200	125	350	350	125	—	140M-CMN-9000	—
200D01E6	6	125	—	147	122	156	172	234	200	350	200	600	450	250	—	140M-CMN-9000	—
—	—	—	—	131	109	125	188	250	175	250	175	500	375	250	—	140M-CMN-9000	—
200D01E80	6	150	—	169	141	180	198	270	225	400	225	600	500	250	—	140M-CMN-9000	—
—	—	—	—	147	122	156	234	312	200	350	200	600	450	250	—	140M-CMN-9000	—
200D02E48	6	200	—	233	194	248	273	392	300	550	300	700	700	400	—	140M-CMN-9000	—
—	—	—	—	169	141	180	270	360	225	400	225	600	500	250	—	140M-CMN-9000	—

480V AC Input Protection Devices, Frames 9...11 (see [Notes on page 9](#))

Cat. No.	Frame	HP Rating		Input Ratings		Output Current Rating		Dual Element Time Delay Fuse [A]		Non-time Delay Fuse [A]		Circuit Breaker [A] (3)	Motor Circuit Protector [A] (4)	140N/MT MPCB with Adjustable Current Range (5)(6)		Power Dissipation Watts	
		ND	HD	A	kVA	Cont.	60 s	3 s	Min (1)	Max (2)	Min (1)			Max (2)	Max (10)		Available Catalog Numbers (7)
480V AC Input																	
200D261	9	200	—	245	204	261	287	410	325	500	325	700	700	400	—	—	2700
		—	150	193	160	205	308	410	250	400	250	550	600	400	—	—	2700
200D300	9	250	—	282	234	300	330	450	375	675	375	800	800	400	—	—	3100
		—	200	230	191	245	368	490	325	500	325	650	700	400	—	—	3100
200D385	10	300	—	362	301	385	424	600	500	800	500	1000	800	800	—	—	4700
		—	250	282	234	300	460	600	375	675	375	800	800	600	—	—	4700
200D460	10	350	—	432	359	460	506	770	575	900	575	1200	1200	800	—	—	5500
		—	300	362	301	385	578	770	500	800	500	1000	800	800	—	—	5500
200D500	10	450	—	469	390	500	550	750	625	1100	625	1400	1200	800	—	—	6400
		—	350	394	328	420	630	840	525	1000	525	1000	1200	800	—	—	6400
200D590	11	500	—	590	490	590	649	956	750 (1 per phs) 375 (2 per phs)	1300 (1 per phs) 600 (2 per phs)	750 (1 per phs) 375 (2 per phs)	1700 (1 per phs) 850 (2 per phs)	1600	1200	—	—	—
		—	450	520	532	520	780	956	650 (1 per phs) 325 (2 per phs)	1100 (1 per phs) 550 (2 per phs)	650 (1 per phs) 325 (2 per phs)	1500 (1 per phs) 750 (2 per phs)	1200	800	—	—	—
200D650	11	500	—	650	540	650	715	1062	900 (1 per phs) 450 (2 per phs)	1300 (1 per phs) 650 (2 per phs)	900 (1 per phs) 450 (2 per phs)	1700 (1 per phs) 850 (2 per phs)	1600	1200	—	—	—
		—	500	590	490	590	885	1062	750 (1 per phs) 375 (2 per phs)	1300 (1 per phs) 650 (2 per phs)	750 (1 per phs) 375 (2 per phs)	1700 (1 per phs) 850 (2 per phs)	1600	1200	—	—	—
200D730	11	600	—	730	607	730	803	1095	1000 (1 per phs) 500 (2 per phs)	1500 (1 per phs) 750 (2 per phs)	1000 (1 per phs) 500 (2 per phs)	2000 (1 per phs) 1000 (2 per phs)	2000	2000	—	—	—
		—	500	650	540	650	975	1170	900 (1 per phs) 450 (2 per phs)	1300 (1 per phs) 650 (2 per phs)	900 (1 per phs) 450 (2 per phs)	1700 (1 per phs) 850 (2 per phs)	1600	1200	—	—	—

600V AC Input Protection Devices, Frames 1...6 (see [Notes on page 9](#))

Cat. No.	Frame	HP Rating		Temp. °C	PWM Freq. kHz	Input Ratings		Output Current Rating [A]		Dual Element Time Delay Fuse [A]		Non-time Delay Fuse [A]		Circuit Breaker [A] (3)	Motor Circuit Protector [A] (4)	140M/MT MPCB with Adjustable Current Range (5)(6)		Power Dissipation Watts	
		ND	HD			A	kVA	Cont.	60 s	3 s	Min (1)	Max (2)	Min (1)			Max (2)	Available Catalog Numbers (7)		
600V AC Input																			
20DEIP7	1	1	0.5	50	1.3	1.4	1.7	2	2.6	2	4	2	6	15	3	140M-C2E-B16 140MT-C3E-B16	-	-	
20DE2P7	1	2	1	50	2.1	2.1	2.7	3.6	4.8	3	6	3	10	15	3	140M-C2E-B25 140MT-C3E-B25	-	-	
20DE3P9	1	3	2	50	3.0	3.1	3.9	4.3	5.9	6	9	6	15	15	7	140M-C2E-B40 140MT-C3E-B40	140M-D8E-B40 140MT-D9E-B40	-	-
20DE6P1	1	5	3	50	5.3	5.5	6.1	6.7	9.2	9	12	9	20	20	15	140M-C2E-B63 140MT-C3E-B63	140M-D8E-B63 140MT-D9E-B63	-	-
20DE9P0	1	7.5	5	50	7.8	8.1	9	9.9	13.5	10	20	10	35	30	15	140M-C2E-C10 140MT-C3E-C10	140M-D8E-C10 140MT-D9E-C10	-	-
20DE011	1	10	7.5	50	9.9	10.2	11	13.5	18	15	25	15	40	40	15	140M-C2E-C10 140MT-C3E-C10	140M-D8E-C10 140MT-D9E-C10	-	-
20DE017	1	15	10	50	15.4	16.0	17	18.7	25.5	20	40	20	60	50	20	140M-C2E-C16 140MT-C3E-C16	140M-D8E-C16 140MT-D9E-C16	-	-
20DE022	2	20	15	50	20.2	21.0	22	25.5	34	30	50	30	80	80	30	140M-C2E-C25 140MT-C3E-C25	140M-D8E-C25 140MT-D9E-C25	140M-F8E-C25	140M-CMN-2500
20DE027	2	25	20	50	24.8	25.7	27	33	44	35	60	35	100	100	50	-	-	140M-F8E-C25	140M-CMN-2500
20DE032	3	30	25	50	29.4	30.5	32	40.5	54	40	70	40	125	125	50	-	-	140M-F8E-C32	140M-CMN-4000
20DE041	3	40	30	50	37.6	39.1	41	48	64	50	90	50	150	150	100	-	-	140M-F8E-C45	140M-CMN-4000
20DE052	3	50	40	50	47.7	49.6	52	61.5	82	60	110	60	200	200	100	-	-	-	140M-CMN-6300
20DE062	4	60	50	50	58.2	60.5	62	78	104	80	125	80	225	225	100	-	-	-	140M-CMN-6300
20DE077	5	75	-	50	72.3	75.1	77	85	116	90	150	90	300	300	100	-	-	-	140M-CMN-9000
		-	60	50	58.2	60.5	63	94	126	90	125	90	250	250	100	-	-	-	140M-CMN-6300
20DE089	5	100	-	40	92.9	96.6	99	109	126	125	200	125	375	375	150	-	-	-	-
		-	75	40	72.3	75.1	77	116	138	100	175	100	300	300	100	-	-	-	140M-CMN-9000
20DE125	6	125	-	50	117	122	125	-	-	150	250	150	375	375	250	-	-	-	-
		-	100	50	92.9	96.6	99	-	-	125	200	125	375	375	150	-	-	-	-
20DE144	6	150	-	2	135	141	144	-	-	175	300	175	400	400	250	-	-	-	-
		-	125	2	117	122	125	-	-	150	275	150	375	375	250	-	-	-	-

690V AC Input Protection Devices (see [Notes](#))

Cat. No.	Frame	kW Rating		PWM Freq. kHz	Temp. °C	Input Ratings		Output Current Rating [A]			Dual Element Time Delay Fuse [A]		Non-time Delay Fuse [A]		Circuit Breaker [A] ⁽³⁾	Motor Circuit Protector [A] ⁽⁴⁾	Power Dissipation Watts
		ND	HD			A	kVA	Cont.	60 s	3 s	Min ⁽¹⁾	Max ⁽²⁾	Min ⁽¹⁾	Max ⁽²⁾			
690V AC Input																	
20DF052	5	45	—	4	50	46.9	56.1	52	57	78	60	110	60	175	175	—	—
		—	37.5	4	50	40.1	48.0	46	69	92	50	90	50	150	150	—	—
20DF060	5	55	—	4	50	57.7	68.9	60	66	90	80	125	80	225	225	—	—
		—	45	4	50	46.9	56.1	52	78	104	60	110	60	175	175	—	—
20DF082	5	75	—	2	50	79.0	94.4	82	90	123	100	200	100	375	375	—	—
		—	55	2	50	57.7	68.9	60	90	120	80	125	80	225	225	—	—
20DF098	5	90	—	2	40	94.7	113	98	108	127	125	200	125	375	375	—	—
		—	75	2	40	79.0	94.4	82	123	140	100	200	100	375	375	—	—
20DF119	6	110	—	2	50	115	137	119	131	179	150	250	150	400	—	—	—
		—	90	2	50	94.7	113	98	147	196	125	200	125	375	—	—	—
20DF142	6	132	—	2	50	138	165	142	156	213	175	300	175	450	—	—	—
		—	110	2	50	115	137	119	179	238	150	250	150	400	—	—	—

Notes

- (1) Minimum protection device size is the lowest rated device that supplies maximum protection without nuisance tripping.
- (2) Maximum protection device size is the highest rated device that supplies drive protection. For US NEC, the minimum size is 125% of motor FLA. Ratings that are shown are maximum.
- (3) Circuit Breaker - inverse time breaker. For US NEC, the minimum size is 125% of motor FLA. Ratings that are shown are maximum.
- (4) Motor Circuit Protector - instantaneous trip circuit breaker. For US NEC, the minimum size is 125% of motor FLA. Ratings that are shown are maximum.
- (5) Bulletin 140M/MT devices with adjustable current range must have the current trip set to the minimum range that the device does not trip.
- (6) Manual Self-Protected (Type E) Combination Motor Controller, UL Listed for 208V Wye or Delta, 240V Wye or Delta, 480Y/277V or 600Y/347V. Not UL Listed for use on 480V or 600V Delta/Delta, corner ground, or high-resistance ground systems.
- (7) The AIC ratings of the Bulletin 140M/MT devices can vary. See publication [140-TD005](#) or [140M-TD002](#).
- (8) 20BC085 current rating is limited to 45 °C (113 °F) ambient.
- (9) 20BC205 current rating is limited to 40 °C (104 °F) ambient.
- (10) Maximum allowable rating by US NEC. Exact size must be chosen for each installation

540V DC Input Protection Devices (see [Notes on page 11](#))

Cat. No.	Frame	HP Rating		DC Input Ratings		Output [A]			Fuse ⁽¹⁾	Non-time Delay Fuse ⁽²⁾
		ND	HD	A	kW	Cont.	60 s	3 s		
650V DC Input										
20DD2P1	0	1	0.75	1.9	1.2	2.1	2.4	3.2	6	JKS-6
20DD3P4	0	2	1.5	3.0	2.0	3.4	4.5	6.0	6	JKS-6
20DD5P0	0	3	2	4.5	2.9	5.0	5.5	7.5	10	JKS-10
20DD8P0	0	5	3	8.1	5.2	8.0	8.8	12	15	JKS-15
20DD011	0	7.5	5	11.1	7.2	11	12.1	16.5	20	JKS-20
20DD014	1	10	7.5	14.7	9.5	14	16.5	22	30	JKS-30
20DD022	1	15	10	23.3	15.1	22	24.2	33	45	JKS-45
20DD027	2	20	15	28.9	18.8	27	33	44	60	JKS-60
20DD034	2	25	20	36.4	23.6	34	40.5	54	70	JKS-70
20DD040	3	30	25	42.9	27.8	40	51	68	80	JKS-80
20DD052	3	40	30	55.7	36.1	52	60	80	100	JKS-100
20DD065	3	50	40	69.7	45.4	65	78	104	150	JKS-150
20DD077	4	60	—	84.5	54.7	77	85	116	150	JKS-150
		—	50	67.9	45.4	65	98	130	150	JKS-150
20DJ096 ⁽³⁾	5	75	—	105.3	68.3	96	106	144	200	JKS-200
		—	60	84.5	54.7	77	116	154	150	JKS-150
20DJ125 ⁽³⁾	5	100	—	137.1	88.9	125	138	163	250	JKS-250
		—	75	105.3	68.3	96	144	168	200	JKS-200
20DJ156 ⁽³⁾	6	125	—	171.2	110.9	156	172	234	300	JKS-300
		—	100	137.1	88.9	125	188	250	250	JKS-250
20DJ180 ⁽³⁾	6	150	—	204.1	132.2	180	198	270	400	JKS-400
		—	125	171.2	110.9	156	234	312	300	JKS-300
20DJ248	6	200	—	—	—	248	273	392	550	—
		—	150	—	—	180	270	360	400	—
20DJ261	9	200	—	299	186	261	287	410	500	170M6608
		—	150	235	146	205	308	410	500	170M6608

540V DC Input Protection Devices (Continued) (see [Notes on page 11](#))

Cat. No.	Frame	HP Rating		DC Input Ratings		Output [A]			Fuse (1)	Non-time Delay Fuse (2)
		ND	HD	A	kW	Cont.	60 s	3 s		
20DJ300	9	250	—	343	213	300	330	500	630	170M6610
		—	200	281	174	245	368	490	630	170M6610
20DJ385	10	300	—	441	274	385	424	600	700	170M6611
		—	250	343	213	300	450	600	700	170M6611
20DJ460	10	350	—	527	327	460	506	770	900	170M6613
		—	300	441	274	385	578	770	900	170M6613
20DJ500	10	450	—	572	356	500	550	750	1000	170M6614
		—	350	481	299	420	630	840	1000	170M6614
20DJ590	11	500	—	676	420	590	649	956	630 (2 per phs)	170M6610
		—	450	595	370	520	780	956	630 (2 per phs)	170M6610
20DJ650	11	500	—	744	463	650	715	1062	700 (2 per phs)	170M6611
		—	500	676	420	590	885	1062	700 (2 per phs)	170M6611
20DJ730	11	600	—	836	520	730	803	1095	700 (2 per phs)	170M6611
		—	500	744	463	650	975	1170	700 (2 per phs)	170M6611

650V DC Input Protection Devices (see [Notes on page 11](#))

Cat. No.	Frame	HP Rating		DC Input Ratings		Output [A]			Fuse (1)	Non-time Delay Fuse (2)
		ND	HD	A	kW	Cont.	60 s	3 s		
650V DC Input										
20DD2P1	0	1	0.75	1.9	1.2	2.1	2.4	3.2	6	JKS-6
20DD3P4	0	2	1.5	3.0	2.0	3.4	4.5	6.0	6	JKS-6
20DD5P0	0	3	2	4.5	2.9	5.0	5.5	7.5	10	JKS-10
20DD8P0	0	5	3	8.1	5.2	8.0	8.8	12	15	JKS-15
20DD011	0	7.5	5	11.1	7.2	11	12.1	16.5	20	JKS-20
20DD014	1	10	7.5	14.7	9.5	14	16.5	22	30	JKS-30
20DD022	1	15	10	23.3	15.1	22	24.2	33	45	JKS-45
20DD027	2	20	15	28.9	18.8	27	33	44	60	JKS-60
20DD034	2	25	20	36.4	23.6	34	40.5	54	70	JKS-70
20DD040	3	30	25	42.9	27.8	40	51	68	80	JKS-80
20DD052	3	40	30	55.7	36.1	52	60	80	100	JKS-100
20DD065	3	50	40	69.7	45.4	65	78	104	150	JKS-150
20DD077	4	60	—	84.5	54.7	77	85	116	150	JKS-150
		—	50	67.9	45.4	65	98	130	150	JKS-150
20DJ096 (3)	5	75	—	105.3	68.3	96	106	144	200	JKS-200
		—	60	84.5	54.7	77	116	154	150	JKS-150
20DJ125 (3)	5	100	—	137.1	88.9	125	138	163	250	JKS-250
		—	75	105.3	68.3	96	144	168	200	JKS-200
20DJ156 (3)	6	125	—	171.2	110.9	156	172	234	300	JKS-300
		—	100	137.1	88.9	125	188	250	250	JKS-250
20DJ180 (3)	6	150	—	204.1	132.2	180	198	270	400	JKS-400
		—	125	171.2	110.9	156	234	312	300	JKS-300
20DJ248	6	200	—	—	—	248	273	392	550	—
		—	150	—	—	180	270	360	400	—
20DJ261	9	200	—	299	186	261	287	410	500	170M6608
		—	150	235	146	205	308	410	500	170M6608
20DJ300	9	250	—	343	213	300	330	500	630	170M6610
		—	200	281	174	245	368	490	630	170M6610
20DJ385	10	300	—	441	274	385	424	600	700	170M6611
		—	250	343	213	300	450	600	700	170M6611

650V DC Input Protection Devices (Continued) (see [Notes on page 11](#))

Cat. No.	Frame	HP Rating		DC Input Ratings		Output [A]			Fuse (1)	Non-time Delay Fuse (2)
		ND	HD	A	kW	Cont.	60 s	3 s		
20DJ460	10	350	—	527	327	460	506	770	900	170M6613
		—	300	441	274	385	578	770	900	170M6613
20DJ500	10	450	—	572	356	500	550	750	1000	170M6614
		—	350	481	299	420	630	840	1000	170M6614
20DJ590	11	500	—	676	420	590	649	956	630 (2 per phs)	170M6610
		—	450	595	370	520	780	956	630 (2 per phs)	170M6610
20DJ650	11	500	—	744	463	650	715	1062	700 (2 per phs)	170M6611
		—	500	676	420	590	885	1062	700 (2 per phs)	170M6611
20DJ730	11	600	—	836	520	730	803	1095	700 (2 per phs)	170M6611
		—	500	744	463	650	975	1170	700 (2 per phs)	170M6611

Notes

- (1) Also applies to P-voltage class.
Fuses must be applied in the (+) leg and (-) leg of the DC Common Bus.
- (2) The power source to Common Bus inverters must be derived from AC voltages 600V or less, as defined in NFPA70; Art 430-18 (NEC). Battery supplies or MG sets are not included.
The following devices were validated to the break current of the derived power DC Bus.
Disconnects: Allen-Bradley® Bulletin 1494, 30...400 A; Bulletin 194, 30...400 A, or ABB: OESA, 600 and 800 A; OESL, all sizes.
Fuses: Busmann Type JKS, all sizes; Type 170M, Case Sizes 1, 2 and 3, or Ferraz-Shawmut Type HSJ, all sizes.
For any other devices, contact the factory.
- (3) Also applies to R-voltage class.

Rockwell Automation Support

Use these resources to access support information.

Technical Support Center	Find help with how-to videos, FAQs, chat, user forums, and product notification updates.	rok.auto/support
Knowledgebase	Access Knowledgebase articles.	rok.auto/knowledgebase
Local Technical Support Phone Numbers	Locate the telephone number for your country.	rok.auto/phonesupport
Literature Library	Find installation instructions, manuals, brochures, and technical data publications.	rok.auto/literature
Product Compatibility and Download Center (PCDC)	Download firmware, associated files (such as AOP, EDS, and DTM), and access product release notes.	rok.auto/pcdc

Documentation Feedback

Your comments help us serve your documentation needs better. If you have any suggestions on how to improve our content, complete the form at rok.auto/docfeedback.





Waste Electrical and Electronic Equipment (WEEE)



At the end of life, this equipment should be collected separately from any unsorted municipal waste.

Rockwell Automation maintains current product environmental compliance information on its website at rok.auto/pec.

Rockwell Otomasyon Ticaret A.Ş. Kar Plaza İş Merkezi E Blok Kat:6 34752 İçerenköy, İstanbul, Tel: +90 (216) 5698400 EEE Yönetmeliğine Uygundur

Connect with us.    

rockwellautomation.com

expanding human possibility®

AMERICAS: Rockwell Automation, 1201 South Second Street, Milwaukee, WI 53204-2496 USA, Tel: (1) 414.382.2000, Fax: (1) 414.382.4444

EUROPE/MIDDLE EAST/AFRICA: Rockwell Automation NV, Pegasus Park, De Kleetlaan 12a, 1831 Diegem, Belgium, Tel: (32) 2 663 0600, Fax: (32) 2 663 0640

ASIA PACIFIC: Rockwell Automation, Level 14, Core F, Cyberport 3, 100 Cyberport Road, Hong Kong, Tel: (852) 2887 4788, Fax: (852) 2508 1846

Allen-Bradley, expanding human possibility, PowerFlex, and Rockwell Automation are trademarks of Rockwell Automation, Inc. Trademarks not belonging to Rockwell Automation are property of their respective companies.

Publication 20D-DU002A-EN-P - April 2022

Copyright © 2022 Rockwell Automation, Inc. All rights reserved. Printed in the U.S.A.

List of Motors with Compatible Thermistor Ratings

Motor Type	Motor (kW)	Type (Catalog No.) ⁽¹⁾	Poles	Base Speed (RPM)	Voltage (Vrms)	Rate Current (Arms)	Ex. Current (Arms)	GD2 (Kg/m ²)
200 STD Motor	1.5	M-51027	4	1500	180	7.5	-	0.024
	2.2	M-51028	4	1500	180	11	-	0.045
	3.7	M-51001	4	1500	180	18	-	0.066
	3.7	M-51007-1	4	1500	180	18	-	0.066
	5.5	M-51002	4	1500	180	25	-	0.12
	5.5	M-51008-1	4	1500	180	25	-	0.12
	7.5	M-51003	4	1500	180	33	-	0.15
	7.5	M-51009-1	4	1500	180	33	-	0.15
	11	M-51004	4	1500	180	47	-	0.32
	11	M-51010-1	4	1500	180	47	-	0.32
	15	M-51005	4	1500	180	63	-	0.43
	15	M-51011-1	4	1500	180	63	-	0.43
	18.5	M-51012	4	1500	180	81	-	0.71
	18.5	M-51012-1	4	1500	180	81	-	0.71
	22	M-51013	4	1500	180	95	-	0.82
	22	M-51013-1	4	1500	180	95	-	0.82
	30	M-51050	4	1500	155	145	-	0.83
	37	M-51051	4	1500	155	183	-	1.1
	45	M-51052	4	1500	155	220	-	1.4
	55	M-51053	4	1500	155	265	-	2
75	M-51054	4	1500	155	346	-	2.7	
200 SVO Motor	0.75	M-51043	4	1500	140	5.3	-	0.0075
	1.5	M-51015	4	1500	140	11.4	-	0.0100
	2.2	M-51016	4	1500	140	15	-	0.0120
	3.7	M-51017	4	1500	140	24.5	-	0.0180
	5.5	M-51018	4	1500	140	34.8	-	0.0390
	7.5	M-51019	4	1500	140	44	-	0.0470
	11	M-51020	4	1500	140	67.1	-	0.0810
	15	M-51021	4	1500	140	80.7	-	0.1370
	22	M-51022	4	1500	140	120	-	0.2000
	30	M-51023	6	1000	155	176	-	0.5800
	37	M-51024	6	1000	155	210	-	0.7000
	55	M-51026	6	1000	135	334	-	1.1000
	55	M-51027	6	500	155	315	-	4.0000
400 STD Motor	1.5	MC-M2051	4	1500	320	4.7	2.045	-
	2.2	MC-M2052	4	1500	320	6.3	3.24	-
	3.7	MC-M2053	4	1500	320	10	5.25	-
	5.5	MC-M2054	4	1500	320	15.5	8.8	-
	7.5	MC-M2055	4	1500	320	20.5	11.25	-
	11	MC-M2056	4	1500	320	29	14.3	-
	15	MC-M2057	4	1500	320	37	16.4	-
	18.5	MC-M2058	4	1500	320	45	19.65	-
	22	MC-M2059	4	1500	320	53	23	-
	30	MC-M2060	4	1500	320	71	28.15	-
	37	MC-M2061	4	1500	320	85	29.7	-
	45	MC-M2062	4	1500	320	97	30.55	-
	55	MC-M2063	4	1500	320	121	-	-
	75	MC-M2064	4	1500	320	163	-	-
	90	MC-M2065	4	1500	320	188	-	-
	110	MC-M2066	4	1500	320	227	-	-
	132	MC-M2067	4	1500	320	280	-	-
160	MC-M2068	4	1500	320	335	-	-	
200	MC-M2069	4	1500	320	375	-	-	

Motor Type	Motor (kW)	Type (Catalog No.) ⁽¹⁾	Poles	Base Speed (RPM)	Voltage (Vrms)	Rate Current (Arms)	Ex. Current (Arms)	GD2 (Kg/m ²)
400 SVO Motor	1.5	MC-M20	4	1500	280	5.4	-	-
	2.2	MC-M20	4	1500	280	7.3	-	-
	3.7	MC-M20	4	1500	280	12.3	-	-
	5.5	MC-M20	4	1500	280	17.3	-	-
	7.5	MC-M20	4	1500	280	22	-	-
	11	MC-M20	4	1500	280	34	-	-
	15	MC-M20	4	1500	280	42	-	-
	22	MC-M20	4	1500	280	58.5	-	-
	22	MC-M20	4	1500	280	58.5	-	-
	30	MC-M20	6	1000	280	88	-	-
37	MC-M20	6	1000	280	125	-	-	

(1) Manufacturer, Reliance Electric-Japan, catalog number for ordering.

Spare Connectors

This section provides part numbers for “Customer-I/O” plugs (both Allen-Bradley numbers and connector manufacture numbers). This allows users to procure spare or replacement parts from Allen-Bradley or directly from the connector manufacturer.

Main Control Board

Phoenix Contact manufactures all four “Customer-I/O” connectors for the Main Control Board, according to Allen-Bradley specifications. Allen-Bradley specifies custom markings on standard Phoenix Contact plugs.

Connector	Allen-Bradley Number	Phoenix Contact Standard Number
TB1 - Row T	305334-Q01	MCV 1,5/13-ST3, 81 27 21 1
TB1 - Row B	305334-Q02	MCV 1,5/13-ST3, 81 27 21 1
TB2 - Row T	305335-Q01	MCV 1,5/13-ST3, 81 18 03 68 8
TB2 - Row B	305335-Q02	MCV 1,5/13-ST3, 81 18 03 68 8

High Resolution Encoder Interface Board

Weidmuller manufactures the “Customer-I/O” plug on the High Resolution Encoder Interface Board.

Connector	Allen-Bradley Number	Weidmuller Number
P1	S94262912	BL3.50/90/12BK

Resolver Interface Board

Weidmuller manufactures the “Customer-I/O” plug on the Resolver Interface Board.

Connector	Allen-Bradley Number	Weidmuller Number
P1	S94262908	BL3.50/90/8BK

Dimensions

Table A.A PowerFlex 700S Frames

Frame	AC Input												DC Input			
	208		240		380 . . . 400V		480V		600V		690V		540V		650V	
	ND HP	HD HP	ND HP	HD HP	ND kW	HD kW	ND HP	HD HP	ND HP	HD HP	ND HP	HD HP	ND HP	HD HP	ND HP	HD HP
1	0.75	0.37	1.0	0.75	0.75	0.55	1	0.75	1	0.5	—	—	—	—	—	—
	1.5	0.75	2.0	1.5	1.5	0.75	2	1.5	2	1	—	—	—	—	—	—
	2.2	1.5	3.0	2.0	2.2	1.5	3	2	3	2	—	—	—	—	—	—
	4.0	2.2	5.0	3.0	4.0	2.2	5	3	5	3	—	—	—	—	—	—
	5.5	4.0	7.5	5.0	5.5	4.0	7.5	5	7.5	5	—	—	—	—	—	—
	—	—	—	—	7.5	5.5	10	7.5	10	7.5	—	—	—	—	—	—
2	—	—	—	—	11	7.5	15	10	15	10	—	—	—	—	—	—
	7.5	5.5	10	7.5	15	11	20	15	20	15	—	—	—	—	—	—
3	—	—	—	—	18.5	15	25	20	25	20	—	—	—	—	—	—
	11	7.5	15	10	22	18.5	30	25	30	25	—	—	—	—	—	—
4	15	11	20	15	30	22	40	30	40	30	—	—	—	—	—	—
	—	—	—	—	37	30	50	40	50	40	—	—	—	—	—	—
5	18.5	15	25	20	45	37	60	50	60	50	—	—	—	—	—	—
	22	18.5	30	25	—	—	—	—	—	—	—	—	—	—	—	—
6	30	22	40	30	55	45	75	60	75	60	75	55	55	45	75	60
	30	30	50	40	55	45	100	75	100	75	90	75	55	45	75	60
	—	—	—	—	—	—	—	—	—	—	—	—	55	45	100	75
	—	—	—	—	—	—	—	—	—	—	—	—	55	45	100	75
7	45	37	60	50	90	75	125	100	125	100	110	90	90	75	125	100
	55	45	75	60	110	90	150	125	150	125	132	110	90	75	125	100
	66	55	100	75	132	110	200	150	—	—	—	—	110	90	150	125
	—	—	—	—	—	—	—	—	—	—	—	—	110	90	150	125
	—	—	—	—	—	—	—	—	—	—	—	—	132	110	200	150
	—	—	—	—	—	—	—	—	—	—	—	—	132	110	200	150
9	—	—	—	—	132	110	200	150	150	150	160	132	—	—	—	—
	—	—	—	—	160	130	250	200	200	150	200	160	—	—	—	—
10	—	—	—	—	200	160	300	250	250	200	250	200	—	—	—	—
	—	—	—	—	250	200	350	300	350	250	315	250	—	—	—	—
	—	—	—	—	250	250	450	350	400	350	355	315	—	—	—	—
	—	—	—	—	—	—	—	—	450	350	400	315	—	—	—	—
11	—	—	—	—	315	250	500	450	450	400	450	355	—	—	—	—
	—	—	—	—	355	315	500	500	500	450	500	450	—	—	—	—
	—	—	—	—	400	355	600	500	600	500	560	500	—	—	—	—

Figure A.1 PowerFlex 700S Frame 1-3 (Frame 1 Shown)

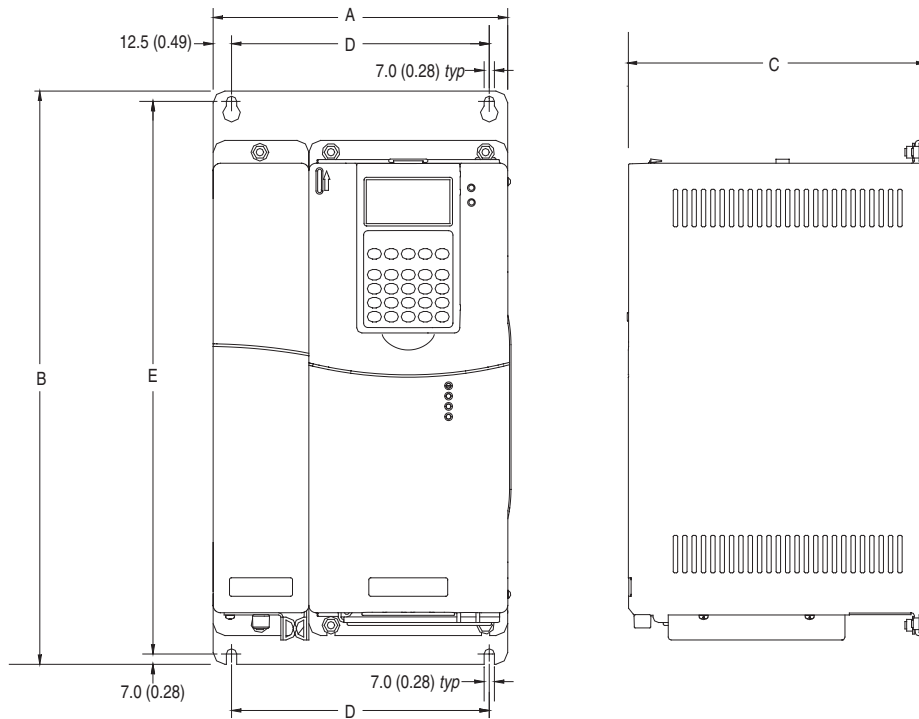

Dimensions are in millimeters and (inches)

Frame	A	B	C	D	E	Weight ⁽¹⁾ kg (lbs.)
						Drive
1	200.0 (7.87)	389.0 (15.31)	202.8 (7.98)	175.0 (6.89)	375.0 (14.76)	11.3 (24.92)
2	285.0 (11.22)	389.0 (15.31)	202.7 (7.98)	250.0 (9.84)	375.0 (14.76)	18.4 (40.57)
3	285.0 (11.22)	564.0 (22.20)	202.7 (7.98)	250.0 (9.84)	550.0 (21.65)	26.6 (58.65)

(1) Weights include HIM, DriveLogix controller with ControlNet daughtercard, Hi-Resolution Encoder Option, and 20-COMM-C ControlNet adapter

Figure A.2 PowerFlex 700S Frame 4

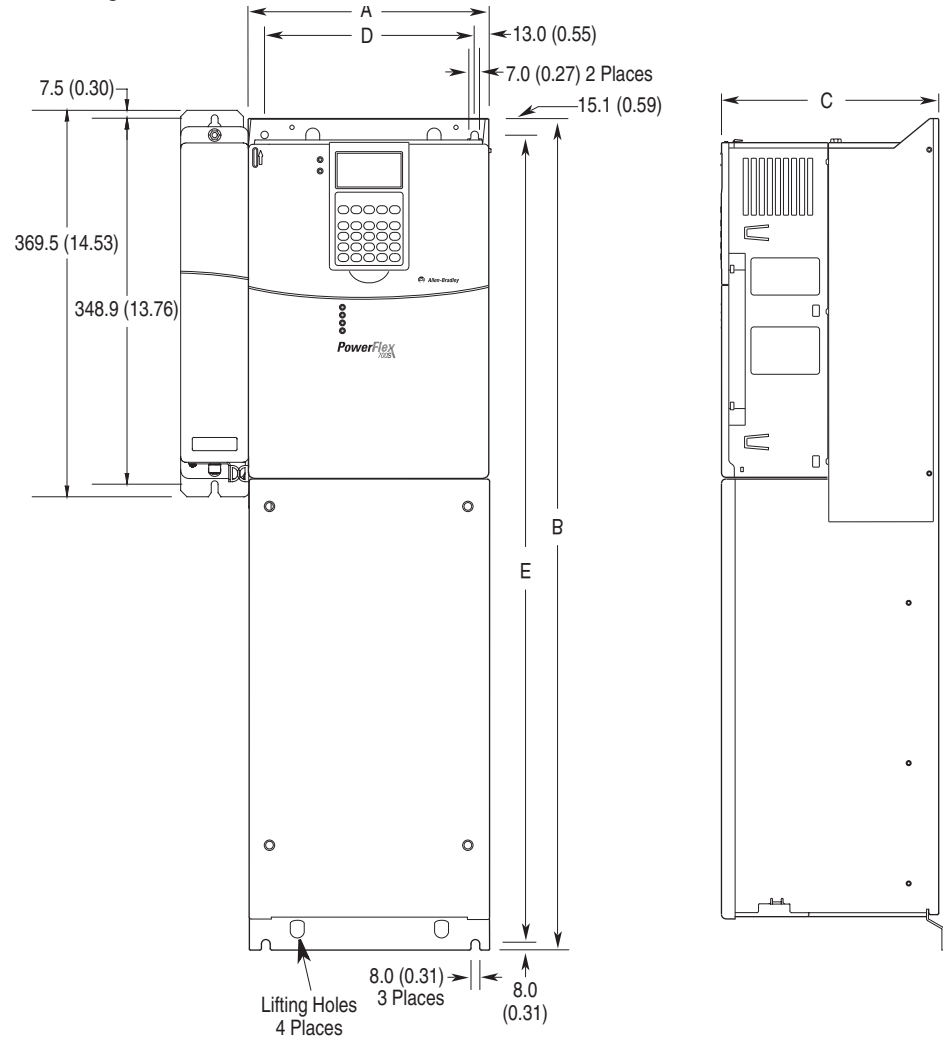

Dimensions are in millimeters and (inches)

Frame	A (Max.)	B	C (Max.)	D	E	Approx. Weight ⁽¹⁾ kg (lbs.)	
						Drive	Drive & Packaging
4	220.8 (8.69)	758.8 (29.9)	201.8 (7.94)	192.0 (7.56)	741.7 (29.2)	28.4 (62.5)	29.03 (63.9)

(1) Weights include HIM and Standard I/O.

Figure A.3 PowerFlex 700S Frame 5

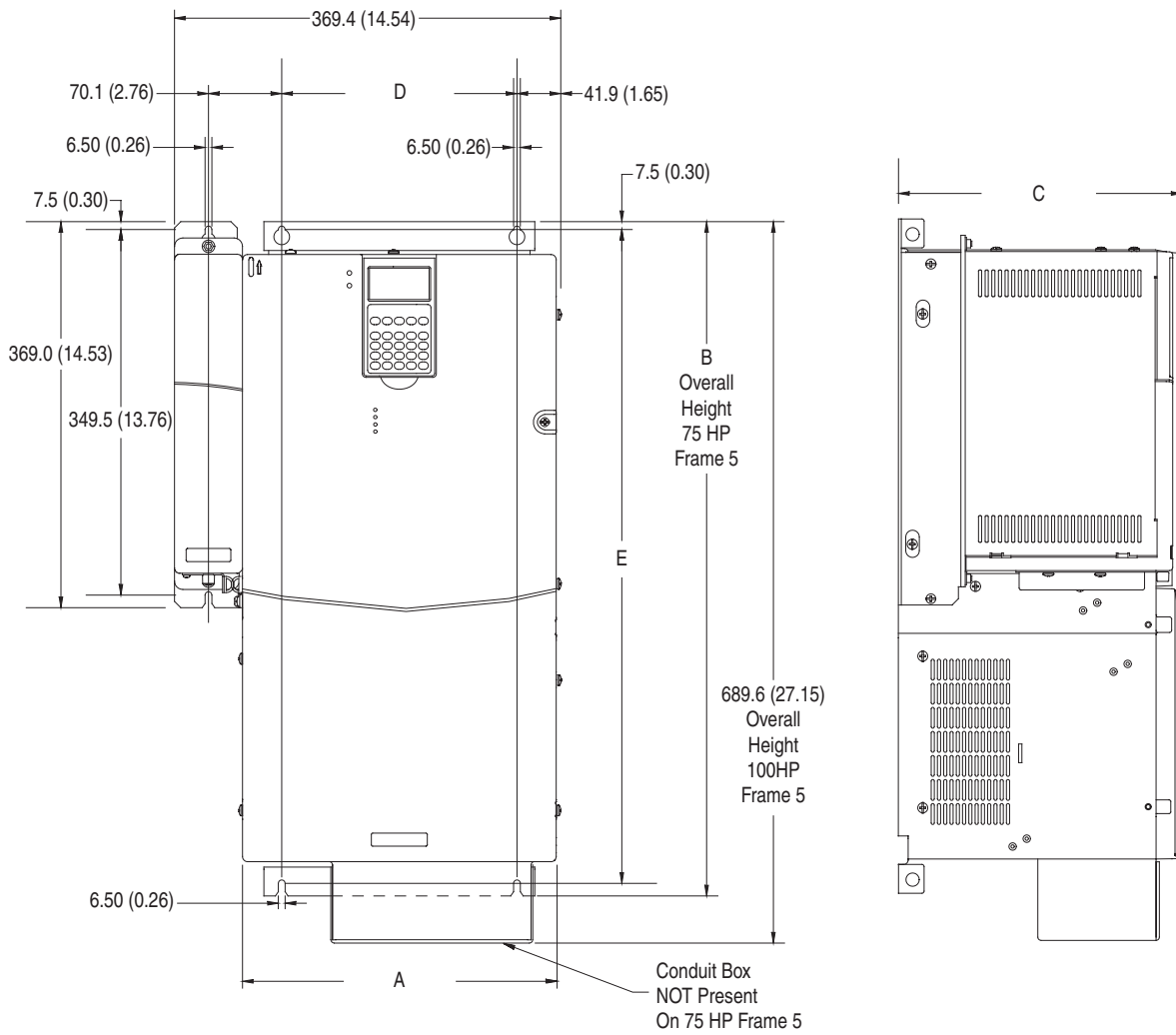

Dimensions are in millimeters and (inches)

Weight⁽¹⁾ kg (lbs.)

Drive

42.6 (93.93)

(1) Weights include HIM, DriveLogix controller with ControlNet daughtercard, Hi-Resolution Encoder Option, and 20-COMM-C ControlNet adapter

Figure A.4 PowerFlex 700S Frame 6

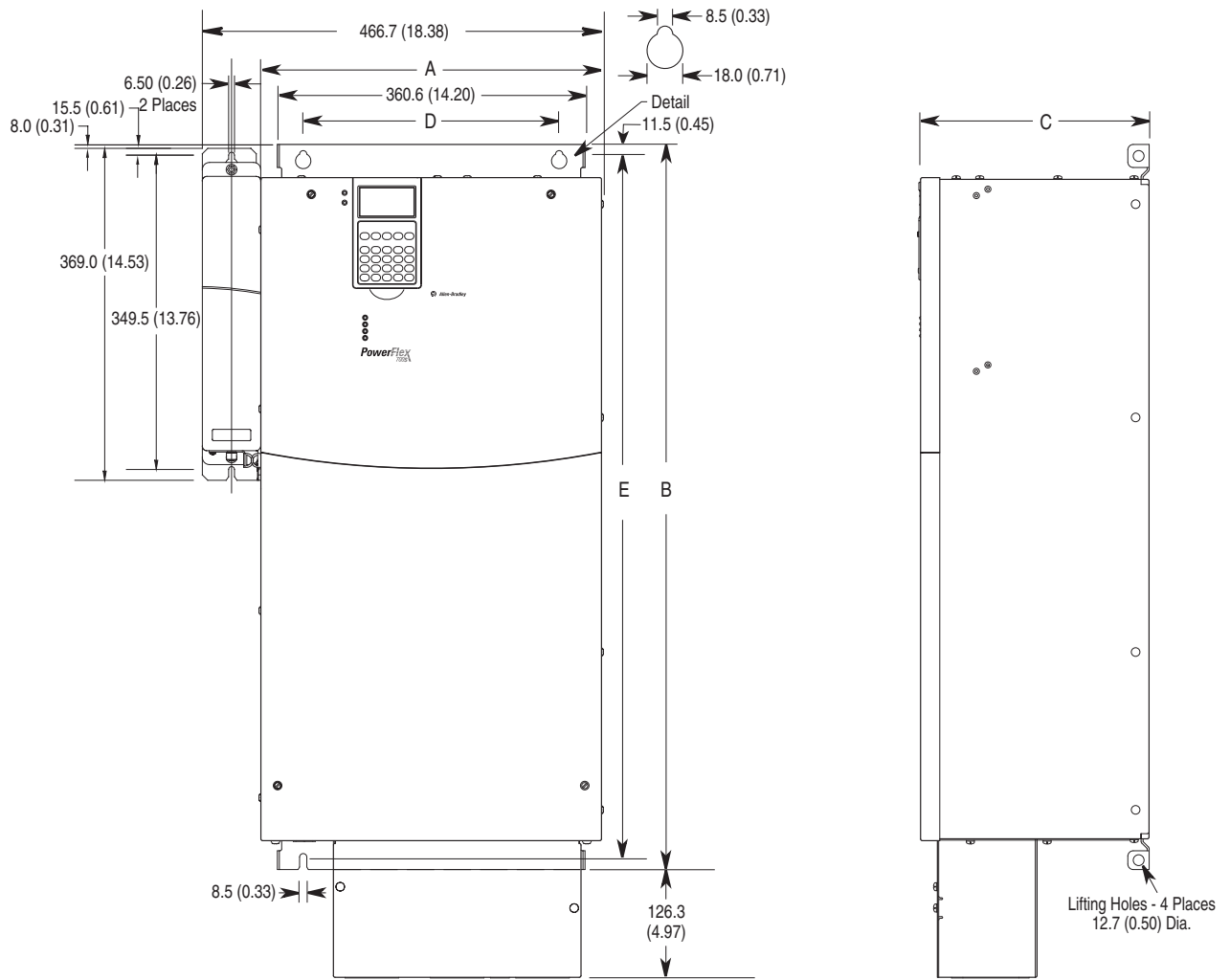

Dimensions are in millimeters and (inches)

Frame	A (Max.)	B	C (Max.)	D	E	Weight ⁽¹⁾ kg (lbs.)	
						Drive	Drive and Packaging
6	403.80 (15.90)	850.00 (33.46)	275.50 (10.85)	300.00 (11.81)	825.0 (157.5)	70.31 (154.70)	89.09 (196.00)

(1) Weights include HIM, DriveLogix controller with ControlNet daughtercard, Hi-Resolution Encoder Option, and 20-COMM-C ControlNet adapter

Figure A.5 PowerFlex 700S Frame 9

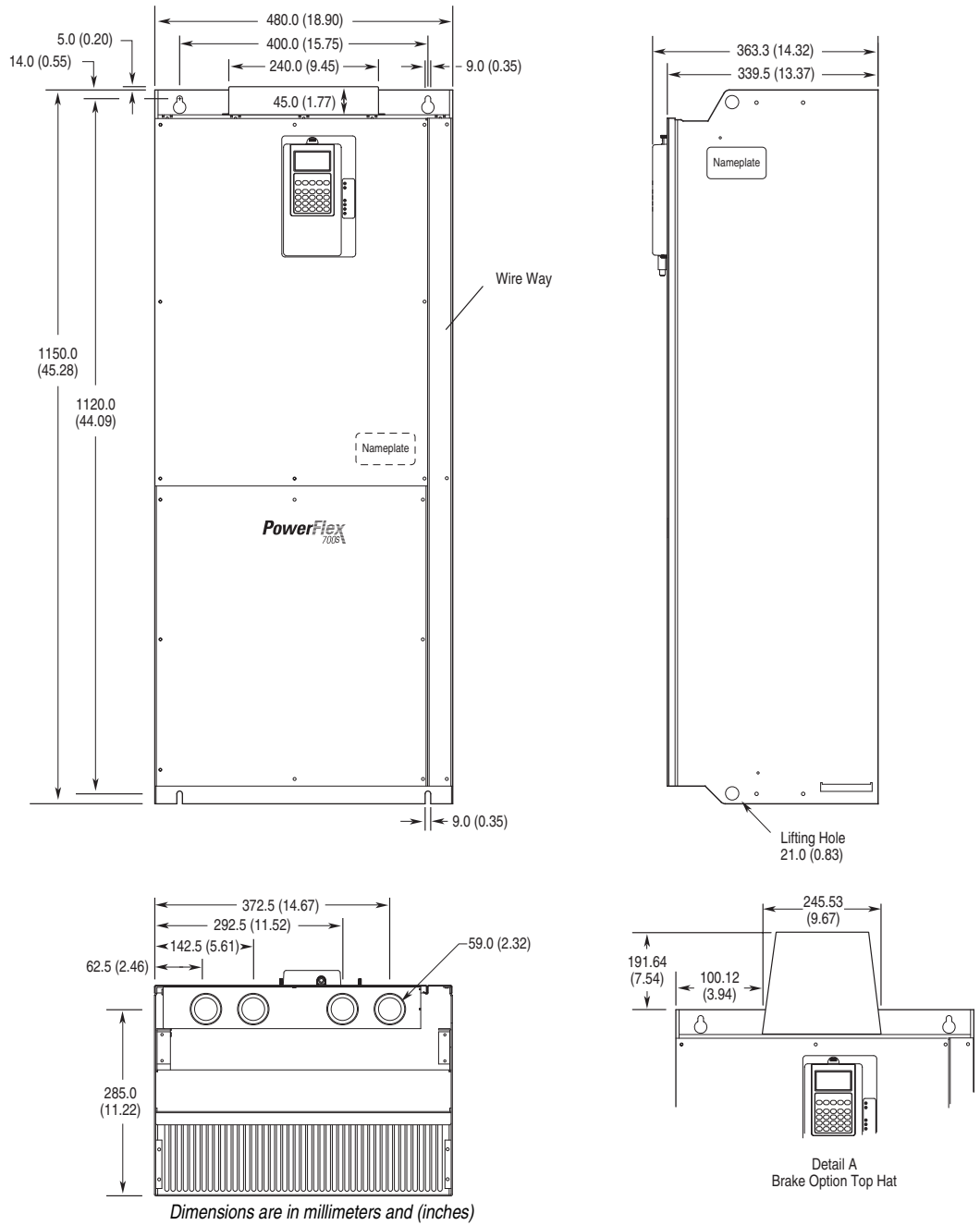

Frame	A	B	C	D	E	Weight kg (lbs.)	
						Drive	Drive & Packaging
9	480 (18.9)	1150 (45.28)	339 (13.37)	400 (15.75)	1120 (44.09)	142.9 (315)	176.9 (390)

Figure A.6 PowerFlex 700S Frame 10

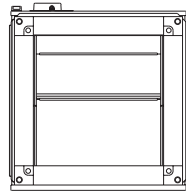
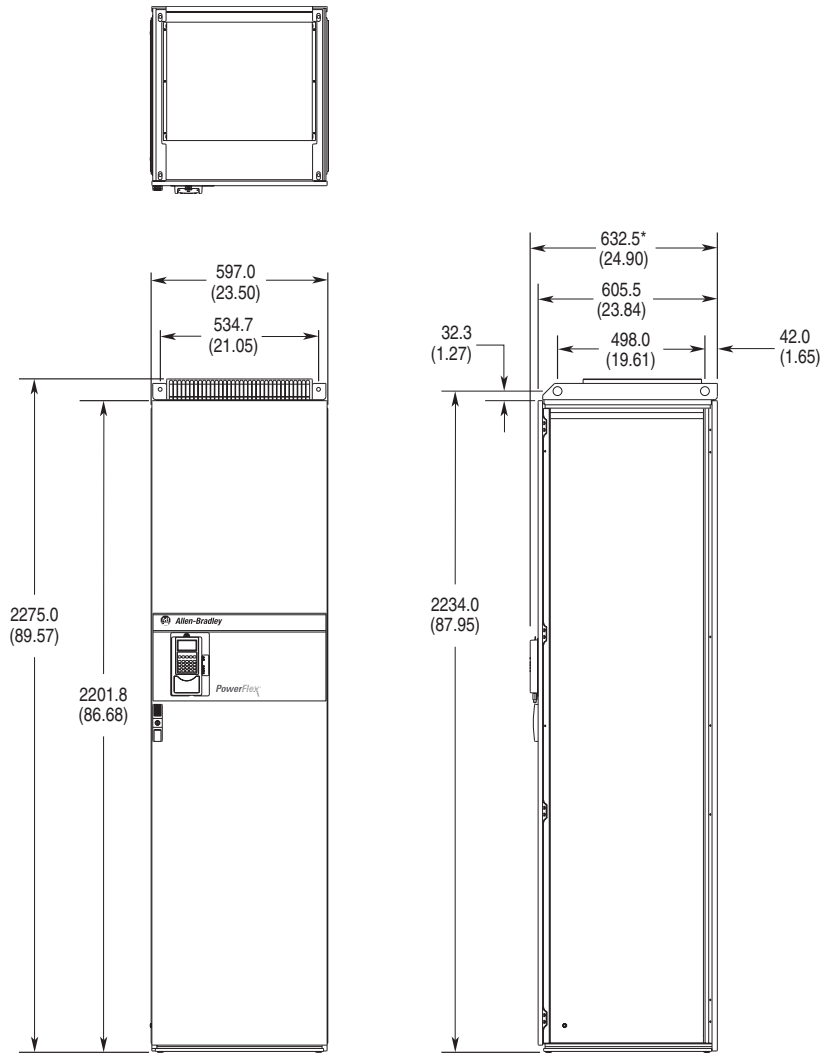

* This dimension is the depth for drives with the optional door-mounted HIM installed

Dimensions are in millimeters and (inches)

Frame	A	B	C	D	E	Weight <i>kg (lbs.)</i>	
						Drive	Drive & Packaging
10	597 (23.5)	2275 (89.57)	632.45 (24.9)	534 (21.05)	2201.75 (86.68)	432 (950)	447 (985)

Figure A.7 PowerFlex 700S Frame 11

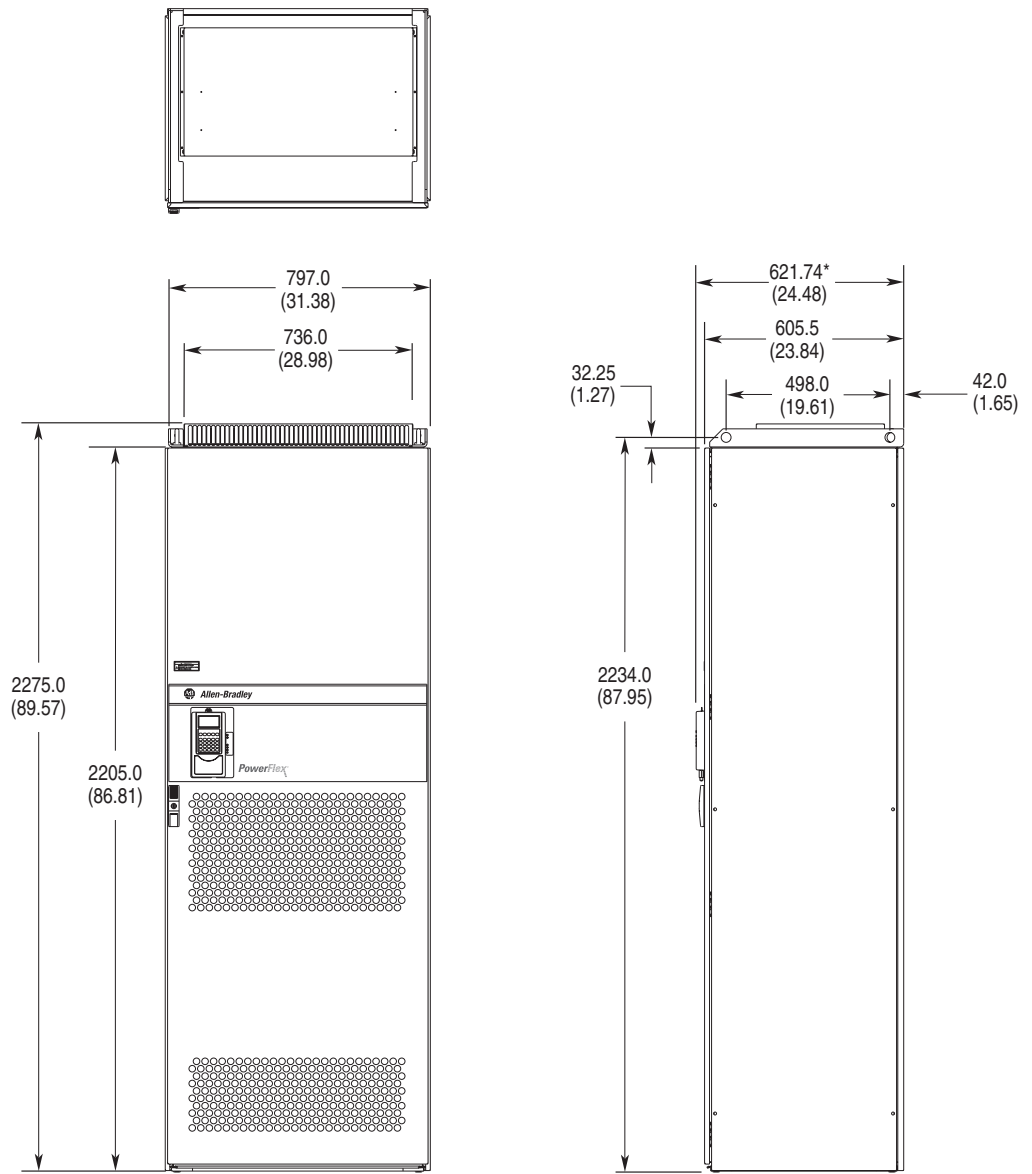

Dimensions are in millimeters and (inches)

Figure A.8 PowerFlex 700S Bottom View Dimensions

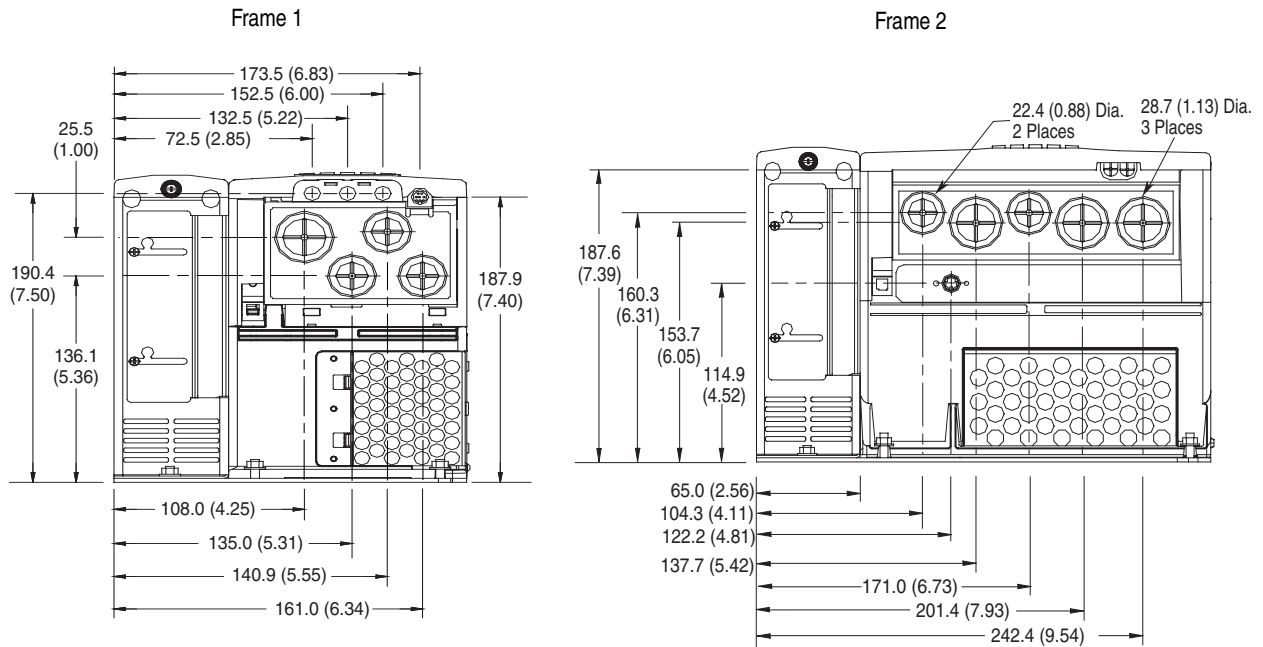

Frame 3 - All Drives except 50 HP, 480V (37 kW, 400V)

Frame 3 - 50 HP, 480V (37 kW, 400V) Normal Duty Drive

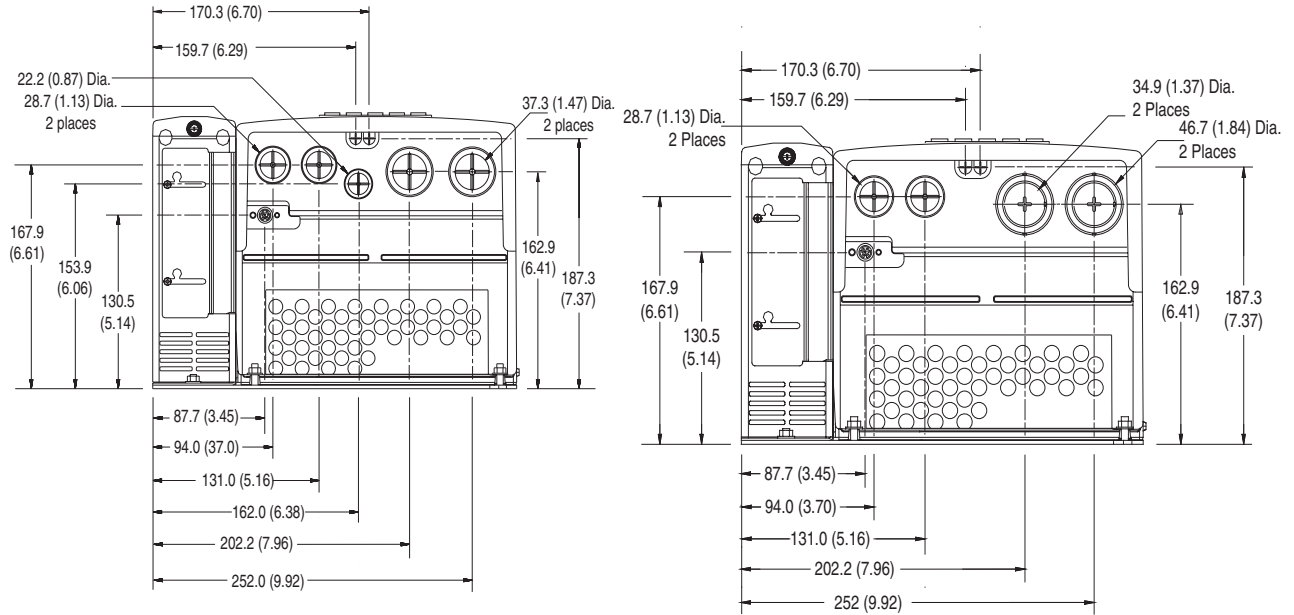

Dimensions are in millimeters and (inches)

Figure A.9 PowerFlex 700S Bottom View Dimensions (continued)

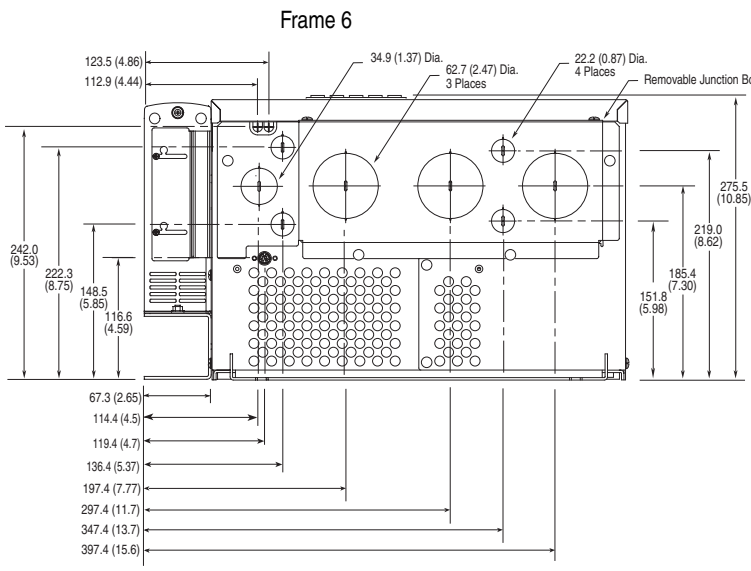
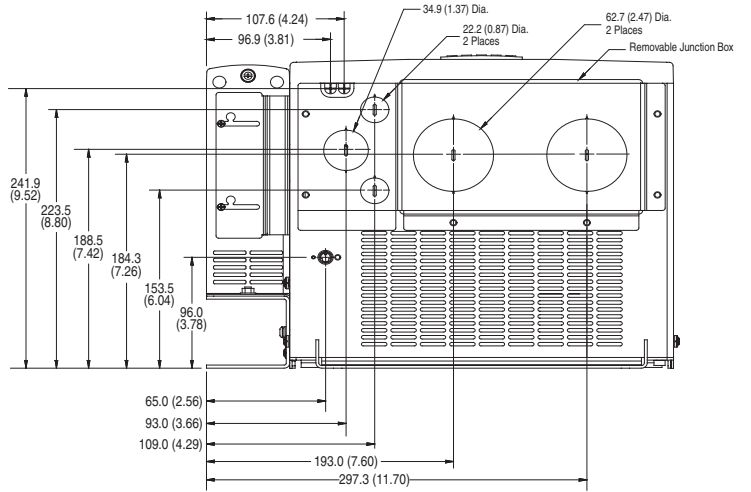
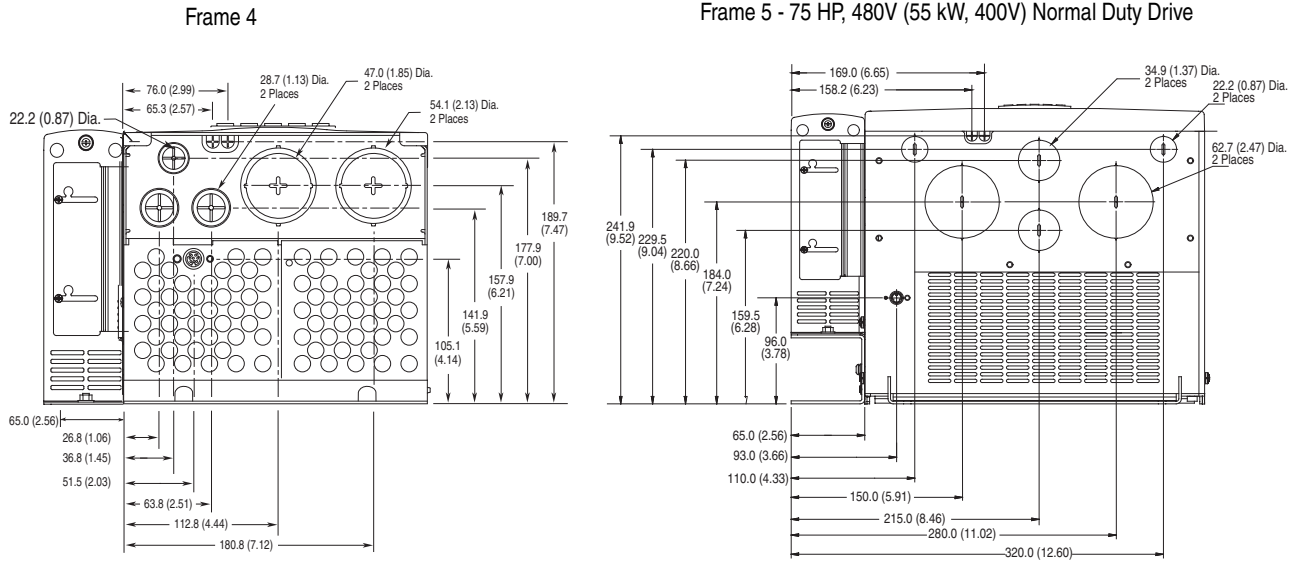

Dimensions are in millimeters and (inches)

Control Block Diagrams

List of Control Block Diagrams

Flow diagrams on the following pages illustrate the drives' control algorithms.

For Information on ...	See Page...
Overview	B-2
Speed Control - Reference	B-3
Speed Control - Regulator	B-4
Process Control	B-5
Position Control - Interpolated/Direct	B-6
Position Control - Point to Point	B-7
Position Control - Auxiliary/Control	B-8
Torque Control-Torque	B-9
Torque Control-Current	B-10
Speed/Position Feedback	B-11
Inputs & Outputs - Discrete	B-12
Inputs & Outputs - Analog	B-13
Inverter Overload IT	B-14
User Functions	B-15
Control Logic	B-16
Trend	B-17

PowerFlex 700S Block Diagrams

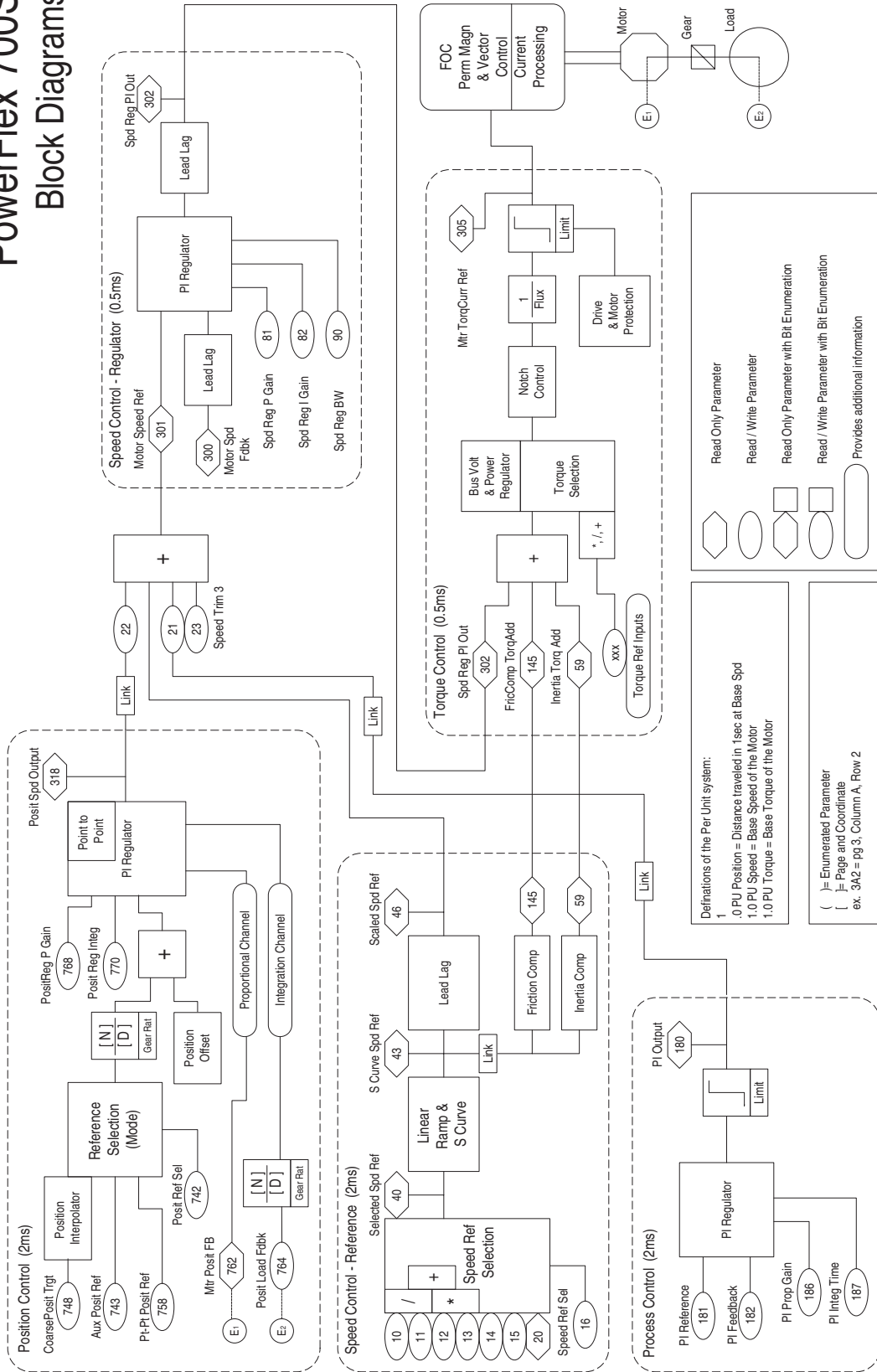

Speed Control - Regulator (0.5 ms)

* set param 90 = 0 to manually adjust param 82

- 90 Spd Reg BW
- 91 Spd Reg Damping
- 92 SpdReg P Gain Mx
- 8 Motor Inertia
- 9 Total Inertia

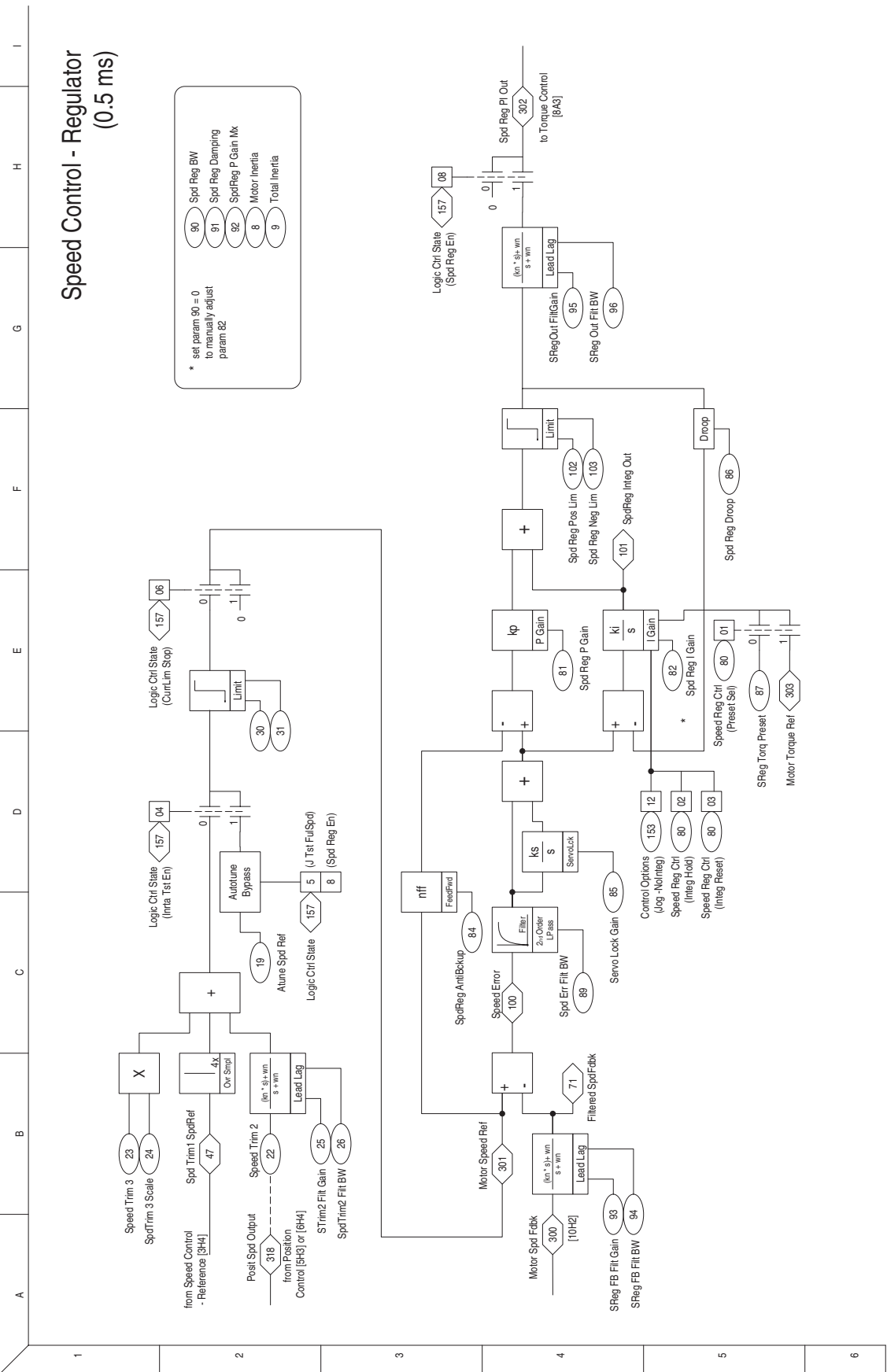

Process Control (2 ms)

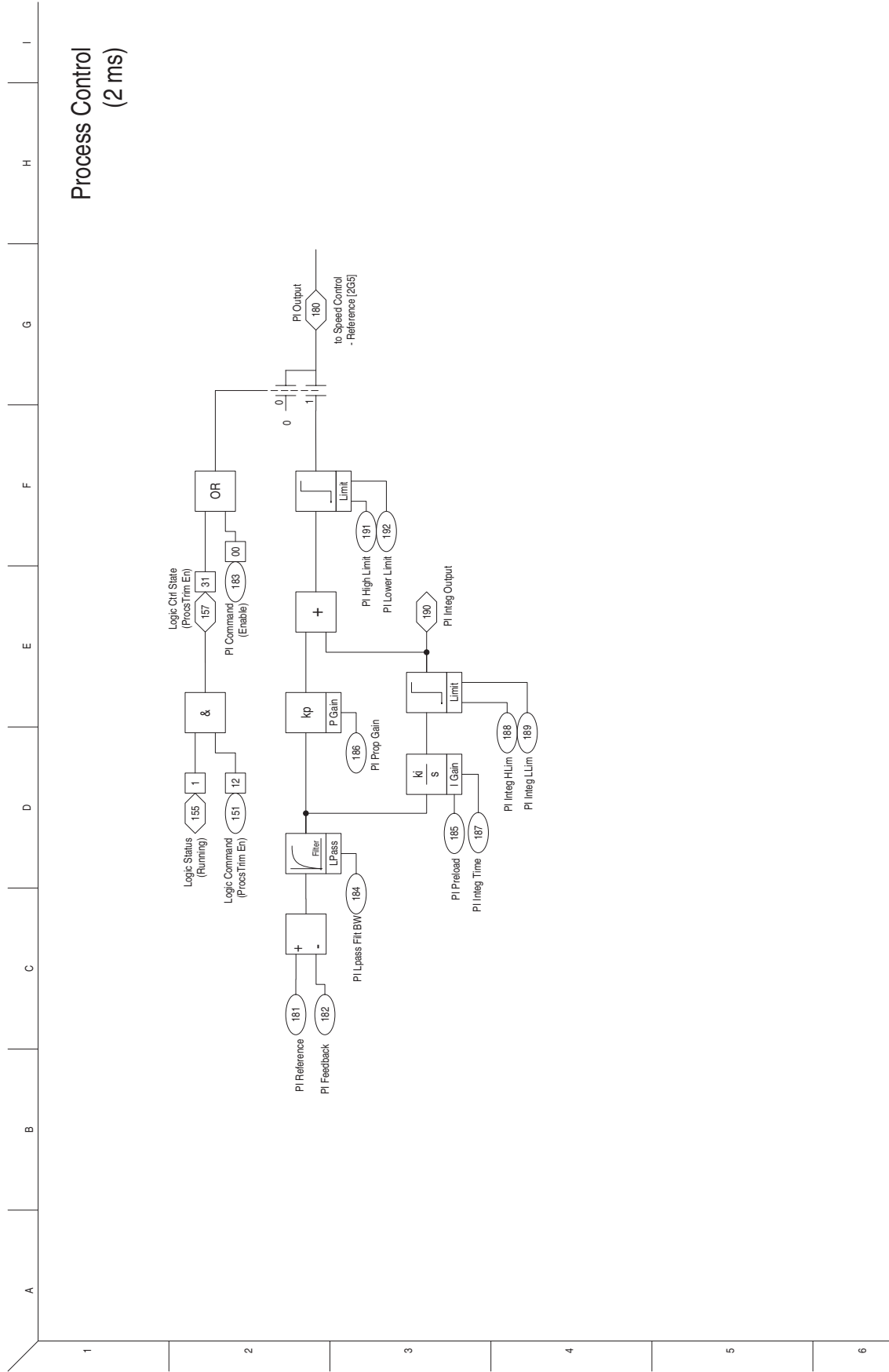

Position Control (2ms) Point-To-Point

Position Control
Act/Post Fdbk (740) 06
Position Control
Zero Preset (740) 08

On the rising edge (activation) of p741 bit 7 [865] the following bit assignments occur:
 If p740 bit 8 is set, then p763, p765, p744, and p747 get loaded with [Mtr Posit Fdbk (p762) - Abs Posit Offset (p757)].
 If p740 bit 6 is reset and p740 bit 6 is set, then p763, p765, p744, and p747 get loaded with [Mtr Posit Fdbk (p762) - Abs Posit Offset (p757)].
 If p740 bit 6 is reset and p740 bit 6 is set, then p763, p765, p744, and p747 get loaded with the reference value (prior to reference derivative function [702]).

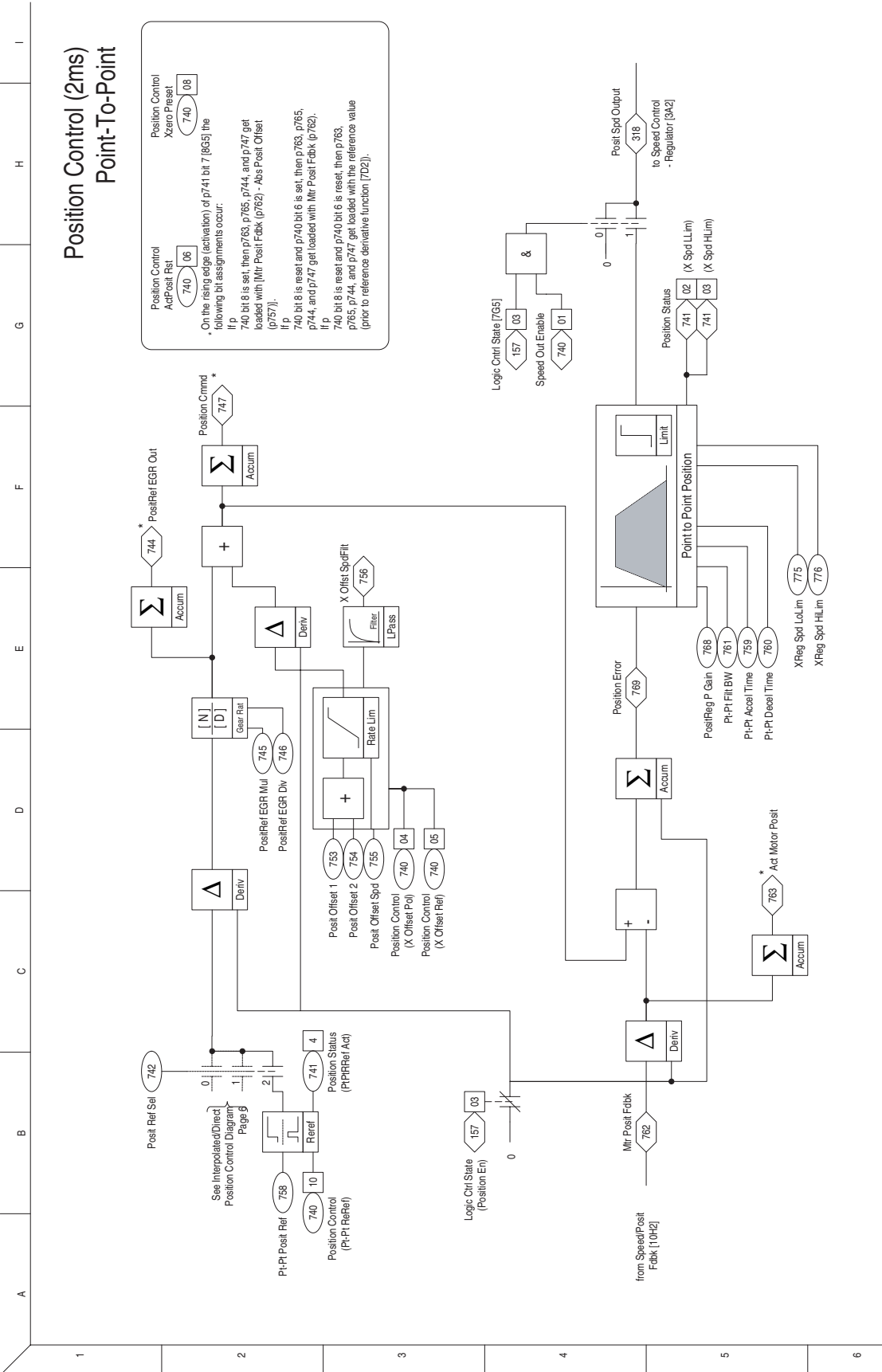

Position Control (2ms) Auxiliary / Control

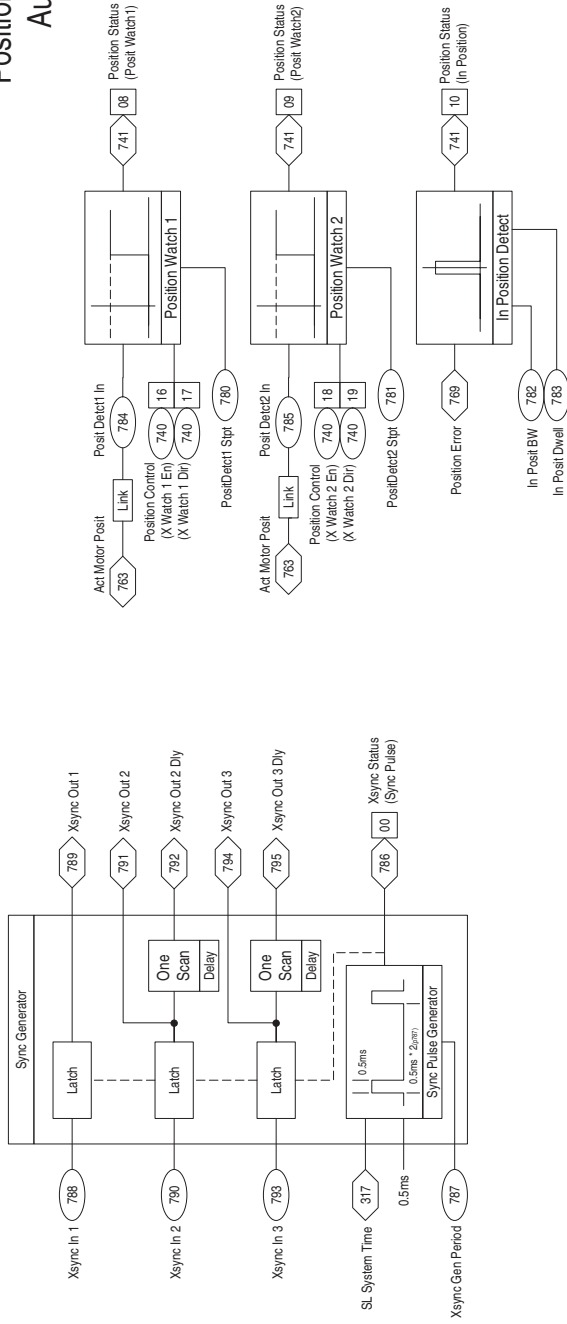

Auxiliary Control

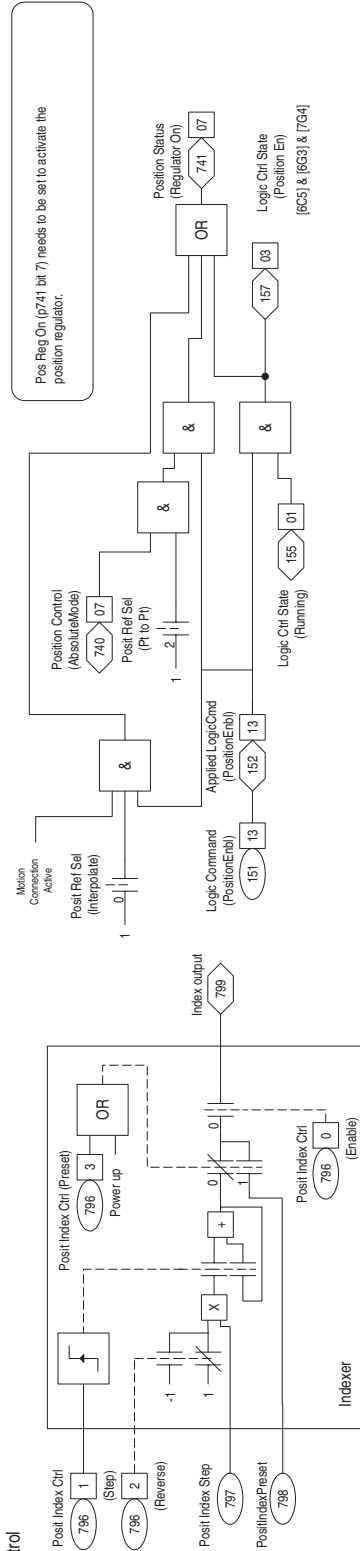

Torque Control - Torque (Task 1)

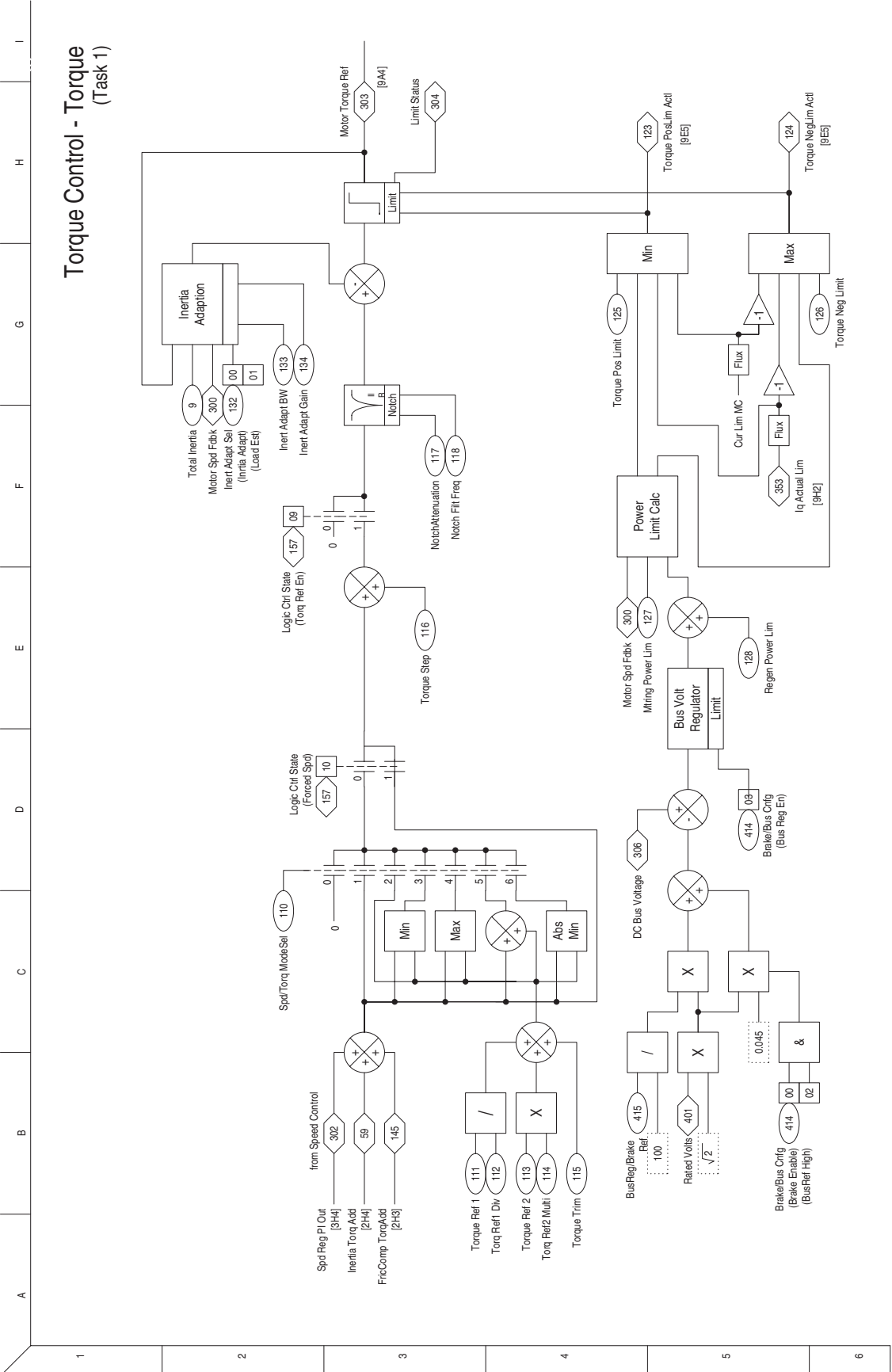

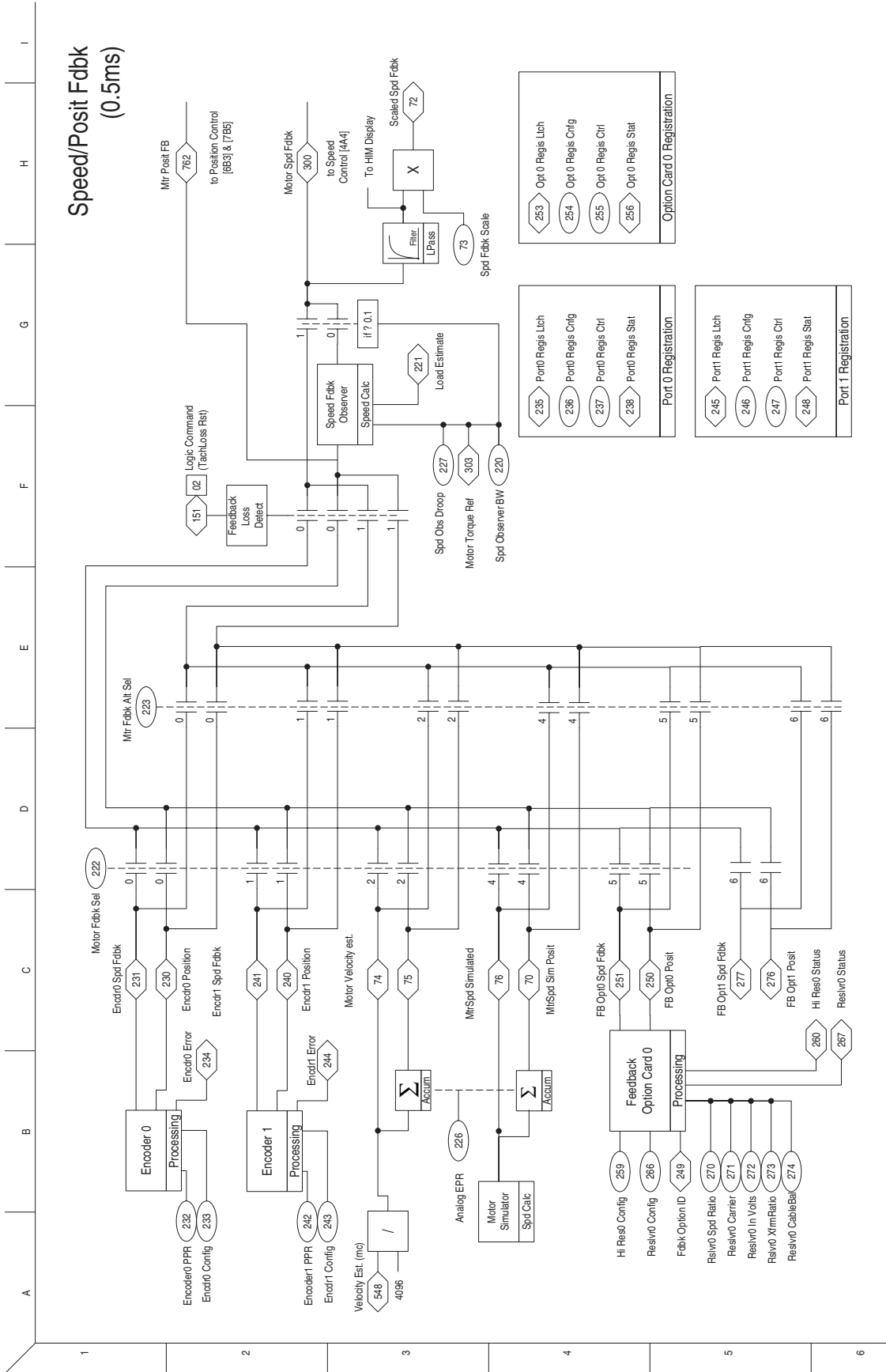

Inputs & Outputs - Digital (0.5ms)

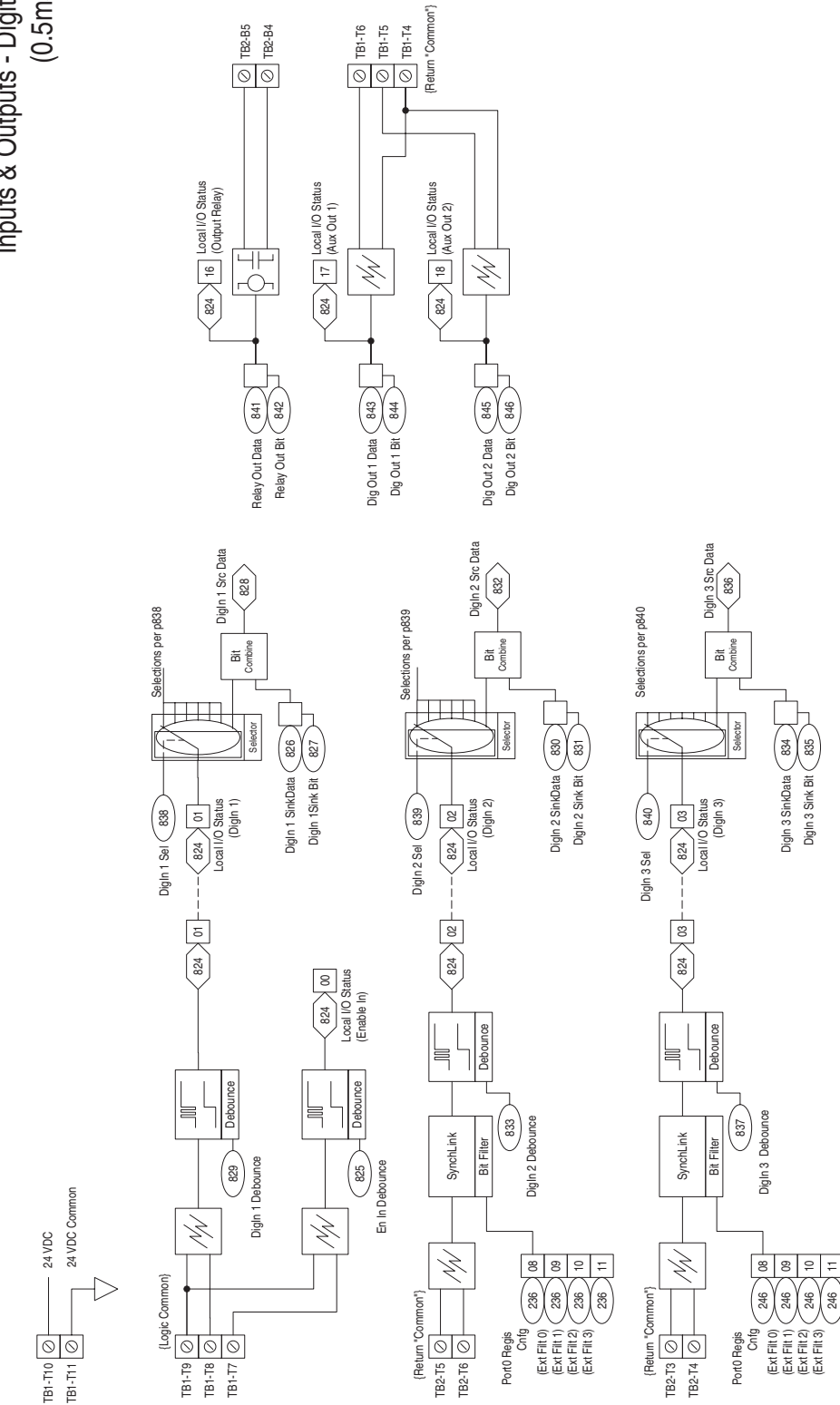

Inputs & Outputs - Analog (0.5ms)

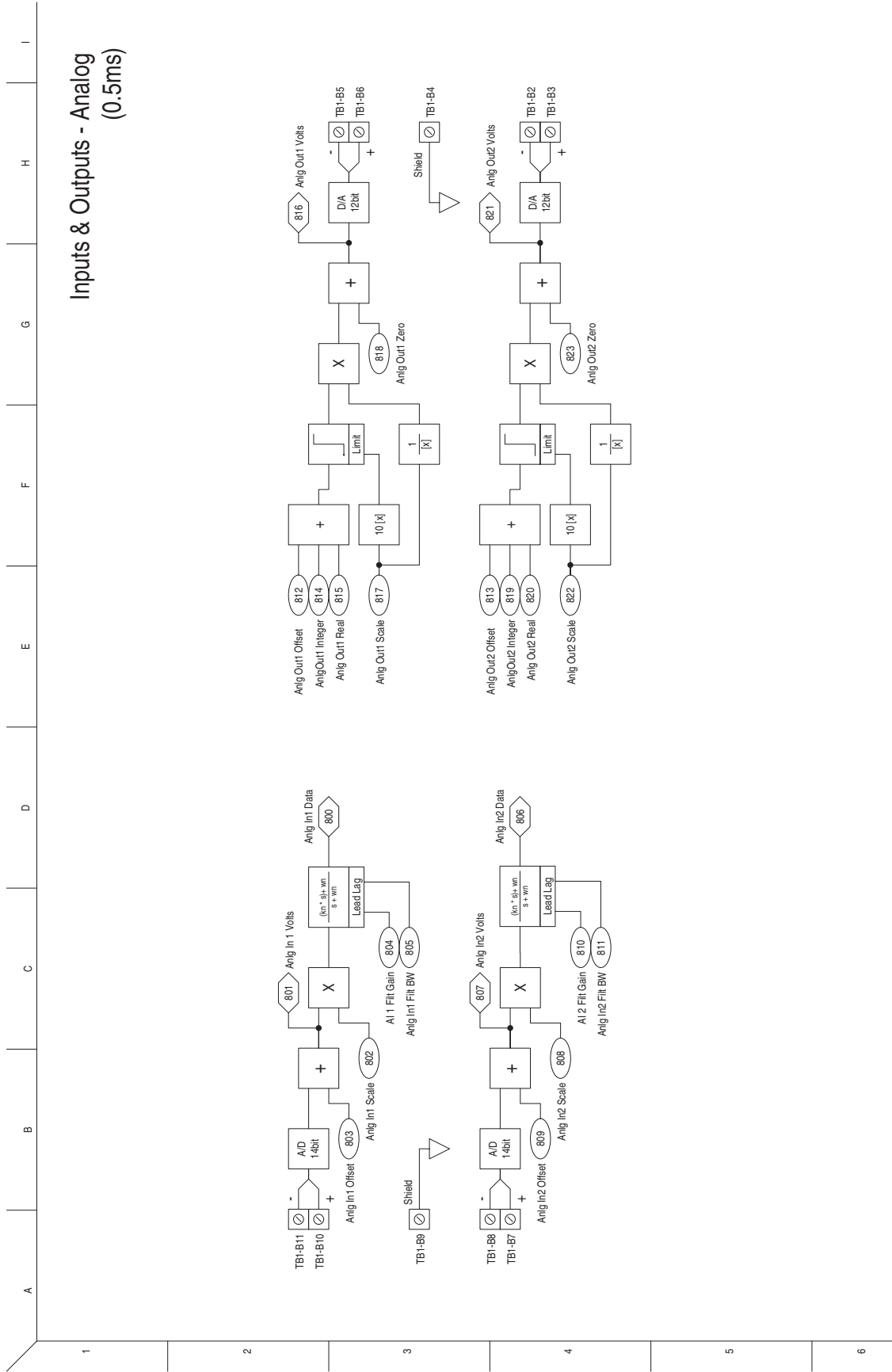

Inverter Overload IT

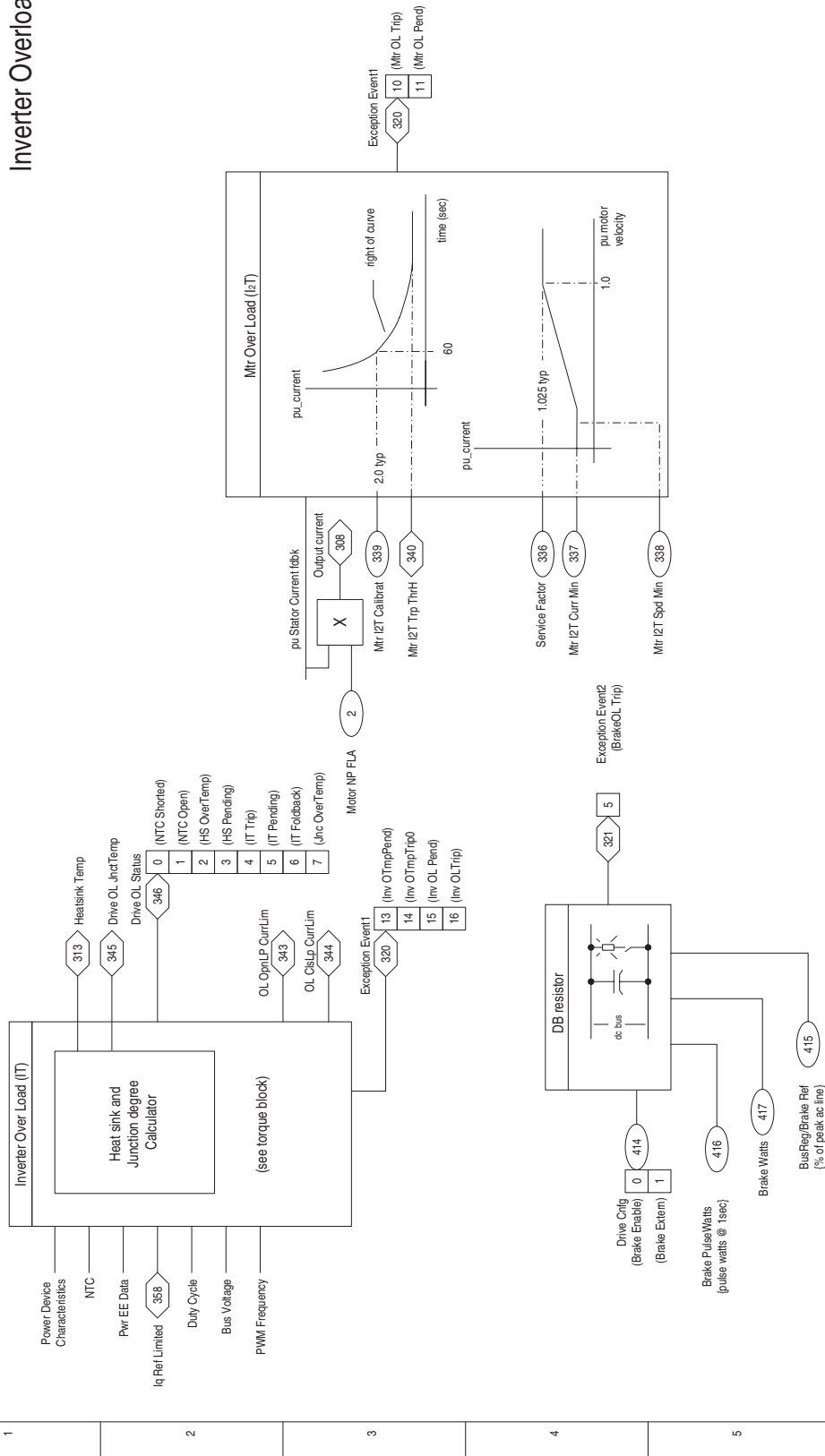

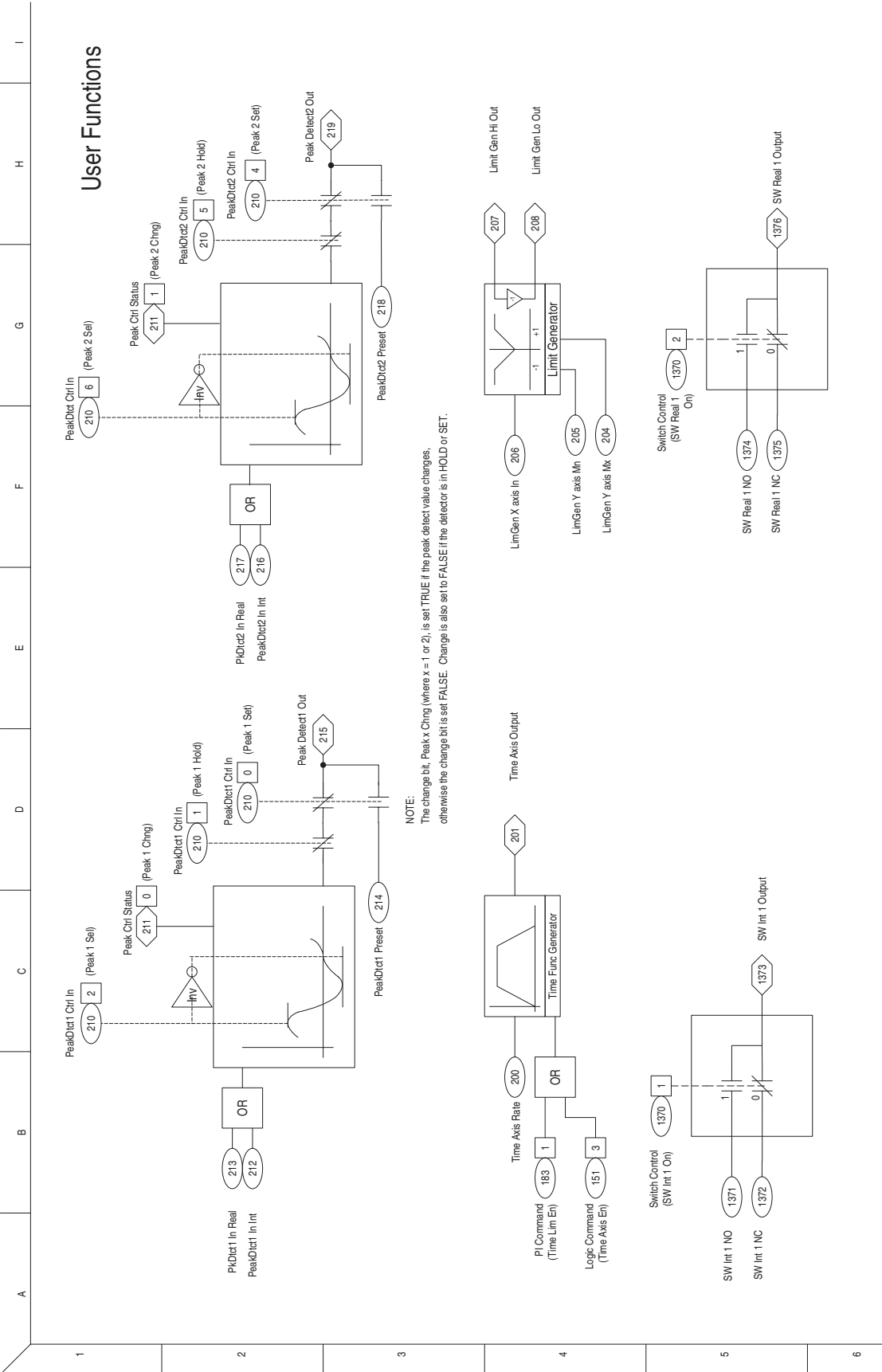

Control Logic

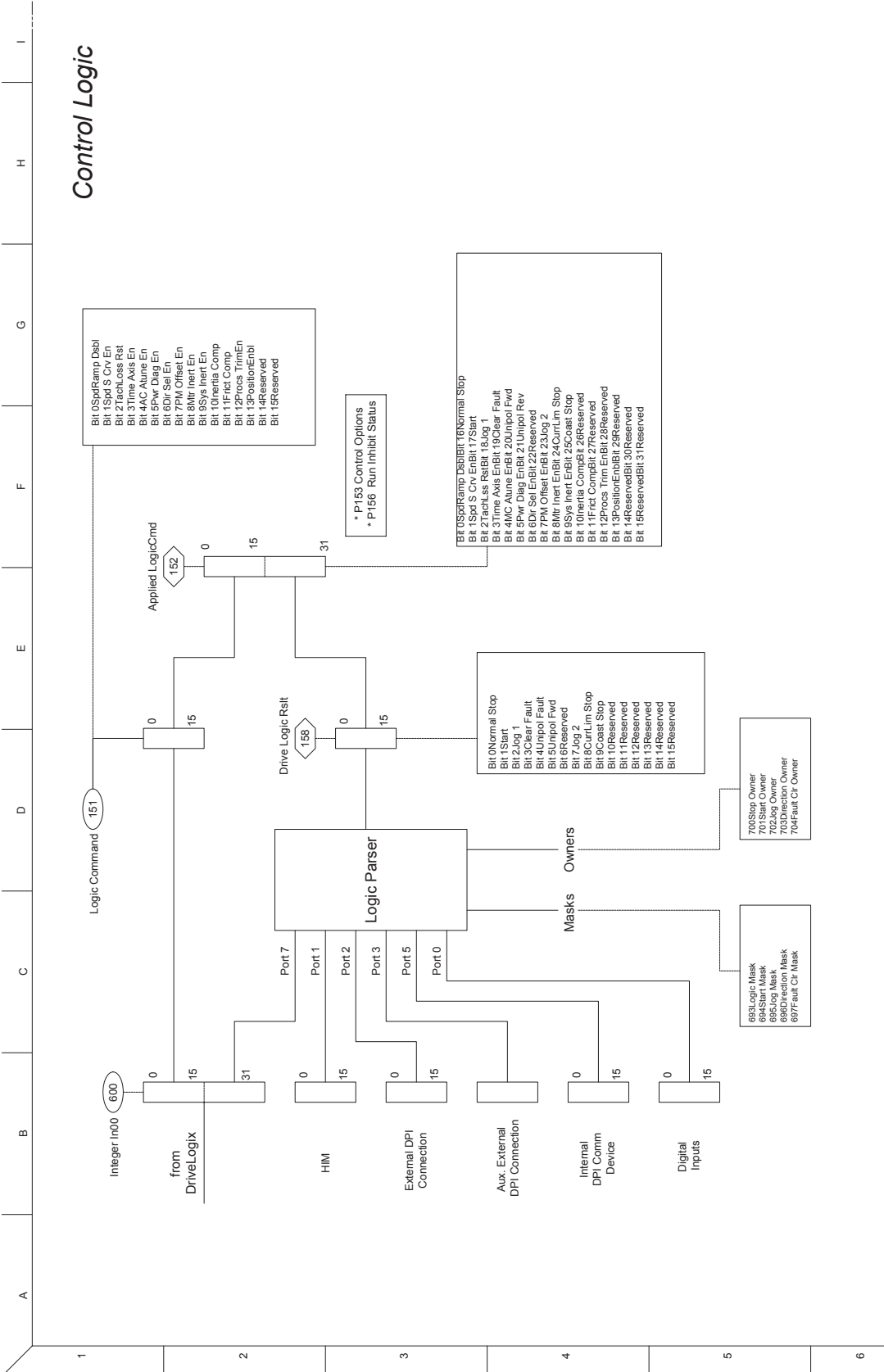

Trend

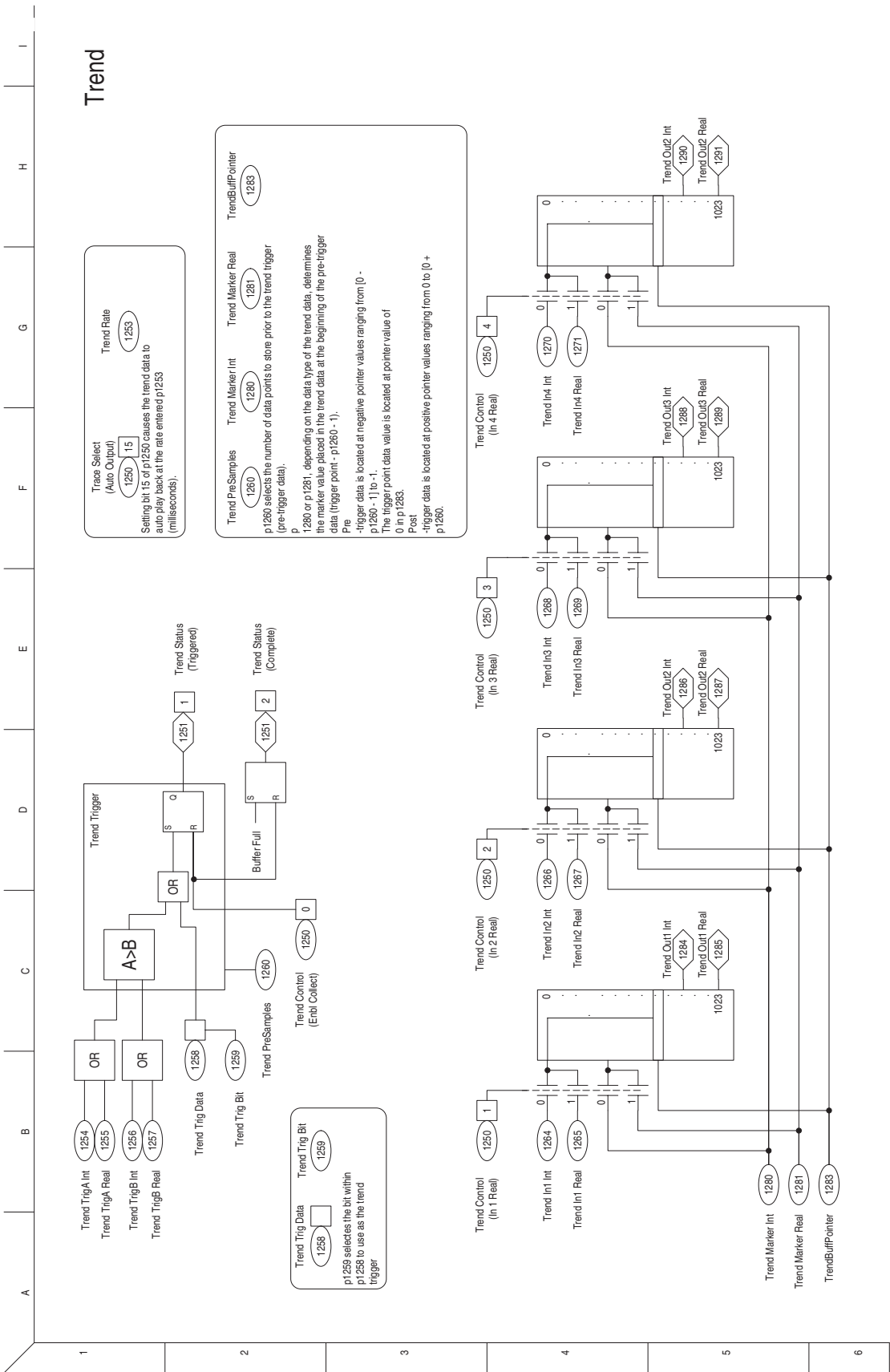

Notes:

Application Notes

For additional application notes, refer to the *PowerFlex 700S Adjustable Frequency AC Drive with Phase I Control - Reference Manual*, publication PFLEX-RM002.

For Information on ...	See Page...
Input Voltage Range/Tolerance	C-1
Motor Control Mode	C-2
Motor Overload	C-3
Overspeed Limit	C-4
Stop Dwell Time	C-5
Setpt 1 Data	C-6
Setpt 2 Data	C-6

Input Voltage Range/ Tolerance

Drive Rating	Nominal Line Voltage	Nominal Motor Voltage	Drive Full Power Range	Drive Operating Range
200-240	200	200†	200-264	180-264
	208	208	208-264	
	240	230	230-264	
380-400	380	380†	380-528	342-528
	400	400	400-528	
	480	460	460-528	
500-600 (Frames 1-4 Only)	600	575†	575-660	432-660
500-690 (Frames 5 & 6 Only)	600	575†	575-660	475-759
	690	690	690-759	475-759

Drive Full Power Range =	Nominal Motor Voltage to Drive Rated Voltage + 10%. Rated current is available across the entire Drive Full Power Range
Drive Operating Range =	Lowest† Nominal Motor Voltage - 10% to Drive Rated Voltage + 10%. Drive Output is linearly derated when Actual Line Voltage is less than the Nominal Motor Voltage

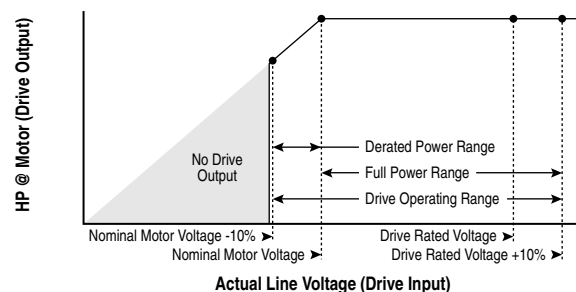

Example:

Calculate the maximum power of a 5 HP, 460V motor connected to a 480V rated drive supplied with 342V Actual Line Voltage input.

- Actual Line Voltage / Nominal Motor Voltage = 74.3%
- $74.3\% \times 5 \text{ HP} = 3.7 \text{ HP}$
- $74.3\% \times 60 \text{ Hz} = 44.6 \text{ Hz}$

At 342V Actual Line Voltage, the maximum power the 5 HP, 460V motor can produce is 3.7 HP at 44.6 Hz.

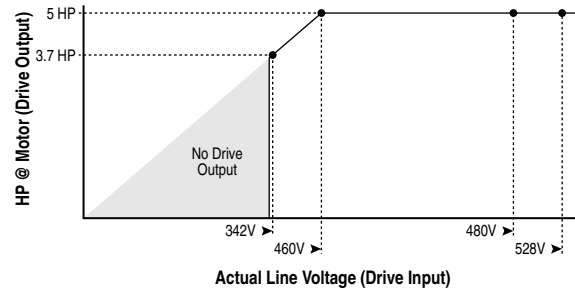
**Motor Control Mode**

Parameter 485 [Motor Ctrl Mode] selects the type of motor control to use. This parameter is set during the HIM assisted startup when asked to select the Motor Control. The settings for Parameter 485 [Motor Ctrl Mode] are

- 0 - "FOC" selects field oriented control. Field oriented control is used with AC squirrel cage induction motors for high performance.
- 1 - "FOC2" selects field oriented control and is only used for a specific type of AC induction motor with motor thermal feedback.
- 2 - "Pmag Motor" selects control for permanent magnet motors.
- 3 - "Reserved"
- 4 - "Test" puts the drive in a test mode to perform the direction test. "Test" is automatically selected during the direction test portion of the Start-Up routine and does not need to be set manually by the user.

Field Oriented Control, Permanent Magnet Motor Control, and Volts/Hertz Control are described in further detail below.

Field Oriented Control

Field oriented control is used with AC squirrel cage induction motors for high performance. Motor data and an autotune is required for correct operation in this mode. Field oriented control is selected by setting parameter 485 [Motor Ctrl Mode] = 0 "FOC".

In field oriented control, the drive takes the speed reference that is specified by the Speed Reference Selection Block and compares it to the speed feedback. The speed regulator uses Proportional and Integral gains to adjust the torque reference for the motor. This torque reference attempts to operate the motor at the specified speed. The torque reference is then converted to the torque producing component of the motor current.

This type of speed regulator produces a high bandwidth response to speed command and load changes. In field oriented control the flux and torque producing currents are independently controlled. Therefore, you can send a torque reference directly instead of a speed reference. The independent flux control also allows you to reduce the flux in order to run above base motor speed.

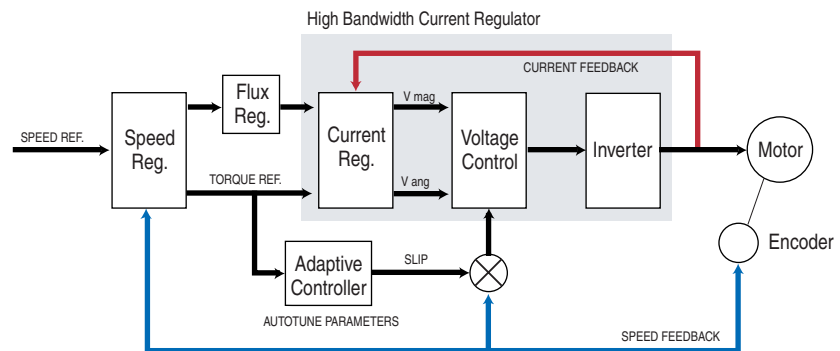

Permanent Magnet Control

Permanent magnet control is used with permanent magnet motors. Permanent magnet motor control is selected by setting parameter 485 [Motor Ctrl Mode] = 2 "Pmag Motor".

- Permanent magnet motor control requires either a hi-resolution Stegmann encoder or compatible resolver feedback on the motor. Refer to [PowerFlex 700S Stegmann Hi-Resolution Encoder Feedback Option on page E-1](#) for a list of compatible hi-resolution Stegmann encoders and compatible resolvers.
- Motor data and an autotune is required for correct operation in this mode. Refer to [PowerFlex 700S Permanent Magnet Motor Specifications on page I-1](#) for a list of compatible Allen-Bradley permanent magnet motors and motor data to be used with the PowerFlex 700S.

Motor Overload

Mtr I²T Spd Min

Sets the minimum speed for the motor overload (I^2T) function. The value indicates minimum speed below the minimum current threshold [Mtr I²T Curr Min], and these are the first current/speed breakpoint. From this point the current threshold is linear to the value specified by the motor service factor [Service Factor].

Figure C.1 Motor Overload Curve With Parameter 338 [Mtr I2T Spd Min] Is Less Than 1.0

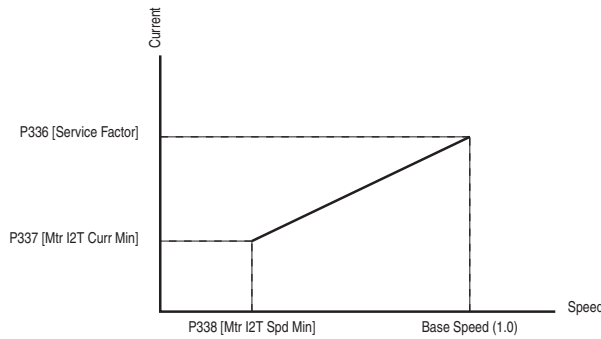

When motor current exceeds the value of the curve, Mtr OL Output integrates. A motor overload exception event occurs when the value in Mtr OL Output reaches 1.0. The value of Mtr OL Output is visible in parameter 330 [Fault TP Data] when the value of parameter 329 [Fault TP Sel] equals 13.

Figure C.2 Motor Overload Curve With Parameter 338 [Mtr I2T Spd Min] Is Equal To 1.0

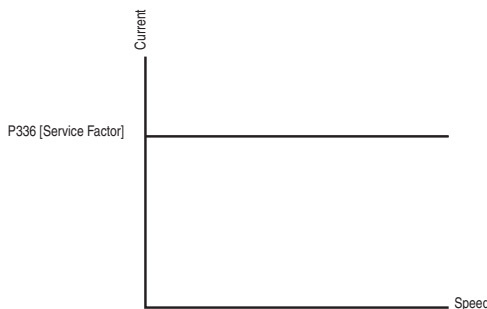

When the value of parameter 338 [Mtr I2T Spd Min] equals 1.0, the curve is flat - at the value of rated motor current times the value of parameter 336 [Service Factor]. If motor current exceeds the value of the curve, the value of Mtr OL Output integrates. The value of Mtr OL Output is visible in parameter 330 [Fault TP Data] when the value of parameter 329 [Fault TP Sel] equals 13.

Overspeed Limit

The absolute overspeed limit parameter, parameter 335 [Abs OverSpd Lim], is an adjustable setting. This sets a limit tolerance below parameter 30 [Rev Speed Lim] and above parameter 31 [Fwd Speed Lim], that is allowable. This can be used as a safe working speed limit.

Example 1 Speed reference is set to equal parameter 31 [Fwd Speed Lim]. Based on tuning of the drive, the speed could overshoot the commanded speed. If parameter 335 [Abs OverSpd Lim] is set equal to the forward speed limit and an overshoot is speed occurs, the drive will fault on an absolute overspeed.

Example 2 Drive is configured as a torque follower. If the mechanical connection to the load is severed, the torque command to the drive will probably be greater than the motor unloaded will require to maintain the system speed. This will cause the motor speed to increase until the torque command is met. Setting parameter 335 [Abs OverSpd Lim] to the safe motor speed will cause the fault to occur when the motor speed increase beyond this limit.

Stop Dwell Time

Sets an adjustable delay time between detecting zero speed and disabling the speed and torque regulators, when responding to a stop command.

Important: Consult industry and local codes when setting the value of this parameter.

Figure C.3 Drive Operation When Parameter 154 [Stop Dwell Time] Equals Zero

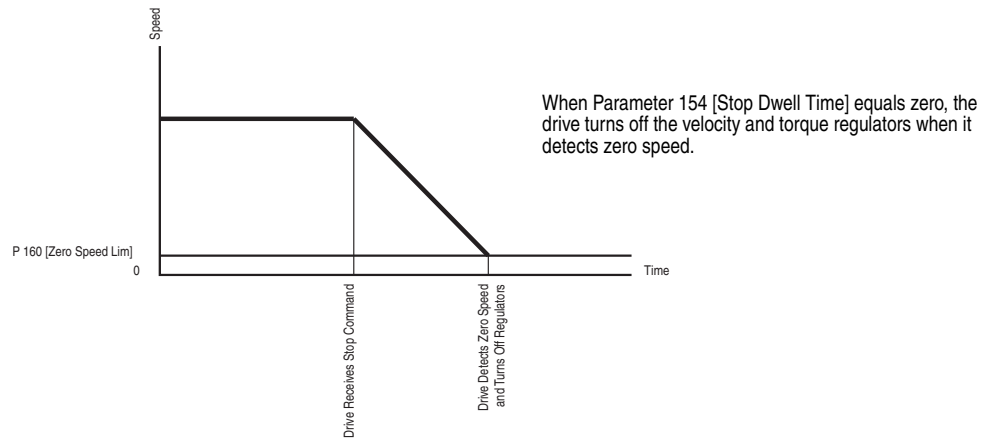
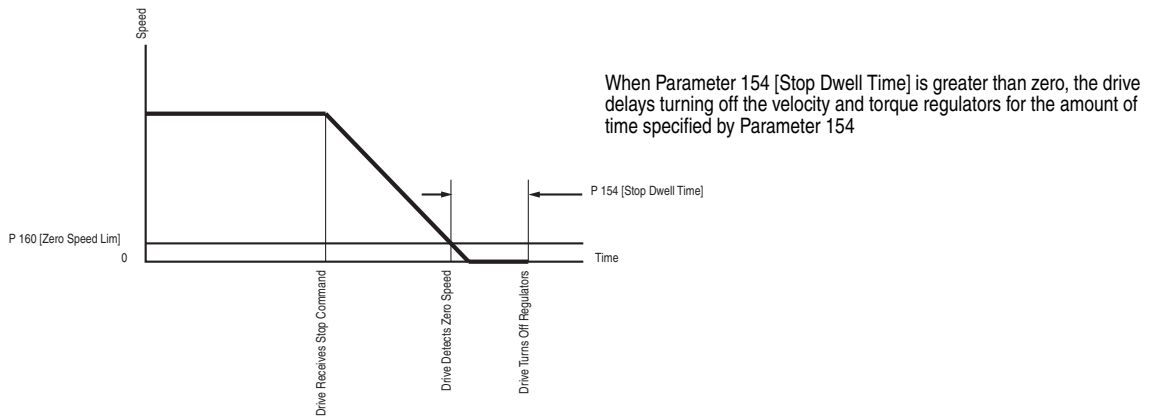

Figure C.4 Drive Operation When Parameter 154 [Stop Dwell Time] Equals Zero



Setpt 1 Data

Provides data for comparison of Par 172 [Setpt 1 Data] to Par 173 [Setpt1 TripPoint], driving bit 16 [At Setpt 1] of Par 155 [Logic Status].

Figure C.5 At Setpoint 1 Status

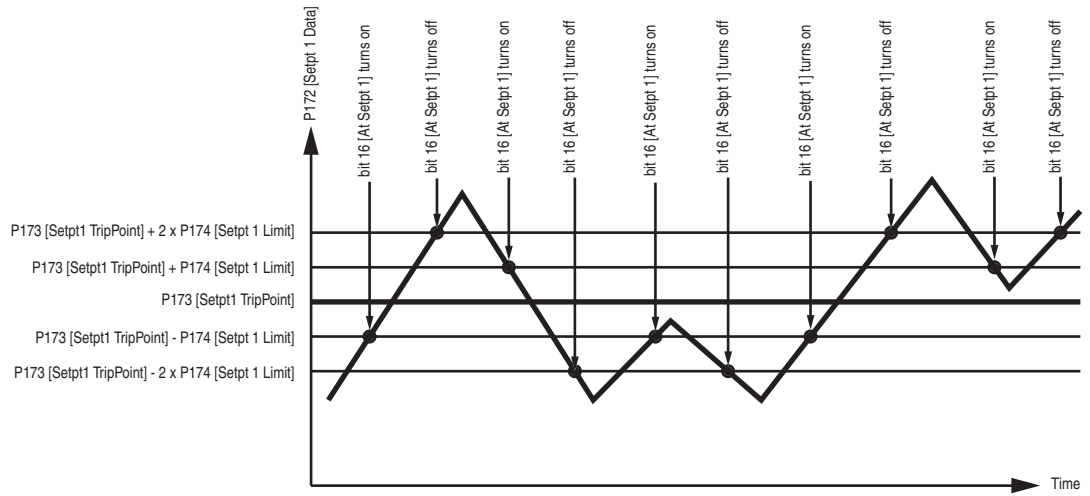

Setpt 2 Data

Provides data for comparison of Par175 [Setpt 2 Data] to Par 176 [Setpt2 TripPoint], driving bit 17 [Above Setpt 2] of Par 155 [Logic Status].

Figure C.6 Above Setpoint 2 Status

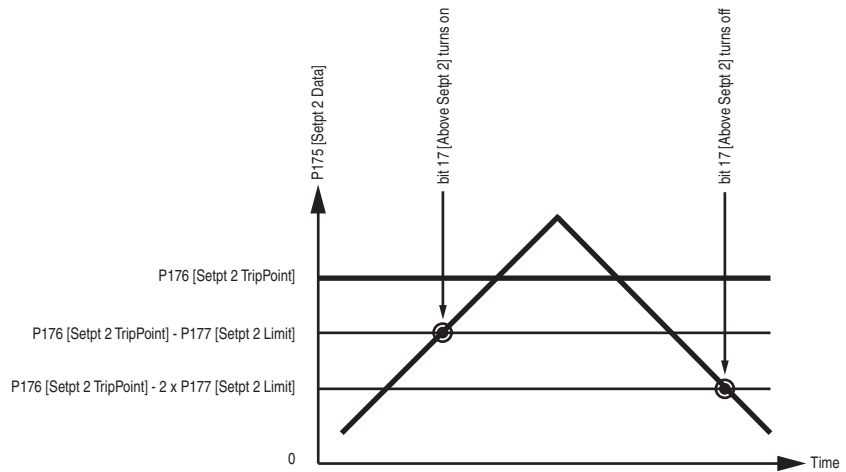

HIM Overview

For Information on ...	See Page...
External and Internal Connections	D-1
LCD Display Elements	D-2
Removing/Installing the HIM	D-3

External and Internal Connections

The PowerFlex 700S provides cable connection for a handheld HIM or Port Expander/Splitter (Frame 1 shown).

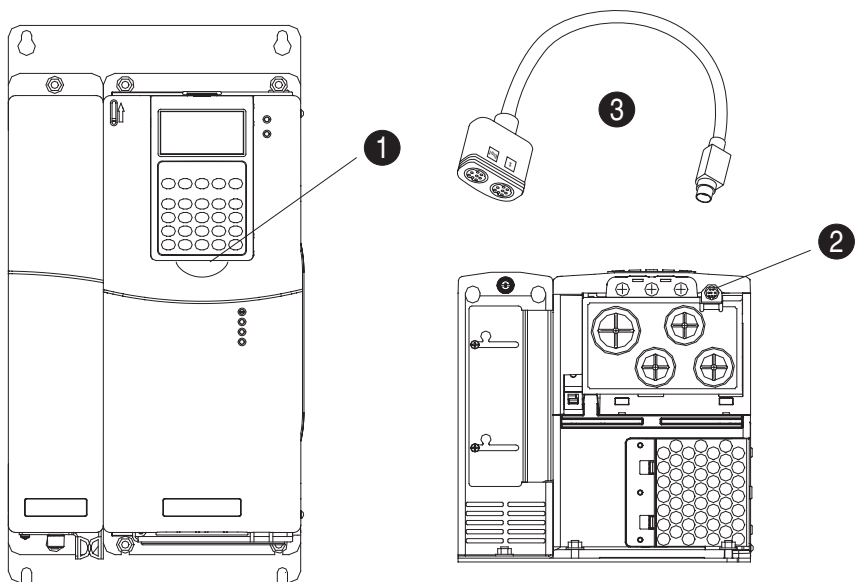

No.	Connector	Description
❶	DPI Port 1	HIM connection when installed in cover.
❷	DPI Port 2	Cable connection for handheld and remote options.
❸	DPI Port 3 or 2	Splitter cable connected to DPI Port 2 provides additional port.



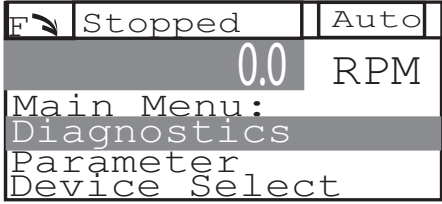





LCD Display Elements

Display	Description					
	<table border="1"> <tr> <td>Direction</td> <td>Drive Status</td> <td>Alarm</td> <td>Auto/Manual</td> <td>Information</td> </tr> </table> <p>Commanded or Output Frequency</p>	Direction	Drive Status	Alarm	Auto/Manual	Information
Direction	Drive Status	Alarm	Auto/Manual	Information		
	Programming / Monitoring / Troubleshooting					

ALT Functions

To use an ALT function, press the ALT key release it, then press the programming key associated with one of the following functions:

Table D.A ALT Key Functions

ALT Key and then...			
		S.M.A.R.T.	Function not available
		View	Allows the selection of how parameters will be viewed or detailed information about a parameter or component.
		Lang	Not Functional at this time
		Auto/Man	Function not available
		Remove	Allows HIM removal without causing a fault if the HIM is not the last controlling device and does not have Manual control of the drive.
		Exp	Allows the value to be entered as an exponent.
		Param #	Allows entry of a parameter number for viewing/editing.

Removing/Installing the HIM The HIM can be removed or installed while the drive is powered.

Step	Key(s)	Example Displays
<p>To remove the HIM...</p> <ol style="list-style-type: none">1. Press ALT and then Enter (Remove). The Remove HIM configuration screen appears.2. Press Enter to confirm that you want to remove the HIM.3. Remove the HIM from the drive. <p>To install HIM...</p> <ol style="list-style-type: none">1. Insert into drive or connect cable.	 The image shows the ALT key (a black circle with 'ALT' in yellow) followed by a plus sign and the Enter key (a blue circle with a white arrow pointing down and to the right).	<pre data-bbox="1122 386 1446 541">Remove Op Intrfc: Press Enter to Disconnect Op Intfc? (Port 1 Control)</pre>

Notes:

PowerFlex 700S Stegmann Hi-Resolution Encoder Feedback Option

Chapter Objectives

For Information on ...	See Page...
Specifications	E-1
Wiring the Stegmann Hi-Resolution Feedback Option Card to an Encoder	E-2

Specifications

Stegmann Hi-Resolution Feedback Option Card Specifications

Consideration	Description
Encoder Voltage Supply	11.5V dc @ 130 mA
Hi-Resolution Feedback	Sine/Cosine 1V P-P Offset 2.5
Maximum Cable Length	90m (295 ft)
Maximum Frequency (Encoder Speed)	12.5 μ s/cycle (4687.5 RPM for encoders with 1024 sine cycles per revolution) (9375 RPM for encoders with 512 sine cycles per revolution)
RS-485 Interface	The Hi-Resolution Feedback Option card obtains the following information via the Hiperface RS-485 interface shortly after power-up: <ul style="list-style-type: none"> • Address • Command Number • Mode • Number of turns • Number of Sine/Cos cycles • Checksum
Customer-I/O plug (P1)	Allen-Bradley PN: S94262912 Weidmuller PN: BL3.50/90/12BK

Supported Encoders

[Table E.A](#) specifies which encoders are supported by the 700S Hi-Resolution Stegmann Encoder Feedback Option module.

Important: Please note that encoders must be ordered as "Single Ended". This will ensure that the RS-485 channel has the proper termination network installed at the factory.

Table E.A Supported Stegmann Encoders

Model	Resolution	Comment
SINCOS® SCS-60, SCS-70, SCM-60, and SCM-70	512 sine cycles per revolution.	SCM-60 and SCM-70 have built-in mechanical turns counter.
SINCOS® SCS-KIT-101 and SCM-KIT-101	1024 sine cycles per revolution.	SCM-60 and SCM-70 have built-in mechanical turns counter.
SINCOS® SRS-50, SRS-60, SRM-50, and SRM-60	1024 sine cycles per revolution.	SRM-50 and SRM-60 have built-in mechanical turns counter.
SINCOS® SRS/M 25	1024 sine cycles per revolution	SRS25 and SRM25 have built-in mechanical turns counter. IP65 Protection Class. Size 25 square flange mounting.
SINCOS® SRS660	1024 sine cycles per revolution	Hollow-shaft up to 14 mm diameter
SINCOS® SHS-170	512 sine cycles per revolution.	While the software supports this encoder, the SHS-170 draws excessive current and should only be used with an external power supply.

SINCOS®, SINCODER® and LINCODER® are registered trademarks of Stegmann Inc.

Wiring the Stegmann Hi-Resolution Feedback Option Card to an Encoder

Terminal block P1 contains connection points for a Stegmann Hiperface® encoder. This terminal block resides on the Hi-Resolution Encoder Feedback Option card.

Hiperface® is a registered trademark of Stegmann Inc.

Figure E.1 Control Assembly Sliding Access Panel

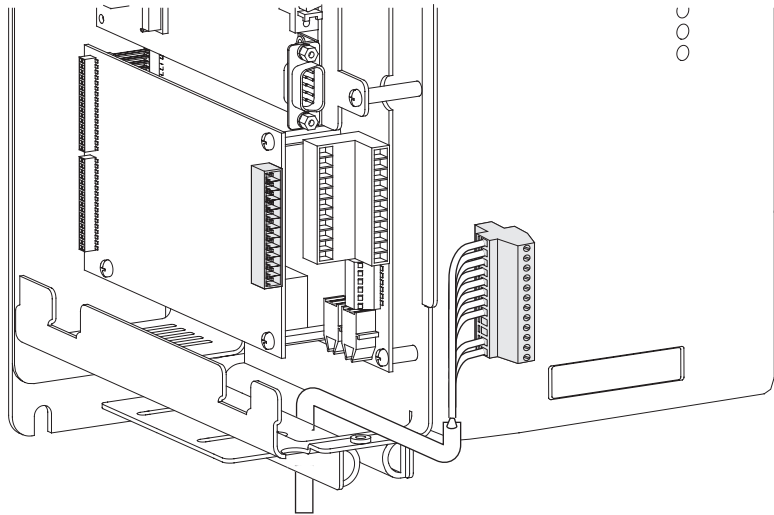

TIP: Remember to route wires through the sliding access panel at the bottom of the Control Assembly.

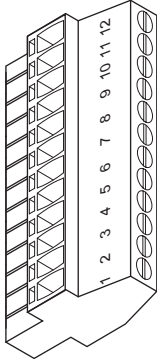

Terminal	Signal	Description
12	POWER COMMON	Power supply for encoder interface.
11	POWER	
10	REFSIN	Negative Sine signal.
9	+SIN	Positive Sine signal.
8	REFCOS	Negative Cosine signal.
7	+COS	Positive Cosine signal.
6	SHIELD	Connection point for encoder cable shield.
5	SHIELD	
4	N/C	Not connected.
3	N/C	
2	DATA+ (RS 485)	Positive DH485 terminal.
1	DATA- (RS 485)	Negative DH485 terminal.

Recommended Cables

If you are using this motor and feedback device:	Use this cable:	See this wiring diagram:
Allen-Bradley 1326AB-BXXXX-21ML, and -21MKXL motors with embedded Stegmann rotary encoder	Allen-Bradley 1326-CECU-XXL-XXX	Figure E.2 on page E-3
Allen-Bradley 1326AB-BXXXX-M2L, -M2KXL, -S2L, and -S2KXL motors with embedded Stegmann rotary encoder	Allen-Bradley 2090-CDNFDMP-SXX	Figure E.3 on page E-4
Allen-Bradley MP-Series 460V motors with embedded Stegmann rotary encoder	Allen-Bradley 2090-CDNFDMP-SXX or 2090-XXNFMP-SXX	Figure E.3 on page E-4
Allen-Bradley MP-Series 230V motors with embedded Stegmann rotary encoder	Allen-Bradley 2090-UXNFDMP-SXX or 2090-XXNFMP-SXX	Figure E.4 on page E-4
Any other motor with external Stegmann SHS-170 rotary encoder	Stegmann shielded twisted-pair cable with 12-pin DIN style connector	Figure E.5 on page E-4
Any other motor with external Stegmann SCS-60, SCS-70, SCM-60 or SCM-70, SRS-50, SRS-60, SRM-60, SRM-60, SRS-25 or SRM-252 rotary encoder	Stegmann shielded twisted-pair cable with 12-pin DIN style connector or 8-pin Berg style connector	Figure E.5 on page E-4 or Figure E.7 on page E-5
Any other motor with external Stegmann SCS-Kit 101 or SCK-Kit 101 rotary encoder	Stegmann shielded twisted-pair cable with 8-pin Berg style connector	Figure E.7 on page E-5
Any other motor with external Stegmann SRS660 rotary encoder	Is available only with pre-attached Stegmann shielded twisted-pair cable of various lengths	Figure E.8 on page E-5

Connection Examples

Figure E.2 1326-CECU-XXL-XXX cable

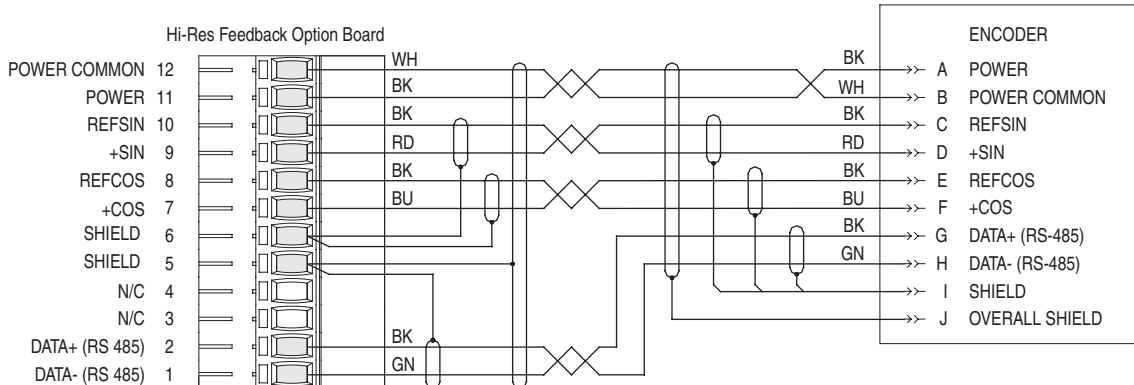

Connection Examples

Figure E.3 460V MP Series Motor with 2090-CDNFDMP-SXX or 2090-XXNFMP-SXX cable; or 1326AB-BXXXX-M2L, -M2KXL, -S2L, and -S2KXL motor with 2090-XXNFMP-SXX cable

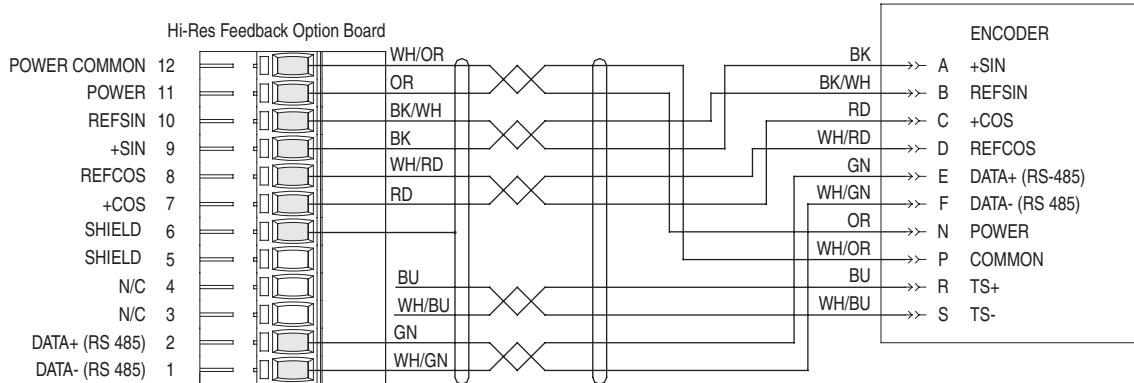

Figure E.4 230V MP Series Motor with 2090-UXNFDMP-SXX or 2090-XXNFMP-SXX cable

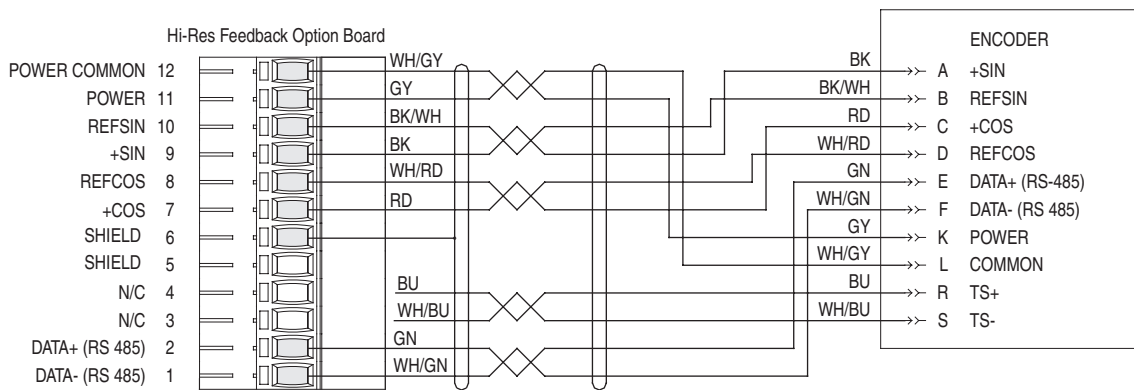
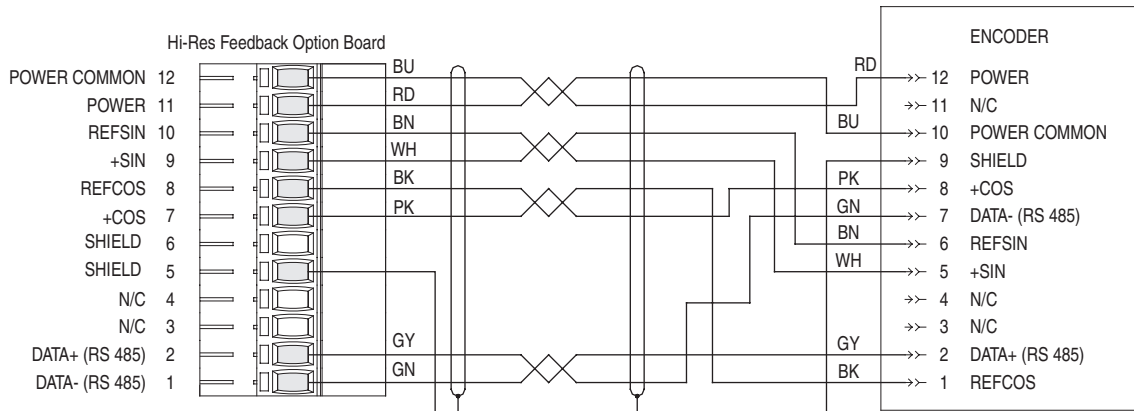

Figure E.5 Stegmann shielded twisted-pair cable with 12-pin DIN style connector



Connection Examples

Figure E.6 Stegmann shielded twisted-pair cable with 10-pin MS style connector

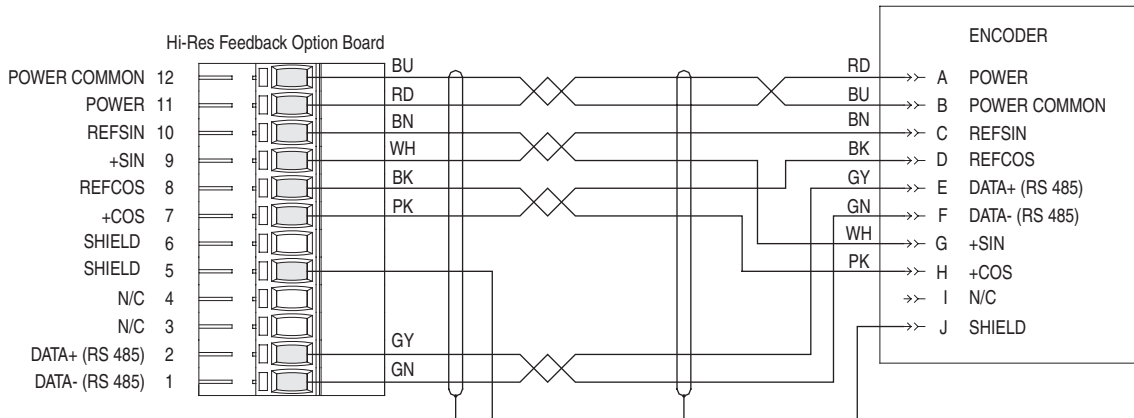

Figure E.7 Stegmann shielded twisted-pair cable with 8-pin Berg style connector

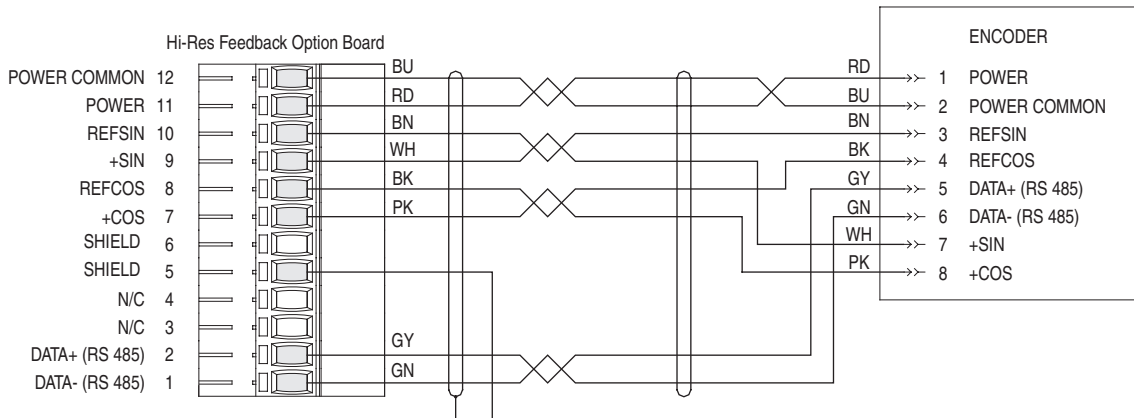
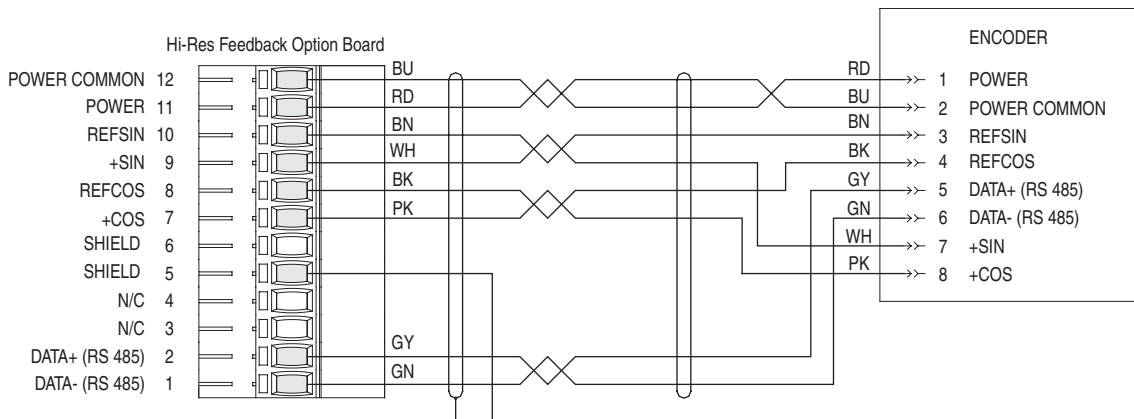

Figure E.8 Stegmann pre-attached shielded twisted-pair cable



Notes:

PowerFlex 700S Resolver Feedback Option Card

Chapter Objectives

For Information on ...	See Page...
Chapter Objectives	E-1
Specifications	E-1

Specifications

Resolver Feedback Option Card Specifications

Consideration	Description
Excitation Frequency	2400 Hz
Excitation Voltage	26 Vrms
Resolver Feedback Voltage	2 Vrms +/- 300 mV
Customer-I/O plug (P1)	Allen-Bradley PN: S94262908 Weidmuller PN: BL3.50/90/8BK

Compatible Resolvers

[Table G](#) specifies which resolvers are supported by the 700S Resolver Feedback Option module.

Table G Compatible Resolvers.

Manufacturer	Manufacturer Catalog Number	Notes
Tamagawa	TS-2014N181E32	x 1, flange-mounted enclosure
Tamagawa	TS-2014N182E32	x 2, flange-mounted enclosure
Tamagawa	TS-2014N185E32	x 5, flange-mounted enclosure
Tamagawa	TS-2087N12E9	x 2, HD foot-mounted enclosure, double shaft
Tamagawa	TS-2087N1E9	x 1, HD foot-mounted enclosure
Tamagawa	TS-2087N2E9	x 2, HD foot-mounted enclosure
Tamagawa	TS-2087N5E9	x 5, HD foot-mounted enclosure
Tamagawa	TS-2087N11E9	x 1, HD foot-mounted enclosure, double shaft
Advanced Micro Controls Inc. (AMCI)	R11X-C10/7	

Allen-Bradley servo motors may be ordered with factory installed resolvers. [Table H](#) specifies which factory installed resolvers are supported by the 700S Resolver Feedback Option module.

Table H Compatibility with Resolvers on Allen-Bradley Motors

Motor / Resolver Type	Compatible	Notes
1326 AB 230V Primary Resolver	No	Receiver type - not supported
1326 AB 230V Secondary Resolver	Yes	Transmitter type - supported Secondary resolver is geared to motor - not intended for motor speed / position feedback
1326 AB 460V Primary Resolver	Yes	Transmitter type - supported
1326 AB 460V Secondary Resolver	Yes	Transmitter type - supported Secondary resolver is geared to motor - not intended for motor speed / position feedback
1326AD 230V Rare Earth	No	Receiver type - not supported
1326AH 460V Explosion Proof Motor Primary Resolver	Yes	Transmitter type - supported
1326AH 460V Explosion Proof Motor Secondary Resolver	Yes	Transmitter type - supported Secondary resolver is geared to motor - not intended for motor speed / position feedback
1326AS 460V Rare Earth	Yes	Transmitter type - supported
MPL 460V	Yes	Transmitter type - supported

Wiring the Resolver Feedback Option Card to a Resolver

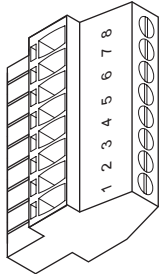
	Terminal	Signal	Description
	8	REF HIGH	Positive Reference signal
	7	SHIELD	Connection point for resolver cable shield
	6	REF LOW	Negative Reference signal
	5	SIN HIGH	Positive Sine signal
	4	SHIELD	Connection point for resolver cable shield
	3	SIN LOW	Negative Sine signal
	2	COS HIGH	Positive Cosine signal
	1	COS LOW	Negative Cosine signal

Connection Examples

Resolver Interface - Clockwise Rotation = Count Up

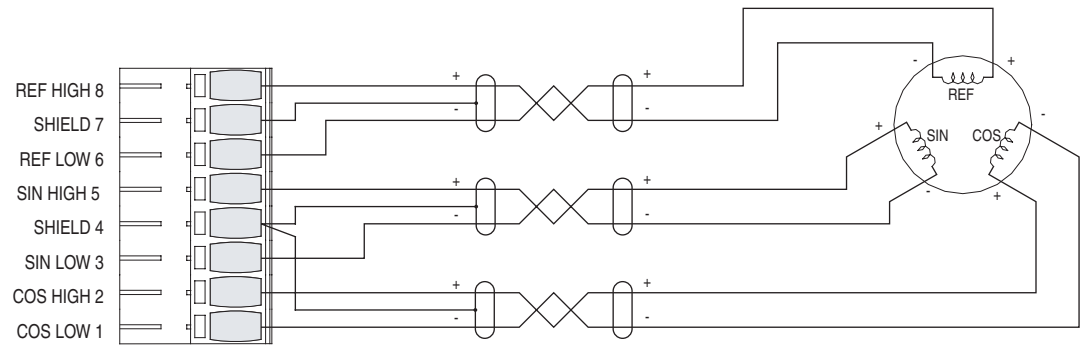

Resolver Interface - Clockwise Rotation = Count Down (Reverse Polarity of Sine or Cosine Signals)

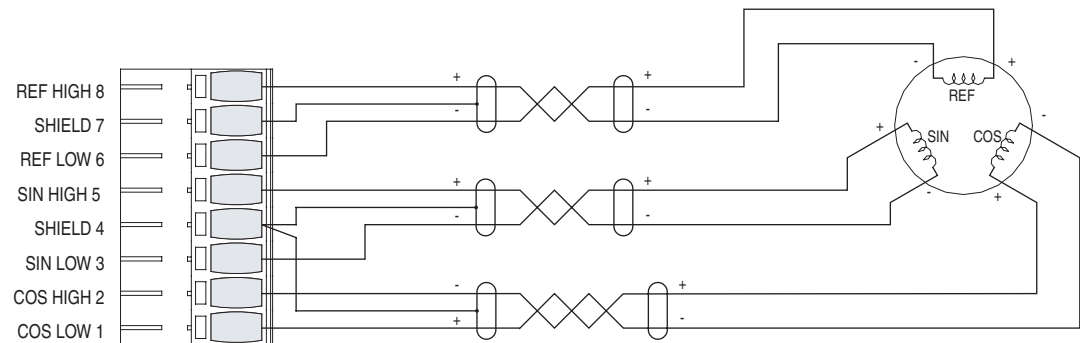
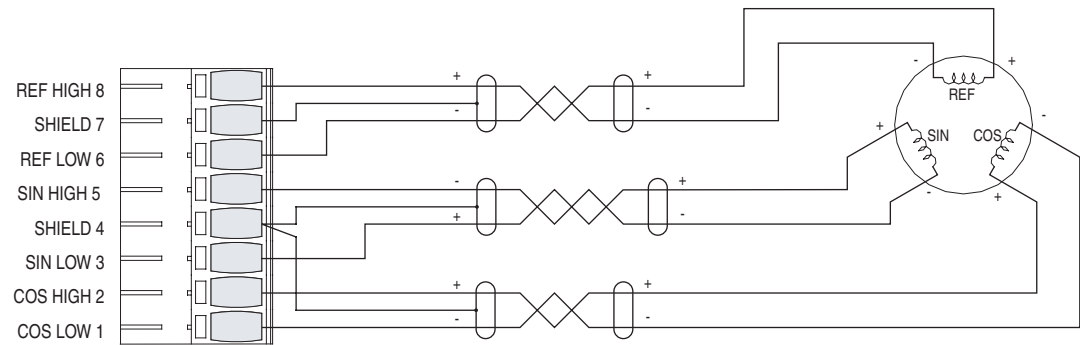

Notes

Access Procedures

Using this Appendix

For information about:	See page
Removing Cover(s)	G-1
Replacing Cover(s)	G-2

Removing Cover(s)

Task	Description
(A)	Loosen captive screw
(B)	Push down on front cover
(C)	Pull front cover away from assembly
(D)	Pull side cover forward
(E)	Lift side cover off of control assembly

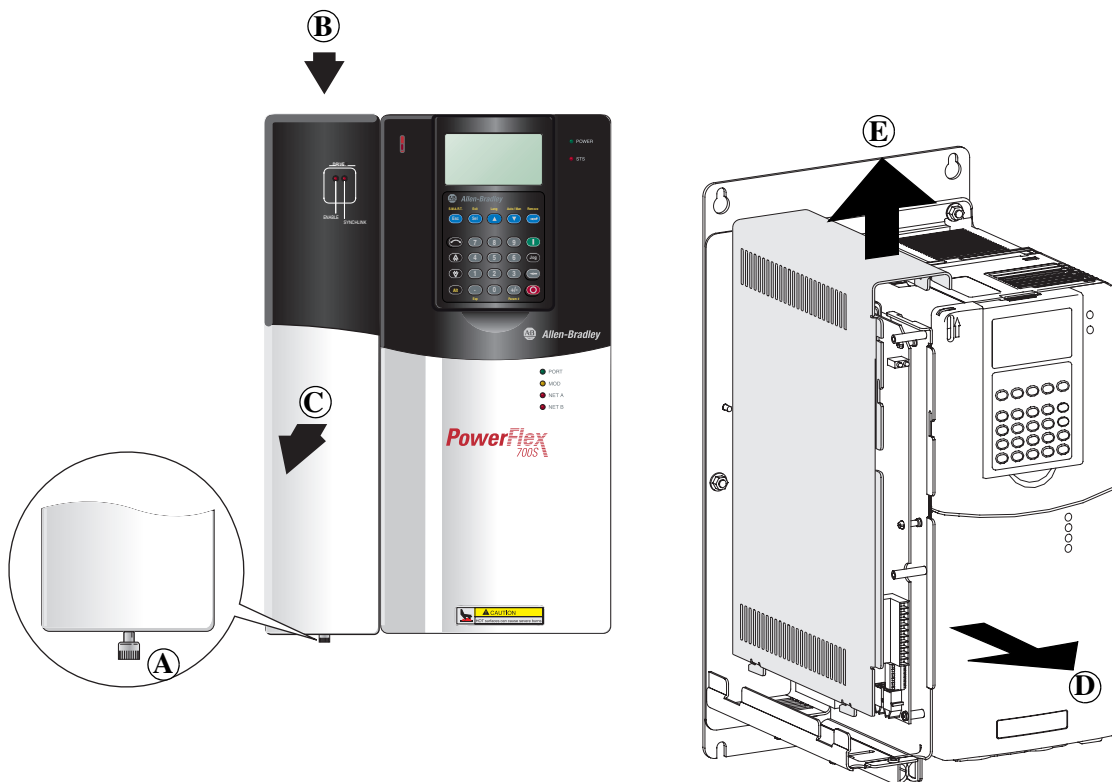

Replacing Cover(s)

Task	Description
Ⓐ	Align tabs on side cover with slots on drive
Ⓑ	Push side cover down onto control assembly
Ⓒ	Push side cover back onto control assembly

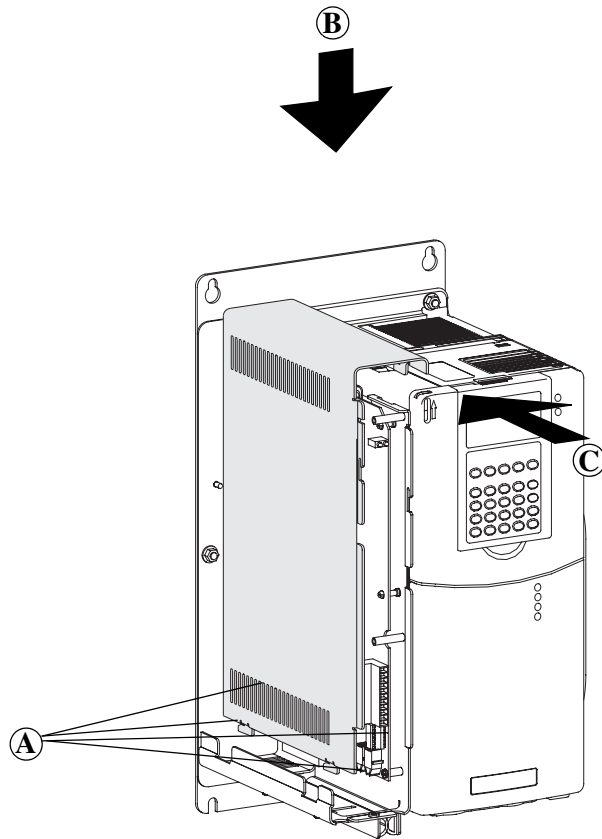

Task	Description
Ⓓ	Locate tabs on inside of front cover
Ⓔ	Align tabs on front cover with slots on flanges
Ⓕ	Push front cover onto drive
Ⓖ	Push front cover up into slots
Ⓕ	Tighten captive screw

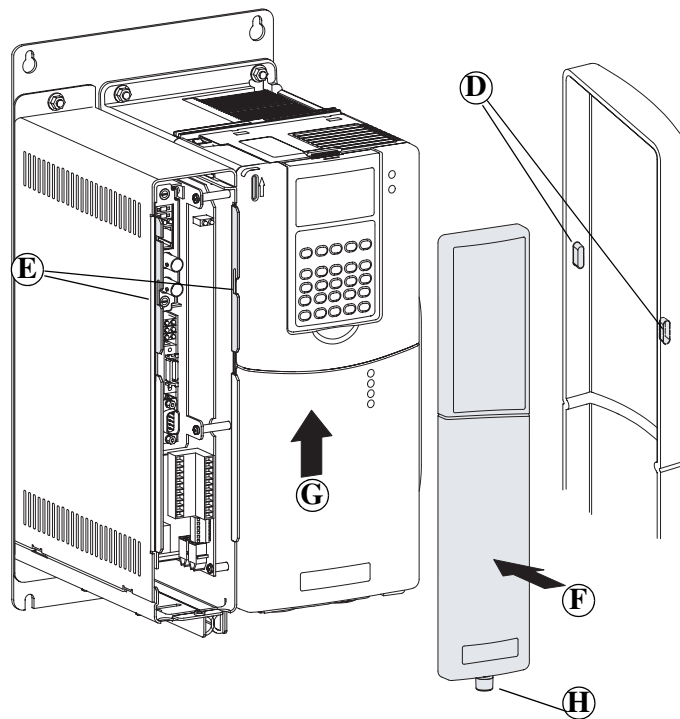

Notes

PowerFlex 700S Multi-Device Interface Option Card

For information about:	See page
Specifications	H-1
Wiring the MDI Option Card	H-3

Specifications

MDI Option Card Specifications

Consideration	Description
Rotary Encoder Voltage Supply	11.5V dc @ 130 mA
Rotary Encoder Hi-Resolution Feedback	Sine/Cosine 1V P-P Offset 2.5
Rotary Encoder Maximum Cable Length	182m (600 ft.)
Rotary Encoder RS-485 Interface	The MDI Option card obtains the following information via the Hiperface RS-485 interface shortly after power-up: <ul style="list-style-type: none"> • Address • Command Number • Mode • Number of turns • Number of Sine/Cos cycles • Checksum
Registration Inputs	high speed 12-24V dc sinking digital inputs
Customer-I/O plug (P1)	Allen-Bradley PN: S94274917 Weidmuller PN: 67601782

Supported Linear Sensors

Temposonics® III Linear sensors with MTS® part numbers ending in 1S2G1102 work with the MDI Option.

Part Number Character	Characteristic
1	Input Voltage = +24Vdc
S	SSI output
2	Data Length = 24 Bits
G	Output Format = Gray Code
1	Resolution = 0.005 mm
1	Performance = Standard
02	Scale Orientation = Forward-acting Synchronized

Temposonics® is a registered trademark of MTS Systems Corporation.

Supported Rotary Encoders

[Table H.A](#) specifies which encoders work with the MDI Option.

Important: Please note that encoders must be ordered as "Single Ended". This will ensure that the RS-485 channel has the proper termination network installed at the factory.

Table H.A Supported Stegmann Rotary Encoders

Model	Resolution	Comment
SINCOS® SCS-60, SCS-70, SCM-60, and SCM-70	512 sine cycles per revolution.	SCM-60 and SCM-70 have built-in mechanical turns counter.
SINCOS® SCS-KIT-101 and SCM-KIT-101	1024 sine cycles per revolution.	SCM-60 and SCM-70 have built-in mechanical turns counter.
SINCOS® SRS-50, SRS-60, SRM-50, and SRM-60	1024 sine cycles per revolution.	SRM-50 and SRM-60 have built-in mechanical turns counter.
SINCOS® SRS/M 25	1024 sine cycles per revolution	SRS25 and SRM25 have built-in mechanical turns counter. IP65 Protection Class. Size 25 square flange mounting.
SINCOS® SRS660	1024 sine cycles per revolution	Hollow-shaft up to 14 mm diameter
SINCOS® SHS-170	512 sine cycles per revolution.	While the software supports this encoder, the SHS-170 draws excessive current and should only be used with an external power supply.

SINCOS®, SINCODER® and LINCODER® are registered trademarks of Stegmann Inc.

Recommended Cables

If you are using this motor and feedback device:	Use this cable:
Temposonics III Linear sensors with MTS part numbers ending in 1S2G1102	Mating MTS molded extension cable for RG connector or integral P cable
Allen-Bradley 1326AB-BXXXX-21ML, and -21MKXL motors with embedded Stegmann rotary encoder	Allen-Bradley 1326-CECU-XXL-XXX
Allen-Bradley 1326AB-BXXXX-M2L, -M2KXL, -S2L, and -S2KXL motors with embedded Stegmann rotary encoder	Allen-Bradley 2090-CDNFDMP-SXX
Any other motor with external Stegmann SRS/SRM25 rotary encoder	Stegmann 6-411562-XX cables with 10-Pin MS connector assembly 6-430080-00
Any other motor with other external Stegmann rotary encoders	Stegmann 6-411682-XX cables with C12 FUR connectors

Important: Please note that encoders must be ordered with the C12 FUR connectors to accommodate these cables.

Wiring the MDI Option Card

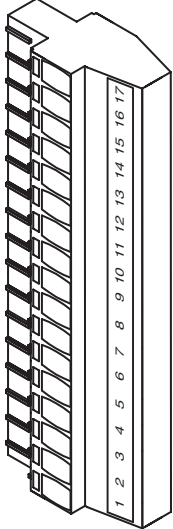
	Terminal	Signal	Description
	17	Rotary Encoder POWER COMMON	Power supply for Rotary Encoder interface
	16	Rotary Encoder POWER	
	15	Rotary Encoder REFSIN	Positive Sine signal for Rotary Encoder interface
	14	Rotary Encoder +SIN	Negative Sine signal for Rotary Encoder interface
	13	Rotary Encoder REFCOS	Negative Cosine signal for Rotary Encoder interface
	12	Rotary Encoder +COS	Positive Cosine signal for Rotary Encoder interface
	11	Rotary Encoder DATA+ (RS485)	Positive DH485 terminal for Rotary Encoder interface
	10	Rotary Encoder DATA- (RS485)	Negative DH485 terminal for Rotary Encoder interface
	9	Linear Sensor CLOCK+	Positive Clock terminal for Linear Sensor interface
	8	Linear Sensor CLOCK-	Negative Clock terminal for Linear Sensor interface
	7	Linear Sensor DATA+	Positive SSI terminal for Linear Sensor interface
	6	Linear Sensor DATA-	Negative SSI terminal for Linear Sensor interface
	5	Rotary Encoder REGISTRATION+	Positive terminal for Rotary Encoder registration strobe
	4	Rotary Encoder REGISTRATION-	Negative terminal for Rotary Encoder registration strobe
	3	Linear Sensor REGISTRATION+	Positive terminal for Linear Sensor registration strobe
	2	Linear Sensor REGISTRATION-	Negative terminal for Linear Sensor registration strobe
	1	CHASSIS GND	Connection point for cable shields

Connection Examples

Linear Sensor Connections with MDI RG Connector or P Integral Cable

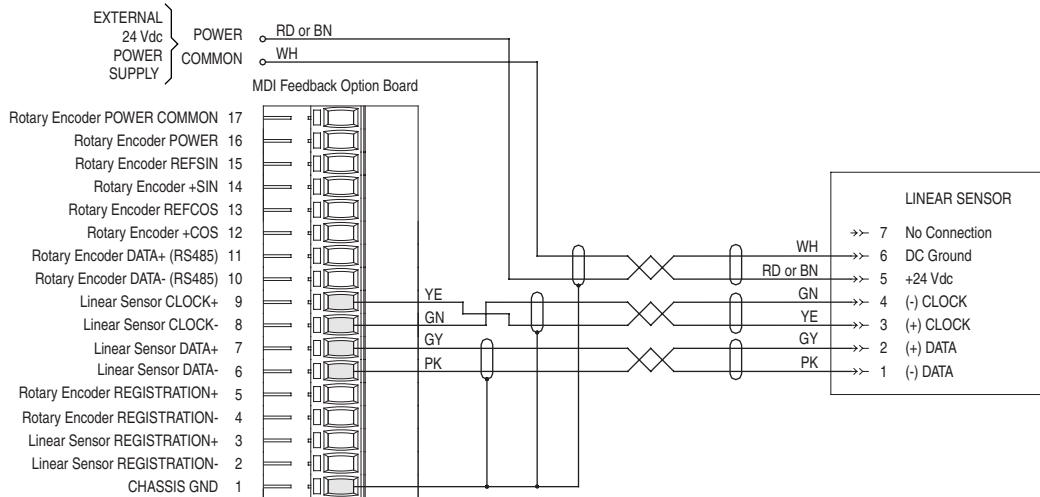

Rotary Encoder Connections with Allen-Bradley 1326-CECU-XXL-XXX Cable

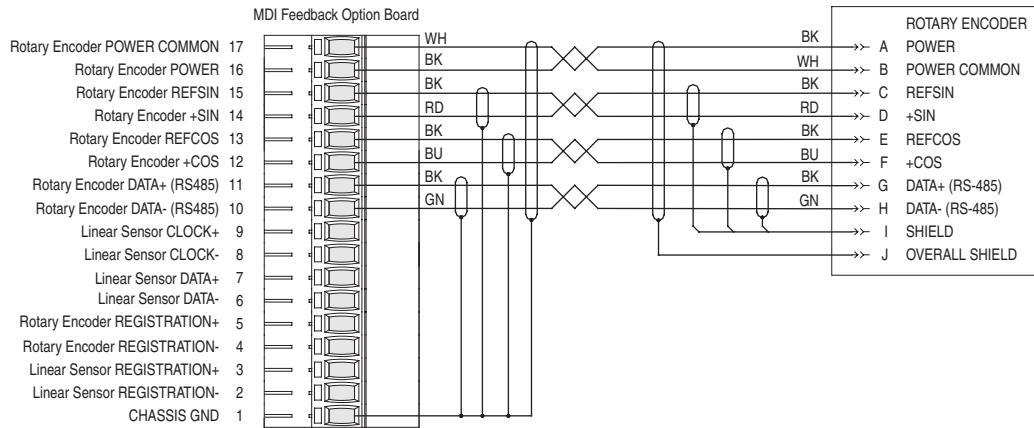

Rotary Encoder Connections for 460V MP Series Motor with 2090-CDNFDMP-SXX or 2090-XXNFMP-SXX cable; or 1326AB-BXXXX-M2L, -M2KXL, -S2L, and -S2KXL motor with 2090-XXNFMP-SXX cable

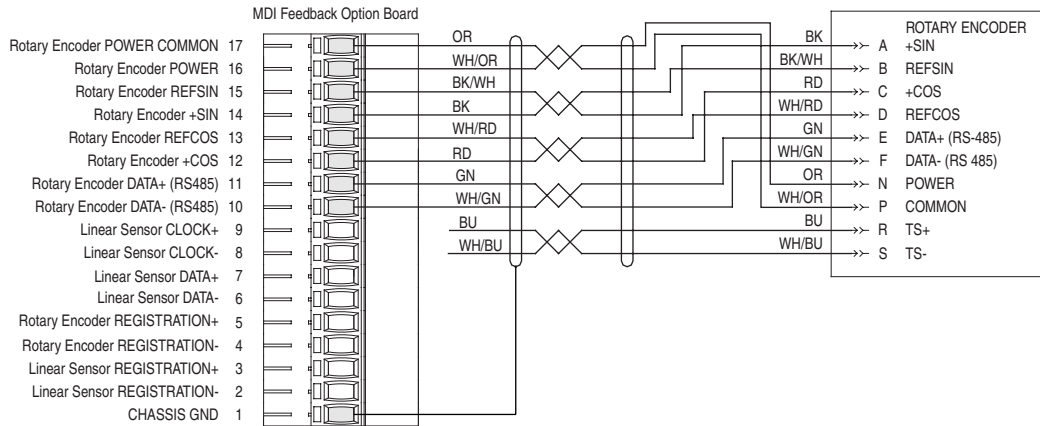

Connection Examples

Rotary Encoder Connections for 230V MP Series Motor with 2090-UXNFDMP-SXX or 2090-XXNFMP-SXX cable

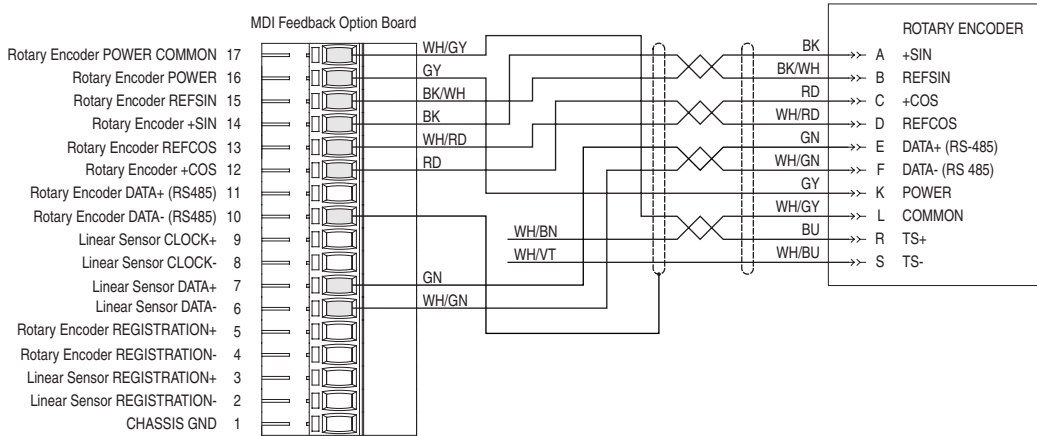

Stegmann shielded twisted-pair cable with 10-pin MS style connector

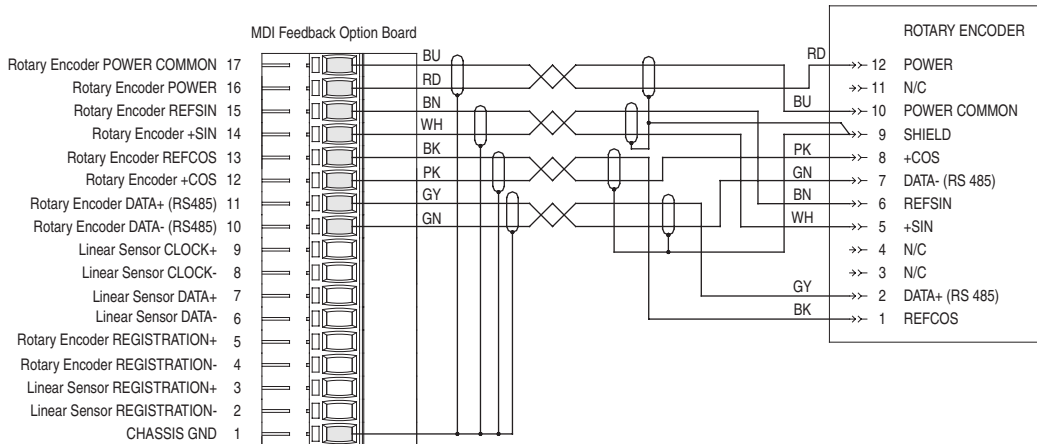

Rotary Encoder Connections with Stegmann shielded twisted-pair cable and 10-pin MS style connector

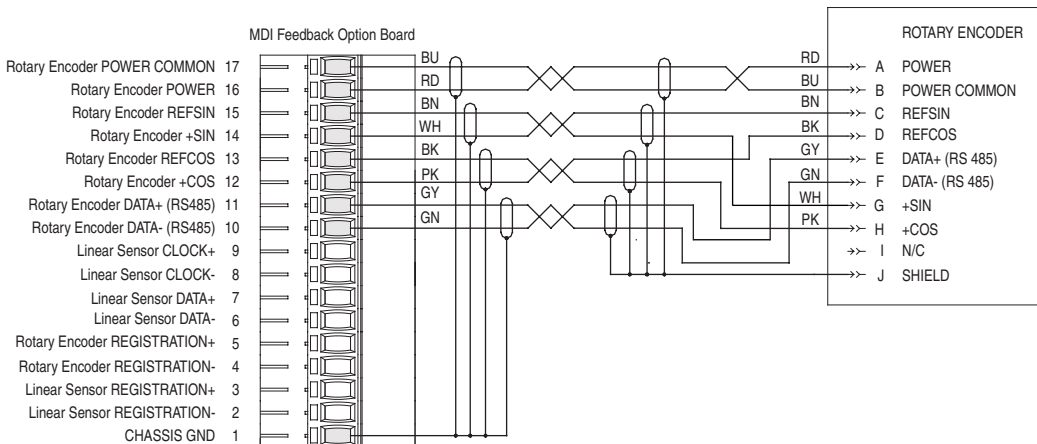

Connection Examples

Rotary Encoder Connections with Stegmann shielded twisted-pair cable and 8-pin Berg style connector

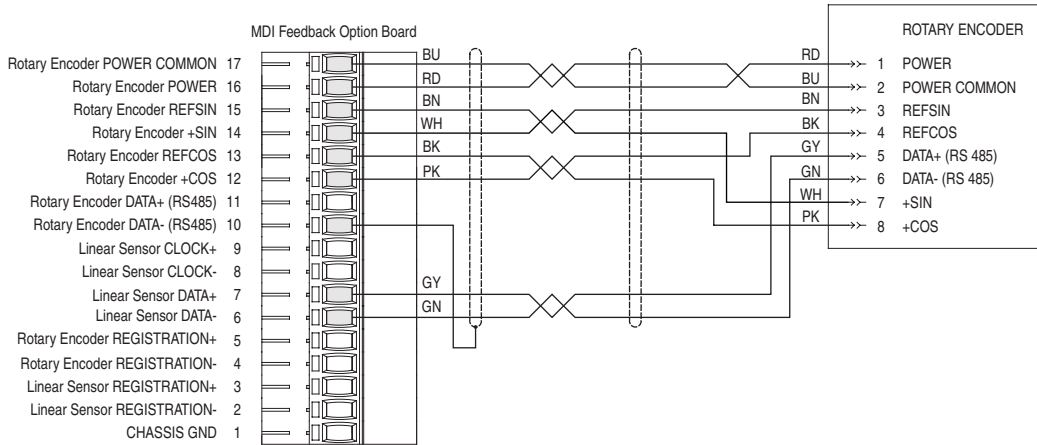

Rotary Encoder Connections with Stegmann pre-attached shielded twisted-pair cable

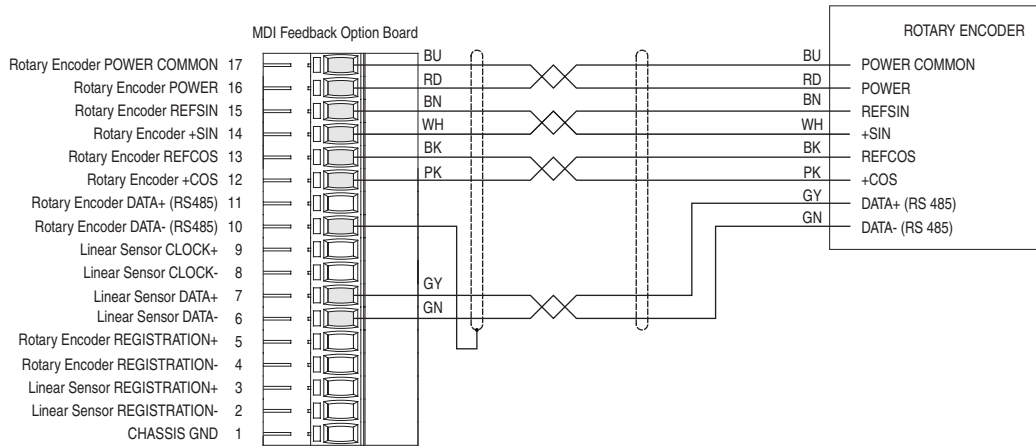

Registration Sensor Connection

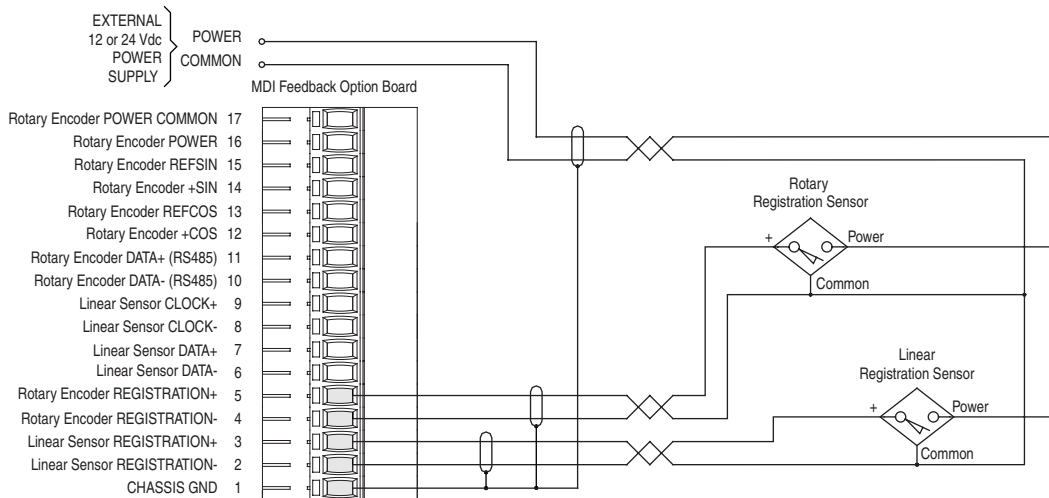

PowerFlex 700S Permanent Magnet Motor Specifications

Compatible Permanent Magnet Motors

The following table contains a list of specifications for the permanent magnet motors compatible with PowerFlex 700S drives. Note that you must have a high resolution Stegmann or compatible resolver.

Table I.A Motor Name Plate and Rating Specifications

Model Number	Motor NP Volts (line to line V rms)	Motor NP FLA (A rms)	Motor NP Frequency (Hz)	Motor NP RPM (oper. rpm)	Motor NP Power (KW)	Motor Poles	Current peak (A rms)	System Cont. Stall Torque (N-m)	Motor Max RPM (rpm)
Parameter #	1	2	3	4	5	7			
MPL-A310P	230	3.4	294.0	4410	0.73	8	9.9,	1.58	5000
MPL-A310F	230	2.1	185.3	2780	0.46	8	6.6	1.58	3000
MPL-A320P	230	6.4	271.3	4070	1.30	8	20.9	3.05	5000
MPL-A320H	230	4.6	208.7	3130	1.00	8	13.6	3.05	3500
MPL-A330P	230	8.5	280.7	4210	1.80	8	26.9	4.08	5000
MPL-A420P	230	9.0	268.7	4030	2.00	8	32.5	4.74	5000
MPL-A430P	230	11.9	234.0	3510	2.20	8	47.4	5.99	5000
MPL-A430H	230	8.6	184.7	2770	1.80	8	31.8	6.21	3500
MPL-A4520P	230	12.4	234.0	3510	2.20	8	35.4	5.99	5000
MPL-A4520K	230	10.6	223.3	3350	2.10	8	30.4	5.99	4000
MPL-A4530F	230	9.5	144.7	2170	1.90	8	29.7	8.36	2800
MPL-A4530K	230	14.4	196.0	2940	2.50	8	43.8	8.13	4000
MPL-A4540C	230	6.6	93.3	1400	1.50	8	20.5	10.20	1500
MPL-A4540F	230	13.0	162.0	2430	2.60	8	38.2	10.20	3000
MPL-A520K	230	16.3	208.0	3120	3.50	8	46.0	10.70	4000
MPL-A540K	230	29.3	180.7	2710	5.50	8	84.9	19.40	4000
MPL-A560F	230	29.3	125.3	1880	5.50	8	84.9	27.90	3000
MPL-B310P	460	1.7	310.0	4650	0.77	8	3.0	1.58	5000
MPL-B320P	460	3.2	313.3	4700	1.50	8	5.0	3.05	5000
MPL-B330P	460	4.3	274.0	4110	1.80	8	7.0	4.18	5000
MPL-B420P	460	4.5	255.3	3830	1.90	8	9.2	4.74	5000
MPL-B430P	460	6.5	214.0	3210	2.20	8	12.0	6.55	5000
MPL-B4520P	460	6.0	236.7	3550	2.10	8	17.0	5.65	5000
MPL-B4530F	460	5.0	162.0	2430	2.10	8	13.4	8.25	3000
MPL-B4530K	460	7.8	200.7	3010	2.60	8	19.1	8.25	4000
MPL-B4540F	460	6.4	162.0	2430	2.60	8	16.3	10.20	3000
MPL-B4560F	460	8.3	144.7	2170	3.20	8	25.5	14.10	3000
MPL-B520K	460	8.1	208.0	3120	3.50	8	23.3	10.70	4000
MPL-B540K	460	14.5	177.3	2660	5.40	8	42.4	19.40	4000
MPL-B560F	460	14.5	130.7	1960	5.50	8	42.4	26.80	3000
MPL-B580F	460	18.4	132.7	1990	7.10	8	66.5	34.00	3000
MPL-B580J	460	22.6	148.0	2220	7.90	8	66.5	34.00	3800
MPL-B640F	460	22.7	106.0	1590	6.11	8	46.0	36.70	3000
MPL-B660F	460	27.2	81.3	1220	6.15	8	67.9	48.00	3000
MPL-B680D	460	24.0	94.0	1410	9.30	8	66.5	62.80	2000
MPL-B680F	460	33.9	79.3	1190	7.50	8	67.9	60.00	3000
MPL-B860D	460	33.6	96.0	1440	12.50	8	67.5	83.10	2000
MPL-B880C	460	33.6	72.7	1090	12.60	8	69.0	110.00	1500
MPL-B880D	460	40.3	86.7	1300	15.00	8	113.2	110.00	2000
MPL-B960B	460	29.7	62.0	930	12.70	8	63.6	130.00	1200
MPL-B960C	460	38.9	76.0	1140	14.80	8	88.4	124.30	1500
MPL-B960D	460	50.2	76.7	1150	15.00	8	102.5	124.30	2000
MPL-B980B	460	31.8	59.3	890	15.02	8	70.7	162.70	1000
MPL-B980C	460	48.2	67.3	1010	16.80	8	99.0	158.20	1500
MPL-B980D	460	63.6	74.7	1120	18.60	8	141.4	158.20	2000

Model Number	Motor NP Volts (line to line V rms)	Motor NP FLA (A rms)	Motor NP Frequency (Hz)	Motor NP RPM (oper. rpm)	Motor NP Power (KW)	Motor Poles	Current peak (A rms)	System Cont. Stall Torque (N-m)	Motor Max RPM (rpm)
MPG-A004-031	230	1.8	222.7	3340	0.21	8	4.0	0.60	6000
MPG-A010-031	230	2.1	189.3	2840	0.36	8	6.0	1.21	4875
MPG-A010-091	230	0.9	295.3	4430	0.19	8	2.3	0.41	5900
MPG-A025-031	230	9.9	181.0	1810	0.88	12	19.8	4.65	5200
MPG-A025-091	230	3.0	168.0	1680	0.52	12	8.5	2.95	5625
MPG-A050-031	230	24.7	120.0	1200	1.50	12	53.0	11.90	2510
MPG-A050-091	230	5.0	275.0	2750	0.75	12	15.6	2.60	3775
MPG-A110-031	230	20.2	122.0	1220	2.20	12	53.0	17.20	2875
MPG-A110-091	230	17.0	184.0	1840	1.60	12	33.2	8.30	3500
MPG-B010-031	460	1.6	162.7	2440	0.34	8	4.4	1.33	6450
MPG-B010-091	460	0.7	357.3	5360	0.23	8	1.5	0.41	6450
MPG-B025-031	460	4.0	219.0	2190	0.92	12	11.3	4.02	4838
MPG-B025-091	460	1.9	175.0	1750	0.54	12	5.2	2.95	5900
MPG-B050-031	460	16.3	92.0	920	1.20	12	32.5	12.40	2510
MPG-B050-091	460	3.4	290.0	2900	0.79	12	9.9	2.60	4560
MPG-B110-031	460	12.9	112.0	1120	2.00	12	31.1	17.00	2420
MPG-B110-091	460	10.6	184.0	1840	1.60	12	20.5	8.30	3500
1326AB-B410G	460	2.5	118.0	3540	1.00	4	7.4	2.70	5000
1326AB-B410J	460	3.5	165.0	4950	1.40	4	10.4	2.70	7250
1326AB-B420E	460	2.8	70.0	2100	1.10	4	8.5	5.00	3000
1326AB-B420H	460	5.5	137.3	4120	2.20	4	15.6	5.10	6000
1326AB-B430E	460	3.9	67.7	2030	1.40	4	11.7	6.60	3000
1326AB-B430G	460	5.6	114.3	3430	2.30	4	16.8	6.40	5000
1326AB-B515E	460	6.1	70.3	2110	2.30	4	18.3	10.40	3000
1326AB-B515G	460	9.5	88.7	2660	2.90	4	28.5	10.40	5000
1326AB-B520E	460	6.7	71.0	2130	2.90	4	20.1	13.00	3000
1326AB-B520F	460	8.8	70.3	2110	2.90	4	26.4	13.10	3500
1326AB-B530E	460	9.5	74.3	2230	4.20	4	28.5	18.00	3000
1326AB-B720E	460	17.5	70.0	2100	6.80	4	52.5	30.90	3500
1326AB-B720F	460	27.5	117.0	3510	11.70	4	66.5	31.80	5000
1326AB-B730E	460	22.8	78.3	2350	9.60	4	66.5	39.00	3350
1326AB-B740C	460	20.9	52.3	1570	8.70	4	62.7	53.00	2200
1326AB-B740E	460	32.0	79.7	2390	12.70	4	66.5	50.80	3400
			0.0						
1326AS-B310H	460	0.8	204.5	4090	0.30	6	2.4	0.70	6200
1326AS-B330H	460	2.1	204.5	4090	0.90	6	6.0	2.10	6500
1326AS-B420G	460	2.6	179.0	3580	1.20	6	7.8	3.20	5250
1326AS-B440G	460	5.4	149.0	2980	2.00	6	16.2	6.40	5250
1326AS-B460F	460	6.2	148.5	2970	2.80	6	18.6	9.00	4300
1326AS-B630F	460	7.8	142.7	2140	2.40	8	18.5	10.70	4500
1326AS-B660E	460	11.8	100.7	1510	3.40	8	29.8	21.50	3000
1326AS-B690E	460	19.0	87.3	1310	5.00	8	41.3	36.40	3000
1326AS-B840E	460	21.2	79.3	1190	4.70	8	39.5	37.60	3000
1326AS-B860C	460	17.6	77.3	1160	6.00	8	44.4	49.30	2000
1326AH-B330F	460	2.1	0.0	3000	0.75		9.0		3000
1326AH-B440F	460	3.3	0.0	2500	1.22		13.8		2500
1326AH-B540F	460	11.1	0.0	2500	2.60		47.2		2500
3050R-7	390	66.0	50.0	500	30.00	12	132.0		500
11050R-7	390	218.0	50.0	500	110.00	12	436.0		500

A

- AC Supply
 - Source **1-3**
 - Unbalanced **1-3**
 - Ungrounded **1-3**
- AC Supply Source Consideration **1-3**
- Access **1-8**
 - Transformer Tap **1-10**
- Access Panel **1-8**
- Access Panel Removal **1-8**
- Ambient Operating Temperatures **1-3**
- Ambient Temperature **1-3**
- Armored Cable **1-6**
- Assisted Start-Up **2-3**
- Auxiliary Power Supply **1-20**

B

- Before Applying Power **2-1**
- Bipolar Inputs **1-19**
- Bottom Plate Removal **1-8**
- Bottom View Dimensions **A-27**
- Brake Resistor **1-14**

C

- Cable **1-8**
- Cable Entry Plate
 - Removal **1-8**
 - SHLD Terminal **1-5**
- Cable Length
 - Motor **1-8**
- Cable Trays **1-7**
- Cables, Power
 - Armored **1-6**
 - Insulation **1-6**
 - Separation **1-6**
 - Shielded **1-6**
 - Type **1-6**
 - Unshielded **1-6**
- Catalog Number Explanation **P-5, P-6**
- CE
 - Conformity **1-35**
- Checklist, Start-Up **2-1**
- Circuit Breaker Ratings **A-6**
- Circuitry **1-21**

Clear

- Faults Manually **4-4**

- Common Bus
 - DC Input **1-10**

- Common Mode Capacitors **1-16**
- Common Mode Interference **1-19**

- Communications
 - Programmable Controller Configurations **A-4**

- Compatible Motors
 - Thermistor **A-17**

- Conduit **1-7**

- Control Assembly **1-2**

- Control Block Diagrams **B-1**

- Control Block Diagrams - Overview **B-2**

- Control Logic **B-2**

- Control Wire **1-19**

- Conventions **P-3**

- Cooling Fan Voltage **1-9**

cover

- removing **G-1**

- replacing **G-2**

D

- Dimensions **A-19**

- Dimensions Frame 1-3 **A-20**

- Dimensions Frame 4 **A-21**

- Dimensions Frame 5 **A-22**

- Dimensions Frame 6 **A-23**

- Distribution Systems

- Unbalanced **1-3**

- Ungrounded **1-3**

- Documentation **P-2**

- DPI Communication Configurations **A-4**

- Drive Frame Sizes **P-3**

- Drive Ratings **A-8, A-9**

- Drive Status **4-1**

- Dynamic Brake Resistor **1-14**

E

- EMC

- Directive **1-35**

- EMC Instructions **1-35**

- EMI/RFI Filter Grounding, RFI Filter **1-5**

Enclosure Rating **1-3**

F

Fan Voltage **1-9**

Fault Descriptions **4-4**

Faults

Manually Clear **4-4**

Faults and Alarms **4-1**

Filter, RFI **1-5**

Frame Sizes **P-3**

Fuse & Circuit Breaker Ratings **A-6**

Fuse Ratings **A-8, A-9**

Fuse Size **A-6**

Fuse Type **A-7**

Fuses **1-5**

G

General Precautions **P-4**

Grounding

Filter **1-5**

Shields **1-5**

Grounding Requirements **1-4**

H

Hard Enable Circuitry **1-21**

High Resolution (Stegmann)

Specifications **E-1**

High Resolution Encoder Interface Board
A-18

HIM **D-1**

ALT Functions **D-2**

External and Internal Connections **D-1**

External Connections **D-1**

Internal Connections **D-1**

LCD Display Elements **D-2**

Removing the HIM **D-3**

HIM Indication **4-4**

Hi-Resolution Encoder Feedback Option

PowerFlex 700S **E-1**

I

I/O Wiring **1-19**

Input Phase Selection **1-9**

Input Power Conditioning **1-4**

Input/Output Contactors

Using **1-15**

Inputs & Outputs - Analog **B-2**

Inputs & Outputs - Digital **B-2**

Installation **1-1**

Installation/Wiring

Chapter 1 **1-1**

installing

cover **G-2**

Inverter Overload IT **B-2**

J

Jumper Removal **1-16**

L

LED Indications **4-2**

Logic Command Word **A-5**

Logic Status Word **A-6**

M

Main Control Board **A-18**

I/O Terminal Locations **1-20**

Main Control Board I/O Configuration

Settings **1-32**

Manual Conventions **P-3**

Manually Clearing Faults **4-4**

Motor **1-8**

Motor Cable Lengths **1-8**

Motor Control Mode

Field Oriented Control **C-2**

Permanent Magnet Control **C-3**

Motor Control Technology **C-2**

Motor Ratings **A-17**

Mounting

Clearances **1-2**

MOVs **1-16**

N

Non-Resettable **4-1**

O

Opening

Cover **1-2**

Opening the Cover **1-2**

Operating Temperature **1-3**

Output Devices **A-6**

Overspeed **C-4**

P

Parameter

By Name **3-96**

Data **3-16**

Linear List Format **3-16**

Parameters **3-1**

About **3-1**

Cross Reference **3-96**

Organization **3-3**

Programming **3-1**

Parameters, Groups

Communication **3-4**

Dynamic Control **3-3**

Inputs & Outputs **3-4**

Monitor **3-3**

Motor Control **3-3**

Position Control **3-4**

Process Control **3-3**

Speed Control **3-3**

Speed/Posit Fdbk **3-4**

SynchLink **3-4**

Torque Control **3-3**

Utility **3-4**

Peak Detector **B-2**

Permanent Magnet Motor Specifications **I-1**

Permanent Magnet Motors

Compatible Motors **I-1**

Motor Name Plate and Rating
Specifications **I-1**

Position Control - Auxiliary **B-2**

Position Control - Interpolated/Direct **B-2**

Position Control - Point to Point **B-2**

Power **1-8**

Power Conditioning, Input **1-4**

Power Supply

Auxiliary **1-20**

Power Terminal Block **1-8**

Power Wiring **1-6**

Access Panel **1-8**

General **1-8**

Powering Up the Drive **2-1**

Process Control **B-2**

Programmable Controller Configurations
A-4

R

Recommended **1-19, E-3**

Recommended Cables

Cables **E-3**

Recommended Documentation **P-2**

Removal **1-8**

Access Panel **1-8**

removing

cover **G-1**

replacing

cover **G-2**

Resolver Interface Board **A-18**

S

Selecting/Verifying Fan Voltage **1-9**

Shielded Cables

Power **1-6**

SHLD Terminal **1-5**

Signal Wire **1-19**

Spare Connectors **A-18, F-1**

Specifications **A-1**

Speed Control - Reference **B-2**

Speed Control - Regulator **B-2**

Speed/Position Feedback **B-2**

Start-Up **2-1**

Assisted **2-3**

Checklist **2-1**

Stegmann High Resolution **E-1**

Support Encoders **E-1**

Stegmann Hi-Resolution

Connection Examples **E-3**

Stegmann Hi-Resolution Specifications **E-1**

Supplemental Information **A-1**

Supply Source **1-3**

SynchLink **1-33**

SynchLink Cables and Connector Parts
A-19

T

TB1 - Row B (Bottom) Terminals **1-24**

TB1 - Row T (Top) Terminals **1-21**

TB2 - Row B (Bottom) Terminals **1-30**

TB2 - Row T (Top) Terminals **1-26**

Terminal Block **1-8**

Wire Size

Power **1-11**

Thermistor Ratings **A-17**

Torque Control **B-2**

Transformer Tap Access **1-10**

U

Unbalanced/Ungrounded Supply **1-3**

Ungrounded Distribution Systems **1-16**

Unshielded Power Cables **1-6**

W

Web Sites, see *WWW, World Wide Web*

Wire

Signal **1-19**

Wiring

Access Panel Removal **1-8**

Cable Entry Plate Removal **1-8**

Power **1-6**

Wiring Examples

TB1 - Row B (Bottom) **1-25**

TB1 - Row T (Top) **1-22**

TB2 - Row R (Top) **1-27**

WWW, World Wide Web **P-1**

Rockwell Automation Support

Rockwell Automation provides technical information on the Web to assist you in using its products.

At <http://www.rockwellautomation.com/support> you can find technical and application notes, sample code, and links to software service packs. You can also visit our Support Center at <https://rockwellautomation.custhelp.com/> for software updates, support chats and forums, technical information, FAQs, and to sign up for product notification updates.

In addition, we offer multiple support programs for installation, configuration, and troubleshooting. For more information, contact your local distributor or Rockwell Automation representative, or visit <http://www.rockwellautomation.com/services/online-phone>.

Installation Assistance

If you experience a problem within the first 24 hours of installation, review the information that is contained in this manual. You can contact Customer Support for initial help in getting your product up and running.

United States or Canada	1.440.646.3434
Outside United States or Canada	Use the Worldwide Locator at http://www.rockwellautomation.com/rockwellautomation/support/overview.page , or contact your local Rockwell Automation representative.

New Product Satisfaction Return

Rockwell Automation tests all of its products to help ensure that they are fully operational when shipped from the manufacturing facility. However, if your product is not functioning and needs to be returned, follow these procedures.

United States	Contact your distributor. You must provide a Customer Support case number (call the phone number above to obtain one) to your distributor to complete the return process.
Outside United States	Please contact your local Rockwell Automation representative for the return procedure.

Documentation Feedback

Your comments will help us serve your documentation needs better. If you have any suggestions on how to improve this document, complete this form, publication [RA-DU002](#), available at <http://www.rockwellautomation.com/literature/>.

Rockwell Otomasyon Ticaret A.Ş., Kar Plaza İş Merkezi E Blok Kat:6 34752 İçerenköy, İstanbul, Tel: +90 (216) 5698400

www.rockwellautomation.com

Power, Control and Information Solutions Headquarters

Americas: Rockwell Automation, 1201 South Second Street, Milwaukee, WI 53204-2496 USA, Tel: (1) 414.382.2000, Fax: (1) 414.382.4444
Europe/Middle East/Africa: Rockwell Automation NV, Pegasus Park, De Kleetlaan 12a, 1831 Diegem, Belgium, Tel: (32) 2 663 0600, Fax: (32) 2 663 0640
Asia Pacific: Rockwell Automation, Level 14, Core F, Cyberport 3, 100 Cyberport Road, Hong Kong, Tel: (852) 2887 4788, Fax: (852) 2508 1846

Publication 20D-UM001G-EN-P - August 2013

Supersedes Publication 20D-UM001F-EN-P - October 2005

Copyright © 2013 Rockwell Automation, Inc. All rights reserved. Printed in the U.S.A.