



This manual links to PowerFlex Drives with TotalFORCE Control Parameters Reference Data, publication [750-RD101](#), for parameters and PowerFlex Drives with TotalFORCE Control Conditions Reference Data, publication [750-RD102](#), for fault, alarm, and condition codes. Download the spreadsheets now for offline access.



# PowerFlex Drives with TotalFORCE Control

Firmware Revisions 10.xxx...13.xxx



**Allen-Bradley**

by ROCKWELL AUTOMATION

Programming Manual

Original Instructions

## Important User Information

Read this document and the documents listed in the additional resources section about installation, configuration, and operation of this equipment before you install, configure, operate, or maintain this product. Users are required to familiarize themselves with installation and wiring instructions in addition to requirements of all applicable codes, laws, and standards.

Activities including installation, adjustments, putting into service, use, assembly, disassembly, and maintenance are required to be carried out by suitably trained personnel in accordance with applicable code of practice.

If this equipment is used in a manner not specified by the manufacturer, the protection provided by the equipment may be impaired.

In no event will Rockwell Automation, Inc. be responsible or liable for indirect or consequential damages resulting from the use or application of this equipment.

The examples and diagrams in this manual are included solely for illustrative purposes. Because of the many variables and requirements associated with any particular installation, Rockwell Automation, Inc. cannot assume responsibility or liability for actual use based on the examples and diagrams.

No patent liability is assumed by Rockwell Automation, Inc. with respect to use of information, circuits, equipment, or software described in this manual.

Reproduction of the contents of this manual, in whole or in part, without written permission of Rockwell Automation, Inc., is prohibited.

Throughout this manual, when necessary, we use notes to make you aware of safety considerations.



**WARNING:** Identifies information about practices or circumstances that can cause an explosion in a hazardous environment, which may lead to personal injury or death, property damage, or economic loss.

---



**ATTENTION:** Identifies information about practices or circumstances that can lead to personal injury or death, property damage, or economic loss. Attentions help you identify a hazard, avoid a hazard, and recognize the consequence.

---

**IMPORTANT** Identifies information that is critical for successful application and understanding of the product.

---

These labels may also be on or inside the equipment to provide specific precautions.



**SHOCK HAZARD:** Labels may be on or inside the equipment, for example, a drive or motor, to alert people that dangerous voltage may be present.

---



**BURN HAZARD:** Labels may be on or inside the equipment, for example, a drive or motor, to alert people that surfaces may reach dangerous temperatures.

---



**ARC FLASH HAZARD:** Labels may be on or inside the equipment, for example, a motor control center, to alert people to potential Arc Flash. Arc Flash will cause severe injury or death. Wear proper Personal Protective Equipment (PPE). Follow ALL Regulatory requirements for safe work practices and for Personal Protective Equipment (PPE).

---

The following icon may appear in the text of this document.



Identifies information that is useful and can help to make a process easier to do or easier to understand.

Rockwell Automation recognizes that some of the terms that are currently used in our industry and in this publication are not in alignment with the movement toward inclusive language in technology. We are proactively collaborating with industry peers to find alternatives to such terms and making changes to our products and content. Please excuse the use of such terms in our content while we implement these changes.

	<b>Preface</b>	
	Summary of Changes . . . . .	5
	Access Fault Codes and Parameter List . . . . .	5
	Download Firmware, AOP, EDS, and Other Files . . . . .	5
	<b>Chapter 1</b>	
<b>Overview</b>	Parameter Descriptions . . . . .	7
	Startup Information . . . . .	7
	CIP Security . . . . .	7
	Apply and Remove Power . . . . .	8
	<b>Chapter 2</b>	
<b>Parameter Organization</b>	Parameter Descriptions . . . . .	17
	About Parameters . . . . .	17
	Parameter Access Level . . . . .	17
	Parameter References . . . . .	18
	How Drive Parameters are Organized . . . . .	18
	Overview and System Architecture . . . . .	18
	Predictive Maintenance . . . . .	20
	<b>Chapter 3</b>	
<b>PowerFlex 755T Control Block Diagrams</b>	Diagram Conventions and Definitions . . . . .	23
	Line Side Converter Control Diagrams . . . . .	24
	Motor Side Inverter Control Diagrams . . . . .	41
	<b>Chapter 4</b>	
<b>Troubleshooting</b>	Fault and Alarm Code Descriptions . . . . .	89
	Faults . . . . .	90
	Alarms . . . . .	90
	Events . . . . .	90
	Configurable Conditions . . . . .	90
	Viewing Faults, Alarms, Events, and Exceptions . . . . .	90
	HIM Indication (Fault Display Screen) . . . . .	91
	Manually Clearing Faults . . . . .	91
	Status Indicators . . . . .	92
	Setting Factory Defaults . . . . .	100
	Fan Usage by Product . . . . .	102
	Hardware Service Manual . . . . .	104
	Fault and Alarm Display Codes . . . . .	104
	Common Symptoms and Corrective Actions . . . . .	104
	Testpoint Codes and Functions . . . . .	107
	Reset as Shipped . . . . .	114
	Recovery Mode . . . . .	115
	Secure Erase . . . . .	116

---

	Configurable LCL Filter Capacitor Failure Response .....	117
	Configurable LCL Filter Capacitor Over Resonance Response .....	117
	PowerFlex 755T Lifting/Torque Proving.....	118
	Technical Support Options .....	119
	<b>Appendix A</b>	
<b>Permanent Magnet Motors</b>	Compatible Allen-Bradley Servo Motors.....	121
	<b>Appendix B</b>	
<b>Develop Secure Applications</b>	Drive Security Features .....	126
	<b>Index</b> .....	133
	Additional Resources .....	137

This publication contains the basic information to start up and troubleshoot PowerFlex® 750T Products with TotalFORCE® Control, firmware revision 10 and later.

Firmware revisions 6 and earlier are documented in the PowerFlex Drives with TotalFORCE Control Programming Manual (firmware revision 6.xxx and earlier), publication [750-PM100](#).

This publication is intended for qualified personnel.

- You must understand the hazards that are associated with electromechanical equipment installations.
- You must understand and follow all applicable local, national, and/or international electrical codes.
- You must be able to program and operate adjustable frequency AC drive devices.
- You must have an understanding of the parameter settings and functions.

## Summary of Changes

This publication contains the following new or updated information. This list includes substantive updates only and is not intended to reflect all changes. Translated versions are not always available for each revision.

Topic	Page
New information added to the Apply and Remove Power section.	8
Frame 6L added to the Fan Usage by Product section.	102
Updated the PowerFlex 755T Lifting/Torque Proving section.	118
Appendix B: Develop Secure Applications added.	125

## Access Fault Codes and Parameter List



This manual links to PowerFlex Drives with TotalFORCE Control Parameters Reference Data, publication [750-RD101](#), for parameters and PowerFlex Drives with TotalFORCE Control Conditions Reference Data, publication [750-RD102](#), for fault, alarm, event, and exception codes. Download the spreadsheets for offline access.

## Download Firmware, AOP, EDS, and Other Files

Download firmware, associated files (such as AOP, EDS, and DTM), and access product release notes from the Product Compatibility and Download Center at [rok.auto/pcdc](http://rok.auto/pcdc).

---

**Notes:**

## Overview

### Parameter Descriptions

TotalFORCE® control parameters are listed in the Microsoft® Excel® spreadsheet publication that is available on at [rok.auto/literature](http://rok.auto/literature).



Use this link to access the PowerFlex® Drives with TotalFORCE Control Parameters Reference Data, publication [750-RD101](#), for parameters. Download the spreadsheet for offline access.

---

To view the parameter descriptions and for full functionality (filter and search), open the file in the Microsoft Excel application.

### Startup Information

See the PowerFlex 750-Series AC Drives with TotalFORCE Control Quick Start, publication [750-QS100](#) for detailed startup information.

### CIP Security

CIP Security™ is a standard, open-source communication mechanism that helps to provide a secure data transport across an EtherNet/IP™ network. CIP Security lets CIP™-connected devices authenticate each other before transmitting and receiving data.

CIP Security uses the following security properties to help devices protect themselves from malicious communication:

- Device Identity and Authentication
- Data Integrity and Authentication
- Data Confidentiality

Rockwell Automation uses the following products to implement CIP Security:

- FactoryTalk® Policy Manager software (includes FactoryTalk System Services, version 6.30 or later)
- FactoryTalk Linx software, version 6.11 or later (lets workstation software communicate securely using CIP Security)
- Studio 5000 Logix Designer® application, version 32.04.00 or later

This application is required to interface with CIP Security-enabled Logix controllers. The minimum application version varies by controller product family.

For more information on CIP Security, for example, a list of CIP Security-capable products and publications that describe how to use the products, including limitations and considerations, see the following:

- <https://www.rockwellautomation.com/en-us/capabilities/industrial-cybersecurity.html>
- CIP Security with Rockwell Automation Products Application Technique, publication [SECURE-AT001](#)

## Apply and Remove Power

The following procedures describe how to energize PowerFlex 755T products in both stand-alone and in system installations.

### 755TL and TR Drives without 24V Auxiliary Power

This procedure applies to drives without 24V auxiliary power.

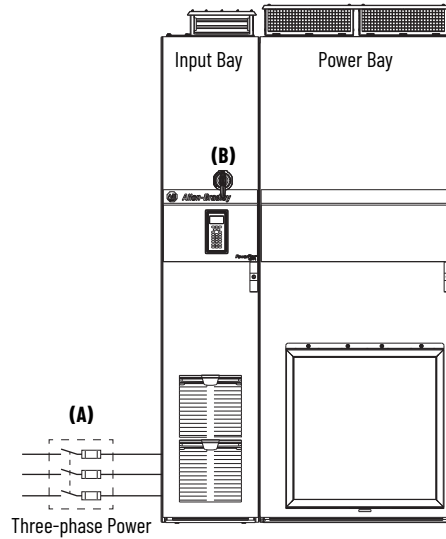

#### Energize

Energize the product in the following sequence:

1. Energize three-phase power (A).
2. Turn the fused disconnect handle (B) to the 'On' position.

#### De-energize

De-energize the product in the following sequence:

1. Turn the fused disconnect handle (B) to the 'Off' position.
2. De-energize three-phase power (A). This may not be needed.



## 755TL and TR Drives with 24V Auxiliary Power

This procedure covers drives with 24V auxiliary power.

### Initial Power Up

When you power up the drive for the first time, energize three-phase power first. When the three-phase power up is complete, then energize the 24V auxiliary power.

---

**IMPORTANT** This procedure assumes that 24V auxiliary power was not removed when the product was de-energized. If you are conducting an initial powerup, or if 24V auxiliary power was removed, only apply 24V auxiliary power as the final step in the Energize sequence.

---

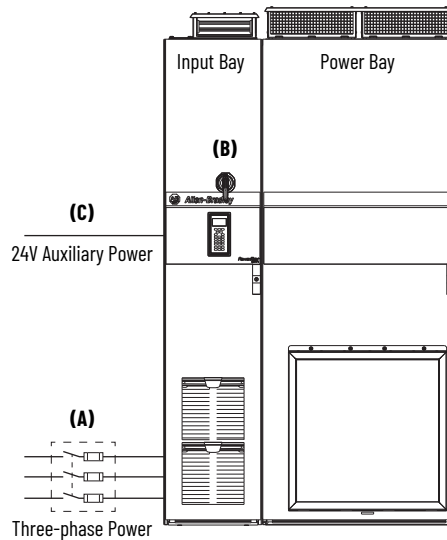

### Energize

Energize the product in the following sequence:

1. Leave 24V auxiliary power (C) energized when the drive is not in operation. This keeps up the control and communication.
2. Energize three-phase power (A).
3. Turn the fused disconnect switch (B) to the 'On' position.
4. After drive boots up, clear faults related to the three-phase outage.

### De-energize

De-energize the product in the following sequence:

1. Turn the fused disconnect switch (B) to the 'Off' position.
2. De-energize three-phase power (A). This may not be needed.

Leave 24V auxiliary power (C) energized when the drive is not in operation.

## Systems with 755TM Bus Supplies and Common Bus Inverters

This procedure covers systems without 24V auxiliary power and without separate 240V control power.

Bus supplies ordered with the -C1 Control Transformer option do not require separate 240V control power.

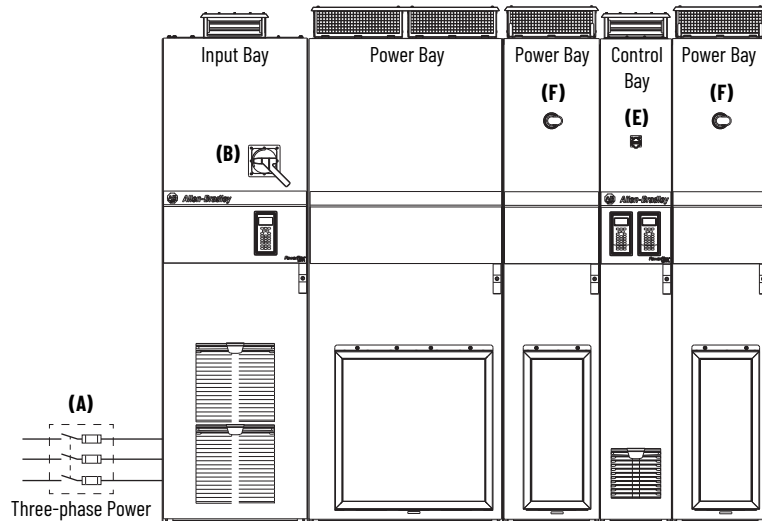

### Before You Apply Power

1. Verify that the Control Bay switch (E) is in the 'Off' position.
2. Verify that the DC Precharge switches (F) are in the 'Off' position

### Energize

Energize the product in the following sequence:

1. Leave the Control Power switches (E) for the Common Bus Inverters in the 'Off' position when the drive system is not in operation.
2. Leave the DC Precharge switches (F) for the Common Bus Inverters in the 'Off' position when the drive system is not in operation. This step is not required for Common Bus Inverters without DC Precharge.
3. Energize three-phase power (A).
4. Turn the fused disconnect switch (B) to the 'On' position.
5. Turn the DC Precharge switches (F) to the 'On' position.
6. Wait 60 seconds.
7. Turn the Control Power switch (E) to the 'On' position.

### De-energize

De-energize the product in the following sequence:

1. Turn the Control Power switches (E) for the Common Bus Inverters to the 'Off' position when the drive system is not in operation.
2. Turn the DC Precharge switches (F) for the Common Bus Inverters to the 'Off' position when the drive system is not in operation. This step is not required for Common Bus Inverters without DC Precharge.
3. Turn the fused disconnect switch (B) to the 'Off' position.
4. De-energize three-phase power (A). This may not be needed.

## Systems with 24V Auxiliary Power and without Separate 240V Control Power

This procedure covers systems with 24V auxiliary power and without separate 240V control power.

### Initial Power Up

When you power up the drive for the first time, energize three-phase power first. When the three-phase power up is complete, then energize the 24V auxiliary power.

---

**IMPORTANT** This procedure assumes that 24V auxiliary power was not removed when the product was de-energized. If you are conducting an initial powerup, or if 24V auxiliary power was removed, only apply 24V auxiliary power as the final step in the Energize sequence.

---

Bus supplies ordered with the -C1 Control Transformer option do not require separate 240V control power.

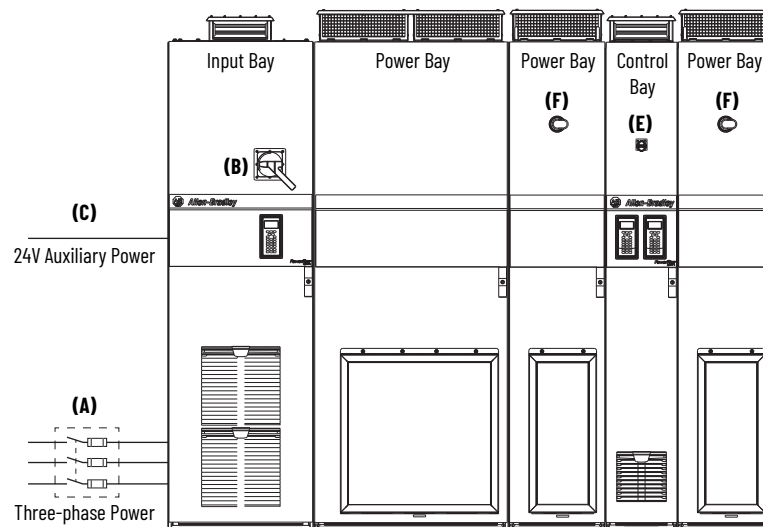

### Energize

Energize the product in the following sequence:

1. Leave 24V auxiliary power (C) energized when the drive is not in operation. This keeps up the control and communication.
2. Leave the Control Power switches (E) for the Common Bus Inverters in the 'On' position when the drive system is not in operation. This is not needed if 24V auxiliary power (C) remains energized.
3. Leave the DC Precharge switches (F) for the Common Bus Inverters in the 'On' position when the drive system is not in operation. This step is not required for Common Bus Inverters without DC Precharge.
4. Energize three-phase power (A).
5. Turn the fused disconnect switch (B) to the 'On' position.
6. After drive system boots up, clear faults related to the three-phase outage.

### De-energize

De-energize the product in the following sequence:

1. Leave the Control Power switches (E) for the Common Bus Inverters in the 'On' position when the drive system is not in operation. This is not needed if 24V auxiliary power (C) remains energized. If 24V is removed, the Control Power switch (E) should be 'Off'.

2. Leave the DC Precharge switches (F) for the Common Bus Inverters in the 'On' position when the drive system is not in operation. This step is not required for Common Bus Inverters without DC Precharge. If 24V is removed, the DC Precharge switch (F) should be 'Off'.
3. Turn the fused disconnect switch (B) to the 'Off' position.
4. De-energize three-phase power (A). This may not be needed.
5. Leave 24V auxiliary power (C) energized when the drive is not in operation.

## Systems without 24V Auxiliary Power and with Separate 240V Control Power

Bus supplies ordered without the -C1 Control Transformer option require separate 240V control power.

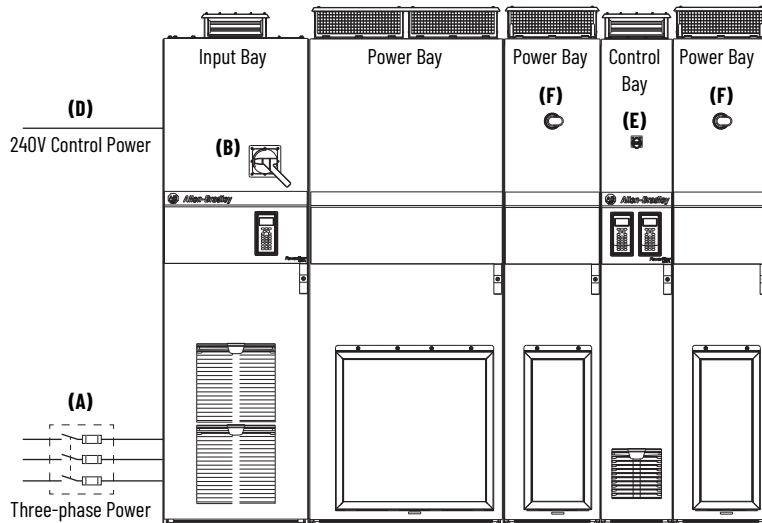

### Energize

Energize the product in the following sequence:

1. Turn the Control Power switches (E) for the Common Bus Inverters to the 'Off' position when the drive system is not in operation.
2. Turn the DC Precharge switches (F) for the Common Bus Inverters to the 'Off' position when the drive system is not in operation. This step is not required for Common Bus Inverters without DC Precharge.
3. Energize 240V control power (D).
4. Wait 60 Seconds.
5. Energize three-phase power (A).
6. Turn the fused disconnect switch (B) to the 'On' position.
7. Turn the DC Precharge switches (F) for the Common Bus Inverters to the 'On' position.
8. Wait 60 Seconds.
9. Turn the Control Power switches (E) for the Common Bus Inverters to the 'On' position.
10. Clear any faults.

### De-energize

De-energize the product in the following sequence:

1. Turn the DC Precharge switches (F) for the Common Bus Inverters to the 'Off' position when the drive system is not in operation. This step is not required for Common Bus Inverters without DC Precharge.
2. Turn the Control Power switches (E) for the Common Bus Inverters to the 'Off' position when the drive system is not in operation.
3. De-energize 240V control power (D).

---

**IMPORTANT** Step 3, de-energize 240V control power is required. If three-phase power is de-energized and re-energized while 240V control power stays energized, Common Bus Inverter non-resettable functional safety faults result. To clear these faults, de-energize and re-energize 240V control power.

---

4. Turn the fused disconnect switch (B) to the 'Off' position.
5. De-energize three-phase power (A). This may not be needed.

## Systems with 24V Auxiliary Power and with 240V Control Power

This procedure covers systems with 24V auxiliary power and with separate 240V control power.

### Initial Power Up

When you power up the drive for the first time, energize three-phase power first. When the three-phase power up is complete, energize the 24V auxiliary power.

---

**IMPORTANT** This procedure assumes that 24V auxiliary power was not removed when the product was de-energized. If you are conducting an initial power-up, or if 24V auxiliary power was removed, only apply 24V auxiliary power as the final step in the Energize sequence.

---

Bus supplies ordered without the -C1 Control Transformer option require separate 240V control power.

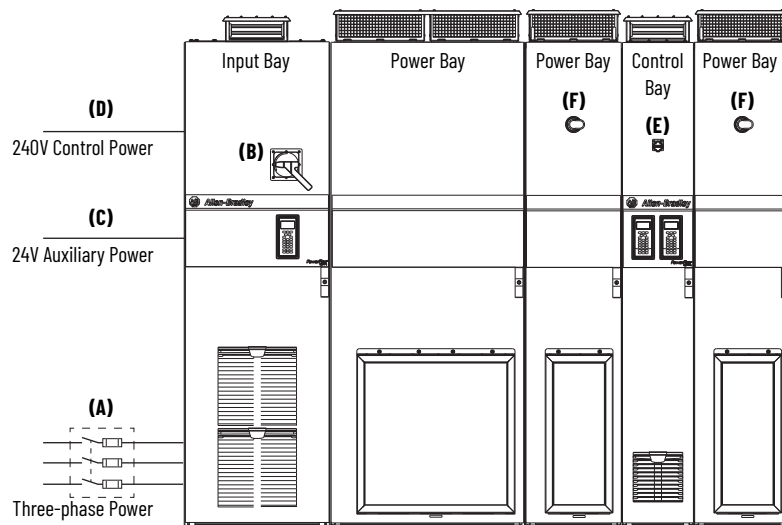

### Energize

Energize the product in the following sequence:

1. Leave 24V auxiliary power (C) energized when the drive is not in operation. This keeps up the control and communication.
2. Leave the Control Power switches (E) for the Common Bus Inverters in the 'On' position when the drive system is not in operation.
3. Leave the DC Precharge switches (F) for the Common Bus Inverters in the 'On' position when the drive system is not in operation. This step is not required for Common Bus Inverters without DC Precharge.
4. Energize 240V control power (D).
5. Energize three-phase power (A).
6. Turn the fused disconnect switch (B) to the 'On' position.
7. After drive system boots up, clear faults related to the three-phase outage.

### De-energize

De-energize the product in the following sequence:

1. Leave 24V auxiliary power (C) energized when the drive is not in operation.
2. Leave the DC Precharge switches (F) for the Common Bus Inverters in the 'On' position when the drive system is not in operation. This step is not required for Common Bus

Inverters without DC Precharge. If 24V is removed, the DC Precharge switch (F) should be 'Off'.

3. Leave the Control Power switches (E) for the Common Bus Inverters in the 'On' position when the drive system is not in operation. If 24V is removed, the Control Power switch (E) should be 'Off'.
4. De-energize 240V control power (D). This is only needed to turn off heatsink fans on LCL filters.
5. Turn the fused disconnect switch (B) to the 'Off' position.
6. De-energize three-phase power (A). This may not be needed.

**Notes:**



## Parameter Organization

This chapter describes the parameters in PowerFlex® 750-Series Products with TotalFORCE® Control. The parameters can be programmed (viewed/edited) using a Human Interface Module (HIM). See the Enhanced PowerFlex 7-Class Human Interface Module (HIM) User Manual, publication [20HIM-UM001](#), for information on using the HIM to view and edit parameters. You can also use Connected Components Workbench™ (version 10 or later) software. If the drive is connected to a ControlLogix® or CompactLogix™ controller you can also use Studio 5000 Logix Designer® (version 20 or later).

### Parameter Descriptions

TotalFORCE control parameters are PowerFlex Drives with TotalFORCE Control Parameters Reference Data, publication [750-RD101](#) that is available through the Rockwell Automation Literature Library.



Use this link to access the PowerFlex Drives with TotalFORCE Control Parameters Reference Data, publication [750-RD101](#), for parameters. Download the spreadsheet for offline access.

### About Parameters

To configure a drive module to operate in a specific way, certain drive parameters may have to be configured appropriately. Four types of parameters exist:

- **Numeric Parameters**  
These parameters have a single numeric value (such as 1750.0 RPM).
- **ENUM Parameters**  
These parameters allow a selection from two or more items. The LCD HIM will display a text message for each item.
- **Indirect Parameters**  
These parameters assign or select sources for data. They have a maximum value of 159999.15. The two most significant digits select the port of the source. The following four digits select the parameter number of the source. The two digits below the decimal point select the bit number of the source.  
For example, parameter 0:117 [DI M Start] is an indirect parameter for selecting the source of the Start digital input function. You may want to select input 01 on an IO card in port 4. You would enter 04 and 0001 and .01. This assigns bit 01 of parameter 0001 [Dig In Sts] of the card in port 4 to the Start function.
- **Bit Parameters**  
These parameters have individual bits associated with features or conditions. If the bit is 0, the feature is off or the condition is false. If the bit is 1, the feature is on or the condition is true.

### Parameter Access Level

Three parameter access level options are selectable by 0:30 [Access Level].

- Option 0 'Basic' is the most limited view that only displays parameters and options that are commonly used by operators.
- Option 1 'Advanced' is an expanded view of parameters that is helpful to maintenance technicians and for engineers to access more advanced drive features when they commission the drive.
- Option 2 'Expert' provides design engineers with a comprehensive view of the entire parameter set.

## Parameter References

Parameter references are shown as Port#:Parameter# [Parameter Display Name] convention. For example, 0:30 [Access Level] tells you that the Access Level parameter is number 30 in port 0.

## How Drive Parameters are Organized

Connected Components Workbench programming software displays parameters in 'Linear List' or 'File Group Parameter' format. The 'File Group Parameter' format simplifies programming by dividing Files into groups of parameters that are used for similar functions.

## Overview and System Architecture

The PowerFlex 755T architecture is an evolution of the high power (frames 8...10) PowerFlex 755 architecture. There are changes to improve usability and performance. There are changes to include new functionality and additional power modules.

Ports, files, and groups are containers for control and parameters. This architecture organizes the parameters among these containers to make them easy to find. It also limits which parameters are presented. It only presents the parameters that are related to the active configuration.

Figure 1 - System Architecture

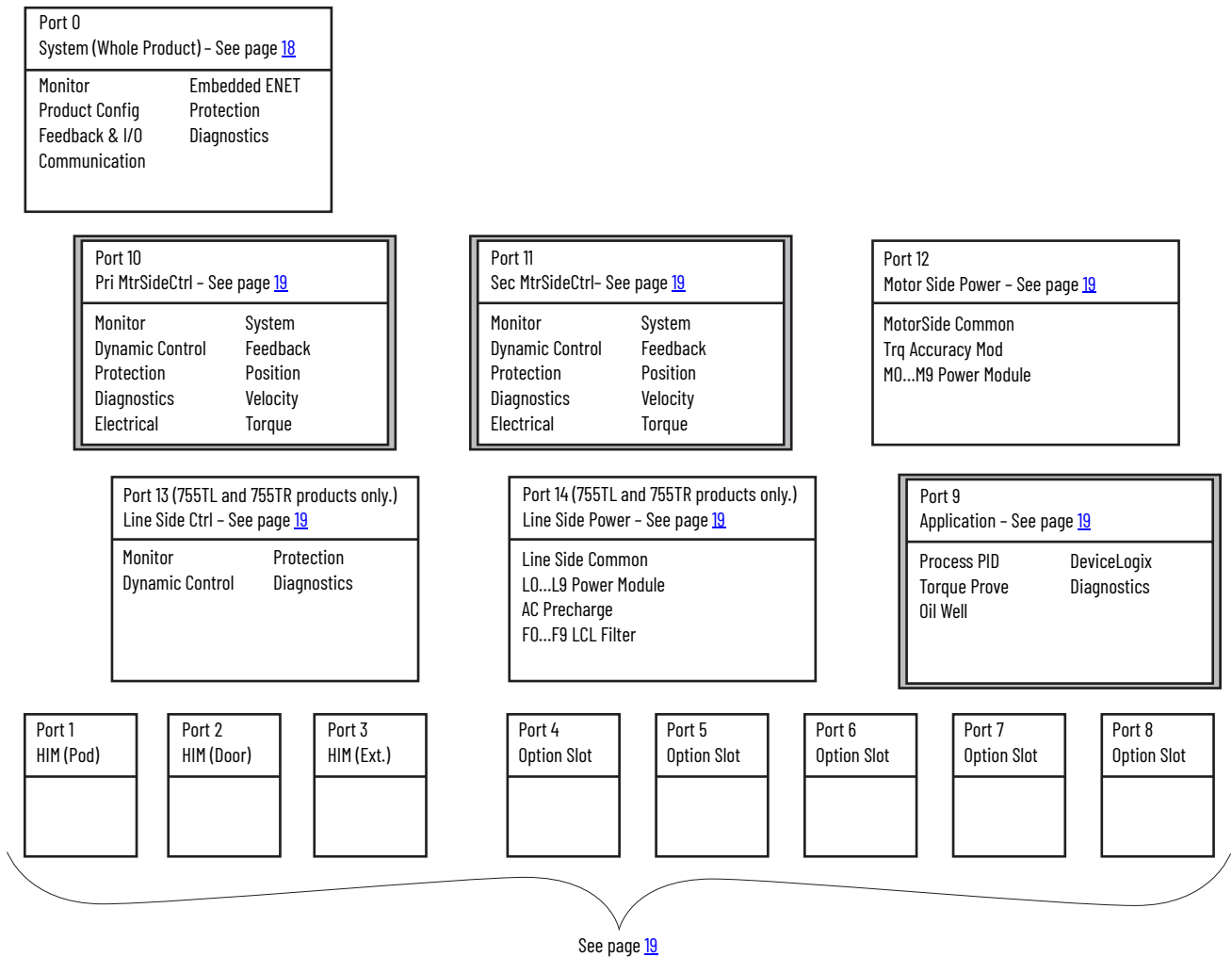

### Port 0 PowerFlex 755T System Port

This port contains parameters for monitoring and configuring the whole product (drive or bus supply). It contains parameters for configuring digital input functions and motor encoder feedback channels. It includes parameters for the Embedded EtherNet/IP interface.

This port also contains parameters that configure port 9 (the application port) and port 10 (the primary motor control port). These parameters determine what ports 9 and 10 contain. Ports 9 and 10 do not display parameters or software that is related to unused configurations. For example, if you do not select Torque Prove in the Application Selection parameter then port 9 does not contain parameters for Torque Prove. If you do not select the Flux Vector motor control mode, then port 10 does not display Flux Vector parameters or software.

## Port 9 Application Parameters

This port contains parameters and software that is related to specific applications. The contents of this port depend the setting of parameter 0:70 [Application Sel]. It can contain nothing, Process PID, Torque Prove, or Oil Well Pump. If enabled in parameter 0:72 [Emb Logic Select], port 9 will also display DeviceLogix parameters.

## Port 10 Primary and Port 11 Secondary Motor Side Control Parameters

These ports contain parameters and software that is related to the primary and secondary control of the motor side inverter. Port 10 is the primary motor side control port and port 11 is the secondary port. The contents of these ports depend the setting of parameters 0:65 [Pri MtrCtrl Mode] and 0:67 [Sec MtrCtrl Mode]. They can contain Volts per Hertz, Sensorless Vector, Economizer, or Flux Vector control. They contain parameters for configuring the starting and stopping of the motor side inverter. They contain parameters for entering the electrical attributes of the motor. They contain parameters for configuring and monitoring the Position, Velocity, and Torque loops.

## Port 12 Motor Side Power Parameters—PowerFlex 755T Products

This port contains parameters that are related to the power hardware in the motor side inverter. These parameters monitor and configure the power modules.

## Port 13 Line Side Control Parameters—PowerFlex 755T Products

This port contains parameters and software that is related to control of the line side converter. It contains parameters for configuring and monitoring the control of the converter. It contains parameters for entering the electrical attributes of the AC line source.

## Port 14 Line Side Power Parameters—PowerFlex 755T Products

This port contains parameters that are related to the power hardware in the line side converter. These parameters monitor and configure the power modules, AC precharge, and LCL filters.

## Port 1 HIM on Control Pod

The Human Interface Module (HIM) on the control pod connects through port 1.

## Port 2 HIM (Door Mount or Handheld)

A second HIM or 1203-USB programming interface connects through port 2. The factory installed door-mounted HIM connects through port 2.

### Port 3 HIM or 1203-USB

A third HIM or 1203-USB programming interface connects through port 3. Port 3 is visible when using a 1203-S03 splitter cable.

### Port 4...8 Option Slot

Ports 4...8 are the DPI and DSI option slots. I/O, feedback, communication, and functional safety option modules can be installed in these option slots.

## Predictive Maintenance

For firmware revisions 10.xxx or later, the remaining life of components with predictive maintenance appear on the Predictive Maintenance page in the Device Details window in Connected Components Workbench software and the Drive Details window in Studio Logix 5000 Designer application.

Figure 2 - Connected Components Workbench - Predictive Maintenance Page

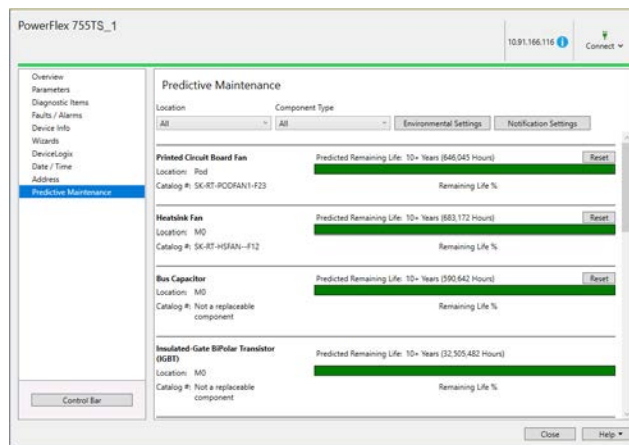

Predictive Maintenance objects and instances are listed in the PowerFlex Drives with TotalFORCE Control Parameters Reference Data, publication [750-RD101](#).

## PowerFlex 755T Control Block Diagrams

Flow diagrams on the following pages illustrate the PowerFlex® 755T drive control algorithms.

### Line Side Converter Block Diagrams (PowerFlex 755TL Drives, 755TR Drives, and 755TM Bus Supplies)

Diagram	Page
PowerFlex 755T Converter – Overview	24
Metering	25
Phase Locked Loop	26
Power Loss	27
Line Side Converter Data	28
Current Reference Generator	29
Reactive Power Control	30
Droop Control	31
Dynamic Bus Control	32
Voltage Reference Generator	33
Voltage Control	34
DC Bus Observer	35
Power Factor Correction	36
Current/Power Limits	37
Current Control	38
LSC Control Configuration	39
Drive Derating	40

### Motor Side Inverter Block Diagrams

Diagram	Page
Flux Vector Overview	41
Variable Frequency, SV Overview	42
CBI Metering	43
Feedback Configuration & Status	44
Position Homing	45
Position Reference 1	46
Position Reference – Move Profiles	47
Position Reference 2	48
Position Regulator	49
Position Control – Phase Locked Loop	50
Position Control – Position Reference CAM	51
Position Control – Profiler/Indexer 1	52
Position Control – Profiler/Indexer 2	53
Position Control – Roll Position Indicator	54
Position Control – Spindle Orient	55
Velocity Reference Overview	56
Velocity Reference Selection	57
Velocity Reference – All	58

### Motor Side Inverter Block Diagrams

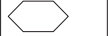







Diagram	Page
Velocity Reference - Flux Vector	59
Velocity Reference Flux Vector - Move Profiles	60
Velocity Reference CAM	61
Velocity Regulator - Flux Vector	62
Torque Overview	63
Torque Reference Selection	64
Load Observer	65
Friction Compensation	66
Torque Reference CAM	67
Torque Reference	68
Torque Filters	69
Torque Control - Current, for Induction Motor	70
Torque Control - Current, for Permanent Magnet Motor	71
Torque Control - Current, for Synchronous Reluctance Motor	72
Process Control 1	73
Process Control 2	74
Reference Notch Filter 1 for Crane Application	75
Pump Jack and Progressive Cavity Pump	76
Pump Off	77
MOP Control	78
22-Series Inputs & Outputs - Digital <sup>(1)</sup>	79
22-Series Inputs & Outputs - Analog <sup>(1)</sup>	80
11-Series Inputs & Outputs - Digital <sup>(1)</sup>	81
11-Series Inputs & Outputs - Analog <sup>(1)</sup>	82
11-Series Inputs & Outputs - ATEX <sup>(1)</sup>	83
Control Logic	84
Inverter Overload IT	85
Motor Overload	86

(1) This diagram is applicable to PowerFlex 755TS, 755TL, 755TR, and 755TM products.

# Diagram Conventions and Definitions

*Definitions of the Per Unit system:*  
 1.0 PU Position = Distance traveled / 1 second at Base Velocity  
 1.0 PU Velocity = Base Velocity of the Motor  
 1.0 PU Torque = Base Torque of the Motor

**Symbol Legend:**

<p>Drive Parameters</p>     	<p>Option Module Parameters</p>    	<p>→ Requires port number.</p> <p>Read Only Parameter</p> <p>Read / Write Parameter</p> <p>Read Only Parameter with Bit Enumeration</p> <p>Read / Write Parameter with Bit Enumeration</p> <p>Provides additional information.</p> <p>( ) = Enumeration Parameter              XX[ ] = Page and Coordinate              ex. Tst [A2] = pg Tst, Column A, Row 2</p> <p>⋯ = Constant value</p> <p>'d' = Prefix refers to Diagnostic Item Number              ex. d33 = Diagnostic Item 33</p> <p>'X:YY' = Parameter in PORT X</p> <p><span style="border: 1px solid red; padding: 2px;">TPO000</span> = Software Testpoint (Name and Number)</p>
---	---	--

**\* Notes, Important:**

(1) These diagrams are for reference only and may not accurately reflect all logical control signals; actual functionality is implied by the approximated diagrams. Accuracy of these diagrams is not guaranteed.

# Line Side Converter Control Diagrams

Figure 3 - PowerFlex 755T Converter - Overview

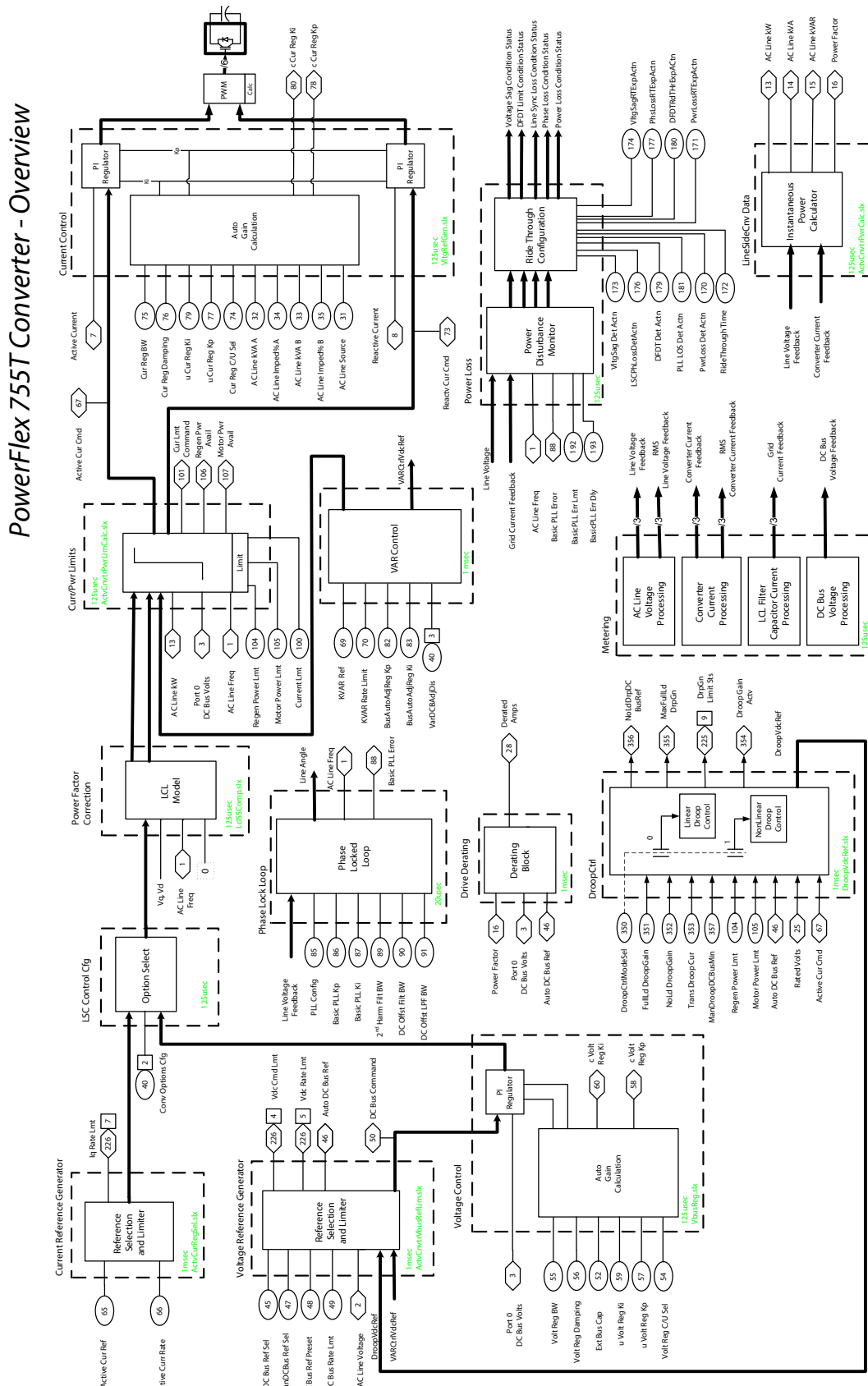



Figure 4 - Metering

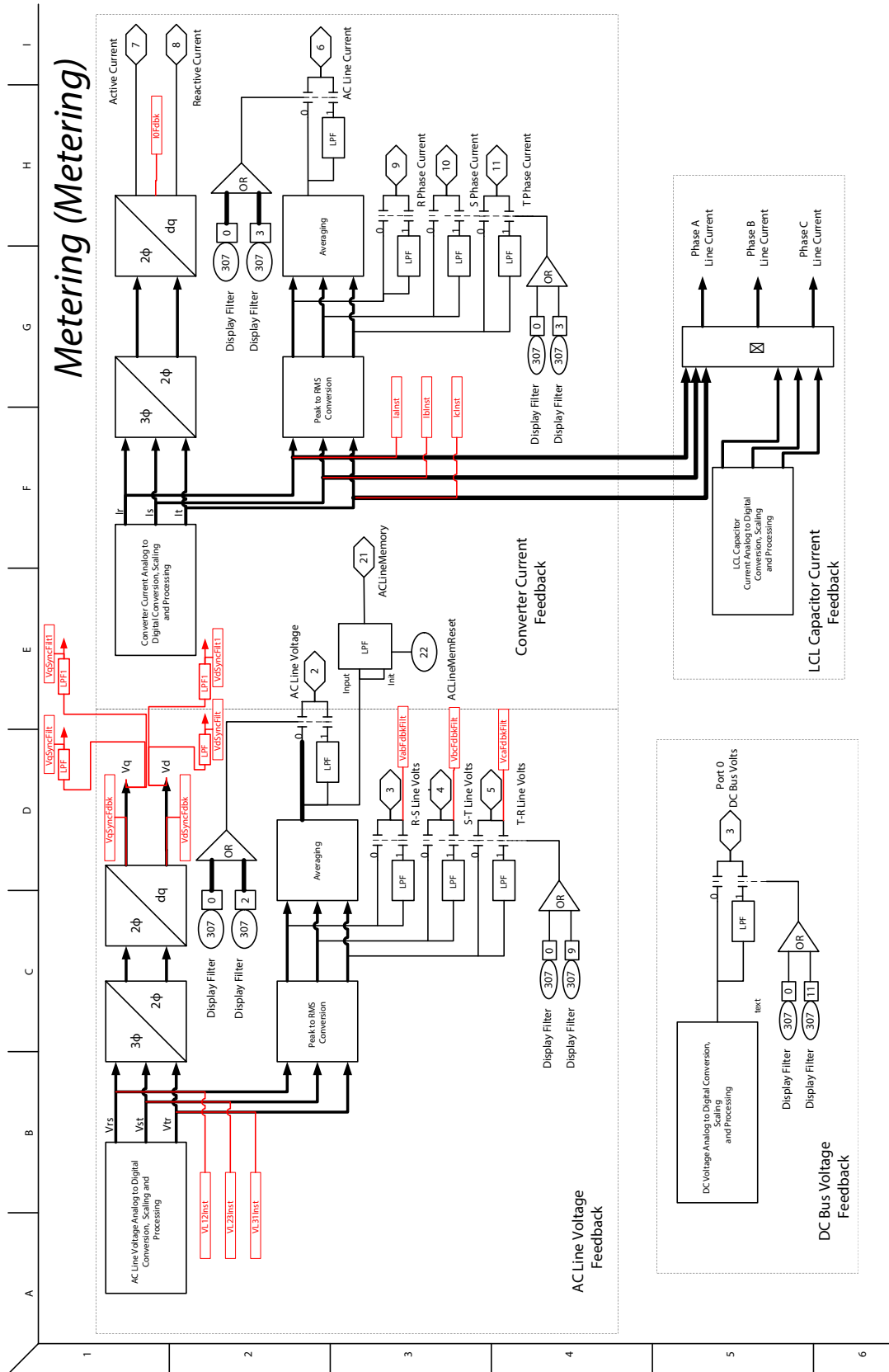

Figure 5 - Phase Locked Loop

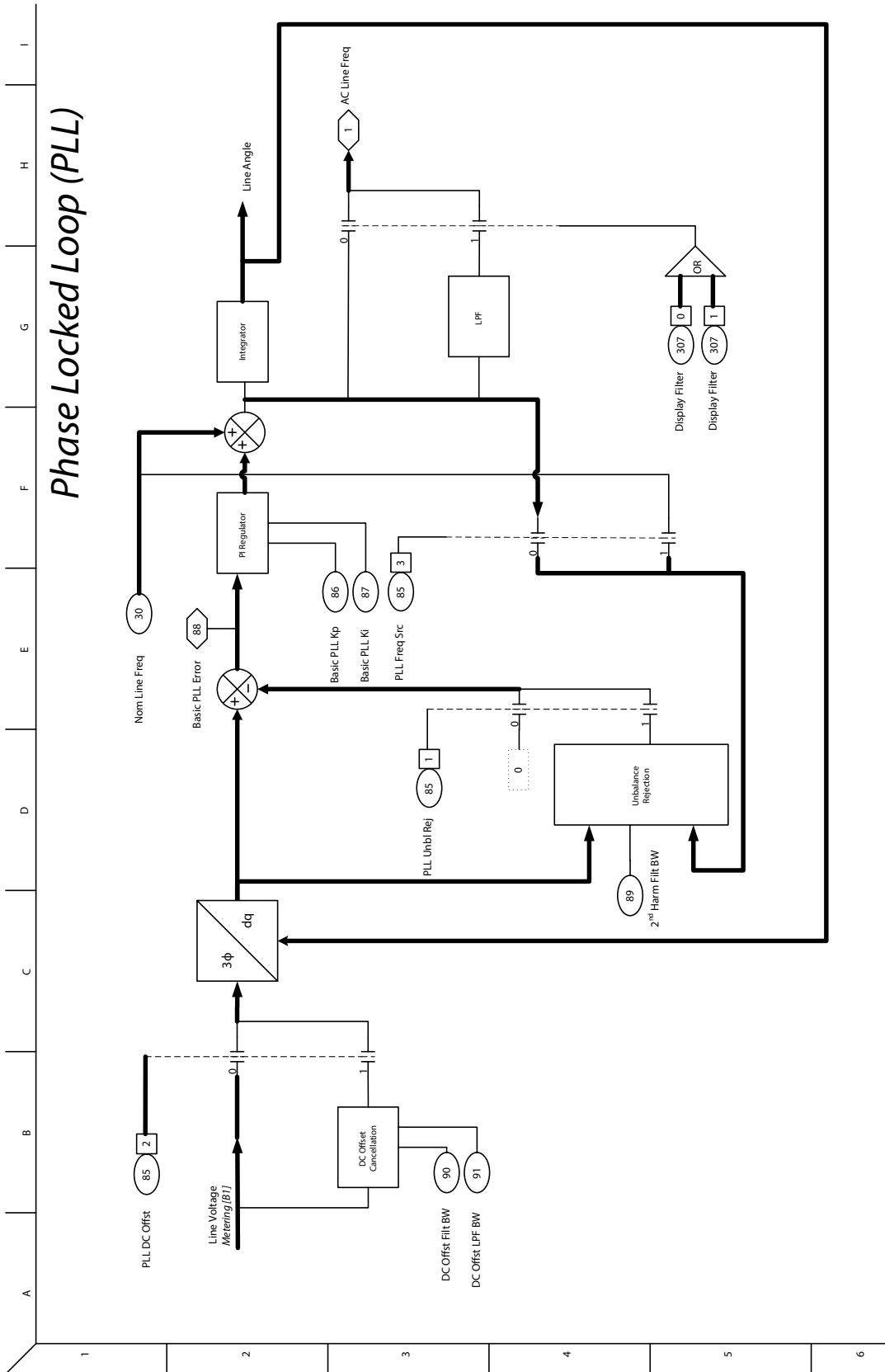

Figure 6 - Power Loss

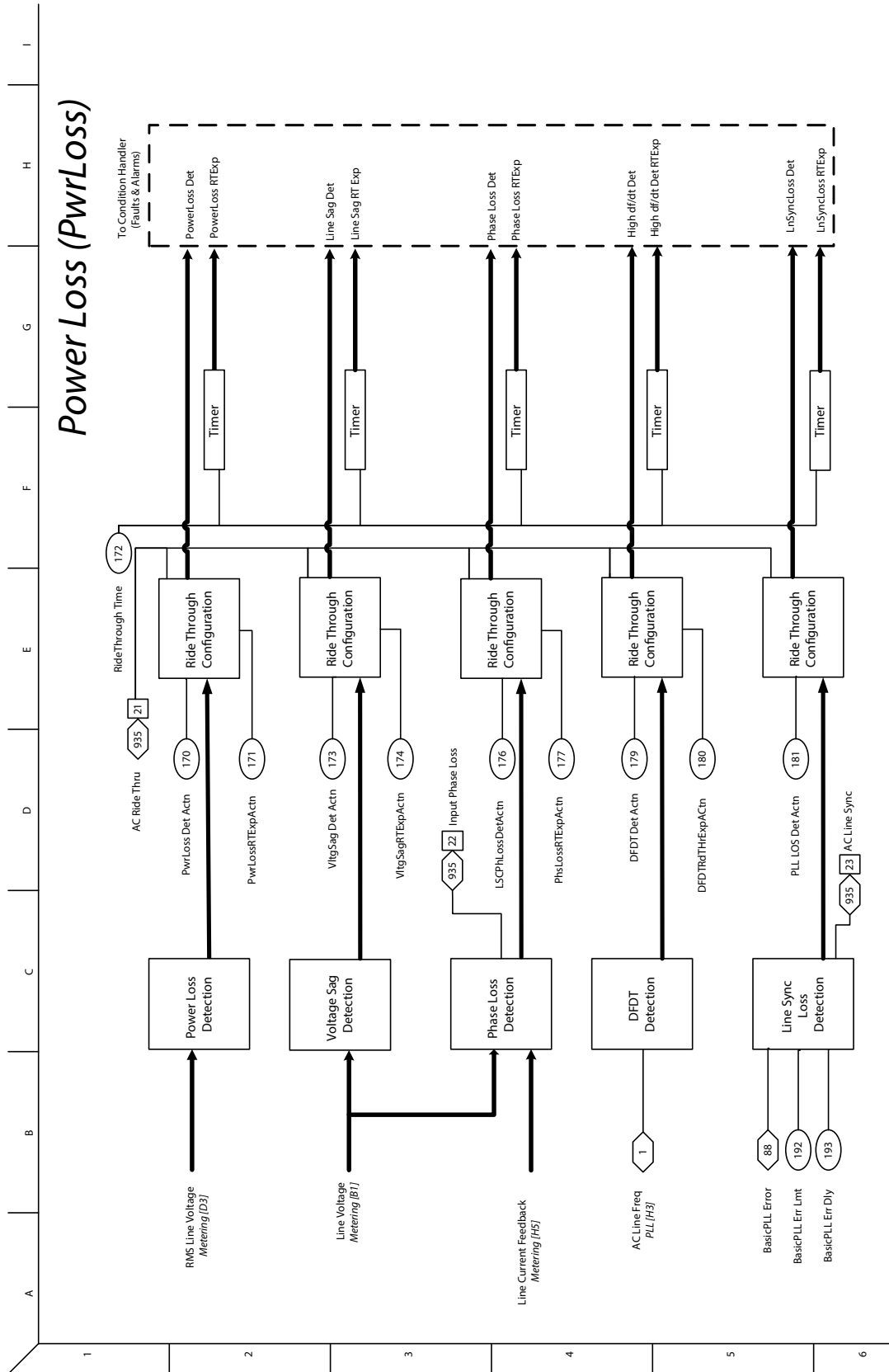

Figure 7 - Line Side Converter Data

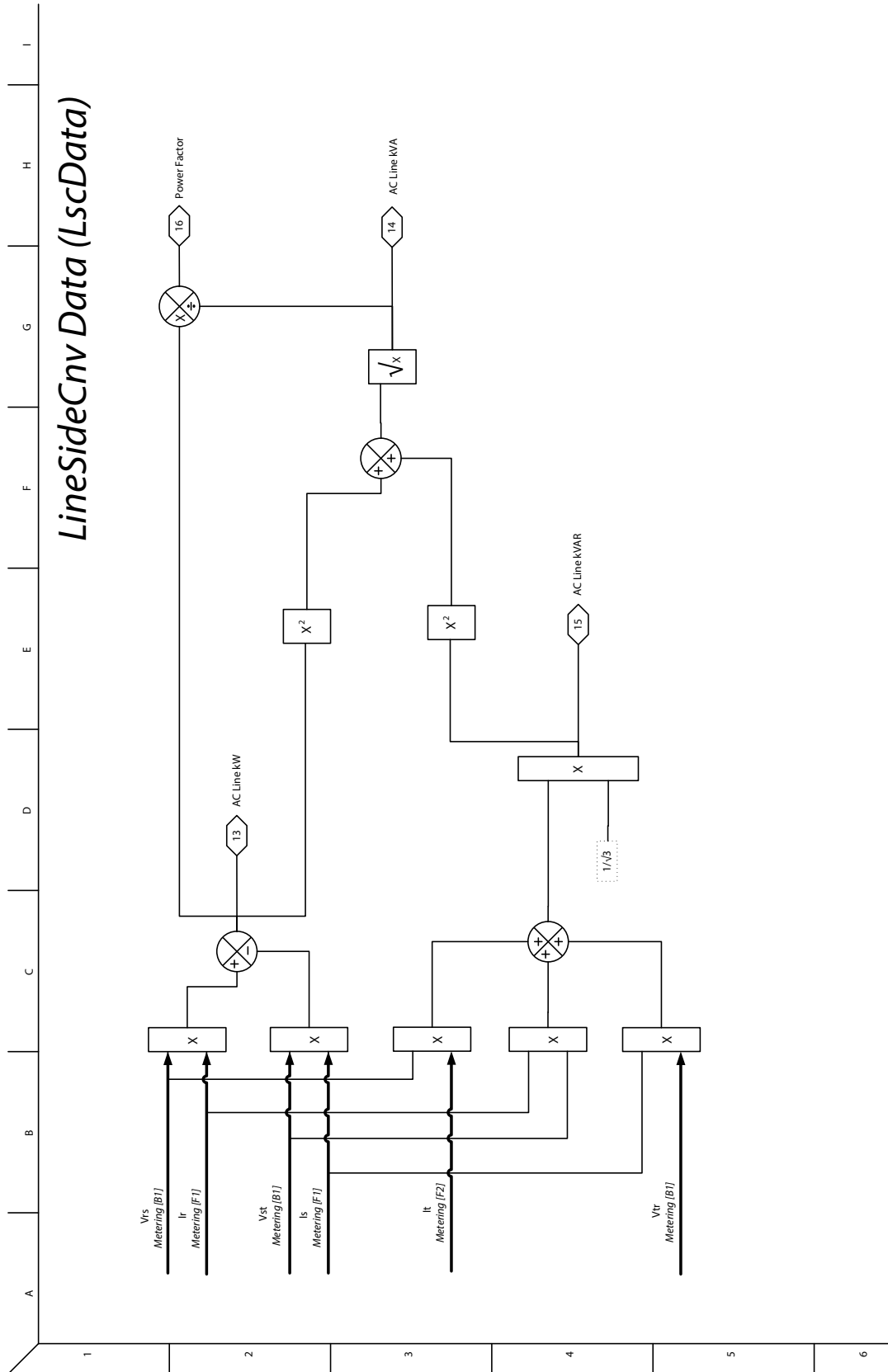

Figure 8 - Current Reference Generator

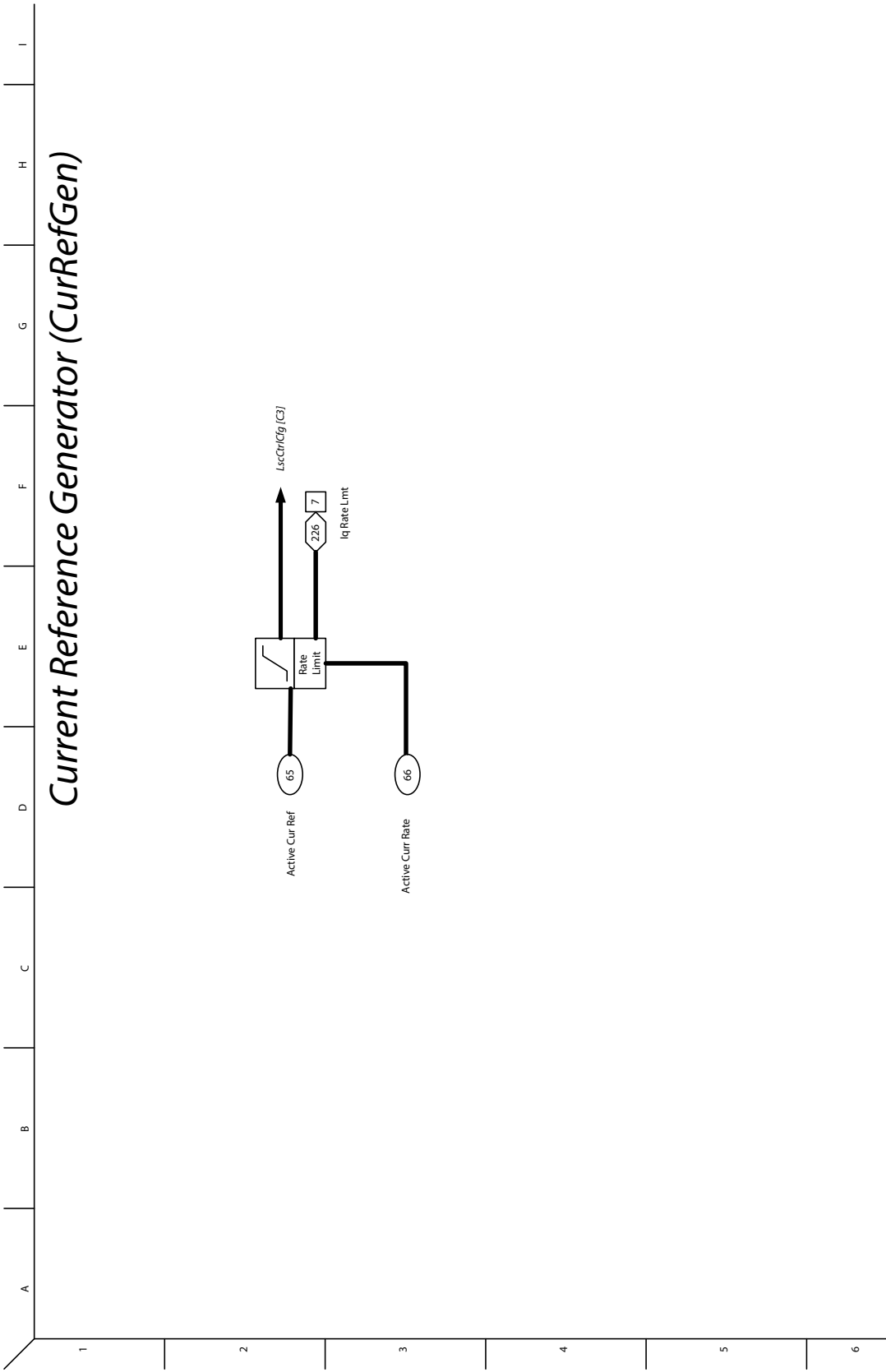

Figure 9 - Reactive Power Control

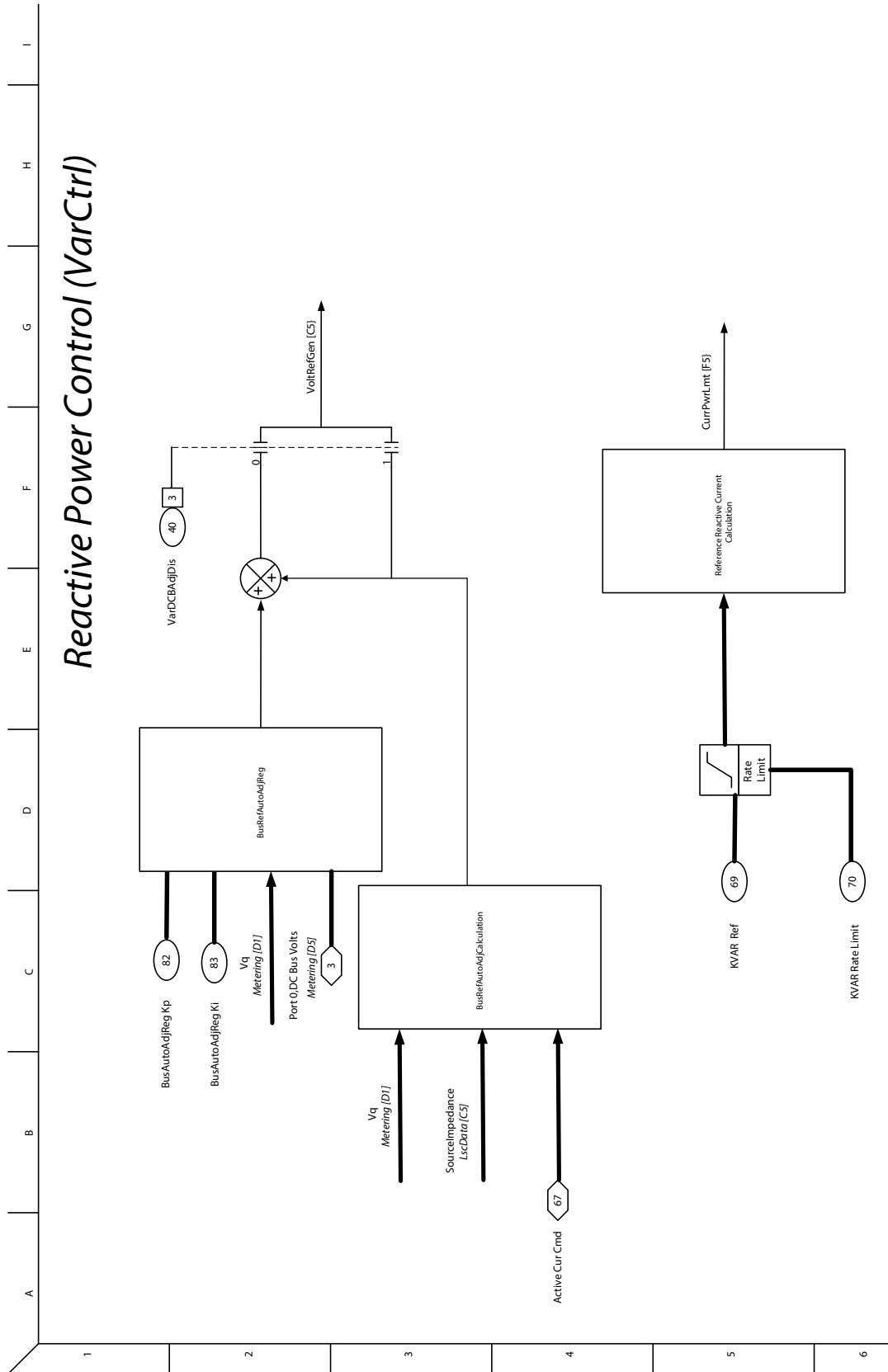

Figure 10 - Droop Control

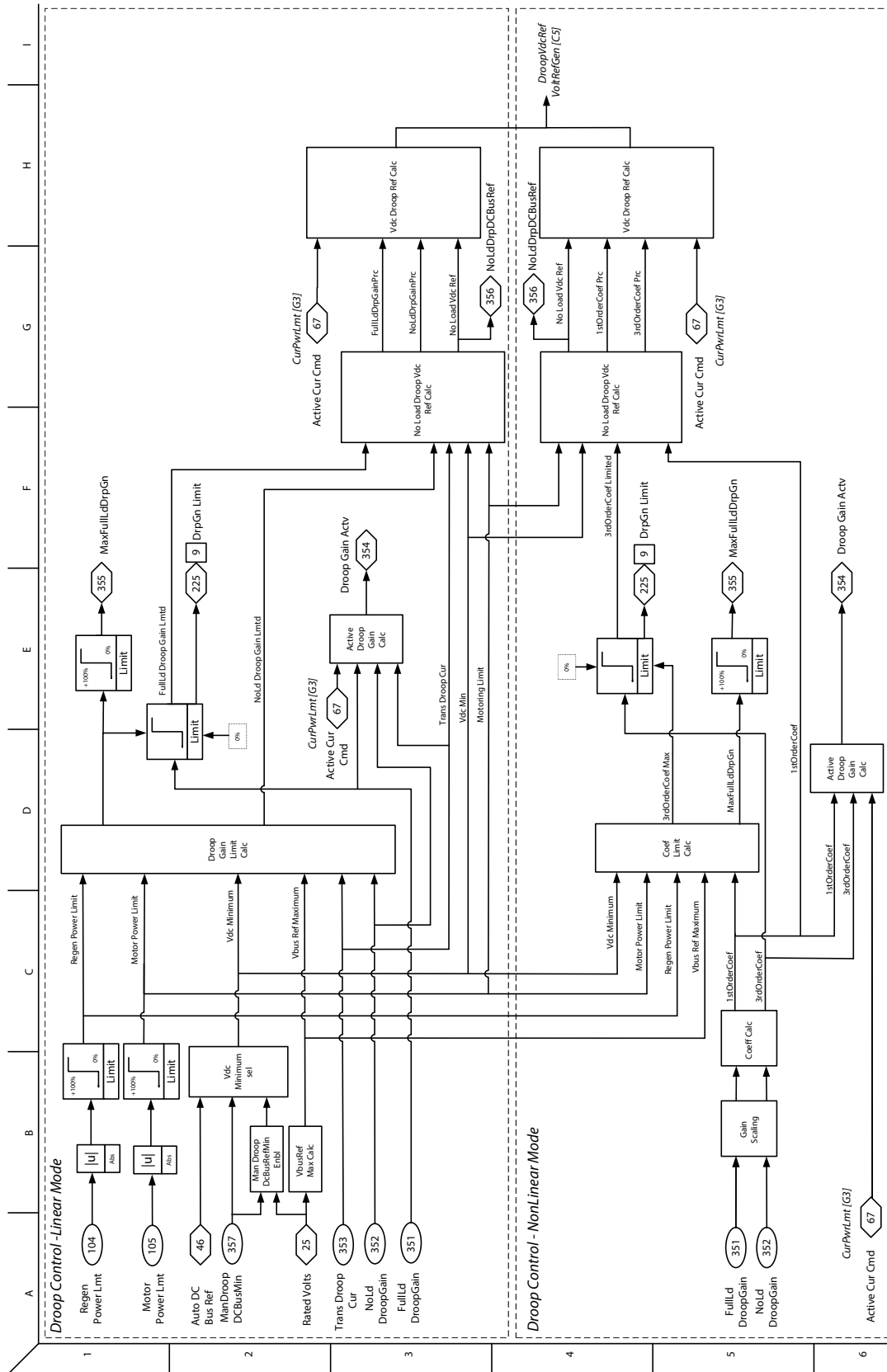

Figure 11 - Dynamic Bus Control

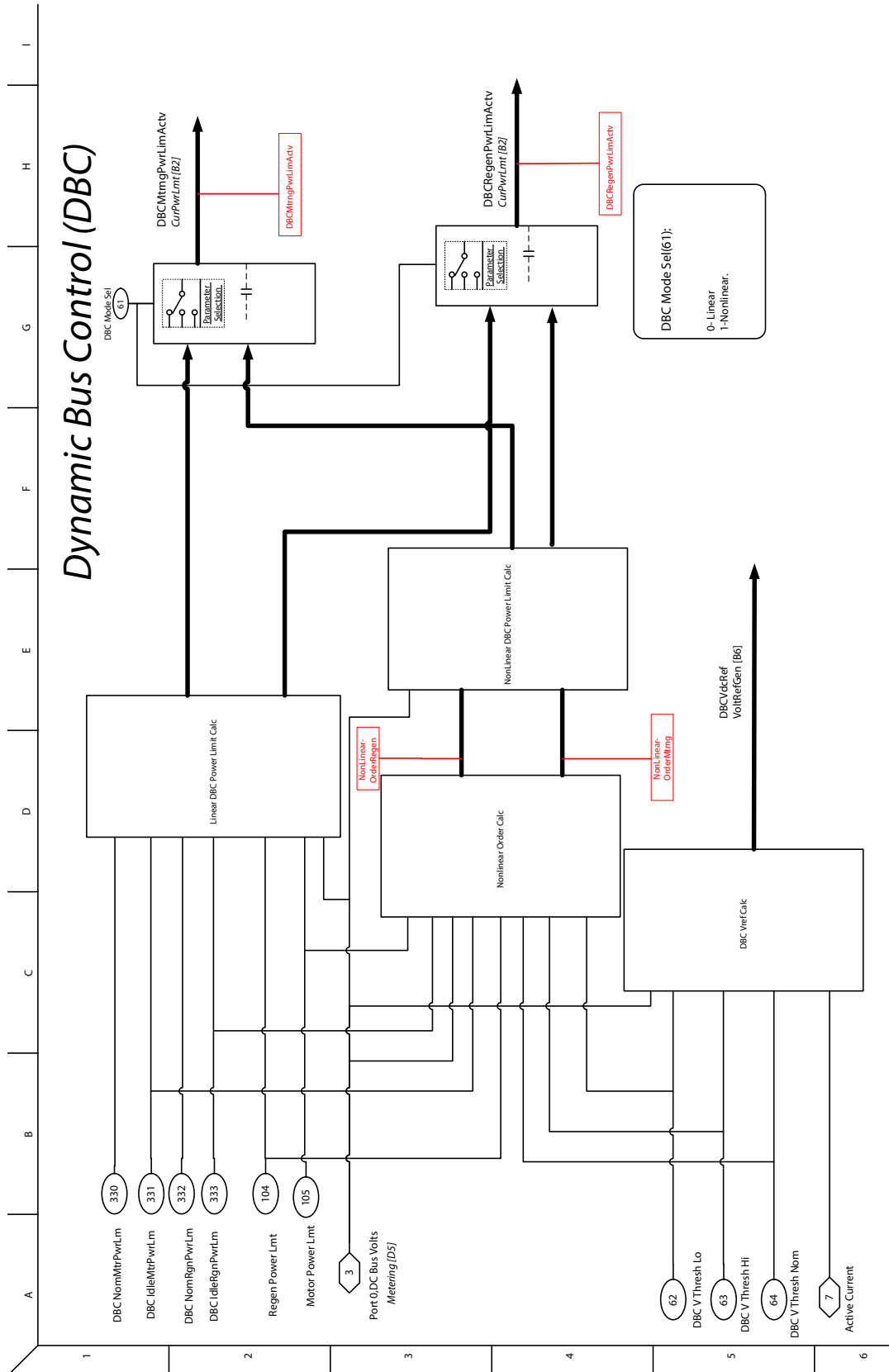



Figure 12 - Voltage Reference Generator

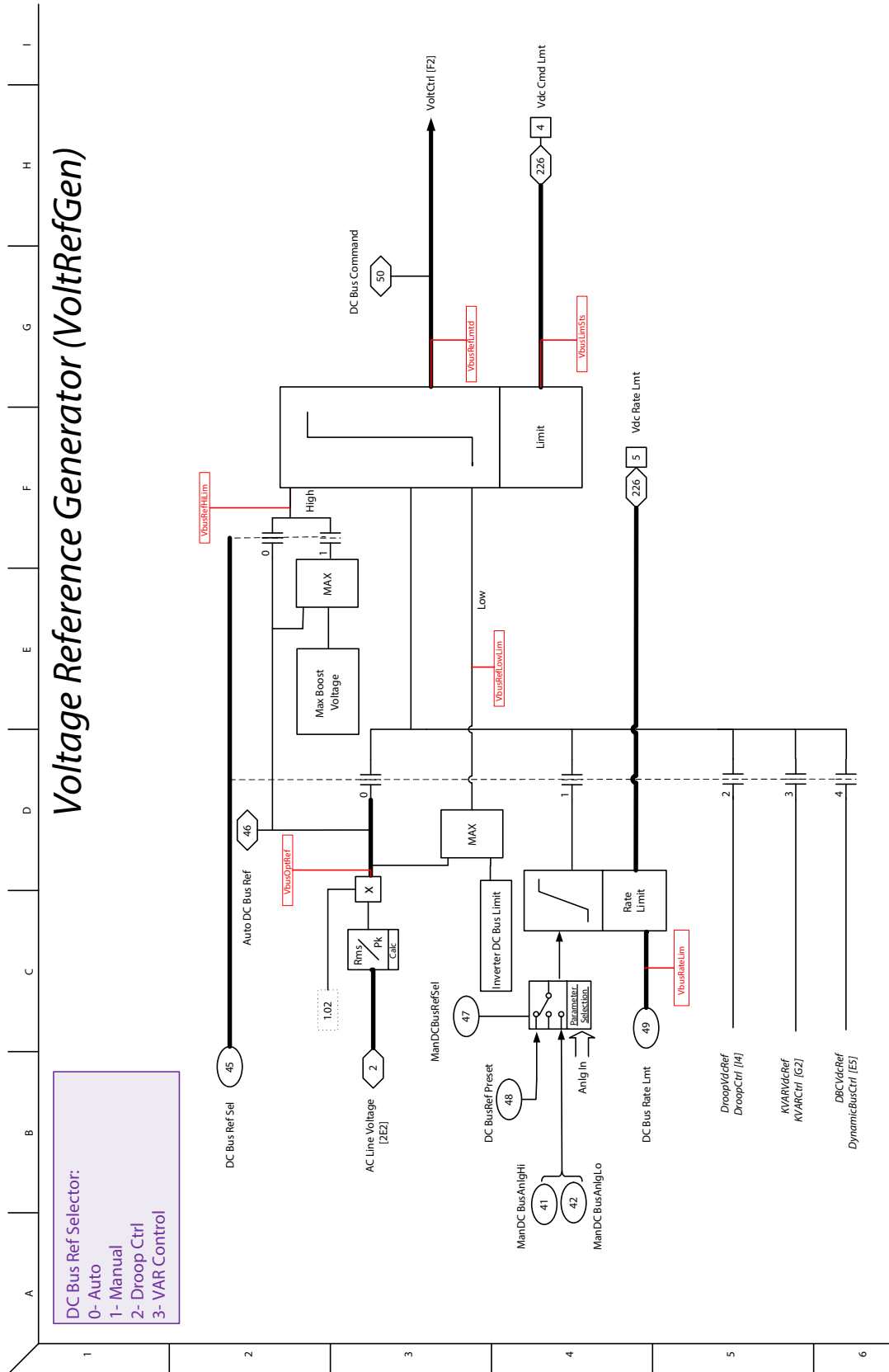

Figure 13 - Voltage Control

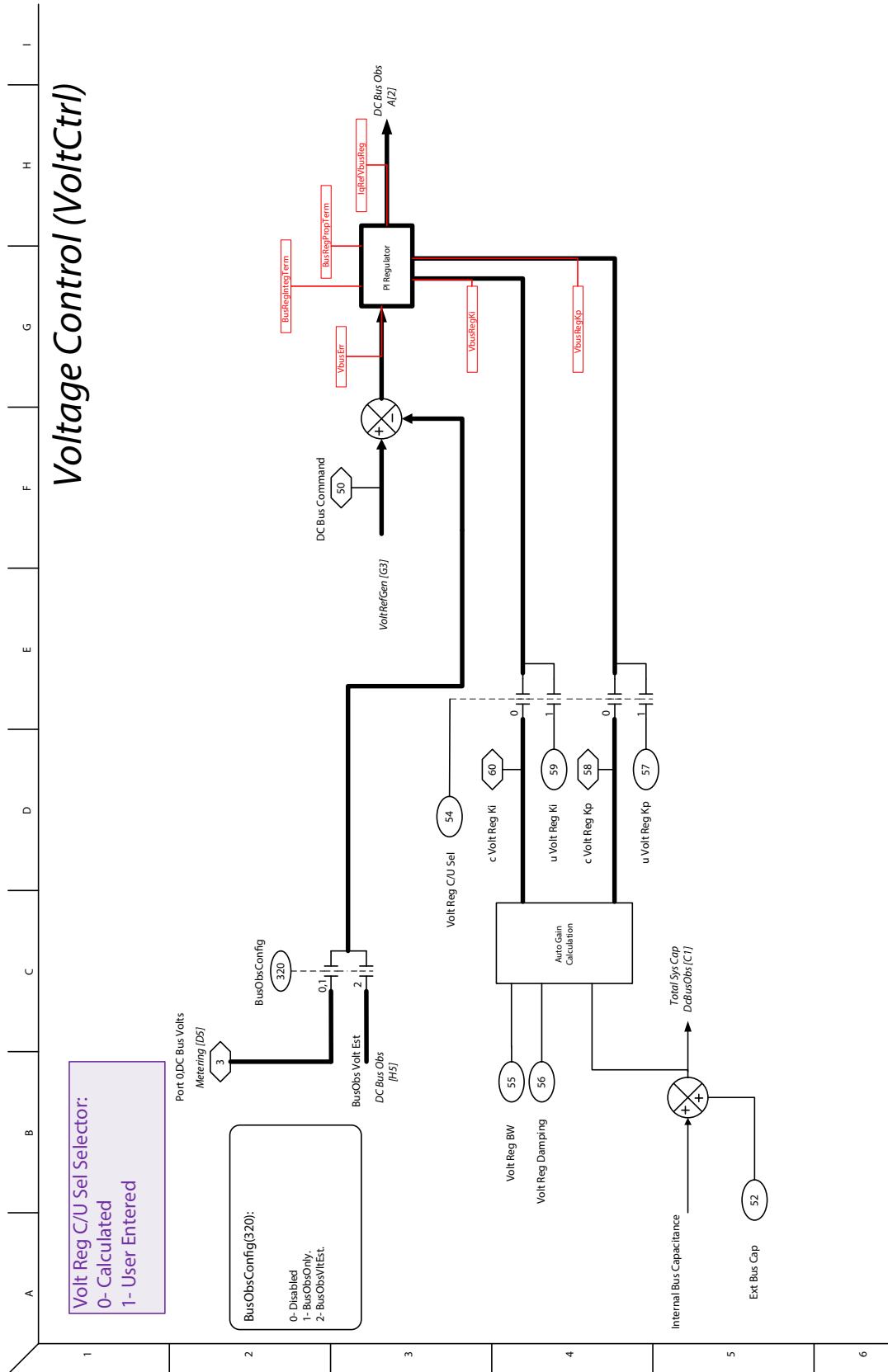

Figure 14 - DC Bus Observer

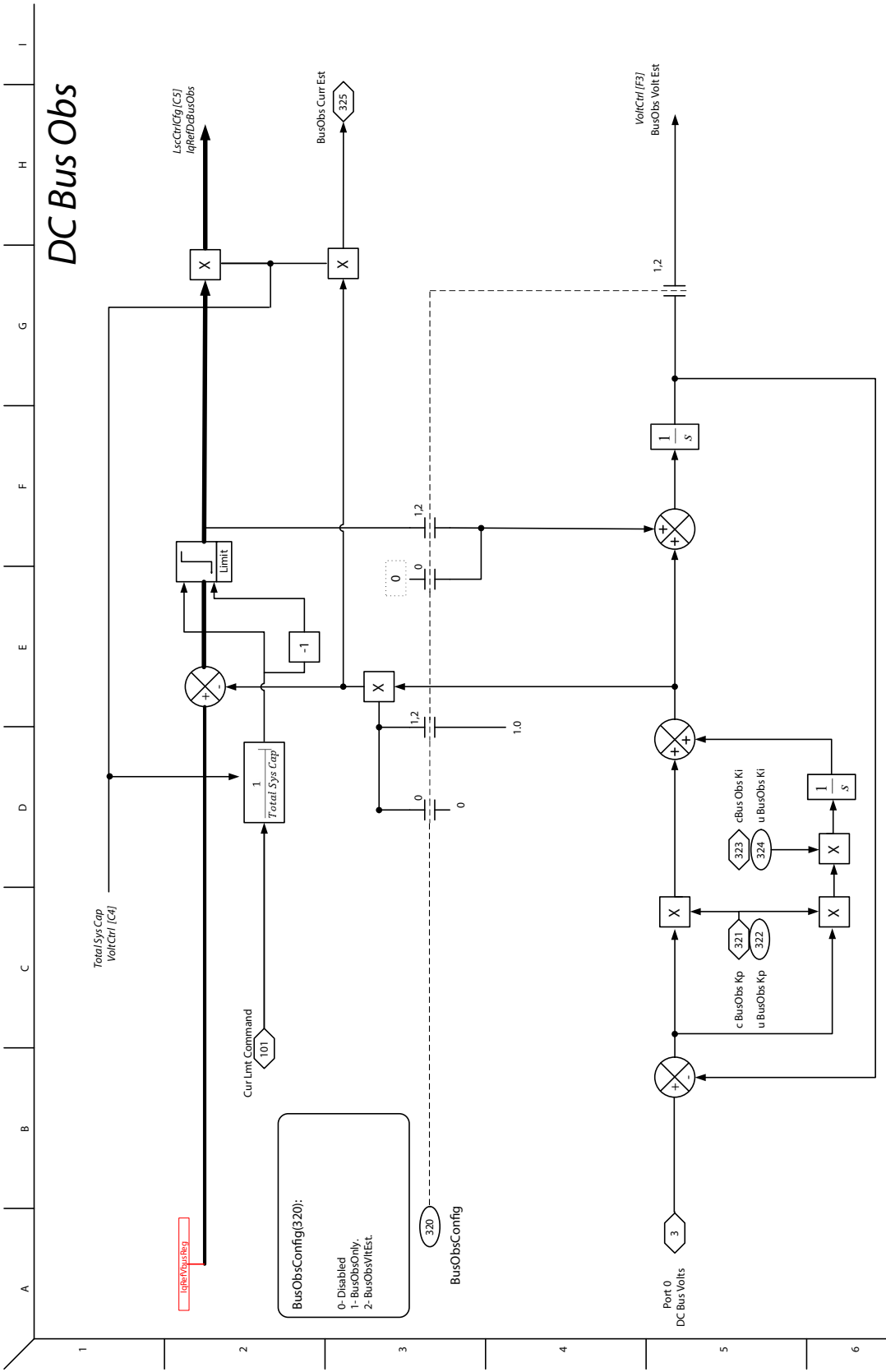

Figure 15 - Power Factor Correction

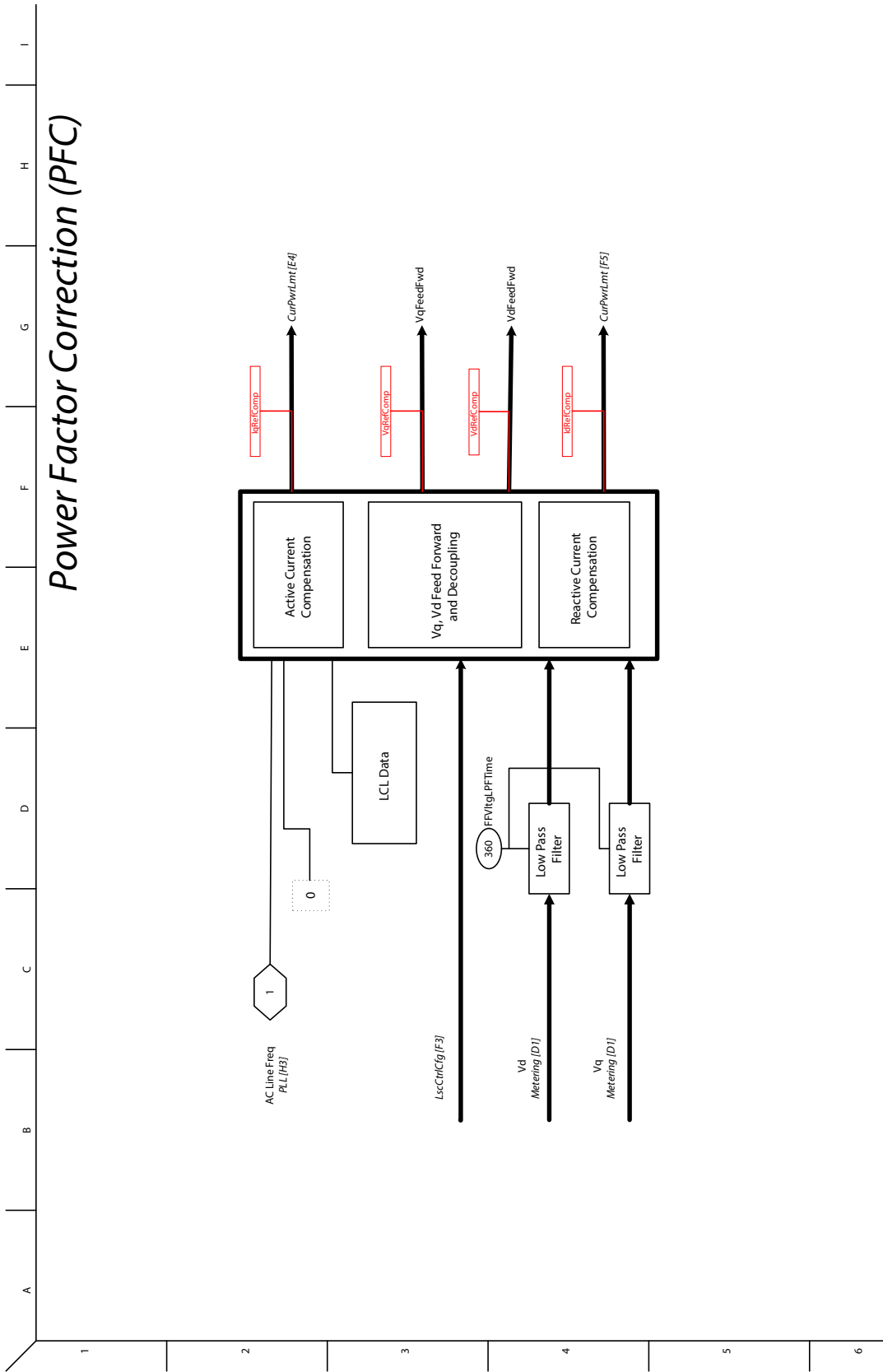

Figure 16 - Current/Power Limits

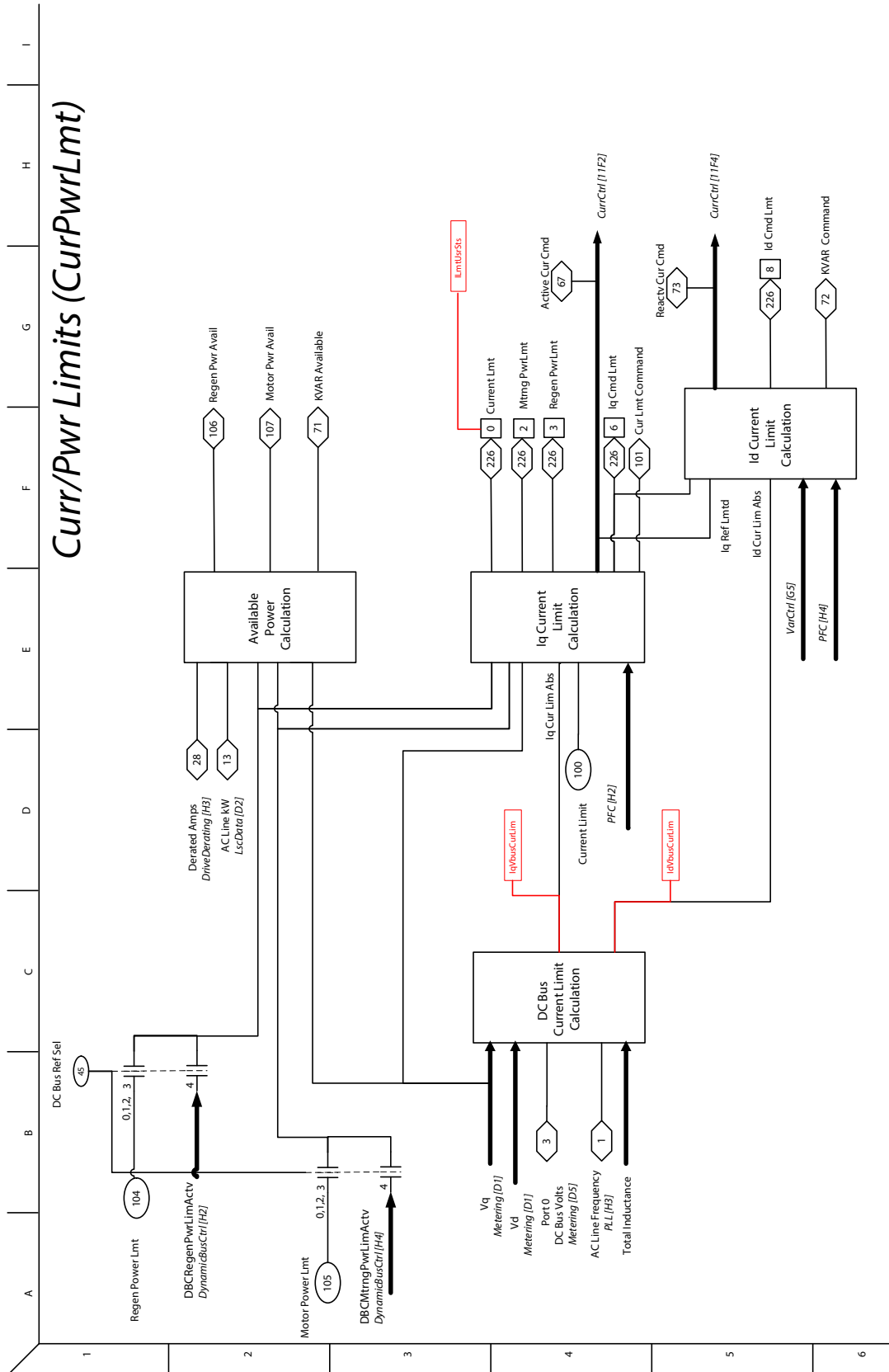

Figure 17 - Current Control

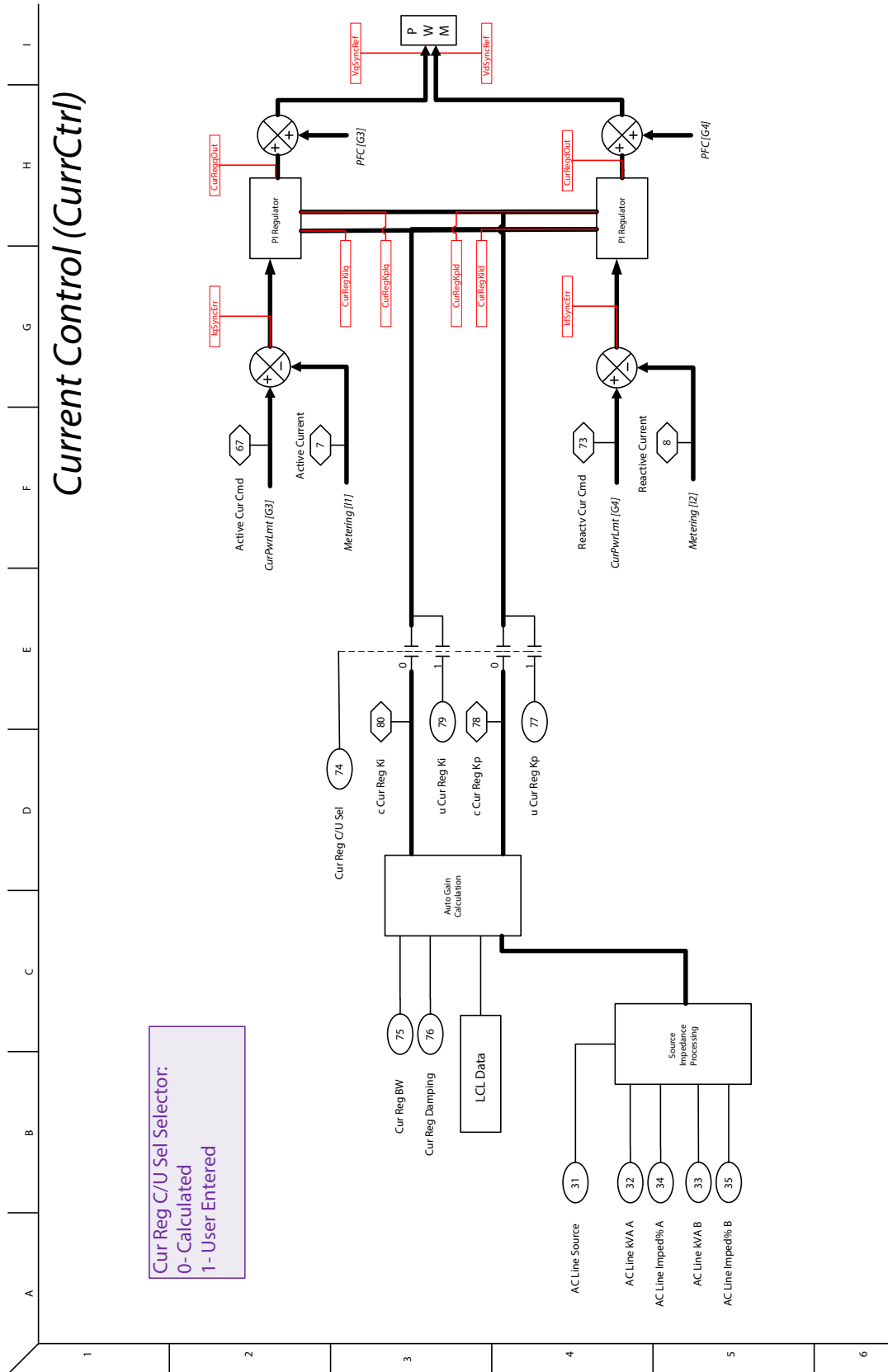

Figure 18 - LSC Control Configuration

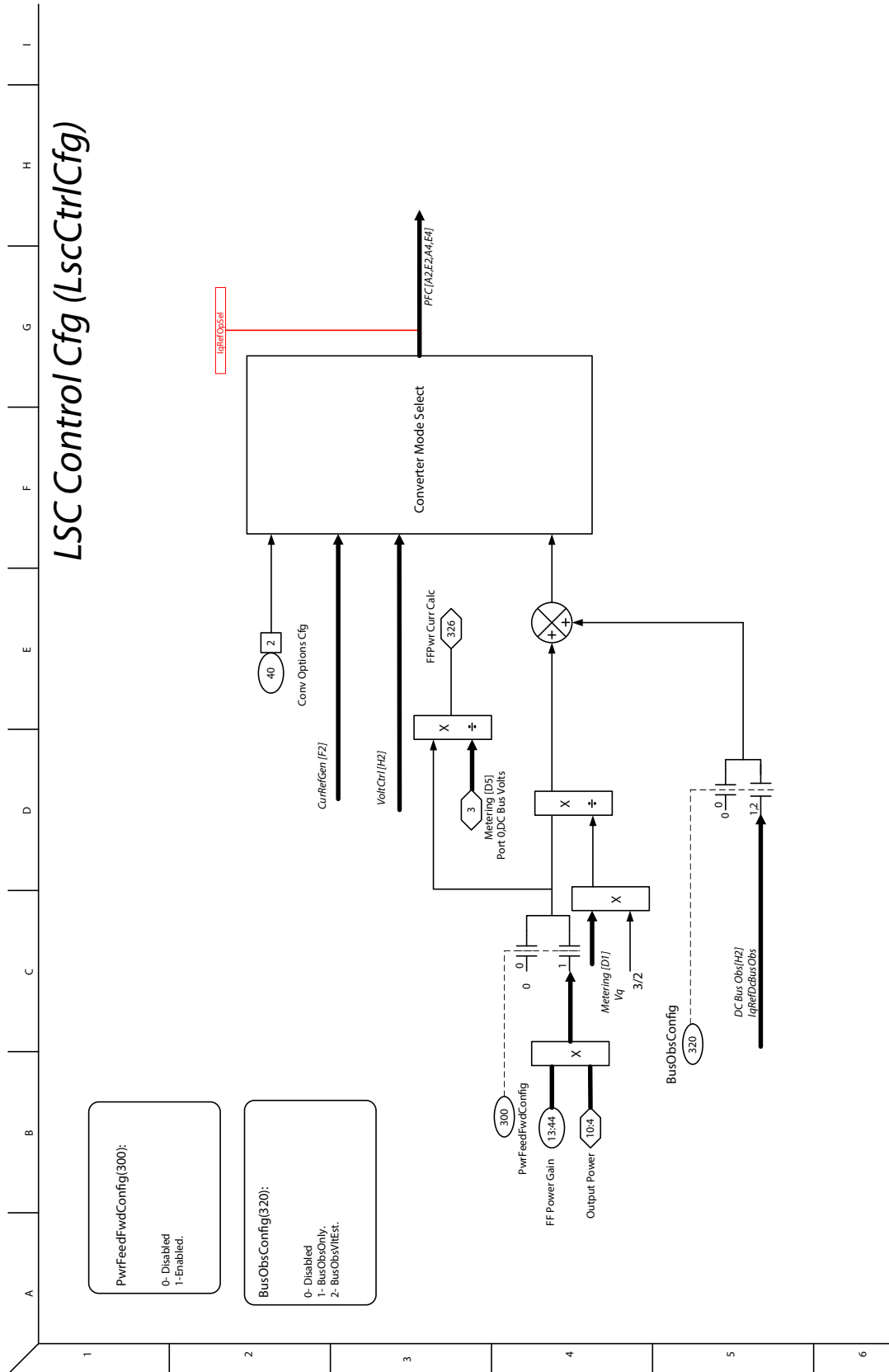
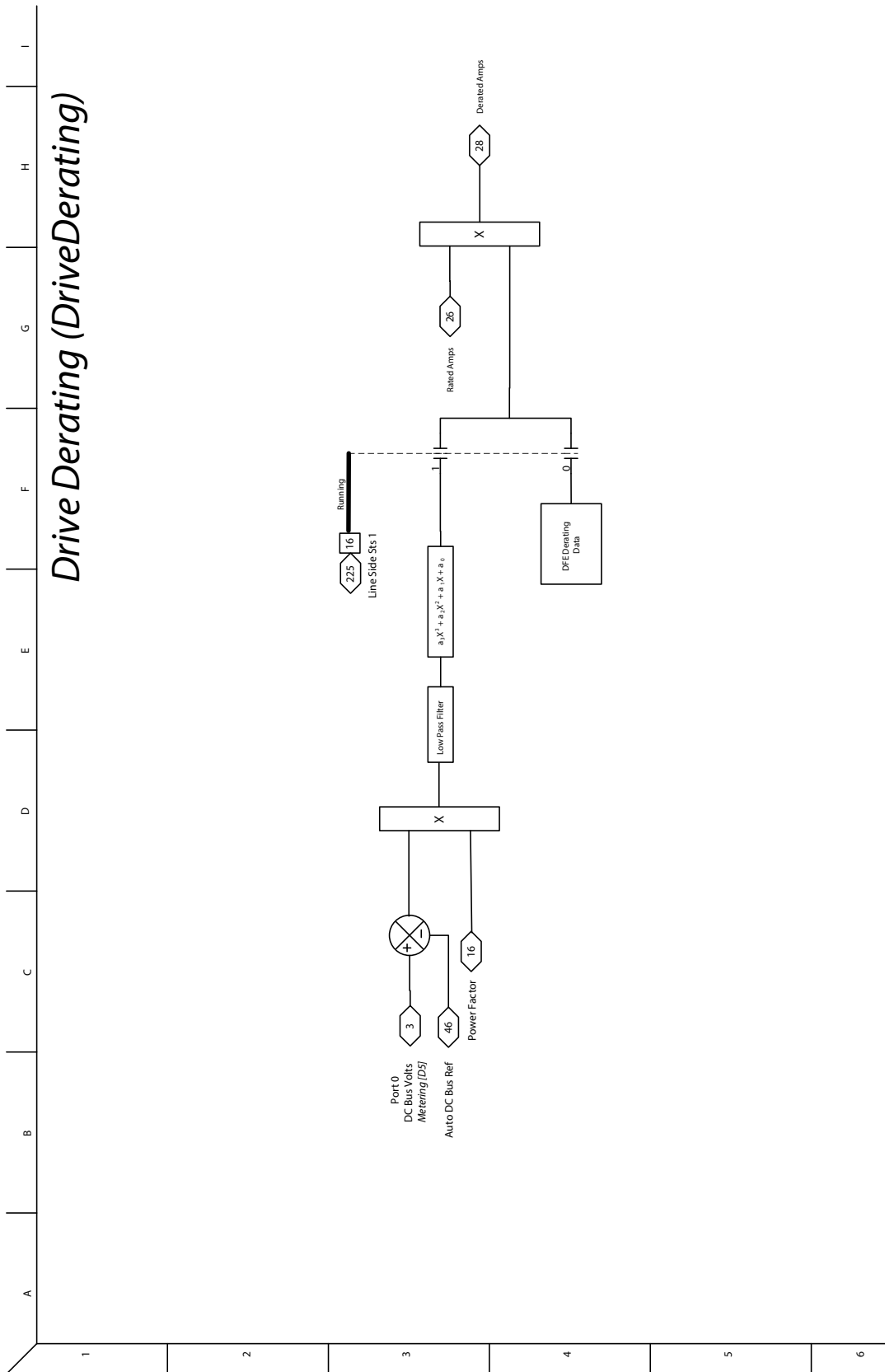

Figure 19 - Drive Derating





# Motor Side Inverter Control Diagrams

Figure 20 - Flux Vector Overview

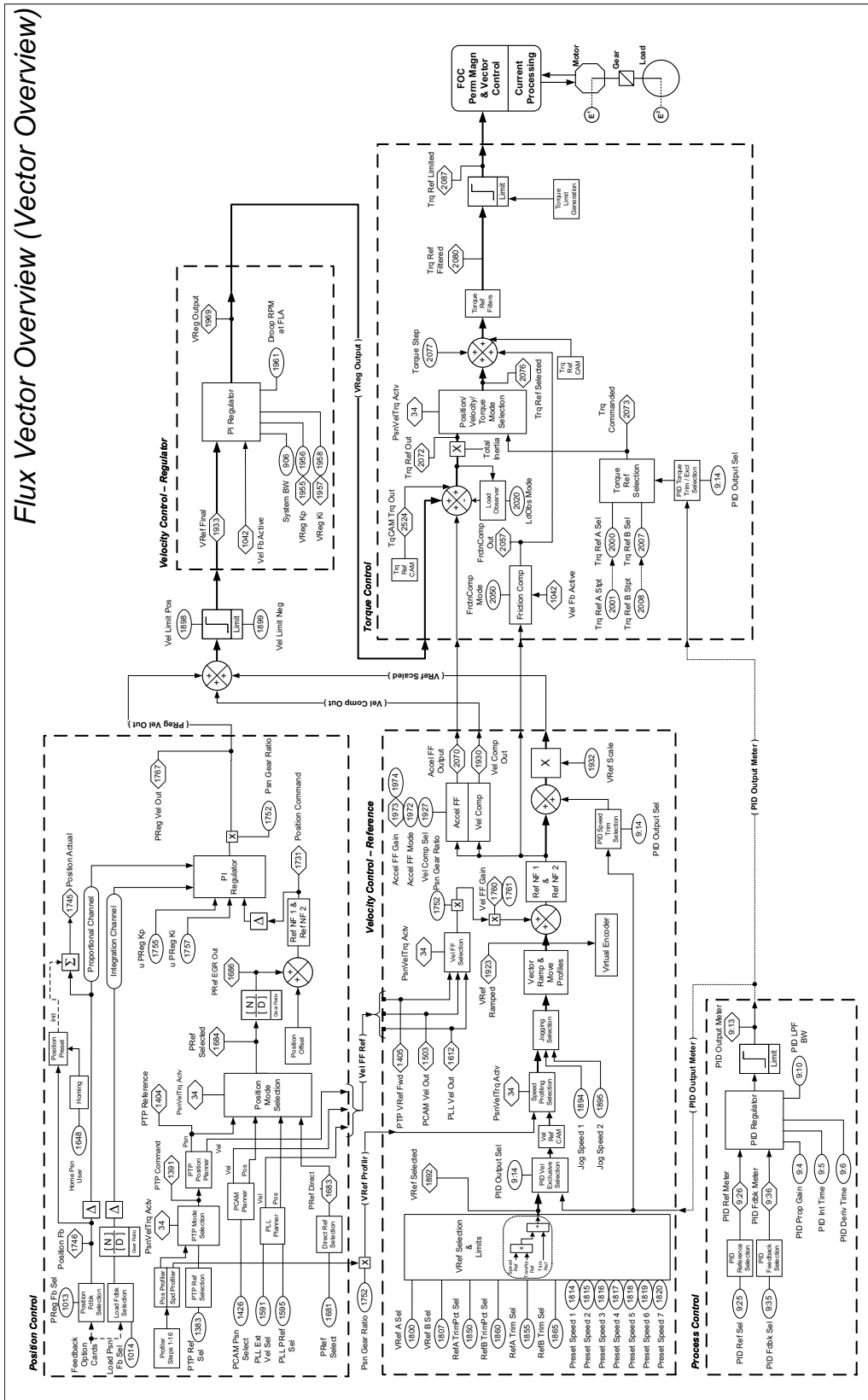

Figure 21 - Variable Frequency, SV Overview

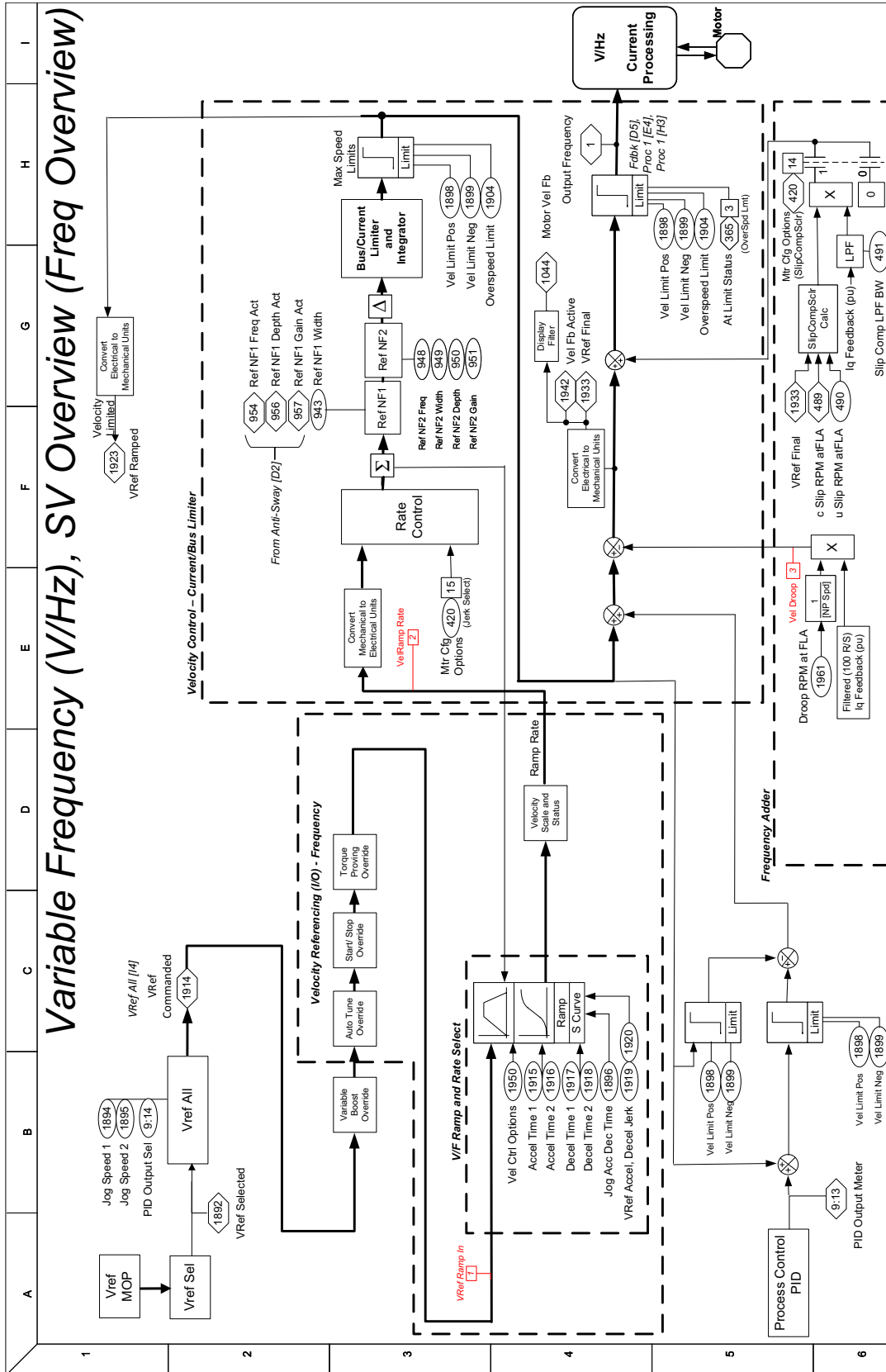

Figure 22 - CBI Metering

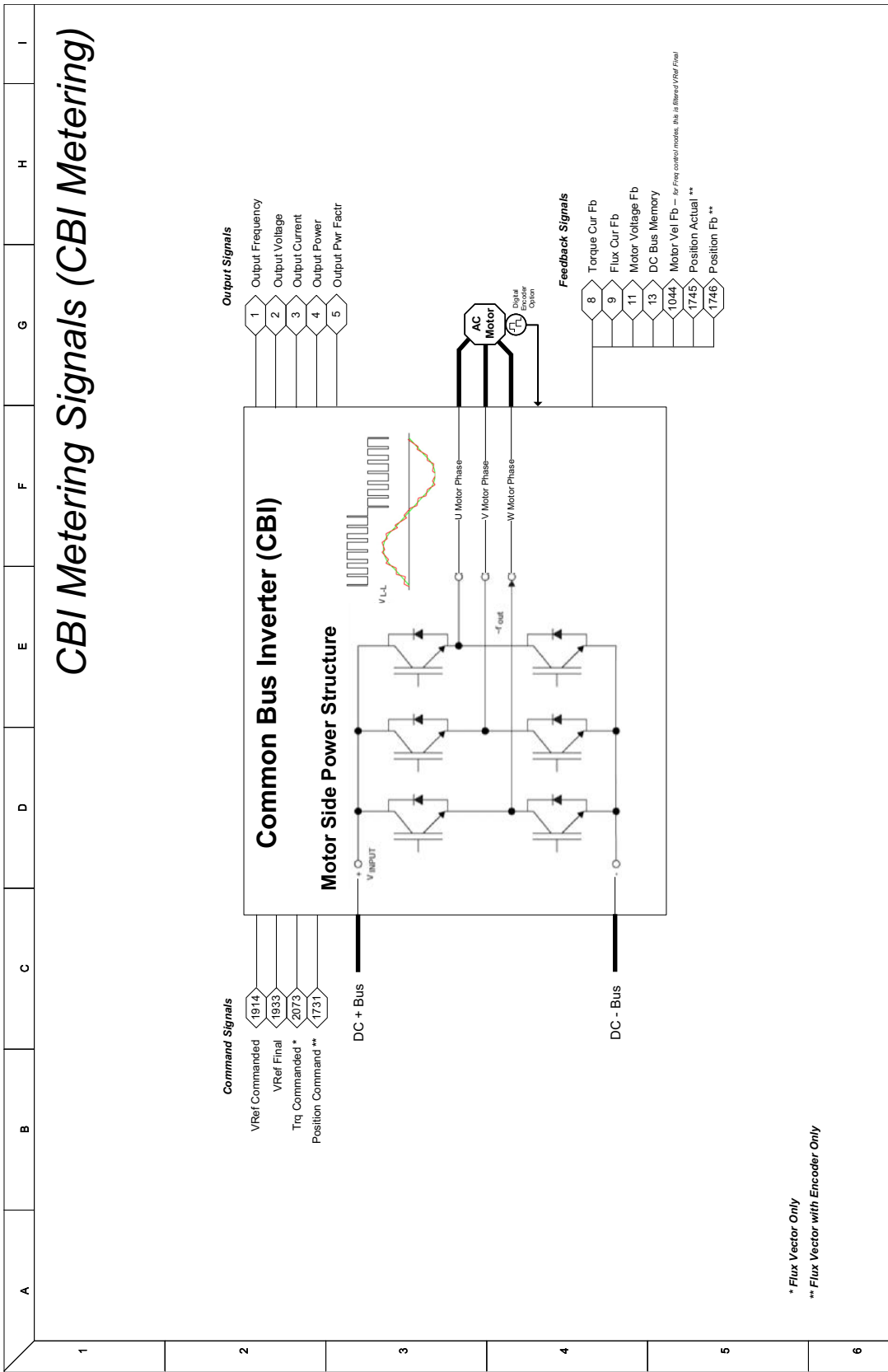

Figure 23 - Feedback Configuration & Status (Fdbk)

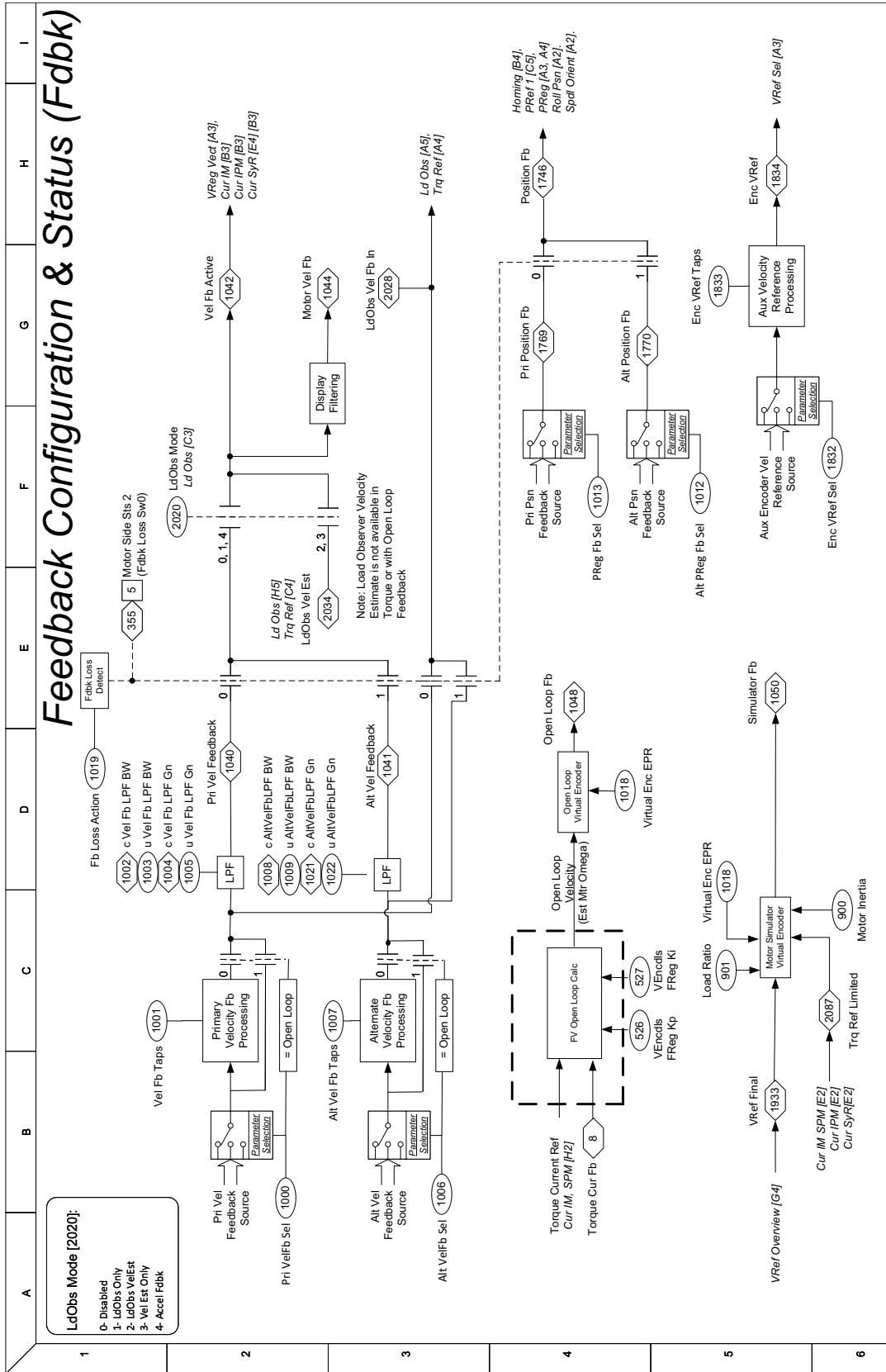

Figure 24 - Position Homing

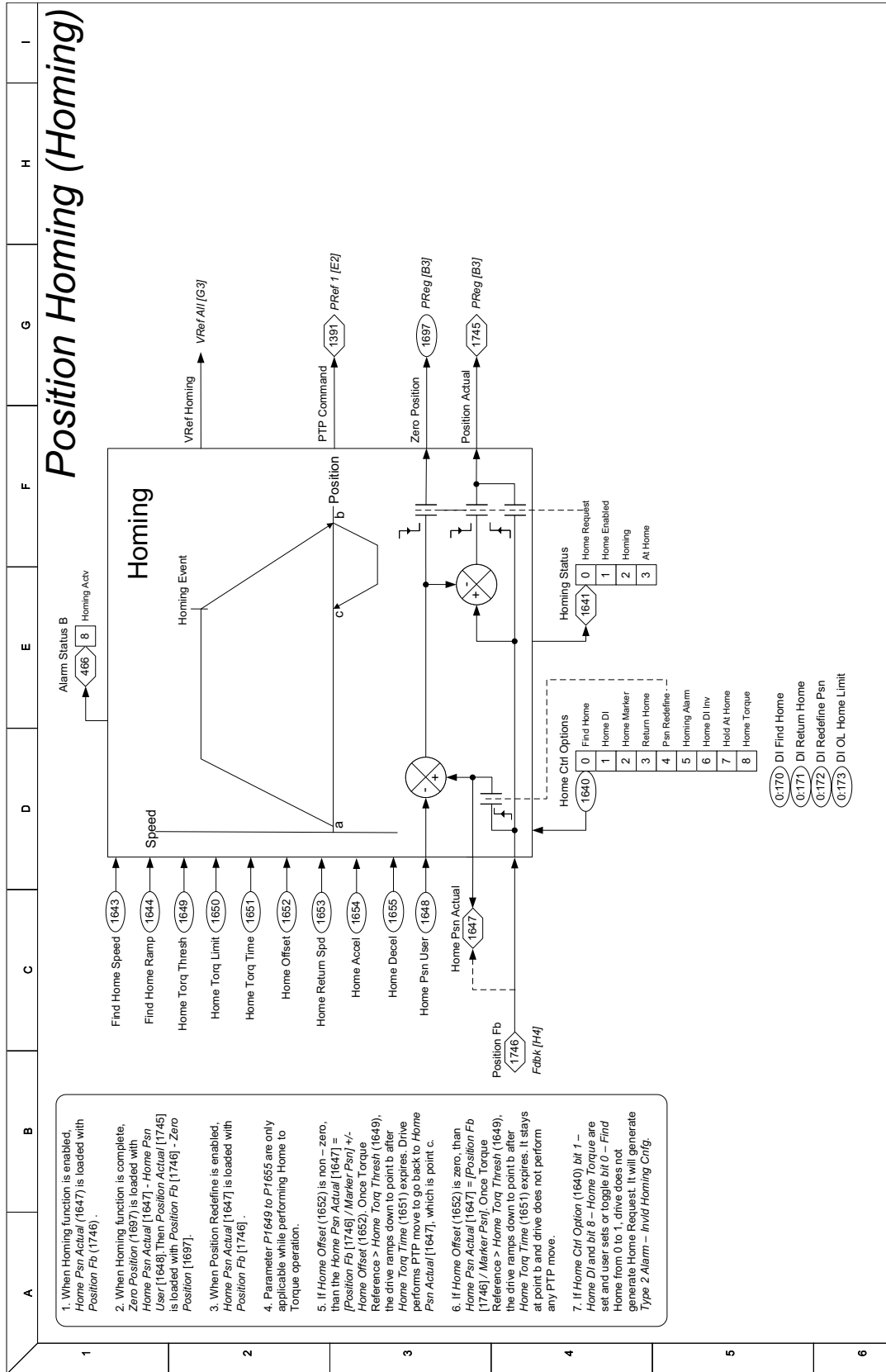

Figure 25 - Position Reference 1

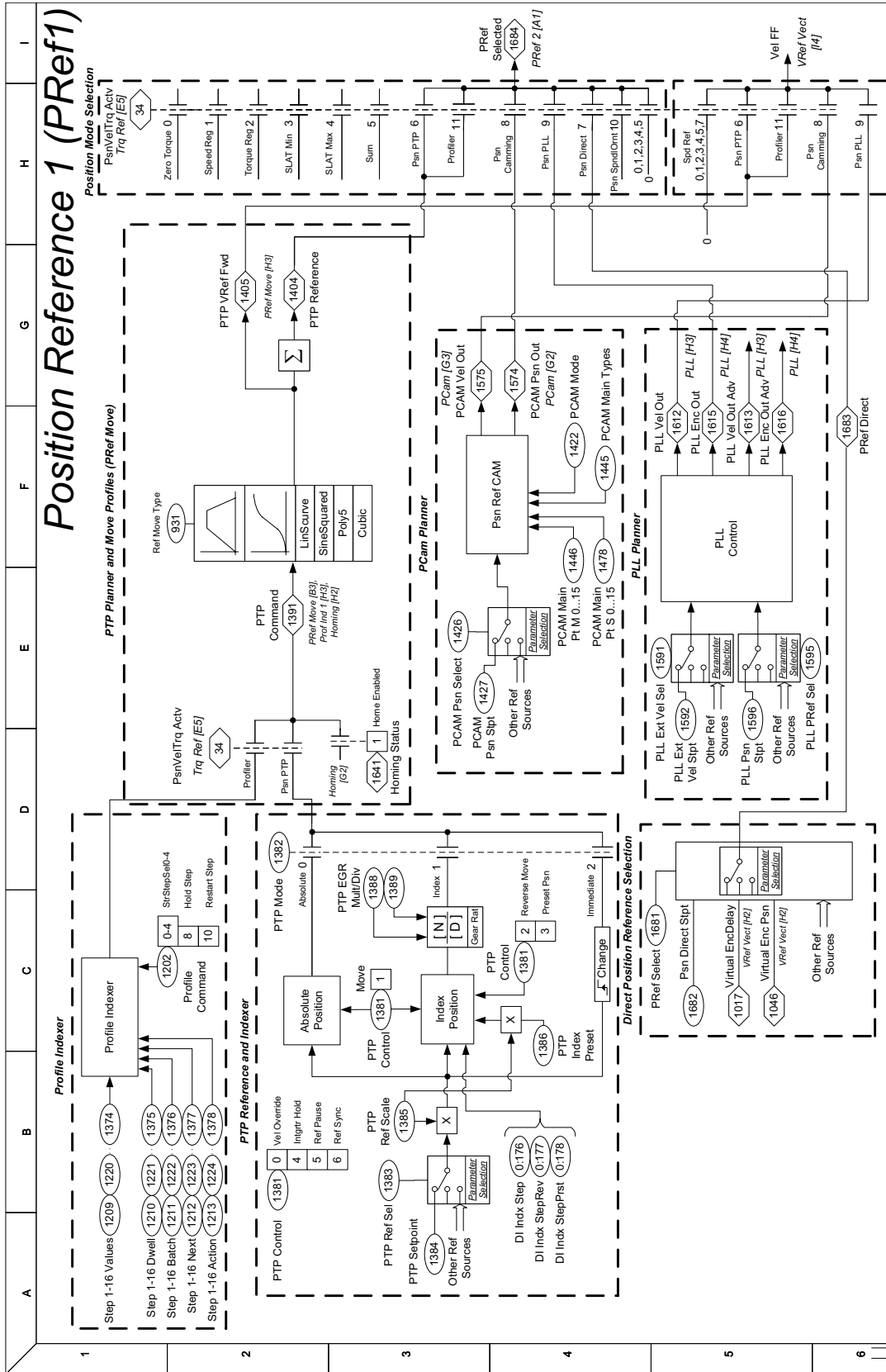

Figure 26 - Position Reference - Move Profiles

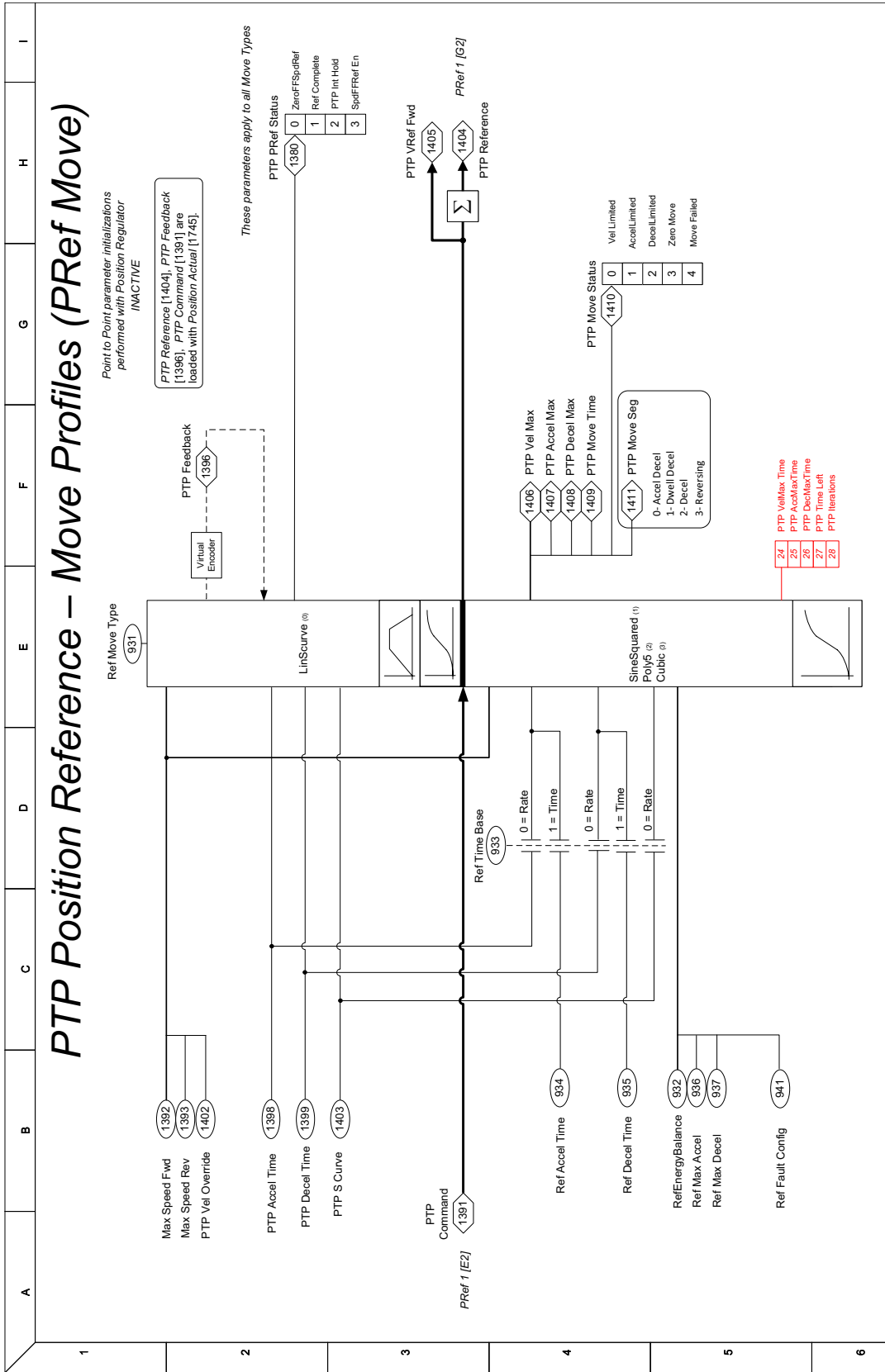

Figure 27 - Position Reference 2

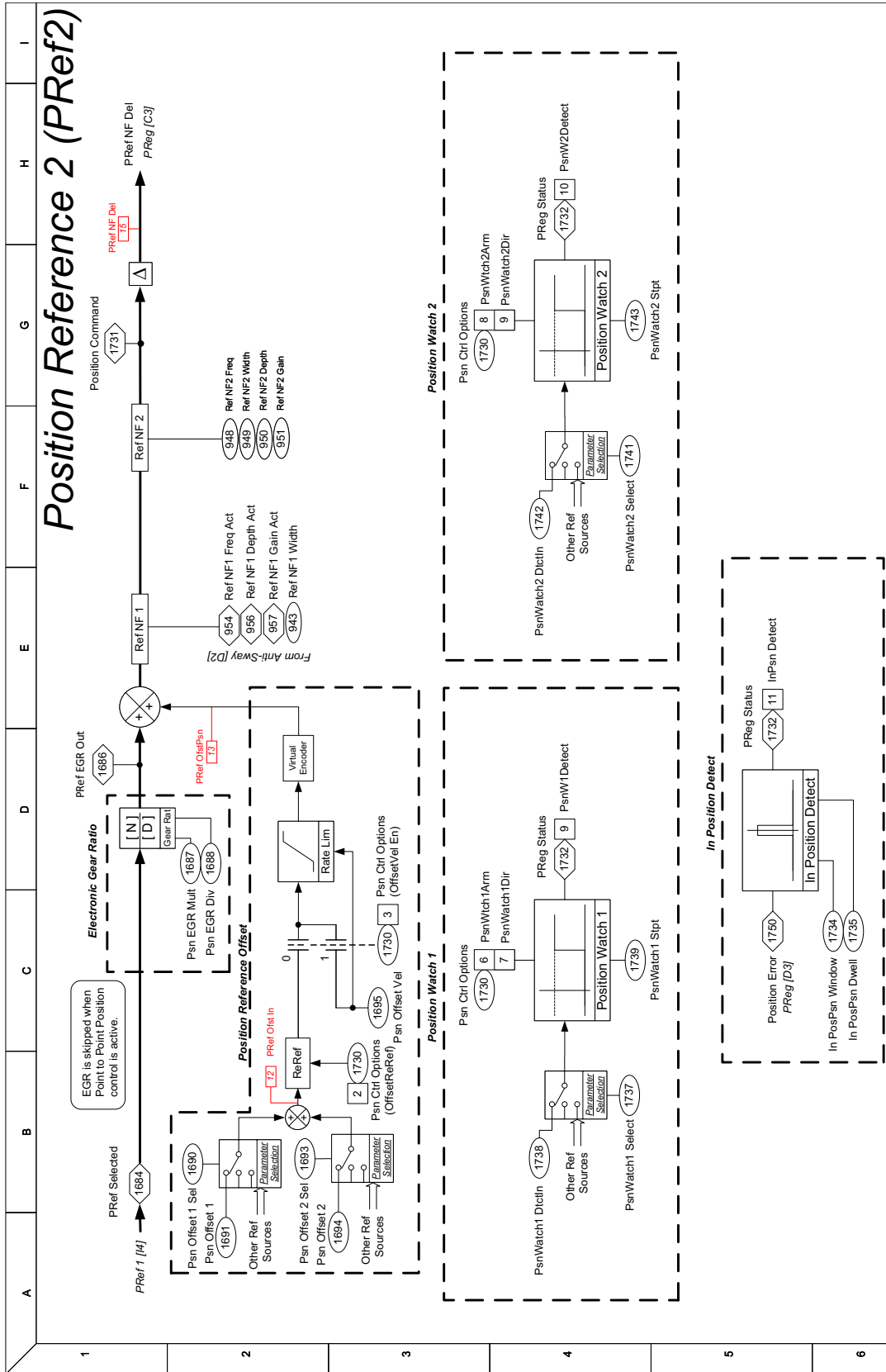



Figure 28 - Position Regulator

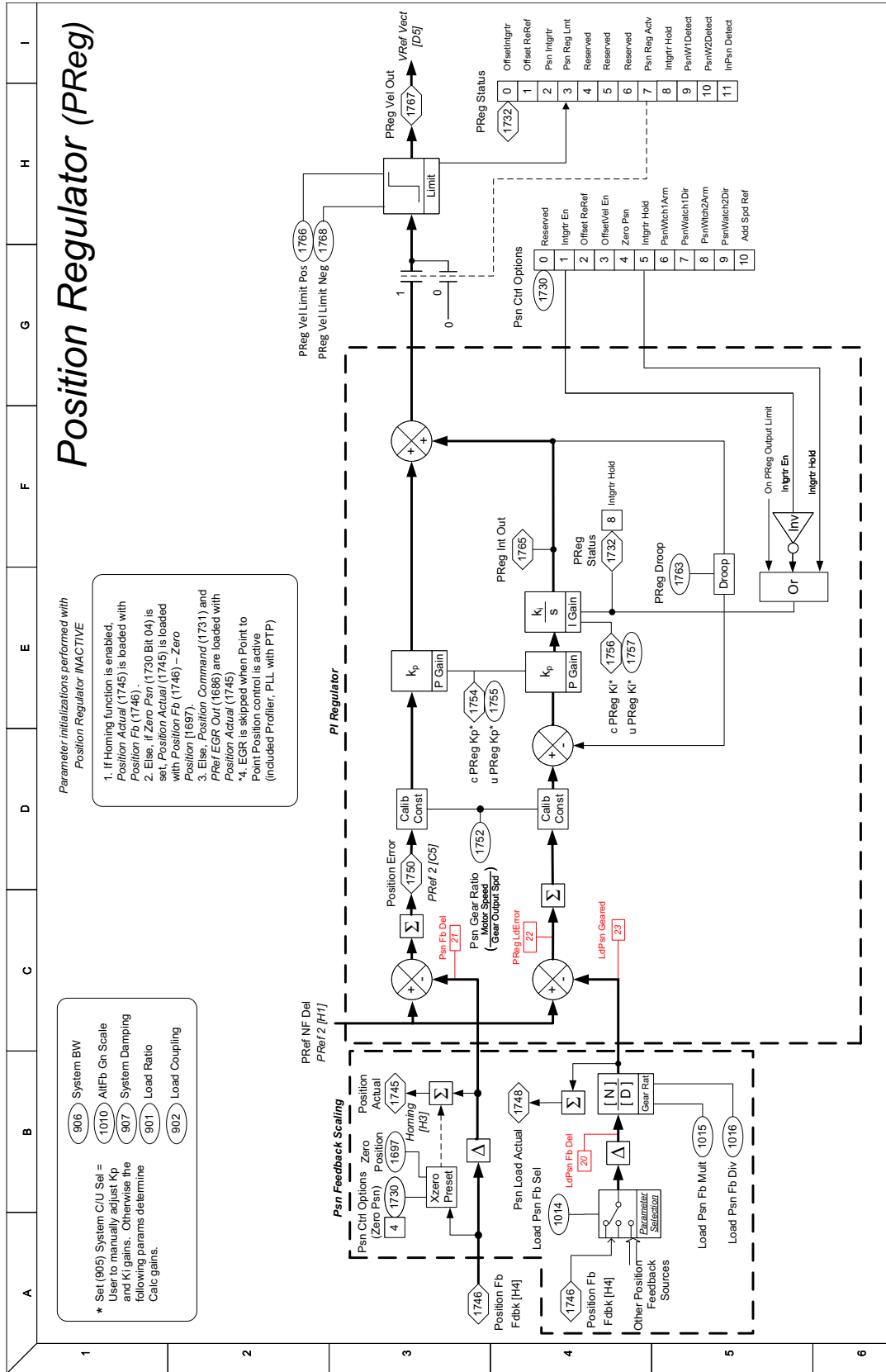

Figure 29 - Position Control - Phase Locked Loop

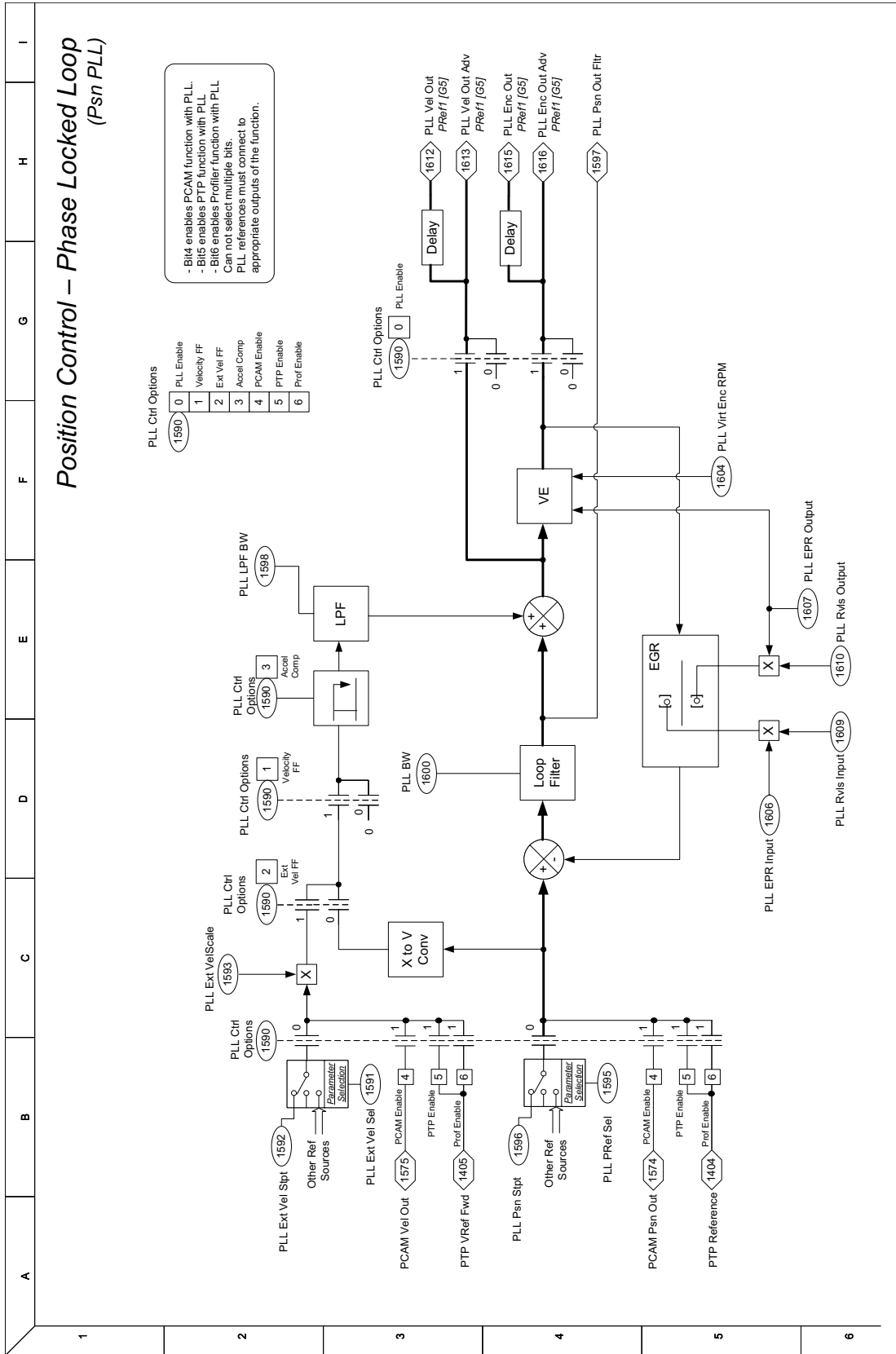

Figure 30 - Position Control - Position Reference CAM

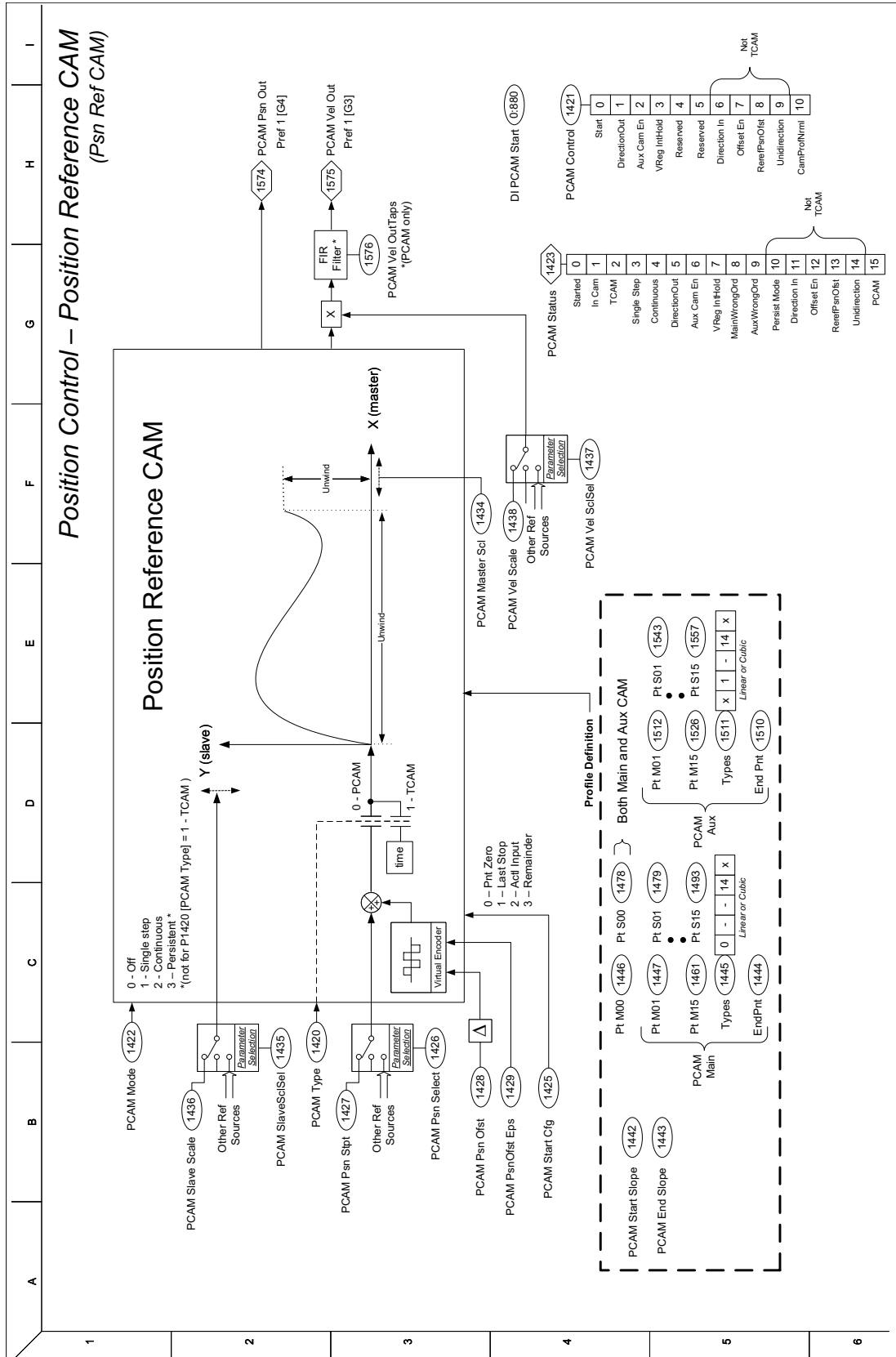

Figure 31 - Position Control - Profiler/Indexer 1

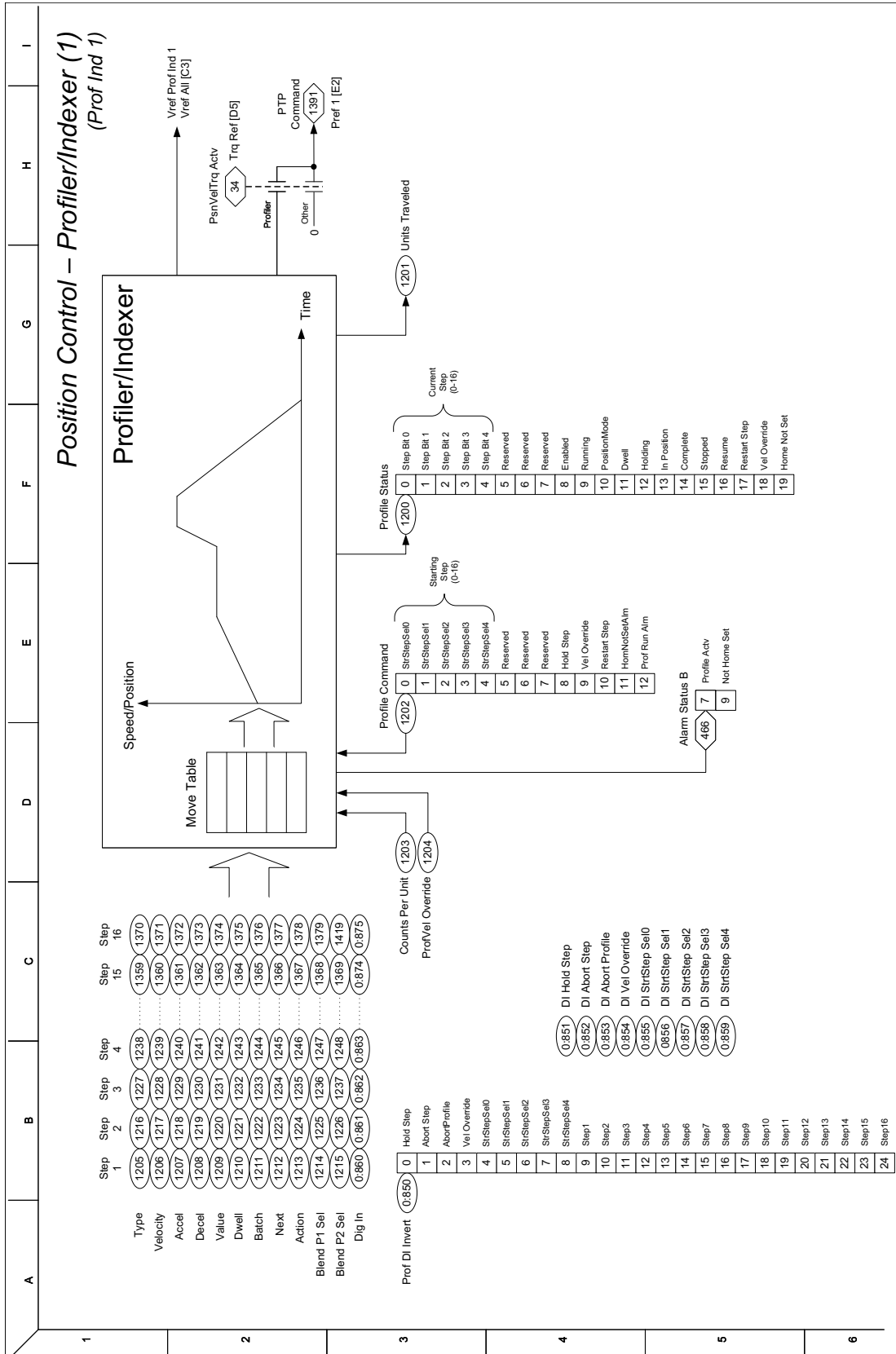

Figure 32 - Position Control - Profiler/Indexer 2

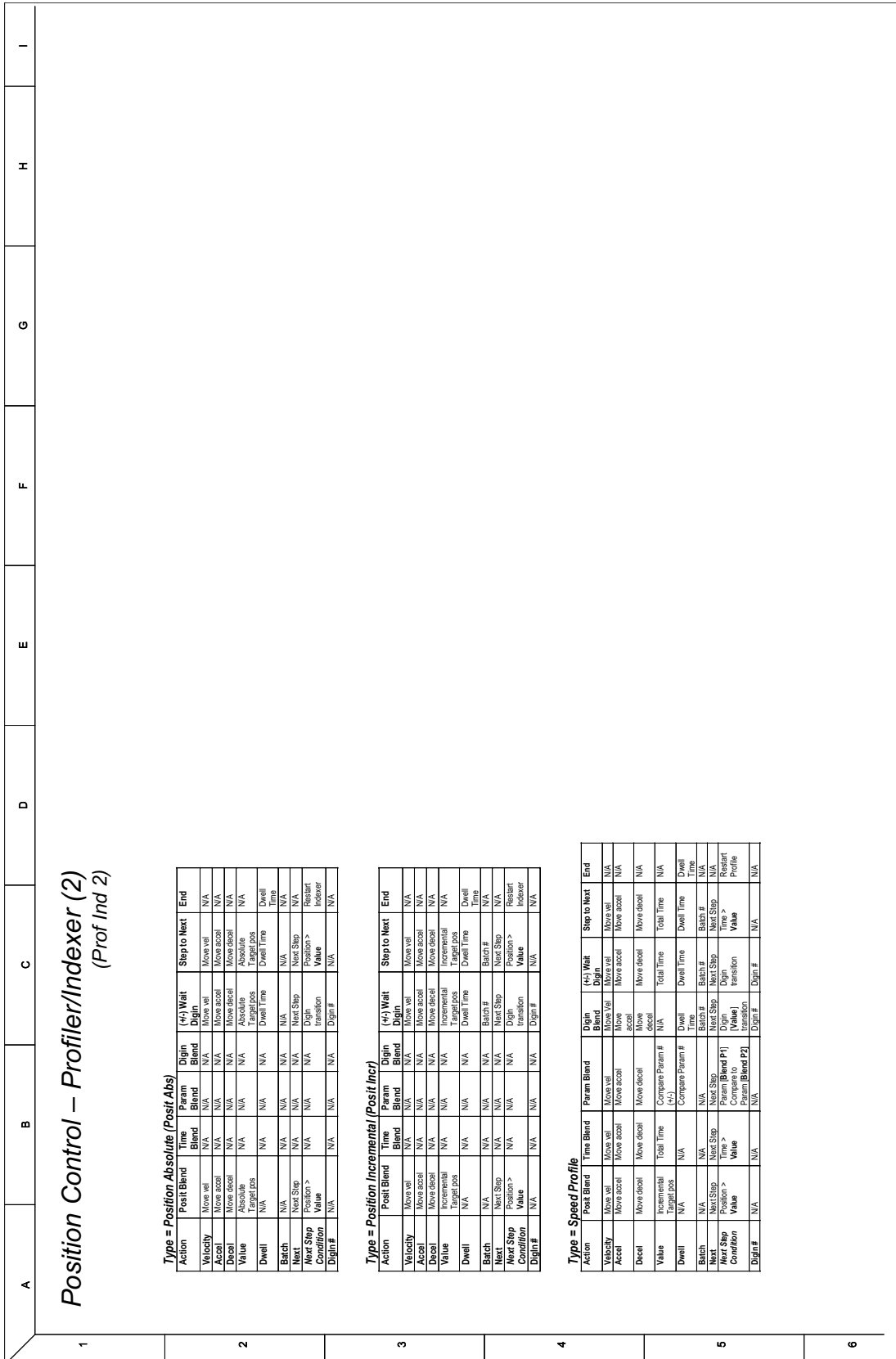

Figure 33 - Position Control - Roll Position Indicator

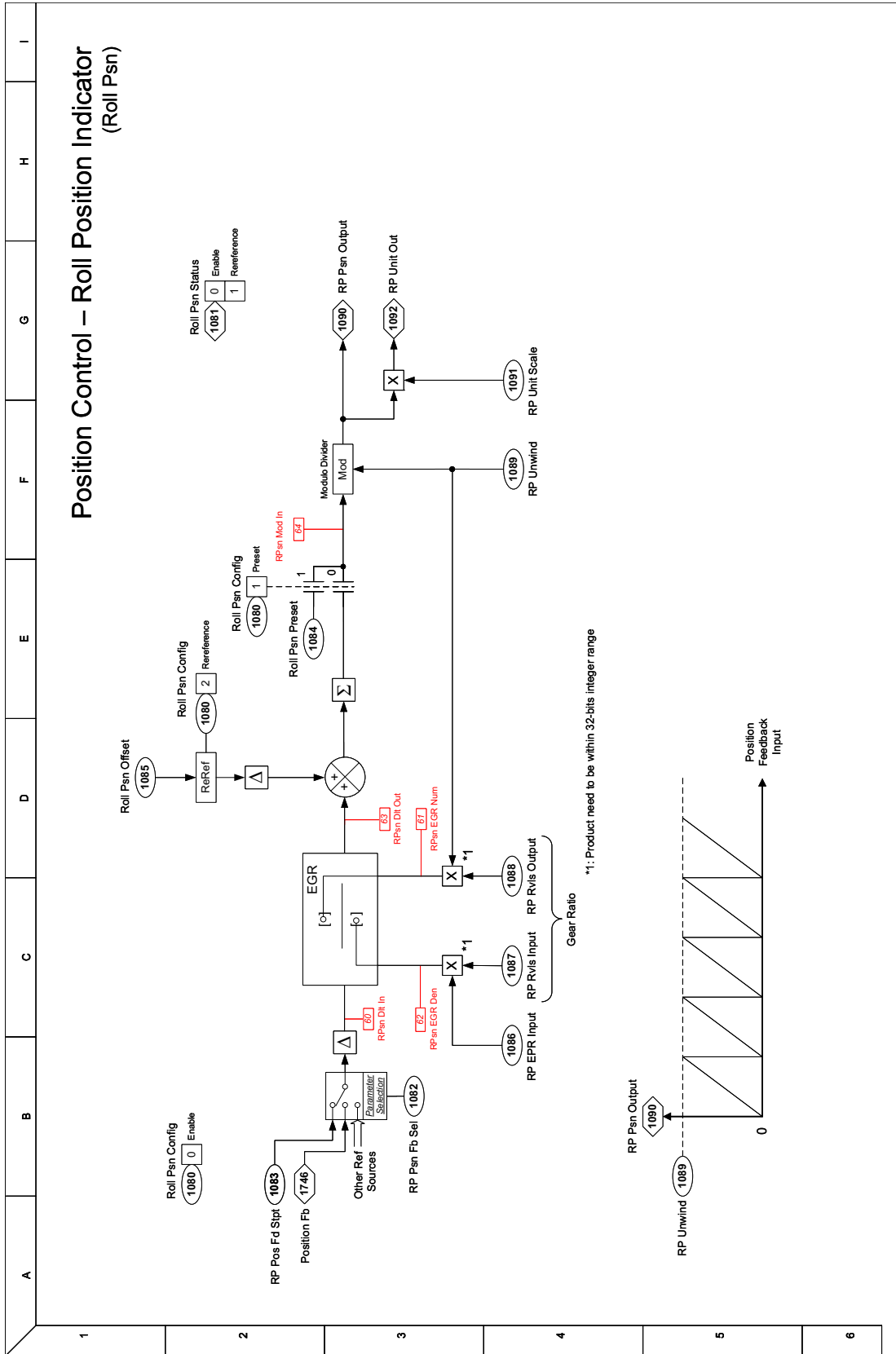

Figure 34 - Position Control - Spindle Orient

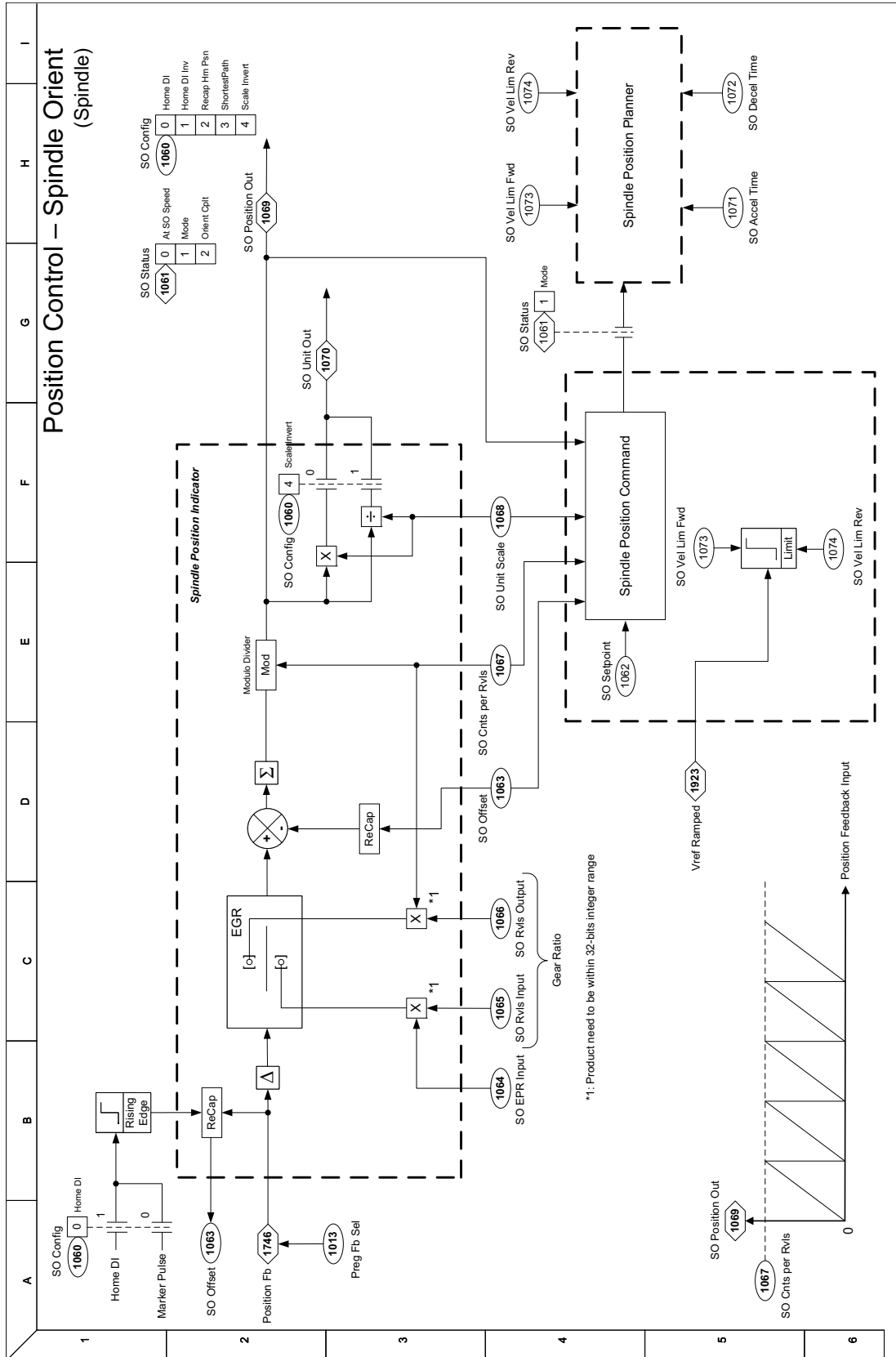

Figure 35 - Velocity Reference Overview

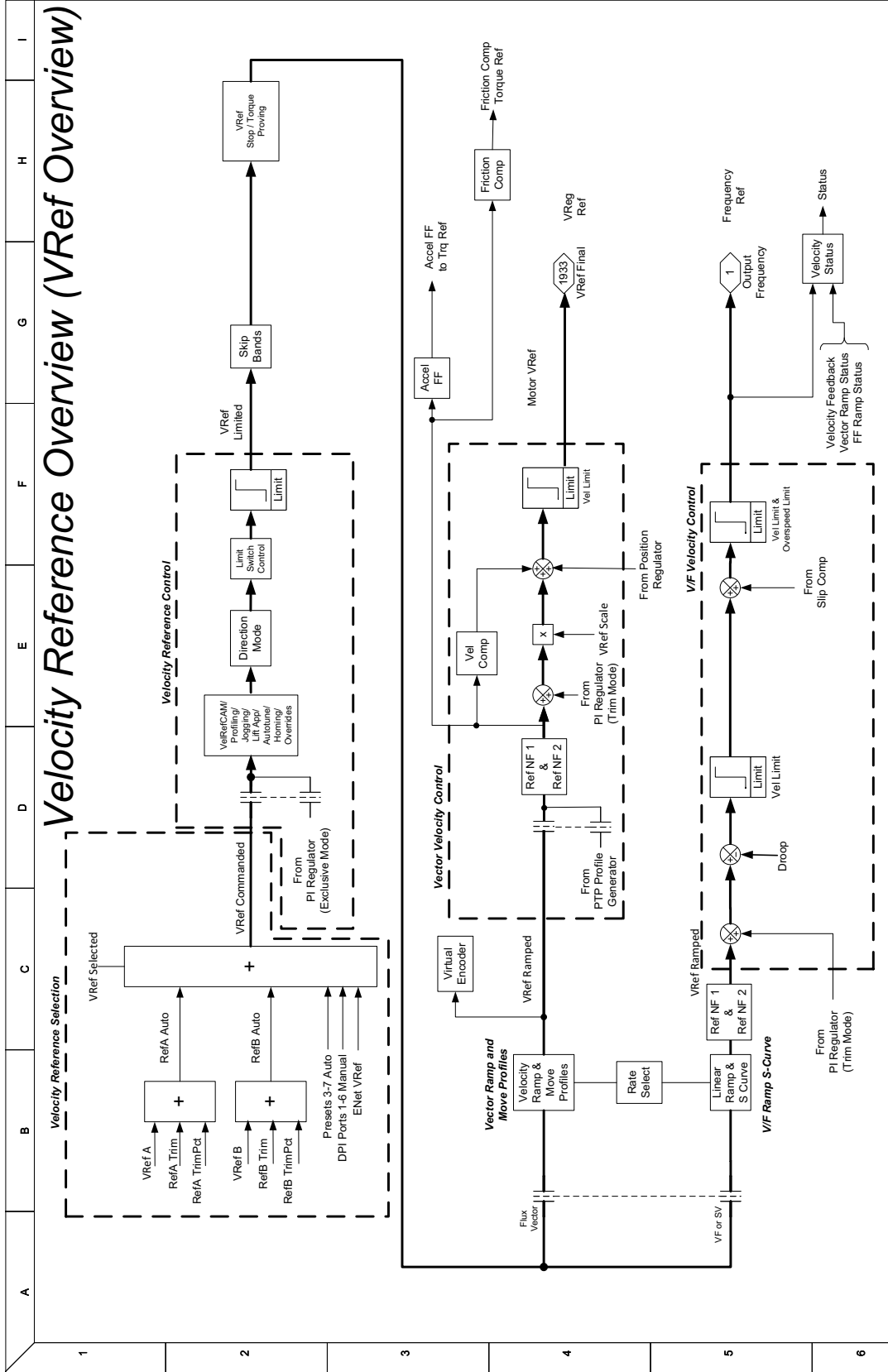





Figure 37 - Velocity Reference - All

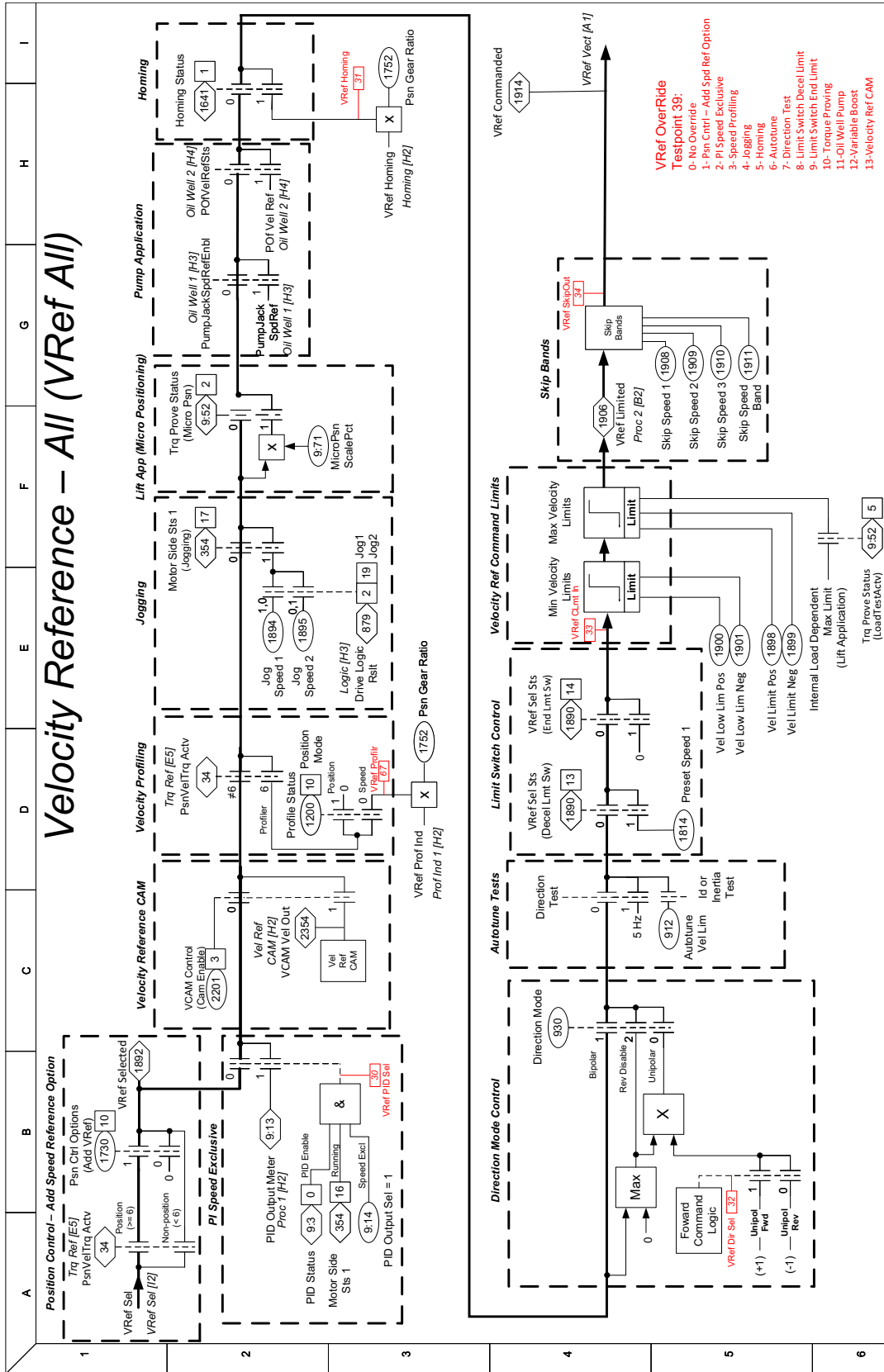

Figure 38 - Velocity Reference - Flux Vector

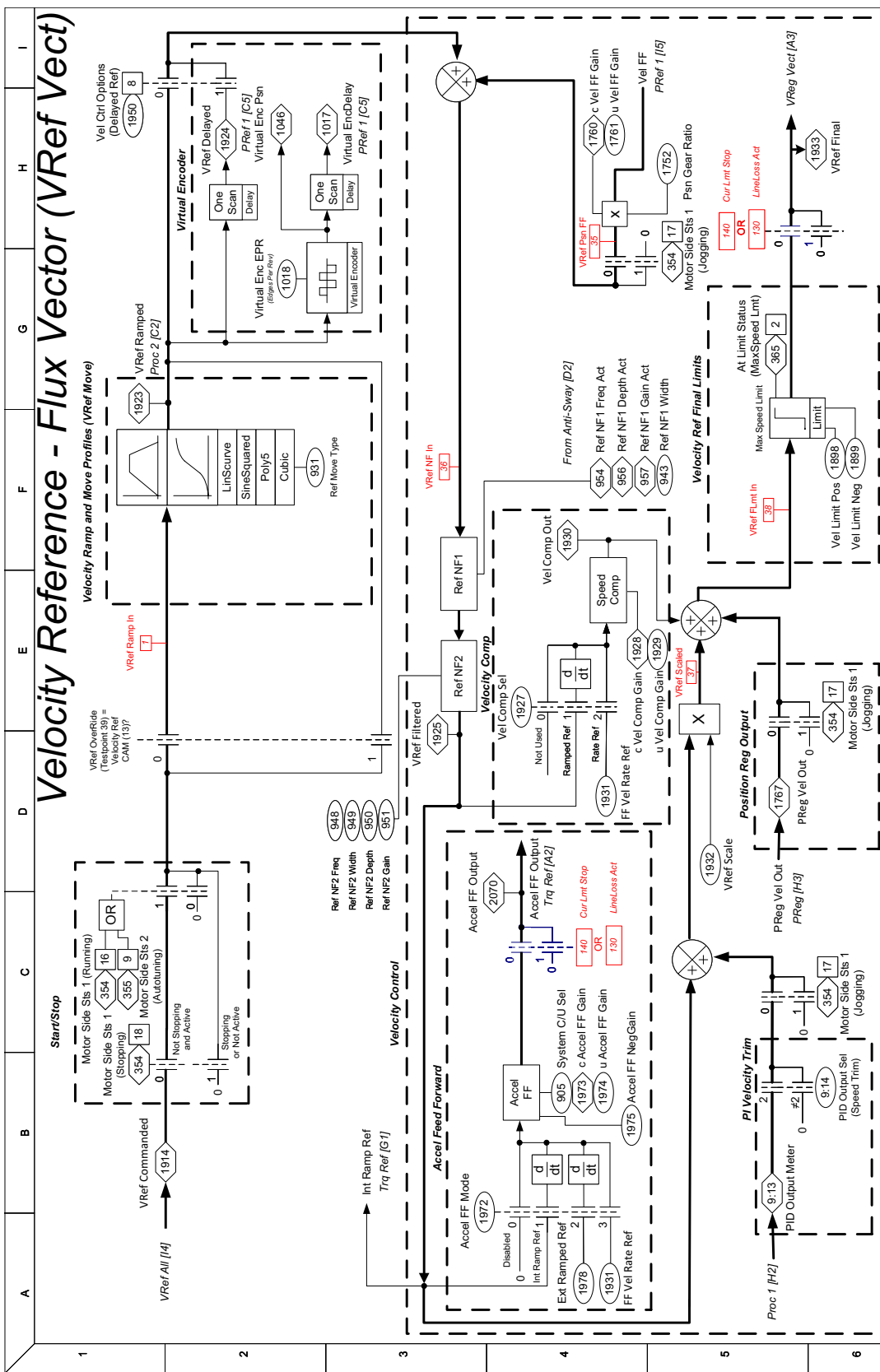

Figure 39 - Velocity Reference Flux Vector - Move Profiles

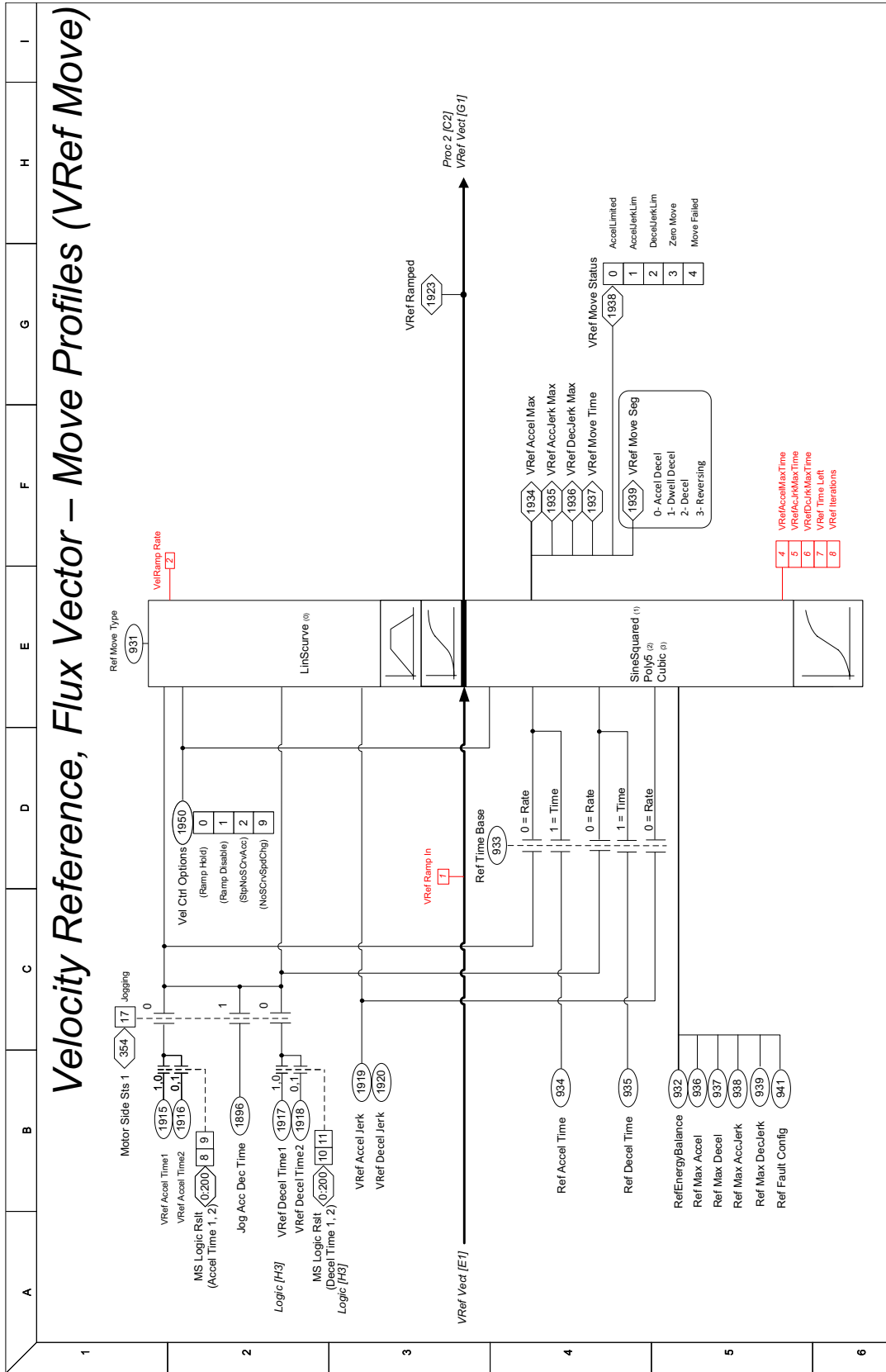

Figure 40 - Velocity Reference CAM

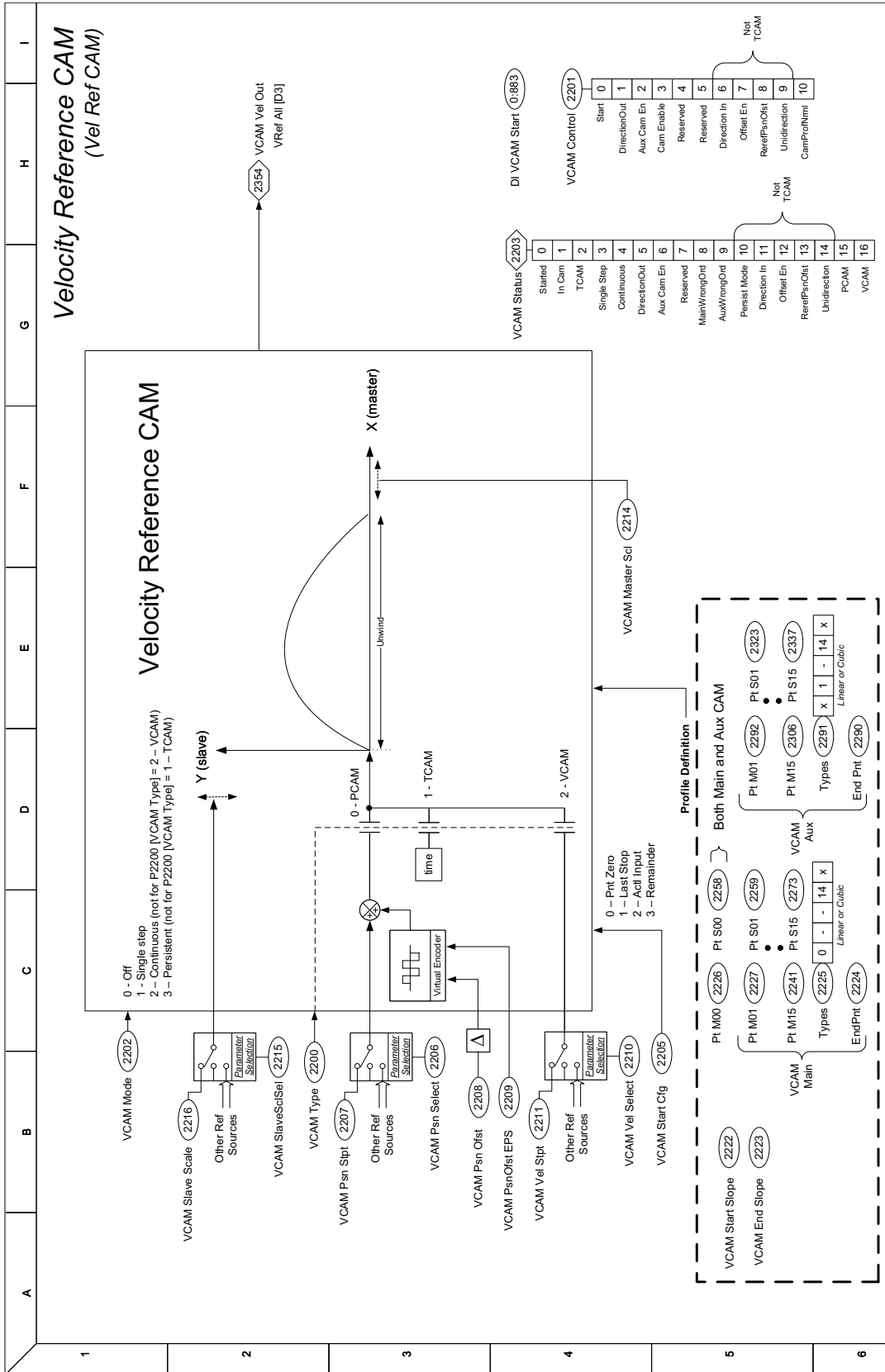

Figure 41 - Velocity Regulator - Flux Vector

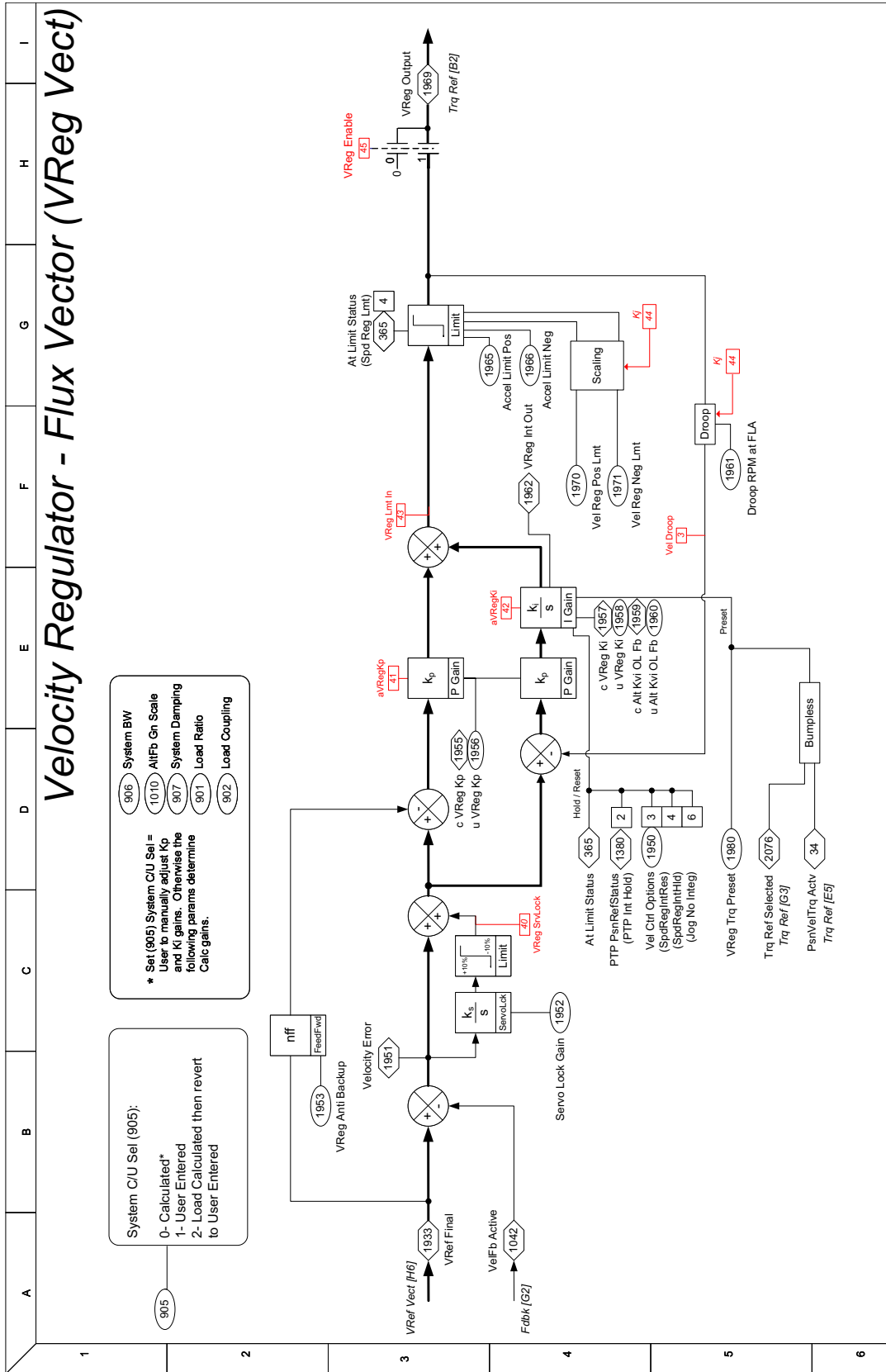

Figure 42 - Torque Overview

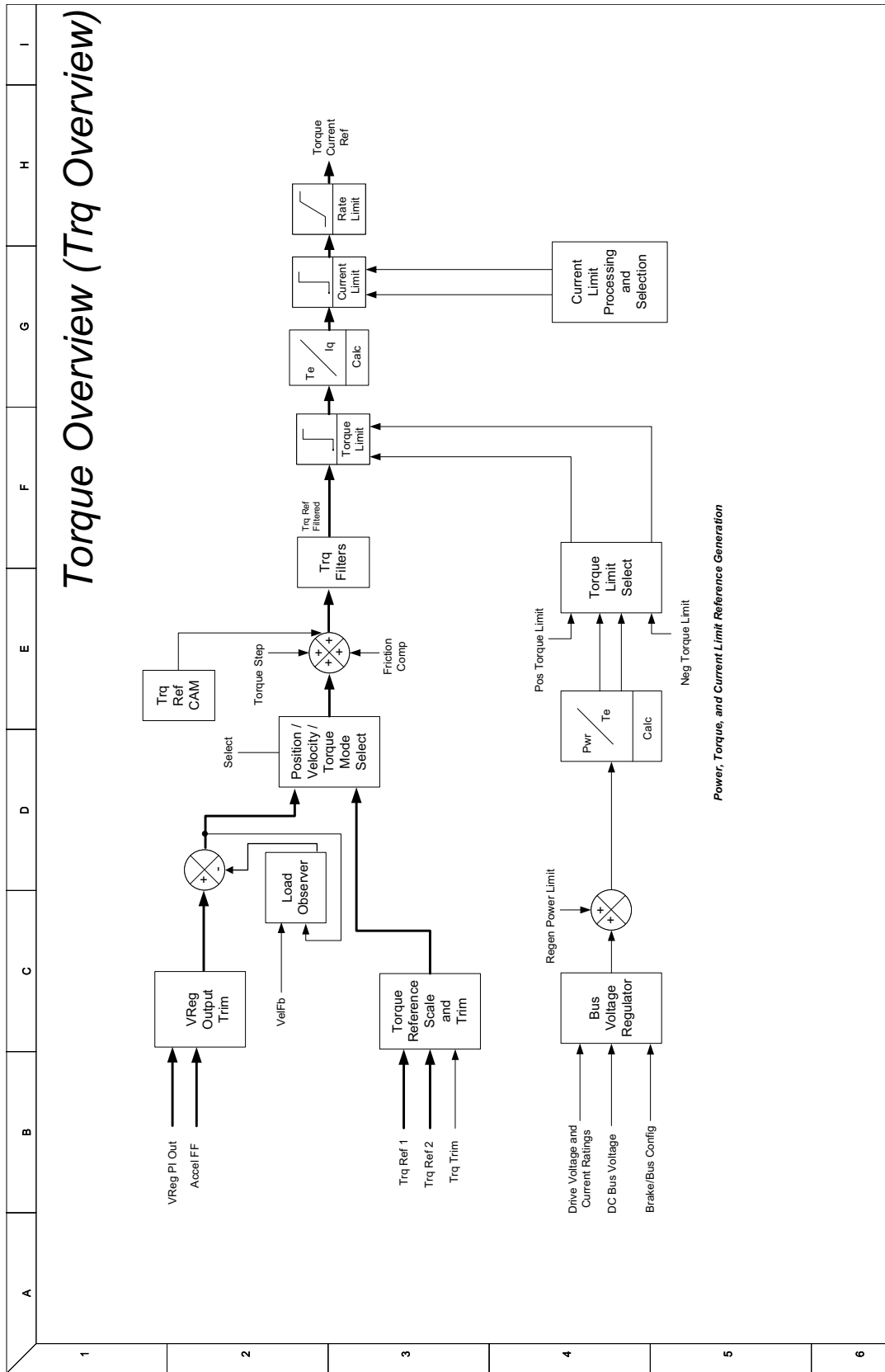

Figure 43 - Torque Reference Selection

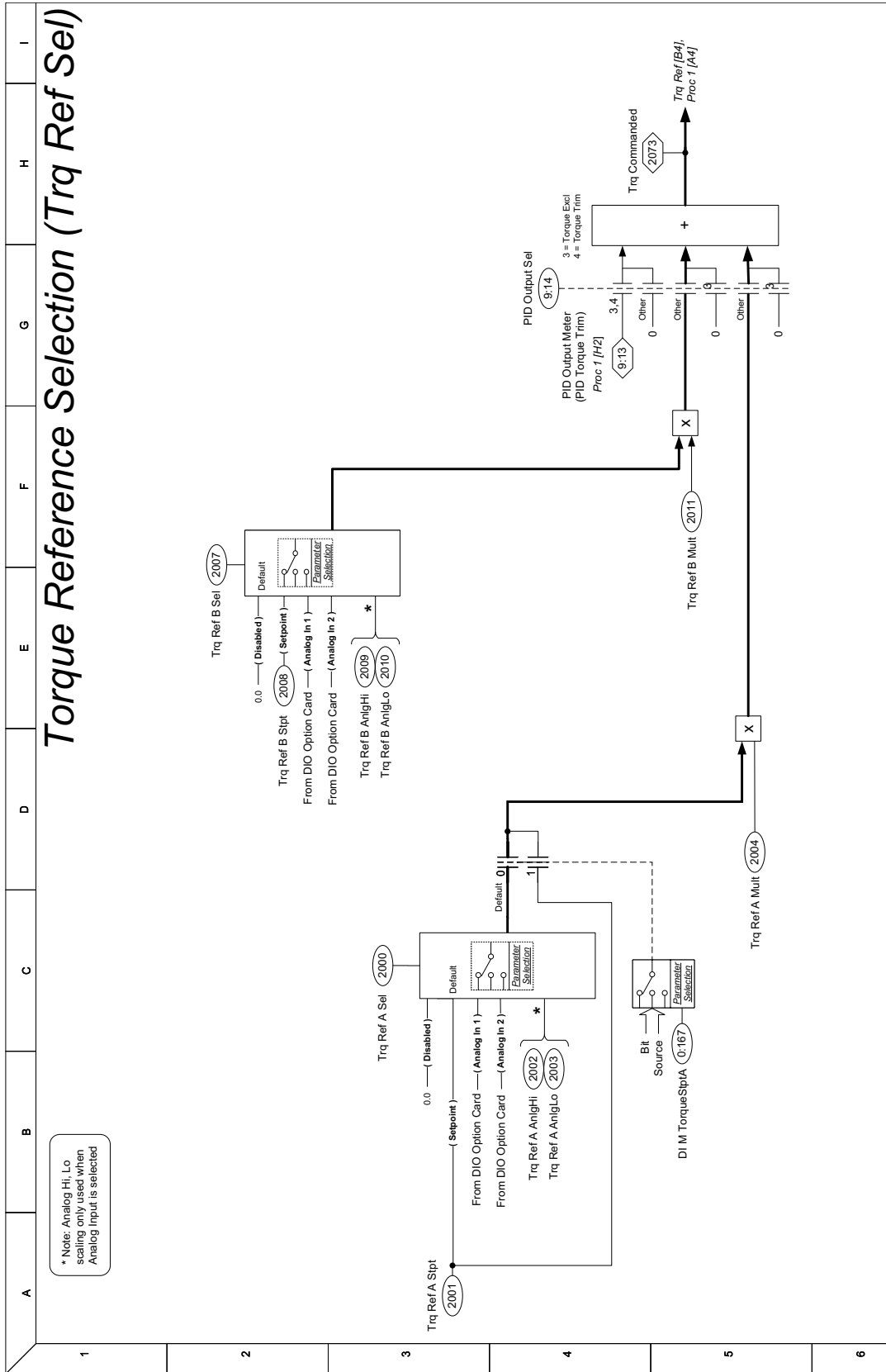



Figure 44 - Load Observer

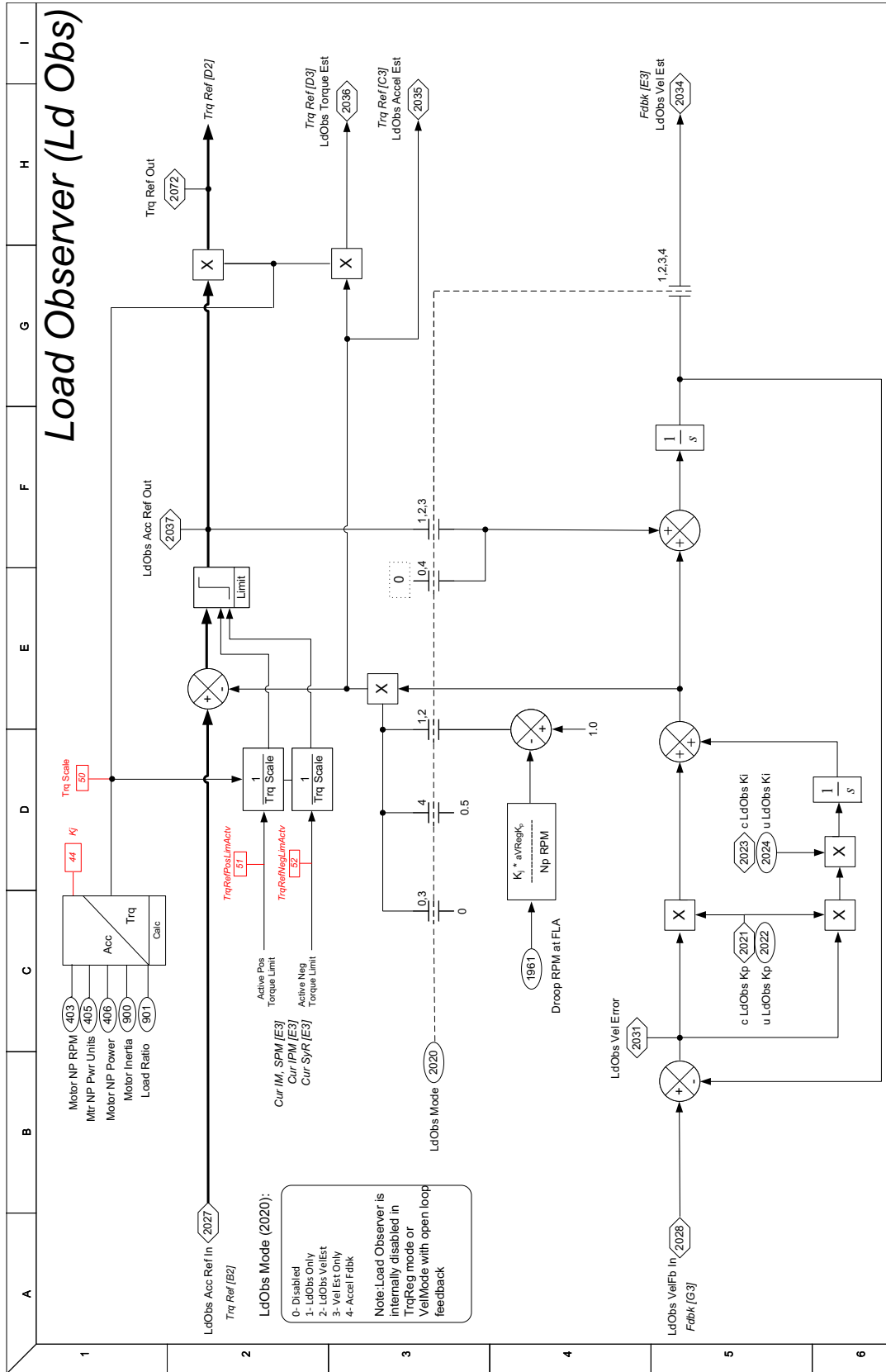

Figure 45 - Friction Compensation

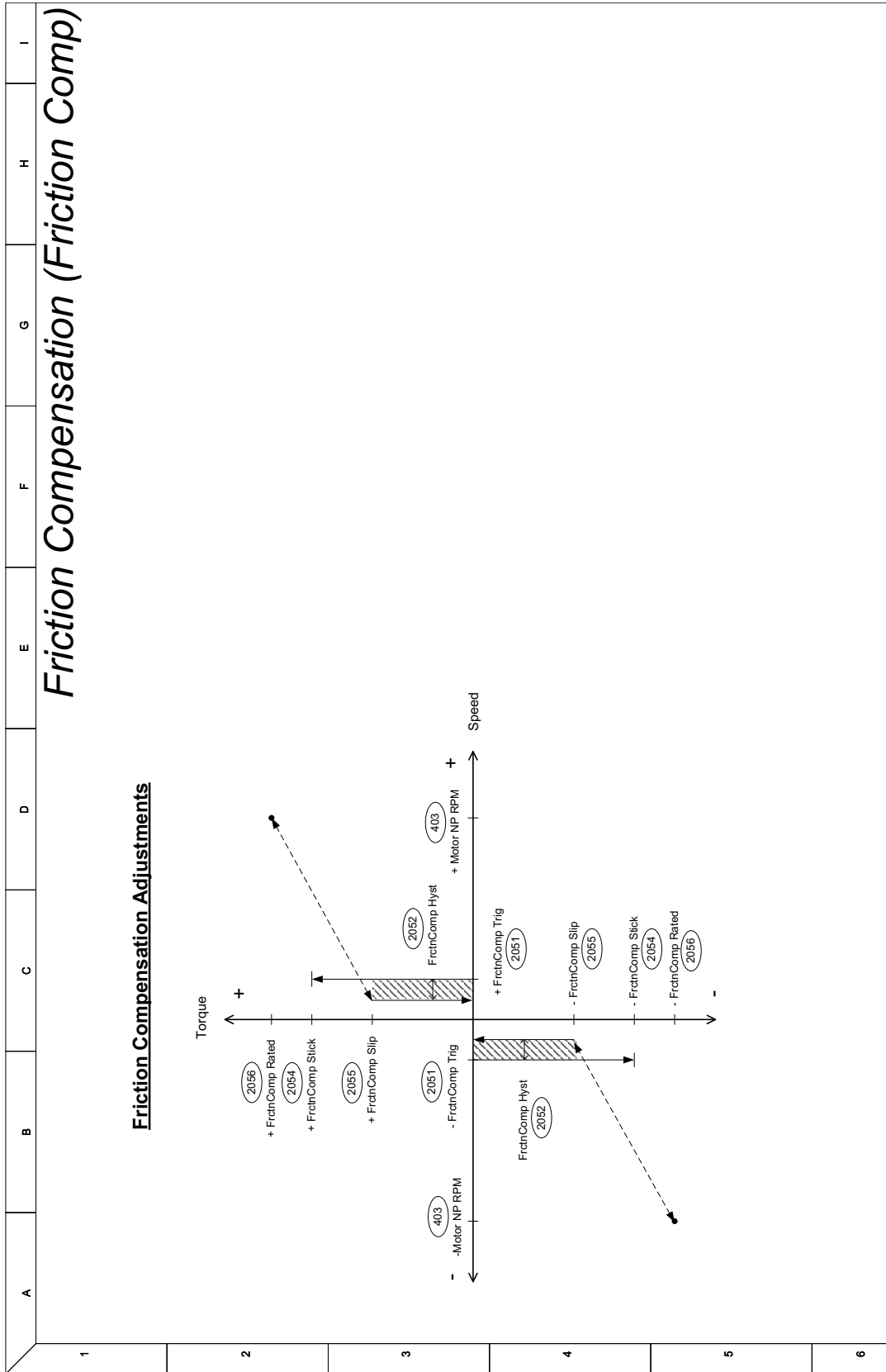

Figure 46 - Torque Reference CAM

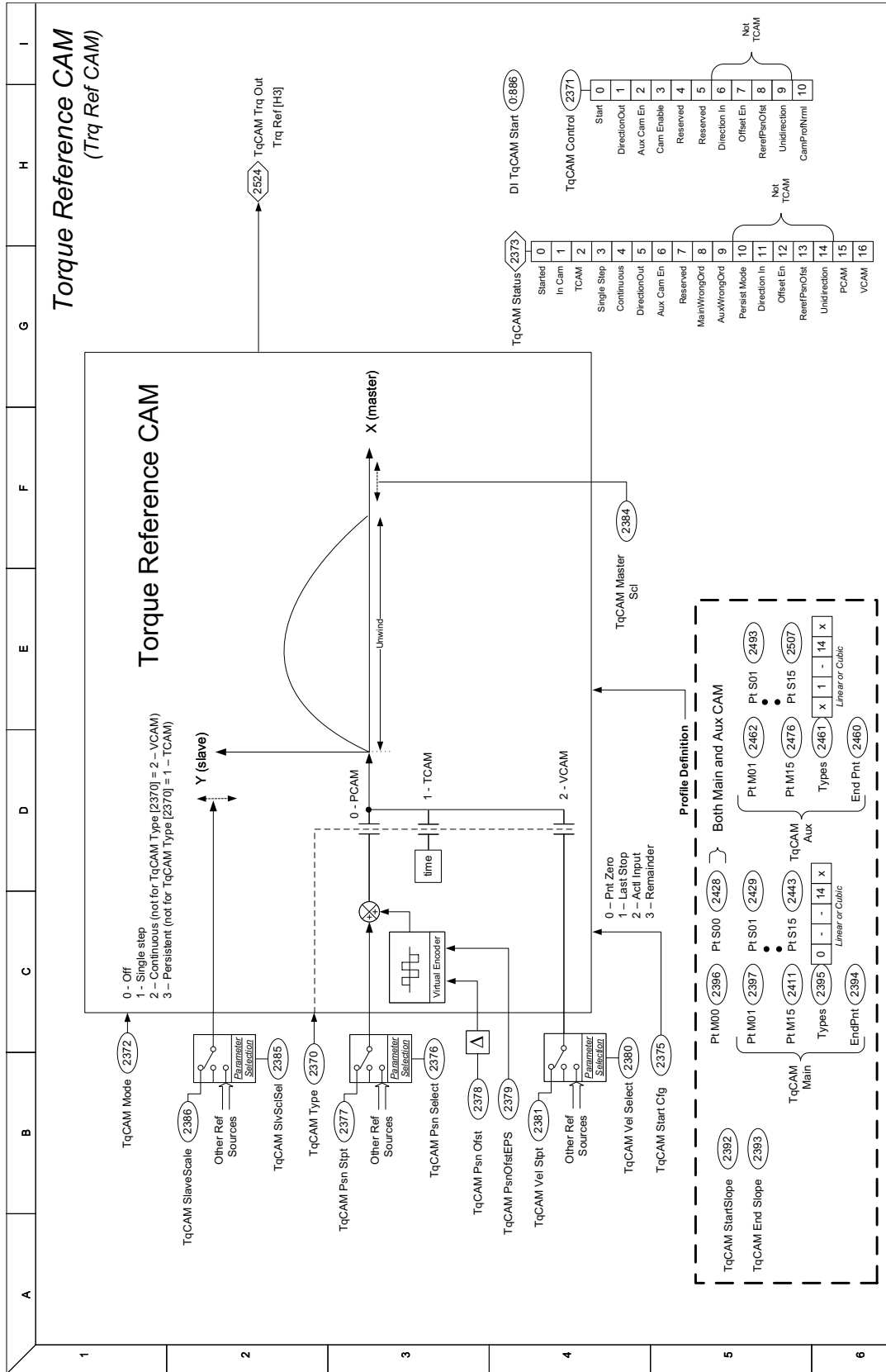

Figure 47 - Torque Reference

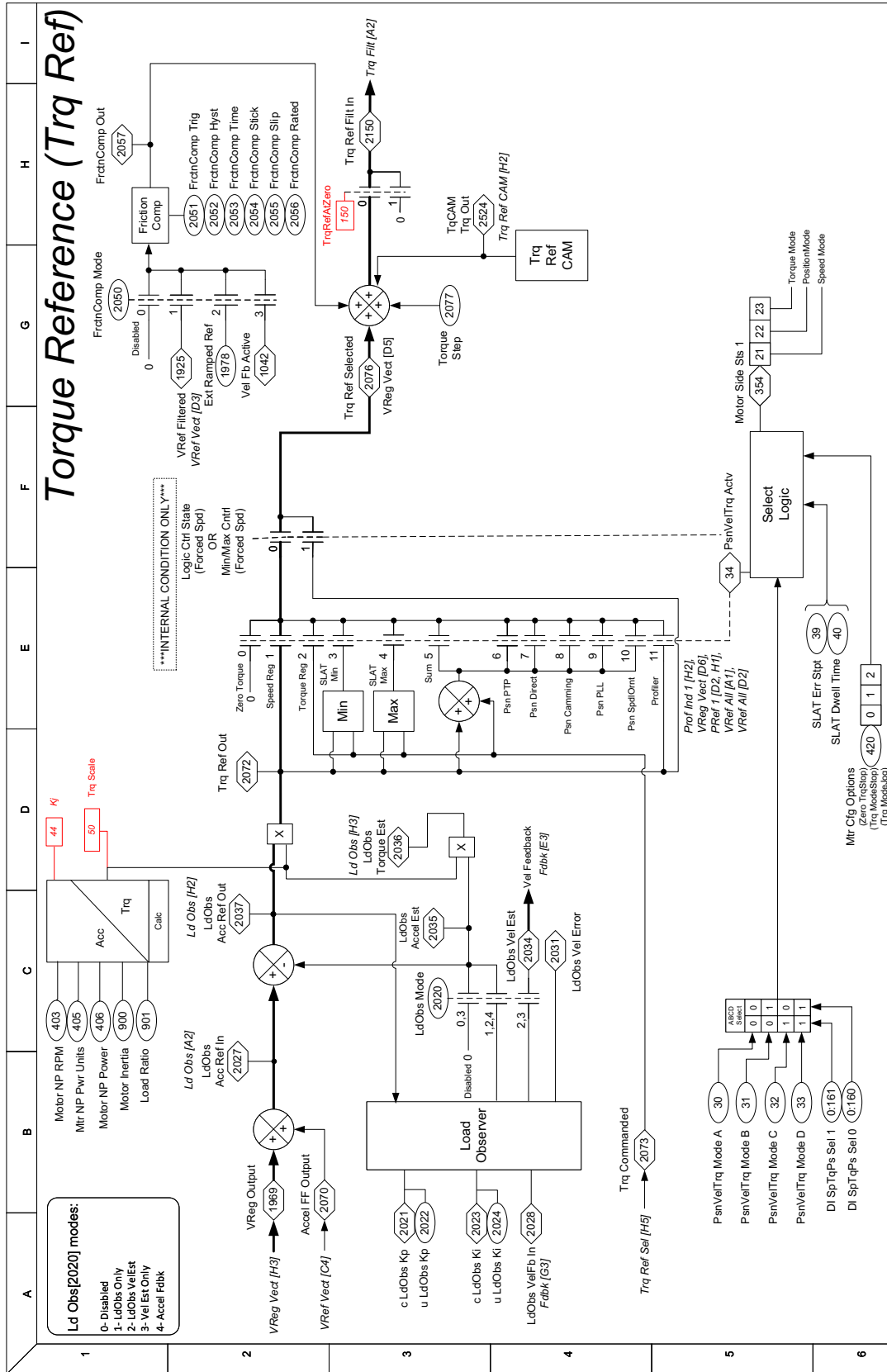

Figure 48 - Torque Filters

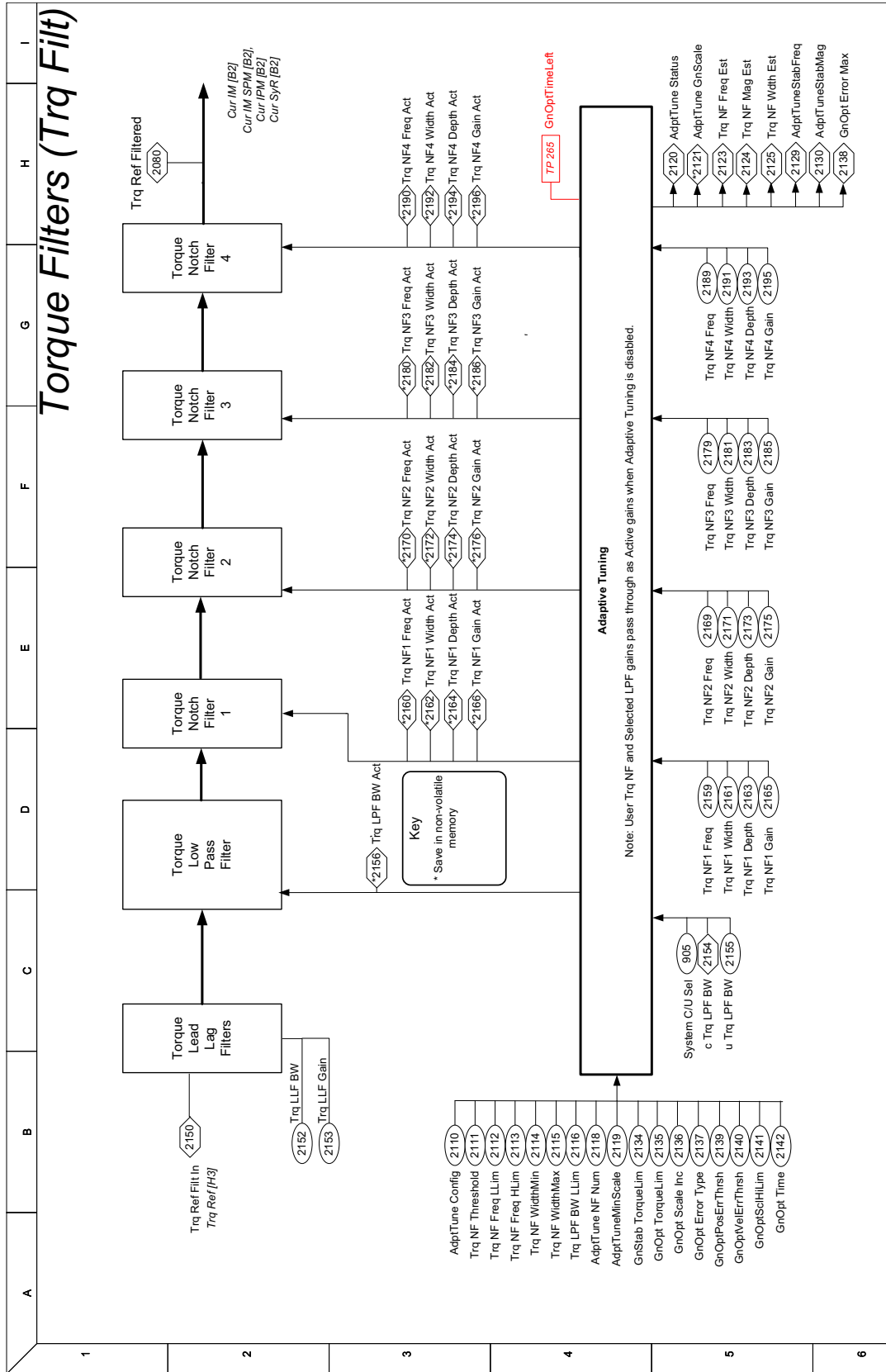

Figure 49 - Torque Control - Current, for Induction Motor

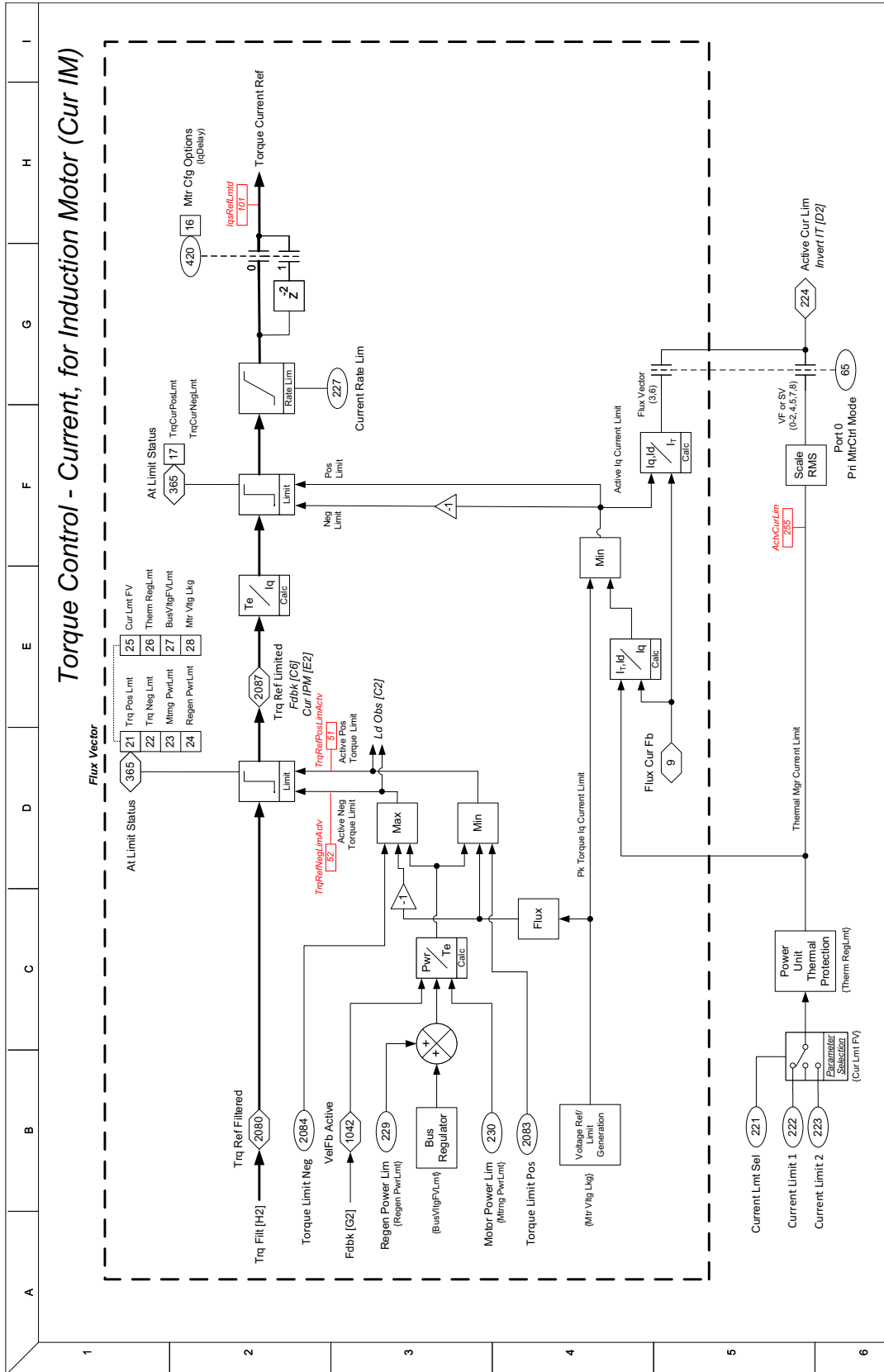

Figure 50 - Torque Control - Current, for Permanent Magnet Motor

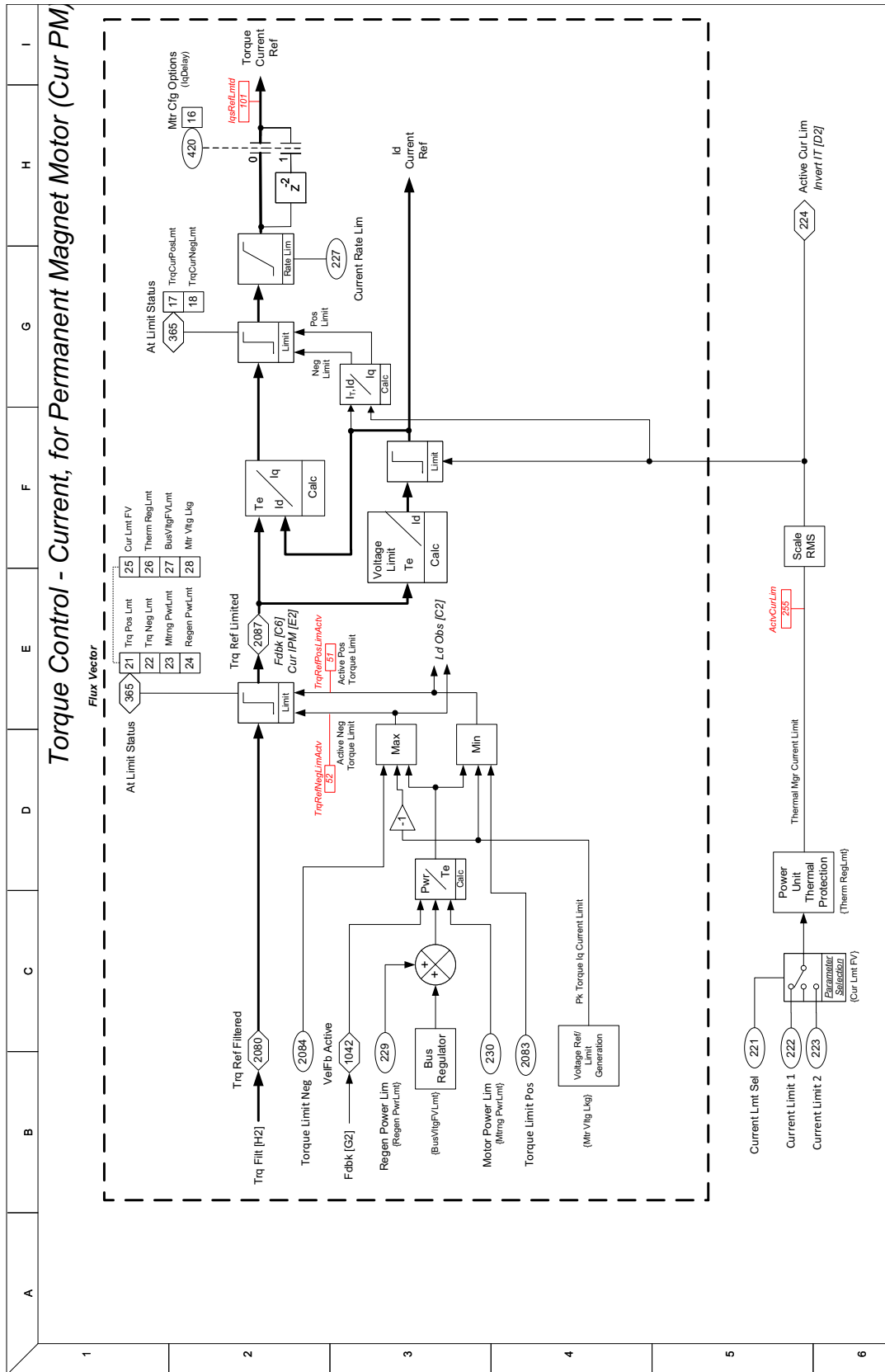

Figure 51 - Torque Control - Current, for Synchronous Reluctance Motor

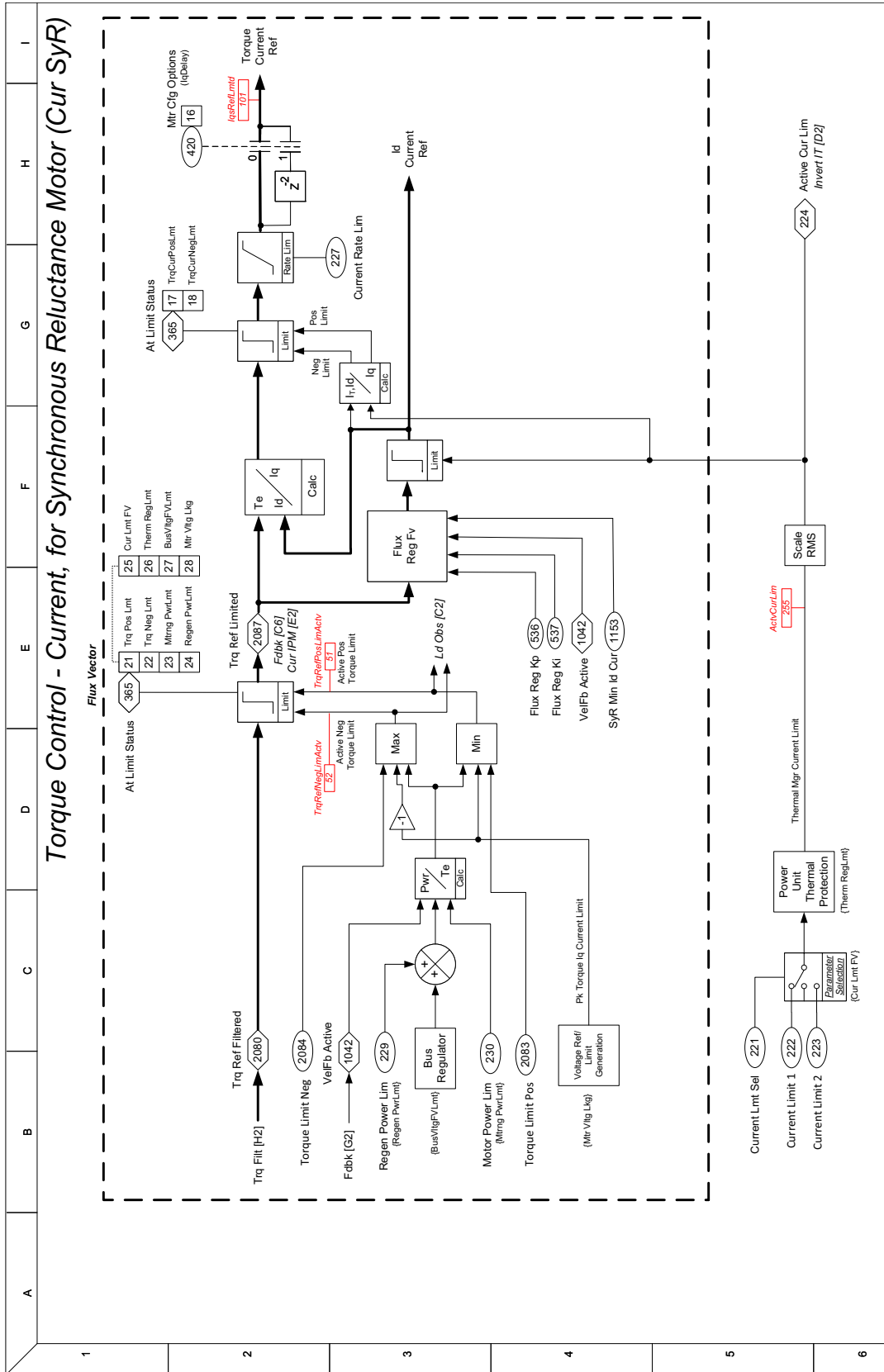



Figure 52 - Process Control 1

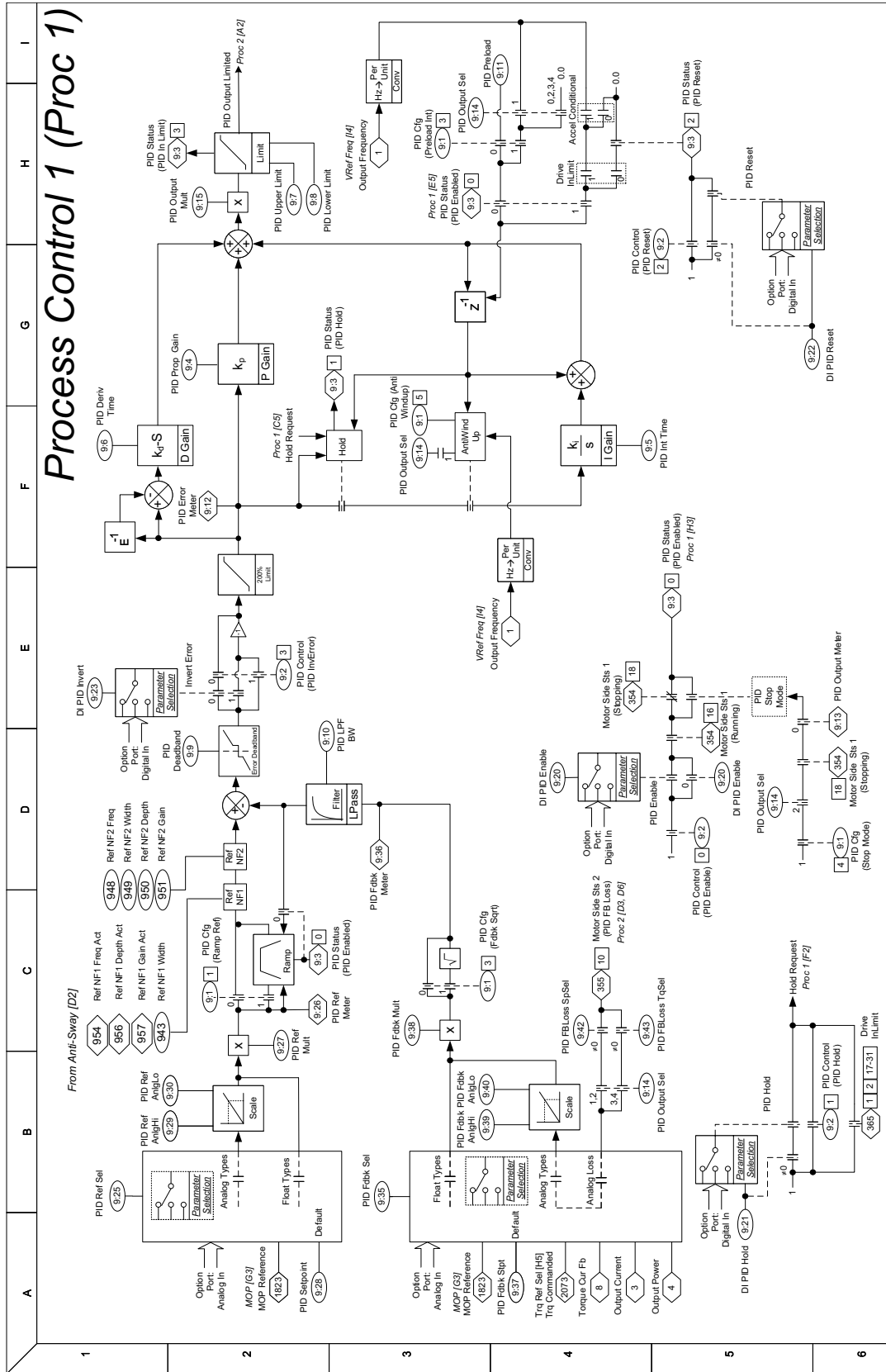

Figure 53 - Process Control 2

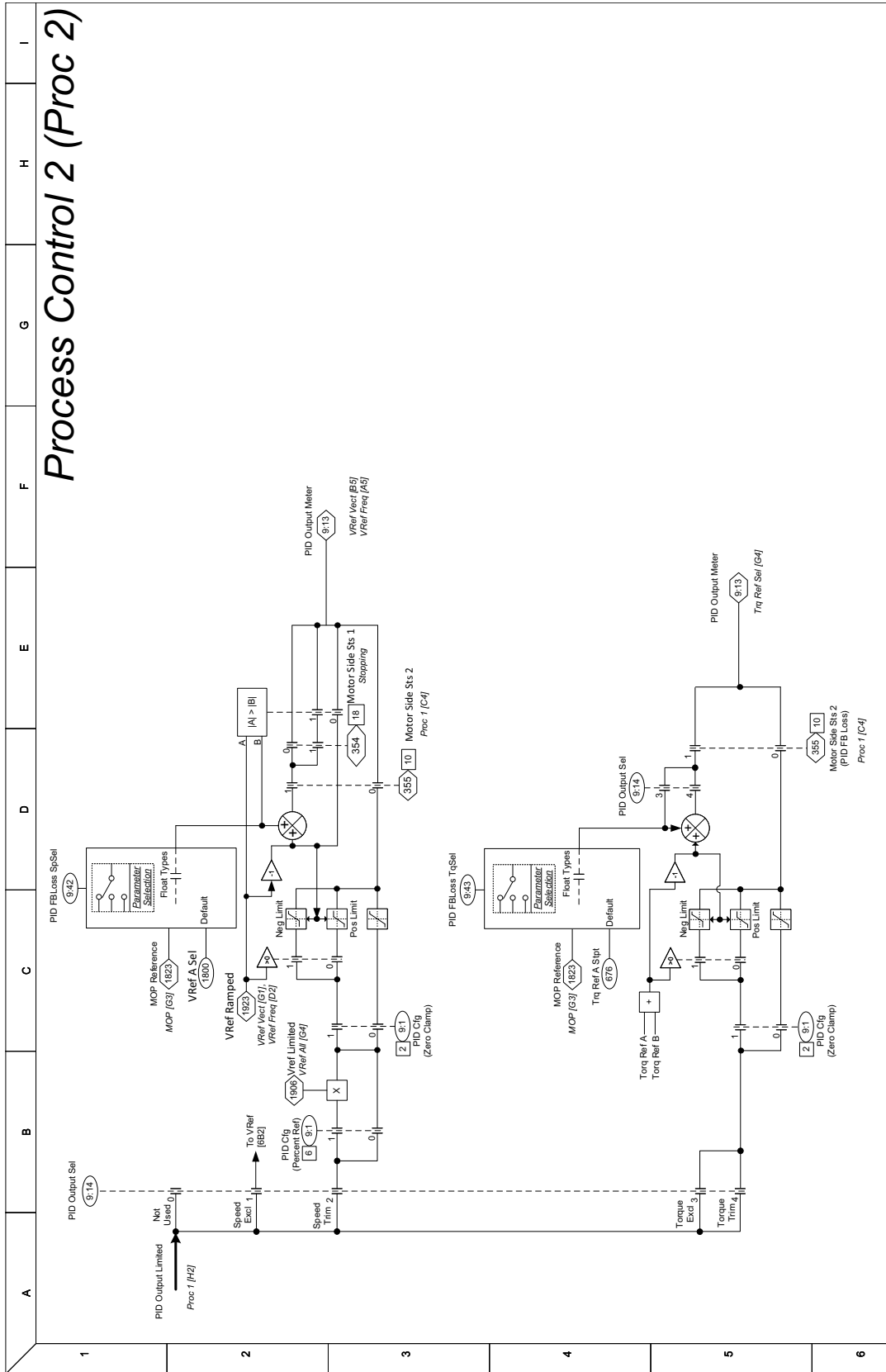

Figure 54 - Reference Notch Filter 1 for Crane Application

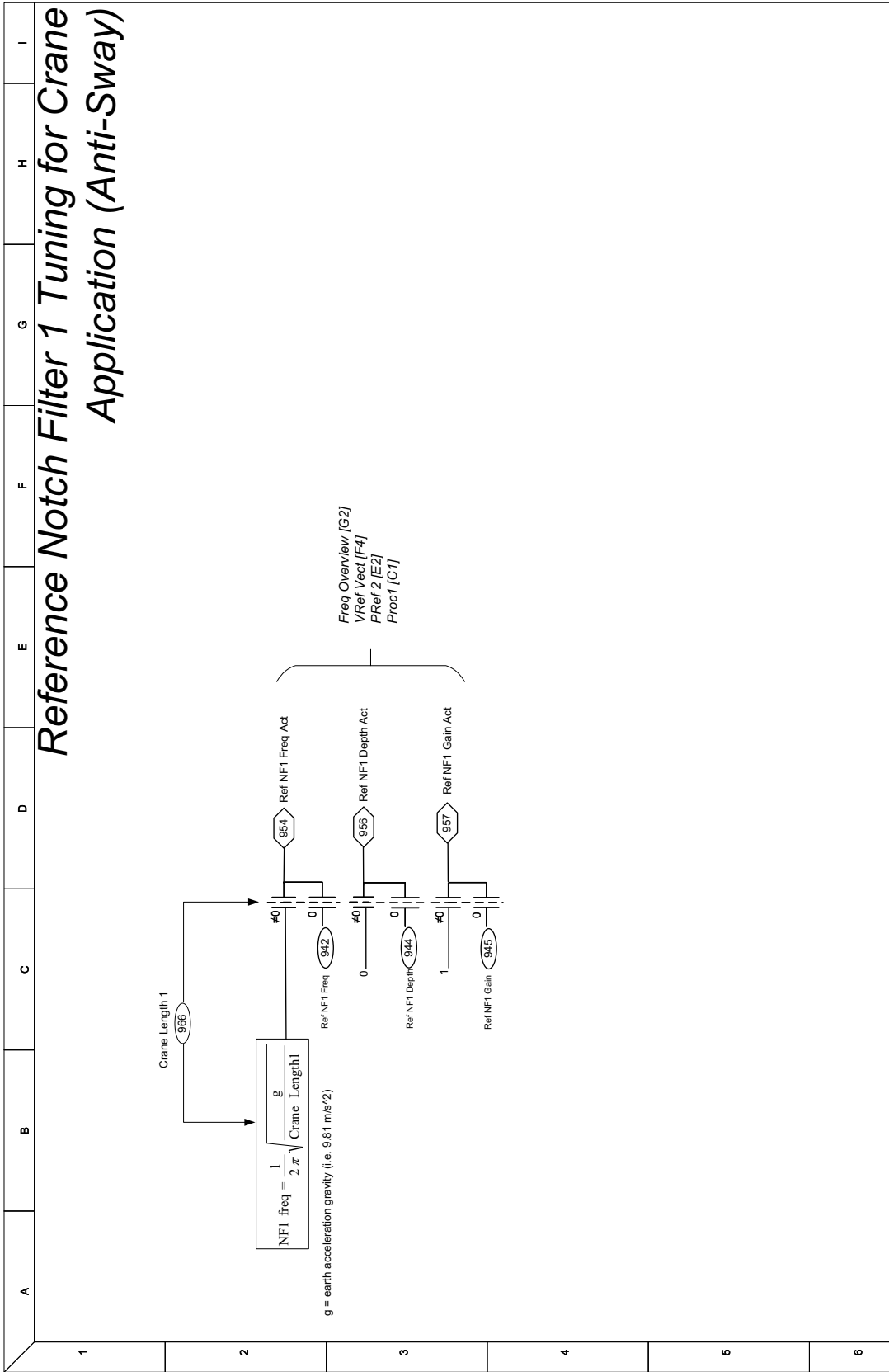

Figure 55 - Pump Jack and Progressive Cavity Pump

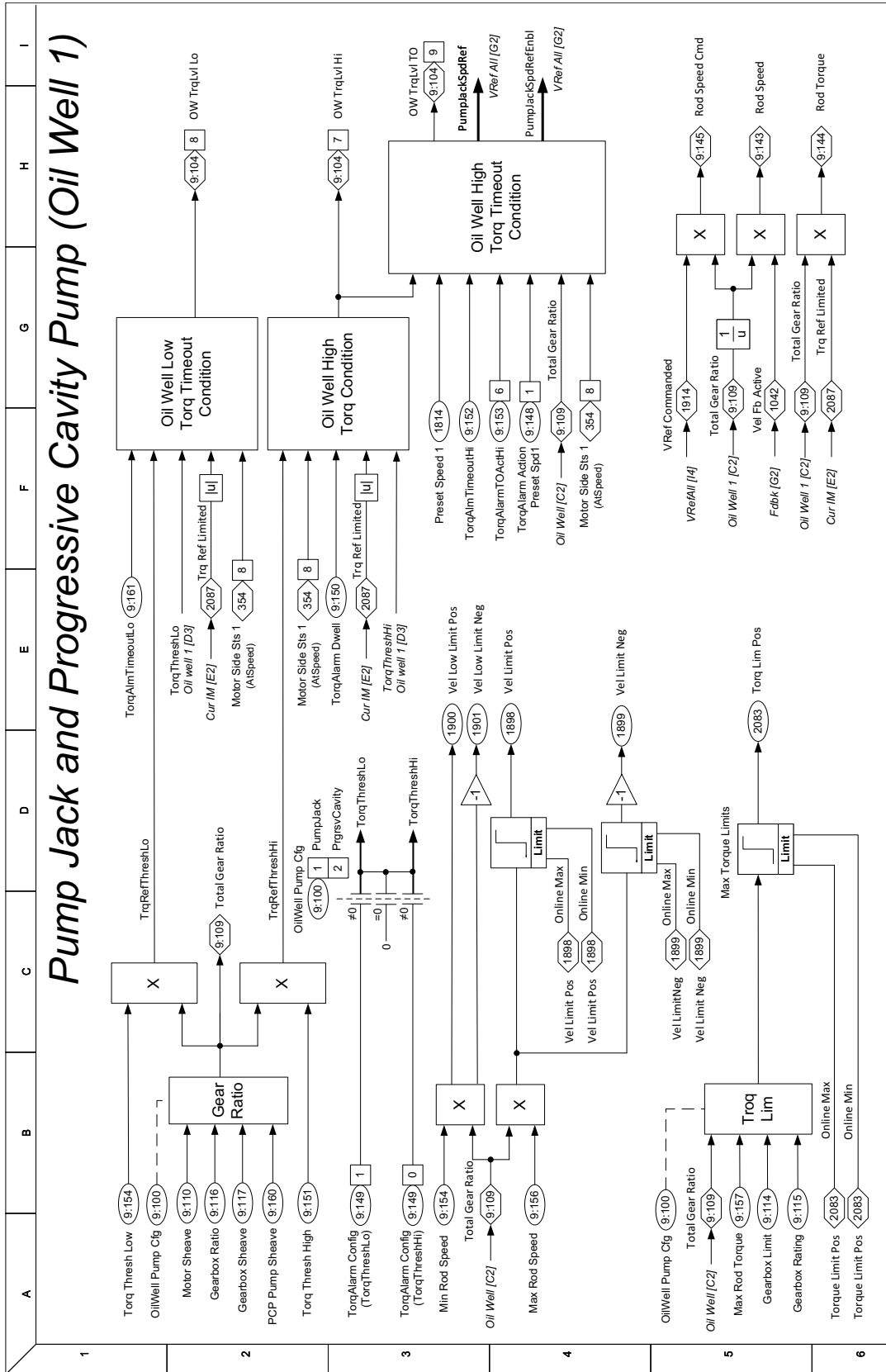

Figure 56 - Pump Off

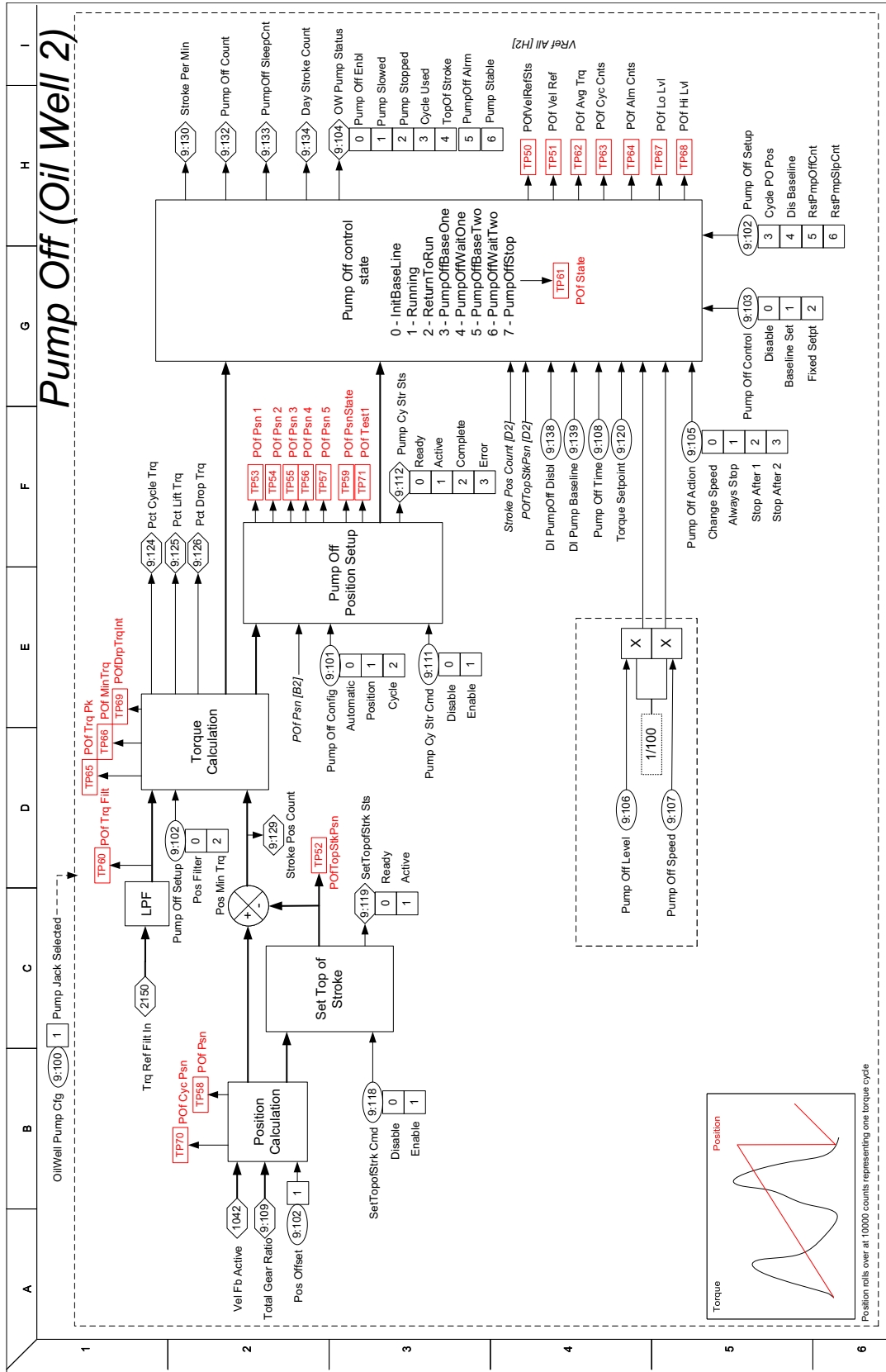

Figure 57 - MOP Control

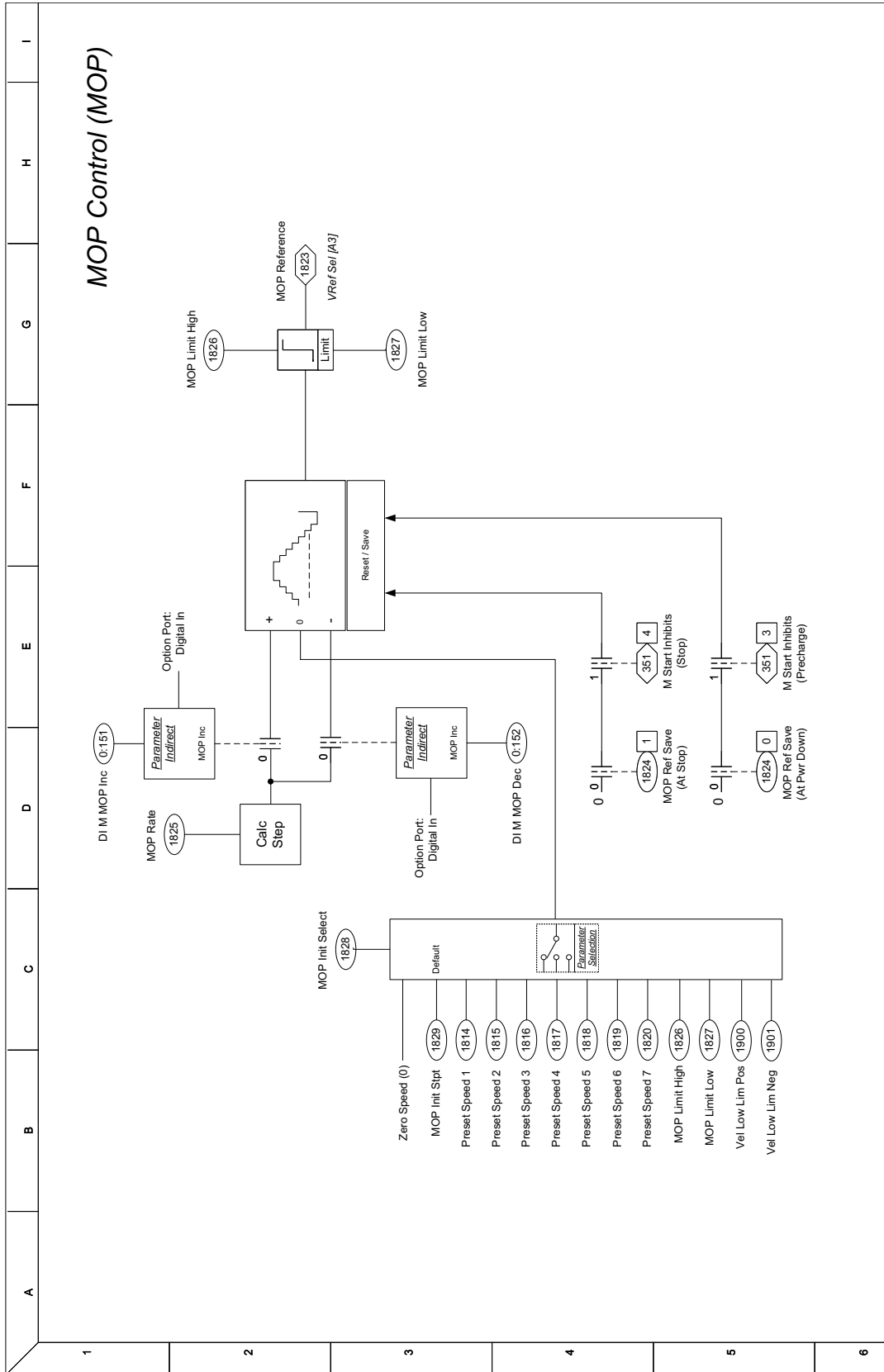

Figure 58 - 22-Series Inputs & Outputs - Digital

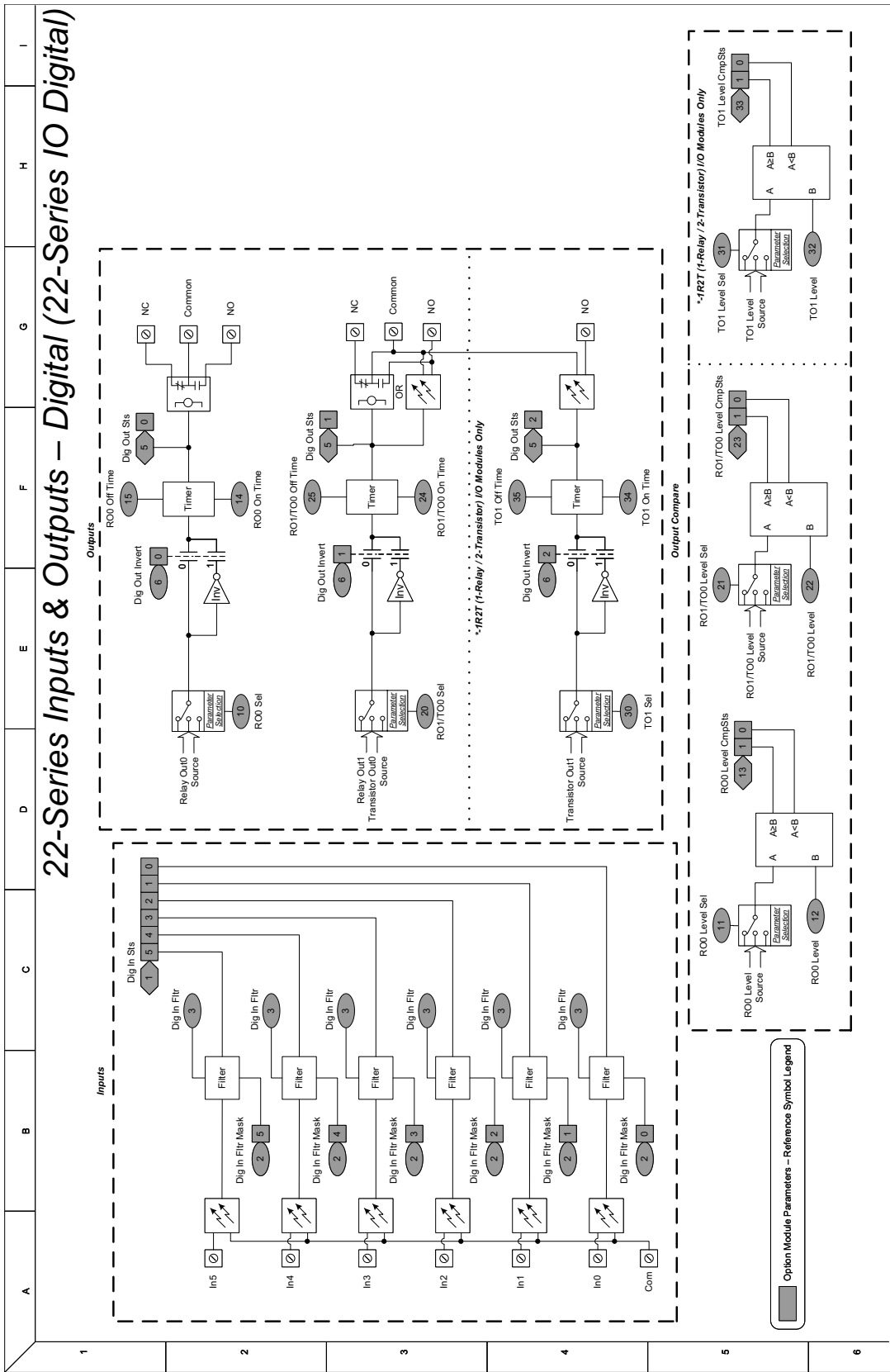

Figure 59 – 22-Series Inputs & Outputs – Analog

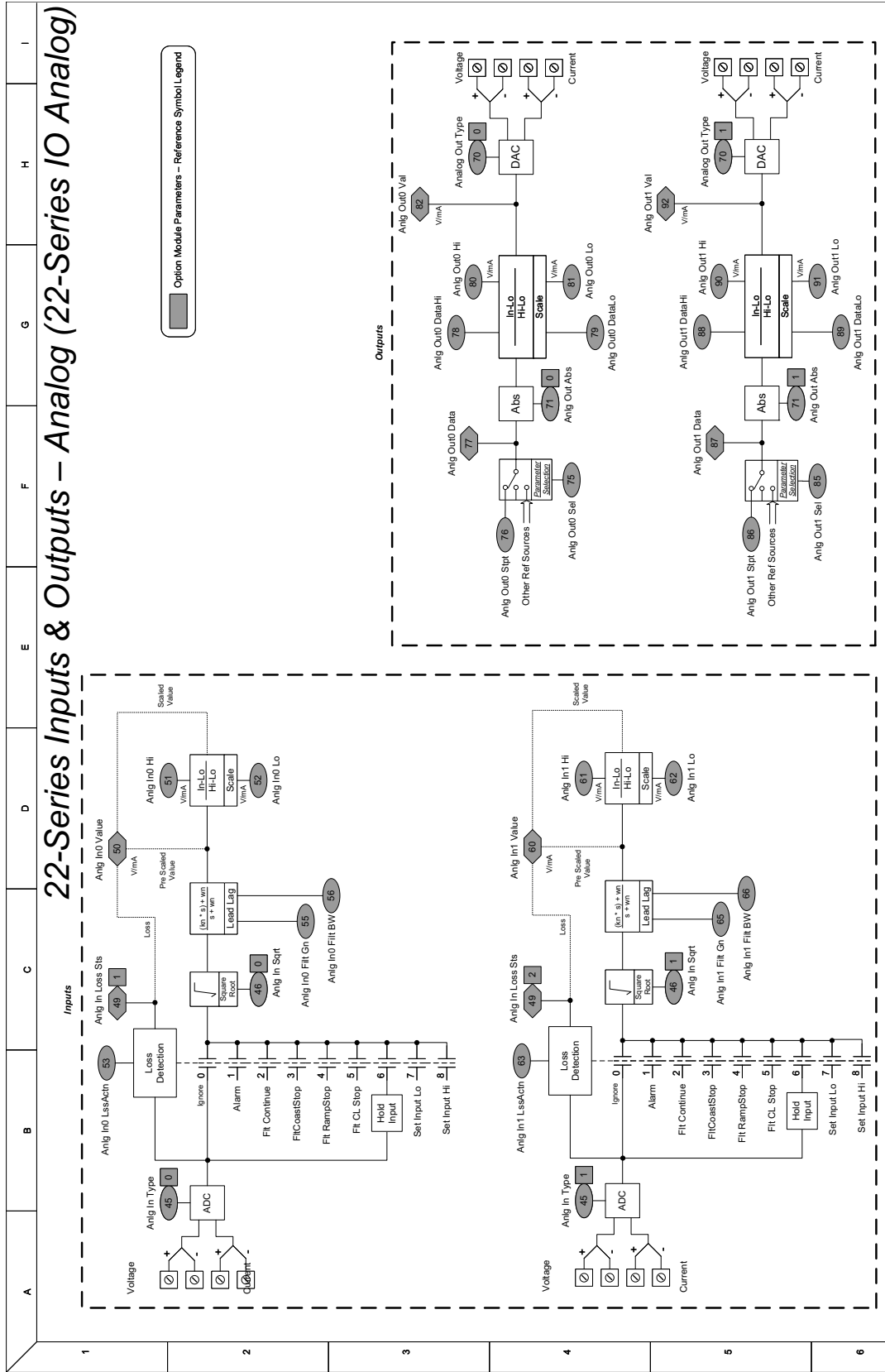



Figure 60 - 11-Series Inputs & Outputs - Digital

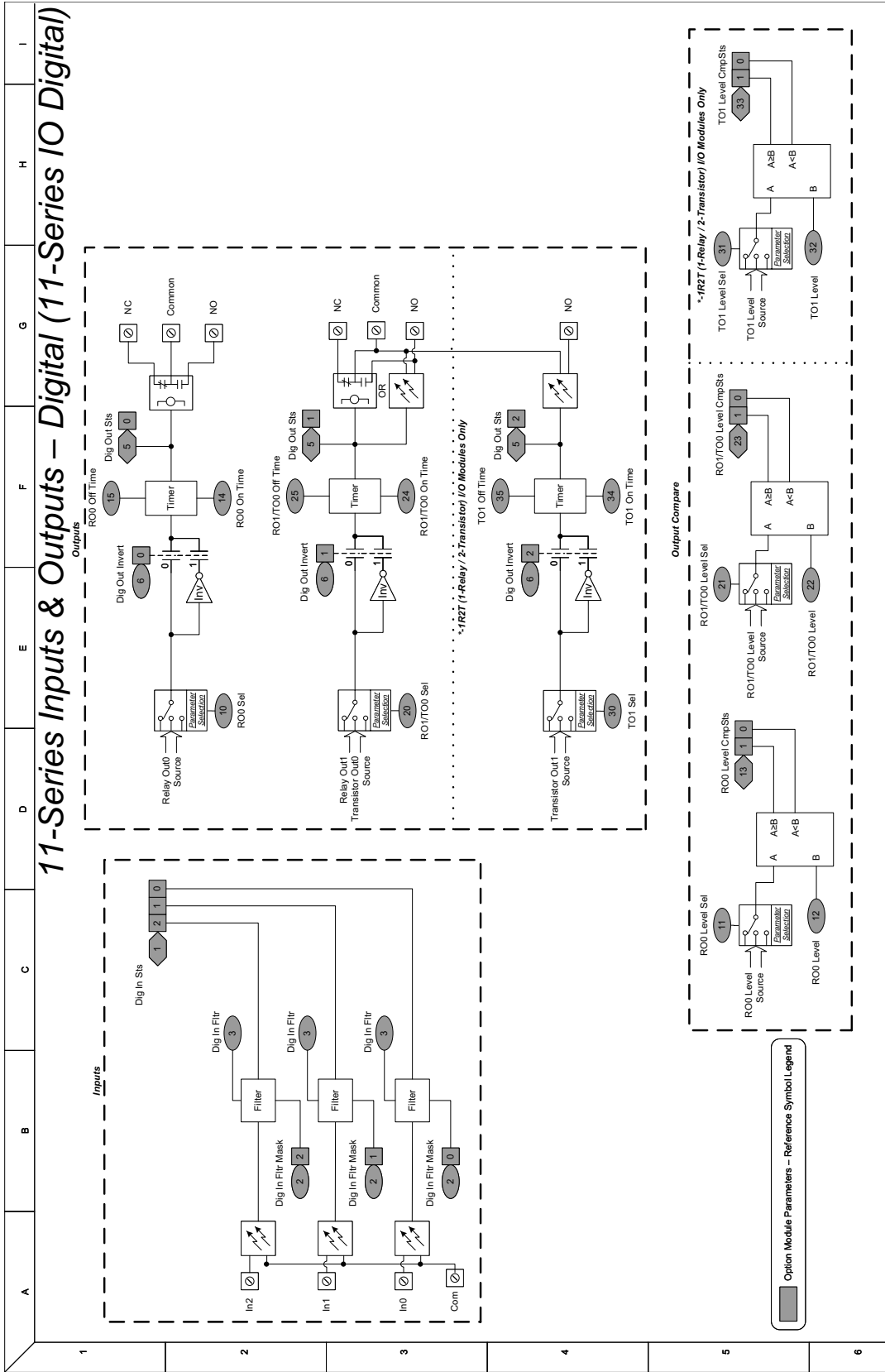

Figure 61 - 11-Series Inputs & Outputs - Analog

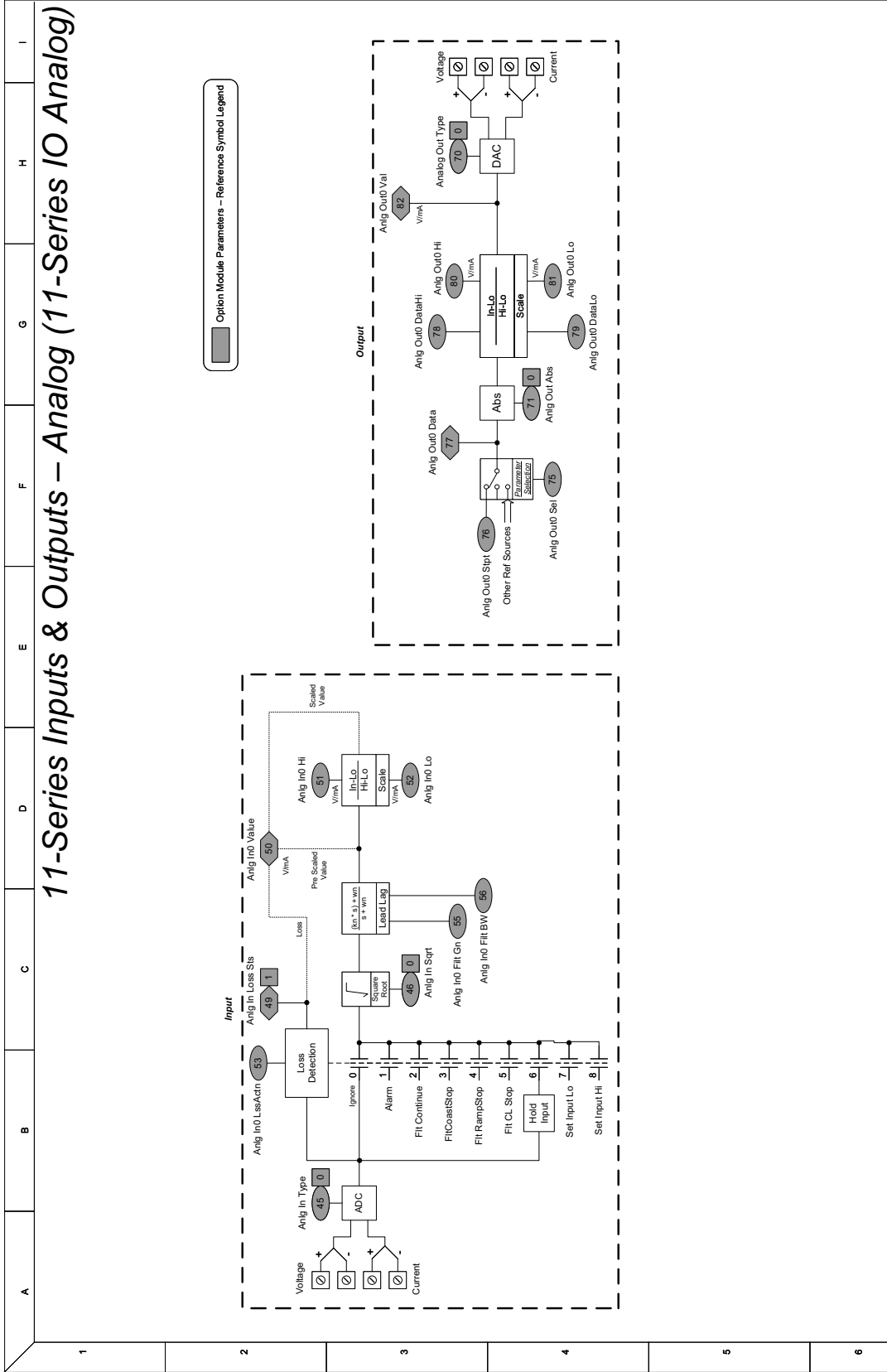

Figure 62 - 11-Series Inputs & Outputs - ATEX

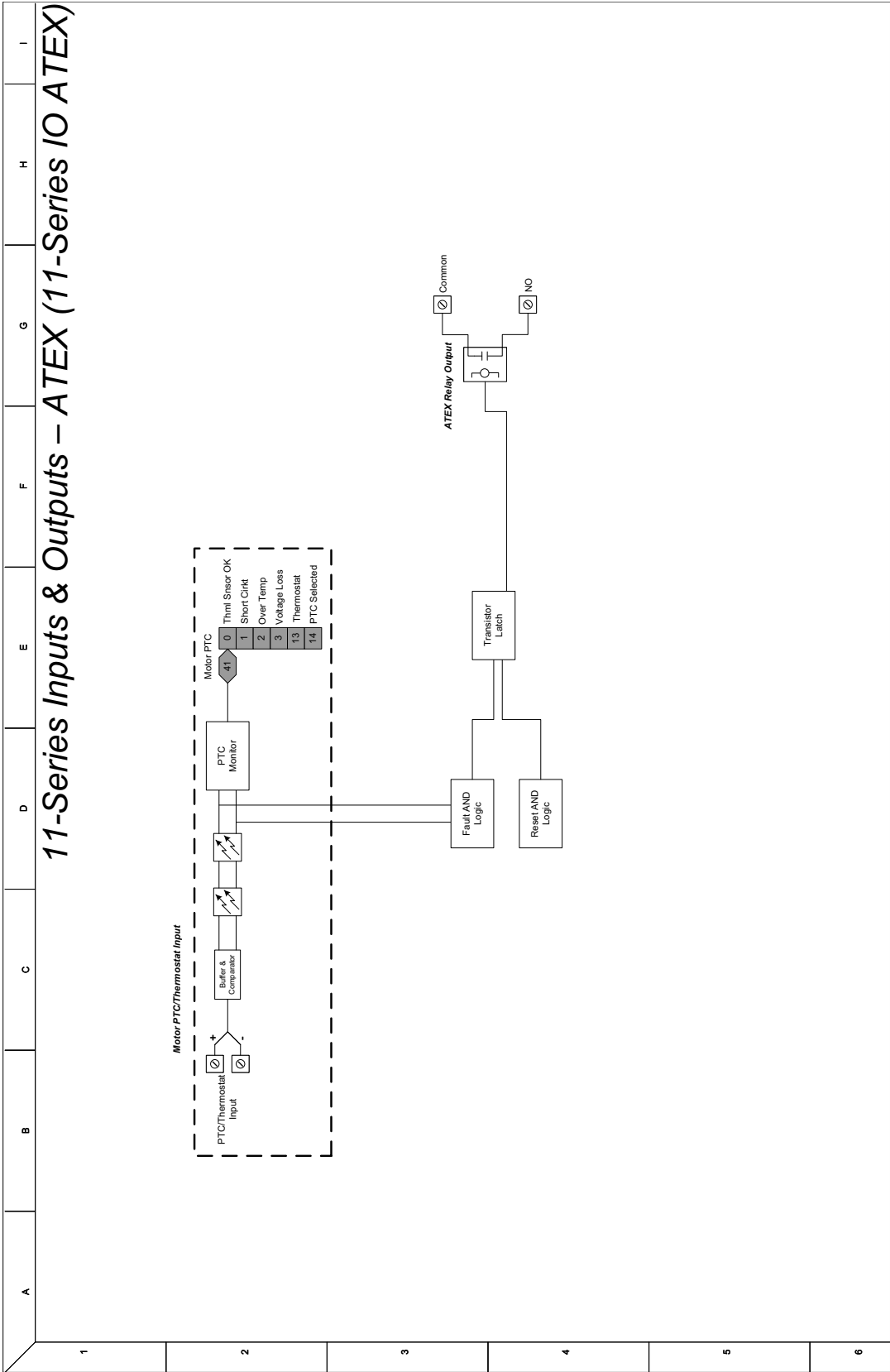

Figure 63 - Control Logic

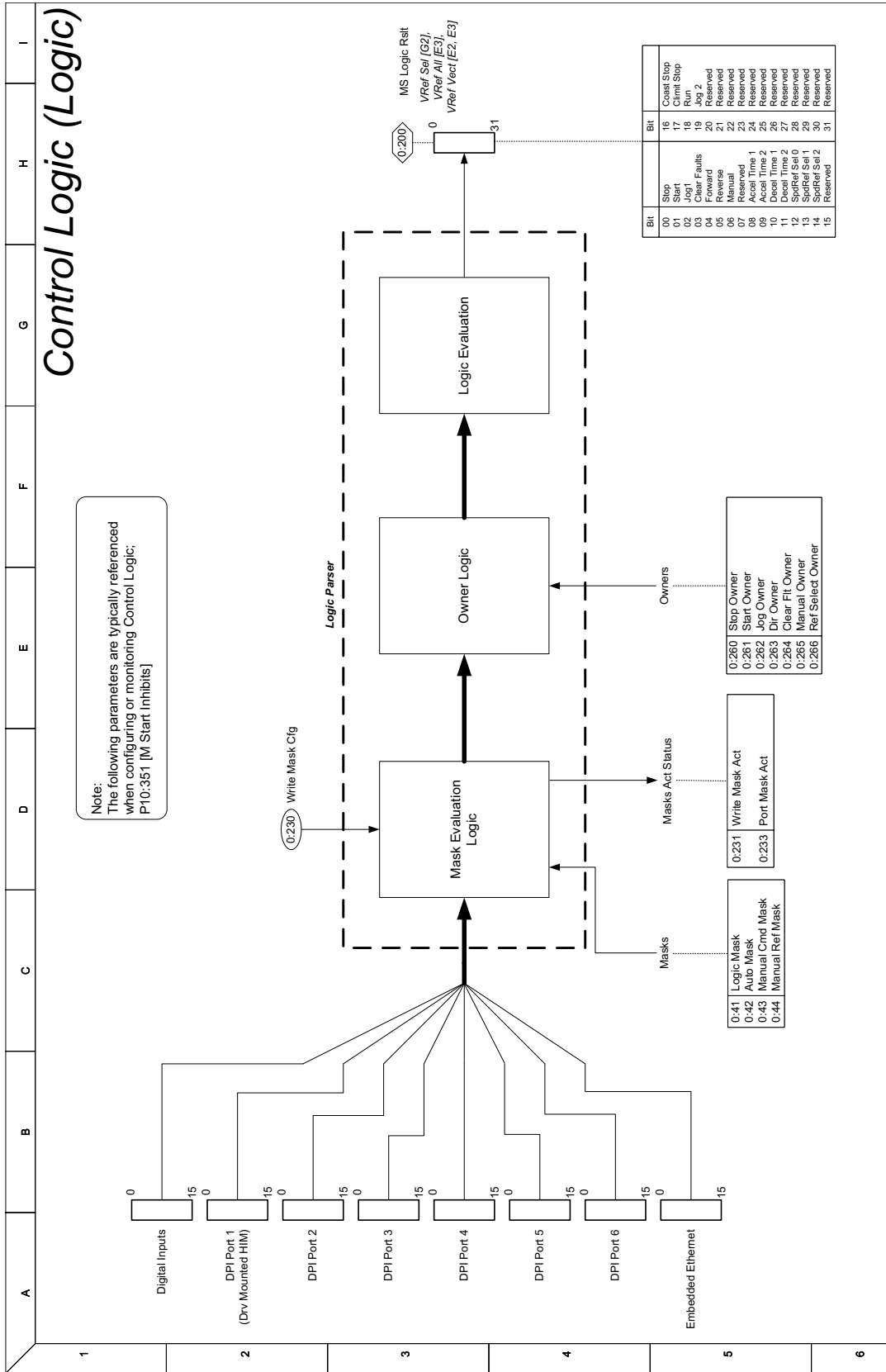

Figure 64 - Inverter Overload IT

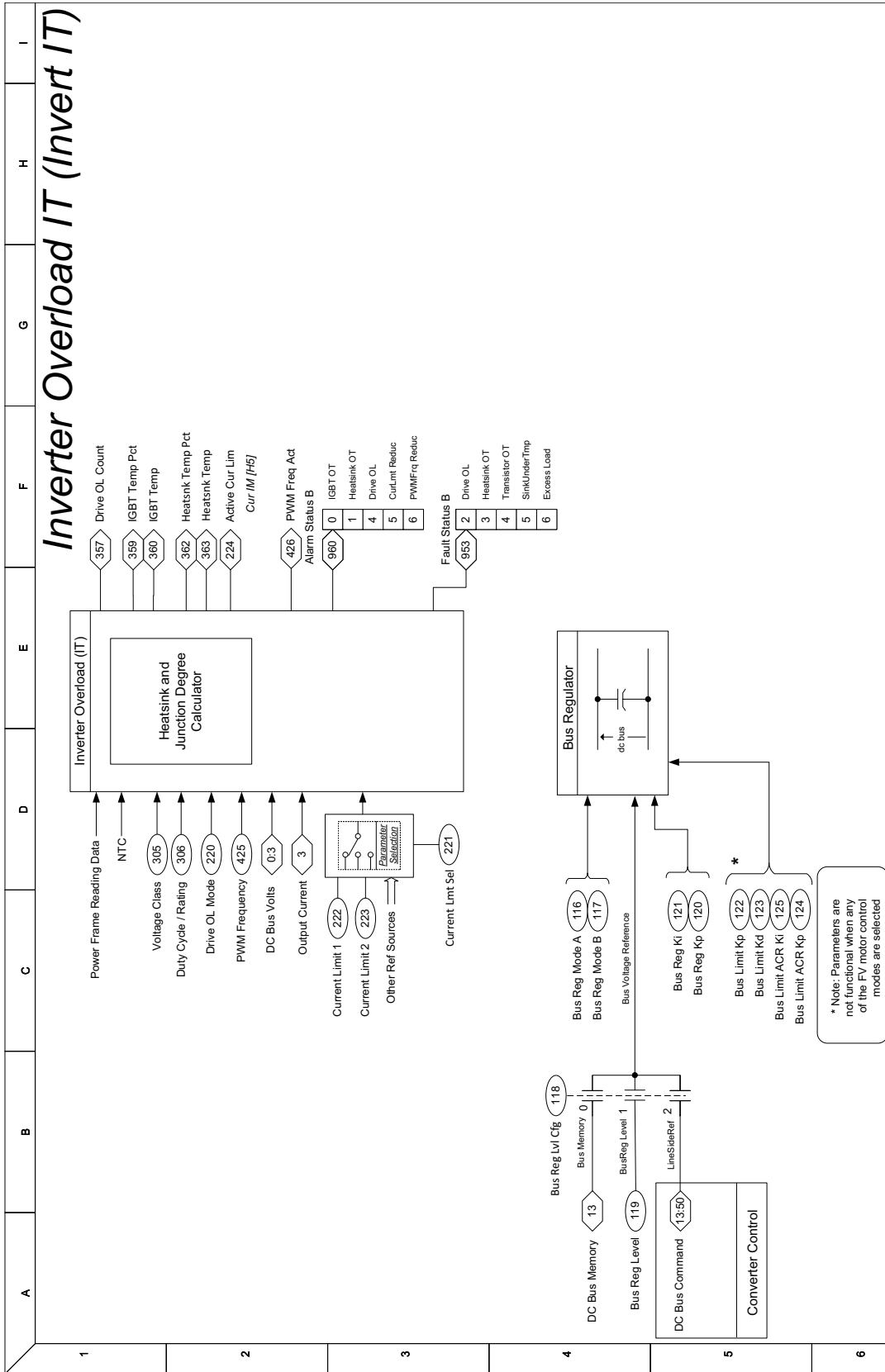

Figure 65 - Motor Overload

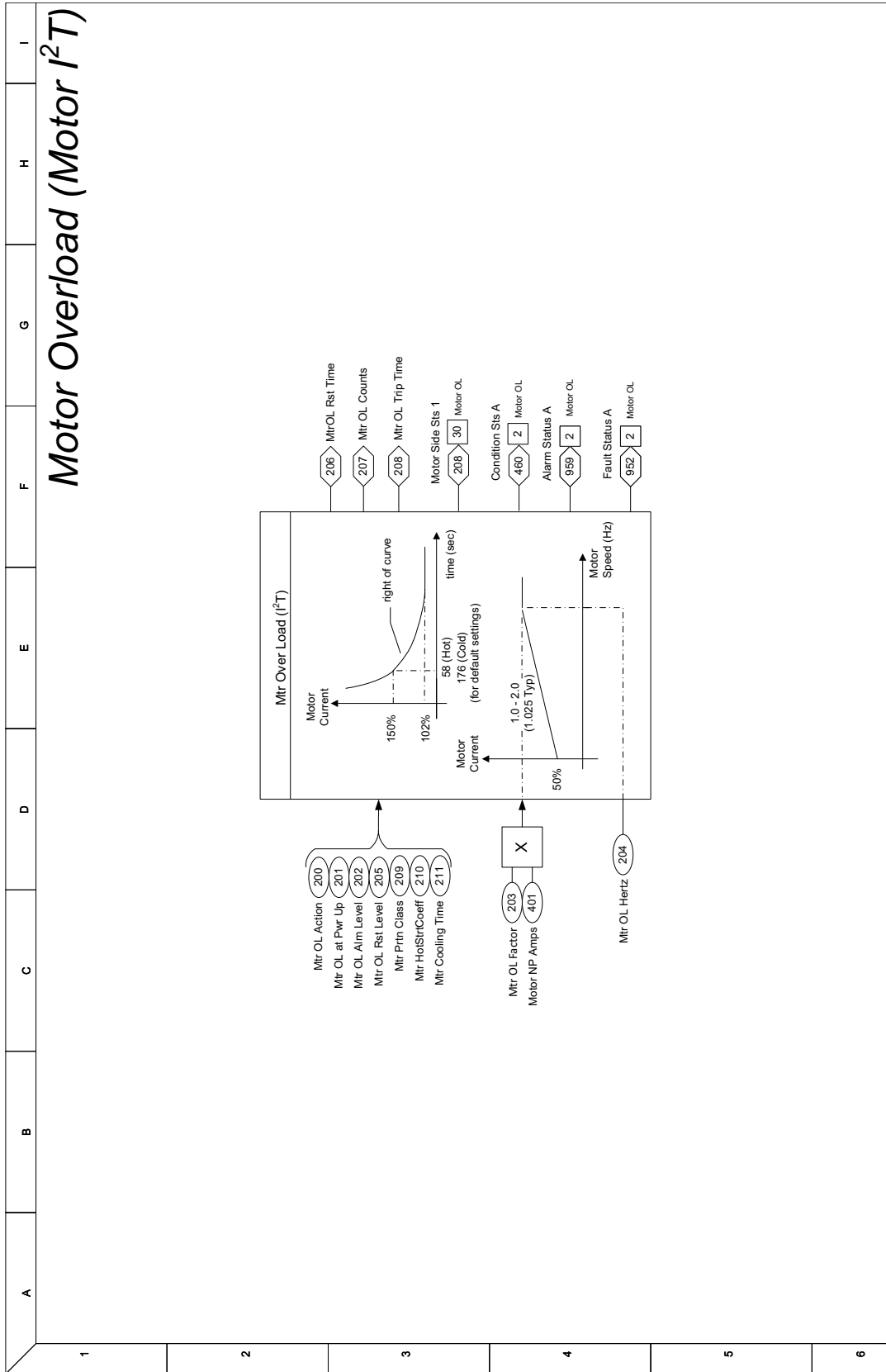
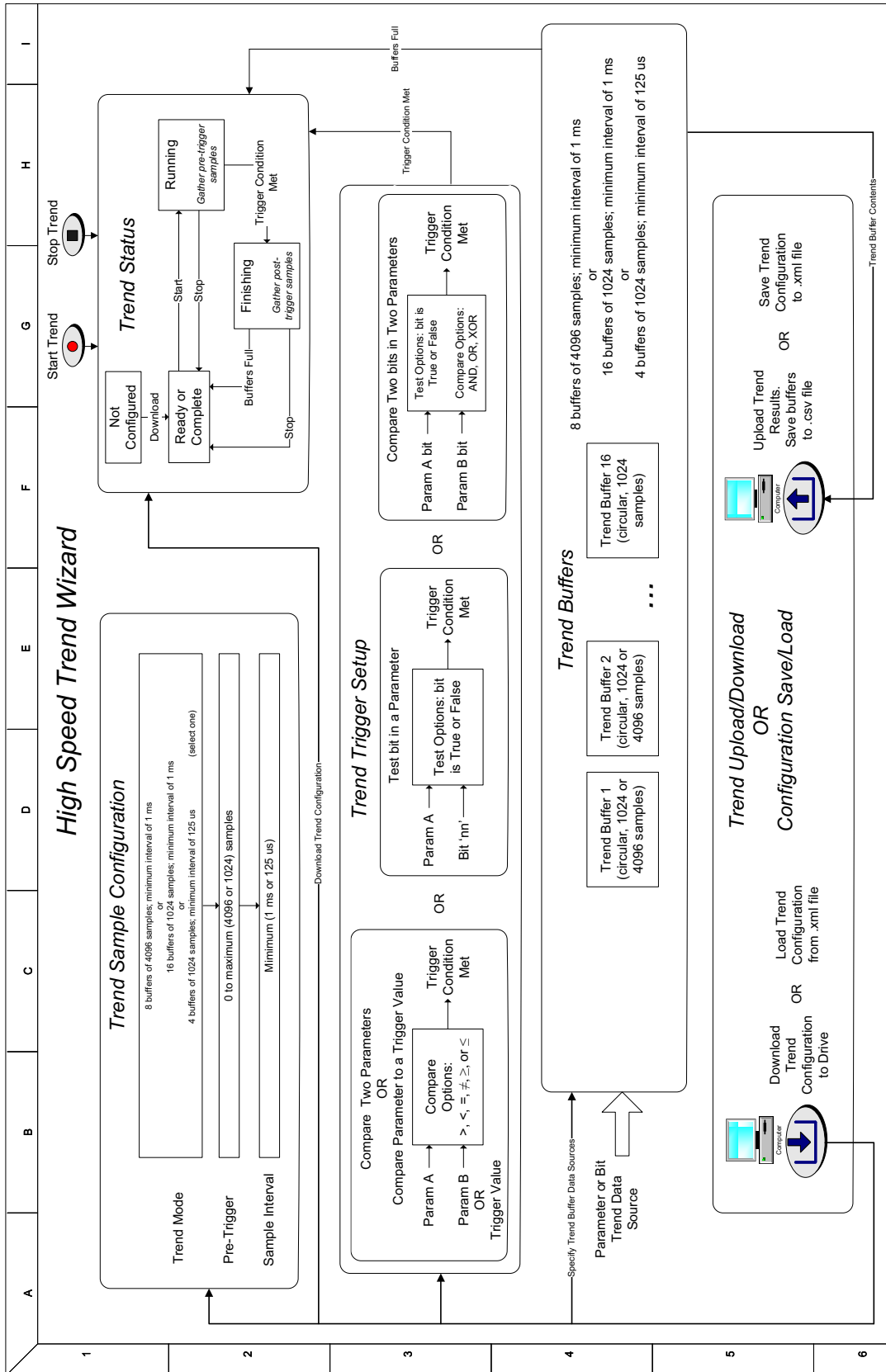

Figure 66 - High Speed Trend Wizard



**Notes:**



## Troubleshooting

This chapter provides information to guide through troubleshooting PowerFlex® TotalFORCE® Control common symptoms and corrective actions.

Topic	Page
Fault and Alarm Code Descriptions	89
Faults	90
Alarms	90
Events	90
Configurable Conditions	90
Viewing Faults, Alarms, Events, and Exceptions	90
HIM Indication (Fault Display Screen)	91
Manually Clearing Faults	91
Status Indicators	92
Setting Factory Defaults	100
Fan Usage by Product	102
Hardware Service Manual	104
Fault and Alarm Display Codes	104
Common Symptoms and Corrective Actions	104
Testpoint Codes and Functions	107
Reset as Shipped	114
Configurable LCL Filter Capacitor Failure Response	117
Configurable LCL Filter Capacitor Over Resonance Response	117
PowerFlex 755T Lifting/Torque Proving	118
Technical Support Options	119

### Fault and Alarm Code Descriptions

TotalFORCE control fault, alarm, event, and exception codes are listed in the Microsoft® Excel® spreadsheet publication that is available on at [rok.auto/literature](http://rok.auto/literature).



Use this link to access the PowerFlex Drives with TotalFORCE Control Conditions Reference Data, publication [750-RD102](#), for fault, alarm, event, and exception codes. Download the spreadsheet for offline access.

To view the fault, alarm, event, and exception code descriptions and for full functionality (filter and search), open the file in the Microsoft Excel application.

## Faults

A fault is a condition that stops the drive. There are four types of faults.

Type	Description
Major Fault	If this type of fault occurs while the line side converter or motor side inverter is modulating, it stops modulating. If it occurs while the line side converter or motor side inverter is not modulating, it prevents starting. It prevents starting until the fault is cleared.
Minor Fault	If this type of fault occurs while the line side converter or motor side inverter is modulating, it allows modulation to continue. If it occurs while the line side converter or motor side inverter is not modulating, it prevents starting. It prevents starting until the fault is cleared.
Resettable	This type of fault can be cleared. Resettable faults are identified by 'Resettable Fault'.
Non-resettable	This type of fault normally requires drive or motor repair. You must correct the cause of the fault before the fault can be cleared. The fault will be reset on powerup after repair. Non-resettable faults are identified by 'Non-Reset Fault'.

## Alarms

An alarm is a condition that, if left unaddressed, can stop the drive if the drive running or does not allow you to start the drive. There are two types of alarms.

Type	Description
Alarm 1	Alarms of type 1 indicate that a condition exists. Type 1 alarms are user configurable.
Alarm 2	Alarms of type 2 indicate that a configuration error exists and the drive cannot be started. Type 2 alarms are not configurable.

## Events

Events occur under normal operation of the product. When an event occurs, the drive records an entry consisting of a numeric event code and a time stamp in an event queue. Events can help to troubleshoot problems.

## Configurable Conditions

You can use a configuration parameter to set user-configurable conditions to either fault, alarm, or ignore.

Type	Description
Configurable	<p><b>Options can include:</b></p> <ul style="list-style-type: none"> <li>'Ignore' (0) - No action is taken. <sup>(1)</sup></li> <li>'Alarm' (1) - Type 1 alarm indicated.</li> <li>'Flt Minor' (2) - Minor fault indicated. If running, drive continues to run.</li> <li>'FltCoastStop' (3) - Major fault indicated. Coast to Stop.</li> <li>'Flt RampStop' (4) - Major fault indicated. Ramp to Stop.</li> <li>'Flt CL Stop' (5) - Major fault indicated. Current Limit Stop.</li> </ul>

(1) When 'Ignore' (0) is the default setting, the occurrence is recorded in the exceptions queue. When you set a configuration parameter to 'Ignore' (0), the occurrence is recorded in the event queue.

## Viewing Faults, Alarms, Events, and Exceptions

When a condition occurs, the drive records the occurrence in the fault, alarm, event, or exception queue. These queues are accessible through software or the HIM and provide you with a history of each type of occurrence. You can also access diagnostic file parameters for additional information.

- Port 0: Diagnostics File, Status Group
- Port 0: Diagnostics File, Fault/Alarm Info Group
- Port 10: Diagnostics File, Status Group
- Port 10: Diagnostics File, Fault/Alarm Info Group
- Port 13: Diagnostics File, Status Group
- Port 13: Diagnostics File, Fault/Alarm Info Group

## HIM Indication (Fault Display Screen)

The popup fault display screen automatically appears when the drive detects a fault condition for the host drive or any connected peripheral. By default, the status bar flashes to alert the operator. To change the display flash mode, see the PowerFlex 20-HIM-A6 and 20-HIM-C6S HIM User Manual, publication [20HIM-UM001](#), for instructions.

The fault display screen displays the following information.

- Fault Code number (See [Fault and Alarm Display Codes on page 104.](#))
- Fault description
- Elapsed time (in hh:mm:ss format) from fault detection

Figure 67 - Pop-Up/Flashing Fault Display Screen

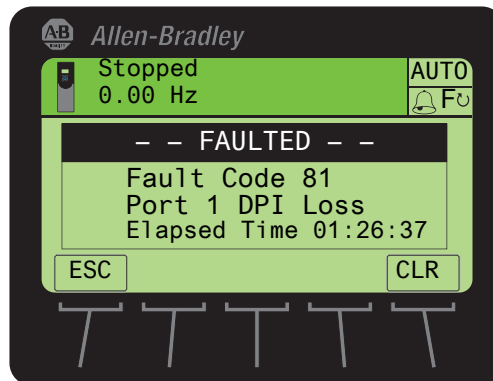



### Soft Key Functions

Label	Name	Description
ESC	Escape	Reverts back to the previous screen without clearing the fault.
CLR	Clear	Removes the pop-up Fault Display screen from the display and clears the fault.

### Single Function Key

Key	Name	Description
	Stop	Removes the pop-up Fault Display screen from the display and clears the fault.

## Manually Clearing Faults

Step	Key(s)
1. Press the 'Clear' soft key to acknowledge the fault. The fault information is removed so that you can use the HIM.	
2. Address the condition that caused the fault. The cause must be corrected before the fault can be cleared.	
3. After corrective action has been taken, clear the fault by one of these methods: Press Stop (if running the drive will stop) Cycle drive power Select the 'Clear' soft key on the HIM Diagnostic folder Faults menu.	

# Status Indicators

Status indicators report the condition of the product.

## HIM Cradle Status Indicators



The status indicators on the HIM cradle do not indicate the status of an installed communication adapter option. If an optional communication adapter is installed, refer to the adapter user manual for the location a description of any status indicators.

**Table 1 - PowerFlex 755T Status Indicator Descriptions**

Name	Color	State	Description
STS (Status)	Green	Flashing	The product is ready, but not running, with no converter or inverter faults or alarms present.
		Steady	The product is running (that is, the converter and inverter are active) with no faults or alarms present.
	Yellow	Flashing	A start inhibit condition is present in the converter or inverter. The product cannot be started until the start inhibit condition is cleared.
		Steady	A type 1 (user configurable) alarm condition is present in the converter or inverter while the drive is not running. The product can be started without clearing the alarm condition. See parameters 10:465 [Alarm Status A] and 10:466 [Alarm Status B].
	Red	Flashing	A major fault (for example, an EEPROM CRC fault) is present causing converter and inverter modulation to stop. The product cannot be restarted until the fault condition is cleared. See parameter 0:610 [Last Fault Code].
		Steady	A non-resettable fault (for example, a user FPGA configuration not loaded) is present in the converter or inverter.
	Red / Yellow	Flashing Alternately	A minor fault is present that does not stop converter or inverter modulation. However, the product cannot be restarted until the fault condition is cleared.
	Yellow / Green	Flashing Alternately	The product is running with a type 1 alarm present that does not stop modulation in the converter or inverter. The product can be restarted without clearing the alarm condition. See parameters 10:465 [Alarm Status A] and 10:466 [Alarm Status B].
Green / Red	Flashing Alternately	The product is updating the nonvolatile memory for firmware on the main control board, an option card, or a peripheral device.	
Unlit	Off	Main control board is not powered.	
ENET	Unlit	Off	Embedded EtherNet/IP™ is not properly connected to the network or needs an IP address.
	Red	Flashing	An EtherNet/IP connection has timed out. Explicit messaging control timed out. Network address rotary switches have changed or IP address is invalid (defaulting to DHCP) or DHCP lease expired.
		Steady	Adapter failed the duplicate IP address detection test. Rotary switches are set to 888 or the DHCP lease has expired.
	Red / Green	Flashing Alternately	Adapter is performing a self-test.
	Green	Flashing	Adapter is properly connected but is not communicating with any devices on the network.
Steady		Adapter is properly connected and communicating on the network.	
LNK1 (Link 1) LNK2 (Link 2)	Unlit	Off	Adapter is not powered or is not transmitting on the network.
	Green	Flashing	Adapter is properly connected (100 Mbps or 1 Gbps) and transmitting data packets on the network.
		Steady	Adapter is properly connected (100 Mbps or 1 Gbps) but is not transmitting on the network.
	Yellow	Flashing	Adapter is properly connected (10 Mbps) and transmitting data packets on the network.
		Steady	Adapter is properly connected (10 Mbps) but is not transmitting on the network.

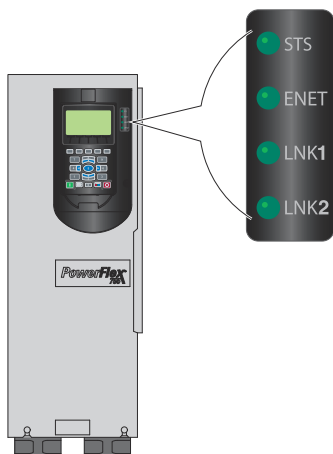

## Power Layer Interface (PLI) Circuit Board Status Indicators

PowerFlex 755T power modules use status indicators and a 7-segment display to report conditions. The power layer interface circuit board is located behind the connections cover of the power module chassis.

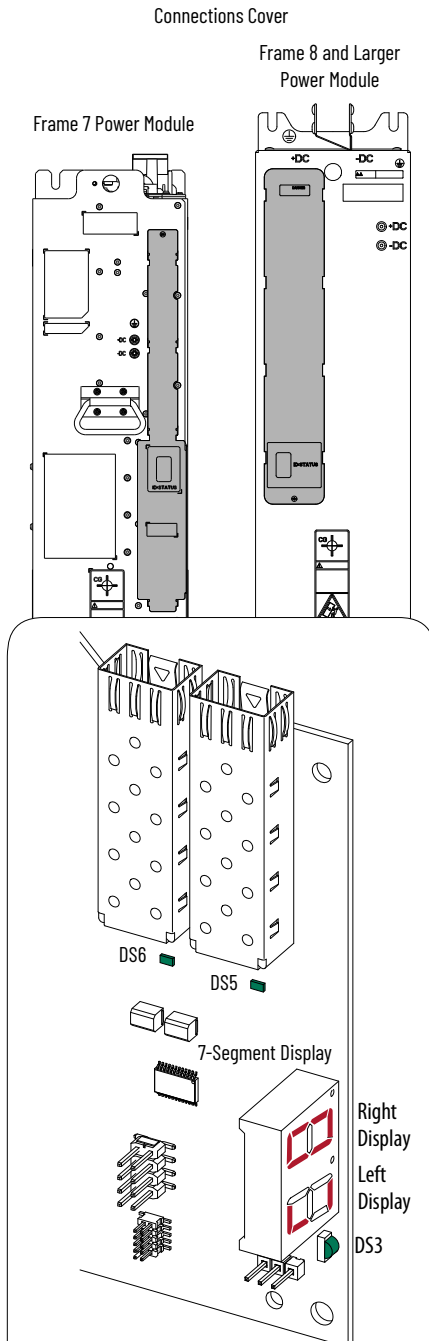

Name	Color	State	Description
DS3	Green	Flashing at 2 Hz	Active mode in process.
		Flashing at 0.5 Hz	Update in process.
	Green / Yellow	Flashing Alternately	Login mode in process.
		Flashing Alternately	Erase in process.
	Yellow	Flashing at 2 Hz	Loopback fiber test mode is in process.
		Flashing at 0.5 Hz	Boot mode is in process.
	Red	Blink 2 Count	Clock fault
Blink 3 Count		Firmware fault	
Blink 4 Count		FLEXBUS fault	
Blink 5 Count		PRGM fault	
Blink 6 Count		FPGA PRGM fault	
Blink 7 Count		SFLASH PRGM fault	
DS5/DS6	Green	Flashing	Fiber connection is online.
	Red	Flashing	Fiber connection is offline.

Lit Segment	Description
	Fiber loss
	The PLI is not online.
	The PLI is online but not initialized or logged in.
	The PLI is initialized and logged in. The right display indicates the module number (Lx/Mx). This display indicates that the module is in a ready state.
	The PLI is initialized, logged in, and PWM active. The right display indicates the module number (Lx/Mx).
	The PLI is initialized, logged in, and faulted. The right display indicates the module number (Lx/Mx).
	The PLI initialization is complete.
	Fiber is online.
	The PLI is faulted.
	PWM is enabled.

Frame 8 and larger board orientation shown. Frame 7 is the opposite orientation.

## AC Precharge Circuit Board Status Indicators

The PowerFlex 755T AC precharge module uses status indicators and a 7-segment display to report conditions. See [Figure 68 on page 95](#) for the location of the AC precharge board.

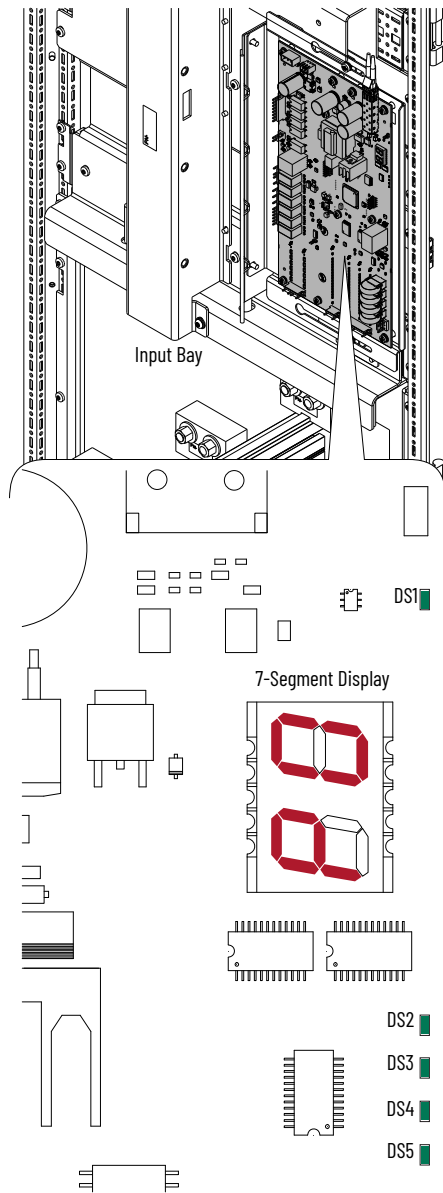

Name	Color	State	Description
DS1 (AC Precharge)	Green	Flashing	Fiber connection is online.
	Red	Flashing	Fiber connection is offline.
DS2 (240V AC)	Green	Steady	240V AC Okay
	Yellow	Steady	240V AC Low Alarm
	Red	Flashing	240V AC Loss Fault
	Unlit	Off	240V AC Loss Alarm
DS3 (Communications)	Green	Steady	Fiber connection is online.
	Yellow	Flashing	Communications Loss
	Unlit	Off	Inactive
DS4 (AC Precharge)	Green	Steady	Precharge Done (Main circuit breaker is closed.)
		Flashing	Main circuit breaker is closing.
	Yellow	Steady	Main circuit breaker is opening.
		Flashing	Not Ready
	Red	Flashing	Main circuit breaker opened.
Unlit	Off	Ready	
DS5 (Firmware Status)	Green	Steady	No faults or alarms are present.
	Green / Red	Flashing Alternately	Update in progress.
	Yellow	Steady	Alarm is present.
	Red	Flashing	Fault is present.
7-Segment Display	Red	Steady	Normal Operation <ul style="list-style-type: none"> <li>At powerup, the display indicates the major firmware revision number, the minor revision number, and the build number for 1 second each.</li> <li>After powerup is complete, the display indicates the number that is assigned to the module by the main control board. (Shown: P0 = Precharge 0)</li> </ul> Alarms <ul style="list-style-type: none"> <li>When an alarm condition exists, the display indicates the alarm code.</li> <li>If there are multiple alarm codes, the display cycles through the codes and displays each code for 2 seconds.</li> </ul>
		Flashing	Faults <ul style="list-style-type: none"> <li>When a fault condition exists, the display indicates the fault code for Port 14.</li> <li>If there are multiple fault codes, the display cycles through the codes and displays each code for 2 seconds.</li> <li>If the device is faulted, the display only indicates fault codes. Alarm codes are omitted.</li> </ul>

Figure 68 - AC Precharge Location

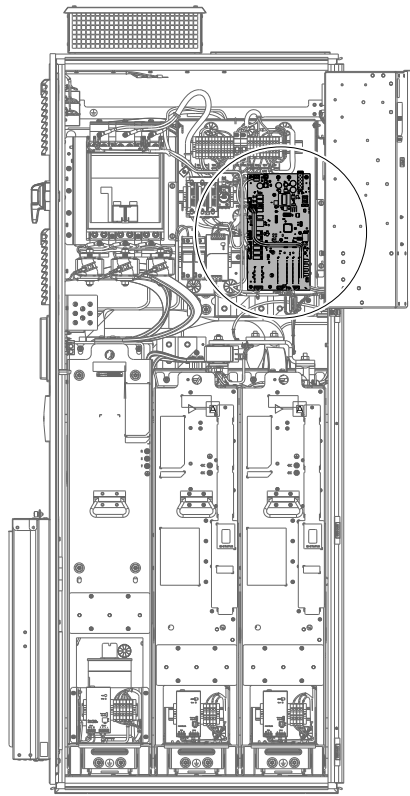

Frame 7 Drive

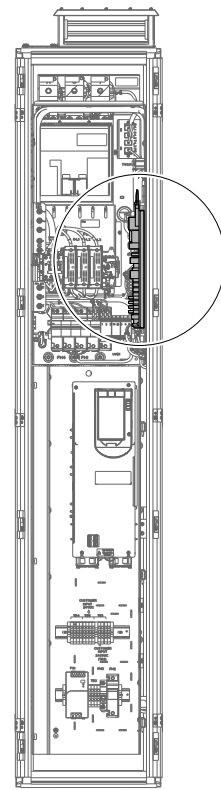

Frame 8 Input Bay

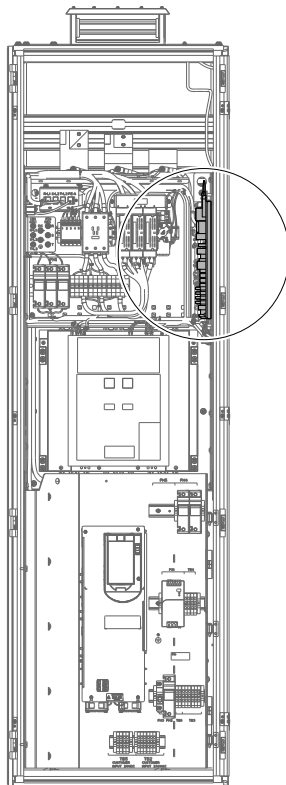

Frame 9 Input Bay

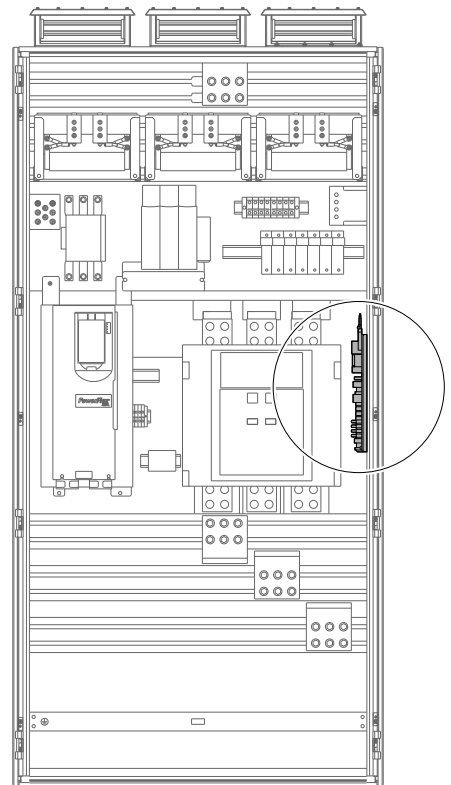

Frame 10...15 Input Bay

Table 2 - AC Precharge 7-Segment Display Fault and Alarm Codes

Display Code	Display State	Condition Code	Condition Name
0	Flashing	14001	Image Watchdog Fault
	Steady	14070	Board Over Temperature Alarm
1	Flashing	14002	Constants Message Invalid
	Steady	14071	Board Over Temperature Fault
2	Flashing	14003	Constants Checksum
	Steady	14072	Board Under Temperature Alarm
3	Steady	14073	Board Under Temperature Fault
4	Flashing	14004	Nonvolatile Data Checksum Fault
5	Flashing	14005	Power Supply Undervoltage
6	Flashing	14006	Precharge Fault
	Steady	14108	240V AC Low
7	Flashing	14007	MCB Failed to Close or Wiring Bay Overtemp
	Steady	14109	240V AC Loss
8	Flashing	14008	MCB Failed to Open
	Steady	14110	Fused Disconnect Open (MCB open)
9	Flashing	14009	MCB Aux Mismatch or Wiring Bay Overtemp
	Steady	14130	TVSS Open
10	Flashing	14120	PCC Failed to Close
11	Flashing	14121	PCC Failed to Open
12	Flashing	14122	PCC Aux Mismatch
	Steady	14126	AC Line Over Voltage
13	Flashing	14123	MCB Trip Reset
14	Flashing	14124	MCB Overcurrent
15	Flashing	14010	240V AC Loss Fault
16	Flashing	14011	240V AC Over Voltage
17	Flashing	14012	Fused Disconnect Open (MCB closed)
32	Steady	14127	MCB Life Threshold Exceeded
33	Steady	14128	PCC Life Threshold Exceeded



## DC Precharge Circuit Board Status Indicators

The PowerFlex 755T DC precharge module uses status indicators and a 7-segment display to report conditions. The DC precharge circuit board is located behind a transparent panel on the left side of the DC precharge module chassis. The DC precharge circuit board status indicators are not visible while installed in a DC precharge module.

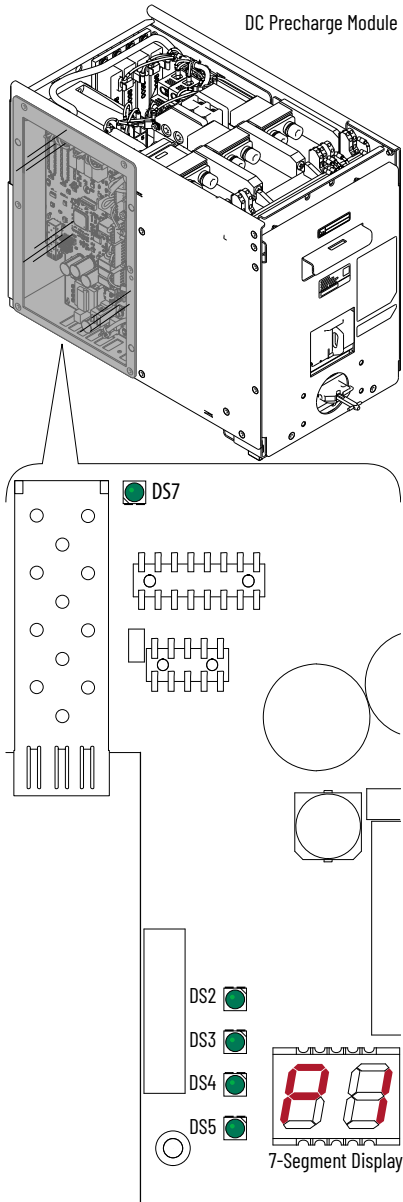

Name	Color	State	Description
DS7 (DC Precharge)	Green	Flashing	Fiber connection is online.
	Red	Flashing	Fiber connection is offline.
DS2 (240V AC)	Green	Steady	240V AC Okay
	Yellow	Steady	240V AC Low Alarm
	Red	Flashing	240V AC Loss Fault
	Unlit	Off	240V AC Loss Alarm
DS3 (Communications)	Green	Steady	Fiber connection is online.
	Yellow	Flashing	Communications Loss
	Unlit	Off	Inactive
DS4 (DC Precharge)	Green	Steady	Precharge Done (Molded case switch is closed.)
	Green	Flashing	Molded case switch is closing.
	Yellow	Steady	Molded case switch is opening.
	Yellow	Flashing	Not Ready
	Red	Flashing	Molded case switch opened.
DS5 (Firmware Status)	Unlit	Off	Ready
	Green	Steady	No faults or alarms are present.
	Green / Red	Flashing Alternately	Update in progress.
	Yellow	Steady	Alarm is present.
7-Segment Display	Red	Steady	Normal Operation <ul style="list-style-type: none"> <li>At powerup, the display indicates the major firmware revision number, the minor revision number, and the build number for 1 second each.</li> <li>After powerup is complete, the display indicates the number that is assigned to the module by the main control board. (Shown: P1 = Precharge 1)</li> </ul> Alarms <ul style="list-style-type: none"> <li>When an alarm condition exists, the display indicates the alarm code.</li> <li>If there are multiple alarm codes, the display cycles through the codes and displays each code for 2 seconds.</li> </ul>
		Flashing	Faults <ul style="list-style-type: none"> <li>When a fault condition exists, the display indicates the fault code.</li> <li>If there are multiple fault codes, the display cycles through the codes and displays each code for 2 seconds.</li> <li>If the device is faulted, the display only indicates fault codes. Alarm codes are omitted.</li> </ul>

**Table 3 - DC Precharge 7-Segment Display Fault and Alarm Codes**

Display Code	Display State	Condition Code	Condition Name
0	Flashing	12001	Image Watchdog Fault
	Steady	12070	Board Over Temperature Alarm
1	Flashing	12002	Constants Message Invalid
	Steady	12071	Board Over Temperature Fault
2	Flashing	12003	Constants Checksum
	Steady	12072	Board Under Temperature Alarm
3	Steady	12073	Board Under Temperature Fault
4	Flashing	12004	Nonvolatile Data Checksum Fault
5	Flashing	12005	Power Supply Undervoltage
6	Flashing	12006	Precharge Fault
	Steady	12108	240V AC Low
7	Flashing	12007	MCS Failed to Close or Wiring Bay Overtemp
	Steady	12109	240V AC Loss
8	Flashing	12008	MCS Shunt Trip
9	Flashing	12009	MCS Aux Mismatch or Wiring Bay Overtemp
10	Flashing	12010	240V AC Loss Fault
	Steady	12110	Fused Disconnect Open (MCS Open)
11	Flashing	12011	240V AC Over Voltage
12	Flashing	12012	Fused Disconnect Open (MCS closed)
15	Flashing	12050	Bus Fuse Harness
16	Flashing	12051	Bus Positive Fuse Blown
17	Flashing	12052	Bus Negative Fuse Blown
32	Steady	12053	Molded Case Switch Life Threshold Exceeded

## Fiber-optic Interface Circuit Board Status Indicator

The PowerFlex 755T fiber-optic interface uses a status indicator to report conditions. The fiber-optic interface circuit board is mounted on the rear panel of the control pod assembly and is used with frame 7...15 drives and bus supplies.

Name	Color	State	Description
DS1	Green	Flashing at 2 Hz	Active mode in process.
		Flashing at 0.5 Hz	Update in process.
	Green / Yellow	Flashing Alternately	Login mode in process.
	Green / Red	Flashing Alternately	Erase in process.
	Yellow	Flashing at 2 Hz	Loopback fiber test mode is in process.
		Flashing at 0.5 Hz	Boot mode is in process.
	Red	Blink 2 Count	Clock fault
		Blink 3 Count	Firmware fault
		Blink 4 Count	FLEXBUS fault
		Blink 5 Count	PRGM fault
Blink 6 Count		FPGA PRGM fault	
		Blink 7 Count	SFLASH PRGM fault

Control Pod Assembly

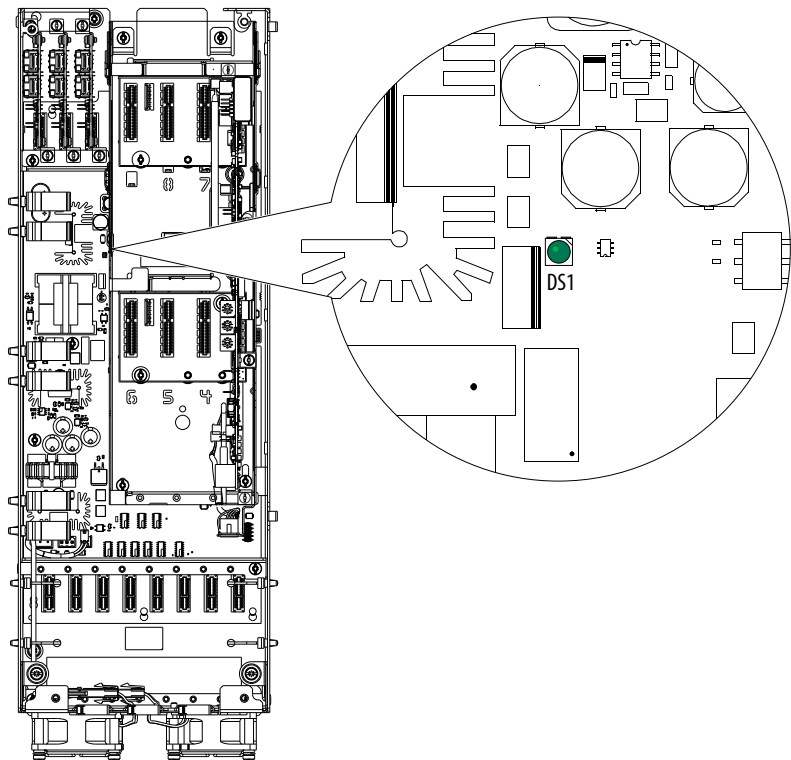

## Fiber-optic Transceiver Circuit Board Status Indicators

PowerFlex 755T fiber-optic transceiver circuit boards use status indicators to report conditions. The fiber-optic transceiver circuit boards plug into edge connectors on the fiber interface circuit board in the control pod assembly of frame 7...15 drives and bus supplies.

Name	Color	State	Description
DS1, DS2	Green	Flashing	Fiber connection is online.
	Red	Flashing	Fiber connection is offline.

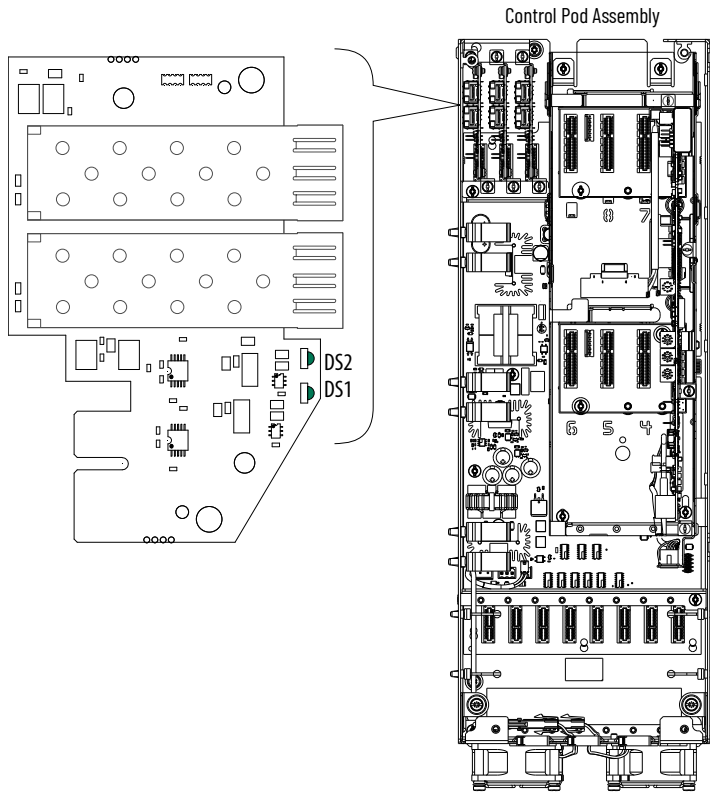

## Setting Factory Defaults

The PowerFlex 20-HIM-A6/-C6S HIM User Manual, publication [20HIM-UM001](#), provides detailed instructions on using Human Interface Module capabilities, including, setting the PowerFlex 750-Series drive to factory settings.

The following tables list the parameters that are not reset when Set Defaults 'Most' is executed.

Also, the High Speed Trending configuration and the internal date and time properties are not reset by this operation.

### Port 0: Product Config File, Preferences Group

Number	Display Name	Full Name
30	Access Level	User Access Level
31	Language	Display Language
46	Velocity Units	Velocity Units

### Port 0: Product Config File, Control Config Group

Number	Display Name	Full Name
33	VoltageClass Cfg	Voltage Class Configure
35	Duty Rating Cfg	Duty Rating Configure

**Port 0: Product Config File, Port Mode Group**

Number	Display Name	Full Name
65	Pri MtrCtrl Mode	Primary Motor Control Mode
70	Application Sel	Application Select

**Port 0: Product Config File, Option Cfg Group**

Number	Display Name	Full Name
80	DCP Option	DC Precharge Option
82	TAM Option	Torque Accuracy Module Option

**Port 0: Feedback & I/O File, Command Group**

Number	Display Name	Full Name
134	DI EmergencyOVRD	Digital Input Emergency Override

**Port 0: Embedded ENET File, Address Config Group**

Number	Display Name	Full Name
300	Net Addr Sel	Network Address Selection
302	IP Addr Cfg 1	IP Address Configuration 1
303	IP Addr Cfg 2	IP Address Configuration 2
304	IP Addr Cfg 3	IP Address Configuration 3
305	IP Addr Cfg 4	IP Address Configuration 4
306	Subnet Cfg 1	Subnet Configuration 1
307	Subnet Cfg 2	Subnet Configuration 2
308	Subnet Cfg 3	Subnet Configuration 3
309	Subnet Cfg 4	Subnet Configuration 4
310	Gateway Cfg 1	Gateway Configuration 1
311	Gateway Cfg 2	Gateway Configuration 2
312	Gateway Cfg 3	Gateway Configuration 3
313	Gateway Cfg 4	Gateway Configuration 4
314	Net Rate Cfg 1	Net Rate Configuration 1
316	Net Rate Cfg 3	Net Rate Configuration 3

**Port 0: Protection File, Overrides Group**

Number	Display Name	Full Name
454	Emerg OVRD Mode	Emergency Override Mode
455	Emerg Prot OVRD	ProtectionsOverridenbyEmergencyOverride

**Parameter 0:457 [Purge Frequency]**

**ATTENTION:** Unintended parameter value can result due to This Port Only reset. Parameter 0:457 [Purge Frequency] is reset to the default value when a Set Defaults for This Port Only is applied to port 10 or port 11.

**Peripheral Set Defaults Operation Resets Host Product**

The parameters for some PowerFlex 750-Series option modules reside on the main control board of the host product. Because of this scheme, performing a Set Defaults operation for one of these peripheral devices resets the host product. The peripherals that behave in this way are listed in this table.

Peripheral	Cat. No.
11-Series I/O option modules	20-750-1132C-2R
	20-750-1133C-1R2T
	20-750-1132D-2R
22-Series I/O option modules	20-750-2232C-2R
	20-750-2233C-1R2T
	20-750-2232D-2R
Single incremental encoder option module	20-750-ENC-1
Dual incremental encoder option module	20-750-DENC-1

## Fan Usage by Product

These tables list the fans that are present in each product frame size and enclosure rating.

### PowerFlex 755TS Drives

Fan Type	Frame 1	
	IP20, NEMA/UL Open Type	IP20, NEMA/UL Type1
Control Pod Fan	None	None
Stirring Fan	None	None
Heatsink Fan	Present	Present

Fan Type	Frame 2			
	IP20, NEMA/UL Open Type	IP20, NEMA/UL Type 1	IP66, NEMA/UL Type 4X/12	IP54, NEMA/UL Type 12
Control Pod Fan	Present	Present	Present	None
Stirring Fan	None	None	None	None
Heatsink Fan	Present	Present	Present	Present

Fan Type	Frame 3			
	IP20, NEMA/UL Open Type	IP20, NEMA/UL Type 1	IP66, NEMA/UL Type 4X/12	IP54, NEMA/UL Type 12
Control Pod Fan	Present	Present	Present	Present
Stirring Fan	None	None	None	None
Heatsink Fan	Present	Present	Present	Present

Fan Type	Frame 4			
	IP20, NEMA/UL Open Type	IP20, NEMA/UL Type 1	IP66, NEMA/UL Type 4X/12	IP54, NEMA/UL Type 12
Control Pod Fan	Present	Present	Present	None
Stirring Fan	Present	Present	Present	Present
Heatsink Fan	Present	Present	Present	Present

Fan Type	Frame 5			
	IP20, NEMA/UL Open Type	IP20, NEMA/UL Type 1	IP66, NEMA/UL Type 4X/12	IP54, NEMA/UL Type 12
Control Pod Fan	Present	Present	Present	None
Stirring Fan	Present	Present	Present	Present
Heatsink Fan	Present	Present	Present	Present

Fan Type	Frame 6			
	IP20, NEMA/UL Open Type	IP20, NEMA/UL Type 1	IP66, NEMA/UL Type 4X/12	IP54, NEMA/UL Type 12
Control Pod Fan	None	None	None	None
Stirring Fan	Present	Present	Present	Present
Heatsink Fan	Present	Present	Present	Present

Fan Type	Frame 6L
	IP20, NEMA/UL Open Type
Control Pod Fan	None
Stirring Fan	Present
Heatsink Fan	Present

Fan Type	Frame 7			
	IP20, NEMA/UL Open Type	IP20, NEMA/UL Type 1	IP66, NEMA/UL Type 4X/12	IP54, NEMA/UL Type 12
Control Pod Fan	None	None	None	None
Stirring Fan	Present	Present	Present	Present
Heatsink Fan	Present	Present	Present	Present

Fan Type	Frame 7A
	IP20, NEMA/UL Type1
Control Pod Fan	None
Stirring Fan	Present
Heatsink Fan	Present

### PowerFlex 755TL, 755TR, and 755TM Products

Fan Type	Frame 5 Drives	Frame 6 Drives	Frame 6L Drives	Frame 7 Drives	
				IP21, NEMA/UL Type 1	IP54, NEMA/UL Type 12
Control Pod Fan	None	None	None	Single	Single
Stirring Fan	Present	Present	Present	None	None
Heatsink Fan	Present	Present	Present	Present	Present
Input Bay Fan	None	None	None	None	None
Power Bay Roof Fan	None	None	None	None	None
Wire Bay Fan	None	None	None	None	None
Control Bay Fan	None	None	None	None	None

Fan Type	Frame 8 Drives		Frame 9 Drives		Frame 10...15 Drives	
	IP21, NEMA/UL Type 1	IP54, NEMA/UL Type 12	IP21, NEMA/UL Type 1	IP54, NEMA/UL Type 12	IP21, NEMA/UL Type 1	IP54, NEMA/UL Type 12
Control Pod Fan	Dual	Dual	Dual	Dual	Dual	Dual
Stirring Fan	None	None	None	None	None	None
Heatsink Fan	Present	Present	Present	Present	Present	Present
Input Bay Fan	Present	Present	Present	Present	Present	Present
Power Bay Roof Fan	None	Present	None	Present	None	Present
	Present (with option)	Present (with option)	Present (with option)	Present (with option)	Present (with option)	Present (with option)
Wire Bay Fan	Present	Present	Present	Present	Present	Present
Control Bay Fan	None	None	None	None	None	None

Fan Type	Frame 8 Bus Supplies		Frame 9 Bus Supplies		Frame 10...15 Bus Supplies	
	IP21, NEMA/UL Type 1	IP54, NEMA/UL Type 12	IP21, NEMA/UL Type 1	IP54, NEMA/UL Type 12	IP21, NEMA/UL Type 1	IP54, NEMA/UL Type 12
Control Pod Fan	Dual	Dual	Dual	Dual	Dual	Dual
Stirring Fan	None	None	None	None	None	None
Heatsink Fan	Present	Present	Present	Present	Present	Present
Input Bay Fan	Present	Present	Present	Present	Present	Present
Power Bay Roof Fan	None	Present	None	Present	None	Present
	Present (with option)	Present (with option)	Present (with option)	Present (with option)	Present (with option)	Present (with option)
Wire Bay Fan	Present	Present	Present	Present	Present	Present
Control Bay Fan	None	None	None	None	None	None

Fan Type	Frame 8 Common Bus Inverters		Frame 9 Common Bus Inverters		Frame 10...15 Common Bus Inverters	
	IP21, NEMA/UL Type 1	IP54, NEMA/UL Type 12	IP21, NEMA/UL Type 1	IP54, NEMA/UL Type 12	IP21, NEMA/UL Type 1	IP54, NEMA/UL Type 12
Control Pod Fan	Dual	Dual	Dual	Dual	Dual	Dual
Stirring Fan	None	None	None	None	None	None
Heatsink Fan	Present	Present	Present	Present	Present	Present
Input Bay Fan	None	None	None	None	None	None
Power Bay Roof Fan	None	Present	None	Present	None	Present
Wire Bay Fan	Present (with option)	Present (with option)	Present (with option)	Present (with option)	Present (with option)	Present (with option)
Control Bay Fan	Present (with option)	Present (with option)	Present (with option)	Present (with option)	Present (with option)	Present (with option)

## Hardware Service Manual

The PowerFlex 750-Series AC Drive Hardware Service Manual, publication [750-TG100](#), provides schematics and detailed instructions on part replacement for PowerFlex 755T products.

The PowerFlex 755TS Products with TotalFORCE Control Hardware Service Manual, publication [750-TG101](#), provides schematics and detailed instructions on part replacement for PowerFlex 755TS products.

## Fault and Alarm Display Codes

Event numbers for PowerFlex 750-Series faults and alarms are displayed in one of three formats.

- Port 00 (Host Drive) displays the event number only. For example, code 21 'Clr Fault Queue' is displayed as:  
**Fault Code 21.**
- Ports 01 through 09 use the format PEEE, indicating port number (P) and event number (EEE). For example, code 1 'Analog In Loss' on an I/O module installed in Port 4 is displayed as:  
**Fault Code 4001.**
- Ports 10 through 14 use the format PEEEE, indicating port number (PP) and event number (EEE). For example, code 37 'S OverTemp Alm' on Port 14 is displayed as:  
**Fault Code 14037.**

## Common Symptoms and Corrective Actions

**Drive does not start from Start or Run inputs that are wired to the terminal block.**

Cause(s)	Indication	Corrective Action
Drive is faulted	Flashing red status light	Clear fault. <ul style="list-style-type: none"> <li>• Press Stop</li> <li>• Cycle power</li> <li>• 'Clear Faults' on the HIM Diagnostic menu</li> </ul>
Incorrect input wiring. See PowerFlex 750-Series I/O, Feedback, and Power Option Modules Installation Instructions, publication <a href="#">750-IN111</a> , for wiring examples. <ul style="list-style-type: none"> <li>• 2-wire control requires Run, Run Forward, Run Reverse, or Jog input</li> <li>• 3-wire control requires Start and Stop inputs</li> <li>• Verify 24 Volt Common is connected to Digital Input Common</li> </ul>	None	Wire inputs correctly.
Incorrect digital input programming. <ul style="list-style-type: none"> <li>• Mutually exclusive choices have been made (for example, Jog and Jog Forward)</li> <li>• 2-wire and 3-wire programming may be conflicting</li> <li>• Start configured without a Stop configured</li> </ul>	None Flashing yellow status light and 'DigIn Cnfg B' or 'DigIn Cnfg C' indication on LCD HIM. 10:355 [Motor Side Sts 2] shows type 2 alarm(s).	Configure input function.  Resolve input function conflicts.
Terminal block does not have control.	None	Check 0:41 [Logic Mask].



**Drive does not Start from HIM.**

Cause(s)	Indication	Corrective Action
Drive is configured for 2-wire level control.	None	Change 0:101 [Digital In Cfg] to correct control function.
Another device has Manual control.	None	—
Port does not have control.	None	Change 0:41 [Logic Mask] to enable correct port.

**Drive does not respond to changes in speed command.**

Cause(s)	Indication	Corrective Action
No value is coming from the source of the command.	LCD HIM Status Line indicates 'At Speed' and output is 0 Hz.	<ul style="list-style-type: none"> <li>If the source is an analog input, check wiring and use a meter to check for presence of signal</li> </ul>
Incorrect reference source has been programmed.	None	<ul style="list-style-type: none"> <li>Check 10:1800 [VRef A Sel] for the source of the speed reference</li> <li>Reprogram 10:1800 [VRef A Sel] for correct source</li> </ul>
Incorrect Reference source is being selected via remote device or digital inputs.	None	<ul style="list-style-type: none"> <li>Check 10:354 [Motor Side Sts 1], bits 12 and 13 for unexpected source selections</li> <li>Check 0:100 [Digital In Sts], to see if inputs are selecting an alternate source</li> <li>Check configuration of 173...175 [DI Speed Sel n] functions</li> </ul>

**Motor and/or drive will not accelerate to commanded speed.**

Cause(s)	Indication	Corrective Action
Acceleration time is excessive.	None	Reprogram 10:1915/1916 [VRef Accel Timen].
Excess load or short acceleration times force the drive into current limit, slowing or stopping acceleration.	None	Check 10:354 [Motor Side Sts 1], bit 27 to see if the drive is in Current Limit. Remove excess load or reprogram 10:1915/1916 [VRef Accel Timen].
Speed command source or value is not as expected.	None	Check for the proper Speed Command using Steps 1 through 7 above.
Programming is preventing the drive output from exceeding limiting values.	None	Check 10:1898 [Vel Limit Pos], 10:1899 [Vel Limit Neg], and 10:422 [Maximum Freq] to assure that speed is not limited by programming.

**Motor operation is unstable.**

Cause(s)	Indication	Corrective Action
Motor data was incorrectly entered or Autotune was not performed.	None	<ol style="list-style-type: none"> <li>Correctly enter motor nameplate data.</li> <li>Perform 'Static Tune' or 'Rotate Tune' Autotune procedure. See parameter 10:910 [Autotune].</li> </ol>

**Drive will not reverse motor direction.**

Cause(s)	Indication	Corrective Action
Digital input is not selected for reversing control.	None	Check that the DI Reversing function is correctly configured.
Digital input is incorrectly wired.	None	Check digital input wiring.

**Drive will not reverse motor direction.**

Cause(s)	Indication	Corrective Action
Direction mode parameter is incorrectly programmed.	None	Reprogram 10:930 [Direction Mode], for analog 'Bipolar' or digital 'Unipolar' control.
Motor wiring is improperly phased for reverse.	None	Switch any two motor leads.
A bipolar analog speed command input is incorrectly wired or signal is absent.	None	<ol style="list-style-type: none"> <li>1. Use meter to check that an analog input voltage is present.</li> <li>2. Check bipolar analog signal wiring. Positive voltage commands forward direction. Negative voltage commands reverse direction.</li> </ol>

**Stopping the drive results in a Decel Inhibit fault.**

Cause(s)	Indication	Corrective Action
The bus regulation feature is enabled and is halting deceleration due to excessive bus voltage. Excess bus voltage is normally due to excessive regenerated energy or unstable AC line input voltages.	Decel Inhibit fault screen. LCD Status Line indicates 'Faulted.'	<ol style="list-style-type: none"> <li>1. Reprogram parameters 10:116/117 [Bus Reg Mode <i>n</i>] to eliminate any 'Adjust Freq' selection.</li> <li>2. Disable bus regulation (parameters 10:116/117 [Bus Reg Mode <i>n</i>]) and add a dynamic brake.</li> <li>3. Correct AC input line instability or add an isolation transformer.</li> <li>4. Access 10:170 [Dec Inhibit Actn] to select desired fault action.</li> <li>5. Reset drive.</li> </ol>
Internal timer has halted drive operation.		

**Problems adding a datalink.**

Cause(s)	Indication	Corrective Action
Another device is communicating with the processor.	None	Verify that a PLC is not communication with the drive. Disconnect communication cable or inhibit communication in PLC software.

## Testpoint Codes and Functions

Select testpoint with a [Testpoint Sel *n*] parameter. View testpoint values with [Testpoint REAL *n*] and [Testpoint DINT *n*] parameters.

### Port 9 Testpoint Codes

No.	Name	Description	Data Type	Units
1	TrqPrvState	The present state of the Torque Proving state machine.	DINT	t/f
2	TrqPrvSpdBandTimer	Timer count for the Speed Band function in Torque Proving.	REAL	Sec
3	TrqPrvBrkSlipStartActv	Indicated the Brake Slip start has occurred and is presently active.	DINT	t/f

### Port 10 Testpoint Codes

No.	Name	Description	Data Type	Units
1	VRef Ramp In	Velocity Reference at the input to the ramp and S Curve function.	REAL	PU
2	VelRamp Rate	This signal is the active rate of change of the velocity reference. It is produced by the velocity reference ramp and S curve function.	REAL	PU/S
3	Vel Droop	Velocity Droop offset signal output from droop function.	REAL	PU
10	PRef Sel Del	The change in 10:1684 [PRef Selected] every millisecond. It is applied to the input of the Electronic Gear Ratio (EGR) function. Position units are encoder edge counts.	DINT	Cnts
11	PRef Sel EGR	The output of the Position Reference Electronic Gear Ratio function. It is similar to the EGR input in that it is a position change over 1 millisecond. This signal is re-accumulated to create 10:1686 [PRef EGR Out]. Position units are encoder edge counts.	DINT	C/ms
12	PRef Ofst In	The summation of 10:1691 [Psn Offset 1] and 10:1694 [Psn Offset 2]. It is the user input to the Position Reference Offset function. Position units are encoder edge counts.	DINT	Cnts
13	PRef OfstPsn	The output of the Position Reference Offset function. It represents the total offset that is to be applied to the Position Reference. Position units are encoder edge counts.	DINT	Cnts
14	PRef OfstOut	The change in Position Reference Offset that is to be applied to every millisecond. It is summed with the output of the position reference EGR. Position units are encoder edge counts.	DINT	Cnts
15	PRef NF Out	The output of the Position Reference Notch Filters. It represents a Position Command change over 1 millisecond. This signal is re-accumulated to create 10:1731 [Position Command]. Position units are encoder edge counts.	DINT	Cnts
20	LdPsn Fb Del	The change in the Load Position Feedback every millisecond. It is the input to the Load Position Feedback Gear Ratio. Position units are encoder edge counts.	DINT	C/ms
21	Psn Fb Del	The change in 10:1746 [Position Fb] every millisecond. It is subtracted from the output of the Position Reference Notch Filters. The result of this subtraction when re-accumulated becomes 10:1750 [Position Error]. Position units are encoder edge counts.	DINT	C/ms
22	PReg LdError	The difference between the output of the Position Reference Notch Filters and the Load Position Feedback Gear Ratio function. Position units are encoder edge counts.	DINT	Cnts
23	LdPsn Geared	The output of the Load Position Feedback Gear Ratio function. When re-accumulated this becomes 10:1748 [Psn Load Actual]. Position units are encoder edge counts.	DINT	Cnts

## Port 10 Testpoint Codes (Continued)

No.	Name	Description	Data Type	Units
30	VRef PID Sel	If this signal is non-zero, then the PID Output Meter has exclusive control of the Velocity Reference. If this signal is zero, then the Velocity Reference is controlled by 10:1892 [VRef Selected].	DINT	t/f
31	VRef Homing	Velocity reference signal used for the Homing function.	REAL	PU
32	VRef DIR Sel	If this signal is non-zero, then the active direction for Unipolar Direction Mode will be forward. If this signal is zero, then the active direction for Unipolar Direction Mode will be reverse.	DINT	t/f
33	Vref CLmt In	Velocity Reference signal at the input to the Min and Max Velocity Command Limiters.	REAL	PU
34	VRef SkipOut	Velocity Reference signal at the output of the Skip Band function.	REAL	PU
35	VRef Psn FF	Velocity feed forward reference signal used when position control is active. Sums with velocity ramp output.	REAL	PU
36	VRef NF In	Velocity Reference at the input to the reference notch filters. The output of these filters is 10:1925 [Vref Filtered].	REAL	PU
37	VRef Scaled	Velocity Reference at the output of the multiply block that applies 10:1932 [VRef Scale].	REAL	PU
38	VRef FLmt In	Velocity Reference signal at the input to the Final velocity limiter. The output of this limiter is 10:1933 [VRef Final].	REAL	PU
40	VReg SrvLock	Output of the Servo Lock function in the Velocity Regulator. Sums with 10:1951 [Velocity Error].	REAL	PU
41	aVRegKp	Internal proportional gain used in the velocity regulator. Incorporates gain scaling from Adaptive Tuning and Alternate Feedback. Also includes conversion from Hz to rad/sec.	REAL	R/S
42	aVRegKi	Internal integral gain used in the velocity regulator. Incorporates gain scaling from Adaptive Tuning and Alternate Feedback. Also includes Kp gain and conversion from Hz to rad/sec.	REAL	R/S
43	VReg Lmt In	Input signal to the Acceleration Limiter in the Velocity Regulator. Units are PU Velocity per second.	REAL	PU/S
44	Kj	Scale factor used to convert acceleration signals to torque signals. Proportional to system inertia. Acceleration units are PU Vel/sec. Torque units are PU motor torque.	REAL	Sec
50	Trq Scale	Scale factor used to convert acceleration signals to torque signals. Proportional to system inertia. Acceleration units are rev/sec <sup>2</sup> . Torque units are percent of rated motor torque.	REAL	
51	TrqRefPosLimActv	Positive limit that is being applied to the Trq Ref Filtered parameter. Result is displayed in Trq Ref Limited parameter.	REAL	Nm
52	TrqRefNegLimActv	Negative limit that is being applied to the Trq Ref Filtered parameter. Result is displayed in Trq Ref Limited parameter.	REAL	Nm
100	EncdrlsCompTestState	Encoderless test state.	DINT	n/a
101	IqsRefLmtd	Torque producing Current Reference. Output of the Current Rate Limiter.	REAL	PkA
105	PhsLossAmptdR0	Ratio of second harmonocs amplitdue to sixth harmonics.	DINT	n/a
106	PhsLossDtctCnts	Input phase loss detection counts.	REAL	Cnts
110	OloopOmegaOutput	Electrical speed generated in FV open loop control mode.	REAL	R/S
111	OmegaRotor	Rotor speed generated in FV open loop control mode.	REAL	R/S
115	IaFbk	A-phase simultaneously sampled current feedback scaled to units of the system.	REAL	PkA

## Port 10 Testpoint Codes (Continued)

No.	Name	Description	Data Type	Units
116	IbFbk	B-phase simultaneously sampled current feedback scaled to units of the system.	REAL	PKA
117	IcFbk	C-phase simultaneously sampled current feedback scaled to units of the system.	REAL	PKA
120	FreqSync Enhanced Delay	This signal indicates the status of the delay when Flying Start function is activated. This is for the CEMF mode of the Flying Start function.	DINT	t/f
121	FreqSync Enhanced State	This signal indicates the status of flying start operating state. This is for the CEMF mode of the Flying Start function.	DINT	t/f
122	FreqSync Sweep State	This signal indicates the status of flying start operating state. This is for the Sweep mode of the Flying Start function.	DINT	t/f
125	PrchrgState	State of the Precharge state machine.	DINT	t/f
130	LineLoss Act	If this signal is non-zero, then a Line Loss condition is active. If this signal is zero, then a Line Loss condition is not active.	DINT	t/f
135	Power State Handler	The present state being executed by the power state handler.	DINT	t/f
136	PwrStateCmd	Commanded state from the PowerStateMach to the PowerStateHandler.	DINT	t/f
140	Current Limit Stop Active	If this signal is non-zero, then a Current Limit Stopping Sequence is active. If this signal is zero, then a Current Limit Stopping Sequence is not active.	DINT	t/f
141	Sequencer State	The present state of the Sequencer.	DINT	t/f
145	ActvPwmFreq	Active PWM frequency	REAL	Hz
146	MaxJuncTemp	Active max junction temperature used in thermal manager.	REAL	°C
150	TrqRefAtZero	If this signal is non-zero, then the 10:2150 [Trq Ref Filt In] will be forced to a value of zero. If this signal is zero, then the Torque Reference is supplied by 10:2076 [Trq Ref Selected] after offset by the Friction Compensation and Torque Step signals. This signal could become non-zero as part of a stop sequence or during Autotune.	DINT	t/f
155	RideThruRcvrLvl	This is the level of DC Bus voltage where the PWM can become active again when power loss has occurred and power is recovered.	REAL	VDC
156	RideThruStrtLvl	This is the level of bus voltage where the PwrLoss mode is triggered.	REAL	VDC
157	VbusUnderVltgLvl	This is the level set to trigger a bus under voltage event.	REAL	VDC
160	Theta_e	This signal is the Theta_e, the electrical stator angle, in radians.	REAL	Rad
161	Theta_r	This signal is the Theta_r, the electrical rotor angle, in radians.	REAL	Rad
170	IdSyncFdbk	Flux current feedback.	REAL	PKA
171	IqSyncFdbk	Torque current feedback.	REAL	PKA
172	VdSyncFdbk	This signal is the d-axis voltage feedback.	REAL	PKV
173	VqSyncFdbk	This signal is the q-axis voltage feedback.	REAL	PKV
180	VdsCmd	D-axis voltage command in synchronous reference frame.	REAL	PKV
181	VqsCmd	Q-axis voltage command in synchronous reference frame.	REAL	PKV
190	FieldWeakSts	If this signal is non-zero, then the field weakening control is active.	DINT	t/f
191	FluxRegFdFwd	This signal is the flux regulator output feed forward term.	REAL	PKA
192	FlxRegOmgLim	If this signal is non-zero, then the flux regulator is not active. If this signal is zero, then the flux regulator is active.	DINT	t/f

## Port 10 Testpoint Codes (Continued)

No.	Name	Description	Data Type	Units
193	IdCompMtrnlq	This signal displays the corresponding Iq Ref values for IdComp during motoring operation.	REAL	PU
194	IdCompMtrnPu	This signal displays the required IdComp values during motoring.	REAL	PU
195	IdCompRegnlq	This signal displays the corresponding Iq Ref values for IdComp during regen operation.	REAL	PU
196	IdCompRegnPu	This signal displays the required IdComp values during regen operation.	REAL	PU
197	FlxldSyncRef	This signal is the d-axis current reference, which is the output of the flux regulator.	REAL	PkA
198	NegldLim	If this signal is non-zero, then the flux regulator is at negative Id current limit.	DINT	t/f
199	PosldLim	If this signal is non-zero, then the flux regulator is at positive Id current limit.	DINT	t/f
200	VqsFdbkFltrd	This signal is the filtered q-axis voltage feedback.	REAL	PKV
210	FLARPM	This signal is the Slip RPM at full load amps, which is calculated based on the filtered slip gain.	REAL	RPM
211	OmegSlipFilt	This signal is the filtered slip in rad/sec.	REAL	R/S
212	RsGain	This signal is the Rs gain, which is calculated based on the filtered slip gain.	REAL	PU
213	SlipGnFltrd	This signal is the filtered slip gain.	REAL	R/S/A
214	SlipGnLatchd	This signal is the latched slip gain in the slip regulator.	REAL	R/S/A
215	SlipGnLmtd	This signal is the limited slip gain, which is the slip regulator output.	REAL	R/S/A
216	SlipLoTrqLim	If this signal is non-zero, then the slip regulator is not active because the q-axis current reference is below the set value.	DINT	t/f
217	SlipGnMaxLim	If this signal is non-zero, then the slip regulator is at maximum slip gain limit.	DINT	t/f
218	SlipGnMinLim	If this signal is non-zero, then the slip regulator is at minimum slip gain limit.	DINT	t/f
219	SlipIntegOut	This signal is the integration term of the slip regulator output.	REAL	R/S/A
220	SlipPropOut	This signal is the proportional term of the slip regulator output.	REAL	R/S/A
221	VdsFdbkFltrd	This signal is the filtered d-axis voltage feedback.	REAL	PKV
230	IdSyncRef	Flux current command.	REAL	PkA
231	IqSyncRef	Torque command.	REAL	PkA
232	VdSyncFF_Ref	This signal is the feed forward d-axis voltage reference.	REAL	PKV
233	VqSyncFF_Ref	This signal is the feed forward q-axis voltage reference.	REAL	PKV
240	LambdaDsSync	This signal is the d-axis stator flux.	REAL	VSec
241	LambdaDsFilt	This signal is the filtered d-axis stator flux.	REAL	VSec
242	LambdaQsSync	This signal is the q-axis stator flux.	REAL	VSec
243	LambdaQsFilt	This signal is the filtered q-axis stator flux.	REAL	VSec
250	TrqEst	This signal is the estimated torque in N•m.	REAL	Nm
251	TrqEstFltrd	This signal is the filtered estimated torque in N•m.	REAL	Nm
255	ActvCurLim	This is the active current limit value.	REAL	PkA
260	FluxCurMax	This is the maximum flux current value.	REAL	PkA
261	FluxCurMin	This is the minimum flux current value.	REAL	PkA
262	LambdaDsRtd	This signal is the rated d-axis stator flux.	REAL	VSec
263	MtrRtdTrq	This is the motor rated torque value in N•m that is calculated from motor name plate data.	REAL	Nm
264	SlipGnRtd	This is the rated slip gain value.	REAL	R/S/A

## Port 13 Testpoint Codes

No.	Display Name	Description	Data Type	Units
1	VL12Inst	The grid line voltage L12 instantaneously sampled voltage feedback scaled to units of the system.	REAL	Volts
2	VL23Inst	The grid line voltage L23 instantaneously sampled voltage feedback scaled to units of the system.	REAL	Volts
3	VL31Inst	The grid line voltage L31 instantaneously sampled voltage feedback scaled to units of the system.	REAL	Volts
4	VqSyncFdbk	The instantaneous value of the grid line voltage q-axis voltage component in the synchronous reference frame scaled to units of the system.	REAL	Volts
5	VqSyncFilt	The grid line voltage q-axis voltage component in the synchronous reference frame filtered with a low pass filter that has a cutoff frequency of 1 ms, and scaled to units of the system.	REAL	Volts
6	VqSyncFilt1	The grid line voltage q-axis voltage component in the synchronous reference frame filtered with a low pass filter that has a cutoff frequency of 10 ms, and scaled to units of the system.	REAL	Volts
7	VdSyncFdbk	The instantaneous value of the grid line voltage d-axis voltage component in the synchronous reference frame scaled to units of the system.	REAL	Volts
8	VdSyncFilt	The grid line voltage d-axis voltage component in the synchronous reference frame filtered with a low pass filter that has a cutoff frequency of 1 ms, and scaled to units of the system.	REAL	Volts
9	VdSyncFilt1	The grid line voltage d-axis voltage component in the synchronous reference frame filtered with a low pass filter that has a cutoff frequency of 10 ms, and scaled to units of the system.	REAL	Volts
10	VabFdbkFilt	The grid line voltage L12 instantaneously sampled voltage feedback filtered by a low pass filter that has 0.1 ms cutoff frequency and scaled to units of the system.	REAL	Volts
11	VbcFdbkFilt	The grid line voltage L23 instantaneously sampled voltage feedback filtered by a low pass filter that has 0.1 ms cutoff frequency and scaled to units of the system.	REAL	Volts
12	VcaFdbkFilt	The grid line voltage L31 instantaneously sampled voltage feedback filtered by a low pass filter that has 0.1 ms cutoff frequency and scaled to units of the system.	REAL	Volts
13	IaInst	A-phase simultaneously sampled current feedback scaled to units of the system.	REAL	A
14	IbInst	B-phase simultaneously sampled current feedback scaled to units of the system.	REAL	A
15	IcInst	C-phase simultaneously sampled current feedback scaled to units of the system.	REAL	A
16	IOFdbk	The instantaneous value of the zero sequence current/summation of the feedback currents.	REAL	A
17	VbusRateLim	Selected voltage rate of change of the bus voltage, this value is set by a user parameter in case of manual bus reference and it is set to a very high value when it is in optimized mode.	REAL	V/S
18	VbusOptRef	Optimized value of the DC Bus Reference.	REAL	Volts
19	VbusRefLoLim	The calculated minimum possible value of the DC Bus command.	REAL	Volts
20	VbusRefHiLim	The calculated maximum possible value of the DC Bus command.	REAL	Volts
21	VbusLimSts	A status signal indicates if the bus reference is limited.	DINT	t/f
22	VbusErr	The instantaneous error signal between the DC Bus command and the measured DC bus. This signal is processed through the controller of the bus regulator to generate the current reference command.	REAL	Volts

## Port 13 Testpoint Codes (Continued)

No.	Display Name	Description	Data Type	Units
23	VbusRegKi	The integral gain of the bus voltage regulator.	REAL	AS/V
24	VbusRegKp	The proportional gain of the bus voltage regulator.	REAL	A/V
25	IqRefVbusReg	The instantaneous value of the active current command generated by the DC bus voltage regulator.	REAL	A
26	IqRefComp	The instantaneous value of the active current (q-axis current component in the synchronous reference frame) calculated by the LCL steady state compensation algorithm.	REAL	A
27	VqRefComp	The instantaneous value of the grid line voltage (q-axis voltage component in the synchronous reference frame) calculated by the LCL steady state compensation algorithm.	REAL	Volts
28	VdRefComp	The instantaneous value of the grid line voltage (d-axis voltage component in the synchronous reference frame) calculated by the LCL steady state compensation algorithm.	REAL	Volts
29	IdRefComp	The instantaneous value of the reactive current (d-axis current component in the synchronous reference frame) calculated by the LCL steady state compensation algorithm.	REAL	A
30	IqVbusCurLim	The maximum value of the active current component for a given DC bus value, line voltage magnitude, and line reactance, this limit is calculated based on the maximum active power transfer theoretically achievable between the AFE converter and the grid.	REAL	A
31	IdVbusCurLim	The maximum value of the reactive current component for a given DC bus value, line voltage magnitude, and line reactance, this limit is calculated based on the maximum reactive power transfer theoretically achievable between the AFE converter and the grid.	REAL	A
32	ILmtUserSts	A status signal that indicates current is limited by the user current limit parameter.	DINT	t/f
33	IdRefSts	A status signal that indicates d-axis current at limit.	DINT	t/f
34	IqSyncErr	The instantaneous error signal between the active current command and the calculated active current. This signal is processed through the controller of the current regulator to generate the reference voltage command.	REAL	A
35	IdSyncErr	The instantaneous error signal between the reactive current command and the calculated reactive current component. This signal is processed through the controller of the current regulator to generate the reference voltage command.	REAL	A
36	CurRegKilq	The integral gain of the current regulator of the active current component.	REAL	VSec/A
37	CurRegKplq	The proportional gain of the current regulator of the active current component.	REAL	V/A
38	CurRegKild	The integral gain of the current regulator of the reactive current component.	REAL	VSec/A
39	CurRegKpld	The proportional gain of the current regulator of the reactive current component.	REAL	V/A
40	CurRegqOut	The output signal of the current regulator used to regulate the active current component which includes the effect of both the proportional action and the integral action.	REAL	Volts
41	CurRegdOut	The output signal of the current regulator used to regulate the reactive current component which includes the effect of both the proportional action and the integral action.	REAL	Volts



## Port 13 Testpoint Codes (Continued)

No.	Display Name	Description	Data Type	Units
42	VqSyncRef	The final q-axis component of the voltage reference that is connected to the modulator. This component is used along with the d-axis component of the voltage reference to generate the magnitude and the angle of the final voltage reference connected to the modulator.	REAL	Volts
43	VdSyncRef	The final d-axis component of the voltage reference that is connected to the modulator. This component is used along with the q-axis component of the voltage reference to generate the magnitude and the angle of the final voltage reference connected to the modulator.	REAL	Volts
45	CurRegqI	The output of the integral term of the of the current regulator used to regulate the active current component.	REAL	Volts
46	CurRegqP	The output of the proportional term of the of the current regulator used to regulate the active current component.	REAL	Volts
47	VltRefLim	The limited value of the magnitude of the voltage reference used to generate the three phase modulator signals.	REAL	Volts

## Reset as Shipped

The TotalForce control platform can be reset as shipped using the IP address rotary switches. All parameter data is defaulted. Use the following procedure to perform a reset as shipped.

### Reset as Shipped Procedure

1. Power down the product.
2. Locate the three IP address switches on the main control board.
3. Record the positions of the switches so they can be set back to these positions at the end of the procedure.

Hundreds Position	Tens Position	Ones Position

4. Set all three switches to position 8, for an overall value of 888.

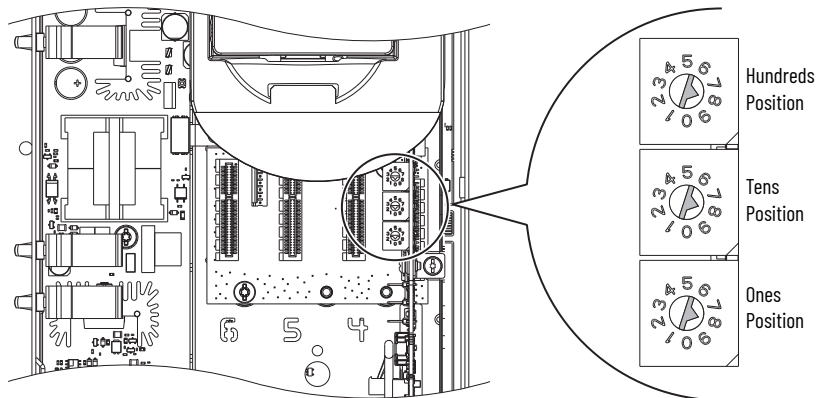

5. Power up the product.  
Wait for the STS indicator to turn flashing red and the ENET indicator to turn solid red.
6. Power down the product.
7. Set the IP address switches to the positions recorded in step 3.
8. Power up the product.

## Recovery Mode

The TotalFORCE control platform has a recovery mode. Recovery mode recreates the product file system and all parameter data is defaulted. Use the following procedure if the processor fails to start up.

### Recovery Mode Procedure

1. Power down the product.
2. Locate the three IP address Switches on the main control board.
3. Record the positions of the switches so they can be set back to these positions at the end of the procedure.

Hundreds Position	Tens Position	Ones Position

4. Set all three switches to position 8, for an overall value of 888.

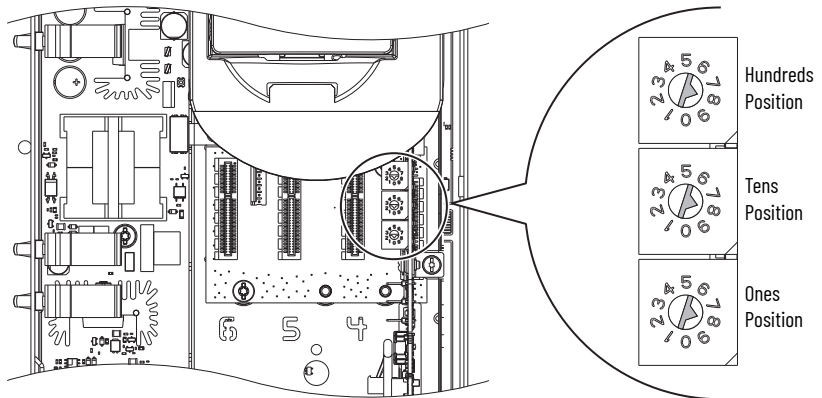

5. Power up the product.
6. Wait for the STS indicator to turn flashing red and the ENET indicator to turn steady red.
7. Power down the product.
8. Set the tens position switch to position 9 and the ones position switch to position 7, for an overall value of 897.

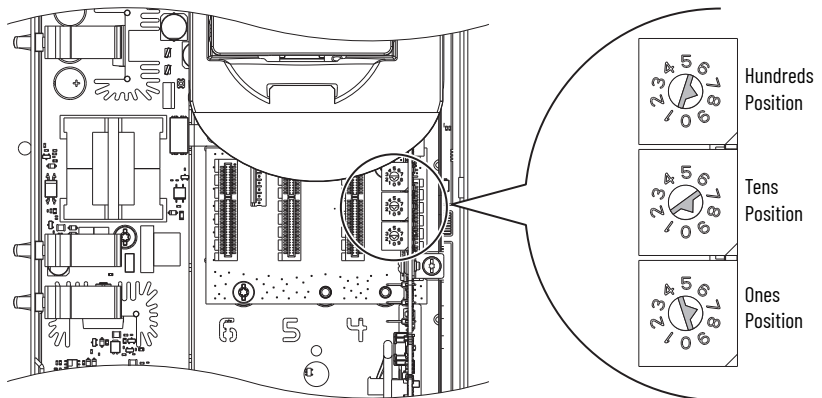

9. Power up the product.
10. Wait for the STS indicator to turn flashing red and ENET indicator to turn steady red.
11. Power down the product.
12. Set the IP address switches to the positions recorded in step 3.
13. Power up the product.

## Secure Erase

PowerFlex 750-Series drives with TotalFORCE control firmware revision 11.xxx and later can be reset with the Secure Erase feature. Secure Erase permanently removes all control and network configurations from the product. This technology protects the product from any attempt at data recovery.

### Use Secure Erase

- When the product is decommissioned for disposal
- When the product is decommissioned and repurposed
- Before return for repair

### Secure Erase Procedure

1. Power down the product.
2. Locate the three IP address Switches on the main control board.
3. Record the positions of the switches so they can be set back to these positions at the end of the procedure.

Hundreds Position	Tens Position	Ones Position

4. Set all three switches to position 8, for an overall value of 888.

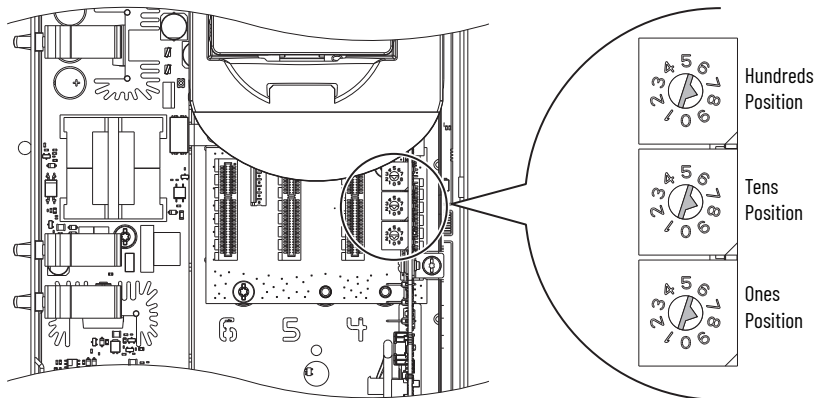

5. Power up the product.
6. Wait for the STS indicator to turn flashing red and the ENET indicator to turn steady red.
7. Power down the product.
8. Set the Ones Position switch to position 9, for an overall value of 889.

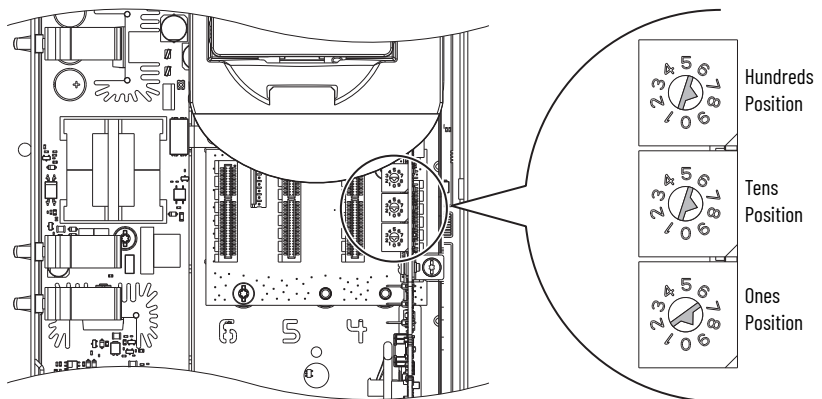

9. Power up the product.  
As Secure Erase executes, the STS indicator and ENET indicator turn flashing red. Wait for the ENET indicator to turn steady red meaning a successful completion of Secure Erase. The procedure takes approximately 15 minutes to complete.
10. Power down the product.

*To return the product to service:*

1. Set the IP address switches to the positions recorded in step 3.
2. Power up the product.
3. Recommission the product.

## Configurable LCL Filter Capacitor Failure Response

Review the Attention statement that follows if you intend to configure the Line Side Converter to produce an alarm instead of a fault when the LCL Capacitor Failure event occurs.



**ATTENTION:** You must read the following information before you can enable the Line Side Converter to produce an alarm instead of a fault when the **LCL Filter Capacitor Failure** event occurs.

Operating the product (drive or bus supply) during the LCL Capacitor Failure event may damage the LCL filter. This damage may lead to catastrophic product failure and collateral damages.

It is your responsibility to configure drive parameters, understand the causes and consequences of LCL capacitor failure, and meet safety requirements in accordance with all applicable codes and standards. If enabling the Line Side Converter to produce an alarm instead of a fault when the LCL Capacitor Failure event occurs is desired, you must certify the safety of the application. To acknowledge that you have read this 'Attention' and properly certified the application, set bit 6 'CapFailAlrm' of parameter 13:40 [Conv Options Cfg]. This action removes Fault 24, 'CapFailureCfg'. It allows parameter 0:452 [LCLCapFailActn] to be set to 0 'Alarm', enabling an alarm instead of a fault.

## Configurable LCL Filter Capacitor Over Resonance Response

Review the Attention statement that follows if you intend to configure the line side converter to produce an alarm instead of a fault when the LCL Capacitor Over Resonance event occurs.



**ATTENTION:** You must read the following information before you can enable the Line Side Converter to produce an alarm instead of a fault when the **LCL Filter Capacitor Over Resonance** event occurs.

Operating the product (drive or bus supply) during the LCL Capacitor Over Resonance event may damage the LCL filter. This damage may lead to catastrophic product failure and collateral damages.

It is your responsibility to configure drive parameters, understand the causes and consequences of LCL capacitor over resonance, and meet safety requirements in accordance with all applicable codes and standards. If enabling the Line Side Converter to produce an alarm instead of a fault when the LCL Capacitor Over Resonance event occurs is desired, you must certify the safety of the application. To acknowledge that you have read this 'Attention' and properly certified the application, set bit 5 'CapORsncAlrm' of parameter 13:40 [Conv Options Cfg]. This action removes Fault 56, 'CapOvrRsncCfg'. It allows parameter 0:453 [CapOvrRsncActn] to be set to 0 'Alarm', enabling an alarm instead of a fault.

## PowerFlex 755T Lifting/ Torque Proving

This section provides important information and instructions for configuring TorqProve™ applications.

### Encoderless TorqProve

Review the Attention statement that follows if you intend to use the TorqProve feature without an encoder.



**ATTENTION:** You must read the following information before you can use TorqProve with no encoder.

Encoderless TorqProve must be limited to lifting applications where personal safety is not a concern. Encoders offer additional protection and must be used where personal safety is a concern. Encoderless TorqProve cannot hold a load at zero speed without a mechanical brake and does not offer additional protection if the brake slips/fails. Loss of control in suspended load applications can cause personal injury and/or equipment damage.

It is your responsibility to configure drive parameters, test any lifting functionality, and meet safety requirements in accordance with all applicable codes and standards. If encoderless TorqProve is desired, you must certify the safety of the application. To acknowledge that you have read this 'Attention' and properly certified the encoderless application, set bit 3 'EnclsTrqProv' of parameter 10:420 [Mtr Cfg Options] to a value of 1. This action removes Alarm 9014 'TP Encls Config' and allows bit 1 'Encoderless' of parameter 9:50 [Trq Prove Cfg] to be changed to 1 enabling encoderless TorqProve.

### TorqProve with Secondary Motor Control

Review the Attention statement that follows if you intend to use the TorqProve feature and allow the drive to switch to the secondary motor control port.



**ATTENTION:** You must read the following information before you can use TorqProve with an active secondary motor control port.

Loss of control in suspended load applications can cause personal injury and/or equipment damage.

It is your responsibility to configure drive parameters, test any lifting functionality, and meet safety requirements in accordance with all applicable codes and standards. If you want to use both the primary and secondary motor control ports, you must certify the safety of the application. To acknowledge that you have read this 'Attention' and properly certified the application, set bit 7 'SecMtrTqProv' of parameter 10:420 [Mtr Cfg Options] to a value of 1. This action removes Alarm 9015 'TP Sec Mtr Ctrl' when bit 0 'TP Enable' of parameter 9:50 [Trq Prove Cfg] is set to 1 enabling TorqProve with secondary motor control.

#### IMPORTANT

The torque prove function can be configured for the primary motor control port only. You cannot configure the torque prove function for the secondary motor control port.

For information on TorqProve applications, see the PowerFlex 750-Series with TotalFORCE Control reference manual, publication [750-RM100](#).

## Technical Support Options

When you contact Technical Support, please be prepared to provide the following information.

### What You Need When You Call Tech Support

- Order number
- Product catalog number and drive series number (if applicable)
- Product serial number
- Firmware revision number
- Fault code listed in 0:610 [Last Fault Code]
- Installed options and port assignments
- Technical Support Wizard; see [page 119](#) or drive parameter list

Also be prepared with:

- A description of your application
- A detailed description of the problem
- A brief history of the drive installation
- First-time installation, product has not been running
- Established installation, product has been running

The data contained in the following parameters will help in initial troubleshooting of a faulted drive. You can use the table below to record the data provided in each parameter listed.

Parameter No.	Parameter Name	Parameter Data
0:610	Last Fault Code	
10:460	Condition Sts A	
10:461	Fault Status A	
10:462	Fault Status B	
10:465	Alarm Status A	
10:466	Alarm Status B	
10:467	Type 2 Alarms	
13:240	Fault Status A	
13:241	Fault Status B	
13:258	Alarm Status A	
13:259	Alarm Status B	
13:260	Type 2 Alarms	

### Technical Support Wizards

If you are connected to a drive via Connected Components Workbench™ (version 11 or later) software, you can run a Tech Support wizard to gather information that will help diagnose problems with your drive and/or peripheral device. The information gathered by the wizard is saved as a text file and can be emailed to your remote technical support contact.

---

**IMPORTANT** The Tech Support wizard cannot be accessed when not connected.

---

**Notes:**



## Permanent Magnet Motors

Allen-Bradley® servo motors are compatible with PowerFlex® 755TS drives.

### Compatible Allen-Bradley Servo Motors

The following table is a list of specifications for Allen-Bradley servo motors that compatible with PowerFlex 755TS drives. This information is provided to help configure PowerFlex 750-Series drives with the appropriate servo motor data. For information regarding compatibility and configuration of any Allen-Bradley servo motors (including RDB Series Direct Drive Motors) and third-party PM motors that are not listed here, contact Allen-Bradley Drives Technical Support.

**Table 4 - Motor Name Plate and Rating Specifications**

Model Number	Motor NP Volts [line to line V rms]	Motor NP Amps [A rms]	Motor NP Hertz [Hz]	Motor NP RPM [oper. rpm]	Motor NP Power [kW]	Motor Poles	Current peak [A rms]	System Cont. Stall Torque [N·m]	Motor Max RPM [rpm]
MPM-A1151M	240	4.2	333.3	5000	0.90	8	21.6	2.18	6000
MPM-A1152F	240	5.9	266.7	4000	1.40	8	31.7	4.74	5000
MPM-A1302F	240	7.4	266.7	4000	1.65	8	35.6	5.99	4500
MPM-A1304F	240	8.1	233.3	3500	2.20	8	34.2	9.30	4000
MPM-A1651F	240	14.5	200.0	3000	2.50	8	52.2	10.70	5000
MPM-A1652F	240	18.1	233.3	3500	4.03	8	73.0	13.50	4000
MPM-A1653F	240	23.2	200.0	3000	5.10	8	84.3	18.60	4000
MPM-A2152F	240	33.7	133.3	2000	5.20	8	89.0	27.00	4000
MPM-A2153F	240	32.8	133.3	2000	5.80	8	85.2	34.00	4600
MPM-A2154C	240	24.8	116.7	1750	6.50	8	89.8	55.00	2000
MPM-A2154E	240	29.6	133.3	2000	7.00	8	90.7	44.00	2650
MPM-B1151F	480	1.5	266.7	4000	0.75	8	7.0	2.18	5000
MPM-B1151T	480	3.1	333.3	5000	0.90	8	14.5	2.18	7000
MPM-B1152C	480	2.3	166.7	2500	1.20	8	8.8	2.18	3000
MPM-B1152F	480	2.9	266.7	4000	1.40	8	15.5	4.74	5200
MPM-B1152T	480	5.2	266.7	4000	1.40	8	26.8	4.74	7000
MPM-B1153E	480	2.7	200.0	3000	1.40	8	15.3	6.55	3500
MPM-B1153F	480	3.2	266.7	4000	1.45	8	22.6	6.55	5500
MPM-B1153T	480	5.5	266.7	4000	1.45	8	39.2	6.55	7000
MPM-B1302F	480	3.4	266.7	4000	1.65	8	15.6	5.99	4500
MPM-B1302M	480	5.0	266.7	4000	1.65	8	22.6	5.99	6000
MPM-B1302T	480	6.6	266.7	4000	1.65	8	30.7	5.99	7000
MPM-B1304C	480	3.4	183.3	2750	2.00	8	15.8	10.20	2750
MPM-B1304E	480	4.1	166.7	2500	2.20	8	24.2	10.20	4000
MPM-B1304M	480	7.3	233.3	3500	2.20	8	42.9	10.20	6000
MPM-B1651C	480	4.7	200.0	3000	2.50	8	20.6	10.70	3500
MPM-B1651F	480	8.2	200.0	3000	2.50	8	36.0	10.70	5000
MPM-B1651M	480	10.9	200.0	3000	2.50	8	40.2	10.70	5000
MPM-B1652C	480	7.0	166.7	2500	3.80	8	23.8	16.00	2500
MPM-B1652E	480	8.0	233.3	3500	4.30	8	42.8	19.40	3500
MPM-B1652F	480	11.0	233.3	3500	4.30	8	59.5	19.40	4500
MPM-B1653C	480	10.5	133.3	2000	4.60	8	41.9	26.80	2500
MPM-B1653E	480	10.2	200.0	3000	5.10	8	51.6	26.80	3500
MPM-B1653F	480	13.2	200.0	3000	5.10	8	66.7	26.80	4000

Table 4 - Motor Name Plate and Rating Specifications (Continued)

Model Number	Motor NP Volts [line to line V rms]	Motor NP Amps [A rms]	Motor NP Hertz [Hz]	Motor NP RPM [oper. rpm]	Motor NP Power [kW]	Motor Poles	Current peak [A rms]	System Cont. Stall Torque [N·m]	Motor Max RPM [rpm]
MPM-B2152C	480	12.3	133.3	2000	5.60	8	39.2	36.70	2500
MPM-B2152F	480	18.7	166.7	2500	5.90	8	69.3	33.00	4500
MPM-B2152M	480	21.0	166.7	2500	5.90	8	54.0	30.00	5000
MPM-B2153B	480	12.7	116.7	1750	6.80	8	42.4	48.00	2000
MPM-B2153E	480	19.3	133.3	2000	7.20	8	69.7	48.00	3000
MPM-B2153F	480	22.1	133.3	2000	7.20	8	69.6	45.00	3800
MPM-B2154B	480	13.9	116.7	1750	6.90	8	69.3	62.80	2000
MPM-B2154E	480	18.3	133.3	2000	7.50	8	69.5	56.00	3000
MPM-B2154F	480	19.8	133.3	2000	7.50	8	59.3	56.00	3300
MPL-A310P	230	3.4	294.0	4410	0.73	8	9.9,	1.58	5000
MPL-A310F	230	2.1	185.3	2780	0.46	8	6.6	1.58	3000
MPL-A320P	230	6.4	271.3	4070	1.30	8	20.9	3.05	5000
MPL-A320H	230	4.6	208.7	3130	1.00	8	13.6	3.05	3500
MPL-A330P	230	8.5	280.7	4210	1.80	8	26.9	4.08	5000
MPL-A420P	230	9.0	268.7	4030	2.00	8	32.5	4.74	5000
MPL-A430P	230	11.9	234.0	3510	2.20	8	47.4	5.99	5000
MPL-A430H	230	8.6	184.7	2770	1.80	8	31.8	6.21	3500
MPL-A4520P	230	12.4	234.0	3510	2.20	8	35.4	5.99	5000
MPL-A4520K	230	10.6	223.3	3350	2.10	8	30.4	5.99	4000
MPL-A4530F	230	9.5	144.7	2170	1.90	8	29.7	8.36	2800
MPL-A4530K	230	14.4	196.0	2940	2.50	8	43.8	8.13	4000
MPL-A4540C	230	6.6	93.3	1400	1.50	8	20.5	10.20	1500
MPL-A4540F	230	13.0	162.0	2430	2.60	8	38.2	10.20	3000
MPL-A520K	230	16.3	208.0	3120	3.50	8	46.0	10.70	4000
MPL-A540K	230	29.3	180.7	2710	5.50	8	84.9	19.40	4000
MPL-A560F	230	29.3	125.3	1880	5.50	8	84.9	27.90	3000
MPL-B310P	460	1.7	310.0	4650	0.77	8	3.0	1.58	5000
MPL-B320P	460	3.2	313.3	4700	1.50	8	5.0	3.05	5000
MPL-B330P	460	4.3	274.0	4110	1.80	8	7.0	4.18	5000
MPL-B420P	460	4.5	255.3	3830	1.90	8	9.2	4.74	5000
MPL-B430P	460	6.5	214.0	3210	2.20	8	12.0	6.55	5000
MPL-B4520P	460	6.0	236.7	3550	2.10	8	17.0	5.65	5000
MPL-B4530F	460	5.0	162.0	2430	2.10	8	13.4	8.25	3000
MPL-B4530K	460	7.8	200.7	3010	2.60	8	19.1	8.25	4000
MPL-B4540F	460	6.4	162.0	2430	2.60	8	16.3	10.20	3000
MPL-B4560F	460	8.3	144.7	2170	3.20	8	25.5	14.10	3000
MPL-B520K	460	8.1	208.0	3120	3.50	8	23.3	10.70	4000
MPL-B540K	460	14.5	177.3	2660	5.40	8	42.4	19.40	4000
MPL-B560F	460	14.5	130.7	1960	5.50	8	42.4	26.80	3000
MPL-B580F	460	18.4	132.7	1990	7.10	8	66.5	34.00	3000
MPL-B580J	460	22.6	148.0	2220	7.90	8	66.5	34.00	3800
MPL-B640F	460	22.7	106.0	1590	6.11	8	46.0	36.70	3000
MPL-B660F	460	27.2	81.3	1220	6.15	8	67.9	48.00	3000
MPL-B680D	460	24.0	94.0	1410	9.30	8	66.5	62.80	2000
MPL-B680F	460	33.9	79.3	1190	7.50	8	67.9	60.00	3000
MPL-B860D	460	33.6	96.0	1440	12.50	8	67.5	83.10	2000
MPL-B880C	460	33.6	72.7	1090	12.60	8	69.0	110.00	1500
MPL-B880D	460	40.3	86.7	1300	15.00	8	113.2	110.00	2000
MPL-B960B	460	29.7	62.0	930	12.70	8	63.6	130.00	1200
MPL-B960C	460	38.9	76.0	1140	14.80	8	88.4	124.30	1500
MPL-B960D	460	50.2	76.7	1150	15.00	8	102.5	124.30	2000
MPL-B980B	460	31.8	59.3	890	15.02	8	70.7	162.70	1000
MPL-B980C	460	48.2	67.3	1010	16.80	8	99.0	158.20	1500
MPL-B980D	460	63.6	74.7	1120	18.60	8	141.4	158.20	2000

Table 4 - Motor Name Plate and Rating Specifications (Continued)

Model Number	Motor NP Volts [line to line V rms]	Motor NP Amps [A rms]	Motor NP Hertz [Hz]	Motor NP RPM [oper. rpm]	Motor NP Power [kW]	Motor Poles	Current peak [A rms]	System Cont. Stall Torque [N·m]	Motor Max RPM [rpm]
MPG-A004-031	230	1.8	222.7	3340	0.21	8	4.0	0.60	6000
MPG-A010-031	230	2.1	189.3	2840	0.36	8	6.0	1.21	4875
MPG-A010-091	230	0.9	295.3	4430	0.19	8	2.3	0.41	5900
MPG-A025-031	230	9.9	181.0	1810	0.88	12	19.8	4.65	5200
MPG-A025-091	230	3.0	168.0	1680	0.52	12	8.5	2.95	5625
MPG-A050-031	230	24.7	120.0	1200	1.50	12	53.0	11.90	2510
MPG-A050-091	230	5.0	275.0	2750	0.75	12	15.6	2.60	3775
MPG-A110-031	230	20.2	122.0	1220	2.20	12	53.0	17.20	2875
MPG-A110-091	230	17.0	184.0	1840	1.60	12	33.2	8.30	3500
MPG-B010-031	460	1.6	162.7	2440	0.34	8	4.4	1.33	6450
MPG-B010-091	460	0.7	357.3	5360	0.23	8	1.5	0.41	6450
MPG-B025-031	460	4.0	219.0	2190	0.92	12	11.3	4.02	4838
MPG-B025-091	460	1.9	175.0	1750	0.54	12	5.2	2.95	5900
MPG-B050-031	460	16.3	92.0	920	1.20	12	32.5	12.40	2510
MPG-B050-091	460	3.4	290.0	2900	0.79	12	9.9	2.60	4560
MPG-B110-031	460	12.9	112.0	1120	2.00	12	31.1	17.00	2420
MPG-B110-091	460	10.6	184.0	1840	1.60	12	20.5	8.30	3500
1326AB-B410G	460	2.5	118.0	3540	1.00	4	7.4	2.70	5000
1326AB-B410J	460	3.5	165.0	4950	1.40	4	10.4	2.70	7250
1326AB-B420E	460	2.8	70.0	2100	1.10	4	8.5	5.00	3000
1326AB-B420H	460	5.5	137.3	4120	2.20	4	15.6	5.10	6000
1326AB-B430E	460	3.9	67.7	2030	1.40	4	11.7	6.60	3000
1326AB-B430G	460	5.6	114.3	3430	2.30	4	16.8	6.40	5000
1326AB-B515E	460	6.1	70.3	2110	2.30	4	18.3	10.40	3000
1326AB-B515G	460	9.5	88.7	2660	2.90	4	28.5	10.40	5000
1326AB-B520E	460	6.7	71.0	2130	2.90	4	20.1	13.00	3000
1326AB-B520F	460	8.8	70.3	2110	2.90	4	26.4	13.10	3500
1326AB-B530E	460	9.5	74.3	2230	4.20	4	28.5	18.00	3000
1326AB-B720E	460	17.5	70.0	2100	6.80	4	52.5	30.90	3500
1326AB-B720F	460	27.5	117.0	3510	11.70	4	66.5	31.80	5000
1326AB-B730E	460	22.8	78.3	2350	9.60	4	66.5	39.00	3350
1326AB-B740C	460	20.9	52.3	1570	8.70	4	62.7	53.00	2200
1326AB-B740E	460	32.0	79.7	2390	12.70	4	66.5	50.80	3400
1326AS-B310H	460	0.8	204.5	4090	0.30	6	2.4	0.70	6200
1326AS-B330H	460	2.1	204.5	4090	0.90	6	6.0	2.10	6500
1326AS-B420G	460	2.6	179.0	3580	1.20	6	7.8	3.20	5250
1326AS-B440G	460	5.4	149.0	2980	2.00	6	16.2	6.40	5250
1326AS-B460F	460	6.2	148.5	2970	2.80	6	18.6	9.00	4300
1326AS-B630F	460	7.8	142.7	2140	2.40	8	18.5	10.70	4500
1326AS-B660E	460	11.8	100.7	1510	3.40	8	29.8	21.50	3000
1326AS-B690E	460	19.0	87.3	1310	5.00	8	41.3	36.40	3000
1326AS-B840E	460	21.2	79.3	1190	4.70	8	39.5	37.60	3000
1326AS-B860C	460	17.6	77.3	1160	6.00	8	44.4	49.30	2000
1326AH-B330F	460	2.1	0.0	3000	0.75	-	9.0	-	3000
1326AH-B440F	460	3.3	0.0	2500	1.22	-	13.8	-	2500
1326AH-B540F	460	11.1	0.0	2500	2.60	-	47.2	-	2500
3050R-7	390	66.0	50.0	500	30.00	12	132.0	-	500
11050R-7	390	218.0	50.0	500	110.00	12	436.0	-	500

**Notes:**

## Develop Secure Applications

These PowerFlex® 755T products with TotalFORCE® Control firmware revision 13.002 or later support IEC-62443-4-2 SL 1 security requirements:

- PowerFlex 755TL low harmonic non-regenerative drives
- PowerFlex 755TR regenerative drives
- PowerFlex 755TM regenerative bus-supplies
- PowerFlex 755TM common-bus inverters
- PowerFlex 755TS AC drives

To help meet these requirements, you must use this publication and the Configure System Security Features User Manual, publication [SECURE-UM001](#). The Configure System Security Features User Manual describes how to configure and use Rockwell Automation products to improve the security of your industrial automation system.

If ControlLogix® 5580 or GuardLogix® 5580 controller is used in your control system, the ControlLogix 5580 and GuardLogix 5580 Controllers User Manual, [1756-UM543](#) must be used to complement the requirements in this publication.

You can apply these same measures to other PowerFlex drives. IEC 62443-4-2 SL1 certification for the devices that are listed is pending. For the most recent product certification information, see [rok.auto/certifications](http://rok.auto/certifications).

Resource	Description
System Security Design Guidelines Reference Manual, publication <a href="#">SECURE-RM001</a>	Provides guidance on how to conduct security assessments, implement Rockwell Automation products in a secure system, harden the control system, manage user access, and dispose of equipment.
Logix 5000 Controllers Security Programming Manual, publication <a href="#">1756-PM016</a>	Describes how to configure security for the Studio 5000 Logix Designer® application, and explains how to configure source protection for your logic and projects.
CIP Security with Rockwell Automation Products Application Technique, publication <a href="#">SECURE-AT001</a>	Describes how to plan and implement a Rockwell Automation system that supports the CIP Security™ protocol.
FactoryTalk Security Application Technique, publication <a href="#">SECURE-AT002</a>	Describes how to use FactoryTalk Security to implement authentication and authorization in your industrial automation system, how to enforce product-specific security for Studio 5000 Logix Designer, FactoryTalk View, and FactoryTalk AssetCentre.
Converged Plantwide Ethernet (CPwE) Design and Implementation Guide, publication <a href="#">ENET-TD001</a>	Defines manufacturing-focused reference architectures to help accelerate the successful deployment of standard networking technologies and convergence of manufacturing and enterprise/business networks.

# Drive Security Features

For PowerFlex 755T products to comply with the certification requirements, implement the control system with these other security-focused products.

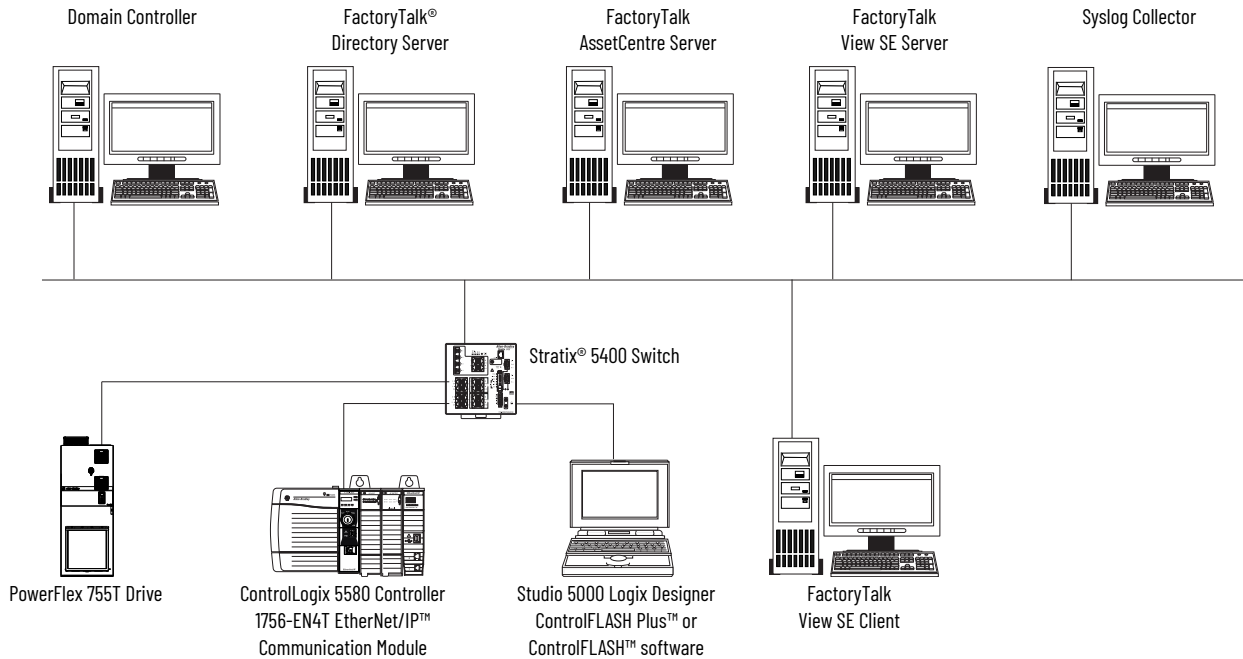

## Security Checklists

Follow the security checklists in this chapter to secure the system and the drive. It is your responsibility to monitor the system periodically to make sure that the security settings function as you configured them.

**Table 5 - Requirements for Identification and Authorization**

✓	Product	Required to Meet IEC-62443-4-2 SL 1	Details
	FactoryTalk® Security software Studio 5000 Logix Designer application	Yes	Configure FactoryTalk Security to define policies, user groups, and other permission sets. <ul style="list-style-type: none"> <li>The Logix Designer application enforces the policy based on the access policies that are provided to it by FactoryTalk Security for the software authenticated user. Once authenticated, the Logix Designer application acts as your interface to the drives via the controller. This applies to all protected CIP™ communications to the drive, whether from Ethernet, backplane, or USB.</li> <li>The FactoryTalk Services Platform offers feature access control to manage user access to product features such as controller download, project import, project create, and firmware update.</li> </ul> For more information, see the following: <ul style="list-style-type: none"> <li>Configure System Security Features User Manual, publication <a href="#">SECURE-UM001</a></li> <li>FactoryTalk Security System Configuration Guide, publication <a href="#">FTSEC-QS001</a></li> </ul>
	Microsoft® Active Directory service	Yes	Active Directory is used to create and configure the policies for each user and user group. <ul style="list-style-type: none"> <li>Create at least two user types and assign a minimum level of user permission for each type.</li> <li>Enforces the password policy according to industry password standard.</li> <li>Define the user account access settings.</li> <li>Define the System use notifications settings.</li> <li>Define the System inactivity lockout setting.</li> </ul> For more information, see the following: <ul style="list-style-type: none"> <li>Configure System Security Features User Manual, publication <a href="#">SECURE-UM001</a></li> </ul>

Table 6 - Requirements for Use Control

✓	Product	Required to Meet IEC-62443-4-2 SL 1	Details
	FactoryTalk® Security software Studio 5000 Logix Designer application	Yes	<p>Configure FactoryTalk Security to define policies, user groups, and other permission sets.</p> <ul style="list-style-type: none"> <li>The Logix Designer application enforces the policy based on the access policies that are provided to it by FactoryTalk Security for the software authenticated user. Once authenticated, the Logix Designer application acts as your interface to the drives via the controller. This applies to all protected CIP™ communications to the drive, whether from Ethernet, backplane, or USB.</li> <li>The FactoryTalk Services Platform offers feature access control to manage user access to product features, such as project import, project create, enable DeviceLogix (applicable for I/O mode only), change logic, project download to drive and firmware update.</li> <li>In FactoryTalk Security, define which users can change and download projects to the drive.</li> <li>Security authority binding restricts the controller to a specific FactoryTalk Security instance. This binding reduces the attack surface for security server spoofing because the client software and the security software determine the identity of the security authority responsible for controlling access.</li> </ul> <p>For more information, see the following:</p> <ul style="list-style-type: none"> <li>Configure System Security Features User Manual, publication <a href="#">SECURE-UM001</a>.</li> <li>FactoryTalk Security System Configuration Guide, publication <a href="#">FTSEC-OS001</a>.</li> </ul>
	Microsoft® Active Directory service	Yes	<p>Active Directory is used to create and configure the policies for each user and user group.</p> <ul style="list-style-type: none"> <li>Create at least two user types and assign a minimum level of user permission for each type.</li> <li>Enforces the password policy according to industry password standard.</li> <li>Define the user account access settings.</li> <li>Define the System use notifications settings.</li> <li>Define the System inactivity lockout setting.</li> </ul> <p>For more information, see the following:</p> <ul style="list-style-type: none"> <li>Configure System Security Features User Manual, publication <a href="#">SECURE-UM001</a>.</li> </ul>
	Secure DPI Ports	Yes	<p>Applicable for I/O mode only: HIM and Communication option cards are connected to the drive through DPI ports and should be secured by configuring the mask parameters in the drive. After product commissioning, HIM should be either removed or set to read-only mode. To remove HIM, see instructions in the PowerFlex 20-HIM-A6 and 20-HIM-C6S HIM User Manual, publication <a href="#">20HIM-UM001</a>. Communication option cards should also be disallowed from controlling the logic command (start, jog, change of direction, and so forth) of the drive. The following mask parameters can be used to configure the control to logic command and to set read-only mode:</p> <ul style="list-style-type: none"> <li>0:41 [Logic Mask]</li> <li>0:230 [Write Mask Cfg]</li> </ul> <p>For more information, see CIP Security with Rockwell Automation Products, publication <a href="#">SECURE-AT001</a>.</p> <hr/> <p>Applicable for CIP Motion mode only: HIM can only be used for monitoring and cannot be used to control the drive or change configuration settings. For more information, see Integrated Motion on the EtherNet/IP Network: Configuration and Startup User Manual, publication <a href="#">MOTION-UM003</a>.</p>
	FactoryTalk Policy Manager	Yes	<p>FactoryTalk Policy Manager is a secure configuration tool that is one of a set of products that Rockwell Automation uses to implement CIP Security. CIP Security helps to provide a secure data transport across an EtherNet/IP network. Use FactoryTalk Policy Manager software to create zones and turn on CIP Security to check for data integrity.</p> <ul style="list-style-type: none"> <li>Enable integrity + Confidentiality in both I/O Data Security and Messaging Security.</li> </ul> <p>For more information, see CIP Security with Rockwell Automation Products, publication <a href="#">SECURE-AT001</a>.</p>

Table 6 - Requirements for Use Control (Continued)

✓	Product	Required to Meet IEC-62443-4-2 SL 1	Details
	FactoryTalk AssetCentre software	Yes	Configure and use the following: <ul style="list-style-type: none"> <li>• Audit log accessibility</li> <li>• Continuous monitoring</li> </ul> For more information, see the following: <ul style="list-style-type: none"> <li>• Configure System Security Features User Manual, publication <a href="#">SECURE-UM001</a>.</li> <li>• System Security Design Guidelines Reference Manual, publication <a href="#">SECURE-RM001</a>.</li> </ul>
	Syslog collector	Yes, if not using FactoryTalk AssetCentre for logging	The Drive supports syslog event logging. Choose a syslog collector that supports the following: <ul style="list-style-type: none"> <li>• RFC-5424 syslog protocol</li> <li>• Ability to receive messages from the drives</li> </ul> <b>IMPORTANT:</b> The drive sends events to a syslog collector through its Ethernet port. The Ethernet port must be connected to the same network as the syslog collector. To set the IP address of the syslog collector, use FactoryTalk Policy Manager software. For more information, see CIP Security with Rockwell Automation Products Application Technique, publication <a href="#">SECURE-AT001</a> . To view a list of syslog messages and their descriptions, see the PowerFlex Drives with TotalFORCE Control Conditions Reference Data, publication <a href="#">750-RD102</a> .
	Secure Hardware Input Device	Yes, if the hardware input device is programmed to control critical function	Hardware input devices such as pushbuttons can be programmed to control critical functions such as start, stop, and reset via discrete I/O port available on drive using DeviceLogix. To apply security measures, for example, limiting physical access on such hardware input devices to prevent accidental or intentional alteration of drive critical function state.

Table 7 - Requirements for System Integrity

✓	Product	Required to Meet IEC-62443-4-2 SL 1	Details
	FactoryTalk AssetCentre software		The FactoryTalk AssetCentre server centrally tracks and manages configuration changes and restricts who can make changes based on FactoryTalk Security settings. This server functionality assists with diagnostics and troubleshooting and reduces maintenance time for production assets.
	FactoryTalk Services Platform (includes FactoryTalk Security, FactoryTalk Diagnostics)	Yes	Configure the feature security for users to limit access to action such as triggering download of DeviceLogix (applicable for I/O mode only) program, downloading firmware to the drive and configure the Device Monitor - Change Detect operation. For more information, see Configure System Security Features User Manual, publication <a href="#">SECURE-UM001</a> . Configure the routing and logging option of the FactoryTalk Diagnostics. Monitor security-related events by setting up audit policies. For more information, see FactoryTalk Security System Configuration Guide, publication <a href="#">FTSEC-OS001</a> .
	FactoryTalk Policy Manager	Yes	FactoryTalk Policy Manager is a secure configuration tool that is one of a set of products that Rockwell Automation uses to implement CIP Security. CIP Security helps to provide a secure data transport across an EtherNet/IP network. Use FactoryTalk Policy Manager software to create zones and turn on CIP Security to differentiate trusted and untrusted devices. For more information, see CIP Security with Rockwell Automation Products, publication <a href="#">SECURE-AT001</a> .
	Secure DPI Ports	Yes	Applicable for I/O mode only: HIM and Communication option cards are connected to the drive through DPI ports and should be secured by configuring the mask parameters in the drive. After product commissioning, HIM should be either removed or set to read-only mode. To remove HIM, see instruction on PowerFlex 20-HIM-A6 and 20-HIM-C6S HIM User Manual, publication <a href="#">20HIM-UM001</a> . Communication option cards should also be disallowed from controlling the logic command (start, jog, change of direction, and so forth) of the drive. The following mask parameters can be used to configure the control to logic command and to set read-only mode: <ul style="list-style-type: none"> <li>• 0:41 [Logic Mask]</li> <li>• 0:230 [Write Mask Cfg]</li> </ul> For more information, see CIP Security with Rockwell Automation Products, publication <a href="#">SECURE-AT001</a> .
	Limit physical access to drive and its HIM	Yes	Actively managed physical access to the drive and its HIM. Secure physical access to the drive and HIM by limiting physical access through locked cabinets and raising awareness of threats through training and communication to personnel. For more information, see System Security Design Guidelines Reference Manual, publication <a href="#">SECURE-RM001</a> .



Table 7 - Requirements for System Integrity (Continued)

✓	Product	Required to Meet IEC-62443-4-2 SL 1	Details
	ControlFLASH Plus™ or ControlFLASH™ software	Yes	Use ControlFLASH Plus or ControlFLASH software to update drive firmware. Digitally signed firmware files have a DMK (Device Management Kit) extension. ControlFLASH software authenticates the origin of a DMK file and validates the file before download in the device.
	Studio 5000 Logix Designer application	Yes	This application is required to interface with CIP Security-enabled Logix controllers. There is a feature to generate a signature on an Add-On Instruction. This signature seals (encrypts) the Add-On Instruction to help prevent modification.
	Digitally signed firmware	Yes	To meet IEC-62443-4-2 SL 1 security requirements, you must use a certified version of the TotalFORCE Control drive firmware revision 13.002 or later. We recommend that you use the latest revision from Rockwell Automation official download portal Product Compatibility & Download Center at <a href="http://rok.auto/pcdc">rok.auto/pcdc</a> .
	User-configurable fault handling	Yes	Applicable for I/O mode only: There are 5 fault action options (fault, stop, zero data, hold last and send Flt Cfg) available that can be set when certain fault occurs. Configure based on use case if the default action (fault) is not suitable. For more information, see PowerFlex Drives with TotalFORCE Control Built-in EtherNet/IP Adapter User Manual, publication <a href="#">750COM-UM009</a> .

Table 8 - Requirements for Data Confidentiality

✓	Product	Required to Meet IEC-62443-4-2 SL 1	Details
	FactoryTalk Policy Manager software	Yes	Use the FactoryTalk Policy Manager software to define a secure data transport over an EtherNet/IP™ network by enabling CIP Security. CIP Security protects EtherNet/IP data while in transit with TLS and DTLS. Configure the CIP Security to include data confidentiality so that messages will be encrypted during exchanged across the EtherNet/IP network. For more information, see CIP Security with Rockwell Automation Products Application Technique, publication <a href="#">SECURE-AT001</a> .
	License-based source and execution protection	May be required based on system design, threat model, and risk assessment.	Configure licenses to manage access to DeviceLogix program with Studio 5000 Logix Designer application. For more information, see ControlLogix 5580 and GuardLogix 5580 Controllers User Manual, publication <a href="#">1756-UM543</a> .
	Secure DPI Ports	Yes	Applicable for I/O mode only: HIM and Communication option cards are connected to the drive through DPI ports and should be secured by configuring the mask parameters in the drive. After product commissioning, HIM should be either remove or set to read-only mode. To remove HIM, see instructions in the PowerFlex 20-HIM-A6 and 20-HIM-C6S HIM (Human Interface Module) User Manual, publication <a href="#">20HIM-UM001</a> . Communication option cards should also be disallowed from controlling the logic command (start, jog, change of direction, and so forth) of the drive. The following mask parameters can be used to configure the control to logic command and to set read-only mode: <ul style="list-style-type: none"> <li>• 0:41 [Logic Mask]</li> <li>• 0:230 [Write Mask Cfg]</li> </ul> For more information, see CIP Security with Rockwell Automation Products, publication <a href="#">SECURE-AT001</a> . Applicable for CIP Motion mode only: HIM can only be used for monitoring and cannot be used to control the drive or change configuration settings. For more information, see Integrated Motion on the EtherNet/IP Network: Configuration and Startup User Manual, publication <a href="#">MOTION-UM003</a> .
	Limit physical access to drive and its HIM	Yes	Actively managed physical access to the drive and its HIM. Secure physical access to the drive and HIM by limiting physical access through locked cabinets and raising awareness of threats through training and communication to personnel. For more information, see System Security Design Guidelines Reference Manual, publication <a href="#">SECURE-RM001</a> .

Table 9 - Requirements for Restricted Data Flow

✓	Product	Required to Meet IEC-62443-4-2 SL 1	Details
	CIP Security™	Yes	<p>Configure FactoryTalk Policy Manager software to define the zones, devices, and conduits for secure data transport through CIP Security. CIP Security shall be enabled for the devices within a security zone and each device identity shall be authenticated with a pre-shared key or certificate. For more information, see the following:</p> <ul style="list-style-type: none"> <li>• CIP Security with Rockwell Automation Products Application Technique, publication <a href="#">SECURE-AT001</a>.</li> <li>• FactoryTalk Policy Manager Getting Results Guide, publication <a href="#">FTALK-GRO01</a>.</li> </ul>

Table 10 - Requirements for Timely Response to Events

✓	Product	Required to Meet IEC-62443-4-2 SL 1	Details
	FactoryTalk AssetCentre software	Yes	<p>Configure and use the following:</p> <ul style="list-style-type: none"> <li>• Audit log accessibility</li> <li>• Continuous monitoring</li> </ul> <p>For more information, see the following:</p> <ul style="list-style-type: none"> <li>• Configure System Security Features User Manual, publication <a href="#">SECURE-UM001</a>.</li> <li>• System Security Design Guidelines Reference Manual, publication <a href="#">SECURE-RM001</a>.</li> </ul>
	Syslog collector	Yes, if not using FactoryTalk AssetCentre for logging	<p>The Drive supports syslog event logging. Choose a syslog collector that supports the following:</p> <ul style="list-style-type: none"> <li>• RFC-5424 syslog protocol</li> <li>• Ability to receive messages from the drives</li> </ul> <p><b>IMPORTANT:</b> The drive sends events to a syslog collector through its Ethernet port. The Ethernet port must be connected to the same network as the syslog collector. To set the IP address of the syslog collector, use FactoryTalk Policy Manager software. For more information, see CIP Security with Rockwell Automation Products Application Technique, publication <a href="#">SECURE-AT001</a>. To view a list of syslog messages and their descriptions, see PowerFlex Drives with TotalFORCE Control Conditions Reference Data, publication <a href="#">750-RD102</a>.</p>

Table 11 - Requirements for Resource Availability

✓	Product	Required to Meet IEC-62443-4-2 SL 1	Details
	FactoryTalk AssetCentre software	Yes	<p>Configure and use the following:</p> <ul style="list-style-type: none"> <li>• Asset inventory</li> <li>• Control system backup</li> <li>• Disaster recovery</li> </ul> <p>For more information, see the following:</p> <ul style="list-style-type: none"> <li>• Configure System Security Features User Manual, publication <a href="#">SECURE-UM001</a>.</li> <li>• System Security Design Guidelines Reference Manual, publication <a href="#">SECURE-RM001</a>.</li> </ul>
	CIP Security™	Yes	<p>Configure FactoryTalk Policy Manager software to define the zones, devices, and conduits for secure data transport through CIP Security. CIP Security shall be enabled for the devices within a security zone and each device identity shall be authenticated with a pre-shared key or certificate. For more information, see the following:</p> <ul style="list-style-type: none"> <li>• CIP Security with Rockwell Automation Products Application Technique, publication <a href="#">SECURE-AT001</a>.</li> <li>• FactoryTalk Policy Manager Getting Results Guide, publication <a href="#">FTALK-GRO01</a>.</li> </ul>
	Automatic Device Configuration (ADC)	Yes	<p>Applicable for I/O mode only:</p> <p>Enable the ADC feature to allow the controller to automatically load the saved drive parameter settings into a drive on Ethernet/IP connection establishment if the controller detects a difference with the saved configuration. For more information, refer to the PowerFlex Drives with TotalFORCE Control Built-in EtherNet/IP Adapter, publication <a href="#">750COM-UM009</a>.</p>

Table 11 - Requirements for Resource Availability (Continued)

✓	Product	Required to Meet IEC-62443-4-2 SL 1	Details
	CopyCat	Yes, if ADC is not enabled	Applicable for I/O mode only: The drives support CopyCat function that allows user to upload individual or multiple parameters set for the host drive or any of its connected peripherals into the HIM. For more information, see the PowerFlex 20-HIM-A6 and 20-HIM-C6S HIM (Human Interface Module) User Manual, publication <a href="#">20HIM-UM001</a> .
	Studio 5000 Logix Designer application	Yes, if ADC is not enabled	Drive configuration settings, including drive parameters, can be kept in the controller project file (.ACD). For more information, see PowerFlex Drives with TotalFORCE Control Built-in EtherNet/IP Adapter, publication <a href="#">750COM-UM009</a> .
	Restrict Unused Open Ports	Yes	To restrict the unused open ports, user is required to identify the open ports and send CIP command with TCP/IP Interface object (0xF5) and services code as below: 0x4C: To configure the state (open / closed) of a specific port number. 0x4D: To configure the state (enabled / disabled) of a specific protocol number. For more information, see PowerFlex Drives with TotalFORCE Control Built-in EtherNet/IP Adapter, publication <a href="#">750COM-UM009</a> .

**Notes:**

## Numerics

### 11-Series inputs & outputs

analog 82  
ATEX 83  
digital 81

### 22-Series inputs & outputs

analog 80  
digital 79

## A

### alarm codes

types 90  
viewing 90

### alarms

access documentation on 5, 89  
display codes explained 104

## B

### basic parameter view 18, 19

### block diagrams 21

11-Series inputs & outputs  
analog 82  
ATEX 83  
digital 81

22-Series inputs & outputs  
analog 80  
digital 79

CBI metering signals 43  
control logic 84  
current control 38  
current reference generator 29  
current/power limits 37  
DC bus observer 35  
drive derating 40  
droop control 31  
dynamic bus control 32  
feedback configuration & status 44  
flux vector overview 41  
friction compensation 66  
high speed trend wizard 86  
inverter overload IT 85  
line side converter data 28  
load observer 65  
LSC control configuration 39  
metering 25  
MOP control 78  
motor overload 86  
phase locked loop 26  
position control  
phase locked loop 50  
position reference CAM 51  
profiler/indexer 1 52  
profiler/indexer 2 53  
roll position indicator 54  
spindle orient 55  
position homing 45  
position reference

move profile 47  
position reference 1 46  
position reference 2 48  
position regulator 49  
power factor correction 36  
power loss 27  
PowerFlex 755T converter overview 24  
process control 1 73  
process control 2 74  
progressive cavity pump 76  
pump jack 76  
pump off 77  
reactive power control 30  
reference notch filter  
crane application 75  
torque control  
current IPM 71  
current SRM 72  
torque filters 69  
torque overview 63  
torque reference 68  
current IM, SPM 70  
selection 64  
torque reference CAM 67  
variable frequency, SV overview 42  
velocity reference  
all 58  
CAM 61  
flux vector 59  
flux vector move profiles 60  
overview 56  
selection 57  
velocity regulator  
flux vector 62  
voltage control 34  
voltage reference generator 33

## C

### CBI metering signals 43

### CIP security 7

### common symptoms, troubleshooting 104

### control logic 84

### current control 38

### current reference generator 29

### current/power limits 37

## D

### datalinks

problems adding 106

### DC bus observer 35

### default parameter settings 100

### downloads, firmware and other files 5

### drive derating 40

### drive faults when stopped 106

### drive state 92

### drive will not

accelerate 105  
change motor direction 105  
change speed 105  
start 104

**droop control** 31  
**dynamic bus control** 32

## E

**events** 90  
 access documentation on 5, 89  
 viewing 90

## F

**faults**  
 AC precharge 7-segment display 94  
 access documentation on 5, 89  
 clearing 91  
 DC precharge 7-segment display 97  
 display codes explained 104  
 display screen 91  
 types 90  
 viewing 90  
**feedback configuration & status** 44  
**file group parameter organization** 18  
**firmware, download** 5  
**flux vector overview** 41  
**friction compensation** 66

## H

**high speed trend wizard** 86

## I

**inverter overload IT** 85

## L

**LEDs** 92  
**line side converter data** 28  
**load observer** 65  
**LSC control configuration** 39

## M

**metering** 25  
**MOP control** 78  
**motor**  
 direction 105  
 operation is unstable 105  
**motor overload** 86

## P

**Parameter Access Level**  
 Explanation 17  
**parameter descriptions**  
 access documentation 7, 89  
 access documentation on 5  
**parameters**  
 basic view 18, 19  
 how organized 18  
 setting to factory defaults 100  
**phase locked loop** 26

## position control

phase locked loop 50  
 position reference CAM 51  
 profiler/indexer 1 52  
 profiler/indexer 2 53  
 roll position indicator 54  
 spindle orient 55

**position homing** 45

**position reference**

move profile 47

**position reference 1** 46

**position reference 2** 48

**position regulator** 49

**power factor correction** 36

**power loss** 27

**PowerFlex 755T converter overview** 24

**problems with**

motor direction 105  
 speed command 105  
 starting the drive 104  
 stopping the drive 106

**process control 1** 73

**process control 2**

block diagram 74

**progressive cavity pump** 76

**pump jack** 76

**pump off** 77

## R

**reactive power control** 30

**reference notch filter** 75

**reset parameter defaults** 100

## S

**speed command**

problems with 105

**start**

problems with 104

**startup information** 7

**status indicators** 92

AC precharge 94

DC precharge 97

fiber-optic interface 99

power layer interface 93

**status indicators fiber-optic transceiver** 100

**stop**

problems with 106

**support, product** 119

## T

**technical support**

contacting 119

**testpoints** 107

**torque control**

current IM, SPM 70

current IPM 71

current SRM 72

**torque filters** 69

**torque overview** 63

**torque reference** 68  
    selection 64  
**torque reference CAM** 67  
**troubleshooting** 89  
    common symptoms 104

## V

**variable frequency, SV overview** 42  
**velocity reference**  
    all 58  
    CAM 61  
    flux vector 59  
    flux vector move profiles 60  
    overview 56  
    selection 57  
**velocity regulator**  
    flux vector 62  
**voltage control** 34  
**voltage reference generator** 33

**Notes:**



## Additional Resources

These documents contain additional information concerning related products from Rockwell Automation.

Resource	Description
PowerFlex Drives with TotalFORCE Control Parameters Reference Data, publication <a href="#">750-RD101</a>	Provides the parameters for PowerFlex products with TotalFORCE control.
PowerFlex Drives with TotalFORCE Control Conditions Reference Data, publication <a href="#">750-RD102</a>	Provides the fault, alarm, event, and exception codes for PowerFlex products with TotalFORCE control.
PowerFlex 750-Series Products with TotalFORCE Control Technical Data, publication <a href="#">750-TD100</a>	Provides detailed information on: <ul style="list-style-type: none"> <li>• Drive and bus supply specifications</li> <li>• Option specifications</li> <li>• Fuse and circuit breaker ratings</li> </ul>
PowerFlex 755TM IP00 Open Type Kits Technical Data, publication <a href="#">750-TD101</a>	Provides detailed information on: <ul style="list-style-type: none"> <li>• Kit selection</li> <li>• Kit ratings and specifications</li> <li>• Option specifications</li> </ul>
PowerFlex 755TS Products with TotalFORCE Control Technical Data, publication <a href="#">750-TD104</a>	Provides detailed information on: <ul style="list-style-type: none"> <li>• Drive specifications</li> <li>• Option specifications</li> <li>• Fuse and circuit breaker ratings</li> </ul>
PowerFlex 750-Series Products with TotalFORCE Control Installation Instructions, publication <a href="#">750-IN100</a>	Provides the basic steps to install PowerFlex 755TL low harmonic drives, PowerFlex 755TR regenerative drives, and PowerFlex 755TM drive systems.
PowerFlex 755TS Products with TotalFORCE Control Installation Instructions, publication <a href="#">750-IN119</a>	Provides the basic steps to install PowerFlex 755TS drives.
PowerFlex 755T Flux Vector Tuning, publication <a href="#">750-AT006</a>	Provides guidance on how to tune Flux Vector position and velocity loops, filters, and other features to achieve the level of performance that is required for a given application. This publication is intended for novice drives users and users with advanced skills.
PowerFlex 20-HIM-A6 / -C6S HIM (Human Interface Module) User Manual, publication <a href="#">20HIM-UM001</a>	Provides detailed information on HIM components, operation, and features.
PowerFlex 755TM IP00 Open Type Kits Installation Instructions, publication <a href="#">750-IN101</a>	Provides instructions to install IP00 Open Type kits in user-supplied enclosures.
PowerFlex 755TM AC Precharge Modules Unpacking and Lifting Instructions, publication <a href="#">750-IN102</a>	These publications provide detailed information on: <ul style="list-style-type: none"> <li>• Component weights</li> <li>• Precautions and recommendations</li> <li>• Hardware attachment points</li> <li>• Lifting the component out of the packaging</li> </ul>
PowerFlex 755TM DC Precharge Modules Unpacking and Lifting Instructions, publication <a href="#">750-IN103</a>	
PowerFlex 755TM Power and Filter Modules Unpacking and Lifting Instructions, publication <a href="#">750-IN104</a>	
PowerFlex 750-Series Service Cart and DCPC Module Lift Instructions, publication <a href="#">750-IN105</a>	Provides detailed setup and operating instructions for the module service cart and DC precharge module lift.
PowerFlex 755TM Power and Filter Module Storage Hardware Instructions, publication <a href="#">750-IN106</a>	Provides detailed installation and usage instructions for this hardware accessory.
PowerFlex 755T Module Service Ramp Instructions, publication <a href="#">750-IN108</a>	Provides detailed usage instructions for the module service ramp.
PowerFlex 750-Series I/O, Feedback, and Power Option Modules Installation, publication <a href="#">750-IN111</a>	Provides instructions to install and wire 750-Series option modules.
PowerFlex Drives with TotalFORCE Control Programming Manual (firmware revision 6.xxx and earlier), publication <a href="#">750-PM100</a>	Provides detailed information on: <ul style="list-style-type: none"> <li>• I/O, control, and feedback options</li> <li>• Parameters and programming</li> <li>• Faults, alarms, and troubleshooting</li> </ul>
PowerFlex 750-Series Products with TotalFORCE Control Reference Manual, publication <a href="#">750-RM100</a>	Provides detailed setup and programming instructions for common applications.
PowerFlex 750-Series Products with TotalFORCE Control Hardware Service Manual, publication <a href="#">750-TG100</a>	Provides detailed information on: <ul style="list-style-type: none"> <li>• Preventive maintenance</li> <li>• Component testing</li> <li>• Hardware replacement procedures</li> </ul>

Resource	Description
PowerFlex 750-Series Safe Speed Monitor Option Module Safety Reference Manual, publication <a href="#">750-RM001</a>	These publications provide detailed information on installation, setup, and operation of the 750-Series safety option modules.
PowerFlex 750-Series Safe Torque Off Option Module User Manual, publication <a href="#">750-UM002</a>	
PowerFlex 750-Series ATEX Option Module User Manual, publication <a href="#">750-UM003</a>	
PowerFlex 755 Integrated Safety - Safe Torque Off Option Module User Manual, publication <a href="#">750-UM004</a>	
PowerFlex 755/755T Integrated Safety Functions Option Module User Manual, publication <a href="#">750-UM005</a>	
PowerFlex Drives with TotalFORCE Control Built-in EtherNet/IP™ Adapter User Manual, publication <a href="#">750COM-UM009</a>	Provides information on how to install, configure, and troubleshoot applications for the PowerFlex drives with the built-in EtherNet/IP adapter.
Industry Installation Guidelines for Pulse Width Modulated (PWM) AC Drives, publication <a href="#">DRIVES-AT003</a>	Provides basic information on enclosure systems, considerations to help protect against environmental contaminants, and power and grounding considerations for installing Pulse Width Modulated (PWM) AC drives.
Drives in Common Bus Configurations with PowerFlex 755TM Bus Supplies Application Techniques, publication <a href="#">DRIVES-AT005</a>	Provides basic information to properly wire and ground the following products in common bus applications: <ul style="list-style-type: none"> <li>• PowerFlex 755TM drive system for common bus solutions</li> <li>• PowerFlex 750-Series AC and DC input drives</li> <li>• Kinetix™ 5700 servo drives</li> </ul>
Wiring and Grounding Guidelines for Pulse Width Modulated (PWM) AC Drives, publication <a href="#">DRIVES-IN001</a>	Provides basic information to properly wire and ground PWM AC drives.
EtherNet/IP Network Devices User Manual, publication <a href="#">ENET-UM006</a>	Describes how to configure and use EtherNet/IP devices to communicate on the EtherNet/IP network.
Ethernet Reference Manual, publication <a href="#">ENET-RM002</a>	Describes basic Ethernet concepts, infrastructure components, and infrastructure features.
CIP Security with Rockwell Automation Products Application Technique, publication <a href="#">SECURE-AT001</a>	Describes how to plan and implement a Rockwell Automation system that supports the CIP Security protocol.
System Security Design Guidelines Reference Manual, publication <a href="#">SECURE-RM001</a>	Provides guidance on how to conduct security assessments, implement Rockwell Automation products in a secure system, harden the control system, manage user access, and dispose of equipment.
Industrial Components Preventive Maintenance, Enclosures, and Contact Ratings Specifications, publication <a href="#">IC-TD002</a>	Provides a quick reference tool for Allen-Bradley industrial automation controls and assemblies.
Safety Guidelines for the Application, Installation, and Maintenance of Solid-state Control, publication <a href="#">SGI-1.1</a>	Designed to harmonize with NEMA Standards Publication No. ICS 1.1-1987 and provides general guidelines for the application, installation, and maintenance of solid-state control in the form of individual devices or packaged assemblies incorporating solid-state components.
Industrial Automation Wiring and Grounding Guidelines, publication <a href="#">1770-4.1</a>	Provides general guidelines for installing a Rockwell Automation industrial system.
Product Certifications website, <a href="http://rok.auto/certifications">rok.auto/certifications</a>	Provides declarations of conformity, certificates, and other certification details.
<a href="http://rok.auto/knowledgebase">rok.auto/knowledgebase</a>	The Rockwell Automation Support Forum

You can view or download publications at [rok.auto/literature](http://rok.auto/literature).



# Rockwell Automation Support

Use these resources to access support information.

<b>Technical Support Center</b>	Find help with how-to videos, FAQs, chat, user forums, Knowledgebase, and product notification updates.	<a href="http://rok.auto/support">rok.auto/support</a>
<b>Local Technical Support Phone Numbers</b>	Locate the telephone number for your country.	<a href="http://rok.auto/phonesupport">rok.auto/phonesupport</a>
<b>Technical Documentation Center</b>	Quickly access and download technical specifications, installation instructions, and user manuals.	<a href="http://rok.auto/techdocs">rok.auto/techdocs</a>
<b>Literature Library</b>	Find installation instructions, manuals, brochures, and technical data publications.	<a href="http://rok.auto/literature">rok.auto/literature</a>
<b>Product Compatibility and Download Center (PCDC)</b>	Download firmware, associated files (such as AOP, EDS, and DTM), and access product release notes.	<a href="http://rok.auto/pcdc">rok.auto/pcdc</a>

## Documentation Feedback

Your comments help us serve your documentation needs better. If you have any suggestions on how to improve our content, complete the form at [rok.auto/docfeedback](http://rok.auto/docfeedback).

## Waste Electrical and Electronic Equipment (WEEE)



At the end of life, this equipment should be collected separately from any unsorted municipal waste.





Rockwell Automation maintains current product environmental compliance information on its website at [rok.auto/pec](http://rok.auto/pec).

Allen-Bradley, CompactLogix, Connected Components Workbench, ControlLogix, DeviceLogix, expanding human possibility, FactoryTalk, GuardLogix, Logix 5000, PowerFlex, Rockwell Automation, Studio 5000, Studio 5000 Logix Designer, TorqProve, and TotalFORCE are trademarks of Rockwell Automation, Inc.

CIP Security and EtherNet/IP are trademarks of ODVA, Inc.

Trademarks not belonging to Rockwell Automation are property of their respective companies.

Rockwell Otomasyon Ticaret A.Ş. Kar Plaza İş Merkezi E Blok Kat:6 34752, İçerenköy, İstanbul, Tel: +90 (216) 5698400 EEE Yönetmeliğine Uygundur

Connect with us.    

**rockwellautomation.com** ————— **expanding human possibility®**

AMERICAS: Rockwell Automation, 1201 South Second Street, Milwaukee, WI 53204-2496 USA, Tel: (1) 414.382.2000

EUROPE/MIDDLE EAST/AFRICA: Rockwell Automation NV, Pegasus Park, De Kleetlaan 12a, 1831 Diegem, Belgium, Tel: (32) 2663 0600

ASIA PACIFIC: Rockwell Automation SEA Pte Ltd, 2 Corporation Road, #04-05, Main Lobby, Corporation Place, Singapore 618494, Tel: (65) 6510 6608

UNITED KINGDOM: Rockwell Automation Ltd., Pitfield, Kiln Farm, Milton Keynes, MK11 3DR, United Kingdom, Tel: (44)(1908) 838-800

Publication 750-PM101D-EN-P - March 2024

Supersedes Publication 750-PM101C-EN-P - May 2023

Copyright © 2024 Rockwell Automation, Inc. All rights reserved. Printed in the U.S.A.