

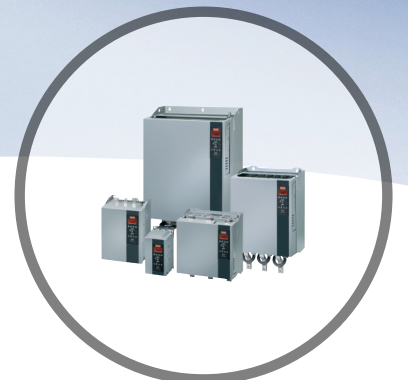

# Operating Guide

## VLT<sup>®</sup> Soft Starter MCD 500







**Danfoss A/S**

6430 Nordborg  
Denmark  
CVR nr.: 20 16 57 15

Telephone: +45 7488 2222  
Fax: +45 7449 0949

**EU DECLARATION OF CONFORMITY**

**Danfoss A/S**  
**Danfoss Drives A/S**

declares under our sole responsibility that the

**Product category:** Soft Starter

**Type designation(s):** MCD5- aaaau-Tm-GfX-pp-CVc

- aaaa designates the nominal current rating: 23 A to 1600 A
- u designates the utilisation category: B = internal bypass (IEC 60947 rating of AC53b) C = non bypassed (IEC 60947 rating of AC53a)
- m designates the mains supply voltage: 5 = 200 ~ 525 VAC 7 = 380 ~ 690 VAC
- f designates the frame size: 1 to 5
- pp designates the IP rating: IP00 or IP20
- c designates the control supply voltage: 1 = 24 VAC/VDC 2 = 110 ~ 120 VAC and 220 ~ 240 VAC

Covered by this declaration is in conformity with the following directive(s), standard(s) or other normative document(s), provided that the product is used in accordance with our instructions.

**Low Voltage Directive 2014/35/EU**

EN60947-4-2: 2012 Low-voltage switchgear and controlgear. Contactors and motor-starters. AC semiconductor motor controllers and starters.

**EMC Directive 2014/30/EU**

EN60947-4-2: 2012 Low-voltage switchgear and controlgear. Contactors and motor-starters. AC semiconductor motor controllers and starters.

**RoHS Directive 2011/65/EU including amendment 2015/863.**

EN63000: 2018 Technical documentation for the assessment of electrical and electronic products with respect to the restriction of hazardous substances.

Date: 2020.09.15 Place of issue:	Issued by  <b>Signature:</b> <b>Name: Gert Kjær</b> <b>Title: Senior Director, GDE</b>	Date: 2020.09.15 Place of issue:	Approved by  <b>Signature:</b> <b>Name: Michael Termansen</b> <b>Title: VP, PD Center Denmark</b>
Graasten, DK		Graasten, DK	

Danfoss only vouches for the correctness of the English version of this declaration. In the event of the declaration being translated into any other language, the translator concerned shall be liable for the correctness of the translation



## Contents

<b>1 Introduction</b>	6
<b>2 Safety</b>	11
2.1 Safety	11
<b>3 Installation</b>	13
3.1 Mechanical Installation	13
3.2 Dimensions and Weight	14
<b>4 Electrical Installation</b>	16
4.1 Control Wiring	16
4.1.1 Ways to Control the Soft Starter	16
4.1.2 Control Terminals	16
4.1.3 Remote Inputs	16
4.1.4 Serial Communication	17
4.1.5 Ground Terminal	17
4.1.6 Power Terminations	17
4.1.7 Finger Guard Kit	18
4.2 Power Input and Output Configurations	18
4.2.1 Internally Bypassed Models (MCD5-0021B to MCD5-0961B)	18
4.2.2 MCD5-0245C	19
4.2.3 MCD5-0360C to MCD5-1600C	19
4.3 Motor Connection	19
4.3.1 Testing the Installation	20
4.3.2 In-line Installation	20
4.3.2.1 Internally Bypassed	20
4.3.2.2 Non-bypassed	20
4.3.2.3 Externally Bypassed	20
4.3.3 Inside Delta Installation	21
4.3.3.1 Internally Bypassed	21
4.3.3.2 Non-bypassed	22
4.3.3.3 Externally Bypassed	22
4.4 Current Ratings	23
4.4.1 In-line Connection (Bypassed)	24
4.4.2 In-line Connection (Non-bypassed/Continuous)	25
4.4.3 Inside Delta Connection (Bypassed)	26
4.4.4 Inside Delta Connection (Non-bypassed/Continuous)	27
4.5 Minimum and Maximum Current Settings	28
4.6 Bypass Contactor	28
4.7 Main Contactor	28

4.8 Circuit Breaker	28
4.9 Power Factor Correction	29
4.10 Fuses	29
4.10.1 Power Supply Fuses	29
4.10.2 Bussmann Fuses	30
4.10.3 Ferraz Fuses	32
4.10.4 UL Fuse Selection and Short Circuit Ratings	34
4.11 Schematic Diagrams	37
<b>5 Product Features</b>	<b>39</b>
5.1 Motor Overload Protection	39
5.2 Adaptive Control	39
5.3 Starting Modes	40
5.3.1 Constant Current	40
5.3.2 Current Ramp	40
5.3.3 Adaptive Control	40
5.3.4 Kick-start	41
5.4 Stopping Modes	41
5.4.1 Coast to Stop	41
5.4.2 TVR Soft Stop	41
5.4.3 Adaptive Control	42
5.4.4 Pump Stopping	42
5.4.5 Brake	42
5.5 Jog Operation	43
5.6 Inside Delta Operation	44
5.7 Typical Start Currents	45
5.8 Installation with Main Contactor	46
5.9 Installation with Bypass Contactor	47
5.10 Emergency Run Operation	48
5.11 Auxiliary Trip Circuit	49
5.12 DC Brake with External Zero-speed Sensor	50
5.13 Soft Braking	51
5.14 Two-speed Motor	52
<b>6 Operation</b>	<b>54</b>
6.1 Control Methods	54
6.2 Operation and LCP	55
6.2.1 Operating Modes	55
6.3 Remote-mounted LCP	56
6.3.1 Synchronizing the LCP and the Soft Starter	56
6.4 Welcome Screen	56

6.5 Local Control Keys	56
6.6 Displays	56
6.6.1 Temperature Monitoring Screen (S1)	57
6.6.2 Programmable Screen (S2)	57
6.6.3 Average Current (S3)	57
6.6.4 Current Monitoring Screen (S4)	57
6.6.5 Frequency Monitoring Screen (S5)	57
6.6.6 Motor Power Screen (S6)	57
6.6.7 Last Start Information (S7)	57
6.6.8 Date and Time (S8)	57
6.6.9 SCR Conduction Bar Graph	58
6.6.10 Performance Graphs	58
<b>7 Programming</b>	<b>59</b>
7.1 Access Control	59
7.2 Quick Menu	59
7.2.1 Quick Set-up	59
7.2.2 Application Set-up Examples	60
7.2.3 Loggings	61
7.3 Main Menu	61
7.3.1 Parameters	61
7.3.2 Parameter Shortcut	61
7.3.3 Parameter List	62
<b>8 Parameter Descriptions</b>	<b>63</b>
8.1 Primary Motor Settings	63
8.1.1 Brake	64
8.2 Protection	65
8.2.1 Current Imbalance	65
8.2.2 Undercurrent	65
8.2.3 Instant Overcurrent	65
8.2.4 Frequency Trip	65
8.3 Inputs	66
8.4 Outputs	67
8.4.1 Relay A Delays	67
8.4.2 Relays B and C	67
8.4.3 Low Current Flag and High Current Flag	68
8.4.4 Motor Temperature Flag	68
8.4.5 Analog Output A	68
8.5 Start/Stop Timers	69
8.6 Auto-reset	69

8.6.1 Auto-reset Delay	70
8.7 Secondary Motor Set	70
8.8 Display	71
8.8.1 User-programmable Screen	71
8.8.2 Performance Graphs	72
8.9 Restricted Parameters	72
8.10 Protection Action	74
8.11 Factory Parameters	74
<b>9 Tools</b>	<b>75</b>
9.1 Set Date and Time	75
9.2 Load/Save Settings	75
9.3 Reset Thermal Model	75
9.4 Protection Simulation	76
9.5 Output Signal Simulation	76
9.6 Digital I/O State	76
9.7 Temp Sensors State	76
9.8 Alarm Log	77
9.8.1 Trip Log	77
9.8.2 Event Log	77
9.8.3 Counters	77
<b>10 Troubleshooting</b>	<b>78</b>
10.1 Trip Messages	78
10.2 General Faults	83
<b>11 Specifications</b>	<b>85</b>
11.1 UL-compliant Installation	86
11.1.1 Models MCD5-0021B to MCD5-0105B	86
11.1.2 Models MCD5-0131B to MCD5-0215B	86
11.1.3 Models MCD5-0245B to MCD5-0396B	86
11.1.4 Models MCD5-0245C	86
11.1.5 Models MCD5-0360C to MCD5-1600C	87
11.1.6 Models MCD5-0469B to MCD5-0961B	87
11.1.7 Pressure Terminal/Connector Kits	87
11.2 Accessories	87
11.2.1 LCP Remote Mounting Kit	87
11.2.2 Communication Modules	87
11.2.3 PC Software	87
11.2.4 Finger Guard Kit	88
11.2.5 Surge Protection Kit (Lightning Protection)	88



<b>12 Busbar Adjustment Procedure (MCD5-0360C to MCD5-1600C)</b>	<b>89</b>
<b>13 Appendix</b>	<b>91</b>
13.1 Symbols, Abbreviations, and Conventions	91
<b>Index</b>	<b>92</b>

# 1 Introduction

The VLT® Soft Starter MCD 500 is an advanced digital soft start solution for 11–850 kW (15–1150 hp) motors. The soft starters provide a complete range of motor and system protection features and are designed for reliable performance in the most demanding installation situations.

## 1.1.1 Document Version

This operating guide is regularly reviewed and updated. All suggestions for improvement are welcome. *Table 1.1* shows the document version.

Edition	Remarks
MG17K8xx	Instruction about using finger guard kits for IP00 installations added to <i>chapter 4 Electrical Installation</i> .

Table 1.1 Document Version

## 1.1.2 Feature List

### Models for all connection requirements

- 21–1600 A (in-line connection).
- In-line or inside delta connection.
- Internally bypassed up to 961 A.
- Mains voltage: 200–525 V AC or 380–690 V AC.
- Control voltage: 24 V AC/V DC, 110–120 V AC, or 220–240 V AC.

### User-friendly LCP

- Loggings.
- Real-time graphs.
- SCR conduction bar graph.

### Tools

- Application set-ups.
- Date and time stamped event log with 99 entries.
- 8 most recent trips.
- Counters.
- Protection simulation.
- Output signal simulation.

### Inputs and outputs

- Local or remote control input options. (3 x fixed, 1 x programmable).
- Relay outputs (3 x programmable).
- Analog programmable output.
- 24 V DC 200 mA supply output.

### Start and run modes

- Adaptive control.
- Constant current.
- Current ramp.
- Kick-start.
- Jog.
- Emergency run operation.

### Stop modes

- Adaptive deceleration control.
- Timed voltage ramp soft stop.
- DC brake.
- Soft brake.
- Starter disable.

### Other features

- Autostart/stop timer.
- Second-order thermal model.

- Battery back-up of clock and thermal model.
- Optional DeviceNet, Modbus, Ethernet, or PROFIBUS communication modules.

**Comprehensive protection**

- Wiring/connection/supply.
  - Motor connection.
  - Phase sequence.
  - Power loss.
  - Individual phase loss.
  - Mains frequency.
- Current
  - Excess start time.
  - Current imbalance.
  - Undercurrent.
- Instant overcurrent.
- Thermal
  - Motor thermistor.
  - Motor overload.
  - Bypass contactor overload.
  - Heat sink temperature.
- Communication
  - Network comms.
  - Starter comms.
- External
  - Input trip.
- Starter
  - Individually short-circuited SCR.
  - Battery/clock.



1.1.4 Ordering Numbers

	Supply voltage	T5, 200–525 V AC			
	Control supply	CV1, 24 V AC/V DC		CV2, 110–120 or 220–240 V AC	
	Ampere rating	Ordering number	Type code	Ordering number	Type code
G1B	MCD5-0021B	175G5500	MCD5-0021B-T5-G1X-20-CV1	175G5525	MCD5-0021B-T5-G1X-20-CV2
	MCD5-0037B	175G5501	MCD5-0037B-T5-G1X-20-CV1	175G5526	MCD5-0037B-T5-G1X-20-CV2
	MCD5-0043B	175G5502	MCD5-0043B-T5-G1X-20-CV1	175G5527	MCD5-0043B-T5-G1X-20-CV2
	MCD5-0053B	175G5503	MCD5-0053B-T5-G1X-20-CV1	175G5528	MCD5-0053B-T5-G1X-20-CV2
	MCD5-0068B	175G5504	MCD5-0068B-T5-G1X-20-CV1	175G5529	MCD5-0068B-T5-G1X-20-CV2
	MCD5-0084B	175G5505	MCD5-0084B-T5-G1X-20-CV1	175G5530	MCD5-0084B-T5-G1X-20-CV2
	MCD5-0089B	175G5506	MCD5-0089B-T5-G1X-20-CV1	175G5531	MCD5-0089B-T5-G1X-20-CV2
	MCD5-0105B	175G5507	MCD5-0105B-T5-G1X-20-CV1	175G5532	MCD5-0105B-T5-G1X-20-CV2
G2B	MCD5-0131B	175G5508	MCD5-0131B-T5-G2X-00-CV1	175G5533	MCD5-0131B-T5-G2X-00-CV2
	MCD5-0141B	175G5509	MCD5-0141B-T5-G2X-00-CV1	175G5534	MCD5-0141B-T5-G2X-00-CV2
	MCD5-0195B	175G5510	MCD5-0195B-T5-G2X-00-CV1	175G5535	MCD5-0195B-T5-G2X-00-CV2
	MCD5-0215B	175G5511	MCD5-0215B-T5-G2X-00-CV1	175G5536	MCD5-0215B-T5-G2X-00-CV2
G3C	MCD5-0245C	175G5512	MCD5-0245C-T5-G3X-00-CV1	175G5537	MCD5-0245C-T5-G3X-00-CV2
G3B	MCD5-0245B	134N9344	MCD5-0245B-T5-G3X-00-CV1	134N9345	MCD5-0245B-T5-G3X-00-CV2
	MCD5-0331B	134N9348	MCD5-0331B-T5-G3X-00-CV1	134N9349	MCD5-0331B-T5-G3X-00-CV2
	MCD5-0396B	134N9352	MCD5-0396B-T5-G3X-00-CV1	134N9353	MCD5-0396B-T5-G3X-00-CV2
G4B	MCD5-0469B	134N9356	MCD5-0469B-T5-G4X-00-CV1	134N9357	MCD5-0469B-T5-G4X-00-CV2
	MCD5-0525B	134N9360	MCD5-0525B-T5-G4X-00-CV1	134N9361	MCD5-0525B-T5-G4X-00-CV2
	MCD5-0632B	134N9364	MCD5-0632B-T5-G4X-00-CV1	134N9365	MCD5-0632B-T5-G4X-00-CV2
	MCD5-0744B	134N9368	MCD5-0744B-T5-G4X-00-CV1	134N9369	MCD5-0744B-T5-G4X-00-CV2
	MCD5-0826B	134N9372	MCD5-0826B-T5-G4X-00-CV1	134N9373	MCD5-0826B-T5-G4X-00-CV2
	MCD5-0961B	134N9376	MCD5-0961B-T5-G4X-00-CV1	134N9377	MCD5-0961B-T5-G4X-00-CV2
G4C	MCD5-0360C	175G5513	MCD5-0360C-T5-G4X-00-CV1	175G5538	MCD5-0360C-T5-G4X-00-CV2
	MCD5-0380C	175G5514	MCD5-0380C-T5-G4X-00-CV1	175G5539	MCD5-0380C-T5-G4X-00-CV2
	MCD5-0428C	175G5515	MCD5-0428C-T5-G4X-00-CV1	175G5540	MCD5-0428C-T5-G4X-00-CV2
	MCD5-0595C	175G5516	MCD5-0595C-T5-G4X-00-CV1	175G5541	MCD5-0595C-T5-G4X-00-CV2
	MCD5-0619C	175G5517	MCD5-0619C-T5-G4X-00-CV1	175G5542	MCD5-0619C-T5-G4X-00-CV2
	MCD5-0790C	175G5518	MCD5-0790C-T5-G4X-00-CV1	175G5543	MCD5-0790C-T5-G4X-00-CV2
	MCD5-0927C	175G5519	MCD5-0927C-T5-G4X-00-CV1	175G5544	MCD5-0927C-T5-G4X-00-CV2
G5C	MCD5-1200C	175G5520	MCD5-1200C-T5-G5X-00-CV1	175G5545	MCD5-1200C-T5-G5X-00-CV2
	MCD5-1410C	175G5523	MCD5-1410C-T5-G5X-00-CV1	175G5546	MCD5-1410C-T5-G5X-00-CV2
	MCD5-1600C	175G5524	MCD5-1600C-T5-G5X-00-CV1	175G5547	MCD5-1600C-T5-G5X-00-CV2

Table 1.2 Ordering Numbers, T5, 200–525 V AC

	Supply voltage	T7, 380–690 V AC			
	Control supply	CV1, 24 V AC/V DC		CV2, 110–120 or 220–240 V AC	
	Ampere rating	Ordering number	Type code	Ordering number	Type code
G1B	MCD5-0021B	175G5548	MCD5-0021B-T7-G1X-20-CV1	175G5571	MCD5-0021B-T7-G1X-20-CV2
	MCD5-0037B	175G5549	MCD5-0037B-T7-G1X-20-CV1	175G5572	MCD5-0037B-T7-G1X-20-CV2
	MCD5-0043B	175G5550	MCD5-0043B-T7-G1X-20-CV1	175G5573	MCD5-0043B-T7-G1X-20-CV2
	MCD5-0053B	175G5551	MCD5-0053B-T7-G1X-20-CV1	175G5574	MCD5-0053B-T7-G1X-20-CV2
	MCD5-0068B	175G5552	MCD5-0068B-T7-G1X-20-CV1	175G5575	MCD5-0068B-T7-G1X-20-CV2
	MCD5-0084B	175G5553	MCD5-0084B-T7-G1X-20-CV1	175G5576	MCD5-0084B-T7-G1X-20-CV2
	MCD5-0089B	175G5554	MCD5-0089B-T7-G1X-20-CV1	175G5577	MCD5-0089B-T7-G1X-20-CV2
G2B	MCD5-0105B	175G5555	MCD5-0105B-T7-G1X-20-CV1	175G5578	MCD5-0105B-T7-G1X-20-CV2
	MCD5-0131B	175G5556	MCD5-0131B-T7-G2X-00-CV1	175G5579	MCD5-0131B-T7-G2X-00-CV2
	MCD5-0141B	175G5557	MCD5-0141B-T7-G2X-00-CV1	175G5580	MCD5-0141B-T7-G2X-00-CV2
	MCD5-0195B	175G5558	MCD5-0195B-T7-G2X-00-CV1	175G5581	MCD5-0195B-T7-G2X-00-CV2
G3C	MCD5-0215B	175G5559	MCD5-0215B-T7-G2X-00-CV1	175G5582	MCD5-0215B-T7-G2X-00-CV2
	MCD5-0245C	175G5560	MCD5-0245C-T7-G3X-00-CV1	175G5583	MCD5-0245C-T7-G3X-00-CV2
G3B	MCD5-0245B	134N9346	MCD5-0245B-T7-G3X-00-CV1	134N9347	MCD5-0245B-T7-G3X-00-CV2
	MCD5-0331B	134N9350	MCD5-0331B-T7-G3X-00-CV1	134N9351	MCD5-0331B-T7-G3X-00-CV2
	MCD5-0396B	134N9354	MCD5-0396B-T7-G3X-00-CV1	134N9355	MCD5-0396B-T7-G3X-00-CV2
G4B	MCD5-0469B	134N9358	MCD5-0469B-T7-G4X-00-CV1	134N9359	MCD5-0469B-T7-G4X-00-CV2
	MCD5-0525B	134N9362	MCD5-0525B-T7-G4X-00-CV1	134N9363	MCD5-0525B-T7-G4X-00-CV2
	MCD5-0632B	134N9366	MCD5-0632B-T7-G4X-00-CV1	134N9367	MCD5-0632B-T7-G4X-00-CV2
	MCD5-0744B	134N9370	MCD5-0744B-T7-G4X-00-CV1	134N9371	MCD5-0744B-T7-G4X-00-CV2
	MCD5-0826B	134N9374	MCD5-0826B-T7-G4X-00-CV1	134N9375	MCD5-0826B-T7-G4X-00-CV2
	MCD5-0961B	134N9378	MCD5-0961B-T7-G4X-00-CV1	134N9379	MCD5-0961B-T7-G4X-00-CV2
G4C	MCD5-0360C	175G5561	MCD5-0360C-T7-G4X-00-CV1	175G5584	MCD5-0360C-T7-G4X-00-CV2
	MCD5-0380C	175G5562	MCD5-0380C-T7-G4X-00-CV1	175G5585	MCD5-0380C-T7-G4X-00-CV2
	MCD5-0428C	175G5563	MCD5-0428C-T7-G4X-00-CV1	175G5586	MCD5-0428C-T7-G4X-00-CV2
	MCD5-0595C	175G5564	MCD5-0595C-T7-G4X-00-CV1	175G5587	MCD5-0595C-T7-G4X-00-CV2
	MCD5-0619C	175G5565	MCD5-0619C-T7-G4X-00-CV1	175G5588	MCD5-0619C-T7-G4X-00-CV2
	MCD5-0790C	175G5566	MCD5-0790C-T7-G4X-00-CV1	175G5589	MCD5-0790C-T7-G4X-00-CV2
	MCD5-0927C	175G5567	MCD5-0927C-T7-G4X-00-CV1	175G5590	MCD5-0927C-T7-G4X-00-CV2
G5C	MCD5-1200C	175G5568	MCD5-1200C-T7-G5X-00-CV1	175G5591	MCD5-1200C-T7-G5X-00-CV2
	MCD5-1410C	175G5569	MCD5-1410C-T7-G5X-00-CV1	175G5592	MCD5-1410C-T7-G5X-00-CV2
	MCD5-1600C	175G5570	MCD5-1600C-T7-G5X-00-CV1	175G5593	MCD5-1600C-T7-G5X-00-CV2

Table 1.3 Ordering Numbers, T7, 380–690 V AC

## 2 Safety

### 2.1 Safety

The following symbols are used in this guide:

#### **⚠ WARNING**

Indicates a potentially hazardous situation that could result in death or serious injury.

#### **⚠ CAUTION**

Indicates a potentially hazardous situation that could result in minor or moderate injury. It can also be used to alert against unsafe practices.

#### **NOTICE**

Indicates important information, including situations that can result in damage to equipment or property.

#### 2.1.1 Qualified Personnel

Correct and reliable transport, storage, installation, operation, and maintenance are required for the trouble-free and safe operation of the soft starter. Only qualified personnel are allowed to install or operate this equipment.

Qualified personnel is defined as trained staff, who are authorized to install, commission, and maintain equipment, systems, and circuits in accordance with pertinent laws and regulations. Additionally, the personnel must be familiar with the instructions and safety measures described in this manual.

#### **⚠ WARNING**

##### **ELECTRICAL SHOCK HAZARD**

VLT® Soft Starter MCD 500 contains dangerous voltages when connected to mains voltage. Only a qualified electrician should carry out the electrical installation. Improper installation of the motor or the soft starter can cause death, serious injury, or equipment failure. Follow the guidelines in this manual and local electrical safety codes.

Models MCD5-0360C ~ MCD5-1600C:

Treat the busbar and heat sink as live parts whenever the unit has mains voltage connected (including when the soft starter is tripped or waiting for a command).

#### **⚠ WARNING**

##### **PROPER GROUNDING**

Disconnect the soft starter from mains voltage before carrying out repair work.

It is the responsibility of the person installing the soft starter to provide proper grounding and branch circuit protection according to local electrical safety codes.

Do not connect power factor correction capacitors to the output of the VLT® Soft Starter MCD 500. If static power factor correction is employed, it must be connected to the supply side of the soft starter.

#### **⚠ WARNING**

##### **IMMEDIATE START**

In auto-on mode, the motor can be controlled remotely (via remote inputs) while the soft starter is connected to mains.

MCD5-0021B ~ MCD5-0961B:

Transportation, mechanical shock, or rough handling may cause the bypass contactor to latch into the On state.

To prevent the motor from starting immediately on first commissioning or operation after transportation:

- Always ensure that the control supply is applied before the power.
- Applying control supply before power ensures that the contactor state is initialized.

#### **⚠ WARNING**

##### **UNINTENDED START**

When the soft starter is connected to AC mains, DC supply, or load sharing, the motor can start at any time. Unintended start during programming, service, or repair work can result in death, serious injury, or property damage. The motor can start with an external switch, a fieldbus command, an input reference signal from the LCP or LOP, via remote operation using MCD PC Software, or after a cleared fault condition.

To prevent unintended motor start:

- Press [Off]/[Reset] on the LCP before programming parameters.
- Disconnect the soft starter from mains.
- Completely wire and assemble the soft starter, motor, and any driven equipment before connecting the soft starter to AC mains, DC supply, or load sharing.

**⚠ WARNING****SAFETY OF PERSONNEL**

The soft starter is not a safety device and does not provide electrical isolation or disconnection from the supply.

- If isolation is required, the soft starter must be installed with a main contactor.
- Do not rely on the start and stop functions for safety of personnel. Faults occurring in the mains supply, the motor connection, or the electronics of the soft starter can cause unintended motor starts or stops.
- If faults occur in the electronics of the soft starter, a stopped motor may start. A temporary fault in the supply mains or loss of motor connection can also cause a stopped motor to start.

To provide safety of personnel and equipment, control the isolation device through an external safety system.

**NOTICE**

Before changing any parameter settings, save the current parameter to a file using MCD PC Software or the *Save User Set* function.

**NOTICE**

Use the *autostart* feature with caution. Read all the notes related to *autostart* before operation.

The examples and diagrams in this manual are included solely for illustrative purposes. The information contained in this manual is subject to change at any time and without prior notice. Responsibility or liability is never accepted for direct, indirect, or consequential damage resulting from the use or application of this equipment.



### 3 Installation

#### 3.1 Mechanical Installation

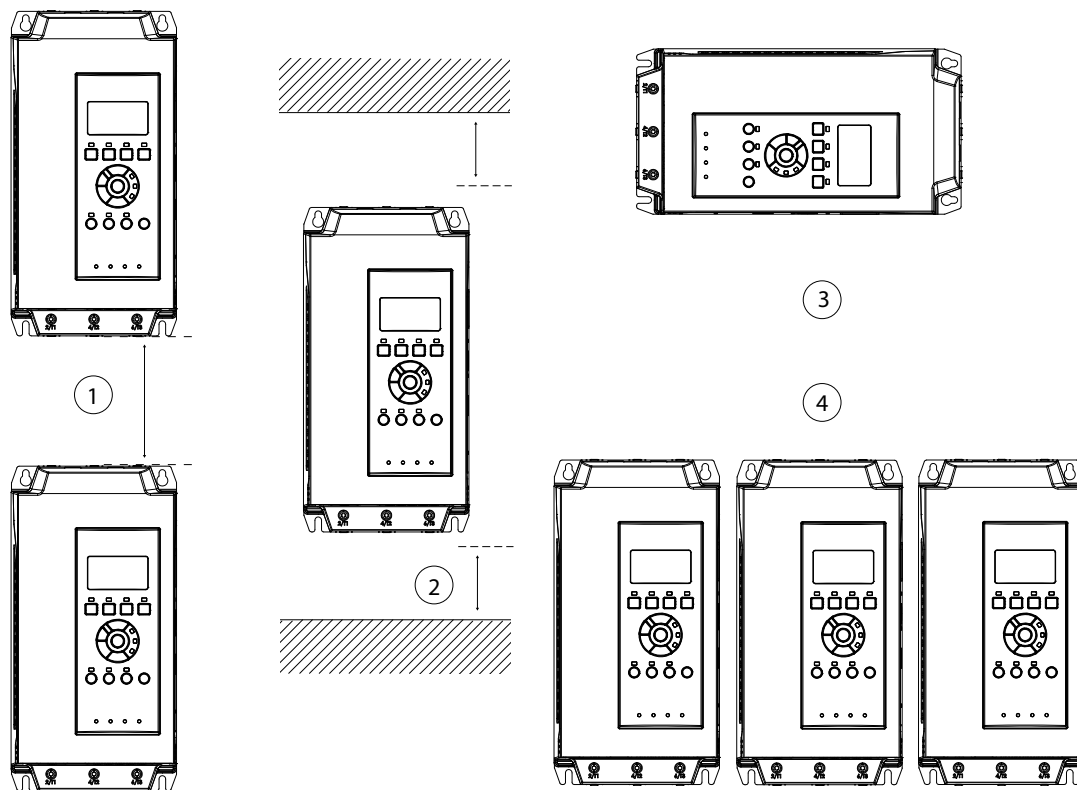

177HA427.10

3

1	MCD5-0021B to MCD5-0215B: Allow 100 mm (3.94 in) between the soft starters. MCD5-0245B to MCD5-0961B: Allow 200 mm (7.88 in) between the soft starters. MCD5-0245C: Allow 100 mm (3.94 in) between the soft starters. MCD5-0360C to MCD5-1600C: Allow 200 mm (7.88 in) between the soft starters.
2	MCD5-0021B to MCD5-0215B: Allow 50 mm (1.97 in) between the soft starter and solid surfaces. MCD5-0245B to MCD5-0961B: Allow 200 mm (7.88 in) between soft starters. MCD5-0245C: Allow 100 mm (3.94 in) between the soft starter and solid surfaces. MCD5-0360C to MCD5-1600C: Allow 200 mm (7.88 in) between the soft starter and solid surfaces.
3	It is possible to mount the soft starter on its side. Derate the soft starter rated current by 15%.
4	If mounted without communication modules, soft starters may be mounted side by side with no clearance.

Illustration 3.1 Clearances and Derating Values at Installation

### 3.2 Dimensions and Weight

3

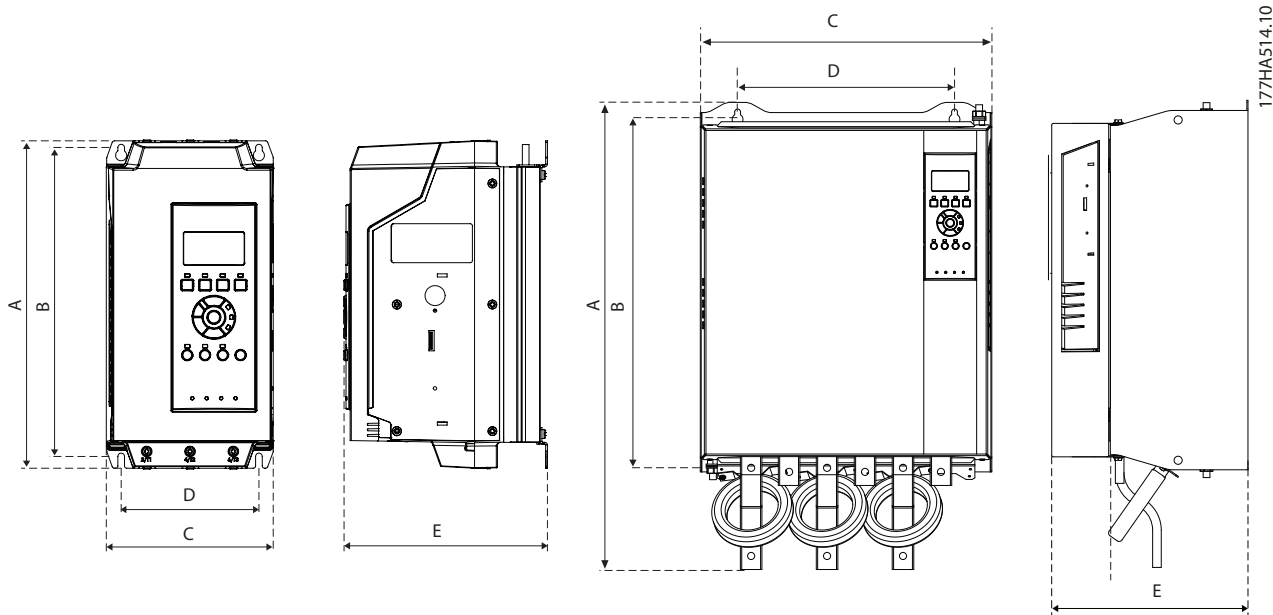

Model	A [mm] (in)	B [mm] (in)	C [mm] (in)	D [mm] (in)	E [mm] (in)	Weight [kg] (lbs)
MCD5-0021B	295 (11.6)	278 (10.9)	150 (5.9)	124 (4.9)	183 (7.2)	4.2 (9.3)
MCD5-0037B						
MCD5-0043B						
MCD5-0053B					213 (8.14)	4.5 (9.9)
MCD5-0068B						
MCD5-0084B						
MCD5-0089B						
MCD5-0105B	438 (17.2)	380 (15.0)	275 (10.8)	248 (9.8)	250 (9.8)	14.9 (32.8)
MCD5-0131B						
MCD5-0141B						
MCD5-0195B						
MCD5-0215B	440 (17.3)	392 (15.4)	424 (16.7)	376 (14.8)	296 (11.7)	26 (57.2)
MCD5-0245B						
MCD5-0331B						
MCD5-0396B	640 (25.2)	600 (23.6)	433 (17.0)	320 (12.6)	295 (11.6)	30.2 (66.6)
MCD5-0469B						
MCD5-0525B						
MCD5-0632B						
MCD5-0744B						
MCD5-0826B						
MCD5-0961B	460 (18.1)	400 (15.0)	390 (15.4)	320 (12.6)	279 (11.0)	49.5 (109.1)
MCD5-0245C						
MCD5-0360C	689 (27.1)	522 (20.5)	430 (16.9)	320 (12.6)	300 (11.8)	23.9 (52.7)
MCD5-0380C						
MCD5-0428C						
MCD5-0595C						
MCD5-0619C						
MCD5-0790C						
MCD5-0927C						
						35 (77.2)
						45 (99.2)

Model	A [mm] (in)	B [mm] (in)	C [mm] (in)	D [mm] (in)	E [mm] (in)	Weight [kg] (lbs)
MCD5-1200C	856 (33.7)	727 (28.6)	585 (23.0)	500 (19.7)	364 (14.3)	120 (264.6)
MCD5-1410C						
MCD5-1600C						

Illustration 3.2 Dimensions and Weight

## 4 Electrical Installation

### 4.1 Control Wiring

#### 4.1.1 Ways to Control the Soft Starter

Control the VLT® Soft Starter MCD 500 in 3 ways:

- Pressing the keys on the LCP.
- Via remote inputs.
- Via a serial communication link.

The soft starter always responds to a local start or stop command (via the [Hand On] and [Off] keys on the LCP). Pressing the [Auto On] key selects remote control (the soft starter accepts commands from the remote inputs). In remote mode, the Auto On LED is on. In hand-on mode, the Hand On LED is on if the soft starter starts or runs. The Off LED is on if the soft starter is stopped or stops.

#### 4.1.2 Control Terminals

Control terminations use 2.5 mm<sup>2</sup> (14 AWG) plug-in terminal blocks. Different models require control voltage to different terminals:

- CV1 (24 V AC/V DC): A5, A6.
- CV2 (110–120 V AC): A5, A6.
- CV2 (220–240 V AC): A4, A6.

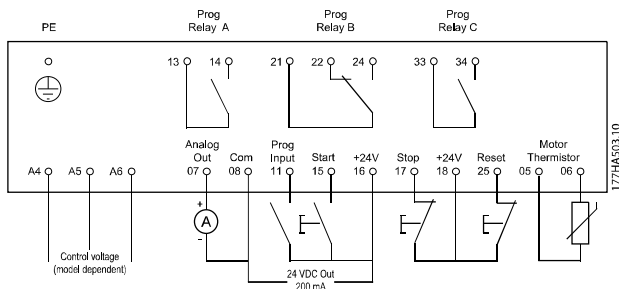

Illustration 4.1 Wiring to Control Terminals

### NOTICE

Do not short terminals 05 and 06 without using a thermistor.

All control terminals and relay terminals comply with SELV (safety extra low voltage). This protection does not apply to grounded delta leg above 400 V.

To maintain SELV, all connections made to the control terminals must be PELV (for example thermistor must be reinforced/double insulated from motor).

### NOTICE

SELV offers protection by way of extra low voltage. Protection against electric shock is ensured when the electrical supply itself is of the SELV type and the installation follows local/national regulations on SELV supplies.

### NOTICE

Galvanic (ensured) isolation is obtained by fulfilling requirements for higher isolation and by providing the relevant creepages/clearance distances. These requirements are described in the IEC 61140 standard. The components that make up the electrical isolation also comply with the requirements for higher isolation and the relevant test as described in IEC 61140.

#### 4.1.3 Remote Inputs

The soft starter has 3 fixed inputs for remote control. Control these inputs by contacts rated for low voltage, low current operation (gold flash or similar).

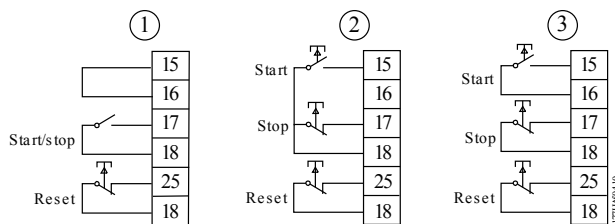

1	2-wire control
2	3-wire control
3	4-wire control

Illustration 4.2 2-, 3-, and 4-wire Control

The reset input can be normally open or normally closed. To select the configuration, use *parameter 3-8 Remote Reset Logic*.

### WARNING

#### ELECTRICAL SHOCK HAZARD

Do not apply voltage to the control input terminals. These terminals are active 24 V DC inputs and must be controlled with potential-free contacts.

- Segregate cables to the control inputs from mains voltage and motor cabling.

4.1.4 Serial Communication

Control via the serial communication network is always enabled in hand-on mode and can be enabled or disabled in remote control mode (see *parameter 3-2 Comms in Remote*). Control via the serial communication network requires an optional communication module.

4.1.5 Ground Terminal

Ground terminals are at the back of the soft starter.

- MCD5-0021B to MCD5-0105B have 1 terminal on the input side (top).
- MCD5-0131B to MCD5-0961B and MCD5-0245C to MCD5-1600C have 2 terminals; 1 on the input side (top), and 1 on the output side (bottom).

4.1.6 Power Terminations

**NOTICE**

For personnel safety, snap-off tabs protect the power terminals on models up to MCD5-0105B. When using large cables, it may be necessary to break off these tabs.

**NOTICE**

Some units use aluminum busbars. When connecting power terminations, clean the surface contact area thoroughly (using an emery or stainless steel brush), and use an appropriate jointing compound to prevent corrosion.

Use only copper stranded or solid conductors, rated for 75 °C (167°F) or higher.

 <p>Cable size: 6–50 mm<sup>2</sup> (AWG 10-1/0) Torque: 4 Nm (35.4 in-lb)</p>	 <p>14 mm (0.55 in)</p>	 <p>Torx T20 x 150</p>  <p>Flat 7 mm x 150</p>
MCD5-0021B to MCD5-0105B		
 <p>8.5 mm 12.5 mm 19 mm 6 mm 177HA517.10 8.5 Nm (6.3 ft-lb)</p>	 <p>10.5 mm 12.5 mm 19 mm 6 mm 177HA518.10 8.5 Nm (6.3 ft-lb)</p>	 <p>38 Nm (336.3 in-lb) 11 mm (M10) 15 mm 28 mm 5 mm 177HA643.10</p>
MCD5-0131B	MCD5-0141B to MCD5-0215B	MCD5-0245B
 <p>38 Nm (336.3 in-lb) 11 mm (M10) 15 mm 28 mm 6 mm 177HA644.10</p>	 <p>38 Nm (336 in-lb) 11 mm (M10) 12 mm 32 mm 13 mm 177HA645.10</p>	 <p>10.5 mm 16 mm 32 mm 6 mm 177HA519.10 17 Nm (12.5 ft-lb)</p>
MCD5-0331B to MCD5-0396B	MCD5-0469B to MCD5-0961B	MCD5-0245C
 <p>10.5 mm 23 mm 32 mm 13 mm 177HA520.10 38 Nm (28.5 ft-lb)</p>	 <p>12.5 mm 25 mm 51 mm 16 mm 177HA521.10 58 Nm (42.7 ft-lb)</p>	
MCD5-0360C to MCD5-0927C	MCD5-1200C to MCD5-1600C	

Table 4.1 Measurements and Torques for Power Terminations

### 4.1.7 Finger Guard Kit

**NOTICE**

When installing IP00 soft starters (MCB5-131B and above), finger guards are specified for personnel safety. Finger guards fit over the soft starter terminals to prevent accidental contact with live terminals. Finger guards provide IP20 protection when correctly installed.

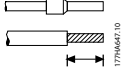
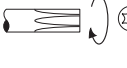
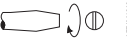
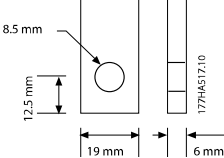
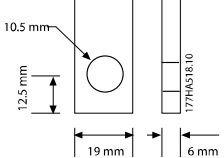
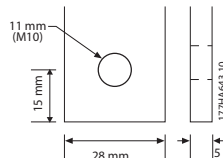
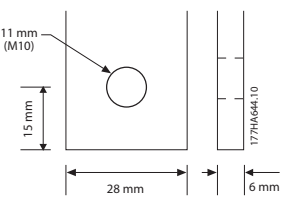
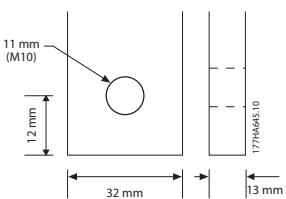
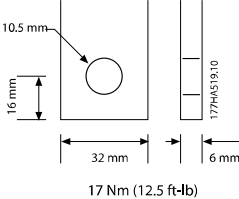
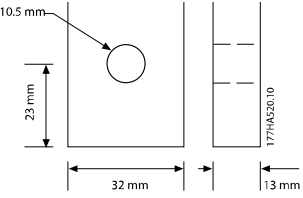
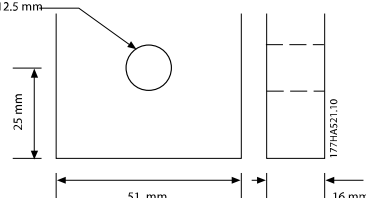
- MCD5-0131B to MCD5-0215B: 175G5662.
- MCD5-0245B to MCD5-0396B: 175G5730.
- MCD5-0469B to MCD5-0961B: 175G5731.
- MCD5-245C: 175G5663.
- MCD5-0360C to MCD5-0927C: 175G5664.
- MCD5-1200C to MCD5-1600C: 175G5665.

**NOTICE**

To be UL-compliant, the models MCD5-0131B to MCD5-0396B require finger guards.

### 4.2 Power Input and Output Configurations

#### 4.2.1 Internally Bypassed Models (MCD5-0021B to MCD5-0961B)

Models MCD5-0021B to MCD5-0215B have power inputs at the top of the unit and outputs at the bottom of the unit.

Internally bypassed models MCD5-0245B to MCD5-0396B have output busbars at the bottom of the unit and input busbars at both the top and bottom. The AC supply can be connected:

- Top-in/bottom-out.
- Bottom-in/bottom-out

Internally bypassed models MCD5-0469B to MCD5-0961B have input and output busbars at the top and bottom of the unit. The AC supply can be connected:

- Top-in/bottom-out.
- Top-in/top-out.
- Bottom-in/bottom-out.
- Bottom-in/top-out.

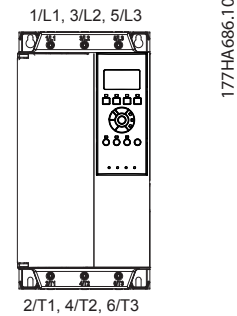

Illustration 4.3 MCD5-0021B to MCD5-0105B, 21-105 A

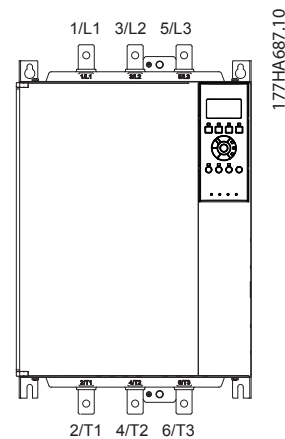

Illustration 4.4 MCD5-0131B to MCD5-0215B, 131-215 A

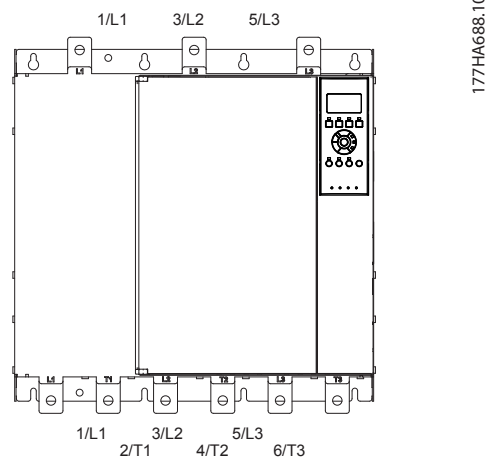

Illustration 4.5 MCD5-0245B to MCD5-0396B, 245-396 A

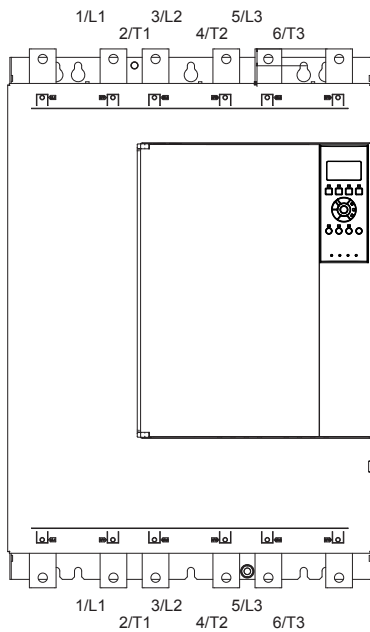

Illustration 4.6 MCD5-0469B to MCD5-0961B, 469–961 A

### 4.2.2 MCD5-0245C

MCD5-0245C has dedicated bypass terminals at the bottom of the unit. The bypass terminals are:

- T1B.
- T2B.
- T3B.

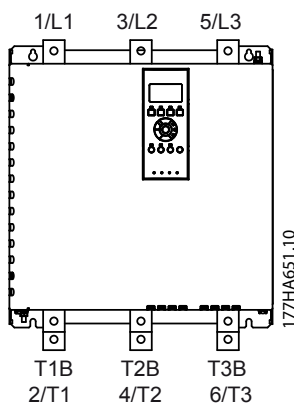

Illustration 4.7 Bypass Terminals on MCD5-0245C, 245 A

### 4.2.3 MCD5-0360C to MCD5-1600C

MCD5-0360C to MCD5-1600C have dedicated bypass terminals on the input busbars. The bypass terminals are:

- L1B.
- L2B.
- L3B.

The busbars on non-bypassed models MCD5-0360C to MCD5-1600C can be adjusted for top or bottom input and output as required. See *chapter 12 Busbar Adjustment Procedure (MCD5-0360C to MCD5-1600C)* for step-by-step instructions. The soft starters are manufactured top-in/ bottom-out.

#### NOTICE

For models MCD5-0360C to MCD5-1600C to be UL-compliant, mount them *top-in/bottom-out*, or *top-out/bottom-in*. See *chapter 11.1 UL-compliant Installation* for more information.

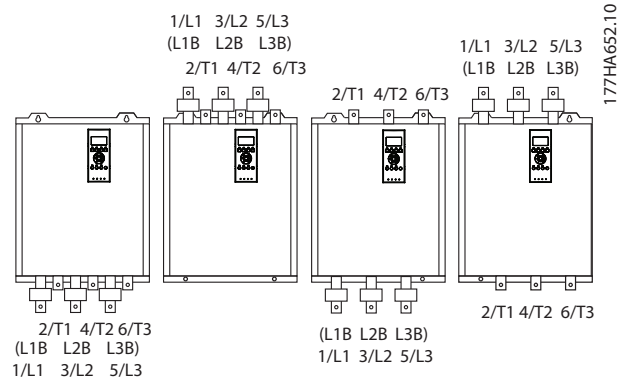

Illustration 4.8 Location of Bypass Terminals, MCD5-0360C to MCD5-1600C, 360–1600 A

### 4.3 Motor Connection

VLT® Soft Starters MCD 500 can be connected to the motor in-line or inside delta (also called 3-wire and 6-wire connection). When connecting in inside delta, enter the motor full load current (FLC) in *parameter 1-1 Motor Full Load Current*. The MCD 500 automatically calculates inside delta current based on this data. *Parameter 15-7 Motor Connection* is set to *Auto Detect* as default and can be set to force the soft starter in inside delta or in-line.

4

4.3.1 Testing the Installation

The VLT® Soft Starter MCD 500 can be connected to a small motor for testing. During this test, the control input and relay output protection settings can be tested. This test mode is not suitable for testing soft starting or soft stopping performance.

The minimum FLC of the test motor is 2% of the minimum FLC of the soft starter (see *chapter 4.5 Minimum and Maximum Current Settings*).

**NOTICE**

When testing the soft starter with a small motor, set parameter 1-1 Motor FLC to the minimum allowable value.

Models which are internally bypassed do not require an external bypass contactor.

4.3.2 In-line Installation

4.3.2.1 Internally Bypassed

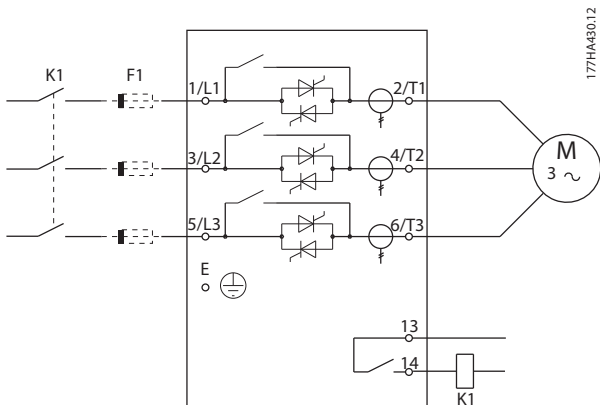

K1	Main contactor (optional)
F1	Semiconductor fuses (optional) <sup>1)</sup>
1) To keep the warranty on the SCRs, use semiconductor fuses.	

Illustration 4.9 In-line Installation, Internally Bypassed

4.3.2.2 Non-bypassed

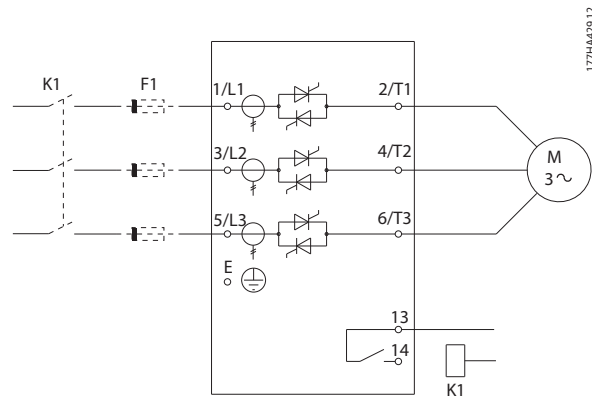

K1	Main contactor (optional)
F1	Semiconductor fuses (optional) <sup>1)</sup>
1) To keep the warranty on the SCRs, use semiconductor fuses.	

Illustration 4.10 In-line Installation, Non-bypassed

4.3.2.3 Externally Bypassed

Non-bypassed models have dedicated bypass terminals, which allow the soft starter to continue providing protection and monitoring functions even when bypassed via an external contactor. Connect the bypass contactor to the bypass terminals and control it by a programmable output configured to Run (see *parameters 4-1 to 4-9*).

**NOTICE**

The bypass terminals on MCD5-0245C are:

- T1B.
- T2B.
- T3B.

The bypass terminals on MCD5-0360C to MCD5-1600C are:

- L1B.
- L2B.
- L3B.

If necessary, the fuses can be installed on the input side.



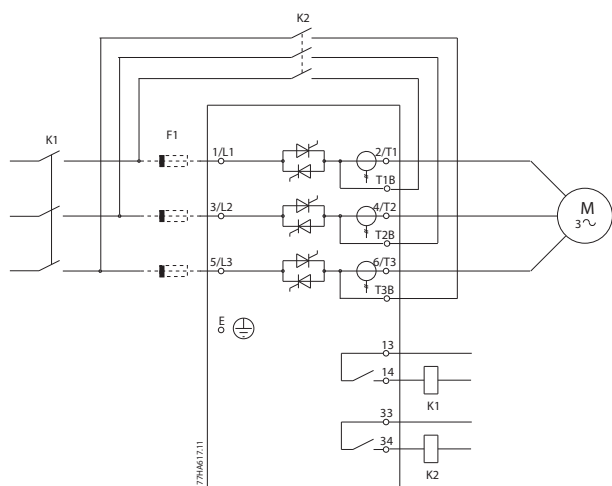

K1	Main contactor
K2	Bypass contactor (external)
F1	Semiconductor fuses (optional) <sup>1)</sup>

1) To keep the warranty on the SCRs, use semiconductor fuses.

Illustration 4.11 In-line Installation, Externally Bypassed, MCD5-0245C

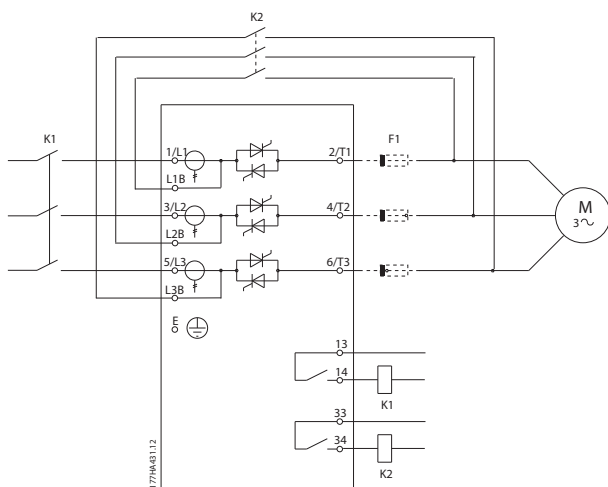

K1	Main contactor
K2	Bypass contactor (external)
F1	Semiconductor fuses (optional) <sup>1)</sup>

1) To keep the warranty on the SCRs, use semiconductor fuses.

Illustration 4.12 In-line Installation, Externally Bypassed, MCD5-0360C to MCD5-1600C

### 4.3.3 Inside Delta Installation

#### NOTICE

When connecting the VLT® Soft Starter MCD 500 in inside delta configuration, always install a main contactor or shunt trip circuit breaker.

#### NOTICE

When connecting in inside delta, enter the motor full load current (FLC) in *parameter 1-1 Motor FLC*. The MCD 500 automatically calculates inside delta currents based on this data. *Parameter 15-7 Motor Connection* is set to *Auto detect* as default and can be set to force the soft starter in inside delta or in-line.

4

#### 4.3.3.1 Internally Bypassed

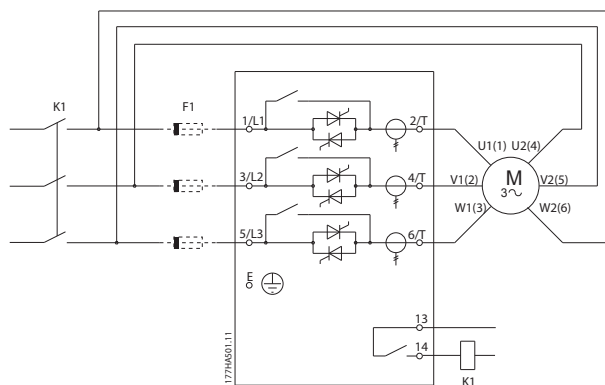

K1	Main contactor
F1	Semiconductor fuses (optional) <sup>1)</sup>

1) To keep the warranty on the SCRs, use semiconductor fuses.

Illustration 4.13 Inside Delta Installation, Internally Bypassed

4.3.3.2 Non-bypassed

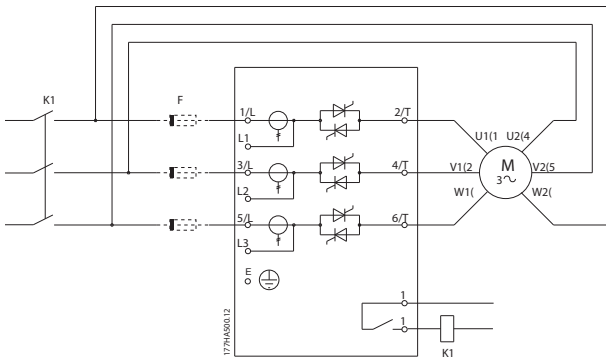

K1	Main contactor
F1	Semiconductor fuses (optional) <sup>1)</sup>
1) To keep the warranty on the SCRs, use semiconductor fuses.	

Illustration 4.14 Inside Delta Installation, Non-bypassed

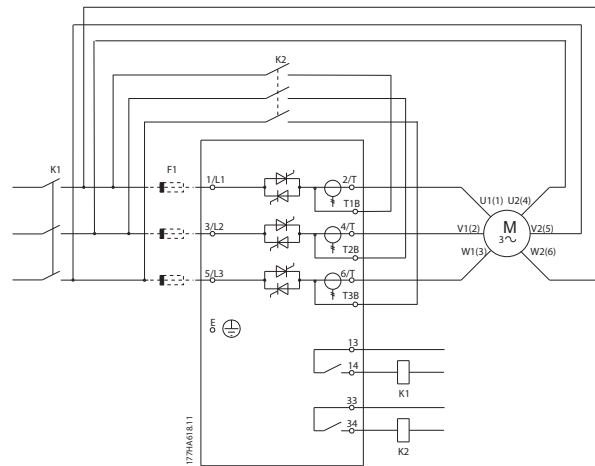

K1	Main contactor
K2	Bypass contactor (external)
F1	Semiconductor fuses (optional) <sup>1)</sup>
1) To keep the warranty on the SCRs, use semiconductor fuses.	

Illustration 4.15 Inside Delta Installation, Externally Bypassed, MCD5-0245C

4.3.3.3 Externally Bypassed

Non-bypassed models have dedicated bypass terminals, which allow the soft starter to continue providing protection and monitoring functions even when bypassed via an external bypass contactor. Connect the bypass contactor to the bypass terminals and control the contactor by a programmable output configured to Run (see parameters 4-1 to 4-9).

**NOTICE**

The bypass terminals on MCD5-0245C are:

- T1B.
- T2B.
- T3B.

The bypass terminals on MCD5-0360C to MCD5-1600C are:

- L1B.
- L2B.
- L3B.

If necessary, the fuses can be installed on the input side.

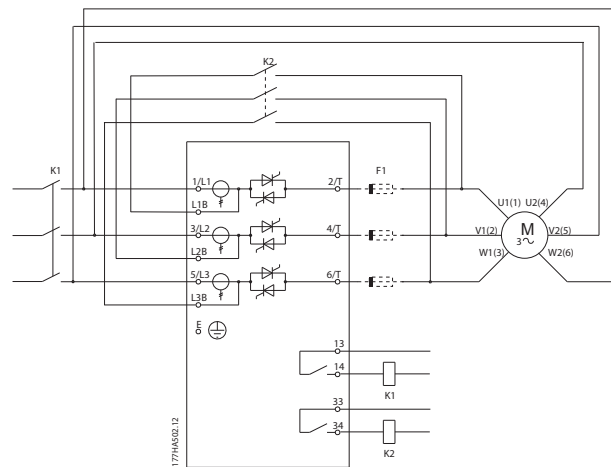

K1	Main contactor
K2	Bypass contactor (external)
F1	Semiconductor fuses (optional) <sup>1)</sup>
1) To keep the warranty on the SCRs, use semiconductor fuses.	

Illustration 4.16 Inside Delta Installation, Externally Bypassed, MCD5-0360C to MCD5-1600C

## 4.4 Current Ratings

Contact the local supplier for ratings under operating conditions not covered by these ratings charts.

All ratings are calculated at an altitude of 1000 m (3281 ft) and ambient temperature of 40 °C (104 °F).

## 4.4.1 In-line Connection (Bypassed)

**NOTICE**

Models MCD5-0021B to MCD5-0961B are internally bypassed. Models MCD5-0245C to MCD5-1600C require an external bypass contactor.

4

Type code	Ampere rating [A]		
	AC-53b 3-30:330	AC-53b 4-20:340	AC-53b 4.5-30:330
MCD5-0021B	21	17	15
MCD5-0037B	37	31	26
MCD5-0043B	43	37	30
MCD5-0053B	53	46	37
	AC-53b 3-30:570	AC-53b 4-20:580	AC-53b 4.5-30:570
MCD5-0068B	68	55	47
MCD5-0084B	84	69	58
MCD5-0089B	89	74	61
MCD5-0105B	105	95	78
MCD5-0131B	131	106	90
MCD5-0141B	141	121	97
MCD5-0195B	195	160	134
MCD5-0215B	215	178	148
MCD5-0245B	245	194	169
MCD5-0245C	255	201	176
MCD5-0331B	331	266	229
MCD5-0360C	360	310	263
MCD5-0380C	380	359	299
MCD5-0396B	396	318	273
MCD5-0428C	430	368	309
MCD5-0469B	496	383	326
MCD5-0525B	525	425	364
MCD5-0595C	620	540	434
MCD5-0619C	650	561	455
MCD5-0632B	632	512	438
MCD5-0790C	790	714	579
MCD5-0744B	744	606	516
MCD5-0826B	826	684	571
MCD5-0927C	930	829	661
MCD5-0961B	961	796	664
MCD5-1200C	1200	1200	1071
MCD5-1410C	1410	1319	1114
MCD5-1600C	1600	1600	1353

Table 4.2 Internally Bypassed Models

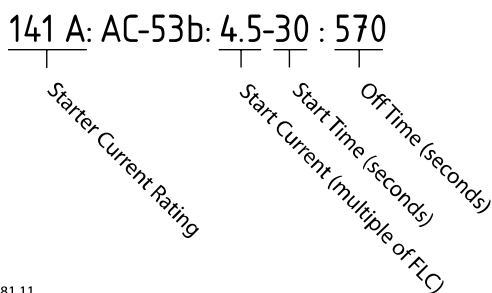

177HA281.11

Illustration 4.17 AC-53 Rating for Bypassed Operation

All ratings are calculated at an altitude of 1000 m (3281 ft) and ambient temperature of 40 °C (104 °F).

4.4.2 In-line Connection (Non-bypassed/Continuous)

Type code	Ampere ratings [A]		
	AC-53a 3-30:50-6	AC-53a 4-20:50-6	AC-53a 4.5-30:50-6
MCD5-0245C	245	195	171
MCD5-0360C	360	303	259
MCD5-0380C	380	348	292
MCD5-0428C	428	355	300
MCD5-0595C	595	515	419
MCD5-0619C	619	532	437
MCD5-0790C	790	694	567
MCD5-0927C	927	800	644
MCD5-1200C	1200	1135	983
MCD5-1410C	1410	1187	1023
MCD5-1600C	1600	1433	1227

Table 4.3 Non-bypassed Models

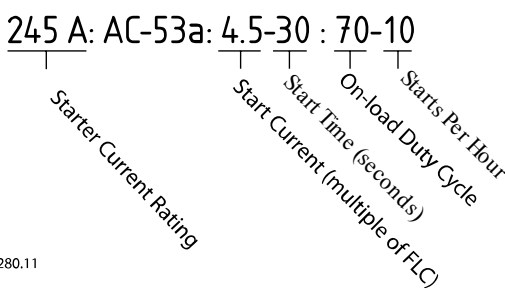

177HA280.11

Illustration 4.18 AC-53 Rating for Continuous Operation

All ratings are calculated at an altitude of 1000 m (3281 ft) and ambient temperature of 40 °C (104 °F).

Contact a local supplier for ratings under operating conditions not covered by these ratings charts.

## 4.4.3 Inside Delta Connection (Bypassed)

**NOTICE**

Models MCD5-0021B to MCD5-0961B are internally bypassed. Models MCD5-0245C to MCD5-1600C require an external bypass contactor.

**4**

Type code	Ampere ratings [A]		
	AC-53b 3-30:330	AC-53b 4.20-:340	AC-53b 4.5-30:330
MCD5-0021B	32	26	22
MCD5-0037B	56	47	39
MCD5-0043B	65	56	45
MCD5-0053B	80	69	55
	AC-53b 3-30:570	AC-53b 4-20:580	AC-53b 4.5-30:570
MCD5-0068B	102	83	71
MCD5-0084B	126	104	87
MCD5-0089B	134	112	92
MCD5-0105B	158	143	117
MCD5-0131B	197	159	136
MCD5-0141B	212	181	146
MCD5-0195B	293	241	201
MCD5-0215B	323	268	223
MCD5-0245B	368	291	254
MCD5-0245C	383	302	264
MCD5-0331B	497	400	343
MCD5-0360C	540	465	395
MCD5-0380C	570	539	449
MCD5-0396B	594	478	410
MCD5-0428C	645	552	463
MCD5-0469B	704	575	490
MCD5-0525B	787	637	546
MCD5-0595C	930	810	651
MCD5-0619C	975	842	683
MCD5-0632B	948	768	658
MCD5-0790C	1185	1072	869
MCD5-0744B	1116	910	774
MCD5-0826B	1239	1026	857
MCD5-0927C	1395	1244	992
MCD5-0961B	1441	1194	997
MCD5-1200C	1800	1800	1607
MCD5-1410C	2115	1979	1671
MCD5-1600C	2400	2400	2030

Table 4.4 Bypassed Models

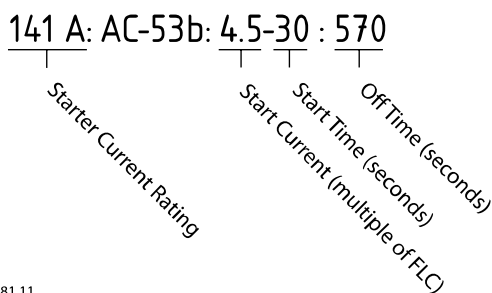

177HA281.11

Illustration 4.19 AC-53 Rating for Bypassed Operation

All ratings are calculated at an altitude of 1000 m (3281 ft) and ambient temperature of 40 °C (104 °F).

4.4.4 Inside Delta Connection (Non-bypassed/Continuous)

Type code	Ampere ratings [A]		
	AC-53a 3-30:50-6	AC-53a 4-20:50-6	AC-53a 4.5-30:50-6
MCD5-0245C	368	293	257
MCD5-0360C	540	455	389
MCD5-0380C	570	522	438
MCD5-0428C	643	533	451
MCD5-0595C	893	773	629
MCD5-0619C	929	798	656
MCD5-0790C	1185	1042	851
MCD5-0927C	1391	1200	966
MCD5-1200C	1800	1702	1474
MCD5-1410C	2115	1780	1535
MCD5-1600C	2400	2149	1841

Table 4.5 Non-bypassed Models

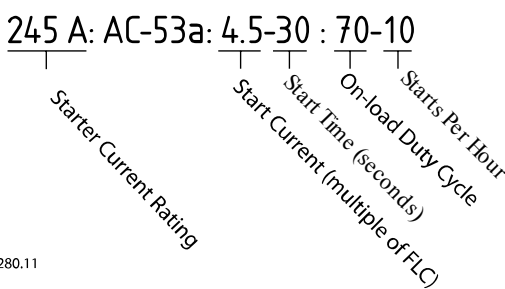

177HA280.11

Illustration 4.20 AC-53 Rating for Continuous Operation

All ratings are calculated at an altitude of 1000 m (3281 ft) and ambient temperature of 40 °C (104 °F).

Contact a local supplier for ratings under operating conditions not covered by these ratings charts.

## 4.5 Minimum and Maximum Current Settings

The minimum and maximum full load current settings depend on the model:

Model	In-line connection		Inside delta connection	
	Minimum [A]	Maximum [A]	Minimum [A]	Maximum [A]
MCD5-0021B	5	23	7	34
MCD5-0037B	9	43	13	64
MCD5-0043B	10	50	15	75
MCD5-0053B	11	53	16	79
MCD5-0068B	15	76	23	114
MCD5-0084B	19	97	29	145
MCD5-0089B	20	100	30	150
MCD5-0105B	21	105	32	157
MCD5-0131B	29	145	44	217
MCD5-0141B	34	170	51	255
MCD5-0195B	40	200	60	300
MCD5-0215B	44	220	66	330
MCD5-0331B	70	350	70	525
MCD5-0396B	85	425	85	638
MCD5-0469B	100	500	100	750
MCD5-0525B	116	580	116	870
MCD5-0632B	140	700	140	1050
MCD5-0744B	164	820	164	1230
MCD5-0825B	184	920	184	1380
MCD5-0961B	200	1000	200	1500
MCD5-0245C	51	255	77	382
MCD5-0360C	72	360	108	540
MCD5-0380C	76	380	114	570
MCD5-0428C	86	430	129	645
MCD5-0595C	124	620	186	930
MCD5-0619C	130	650	195	975
MCD5-0790C	158	790	237	1185
MCD5-0927C	186	930	279	1395
MCD5-1200C	240	1200	360	1800
MCD5-1410C	282	1410	423	2115
MCD5-1600C	320	1600	480	2400

Table 4.6 Minimum and Maximum Full Load Current

## 4.6 Bypass Contactor

Some VLT® Soft Starters MCD 500 are internally bypassed and do not require an external bypass contactor.

Non-bypassed soft starters may be installed with an external bypass contactor. Select a contactor with an AC1 rating greater than or equal to the full load current rating of the connected motor.

## 4.7 Main Contactor

Install a main contactor if the VLT® Soft Starter MCD 500 is connected to the motor in inside delta format and is optional for in-line connection. Select a contactor with an AC3 rating greater than or equal to the full load current rating of the connected motor.

## 4.8 Circuit Breaker

A shunt trip circuit breaker may be used instead of a main contactor to isolate the motor circuit if a soft starter trips. The shunt trip mechanism must be powered from the supply side of the circuit breaker or from a separate control supply.



## 4.9 Power Factor Correction

### **CAUTION**

#### **EQUIPMENT DAMAGE**

Connecting power factor correction capacitors to the output side damages the soft starter.

- Connect power factor correction capacitors to the input side of the soft starter.

If power factor correction is used, use a dedicated contactor to switch in the capacitors.

## 4.10 Fuses

### 4.10.1 Power Supply Fuses

#### **NOTICE**

##### **WARRANTY**

To keep the warranty on the SCRs, all fuses should be semiconductor fuses.

#### **NOTICE**

Use semiconductor fuses for Type 2 coordination (according to the IEC 60947-4-2 standard) to prevent damaging the SCRs. VLT® Soft Starter MCD 500 has integrated SCR protection against overload transient currents, but if there is a short circuit (for example due to a defective motor winding) this protection is not sufficient.

HRC fuses (such as Ferraz AJT fuses) can be used for Type 1 coordination according to the IEC 60947-4-2 standard.

#### **NOTICE**

Adaptive control regulates the speed profile of the motor within the programmed time limit. This control may result in a higher level of current than traditional control methods.

For applications using adaptive control to soft stop the motor with stop times greater than 30 s, select motor branch protection as follows:

- Standard HRC mains fuses: Minimum 150% motor full load current.
- Motor rated mains fuses: Minimum rating 100/150% motor full load current.
- Motor control circuit breaker minimum long time setting: 150% motor full load current.
- Motor control circuit breaker minimum short time setting: 400% motor full load current for 30 s.

Fuse recommendations are calculated for 40 °C (104 °F), and at an altitude of up to 1000 m (3281 ft).

#### **NOTICE**

Fuse selection is based on a 400% FLC start for 20 s with:

- Standard published starts per hour.
- Duty cycle.
- 40 °C (104 °F) ambient temperature.
- Up to 1000 m (3281 ft) altitude.

For installations operating outside these conditions, consult a local Danfoss supplier.

*Table 4.7 to Table 4.13 contain recommendations only. To confirm the selection for a particular application, always consult a local supplier.*

## 4.10.2 Bussmann Fuses

4

Model	SCR I <sup>2</sup> t (A <sup>2</sup> s)	Supply voltage (≤440 V AC)	Supply voltage (≤575 V AC)	Supply voltage (≤690 V AC)
MCD5-0021B	1150	170M1314	170M1314	170M1314
MCD5-0037B	8000	170M1316	170M1316	170M1316
MCD5-0043B	10500	170M1318	170M1318	170M1318
MCD5-0053B	15000	170M1318	170M1318	170M1318
MCD5-0068B	15000	170M1319	170M1319	170M1318
MCD5-0084B	512000	170M1321	170M1321	170M1319
MCD5-0089B	80000	170M1321	170M1321	170M1321
MCD5-0105B	125000	170M1321	170M1321	170M1321
MCD5-0131B	125000	170M1321	170M1321	170M1321
MCD5-0141B	320000	170M2621	170M2621	170M2621
MCD5-0195B	320000	170M2621	170M2621	170M2621
MCD5-0215B	320000	170M2621	170M2621	170M2621
MCD5-0245B	320000	170M2621	170M2621	170M2621
MCD5-0331B	202000	170M5011	170M5011	-
MCD5-0396B	320000	170M6011	-	-
MCD5-0469B	320000	170M6008 <sup>1)</sup>	-	-
MCD5-0525B	781000	170M6013	170M6013	170M6013
MCD5-0632B	781000	170M5015	170M5015	-
MCD5-0744B	1200000	170M5017	170M6017	-
MCD5-0826B	2530000	170M6017	170M6017	-
MCD5-0961B	2530000	170M6018	170M6013 <sup>1)</sup>	-
MCD5-0245C	320000	170M2621	170M2621	170M2621
MCD5-0360C	320000	170M6010	170M6010	170M6010
MCD5-0380C	320000	170M6011	170M6011	-
MCD5-0428C	320000	170M6011	170M6011	-
MCD5-0595C	1200000	170M6015	170M6015	170M6014
MCD5-0619C	1200000	170M6015	170M6015	170M6014
MCD5-0790C	2530000	170M6017	170M6017	170M6016
MCD5-0927C	4500000	170M6019	170M6019	170M6019
MCD5-1200C	4500000	170M6021	-	-
MCD5-1410C	6480000	-	-	-
MCD5-1600C	12500000	170M6019 <sup>1)</sup>	-	-

Table 4.7 Square Body (170M)

1) Two fuses connected in parallel are required per phase.

Model	SCR I <sup>2</sup> t (A <sup>2</sup> s)	Supply voltage (<440 V AC)	Supply voltage (<575 V AC)	Supply voltage (<690 V AC)
MCD5-0021B	1150	63FE	63FE	63FE
MCD5-0037B	8000	120FEE	120FEE	120FEE
MCD5-0043B	10500	120FEE	120FEE	120FEE
MCD5-0053B	15000	200FEE	200FEE	200FEE
MCD5-0068B	15000	200FEE	200FEE	200FEE
MCD5-0084B	512000	200FEE	200FEE	200FEE
MCD5-0089B	80000	280FM	280FM	280FM
MCD5-0105B	125000	280FM	280FM	280FM
MCD5-0131B	125000	280FM	280FM	280FM
MCD5-0141B	320000	450FMM	450FMM	450FMM
MCD5-0195B	320000	450FMM	450FMM	450FMM
MCD5-0215B	320000	450FMM	450FMM	450FMM
MCD5-0245B	320000	450FMM	450FMM	450FMM
MCD5-0331B	202000	315FM <sup>1)</sup>	-	-
MCD5-0396B	320000	400FMM <sup>1)</sup>	-	-
MCD5-0469B	320000	450FMM <sup>1)</sup>	-	-
MCD5-0525B	781000	500FMM <sup>1)</sup>	500FMM <sup>1)</sup>	500FMM <sup>1)</sup>
MCD5-0632B	781000	630FMM <sup>1)</sup>	-	-
MCD5-0744B	1200000	-	-	-
MCD5-0826B	2530000	-	-	-
MCD5-0961B	2530000	-	-	-
MCD5-0245C	320000	450FMM	450FMM	450FMM
MCD5-0360C	320000	-	-	-
MCD5-0380C	320000	400FMM <sup>1)</sup>	400FMM	400FMM <sup>1)</sup>
MCD5-0428C	320000	-	-	-
MCD5-0595C	1200000	630FMM <sup>1)</sup>	630FMM <sup>1)</sup>	-
MCD5-0619C	1200000	630FMM <sup>1)</sup>	630FMM <sup>1)</sup>	-
MCD5-0790C	2530000	-	-	-
MCD5-0927C	4500000	-	-	-
MCD5-1200C	4500000	-	-	-
MCD5-1410C	6480000	-	-	-
MCD5-1600C	12500000	-	-	-

**Table 4.8 British Style (BS88)**

1) Two fuses connected in parallel are required per phase.

## 4.10.3 Ferraz Fuses

4

Model	SCR I <sup>2</sup> t (A <sup>2</sup> s)	Supply voltage (<440 V AC)	Supply voltage (<575 V AC)	Supply voltage (<690 V AC)		
MCD5-0021B	1150	HSJ40 <sup>1)</sup>	HSJ40 <sup>1)</sup>	Not applicable		
MCD5-0037B	8000	HSJ80 <sup>1)</sup>	HSJ80 <sup>1)</sup>			
MCD5-0043B	10500	HSJ90 <sup>1)</sup>	HSJ90 <sup>1)</sup>			
MCD5-0053B	15000	HSJ110 <sup>1)</sup>	HSJ110 <sup>1)</sup>			
MCD5-0068B	15000	HSJ125 <sup>1)</sup>	HSJ125 <sup>1)</sup>			
MCD5-0084B	51200	HSJ175	HSJ175 <sup>1)</sup>			
MCD5-0089B	80000	HSJ175	HSJ175			
MCD5-0105B	125000	HSJ225	HSJ225			
MCD5-0131B	125000	HSJ250	HSJ250 <sup>1)</sup>			
MCD5-0141B	320000	HSJ300	HSJ300			
MCD5-0195B	320000	HSJ350	HSJ350			
MCD5-0215B	320000	HSJ400 <sup>1)</sup>	HSJ400 <sup>1)</sup>			
MCD5-0245B	320000	HSJ450 <sup>1)</sup>	HSJ450 <sup>1)</sup>			
MCD5-0331B	202000	HSJ500 <sup>1)</sup>	Not applicable			
MCD5-0396B	320000	Not applicable				
MCD5-0469B	320000					
MCD5-0525B	781000					
MCD5-0632B	781000					
MCD5-0744B	1200000					
MCD5-0826B	2530000					
MCD5-0961B	2530000					
MCD5-0245C	320000				HSJ450 <sup>1)</sup>	HSJ450 <sup>1)</sup>
MCD5-0360C	320000				Not applicable	
MCD5-0380C	320000					
MCD5-0428C	320000					
MCD5-0595C	1200000					
MCD5-0619C	1200000					
MCD5-0790C	2530000					
MCD5-0927C	4500000					
MCD5-1200C	4500000					
MCD5-1410C	6480000					
MCD5-1600C	12500000					

Table 4.9 HSJ

1) Two series connected fuses required per phase.

Model	SCR I <sup>2</sup> t (A <sup>2</sup> s)	Supply voltage (<440 V AC)	Supply voltage (<575 V AC)	Supply voltage (<690 V AC)
MCD5-0021B	1150	A070URD30XXX0063	A070URD30XXX0063	-
MCD5-0037B	8000	A070URD30XXX0125	A070URD30XXX0125	A070URD30XXX0125
MCD5-0043B	10500	A070URD30XXX0125	A070URD30XXX0125	A070URD30XXX0125
MCD5-0053B	15000	A070URD30XXX0125	A070URD30XXX0125	A070URD30XXX0125
MCD5-0068B	15000	A070URD30XXX0160	A070URD30XXX0160	A070URD30XXX0160
MCD5-0084B	51200	A070URD30XXX0200	A070URD30XXX0200	A070URD30XXX0200
MCD5-0089B	80000	A070URD30XXX0200	A070URD30XXX0200	A070URD30XXX0200
MCD5-0105B	125000	A070URD30XXX0315	A070URD30XXX0315	A070URD30XXX0315
MCD5-0131B	125000	A070URD30XXX0315	A070URD30XXX0315	A070URD30XXX0315
MCD5-0141B	320000	A070URD30XXX0315	A070URD30XXX0315	A070URD30XXX0315
MCD5-0195B	320000	A070URD30XXX0450	A070URD30XXX0450	A070URD30XXX0450
MCD5-0215B	320000	A070URD30XXX0450	A070URD30XXX0450	A070URD30XXX0450
MCD5-0245B	32000	A070URD30XXX0450	A070URD30XXX0450	A070URD30XXX0450
MCD5-0331B	202000	A070URD31XXX0550	-	-
MCD5-0396B	238000	A070URD32XXX0630	-	-
MCD5-0469B	320000	A070URD32XXX0700	-	-
MCD5-0525B	781000	A070URD32XXX0800	-	-
MCD5-0632B	781000	A070URD33XXX0900	-	-
MCD5-0744B	1200000	A070URD33XXX1100	-	-
MCD5-0826B	2530000	A070URD33XXX1250	-	-
MCD5-0961B	2530000	A070URD33XXX1400	-	-
MCD5-0245C	320000	A070URD30XXX0450	A070URD30XXX0450	A070URD30XXX0450
MCD5-0360C	320000	A070URD33XXX0630	A070URD33XXX0630	A070URD33XXX0630
MCD5-0380C	320000	A070URD33XXX0700	A070URD33XXX0700	-
MCD5-0428C	320000	A070URD33XXX0700	A070URD33XXX0700	-
MCD5-0595C	1200000	A070URD33XXX1000	A070URD33XXX1000	A070URD33XXX1000
MCD5-0619C	1200000	A070URD33XXX1000	A070URD33XXX1000	A070URD33XXX1000
MCD5-0790C	2530000	A070URD33XXX1400	A070URD33XXX1400	A070URD33XXX1400
MCD5-0927C	4500000	A070URD33XXX1400	A070URD33XXX1400	A070URD33XXX1400
MCD5-1200C	4500000	A055URD33XXX2250	-	-
MCD5-1410C	6480000	A055URD33XXX2250	-	-
MCD5-1600C	12500000	-	-	-

Table 4.10 North American Style (PSC 690)

Model	SCR I <sup>2</sup> t (A <sup>2</sup> s)	Supply voltage (<440 V AC)	Supply voltage (<575 V AC)	Supply voltage (<690 V AC)
MCD5-0021B	1150	6.9URD30D11A0050	6.9URD30D11A0050	6.9URD30D11A0050
MCD5-0037B	8000	6.9URD30D11A0125	6.9URD30D11A0125	6.9URD30D11A0125
MCD5-0043B	10500	6.9URD30D11A0125	6.9URD30D11A0125	6.9URD30D11A0125
MCD5-0053B	15000	6.9URD30D11A0125	6.9URD30D11A0125	6.9URD30D11A0125
MCD5-0068B	15000	6.9URD30D11A0160	6.9URD30D11A0160	6.9URD30D11A0160
MCD5-0084B	51200	6.9URD30D11A0200	6.9URD30D11A0200	6.9URD30D11A0200
MCD5-0089B	80000	6.9URD30D11A0200	6.9URD30D11A0200	6.9URD30D11A0200
MCD5-0105B	125000	6.9URD30D11A0315	6.9URD30D11A0315	6.9URD30D11A0315
MCD5-0131B	125000	6.9URD30D11A0315	6.9URD30D11A0315	6.9URD30D11A0315
MCD5-0141B	320000	6.9URD30D11A0315	6.9URD30D11A0315	6.9URD30D11A0315
MCD5-0195B	320000	6.9URD31D11A0450	6.9URD31D11A0450	6.9URD31D11A0450
MCD5-0215B	320000	6.9URD31D11A0450	6.9URD31D11A0450	6.9URD31D11A0450
MCD5-0245B	320000	6.9URD31D11A0450	6.9URD31D11A0450	6.9URD31D11A0450
MCD5-0331B	202000	6.9URD31D11A0550	-	-
MCD5-0396B	320000	6.9URD32D11A0630	-	-

Model	SCR I <sup>2</sup> t (A <sup>2</sup> s)	Supply voltage (<440 V AC)	Supply voltage (<575 V AC)	Supply voltage (<690 V AC)
MCD5-0469B	320000	6.9URD32D11A0700	–	–
MCD5-0525B	781000	6.9URD32D11A0800	–	–
MCD5-0632B	781000	6.9URD33D11A0900	–	–
MCD5-0744B	1200000	6.9URD33D11A1100	–	–
MCD5-0826B	2530000	6.9URD33D11A1250	–	–
MCD5-0961B	2530000	6.9URD33D11A1400	–	–
MCD5-0245C	320000	6.9URD31D11A0450	6.9URD31D11A0450	6.9URD31D11A0450
MCD5-0360C	320000	6.9URD33D11A0630	6.9URD33D11A0630	6.9URD33D11A0630
MCD5-0380C	320000	6.9URD33D11A0700	6.9URD33D11A0700	6.9URD33D11A0700
MCD5-0428C	320000	6.9URD33D11A0700	6.9URD33D11A0700	6.9URD33D11A0700
MCD5-0595C	1200000	6.9URD33D11A1000	6.9URD33D11A1000	6.9URD33D11A1000
MCD5-0619C	1200000	6.9URD33D11A1000	6.9URD33D11A1000	6.9URD33D11A1000
MCD5-0790C	2530000	6.6URD33D11A1400	6.6URD33D11A1400	–
MCD5-0927C	4500000	6.6URD33D11A1400	6.6URD33D11A1400	–
MCD5-1200C	4500000	6URD233PLAF2200	6URD233PLAF2200	–
MCD5-1410C	6480000	6URD233PLAF2200	6URD233PLAF2200	–
MCD5-1600C	12500000	6URD233PLAF2800	6URD233PLAF2800	–

Table 4.11 European Style (PSC 690)

#### 4.10.4 UL Fuse Selection and Short Circuit Ratings

Two short-circuit current ratings (SCCR) are available for UL-compliant applications.

##### Standard fault currents (@600 V AC circuits)

The standard fault currents are determined referring to UL 508, section 1, table 51.2. This standard specifies the short-circuit current that the soft starter must withstand based on the horse power rating (or full load current (FLC) rating, or locked rotor amps (LRA) depending on the model).

If using the standard fault current ratings, the fuse must be in accordance with the information in *Table 4.12* (model- and manufacturer-specific).

##### High available fault currents (@480 V AC circuits)

It is possible to specify short-circuit current ratings exceeding the minimum ratings set by the standard fault currents when the soft starter is able to withstand the high available short-circuit current in accordance with the UL 508 test.

If using the high available fault current ratings, select a suitable fuse based on amperage and fuse class (J or L as applicable).

Model	Nominal rating [A]	Short-circuit ratings					600 V short-circuit current rating [kA] 3 cycles <sup>1)</sup>
		High available		Standard fault current			
		@480 V AC maximum [kA]	Maximum fuse rating [A] (fuse class)	@600 V AC [kA]	Ferraz/Mersen fuse, listed J, L, or RK5 class fuse	Ferraz/Mersen fuse, R/C semiconductor fuses	
MCD5-0021B	23	65	25 (J)	10	AJT25	A070URD30XXX 0063	N/A
MCD5-0037B	43	65	50 (J)	10	AJT50	A070URD30XXX 0125	
MCD5-0043B	50	65	50 (J)	10	AJT50	A070URD30XXX 0125	
MCD5-0053B	53	65	60 (J)	10	AJT60	A070URD30XXX 0125	
MCD5-0068B	76	65	80 (J)	10	AJT80	A070URD30XXX 0200	
MCD5-0084B	97	65	100 (J)	10	AJT100	A070URD30XXX 0200	
MCD5-0089B	100	65	100 (J)	10	AJT100	A070URD30XXX 0200	
MCD5-0105B	105	65	125 (J)	10	AJT125	A070URD30XXX 0315	
MCD5-0131B	145	65	150 (J)	18	AJT150/RK5 200	A070URD30XXX 0315	
MCD5-0141B	170	65	175 (J)	18	AJT175/RK5 200	A070URD30XXX 0315	
MCD5-0195B	200	65	200 (J)	18	AJT200/RK5 300	A070URD30XXX 0450	
MCD5-0215B	220	65	250 (J)	18	AJT250/RK5 300	A070URD30XXX 0450	
MCD5-0245B	255	65	350 (RK1/J)	18	<sup>1)</sup>	–	18
MCD5-0331B	350	65	400 (J)	18	<sup>1)</sup>	–	3 cycles
MCD5-0396B	425	65	450 (J)	30	<sup>1)</sup>	A070URD33XXX 0630	30 3 cycles
MCD5-0469B	500	65	600 (J)	30	600, Class J	A070URD33XXX 0700	
MCD5-0525B	580	65	800 (L)	30	800, Class L	–	42 3 cycles
MCD5-0632B	700	65	800 (L)	42	800, Class L	–	
MCD5-0744B	820	65	1200 (L)	42	1200, Class L	A070URD33XXX 1000	
MCD5-0826B	920	65	1200 (L)	85	1200, Class L	A070URD33XXX 1400	
MCD5-0961B	1000	65	1200 (L)	85	1200, Class L	A070URD33XXX 1400	

**Table 4.12 Short-circuit Ratings, Bypassed Models**

XXX = blade type: See Ferraz/Mersen catalog for details.

1) When protected by any UL listed fuses or UL listed circuit breakers sized according to the NEC, models provided with a 3-cycle rating are suitable for use in a circuit with the prospective current noted.

Model	Nominal rating [A]	Short-circuit ratings					600 V short-circuit current rating [kA] 3 cycles <sup>1)</sup>
		High available		Standard fault current			
		@480 V AC maximum [kA]	Maximum fuse rating [A] (fuse class)	@600 V AC [kA]	Ferraz/Mersen fuse, listed J, L, or RK5 class fuse	Ferraz/Mersen fuse, R/C semiconductor fuses	
MCD5-0245C	255	65	350 (RK1/J)	18	AJT300	A070URD33XXX 0450	N/A
MCD5-0360C	360	65	400 (J)	18	AJT400/RK5 500	A070URD33XXX 0630	
MCD5-0380C	380	65	450 (J)	18	AJT450/RK5 500	A070URD33XXX 0700	
MCD5-0428C	430	65	450 (J)	30	AJT450	A070URD33XXX 0700	
MCD5-0595C	620	65	800 (L)	42	A4BQ800	A070URD33XXX 1000	
MCD5-0619C	650	65	800 (L)	42	A4BQ800	A070URD33XXX 1000	
MCD5-0790C	790	65	1200 (L)	42	A4BQ1200	070URD33XXX1 400	
MCD5-0927C	930	65	1200 (L)	42	A4BQ1200	A070URD33XXX 1400	
MCD5-1200C	1200	65	1600 (L)	85	A4BQ1600	A065URD33XXX 1800	
MCD5-1410C	1410	65	2000 (L)	85	A4BQ2000	A055URD33XXX 2250	
MCD5-1600C	1600	65	2000 (L)	85	A4BQ2500	A055URD33XXX 2500	

**Table 4.13 Short-circuit Ratings, Non-bypassed Models**

XXX = blade type: See Ferraz/Mersen catalog for details.

1) When protected by any UL listed fuses or UL listed circuit breakers sized according to the NEC, models provided with a 3-cycle rating are suitable for use in a circuit with the prospective current noted.



4.11 Schematic Diagrams

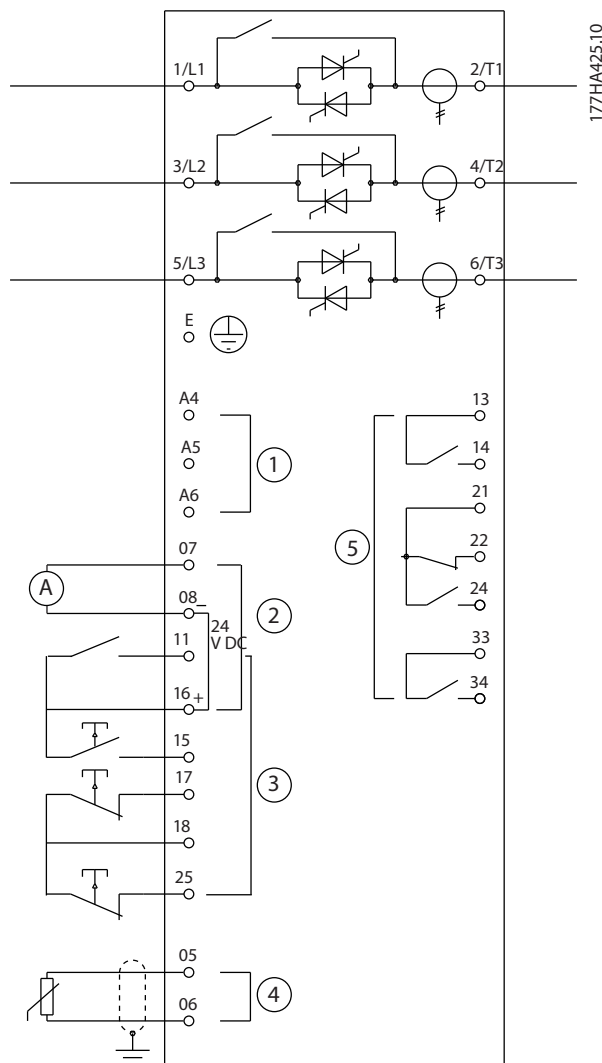

4

1	Control supply (model dependent)	11, 16	Programmable input
2	Outputs	15, 16	Start
3	Remote control inputs	17, 18	Stop
4	Motor thermistor input (PTC only)	25, 18	Reset
5	Relay outputs	13, 14	Relay output A
07, 08	Programmable analog output	21, 22, 24	Relay output B
16, 08	24 V DC output	33, 34	Relay output C

Illustration 4.21 Internally Bypassed Models

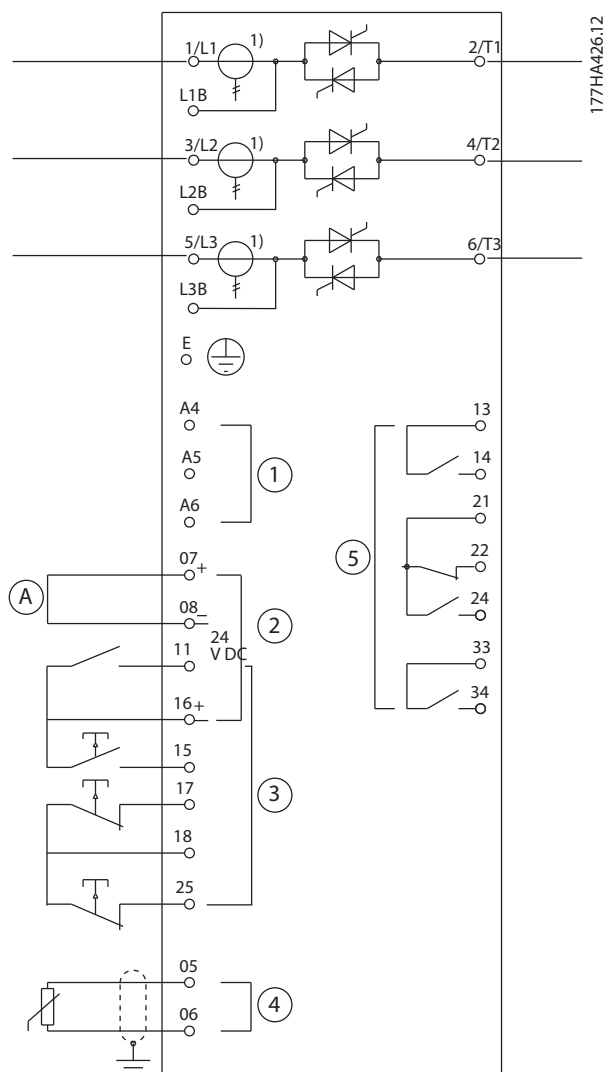

1	Control supply (model dependent)	11, 16	Programmable input
2	Outputs	15, 16	Start
3	Remote control inputs	17, 18	Stop
4	Motor thermistor input (PTC only)	25, 18	Reset
5	Relay outputs	13, 14	Relay output A
07, 08	Programmable analog output	21, 22, 24	Relay output B
16, 08	24 V DC output	33, 34	Relay output C

Illustration 4.22 Non-bypassed Models

1) MCD5-0245C current transformers are placed on the output. Bypass terminals are labeled T1B, T2B, and T3B.

## 5 Product Features

### 5.1 Motor Overload Protection

The thermal model used for motor overload in the soft starter has 2 components:

- Motor windings: The motor windings have a low thermal capacity and affect the short-term thermal behavior of the motor. The motor windings are where the current generates heat.
- Motor body: The motor body has a large thermal capacity and affects the long-term behavior of the motor. The thermal model includes considerations for the following:
  - Motor current.
  - Iron losses.
  - Winding resistance losses.
  - Motor body and winding thermal capacities.
  - Cooling during run and cooling at standstill.
  - The percentage of the rated capacity of the motor. This sets the shown value for the winding model and is affected by the motor FLC setting among others.

**NOTICE**

Set *parameter 1-1 Motor FLC* to the rated motor FLC. Do not add the overload rating as the soft starter calculates this rating.

The thermal overload protection used in the soft starter has several advantages over the thermal relays.

- The effect of fan cooling is accounted for when the motor is running.
- The actual full load current and locked rotor time can be used to tune the model more accurately. The thermal characteristics of the windings are treated separately from the rest of the motor (that is the model recognizes that the windings have low thermal mass and high thermal resistance).
- The winding portion of the thermal model responds rapidly compared with the body portion. Thus, the motor can be run closer to its safe maximum operating temperature while still being protected from thermal damage.
- The percentage of motor thermal capacity used during each start is stored in memory. The soft starter can be configured to determine automatically whether the motor has sufficient thermal

capacity remaining to complete another start successfully.

- The memory function of the model ensures that the motor is fully protected in warm-start situations. The model uses data from the real-time clock to account for elapsed cooling time, even if control power has been removed.

The overload protection function provided by this model is compliant with a NEMA 10 curve, but provides superior protection at low levels of overload due to the separation of the winding thermal model.

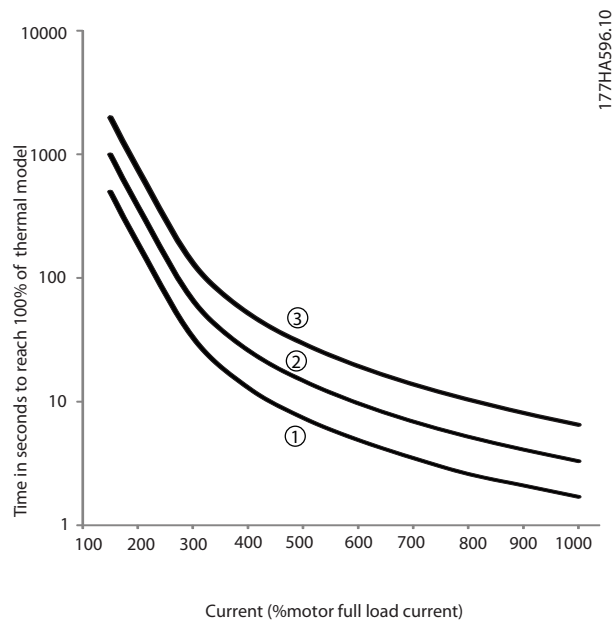

1	MSTC <sup>1)</sup> =5
2	MSTC <sup>1)</sup> =10
3	MSTC <sup>1)</sup> =20

1) MSTC is the motor start time constant. It is defined as the locked rotor time (in parameter 1-2 Locked Rotor Time) when the locked rotor current is 600% of FLC.

Illustration 5.1 Protection Degree Compared to Overload

### 5.2 Adaptive Control

Adaptive control is motor control based on the performance characteristics of the motor. With adaptive control, select the starting or stopping profile that best matches the load type. The soft starter automatically controls the motor to match the profile. The VLT® Soft Starter MCD 500 offers 3 profiles:

- Early acceleration and deceleration.
- Constant acceleration and deceleration.
- Late acceleration and deceleration.

Adaptive control uses 2 algorithms; 1 to measure the motor characteristics, and 1 to control the motor. The soft starter uses the first start to determine the motor characteristics at 0 speed and at maximum speed. During each subsequent start and stop, the soft starter dynamically adjusts its control to ensure that the actual motor performance matches the selected profile throughout the start. If the actual speed is too low for the profile, the soft starter increases power to the motor. If the speed is too high, the soft starter decreases power.

### 5.3 Starting Modes

#### 5.3.1 Constant Current

Constant current is the traditional form of soft starting. It raises the current from 0 to a specified level and keeps the current stable at that level until the motor has accelerated.

Constant current starting is ideal for applications where the start current must be kept below a specific level.

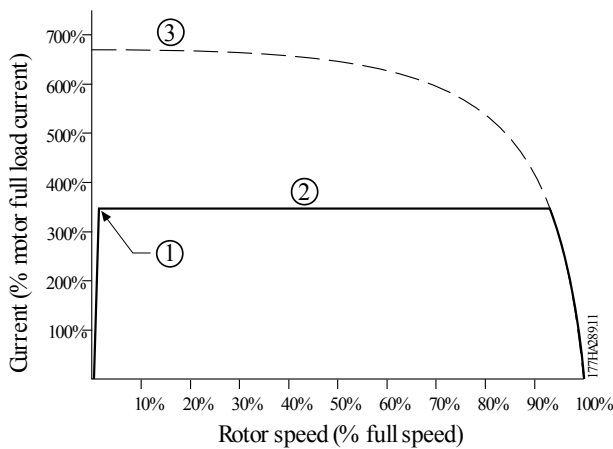

1	Parameter 1-5 Initial current
2	Parameter 1-4 Current limit
3	Full voltage current

Illustration 5.2 Example of Constant Current

#### 5.3.2 Current Ramp

Current ramp soft starting raises the current from a specified starting level (1) to a maximum limit (3), over an extended period (2), see *Illustration 5.3*.

Current ramp starting can be useful for applications where:

- The load can vary between starts (for example a conveyor, which may start loaded or unloaded).

- Set *parameter 1-5 Initial Current* to a level that starts the motor with a light load.
- Set *parameter 1-4 Current Limit* to a level that starts the motor with a heavy load.

- The load breaks away easily, but starting time must be extended (for example a centrifugal pump where pipeline pressure must build up slowly).
- The electricity supply is limited (for example a generator set), and a slower increase of load allows more time for the supply to respond.

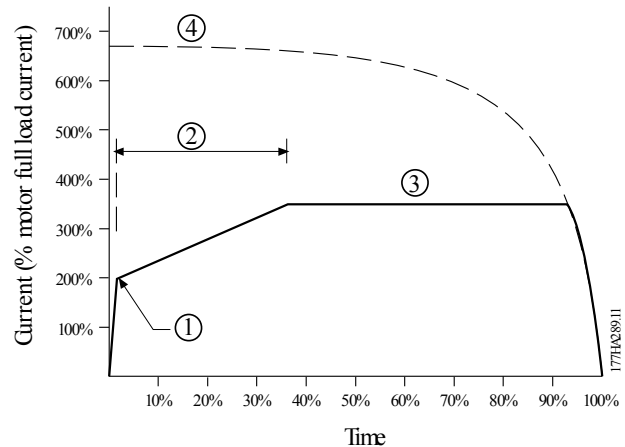

1	Parameter 1-5 Initial current
2	Parameter 1-6 Start ramp time
3	Parameter 1-4 Current limit
4	Full voltage current

Illustration 5.3 Example of a 10 s Current Ramp Time

#### 5.3.3 Adaptive Control

In an adaptive control soft start, the soft starter adjusts the current to start the motor within a specified time and uses a selected acceleration profile.

#### NOTICE

Adaptive control cannot start the motor faster than a direct on-line (DOL) start. If the time set in *parameter 1-6 Start ramp time* is shorter than the motor DOL start time, starting current may reach DOL levels.

Every application has a particular starting profile based on characteristics of the load and the motor. To meet the requirements of different applications, adaptive control offers 3 different starting profiles. Selecting a profile that matches the inherent profile of the application can help smooth out acceleration across the full start time. Selecting a different adaptive control profile can neutralize the inherent profile to some extent.

To use adaptive control to control starting performance:

1. Select *Adaptive control* in *parameter 1-3 Start Mode*.
2. Set *parameter 1-6 Start Ramp Time*.
3. Select the wanted profile in *parameter 1-13 Adaptive Start Profile*.
4. Set *parameter 1-4 Current Limit* sufficiently high to allow a successful start.

The 1<sup>st</sup> adaptive control start is a constant current start. This start type allows the soft starter to learn the characteristics of the connected motor. The soft starter uses this motor data during subsequent adaptive control starts.

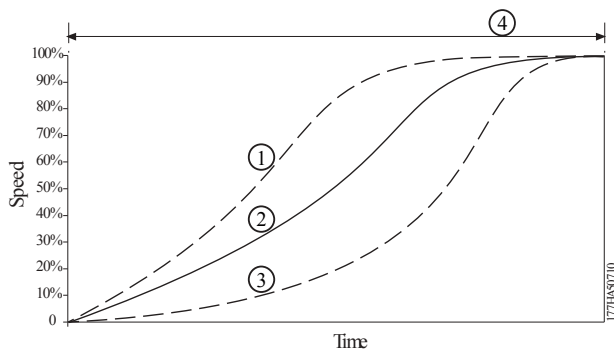

1	Early acceleration
2	Constant acceleration
3	Late acceleration
4	Parameter 1-16 Start Ramp Time

Illustration 5.4 Parameter 1-13 Adaptive Start Profile

**NOTICE**

Adaptive control regulates the load according to the programmed profile. Start current varies according to the selected acceleration profile and the programmed start time.

The soft starter has to learn the characteristics of a new motor:

- If replacing a motor connected to a soft starter programmed for adaptive control starting or stopping.
- If the soft starter has been tested on a different motor before actual installation.

If *parameter 1-1 Motor Full Load Current* or *parameter 1-12 Adaptive Control Gain* is changed, the soft starter automatically relearns the motor characteristics.

5.3.4 Kick-start

Kick-start provides a short boost of extra torque at the beginning of a start and can be used with current ramp or constant current starting.

Kick-start can be useful to help start loads that require high breakaway torque but then accelerate easily once they are started (for example flywheel loads such as presses).

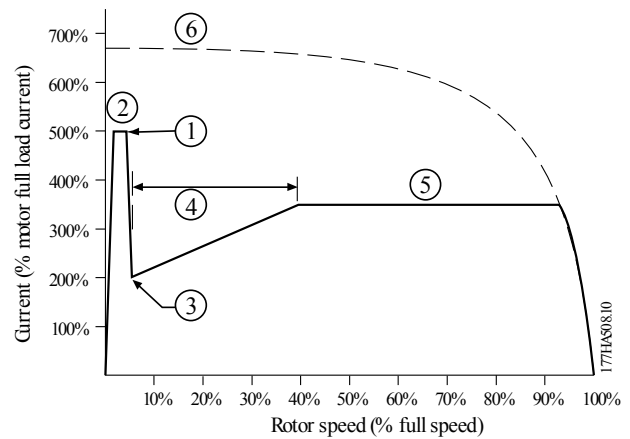

1	Parameter 1-7 Kick-start Level
2	Parameter 1-8 Kick-start Time
3	Parameter 1-5 Initial Current
4	Parameter 1-6 Start Ramp Time
5	Parameter 1-4 Current Limit
6	Full voltage current

Illustration 5.5 Example of Rotor Speed when using Kick-start

5.4 Stopping Modes

5.4.1 Coast to Stop

Coast to stop lets the motor slow at its natural rate, with no control from the soft starter. The time required to stop depends on the type of load.

5.4.2 TVR Soft Stop

Timed voltage ramp reduces the voltage to the motor gradually over a defined time. The load may continue to run after the stop ramp is complete.

Timed voltage ramp stopping can be useful for applications where the stop time has to be extended, or to avoid transients on generator-set supplies.

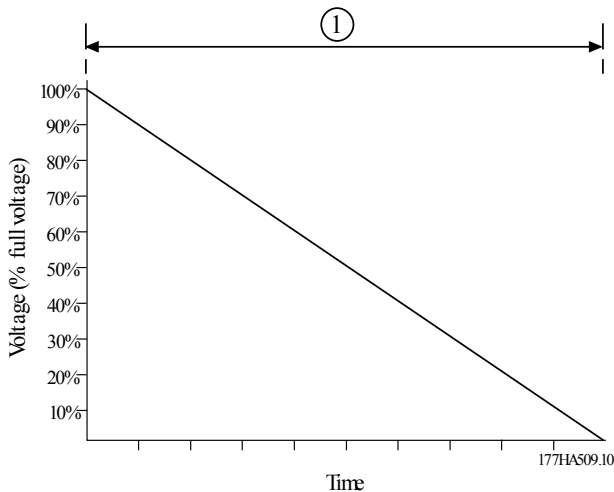

1 Parameter 1-11 Stop Time

Illustration 5.6 TVR Soft Stop

### 5.4.3 Adaptive Control

To use adaptive control to control stopping performance:

1. Select *Adaptive control* from the *Stop Mode* menu.
2. Set *parameter 1-11 Stop Time*.
3. Select the required profile in *parameter 1-14 Adaptive Stop Profile*.

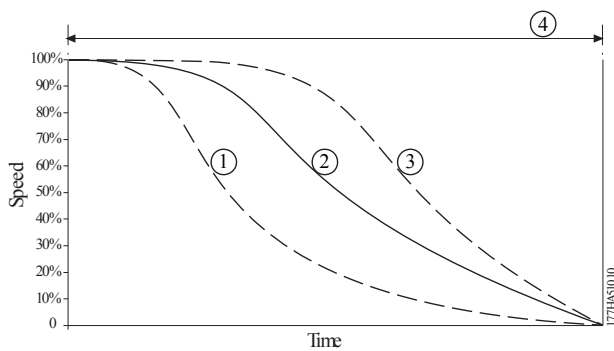

1	Early deceleration
2	Constant deceleration
3	Late deceleration
4	Parameter 1-10 Stop Time

Illustration 5.7 Parameter 1-14 Adaptive Stop Profile

### NOTICE

Adaptive control does not actively slow the motor down and does not stop the motor faster than a coast to stop. To shorten the stopping time of high-inertia loads, use a brake function, see *chapter 5.4.5 Brake*.

The first adaptive control stop is a normal soft stop. This stop type allows the soft starter to learn the characteristics

of the connected motor. The soft starter uses this motor data during subsequent adaptive control stops.

### NOTICE

Adaptive control regulates the load according to the programmed profile. Stopping current varies according to the selected deceleration profile and stop time.

The soft starter has to learn the characteristics of a new motor:

- If replacing a motor connected to a soft starter programmed for adaptive control starting or stopping.
- If the soft starter has been tested on a different motor before actual installation.

If *parameter 1-1 Motor Full Load Current* or *parameter 1-12 Adaptive Control Gain* is changed, the soft starter automatically relearns the motor characteristics.

### 5.4.4 Pump Stopping

The hydraulic characteristics of pump systems vary considerably. This variation means that the ideal deceleration profile and stop time vary from application to application. *Table 5.1* provides guidelines on selecting between adaptive control profiles. For identification of the best profile for the application, test all 3 profiles.

Adaptive stop profile	Application
Late deceleration	High-head systems, where even a small decrease in motor/pump speed results in a rapid transition between forward flow and reverse flow.
Constant deceleration	Low to medium head, high-flow applications, where the fluid has high momentum.
Early deceleration	Open pump systems, where fluid must drain back through the pump without driving the pump in reverse.

Table 5.1 Selection of Adaptive Control Deceleration Profiles

### 5.4.5 Brake

A brake reduces the required stop time of the motor.

During braking, an increased noise level from the motor may be audible. This noise is a normal part of motor braking.

**CAUTION**

**EQUIPMENT DAMAGE**

If the brake torque is set too high, the motor stops before the end of the brake time. The motor suffers unnecessary heating, which could result in damage. Careful configuration is required to ensure safe operation of the soft starter and the motor.

A high brake torque setting can result in peak currents up to motor DOL being drawn while the motor is stopping. Ensure that protection fuses installed in the motor branch circuit are selected appropriately.

**CAUTION**

**RISK OF OVERHEATING**

Brake operation causes the motor to heat faster than the rate calculated by the motor thermal model. If using brake functionality, install a motor thermistor or allow sufficient restart delay (*parameter 2-11 Restart Delay*).

When brake is selected, the soft starter uses DC injection to slow the motor.

**Braking**

- Does not require the use of a DC brake contactor.
- Controls all 3 phases so that the braking currents and associated heating are evenly distributed through the motor.

Braking has 2 stages:

1. Prebrake: Provides an intermediate level of braking to slow motor speed to a point where full brake can be operated successfully (approximately 70% speed).
2. Full brake: Provides maximum braking torque but is ineffective at speeds greater than approximately 70%.

To configure the VLT® Soft Starter MCD 500 for brake operation:

1. Set *parameter 1-11 Stop Time* for the wanted stopping time duration (1), see *Illustration 5.8*. The stop time is the total brake time. Set the stop time sufficiently longer than the brake time (*parameter 1-16 Brake Time*) to allow the prebraking stage to reduce motor speed to approximately 70%. If the stop time is too short, braking is not successful and the motor coasts to stop.
2. Set *parameter 1-16 Brake Time* to approximately 25% of the programmed stop time. The brake time sets the time for the full brake-stage (2), see *Illustration 5.8*.
3. Adjust *parameter 1-15 Brake Torque* so that the wanted stopping performance is achieved. If set

too low, the motor does not stop completely and coasts to stop by the end of the braking period.

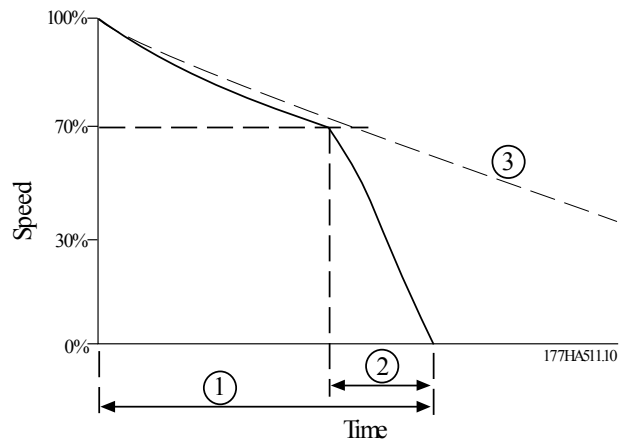

Illustration 5.8 Brake Time

**NOTICE**

When using DC brake:

1. Connect the mains supply to the soft starter (input terminals L1, L2, L3) in positive phase sequence.
2. Set *parameter 2-1 Phase Sequence* to *Positive only*.

**NOTICE**

For loads which may vary between braking cycles, install a zero-speed sensor to ensure that the soft starter ends DC braking when the motor stops. This installation avoids unnecessary heating of the motor.

For more information on using the MCD 500 with an external speed sensor (for example for applications with variable load during the braking cycle), see *chapter 5.12 DC Brake with External Zero-speed Sensor*.

**5.5 Jog Operation**

Jog runs the motor at reduced speed to allow alignment of the load or to assist servicing. The motor can be jogged in either forward or reverse direction.

The maximum available torque for jog forward is approximately 50–75% of motor full load torque (FLT) depending on the motor. When the motor is jogged in reverse, the torque is approximately 25–50% of FLT. *Parameter 15-8 Jog Torque* controls how much of the maximum available jog torque the soft starter applies to the motor.

**NOTICE**

Setting parameter 15-8 Jog Torque above 50% may cause increased shaft vibration.

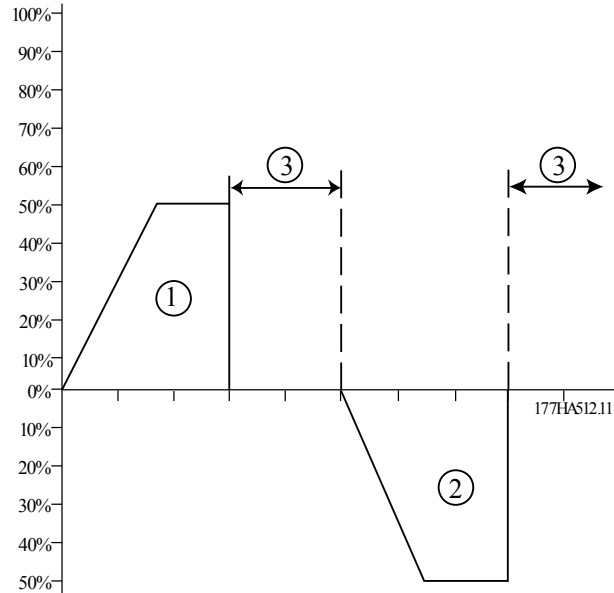

1	Jog forward
2	Jog reverse
3	Normal operation

Illustration 5.9 Jog Operation

To activate jog operation, use a programmable input (parameter 3-3 Input A Function).

To stop a jog operation, perform either of the following:

- Remove the jog command.
- Press [Off] on the LCP.
- Activate *Starter disable* using the LCP programmable inputs.

If the jog command is still present, jog recommences at the end of a restart delay. All other commands except the ones listed are ignored during jog operation.

**NOTICE**

Soft start and soft stop are not available during jog operation. Jog is only available for the primary motor.

**CAUTION**

**REDUCED MOTOR COOLING**

Slow speed running is not intended for continuous operation due to reduced motor cooling. Jog operation causes the motor to heat faster than the rate calculated by the motor thermal model.

- If using jog, install a motor thermistor, or allow sufficient restart delay (parameter 2-11 Restart Delay).

5.6 Inside Delta Operation

Adaptive control, jog, and brake functions are not supported in inside delta (6-wire) operation. If these functions are programmed when the soft starter is connected inside delta, the behavior is as in Table 5.2:

Adaptive control start	The soft starter performs a constant current start.
Adaptive control stop	If stop time is >0 s, the starter performs a TVR soft stop. If stop time is set to 9 s, the starter performs a coast to stop.
Jog	The soft starter issues a warning with the error message <i>Unsupported Option</i> .
Brake	The starter performs a coast to stop.

Table 5.2 Inside Delta Behavior at Adaptive Control, Jog, and Brake

**NOTICE**

When connected in inside delta, current imbalance is the only phase loss protection that is active during run. Do not disable parameter 2-2 Current Imbalance during inside delta operation.

**NOTICE**

Inside delta operation is only possible with mains voltage ≤600 V AC.



## 5.7 Typical Start Currents

To determine the typical start current for an application, use this information.

### **NOTICE**

These start current requirements are appropriate and typical in most circumstances. However, the performance and start torque requirements of motors and machines do vary. For further assistance, contact the local Danfoss supplier.

#### General and water

Agitator	4.0 x FLC
Centrifugal pump	3.5 x FLC
Compressor (screw, unloaded)	3.0 x FLC
Compressor (reciprocating, unloaded)	4.0 x FLC
Conveyor	4.0 x FLC
Fan (damped)	3.5 x FLC
Fan (undamped)	4.5 x FLC
Mixer	4.5 x FLC
Positive displacement pump	4.0 x FLC
Submersible pump	3.0 x FLC

Table 5.3 Typical Start Currents for General and Water Applications

#### Metals and mining

Belt conveyor	4.5 x FLC
Dust collector	3.5 x FLC
Grinder	3.0 x FLC
Hammer mill	4.5 x FLC
Rock crusher	4.0 x FLC
Roller conveyor	3.5 x FLC
Roller mill	4.5 x FLC
Tumbler	4.0 x FLC
Wire draw-machine	5.0 x FLC

Table 5.4 Typical Start Currents for Metals and Mining Applications

#### Food processing

Bottle washer	3.0 x FLC
Centrifuge	4.0 x FLC
Dryer	4.5 x FLC
Mill	4.5 x FLC
Palletizer	4.5 x FLC
Separator	4.5 x FLC
Slicer	3.0 x FLC

Table 5.5 Typical Start Currents for Food Processing Applications

#### Pulp and paper

Dryer	4.5 x FLC
Repulper	4.5 x FLC
Shredder	4.5 x FLC

Table 5.6 Typical Start Currents for Pulp and Paper Applications

#### Petrochemical

Ball mill	4.5 x FLC
Centrifuge	4.0 x FLC
Extruder	5.0 x FLC
Screw conveyor	4.0 x FLC

Table 5.7 Typical Start Currents for Petrochemical Applications

#### Transport and machine tool

Ball mill	4.5 x FLC
Grinder	3.5 x FLC
Material conveyor	4.0 x FLC
Palletizer	4.5 x FLC
Press	3.5 x FLC
Roller mill	4.5 x FLC
Rotary table	4.0 x FLC

Table 5.8 Typical Start Currents for Transport and Machine Tool Applications

#### Lumber and wood products

Bandsaw	4.5 x FLC
Chipper	4.5 x FLC
Circular saw	3.5 x FLC
Debarker	3.5 x FLC
Edger	3.5 x FLC
Hydraulic power pack	3.5 x FLC
Planer	3.5 x FLC
Sander	4.0 x FLC

Table 5.9 Typical Start Currents for Lumber and Wood Products Applications

### 5.8 Installation with Main Contactor

The VLT® Soft Starter MCD 500 is installed with a main contactor (AC3 rated). Supply control voltage from the input side of the contactor.

The soft starter main contactor output controls the main contactor. The main contactor output is by default assigned to output relay A (terminals 13, 14).

5

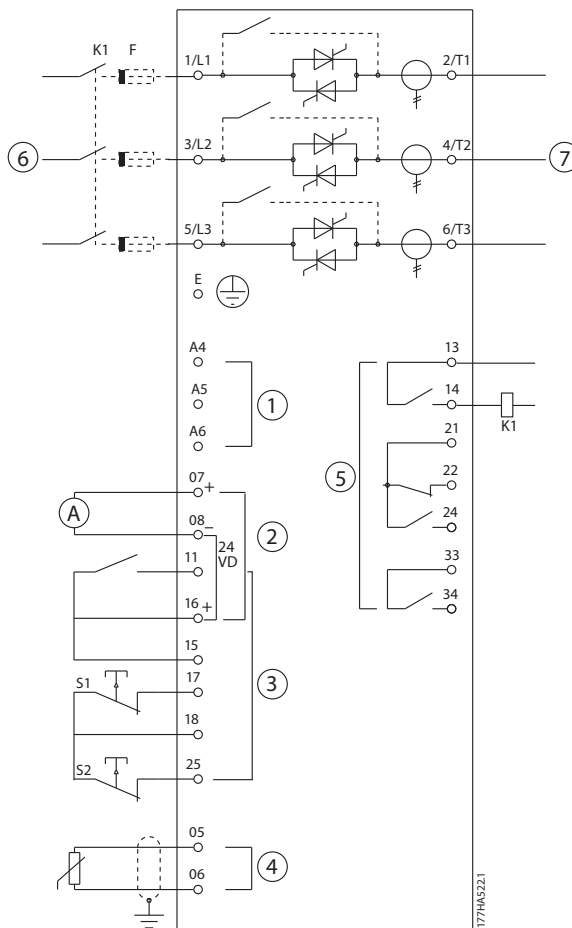

1	Control voltage (model dependent)	K1	Main contactor
2	24 V DC output	F1	Semiconductor fuses (optional)
3	Remote control inputs	S1	Start/stop
4	Motor thermistor input (PTC only)	S2	Reset contact
5	Relay outputs	13, 14	Relay output A
6	3-phase supply	21, 22, 24	Relay output B
7	Motor terminals	33, 34	Relay output C

Illustration 5.10 Installation with Main Contactor

**Parameter settings:**

- *Parameter 4-1 Relay A Function*
  - Select *Main contactor* - assigns the main contactor function to relay output A (default value).

### 5.9 Installation with Bypass Contactor

The VLT® Soft Starter MCD 500 is installed with a bypass contactor (AC1 rated). The soft starter run output controls the bypass contactor. The run output is by default assigned to output relay B (terminals 21, 22, 24).

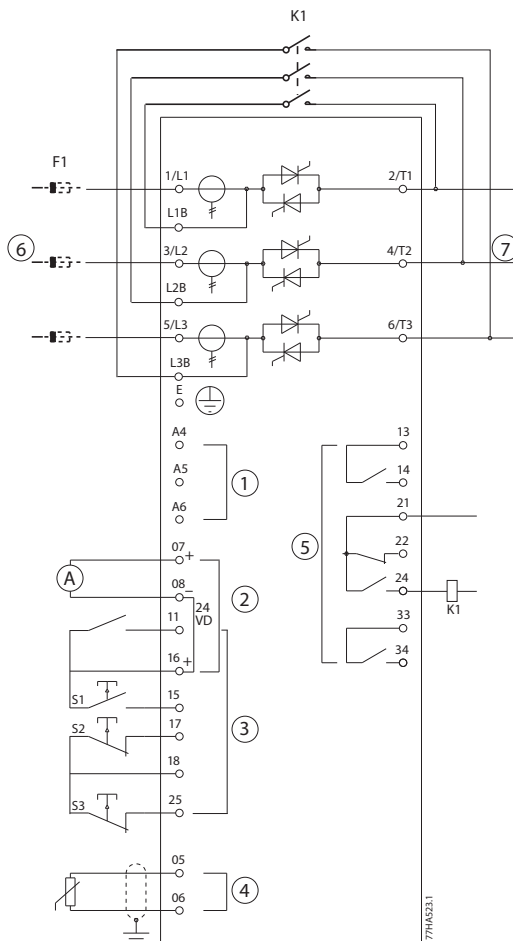

5

1	Control voltage (model dependent)	K1	Bypass contactor
2	24 V DC output	F1	Semiconductor fuses (optional)
3	Remote control inputs	S1	Start contact
4	Motor thermistor input (PTC only)	S2	Stop contact
5	Relay outputs	S3	Reset contact
6	3-phase supply	13, 14	Relay output A
7	Motor terminals	21, 22, 24	Relay output B
		33, 34	Relay output C

Illustration 5.11 Installation with Bypass Contactor

**Parameter settings:**

- *Parameter 4-4 Relay B Function.*
  - Select *Run* - assigns the run output function to output relay B (default value).

### 5.10 Emergency Run Operation

In normal operation, the VLT® Soft Starter MCD 500 is controlled via a remote 2-wire signal (terminals 17, 18).

A 2-wire circuit connected to input A (terminals 11, 16) controls emergency run. Closing input A causes the soft starter to run the motor and ignore all trip conditions.

5

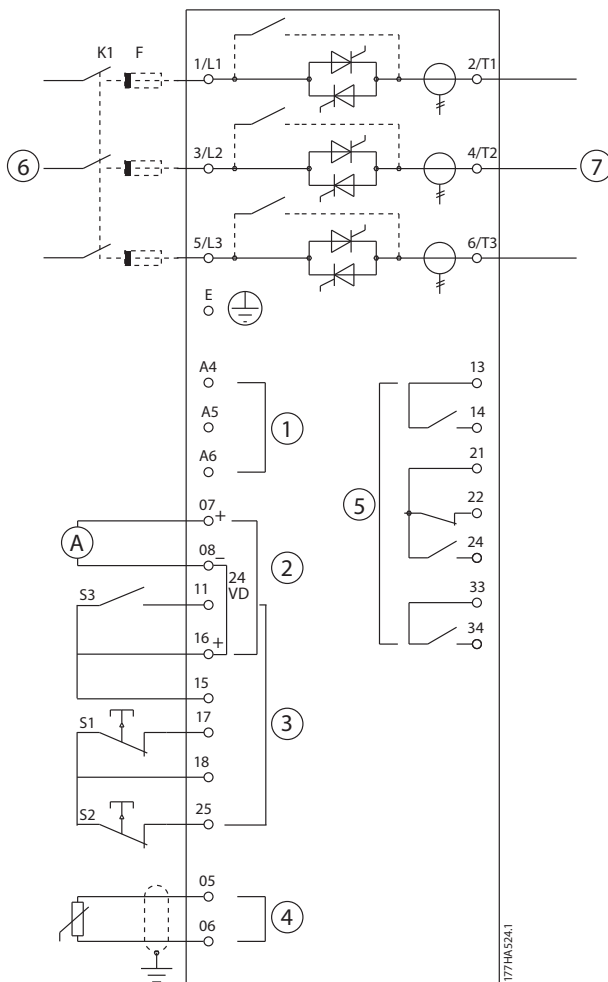

1	Control voltage (model dependent)	S1	Start/stop contact
2	24 V DC output	S2	Reset contact
3	Remote control inputs	S3	Emergency run contact
4	Motor thermistor input (PTC only)	13, 14	Relay output A
5	Relay outputs	21, 22, 24	Relay output B
6	3-phase supply	33, 34	Relay output C
7	Motor terminals		

Illustration 5.12 Emergency Run Operation

**Parameter settings:**

- *Parameter 3-3 Input A Function.*
  - Select *Emergency Run* - assigns input A to emergency run function.
- *Parameter 15-3 Emergency Run.*

- Select *Enable* - enables the emergency run-mode.

**NOTICE**

Although *Emergency run* fulfills the functionality requirements of fire mode, Danfoss does not recommend its use in situations that require testing and/or compliance with specific standards as it is not certified.

5.11 Auxiliary Trip Circuit

In normal operation, the VLT® Soft Starter MCD 500 is controlled via a remote 2-wire signal (terminals 17, 18).

Input A (terminals 11, 16) is connected to an external trip circuit (such as a low-pressure alarm switch for a pumping system). When the external circuit activates, the soft starter trips and stops the motor.

5

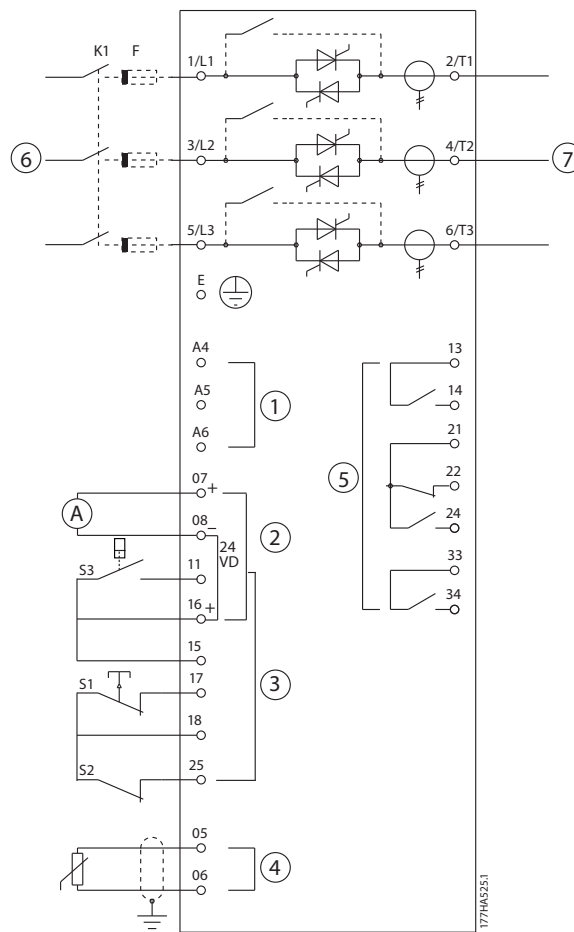

1	Control voltage (model dependent)	S1	Start/stop contact
2	24 V DC output	S2	Reset contact
3	Remote control inputs	S3	Auxiliary trip contact
4	Motor thermistor input (PTC only)	13, 14	Relay output A
5	Relay outputs	21, 22, 24	Relay output B
6	3-phase supply	33, 34	Relay output C
7	Motor terminals		

Illustration 5.13 Auxiliary Trip Circuit



### 5.13 Soft Braking

For high inertia loads, the VLT® Soft Starter MCD 500 can be configured for soft braking.

In this application, the MCD 500 is employed with forward run and braking contactors. When the soft starter receives a start signal (push-button S1), it closes the forward run contactor (K1) and controls the motor according to the programmed primary motor settings.

When the soft starter receives a stop signal (push-button S2), it opens the forward run contactor (K1) and closes the braking contactor (K2) after a delay of approximately 2–3 s (K1T). K12 is also closed to activate the secondary motor settings, which are user-programmed for the wanted stopping performance characteristics.

When motor speed approaches 0, the external zero-speed sensor (A2) stops the soft starter and opens the braking contactor (K2).

5

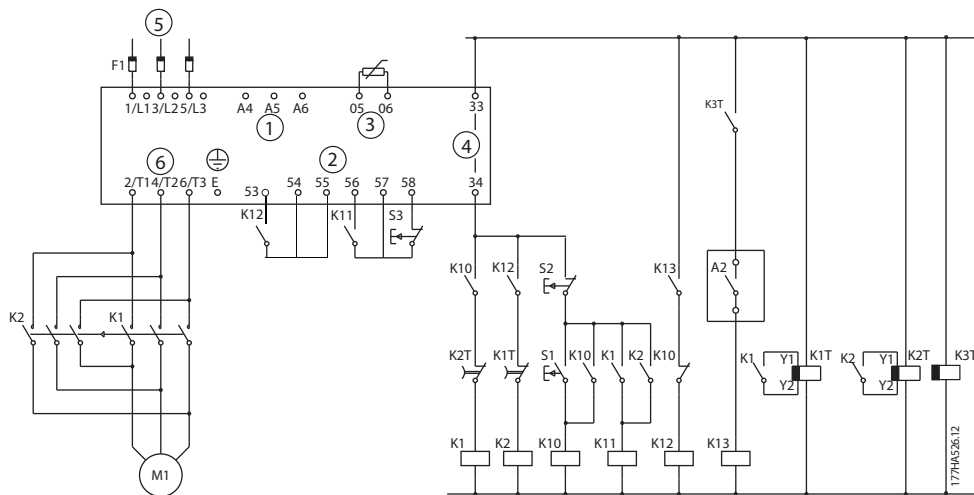

1	Control voltage (model dependent)	K10	Run relay
2	Remote control inputs	K11	Start relay
3	Motor thermistor input (PTC only)	K12	Brake relay
4	Relay outputs	K13	Zero-speed detector relay
5	3-phase supply	K1	Line contactor (run)
6	Motor terminals	K2	Line contactor (brake)
A2	Zero-speed sensor	K1T	Run delay timer
S1	Start contact	K2T	Brake delay timer
S2	Stop contact	K3T	Zero-speed detector delay timer
S3	Reset contact		

Illustration 5.15 Soft Braking Configuration

**Parameter settings:**

- *Parameter 3-3 Input A Function.*
  - Select *Motor Set Select* - assigns input A for motor set selection.
  - Set starting performance characteristics using the primary motor set (*parameter group 1 Primary Motor Settings*).

- Set braking performance characteristics using the secondary motor settings (*parameter group 7 Secondary Motor Set*).
- *Parameter 4-7 Relay C Function.*
  - Select *Trip* - assigns trip function to output relay C.

**NOTICE**

If the soft starter trips on supply frequency (*parameter 16-5 Frequency*) when the braking contactor K2 opens, modify the settings of *parameters 2-8 to 2-10*.

## 5.14 Two-speed Motor

The VLT® Soft Starter MCD 500 can be configured for control of 2-speed Dahlander type motors, using a high-speed contactor (K1), low-speed contactor (K2), and a star contactor (K3).

**NOTICE**

Pole amplitude modulated (PAM) motors alter the speed by effectively changing the stator frequency using external winding configuration. Soft starters are not suitable for use with this type of 2-speed motor.

When the soft starter receives a high-speed start signal, it closes the high-speed contactor (K1) and star contactor (K3). Then it controls the motor according to the primary motor settings (*parameters 1-1 to 1-16*).

When the soft starter receives a low-speed start signal, it closes the low-speed contactor (K2). This action closes input A and the soft starter controls the motor according to the secondary motor settings (*parameters 7-1 to 7-16*).

**NOTICE**

If the soft starter trips on supply frequency (*16-5 Frequency*) when the high-speed start signal (7) is removed, modify the settings of *parameters 2-8 to 2-10*.



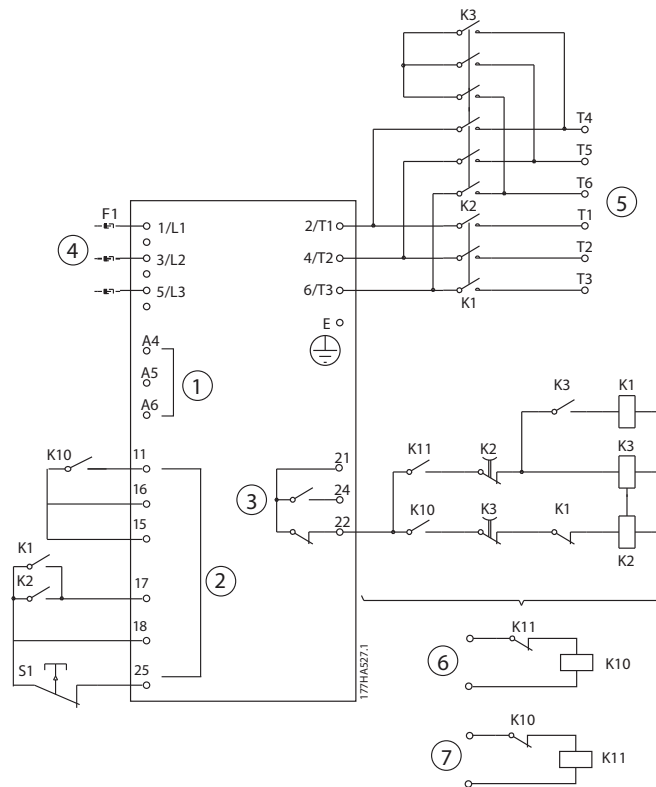

1	Control voltage	6	Remote low-speed start input	K2	Line contactor (low speed)
2	Remote control inputs	7	Remote high-speed start input	K3	Star contactor (high speed)
3	Relay outputs	K10	Remote start relay (low speed)	S1	Reset contact
4	3-phase supply	K11	Remote start relay (high speed)	21, 22, 24	Relay output B
5	Motor terminals	K1	Line contactor (high speed)		

Illustration 5.16 Two-speed Motor Configuration

**NOTICE**

Contactors K2 and K3 must be mechanically interlocked.

**Parameter settings:**

- *Parameter 3-3 Input A Function.*
  - Select *Motor Set Select* - assigns input A for motor set selection.
  - Set high-speed performance characteristics using *parameters 1-1 to 2-9.*
  - Set low-speed performance characteristics using *parameters 7-1 to 7-16.*
- *Parameter 4-4 Relay B Function.*
  - Select *Trip* - assigns trip function to relay output B.

**NOTICE**

If the soft starter trips on supply frequency (*parameter 16-5 Frequency*) when the high-speed signal (7) is removed, modify the settings of *parameters 2-9 to 2-10.*

## 6 Operation

### 6.1 Control Methods

The VLT® Soft Starter MCD 500 can be controlled:

- Via the control keys on the LCP (local control).
- Via the remote inputs (remote control).
- Via the serial communication network.

#### Control functions

- Local control is only available in hand-on mode.
- Remote control is only available in auto-on mode.
- Control via the serial communication network is always disabled in hand-on mode. Enable or disable start/stop commands via the serial network in auto-on mode by changing the setting of *parameter 3-2 Comms in Remote*.

The MCD 500 can also be configured to autostart or autostop. Autostart/stop operation is only available in auto-on mode. In hand-on mode, the soft starter ignores any autostart/stop setting. To configure autostart/stop operation, set *parameters 5-1 to 5-4*.

To switch between hand-on mode and auto-on mode, press the keys on the LCP.

- [Hand On]: Start the motor and enter hand-on mode.
- [Off]: Stop the motor and enter hand-on mode.
- [Auto On]: Set the soft starter to auto-on mode.
- [Reset]: Reset a trip (hand-on mode only).

The MCD 500 can also be set to allow local control only or remote control only, using *parameter 3-1 Local/Remote*.

If *parameter 3-1 Local/Remote* is set to *Remote Control Only*, the [Off] key is disabled. Stop the motor by remote control or via the serial communication network.

	Hand-on mode	Auto-on mode
To soft start the motor.	Press [Hand On] on the LCP.	Activate the <i>Start remote</i> input.
To stop the motor.	Press [Off] on the LCP.	Activate the <i>Stop remote</i> input.
To reset a trip on the soft starter.	Press [Reset] on the LCP.	Activate the <i>Reset remote</i> input.
Autostart/stop operation.	Disabled.	Enabled.

**Table 6.1 Start, Stop, and Reset in Hand-on Mode and Auto-on Mode**

To stop the motor with a coast to stop, regardless of the setting in *parameter 1-10 Stop Mode*, press [Off] and [Reset] at the same time. The soft starter removes power from the motor and opens the main contactor, and the motor coasts to stop.

#### **NOTICE**

Brake and jog functions operate only with in-line connected motors (see *chapter 5.6 Inside Delta Operation*).

## 6.2 Operation and LCP

### 6.2.1 Operating Modes

In hand-on mode:

- To soft start the motor, press [Hand On] on the LCP.
- To stop the motor, press [Off] on the LCP.
- To reset a trip on the soft starter, press [Reset] on the LCP.
- To stop the motor with a coast to stop, regardless of the setting of *parameter 1-10 Stop mode*, press [Off] and [Reset] at the same time. The soft starter removes power from the motor and opens the main contactor, and then the motor coasts to stop.

In auto-on mode:

- To soft start the motor, activate the *Start* remote input.
- To stop the motor, activate the *Stop* remote input.
- To reset a trip on the soft starter, activate the *Reset* remote input.

#### **NOTICE**

Brake and jog functions operate only with in-line connected motors (see *chapter 4.3.3 Inside Delta Installation*).

### 6.2.2 The LCP

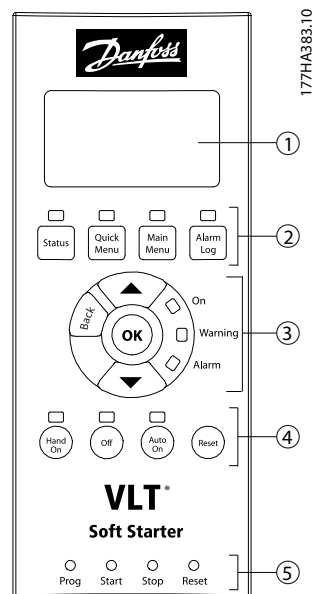

1	4-line display for status and programming details.
2	Display control keys: [Status]: Returns to the status displays. [Quick Menu]: Opens the Quick Menu. [Main Menu]: Opens the Main Menu. [Alarm Log]: Opens the Alarm Log.
3	Menu navigation keys: [Back]: Exits the menu or parameter, or cancels a parameter change. [OK]: Enters a menu or parameter, or saves a parameter change. [▲]/[▼]: Scroll to the next or previous menu or parameter. Change the setting of the current parameter. Scroll through the status screens.
4	Soft starter local control keys: [Hand On]: Starts the motor and enters local control mode. [Off]: Stops the motor (only active in hand-on mode). [Auto On]: Sets the soft starter to auto-on mode. [Reset]: Resets a trip (hand-on mode only).
5	Remote input status indicators.

Illustration 6.1 LCP Layout

### 6.3 Remote-mounted LCP

A remote-mounted LCP can be installed with the VLT® Soft Starter MCD 500. The control panel LCP 501 can be mounted up to 3 m (9.8 ft) away from the soft starter, for control and monitoring.

The soft starter can be controlled and programmed from either the remote LCP or the LCP on the soft starter. Both displays show the same information.

The remote LCP also allows parameter settings to be copied between soft starters.

#### 6.3.1 Synchronizing the LCP and the Soft Starter

The DB9 cable can be connected/disconnected from the LCP while the soft starter runs.

The first time an LCP is plugged into a soft starter, the soft starter copies its parameter settings to the LCP.

New display detected
----------------------

If the LCP has previously been used with a VLT® Soft Starter MCD 500, select whether to copy the parameters from the LCP to the soft starter, or from the soft starter to the LCP.

To select the required option:

1. Press the [▲] and [▼] keys.

A dotted line surrounds the selected option.

2. Press [OK] to proceed with the *Copy Parameters* selection.
  - 2a Display to soft starter.
  - 2b Soft starter to display.

Copy parameters
Display to soft starter Soft starter to display

#### **NOTICE**

If the parameter software version in the LCP is different from the software version of the soft starter, only *Starter to Display* is available.

#### **NOTICE**

While the LCP synchronizes, only the [▲], [▼], [OK], and [Off] keys are enabled.

#### **NOTICE**

The LCP can be removed or replaced while the soft starter is running. It is not necessary to remove mains or control voltage.

### 6.4 Welcome Screen

When control power is applied, the soft starter shows the welcome screen.

Ready	S1
Welcome 1.05/2.0/1.13 MCD5-0053-T5-G1- CV2	

*Third display line: Software versions for remote LCP, control software, model software.*

*Fourth display line: Product model number.*

#### **NOTICE**

The LCP version is only shown if a remote LCP 501 is connected when control power is applied. If no remote LCP is present, only the control software and model software versions are shown.

### 6.5 Local Control Keys

If *parameter 3-1 Local/Remote* is set to *LCL/RMT Anytime* or *LCL/RMT When OFF*, the [Hand On] and [Auto On] keys are always active. If the soft starter is in auto-on mode, pressing [Hand On] enters hand-on mode and starts the motor.

If *parameter 3-1 Local/Remote* is set to *Remote Control Only*, the [Off] key is disabled. Stop the motor by remote control or via the serial communication network.

### 6.6 Displays

The LCP shows a wide range of performance information about the soft starter. Press [Status] to access the status display screens, then press [▲] and [▼] to select the information to be shown. To return to the status screens from within a menu, press [Back] repeatedly, or press [Status]. Available status information:

- Temperature monitoring.
- Programmable screen (see *parameters 8-2 to 8-5*).
- Current.
- Frequency.



### 6.6.9 SCR Conduction Bar Graph

The SCR conduction bar graph shows the level of conduction on each phase.



Illustration 6.2 Bar Graph

## 6

### 6.6.10 Performance Graphs

The VLT® Soft Starter MCD 500 can show real-time performance information for:

- Current.
- Motor temperature.
- Motor kW.
- Motor kVA.
- Motor power factor.

The newest information is shown at the right side of the screen. Older data is not stored. To allow past performance to be analyzed, the graph can also be paused. To pause or unpaue the graph, press and hold [OK] for more than 0.5 s.

#### **NOTICE**

The soft starter does not collect data while the graph is paused. When graphing resumes, a small gap is shown between the old data and the new data.

# 7 Programming

It is possible to access the programming menus at any time, including while the soft starter is running. All changes take effect immediately.

## 7.1 Access Control

A 4-digit security access code protects critical parameters (*parameter group 15 Restricted Parameters* and higher), preventing unauthorized users from viewing or modifying parameter settings.

If attempts are made to enter a restricted parameter group, the LCP prompts for an access code. The access code is requested once for the programming session, and authorization continues until the menu is closed.

To enter the access code:

1. Press [Back] and [OK] to select a digit.
2. Press [▲] and [▼] to change the value.
3. When all 4 digits match the access code, press [OK].

The LCP shows an acknowledgement message before continuing.

Enter Access Code	
####	
	OK
Access Allowed	
SUPERVISOR	

To change the access code, use *parameter 15-1 Access Code*.

### **NOTICE**

The security access code also protects the protection simulation and output simulation. The counters and thermal model reset can be viewed without entering an access code, but an access code must be entered to reset.

The default access code is 0000.

To prevent users from altering parameter settings, lock the menus. The adjustment lock can be set to allow *Read & Write*, *Read Only*, or *No Access* in *parameter 15-2 Adjustment Lock*.

If attempting to change a parameter value or access the Main Menu when the adjustment lock is active, an error message is shown:

Access Denied
Adj Lock is On

## 7.2 Quick Menu

[Quick Menu] provides access to the menus for setting up the soft starter for simple applications.

### 7.2.1 Quick Set-up

Quick set-up provides access to commonly used parameters, allowing configuration of the soft starter as required for the application. For details of individual parameters, see *chapter 8 Parameter Descriptions*.

<b>1</b>	<b>Primary Mtr Set</b>
1-1	Motor FLC
1-3	Start Mode
1-4	Current Limit
1-5	Initial Current
1-6	Start Ramp Time
1-9	Excess Start Time
1-10	Stop Mode
1-11	Stop Time
<b>2</b>	<b>Protection</b>
2-1	Phase Sequence
2-4	Undercurrent
2-5	Undercurrent Dly
2-6	Inst Overcurrent
2-7	Inst Overcurrent Dly
<b>3</b>	<b>Inputs</b>
3-3	Input A Function
3-4	Input A Name
3-5	Input A Trip
3-6	Input A Trip Dly
3-7	Input A Initial Dly
<b>4</b>	<b>Outputs</b>
4-1	Relay A Function
4-2	Relay A On Delay
4-3	Relay A Off Delay
4-4	Relay B Function
4-5	Relay B On Delay
4-6	Relay B Off Delay
4-7	Relay C Function
4-8	Relay C On Delay
4-9	Relay C Off Delay
4-10	Low Current Flag
4-11	High Current Flag
4-12	Motor Temp Flag
<b>5</b>	<b>Start/Stop Timers</b>
5-1	Auto-Start Type
5-2	Auto-Start Time
5-3	Auto-Stop Type

1	Primary Mtr Set
5-4	Auto-Stop Time
8	Display
8-1	Language
8-2	User Scrn Top L
8-3	User Scrn Top R
8-4	User Scrn Btm L
8-5	User Scrn Btm R

Table 7.1 Parameters in the Quick Set-up Menu

## 7.2.2 Application Set-up Examples

The application set-ups menu makes it easy to configure the soft starter for common applications. The soft starter selects the parameters relevant to the application and suggests a typical setting. Each parameter can be adjusted to suit the exact requirements.

On the display, the highlighted values are suggested values. The values indicated by ► are the loaded values.

Always set *parameter 1-1 Motor FLC* to match the motor nameplate full load current. The suggested value for motor FLC is the minimum FLC of the soft starter.

### Centrifugal pump

Motor full load current	
Start mode	Adaptive control
Adaptive start profile	Early acceleration
Start ramp time	10 s
Stop mode	Adaptive control
Adaptive stop profile	Late deceleration
Stop time	15 s

Table 7.2 Suggested Values for Centrifugal Pump Applications

### Submersible pump

Motor full load current	
Start mode	Adaptive control
Adaptive start profile	Early acceleration
Start ramp time	5 s
Stop mode	Adaptive control
Adaptive stop profile	Late deceleration
Stop time	5 s

Table 7.3 Suggested Values for Submersible Pump Applications

### Damped fan

Motor full load current	
Start mode	Constant current
Current limit	350%

Table 7.4 Suggested Values for Damped Fan Applications

### Undamped fan

Motor full load current	
Start mode	Adaptive control
Adaptive start profile	Constant acceleration
Start ramp time	20 s
Excess start time	30 s
Locked rotor time	20 s

Table 7.5 Suggested Values for Undamped Fan Applications

### Compressor screw

Motor full load current	
Start mode	Constant current
Start ramp time	5 s
Current limit	400%

Table 7.6 Suggested Values for Compressor Screw Applications

### Compressor recip

Motor full load current	
Start mode	Constant current
Start ramp time	10 s
Current limit	450%

Table 7.7 Suggested Values for Compressor Recip Applications

### Conveyor

Motor full load current	
Start mode	Constant current
Start ramp time	5 s
Current limit	400%
Stop mode	Adaptive control
Adaptive stop profile	Constant deceleration
Stop time	10 s

Table 7.8 Suggested Values for Conveyor Applications

### Crusher rotary

Motor full load current	
Start mode	Constant current
Start ramp time	10 s
Current limit	400%
Excess start time	30 s
Locked rotor time	20 s

Table 7.9 Suggested Values for Crusher Rotary Applications



### Crusher jaw

Motor full load current	
Start mode	Constant current
Start ramp time	10 s
Current limit	450%
Excess start time	40 s
Locked rotor time	30 s

Table 7.10 Suggested Values for Crusher Jaw Applications

### 7.2.3 Loggings

To view performance information in real-time graphs, enter the *Loggings* menu.

- Current (%FLC).
- Motor Temp (%).
- Motor kW (%).
- Motor kVA (%).
- Motor pf.

The newest information is shown at the right side of the screen. The graph can be paused to analyze data by pressing and holding the [OK] key. To restart the graph, press and hold [OK].

### 7.3 Main Menu

[Main Menu] provides access to menus for setting up the soft starter for advanced applications and for monitoring performance.

### 7.3.1 Parameters

Parameters allow viewing and changing all programmable parameters that control how the soft starter operates.

To open *Parameters*, press [Main Menu] then select *Parameters*.

#### Navigating through parameters

- To scroll through parameter groups, press [▲] or [▼].
- To view the parameters in a group, press [OK].
- To return to the previous level, press [Back].
- To close *Parameters*, press the [Back].

#### Changing a parameter value

- Scroll to the appropriate parameter and press [OK] to enter edit mode.
- To alter the parameter setting, press [▲] and [▼].
- To save changes, press [OK]. The setting shown on the display is saved and the LCP returns to the parameter list.
- To cancel changes, press [Back]. The LCP returns to the parameter list without saving changes.

### 7.3.2 Parameter Shortcut

The VLT® Soft Starter MCD 500 also includes a parameter shortcut, which gives direct access to a parameter within the *Parameters* menu.

- To access the parameter shortcut, press [Main Menu] for 3 s.
- Press [▲] or [▼] to select the parameter group.
- Press [OK] or [Back] to move the cursor.
- Press [▲] or [▼] to select the parameter number.

Parameter shortcut
Please enter a parameter number 01-01



### 7.3.3 Parameter List

<b>1</b>	<b>Primary Mtr Set</b>	<b>4</b>	<b>Outputs</b>	7-12	Adaptv Ctrl Gain-2
1-1	Motor FLC	4-1	Relay A Function	7-13	Adaptv Start Prof-2
1-2	Locked Rotor Time	4-2	Relay A On Delay	7-14	Adaptv Stop Prof-2
1-3	Start Mode	4-3	Relay A Off Delay	7-15	Brake Torque-2
1-4	Current Limit	4-4	Relay B Function	7-16	Brake Time-2
1-5	Initial Current	4-5	Relay B On Delay	<b>8</b>	<b>Display</b>
1-6	Start Ramp Time	4-6	Relay B Off Delay	8-1	Language
1-7	Kick-start Level	4-7	Relay C Function	8-2	User Scrn Top L
1-8	Kick-start Time	4-8	Relay C On Delay	8-3	User Scrn Top R
1-9	Excess Start Time	4-9	Relay C Off Delay	8-4	User Scrn Btm L
1-10	Stop Mode	4-10	Low Current Flag	8-5	User Scrn Btm R
1-11	Stop Time	4-11	High Current Flag	8-6	Graph Timebase
1-12	Adaptv Control Gain	4-12	Motor Temp Flag	8-7	Graph Max Adj
1-13	Adaptv Start Profile	4-13	Analog Output A	8-8	Graph Min Adj
1-14	Adaptv Stop Profile	4-14	Analog A Scale	8-9	Mains Ref Volt
1-15	Brake Torque	4-15	Analog A Max Adj	<b>15</b>	<b>Restrict Paramtr</b>
1-16	Brake Time	4-16	Analog A Min Adj	15-1	Access Code
<b>2</b>	<b>Protection</b>	<b>5</b>	<b>Start/Stop Timers</b>	15-2	Adjustment Lock
2-1	Phase Sequence	5-1	Auto-Start Type	15-3	Emergency Run
2-2	Current Imbalance	5-2	Auto-Start Time	15-4	Current Calibrat
2-3	Current Imbal Dly	5-3	Auto-Stop Type	15-5	Main Cont Time
2-4	Undercurrent	5-4	Auto-Stop Time	15-6	Bypass Cont Time
2-5	Undercurrent Dly	<b>6</b>	<b>Auto-Reset</b>	15-7	Motor Connection
2-6	Inst Overcurrent	6-1	Auto-Reset Action	15-8	Jog Torque
2-7	Inst Ocrnt Dly	6-2	Maximum Resets	<b>16</b>	<b>Protection Action</b>
2-8	Frequency Check	6-3	Reset Dly Grp A & B	16-1	Motor Overload
2-9	Freq Variation	6-4	Reset Delay Grp C	16-2	Current Imbalance
2-10	Frequency Delay	<b>7</b>	<b>Secondary Mtr Set</b>	16-3	Undercurrent
2-11	Restart Delay	7-1	Motor FLC-2	16-4	Inst Overcurrent
2-12	Motor Temp Check	7-2	Lock Rotor Time-2	16-5	Frequency
<b>3</b>	<b>Inputs</b>	7-3	Start Mode-2	16-6	Heat sink Overtemp
3-1	Local/Remote	7-4	Current Limit-2	16-7	Excess Start Time
3-2	Comms in Remote	7-5	Initial Crnt-2	16-8	Input A Trip
3-3	Input A Function	7-6	Start Ramp-2	16-9	Motor Thermistor
3-4	Input A Name	7-7	Kick-start Lvl-2	16-10	Starter Comms
3-5	Input A Trip	7-8	Kick-start Time-2	16-11	Network Comms
3-6	Input A Trip Dly	7-9	Excess Strt Time-2	16-12	Battery/Clock
3-7	Input A Initial Dly	7-10	Stop Mode-2	16-13	Low Control Volts
3-8	Remote Reset Logic	7-11	Stop Time-2	-	-

## 8 Parameter Descriptions

### 8.1 Primary Motor Settings

#### NOTICE

Default settings are marked with \*.

The parameters in *Primary Motors Settings* configure the soft starter to match the connected motor. These parameters describe the operating characteristics of the motor and allow the soft starter to model the motor temperature.

#### NOTICE

**Parameter 1-2 Locked Rotor Time determines the trip current for motor overload protection. Its default setting provides motor overload protection:**

- Class 10.
- Trip current 105% of FLA, or equivalent.

#### 1-1 Motor FLC

**Option:**                      **Function:**

Model dependent	Matches the soft starter to the connected motor full load current. Set to the full load current (FLC) rating shown on the motor nameplate. <b>NOTICE</b> The setting for this parameter sets the basis for calculation of all current-based protection settings.
-----------------	--

#### 1-2 Locked Rotor Time

**Range:**                      **Function:**

10 s*	[0:01–2:00 (min:s)]	Sets the maximum length of the time the motor can sustain locked rotor current from cold before reaching its maximum temperature. Set according to the motor datasheet.
-------	---------------------	---

#### 1-3 Start Mode

**Option:**                      **Function:**

		Selects the soft start mode. See <i>chapter 5.3 Starting Modes</i> for more details.
Constant current*		
Adaptive control		

#### 1-4 Current Limit

**Range:**                      **Function:**

350%*	[100–600% FLC]	Sets the current limit for constant current and current ramp soft starting as a percentage of motor full load current. See <i>chapter 5.3 Starting Modes</i> for more details.
-------	----------------	--

#### 1-5 Initial Current

**Range:**                      **Function:**

350%*	[100–600% FLC]	Sets the initial start current level for current ramp starting as a percentage of motor full load current. Set so that the motor begins to accelerate immediately after a start is initiated. If current ramp starting is not required, set the initial current equal to the current limit. See <i>chapter 5.3 Starting Modes</i> for more details.
-------	----------------	---

#### 1-6 Start Ramp Time

**Range:**                      **Function:**

10 s*	[1–180 s]	Sets the total start time for an adaptive control start or the ramp time for current ramp starting (from the initial current to the current limit). See <i>chapter 5.3 Starting Modes</i> for more details.
-------	-----------	---

#### 1-7 Kick-start Level

**Range:**                      **Function:**

500%*	[100–700% FLC]	<div style="border: 1px solid black; padding: 5px; margin-bottom: 5px;"> <p><b>CAUTION</b></p> <p><b>INCREASED TORQUE LEVEL</b></p> <p>Kick-start subjects the mechanical equipment to increased torque levels.</p> <ul style="list-style-type: none"> <li>• Ensure that the motor, load, and couplings can handle the additional torque before using this feature.</li> </ul> </div> <p>Sets the level of the kick-start current.</p>
-------	----------------	--

1-8 Kick-start Time		
Range:	Function:	
0000 ms* [0–2000 ms]	<p><b>CAUTION</b></p> <p><b>INCREASED TORQUE LEVEL</b> Kick-start subjects the mechanical equipment to increased torque levels.</p> <ul style="list-style-type: none"> <li>Ensure that the motor, load, and couplings can handle the additional torque before using this feature.</li> </ul> <p>Sets the kick-start duration. A setting of 0 disables kick-start. See <i>chapter 5.3 Starting Modes</i> for more details.</p>	

1-9 Excess Start Time		
Range:	Function:	
20 s* [0:00–4:00 (min:s)]	<p>Excess start time is the maximum time the soft starter attempts to start the motor. If the motor does not reach full speed within the programmed limit, the soft starter trips. Set for a period slightly longer than required for a normal healthy start. A setting of 0 disables excess start time protection.</p> <p>Set as required.</p>	

1-10 Stop Mode		
Option:	Function:	
	Selects the stop mode. See <i>chapter 5.4 Stopping Modes</i> for more details.	
Coast to stop*		
TVR soft stop		
Adaptive control		
Brake		

1-11 Stop Time		
Range:	Function:	
0 s* [0:00–4:00 (min:s)]	<p>Sets the time for soft stopping the motor using timed voltage ramp or adaptive control. If a main contactor is installed, the contactor must remain closed until the end of the stop time. To control the main contactor, use a programmable output configured to <i>Run</i>. Sets the total stopping time when using brake. See <i>chapter 5.4 Stopping Modes</i> for more details.</p>	

1-12 Adaptive Control Gain		
Range:	Function:	
75%* [1–200%]	<p>Adjusts the performance of adaptive control. This setting affects both starting and stopping control.</p>	

1-12 Adaptive Control Gain		
Range:	Function:	
	<p><b>NOTICE</b></p> <p>Leave the gain setting at the default level unless adaptive control performance is not satisfactory. If the motor accelerates or decelerates too quickly at the end of a start or stop, increase the gain setting by 5–10%. If the motor speed fluctuates during starting or stopping, decrease the gain setting slightly.</p>	

1-13 Adaptive Start Profile		
Option:	Function:	
	Selects which profile the soft starter uses for an adaptive control soft start. See <i>chapter 5.4 Stopping Modes</i> for more details.	
Early acceleration		
Constant acceleration*		
Late acceleration		

1-14 Adaptive Stop Profile		
Option:	Function:	
	Selects which profile the soft starter uses for an adaptive control soft stop. See <i>chapter 5.4 Stopping Modes</i> for more details.	
Early deceleration		
Constant deceleration*		
Late acceleration		

### 8.1.1 Brake

Brake uses DC injection to slow the motor actively. See *chapter 5.4 Stopping Modes* for more details.

1-15 Brake Torque		
Range:	Function:	
20%* [20–100%]	Sets the amount of brake torque the soft starter uses to slow the motor.	

1-16 Brake Time		
Range:	Function:	
1 s* [1–30 s]	<p>Sets the duration for DC injection during a braking stop.</p> <p><b>NOTICE</b></p> <p>This parameter is used with <i>parameter 1-11 Stop Time</i>. See <i>chapter 5.4 Stopping Modes</i> for details.</p>	

## 8.2 Protection

### 2-1 Phase Sequence

**Option:**      **Function:**

	Selects which phase sequences the soft starter allows at a start. During its prestart checks, the soft starter examines the sequence of the phases at its input terminals. If the actual sequence does not match the selected option, the soft starter trips.
Any sequence*	
Positive only	
Negative only	

### 8.2.1 Current Imbalance

If the currents on the 3 phases vary by more than a specified amount, the soft starter can be configured to trip. The imbalance is calculated as the difference between the highest and lowest currents on all 3 phases, as a percentage of the highest current.

Current imbalance detection is desensitized by 50% during starting and soft stopping.

### 2-2 Current Imbalance

**Range:**      **Function:**

30%*	[10–50%]	Sets the trip point for current imbalance protection.
------	----------	---

### 2-3 Current Imbalance Delay

**Range:**      **Function:**

3 s*	[0:00–4:00 (min:s)]	Slows the response of the soft starter to current imbalance, avoiding trips due to momentary fluctuations.
------	------------------------	--

### 8.2.2 Undercurrent

If the average current of all 3 phases drops below a specified level while the motor is running, the soft starter can be configured to trip.

### 2-4 Undercurrent

**Range:**      **Function:**

20%*	[0–100%]	Sets the trip point for undercurrent protection, as a percentage of motor full load current. Set to a level between the normal motor working range and the motor magnetizing (no load) current (typically 25–35% of full load current). A setting of 0% disables undercurrent protection.
------	----------	---

### 2-5 Undercurrent Delay

**Range:**      **Function:**

5 s*	[0:00–4:00 (min:s)]	Slows the response of the soft starter to undercurrent, avoiding trips due to momentary fluctuations.
------	------------------------	---

### 8.2.3 Instant Overcurrent

If the average current of all 3 phases exceeds a specified level while the motor is running, the soft starter can be configured to trip.

### 2-6 Instantaneous Overcurrent

**Range:**      **Function:**

400%*	[80–600% FLC]	Sets the trip point for instant overcurrent protection as a percentage of motor full load current.
-------	------------------	--

### 2-7 Instantaneous Overcurrent Delay

**Range:**      **Function:**

0 s*	[0:00–1:00 (min:s)]	Slows the response of the soft starter to overcurrent, avoiding trips due to momentary overcurrent events.
------	------------------------	--

### 8.2.4 Frequency Trip

The soft starter monitors mains frequency throughout operation and can be configured to trip if the frequency varies beyond a specified tolerance.

### 2-8 Frequency Check

**Option:**      **Function:**

	Determines when the soft starter monitors for a frequency trip.
Do not check	
Start only	
Start/run*	
Run only	

### 2-9 Frequency Variation

**Option:**      **Function:**

	Selects the soft starter tolerance for frequency variation.
±2 Hz	
±5 Hz*	
±10 Hz	
±15 Hz	

### 2-10 Frequency Delay

**Range:**      **Function:**

1 s*	[0:01–4:00 (min:s)]	Slows the response of the soft starter to frequency disturbances, avoiding trips due to momentary fluctuations. <b>NOTICE</b> If the mains frequency drops below 35 Hz or rises above 75 Hz, the soft starter trips immediately.
------	------------------------	--

**2-11 Restart Delay**
**Range:**                      **Function:**

10 s*	[00:01–60:00 (min:s)]	The soft starter can be configured to force a delay between the end of a stop and the beginning of the next start. During the restart delay, the display shows the time remaining before another start can be attempted. <b>NOTICE</b> The restart delay is measured from the end of each stop. Changes to the restart delay setting take effect after the next stop.
-------	-----------------------	---

**2-12 Motor Temperature Check**
**Option:**                      **Function:**

		Selects whether the soft starter verifies that the motor has sufficient thermal capacity for a successful start. The soft starter compares the calculated motor temperature with the temperature rise from the last motor start. The soft starter only operates if the motor is cool enough to start successfully.
Do not check*		
Check		

**8.3 Inputs**
**3-1 Local/Remote**
**Option:**                      **Function:**

		Selects when the [Auto On] and [Hand On] can be used to switch to hand-on mode or auto-on mode.
Lcl/rmt anytime*		Change between local and remote control at any time.
Local control only		All remote inputs are disabled.
Remote control only		[Hand On] and [Auto On] are disabled.

**3-2 Comms in Remote**
**Option:**                      **Function:**

		Selects whether the soft starter accepts start and stop commands from the serial communication network when in <i>Remote</i> mode.  Commands that are always enabled: <ul style="list-style-type: none"> <li>• Force comms trip.</li> <li>• Local/remote control.</li> <li>• Test start.</li> <li>• Reset.</li> </ul>
Disable ctrl in RMT		
Enable ctrl in RMT*		

**3-3 Input A Function**
**Option:**                      **Function:**

		Selects the function of input A.
Motor set select*		The soft starter can be configured with 2 separate sets of motor data. The primary motor data is programmed using <i>parameters 1-1 to 1-16</i> . The secondary motor data is programmed using <i>parameters 7-1 to 7-16</i> .  To use the secondary motor data, set this parameter to <i>Motor Set Select</i> and close terminals 11 and 16 before giving a start command. The soft starter checks which motor data to use at a start and uses that motor data for the entire start/stop cycle.
Input trip (N/O)		Input A can be used to trip the soft starter. When this parameter is set to <i>Input Trip (N/O)</i> , a closed circuit across terminals 11 and 16 trips the soft starter ( <i>parameters 3-5 to 3-7</i> ).
Input trip (N/C)		When this parameter is set to <i>Input Trip (N/C)</i> , an open circuit across terminals 11 and 16 trips the soft starter ( <i>parameters 3-5 to 3-7</i> ).
Local/remote select		Input A can be used to select between local and remote control, instead of using the LCP keys. When the input is open, the soft starter is in hand-on mode and can be controlled via the LCP. When the input is closed, the soft starter is in remote mode. The [Hand On] and [Auto On] keys are disabled, and the soft starter ignores any local/remote select command from the serial communications network.  To use Input A to select between local and remote control, set <i>parameter 3-1 Local/Remote</i> to <i>LCL/RMT Anytime</i> .
Emergency run		In emergency run, the soft starter continues to run until stopped, ignoring all trips and warnings (see <i>parameter 15-3 Emergency Run</i> for details). Closing the circuit across terminals 11 and 16 activates emergency run. Opening the circuit ends emergency run and the soft starter stops the motor.
Starter disable		The soft starter can be disabled via the control inputs. An open circuit across terminals 11 and 16 disables the soft starter. The soft starter does not respond to start commands. If running, the soft starter allows the motor to coast to stop, ignoring the soft stop mode set in <i>parameter 1-10 Stop Mode</i> .  When the circuit across terminals 11 and 16 is opened, the soft starter allows the motor to coast to stop.
Jog forward		Activates jog operation in a forward direction (operates only in Remote mode).
Jog reverse		Activates jog operation in reverse direction (operates only in Remote mode).

**3-4 Input A Name**
**Option:                      Function:**

	Selects a message for the LCP to show when input A is active.
Input trip*	
Low pressure	
High pressure	
Pump fault	
Low level	
High level	
No flow	
Starter disable	
Controller	
PLC	
Vibration alarm	

**3-5 Input A Trip**
**Option:                      Function:**

	Selects when an input trip can occur.
Always active*	A trip can occur at any time when the soft starter is receiving power.
Operating only	A trip can occur while the soft starter is running, stopping, or starting.
Run only	A trip can only occur while the soft starter is running.

**3-6 Input A Trip Delay**
**Range:                      Function:**

0 s*	[0:00–4:00 (min:s)]	Sets delay between the input activating and soft starter tripping.
------	---------------------	--

**3-7 Input A Initial Delay**
**Range:                      Function:**

0 s*	[00:00–30:00 (min:s)]	Sets a delay before an input trip can occur. The initial delay is counted from the time a start signal is received. The state of the input is ignored until the initial delay has elapsed.
------	-----------------------	--

**3-8 Remote Reset Logic**
**Option:                      Function:**

	Selects whether the remote reset input of the soft starter (terminals 25 and 18) is normally open or normally closed.
Normally closed*	
Normally open	

## 8.4 Outputs

**4-1 Relay A Function**
**Option:                      Function:**

	Selects the function of relay A (normally open).
Off	Relay A is not used
Main contactor*	The relay closes when the soft starter receives a start command and remains closed as long as the motor receives voltage.

**4-1 Relay A Function**
**Option:                      Function:**

Run	The relay closes when the starter changes to run state.
Trip	The relay closes when the starter trips.
Warning	The relay closes when the starter issues a warning.
Low current flag	The relay closes when the low current flag activates ( <i>parameter 4-10 Low Current Flag</i> ).
High current flag	The relay closes when the high current flag activates ( <i>parameter 4-11 High Current Flag</i> ).
Motor temp flag	The relay closes when the motor temperature flag activates ( <i>parameter 4-12 Motor Temperature Flag</i> ).

### 8.4.1 Relay A Delays

The soft starter can be configured to wait before opening or closing relay A.

**4-2 Relay A On Delay**
**Range:                      Function:**

0 s*	[0:00–5:00 (min:s)]	Sets the delay for closing relay A.
------	---------------------	-------------------------------------

**4-3 Relay A Off Delay**
**Range:                      Function:**

0 s*	[0:00–5:00 (min:s)]	Sets the delay for reopening relay A.
------	---------------------	---------------------------------------

### 8.4.2 Relays B and C

*Parameters 4-4 to 4-9* configure the operation of relays B and C in the same way as *parameters 4-1 to 4-3* configure relay A. See *parameter 4-2 Relay A On Delay* and *parameter 4-3 Relay A Off Delay* for details.

- Relay B is a changeover relay.
- Relay C is normally open.

**4-4 Relay B Function**
**Option:                      Function:**

	Selects the function of relay B (changeover).
Off	Relay B is not used.
Main contactor	The relay closes when the soft starter receives a start command and remains closed as long as the motor is receiving voltage.
Run*	The relay closes when the soft starter changes to run state.
Trip	The relay closes when the soft starter trips.
Warning	The relay closes when the soft starter issues a warning.
Low current flag	The relay closes when the low current flag activates ( <i>parameter 4-10 Low Current Flag</i> ).
High current flag	The relay closes when the high current flag activates ( <i>parameter 4-11 High Current Flag</i> ).

**4-4 Relay B Function**

Option:	Function:
Motor temp flag	The relay closes when the motor temperature flag activates ( <i>parameter 4-12 Motor Temperature Flag</i> ).

**4-5 Relay B On Delay**

Range:	Function:
0 s* [0:00–5:00 (min:s)]	Sets the delay for closing relay B.

**4-6 Relay B Off Delay**

Range:	Function:
0 s* [0:00–5:00 (min:s)]	Sets the delay for reopening relay B.

**4-7 Relay C Function**

Option:	Function:
	Selects the function of relay C (normally open).
Off	Relay C is not used.
Main contactor	The relay closes when the soft starter receives a start command and remains closed as long as the motor is receiving voltage.
Run	The relay closes when the soft starter changes to run state.
Trip*	The relay closes when the soft starter trips.
Warning	The relay closes when the soft starter issues a warning.
Low current flag	The relay closes when the low current flag activates ( <i>parameter 4-10 Low Current Flag</i> ).
High current flag	The relay closes when the high current flag activates ( <i>parameter 4-11 High Current Flag</i> ).
Motor temp flag	The relay closes when the motor temperature flag activates ( <i>parameter 4-12 Motor Temperature Flag</i> ).

**4-8 Relay C On Delay**

Range:	Function:
0 s* [0:00–5:00 (min:s)]	Sets the delay for closing relay C.

**4-9 Relay C Off Delay**

Range:	Function:
0 s* [0:00–5:00 (min:s)]	Sets the delay for reopening relay C.

**8.4.3 Low Current Flag and High Current Flag**

The soft starter has low and high current flags to give early warning of abnormal operation. The current flags can be configured to indicate an abnormal current level during operation between the normal operating level and the undercurrent or instant overcurrent trip levels. The flags can signal the situation to external equipment via 1 of the programmable outputs. The flags clear when the current returns within the normal operating range by 10% of the programmed flag value.

**4-10 Low Current Flag**

Range:	Function:
50%* [1–100% FLC]	Sets the level at which the low current flag operates, as a percentage of motor full load current.

**4-11 High Current Flag**

Range:	Function:
100%* [50–600% FLC]	Sets the level at which the high current flag operates, as a percentage of motor full load current.

**8.4.4 Motor Temperature Flag**

The soft starter has a motor temperature flag to give early warning of abnormal operation. The flag can indicate that the motor is operating above its normal operating temperature, but lower than the overload limit. The flag can signal the situation to external equipment via 1 of the programmable outputs.

**4-12 Motor Temperature Flag**

Range:	Function:
80%* [0–160%]	Sets the level at which the motor temperature flag operates, as a percentage of the motor thermal capacity.

**8.4.5 Analog Output A**

The soft starter has an analog output, which can be connected to associated equipment to monitor motor performance.

**4-13 Analog Output A**

Option:	Function:
	Selects which information is reported via analog output A.
Current (% FLC)*	Current as a percentage of motor full load current.
Motor temp (%)	Motor temperature as a percentage of the thermal capacity of the motor.
Motor kW (%)	Measured motor kW, as a percentage of maximum kW.
Motor kVA (%)	Measured motor kilovolt amperes, as a percentage of maximum kVA.
Motor pf	Motor power factor, measured by the soft starter. <ul style="list-style-type: none"> <li>Measure motor kW: <math>\sqrt{3} \times \text{average current} \times \text{mains reference voltage} \times \text{measure power factor}</math>.</li> <li>Maximum motor kW: <math>\sqrt{3} \times \text{motor FLC} \times \text{mains reference voltage}</math>. Power factor is assumed to be 1.</li> <li>Measure motor kVA: <math>\sqrt{3} \times \text{average current} \times \text{main reference voltage}</math>.</li> </ul>



**4-13 Analog Output A**

**Option: Function:**

	<ul style="list-style-type: none"> <li>Maximum motor kVA: <math>\sqrt{3}</math> x motor FLC x mains reference voltage.</li> </ul>
--	---

**4-14 Analog A Scale**

**Option: Function:**

	Selects the range of the output.
0–20 mA	
4–20 mA*	

**4-15 Analog A Maximum Adjustment**

**Range: Function:**

100%*	[0–600%]	Calibrates the upper limit of the analog output to match the signal measured on an external current measuring device.
-------	----------	---

**4-16 Analog A Minimum Adjustment**

**Range: Function:**

0%*	[0–600%]	Calibrates the lower limit of the analog output to match the signal measured on an external current measuring device.
-----	----------	---

**8.5 Start/Stop Timers**

**CAUTION**

**UNINTENDED START**

The autostart timer overrides any other form of control. The motor may start without warning.

**5-1 Auto-Start Type**

**Option: Function:**

	Selects whether the soft starter autostarts after a specified delay or at a specific time of day.
Off*	The soft starter does not autostart.
Timer	The soft starter does autostart after a delay from the next stop, as specified in <i>parameter 5-2 Auto-start Time</i> .
Clock	The soft starter autostarts at the time programmed in <i>parameter 5-2 Auto-start Time</i> .

**5-2 Auto-Start Time**

**Range: Function:**

1 min*	[00:01–24:00 (hrs:min)]	Sets the time for the soft starter to autostart in 24-hour clock format.
--------	-------------------------	--

**5-3 Auto-Stop Type**

**Option: Function:**

	Selects whether the soft starter autostops after a specified delay or at a specific time of day.
Off*	The soft starter does not autostop.
Time	The soft starter autostops after a delay from the next start, as specified in <i>parameter 5-4 Auto-stop Time</i> .
Clock	The soft starter autostops at the time programmed in <i>parameter 5-4 Auto-stop Time</i> .

**5-4 Auto-Stop Time**

**Range: Function:**

1 min*	[00:01–24:00 (hrs:min)]	<p>Sets the time for the soft starter to autostop in 24-hour clock format.</p> <p><b>NOTICE</b></p> <p>Do not use this function with remote 2-wire control. The soft starter still accepts start and stop commands from the remote inputs or serial communication network. To disable local or remote control, use <i>parameter 3-1 Local/Remote</i>. If autostart is enabled and the user is in the menu system, autostart becomes active if the menu times out (if no LCP activity is detected for 5 minutes).</p>
--------	-------------------------	--

**8.6 Auto-reset**

The soft starter can be programmed to reset certain trips automatically, which can help minimize operating downtime. Trips are divided into 3 categories for auto-reset, depending on the risk to the soft starter:

Group	
A	Current imbalance
	Phase loss
	Power loss
	Frequency
B	Undercurrent
	Instant overcurrent
	Input A trip
C	Motor overload
	Motor thermistor
	Heat overtemperature

**Table 8.1 Trip Categories for Auto-reset**

Other trips cannot be automatically reset.

This function is ideal for remote installations using 2-wire control in auto-on mode. If the 2-wire start signal is present after an auto-reset, the soft starter restarts.

**6-1 Auto-Reset Action**

**Option: Function:**

	Selects which trips can be auto-reset.
Do not Auto-Reset*	
Reset group A	
Reset group A & B	
Reset group A, B & C	

**6-2 Maximum Resets**
**Range:**      **Function:**

1*	[1–5]	Sets how many times the soft starter auto-resets if it continues to trip. The reset counter increases by 1 each time the soft starter auto-resets and decreases by 1 after each successful start/stop cycle.
----	-------	--

**NOTICE**

If the starter is manually reset, the reset counter returns to 0.

### 8.6.1 Auto-reset Delay

The soft starter can be configured to wait before auto-resetting a trip. Separate delays can be set for trips in groups A and B, or in group C.

**6-3 Reset Delay Groups A & B**
**Range:**      **Function:**

5 s*	[00:05–15:00 (min:s)]	Sets the delay before resetting group A and group B trips.
------	-----------------------	--

**6-4 Reset Delay Group C**
**Range:**      **Function:**

5 minutes*	[5–60 (minutes)]	Sets the delay before resetting group C trips.
------------	------------------	--

### 8.7 Secondary Motor Set

See *parameters 1-1 to 1-16* for details.

**7-1 Motor FLC-2**
**Range:**      **Function:**

	[Motor dependent]	Sets the secondary motor full load current.
--	-------------------	---

**7-2 Locked Rotor Time-2**
**Range:**      **Function:**

10 s*	[0:01–2:00 (min:s)]	Sets the maximum length of the time the motor can run at locked rotor current from cold before reaching its maximum temperature. Set according to the motor datasheet. If this information is not available, set the value to <20 s.
-------	---------------------	---

**7-3 Start Mode-2**
**Option:**      **Function:**

		Selects the soft start mode.
	Constant current*	
	Adaptive control	

**7-4 Current Limit-2**
**Range:**      **Function:**

350%*	[100–600% FLC]	Sets the current limit for constant current and current ramp soft starting, as a percentage of motor full load current.
-------	----------------	---

**7-5 Initial Current-2**
**Range:**      **Function:**

350%*	[100–600% FLC]	Sets the initial start current level for current ramp starting, as a percentage of motor full load current. Set so that the motor begins to accelerate immediately after a start is initiated. If current ramp starting is not required, set the initial current equal to the current limit.
-------	----------------	--

**7-6 Start Ramp Time-2**
**Range:**      **Function:**

10 s*	[1–180 s]	Sets the total start time for an adaptive control start or the ramp time for current ramp starting (from the initial current to the current limit).
-------	-----------	---

**7-7 Kick-start Level-2**
**Range:**      **Function:**

500%*	[100–700% FLC]	Sets the level of the kick-start current.
-------	----------------	---

**7-8 Kick-start Time-2**
**Range:**      **Function:**

0000 ms*	[0–2000 ms]	Sets the kick-start duration. A setting of 0 disables kick-start.
----------	-------------	---

**7-9 Excess Start Time-2**
**Range:**      **Function:**

		Excess start time is the maximum time the soft starter attempts to start the motor. If the motor does not reach full speed within the programmed limit, the soft starter trips. Set for a period slightly longer than required for a normal healthy start. A setting of 0 disables excess start time protection.
20 s*	[0:00–4:00 (min:s)]	Set as required.

**7-10 Stop Mode-2**
**Option:**      **Function:**

		Selects the stop mode.
	Coast to stop*	
	TVR soft stop	
	Adaptive control	
	Brake	

**7-11 Stop Time-2**
**Range:**      **Function:**

0 s*	[0:00–4:00 (min:s)]	Sets the stop time.
------	---------------------	---------------------

**7-12 Adaptive Control Gain-2**
**Range:**                      **Function:**

75%*	[1–200%]	Adjusts the performance of adaptive control. The setting affects both starting and stopping control. <b>NOTICE</b> Leave the gain setting at the default level unless adaptive control performance is not satisfactory. If the motor accelerates or decelerates quickly at the end of a start or stop, increase the gain setting by 5–10%. If the motor speed fluctuates during starting or stopping, decrease the gain setting slightly.
------	----------	---

**7-13 Adaptive Start Profile-2**
**Option:**                      **Function:**

		Selects which profile the soft starter uses for an adaptive control soft start.
Early acceleration		
Constant acceleration*		
Late acceleration		

**7-14 Adaptive Stop Profile-2**
**Option:**                      **Function:**

		Selects which profile the soft starter uses for an adaptive control soft stop.
Early deceleration		
Constant deceleration*		
Late acceleration		

**7-15 Brake Torque-2**
**Range:**                      **Function:**

20%*	[20–100%]	Sets the amount of brake torque the soft starter uses to slow the motor.
------	-----------	--

**7-16 Brake Time-2**
**Range:**                      **Function:**

1 s*	[1–30 s]	<b>NOTICE</b> This parameter is used with <i>parameter 7-11 Stop Time-2</i> . Sets the duration for DC injection during a braking stop.
------	----------	---

## 8.8 Display

**8-1 Language**
**Option:**                      **Function:**

		Selects in which language the LCP shows messages and feedback.
English*		
Chinese (中文)		
Spanish (Español)		
German (Deutsch)		
Portuguese (Português)		

**8-1 Language**
**Option:**                      **Function:**

French (Français)	
Italian (Italiano)	
Russian (Русский)	

### 8.8.1 User-programmable Screen

Selects which 4 items to show on the programmable monitoring screen.

**8-2 User Screen - Top Left**
**Option:**                      **Function:**

	Selects the item shown in the top left part of the screen.
Blank	Shows no data in the selected area, allowing long messages to be shown without overlapping.
Starter state	The operating state of the soft starter (starting, running, stopping, or tripped). Only available for <i>Top L</i> and <i>Btm L</i> .
Motor current	The average current measured on 3 phases.
Motor pf*	The motor power factor measured by the soft starter.
Mains frequency	The average frequency measured on 3 phases.
Motor kW	The motor running power in kW.
Motor hp	The motor running power in horse power.
Motor temp	The motor temperature, calculated by the thermal model.
kWh	The number of kWh the motor has run via the soft starter.
Hours run	The number of hours the motor has run via the soft starter.

**8-3 User Screen - Top Right**
**Option:**                      **Function:**

	Selects the item shown in the top right part of the screen.
Blank*	Shows no data in the selected area, allowing long messages to be shown without overlapping.
Starter state	The operating state of the soft starter (starting, running, stopping, or tripped). Only available for <i>Top L</i> and <i>Btm L</i> .
Motor current	The average current measured on 3 phases.
Motor pf	The motor power factor measured by the soft starter.
Mains frequency	The average frequency measured on 3 phases.
Motor kW	The motor running power in kW.
Motor hp	The motor running power in horse power.
Motor temp	The motor temperature, calculated by the thermal model.

**8-3 User Screen - Top Right**
**Option:                      Function:**

kWh	The number of kWh the motor has run via the soft starter.
Hours run	The number of hours the motor has run via the soft starter.

**8-4 User Screen - Bottom Left**
**Option:                      Function:**

	Selects the item shown in the bottom left part of the screen.
Blank	Shows no data in the selected area, allowing long messages to be shown without overlapping.
Starter state	The operating state of the soft starter (starting, running, stopping, or tripped). Only available for <i>Top L</i> and <i>Btm L</i> .
Motor current	The average current measured on 3 phases.
Motor pf	The motor power factor, measured by the soft starter.
Mains frequency	The average frequency measured on 3 phases.
Motor kW	The motor running power in kW.
Motor hp	The motor running power in horse power.
Motor temp	The motor temperature, calculated by the thermal model.
kWh	The number of kWh the motor has run via the soft starter.
Hours run*	The number of hours the motor has run via the soft starter.

**8-5 User Screen - Bottom Right**
**Option:                      Function:**

	Selects the item shown in the bottom right part of the screen.
Blank*	Shows no data in the selected area, allowing long messages to be shown without overlapping.
Starter state	The operating state of the soft starter (starting, running, stopping, or tripped). Only available for <i>Top L</i> and <i>Btm L</i> .
Motor current	The average current measured on 3 phases.
Motor pf	The motor power factor measured by the soft starter.
Mains frequency	The average frequency measured on 3 phases.
Motor kW	The motor running power in kW.
Motor hp	The motor running power in horse power.
Motor temp	The motor temperature, calculated by the thermal model.
kWh	The number of kWh the motor has run via the soft starter.
Hours run	The number of hours the motor has run via the soft starter.

**8.8.2 Performance Graphs**

The loggings menu allows the viewing of performance information in real-time graphs.

The newest information is shown at the right side of the screen. The graph can be paused to analyze data by pressing and holding [OK]. To restart the graph, press and hold [OK].

**8-6 Graph Timebase**
**Option:                      Function:**

	Sets the graph time scale. The graph progressively replaces the old data with new data.
10 s*	
30 s	
1 minute	
5 minutes	
10 minutes	
30 minutes	
1 hour	

**8-7 Graph Maximum Adjustment**
**Range:                      Function:**

400%*	[0-600%]	Adjusts the upper limit of the performance graph.
-------	----------	---

**8-8 Graph Minimum Adjustment**
**Range:                      Function:**

0%*	[0-600%]	Adjusts the lower limit of the performance graph.
-----	----------	---

**8-9 Mains Reference Voltage**
**Range:                      Function:**

400 V*	[100-690 V]	Sets the nominal voltage for the monitoring functions of the LCP. The nominal voltage is used to calculate motor kW and kilovolt amperes (kVA), but does not affect the motor control protection of the soft starter. Enter the measured mains voltage.
--------	-------------	---

**8.9 Restricted Parameters**
**15-1 Access Code**
**Range:                      Function:**

0000*	[0000-9999]	<p>Sets the access code to enter the simulation tools and counter resets or the restricted section of the programming menu (<i>parameter group 15 Restricted Parameters</i> and higher). Press [Back] and [OK] to select which digit to alter, and use [▲] and [▼] to change the value.</p> <p><b>NOTICE</b></p> <p>If the access code is lost, contact the local Danfoss supplier for master access code that allows the reprogramming of a new access code.</p>
-------	-------------	---

**15-2 Adjustment Lock**

**Option: Function:**

	Selects whether the LCP allows parameters to be changed via the programming menu.
Read & write*	Allows altering parameter values in the programming menu.
Read only	Prevents users altering parameter values in the programming menu. Parameter values can still be viewed.
No access	Prevents users adjusting parameters in the programming menu unless an access code is entered.
	<b>NOTICE</b> Changes to the adjustment lock setting take effect only after the programming menu has been closed.

**15-3 Emergency Run**

**Option: Function:**

	<p><b>CAUTION</b> <b>EQUIPMENT DAMAGE</b> Continued use of emergency run is not recommended. Emergency run may compromise the soft starter life as all protections and trips are disabled. Using the soft starter in Emergency run mode voids the product warranty.</p> <p>Selects whether the soft starter allows emergency run operation. In emergency run, the soft starter starts (if not already running) and continues to operate until emergency run ends, ignoring stop commands and trips.</p> <p>Emergency run is controlled using a programmable input.</p> <p>When emergency run is activated in internally bypassed models which are not running, the soft starter attempts a normal start while ignoring all trips. If a normal start is not possible, a DOL start via the internal bypass contactors is attempted. For non-bypassed models, an external emergency run bypass contactor may be used.</p>
--	--

**15-4 Current Calibration**

**Range: Function:**

100%*	[85–115%]	<p>Motor current calibration calibrates the soft starter's current monitoring circuits to match an external current metering device.</p> <p>Use the following formula to determine the necessary adjustment:</p> $\text{Calibration (\%)} = \frac{\text{Current shown on MCD 500 display}}{\text{Current measured by external device}}$ <p>e.g. <math>102\% = \frac{66\text{ A}}{65\text{ A}}</math></p> <p><b>NOTICE</b> This adjustment affects all current-based functions.</p>
-------	-----------	--

**15-5 Main Contactor Time**

**Range: Function:**

400 ms*	[100–2000 ms]	Sets the delay period between the soft starter switching the main contactor output (terminals 13 and 14) and beginning the prestart checks (before start) or entering the not ready state (after a stop). Set according to the specifications of the main contactor used.
---------	---------------	---

**15-6 Bypass Contactor Time**

**Range: Function:**

150 ms*	[100–2000 ms]	Sets the soft starter to match the bypass contactor closing/opening time. Set according to the specifications of the bypass contactor used. If the time is too short, the soft starter trips.
---------	---------------	---

**15-7 Motor Connection**

**Option: Function:**

	The soft starter automatically detects the format of the connection to the motor.
Auto-Detect*	
In-line	
Inside Delta	

**15-8 Jog Torque**

**Range: Function:**

50%*	[20–100%]	<p><b>NOTICE</b> Setting this parameter above 50% may cause increased shaft vibration.</p> <p>Sets the torque level for jog operation. See chapter 5.5 Jog Operation for more details.</p>
------	-----------	--

## 8.10 Protection Action

### 16-1 to 16-13 Protection Action

**Option:**      **Function:**

	<p>Selects the soft starter response to each protection.</p> <ul style="list-style-type: none"> <li>• <i>Parameter 16-1 Motor Overload.</i></li> <li>• <i>Parameter 16-2 Current Imbalance.</i></li> <li>• <i>Parameter 16-3 Undercurrent.</i></li> <li>• <i>Parameter 16-4 Inst Overcurrent.</i></li> <li>• <i>Parameter 16-5 Frequency.</i></li> <li>• <i>Parameter 16-6 Heat sink Overtemp.</i></li> <li>• <i>Parameter 16-7 Excess Start Time.</i></li> <li>• <i>Parameter 16-8 Input A Trip.</i></li> <li>• <i>Parameter 16-9 Motor Thermistor.</i></li> <li>• <i>Parameter 16-10 Starter/Comms.</i></li> <li>• <i>Parameter 16-11 Network/Comms.</i></li> <li>• <i>Parameter 16-12 Battery/Clock.</i></li> <li>• <i>Parameter 16-13 Low Control Volts.</i></li> </ul>
Trip starter*	
Warn and log	
Log only	

8

## 8.11 Factory Parameters

These parameters are restricted for factory use and are not available to the user.

## 9 Tools

To access *Tools*:

1. Open the Main Menu.
2. Scroll to *Tools*.
3. Press [OK].

### **NOTICE**

The security access code also protects simulation tools and counter-resets. The default access code is 0000.

### 9.1 Set Date and Time

To set the date and time:

1. Open the Tools Menu.
2. Scroll to *Set Date & Time*.
3. Press [OK] to enter edit mode.
4. Press [OK] to select which part of the date or time to edit.
5. Use [▲] and [▼] to change the value.

To save changes, press [OK] repeatedly. The soft starter confirms the changes. To cancel changes, press [Back] repeatedly.

### 9.2 Load/Save Settings

The VLT® Soft Starter MCD 500 includes options to:

- Load defaults: Load the soft starter parameters with default values.
- Load User Set 1: Reload previously saved parameter settings from an internal file.
- Save User Set 1: Save the current parameter settings to an internal file.

In addition to the factory default values file, the soft starter can store a user-defined parameter file. This file contains default values until a user file is saved.

To load or save parameter settings:

1. Open the Tools Menu.
2. Use [▼] to select the required function, then press [OK].
3. At the confirmation prompt, select *Yes* to confirm or *No* to cancel.
4. Press [OK] to load/save the selection or exit the screen.

Tools	Load Defaults
	Load User Set 1
	Save User Set 1

Table 9.1 Tools Menu

Load Defaults
No
Yes

Table 9.2 Load Defaults Menu

When the action has been completed, the screen briefly shows a confirmation message and then returns to the status screens.

### 9.3 Reset Thermal Model

### **NOTICE**

The security access code protects the reset thermal model.

The advanced thermal modeling software in the soft starter constantly monitors the motor performance. This monitoring allows the soft starter to calculate the motor temperature and ability to start successfully at any time.

If necessary, reset the thermal model.

### **NOTICE**

Resetting the motor thermal model may compromise motor life and should only be done in the case of emergency.

1. Open *Tools*.
2. Scroll to *Reset Thermal Model* and press [OK].
3. At the confirmation prompt, press [OK] to confirm, then enter the access code, or press [Back] to cancel the action.
4. Select *Reset* or *Do Not Reset*, then press [OK]. When the thermal model has been reset, the soft starter returns to the previous screen.

Reset Thermal Model
M1 X%
OK to Reset

Table 9.3 Accept to Reset the Thermal Model

Reset Thermal Model
Do Not Reset
Reset

Table 9.4 Reset Thermal Model Menu

## 9.4 Protection Simulation

### NOTICE

Protection simulation is protected by the security access code.

To test the operation and control circuits of the soft starter without connecting it to mains voltage, use the software simulation functions.

The protection simulation feature enables the soft starter to confirm that it responds correctly and reports the situation on the display and across the communication network.

To use the protection simulation:

1. Open the Main Menu.
2. Scroll to *Protection Sim* and press [OK].
3. To select the protection to simulate, press [▲] and [▼].
4. To simulate the selected protection, press [OK].
5. The screen is shown while [OK] is pressed. The soft starter response depends on the protection action setting (*parameter group 16 Protection Actions*).
6. To return to the simulation list, press [Back].
7. To select another simulation, press [▲] or [▼], or press [Back] to return to the Main Menu.

MS1	000.0A	0000.0kW
Tripped		
Selected Protection		

Table 9.5 Protection Simulation Menu

### NOTICE

If the protection trips the soft starter, reset before simulating another protection. If the protection action is set to *Warn or Log*, no reset is required.

If the protection is set to *Warn & Log*, the warning message can be viewed only while [OK] is pressed.

If the protection is set to *Log only*, nothing appears on the screen, but an entry appears in the log.

## 9.5 Output Signal Simulation

### NOTICE

The security access code protects the output signal simulation.

The LCP allows simulation of output signaling to confirm that the output relays are operating correctly.

### NOTICE

To test operation of the flags (motor temperature and low/high current), set an output relay to the appropriate function and monitor the relay behavior.

To use the output signal simulation:

1. Open the Main Menu.
2. Scroll to *Output Signal Sim* and press [OK], then enter the access code.
3. To select a simulation, press [▲] and [▼], then press [OK].
4. To turn the signal on and off, press [▲] and [▼]. To confirm correct operation, monitor the state of the output.
5. To return to the simulation list, press [Back].

Prog Relay A	
Off	
On	

Table 9.6 Output Signal Simulation Menu

## 9.6 Digital I/O State

This screen shows the status of the digital I/O in order.

The top line of the screen shows:

- Start.
- Stop.
- Reset.
- Programmable input.

The bottom line of the screen shows programmable outputs A, B, and C.

Digital I/O State	
Inputs: 0100	
Outputs: 100	

Table 9.7 Digital I/O Status Screen

## 9.7 Temp Sensors State

This screen shows the state of the motor thermistor. The screenshot shows the thermistor state as O (open).

Temp Sensors State	
Thermistor: O	
S = shrt H=hot C=cld O=opn	

Table 9.8 Motor Thermistor Status Screen



## 9.8 Alarm Log

The [Alarm Log] key opens the alarm logs, which contain:

- Trip log.
- Event log.
- Counters which store information on the soft starter operating history.

### 9.8.1 Trip Log

The trip log stores details of the 8 most recent trips, including the date and time the trip happened. Trip 1 is the most recent and trip 8 is the oldest stored trip.

To open the trip log:

1. Press [Alarm Log].
2. Scroll to *Trip Log* and press [OK].
3. To select a trip to view, press [▲] and [▼], then press [OK] to show details.

To close the log and return to the main display, press [Back].

### 9.8.2 Event Log

The event log stores time-stamped details of the 99 most recent events (actions, warnings, and trips), including the date and time of the event. Event 1 is the most recent and event 99 is the oldest stored event.

To open the event log:

1. Press [Alarm Log].
2. Scroll to *Event Log* and press [OK].
3. To select an event to view, press [▲] and [▼], then press [OK] to show details.

To close the log and return to the main display, press [Back].

### 9.8.3 Counters

#### **NOTICE**

The security access code protects the counters function.

The performance counters store statistics on the soft starter operation:

- Hours run (lifetime and time since the last reset of the counter).
- Number of starts (lifetime and time since the last reset of the counter).
- Motor kWh (lifetime and time since the last reset of the counter).
- Number of times the thermal model has been reset.

The resettable counters (hours run, starts, and motor kWh) can only be reset if the correct access code is entered.

To view the counters:

1. Press [Alarm Log].
2. Scroll to *Counters* and press [OK].
3. To scroll through the counters, press [▲] and [▼]. Press [OK] to view details.
4. To reset a counter, press [OK], then enter the access code. Select Reset, then press [OK] to confirm.

To close the counter and return to the alarm logs, press [Back].

# 10 Troubleshooting

When a protection condition is detected, the VLT® Soft Starter MCD 500 writes this condition to the event log and may also trip or issue a warning. The soft starter response depends on the protection action settings (*parameter group 16 Protection Actions*).

Some protection responses cannot be adjusted. Usually, external events (for example phase loss) or a fault within the soft starter cause these trips. These trips do not have associated parameters and cannot be set to *Warn* or *Log*.

If the soft starter trips:

1. Identify and clear the condition that triggered the trip.
2. Reset the soft starter.
3. Restart the soft starter.

To reset the soft starter, press [Reset] or activate the *Reset remote* input.

If the soft starter has issued a warning, it resets itself when the cause of the warning has been resolved.

## 10.1 Trip Messages

Table 10.1 lists the protection mechanisms in the soft starter and the probable cause of the trip. Some of these protection mechanisms can be adjusted using *parameter group 2 Protection* and *parameter group 16 Protection Action*. Other settings are built-in system protections and cannot be set or adjusted.

Display	Possible cause/suggested solution
Awaiting data	The LCP does not receive data from the control PCB. Check the cable connection and the fitting of the display on the soft starter.
Battery/clock	A verification error has occurred on the real-time clock, or the back-up battery voltage is low. If the battery is low and the power is off, date/time settings are lost. Reprogram the date and time. Related parameter: <ul style="list-style-type: none"> <li>• <i>Parameter 16-12 Battery Clock</i>.</li> </ul>
Controller	Name selected for a programmable input. Refer to <i>Input A trip</i> .
Current imbalance	Problems with the motor, the environment, or the installation can cause current imbalance, such as: <ul style="list-style-type: none"> <li>• An imbalance in the incoming mains voltage.</li> <li>• A problem with the motor windings.</li> <li>• A light load on the motor.</li> <li>• A phase loss on mains terminals L1, L2, or L3 during run mode.</li> </ul> An SCR that has failed open circuit. A failed SCR can only be diagnosed accurately by replacing the SCR and checking the soft starter performance. Related parameters: <ul style="list-style-type: none"> <li>• <i>Parameter 2-2 Current Imbalance</i>.</li> <li>• <i>Parameter 2-3 Current Imbalance Delay</i>.</li> <li>• <i>Parameter 16-2 Current Imbalance</i>.</li> </ul>
Current read err lx	Where X is 1, 2, or 3. Internal fault (PCB fault). The output from the current transformer circuit is not close enough to 0 when the SCRs are turned off. Contact the local Danfoss supplier for advice. This trip is not adjustable. Related parameters: None.

Display	Possible cause/suggested solution
Excess start time	<p>Excess start time trip can occur under the following conditions:</p> <ul style="list-style-type: none"> <li>• <i>Parameter 1-1 Motor FLC</i> is not appropriate for the motor.</li> <li>• <i>Parameter 1-4 Current Limit</i> has been set too low.</li> <li>• <i>Parameter 1-6 Start Ramp Time</i> has been set higher than the setting in <i>parameter 1-9 Excess Start Time Setting</i>.</li> <li>• <i>Parameter 1-6 Start Ramp Time</i> is set too short for a high inertia load when using adaptive control.</li> </ul> <p>Related parameters:</p> <ul style="list-style-type: none"> <li>• <i>Parameter 1-1 Motor FLC</i>.</li> <li>• <i>Parameter 1-4 Current Limit</i>.</li> <li>• <i>Parameter 1-6 Start Ramp Time</i>.</li> <li>• <i>Parameter 1-9 Excess Start Time</i>.</li> <li>• <i>Parameter 7-1 Motor FLC-2</i>.</li> <li>• <i>Parameter 7-4 Current Limit-2</i>.</li> <li>• <i>Parameter 7-6 Start Ramp-2</i>.</li> <li>• <i>Parameter 7-9 Excess Strt Time-2</i>.</li> <li>• <i>Parameter 16-7 Excess Start Time</i>.</li> </ul>
Firing fail px	<p>Where X is phase 1, 2, or 3.</p> <p>The SCR did not fire as expected. Check for faulty SCRs and internal wiring faults.</p> <p>This trip is not adjustable.</p> <p>Related parameters: None.</p>
FLC too high	<p>The soft starter can support higher motor full load current values when connected to the motor using inside delta configuration rather than in-line connection. If the soft starter is connected in-line, but the programmed setting for <i>parameter 1-1 Motor FLC</i> exceeds the in-line maximum, the soft starter trips at start (see <i>chapter 4.5 Minimum and Maximum Current Settings</i>).</p> <p>If the soft starter is connected to the motor using inside delta configuration, check that the soft starter detects the connection correctly. Contact the local Danfoss supplier for advice.</p> <p>Related parameters:</p> <ul style="list-style-type: none"> <li>• <i>Parameter 1-1 Motor FLC</i>.</li> <li>• <i>Parameter 7-1 Motor FLC-2</i>.</li> </ul>
Frequency	<p>The mains frequency is outside of the specified range.</p> <p>Check for other equipment in the area that could be affecting the mains supply, particularly frequency converters and switch mode power supplies (SMPS).</p> <p>If the soft starter is connected to a generator-set supply, the generator may be too small or could have a speed control problem.</p> <p>Related parameters:</p> <ul style="list-style-type: none"> <li>• <i>Parameter 2-8 Frequency Check</i>.</li> <li>• <i>Parameter 2-9 Frequency Variation</i>.</li> <li>• <i>Parameter 2-10 Frequency Delay</i>.</li> <li>• <i>Parameter 16-5 Frequency</i>.</li> </ul>
Heat sink overtemp	<p>Check that cooling fans are operating. If mounted in an enclosure, check if ventilation is adequate. Fans operate during start, run, and for 10 minutes after the soft starter exits the stop state.</p> <p><b>NOTICE</b>  <b>Models MCD5-0021B ~ MCD4-0053B and MCD5-0141B do not have a cooling fan.</b>  <b>Models with fans operate the cooling fans from a start until 10 minutes after a stop.</b></p> <p>Related parameter:</p> <ul style="list-style-type: none"> <li>• <i>Parameter 16-6 Heat sink Overtemp</i>.</li> </ul>

Display	Possible cause/suggested solution
High level	Name selected for a programmable input. Refer to <i>Input A trip</i> .
High pressure	Name selected for a programmable input. Refer to <i>Input A trip</i> .
Input A trip	The programmable input is set to a trip function and has activated. Resolve the trigger condition. Related parameters: <ul style="list-style-type: none"> <li>• <i>Parameter 3-3 Input A Function.</i></li> <li>• <i>Parameter 3-4 Input A Name.</i></li> <li>• <i>Parameter 3-5 Input A Trip.</i></li> <li>• <i>Parameter 3-6 Input A Trip Delay.</i></li> <li>• <i>Parameter 3-7 Input A Initial Delay.</i></li> <li>• <i>Parameter 16-8 Input A Trip.</i></li> </ul>
Instantaneous overcurrent	There has been a sharp rise in motor current, probably caused by a locked rotor condition (shear pin) while running. Check for a jammed load. Related parameters: <ul style="list-style-type: none"> <li>• <i>Parameter 2-6 Instantaneous Overcurrent.</i></li> <li>• <i>Parameter 2-7 Instantaneous Overcurrent Delay.</i></li> <li>• <i>Parameter 16-4 Inst Overcurrent.</i></li> </ul>
Internal fault X	The soft starter has tripped on an internal fault. Contact the local Danfoss supplier with the fault code (X). Related parameters: None.
L1 phase loss L2 phase loss L3 phase loss	During prestart, check that the soft starter has detected a phase loss as indicated. In run state, the soft starter has detected that the current on the affected phase has dropped below 3.3% of the programmed motor FLC for more than 1 s. This current drop indicates that either the incoming phase or connection to the motor has been lost. For the soft starter and the motor, check: <ul style="list-style-type: none"> <li>• The supply connections.</li> <li>• The input connections.</li> <li>• The output connections.</li> </ul> A failed SCR can also cause phase loss, particularly an SCR that has failed open circuit. A failed SCR can only be diagnosed accurately by replacing the SCR and checking the soft starter performance. Related parameters: None.
L1-T1 shorted L2-T2 shorted L3-T3 shorted	During prestart checks, the soft starter has detected a short-circuited SCR or a short circuit within the bypass contactor as indicated. Related parameters: None.
Low control volts	The soft starter has detected a drop in the control voltage. <ul style="list-style-type: none"> <li>• Check the external control supply (terminals A4, A5, A6) and reset the soft starter.</li> </ul> If the external control supply is stable: <ul style="list-style-type: none"> <li>• Check if the 24 V supply on the main control PCB is faulty; or</li> <li>• Check if the bypass driver PCB is faulty (internally bypassed models only).</li> </ul> This protection is not active in ready state. Related parameter: <ul style="list-style-type: none"> <li>• <i>Parameter 16-13 Low Control Volts.</i></li> </ul>
Low level	Name selected for a programmable input. Refer to <i>Input A trip</i> .
Low pressure	Name selected for a programmable input. Refer to <i>Input A trip</i> .

Display	Possible cause/suggested solution
Motor overload/ Motor 2 overload	<p>The motor has reached its maximum thermal capacity.</p> <p>The following can cause overload:</p> <ul style="list-style-type: none"> <li>• The soft starter protection settings do not match the motor thermal capacity.</li> <li>• Excessive starts per hour.</li> <li>• Excessive throughput.</li> <li>• Damage to the motor windings.</li> </ul> <p>Resolve the cause of the overload and allow the motor to cool.</p> <p>Related parameters:</p> <ul style="list-style-type: none"> <li>• <i>Parameter 1-1 Motor FLC.</i></li> <li>• <i>Parameter 1-2 Locked Rotor Time.</i></li> <li>• <i>Parameter 1-3 Start Mode.</i></li> <li>• <i>Parameter 1-4 Current Limit.</i></li> <li>• <i>Parameter 7-1 Motor FLC-2.</i></li> <li>• <i>Parameter 7-2 Locked Rotor Time-2.</i></li> <li>• <i>Parameter 7-3 Start Mode-2.</i></li> <li>• <i>Parameter 7-4 Current Limit-2.</i></li> <li>• <i>Parameter 16-1 Motor Overload.</i></li> </ul>
Motor connection tx	<p>Where X is 1, 2, or 3.</p> <p>The motor is not connected correctly to the soft starter for in-line or inside delta use.</p> <ul style="list-style-type: none"> <li>• Check individual motor connections to the soft starter for power circuit continuity.</li> <li>• Check connections at the motor terminal box.</li> </ul> <p>This trip is not adjustable.</p> <p>Related parameter:</p> <ul style="list-style-type: none"> <li>• <i>Parameter 15-7 Motor Connection.</i></li> </ul>
Motor thermistor	<p>The motor thermistor input has been enabled and:</p> <ul style="list-style-type: none"> <li>• The resistance at the thermistor input has exceeded 3.6 kΩ for more than 1 s.</li> <li>• The motor winding has overheated. Identify the cause of the overheating and allow the motor to cool before restarting.</li> <li>• The motor thermistor input has been opened.</li> </ul> <p><b>NOTICE</b> If a valid motor thermistor is no longer used, fit a 1.2 kΩ resistor across terminals 05 and 06.</p> <p>Related parameter:</p> <ul style="list-style-type: none"> <li>• <i>Parameter 16-9 Motor Thermistor.</i></li> </ul>
Network communication (between module and network)	<p>The network master has sent a trip command to the soft starter, or there could be a network communication problem.</p> <p>Check the network for causes of communication inactivity.</p> <p>Related parameter:</p> <ul style="list-style-type: none"> <li>• <i>Parameter 16-11 Network/Comms.</i></li> </ul>
No flow	<p>Name selected for a programmable input. Refer to <i>Input A trip</i>.</p>
Not ready	<p>Check if the soft starter disable function is active. If <i>parameter 3-3 Input A Function</i> is set to <i>Starter disable</i> and there is an open circuit on terminals 11 and 16, the soft starter does not start.</p>
Parameter out of range	<ul style="list-style-type: none"> <li>• A parameter value is outside the valid range.</li> </ul> <p>The soft starter loads the default value for all affected parameters. To go to the first invalid parameter and adjust the setting, press [Main Menu].</p> <p>Related parameters: None.</p>

Display	Possible cause/suggested solution
Phase sequence	The phase sequence on the soft starter mains terminals (L1, L2, L3) is not valid. Check the phase sequence on L1, L2, and L3, and ensure that the setting in <i>parameter 2-1 Phase Sequence</i> is suitable for the installation. Related parameter: <ul style="list-style-type: none"> <li>• <i>Parameter 2-1 Phase Sequence.</i></li> </ul>
PLC	Name selected for a programmable input. Refer to <i>Input A trip</i> .
Power loss	The soft starter is not receiving mains supply on 1 or more phases when a start command is given. Check that the main contactor closes when a start command is given and remains closed until the end of a soft stop. If testing the soft starter with a small motor, it must draw at least 2% of its minimum FLC setting on each phase. Related parameters: None.
Pump fault	Name selected for a programmable input. Refer to <i>Input A trip</i> .
Starter/communication (between module and soft starter)	<ul style="list-style-type: none"> <li>• There is a problem with the connection between the soft starter and the optional communications module. Remove and reinstall the module. If the problem persists, contact the local distributor.</li> <li>• There is an internal communication error within the soft starter. Contact the local distributor.</li> </ul> Related parameter: <ul style="list-style-type: none"> <li>• <i>Parameter 16-10 Starter/Comms.</i></li> </ul>
Starter disable	Name selected for a programmable input. Refer to <i>Input A trip</i> .
Thermistor cct (thermistor circuit)	The thermistor input has been enabled and: <ul style="list-style-type: none"> <li>• The resistance at the input has dropped below 20 Ω (the cold resistance of most thermistors is above this value) or</li> <li>• A short circuit has occurred. Check and resolve this condition.</li> </ul> Check that a PT100 (RTD) is not connected to terminals 05 and 06. Related parameters: None.
Time - overcurrent	The soft starter is internally bypassed and has drawn high current during running. (The 10 A protection curve trip has been reached, or the motor current has risen to 600% of the motor FLC setting.) Related parameters: None.
Undercurrent	The motor has experienced a sharp drop in current, caused by loss of load. Causes can include broken components (shafts, belts, or couplings) or a pump running dry. Related parameters: <ul style="list-style-type: none"> <li>• <i>Parameter 2-4 Undercurrent.</i></li> <li>• <i>Parameter 2-5 Undercurrent Delay.</i></li> <li>• <i>Parameter 16-3 Undercurrent.</i></li> </ul>
Unsupported option (function not available in inside delta)	The selected function is not available (for example jog is not supported in inside delta configuration). Related parameters: None.
Vibration	Name selected for a programmable input. Refer to <i>Input A trip</i> .
VZC fails px	Where X is 1, 2, or 3. Internal fault (PCB fault). Contact the local Danfoss supplier for advice. This trip is not adjustable. Related parameters: None.

Table 10.1 Trip Messages

## 10.2 General Faults

Table 10.2 describes situations where the soft starter does not operate as expected but neither trips nor issues a warning.

Symptom	Probable cause
The soft starter is not ready.	Check input A (11, 16). Check if the soft starter is disabled via a programmable input. If <i>parameter 3-3 Input A Function</i> is set to <i>Starter disable</i> , and there is an open circuit on the corresponding input, the soft starter does not start.
The soft starter does not respond to the [Hand On] and [Reset] keys.	Check if the soft starter is in auto-on mode. When the soft starter is in auto-on mode, the hand-on LED on the soft starter is off. Press [Auto On] once to change to local control.
The soft starter does not respond to commands from the control inputs.	<ul style="list-style-type: none"> <li>The soft starter is waiting for the restart delay to elapse. <i>Parameter 2-11 Restart delay</i> controls the length of the restart delay.</li> <li>The motor may be too hot to allow a start. If <i>parameter 2-12 Motor temperature check</i> is set to <i>Check</i>, the soft starter only allows a start when it calculates that the motor has sufficient thermal capacity to complete the start successfully. Wait for the motor to cool before attempting another start.</li> <li>Check if the soft starter is disabled via a programmable input. If <i>parameter 3-3 Input A Function</i> is set to <i>Starter disable</i>, and there is an open circuit on terminals 11 and 16, the soft starter does not start. If there is no further need to disable the soft starter, close the circuit on the input.</li> </ul> <p><b>NOTICE</b> <i>Parameter 3-1 Local/remote controls when the [Auto On] is enabled.</i></p>
The soft starter does not respond to a start command from either the local or remote controls.	<ul style="list-style-type: none"> <li>The soft starter may be waiting for the restart delay to elapse. <i>Parameter 2-11 Restart delay</i> controls the length of the restart delay.</li> <li>The motor may be too hot to allow a start. If <i>parameter 2-12 Motor temperature check</i> is set to <i>Check</i>, the soft starter only allows a start when it calculates that the motor has sufficient thermal capacity to complete the start successfully.</li> <li>Check if the soft starter is disabled via a programmable input. If <i>parameter 3-3 Input A function</i> is set to <i>Starter disable</i>, and there is an open circuit on terminals 11 and 16, the soft starter does not start. If there is no further need to disable the soft starter, close the circuit on the input.</li> </ul> <p><b>NOTICE</b> <i>Parameter 3-1 Local/remote controls when [Auto On] is enabled.</i></p>
The soft starter does not control the motor correctly during start.	<ul style="list-style-type: none"> <li>Start performance may be unstable when using a low motor FLC setting (<i>parameter 1-1 Motor FLC</i>). This can affect use on a small test motor with full load current of 5–50 A.</li> <li>Install power factor correction (PFC) capacitors on the supply side of the soft starter. To control a dedicated PFC capacitor contactor, connect the contactor to run relay terminals.</li> </ul>

Symptom	Probable cause
Motor does not reach full speed.	<ul style="list-style-type: none"> <li>If the start current is too low, the motor does not produce enough torque to accelerate to full speed. The soft starter may trip on excess start time.</li> </ul> <p><b>NOTICE</b>  <b>Make sure that the motor starting parameters are appropriate for the application and that the intended motor starting profile is used. If parameter 3-3 Input A Function is set to Motor Set Select, check that the corresponding input is in the expected state.</b></p> <ul style="list-style-type: none"> <li>Check if the load is jammed. Check the load for severe overloading or a locked rotor situation.</li> </ul>
Erratic motor operation.	<ul style="list-style-type: none"> <li>The SCRs in the soft starter require at least 5 A of current to latch. If testing the soft starter on a motor with full load current less than 5 A, the SCRs may not latch correctly.</li> </ul>
Erratic and noisy motor operation.	If the soft starter is connected to the motor using inside delta configuration, the soft starter may not be detecting the connection correctly. Contact the local Danfoss supplier for advice.
Soft stop ends too quickly.	<ul style="list-style-type: none"> <li>The soft stop settings may not be appropriate for the motor and load. Review the settings of: <ul style="list-style-type: none"> <li>Parameter 1-10 Stop Mode.</li> <li>Parameter 1-11 Stop Time.</li> <li>Parameter 7-10 Stop Mode-2.</li> <li>Parameter 7-11 Stop Time-2.</li> </ul> </li> <li>If the motor is lightly loaded, soft stop has limited effect.</li> </ul>
Adaptive control, DC brake, and jog functions not working.	<ul style="list-style-type: none"> <li>These features are only available with in-line installation. If the soft starter is installed inside delta, these features do not operate.</li> </ul>
A reset does not occur after an auto-reset when using a remote 2-wire control.	<ul style="list-style-type: none"> <li>Remove and reapply the remote 2-wire start signal for a restart.</li> </ul>
Remote start/stop command overrides autostart/stop settings when using remote 2-wire control.	<ul style="list-style-type: none"> <li>Only use autostart/stop in auto-on mode with 3-wire or 4-wire control.</li> </ul>
After selecting adaptive control, the motor used an ordinary start and/or the 2 <sup>nd</sup> start was different from the 1 <sup>st</sup> start.	<ul style="list-style-type: none"> <li>The 1<sup>st</sup> adaptive control start is <i>Current limit</i>. The soft starter then learns from the motor characteristics. Subsequent starts use adaptive control.</li> </ul>
Non-resettable <i>Thermistor Cct</i> trip, when there is a link between thermistor inputs 05 and 06, or when the motor thermistor connected between 05 and 06 is permanently removed.	<ul style="list-style-type: none"> <li>The thermistor input is enabled once a link is fitted and short-circuit protection has activated.</li> </ul> <p>Remove the link, then load the default parameter set. This disables the thermistor input and clears the trip.  Place a 1.2 kΩ resistor across the thermistor input.  Turn thermistor protection to <i>Log only</i> (parameter 16-9 Motor Thermistor).</p>
Parameter settings cannot be stored.	<ul style="list-style-type: none"> <li>Make sure to save the new value by pressing [OK] after adjusting a parameter setting. If pressing [Back], the change is not saved.</li> <li>Check that the adjustment lock (parameter 15-2 Adjustment Lock) is set to <i>Read/Write</i>. If the adjustment lock is on, settings can be viewed, but not changed. Knowing the security access code is necessary to change the adjustment lock setting.</li> <li>The EEPROM may be faulty on the main control PCB. A faulty EEPROM also trips the soft starter, and the LCP shows the message <i>Par. Out of Range</i>. Contact the local Danfoss supplier for advice.</li> </ul>
The LCP shows message <i>Awaiting data</i> .	The LCP does not receive data from the control PCB. Check the cable connection.

Table 10.2 General Fault Messages



## 11 Specifications

### Supply

Mains voltage (L1, L2, L3)	
MCD5-xxxx-T5	200–525 V AC ( $\pm 10\%$ )
MCD5-xxxx-T7	380–690 V AC ( $\pm 10\%$ ) (in-line connection)
MCD5-xxxx-T7	380–690 V AC ( $\pm 10\%$ ) (inside delta connection)
Control voltage (A4, A5, A6)	
CV1 (A5, A6)	24 V AC/V DC ( $\pm 20\%$ )
CV2 (A5, A6)	110–120 V AC (+10%/-15%)
CV2 (A4, A6)	220–240 V AC (+10%/-15%)
Current consumption (maximum)	
CV1	2.8 A
CV2 (110–120 V AC)	1 A
CV2 (220–240 V AC)	500 mA
Mains frequency	45–66 Hz
Rated insulation voltage to ground	690 V AC
Rated impulse withstand voltage	4 kV
Form designation	Bypassed or continuous, semiconductor motor starter form 1

### Short-circuit capability (IEC)

Coordination with semiconductor fuses	Type 2
Coordination with HRC fuses	Type 1
MCD5-0021B to MCD5-0215B	Prospective current 65 kA
MCD5-0245B to MCD5-0961B	Prospective current 85 kA
MCD5-0245C to MCD5-0927B	Prospective current 85 kA
MCD5-1200C to MCD5-1600C	Prospective current 100 kA

For UL short-circuit current ratings, see Table 4.12.

### Electromagnetic capability (compliant with EU Directive 2014/30/EU)

EMC emissions	IEC 60947-4-2 Class B and Lloyds Marine No 1 Specification
EMC immunity	IEC 60947-4-2

### Inputs

Input rating	Active 24 V DC, 8 mA approximately
Start (15, 16)	Normally open
Stop (17, 18)	Normally closed
Reset (25, 18)	Normally closed
Programmable input (11, 16)	Normally open
Motor thermistor (05, 06)	Trip >3.6 k $\Omega$ , reset <1.6 k $\Omega$

### Outputs

Relay outputs	10 A @ 250 V AC resistive, 5 A @ 250 V AC AC15 pf 0.3
Programmable outputs	
Relay A (13, 14)	Normally open
Relay B (21, 22, 24)	Changeover
Relay C (33, 34)	Normally open
Analog output (07, 08)	0–20 mA or 4–20 mA (selectable)
Maximum load	600 $\Omega$ (12 V DC @ 20 mA)
Accuracy	$\pm 5\%$
24 V DC output (16, 08) maximum load	200 mA
Accuracy	$\pm 10\%$

**Environmental**
**Protection**

MCD5-0021B to MCD5-0105B	IP20 & NEMA, UL Indoor Type 1
MCD5-0131B to MCD5-1600C	IP00, UL Indoor Open Type
Operating temperature	-10 °C (14 °F) to +60 °C (140 °F), above 40 °C (104 °F) with derating
Storage temperature	-25 °C (-13 °F) to +60 °C
Operating altitude (using MCD PC software)	0–1000 m (0–3281 ft), above 1000 m (3281 ft) with derating
Humidity	5–95% relative humidity
Pollution degree	Pollution degree 3
Vibration	IEC 60068-2-6

**Heat dissipation**

During start	4.5 W per ampere
During run	
MCD5-0021B to MCD5-0053B	≤39 W approximately
MCD5-0068B to MCD5-0105B	≤51 W approximately
MCD5-0131B to MCD5-0215B	≤120 W approximately
MCD5-0245B to MCD5-0469B	≤140 W approximately
MCD5-0525B to MCD5-0961B	≤357 W approximately
MCD5-0245C to MCD5-0927C	4.5 W per ampere approximately
MCD5-1200C to MCD5-1600C	4.5 W per ampere approximately

**Certification**

C✓	IEC 60947-4-2
UL/C-UL	
MCD5-0021B to MCD5-0396B, MCD5-0245C to MCD5-1600C	UL 508 <sup>1)</sup>
MCD5-0469B to MCD5-0961B	UL listed
MCD5-0021B to MCD5-105B	UL recognized
MCD5-0131B to MCD5-1600C	IP20, when fitted with optional finger guard kit
CE	IEC 60947-4-2
CCC	GB 14048-6
Marine	
(MCD5-0021B to MCD5-0961B)	Lloyds Marine No 1 Specification
RoHS	Compliant with EU Directive 2002/95/EC

1) For UL certification extra requirements may apply, depending on the models. For details, see chapter 11.1 UL-compliant Installation.

## 11.1 UL-compliant Installation

This section details more requirements and configuration settings for the VLT® Soft Starter MCD 500 to be UL-compliant. See also *Table 4.12*.

### 11.1.1 Models MCD5-0021B to MCD5-0105B

There are no additional requirements for these models.

### 11.1.2 Models MCD5-0131B to MCD5-0215B

- Use with finger guard kit, ordering number 175G5662.
- Use the recommended pressure terminal/connector kit. See *Table 11.1* for more information.

### 11.1.3 Models MCD5-0245B to MCD5-0396B

- Use with finger guard kit, ordering number 175G5730.
- Use the recommended pressure terminal/connector kit. See *Table 11.1* for more information.

### 11.1.4 Models MCD5-0245C

- Use the recommended pressure terminal/connector kit. See *Table 11.1* for more information.

### 11.1.5 Models MCD5-0360C to MCD5-1600C

- Configure the busbars for line/load terminals at opposite ends of the soft starter (that is *Top in/Bottom out*, or *Top out/Bottom in*).
- Use the recommended pressure terminal/connector kit. See *Table 11.1* for more information.

### 11.1.6 Models MCD5-0469B to MCD5-0961B

These models are UL recognized components. Separate cable landing busbars may be required within the electrical cabinet when terminating cables sized according to the National Wiring Code (NEC) regulations.

### 11.1.7 Pressure Terminal/Connector Kits

For models MCD50131B to MCD5-0396B and MCD5-0245C to MCD5-1600C to be UL-compliant, use the recommended pressure terminal/connector as detailed in *Table 11.1*.

Model	FLC (A)	Number of wires	Recommended lugs ordering numbers
MCD5-0131B	145	1	OPHD 95-16
MCD5-0141B	170	1	OPHD 120-16
MCD5-0195B	200	1	OPHD 150-16
MCD5-0215B	220	1	OPHD 185-16
MCD5-0245B	255	1	OPHD 240-20
MCD5-0331B	350	1	OPHD 400-16
MCD5-0396B	425	2	OPHD 185-16
MCD5-0245C	255	1	OPHD 240-20
MCD5-0360C	360	2	1 x 600T-2
MCD5-0380C	380		
MCD5-0428C	430		
MCD5-0595C	620		
MCD5-0619C	650		
MCD5-0790C	790	4	2 x 600T-2
MCD5-0927C	930	3	2 x 600T-2
MCD5-1200C	1200	4	1 x 750T-4
MCD5-1410C	1410		
MCD5-1600C	1600	5	1 x 750T-4 and
			1 x 600T-3

Table 11.1 Pressure Terminal/Connector Kits

## 11.2 Accessories

### 11.2.1 LCP Remote Mounting Kit

The VLT® Soft Starter MCD 500 LCP can be mounted up to 3 m (9.8 ft) away from the soft starter, allowing remote control and monitoring. The remote LCP also allows parameter settings to be copied between soft starters.

- 175G0096 Control Panel LCP 501.

### 11.2.2 Communication Modules

VLT® Soft Starter MCD 500 supports network communication via easy-to-install communication modules. Each soft starter can support 1 communication module at a time.

Available protocols:

- Ethernet (PROFINET, Modbus TCP, EtherNet/IP).
- PROFIBUS.
- DeviceNet.
- Modbus RTU.
- USB.

#### Ordering numbers for communication modules

- 175G9000 Modbus module.
- 175G9001 PROFIBUS module.
- 175G9002 DeviceNet module.
- 175G9009 MCD USB module.
- 175G9904 Modbus TCP module.
- 175G9905 PROFINET module.
- 175G9906 EtherNet/IP module.

### 11.2.3 PC Software

WinMaster PC software provides:

- Monitoring.
- Programming.
- Control of up to 99 soft starters.

A Modbus or USB communication module is required for each soft starter to use WinMaster.

### 11.2.4 Finger Guard Kit

Finger guards may be specified for personnel safety. Finger guards fit over the soft starter terminals to prevent accidental contact with live terminals. Finger guards provide IP20 protection when correctly installed.

- MCD5-0131B to MCD5-0215B: 175G5662.
- MCD5-0245B to MCD5-0396B: 175G5730.
- MCD5-0469B to MCD5-0961B: 175G5731.
- MCD5-245C: 175G5663.
- MCD5-0360C to MCD5-0927C: 175G5664.
- MCD5-1200C to MCD5-1600C: 175G5665.

#### **NOTICE**

To be UL-compliant, the models MCD5-0131B to MCD5-0396B require finger guards.

### 11.2.5 Surge Protection Kit (Lightning Protection)

As standard, VLT® Soft Starter MCD 500 rated impulse withstand voltage is limited to 4 kV. The surge protection kits protect the system and make the soft starter immune to high-voltage impulses.

#### 6 kV

- 175G0100 SPD Surge protection kit for G1.
- 175G0101 SPD Surge protection kit, G2-G5.

#### 12 kV

- 175G0102 SPD Surge protection kit for G1.
- 175G0103 SPD Surge protection kit, G1-G5.

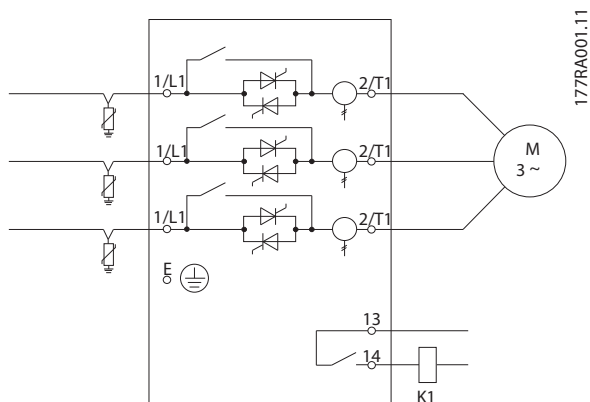

Illustration 11.1 System with Surge Protection Kit

## 12 Busbar Adjustment Procedure (MCD5-0360C to MCD5-1600C)

The busbars on non-bypassed models MCD5-0360C to MCD5-1600C can be adjusted for top or bottom input and output as required.

### **NOTICE**

Many electronic components are sensitive to static electricity. Voltages so low that they cannot be felt, seen, or heard can reduce the life, affect performance, or completely destroy sensitive electronic components. When performing service, use proper ESD equipment to prevent possible damage from occurring.

All units are manufactured with input and output busbars at the bottom of the unit as standard. If necessary, the input and/or output busbars can be moved to the top of the unit.

1. Remove all wiring and links from the soft starter before dismantling the unit.
2. Remove the unit cover (4 screws).
3. Remove the LCP front cover, then gently remove the LCP (2 screws).
4. Remove the control card terminal plugs.
5. Gently fold the main plastic away from the soft starter (12 screws).
6. Unplug the LCP loom from CON 1 (see *Notice*).
7. Label each SCR firing loom with the number of the corresponding terminal on the main control PCB, then unplug the looms.
8. Unplug the thermistor, fan, and current transformer wires from the main control PCB.
9. Remove the plastic tray from the soft starter (4 screws).

### **NOTICE**

Remove the main plastic slowly to avoid damaging the LCP wiring loom (wiring harness), which runs between the main plastic and the backplane PCB.

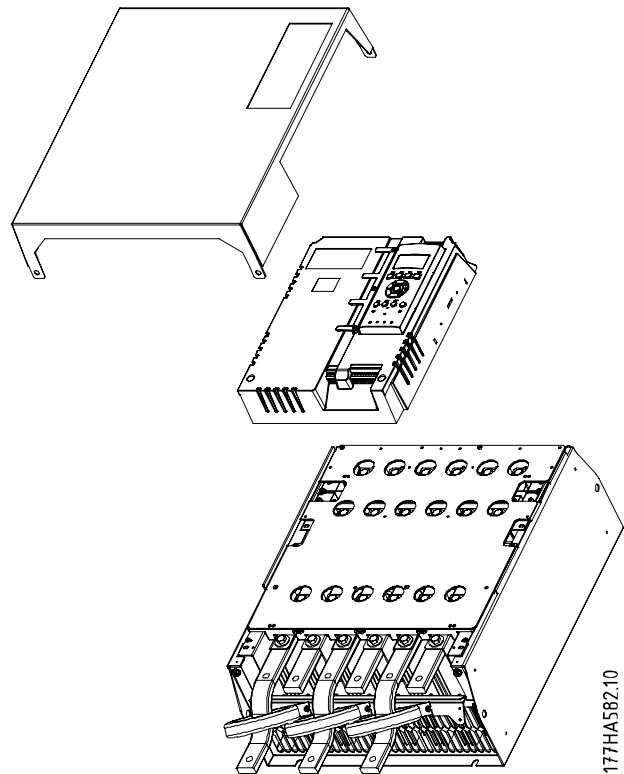

Illustration 12.1 Removing Front Cover and LCP

10. Unscrew and remove the magnetic bypass plates (models MCD5-0620C to MCD5-1600C only).
11. Remove the current transformer assembly (3 screws).
12. Identify which busbars to remove. Remove the bolts holding these busbars in place, then slide out the busbars through the bottom of the soft starter (4 bolts per busbar).

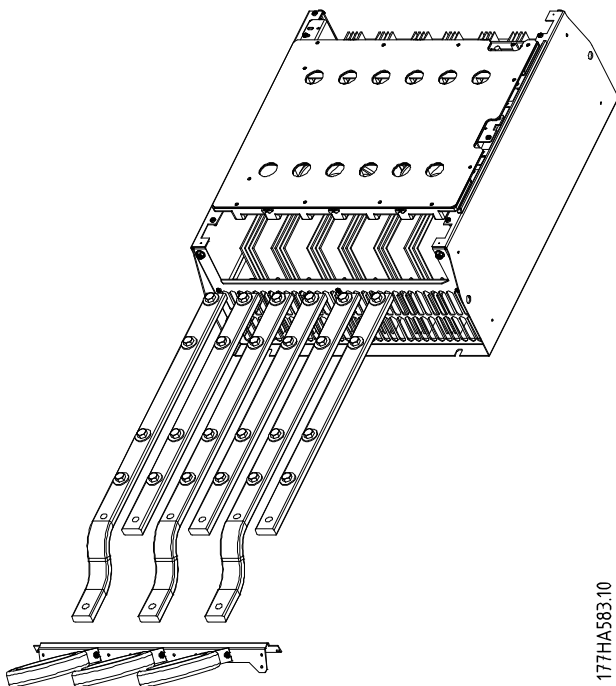

Illustration 12.2 Busbars

177HA583.10

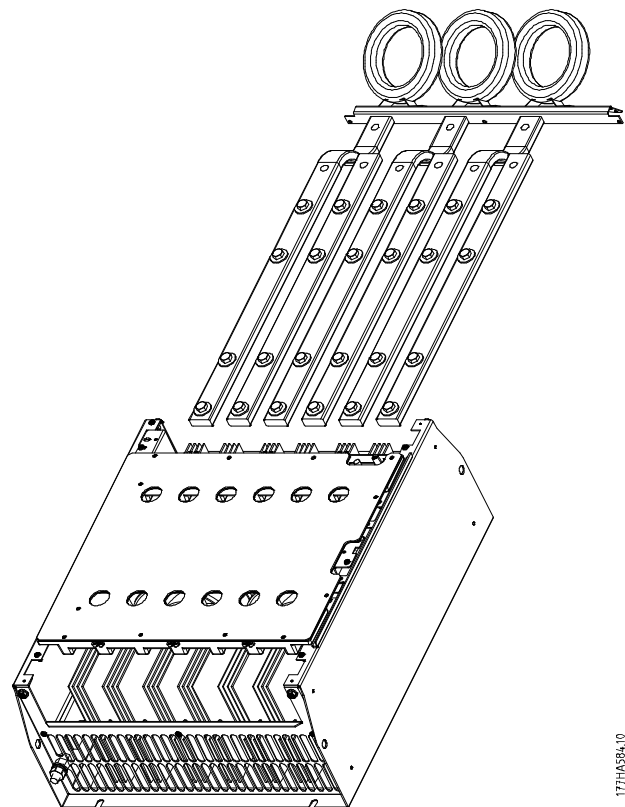

Illustration 12.3 Busbars with Cable Ties

177HA584.10

13. Slide the busbars in through the top of the soft starter. For input busbars, place the short curved end outside the soft starter. For output busbars, place the unthreaded hole outside the soft starter.
14. Replace the dome washers with the flat face towards the busbar.
15. Tighten the bolts holding the busbars in place to 20 Nm (177 in-lb).
16. Place the current transformer assembly over the input busbars and screw the assembly to the body of the soft starter (see *Notice*).
17. Run all wiring to the side of the soft starter and secure with cable ties.

**NOTICE**

If moving the input busbars, the current transformers must also be reconfigured.

1. Label the current transformers L1, L2, and L3 (L1 is leftmost when working from the front of the soft starter). Remove the cable ties and unscrew the current transformers from the bracket.
2. Move the current transformer bracket to the top of the soft starter. Position the current transformers for the correct phases, then screw the current transformers to the bracket. For models MCD5-0360C to MCD5-0930, place the current transformers on an angle. The left-hand legs of each current transformer are on the top row of holes and the right-hand legs are on the bottom tabs.

## 13 Appendix

### 13.1 Symbols, Abbreviations, and Conventions

°C	Degrees Celsius
°F	Degrees Fahrenheit
AC	Alternating current
DC	Direct current
DOL	Direct on-line
EMC	Electro magnetic compatibility
FLA	Full load amperage
FLC	Full load current
FLT	Full load torque
IP	Ingress protection
LCP	Local control panel
LRA	Locked rotor amps
MSTC	Motor start time constant
PAM	Pole amplitude modulated
PCB	Printed circuit board
PELV	Protective extra low voltage
PFC	Power factor correction
SCCR	Short-circuit current rating
SELV	Safety extra low voltage
TVR	Timed voltage ramp

Table 13.1 Symbols and Abbreviations

#### Conventions

Numbered lists indicate procedures.

Bullet lists indicate other information.

Italicized text indicates:

- Cross-reference.
- Link.
- Parameter name.

All dimensions in drawings are in [mm (in)].

## Index

### A

Abbreviations.....	91
AC supply.....	18
AC1 rating.....	28
AC3 rating.....	28
AC-53 rating.....	25, 27
Access code.....	59, 62, 72, 73, 75, 76, 77, 84
Accessories	
Connector kit.....	86, 87
<i>see also Pressure terminal</i>	
Finger guard kit.....	86, 88
Pressure terminal.....	86, 87
<i>see also Connector kit</i>	
Surge protection kit.....	88
Alarm log.....	55, 77
Altitude.....	23, 25, 27, 29, 86
Ambient temperature.....	23, 25, 27, 29
Applications	
UL-compliant.....	34
Auto-on mode.....	11, 54, 55, 56, 66, 69, 84
Autostart.....	54
Auto-start.....	69
Autostart timer.....	69
Autostop.....	54, 69
Auto-stop.....	69

### B

Brake	
Brake.....	42, 43, 44, 54, 55, 64, 70, 71
torque.....	43, 62, 64, 71
DC brake.....	6, 43, 50, 84
DC injection.....	43, 64, 71
Full brake.....	43
Pre-brake.....	43
Soft brake.....	6
Starter disable.....	6, 44, 66, 67, 81, 82, 83
Busbar.....	11, 17, 87, 89, 90
Busbar, input.....	18, 19
Busbar, output.....	18
Bypassed operation.....	25, 27

### C

Calculated motor temperature.....	66
Capacitors	
Power factor correction capacitor.....	11, 29, 83
Certification.....	86

### Communication modules

DeviceNet.....	7, 87
Ethernet.....	7, 87
EtherNet/IP.....	87
Modbus.....	7
Modbus RTU.....	87
Modbus TCP.....	87
PROFIBUS.....	7, 87
PROFINET.....	87
USB.....	87

### Connections

In-line connection.....	6, 19, 21, 24, 25, 28, 54, 79, 81, 85
Inside delta.....	81
Inside delta connection.....	6, 19, 26, 27, 28, 44, 79, 84, 85
Internal bypass.....	6
Motor connection.....	7, 19, 21, 62, 73, 81

### Contactors

Bypass contactor.....	11, 20, 21, 22, 24, 26, 28, 47, 73, 78, 80
Bypass contactor overload.....	7
High-speed contactor.....	52
Internal bypass.....	73
Low-speed contactor.....	52
Main contactor....	12, 20, 21, 22, 28, 46, 54, 55, 64, 67, 68, 73, 82
Star contactor.....	52

### Continuous operation.....

25, 27, 44

Control supply..... 37, 38

Conventions..... 91

Counter..... 6, 59, 70, 72, 75, 77

Current flag..... 59, 62, 67, 68

Current imbalance..... 7, 44, 62, 65, 69, 74, 78

### D

Delay..... 51, 59, 62, 65, 67, 68, 69, 70, 73, 83

Direct on-line..... 40, 43, 73, 91  
*see also DOL*

DOL..... 40, 43, 73, 91  
*see also Direct on-line*

### E

Electromagnetic capability..... 85

Environmental..... 86

Event log..... 6, 77, 78

Excess start time..... 7, 59, 60, 62, 64, 70, 74, 79

External zero-speed sensor..... 50, 51

### F

Fan cooling..... 39



## Features

Adaptive control...	6, 29, 39, 40, 41, 42, 44, 60, 63, 64, 70, 71, 79, 84
Adaptive deceleration control.....	6
Coast to stop.....	41, 42, 43, 44, 54, 55, 64, 66, 70
DC brake.....	6, 43, 50, 84
Emergency run.....	6, 48, 49, 62, 66, 73
In-line connection.....	6, 19, 21, 24, 25, 28, 54, 79, 81, 85
In-line installation.....	20, 21, 84
Inside delta.....	81
Inside delta connection.....	6, 19, 26, 27, 28, 44, 79, 84, 85
Inside delta installation.....	21, 22, 84
Internal bypass.....	6, 73
Jog.....	6, 43, 44, 54, 55, 62, 66, 73, 82, 84
Kick-start.....	6, 41, 62, 63, 70
Output signal simulation.....	6, 76
Output simulation.....	59
Protection simulation.....	6, 59, 76
Soft brake.....	6
Soft braking configuration.....	51
Starter disable.....	6, 44, 50, 66, 67, 81, 82, 83
Thermal model.....	6, 39, 43, 44, 59, 71, 72, 75, 77
Timed voltage ramp.....	6, 41, 44, 64, 70, 91
see also <i>TVR</i>	
TVR.....	6, 41, 44, 64, 70, 91
see also <i>Timed voltage ramp</i>	
Finger guard kit.....	18
FLC.....	19, 21, 28, 29, 34, 39, 41, 42, 57, 60, 63, 65, 68, 70, 79, 82, 83, 84, 91
see also <i>Full load current</i>	
FLT.....	43, 91
see also <i>Full load torque</i>	
Frequency trip.....	65
Full load current.....	19, 21, 28, 29, 34, 39, 41, 42, 57, 60, 63, 65, 68, 70, 79, 82, 83, 84, 91
see also <i>FLC</i>	
Full load torque.....	43, 91
see also <i>FLT</i>	
Fuses	
British style (BS88).....	31
Bussmann fuse.....	30
European style (PSC 690).....	34
Ferraz.....	32, 35, 36
Fuse.....	20, 22
Fuse recommendation.....	29
HRC fuse.....	29, 85
HSJ.....	32
Motor branch circuit.....	43
Motor rated mains fuse.....	29
North American Style (PSC 690).....	33
Power supply fuse.....	29
Protection fuse.....	43
Semiconductor fuse.....	20, 21, 22, 29, 35, 36, 46, 47, 85
Short-circuit rating.....	34, 35, 36
Square body.....	30
Type 1.....	29, 85
Type 2.....	29, 85
UL fuse selection.....	34

## G

Gain setting.....	64, 71
General fault messages.....	84

## H

Hand-on mode.....	54, 55, 56
Heat dissipation.....	86
Heat sink.....	11, 62, 74, 79
Heat sink temperature.....	7

## I

Initial current.....	70
Input A trip.....	78, 80, 81, 82
Input rating.....	85
Input trip.....	7, 50, 66, 67
Inputs	
Control input.....	20
Input A.....	44, 48, 49, 50, 51, 52, 53, 59, 62, 66, 67, 69, 74, 80, 81, 83, 84
Local control input.....	6
Power input.....	18
Programmable input.....	37, 38, 44, 73, 76, 78, 80, 81, 82, 83, 85
Remote.....	11, 16, 54, 55, 66, 69, 78
Remote control input.....	6, 37, 38, 46, 47, 48, 49, 51, 53
Reset.....	16, 67
Inside delta current.....	19, 21

## Installation

Bypass contactor.....	47
Clearance.....	13
Derating values.....	13
Dimension.....	15
Externally bypassed.....	21
In-line installation.....	20, 21, 84
Inside delta installation.....	21, 22, 84
Internally bypassed.....	20, 21
Main contactor.....	46
Non-bypassed.....	20, 22
Side-by-side.....	13
UL-compliant.....	18, 19, 86, 87, 88
Weight.....	15
Instantaneous overcurrent protection.....	65

## K

## Keys

Control keys.....	54, 55, 56
LCP keys.....	66
Navigation keys.....	55

## L

LCP.....	6, 16, 44, 54, 55, 56, 59, 61, 66, 67, 69, 71, 72, 73, 76, 78, 84, 87, 89, 91
----------	---

see also *Local control panel*

Local control..... 17, 54, 55, 66, 83

Local control panel... 6, 16, 44, 54, 55, 56, 59, 61, 66, 67, 69, 71,  
72, 73, 76, 78, 84, 87, 89, 91  
see also *LCP*

Local mode..... 16, 66

Locked rotor amp..... 34, 91  
see also *LRA*

LRA..... 34, 91  
see also *Locked rotor amp*

**M**

Main menu..... 55, 59, 61, 75, 76, 81

Models

- Internally bypassed..... 18, 20, 24, 26, 37, 80, 82
- Non-bypassed..... 19, 20, 22, 25, 28, 38, 73, 89

Motor

- body..... 39
- connection..... 7, 12, 19, 21, 62, 73, 81
- temperature..... 83
- windings..... 39, 78, 81
- Overload..... 7, 39, 62, 63, 69, 74, 81
- Thermal behavior..... 39
- Thermal capacity..... 39, 57, 66, 68, 81, 83
- Thermistor..... 7, 16, 37, 38, 43, 44, 46, 47, 48, 49, 51, 62, 69,  
74, 76, 81, 82, 84, 85, 89

Motor branch protection..... 29

Motor temperature..... 57, 58, 63, 68, 71, 72, 75, 76

Motor temperature flag..... 67, 68

**N**

Network communication..... 81

**O**

Ordering

- form..... 8
- Type code..... 8

Outputs

- Analog output..... 68
- Analog programmable output..... 6
- Output A..... 68
- Output relay B..... 47, 53
- Output relay C..... 52
- Power output..... 18
- Programmable output..... 20, 22, 64, 68, 76, 85
- Relay output..... 6, 20, 37, 38
- Relay output A..... 37, 38, 46, 47, 48, 49
- Relay output B..... 37, 38, 46, 47, 48, 49, 53
- Relay output C..... 37, 38, 46, 47, 48, 49
- Supply output..... 6

Overcurrent..... 7, 59, 62, 65, 68, 69, 74, 80, 82

**P**

PC software..... 87

Power factor..... 57, 68, 71, 72, 83

Power factor correction..... 91

Power loss..... 7, 69, 82

Primary motor settings..... 51, 52, 63

Programming details..... 55

Protection settings..... 20, 63, 81

**Q**

Qualified personnel..... 11

Quick menu..... 55, 59

Quick set-up..... 59

**R**

Relays

- Output relay..... 76
- Output relay A..... 46
- Output relay B..... 47, 53
- Output relay C..... 52
- Relay A..... 59, 62, 67, 76, 85
- Relay B..... 59, 62, 67, 68, 85
- Relay C..... 59, 62, 68, 85

Remote control..... 16, 17, 54, 56, 66, 69, 83, 87

Remote mode..... 16, 50, 66

Restart delay..... 43, 44, 62, 66, 83

Run modes

- Emergency run..... 6, 48, 49, 62, 73

**S**

Safety

- Instructions..... 11

Schematic diagrams

- Internally bypassed..... 37
- Non-bypassed..... 38

Secondary motor set..... 51, 52, 70

Serial communication..... 16, 17, 54, 56, 66, 69

Short-circuit capability..... 85

Shunt trip circuit breaker..... 28

Speed profile..... 29

Standards

- EU directive 2002/95/EC..... 86
- GB 14048-6..... 86
- IEC 60947-4-2..... 29, 85, 86
- IEC 61140..... 16
- Lloyds Marine No 1 Specification..... 86
- RoHS..... 86
- UL 508..... 34
- UL 508C..... 86

Start current requirement..... 45

Start modes

- Adaptive control... 6, 29, 40, 41, 42, 44, 60, 63, 64, 70, 71, 79,  
84
- Constant current..... 6, 40, 41, 44, 60, 61, 63, 70
- Current ramp..... 6, 40, 41, 63, 70
- Jog..... 6, 43, 44, 54, 55, 62, 66, 73, 82, 84
- Kick-start..... 6, 41, 62, 63, 70

Start torque requirement.....	45
Starting profile.....	39, 40, 84
Status.....	55, 76
Status details.....	55
Status screen.....	56, 57, 75, 76
Stop modes	
Adaptive control.....	42, 64, 70
Adaptive deceleration control.....	6
Brake.....	42, 43, 44, 54, 55, 64, 66, 70, 71
Coast to stop.....	41, 42, 43, 44, 54, 55, 64, 66, 70
DC brake.....	6, 43, 50, 84
Soft brake.....	6
Starter disable.....	6, 44, 50, 66, 67, 81, 82, 83
Timed voltage ramp.....	6, 41, 44, 64, 70, 91
see also <i>TVR</i>	
TVR.....	6, 41, 44, 64, 70, 91
see also <i>Timed voltage ramp</i>	
Stop time.....	41, 42, 43, 44, 59, 60, 62, 64, 69, 70, 71, 84
Stopping profile.....	39
Suggested values.....	60, 61
Supply.....	7, 11, 12, 16, 28, 40, 43, 46, 47, 48, 49, 50, 51, 52, 53, 79, 80, 82, 83, 85
Supply voltage.....	30, 31, 32, 33
Symbols.....	91
 <b>T</b>	
Terminals	
A4.....	16, 80, 85
A5.....	16, 80, 85
A6.....	16, 80, 85
Bypass.....	19
Bypass terminal.....	20, 22, 38
Control input.....	16
Control terminal.....	16
Power.....	17
Relay terminal.....	16, 83
Terminal 05.....	82, 85
Terminal 06.....	82, 85
Terminal 07.....	85
Terminal 08.....	85
Terminal 11.....	48, 49, 50, 66, 81, 83, 85
Terminal 13.....	46, 73, 85
Terminal 14.....	46, 73, 85
Terminal 15.....	85
Terminal 16.....	48, 49, 50, 66, 81, 83, 85
Terminal 17.....	48, 49, 85
Terminal 18.....	48, 49, 67, 85
Terminal 21.....	47, 85
Terminal 22.....	47, 85
Terminal 24.....	47, 85
Terminal 25.....	67, 85
Terminal 33.....	85
Terminal 34.....	85
Thermal characteristics.....	39
Thermal overload protection.....	39
Trip categories.....	69
Trip log.....	77
Trip messages.....	82
 <b>U</b>	
UL listed.....	86
UL recognized.....	86
Undercurrent.....	7, 59, 62, 65, 68, 69, 74, 82
Undercurrent protection.....	65
Unintended start.....	11
 <b>W</b>	
WinMaster.....	87
Wiring	
Soft braking configuration.....	51
Two-speed configuration.....	53



.....  
Danfoss can accept no responsibility for possible errors in catalogues, brochures and other printed material. Danfoss reserves the right to alter its products without notice. This also applies to products already on order provided that such alterations can be made without subsequential changes being necessary in specifications already agreed. All trademarks in this material are property of the respective companies. Danfoss and the Danfoss logotype are trademarks of Danfoss A/S. All rights reserved.  
.....

Danfoss A/S  
Ulsnaes 1  
DK-6300 Graasten  
[vlt-drives.danfoss.com](http://vlt-drives.danfoss.com)

