

■ Contents

Introduction to VLT 2800	3
Software version	3
General warning	4
These rules concern your safety:	4
Warnings against unintended start:	4
Installation	5
Mechanical dimensions	5
Mechanical installation	7
Installation to minimize EMI/RFI	9
Grounding of screened/armored control cables	10
Input fuses	11
AC line connection	11
Motor connection	11
Direction of motor rotation	11
Motor thermal protection	11
Parallel connection of motors	12
Motor cables	12
Brake connection	12
Ground connection	12
Load sharing	12
Access to control terminals	13
Electrical installation, control circuitry	14
Electrical installation, control terminals	15
Relay connection	15
VLT Software Dialog	16
Connection examples	17
Control unit	19
Manual initialization	19
Programming the adjustable frequency drive	21
Status messages	22
Hand /Auto mode operation	22
Warnings/alarms	23
Special conditions	24
Temperature-related switching frequency	24
Derating for long motor cables	24
VLT 2800 start-up	24
Programming	26
Operation & Display	26
Load and Motor	34
References & Limits	44
Inputs and Outputs	52
Special functions	61
Serial communication	70
Technical functions	78

All about VLT 2800	82
Warnings/alarm messages and corrective actions	82
Warning words, extended status words and alarm words	86
Special conditions	87
Galvanic isolation (PELV)	87
UL/cUL Standards	88
General technical data	89
Technical data, AC line supply 1 x 220 - 240 V / 3 x 200-240V	93
Technical data, AC line supply 3 x 380 - 480 V	94
Available literature	95
Supplied with the unit	95
Factory Settings	96

■ Software version

Document Version Number 5.00.

195NA009.14

Introduction to VLT 2800

VLT 2800 Series

Operating instructions
Software version: 2.3x



These operating instructions can be used for all VLT 2800 Series adjustable frequency drives (AFD) with software version 2.3x.

The software version number can be seen from parameter 640 Software Version.



NOTE!

Indicates something to be noted by the reader.



Indicates a high-voltage warning.



Indicates a general warning.

■ General warning

The voltage of the adjustable frequency drive is dangerous whenever the drive is connected to the AC line. Incorrect installation of the motor or drive may cause damage to the equipment, serious injury or death. Comply with the safety instructions in this manual as well as local and national rules and safety regulations.

■ These rules concern your safety:

1. Disconnect the adjustable frequency drive from the AC line if repair work is to be carried out. Wait 4 minutes to allow for electrical discharge before removing motor and AC line connectors.
2. The [STOP/RESET] key on the control panel of the adjustable frequency drive does not disconnect the equipment from the AC line. Do not use it as a safety switch.
3. The unit must be grounded correctly. The user must be protected against supply voltage and the motor protected against overload in accordance with applicable national and local regulations.
4. The ground leakage currents are higher than 3.5 mA.
5. Protection against motor overload is not included in the factory setting. If this function is required, set parameter 128 *Motor thermal protection to ETR trip or ETR warning*. For North America: The ETR functions provide class 20 overload protection for the motor, in accordance with NEC requirements.
6. Do not remove the terminal plugs for the motor and AC line supply while the adjustable frequency drive is connected to the AC line. Ensure

that the AC line supply has been disconnected and that 4 minutes has passed before removing motor and AC line plugs.

7. The DC bus terminals are another high voltage input that must be disconnected before servicing the drive. Ensure that all voltage inputs have been disconnected and that 4 minutes has passed before repair work begins.
-

■ Warnings against unintended start:

1. The motor can be started by means of digital commands, bus commands, references or a local start command whenever the drive is connected to the AC line. Therefore, an unintended start may occur anytime power is applied. Never service the drive or equipment when power is applied to the drive.
 2. The motor may start while parameters are being changed. Always activate the stop key [STOP/RESET] by pressing it before data is modified.
 3. A motor that has been stopped may start if faults occur in the electronics of the drive, or if a temporary overload or fault clears in the AC line or motor connection.
-

■ Motor overload protection

The electronic thermal relay (ETR) in UL listed VLTs provides Class 20 motor overload protection in accordance with the NEC in single motor applications when parameter 128 is set for "ETR TRIP" and parameter 105 *Motor current* is set for the rated motor current.

**Warning:**

It can be extremely dangerous to touch the electrical parts even when the mains supply has been disconnected. Also ensure that other voltage inputs are disconnected from load sharing through the DC bus. Wait at least 4 minutes after the input power has been removed before servicing the drive.

195NA139.10

VLT® 2800 Series

■ Mechanical dimensions

The drawing below gives the mechanical dimensions of VLT 2803-2815 (1/2 - 2 HP) 200-240 Volts and VLT 2805-2815 (3/4 - 2 HP) 380-480 Volts. All dimensions are in inches.

VLT 2803-2815 200-240 Volt
VLT 2805-2815 380-480 Volt

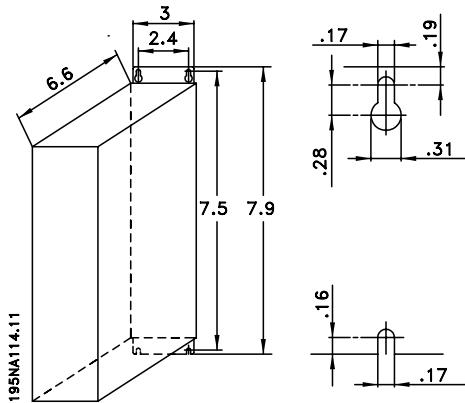

The drawing below gives the mechanical dimensions of VLT 2840 (5 HP) 200-240 Volt and VLT 2855-2875 (7 - 10HP) 380-480 Volt. All dimensions are in inches.

VLT 2840 200-240 Volt
VLT 2855-2875 380-480 Volt

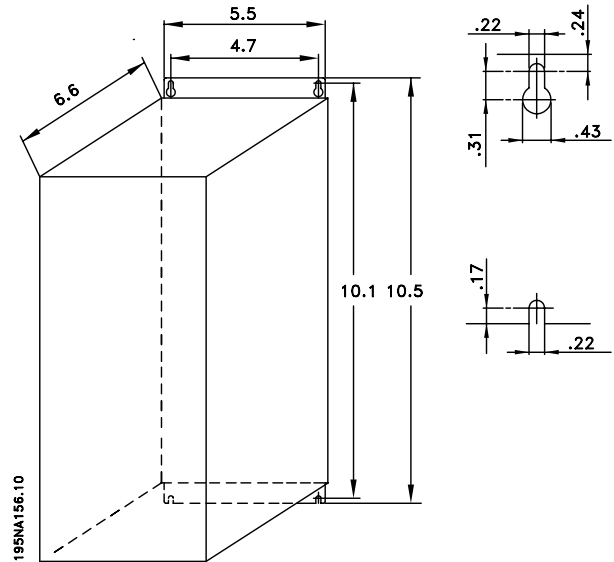

The drawing below gives the mechanical dimensions of VLT 2822 (3 HP) 200-240 Volts and VLT 2822-2840 (3 - 5 HP) 380-480 Volts. All dimensions are in inches.

VLT 2822 200-240 Volt
VLT 2822-2840 380-480 Volt

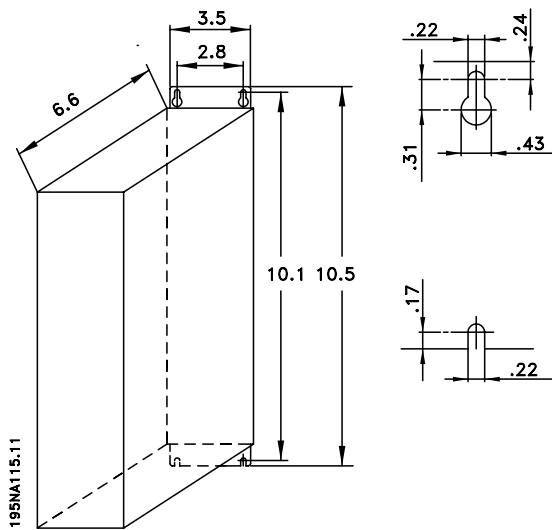

VLT 2880-82 380-480V

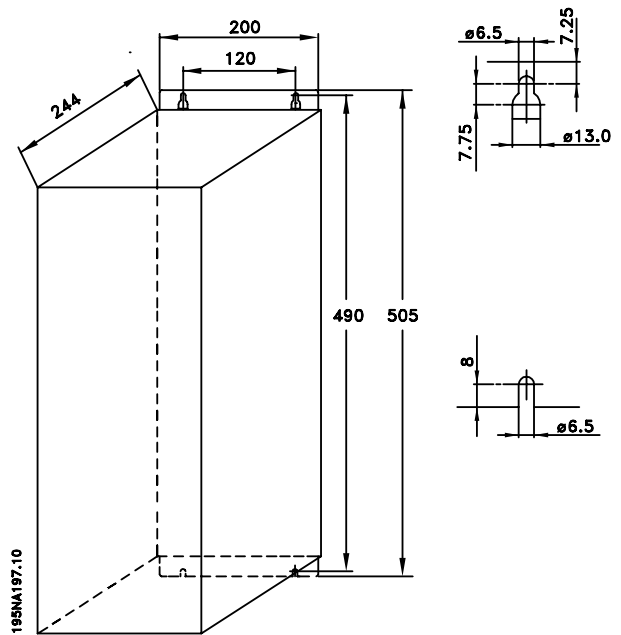

■ Terminal cover

The drawing below gives the dimensions for the NEMA 1 terminal covers.

Dimension 'a' depends on the unit type.

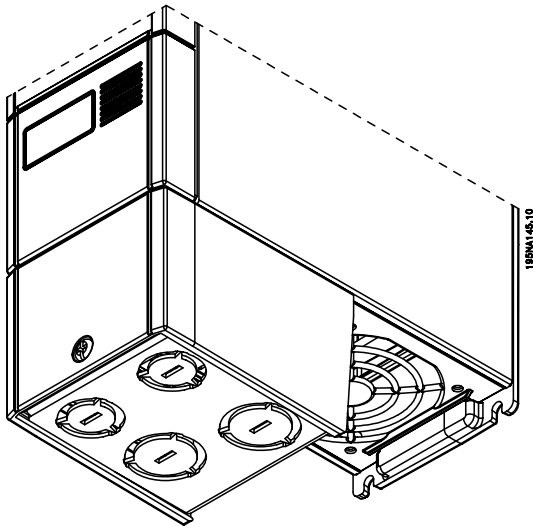
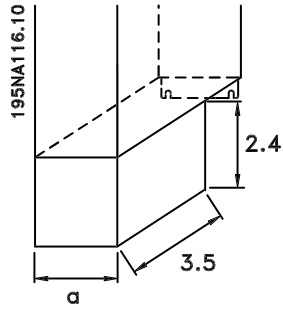

■ Mechanical installation

The adjustable frequency drive is cooled by air circulation. For proper cooling, allow a minimum of 4 inches (100 mm) of open space above and below the unit. To protect the unit from overheating, ensure that both the ambient temperature and the 24-hour average temperature are not exceeded. The maximum temperature and 24-hour average are listed in *General technical data* in this manual. If the ambient temperature is in the range of 113°F - 131°F (45°C - 55°C), derating of the drive must be carried out. See *Derating for ambient temperature* in this manual. The service life of the unit will be reduced without applicable derating.



The requirements that apply to enclosures and remote mounting must be complied with to avoid serious injury or equipment damage, especially when installing large units.

■ Enclosures

In the USA and some other countries, a NEMA 1 terminal cover enclosing terminal connectors is required if the drive is not installed within another enclosure.

■ Spacing for mechanical installation

All units require a minimum of 4 inches (100 mm) open air space at the fan inlet and outlet of the drive.

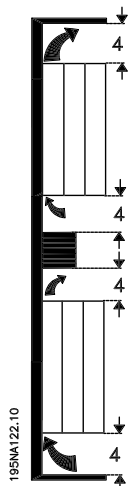

■ Side-by-side

All VLT 2800 units can be installed side-by-side since they do not require side cooling.

The VLT 2800 mounts in virtually any position. This free mounting position offers wide flexibility in system design and motor connection.

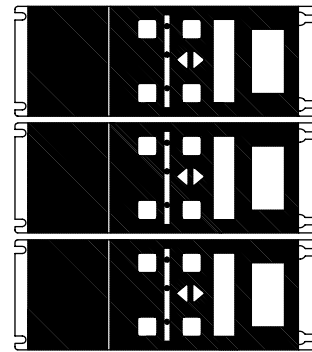
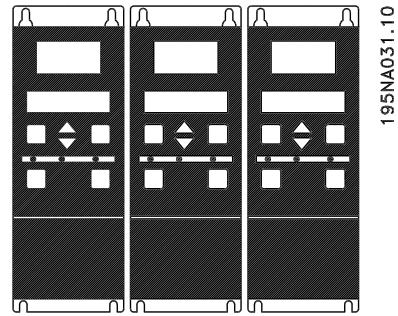

■ High voltage warning

The voltage of the adjustable frequency drive is dangerous whenever the drive is connected to the AC line. Incorrect installation of the motor or drive may cause damage to the equipment, serious injury or death. Comply with the safety instructions in this manual as well as local and national rules and safety regulations. Touching electrical parts may be fatal - even after the equipment has been disconnected from the AC line. Wait at least 4 minutes for current to dissipate.

**NOTE!**

It is the responsibility of the user or installer to ensure correct grounding and protection in accordance with national and local standards.

■ Grounding

Comply with the following at installation:

- Safety grounding: The drive has a high leakage current and must be grounded properly for safety. Follow all local safety regulations.
- High frequency grounding: Keep grounding cables as short as possible.

Connect all grounds to ensure the lowest possible conductor impedance. The lowest possible conductor impedance is achieved by keeping the conductor as short as possible and by grounding with the greatest possible surface area. If multiple drives are installed in a cabinet, the cabinet backplate, which must be made of metal, should be used as a joint ground reference plate. The drives must be fitted to the backplate at the lowest possible impedance.

To achieve low impedance, connect the drive to the backplate with the drive fastening bolts. Remove all paint from the contact points.

■ Installation to minimize EMI/RFI



NOTE!

Using unshielded/unarmored cable may not comply with some EMC/RFI requirements.

- Ensure good electrical contact between the drive and the metal control panel using the drive installation screws.
- Use lock washers and conductive fasteners.
- Use shielded/armored motor cables in the control panel.

To minimize conducted and radiated high frequency emissions, comply with the following procedures:

- Use only shielded/armored motor cables and shielded/armored control cables.
- Connect the shield to ground at both ends.
- Use cable clamps rather than twisted shield ends (pigtailed), for installation to provide shielding at high frequencies.

The illustration below shows proper electrical installation, with the drive installed in a control panel and connected to a PLC.

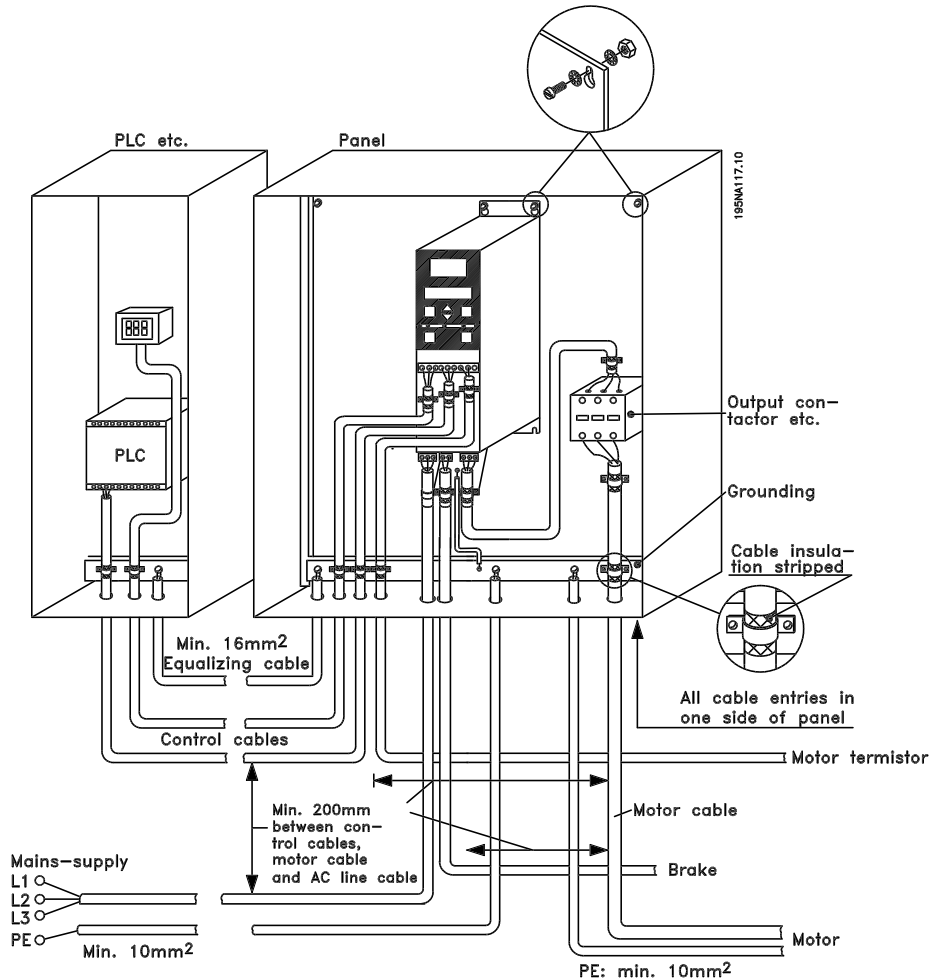

■ **Grounding of screened/armored control cables**

In general, control cables must be screened/armored, and the screen must be connected to the unit's grounding plate with a cable clamp at each end. The drawing shows the correct way to perform grounding.

1. **Correct grounding**

Control cables and cables for serial communication must be attached with cable clamps at both ends to ensure maximum possible electrical contact.

2. **Incorrect grounding**

Do not use screen ends that are twisted together (pigtailed), as these increase screen impedance at higher frequencies.

3. **Equalizing the ground potential between a PLC and the adjustable frequency drive**

If there is a different ground potential between the drive and the PLC, electrical noise can be generated which could interfere with the whole system. This problem can be solved by attaching a compensation cable, which is placed beside the control cable. Minimum cable diameter: 6 AWG.

4. **In the event of a 50/60 Hz ground loop**

If very long control cables are used, 50/60 Hz ground loops can arise which can interfere with the whole system. This problem is resolved by attaching one end of the screen to ground via a 100 μ F condenser (short pin length).

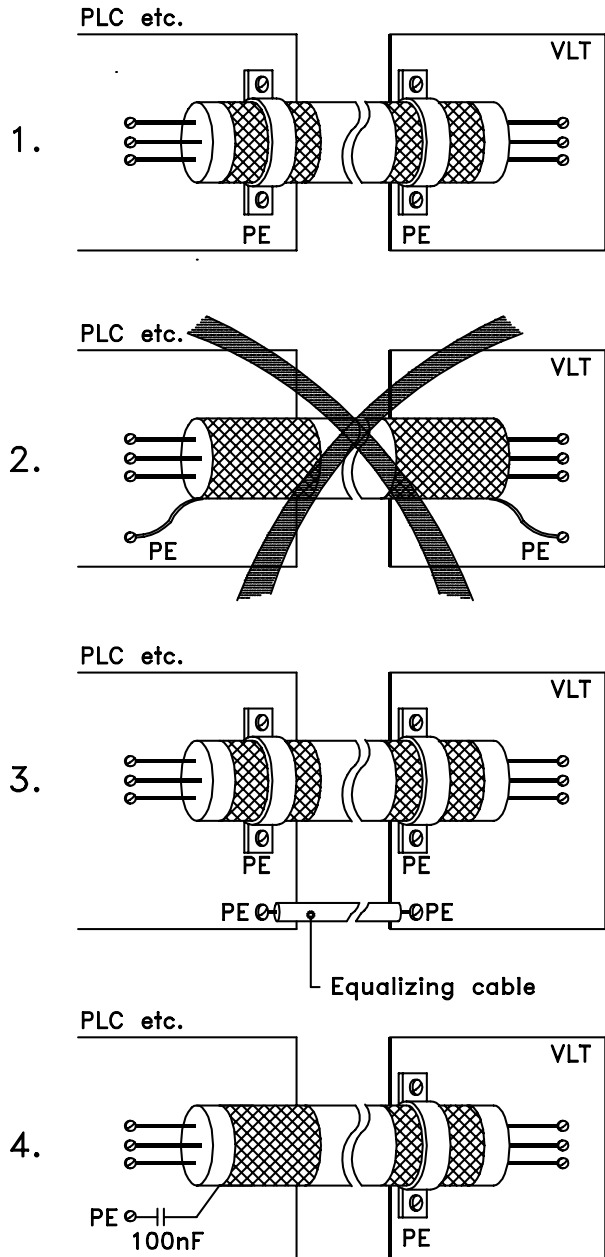

195NA100.12

■ Input fuses

For all unit types, external fuses must be fitted in the AC line supply to the drive. For UL/cUL applications with an AC voltage of 200-240 Volts, use fuses type Bussmann KTN-R (200-240 Volts) or Ferraz Shawmut type ATMR (max. 30A). For UL/ cUL applications with an AC voltage of 380-480 Volts, use fuses type Bussmann KTS-R (380-480 Volts). See *Technical data* in this manual for correct dimensioning of fuses.



It is the responsibility of the installer or user to insure proper external AC power input fusing to the drive.

■ AC line connection



All drives that are equipped with an RFI filter cannot be connected to a grounded DELTA or IT mains/AC line system.



NOTE!

Check that the AC voltage matches the voltage rating of the drive. The drive rating is on the drive nameplate. See *Technical data* in this manual for correct dimensioning of cable cross-section.

For single phase 220-240 Volts input, attach the neutral wire to terminal N (L₂) and connect the phase wire to terminal L1 (L₁).

No.	N(L ₂)	L1(L ₁)	(L ₃)	AC line voltage 1 x 220-240 V
	N	L1		
No.	95			Ground connection

No.	N(L ₂)	L1(L ₁)	(L ₃)	AC line voltage 3 x 220-240 V
	L2	L1	L3	
No.	95			Ground connection

No.	91	92	93	AC line voltage 3 x 380-480 V
	L1	L2	L3	
No.	95			Ground connection



380-460 Volt units with RFI-filters may not be connected to AC line supplies in which the voltage between phase and ground is more than 300 Volts. Please note that for the AC line for IT and the delta ground the AC line voltage can exceed 300 Volts between phase and ground.

See *Technical data* for correct dimensioning of cable cross-section.

■ Motor connection



NOTE!

It is recommended that an LC filter be connected to the output of the drive for motors without phase insulation paper.

See *Technical data* in this manual for correct dimensioning for cable cross-section. All types of three-phase asynchronous standard motors can be connected to a drive.

Connect the motor to terminals 96, 97, 98. Connect ground to terminal 99.

Nr.	96	97	98	Motor voltage 0-100% of AC line voltage.
	U	V	W	
Nr.	99			Ground connection

See *Technical data* for correct dimensioning of cable cross-section.

Ensure that the motor is wired for the line voltage before connecting to the drive.

■ Direction of motor rotation

To change the direction of motor rotation, switch any two phases at the drive output or at motor terminals.

■ Motor thermal protection

The electronic thermal relay in the adjustable frequency drive has received the UL-approval for single motor protection, when the following parameters have been set. Enter the rated motor current from the motor nameplate in parameter 105, *Motor current*. Set parameter 128, *Motor thermal protection*, for *ETR Trip*. See *Programming the adjustable frequency drive* in this manual for instructions on programming parameters.

■ Parallel connection of motors

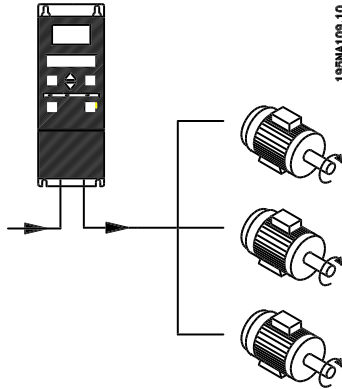

The adjustable frequency drive is able to control several motors connected in parallel. The combined total current consumption of the motors is not to exceed the maximum rated output current (I_{INV}) for the adjustable frequency drive. If the motors are to have different rpm values, use motors with different rated rpm values. Motor frequency is changed simultaneously, which means that the ratio between the rated rpm values is maintained.

Problems may arise at start-up and when operating at low rpm if the motor sizes are widely different. This is because the small motors' relatively high resistance in the stator calls for a higher voltage at the start-up and at low rpm.



In systems with motors connected in parallel, the electronic thermal relay (ETR) of the adjustable frequency drive cannot be used as motor protection for the individual motor. Protection must be provided individually for each motor.

■ Motor cables

See *Technical data* in this manual for correct dimensioning of motor cable cross-section and length. Always comply with national and local regulations on cable cross-section.



NOTE!

Using unshielded/unarmored cable may not comply with some RFI requirements

Keep the motor cable as short as possible to reduce the noise level and to keep leakage currents to a

minimum. Connect the motor cable shield to the ground connection of both the unit and the motor. Use cable clamps rather than twisted shield ends (pigtailed), for installation to provide shielding at high frequencies. If it is necessary to break the shield to install a motor isolator or motor relay, the shield must be continued at the lowest possible HF impedance.

■ Brake connection



NOTE!

Voltages up to 850 VDC occur on the terminals.

No.	81	82	Brake resistor terminals
	R-	R+	

Connect the brake resistor wiring to drive terminals 81 and 82. The connection cable to the brake resistor must be shielded/armored. Connect the shield to both the ground of the drive and the brake resistor by means of cable clamps. Dimension the cross-section of the brake cable to match the brake torque.

■ Ground connection

Since the leakage currents to ground may be higher than 3.5 mA, the adjustable frequency drive must always be connected to ground in accordance with applicable national and local regulations. To ensure that the ground cable has good mechanical connection to terminal 95, the cable cross section must be a minimum 7 AWG (10 mm²). To improve protection even further, a Residual Current Device (RCD) can be fitted to ensure that the adjustable frequency drive cuts out when the leakage currents get too high. Also see RCD Application note MN.90.GX.02.

■ Load sharing

The DC buses of a number of drives may be linked to provide load sharing. This requires that the installation includes DC fuses and AC coils as shown (see drawing). For load sharing parameter 400 *Brake function* must be set to *Load sharing* [5]. Contact Danfoss for further information.

No.	88	89	Loadsharing
	-	+	

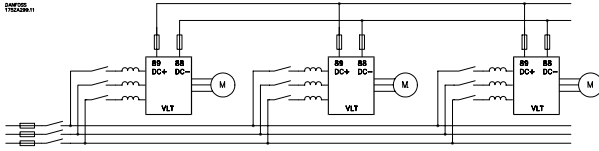

Voltage up to 850 VDC
may be present on terminals 88 and 89.

■ Access to control terminals

All control terminals are located underneath the protective plate on the front of the adjustable frequency drive. Remove the protective plate by sliding it downwards (see drawing).

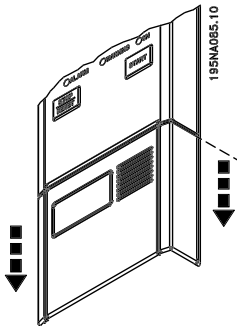

Electrical installation, control circuitry



NOTE!

Using unshielded/unarmored cable may not comply with some EMI/RFI requirements.

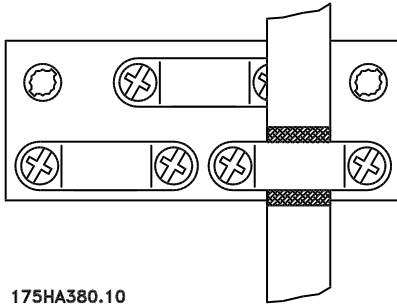

175HA380.10

Control wires must be shielded/armored. Connect the shield to the drive chassis with a clamp. Normally, the shield must also be connected to the chassis of the controlling device. (See the instructions for the specific device.) In analog signals or connections using very long wires, 50/60 Hz ground loops may occur because of noise transmitted from the AC line. It may be necessary to break the shield and insert a 100 μ F capacitor between the shield and the chassis.

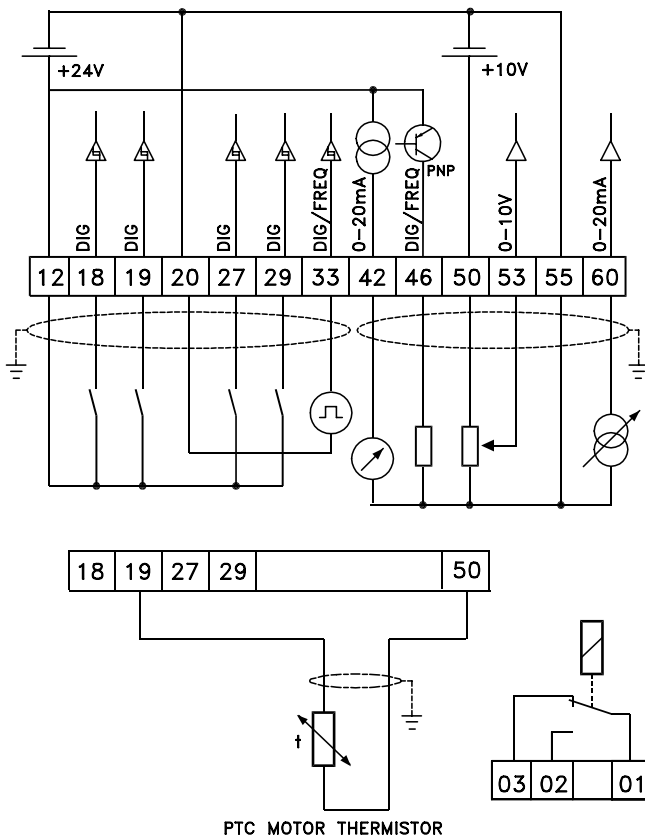

195NA028.12

DeviceNet/CANopen

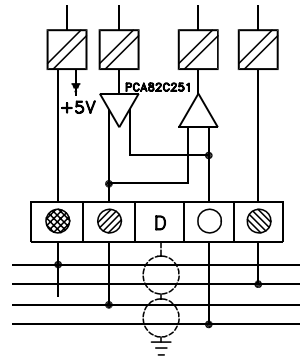

- Black V-
- Blue CAN_L
- D DRAIN
- White CAN_H
- Red V+

Profibus

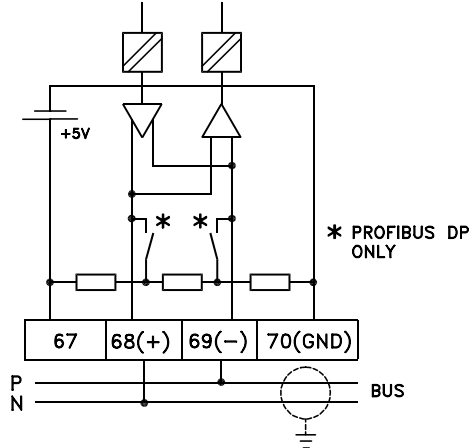

■ Electrical installation, control terminals



NOTE!

Using unshielded/unarmored cable may not comply with some EMC/RFI requirements.

Refer to the following table for VLT 2800 terminal designations and their functional descriptions.

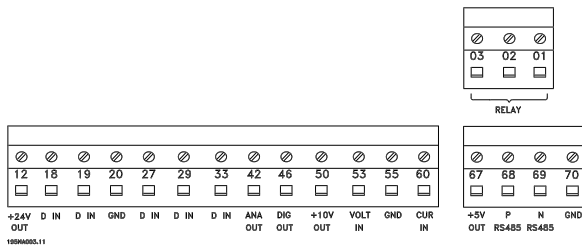

No.	Function
01-03	Relay outputs 01-03 can be used for indicating status and alarms/warnings.
12	24 VDC voltage supply.
18-33	Digital inputs.
20, 55	Common frame for input and output terminals.
42	Analog output for displaying frequency, reference, current or torque.
46 ¹	Digital output for displaying status, warnings or alarms, as well as frequency output.
50	+10 VDC supply voltage for potentiometer or thermistor.
53	Analog voltage input 0 - 10 V DC.
60	Analog current input 0/4 - 20 mA.
67 ¹	+ 5 VDC supply voltage to Profibus.
68, 69 ¹	RS-485, Serial communication.
70 ¹	Frame for terminals 67, 68 and 69. Normally this terminal is not to be used.

1. The terminals are not valid for DeviceNet/CANopen. See also the DeviceNet manual, MG.90.BX.YY for further details.



NOTE!

To supply internal 24 VDC voltage to the digital input terminals, jumper terminal 12 to terminal 27.

■ Relay connection

See parameter 323, *Relay output* for programming of relay output.

No.	01 - 02	1 - 2 make (normally open)
	01 - 03	1 - 3 break (normally closed)



NOTE!

The cable jacket for the relay must cover the first row of control card terminals - otherwise the galvanic isolation (PELV) cannot be maintained. Maximum cable diameter: 0-160 in (4 mm). See drawing.

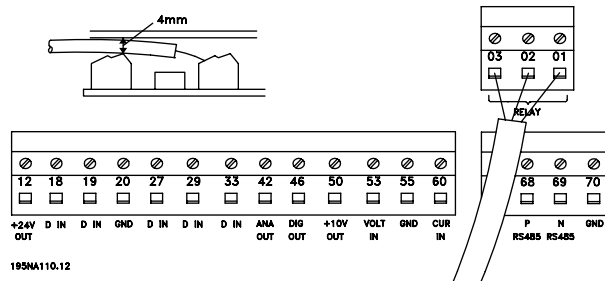

■ Profibus DIP switches setting

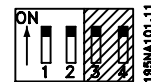

The dip switch is only on the control card with Profibus DP communication. The switch position shown is the factory setting. Switches 1 and 2 are used as cable termination for the RS-485 interface. If the adjustable frequency drive is located as the first or last (or only) unit in the bus system, switches 1 and 2 must be ON. On the remaining adjustable frequency drives, switches 1 and 2 must be OFF. Switches 3 and 4 are not applied.

■ VLT Software Dialog

Connection to terminals 68–70 or

Sub D:

- PIN 3 GND
 - PIN 8 P-RS 485
 - PIN 9 N-RS 485
-

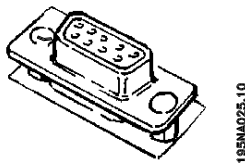
■ Sub D plug

An LCP 2 control unit can be connected to the Sub D plug on the control card. Ordering number: 175N0131.

LCP control units with ordering number 175Z0401 are not to be connected.

■ Connection examples

■ Start/stop

See *Programming the adjustable frequency drive* in this manual for instructions on programming parameters.

Start/stop using terminal 18 and coasting stop using terminal 27.

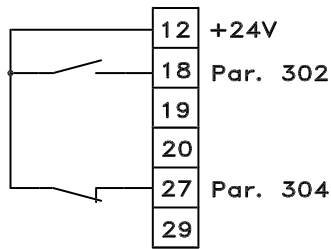

195NA011.11

Par. 302 *Digital input* = Start [7]

Par. 304 *Digital input* = Coasting stop inverse [2]

For Precise start/stop the following settings are used:

Par. 302 *Digital input* = Precise start/stop [27]

Par. 304 *Digital input* = Coasting stop inverted [2]

■ Pulse start/stop

Pulse start using terminal 18 and pulse stop using terminal 19. In addition, the jog frequency is activated via terminal 29.

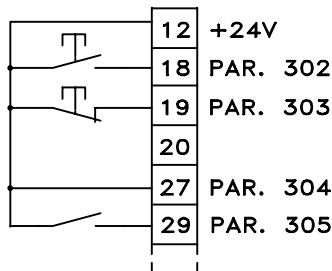

195NA012.11

Par. 302 *Digital input* = Pulse start [8]

Par. 303 *Digital input* = Stop inverse [6]

Par. 304 *Digital input* = Coasting stop inverse [2]

Par. 305 *Digital input* = Jog [13]

■ Speed up/down

Speed up/down using terminals 29/33.

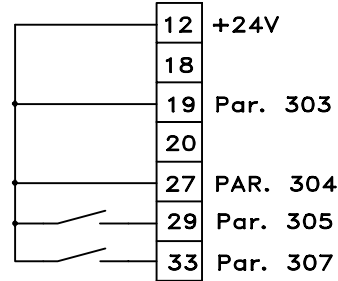

195NA014.11

Par. 303 *Digital input* = Freeze reference [14]

Par. 305 *Digital input* = Speed up [16]

Par. 307 *Digital input* = Speed down [17]

■ Potentiometer reference

Voltage reference via a potentiometer.

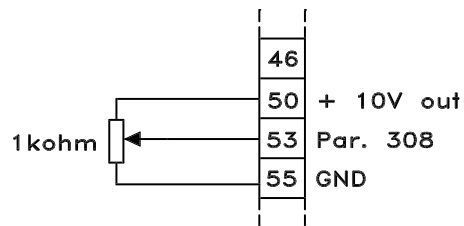

195NA016.10

Par. 308 *Analog input* = Reference [1]

Par. 309 *Terminal 53, min. scaling* = 0 Volt.

Par. 310 *Terminal 53, max. scaling* = 10 Volt.

■ **Connection of a 2-wire transmitter**

Connection of a 2-wire transmitter as feedback to terminal 60.

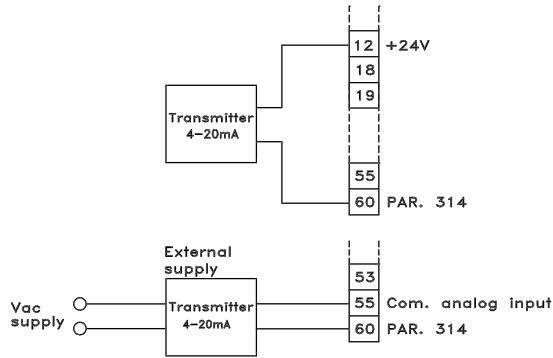

185NA013.11

- Par. 314 Analog input = Feedback [2]
- Par. 315 Terminal 60, min. scaling = 4 mA
- Par. 316 Terminal 60, max. scaling = 20 mA

■ Control unit

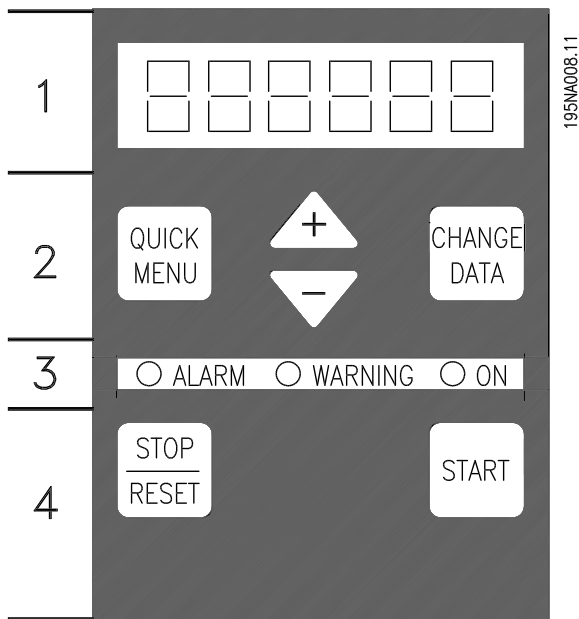

The control panel is divided into four function groups:

1. Six-digit LED display.
2. Keys for changing parameters and shifting display functions..
3. Indicator lamps.
4. Keys for local operation.

All data is displayed on a six-digit LED. The LED can show one item of operating data continuously during normal operation. There are three indicator lamps for indication of AC line connection (ON), warning (WARNING) and alarm (ALARM). Most of the adjustable frequency drive parameters can be changed via the control panel. This function can be programmed as *Locked* in parameter 018, *Lock for data changes*, to prevent tampering or local data entry.

A keypad, similar to the larger VLT 6000, is available for cable connection to the VLT 2800. This optional LCP 2 allows full text displays and programming multiple drives. Drive set up data can be loaded onto the LCP 2. The keypad can then be connected to other drives and the data downloaded for ease of programming.

■ Control keys

[QUICK MENU] allows access to the parameters in the Quick menu. This menu is for initial setup of the

drive. The **[QUICK MENU]** key is also used to cancel a change of parameter values and to toggle between Display mode and Quick menu mode.

[CHANGE DATA] is used to change a setting. The **[CHANGE DATA]** key is also used to confirm a parameter change.

[+] and [-] are used to scroll through parameters and to change parameter values. These keys are also used in Display mode to select a value for display.

The **[QUICK MENU]** and **[+]** keys pressed at the same time give access to all parameters by entering Menu mode. See *Menu mode*.

[STOP/RESET] is used to stop the connected motor or to reset the adjustable frequency drive after a trip. The key can be selected as Active [1] or Not active [0] via parameter 014 *Local stop/reset*. In Display mode, the display will flash if the stop function is activated.



NOTE!

If the **[STOP/RESET]** key has been selected as *Not active* [0] in parameter 014 *Local stop/reset* and there is no stop command via the digital inputs or serial communication, the motor can only be stopped by disconnecting the AC line voltage to the adjustable frequency drive.

[START] is used for starting the adjustable frequency drive. It is always available, but the **[START]** key cannot override a stop command issued through terminal 27 or a digital communication bus (see connection examples).

■ Manual initialization

To manually initialize the adjustable frequency drive to factory default settings, first disconnect AC line voltage. Hold the **[QUICK MENU]** and **[+]** and **[CHANGE DATA]** keys down while simultaneously reconnecting the AC line voltage. Release the keys. The drive has now been programmed for factory settings.

■ Display readout states

Display mode

Fr 50.3

In normal operation, one item of operating data can be selected for continuous display.

Use the [+] and [-] keys to select from the following options for display:

- Output frequency [Hz]
- Output current [A]
- Output voltage [V]
- DC bus voltage [V]
- Output power [kW]

See *Status messages* for code explanations.

Quick menu

103 380

Use the [QUICK MENU] key to access the 12 most important parameters of the adjustable frequency drive. After programming the Quick menu parameters, the adjustable frequency drive is, in most cases, ready for operation. See *Programming the adjustable frequency drive*.

The Quick menu parameters are:

- Par. 102 Motor power $P_{M,N}$
- Par. 103 Motor voltage $U_{M,N}$
- Par. 104 Motor frequency $f_{M,N}$
- Par. 105 Motor current $I_{M,N}$
- Par. 106 Rated motor speed $n_{M,N}$
- Par. 107 Automatic motor adaptation.
- Par. 204 Minimum reference Ref_{MIN}
- Par. 205 Maximum reference Ref_{MAX}
- Par. 207 Ramp-up time
- Par. 208 Ramp-down time
- Par. 002 Local/remote operation
- Par. 003 Local reference

Parameter 102 - 106 can be read out from the motor nameplate.

Menu mode

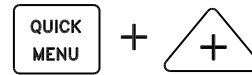

To enter the Menu mode, press [QUICK MENU] and [+] at the same time.

In Menu mode, most of the adjustable frequency drive parameters can be changed. Scroll through the parameters using the [+] and [-] keys. The current parameter number will flash while scrolling through the menu items.

1020.75

The display example shows that the setting in parameter 102 Motor power $P_{M,N}$ is 0.75. In order to change the value of 0.75, press [CHANGE DATA]. Use the [+] and [-] keys to change the parameter value.

204...

When, for a given parameter, the display shows three dots at the right, it means that the parameter value has more than three digits. In order to see the value, press [CHANGE DATA].

128.2

The display shows that in parameter 128, *Motor thermal protection*, the second [2] selection is active, *Thermistor trip*.

Programming the adjustable frequency drive



NOTE!

The motor must be stopped to change parameter data.

Program the drive in accordance with the following procedure:

1. Press the [QUICK MENU] key to enter the Quick menu.
2. Scroll through the Quick menu using the [+] and [-] keys.
3. Change the data values by first pressing [CHANGE DATA] key
4. and then change the parameter value with the [+] and [-] keys.
5. Press [CHANGE DATA] again to accept the change or [QUICK MENU] to cancel the change. Press [QUICK MENU] once more to exit Quick menu mode and enter Display mode. (The drive will default from Quick menu mode to Display mode in 2 minutes if no activity has taken place.)



NOTE!

Enter parameters 102 through 106 data, at minimum, to ready the drive for operation. Data for parameters 102 through 106 can be read from the motor nameplate.

Automatic motor tuning

Automatic motor tuning (AMT) measures stator resistance R_s without the motor turning. This means that the motor is not delivering any torque. AMT can optimize adjustment of the adjustable frequency drive to the motor. For best possible tuning, it is recommended that AMT be performed on a cold motor. Repeated AMT runs can cause motor heating, resulting in an increase in the stator resistance. As a rule, however, this is not critical. (See parameter 107, *Automatic motor tuning, AMT*, description for more detail before running AMT.)

Perform AMT in accordance with the following procedure:

1. Press the [QUICK MENU] key to enter Quick menu mode
 2. Use the [+] key to scroll to parameter 107.
 3. In parameter 107, *Automatic motor tuning*, "107" will now flash.
 4. Press [CHANGE DATA] and use the [+] key to select data value [2], *Optimization on (AMT START)*. [2] will now flash.
 5. Press [START] key to activate AMT. "107" will now flash and dashes will move from left to right in the data value field.
 6. When "107" appears once more with the data value [0], AMT is complete. Press [STOP/RESET] to save the motor data into the drive memory.
 7. "107" will then continue to flash with the data value [0]. Press [QUICK MENU] to exit Menu mode and enter Display mode.
-

■ Status messages
Fr

The drive displays the present output frequency in Hertz [Hz].

Io

The drive displays the present output current in Amps [A].

Uo

The drive displays the present output voltage in Volts [V].

Ud

The drive displays the DC bus voltage in Volts [V].

Po

The drive displays the calculated output in kilowatt [kW].

notrun

This message is shown if an attempt is made to change a parameter value while the motor is running. Stop the motor to change the parameter value.

LCP

This message is shown if an LCP2 control unit is connected and the [QUICK MENU] or [CHANGE DATA] key is pressed. With an LCP2 control unit connected, it is only possible to change parameters via the LCP2.

HA

HA indicates the drive is in Hand mode, which means the drive's speed is controlled at the keypad with the [+] and [-] keys. Only output frequency is shown on the display in Hand mode.

■ Hand /Auto mode operation

During Auto mode operation, the adjustable frequency drive receives an external reference through the control terminals as analog or digital signals. In Auto mode, use the [+] and [-] keys to scroll through the display of drive status messages. In Hand mode, it is possible to control the speed of the drive locally through the keypad.

On the control terminals, the following control signals will remain active when Hand mode is activated:

- Hand Start (LCP2)
- Off Stop (LCP2)
- Auto Start (LCP2)
- Reset
- Coasting Stop Inverse
- Reset and Coasting Stop Inverse
- Quick Stop Inverse
- Stop Inverse
- Reversing
- DC Braking Inverse
- Setup Select LSB
- Setup Select MSB
- Thermistor
- Precise Stop Inverse
- Precise Stop/Start
- Jog
- Stop Command Via Serial Comm.

Switching between Auto and Hand mode:

To switch between operational modes, press the [Change Data] key. The display will indicate the current mode of operation.

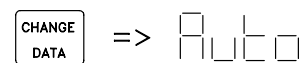

Use the [+] and [-] keys to toggle between Hand and Auto mode. Press the [Change Data] key again to activate the selected mode, otherwise the mode displayed will take effect automatically in about three seconds.

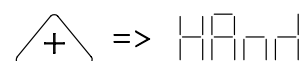

Operation in Hand mode:

When the adjustable frequency drive is running normally in Hand mode, the display will show HA to

indicate Hand mode along with the drive output frequency.

HA 50.3

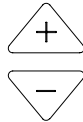
In Hand mode, the local speed reference can be increased or decreased with the [+] and [-] keys:



In Hand mode, the [+] and [-] keys are also used to toggle through status messages. Press and hold the [Change Data] key for approximately 3 seconds. When the display begins to flash, use the [+] and [-] keys to change the drive status display. The displays are temporary and will default back to output frequency.

 **NOTE!**
Parameter 020 can be used to disable Hand mode operation.

■ Warnings/alarms

Warnings or alarms appear in the LED display as a numerical code [Err. xx]. A warning is displayed until the fault has been corrected, while an alarm will flash until the [STOP/RESET] key is pressed. The table in *Warnings/alarms messages* in this manual explains the various warnings and alarms, and whether a fault locks the adjustable frequency drive. After a Trip locked fault, cut off the AC line supply and correct the fault. Then reconnect the AC line supply and press the [STOP/RESET] key. The adjustable frequency drive is now reset and ready. See *Warnings/alarms messages* in this manual for more detail.

■ **Special conditions**

■ **Derating for ambient temperature**

The ambient temperature ($T_{AMB,MAX}$) is the maximum temperature allowed. The average ($T_{AMB,AVG}$) measured over 24 hours, must be at least 9°F (5°C) lower. If the adjustable frequency drive operates at temperatures above 113°F (45°C), a derating of the rated output current is necessary as shown in the diagram below.

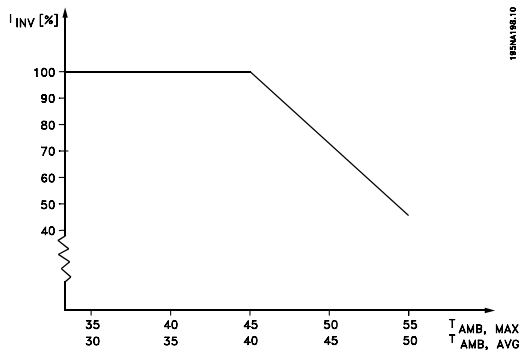

■ **Temperature-related switching frequency**

This function ensures the highest possible switching frequency without the adjustable frequency drive becoming thermally overloaded. The internal temperature determines the switching frequency based on the load, the ambient temperature, the supply voltage and the cable length. The function ensures that the drive automatically adjusts the switching frequency between the minimum and maximum switching frequency (parameter 411), see drawing below.

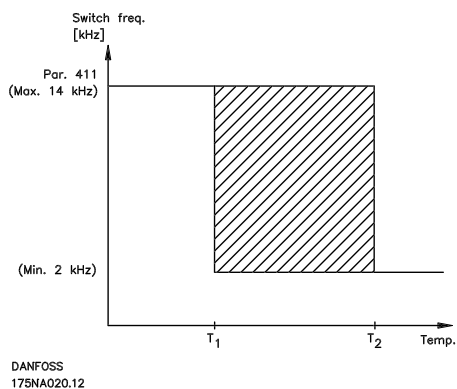

When using the LC filter the minimum switch frequency is 4.5 kHz.

■ **Derating for long motor cables**

The adjustable frequency drive has been designed for a 240 ft (75 m) unscreened/unarmored cable or a 80 ft (25 m) screened/armored cable and a motor cable with a rated cross-section. If a cable with a larger cross-section is required, it is recommended to reduce the output current by 5% for each step that the cable cross-section is increased. (Increased cable cross-section leads to increased capacitance to ground, and thus to an increased ground leakage current.)

■ **VLT 2800 start-up**

Pre-installation checks

1. Compare drive model number to what was ordered.
2. Ensure each of following are rated for same voltage:
 - Drive
 - Power line
 - Motor
3. Record following motor data:
 - Voltage
 - Frequency
 - Full load current
 - Full load speed
 - Power - convert HP to kW (See conversion table in parameter 102, *Motor Power*, in this manual.)
4. Ensure that rated drive current is equal to or greater than total full load current.
 - Drive can be *at most* one size smaller than motor.
 - For multiple motor operations, add full load current ratings of all motors.
 - If drive rating is less than motor(s), full motor output cannot be achieved.
5. Check motor wiring:
 - Any disconnect between drive and motor should be interlocked to drive safety interlock circuit to avoid unwanted drive trips.
 - No power factor correction capacitors can be connected between drive and motor.

- Two speed motors must be wired permanently for full speed.
- Y-start, Δ -run motors must be wired permanently for run.

Installation checks

1. Input fusing in power supply for all drives must be provided.
2. Environmental concerns - for standard NEMA 1 drive:
 - Clean air supply
 - Dry air (5% to 85% relative humidity, non-condensing)
 - 32°F (0°C) to 104°F (40°C) ambient temperature operating range, or as rated
 - 1000m (3,300 ft) maximum elevation with no derating
 - Keep any construction dirt out of drive.
3. Wiring
 - Wire drive in accordance with instructions and diagrams received with drive.
 - Separate conduits must be provided to drive for input power, output power, and control wiring.
 - Protect signal wires from noise.
 - Ground each drive individually.
 - Double check input and output power wiring for correct location.

Setting up drive for motor start

Ensure that all warnings provided in this manual have been adhered to. Apply power to the unit. Enter motor nameplate data into drive through Quick Menu.

1. Parameter 102, MOTOR POWER (in kW) (See conversion table in parameter 102, *Motor Power*, in this manual.)
2. Parameter 103, MOTOR VOLTAGE
3. Parameter 104, MOTOR FREQUENCY
4. Parameter 105, MOTOR CURRENT
5. Parameter 106, MOTOR SPEED
6. Parameter 107, select AUTOMATIC MOTOR TUNING

Operational tests - HAND

1. Check motor rotation from drive. If incorrect, disconnect input power from drive and reverse two leads between drive and motor.
2. Accelerate motor quickly to full speed and verify operation.
3. Decelerate motor quickly to stop and verify operation.

4. Operate motor over entire speed range while closely checking for resonance.

Operational tests - AUTO

1. Ensure that drive follows run/stop and safety interlock commands from system.
 2. Ensure drive follows speed reference, or feedback, from system.
-

■ Operation & Display

001 Language

(LANGUAGE)

Value:

★English (ENGLISH)	[0]
German (DEUTSCH)	[1]
French (FRANCAIS)	[2]
Danish (DANSK)	[3]
Spanish (ESPANOL)	[4]
Italian (ITALIANO)	[5]

Function:

This parameter is used to choose the language shown in the display whenever an optional LCP control unit is connected.

Description of choice:

Choose the language to display. The factory setting may vary.

002 Local/remote operation

(OPERATION SITE)

Value:

★Remote operation (REMOTE)	[0]
Local operation (LOCAL)	[1]

Function:

There is a choice between two modes of operation for the adjustable frequency drive: *Remote operation* [0] or *Local operation* [1]. See also parameter 013 *Local control* if *Local operation* [1] is selected.

Description of choice:

If *Remote operation* [0] is selected, the adjustable frequency drive is controlled via:

1. the control terminals or serial communication.
2. the [START] key. This cannot, however, override stop commands transmitted via the digital inputs or via serial communication (see parameter 505 *Start*).
3. the [STOP/RESET] and [JOG] keys, on the condition that these are active. (See parameters 014 *Local stop* and 015 *Local jog*.)

If *Local operation* [1] is selected, the adjustable frequency drive is controlled via:

1. the [START] key. This cannot, however, override stop commands via the digital inputs (see parameter 013 *Local control*).

2. the [STOP/RESET] and [JOG] keys, on the condition that these are active. (See parameters 014 and 015.)
3. the [FWD/REV] key, on the condition that it has been selected as active in parameter 016 *Local reversing*, and that parameter 013 *Local control* is set at *Local control and open loop* [1] or *Local control as parameter 100* [3]. Parameter 200 *Output frequency range* is set at *Both directions* [4].
4. parameter 003 *Local reference* where the reference can be set using the [+] and [-] keys.
5. an external control command that can be connected to the digital inputs (see parameter 013 *Local control*).



NOTE!

The [JOG] and [FWD/REV] keys are located on the optional LCP control unit.

003 Local reference

(LOCAL REFERENCE)

Value:

Par. 013 *Local control* must be set to [1] or [2]:
 0 - f_{MAX} (par. 202) ★ 000,000.000

Par. 013 *Local control* must be set to [3] or [4] and parameter 203 *Reference/feedback range* to [0]:
 Ref_{MIN} - Ref_{MAX} (par. 204-205) ★ 000,000.000

Par. 013 *Local control* must be set to [3] or [4] and parameter 203 *Reference/feedback range* to [1]:
 - Ref_{MAX} - + Ref_{MAX} (par. 204-205) ★ 000,000.000

Function:

In this parameter, the local reference can be set manually. The unit of the local reference depends on the configuration selected in parameter 100 *Configuration*.

Description of choice:

In order to protect the local reference, parameter 002 *Local/remote operation* must be set to *Local operation* [1]. Local reference cannot be set via serial communication.

★ = factory setting. () = display text [] = value for use in communication via serial communication port

004 Active Setup
(ACTIVE SETUP)

Value:

Factory Setup (FACTORY SETUP)	[0]
★Setup 1 (SETUP 1)	[1]
Setup 2 (SETUP 2)	[2]
Setup 3 (SETUP 3)	[3]
Setup 4 (SETUP 4)	[4]
Multi Setup (MULTI SETUP)	[5]

Function:

The active operational Setup is selected here. All parameters can be programmed in four individual Setups. Selections between Setups can be made in this parameter via a digital input or via serial communication.

Description of choice:

Factory Setup [0] contains the factory-set parameter values. *Setups 1-4* [1]-[4] are four individual Setups which can be selected for active operation. *Multi Setup* [5] is used for remote-controlled selection between the four Setups via a digital input or via serial communication.

005 Programming Setup
(EDIT SETUP)

Value:

Factory Setup (FACTORY SETUP)	[0]
Setup 1 (SETUP 1)	[1]
Setup 2 (SETUP 2)	[2]
Setup 3 (SETUP 3)	[3]
Setup 4 (SETUP 4)	[4]
★Active Setup (ACTIVE SETUP)	[5]

Function:

You can select which Setup you want to program. You can program a Setup during operation (from the control panel or the serial communication port). It is, for example, possible to program *Setup 2* [2], while the active Setup is set to *Setup 1* [1] in parameter 004 *Active Setup*. You cannot, however, change *Factory Setup* [0].

Description of choice:

Factory Setup [0] contains the factory-set data and can be used as a source of data or to reset to a known status. *Setup 1-4* [1]-[4] are individual Setups that can be programmed freely during operation. If *Active Setup* [5] is selected, the programming Setup

will be equal to parameter 004 *Active Setup*. Each *Setup 1-4* initially has the *Factory Setup*.



NOTE!

If data is modified or copied to the active Setup, the modifications have an immediate effect on the unit's operation.

006 Setup copying
(SETUP COPY)

Value:

★No copying (NO COPY)	[0]
Copy to Setup 1 from # (COPY TO SETUP 1)	[1]
Copy to Setup 2 from # (COPY TO SETUP 2)	[2]
Copy to Setup 3 from # (COPY TO SETUP 3)	[3]
Copy to Setup 4 from # (COPY TO SETUP 4)	[4]
Copy to all Setups from # (COPY TO ALL)	[5]

Function:

You can copy from the selected active Setup in parameter 005 *Programming setup* to the selected Setup in this parameter.



NOTE!

Copying is only possible in [STOP/RESET] with the motor stopped.

Description of choice:

Copying begins when the required copying function has been selected and the [CHANGE DATA] key has been pushed. The display indicates when copying is in progress. Press [OK] to complete copying for the optional LCP.

007 LCP copy
(LCP COPY)

Value:

★No copying (NO COPY)	[0]
Upload all parameters (UPL. ALL PAR.)	[1]
Download all parameters (DWNL. ALL PAR.)	[2]
Download size-independent parameters (DWNL. OUTPIND. PAR.)	[3]

Function:

Parameter 007 *LCP copy* is used if the LCP2 control panel is to be used to transfer settings. Use this

★ = factory setting. () = display text [] = value for use in communication via serial communication port

function if all parameter Setups 1-4 are to be copied from one unit to another by connecting the LCP2 control panel to different drives.

Description of choice:

Select *Upload all parameters* [1] to transfer all parameter values to the LCP. Select *Download all parameters* [2] to transfer parameter values to the unit on which the control panel has been connected. Select *Download power-independent parameters* [3] if only the power-independent parameters are to be downloaded. Use this facility when downloading to a unit with a different rated power size than the unit from which the parameter Setup originates.



NOTE!

Upload/download can only be performed in stop mode. Download can only be performed to an adjustable frequency drive with the same software version number, see parameter 626 *Database identification no.*

008 Display scaling of output frequency (FREQUENCY SCALE)

Value:

0.01 - 100.00 ★ 1.00

Function:

In this parameter, the factor is selected by which the output frequency is to be multiplied. The value is shown in the display, provided parameters 009-012 *Display readout* have been set to *Output frequency x scaling* [5].

Description of choice:

Set the required scaling factor.

009 Large display readout (DISPLAY LINE 2)

Value:

- No readout (NONE) [0]
- Resulting reference [%] (REFERENCE [%]) [1]
- Resulting reference [unit] (REFERENCE [UNIT]) [2]
- Feedback [unit] (FEEDBACK [UNIT]) [3]
- ★ Frequency [Hz] (FREQUENCY [HZ]) [4]
- Output frequency x scaling (FREQUENCY X SCAL.) [5]
- Motor current [A] (MOTOR CURRENT [A]) [6]

- Torque [%] (TORQUE [%]) [7]
- Power [kW] (POWER [KW]) [8]
- Power [HP] (POWER [HP]) [9]
- Motor voltage [V] (MOTOR VOLTAGE [V]) [11]
- DC link voltage [V] (DC LINK VOLTAGE [V]) [12]
- Thermal load motor [%] (THERM. LOAD MOTOR [%]) [13]
- Thermal load [%] (THERM. LOAD [%]) [14]
- Running hours [Hours] (RUN HOURS [HOURS]) [15]
- Digital input [Bin] (DIGITAL INPUT [BIN]) [16]
- Analog input 53 [V] (ANA.INP. 53 [V]) [17]
- Analog input 60 [mA] (ANA. INP. 60 [MA]) [19]
- Pulse reference [Hz] (PULSE REFERENCE [HZ]) [20]
- External reference [%] (EXT. REFERENCE [%]) [21]
- Status word [Hex] (STATUS WORD [HEX]) [22]
- Heatsink temperature [°C] (HEATSINK TEMP. [°C]) [25]
- Alarm word [Hex] (ALARM WORD [HEX]) [26]
- Control word [Hex] (CONTROL WORD [HEX]) [27]
- Warning word [Hex] (WARNING WORD [HEX]) [28]
- Extended status word [Hex] (EXT. STATUS WORD [HEX]) [29]
- Communication option card warning (COMM.OPT. WARN [HEX]) [30]
- Pulse count (PULSE COUNT) [31]

Function:

In this parameter you can select the data value that you wish to display in the LCP control unit display line 2 when the adjustable frequency drive is switched on. The display will also be included in the scrollbar in display mode. In parameters 010-012 *Display readout* three additional data values are selectable, which are displayed in display line 1.

Description of choice:

No readout:

Can only be selected in parameters 010-012 *Small display readout*.

Resulting reference [%]:

★ = factory setting. () = display text [] = value for use in communication via serial communication port

Gives, as a percentage, the resulting reference in the range from Minimum reference, Ref_{MIN} to Maximum reference, Ref_{MAX}.

Reference [unit]:

Gives the resulting reference with unit Hz in *Open loop*. In *Closed loop* the reference unit is selected in parameter 416 *Process units*.

Feedback [unit]:

Gives the resulting signal value using the unit/scaling selected in parameter 414 *Minimum feedback*, *FB_{LOW}*, 415 *Maximum feedback*, *FB_{HIGH}* and 416 *Process units*.

Frequency [Hz]:

Gives the output frequency of the adjustable frequency drive.

Output frequency x scaling [-]:

Equals the present output frequency f_M multiplied by the factor set in parameter 008 *Display scaling of output frequency*.

Motor current [A]:

Gives the phase current of the motor measured as an effective value.

Torque [%]:

Denotes the motor's present load in relation to the motor's rated torque.

Power [kW]:

Gives the present power that the motor is absorbing in kW.

Power [HP]:

Gives the present power that the motor is absorbing in HP.

Motor voltage [V]:

Gives the voltage supplied to the motor.

DC link voltage [V]:

Gives the DC bus voltage of the adjustable frequency drive.

Thermal load motor [%]:

Gives the calculated/estimated load on the motor. 100 % is the cut-out limit.

Thermal load [%]:

Gives the calculated/estimated thermal load on the adjustable frequency drive. 100 % is the cut-out limit.

Running hours [Hours]:

Gives the number of hours that the motor has run since the last reset in parameter 619 *Reset of running hours counter*.

Digital input [Binary code]:

Gives the signal status from the 5 digital inputs (18, 19, 27, 29 and 33). Terminal 18 corresponds to the bit on the extreme left. '0' = no signal, '1' = signal connected.

Analog input 53 [V]:

Gives the voltage value of terminal 53.

Analog input 60 [mA]:

Gives the present value of terminal 60.

Pulse reference [Hz]:

Gives the reference in Hz connected to terminal 33.

External reference [%]:

Gives the sum of external references as a percentage (sum of analog/pulse/serial communication) in the range from Minimum reference, Ref_{MIN} to Maximum reference, Ref_{MAX}.

Status word [Hex]:

Gives one or several status conditions in a Hex code. Further information is available on serial communication in the *VLT 2800 Design Guide*.

Heatsink temp [°C]:

Gives the present heatsink temperature of the adjustable frequency drive. The cut-out limit is 90°C - 100°C (194°F - 212°F), while cutting back in occurs at 70°C ± 5°C (158°F ± 9°F).

Alarm word [Hex]:

Gives one or several alarms in hex code. Further information is available on serial communication in the *VLT 2800 Design Guide*.

Control word [Hex]:

Gives the control word for the adjustable frequency drive. Further information is available on serial communication in the *VLT 2800 Design Guide*.

Warning word [Hex]:

Gives one or several warnings in hex code. Further information is available on serial communication in the *VLT 2800 Design Guide*.

★ = factory setting. () = display text [] = value for use in communication via serial communication port

Extended status word [Hex]:

Gives one or several status modes in Hex code. Further information is available on serial communication in the *VLT 2800 Design Guide*.

Communication option card warning [Hex]:

Gives a warning word if there is a fault in the communication bus. Only active if communication options are installed.

If there are no communication options 0 Hex is displayed.

Pulse count:

Gives the number of pulses that the unit has registered.

010 Small display line 1.1
(DISPLAY LINE 1.1)
Value:

See par. 009 *Large display readout*
 ★ Reference [%] [1]

Function:

Select the first of three data values to be displayed in the optional LCP control unit display, line 1, position 1. This is a useful when setting the PID control, as it gives a view of process reactions to reference changes. The display readout is activated by pushing the [DISPLAY MODE] key.

Description of choice:

See parameter 009 *Large display readout*.

011 Small display readout 1.2
(DISPLAY LINE 1.2)
Value:

See parameter 009 *Large display readout*
 ★ Motor current [A][6]

Function:

See the functional description given under parameter 010 *Small display readout*.

Description of choice:

See parameter 009 *Large display readout*.

012 Small display readout 1.3
(DISPLAY LINE 1.3)
Value:

See parameter 009 *Large display readout*
 ★ Power [kW][8]

Function:

See the functional description given under parameter 010 *Small display readout*.

Description of choice:

See parameter 009 *Large display readout*.

013 Local control
(LOC CTRL/CONFIG.)
Value:

Local not active (DISABLE)	[0]
Local control and open loop (LOC CTRL/OPEN LOOP)	[1]
Remote-operated control and open loop (LOC+DIG CTRL/OPEN LOOP)	[2]
Local control as parameter 100 (LOC CTRL/AS P100)	[3]
★ Remote-operated control as parameter 100 (LOC+DIG CTRL/AS P100)	[4]

Function:

Select the required function when, in parameter 002 *Local/remote operation*, *Local operation* [1] has been chosen.

Description of choice:

If *Local not active* [0] is selected, it is not possible to set a reference via parameter 003 *Local reference*. To select *Local not active* [0], parameter 002 *Local/remote operation* must be set to *Remote operation* [0].

Local control and open loop [1] is used if the motor speed is to be set via parameter 003 *Local reference*. When this choice is made, parameter 100 *Configuration* automatically shifts to *Speed regulation, open loop* [0].

Remote-operated control and open loop [2] functions in the same way as *Local control and open loop* [1]; however, the unit can also be controlled via the digital inputs.

Local control as parameter 100 [3] is used when the motor speed is to be set via parameter 003 *Local*

★ = factory setting. () = display text [] = value for use in communication via serial communication port

reference, but without parameter 100 Configuration automatically shifting to Speed regulation, open loop [0].

Remote-operated control as parameter 100 [4] works the same way as Local control as parameter 100 [3]; however, the unit can also be controlled via the digital inputs.

Shifting from Remote operation to Local operation in parameter 002 Local/remote operation, while this parameter 013 is set to Remote-operated control and open loop [2]: The present motor frequency and direction of rotation will be maintained. If the present direction of rotation does not respond to the reversing signal (negative reference), the reference will be set to 0.

Shifting from Local operation to Remote operation in parameter 002 Local/remote control, while this parameter 013 is set to Remote-operated control and open loop [2]: The configuration selected in parameter 100 Configuration will be active. The transition will be smooth.

Shifting from Remote control to Local control in parameter 002 Local/remote operation, while this parameter 013 is set to Remote-operated control as parameter 100 [4]: the present reference will be maintained. If the reference signal is negative, the local reference will be set to 0.

Shifting from Local operation to Remote operation in parameter 002 Local/remote operation, while parameter 013 is set to Remote-operated control as parameter 100 [4]: The local reference will be replaced by the remote-operated reference signal.

014 Local stop
(LOCAL STOP)

Value:

Not active (DISABLE)	[0]
★Active (ENABLE)	[1]

Function:
In this parameter, the local stop function of the [STOP/RESET] key can be engaged or disengaged on the control panel and on the optional LCP 2 control panel.

Description of choice:

If *Not active* [0] is selected in this parameter, the [STOP]-key will be inactive.



If *Not active* [0] is selected, the motor cannot be stopped by means of the [STOP]-key.

015 Local jog
(LOCAL JOGGING)

Value:

★Not active (DISABLE)	[0]
Active (ENABLE)	[1]

Function:

In this parameter, the jog function on the optional LCP 2 control panel can be engaged/disengaged.

Description of choice:

If *Not active* [0] is selected in this parameter, the [JOG]-key will be inactive.

016 Local reversing
(LOCAL REVERSING)

Value:

★Not active (DISABLE)	[0]
Active (ENABLE)	[1]

Function:

In this parameter you can select/deselect the reversing function on the optional LCP 2 control panel. The key can only be used if parameter 002 Local/remote operation is set to Local operation [1] and parameter 013 Local control to Local control, open loop [1] or Local control as parameter 100 [3].

Description of choice:

When *Disable* [0] is selected, the [FWD/REV] key will be disabled. See also parameter 200 Output frequency range.

017 Local reset of trip
(LOCAL RESET)

Value:

Not active (DISABLE)	[0]
★Active (ENABLE)	[1]

★ = factory setting. () = display text [] = value for use in communication via serial communication port

Function:

The reset function of the [STOP/RESET] key on the control panel can be engaged/disengaged.

Description of choice:

If *Not active* [0] is selected in this parameter, the reset function will be inactive.



NOTE!

Select *Not active* [0], only if an external reset signal has been connected via the digital inputs.

018 Lock for data changes (DATA CHANGE LOCK)

Value:

- ★Not locked (NOT LOCKED) [0]
- Locked (LOCKED) [1]

Function:

In this parameter, it is possible to 'lock' the controls to disable data changes via the control keys.

Description of choice:

If *Locked* [1] is selected, data changes in the parameters cannot be made; however, it will still be possible to make data changes via serial communication. Parameter 009-012 *Display readout* can be changed via the control panel.

019 Operating mode at power-up, local operation (POWER UP ACTION)

Value:

- Auto restart, use saved reference (AUTO RESTART) [0]
- ★Forced stop, use saved reference (LOCAL=STOP) [1]
- Forced stop, set ref. to 0 (LOCAL=STOP, REF=0) [2]

Function:

Sets the operating mode when the AC line voltage is applied. This function can only be active if *Local operation* [1] has been selected in parameter 002 *Local/remote operation*.

Description of choice:

Auto restart, use saved ref. [0] is selected if the unit is to start using the local reference (set in parameter 003 *Local reference*) and the start/stop state given

★ = factory setting. () = display text [] = value for use in communication via serial communication port

via the control keys immediately prior to the AC line voltage being cut out.

Forced stop, use saved ref. [1] is selected if the unit is to remain stopped when the line voltage is engaged, until the [START]-key is activated. After a start command the motor speed is ramped up to the saved reference in parameter 003 *Local reference*. *Forced stop, set ref. to 0* [2] is selected if the unit is to remain stopped when the line voltage is cut back in. Parameter 003 *Local reference* is to be zeroed.



NOTE!

In remote operation (parameter 002 *Local/remote operation*) the start/stop state at the time of AC line connection will depend on the external control signals. If *Pulse start* [8] is selected in parameter 302 *Digital input*, the motor will remain stopped after power is supplied.

020 Lock for Hand mode (LOCK HAND MODE)

Value:

- Not active (DISABLE) [0]
- ★Active (ENABLE) [1]

Function:

In this parameter, select whether switching between Auto and Hand mode at the local keypad is permitted. The keypad can be disabled to prevent local control.

Description of choice:

If *Not active* [0] is selected, the Hand mode function will be inactive. If *Active* [1] is selected, switching between Auto and Hand mode at the keypad is permitted. For further information, see the *Control Unit* section.

024 User-defined Quick Menu (USER QUICK MENU)

Value:

- ★Not active (DISABLE) [0]
- Active (ENABLE) [1]

Function:

In this parameter you can opt out of the standard setup of the Quick menu key on the control panel and the LCP control panel.

Using this function, in parameter 025 *Quick Menu setup* the user can select up to 20 parameters for the Quick Menu key.

Description of choice:

If *not active* [0] is selected, the standard setup of the Quick Menu key is active.

If *Active* [1] is selected, the user-defined Quick Menu is active.

Please note that parameter 024 *User-defined Quick Menu* and parameter 025 *Quick Menu setup* are reset to the factory setting during initialization.

025 Quick Menu Setup

(QUICK MENU SETUP)

Value:

[Index 1 - 20] Value: 0 - 999 ★ 000

Function:

In this parameter you define which parameters are required in the Quick Menu when parameter 024 *User-defined Quick Menu* is set to *Active* [1].

Up to 20 parameters can be selected for the user-defined Quick Menu.



NOTE!

Please note that this parameter can only be set using an LCP 2 control panel. See *Order form*.

Description of choice:

The Quick Menu is set up as follows:

1. Select parameter 025 *Quick Menu setup* and press [CHANGE DATA].
 2. Index 1 indicates the first parameter in Quick Menu. You can scroll between the index numbers using the [+ / -] keys. Select Index 1.
 3. Using [< >] you can scroll between the three figures. Press the [<] key once and the last number in the parameter number can be selected using the [+ / -] keys.
Set Index 1 to 100 for parameter 100 *Configuration*.
 4. Press [OK] when Index 1 has been set to 100.
 5. Repeat steps 2 - 4 until all parameters required have been set to the Quick Menu key.
 6. Press [OK] to complete the Quick Menu setup.
- If parameter 100 *Configuration* is selected at Index 1, Quick Menu will start with this parameter every time Quick Menu is activated.

★ = factory setting. () = display text [] = value for use in communication via serial communication port

■ Load and Motor

100 Configuration

(CONFIGURATION)

Value:

- ★Speed regulation, open loop (SPEED OPEN LOOP) [0]
- Speed regulation, closed loop (SPEED CLOSED LOOP) [1]
- Process regulation, closed loop (PROCESS CLOSED LOOP) [3]

Function:

This parameter is used to select the configuration to which the unit is to be adapted. The parameters not used in a given configuration are hidden (not active).

Description of choice:

If *Speed regulation, open loop* [0] is selected, normal speed control is obtained (without feedback signal) with automatic load and slip compensation to ensure a constant speed at varying loads. Compensations are active, but may be disabled in parameter 134 *Load compensation* and parameter 136 *Slip compensation* as required.

If *Speed regulation, closed loop* [1] is selected, better speed accuracy is obtained. A feedback signal must be added, and the PID regulator must be set in parameter group 400 *Special functions*.

If *Process regulation, closed loop* [3] is selected, the internal process regulator is activated to enable precise regulation of a process in relation to a given process signal. The process signal can be set to the relevant process unit or as a percentage. A feedback signal must be added from the process and the process regulator must be set in parameter group 400 *Special functions*.

101 Torque characteristic

(TORQUE CHARACT)

Value:

- ★Constant torque (CONSTANT TORQUE) [1]
- Variable torque low (TORQUE: LOW) [2]
- Variable torque medium (TORQUE: MED) [3]
- Variable torque high

- (TORQUE: HIGH) [4]
- Variable torque low with CT start (VT LOW CT START) [5]
- Variable torque medium with CT start (VT MED CT START) [6]
- Variable torque high with CT start (VT HIGH CT START) [7]
- Special motor mode (SPECIAL MOTOR MODE) [8]

★ CT = Constant torque

Function:

This parameter allows tailoring the V/Hz ratio of the adjustable frequency drive to the torque characteristic of the load. See par. 135 *U/f ratio*.

Description of choice:

If *Constant torque* [1] is selected, a load-dependent V/Hz characteristic is obtained, in which output voltage and output frequency increase with increasing loads in order to maintain constant energy to the motor.

Select *Variable torque low* [2], *Variable torque medium* [3] or *Variable torque high* [4], if the load is square (centrifugal pumps, fans).

If a higher break-away torque is required than the three previous choices provide, select *Variable torque - low with CT start* [5], *- medium with CT start* [6] or *high with CT start* [7].



NOTE!

Load and slip compensation are not active if variable torque or special motor mode have been selected.

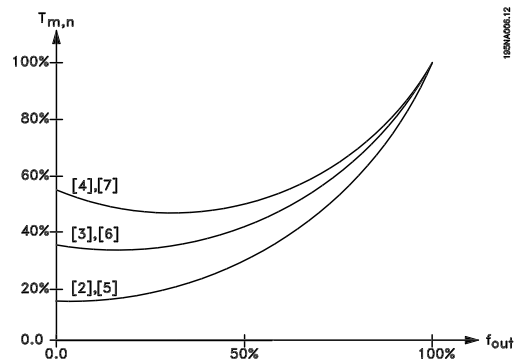

Select *Special motor mode* [8], if a special V/Hz setting is needed that is to be adapted to the present

★ = factory setting. () = display text [] = value for use in communication via serial communication port

motor. The break points are set in parameters 423-428 *Voltage/frequency*.



NOTE!

If a value set in the name-plate parameters 102-106 is changed, parameters 108 *Stator resistance* and 109 *Stator reactance* change automatically. Enter motor name plate data in sequence from parameter 102 to 106. The relationship between values are interdependent.

102 Motor power $P_{M,N}$

(MOTOR POWER)

Value:

0.25 - 11 kW ★ Depends on unit

Function:

Here you must set a power value [kW] $P_{M,N}$, corresponding to the motor's rated power.

Description of choice:

Set a value that matches the nameplate data on the motor. Settings between one size below and one size over the factory setting are possible.

North American HP to kW Conversion Chart	
HP	kW
1/2	0.37
3/4	0.55
1	0.75
1 1/2	1.1
2	1.5
3	2.2
4	3.0
5	4
7 1/2	5.5
10	7.5

103 Motor voltage $U_{M,N}$

(MOTOR VOLTAGE)

Value:

For 200 V units: 50 - 999 V ★ 230 V

For 400 V units: 50 - 999 V ★ 400 V

Function:

This is where to set the rated motor voltage.

Description of choice:

Select a value that corresponds to the nameplate data on the motor, regardless of the adjustable frequency drive's AC line voltage.

104 Motor frequency $f_{M,N}$

(MOTOR FREQUENCY)

Value:

24-1000 Hz ★ 60 Hz

Function:

This is where to select the rated motor frequency $f_{M,N}$.

Description of choice:

Select a value that corresponds to the nameplate data on the motor.

105 Motor current $I_{M,N}$

(MOTOR CURRENT)

Value:

0.01 - I_{MAX} ★ Depends on choice of motor

Function:

The nominal, rated current of the motor $I_{M,N}$ forms part of the unit's calculation for features such as torque and motor thermal protection.

Description of choice:

Set a value that corresponds to the nameplate data on the motor.

106 Rated motor speed

(MOTOR NOM. SPEED)

Value:

100 - $f_{M,N} \times 60$ (max. 60000 rpm)

★ Depends on parameter 102 *Motor power*, $P_{M,N}$

Function:

This is where to set the value that corresponds to the rated motor speed that can be read from the nameplate data.

★ = factory setting. () = display text [] = value for use in communication via serial communication port

Description of choice:

Enter a value that corresponds to the nameplate data on the motor.



NOTE!

The maximum value equals the nominal frequency x 60 as set in parameter 104 *Motor frequency*.

107 Automatic motor tuning, AMT (AUTO MOTOR TUN.)

Value:

- ★ Optimisation off (AMT OFF) [0]
- Optimisation on (AMT START) [2]

Function:



NOTE!

AMT is not possible on VLT 2880-82.

- For AMT to define the motor parameters accurately, the correct nameplate data for the motor connected to the adjustable frequency drive must be keyed into parameters 102 to 106.
- Alarms will appear in the display if faults arise during tuning of the motor. See *Warnings/alarms messages* in this manual.
- As a rule, the AMT function can measure the R_S values for motors that are 1-2 sizes larger or smaller than the adjustable frequency drive's nominal size.
- If you wish to interrupt automatic motor tuning, press the [STOP/RESET] key.



NOTE!

AMT may not be performed on motors connected in parallel, nor may setup changes be made while AMT is running.

See *Automatic motor tuning* in this manual for the AMT procedure.

Description of choice:

Select *Optimization on* [2] as part of the AMT procedure if you want the adjustable frequency drive to perform automatic motor tuning.

108 Stator resistance R_S

(STATOR RESISTAN)

Value:

0.000 - X.XXX Ω

★ Depends on choice of motor

Function:

After setting of parameters 102-106 *Nameplate data*, a number of adjustments of various parameters is carried out automatically, including stator resistance R_S . A manually entered R_S must apply to a cold motor. The shaft performance can be improved by fine-tuning R_S and X_S , see procedure below.



NOTE!

Parameters 108 *Stator resistance R_S* and 109 *Stator reactance X_S* are normally not to be changed if nameplate data has been set.

Description of choice:

R_S can be set as follows:

1. Use the factory settings of R_S which the adjustable frequency drive itself chooses on the basis of the motor nameplate data
2. The value is stated by the motor supplier.
3. The value is obtained through manual measurements: R_S can be calculated by measuring the resistance $R_{PHASE-PHASE}$ between two phase terminals. Where $R_{PHASE-PHASE}$ is lower than 1-2 Ohms (typical for motors > 7.5 HP, 400 V), a special Ohm-meter should be used (Thomson-bridge or similar). **$R_S = 0.5 \times R_{PHASE-PHASE}$**
4. R_S is set automatically when AMT has been completed. See parameter 107 *Auto motor tuning*.

109 Stator reactance X_S

(STATOR REACTANCE)

Value:

0.00 - X.XX Ω

★ Depends on choice of motor

Function:

After setting of parameters 102-106 *Nameplate data*, stator reactance X_S is calculated automatically by the adjustable frequency drive. Shaft performance can be improved by fine tuning X_S , see options below.

★ = factory setting. () = display text [] = value for use in communication via serial communication port

121 Start function
(START FUNCTION)
Value:

DC hold during start delay time (DC HOLD/DELAY TIME)	[0]
DC brake during start delay time (DC BRAKE/DELAY TIME)	[1]
★Coasting during start delay time (COAST/DELAY TIME)	[2]
Start frequency/voltage clockwise (CLOCKWISE OPERATION)	[3]
Start frequency/voltage in reference direction (VERTICAL OPERATION)	[4]

Function:

Choose the required mode during the start delay time (parameter 120 *Start delay time*).

Description of choice:

Select *DC hold during start delay time* [0] to energize the motor with a DC hold voltage during the start delay time. Set voltage in parameter 137 *DC hold voltage*.

Choose *DC brake during start delay time* [1] to energize the motor with a DC brake voltage during the start delay time. Set voltage in parameter 132 *DC brake voltage*.

Choose *Coasting during start delay time* [2] and the motor will not be controlled by the drive during the start delay time. The output of the inverter will be turned off.

Choose *Start frequency/voltage clockwise* [3] to obtain the function described in parameters 130 *Start frequency* and 131 *Voltage at start* during start delay time. Regardless of the value assumed by the reference signal, the output frequency equals the setting in parameter 130 *Start frequency* and the output voltage will correspond to the setting in parameter 131 *Voltage at start*.

This functionality is typically used in hoist applications. It is used in particular in applications in which a cone anchor motor is applied, where the direction of rotation is to start clockwise followed by the reference direction.

Select *Start frequency/voltage in reference direction* [4] to obtain the function described in parameter 130 *Start frequency* and 131 *Voltage at start* during the start delay time.

The direction of motor rotation will always follow the reference direction. If the reference signal equals zero, the output frequency will equal 0 Hz, while the output voltage will correspond to the setting in parameter 131 *Voltage at start*. If the reference signal is different from zero, the output frequency will equal parameter 130 *Start frequency* and the output voltage will equal parameter 131 *Voltage at start*. This functionality is used typically for hoist applications with counterweight. It is used in particular for applications in which a cone anchor motor is applied. The cone anchor motor can break away using parameter 130 *Start frequency* and parameter 131 *Voltage at start*.

122 Function at stop
(FUNCTION AT STOP)
Value:

★Coasting (COAST)	[0]
DC hold (DC HOLD)	[1]

Function:

Determines the function of the drive after the output frequency has become lower than the value in parameter 123 *Min. frequency for activation of function at stop* or after a stop command and when the output frequency has been ramped down to 0 Hz.

Description of choice:

Select *Coasting* [0] if the unit is to 'let go' of the motor (inverter turned off).

Select DC hold [1] if parameter 137 *DC hold voltage* is to be activated.

123 Min. frequency for activation of function at stop
(MIN.F.FUNC.STOP)
Value:

0.1 - 10 Hz ★ 0.1 Hz

Function:

Choose the output frequency at which the function selected in parameter 122 *Function at stop* is to be activated.

★ = factory setting. () = display text [] = value for use in communication via serial communication port

Description of choice:

Set the required output frequency.

126 DC brake time

(DC BRAKING TIME)

Value:

0 - 60 sec. ★ 10 sec

Function:

Select the DC brake time at which parameter 132 *DC brake voltage* is to be active.

Description of choice:

Set the required time.

127 DC brake cut-in frequency

(DC BRAKE CUT-IN)

Value:

0.0 (OFF) - par. 202 *Output frequency high limit*, f_{MAX} ★ OFF

Function:

In this parameter, the DC brake cut-in frequency is set at which the DC brake is to be activated in connection with a stop command.

Description of choice:

Set the required frequency.

128 Thermal motor protection

(MOT.THERM PROTEC)

Value:

★No protection (NO PROTECTION)	[0]
Thermistor warning (THERMISTOR WARN)	[1]
Thermistor trip (THERMISTOR TRIP)	[2]
ETR warning 1 (ETR WARNING 1)	[3]
ETR trip 1 (ETR TRIP 1)	[4]
ETR warning 2 (ETR WARNING 2)	[5]
ETR trip 2 (ETR TRIP 2)	[6]
ETR warning 3 (ETR WARNING 3)	[7]
ETR trip 3 (ETR TRIP 3)	[8]
ETR warning 4 (ETR WARNING 4)	[9]
ETR trip 4 (ETR TRIP 4)	[10]

Function:

The adjustable frequency drive can monitor the motor temperature in two different ways:

★ = factory setting. () = display text [] = value for use in communication via serial communication port

- Via a PTC thermistor that is mounted on the motor. The thermistor is connected between terminal 50 (+10V) and one of the digital input terminals 18, 19, 27 or 29. See parameter 300 *Digital inputs*.
- Thermal load calculation (ETR - Electronic Thermal Relay), based on present load and time. This is compared with the rated motor current $I_{M,N}$ and rated motor frequency $f_{M,N}$. The calculations take into account the need for lower loading at low speeds due to the motor's internal ventilation being reduced.

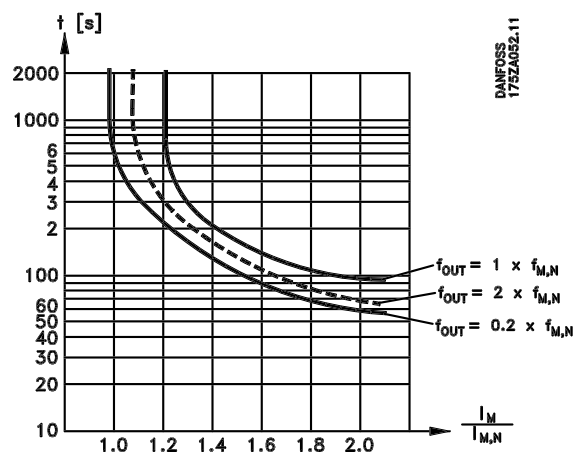

ETR functions 1-4 do not begin to calculate the load until you switch to the Setup in which they have been selected. This means that you can use the ETR function even when changing between two or more motors.



NOTE!

The electronic thermal relay (ETR) in UL listed VLTs provides Class 20 motor overload protection in accordance with the NEC in single motor applications when parameter 128 is set for "ETR TRIP" and parameter 105 *Motor current* is set for rated motor current.

Description of choice:

Select *No protection* [0] if you do not want a warning or trip when a motor is overloaded. Select *Thermistor warning* [1] if you want a warning when the connected thermistor becomes too warm. Select *Thermistor trip* [2] if you want a trip when the connected thermistor becomes too warm.

Select *ETR WARNING* if you want a warning when the motor is overloaded according to the calculations. You can also program the adjustable frequency drive to give a warning signal via the digital output. Select *ETR Trip* if you want a trip when the motor is overloaded according to the calculations. Select *ETR warning 1-4* if you want a warning when the motor is overloaded according to the calculations. You can also program the adjustable frequency drive to give a warning signal via one of the digital outputs. Select *ETR Trip 1-4* if you want a trip when the motor is overloaded according to the calculations.



NOTE!

This function cannot protect the individual motors in the case of motors linked in parallel.

130 Start frequency

(START FREQUENCY)

Value:

0.0 - 10.0 Hz ★ 0.0 Hz

Function:

The start frequency is active for the time set in parameter 120 *Start delay*, after a start command. The output frequency will 'jump' to the next preset frequency. Certain motors, such as conical anchor motors, need an extra voltage/start frequency (boost) at start to disengage the mechanical brake. To achieve this parameters 130 *Start frequency* and 131 *Initial voltage* are used.

Description of choice:

Set the required start frequency. It is a precondition that parameter 121 *Start function*, is set to *Start frequency/voltage clockwise* [3] or *Start frequency/voltage in reference direction* [4] and that in parameter 120 *Start delay* a time is set and a reference signal is present.

131 Initial voltage

(INITIAL VOLTAGE)

Value:

0.0 - 200.0 V ★ 0.0 V

Function:

Initial voltage is active for the time set in parameter 120 *Start delay*, after a start command. This parameter can be used for example for lifting/dropping applications.

★ = factory setting. () = display text [] = value for use in communication via serial communication port

Description of choice:

Set the required voltage necessary to cut out the mechanical brake. It is assumed that parameter 121 *Start function*, is set to *Start frequency/voltage clockwise* [3] or *Start frequency/voltage in reference direction* [4] and that in parameter 120 *Start delay* a time is set, and that a reference signal is present.

132 DC brake voltage

(DC BRAKE VOLTAGE)

Value:

0 - 100% of max. DC brake voltage ★ 0%

Function:

This parameter sets the DC brake voltage at which it is to be activated at stop when the DC brake frequency set in parameter 127 *DC brake cut-in frequency* is reached, or if *DC braking inverse* is active via a digital input or via serial communication. Subsequently, the DC brake voltage will be active for the time set in parameter 126 *DC brake time*.

Description of choice:

To be set as a percentage value of the max. DC brake voltage, which depends on the motor.

133 Start voltage

(START VOLTAGE)

Value:

0.00 - 100.00 V ★ Depends on unit

Function:

A higher start torque can be obtained by increasing the start voltage. Small motors (< 1.0 HP) normally require a high start voltage.

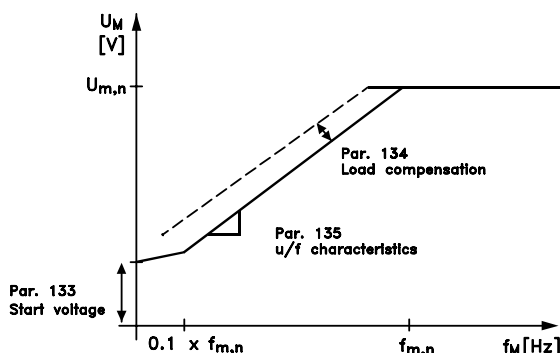

195NA07.12

Description of choice:

The factory setting will be suitable for most applications. The value may need to be increased gradually for high torque application.



Warning: Use of exaggerated start voltage may lead to over-energizing and overheating the motor. The drive may trip.

134 Load compensation

(LOAD COMPENSATION)

Value:

0.0 - 300.0% ★ 100.0%

Function:

In this parameter, the load characteristic is set. By increasing the load compensation, the motor is given an extra voltage and frequency supplement at increasing loads. This is used e.g. in motors/applications in which there is a big difference between the full-load current and idle-load current of the motor.



NOTE!

If this value is set too high, the drive may trip due to overcurrent.

Description of choice:

If the factory setting is not adequate, load compensation must be set to enable the motor to start at the given load.



Warning: Set to 0% in connection with synchronous and parallel-coupled motors and in the cases of quick load changes. Too high load compensation may lead to instability.

135 U/f-ratio

(U/F RATIO)

Value:

0.00 - 20.00 at Hz ★ Depends on unit

Function:

This parameter enables a linear shift in the ratio between output voltage (V) and output frequency (f) to ensure correct energizing of the motor and thus optimum dynamics, accuracy and efficiency. The V/f-ratio only affects the voltage characteristic if *Constant torque* [1] has been selected in parameter 101 *Torque characteristic*.

Description of choice:

Change the V/f-ratio only if it is not possible to set the correct motor data in parameters 102-109. The value programmed in the factory settings is based on idle operation.

136 Slip compensation

(SLIP COMP)

Value:

-500 - +500% of rated slip compensation ★ 100%

Function:

Slip compensation is calculated automatically, on the basis of such data as the rated motor speed $n_{M,N}$. In this parameter, the slip compensation can be fine tuned, thereby compensating for tolerances on the value for $n_{M,N}$. Slip compensation is only active if a selection has been made of *Speed regulation, open loop* [0] in parameter 100 *Configuration* and *Constant torque* [1] in parameter 101 *Torque characteristic*.

Description of choice:

Key in a % value.

137 DC hold voltage

(DC HOLD VOLTAGE)

Value:

0 - 100% of max. DC hold voltage ★ 0%

Function:

This parameter is used to keep the motor (holding torque) at start/stop.

Description of choice:

This parameter can only be used if a selection has been made of DC hold in parameter 121 *Start function* or 122 *Function at stop*. Set as a percentage

★ = factory setting. () = display text [] = value for use in communication via serial communication port

value of the max. DC hold voltage, which depends on the choice of motor.

138 Brake cut out value
(BRAKE CUT OUT)
Value:

0.5 - 132.0/1000.0 Hz ★ 3.0 Hz

Function:

Select the frequency at which the external brake is released, via the output defined in parameter 323 *Relay output 1-3* or 341 *Digital output, terminal 46*.

Description of choice:

Set the required frequency.

139 Brake cut in frequency
(BRAKE CUT IN)
Value:

0.5 - 132.0/1000.0 Hz ★ 3.0 Hz

Function:

Select the frequency at which the external brake is activated; this takes place via the output defined in parameter 323 *Relay output 1-3* or 341 *Digital output terminal 46*.

Description of choice:

Set the required frequency.

140 Current, minimum value
(CURRENT MIN.VAL.)
Value:

0 % of Inom - 100 % of Inom ★ 0 %

Function:

This is where the user selects the minimum motor current running for the mechanical brake to be released. Current monitoring is only active from stop until the point when the brake is released.

Description of choice:

This is an extra safety precaution, aimed at guaranteeing that the load is not lost during a lifting/ lowering operation.

142 Spread reactance X_L
(LEAK. REACTANCE)
Value:

0.000 - XXX.XXX Ω

★ Depends on choice of motor

Function:

After setting parameters 102-106 *Nameplate data*, a number of adjustments of various parameter is made automatically, including the spread reactance X_L .

The shaft performance may be improved by fine tuning the spread reactance X_L

NOTE!

Parameter 142 *Spread reactance X_L* is normally not changed if the nameplate data have been set in parameters 102-106.

Description of choice:

X_L can be set as follows:

1. The value stated by the motor supplier.
2. Use the factory settings of X_L which the drive itself chooses on the basis of the motor nameplate data.

143 Internal fan control
(FAN CONTROL)
Value:

★ Automatic (AUTOMATIC)	[0]
Always switched on (ALWAYS ON)	[1]
Always switched off (ALWAYS OFF)	[2]

Function:

This parameter can be set so that the internal fan is automatically switched on and off. You can also set the internal fan to be permanently switched on or off.

Description of choice:

If *Automatic* [0] is selected, the internal fan is switched on or off depending on the ambient temperature and the loading of the adjustable frequency drive.

★ = factory setting. () = display text [] = value for use in communication via serial communication port

If *Always switched on* [1] or *Always switched off* [2] is selected, the internal fan will be permanently switched on or off, respectively.



NOTE!

If *Always switched off* [2] is selected in combination with high switch frequency, long motor cables or high output power, the adjustable frequency drive's life span is reduced. This applies in particular to 1.5, 2, 4 and 5 HP units.

cision when stopping to be improved. Select Off (0) for example for lifting/lowering operations or synchronous motors. It is an advantage that the motor and the adjustable frequency drive are always synchronized.

144 Gain AC brake

(GAIN AC BRAKE)

Value:

1.00 - 1.50 ★ 1.30

Function:

This parameter is used to set the AC brake. Using this function, it is possible to adjust the size of the generator torque that can be applied to the motor without the DC bus voltage exceeding the warning level.

Description of choice:

The value is increased if a greater possible brake torque is required. If 1.0 is selected, this corresponds to the AC brake being inactive.



If the value in par. 144 is increased, the motor current will simultaneously increase significantly when generator loads are applied. The parameter should therefore only be changed if it is guaranteed during measurement that the motor current in all operating situations will never exceed the maximum permitted current in the motor. Please note: that the current cannot be read out from the display.

146 Reset voltage vector

(RESET VECTOR)

Value:

*Off (OFF) [0]
Reset (RESET) [1]

Function:

When the voltage vector is reset it is set to the same starting point each time a new process commences.

Description of choice:

Select reset (1) when running unique processes each time they arise. This will enable repetitive pre-

★ = factory setting. () = display text [] = value for use in communication via serial communication port

■ References & Limits

200 Output frequency range (OUT FREQ. RNG/ROT)

Value:

- ★ Only clockwise, 0 - 132 Hz (132 HZ CLOCKWISE) [0]
- Both directions, 0 - 132 Hz (132 HZ BOTH DIRECT) [1]
- Counter clockwise only, 0 - 132 Hz (132 HZ COUNTER CLOCK) [2]
- Clockwise only, 0 - 1000 Hz (1000 HZ CLOCK WISE) [3]
- Both directions, 0 - 1000 Hz (1000 HZ BOTH DIRECT) [4]
- Counter clockwise only, 0 - 1000 Hz (1000 HZ COUNTER CLOCK) [5]

Function:

This parameter can protect against unwanted reversing. Furthermore, the maximum output frequency can be selected that will apply regardless of the settings of other parameters. This parameter has no function if *Process regulation, closed loop* has been selected in parameter 100 *Configuration*.

Description of choice:

Select the required direction of rotation as well as the maximum output frequency. Please note that if *Clockwise only* [0]/[3] or *counter clockwise only* [2]/[5] is selected, the output frequency will be limited to the range f_{MIN} - f_{MAX} . If *Both directions* [1]/[4] is selected, the output frequency will be limited to the range \pm the maximum frequency. The minimum frequency will have no significance.

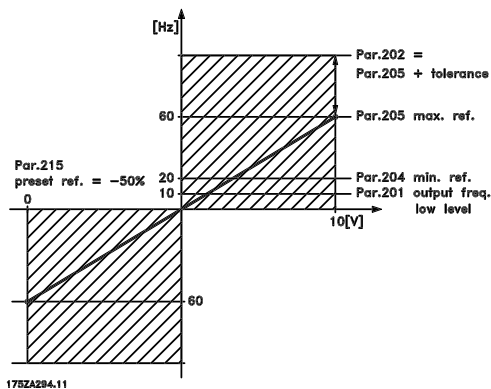

NOTE!

For drives with a bypass, direction of rotation must be checked for both drive and bypass. Direction of rotation in bypass can only be changed by swapping two motor leads. Ensure that bypass rotation is correct prior to setting drive rotation.

201 Output frequency low limit, f_{MIN} (MIN OUTPUT FREQ)

Value:

0.0 - f_{MAX} ★ 0.0 Hz

Function:

In this parameter, a minimum motor frequency limit can be selected that corresponds to the minimum speed at which the motor is allowed to run. If *Both directions* has been selected in parameter 200 *Output frequency range*, the minimum frequency is of no significance.

Description of choice:

The value chosen can range from 0.0 Hz to the frequency set in parameter 202 *Output frequency high limit, f_{MAX}* .



NOTE!

For fan applications, a minimum frequency setting of 6 Hz is recommended. For pump applications, a minimum setting of 18 Hz is recommended.

202 Output frequency high limit, f_{MAX} (MAX. OUTPUT FREQUENCY)

Value:

f_{MIN} - 132/1000 Hz (par. 200 *Output frequency range*) ★ 132 Hz

Function:

In this parameter, a maximum output frequency limit can be selected that corresponds to the highest speed at which the motor is allowed to run.



NOTE!

The output frequency of the drive can never assume a value higher than 1/10 of the switching frequency (parameter 411 *Switching frequency*).

★ = factory setting. () = display text [] = value for use in communication via serial communication port

Description of choice:

A value can be selected from f_{MIN} to the value chosen in parameter 200 *Output frequency range*.

203 Reference range
(REFERENCE RANGE)
Value:

- ★Min. reference - Max reference (MIN - MAX) [0]
- Max. reference - Max. reference (-MAX - +MAX) [1]

Function:

In this parameter you select whether the reference signal must be positive or whether it can be both positive and negative. The minimum limit may be a negative value, unless in parameter 100 *Configuration* a selection has been made of *Speed regulation, closed loop*. You should select *Min ref. - Max. ref.* [0], if *Process regulation, closed loop* [3] has been selected in parameter 100 *Configuration*.

Description of choice:

Select the required range.

204 Minimum reference, Ref_{MIN}
(MIN.REFERENCE)
Value:

- Par. 100 *Config.* = *Open loop* [0].
- 100,000.000 - par. 205 Ref_{MAX} ★ 0.000 Hz
- Par. 100 *Config.* = *Closed loop* [1]/[3].
- Par. 414 *Minimum feedback* - par. 205 Ref_{MAX} ★ 0.000 Hz

Function:

Minimum reference is an expression of the minimum possible value of the total of all references. If in parameter 100 *Configuration*, *Speed regulation, closed loop* [1] or *Process regulation, closed loop* [3] is selected, the minimum reference is limited by parameter 414 *Minimum feedback*. Minimum reference is ignored if the local reference is active.

The reference unit can be defined from the following table:

Par. 100 <i>Configuration</i>	Unit
Open loop [0]	Hz
Speed reg, closed loop [1]	rpm
Process reg, closed loop [3]	Par. 416

Description of choice:

The minimum reference is preset if the motor has to run at a minimum speed, regardless of whether the resulting reference is 0.

205 Maximum reference, Ref_{MAX}
(MAX.REFERENCE)
Value:

- Par. 100 *Config.* = *Open loop* [0].
- Par. 204 Ref_{MIN} - 1000.000 Hz ★ 50.000 Hz
- Par. 100 *Config.* = *Closed loop* [1]/[3].
- Par. 204 Ref_{MIN} - Par. 415 *Max. feedback* ★ 50.000 Hz

Function:

The maximum reference gives the highest value that can be assumed by the sum of all references. If *Closed loop* [1]/[3] is selected in parameter 100 *Configuration* the maximum reference cannot exceed the value in parameter 415 *Maximum feedback*. Maximum reference is ignored if the local reference is active.

The reference unit can be defined from the following table:

Par. 100 <i>Configuration</i>	Unit
Open loop [0]	Hz
Speed reg, closed loop [1]	rpm
Process reg, closed loop [3]	Par. 416

Description of choice:

Maximum reference is set, if the speed of the motor is to be the max. of the set value, regardless of the whether the resulting reference is greater than the maximum reference.

★ = factory setting. () = display text [] = value for use in communication via serial communication port

206 Ramp type

(RAMP TYPE)

Value:

- ★ Linear (LINEAR) [0]
- Sine shaped (S-SHAPED) [1]
- Sine² shaped (S-SHAPED 2) [2]

Function:

You can choose between a linear, a sine-shaped and a sine²-shaped ramp process.

Description of choice:

Select the required ramp type depending on requirements for the acceleration/deceleration process.

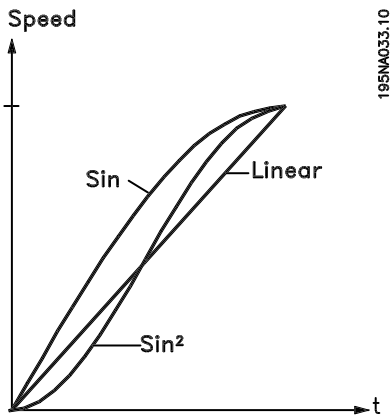

207 Ramp-up time 1

(RAMP-UP TIME 1)

Value:

0.02 - 3600.00 sec ★ 3.00 sec

Function:

The ramp-up time is the acceleration time from 0 Hz to the rated motor frequency $f_{M,N}$ (parameter 104 *Motor frequency, $f_{M,N}$*). It is assumed that the output current will not reach the current limit (set in parameter 221 *Current limit I_{LM}*).

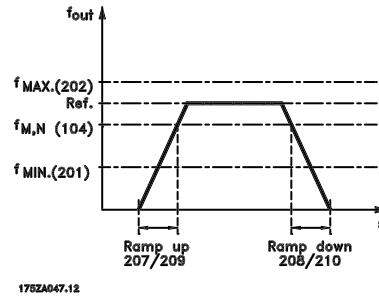

Description of choice:

Set the required ramp-up time.

208 Ramp-down time 1

(RAMP DOWN TIME 1)

Value:

0.02 - 3600.00 sec ★ 3.00 sec

Function:

The ramp-down time is the deceleration time from the rated motor frequency $f_{M,N}$ (parameter 104 *Motor frequency, $f_{M,N}$*) to 0 Hz, provided no overvoltage arises in the inverter because of generating operation of the motor.

Description of choice:

Set the required ramp-down time.

209 Ramp-up time 2

(RAMP UP TIME 2)

Value:

0.02 - 3600.00 sec. ★ 3.00 sec

Function:

See description of parameter 207 *Ramp-up time 1*.

Description of choice:

Set the required ramp-up time. Shift from ramp 1 to ramp 2 by activating *Ramp 2* via a digital input.

★ = factory setting. () = display text [] = value for use in communication via serial communication port

210 Ramp-down time 2

(RAMP DOWN TIME 2)

Value:

0.02 - 3600.00 sec. ★ 3.00 sec

Function:

See description of parameter 208 *Ramp-down time 1*.

Description of choice:

Set the required ramp-down time. Shift from ramp 1 to ramp 2 by activating *Ramp 2* via a digital input.

211 Jog ramp time

(JOG RAMP TIME)

Value:

0.02 - 3600.00 sec. ★ 3.00 sec

Function:

The jog ramp time is the acceleration/deceleration time from 0 Hz to the rated motor frequency $f_{M,N}$ (parameter 104 *Motor frequency, $f_{M,N}$*). It is assumed that the output current will not reach the current limit (set in parameter 221 *Current limit I_{LIM}*).

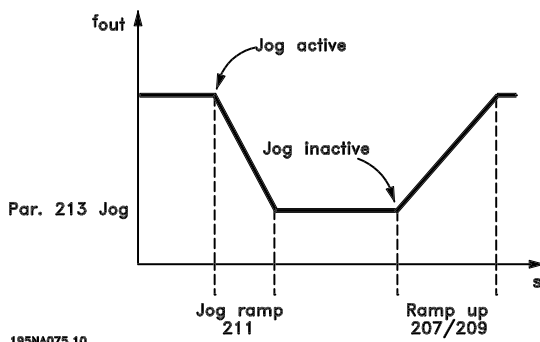

The jog ramp time starts if a jog-signal is given via the optional LCP 2 control panel, one of the digital inputs or the serial communication port.

Description of choice:

Set the required ramp time.

212 Quick-stop ramp-down time

(Q STOP RAMP TIME)

Value:

0.02 - 3600.00 sec. ★ 3.00 sec

Function:

The quick-stop ramp-down time is the deceleration time from the rated motor frequency to 0 Hz, provided no overvoltage arises in the inverter because of generating operation of the motor, or if the generated current exceeds the current limit in parameter 221 *Current limit I_{LIM}* . Quick-stop is activated via one of the digital inputs or the serial communication.

Description of choice:

Set the required ramp-down time.

213 Jog frequency

(JOG FREQUENCY)

Value:

0.0 - Par. 202 Output frequency high limit, f_{MAX}
★ 10.0 Hz

Function:

Jog frequency f_{JOG} means a fixed output frequency that the adjustable frequency drive supplies to the motor when the Jog function is activated. Jog can be activated via the digital inputs, serial communication or via the LCP control panel, on the condition that this is active in parameter 015 *Local jog*.

Description of choice:

Set the required frequency.

214 Reference function

(REFERENCE FUNCTION)

Value:

★ Sum (SUM) [0]
Relative (RELATIVE) [1]
External/preset (EXTERNAL/PRESET) [2]

Function:

It is possible to define how preset references are to be added to the other references; for this purpose, use *Sum* or *Relative*. It is also possible by using the *External/preset* to select whether a shift between external references and preset references is required.

★ = factory setting. () = display text [] = value for use in communication via serial communication port

External reference is the sum of the analog references, pulse references and any references from serial communication.

Description of choice:

If *Sum* [0] is selected, one of the adjusted preset references (parameters 215-218 *Preset reference*) is summarized as a percentage of the reference range ($Ref_{MIN} - Ref_{MAX}$), added to the other external references.

If *Relative* [1] is selected, one of the added preset references (parameters 215-218 *Preset reference*) is summarized as a percentage of the sum of present external references.

If *External/preset* [2] is selected, it is possible via a digital input to shift between external references or preset references. Preset references will be a percentage value of the reference range.

NOTE!

If *Sum* or *Relative* is selected, one of the preset references will always be active. If the preset references are to be without influence, they must be set to 0% (factory setting).

215 Preset reference 1 (PRESET REF. 1)

216 Preset reference 2 (PRESET REF. 2)

217 Preset reference 3 (PRESET REF. 3)

218 Preset reference 4 (PRESET REF. 4)

Value:

-100.00% to +100.00% ★ 0.00%
of the reference range/external reference

Function:

Four different preset references can be programmed in parameters 215-218 *Preset reference*.

The preset reference is stated as a percentage of the reference range ($Ref_{MIN} - Ref_{MAX}$) or as a percentage of the other external references, depending on the choice made in parameter 214 *Reference function*. The choice between preset references can be made via the digital inputs or via serial communication.

Preset ref., msb	Preset ref. lsb	
0	0	Preset ref. 1
0	1	Preset ref. 2
1	0	Preset ref. 3
1	1	Preset ref. 4

Description of choice:

Set the options for the preset reference(s).

219 Catch up/Slow down reference (CATCH UP/SLW DWN)

Value:

0.00 - 100% of the given reference ★ 0.00%

Function:

In this parameter, the percentage value can be set which will either be added to or deducted from the remote-controlled references.

The remote-controlled reference is the sum of preset references, analog references, pulse reference and any references from serial communication.

Description of choice:

If *Catch up* is active via a digital input, the percentage value in parameter 219 *Catch up/Slow down reference* will be added to the remote-controlled reference.

If *Slow down* is active via a digital input, the percentage value in parameter 219 *Catch up/Slow down reference* will be deducted from the remote controlled reference.

Activate the function in parameters 302 through 307.

221 Current limit, I_{LIM}

(CURRENT LIMIT)

Value:

0 - XXX.X % of par. 105 ★ 160 %

Function:

In this parameter, the maximum output current I_{LIM} is set. The factory-set value corresponds to the maximum output current I_{MAX} . If the current limit is to be used as motor protection, set the rated motor current. If the current limit is set above 100% (the rated output current of the drive, I_{INV}), the unit can only handle a load intermittently, i.e. for short periods at a time. After the load has been higher than I_{INV} , it must be ensured that for a period the load is lower than I_{INV} . Please note that if the current limit is set at a lower value than I_{INV} , the acceleration torque will be reduced to the same extent.

★ = factory setting. 0 = display text [] = value for use in communication via serial communication port

Description of choice:

Set the required maximum output current I_{LIM} .

**223 Warning: Low current, I_{LOW}
(WARN. CURRENT LO)**

Value:

0.0 - par. 224 Warning: High current, I_{HIGH} ★ 0.0 A

Function:

If the output current falls below the preset limit I_{LOW} a warning is given. Parameters 223-228 Warning functions are out of function during ramp-up after a start command and after a stop command or during stop. The warning functions are activated when the output frequency reaches the resulting reference. The signal outputs can be programmed to give a warning signal via terminal 46 and via the relay output.

Description of choice:

The lower signal limit of the output current I_{LAV} must be programmed within the normal working range of the unit.

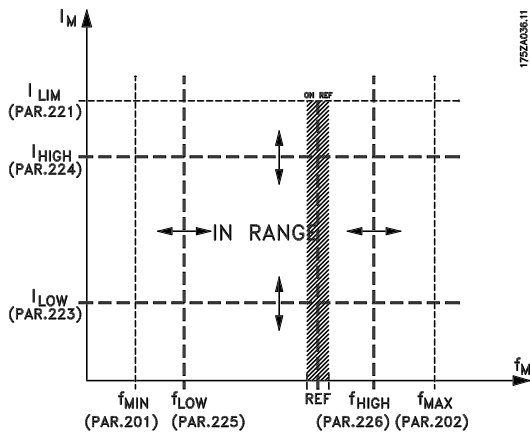

**224 Warning: High current, I_{HIGH}
(WARN. CURRENT HI)**

Value:

Par. 223 Warn.: Low current, I_{LOW} - I_{MAX} ★ I_{MAX}

Function:

If the output current exceeds the preset limit I_{HIGH} a warning is given. Parameters 223-228 Warning functions are inactive during ramp up after a start command, after a stop command or during a stop. The warning functions are activated when the output frequency reaches the resulting reference. The signal outputs can be programmed to give a warning signal via terminal 46 and via the relay output.

Description of choice:

The output current's upper signal limit I_{HIGH} must be programmed within the adjustable frequency drive's normal operating range. See drawing at parameter 223 Warning: Low current, I_{LOW} .

**225 Warning: Low frequency, f_{LOW}
(WARN.FREQ. LOW)**

Value:

0.0 - par. 226 Warn.: High frequency, f_{HIGH} ★ 0.0 Hz

Function:

If the output frequency falls below the preset limit f_{LOW} , a warning is given. Parameters 223-228 Warning functions are inactive during ramp up after a start command, after a stop command or during a stop. The warning functions are activated when the output frequency reaches the resulting reference. The signal outputs can be programmed to give a warning signal via terminal 46 and via the relay output.

Description of choice:

The lower signal limit of the output frequency f_{LOW} must be programmed within the normal operating

★ = factory setting. () = display text [] = value for use in communication via serial communication port

range of the adjustable frequency drive. See drawing at parameter 223 *Warning: Low current, I_{LOW}*.

226 Warning: High frequency f_{HIGH}
(WARN.FREQ.HIGH)
Value:

Par. 200 *Frequency range* = 0-132 Hz [0]/[1].
 par. 225 f_{LOW} - 132 Hz ★ 132.0 Hz

Par. 200 *Frequency range* = 0-1000 Hz [2]/[3].
 par. 225 f_{LOW} - 1000 Hz ★ 132.0 Hz

Function:

If the output frequency exceeds the preset limit f_{HIGH} a warning is given.
 Parameters 223-228 *Warning functions* are inactive during ramp up after a start command, after a stop command or during a stop. The warning functions are activated when the output frequency reaches the resulting reference. The signal outputs can be programmed to give a warning signal via terminal 46 and via the relay output.

Description of choice:

The output frequency's upper signal limit f_{HIGH} must be programmed within the adjustable frequency drive's normal operating range. See drawing at parameter 223 *Warning: Low current, I_{LOW}*.

227 Warning: Low feedback, FB_{LOW}
(WARN.FEEDB. LOW)
Value:

-100,000.000 - par. 228 *Warn.:FB_{HIGH}* ★ -4000.000

Function:

If the feedback signal falls below the preset limit FB_{LOW}, a warning is given.
 Parameters 223-228 *Warning functions* are inactive during ramp up after a start command, after a stop command or during a stop. The warning functions are activated when the output frequency has reached the resulting reference. The signal outputs can be programmed to give a warning signal via terminal 46 and via the relay output. The unit for feedback in Closed loop is programmed in parameter 416 *Process units*.

Description of choice:

Set the required value within the feedback range (parameter 414 *Minimum feedback, FB_{MIN}* and 415 *Maximum feedback, FB_{MAX}*).

228 Warning: High feedback, FB_{HIGH}
(WARN.FEEDB HIGH)
Value:

Par. 227 *Warn.: FB_{LOW}* - 100,000.000 ★ 4000.000

Function:

If the feedback signal gets above the preset limit FB_{HIGH}, a warning is given.
 Parameters 223-228 *Warning functions* are inactive during ramp up after a start command, after a stop command or during a stop. The warning functions are activated when the output frequency reaches the resulting reference. The signal outputs can be programmed to give a warning signal via terminal 46 and via the relay output. The unit for feedback in Closed loop is programmed in parameter 416 *Process units*.

Description of choice:

Set the required value within the feedback range (parameter 414 *Minimum feedback, FB_{MIN}* and 415 *Maximum feedback, FB_{MAX}*).

229 Frequency bypass, bandwidth
(FREQ BYPASS B.W.)
Value:

0 (OFF) - 100 Hz ★ 0 Hz

Function:

Some systems call for certain output frequencies to be avoided because of mechanical resonance problems in the system. In parameters 230-231 *Frequency bypass* these output frequencies can be programmed. In this parameter a bandwidth can be defined on either side of these frequencies.

Description of choice:

The frequency set in this parameter will be centered around parameters 230 *Frequency bypass 1* and 231 *Frequency bypass 2*.

★ = factory setting. () = display text [] = value for use in communication via serial communication port

230 Frequency bypass 1 (FREQ. BYPASS 1)**231 Frequency bypass 2 (FREQ. BYPASS 2)****Value:**0 - 1000 Hz ★ 0.0 Hz**Function:**

Some systems call for certain output frequencies to be avoided because of mechanical resonance problems in the system.

Description of choice:

Enter the frequencies to be avoided. See also parameter 229 *Frequency bypass, bandwidth*.

■ Inputs and Outputs

Digital inputs	Term. no.	18¹	19¹	27	29	33
	par. no.	302	303	304	305	307
Value:						
No function	(NO OPERATION)	[0]	[0]	[0]	[0]	★[0]
Reset	(RESET)	[1]	[1]	[1]	[1]	[1]
Coasting stop inverse	(MOTOR COAST INVERSE)	[2]	[2]	[2]	[2]	[2]
Reset and coasting inverse	(RESET AND COAST INV.)	[3]	[3]	★[3]	[3]	[3]
Quick-stop inverse	(QUICK-STOP INVERSE)	[4]	[4]	[4]	[4]	[4]
DC braking inverse	(DC-BRAKE INVERSE)	[5]	[5]	[5]	[5]	[5]
Stop inverse	(STOP INVERSE)	[6]	[6]	[6]	[6]	[6]
Start	(START)	★[7]	[7]	[7]	[7]	[7]
Pulse start	(LATCHED START)	[8]	[8]	[8]	[8]	[8]
Reversing	(REVERSING)	[9]	★[9]	[9]	[9]	[9]
Reversing and start	(START REVERSING)	[10]	[10]	[10]	[10]	[10]
Start clockwise	(ENABLE FORWARD)	[11]	[11]	[11]	[11]	[11]
Start counterclockwise	(ENABLE REVERSE)	[12]	[12]	[12]	[12]	[12]
Jog	(JOGGING)	[13]	[13]	[13]	★[13]	[13]
Freeze reference	(FREEZE REFERENCE)	[14]	[14]	[14]	[14]	[14]
Freeze output frequency	(FREEZE OUTPUT)	[15]	[15]	[15]	[15]	[15]
Speed up	(SPEED UP)	[16]	[16]	[16]	[16]	[16]
Speed down	(SPEED DOWN)	[17]	[17]	[17]	[17]	[17]
Catch-up	(CATCH-UP)	[19]	[19]	[19]	[19]	[19]
Slow-down	(SLOW-DOWN)	[20]	[20]	[20]	[20]	[20]
Ramp 2	(RAMP 2)	[21]	[21]	[21]	[21]	[21]
Preset ref, LSB	(PRESET REF, LSB)	[22]	[22]	[22]	[22]	[22]
Preset ref, MSB	(PRESET REF, MSB)	[23]	[23]	[23]	[23]	[23]
Preset reference on	(PRESET REFERENCE ON)	[24]	[24]	[24]	[24]	[24]
Thermistor	(THERMISTOR)	[25]	[25]	[25]	[25]	
Precise stop, inverse	(PRECISE STOP INV.)	[26]	[26]			
Precise start/stop	(PRECISE START/STOP)	[27]	[27]			
Pulse reference	(PULSE REFERENCE)					[28]
Pulse feedback	(PULSE FEEDBACK)					[29]
Pulse input	(PULSE INPUT)					[30]
Selection of Setup, lsb	(SETUP SELECT LSB)	[31]	[31]	[31]	[31]	[31]
Selection of Setup, msb	(SETUP SELECT MSB)	[32]	[32]	[32]	[32]	[32]
Reset and start	(RESET AND START)	[33]	[33]	[33]	[33]	[33]

1. Terminals 18 and 19 are controlled by an interrupt, which means that the accuracy of the response time is constant. This results in a precise stop function that can be used for start/stop, setup switching, and for changing digital preset, such as to obtain an accurate stop point when using creep

speed. In this way the position of the sensor is optimized due to a lower cycle time and higher pulse rate.

★ = factory setting. () = display text [] = value for use in communication via serial communication port

Function:

In these parameters 302-307 *Digital inputs* it is possible to choose the functions of the digital inputs (terminals 18-33).

Description of choice:

No operation is selected if the adjustable frequency drive is not to react to signals transmitted to the terminal.

Reset resets the adjustable frequency drive after an alarm. Some alarms cause a trip lock and cannot be reset without first disconnecting the AC line supply and reconnecting it. See table under *List of warnings and alarms*. Reset is activated on the leading edge of the signal.

Coasting stop inverse is used for making the adjustable frequency drive 'let go' of the motor immediately (output transistors are 'turned off'), which means that the motor coasts to a stop. Logic '0' means coasting to stop.

Reset and coasting inverse are used to activate motor coast simultaneously with reset. Logical '0' means motor coast stop and reset. Reset is activated on the falling edge.

Quick stop inverse is used for activating the quick-stop ramp down set in parameter 212 *Quick stop ramp-down time*. Logic '0' leads to quick stop.

DC-braking inverse is used for stopping the motor by energizing it with a DC voltage for a given time, see parameters 126, 127 and 132 *DC brake*. Please note that this function is only active if the value in parameter 126 *DC braking time* and 132 *DC brake voltage* is different from 0. Logic '0' leads to DC braking.

Stop inverse, a logic '0' means that the motor speed is ramped down to stop via the selected ramp.



None of the stop commands listed above removes power from the drive. The adjustable frequency may have other voltage inputs through DC-bus terminals. An external input disconnect switch must be opened. Wait 4 minutes before servicing the drive.

Start is selected if a start/stop command is required. Logic '1' = start, logic '0' = stop.

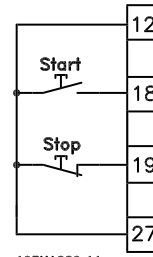

Latched start, if a pulse is applied for min. 14 ms, the adjustable frequency drive will start the motor, provided no stop command has been given. The motor can be stopped by briefly activating *Stop inverse*.

Reversing is used for changing the direction of rotation of the motor shaft. Logic '0' will not lead to reversing. Logic '1' will lead to reversing. The reverse signal only changes the direction of rotation, it does not activate the start. Is not active at *Process regulation, closed loop*. See also parameter 200 *Output frequency range/direction*.

Reversing and start is used for start/stop and for reversing with the same signal. No active start command is allowed at the same time. It is not active for *Process regulation, closed loop*. See also parameter 200 *Output frequency range/direction*.

Start clockwise can be used to set the direction of the rotation of the motor. Do not use in conjunction with a closed loop process. See parameter 200, *Output frequency range/direction*.

Start counterclockwise can be used to set the direction of the rotation of the motor. Do not use in conjunction with a closed loop process. See parameter 200, *Output frequency range/direction*.

Jog is used to override the output frequency to the jog frequency set in parameter 213 *Jog frequency*. Jog is active regardless of whether a start command has been given, yet not when *Coast stop*, *Quick-stop* or *DC braking* are active.

Freeze reference freezes the present reference. The reference can now only be changed via *Speed up* and *Speed down*. If *freeze reference* is active, it will be saved after a stop command and in the event of AC line failure.

★ = factory setting. () = display text [] = value for use in communication via serial communication port

Freeze output freezes the present output frequency (in Hz). The output frequency can now only be changed via *Speed up* and *Speed down*.



NOTE!

If *Freeze output* is active the adjustable frequency drive can only be stopped by selecting *Motor coast*, *Quick stop* or *DC braking* via a digital input.

Speed up and *Speed down* are selected if digital control of the up/down speed is required. This function is only active if *Freeze reference* or *Freeze output frequency* has been selected.

If *Speed up* is active the reference or output frequency will be increased, and if *Speed down* is active the reference or output frequency will be reduced. The output frequency is changed via the preset ramp times in parameters 209-210 *Ramp 2*. One pulse (logic '1' minimum high for 14 ms and a minimum break time of 14 ms) will lead to a speed change of 0.1 % (reference) or 0.1 Hz (output frequency). Example:

Term. 29	Term. 33	Freeze ref/ freeze outp.	Function
0	0	1	No speed change
0	1	1	Speed up
1	0	1	Speed down
1	1	1	Speed down

Freeze reference can be changed even if the adjustable frequency drive has stopped. The reference will also be saved if input power is disconnected.

Catch-up/Slow-down is selected if the reference value is to be increased or reduced by a programmable percentage value set in parameter 219 *Catch-up/Slow-down reference*.

Slow-down	Catch-up	Function
0	0	Unchanged speed
0	1	Increase by % value
1	0	Reduce by % value
1	1	Reduce by % value

Ramp 2 is selected if a shift between ramp 1 (parameters 207-208) and ramp 2 (parameters 209-

210) is required. Logic '0' leads to ramp 1 and logic '1' leads to ramp 2.

Preset reference, lsb and *Preset reference, msb* makes it possible to select one of the four preset references, see the table below:

Preset ref. msb	Preset ref. lsb	Function
0	0	Preset ref. 1
0	1	Preset ref. 2
1	0	Preset ref. 3
1	1	Preset ref. 4

Preset reference on is used for shifting between remote-controlled reference and preset reference. It is assumed that *External/preset* [2] has been selected in parameter 214 *Reference function*. Logic '0' = remote-controlled references are active, logic '1' = one of the four preset references is active, as can be seen from the table above.

Thermistor selects if a thermistor in the motor is to be able to stop the adjustable frequency drive if the motor overheats. The cut-out value is 3 k Ω .

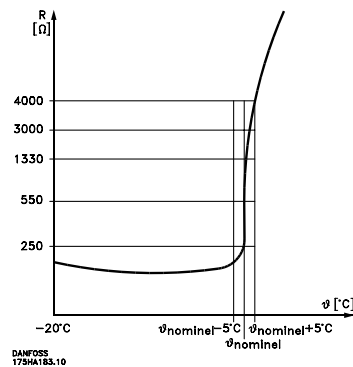

If a motor has a Klaxon thermal switch, this can also be connected to the input. If motors operate in parallel, the thermistors/thermal switches must be connected in series (total resistance lower than 3 k Ω).

Parameter 128 *Motor thermal protection* must be programmed for *Thermistor warning* [1] or *Thermistor trip* [2] and the thermistor is to be connected between a digital input and terminal 50 (+ 10 V supply).

★ = factory setting. () = display text [] = value for use in communication via serial communication port

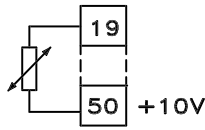

DANFOSS
195NA077.10

Precise stop, inverse is selected to obtain a high degree of accuracy when a stop command is repeated. A logic 0 means that the motor speed is ramped down to stop via the selected ramp.

Precise start/stop is selected to obtain a high degree of accuracy when a start and stop command is repeated.

Pulse reference is selected if the reference signal applied is a pulse train (frequency). 0 Hz corresponds to parameter 204 *Minimum reference, Ref_{MIN}*. The frequency set in parameter 327 *Pulse reference/feedback* corresponds to parameter 205 *Maximum reference Ref_{MAX}*.

Pulse feedback is selected if the feedback signal used is a pulse train (frequency). In parameter 327 *Pulse reference/feedback* the maximum pulse feedback frequency is set.

Pulse input is selected if a specific number of pulses must lead to a *Precise stop*, see parameter 343 *Precise stop* and parameter 344 *Counter value*.

Selection of Setup, Isb and *Selection of Setup, msb* gives the possibility to select one of the four setups. It is, however, a condition that parameter 004 is set to *Multisetup*.

Reset and start can be used as a start function. If 24 V is connected to the digital input, this will cause the adjustable frequency drive to reset and the motor will ramp up to the preset reference.

308 Terminal 53, analog input voltage

(AI [V]53FUNCT.)

Value:

No function (NO OPERATION)	[0]
★Reference (REFERENCE)	[1]
Feedback (FEEDBACK)	[2]

★ = factory setting. () = display text [] = value for use in communication via serial communication port

Function:

In this parameter it is possible to select the function connected to terminal 53. Scaling of the input signal is made in parameter 309 *Terminal 53, min. scaling* and parameter 310 *Terminal 53, max. scaling*.

Description of choice:

No function [0] is selected if the drive is not to react to signals connected to the terminal.

Reference [1]. If this function is selected, the reference can be changed by means of an analog reference signal. If reference signals are connected to more than one input, these reference signals must be added up.

If a voltage feedback signal is connected, select *Feedback* [2] on terminal 53.

309 Terminal 53 Min. scaling

(AI 53 SCALE LOW)

Value:

0.0 - 10.0 Volt ★ 0.0 Volt

Function:

This parameter is used for setting the signal value that is to correspond to the minimum reference or the minimum feedback, parameter 204 *Minimum reference, Ref_{MIN}* / 414 *Minimum feedback, FB_{MIN}*

Description of choice:

Set the required voltage value. For reasons of accuracy, compensation should be made for voltage losses in long signal cables. If the time out function is to be used (parameter 317 *Time out* and 318 *Function after time out*), the value set must be higher than 1 volt.

310 Terminal 53 Max. scaling

(AI 53 SCALE HIGH)

Value:

0 - 10.0 Volt ★ 10.0 Volt

Function:

This parameter is used for setting the signal value that is to correspond to the maximum reference value or maximum feedback, parameter 205 *Maximum reference, Ref_{MAX}* / 414 *Maximum feedback, FB_{MAX}*.

Function:

This parameter allows a choice of the function to be activated after the expiration of the time out (parameter 317 *Time out*). If a time out function occurs at the same time as a bus time out function (parameter 513 *Bus time interval function*), the time out function in parameter 318 will be activated.

Description of choice:

The output frequency of the drive can be:

- frozen at the present frequency [1]
- overruled to stop [2]
- overruled to jog frequency [3]
- overruled to max. output frequency [4]
- overruled to stop with subsequent trip [5]

**319 Analog output terminal 42
(AO 42 FUNCTION)**
Value:

No function (NO OPERATION)	[0]
External reference min.-max. 0-20 mA (REF MIN-MAX = 0-20 MA)	[1]
External reference min.-max. 4-20 mA (REF MIN-MAX = 4-20 MA)	[2]
Feedback min.-max. 0-20 mA (FB MIN-MAX = 0-20 MA)	[3]
Feedback min.-max. 4-20 mA (FB MIN-MAX = 4-20 MA)	[4]
Output frequency 0-max 0-20 mA (O-FMAX = 0-20 MA)	[5]
Output frequency 0-max 4-20 mA (O-FMAX = 4-20 MA)	[6]
★Output current 0-I _{INV} . 0-20 mA (O-IMAX = 0-20 MA)	[7]
Output current 0-I _{INV} . 4-20 mA (O-IMAX = 4-20 MA)	[8]
Output power 0-P _{M,N} 0-20 mA (O-PNOM = 0-20 MA)	[9]
Output power 0-P _{M,N} 4-20 mA (O-PNOM = 4-20 MA)	[10]
Inverter temperature 20-100°C 0-20 mA (TEMP 20-100 C=0-20 MA)	[11]
Inverter temperature 20-100°C 4-20 mA (TEMP 20-100 C=4-20 MA)	[12]

Function:

The analog output can be used for stating a process value. It is possible to choose two types of output signals 0 - 20 mA or 4 - 20 mA.

If used as a voltage output (0 - 10 V), a pull-down resistor of 500 Ω must be fitted to common (terminal

★ = factory setting. () = display text [] = value for use in communication via serial communication port

55). If the output is used as a current output the resulting resistance from the equipment connected may not exceed 500 Ω.

Description of choice:

No function is selected if the analog output is not to be used.

External Ref_{MIN} - Ref_{MAX} 0-20 mA/4-20 mA.

An output signal is obtained, which is proportional to the resulting reference value in the interval Minimum reference, Ref_{MIN} - Maximum reference, Ref_{MAX} (parameters 204/205).

FB_{MIN}-FB_{MAX} 0-20 mA/ 4-20 mA.

An output signal is obtained, which is proportional to the feedback value in the interval Minimum feedback, FB_{MIN} - Maximum feedback, FB_{MAX} (parameter 414/415).

0-f_{MAX} 0-20 mA/4-20 mA.

An output signal is obtained, which is proportional to the output frequency in the interval 0 - f_{MAX} (parameter 202 *Output frequency, high limit, f_{MAX}*).

0 - I_{INV}. 0-20 mA/4-20 mA.

An output signal is obtained, which is proportional to the output current in the interval 0 - I_{INV}.

0 - P_{M,N} 0-20 mA/4-20 mA.

An output signal is obtained, which is proportional to the present output power. 20 mA corresponds to the value set in parameter 102 *Motor power, P_{M,N}*.

0 - Temp._{MAX} 0-20 mA/4-20 mA.

An output signal is obtained, which is proportional to the present heatsink temperature. 0/4 mA corresponds to a heatsink temperature of less than 20°C, and 20 mA corresponds to 100°C.

323 Relay output 1-3
(RELAY 1-3 FUNCT.)
Value:

No function (NO OPERATION)	[0]
★Unit ready (UNIT READY)	[1]
Enable/no warning (ENABLE/NO WARNING)	[2]
Running (RUNNING)	[3]
Running in reference, no warning (RUN ON REF/NO WARN)	[4]
Running, no warnings (RUNNING/NO WARNING)	[5]
Running in reference range, no warnings	

(RUN IN RANGE/ NO WARN)	[6]	A start command has been given.
Ready - AC line voltage within range		
(RDY NO OVER/UNDERVOL)	[7]	<i>Running in reference, no warning:</i> The drive is running at reference speed. No warning.
Alarm or warning		
(ALARM OR WARNING)	[8]	<i>Running, no warning:</i>
Current higher than current limit, par. 221		A start command has been given. No warning.
(CURRENT LIMIT)	[9]	
Alarm (ALARM)	[10]	<i>Running in reference range:</i>
Output frequency higher than f_{LOW} par. 225		The drive is being controlled by a remote reference and is running within range.
(ABOVE FREQUENCY LOW)	[11]	
Output frequency lower than f_{HIGH} par. 226		
(BELOW FREQUENCY HIGH)	[12]	<i>Ready - AC line voltage within range:</i>
Output current higher than I_{LOW} par. 223		The adjustable frequency drive is ready for use; the control card is receiving a supply voltage; and there are no active control signals on the inputs. The AC line voltage lies within the voltage limits.
(ABOVE CURRENT LOW)	[13]	
Output current lower than I_{HIGH} par. 224		
(BELOW CURRENT HIGH)	[14]	
Feedback higher than FB_{LOW} par. 227		
(ABOVE FEEDBACK LOW)	[15]	<i>Alarm or warning:</i> An alarm or a warning exists in the drive.
Feedback lower than FB_{HIGH} par. 228		
(UNDER FEEDBACK HIGH)	[16]	
Relay 123 (RELAY 123)	[17]	<i>Current limit:</i>
Reversing (REVERSE)	[18]	The output current is higher than the value programmed in parameter 221 <i>Current limit</i> I_{LIM} .
Thermal warning (THERMAL WARNING)	[19]	
Local operation (LOCAL MODE)	[20]	
Pulse output (PULSE OUTPUT)	[21]	<i>Alarm:</i>
Out of frequency range, par. 225/226		The output is activated by an alarm.
(OUT OF FREQ RANGE)	[22]	
Out of current range		
(OUT OF CURRENT RANGE)	[23]	<i>Output frequency higher than f_{LOW}:</i> The output frequency is higher than the value set in parameter 225 <i>Warning: Low frequency, f_{LOW}.</i>
Out of feedback range		
(OUT OF FDBK. RANGE)	[24]	<i>Output frequency higher than F_{low}:</i> The output frequency is higher than the value set in parameter 225 <i>Warning: Low frequency, f_{LOW}.</i>
Mechanical brake control		
(MECH. BRAKE CONTROL)	[25]	

Function:

The relay output can be used for giving the present status or warning. The relay is a Form C with contacts 1 and 3 normally closed. The output is activated when a given condition is fulfilled.

Description of choice:

No function:

Is selected if the adjustable frequency drive is not to react to signals.

Unit ready:

The drive's control card receives a supply voltage and the drive is ready for operation.

Enable, no warning:

The adjustable frequency drive is ready for operation, but no start command has been given. No warning.

Running:

★ = factory setting. () = display text [] = value for use in communication via serial communication port

Output current higher than I_{LOW} :

The output current is higher than the value set in parameter 223 *Warning: Low current, I_{LOW}*

Output current lower than I_{HIGH} :

The output current is lower than the value set in parameter 224 *Warning: High current, I_{HIGH} .*

Feedback higher than FB_{LOW} :

The feedback value is higher than the value set in parameter 227 *Warning: Low feedback, FB_{LOW} .*

Feedback lower than FB_{HIGH} :

The feedback value is lower than the value set in parameter 228 *Warning: High current, I_{HIGH} .*

Relay 123:

Only used in connection with Profibus.

Reversing:

The drive is running in reverse direction.

Thermal warning:

Above the temperature limit in either the motor or the adjustable frequency drive, or from a thermistor connected to a digital input.

Local operation:

The output is active when in parameter 002 *Local/remote operation*, *Local operation* [1] has been selected.

Pulse output:

Only selected in par. 341 *Digital output terminal 46*.

Out of the frequency range:

The output frequency is out of the programmed frequency range in parameters 225 and 226.

Out of the current range:

The motor current is out of the programmed range in parameters 223 and 224.

Out of the feedback range:

The feedback signal is out of the programmed range in parameters 227 and 228.

Out of the feedback range:

The feedback signal is out of the programmed range in parameters 227 and 228.

Mechanical brake control:

Enables control of an external mechanical brake.

327 Pulse/reference feedback

(PULSE REF/FB MAX)

Value:

150 - 67600 Hz ★ 5000 Hz

Function:

This parameter is used for setting the signal value that corresponds to the maximum value set in parameter 205 *Maximum reference*, Ref_{MAX} or to the maximum feedback value set in parameter 415 *Maximum feedback*, FB_{MAX} .

Description of choice:

Set the required pulse reference or pulse feedback to be connected to terminal 33.

342 Terminal 46, max. pulse scaling

(DO 46 MAX. PULS)

Value:

150 - 10000 Hz ★ 5000 Hz

Function:

This parameter is used for setting the pulse output signal's maximum frequency.

Description of choice:

Set the required frequency.

343 Precise stop function

(PRECISE STOP)

Value:

- ★ Normal ramp stop (NORMAL) [0]
- Counter stop with reset (COUNT STOP W. RESET) [1]
- Counter stop without reset (COUNT STOP NO RESET) [2]
- Speed-compensated stop (SPEED CMP STOP) [3]
- Speed-compensated counter stop with reset (SPD CMP CSTOP W. RES) [4]
- Speed-compensated counter stop without reset (SPD CMP CSTOP NO RES) [5]

Function:

In this parameter you select which stop function is performed in response to a stop command. All six data selections contain a precise stop routine, thus ensuring a high level of repeat accuracy. The selections are a combination of the functions described below.



NOTE!

Pulse start [8] (see Inputs and Outputs) may not be used together with the precise stop function.

Description of choice:

Normal ramp stop [0] is selected to achieve high repetitive precision at the stopping point.

Counter stop. Once it has received a pulse start signal the adjustable frequency drive runs until the number of pulses programmed by the user have been received at input terminal 33. In this way an internal stop signal will activate the normal ramp down time (parameter 208).

★ = factory setting. () = display text [] = value for use in communication via serial communication port

■ Special functions

400 Brake function

(BRAKE FUNCTION)

Value:

Off (OFF)	[0]
Resistor brake (RESISTOR)	[1]
AC brake (AC BRAKE)	[4]
Load sharing (LOAD SHARING)	[5]

★ Factory setting depends on unit type.

Function:

Resistor brake [1] is selected if the adjustable frequency drive has an integral brake transistor and the brake resistor is connected to terminals 81, 82. A higher intermediate circuit voltage is permitted during braking (generated operation) when a brake resistor is connected.

AC brake [4] can be selected to improve braking without using brake resistors. Please note that *AC brake* [4] is not as effective as *Resistor brake* [1].

Description of choice:

Select *Resistor brake* [1] if a brake resistor is connected.

Select *AC brake* [4] if short-term generated loads occur. See parameter 144 *Gain AC brake* to set the brake.

Select *Load sharing* [5] if this is used.



NOTE!

A change of selection will not become active until the AC line voltage has been disconnected and reconnected.

405 Reset function

(RESET MODE)

Value:

★ Manual reset (MANUAL RESET)	[0]
Automatic reset x 1 (AUTOMATIC X 1)	[1]
Automatic reset x 3 (AUTOMATIC X 3)	[3]
Automatic reset x 10 (AUTOMATIC X 10)	[10]
Reset at power-up (RESET AT POWER UP)	[11]

Function:

This parameter makes it possible to select whether reset and restart after a trip are to be manual or whether the unit is to be reset and restarted automatically. Furthermore, it is possible to select the number of times a restart is to be attempted. The time between each attempt is set in parameter 406 *Automatic restart time*.

Description of choice:

If *Manual reset* [0] is selected, reset is to be carried out via the [STOP/RESET] key, a digital input or serial communication. If the unit is to carry out an automatic reset and restart after a trip, select data value [1], [3] or [10].

If *Reset at power-up* [11] is selected, the unit will carry out a reset if there has been a fault in connection with an AC line.



The motor may start without warning.

406 Automatic restart time

(AUTORESTART TIME)

Value:

0 - 10 sec. ★ 5 sec.

Function:

This parameter allows setting of the time from tripping until the automatic reset function begins. It is assumed that automatic reset has been selected in parameter 405 *Reset function*.

Description of choice:

Set the required time.

409 Trip delay overcurrent, I_{LIM}

(TRIP DELAY CUR.)

Value:

0 - 60 sec. (61=OFF) ★ OFF

Function:

When the adjustable frequency drive registers that the output current has reached the current limit I_{LIM} (parameter 221 *Current limit*) and remains there for the preset time, it is disconnected. Can be used to protect the application, like the ETR will protect the motor if selected.

★ = factory setting. () = display text [] = value for use in communication via serial communication port

Description of choice:

Select how long the adjustable frequency drive should maintain the output current at the current limit I_{LIM} before it disconnects. At OFF parameter 409 *Trip delay overcurrent*, I_{LIM} is not working, i.e. disconnection will not take place.

411 Switching frequency

(SWITCH FREQ.)

Value:

3000 - 14000 Hz (VLT 2803-75) ★ 4500 Hz
 3000 - 10000 Hz (VLT 2880-82) ★ 4500 Hz

Function:

The set value determines the switching frequency of the inverter. If the switching frequency is changed, this may help to minimize possible acoustic noise from the motor.



NOTE!

The output frequency of the adjustable frequency drive can never assume a value higher than 1/10 of the switching frequency.

Description of choice:

When the motor is running, the switching frequency is adjusted in parameter 411 *Switching frequency* until the frequency has been obtained at which the motor is as low-noise as possible.



NOTE!

The switching frequency is reduced automatically as a function of the load. See *Temperature-Dependent Switching Frequency* under *Special Conditions*.

When *LC-filter connected* is selected in parameter 412, the switching frequency is 4.5 kHz.

412 Variable switching frequency

(VAR CARRIER FREQ.)

Value:

★ Without LC-filter (WITHOUT LC-FILTER) [2]
 LC-filter connected
 (LC-FILTER CONNECTED) [3]

Function:

The parameter must be set to *LC-filter connected* if an LC-filter is connected between the adjustable frequency drive and the motor.

Description of choice:

Select *LC-filter connected* [3] when an LC-filter is connected between the adjustable frequency drive and the motor.



NOTE!

When the LC filter is selected, the switching frequency is changed to 4.5 kHz.

413 Overmodulation function

(OVERMODULATION)

Value:

Off (OFF) [0]
 ★ On (ON) [1]

Function:

This parameter allows connection of the overmodulation function for the output voltage.

Description of choice:

Off [0] means that there is no overmodulation of the output voltage, which means that torque ripple on the motor shaft is avoided.

On [1] means that an output voltage can be obtained which is greater than the AC line voltage (up to 5%).

414 Minimum feedback, FB_{MIN}

(MIN. FEEDBACK)

Value:

-100,000.000 - par. 415 FB_{MAX} ★ 0.000

Function:

Parameter 414 *Minimum feedback*, FB_{MIN} and 415 *Maximum feedback*, FB_{MAX} are used to scale the display text to make it show the feedback signal in a process unit proportionally to the signal on the input.

Description of choice:

Set the value to be shown on the display as the minimum feedback signal value on the selected feedback input (parameters 308/314 *Analog inputs*).

★ = factory setting. () = display text [] = value for use in communication via serial communication port

415 Maximum feedback, FB_{MAX}

(MAX. FEEDBACK)

Value:

FB_{MIN} - 100,000.000 ★ 1500.000

Function:

See description of parameter 414 *Minimum feedback, FB_{MIN}*.

Description of choice:

Set the value to be shown on the display when the maximum feedback has been obtained on the selected feedback input (parameter 308/314 *Analog inputs*).

416 Process units

(REF/FEEDB. UNIT)

Value:

★No unit (NO UNIT)	[0]
% (%)	[1]
ppm (PPM)	[2]
rpm (RPM)	[3]
bar (BAR)	[4]
Cycles/min (CYCLE/MI)	[5]
Pulses/s (PULSE/S)	[6]
Units/s (UNITS/S)	[7]
Units/min. (UNITS/MI)	[8]
Units/h (UNITS/H)	[9]
°C (°C)	[10]
Pa (PA)	[11]
l/s (L/S)	[12]
m ³ /s (M ³ /S)	[13]
l/min. (L/M)	[14]
m ³ /min. (M ³ /MIN)	[15]
l/h (L/H)	[16]
m ³ /h (M ³ /H)	[17]
Kg/s (KG/S)	[18]
Kg/min. (KG/MIN)	[19]
Kg/hour (KG/H)	[20]
Tons/min. (T/MIN)	[21]
Tons/hour (T/H)	[22]
Meters (M)	[23]
Nm (NM)	[24]
m/s (M/S)	[25]
m/min. (M/MIN)	[26]
°F (°F)	[27]
In wg (IN WG)	[28]
gal/s (GAL/S)	[29]
Ft ³ /s (FT ³ /S)	[30]
Gal/min. (GAL/MIN)	[31]
Ft ³ /min. (FT ³ /MIN)	[32]
Gal/h (GAL/H)	[33]

Ft ³ /h (FT ³ /H)	[34]
Lb/s (LB/S)	[35]
Lb/min. (LB/MIN)	[36]
Lb/hour (LB/H)	[37]
Lb ft (LB FT)	[38]
Ft/s (FT/S)	[39]
Ft/min. (FT/MIN)	[40]

Function:

Select among different units to be shown on the display. The unit is read out if the optional LCP control unit is connected, and if *Reference [unit]* [2] or *Feedback [unit]* [3] has been selected in one of parameters 009-012 *Display read-out*, and in Display mode. The unit is used in *Closed loop* also as a unit for Minimum/Maximum reference and Minimum/Maximum feedback.

Description of choice:

Select the required unit for the reference/feedback signal.



NOTE!

Parameters 417-421 are only used, if in parameter 100 *Configuration* the selection made is *Speed regulation, closed loop* [1].

417 Speed PID proportional gain

(SPEED PROP GAIN)

Value:

0.000 (OFF) - 1.000 ★ 0.010

Function:

Proportional gain indicates how many times the error (deviation between the feedback signal and the setpoint) is to be amplified.

★ = factory setting. () = display text [] = value for use in communication via serial communication port

Description of choice:

Quick regulation is obtained at high amplification, but if the amplification is too high, the process may become unstable in the case of overshooting.

**418 Speed PID integral time
(SPEED INT. TIME)**
Value:

20.00 - 999.99 ms (1000 = OFF) ★ 100 ms

Function:

The integral time determines how long the PID regulator takes to correct the error. The greater the error, the quicker the integrator frequency contribution will increase. The integral time is the time the integrator needs to achieve the same change as the proportional amplification.

Description of choice:

Quick regulation is obtained through a short integral time. However, if this time is too short, it can make the process unstable. If the integral time is long, major deviations from the required reference may occur, since the process regulator will take long to regulate if an error has occurred.

**419 Speed PID differential time
(SPEED DIFF. TIME)**
Value:

0.00 (OFF) - 200.00 ms ★ 20.00 ms

Function:

The differentiator does not react to a constant error. It only makes a contribution when the error changes. The quicker the error changes, the stronger the gain from the differentiator will be. The contribution is proportional to the speed at which errors change.

Description of choice:

Quick control is obtained by a long differential time. However, if this time is too long, it can make the pro-

cess unstable. When the differential time is 0 ms, the D-function is not active.

**420 Speed PID D- gain limit
(SPEED D-GAIN LIM)**
Value:

5.0 - 50.0 ★ 5.0

Function:

It is possible to set a limit for the gain provided by the differentiator. Since the D-gain increases at higher frequencies, limiting the gain may be useful. This enables obtaining a pure D-gain at low frequencies and a constant D-gain at higher frequencies.

Description of choice:

Select the required gain limit.

**421 Speed PID lowpass filter time
(SPEED FILT. TIME)**

Value:
20 - 500 ms ★ 100 ms

Function:
Noise in the feedback signal is dampened by a first order lowpass filter to reduce noise impact on the regulation. This might be an advantage, e.g. if there is a great amount of noise on the signal. See drawing.

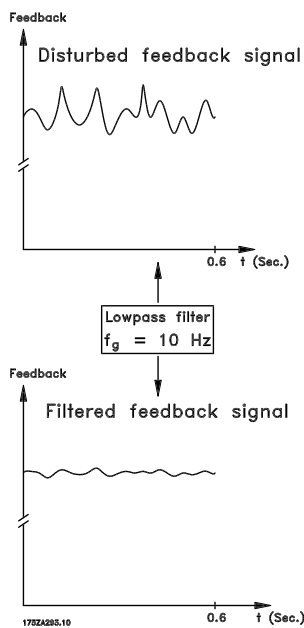

Description of choice:
If a time constant (t) of 100 ms is programmed, the cut-off frequency for the lowpass filter will be $1/0.1 = 10$ RAD/sec., corresponding to $(10 / 2 \times \pi) = 1.6$ Hz. The PID regulator will then only regulate a feedback signal that varies with a frequency of less than 1.6 Hz. If the feedback signal varies by a higher frequency than 1.6 Hz, it will be dampened by the lowpass filter.

**423 V1 voltage
(U1 VOLTAGE)**

Value:
0.0 - 999.0 V ★ par. 103

Function:
Parameters 423-428 are used when, in parameter 101 *Torque characteristic*, a selection has been made of *Special motor characteristic* [8]. It is possible to determine a V/f characteristic on the basis of four definable voltages and three frequencies. The voltage at 0 Hz is set in parameter 133 *Start voltage*.

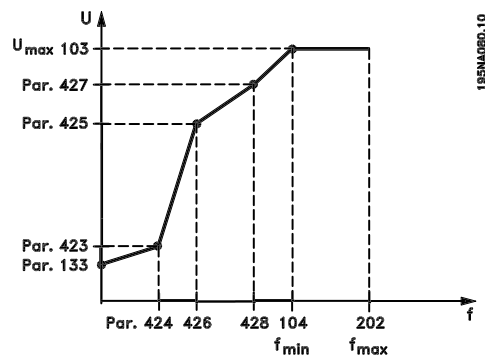

Description of choice:
Set the output voltage (V1) that is to match the first output frequency (F1), parameter 424 *F1 frequency*.

**424 F1 frequency
(F1 FREQUENCY)**

Value:
0.0 - par. 426 *F2 frequency*
★ Par. 104 *Motor frequency*

Function:
See parameter 423 *U1 voltage*.

Description of choice:
Set the output frequency (F1) that is to match the first output voltage (V1), parameter 423 *V1 voltage*.

★ = factory setting. () = display text [] = value for use in communication via serial communication port

425 V2 voltage
(U2 VOLTAGE)
Value:

 0.0 - 999.0 V ★ par. 103
Function:

 See parameter 423 *V1 voltage*.

Description of choice:

 Set the output voltage (V2) that is to match the second output frequency (F2), parameter 426 *F2 frequency*.

426 F2 frequency
(F2 FREQUENCY)
Value:

 Par. 424 *F1 frequency* - par. 428 *F3 frequency*
★ Par. 104 *Motor frequency*
Function:

 See parameter 423 *V1 voltage*.

Description of choice:

 Set the output frequency (F2) that is to match the second output voltage (V2), parameter 425 *V2 voltage*.

427 V3 voltage
(U3 VOLTAGE)
Value:

 0.0 - 999.0 V ★ par. 103
Function:

 See parameter 423 *V1 voltage*.

Description of choice:

 Set the output voltage (V3) that is to match the third output frequency (F3), parameter 428 *F3 frequency*.

428 F3 frequency
(F3 FREQUENCY)
Value:

 Par. 426 *F2 frequency* - 1000 Hz
★ Par. 104 *Motor frequency*
Function:

 See parameter 423 *V1 voltage*.

Description of choice:

 Set the output frequency (F3) that is to match the third output voltage (V3), parameter 427 *V3 voltage*.

NOTE!

 Parameters 437-444 are only used if in parameter 100 *Configuration* a selection has been made of *Process regulation, closed loop*. [3].

437 Process PID normal/inverse control
(PROC NO/INV CTRL)
Value:

★Normal (NORMAL)	[0]
Inverse (INVERSE)	[1]

Function:

It is possible to choose whether the process regulator is to increase/reduce the output frequency if there is a deviation between the reference/setpoint and the actual process mode.

Description of choice:

 If the unit is to reduce the output frequency in case the feedback signal increases, select *Normal* [0]. If the unit is to increase the output frequency in case the feedback signal increases, select *Inverse* [1].

438 Process PID anti-windup
(PROC ANTI WINDUP)
Value:

Not active (DISABLE)	[0]
★Active (ENABLE)	[1]

Function:

It is possible to select whether the process regulator is to continue regulating on a deviation even if it is not possible to increase/reduce the output frequency.

Description of choice:

 The factory setting is *Enable* [1], which means that the integration link is initialized in relation to the actual output frequency if the current limit, the voltage limit, or the max./min. frequency has been reached. The process regulator will not engage again until either the error is zero or its sign has changed. Select *Disable* [0] if the integrator is to continue integrating on the deviation, even if it is not possible to remove the error by such control.

★ = factory setting. () = display text [] = value for use in communication via serial communication port



NOTE!

If *Disable* [0] is selected, it will mean that when the deviation changes its sign, the integrator will first have to integrate down from the level obtained as a result of the former error, before any change in output frequency occurs.

439 Process PID start frequency

(PROC START VALUE)

Value:

f_{MIN} - f_{MAX} (parameter 201/202)

★ Par. 201 *Output frequency, low limit, f_{MIN}*

Function:

Upon a start signal, the drive will react in the form of *Open loop* and will not change to *Closed loop* until the programmed start frequency is reached. This makes it possible to set a frequency that corresponds to the speed at which the process normally runs, which will enable the required process conditions to be reached sooner.

Description of choice:

Set the required start frequency.



NOTE!

If the unit is running at current limit before the required start frequency is obtained, the process regulator will not be activated. For the regulator to be activated anyway, the start frequency must be lower to the required output frequency. This can be done during operation.

440 Process PID proportional gain

(PROC. PROP. GAIN)

Value:

0.0 - 10.00

★ 0.01

Function:

The proportional gain indicates the number of times the deviation between the setpoint and the feedback signal is to be applied.

Description of choice:

Quick regulation is obtained by a high gain, but, if the gain is too high, the process may become unstable. See Optimization of the Process Regulator for information on proper adjustment.

441 Process PID integral time

(PROC. INTEGR. T.)

Value:

0.01 - 9999.99 (OFF)

★ OFF

Function:

The integrator provides an increasing gain at a constant error between the reference/setpoint and the feedback signal. The greater the error, the quicker the integrator frequency contribution will increase. The integral time is the time needed by the integrator to make the same change as the proportional gain.

Description of choice:

Fast regulation is obtained by setting a short integration time. However, if this time is too short, the process will overcorrect and become unstable. See Optimization of the Process Regulator for information on proper adjustment.

442 Process PID differentiation time

(PROC. DIFF. TIME)

Value:

0.00 (OFF) - 10.00 sec.

★ 0.00 sec.

Function:

The differentiator does not react to a constant error. It only makes a gain when an error changes. The quicker the deviation changes, the stronger the gain from the differentiator. The gain is proportional to the speed at which the deviation changes.

Description of choice:

Fast regulation can be obtained by means of a long differentiation time. If this time is too long, the process may overshoot. The differentiator is generally set of OFF in HVAC applications. See Optimization of the Process Regulator for information on proper adjustment.

443 Process PID diff. gain limit

(PROC. DIFF.GAIN)

Value:

5.0 - 50.0

★ 5.0

Function:

It is possible to set a limit for the differentiator gain. The differentiator gain will increase if there are fast changes, which is why it can be beneficial to limit

★ = factory setting. () = display text [] = value for use in communication via serial communication port

this gain. Thereby a pure differentiator gain is obtained at slow changes and a constant differentiator gain where quick changes to the deviation occur.

Description of choice:

A lower limit will improve stability, but will reduce the effect of the differential.

Optimization of the Process Regulator:

To optimize the system, set the proportional gain, the integration time and, if needed, the differentiation time. These are set by parameters 440, 441 and 442. In most processes, this can be done in accordance with the following guidelines:

1. Start the motor.
2. Set parameter 440, *Process PID proportional gain*, to 0.3 and increase it until the feedback signal becomes unstable. Then reduce the value until the feedback signal has stabilized. Now lower the proportional gain by about half (40% to 60%).
3. Set parameter 441, *Process PID integration time*, to 20 seconds and reduce the value until the feedback signal becomes unstable. Increase the integration time until the feedback signal stabilizes. Now increase the integration time from 15% to 50%.
4. Parameter 442, *Process PID differentiation time*, is only used in very fast-acting systems and should be left off for most HVAC applications. When it is used, the typical value is 1/4th the value set in parameter 441, *Process PID integral time*. The differentiator should only be used when the setting of the proportional gain and the integration time have been fully optimized.

Starting and stopping the drive will produce the necessary error signal in the process to set the PID.

444 Process PID lowpass filter time

(PROC FILTER TIME)

Value:

0.02 - 10.00 ★ 0.02

Function:

Noise in the feedback signal is dampened by a first order lowpass filter to reduce noise impact on the process regulation. This can be an advantage e.g. if there is a lot of noise on the signal.

★ = factory setting. () = display text [] = value for use in communication via serial communication port

Description of choice:

Select the required time constant (t). If a time constant (t) of 0.1s is programmed, the cut-off frequency for the lowpass filter will be $1/0.1 = 10 \text{ RAD/sec.}$, corresponding to $(10 / 2 \times \pi) = 1.6 \text{ Hz}$. The process regulator will thus only regulate a feedback signal that varies by a frequency lower than 1.6 Hz. If the feedback signal varies by a higher frequency than 1.6 Hz, it will be dampened by the lowpass filter.

445 Flying start

(FLYINGSTART)

Value:

- ★ Off (DISABLE) [0]
- OK - same direction (OK-SAME DIRECTION) [1]
- OK - both directions (OK-BOTH DIRECTIONS) [2]
- DC brake and start (DC-BRAKE BEF. START) [3]

Function:

This function makes it possible to 'catch' a rotating motor shaft, which is no longer controlled by the unit, e.g. because of a AC line drop-out. The function is activated each time a start command is enabled. For the unit to be able to 'catch' the rotating motor shaft, the motor speed must be lower than the frequency that corresponds to the frequency in parameter 202 *Output frequency, high limit, f_{MAX}*.

Description of choice:

Select *Disable* [0] if this function is not required.

Select *OK - same direction* [1] if the motor shaft is only able to rotate in the same direction when cutting in. *OK - same direction* [1] should be selected if in parameter 200 *Output frequency range* a selection has been of *Clockwise only*.

Select *OK - both directions* [2] if the motor is able to rotate in both directions when cutting in.

Select *DC brake and start* if the drive is to brake the motor by means of the DC brake first, and then start. Ensure that parameters 126, 127, and 132 are set appropriately. Select *DC brake and start* if the motor may be externally driven at a significant speed in the reverse direction.

Limitations:

- Too low inertia will lead to load acceleration, which can be dangerous or prevent correct catching of a rotating motor. Use the DC brake instead.
- A driven rotating motor, or windmilling motor with high inertia, may cause a drive trip with flying start. Use *DC brake and start*.
- Flying start does not work at values lower than 250 rpm.

451 Speed PID feedforward factor
(FEEDFORWARD FACT)
Value:

 0 - 500% ★ 100%
Function:

This parameter is only active if in parameter 100 *Configuration* the selection made is *Speed regulation, closed loop*. The FF function sends a larger or smaller part of the reference signal outside the PID controller in such a way that the PID controller only has an influence on part of the control signal. Any change to the set point will thus have a direct effect on the motor speed. The FF factor provides high dynamism when changing the set point and less overswing.

Description of choice:

The required % value can be selected in the interval between minimum and maximum frequency. Values over 100% are used if the set point variations are only small.

452 Controller range
(PID CONTR. RANGE)
Value:

 0 - 200 % ★ 10 %
Function:

This parameter is only active if in parameter 100 *Configuration* the selection made is *Speed regulation, closed loop*.

The controller range (bandwidth) limits the output from the PID controller as a % of nominal motor frequency.

Description of choice:

The required % value can be selected for nominal motor frequency. If the controller range is reduced the speed variations will be less during initial tuning.

456 Brake Voltage Reduce
(BRAKE VOL.REDUCE)
Value:

 0 - 25 V if 200V device ★ 0

 0 - 50 V if 400V device ★ 0
Function:

The user sets the voltage by which the level for resistor braking is reduced. It is only active when resistor in parameter 400 is selected.

Description of choice:

The greater the reduction value, the faster the reaction to a generator overload. Should only be used if there are problems with overvoltage in the intermediate circuit.

★ = factory setting. () = display text [] = value for use in communication via serial communication port

Serial communication

500 Address

(BUS ADDRESS)

Value:

0 - 126 ★ 1

Function:

This parameter allows the allocation of an address to each adjustable frequency drive in a serial communication network.

Description of choice:

The individual adjustable frequency drive must be allocated a unique address.

If the number of units connected (adjustable frequency drives + master) is higher than 31, a repeater must be used.

Parameter 500 *Address* cannot be selected via the serial communication, but must be preset via the control unit.

501 Baudrate

(BAUDRATE)

Value:

300 Baud (300 BAUD) [0]
 600 Baud (600 BAUD) [1]
 1200 Baud (1200 BAUD) [2]
 2400 Baud (2400 BAUD) [3]
 4800 Baud (4800 BAUD) [4]
 ★9600 Baud (9600 BAUD) [5]

Function:

This parameter is for programming the speed at which data is transmitted via the serial port. Baud rate is defined as the number of bits transmitted per second.

Description of choice:

The frequency converter's transmission speed must be set at a value corresponding to the transmission speed of the master.

Parameter 501 *Baudrate* cannot be selected via the serial port, but must be preset via the operating unit.

502 Coasting Stop

(COASTING SELECT)

Value:

Digital input (DIGITAL INPUT) [0]
 Serial port (SERIAL PORT) [1]
 Logic and (LOGIC AND) [2]
 ★Logic or (LOGIC OR) [3]

Function:

Parameters 502-508 allow a choice between controlling the frequency converter via the digital inputs and/or via the serial port.

If *Serial port* [1] is selected, the relevant command can only be activated if a command is given via the serial port.

In the case of *Logic and* [2] the function must also be activated via a digital input.

Description of choice:

The table below shows when the motor is running and when it is coasting, when each of the following is selected: *Digital input* [0], *Serial port* [1], *Logic and* [2] or *Logic or* [3].



NOTE!

Note that *Coasting stop* and Bit 03 in the control word are active at logic '0'.

Digital input [0]

Dig. input	Ser. port	Function
0	0	Coasting
0	1	Coasting
1	0	Motor running
1	1	Motor running

Serial port [1]

Dig. input	Ser. port	Function
0	0	Coasting
0	1	Motor running
1	0	Coasting
1	1	Motor running

Logic and [2]

Dig. input	Ser. port	Function
0	0	Coasting
0	1	Motor running
1	0	Motor running
1	1	Motor running

★ = factory setting. () = display text [] = value for use in communication via serial communication port

VLT® 2800 Series

Logic or [3]		
Dig. input	Ser. port	Function
0	0	Coasting
0	1	Coasting
1	0	Coasting
1	1	Motor running

Logic and [2]		
Dig. input	Serial port	Function
0	0	Quick-stop
0	1	Motor running
1	0	Motor running
1	1	Motor running

503 Quick-stop

(Q STOP SELECT)

Value:

Digital input (DIGITAL INPUT)	[0]
Serial port (SERIAL PORT)	[1]
Logic and (LOGIC AND)	[2]
★Logic or (LOGIC OR)	[3]

Function:

See function description for parameter 502 *Coasting stop*.

Description of choice:

The table below shows when the motor is running and when it is in Quick-stop mode, when each of the following is selected: *Digital input* [0], *Serial port* [1], *Logic and* [2] or *Logic or* [3].



NOTE!

Note that *Quick-stop inverse* and Bit 04 in the control word are active at logic '0'.

Digital input [0]		
Dig. input	Serial port	Function
0	0	Quick-stop
0	1	Quick-stop
1	0	Motor running
1	1	Motor running

Logic or [3]		
Dig. input	Serial port	Function
0	0	Quick-stop
0	1	Quick-stop
1	0	Quick-stop
1	1	Motor running

504 DC brake

(DC BRAKE SELECT)

Value:

Digital input (DIGITAL INPUT)	[0]
Serial port (SERIAL PORT)	[1]
Logic and (LOGIC AND)	[2]
★Logic or (LOGIC OR)	[3]

Function:

See function description for parameter 502 *Coasting stop*.

Description of choice:

The table below shows when the motor is running and the DC braking when each of the following is selected: *Digital input* [0], *Serial port* [1], *Logic and* [2] or *Logic or* [3].



NOTE!

Note that *DC braking inverse* and Bit 02 in the control word are active at logic '0'.

Serial port [1]		
Dig. input	Serial port	Function
0	0	Quick-stop
0	1	Motor running
1	0	Quick-stop
1	1	Motor running

Digital input [0]		
Dig. input	Ser. port	Function
0	0	DC braking
0	1	DC braking
1	0	Motor running
1	1	Motor running

★ = factory setting. () = display text [] = value for use in communication via serial communication port

VLT® 2800 Series

Serial port [1]		
Dig. input	Ser. port	Function
0	0	DC braking
0	1	Motor running
1	0	DC braking
1	1	Motor running

Logic and [2]		
Dig. input	Ser. port	Function
0	0	DC braking
0	1	Motor running
1	0	Motor running
1	1	Motor running

Logic or [3]		
Dig. input	Ser. port	Function
0	0	DC braking
0	1	DC braking
1	0	DC braking
1	1	Motor running

Serial port [1]		
Dig. input	Ser. port	Function
0	0	Stop
0	1	Start
1	0	Stop
1	1	Start

Logic and [2]		
Dig. input	Ser. port	Function
0	0	Stop
0	1	Stop
1	0	Stop
1	1	Start

Logic or [3]		
Dig. input	Ser. port	Function
0	0	Stop
0	1	Start
1	0	Start
1	1	Start

505 Start

(START SELECT)

Value:

Digital input (DIGITAL INPUT)	[0]
Serial port (SERIAL PORT)	[1]
Logic and (LOGIC AND)	[2]
★Logic or (LOGIC OR)	[3]

Function:

See function description for parameter 502 *Coasting stop*.

Description of choice:

The table below shows when the motor has stopped and when the frequency converter has a start command when each of the following is selected: *Digital input [0]*, *Serial port [1]*, *Logic and [2]* or *Logic or [3]*.

Digital input [0]		
Dig. input	Ser. port	Function
0	0	Stop
0	1	Stop
1	0	Start
1	1	Start

506 Reversing

(REVERSING SELECT)

Value:

Digital input (DIGITAL INPUT)	[0]
Serial port (SERIAL PORT)	[1]
Logic and (LOGIC AND)	[2]
★Logic or (LOGIC OR)	[3]

Function:

See function description for parameter 502 *Coasting stop*.

Description of choice:

The table below shows when the motor is running clockwise and counter clockwise when each of the following is selected: *Digital input [0]*, *Serial port [1]*, *Logic and [2]* or *Logic or [3]*.

Digital input [0]		
Dig. input	Ser. port	Function
0	0	Clockwise
0	1	Clockwise
1	0	Counter clockwise
1	1	Counter clockwise

★ = factory setting. 0 = display text [] = value for use in communication via serial communication port

VLT® 2800 Series

Serial port [1]		
Dig. input	Ser. port	Function
0	0	Clockwise
0	1	Counter clockwise
1	0	Clockwise
1	1	Counter clockwise

Logic and [2]		
Dig. input	Ser. port	Function
0	0	Clockwise
0	1	Clockwise
1	0	Clockwise
1	1	Counter clockwise

Logic or [3]		
Dig. input	Ser. port	Function
0	0	Clockwise
0	1	Counter clockwise
1	0	Counter clockwise
1	1	Counter clockwise

507 Selection of Setup

(SETUP SELECT)

Value:

Digital input (DIGITAL INPUT)	[0]
Serial communication (SERIAL PORT)	[1]
Logic and (LOGIC AND)	[2]
★Logic or (LOGIC OR)	[3]

Function:

See function description of parameter 502 *Coasting stop*.

Description of choice:

The table below shows which Setup (parameter 004 *Active Setup*) is selected for each of the following: *Digital input* [0], *Serial communication* [1], *Logic and* [2] or *Logic or* [3].

Digital input [0]		
Setup msb	Setup lsb	Function
0	0	Setup 1
0	1	Setup 2
1	0	Setup 3
1	1	Setup 4

Serial communication [1]		
Setup msb	Setup lsb	Function
0	0	Setup 1
0	1	Setup 2
1	0	Setup 3
1	1	Setup 4

Logic and [2]				
Bus Setup msb	Bus Setup lsb	Dig. Setup msb	Dig. Setup lsb	Setup no.
0	0	0	0	1
0	0	0	1	1
0	0	1	0	1
0	0	1	1	1
0	1	0	0	1
0	1	0	1	2
0	1	1	0	1
0	1	1	1	2
1	0	0	0	1
1	0	0	1	1
1	0	1	0	3
1	0	1	1	3
1	1	0	0	1
1	1	0	1	2
1	1	1	0	3
1	1	1	1	4

★ = factory setting. 0 = display text [] = value for use in communication via serial communication port

<i>Logic or [3]</i>				
Bus Setup msb	Bus Setup lsb	Dig. Setup msb	Dig. Setup lsb	Setup no.
0	0	0	0	1
0	0	0	1	2
0	0	1	0	3
0	0	1	1	4
0	1	0	0	2
0	1	0	1	2
0	1	1	0	4
0	1	1	1	4
1	0	0	0	3
1	0	0	1	4
1	0	1	0	3
1	0	1	1	4
1	1	0	0	4
1	1	0	1	4
1	1	1	0	4
1	1	1	1	4

**508 Selection of preset ref.
(PRES.REF. SELECT)**
Value:

Digital input (DIGITAL INPUT)	[0]
Serial communication (SERIAL PORT)	[1]
Logic and (LOGIC AND)	[2]
★Logic or (LOGIC OR)	[3]

Function:

See function description of parameter 502 *Coasting stop*.

Description of choice:

Preset references via serial communication are active when parameter 512 *Telegram profile* is set to *FC protocol* [1].

509 Bus jog 1 (BUS JOG 1 FREQ.)
510 Bus jog 2 (BUS JOG 2 FREQ.)
Value:

0.0 - par. 202 *Output frequency high limit* ★ 10,0 Hz

Function:

If parameter 512 *Telegram Profile* shows the selection *Profidrive* [0], two fixed speeds (Jog 1 or Jog 2) can be selected via the serial port.

The function is the same as in parameter 213 *Jog frequency*.

Description of choice:

Jog frequency can be selected between 0 Hz and maximum frequency.

512 Telegram Profile
(TELEGRAM PROFILE)
Value:

Profidrive (PROFIDRIVE)	[0]
★FC protocol (FC PROTOCOL)	[1]

Function:

It is possible to choose between two different control word profiles.

Description of choice:

Select the desired control word profile. See *Serial port for VLT 2800* for further details of control word profiles.

513 Bus time interval
(BUS TIMEOUT TIME)
Value:

1 - 99 sec. ★ 1 sec.

Function:

In this parameter it is possible to preset the maximum time expected to elapse between receipt of two consecutive telegrams. If this time is exceeded, the serial communication is assumed to have stopped and the desired reaction is preset in parameter 514 *Bus time interval function*.

Description of choice:

Preset the required time.

**514 Bus time interval function
(BUS TIMEOUT FUNC)**
Value:

★Off (OFF)	[0]
Freeze output frequency (FREEZE OUTPUT)	[1]
Stop (STOP)	[2]
Jogging (JOGGING)	[3]
Max. speed (MAX SPEED)	[4]
Stop and trip (STOP AND TRIP)	[5]

Function:

In this parameter you can select the required reaction for the adjustable frequency drive when the preset time in parameter 513 *Bus time interval* has been exceeded. If choices [1] to [5] are activated the output relay will be deactivated.

Description of choice:

The output frequency of the adjustable frequency drive can be frozen at the present value, stop the motor, be frozen at parameter 213 *Jogging frequency*, be frozen at parameter 202 *Output frequency, high limit f_{MAX}* or stop and activate a cut out.

★ = factory setting. () = display text [] = value for use in communication via serial communication port

515-544 Data readout
Value:

Par. no.	Description	Display text	Unit	Update interval
515	Res. reference	(REFERENCE %)	%	
516	Res. reference [Unit]	(REFERENCE [UNIT])	Hz, rpm	
517	Feedback [Unit]	(FEEDBACK [UNIT])	Par. 416	
518	Frequency	(FREQUENCY)	Hz	
519	Frequency x scale	(FREQUENCY X SCALE)	Hz	
520	Motor current	(MOTOR CURRENT)	Amp	
521	Torque	(TORQUE)	%	
522	Power[kW]	(POWER (KW))	kW	
523	Power[HP]	(POWER (HP))	HP	
524	Motor voltage	(MOTOR VOLTAGE)	V	
525	DC-link voltage	(DC LINK VOLTAGE)	V	
526	Thermal load motor	(MOTOR THERMAL)	%	
527	Thermal load inverter	(INV. THERMAL)	%	
528	Digital input	(DIGIT AL INPUT)	Bin	
529	Term.53, analog input	(ANALOG INPUT 53)	V	
531	Term.60, analog input	(ANALOG INPUT 60)	mA	
532	Pulse reference	(PULSE REFERENCE)	Hz	
533	External ref.	(EXT . REF.%)	%	
534	Status word, Hex	(STATUS WORD)	Hex	
537	Inverter temperature	(INVERTER TEMP.)	°C	
538	Alarm word	(ALARM WORD)	Hex	
539	Control word	(CONTROL WORD)	Hex	
540	Warning word	(WARN. WORD)	Hex	
541	Extended status word	(STATUS WORD)	Hex	
544	Pulse count	(PULSE COUNT)		

Function:

These parameters can be read out via the serial communication port and the LCP display. See also parameters 009-012 *Display readout*.

NOTE!

Parameters 515-541 can only be read out via an LCP control unit.

Description of choice:

Parameter 515, Resulting reference %:

Gives the resulting reference as a percentage in the range from Minimum reference, Ref_{MIN} to Maximum reference, Ref_{MAX}. See also *Handling of References*.

Parameter 516, Resulting reference [unit]:

Gives the resulting reference in Hz in closed loop (parameter 100). In closed loop the reference unit in parameter 416 *Process units* is selected.

Parameter 517, Feedback [unit]:

Gives the resulting feedback value with the unit/scaling that is selected in parameters 414, 415 and 416. See also handling of feedback.

Parameter 518, Frequency [Hz]:

Gives the output frequency from the adjustable frequency drive.

Parameter 519, Frequency x scaling [-]:

Corresponds to the present output frequency f_M multiplied by the factor preset in parameter 008 *Display scaling of output frequency*.

★ = factory setting. () = display text [] = value for use in communication via serial communication port

Parameter 520, Motor current [A]:

Gives the motor's phase current measured as an effective value.

Parameter 521, Torque [Nm]:

Gives the motor's present load in relation to the motor's rated torque.

Parameter 522, Power [kW]:

Gives the motor's present power in kW which the motor absorbs.

Parameter 523, Power [HP]:

Gives the motor's present voltage in HP which the motor absorbs.

Parameter 524, Motor voltage:

Gives the voltage supplied to the motor.

Parameter 525, DC link voltage:

Gives the intermediate circuit voltage in the adjustable frequency drive.

Parameter 526, Thermal load, motor [%]:

Gives the calculated/estimated thermal load on the motor. 100% is the trip point. See also parameter 128 *Thermal motor protection*.

Parameter 527, Thermal load INV [%]:

Gives the calculated/estimated thermal load on the adjustable frequency drive. 100% is the cut-out limit.

Parameter 528, Digital input:

Gives the signal status from the 5 digital inputs (18, 19, 27, 29 and 33). Input 18 corresponds to the bit on the extreme left. '0' = no signal, '1' = connected signal.

Parameter 529, Terminal 53 analog input [V]:

Gives the voltage value for the signal on terminal 53.

Parameter 531, Terminal 60 analog input [mA]:

Gives the current value for the signal on terminal 60.

Parameter 532, Pulse reference [Hz]:

Gives a pulse frequency in Hz connected to terminal 33.

Parameter 533, External reference:

Gives the sum of external references as a percentage (sum of analog/pulse/serial communication) in the range from Minimum reference, Ref_{MIN} to Maximum reference, Ref_{MAX}.

Parameter 534, Status word:

Gives the present status word for the adjustable frequency drive in Hex. See *Serial communication for the VLT 2800*.

Parameter 537, Inverter temperature:

Gives the heatsink temperature on the adjustable frequency drive. The trip limit is 194°F - 212°F (90°C - 100°C), with reset at 158°F ± 9°F (70 ± 5 °C).

Parameter 538, Alarm word:

Gives in Hex code which alarm is on the adjustable frequency drive. See *Warning word, extended status word and alarm word*.

Parameter 539, Control word:

Gives the present control word on the adjustable frequency drive in Hex. See *Serial communication for the VLT 2800*.

Parameter 540, Warning word:

Gives whether there is a warning on the adjustable frequency drive in Hex. See *Warning word, extended status word and alarm word*.

Parameter 541, Extended status word:

Gives whether there is a warning on the adjustable frequency drive in Hex code. See *Warning word, extended status word and alarm word*.

Parameter 544, Pulse count:

This parameter can be read out via the LCP display (009–012). When you run with counter stop, this parameter enables you, either with or without reset, to read the number of pulses registered by the device. The highest frequency is 67.6 kHz, while the lowest is 5 Hz. The counter is reset when counter stop is restarted.

★ = factory setting. () = display text [] = value for use in communication via serial communication port

■ Technical functions

600-605 Operating Data				
Value:				
Par. no.	Description	Display text	Unit	Range
600	Operating hours	(OPERATING HOURS)	Hours	0-130,000.0
601	Hours run	(RUNNING HOURS)	Hours	0-130,000.0
602	kWh counter	(KWH COUNTER)	kWh	Depends on unit
603	Number of power-ups	(POWER UPS)	Number of times	0-9999
604	Number of overtemperatures	(OVER TEMPS)	Number of times	0-9999
605	Number of overvoltages	(OVER VOLTS)	Number of times	0-9999

Function:

These parameters can be read out via the serial communication port and the LCP control unit.

Description of choice:

Parameter 600, Operating hours:

Gives the number of hours the adjustable frequency drive has been operating. The value is saved every hour and when there is an AC line failure. This value cannot be reset.

Parameter 601, Hours run:

Gives the number of hours the motor has been operating since the reset in parameter 619 *Reset of hours-run counter*. The value is saved every hour and when there is an AC line failure.

Parameter 602, kWh counter:

Gives the adjustable frequency drive's output energy in kWh. The calculation is based on the mean kW value over one hour. This value can be reset using parameter 618 *Reset of kWh counter*.

Range: 0 - depends on unit.

Parameter 603, Number of power-ups:

Gives the number of power-ups of the supply voltage undertaken on the adjustable frequency drive.

Parameter 604, Number of overtemperatures:

Gives the number of overtemperature faults that have been registered on the adjustable frequency drive's heatsink.

Parameter 605, Number of overvoltages:

Gives the number of overvoltages of the intermediate circuit voltage in the adjustable frequency drive. This is only counted when Alarm 7 *Overvoltage* is active.

NOTE!

Parameters 615-617 *Fault log* cannot be read out via the integral control unit.

615 Fault log: Error code
(F.LOG: ERROR COD)
Value:

[Index 1 - 10] Error code: 0 - 99

Function:

In this parameter it is possible to see the reason for a trip (cut-out of the adjustable frequency drive) occurring. 10 [1-10] log values are defined.

The lowest log number [1] contains the latest/most recently saved data value. The highest log number [10] contains the oldest data value saved. If a trip occurs, it is possible to see the cause, time and a possible value of the output current or output voltage.

Description of choice:

Given as a fault code, in which the number refers to a table. See the table in *Warnings/alarm messages*.

★ = factory setting. () = display text [] = value for use in communication via serial communication port

616 Fault log: Time

(F.LOG: TIME)

Value:

[Index 1 - 10] Hours: 0 - 130,000.0

Function:

In this parameter it is possible to see the total number of operating hours in connection with the last 10 trips.

10 [1-10] log values are denoted. The lowest log number [1] contains the latest/most recently saved data value, and the highest log number [10] contains the oldest data value.

Description of choice:

Read out as one value.

617 Fault log: Value

(F.LOG: VALUE)

Value:

[Index 1 - 10] Value: 0 - 9999

Function:

In this parameter it is possible to see at which value a trip occurred. The unit of the value depends on which alarm is active in parameter 615 *Fault log: Fault code*.

Description of choice:

Read out as one value.

618 Reset of kWh counter

(RESET KWH COUNT)

Value:

★No reset (DO NOT RESET)	[0]
Reset (RESET COUNTER)	[1]

Function:

Resetting parameter 602 *kWh counter* to zero.

Description of choice:

If *Reset* [1] is selected and you press the [OK] key, the adjustable frequency drive's parameter 602 is reset to zero *Hours run*. This parameter cannot be selected via serial communication.



NOTE!

When the [OK] key is activated, the counter is reset to zero.

619 Reset Running Hours Counter

(RESET RUN. HOUR)

Value:

★No reset (DO NOT RESET)	[0]
Reset (RESET COUNTER)	[1]

Function:

Resetting of parameter 601 *Hours run* to zero.

Description of choice:

If *Reset* [1] is selected and you press the [OK] key, the adjustable frequency drive's parameter 601 is reset to zero *Hours run*. This parameter cannot be selected via serial communication.



NOTE!

When the [OK] key is activated the parameter is reset to zero.

★ = factory setting. () = display text [] = value for use in communication via serial communication port

620 Operation Mode

(OPERATION MODE)

Value:

★ Normal operation (NORMAL OPERATION)	[0]
Control card test (CONTROL CARD TEST)	[2]
Initialize (INITIALIZE)	[3]

Function:

In addition to its normal function, this parameter can be used to test the control card.

There is also the opportunity to perform an initialization at the factory setting for all parameters in all Setups, with the exception of parameters 500 *Address*, 501 *Baudrate*, 600-605 *Operating data* and 615-617 *Fault log*.

Description of choice:

Normal function [0] is used for normal operation of the motor.

Control card test [2] is selected if you wish to check the control card's analog/digital inputs, analog/digital outputs, relay outputs and 10 V and 24 V voltages.

The test is performed as follows:

27 - 29 - 33 - 46 are connected.

50 - 53 are connected.

42 - 60 are connected.

12 - relay terminal 01 is connected.

18 - relay terminal 02 is connected.

19 - relay terminal 03 is connected.

See also the DeviceNet manual MG.90.BX.YY for further details.

5. The adjustable frequency drive automatically undertakes a test of the control card.

If the adjustable frequency drive displays a fault code from 37-45, the control card test has failed. Change the control card to start up the adjustable frequency drive.

If the adjustable frequency drive comes into Display mode, the test is OK. Remove the test connector and the adjustable frequency drive is ready for operation. Parameter 620 *Operating mode* is automatically set to *Normal operation* [0].

Initialization [3] is selected if you wish to use the unit's factory setting.

Procedure for initialization:

1. Select *Initialization* [3].
2. Disconnect the AC line voltage and wait until the light in the display has disappeared.
3. Connect the AC line voltage.
4. An initialization is performed in all parameters in all Setups, with the exception of parameters 500 *Address*, 501 *Baudrate*, 600-605 *Operating data* and 615-617 *Fault log*.

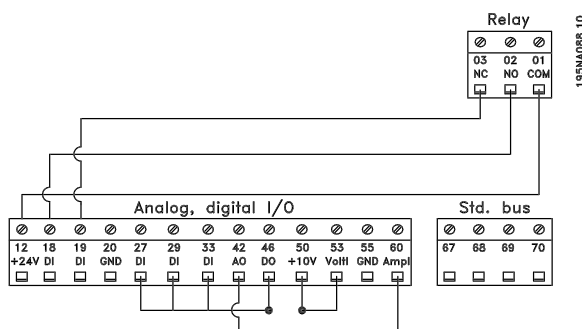

Use the following procedure for the control card test:

1. Select control card test.
2. Disconnect the AC line voltage and wait until the light in the display has disappeared.
3. Mount according to drawing and description.
4. Connect the AC line voltage.

★ = factory setting. () = display text [] = value for use in communication via serial communication port

621-642 Nameplate
Value:

Par. no	Description	Display text
621	Unit type	(DRIVE TYPE)
624	Software version	(SOFTWARE VERSION)
625	LCP identification no.	(LCP VERSION)
626	Database identification no.	(DATABASE VER.)
627	Power parts version	(POWER UNIT DB ID)
628	Application option type	(APP. OPTION)
630	Communication option type	(COM. OPTION)
632	BMC software identification	(BMC-SOFTWARE ID)
634	Unit identification for communication	(UNIT ID)
635	Software parts no.	(SW. PART NO.)
640	Software version	(SOFTWARE VERSION)
641	BMC-software identification	(BMC2 SW)
642	Power card identification	(POWER ID)

Function:

The unit's main data can be read out from parameters 621 to 635 *Nameplate* using the optional LCP 2 control unit or serial communication. Parameters 640 - 642 can also be seen on the unit's integral display.

Description of choice:

Parameter 621 Nameplate: Unit type:

Gives unit size and AC line voltage.

Example: VLT 2811 380-480 V.

Parameter 624 Nameplate: Software version no.:

The unit's present software version number appears here.

Example: V 1.00

Parameter 625 Nameplate: LCP ID number:

The ID number of the unit's LCP appears here.

Example: ID 1.42 2 kB

Parameter 626 Nameplate: Database ID number:

The ID number of the software's database appears here.

Example: ID 1.14.

Parameter 627 Nameplate: Power section version:

The ID number of the unit's power section appears here.

Example: ID 1.15.

Parameter 628 Nameplate: Application option type:

Here you can see which types of application options are installed in the adjustable frequency drive.

Parameter 630 Nameplate: Communication option type:

Here you can see which types of communication options are installed in the adjustable frequency drive.

Parameter 632 Nameplate: BMC software identification:

The ID number of the BMC software appears here.

Parameter 634 Nameplate: Unit identification for communication:

The ID number for communication appears here.

Parameter 635 Nameplate: Software section no.:

The software section number appears here.

Parameter 640 Nameplate: Software version:

The unit's present software version number appears here. Example: 1.00

Parameter 641 Nameplate: BMC software identification:

The ID number of the BMC software appears here.

Parameter 642 Nameplate: Power card identification:

The ID number of the unit's power part appears here. Example: 1.15

★ = factory setting. () = display text [] = value for use in communication via serial communication port

■ Warnings/alarm messages and corrective actions

The table below gives the drive's warnings and alarms and indicates whether the fault trip locks the drive. After a Trip Lock Fault, the input power must be removed, the cause of the fault corrected, and input power restored to reset the drive. A Trip can be reset manually in any one of three ways.

1. Pressing the keypad key RESET
2. A digital input
3. Serial communication

In addition, an automatic reset may be selected in parameter 405, *Reset function* which will reset all non-trip lock faults.

Wherever an "X" is placed under both Warning and Alarm in the table below, this means that a Warning precedes the Alarm. It can also mean that it is possible to program whether a given fault is to result in a Warning or an Alarm. This is possible, for example, through parameter 128, *Motor thermal protection*. After a trip, the motor will be coasting and the drive's Alarm and Warning indications will flash. If the fault is removed, only the Alarm will flash. After a reset, the drive will be ready to start operation again.

In the following detailed descriptions of warning and alarm messages, corrective actions to resolve the condition are recommended.

No.	Description	Warning	Alarm	Trip locked
2	Live zero error (LIVE ZERO ERROR)	X	X	X
4	AC line phase loss (AC LINE PHASE LOSS)	X	X	X
5	Voltage warning high (DC LINK VOLTAGE HIGH)	X		
6	Voltage warning low (DC LINK VOLTAGE LOW)	X		
7	Overvoltage (DC LINK OVERVOL T)	X	X	X
8	Undervoltage (DC LINK UNDERVOL T)	X	X	X
9	Inverter overload (INVERTER TIME)	X	X	
10	Motor overloaded (MOTOR, TIME)	X	X	
11	Motor thermistor (MOTOR THERMISTOR)	X	X	
12	Current limit (CURRENT LIMIT)	X	X	
13	Overcurrent (OVERCURRENT)	X	X	X
14	Ground fault (GROUND FAULT)		X	X
15	Switch mode fault (SWITCH MODE FAULT)		X	X
16	Short-circuit (CURR. SHORT CIRCUIT)		X	X
17	Serial communication timeout (STD BUS TIMEOUT)	X	X	
18	HPFB bus timeout (HPFB TIMEOUT)	X	X	
33	Out of frequency range (OUT FREQ RNG/ROT LIM)	X		
34	HPFB communication fault (PROFIBUS OPT. FAULT)	X	X	
35	Inrush fault (INRUSH FAULT)		X	X
36	Overtemperature (OVERTEMPERA TURE)	X	X	
37-45	Internal fault (INTERNAL FAULT)		X	X
50	AMT not possible		X	
51	AMT fault re. nameplate data (AMT TYPE.DATA FAULT)		X	
54	AMT wrong motor (AMT WRONG MOTOR)		X	
55	AMT timeout (AMT TIMEOUT)		X	
56	AMT warning during AMT (AMT WARN. DURING AMT)		X	
99	Locked (LOCKED)	X		

LED indication	
Warning	yellow
Alarm	red
Trip locked	yellow and red

WARNING/ALARM 2: Live zero fault

The voltage or current signal on terminal 53 or 60 is below 50% of the preset value in parameter 309 or 315 *Terminal, min. scaling*.

WARNING/ALARM 4: AC line phase fault

Missing phase on AC line supply side.

Check the supply voltage to the adjustable frequency drive. This fault is only active in 3-phase AC line.

WARNING 5: Voltage warning high

If the DC bus voltage (VDC) is higher than *Voltage warning high*, the adjustable frequency drive will give a warning and the motor will continue to operate unchanged.

Check whether the supply voltage matches the rating of the adjustable frequency drive. (See *Technical data*.) If the VDC remains above the voltage warning limit, the inverter will trip after a fixed period of time. The time depends on the unit and is set at 5 - 10 sec.

NOTE: The adjustable frequency drive will trip with an alarm 7 (overvoltage). A voltage warning can also occur if the motor frequency is reduced too quickly due to the ramp down time being too short.

WARNING 6: Voltage warning low

If the DC bus voltage (VDC) is lower than *Voltage warn low*, the adjustable frequency drive will give a warning and the motor will continue to operate unchanged.

Check whether the supply voltage matches the rating of the adjustable frequency drive. (See *Technical data*.) If the VDC remains below the voltage warning limit, the inverter will trip after a fixed period of time. The time depends on the unit and is set at 2 - 25 sec.

NOTE: The adjustable frequency drive will trip with an alarm 5 (undervoltage). When the adjustable frequency drive is switched off, a warning 6 (and warning 8) is displayed briefly.

WARNING/ALARM 7: Overvoltage

If the DC bus voltage (VDC) is higher than the inverter's *Overvoltage limit*, the inverter will switch off until the VDC once more falls below the overvoltage limit. If the VDC remains above the overvoltage limit, the inverter will trip after a fixed period of time. The time depends on the unit and is set at 5 - 10 sec.

NOTE: Voltage warning high (warning 5) will thus also be able to generate an alarm 7. An overvoltage in the DC bus can occur if the motor frequency is reduced too quickly due to ramp-down time being too short.

WARNING/ALARM 8: Undervoltage

If the DC bus voltage is lower than the inverter's *Undervoltage limit*, the inverter will switch off until the VDC once more goes above the undervoltage limit.

Check whether the supply voltage fits the adjustable frequency drive. (See *Technical data*.) If the VDC remains under the undervoltage limit, the inverter will trip after a fixed period of time. The time depends on the unit and is set at 1 - 3 sec. When the adjustable frequency drive is switched off a warning 8 (and warning 6) is displayed briefly.

NOTE: Voltage warning low (warning 6) will thus also be able to generate an alarm 8.

WARNING/ALARM 9: Inverter overload

Electronic thermal inverter protection indicates that the adjustable frequency drive is close to disconnecting due to overloading (output current too high for too long). The counter for electronic thermal inverter protection gives a warning at 98% and trips at 100% giving an alarm.

The adjustable frequency drive cannot be reset until the counter is below 90%. Remove the overload condition to the drive.

WARNING/ALARM 10: Motor overloaded

According to the electronic thermal inverter protection the motor is too hot. In parameter 128 the user can select whether the VLT adjustable frequency drive should emit a warning or an alarm when the counter reaches 100%. This fault is due to the motor being overloaded by more than 100% for too long.

Check that motor parameters 102–106 are set correctly.

WARNING/ALARM 11: Motor thermistor

The motor is too hot or the thermistor/thermistor connection is cut off. Parameter 128 *Motor thermal protection* allows a choice of whether the adjustable frequency drive is to give a warning or an alarm.

Check that the PTC thermistor has been correctly connected between terminal 18, 19, 27 or 29 (digital input) and terminal 50 (+10 V supply).

WARNING/ALARM 12: Current limit

The output current is greater than the value in parameter 221 *Current Limit* I_{LIM} .

The adjustable frequency drive will trip after a set period of time, as selected in parameter 409 *Trip delay overcurrent*.

WARNING/ALARM 13: Overcurrent

The inverter's peak current limit (approx. 200% of rated output current) has been exceeded. The warning will last for approx. 1-2 secs, and the adjustable frequency drive will then trip and give an alarm.

Switch off the adjustable frequency drive and check that the motor shaft can be turned and that the motor size fits the adjustable frequency drive.

ALARM: 14: Ground fault

There is a discharge from the output phases to ground, either in the cable between the adjustable frequency drive and the motor, or in the motor.

Turn off the adjustable frequency drive and remove the ground fault.

ALARM: 15: Switch mode fault

Fault in switch mode power supply (internal supply).

Contact your Danfoss supplier.

ALARM: 16: Short-circuit

There is a short-circuit on the motor terminals or in the motor.

Disconnect the AC line supply to the adjustable frequency drive and remove the short-circuit.

WARNING/ALARM 17: Serial communication timeout

There is no serial communication to the adjustable frequency drive.

The warning will only be active when parameter 514 *Bus time interval function* has been set to a value other than OFF. If parameter 514 *Bus time interval function* has been set to *Stop and trip* [5], it will first give a warning and then until it trips and issues an alarm. Parameter 513 *Bus time interval* could possibly be increased.

WARNING/ALARM 18: HPFB bus timeout

There is no serial communication to the adjustable frequency drive's communication option card.

The warning will only be active when parameter 804 *Bus time interval function* has been set to a value other than OFF. If parameter 804 *Bus time interval function* has been set to *Stop and trip*, it will first give a warning and then ramp down, trip and issue an alarm. Parameter 803 *Bus time interval* could possibly be increased.

WARNING 33: Out of frequency range

This warning is active if the output frequency has reached *Output frequency low limit* (parameter 201) or *Output frequency high limit* (parameter 202).

If the VLT adjustable frequency drive is in a mode other than *Process regulation, closed loop* (parameter 100) the warning will be active in the display. If the VLT adjustable frequency drive is in a mode other than *Process regulation, closed loop* bit 008000 *Out of frequency range* in the extended status word will be active, but there will be no warning in the display.

WARNING/ALARM: 34: HPFB communication fault

Communication fault only occurs in Profibus versions.

ALARM 35: Inrush fault

This alarm appears when the adjustable frequency drive has been connected to the AC line supply too many times within 1 minute.

WARNING/ALARM 36: Overtemperature

If the temperature of the heatsink moves above 167°F - 185°F (75° - 85°C), depending on the unit, the adjustable frequency drive gives a warning, and the motor continues to operate unchanged. If the temperature continues to rise, the switching frequency is reduced automatically.

See *Temperature-dependent switching frequency*.

If the temperature of the heatsink rises above 199°F - 212°F (92 - 100 °C), depending on the unit, the adjustable frequency drive will trip.

The temperature fault cannot be reset until the temperature of the heatsink has dropped to below 158°F (70 °C). The tolerance is ±9°F (±5 °C). The temperature can be caused by the following:

- Ambient temperature too high.
- Motor cable too long.
- AC line voltage too high.

ALARMS 37–45: Internal faults

ALARM 37: Internal fault number 0

Communication fault between control card and BMC2.

ALARM 38: Internal fault number 1

Flash EEPROM fault on control card.

ALARM 39: Internal fault number 2

RAM fault on control card.

ALARM 40: Internal fault number 3

Calibration constant error in EEPROM.

ALARM 41: Internal fault number 4

Data values error in EEPROM.

ALARM 42: Internal fault number 5

Fault in motor parameter database.

ALARM 43: Internal fault number 6

General power card fault.

ALARM 44: Internal fault number 7

Minimum software version of control card or BMC2.

ALARM 45: Internal fault number 8

I/O fault (digital input/output, relay or analog input/output).



NOTE!

When restarting after an alarm 38–45, the VLT adjustable frequency drive will display an alarm 37. In parameter 615 the actual alarm code can be read.

ALARMS 50–56: AMT faults

ALARM 50: AMT not possible

One of the following three possibilities can occur:

- The calculated R_s value falls outside permitted limits.

- The motor current in at least one of the motor phases is too low.
- The motor in use is probably too small for AMT calculations to be performed.

ALARM 51: AMT Fault re. nameplate data

There is inconsistency in the registered motor data.

Check the motor data for the relevant setup.

ALARM 52: AMT faulty motor phase

The motor current in at least one of the motor phases is too low.

ALARM 53: AMT motor too small

The motor used is probably too small for the AMT calculations to be carried out.

ALARM 54: AMT incorrect motor

AMT cannot be performed on the motor being used.

ALARM 55: AMT timeout

The calculations are taking too long, possibly due to noise in the motor cables.

ALARM 56: AMT warning during AMT

An adjustable frequency drive warning is given while AMT is being performed.

WARNING 99: Locked

The control panel functions have been locked via parameter 018.

■ Warning words, extended status words and alarm words

Warning words, status words and alarm words appear in the display in Hex format. If there are several warnings, status words or alarms, a total of all will be displayed. Warning words, status words and alarm words can also be read out using the serial bus in parameters 540, 541 and 538 respectively.

Bit (Hex)	Warning words
000008	HPFB bus timeout
000010	Standard bus timeout
000040	Current limit
000080	Motor thermistor
000100	Motor overload
000200	Inverter overload
000400	Undervolt
000800	Overvolt
001000	Voltage warning low
002000	Voltage warning high
004000	Phase loss
010000	Live zero error
400000	Out of frequency range
800000	Profibus communication fault
40000000	Switch mode warning
80000000	Heat sink temperature high

Bit (Hex)	Extended status words
000001	Ramping
000002	AMT running
000004	Start forw./reverse
000008	Slow down
000010	Catch-up
000020	Feedback high
000040	Feedback low
000080	Output current high
000100	Output current low
000200	Output frequency high
000400	Output frequency low
002000	Braking
008000	Out of frequency range

Bit (Hex)	Alarm words
000002	Triplock
000004	AMT tuning fail
000040	HPFP bus timeout
000080	Standard bus timeout
000100	Curr. short circuit
000200	Switch mode fault
000400	Ground fault
000800	Overcurrent
002000	Motor thermistor
004000	Motor overload
008000	Inverter overload
010000	Undervolt
020000	Overvolt
040000	Phase loss
080000	Live zero error
100000	Heat sink temperature too high
2000000	Profibus communication fault
8000000	Inrush fault
10000000	Internal fault

■ Special conditions
■ Extreme environments

An adjustable frequency drive contains a number of mechanical and electronic components which are vulnerable to environmental impact.



Do not install the adjustable frequency drive in environments where liquids, particles or gases in the air would damage the electronics of the drive. Take all necessary measures to protect the drive. There is a risk of fault trips and reduced service life of the drive.

Liquids carried through the air can condense in the adjustable frequency drive. Liquids may facilitate galvanic corrosion of components and metal parts. Steam, oil and brine may also cause corrosion of components and metal parts. In these areas, it is recommended to install units in cabinets. As a minimum, cabinets should meet NEMA 12.

Particles in the air, such as dust, may lead to mechanical, electrical and thermal faults in the adjustable frequency drive. A typical indicator of too many particles in the air is dust around the fan. In very dusty areas, mounting the drive in a cabinet is recommended. As a minimum, cabinets should meet NEMA 12.

Aggressive gases, such as sulfur, nitrogen and chlorine compounds, together with high humidity and temperature, facilitate possible chemical processes on the components of the adjustable frequency drive. These chemical processes quickly damage the electronics. In these areas, mounting in a cabinet with fresh-air circulation is recommended, thereby ensuring that aggressive gases are kept away from the drive.

NOTE!

Installation of adjustable frequency drives in extreme environments increases the risk of down-time, and considerable reduction of the service life of the drive.

Before the adjustable frequency drive is installed, check whether there are liquids, particles or gases in the air. Examine existing installations in the same environment. Typical indicators of harmful airborne liquids are water or oil on metal parts or corrosion. Too many dust particles are typically observed on

top of cabinets. Indication of aggressive gases in the air are black copper rails and cable ends on existing electrical installations.

■ Galvanic isolation (PELV)

PELV (Protective Extra-Low Voltage) separation is achieved with galvanic separators between control circuits and circuits connected to the AC line potential. These separators meet the requirements for increased isolation in standard EN 50 178. Installation must be in accordance with local and national PELV regulations.

All control terminals, terminals for serial communication and relay terminals are safely separated from the AC line potential, i.e. they comply with the PELV requirements. Circuits that are connected to control terminals 12, 18, 19, 20, 27, 29, 33, 42, 46, 50, 55, 53 and 60 are galvanically connected to one another. Serial communication connected to terminals 67 - 70 is galvanically isolated from the control terminals, although this is only a functional isolation. The relay contacts in terminals 1 - 3 are separated from the other control circuits with increased isolation, i.e. these comply with PELV even if there is AC line potential in the relay terminals.

The circuit elements described below form the safe electric separation. They fulfill the requirements for increased isolation and associated testing pursuant to EN 50 178.

1. Optical isolation between basic motor control and control card.
2. Optical isolation between basic motor control and control card.
3. Isolation between the control card and the power part.
4. Relay contacts and terminals relating to other circuits on the control card.

For VLT 2800 series:

PELV isolation of the control card is guaranteed under the following conditions:

- TT network with maximum 300 Vrms between phase and ground.
- TN network with maximum 300 Vrms between phase and ground.
- IT network with maximum 400 Vrms between phase and ground.

At higher voltages only SELV is achieved.

■ **UL/cUL Standards**

All VLT 2800 series adjustable frequency drives are both UL and cUL listed.

■ General technical data

 AC line supply (L1, L2, L3):

Supply voltage VLT 2803-2815 220-240 V (N, L1)	1 x 220/230/240 V ±10%
Supply voltage VLT 2803-2840 200-240 V	3 x 200/208/220/230/240V ±10%
Supply voltage VLT 2805-2882 380-480 V	3 x 380/400/415/440/480V ±10%
Supply frequency	50/60 Hz
Max. imbalance on supply voltage	± 2.0 % of rated supply voltage
True Power Factor (λ)	0.90 nominal at rated load
Displacement Power Factor ($\cos \varphi$)	near unity (> 0.98)
Number of switches on supply input L1, L2, L3	2 times/min.
Max. short-circuit value	100,000 A

 Output data (U, V, W):

Output voltage	0 - 100% of supply voltage
Output frequency	0.2 - 132 Hz, 1 - 1000 Hz
Rated motor voltage, 200-240 V units	200/208/220/230/240V
Rated motor voltage, 380-480 V units	380/400/415/440/460/480V
Rated motor frequency	50/60 Hz
Switching on output	Unlimited
Ramp times	0.02 - 3600 sec.

 Torque characteristics:

Starting torque (parameter 101 Torque characteristic = Constant torque)	160% in 1 min.*
Starting torque (parameter 101 Torque characteristics = Variable torque)	160% in 1 min.*
Starting torque (parameter 119 <i>High starting torque</i>)	180% for 0.5 sec.*
Overload torque (parameter 101 Torque characteristic = Constant torque)	160%*
Overload torque (parameter 101 Torque characteristic = Variable torque)	160%*

*Percentage relates to adjustable frequency drive's nominal current.

 Control card, digital inputs:

Number of programmable digital inputs	5
Terminal number	18, 19, 27, 29, 33
Voltage level	0 - 24 VDC (PNP positive logic)
Voltage level, logic '0'	< 5 VDC
Voltage level, logic '1'	> 10 VDC
Maximum voltage on input	28 VDC
Input resistance, R _i (terminals 18, 19, 27, 29)	approx. 4 kΩ
Input resistance, R _i (terminal 33)	approx. 2 kΩ

All digital inputs are galvanically isolated from the supply voltage (PELV) and other high-voltage terminals. See section entitled Galvanic Isolation.

All about VLT 2800

Control card, analog inputs:

Number of analog voltage inputs	1 pcs.
Terminal number	53
Voltage level	0 - 10 V DC (scalable)
Input resistance, R_i	approx. 10 k Ω
Max. voltage	20 V
Number of analog current inputs	1 pcs.
Terminal number	60
Current level	0/4 - 20 mA (scalable)
Input resistance, R_i	approx. 300 Ω
Max. current	30 mA
Resolution for analog inputs	10 bit
Accuracy of analog inputs	Max. error 1% of full scale
Scan interval	13.3 msec

The analog inputs are galvanically isolated from the supply voltage (PELV) and other high-voltage terminals. See section entitled Galvanic Isolation.

Control card, pulse inputs:

Number of programmable pulse inputs	1
Terminal number	33
Max. frequency on terminal 33	67.6 kHz (Push-pull)
Max. frequency on terminal 33	5 kHz (open collector)
Min. frequency on terminal 33	4 Hz
Voltage level	0 - 24 VDC (PNP positive logic)
Voltage level, logic '0'	< 5 VDC
Voltage level, logic '1'	> 10 VDC
Maximum voltage on input	28 VDC
Input resistance, R_i	approx. 2 k Ω
Scan interval	13.3 msec
Resolution	10 bit
Accuracy (100 Hz - 1 kHz) terminal 33	Max. error: 0.5% of full scale
Accuracy (1 kHz - 67.6 kHz) terminal 33	Max. error: 0.1% of full scale

The pulse input (terminal 33) is galvanically isolated from the supply voltage (PELV) and other high-voltage terminals. See section entitled Galvanic Isolation.

Control card, digital/frequency output:

Number of programmable digital/pulse outputs	1 pcs.
Terminal number	46
Voltage level at digital/frequency output	0 - 24 V DC (O.C PNP)
Max. output current at digital/frequency output	25 mA.
Max. load at digital/frequency output	1 k Ω
Max. capacity at frequency output	10 nF
Minimum output frequency at frequency output	16 Hz
Maximum output frequency at frequency output	10 kHz
Accuracy on frequency output	Max. error: 0.2 % of full scale
Resolution on frequency output	10 bit

The digital output is galvanically isolated from the supply voltage (PELV) and other high-voltage terminals. See section entitled Galvanic Isolation.

Control card, analog output:

Number of programmable analog outputs	1
Terminal number	42
Current range at analog output	0/4 - 20 mA
Max. load to common at analog output	500 Ω
Accuracy on analog output	Max. error: 1.5 % of full scale
Resolution on analog output	10 bit

*The analog output is galvanically isolated from the supply voltage (PELV) and other high-voltage terminals.
See section entitled Galvanic Isolation.*

Control card, 24 V DC supply:

Terminal number	12
Max. load	130 mA

The 24 VDC supply is galvanically isolated from the supply voltage (PELV) , but has the same potential as the analog and digital inputs and outputs. See section entitled Galvanic Isolation.

Control card, 10 VDC supply:

Terminal number	50
Output voltage	10.5 V ±0.5 V
Max. load	15 mA

*The 10 VDC supply is galvanically isolated from the supply voltage (PELV) and other high-voltage terminals.
See section entitled Galvanic Isolation.*

Control card, RS 485 serial communication:

Terminal number	68 (TX+, RX+), 69 (TX-, RX-)
Terminal number 67	+ 5 V
Terminal number 70	Common for terminals 67, 68 and 69

*Full galvanic isolation. See section entitled Galvanic Isolation.
For CANopen/DeviceNet units, see VLT 2800 DeviceNet manual, MG.90.BX.YY.*

Relay outputs:

Number of programmable relay outputs	1
Terminal number, control card	1-3 (break), 1-2 (make)
Max. terminal load (AC) on 1-3, 1-2, control card	240 VAC, 2 A
Min. terminal load on 1-3, 1-2, control card	24 VDC 10 mA, 24 VAC 100 mA

The relay contact is separated from the rest of the circuit by strengthened isolation. See section entitled Galvanic Isolation.

Cable lengths and cross sections:

Max. motor cable length, screened/armored cable	130 ft (40 m)
Max. motor cable length, unscreened/unarmored cable	250 ft (75 m)
Max. motor cable length, screened/armored cable and motor coil	325 ft (100 m)
Max. motor cable length, unscreened/unarmored cable and motor coil	650 ft (200 m)
Max. motor cable length, screened/armored cable and RFI/1B filter	200 V, 325 ft (100 m)
Max. motor cable length, screened/armored cable and RFI/1B filter	400 V, 80 ft (25 m)
Max. motor cable length, screened/armored cable and RFI 1B/LC filter	400 V, 80 ft (25 m)

Max. cross section to motor, see next section.

Max. cross section to control cables, rigid cable	1.5 mm ² /16 AWG (2 x 0.75 mm ²)
Max. cross section to control cables, flexible cable	1 mm ² /18 AWG
Max. cross section to control cables, cable with enclosed core	0.5 mm ² /20 AWG

When complying with EN 55011 1A and EN 55011 1B the motor cable must be reduced in certain instances.

Control characteristics:

Frequency range	0.2 - 132 Hz, 1 - 1000 Hz
Resolution of output frequency	0.013 Hz, 0.2 - 1000 Hz
Repeat accuracy of <i>Precise start/stop</i> (terminals 18, 19)	≤ ± 0.5 msec
System response time (terminals 18, 19, 27, 29, 33)	≤ 26.6 msec
Speed control range (open loop)	1:15 of synchronous speed
Speed control range (closed loop)	1:120 of synchronous speed
Speed accuracy (open loop)	90 - 3600 rpm: Max. error of ±23 rpm
Speed accuracy (closed loop)	30 - 3600 rpm: Max. error of ±7.5 rpm

All control characteristics are based on a 4-pole asynchronous motor

Ambient conditions:

Enclosure	Standard
Optional enclosure	NEMA 1
Vibration test	0.7 g
Max. relative humidity	5% - 85% during operation
Ambient temperature, standard enclosure	Max. 113°F (45 °C) 24-hour average max. 104°F (40 °C)
Ambient temperature NEMA 1	Max. 104°F (40 °C), 24-hour average max. 95°F (35 °C)
Min. ambient temperature during full-scale operation	32°F (0 °C)
Min. ambient temperature at reduced performance	14°F (-10 °C)
Temperature during storage/transport	0°F (-25°C) to 150°F/158°F (+65°C/70 °C)
Max. altitude above sea level	3300 ft (1000 m)
EMC standards used, Emission	EN 50081-2, EN 61800-3, EN 55011
EMC standards used, immunity ..	EN 50082-1/2, EN 61000-4-2, EN 61000-4-3, EN 61000-4-4, EN 61000-4-5, EN 61000-4-6, EN 61800-3

Safeguards:

- Electronic thermal motor protection against overload.
- Temperature monitoring of the heatsink ensures that the adjustable frequency drive cuts out if the temperature reaches 212°F (100 °C). An overload temperature cannot be reset until the temperature of the heatsink is below 70 °C.
- The adjustable frequency drive is protected against short circuits on motor terminals U, V, W.
- If an AC line phase is missing, the adjustable frequency drive will cut out.
- Monitoring of the intermediate circuit voltage ensures that the adjustable frequency drive cuts out if the intermediate circuit voltage is too low or too high.
- The adjustable frequency drive is protected against ground fault on motor terminals U, V, W.

■ Technical data, AC line supply 1 x 220 - 240 V / 3 x 200-240V

Acc. to international requirements		Type	2803	2805	2807	2811	2815	2822	2840
	Output current	I_{INV} [A]	2.2	3.2	4.2	6.0	6.8	9.6	16
	(3 x 200-240V)	I_{MAX} (60s) [A]	3.5	5.1	6.7	9.6	10.8	15.3	25.6
	Output power (230 V)	S_{INV} [KVA]	0.9	1.3	1.7	2.4	2.7	3.8	6.4
	Typical shaft output	$P_{M,N}$ [kW]	0.37	0.55	0.75	1.1	1.5	2.2	3.7
	Typical shaft output	$P_{M,N}$ [HP]	0.5	0.75	1.0	1.5	2.0	3.0	5.0
	Max. cable cross section, motor	[mm ² /AWG] ¹⁾	4/10	4/10	4/10	4/10	4/10	4/10	4/10
	Input current	$I_{L,N}$ [A]	5.9	8.3	10.6	14.5	15.2	-	-
	(1 x 220-240 V)	$I_{L,MAX}$ (60s) [A]	9.4	13.3	16.7	23.2	24.3	-	-
	Input current	$I_{L,N}$ [A]	2.9	4.0	5.1	7.0	7.6	8.8	14.7
	(3 x 200-240 V)	$I_{L,MAX}$ (60s) [A]	4.6	6.4	8.2	11.2	12.2	14.1	23.5
	Max. cable cross section, power	[mm ² /AWG] ¹⁾	4/10	4/10	4/10	4/10	4/10	4/10	4/10
	Max. pre-fuses	[A]/UL ²⁾ [A]	20/20	20/20	20/20	20/20	20/20	20/20	25/25
	Efficiency ³⁾	[%]	95	95	95	95	95	95	95
	Power loss at max. load	[W]	24	35	48	69	94	125	231
	Weight	[kg]	2.0	2.0	2.0	2.0	2.0	3,7	6.0
	Enclosure ⁴⁾	type	IP20	IP20	IP20	IP20	IP20	IP20	IP20

1. American Wire Gauge. Max. cable cross section is the largest cable cross section that can be attached to the terminals. Always follow national and local regulations.

2. To comply with UL/cUL, the pre-fuses must be Bussmann KTN-R 200 V, KTS-R 500 V or Ferraz Shawmut, type ATMR (max. 30A). The fuses must provide protection in a circuit capable of supplying a maximum of 100,000 amps RMS (symmetrical), 500 V maximum.

3. Measured using a 80 ft (25 m) screened/armored motor cable with a rated load and rated frequency.

4. IP20 is standard for VLT 2805-2875, whereas NEMA 1 is an option.

■ Technical data, AC line supply 3 x 380 - 480 V

Acc. to international requirements	Type	2805	2807	2811	2815	2822	2830
 Output current (3 x 380-480V)	I_{INV} [A]	1.7	2.1	3.0	3.7	5.2	7.0
	I_{MAX} (60s) [A]	2.7	3.3	4.8	5.9	8.3	11.2
Output power (400 V)	S_{INV} [KVA]	1.1	1.7	2.0	2.6	3.6	4.8
Typical shaft output	$P_{M,N}$ [kW]	0.55	0.75	1.1	1.5	2.2	3.0
Typical shaft output	$P_{M,N}$ [HP]	0.75	1.0	1.5	2.0	3.0	4.0
Max. cable cross section, motor	[mm ² /AWG] ¹⁾	4/10	4/10	4/10	4/10	4/10	4/10

 Input current (3 x 380-480 V)	$I_{L,N}$ [A]	1.6	1.9	2.6	3.2	4.7	6.1
	$I_{L,MAX}$ (60s)[A]	2.6	3.0	4.2	5.1	7.5	9.8
Max. cable cross section, power	[mm ² /AWG] ¹⁾	4/10	4/10	4/10	4/10	4/10	4/10
Max. pre-fuses	[A]/UL ²⁾ [A]	20/20	20/20	20/20	20/20	20/20	20/20
Efficiency ³⁾	[%]	96	96	96	96	96	96
Power loss at max. load	[W]	28	38	55	75	110	150
Weight	[kg]	2.1	2.1	2.1	2.1	3.7	3.7
Enclosure ⁴⁾	type	IP 20	IP 20	IP 20	IP 20	IP 20	IP 20

Acc. to international requirements	Type	2840	2855	2875	2880	2881	2882
 Output current (3 x 380-480V)	I_{INV} [A]	9.1	12	16	24	32.0	37.5
	I_{MAX} (60s) [A]	14.5	19.2	25.6	38.4	51.2	60.0
Output power (400 V)	S_{INV} [KVA]	6.3	8.3	11.1	16.6	22.2	26.0
Typical shaft output	$P_{M,N}$ [kW]	4.0	5.5	7.5	11.0	15.0	18.5
Typical shaft output	$P_{M,N}$ [HP]	5.0	7.5	10.0	15.0	20.0	25.0
Max. cable cross section, motor	[mm ² /AWG] ¹⁾	4/10	4/10	4/10	16/6	16/6	16/6

 Input current (3 x 380-480 V)	$I_{L,N}$ [A]	8.1	10.6	14.9	24.0	32.0	37.5
	$I_{L,MAX}$ (60s)[A]	13.0	17.0	23.8	38.4	51.2	60
Max. cable cross section, power	[mm ² /AWG] ¹⁾	4/10	4/10	4/10	16/6	16/6	16/6
Max. pre-fuses	[A]/UL ²⁾ [A]	20/20	25/25	25/25	50/50	50/50	50/50
Efficiency ³⁾	[%]	96	96	96	97	97	97
Power loss at max. load	[W]	200	275	372	412	562	693
Weight	[kg]	3.7	6.0	6.0	18.5	18.5	18.5
Enclosure ⁴⁾	type	IP 20	IP 20	IP 20	IP 20 / NEMA 1	IP 20 / NEMA 1	IP 20 / NEMA 1

1. American Wire Gauge. Max. cable cross section is the largest cable cross section that can be attached to the terminals. Always follow national and local regulations.

2. To comply with UL/cUL the pre-fuses used must be Bussmann KTN-R 200 V, KTS-R 500 V or Ferraz Shawmut, type ATMR (max. 30A). The fuses must provide protection in a circuit capable of

supplying a maximum of 100,000 amps RMS (symmetrical), 500 V maximum.

3. Measured using a 80 ft (25 m) screened/armored motor cable with a rated load and rated frequency.

4. IP20 is standard for VLT 2805-2875, whereas NEMA 1 is an option.

■ Available literature**■ Supplied with the unit**

Below is a list of the literature available for VLT 2800. It must be noted that there may be deviations from one country to the next.

Supplied with the unit:

Operating instructions	MG.28.AX.YY
Quick setup	MG.28.BX.YY, MG.28.CX.YY, MG.28.FX.YY
Parameter list	MG.28.DX.YY

Various literature for VLT 2800:

Data sheet	MD.28.AX.YY
------------------	-------------

Instructions for VLT 2800:

LCP remote-mounting kit	MI.56.AX.51
Filter instruction	MI.28.B1.02

Communication with VLT 2800:

Profibus manual	MG.90.AX.YY
VLT 2800 DeviceNet manual	MG.90.BX.YY

X = version number

YY = language version

■ Factory Settings

PNU #	Parameter description	Factory setting	4-setup	Conv. index	Data type
001	Language	English	No	0	5
002	Local/remote operation	Remote-controlled	Yes	0	5
003	Local reference	000,000.000	Yes	-3	4
004	Active Setup	Setup 1	No	0	5
005	Programming Setup	Active Setup	No	0	5
006	Setup copying	No copying	No	0	5
007	LCP copy	No copying	No	0	5
008	Display scaling	1.00	Yes	-2	6
009	Large display readout	Frequency [Hz]	Yes	0	5
010	Small display line 1.1	Reference [%]	Yes	0	5
011	Small display line 1.2	Motor current [A]	Yes	0	5
012	Small display line 1.3	Power [kW]	Yes	0	5
013	Local control	Remote control as par. 100	Yes	0	5
014	Local stop	Active	Yes	0	5
015	Local jog	Not active	Yes	0	5
016	Local reversing	Not active	Yes	0	5
017	Local reset of trip	Active	Yes	0	5
018	Lock for data changes	Not locked	Yes	0	5
019	Operating status at power up	Forced stop, use saved ref.	Yes	0	5
020	Lock for Hand mode	Active	No	0	5
024	User-defined Quick Menu	Not active	No	0	5
025	Quick Menu Setup	000	No	0	6

4-Setup:

'Yes' means that the parameter can be programmed individually in each of the four Setups, i.e. one single parameter can have four different data values. 'No' means that the data value will be the same in all Setups.

Conversion index:

This number refers to a conversion figure to be used when writing or reading via serial communication with an adjustable frequency drive.

Conversion Index	Conversion Factor
74	3.6
2	100.0
1	10.0
0	1.0
-1	0.1
-2	0.01
-3	0.001
-4	0.0001

Data type:

Data type shows the type and length of the telegram.

Data type	Description
3	Integer 16
4	Integer 32
5	Unsigned 8
6	Unsigned 16
7	Unsigned 32
9	Text string



VLT® 2800 Series

PNU #	Parameter-description	Factory setting	4-setup	Conv. index	Data-type
100	Configuration	Speed reg., open loop	Yes	0	5
101	Torque characteristics	Constant torque	Yes	0	5
102	Motor power $P_{M,N}$	depends on unit	Yes	1	6
103	Motor voltage $U_{M,N}$	depends on unit	Yes	0	6
104	Motor frequency $f_{M,N}$	50 Hz	Yes	-1	6
105	Motor current $I_{M,N}$	depends on motor selected	Yes	-2	7
106	Rated motor speed	depends on par. 102	Yes	0	6
107	Automatic motor tuning	Optimization off	Yes	0	5
108	Stator resistance R_S	depends on motor selected	Yes	-3	7
109	Stator reactance X_S	depends on motor selected	Yes	-2	7
119	High start torque	0.0 sec	Yes	-1	5
120	Start delay	0.0 sec	Yes	-1	5
121	Start function	Coast in start del.	Yes	0	5
122	Function at stop	Coast	Yes	0	5
123	Min. freq. for activation of par. 122	0.1 Hz	Yes	-1	5
126	DC braking time	10 sec.	Yes	-1	6
127	DC brake cut-in frequency	OFF	Yes	-2	6
128	Thermal motor protection	No protection	Yes	0	5
130	Start frequency	0.0 Hz	Yes	-1	5
131	Initial voltage	0.0 V	Yes	-1	6
132	DC brake voltage	0%	Yes	0	5
133	Start voltage	depends on unit	Yes	-2	6
134	Load compensation	100.0 %	Yes	-1	6
135	U/f-ratio	depends on unit	Yes	-2	6
136	Slip compensation	100 %	Yes	-1	3
137	DC hold voltage	0%	Yes	0	5
138	Brake cut out value	3.0 Hz	Yes	-1	6
139	Brake cut in frequency	3.0 Hz	Yes	-1	6
140	Current, minimum value	0%	Yes	0	5
142	Spread reactance	depends on motor selected	Yes	-3	7
143	Internal fan control	Automatic	Yes	0	5
144	Gain AC brake	1.30	Yes	-2	5
146	Reset voltage vector	Off	Yes	0	5



VLT® 2800 Series

PNU #	Parameter description	Factory setting	4-setup	Conv. index	Data type
200	Output frequency range	Clockwise only, 0-132 Hz	Yes	0	5
201	Output frequency, low limit f_{MIN}	0.0 Hz	Yes	-1	6
202	Output frequency, high limit f_{MAX}	132 Hz	Yes	-1	6
203	Reference range	Min ref.-Max ref.	Yes	0	5
204	Minimum ref Ref_{MIN}	0.000 Hz	Yes	-3	4
205	Maximum ref Ref_{MAX}	50.000 Hz	Yes	-3	4
206	Ramp type	Linear	Yes	0	5
207	Ramp-up time 1	3.00 sec.	Yes	-2	7
208	Ramp-down time 1	3.00 sec.	Yes	-2	7
209	Ramp-up time 2	3.00 sec.	Yes	-2	7
210	Ramp-down time 2	3.00 sec.	Yes	-2	7
211	Jog ramp time	3.00 sec.	Yes	-2	7
212	Quick stop ramp-down time	3.00 sec.	Yes	-2	7
213	Jog frequency	10.0 Hz	Yes	-1	6
214	Reference function	Sum	Yes	0	5
215	Preset reference 1	0.00%	Yes	-2	3
216	Preset reference 2	0.00%	Yes	-2	3
217	Preset reference 3	0.00%	Yes	-2	3
218	Preset reference 4	0.00%	Yes	-2	3
219	Catch up/slow down reference	0.00%	Yes	-2	6
221	Current limit	160 %	Yes	-1	6
223	Warn. Low current	0.0 A	Yes	-1	6
224	Warn. High current	I_{MAX}	Yes	-1	6
225	Warn. Low frequency	0.0 Hz	Yes	-1	6
226	Warn. High frequency	132.0 Hz	Yes	-1	6
227	Warn. Low Feedback	-4000.000	Yes	-3	4
228	Warn.High Feedback	4000.000	Yes	-3	4
229	Frequency bypass, bandwidth	0 Hz (OFF)	Yes	0	6
230	Frequency bypass 1	0.0 Hz	Yes	-1	6
231	Frequency bypass 2	0.0 Hz	Yes	-1	6

VLT® 2800 Series

PNU #	Parameter description	Factory setting	4-setup	Conv. index	Data type
302	Digital input, term. 18	Start	Yes	0	5
303	Digital input, term. 19	Reversing	Yes	0	5
304	Digital input, term. 27	Reset and coast inverse	Yes	0	5
305	Digital input, term. 29	Jog	Yes	0	5
307	Digital input, term. 33	No function	Yes	0	5
308	Term. 53, analog input voltage	Reference	Yes	0	5
309	Term. 53, min scaling	0.0 VDC	Yes	-1	6
310	Term. 53, max scaling	10.0 VDC	Yes	-1	6
314	Term. 60, analog input current	No function	Yes	0	5
315	Term. 60, min scaling	0.0 mA	Yes	-4	6
316	Term. 60, max scaling	20.0 mA	Yes	-4	6
317	Time out	10 sec.	Yes	0	5
318	Function after timeout	No function	Yes	0	5
319	Term. 42, analog output	0-I _{MAX} = 0-20 mA	Yes	0	5
323	Relay output	Control ready	Yes	0	5
327	Pulse ref./FB	5000 Hz	Yes	0	7
341	Term. 46, digital output	Control ready	Yes	0	5
342	Term. 46, max. pulse scaling	5000 Hz	Yes	0	6
343	Precise stop function	Normal ramp stop	Yes	0	5
344	Counter value	100000 pulses	Yes	0	7
349	Speed comp delay	10 ms	Yes	-3	6

4-Setup:

'Yes' means that the parameter can be programmed individually in each of the four Setups, i.e. one single parameter can have four different data values. 'No' means that the data value will be the same in all Setups.

Conversion index:

This number refers to a conversion figure to be used when writing or reading via serial communication with an adjustable frequency drive.

Conversion Index	Conversion Factor
74	3.6
2	100.0
1	10.0
0	1.0
-1	0.1
-2	0.01
-3	0.001
-4	0.0001

Data type:

Data type shows the type and length of the telegram.

Data type	Description
3	Integer 16
4	Integer 32
5	Unsigned 8
6	Unsigned 16
7	Unsigned 32
9	Text string



VLT® 2800 Series

PNU #	Parameter description	Factory setting	4-setup	Conv. index	Data type
400	Brake function	Depends on unit type	No	0	5
405	Reset function	Manual reset	Yes	0	5
406	Automatic restart time	5 sec.	Yes	0	5
409	Trip delay overcurrent	Off (61 sec.)	Yes	0	5
411	Switching frequency	4.5 kHz	Yes	0	6
412	Var. switching frequency	No LC-filter	Yes	0	5
413	Overmodulation function	On	Yes	0	5
414	Min. feedback	0.000	Yes	-3	4
415	Max. feedback	1500.000	Yes	-3	4
416	Process units	No unit	Yes	0	5
417	Speed PID propor.gain.	0.010	Yes	-3	6
418	Speed PID intergra. time	100 ms	Yes	-5	7
419	Speed PID differen. time	20.00 ms	Yes	-5	7
420	Speed PID diff. gain limit	5.0	Yes	-1	6
421	Speed PID lowpass filter time	20 ms	Yes	-3	6
423	U1 voltage	par. 103	Yes	-1	6
424	F1 frequency	Par. 104	Yes	-1	6
425	U2 voltage	par. 103	Yes	-1	6
426	F2 frequency	par. 104	Yes	-1	6
427	U3 voltage	par. 103	Yes	-1	6
428	F3 frequency	par. 104	Yes	-1	6
437	Proc. PID no/inv.	Normal	Yes	0	5
438	Proc. PID anti wind.	Active	Yes	0	5
439	Proc. PID start frequency	Par. 201	Yes	-1	6
440	Proc. PID start proportional gain.	0.01	Yes	-2	6
441	Proc. PID integration time	Off (9999.99 s)	Yes	-2	7
442	Proc. PID differentiation time	Off (0.00 s).	Yes	-2	6
443	Proc. PID diff. gain limit	5.0	Yes	-1	6
444	Proc. PID lowpass filter time	0.02 s	Yes	-2	6
445	Flying start	Not possible	Yes	0	5
451	Speed PID FF factor	100%	Yes	0	6
452	Controller range	10%	Yes	-1	6
456	Brake voltage reduce	0	Yes	0	5



VLT® 2800 Series

PNU #	Parameter description	Factory setting	4-setup	Conv.index	Datatype
500	Address	1	No	0	5
501	Baudrate	9600 Baud	No	0	5
502	Coasting stop	Logic or	Yes	0	5
503	Quick stop	Logic or	Yes	0	5
504	DC brake	Logic or	Yes	0	5
505	Start	Logic or	Yes	0	5
506	Reversing	Logic or	Yes	0	5
507	Selection of Setup	Logic or	Yes	0	5
508	Selection of preset ref.	Logic or	Yes	0	5
509	Bus jog 1	10.0 Hz	Yes	-1	6
510	Bus jog 2	10.0 Hz	Yes	-1	6
512	Telegram profile	FC protocol	Yes	0	5
513	Bus time interval	1 sec.	Yes	0	5
514	Bus time interval function	Off	Yes	0	5
515	Data readout: Reference %		No	-1	3
516	Data readout: Reference [unit]		No	-3	4
517	Data readout: Feedback [unit]		No	-3	4
518	Data readout: Frequency		No	-1	3
519	Data readout: Frequency x scaling		No	-1	3
520	Data readout: Motor current		No	-2	7
521	Data readout: Torque		No	-1	3
522	Data readout: Power [kW]		No	1	7
523	Data readout: Power [HP]		No	-2	7
524	Data readout: Motor voltage [V]		No	-1	6
525	Data readout: DC Link voltage		No	0	6
526	Data readout: Motor thermal load		No	0	5
527	Data readout: Inverter thermal load		No	0	5
528	Data readout: Digital input		No	0	5
529	Data readout: Analog input, term. 53		No	-1	5
531	Data readout: Analog input, term. 60		No	-4	5
532	Data readout: Pulse reference		No	-1	7
533	Data readout: External reference		No	-1	6
534	Data readout: Status word		No	0	6
537	Data readout: Inverter temperature		No	0	5
538	Data readout: Alarm word		No	0	7
539	Data readout: Control word		No	0	6
540	Data readout: Warning word		No	0	7
541	Data readout: Extended status word		No	0	7
544	Data readout: Pulse Count		No	0	7



VLT® 2800 Series

PNU #	Parameter description	Factory setting	4-setup	Conv.index	Data type
600	Operating hours		No	73	7
601	Hours run		No	73	7
602	kWh counter		No	2	7
603	Number of power-ups		No	0	6
604	Number of overtemperatures		No	0	6
605	Number of overvoltages		No	0	6
615	Fault log: Error code		No	0	5
616	Fault log: Time		No	0	7
617	Fault log: Value		No	0	3
618	Reset of kWh counter	No reset	No	0	7
619	Reset of running hours counter	No reset	No	0	5
620	Operation mode	Normal operation	No	0	5
621	Nameplate: Unit type		No	0	9
624	Nameplate: Software version		No	0	9
625	Nameplate: LCP identification no.		No	0	9
626	Nameplate: Database identification no.		No	-2	9
627	Nameplate: Power parts version		No	0	9
628	Nameplate: Application option type		No	0	9
630	Nameplate: Communication option type		No	0	9
632	Nameplate: BMC software identification		No	0	9
633	Nameplate: Motor database identification		No	0	9
634	Nameplate: Unit identification for communication		No	0	9
635	Nameplate: Software parts no.		No	0	9
640	Software version		No	-2	6
641	BMC software identification		No	-2	6
642	Power card identification		No	-2	6

4-Setup:

'Yes' means that the parameter can be programmed individually in each of the four Setups, i.e. one single parameter can have four different data values. No' means that the data value will be the same in all Setups.

Conversion index:

This number refers to a conversion figure to be used when writing or reading via serial communication with an adjustable frequency drive.

Conversion Index	Conversion Factor
74	3.6
2	100.0
1	10.0
0	1.0
-1	0.1
-2	0.01
-3	0.001
-4	0.0001

Data type:

Data type shows the type and length of the telegram.

Data type	Description
3	Integer 16
4	Integer 32
5	Unsigned 8
6	Unsigned 16
7	Unsigned 32
9	Text string

A

AC brake.....	61
AC line connection.....	11
Address.....	70
Analog input.....	55
Analog output.....	57
Automatic motor tuning.....	36

B

Baudrate.....	70
Brake connection.....	12
Brake cut in frequency.....	42
Brake cut out value.....	42
Brake function.....	61
Brake Voltage Reduce.....	69
Bus jog.....	74
Bus time interval.....	74

C

Catch up.....	48
Constant torque.....	34
Control terminals.....	13
Control wires.....	14
Counter value.....	60
Current limit.....	48
Current, minimum value.....	42

D

DC brake time.....	39
DC brake voltage.....	40
DC hold voltage.....	41
Digital inputs.....	53
Direction of motor rotation.....	11
Display.....	19
Display mode.....	20

E

Electrical installation, control circuitry.....	14
ETR - Electronic ThermalRelay.....	39
Extreme environments.....	87

F

Fan control.....	42
Fault log.....	78
Feedback.....	62

G

Gain AC brake.....	43
Galvanic isolation (PELV).....	87
Ground connection.....	12
Grounding.....	8

H

Hand /Auto mode operation.....	22
Hand mode.....	32
High voltage warning.....	8

I

Initialize.....	80
Input fuses.....	11

J

Jog frequency.....	47
Jog ramp time.....	47

L

Language.....	26
Literature.....	95
Load compensation.....	41
Load sharing.....	12
Local reference.....	26

M

Manual initialization.....	19
Mechanical dimensions.....	5
Mechanical installation.....	7
Menu mode.....	20
Motor cables.....	12
Motor connection.....	11
Motor current.....	35
Motor frequency.....	35
Motor power.....	35
Motor voltage.....	35

O

Output frequency.....	44
Overmodulation function.....	62

P

Parallel connection of motors.....	12
------------------------------------	----

Precise stop function	59
Preset reference	48
Process PID	66
Process regulation, closed loop	34
Process units	63
Programming the adjustable frequency drive	21
Pulse/reference feedback	59

Q

Quick menu	20, 20
Quick-stop ramp-down time	47

R

Ramp type	46
Ramp-down time	46
Ramp-up time	46
Rated motor speed	35
Recidual Current Device	12
Reference	45
Reference function	47
Relative	47
Relay connection	15
Relay output 1-3	57
Reset function	61
Reset voltage vector	43
Reversing	53

S

Slip compensation	41
Slow down	48
Special motor mode	34
Speed comp delay	60
Speed PID	63
Speed regulation, closed loop	34
Speed regulation, open loop	34
Spread reactance	42
Start	68
Start delay	37
Start frequency	40
Start function	38
Start torque	37
Start voltage	40
Stator reactance	36
Stator resistance	36
Status messages	22
STOP/RESET	19
Sub D plug	16

Sum	47
Switching frequency	62

T

Telegram Profile	74
Temperature-related switching frequency	24
Thermal motor protection	39
Thermistor	39, 54
Time out	56

U

U/f-ratio	41
UL/cUL Standards	88
User-defined Quick Menu	32

V

Variable torque	34
VLT 2800 start-up	24
VLT Software Dialog	16

W

Warning functions	49
Warning words, extended status words and alarmwords	86
Warnings/alarm messages and	82
Warnings/alarms	23