



Design Guide VLT[®] 2800



Contents

| | |
|--|----------|
| 1 Introduction to VLT 2800 | 6 |
| 1.1 Purpose of the Manual | 6 |
| 1.2 Available Documentation | 6 |
| 1.3 Document and Software Version | 6 |
| 1.4 Technology | 6 |
| 1.5 Approvals and Certifications | 7 |
| 1.6 Disposal | 8 |
| 1.7 Selecting the Correct Frequency Converter | 9 |
| 1.7.1 Introduction | 9 |
| 1.7.2 Enclosure | 10 |
| 1.7.3 Brake | 10 |
| 1.7.4 RFI Filter | 10 |
| 1.7.5 Harmonic Filter | 10 |
| 1.7.6 Control Unit | 10 |
| 1.7.7 FC Protocol | 11 |
| 1.7.8 Fieldbus Option | 11 |
| 1.7.9 Motor Coils | 11 |
| 1.7.10 RFI 1B Filter | 12 |
| 1.7.11 RFI 1B/LC Filter | 13 |
| 1.8 Order Form | 15 |
| 1.9 PC Software | 16 |
| 1.10 Accessories for VLT 2800 | 17 |
| 1.11 Brake Resistors | 17 |
| 1.11.1 Dynamic Braking | 17 |
| 1.11.2 Brake Set-up | 18 |
| 1.11.3 Calculation of Brake Resistance | 18 |
| 1.11.4 Calculation of Braking Power | 18 |
| 1.11.5 Calculation of Peak Power of Brake Resistor | 19 |
| 1.11.6 Calculation of Mean Power on Brake Resistor | 19 |
| 1.11.7 Continuous Braking | 19 |
| 1.11.8 DC Injection Braking | 19 |
| 1.11.9 AC-braking | 19 |
| 1.11.10 Optimal Braking Using Resistor | 20 |
| 1.11.11 Brake Cable | 20 |
| 1.11.12 Protective Functions During Installation | 20 |
| 1.11.13 Brake Resistors | 22 |
| 1.12 LCP Operation | 23 |
| 1.12.1 Control Unit | 23 |
| 1.12.2 Control Keys | 23 |

| | |
|---|-----------|
| 1.12.3 Manual Initialisation | 24 |
| 1.12.4 Display Readout States | 24 |
| 1.12.5 Hand Auto | 25 |
| 1.12.6 Automatic Motor Tuning | 25 |
| 1.13 LCP 2 Control Unit | 26 |
| 1.13.1 Introduction | 26 |
| 1.13.2 Control Keys for Parameter Set-up | 26 |
| 1.13.3 Indicator Lights | 27 |
| 1.13.4 Local Control | 27 |
| 1.13.5 Displayed Data Items | 28 |
| 1.13.6 Display Modes | 28 |
| 1.13.7 Parameter Set-up | 29 |
| 1.13.8 Quick Menu with LCP 2 Control Unit | 29 |
| 1.13.9 Parameter Selection | 30 |
| 1.13.10 Manual Initialisation | 31 |
| 2 Safety | 32 |
| 2.1 Safety Symbols | 32 |
| 2.2 Qualified Personnel | 32 |
| 2.3 Safety Precautions | 32 |
| 3 Installation | 34 |
| 3.1 Mechanical Dimensions | 34 |
| 3.1.1 Overview | 34 |
| 3.1.2 Enclosure B | 34 |
| 3.1.3 Enclosure C | 34 |
| 3.1.4 Enclosure D | 35 |
| 3.1.5 Motor Coils (195N3110) | 35 |
| 3.1.6 RFI 1B Filter (195N3103) | 35 |
| 3.1.7 Terminal Cover | 35 |
| 3.1.8 IP21 Solution | 36 |
| 3.1.9 EMC Filter for Long Motor Cables | 37 |
| 3.2 Mechanical Installation | 38 |
| 3.3 Electrical Installation | 39 |
| 3.3.1 High Voltage Warning | 39 |
| 3.3.2 Grounding | 39 |
| 3.3.3 Cables | 39 |
| 3.3.4 Screened/armoured Cables | 40 |
| 3.3.5 Extra Protection | 40 |
| 3.3.6 High Voltage Test | 40 |
| 3.3.7 EMC-correct Electrical Installation | 41 |

| | |
|---|-----------|
| 3.3.8 Use of EMC Compliant Cables | 42 |
| 3.3.9 Grounding of Screened/armoured Control Cables | 43 |
| 3.3.10 Electrical Wiring | 44 |
| 3.3.11 Electrical Connection | 45 |
| 3.4 Terminals | 47 |
| 3.4.1 Safety Clamp | 47 |
| 3.4.2 Pre-fuses | 48 |
| 3.4.3 Mains Connection | 48 |
| 3.4.4 Motor Connection | 48 |
| 3.4.5 Direction of Motor Rotation | 49 |
| 3.4.6 Parallel Connection of Motors | 50 |
| 3.4.7 Motor Cables | 50 |
| 3.4.8 Thermal Motor Protection | 50 |
| 3.4.9 Brake Connection | 50 |
| 3.4.10 Ground Connection | 51 |
| 3.4.11 Load Sharing | 51 |
| 3.4.12 Tightening Torque for Power Terminals | 52 |
| 3.4.13 Control of Mechanical Brake | 52 |
| 3.4.14 Access to Control Terminals | 52 |
| 3.4.15 Control Cables | 52 |
| 3.4.16 Control Terminals | 54 |
| 3.4.17 Relay Connection | 55 |
| 3.4.18 Switches 1-4 | 55 |
| 3.4.19 VLT Motion Control Tool MCT 10 Set-up Software | 55 |
| 3.4.20 Sub D Plug | 56 |
| 3.5 Connection Examples | 56 |
| 3.5.1 Start/Stop | 56 |
| 3.5.2 Pulse Start/Stop | 56 |
| 3.5.3 Speed Up/Down | 57 |
| 3.5.4 Potentiometer Reference | 57 |
| 3.5.5 Connection of a 2-Wire Transmitter | 57 |
| 3.5.6 4-20 mA Reference | 57 |
| 3.5.7 50 Hz Counter-clockwise to 50 Hz Clockwise | 58 |
| 3.5.8 Preset References | 58 |
| 3.5.9 Connection of Mechanical Brake | 59 |
| 3.5.10 Counter Stop Through Terminal 33 | 59 |
| 3.5.11 Use of Internal PID-Controller - Closed Loop Process Control | 59 |
| 4 Programming | 61 |
| 4.1 Operation & Display | 61 |
| 4.2 Load and Motor | 68 |

| | |
|--|------------|
| 4.3 References & Limits | 77 |
| 4.4 Inputs and Outputs | 84 |
| 4.5 Special Functions | 92 |
| 4.6 Enhanced Sleep Mode | 101 |
| 4.7 Serial communication | 106 |
| 4.7.1 Protocols | 106 |
| 4.7.2 Telegram Traffic | 106 |
| 4.7.3 Telegram Structure | 106 |
| 4.7.4 Data Character (Byte) | 107 |
| 4.7.5 Process Words | 110 |
| 4.7.6 Control Word According to FC Protocol | 110 |
| 4.7.7 Status Word According to FC Profile | 112 |
| 4.7.8 Control Word According to Fieldbus Profile | 113 |
| 4.7.9 Status Word According to Profidrive Protocol | 113 |
| 4.7.10 Serial Communication Reference | 114 |
| 4.7.11 Present Output Frequency | 115 |
| 4.8 Serial Communication Parameters | 116 |
| 4.9 Technical Functions | 123 |
| 5 All about VLT 2800 | 127 |
| 5.1 Special Conditions | 127 |
| 5.1.1 Galvanic Isolation (PELV) | 127 |
| 5.1.2 Ground Leakage Current and RCD Relays | 127 |
| 5.1.3 Extreme Operating Conditions | 128 |
| 5.1.4 dU/dt on Motor | 128 |
| 5.1.5 Switching on the Input | 128 |
| 5.1.6 Peak Voltage on Motor | 128 |
| 5.1.7 Acoustic Noise | 129 |
| 5.1.8 Derating for Ambient Temperature | 129 |
| 5.1.9 Temperature-Dependent Switching Frequency | 129 |
| 5.1.10 Derating for Air Pressure | 130 |
| 5.1.11 Derating for Running at Low Speed | 130 |
| 5.1.12 Derating for Long Motor Cables | 130 |
| 5.1.13 Derating for High Switching Frequency | 130 |
| 5.1.14 Vibration and Shock | 131 |
| 5.1.15 Air Humidity | 131 |
| 5.1.16 UL Standard | 131 |
| 5.1.17 Efficiency | 131 |
| 5.1.18 Mains Supply Interference/Harmonics | 132 |
| 5.1.19 Power Factor | 132 |
| 5.1.20 Generic EMC Standards / Product Standards | 133 |

| | |
|--|------------|
| 5.1.21 EMC Immunity | 134 |
| 5.1.22 Harmonic Current Emission | 135 |
| 5.1.23 Aggressive Environments | 135 |
| 5.2 Display and Messages | 136 |
| 5.2.1 Display Readout | 136 |
| 5.2.2 Warnings and Alarm Messages | 136 |
| 5.2.3 Warning Words, Extended Status Words and Alarm Words | 140 |
| 5.3 General Technical Data | 141 |
| 5.4 Mains Supply | 146 |
| 5.4.1 Mains Supply 1x220-240 V/3x200-240 V | 146 |
| 5.4.2 Mains Supply 3x380-480 V | 147 |
| 5.5 Parameter List with Factory Settings | 148 |
| Index | 155 |

1 Introduction to VLT 2800

1.1 Purpose of the Manual

This Design Guide is intended for project and systems engineers, design consultants, and application and product specialists. Technical information is provided to understand the capabilities of the frequency converter for integration into motor control and monitoring systems. Details concerning operation, requirements, and recommendations for system integration are described. Information is provided for input power characteristics, output for motor control, and ambient operating conditions for the converter.

Also included are safety features, fault condition monitoring, operational status reporting, serial communication capabilities, and programmable options and features. Design details such as site requirements, cables, fuses, control wiring, the size and weight of units, and other critical information necessary to plan for system integration is also provided.

Reviewing the detailed product information in the design stage is helpful in developing a well-conceived system with optimal functionality and efficiency.

VLT® is a registered trademark.

1.2 Available Documentation

Documentation is available to understand specific frequency converter functions and programming.

- VLT 2800 Quick Guide
- VLT 2800 Design Guide
- VLT 2800 Filter Instruction
- Brake Resistor Manual
- Profibus DP V1 Manual
- Profibus DP Manual
- VLT 2800 DeviceNet Manual
- Metasys N2 Manual
- Modbus RTU Manual
- Precise Stop
- Wobble Function
- VLT 2800 NEMA 1 Terminal Covering
- VLT 2800 LCP Remote-mounting Kit
- Protection against Electrical Hazards

1.3 Document and Software Version

| Edition | Remarks | Software version |
|---------|-----------------|------------------|
| MG27E4 | Replaces MG27E3 | 3.2X |

1.4 Technology

1.4.1 Control Principle

A frequency converter rectifies AC voltage from the mains supply into DC voltage, and changes this voltage to an AC voltage with variable amplitude and frequency. The motor thus receives a variable voltage and frequency, which enables infinitely variable speed control of 3-phase, standard AC motors.

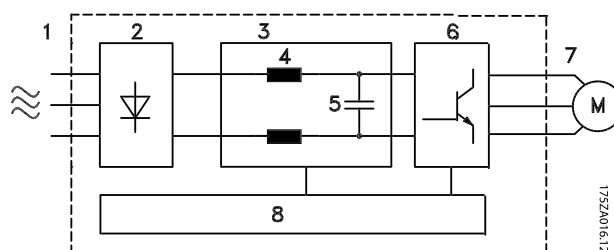

Illustration 1.1 Control Principle

1. Mains voltage

- 1x220-240 V AC, 50/60 Hz
- 3x200-240 V AC, 50/60 Hz
- 3x380-480 V AC, 50/60 Hz

2. Rectifier

3-phase rectifier bridge which rectifies AC voltage into DC voltage.

3. Intermediate circuit

DC voltage 2 x mains voltage [V].

4. Intermediate circuit coils

Evens out the intermediate circuit current and limits the load on mains and components (mains transformer, cables, fuses and contactors).

5. Intermediate circuit condenser

Evens out the intermediate circuit voltage.

6. Inverter

Converts DC voltage into a variable AC voltage with a variable frequency.

7. Motor voltage

Variable AC voltage depending on supply voltage.
Variable frequency: 0.2-132/1-590 Hz.

8. Control card

The control card controls the inverter which generates the pulse pattern converting the DC voltage into variable AC voltage with a variable frequency.

1.4.2 VLT 2800 Control Principle

A frequency converter is an electronic unit which is able to infinitely variably control the RPM of an AC motor. The frequency converter controls the motor speed by converting the regular voltage and frequency from mains, e.g. 400 V/50 Hz, into variable magnitudes. Today, the frequency converter controlled AC motor is a natural part of all types of automated plants.

The frequency converter has an inverter control system called VVC (Voltage Vector Control). VVC controls an induction motor by energising it with a variable frequency and a voltage suitable for it. If the motor load changes, so does its energising and speed. That is why the motor current is measured on an ongoing basis, and a motor model is used to calculate the actual voltage requirement and slip of the motor.

1.4.3 Programmable Inputs and Outputs in 4 Set-ups

In the frequency converter, it is possible to program the different control inputs and signal outputs and to select 4 different user-defined set-ups for most parameters. Program the required functions on the control panel or via serial communication.

1.4.4 Mains Protection

The frequency converter is protected against the transients that occur on the mains sometimes, e.g. if coupling with a phase compensation system, or if fuses blow when lightning strikes.

Rated motor voltage and full torque can be maintained down to approx. 10% undervoltage in the mains supply.

As all 400 V units in the VLT 2800 Series have intermediate circuit coils, there is only a low amount of harmonic mains supply interference. This gives a good power factor (lower peak current), which reduces the load on the mains installation.

1.4.5 Frequency Converter Protection

The current measurement in the intermediate circuit constitutes perfect protection of the frequency in case there is a short-circuit or a ground fault on the motor connection.

Constant monitoring of the intermediate circuit current enables switching on the motor output, e.g. with a contactor.

Efficient monitoring of the mains supply means that the unit stops if a phase drop-out occurs. In this way, the inverter and the condensers in the intermediate circuit are

not overloaded, which would dramatically reduce the service life of the frequency converter. The frequency converter offers temperature protection as standard. If there is a thermal overload, this function cuts out the inverter.

1.4.6 Reliable Galvanic Isolation

In the frequency converter, all digital inputs/outputs, analog inputs/outputs and the terminals for serial communication are supplied from or in connection with circuits that comply with PELV requirements. PELV is also complied with in relation to relay terminals, so that they can be connected to the mains potential.

For further information, see *chapter 5.1.1 Galvanic Isolation (PELV)*.

1.4.7 Advanced Motor Protection

The frequency converter has integral electronic motor protection. The frequency converter calculates the motor temperature on the basis of current, frequency and time. As opposed to traditional, bimetallic protection, electronic protection takes account of reduced cooling at low frequencies because of reduced fan speed (motors with internal fan). This function cannot protect the individual motors when motors are connected in parallel. Thermal motor protection can be compared to a protective motor switch, CTI.

See *chapter 5.1.1 Galvanic Isolation (PELV)* for further information.

WARNING

If motors are connected in parallel, individual motors still have the risk of overheating. To protect the frequency converter from overheating, install a thermistor and connect it to the thermistor input (digital input) of the frequency converter. See *chapter 4.2.2 Termisk motorbeskyttelse -parameter 128* for further information.

1.5 Approvals and Certifications



The frequency converter complies with UL508C thermal memory retention requirements. For more information, refer to *chapter 4.2.2 Termisk motorbeskyttelse -parameter 128*.

What is CE labelling?

The purpose of CE labelling is to avoid technical obstacles to trade within EFTA and the EU. The EU has introduced the CE label as a simple way of showing whether a product complies with the relevant EU directives. The CE label says nothing about the specifications or quality of the product. Frequency converters are regulated by 3 EU directives:

The machinery directive (98/37/EEC)

All machines with critical moving parts are covered by the machinery directive. Since a frequency converter is largely electrical, it does not fall under the machinery directive. However, if a frequency converter is supplied for use in a machine, Danfoss provides information on safety aspects relating to the frequency converter. Danfoss does this with a manufacturer's declaration.

The low-voltage directive (73/23/EEC)

Frequency converters must be CE labelled in accordance with the low-voltage directive. The directive applies to all electrical equipment and appliances used in the 50-1000 V AC and the 75-1500 V DC voltage ranges. Danfoss CE labels in accordance with the directive and issues a declaration of conformity upon request.

The EMC directive (89/336/EEC)

EMC is short for electromagnetic compatibility. The presence of electromagnetic compatibility means that the mutual interference between different components/appliances is so small that the functioning of the appliances is not affected.

Danfoss CE labels in accordance with the directive and issues a declaration of conformity upon request. To carry out EMC-correct installation, this manual gives detailed instructions for installation. In addition, Danfoss specifies the standards which our different products comply with.

The frequency converter is most often used by professionals of the trade as a complex component forming part of a larger appliance, system or installation. It must be noted that the responsibility for the final EMC properties of the appliance, system or installation rests with the installer.

1.6 Disposal

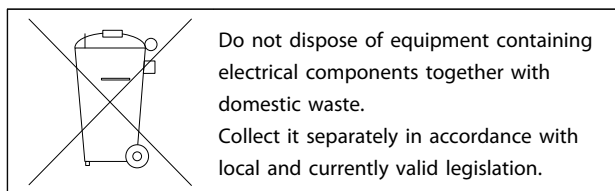

1.7 Selecting the Correct Frequency Converter

1.7.1 Introduction

This section explains how to specify and order a VLT 2800.

The frequency converter must be selected on the basis of the present motor current at maximum loading of the unit. The frequency converter's rated output current I_{INV} must be equal to or greater than the required motor current.

Mains Voltage

VLT 2800 is available for 2 mains voltage ranges:

- 200-240 V and
- 380-480 V.

Select whether the frequency converter is connected to a mains voltage of:

- 1x220-240 V single-phase AC voltage
- 3x200-240 V 3-phase AC voltage
- 3x380-480 V 3-phase AC voltage

| Type | Typical shaft output P_{INV} | | Maximum constant output current I_{INV} [A] | Maximum constant output power at 230 V S_{INV} [kVA] |
|------|-----------------------------------|------|--|--|
| | [kW] | [HP] | | |
| 2803 | 0.37 | 0.5 | 2.2 | 0.9 |
| 2805 | 0.55 | 0.75 | 3.2 | 1.3 |
| 2807 | 0.75 | 1.0 | 4.2 | 1.7 |
| 2811 | 1.1 | 1.5 | 6.0 | 2.4 |
| 2815 | 1.5 | 2.0 | 6.8 | 2.7 |
| 2822 | 2.2 | 3.0 | 9.6 | 3.8 |
| 2840 | 3.7 | 5.0 | 16 | 6.4 |

Table 1.1 1x220-240 V Mains Voltage

| Type | Typical shaft output P_{INV} | | Maximum constant output current I_{INV} [A] | Maximum constant output power at 230 V S_{INV} [kVA] |
|------|-----------------------------------|------|--|--|
| | [kW] | [HP] | | |
| 2803 | 0.37 | 0.5 | 2.2 | 0.9 |
| 2805 | 0.55 | 0.75 | 3.2 | 1.3 |
| 2807 | 0.75 | 1.0 | 4.2 | 1.7 |
| 2811 | 1.1 | 1.5 | 6.0 | 2.4 |
| 2815 | 1.5 | 2.0 | 6.8 | 2.7 |
| 2822 | 2.2 | 3.0 | 9.6 | 3.8 |
| 2840 | 3.7 | 5.0 | 16.0 | 6.4 |

Table 1.2 3x200-240 V Mains Voltage

| Type | Typical shaft output P_{INV} | | Maximum constant output current I_{INV} [A] | Maximum constant output power at 400 V S_{INV} [kVA] |
|------|-----------------------------------|------|--|--|
| | [kW] | [HP] | | |
| 2805 | 0.55 | 0.75 | 1.7 | 1.1 |
| 2807 | 0.75 | 1.0 | 2.1 | 1.7 |
| 2811 | 1.1 | 1.5 | 3.0 | 2.0 |
| 2815 | 1.5 | 2.0 | 3.7 | 2.6 |
| 2822 | 2.2 | 3.0 | 5.2 | 3.6 |
| 2830 | 3.0 | 4.0 | 7.0 | 4.8 |
| 2840 | 4.0 | 5.0 | 9.1 | 6.3 |
| 2855 | 5.5 | 7.5 | 12.0 | 8.3 |
| 2875 | 7.5 | 10.0 | 16.0 | 11.1 |
| 2880 | 11 | 15 | 24 | 16.6 |
| 2881 | 15 | 20 | 32 | 22.2 |
| 2882 | 18.5 | 25 | 37.5 | 26.0 |

Table 1.3 3x380-480 V Mains Voltage

1.7.2 Enclosure

All VLT 2800 units are supplied with IP20 enclosure as standard.

This enclosure level is ideal for panel mounting in areas where a high degree of protection is required; at the same time IP20 enclosures allow side-by-side installation without any need for extra cooling equipment.

IP20 units can be upgraded with IP21/top cover and/or NEMA 1 by fitting a terminal cover. See ordering number for terminal cover in *chapter 1.10 Accessories for VLT 2800*.

In addition, VLT 2880-82 and 2840 PD2 units are supplied with NEMA 1 enclosure as standard.

1.7.3 Brake

Danfoss VLT 2800 is available with an integral brake module (does not apply to 2822 and 2840 in 200 V with combined single-phase/3-phase supply - type code PD2). See also *chapter 1.11.13 Brake Resistors* for brake resistor ordering numbers.

1.7.4 RFI Filter

VLT 2800 is available with or without an integral 1A RFI-filter. The integral 1A RFI filter complies with EMC standards EN 55011-1A.

With an integral RFI filter there is compliance with EN 55011-1B with a maximum 15-metres screened/armoured motor cable on VLT 2803-2815 1x220-240 V.

VLT 2880-82 with integral 1B filter comply with EMC standard EN 50011-1B.

1.7.5 Harmonic Filter

The harmonic currents do not affect power consumption directly, but they increase the heat losses in the installation (transformer, cables). That is why, in a system with a relatively high percentage of rectifier load, it is important to keep the harmonic currents at a low level so as to avoid a transformer overload and high cable temperature. For the purpose of ensuring low harmonic currents, VLT 2822-2840 3x200-240 V and VLT 2805-2882 380-480 V are fitted with coils in their intermediate circuit as standard. This reduces the input current I_{RMS} by typically 40%. Please Note that 1x220-240 V units up to 1.5 kW are not supplied with coils in their intermediate circuit.

1.7.6 Control Unit

The frequency converter is always supplied with an integral control unit.

All displays are in the form of a 6-digit LED display capable of showing one item of operating data continuously during normal operation. As a supplement to the display, there are 3 indicator lights for voltage (ON), warning (WARNING) and alarm (ALARM). Most of the frequency converter's parameter set-ups can be changed immediately via the integral control panel.

An LCP 2 control panel to be connected via a plug to the front of the frequency converter is available as an option. The LCP 2 control panel can be installed up to 3 metres away from the frequency converter, e.g. on a front panel, with the accompanying mounting kit.

All displays of data are via a 4-line alpha-numerical display, which in normal operation is able to show 4 operating data items and 3 operation modes continuously. During programming, all the information required for quick, efficient parameter set-up of the frequency converter is displayed. As a supplement to the display, there are 3

indicator lights for voltage (ON), warning (WARNING) and alarm (ALARM). Most of the frequency converter's parameter set-ups can be changed immediately via the LCP 2 control panel. See *chapter 1.13.1 Introduction* for more details.

1.7.7 FC Protocol

Danfoss frequency converters are able to fulfill many different functions in a monitoring system. The frequency converter can be integrated directly in an overall surveillance system, which allows detailed process data to be transferred via serial communication. The protocol standard is based on an RS-485 bus system with a maximum transmission speed of 9600 baud. The following frequency converter profiles are supported as standard:

- FC Drive, which is a profile adapted to Danfoss.
- Profidrive, which supports the profidrive profile.

See *chapter 4.8 Serial Communication Parameters* for further details of telegram structure and drive profile.

1.7.8 Fieldbus Option

The increasing information requirements in industry make it necessary to collect or visualise different process data. Important process data help the system technician with the daily monitoring of the system. The large amounts of data involved in major systems make a higher transmission speed than 9600 baud desirable.

Fieldbus option

Profibus

Profibus is a fieldbus system, which can be used for linking automation devices such as sensors and actuators with the controls via a 2-conductor cable. Profibus DP is a fast communication protocol made specially for communication between the automation system and various types of equipments.

Profibus is a registered trade mark.

DeviceNet

DeviceNet fieldbus systems can be used for linking automation devices such as sensors and actuators with the controls via a 4-wire conductor cable.

DeviceNet is a medium-speed communication protocol made specially for communication between the automation system and various types of equipment. Units with DeviceNet protocol cannot be controlled by FC protocol and Profidrive protocol.

MCT 10 Set-up Software can be used on the Sub D plug.

1.7.9 Motor Coils

By fitting the motor coil module between the frequency converter and the motor, it is possible to use up to 200 m of unscreened/unarmoured motor cable or 100 m of screened/armoured motor cable. The motor coil module has an IP20 enclosure and can be installed side-by-side.

To have long motor cables and still comply with EN55011-1A, motor coil and EMC filter for long motor cables are needed.

To comply with EN55011-1A, the EMC filter for long motor cables can only be fitted to a VLT 2800 with integral 1A filter (R1 option).

Refer to *chapter 5.1.21 EMC Compliance* for more details.

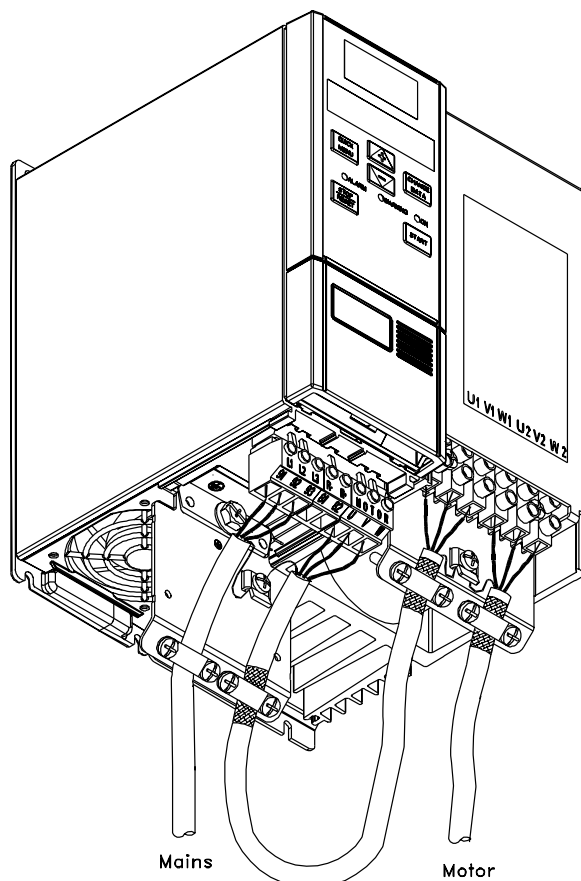

Illustration 1.2 Motor Cable Example

| | |
|---|------------------------|
| Maximum cable length (unscreened/unarmoured) ¹⁾ | 200 m |
| Maximum cable length (screened/armoured) ¹⁾ | 100 m |
| Enclosure | IP20 |
| Maximum rated current ¹⁾ | 16 A |
| Maximum voltage ¹⁾ | 480 V AC |
| Minimum distance between frequency converter and motor coil | Side-by-side |
| Minimum distance above and below motor coil | 100 mm |
| Mounting | Vertical mounting only |
| Dimensions HxWxD (mm) ²⁾ | 200x90x152 |
| Weight | 3.8 kg |

Table 1.4 Technical Data for VLT 2803-2875 Motor Coils

1) Parameter 411 Switching frequency=4500 Hz.

2) For mechanical dimensions see chapter 3.1.1 Overview.

For ordering numbers for motor coil module, see chapter 1.10 Accessories for VLT 2800.

1.7.10 RFI 1B Filter

All frequency converters cause electromagnetic noise in the mains supply when they are operating. An RFI (radio frequency interference) filter reduces the electromagnetic noise in the mains supply. Without an RFI filter, there is a risk that a frequency converter disrupts other electrical components that are connected to the mains and might thus cause operating disruption. By fitting an RFI 1B filter module between the mains supply and the VLT 2800, the VLT 2800 complies with the EMC norm EN 55011-1B.

To comply with EN 55011-1B, the RFI 1B filter module must be fitted together with a VLT 2800 with integral 1A RFI filter.

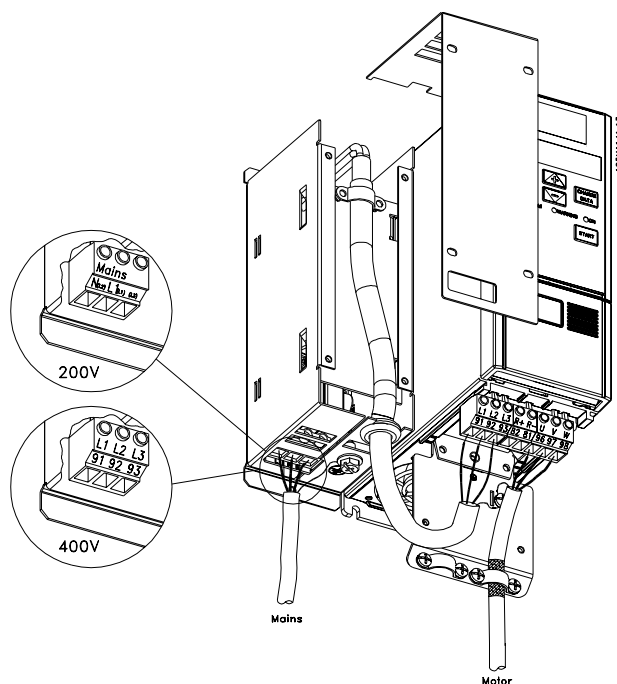
Illustration 1.3 RFI 1B Filter Example

| | |
|--|------------------------|
| Maximum cable length (screened/armoured) 200-240 V | 100 m (At 1A: 100 m) |
| Maximum cable length (screened/armoured) 380-480 V | 25 m (At 1A: 50 m) |
| Enclosure | IP20 |
| Maximum rated current | 16 A |
| Maximum Voltage | 480 V AC |
| Maximum voltage to ground | 300 V AC |
| Minimum distance between VLT and RFI 1B filter | Side-by-side |
| Minimum distance above and below RFI 1B filter | 100 mm |
| Mounting | Vertical mounting only |
| Dimensions HxWxD (mm) | 200x60x87 |
| Weight | 0.9 kg |

Table 1.5 Technical Data for VLT 2803-2875 RFI 1B Filter

For ordering number for RFI 1B filter module, see chapter 1.10 Accessories for VLT 2800.

1.7.11 RFI 1B/LC Filter

The RFI 1B/LC filter contains both an RFI module that complies with EN 55011-1B, and a LC filter that reduces the acoustic noise.

LC filter

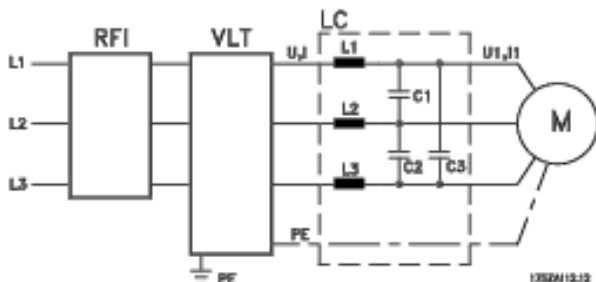

Illustration 1.4 LC Filter

When a motor is controlled by a frequency converter, acoustic noise may be heard from the motor. The noise, which is caused by the design of the motor, is generated every time one of the inverter contacts in the frequency converter is activated. The frequency of the acoustic noise therefore corresponds to the frequency converter's connection frequency.

The filter reduces the voltage's dU/dt , the peak voltage U_{peak} and ripple current ΔI to the motor, so that the current and voltage are almost sine-shaped. The acoustic motor noise is thus reduced to a minimum.

Because of the ripple current in the coils, some noise is emitted by the coils. This problem can be solved completely by fitting the filter inside a cabinet or equivalent.

Danfoss can supply an LC filter for the VLT series 2800, which muffles the acoustic motor noise. Before the filters are put into use, ensure that:

- Rated current is observed.
- Mains voltage is 200-480 V.
- Parameter 412 Variable switching frequency is set to [3] LC filter attached.
- Output frequency is max. 120 Hz.

Refer to *Illustration 1.7* for a connection example of LC filter.

Installation of thermistor (PTC)

The RFI 1B/LC filter has an integral thermistor (PTC), which is activated if an overtemperature arises. The frequency converter can be programmed to stop the motor and activate an alarm via a relay output or a digital output if the thermistor is activated.

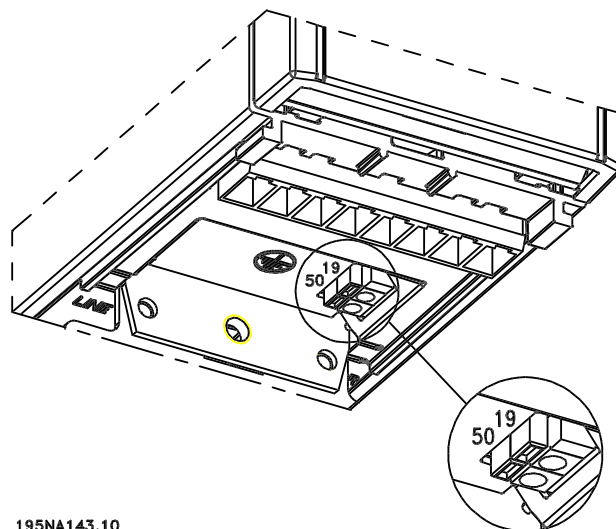

195NA143.10

Illustration 1.5 Thermistor Installation

The thermistor must be connected between terminal 50 (+10 V) and one of the digital inputs 18, 19, 27 and 29. In parameter 128 Thermal motor protection, [1] Thermistor warning or [2] Thermistor trip is selected. *Illustration 1.7* shows the thermistor connection.

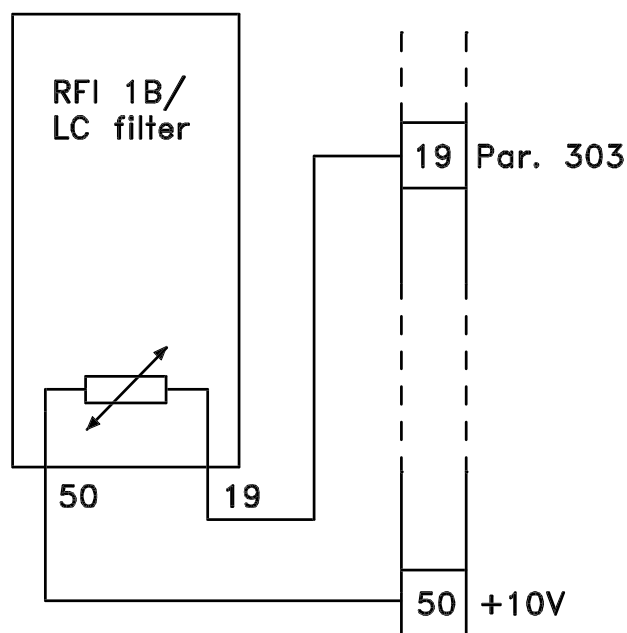

195NA144.10

Illustration 1.6 Thermistor Connection

To comply with EN 55011-1B, the RFI 1B filter module must be fitted to a VLT 2800 with integral 1A RFI filter.

NOTICE

The 1B/LC filter is not suitable for 200 V devices due to the high 1Ø input current.

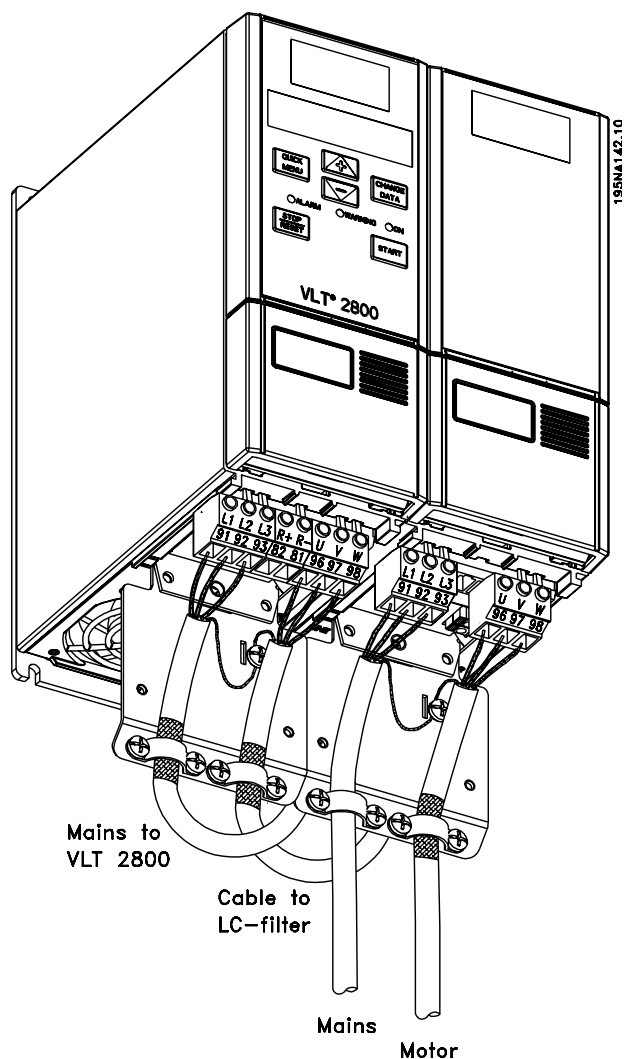

Illustration 1.7 Connection Example for RFI 1B/LC Filter

| | |
|--|--|
| Maximum cable length (screened/armoured) 380-480 V | 25 m (At 1A: 50 m) |
| Enclosure | IP20 |
| Maximum rated current | 4.0 (Order no.: 195N3100); 9.1 (Order no.: 195N3101) |
| Maximum voltage | 480 V AC |
| Maximum voltage to ground | 300 V AC |
| Minimum distance between VLT and RFI 1B/LC filter | Side-by-side |
| Minimum distance above and below RFI 1B/LC filter | 100 mm |
| Mounting | Vertical mounting only |
| Dimensions 195N3100 4.0 A HxWxD (mm) | 200x75x168 |
| Dimensions 195N3101 9.1 A HxWxD (mm) | 267.5x90x168 |
| Weight 195N3100 4.0 A | 2.4 kg |
| Weight 195N3101 9.1 A | 4.0 kg |

Table 1.6 Technical Data for VLT 2803–2875 RFI 1B/LC filter

1.8 Order Form

How to order

A type code defines the specific configuration of the VLT® 2800 frequency converter. Use *Illustration 1.8* to create a type code string for the desired configuration.

A dedicated drive configurator is available at www.danfoss.com/drives. It is recommended to use the configurator to get the specific ordering number.

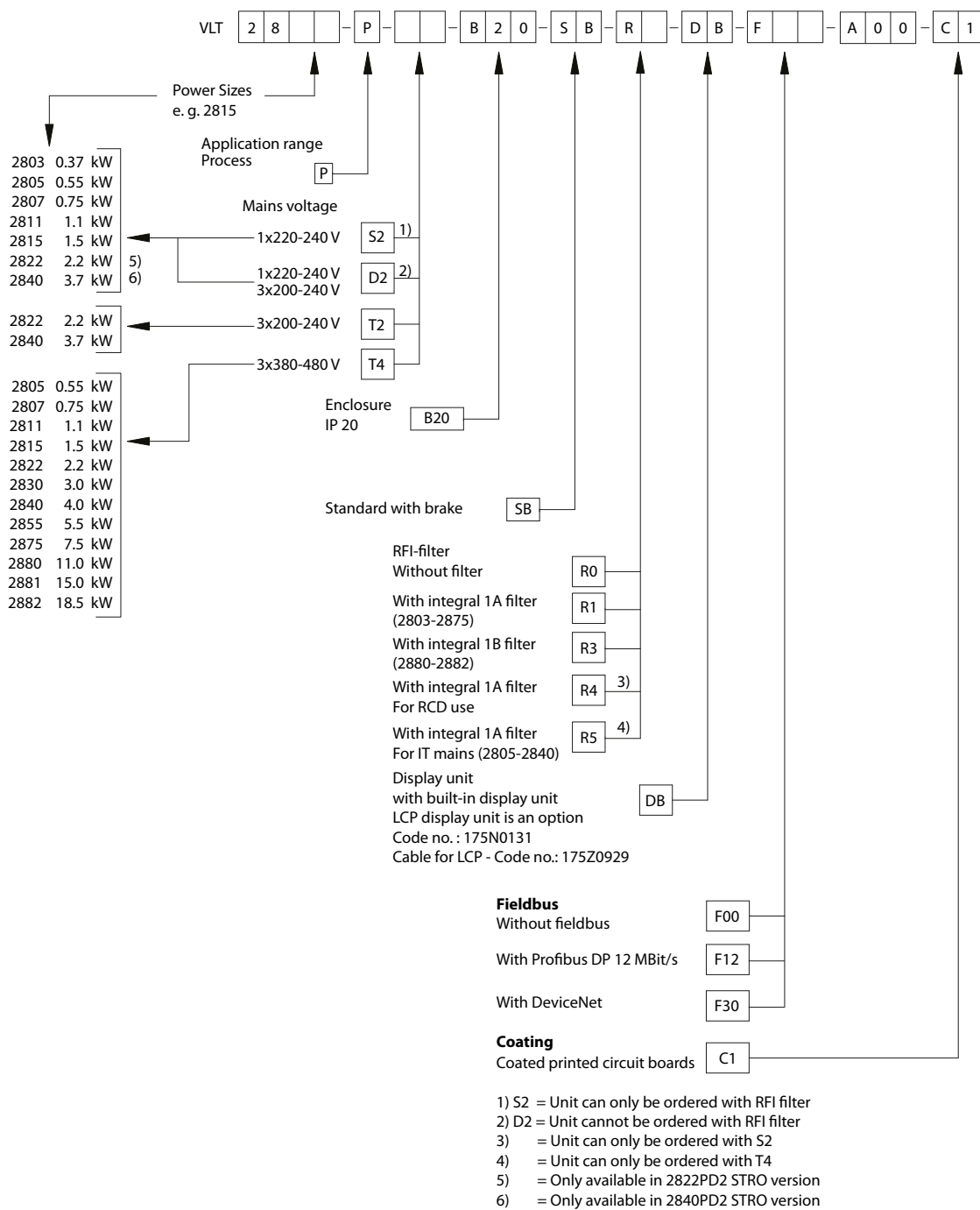

Illustration 1.8 Type Code Definition

1.9 PC Software

MCT 10 Set-up Software

All frequency converters are equipped with a serial communication port. Danfoss provides a PC tool for communication between PC and frequency converter, VLT Motion Control Tool MCT 10 Set-up Software.

MCT 10 Set-up Software has been designed as an easy-to-use interactive tool for setting parameters in the frequency converters.

The MCT 10 Set-up Software can be used for:

- Planning a communication network off-line. MCT 10 Set-up Software contains a complete frequency converter database.
- Commissioning frequency converters on line.
- Saving settings for all frequency converters.
- Replacing a frequency converter in a network.
- Expanding an existing network.
- Supporting future developed frequency converters.

MCT 10 Set-up Software support Profibus DP-V1 via a master class 2 connection. It makes it possible to read/write parameters on-line in a frequency converter via the Profibus network. This eliminates the need for an extra communication network.

The MCT 10 Set-up Software can be downloaded at: www.danfoss.com/BusinessAreas/DrivesSolutions/Software-download/. Select the licensed version to use all functions, or the free version to use limited functions.

MCT 31 Harmonic Calculation Tool

The MCT 31 Harmonic Calculation tool determines the degree of voltage pollution on the grid and needed precaution. Download the free MCT 31 Harmonic Calculation Tool from www.danfoss.com/BusinessAreas/DrivesSolutions/Software-download/.

1.10 Accessories for VLT 2800

| Type | Description | Ordering no. |
|------------------------------|--|--------------|
| Motor coil | The motor coil module can be used for VLT 2803-2875 | 195N3110 |
| RFI 1B filter | The RFI 1B filter module can be used for VLT 2803-2875 | 195N3103 |
| RFI 1B/LC filter 4 A | The RFI 1B/LC filter 4 A can be used for VLT 2803-2805 200-240 V and VLT 2805-2815 380-400 V | 195N3100 |
| RFI 1B/LC filter 9.1 A | RFI 1B/LC filter 9.1 A can be used for VLT 2807-2815 200-240 V and VLT 2822-2840 380-400 V | 195N3101 |
| EMC filter | EMC filter for long motor cables can be used for VLT 2805-2815 380-480 V | 192H4719 |
| EMC filter | EMC filter for long motor cables can be used for VLT 2822-2840 380-480 V | 192H4720 |
| EMC filter | EMC filter for long motor cables can be used for VLT 2855-2875 380-480 V | 192H4893 |
| NEMA 1 terminal cover | VLT 2803-2815 200-240 V, VLT 2805-2815 380-480 V | 195N1900 |
| NEMA 1 terminal cover | VLT 2822 200-240 V, VLT 2822-2840 380-480 V | 195N1901 |
| NEMA 1 terminal cover | VLT 2840, VLT 2840 PD2 200-240 V, VLT 2855-2875 380-480 V | 195N1902 |
| IP 21 top cover | VLT 2803-2815 200-240 V, VLT 2805-2815 380-480 V | 195N2179 |
| IP 21 top cover | VLT 2822 200-240 V, VLT 2822-2840 380-480 V | 195N2180 |
| IP 21 top cover | VLT 2840 200-240 V, VLT 2822 PD2, VLT 2855-2875 380-480 V | 195N2181 |
| IP 21 top cover | VLT 2880-2882 380-480 V, VLT 2840 PD2 | 195N2182 |
| LCP 2 control unit | LCP 2 for programming the frequency converter | 175N0131 |
| Cable for LCP 2 control unit | Cable from LCP 2 to frequency converter | 175Z0929 |
| DeviceNet cable | Cable for DeviceNet connection | 195N3113 |
| LCP 2 remote-mounting kit | Kit for remote-mounting of LCP 2 (incl. 3 m cable, excl. LCP 2) | 175Z0850 |
| LOP (Local Operation Pad) | LOP can be used for setting the reference and start/stop via the control terminals. | 175N0128 |
| MCT 10 | Set-up software | 130B1000 |

Table 1.7 Accessory List

1.11 Brake Resistors

1.11.1 Dynamic Braking

With the VLT 2800, the dynamic braking quality in an application can be improved in 2 ways, either with brake resistors or AC braking.

Danfoss offers a complete range of brake resistors for all VLT 2800 frequency converters.

A brake resistor applies a load to the intermediate circuit during braking, thereby ensuring that the brake power can be absorbed by the brake resistor.

Without a brake resistor, the intermediate circuit voltage of the frequency converter may continue to rise, until cutting out for protection. Using a brake resistor can brake quickly with large loads, e.g. on a conveyor belt.

Danfoss has selected a solution in which the brake resistor is not integrated into the frequency converter. This gives the user the following advantages:

- The resistor's cycle time can be selected as required.
- The heat generated during braking can be diverted outside the panel cabinet, where the energy can possibly be utilised.
- No overheating of the electronic components, even if the brake resistor is overloaded.

AC braking is an integrated function that is used for applications in which there is a need for limited dynamic braking. The AC braking function makes it possible to reduce the brake power in the motor instead of in a brake resistor. The function is intended for applications where the required braking torque is less than 50% of rated torque. AC braking is selected in *parameter 400 Brake function*.

⚠ WARNING

Do not use the AC brake if the required braking torque is more than 50% of rated braking torque. There is a risk of equipment damage and personal injury. To ensure safety of equipments and people, use a brake resistor in such cases.

1.11.2 Brake Set-up

Illustration 1.9 shows a brake set-up with a frequency converter.

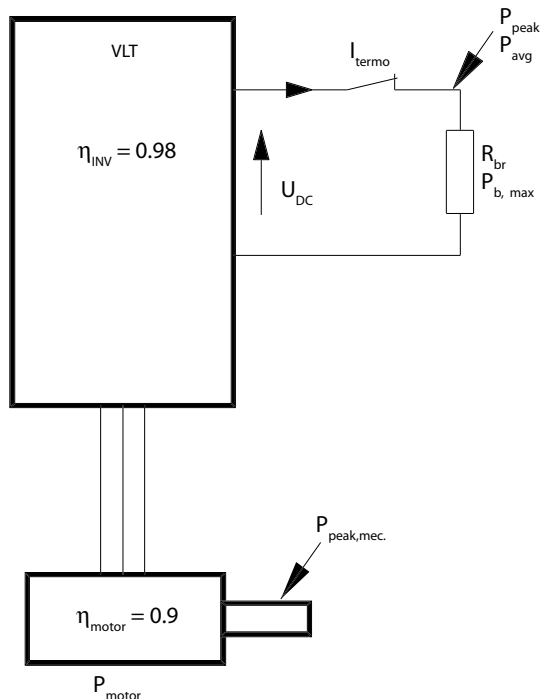

175ZA096.14

Illustration 1.9 A Brake Set-up with a Frequency Converter

The expressions and acronyms that are used in Illustration 1.9 are also used in the following sections.

1.11.3 Calculation of Brake Resistance

The following example and formula only apply to VLT 2800 Series.

To ensure that the frequency converter does not cut out for safety reasons when the motor brakes, the resistance value is selected on the basis of the peak braking effect and the intermediate circuit voltage:

$$R_{br} = \frac{U_{DC}^2}{P_{PEAK}} [\Omega]$$

It can be seen that the brake resistance depends on the intermediate circuit voltage (UDC).

With frequency converters that have a mains voltage of 3x380-480 V, the brake is active at 770 V (UDC); if the frequency converter has a mains voltage of 3x200-240 V, the brake is active at 385 V (UDC).

Using the brake resistance (Rrec) recommended by Danfoss guarantees that the frequency converter is able to brake at the highest braking torque (M_{BR}). The recommended brake resistance is shown in chapter 1.11.13 Brake Resistors.

R_{REC} calculated as:

$$R_{REC} = \frac{U_{DC}^2 \times 100}{P_{motor} \times M_{br}(\%) \times \eta_{motor} \times \eta_{inv}} [\Omega]$$

WARNING

Ensure that the brake resistance can manage a voltage of 850 V or 430 V, if Danfoss brake resistors are not being used. Incompatible brake resistance could result in equipment damage and/or personal injury.

η_{motor} is typically 0.90 and η_{INV} is typically 0.98. For 400 V and 200 V frequency converters, R_{REC} at 160% braking torque can be written as:

$$400 \text{ V } R_{REC} = \frac{420139}{P_{motor}} [\Omega]$$

$$200 \text{ V } R_{REC} = \frac{105035}{P_{motor}} [\Omega]$$

CAUTION

The brake resistance selected should have an ohmic value higher than 90% of the value recommended by Danfoss. Selecting a lower brake resistance could result in overcurrent, which can destroy the unit.

1.11.4 Calculation of Braking Power

When calculating the braking power, ensure that the mean and peak powers can be dissipated to the brake resistor. The mean power is determined by the period time of the process, i.e. for how long the brake is applied in relation to the period time of the process. The peak power is determined by the braking torque, which means that during braking the brake resistor must be able to dissipate the energy input. Illustration 1.10 shows the relation between mean power and peak power.

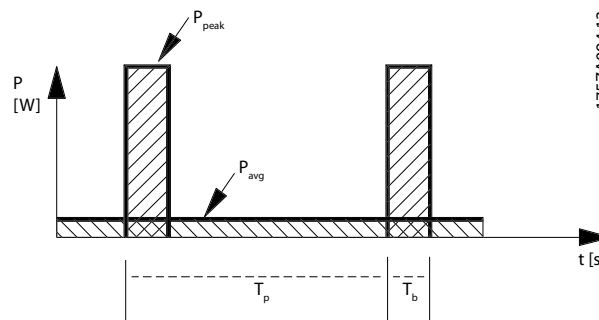

175ZA094.13

Illustration 1.10 Mean Power and Peak Power

1.11.5 Calculation of Peak Power of Brake Resistor

$P_{PEAK, MEC}$ is the peak power at which the motor brakes on the motor shaft. It is calculated as follows:

$$P_{PEAK, MEC} = \frac{P_{MOTOR} \times MBR (\%)}{100} [W]$$

P_{peak} is the term describing the braking power that is applied to the brake resistor when the motor applies the brakes. P_{PEAK} is smaller than $P_{PEAK, MEC}$, as the power is reduced by the efficiency of the motor and the frequency converter. The peak effect is calculated as follows:

$$P_{PEAK} = \frac{P_{MOTOR} \times MBR (\%) \times \eta_{INV} \times \eta_{MOTOR}}{100} [W]$$

With Danfoss' recommended brake resistor (R_{REC}), the brake resistance can generate a braking torque of 160% on the motor shaft.

1.11.6 Calculation of Mean Power on Brake Resistor

The mean power is determined by the period of the process, i.e. how long the brake is in relation to the period of the process.

Duty-cycle for braking is calculated as follows:

$$Duty-cycle = \frac{T_b \times 100}{T_p} [\%]$$

T_p = The process time in seconds.

T_b = The braking time in seconds.

Danfoss sells brake resistors with variable duty-cycles up to 40%. For example, with a 10% duty-cycle, brake resistors can take up P_{peak} in 10% of the process period. The remaining 90% of the period time is spent on redirecting surplus heat.

The mean power at 10% duty cycle can be calculated as follows:

$$P_{avg} = P_{peak} \times 10\% [W]$$

The mean power at 40% duty cycle can be calculated as follows:

$$P_{avg} = P_{peak} \times 40\% [W]$$

These calculations apply to intermittent braking with period times of up to 120 s.

CAUTION

The resistor can become overheated if the period times are longer than 120 s. This can lead to equipment damage. Ensure the period times are less than 120 s.

1.11.7 Continuous Braking

For continuous braking, a brake resistor should be selected in which the constant braking power does not exceed the mean power P_{AVG} of the brake resistor.

Contact the Danfoss supplier for further information.

1.11.8 DC Injection Braking

If the 3-phase winding of the stator is fed with direct current, a stationary magnetic field is set up in the stator bore causing a voltage to be induced in the bars of the cage rotor as long as the rotor is in motion. Since the electrical resistance of the rotor cage is very low, even small induced voltages can create a high rotor current. This current produces a strong braking effect on the bars and hence on the rotor. As the speed drops, the frequency of the induced voltage drops and with it the inductive impedance. The ohmic resistance of the rotor gradually becomes dominant and so increases the braking effect as the speed comes down. The braking torque generated drops steeply just before standstill and finally ceases when there is no further movement. Direct current injection braking is therefore not suitable for holding a load at rest.

1.11.9 AC-braking

When the motor acts as a brake, the DC-link voltage increases because energy is fed back to the DC-link. The principle in AC-braking is to increase the magnetisation during the braking and thereby increasing the thermal losses of the motor. Use *parameter 144 Gain AC brake* in VLT 2800 to adjust the size of the generator torque that can be applied to the motor without the intermediate circuit voltage exceeding the warning level.

The braking torque depends on the speed. With the AC-brake function enabled and *parameter 144 Gain AC brake*=1,3 (factory setting), it is possible to brake with about 50% of rated torque below 2/3 of rated speed and with about 25% at rated speed. The function is not working at low speed (below 1/3 of nominal motor speed). It is only possible to run for about 30 s with *parameter 144 Gain AC brake* greater than 1.2.

The current cannot be read out from the display.

CAUTION

If the value in *parameter 144 Gain AC brake* is increased, the motor current simultaneously increases significantly when generator loads are applied. This could damage the equipments. Change the parameter only if it is guaranteed during measurement that the motor current in all operating situations never exceeds the maximum permitted current in the motor.

1.11.10 Optimal Braking Using Resistor

Dynamic braking is useful from maximum speed down to a certain frequency. Below this frequency, DC braking is to be applied as required. The most efficient way of doing this is by using a combination of dynamic braking and DC braking, as shown in *Illustration 1.11*.

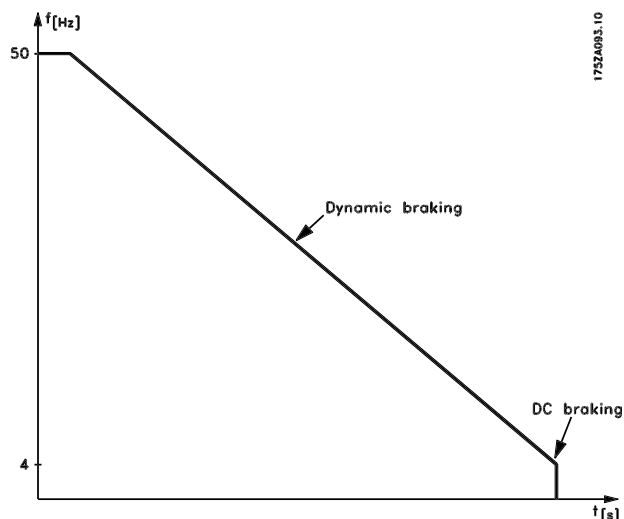

Illustration 1.11 Combination of Dynamic Braking and DC Braking

When changing from dynamic to DC braking, there is a short period (2-6 ms) with very low braking torque.

How to calculate optimum DC-brake cut in frequency:

$$\text{Slip } S = \frac{n_0 - n_n}{n_0} \times 100 \text{ [%]}$$

$$\text{Synchronous speed } n_0 = \frac{f \times 60}{p} \text{ [1 / min]}$$

f = frequency

p = no. of pole pairs

n_n = speed of the rotor

$$\text{DC-brake cut in frequency} = 2 \times \frac{s \times f}{100} \text{ [Hz]}$$

1.11.11 Brake Cable

Max. length [m]: 20 m

Use a screened/armoured connection cable to the brake resistor. Connect the screen to the conductive backplate at the frequency converter and to the brake resistor metal cabinet with cable clamps.

NOTICE

If Danfoss brake resistors are not used, there is a risk of equipment damage. In this case, ensure the brake resistor that is used in induction-free.

1.11.12 Protective Functions During Installation

WARNING

Avoid overloads when a brake resistor is installed. The heat generated from a brake resistor may result in a fire risk.

NOTICE

The brake resistor should be fitted to a nonflammable material to avoid the risk of fire.

For protection of the installation, fit a thermal relay that cuts off the frequency converter if the brake current becomes too high. Flat pack resistors are self-protecting.

Calculate the brake current setting of the thermal relay as follows:

$$I_{\text{therm relay}} = \sqrt{\frac{P_{\text{avg}}}{R_{\text{brake resistor}}}}$$

R_{br} is the current brake resistor value calculated in *chapter 1.11.3 Calculation of Brake Resistance*.

Illustration 1.12 shows an installation with a thermal relay.

The brake current setting of thermal relay for Danfoss 40% brake resistors is shown in *chapter 1.11.13 Brake Resistors*.

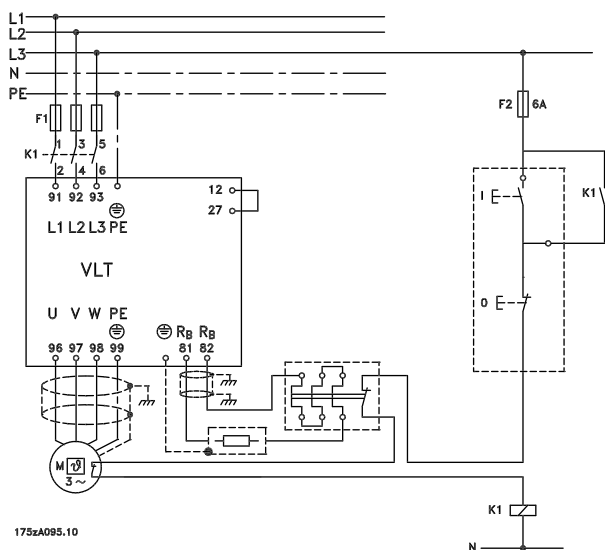

175zA095.10

Illustration 1.12 Frequency Converter with Brake Resistor and Thermal Switch

Some of the Danfoss brake resistors contain a thermal switch (see *chapter 1.11.13 Brake Resistors*). This switch is NC (normally closed) and can be used e.g. coasting stop reverse between terminal 12 and 27. The frequency converter coasts, if the thermal switch is opened.

CAUTION

The thermal switch is not a protective device. To protect people and equipments from the risk of fire and overheating, use a thermal switch as shown in *Illustration 1.12*.

1.11.13 Brake Resistors

| VLT type | P _{motor} [kW] | R _{min} [Ω] | R _{rec} [Ω] | P _{b, cont.} [kW] | Therm. relay [A] | Order no. | Cable cross-section [mm ²] |
|--------------|----------------------------|-------------------------|-------------------------|-------------------------------|---------------------|-----------|---|
| 2803 (200 V) | 0.37 | 275 | 300 | 0.2 | 0.8 | 175U3096 | 1.5 |
| 2805 (200 V) | 0.55 | 185 | 200 | 0.2 | 0.9 | 175U3008 | 1.5 |
| 2807 (200 V) | 0.75 | 135 | 145 | 0.3 | 1.3 | 175U3300 | 1.5 |
| 2811 (200 V) | 1.1 | 91 | 100 | 0.45 | 2 | 175U3301 | 1.5 |
| 2815 (200 V) | 1.5 | 66 | 70 | 0.57 | 2.7 | 175U3302 | 1.5 |
| 2822 (200 V) | 2.2 | 44 | 48 | 0.96 | 4.2 | 175U3303 | 1.5 |
| 2840 (200 V) | 3.7 | 22 | 27 | 1.4 | 6.8 | 175U3305 | 1.5 |
| 2805 (400 V) | 0.55 | 747 | 850 | 0.2 | 0.5 | 175U3308 | 1.5 |
| 2807 (400 V) | 0.75 | 558 | 630 | 0.3 | 0.7 | 175U3309 | 1.5 |
| 2811 (400 V) | 1.1 | 370 | 410 | 0.45 | 1 | 175U3310 | 1.5 |
| 2815 (400 V) | 1.5 | 260 | 270 | 0.57 | 1.4 | 175U3311 | 1.5 |
| 2822 (400 V) | 2.2 | 185 | 200 | 0.96 | 2.1 | 175U3312 | 1.5 |
| 2830 (400 V) | 3 | 135 | 145 | 1.13 | 2.7 | 175U3313 | 1.5 |
| 2840 (400 V) | 4 | 99 | 110 | 1.7 | 3.7 | 175U3314 | 1.5 |
| 2855 (400 V) | 5.5 | 74 | 80 | 2.2 | 5 | 175U3315 | 1.5 |
| 2875 (400 V) | 7.5 | 52 | 56 | 3.2 | 7.1 | 175U3316 | 1.5 |
| 2880 (400 V) | 11 | 35 | 38 | 5.0 | 11.5 | 175U3236 | 1.5 |
| 2881 (400 V) | 15 | 26 | 28 | 6.0 | 14.7 | 175U3237 | 2.5 |
| 2882 (400 V) | 18.5 | 21 | 22 | 8.0 | 19.1 | 175U3238 | 4 |

Table 1.8 Brake Resistors Vertical Braking - 40% Duty Cycle

| VLT type | P _{motor} [kW] | R _{min} [Ω] | R _{rec} [Ω] | P _{b, cont.} [kW] | Order no. | Cable cross-section [mm ²] |
|--------------|----------------------------|-------------------------|-------------------------|-------------------------------|-----------|---|
| 2803 (200 V) | 0.37 | 275 | 300 | 0.1 | 175U3006 | 1.5 |
| 2805 (200 V) | 0.55 | 185 | 200 | 0.1 | 175U3011 | 1.5 |
| 2807 (200 V) | 0.75 | 135 | 145 | 0.1 | 175U3016 | 1.5 |
| 2811 (200 V) | 1.1 | 91 | 100 | 0.1 | 175U3021 | 1.5 |
| 2815 (200 V) | 1.5 | 66 | 70 | 0.2 | 175U3026 | 1.5 |
| 2822 (200 V) | 2.2 | 44 | 48 | 0.2 | 175U3031 | 1.5 |
| 2840 (200 V) | 3.7 | 22 | 27 | 0.36 | 175U3326 | 1.5 |
| 2805 (400 V) | 0.55 | 747 | 850 | 0.1 | 175U3001 | 1.5 |
| 2807 (400 V) | 0.75 | 558 | 630 | 0.1 | 175U3002 | 1.5 |
| 2811 (400 V) | 1.1 | 370 | 410 | 0.1 | 175U3004 | 1.5 |
| 2815 (400 V) | 1.5 | 260 | 270 | 0.2 | 175U3007 | 1.5 |
| 2822 (400 V) | 2.2 | 185 | 200 | 0.2 | 175U3008 | 1.5 |
| 2830 (400 V) | 3 | 135 | 145 | 0.3 | 175U3300 | 1.5 |
| 2840 (400 V) | 4 | 99 | 110 | 0.45 | 175U3335 | 1.5 |
| 2855 (400 V) | 5.5 | 74 | 80 | 0.57 | 175U3336 | 1.5 |
| 2875 (400 V) | 7.5 | 52 | 56 | 0.68 | 175U3337 | 1.5 |
| 2880 (400 V) | 11 | 35 | 38 | 1.1 | 175U3338 | 1.5 |
| 2881 (400 V) | 15 | 26 | 28 | 1.4 | 175U3339 | 1.5 |
| 2882 (400 V) | 18.5 | 21 | 22 | 1.7 | 175U3340 | 1.5 |

Table 1.9 Brake Resistors - Horizontal Braking - 10% Duty Cycle

| | |
|-----------------------|---|
| P _{motor} | Rated motor size for VLT type |
| R _{min} | Minimum permissible brake resistor |
| R _{rec} | Recommended brake resistor (Danfoss) |
| P _{b, cont.} | Continuous braking power |
| Therm. relay | Brake current setting of thermal relay |
| Ordering no. | Ordering numbers for Danfoss brake resistors |
| Cable cross-section | Recommended minimum value based upon PVC insulated copper cable, 30 °C ambient temperature with normal heat dissipation |

Table 1.10 Definition of Variables

1.12 LCP Operation

1.12.1 Control Unit

On the front of the frequency converter there is a control panel.

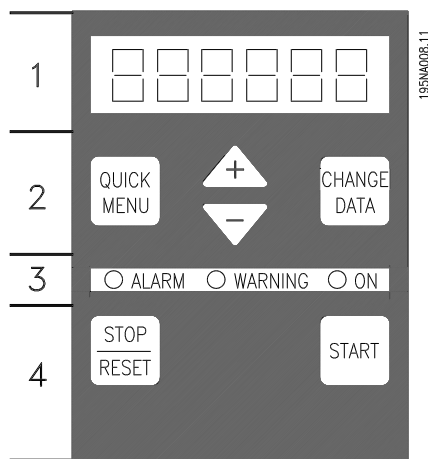

Illustration 1.13 Control Panel

The control panel is divided into 4 function groups:

1. 6-digit LED display.
2. Keys for changing parameters and shifting display function.
3. Indicator lights.
4. Keys for local operation.

All displays of data are in the form of a 6-digit LED display capable of showing one item of operating data continuously during normal operation. As a supplement to the display, there are 3 indicator lights for indication of mains connection (On), warning (Warning) and alarm (Alarm). Most of the frequency converter's parameter set-ups can be changed immediately via the control panel, unless this function has been programmed as [1] Locked via parameter 018 Lock for data changes.

1.12.2 Control Keys

[Quick Menu]

[Quick Menu] allows access to the parameters used for the Quick Menu.

The [Quick Menu] key is also used if a change to a parameter value is not to be implemented. See also [Quick menu] + [+].

[Change Data]

[Change Data] is used for changing a setting.

The [Change Data] key is also used for confirming a change of parameter settings.

[+]/[-]

[+]/[-] are used for selecting parameters and for changing parameter values.

These keys are also used in Display mode for selecting the display of an operating value.

[Quick Menu] and [+]

The [Quick Menu] + [+] keys must be pressed at the same time to give access to all parameters. See *Menu mode*.

[Stop/Reset]

[Stop/Reset] is used for stopping the connected motor or for resetting the frequency converter after a trip.

Can be selected as [1] Active or [0] Not active via parameter 014 Local stop/reset. In Display mode, the display flashes if the stop function is activated

NOTICE

If the [Stop/Reset] key is set at [0] Not active in parameter 014 Local stop/reset, and there is no stop command via the digital inputs or serial communication, the motor can only be stopped by disconnecting the mains voltage to the frequency converter.

[Start]

[Start] is used for starting the frequency converter. It is always active, but the [START] key cannot override a stop command.

1.12.3 Manual Initialisation

Complete the following steps to manually initialise the frequency converter:

1. Disconnect mains voltage.
2. Connect the mains voltage while pressing the [Quick Menu], [+] and [Change Data] keys.
3. Release the keys.

The frequency converter is now programmed for the factory setting.

1.12.4 Display Readout States

Display mode

Illustration 1.14 Normal Operation Display

In normal operation, one item of operating data can be displayed continuously at the operator's own choice. Use [+/-] keys to select the following options in Display mode:

- Output frequency [Hz]
- Output current [A]
- Output voltage [V]
- Intermediate circuit voltage [V]
- Output power [kW]
- Scaled output frequency $f_{out} \times p008$

Menu mode

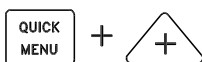

Illustration 1.15 Entering the Menu Mode

Press [Quick menu] and [+] at the same time to enter the Menu mode.

In Menu mode, most of the frequency converter parameters can be changed. Scroll through the parameters with the [+/-] keys. While scrolling in the Menu mode, the parameter number flashes.

Illustration 1.16 Menu Mode Display

The display shows that the setting in parameter 102 Motor power $P_{M,N}$ is 0.75. To change the value of 0.75, press

[Change Data] first; then use [+/-] keys to change the parameter value.

Illustration 1.17 Parameter Display Example 1

If, for a given parameter, the display shows 3 dots at the right, it means that the parameter value has more than 3 digits. To see the value, press [Change Data].

Illustration 1.18 Parameter Display Example 2

The display shows that in parameter 128 Motor thermal protection the selection made is [2] Thermistor trip.

Quick menu

Illustration 1.19 Quick Menu Display

Press [Quick Menu] to access the 12 most important parameters of the frequency converter. After programming, the frequency converter is in most cases ready for operation. When pressing [Quick menu] in Display mode, the Quick Menu starts. Scroll through the Quick Menu with the [+/-] keys and change the data values by first pressing [Change Data] and then changing the parameter value with the [+/-] keys.

The Quick Menu parameters are:

- Parameter 100 Configuration
- Parameter 101 Torque characteristic
- Parameter 102 Motor power $P_{M,N}$
- Parameter 103 Motor voltage $U_{M,N}$
- Parameter 104 Motor frequency $f_{M,N}$
- Parameter 105 Motor current $I_{M,N}$
- Parameter 106 Rated motor speed $n_{M,N}$
- Parameter 107 Automatic motor adaptation
- Parameter 202 Output frequency high limit f_{MAX}
- Parameter 203 Reference range
- Parameter 204 Minimum reference Ref_{MIN}
- Parameter 205 Maximum reference Ref_{MAX}
- Parameter 207 Ramp-up time

- Parameter 208 Ramp-down time
- Parameter 002 Local/remote operation
- Parameter 003 Local reference

Parameters 102-106 can be read out from the motor's nameplate.

1.12.5 Hand Auto

During normal operation, the frequency converter is in Auto mode, where the reference signal is given externally, analog or digital via the control terminals. However, in Hand mode, it is possible to give the reference signal locally via the control panel.

On the control terminals, the following control signals remain active when Hand mode is activated:

- Hand start (LCP2)
- Off stop (LCP2)
- Auto start (LCP2)
- Reset
- Coasting stop inverse
- Reset and coasting stop inverse
- Quick stop inverse
- Stop inverse
- Reversing
- DC braking inverse
- Set-up select LSB
- Set-up select MSB
- Thermistor
- Precise stop inverse
- Precise stop/start
- Jog
- Stop command via serial comm.

Press [Change Data] in display mode to switch the mode of the frequency converter.

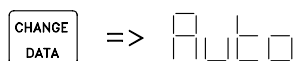

Illustration 1.20 Mode Switch

Scroll up/down to switch to Hand mode.

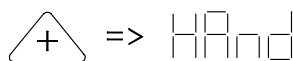

Illustration 1.21 Switch to Hand Mode

When the frequency converter is in Hand mode the readout is like

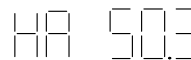

Illustration 1.22 Hand Mode Readout

and the reference can be changed with the following keys:

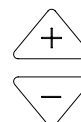

Illustration 1.23 Reference Change

NOTICE

Parameter 020 may block the choice of mode.

1.12.6 Automatic Motor Tuning

Automatic motor tuning (AMT) is performed as follows:

1. In parameter 107 Automatic motor tuning select data value [2] Optimisation on (AMT start). "107" flashes, and "2" does not flash.
2. Press [Start] to activate AMT. "107" now flashes and dashes move from left to right in the data value field.
3. When "107" appears once more with the data value [0] Optimisation off, AMT is complete. Press [Stop/Reset] to save the motor data.
4. "107" continues to flash with the data value [0] Optimisation off.

NOTICE

VLT 2880-2882 do not have AMT function.

1.13 LCP 2 Control Unit

1.13.1 Introduction

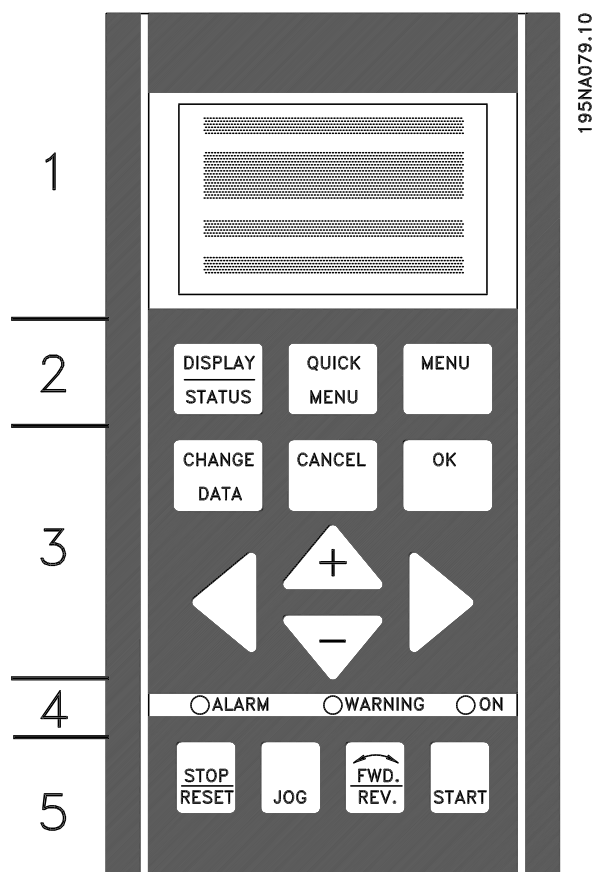

Illustration 1.24 LCP 2 Control Unit

The frequency converter can be used with an LCP control unit (local control panel - LCP 2). The LCP 2 control unit provides a complete interface for operation and programming of the frequency converter. The LCP 2 control unit can be attached up to 3 m from the frequency converter, e.g. on a front panel, using an accessory kit.

The control panel is divided into 5 functional groups:

1. Display
2. Keys used to change the display function
3. Keys used to change the programme parameters
4. Indicator lights
5. Local control keys

All data is displayed in a 4-line alphanumeric display, which, during normal operation, continuously displays 4 items of operating data and 3 operating modes. During programming, all information needed for quick, efficient parameter set-up of the frequency converter is displayed. As a supplement to the display, there are 3 indicator lights

for voltage (On), warning (Warning) and alarm (Alarm). All frequency converter parameter set-ups can be changed immediately from the control panel, unless this function has been programmed as [1] Locked via parameter 018 Lock for data changes.

1.13.2 Control Keys for Parameter Set-up

The control keys are divided into functions. The keys between the display and the indicator lights are used for parameter set-up, including selection of the display's view mode during normal operation.

[Display/Status]

[Display/Status] is used to select the display's view mode or to change back to Display mode from either Quick Menu or Menu mode.

[Quick Menu]

[Quick Menu] provides access to the parameters used in the Quick Menu. It is possible to switch between Quick Menu and Menu mode.

[Menu]

[Menu] gives access to all parameters. It is possible to switch between Menu mode and Quick Menu.

[Change Data]

Press [Change Data] to change a parameter that has been selected either in Menu mode or Quick Menu.

[Cancel]

[Cancel] is used if a change to the selected parameter is not to be implemented.

[OK]

Press [OK] to confirm a change to a selected parameter.

[+]/[-]

Press [+]/[-] to select parameters and change parameter values.

These keys are also used in Display mode to switch between the readouts of operating variables.

[◀][▶]

Press [◀][▶] to select parameter group and to move the cursor when changing a numerical value.

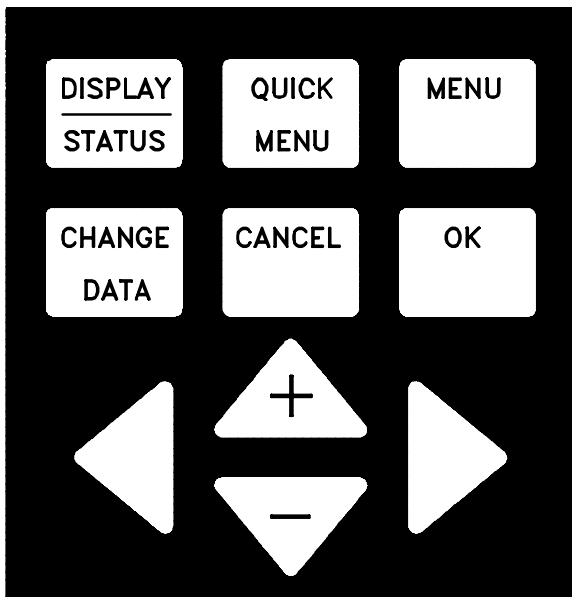

175ZA020.10

Illustration 1.25 Control Keys for Parameter Set-up

1.13.3 Indicator Lights

At the bottom of the control panel are a red alarm light, a yellow warning light and a green voltage indicator light.

If certain threshold values are exceeded, the alarm and/or warning lights are on, while a status or alarm text is shown in the display.

175ZA022.11



Illustration 1.26 Indicator Lights

NOTICE

The voltage indicator light is on when voltage is connected to the frequency converter.

1.13.4 Local Control

[Stop/Reset]

Press [Stop/Reset] to stop the motor connected or to reset the frequency converter after a drop-out (trip). It can be set to active or inactive via *parameter 014 Local stop*. If stop is activated, display line 2 flashes.

CAUTION

Avoid setting the [Stop/Reset] key to inactive if an external stop function is not selected. If the key is inactive and no external stop function is selected, the motor can only be stopped by disconnecting the voltage to the motor or the frequency converter. Failure to stop a motor in time can lead to equipment damage and personal injury.

[Jog]

[Jog] changes the output frequency to a preset frequency while the key is preseed. Use *parameter 015 Local jog* to set it to active or inactive.

[Fwd/Rev]

Press [Fwd/Rev] to change the direction of motor rotation, which is indicated with the arrow in the display. It can be set to active or inactive via *parameter 016 Local reversing*. The [Fwd/Rev] key is only active when *parameter 002 Local/Remote Operation* is set to [1] *Local operation (LOCAL)*.

[Start]

Press [Start] to start the frequency converter. Is always active, but cannot override a stop command.



195NA125.10

Illustration 1.27 Local Control Keys

If the local control keys are set to inactive, they become active when the frequency converter is set to *Local operation (LOCAL)* or *Remote operation (REMOTE)* via *parameter 002 Local/Remote Operation*, with the exception of [Fwd/Rev], which is only active in local control.

1.13.5 Displayed Data Items



Illustration 1.28 Display Mode

In normal operation, up to 4 different display data items can optionally be shown continuously: 1,1, 1,2, 1,3 and 2. The present operation status or alarms and warnings that have been generated are displayed in line 2 in the form of a number.

If alarms occur, this is displayed in lines 3 and 4 with explanatory text.

A warning appears flashing in line 2 with explanatory text in line 1. The active set-up also appears in the display. The arrow indicates the selected direction of rotation. Here the frequency converter shows that it has an active reversing signal. The body of the arrow disappears if a stop command is given, or if the output frequency drops below 0.1 Hz.

The bottom line displays the frequency transformer's status. The scroll bar shows which operating values can be displayed in lines 1 and 2 in Display mode. Use [+] or [-] keys to make changes.

| Operating data | Unit |
|----------------------------|----------|
| Resulting reference | [%] |
| Resulting reference | [unit] |
| Feedback | [unit] |
| Output frequency | [Hz] |
| Output frequency x scaling | [-] |
| Motor current | [A] |
| Torque | [%] |
| Power | [kW] |
| Power | [HP] |
| Motor voltage | [V] |
| DC-link voltage | [V] |
| Thermal load motor | [%] |
| Thermal load | [%] |
| Hours run | [hours] |
| Digital input | [binary] |
| Pulse reference | [Hz] |
| External reference | [%] |
| Status word | [hex] |
| Heat sink temperature | [°C] |
| Alarm word | [hex] |
| Control word | [hex] |
| Warning word | [hex] |
| Extended status word | [hex] |
| Analog input 53 | [V] |
| Analog input 60 | [mA] |

Table 1.11 Operating Data Items

3 operating data items can be shown in the first display line, and one operating variable can be shown in the second display line. This is programmed via parameters 009-012 *Display readout*.

1.13.6 Display Modes

This topic describes the 4 display modes that the LCP control unit supports.

Display Mode I

This Display mode is standard after start-up or initialisation.

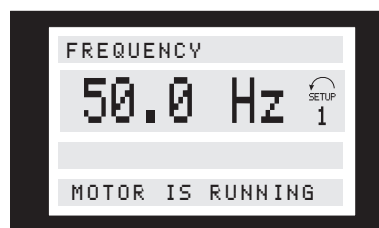

Illustration 1.29 Display Mode I

Line 2 shows the data value of an operating data item with unit, and line 1 contains a text that explains line 2. In the example, [4] *Frequency* has been selected as readout via parameter 009 *Large display readout*. In normal operation, another variable can be entered immediately using the [+] / [-] keys.

Display Mode II

Press [Display/Status] to switch between Display modes I and II.

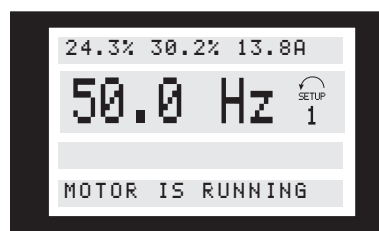

Illustration 1.30 Display Mode II

In this mode, all data values for 4 operating data items with any pertaining units are shown. In the example, the following have been selected: *Frequency*, *Reference*, *Torque* and *Current* as readout in the first and second line.

Display Mode III

This Display mode is started as long as the [Display/Status] key is pressed. When the key is released, it switches back to Display mode II, unless the key is pressed for less than approx. 1 s, in which case the system always reverts to Display mode I.

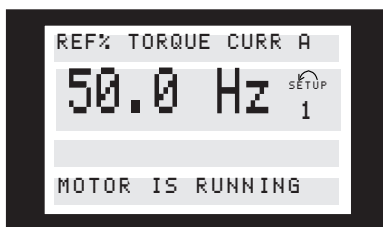

Illustration 1.31 Display Mode III

Displays the parameter names and units for operating data in the first and second lines. Line 2 in the display remains unchanged.

Display Mode IV

This Display mode can be started during operation if a change has to be made in another set-up without stopping the frequency converter. Activate this function using *parameter 005 Programming Setup*.

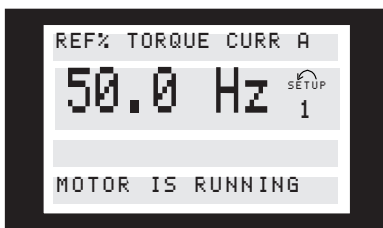

Illustration 1.32 Display Mode IV

The programming set-up number 2 flashes to the right of the active set-up.

1.13.7 Parameter Set-up

A frequency converter's comprehensive work area can be accessed via a large number of parameters, which allows it to adapt its functionality for a specific application. To provide a better overview of the many parameters, there is a choice of 2 programming modes - Menu mode and Quick Menu mode. Menu mode provides access to all parameters. Quick Menu mode takes the user through the parameters, which makes it possible to start operating the frequency converter in most cases, in accordance with the set-up made. Regardless of the programming mode, a change of a parameter takes effect and is visible both in the Menu mode and in the Quick Menu mode.

Structure for Quick Menu mode v Menu mode

In addition to having a name, each parameter is linked with a number which is the same regardless of the programming mode. In Menu mode, parameters are split into groups, with the first digit of the parameter number indicating the group number of the parameter in question.

- Press [Quick Menu] to access the most important parameters of the frequency converter. After programming, the frequency converter is in most cases ready for operation. Scroll through the Quick Menu pressing the [+] / [-] keys and change the data values by pressing [Change Data] + [Ok].
- The Menu mode allows selecting and changing all parameters as required. However, some parameters are be "shaded off", depending on the selection in parameter 100 Configuration.

1.13.8 Quick Menu with LCP 2 Control Unit

Press [QUICK MENU] to start the Start Quick Setup, which brings out the following display values:



Illustration 1.33 Quick Menu Display

At the bottom of the display, the parameter number and name are given together with the status/value of the first parameter under the Quick menu. The first time the [QUICK MENU] key is pressed after the unit has been switched on, the readouts always start at pos. 1. See *Table 1.12* for positions and the corresponding parameters.

| Pos. | Parameter no. | Unit |
|------|----------------------------|-------|
| 1 | 001 Language | |
| 2 | 102 Motor power | [kW] |
| 3 | 103 Motor voltage | [V] |
| 4 | 104 Motor frequency | [Hz] |
| 5 | 105 Motor current | [A] |
| 6 | 106 Rated motor speed | [RPM] |
| 7 | 107 AMT | |
| 8 | 204 Minimum reference | [Hz] |
| 9 | 205 Maximum reference | [Hz] |
| 10 | 207 Ramp-up time | [s] |
| 11 | 208 Ramp-down time | [s] |
| 12 | 002 Local/remote operation | |
| 13 | 003 Local reference | [Hz] |

Table 1.12 Parameters and Positions

1.13.9 Parameter Selection

Press [Menu] to start the Menu mode, which produces the following readout in the display:

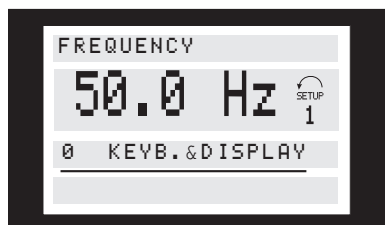

Illustration 1.34 Menu Mode Display

Line 3 in the display shows the parameter group number and name.

In Menu mode, the parameters are divided into groups. Selection of parameter group is effected using the [< >] keys.

The following parameter groups are accessible:

| Group no. | Parameter group |
|-----------|----------------------|
| 0 | Operation & Display |
| 1 | Load & Motor |
| 2 | References & Limits |
| 3 | Inputs & Outputs |
| 4 | Special functions |
| 5 | Serial communication |
| 6 | Technical functions |

When the required parameter group is selected, select the parameter with the [+] / [-] keys:

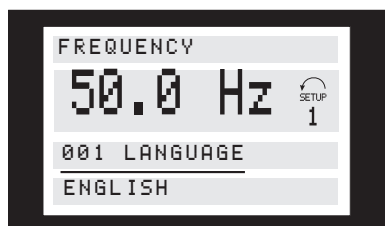

Illustration 1.35 Select a Parameter

The third line of the display shows the parameter number and name, while the status/value of the selected parameter is shown in line 4.

Changing data

Regardless of whether a parameter is selected under the Quick Menu mode or the Menu mode, the procedure for changing data is the same. Press [Change Data] to change the selected parameter, following which the underlining in line 4 flashes on the display. The procedure for changing data depends on whether the selected parameter represents a numerical data value or a text value.

Changing a data value

If the selected parameter is a text value, change the text value with the [+] or [-] key.

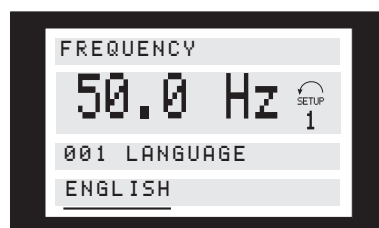

Illustration 1.36 Change a Data Value

The bottom display line shows the value that is entered (saved) when acknowledgment is given [OK].

Change of numeric data value

If the selected parameter is represented by a numerical data value, select a digit with the [◀] or [▶] key.

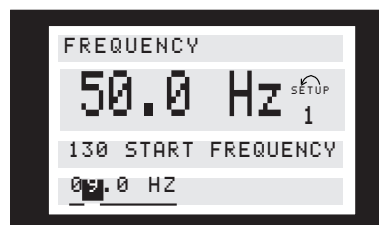

Illustration 1.37 Change a Numeric Data Value - I

The selected digit can then be changed infinitely variably with the [+] or [-] key:

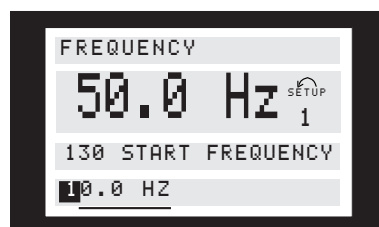

Illustration 1.38 Change a Numeric Data Value - II

The selected digit is indicated by the digit flashing. The bottom display line shows the data value that is entered (saved) when signing off with [OK].

1.13.10 Manual Initialisation

NOTICE

Manual initialisation is not possible on the LCP 2 control unit. Perform an initialisation with parameter 620 *Operation mode*.

The following parameters are not set to 0 when initialising via *parameter 620 Operation mode*.

- parameter 500 *Address*
- parameter 501 *Baud rate*
- parameter 600 *Operating hours*
- parameter 601 *Hours run*
- parameter 602 *kWh counter*
- parameter 603 *Number of power-ups*
- parameter 604 *Number of overtemperatures*
- parameter 605 *Number of overvoltages*
- parameter 615-617 *Fault log*

2 Safety

2.1 Safety Symbols

The following symbols are used in this document:

⚠ WARNING

Indicates a potentially hazardous situation which could result in death or serious injury.

⚠ CAUTION

Indicates a potentially hazardous situation which could result in minor or moderate injury. It can also be used to alert against unsafe practices.

NOTICE

Indicates important information, including situations that can result in damage to equipment or property.

2.2 Qualified Personnel

Correct and reliable transport, storage, installation, operation, and maintenance are required for the trouble-free and safe operation of the frequency converter. Only qualified personnel are allowed to install or operate this equipment.

Qualified personnel are defined as trained staff, who are authorised to install, commission, and maintain equipment, systems, and circuits in accordance with pertinent laws and regulations. Additionally, the personnel must be familiar with the instructions and safety measures described in these operating instructions.

2.3 Safety Precautions

⚠ WARNING

HIGH VOLTAGE

Frequency converters contain high voltage when connected to AC mains input, DC power supply, or load sharing. Failure to perform installation, start-up, and maintenance by qualified personnel can result in death or serious injury.

- Installation, start-up, and maintenance must be performed by qualified personnel only.

⚠ WARNING

UNINTENDED START

When the frequency converter is connected to AC mains, DC power supply, or load sharing, the motor may start at any time. Unintended start during programming, service, or repair work can result in death, serious injury, or property damage. The motor can start by means of an external switch, a serial bus command, an input reference signal from the LCP, or after a cleared fault condition.

To prevent unintended motor start:

- Disconnect the frequency converter from the mains.
- Press [Off/Reset] on the LCP before programming parameters.
- The frequency converter, motor, and any driven equipment must be fully wired and assembled when the frequency converter is connected to AC mains, DC power supply, or load sharing.

⚠ WARNING

DISCHARGE TIME

The frequency converter contains DC-link capacitors, which can remain charged even when the frequency converter is not powered. Failure to wait the specified time after power has been removed before performing service or repair work, can result in death or serious injury.

- Stop the motor.
- Disconnect AC mains and remote DC-link power supplies, including battery back-ups, UPS, and DC-link connections to other frequency converters.
- Disconnect or lock PM motor.
- Wait at least 4 minutes for the capacitors to discharge fully, before performing any service or repair work.

⚠ WARNING

LEAKAGE CURRENT HAZARD

Leakage currents exceed 3.5 mA. Failure to ground the frequency converter properly can result in death or serious injury.

- Ensure the correct grounding of the equipment by a certified electrical installer.

⚠ WARNING**EQUIPMENT HAZARD**

Contact with rotating shafts and electrical equipment can result in death or serious injury.

- Ensure that only trained and qualified personnel perform installation, start up, and maintenance.
- Ensure that electrical work conforms to national and local electrical codes.
- Follow the procedures in these operating instructions.

⚠ CAUTION**INTERNAL FAILURE HAZARD**

An internal failure in the frequency converter can result in serious injury, when the frequency converter is not properly closed.

- Ensure that all safety covers are in place and securely fastened before applying power.

NOTICE**HIGH ALTITUDES**

For installation at altitudes above 2000 m, contact Danfoss regarding PELV.

NOTICE**Use on Isolated Mains**

For details about the use of the frequency converter on isolated mains, refer to section *RFI Switch* in the *Design Guide*.

Follow the recommendations regarding the installation on IT-mains. Use relevant monitoring devices for IT-mains to avoid damage.

3 Installation

3.1 Mechanical Dimensions

3.1.1 Overview

Illustration 3.1 shows the mechanical dimensions. All dimensions are in mm.

NOTICE

All filter options must be vertically mounted.

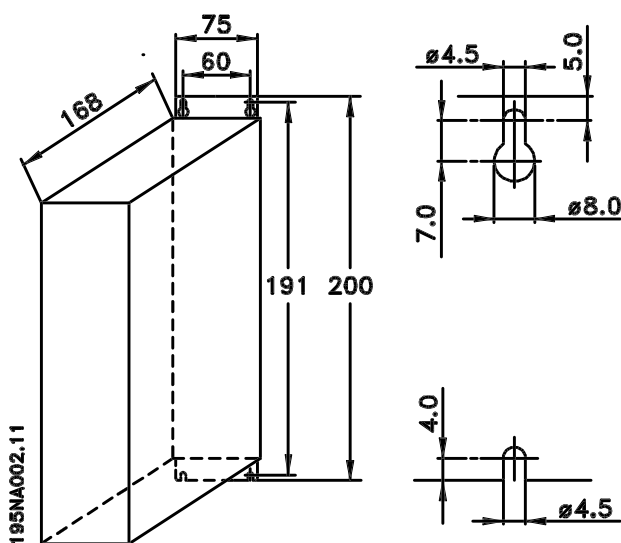

Illustration 3.1 VLT 2803-2815 200-240 V
VLT 2805-2815 380-480 V

3.1.2 Enclosure B

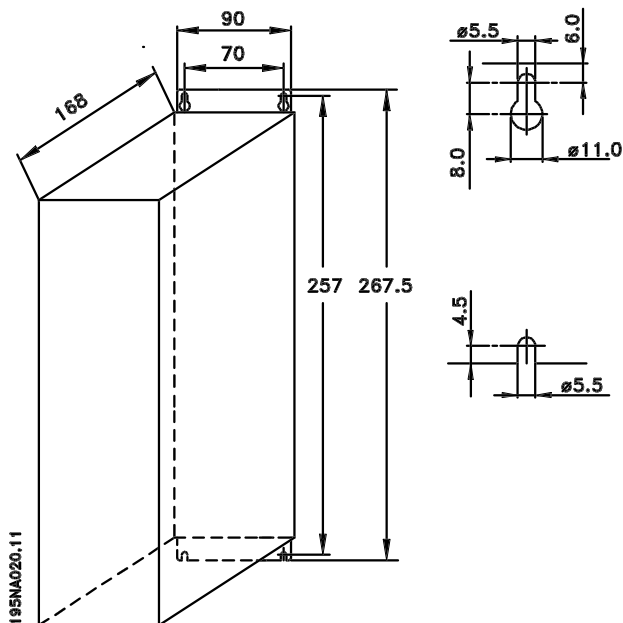

Illustration 3.2 VLT 2822 200-240 V
VLT 2822-2840 380-480 V

3.1.3 Enclosure C

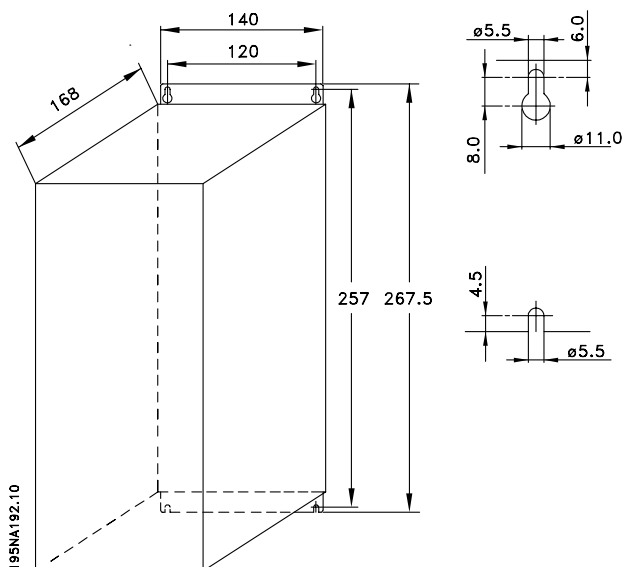

Illustration 3.3 VLT 2822 220-240 V, PD2
VLT 2840 200-240 V
VLT 2855-2875 380-480 V

3.1.4 Enclosure D

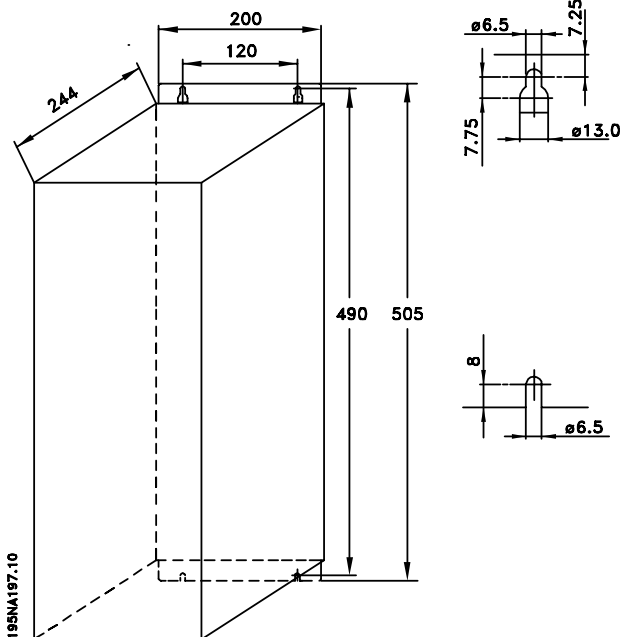
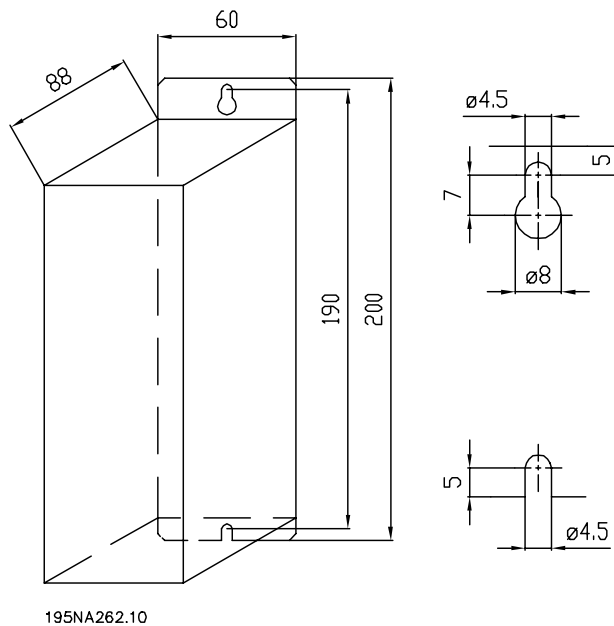

Illustration 3.4 VLT 2840, 220-240 V, PD2
VLT 2880-2882, 380-480 V

3.1.6 RFI 1B Filter (195N3103)



195NA262.10
Illustration 3.6 RFI 1B Filter (195N3103)

3.1.5 Motor Coils (195N3110)

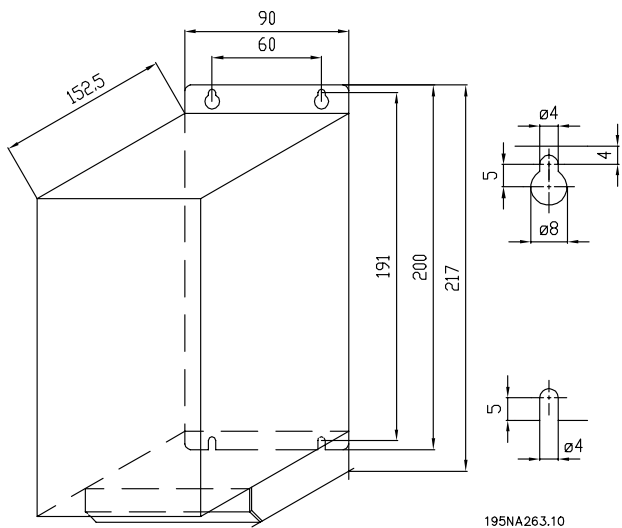

Illustration 3.5 Motor Coils (195N3110)

3.1.7 Terminal Cover

Illustration 3.7 shows the dimensions for NEMA 1 terminal covers for VLT 2803-2875. Dimension *a* depends on the unit type.

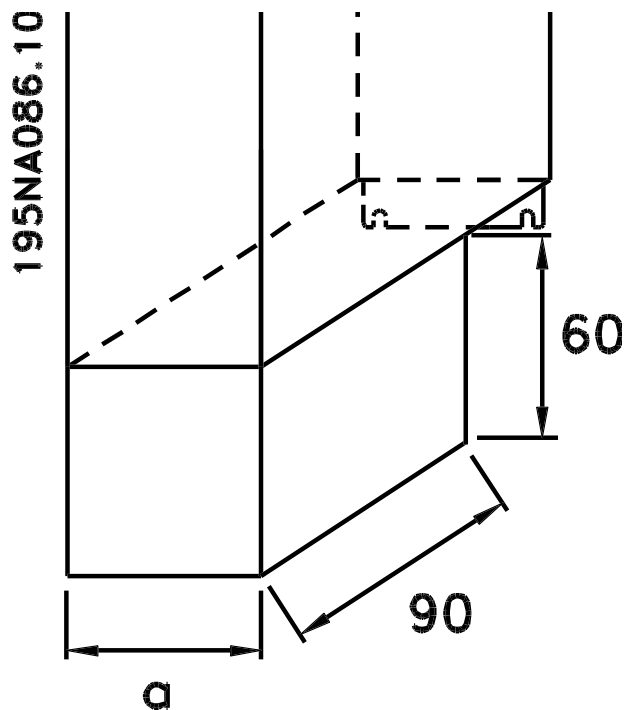

Illustration 3.7 Dimensions for NEMA 1 Terminal Cover

3

3

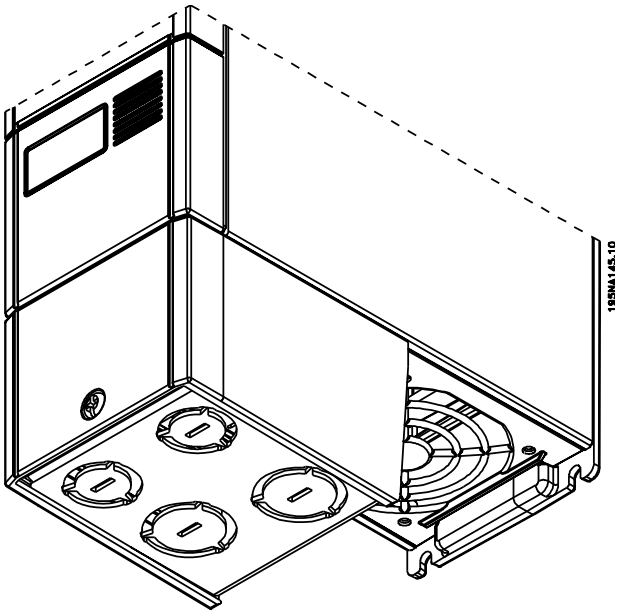

Illustration 3.8 NEMA 1 Terminal Cover

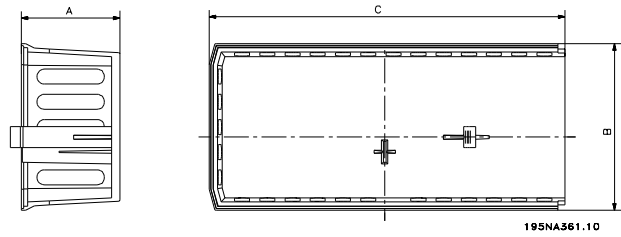

Illustration 3.10 Dimensions for IP21 Solution

| Type | Ordering number | A | B | C |
|-------------------------|-----------------|----|-----|-----|
| VLT 2803-2815 200-240 V | 195N2118 | 47 | 80 | 170 |
| VLT 2805-2815 380-480 V | | | | |
| VLT 2822 200-240 V | 195N2119 | 47 | 95 | 170 |
| VLT 2822-2840 380-480 V | | | | |
| VLT 2840 200-240 V | 195N2120 | 47 | 145 | 170 |
| VLT 2822 PD2 | | | | |
| VLT 2855-2875 380-480 V | | | | |
| VLT 2880-2882 380-480 V | 195N2126 | 47 | 205 | 245 |
| VLT 2840 PD2 | | | | |

Table 3.1 Dimensions

3.1.8 IP21 Solution

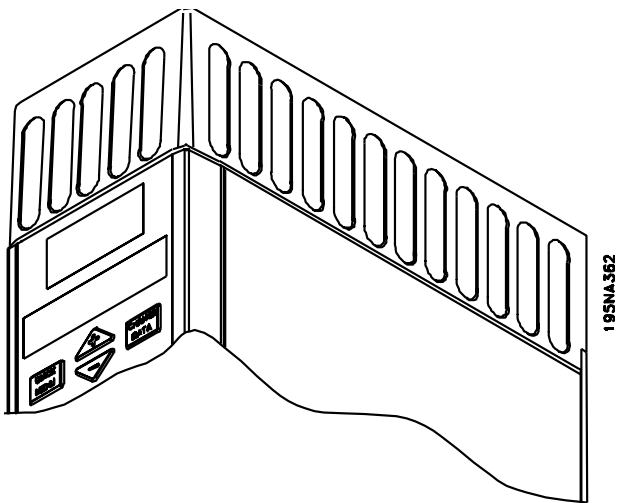

Illustration 3.9 IP21 Solution

3.1.9 EMC Filter for Long Motor Cables

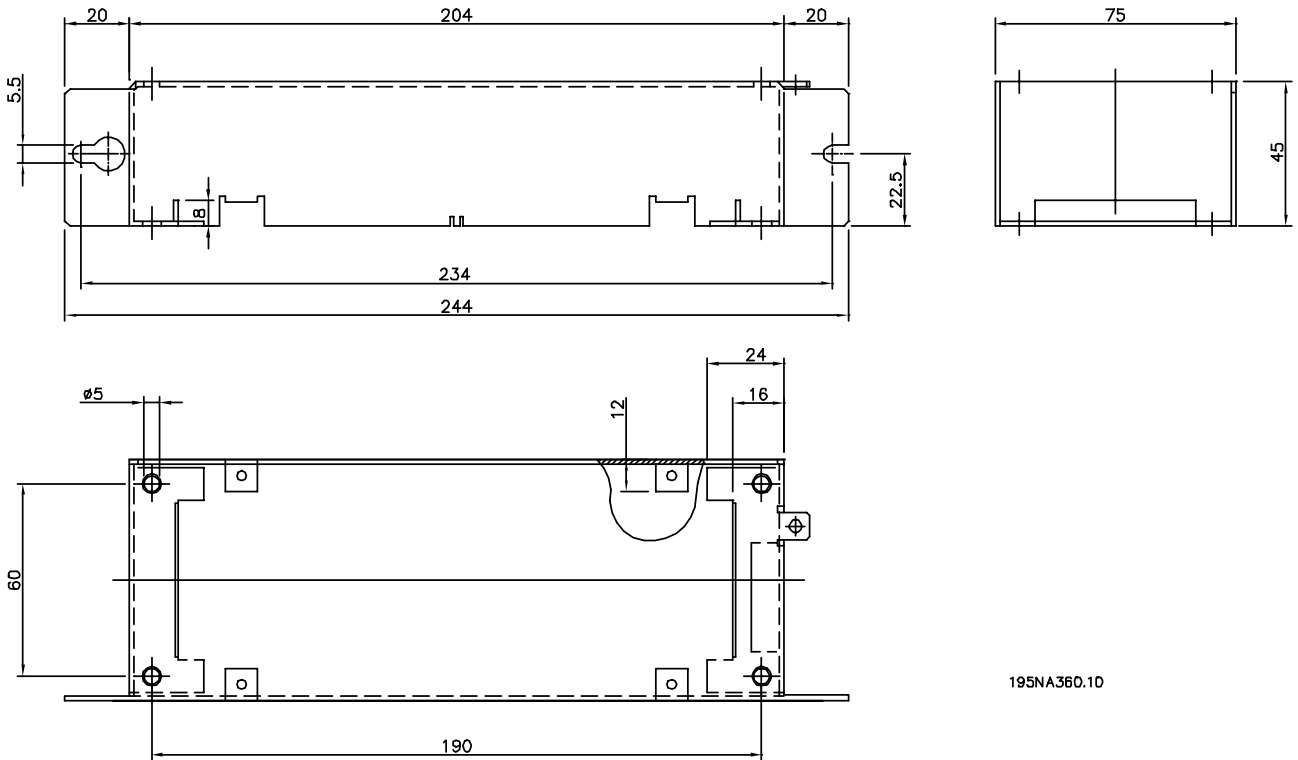

Illustration 3.11 192H4719

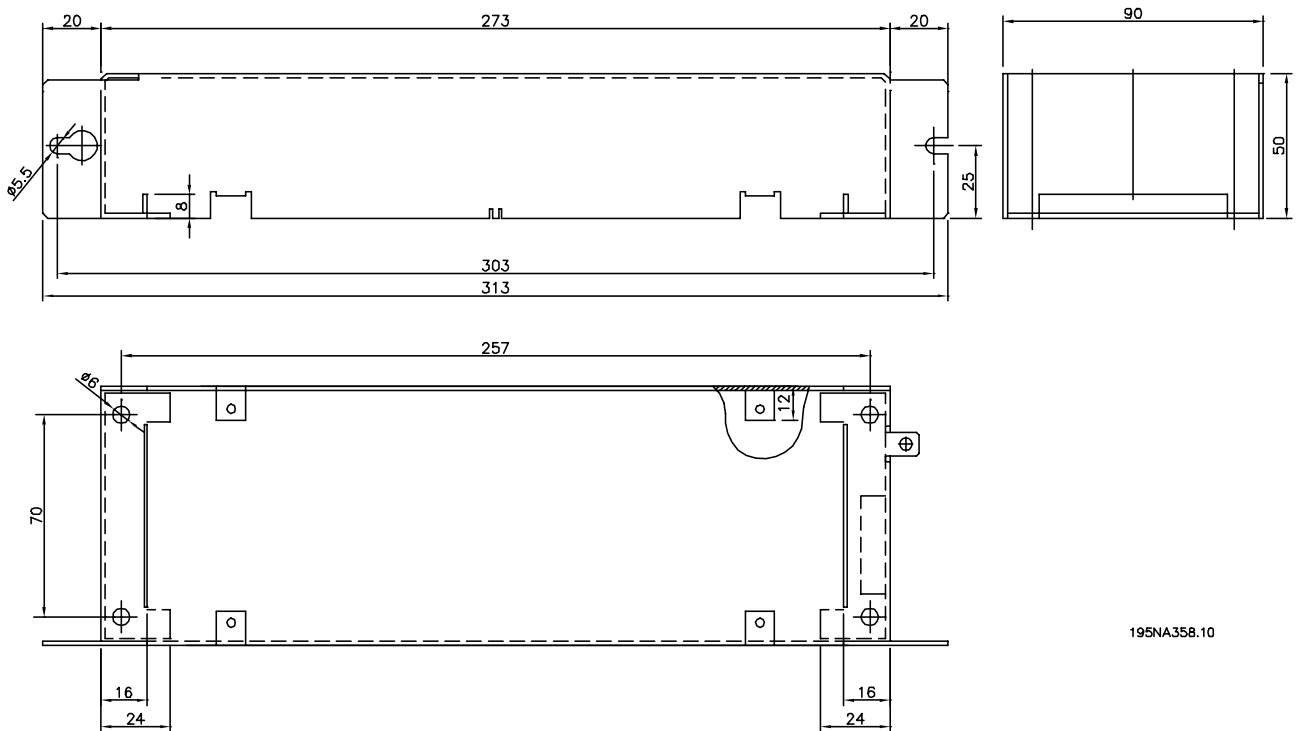
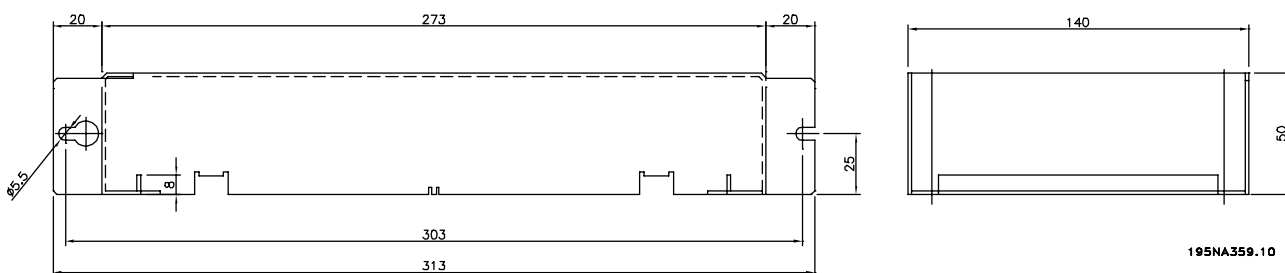

Illustration 3.12 192H4720



195NA359.10

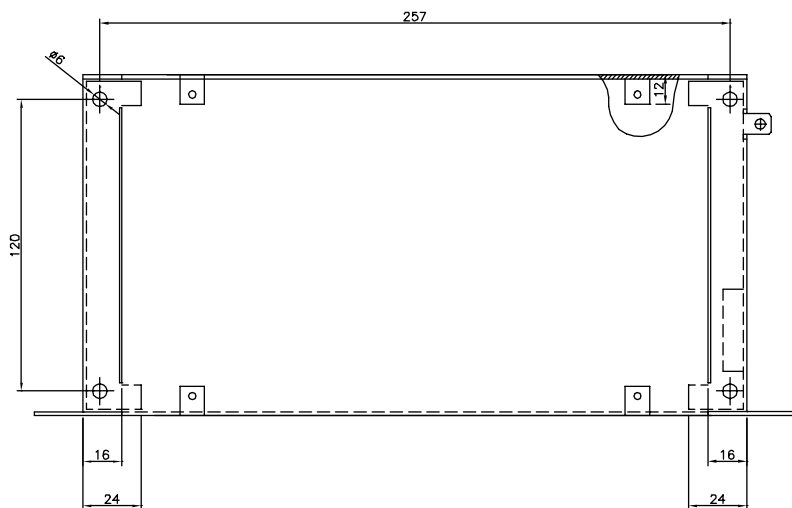

Illustration 3.13 192H4893

3.2 Mechanical Installation

CAUTION

Pay attention to the requirements that apply to integration and field mounting kit. Observe the information in the list to avoid serious injury or equipment damage, especially when installing large units.

WARNING

The frequency converter is cooled with air circulation. For the unit to be able to release its cooling air, the minimum free distance above and below the unit must be 100 mm at minimum. To protect the unit from overheating, ensure that the ambient temperature does not rise above the maximum temperature stated for the frequency converter and that the 24-hour average temperature is not exceeded. Check the maximum temperature and 24-hour average in *chapter 5.3 General Technical Data*. If the ambient temperature is in the range of 45 °C - 55 °C, derating of the frequency converter is to be carried out. See *chapter 5.1.8 Derating for Ambient Temperature*. The service life of the frequency converter may be reduced if no allowance is made for the derating for ambient temperature.

Integration

All units with enclosure IP20 must be integrated in cabinets and panels. IP20 is not suitable for remote mounting. In some countries, e.g. in the USA, units with enclosure NEMA 1 are approved for remote mounting.

Spacing

All units require a minimum of 100 mm air between other components and vents of the enclosure.

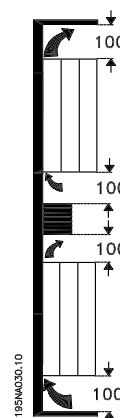

Illustration 3.14 Spacing for Mechanical Installation

Side-by-side installation

All VLT 2800 units can be installed side-by-side and in any position, as the units do not require ventilation on the side.

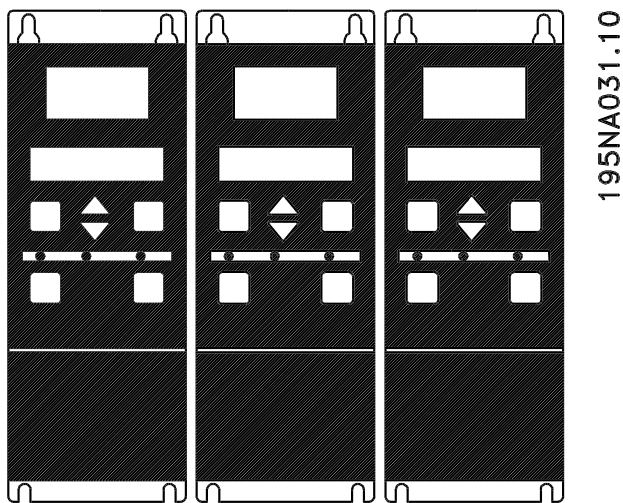
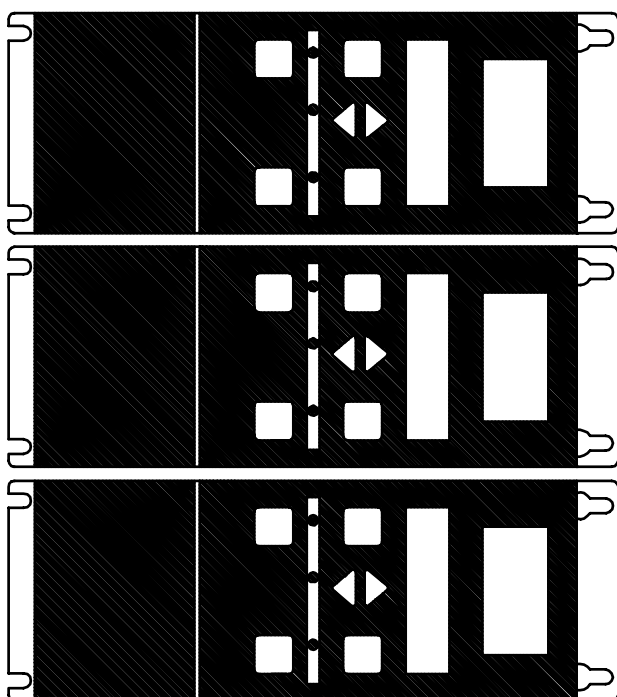

Illustration 3.15 Side-by-side Installation - I



195NA0147.10

Illustration 3.16 Side-by-side Installation - II

CAUTION

If IP21 solution is used, avoid mounting the units side-by-side, which could lead to overheating and unit damages.

3.3 Electrical Installation

3.3.1 High Voltage Warning

WARNING

The voltage of the frequency converter is dangerous whenever the equipment is connected to mains. Incorrect installation of the motor or frequency converter may cause damage to the equipment, serious injury or death. Comply with the instructions in this manual, as well as national and local rules and safety regulations. Touching the electrical parts may be fatal - even after the equipment has been disconnected from mains: Wait at least 4 minutes for current dissipate.

NOTICE

Ensure correct grounding and protection in accordance with national and local standards.

3.3.2 Grounding

Comply with the following at installation:

- Safety earthing: The converter has a high leakage current and must be grounded properly for safety. Follow all local safety regulations.
- High frequency earthing: Keep grounding connections as short as possible.

Connect all grounding systems to ensure the lowest possible conductor impedance. The lowest possible conductor impedance is achieved by keeping the conductor as short as possible, and by grounding with the greatest possible surface area. If multiple converters are installed in a cabinet, use the cabinet backplate, which must be made of metal, as a joint ground reference plate. Fit the converters to the backplate at the lowest possible impedance.

To achieve low impedance, connect the converter to the backplate with the converter fastening bolts. Remove all paint from the contact points.

3.3.3 Cables

Install the control cable and the mains cable separately from motor cables to prevent noise transfer. As a rule, a distance of 20 m is sufficient, but it is recommended that the distance is as great as possible, particularly when cables are installed in parallel over large distances.

For sensitive signal cables such as telephone or data cables, the greatest possible distance is recommended. Note that the required distance depends on the instal-

lation and the sensitivity of the signal cables. For this reason, exact values cannot be given.

When being placed in cable trays, sensitive cables may not be placed in the same cable tray as the motor cable. If signal cables run across power cables, this is done at an angle of 90 °. Only use screened/armoured noise-filled inlet and outlet cables to a cabinet.

See also *chapter 3.3.7 EMC-correct Electrical Installation*.

3.3.4 Screened/armoured Cables

The screen must have low HF impedance, which is achieved by a braided screen of copper, aluminium or iron. Screen reinforcement intended for mechanical protection, for example, is not suitable for EMC-correct installation.

See also *chapter 3.3.8 Use of EMC Compliant Cables*.

3.3.5 Extra Protection

RCD relays, multiple protective earthing or grounding can be used as extra protection, provided that local safety regulations are complied with. If a ground fault occurs, a DC content may develop in the faulty current. Never use an RCD (ELCB relay), type A, as it is not suitable for DC faulty currents. If RCD relays are used, comply with local regulations.

If RCD relays are used, they must be:

- Suitable for protecting equipment with a DC content in the faulty current (3-phase bridge rectifier).
- Suitable for a pulse-shaped, brief discharge on power-up.
- Suitable for a high leakage current.

N must be connected before L1 for single-phase 200 V reduced leakage current units (type code R4).

3.3.6 High Voltage Test

A high-voltage test can be performed by short-circuiting terminals U, V, W, L1, L2 and L3, and applying max. 2160 V DC in 1 s between this short-circuit and terminal 95.

⚠ WARNING

Do not perform a high-voltage test between the control terminals and the chassis, because the voltage potential of the control card cannot exceed approximately 100 V with respect to chassis due to a voltage limiting circuitry. Performing such a test may lead to equipment damage and personal injuries.

The terminals are protected against direct hazardous access through barriers.

3.3.7 EMC-correct Electrical Installation

General points to observe to ensure EMC-correct electrical installation:

- Use only screened/armoured motor cables and screened/armoured control cables.
- Connect the screen to ground at both ends.
- Avoid installation with twisted screen ends (pigtails), since this ruins the screening effect at high frequencies. Use cable clamps instead.
- Ensure good electrical contact from the installation plate through the installation screws to the metal cabinet of the frequency converter.
- Use starwashers and galvanically conductive installation plates.
- Do not use unscreened/unarmoured motor cables in the installation cabinets.

Illustration 3.17 shows EMC-correct electrical installation, in which the frequency converter has been fitted in an installation cabinet and connected to a PLC.

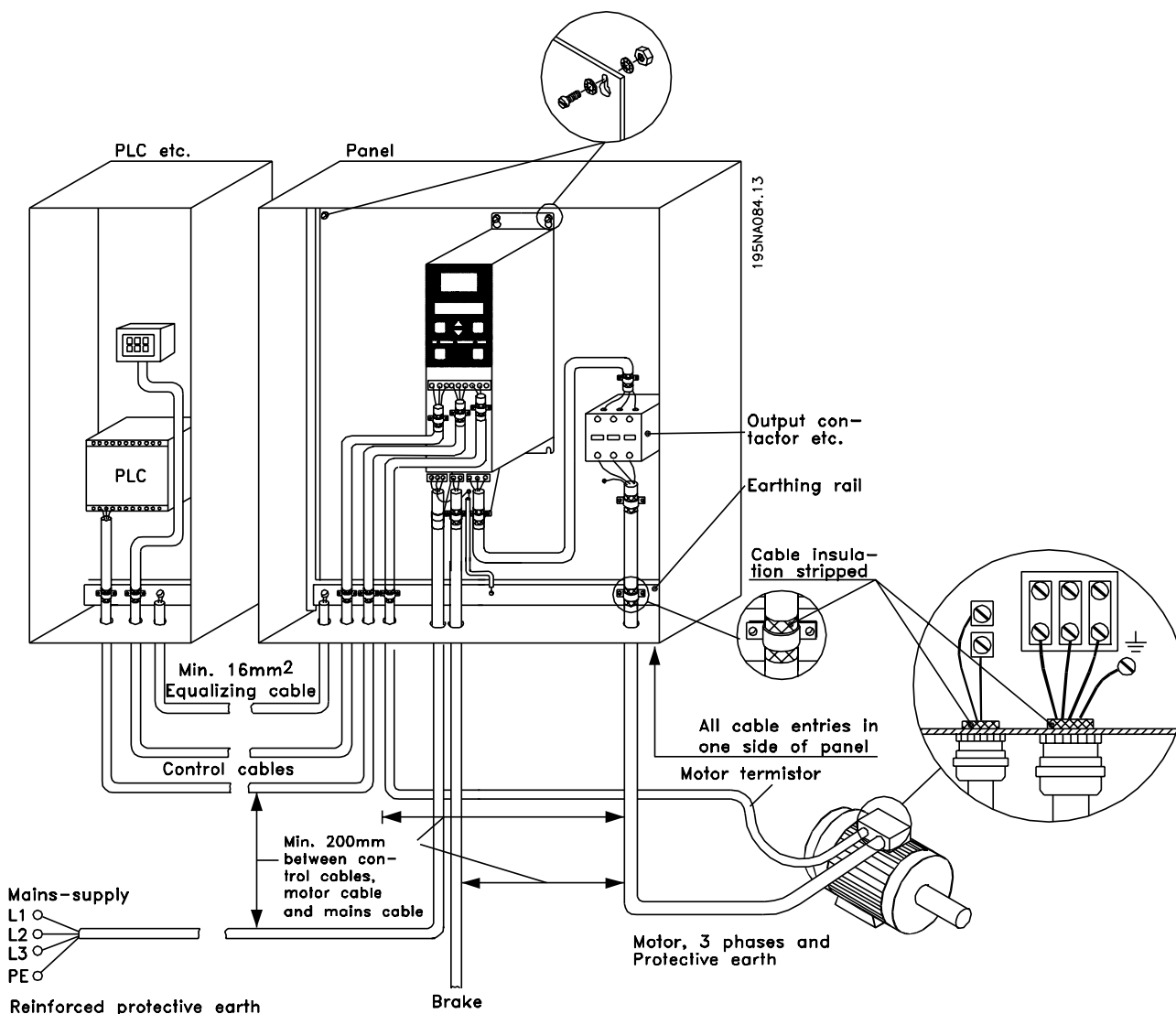

Illustration 3.17 Example of an EMC-correct Electrical Installation

3.3.8 Use of EMC Compliant Cables

To comply with requirements for EMC immunity of the control cables and EMC emissions for the motor cables, use screened/armoured cables.

The ability of a cable to reduce the amount of ingoing and outgoing radiation of electric noise depends on the transfer impedance (Z_T). The screen of a cable is normally designed to reduce the transfer of electric noise, and a screen with a lower Z_T is more effective than a screen with a higher Z_T .

Z_T is rarely stated by cable manufacturers, but it is often possible to estimate Z_T by looking at and assessing the physical design of the cable.

Z_T can be assessed on the basis of the following factors:

- The contact resistance between the individual screen conductors.
- Screen coverage, i.e. the physical area of the cable covered by the screen. Is often stated as a percentage and should be no less than 85%.
- The screen type, i.e. braided or twisted pattern. A braided pattern or closed pipe is recommended.

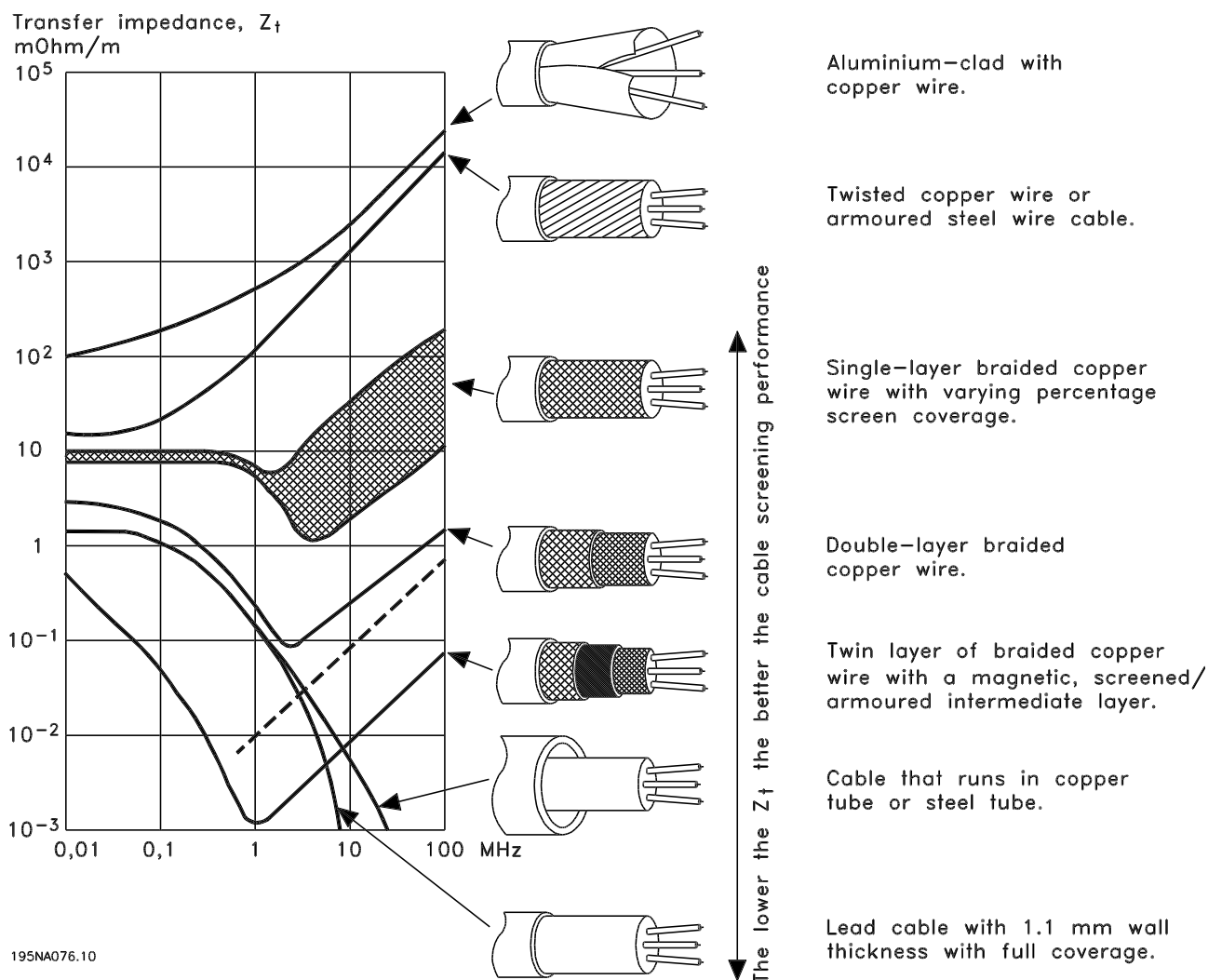

Illustration 3.18 Cable Comparison

3.3.9 Grounding of Screened/armoured Control Cables

Control cables must be screened/armoured, and the screen must be connected to the unit's metal cabinet with a cable clamp at each end.

Illustration 3.19 shows the correct way to perform the grounding, and what to do when in doubt.

Correct grounding

Control cables and cables for serial communication must be attached with cable clamps at both ends to ensure maximum possible electrical contact.

Incorrect grounding

Do not use twisted screen ends that are plaited together (pigtailed), as these increase screen impedance at higher frequencies.

Protection about ground potential between PLC and VLT

If the ground potential between the frequency converter and the PLC (etc.) is different, electric noise may occur that disturbs the whole system. This problem can be solved by fitting an equalising cable next to the control cable.

Minimum cable cross-section: 16 mm².

If 50/60 Hz ground loop occurs

If long control cables are used, 50/60 Hz ground loops can arise, and these can interfere with the whole system. This problem is resolved by attaching one end of the screen to the ground via a 100 nF capacitor (short pin length).

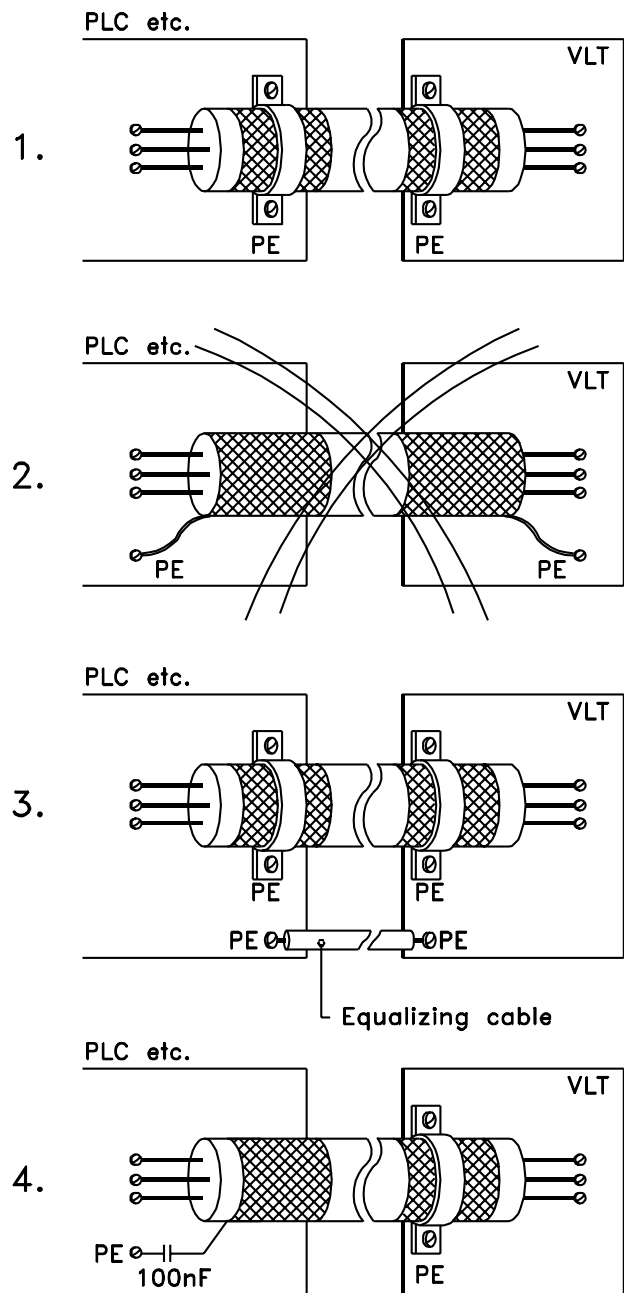

195NA100.12

Illustration 3.19 Grounding Examples

3.3.10 Electrical Wiring

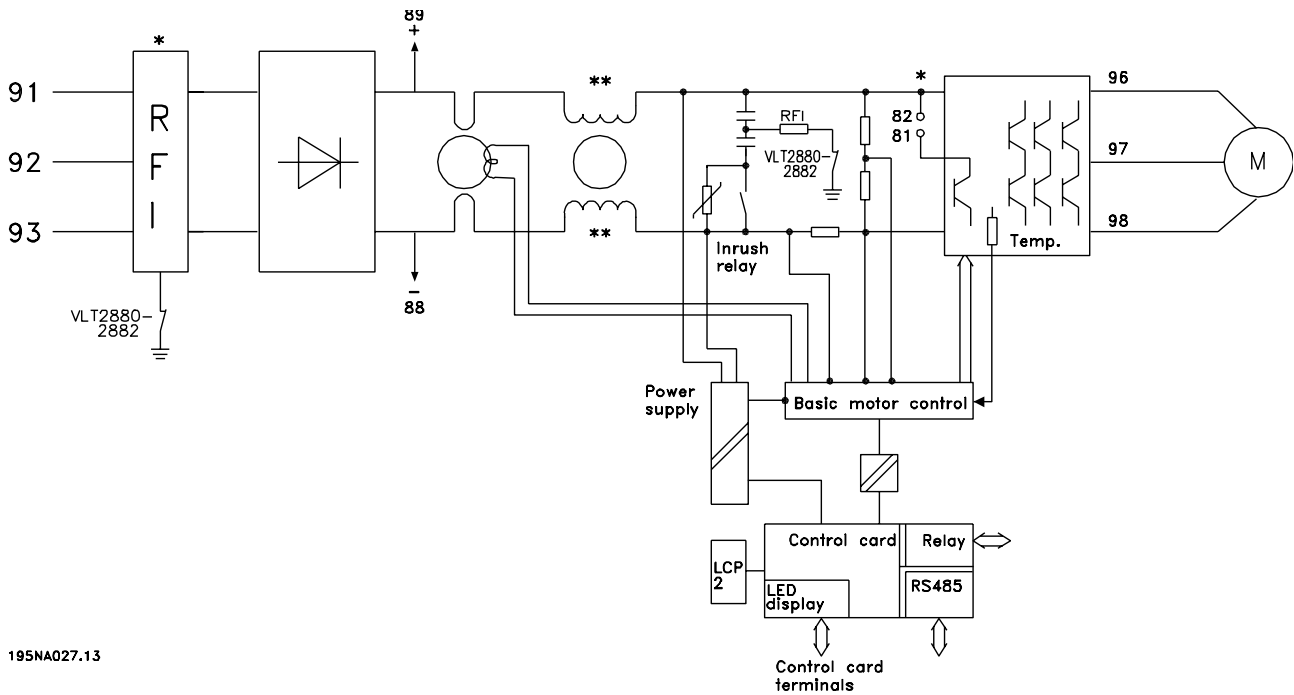

195NA027.13

Illustration 3.20 Electrical Wiring Diagram

* Integrated 1A RFI filter is an option.

** VLT 2803-2815 200-240 V is not supplied with intermediate circuit coils.

3.3.11 Electrical Connection

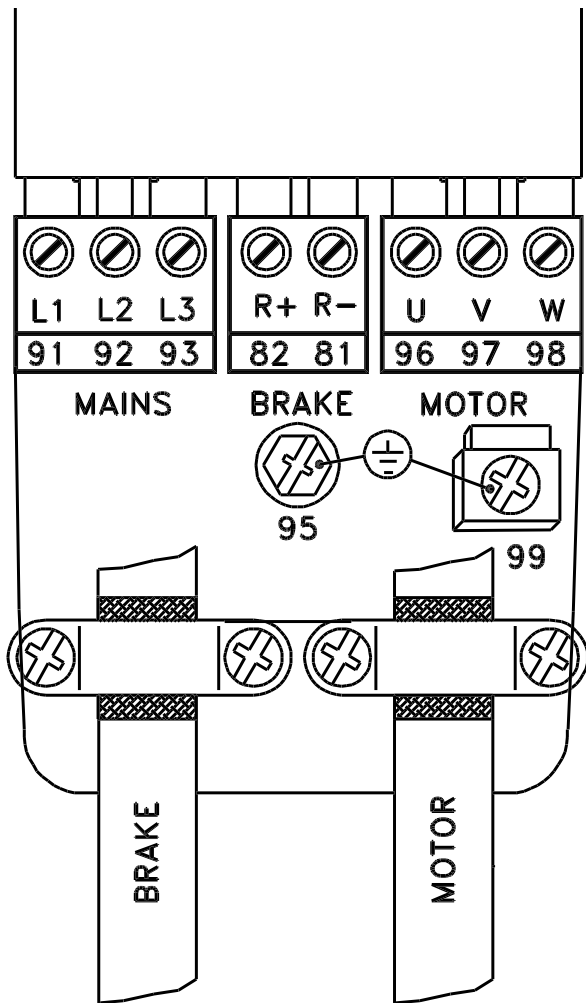

Illustration 3.21 Electrical Connection

195NA005.12

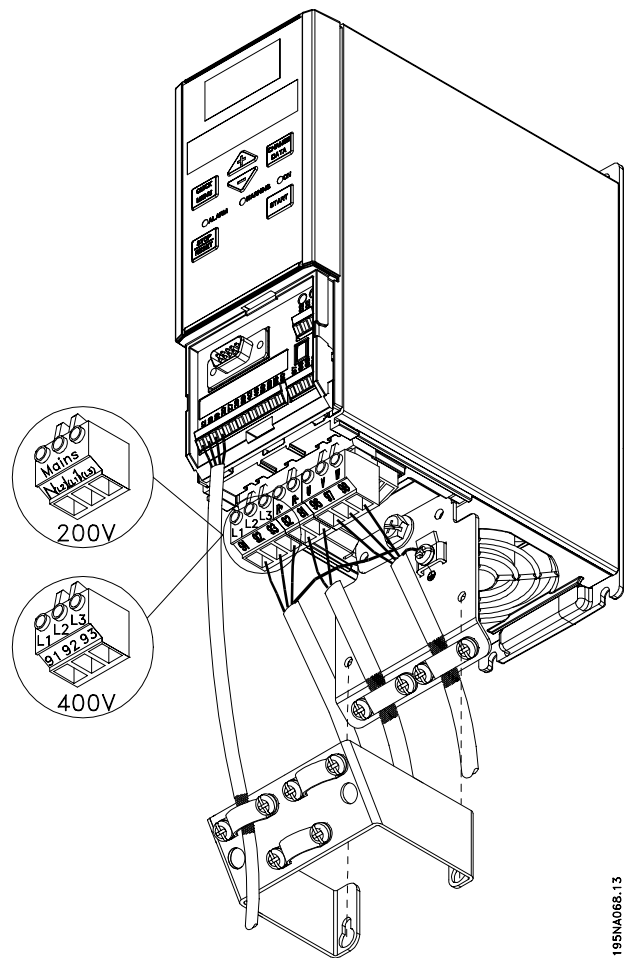

Illustration 3.22 VLT 2803-2815 200-240 V
2805-2815 380-480 V

195NA066.13

See also the section *chapter 3.4.9 Brake Connection*.

3

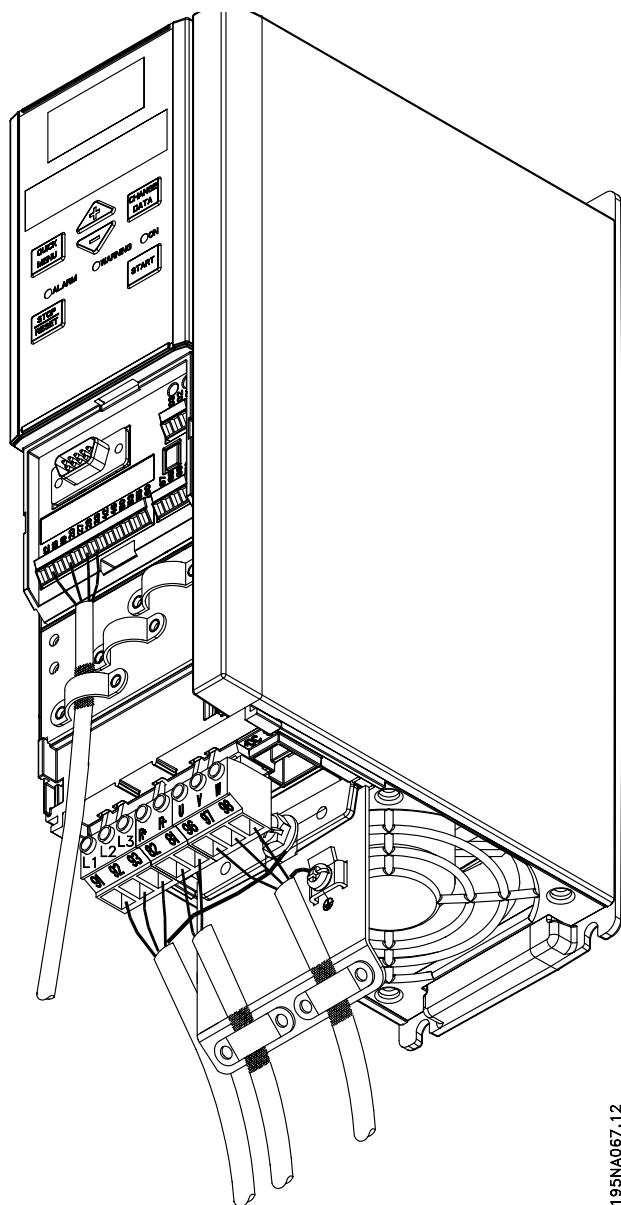

Illustration 3.23 VLT 2822 200-240 V
2822-2840 380-480 V

195NA067.12

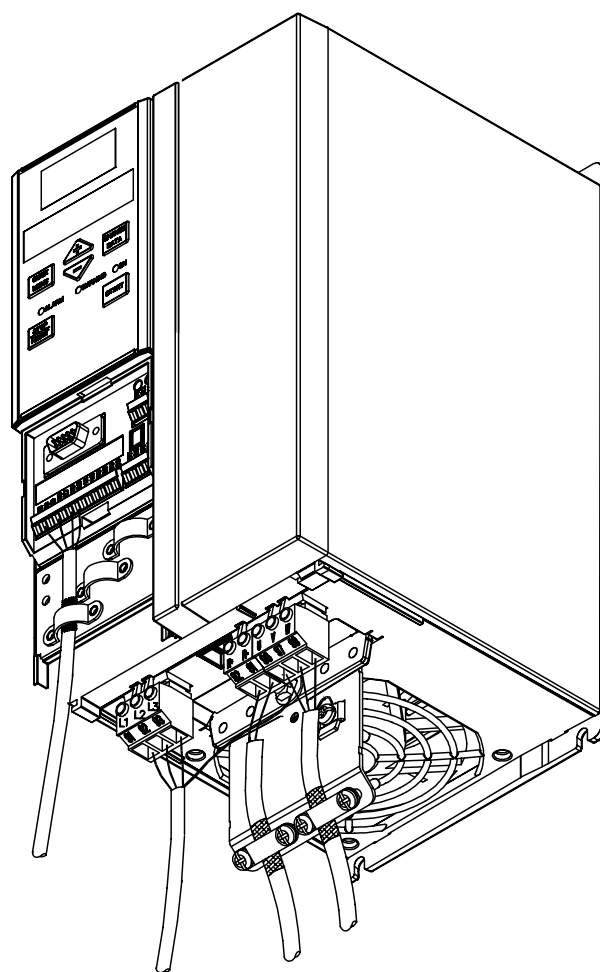
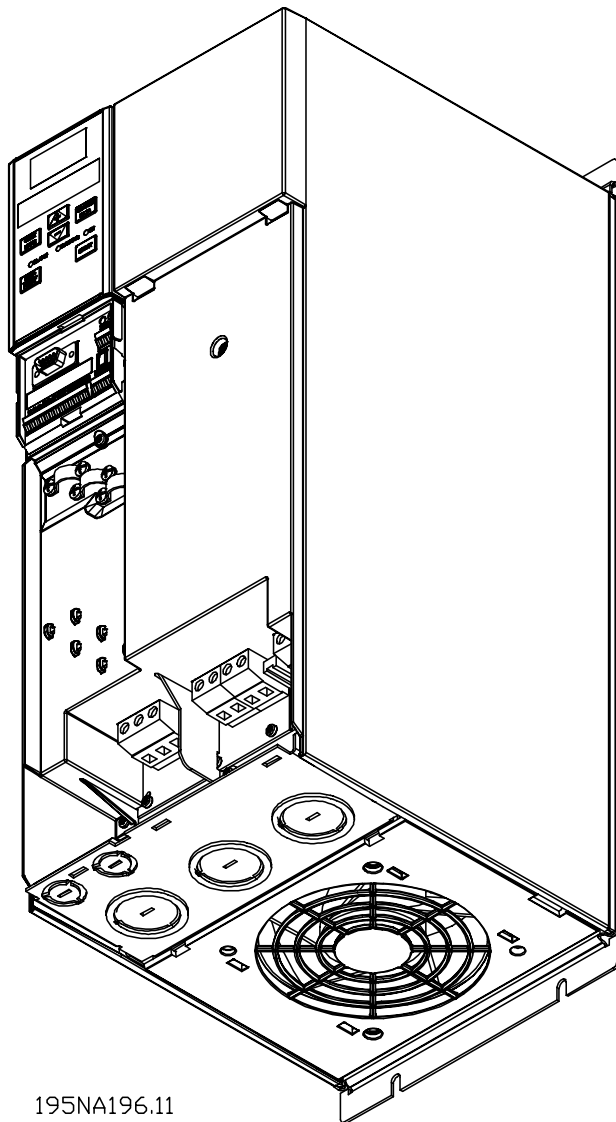

Illustration 3.24 VLT 2840 200-240 V
VLT 2822 PD2
2855-2875 380-480 V

195NA146.11



195NA196.11

Illustration 3.25 VLT 2880-2882 380-480 V
VLT 2840 PD2

NOTICE

The units are supplied with 2 bottom plates; one for metric glands and one for conduits.

3.4 Terminals

3.4.1 Safety Clamp

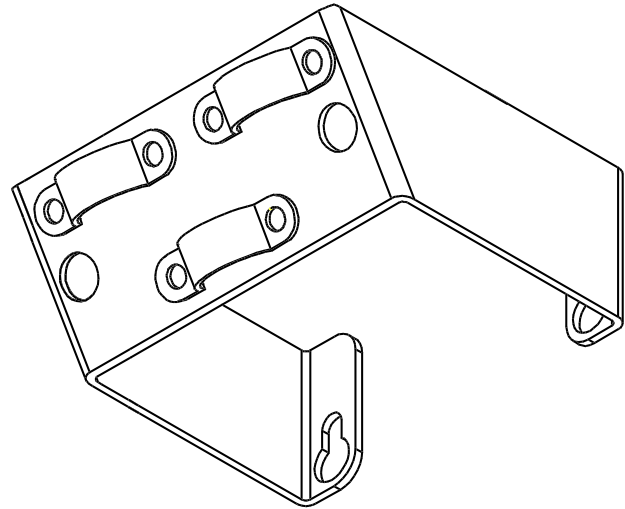

195NA112.10

Illustration 3.26 Safety Clamp

CAUTION

If the galvanic isolation (PELV) between control terminals and high-voltage terminals is to be maintained, the accompanying safety clamp must be fitted to VLT 2803-2815, 200-240 V, and VLT 2805-2815, 380-480 V. Failure to fit the safety clamp could result in equipment damage.

3

3.4.2 Pre-fuses

For all unit types, fit external pre-fuses in the mains supply to the frequency converter. For UL/cUL applications with a mains voltage of 200-240 V, use pre-fuses type Bussmann KTN-R (200-240 V) or Ferraz Shawmut type ATMR (max. 30A). For UL/cUL applications with a mains voltage of 380-480 V, use pre-fuses type Bussmann KTS-R (380-480 V).

| Alternative fuses 380-500 V drives | | | | | | | | | | |
|------------------------------------|------------------------|-------------------|-------------------|-----------------------|-------------------|-----------------------|-----------------|-----------------------|---|---|
| VLT 2800 | Bussman n E52273 | Bussmann E4273 | Bussmann E4273 | Bussman n E4273 | Bussmann E4273 | Bussman n E4273 | SIBA E180276 | Little Fuse E81895 | Ferraz- Shawmut E163267/ E2137 | Ferraz- Shawmut E163267/ E2137 |
| | RK1/JDDZ | J/JDDZ | T/JDDZ | CC/JDDZ | CC/JDDZ | CC/JDDZ | RK1/JDDZ | RK1/JDDZ | CC/JDDZ | RK1/JDDZ |
| 2805- 2822 | KTS-R20 | JKS-20 | JJS-20 | FNQ-R-20 | KTK-R-20 | LP-CC-20 | 5017906-020 | KLS-R20 | ATM-R25 | A6K-20R |
| 2855- 2875 | KTS-R25 | JKS-25 | JJS-25 | | | | 5017906-025 | KLS-R25 | ATM-R20 | A6K-25R |
| 2880- 2882 | KTS-R50 | JKS-50 | JJS-50 | | | | 5014006-050 | KLS-R50 | - | A6K-50R |
| | | | | | | | | | | |
| Alternative Fuses 200-240 V drives | | | | | | | | | | |
| VLT 2800 | Bussman n E52273 | Bussmann E4273 | Bussmann E4273 | | | | SIBA E180276 | Little Fuse E81895 | Ferraz- Shawmut E163267/ E2137 | Ferraz- Shawmut E163267/ E2137 |
| | RK1/JDDZ | J/JDDZ | T/JDDZ | | | | RK1/JDDZ | RK1/JDDZ | CC/JDDZ | RK1/JDDZ |
| 2803-2822 | KTN-R20 | JKS-20 | JJN-20 | | | | 5017906-020 | KLS-R20 | ATM-R25 | A6K-20R |
| 2840 | KTN-R25 | JKS-25 | JJN-25 | | | | 5017906-025 | KLS-R25 | ATM-R20 | A6K-25R |

Table 3.2 Prefuses for UL application /cUL

3.4.3 Mains Connection

WARNING

At 1x220-240 V the neutral wire must be attached to terminal N (L2) and the phase wire must be connected to terminal L1 (L1).

| No. | N(L2) | L1(L1) | (L3) | Mains voltage 1x220-240 V |
|-----|-------|--------|------|---------------------------|
| | N | L1 | | |
| No. | 95 | | | Ground connection |

Table 3.3 Mains Connection - 1x220-240 V

| No. | N(L2) | L1(L1) | (L3) | Mains voltage 3x220-240 V |
|-----|-------|--------|------|---------------------------|
| | L2 | L1 | L3 | |
| No. | 95 | | | Ground connection |

Table 3.4 Mains Connection - 3x220-240 V

| No. | 91 | 92 | 93 | Mains voltage 3x380-480 V |
|-----|----|----|----|---------------------------|
| | L1 | L2 | L3 | |
| No. | 95 | | | Ground connection |

Table 3.5 Mains Connection - 3x380-480 V

WARNING

Ensure that the mains voltage fits the mains voltage of the frequency converter, which can be seen from the nameplate.

WARNING

Do not connect 400 V units with RFI-filters to mains supplies in which the voltage between phase and ground is more than 300 V. For the IT mains and the delta ground, the mains voltage can exceed 300 V between phase and ground. Units with type code R5 can be connected to mains supplies with up to 400 V between phase and ground.

See chapter 5.1.1 Galvanic Isolation (PELV) for details on correct dimensioning of cable cross-section.

3.4.4 Motor Connection

Connect the motor to terminals 96, 97, 98. Connect ground to terminal 99.

See chapter 5.3 General Technical Data for correct dimensioning of cable cross-section.

All types of 3-phase asynchronous standard motors can be connected to a frequency converter. Normally, small motors are star-connected (230/400 V, Δ/Y). Large motors are delta-connected (400/690 V, Δ/Y). The correct connection mode and voltage can be read from the motor nameplate.

| | | | | |
|-----|----------|----------|----------|--|
| No. | 96 | 97 | 98 | Motor voltage 0-100% of mains voltage. |
| | U | V | W | 3 wires out of motor |
| | U1 W2 | V1 U2 | W1 V2 | 6 wires out of motor, Delta connected |
| | U1 | V1 | W1 | 6 wires out of motor, Star connected Interconnect U2, V2, W2 separately (optional terminal block) |
| No. | PE | | | Ground connection |

Table 3.6 Motor Connection

CAUTION

In motors without phase insulation paper, an LC filter should be fitted on the output of the frequency converter.

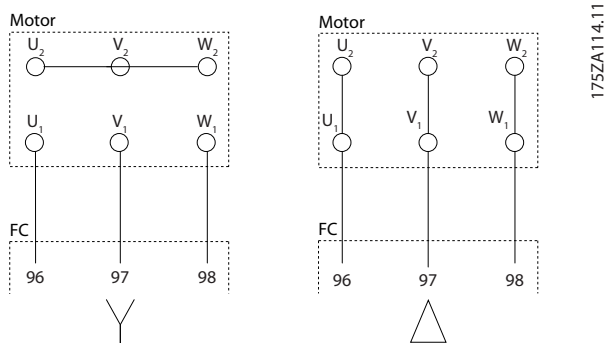

Illustration 3.27 Motor Connection

Mains supply isolated from ground

If the frequency converter is supplied from an isolated mains source (IT mains) or TT/TN-S mains with grounded leg, turn off the RFI switch. For further reference, see IEC 364-3. If optimum EMC performance is needed, parallel motors are connected or the motor cable length is above 25 m, set the switch in ON position.

In OFF position, the internal RFI capacities (filter capacitors) between the chassis and the intermediate circuit are cut off to avoid damage to the intermediate circuit and to reduce the ground capacity currents (according to IEC 61800-3).

Also refer to the application note *VLT on IT mains*. It is important to use isolation monitors that are capable for use together with power electronics (IEC 61557-8).

NOTICE

The RFI switch is not to be operated with mains connected to the unit. Check that the mains supply has been disconnected before operating the RFI switch. The RFI switch disconnects the capacitors galvanically from ground.

Remove the switch Mk9 placed next to terminal 96, to disconnect the RFI-filter.

3.4.5 Direction of Motor Rotation

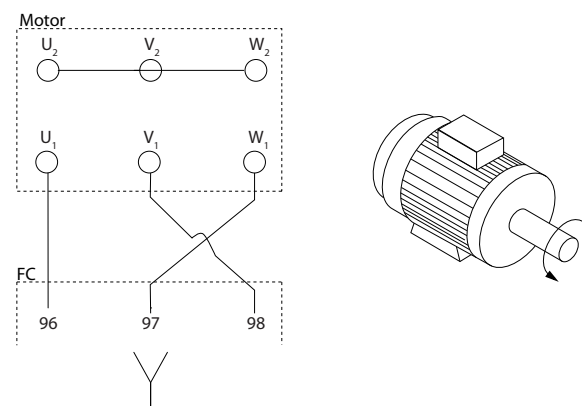
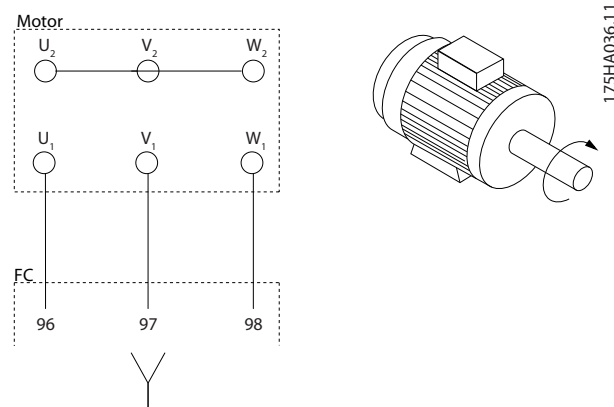

Illustration 3.28 Switch 2 Phases on the Motor Terminals

The factory setting is for clockwise rotation with the frequency converter transformer output connected as follows:

- Terminal 96 connected to U-phase.
- Terminal 97 connected to V-phase.
- Terminal 98 connected to W-phase.

The direction of rotation can be changed by switching 2 phases on the motor terminals.

3.4.6 Parallel Connection of Motors

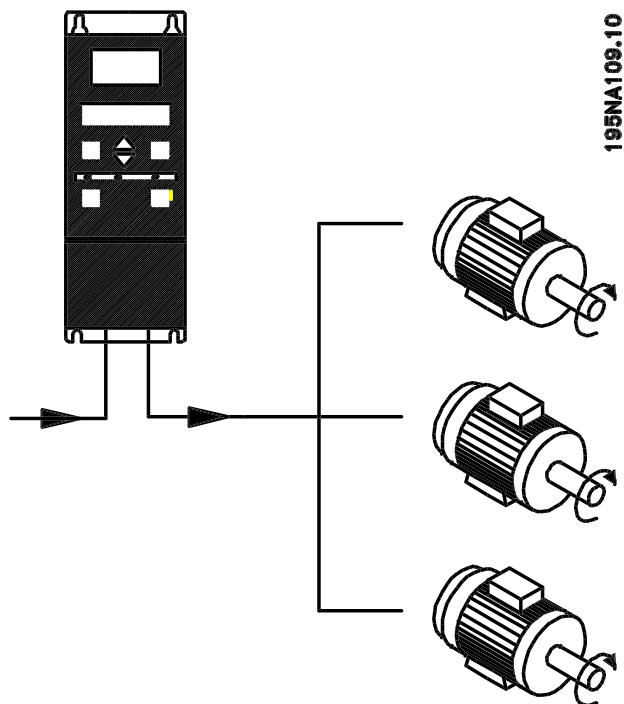

Illustration 3.29 Parallel Connection of Motors

The frequency converter is able to control several motors connected in parallel. If the motors are to have different RPM values, use motors with different rated RPM values. Motor RPM is changed simultaneously, which means that the ratio between the rated RPM values is maintained across the range. The total current consumption of the motors is not to exceed the maximum rated output current I_{INV} for the frequency converter.

Problems may arise at the start and at low RPM values if the motor sizes are widely different. This is because the small motors' relatively high ohmic resistance in the stator calls for a higher voltage at the start and at low RPM values.

In systems with motors connected in parallel, the electronic thermal relay (ETR) of the frequency converter cannot be used as motor protection for the individual motor. For this reason further motor protection must be used, e.g. thermistors in each motor or an individual thermal relay. (Circuit breakers are not suitable as protection).

NOTICE

Parameter 107 Automatic motor adaption, AMT cannot be used when motors are connected in parallel. Parameter 101 Torque characteristic must be set to [8] Special motor characteristics when motors are connected in parallel.

3.4.7 Motor Cables

See chapter 5.3 General Technical Data for correct dimensioning of motor cable cross-section and length. Always comply with national and local regulations on cable cross-section.

NOTICE

If an unscreened/unarmoured cable is used, some EMC requirements are not complied with, see chapter 5.1.21 EMC Compliance.

To comply with EMC specifications regarding emission, use a screened/armoured motor cable, unless otherwise stated for the RFI filter in question. Keep the motor cable as short as possible to reduce the noise level and leakage currents to a minimum. Connect the motor cable screen to the metal cabinet of the frequency converter and to the metal cabinet of the motor. The screen connections are to be made with the biggest possible surface area (cable clamp). This is enabled by different installation devices in different frequency converters. Avoid mounting with twisted screen ends (pigtailed), since these spoil the screening effect at high frequencies. If it is necessary to break the screen to install a motor isolator or motor relay, the screen must be continued at the lowest possible HF impedance.

3.4.8 Thermal Motor Protection

The electronic thermal relay in the frequency converter has received UL-approval for single motor protection, when 1-28 Thermal Motor Protection is set to ETR Trip and 1-24 Motor Current is set to the rated motor current (see the motor name plate).

For thermal motor protection, it is also possible to use the MCB 112 PTC Thermistor Card option. This card provides ATEX certificate to protect motors in explosion hazardous areas, Zone 1/21 and Zone 2/22. When 1-28 Thermal Motor Protection, set to [20] ATEX ETR, is combined with the use of MCB 112, it is possible to control an Ex-e motor in explosion hazardous areas. Consult the Programming Guide for details on how to set up the frequency converter for safe operation of Ex-e motors.

3.4.9 Brake Connection

| | | | |
|-----|----|----|----------------|
| No. | 81 | 82 | Brake resistor |
| | R- | R+ | terminals |

Table 3.7 Brake Connection

The connection cable to the brake resistor must be screened/armoured. Connect the screen to the metal cabinet of the frequency converter and to the metal cabinet of the brake resistor with cable clamps. Dimension

the cross-section of the brake cable to match the brake torque.

See *chapter 1.11 Brake Resistors* for details on the dimensioning of brake resistors.

⚠ WARNING

HIGH VOLTAGE

Voltage can be over 850 V DC on the terminals. Incorrect installation of the motor, frequency converter or fieldbus may cause death, serious injury or equipment damage.

- Comply with the instructions in this manual, as well as national and local rules and safety regulations.

3.4.10 Ground Connection

As leak current to the ground is higher than 3.5 mA, always ground the frequency converter according to prevailing national and local regulations. To guarantee that the ground cable has a good mechanical connection to terminal 95, the cable cross-section must be at least 10 mm² or 2 rated ground wires that are terminated separately. To ensure safety, install an RCD (Residual Current Device), which guarantees that the frequency converter trips when leak current becomes too high. See also *RCD Application Note*.

3.4.11 Load Sharing

Load sharing provides the facility to connect several frequency converters' DC intermediate circuits. This requires that the installation is extended using extra fuses and AC coils (see drawing below). For load sharing, set *parameter 400 Brake function* to [5] *Load sharing*.

Use 6.3 mm Faston Plugs for DC (Load Sharing).

Contact Danfoss for further information.

| | | | | |
|-----|----|----|--|--------------|
| No. | 88 | 89 | | Load sharing |
| | - | + | | |

175ZA299.12

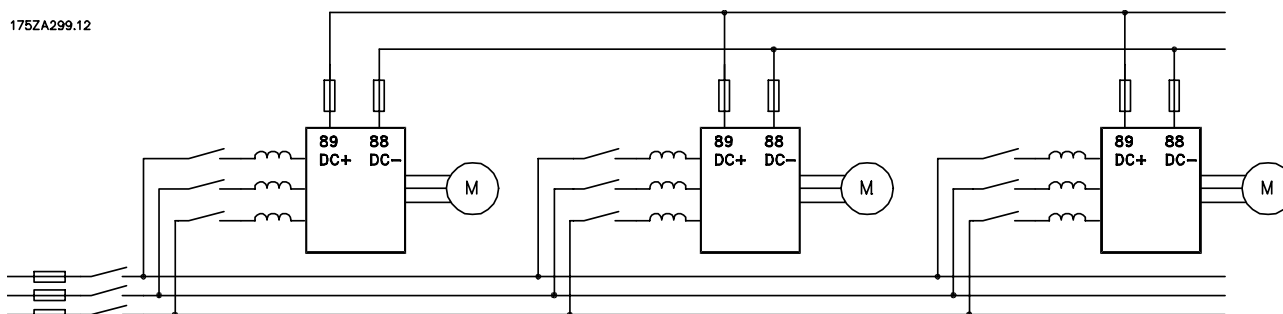

Illustration 3.30 Load Sharing Example

⚠ WARNING

HIGH VOLTAGE

Voltage can be over 850 V DC between terminal 88 and 89. Incorrect installation of the motor, frequency converter or fieldbus may cause death, serious injury or equipment damage.

- Comply with the instructions in this manual, as well as national and local rules and safety regulations.

3

3.4.12 Tightening Torque for Power Terminals

Tighten power and ground terminals with the following torques:

| VLT | Terminals | Torque [Nm] |
|------------------------|-------------------|-------------|
| 2803-2875 | Power mains brake | 0.5-0.6 |
| | Ground | 2-3 |
| 2880-2882, 2840 PD2 | Power mains brake | 1.2-1.5 |
| | Ground | 2-3 |

3.4.13 Control of Mechanical Brake

In lifting/lowering applications, it's necessary to control an electromagnetic brake. The brake is controlled using a relay output or digital output (terminal 46). The output must be kept closed (voltage-free) for the period of time during which the frequency converter is not able to support the motor, for example due to the load being too high. Select [25] *Mechanical brake control* in *parameter 323 Relay output 1-3* or *parameter 341 Digital/Pulse output terminal 46* for applications with an electromagnetic brake. When the output frequency exceeds the brake cut-out value set in *parameter 138 Brake cut out value*, the brake is released if the motor current exceeds the preset value in *parameter 140 Current, minimum value*. The brake is engaged when the output frequency is less than the brake engaging frequency, which is set in *parameter 139 Brake cut in frequency*.

If the frequency converter is in alarm status or in an overvoltage situation, the mechanical brake is cut in immediately.

NOTICE

This application is only for lifting/lowering without a counterbalance.

3.4.14 Access to Control Terminals

All terminals to the control cables are located underneath the protective plate on the front of the frequency converter. Remove the protective plate by pulling it downwards, as shown in *Illustration 3.31*.

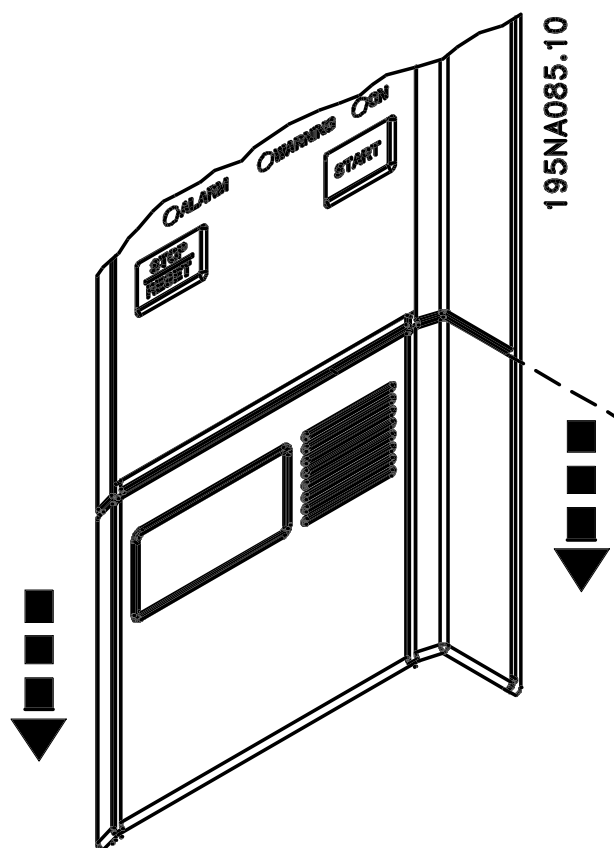

Illustration 3.31 Remove the Protective Cover

3.4.15 Control Cables

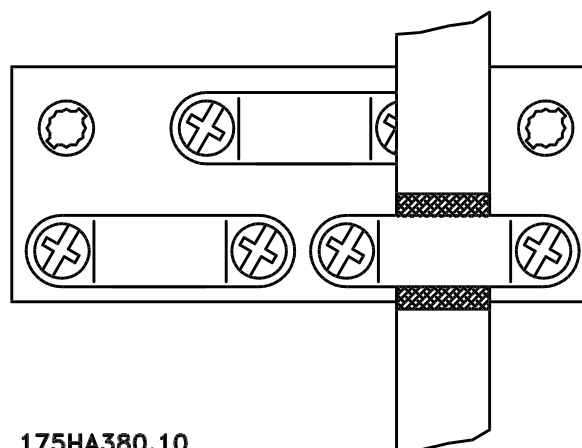
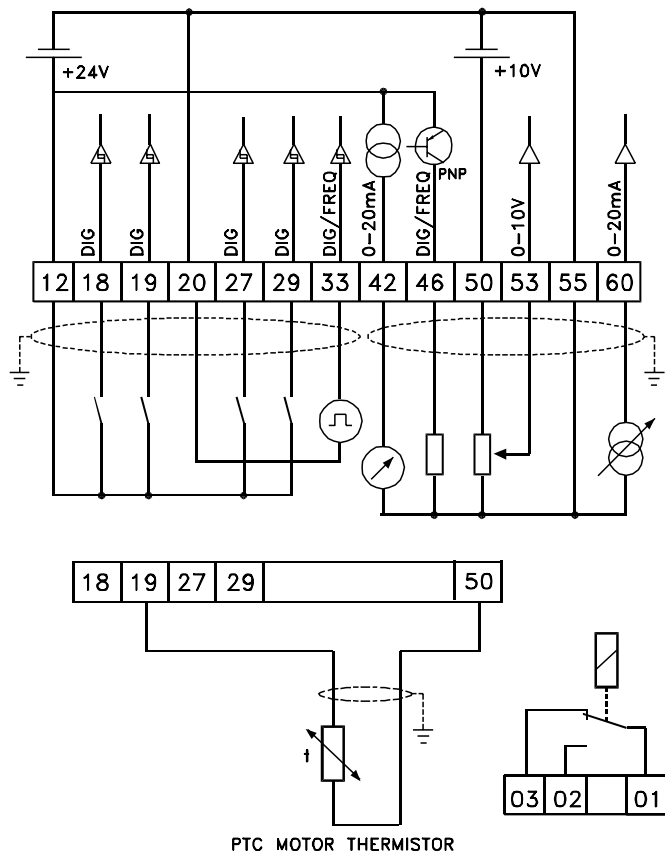

Illustration 3.32 Screen Control Cables

Use screened/armoured control cables. Connect the screen to the frequency converter chassis with a clamp. Normally, the screen must also be connected to the chassis of the controlling unit (use the instructions for the unit in question). In connection with very long control cables and analog signals, 50/60 Hz ground loops may occur because

of noise transmitted from mains supply cables. In this connection, it may be necessary to break the screen and

possibly insert a 100 nF capacitor between the screen and the chassis.



195NA028.14
Illustration 3.33 Control Cables

Tightening Torques for Control Cables

Connect control wires with a tightening torque of 0.22-0.25 Nm.

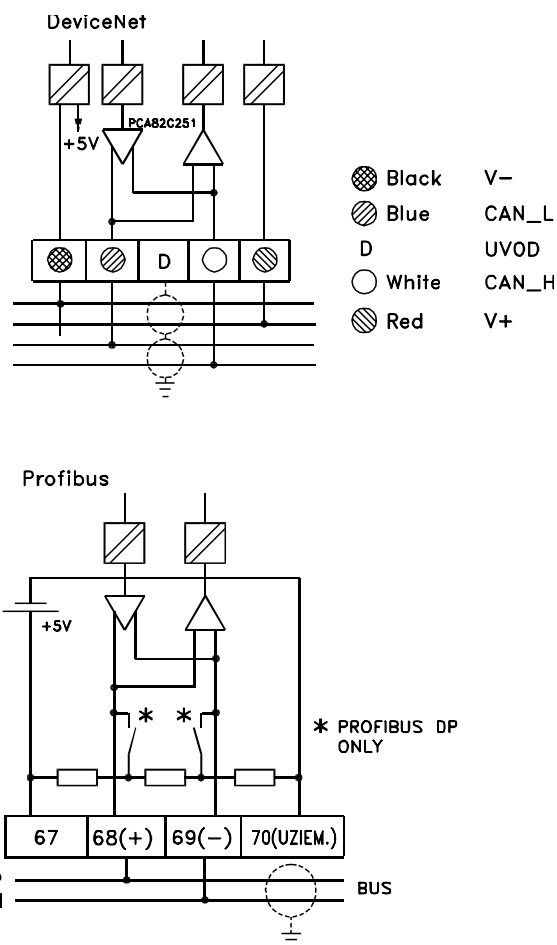

3.4.16 Control Terminals

See chapter 3.3.9 *Grounding of Screened/armoured Control Cables* for the correct termination of control cables.

3

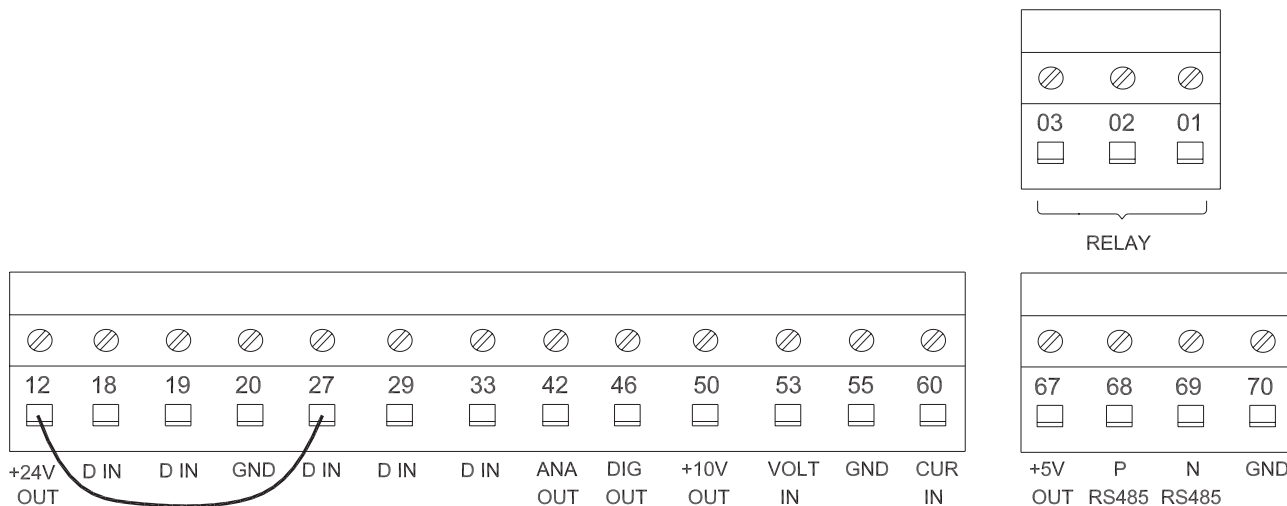

195NA003.12

Illustration 3.34 Control Terminals

| No. | Function |
|----------------------|--|
| 01-03 | Relay outputs 01-03 can be used for indicating status and alarms/warnings. |
| 12 | 24 V DC voltage supply. |
| 18-33 | Digital inputs. |
| 20, 55 | Common frame for input and output terminals. |
| 42 | Analog output for displaying frequency, reference, current or torque. |
| 46 ₁ | Digital output for displaying status, warnings or alarms, as well as frequency output. |
| 50 | +10 V DC supply voltage for potentiometer or thermistor. |
| 53 | Analog voltage input 0-10 V DC. |
| 60 | Analog current input 0/4-20 mA. |
| 67 ¹⁾ | + 5 V DC supply voltage to Profibus. |
| 68, 69 ₁₎ | RS-485, serial communication. |
| 70 ¹⁾ | Frame for terminals 67, 68 and 69. Normally this terminal is not to be used. |

Table 3.8 Functions of Control Terminals

1) The terminals are not valid for DeviceNet/CANopen. See DeviceNet Manual for further details.

3.4.17 Relay Connection

See parameter 323 Relay output for programming of relay output.

| | | | | |
|-----|----|---|----|-------------------------------|
| Nr. | 01 | - | 02 | 1 - 2 make (normally open) |
| | 01 | - | 03 | 1 - 3 break (normally closed) |

⚠ WARNING

The cable jacket for the relay must cover the first row of control card terminals. Otherwise the galvanic isolation (PELV) cannot be maintained, which could result in equipment damage and personal injury. Maximum cable diameter is 4 mm.

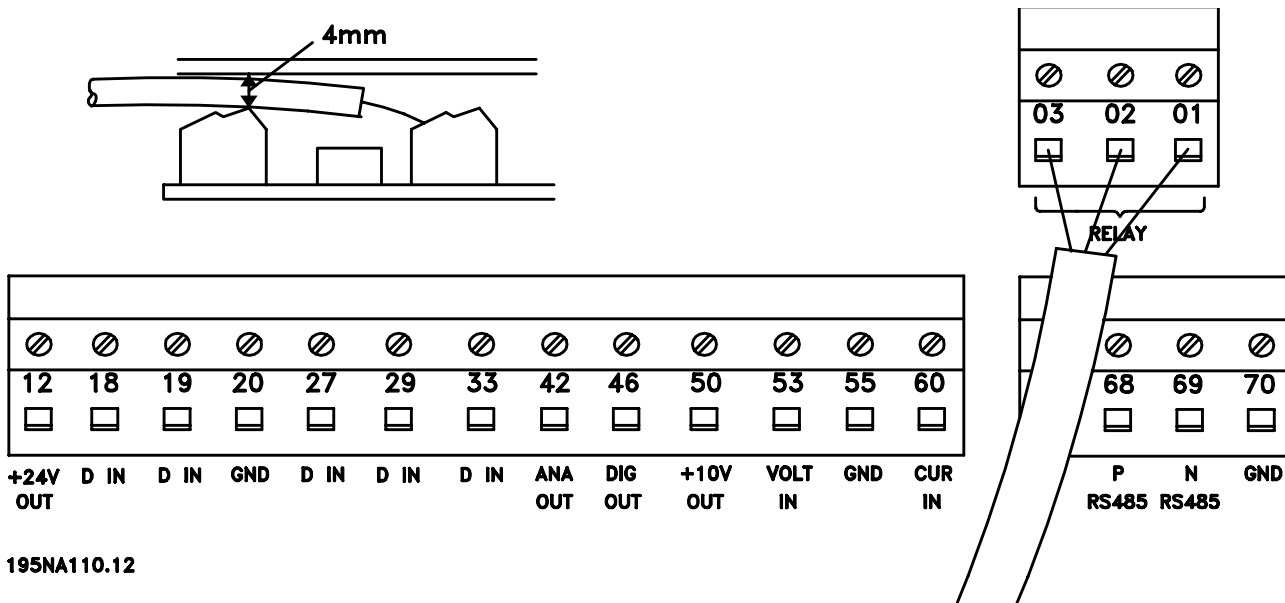

195NA110.12

Illustration 3.35 Relay Connection

3.4.18 Switches 1-4

The dip switch is only on the control card with Profibus DP communication.

The switch position shown is the factory setting.



Switches 1 and 2 are used as cable termination for the RS-485 interface. If the frequency converter is located as the first or last unit in the bus system, switches 1 and 2 must be ON. On the remaining frequency converters, switches 1 and 2 must be OFF.

Switches 3 and 4 are not applied.

3.4.19 VLT Motion Control Tool MCT 10 Set-up Software

Connection to terminals 68-70 or Sub D:

- PIN 3 GND
- PIN 8 P-RS 485
- PIN 9 N-RS 485

3.4.20 Sub D Plug

3

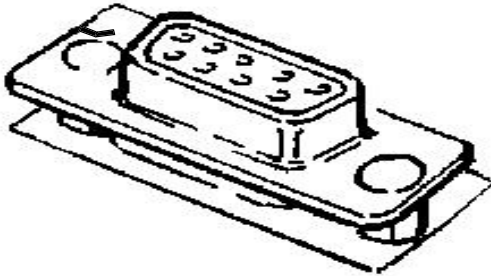

195NA025.10

Illustration 3.36 Sub D Plug

An LCP 2 control unit can be connected to the Sub D plug on the control card. The ordering number of LCP 2 Control Unit is 175N0131. LCP control unit with ordering number 175Z0401 cannot be connected to Sub D plug.

3.5 Connection Examples

3.5.1 Start/Stop

Start/stop using terminal 18 and coasting stop using terminal 27.

- *Parameter 302 Digital input=[7] Start*
- *Parameter 304 Digital input=[2] Coasting stop inverted*

For Precise start/stop the following settings are made:

- *Parameter 302 Digital input=[27] Precise start/stop*
- *Parameter 304 Digital input=[2] Coasting stop inverted*

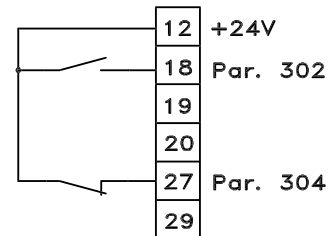

195NA011.11

Illustration 3.37 Start/Stop Connection

3.5.2 Pulse Start/Stop

Pulse start using terminal 18 and pulse stop using terminal 19. In addition, the jog frequency is activated via terminal 29.

- *Parameter 302 Digital input=[8] Pulse start*
- *Parameter 303 Digital input=[6] Stop inverted*
- *Parameter 304 Digital input=[2] Coasting stop inverted*
- *Parameter 305 Digital input=[13] Jog*

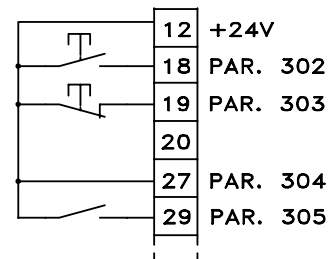

195NA012.11

Illustration 3.38 Pulse Start/Stop Connection

3.5.3 Speed Up/Down

Speed up/down using terminals 29/33.

- Parameter 302 Digital input=[7] Start
- Parameter 303 Digital input=[14] Freeze reference
- Parameter 305 Digital input=[16] Speed up
- Parameter 307 Digital input=[17] Speed down

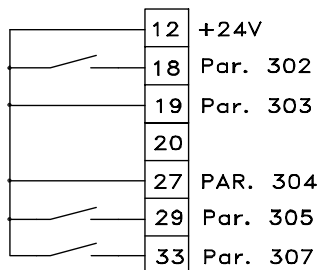

195NA249.10

Illustration 3.39 Speed Up/down Connection

3.5.4 Potentiometer Reference

Voltage reference via a potentiometer.

- Parameter 308 Analog input=Reference [1]
- Parameter 309 Terminal 53, min. scaling=0 V
- Parameter 310 Terminal 53, max. scaling=10 V

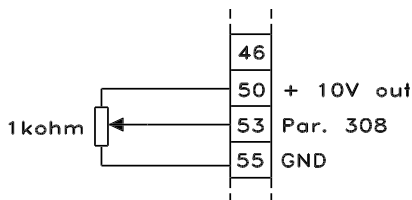

195NA016.10

Illustration 3.40 Potentiometer Reference

3.5.5 Connection of a 2-Wire Transmitter

Connection of a 2-wire transmitter as feedback to terminal 60.

- Parameter 314 Analog input=Feedback [2]
- Parameter 315 Terminal 60, min. scaling=4 mA
- Parameter 316 Terminal 60, max. scaling=20 mA

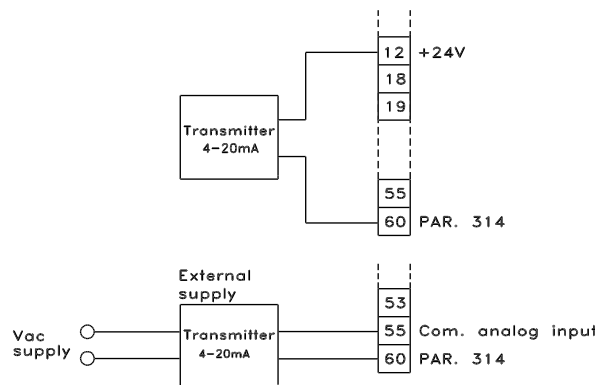

195NA013.11

Illustration 3.41 Connection of a 2-Wire Transmitter

3.5.6 4-20 mA Reference

4-20 mA reference on terminal 60 and speed feedback signal on terminal 53.

- Parameter 100 Configuration=[1] Speed closed loop
- Parameter 308 Analog input=[2] Feedback
- Parameter 309 Terminal 53, min. scaling=0 V
- Parameter 310 Terminal 53, max. scaling=10 V
- Parameter 314 Analog input=[1] Reference
- Parameter 309 Terminal 60, min. scaling=4 mA
- Parameter 310 Terminal 60, max. scaling=20 mA

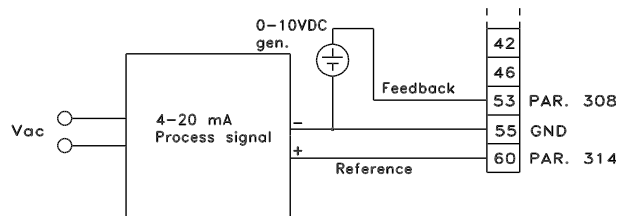

DANFOSS 195NA013.10

Illustration 3.42 4-20 mA Reference Connection

3.5.7 50 Hz Counter-clockwise to 50 Hz Clockwise

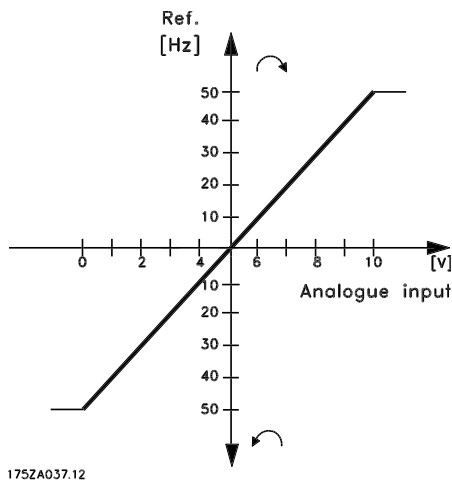

175ZA037.12

Illustration 3.43 50 Hz Counter-Clockwise to 50 Hz Clockwise

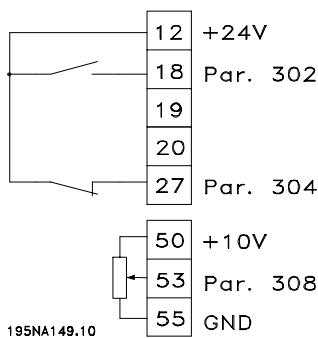

195NA149.10

Illustration 3.44 Terminal Connection

- Parameter 100 Configuration=[0] Speed regulation open loop
- Parameter 200 Output frequency range=[1] Both directions, 0-132 Hz
- Parameter 203 Reference range=[0] Min. ref. - Max. ref.
- Parameter 204 Min. reference=- 50 Hz
- Parameter 205 Max. reference=50 Hz
- Parameter 302 Digital input=[7] Start
- Parameter 304 Digital input=[2] Coasting stop inverted
- Parameter 308 Analogue input=[1] Reference
- Parameter 309 Terminal 53, min. scaling=0 V
- Parameter 310 Terminal 53, max. scaling=10 V

3.5.8 Preset References

Switch between 8 preset references via 2 digital inputs and set-up 1 and set-up 2.

- Parameter 004 Active Setup=[5] Multisetup 1
- Parameter 204 Min. reference=0 Hz
- Parameter 205 Max. reference=50 Hz
- Parameter 302 Digital input=[7] Start
- Parameter 303 Digital input=Choice of Setup, lsb [31]
- Parameter 304 Digital input=[2] Coasting stop inverted
- Parameter 305 Digital input=Preset ref., lsb [22]
- Parameter 307 Digital input=Preset ref., msb [23]

Set-up 1 contains the following preset references:

- Parameter 215 Preset reference 1=5.00%
- Parameter 216 Preset reference 2=10.00%
- Parameter 217 Preset reference 3=25.00%
- Parameter 218 Preset reference 4=35.00%

Set-up 2 contains the following preset references:

- Parameter 215 Preset reference 1=40.00%
- Parameter 216 Preset reference 2=50.00%
- Parameter 217 Preset reference 3=70.00%
- Parameter 218 Preset reference 4=100.00%

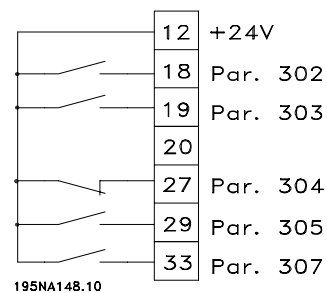

195NA148.10

Illustration 3.45 Preset Reference Connection

Table 3.9 shows the output frequency for different combinations of preset references.

| Preset ref., msb | Preset ref., lsb | Selection of set-up | Output frequency [Hz] |
|---------------------|---------------------|------------------------|--------------------------|
| 0 | 0 | 0 | 2.5 |
| 0 | 1 | 0 | 5 |
| 1 | 0 | 0 | 10 |
| 1 | 1 | 0 | 17.5 |
| 0 | 0 | 1 | 20 |
| 0 | 1 | 1 | 25 |
| 1 | 0 | 1 | 35 |
| 1 | 1 | 1 | 50 |

3.5.9 Connection of Mechanical Brake

Use of the relay for 230 V AC brake

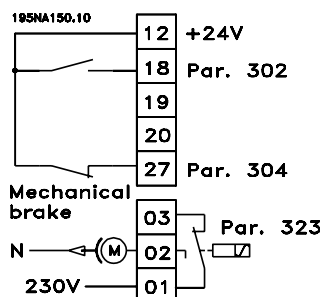

Illustration 3.46 Connection of Mechanical Brake

- Parameter 302 Digital input=[7] Start
- Parameter 304 Digital input=[2] Coasting stop inverted
- Parameter 323 Relay output=[25] Mechanical brake control

[25] Mechanical brake control='0' ⇒ Brake is closed.

[25] Mechanical brake control='1' ⇒ The brake is open.

See more detailed parameter settings in chapter 3.4.13 Control of Mechanical Brake.

⚠ WARNING

Do not use the internal relay for DC brakes or brake voltages > 250 V. There is a risk of equipment damage and personal injury.

3.5.10 Counter Stop Through Terminal 33

The start signal (terminal 18) must be active, i.e. logical '1', until the output frequency is equal to the reference. The start signal (terminal 18 = logical '0') must then be removed before the counter value in parameter 344 Counter value has managed to stop the frequency converter.

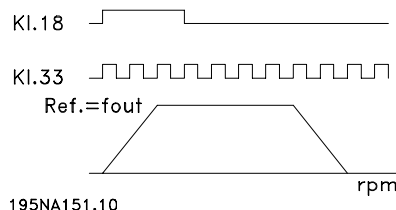

Illustration 3.47 Counter Stop Through Terminal 33

- Parameter 307 Digital input=[30] Pulse input
- Parameter 343 Precise stop function=[1] Counter stop with reset
- Parameter 344 Counter value=100000

3.5.11 Use of Internal PID-Controller - Closed Loop Process Control

1. Connect the frequency converter to mains and motor cables as usual.
2. Connect transmitter (feedback signal) to + terminal 12 and - terminal 60 (applies to 2-wire transmitters 4-20 mA). (Connect transmitters with 0-10 V DC to + terminal 53 and - terminal 55).

NOTICE

Connect terminal 55 as - and terminal 60 as + for current signal (0/4-20 mA) and terminal 53-55 for voltage signal (0-10 V DC) if transmitters with separate voltage supply are used.

3. Connect the start signal between terminal 12 and 18, 12-27 must be connected or set to no function (Parameter 304 Digital input, term. 27=0).
4. Set all parameters in the Quick Menu and enter the Main Menu (to enter the Main Menu: Press [Quick Menu] and [+] simultaneously).
5. Set the following parameters:
 - Parameter 100 Configuration = [3] Process controller closed loop
 - Parameter 101 Torque characteristic= [3] Variable torque medium
 - If used with centrifugal pumps and fans.
 - Parameter 308 Terminal 53, analog input voltage= [2] Feedback (for 0-10 V DC transmitters) or

- *Parameter 314 Terminal 60, analogue input current*= [2] Feedback (for 4-20 mA transmitters)
- *Parameter 414 Minimum feedback FB MIN*=Minimum feedback scaling, must be set to the minimum feedback value
- *Parameter 415 Maximum feedback, FBMAX*=Maximum feedback scaling, must be set to the maximum feedback value
- Example: Pressure transmitter 0-10 bar: *Parameter 414 Minimum feedback FB MIN*=0 and *Parameter 415 Maximum feedback, FBMAX*=10
- *Parameter 416 Process units*=Process units: As shown in the LCP (example: [4] bar)
- *Parameter 437 Process PID normal/inverse control*= [0] Normal: Reduce the output frequency when the feedback signal increases [1] Inverse: Increase the output frequency when the feedback signal increases
- *Parameter 440 Proces PID proportioanl gain*=Proportional gain (P-gain) 0.3-1.0 (experienced value)
- *Parameter 441 Process PID integration time*=Integration time (I-time) 3-10 s (experienced value)
- *Parameter 442 Process PID differentiation time* Differentiation time (D-time) 0-10 s (experienced value)
- *Parameter 205 Maximum reference, RefMAX*=Max. reference is to be set equal to *Parameter 415 Maximum feedback, FBMAX* (example: 10 bar)
- *Parameter 215 Preset reference 1 (PRESET REF. 1)*=Preset reference 1. Set the preset reference to the wanted min. reference value (example: 5 bar)
- (*Parameter 205 Maximum reference, RefMAX* and *Parameter 215 Preset reference 1 (PRESET REF. 1)*) are shown in the process unit chosen in parameter 416).
- The value in brackets [] are data values corresponding to the wanted function. Example: *Parameter 308 Terminal 53, analog input voltage*Feedback signal=[2] Feedback
- If the motor is supposed to always run at a minimum speed, a such can be selected in *Parameter 204 Minimum reference, Ref MIN*=output frequency low limit. (For pump works it is typically 15-20 Hz).
- With the above connections and settings, all normal pump and fan applications work properly. In certain cases it might be necessary to optimise the PID-controllerr (*Parameter 440 Proces PID proportioanl gain*, *Parameter 441 Process PID integration time* and *Parameter 442 Process PID*

differentiation time) beyond the mentioned experienced values.

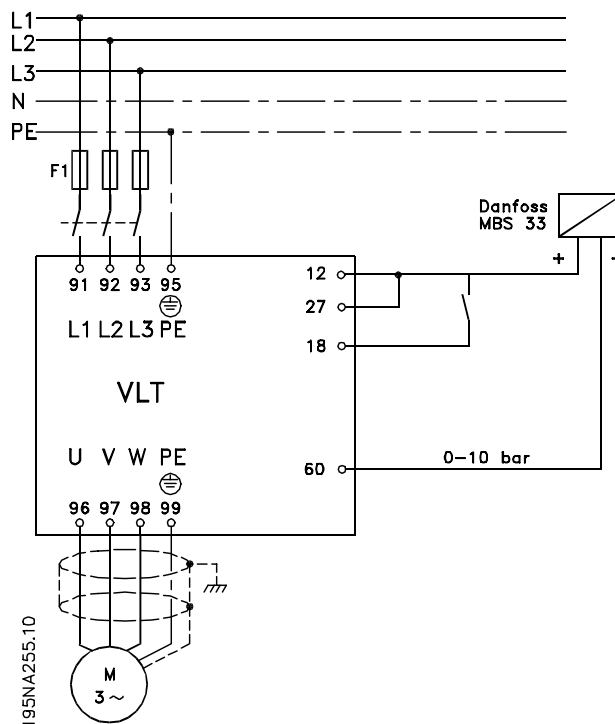

Illustration 3.48 Connection for Closed Loop Process Control

4 Programming

4.1 Operation & Display

| 001 | Language |
|---------------------|----------|
| Value: | |
| * English (english) | [0] |
| German (deutsch) | [1] |
| French (français) | [2] |
| Danish (dansk) | [3] |
| Spanish (español) | [4] |
| Italian (italiano) | [5] |

Function:

This parameter is used to select the language to be shown in the display whenever the LCP control unit is connected.

Description of choice:

There is a choice of the languages shown. The factory setting may vary.

| 002 | Local/Remote Operation |
|-----------------------------|------------------------|
| Value: | |
| * Remote operation (REMOTE) | [0] |
| Local operation (LOCAL) | [1] |

Function:

2 different operation modes of the frequency converter are available. [0] Remote operation or [1] Local operation. See also parameter 013 Local control if [1] Local operation is selected.

Description of choice:

If [0] Remote operation is selected, the frequency converter is controlled via:

- The control terminals or via serial communication.
- The [START] key. This cannot, however, override stop commands transmitted via the digital inputs or via serial communication.
- The [STOP/RESET] and [JOG] keys, on the condition that these are active.

If [1] Local operation is selected, the frequency converter is controlled via:

- The [START] key. This cannot, however, override stop commands via the digital inputs (see parameter 013 Local control).
- The [STOP/RESET] and [JOG] keys, on the condition that these are active.
- The [FWD/REV] key, on the condition that it has been selected as active in parameter 016 Local reversing, and that parameter 013 Local control is set at [1] Local control and open loop or [3] Local control as parameter 100. Parameter 200 Output frequency range is set at [1] Both directions.

- Parameter 003 Local reference where the reference can be set using the [+] and [-] keys.
- An external control command that can be connected to the digital inputs (see parameter 013 Local control).

NOTICE

The [JOG] and [FWD/REV] keys are located on the LCP control unit.

| 003 | Local Reference |
|--|-----------------|
| Value: | |
| Parameter 013 Local control must be set to [1] LOC CTRL/OPEN LOOP or [2] LOC+DIG CTRL: | * 50 |
| 0 - f _{MAX} (parameter 205) | Hz |
| Parameter 013 Local control must be set to [3] LOC CTRL/AS P100 or [4] LOC+DIG CTRL/AS P100. | |
| Ref _{MIN} - Ref _{MAX} (parameter 204-205) | * 0,0 |

Function:

In this parameter, the local reference can be set manually. The unit of the local reference depends on the configuration selected in parameter 100 Configuration.

Description of choice:

To protect the local reference, parameter 002 Local/remote operation must be set to [1] Local operation. Local reference cannot be set via serial communication. There is a choice of 4 set-ups (parameter set-ups), which can be programmed independently of one another. The active set-up can be selected in parameter 004 Active Setup. When an LCP 2 control unit is connected, the active set-up number appears in the display under set-up. It is also possible to preset the frequency converter to Multisetup, so that it is possible to shift Setups using the digital inputs or serial communication. Setup shift can be used in a plant in which, for example, one Setup is used for daytime operation and another one for night time operation. In parameter 006 Setup copying it is possible to copy from one Setup to another. Using parameter 007 LCP copy, all Setups can be transferred from one frequency converter to another by moving the LCP 2 control panel. First all parameter values are copied to the LCP 2 control panel, which can then be moved to another frequency converter. Here all parameter values can be copied from the LCP 2 control unit to the frequency converter.

4.1.1 Setup Shift

- Selection of Setup via terminals 29 and 33.
- *Parameter 305 Digital input=[31] Selection of Setup, lsb*
- *Parameter 307 Digital input=[32] Selection of Setup, msb*
- *Parameter 004 Active setup=[5] Multi Setup*

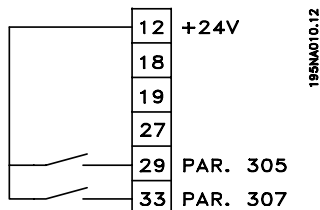

Illustration 4.1 Setup Selection

| 004 Active Set-up | |
|---------------------------------|-----|
| Value: | |
| Factory Set-up (FACTORY SET-UP) | [0] |
| * Set-up 1 (setup 1) | [1] |
| Set-up 2 (setup 2) | [2] |
| Set-up 3 (setup 3) | [3] |
| Set-up 4 (setup 4) | [4] |
| Multi Setup (MULTI SET-UP) | [5] |

Function:

The active parameter set-up is selected here. All parameters can be programmed in 4 individual parameter set-ups. Use this parameter to shift between set-ups via a digital input or via serial communication.

Description of choice:

[0] *Factory Set-up* contains the factory-set parameter values. *Set-up 1-4* [1]-[4] are 4 individual set-ups which can be selected as required. [5] *Multi Set-up* is used where remote-controlled shifts between the 4 set-ups via a digital input or via serial communication is required.

| 005 Programming Setup | |
|-------------------------------|-----|
| Value: | |
| Factory Setup (FACTORY SETUP) | [0] |
| Setup 1 (setup 1) | [1] |
| Setup 2 (setup 2) | [2] |
| Setup 3 (setup 3) | [3] |
| Setup 4 (setup 4) | [4] |
| * Active Setup (ACTIVE SETUP) | [5] |

Function:

Select which set-up to programme during operation (applies both via the control panel and the serial communication port). It is, for example, possible to programme [2] *Setup 2*, while the active set-up is set to [1] *Setup 1* in *parameter 004 Active Setup*.

Description of choice:

[0] *Factory Setup* contains the factory-set data and can be used as a source of data if the other set-ups are to be reset to a known status. *Setup 1-4* [1]-[4] are individual set-ups that can be programmed freely during operation. If [5] *Active Setup* is selected, the programming set-up is equal to *parameter 004 Active Setup*.

NOTICE

If data is modified or copied to the active set-up, the modifications have an immediate effect on the unit's operation.

| 006 Setup Copying | |
|--|-----|
| Value: | |
| * No copying (NO COPY) | [0] |
| Copy to Setup 1 from # (COPY TO SETUP 1) | [1] |
| Copy to Setup 2 from # (COPY TO SETUP 2) | [2] |
| Copy to Setup 3 from # (COPY TO SETUP 3) | [3] |
| Copy to Setup 4 from # (COPY TO SETUP 4) | [4] |
| Copy to all Setups from # (copy to all) | [5] |

Function:

Copy from the selected active set-up in *parameter 005 Programming set-up* to the selected set-up or set-ups in this parameter.

Description of choice:

Copying begins when the required copying function has been selected and the [OK]/[CHANGE DATA] key has been pressed. The display indicates when copying is in progress.

NOTICE

Copying is only possible in Stop (motor stopped in connection with a stop command).

| 007 LCP Copy | |
|--|-----|
| Value: | |
| * No copying (NO COPY) | [0] |
| Upload all parameters (UPL. ALL PAR.) | [1] |
| Download all parameters (DWNL. ALL PAR.) | [2] |
| Download size-independent parameters (DWNL.OUTPIND.PAR.) | [3] |

Function:

Use *parameter 007 LCP copy* to use the LCP 2 control panel's integral copy function. Use the function to copy all parameter set-ups from one frequency converter to another by moving the LCP 2 control panel.

Description of choice:

Select [1] *Upload all parameters* to transfer all parameter values to the control panel. Select [2] *Download all parameters* if all parameter values transferred are to be

copied to the frequency converter to which the control panel is attached. Select [3] *Download size-independent parameter* to download only the size-independent parameters. This is used when downloading to a frequency converter with a different rated power size than that from which the parameter set-up originates.

NOTICE

Upload/download can only be performed in stop mode. Download can only be performed to a adjustable frequency drive with the same software version number, see parameter 626 *Database identification no.*

008 Display scaling of output frequency

Value:
0.01 - 100.00 * 1.00

Function:
In this parameter, the factor is selected by which the output frequency is to be multiplied. The value is shown in the display, provided *parameters 009-012 Display readout* have been set to [5] *Output frequency x scaling*.

Description of choice:
Set the required scaling factor.

009 Large display readout

- Value:**
- No readout (none) [0]
 - Resulting reference [%] (reference [%]) [1]
 - Resulting reference [unit] (reference [unit]) [2]
 - Feedback [unit] (feedback [unit]) [3]
 - * Frequency [Hz] (Frequency [Hz]) [4]
 - Output frequency x scaling (frequency x scale) [5]
 - Motor current [A] (Motor current [A]) [6]
 - Torque [%] (Torque [%]) [7]
 - Power [kW] (Power [kW]) [8]
 - Power [HP] (Power [HP][US]) [9]
 - Motor voltage [V] (Motor voltage [V]) [11]
 - DC link voltage [V] (DC link voltage [V]) [12]
 - Thermal load motor [%] (Motor thermal [%]) [13]
 - Thermal load [%] (FC. thermal[%]) [14]
 - Running hours [Hours] (RUNNING HOURS) [15]
 - Digital input [Bin] (Digital input[bin]) [16]
 - Analog input 53 [V] (analog input 53 [V]) [17]

- Analog input 60 [mA] (analog input 60 [mA]) [19]
- Pulse reference [Hz] (Pulse ref. [Hz]) [20]
- External reference [%] (external ref. [%]) [21]
- Status word [Hex] (Status word [hex]) [22]
- Heatsink temperature [°C] (Heatsink temp [°C]) [25]
- Alarm word [Hex] (Alarm word [hex]) [26]
- Control word [Hex] (Control word [Hex]) [27]
- Warning word [Hex] (warning word [Hex]) [28]
- Extended status word [Hex] (Ext. status [hex]) [29]
- Communication option card warning (COMM OPT WARN [HEX]) [30]
- Pulse count (PULSE COUNTER) [31]
- Power [W] (POWER [W]) [32]

Function:

Use this parameter to select the data value to display in the LCP 2 control unit display line 2 when the frequency converter is switched on. The display is also included in the scrollbar in display mode. Use *parameters 010-012 Display readout* to select 3 more data values, which are displayed in display line 1.

Description of choice:

No readout can only be selected in *parameters 010-012 Small display readout*.
Resulting reference [%] gives, as a percentage, the resulting reference in the range from Minimum reference, Ref_{MIN} to Maximum reference, Ref_{MAX}.
Reference [unit] gives the resulting reference with unit Hz in *Open loop*. In *Closed loop*, the reference unit is selected in *parameter 416 Process units*.
Feedback [unit] gives the resulting signal value using the unit/scaling selected in *parameter 414 Minimum feedback, FB_{LOW}*, *415 Maximum feedback, FB_{HIGH}* and *416 Process units*.
Frequency [Hz] gives the output frequency of the frequency converter.
Output frequency x scaling [-] equals the present output frequency f_M multiplied by the factor set in *parameter 008 Display scaling of output frequency*.
Motor current [A] gives the phase current of the motor measured as an effective value.
Torque [%] denotes the motor's present load in relation to the motor's rated torque.
Power [kW] gives the present power that the motor is absorbing in kW.
Power [HP] gives the present power that the motor is absorbing in HP.
Motor voltage [V] gives the voltage supplied to the motor.

DC link voltage [V] gives the intermediate circuit voltage of the frequency converter.

Thermal load motor [%] gives the calculated/estimated load on the motor. 100 % is the cut-out limit.

Thermal load [%] gives the calculated/estimated thermal load on the frequency converter. 100 % is the cut-out limit.

Running hours [Hours] gives the number of hours that the motor has run since the last reset in *parameter 619 Reset of running hours counter*.

Digital input [Binary code] gives the signal status from the 5 digital inputs (18, 19, 27, 29 and 33). Terminal 18 corresponds to the bit on the extreme left. `0`=no signal, `1`=signal connected.

Analog input 53 [V] gives the voltage value of terminal 53.

Analog input 60 [mA] gives the present value of terminal 60.

Pulse reference [Hz] gives the reference in Hz connected to terminal 33.

External reference [%] gives the sum of external references as a percentage (sum of analog/pulse/serial communication) in the range from Minimum reference, Ref_{MIN} to Maximum reference, Ref_{MAX}.

Status word [Hex] gives one or several status conditions in a hex code. See *chapter 4.7 Serial communication* for further information.

Heat sink temp.[°C] gives the present heat sink temperature of the frequency converter. The cut-out limit is 90-100 °C, while cutting back in occurs at 70 ±5 °C.

Alarm word [Hex] gives one or several alarms in hex code. See *chapter 4.7 Serial communication* for further information.

Control word [Hex] gives the control word for the frequency converter. See *chapter 4.8 Serial Communication Parameters* for further information.

Warning word [Hex] gives one or several warnings in hex code. See *chapter 4.8 Serial Communication Parameters* for further information.

Extended status word [Hex] gives one or several status modes in hex code. See *chapter 4.7 Serial communication* for further information.

Communication option card warning [Hex] gives a warning word if there is a fault in the communication bus. Only active if communication options are installed.

If there are no communication options, 0 hex is displayed. *Pulse count* gives the number of pulses that the unit has registered.

Power [W] gives the present power that the motor is absorbing in W.

010 Small display line 1.1

Value:

See *par. 009 Large display readout* * Analog input 53 [V] [17]

Function:

In this parameter, the first of 3 data values can be selected that is to be displayed in the LCP control unit display, line 1, position 1. This is a useful function, e.g. when setting

the PID regulator, as it gives a view of process reactions to reference changes. Press [Display Status] to activate the display readout.

Description of choice:

See *parameter 009 Large display readout*.

011 Small display readout 1.2

Value:

See *parameter 009 Large display readout* * Motor current [A] [6]

Function:

See the functional description given in *parameter 010 Small display readout*.

Description of choice:

See *parameter 009 Large display readout*.

012 Small display readout 1.3

Value:

See *parameter 009 Large display readout* * Feedback [unit] [3]

Function:

See the functional description given under *parameter 010 Small display readout*.

Description of choice:

See *parameter 009 Large display readout*.

013 Local control

Value:

- Local not active (DISABLE) [0]
- Local control and open loop without slip compensation (LOC CTRL/OPEN LOOP) [1]
- Remote-operated control and open loop without slip compensation (LOC+DIG CTRL) [2]
- Local control as *parameter 100 Configuration* (LOC CTRL/AS P100) [3]
- * Remote-operated control as *parameter 100 Configuration* (LOC+DIG CTRL/AS P100) [4]

Function:

This is where the required function is selected if [1] *Local operation* has been selected in Parameter 002.

Description of choice:

If [0] *Local not active* is selected, it is not possible to set a reference via *parameter 003 Local reference*.

To enable a shift to [0] *Local not active*, set *parameter 002 Local/remote operation* to [0] *Remote operation*.

Select [1] *Local control and open loop* if the motor speed is to be set via *parameter 003 Local reference*. When this selection is made, *parameter 100 Configuration* automatically shifts to [0] *Speed regulation, open loop*.

[2] *Remote-operated control and open loop* functions in the same way as [1] *Local control and open loop*; however, the

adjustable frequency drive can also be controlled via the digital inputs.

For selections [1-2] control is shifted to open loop, no slip compensation.

[3] *Local control as parameter 100* is used when the motor speed is to be set via *parameter 003 Local reference*, but without *parameter 100 Configuration* automatically shifting to [0] *Speed regulation, open loop*.

[4] *Remote-operated control as parameter 100* works the same way as *Local control as parameter 100* [3]; however, the adjustable frequency drive can also be controlled via the digital inputs.

Shifting from *Remote operation* to *Local operation* in *parameter 002 Local/remote operation*, while this parameter has been set to [1] *Remote-operated control and open loop*: The present motor frequency and direction of rotation is maintained. If the present direction of rotation does not respond to the reversing signal (negative reference), the reference is set to 0.

Shifting from *Local operation* to *Remote operation* in *parameter 002 Local/remote control*, while this parameter is set to [1] *Remote-operated control and open loop*: The configuration selected in *parameter 100 Configuration* is active. The shift is smooth.

Shifting from *Remote control* to *Local control* in *parameter 002 Local/remote operation*, while this parameter has been set to [4] *Remote-operated control as parameter 100*: The present reference is maintained. If the reference signal is negative, the local reference is set to 0.

Shifting from *Local operation* to *Remote operation* in *parameter 002 Local/remote operation*, while this parameter has been set to *Remote operation*: The local reference is replaced by the remote-operated reference signal.

014 Local stop

Value:

Not active (DISABLE) [0]

* Active (ENABLE) [1]

Function:

In this parameter, the local [STOP]-key can be engaged or disengaged on the control panel and on the LCP control panel.

Description of choice:

If *Not active* [0] is selected in this parameter, the [STOP]-key is inactive.

⚠ WARNING

If [0] *Not active* is selected, the motor cannot be stopped with the [STOP]-key. Failure to stop the frequency converter immediately can lead to equipment damage or personal injury in some cases.

015 Local jog

Value:

* Not active (DISABLE) [0]

Active (ENABLE) [1]

Function:

In this parameter, the jog function on the LCP control panel can be engaged/disengaged.

Description of choice:

If [0] *Not active* is selected in this parameter, the [JOG]-key is inactive.

016 Local reversing

Value:

* Not active (DISABLE) [0]

Active (ENABLE) [1]

Function:

Use this parameter to select/deselect the reversing function on the LCP. The key can only be used if *parameter 002 Local/remote operation* is set to [1] *Local operation* and *parameter 013 Local control* to [1] *Local control, open loop* or [3] *Local control as parameter 100 Configuration*.

Description of choice:

If [0] *Disable* is selected in this parameter, the [FWD/REV] key is disabled. See also *parameter 200 Output frequency range*.

017 Local reset of trip

Value:

Not active (DISABLE) [0]

* Active (ENABLE) [1]

Function:

Use this parameter to engage or disengage the reset function on the control panel.

Description of choice:

If [0] *Not active* is selected in this parameter, the reset function is inactive.

NOTICE

Select [0] *Not active*, only if an external reset signal has been connected via the digital inputs.

018 Lock for data changes

Value:

- * Not locked (NOT LOCKED) [0]
- Locked (LOCKED) [1]

Function:

In this parameter, it is possible to 'lock' the controls to disable data changes via the control keys.

Description of choice:

If [1] *Locked* is selected, data changes in the parameters cannot be made; however, it is still possible to make data changes via serial communication. *Parameters 009-012 Display readout* can be changed via the control panel.

019 Operating mode at power-up, local operation

Value:

- Auto restart, use saved reference (AUTO RESTART) [0]
- * Forced stop, use saved reference (LOCAL=STOP) [1]
- Forced stop, set ref. to 0 (LOCAL=STOP, REF=0) [2]

Function:

Setting of the required operating mode when the mains voltage is engaged. This function can only be active if [1] *Local operation* has been selected in *parameter 002 Local/remote operation*.

Description of choice:

[0] *Auto restart, use saved ref.* is selected if the adjustable frequency drive is to start using the local reference (set in *parameter 003 Local reference*) and the start/stop state given via the control keys immediately before the mains voltage being cut out.

[1] *Forced stop, use saved ref.* is selected if the adjustable frequency drive is to remain stopped when the mains voltage is engaged, until the [START]-key is activated. After a start command, the motor speed is ramped up to the saved reference in *parameter 003 Local reference*.

[2] *Forced stop, set ref. to 0* is selected if the adjustable frequency drive is to remain stopped when the mains voltage is cut back in. *Parameter 003 Local reference* is to be zeroed.

CAUTION

In remote operation (*parameter 002 Local/remote operation*) the start/stop state at the time of mains connection depends on the external control signals. If [8] *Pulse start* is selected in *parameter 302 Digital input*, the motor remains stopped after mains connection.

020 Hand operation

Value:

- * Not active (DISABLE) [0]
- Active (ENABLE) [1]

Function:

Use this parameter to select whether it should be possible or not to switch between Auto- and Hand mode. In Auto mode, the adjustable frequency drive is controlled by external signals. In Hand mode, the frequency converter is controlled via a local reference directly from the control unit.

Description of choice:

If [0] *Not active* is selected in this parameter, the Hand mode function is inactive. Select [1] *Active* to switch between Auto- and Hand mode. For further information, see *chapter 1.12.1 Control Unit*.

024 Userdefined Quick Menu

Value:

- * Not active (Disable) [0]
- Active (Enable) [1]

Function:

Use this parameter to select the standard setup of the [Quick Menu] key on the control panel and the LCP 2 control panel.

Using this function, in *parameter 025 Quick Menu setup*, the user can select up to 20 parameters for the [Quick Menu] key.

Description of choice:

If [0] *not active* is selected, the standard setup of the Quick Menu is active.

If [1] *Active* is selected, the user-defined Quick Menu is active.

025 Quick Menu setup

Value:

[Index 1 - 20] Value: 0 - 999 * 000

Function:

Use this parameter to define which parameters are required in the Quick Menu when *parameter 024 User-defined Quick Menu* is set to [1] *Active*. Up to 20 parameters can be selected for the user-defined Quick Menu.

Description of choice:

The Quick Menu is set up as follows:

1. Select *parameter 025 Quick Menu setup* and press [CHANGE DATA].
2. Index 1 indicates the first parameter in Quick Menu. Press [+]/[-] to scroll between the index numbers. Select Index 1.
3. Press [<]/[>] to scroll between the 3 figures. Press the [<] key once ad the last number in the

parameter number can be selected by pressing [+]/[-].

Set Index 1 to 100 for *parameter 100 Configuration*.

4. Press [OK] when Index 1 has been set to 100.
5. Repeat steps 2 - 4 until all parameters required have been set in the Quick Menu.
6. Press [OK] to complete the Quick Menu setup.

If *parameter 100 Configuration* is selected at Index 1, the Quick Menu starts with this parameter every time Quick Menu is activated.

Note that *parameter 024 User-defined Quick Menu* and *parameter 025 Quick Menu setup* are reset to the factory setting during initialisation.

NOTICE

Parameter 025 Quick Menu setup can only be set using an LCP 2 control panel. See *chapter 1.8 Order Form* for information about LCP 2 control panel.

4.2 Load and Motor

4.2.1 Configuration

Selection of configuration and torque characteristics has an effect on which parameters can be seen in the display. If [0] *Open loop* is selected, all parameters relating to PID regulation is filtered out. This means that the user only sees the parameters that are relevant for a given application.

100 Configuration

Value:

- * Speed control, open loop (SPEED OPEN LOOP) [0]
- Speed control, closed loop (SPEED CLOSED LOOP) [1]
- Process control, closed loop (PROCESS CLOSED LOOP) [3]

Function:

This parameter is used to select the configuration to which the frequency converter is to be adapted. This makes adaptation to a given application simple, since the parameters not used in a given configuration are hidden (not active).

Description of choice:

If [0] *Speed control, open loop* is selected, normal speed control is obtained (without feedback signal) with automatic load and slip compensation to ensure a constant speed at varying loads. Compensations are active, but may be disabled in *parameter 134 Load compensation* and *parameter 136 Slip compensation* as required.

If [1] *Speed control, closed loop* is selected, better speed accuracy is obtained. Add feedback signal, and set the PID regulator in parameter group 400 *Special functions*.

If [3] *Process control, closed loop* is selected, the internal process regulator is activated to enable precise control of a process in relation to a given process signal. The process signal can be set to the relevant process unit or as a percentage. Add feedback signal from the process and set the process regulator in parameter group 400 *Special functions*. Process closed loop is not active if a DeviceNet card is mounted and Instance 20/70 or 21/71 is selected in *parameter 904 Instance types*.

101 Torque characteristic

Value:

- * Constant torque (Constant torque) [1]
- Variable torque low (torque: low) [2]
- Variable torque medium (torque: med) [3]
- Variable torque high (torque: high) [4]

- Variable torque low with CT start (VT LOW CT START) [5]
- Variable torque medium with CT start (VT MED CT START) [6]
- Variable torque high with CT start (VT HIGH CT START) [7]
- Special motor mode (Special motor mode) [8]

CT = Constant torque

Function:

Use this parameter to adapt the U/f ratio of the frequency converter to the torque characteristic of the load. See *parameter 135 U/f ratio*.

Description of choice:

If [1] *Constant torque* is selected, a load-dependent U/f characteristic is obtained, in which output voltage and output frequency are increased at increasing loads to maintain constant magnetisation of the motor. Select [2] *Variable torque low*, [3] *Variable torque medium* or [4] *Variable torque high*, if the load is square (centrifugal pumps, fans). Select [5] *Variable torque - low with CT start*, [6] *Variable torque - medium with CT start* or [7] *Variable torque - high with CT start* if a greater breakaway torque is needed than can be achieved with the 3 first characteristics.

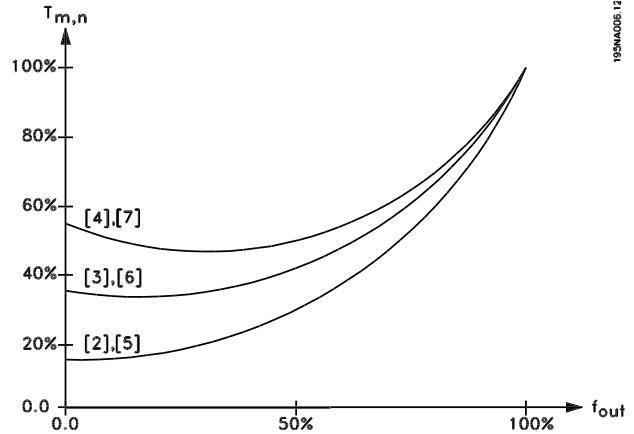

Illustration 4.2 Torque Characteristics

Select [8] *Special motor mode* if a special U/f setting is needed that is to be adapted to the present motor. The break points are set in *parameters 423-428 Voltage/frequency*.

NOTICE

Load and slip compensation are not active if variable torque or special motor mode have been selected.

NOTICE

Note that if a value set in the nameplate parameters 102-106 is changed, there is an automatic change of parameter 108 Stator resistance and parameter 109 Stator reactance.

| 102 | Motor power $P_{M,N}$ |
|------------------|--|
| Value: | 0.25 - 22 kW * Depends on unit |
| Function: | Set a power value [kW] $P_{M,N}$, corresponding to the motor's rated power. The factory sets a rated power value [kW] $P_{M,N}$, that depends on the type of unit. |

Description of choice:
Set a value that matches the nameplate data on the motor. Settings between one size below and one size over the factory setting are possible.

| 103 | Motor voltage $U_{M,N}$ |
|------------------|---|
| Value: | For 200 V units: 50 - 999 V * 230 V For 400 V units: 50 - 999 V * 400 V |
| Function: | Set the rated motor voltage $U_{M,N}$ for either star Y or delta Δ . |

Description of choice:
Select a value that corresponds to the nameplate data on the motor, regardless of the frequency converter's mains voltage.

| 104 | Motor frequency $f_{M,N}$ |
|-------------------------------|---|
| Value: | 24-1000 Hz * 50 Hz |
| Function: | Select the rated motor frequency $f_{M,N}$. |
| Description of choice: | Select a value that corresponds to the nameplate data on the motor. |

| 105 | Motor current $I_{M,N}$ |
|---------------|---|
| Value: | 0,01 - I_{MAX} * Depends on choice of motor |

Function:
The nominal, rated current of the motor $I_{M,N}$ forms part of the frequency converter calculation of features such as torque and motor thermal protection.

Description of choice:
Set a value that corresponds to the nameplate data on the motor. Set the motor current $I_{M,N}$ taking into account whether the motor is star-connected Y or delta-connected Δ .

| 106 | Rated motor speed |
|---------------|--|
| Value: | 100 - $f_{M,N} \times 60$ (max.) * Depends on parameter 104 Motor frequency, $f_{M,N}$ 60000 rpm) |

Function:
Set the value that corresponds to the rated motor speed $n_{M,N}$ that can be seen from the nameplate data.

Description of choice:
Select a value that corresponds to the nameplate data on the motor.

NOTICE

The maximum value equals $f_{M,N} \times 60$. $f_{M,N}$ to be set in parameter 104 Motor frequency, $f_{M,N}$.

| 107 | Automatic motor tuning, AMT |
|------------------|---|
| Value: | * Optimisation off (AMT off) [0] Optimisation on (AMT start) [2] |
| Function: | Automatic motor tuning is an algorithm that measures stator resistance R_s without the motor axle turning. This means that the motor is not delivering any torque. AMT can be used for optimising adjustment of the frequency converter to the motor being used. This is used in particular when the factory setting does not sufficiently cover the motor. |

Automatic motor tuning is an algorithm that measures stator resistance R_s without the motor axle turning. This means that the motor is not delivering any torque. AMT can be used for optimising adjustment of the frequency converter to the motor being used. This is used in particular when the factory setting does not sufficiently cover the motor.

For the best possible tuning of the frequency converter, it is recommended that AMT is performed on a cold motor. Note that repeated AMT runs can cause heating of the motor, resulting in an increase in the stator resistance R_s . As a rule, however, this is not critical.

AMT is performed as follows:

Start AMT:

1. Give a STOP signal.
2. Parameter 107 Automatic motor tuning is set at value [2] Optimisation on.
3. A START signal is given and parameter 107 Automatic motor tuning is reset to [0] Optimisation off when AMT has been completed.

Complete AMT:

AMT is completed by giving a RESET signal. *Parameter 108 Stator resistance, R_S* is updated with the optimised value.

Interrupting AMT:

AMT can be interrupted during the optimisation procedure by giving a STOP signal.

When using the AMT function the following points should be observed:

- For AMT to be able to define the motor parameters as well as possible, enter the correct name plate data for the motor connected to the frequency converter in *parameters 102 to 106*.
- Alarms appear in the display if faults arise during tuning of the motor.
- As a rule the AMT function is able to measure the R_S values for motors that are 1-2 times larger or smaller than the frequency converter's nominal size.
- Press the [STOP/RESET] key to interrupt automatic motor tuning.

Description of choice:

Select [2] *Optimisation on* to perform automatic motor tuning.

NOTICE

AMT is not possible on VLT 2880-82.

WARNING

Do not perform AMT on motors connected in parallel. Do not make set-up changes while AMT is running. There is a risk of equipment damage and personal injury.

108 Stator resistance R_S

Value:

0.000 - X.XXX Ω * Depends on choice of motor

Function:

After setting of *parameters 102-106 Nameplate data*, a number of adjustments of various parameters is carried out automatically, including stator resistance R_S. A manually entered R_S must apply to a cold motor. The shaft performance can be improved by fine-tuning R_S and X_S, see procedure below.

Description of choice:

R_S can be set as follows:

1. Use the factory settings of R_S which the frequency converter selects on the basis of the motor nameplate data.
2. The value is stated by the motor supplier.
3. The value is obtained through manual measurements: R_S can be calculated by

measuring the resistance R_{PHASE-PHASE} between 2 phase terminals. Where R_{PHASE-PHASE} is lower than 1-2 Ohms (typical for motors > 5.5 kW, 400 V), a special Ohm-meter should be used (Thomson-bridge or similar). $R_S = 0.5 \times R_{PHASE-PHASE}$.

4. R_S is set automatically when AMT has been completed. See *parameter 107 Auto motor adaption*.

NOTICE

Parameters 108 Stator resistance R_S and 109 Stator reactance X_S are normally not to be changed if nameplate data has been set.

109 Stator reactance X_S

Value:

0.00 - X,XX Ω * Depends on choice of motor

Function:

After setting of *parameters 102-106 Nameplate data*, a number of adjustments of various parameters are made automatically, including stator reactance X_S. The shaft performance can be improved by fine-tuning R_S and X_S, see procedure below.

Description of choice:

X_S can be set as follows:

1. The value is stated by the motor supplier.
2. The value is obtained through manual measurements X_S is obtained by connecting a motor to mains and measuring the phase-phase voltage U_M and the idle current I_φ.

$$X_S = \frac{U_M}{\sqrt{3} \times I_\phi} - \frac{X_L}{2}$$

X_L: See parameter 142.

3. Use the factory settings of X_S which the frequency converter selects on the basis of the motor nameplate data.

117 Resonance damping

Value:

OFF - 100% [OFF - 100]

* OFF % [OFF]

Function:

It is possible to optimise the resonance damping in CT mode. The grade of the influence is adjusted in this parameter.

The value may be set between 0% (OFF) and 100%. 100% corresponds to 50% reduction of U/F ratio.

Default value is OFF.

Internal settings (fixed):

The resonance filter is active from 10% of nominal speed and above.

In this case 5Hz and above.

Speed to go from 0 to nominal flux level: 500ms

Speed to go from nominal to 0 flux level: 500ms

Description of functionality:

The filter monitors the active motor current and changes the motor voltage according to *Illustration 4.3*. The filter reacts on levels referring to the nominal motor current.

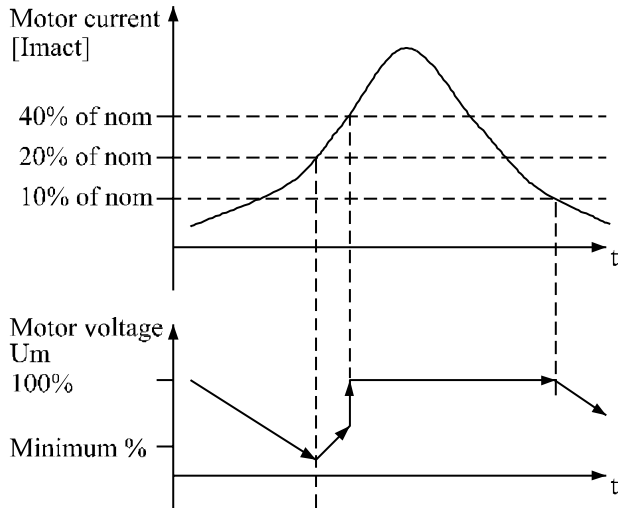

175NA105.10

Illustration 4.3 Resonance Damping

If the active motor current is below 10%, the motor voltage is decreased by the speed mentioned above until the voltage reaches the setting for *Parameter 117 Resonance damping*. If the active motor current exceeds 20%, the voltage is increased by the above mentioned speed. If the active motor current reaches 40%, the motor voltage is increased immediately to normal motor voltage. The reduction in motor voltage depends on the *parameter 117 Resonance damping* setting.

Description of choice:

Set the grade of motor current [I_{mact}] influence on the U/F ratio between 0% (OFF) and 100%. 100% corresponds to 50% reduction of U/F ratio. Default value is OFF.

119 High start torque

Value:

0.0 - 0.5 s * 0.0 s

Function:

To ensure a high start torque approx. $1.8 \times I_{INV}$ can be permitted for max. 0.5 s. The current is, however, limited by the frequency converter's (inverter's) safety limit. 0 s corresponds to no high start torque.

Description of choice:

Set the necessary time for which a high start torque is required.

120 Start delay

Value:

0.0 - 10.0 s * 0.0 s

Function:

This parameter enables a delay of the start-up time after the conditions for start have been fulfilled. When the time has passed, the output frequency starts by ramping up to the reference.

Description of choice:

Set the necessary time before commencing to accelerate.

121 Start function

Value:

DC hold during start delay time (DC HOLD/DELAY TIME) [0]

DC brake during start delay time (DC BRAKE/DELAY TIME) [1]

* Coasting during start delay time (COAST/DELAY TIME) [2]

Start frequency/voltage clockwise (CLOCKWISE OPERATION) [3]

Start frequency/voltage in reference direction (VERTICAL OPERATION) [4]

Function:

Select the required mode during the start delay time (*parameter 120 Start delay time*).

Description of choice:

Select [0] *DC hold during start delay time* to energise the motor with a DC hold voltage during the start delay time. Set voltage in *parameter 137 DC hold voltage*.

Select [1] *DC brake during start delay time* to energise the motor with a DC brake voltage during the start delay time. Set voltage in *parameter 132 DC brake voltage*.

Select [2] *Coasting during start delay time* and the motor is not controlled by the adjustable frequency drive during the start delay time (inverter turned off).

Select [3] *Start frequency/voltage clockwise* to obtain the function described in *parameters 130 Start frequency* and *131 Voltage at start* during start delay time. Regardless of the value assumed by the reference signal, the output frequency equals the setting in *parameter 130 Start frequency* and the output voltage corresponds to the setting in *parameter 131 Voltage at start*.

This functionality is typically used in hoist applications. It is particularly used in applications in which a cone anchor motor is applied, where the direction of rotation is to start clockwise followed by the reference direction.

Select [4] *Start frequency/voltage in reference direction* to obtain the function described in *parameters 130 Start frequency* and *131 Voltage at start* during the start delay time.

The direction of rotation of the motor always follows in the reference direction. If the reference signal equals 0, the output frequency equals 0 Hz, while the output voltage corresponds to the setting in *parameter 131 Voltage at start*. If the reference signal is different from zero, the

output frequency equals *parameter 130 Start frequency* and the output voltage is equal to *parameter 131 Voltage at start*. This functionality is used typically for hoist applications with counterweight. It is particularly used in for applications in which a cone anchor motor is applied. The cone anchor motor can break away using *parameter 130 Start frequency* and *parameter 131 Voltage at start*.

| 122 Function at stop | |
|----------------------|-----|
| Value: | |
| * Coasting (COAST) | [0] |
| DC hold (DC HOLD) | [1] |
| Function: | |

Select the function of the frequency converter after the output frequency has become lower than the value in *parameter 123 The min. frequency for activation of function at stop* or after a stop command and when the output frequency has been ramped down to 0 Hz.

Description of choice:
 Select [0] *Coasting* if the frequency converter is to 'let go' of the motor (inverter turned off).
 Select [1] *DC hold* if *parameter 137 DC hold voltage* is to be activated.

| 123 Min. frequency for activation of function at stop | |
|---|----------|
| Value: | |
| 0,1-10 Hz | * 0,1 Hz |
| Function: | |

In this parameter, the output frequency is set at which the function selected in *parameter 122 Function at stop* is to be activated.

Description of choice:
 Set the required output frequency.
 If *parameter 123* is set too high, and DC hold has been select in *parameter 122*, the output frequency jumps to the value in *parameter 123* without ramping up. This may cause an overcurrent warning / alarm.

NOTICE

If *parameter 123* is set higher than *parameter 130*, then the start delay function (*parameters 120 and 121*) is skipped.

CAUTION

If *parameter 123* is set too high, and DC hold is selected in *parameter 122*, the output frequency jumps to the value in *parameter 123* without ramping up. This may cause an overcurrent warning or alarm.

During DC braking DC voltage is supplied to the motor, and this causes the shaft to be brought to a standstill. In *parameter 132 DC brake voltage* DC brake voltage can be preset from 0-100%. Max. DC brake voltage depends on the motor data selected.

In *parameter 126 DC braking time* DC braking time is determined, and in *parameter 127 DC brake cut-in frequency* the frequency at which DC braking becomes active is selected. If a digital input is programmed to [5] *DC braking inverse* and shifts from logic '1' to logic '0', DC braking is activated. When a stop command becomes active, DC braking is activated when the output frequency is less than the brake cut-in frequency.

WARNING

Do not use DC braking if the inertia in the motor shaft is more than 20 times greater than the motor's internal inertia.

| 126 DC brake time | |
|-------------------|--------|
| Value: | |
| 0 - 60 s | * 10 s |
| Function: | |

In this parameter, the DC brake time is set at which *parameter 132 DC brake voltage* is to be active.

Description of choice:
 Set the required time.

| 127 DC brake cut-in frequency | |
|---|-------|
| Value: | |
| 0.0 (OFF) - par. 202 | * OFF |
| <i>Output frequency high limit, f_{MAX}</i> | |
| Function: | |

In this parameter, the DC brake cut-in frequency is set at which the DC brake is to be activated in connection with a stop command.

Description of choice:
 Set the required frequency.

| 128 Thermal motor protection | |
|--------------------------------------|------|
| Value: | |
| * No protection (NO PROTECTION) | [0] |
| Thermistor warning (THERMISTOR WARN) | [1] |
| Thermistor trip (THERMISTOR TRIP) | [2] |
| ETR warning 1 (ETR WARNING 1) | [3] |
| ETR trip 1 (ETR TRIP 1) | [4] |
| ETR warning 2 (ETR WARNING 2) | [5] |
| ETR trip 2 (ETR TRIP 2) | [6] |
| ETR warning 3 (ETR WARNING 3) | [7] |
| ETR trip 3 (ETR TRIP 3) | [8] |
| ETR warning 4 (ETR WARNING 4) | [9] |
| ETR trip 4 (ETR TRIP 4) | [10] |
| Function: | |

The frequency converter can monitor the motor temperature in 2 different ways:

- Via a PTC thermistor that is mounted on the motor. The thermistor is connected between terminal 50 (+10 V) and one of the digital input terminals 18, 19, 27 or 29. See *parameter 300 Digital inputs*.
- Thermal load calculation (ETR - Electronic Thermal Relay), based on present load and time. This is compared with the rated motor current $I_{M,N}$ and rated motor frequency $f_{M,N}$. The calculations take into account the need for lower loading at low speeds due to the motor's internal ventilation being reduced.

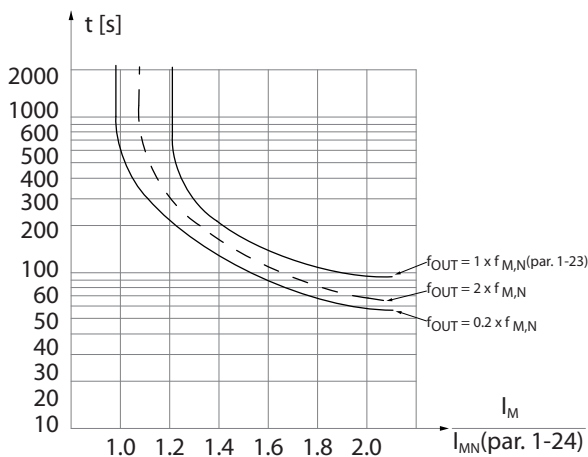

Illustration 4.4 Thermal Load Calculation

ETR functions 1-4 do not begin to calculate the load until the set-up in which they have been selected is activated. This means that the ETR function can be used even when changing between 2 or more motors.

Description of choice:

Select [0] *No protection* to disable a warning or trip when a motor is overloaded.

Select [1] *Thermistor warning* to activate a warning when the connected thermistor becomes too hot.

Select [2] *Thermistor trip* to activate a trip when the connected thermistor becomes too hot.

Select *ETR warning 1-4* to enable a warning when the motor is overloaded according to the calculations. It is possible to programme the frequency converter to give a warning signal via one of the digital outputs. Select *ETR Trip 1-4* to activate a trip when the motor is overloaded according to the calculations.

⚠ WARNING

This function cannot protect the individual motors in the case of motors linked in parallel.

130 Start frequency

Value:
0.0 - 10.0 Hz * 0.0 Hz

Function:

The start frequency is active for the time set in *parameter 120 Start delay*, after a start command. The output frequency jumps to the next preset frequency. Certain motors, such as conical anchor motors, need an extra voltage/start frequency (boost) at start to disengage the mechanical brake. To achieve this, *parameters 130 Start frequency* and *131 Initial voltage* are used.

Description of choice:

Set the required start frequency. It is a precondition that *parameter 121 Start function*, is set to [3] *Start frequency/voltage clockwise* or [4] *Start frequency/voltage in reference direction* and that a time is set and a reference signal is present in *parameter 120 Start delay*.

NOTICE

If *parameter 123* is set higher than *parameter 130*, the start delay function (*parameter 120 and 121*) is skipped.

131 Initial voltage

Value:
0.0 - 200.0 V * 0.0 V

Function:

Initial voltage is active for the time set in *parameter 120 Start delay*, after a start command. This parameter can be used for example for lifting/dropping applications (conical anchor motors).

Description of choice:

Set the required voltage necessary to cut out the mechanical brake. It is assumed that *parameter 121 Start function*, is set to [3] *Start frequency/voltage clockwise* or [4] *Start frequency/voltage in reference direction* and that in *parameter 120 Start delay* a time is set, and that a reference signal is present.

132 DC brake voltage

Value:
0 - 100% of max. DC brake voltage * 0%

Function:

Use this parameter to set the DC brake voltage at which the frequency converter brakes. This parameter is valid when the DC brake cut-in frequency is reached, or when *DC braking inverse* is activated via a digital input or serial communication. The DC brake cut-in frequency is set in *parameter 127 DC brake cut-in frequency*. The DC brake voltage is active for the time set in *Parameter 126 DC brake time* sets the duration during which the DC brake voltage is active.

Description of choice:

To be set as a percentage value of the maximum DC brake voltage, which depends on the motor.

133 Start voltage

Value:

0.00-100.00 V * Depends on unit

Function:

A higher start torque can be obtained by increasing the start voltage. Small motors (< 1.0 kW) normally require a high start voltage.

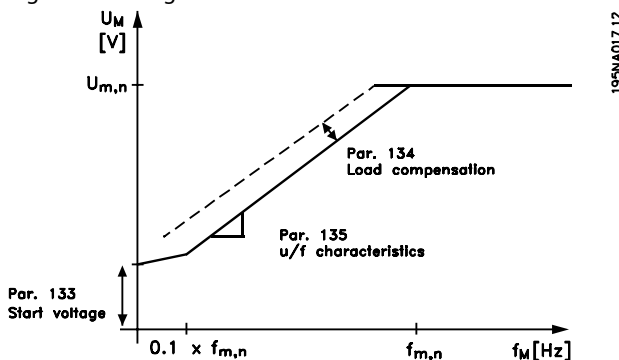

Illustration 4.5 Start Voltage and Torque

Description of choice:

The factory setting is suitable for most applications. The value may need to be increased gradually for high torque applications.

⚠ WARNING

If the use of start voltage is exaggerated, this may lead to overenergising and overheating of the motor, and the frequency converter may cut out.

134 Load compensation

Value:

0.0-300.0% * 100.0%

Function:

Use this parameter to set the load characteristic. By increasing the load compensation, the motor is given an extra voltage and frequency supplement at increasing loads. This is used e.g. in motors/applications in which there is a big difference between the full-load current and idle-load current of the motor.

Description of choice:

If the factory setting is not adequate, set load compensation to enable the motor to start at the given load.

⚠ WARNING

If this value is set too high, the frequency converter may cut out because of overcurrent.

⚠ WARNING

Set to 0% if the frequency converter is connected with synchronous and parallel-coupled motors and in the case of quick load changes. Too high load compensation may lead to instability.

135 U/f-ratio

Value:

0.00-20.00 at Hz * Depends on unit

Function:

This parameter enables a shift in the ratio between output voltage (U) and output frequency (f) linearly, to ensure correct energising of the motor and thus optimum dynamics, accuracy and efficiency. The U/f-ratio only affects the voltage characteristic if a selection has been made of [1] Constant torque parameter 101 Torque characteristic.

Description of choice:

The U/f-ratio is only to be changed if it is not possible to set the correct motor data in parameters 102-109. The value programmed in the factory settings is based on idle operation.

136 Slip compensation

Value:

-500 - +500% of rated slip compensation * 100%

Function:

Slip compensation is calculated automatically, on the basis of data as the rated motor speed $n_{M,N}$. In this parameter, the slip compensation can be fine-tuned, thereby compensating for tolerances on the value for $n_{M,N}$. Slip compensation is only active if a selection has been made of [0] Speedregulation, open loop in parameter 100 Configuration and [1] Constant torque in parameter 101 Torque characteristic.

Description of choice:

Enter a % value.

137 DC hold voltage

Value:

0-100% of max. DC hold voltage * 0%

Function:

This parameter is used to keep the motor (holding torque) at start/stop.

Description of choice:

This parameter can only be used if a selection has been made of DC hold in parameter 121 Start function or 122 Function at stop. To be set as a percentage value of the max. DC hold voltage, which depends on the choice of motor.

138 Brake cut out value**Value:**

0.5 - 132.0/590.0 Hz * 3.0 Hz

Function:

Select the frequency at which the external brake is released, via the output defined in *parameter 323 Relay output 1-3* or *341 Digital output, terminal 46*.

Description of choice:

Set the required frequency.

139 Brake cut in frequency**Value:**

0.5 - 132.0/590.0 Hz * 3.0 Hz

Function:

Select the frequency at which the external brake is activated; this takes place via the output defined in *parameter 323 Relay output 1-3* or *parameter 341 Digital output terminal 46*.

Description of choice:

Set the required frequency.

140 Current, minimum value**Value:**

0 % - 100 % of inverter output current * 0 %

Function:

Select the minimum motor current running for the mechanical brake to be released. Current monitoring is only active from stop until the point when the brake is released.

Description of choice:

This is an extra safety precaution, aimed at guaranteeing that the load is not lost during start of a lifting/lowering operation.

142 Leakage reactance X_L **Value:**

0.000 - * Depends on choice of motor
XXX,XXX Ω X_L is sum of rotor and stator leakage reactance.

Function:

After setting of *parameters 102-106 Nameplate data*, a number of adjustments of various parameter is made automatically, including the leakage reactance X_L . The shaft performance can be improved by fine-tuning the leakage reactance X_L .

Description of choice:

X_L can be set as follows:

- The value is stated by the motor supplier.
- Use the factory settings of X_L which the frequency converter itself chooses on the basis of the motor nameplate data.

NOTICE

Do not change *parameter 142 The leakage reactance X_L* if the nameplate data is set in *parameters 102-106*.

143 Internal fan control**Value:**

- * Automatic (automatic) [0]
- Always switched on (always on) [1]
- Always switched off (always off) [2]

Function:

This parameter can be set so that the internal fan is automatically switched on and off. It is also possible to set the internal fan to be permanently switched on or off.

Description of choice:

If [0] *Automatic* is selected, the internal fan is switched on or off depending on the ambient temperature and the loading of the frequency converter.

If [1] *Always switched on* or [2] *Always switched off* is selected, the internal fan is permanently switched on or off.

CAUTION

If [2] *Always switched off* is selected with high switch frequency, long motor cables or high output power, the life span of the frequency converter is reduced.

144 Gain AC brake**Value:**

1.00 - 1.50 * 1.30

Function:

This parameter is used to set the AC brake. Using *parameter 144* it is possible to adjust the size of the generator torque that can be applied to the motor without the intermediate circuit voltage exceeding the warning level.

Description of choice:

The value is increased if a higher possible brake torque is required. If 1.0 is selected, this corresponds to the AC brake being inactive.

WARNING

If the value in *parameter 144* is increased, the motor current simultaneously increases significantly when generator loads are applied. The parameter should therefore only be changed if it is guaranteed during measurement that the motor current in all operating situations does not exceed the maximum permitted current in the motor. The current cannot be read out from the display.

146 Reset voltage vector**Value:**

| | |
|---------------|-----|
| *Off (OFF) | [0] |
| Reset (RESET) | [1] |

Function:

When the voltage vector is reset it is set to the same starting point each time a new process commences.

Description of choice:

Select [1] Reset when running unique processes each time they arise. This enables repetitive precision when stopping to be improved. Select [0] Off for example for lifting/lowering operations or synchronous motors. It is an advantage that the motor and the frequency converter are always synchronised.

4.3 References & Limits

| 200 | Output frequency range |
|---|------------------------|
| Value: | |
| * Only clockwise, 0-132 Hz (132 Hz CLOCKWISE) | [0] |
| Both directions, 0-132 Hz (132 Hz BOTH DIRECT) | [1] |
| Anti-clockwise only, 0-132 Hz (132 Hz COUNTER CLOCK) | [2] |
| Clockwise only, 0-590 Hz (590 Hz CLOCK WISE) | [3] |
| Both directions, 0-590 Hz (590 Hz BOTH DIRECT) | [4] |
| Anti-clockwise only, 0-590 Hz (590 Hz COUNTER CLOCK) | [5] |

Function:
This parameter guarantees protection against unwanted reversing. Furthermore, the maximum output frequency can be selected that is to apply regardless of the settings of other parameters. This parameter has no function if *Process regulation, closed loop* has been selected in *parameter 100 Configuration*.

Description of choice:
Select the required direction of rotation as well as the maximum output frequency. Note that if [0]/[3] *Clockwise only* or [2]/[5] *Anti-clockwise only* is selected, the output frequency is limited to the range $f_{MIN}-f_{MAX}$. If [1]/[4] *Both directions* is selected, the output frequency is limited to the range $\pm f_{MAX}$ (the minimum frequency is of no significance).

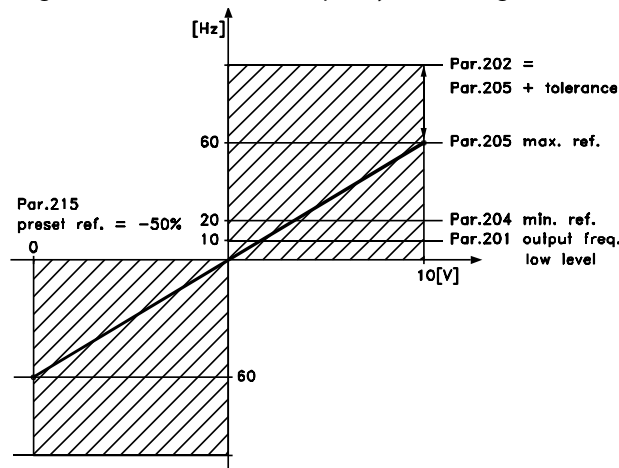

175ZA284.11
Illustration 4.6 Rotation Direction and Output Frequency Range

201 Output frequency low limit, f_{MIN}

Value:
0.0 - f_{MAX} * 0.0 Hz

Function:
In this parameter, a minimum motor frequency limit can be selected that corresponds to the minimum speed at which the motor is allowed to run. If *Both directions* has been selected in *parameter 200 Output frequency range*, the minimum frequency is of no significance.

Description of choice:
The value select can range from 0.0 Hz to the frequency set in *parameter 202 Output frequency high limit, f_{MAX}* .

202 Output frequency high limit, f_{MAX}

Value:
 $f_{MIN} - 132/590$ Hz (par. 200 *Output frequency range*) * 132 Hz

Function:
In this parameter, a maximum output frequency limit can be selected that corresponds to the highest speed at which the motor is allowed to run.

Description of choice:
A value can be selected from f_{MIN} to the value select in *parameter 200 Output frequency range*.

CAUTION

The output frequency of the frequency converter can never assume a value higher than 1/10 of the switching frequency (*parameter 411 Switching frequency*).

Illustration 4.7 shows how a change in one parameter can affect the resulting reference.

Parameters 203 to 205 Reference and *parameter 214 Reference function* define how the handling of references can be performed. The parameters mentioned can be active in both closed and open loop.

Remote controlled references are defined as:

- External references, such as analog inputs 53 and 60, pulse references via terminal 33 and references from serial communication.
- Preset references.

The resulting reference can be shown in the LCP display by selecting *Reference [%]* in *parameters 009-012 Display readout* and can be shown as one unit by selecting *Reference [unit]*. The sum of the external references can be shown in the LCP display as a % of the area from *Minimum reference, Ref_{MIN}* to *Maximum reference, Ref_{MAX}* . Select [25] *External reference, %* in *parameters 009-012 Display readout* if a readout is desired.

It is possible to have both references and external references simultaneously. In *parameter 214 Reference*

function a selection can be made to determine how preset references should be added to the external references.

There is also an independent local reference in *parameter 003 Local reference*, in which the resulting reference is set pressing the [+]/[-] keys. When the local reference has

been selected, the output frequency range is limited by *parameter 201 Output frequency low limit, f_{MIN}* and *parameter 202 Output frequency high limit, f_{MAX}* .

The local reference unit depends on the selection in *parameter 100 Configuration*.

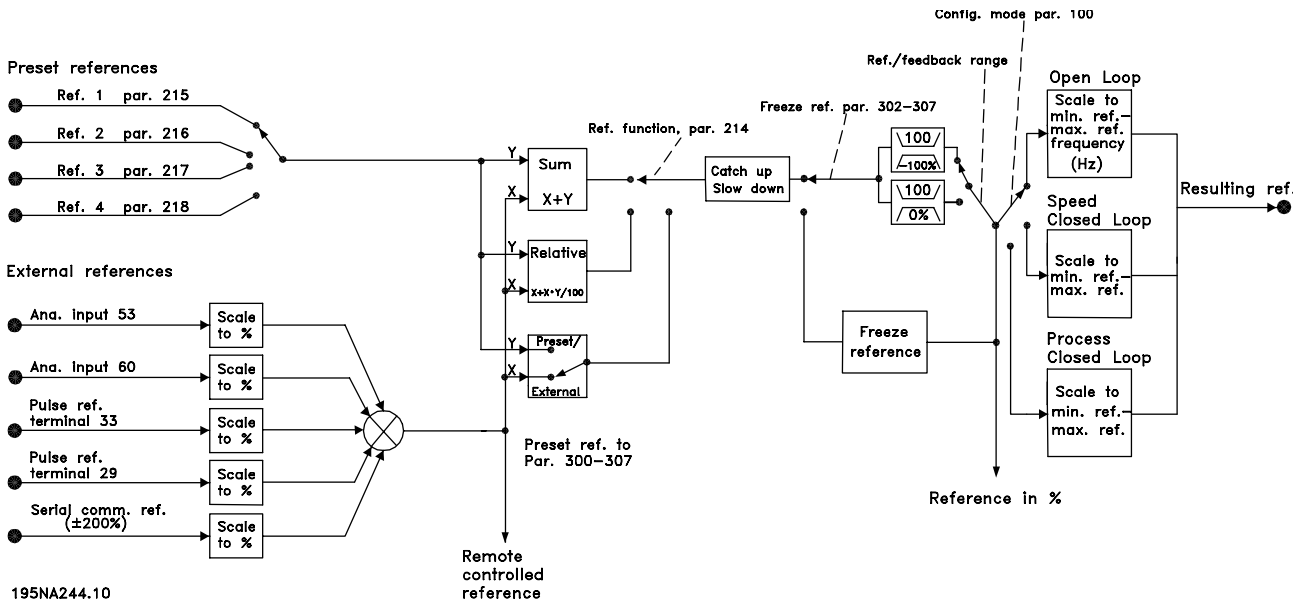

195NA244.10
Illustration 4.7 Reference Handling

| 203 Reference range | |
|--|-----|
| Value: | |
| * Min. reference - Max reference (min - max) | [0] |
| -Max. reference - Max. reference | |
| (-max - +max) | [1] |

Function:
Select whether the reference signal must be positive or whether it can be both positive and negative. The minimum limit may be a negative value, unless a selection has been made of *Speed regulation, closed loop* in *parameter 100 Configuration*. If [3] *Process regulation, closed loop* is selected for *parameter 100 Configuration*, select [0] *Min ref. - Max. ref.*.

Description of choice:
Select the required range.

| 204 Minimum reference, Ref _{MIN} | |
|---|---------------------|
| Value: | |
| Parameter 100 Config. = <i>Open loop</i> | |
| [0].-100,000.000 - par. 205 Ref _{MAX} | * 0.000 Hz |
| Parameter 100 Config. = [1]/[3] <i>Closed loop</i> .Parameter 414 <i>Minimum feedback</i> - | |
| par. 205 Ref _{MAX} | * 0.000 rpm/par 416 |

Function:
Minimum reference is an expression of the minimum possible value of the total of all references. If [1] *Speed regulation, closed loop* or [3] *Process regulation, closed loop*

is selected in *parameter 100 Configuration*, the minimum reference is limited by *parameter 414 Minimum feedback*. Minimum reference is ignored if the local reference is active.
The reference unit is defined in *Table 4.1*.

| Parameter 100 Configuration | Unit |
|-------------------------------------|---------------|
| [0] <i>Open loop</i> | Hz |
| [1] <i>Speed reg, closed loop</i> | RPM |
| [3] <i>Process reg, closed loop</i> | Parameter 416 |

Description of choice:
The minimum reference is preset if the motor has to run at a minimum speed, regardless of whether the resulting reference is 0.

| 205 Maximum reference, Ref _{MAX} | |
|--|----------------------|
| Value: | |
| Parameter 100 Config. = [0] <i>Open loop</i> .Parameter 204 Ref _{MIN} - 590.000 Hz | * 50.000 Hz |
| Parameter 100 Config. = [1]/[3] <i>Closed loop</i> . Parameter 204 Ref _{MIN} - Parameter 415 <i>Max. feedback</i> | * 50.000 rpm/par 416 |

Function:
The maximum reference gives the highest value that can be assumed by the sum of all references. If [1]/[3] *Closed loop* is selected in *parameter 100 Configuration* the

maximum reference cannot exceed the value in *parameter 415 Maximum feedback*.

Maximum reference is ignored if the local reference is active.

The reference unit can be defined from the following table:

| Parameter 100 Configuration | Unit |
|------------------------------|---------------|
| [0] Open loop | Hz |
| [1] Speed reg, closed loop | RPM |
| [3] Process reg, closed loop | Parameter 416 |

Description of choice:

Maximum reference is set, if the speed of the motor is to be max. the set value, regardless of the whether the resulting reference is greater than the maximum reference.

206 Ramp type

Value:

- * Linear (Linear) [0]
- Sin shaped (SIN SHAPED) [1]
- Sin² shaped (S-SHAPED 2) [2]

Function:

Select between a linear, an S-shaped and an S² ramp process.

Description of choice:

Select the required ramp type depending on the required acceleration/deceleration process.

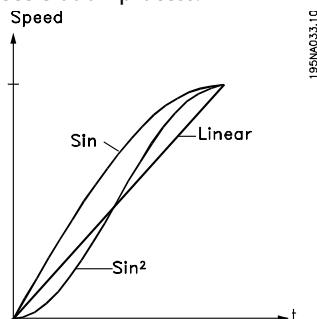

Illustration 4.8 Ramp Type and Acceleration Process

207 Ramp-up time 1

Value:

- 0.02 - 3600.00 s
- * 3.00 s (VLT 2803-2875)
- 10.00 s (VLT 2880-2882)

Function:

The ramp-up time is the acceleration time from 0 Hz to the rated motor frequency $f_{M,N}$ (*parameter 104 Motor frequency, $f_{M,N}$*). It is assumed that the output current does not reach the current limit (set in *parameter 221 Current limit I_{LIM}*).

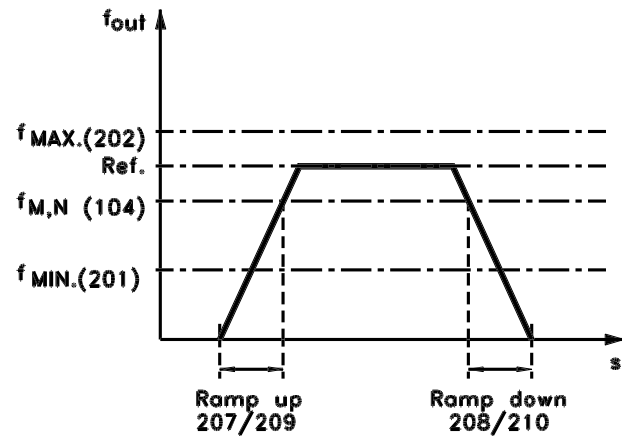

1752A047.12

Illustration 4.9 Ramp Up and Ramp Down

Description of choice:

Set the required ramp-up time.

208 Ramp-down time 1

Value:

- 0.02-3600.00 s
- * 3.00 s (VLT 2803-2875)
- 10.00 s (VLT 2880-2882)

Function:

The ramp-down time is the deceleration time from the rated motor frequency $f_{M,N}$ (*parameter 104 Motor frequency, $f_{M,N}$*) to 0 Hz, provided no overvoltage arises in the inverter because of generating operation of the motor.

Description of choice:

Set the required ramp-down time.

| | |
|----------------|---|
| 209 | Ramp-up time 2 |
| Value: | |
| 0.02-3600.00 s | * 3.00 s (VLT 2803-2875) 10.00 s (VLT 2880-2882) |

Function:
See description of *parameter 207 Ramp-up time 1*.

Description of choice:
Set the required ramp-up time. Shift from ramp 1 to ramp 2 by activating *Ramp 2* via a digital input.

| | |
|----------------|---|
| 210 | Ramp-down time 2 |
| Value: | |
| 0.02-3600.00 s | * 3.00 s (VLT 2803-2875) 10.00 s (VLT 2880-2882) |

Function:
See description of *parameter 208 Ramp-down time 1*.

Description of choice:
Set the required ramp-down time. Shift from ramp 1 to ramp 2 by activating *Ramp 2* via a digital input.

| | |
|----------------|---|
| 211 | Job ramp time |
| Value: | |
| 0.02-3600.00 s | * 3.00 s (VLT 2803-2875) 10.00 s (VLT 2880-2882) |

Function:
The jog ramp time is the acceleration/deceleration time from 0 Hz to the rated motor frequency $f_{M,N}$ (*parameter 104 Motor frequency, $f_{M,N}$*). It is assumed that the output current does not reach the current limit (set in *parameter 221 Current limit I_{LIM}*).

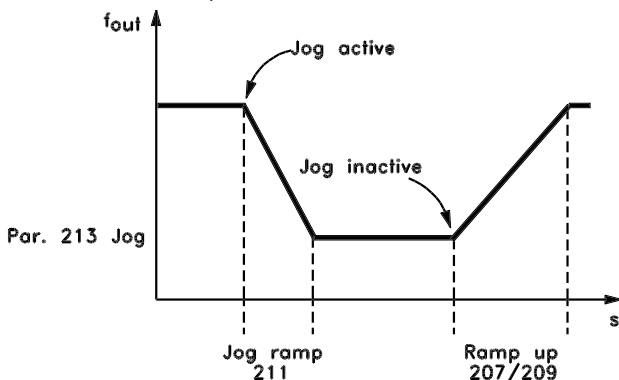

Illustration 4.10 Jog Ramp

The jog ramp time starts if a jog-signal is given via the LCP, one of the digital inputs or the serial communication port.

Description of choice:
Set the required ramp time.

| | |
|----------------|---|
| 212 | Quick-stop ramp-down time |
| Value: | |
| 0.02-3600.00 s | * 3.00 s (VLT 2803-2875) 10.00 s (VLT 2880-2882) |

Function:
The quick-stop ramp-down time is the deceleration time from the rated motor frequency to 0 Hz, provided no overvoltage arises in the inverter because of generating operation of the motor, or if the generated current exceeds the current limit in *parameter 221 Current limit I_{LIM}* . Quick-stop is activated via one of the digital inputs or the serial communication.

Description of choice:
Set the required ramp-down time.

| | |
|--|----------------------|
| 213 | Jog frequency |
| Value: | |
| 0.0 - Parameter 202 Output frequency high limit, f_{MAX} | * 10.0 Hz |

Function:
Jog frequency f_{JOG} means a fixed output frequency that the frequency converter supplies to the motor when the jog function is activated. Jog can be activated via the digital inputs, serial communication or via the LCP, on the condition that this is active in *parameter 015 Local jog*.

Description of choice:
Set the required frequency.
The example shows how the resulting reference is calculated when *Preset references* is used with *Sum* and *Relative* in *parameter 214 Reference function*. The formula for the calculation of the resulting reference is described in *chapter 5 All about VLT 2800*. Also see *Illustration 4.7* for more details.

| | |
|---|-----------|
| The following parameters are preset: | |
| <i>Parameter 204 Minimum reference</i> | 10 Hz |
| <i>Parameter 205 Maximum reference</i> | 50 Hz |
| <i>Parameter 215 Preset reference</i> | 15 % |
| <i>Parameter 308 Term. 53, Analogue input</i> | Reference |
| <i>Parameter 309 Term. 53, min. scaling</i> | 0 V |
| <i>Parameter 310 Term. 53, max. scaling</i> | 10 V |

When *parameter 214 Reference function* is set to [0] *Sum*, one of the preset *Preset references* (parameter 215-218) is added to the external references as a percentage of the reference range. If terminal 53 is applied to an analog input voltage of 4 V, the resulting reference is:

| | |
|--|---------|
| <i>Parameter 214 Reference function = Sum [0]:</i> | |
| <i>Parameter 204 Minimum reference</i> | 10.0 Hz |
| Reference contribution at 4 V | 16.0 Hz |
| <i>Parameter 215 Preset reference</i> | 6.0 Hz |
| Resulting reference | 32.0 Hz |

When parameter 214 Reference function is set to [1] Relative, the defined Preset references (par. 215-218) are added as a percentage of the total of the present external references. If terminal 53 is applied to an analogue input voltage of 4 V, the resulting reference is:

| | |
|---|---------|
| Parameter 214 Reference function = [1] Relative : | |
| Parameter 204 Minimum reference | 10.0 Hz |
| Reference effect at 4 V | 16.0 Hz |
| Parameter 215 Preset reference | 2.4 Hz |
| Resulting reference | 28.4 Hz |

Illustration 4.11 shows the resulting reference in relation to the external reference, which varies from 0-10 V. Parameter 214 Reference function is set to [0] Sum and [1] Relative. Illustration 4.11 also shows parameter 215 Preset reference 1 is programmed to 0 %.

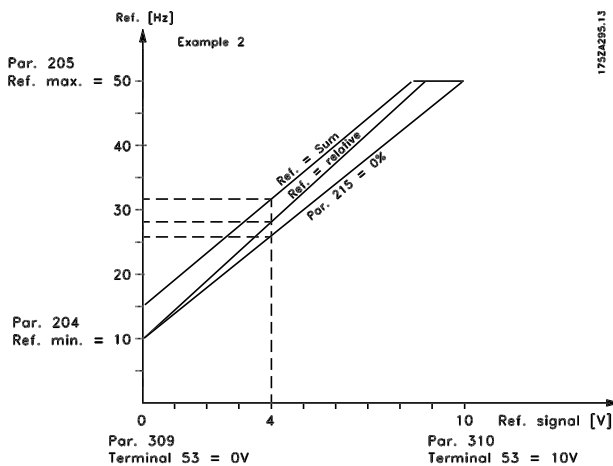

Illustration 4.11 Resulting Reference vs. External Reference

| | |
|-----------------------------------|---------------------------|
| 214 | Reference function |
| Value: | |
| * Sum (sum) | [0] |
| Relative (relative) | [1] |
| External/preset (external/preset) | [2] |

Function:

It is possible to define how to add preset references to the other references; for this purpose, use [0] Sum or [1] Relative. It is also possible by using the [2] External/preset to select whether a shift between external references and preset references is required.

External reference is the sum of the analog references, pulse references and any references from serial communication.

Description of choice:

If [0] Sum is selected, one of the adjusted preset references (parameters 215-218 Preset reference) is summarised as a percentage of the reference range (Ref_{MIN} - Ref_{MAX}), added to the other external references.

If [1] Relative is selected, one of the added preset references (parameters 215-218 Preset reference) is summarised as a percentage of the sum of present external references.

If [2] External/preset is selected, it is possible via a digital input to shift between external references or preset references. Preset references is a percentage value of the reference range.

NOTICE

If Sum or Relative is selected, one of the preset references is always active. If the preset references are to be without influence, they must be set to 0% (factory setting).

| | |
|------------|---|
| 215 | Preset reference 1 (PRESET REF. 1) |
| 216 | Preset reference 2 (PRESET REF. 2) |
| 217 | Preset reference 3 (PRESET REF. 3) |
| 218 | Preset reference 4 (PRESET REF. 4) |

Value:
-100.00% - +100.00% * 0.00%
of the reference range/external reference

Function:

4 different preset references can be programmed in parameters 215-218 Preset reference. The preset reference is stated as a percentage of the reference range (Ref_{MIN} - Ref_{MAX}) or as a percentage of the other external references, depending on the selection made in parameter 214 Reference function. Select the preset references via the digital inputs or via serial communication.

| Preset ref., msb | Preset ref. lsb | |
|------------------|-----------------|---------------|
| 0 | 0 | Preset ref. 1 |
| 0 | 1 | Preset ref. 2 |
| 1 | 0 | Preset ref. 3 |
| 1 | 1 | Preset ref. 4 |

Table 4.1 Preset Reference Selection

Description of choice:

Set the preset reference(s) that is/are to be the options.

| | |
|------------|-------------------------------------|
| 219 | Catch up/Slow down reference |
|------------|-------------------------------------|

Value:
0.00 - 100% of the given reference * 0.00%

Function:

In this parameter, the percentage value can be set which is either added to or deducted from the remote-controlled references.

The remote-controlled reference is the sum of preset references, analog references, pulse reference and any references from serial communication.

Description of choice:

If Catch up is active via a digital input, the percentage value in parameter 219 Catch up/Slow down reference is added to the remote-controlled reference.

If *Slow down* is active via a digital input, the percentage value in *parameter 219 Catch up/Slow down reference* is deducted from the remote-controlled reference.

221 Current limit, I_{LIM}

Value:

0 - XXX.X % of par. 105 * 160 %

Function:

In this parameter, the maximum output current I_{LIM} is set. The factory-set value corresponds to the maximum output current I_{MAX} . If the current limit is to be used as motor protection, set the rated motor current. If the current limit is set above 100% (the rated output current of the frequency converter, I_{INV}), the frequency converter can only handle a load intermittently, i.e. for short periods at a time. After the load has been higher than I_{INV} , ensure that the load is lower than I_{INV} for a period of time. Note that if the current limit is set at a lower value than I_{INV} , the acceleration torque is reduced to the same extent.

Description of choice:

Set the required maximum output current I_{LIM} .

223 Warning: Low current, I_{LOW}

Value:

0.0 - parameter 224 Warning: High current, I_{HIGH} * 0.0 A

Function:

If the output current drops below the preset limit I_{LOW} , a warning is given.

The signal outputs can be programmed to give a warning signal via terminal 46 and via the relay output.

Description of choice:

Programme the lower signal limit of the output current I_{LAV} within the normal working range of the frequency converter.

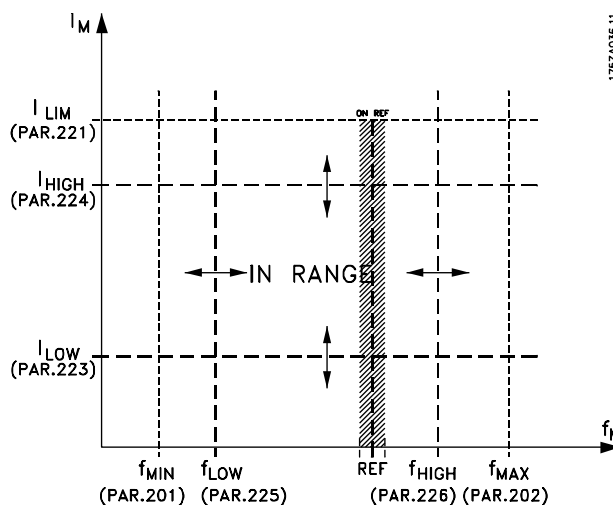

Illustration 4.12 Parameters for Output Current and Frequency Limits

224 Warning: High current, I_{HIGH}

Value:

0 - I_{MAX} * I_{MAX}

Function:

If the output current exceeds the preset limit I_{HIGH} , a warning is given.

The warning functions are activated when the output frequency has reached the resulting reference. The signal outputs can be programmed to give a warning signal via terminal 46 and via the relay output.

Description of choice:

Programme the output current's upper signal limit I_{HIGH} within the frequency converter's normal operating range. See *Illustration 4.12* for more details.

225 Warning: Low frequency, f_{LOW}

Value:

0.0 - par. 226
Warn.: High frequency, f_{HIGH} * 0.0 Hz

Function:

If the output frequency drops below the preset limit f_{LOW} , a warning is given.

Parameters 223-228 Warning functions are out of function during ramp-up after a start command and after stop command or during stop. The warning functions are activated when the output frequency has reached the resulting reference. The signal outputs can be programmed to give a warning signal via terminal 46 and via the relay output.

Description of choice:

The lower signal limit of the output frequency f_{LOW} must be programmed within the normal operating range of the frequency converter. See *Illustration 4.12* for more details.

226 Warning: High frequency f_{HIGH}
Value:

Par. 200 Frequency range = 0-132 Hz [0]/
 [1].par. 225 f_{LOW} - 132 Hz * 132.0 Hz
 Par. 200 Frequency range = 0-590 Hz
 [2]/[3].par. 225 f_{LOW} - 590 Hz * 132.0 Hz

Function:

If the output frequency exceeds the preset limit f_{HIGH} , a warning is given.
 Parameters 223-228 Warning functions do not work during ramp-up after a start command and after stop command or during stop. The warning functions are activated when the output frequency has reached the resulting reference. The signal outputs can be programmed to give a warning signal via terminal 46 and via the relay output.

Description of choice:

Programme the output frequency's upper signal limit f_{HIGH} within the frequency converter's normal operating range. See *Illustration 4.12* for more details.

227 Warning: Low feedback, FB_{LOW}
Value:

-100,000.000 - par. 228 Warn.: FB_{HIGH} * -4000.000

Function:

If the feedback signal drops below the preset limit FB_{LOW} , a warning is given.
 Parameters 223-228 Warning functions are out of function during ramp-up after a start command and after a stop command or during stop. The warning functions are activated when the output frequency has reached the resulting reference. The signal outputs can be programmed to give a warning signal via terminal 46 and via the relay output. The unit for feedback in Closed loop is programmed in *parameter 416 Process units*.

Description of choice:

Set the required value within the feedback range (*parameters 414 Minimum feedback, FB_{MIN} and 415 Maximum feedback, FB_{MAX}*).

228 Warning: High feedback, FB_{HIGH}
Value:

Parameter 227 Warn.: FB_{LOW} - 100,000.000 * 4000.000

Function:

If the feedback signal gets above the preset limit FB_{HIGH} , a warning is given.
 Parameters 223-228 Warning functions are out of function during ramp-up after a start command and after a stop command or during stop. The warning functions are activated when the output frequency has reached the resulting reference. The signal outputs can be programmed to give a warning signal via terminal 46 and via the relay

output. The unit for feedback in closed loop is programmed in *parameter 416 Process units*.

Description of choice:

Set the required value within the feedback range (*parameter 414 Minimum feedback, FB_{MIN} and 415 Maximum feedback, FB_{MAX}*).

229 Frequency bypass, bandwidth
Value:

0 (OFF) - 100 Hz * 0 Hz

Function:

Some systems call for some output frequencies to be avoided because of mechanical resonance problems in the system. In *parameters 230-231 Frequency bypass*, these output frequencies can be programmed. In this parameter, a bandwidth can be defined on either side of these frequencies.

Description of choice:

The frequency set in this parameter is centered around *parameters 230 Frequency bypass 1 and 231 Frequency bypass 2*.

230 Frequency bypass 1 (FREQ. BYPASS 1)
231 Frequency bypass 2 (FREQ. BYPASS 2)
Value:

0 - 1000 Hz * 0.0 Hz

Function:

Some systems call for some output frequencies to be avoided because of mechanical resonance problems in the system.

Description of choice:

Enter the frequencies to be avoided. See also *chapter 4.3.1 Frequency bypass, bandwidth parameter 229* for more details.

4.4 Inputs and Outputs

| Digital inputs | Term. no. | 18 ¹⁾ | 19 ¹⁾ | 27 | 29 | 33 |
|----------------------------|------------------------|------------------|------------------|------|-------|------|
| | par. no. | 302 | 303 | 304 | 305 | |
| Value: | | | | | | |
| No function | (NO OPERATION) | [0] | [0] | [0] | [0] | *[0] |
| Reset | (RESET) | [1] | [1] | [1] | [1] | [1] |
| Coasting stop inverse | (MOTOR COAST INVERSE) | [2] | [2] | [2] | [2] | [2] |
| Reset and coasting inverse | (RESET AND COAST INV.) | [3] | [3] | *[3] | [3] | [3] |
| Quick-stop inverse | (QUICK-STOP INVERSE) | [4] | [4] | [4] | [4] | [4] |
| DC braking inverse | (DC-BRAKE INVERSE) | [5] | [5] | [5] | [5] | [5] |
| Stop inverse | (STOP INVERSE) | [6] | [6] | [6] | [6] | [6] |
| Start | (START) | *[7] | [7] | [7] | [7] | [7] |
| Pulse start | (LATCHED START) | [8] | [8] | [8] | [8] | [8] |
| Reversing | (REVERSING) | [9] | *[9] | [9] | [9] | [9] |
| Reversing and start | (START REVERSING) | [10] | [10] | [10] | [10] | [10] |
| Start clockwise | (ENABLE FORWARD) | [11] | [11] | [11] | [11] | [11] |
| Start anti-clockwise | (ENABLE REVERSE) | [12] | [12] | [12] | [12] | [12] |
| Jog | (JOGGING) | [13] | [13] | [13] | *[13] | [13] |
| Freeze reference | (FREEZE REFERENCE) | [14] | [14] | [14] | [14] | [14] |
| Freeze output frequency | (FREEZE OUTPUT) | [15] | [15] | [15] | [15] | [15] |
| Speed up | (SPEED UP) | [16] | [16] | [16] | [16] | [16] |
| Speed down | (SPEED DOWN) | [17] | [17] | [17] | [17] | [17] |
| Catch-up | (CATCH-UP) | [19] | [19] | [19] | [19] | [19] |
| Slow-down | (SLOW-DOWN) | [20] | [20] | [20] | [20] | [20] |
| Ramp 2 | (RAMP 2) | [21] | [21] | [21] | [21] | [21] |
| Preset ref, LSB | (PRESET REF, LSB) | [22] | [22] | [22] | [22] | [22] |
| Preset ref, MSB | (PRESET REF, MSB) | [23] | [23] | [23] | [23] | [23] |
| Preset reference on | (PRESET REFERENCE ON) | [24] | [24] | [24] | [24] | [24] |
| Thermistor | (THERMISTOR) | [25] | [25] | [25] | [25] | |
| Precise stop, inverse | (PRECISE STOP INV.) | [26] | [26] | | | |
| Precise start/stop | (PRECISE START/STOP) | [27] | [27] | | | |
| Pulse reference | (PULSE REFERENCE) | | | | | [28] |
| Pulse feedback | (PULSE FEEDBACK) | | | | | [29] |
| Pulse input | (PULSE INPUT) | | | | | [30] |
| Selection of Setup, lsb | (SETUP SELECT LSB) | [31] | [31] | [31] | [31] | [31] |
| Selection of Setup, msb | (SETUP SELECT MSB) | [32] | [32] | [32] | [32] | [32] |
| Reset and start | (RESET AND START) | [33] | [33] | [33] | [33] | [33] |
| Pulse counter start | (PULSE COUNTER START) | [34] | [34] | | | |

Table 4.2 Output for Digital Inputs 18, 19, 27, 33- Parameter 302, 303, 304, 307

¹ All functions on terminals 18 and 19 are controlled by an interrupter, which means that the repetitive accuracy of the response time is constant. Can be used for start/stop, set-up switch and especially for changing digital preset, i.e. to obtain a reproducible stop point when using creep speed. For further information, see VLT 2800 Precise Stop Instruction.

Function:

In the parameters 302-307 Digital inputs it is possible to select between the different enabled functions related to the digital inputs (terminals 18-33).

Description of choice:

Select *No operation* if the frequency converter is not to react to signals transmitted to the terminal.

Reset resets the frequency converter after an alarm; however, a few alarms cannot be reset (trip locked) without first disconnecting the mains supply and reconnecting it. See Table 5.7 for more details. Reset is activated on the leading edge of the signal.
Coasting stop inverse is used for making the frequency converter release the motor immediately (output

transistors are turned off), which means that the motor runs freely to stop. Logic '0' leads to coasting to stop. *Reset and coasting inverse* are used to activate motor coast simultaneously with reset. Logical '0' means motor coast stop and reset. Reset is activated on the falling edge. *Quick stop inverse* is used for activating the quick-stop ramp down set in *parameter 212 Quick stop ramp-down time*. Logic '0' leads to quick stop. *DC-braking inverse* is used for stopping the motor by energising it with a DC voltage for a given time, see *parameters 126, 127 and 132 DC brake*. Note that this function is only active if the value in *parameters 126 DC braking time* and *132 DC brake voltage* is different from 0. Logic '0' leads to DC braking. *Stop inverse*, a logic '0' means that the motor speed is ramped down to stop via the selected ramp.

Select *Start* if a start/stop command is required. Logic '1' = start, logic '0' = stop.

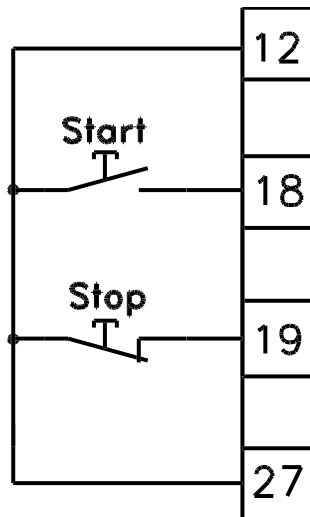

195NA029.11

Illustration 4.13 Start and Stop Commands

Latched start, if a pulse is applied for minimum 14 ms, the frequency converter starts the motor, provided no stop command has been given. The motor can be stopped by briefly activating *Stop inverse*.

Select *Reversing* to change the direction of rotation of the motor shaft. Logic '0' does not lead to reversing. Logic '1' leads to reversing. The reverse signal only changes the direction of rotation, it does not activate the start. Is not active at *Process regulation, closed loop*. See also *chapter 4.3.1 Output frequency range parameter 200*.

Reversing and start is used for start/stop and for reversing with the same signal. No active start command is allowed at the same time. Acts as latch start reversing, provided latch start has been selected for terminal 18. Is not active for *Process regulation, closed loop*. See also *chapter 4.3.1 Output frequency range parameter 200*.

Use *Start clockwise* to configure the motor to only rotate clockwise when started. Should not be used for *Process regulation, closed loop*.

Use *Start anticlockwise* to configure the motor to rotate counter-clockwise when started. Should not be used for *Process regulation, closed loop*. See also *chapter 4.3.1 Output frequency range parameter 200*.

Jog is used to override the output frequency to the jog frequency set in *parameter 213 Jog frequency*. Jog is active regardless of whether a start command has been given, yet not when *Coast stop, Quick-stop or DC braking* are active.

Freeze reference freezes the present reference. The reference can now only be changed via *Speed up* and *Speed down*. If *freeze reference* is active, it is saved after a stop command and in the event of mains failure.

Freeze output freezes the present output frequency (in Hz). The output frequency can now only be changed via *Speed up* and *Speed down*.

Speed up and *Speed down* are selected if digital control of the up/down speed is required. This function is only active if *Freeze reference* or *Freeze output frequency* has been selected.

If *Speed up* is active, the reference or output frequency is increased, and if *Speed down* is active the reference or output frequency is reduced. The output frequency is changed via the preset ramp times in *parameters 209-210 Ramp 2*.

One pulse (logic '1' minimum high for 14 ms and a minimum break time of 14 ms) leads to a speed change of 0.1 % (reference) or 0.1 Hz (output frequency).

| Term. 29 | Term. 33 | Freeze ref/freeze outp. | Function |
|----------|----------|-------------------------|-----------------|
| 0 | 0 | 1 | No speed change |
| 0 | 1 | 1 | Speed up |
| 1 | 0 | 1 | Speed down |
| 1 | 1 | 1 | Speed down |

Table 4.3 Speed-up and Speed-down Functions

Freeze reference can be changed even if the frequency converter has stopped. The reference is also saved if the mains are disconnected.

Catch-up/Slow-down is selected if the reference value is to be increased or reduced by a programmable percentage value set in *parameter 219 Catch-up/Slow-down reference*.

| Slow-down | Catch-up | Function |
|-----------|----------|---------------------|
| 0 | 0 | Unchanged speed |
| 0 | 1 | Increase by % value |
| 1 | 0 | Reduce by % value |
| 1 | 1 | Reduce by % value |

Table 4.4 Slow-down and Catch-up Functions

Ramp 2 is selected if a shift between ramp 1 (parameters 207-208) and ramp 2 (parameters 209-210) is required. Logic '0' leads to ramp 1 and logic '1' leads to ramp 2. Preset reference, *lsb* and Preset reference, *msb* make it possible to select one of the 4 preset references in Table 4.5.

| Preset ref. <i>msb</i> | Preset ref. <i>lsb</i> | Function |
|------------------------|------------------------|---------------|
| 0 | 0 | Preset ref. 1 |
| 0 | 1 | Preset ref. 2 |
| 1 | 0 | Preset ref. 3 |
| 1 | 1 | Preset ref. 4 |

Table 4.5 Function of Present Reference *lsb* and *msb*

Preset reference *on* is used for shifting between remote-controlled reference and preset reference. It is assumed that [2] External/preset has been selected in parameter 214 Reference function. Logic '0' = remote-controlled references are active, logic '1' = one of the 4 preset references is active, as shown in Table 4.5.

Select Thermistor if a possibly integrated thermistor in the motor is able to stop the frequency converter if the motor overheats. The cut-out value is 3 kΩ.

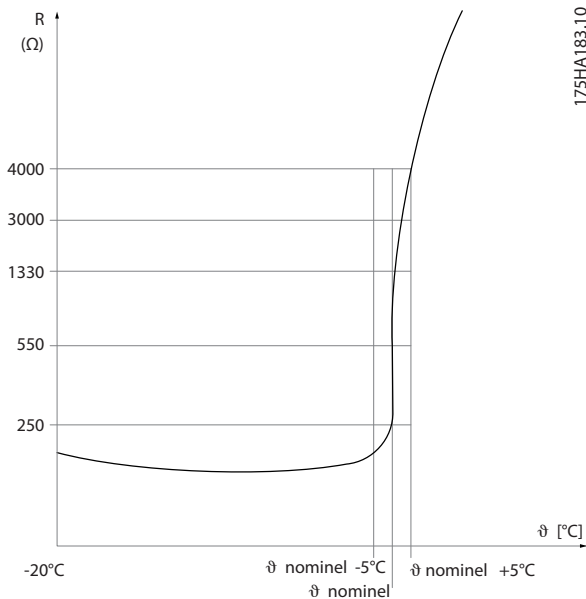
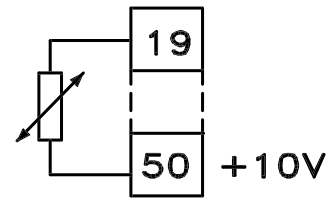

Illustration 4.14 Resistance of a Thermistor

If a motor features a Klaxon thermal switch instead, this can also be connected to the input. If motors operate in parallel, the thermistors/thermal switches can be connected in series (total resistance lower than 3 kΩ). Parameter 128 Motor thermal protection must be set to [1] Thermistor warning or [2] Thermistor trip and the thermistor is to be connected between a digital input and terminal 50 (+10 V supply).



195NA077.10

Illustration 4.15 Thermistor Connection

Select *Precise stop, inverse* to obtain a high degree of accuracy when a stop command is repeated. A logic 0 means that the motor speed is ramped down to stop via the selected ramp.

Select *Precise start/stop* to obtain a high degree of accuracy when a start and stop command is repeated.

Select *Pulse reference* if the reference signal applied is a pulse train (frequency). 0 Hz corresponds to parameter 204 Minimum reference, *Ref_{MIN}*. The frequency set in parameter 327 Pulse reference/feedback corresponds to parameter 205 Maximum reference *Ref_{MAX}*.

Select *Pulse feedback* if the feedback signal used is a pulse train (frequency). In parameter 327 Pulse reference/feedback the maximum pulse feedback frequency is set.

Select *Pulse input* if a specific number of pulses must lead to a *Precise stop*, see parameter 343 *Precise stop* and parameter 344 Counter value.

Selection of Setup, lsb and *Selection of Setup, msb* give the possibility to select one of the 4 setups. It is, however, a condition that parameter 004 Active Setup is set to [5] *Multisetup*.

Reset and start can be used as a start function. If 24 V are connected to the digital input, this causes the frequency converter to reset and the motor ramps up to the preset reference.

Pulse counter start is used to start a counter stop sequence with a pulse signal. The pulse width must at least be 14 ms and not longer than the count period. See also parameter 343 *Precise stop function* and the VLT 2800 *Precious Stop Instruction*.

308 Terminal 53, analog input voltage

Value:

- No function (NO OPERATION) [0]
- * Reference (reference) [1]
- Feedback (feedback) [2]
- Wobble (WOBB.DELTA FREQ [%]) [10]

Function:

Use this parameter to select the function required to be connected to terminal 53. Scaling of the input signal is set in parameter 309 Terminal 53, *min. scaling* and parameter 310 Terminal 53, *max. scaling*.

Description of choice:

Select [0] *No function* if the frequency converter is not to react to signals connected to the terminal.

Select [1] *Reference* to change the reference with an analog reference signal. If reference signals are connected to more than one input, these reference signals must be added up. If a voltage feedback signal is connected, select [2] *Feedback* on terminal 53.

[10] *Wobble*

The delta frequency can be controlled by the analog input. If *WOBB.DELTA FREQ* is selected as analog input (*parameter 308 Terminal 53, analog input voltage or parameter 314 Terminal 60, analogue input current*), the value selected in *parameter 702* equals 100 % analog input.

Example: Analog input = 4-20 mA, Delta freq. par. 702 = 5 Hz \Rightarrow 4 mA = 0 Hz and 20 mA = 5 Hz. If this function is selected, see *Wobble Instruction* for further information.

309 Terminal 53 Min. scaling

Value:

0.0 - 10.0 V * 0.0 V

Function:

This parameter is used for setting the signal value that is to correspond to the minimum reference or the minimum feedback, *parameter 204 Minimum reference, Ref_{MIN}/414 Minimum feedback, FB_{MIN}*.

Description of choice:

Set the required voltage value. For reasons of accuracy, compensation should be made for voltage loss in long signal cables. If the time-out function is to be used (*parameters 317 Time out and 318 Function after time out*), set the value higher than 1 V.

310 Terminal 53 Max. scaling

Value:

0-10.0 V * 10.0 V

Function:

This parameter is used for setting the signal value that is to correspond to the maximum reference value or maximum feedback, *parameter 205 Maximum reference, Ref_{MAX}/414 Maximum feedback, FB_{MAX}*.

Description of choice:

Set the required voltage value. For reasons of accuracy, compensation should be made for voltage losses in long signal cables.

314 Terminal 60, analogue input current

Value:

- No function (no operation) [0]
- Reference (reference) [1]
- * Feedback (feedback) [2]
- Wobble (*WOBB.DELTA FREQ* [%]) [10]

Function:

Select between the different functions available for the input, terminal 60. Scaling of the input signal is effected in *parameter 315 Terminal 60, min. scaling* and *parameter 316 Terminal 60, max. scaling*.

Description of choice:

[0] *No function*. Is selected if the frequency converter is not to react to signals connected to the terminal.

[1] *Reference*. If this function is selected, the reference can be changed with an analog reference signal. If reference signals are connected to more than one input, these reference signals must be added up.

If one current feedback signal is connected, select [2] *Feedback* on terminal 60.

[10] *Wobble*

The delta frequency can be controlled by the analog input. If *WOBB.DELTA FREQ* is selected as analog input (*parameter 308 Terminal 53, analog input voltage or parameter 314 Terminal 60, analogue input current*) the value selected in *parameter 702* equals 100 % analog input.

Example: Analog input = 4-20 mA, Delta freq. parameter 702 = 5 Hz \Rightarrow 4 mA = 0 Hz and 20 mA = 5 Hz. If this function is selected, see *Wobble Instruction* for further information.

315 Terminal 60 Min. scaling

Value:

0.0 - 20.0 mA * 4.0 mA

Function:

Use this parameter to set the signal value that corresponds to the minimum reference or minimum feedback, *parameter 204 Minimum reference, Ref_{MIN}/414 Minimum feedback, FB_{MIN}*.

Description of choice:

Set the required current value. If the time-out function is to be used (*parameters 317 Time out and 318 Function after time out*), the value set must be higher than 2 mA.

316 Terminal 60 Max. scaling

Value:

0.0 - 20.0 mA * 20.0 mA

Function:

This parameter is used for setting the signal value that is to correspond to the maximum reference value, *parameter 205 Maximum reference value, Ref_{MAX}*.

Description of choice:

Set the required current value.

317 Time out

Value:

1 - 99 * 10

Function:

If the signal value of the reference or feedback signal connected to one of the input terminals 53 or 60 drops below 50% of the minimum scaling for a period longer than the time set, the function selected in *parameter 318 Function after time out* is activated. This function is only active if a value higher than 1 V has been selected in *parameter 309 Terminal 53, min. scaling*, or if a value higher than 2 mA has been selected in *parameter 315 Terminal 60, min. scaling*.

Description of choice:

Set the required time.

318 Function after time out

Value:

- * No operation (NO OPERATION) [0]
- Freeze output frequency (FREEZE OUTPUT FREQ.) [1]
- Stop (stop) [2]
- Jog (jog) [3]
- Max. speed (MAX SPEED) [4]
- Stop and trip (STOP AND TRIP) [5]

Function:

Select the function to be activated after the expiry of the time-out (*parameter 317 Time out*). If a time-out function occurs at the same time as a bus time-out function (*parameter 513 Bus time interval function*), the time-out function in *parameter 318 Function after time out* is activated.

Description of choice:

The output frequency of the adjustable frequency drive can be:

- Frozen at the [1] present frequency.
- Overruled to [2] stop.
- Overruled to [3] jog frequency.
- Overruled to [4] max. output frequency.
- Overruled to [5] stop with subsequent trip.

319 Analog output terminal 42

Value:

- No function (NO OPERATION) [0]
- External reference min.-max. 0-20 mA (ref min-max = 0-20 mA) [1]
- External reference min.-max. 4-20 mA (ref min-max = 4-20 mA) [2]
- Feedback min.-max. 0-20 mA (fb min-max = 0-20 mA) [3]
- Feedback min.-max. 4-20 mA (fb min-max = 4-20 mA) [4]
- Output frequency 0-max 0-20 mA (0-fmax = 0-20 mA) [5]
- Output frequency 0-max 4-20 mA (0-fmax = 4-20 mA) [6]
- * Output current 0- $I_{INV, max}$ 0-20 mA (0-iiinv = 0-20 mA) [7]
- Output current 0- $I_{INV, max}$ 4-20 mA (0-iiinv = 4-20 mA) [8]
- Output power 0- $P_{M,N}$ 0-20 mA (0-Pnom = 0-20 mA) [9]
- Output power 0- $P_{M,N}$ 4-20 mA (0-Pnom = 4-20 mA) [10]

Inverter temperature 20-100 °C 0-20 mA (TEMP 20-100 C=0-20 mA) [11]

Inverter temperature 20-100 °C 4-20 mA (TEMP 20-100 C=4-20 mA) [12]

Function:

The analog output can be used for stating a process value. Select between 2 types of output signals 0-20 mA or 4-20 mA.

If used as a voltage output (0-10 V), a pull-down resistor of 500 Ω must be fitted to common (terminal 55). If the output is used as a current output the resulting resistance from the equipment connected may not exceed 500 Ω.

Description of choice:

No function. Is selected if the analog output is not to be used.

External Ref_{MIN} - Ref_{MAX} 0-20 mA/4-20 mA.

An output signal is obtained, which is proportional to the resulting reference value in the interval minimum reference, Ref_{MIN} - maximum reference, Ref_{MAX} (*parameters 204 Minimum reference, Ref_{MIN}/205 Maximum reference, Ref_{MAX}*).

FB_{MIN}-FB_{MAX} 0-20 mA/ 4-20 mA.

An output signal is obtained, which is proportional to the feedback value in the interval minimum feedback, FB_{MIN} - maximum feedback, FB_{MAX} (*parameter 414 Minimum feedback FB_{MIN} /415 Maximum feedback, FB_{MAX}*).

0-f_{MAX} 0-20 mA/4-20 mA.

An output signal is obtained, which is proportional to the output frequency in the interval 0 - f_{MAX} (*parameter 202 Output frequency, high limit, f_{MAX}*).

0 - I_{INV, max} 0-20 mA/4-20 mA.

An output signal is obtained, which is proportional to the output current in the interval 0 - I_{INV, max}

0 - P_{M,N} 0-20 mA/4-20 mA.

An output signal is obtained, which is proportional to the present output power. 20 mA corresponds to the value set in *parameter 102 Motor power, P_{M,N}*.

0 - Temp._{MAX} 0-20 mA/4-20 mA.

An output signal is obtained, which is proportional to the present heat sink temperature. 0/4 mA corresponds to a heat sink temperature of less than 20 °C, and 20 mA corresponds to 100 °C.

323 Relay output 1-3

Value:

- No function (no operation) [0]
- * Unit ready (unit ready) [1]
- Enable/no warning (enable/no warning) [2]
- Running (RUNNING) [3]
- Running in reference, no warning (run on ref/no warn) [4]
- Running, no warnings (RUNNING/NO WARNING) [5]
- Running in reference range, no warnings (RUN IN RANGE/ NO WARN) [6]

| | |
|--|------|
| Ready - mains voltage within range (RDY NO OVER/UNDERVOL) | [7] |
| Alarm or warning (ALARM OR WARNING) | [8] |
| Current higher than current limit, par. 221 (Current limit) | [9] |
| Alarm (ALARM) | [10] |
| Output frequency higher than f_{LOW} par. 225 (above frequency low) | [11] |
| Output frequency lower than f_{HIGH} par. 226 (below frequency high) | [12] |
| Output current higher than I_{LOW} par. 223 (above current low) | [13] |
| Output current lower than I_{HIGH} par. 224 (below current high) | [14] |
| Feedback higher than FB_{LOW} par. 227 (above feedback low) | [15] |
| Feedback lower than FB_{HIGH} par. 228 (under feedback high) | [16] |
| Relay 123 (RELAY 123) | [17] |
| Reversing (REVERSE) | [18] |
| Thermal warning (THERMAL WARNING) | [19] |
| Local operation (LOCAL MODE) | [20] |
| Out of frequency range par. 225/226 (out of freq range) | [22] |
| Out of current range (out of current range) | [23] |
| Out of feedback range (out of fdbk. range) | [24] |
| Mechanical brake control (Mech. brake control) | [25] |
| Control word bit 11 (control word bit 11) | [26] |
| Sleep Mode (sleep mode) | [27] |

Function:

The relay output can be used for giving the present status or warning. The output is activated (1-2 make) when a given condition is fulfilled.

Description of choice:

No function. Is selected if the frequency converter is not to react to signals.

Unit ready, there is a supply voltage on the control card of the frequency converter, and the frequency converter is ready for operation.

Enable, no warning, the frequency converter is ready for operation, but no start command has been given. No warning.

Running is active when there is a start command or the output frequency is above 0.1 Hz. Also active during ramp-down.

Running in reference, no warning speed according to reference.

Running, no warning, a start command has been given. No warning.

Ready - mains voltage within range, the frequency converter is ready for use; the control card is receiving a supply voltage; and there are no active control signals on the inputs. The mains voltage lies within the voltage limits. *Alarm or warning,* the output is activated by an alarm or warning.

Current limit, the output current is higher than the value programmed in *parameter 221 Current limit I_{LIM} .*

Alarm, The output is activated by an alarm.

Output frequency higher than f_{LOW} , the output frequency is higher than the value set in *parameter 225 Warning: Low frequency, f_{LOW} .*

Output frequency lower than f_{HIGH} , the output frequency is lower than the value set in *parameter 226 Warning: High frequency, f_{HIGH} .*

Output current higher than I_{LOW} , the output current is higher than the value set in *parameter 223 Warning: Low current, I_{LOW} .*

Output current lower than I_{HIGH} , the output current is lower than the value set in *parameter 224 Warning: High current, I_{HIGH} .*

Feedback higher than FB_{LOW} , the feedback value is higher than the value set in *parameter 227 Warning: Low feedback, FB_{LOW} .*

Feedback lower than FB_{HIGH} , the feedback value is lower than the value set in *parameter 228 Warning: High current, I_{HIGH} .*

Relay 123 is only used in connection with Profidrive.

Select *Reversing* to activate the relay output when the direction of motor rotation is anti-clockwise. When the direction of motor rotation is clockwise, the value is 0 V DC.

Thermal warning, above the temperature limit in either the motor or the frequency converter, or from a thermistor connected to a digital input.

Local operation, the output is active when [1] *Local operation* is selected for *parameter 002 Local/remote operation.*

Out of the frequency range, the output frequency is out of the programmed frequency range in *parameters 225 and 226.*

Out of the current range the motor current is out of the programmed range in *parameters 223 and 224.*

Out of the feedback range the feedback signal is out of the programmed range in *parameters 227 and 228.*

Use *Mechanical brake control* to control an external mechanical brake. See *chapter 3.4.13 Control of Mechanical Brake* for more details about mechanical brake control.

Control word bit 11 is active if bit 11 is high on the Bus Communication.

Sleep Mode is active if the frequency is lower than 0.1 Hz.

327 pulse reference/feedback

Value:

150 - 67600 Hz * 5000 Hz

Function:

This parameter is used for setting the signal value that corresponds to the maximum value set in *parameter 205 Maximum reference, Ref_{MAX}* or to the maximum feedback value set in *parameter 415 Maximum feedback, FB_{MAX}*.

Description of choice:

Set the required pulse reference or pulse feedback to be connected to terminal 33.

328 Maximum Pulse 29

Value:

150 - 67600 Hz * 5000 Hz

Function:

This parameter is used for setting the signal value that corresponds to the maximum value set in *parameter 205 Maximum reference, Ref_{MAX}* or to the maximum feedback value set in *parameter 415 Maximum feedback, FB_{MAX}*.

NOTICE

Only relevant for DeviceNet. See *VLT® 2800 DeviceNet Manual* for further information.

341 Digital/Pulse output terminal 46

Value:

- Unit ready (UNIT READY) [0]
- Parameter [0] - [20] see parameter 323
- Pulse reference (PULSE REFERENCE) [21]
- Parameter [22] - [25] see parameter 323
- Pulse feedback (PULSE FEEDBACK) [26]
- Output frequency (PULSE OUTPUTFREQ) [27]
- Pulse current (PULSE CURRENT) [28]
- Pulse power (PULSE POWER) [29]
- Pulse temperature (PULSE TEMP) [30]
- Control Word Bit 12 (control word bit 12) [31]
- Sleep Mode (sleep mode) [32]

Function:

The digital output can be used for giving the present status or warning. The digital output (terminal 46) gives a 24 V DC signal when a given condition is fulfilled. Terminal can also be used for frequency output.

Parameter 342 Terminal 46, max. pulse scaling sets the maximum pulse frequency.

Description of choice:

Pulse reference Ref_{MIN} - Ref_{MAX}

An output signal is obtained, which is proportional to the resulting reference value in the interval Minimum reference, Ref_{MIN} - Maximum reference, Ref_{MAX} (*parameters 204 Minimum reference, Ref_{MIN}/205 Maximum reference, Ref_{MAX}*).

Pulse feedback FB_{MIN}-FB_{MAX}.

An output signal is obtained, which is proportional to the feedback value in the interval Minimum feedback, FB_{MIN} - Maximum feedback, FB_{MAX} (*parameter 414/415*).

Output frequency 0-f_{MAX}.

An output signal is obtained, which is proportional to the output frequency in the interval 0 - f_{MAX} (*parameter 202 Output frequency, high limit, f_{MAX}*).

Pulse current 0 - I_{INV}.

An output signal is obtained, which is proportional to the output current in the interval 0 - I_{INV}.

Pulse power 0 - P_{M,N}.

An output signal is obtained, which is proportional to the present output power. Parameter 342 corresponds to the value set in *parameter 102 Motor power, P_{M,N}*.

Pulse temperature 0 - Temp_{MAX}.

An output signal is obtained, which is proportional to the present heat sink temperature. 0 Hz corresponds to a heat sink temperature of less than 20 °C, and *parameter 342* corresponds to 100 °C.

Control word bit 12 Output is active if bit 12 is high on the bus communication.

Sleep Mode is active if the frequency is lower than 0.1 Hz.

NOTICE

Output terminal 46 is not available on DeviceNet.

Minimum output frequency at frequency output = 16 Hz.

342 Terminal 46, max. pulse scaling

Value:

150 - 10000 Hz * 5000 Hz

Function:

This parameter is used for setting the pulse output signal's maximum frequency.

Description of choice:

Set the required frequency.

343 Precise stop function

Value:

- * Precise ramp stop (normal) [0]
- Counter stop with reset (Count stop reset) [1]
- Counter stop without reset (Count stop no reset) [2]
- Speed-compensated stop (Spd cmp stop) [3]
- Speed-compensated counter stop with reset (Spd cmp cstop w. res) [4]
- Speed-compensated counter stop without reset (Spd cmp cstop no res) [5]

Function:

Select which stop function is performed in response to a stop command. All 6 data selections contain a precise stop routine, thus ensuring a high level of repeat accuracy. The selections are a combination of the functions described below.

Description of choice:

[0] *Precise ramp stop* is selected to achieve high repetitive precision at the stopping point.

Counter stop. Once it has received a pulse start signal, the frequency converter runs until the number of programmed pulses has been received at input terminal 33. In this way, an internal stop signal activates the normal ramp down time (*parameter 208*).

The counter function is activated (starts timing) at the flank of the start signal (when it changes from stop to start).

Speed compensated stop. To stop at precisely the same point, regardless of the present speed, a stop signal received is delayed internally when the present speed is lower than the maximum speed (set in *parameter 202*).

Reset. *Counter stop* and *Speed-compensated stop* can be combined with or without reset.

Counter stop with reset. After each precise stop the number of pulses counted during ramp down 0 Hz is reset.

Counter stop without reset. The number of pulses counted during ramp down to 0 Hz is deducted from the counter value in *parameter 344*.

⚠ WARNING

Do not use [8] *Pulse start* with the precise stop function.

344 Counter value**Value:**

0 - 999999 * 100000 pulses

Function:

Use this parameter to select the counter value to be used in the integrated precise stop function (*parameter 343*).

Description of choice:

The factory setting is 100000 pulses. The highest frequency (maximum-resolution) that can be registered at terminal 33 is 67.6 kHz.

349 Speed comp. delay**Value:**

0 ms - 100 ms * 10 ms

Function:

Set the system's delay time (Sensor, PLC, etc.). For a speed-compensated stop, the delay time at different frequencies has a major influence on the way of the stop.

Description of choice:

The factory setting is 10 ms. This means that it is assumed that the total delay from the Sensor, PLC and other hardware corresponds to this setting.

NOTICE

Only active for speed-compensated stop.

4.5 Special Functions

| 400 | Brake function |
|-----------------------------|----------------|
| Value: | |
| Off (off) | [0] |
| Resistor brake (Resistor) | [1] |
| AC brake (AC Brake) | [4] |
| Load sharing (load sharing) | [5] |

Factory setting depends on unit type.

Function:
 [1] Resistor brake is selected if the adjustable frequency drive has an integral brake transistor and brake resistor is connected to terminals 81, 82. A higher intermediate circuit voltage is permitted during braking (generated operation) when a brake resistor is connected.
 [4] AC brake can be selected to improve braking without using brake resistors. Note that [4] AC brake is not as effective as [1] Resistor brake.

Description of choice:
 Select [1] Resistor brake if a brake resistor is connected. Select [4] AC brake if short-term generated loads occur. See parameter 144 Gain AC brake to set the brake. Select [5] Load sharing if this is used.

NOTICE

A change of selection does not become active until the mains voltage has been disconnected and reconnected.

| 405 | Reset function |
|---------------------------------------|----------------|
| Value: | |
| * Manual reset (manual reset) | [0] |
| Automatic reset x 1 (AUTOMATIC x 1) | [1] |
| Automatic reset x 3 (AUTOMATIC x 3) | [3] |
| Automatic reset x 10 (AUTOMATIC x 10) | [10] |
| Reset at power-up (RESET AT POWER UP) | [11] |

Function:
 Select whether reset and restart after a trip are to be manual, or whether the adjustable frequency drive is to be reset and restarted automatically. Furthermore, it is possible to select the number of times a restart is to be attempted. The time between each attempt is set in parameter 406 Automatic restart time.

Description of choice:
 If [0] Manual reset is selected, reset is to be carried out via the [STOP/RESET] key, a digital input or serial communication. If the adjustable frequency drive is to carry out an automatic reset and restart after a trip, select data value [1] Automatic reset x 1, [3] Automatic reset x 3 or [10] Automatic reset x 10.

If [11] Reset at power-up is selected, the adjustable frequency drive carries out a reset if there has been a fault in connection with the mains failure.

WARNING

The motor may start without warning.

| 406 | Automatic restart time |
|--|------------------------|
| Value: | |
| 0 - 1800 | * 5 |
| Function: | |
| This parameter allows setting of the time from tripping until the automatic reset function begins. It is assumed that automatic reset has been selected in parameter 405 Reset function. | |

Description of choice:
 Set the required time.

| 409 | Trip delay overcurrent, I _{LIM} |
|------------------|--|
| Value: | |
| 0 - 60 (61=OFF) | * OFF |
| Function: | |

When the adjustable frequency drive registers that the output current has reached the current limit I_{LIM} (parameter 221 Current limit) and remains there for the preset time, it is disconnected. Can be used to protect the application, like the ETR protects the motor if selected.

Description of choice:
 Select how long the adjustable frequency drive should maintain the output current at the current limit I_{LIM} before it disconnects. At OFF, parameter 409 Trip delay overcurrent, I_{LIM} is not working, i.e. disconnection does not take place.

| 411 | Switching frequency |
|-----------------------------------|---------------------|
| Value: | |
| 3000 - 14000 Hz (VLT 2803 - 2875) | * 4500 Hz |
| 3000 - 10000 Hz (VLT 2880 - 2882) | * 4500 Hz |
| Function: | |

The set value determines the switching frequency of the inverter. If the switching frequency is changed, this may help to minimise possible acoustic noise from the motor.

Description of choice:
 When the motor is running, the switching frequency is adjusted in parameter 411 Switching frequency until the frequency has been obtained at which the motor is as low-noise as possible.

WARNING

The output frequency of the adjustable frequency drive can never assume a value higher than 1/10 of the switching frequency.

NOTICE

The switching frequency is reduced automatically as a function of the load. See *Temperature-Dependent Switching Frequency* under *Special Conditions*.

When *LC-filter connected* is selected in parameter 412 *Variable switching frequency*, the minimum switching frequency is 4.5 kHz.

| 412 Variable switching frequency | |
|---|-----|
| Value: | |
| * Without LC-filter (WITHOUT LC-FILTER) | [2] |
| LC-filter connected | |
| (LC-filter connected) | [3] |

Function:
Set the parameter to [3] *LC-filter connected* if an LC-filter is connected between the adjustable frequency drive and the motor.

Description of choice:
Select [3] *LC-filter connected* if an LC-filter is connected between the adjustable frequency drive and the motor, as otherwise the adjustable frequency drive cannot protect the LC-filter.

NOTICE

When the LC filter is selected, the switching frequency is changed to 4.5 kHz.

| 413 Overmodulation function | |
|-----------------------------|-----|
| Value: | |
| Off (off) | [0] |
| * On (on) | [1] |

Function:
This parameter allows connection of the overmodulation function for the output voltage.

Description of choice:
[0] *Off* means that there is no overmodulation of the output voltage, which means that torque ripple on the motor shaft is avoided. This can be a good feature, e.g. on grinding machines.

[1] *On* means that an output voltage can be obtained which is greater than the mains voltage (up to 5 %).

| 414 Minimum feedback FB_{MIN} | |
|------------------------------------|---------|
| Value: | |
| -100,000.000 - par. 415 FB_{MAX} | * 0.000 |

Function:
Parameters 414 Minimum feedback, FB_{MIN} and 415 Maximum feedback, FB_{MAX} are used to scale the display text to make it show the feedback signal in a process unit proportionally to the signal on the input.

Description of choice:
Set the value to be shown in the display as the minimum feedback signal value on the selected feedback input

(parameters 308 Terminal 53, analog input voltage/314 Terminal 60, analogue input current).

| 415 Maximum feedback, FB_{MAX} | |
|----------------------------------|------------|
| Value: | |
| $FB_{MIN} - 100,000.000$ | * 1500.000 |
| Function: | |

See description of parameter 414 *Minimum feedback, FB_{MIN} .*

Description of choice:
Set the value to be shown in the display when the maximum feedback has been obtained on the selected feedback input (*parameters 308 Terminal 53, analog input voltage/314 Terminal 60, analogue input current*).

| 416 Process units | |
|---------------------------------|------|
| Value: | |
| * No unit (No unit) | [0] |
| % (%) | [1] |
| ppm (ppm) | [2] |
| rpm (rpm) | [3] |
| bar (bar) | [4] |
| Cycles/min (CYCLE/MI) | [5] |
| Pulses/s (PULSE/S) | [6] |
| Units/s (UNITS/S) | [7] |
| Units/min. (UNITS/MI) | [8] |
| Units/h (Units/h) | [9] |
| °C (°C) | [10] |
| Pa (pa) | [11] |
| l/s (l/s) | [12] |
| m ³ /s (m3/s) | [13] |
| l/min. (l/m) | [14] |
| m ³ /min. (m3/min) | [15] |
| l/h (l/h) | [16] |
| m ³ /h (m3/h) | [17] |
| Kg/s (kg/s) | [18] |
| Kg/min. (kg/min) | [19] |
| Kg/hour (kg/h) | [20] |
| Tons/min. (T/min) | [21] |
| Tons/hour (T/h) | [22] |
| Metres (m) | [23] |
| Nm (nm) | [24] |
| m/s (m/s) | [25] |
| m/min. (m/min) | [26] |
| °F (°F) | [27] |
| ln wg (in wg) | [28] |
| gal/s (gal/s) | [29] |
| Ft ³ /s (ft3/s) | [30] |
| Gal/min. (gal/min) | [31] |
| Ft ³ /min. (Ft3/min) | [32] |
| Gal/h (gal/h) | [33] |
| Ft ³ /h (Ft3/h) | [34] |

| | |
|------------------|------|
| Lb/s (lb/s) | [35] |
| Lb/min. (lb/min) | [36] |
| Lb/hour (lb/h) | [37] |
| Lb ft (lb ft) | [38] |
| Ft/s (ft/s) | [39] |
| Ft/min. (ft/min) | [40] |
| Psi (Psi) | [41] |

Function:

Select among different units to be shown on the display. The unit is read out if an LCP control unit can be connected, and if [2] *Reference [unit]* or [3] *Feedback [unit]* has been selected in one of *parameters 009-012 Display read-out*, and in Display mode. The unit is used in *Closed loop* also as a unit for minimum/maximum reference and minimum/maximum feedback.

Description of choice:

Select the required unit for the reference/feedback signal.

4.5.1 VLT 2800 Regulators

The VLT 2800 has 2 integrated PID regulators, one to regulate speed and one to regulate processes. Speed regulation and process regulation require a feedback signal back to an input. There are a number of settings for both PID regulators that are made in the same parameters, but selection of regulator type affects the selections that have to be made in the shared parameters. In *parameter 100 Configuration*, it is possible to select regulator type, [1] *Speed regulation, closed loop* or [3] *Process regulation, closed loop*.

Speed regulation

This PID regulation is optimised for use in applications in which there is a need to maintain a particular motor speed. The parameters that are specific for the speed regulator are *parameters 417 Speed PID proportional gain* to *421 Speed PID low pass filter time*.

Process regulation

The PID regulator maintains a constant process mode (pressure, temperature, flow, etc.) and adjusts the motor speed on the basis of the reference/setpoint and feedback signal.

A transmitter provides the PID regulator with a feedback signal from the process as an expression of the process's actual mode. The feedback signal varies as the process load varies.

This means that there is a variance between the reference/setpoint and the actual process mode. This variance is compensated by the PID regulator by adjusting the output frequency up or down in relation to the variance between the reference/setpoint and the feedback signal.

The integrated PID regulator in the frequency converter has been optimised for use in process applications. This

means that there are a number of special functions available in the frequency converter.

Previously, it was necessary to obtain a system to handle these special functions by installing extra I/O modules and programming the system. With the frequency converter the need to install extra modules can be avoided. The parameters that are specific to the process regulator are *parameters 437 Process PID normal/inverse control* to *444 Process PID low pass filter time*.

4.5.2 PID functions

Unit of reference/feedback

When *Speed regulation, closed loop* is selected in *parameter 100 Configuration* the unit of reference/feedback is always [3] RPM.

When *Process regulation, closed loop* is selected in *parameter 100 Configuration*, the unit is defined in *parameter 416 Process units*.

Feedback

Preset a feedback range for both regulators. At the same time, this feedback range limits the potential reference range so that if the sum of all references lies outside the feedback range, the reference is limited to lie within the feedback range. The feedback signal must be connected to a terminal on the frequency converter. If feedback is selected on 2 terminals simultaneously, the 2 signals are added. Use the overview below to determine which terminal is to be used and which parameters are to be programmed.

| Feedback type | Terminal | Parameters |
|---------------|----------|---------------|
| Pulse | 33 | 307, 327 |
| Voltage | 53 | 308, 309, 310 |
| Current | 60 | 314, 315, 316 |

Table 4.6

A correction can be made for loss of voltage in long signal cables when a transmitter with a voltage output is used. This is done in parameter group *300 Min./Max scaling*.

Parameters 414/415 Minimum/Maximum feedback must also be preset to a value in the process unit corresponding to the minimum and maximum scaling values for signals that are connected to the terminal.

Reference

In *parameter 205 Maximum reference, Ref_{MAX}*, it is possible to preset a maximum reference that scales the sum of all references, i.e. the resulting reference.

The minimum reference in *parameter 204 Minimum reference, Ref_{MIN}* is an expression of the minimum value that the resulting reference can assume.

All references are added and the sum is the reference against which regulation takes place. It is possible to limit the reference range to a range that is smaller than the feedback range. This can be helpful to avoid an uninten-

tional change to an external reference making the sum of the references move too far away from the optimal reference. The reference range cannot exceed the feedback range.

If preset references are desired, they are preset in *parameters 215 to 218 Preset reference*. See the description in *chapter 4.3.1 Reference function* and *chapter 4.3.1 Handling of References*.

If a current signal is used as the feedback signal, it is only possible to use voltage as an analog reference. Use *Table 4.7* to determine which terminal is to be used and which parameters are to be programmed.

| Reference type | Terminal | Parameters |
|-------------------|----------|---------------|
| Pulse | 33 | 307, 327 |
| Voltage | 53 | 308, 309, 310 |
| Current | 60 | 314, 315, 316 |
| Preset references | | 215-218 |
| Bus reference | 68+69 | |

The bus reference can only be preset via serial communication.

NOTICE

It is recommended to preset terminals that are not being used to [0] No function.

Differentiator gain limit

If very rapid variations occur in an application in either the reference signal or the feedback signal, the deviation between the reference/setpoint and the process's actual mode changes quickly. The differentiator can then become too dominant. This is because it is reacting to the deviation between the reference and the process's actual mode, and the quicker the variance changes, the more powerful the differentiator's frequency contribution becomes. The differentiator's frequency contribution can therefore be limited in such a way that both a reasonable differentiation time for slow changes and an appropriate frequency contribution for quick changes can be preset. This is done using the speed regulation in *parameter 420 Speed PID Differentiator gain limit* and process regulation in *parameter 443 Process PID Differentiator gain limit*.

Lowpass filter

If there is a lot of noise in the feedback signal, these can be dampened using an integrated lowpass filter. A suitable lowpass filter time constant is preset. If the lowpass filter is preset to 0.1 s, the cut-off frequency is 10 RAD/s, corresponding to $(10/2 \times \pi) = 1.6$ Hz. This means that all currents/voltages that vary by more than 1.6 oscillations/s are dampened. In other words, there is only regulation on the basis of a feedback signal that varies by a frequency of less than 1.6 Hz. The appropriate time constant is selected in speed regulation in *parameter 421 Speed PID lowpass filter time* and in process regulation in *parameter 444 Process PID lowpass filter time*.

Inverse regulation

Normal regulation means that the motor speed is increased when the reference/setpoint is greater than the feedback signal. If it is necessary to run inverse regulation, in which the speed is reduced when the reference/setpoint is greater than the feedback signal, programme *parameter 437 PID normal/inverted control [1] Inverted*.

Anti-Windup

In the factory the process regulator is preset with an active anti-windup function. When either a frequency limit, a current limit or a voltage limit is reached, the integrator is initialised at a frequency corresponding to the present output frequency. This is a means of avoiding the integration of a variance between the reference and the process's actual mode that cannot be deregulated by changing the speed. This function can be deselected in *parameter 438 Process PID anti windup*.

Starting conditions

In some applications, the optimal setting of the process regulator means that a relatively long period of time passes before the required process condition is achieved. In these applications, define an output frequency to which the frequency converter must run the motor before the process regulator is activated. This is done by programming a start frequency in *parameter 439 Process PID start frequency*.

4.5.3 Handling of Feedback

Feedback handling is shown in *Illustration 4.16*.

The flowchart shows which parameters can affect the handling of feedback and how. Select between voltage, current and pulse feedback signals.

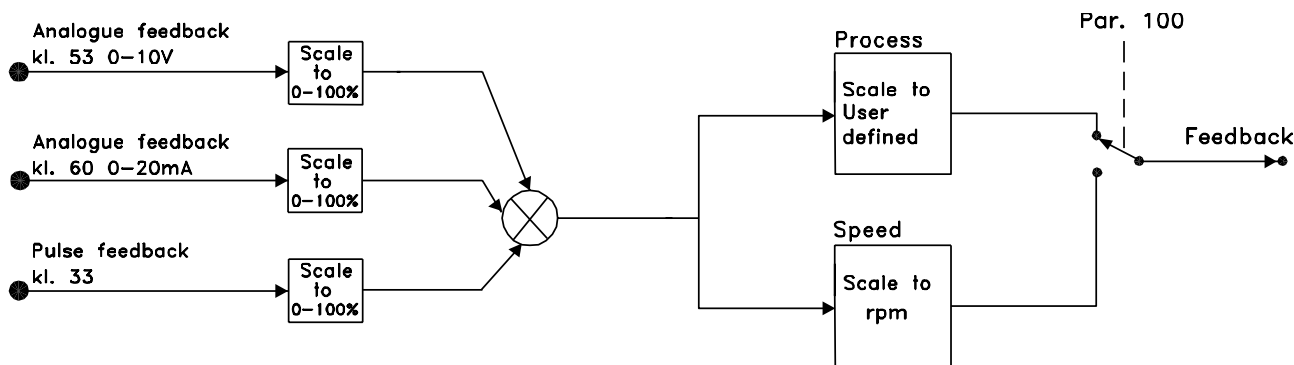

195NA019.11

Illustration 4.16 Feedback Handling

NOTICE

Parameters 417-421 are only used, if in parameter 100 Configuration the selection made is [1] Speed regulation, closed loop.

| | |
|------------------|------------------------------------|
| 417 | Speed PID proportional gain |
| Value: | 0.000 (OFF) - 1.000 * 0.010 |
| Function: | |

Proportional gain indicates how many times the fault (deviation between the feedback signal and the setpoint) is to be amplified.

Description of choice:
Quick regulation is obtained at high amplification, but if the amplification is too high, the process may become unstable in the case of overshooting.

| | |
|------------------|---|
| 418 | Speed PID integral time |
| Value: | 20.00 - 999.99 ms (1000 = OFF) * 100 ms |
| Function: | |

The integral time determines how long the PID regulator takes to correct the error. The greater the error, the quicker the integrator frequency contribution increases. The integral time is the time the integrator needs to achieve the same change as the proportional amplification.

Description of choice:
Quick regulation is obtained through a short integral time. However, if this time is too short, it can make the process unstable. If the integral time is long, major deviations from

the required reference may occur, since the process regulator takes long to regulate if an error has occurred.

| | |
|------------------|------------------------------------|
| 419 | Speed PID differential time |
| Value: | 0.00 (OFF) - 200.00 ms * 20.00 ms |
| Function: | |

The differentiator does not react to a constant error. It only makes a contribution when the error changes. The quicker the error changes, the stronger the gain from the differentiator is. The contribution is proportional to the speed at which errors change.

Description of choice:
Quick control is obtained by a long differential time. However, if this time is too long, it can make the process unstable. When the differential time is 0 ms, the D-function is not active.

| | |
|------------------|--------------------------------|
| 420 | Speed PID D- gain limit |
| Value: | 5.0 - 50.0 * 5.0 |
| Function: | |

It is possible to set a limit for the gain provided by the differentiator. Since the D-gain increases at higher frequencies, limiting the gain may be useful. This enables obtaining a pure D-gain at low frequencies and a constant D-gain at higher frequencies.

Description of choice:
Select the required gain limit.

421 Speed PID lowpass filter time

Value:
20 - 500 ms * 100 ms

Function:

Noise in the feedback signal is dampened by a first-order lowpass filter to reduce the noise's impact on the regulation. This might be an advantage, e.g. if there is a great amount of noise on the signal.

Feedback

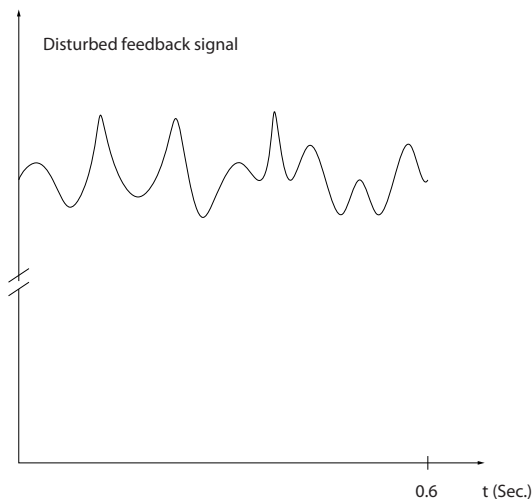

175ZA293.11

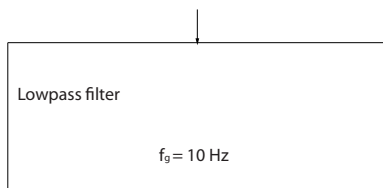

Feedback

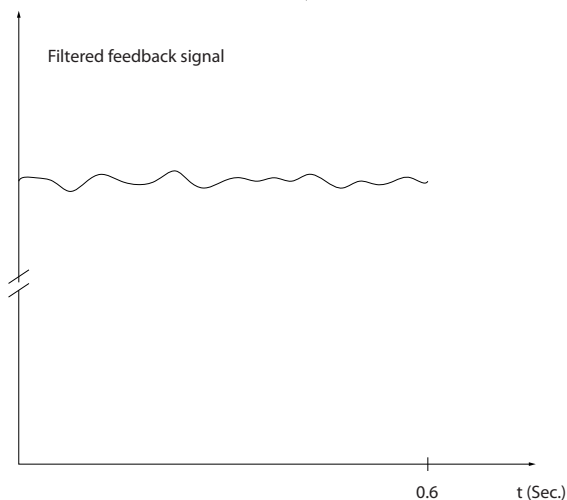

Illustration 4.17 Lowpass Filter Example

Description of choice:

If a time constant (t) of 100 ms is programmed, the cut-off frequency for the lowpass filter is $1/0.1=10 \text{ RAD/s}$, corresponding to $(10/2 \times \pi)=1.6 \text{ Hz}$. The PID regulator then only regulates a feedback signal that varies with a

frequency of less than 1.6 Hz. If the feedback signal varies by a higher frequency than 1.6 Hz, it is dampened by the lowpass filter.

423 U1 voltage

Value:
0.0 - 999.0 V * par. 103

Function:

Parameters 423-428 are used when [8] Special motor characteristic has been selected in parameter 101 Torque characteristic. It is possible to determine a U/f characteristic on the basis of 4 definable voltages and 3 frequencies. The voltage at 0 Hz is set in parameter 133 Start voltage.

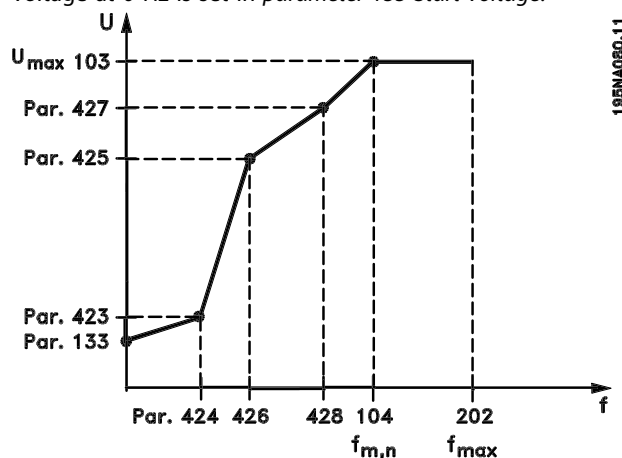

198NA060.11

Illustration 4.18 Output Voltage vs. Output Frequency

Description of choice:

Set the output voltage (U1) that is to match the first output frequency (F1), parameter 424 F1 frequency.

424 F1 frequency

Value:
0.0 - parameter 426 F2 * Parameter 104 Motor frequency

Function:

See parameter 423 U1 voltage.

Description of choice:

Set the output frequency (F1) that is to match the first output voltage (U1), parameter 423 U1 voltage.

425 U2 voltage

Value:

0.0 - 999.0 V * parameter 103

Function:

See parameter 423 U1 voltage.

Description of choice:

Set the output voltage (U2) that is to match the second output frequency (F2), parameter 426 F2 frequency.

426 F2 frequency

Value:

Parameter 424 F1 frequency - * Parameter 104
parameter 428 F3 frequency Motor frequency

Function:

See parameter 423 U1 voltage.

Description of choice:

Set the output frequency (F2) that is to match the second output voltage (U2), parameter 425 U2 voltage.

427 U3 voltage

Value:

0.0 - 999.0 V * parameter 103

Function:

See parameter 423 U1 voltage.

Description of choice:

Set the output voltage (U3) that is to match the third output frequency (F3), parameter 428 F3 frequency.

428 F3 frequency

Value:

Parameter 426 F2 frequency - * Parameter 104 Motor
1000 Hz frequency

Function:

See parameter 423 U1 voltage.

Description of choice:

Set the output frequency (F3) that is to match the third output voltage (U3), parameter 427 U3 voltage.

NOTICE

Parameters 437-444 are only used if [3] Process regulation, closed loop has been selected in parameter 100 Configuration.

437 Process PID normal/inverse control

Value:

* Normal (normal) [0]
Inverse (inverse) [1]

Function:

Select whether the process regulator is to increase/decrease the output frequency if there is a deviation between the reference/setpoint and the actual process mode.

Description of choice:

If the adjustable frequency drive is to reduce the output frequency in case the feedback signal increases, select [0] Normal. If the adjustable frequency drive is to increase the output frequency in case the feedback signal increases, select [1] Inverse.

438 Proces PID anti windup

Value:

Not active (DISABLE) [0]
* Active (ENABLE) [1]

Function:

Select whether the process regulator is to continue regulating on a deviation, even if it is not possible to increase/decrease the output frequency.

Description of choice:

The factory setting is [1] Enable, which means that the integration link is initialised in relation to the actual output frequency if either the current limit, the voltage limit or the maximum/minimum frequency has been reached. The process regulator does not engage again until either the error is 0, or its sign has changed. Select [0] Disable if the integrator is to continue integrating on the deviation, even if it is not possible to remove the fault by such control.

NOTICE

If [0] Disable is selected, it means that when the deviation changes its sign, the integrator has to integrate down from the level obtained as a result of the former error, before any change in output frequency occurs.

439 Process PID start frequency

Value:

$f_{MIN} - f_{MAX}$ (parameter * Parameter 201 Output
201/202) frequency, low limit, f_{MIN}

Function:

When the start signal comes, the frequency converter reacts in the form of Open loop and does not change to Closed loop until the programmed start frequency is reached. This allows for setting a frequency that corresponds to the speed at which the process normally runs, which enables the required process conditions to be reached sooner.

Description of choice:

Set the required start frequency.

NOTICE

If the frequency converter is running at the current limit before the required start frequency is obtained, the process regulator is not activated. For the regulator to be activated anyway, the start frequency must be lower to the required output frequency. This can be done during operation.

PID start frequency may not be set higher than f_{MIN} if using pipe fill mode.

| 440 | Process PID proportional gain |
|---------------|-------------------------------|
| Value: | 0.0 - 10.00 * 0.01 |

Function:
The proportional gain indicates the number of times the deviation between the setpoint and the feedback signal is to be applied.

Description of choice:
Quick regulation is obtained by a high gain, but if the gain is too high, the process may become unstable due to overshoot.

| 441 | Process PID integration time |
|---------------|------------------------------|
| Value: | 0.01 - 9999.99 (OFF) * OFF |

Function:
The integrator provides an increasing gain at a constant error between the reference/setpoint and the feedback signal. The greater the error, the quicker the integrator frequency contribution increases. The integral time is the time needed by the integrator to make the same change as the proportional gain.

Description of choice:
Quick regulation is obtained at a short integral time. However, this time may become too short, which can make the process unstable due to overshoot. If the integral time is long, major deviations from the required setpoint may occur, since the process regulator takes a long time to regulate in relation to a given error.

| 442 | Process PID differentiation time |
|---------------|----------------------------------|
| Value: | 0.00 (OFF) - 10.00 s * 0.00 s |

Function:
The differentiator does not react to a constant error. It only makes a gain when an error changes. The quicker the deviation changes, the stronger the gain from the differentiator. The gain is proportional to the speed at which the deviation changes.

Description of choice:
Quick regulation is obtained with a long differentiation time. However, this time may become too long, which can make the process unstable due to overshoot.

| 443 | Process PID diff. gain limit |
|---------------|------------------------------|
| Value: | 5.0 - 50.0 * 5.0 |

Function:
It is possible to set a limit for the differentiator gain. The differentiator gain increases if there are fast changes. Therefore it's necessary to limit this gain. Thereby a pure differentiator gain is obtained at slow changes and a constant differentiator gain where quick changes to the deviation occur.

Description of choice:
Select a differentiator gain limit as required.

| 444 | Process PID lowpass filter time |
|---------------|---------------------------------|
| Value: | 0.02 - 10.00 * 0.02 |

Function:
Noise in the feedback signal is dampened by a first order lowpass filter to reduce the noise's impact on the process regulation. This can be an advantage e.g. if there is a lot of noise on the signal.

Description of choice:
Select the required time constant (t). If a time constant (t) of 0.1 s is programmed, the cut-off frequency for the lowpass filter is $1/0.1=10$ RAD/s, corresponding to $(10/2 \times \pi)=1.6$ Hz. The process regulator thus only regulates a feedback signal that varies by a frequency lower than 1.6 Hz. If the feedback signal varies by a higher frequency than 1.6 Hz, it is dampened by the lowpass filter.

| 445 | Flying start |
|---------------|---------------------|
| Value: | * Off (DISABLE) [0] |

- OK - same direction (OK-same direction) [1]
- OK - both directions (OK-both directions) [2]
- DC brake and start (DC-BRAKE BEF. START) [3]

Function:
This function enables catching a rotating motor shaft, which is no longer controlled by the adjustable frequency drive, e.g. because of a mains drop-out. The function is activated each time a start command is enabled. For the adjustable frequency drive to be able to catch the rotating motor shaft, the motor speed must be lower than the frequency that corresponds to the frequency in *parameter 202 Output frequency, high limit, f_{MAX}* .

Description of choice:
Select [0] *Disable* if this function is not required.

Select [1] *OK - same direction* if the motor shaft is only able to rotate in the same direction when cutting in. Select [1] *OK - same direction* if [0] *Clockwise only* has been selected in *parameter 200 Output frequency range*.

Select [2] *OK - both directions* if the motor is able to rotate in both directions when cutting in.

Select [3] *DC brake and start* if the adjustable frequency drive is to be able to brake the motor using the DC brake first, followed by start. It is assumed that *parameters 126-127/132 DC brake* are enabled. In the case of higher windmilling (rotating motor) effects, the adjustable frequency drive is not able to catch a rotating motor without selecting [3] *DC brake and start*.

Limitations:

- Too low inertia leads to load acceleration, which can be dangerous or prevent correct catching of a rotating motor. Use the DC brake instead.
- If the load is driven, e.g. by windmilling (rotating motor) effects, the unit may cut out because of overvoltage.
- Flying start does not work at lower values than 250 RPM.

451 Speed PID feedforward factor

Value:

0 - 500% * 100%

Function:

This parameter is only active if in *parameter 100 Configuration* the selection made is *Speed regulation, closed loop*. The FF function sends a larger or smaller part of the reference signal outside the PID controller in such a way that the PID controller only has an influence on part of the control signal. Any change to the set point has a direct effect on the motor speed. The FF factor provides high dynamism when changing the set point and less overswing.

Description of choice:

The required % value can be selected in the interval f_{MIN} - f_{MAX} . Values over 100% are used if the set point variations are only small.

452 Controller range

Value:

0 - 200% * 10%

Function:

This parameter is only active if [1] *Speed control, closed loop* has been selected in *parameter 100 Configuration*. The controller range (bandwidth) limits the output from the PID controller as a % of motor frequency $f_{M,N}$.

Description of choice:

The required % value can be selected for motor frequency $f_{M,N}$. If the controller range is reduced, the speed variations is less during initial tuning.

455 Frequency range monitor

Value:

Disable [0]
* Enable [1]

Function:

Use this parameter to turn off warning *33 Out of frequency range* in the display in process control closed loop. This parameter does not affect the extended status word.

Description of choice:

Select [1] *Enable* to enable the readout in the display if warning *33 Out of frequency range* occurs. Select [0] *Disable* to disable the readout in the display if warning *33 out of frequency range* occurs.

456 Brake Voltage Reduce

Value:

0-25 V if 200 V device * 0
0-50 V if 400 V device * 0

Function:

The user sets the voltage by which the level for resistor braking is reduced. It is only active when resistor in *parameter 400 Brake function* is selected.

Description of choice:

The greater the reduction value, the faster the reaction to a generator overload. Should only be used if there are problems with overvoltage in the intermediate circuit.

457 Phase loss function

Value:

| | |
|---|-----|
| * Trip (TRIP) | [0] |
| Autoderate & warning (AUTODERATE & WARNING) | [1] |
| Warning (WARNING) | [2] |

Function:

Select the function which is to be activated if the mains imbalance becomes too high or if a phase is missing.

Description of choice:

At [0] *Trip*, the adjustable frequency drive stops the motor within a few seconds (depending on frequency converter size).

If [1] *Autoderate & warning* is selected, the frequency converter exports a warning and reduces the output current to 50 % of $I_{MLT,N}$ to maintain operation.

At [2] *Warning*, only a warning is exported when a mains failure occurs, but in severe cases, other extreme conditions might result in a trip.

⚠ WARNING

If *Warning* is selected, the life expectancy of the drive may be reduced when the mains failure persists.

461 Feedback conversion

Value:

| | |
|---------------------------|-----|
| * Linear (LINEAR) | [0] |
| Square root (SQUARE ROOT) | [1] |

Function:

In this parameter, a function is selected which converts a connected feedback signal from the process to a feedback value that equals the square root of the connected signal. This is used, e.g. where regulation of a flow (volume) is required on the basis of pressure as feedback signal (flow = constant $\times \sqrt{\text{pressure}}$). This conversion makes it possible to set the reference in such a way that there is a linear connection between the reference and the flow required.

Description of choice:

If [0] *Linear* is selected, the feedback signal and the feedback value is proportional. If [1] *Square root* is selected, the frequency converter translates the feedback signal to a squared feedback value.

4.6 Enhanced Sleep Mode

The enhanced sleep mode has been developed to work under all conditions and to overcome problems when using pumps with flat pump curves or when suction pressure varies. Enhanced sleep mode provides excellent control for shutting down the pump at low flow, thus saving energy.

If the system operates with constant pressure control, a drop in the suction pressure may lead to an increase in frequency to maintain pressure. Consequently, the frequency may vary independent of the flow. This can lead to inappropriate activation of sleep mode or wake-up of the adjustable frequency drive.

Flat pump curves leads to a situation where there is little or no change in frequency in response to flow variation. Consequently, the adjustable frequency drive might not reach the sleep frequency when setting it at a low value.

Enhanced sleep mode is based on power/frequency monitoring and works in closed loop only. Stop due to the enhanced sleep mode function is initiated under the following conditions:

- Power consumption is below the no/low flow power curve and stays there for a certain time (*parameter 462 Enhanced sleep mode timer*) **or**
- The pressure feedback is above the reference when running at minimum speed and stays there for a certain time (*parameter 462 Enhanced sleep mode timer*).

If the feedback pressure drops below the wake-up pressure (*parameter 464 Wake-up pressure*), the adjustable frequency drive restarts the motor.

4.6.1 Dry Run Detection

For most pumps, especially submersible bore-hole pumps, it must be assured that the pump is stopped in case of dry run. This is assured by the *Dry-run detection* feature.

How does it work?

Dry-run detection is based on power/frequency monitoring and works in both closed and open loop.

Stop (trip) due to dry run is initiated under following conditions:

Closed loop:

- The adjustable frequency drive is running at maximum frequency (*parameter 202 Output frequency high limit, f_{MAX}*) and
- Feedback is below minimum reference (*parameter 204 Minimum reference, Ref_{MIN}*) and
- Power consumption is below the no/low flow power curve for a certain time (*parameter 470 Dry run time out*)

Open loop:

- Whenever the power consumption is below the no/low flow power curve for a certain time

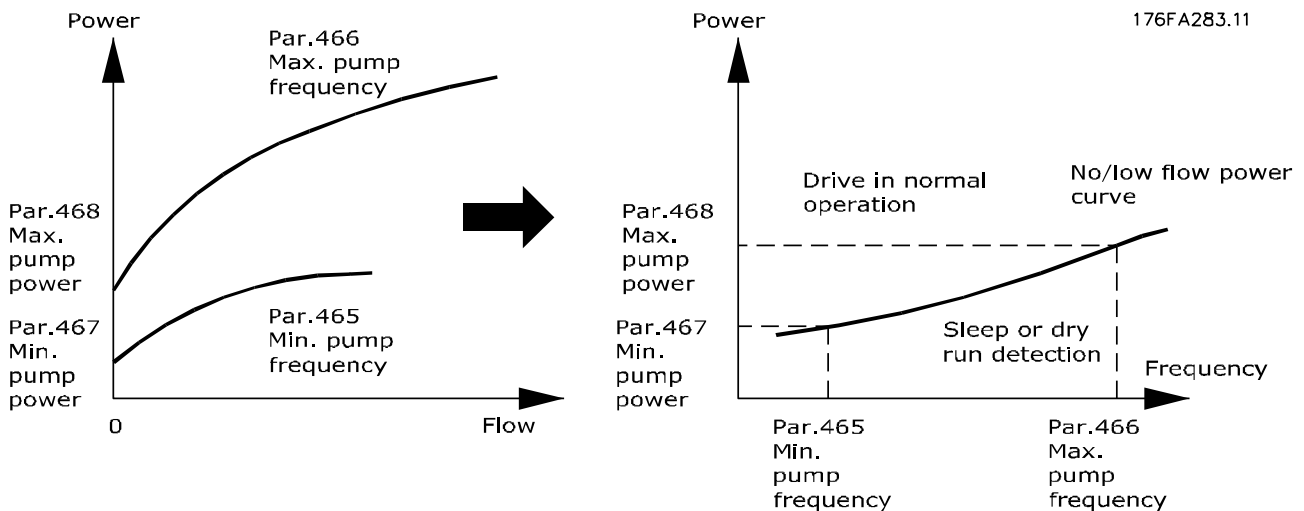

Illustration 4.19 Relation between Power Consumption and Flow

4.6.2 Benefits

- Dry run protection. Shuts down at no or low flow and protects the motor and pump from overheating.
- Improved energy savings with enhanced sleep mode.
- Minimised risk of bacterial growth in drinking water because of insufficient motor cooling.
- Easy commissioning.

(*parameter 470 Dry run time out*) the adjustable frequency drive trips.

The adjustable frequency drive can be set up for either manual or automatic restart after stop (*parameters 405 Reset function and 406 Automatic restart time*).

- Enhanced sleep mode and dry-run detection can be enabled and disabled independently. This is done in *parameter 462 Enhanced sleep mode timer* and *parameter 470 Dry run time out*.

Centrifugal pumps with radial impellers show a clear one-to-one relation between power consumption and flow, which is utilised to detect a no or low flow situation. It is only necessary to enter 2 sets of values for power and frequency (minimum and maximum) at no or low flow. The adjustable frequency drive then automatically calculates all data in-between those 2 sets of values and generates the no/low flow power curve. If the power consumption drops below the power curve, the adjustable frequency drive enters sleep mode or trips due to dry-run, depending on the configuration.

462 Enhanced Sleep Mode Timer

Value:
Value 0 – 9999 s * 0 = OFF

Function:
The timer prevents cycling between sleep mode and normal operation. If for instance the power consumption drops below the no/low flow power curve, the adjustable frequency drive changes mode when the timer expires.

Description of choice:
In case of cycling, set the timer to an appropriate value that limits the number of cycles.
The value 0 disables enhanced sleep mode.
Note: In *parameter 463 Boost set point*, it is possible to set up the adjustable frequency drive to provide a pressure boost before the pump is stopped.

463 Boost setpoint

Value:
1 - 200% * 100% of setpoint

Function:
This function can only be used if *Closed loop* has been selected in *parameter 100 Configuration*.
In systems with constant pressure regulation, it is advantageous to increase the pressure in the system before the adjustable frequency drive stops the motor. This extends the time during which the adjustable frequency drive stops the motor and helps to avoid frequent starting and stopping of the motor, e.g. in the case of leaks in the water supply system.
There is a fixed boost time-out on 30 s if the boost setpoint cannot be reached.

Description of choice:
Set the required *Boost setpoint* as a percentage of the resulting reference under normal operation. 100% corresponds to the reference without boost (supplement).

464 Wakeup Pressure

Value:
Parameter 204 Ref_{MIN} – parameter 215 - 218 Setpoint * 0

Function:
When in sleep mode, the adjustable frequency drive wakes up when the pressure is below the wake-up pressure for the time set in *parameter 462 Enhanced sleep mode timer*.

Description of choice:
Set an appropriate value for the system. The unit is set in *parameter 416 Process units*.

465 Minimum pump frequency

Value:
Value parameter 201 f_{MIN} – parameter 202 f_{MAX} (Hz) * 20

Function:
This parameter is linked to *parameter 467 Minimum Power* and is used for no/low flow power curve.

Description of choice:
Enter a value equal to or close to the desired minimum frequency set in *parameter 201 Output frequency low limit, f_{MIN}* . Note, that the extension of the no/low flow power curve is limited by *parameters 201 Output frequency low limit, f_{MIN}* and *202 Output frequency high limit, f_{MAX}* and not by *parameters 465 Minimum pump frequency* and *466 Maximum pump frequency*.

466 Maximum Pump Frequency

Value:
Value parameter 201 f_{MIN} - parameter 202 f_{MAX} (Hz) * 50

Function:
This parameter is linked to *parameter 468 Maximum pump power* and is used for the no/low flow power curve.

Description of choice:
Enter a value equal to or close to the desired maximum frequency set in *parameter 202 Output frequency high limit, f_{MAX}* .

467 Minimum Pump Power

Value:
0 – 500.000 W * 0

Function:
The associated power consumption at the frequency entered in *parameter 465 Minimum pump frequency*.

Description of choice:
Enter the no/low flow power reading at minimum pump frequency entered in *parameter 465 Minimum pump frequency*.
Depending on pump size or curve select [32] W or [8] kW in *parameter 009 Large display readout* for fine tuning.

468 Maximum Pump Power

Value:
0 – 500.000 W * 0

Function:
The associated power consumption at the frequency entered in *parameter 466 Minimum pump frequency*.

Description of choice:
Enter the no/low flow power reading at maximum pump frequency entered in *parameter 466 Minimum pump frequency*.

Depending on pump size or curve select [32] W or [8] kW in parameter 009 Large display readout for fine tuning.

| | |
|------------------|-----------------------------------|
| 469 | No Flow Power Compensation |
| Value: | 0.01 - 2 * 1.2 |
| Function: | |

This function is used for an off-set of the no/low flow power curve, which can be used as a safety factor or for fine tuning of the system.

Description of choice:
The factor is multiplied to the power values. E.g. 1.2 increases the power value with 1.2 over the whole frequency range.

| | |
|------------------|-------------------------|
| 470 | Dry Run Time Out |
| Value: | 5-30 s * 31 = OFF |
| Function: | |

If the power is below the no/low flow power curve, running at maximum speed for the time set in this parameter, the adjustable frequency drive trips on Alarm 75 dry-run. In open loop operation, the maximum speed does not necessarily need to be reached before tripping.

Description of choice:
Set the value to obtain the desired delay before tripping. Manual or automatic restart can be programmed in parameters 405 Reset function and 406 automatic restart time.
The value 30 disables dry-run detection.

| | |
|------------------|--------------------------------|
| 471 | Dry Run Interlock Timer |
| Value: | 0.5-60 min. * 30 min. |
| Function: | |

This timer determines when a trip due to dry run can be automatically reset. When the timer expires, the automatic reset of the trip can automatically restart the adjustable frequency drive.

Description of choice:
Parameter 406 Automatic restart time still determines how frequent an attempt to reset a trip is performed. If, for instance, parameter 406 Automatic restart time is set to 10 s and parameter 405 Reset function is set to [10] Automatic Reset x10, the adjustable frequency drive attempts to reset the trip 10 times within 100 s. If parameter 471 Dry Run Interlock Timer is set to 30 minutes, the adjustable frequency drive consequently is unable to perform automatic reset of dry run trip and needs a manual reset.

| | |
|---------------|----------------------------|
| 484 | Initial ramp |
| Value: | OFF/000.1s - 360.0 s * OFF |

Function:
Allows the motor/equipment to be brought up to minimum speed (frequency) at a rate different than the normal ramp-up rate (parameter 207 Ramp-up time 1).

Description of choice:
As an example, vertical pumps and other equipment often have a requirement not to operate below a minimum speed any longer than necessary. Damage and excessive wear can occur when operating below minimum speed (frequency) for too long time. The initial ramp is used to accelerate the motor/equipment quickly to minimum speed at which point, the normal ramp-up rate (parameter 207 Ramp-up time 1) is made active. The range of adjustment of the initial ramp is from 000.1 s to 360.0 s; adjustable in 0.1 second increments. If this parameter is set to 000.0, OFF is displayed in this parameter, the initial ramp is not active, and the normal ramp-up is active.

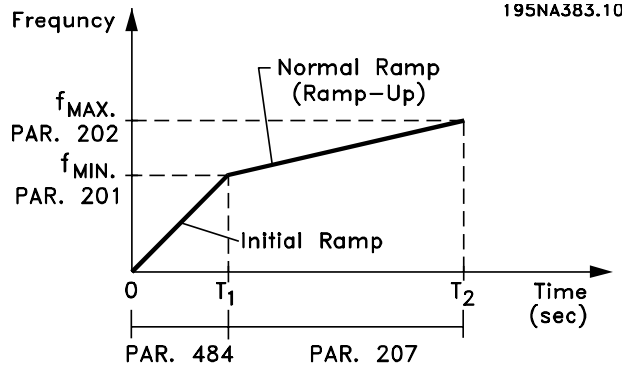

Illustration 4.20 Initial Ramp Example

4.6.3 Fill Mode

Fill Mode eliminates the occurrence of water hammer associated with the rapid exhausting of air from piping systems (such as irrigation systems).

The adjustable frequency drive, set for closed loop operation, uses an adjustable fill rate, a filled-pressure setpoint, an operating pressure setpoint, and a pressure feedback.

Fill mode is available when:

- The frequency converter is in closed loop mode (parameter 100 Configuration).
- Parameter 485 Fill Rate is not 0
- Parameter 437 Process PID normal/inverse control is set to normal

After a start command, fill-mode operation begins when the adjustable frequency drive reaches minimum frequency - set in *parameter 201 Output frequency low limit, f_{MIN}* .

The filled setpoint is a setpoint limit. When minimum speed is reached, the pressure feedback is evaluated, and the adjustable frequency drive begins to ramp to the filled-pressure setpoint at the rate set in *parameter 485 fill rate*.

The fill rate is dimensioned in units/S. The units are the units selected in *parameter 416 Process units*.

When the pressure feedback equals the filled setpoint, the control transitions to the operating setpoint (Setpoint 1-4, *parameter 215-218*) and continues operation in standard (normal) closed loop mode.

The value to use for the filled setpoint, can be determined by:

1. Press DISPLAY MODE on the LCP to display FEEDBACK 1.

NOTICE

Select the units in *parameter 416 Process units* before this step.

2. Operate the frequency converter in HAND mode and slowly advance the speed to fill the pipe while being careful not to create a water hammer.
3. An observer at the end of the pipe must be able to report when the pipe is filled.
4. At that instant, stop the motor, and observe the value of pressure feedback (have the LCP display set to observe the feedback before starting).
5. The value of feedback in step 4 is the value to use in *parameter 486 filled setpoint*.

The value to set in *parameter 485 fill rate* can be supplied by the system engineer from proper calculation or from experience, or it can be determined experimentally by performing numerous fill-mode sequences and either increasing or decreasing the value of this parameter to obtain the fastest fill without causing a water hammer.

The fill mode is also beneficial when bringing the motor to a stop as it prevents sudden changes in pressure and flow which could also cause a water hammer.

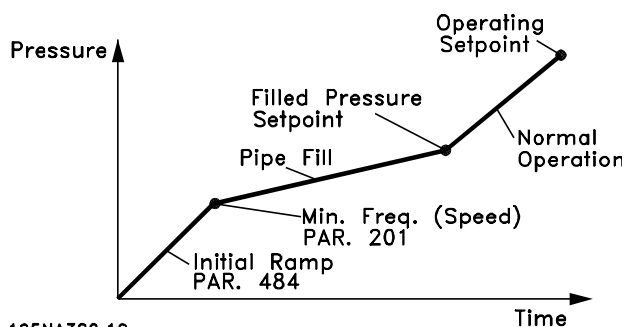

195NA382.10
Illustration 4.21 Fill Mode Example

485 Fill Rate

Value:
OFF/000000.001 - 999999.999 (units/s) - * OFF

Function:
Establishes the rate at which the pipe is filled.

Description of choice:
The dimension of this parameter is units/S. The units is the value selected in *parameter 416 Process units*. As an example, the units could be Bar, or MPa, or PSI, etc. If [4] Bar is the selected unit in *parameter 416 Process units*, the number set in this *parameter 485* would be dimensioned as Bar/S. Changes to this parameter can be made in steps of .001 units.

486 Filled Setpoint

Value:
Parameter 414 - Parameter 205 - * Parameter 414

Function:
The value set in this parameter corresponds to the pressure that exists at the pressure sensor when the pipe is filled.

Description of choice:
The units of this parameter correspond to the units selected in *Parameter 416 Process units*. The minimum value of this parameter is $F_{b_{min}}$ (*parameter 414 Minimum feedback $F_{B_{MIN}}$*). The maximum value for this parameter is Ref_{max} (*parameter 205 Maximum reference, Ref_{MAX}*). The setpoint can be changed in .01 steps.

4.7 Serial communication

4.7.1 Protocols

All frequency converters are equipped with an RS-485 port as standard, which makes it possible to select between 2 protocols. The 2 protocols that can be selected in *parameter 512 Telegram Profile*, are:

- Profidrive protocol
- Danfoss FC protocol

To select Danfoss FC protocol, set *parameter 512 Telegram Profile* to [1] FC protocol.

4.7.2 Telegram Traffic

Control and response telegrams

Telegram traffic in a master-follower system is controlled by the master. A maximum of 31 followers can be connected to a master, unless repeaters are used. If repeaters are used, a maximum of 126 followers can be connected to a master.

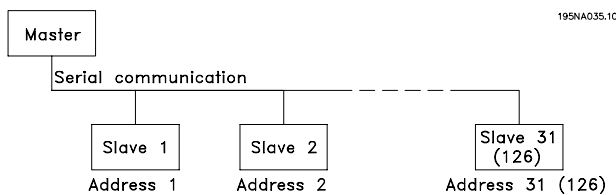

Illustration 4.22 Master-follower System

The master constantly sends telegrams addressed to the slaves and waits for response telegrams from them. The slave's response time is a maximum of 50 ms.

Only a slave that has received an error-free telegram, addressed to that slave can send a response telegram.

Broadcast

A master can send the same telegram simultaneously to all slaves connected to the bus. During this broadcast communication the slave does not send any response telegrams back to the master as to whether the telegram has been correctly received. Broadcast communication is set up in address format (ADR), see *chapter 4.7.3 Telegram Structure* for more details.

Content of a character (byte)

Each character transferred begins with a start bit. Then 8 data bits are transferred, corresponding to a byte. Each character is secured via a parity bit, which is set at "1" when it reaches parity (i.e. when there is an equal number of 1's in the 8 data bits and the parity bit in total). A character is completed by a stop bit, thus consisting of 11 bits in all.



Illustration 4.23 Character Structure

4.7.3 Telegram Structure

Each telegram begins with a start character (STX)=02 hex, followed by a byte that denotes the length of the telegram (LGE) and a byte that denotes the address of the frequency converter (ADR). Then follows a number of data bytes (variable, depending on the type of telegram). The telegram is completed by a data control byte (BCC).

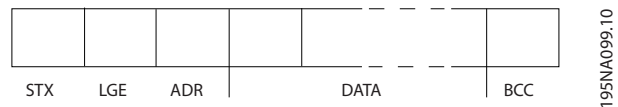

Illustration 4.24 Telegram Structure

Telegram timing

The communication speed between a master and a slave depends on the baud rate. The frequency converter's baud rate must be the same as the master's baud rate and be selected in *parameter 501 Baudrate*.

After a response telegram from the slave, there must be a pause of at least 2 characters (22 bits) before the master can send a new telegram. At a baud rate of 9600 baud, there must be a pause of at least 2.3 ms. When the master has completed the telegram, the slave's response time back to the master is a maximum of 20 ms, and there is a pause of at least 2 characters.

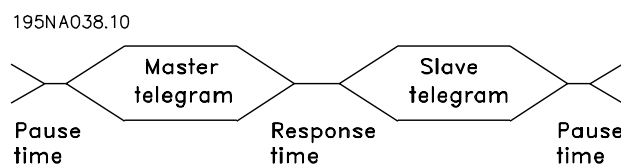

Illustration 4.25 Telegram Time

- Pause time, minimum 2 characters
- Response time, minimum 2 characters
- Response time, maximum 20 ms

The time between the individual characters in a telegram may not exceed 2 characters and the telegram must be completed within 1.5 x nominal telegram time. At a baud rate of 9600 baud and a telegram length of 16 bytes, the telegram is completed after 27.5 ms.

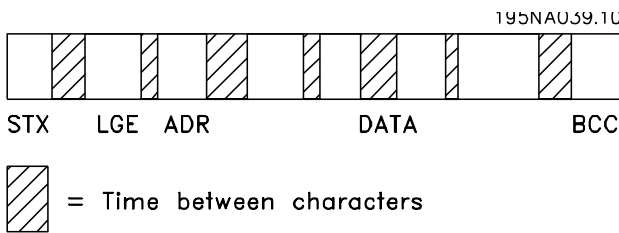

Illustration 4.26 Telegram Transmission Timing

Telegram length (LGE)

The telegram length is the number of data bytes plus the address byte ADR plus the data control byte BCC.

The length of telegrams with 4 data bytes is:

$$LGE = 4+1+1=6 \text{ bytes}$$

The length of telegrams with 12 data bytes is:

$$LGE = 12+1+1=14 \text{ bytes}$$

The length of telegrams containing texts is 10+n bytes. 10 represents the fixed characters, while the 'n' is variable (depending on the length of the text).

Frequency converter address (ADR)

2 different address formats are used, with the frequency converter's address range being either 1-31 or 1-126.

1. Address format 1-31

The byte for address range 1-31 has the following profile:

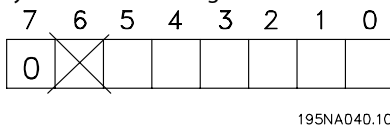

- Bit 7=0 (address format 1-31 active)
- Bit 6 is not used
- Bit 5=1: Broadcast, address bits (0-4) are not used
- Bit 5=0: No broadcast
- Bit 0-4=Frequency converter address 1-31

2. Address format 1-126

The byte for address range 1-126 has the following profile:

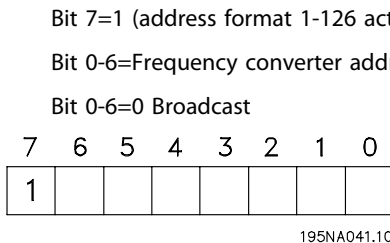

The slave sends the address byte back unchanged in the response telegram to the master.

Example:

Illustration 4.27 shows writing to frequency converter address 22 (16H) with address format 1-31:

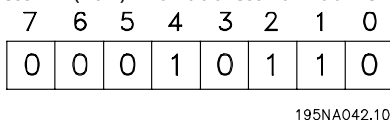

Data control byte (BCC)

The data control byte is explained in this example: Before the first byte in the telegram is received, the calculated checksum (BCS) is 0.

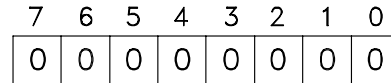

When the first byte (02H) has been received:

BCS=BCC EXOR "first byte"
(EXOR=exclusive-or)

Each subsequent byte gates with BCS EXOR and produces a new BCC. Table 4.7 is an example.

| | |
|----------|-------------------------|
| BCS | = 0 0 0 0 0 0 1 0 (02H) |
| | EXOR |
| 2nd byte | = 1 1 0 1 0 1 1 0 (D6H) |
| BCC | = 1 1 0 1 0 1 0 0 (D4H) |

4.7.4 Data Character (Byte)

The structure of data blocks depends on the type of telegram. There are 3 types of telegram, and the type of telegram applies for both control telegrams (masterslave) and response telegrams (slavemaster). The 3 types of telegrams are:

- Parameter block, used to transfer parameters between master and slave. The data block is made up of 12 bytes (6 words) and also contains the process block.

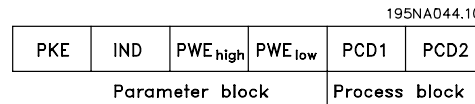

- The process block is made up of a data block of 4 bytes (2 words) and contains:
 - Control word and reference value
 - Status word and present output frequency (from slave to master)

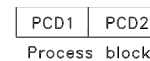

- Text block, which is used to read or write texts via the data block.

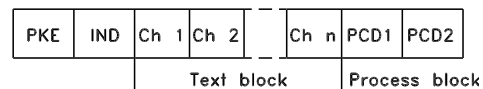

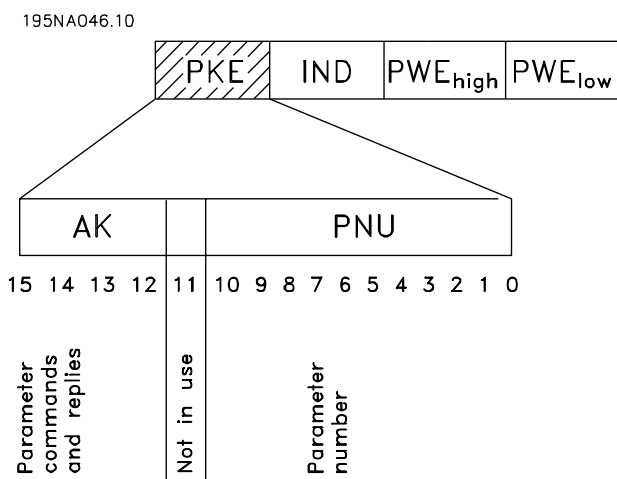

Illustration 4.27 Parameter Commands and Responses (AK)

Bits no. 12-15 are used to transfer control commands from master to slave and response commands from slave back to the master.

| Bit no. | | | | Parameter command |
|---------|----|----|----|---|
| 15 | 14 | 13 | 12 | |
| 0 | 0 | 0 | 0 | No command |
| 0 | 0 | 0 | 1 | Read parameter value |
| 0 | 0 | 1 | 0 | Write parameter value in RAM (word) |
| 0 | 0 | 1 | 1 | Write parameter value in RAM (double word) |
| 1 | 1 | 0 | 1 | Write parameter value in RAM and EEprom (double word) |
| 1 | 1 | 1 | 0 | Write parameter value in RAM and EEprom (word) |
| 1 | 1 | 1 | 1 | Read/write text |

Table 4.7 Parameter Commands

| Bit no. | | | | Response |
|---------|----|----|----|---|
| 15 | 14 | 13 | 12 | |
| 0 | 0 | 0 | 0 | No response |
| 0 | 0 | 0 | 1 | Parameter value transferred (word) |
| 0 | 0 | 1 | 0 | Parameter value transferred (double word) |
| 0 | 1 | 1 | 1 | Command cannot be performed |
| 1 | 1 | 1 | 1 | Text transferred |

Table 4.8 Response Commands

If the command cannot be performed, the slave sends this response: 0111 *Command cannot be performed* and gives the following fault report in the parameter value (PWE):

| Response (0111) | Fault report |
|-----------------|---|
| 0 | The parameter number used does not exist |
| 1 | There is no write access to the defined parameter |
| 2 | Data value exceeds the parameter's limits |
| 3 | The sub index used does not exist |
| 4 | The parameter is not the array type |
| 5 | The data type does not match the defined parameter |
| 17 | Data change in the defined parameter is not possible in the frequency converter's present mode. Certain parameters can only be changed when the motor is turned off |
| 130 | There is no bus access to the defined parameter |
| 131 | Data change is not possible because factory Setup is selected |

Table 4.9 Fault Report

Parameter number (PNU)

Bits no. 0-10 are used to transfer parameter numbers. Parameters are described in *chapter 4 Programming*.

Index



Index is used with the parameter number to read/write-access parameters that have an index, e.g. *parameter 615 Error code*. The index is made up of 2 bytes, one lowbyte and one highbyte, but only the lowbyte is used as an index.

Example - Index

The first error code (index [1]) in *parameter 615 Error code* must be read.

PKE=1267 hex (read *parameter 615 Error code*.)

IND=0001 hex - Index no. 1.

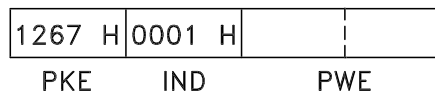

The frequency converter responds in the parameter value block (PWE) with a fault code value from 1-99. See *chapter 5.2.2 Warnings and Alarm Messages* to identify the fault code.

Parameter value (PWE)

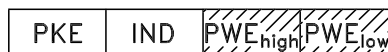

The parameter value block consists of 2 words (4 bytes), and the value depends on the defined command (AK). If the master prompts for a parameter value, the PWE block does not contain a value.

If the master changes a parameter value (write), the new value is written in the PWE block and sent to the slave.

If the slave responds to a parameter request (read command), the present parameter value in the PWE block is transferred and returned to the master.

If a parameter does not contain a numerical value, but several data options, e.g. *parameter 001 Language* where corresponds to [0] *English*, and corresponds to [3] *Danish*, the data value is selected by entering the value in the PWE block. See *Example - Selecting a data value*.

Via serial communication it is only possible to read parameters that have data type 9 (text string). *Parameters 621 - 635 Nameplate data* is data type 9. For example, in *parameter 621 Unit type* it is possible to read the unit size and mains voltage range.

When a text string is transferred (read), the length of the telegram is variable, as the texts are of different lengths. The telegram length is defined in the telegram's second byte, known as LGE.

To be able to read a text via the PWE block, the parameter command (AK) must be set to F hex.

The index character is used to indicate whether it is a read or write command.

In a read command, the index must have the following format:

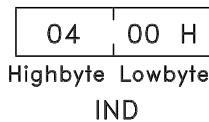

Some frequency converters have parameters to which a text may be written. To be able to write a text via the PWE block, the parameter command (AK) must be set to F hex. For a write command the text must have the following format:

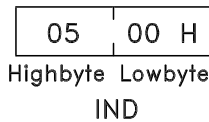

Data types supported by frequency transformer:

| Data types | Description |
|------------|-------------|
| 3 | Integer 16 |
| 4 | Integer 32 |
| 5 | Unsigned 8 |
| 6 | Unsigned 16 |
| 7 | Unsigned 32 |
| 9 | Text string |

Unsigned means that there is no operational sign in the telegram.

Example - Write a parameter value

Parameter 202 Output frequency high limit, f_{MAX} to be changed to 100 Hz. The value must be recalled after a mains failure, so it is written in EEPROM.

PKE=E0CA hex-Write for *parameter 202 Output frequency high limit, f_{MAX}*

IND=0000 hex

PWE_{HIGH}=0000 hex

PWE_{LOW}=03E8 hex-Data value 1000, corresponding to 100 Hz, see conversion.

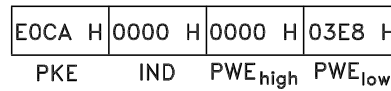

The response from the slave to the master is:

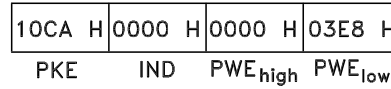

Example - Selection of a data value

To select [20] *kg/hour* in *parameter 416 Process units*, recall the value after a mains failure, so it is written in EEPROM.

PKE=E19F hex-Write for *parameter 416 Process units*

IND=0000 hex

PWE_{HIGH}=0000 hex

PWE_{LOW}=0014 hex-Select data option [20] *kg/hour*

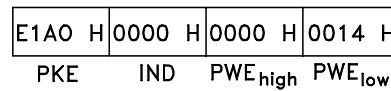

The response from the slave to the master is:

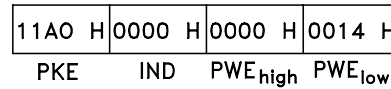

Example - Reading a parameter value

The value in *parameter 207 Ramp up time 1* is required. The master sends the following request:

PKE=10CF hex-read *parameter 207 Ramp up time 1*

IND=0000 hex

PWE_{HIGH}=0000 hex

PWE_{LOW}=0000 hex

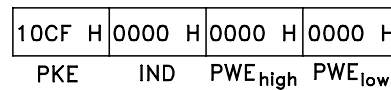

If the value in *parameter 207 Ramp-up time 1* is 10 s, the response from the slave to the master is:

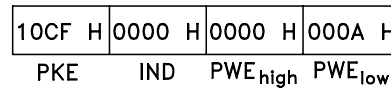

Conversion

See *chapter 5.5 Parameter List with Factory Settings* for various attributes of each parameter. As a parameter value can only be transferred as a whole number, a conversion factor must be used to transfer decimals.

Example

Parameter 201 Output frequency, low limit f_{MIN} has a conversion factor of 0.1. If the minimum frequency is preset to 10 Hz, the value 100 must be transferred, as a conversion factor of 0.1 means that the value transferred is multiplied by 0.1. The value 100 is perceived as 10.0.

| Conversion index | Conversion factor |
|------------------|-------------------|
| 73 | 0.1 |
| 2 | 100 |
| 1 | 10 |
| 0 | 1 |
| -1 | 0.1 |
| -2 | 0.01 |
| -3 | 0.001 |
| -4 | 0.0001 |
| -5 | 0.00001 |

4.7.5 Process Words

The block of process words is divided into 2 blocks of 16 bits, which always occur in the defined sequence.

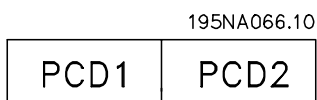

Illustration 4.28 Block of Process Words

| | PCD 1 | PCD 2 |
|---------------------------------|--------------|--------------------------|
| Control telegram (master⇒slave) | Control word | Reference-value |
| Control telegram (slave⇒master) | Status word | Present output frequency |

Table 4.10 Function of PCD 1 and PCD 2

4.7.6 Control Word According to FC Protocol

To select *FC protocol* in the control word, set *parameter 512 Telegram Profile* to [1] *FC protocol*.

The control word is used to send commands from a master (e.g. a PC) to a slave (frequency converter).

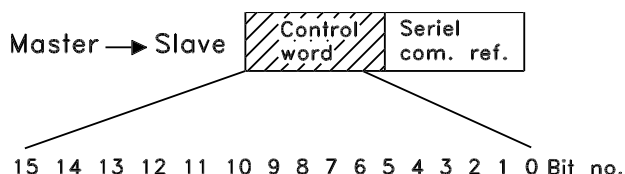

Illustration 4.29 Control Word According to FC Protocol

| Bit | Bit=0 | Bit=1 |
|-----|--------------------|--------------------------------------|
| 00 | | Preset ref. lsb |
| 01 | | Preset ref. msb |
| 02 | DC braking | |
| 03 | Coasting stop | |
| 04 | Quick stop | |
| 05 | Freeze outp. freq. | |
| 06 | Ramp stop | Start |
| 07 | | Reset |
| 08 | | Jog |
| 09 | Ramp 1 | Ramp 2 |
| 10 | Data not valid | Data valid |
| 11 | No function | Relay 01 activated |
| 12 | No function | Digital output Terminal 46 activated |
| 13 | Select Setup, lsb | |
| 14 | Select Setup, msb | |
| 15 | | Reversing |

Table 4.11 Bit Definition

Bit 00/01

Bit 00/01 is used to select between the 4 pre-programmed references (*parameters 215-218 Preset reference*) according to *Table 4.12*.

| Preset ref. | Parameter | Bit 01 | Bit 00 |
|-------------|-----------|--------|--------|
| 1 | 215 | 0 | 0 |
| 2 | 216 | 0 | 1 |
| 3 | 217 | 1 | 0 |
| 4 | 218 | 1 | 1 |

Table 4.12 Bit 00/01

NOTICE

In *parameter 508 Selection of preset reference*, a selection is made to define how bit 00/01 gates with the corresponding function on the digital inputs.

Bit 02, DC brake

Bit 02='0' causes DC braking and stop. Brake voltage and duration are preset in *parameters 132 DC brake voltage* and *126 DC braking time*.

NOTICE

In *parameter 504 DC brake*, a selection is made to define how bit 02 gates with the corresponding function on a digital input

Bit 03, Coasting stop

Bit 03='0' causes the frequency converter to immediately release the motor (the output transistors are shut off), so that it coasts to a standstill.

Bit 03='1' causes the frequency converter to be able start the motor if the other starting conditions have been fulfilled.

NOTICE

In *parameter 502 Coasting stop*, a selection is made to define how bit 03 gates with the corresponding function on a digital input.

Bit 04, Quick stop

Bit 04='0' causes a stop, in which the motor's speed is ramped down to stop via *parameter 212 Quick stop ramp-down time*.

Bit 05, Freeze output frequency

Bit 05='0' causes the present output frequency (in Hz) to freeze. The frozen output frequency can now only be changed with the digital inputs programmed to *Speed up* and *Speed down*.

NOTICE

If *Freeze output* is active, the frequency converter cannot be stopped via bit 06 *Start* or via a digital input. The frequency converter can only be stopped by the following:

- Bit 03 *Coasting stop*
- Bit 02 *DC braking*
- Digital input programmed to *DC braking*, *Coasting stop* or *Reset and coasting stop*.

Bit 06, Ramp stop/start

Bit 06='0' causes a stop, in which the motor's speed is ramped down to stop via the selected *ramp down* parameter.

Bit 06='1' causes the frequency converter to be able to start the motor, if the other starting conditions have been fulfilled.

NOTICE

In *parameter 505 Start*, a selection is made to define how bit 06 ramp stop/start gates with the corresponding function on a digital input.

Bit 07, Reset

Bit 07='0' does not cause a reset.

Bit 07='1' causes the reset of a trip. Reset is activated on the signal's leading edge, i.e. when changing from logic '0' to logic '1'.

Bit 08, Jog

Bit 08='1' causes the output frequency to be determined by *parameter 213 Jog frequency*.

Bit 09, Selection of ramp 1/2

Bit 09="0" means that ramp 1 is active (*parameters 207 Ramp-up time 1/208 Ramp-down time 1*).

Bit 09="1" means that ramp 2 (*parameters 209 Ramp-up time 2/210 Ramp-down time 2*) is active.

Bit 10, Data not valid/Data valid

Is used to tell the frequency converter whether the control word is to be used or ignored.

Bit 10='0' causes the control word to be ignored.

Bit 10='1' causes the control word to be used. This function is relevant, because the control word is always contained in the telegram, regardless of which type of telegram is used, i.e. it is possible to turn off the control word if it is not used for updating or reading parameters.

Bit 11, Relay 01

Bit 11="0" Relay not activated.

Bit 11="1" Relay 01 activated, provided [26] *Control word bit* has been selected in *parameter 323 Relay output 1-3*.

Bit 12, Digital output, terminal 46

Bit 12="0" Digital output has not been activated.

Bit 12="1" Digital output has been activated, provided [26] *Control word bit* has been selected in *parameter 341 Digital/Pulse output terminal 46*.

Bit 13/14, Selection of set-up

Bits 13 and 14 are used to selected from the 4 menu set-ups according to *Table 4.13*.

| Setup | Bit 14 | Bit 13 |
|-------|--------|--------|
| 1 | 0 | 0 |
| 2 | 0 | 1 |
| 3 | 1 | 0 |
| 4 | 1 | 1 |

Table 4.13 Bit 13/14

The function is only possible when [5] *Multi-Setups* is selected in *parameter 004 Active Setup*.

NOTICE

In *parameter 507 Selection of Setup* a selection is made to define how bit 13/14 gates with the corresponding function on the digital inputs.

Bit 15 Reversing

Bit 15='0' causes no reversing.

Bit 15='1' causes reversing.

NOTICE

In the factory setting, reversing is set to [0] *digital* in *parameter 506 Reversing*. Bit 15 only causes reversing when either [1] *Serial communication*, [3] *Logic or*, or [2] *Logic and* is selected.

4.7.7 Status Word According to FC Profile

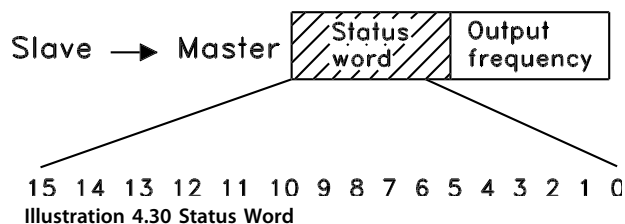

4

The status word is used to inform the master (e.g. a PC) of the slave's (frequency converter) mode. Slave⇒Master.

| Bit | Bit=0 | Bit=1 |
|-----|-------------------------|--------------------|
| 00 | | Control ready |
| 01 | | Drive ready |
| 02 | Coasting stop | |
| 03 | No trip | Trip |
| 04 | Not used | |
| 05 | Not used | |
| 06 | | Trip lock |
| 07 | No warning | Warning |
| 08 | Speed≠ref. | Speed=ref. |
| 09 | Local control | Ser. communi. |
| 10 | Outside frequency range | Frequency limit OK |
| 11 | | Motor running |
| 12 | | |
| 13 | | Voltage warn. |
| 14 | | Current limit |
| 15 | | Thermal warn. |

Table 4.14 Status Word Bit Definition

Bit 00, Control ready

Bit 00='1'. The frequency converter is ready for operation.
 Bit 00='0'. The frequency converter is not ready for operation.

Bit 01, Drive ready

Bit 01='1'. The frequency converter is ready for operation, but there is an active coasting command via the digital inputs or via serial communication.

Bit 02, Coasting stop

Bit 02='0'. The frequency converter has released the motor.
 Bit 02='1'. The frequency converter can start the motor when a start command is given.

Bit 03, No trip/trip

Bit 03='0' means that the frequency converter is not in fault mode.
 Bit 03='1' means that the frequency converter is tripped, and that it needs a reset signal for operation to be reestablished.

Bit 04, Not used

Bit 04 is not used in the status word.

Bit 05, Not used

Bit 05 is not used in the status word.

Bit 06, Trip lock

Bit 06='0' means that the frequency converter is not trip locked.

Bit 06='1' means that the frequency converter is trip locked and it cannot be reset before the mains supply has been removed. The trip can be reset either with 24 V external control back-up, or after the power is connected again.

Bit 07, No warning/warning

Bit 07='0' means that there are no warnings.
 Bit 07='1' means that a warning has occurred.

Bit 08, Speed≠ref/speed=ref.

Bit 08='0' means that the motor is running, but that the present speed is different from the preset speed reference. It might, for example, be the case while the speed is being ramped up/down during start/stop.

Bit 08='1' means that the motor's present speed is the same as the preset speed reference.

Bit 09, Local operation/serial communication control

Bit 09='0' means that [STOP/RESET] is activated on the control unit, or that [1] Local control in parameter 002 Local/remote operation is selected. It is not possible to control the frequency converter via serial communication.
 Bit 09='1' means that it is possible to control the frequency converter via serial communication.

Bit 10, Outside frequency range

Bit 10='0', if the output frequency has reached the value in parameter 201 Output frequency low limit or parameter 202 Output frequency high limit.

Bit 10='1', means that the output frequency is within the defined limits.

Bit 11, Running/not running

Bit 11='0' means that the motor is not running.

Bit 11='1' means that the frequency converter has a start signal or that the output frequency is greater than 0 Hz.

Bit 13, Voltage warning high/low

Bit 13='0' means that there are no voltage warnings.

Bit 13='1' means that the DC voltage in the frequency converter's intermediate circuit is too low or too high.

Bit 14, Current limit

Bit 14='0' means that the output current is less than the value in parameter 221 Current Limit I_{LIM} .

Bit 14='1' means that the output current is greater than the value in parameter 221 Current Limit I_{LIM} and that the frequency converter trips after a set period of time.

Bit 15, Thermal warning

Bit 15='0' means that there is no thermal warning.

Bit 15='1' means that the temperature limit has been exceeded in either the motor, frequency converter or from a thermistor that is connected to a digital input.

4.7.8 Control Word According to Fieldbus Profile

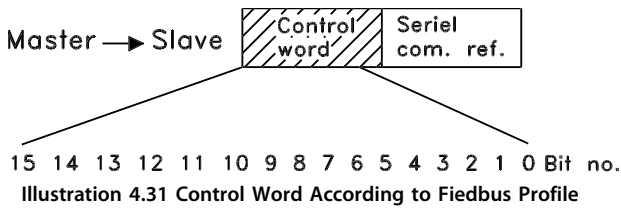

Illustration 4.31 Control Word According to Fiedbus Profile

To select *Profdrive* in the control word, set *parameter 512 Telegram Profile* to [0] *Profdrive*.

The control word is used to send commands from a master (e.g. a PC) to a slave (frequency converter). MasterSlave.

| Bit | Bit = 0 | Bit =1 |
|-----|--------------------|------------|
| 00 | OFF 1 | ON 1 |
| 01 | OFF 2 | ON 2 |
| 02 | OFF 3 | ON 3 |
| 03 | Coasting stop | |
| 04 | Quick stop | |
| 05 | Freeze outp. freq. | |
| 06 | Ramp stop | Start |
| 07 | | Reset |
| 08 | | Bus jog 1 |
| 09 | | Bus jog 2 |
| 10 | Data not valid | Data valid |
| 11 | | Slow down |
| 12 | | Catch-up |
| 13 | Select Setup (lsb) | |
| 14 | Select Setup (msb) | |
| 15 | | Reversing |

Table 4.15 Bit Definition

Bit 00-01-02, OFF1-2-3/ON1-2-3

Bit 00-01-02='0' causes ramp stop, which uses the ramp time in *parameters 207/208 or 209/210*.

If *Relay 123* is selected in *parameter 323 Relay output*, the output relay is activated when the output frequency is 0 Hz.

Bit 00-01-02='1' means that the frequency converter can start the motor if the other starting conditions are fulfilled.

Bit 03, Coasting stop

See description in *chapter 4.7.6 Control Word According to FC Protocol*.

Bit 04, Quick stop

See description in *chapter 4.7.6 Control Word According to FC Protocol*.

Bit 05, Freeze output frequency

See description in *chapter 4.7.6 Control Word According to FC Protocol*.

Bit 06, Ramp stop/start

See description in *chapter 4.7.6 Control Word According to FC Protocol*.

Bit 07, Reset

See description in *chapter 4.7.6 Control Word According to FC Protocol*.

Bit 08, Jog 1

Bit 08="1" means that the output frequency is determined by *parameter 509 Bus jog 1*.

Bit 09, Jog 2

Bit 09="1" means that the output frequency is determined by *parameter 510 Bus jog 2*.

Bit 10, Data not valid/Data valid

See description in *chapter 4.7.6 Control Word According to FC Protocol*.

Bit 11, Slow-down

Used to reduce the speed reference by the value in *parameter 219 Catch-up/slow-down reference*.

Bit 11='0' does not cause any change to the reference.

Bit 11='1' means that the reference is reduced.

Bit 12, Catch-up

Used to increase the speed reference by the value in *parameter 219 Catch-up/slow-down reference*.

Bit 12='0' does not cause any change to the reference.

Bit 12='1' means that the reference is increased.

If both *Slow down* and *Catch-up* are activated (Bits 11 and 12="1"), slow down has the highest priority, i.e. that the speed reference is reduced.

Bit 13/14, Selection of Setup

See description in *chapter 4.7.6 Control Word According to FC Protocol*.

Bit 15 Reversing

See description in *chapter 4.7.6 Control Word According to FC Protocol*.

4.7.9 Status Word According to Profdrive Protocol

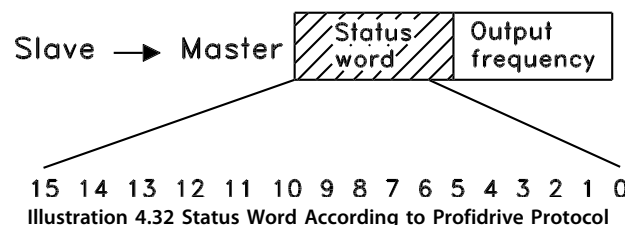

Illustration 4.32 Status Word According to Profdrive Protocol

The status word is used to inform the master (e.g. a PC) of the slave's (frequency converter) mode. SlaveMaster.

| Bit | Bit=0 | Bit=1 |
|-----|-------------------------|--------------------|
| 00 | | Control ready |
| 01 | | Drive ready |
| 02 | Coasting stop | |
| 03 | No trip | Trip |
| 04 | ON 2 | OFF 2 |
| 05 | ON 3 | OFF 3 |
| 06 | Start enable | Start disable |
| 07 | | Warning |
| 08 | Speed ref. | Speed=ref. |
| 09 | Local control | Ser. communi. |
| 10 | Outside frequency range | Frequency limit OK |
| 11 | | Motor running |
| 12 | | |
| 13 | | Voltage warn. |
| 14 | | Current limit |
| 15 | | Thermal warn. |

Table 4.16 Bit Definition

Bit 00, Control not ready/ready

Bit 00='0' means that the Bit 00, 01 or 02 in the control word are '0' (OFF1, OFF2 or OFF3) or the frequency converter is not ready for operation.

Bit 00='1' means that the frequency converter is ready for operation.

Bit 01, Drive ready

See description in *chapter 4.7.7 Status Word According to FC Profile*.

Bit 02, Coasting stop

Bit 02='0' means that bits 00, 02 or 03 in the control word are '0' (OFF1, OFF3 or Coasting stop).

Bit 02='1' means that bits 00, 01, 02 and 03 in the control word are '1', and that the frequency converter has not tripped.

Bit 03, No trip/trip

See description in *chapter 4.7.7 Status Word According to FC Profile*.

Bit 04, ON 2/OFF 2

Bit 04='0' means that bit 01 in the control word='1'.

Bit 04='1' means that bit 01 in the control word='0'.

Bit 05, ON 3/OFF 3

Bit 05='0' means that bit 02 in the control word='1'.

Bit 05='1' means that bit 02 in the control word='0'.

Bit 06, Start enable/start disable

Bit 06='1' after reset of a trip, after activation of OFF2 or OFF3 and after connection of mains voltage. *Start disable* is reset by setting bit 00 in the control word to '0', and bit 01, 02 and 10 are set to '1'.

Bit 07, Warning

See description in *chapter 4.7.7 Status Word According to FC Profile*.

Bit 08, Speed

See description in *chapter 4.7.7 Status Word According to FC Profile*.

Bit 09, No warning/warning

See description in *chapter 4.7.7 Status Word According to FC Profile*.

Bit 10, Speed ref/speed = ref.

See description in *chapter 4.7.7 Status Word According to FC Profile*.

Bit 11, Running/not running

See description in *chapter 4.7.7 Status Word According to FC Profile*.

Bit 13, Voltage warning high/low

See description in *chapter 4.7.7 Status Word According to FC Profile*.

Bit 14, Current limit

See description in *chapter 4.7.7 Status Word According to FC Profile*.

Bit 15, Thermal warning

See description in *chapter 4.7.7 Status Word According to FC Profile*.

4.7.10 Serial Communication Reference

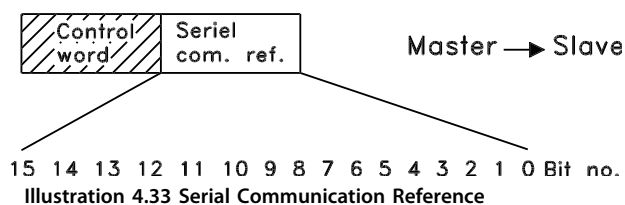

Illustration 4.33 Serial Communication Reference

The serial communication reference is transferred to the frequency converter as a 16-bit word. The value is transferred in whole numbers 0 to ±32767 (±200%). 16384 (4000 Hex) corresponds to 100%.

The serial communication reference has the following format: 0-16384 (4000 Hex) ≅ 0-100% (*Parameter 204 Minimum ref.-Parameter 205 Maximum ref.*).

It is possible to change the direction of rotation via the serial reference. This is done by converting the binary reference value to 2' complement. See example.

Example - Control word and serial communication ref.:

The frequency converter is to receive a start command and the reference is to be set to 50% (2000 Hex) of the reference range.

Control word = 047F Hex ⇒ Start command.

Reference = 2000 Hex ⇒ 50% reference.

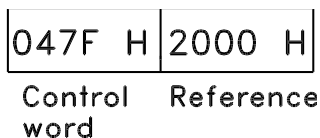

Illustration 4.34 Control Word and Reference

The frequency converter is to receive a start command and the reference is to be set to -50% (-2000 Hex) of the reference range.

The reference value is first converted to 1' complement, and then 1 is added binary to obtain 2' complement:

| | |
|---------------|--------------------------|
| 2000 Hex | 0010 0000 0000 0000 0000 |
| 1' complement | 1101 1111 1111 1111 1111 |
| | + 1 |
| 2' complement | 1110 0000 0000 0000 0000 |

Table 4.17 Reference Value

Control word = 047F Hex ⇒ Start command.

Reference = E000 Hex ⇒ -50% reference.

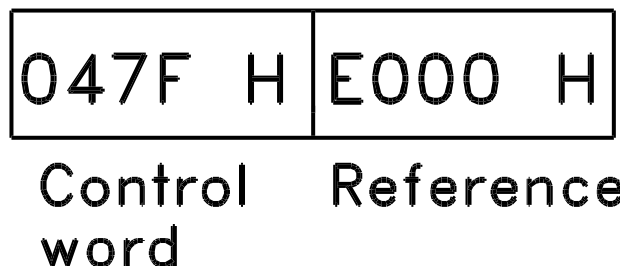

Illustration 4.35 Resulting Control Word and Reference

4.7.11 Present Output Frequency

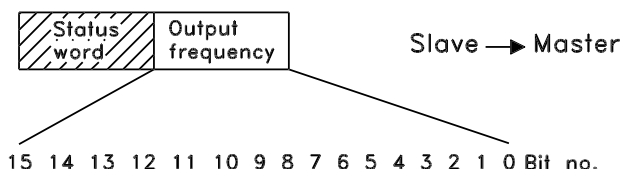

Illustration 4.36 Present Output Frequency

The value of the frequency converter's present output frequency is transferred as a 16-bit word. The value is transferred as whole numbers 0 to ±32767 (±200%). 16384 (4000 Hex) corresponds to 100%.

Output frequency has the following format:
 0-16384 (4000 Hex) ≅ 0-100% (Parameter 201 Output frequency low limit-Parameter 202 Output frequency high limit).

Example - Status word and current output frequency:
 The master receives a status message from the frequency converter that the current output frequency is 50% of the output frequency range.

Parameter 201 Output frequency low limit = 0 Hz

Parameter 202 Output frequency high limit = 50 Hz

Status word = 0F03 Hex.

Output frequency = 2000 Hex ⇒ 50% of the frequency range, corresponding to 25 Hz.

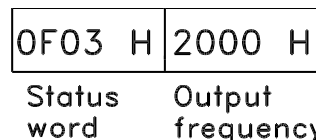

Illustration 4.37 Status Word and Output Frequency

4.8 Serial Communication Parameters

| 500 | Address |
|--|---------|
| Value: | |
| Parameter 500 Protocol = FC protocol [0] | * 1 |
| 0 - 247 | |
| Parameter 500 Protocol = Metasys N2 [1] | * 1 |
| 1 - 255 | |
| Parameter 500 Protocol = MODBUS RTU [3] | * 1 |
| 1 - 247 | |

Function:
This parameter allows the allocation of an address to each frequency converter in a serial communication network.

Description of choice:
Allocate a unique address to the individual frequency converter.
If the number of units connected (frequency converters + master) is higher than 31, use a repeater.
Parameter 500 Address cannot be selected via the serial communication, but must be preset via the control unit.

| 501 | Baudrate |
|-------------------------|----------|
| Value: | |
| 300 Baud (300 BAUD) | [0] |
| 600 Baud (600 BAUD) | [1] |
| 1200 Baud (1200 BAUD) | [2] |
| 2400 Baud (2400 BAUD) | [3] |
| 4800 Baud (4800 BAUD) | [4] |
| * 9600 Baud (9600 BAUD) | [5] |

Function:
This parameter is for programming the speed at which data is transmitted via the serial port. Baud rate is defined as the number of bits transmitted per s.

Description of choice:
Set the frequency converter's transmission speed at a value corresponding to the transmission speed of the master.
Parameter 501 Baudrate cannot be selected via the serial port, but must be preset via the operating unit.

| 502 | Coasting Stop |
|-------------------------------|---------------|
| Value: | |
| Digital input (DIGITAL INPUT) | [0] |
| Serial port (SERIAL PORT) | [1] |
| Logic and (LOGIC AND) | [2] |
| * Logic or (LOGIC OR) | [3] |

Function:
Parameters 502-508 allow a selection between controlling the adjustable frequency drive via the digital inputs and/or via the serial port.
If [1] *Serial port* is selected, the relevant command can only be activated if a command is given via the serial port. In the case of [2] *Logic and* the function must also be activated via a digital input.

Description of choice:

Table 4.18, Table 4.19, Table 4.20, and Table 4.21 show when the motor is running and when it is coasting, when each of the following is selected:

- [0] *Digital input*
- [1] *Serial port*
- [2] *Logic and* or [3] *Logic or*

| Dig. input | Ser. port | Function |
|------------|-----------|---------------|
| 0 | 0 | Coasting |
| 0 | 1 | Coasting |
| 1 | 0 | Motor running |
| 1 | 1 | Motor running |

Table 4.18 Function Description for [0] *Digital input*

| Dig. input | Ser. port | Function |
|------------|-----------|---------------|
| 0 | 0 | Coasting |
| 0 | 1 | Motor running |
| 1 | 0 | Coasting |
| 1 | 1 | Motor running |

Table 4.19 Function Description for [1] *Serial port*

| Dig. input | Ser. port | Function |
|------------|-----------|---------------|
| 0 | 0 | Coasting |
| 0 | 1 | Motor running |
| 1 | 0 | Motor running |
| 1 | 1 | Motor running |

Table 4.20 Function Description for [2] *Logic and*

| Dig. input | Ser. port | Function |
|------------|-----------|---------------|
| 0 | 0 | Coasting |
| 0 | 1 | Coasting |
| 1 | 0 | Coasting |
| 1 | 1 | Motor running |

Table 4.21 Function Description for [3] *Logic or*

NOTICE

Coasting stop and bit 03 in the control word are active at logic '0'.

| 503 | Quick-stop |
|-------------------------------|------------|
| Value: | |
| Digital input (DIGITAL INPUT) | [0] |
| Serial port (SERIAL PORT) | [1] |
| Logic and (LOGIC AND) | [2] |
| * Logic or (LOGIC OR) | [3] |

Function:
See function description for *parameter 502 Coasting stop*.

Description of choice:

Table 4.22, Table 4.23, Table 4.24, and Table 4.25 show when the motor is running and when it is in Quick-stop mode, when each of the following is selected:

- [0] Digital input
- [1] Serial port
- [2] Logic and or [3] Logic or

| Dig. input | Serial port | Function |
|------------|-------------|---------------|
| 0 | 0 | Quick-stop |
| 0 | 1 | Quick-stop |
| 1 | 0 | Motor running |
| 1 | 1 | Motor running |

Table 4.22 Function Description for [0] Digital input

| Dig. input | Serial port | Function |
|------------|-------------|---------------|
| 0 | 0 | Quick-stop |
| 0 | 1 | Motor running |
| 1 | 0 | Quick-stop |
| 1 | 1 | Motor running |

Table 4.23 Function Description for [1] Serial port

| Dig. input | Serial port | Function |
|------------|-------------|---------------|
| 0 | 0 | Quick-stop |
| 0 | 1 | Motor running |
| 1 | 0 | Motor running |
| 1 | 1 | Motor running |

Table 4.24 Function Description for [2] Logic and

| Dig. input | Serial port | Function |
|------------|-------------|---------------|
| 0 | 0 | Quick-stop |
| 0 | 1 | Quick-stop |
| 1 | 0 | Quick-stop |
| 1 | 1 | Motor running |

Table 4.25 Function Description for [3] Logic or

NOTICE

Quick-stop inverse and bit 04 in the control word are active at logic '0'.

| 504 | DC brake |
|-------------------------------|----------|
| Value: | |
| Digital input (DIGITAL INPUT) | [0] |
| Serial port (SERIAL PORT) | [1] |
| Logic and (LOGIC AND) | [2] |
| * Logic or (LOGIC OR) | [3] |
| Function: | |

See function description for parameter 502 Coasting stop.

Description of choice:

Table 4.26, Table 4.27, Table 4.28, and Table 4.29 show when the motor is running and the DC braking when each of the following is selected:

- [0] Digital input
- [1] Serial port
- [2] Logic and or [3] Logic or

| Dig. input | Ser. port | Function |
|------------|-----------|---------------|
| 0 | 0 | DC braking |
| 0 | 1 | DC braking |
| 1 | 0 | Motor running |
| 1 | 1 | Motor running |

Table 4.26 Function Description for [0] Digital input

| Dig. input | Ser. port | Function |
|------------|-----------|---------------|
| 0 | 0 | DC braking |
| 0 | 1 | Motor running |
| 1 | 0 | DC braking |
| 1 | 1 | Motor running |

Table 4.27 Function Description for [1] Serial port

| Dig. input | Ser. port | Function |
|------------|-----------|---------------|
| 0 | 0 | DC braking |
| 0 | 1 | Motor running |
| 1 | 0 | Motor running |
| 1 | 1 | Motor running |

Table 4.28 Function Description for [2] Logic and

| Dig. input | Ser. port | Function |
|------------|-----------|---------------|
| 0 | 0 | DC braking |
| 0 | 1 | DC braking |
| 1 | 0 | DC braking |
| 1 | 1 | Motor running |

Table 4.29 Function Description for [3] Logic or

NOTICE

DC braking inverse and bit 02 in the control word are active at logic '0'.

| 505 | Start |
|-------------------------------|-------|
| Value: | |
| Digital input (DIGITAL INPUT) | [0] |
| Serial port (SERIAL PORT) | [1] |
| Logic and (LOGIC AND) | [2] |
| * Logic or (LOGIC OR) | [3] |
| Function: | |

See function description for parameter 502 Coasting stop.

Description of choice:

Table 4.30, Table 4.31, Table 4.32, and Table 4.33 show when the motor has stopped and when the frequency converter has a start command when each of the following is selected:

- [0] Digital input,
- [1] Serial port,
- [2] Logic and or [3] Logic or.

| Dig. input | Ser. port | Function |
|------------|-----------|----------|
| 0 | 0 | Stop |
| 0 | 1 | Stop |
| 1 | 0 | Start |
| 1 | 1 | Start |

Table 4.30 Function Description for [0] Digital input

| Dig. input | Ser. port | Function |
|------------|-----------|----------|
| 0 | 0 | Stop |
| 0 | 1 | Start |
| 1 | 0 | Stop |
| 1 | 1 | Start |

Table 4.31 Function Description for [1] Serial port

| Dig. input | Ser. port | Function |
|------------|-----------|----------|
| 0 | 0 | Stop |
| 0 | 1 | Stop |
| 1 | 0 | Stop |
| 1 | 1 | Start |

Table 4.32 Function Description for [2] Logic and

| Dig. input | Ser. port | Function |
|------------|-----------|----------|
| 0 | 0 | Stop |
| 0 | 1 | Start |
| 1 | 0 | Start |
| 1 | 1 | Start |

Table 4.33 Function Description for [3] Logic or

| 506 Reversing | |
|-------------------------------|-----|
| Value: | |
| Digital input (DIGITAL INPUT) | [0] |
| Serial port (SERIAL PORT) | [1] |
| Logic and (LOGIC AND) | [2] |
| * Logic or (LOGIC OR) | [3] |

Function:

See function description for parameter 502 Coasting stop.

Description of choice:

Table 4.34, Table 4.35, Table 4.36, and Table 4.37 show when the motor is running clockwise and anti-clockwise when each of the following is selected:

- [0] Digital input,
- [1] Serial port,
- [2] Logic and or [3] Logic or.

| Dig. input | Ser. port | Function |
|------------|-----------|----------------|
| 0 | 0 | Clockwise |
| 0 | 1 | Clockwise |
| 1 | 0 | Anti-clockwise |
| 1 | 1 | Anti-clockwise |

Table 4.34 Function Description for [0] Digital input

| Dig. input | Ser. port | Function |
|------------|-----------|----------------|
| 0 | 0 | Clockwise |
| 0 | 1 | Anti-clockwise |
| 1 | 0 | Clockwise |
| 1 | 1 | Anti-clockwise |

Table 4.35 Function Description for [1] Serial port

| Dig. input | Ser. port | Function |
|------------|-----------|----------------|
| 0 | 0 | Clockwise |
| 0 | 1 | Clockwise |
| 1 | 0 | Clockwise |
| 1 | 1 | Anti-clockwise |

Table 4.36 Function Description for [2] Logic and

| Dig. input | Ser. port | Function |
|------------|-----------|----------------|
| 0 | 0 | Clockwise |
| 0 | 1 | Anti-clockwise |
| 1 | 0 | Anti-clockwise |
| 1 | 1 | Anti-clockwise |

Table 4.37 Function Description for [3] Logic or

| 507 Selection of Setup | |
|------------------------------------|-----|
| Value: | |
| Digital input (DIGITAL INPUT) | [0] |
| Serial communication (SERIAL PORT) | [1] |
| Logic and (LOGIC AND) | [2] |
| * Logic or (LOGIC OR) | [3] |

Function:

See function description of parameter 502 Coasting stop.

Description of choice:

Table 4.38, Table 4.39, Table 4.40, and Table 4.41 show which Set-up (parameter 004 Active Setup) is selected for each of the following:

- [0] Digital input,
- [1] Serial communication,
- [2] Logic and or [3] Logic or.

| Setup msb | Setup lsb | Function |
|-----------|-----------|----------|
| 0 | 0 | Setup 1 |
| 0 | 1 | Setup 2 |
| 1 | 0 | Setup 3 |
| 1 | 1 | Setup 4 |

Table 4.38 Function Description for [0] Digital input

| Setup msb | Setup lsb | Function |
|-----------|-----------|----------|
| 0 | 0 | Setup 1 |
| 0 | 1 | Setup 2 |
| 1 | 0 | Setup 3 |
| 1 | 1 | Setup 4 |

Table 4.39 Function Description for [1] Serial communication

| Bus Setup msb | Bus Setup lsb | Dig. Setup msb | Dig. Setup lsb | Setup no. |
|---------------|---------------|----------------|----------------|-----------|
| 0 | 0 | 0 | 0 | 1 |
| 0 | 0 | 0 | 1 | 1 |
| 0 | 0 | 1 | 0 | 1 |
| 0 | 0 | 1 | 1 | 1 |
| 0 | 1 | 0 | 0 | 1 |
| 0 | 1 | 0 | 1 | 2 |
| 0 | 1 | 1 | 0 | 1 |
| 0 | 1 | 1 | 1 | 2 |
| 1 | 0 | 0 | 0 | 1 |
| 1 | 0 | 0 | 1 | 1 |
| 1 | 0 | 1 | 0 | 3 |
| 1 | 0 | 1 | 1 | 3 |
| 1 | 1 | 0 | 0 | 1 |
| 1 | 1 | 0 | 1 | 2 |
| 1 | 1 | 1 | 0 | 3 |
| 1 | 1 | 1 | 1 | 4 |

Table 4.40 Function Description for [2] Logic and

| Bus Setup msb | Bus Setup lsb | Dig. Setup msb | Dig. Setup lsb | Setup no. |
|---------------|---------------|----------------|----------------|-----------|
| 0 | 0 | 0 | 0 | 1 |
| 0 | 0 | 0 | 1 | 2 |
| 0 | 0 | 1 | 0 | 3 |
| 0 | 0 | 1 | 1 | 4 |
| 0 | 1 | 0 | 0 | 2 |
| 0 | 1 | 0 | 1 | 2 |
| 0 | 1 | 1 | 0 | 4 |
| 0 | 1 | 1 | 1 | 4 |
| 1 | 0 | 0 | 0 | 3 |
| 1 | 0 | 0 | 1 | 4 |
| 1 | 0 | 1 | 0 | 3 |
| 1 | 0 | 1 | 1 | 4 |
| 1 | 1 | 0 | 0 | 4 |
| 1 | 1 | 0 | 1 | 4 |
| 1 | 1 | 1 | 0 | 4 |
| 1 | 1 | 1 | 1 | 4 |

Table 4.41 Function Description for [3] Logic or

508 Selection of preset ref.

- Value:**
- Digital input (DIGITAL INPUT) [0]
 - Serial communication (SERIAL PORT) [1]
 - Logic and (LOGIC AND) [2]
 - * Logic or (LOGIC OR) [3]

Function:

See function description of parameter 502 Coasting stop.

Description of choice:

Preset references via serial communication are active when parameter 512 Telegram profile is set to [1] FC protocol.

509 Bus jog 1 (BUS JOG 1 FREQ.)

510 Bus jog 2 (BUS JOG 2 FREQ.)

Value:

- 0.0 - parameter 202 Output frequency high limit * 10,0 Hz

Function:

If parameter 512 Telegram Profile shows the selection [0] Profdrive, 2 fixed speeds (Jog 1 or Jog 2) can be selected via the serial port.

The function is the same as in parameter 213 Jog frequency.

Description of choice:

Jog frequency f_{JOG} can be selected between 0 Hz and f_{MAX} .

512 Telegram Profile

Value:

- Profdrive (Profdrive) [0]
- * FC protocol (FC protocol) [1]

Function:

It is possible to select between 2 different control word profiles.

Description of choice:

Select the desired control word profile.

See *chapter 4.7 Serial communication* for further details of control word profiles.

513 Bus time interval**Value:**

1-99 s * 1 s

Function:

Preset the maximum time expected to elapse between receipt of 2 consecutive telegrams. If this time is exceeded, the serial communication is assumed to have stopped and the desired reaction is preset in *parameter 514 Bus time interval function*.

Description of choice:

Preset the required time.

514 Bus time interval function**Value:**

| | |
|---|-----|
| * Off (off) | [0] |
| Freeze output frequency (FREEZE OUTPUT) | [1] |
| Stop (STOP) | [2] |
| Jogging (JOGGING) | [3] |
| Max. speed (MAX SPEED) | [4] |
| Stop and trip (STOP AND TRIP) | [5] |

Function:

Select the required reaction for the frequency converter when the preset time in *parameter 513 Bus time interval* has been exceeded. If options [1] to [5] are activated, the output relay is deactivated.

Description of choice:

The output frequency of the frequency converter can

- be frozen at the present value,
- stop the motor,
- be frozen at parameter 213 *Jogging frequency*,
- be frozen at parameter 202 *Output frequency, high limit* f_{MAX} or
- stop and activate a cut out.

515-544 Data readout

| Par. no. | Description | Display text | Unit | Update interval |
|----------|-------------------------|---------------------|----------|-----------------|
| 515 | Res. reference | (REFERENCE %) | % | |
| 516 | Res. reference [Unit] | (REFERENCE [UNIT]) | Hz, RPM | |
| 517 | Feedback [Unit] | (FEEDBACK [UNIT]) | Par. 416 | |
| 518 | Frequency | (FREQUENCY) | Hz | |
| 519 | Frequency x scale | (FREQUENCY X SCALE) | Hz | |
| 520 | Motor current | (MOTOR CURRENT) | Amp | |
| 521 | Torque | (TORQUE) | % | |
| 522 | Power[kW] | (POWER (KW)) | kW | |
| 523 | Power[HP] | (POWER (HP)) | HP | |
| 524 | Motor voltage | (MOTOR VOLTAGE) | V | |
| 525 | DC-link voltage | (DC LINK VOLTAGE) | V | |
| 526 | Thermal load motor | (MOTOR THERMAL) | % | |
| 527 | Thermal load inverter | (INV. THERMAL) | % | |
| 528 | Digital input | (DIGITAL INPUT) | Bin | |
| 529 | Term.53, analogue input | (ANALOG INPUT 53) | V | |
| 531 | Term.60, analogue input | (ANALOG INPUT 60) | mA | |
| 532 | Pulse reference | (PULSE REFERENCE) | Hz | |
| 533 | External ref. | (EXT. REF.%) | % | |
| 534 | Status word, Hex | (STATUS WORD) | Hex | |
| 535 | Bus feedback 1 | (BUS FEEDBACK1) | Hex | |
| 537 | Inverter temperature | (INVERTER TEMP.) | °C | |
| 538 | Alarm word | (ALARM WORD) | Hex | |
| 539 | Control word | (CONTROL WORD) | Hex | |
| 540 | Warning word | (WARN. WORD) | Hex | |
| 541 | Extended status word | (STATUS WORD) | Hex | |
| 544 | Pulse count | (PULSE COUNT) | | |

Function:

These parameters can be read out via the serial communication port and the LCP display. See also *parameters 009-012 Display readout*.

Description of choice:

Parameter 515 Resulting reference %:

Gives the resulting reference as a percentage in the range from minimum reference, Ref_{MIN} to maximum reference, Ref_{MAX} . See also *Dealing with references*.

Parameter 516 Resulting reference [unit]:

Gives the resulting reference in Hz in open loop (*parameter 100*). In a closed loop, the reference unit is selected in *parameter 416 Process units*.

Parameter 517 Feedback [unit]:

Gives the resulting feedback value with the unit/scaling selected in *parameter 414 Minimum feedback*, *parameter 415 Maximum feedback* and *parameter 416 Process units*. See *chapter 4.3.1 Handling of References* for more details.

Parameter 518 Frequency [Hz]:

Gives the output frequency from the adjustable frequency drive.

Parameter 519 Frequency x scaling [-]:

Corresponds to the present output frequency f_M multiplied by the factor preset in *parameter 008 Display scaling of output frequency*.

Parameter 520 Motor current [A]:

Gives the motor's phase current measured as an effective value.

Parameter 521 Torque [Nm]:

Gives the motor's present load in relation to the motor's rated torque.

Parameter 522 Power [kW]:

Gives the present power absorbed by the motor in kW.

Parameter 523 Power [HP]:

Gives the present power absorbed by the motor in HP.

Parameter 524 Motor voltage:

Gives the voltage being supplied to the motor.

Parameter 525 DC link voltage:

Gives the intermediate circuit voltage in the adjustable frequency drive.

Parameter 526 Thermal load, motor [%]:

Gives the calculated/estimated thermal load on the motor. 100% is the cut-out limit. See also *parameter 128 Thermal motor protection*.

Parameter 527 Thermal load INV [%]:

Gives the calculated/estimated thermal load on the adjustable frequency drive. 100% is the cut-out limit.

Parameter 528 Digital input:

Gives the signal status from the 5 digital inputs (18, 19, 27, 29 and 33). Input 18 corresponds to the bit on the extreme left. '0' = no signal, '1' = connected signal.

Parameter 529 Terminal 53 analogue input [V]:

Gives the voltage value for the signal on terminal 53.

Parameter 531 Terminal 60 analogue input [mA]:

Gives the present value for the signal on terminal 60.

Parameter 532 Pulse reference [Hz]:

Gives a pulse frequency in Hz connected to terminal 33.

Parameter 533 External reference:

Gives the sum of external references as a percentage (sum of analog/pulse/serial communication) in the range from minimum reference, Ref_{MIN} to maximum reference, Ref_{MAX}.

Parameter 534 Status word:

Gives the present status word for the adjustable frequency drive in hex. See *chapter 4.7 Serial communication* for more details.

Parameter 535 Bus feedback 1:

Allows writing of a bus feedback value which then forms part of the feedback handling.

Parameter 537 Inverter temperature:

Gives the present inverter temperature on the adjustable frequency drive. The cut-out limit is 90-100 °C, with cut back in at 70 °C±5 °C.

Parameter 538 Alarm word:

Shows the active alarm on the adjustable frequency drive in hex code. See *chapter 5.2.3 Warning Words, Extended Status Words and Alarm Words* for more details.

Parameter 539 Control word:

Gives the present control word on the adjustable frequency drive in Hex. See *chapter 4.7 Serial communication* for more details.

Parameter 540 Warning word:

States whether there is a warning on the adjustable frequency drive in hex. See *chapter 5.2.3 Warning Words, Extended Status Words and Alarm Words* for more details.

Parameter 541 Extended status word:

States whether there is a warning on the adjustable frequency drive in hex code. See *chapter 5.2.3 Warning Words, Extended Status Words and Alarm Words* for more details.

Parameter 544 Pulse count:

This parameter can be read out via the LCP display (parameters 009-012). When counter stop is enabled, use this parameter, either with or without reset, to read the number of pulses registered by the device. The highest frequency is 67.6 kHz, while the lowest is 5 Hz. The counter is reset when counter stop is restarted.

NOTICE

Parameters 515-541 can only be read out via an LCP control unit.

| 560 | N2 Override release time |
|-------------------|--------------------------|
| Value: | |
| 1 - 65534 (OFF) s | * OFF |

Function:
In this parameter, the maximum time is set which is expected to pass between the receipt of 2 N2 telegrams in a row. If this time is exceeded, the serial communication is assumed to have stopped and all points in the N2 point-map which are overridden are released in the order below:

1. Release analog outputs from point address (NPA) 0 to 255.
2. Release binary outputs from point address (NPA) 0 to 255.
3. Release internal floating points from point address (NPA) 0 to 255.
4. Release internal integer points from point address (NPA) 0 to 255.
5. Release internal byte points from point address (NPA) 0 to 255.

Description of choice:
Set the required time.

| 561 | Protocol |
|-----------------------------|----------|
| Value: | |
| * FC protocol (FC PROTOKOL) | [0] |
| Metasys N2 (METASYS N2) | [1] |
| Modbus RTU | [2] |

Function:
Select between 3 different protocols.

Description of choice:
Select the required control word protocol. For further information about using the Metasys N2 Protocol, see *Metasys N2 Manual*. For further information about using Modbus RTU, see *Modbus RTU Manual*.

| 570 | Modbus parity and message framing |
|-------------------------|-----------------------------------|
| Value: | |
| (EVEN/1 STOPBIT) | [0] |
| (ODD/1 STOPBIT) | [1] |
| * (NO PARITY/1 STOPBIT) | [2] |
| (NO PARITY/2 STOPBIT) | [3] |

Function:
This parameter sets up the frequency converter's Modbus RTU interface to communicate properly with the master controller. Set the parity (EVEN, ODD, or NO PARITY) to match the setting of the master controller.

Description of choice:

Select the parity that matches the setting for the Modbus master controller. Even or odd parity is sometimes used to allow a transmitted word to be checked for errors. Because Modbus RTU uses the more efficient CRC (Cyclic Redundancy Check) method of checking for errors, parity checking is seldom used in Modbus RTU networks.

571 Modbus communications timeout**Value:**

10 ms-2000 ms * 100 ms

Function:

This parameter determines the maximum amount of time that the frequency converter's Modbus RTU waits between characters that are sent by the master controller. When this amount of time expires, the frequency converter's Modbus RTU interface assumes that it has received the entire message.

Description of choice:

Generally, the value of 100 ms is sufficient for Modbus RTU networks, although some Modbus RTU networks may operate on a time-out value as short as 35 ms. If this value is set too short, the frequency converter's Modbus RTU interface may miss a part of the message.

4.9 Technical Functions

| Par. no. | Description | Display text | Unit | Range |
|----------|----------------------------|-------------------|-----------------|-----------------|
| 600 | Operating hours | (OPERATING HOURS) | Hours | 0-130,000.0 |
| 601 | Hours run | (RUNNING HOURS) | Hours | 0-130,000.0 |
| 602 | kWh counter | (KWH COUNTER) | kWh | Depends on unit |
| 603 | Number of power-up's | (POWER UP'S) | Number of times | 0-9999 |
| 604 | Number of overtemperatures | (OVER TEMP'S) | Number of times | 0-9999 |
| 605 | Number of overvoltages | (OVER VOLT'S) | Number of times | 0-9999 |

Table 4.42 600-605 Operating Data

Function:

These parameters can be read out via the serial communication port and the LCP control unit.

Description of choice:

Parameter 600, Operating hours:

Gives the number of hours the frequency converter has been operating. The value is saved every hour and when there is a mains failure. This value cannot be reset.

Parameter 601, Hours run:

Gives the number of hours the motor has been operating since the reset in *parameter 619 Reset of hours-run counter*. The value is saved every hour and when there is a mains failure.

Parameter 602, kWh counter:

Gives the frequency converter's output energy in kWh. The calculation is based on the mean kW value over one hour. This value can be reset using *parameter 618 Reset of kWh counter*.

Range: 0 - depends on unit.

Since the CRC check is not valid, the frequency converter ignores the message. The resulting retransmissions of messages slows the communications on the network. If this value is set too long, the frequency converter waits longer than necessary to determine that the message is completed. This delays the frequency converter's response to the message and possibly cause the master controller to time out. The resulting retransmissions of messages slow the communications on the network.

580-582 Defined parameters**Value:**

Read only

Function:

The 3 parameters hold a list of all the parameters that are defined in the frequency converter. It is possible to read single elements of the list by using the corresponding subindex. The subindexes start at 1 and follow the order of the parameter numbers.

Each parameter holds up to 116 elements (parameter numbers).

When a 0 is returned as parameter number, the list ends.

Parameter 603, Number of power-ups:

Gives the number of power-ups of the supply voltage undertaken on the frequency converter.

Parameter 604, Number of overtemperatures:

Gives the number of overtemperature faults that have been registered on the frequency converter's heat sink.

Parameter 605, Number of overvoltages:

Gives the number of overvoltages of the intermediate circuit voltage in the frequency converter. This is only counted when Alarm 7 *Overvoltage* is active.

NOTICE

Parameters 615-617 Fault log cannot be read out via the integral control unit.

615 Fault log: Error code**Value:**

[Index 1-10] Error code: 0-99

Function:

In this parameter it is possible to see the reason for a trip (cut-out of the frequency converter) occurring. 10 [1-10] log values are defined.

The lowest log number [1] contains the latest/most recently saved data value. The highest log number [10] contains the oldest data value saved. If a trip occurs, it is possible to see the cause, time and a possible value of the output current or output voltage.

Description of choice:

Given as a fault code, in which the number refers to a table. See *chapter 5.2.2 Warnings and Alarm Messages*

616 Fault log: Time

Value:

[Index 1 - 10] Hours: 0 - 130,000.0

Function:

In this parameter it is possible to see the total number of operating hours in connection with the last 10 trips. 10 [1-10] log values are denoted. The lowest log number [1] contains the latest/most recently saved data value, and the highest log number [10] contains the oldest data value.

Description of choice:

Read out as one value.

617 Fault log: Value

Value:

[Index 1 - 10] Value: 0 - 9999

Function:

In this parameter it is possible to see at which value a trip occurred. The unit of the value depends on which alarm is active in *parameter 615 Fault log: Fault code*.

Description of choice:

Read out as one value.

618 Reset of kWh counter

Value:

- * No reset (DO NOT RESET) [0]
- Reset (RESET COUNTER) [1]

Function:

Resetting *parameter 602 kWh counter* to zero.

Description of choice:

If [1] *Reset* is selected, press the [OK] key to reset the frequency converter's kWh counter to 0. This parameter cannot be selected via serial communication.

NOTICE

When the [OK] key is activated, the counter is reset to zero.

619 RESET RUNNING HOURS COUNTER

Value:

- * No reset (DO NOT RESET) [0]
- Reset (RESET COUNTER) [1]

Function:

Resetting of *parameter 601 Hours run* to zero.

Description of choice:

If [1] *Reset* is selected, press the [OK] key to reset the frequency converter's *parameter 601 Hours run* to 0 *Hours run*. This parameter cannot be selected via serial communication.

NOTICE

When the [OK] key is pressed the parameter is reset to zero.

620 Operation Mode

Value:

- * Normal operation (NORMAL OPERATION) [0]
- Control card test (CONTROL CARD TEST) [2]
- Initialise (INITIALIZE) [3]

Function:

In addition to its normal function, this parameter can be used to test the control card.

There is also the opportunity to perform an initialisation at the factory setting for all parameters in all set-ups, with the exception of *parameters 500 Address, 501 Baudrate, 600-605 Operating data* and *615-617 Fault log*.

Description of choice:

[0] *Normal function* is used for normal operation of the motor.

Select [2] *Control card test* to check the control card's analog/digital inputs, analog/digital outputs, relay outputs and 10 V and 24 V voltages.

The test is performed as follows:

- 27-29-33-46 are connected.
- 50-53 are connected.
- 42-60 are connected.
- 12-relay terminal 01 is connected.
- 18-relay terminal 02 is connected.
- 19-relay terminal 03 is connected.

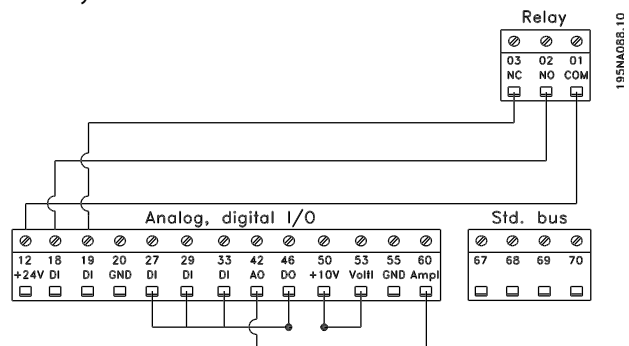

Illustration 4.38 Control Card Test

Use the following procedure for the control card test:

1. Select control card test.
2. Disconnect the mains voltage and wait until the light in the display has disappeared.
3. Mount the control card.
4. Connect the mains voltage.
5. The frequency converter automatically tests the control card.

If the frequency converter displays a fault code from 37-45, the control card test has failed. Change the control card to start up the frequency converter.

If the frequency converter enters Display mode, the test is OK. Remove the test connector and the frequency converter is ready for operation. *Parameter 620 Operating mode* is automatically set to [0] Normal operation. Select [3] Initialisation to use the unit's factory setting.

Procedure for initialisation:

1. Select [3] Initialisation.
2. Disconnect the mains voltage and wait until the light in the display has disappeared.
3. Connect the mains voltage.
4. An initialisation is performed in all parameters in all set-ups, with the exception of *parameters 500 Address, 501 Baudrate, 600-605 Operating data and 615-617 Fault log.*

NOTICE

The control card is different on DeviceNet units. See the DeviceNet manual for further details.

621-642 Nameplate data

| Par. no | Description Nameplate | Display text |
|---------|---------------------------------------|--------------------|
| 621 | Unit type | (DRIVE TYPE) |
| 624 | Software version | (SOFTWARE VERSION) |
| 625 | LCP identification no. | (LCP VERSION) |
| 626 | Database identification no. | (DATABASE VER.) |
| 627 | Power parts version | (POWER UNIT DB ID) |
| 628 | Application option type | (APP. OPTION) |
| 630 | Communication option type | (COM. OPTION) |
| 632 | BMC software identification | (BMC-SOFTWARE ID) |
| 634 | Unit identification for communication | (UNIT ID) |
| 635 | Software parts no. | (SW. PART NO.) |
| 640 | Software version | (SOFTWARE VERSION) |
| 641 | BMC-software identification | (BMC2 SW) |
| 642 | Power card identification | (POWER ID) |

Table 4.43 Nameplate

Function:

The unit's main data can be read out from *parameters 621 to 635 Nameplate* using the LCP 2 control unit or serial communication. *Parameters 640 - 642* can also be seen on the unit's integral display.

Description of choice:

Parameter 621 Nameplate: Unit type:

Gives unit size and mains voltage.

Example: VLT 2811 380-480 V.

Parameter 624 Nameplate: Software version no.

Shows the unit's present software version number.

Example: V 1.00

Parameter 625 Nameplate: LCP 2 ID number:

Shows the ID number of the unit's LCP 2.

Example: ID 1.42 2 kB

Parameter 626 Nameplate: Database ID number:

Shows the ID number of the software's database.

Example: ID 1.14.

Parameter 627 Nameplate: Power section version:

Shows the ID number of the unit's power section.

Example: ID 1.15.

Parameter 628 Nameplate: Application option type:

Specifies which types of application options are installed in the frequency converter.

Parameter 630 Nameplate: Communication option type:

Specifies which types of communication options are installed in the frequency converter.

Parameter 632 Nameplate: BMC software identification:

Shows the ID number of the BMC software.

Parameter 634 Nameplate: Unit identification for communication:

Shows the ID number for communication.

Parameter 635 Nameplate: Software section no.:

Shows the software section number.

Parameter 640 Nameplate: Software version:

The unit's present software version number appears here.

Example: 1.00

Parameter 641 Nameplate: BMC software identification:

Shows the ID number of the BMC software.

Parameter 642 Nameplate: Power card identification:

Shows the ID number of the unit's power part. Example:

1.15

Parameter 700 -

Only for wobble functions: To use this function or for further information, see *Wobble Function Instruction*.

678 Configure Control Card

Value:

| | |
|---|-----|
| Standard version (STANDARD VERSION) | [1] |
| Profibus 3 Mbaud Version (PROFIBUS 3 MB Ver.) | [2] |
| Profibus 12 Mbaud Version (PROFIBUS 12 MB Ver.) | [3] |

Function:

Configure a Profibus control card. The default value depends on the produced unit, also being the maximum obtainable value. This means that a control card only can be downgraded to a lower performance version.

5 All about VLT 2800

5.1 Special Conditions

5.1.1 Galvanic Isolation (PELV)

Achieve PELV (Protective Extra Low Voltage) isolation by inserting galvanic isolators between the control circuits and circuits that are connected to the mains. The frequency converter is designed to meet the requirements for protective separation with necessary creepage and clearance distances. These requirements are described in standard EN 50 178. It is also a requirement that the installation is carried out as described in local/national regulations regarding PELV.

All control terminals, terminals for serial communication and relay terminals are safely separated from the mains potential, that is, they comply with the PELV requirements. Circuits that are connected to control terminals 12, 18, 19, 20, 27, 29, 33, 42, 46, 50, 53, 55 and 60 are galvanically connected to one another. Serial communication connected to fieldbus is galvanically isolated from the control terminals, although this is only a functional isolation.

The relay contacts on terminals 1-3 are isolated from the other control circuits with reinforced/double isolation, that is, PELV is observed, even though there is mains potential at the relay terminals.

The circuit elements described below form the safe electric separation. They fulfil the requirements for reinforced/double insulation and associated testing according to EN 50 178.

1. Transformer and optical separation in voltage supply.
2. Optical isolation between Basic Motor Control and control card.
3. Isolation between the control card and the power part.
4. Relay contacts and terminals relating to other circuits on the control card.

PELV isolation of the control card is guaranteed under the following conditions:

- TT network with maximum 300 V_{rms} between phase and ground.
- TN network with maximum 300 V_{rms} between phase and ground.
- IT network with maximum 400 V_{rms} between phase and ground.

To maintain PELV all connections made to the control terminals must be PELV, for example, thermistor must be reinforced/double insulated.

5.1.2 Ground Leakage Current and RCD Relays

Ground leakage current is primarily caused by the parasitic capacitance between motor phases and motor cable screen. When an RFI filter is used, this contributes additional leakage current, as the filter circuit is connected to ground through capacitors.

The size of the ground leakage current depends on the following factors, in order of priority:

1. Length of the motor cable.
2. Motor cable with/without screen.
3. High switching frequency.
4. RFI filter used or not.
5. Motor grounded on site or not.

The leakage current must be handled carefully during handling/operation of the frequency converter if (by mistake) the frequency converter has not been grounded.

⚠ WARNING

Since the leakage current is > 3.5 mA, reinforced grounding must be established, as this is required to ensure compliance with EN 50178. The cable cross-section must be at least 10 mm² or 2 rated ground wires that are terminated separately.

⚠ WARNING

Do not use RCD relays (type A) that are not suitable for DC fault currents from 3-phase rectifier loads.

If RCD relays are used, they must be:

- Suitable for protecting equipment with a DC component in the faulty current (3-phase bridge rectifier).
- Suitable for a pulse-shaped, brief discharge on power-up.
- Suitable for a high leakage current (300 mA).

See chapter 3.4.10 Ground Connection for further information.

5.1.3 Extreme Operating Conditions

Short circuit

The frequency converter is protected against short circuits on motor terminals U, V, W (96, 97, 98). A short circuit between 2 motor terminals would lead to an overcurrent in the IGBT module, which means that all transistors in the IGBT module would independently cut out.

The inverter turns off after 5-10 s and the frequency converter displays a fault code, although this depends on impedance and motor frequency.

Ground fault

The IGBT module cuts out within 100 s if there is a ground fault on one of the motor terminals U, V, W (96, 97, 98), although depending on impedance and motor frequency.

Output connection

Motor terminals U, V, W (96, 97, 98) for the motor can be connected/disconnected as often as required. The frequency converter cannot be destroyed by connecting/disconnecting the motor terminals. However, fault messages may appear.

Motor-generated overvoltage

The voltage in the intermediate circuit is increased when the motor acts as a generator. To protect the frequency converter, the IGBT module is disconnected when a specific voltage level is reached.

Motor-generated overvoltage can occur in 2 instances:

1. The load drives the motor, that is, the load generates energy.
2. During deceleration (ramp-down) if the inertia moment is high, the load is low and the ramp-down time too short for the energy to be dissipated as a loss in the frequency converter, the motor and the unit. The control unit attempts to correct the ramp if possible.

The fault can be removed by connecting a brake resistor, if the frequency converter has an integrated brake module. If the frequency converter does not have an integrated brake module, an AC brake can be used, see *parameter 400 Brake function*.

See the section *chapter 1.11 Brake Resistors* for further details.

Static overloading

When the frequency converter is overloaded (current limit in *parameter 221 Current limit I_{LIM}* is reached), the control reduces the output frequency in an attempt to reduce the load. If the overloading is extreme, there might be an output current that causes the frequency converter to trip after approx. 1.5 s. See *parameter 409 Trip delay overcurrent, I_{LIM}* .

An extreme overload may cause the switching frequency to be derated to 3000 Hz.

5.1.4 dU/dt on Motor

When a transistor in the inverter is opened, the voltage across the motor terminals rises by a voltage/time ratio (dU/dt) determined by:

- the motor cable (type, cross-section, induction, capacity, length and screened/armoured/unscreened/unarmoured).
- the mains voltage.

Self-induction in the motor cable leads to an overshoot U_{PEAK} of the output voltage each time a transistor in the inverter is opened. After U_{PEAK} , the output voltage stabilises at a level determined by the voltage in the intermediate circuit. U_{PEAK} and dU/dt influence the lifetime of the motor, especially motors without phase insulation paper in the coils. If the motor cable is short (a few metres), the overshoot U_{PEAK} is low, while the dU/dt is high. If the motor cable is long (>20 m), U_{PEAK} is increased to about twice the intermediate voltage, while dU/dt decreases. When using small motors without phase insulation paper or submerged water pumps, connect an LC-filter after the frequency converter.

5.1.5 Switching on the Input

The waiting time between switching the mains voltage on terminals 91, 92 and 93 must be minimum 30 s. Start up time appr. 2.3 s.

5.1.6 Peak Voltage on Motor

When a transistor in the inverter is opened, the voltage across the motor increases by a dU/dt ratio that depends on:

- the motor cable (type, cross-section, length screened or unscreened).
- inductance.

The natural induction causes an overshoot U_{PEAK} in the motor voltage before it stabilises itself at a level which depends on the voltage in the intermediate circuit. The rise time and the peak voltage U_{PEAK} affect the service life of the motor. If the peak voltage is too high, motors without phase coil insulation are primarily affected. If the motor cable is short (a few metres), the rise time is higher and the peak voltage is lower. If the motor cable is long (100 m), the rise time decreases and the peak voltage increases to about twice the intermediate voltage.

If very small motors without phase insulation, paper or submerged water pumps are used, fit an LC filter after the frequency converter.

Typical values for the rise time and peak voltage U_{PEAK} are measured on the motor terminals between 2 phases.

To obtain approximate values for cable lengths and voltages not mentioned below, use the general principle:

1. Rise time increases/decreases proportionally with cable length.
2. $U_{PEAK} = \text{DC-link voltage} \times 1.9$
(DC-link voltage = Mains voltage \times 1.35).
3.
$$dU/dt = \frac{0.5 \times U_{PEAK}}{\text{Risetime}}$$

Data are measured according to IEC 60034-17.

| Cable length[m] | Mains voltage[V] | Rise time [μ s] | Peak voltage[V] | dU/dt V/ μ s] |
|-----------------|------------------|----------------------|-----------------|-------------------|
| 5 | 220 | 0.137 | 348 | 2.116 |
| 42 | 220 | 0.362 | 460 | 1.016 |
| 5 | 240 | 0.129 | 365 | 2.294 |
| 42 | 240 | 0.310 | 498 | 1.303 |

Table 5.1 VLT 2803-2815

| Cable length[m] | Mains voltage[V] | Rise time [μ s] | Peak voltage[V] | dU/dt V/ μ s] |
|-----------------|------------------|----------------------|-----------------|-------------------|
| 5 | 380 | 0.081 | 680 | 6716 |
| 15 | 380 | 0.167 | 960 | 4593 |
| 30 | 380 | 0.306 | 992 | 2593 |
| 5 | 480 | 0.086 | 840 | 7778 |
| 15 | 480 | 0.177 | 1168 | 5279 |
| 30 | 480 | 0.323 | 1232 | 3050 |

Table 5.2 VLT 2805-2840

| Cable length[m] | Mains voltage[V] | Rise time [μ s] | Peak voltage[V] | dU/dt V/ μ s] |
|-----------------|------------------|----------------------|-----------------|-------------------|
| 5 | 380 | 0.120 | 772 | 4438 |
| 40 | 380 | 0.188 | 1004 | 3482 |
| 78 | 380 | 0.220 | 1012 | 2854 |
| 5 | 480 | 0.120 | 920 | 4667 |
| 40 | 480 | 0.245 | 1252 | 3646 |
| 78 | 480 | 0.225 | 1220 | 3168 |

Table 5.3 VLT 2805-2840

5.1.7 Acoustic Noise

The acoustic noise from the frequency converter comes from 2 sources:

- DC intermediate circuit coils.
- Integral fan.

Below are the typical values measured at a distance of 1 m from the unit at full load:

- VLT 2803-2815 1x220 V: 52 dB(A).
- VLT 2822 1x220 V PD2: 54 dB(A).
- VLT 2840 1x220 V PD2: 55 dB (A).
- VLT 2840 3x200 V PT2: 54 dB (A).
- VLT 2803-2822 3x220 V: 52 dB(A).
- VLT 2805-2840 3x400 V: 52 dB(A).
- VLT 2855-2875 3x400 V: 54 dB(A).
- VLT 2880-2882 3x400 V: 55 dB(A).

5.1.8 Derating for Ambient Temperature

The ambient temperature ($T_{AMB,MAX}$) is the maximum temperature allowed. The average ($T_{AMB,AVG}$) measured over 24 hours, must be at least 5 °C lower. If the frequency converter operates at temperatures above 45 °C, a derating of the rated output current is necessary.

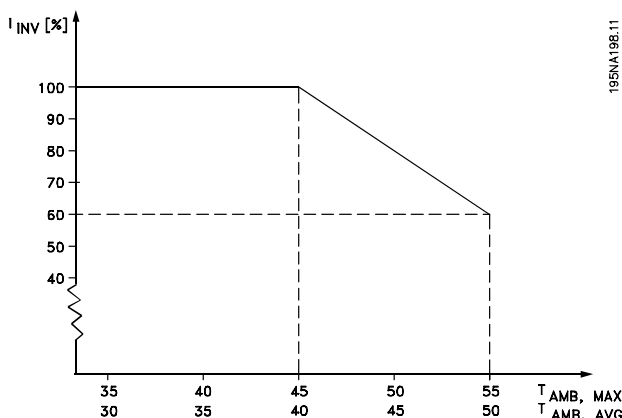

Illustration 5.1 Derating for Ambient Temperature

5.1.9 Temperature-Dependent Switching Frequency

This function ensures the highest possible switching frequency without the frequency converter becoming thermally overloaded. The internal temperature is the actual expression of the degree to which the switching frequency can achieve based on the load, the ambient temperature, the supply voltage and the cable length.

5

The function ensures that the frequency converter automatically adjusts the switching frequency between $f_{sw, min}$ and $f_{sw, max}$ (parameter 411 Switching frequency), as shown in *Illustration 5.2*.

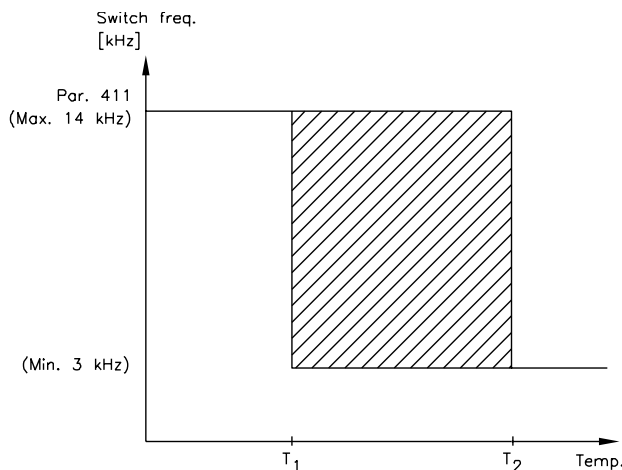

175NA020.13

Illustration 5.2 Switching Frequencies vs. Temperature

When an LC filter is used, the minimum switching frequency is 4.5 kHz.

5.1.10 Derating for Air Pressure

Protective Extra Low Voltage (PELV) requirements stated in IEC 61800-5-1 are not fulfilled at altitudes above 2000 m (6562 ft.). Contact Danfoss for further information.

Below 1000 m derating is not necessary. Above 1000 m, derate the ambient temperature (T_{AMB}) or maximum output current (I_{MAX}) in accordance with the diagram in *Illustration 5.3*:

1. Derating of output current versus altitude at T_{AMB} =maximum 45 °C.
2. Derating of max. T_{AMB} versus altitude at 100% output current.

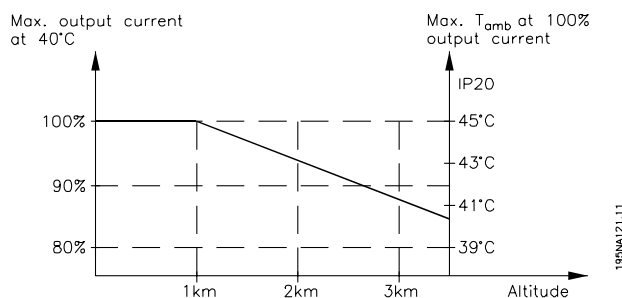

Illustration 5.3 Derating for Air Pressure

5.1.11 Derating for Running at Low Speed

When a motor is connected to a frequency converter, it is necessary to ensure adequate cooling of the motor. At low RPM values, the motor fan is not able to supply an adequate volume of cooling air. This problem occurs when the load torque is constant (for example, with a conveyor belt) across the full regulating range. The reduced amount of ventilation determines the permissible torque in continuous operation. If the motor is to run continuously at an RPM lower than half the rated value, extra cooling air must be supplied to the motor. Instead of providing extra cooling, reduce the motor load ratio by selecting a larger motor. However, the design of the frequency converter puts limits on the size of motors that can be connected to the frequency converter.

5.1.12 Derating for Long Motor Cables

The frequency converter has been tested using a 75 m unscreened/unarmoured cable and a 25 m screened/armoured cable and has been designed to work using a motor cable with a rated cross-section. If a cable with a larger cross-section is required, reduce the output current by 5% for each step the cable cross-section is increased. (Increased cable cross-section leads to increased capacitance to ground, and thus to an increased ground leakage current).

5.1.13 Derating for High Switching Frequency

A higher switching frequency (to be set in *parameter 411 Switching frequency*) leads to higher losses in the electronics of the frequency converter.

VLT 2800 has a pulse pattern in which it is possible to set the switching frequency from 3.0- 10.0/14.0 kHz.

The frequency converter automatically derates the rated output current $I_{VLT,N}$, when the switching frequency exceeds 4.5 kHz.

In both cases, the reduction is carried out linearly, down to 60% of $I_{VLT,N}$.

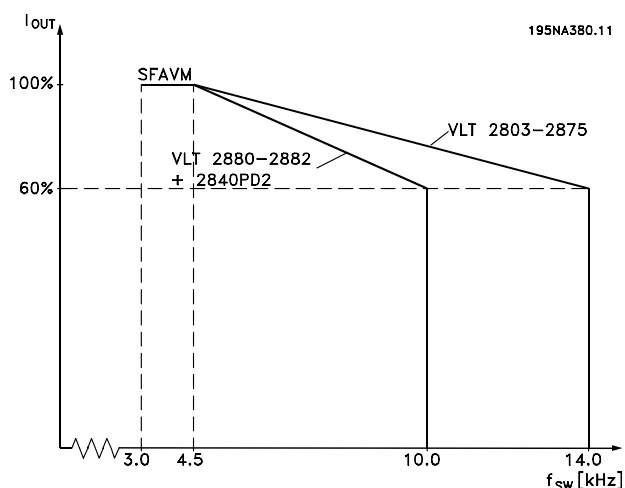

Illustration 5.4 Derating for High Switching Frequency

5.1.14 Vibration and Shock

The frequency converter has been tested according to a procedure based on the following standards:

- IEC 68-2-6: Vibration (sinusoidal) - 1970.
- IEC 68-2-34: Random vibration broad-band - general requirements.
- IEC 68-2-35: Random vibration broad-band - high reproducibility.
- IEC 68-2-36: Random vibration broad-band - medium reproducibility.

The frequency converter complies with requirements that correspond to conditions when the unit is mounted on the walls and floors of production premises, as well as in panels bolted to walls or floors.

5.1.15 Air Humidity

The frequency converter has been designed to meet the IEC 68-2-3 standard, EN 50178 item 9.4.2.2/ DIN 40040 class E at 40 °C.

5.1.16 UL Standard

This device is UL-approved.

5.1.17 Efficiency

To reduce energy consumption it is important to optimise the efficiency of a system. The efficiency of each single element in the system should be as high as possible.

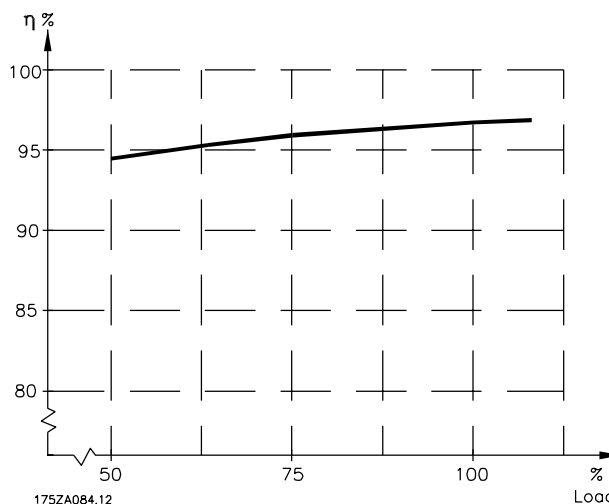

Illustration 5.5 Efficiency vs. Load

Efficiency of frequency converters (η_{INV})

The load on the frequency converter has little effect on its efficiency. In general, the efficiency is the same at the rated motor frequency $f_{M,N}$, regardless of whether the motor supplies 100% rated shaft torque or only 75%, e.g. in case of part loads.

This also means that the efficiency of the frequency converter does not change even if other U/f characteristics are selected. However, the U/f characteristics influence the efficiency of the motor.

The efficiency decreases a little when the switching frequency is set to a value above 4.5 kHz (*parameter 411 Switching frequency*). The rate of efficiency is also slightly reduced at a high mains voltage (480 V), or if the motor cable is longer than 25 m.

Efficiency of the motor (η_{MOTOR})

The efficiency of a motor connected to the frequency converter depends on the sine shape of the current. In general, the efficiency is just as good as in mains operation. The efficiency of the motor depends on the motor type.

In the range of 75-100% of the rated torque, the efficiency of the motor is practically constant, both when it is controlled by the frequency converter and when it runs directly on mains.

In general, the switching frequency does not affect the efficiency of small motors.

Efficiency of the system (η_{SYSTEM})

To calculate the system efficiency, the efficiency of the frequency converters (η_{INV}) should be multiplied by the efficiency of the motor (η_{MOTOR}):

$$\eta_{\text{SYSTEM}} = \eta_{\text{INV}} \times \eta_{\text{MOTOR}}$$

Based on *Illustration 5.5*, it is possible to calculate the system efficiency at different loads.

5.1.18 Mains Supply Interference/ Harmonics

5

A frequency converter takes up a non-sinusoidal current from mains, which increases the input current I_{RMS} . A non-sinusoidal current can be transformed with a Fourier analysis and split up into sinusoidal currents with different frequencies, that is, different harmonic currents I_n with 50 Hz as the basic frequency:

| Harmonic currents | I_1 | I_5 | I_7 |
|-------------------|-------|-------|-------|
| Frequency [Hz] | 50 | 250 | 350 |
| | 0,9 | 0,4 | 0,3 |

Table 5.4 Harmonic Currents

The harmonic currents do not affect power consumption directly, but they increase the heat losses in the installation (transformer, cables). Therefore, in plants with a rather high percentage of rectifier load, maintain harmonic currents at a low level to avoid overload of the transformer and high temperature in the cables.

Some of the harmonic currents disturb communication equipment connected to the same transformer or cause resonance with power-factor correction batteries.

5.1.19 Power Factor

The power factor (Pf) is the relation between I_1 and I_{RMS} . The power factor for 3-phase supply:

$$Pf = \frac{\sqrt{3} \times U \times I \times \cos\varphi}{\sqrt{3} \times U \times I_{\text{RMS}}}$$

The power factor indicates the extent to which the frequency converter imposes a load on the mains supply. The lower the power factor, the higher the I_{RMS} for the same kW performance. In addition, a high-power factor indicates that the different harmonic currents are low.

5.1.20 Generic EMC Standards / Product Standards

| Standard/environment | Industrial environment | | Residential, commercial and light industry | |
|---|------------------------|------------------------|--|------------|
| EMC Product Standard | EN61800-3 | | EN61800-3 | |
| 1st edition, 1996 | Unrestricted | Restricted | Unrestricted | Restricted |
| 2nd edition, 2004 | Category 3 | Category 4 | Category 1 | Category 2 |
| EMC Basic Standard, EN55011, Cable-borne/Radiated | Class A2 | EMC plan ¹⁾ | Class B | Class A1 |
| Generic EMC standards | EN 61000-6-4 | | EN 61000-6-3 | |
| EMC Basis Standard, EN55011, Cable-borne/Radiated | Class A | | Class B | |

1) Described in details in the EMC Product Standard. This category is among other things for complex installations (for instance IT supply networks).

The following system results are achieved on a system consisting of a VLT[®] 2800 frequency converter with screened/armoured control cable, control box with potentiometer, screened/armoured motor cable and screened/armoured brake cable as well as an LCP2 with cable.

| VLT 2803-2875 | Emission | | | |
|---|--------------------------------|--------------------------------|--|--------------------------|
| | Industrial environment | | Residential, commercial and light industry | |
| | EN 55011 class 1A | | EN 55011 class 1B | |
| Set-up | Cable-borne 150 kHz-30 MHz | Radiated 30 MHz-1 GHz | Cable-borne 150 kHz-30 MHz | Radiated 30 MHz-1 GHz |
| 3x480 V version with 1A RFI filter | Yes 25 m screened/armoured | Yes 25 m screened/armoured | No | No |
| 3x480 V version with 1A RFI filter (R5: For IT mains) | Yes 5 m screened/armoured | Yes 5 m screened/armoured | No | No |
| 1x200 V version with 1A RFI filter ¹⁾ | Yes 40 m screened/armoured | Yes 40 m screened/armoured | Yes 15 m screened/armoured | No |
| 3 x 200 V version with 1A RFI filter (R4: For use with RCD) | Yes 20 m screened/armoured | Yes 20 m screened/armoured | Yes 7 m screened/armoured | No |
| 3x480 V version with 1A+1B RFI filter | Yes 50 m screened/armoured | Yes 50 m screened/armoured | Yes 25 m screened/armoured | No |
| 1x200 V version with 1A+1B RFI filter ¹⁾ | Yes 100 m screened/armoured | Yes 100 m screened/armoured | Yes 40 m screened/armoured | No |
| VLT 2880-2882 | Emission | | | |
| | Industrial environment | | Residential, commerce and light industry | |
| | EN 55011 class 1A | | EN 55011 class 1B | |
| Set-up | Cable-borne 150 kHz-30 MHz | Radiated 30 MHz-1 GHz | Cable-borne 150 kHz-30 MHz | Radiated 30 MHz-1GHz |
| 3x480 V version with 1B RFI filter | Yes 50 m | Yes 50 m | Yes 50 m | No |

Table 5.5 EMC Emission Compliance

1) For VLT 2822-2840 3x200-240 V, the same values apply as for the 480 V version with 1A RFI filter.

- **EN 55011: Emission**
Limits and methods of measurement of radio disturbance characteristics of industrial, scientific and medical (ISM) high-frequency equipment.
 - **Class 1A:** Equipment used in an industrial environment.
 - **Class 1B:** Equipment used in areas with a public supply network (residential, commerce and light industry).

5.1.21 EMC Immunity

To document immunity against electrical interference, the following immunity tests have been made on a system consisting of a frequency converter, a screened/armoured control cable and a control box with potentiometer, screened/armoured motor cable, screened/armoured brake cable and an LCP 2 with a cable.

The tests were performed in accordance with the following basic standards:

- **EN 61000-4-4 (IEC 61000-4-4): Burst transients** Simulation of interference brought about by switching with contactors, relays, or similar devices.
- **EN 61000-4-5 (IEC 61000-4-5): Surge transients** Simulation of transients brought about, for example, by lightning that strikes near installations.
- **EN 61000-4-2 (IEC 61000-4-2): Electrostatic discharges (ESD)** Simulation of electrostatic discharges from human beings.
- **EN 61000-4-3(IEC 61000-4-3): Incoming electromagnetic field radiation, amplitude modulated** Simulation of the effects of radar and radio broadcast devices as well as mobile communication devices.
- **VDE 0160 class W2 test pulse: Mains transients** Simulation of high-energy transients generated by breaks in master fuses, connection to phase advancer batteries and the like.
- **EN 61000-4-6 (IEC 61000-4-6): RF common mode** Simulation of the effect from radio-transmitting equipment connected to connection cables.

| Basic standard | Burst 61000-4-4 | Surge 61000-4-5 | ESD 61000-4-2 | Radiated 61000-4-3 | Mains distortion VDE 0160 | RF CM voltage ²⁾ 61000-4-6 |
|-----------------------------|--------------------|------------------------|--------------------|-----------------------|---------------------------------|---|
| Acceptance criterion | B | B | B | A | | A |
| Port connection | CM | DM/CM | | Field | DM | CM |
| Line | | OK/OK | | | | OK |
| Motor | OK | | | | | |
| Control lines | OK | -/OK ¹⁾ | | | | OK |
| Relay | OK | -/OK | | | | OK |
| Profibus | OK | -/OK ¹⁾ | | | | OK |
| Signal interface <3 m | OK | | | | | |
| Enclosure | | | OK | OK | | |
| Standard bus | OK | -/OK ¹⁾ | | | | OK |
| Basic specifications | | | | | | |
| Line | 2 kV/DCN | 2 kV/4kV | | | | 10 V _{rms} |
| Motor | | | | | | 10 V _{rms} |
| Control lines | 2 kV/CCC | 2 kV/2 Ω ¹⁾ | | | | 10 V _{rms} |
| Relay | 2 kV/CCC | 2 kV/2 Ω ¹⁾ | | | | 10 V _{rms} |
| Profibus | 2 kV/CCC | 2 kV/2 Ω ¹⁾ | | | | 10 V _{rms} |
| Signal interface <3 m | 2 kV/CCC | | | | | |
| Enclosure | | | 8 kV AD 6 kV CD | 10 V/m | | |
| Standard bus | 2 kV/CCC | 2 kV/2 Ω ¹⁾ | | | | 10 V _{rms} |

Table 5.6 EMC Immunity Data

1) Injection on cable screen

DM: Differential mode

CM: Common mode

CCC: Capacitive clamp coupling (5 kHz)

DCN: Direct coupling network (5 kHz)

5.1.22 Harmonic Current Emission

All 3-phase 380-480 V units comply with EN 61000-3-2.

5.1.23 Aggressive Environments

As all other electronic equipment, a frequency converter contains a number of mechanical and electronic components, which to a varying extent are vulnerable to environmental impact.

CAUTION

Do not install the frequency converter in environments where liquids, particles or gases are in the air that would impact and damage the electronics. Unless the necessary measures are taken to protect the frequency converter, there is a risk of stoppages, which reduce the service life of the frequency converter.

Liquids can be carried through the air and condense in the frequency converter. In addition, liquids may facilitate galvanic corrosion of components and metal parts. Steam, oil and brine may cause corrosion of components and metal parts. In these areas, fit units in cabinets. As a minimum, cabinets should be enclosure IP54.

Particles in the air, such as dust particles, may lead to mechanical, electrical and thermal faults on the frequency converter. Typical indicators that there are too many particles in the air are dust particles around the frequency converter fan. In very dusty areas, cabinet fitting of units is recommended. As a minimum, cabinets should be enclosure IP54.

Aggressive gases, such as sulphur, nitrogen and chlorine compounds, together with high humidity and temperature, facilitate possible chemical processes on the components of the frequency converter. These chemical processes

quickly impact and damage the electronics. In these areas, cabinet fitting with fresh-air circulation in the cabinet is recommended, thereby ensuring that aggressive gases are kept away from the frequency converter.

⚠ CAUTION

Fitting of frequency converters in aggressive environments increases the risk of stoppages, in addition to considerably reducing the service life of the unit.

Before installing the frequency converter, ensure there are no liquids, particles, or gases in the air by looking at existing installations in the same environment. Typical indicators of harmful airborne liquids are water or oil on metal parts or corrosion of metal parts. Too many dust particles are typically observed on top of installation cabinets and on existing electrical installations. Indicators that there are aggressive gases in the air are copper rails and cable ends that are black on existing electrical installations.

5.2 Display and Messages

5.2.1 Display Readout

Fr

The frequency converter shows the present output frequency in Hertz [Hz].

Io

The frequency converter shows the present output current in Amps [A].

Uo

The frequency converter shows the present output voltage in Volt [V].

Ud

The frequency converter shows the intermediate circuit voltage in Volt [V].

Po

The frequency converter shows the calculated output in kilowatt [kW].

notrun

This message is shown if an attempt is made to change a parameter value while the motor is running. Stop the motor to change the parameter value.

LCP

This message is shown if an LCP 2 control unit is fitted and the [QUICK MENU] or [CHANGE DATA] key is pressed. If an LCP 2 control unit is fitted it is only possible to change parameters with LCP 2.

Ha

The frequency converter shows the present Hand mode reference frequency in Herz (Hz).

SC

The frequency converter shows scaled output frequency (the present output frequency x parameter 008).

5.2.2 Warnings and Alarm Messages

A warning or an alarm appears in the display as a numerical code *Err. xx*. A warning is shown in the display until the fault has been corrected, while an alarm continues to flash until the [STOP/RESET] key is pressed. *Table 5.7* shows the various warnings and alarms, and whether the fault locks the frequency converter. After a *Trip lock*, the mains supply is cut off and the fault is corrected. The mains supply is reconnected and the frequency converter is reset. The frequency converter is now ready. A *Trip* can be reset manually in 3 ways:

- Via the operating key [STOP/RESET].
- Via a digital input.
- Via serial communication.

It is also possible to select an automatic reset in *parameter 405 Reset function*. When a cross appears in both warning and alarm, this can mean that a warning comes before an alarm. It can also mean that it is possible for the user to programme whether a warning or an alarm appears for a given fault. For example, this is possible in *parameter 128 Motor thermal protection*. After a trip, the motor coasts, and alarm and warning blink on the frequency converter, but if

the fault disappears only the alarm flashes. After a reset the frequency converter is ready to start operation again.

| No. | Description | Warning | Alarm | Trip locked |
|-------|--|---------|-------|-------------|
| 2 | Live zero error (LIVE ZERO ERROR) | X | X | X |
| 4 | Mains phase loss (MAINS PHASE LOSS) | X | X | X |
| 5 | Voltage warning high (DC LINK VOLTAGE HIGH) | X | | |
| 6 | Voltage warning low (DC LINK VOLTAGE LOW) | X | | |
| 7 | Overvoltage (DC LINK OVERVOLT) | X | X | X |
| 8 | Undervoltage (DC LINK UNDERVOLT) | X | X | X |
| 9 | Inverter overload (INVERTER TIME) | X | X | |
| 10 | Motor overloaded (MOTOR, TIME) | X | X | |
| 11 | Motor thermistor (MOTOR THERMISTOR) | X | X | |
| 12 | Current limit (CURRENT LIMIT) | X | X | |
| 13 | Overcurrent (OVERCURRENT) | X | X | X |
| 14 | Earth fault (EARTH FAULT) | | X | X |
| 15 | Switch mode fault (SWITCH MODE FAULT) | | X | X |
| 16 | Short-circuit (CURR. SHORT CIRCUIT) | | X | X |
| 17 | Serial communication timeout (STD BUS TIMEOUT) | X | X | |
| 18 | HPFB bus timeout (HPFB TIMEOUT) | X | X | |
| 33 | Out of frequency range (OUT FREQ RNG/ROT LIM) | X | | |
| 34 | HPFB communication fault (PROFIBUS OPT. FAULT) | X | X | |
| 35 | Inrush fault (INRUSH FAULT) | | X | X |
| 36 | Overtemperature (OVERTEMPERATURE) | X | X | |
| 37-45 | Internal fault (INTERNAL FAULT) | | X | X |
| 50 | AMT not possible | | X | |
| 51 | AMT fault re. nameplate data (AMT TYPE.DATA FAULT) | | X | |
| 54 | AMT wrong motor (AMT WRONG MOTOR) | | X | |
| 55 | AMT timeout (AMT TIMEOUT) | | X | |
| 56 | AMT warning during AMT (AMT WARN. DURING AMT) | | X | |
| 99 | Locked (LOCKED) | X | | |

Table 5.7 Warnings and Alarms

| | |
|-------------|----------------|
| Warning | yellow |
| Alarm | red |
| Trip locked | yellow and red |

Table 5.8 LED Indication

WARNING/ALARM 2: Live zero fault

The voltage or current signal on terminal 53 or 60 is below 50% of the preset value in *parameter 309 Terminal 53, minimum scaling* or *parameter 315 Terminal 60, minimum scaling*.

WARNING/ALARM 4: Mains phase fault

No phase on mains supply side. Check the supply voltage to the adjustable frequency drive. This fault is only active in 3-phase mains supply. The alarm can also occur when the load is pulsing. In this instance the pulses must be dampened, e.g. using an inertia disc.

WARNING 5: Voltage warning high

If the intermediate circuit voltage (UDC) is higher than *Voltage warning high*, the adjustable frequency drive gives a warning and the motor continues to run unchanged. If the UDC remains above the voltage warning limit, the frequency converter trips after a set time. The time depends on the device, and is set at 5-10 s. Note: The adjustable frequency drive trips with an alarm 7 (overvoltage). A voltage warning can occur when the connected mains voltage is too high. Check whether the supply voltage is suitable for the adjustable frequency drive, see *chapter 5.3 General Technical Data* for further details. A voltage warning can also occur if the motor frequency is reduced too quickly due to ramp-down time being too short.

WARNING 6: Voltage warning low

If the intermediate circuit voltage (UDC) is lower than *Voltage warning low* the adjustable frequency drive gives a warning and the motor continues to run unchanged. A voltage warning can occur when the connected mains voltage is too low. Check whether the supply voltage is

suitable for the adjustable frequency drive, see *chapter 5.3 General Technical Data* for further details. When the adjustable frequency drive is switched off, a brief warning 6 (and warning 8) appears.

WARNING/ALARM 7: Overvoltage

If the intermediate voltage (UDC) exceeds the *Overvoltage limit* of the frequency converter, the inverter is switched off until the UDC drops below the overvoltage limit. If the UDC remains above the overvoltage limit, the inverter trips after a set time. The time depends on the device, and is set at 5-10 s. An overvoltage in the UDC can occur when the motor frequency is reduced too quickly due to ramp down time being too short. When the inverter is switched off, a trip reset is generated. *Voltage warning high* (warning 5) is able to generate an alarm 7.

WARNING/ALARM 8: Undervoltage

If the intermediate circuit voltage (UDC) is lower than the inverter's *Undervoltage limit*, the inverter is switched off until the UDC exceeds the undervoltage limit. If the UDC remains under the *undervoltage limit*, the inverter trips after a set time. The time depends on the device, and is set at 2-15 s. An undervoltage can occur when the connected mains voltage is too low. Check whether the supply voltage is suitable for the adjustable frequency drive. See *chapter 5.3 General Technical Data* for further details. When the adjustable frequency drive is switched off, an alarm 8 (and alarm 6) is displayed briefly and a trip reset is generated. *Voltage warning low* (warning 6) is also able to generate an alarm 8.

WARNING/ALARM 9: Inverter overload

Electronic thermal inverter protection indicates that the adjustable frequency drive is close to tripping due to overloading (output current too high for too long). The counter for electronic thermal inverter protection triggers a warning at 98% and trips at 100% accompanied by an alarm. The adjustable frequency drive cannot be reset until the counter drops below 90%. This fault arises because the adjustable frequency drive has been overloaded for too long.

WARNING/ALARM 10: Motor overloaded

According to the electronic thermal inverter protection the motor is too hot. In *parameter 128 Thermal motor protection* the user can select whether the adjustable frequency drive should emit a warning or an alarm when the counter reaches 100%. This fault is due to the motor being overloaded by more than 100% for too long. Check that motor *parameters 102-106* are set correctly.

WARNING/ALARM 11: Motor thermistor

The motor is too hot or the thermistor/thermistor connection has been disconnected. In *parameter 128 Thermal motor protection*, select whether the frequency transformer emits a warning or an alarm. Check that the PTC thermistor is correctly connected between terminals 18, 19, 27 or 29 (digital input) and terminal 50 (+ 10 V supply).

WARNING/ALARM 12: Current limit

The output current is higher than the value in *parameter 221 Current Limit LIM_r*, and the adjustable frequency drive trips after a set time, selected in *parameter 409 Trip delay overcurrent*.

WARNING/ALARM 13: Overcurrent

The inverter's peak current limit (approx. 200% of rated output current) has been exceeded. The warning lasts approx. 1-2 s, and the adjustable frequency drive trips and emits an alarm. Switch off the adjustable frequency drive and check whether the motor shaft can be turned, and whether the size of the motor is suitable for the adjustable frequency drive.

ALARM 14: Ground fault

There is a discharge from the output phases to ground, either in the cable between the adjustable frequency drive and the motor, or in the motor. Turn off the adjustable frequency drive and remove the ground fault.

ALARM 15: Switch mode fault

Fault in switch mode power supply (internal supply). Contact the Danfoss supplier.

ALARM: 16: Short-circuit

There is a short-circuit on the motor terminals or in the motor. Disconnect the mains supply to the adjustable frequency drive and remove the short-circuit.

WARNING/ALARM 17: Serial communication timeout

There is no serial communication to the adjustable frequency drive. The warning is only active when *parameter 514 Bus timeout function* is set to a value other than OFF. If *parameter 514 Bus timeout function* is set to [5] *Stop and trip*, it first gives a warning and then ramps down and trips out accompanied by an alarm. *Parameter 513 Bus timeout* can be increased.

WARNING/ALARM 18: HPFB bus timeout

There is no serial communication to the adjustable frequency drive's communication option card. This warning is only active when *parameter 804 Bus timeout function* is set to a value other than OFF. If *parameter 804 Bus timeout function* is set to *Stop and trip*, it first gives a warning and then ramps down and trips out accompanied by an alarm. *Parameter 803 Bus timeout* can if required be increased.

WARNING 33: Out of frequency range

This warning is active if the output frequency has reached the limit set in *parameter 201 Output frequency low limit* or *parameter 202 Output frequency high limit*. If the adjustable frequency drive is in closed loop operation, the warning is active in the display. If the adjustable frequency drive is in another mode than closed loop, bit 008000 *Out of frequency range* in extended status word is active, but there are no warnings in the display.

WARNING/ALARM 34: HPFB communication fault

Communication fault only occurs in Fieldbus versions. Regarding alarm type, refer to information about *parameter 953*.

ALARM 35: Inrush fault

This alarm occurs when the adjustable frequency drive has been connected to the mains supply too many times within 1 minute.

WARNING/ALARM 36: Overtemperature

If the temperature inside the power module rises above 75-85 °C (depending on the device), the adjustable frequency drive emits a warning, and the motor continues to run unchanged. If the temperature continues to rise, the switch frequency is reduced automatically. See *chapter 5.1.9 Temperature-Dependent Switching Frequency* for further details.

If the temperature inside the power module rises above 92-100 °C (depending on the unit), the adjustable frequency drive cuts out. The temperature fault cannot be reset until the temperature has dropped below 70 °C. The tolerance is ±5 °C. Causes for overtemperature:

- The ambient temperature too high.
- Motor cables are too long.
- Too high mains voltage.

ALARM 37-45: Internal fault

If one of these failures occurs, contact Danfoss.

Alarm 37, internal fault number 0: Communication fault between control card and BMC.

Alarm 38, internal fault number 1: Flash EEPROM fault on control card.

Alarm 39, internal fault number 2: RAM fault on control card.

Alarm 40, internal fault number 3: Calibration constant in EEPROM.

Alarm 41, internal fault number 4: Data values in EEPROM.

Alarm 42, internal fault number 5: Fault in motor parameter database.

Alarm 43, internal fault number 6: General power card fault.

Alarm 44, internal fault number 7: Minimum software version of control card or BMC.

Alarm 45, internal fault number 8: I/O fault (digital input/output, relay or analog input/output).

NOTICE

When restarting after an alarm 38-45, the adjustable frequency drive displays an alarm 37. In *parameter 615 Fault log: Error code*, the actual alarm code can be read.

ALARM 50: AMT not possible

One of the following three possibilities can occur:

- The calculated R_s value is outside permitted limits.
- The motor current in at least one of the motor phases is too low.
- The motor in use is too small for AMT calculations to be performed.

ALARM 51: AMT Fault regarding nameplate data

There is inconsistency between the registered motor data. Check the motor data for the relevant set-up.

ALARM 52: AMT missing motor phase

The AMT function has detected a missing motor phase.

ALARM 55: AMT time-out

Calculations are taking too long, possibly due to noise on the motor cables.

ALARM 56: AMT warning during AMT

A adjustable frequency drive warning is given while AMT is being performed.

WARNING 99: Locked

See parameter 18.

| | Without brake | With brake | Without brake | With brake |
|----------------------|---------------------------|---------------------------|-----------------------|-----------------------|
| VLT 2800 | 1/3 x 200-240 V [V DC] | 1/3 x 200-240 V [V DC] | 3x380-480 V [V DC] | 3x380-480 V [V DC] |
| Undervoltage | 215 | 215 | 410 | 410 |
| Voltage warning low | 230 | 230 | 440 | 440 |
| Voltage warning high | 385 | 400 | 765 | 800 |
| Overvoltage | 410 | 410 | 820 | 820 |

Table 5.9 Alarm/Warning Limits

The voltages stated are the intermediate circuit voltage of the adjustable frequency drive with a tolerance of ±5 %. The corresponding line voltage is the intermediate circuit voltage divided by 1.35.

5.2.3 Warning Words, Extended Status Words and Alarm Words

Warning words, status words and alarm words appear in the display in hex format. If there are several warnings, status words or alarms, a total of all the warnings, status words or alarms are displayed. Warning words, status words and alarm words can also be read with the serial bus in *parameters 540, 541 and 538*.

5

| Bit (hex) | Warning words |
|-----------|------------------------------|
| 000008 | HPFB bus timeout |
| 000010 | Standard bus timeout |
| 000040 | Current limit |
| 000080 | Motor thermistor |
| 000100 | Motor overload |
| 000200 | Inverter overload |
| 000400 | Undervolt |
| 000800 | Overvolt |
| 001000 | Voltage warning low |
| 002000 | Voltage warning high |
| 004000 | Phase loss |
| 010000 | Live zero error |
| 400000 | Out of frequency range |
| 800000 | Profibus communication fault |
| 40000000 | Switch mode warning |
| 80000000 | Heat sink temperature high |

Table 5.10 Warning Words

| Bit (hex) | Extended status words |
|-----------|------------------------|
| 000001 | Ramping |
| 000002 | AMT running |
| 000004 | Start forw./reverse |
| 000008 | Slow down |
| 000010 | Catch-up |
| 000020 | Feedback high |
| 000040 | Feedback low |
| 000080 | Output current high |
| 000100 | Output current low |
| 000200 | Output frequency high |
| 000400 | Output frequency low |
| 002000 | Braking |
| 008000 | Out of frequency range |

Table 5.11 Extended Status Words

| Bit (hex) | Alarm words |
|-----------|--------------------------------|
| 000002 | Triplock |
| 000004 | AMT tuning fail |
| 000040 | HPFB bus timeout |
| 000080 | Standard bus timeout |
| 000100 | Curr. short circuit |
| 000200 | Switch mode fault |
| 000400 | Earth fault |
| 000800 | Overcurrent |
| 002000 | Motor thermistor |
| 004000 | Motor overload |
| 008000 | Inverter overload |
| 010000 | Undervolt |
| 020000 | Overvolt |
| 040000 | Phase loss |
| 080000 | Live zero error |
| 100000 | Heat sink temperature too high |
| 2000000 | Profibus communication fault |
| 8000000 | Inrush fault |
| 10000000 | Internal fault |

Table 5.12 Alarm Words

5.3 General Technical Data

| | |
|--|--------------------------------------|
| Supply voltage VLT 2803-2840 220-240 V (N, L1) | 1 x 220/230/240 V $\pm 10\%$ |
| Supply voltage VLT 2803-2840 200-240 V | 3 x 200/208/220/230/240 V $\pm 10\%$ |
| Supply voltage VLT 2805-2882 380-480 V | 3 x 380/400/415/440/480 V $\pm 10\%$ |
| Supply voltage VLT 2805-2840 (R5) | 380/400 V $+10\%$ |
| Supply frequency | 50/60 Hz ± 3 Hz |
| Max. imbalance on supply voltage | $\pm 2.0\%$ of rated supply voltage |
| True power factor (λ) | 0.90 nominal at rated load |
| Displacement power factor ($\cos \varphi$) | near unity (> 0.98) |
| Number of connections at supply input L1, L2, L3 | 2 times/min. |
| Max. short-circuit value | 100,000 A |

See chapter 5.1 Special Conditions for further information.

Output data (U, V, W)

| | |
|--------------------------------------|---------------------------|
| Output voltage | 0-100% of supply voltage |
| Output frequency | 0.2-132 Hz, 1-590 Hz |
| Rated motor voltage, 200-240 V units | 200/208/220/230/240 V |
| Rated motor voltage, 380-480 V units | 380/400/415/440/460/480 V |
| Rated motor frequency | 50/60 Hz |
| Switching on output | Unlimited |
| Ramp times | 0.02-3600 s |

Torque characteristics

| | |
|--|------------------------------|
| Starting torque (parameter 101 Torque characteristic=Constant torque) | 160% in 1 min. ¹⁾ |
| Starting torque (parameter 101 Torque characteristics=Variable torque) | 160% in 1 min. ¹⁾ |
| Starting torque (parameter 119 High starting torque) | 180% for 0.5 s |
| Overload torque (parameter 101 Torque characteristic=Constant torque) | 160% ¹⁾ |
| Overload torque (parameter 101 Torque characteristic=Variable torque) | 160% ¹⁾ |

Percentage relates to frequency converter's nominal current.

1) VLT 2822 PD2/2840 PD2 1x220 V only 110% in 1 min

Control card, digital inputs

| | |
|--|--------------------------------|
| Number of programmable digital inputs | 5 |
| Terminal number | 18, 19, 27, 29, 33 |
| Voltage level | 0-24 V DC (PNP positive logic) |
| Voltage level, logic '0' | < 5 V DC |
| Voltage level, logic '1' | > 10 V DC |
| Maximum voltage on input | 28 V DC |
| Input resistance, R_i (terminals 18, 19, 27, 29) | approx. 4 k Ω |
| Input resistance, R_i (terminal 33) | approx. 2 k Ω |

All digital inputs are galvanically isolated from the supply voltage (PELV) and other high-voltage terminals. See chapter 5.1.1 Galvanic Isolation (PELV) for further information.

Control card, analog inputs

| | |
|---------------------------------|-----------------------------|
| Number of analog voltage inputs | 1 pcs. |
| Terminal number | 53 |
| Voltage level | 0-10 V DC (scaleable) |
| Input resistance, R_i | approx. 10 k Ω |
| Maximum voltage | 20 V |
| Number of analog current inputs | 1 pics. |
| Terminal number | 60 |
| Current level | 0/4-20 mA (scaleable) |
| Input resistance, R_i | approx. 300 Ω |
| Max. current | 30 mA |
| Resolution for analog inputs | 10 bit |
| Accuracy of analog inputs | Max. error 1% of full scale |
| Scan interval | 13.3 ms |

The analog inputs are galvanically isolated from the supply voltage (PELV) and other high-voltage terminals. See chapter 5.1.1 Galvanic Isolation (PELV) for further information.

Control card, pulse inputs

| | |
|---------------------------------------|--------------------------------|
| Number of programmable pulse inputs | 1 |
| Terminal number | 33 |
| Max. frequency at terminal 33 | 67.6 kHz (Push-pull) |
| Max. frequency at terminal 33 | 5 kHz (open collector) |
| Min. frequency at terminal 33 | 4 Hz |
| Voltage level | 0-24 V DC (PNP positive logic) |
| Voltage level, logic '0' | < 5 V DC |
| Voltage level, logic '1' | > 10 V DC |
| Maximum voltage on input | 28 V DC |
| Input resistance, R_i | approx. 2 k Ω |
| Scan interval | 13.3 ms |
| Resolution | 10-bit |
| Accuracy (100 Hz-1 kHz) terminal 33 | Max. error: 0.5% of full scale |
| Accuracy (1 kHz-67.6 kHz) terminal 33 | Max. error: 0.1% of full scale |

The pulse input (terminal 33) is galvanically isolated from the supply voltage (PELV) and other high-voltage terminals. See chapter 5.1.1 Galvanic Isolation (PELV) for further information.

Control card, digital/frequency output

| | |
|---|--------------------------------|
| Number of programmable digital/pulse outputs | 1 pcs. |
| Terminal number | 46 |
| Voltage level at digital/frequency output | 0 - 24 V DC (O.C PNP) |
| Max. output current at digital/frequency output | 25 mA. |
| Max. load at digital/frequency output | 1 k Ω |
| Max. capacity at frequency output | 10 nF |
| Minimum output frequency at frequency output | 16 Hz |
| Maximum output frequency at frequency output | 10 kHz |
| Accuracy on frequency output | Max. error: 0.2% of full scale |
| Resolution on frequency output | 10 bit |

The digital output is galvanically isolated from the supply voltage (PELV) and other high-voltage terminals. See chapter 5.1.1 Galvanic Isolation (PELV) for further information.

Control card, analog output

| | |
|---------------------------------------|--------------------------------|
| Number of programmable analog outputs | 1 |
| Terminal number | 42 |
| Current range at analog output | 0/4-20 mA |
| Max. load to common at analog output | 500 Ω |
| Accuracy on analog output | Max. error: 1.5% of full scale |
| Resolution on analog output | 10 bit |

The analog output is galvanically isolated from the supply voltage (PELV) and other high-voltage terminals. See chapter 5.1.1 Galvanic Isolation (PELV) for further information.

Control card, 24 V DC output

| | |
|-----------------|--------|
| Terminal number | 12 |
| Maximum load | 130 mA |

The 24 V DC supply is galvanically isolated from the supply voltage (PELV), but has the same potential as the analogue and digital inputs and outputs. See chapter 5.1.1 Galvanic Isolation (PELV) for further information.

Control card, 10 V DC output

| | |
|-----------------|---------------|
| Terminal number | 50 |
| Output voltage | 10.5 V ±0.5 V |
| Max. load | 15 mA |

The 10 V DC supply is galvanically isolated from the supply voltage (PELV) and other high-voltage terminals. See chapter 5.1.1 Galvanic Isolation (PELV) for further information.

Control card, RS-485 serial communication

| | |
|--------------------|------------------------------------|
| Terminal number | 68 (TX+, RX+), 69 (TX-, RX-) |
| Terminal number 67 | +5 V |
| Terminal number 70 | Common for terminals 67, 68 and 69 |

Full galvanic isolation. See chapter 5.1.1 Galvanic Isolation (PELV) for further information.

For information about CANopen/DeviceNet units, see VLT 2800 DeviceNet Manual.

Relay outputs¹⁾

| | |
|--|--------------------------------|
| Number of programmable relay outputs | 1 |
| Terminal number, control card (resistive and inductive load) | 1-3 (break), 1-2 (make) |
| Max. terminal load (AC1) on 1-3, 1-2, control card | 250 V AC, 2 A, 500 VA |
| Max. terminal load (DC1 (IEC 947)) on 1-3, 1-2, control card | 25 V DC, 2 A/50 V DC, 1A, 50 W |
| Min. terminal load (AC/DC) on 1-3, 1-2, control card | 24 V DC 10 mA, 24 V AC 100 mA |

1) The relay contact is separated from the rest of the circuit by strengthened isolation.

NOTICE

Rated values resistive load - $\cos\Phi > 0.8$ for up to 300000 operations.
 Inductive loads at $\cos\Phi 0.25$ approximately 50% load or 50% life time.

Cable lengths and cross-sections

| | |
|---|--------------|
| Max. motor cable length, screened/armoured cable | 40 m |
| Max. motor cable length, unscreened/unarmoured cable | 75 m |
| Max. motor cable length, screened/armoured cable and motor coil | 100 m |
| Max. motor cable length, unscreened/unarmoured cable and motor coil | 200 m |
| Max. motor cable length, screened/armoured cable and RFI/1B filter | 200 V, 100 m |
| Max. motor cable length, screened/armoured cable and RFI/1B filter | 400 V, 25 m |
| Max. motor cable length, screened/armoured cable and RFI 1B/LC filter | 400 V, 25 m |

Max. cross section to motor, see next section.

| | |
|--|---|
| Max. cross section to control wires, rigid wire | 1.5 mm ² /16 AWG (2x0.75 mm ²) |
| Max. cross section to control cables, flexible cable | 1 mm ² /18 AWG |
| Max. cross section to control cables, cable with enclosed core | 0.5 mm ² /20 AWG |

When complying with EN 55011 1A and EN 55011 1B the motor cable must in certain instances be reduced. See chapter 5.1.21 EMC Compliance for more details.

Control characteristics

| | |
|--|-------------------------------------|
| Frequency range | 0.2-132 Hz, 1-590 Hz |
| Resolution of output frequency | 0.013 Hz, 0.2-590 Hz |
| Repeat accuracy of Precise start/stop (terminals 18, 19) | ±0.5 ms |
| System response time (terminals 18, 19, 27, 29, 33) | 26.6 ms |
| Speed control range (open loop) | 1:10 of synchronous speed |
| Speed control range (closed loop) | 1:120 of synchronous speed |
| Speed accuracy (open loop) | 150-3600 RPM: Max. error of ±23 RPM |
| Speed accuracy (closed loop) | 30-3600 RPM: Max. error of ±7.5 RPM |

All control characteristics are based on a 4-pole asynchronous motor.

Surroundings

| | |
|---------------------------|---|
| Enclosure | IP20 |
| Enclosure with options | NEMA 1 |
| Vibration test | 0.7 g |
| Maximum relative humidity | 5%-93% during operation |
| Ambient temperature | Maximum 45 °C (24-hour average maximum 40 °C) |

For more information about derating for high ambient temperature, see chapter 5.1 Special Conditions.

| | |
|---|------------------|
| Minimum ambient temperature during full-scale operation | 0 °C |
| Minimum ambient temperature at reduced performance | -10 °C |
| Temperature during storage/transport | -25 to +65/70 °C |
| Maximum altitude above sea level | 1000 m |

For more information about dedrating for high air pressure, see chapter 5.1 Special Conditions.

| | |
|-------------------------|--|
| EMC standards, Emission | EN 61081-2, EN 61800-3, EN 55011 EN 50082-1/2, EN 61000-4-2, EN 61000-4-3, EN 61000-4-4, EN 61000-4-5, EN 61000-4-6, EN |
| EMC standards, Immunity | 61800-3 |

For more details, see chapter 5.1 Special Conditions.

Safeguards

- Electronic thermal motor protection against overload.
- Temperature monitoring of the power module ensures that the frequency converter cuts out if the temperature reaches 100 °C. An overload temperature cannot be reset until the temperature of the power module is below 70 °C.
- The frequency converter is protected against short-circuits on motor terminals U, V, W.
- If a mains phase is missing, the frequency converter cuts out.
- Monitoring of the intermediate circuit voltage ensures that the frequency converter cuts out if the intermediate circuit voltage is too low or too high.
- The frequency converter is protected against ground fault on motor terminals U, V, W.

5.4 Mains Supply

5.4.1 Mains Supply 1x220-240 V/3x200-240 V

| According to international standards | | Type | 2803 | 2805 | 2807 | 2811 | 2815 | 2822 | 2822 PD2 | 2840 | 2840 PD2 |
|---|------------------------------------|--------------------------------------|-------|-------|-------|-------|-------|-------|----------|-------|-----------------|
|  | Output current (3x200-240V) | I_{INV} [A] | 2.2 | 3.2 | 4.2 | 6.0 | 6.8 | 9.6 | 9.6 | 16 | 16 |
| | | I_{MAX} (60 s) [A] | 3.5 | 5.1 | 6.7 | 9.6 | 10.8 | 15.3 | 10.6 | 25.6 | 17.6 |
| | Output power (230 V) | S_{INV} [KVA] | 0.9 | 1.3 | 1.7 | 2.4 | 2.7 | 3.8 | 3.8 | 6.4 | 6.4 |
| | Typical shaft output | $P_{M,N}$ [kW] | 0.37 | 0.55 | 0.75 | 1.1 | 1.5 | 2.2 | 2.2 | 3.7 | 3.7 |
| | Typical shaft output | $P_{M,N}$ [HP] | 0.5 | 0.75 | 1.0 | 1.5 | 2.0 | 3.0 | 3.0 | 5.0 | 5.0 |
| | Max. cable cross-section, motor | [mm ² /AWG] ¹⁾ | 4/10 | 4/10 | 4/10 | 4/10 | 4/10 | 4/10 | 4/10 | 4/10 | 4/10 |
|  | Input current (1x220-240 V) | $I_{L,N}$ [A] | 5.9 | 8.3 | 10.6 | 14.5 | 15.2 | - | 22.0 | - | 31.0 |
| | | $I_{L,MAX}$ (60 s) [A] | 9.4 | 13.3 | 16.7 | 23.2 | 24.3 | - | 24.3 | - | 34.5 |
| | Input current (3x200-240 V) | $I_{L,N}$ [A] | 2.9 | 4.0 | 5.1 | 7.0 | 7.6 | 8.8 | 8.8 | 14.7 | 14.7 |
| | | $I_{L,MAX}$ (60s) [A] | 4.6 | 6.4 | 8.2 | 11.2 | 12.2 | 14.1 | 9.7 | 23.5 | 16.2 |
| | Maximum cable cross-section, power | [mm ² /AWG] ¹⁾ | 4/10 | 4/10 | 4/10 | 4/10 | 4/10 | 4/10 | 4/10 | 4/10 | 16/6 |
| | Maximum pre-fuses | IEC/UL ²⁾ [A] | 20/20 | 20/20 | 20/20 | 20/20 | 20/20 | 20/20 | 35/35 | 25/25 | 50/50 |
| | Efficiency ³⁾ | [%] | 95 | 95 | 95 | 95 | 95 | 95 | 95 | 95 | 95 |
| | Power loss at 100% load | [W] | 24 | 35 | 48 | 69 | 94 | 125 | 125 | 231 | 231 |
| | Weight | [kg] | 2.0 | 2.0 | 2.0 | 2.0 | 2.0 | 3,7 | 6.0 | 6.0 | 18.50 |
| | Enclosure ⁴⁾ | type | IP20 | IP20 | IP20 | IP20 | IP20 | IP20 | IP20 | IP20 | IP20/ NEMA 1 |

Table 5.13 Mains Supply 1x220-240 V/3x200-240 V

1) American wire Gauge. Maximum cable cross-section is the largest cable cross section that can be attached to the terminals. Always observe national and local regulations.

2) Use Type gG pre-fuses for installation according to IEC rules. To maintain UL/cUL, use pre-fuses of the type Bussmann KTN-R 200 V, KTS-R 500 V or Ferraz Shawmut, type ATMR (maximum 30 A). Place the fuses for protection in a circuit that is capable of supplying a maximum of 100,000 amps RMS (symmetrical), 500 V maximum.

3) Measured using a 25 m screened/armoured motor cable with a rated load and rated frequency.

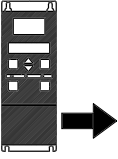
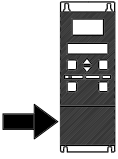
4) IP20 is standard for VLT 2805-2875, whereas NEMA 1 is an option.

5.4.2 Mains Supply 3x380-480 V

| According to international standards | | Type | 2805 | 2807 | 2811 | 2815 | 2822 | 2830 |
|--------------------------------------|------------------------------------|--------------------------------------|-------|-------|-------|-------|-------|-------|
| | Output current (3x380-480V) | I_{INV} [A] | 1.7 | 2.1 | 3.0 | 3.7 | 5.2 | 7.0 |
| | | I_{MAX} (60 s) [A] | 2.7 | 3.3 | 4.8 | 5.9 | 8.3 | 11.2 |
| | Output power (400 V) | S_{INV} [KVA] | 1.1 | 1.7 | 2.0 | 2.6 | 3.6 | 4.8 |
| | Typical shaft output | $P_{M,N}$ [kW] | 0.55 | 0.75 | 1.1 | 1.5 | 2.2 | 3.0 |
| | Typical shaft output | $P_{M,N}$ [HP] | 0.75 | 1.0 | 1.5 | 2.0 | 3.0 | 4.0 |
| | Maximum cable cross-section, motor | [mm ² /AWG] ¹⁾ | 4/10 | 4/10 | 4/10 | 4/10 | 4/10 | 4/10 |
| <hr/> | | | | | | | | |
| | Input current (3x380-480 V) | $I_{L,N}$ [A] | 1.6 | 1.9 | 2.6 | 3.2 | 4.7 | 6.1 |
| | | $I_{L,MAX}$ (60 s)[A] | 2.6 | 3.0 | 4.2 | 5.1 | 7.5 | 9.8 |
| | Maximum cable cross-section, power | [mm ² /AWG] ¹⁾ | 4/10 | 4/10 | 4/10 | 4/10 | 4/10 | 4/10 |
| | Maximum pre-fuses | IEC/UL ²⁾ [A] | 20/20 | 20/20 | 20/20 | 20/20 | 20/20 | 20/20 |
| | Efficiency ³⁾ | [%] | 96 | 96 | 96 | 96 | 96 | 96 |
| | Power loss at 100% load | [W] | 28 | 38 | 55 | 75 | 110 | 150 |
| | Weight | [kg] | 2.1 | 2.1 | 2.1 | 2.1 | 3.7 | 3.7 |
| | Enclosure ⁴⁾ | type | IP20 | IP20 | IP20 | IP20 | IP20 | IP20 |

5

Table 5.14 Mains Supply 3x380-480 V, Part 1

| According to international standards | | Type | 2840 | 2855 | 2875 | 2880 | 2881 | 2882 |
|--------------------------------------|------------------------------------|--------------------------------------|-------|-------|-------|-----------------|-----------------|-----------------|
| | Output current (3x380-480V) | I_{INV} [A] | 9.1 | 12 | 16 | 24 | 32.0 | 37.5 |
| | | I_{MAX} (60 s) [A] | 14.5 | 19.2 | 25.6 | 38.4 | 51.2 | 60.0 |
| | Output power (400 V) | S_{INV} [KVA] | 6.3 | 8.3 | 11.1 | 16.6 | 22.2 | 26.0 |
| | Typical shaft output | $P_{M,N}$ [kW] | 4.0 | 5.5 | 7.5 | 11.0 | 15.0 | 18.5 |
| | Typical shaft output | $P_{M,N}$ [HP] | 5.0 | 7.5 | 10.0 | 15.0 | 20.0 | 25.0 |
| | Maximum cable cross-section, motor | [mm ² /AWG] ¹⁾ | 4/10 | 4/10 | 4/10 | 16/6 | 16/6 | 16/6 |
| <hr/> | | | | | | | | |
| | Input current (3x380-480 V) | $I_{L,N}$ [A] | 8.1 | 10.6 | 14.9 | 24.0 | 32.0 | 37.5 |
| | | $I_{L,MAX}$ (60 s) [A] | 13.0 | 17.0 | 23.8 | 38.4 | 51.2 | 60 |
| | Maximum cable cross section, power | [mm ² /AWG] ¹⁾ | 4/10 | 4/10 | 4/10 | 16/6 | 16/6 | 16/6 |
| | Maximum pre-fuses | IEC/UL ²⁾ [A] | 20/20 | 25/25 | 25/25 | 50/50 | 50/50 | 50/50 |
| | Efficiency ³⁾ | [%] | 96 | 96 | 96 | 97 | 97 | 97 |
| | Power loss at 100% load | [W] | 200 | 275 | 372 | 412 | 562 | 693 |
| | Weight | [kg] | 3.7 | 6.0 | 6.0 | 18.5 | 18.5 | 18.5 |
| | Enclosure ⁴⁾ | type | IP20 | IP20 | IP20 | IP20/ NEMA 1 | IP20/ NEMA 1 | IP20/ NEMA 1 |

Table 5.15 Mains Supply 3x380-480 V, Part 2

1) American wire gauge. Maximum cable cross-section is the largest cable cross-section that can be attached to the terminals. Always observe national and local regulations.

2) Use type gG pre-fuses for installation according to IEC rules. To maintain UL/cUL, use pre-fuses of the type Bussmann KTN-R 200 V, KTS-R 500 V or Ferraz Shawmut, type ATMR (maximum 30 A). Place the fuses for protection in a circuit that is capable of supplying a maximum of 100,000 amps RMS (symmetrical), 500 V maximum.

See Table 3.2 for more details.

3) Measured using a 25 m screened/armoured motor cable with a rated load and rated frequency.

4) IP20 is standard for VLT 2805-2875, whereas NEMA 1 is an option.

5.5 Parameter List with Factory Settings

| PNU # | Parameter description | Factory setting | 4-set-up | Conv. index | Data type |
|-------|------------------------------|-----------------------------|----------|-------------|-----------|
| 001 | Language | English | No | 0 | 5 |
| 002 | Local/remote operation | Remote-controlled | Yes | 0 | 5 |
| 003 | Local reference | 000,000.000 | Yes | -3 | 4 |
| 004 | Active Setup | Setup 1 | No | 0 | 5 |
| 005 | Programming Setup | Active Setup | No | 0 | 5 |
| 006 | Setup copying | No copying | No | 0 | 5 |
| 007 | LCP copy | No copying | No | 0 | 5 |
| 008 | Display scaling | 1.00 | Yes | -2 | 6 |
| 009 | Large display readout | Frequency [Hz] | Yes | 0 | 5 |
| 010 | Small display line 1.1 | Reference [%] | Yes | 0 | 5 |
| 011 | Small display line 1.2 | Motor current [A] | Yes | 0 | 5 |
| 012 | Small display line 1.3 | Power [kW] | Yes | 0 | 5 |
| 013 | Local control | Remote control as par. 100 | Yes | 0 | 5 |
| 014 | Local stop/reset | Active | Yes | 0 | 5 |
| 015 | Local jog | Not active | Yes | 0 | 5 |
| 016 | Local reversing | Not active | Yes | 0 | 5 |
| 017 | Local reset of trip | Active | Yes | 0 | 5 |
| 018 | Data change lock | Not locked | Yes | 0 | 5 |
| 019 | Operating status at power up | Forced stop, use saved ref. | Yes | 0 | 5 |
| 020 | Lock for Hand mode | Active | No | 0 | 5 |
| 024 | User-defined Quick Menu | Not active | No | 0 | 5 |
| 025 | Quick Menu Setup | 000 | No | 0 | 6 |

Table 5.16 Factory Settings for Parameters 001-025

4-Set-up

Yes means that the parameter can be programmed individually in each of the 4 set-ups, i.e. one single parameter can have 4 different data values. No means that the data value is the same in all set-ups.

Conversion index

This number refers to a conversion factor to be used when writing or reading via serial communication with a frequency converter.

See *chapter 4.7.4 Data Character (Byte)* for further information.

Data type

Data type shows the type and length of the telegram.

| Data type | Description |
|-----------|-------------|
| 3 | Integer 16 |
| 4 | Integer 32 |
| 5 | Unsigned 8 |
| 6 | Unsigned 16 |
| 7 | Unsigned 32 |
| 9 | Text string |

Table 5.17 Data Type

| PNU # | Parameter description | Factory setting | 4-set-up | Conv. index | Data type |
|-------|---------------------------------------|---------------------------|----------|-------------|-----------|
| 100 | Configuration | Speed reg., open loop | Yes | 0 | 5 |
| 101 | Torque characteristics | Constant torque | Yes | 0 | 5 |
| 102 | Motor power $P_{M,N}$ | Depends on unit | Yes | 1 | 6 |
| 103 | Motor voltage $U_{M,N}$ | Depends on unit | Yes | 0 | 6 |
| 104 | Motor frequency $f_{M,N}$ | 50 Hz | Yes | 0 | 6 |
| 105 | Motor current $I_{M,N}$ | Depends on motor selected | Yes | -2 | 7 |
| 106 | Rated motor speed | Depends on par. 102 | Yes | 0 | 6 |
| 107 | Automatic motor adjustment | Optimisation off | Yes | 0 | 5 |
| 108 | Stator resistance R_s | Depends on motor selected | Yes | -3 | 7 |
| 109 | Stator reactance X_s | Depends on motor selected | Yes | -2 | 7 |
| 117 | Resonance damping | OFF | Yes | 0 | 6 |
| 119 | High start torque | 0.0 s | Yes | -1 | 5 |
| 120 | Start delay | 0.0 s | Yes | -1 | 5 |
| 121 | Start function | Coast in start del. | Yes | 0 | 5 |
| 122 | Function at stop | Coast | Yes | 0 | 5 |
| 123 | Min. freq. for activation of par. 122 | 0.1 Hz | Yes | -1 | 5 |
| 126 | DC braking time | 10 s | Yes | -1 | 6 |
| 127 | DC brake engaging frequency | OFF | Yes | -1 | 6 |
| 128 | Thermal motor protection | No protection | Yes | 0 | 5 |
| 130 | Start frequency | 0.0 Hz | Yes | -1 | 5 |
| 131 | Voltage at start | 0.0 V | Yes | -1 | 6 |
| 132 | DC brake voltage | 0% | Yes | 0 | 5 |
| 133 | Start voltage | depends on unit | Yes | -2 | 6 |
| 134 | Load compensation | 100% | Yes | -1 | 6 |
| 135 | U/f-ratio | Depends on unit | Yes | -2 | 6 |
| 136 | Slip compensation | 100% | Yes | -1 | 3 |
| 137 | DC hold voltage | 0% | Yes | 0 | 5 |
| 138 | Brake cut out value | 3.0 Hz | Yes | -1 | 6 |
| 139 | Brake cut in frequency | 3.0 Hz | Yes | -1 | 6 |
| 140 | Current, minimum value | 0% | Yes | 0 | 5 |
| 142 | Leak reactance | Depends on motor selected | Yes | -3 | 7 |
| 143 | Internal ventilator control | Automatic | Yes | 0 | 5 |
| 144 | AC brake factor | 1.30 | Yes | -2 | 5 |
| 146 | Reset voltage vector | Off | Yes | 0 | 5 |

Table 5.18 Factory Settings for Parameters 100-146

| PNU # | Parameter description | Factory setting | Changes during operation | 4-set-up | Conv. index | Data type |
|-------|--|--------------------------|--------------------------|----------|-------------|-----------|
| 200 | Output frequency range | Clockwise only, 0-132 Hz | No | Yes | 0 | 5 |
| 201 | Output frequency, low limit f_{MIN} | 0.0 Hz | Yes | Yes | -1 | 6 |
| 202 | Output frequency, high limit f_{MAX} | 132 Hz | Yes | Yes | -1 | 6 |
| 203 | Reference range | Min ref.-Max ref. | Yes | Yes | 0 | 5 |
| 204 | Minimum ref Ref_{MIN} | 0.000 Hz | Yes | Yes | -3 | 4 |
| 205 | Maximum ref Ref_{MAX} | 50.000 Hz | Yes | Yes | -3 | 4 |
| 206 | Ramp type | Linear | Yes | Yes | 0 | 5 |
| 207 | Ramp-up time 1 | 3.00 s | Yes | Yes | -2 | 7 |
| 208 | Ramp-down time 1 | 3.00 s | Yes | Yes | -2 | 7 |
| 209 | Ramp-up time 2 | 3.00 s | Yes | Yes | -2 | 7 |
| 210 | Ramp-down time 2 | 3.00 s | Yes | Yes | -2 | 7 |
| 211 | Jog ramp time | 3.00 s | Yes | Yes | -2 | 7 |
| 212 | Quick stop ramp-down time | 3.00 s | Yes | Yes | -2 | 7 |
| 213 | Jog frequency | 10.0 Hz | Yes | Yes | -1 | 6 |
| 214 | Reference function | Sum | Yes | Yes | 0 | 5 |
| 215 | Preset reference 1 | 0.00% | Yes | Yes | -2 | 3 |
| 216 | Preset reference 2 | 0.00% | Yes | Yes | -2 | 3 |
| 217 | Preset reference 3 | 0.00% | Yes | Yes | -2 | 3 |
| 218 | Preset reference 4 | 0.00% | Yes | Yes | -2 | 3 |
| 219 | Catch up/slow down reference | 0.00% | Yes | Yes | -2 | 6 |
| 221 | Current limit | 160 % | Yes | Yes | -1 | 6 |
| 223 | Warn. Low current | 0.0 A | Yes | Yes | -1 | 6 |
| 224 | Warn. High current | I_{MAX} | Yes | Yes | -1 | 6 |
| 225 | Warn. Low frequency | 0.0 Hz | Yes | Yes | -1 | 6 |
| 226 | Warn. High frequency | 132.0 Hz | Yes | Yes | -1 | 6 |
| 227 | Warn. Low Feedback | -4000.000 | Yes | Yes | -3 | 4 |
| 228 | Warn. High Feedback | 4000.000 | Yes | Yes | -3 | 4 |
| 229 | Frequency bypass, bandwidth | 0 Hz (OFF) | Yes | Yes | 0 | 6 |
| 230 | Frequency bypass 1 | 0.0 Hz | Yes | Yes | -1 | 6 |
| 231 | Frequency bypass 2 | 0.0 Hz | Yes | Yes | -1 | 6 |

Table 5.19 Factory Settings for Parameters 200-231

| PNU # | Parameter description | Factory setting | 4-set-up | Conv. index | Data type |
|-------|--------------------------------|------------------------------|----------|-------------|-----------|
| 302 | Digital input, term. 18 | Start | Yes | 0 | 5 |
| 303 | Digital input, term. 19 | Reversing | Yes | 0 | 5 |
| 304 | Digital input, term. 27 | Reset and coast inverse | Yes | 0 | 5 |
| 305 | Digital input, term. 29 | Jog | Yes | 0 | 5 |
| 307 | Digital input, term. 33 | No function | Yes | 0 | 5 |
| 308 | Term. 53, analog input voltage | Reference | Yes | 0 | 5 |
| 309 | Term. 53, min scaling | 0.0 V | Yes | -1 | 6 |
| 310 | Term. 53, max scaling | 10.0 V | Yes | -1 | 6 |
| 314 | Term. 60, analog input current | No function | Yes | 0 | 5 |
| 315 | Term. 60, min scaling | 0.0 mA | Yes | -4 | 6 |
| 316 | Term. 60, max scaling | 20.0 mA | Yes | -4 | 6 |
| 317 | Time out | 10 s | Yes | -1 | 5 |
| 318 | Function after time-out | No function | Yes | 0 | 5 |
| 319 | Term. 42, analog output | 0-I _{MAX} = 0-20 mA | Yes | 0 | 5 |
| 323 | Relay output | Control ready | Yes | 0 | 5 |
| 327 | Pulse ref./FB | 5000 Hz | Yes | 0 | 7 |
| 341 | Term. 46 digital output | Control ready | Yes | 0 | 5 |
| 342 | Term. 46 Max. pulse output | 5000 Hz | Yes | 0 | 6 |
| 343 | Precise stop function | Normal ramp stop | Yes | 0 | 5 |
| 344 | Counter value | 100000 pulses | Yes | 0 | 7 |
| 349 | Speed comp delay | 10 ms | Yes | -3 | 6 |

Table 5.20 Factory Settings for Parameters 302-349

4-Set-up

Yes means that the parameter can be programmed individually in each of the 4 set-ups, that is, one single parameter can have 4 different data values. No means that the data value is the same in all set-ups.

Conversion index

This number refers to a conversion factor to be used when writing or reading via serial communication with a frequency converter.

See *chapter 4.7.4 Data Character (Byte)* for more information.

Data type

Data type shows the type and length of the telegram.

| Data type | Description |
|-----------|-------------|
| 3 | Integer 16 |
| 4 | Integer 32 |
| 5 | Unsigned 8 |
| 6 | Unsigned 16 |
| 7 | Unsigned 32 |
| 9 | Text string |

Table 5.21 Data Type

| PNU # | Parameter description | Factory setting | 4-set-up | Conv. index | Data type |
|-------|-------------------------------------|---|----------|-------------|-----------|
| 400 | Brake function | Depends on unit type | No | 0 | 5 |
| 405 | Reset function | Manual reset | Yes | 0 | 5 |
| 406 | Aut. restart time | 5 s | Yes | 0 | 5 |
| 409 | Trip delay overcurrent | Off (61 s) | Yes | 0 | 5 |
| 411 | Switching frequency | 4.5 kHz | Yes | 0 | 6 |
| 412 | Var. carrier frequency | No LC-filter | Yes | 0 | 5 |
| 413 | Overmodulation function | On | Yes | 0 | 5 |
| 414 | Min. feedback | 0.000 | Yes | -3 | 4 |
| 415 | Max. feedback | 1500.000 | Yes | -3 | 4 |
| 416 | Process units | No unit | Yes | 0 | 5 |
| 417 | Speed PID propor.ampl. | 0.010 | Yes | -3 | 6 |
| 418 | Speed PID intergra. | 100 ms | Yes | -5 | 7 |
| 419 | Speed PID differentiation time | 20.00 ms | Yes | -5 | 7 |
| 420 | Speed PID diff. amplification limit | 5.0 | Yes | -1 | 6 |
| 421 | Speed PID lowpass filter | 20 ms | Yes | -3 | 6 |
| 423 | U1 voltage | Parameter 103 Motor voltage $U_{M,N}$ | Yes | -1 | 6 |
| 424 | F1 frequency | Parameter 104 Motor frequency $f_{M,N}$ | Yes | -1 | 6 |
| 425 | U2 voltage | Parameter 103 Motor voltage $U_{M,N}$ | Yes | -1 | 6 |
| 426 | F2 frequency | Parameter 104 Motor frequency $f_{M,N}$ | Yes | -1 | 6 |
| 427 | U3 voltage | Parameter 103 Motor voltage $U_{M,N}$ | Yes | -1 | 6 |
| 428 | F3 frequency | Parameter 104 Motor frequency $f_{M,N}$ | Yes | -1 | 6 |
| 437 | Proc. PID no/inv. | Normal | Yes | 0 | 5 |
| 438 | Proc. PID anti wind. | Active | Yes | 0 | 5 |
| 439 | Proc. PID start frequency | Parameter 201 Output frequency low limit, f_{MIN} | Yes | -1 | 6 |
| 440 | Proc. PID start proportional ampl. | 0.01 | Yes | -2 | 6 |
| 441 | Proc. PID integration time | Off (9999.99 s) | Yes | -2 | 7 |
| 442 | Proc. PID differentiation time | Off (0.00 s). | Yes | -2 | 6 |
| 443 | Proc. PID diff. ampl. limit | 5.0 | Yes | -1 | 6 |
| 444 | Proc. PID lowpass filter time | 0.02 s | Yes | -2 | 6 |
| 445 | Flying start | Not possible | Yes | 0 | 5 |
| 451 | Speed PID feedforward factor | 100% | Yes | 0 | 6 |
| 452 | Controller range | 10% | Yes | -1 | 6 |
| 456 | Brake voltage reduce | 0 | Yes | 0 | 5 |
| 461 | Feedback conversion | Linear | Yes | 0 | 5 |
| 462 | Enhanced sleep mode timer | Off | | | |
| 463 | Boost setpoint | 100% | | | |
| 464 | Wakeup pressure | 0 | | | |
| 465 | Minimum pump frequency | 20 | | | |
| 466 | Maximum pump frequency | 50 | | | |
| 467 | Minimum pump power | 0 W | | | |
| 468 | Maximum pump power | 0 W | | | |
| 469 | No flow power compensation | 1.2 | | | |
| 470 | Dry run time out | Off | | | |
| 471 | Dry run interlock timer | 30 min. | | | |
| 484 | Initial ramp | Off | | | |
| 485 | Fill rate | Off | | | |
| 486 | Filled setpoint | Parameter 414 Minimum feedback, FB_{LOW} | | | |

Table 5.22 Factory Settings for Parameters 400-486

| PNU # | Parameter description | Factory setting | 4-set-up | Conv. index | Data type |
|-------|--------------------------------------|-----------------|----------|-------------|-----------|
| 500 | Address | 1 | No | 0 | 5 |
| 501 | Baudrate | 9600 Baud | No | 0 | 5 |
| 502 | Coasting stop | Logic or | Yes | 0 | 5 |
| 503 | Quick stop | Logic or | Yes | 0 | 5 |
| 504 | DC brake | Logic or | Yes | 0 | 5 |
| 505 | Start | Logic or | Yes | 0 | 5 |
| 506 | Reversing | Logic or | Yes | 0 | 5 |
| 507 | Selection of Setup | Logic or | Yes | 0 | 5 |
| 508 | Selection of preset ref. | Logic or | Yes | 0 | 5 |
| 509 | Bus jog 1 | 10.0 Hz | Yes | -1 | 6 |
| 510 | Bus jog 2 | 10.0 Hz | Yes | -1 | 6 |
| 512 | Telegram profile | FC protocol | Yes | 0 | 5 |
| 513 | Bus time interval | 1 s | Yes | 0 | 5 |
| 514 | Bus time interval function | Off | Yes | 0 | 5 |
| 515 | Data readout: Reference % | | No | -1 | 3 |
| 516 | Data readout: Reference [unit] | | No | -3 | 4 |
| 517 | Data readout: Feedback [unit] | | No | -3 | 4 |
| 518 | Data readout: Frequency | | No | -1 | 3 |
| 519 | Data readout: Frequency x scaling | | No | -1 | 3 |
| 520 | Data readout: Motor current | | No | -2 | 7 |
| 521 | Data readout: Torque | | No | -1 | 3 |
| 522 | Data readout: Power [kW] | | No | 1 | 7 |
| 523 | Data readout: Power [HP] | | No | -2 | 7 |
| 524 | Data readout: Motor voltage [V] | | No | -1 | 6 |
| 525 | Data readout: DC Link voltage | | No | 0 | 6 |
| 526 | Data readout: Motor thermal load | | No | 0 | 5 |
| 527 | Data readout: Inverter thermal load | | No | 0 | 5 |
| 528 | Data readout: Digital input | | No | 0 | 5 |
| 529 | Data readout: Analog input, term. 53 | | No | -1 | 5 |
| 531 | Data readout: Analog input, term. 60 | | No | -4 | 5 |
| 532 | Data readout: Pulse reference | | No | -1 | 7 |
| 533 | Data readout: External reference | | No | -1 | 6 |
| 534 | Data readout: Status word | | No | 0 | 6 |
| 535 | Data readout: Bus feedback 1 | | No | 0 | 3 |
| 537 | Data readout: Inverter temperature | | No | 0 | 5 |
| 538 | Data readout: Alarm word | | No | 0 | 7 |
| 539 | Data readout: Control word | | No | 0 | 6 |
| 540 | Data readout: Warning word | | No | 0 | 7 |
| 541 | Data readout: Extended status word | | No | 0 | 7 |
| 544 | Data readout: Pulse count | | No | 0 | 7 |

Table 5.23 Factory Settings for Parameters 500-544

| PNU # | Parameter description | Factory setting | 4-set-up | Conv. index | Data type |
|-------|--|------------------|----------|-------------|-----------|
| 600 | Operating hours | | No | 73 | 7 |
| 601 | Hours run | | No | 73 | 7 |
| 602 | kWh counter | | No | 2 | 7 |
| 603 | Number of cut ins | | No | 0 | 6 |
| 604 | Number of overtemperatures | | No | 0 | 6 |
| 605 | Number of overvoltages | | No | 0 | 6 |
| 615 | Fault log: Error code | | No | 0 | 5 |
| 616 | Fault log: Time | | No | 0 | 7 |
| 617 | Fault log: Value | | No | 0 | 3 |
| 618 | Reset of kWh counter | No reset | No | 0 | 7 |
| 619 | Reset of running hours counter | No reset | No | 0 | 5 |
| 620 | Operation mode | Normal operation | No | 0 | 5 |
| 621 | Nameplate: Unit type | | No | 0 | 9 |
| 624 | Nameplate: Software version | | No | 0 | 9 |
| 625 | Nameplate: LCP identification no. | | No | 0 | 9 |
| 626 | Nameplate: Database identification no. | | No | -2 | 9 |
| 627 | Nameplate: Power parts version | | No | 0 | 9 |
| 628 | Nameplate: Application option type | | No | 0 | 9 |
| 630 | Nameplate: Communication option type | | No | 0 | 9 |
| 632 | Nameplate: BMC software identification | | No | 0 | 9 |
| 634 | Nameplate: Unit identification for communication | | No | 0 | 9 |
| 635 | Nameplate: Software parts no. | | No | 0 | 9 |
| 640 | Software version | | No | -2 | 6 |
| 641 | BMC software identification | | No | -2 | 6 |
| 642 | Power card identification | | No | -2 | 6 |
| 678 | Configure control card | | | | |
| 700 | Used for wobble function. See the <i>Wobble Function Instruction</i> for more details. | | | | |

Table 5.24 Factory Settings for Parameters 600-700

4-Set-up

Yes means that the parameter can be programmed individually in each of the 4 set-ups, i.e. one single parameter can have 4 different data values. No means that the data value is the same in all set-ups.

Conversion index

This number refers to a conversion factor to be used when writing or reading via serial communication with a frequency converter.

See *chapter 4.7.4 Data Character (Byte)* for further information.

Data type

Data type shows the type and length of the telegram.

| Data type | Description |
|-----------|-------------|
| 3 | Integer 16 |
| 4 | Integer 32 |
| 5 | Unsigned 8 |
| 6 | Unsigned 16 |
| 7 | Unsigned 32 |
| 9 | Text string |

Table 5.25

Index

A

AC brake..... 92
 AC-braking..... 19
 Accessory..... 17
 Acoustic noise..... 129
 Active set-up..... 62
 Aggressive environment..... 135
 Air humidity..... 131
 Analog input..... 86
 Analog input current..... 87
 Analog output..... 88
 Automatic motor tuning..... 25, 69

B

Baudrate..... 116
 Brake cable..... 20
 Brake connection..... 50
 Brake cut-in frequency..... 75
 Brake cut-out value..... 75
 Brake function..... 92
 Brake resistor..... 10, 22
 Brake set-up..... 18
 Brake voltage reduce..... 100
 Bus jog..... 119
 Bus time interval..... 120

C

Cable..... 39
 Calculation of brake power..... 18
 Calculation of brake resistance..... 18
 CE labelling..... 8
 Change data..... 23
 Configure control card..... 126
 Connection of a 2-wire transmitter..... 57
 Constant torque..... 68
 Continuous braking..... 19
 Control cable..... 39, 52
 Control key..... 23
 Control key for parameter set-up..... 26
 Control panel..... 23
 Control principle..... 6
 Control terminal..... 52
 Control unit..... 10, 23
 Control word..... 110, 113

Counter value..... 91
 Current limit..... 82

D

Data character..... 107
 DC brake time..... 72
 DC brake voltage..... 73
 DC braking..... 72
 DC hold voltage..... 74
 DC injection braking..... 19
 Derating for air pressure..... 130
 Derating for ambient temperature..... 129
 Derating for high switching frequency..... 130
 Derating for long motor cable..... 130
 Derating for running at low speed..... 130
 DeviceNet..... 11
 Differentiator..... 95
 Digital input..... 84
 Digital/pulse output..... 90
 Discharge time..... 32
 Display..... 23
 Display mode..... 26, 28
 Display readout..... 136
 Display readout state..... 24
 DU/dt on motor..... 128
 Dynamic braking..... 17

E

Efficiency..... 131
 Electrical wiring..... 44
 EMC compliance..... 133
 EMC compliant cable..... 42
 EMC immunity..... 134
 EMC standard..... 133
 EMC-correct electrical installation..... 41
 Enclosure..... 10
 ETR..... 73
 Extra protection..... 40
 Extreme operating condition..... 128

F

Fan control..... 75
 FC protocol..... 11
 Feedback..... 93
 Feedback conversion..... 101
 Feedback handling..... 96

| | | | |
|---|--------|-------------------------------------|---------|
| Feedback range..... | 94 | Lock for data change..... | 66 |
| Fieldbus..... | 113 | Lowpass filter..... | 95 |
| Fieldbus option..... | 11 | M | |
| Flying start..... | 99 | Mains cable..... | 39 |
| Frequency bypass..... | 83 | Mains connection..... | 48 |
| Function at stop..... | 72 | Mains protection..... | 7 |
| G | | Mains supply..... | 146 |
| Gain AC brake..... | 75 | Mains voltage..... | 9 |
| Galvanic isolation..... | 7 | Manual initialisation..... | 24, 31 |
| Galvanic isolation (PELV)..... | 127 | Maximum pulse..... | 90 |
| Ground connection..... | 51 | Maximum reference..... | 78 |
| Ground leakage current..... | 127 | MCT 10..... | 16 |
| Grounding..... | 39 | Mean power on brake resistor..... | 19 |
| Grounding of screened/armoured control cable..... | 43 | Mechanical brake..... | 52, 59 |
| H | | Mechanical brake connection..... | 59 |
| Hand auto..... | 25 | Mechanical dimension..... | 34 |
| Hand operation..... | 66 | Mechanical installation..... | 38 |
| Harmonic filter..... | 10 | Menu mode..... | 24 |
| High altitude..... | 33 | Minimum motor current..... | 75 |
| High voltage..... | 32 | Minimum reference..... | 78 |
| High voltage test..... | 40 | Motor cable..... | 50 |
| High voltage warning..... | 39 | Motor coil..... | 11, 35 |
| I | | Motor connection..... | 48 |
| Indicator light..... | 27 | Motor current..... | 69 |
| Initialise..... | 124 | Motor frequency..... | 69 |
| J | | Motor power..... | 69 |
| Jog frequency..... | 80 | Motor protection..... | 7 |
| Jog ramp time..... | 80 | Motor rotation direction..... | 49 |
| L | | Motor voltage..... | 69 |
| Language..... | 61 | O | |
| Large display readout..... | 63 | Operating data..... | 123 |
| LC filter..... | 13 | Operating mode at power-up..... | 66 |
| LCP 2 control unit..... | 26, 29 | Optimal braking using resistor..... | 20 |
| LCP copy..... | 62 | Order form..... | 15 |
| Leakage current..... | 32 | Output frequency..... | 77, 115 |
| Leakage reactance..... | 75 | Overmodulation function..... | 93 |
| Load compensation..... | 74 | P | |
| Load sharing..... | 32, 51 | Parallel motor connection..... | 50 |
| Local control..... | 27 | Parameter list..... | 148 |
| Local reference..... | 61 | Parameter selection..... | 30 |
| Local/remote operation..... | 61 | Parameter set-up..... | 29 |
| | | PC software tool..... | 16 |
| | | Peak power of brake resistor..... | 19 |

| | | | |
|--|----------|-------------------------------------|----------|
| Peak voltage..... | 128 | Resonance damping..... | 70 |
| PELV..... | 33 | Reversing..... | 85 |
| Phase loss function..... | 101 | RFI 1B filter..... | 12, 35 |
| PID function..... | 94 | RFI 1B/LC filter..... | 13 |
| Potentiometer reference..... | 57 | RFI filter..... | 10 |
| Power factor..... | 132 | RFI switch..... | 49 |
| Precise stop function..... | 90 | Rise time..... | 129 |
| Pre-fuse..... | 48 | | |
| Preset reference..... | 58, 81 | S | |
| Process control, closed loop..... | 68 | Safety..... | 33 |
| Process PID..... | 98 | Scaling of output frequency..... | 63 |
| Process regulation..... | 94 | Screened/armoured cable..... | 40 |
| Process unit..... | 93 | Serial communication parameter..... | 116 |
| Profibus..... | 11 | Set-up configuration..... | 61 |
| Profibus DP-V1..... | 16 | Set-up copy..... | 62 |
| Programming set-up..... | 62 | Set-up shift..... | 62 |
| Protection..... | 7 | Short circuit..... | 128 |
| Protective function during installation..... | 20 | Side-by-side installation..... | 39 |
| Protocol..... | 106, 122 | Slip compensation..... | 74 |
| Pulse reference/feedback..... | 90 | Special motor mode..... | 68 |
| Pulse start/stop..... | 56 | Speed compensation delay..... | 91 |
| | | Speed control, closed loop..... | 68 |
| Q | | Speed control, open loop..... | 68 |
| Qualified personnel..... | 32 | Speed PID..... | 96 |
| Quick menu..... | 23, 24 | Speed regulation..... | 94 |
| Quick menu set-up..... | 66 | Speed up/down..... | 57 |
| Quick-stop ramp-down time..... | 80 | Square root..... | 101 |
| | | Start delay..... | 71 |
| R | | Start frequency..... | 73 |
| Ramp type..... | 79 | Start function..... | 71 |
| Ramp-down time..... | 79 | Start torque..... | 71 |
| Ramp-up time..... | 79 | Start voltage..... | 74 |
| Rated motor speed..... | 69 | Start/stop..... | 56 |
| RCD..... | 51 | Stator reactance..... | 70 |
| RCD relay..... | 40 | Stator resistance..... | 70 |
| Reference..... | 95 | Status word..... | 112, 113 |
| Reference catch up..... | 81 | Stop/reset key..... | 23 |
| Reference function..... | 81 | Sum..... | 81 |
| Reference handling..... | 77 | Switching frequency..... | 92, 130 |
| Reference slow down..... | 81 | | |
| Regulator..... | 94 | T | |
| Relative..... | 81 | Telegram profile..... | 119 |
| Relay connection..... | 55 | Telegram structure..... | 106 |
| Relay output..... | 88 | Telegram traffic..... | 106 |
| Reset function..... | 92 | Terminal cover..... | 35 |
| Reset voltage vector..... | 76 | Thermal motor protection..... | 50, 72 |

| | |
|--|--------|
| Thermal protection..... | 7 |
| Thermistor..... | 73, 86 |
| Thermistor connection..... | 86 |
| Tightening torque for power terminal..... | 52 |
| Time-out..... | 87 |
| Torque characteristic..... | 68 |
| | |
| U | |
| Unintended start..... | 32 |
| | |
| V | |
| Variable torque..... | 68 |
| Vibration and shock..... | 131 |
| | |
| W | |
| Warning and alarm..... | 137 |
| Warning words, extended status words and alarm word... | 140 |



www.danfoss.com/drives

.....
Danfoss can accept no responsibility for possible errors in catalogues, brochures and other printed material. Danfoss reserves the right to alter its products without notice. This also applies to products already on order provided that such alterations can be made without subsequential changes being necessary in specifications already agreed. All trademarks in this material are property of the respective companies. Danfoss and the Danfoss logotype are trademarks of Danfoss A/S. All rights reserved.
.....

Danfoss A/S
Ulsnaes 1
DK-6300 Graasten
www.danfoss.com/drives

