

VLT[®] 3000 Series

Product Manual
Software version: 3.0 and 3.11



This product manual applies to all VLT[®] 3000 frequency converters with software version 3.0 and 3.11:

* Version 3.0 covers VLT[®] 3002-3022, 200/400/500 V and VLT[®] 3032-3052, 400/500 V.

* Version 3.11 covers VLT[®] 3032-3052, 230 V, and VLT[®] 3060-3250, 380/500 V.

Where version 3.11 deviates from version 3.0 this is described.

The size and voltage of the frequency converter will be identified automatically on start-up.

Warning:

Touching the electrical parts, even when the mains supply has been switched off, can cause serious injury or death.

When using VLT[®] types 3002-3052: Wait 4 minutes

When using VLT[®] types 3060-3250: Wait 14 minutes

Electrical safety

Warning



The frequency converter contains dangerous voltages when connected to the mains. Improper connection of the motor or frequency converter may cause equipment failure, serious injury or death.

Therefore follow the directions in this manual, as well as local and national safety codes.

Touching the electrical parts, even when the power supply has been switched off, can cause serious injury or death.

When using VLT® 3002-3052: Wait 4 minutes.

When using VLT® 3060-3250: Wait 14 minutes.

These rules concern your safety

1. When repairs are undertaken, the mains supply to the VLT® must be disconnected.
2. The "Stop/Reset" key on the frequency converter's keyboard does **not** disconnect the power supply and may therefore **not be used as a safety switch**.
3. The unit must be properly grounded, the user must be protected against supply voltage and the motor against overload according to national and local codes.
4. The leakage currents to ground are higher than 3 mA.
5. The factory setting does **not** incorporate protection against motor overload. For this function parameter 315 is set at data value "trip" [2] or data value "warning" [1].

Note:

This function is initialised at 1.16 x rated motor current (parameter 107).

Warning against improper start

1. The motor can be stopped using digital commands, bus commands, references or local stop, while the frequency converter is connected to the mains. If personal safety requires elimination of any possibility of unintended start, **these stops will not be sufficient**.
2. The motor can start during parameter operation. Therefore **always activate the "Stop/Reset" key**, after which data can be changed.
3. A stopped motor can start if a fault occurs in the frequency converter's electronics or after a temporary overload, mains fault or faulty motor connection.

For the North American market

CAUTION: It is the responsibility of the user or person installing the drive to provide proper grounding and branch circuit protection for incoming power and motor overload according to National Electrical Codes (NEC) and local codes.

The Electronic Thermal Relay (ETR) in UL listed VLT®'s provides class 20 motor overload protection in accordance with NEC in single motor applications, when parameter 315 is set for "TRIP" and parameter 107 is set for nominal motor rated (nameplate) current. Effective from software version 1.10.

Contents

About this manual

How to use this manual	5
For first-time Danfoss VLT® users	5
For experienced Danfoss VLT® users ...	5
Available documentation	5

Quick setup

In most cases	6
Programming keys	6
External operation	6
Start-up	6
If the factory setting has been changed	7
Quick setup	7

Product description

Introduction	8
Technology	9
Sizing	12
Product range	14
Technical data	23
Dimensions	28
Description of terminals	31
Connection examples	32

Installation

Mechanical installation	40
Electrical installation	45
Connection of VLT®	46
Connection of motor	50
EMC installation	51
What is CE-labelling?	51

Operational instructions

The control panel	60
Display layout	61
Initialization	63
Avoid unwanted data change	64
Menu build-up	65
Group description	66
Parameter description	82
Display messages	123

Special conditions

Galvanic isolation -	
Earth leakage current	128
Extreme running conditions	129
du/dt and peak voltage on motor	130
Acoustic noise	130
Thermal motor protection	130
Derating	131
EMC testresults	134
Vibration and shock	137
Air humidity	137
Efficiency	138
Mains supply	
interference / harmonics	139
Power factor	139

Service

Fault messages	140
Electrostatic discharge (ESD)	141
Fault location	142

Accessories

External mounting	
of display	146
Connection of brake resistors	146
Connection of option cards	146
Mounting of bonding plate for	
UL approval	148
Mounting of fan option	148

Factory settings

Factory settings	149
------------------------	-----

Index

Index	154
-------------	-----

About this manual

How to use this manual

This manual has sections on the VLT®'s performance and on installation and operation of the VLT®, as well as a section on special conditions.

There is also a section on service and an appendix for quick referral to factory settings. The index can be a help if you wish to look up a specific item in the manual.

For first-time Danfoss VLT® users

If you have not used a Danfoss VLT® before, "Quick setup" will be a help, and also "Installation" and "Operational instructions".

Pay attention to the safety rules on page 2 before start-up.

For experienced Danfoss VLT® users

If you already have experience with the Danfoss VLT®, you will find the "Quick setup" section most useful.

For more information see the other sections, of which "EMC-correct installation" and "Special conditions" will be particularly useful.

Available documentation

The following chart shows what literature is available on the VLT® 3000 Series.

Note that there can be deviations between different countries.

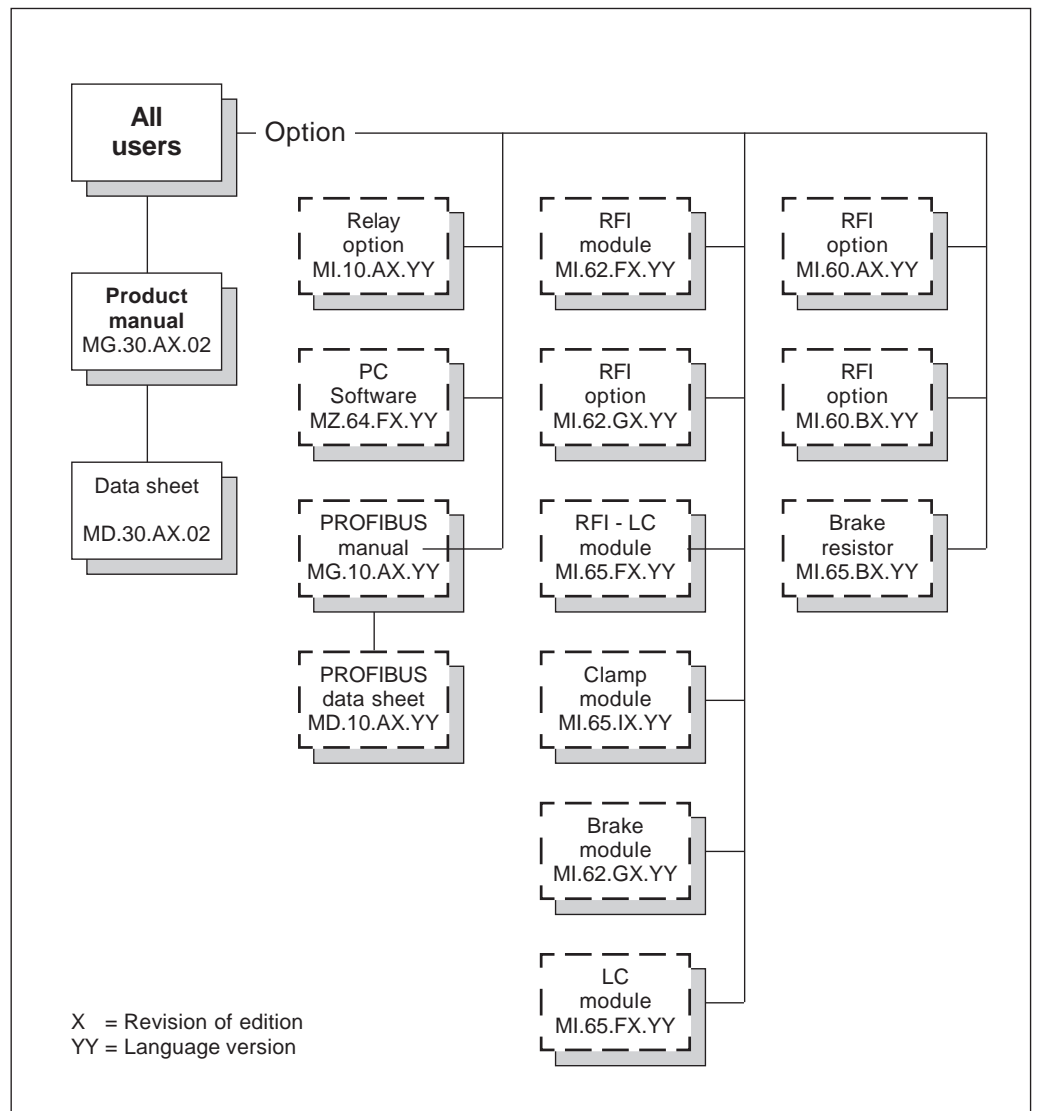

Quick setup

In most cases

In most cases it is sufficient to program the VLT® according to items 1-10 (see next page).

Programming keys

When the supply voltage is connected, the VLT® is automatically in DISPLAY MODE after start-up. Please note that the size and voltage of the VLT® are shown on the display during start-up. If the VLT® voltage and size shown do not correspond to the actual VLT®/mains voltage, the correct VLT® size and mains voltage can be selected in parameter 650.

Press once to switch to MENU GROUP MODE. From MENU GROUP MODE press

once to switch to MENU PARAMETER MODE.

Use the key to switch to DATA MODE. Data can now be changed.

The and keys are used to select a group of parameters, one particular parameter or a data value.

Data values can only be changed using the and keys. Pressing the key stores the new data value in the memory. This also takes place automatically after 20 seconds if data values have been changed.

External operation

A potentiometer 1 kΩ is connected to terminals 50, 53 and 55, see connection example.

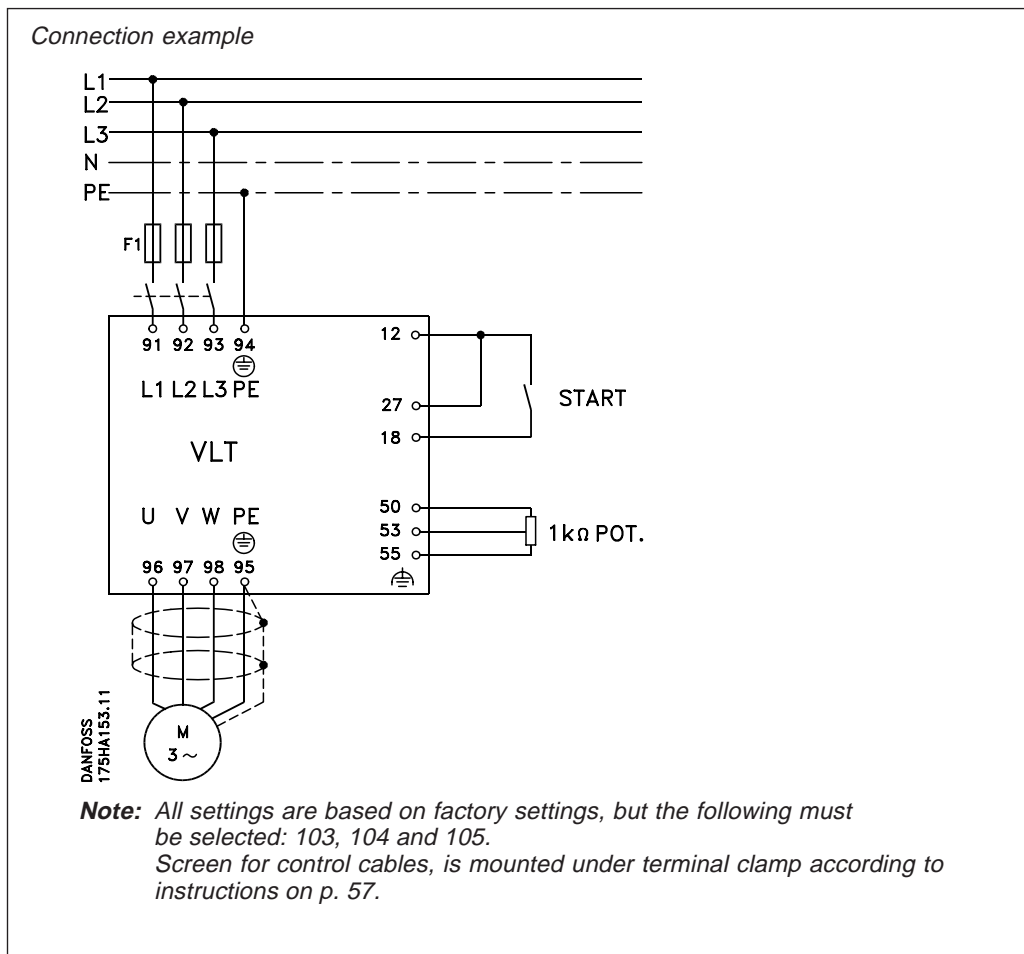

Start-up

Start the frequency converter by connecting +24 V D.C. (terminal 12) to start (terminal 18) and freewheel stop (terminal 27).

Quick setup

If the factory setting has been changed

If the factory setting has been changed initialisation must be carried out.

Quick setup

In most cases it is sufficient to program the VLT® according to items 1-10.

Standard motor running in constant torque application without a brake module on the frequency converter

Item	Parameter	Description	Settings	Display
1	000	Language	Select: "English"	ENGLISH
2	103	Motor output	See nameplate and select closest setting	
3	104	Motor voltage	See nameplate	
4	105	Motor frequency	See nameplate	
5	106	Automatic motor adaption	<p>Items 1-4 must be carried out first. Select: "On". The compensation menus 109-113 are now tuned automatically. During automatic motor adaption the motor should be unloaded or loaded at max. 50%. Automatic motor adaption is not possible in connection with parallel running of several motors on one VLT®. This also applies to motor outputs which cannot be set in parameter 103, and synchronous, reluctance and other specialised motors. After tuning the VLT® is reset by pressing the Stop/Reset key and restarted by pressing the Start key. Note: During automatic motor adaption the motor will start for a short period.</p>	ON
6	201	Min. frequency	Set required frequency	
7	202	Max. frequency	Set required frequency	
8	215	Ramp-up 1	Set required ramp time	
9	216	Ramp-down 1	Set required ramp time	
10		Start frequency converter	This is by supplying terminals 18 and 27 with 24 V D.C. from terminal 12 or by using an external 24 V D.C. voltage.	

The following settings are also used for specialised motors and parallel coupled motors, or variable torque application or when a brake module is mounted

Item	Parameter	Description	Settings	Display
1	100	Load	<p>For normal applications with <i>constant torque</i>: Select: "Constant torque compensated" For <i>centrifugal pumps and fans</i>: Select: "VT medium" For <i>centrifugal pumps and fans with heavy start</i>: Select: "VT Medium CT Start" For <i>synchronous motors, parallel coupled motors or specialised motors</i> Select: "Constant torque"</p>	CTWITHCOMP VT MODE-MED VT MED W/CT CTMODE
2	300	Brake option	If <i>brake option/module</i> is used: Select: "Applied"	APPLIED
3		Start frequency converter	This is by applying 24 V D.C. to terminals 18 and 27 from terminal 12 or by using external 24 V D.C. voltage.	

The following settings are used for local operation and start

Item	Parameter	Description	Settings	Display
1	003	Operation mode	Select: "Local"	LOCAL
2	004	Local reference	Set required output frequency using the "+" or "-" keys.	

Introduction

Control principle

A frequency converter rectifies the a.c. voltage to D.C. voltage and then converts this D.C. voltage to A.C. voltage with variable amplitude and frequency.

The variable voltage and frequency supplying the motor make possible infinite speed control of standard three-phase asynchronous motors.

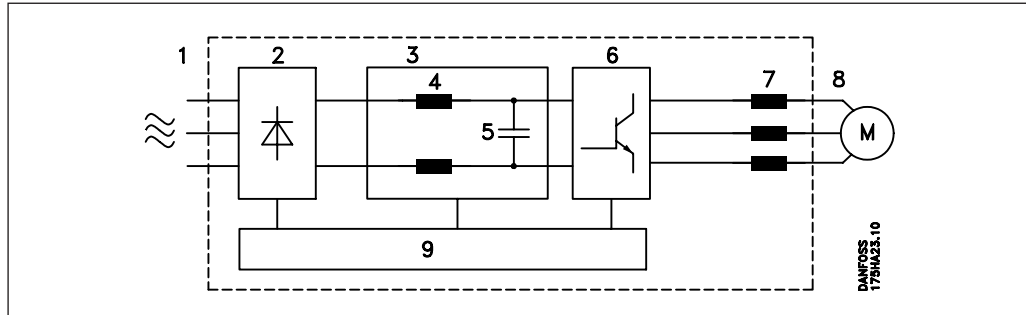

1. Mains supply

3 x 200 / 220 / 230 V A.C., 50/60 Hz
 3 x 380 / 400 / 415 V A.C., 50/60 Hz
 3 x 440 / 460 / 500 V A.C., 50/60 Hz

2. Rectifier

Three-phase rectifier bridge rectifies A.C. to D.C..

3. Intermediate circuit

D.C. voltage = $\sqrt{2}$ x supply voltage.

4. Coils in the intermediate circuit

Smooth the D.C. voltage and limit the mains supply harmonics.

5. Capacitors in the intermediate circuit

Smooth- the D.C. voltage.

6. Inverter

Converts D.C. voltage to variable A.C. voltage and variable frequency.

7. Motor coils

Advantages of motor coils:

- You can use longer motor cables
- 100% short-circuit and earth-fault protected
- Unlimited switching at the output of the frequency converter.
- Reduces du/dt.

8. Output

Variable A.C. voltage, 10 -100% of the supply voltage.

Variable frequency: 0.5-120 / 0.5-500 Hz.

9. Control card

This section controls and monitors the power and inverter section, which generates the pulse pattern by means of which the D.C. voltage is converted to variable A.C. voltage and variable frequency.

Technology

VLT® 3000 Series frequency converters use an inverter control system known as the Voltage Vector Control (VVC) developed by Danfoss.

The VVC principle is superior to the traditional PWM (Pulse Width Modulation) principle used in most modern frequency converters in the following ways:

- Full-rated motor voltage at rated motor frequency
- Near perfect resemblance to the sinusoidal mains supply
- Extremely low switching losses, resulting in high converter efficiency

The features are obtained through a special switching pattern: the switching intervals are very short, which means high switching frequency, and the six semi-conductors of the inverter section are alternately held inactive, in pairs, throughout a 60° sine period. The current wave form of the motor current closely resembles that obtained on mains operation. The switching pause in 60° of the sine period also means that full-rated motor voltage can be obtained – and inverter switching losses are reduced by about one third.

The figures below show the switching pattern and the maximum motor voltage in relation to the mains voltage according to the VVC principle and the traditional PWM principle, respectively.

The full-rated motor voltage and the perfect current wave form mean that the Danfoss VLT® 3000 Series allows full motor performance without any derating – just like running the motor on the mains.

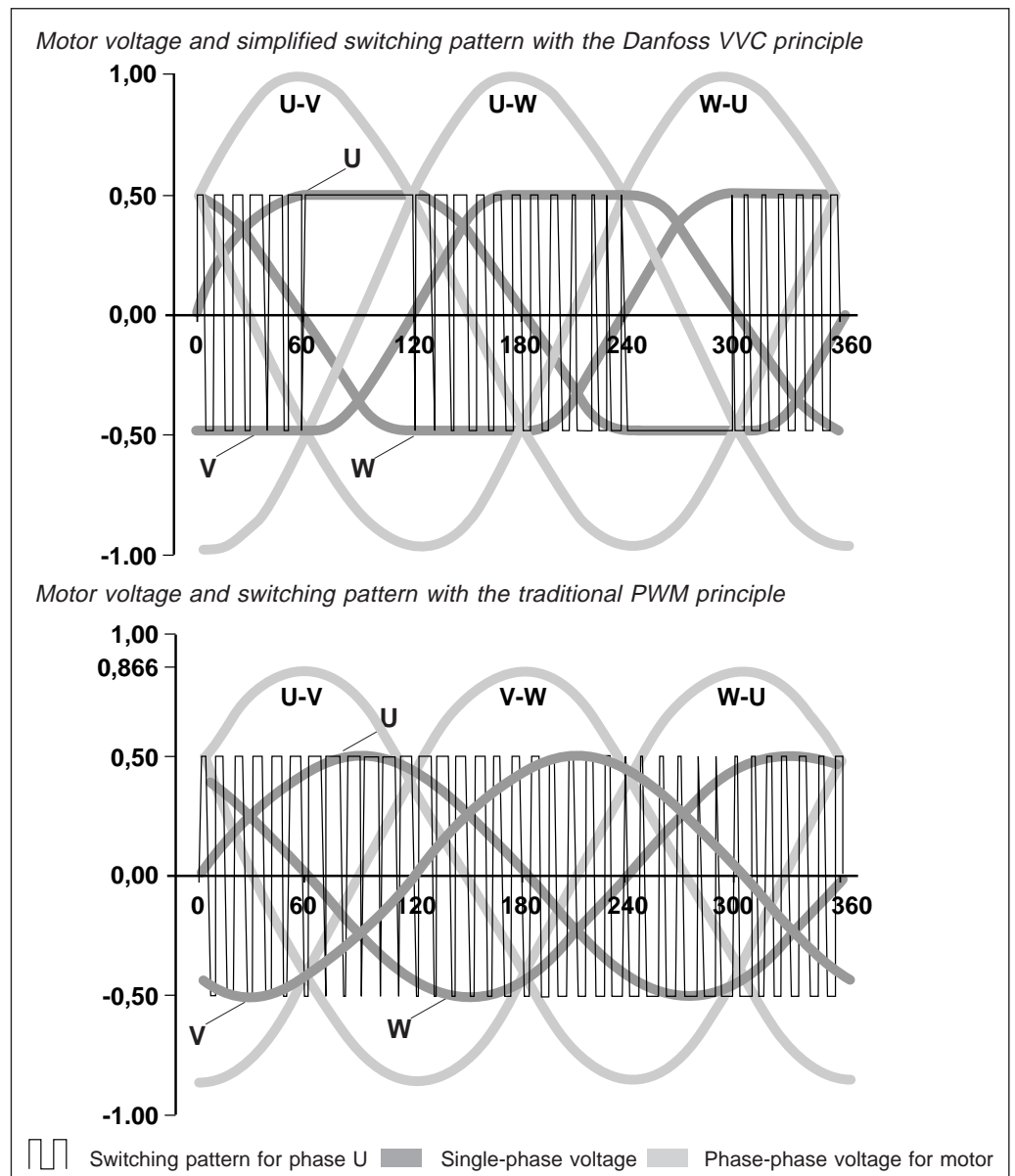

The VLT® 3000 Series is delivered with a number of standard components which you would normally have to buy separately such as motor coils, mains reactor DC link coil and galvanic insulation (PELV).

These components built-in as standard give you the following advantages:

- Save space and reduce costs
- Simplify the installation as the VLT® 3000 will meet most demands.

Factory programmed U/f characteristics

Depending on the type of load, the VLT® 3000 Series has dynamic adapting or factory programmed U/f characteristics (motor voltage/frequency) giving the correct magnetisation of the motor, thus ensuring optimum dynamic, accuracy or efficiency.

It is possible to choose between 3 U/f characteristics for VT operation, offering the choice of optimising the start torque or reducing the noise level or power losses from the motor. A new parameter (106) called “Automatic motor tuning” optimizes the motor parameters at constant load torque.

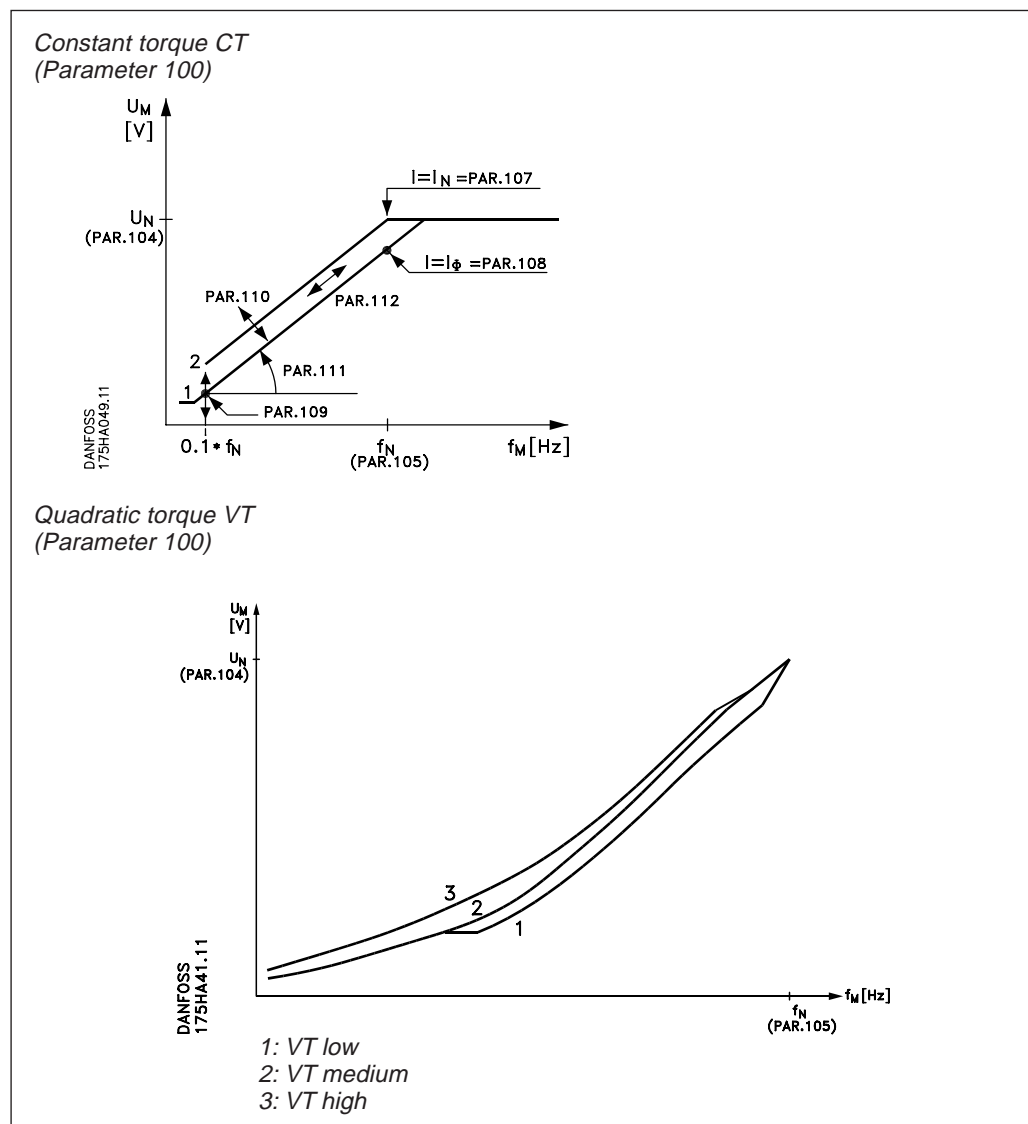

Control accuracy

Slip-compensated (depending on motor size)	$\pm 0.5\%$	5-50 Hz: VLT® 3011-3052 (10-90% load change) 10-50 Hz: VLT® 3004-3008
	$\pm 1.0\%$	5-50 Hz: VLT® 3004-3052 (10-140% load change)
PID (closed loop)	$\pm 0.1\%$	5-50 Hz: (-140 - +140% load change)
Open loop (digital)	$\pm 0.01\%$	0.5-120 Hz (frequency stability)
	$\pm 0.05\%$	0.5-500 Hz (frequency resolution (digital))

Technology

Programmable control inputs and signal outputs in 4 setups

The digital technique used in the VLT® 3000 Series makes it possible to program the different control inputs and signal outputs, and to select 4 different user-defined setups.

It is easy for the user to program the required functions on the keyboard of the VLT® 3000 Series or via the terminals or the RS 485 interface.

Protected against mains disturbance

The VLT® 3000 Series is protected against transients arising on the mains, e.g. when you switch in power factor phase correction capacitors or when the supply is subject to lightning strikes.

Rated motor voltage and full torque can be maintained down to 10% undervoltage on the supply mains.

Low disturbance on the mains

As the VLT® 3000 Series has coils in the intermediate circuit built-in as standard the harmonic generation is low.

This gives a good power factor, thus reducing the harmonic load on the mains supply.

Effective radio frequency interference suppression (EMC)

The VLT® 3000 Series can be delivered with an RFI filter complying with EN 55011. Filters are available as options or modules.

Some VLT® types have a mains filter as standard in compliance with grade 1, class A.

Long motor cables

As standard the VLT® 3000 Series is delivered with built-in motor coils. This means that it is possible to install a long

cable between motor and frequency converter without any additional coils.

Advanced VLT® protection

Current measurement in all three motor phases gives perfect protection of the VLT® 3000 series in the event of short circuits or earth faults on the motor terminals.

The continuous monitoring of the three motor phases makes switching on the motor cables possible e.g. by opening/closing a contactor.

The effective monitoring of the three supply phases means that the VLT® 3000 Series stops in the event of a missing phase. In this way overloading of the inverter and the capacitors of the intermediate circuit, which would reduce the lifetime of the frequency converter drastically, can be avoided.

The VLT® 3000 Series has built-in thermal protection of the unit as standard. The function turns off the inverter on thermal overload.

Galvanic isolation

With the VLT® 3000 Series safety isolation is standard, as the high-voltage parts of the power section are galvanically isolated from the low-voltage parts of the control section in accordance with VDE 0160/0106 (PELV).

Advanced motor protection

The VLT® 3000 Series has a built-in electronic thermal motor protection. The frequency converter calculates the motor temperature on the basis of voltage, current, frequency and time. Therefore it is superior to the traditional bi-metallic protection where the altered cooling conditions due to the speed control are not taken into consideration.

The thermal motor protection is comparable with thermal relay in the motor cables. To achieve optimum protection against overheating of the motor when covered or blocked, or in case the ventilation should fail, it is possible to build in a thermistor and connect this to the frequency converter thermistor input (terminal 16, see page 102).

Sizing

Choice of frequency converter size

The frequency converter must be chosen on the basis of the actual motor current I_M at maximum load of the plant.

The rated continuous output current $I_{VLT,N}$ must be equal to or higher than the required motor current.

Example:

In a heating plant (quadratic load) the pump motor is a 7.5 kW, 3 x 380 V, which at max. load takes up 14 A. Choose a VLT® 3008 which can supply 16 A ($I_{VLT,N}$) continuously.

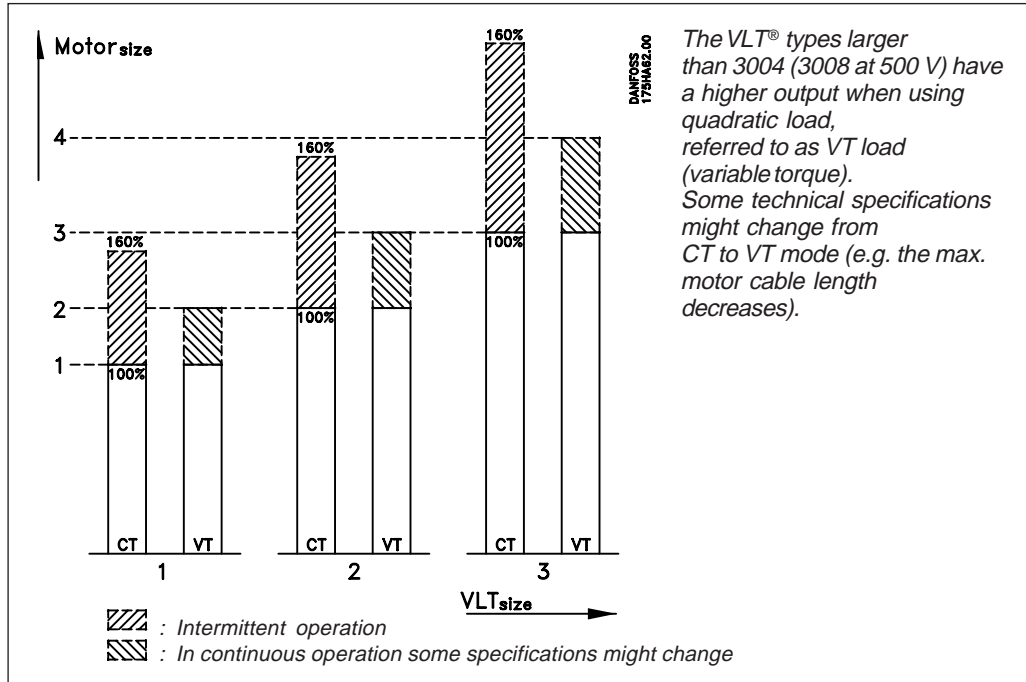

Which one to choose?

Mains: 3 x 200/220/230 V and 3 x 220/230/240 V (see technical data)

VLT® type	Typical shaft output		Constant output current $I_{VLT,N}$		Constant output power at 230 V	
	CT [kW]	VT	CT [A]	VT	CT [kVA]	VT
3002	1.1		5.4		2.1	
3003	1.5		7.8		3.1	
3004	2.2		10.5		4.2	
3006	4.0	5.5	19	25	7.6	10.0
3008	5.5	7.5	25	32	10.0	12.7
3011	7.5	11	32	46	12.7	18.3
3016	11	15	46	61	18.3	24.3
3022	15	22	61	88	24.3	35.1
3032	22	30	80	104	31.9	41.4
3042	30	37	104	130	41.4	51.8
3052	37	45	130	154	51.8	61.3

CT: Constant torque
VT: Variable torque (quadratic load)

Sizing

Mains: 380/400/415 V

VLT® type	Typical shaft output		Constant output current $I_{VLT,N}$		Constant output power at 415 V	
	CT [kW]	VT	CT [A]	VT	CT [kVA]	VT
3002	1.1		2.8		2.0	
3003	1.5		4.1		2.9	
3004	2.2		5.6		4.0	
3006	4.0	5.5	10.0	13.0	7.2	9.3
3008	5.5	7.5	13.0	16.0	9.3	11.5
3011	7.5	11	16.0	24.0	11.5	17.3
3016	11	15	24.0	32.0	17.3	23.0
3022	15	22	32.0	44.0	23.0	31.6
3032	22	30	44.0	61.0	31.6	43.8
3042	30	37	61.0	73.0	43.8	52.5
3052	37	45	73.0	88.0	52.3	63.3
3060	45	55	86.0	105	61.8	75.5
3075	55	75	105	139	75.5	99.9
3100	75	90	139	168	99.9	120
3125	90	110	168	205	120	147
3150	110	132	205	243	147	174
3200	132	160	243	302	174	217
3250	160	200	302	368	217	264

CT: Constant torque

VT: Variable torque (quadratic load)

Mains: 440/460/500 V

VLT® type	Typical shaft output		Constant output current $I_{VLT,N}$		Constant output power at 500 V	
	CT [kW]	VT	CT [A]	VT	CT [kVA]	VT
3002	1.1		2.6		2.3	
3003	1.5		3.4		2.9	
3004	2.2		4.8		4.1	
3006	4.0		8.2		7.1	
3008	5.5		11.1		9.6	
3011	7.5	11	14.5	21.7	12.6	18.8
3016	11	15	21.7	27.9	18.8	24.1
3022	15	22	27.9	41.4	24.1	36.0
3032	22	30	41.4	54.0	36.0	46.8
3042	30	37	54.0	65.0	46.8	56.3
3052	37	45	65.0	78.0	56.3	67.5
3060	45	55	77.0	96.0	66.7	83.1
3075	55	75	96.0	124	83.1	107
3100	75	90	124	156	107	135
3125	90	110	156	180	135	156
3150	110	132	180	240	156	208
3200	132	160	240	302	208	262
3250	160	200	302	361	262	313

CT: Constant torque

VT: Variable torque (quadratic load)

Product range

VLT® type 3002 - 3004, 200/230 V / VLT® type 3002 - 3008, 380/415 V / VLT® type 3002 - 3008, 440/500 V

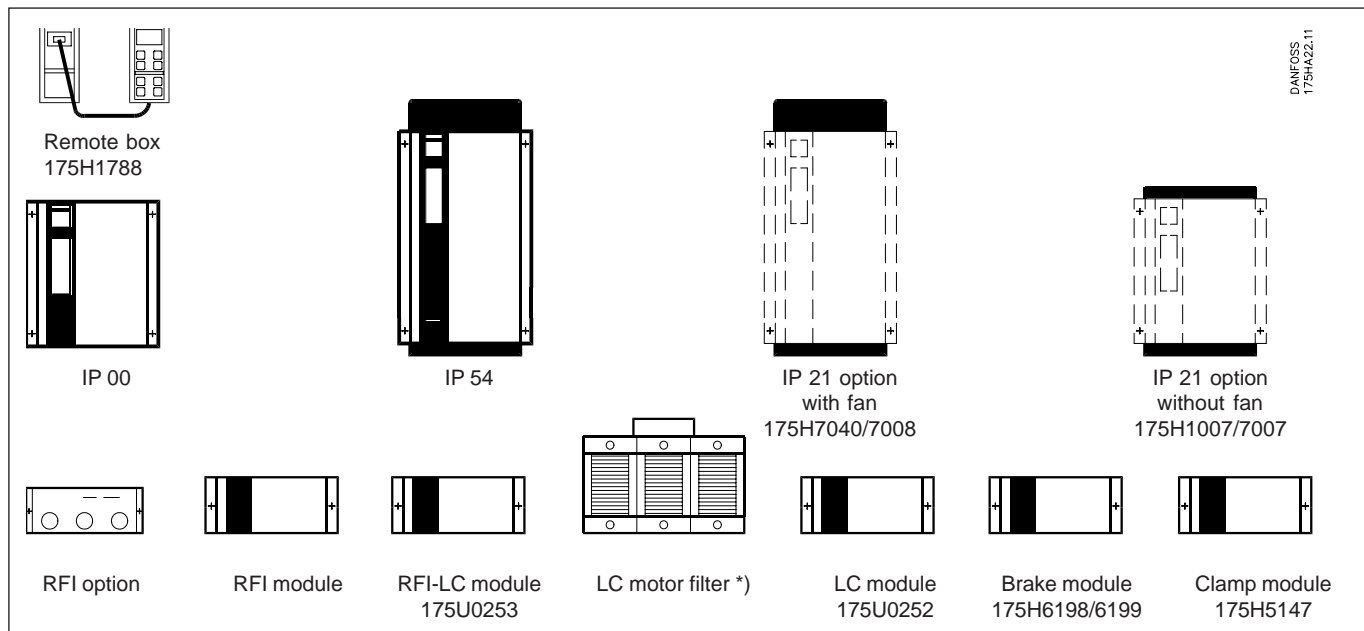

*) Made for Danfoss A/S by the firm Plaththaus

200 / 220 / 230 V

VLT® type	Description	kW	Code no.
3002	IP 00	1,1	175H4131
	IP 00 with brake	1,1	175H4132
	IP 21 (as option)	1,1	175H1007
	IP 54	1,1	175H4133
	IP 54 with brake	1,1	175H4134
3003	IP 00	1,5	175H4135
	IP 00 with brake	1,5	175H4136
	IP 21 (as option)	1,5	175H1007
	IP 54	1,5	175H4137
	IP 54 with brake	1,5	175H4138
3004	IP 00	2,2	175H4139
	IP 00 with brake	2,2	175H4140
	IP 21 (as option)	2,2	175H7040
	IP 54	2,2	175H4141
	IP 54 with brake	2,2	175H4142

380 / 400 / 415 V

VLT® type	Description	kW	Code no.
3002	IP 00	1,1	175H7238
	IP 00 with brake	1,1	175H7239
	IP 21 (as option)	1,1	175H1007
	IP 54	1,1	175H7240
	IP 54 with brake	1,1	175H7241
3003	IP 00	1,5	175H7242
	IP 00 with brake	1,5	175H7243
	IP 21 (as option)	1,5	175H1007
	IP 54	1,5	175H7244
	IP 54 with brake	1,5	175H7245
3004	IP 00	2,2	175H7246
	IP 00 with brake	2,2	175H7247
	IP 21 (as option)	2,2	175H1007
	IP 54	2,2	175H7248
	IP 54 with brake	2,2	175H7249
3006	IP 00	4,0	175H7264
	IP 00 with brake	4,0	175H7265
	IP 21 (as option)	4,0	175H7040
	IP 54	4,0	175H7266
	IP 54 with brake	4,0	175H7267
3008	IP 00	5,5	175H7268
	IP 00 with brake	5,5	175H7269
	IP 21 (as option)	5,5	175H1007
	IP 54	5,5	175H7270
	IP 54 with brake	5,5	175H7271

440 / 460 / 500 V

VLT® type	Description	kW	Code no.
3002	IP 00	1,1	175H1729
	IP 00 with brake	1,1	175H1730
	IP 21 (as option)	1,1	175H1007
	IP 54	1,1	175H1731
	IP 54 with brake	1,1	175H1732
3003	IP 00	1,5	175H1733
	IP 00 with brake	1,5	175H1734
	IP 21 (as option)	1,5	175H1007
	IP 54	1,5	175H1735
	IP 54 with brake	1,5	175H1736
3004	IP 00	2,2	175H1737
	IP 00 with brake	2,2	175H1738
	IP 21 (as option)	2,2	175H1007
	IP 54	2,2	175H1739
	IP 54 with brake	2,2	175H1740
3006	IP 00	4,0	175H1741
	IP 00 with brake	4,0	175H1742
	IP 21 (as option)	4,0	175H1007
	IP 54	4,0	175H1743
	IP 54 with brake	4,0	175H1744
3008	IP 00	5,5	175H1745
	IP 00 with brake	5,5	175H1746
	IP 21 (as option)	5,5	175H1007
	IP 54	5,5	175H1747
	IP 54 with brake	5,5	175H1748

Description	3002 / 3003			3004			3006			3008		
	220 V	380 V	500 V	220 V	380 V	500 V	380 V CT	380 V VT	500 V	380 V CT	380 V VT	500 V
IP 21 option	H1007	H1007	H1007	H7040	H1007	H1007	H1007	H7040	H1007	H1007 ³⁾	H1007 ³⁾	H1007 ³⁾
IP 21 option with UL approval	H7007	-	H7007	H7008	-	H7007	-	-	H7007	-	-	H7007 ³⁾
RFI module for IP 00 / 21	H7037	H7037	H7037	H7037	H7037	H7037	H7037 ²⁾	H7037 ²⁾	H7037 ²⁾	H7037 ²⁾	H7037 ²⁾	H7037 ²⁾
RFI option for IP 00 / 21	H7038 ¹⁾	H7038 ¹⁾	H7038 ¹⁾	H7038 ¹⁾	H7038 ¹⁾	H7038 ¹⁾	H7038	H7038	H7038	H7038	H7038	H7038
RFI option for IP 54	H7038	H7038	H7038	H7038	H7038	H7038	H7038	H7038	H7038	H7038	H7038	H7038
RFI-LC module for IP 00	-	U0253	U0253	-	U0253 ⁴⁾	U0253	-	-	-	-	-	-
RFI motor filter option for unscreened motor cable	H7083	H7083	H7083	H7083	H7083	H7083	H7083	H7083	H7083	H7083	H7083	H7083
RFI motor filter module for unscreened motor cable	H7084	H7084	H7084	H7084	H7084	H7084	H7084	H7084	H7084	H7084	H7084	H7084
LC module for IP 00	U0252	U0252	-	U0252	U0252	-	U0252	U0252	-	U0252	U0252	-
LC motor filter for IP 00	191G0216	-	191G0209	191G0217	-	191G0209	-	-	191G0209	-	-	191G0210
Clamp module for IP 00	H5147	H5147	H5147	H5147	H5147	H5147	H5147	H5147	H5147	H5147	H5147	H5147
Brake module for IP 00 / 21	H6198	H6199	H6199	H6198	H6199	H6199	H6199	H6199	H6199	H6199	H6199	H6199
Remote box	H1788	H1788	H1788	H1788	H1788	H1788	H1788	H1788	H1788	H1788	H1788	H1788
Relay option	H7063	H7063	H7063	H7063	H7063	H7063	H7063	H7063	H7063	-	-	-
PROFIBUS option	H4696											
Modbus Plus option	contact Danfoss											
PC software	(GB 175H2850) (D 175H2876) (DK 175H2877)											

All code numbers: 175XXXXX. CT: Constant torque / VT: Variable torque (quadratic load)

¹⁾ Can only be mounted in units with brake function. ²⁾ The RFI filter option (175H7038) may be beneficial. ³⁾ Only bottom can be used. ⁴⁾ Forced cooling needed.

"-" Cannot be delivered.

Product range

VLT® type 3006 - 3022, 200/230 V / VLT® type 3011 - 3052, 380/415 V / VLT® type 3011 - 3052, 440/500 V

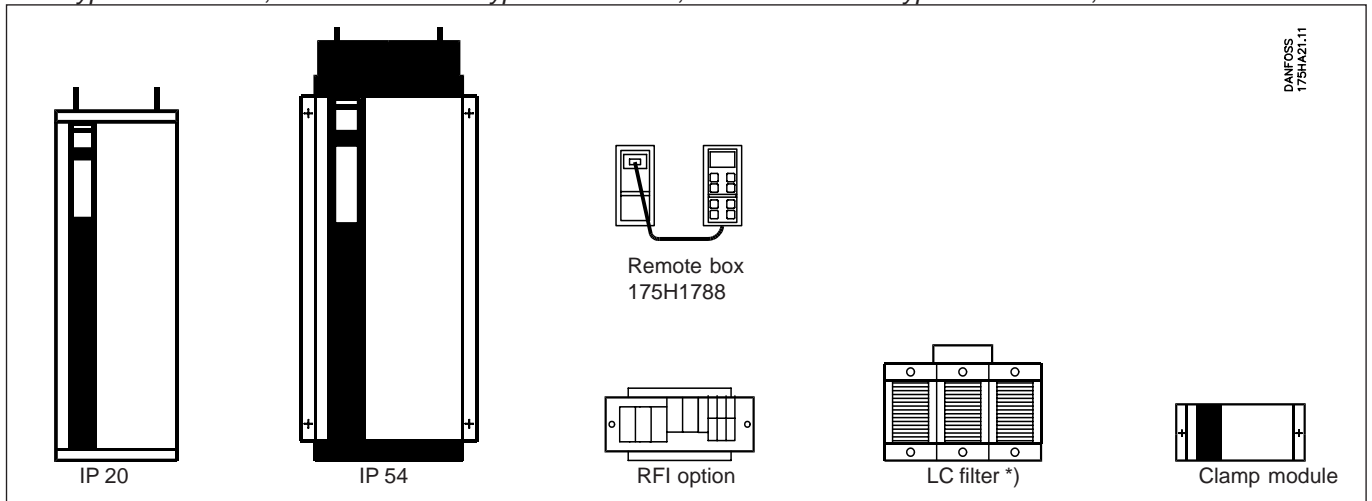

*) Made for Danfoss A/S by the firm Platthaus

200 / 220 / 230 V

VLT® type	Description	kW	Code no.
3006	IP 20	4.0	175H4449
	IP 20 with RFI	4.0	175H4450
	IP 20 with brake	4.0	175H4451
	IP 20 with RFI + brake	4.0	175H4452
	IP 54	4.0	175H4453
	IP 54 with RFI	4.0	175H4454
	IP 54 with RFI + brake	4.0	175H4455
3008	IP 20	5.5	175H4457
	IP 20 with RFI	5.5	175H4458
	IP 20 with brake	5.5	175H4459
	IP 20 with RFI + brake	5.5	175H4460
	IP 54	5.5	175H4461
	IP 54 with RFI	5.5	175H4462
	IP 54 with RFI + brake	5.5	175H4463
3011	IP 20	7.5	175H4465
	IP 20 with RFI	7.5	175H4466
	IP 20 with brake	7.5	175H4467
	IP 20 with RFI + brake	7.5	175H4468
	IP 54	7.5	175H4469
	IP 54 with RFI	7.5	175H4470
	IP 54 with RFI + brake	7.5	175H4471
3016	IP 20	11.0	175H4473
	IP 20 with RFI	11.0	175H4474
	IP 20 with brake	11.0	175H4475
	IP 20 with RFI + brake	11.0	175H4476
	IP 54	11.0	175H4477
	IP 54 with RFI	11.0	175H4478
	IP 54 with RFI + brake	11.0	175H4479
3022	IP 20	15.0	175H4520
	IP 20 with RFI	15.0	175H4521
	IP 20 with brake	15.0	175H4522
	IP 20 with RFI + brake	15.0	175H4523
	IP 54	15.0	175H4524
	IP 54 with RFI	15.0	175H4525
	IP 54 with RFI + brake	15.0	175H4526

380 / 400 / 415 V

VLT® type	Description	kW	Code no.
3011	IP 20	7.5	175H7272
	IP 20 with RFI	7.5	175H7273
	IP 20 with brake	7.5	175H7274
	IP 20 with RFI + brake	7.5	175H7275
	IP 54	7.5	175H7276
	IP 54 with RFI	7.5	175H7277
	IP 54 with RFI + brake	7.5	175H7278
3016	IP 20	11.0	175H7280
	IP 20 with RFI	11.0	175H7281
	IP 20 with brake	11.0	175H7282
	IP 20 with RFI + brake	11.0	175H7283
	IP 54	11.0	175H7284
	IP 54 with RFI	11.0	175H7285
	IP 54 with RFI + brake	11.0	175H7286
3022	IP 20	15.0	175H7288
	IP 20 with RFI	15.0	175H7289
	IP 20 with brake	15.0	175H7290
	IP 20 with RFI + brake	15.0	175H7291
	IP 54	15.0	175H7292
	IP 54 with RFI	15.0	175H7293
	IP 54 with RFI + brake	15.0	175H7294
3032	IP 20	22.0	175H1671
	IP 20 with RFI	22.0	175H1672
	IP 20 with brake	22.0	175H1673
	IP 20 with RFI + brake	22.0	175H1674
	IP 54	22.0	175H1675
	IP 54 with RFI	22.0	175H1676
	IP 54 with RFI + brake	22.0	175H1677
3042	IP 20	30.0	175H1679
	IP 20 with RFI	30.0	175H1680
	IP 20 with brake	30.0	175H1681
	IP 20 with RFI + brake	30.0	175H1682
	IP 54	30.0	175H1683
	IP 54 with RFI	30.0	175H1684
	IP 54 with RFI + brake	30.0	175H1685
3052	IP 20	37.0	175H1687
	IP 20 with RFI	37.0	175H1688
	IP 20 with brake	37.0	175H1689
	IP 20 with RFI + brake	37.0	175H1690
	IP 54	37.0	175H1691
	IP 54 with RFI	37.0	175H1692
	IP 54 with RFI + brake	37.0	175H1693

440 / 460 / 500 V

VLT® type	Description	kW	Code no.
3011	IP 20	7.5	175H4401
	IP 20 with RFI	7.5	175H4402
	IP 20 with brake	7.5	175H4403
	IP 20 with RFI + brake	7.5	175H4404
	IP 54	7.5	175H4405
	IP 54 with RFI	7.5	175H4406
	IP 54 with RFI + brake	7.5	175H4407
3016	IP 20	11.0	175H4409
	IP 20 with RFI	11.0	175H4410
	IP 20 with brake	11.0	175H4411
	IP 20 with RFI + brake	11.0	175H4412
	IP 54	11.0	175H4413
	IP 54 with RFI	11.0	175H4414
	IP 54 with RFI + brake	11.0	175H4415
3022	IP 20	15.0	175H4417
	IP 20 with RFI	15.0	175H4418
	IP 20 with brake	15.0	175H4419
	IP 20 with RFI + brake	15.0	175H4420
	IP 54	15.0	175H4421
	IP 54 with RFI	15.0	175H4422
	IP 54 with RFI + brake	15.0	175H4423
3032	IP 20	22.0	175H4425
	IP 20 with RFI	22.0	175H4426
	IP 20 with brake	22.0	175H4427
	IP 20 with RFI + brake	22.0	175H4428
	IP 54	22.0	175H4429
	IP 54 with RFI	22.0	175H4430
	IP 54 with RFI + brake	22.0	175H4431
3042	IP 20	30.0	175H4433
	IP 20 with RFI	30.0	175H4434
	IP 20 with brake	30.0	175H4435
	IP 20 with RFI + brake	30.0	175H4436
	IP 54	30.0	175H4437
	IP 54 with RFI	30.0	175H4438
	IP 54 with RFI + brake	30.0	175H4439
3052	IP 20	37.0	175H4441
	IP 20 with RFI	37.0	175H4442
	IP 20 with brake	37.0	175H4443
	IP 20 with RFI + brake	37.0	175H4444
	IP 54	37.0	175H4445
	IP 54 with RFI	37.0	175H4446
	IP 54 with RFI + brake	37.0	175H4447

Description	3006-3011 220 V	3016-3022 220 V	3011-3022 380 V	3032-3052 380 V	3011-3022 500 V	3032 500 V	3042-3052 500 V
RFI option for IP 20 / 54	H5353	H5355	H5353	H5355	H5353	H5355	H5355
Clamp module for IP 00	H5147	H5147	H5147	H5147	H5147	H5147	H5147
Remote box	H1788	H1788	H1788	H1788	H1788	H1788	H1788
LC motor filter IP 00	191G0218-219-220	-	191G0202-203-204	191G0205-206-207	191G0210-211-212	191G0213	191G0214-215
PROFIBUS option	H4696						
Modbus Plus option	contact Danfoss						
PC software	(GB 175H2850) (D 175H2876) (DK 175H2877)						

All code numbers: 175XXXXX.

"-" Cannot be delivered.

Product range

VLT® type 3032 - 3052, 220/440 V, VLT® type 3060 - 3250, 380/440/500 V

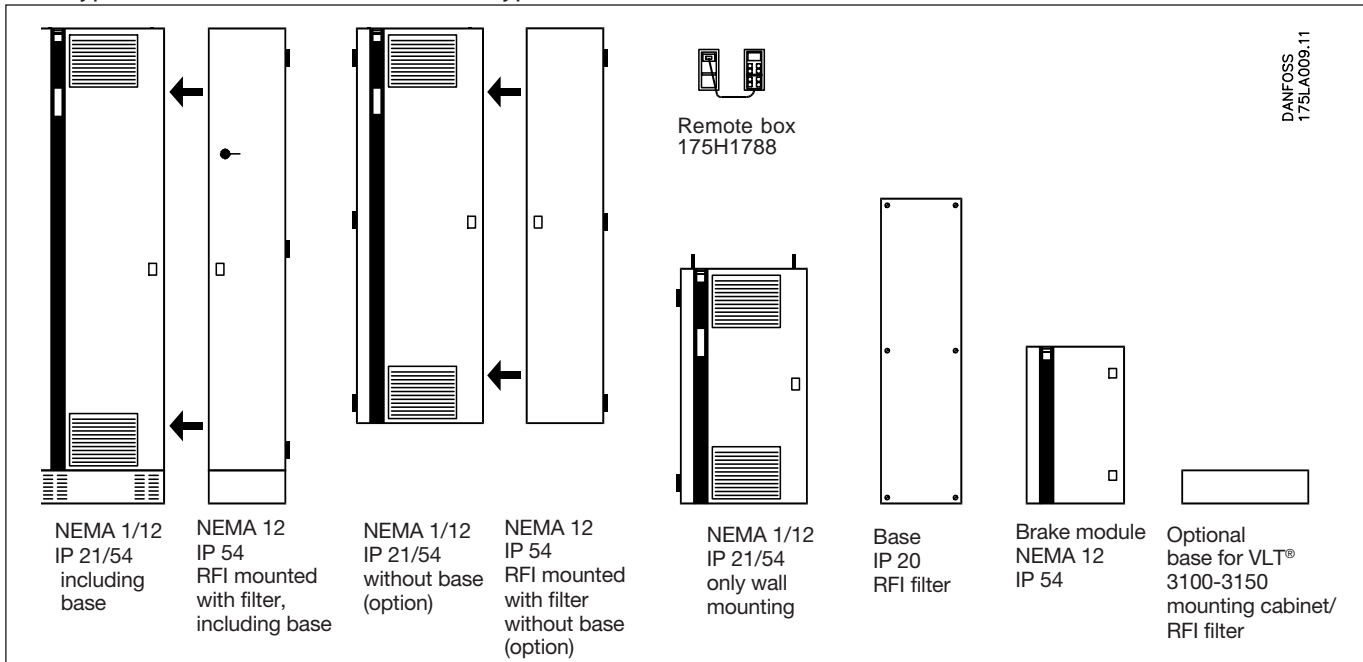

220/230/240 V

VLT® type	Description	kW	Code no.
3032	IP 21	22	175L4500
	IP 54	22	175L4503
3042	IP 21	30	175L4501
	IP 54	30	175L4504
3052	IP 21	37	175L4502
	IP 54	37	175L4505
Options			
	Brake module IP54		175L3656
	Mounting cabinet with main switch, IP 54		175L3038 (175A)
	Mounting cabinet with main switch, IP 54		175L3039 (200A)
	Mounting cabinet without main switch IP 54		175L3653
	RFI module IP20 VLT 3032-3052		175L3665
	RFI module IP54 VLT 3032-3052		175L3666

Fuses

Description	Amp	Bussmann name	3032 - 3052		3100	3125	3150	3200	3250
			3060	3075					
Input fuse	150	T-Tron JJS	175L3490						
Input fuse	250	T-Tron JJS			175L3414				
Input fuse	300	T-Tron JJS					175L3415		
Input fuse	450	T-Tron JJS						175L3534	
Input fuse	500	T-Tron JJS							175L3535
Charge fuse	9	KT-9	175L3489						
Charge fuse	10	KT-10			175L3419				
Charge fuse	12	KT-12						175L3432	
Fuse for fan	1.5	FNQ-R-1-1/2					175L3439		
Voltage supply	5	KTK-5			175L3437				
Fuse	250	170L5021 1BK/75						175L3462	
Fuse	315	170L5015 1BK/75							175L3563
Fuse, dynamic brake	20	KTK-20			175L3475				

380/440/500 V

VLT® type	Description	kW	Code no.
3060	IP 21	45	175L3000
	IP 54	45	175L3007
3075	IP 21	55	175L3001
	IP 54	55	175L3008
3100	IP 21	75	175L3002
	IP 54	75	175L3009
3125	IP 21	90	175L3003
	IP 54	90	175L3010
3150	IP 21	110	175L3004
	IP 54	110	175L3011
3200	IP 21	132	175L3005
	IP 54	132	175L3012
3250	IP 21	160	175L3006
	IP 54	160	175L3013

Description	3060	3075	3100	3125	3150	3200	3250
Brake module IP 54	175L3030				175L3031		
RFI module IP20	175L3657			175L3658		175L3659	175L3660
RFI module IP54	175L3661			175L3662		175L3663	175L3664
Mounting cabinet IP54 with main switch	175L3038(175A)			175L3040(200A)		175L3042(400A)	
Mounting cabinet IP54 with main switch	175L3039(200A)			175L3041(400A)		175L3043(600A)	
Mounting cabinet IP54 without main switch	175L3653			175L3654		175L3655	
Base for floor installation for VLT®	-			175L3047		Included	
Base for RFI/mounting cabinet IP54	-			175L3048		Included	
PROFIBUS option	175H4754						
Modbus Plus option	Contact Danfoss						
PC software	(GB 175H2850) (D 175H2876) (DK 175H2877)						
Remote box	175H1788						
Terminal adapter kit	175L3640			175L3641		175L3642	

Product range

Function diagram for
 VLT® type 3002 - 3006 380/415 V, VLT® type 3002 - 3008 440/500 V and VLT® type 3002 - 3004 200/230 V

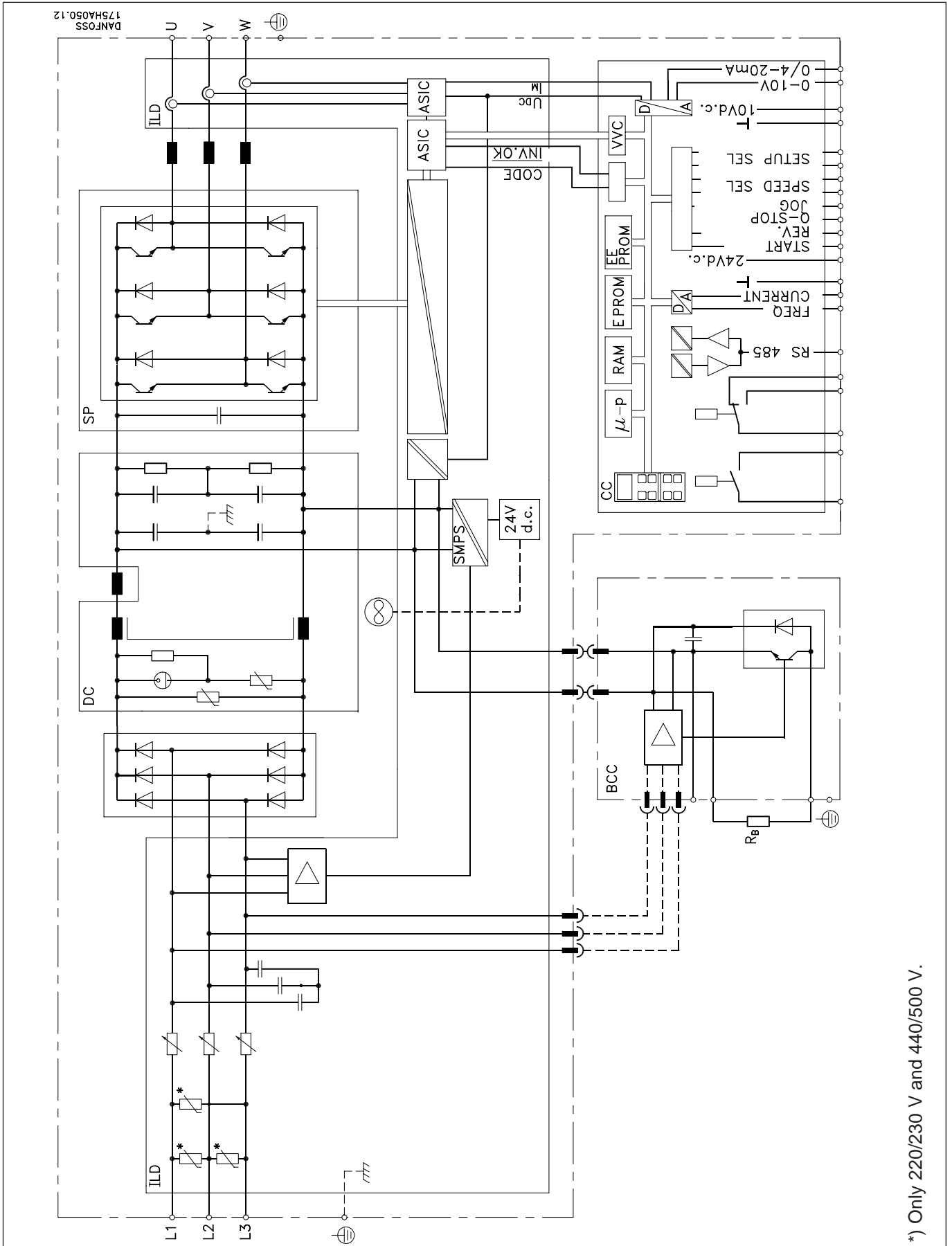

*) Only 220/230 V and 440/500 V.

Product range

Function diagram for VLT® type 3008, 385/415 V

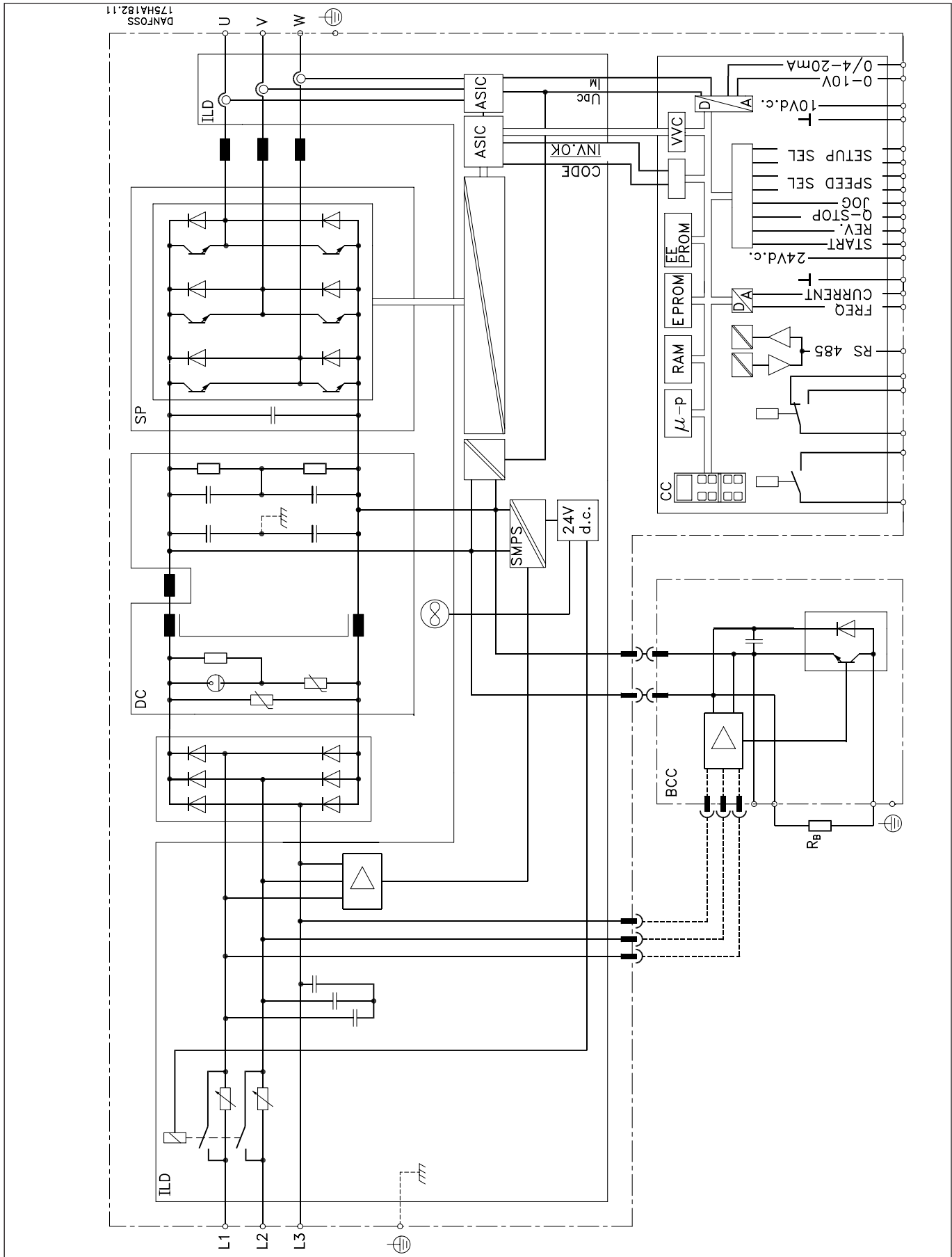

Product range

Function diagram for VLT® type 3011 - 3052 380/500 V, VLT® type 3006 - 3022 200/230 V

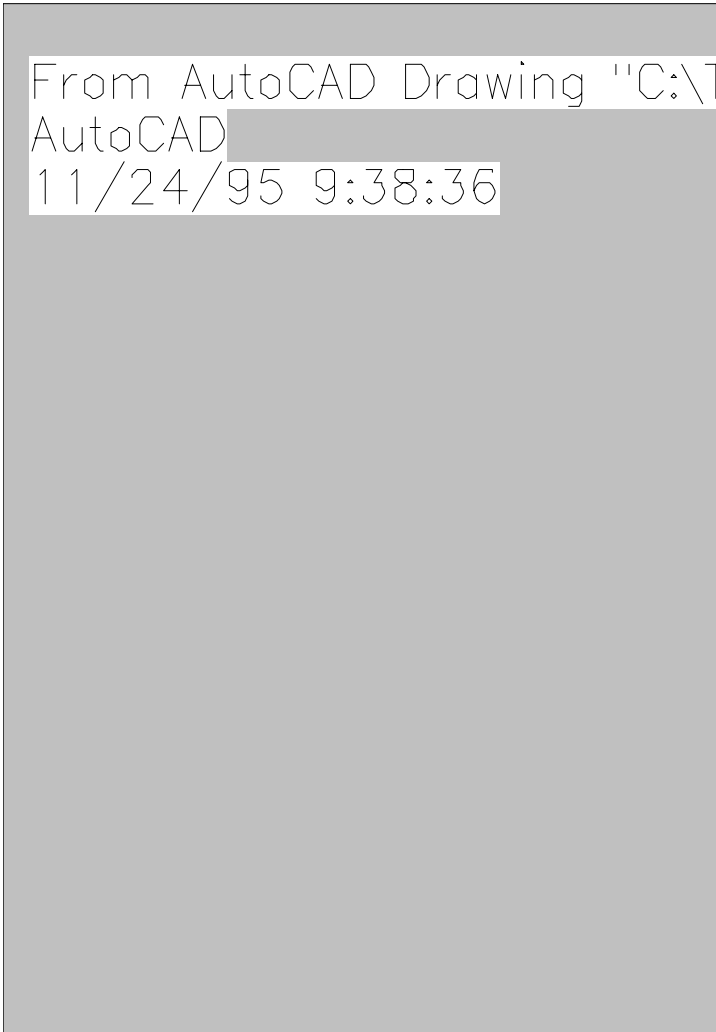

From AutoCAD Drawing "C:\T
AutoCAD
11/24/95 9:38:36

Product range

Function diagram for VLT® type 3032 - 3052, 220/240 V, VLT® type 3060 - 3075 (380/500 V)

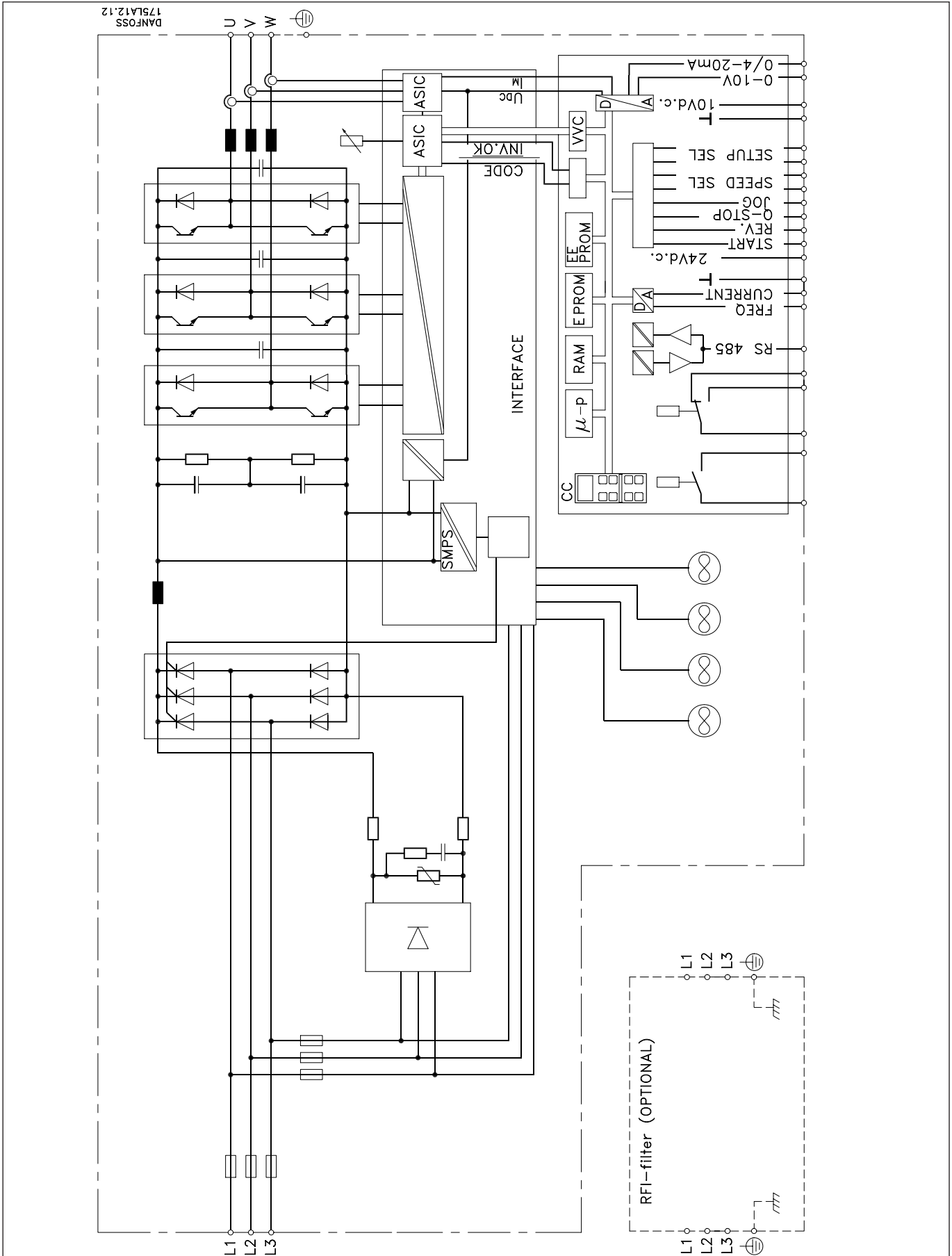

Product range

Function diagram for VLT® type 3100 - 3150 (380-500 V)

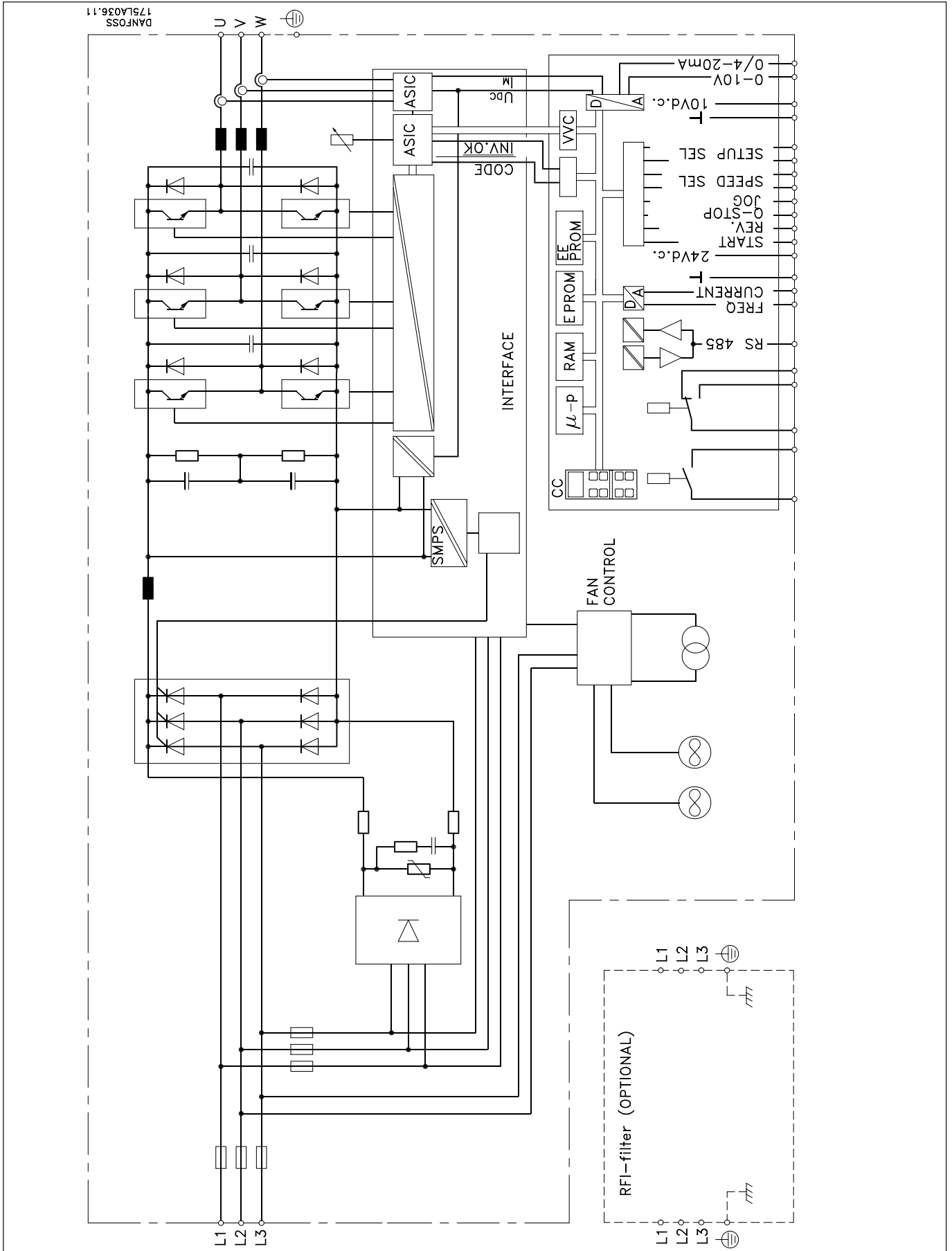

Product range

Function diagram for VLT® type 3200 - 3250 (380-500 V)

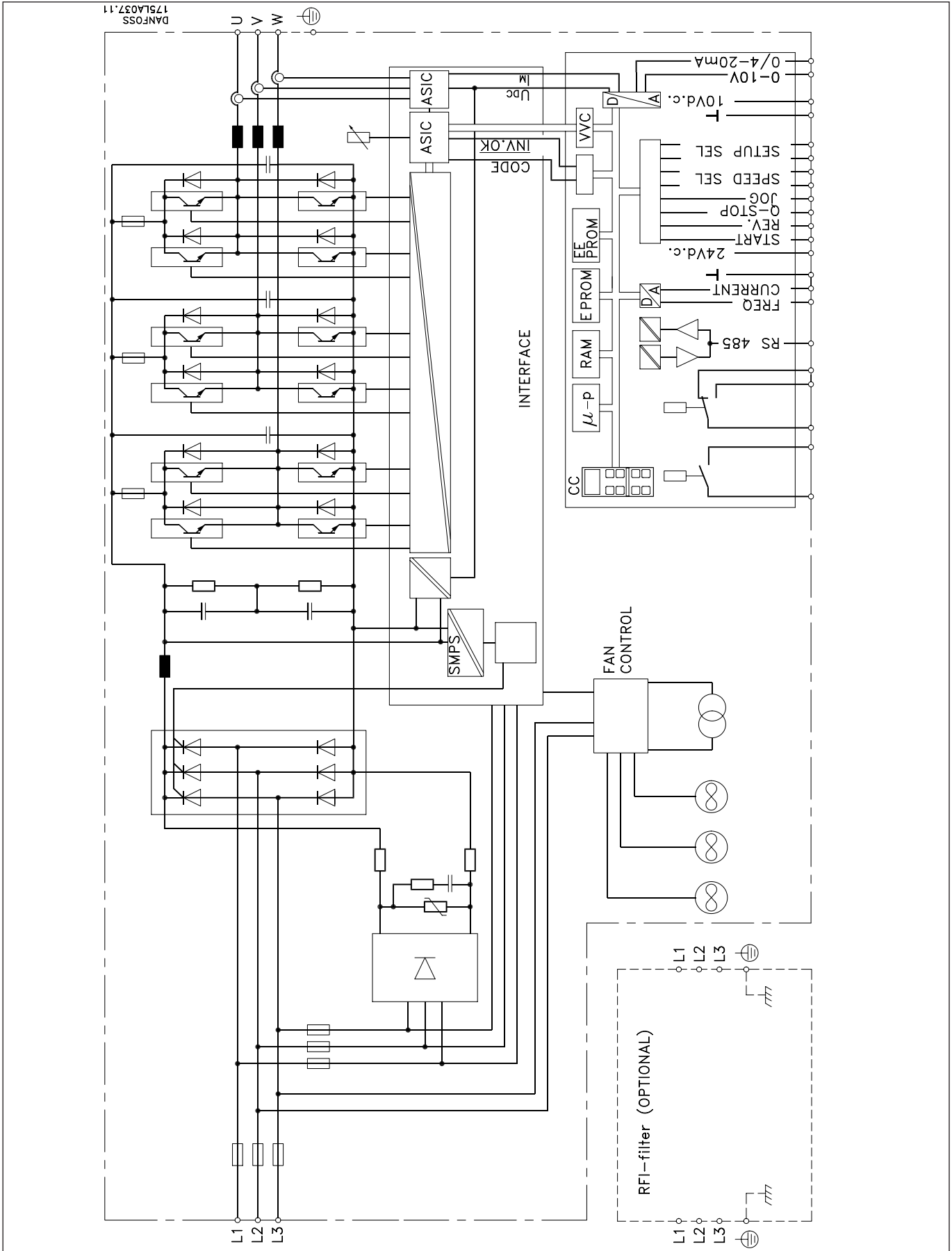

According to international VDE and UL/CSA requirements		VLT type 3002 3003 3004 3006 3008 3011 3016 3022 3032 3042 3052												
Constant torque (CT):														
Output current	$I_{VLT,N}$ [A]	5.4	7.8	10.5	19.0	25.0	32.0	46.0	61.0	80.0	104.0	130.0		
	$I_{VLT,MAX}$ [A] (60 s)	6.7	12.5	17.0	30.0	40.0	51.2	73.6	97.6	120.0	156.0	195.0		
Output	$S_{VLT,N}$ [kVA]	2.1	3.1	4.2	7.6	10.0	12.7	18.3	24.3	31.9	41.4	51.8		
	$S_{VLT,MAX}$ [kVA] (60 s)	2.7	4.9	6.7	12.0	15.9	20.4	29.2	38.9	47.8	62.1	77.7		
Typical shaft output	$P_{VLT,N}$ [kW]	1.1	1.5	2.2	4.0	5.5	7.5	11.0	15.0	22.0	30.0	37.0		
Quadratic torque (VT):														
Output current	$I_{VLT,N}$ [A]	5.4	7.8	10.5	25.0	32.0	46.0	61.0	88.0	104.0	130.0	154.0		
Output	$S_{VLT,N}$ [kVA]	1.9	2.9	4.0	10.0	12.7	18.3	24.3	35.1	41.4	51.8	61.3		
Typical shaft output	$P_{VLT,N}$ [kW]	1.1	1.5	2.2	5.5	7.5	11.0	15.0	22.0	33.0	37.0	45.0		
Max. cable cross-section	[mm ²]	2.5	2.5	2.5	16.0	16.0	16.0	35.0	50.0	70.0	70.0	70.0		
Max. motor cable length	[m]	300, with screened cables: 150 m										300		
Output voltage	U_M [%]	0-100, of mains voltage										max. 230 V		
Output frequency	f_M [Hz]	0-120 or 0-500; programmable												
Rated motor voltage	$U_{M,N}$ [V]	200/220/230												
Rated motor frequency	$f_{M,N}$ [Hz]	50/60/87/100												
Thermal protection during operation		Integrated thermal motor protection (electronic); thermistor to DIN 44081												
Switching on output		Unlimited (frequent switching on output may result in fault message)												
Ramp times	[s]	0.1 - 3600												
		VLT type 3002 3003 3004 3006 3008 3011 3016 3022 3032 3042 3052												
Max. input current	const. load $I_{L,N}$ [A]	6.8	9.1	13.3	17.5	22.2	26.4	41.7	52.2	78.0	102.0	128.0		
	quad. load $I_{L,N}$ [A]	6.8	9.1	13.3	23.1	29.6	42.0	56.8	72.3	102.0	128.0	152.0		
Max. cable cross-section	[mm ²]	2.5	2.5	2.5	16.0	16.0	16.0	35.0	50.0	120.0	120.0	120.0		
Max. pre-fuses ¹⁾	[A]	16.0	16.0	25.0	40.0	50.0	60.0	80.0	125.0	150.0	150.0	150.0		
Supply voltage (VDE 0160)	[V]	3 x 200/220/230 ±10%									3 x 220/230/240 ±10%			
Supply frequency	[Hz]	50/60												
Power factor / cos. ϕ_1		0.9/1.0												
Efficiency		0.96 at 100% load												
Switching on input	times/min.	2												
		VLT type 3002 3003 3004 3006 3008 3011 3016 3022 3032 3042 3052												
Weight (kg)	IP 00	7.4	7.4	7.4	-	-	-	-	-	-	-	-		
	IP 20	-	-	-	24.0	26.0	32.0	49.0	51.0	-	-	-		
	IP 21	8.0	8.0	8.0	-	-	-	-	-	143.0	145.0	147.0		
	IP 54	11.0	11.0	11.0	34.0	37.0	48.0	63.0	65.0	143.0	145.0	147.0		
Power loss	CT [W]	60.0	100.0	130.0	270.0	425.0	399.0	615.0	935.0	760.0	910.0	1110		
at max. load	VT [W]	60.0	100.0	130.0	425.0	580.0	651.0	929.0	1350	950.0	1110	1290		
Enclosure		VLT type 3002-04: IP 00 / IP 21 / IP 54 VLT type 3006-22: IP 20 / IP 54 VLT type 3032-52: NEMA 1 / 2, IP 21 / 54												
Vibration test	[g]	0.7												
Relative humidity	[%]	VDE 0160 5.2.1.2.												
Ambient temperature (to VDE 0160)	[°C]	VLT 3002-3004: -10 → +40, operation at full load ²⁾												
		VLT 3006-3052: -10 → +45/40(CT/VT) at full load ²⁾												
	[°C]	VLT 3002-3004: -30/25 → +65/70, in storage/transport VLT 3006-3052: -25 → +65/70, in storage/transport												
Frequency converter protection		Protection against earthing and short-circuiting												
EMC standards	Emission	EN 55011, EN 55014												
(See section "EMC test results")	Immunity	EN 50082-2, IEC 1000-4-2, IEC 1000-4-3, IEC 1000-4-4, IEC 1000-4-5 VDE 0160, ENV 50140, ENV 50141												

1) VLT 3022: Only semi-conductor fuses; VLT 3032-3052: Bussman rapid type JJS built-in (see list)

2) In the range -10 to 0°C, the equipment can start and run; however, the display values and certain operating characteristics will not fulfil the specifications.

Acc. to international VDE and UL/CSA requirements **VLT type 3002 3003 3004 3006 3008 3011 3016 3022 3032 3042 3052**
Constant torque (CT):

Output current	$I_{VLT,N}$ [A]	2.8	4.1	5.6	10.0	13.0	16.0	24.0	32.0	44.0	61.0	73.0
	$I_{VLT,MAX}$ [A] (60 s)	3.5	6.5	9.0	16.0	20.8	25.6	38.4	51.2	70.4	97.6	117.0
Output	$S_{VLT,N}$ [kVA]	2.0	2.9	4.0	7.2	9.3	11.5	17.2	23.0	31.6	44.0	52.5
	$S_{VLT,MAX}$ [kVA] (60 s)	2.5	4.6	6.4	11.5	15.0	18.4	27.6	36.8	50.5	70.2	84.1
Typical shaft output	$P_{VLT,N}$ [kW]	1.1	1.5	2.2	4.0	5.5	7.5	11.0	15.0	22.0	30.0	37.0

Quadratic torque (VT):

Output current	$I_{VLT,N}$ [A]	2.8	4.1	5.6	13.0	16.0	24.0	32.0	44.0	61.0	73.0	88.0
Output	$S_{VLT,N}$ [kVA]	2.0	2.9	4.0	9.3	11.5	17.2	23.0	31.6	44.0	52.5	63.3
Typical shaft output	$P_{VLT,N}$ [kW]	1.1	1.5	2.2	5.5	7.5	11.0	15.0	22.0	30.0	37.0	45.0
Max. cable cross-section	[mm ²]	2.5	2.5	2.5	2.5	2.5	16.0	16.0	16.0	35.0	35.0	50.0
Max. motor cable length	[m]	300, with screened cables: 150 m										
Output voltage	U_M [%]	0-100, of mains voltage										
Output frequency	f_M [Hz]	0-120 or 0-500; programmable										
Rated motor voltage	$U_{M,N}$ [V]	380/400/415										
Rated motor frequency	$f_{M,N}$ [Hz]	50/60/87/100										
Thermal protection during operation		Integrated thermal motor protection (electronic); thermistor to DIN 44081										
Switching on output		Unlimited (frequent switching on output may result in fault message)										
Ramp times	[s]	0.1 - 3600										

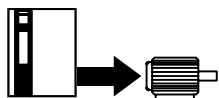
VLT type 3002 3003 3004 3006 3008 3011 3016 3022 3032 3042 3052

Max. input current	const. load $I_{L,N}$ [A]	2.8	4.8	7.0	10.0	13.0	13.8	21.8	30.7	41.9	55.6	66.5
	quad. load. $I_{L,N}$ [A]	2.8	4.8	7.0	13.0	17.0	22.0	31.0	41.5	57.5	66.5	80.0
Max. cable cross-section	[mm ²]	2.5	2.5	2.5	2.5	2.5	16.0	16.0	16.0	35.0	35.0	50.0
Max. pre-fuses	[A]	16.0	16.0	16.0	25.0	25.0	50.0	63.0	63.0	80.0	100 ¹⁾	125 ¹⁾
Supply voltage	[V]	3 x 380/400/415 ±10% (VDE 0160)										
Supply frequency	[Hz]	50/60 Hz										
Power factor / cos. ϕ_1		0.9/1.0										
Efficiency		0,96 at 100% load										
Switching on input	times/min.	2										

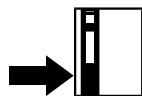

VLT type 3002 3003 3004 3006 3008 3011 3016 3022 3032 3042 3052

Weight (kg)	IP 00	7.4	7.4	7.4	12.0	14.0	-	-	-	-	-	-	
	IP 20	-	-	-	-	-	24.0	26.0	32.0	49.0	54.0	54.0	
	IP 21	8.0	8.0	8.0	13.0	15.0	-	-	-	-	-	-	
	IP 54	11.0	11.0	11.0	14.0	15.0	34.0	37.0	48.0	63.0	69.0	69.0	
Power loss at max. load	CT [W]	60	100	130	195	200	270	425	580	880	1390	1875	
	VT [W]	60	100	130	280	300	425	580	880	1390	1875	2155	
Enclosure		VLT type 3002-08: IP 00 / IP 21 / IP 54 VLT type 3011-52: IP 20 / IP 54											
Vibration test	[g]	0.7											
Relative humidity	[%]	VDE 0160 5.2.1.2.											
Ambient temperature (to VDE 0160)	[°C]	-10 → +40						-10 → +45/40 (CT/VT)					
	[°C]	operation at full load ²⁾						at full load ²⁾					
		-25 → +65/70, in storage/transport						-25 → +65/70, in storage/transport					
EMC standards (See section "EMC test results")	Emission	EN 55011, EN 55014, EN 61000-3-2											
	Immunity	EN 50082-2, IEC 1000-4-2, IEC 1000-4-3, IEC 1000-4-4, IEC 1000-4-5, VDE 0160, ENV 50140, ENV 50141											

1) Only semi-conductor fuses.

2) In the range -10 to 0°C, the equipment can start and run; however, the display values and certain operating characteristics will not fulfil the specifications.

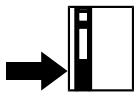
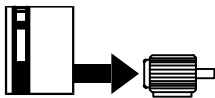
According to international VDE and UL/CSA requirements		VLT type	3060	3075	3100	3125	3150	3200	3250
Constant torque (CT):									
Output current	$I_{VLT,N}$ [A]		86	105	139	168	205	243	302
	$I_{VLT,MAX}$ [A] (60s)		129	158	209	252	308	365	453
Output	$S_{VLT,N}$ [kVA]		61.8	73	96	116	142	168	209
	$S_{VLT,MAX}$ (60s)		89	109	144	175	213	253	314
Typical shaft output	$P_{VLT,N}$ [kW]		45	55	75	90	110	132	160
Quadratic torque (VT):									
Output current	$I_{VLT,N}$ [A]		105	139	168	205	243	302	368
	$I_{VLT,MAX}$ [A] (60s)		116	153	185	226	267	332	405
Output	$S_{VLT,N}$ [kVA]		73	96	116	142	168	209	255
Typical shaft output	$P_{VLT,N}$ [kW]		55	75	90	110	132	160	200
Max. cable cross-section	[mm ²]		70	70	150	150	150	2x95	2x95
Max. motor cable length	[m]		300						
Output voltage	U_M [%]		0-100 of mains voltage						
Output frequency	f_M [Hz]		0-120 or 0-500, programmable						
Rated motor voltage	$U_{M,N}$ [V]		380/400/415/440/460/500						
Rated motor frequency	$f_{M,N}$ [Hz]		50/60/87/100						
Thermal protection during operation			Integrated thermal motor protection (electronic); thermistor to DIN 44081						
Switching on output			Unlimited (frequent switching on output may result in fault message)						
Ramp times	[s]		0.1 - 3600						
		VLT Type	3060	3075	3100	3125	3150	3200	3250
Input current	$I_{L,N}$ [A]		84.6	103.3	138.4	167.2	201.7	241.9	307.6
	$I_{L,MAX}$ (60s) [A]		129.0	158.0	209.0	252.0	308.0	365.0	453.0
Quadratic load	$I_{L,N}$ [A]		103.3	138.4	167.2	201.7	241.9	293.3	366.3
	$I_{L,MAX}$ (60s) [A]		116.0	153.0	185.0	226.0	267.0	332.0	405.0
Max. cable cross-section	[mm ²]		120.0	120.0	2 x 120	2 x 120	2 x 120	2 x 240	2 x 240
Pre-fuses ¹⁾	[A]		150.0	150.0	250.0	250.0	300.0	450.0	500.0
Supply voltage (VDE 0160)	[V]		3 x 380/400/415/440/460/500 ±10%						
Supply frequency	[Hz]		50/60						
Power factor / cos. ϕ_1			0.9/1.0						
Efficiency			0,96 at 100% load						
Switching on input	times/min.		1						
		VLT type	3060	3075	3100	3125	3150	3200	3250
Weight (kg)	IP 21		147	147	211	211	220	306	306
	IP 54		147	147	211	211	220	306	306
Power loss at max. load CT [W]	Front		423	529	713	910	1091	1503	1812
	Heat sink		859	1074	1447	1847	2216	3051	3679
Power loss at max. load VT [W]	Front		529	713	910	1091	1503	1812	2209
	Heat sink		1074	1447	1847	2216	3051	3679	4485
Enclosure	IP 21 / IP 54		NEMA 1/12						
Vibration test	[g]		0.7						
Relative humidity	[%]		VDE 0160 5.2.1.2.						
Ambient temperature (to VDE 0160)	[°C]		-10 → +40 operation at full load (VT) -10 → +45 (CT) ²⁾						
	[°C]		-30/25 → +65/70 in storage/transport						
Frequency converter protection			Protection against earthing and short-circuiting						
EMC standards	Emission		EN 55011, EN 55014						
(See section "EMC test results")	Immunity		EN 50082-2, IEC 1000-4-2, IEC 1000-4-3, IEC 1000-4-4, IEC 1000-4-5, VDE 0160						



1) Bussman rapid type JJS integrated.

2) In the range -10 to 0°C, the equipment can start and run; however, the display values and certain operating characteristics will not fulfil the specifications.

Acc. to international VDE and UL/CSA requirements		VLT type	3002	3003	3004	3006	3008	3011	3016	3022	3032	3042	3052
Constant torque (CT):													
Output current	$I_{VLT,N}$ [A]		2.6	3.4	4.8	8.2	11.1	14.5	21.7	27.9	41.4	54.0	65.0
	$I_{VLT,MAX}$ [A] (60s)		3.4	5.5	7.7	13.1	17.6	23.2	34.7	44.6	67.2	86.4	104.0
Output	$S_{VLT,N}$ [kVA]		2.3	2.9	4.1	7.1	9.6	12.6	18.8	24.2	36.0	46.8	56.3
	$S_{VLT,MAX}$ [kVA] (60s)		2.9	4.7	6.7	11.3	15.2	20.1	30.1	38.6	58.2	7.8	90.1
Typical shaft output	$P_{VLT,N}$ [kW]		1.1	1.5	2.2	4.0	5.5	7.5	11.0	15.0	22.0	30.0	37.0
Quadratic torque (VT):													
Output current	$I_{VLT,N}$ [A]		2.6	3.4	4.8	8.2	11.1	21.7	27.9	41.4	54.0	65.0	78.0
Output	$S_{VLT,N}$ [kVA]		1.6	2.9	4.1	7.1	9.6	18.8	24.2	35.9	46.8	56.3	67.5
Typical shaft output	$P_{VLT,N}$ [kW]		1.1	1.5	2.2	4.0	5.5	11.0	15.0	22.0	30.0	37.0	45.0
Max. cable cross-section	[mm ²]		2.5	2.5	2.5	2.5	2.5	16.0	16.0	16.0	35.0	35.0	50.0
Max. motor cable length	[m]		300, with screened cables: 150 m (3011-3052 in VT: 150 m and 40 m)										
Output voltage	U_M [%]		0-100, of mains voltage										
Output frequency	f_M [Hz]		0-120 eller 0-500, programmable										
Rated motor voltage	$U_{M,N}$ [V]		440/460/500										
Rated motor frequency	$f_{M,N}$ [Hz]		50/60/87/100										
Thermal protection during operation			Integrated thermal motor protection (electronic); thermistor to DIN 44081										
Switching on output			Unlimited (frequent switching on output may result in fault message)										
Ramp times	[s]		0.1 – 3600										
		VLT type	3002	3003	3004	3006	3008	3011	3016	3022	3032	3042	3052
Max. const. load	[A]		2.6	3.4	4.8	8.2	11.1	12.6	20.1	26.8	37.3	50.2	61.3
input current quadratic load	[A]		2.6	3.4	4.8	8.2	11.1	19.6	26.0	34.8	48.6	60.3	72.0
Max. cable cross-section	[mm ²]		2.5	2.5	2.5	2.5	2.5	16.0	16.0	16.0	35.0	35.0	50.0
Max. pre-fuses	[A]		16.0	16.0	16.0	25.0	25.0	30.0	40.0	50.0	60.0	100.0 ¹⁾	125.0 ¹⁾
Supply voltage (VDE 0160)	[V]		3 x 440/460/500 ±10% (VDE 0160)										
Supply frequency	[Hz]		50/60										
Power factor / cos. ϕ_1			0.9/1.0										
Efficiency			0.96 at 100% load										
Switching on input	times/min.		2										
		VLT type	3002	3003	3004	3006	3008	3011	3016	3022	3032	3042	3052
Weight (kg)	IP 00		7.4	7.4	7.4	12	14	-	-	-	-	-	-
	IP 20		-	-	-	-	-	25	26	31	49	54	54
	IP 21		8.0	8.0	8.0	13	15	-	-	-	-	-	-
	IP 54		11	11	11	14	15	34	37	48	63	69	69
Power loss at max. load	CT [W]		60	100	130	160	200	174	287	580	958	1125	1467
	VT [W]		60	100	130	160	200	281	369	880	1133	1440	1888
Enclosure			VLT type 3002-08: IP 00 / IP 21 / IP 54					VLT type 3011-52: IP 20 / IP54					
			VLT type 3042-52: IP 20 / IP 54										
Vibration test	[g]		0.7										
Relative humidity	[%]		VDE 0160 5.2.1.2.										
Ambient temperature (to VDE 0160)	[°C]		-10 → +40					-10 → +45/40(CT/VT)					
	[°C]		at full load ²⁾					at full load ²⁾					
	[°C]		-25 → +65/70					-25 → +65/70					
			in storage/transport					in storage/transport					
Frequency converter protection			Protection against earthing and short-circuiting										
EMC standards (See section "EMC test results")	Emission		EN 55011, EN 55014										
	Immunity		EN 50082-2, IEC 1000-4-2, IEC 1000-4-3, IEC 1000-4-4, IEC 1000-4-5, VDE 0160, ENV 50140, ENV 50141										

1) Semi-conductor fuses.

2) In the range -10 to 0°C, the equipment can start and run; however, the display values and certain operating characteristics will not fulfil the specifications.

According to international VDE and UL/CSA requirements		VLT type	3060	3075	3100	3125	3150	3200	3250
Constant torque (CT):									
Output current	$I_{VLT,N}$ [A]		77	96	124	156	180	240	302
	$I_{VLT,MAX}$ [A](60s)		116	144	186	234	270	360	453
Output	$S_{VLT,N}$ [kVA]		67	83	107	135	156	208	262
	$S_{VLT,MAX}$ (60s) [kVA]		100	125	161	203	234	312	392
Typical shaft output	$P_{VLT,N}$ [kW]		55	75	90	110	132	160	200
Quadratic torque (VT):									
Output current	$I_{VLT,N}$ [A]		96	124	156	180	240	302	361
	$I_{VLT,MAX}$ [A](60s)		106	136	172	198	264	332	397
Output	$S_{VLT,N}$ [kVA]		83	107	135	156	208	262	313
Typical shaft output	$P_{VLT,N}$ [kW]		75	90	110	132	160	200	250
Max. cable cross-section	[mm ²]		70	70	150	150	150	2 x 95	2 x 95
Max. motor cable length	[m]		300						
Output voltage	U_M [%]		0-100 of mains voltage						
Output frequency	f_M [Hz]		0-120 or 0-500; programmable						
Rated motor voltage	$U_{M,N}$ [V]		380/400/415/440/460/500						
Rated motor frequency	$f_{M,N}$ [Hz]		50/60/87/100						
Thermal protection during operation			Integrated thermal motor protection (electronic); thermistor to DIN 44081						
Switching on output			Unlimited (frequent switching on output may result in fault message)						
Ramp times	[s]		0.1 - 3600						
		VLT type	3060	3075	3100	3125	3150	3200	3250
Input current	$I_{L,N}$ [A]		75.8	94.4	123.4	155.3	177.1	238.9	307.6
	$I_{L,MAX}$ (60s)[A]		113.7	141.6	185.1	233.0	265.7	358.4	461.4
Quadratic load	$I_{L,N}$ [A]		94.4	123.4	155.3	177.1	238.9	307.6	359.3
	$I_{L,MAX}$ (60s)[A]		106.0	136.0	172.0	198.0	264.0	332.0	397.0
Max. cable cross-section	[mm ²]		120.0	120.0	2 x 120	2 x 120	2 x 120	2 x 240	2 x 240
Max. pre-fuses ¹⁾	[A]		150.0	150.0	250.0	250.0	300.0	450.0	500.0
Supply voltage (VDE 0160)	[V]		3 x 380/400/415/440/460/500 ±10%						
Supply frequency	[Hz]		50/60						
Power factor / cos. ϕ_1			0.9/1.0						
Efficiency			0.96 at 100% load						
Switching on input	times/min.		1						
		VLT type	3060	3075	3100	3125	3150	3200	3250
Weight (kg)	IP 21		147	147	211	211	220	306	306
	IP 54		147	147	211	211	220	306	306
Power loss at max. load CT [W]	Front		423	529	713	910	1091	1503	1812
	Heat sink		859	1074	1447	1847	2216	3051	3679
Power loss at max. load VT [W]	Front		529	713	910	1091	1503	1812	2209
	Heat sink		1074	1447	1847	2216	3051	3679	4485
Enclosure			IP 21 / IP 54, NEMA 1/12						
Vibration test	[g]		0.7						
Relative humidity	[%]		VDE 0160 5.2.1.2.						
Ambient temperature (to VDE 0160)	[°C]		-10→ +40 at full load ²⁾			(VT) -10→ +45 (CT) ²⁾			
	[°C]		-30/25→ +65/70 in storage/transport						
Frequency converter protection			Jord- og kortslutningssikker						
EMC standards	Emission		EN 55011, EN 55014						
(See section "EMC test results")	Immunitet		EN 50082-2, IEC 1000-4-2, IEC 1000-4-3, IEC 1000-4-4, IEC 1000-4-5 VDE 0160						

1) Bussman rapid type JJS integrated.

2) In the range -10 to 0°C, the equipment can start and run; however, the display values and certain operating characteristics will not fulfil the specifications.

Dimensions

IP 00

220 volt

VLT® type	3002-3004	With brake
A (mm)	300	440
B (mm)	281	281
C (mm)	178	178
D (mm)	55	55
a (mm)	191	330
b (mm)	258	258
above/below (mm)	150	150
left/right (mm)	0	0

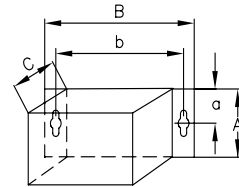
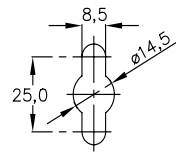
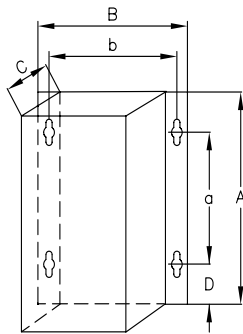

DANFOSS
175HA129.11

380 / 500 volt

VLT® type	3002-04	With brake	3006	With brake	3008	With brake
A (mm)	300	440	440	550	500	610
B (mm)	281	281	281	281	281	281
C (mm)	178	178	178	178	178	178
D (mm)	55	55	55	55	55	55
a (mm)	191	330	330	440	330	440
b (mm)	258	258	258	258	258	258
above/below (mm)	150	150	150	150	150	150
left/right (mm)	0	0	0	0	0	0

Options	RFI module RFI-LC filter module LC module Clamp module Brake module
A (mm)	115
B (mm)	281
C (mm)	178
D (mm)	-
a (mm)	57.5
b (mm)	258
above/below (mm)	150
left/right (mm)	0

IP 20

220 volt

VLT® type	3006-3008	3011	3016-3022
A (mm)	660	780	950
B (mm)	242	242	308
C (mm)	260	260	296
a (mm)	640	760	930
b (mm)	200	200	270
above/below (mm)	200	200	200
left/right (mm)	0	0	0

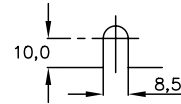
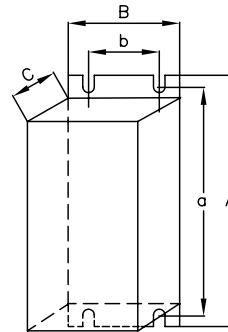

DANFOSS
175HA132.00

380 / 500 volt

VLT® type	3011-3016	3022	3032-3052
A (mm)	660	780	950
B (mm)	242	242	308
C (mm)	260	260	296
a (mm)	640	760	930
b (mm)	200	200	270
above/below (mm)	200	200	200
left/right (mm)	0	0	0

Dimensions

IP 21

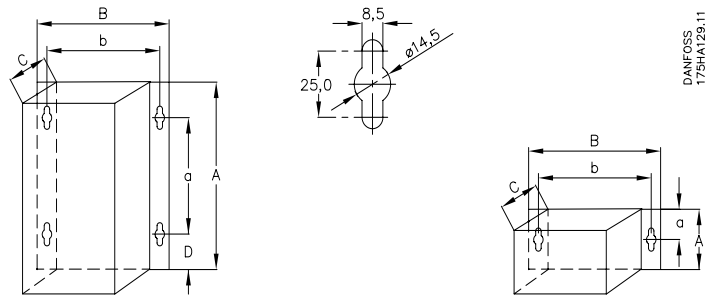

220 volt

VLT® type	3002-03	With brake	3004	With brake
A (mm)	360	500	390	530
B (mm)	281	281	281	281
C (mm)	178	178	178	178
D (mm)	85	85	85	85
a (mm)	191	330	191	330
b (mm)	258	258	258	258
above/below (mm)	150	150	150	150
left/right (mm)	0	0	0	0

Options	RFI module Brake module
A (mm)	115
B (mm)	281
C (mm)	178
D (mm)	-
a (mm)	57.5
b (mm)	258
above/below (mm)	150
left/right (mm)	0

380 / 500 volt

VLT® type	3002-04	With brake	3006	With brake	3008	With brake
A (mm)	360	500	500	610	530	640
B (mm)	281	281	281	281	281	281
C (mm)	178	178	178	178	178	178
D (mm)	85	85	85	85	85	85
a (mm)	191	330	330	440	330	440
b (mm)	258	258	258	258	258	258
above/below (mm)	150	150	150	150	150	150
left/right (mm)	0	0	0	0	0	0

IP 54

220 volt

VLT® type	3002-04	With brake	3006-11	3016-22
A (mm)	530	530	810	940
B (mm)	281	281	355	400
C (mm)	178	178	280	280
D (mm)	85	85	70	70
a (mm)	330	330	560	690
b (mm)	258	258	330	375
above/below (mm)	150	150	150	150
left/right (mm)	0	0	0	0

380 / 500 volt

VLT® type	3002-04 *)	3002-08	3006-08 *)	3011-22	3032-52
A (mm)	530	530	640	810	940
B (mm)	281	281	281	355	400
C (mm)	178	178	178	280	280
D (mm)	85	85	85	70	70
a (mm)	330	330	440	560	690
b (mm)	258	258	258	330	375
above/below (mm)	150	150	150	150	150
left/right (mm)	0	0	0	0	0

*) With brake

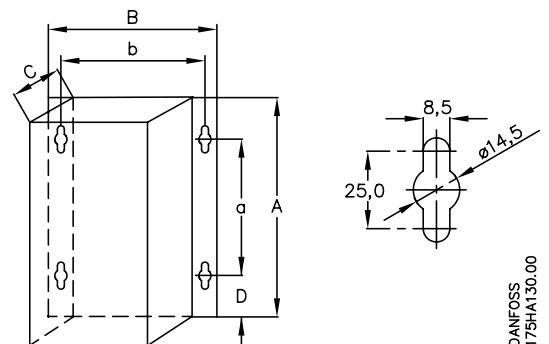

Dimensions

IP 21 / IP 54

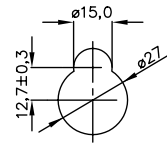
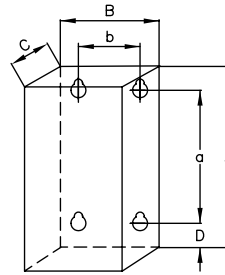

DANFOSS
175HA131.11

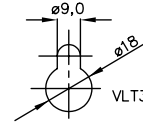

NEMA 1
VLT3060-3075

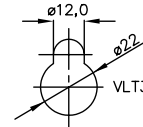

NEMA 1
VLT3100-3250

220 / 230 / 240 / 380 / 500 volt

VLT® type	3032-3052, 230 V, 3060-3075	3100-3150	3200-3252
A (mm)	954 with ring bolts	1569 with ring bolts 1696 with ring bolts and optional base	1877 base and bolts
B (mm)	506 with hinges	513 with hinges	513 with hinges
C (mm) IP21	353	394	508
C (mm) IP54	376	417	531
a (mm)	851	1453	placed on base
b (mm)	446	432	placed on base
Floor mounting on base above (mm)	-	230	262
Wall mounting above/below (mm)	170	230	-
Floor mounting on base left/right (mm)	-	130	130
Wall mounting left/right (mm)	*)	*)	*)

Brake module IP54 for VLT® 3032-3052, 230 V, VLT® 3060-3250	
A (mm)	600
B (mm)	380
C (mm)	274
D (mm)	57
a (mm)	485
b (mm)	340
above/below (mm)	80
left/right (mm)	0

- *) Only limited by hinges on sides.
Note also that the door opens to the left and the option door to the right.

Mounting cabinet IP54

	3032-3052, 230 V 3060-3075	3100-3150	3200-3252
A (mm)	900	1515	1695
B (mm)	267	305	349
C (mm)	388	427	554

Internal mounting panel in mounting cabinet IP54

	3032-3052, 230 V 3060-3075	3100-3150	3200-3252
A (mm)	845	1459	1640
B (mm)	229	267	311

RFI module IP21

	3060-3075	3100-3150	3200-3252
A (mm)	864	1168	1168
B (mm)	254	317	317
C (mm)	254	254	254
D (mm)	45	52	52
a (mm)	772	1063	1063
b (mm)	174	235	235

Description of terminals

Control:

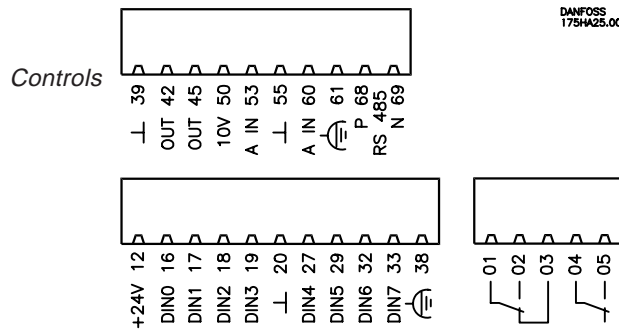

Terminal 39:	Common for analogue/digital outputs
Terminals 42-45:	Analogue/digital outputs to display frequency, reference, current and torque (0-20 mA or 4-20 mA at max. 470 Ω)/statement of selected status, alarm or warning (24 V D.C. at min. 600 Ω). See parameters 407 and 408.
Terminal 50:	10 V D.C., max. 17 mA. Supply voltage to potentiometer and thermistor.
Terminal 53:	0- ±10 V D.C., $R_i = 10 \text{ k}\Omega$. Analogue reference input, voltage. See parameter 412.
Terminal 55:	Common for analogue reference inputs.
Terminal 60:	0/4-20 mA, $R_i = \sim 188 \Omega$. Analogue reference input, current. See parameter 413.
Terminal 61:	Earth connection, via switch 04, to screen for communication cable. See description in parameter group 5.
Terminals 68-69:	RS 485 interface. Serial bus communication. See description of parameter group 5.
Terminal 12:	24 V D.C., max. 140 mA. Supply voltage to digital inputs (DIN0 - DIN7).
Terminals 16-33:	0/24 V, $R_i = 2 \text{ k}\Omega$. < 5 V = logic "0", > 10 V = logic "1". Digital inputs. See p. 35 and parameters 400-406.
Terminal 20:	Common for digital inputs.
Terminal 38:	Earth connection to screen for control cables in units with no terminal clamps for screen.
Terminals 01-03*):	Relay output. Max. 250 V A.C., 2 A. Min. 24 V D.C., 100 mA or 24 V a.c., 100 mA. See parameter 409.
Terminals 04-05*):	Relay output. Max. 250 V A.C., 2 A. Min. 24 V D.C., 10 mA or 24 V A.C., 100 mA. See parameter 410.

*) in UL versions: Max. 240 V A.C., 2 A.

NB: On using a thermistor for motor protection, it is connected between terminal 50 and terminal 16 (see description of selection in parameter 400 and outline of thermistor function, **page 102**).

Description of terminals

Cross reference for terminals/parameter functions.

Terminal 16 / par. 400	★ Reset	Stop *)	Freeze reference	Setup select	Thermistor **)		
Terminal 17 / par. 401	Reset	Stop *)	★ Freeze ref.		Pulse 100 Hz	Pulse 1kHz	Pulse 10 kHz
Terminal 18 / par. 402	★ Start	Pulse start	No function				
Terminal 19 / par. 403	★ Reversing	Start revers***)	No function				
Terminal 27 / par. 404	★ Motor coasting *)	Quick stop *)	DC-brake *)	Reset and motor coasting *)	Stop *)		
Terminal 29 / par. 405	★ Jogging	Freeze jogging	Freeze reference	Digital reference	Ramp selection		
Terminal 32 / par. 406	Speed select	Speed up	Setup select	★ 4 Setup extended			
Terminal 33 / par. 406		Speed down					

★ = Factory setting.

*) Must be with break contact function (NCL), since the function is activated at 0 V on the input.

***) Choose the thermistor function if terminal 50 (10 V D.C.) and terminal 16 (parameter 400) are connected.

***) Terminal 19 is pulse start revers if terminal 18 is set to pulse start

Connection examples

The following shows 8 different connection examples with relevant programming suggestions

Example 1:

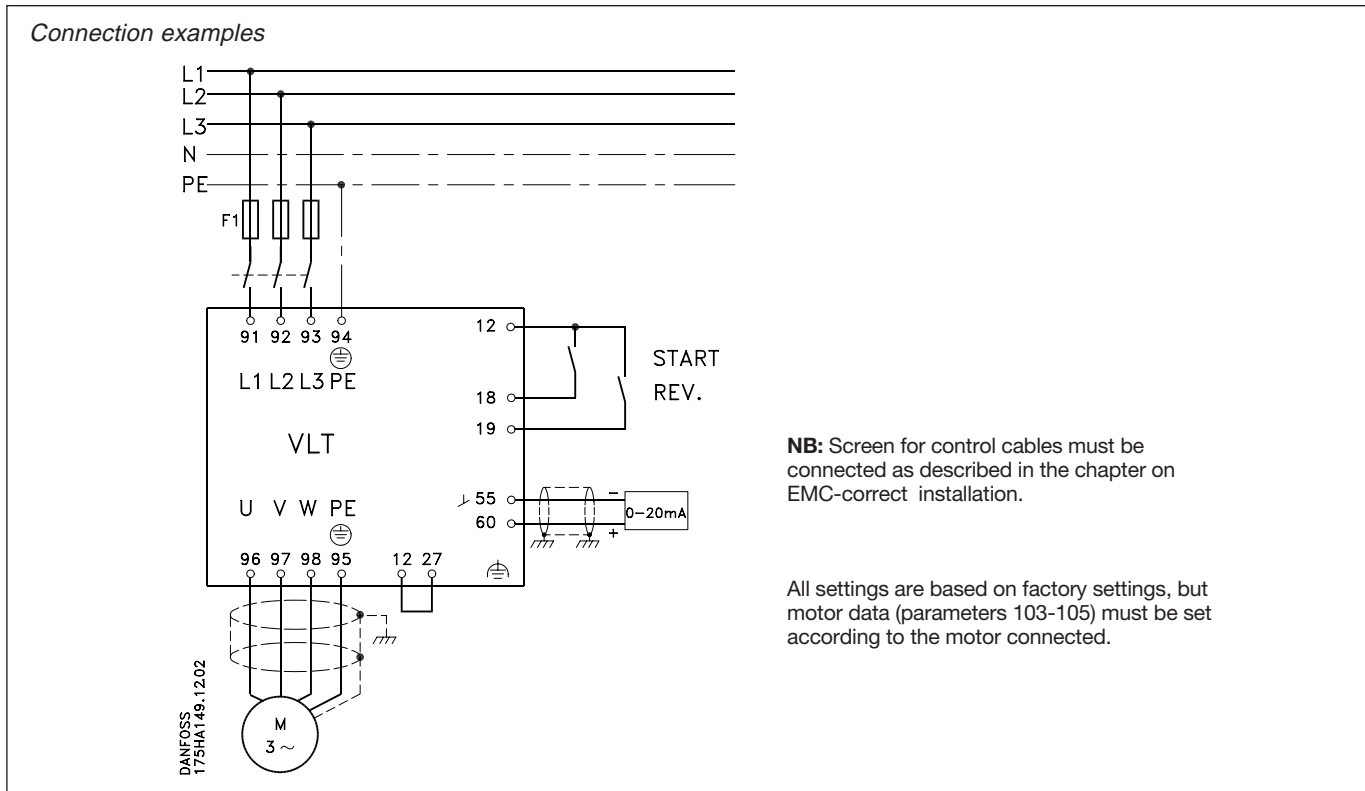

START/STOP REVERSING Reference: 4-20 mA ~ 0-100% speed

Connection examples

Example 2:

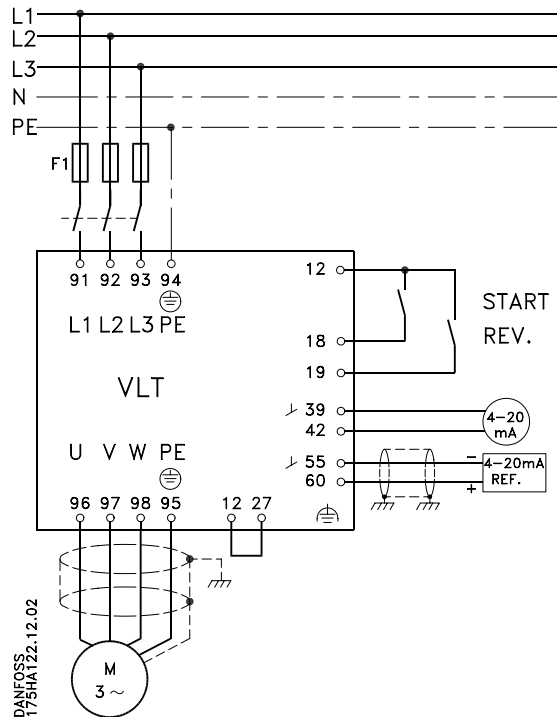

NB: Screen for control cables must be connected as described in the chapter on EMC-correct installation.

All settings are based on factory settings, but motor data (parameters 103-105) must be set according to the motor connected.

START/STOP REVERSING, 4-20 mA output signal ($0-f_{MAX}$)
Reference: 4-20 mA ~ 0-100% speed

The following must be programmed:

Function	Parameter no.	Parameter value
$0-f_{MAX} \sim 4-20 \text{ mA}$	407	$F_{MAX} = 4-20 \text{ mA}$
Ref. 4-20 mA	413	4-20 mA

Connection examples

Example 3:

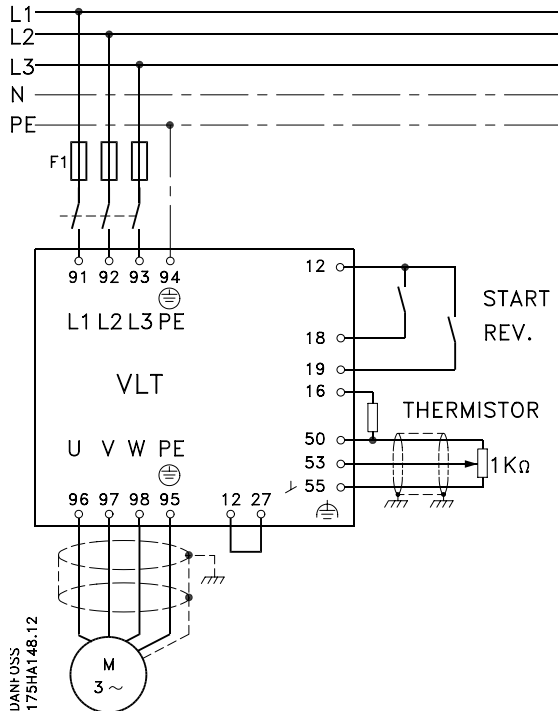

NB: Screen for control cables must be connected as described in the chapter on EMC-correct installation.

All settings are based on factory settings, but motor data (parameters 103-105) must be set according to the motor connected

START/STOP REVERSING, thermistor built-in motor connected to VLT[®] frequency converter.
Reference: 1 k Ω potentiometer, 0-10 V ~0-100% speed

The following must be programmed:

Function	Parameter no.	Parameter value
Thermistor on terminal 16	400	Thermistor

Connection examples

Example 4:

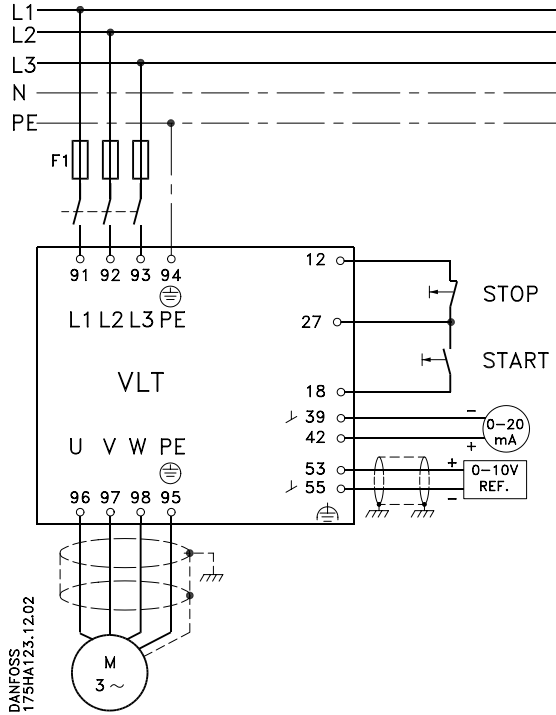

NB: Screen for control cables must be connected as described in the chapter on EMC-correct installation.

All settings are based on factory settings, but motor data (parameters 103-105) must be set according to the motor connected.

3 conductor START/STOP, 0-20 mA output signal $\sim (0-I_{MAX})$,
0-10 V Reference: $\sim 0-100\%$ speed

The following must be programmed:

Function	Parameter no.	Parameter value
STOP	404	STOP
START	402	Latched START
0- I_{MAX} \sim 0-20 mA	407	0- I_{MAX}
Ref. 0-10 V	412	0-10 V

Connection examples

Example 5:

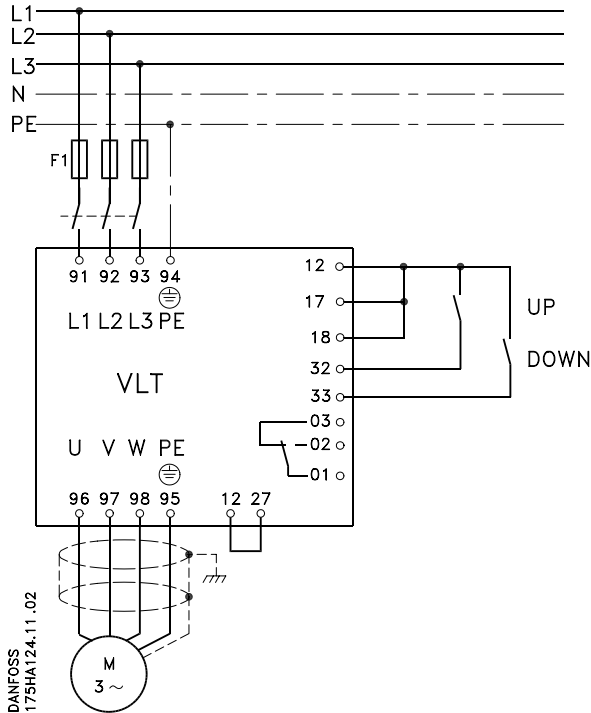

NB: Screen for control cables must be connected as described in the chapter on EMC-correct installation.

All settings are based on factory settings, but motor data (parameters 103-105) must be set according to the motor connected

Digital speed up and down

Relay output:

Indication that the output frequency is outside the range 10-45 Hz.

The following must be programmed:

Function	Parameter no.	Parameter value
Speed up and down	401	freeze reference
Speed up and down	406	speed up/down
Frequency warning on relay	409	Frequency too low
Frequency too low	210(F. low)	10 Hz
Frequency too high	211(F. high)	45 Hz

Warning: On power-up the motor will restart at the last speed that was maintained for 20 sec.

Connection examples

Example 6:

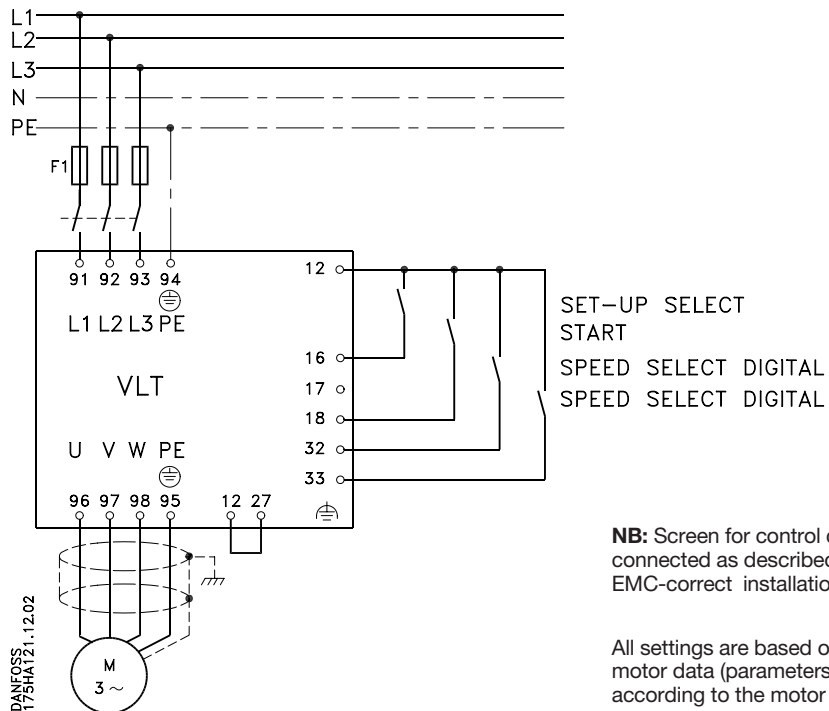

6 fixed speeds, max. speed 60 Hz
 1 speed = 6 Hz (10%), 2 speeds = 12 Hz (20%),
 3 speeds = 18 Hz (30%), 4 speeds = 24 Hz (40%),
 5 speeds = 42 Hz (70%), 6 speeds = 60 Hz (100%)

The following must be programmed:

Function	Parameter no.	Parameter value
Setup selection	001	multi setup
Setup selection	400	setup selection
Speed selection	406	digital ref. selection
Select setup 1		
Max. frequency	202	60 Hz
Digital reference 1	205	10%
Digital reference 2	206	20%
Digital reference 3	207	30%
Digital reference 4	208	40%
Select setup 2		
Max. frequency	202	60 Hz
Digital reference 5	205	70%
Digital reference 6	205	100%

Connection examples

Example 7:

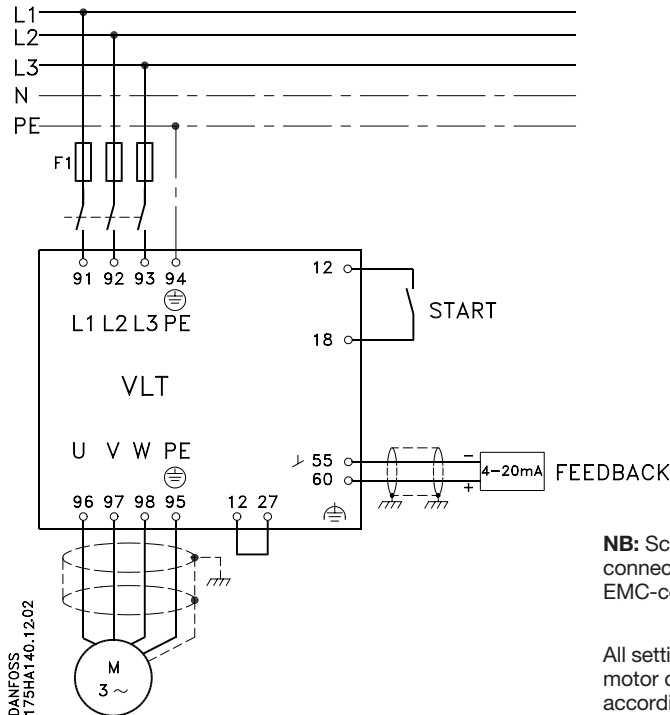

NB: Screen for control cables must be connected as described in the chapter on EMC-correct installation.

All settings are based on factory settings, but motor data (parameters 103-105) must be set according to the motor connected

Use of the VLT[®] frequency converter's internal PID regulator
with internal set-point (digital reference = 50%)
Feedback 0-10 bar ~ 4-20 mA
Min. speed = 10 Hz
Max. speed = 50 Hz

The following must be programmed:

Function	Parameter no.	Parameter value
Activation of PID regulator	101	closed loop
Internal setpoint	205	50 %
Feedback type	114	current
Current signal	413	4-20 mA
Min. speed	201	10 Hz
Max. speed	202	50 Hz
Regulator range	120	Depends on application
Proportional amplification	121	Depends on application
Integration time	122	Depends on application
Differentiation time	123	Depends on application

Connection examples

Example 7:

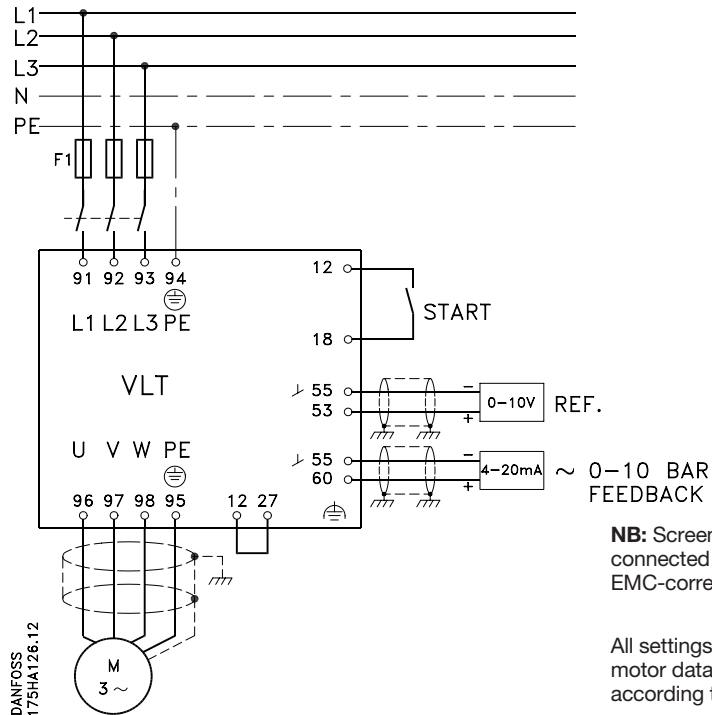

Use of the VLT® frequency converter's internal PID regulator
 with external set-point (0-10 V)
 Feedback 0-10 bar ~ 4-20 mA
 Min. speed = 10 Hz
 Max. speed = 50 Hz

The following must be programmed:

Function	Parameter no.	Parameter value
Activation of PID regulator	101	closed loop
Feedback type	114	current
Current signal	413	4-20 mA
Min. speed	201	10 Hz
Max. speed	202	50 Hz
Regulator range	120	Depends on application
Proportional amplification	121	Depends on application
Integration time	122	Depends on application
Differentiation time	123	Depends on application

Mechanical installation

Warning

The VLT® 3000 Series must always be attached to the wall or floor before further installation. This rule must be complied with, particularly with regard to the very heavy larger VLT® types, to avoid injury to people and equipment.

General

The VLT® 3000 Series is cooled by natural convection. Therefore air must be able to pass freely under and above the unit.

VLT® 3002-3052

This series must be installed on a flat surface so that the air flow can follow the cooling ribs right from the bottom of the VLT®. The VLT® with fixing holes in the side flanges can be installed with flange against flange. The VLT® without side flanges has fixing holes in top and base (IP 20) and can be installed without side spacing. See also section on cooling.

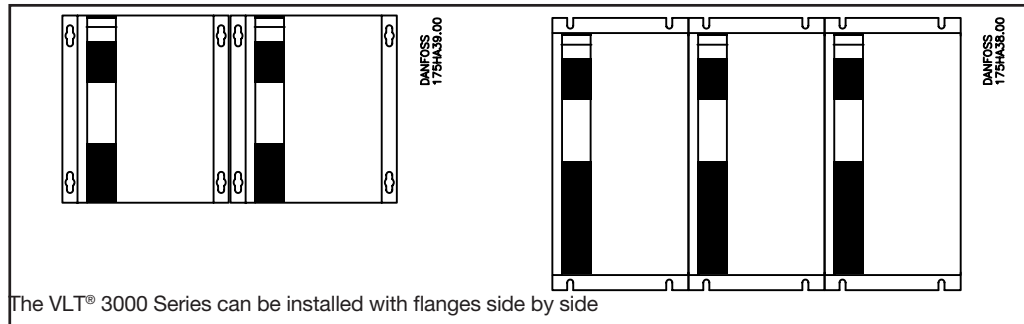

The VLT® 3000 Series can be installed with flanges side by side

VLT® 3060-3250

VLT® 3060-3150 is supplied with a mounting console placed behind the VLT®. This console also serves as an air channel for the cooling ribs, and on operation the console must be mounted on the VLT®.

The console does not have to be dismantled for installation, but it can be removed temporarily by loosening the connecting bolts from the inside of the VLT®.

Remember to attach the console again. Otherwise there is great danger of cut-out due to overheating.

The 4 drop-shaped holes in the mounting console make it possible to attach the fixing bolts to the wall or in the panel before suspension of the VLT®.

The fixing bolts will be accessible through the top and bottom of the console to facilitate tightening.

VLT® 3060-3075 is only for wall installation.

VLT® 3100-3150 is supplied for wall installation as standard.

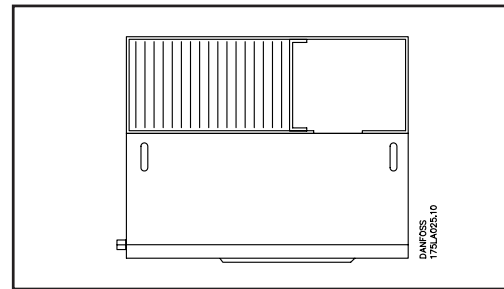

Base VLT® 3100-3250

As an option for VLT® 3100-3150 a base for floor installation can be supplied (code nr. 175L3047).

VLT® 3200-3250 is only intended for floor installation, and the base is therefore supplied as part of the VLT®. The base must be attached to the floor using 4 bolts before installation of the VLT®. The front panel of the base is unscrewed so that the VLT® can be secured through the 4 top holes in the base.

See also section on cooling.

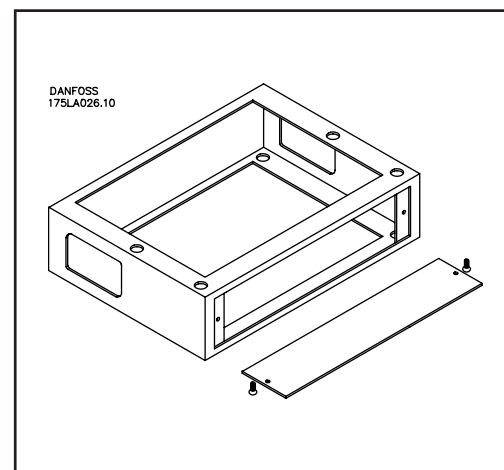

Mechanical installation

The drawing shows the base and its dimensions.

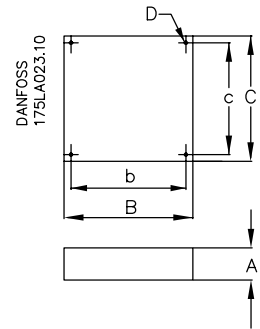

VLT® type	3100-3150	3200-3250
A [mm]	127	127
B [mm]	495	495
C [mm]	361	495
D [mm]	4 x 12.7	4 x 12.7
b [mm]	445	445
c [mm]	310	445

The bases for VLT® and options have been updated to match VLT® 3100-3250 with the removable plate in the bottom. Note that the ventilation slots have been replaced with two apertures in the sides. When a base is also used for the mounting console and RFI in IP 54 enclosure, remember to match up the ventilation apertures.

The new base design can be used with

previous versions of VLT® 3100-3250 units, but never use the previous base design for the VLT® units with the removable base plate.

Base seen from side:

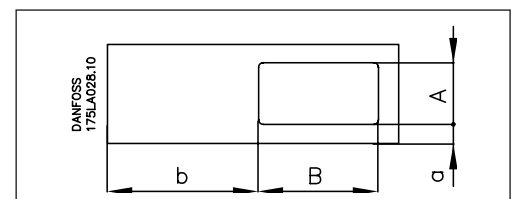

Base:

VLT® type	3100-3150	3200-3250
A [mm]	76	100
B [mm]	151	176
a [mm]	23	10
b [mm]	191	287

Base for mounting console and IP 54, RFI module:

VLT® type	3100-3150	3200-3250
A [mm]	79	102
B [mm]	153	178
a [mm]	23	10
b [mm]	191	287

Mechanical installation

VLT® 3032-3052, 230 V, VLT® 3060-3250

The front door to VLT® 3032-3052, 230 V, and VLT® 3060-3250 has hinges on the left-hand side.

The table below shows the door radius and the distance necessary from the installation surface to be able to open the door without difficulty.

VLT-type	3032-52, 230 V,		3100	3125	3150	3200	3250
	3060	3075					
C [mm]	846	846	894	894	894	1008	1008
R [mm]	505	505	513	513	513	513	513

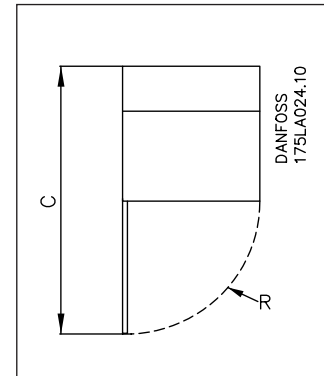

Cable access:

VLT® types 3002-3008, 400/500 V, and VLT® 3002-3004, 200 V, with IP 54 enclosure have a plastic base with holes marked for cable unions.

Note that for the above VLT®s for 200 V and 500 V (UL-approved) a metallic bonding plate is included in the plastic base. The metal plate is used to terminate cable conductor or armouring. See the information on p. 148 concerning connection of the bonding plate when IP 00 VLT®s are converted to IP 21 enclosure with UL approval.

The cable unions mechanically support the cables for IP 21/54 enclosure. For the IP 00 version, the cables must be relieved by other means (cable stirrups). The cables end in removable plugs.

VLT® 3011-3052, 400/500 V, and VLT® 3006-3022, 200 V, have a metal base with cut-outs for cable lead-through.

The bottom of the VLT® types 3032-3052, 230 V, and VLT® types 3060-3250 has a plate mounted with 6 cross-head screws. The plate can be removed to ease installation of the cable unions. After cable lead-through has been completed, the plate must be screwed back in place to ensure correct IP enclosure grade and cooling.

It is recommended that the cables be lead through the base, but the sides can also be used.

The plate in the right-hand side of the VLT® enclosure can be removed, and the hole can be used for cable lead-through if an extra enclosure or an IP 54 RFI module is required. If one of these modules is to be used, the right-hand side of the VLT® enclosure may not be bored for other cables.

The VLT® enclosure is made of steel. To avoid metal flakes flying into the VLT®s electronics, cable holes should not be bored until the unit has been vertically installed.

The drawing below shows the VLT® types 3060-3250 seen from the bottom with the removable base plate.

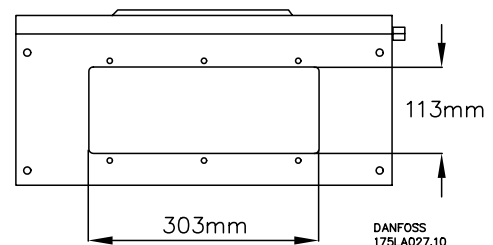

Mechanical installation

Cooling

To enable the VLT® to get rid of the cooling air, there must be a free air space both above and below the VLT®. The minimum spacing requirements depend on the VLT® type and enclosure.

See the dimensioning tables. The following applies to VLT® types 3002-3052:

Model 3002-3052

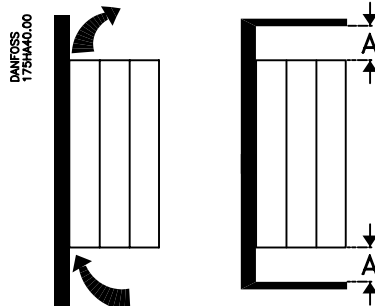

Enclosure grade	A
IP 00	100 mm
IP 21	100 mm
IP 20	200 mm
IP 54	150 mm

The following applies to VLT® types 3060-3150 with wall installation:

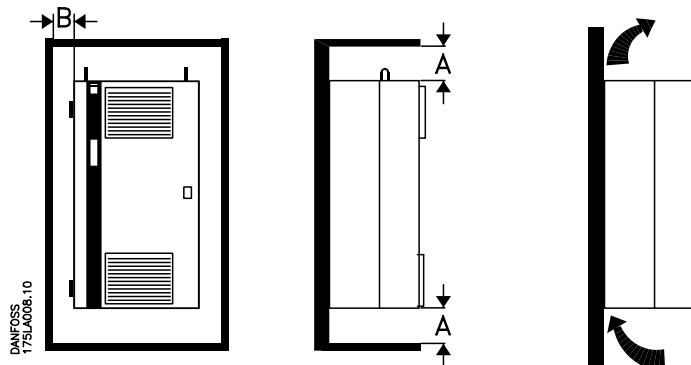

Note that the VLT®s can be installed without side spacing, but it must be possible to move the hinges freely.

Model	A	B
3060-3075	170	25
3100-3150	230	25

The following applies to VLT® types 3100-3250 with floor installation:

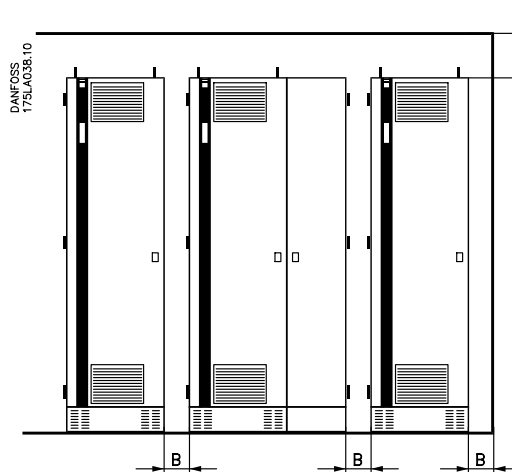

Model	A	B
3100-3150	230	130
3200-3250	260	130

Note! The side spacing to the next VLT® must be 130 mm due to the base's air intake on the side. VLT® types 3060-3250 are equipped with a fan in the front door to cool the internal components. A distance permitting free opening of the door is sufficient in front of the VLT®. See the section: "Door radius VLT® 3060-3250".

Mechanical installation

Heat emission from the VLT® 3000

The tables on pp. 25-29 show the output loss P_2 (W) from the VLT® 3000. The maximum cooling air temperature $t_{IN,MAX}$ is 40° C at 100% load (of rated value).

Ventilation of VLT® units when panel-mounted

The quantity of air needed to cool the VLT® frequency converters can be calculated as follows:

1. Add up the values of P_ϕ for all the VLT®'s to be installed in the same panel.

The highest cooling air temperature (t_{IN}) occurring must be lower than $t_{IN,MAX}$ (40° C).

The day/night average must be 5° C lower (VDE 160).

The outlet temperature of the cooling air may not exceed: $t_{OUT,MAX}$ (45° C).

2. Calculate the permitted temperature difference between the cooling air temperature (t_{IN}) and the cooling air outlet temperature (t_{OUT}): $\Delta t = 45^\circ\text{C} - t_{IN}$

3. Calculate the necessary quantity of air in $\text{m}^3/\text{h} =$

$$\frac{\sum P_\phi \times 3.1}{\Delta t} \quad \text{Insert } \Delta t \text{ in Kelvin}$$

The outlet from the fan must be located above the highest mounted frequency converter.

Remember to take pressure drops over filters into account and that the pressure decreases as the filters are choked.

Example:

The total output loss and the total air requirement at 100% load for 8 VLT® type 3006 units mounted in the same panel.

Cooling air temperature (t_{IN}) = 40° C and max. cooling air outlet temperature ($t_{OUT,MAX}$) = 45° C.

$P_\phi = 280 \text{ W}$ and $t_{IN,MAX} = 40^\circ\text{C}$.

1. $\sum P_\phi = 8 \times P_\phi \text{ W} = t_{IN,MAX} = 2240 \text{ W}$.

2. $\Delta t = 45^\circ\text{C} - t_{IN} = 45^\circ\text{C} - 40^\circ\text{C} = 5^\circ\text{K}$.

2. Quantity of air (at 40° C) =

$$\frac{2240 \times 3.1}{5} = 1388 \text{ m}^3/\text{h}$$

Electrical installation

Warning	<p>The VLT®'s voltage is dangerous when it is connected to the mains supply and for up to 14 minutes after disconnection of the VLT®. Electrical installation may therefore only be carried out by an authorized technician.</p>	<p>Incorrect installation of the motor or VLT® can damage equipment and cause serious injury or death. Therefore comply with the instructions in this manual, as well as local and national safety regulations.</p> <p>Note: It is the responsibility of the user or technician to ensure correct earthing and protection according to current local and national standards.</p>
Pre-fuses	<p>For VLT® types 3002-3052, external pre-fuses must be installed in the current supply to the frequency converter. The technical data section on pp. 23-27 states correct size and dimensioning.</p>	<p>For VLT® types 3032-3052, 230 V, and VLT® types 3060-3250, pre-fuses are included in the VLT®'s mains connection.</p>
General	<p>The terminals for the 3-phase supply and the motor are placed in the lowest section of the VLT®'s enclosure.</p> <p>The motor cable's screen is connected to both the VLT® and the motor. The VLT® has been tested with a given length of screened cable and a particular cross-section. If the cross-section is increased, the capacitance leakage of the cable increases and thereby the discharge current. The length must be reduced</p>	<p>proportionally. The electronic thermal relay (ETR) in UL-approved VLT® frequency converters is UL-approved for single-motor application when parameter 315 is set at trip, parameter 311 at "0 sec." and parameter 107 programmed for the motor's nominal current (read on the motor's type plate).</p>
High voltage test	<p>A high voltage test can be performed by short-circuiting terminals U, V, W, L₁, L₂, L₃, and impressing 2.5 kW D.C. for 1 second between this short circuit and the chassis.</p> <p>After the high voltage test, the filter condensers should be discharged using a resistor of e.g. 100 ohm, 1/4 W- 1/2 W.</p>	<p>The resistors is placed between +D.C. bus to the chassis and -D.C. bus to the chassis, for a few seconds.</p>
Extra protection	<p>Error voltage relays, or neutral earthing, current in the discharged current.</p> <p>Any ELCB relays used must comply with local regulations.</p> <p>The relays must be suitable to protect 3-phase equipment with bridge rectifier and short discharge on power-up.</p> <p>See also the section on discharge currents on p. 128.</p>	

Connection of VLT®

Mains and motor connection for VLT® types 3002-3052

The max. cable cross-section and equivalent max. length and terminal size are shown in the technical data section, pp. 25-29.

The mains supply and the motor are connected in accordance with the drawing below.

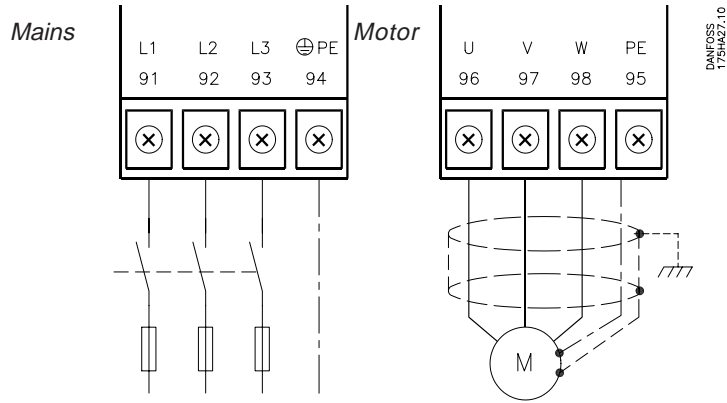

Connection of VLT®

Mains and motor connection for VLT® types 3032-3052, 230 V, and VLT® types 3060-3075

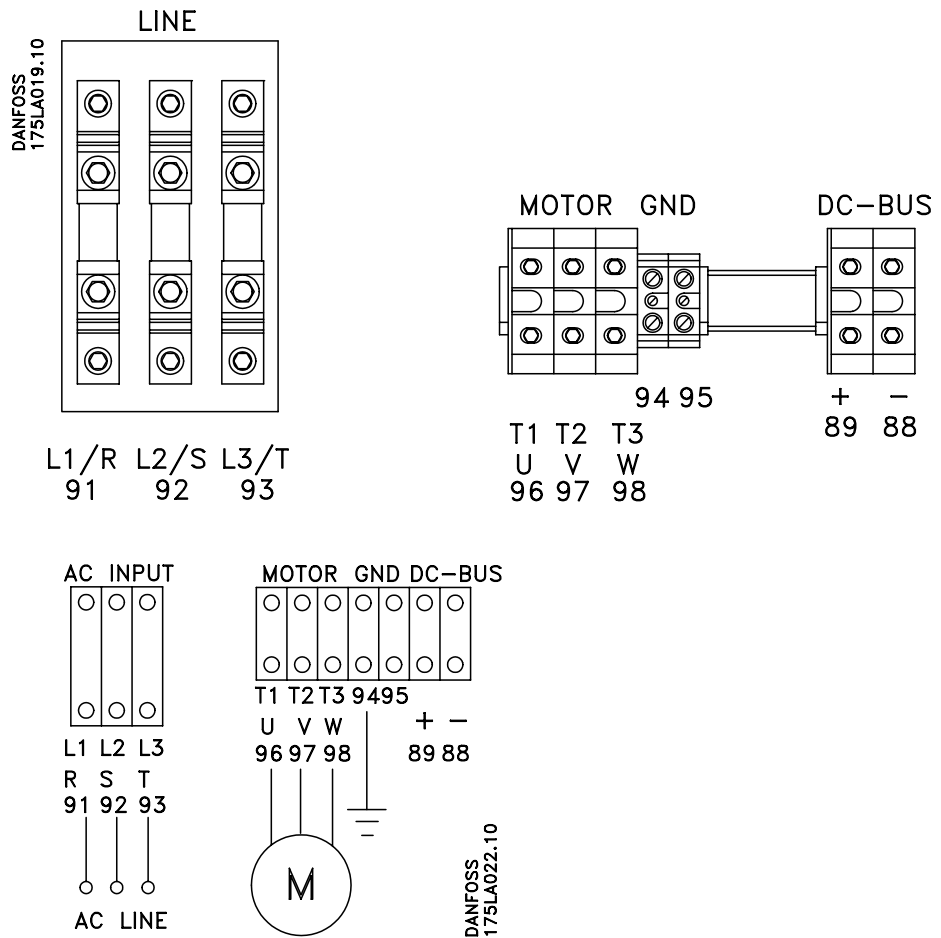

	VLT® type	3032-3052, 230 V, 3060-3075
Input	Cable sizes	See technical data
	Cable end, type	Screw terminal
	Terminal torque [Nm]	31.1
Motor	Cable sizes	See technical data
	Cable end, type	M6 Bolt
	Terminal torque [Nm]	6
Fuses*	Bussmann type	JJS 150 150 A/600 V

*) **Note:** With the above fuses, VLT® types 3060-3075 have a short-circuiting capacity of 100,000 A.

Connection of VLT®

Mains and motor connection for VLT® types 3100-3150

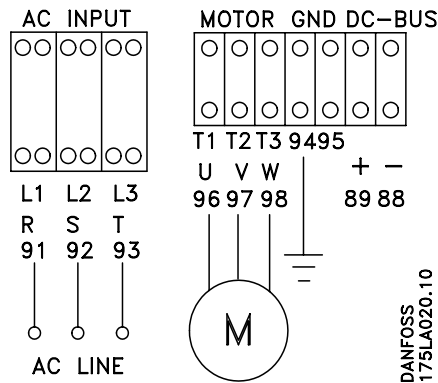
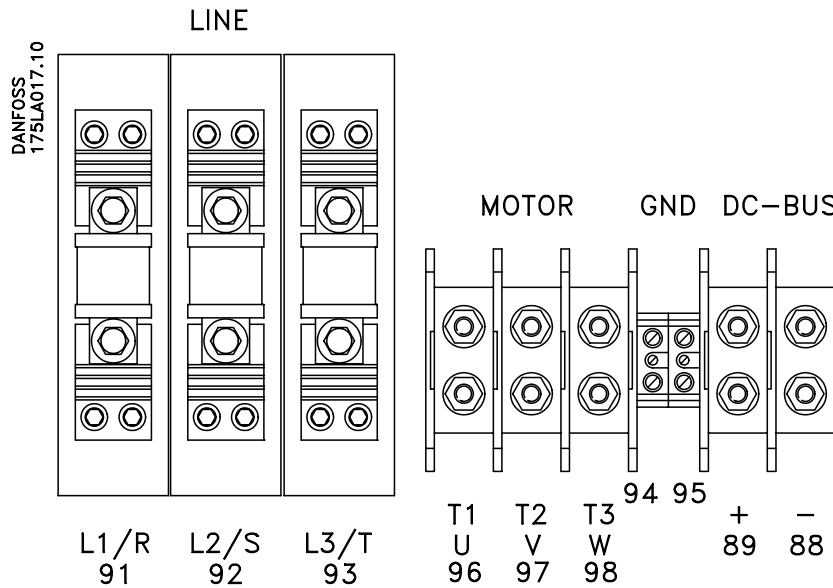

	VLT® type	3100	3125	3150
Input	Cable sizes	See technical data	See technical data	See technical data
	Cable end, type	Screw terminal	Screw terminal	Screw terminal
	Terminal torque [Nm]	31.1	31.1	31.1
Motor	Cable sizes	See technical data	See technical data	See technical data
	Cable end, type	M10 Bolt	M10 Bolt	M10 Bolt
	Terminal torque [Nm]	10	10	10
Fuses*	Bussmann type	JJS 250 250 A/600 V	JJS 250 250 A/600 V	JJS 300 300 A/600 V

*) **Note:** With the above fuses, VLT® types 3100-3150 have a short-circuiting capacity of 100,000 A.

Connection of VLT®

Mains and motor connection for VLT® types 3200-3250

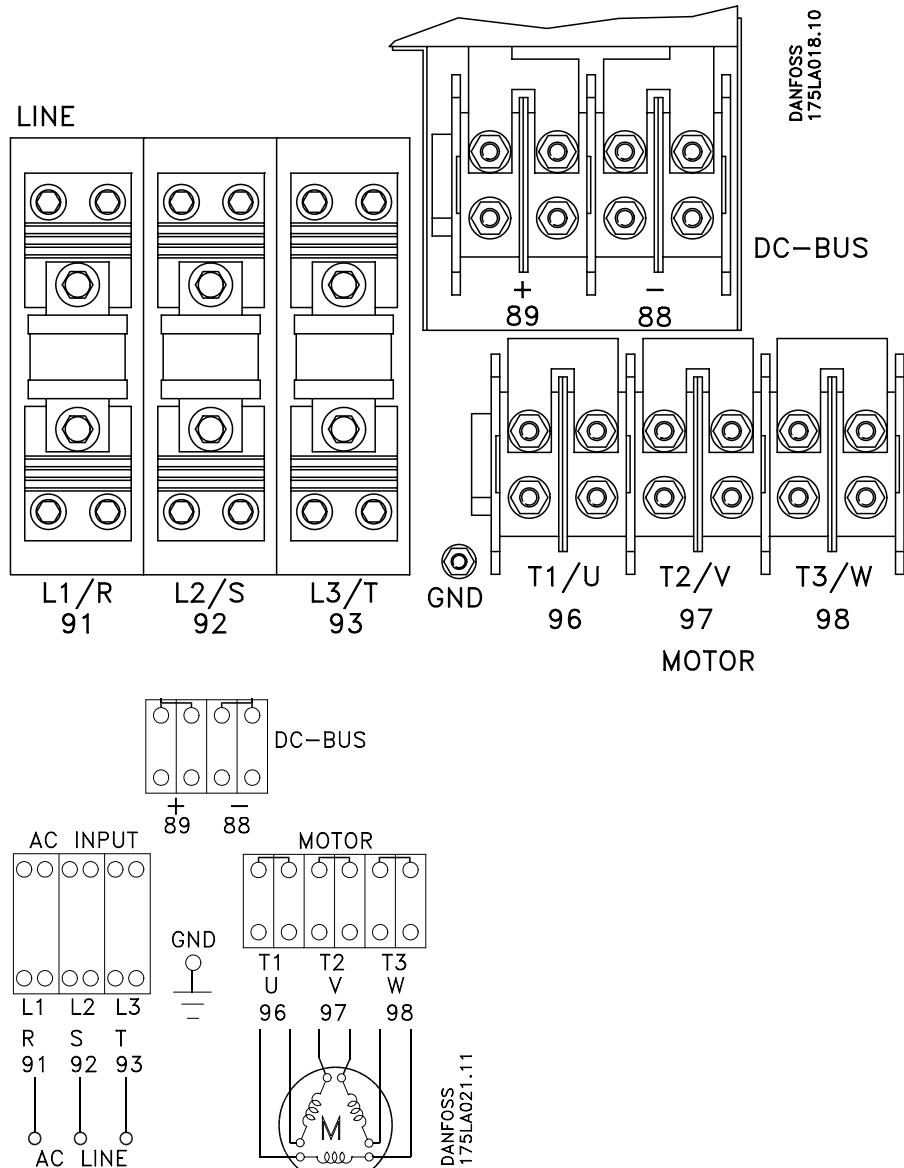

	VLT® type	3200	3250
Input	Cable sizes	See technical data	See technical data
	Cable end, type	Screw terminal	Screw terminal
	Terminal torque [Nm]	42	42
Motor	Cable sizes	See technical data	See technical data
	Cable end, type	M8 Bolt	M8 Bolt
	Terminal torque [Nm]	6	6
Fuses*	Bussmann type	JJS 450 450 A/600 V	JJS 500 500 A/600 V

*) **Note:** With the above fuses, VLT® types 3100-3150 have a short-circuiting capacity of 100,000 A.

Connection of motor

Motor connection

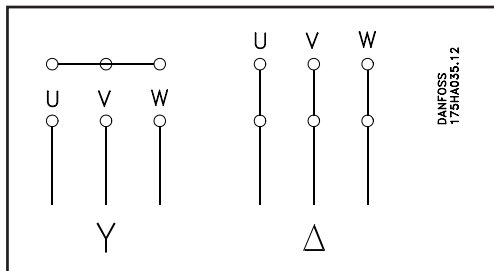

With the VLT® 3000 Series, all types of 3-phase asynchronous standard motors can be used.

In general, small motors (220/380 V, Δ/λ) are star-connected. Large motors are delta-connected (380/660 V, Δ/λ).

Direction of rotation

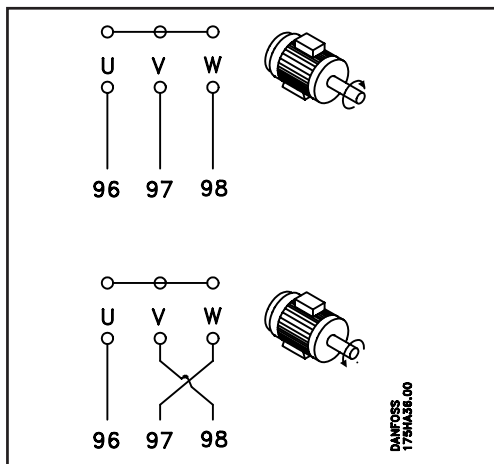

The factory setting will give clockwise rotation when the output of the VLT® 3000 Series is connected as follows:

Terminal 96 connected with U phase
Terminal 97 connected with V phase
Terminal 98 connected with W phase

The rotation direction can be changed by swapping the two motor cable phases.

With the VLT® 3000 Series controls, the rotation direction can also be changed using the “reverse” function.

Parallel connection of motors

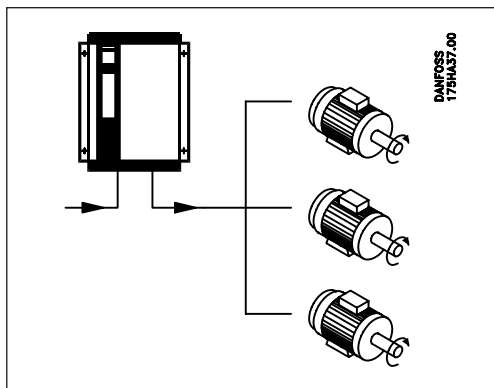

VLT® 3000 Series can control several motors connected in parallel. If the motor speeds must be different, motors of different rated speeds must be applied. The motor speed can be changed simultaneously and the ratio between the rated motor speeds is maintained in the whole range.

The total current consumed by the motors may not exceed the maximum rated output current $I_{VLT,N}$ of the VLT® 3000 Series.

If motor sizes deviate considerably, problems may arise during start and at low speed. This is due to the fact that small motors have a relatively high ohmic resistance in the stator, and therefore they require more start voltage during start and at low speed.

In systems with parallel motor operation, the internal overcurrent protection cannot be used as motor protection for the individual motor, since the output current must be programmed for the total motor current. Additional motor protection should therefore be used, e.g. thermistors in each motor (or individual thermal relay).

EMC installation

What is CE-labelling?

The purpose of CE-labelling is to avoid technical obstacles to trade within EFTA and the EU. The EU has introduced the CE-label as a simple way of showing whether a product complies with the

relevant EU directives. The CE-label says nothing about the quality or specifications of a product. Three EU directives relate to frequency converters:

The machine directive (89/392/EEC)

All machines with critical, moving parts are comprised by the machine directive which came into force on 1 January 1995. Since a frequency converter is largely electrical by function, it does not fall under the

machine directive. However, if a frequency converter is supplied for use in a machine, we provide information about the safety aspects relating to the frequency converter. We do that by means of a manufacturer's declaration.

The low-voltage directive (73/23/EEC)

Frequency converters must be CE-labelled in accordance with the low-voltage directive, which will come into force on 1 January 1997.

This directive applies to all electrical equipment and appliances used in the voltage range of 50-1000 VAC and 75-1500 VDC.

The EMC directive (89/336/EEC)

EMC is short for electromagnetic compatibility. The presence of electromagnetic compatibility means that the mutual interference between different components/appliances is so small that the

functioning of the appliances is not affected. The EMC directive comes into force on 1 January 1996. The directive distinguishes between components, appliances, systems and installations.

The EU "Guidelines on the Application of Council Directive 89/336/EEC" outline four typical situations of using a frequency converter. For each of these situations, explanations are offered as to whether the situation in question is covered by the EMC directive and must be CE-labelled.

1. The frequency converter is sold direct to the end-user. This applies for example if the frequency converter is sold to a DIY-market. The end-user is not an expert. He installs the frequency converter himself, e.g. for controlling a hobby machine or a domestic appliance. This frequency converter must be CE-labelled in accordance with the EMC directive.
2. The frequency converter is intended for use in a complete product. It is sold e.g. to a professional machine builder who has the technical knowledge it takes to install the frequency converter correctly. The frequency converter need not be CE-labelled in accordance with the EMC directive. Instead, the frequency converter manufacturer must be provide detailed guidelines on how to carry out an EMC-correct installation.

3. The frequency converter is intended for use in an installation built up on the site of use by a professional. This could be e.g. a complete installation for manufacturing purposes or for the generation of heat/ventilation. The installation is planned and made by a professional installation builder. The complete system is not to be CE-labelled in accordance with the EMC directive. The system must comply with the basic requirements contained in the directive. This is ensured by using components, appliances and systems which are CE-labelled in accordance with the EMC directive.
4. The frequency converter is sold as part of a complete system, such as an air-conditioning system. The complete system must be CE-labelled in accordance with the EMC directive.

EMC installation

Danfoss VLT® frequency converter and CE-labelling

CE-labelling is a positive feature when used for its original purpose, i.e. to facilitate trade within the EU and EFTA.

However, CE-labelling may cover many different specifications. This means that it has to be checked what a given CE-label specifically covers.

The specifications covered can in fact be widely different. That is why the CE-label can give installers a false feeling of security when using a frequency converter as a component in a system or an appliance.

We CE-label our VLT frequency converters in accordance with the low-voltage directive. This means that as long as the frequency converter is installed correctly, we guarantee that it complies with the low-voltage directive. We issue a declaration of conformity confirming that our CE-label complies with the low-voltage directive.

The CE-label also applies to the EMC directive on the condition that the EMC-correct installation and filtering instructions in the manual have been followed. On this basis a conformity declaration is issued in accordance with the EMC directive.

To help ensure that your installation is EMC-correct, the manual provides detailed instructions for installation. Furthermore, we specify which norms that are complied with by our products.

We offer the filters that meet the specifications and can gladly provide other types of assistance that can help you obtain the best possible EMC result.

EMC installation

Compliance with EMC directive 89/336/EEC

In support of our claim that the VLT[®] frequency converter complies with the protection requirements for emission and immunity under EMC directive 89/336/EEC, a Technical Construction File (TCF) has been prepared for each model. Such a file defines the EMC requirements and the measurements made in accordance with harmonised EMC standards in a Power Drive System (PDS) that consists of a VLT[®] frequency converter, a control cable and the controls (control box), motor cable and motor plus any options added. The Technical Construction File is prepared on this basis in cooperation with an authorised EMC laboratory (Competent Body).

In most cases the VLT frequency converter is used by professionals of the trade as a complex component forming part of a larger appliance, system or installation. It must be noted that the responsibility for the final EMC properties of the appliance, system or installation rests with the fitter. As an aid to the fitter, Danfoss has prepared EMC installation guidelines for the Power Drive System. The standards and testing levels stated for the Power Drive System are complied with, provided that the EMC-correct installation guidelines are applied.

Earthing

The following basic issues need to be considered when installing a frequency converter, so as to obtain electromagnetic compatibility (EMC).

Safety earthing:

Please note: The frequency converter has a high leakage current and must be earthed appropriately for safety reasons. Apply local safety regulations.

High-frequency earthing:

Keep the earth wire connections as short as possible.

Connect the different earth systems at the lowest possible conductor impedance. The lowest possible conductor impedance is obtained by keeping the conductor as short as possible and by using the greatest possible surface area. A flat conductor,

for example, has a lower HF impedance than a round conductor for the same conductor square value.

If more than one appliance is installed in cabinets, the cabinet rear plate, which must be made of metal, should be used as a common earth reference plate. The metal cabinets of the different appliances are mounted on the cabinet rear plate using the lowest possible HF impedance. This avoids having different HF voltages for the individual appliances and avoids the risk of radio interference currents running in connection cables that may be used between the appliances.

In order to obtain a low HF impedance, use the fastening bolts of the appliances as HF connection to the rear plate. It is necessary to remove insulating paint or similar from the fastening points.

Cables

The control cable and the filtered mains cable should be installed separately from the motor and brake cables to prevent interference coupling. Normally, a distance of 20 cm will be sufficient, but it is recommended to keep the greatest possible distance wherever possible, especially where cables are installed in parallel over a substantial distance. (Separation should increase in proportion).

With respect to sensitive signal cables, such as telephone cables and data cables, the greatest possible distance is recommended with a minimum of 1 m per 5 m of power cable (mains, motor and brake cable). It must be pointed out that the

necessary distance depends on the sensitivity of the installation and the signal cables, and that therefore no precise values can be stated.

If cable clamps are used, sensitive signal cables are not to be placed in the same cable clamps as the motor cable or brake cable.

If signal cables are to cross power cables, this should be done at an angle of 90 degrees.

Remember that all noisy in- or outgoing cables to/from a cabinet should be screened or filtered.

Screened cables

The screen must be a low HF-impedance screen. This is ensured by using a braided screen of copper, aluminium or iron.

Screen armour intended for mechanical protection, for example, is not suitable for an EMC-correct installation.

EMC installation

Radio interference in general

Electrical interference from the cable network, cable-borne interference, 150 kHz-30 MHz, and airborne interference from the drive system, 30 MHz-1 GHz, is for frequencies under approx. 50 MHz produced in particular by the inverter, the motor cable and the motor system.

As the sketch below shows, capacitive currents in the motor cable together with high du/dt from the motor voltage will produce interference.

Use of screened motor cable increases the leakage current I_1 (see fig. below). This is because screened cables have higher capacitance to earth than unscreened cables. If the leakage current is not filtered, it will cause greater interference on the mains in the radio leakage range under approx. 5 MHz. Since the leakage current I_1 is carried back to units through the screen (I_4), in principle this will give only a small electromagnetic field from the screened motor cable, according to the figure below.

The screen reduces the radiated interference, but increases the low frequency interference on the mains. With a mains filter, the interference level on the mains will be reduced to around the same level for both screened and unscreened cables.

The motor cable screen must be connected to the VLT®'s enclosure as well as the motor enclosure. The best way to do this is to use screen clamps to avoid unravelled screen ends. These increase the screen impedance at higher frequencies, which reduces the screen effect and increases the interference current (I_4).

When screened cable is used for PROFIBUS, control cable, signal interface and brake, the screen must be mounted on the enclosure at both ends. In certain situations, however, it will be necessary to break the screen to avoid current loops.

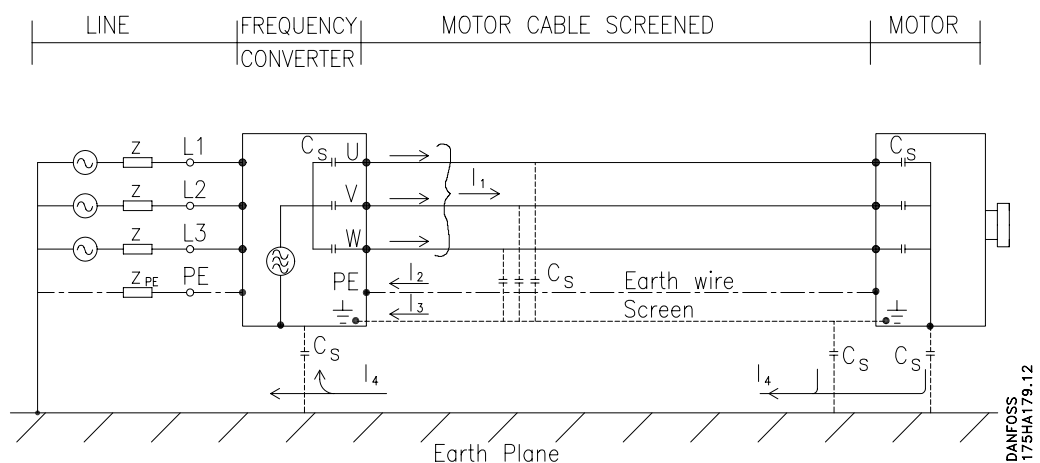

In cases where the screen must be placed on a mounting panel for the VLT® frequency converter, the mounting panel must be of metal because the screen currents must be led back to the unit. It is also important to ensure good electrical contact from the mounting screws through the mounting curve to the VLT® frequency converter.

With regard to installation, it is generally less complicated to use unscreened cables than screened cables. To observe the EN55011-1A requirements to radiated interference (30MHz-1GHz) a motor filter

must be installed when using unscreened cables.

In order to reduce the interference level from the system overall (unit + installation) as far as possible, it is important to make motor and brake cables as short as possible.

Cables with a sensitive signal level may not be led together with motor and brake cables.

Radio interference higher than 50 MHz (airborne) will be particularly affected by the control electronics.

EMC installation

Instructions for installation

Filtering

Electrical interference from the cable network - cable-borne as well as air-borne - can be prevented by using the correct filters. The filters or equivalent stated in the product programme must be installed, and when re-mounting, the filter installation instructions are to be observed.

VLT® 3002-3052

All models have filters for integration into/ mounting on the appliance itself. Some

models offer the feature of ordering the appliance with the filter already integrated. See the product range. In the case of subsequent installation, the instructions for installation of the filter must be complied with (see also the instructions for installation, item F).

VLT® 3060-3250

The filter is supplied as an IP54 option or an IP20 option that cannot be integrated in the appliance itself, but can be bolted directly on the side.

Mechanical installation

VLT® 3002-3008, IP00/IP21 enclosure

VLT® 3002-3008, IP00/IP21/IP54 enclosure with brake:

VLT® 3002 - VLT® 3008, IP00/IP21 enclosure and VLT® 3002-3008, IP00/IP21/IP54 enclosure with brake must always be installed against a conductive rear plate.

Install the metal cabinet of the VLT® frequency converter up against the rear plate. The rear plate must be electrically conductive and act as a common HF earth reference for the VLT® frequency converter, the RFI/brake module and any brake cables used. The VLT® frequency converter and the RFI/brake module must be installed with the lowest possible HF impedance to the rear plate. This can best be done through the fastening bolts for the enclosure (see instructions for installation, pp. 57-59, item A). Since the aluminium enclosure of the appliances is anodised and thus electrically insulating, toothed (serrated) washers should be used to penetrate the anodisation - or the anodised surface has to be removed. Remember also to remove any varnish or paint from the rear plate.

VLT® 3002-3008, IP54 enclosure without brake

VLT® 3011-3052, IP20/IP54 enclosure:

Appliances can be installed on an electrically conductive or a non-conductive rear plate, since the RFI filter can be or is integrated and the screen from control cables, motor cable and brake cable (not VLT® 3002-3008) can be terminated in the appliances (see instructions for installation, pp. 57-59, items B, C and D).

If an electrically conductive rear plate is used, the VLT® frequency converter must be installed with the lowest possible HF impedance to the rear plate, and the instructions for installation, pp. 57-59, items A, B, C, D and E, must be complied with.

If a non-conductive rear plate is used (i.e. in the case of installation directly against a brick wall), use the instructions for installation, pp. 57-59, items B, C and D.

VLT® 3032-3052 200V and

VLT® 3060-3250 380-500V, IP20 RFI option

See further examples of installation on page 59.

- The filter should be installed on the same panel as the frequency converter. The panel must be electrically conductive. Both the frequency converter and the filter must have a good high-frequency connection to the panel.
- The filter should be connected as close as possible to the frequency converter input, the maximum distance being 1 metre.
- The mains filter should be earthed at both ends.
- Before mounting the filter on the panel, remove any surface treatment, etc.

NB! The filter must be earthed before connection to mains.

VLT® 3032-3052 200V and

VLT® 3060-3250 380-500V, IP54 RFI module

See further examples of installation on page 59.

1. Remove the wire plate and the Philips screw in the right-hand side of the VLT® 3000 (save the screws for the wire plate for later use).
2. Place the IP54 RFI option in the right-hand side of the VLT® 3000.
3. Before fastening the RFI option to the VLT® 3000, place the accompanying gasket and mount it around the cable inlet to maintain the IP54 enclosure grade.
4. Fasten and earth the RFI module to the VLT® 3000 with 2 screws plus screw washers. With the RFI module door open, mount the two screws and fasten the module.
5. Use the screws from item 1) to fasten and seal off the wire inlet between the RFI option and the VLT® 3000.
6. Using the wire net supplied with the RFI option, connect the RFI filter to the VLT® 3000 AC mains input and earth.
7. Connect the AC mains input and earth to the terminals placed at the top of the RFI filter.

EMC installation

Motor cable

In order to comply with the EMC specifications concerning emission and immunity, the motor cable must be screened unless otherwise stated for the mains filter in question. It is important to keep the motor cable as short as possible so as to reduce the interference level and the leakage currents to a minimum.

The motor cable screen should be connected to the metal cabinet of the frequency converter and to the metal casing of the motor. Screen connections should be made using as large a surface as possible. (See the instructions for installation, pp. 57-59, item D). The motor cable

screen should basically not be broken and not be earthed in the process. If it becomes necessary to break the screen to install a motor isolator or motor relays, the screen should be continued at the lowest possible HF impedance.

Using filters 175H7083 and 175H7084, the VLT® 3002-3008 complies with EN55011-1A using an unscreened motor cable. In addition to reducing the mains interference, the filters also reduce the interference radiating from the unscreened motor cable. As far as the motor cable is concerned, only interference above 30MHz is reduced (see EN55011-1A).

Brake cables

If a brake module is used, the cable to the brake resistor must be screened. In the case of VLT 3002 - VLT 3008, connect the screen to the conductive rear plate, on which the VLT frequency converter has been mounted. If VLT 3011 - VLT 3052 are used, mount the screen by means of a

special union. In the case of VLT 3060 - VLT 3250, where the brake module is a separate module in its own casing, it is possible to use special unions or to terminate the screen in the conventional way. All sizes of unit require the screen to be connected to the brake resistor casing.

Control cables

Control cables should be screened. The screen should be connected using a clamp to the VLT® frequency converter base (see the instructions for installation, pp. 57-59, item C). Normally, the screen should also be connected to the base of the controlling appliance (follow the instructions for use of the appliance in question).

In connection with very long control cables and analogue signals, 50 Hz ripple loops may occur in rare cases, depending on the installation. This is because of interference coupling from the mains supply cables. In this connection it can be necessary to break the screen or possibly insert a 100 nF condenser between screen and base.

Cable for serial communication

The cable for serial communication should be screened.

The screen should be installed using a clamp on the VLT® frequency converter (see the instructions for installation, pp. 57-59, item B).

With regard to cable specifications and instructions for installation in general, reference is made to the PROFIBUS product manual.

Equalising currents

Efforts should be made to avoid possible equalising currents that may occur when the control cable screen is connected to the base (earthed) at both ends. Equalising currents occur because of voltage differences between the VLT® frequency converter base and the base of the con-

trolling appliance. They can be avoided by making a tight fit with the cabinet base rear plate, thereby ensuring that any equalising currents will run via the base rear plates and their joints, not via the cable screens.

EMC installation

VLT 3002-3008

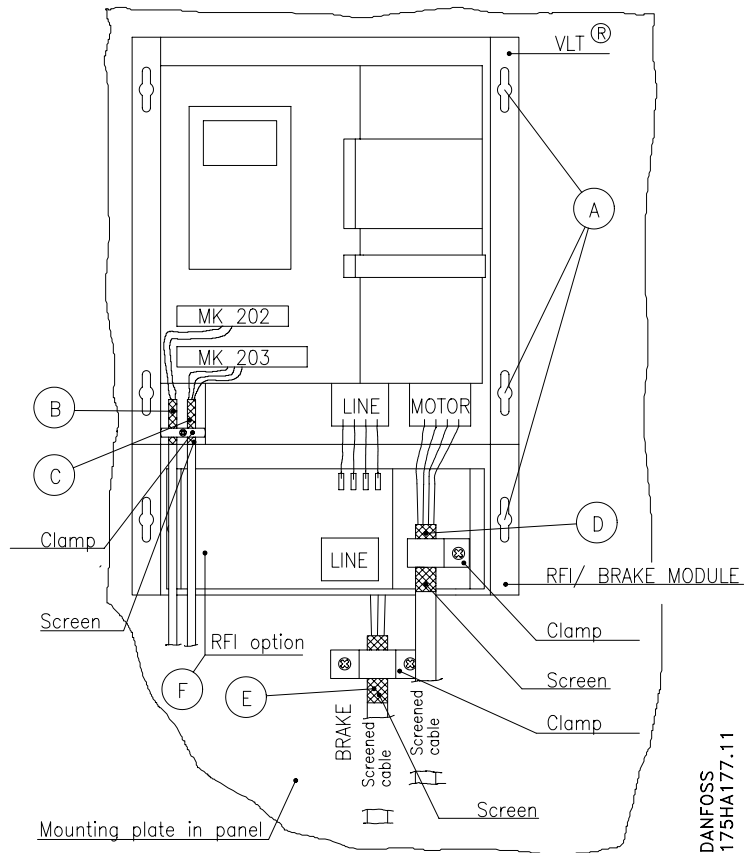

DANFOSS
175HA177.11

VLT 3011-3052

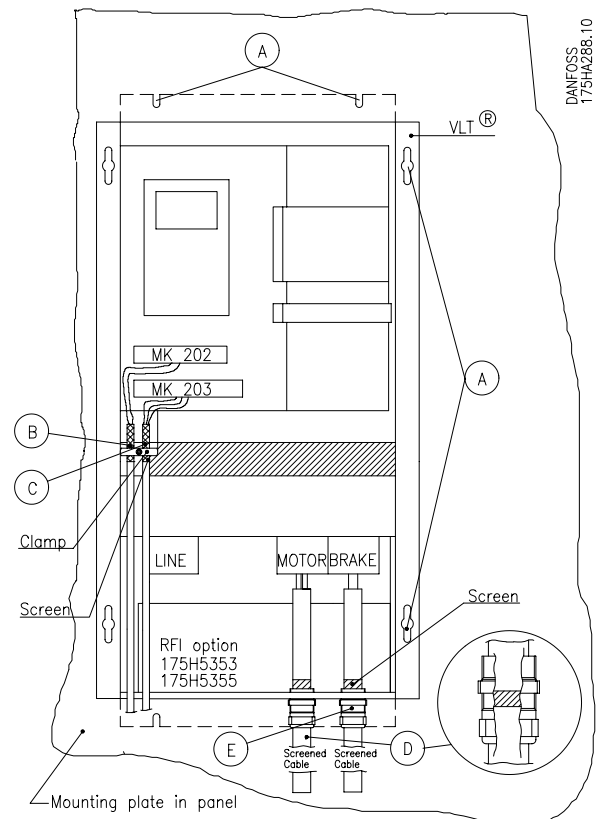

DANFOSS
175HA288.10

Hole size	Cable ø	Screen ø	Danfoss code No.
PG 21	17.0 - 20.0	12.5 - 17.5	175H2882
PG 29	22.0 - 26.0	15.0 - 21.0	175H2883
PG 36	30.0 - 32.0	24.0 - 30.0	175H2884

VLT 3060-3250

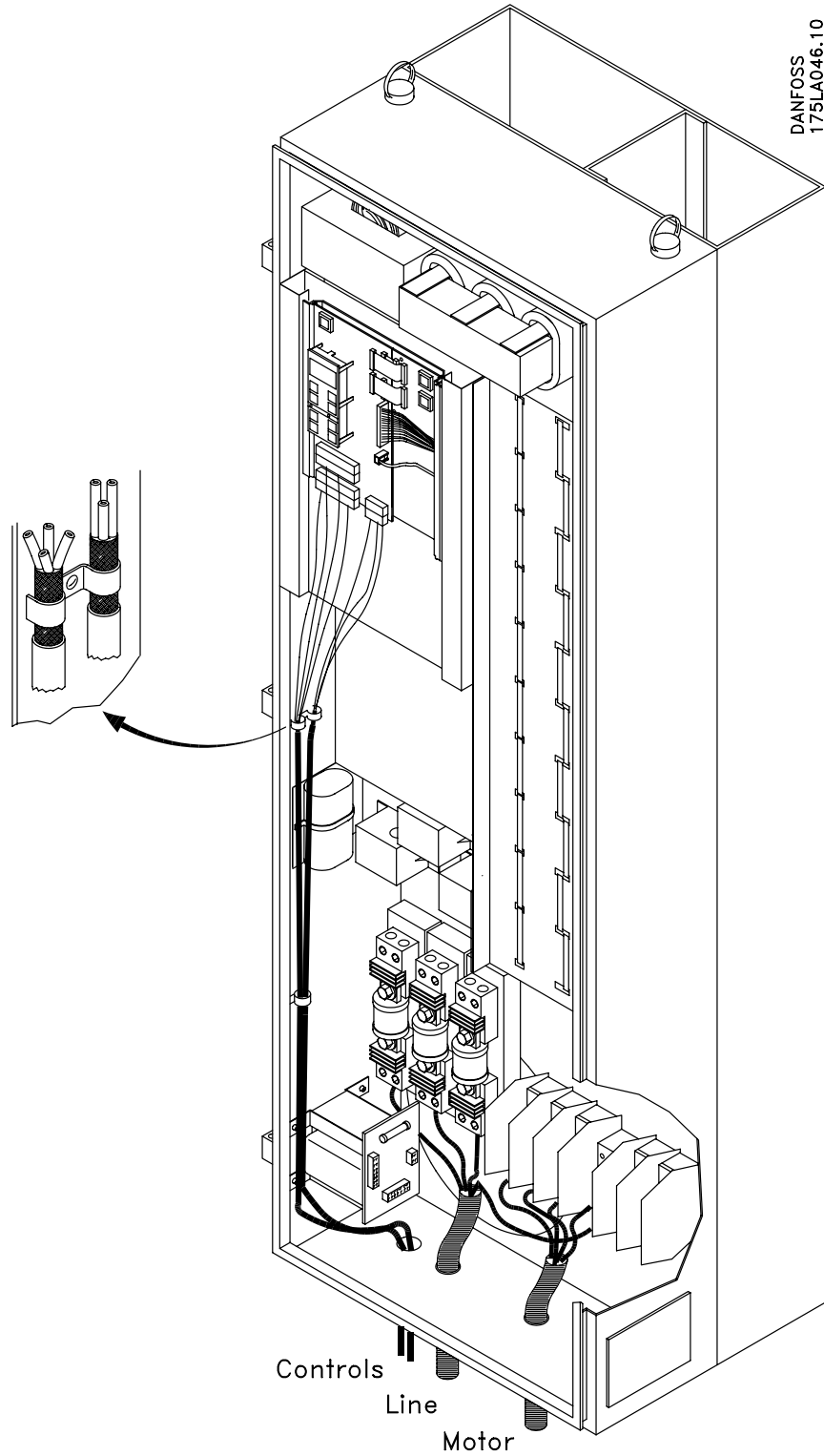

EMC installation

VLT 3032-3052 200V.
3060-3075 400/500V.

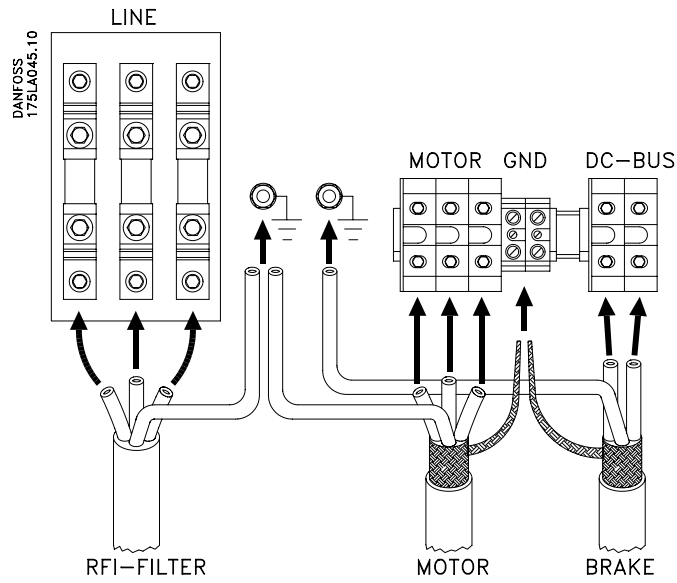

VLT 3100-3150

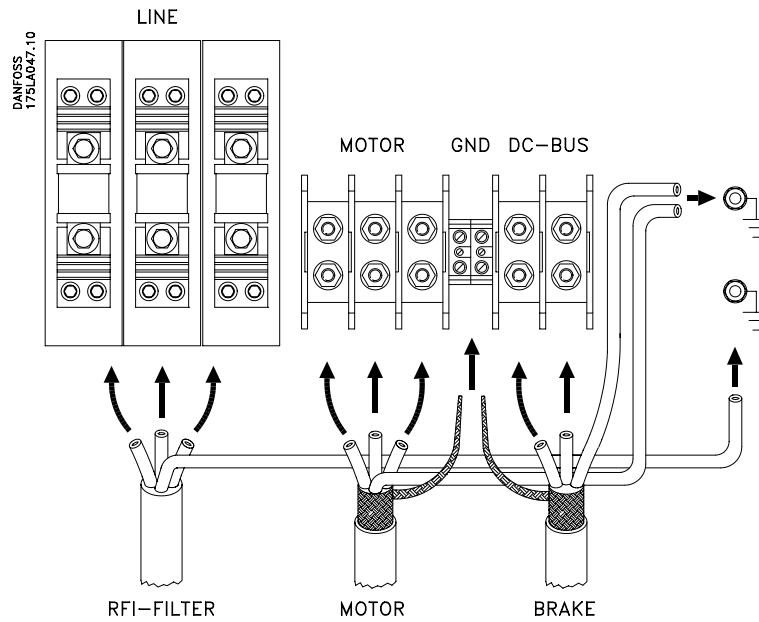

VLT 3200-3250

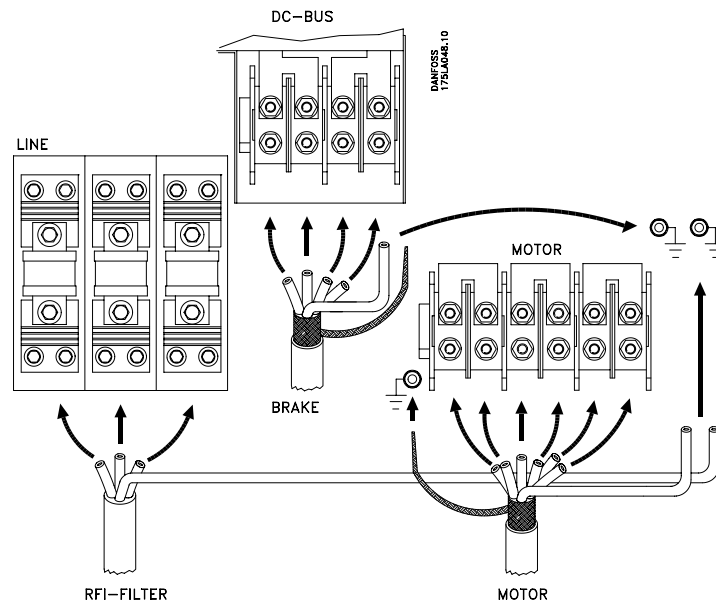

The control panel

Control panel

The control panel for programming and local control and information is placed on the front of the frequency converter. The control panel consists of a keyboard and a display.

The keyboard is used for two purposes: local operation and programming.

The display is used for communication between the frequency converter and the operator.

On the control panel you will see a red and a green LED.

When the green LED (On) lights up, there is voltage to the frequency converter.

The red LED (Alarm) is used for alarm indications.

In an ALARM MODE the LED will flash.

Using an optional adaptor and cable, the control panel can be mounted in a cabinet cover. The maximum distance between the frequency converter and the remote box is 3 m.

The enclosure of the adapter (front) is IP 54.

Minimum panel aperture: 112 x 51 mm ± 0.5 mm.

External mounting of the control panel (remote box)

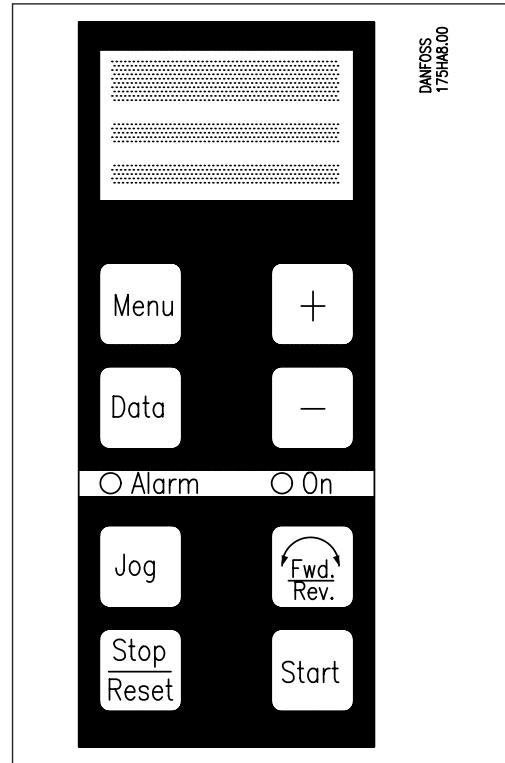

Keys for local operation

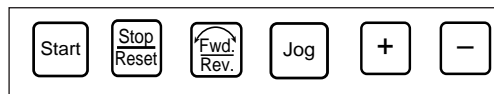

Parameters 003/004 are used for local reference setting.

is used to run the motor at a fixed pre-programmed frequency (parameter 203).

is used to change direction.

Note: For safety reasons the key can only be activated when the frequency converter is set for local operation (parameter 003), and the functions and must be selected in parameters 008 and 009.

In normal operation (in DISPLAY MODE)

and are used to scroll between 12 display read-outs:

- Reference %
- Frequency Hz
- Display / Feedback %
- Current A
- Torque %
- Power kW
- Power HP
- Energy kWh
- Motor voltage V
- D.C. voltage V
- Motor load therm. %
- Inverter load therm %

Keys for programming

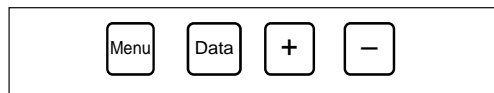

Programming is carried out by changing the data values of parameters grouped in a menu.

Some parameters can have different settings in four separate setup functions (parameter 001). See p. 81 for more information. is used to find (select) the parameter to be changed.

is used to enter MENU MODE from either DATA MODE or DISPLAY MODE.

is also used to enter a specific group of parameters.

is used to enter DATA MODE or DISPLAY MODE from MENU MODE. is also used to move the cursor between data values.

and are used to select a group of parameters, a specific parameter or a data value.

From any status you can enter DISPLAY MODE by pressing and at the same time.

Display layout

Different modes, different information

The display will give you different information, depending on the mode and the operation setting.

See the list of status, reset and alarm messages on **page 122**.

See the list of parameters on **pages 151-152**.

DISPLAY MODE

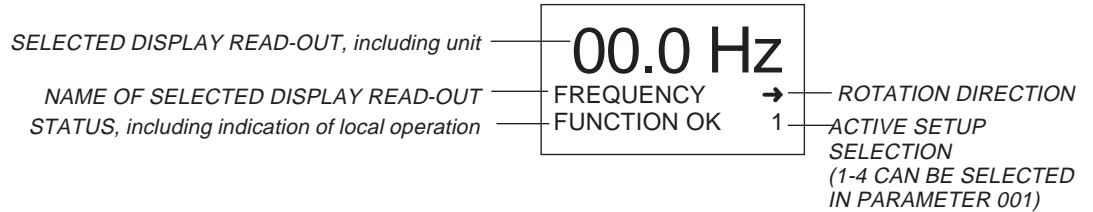

MENU MODE

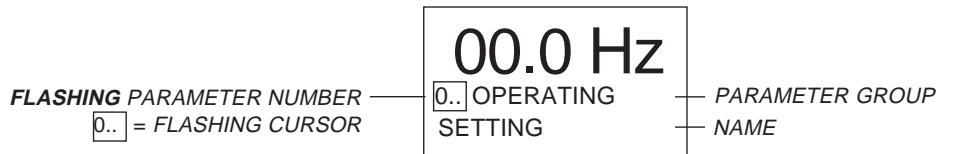

PARAMETER MODE

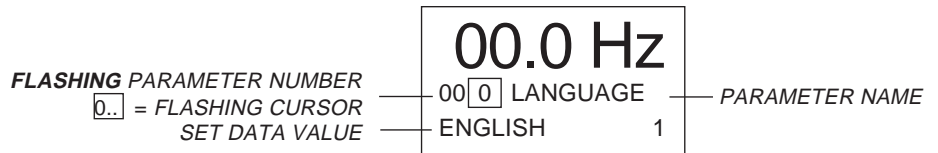

DATA MODE

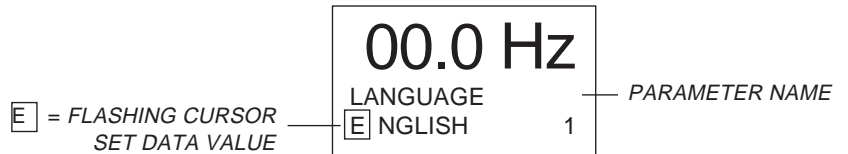

ALARM MODE

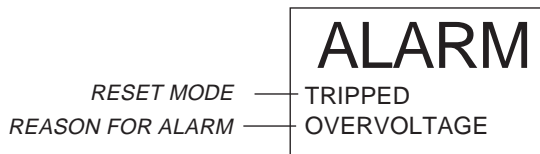

Display layout

How the display looks in the four modes

DANFOSS
175H4138.10

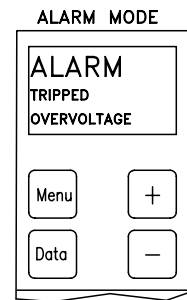
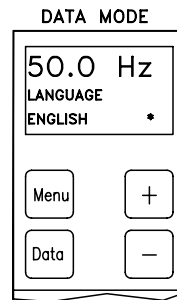
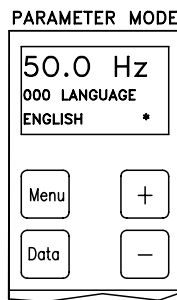
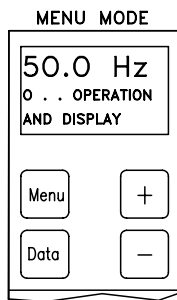
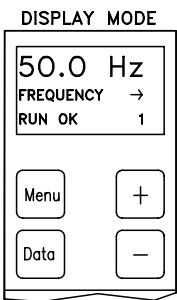
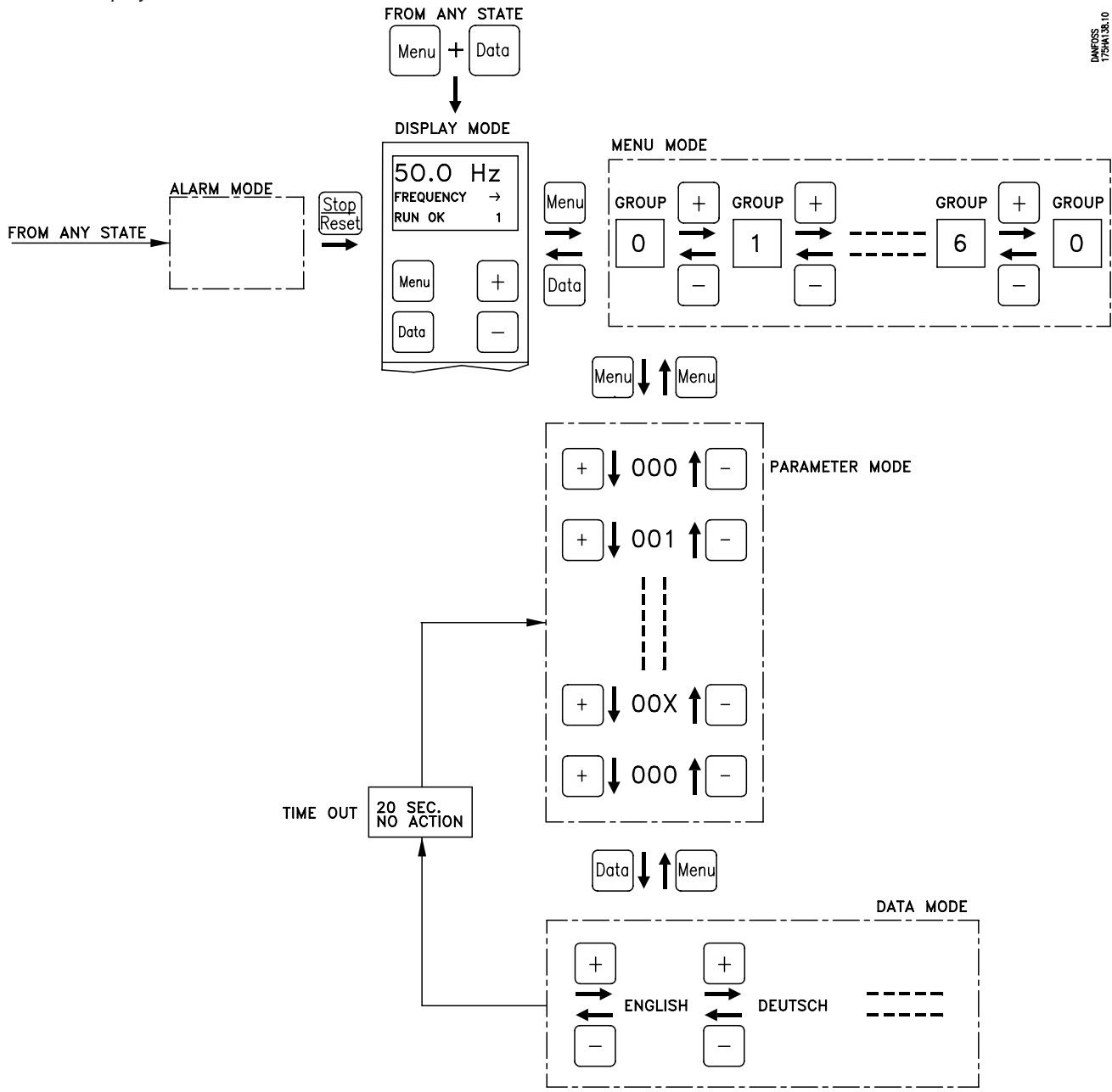

Initialization

General

Initialization is used to return to a known initial status (factory setting). This requirement arises on change of software version, if so many of the parameters have been changed that the situation is no longer clear, or if the VLT® is

behaving strangely and cannot be reset in the normal way.

Fundamentally, initialization takes place in two ways:

Manual initialization

(Press the keys MENU + DATA + JOG simultaneously with mains connection until "init eeprom" is shown in the third line).

This method is used on:

- Replacement of software version.

This results in:

- First time setup of communication parameters to ensure factory setting. (These parameters are set from the unit's operating panel):

Standard (RS 485)	500 Address 501 Baud Rate
----------------------	------------------------------

Profibus	820 Baud Rate 821 FMS/DP select 822 Station Delay 904 PPO Write 918 Station Address
----------	---

- Reset of operation data (para. 600) and fault memory (para. 602)
- Initialization of all other parameters as described under initialization via parameter 604

Initialization via parameter 604

This method is used on:

- Initialization of all parameters to factory setting, except for: Communication parameters (para. 500 and 501) and the aforementioned Profibus parameters if this option is installed.
Operation data (para. 600)
Fault memory (para. 602)

NB! If only factory setting of data in a single setup is required, "Factory set" can be selected in para. 001.

In para. 002 this setting is copied to the chosen setup.

Avoid unwanted data change

Display layout

The display is a three-line LCD display.

Line A is used to display operator read-outs. It will show the value corresponding to the setting in DISPLAY MODE. The selected value will remain in the display line during programming of parameters.

Line B displays information on parameters, direction, and re-set status.
Line C displays information on status and setup or data value.

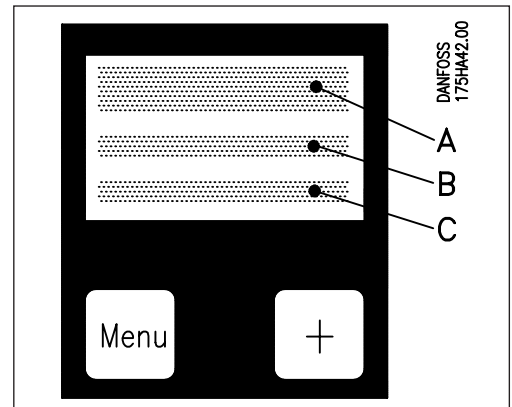

Time out

The software automatically leaves DATA MODE after 20 seconds if no operation is recorded.

By pressing  once, it is possible to return to DATA MODE and program the parameter which was left after 20 sec.





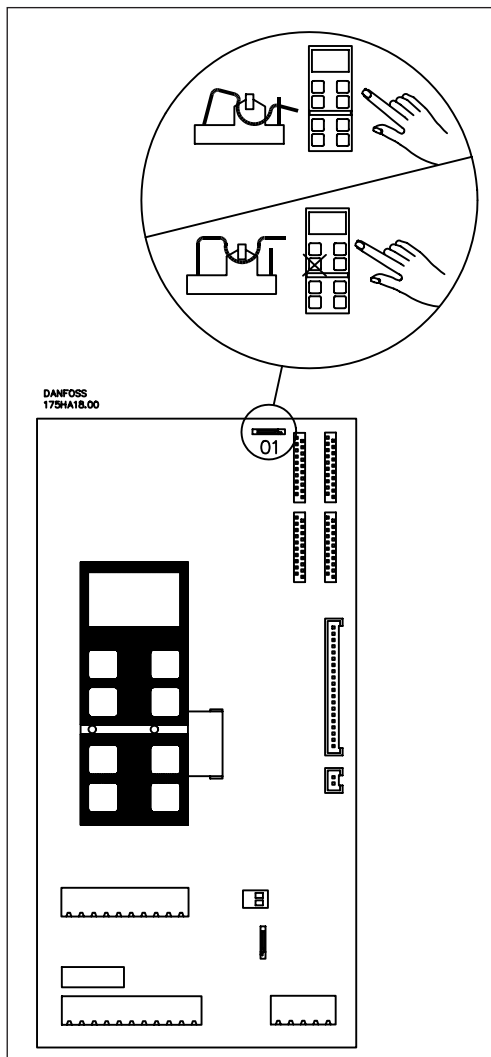

















Local reference (parameter 004) is not left automatically after 20 seconds.

“LOCK” switch



There is a way to avoid unwanted programming. It is done by opening the switch pin 01 on the control card.

Menu build-up

Menu build-up	<p>The frequency converter has a menu system with several parameters to be used to optimise your motor operation. The parameters are divided into 7 groups (group 0 - group 6).</p> <p>There are also groups for different options. They are described in guidelines for each option.</p>	<p><i>Parameter grouping</i></p> <table border="0"> <tr><td>0..</td><td>Operation and display</td><td>000-099</td></tr> <tr><td>1..</td><td>Load and motor</td><td>100-199</td></tr> <tr><td>2..</td><td>References and limits</td><td>200-299</td></tr> <tr><td>3..</td><td>Functions and timers</td><td>300-399</td></tr> <tr><td>4..</td><td>Inputs and outputs</td><td>400-499</td></tr> <tr><td>5..</td><td>Serial data interface</td><td>500-599</td></tr> <tr><td>6..</td><td>Service and diagnosis</td><td>600-699</td></tr> </table>	0..	Operation and display	000-099	1..	Load and motor	100-199	2..	References and limits	200-299	3..	Functions and timers	300-399	4..	Inputs and outputs	400-499	5..	Serial data interface	500-599	6..	Service and diagnosis	600-699
0..	Operation and display	000-099																					
1..	Load and motor	100-199																					
2..	References and limits	200-299																					
3..	Functions and timers	300-399																					
4..	Inputs and outputs	400-499																					
5..	Serial data interface	500-599																					
6..	Service and diagnosis	600-699																					
Parameter numbering	<p>The parameter number is made up of three digits. The digit on the left indicates the group.</p>	<p>Within each group the parameters are numbered, starting with 0. For example, in group 1...: 100, 101, 102....</p>																					
Travelling through the menu	<p>After the first power-up you will find the frequency converter in DISPLAY MODE.</p> <p><i>Changing group</i> If you want to travel through the menu, use the key  followed by the keys  or  (see page 61).</p>	<p><i>Changing a parameter number</i> You can enter the parameters of the selected group with the key  followed by  or .</p> <p> increases and  decreases the parameter number.</p>																					
Data value of a parameter	<p>When you have chosen a parameter and want to change its data value, press the  key followed by the  or  key.</p>	<p>The data value can be a digit or a text.</p>																					
Changing a data value: digit	<p>When you have pressed  the digit to the right will be active and be shown flashing. The other digits can be activated one by one by pressing  one, two or three times. The activated digit can be changed by pressing  or .</p>	<p>A new data value is stored on leaving DATA MODE, or automatically after 20 seconds.</p> <p>Please note: You have to press  to stop the motor before changing the data values of some parameters (see factory settings).</p>																					
Changing a data value: text	<p>If the data value of the chosen parameter is a text, the display shows the selected text. This can be changed by pressing  and then  or . All options are then shown one by one. The text shown in the display will be stored at the same moment you leave DATA MODE.</p>	<p>Please note: You have to press  to stop the motor before changing the data values of some parameters (see factory settings).</p>																					
Leaving DATA mode	<p>You are storing the data value by pressing . Now you have activated the parameter number and can travel through the group of parameters again using  and .</p>																						

Group description

Operation and display Group 0..

In this group you will find parameters concerning the display read-out, local operation and setup handling.

Note: The choice between the 12 different display read-outs mentioned on **page 60** is not an element of this group.

Load and motor Group 1..

This group of parameters has been reserved for the adjustments necessary to adapt the VLT® frequency converter to the application and motor.

Closed loop

If closed loop control is required the transmitter, tachometer or encoder should supply one of the standard analogue signals (e.g. 0-10 V, 0-20 mA; 4-20 mA) or a pulse signal frequency of max. 100 Hz, 1 kHz or 10 kHz (programmable).
The full-scale value is always 100%.

The preprogrammed values in parameters 100-105 are suitable for normal application using standard asynchronous motors with constant torque load without parallel-coupled motors.

The transmitter signal should be selected to utilise the full scale range as far as possible, but with due allowance for overshooting.

If quadratic torque load is applied, select one of the VT (variable torque) modes or VT modes with CT starting torque (high break-away torque).

The pulse signal has an over-shooting range of up to 200% for the 100 Hz and 1 kHz signals, and up to 130% for the 10 kHz signal.

Parallel-coupled motors:

If parallel-coupled motors or any synchronous type of motor are used at the output from a VLT® frequency converter, constant torque is selected without start compensation in parameter 100, and open-loop speed control is selected in parameter 101.

To optimise dynamics and accuracy an impulse frequency as close to 10 kHz as possible should be selected (at max. motor speed).

If this is not possible, the transmitter signal can be corrected by the feedback scaling factor (parameter 125).

Auto-optimization:

An additional tuning might improve the torque yield or speed accuracy, if the motor data differ from the typical values assumed as default.

The equivalent reference signal can either be fixed internally (digital reference) or supplied via standard analogue signals or the pulse signal (range 0-100%). It is not possible to select the same type of signal (voltage, current, pulses) for both the reference and the feedback.

Items 1-4 in Quick setup must be carried out first.

The adaptive tuning facility offers you an easy way to perform that tuning. Initiate the tuning by setting parameter 106 to "ON" and pressing .

At start the output frequency is determined by the frequency converter's reference and the feed forward factor and the min/max frequency settings. The feed forward factor is used to set the steady state output frequency.

The VLT® will perform a test measurement of vital motor data and automatically adjust the appropriate parameters (108-113).

Feedback scaling is used if the transmitter cannot be optimally selected for the input signals' scale range.

For optimum adjustment automatic parameter tuning on a cold motor is recommended.

The PID regulator then adjusts the output frequency by comparing reference and feedback.

Caution: the motor will start running without warning.

Manual tuning is possible in parameters 109-113 for correction of default or automatically tuned values.

At stop the controller output (integrator) is set to 0 so that a restart follows the normal start situation.

Continued...

Group description

Load and motors Group 1.. (continued)

PID optimisation

Parameter 121
(proportional gain) is set for 0.01
(min. value, factory setting).

Parameter 122
(integration time) is set for infinite
(max. value, factory setting).

Parameter 123
(differentiation time) is set for 0 sec.

1. Start the frequency converter.
2. Increase the value in parameter 121 (proportional amplification) until the feedback signal (FB) oscillates constantly. Reduce the value until the oscillation ceases. Reduce further (0.4-0.6 times).
3. Reduce the value in parameter 122 (integration time) until the feedback signal (FB) oscillates again. Increase the value until the oscillation ceases. Then increase further 1.15-1.5 times.
4. Parameter 123 (differentiation time) is only used in fast systems. The typical value is the integration time divided by 4.
5. Reduce control range if necessary (parameter 120) to reduce overshooting.

Note:

The drive should be started / stopped repeatedly to ensure stability.

Group description

Load and motor, group 1.. (continued)

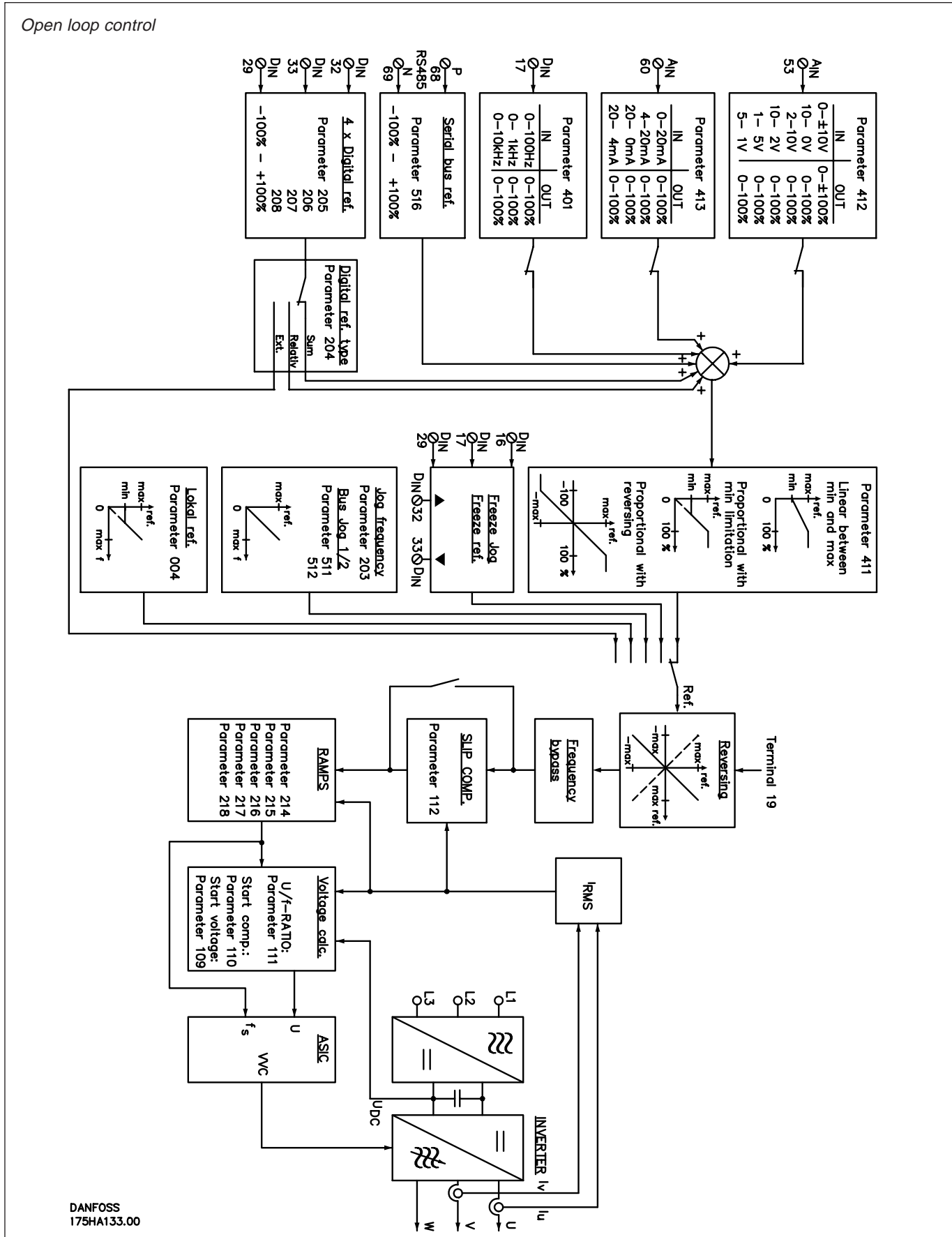

Group description

Load and motor, group 1.. (continued)

Closed loop control

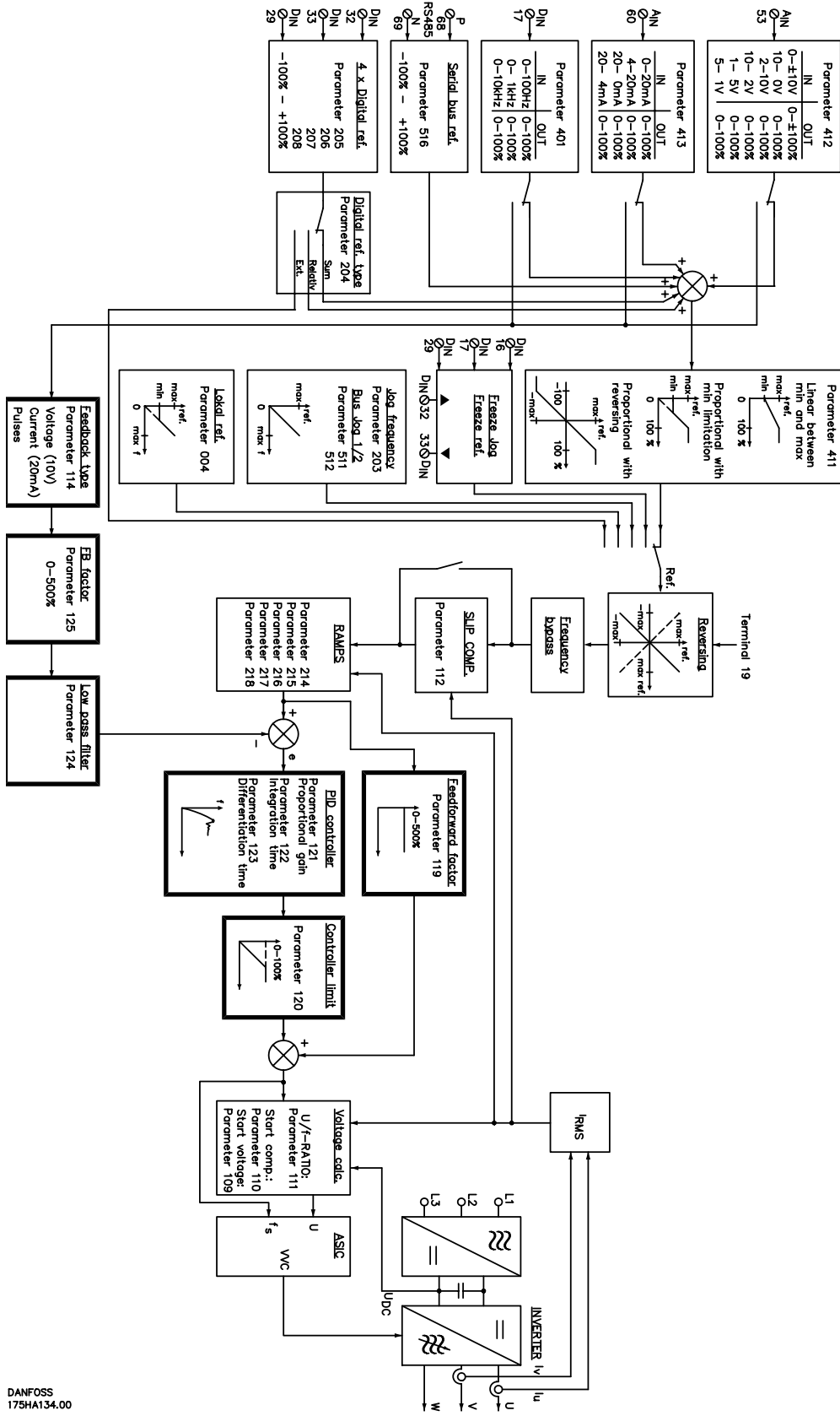

DANFOSS
175HA134.00

Groups

Introduction

The brake control for the electromechanical brake features functions which among other things improve positioning.

The motor current monitoring features a function which automatically activates the brake when the motor current drops to or below the programmed minimum value.

Brake control

The brake control features an optimized relay function with a short reaction time, to control the electromechanical brake. The brake must be active (without voltage) while the unit is running idle. Relay 01/04 can be programmed so that the motor brake is released automatically when the programmed motor frequency is exceeded. It is possible to set separate ramp-up (start) and ramp-down (stop), cut-out and cut-in frequencies.

It is possible to override motor current monitoring during start-up. How long it is to be inactive depends on the delay setting.

To achieve high dynamics, start compensation is deselected in parameter 100.

The parameters for brake control are described below:

Para. 100	Data value [6]
Para. 230-231-232-233	See drawing below
Para. 409/410	Data value [16][17]

Programming of ramp-up and ramp-down times

In parameter 405 (terminal 29 input), two different ramp times can be selected. For normal start/stop, either ramp 1 or 2 can be selected. Quick stop is always ramp 2.

WARNING:
The parameters for the relay used for brake control must not be changed (para. 409 or 410) as this can cause the brake to be released and thus damage equipment or endanger human life.

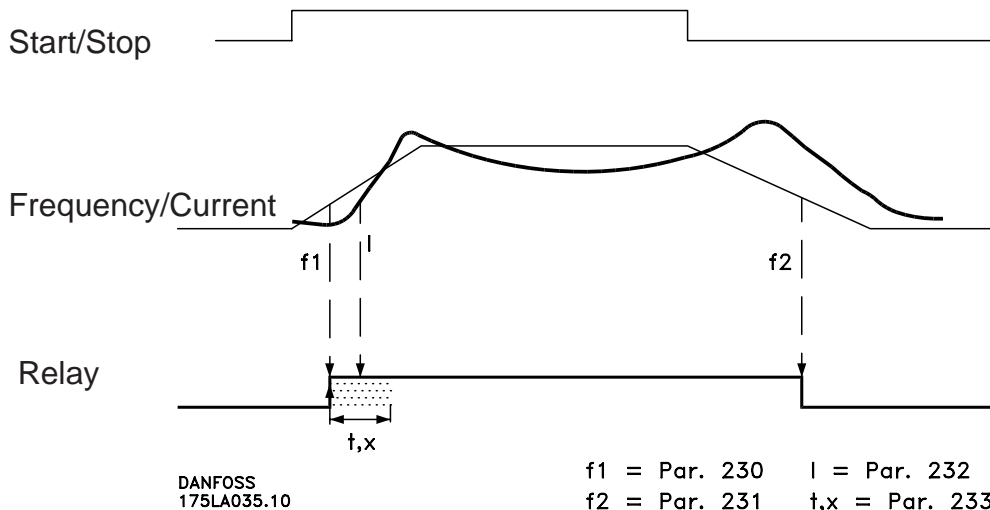

Group description

References and limits Group 2..

The VLT® frequency converter distinguishes between different types of references.
Note that the analogue reference type is

programmed in group 4...
 Unused references are set at 0, or switched out (parameters 205-208, 412-413).

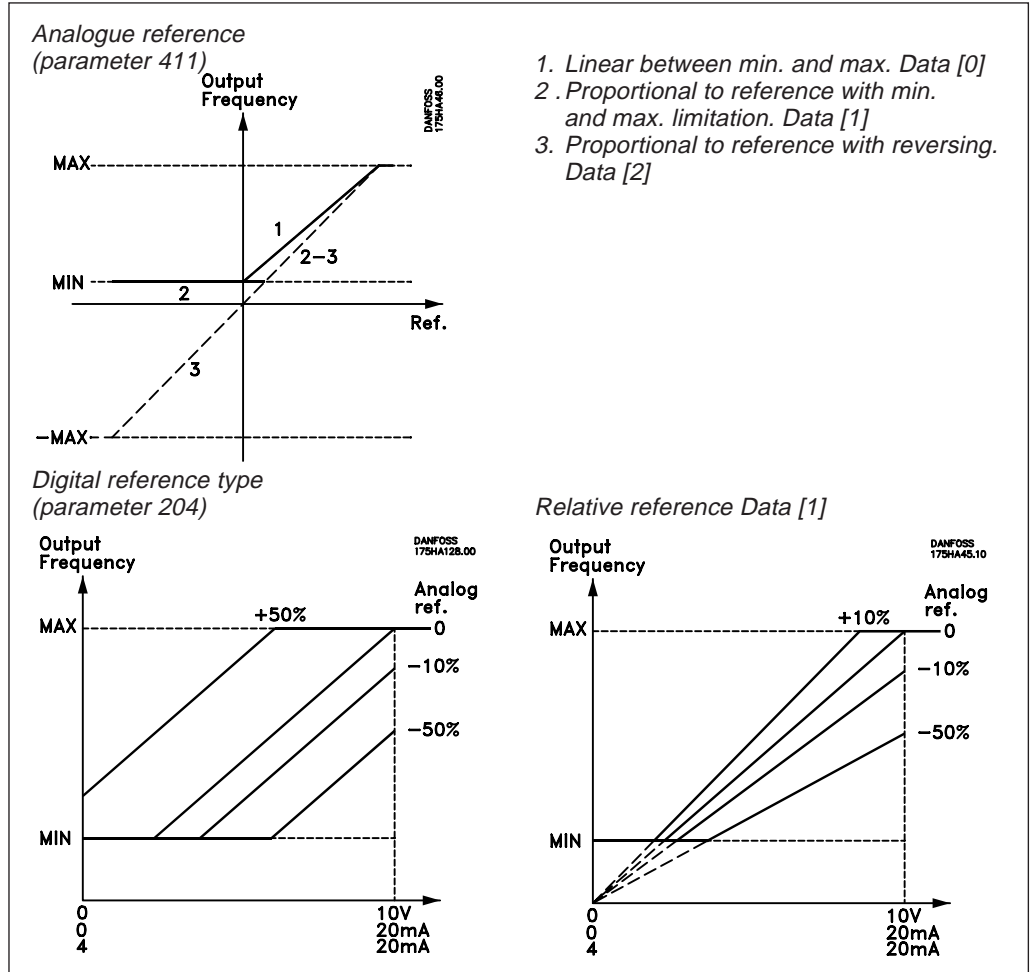

Frequency and current range
 In this group you can define a range within which you want your motor to run. The

frequency converter can be programmed to give output signals if the limits are exceeded (parameters 407-410).

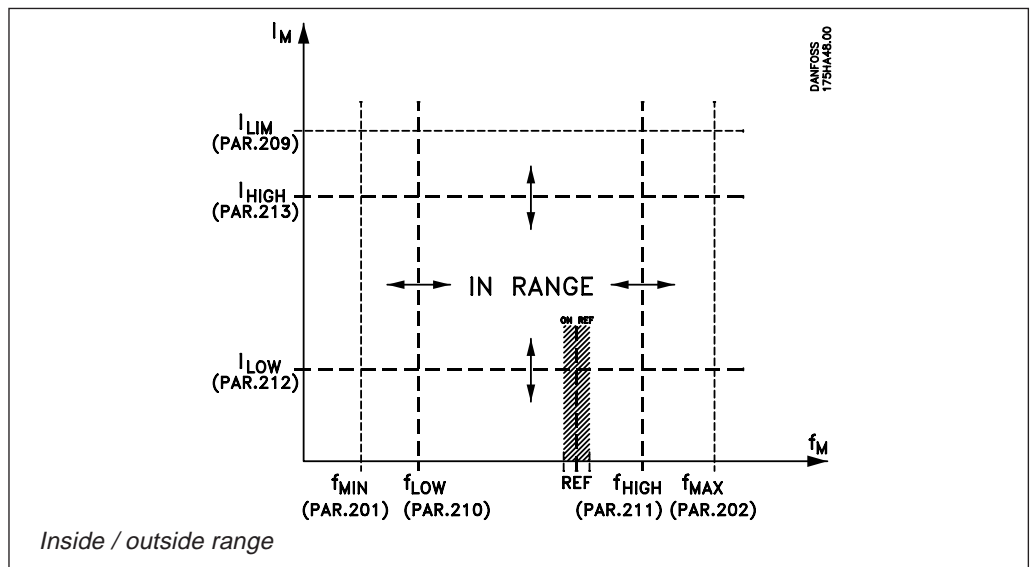

Group description

Functions and timers, Group 3..

This group includes a parameter called "flying start".

This function tells the frequency converter how to handle a motor with a rotating shaft.

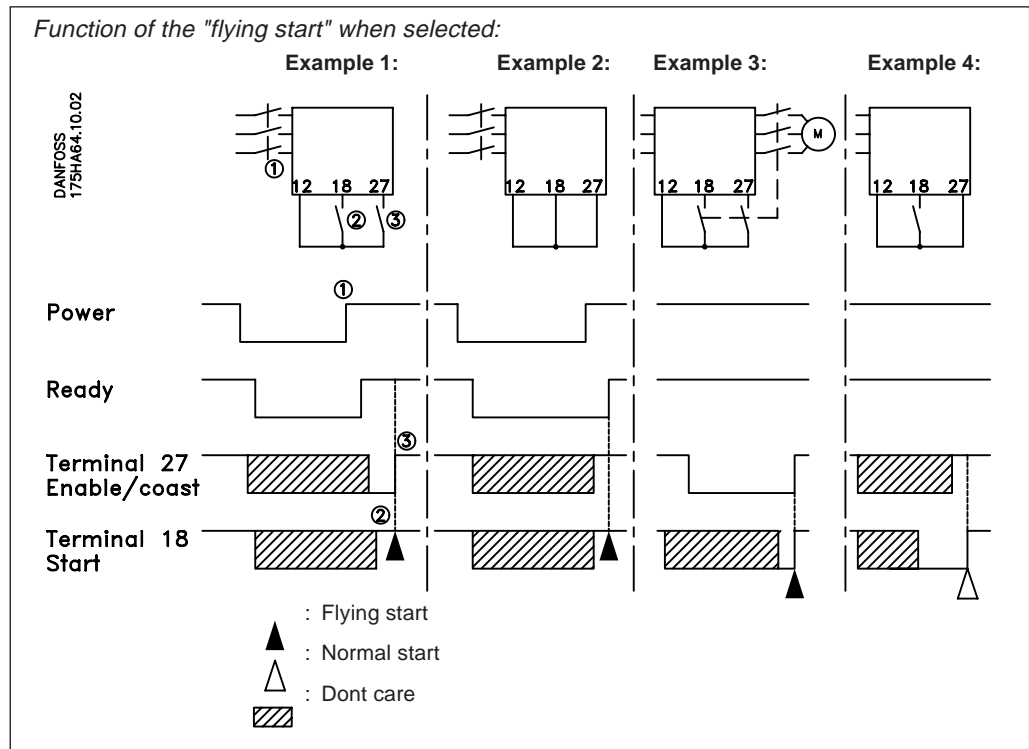

Inputs and outputs Group 4..

Group 4.. is used to program other configurations of the terminals than the default configuration. See the configuration of the digital input signals on **page 32**.

The analogue output signals and the relays can be used for different types of indication. See parameters 407 and 408.

The analogue output signals on terminals 42/45 set in parameters 407/408.

Data 13/14

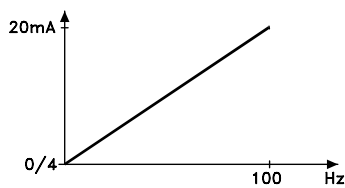

Data 19/20

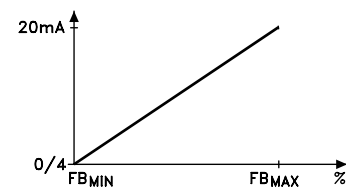

Data 25/26

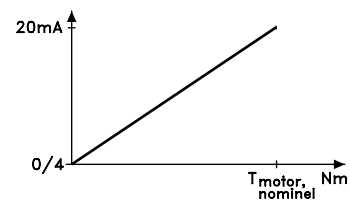

Data 15/16



Data 21/22

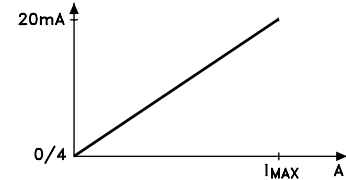

Data 0/12

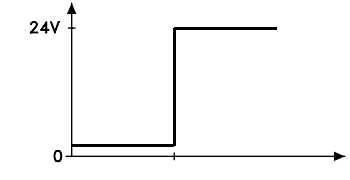

Data 17/18

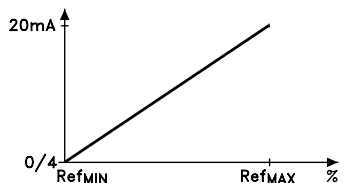

Data 23/24

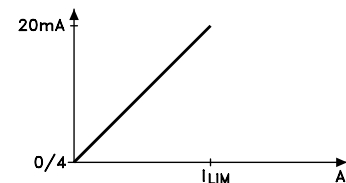

Condition fulfilled (see page 108-109)

DANFOSS 175HA070.11

Group description

Serial data interface Group 5..

The serial bus communicates using RS 485 (terminals 68 and 69). It is possible to read and set the parameters of the VLT[®] frequency converter, and to give it reference and control commands. The serial port can be used by up to 31 VLT[®] frequency converters per master without using a repeater. If 3 repeaters are used, up to 99 VLT[®] frequency converters can be connected to one master.

It is important to connect and terminate the serial bus with the correct impedance to avoid any reflections which may disturb the cable's data transmission.

This adjustment can take place by setting the 03.1 and 03.2 switches in the "on" position (see p. 148) in the last VLT[®] frequency converter connected to the serial BUS.

Communication takes place by means of a protocol specified by Danfoss.

The data format consists of 10 bits: one start bit (logically 0), eight data bits, and one

stop bit (logically 1). There is no parity check. Set the baud rate (speed of transmission) in parameter 501 and the address of each unit in parameter 500.

Telegram format / protocol

The communication protocol for the VLT[®] 3000 Series consists of a 22-byte telegram using ASCII characters. These characters make it possible to operate, set and read parameters, and to receive status feedback from the VLT[®] frequency converter.

Communication takes place in the following way: The master sends a telegram to a VLT[®] frequency converter. Then the master awaits a reply from that frequency converter before sending a new message. The reply to the master is a copy of the telegram sent by the master, now containing any updated data values and the status of the VLT[®] frequency converter.

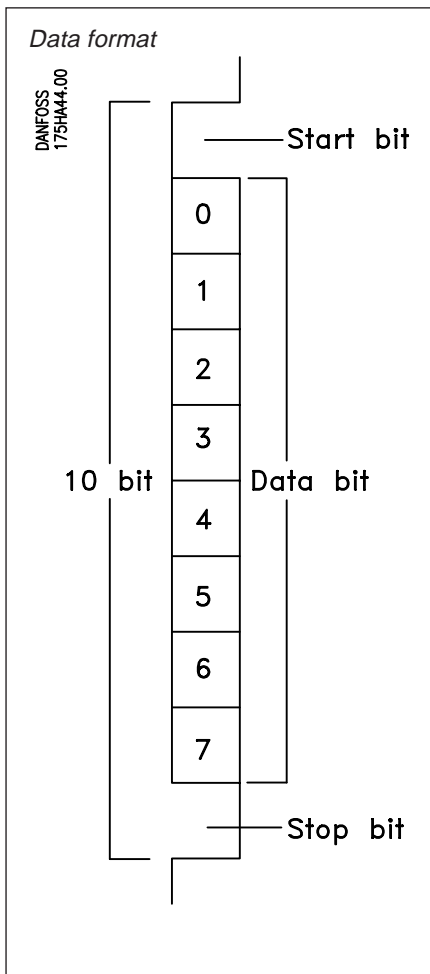

Telegram format

Function	byte #	ASCII
Start byte	1	<
Address	2	
	3	
	4	
Control char. Control/status word	5	
	6	
	7	
	8	
Parameter #	9	
	10	
	11	
	12	
Sign	13	
Data	14	
	15	
	16	
	17	
	18	
	19	
Comma	19	
Check sum	20	
	21	
Stop byte	22	>

DANFOSS
175HA043.11

Continued...

Group description

Serial data interface Group 5.. (continued)

Byte 1:
Start byte which in this case must be the character "<" (ASCII: 60).

Bytes 2 and 3:
The two-digit address of the frequency converter with which communication is required. This address is also programmed in parameter 500.
Sending to address 00 means broadcast to all units connected to the bus. None of the units will reply, but they will carry out the command.

Byte 4:
Control parameter telling the VLT® frequency converter what to do with the following data values.

U (update) means that the data value (bytes 13-19) must be read into the frequency converter's parameter (bytes 9-13).

R (read) means that the master wants to read the data value of the parameter stated in bytes 9-12.

C (control) means that the frequency converter reads only the four command bytes (5-8) and returns with status. Parameter number and data value will be ignored.

I (read index) means that the frequency converter reads index and parameter, and returns with status.

Parameter is stated in bytes 9-12 and index is stated in bytes 13-18.

Parameters with indices are read-only parameters. Action will be taken on the control word.

Two-dimensional indices (x,y) (parameters 601 and 602) are separated by a comma, see byte 19.

Example:

Index = x, y
Data value = 013,05

Byte 14-18 = 013 05

Byte 19 = 2

Bytes 5-8:
Control and status words are used to send commands to the frequency converter and to send status from frequency converter to master.

Bytes 9-12:
In these bytes the parameter number is set.

Bytes 13:
Used for the sign before data value in bytes 14-18. All characters other than "-" are taken as "+".

Bytes 14-18:
Here is placed the data value of the parameter stated in bytes 9-12.

The value must be a whole number. If a decimal point is needed it is stated in byte 19.

Note: Some data values have square brackets with a number, e.g. [0]. Use this number instead of the "text" data value.

Bytes 19:
The position of the decimal point in the data value stated in bytes 14-18. The number states the number of characters after the decimal point.

Byte 19 can then be 0, 1, 2, 3, 4 or 5.

For example, the number 23.75 is stated:

Byte no.	13	14	15	16	17	18	19
----------	----	----	----	----	----	----	----

ASCII character	+	2	3	7	5	0	3
-----------------	---	---	---	---	---	---	---

If byte 19 = 9 in the response telegram see table **page 80**.

Bytes 20, 21:
Used for counter control from byte 2 up to and including 19. The decimal values of the ASCII characters are added and reduced to the two "low" characters, e.g. Σ 235 [] reduced = 35. If no control is necessary cancel the function with "?" (ASCII: 63) in the two bytes.

Byte 22:
Stop byte stating the end of the telegram. The character ">" is used (ASCII: 62).

Groups

Serial data interface, group 5.. (continued)

Control words, bytes 5-8 in the telegram
The control word is used to send control commands from a master (e.g. a PC) to the VLT[®] frequency converter.

According to the data format, 1 byte consists of 8 data bits, but in the control word only the 4 least significant bits of each byte are used, so that ASCII characters from A to 0 can be used. The table below shows the significance of the individual bits of the control word:

	ASCII	Control word															
		Byte 8				Byte 7				Byte 6				Byte 5			
		NO F U C T T I O N	S E L E C T S E T - U P	S E L E C T S E T - U P	NO F U C T T I O N	NO F U C T T I O N	D A T A N O T V A L I D	J O G O F F O N	J O G O F F O N	NO F U C T T I O N	R A M P S T O P S T A R T	H O L D R A M P P O S S I B L E	Q U I C K S T O P R A M P	F R E E W H E E L P O S S.	O F F O N	O F F O N	O F F O N
15	14	13	12	11	10	09	08	07	06	05	04	03	02	01	00		
@		0	0	0	0	0	0	0	0	0	0	0	0	0	0	0	0
A		0	0	0	1	0	0	0	1	0	0	0	1	0	0	0	1
B		0	0	1	0	0	0	1	0	0	0	1	0	0	0	1	0
C		0	0	1	1	0	0	1	1	0	0	1	1	0	0	1	1
D		0	1	0	0	0	1	0	0	0	1	0	0	0	1	0	0
E		0	1	0	1	0	1	0	1	0	1	0	1	0	1	0	1
F		0	1	1	0	0	1	1	0	0	1	1	0	0	1	1	0
G		0	1	1	1	0	1	1	1	0	1	1	1	0	1	1	1
H		1	0	0	0	1	0	0	0	1	0	0	0	1	0	0	0
I		1	0	0	1	1	0	0	1	1	0	0	1	1	0	0	1
J		1	0	1	0	1	0	1	0	1	0	1	0	1	0	1	0
K		1	0	1	1	1	0	1	1	1	0	1	1	1	0	1	1
L		1	1	0	0	1	1	0	0	1	1	0	0	1	1	0	0
M		1	1	0	1	1	1	0	1	1	1	0	1	1	1	0	1
N		1	1	1	0	1	1	1	0	1	1	1	0	1	1	1	0
O		1	1	1	1	1	1	1	1	1	1	1	1	1	1	1	1
P		X	X	X	X	X	X	X	X	X	X	X	X	X	X	X	X

X = Dont care, if P is used in a group of 4 bits, current status is retained. Only the groups with the characters in P are activated. Bit 10 = 0 signifies no change from current status.

Bit 00, OFF1/ON1:

Ordinary ramp stop which uses the ramp time in parameter 215/216. Bit 00 = "0" means stop, bit 00 = "1" means that the frequency converter can start if the other start conditions are fulfilled.

Bit 01, OFF2/ON2:

Free-wheeling stop. Bit 01 = "0" means free-wheeling stop, bit 01 = "1" means that the frequency converter can start if the other start conditions are fulfilled.

Bit 02, OFF3/ON3:

Quick stop, which uses the ramp time in parameter 218. Bit 02 = "0" means quick stop, bit 02 = "1" means that the frequency converter can start if the other start conditions are fulfilled.

Bit 03, Free-wheeling/possible:

Free-wheeling stop. Bit 03 = "0" means stop, bit 03 = "1" means that the frequency converter can start if the other start conditions are fulfilled. Note: In parameter 503 it is selected how bit 03 is connected (gates) with the equivalent function on the digital inputs.

Bit 04, Quick stop/ramp:

Quick stop, which uses the ramp time in parameter 218. Bit 04 = "0" means quick stop, bit 04 = "1" means that the frequency converter can start if the other start conditions are fulfilled.

Groups

Serial data interface, group 5.. (continued)

The function of bit 04 can be redefined to D.C. brake in parameter 514. Otherwise the function is as described above. Note: In parameter 504/505 it is selected how bit 04 is connected (gates) with the equivalent function on the digital inputs.

Bit 05, Hold/ramp possible:

Ordinary ramp stop which uses the ramp time in parameter 215/216. Bit 05 = "0" means stop, bit 05 = "1" means that the frequency converter can start if the other start conditions are fulfilled.

Bit 06, Ramp stop/start:

Ordinary ramp stop which uses the ramp time in parameter 215/216. Bit 06 = "0" means stop, bit 06 = "1" means that the frequency converter can start if the other start conditions are fulfilled. Note: In parameter 506 it is selected how bit 06 is connected (gates) with the equivalent function on the digital inputs.

Bit 07, No function/reset:

Reset of trip. Bit 07 = "0" means no reset, bit 07 = "1" means reset of a trip. Note: In parameter 508 it is selected how bit 07 is connected (gates) with the equivalent function on the digital inputs.

Bit 08, JOG 1 OFF/ON:

Activation of preprogrammed speed in parameter 511 (Bus JOG 1). JOG 1 is only possible when bit 04 = "0" and bit 00-03 = "1".

Bit 09, JOG 2 OFF/ON:

Activation of preprogrammed speed in parameter 512 (Bus JOG 2). JOG 2 is only possible when bit 04 = "0" and bit 00-03 = "1". If both JOG 1 and JOG 2 are activated (bit 08 and 09 = "1"), JOG has highest priority, i.e. the speed programmed in parameter 511 is used.

Bit 10, Data not valid/valid:

Used to tell the VLT[®] frequency converter whether the control word must be used or ignored. Bit 10 = "0" means that the control word is ignored. Bit 10 = "1" means that the control word is used. This function is relevant because the control word is always contained in the telegram, no matter which telegram type is used (see byte 4 in "telegram format"), i.e. it is possible to discon-

nect the control word if it is not to be used in connection with updating or reading of parameters.

Bit 11, No function/slow down:

Used to reduce the speed reference with the value in parameter 513. Bit 11 = "0" means no change of reference, bit 11 = "1" means that the reference is reduced. The function of bit 11 and 12 can be redefined to selection of digital reference in parameter 515, according to the following table:

Digital reference/ parameter	Bit 14	Bit 13
1/205	0	0
2/206	0	1
3/207	1	0
4/208	1	1

Note: In parameter 510 it is selected how bit 11/12 is connected (gates) with the equivalent function on the digital inputs.

Bit 12, no function/catch up:

Used to increase a speed reference with the value in parameter 513. Bit 12 = "0" gives no change of reference, bit 12 = "1" increases the reference. If both slow-down and catch-up are activated (bit 11 and 12 = "1"), slow-down has highest priority, i.e. the speed reference is reduced. The function of bit 11 and 12 can be redefined to selection of digital reference, see description of bit 11 above.

Bit 13/14, selection of setup:

Bit 13 and 14 are used to select between four menu setups according to the following table:

Setup	Bit 14	Bit 13
1	0	0
2	0	1
3	1	0
4	1	1

The function is only possible when *multi setup* is selected in parameter 001.

Note: In parameter 509 it is selected how bit 13/14 are connected (gates) with the equivalent function on the digital inputs.

Groups

Serial data interface, group 5.. (continued)

Bit 15, No function/reversing:
Reversing of the motor's speed direction.
Bit 15 = "0" means no reversing,
bit 15 = "1" means reversing.
Note that as starting point reversing is selected to *digital* in parameter 507,

bit 15 only means reversing when bus, *logical or* or *logical and* (*logical and*, however, only with terminal 19) is selected.

Example:

The following code word can be used to give the VLT[®] frequency converter the start command:

Bit	15	14	13	12	11	10	09	08	07	06	05	04	03	02	01	00
0/1	0	0	0	0	0	1	0	0	0	1	1	1	1	1	1	1
ASCII	@			D				G			O					

Status word, bytes 5-8 in the telegram

The status word is used to inform the master (e.g. a PC) of the VLT[®] frequency converter's status. The status word is

located in bytes 5-8 of the response telegram from the VLT[®] frequency converter to the master.
The table below shows the significance of the individual bits of the status word:

ASCII	0 / 1	Status word															
		Byte 8				Byte 7				Byte 6				Byte 5			
		T I M E R S O K / O V E R L I M I T	C U R R E N T O K / O V E R L I M I T	V O L T A G E O K / O V E R L I M I T	V L T O K / S T A L L S A U T O S T A R T	N O T R U N N I N G / R U N N I N G	O U T O F O P E R A T I O N R A N G E / F R E Q U E N C Y L I M I T S O K	L O C A L O P E R A T I O N / B U S C O N T R O L	N O T O N R E F / O N R E F	N O W A R N I N G / W A R N I N G	S T A R T P O S S I B L E / S T A R T N O T P O S S I B L E	O N 3 / o F F 3	O N 2 / O F F 2	N O F A U L T / T R I P	N O T E N A B L E D / E N A B L E D	V L T N O T R E A D Y / R E A D Y	C O N T R O L N O T R E A D Y / R E A D Y
15	14	13	12	11	10	09	08	07	06	05	04	03	02	01	00		
@	0	0	0	0	0	0	0	0	0	0	0	0	0	0	0	0	
A	0	0	0	0	1	0	0	0	1	0	0	0	1	0	0	1	
B	0	0	1	0	0	0	1	0	0	0	1	0	0	0	1	0	
C	0	0	1	1	0	0	1	1	0	0	0	1	1	0	0	1	
D	0	1	0	0	0	1	0	0	0	1	0	0	0	1	0	0	
E	0	1	0	1	0	1	0	1	0	1	0	1	0	1	0	1	
F	0	1	1	0	0	1	1	0	0	1	1	0	0	1	1	0	
G	0	1	1	1	1	1	1	1	0	1	1	1	0	1	1	1	
H	1	0	0	0	1	0	0	0	1	0	0	0	1	0	0	0	
I	1	0	0	1	1	0	0	1	1	0	0	1	1	0	0	1	
J	1	0	1	0	1	1	0	1	0	1	1	0	1	0	1	0	
K	1	0	1	1	1	0	1	1	1	0	1	1	1	0	1	1	
L	1	1	0	0	1	1	0	0	1	1	0	0	1	1	0	0	
M	1	1	0	1	1	1	0	1	1	1	0	1	1	1	0	1	
N	1	1	1	0	1	1	1	1	1	1	1	0	1	1	1	0	
O	1	1	1	1	1	1	1	1	1	1	1	1	1	1	1	1	

Groups

Serial data interface, group 5.. (continued)

Bit 00, Control not ready/ready:

Bit 00 = "0" means that the control word's bit 00, 01 or 02 = "0" (OFF1, OFF2 or OFF3), or the VLT[®] frequency converter has tripped. Bit 00 = "1" means that the VLT[®] frequency converter is ready to operate when it receives the necessary start signals.

Bit 01, VLT[®] not ready/ready:

Same significance as bit 00.

Bit 02, Free-wheeling/possible:

Bit 02 = "0" means that the control word's bit 00, 02 or 03 = "0" (OFF1, OFF2 or OFF3 or Free-wheeling), or the VLT[®] frequency converter has tripped. Bit 02 = "1" means that the control word's bit 00, 01, 02 and 03 = "1", and the VLT[®] frequency converter has not tripped.

Bit 03, No fault/trip:

Bit 03 = "0" means that the VLT[®] frequency converter is not in a fault status. Bit 03 = "1" means that the VLT[®] frequency converter has tripped and it requires a reset signal before it can run.

Bit 04, ON2/OFF2:

Bit 04 = "0" means that the control word's bit 01 = "1".
Bit 04 = "1" means that the control word's bit 01 = "0".

Bit 05, ON3/OFF3:

Bit 05 = "0" means that the control word's bit 02 = "1".
Bit 05 = "1" means that the control word's bit 02 = "0".

Bit 06, Start possible/not possible:

Bit 06 is always "0" if "Start not possible" [11] has not been selected in parameter 309. When "Start not possible" [11] is selected in parameter 309, bit 06 will be "1" after reset of a trip, after activation of OFF2 or OFF3 and after connection of mains voltage. "Start not possible" is reset, the control word's bit 00 being set at "0" and bit 01, 02 and 10 at "1".

Bit 07, No warning/warning:

Bit 07 = "0" means that there is no extraordinary situation. Bit 07 = "1" means that an abnormal status has arisen for the VLT[®] frequency converter. All warnings described on pp. 124-125 will set bit 07 at "1".

Bit 08, Speed in ref./speed = ref.:

Bit 08 = "0" means that the motor's current speed is different from the set speed reference. This can e.g. be the case while the speed is ramped up/down on start/stop. Bit 08 = "1" means that the motor's current speed is equal to the set speed reference.

Bit 09, Local control/bus control:

Bit 09 = "0" means that the VLT[®] frequency converter has stopped with the help of the stop key on the operating panel, or "local" or "local with external free-wheeling stop" has been selected in parameter 003. Bit 09 = "1" means that it is possible to control the VLT[®] frequency converter via the serial port.

Bit 10, Out of range/frequency OK:

Bit 10 = "0" means that the output frequency is outside the limits set in parameter 210 (Warning: Low frequency) and parameter 211 (Warning: High frequency). Bit 10 = "1" means that the output frequency is within the aforementioned limits.

Bit 11, Not running/running:

Bit 11 = "0" means that the motor is not running. Bit 11 = "1" means that the VLT[®] frequency converter has a start signal or the output frequency is greater than 0.5 Hz.

Bit 12, VLT[®] OK/stalls, auto start:

Bit 12 = "0" means that there is no temporary overload of the inverter. Bit 12 = "1" means that the inverter has stopped due to overload, but the VLT[®] frequency converter has not tripped and it will continue when the overload disappears.

Bit 13, OK/over/undervoltage:

Bit 13 = "0" means that the VLT[®] frequency converter's voltage limits have not been exceeded. Bit 13 = "1" means that the D.C. voltage in the VLT[®] frequency converter's intermediate circuit is too low or too high.

Bit 14, Current OK/above limit:

Bit 14 = "0" means that the motor current is lower than the current limit selected in parameter 209. Bit 14 = "1" means that the current limit in parameter 209 has been exceeded.

Groups

Serial data interface, group 5.. (continued)

Bit 15, Timers OK/above limit:

Bit 15 = "0" means that the timers for respectively thermal motor protection (described on p. 130) and thermal VLT® protection have not exceeded 100%. Bit 15 = "1" means that one of the timers has exceeded 100%.

Example:

The status word below states that the motor is running at the required speed reference but outside the defined frequency range and therefore bit 10 = "0" (out of frequency range) and bit 07 = "1" (warning). Voltage, current and timers are OK.

Bit	15	14	13	12	11	10	09	08	07	06	05	04	03	02	01	00
0/1	0	0	0	0	1	0	1	1	1	0	0	0	0	1	1	1
ASCII	@			K			H			G						

Communication example:

A VLT® frequency converter with address 1 is to have a start signal and speed reference equivalent to 40 Hz. A start signal is given with the help of the control word (see

example on p. 77), and the speed reference is written to parameter 516, bus reference, 80% equivalent to 40 Hz, the maximum frequency being 50 Hz. This gives the following telegram structure:

Telegram from master (PC or PLC) to frequency converter

Function	Byte no.	ASCII character	Decimal value
Start byte	1	<	60
Address	2	0	48
	3	1	49
Control character	4	U	85
Control/status word	5	O	79
	6	G	71
	7	D	68
	8	@	64
Parameter no.	9	0	48
	10	5	53
	11	1	49
	12	6	54
Sign	13	+	43
Data value	14	0	48
	15	0	48
	16	0	48
	17	8	56
	18	0	48
Comma	19	0	48
Check sum	20	0	48
	21	7	55
Stop byte	22	>	62

Check sum: Byte 2-19 = 1007 reduced to 07

Groups

Serial data interface, group 5.. (continued)

Response telegram from VLT® frequency converter to master (PC or PLC)

Function	Byte no.	ASCII character	Decimal value
Start byte	1	<	60
Address	2	0	48
	3	1	49
Control character	4	U	85
Control/status word	5	G	71
	6	H	72
	7	K	75
	8	@	64
Parameter no.	9	0	48
	10	5	53
	11	1	49
	12	6	54
Sign	13	+	43
Data value	14	0	48
	15	0	48
	16	0	48
	17	8	56
	18	0	48
Comma	19	0	48
Check sum	20	0	48
	21	7	55
Stop byte	22	>	62

Check sum: Byte 2-19 = 1007 reduced to 07
Status word equivalent to the example on p. 79.

Fault reports parameters (read/write)

Byte 19 in the response telegram from the VLT® frequency converter assumes the value 9 if it is not possible to perform the selected write or read command, and simultaneously a reason code is given in bytes 17 and 18. The following reason codes are found:

Code	Reason
00	Parameter number does not exist
01	There is no read/write access to the selected parameter
02	A non-existent index no. has been selected
03	Index reading is used for a parameter which does not have indexes
04	The parameter is read-only. Can be because factory setup has been selected
05	The parameter cannot be changed when the motor is running
06	The data value is outside the parameter's range
07	Illegal comma value (byte 19)
08	The read data value > 99999
99	Other faults

Switch 04:

The drawing on p. 147 shows the position of switch 04.

04 closed: Terminal 61 is connected directly to earth.

04 open: Terminal 61 is connected to earth via an RC link.

When switch 04 is closed, there is no galvanic separation between the signal cables (terminals 68 and 69) and earth,

which can give problems if a master without galvanic separation is used. Therefore the following connection method should be used: Switch 04 must be open, the signal cable's screen must be connected to the relief stirrup below the control card, but not to terminal 61. The screen is uncovered and clamped under the relief stirrup, the screen may not end at the relief stirrup, but must be led as close to the terminal block as possible, so that the unscreened signal cable ends are as short as possible.

Groups

**Service and diagnosis,
Group 6..**

In group 6, different operating data for use in connection with service and diagnosis are registered. There are also details of the VLT®'s identity and software version.

Parameter description 0.. Operation and display

000
Language select
 (Language)

Value:	
★ English (ENGLISH)	[0]
German (DEUTSCH)	[1]
French (FRANCAIS)	[2]
Danish (DANSK)	[3]
Spanish (ESPAÑOL)	[4]
Italian (ITALIANO)	[5]

The choice in this parameter defines the language of the display.

001
Setup selection, operation
 (Setup operatio)

Value:	
Factory setup (FACTORY SET)	[0]
★ Setup (SETUP 1)	[1]
Setup (SETUP 2)	[2]
Setup (SETUP 3)	[3]
Setup (SETUP 4)	[4]
Multi setup (MULTI SETUP)	[5]

Function:
 The menu setup to control the VLT® frequency converter can be selected. The parameters which can be changed are stated on pp. 149-150. If several setups are required, up to four different alternatives can be selected. Remote-controlled selection between different setups can be operated from terminals 16/17 or 32/33 and the serial port.

Example:

Setup	Terminal 17	Terminal 16
1	0	0
2	0	1
3	1	0
4	1	1

Description of choices:
Factory setup contains the factory-programmed data. Can be used as a data source if the other setups are to be returned to a known status. Here the language is always English. It is not possible to change any other data when this setup is selected.
Setup 1-4 is four individual setups which can be used as required. The current running setup can be changed, and the changes have an immediate impact on the unit's function.
Multi setup is used for remote-controlled operation between more than one setup. Terminal 16/17 (para. 400/401), terminal 32/33 (para. 406) or the serial bus can be used to alternate between the setups.

★ = Factory setting. Text in () = Display text.
 The figures in [] are used in bus communication.

002
Setup copy
(Menu set copy)

- Value:
- ★ No copy (Do not copy) [0]
 - Copy to 1 from # (COPY TO 1 FROM #) [1]
 - Copy to 2 from # (copy to 2 from #) [2]
 - Copy to 3 from # (copy to 3 from #) [3]
 - Copy to 4 from # (copy to 4 from #) [4]
 - Copy to ALL from # (copy all from) [5]

Function:
 A menu setup can be copied to one of the other setups, or all other setups simultaneously, but not to setup [0]. Copying can only take place in Stop Mode.

Description of choices:
 Copying begins when the required data value has been entered, and the data mode is left by pressing MENU or automatically after 20 seconds.

Line 3 in the display flashes while copying is taking place.

The display shows the setup copied to and from. The active setup is always copied from (selected in parameter 001 or via the terminals 16/17 or 32/33).

When copying is completed, the data value automatically switches to “No copying” [0].

003
Operation site
 (Local / remote)

- Value:
- ★ Remote (remote) [0]
 - Local with external stop (loc/ext stop) [1]
 - Local (local) [2]

Function:
 Three modes of operation of the VLT® frequency converter can be selected: Remote control, local with external stop option and local operation.

Description of choices:
Remote control is selected for control via the control terminals or serial port (RS485).

The keyboard functions are still active, assuming that they have not been deselected in parameter 006-009. Note: Local reversing is not possible, however, irrespective of what has been selected in parameter 008.

Local with external stop is selected to operate the VLT® frequency converter from the keyboard without using external control signals but with the possibility of an external stop function. The external stop function must be connected between terminals 12 and 27. A circuit breaker (NC) and terminal 27 (parameter 404) must be programmed for freewheeling stop or reset and freewheeling stop).

Local is selected to exclusively operate the VLT® from the keyboard without any kind of external control signals (nor RS485).

Note:
 For both local selections, speed can be controlled on parameter 004.

★ = Factory setting. Text in () = Display text.
 The figures in [] are used in bus communication.

<p>004 Local reference (Local speed)</p>	<p>Value: 0.00 - REF_{MAX}</p>	<p><i>Function:</i> Local reference is selected to set speed (frequency) from the operating panel. Note: Local reference cannot be used if remote operation has been selected in parameter 003. <i>Description of choices:</i> The VLT[®] frequency converter's output frequency can be set directly in Hz using the +/- keys. The set value is saved 20 sec. after the last change and remembered after mains cut-out. <i>Warning:</i> This implies that the motor can start without warning on mains cut-in if parameter 014 is changed to Auto restart [0]. - Note: In this parameter data mode is not left automatically. - Local reference cannot be controlled via the serial bus, RS485. - Data changes in parameter 004 are blocked if parameter 010 is set at NOT POSSIBLE.</p>
<p>005 Display value (Value at max)</p>	<p>Value: 1 - 9999</p>	<p><i>Function:</i> On selection of the DISPLAY/FEED BACK function in the display mode, a user read-out is obtained which is a scaling of the reference sum if "Open loop" or slip-compensated has been selected in parameter 101. Unit can be selected in parameter 117. <i>Description of choices:</i> The programmed value will be read out when the output frequency is equivalent to F_{MAX} (parameter 202).</p>
<p>006 Local reset (Local reset)</p>	<p>Value: Disable (disable) [0] ★ Enable (enable) [1]</p>	<p><i>Function:</i> Local/reset can be selected/deselected on the keyboard.</p>
<p>007 Local stop (Local stop)</p>	<p>Value: Disable (disable) [0] ★ Enable (enable) [1]</p>	<p><i>Function:</i> Local Stop can be selected/deselected. The current status of Local Start or Local Stop command is stored. <i>Description of choices:</i> <u>Enable</u> is selected if Local Stop is to be active. <u>Disable</u> is selected if one of the following situations is required: 1) If Local Stop is activated before "Local Stop disable" is selected, the unit can be started with the help of the Local Start key (if remote control has been selected, the remote-controlled start function must be active). 2) If Local Start is activated before "Local Stop disable" is selected, the unit cannot be stopped with the help of the Local Stop key, and therefore the unit cannot be stopped via the operating panel.</p> <p>★ = Factory setting. Text in () = Display text. The figures in [] are used in bus communication.</p>

<p>008 Local reversing (Local fwd / rev)</p>	<p>Value: ★ Disable (disable) Enable (enable)</p>	<p>[0] [1]</p>	<p><i>Function:</i> Local reversing can be selected/deselected via the keyboard. Locally selected or Local with external stop: Para. 003. <i>Warning:</i> Note: If local rotation direction (parameter 008) has been selected, the function will only be active if reversing via terminal 19 has not been selected (parameter 403).</p>
<p>009 Local jogging (Local jog)</p>	<p>Value: ★ Disable (disable) Enable (enable)</p>	<p>[0] [1]</p>	<p><i>Function:</i> Local jogging can be selected/deselected on the keyboard. Local jogging is possible regardless of choice: Para. 003. Jog speed: Only as long as the key is kept in.</p>
<p>010 Local reference (Loc reference)</p>	<p>Value: Disable (disable) ★ Enable (enable)</p>	<p>[0] [1]</p>	<p><i>Function:</i> Local speed selection can be selected/deselected. <i>Description of choices:</i> DISABLE is selected if the possibility of changing speed with the help of parameter 004 is not required.</p>
<p>011 Reset energy counter (Energy counter)</p>	<p>Value: ★ No reset (no reset) Reset (reset)</p>	<p>[0] [1]</p>	<p><i>Function:</i> Zero setting of kW hour counter. <i>Description of choices:</i> Reset starts up when DATA MODE is left. Cannot be selected via the serial bus, RS485.</p>
<p>012 Reset hour counter (Hour counter)</p>	<p>Value: ★ No reset (no reset) Reset (reset)</p>	<p>[0] [1]</p>	<p><i>Function:</i> Zero setting of run hour counter. <i>Description of choices:</i> Reset starts up when DATA MODE is left. Cannot be selected via the serial bus, RS485.</p>

★ = Factory setting. Text in () = Display text.
The figures in [] are used in bus communication.

014
Power Up Mode
 (Power-up mode)

Value:
 Auto restart in local operation, use saved ref. (Auto restart)
 ★ Stopped in local operation, use saved ref. (Loc=Stop)
 Stopped at local operation, set ref. to 0 (Loc=Stp+Ref=0)

[0]
 [1]
 [2]

Function:
 Initial situation for Local Start/Stop, Local Reference (para. 004) and Freeze Reference (para. 400, 401 or 405) can be selected on start up (mains connection).
Description of choices:
Auto Restart in Local Operation, use saved ref. is selected if the unit is to start up with the references/values which applied on power off.
Stopped on Local Operation, use saved ref. is selected if the unit is to remain stopped on mains connection until the start command is given. After start command the VLT® runs with the saved references.
Stopped on local operation, set ref. to 0 is selected if the unit is to remain stopped on mains connection. Local Reference (para. 004) and Freeze Reference (para. 400, 401 or 405) are set at zero.
 If remote control is used together with a Freeze Reference function on power off, Freeze Reference will be set at zero on mains connection. The speed must therefore be reset with the Speed-Up function (e.g. para. 406).
NB!
 On remote controlled operation, the restart function will always be "Auto Restart". If the unit is to remain stopped after mains connection, Pulse start in para. 402 must be selected. However, it is a condition that the start function is not activated.

★ = Factory setting. Text in () = Display text.
 The figures in [] are used in bus communication.

015
**Setup selection,
Programming**
(setup program)

Value:

Preprogrammed	(Factory Set)	[0]
Setup 1	(Setup 1)	[1]
Setup 2	(Setup 2)	[2]
Setup 3	(Setup 3)	[3]
Setup 4	(Setup 4)	[4]
(★)Setup=Parameter 001	(Set-up=P001)	[5]

The menu setup in which to program (change data) can be selected.

It is possible to program the 4 menu setups independently of which setup the VLT[®] frequency converter is operating in (selected in parameter 001). This concerns programming via the keyboard and the serial bus (RS485).

Description of choices:

Preprogrammed contains the factory-set data and can be used as data source if the other setups are to be brought to a known status. The language is always English.

It is not possible to change data once this setup has been chosen.

Setup 1-4 is 4 individual setups which can be used as required. These can be programmed freely, irrespective of which setup the VLT[®] is running in.

Setup = Parameter 001 is the preset value normally used. This function can be deselected for access to program during operation in other setups than the VLT[®] is currently running in.

NB! If data is changed in the setup the VLT[®] is currently running in, the changes have an immediate impact on the unit's function. This applies to both parameters 001 and 015.

★ = Factory setting. Text in () = Display text.
The figures in [] are used in bus communication.

100
Load
(Load type)

Value:

Variable torque low (VT mode-low)	[0]
Variable torque medium (VT mode-med)	[1]
Variable torque high (VT mode-high)	[2]
VT low CT start (VT low W/CT)	[3]
VT medium CT start (VT med W/CT)	[4]
VT high CT start (VT high W/CT)	[5]
Constant torque (CT mode)	[6]
★ Constant torque compensated (CT with comp)	[7]
CT 4 quadratic with slip compensation (CT W 4Q COMP)	[8]

Function:

Adjustment of the VLT® frequency converter's U/f characteristics to the load torque's characteristics.

Description of choices:

Variable torque (VT) low, medium or high is selected if the load is quadratic (centrifugal pumps, fans). Choice of torque should normally be made with due consideration of problem-free operation, lowest possible energy consumption and least possible acoustic noise.

Variable torque (VT) low, medium or high with constant torque (CT) start is selected if there is a need for higher break-away torque than can be achieved with the three aforementioned characteristics. The constant torque curve is followed until the set reference is reached, after which the variable torque characteristics are followed.

Constant torque without start compensation is a load-independent U/f characteristic used for parallel-coupled motors and synchronous type motors.

Constant torque with start compensation is a load-dependent U/f characteristic where the output voltage is increased on increasing load (current) to maintain constant magnetization of the motor and to compensate for loss in the motor during start.

Constant torque with 4 quadratic slip compensation has the same function as described for [7] but with slip compensation for both motor and regenerative operation. Slip compensation on regenerative operation will usually require use of the brake option/module. However, the slip compensation is only active if the function is selected in parameter 101.

★ = Factory setting. Text in () = Display text.
The figures in [] are used in bus communication.

101
Speed control
(Speed control)

Value:
Open loop (open loop)
★ Slip compensated (slip comp)
Closed loop (closed loop)

Function:
[0] It is possible to select three different types of speed control: open loop, slip compensation and closed loop.
[1]
[2]

Description of choices:
Open loop is selected when parallel-coupled motors or synchronous type motors are used, or if slip compensation is not required for another reason.
Slip compensation is selected on normal operation where constant motor speed is required, with varying load.
Closed loop is selected if operation with process feedback is required. This selection also requires selection of feedback type in parameter 114 (current, voltage or pulsations) and setting of PID regulator parameters (119-125).

102
Current limit control
(Set cur.limit)

Value:
★ Preprogrammed value (Program.value)
Voltage signal (10 VDC signal)
Current signal (20 mA signal)

Function:
[0] The current limit can be set in parameter 209 and in parameter 412 or 413 with the help of a current or voltage signal.
[1]
[2]

Description of choices:
Preprogrammed value is selected when a fixed set limit for current is required. This current limit is set in parameter 209.
Voltage signal is selected if the current limit is to be changed during operation with the help of a control signal of e.g. 0-10 V on analogue input 53 (parameter 412) where 0 V will correspond to 0% current and 10 V to the value in parameter 209.
Current signal is selected on e.g. 0-20 mA on analogue input 60 (parameter 413). Here 0 mA will correspond to 0% current limit and 20 mA will correspond to the value in parameter 209.

Note:
The start conditions (terminals 18 and 27) must be present together with a speed reference (possibly digital ref. parameter 205-208) so that current limit control can be used.

Warning:
If the aforementioned conditions exist when the unit is switched on, the motor can rotate for up to 5 sec. even though the current limit setting is 0.

★ = Factory setting. Text in () = Display text.
The figures in [] are used in bus communication.

<p>103 Motor power (Motor power)</p>	<p>Value: (Depending on unit) Undersize [0] ★ Rated size [1] Oversize</p>	<p><i>Function:</i> Selection of connected motor size in kW. This data value is e.g. used for automatic setting of other motor parameters 107-113.</p>
<p>104 Motor voltage (U_{M,N}) (Motor voltage)</p>	<p>Value: <i>Only for 200-230 V units</i> ★ 200 V 220 V 230 V <i>Only for 380-415 V units</i> ★ 380 V 400 V 415 V <i>Only for 440-500 V units</i> ★ 440 V 460 V 500 V</p>	<p>[2] <i>Description of choices:</i> Read rated motor output in kW from the motor's type plate and select this value. If this value deviates significantly from the setting options, select the closest low or high value (under- or oversize). The parameters 107-113 must then be optimized manually with standard settings for motors from 0.55-200 kW.</p> <hr/> <p>Select the rated motor output (V) on the motor plate. [0] Parameters 107-113 are changed automatically. [1] All values can be addressed via the bus. [2] It is possible to select 440 V motor voltage on a 400 V unit. This can be used to optimise motor voltage on using e.g. a 440 V motor on 415 V mains voltage. [3] If the VLT® types 3060-3250 is factory set to 500 V, so that the lowest motor voltage which can be selected is 440 V, this can be adjusted in parameter 650 by changing the data values to the same VLT® type, but 400 V mains voltage. [4] [5] [6] [7] [8]</p>
<p>105 Motor frequency (f_N) (Motor freq)</p>	<p>Value: 50 Hz (50 Hz) 60 Hz (60 Hz) 87 Hz (87 Hz) 100 Hz (100 Hz) ★ Depending on unit</p>	<p>Select the rated motor frequency (Hz) on the motor plate. If a motor for 220/230 V is connected to a 380/415 V frequency converter, the default value (50 Hz) must be changed to 87 Hz. Parameters 107-113 are changed automatically. [0] [1] [2] [3]</p>



★ = Factory setting. Text in () = Display text.
The figures in [] are used in bus communication.

106
Automatic motor adaption

(Auto motor set)

Value:
★ From (Tuning-off)
To (Tuning-on)

[0]
[1]

If this parameter is set to "on", the frequency converter automatically sets the compensation parameters 108-113. Automatic motor adaption is started by pressing  if the unit is in local setting. If the unit is set to remote control, an external start signal is given (terminals 18 and 27). After automatic motor adaption, the values switches automatically to "from" and the unit trips. After automatic motor adaption the unit goes into alarm mode, trips and displays "AUTOTUN.OK" or "AUTOTUN.FAULT". The unit can be reset by pressing  or by activating the reset input (parameter 400, terminal 16 or parameter 401, terminal 17). Automatic motor adaption is possible with up to 50% load on the shaft. Automatic motor adaption is possible only on motor sizes which can be selected in parameter 103 and after setting parameters 103-105.
Warning: The motor will run at 20 Hz during part of the tuning. The direction is determined by the reversing signal to terminal 19 (parameter 403), serial bus (parameter 507), local rotation direction (parameter 008) and the sign of the reference signal.

107
Motor current ($I_{M,N}$)

(Motor current)

Value:
 $I_{\Phi} - I_{VLT,MAX}$

Read the rated motor current on the motor's type plate and set the value in ampere. The value is used for different calculations in the frequency converter; for instance thermal overload and torque indication.

108
Motor magnetizing current (I_{Φ})

(motor mag. amp)

Value:
 $0.3 - I_{M,N}$

The value is used for different calculations in the frequency converter; for instance compensation and torque indication. If you record a value that is too low the motor will be over-compensated and the frequency converter can cut out.

109
Start voltage

(Start voltage)

Value:
 $0.0 - (U_{M,N} + 10\%)$

You can set the motor voltage below the field weakening point independently of the motor current. Use this parameter to compensate too low starting torque. If several motors are operating in parallel the start voltage must normally be raised.
Warning: If the use of start voltage is overdone it can lead to magnetic saturation and motor overheating and the frequency converter may trip out. Therefore take care when using the start voltage.

★ = Factory setting. Text in () = Display text.
The figures in [] are used in bus communication.

110 Start compensation (Start comp.)	Value: 0.00 - 99 V/A	The output voltage is regulated as a function of the load. If the value is set too high, the VLT® frequency converter can cut out due to excess current.
111 U/f ratio (U/f ratio)	Value: 0.00 - 20 V/Hz	The output voltage can be adjusted to the motor on a linear basis from 0 to rated frequency (para. 105). The setting must only be changed if it is not possible to record correct motor data in parameters 104 and 105.
112 Slip compensation (Slip comp)	Value: 0.0 - 20%	The output frequency is changed as a function of the load. This makes the motor speed less load-dependent. <i>Description of choices:</i> $\text{Para. 112} = \frac{N_{\text{slip}}}{N_{\text{synchron}}} \times 100\%$ Example: 4 pole motor → $N_{\text{synchron}} = 1500 \text{ rev./min.}$ $N_{\text{nominal}} = 1420 \text{ rev.} \rightarrow N_{\text{slip}} = 80 \text{ rev./min.}$ $\text{Para. 112} = \frac{80}{1500} \times 100 = 5,33 \%$ If the set value is too high, the number of revolutions is increased with the load. Entered as a percentage of rated motor frequency (parameter 105).
113 Negative slip compensation (Neg slip comp)	Value: 0.0 - 20%	If the load is regenerating the frequency will be decreased at increasing regenerating load. The value might be different from that in parameter 112. Parameter 100 must be set to 4 quadratic with slip compensation [8].
114 Feedback type (Feedback type)	Value: Voltage (voltage) [0] ☆ Current (current) [1] Pulses (pulses) [2]	When using the PID controller one of the inputs on terminal 17, 53 or 60 must be used for the feedback signal. Naturally these choices block the same type as reference signal.
115 Display value at min. feedback (Dis VLU@min FB)	Value: ☆ 0 - 9999 ☆ 0	Parameters 115 and 116 are used to scale the display wich can be given proportional to a transmitter signal. If, for example, a transmitter has a range of 6 to 10 bar, you can enter 6 in parameter 115 and 10 in parameter 116.
116 Display value at max. feedback (Dis VLU@max FB)	Value: 0 - 9999 ☆ 100	The value will be read out if "Display/feedback" is selected in DISPLAY MODE.

☆ = Factory setting. Text in () = Display text.
 The figures in [] are used in bus communication.

117 Display unit (Display unit)	Value: ★ % (standard) [0] [20] °C [1] °F [21] PPM [2] PPM [22] Pa [3] In HG [23] bar [4] bar [24] rpm [5] RPM [25] l/s. [6] gal/s. [26] m ³ /s. [7] ft ³ /s. [27] l/min [8] gal/min. [28] m ³ /min. [9] ft ³ /min. [29] l/h [10] gal/h [30] m ³ /h [11] ft ³ /h [31] kg/s. [12] LB/s. [32] kg/min. [13] LB/min. [33] kg/h [14] LB/h [34] T/h [15] t/min. [35] m [16] FT [36] Nm [17] LP FT [37] m/s. [18] FT/s. [38] m/min. [19] FT/min. [39]	Choose between a various number of unit read-outs to be displayed together with the feedback display value. Display scaling is made in parameters 115, 116 and 005.
119 FF factor (Feed fwd factor)	Value: 0 - 500% ★ 100%	The feed forward function determines the start frequency proportional to the set point.
120 Controller range (Contrl range)	Value: 0 - 100% ★ 100%	The controller range (band width) limits the output from the PID controller as a percentage of f_{MAX} . This indicates the maximum deviation from the start frequency.
121 Proportional gain (Proprt / L gain)	Value: OFF - 10.00 ★0.01	Fast control is obtained when the value is high. The value can be too high, and then the process may become unstable.
122 Integral time (Integral time)	Value: 0.01 - 9999 sec. (OFF) ★(OFF)	Fast control is obtained when the integral time is short. The value can be too short, and then the process may become unstable. 9999 = OFF. Means that the integration function is inactive.
123 Differentiation time (Differntl time)	Value: OFF - 10.00 sec. ★(OFF)	Fast control is obtained when the differentiation time is short. The value can be too short, and then the process may become unstable. When the differentiation time is 0 sec., the D-function is not active.
124 Low pass filter (Lowpass filter)	Value: 0.0 - 10.00 sec. ★0.0	The feedback signal is dampened with a low pass filter with a time constant (τ) of 0-10 sec. 0 sec. = non-activated.
125 Feedback factor (Feedback factor)	Value: 0 - 500% ★ 100%	Used to adapt a non-optimal feedback signal.

★ = Factory setting. Text in () = Display text.
 The figures in [] are used in bus communication.

<p>200 Frequency range (f_{RANGE}) (Freq range)</p>	<p>Value: ★ 0 - 120 Hz 0 - 500 Hz</p>	<p>[0] [1]</p>	<p>Set the maximum of the frequency converter's output frequency range.</p>												
<p>201 Min. frequency (f_{MIN}) (Min frequency)</p>	<p>Value: 0,0 - f_{MAX} ★ 0,0</p>		<p>The output frequency corresponding to the minimum reference input.</p>												
<p>202 Max. frequency (f_{MAX}) (Max frequency)</p>	<p>Value: $f_{\text{MIN}} - f_{\text{RANGE}}$ ★ Depending on unit</p>		<p>The output frequency corresponding to the maximum reference input.</p>												
<p>203 JOG frequency (JOG frequency)</p>	<p>Value: 0.0 - f_{RANGE} ★ 10 Hz</p>		<p>A preset output frequency. The jog frequency can be lower than the minimum output frequency recorded in parameter 201, but is limited by the f_{MAX} setting in parameter 202. The JOG frequency can be activated via the keyboard or terminal 29 (para. 405).</p>												
<p>204 Digital reference type (Dig. ref. type)</p>	<p>Value: ★ Sum (sum) Relative (relative) External on / off (ext. on / off)</p>	<p>[0] [1] [2]</p>	<p>On selection of <i>sum</i> one of the digital references (parameters 205-208) as a percentage of f_{MAX} is added to the other references.</p>												
<p>205 Digital reference 1 (REF. 1 digital)</p>	<p>Value: -100.00% - +100.00% ★ 0 of f_{MAX}/analog ref.</p>		<p>On selection of <i>relative</i> one of the digital references (parameters 205-208) is added as a percentage of the other references.</p>												
<p>206 Digital reference 2 (REF. 2 digital)</p>	<p>Value: -100.00% - +100.00% ★ 0 of f_{MAX}/analog ref.</p>		<p>On selection of <i>external on/off</i> none of the digital references is added.</p>												
<p>207 Digital reference 3 (REF. 3 digital)</p>	<p>Value: -100.00% - +100.00% ★ 0 of f_{MAX}/analog ref.</p>		<p>It is possible to switch between the other references and one of the digital references (parameters 205-208) via terminal 29 (parameter 405).</p>												
<p>208 Digital reference 4 (REF. 4 digital)</p>	<p>Value: -100.00% - +100.00% ★ 0 of f_{MAX}/analog ref.</p>		<p>NB: The sign determines only the running direction when external to/from is selected.</p> <p><i>Other references</i> are the sum of the analogue, pulse and bus references.</p> <p><i>One of the digital references</i> is selected via terminals 32 and 33, (para. 406) cf. the table below.</p>												
<p>Terminal 33/ Terminal 32</p>															
<table border="0"> <tr> <td>0</td> <td>0</td> <td>Digital ref. 1</td> </tr> <tr> <td>0</td> <td>1</td> <td>Digital ref. 2</td> </tr> <tr> <td>1</td> <td>0</td> <td>Digital ref. 3</td> </tr> <tr> <td>1</td> <td>1</td> <td>Digital ref. 4</td> </tr> </table>			0	0	Digital ref. 1	0	1	Digital ref. 2	1	0	Digital ref. 3	1	1	Digital ref. 4	
0	0	Digital ref. 1													
0	1	Digital ref. 2													
1	0	Digital ref. 3													
1	1	Digital ref. 4													

★ = Factory setting. Text in () = Display text.
The figures in [] are used in bus communication.

209 Current limit (I_{LIM}) (Current limit)	Value: $0.0 - I_{VLT,MAX}$	★ Depending on unit	Max. allowable output current. The factory-set value corresponds to a 160% load of the rated motor size. Not applicable to all types. Settings between 105% and 160% may only be applied on intermittent operation. If the set value is too low the motor will not start.
210 Warning frequency low (f_{LOW}) (LOW freq warn)	Value: $0.0 - f_{RANGE}$	★ 0.0	This value sets the lower warning frequency f_{LOW} of the normal frequency converter operation range, see page 71 . If the output frequency is below f_{LOW} the display shows FREQ. VAR. LOW . The signal outputs can be programmed to give a warning signal (parameters 407-410).
211 Warning frequency high (f_{HIGH}) (HI freq warn)	Value: $0.0 - f_{RANGE} + 10\%$	★ 132 Hz	This value sets the higher warning frequency f_{HIGH} of the normal frequency converter operation range, see page 71 . If the output frequency is higher than f_{HIGH} the display shows FREQ. VAR. HIGH . The signal outputs can be programmed to give a warning signal (see parameters 407-410).
212 Warning current low (I_{LOW}) (Lo curr. warn)	Value: $0.0 - I_{VLT,MAX}$	★ 0.0	This value sets the lower warning current I_{LOW} of the normal frequency converter operation range, see page 71 . If the output current is below I_{LOW} the display shows CURR VAR. LOW . You can program the signal outputs to give an alarm signal (see parameters 407-410).
213 Warning current high (I_{HIGH}) (Hi curr. warn)	Value: $0.0 - I_{VLT,MAX}$	★ $I_{VLT,MAX}$	This value sets the higher warning current I_{HIGH} of the normal frequency converter operation range, see page 71 . If the output current is higher than I_{HIGH} the display shows CURR VAR. HIGH . The signal outputs can be programmed to give a warning signal (see parameters 407-410).
214 Ramp type (Ramp type)	Value: ★ Linear (linear) Sine shape (s curve 1) Sine ² shape (s curve 2) Sine ³ shape (s curve 3)	[0] [1] [2] [3]	Select the shape of the ramp up and the ramp down. The sine shapes give a softer start and stop of the acceleration and deceleration. The sinusoidal ramps cannot be set with steps as small as the linear ramp, even though the display indication appears to be continuous.

★ = Factory setting. Text in () = Display text.
 The figures in [] are used in bus communication.

<p>215 Ramp-up time (Ramp up time)</p>	<p>Value: 0.00 - 3600 sec.</p>	<p>★ Depending on unit</p>	<p>The ramp-up time t_a is the acceleration time from 0 Hz to the rated motor frequency, provided that the output current is not higher than the current limit (parameter 209).</p>
<p>216 Ramp-down time (Ramp down time)</p>	<p>Value: 0.00 - 3600 sec.</p>	<p>★ Depending on unit</p>	<p>The ramp-down time t_d is the deceleration time from rated motor frequency to 0 Hz, provided that there is no excess voltage in the inverter due to regenerative operation of the motor. The requirement of rapid braking can make it necessary to install a brake option.</p>
<p>217 Alternative ramp-up time (ALT. up ramp)</p>	<p>Value: 0.00 - 3600 sec.</p>	<p>★ Depending on unit</p>	<p>The alternative ramp time is activated using start on jog speed via terminal 29, parameter 405. A start signal must <i>not</i> have been given (e.g. terminal 18, parameter 402).</p>
<p>218 Alternative ramp-down time (ALT. down ramp)</p>	<p>Value: 0.00 - 3600 sec.</p>	<p>★ Depending on unit</p>	<p>The alternative ramp time is activated using quick stop via terminal 27, parameter 404 or via serial bus (RS485).</p>
<p>219 Frequency bypass 1 (Freq 1 bypass)</p>	<p>Value: 0 - f_{RANGE}</p>	<p>★ f_{RANGE}</p>	<p>Some systems require that certain output frequencies are avoided due to resonance problems in the installation.</p>
<p>220 Frequency bypass 2 (Freq 2 bypass)</p>	<p>Value: 0 - f_{RANGE}</p>	<p>★ f_{RANGE}</p>	<p>Record the frequencies to be avoided and record the bandwidth as a percentage of the recorded frequencies. The bypass band is the bypass frequency +/- the set bandwidth.</p>
<p>221 Frequency bypass 3 (Freq 3 bypass)</p>	<p>Value: 0 - f_{RANGE}</p>	<p>★ f_{RANGE}</p>	
<p>222 Frequency bypass 4 (Freq 4 bypass)</p>	<p>Value: 0 - f_{RANGE}</p>	<p>★ f_{RANGE}</p>	
<p>223 Frequency bypass band width (Bypass B. width)</p>	<p>Value: 0 - 100%</p>	<p>★ 0</p>	
<p>224 Carrier frequency (Carrier freq.)</p>	<p>Value: 2.0 - 14.0 kHz</p>	<p>★ 4.5 kHz</p>	<p>The set value determines the carrier frequency. Changing the switching frequency will minimise any acoustic noise from the motor. VLT® 3060-3250 and certain old types may not operate at a higher switching frequency than 4.5 kHz.</p>
<p>225 (version 3.0) Output frequency-dependent switch frequency (output.sw.freq.)</p>	<p>Value: ★ DISABLE ENABLE</p>	<p>[0] [1]</p>	<p>Note: Switching frequencies higher than 4.5 kHz give certain deratings, see p. 131.</p> <p>The switching frequency depends on the output frequency. The switching frequency can either be fixed at "DISABLE" or decreasing with increasing output frequency "ENABLE". Maximum switch frequency is, however, determined by parameter 224.</p>

★ = Factory setting. Text in () = Display text.
The figures in [] are used in bus communication.

<p>225 (version 3.11) Output frequency-dependent switch frequency (output.sw.freq.)</p>	<p>Value: Disable (DISABLE) [0] High switching frequency at low speed [1] (HIGH CARR @LO) ☆ Low switching frequency at low speed [2] (LOW CARR @LO)</p>	<p><i>Description of choices:</i> <u>Disable:</u> This gives a fixed switching frequency. This is to be chosen, when using LC filter (set par. 224 to 4.5 kHz). <u>High switching frequency at low speed:</u> This is to be chosen for variable torque. The function is not available for VLT 3060-3250. 0-50% of rated output frequency is switching frequency = data for par. 224. 50-100% of rated output frequency reduces the switching frequency to 4.5 kHz. The function can reduce the acoustic motor noise. <u>Low switching frequency at low speed:</u> At low output frequency and current the switching frequency starts at 1.1 kHz. From 8 Hz the switching frequency increases to 4.5 kHz. The function improves the motor stability.</p>
<p>230 Brake cut-out frequency (Brake of freq.)</p>	<p>Value 0.5 Hz-f_{RANGE} ☆ 3 Hz</p>	<p><i>Function:</i> Here the frequency at which the external brake is to be released via Relay 01/04 is selected. <i>Description of choices:</i> The electromechanical brake must hold the motor until the selected frequency is reached, after which the brake is released (voltage impressed via a relay). If the frequency with connected start signal comes below the selected value, the voltage to the brake is removed and it again becomes active.</p>
<p>231 Brake cut-in frequency (Brake on freq.)</p>	<p>Value 0.5 Hz-f_{RANGE} ☆ 3 Hz</p>	<p><i>Function:</i> Here the frequency at which the external brake is to be activated by stop via Relay 01/04 is selected. <i>Description of choices:</i> The electromechanical motor brake must first be activated (voltage removed) when the frequency during ramp-down reaches the set value.</p>
<p>232 Current, Minimum value (Curr. min value)</p>	<p>Value 0.0 ☆0.5 x I_{MAG}</p>	<p><i>Function:</i> Here the minimum current value to release the brake is selected. <i>Description of choices:</i> The brake is released/kept open (voltage impressed via a relay) when the minimum current value is reached. This function is not active until expiry of the time in para. 233.</p>
<p>233 Current, Delay time (Curr .dlay. time)</p>	<p>Value 0.00 - 1.00 sec. ☆ 0,10 sec.</p>	<p><i>Function:</i> Here the delay time for current monitoring is selected (in para. 232). <i>Description of choices:</i> The brake is activated (de-energized) if the motor current has not reached the value set in par. 232 after the time delay has run out. If 0.0 sec. is selected, the brake is not released until the preselected minimum current is reached.</p>

☆ = Factory setting. Text in () = Display text.
 The figures in [] are used in bus communication.

300 Brake option (Brake option)	Value: ☆ Not applied (not applied) [0] Applied (applied) [1]	The parameter is used with the brake option and brake resistor. A higher intermediate circuit voltage during braking is permitted.
301 Start frequency (Start freq.)	Value: 0.0 - 10 Hz ☆0.0	Insert the start frequency at which the motor is to start (can e.g. be used on raise/lower application).
302 Start delay (Start delay)	Value: 0.0 - 1 sec. ☆0.0	The VLT® frequency converter will start on the start frequency (parameter 301) and start ramping up after the start delay time is over.
303 High starting torque (HI start torq)	Value: 0.0 - 1 sec. ☆0.0	Set the time needed for high starting torque. A high initial torque means that a current of 2 x the current limit in parameter 209 is permitted. However, the current is limited by the inverter's protection limit.
304 Mains failure (Power fail)	Value: ☆ Uncontrolled stop (stop) [0] Ramp-down 1 (ramp stop) [1] Ramp-down 2 (alt. ramp st.) [2]	<p><i>Function:</i> Select one of the 3 ramp-down functions to prolong the ride through time at mains failure. The effect will depend on the load and the mains voltage before failure.</p> <p><i>Description of choices:</i> UNCONTROLLED STOP: The motor will continue running at the selected speed until control trips. RAMP-DOWN 1: The motor will start to ramp down immediately (parameter 216) until control trips. RAMP-DOWN 2: The motor will start to ramp down immediately (parameter 218). Reliable regenerative operation of the frequency converter over the ramp down 1 or 2 function requires a large inertia force and negligible operational motor load on the frequency converter.</p>
305 Flying start (Flying start)	Value: ☆ Disable (disable) [0] OK - same direction (same direct) [1] OK - both directions (both direct) [2] DC-brake before start (DC-brake 1st) [3]	<p><i>Function:</i> The parameter is used when the VLT® frequency converter is cut in on a rotating motor (e.g. after current has been disconnected). This function is optimal at a 4.5 kHz switching frequency. The function may not work properly when using another switching frequency.</p> <p><i>Description of choices:</i> OK - same direction: Chosen if the motor can only rotate in same direction on cut-in. OK - both directions: Chosen when the motor can only rotate in both directions on cut-in. Stop - before start: Selected if the motor is to be stopped using d.c brake before the motor is ramped up to the desired speed. The D.C. brake time must be set in parameter 306. The selected function is activated in accordance with the diagram on p. 72.</p>

☆ = Factory setting. Text in () = Display text.
 The figures in [] are used in bus communication.

<p>306 DC braking time (DC-brake time)</p>	<p>Value: 0.0 - 60.0 sec. ★ 0</p>	<p>If the stator in an asynchronous motor is supplied with D.C. voltage, a braking torque will arise. Select the duration of the impressed D.C. current injection (306). Pay attention to the motor's power set-off.</p>
<p>307 DC brake cut-in frequency at stop (DC-brk on freq)</p>	<p>Value: 0.0 - f_{RANGE} ★ 1.0</p>	<p>Thermal motor protection is also updated at DC braking.</p>
<p>308 DC brake voltage (DC-brk voltage)</p>	<p>Value: 0 - 50 V ★ Depending on unit</p>	<p>Select at what output frequency the D.C. brake is to be activated on ramp-down to stop (para. 307). Parameters 306 and 307 must be other than 0 to activate the D.C. brake. The D.C. brake can also be activated via terminal 27 (parameter 404). The brake torque depends on the selected D.C. brake voltage (para. 308).</p>
<p>309 Reset mode (Reset mode)</p>	<p>Software version 3.11 Value: 0.0 - 50.0 V ★ 0.0</p>	<p>A start signal must be present after power-up to provide DC-braking by means of a stop signal.</p>
<p>309 Reset mode (Reset mode)</p>	<p>Value: ★ Manual reset (manual) [0] Auto reset (automatic x 1) [1] Auto reset (automatic x 2) [2] Auto reset (automatic x 3) [3] Auto reset (automatic x 4) [4] Auto reset (automatic x 5) [5] Auto reset (automatic x 6) [6] Auto reset (automatic x 7) [7] Auto reset (automatic x 8) [8] Auto reset (automatic x 9) [9] Auto reset (automatic x 10) [10] Start disabled (start bloc.) [11]</p>	<p>If the frequency converter is to reset automatically, select automatic reset 1-10.</p> <p>Warning: The motor can start without warning. Select how many times the frequency converter is to reset automatically after cut-out within 20 min. Start disabled blocks re-start after tripping.</p> <p>Start disabled functions only in connection with serial communication, since re-start is only possible via the bus.</p> <p>If start disabled is used <i>without</i> simultaneous use of the bus, re-start is disabled.</p> <p>Start disabled provides for application of the status table as in PROFIBUS when the control word is ON1, ON2 and ON3. The status table can be found in PROFIBUS literature, MG.10.AX.02.</p>
<p>310 Trip delay at current limit (Trip dly@c.lim)</p>	<p>Value: 0 - 60 sec. ★ OFF</p>	<p>When the frequency converter registers that the output current has exceeded the current limit I_{LIM} (parameter 209) it will await a trip. Record for how long you want the frequency converter to wait before tripping out. OFF signifies that the time is infinite.</p>

★ = Factory setting. Text in () = Display text.
The figures in [] are used in bus communication.

311 Trip delay at inverter fault (Trip dly@fault)	Value: 0 - 35 sec. ☆ Depending on unit Software version 3.11: Under voltage fixed ☆ 25 sec. Over voltage ☆ 0 sec.	When the frequency converter registers an over- or under-voltage in the inverter it will await a final trip. Record for how long you want the frequency converter to wait before tripping out. Note: If this value is reduced from the factory setting, the unit may report a fault at Power on (undervoltage).
312 Max. auto restart time (Auto restart t)	Value: 0 - 10 sec. ☆5 sec.	Sets the max. time allowed for auto restart before a final trip, if selected in para. 309.
313 Motor check (Motor check)	Value: ☆ Off (OFF) [0] On (ON) [1]	If "on" is selected the presence of a motor is checked when there is 24 V voltage to terminal 27 and no start command has been given (START, START REV. or JOG). If a motor is not connected, the message NO MOTOR is shown. This function is not found for VLT® types 3032-3052, 230 V, and VLT® types 3060-3250.
314 Motor pre-heat (Motor pre-heat)	Value: ☆ Off (OFF) [0] On (ON) [1]	If "on" is selected the motor will be pre-heated by a DC current when motor coasting is permitted (terminal 27 = on) and no start command has been given (START, START REV. or JOG). This function is not found for VLT® types 3032-3052, 230 V, and VLT® types 3060-3250.
315 Motor thermal protection (Motor thermal)	Value: ☆ Off (OFF) [0] Warning 1 (warning 1) [1] Trip 1 (trip 1) [2] Warning 2 (warning 2) [3] Trip 2 (trip 2) [4] Warning 3 (warning 3) [5] Trip 3 (trip 3) [6] Warning 4 (warning 4) [7] Trip 4 (trip 4) [8]	The frequency converter calculates whether the motor temperature exceeds the permissible limits. The calculation is based on 1.16 x rated motor current (set in parameter 107). Four separate calculations are possible, so that one can be chosen for each setup or the same calculation can be used in several setups. Select <i>off</i> if you do not want either warning or trip. Select <i>warning only</i> if you want a warning in the display when the motor is overheating. You can also program the frequency converter to give a warning signal via the signal outputs (parameters 407-410). Select <i>"trip"</i> if trip is required when the motor is overloaded. You can also program the frequency converter to give an alarm signal via the signal outputs (parameters 407-410). See graph on page 130 .
316 Relay ON-delay (Relay on delay)	Value: 0.00 - 10.00 sec. ☆ 0.00	The delay timers will influence the switch in/out delay of the relay associated with terminals 01-02-03.
317 Relay OFF-delay (Relay off dela)	Value: 0.00 - 10.00 sec. ☆ 0.00	

☆ = Factory setting. Text in () = Display text.
 The figures in [] are used in bus communication.

400
Binary input 16
 (Input 16)

- Value:
- ★ Reset (reset)
 - Stop (stop)
 - Freeze reference (freeze ref.)
 - Select setup (setup selection)
 - Thermistor (thermistor)

Function:
 [0] Used to select between different function options for terminal 16.

[1]
 [2] *Description of choices:*
 [3]
 [4]

Reset: With voltage to terminal 16 (see voltage levels on p. 31), the frequency converter can be reset after a trip. Reference is also made to the section on RESET messages on p. 124.

Stop: The stop function is activated by breaking the voltage to terminal 16, i.e. there must be voltage to terminal 16 for the motor to run. Stop will take place in accordance with the selected ramp time in parameter 216. The function is normally used together with pulse start, terminal 18 (parameter 402). A pulse ("0" for min. 20 msec.) to terminal 16 will stop the motor, and a pulse ("1" for min. 20 msec.) to terminal 18 will start the motor.

Freeze reference: Selected if terminals 32/33 (parameter 406) are to be used for digital speed control UP/DOWN (motorized potentiometer). Logic "1" on terminal 16 will freeze the current reference, and the speed can be changed with the help of terminal 32/33 (parameter 406 = speed UP/DOWN).

Select setup: If multi setup has been selected in parameter 001, selection can be made with terminal 16 between setup 1 ("0") and setup 2 ("1"). If there is a need for more than 2 setups, both terminals 16 and 17 (parameter 401) are used to select setup.

Setup	Terminal 17	Terminal 16
1	0	0
2	0	1
3	1	0
4	1	1

★ = Factory setting. Text in () = Display text.
 The figures in [] are used in bus communication.

400
Binary input 16

(Input 16)
(Continued)

Typical thermistor characteristics

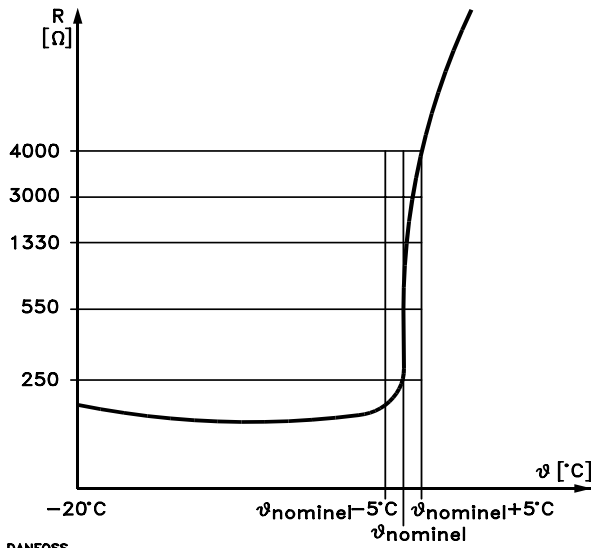

DANFOSS
175HA183.10

Thermistor: Selected if a motor's possible built-in thermistor is to be able to stop the frequency converter if the motor overheats. The cut-out value is $\geq 3 \text{ k}\Omega$. The thermistor is connected between terminal 50 (+10 V) and terminal 16 (see p. 37). When the thermistor's resistance exceeds $3 \text{ k}\Omega$, the frequency converter will cut out with the following display:

ALARM
TRIP
MOTOR TRIP

If a motor instead of the thermistor is equipped with a Klaxon thermal contact, this can also be used on this input. On operation of parallel-coupled motors, the thermistors can be connected in series, the number depending on the thermistor's ohmic value in heated operating status.

NB: If a thermistor is selected in parameter 400 without being connected, the frequency converter goes into ALARM mode. To come out of this status, the stop/reset button must to be kept down while the data value is changed using the +/- keys.

401
Binary input 17

(Input 17)

Value:

- Reset (reset)
- Stop (stop)
- ★ Freeze reference (freeze ref.)
- Select setup (setup selection)
- Pulse input 100 Hz (pulses 100 Hz)
- Pulse input 1 kHz (pulses 1 kHz)
- Pulse input 10 kHz (pulses 10 kHz)

Function:

- [0] Used to select between different function options for terminal 17.
- [1]
- [2]
- [3] *Description of choices:* Reset, stop, freeze ref. and select setup as for terminal 16.
- [4] *Pulses:* Terminal 17 can be used for pulsing signals in the ranges: 0-100 Hz, 0-1 kHz and 0-10 kHz (see also data p. 31).
- [5]
- [6]

The pulsing signal can be used as a speed reference for ordinary operation and as either set-point or feedback signal on operation in "closed loop" (PID regulator), also see parameter 101. Pulse generators with PNP signal can be used between terminals 12 and 17.

NB: Frequencies higher than about 1 kHz require pulse generators with a push-pull output.

★ = Factory setting. Text in () = Display text.
The figures in [] are used in bus communication.

402
Binary input 18
 (Input 18)

- Value:
- ★ Start (start)
 - Pulse start (latch start)
 - No operation (no operation)

Function:
 Used to select between different function options for terminal 18. Start and stop will take place according to the selected ramp times in parameters 215 and 216.

Description of choices:
Start: Selected if a start/stop function is required. Logic "1" = start, logic "0" = stop.

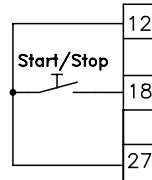

DANFOSS
175HA135.12

Pulse start: To be selected if you want start and stop function on 2 different inputs (can be used with terminals 16, 17 or 27).

A pulse ("1" for minimum 20 msec) on terminal 18 will start the motor.

A pulse ("0" for minimum 20 msec.) on terminals 16, 17 or 27 will stop the motor.

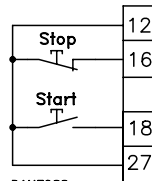

DANFOSS
175HA184.10

No function: To be selected if you do not want the frequency converter to react on signals applied on terminal 18. When using serial communication the input status can be read and used by the master.

★ = Factory setting. Text in () = Display text.
 The figures in [] are used in bus communication.

403
Binary input 19
(Input 19)

- Value:
- ★ Reversing (reversing)
 - Start – rev (start rev.)
 - No operation (no operation)

Description of choices:

[0] Reversing is selected if it is to be possible to change the motor's speed direction.

[1] Logical "0" to terminal 19 will not give reversing.

[2] Logical "1" to terminal 19 will give reversing. The motor can only start if simultaneously with a signal to terminal 19 a start command is given to e.g. terminal 18.

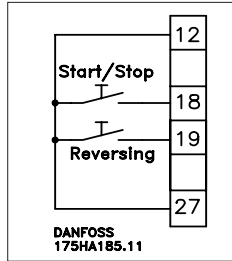

Reversing

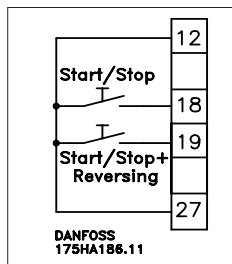

Start with reversing

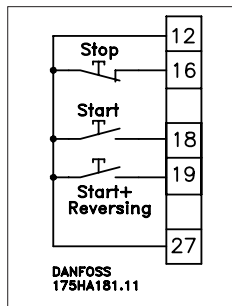

Start with reversing is selected if start and reversing are to be activated with one input.

If pulse start is selected in para. 402, the same function is changed automatically to pulse start with reversing.

NB:
If the start command (logic "1") is given to terminals 18 and 19 simultaneously, the motor is stopped.

No operation:
As para. 402.

★ = Factory setting. Text in () = Display text.
The figures in [] are used in bus communication.

404
Terminal 27 Stop
(input 27)

Value:

- ★ Free-wheeling stop (free-wheeling stop)
- Quick stop (quick stop)
- D.c. brake (D.C. brake)
- Reset and free-wheeling stop (reset & fws)
- Stop (stop - press)

- [0]
- [1]
- [2]
- [3]
- [4]

Function:

Used to select between different function options for terminal 27.

NB: The motor can only operate if terminal 27 is logical "1". However, this can be deselected by using serial communication.

Description of choices:

Free-wheeling stop: Selected if the frequency converter is to "release" the motor which then runs freely until it stops. Logical "0" will lead to free-wheeling stop.

Quick stop: Selected if the motor is to be stopped according to alternative ramp time in parameter 218. Logical "0" will mean quick stop.

D.c. brake: Selected if the motor is to be stopped by impressing a D.C. voltage to the motor for a certain period as selected in parameters 306 and 308. The function is only active when the value in parameters 306 and 308 is different from 0. Logical "0" will lead to D.C. braking.

Reset and free-wheeling stop: Selected when free-wheeling stop is to be activated (see under free-wheeling stop at the top of this description) and reset (see description of reset in parameters 400, 401), simultaneously.

Logic "0" will mean reset and free-wheeling stop.

Stop: Selected if the frequency converter is to be stopped (see description of stop in parameters 400, 401). Logical "0" will mean stop.

★ = Factory setting. Text in () = Display text.
The figures in [] are used in bus communication.

405
Binary input 29
 (Input 29)

- Value:
- ★ Jogging (jog)
 - Freeze jogging (jog freeze)
 - Freeze reference (ref freeze)
 - Digital reference (digital ref)
 - Ramp selection (Ramp selection)

Function:

- [0] Used to select between different function options for terminal 29.
- [1]
- [2] *Description of choices:*
- [3] Jogging: Selected if the output frequency is to be set to the preprogrammed value in parameter 203. No separate start command to activate jogging is required.
- [4] Freeze jogging reference: Selected if terminals 32/33 (parameter 406) are to be used for digital speed control UP/DOWN, with the jogging speed as the basis. Logical "1" on terminal 29 will freeze the jogging reference and the speed can be changed with the help of terminal 32/33 (parameter 406 = speed UP/DOWN).

Freeze reference: Selected to use terminals 32/33 (parameter 406) for digital speed control UP/DOWN (motor potentiometer). Logical "1" on terminal 29 will freeze the current reference, and the speed can be changed using terminal 32/33 (parameter 406 = speed UP/DOWN).

Digital reference: Selected to either select one of the digital references (parameters 205-208) or other references (analogue voltage parameter 412, current parameter 413), pulses (parameter 401), bus reference (parameter 516).

Digital reference functions only if "external to/from" has been selected in parameter 204. When the digital reference is activated, the speed direction is determined exclusively by the reference sign.

Ramp selection:
 Different ramp times can be selected using terminal 29:

Terminal 29 = "0" - Ramp 1 (para. 215/216).

Terminal 29 = "1" - Ramp 1 (para. 217/218).

The selected ramp UP/DOWN times apply on START/STOP via terminal 18 (19 if programmed) and if the reference is changed.
 Selection of Quick Stop via terminal 27 will automatically activate ramp-down time 2 (para. 218).

★ = Factory setting. Text in () = Display text.
 The figures in [] are used in bus communication.

406
Binary input 32/33
(Input 32/33)

- Value:
- Digital reference select (speed select) [0]
 - Speed up / down (speed up/down) [1]
 - Setup selection (setup select) [2]
 - ★ 4 setup extended (4 setup ext.) [3]

Function:
Used to select between different function options for terminal 32/33.
Description of choices:
Digital reference: Selected to select between 4 different preprogrammed speed references, with the help of a binary code according to this table:

Digital reference	Terminal 33	Terminal 32
1 (parameter 205)	0	0
2 (parameter 206)	0	1
3 (parameter 207)	1	0
4 (parameter 208)	1	1

Speed up/down: Selected for digital speed control up/down (motor potentiometer). The function is only active if Freeze reference/Freeze jogging reference has been selected in parameters 400, 401 or 405, and the equivalent terminal 16, 17 or 29 is “on” (+24 V). As long as terminal 32 is “1” (+24 V), the output frequency will increase towards f_{MAX} (parameter 202). For as long as terminal 33 is “1” (+24 V), the output frequency will drop towards f_{MIN} (parameter 201). Terminal 33 is most significant.

	Terminal 33	Terminal 32
No reference-change	0	0
Increase reference	0	1
Reduce reference	1	0
Reduce reference	1	1

A pulse (logical “1” with duration between 20 ms and 500 ms) will cause a speed change of 0.1 Hz to the output.

Logic “1” for more than 500 ms will cause the output frequency to change according to the set ramps (parameters 215 and 216).

Speed reference can be set even though the unit has stopped (does not apply to free-wheeling stop, quick stop or D.C. brake on terminal 27). Speed reference is remembered after mains cut-out if it has been constant for at least 15 sec. (See also parameter 014).

Setup select: If “multi setup” has been selected in parameter 001, there is a choice between setup 1, setup 2, setup 3, or setup according to this table:

Setup	Terminal 33	Terminal 32
1	0	0
2	0	1
3	1	0
4	1	1

★ = Factory setting. Text in () = Display text.
The figures in [] are used in bus communication.

406
Binary input 32/33
 (Input 32/33)
 (Continued)

4 setup extended: Selected if the same function is required on terminals 32/33 as on the first generation of VLT® 3000 Series with extended control card and 4 setup functions. If freeze reference is not selected in parameters 400, 401 and 405, the setups are follows:

Setup	Terminal 32	Terminal 33
1	0	0
2	0	1
3	1	0
4	1	1

If, on the other hand, freeze reference is selected in either parameter 400, 401 or 405, selection can be made between two functions using terminal 16, 17 or 29. Terminal 16, 17 or 29 = "0".

Setup	Terminal 32	Terminal 33
1	0	0
2	0	1
3	1	0
4	1	1

Terminal 16, 17 or 29 = "1".

	Terminal 32	Terminal 33
Freeze reference (sum)	0	0
Increase reference	0	1
Reduce reference	1	0
Reduce reference	1	1

★ = Factory setting. Text in () = Display text.
 The figures in [] are used in bus communication.

407

Signal output 42

(Output 42)

Value:			At signal outputs 42 and 45, selection can be made between 3 types of signal: 24 V (max. 40 mA), 0-20 mA or 4-20 mA. Signal 24 V is used to indicate selected status and warnings; 0-20 mA and 4-20 mA are used for analogue reading.
Control ready (control ready)		[0]	[0] VLT® ready for use.
Unit ready (unit ready)		[1]	[1] VLT® ready for use.
Unit ready remote control (UNT RDY RCTL)		[2]	[2] VLT® set at remote control and ready for use.
Enabled (enabled no WR)		[3]	[3] VLT® ready, no warning.
Running (running)		[4]	[4] VLT® running (output frequency > 0.5 Hz or start signal).
Running no warning (running no WR)		[5]	[5] VLT® running (output frequency > 0.5 Hz or start signal), no warning.
Running in range (RUNinRANGE)		[6]	[6] VLT® running in programmed frequency range and/or current parameters, no warning.
Speed = reference no warning (RUN@REF no WR)		[7]	[7] VLT® output running on reference, no warning.
Alarm (alarm)		[8]	[8] Output activated by alarm.
Alarm or warning (alarm or warn)		[9]	[9] Output activated by alarm or warning.
Current limit (current limit)		[10]	[10] Current range in parameter 209 exceeded.
Out of frequency range (OUT FRQ RGE)		[11]	[11] Motor running out of the programmed frequency range in parameters 210-211.
Out of current range (OUT CURR RGE)		[12]	[12] Motor running out of the programmed current range in parameters 212-213.
0 - 100 Hz	0-20 mA	[13]	[13] 0-100 Hz used to read the actual
0 - 100 Hz	4-20 mA	[14]	[14] output frequency, disregarding the frequency in parameter 202 (f_{MAX}).
0 - f_{MAX}	0-20 mA	[15]	[15] 0- f_{MAX} used to read out the actual
0 - f_{MAX}	4-20 mA	[16]	[16] output frequency, where f_{MAX} is indicated in parameter 202.
REF _{MIN} - REF _{MAX}	0-20 mA	[17]	[17] REF _{MIN} -REF _{MAX} sets the output signal
REF _{MIN} - REF _{MAX}	4-20 mA	[18]	[18] range equivalent to the sum of analogue and pulse input ranges in parameters 401, 412 and 413, and bus reference (parameter 516).
FB _{MIN} - FB _{MAX}	0-20 mA	[19]	[19] FB _{MIN} -FB _{MAX} sets the output signal
FB _{MIN} - FB _{MAX}	4-20 mA	[20]	[20] range equivalent to the feedback signal range selected in parameters 401, 412 or 413.
★ 0 - I_{MAX}	0-20 mA	[21]	[21] 0- I_{MAX} sets the output signal range
0 - I_{MAX}	4-20 mA	[22]	[22] from 0 to $I_{N \times 1.6}$.
0 - I_{LIM}	0-20 mA	[23]	[23] 0- I_{LIM} sets the output signal range
0 - I_{LIM}	4-20 mA	[24]	[24] from 0 to current limit I_{LIM} recorded in parameter 209.
0 - $T_{MOTOR, RATED 100\%}$	0-20 mA	[25]	[25] 0- $T_{MOTOR, RATED}$ indicates the output signal
0 - $T_{MOTOR, RATED 100\%}$	4-20 mA	[26]	[26] range from 0 to the highest permitted torque calculated by the frequency converter.

★ = Factory setting. Text in () = Display text.
The figures in [] are used in bus communication.

408 Signal output 45 (Output 45)	Value:	See breakdown of parameter 407.
	Control ready (control ready)	[0]
	Unit ready (unit ready)	[1]
	Unit ready remote control (UNT RDY RCTL)	[2]
	Enabled (enabled no WR)	[3]
	Running (running)	[4]
	Running no warning (running no WR)	[5]
	Running in range (RUNinRANGE)	[6]
	Speed = reference no warning (RUN@REF no WR)	[7]
	Alarm (alarm)	[8]
	Alarm or warning (alarm/warn)	[9]
	Current limit (current limit)	[10]
	Out of frequency range (OUT FRQ RGE)	[11]
	Out of current range (OUT CURR RGE)	[12]
	0 - 100 Hz 0-20 mA	[13]
	0 - 100 Hz 4-20 mA	[14]
	★ 0 - f_{MAX} 0-20 mA	[15]
	0 - f_{MAX} 4-20 mA	[16]
	$REF_{MIN} - REF_{MAX}$ 0-20 mA	[17]
	$REF_{MIN} - REF_{MAX}$ 4-20 mA	[18]
	$FB_{MIN} - FB_{MAX}$ 0-20 mA	[19]
	$FB_{MIN} - FB_{MAX}$ 4-20 mA	[20]
	0 - I_{MAX} 0-20 mA	[21]
	0 - I_{MAX} 4-20 mA	[22]
	0 - I_{LIM} 0-20 mA	[23]
	0 - I_{LIM} 4-20 mA	[24]
	0 - $T_{MOTOR, RATED 100\%}$ 0-20 mA	[25]
	0 - $T_{MOTOR, RATED 100\%}$ 4-20 mA	[26]

409 Relay output 01 (Relay 01)	Value:	You can use relay outputs 01 and 04 to indicate status and warnings.
	Control ready (control ready)	[0]
	Unit ready (unit ready)	[1]
	Unit ready remote control (UNT RDY RCTL)	[2]
	Enabled (enabled no WR)	[3]
	Running (running)	[4]
	Running no warning (RUNNINGNOWR)	[5]
	Running in range (RUNinRANGE)	[6]
	Speed = reference no warning (RUN@REF no WR)	[7]
	Alarm (alarm)	[8]
	Alarm or warning (alarm/warn)	[9]
	Current limit (current limit)	[10]
	Out of frequency range (OUT FRQ RGE)	[11]
	Out of current range (OUT CURR RGE)	[12]
	Motor thermal overload (mot. therm.W)	[13]
	★ Ready and no motor thermal overload (ready-mot.OK)	[14]
	Ready and no motor (rdy.mot.rem)	[15]
	Ready and no over/undervoltage (ready + D.C. V ok)	[16]
	Motor magnetized (motor mag.)	[17]

The relay is activated when the conditions for the selected data values are fulfilled.

Activation/deactivation can be delayed in parameters 316 and 317.

When relay output 01 is not active there is connection between terminals 01 and terminal 03, but no connection between terminal 01/03 and terminal 02. (Changeover contact).

Description of choices:
[0] [12]: See explanation in parameter 407 [17]. Motor magnetized must be selected for use of the relay for brake control with external brake. (See description of brake control on p. 69).

★ = Factory setting. Text in () = Display text.
The figures in [] are used in bus communication.

<p>410 Relay output 04 (Relay 04)</p>	<p>Value:</p> <ul style="list-style-type: none"> Control ready (control ready) [0] Unit ready (unit ready) [1] ★ Unit ready remote control (UNT RDY RCTL) [2] Enabled (enabled no WR) [3] Running (running) [4] Running no warning (RUNNING NO WR) [5] Running in range (RUNinRANGE) [6] Speed = reference no warning (RUN@REF no WR) [7] Alarm (alarm) [8] Alarm or warning (alarm/warn) [9] Current limit (current limit) [10] Out of frequency range (OUT FRQ RGE) [11] Out of current range (OUT CURR RGE) [12] Motor thermal overload (mot. therm.W) [13] Ready and no motor thermal overload (ready-mot.OK) [14] Ready and no motor (rdy.mot.rem) [15] Ready and no over/undervoltage (ready + D.C. V ok) [16] Motor magnetized (motor mag.) [17] 	<p>You can use relay output 04 and relay output 04 to indicate status and warnings.</p> <p>The relay is activated when the conditions for the selected data values are fulfilled.</p> <p>When relay 04 is active there is connection between terminals 4 and 5.</p> <p>(Make contact). [0]-[12]: See explanation in parameter 407 [17]. See explanation in parameter 409.</p>
<p>411 Analogue reference type (Analog ref type)</p>	<p>Value:</p> <ul style="list-style-type: none"> ★ Linear between min. and max. (linear) [0] Proportional with min. limit (prop w/min.) [1] Proportional with reversing (PROP W/REV) [2] 	<p>Used to determine how the frequency converter is to follow an analogue reference signal, see graph on page 71.</p>
<p>412 Terminal 53 Analogue input voltage (Input # 53 ana)</p>	<p>Value:</p> <ul style="list-style-type: none"> No operation (no operation) *) [0] ★ 0-±10 V (0-10 volt) [1] 10-0 V (10-0 VDC) [2] 2-10 V (2-10 VDC) [3] 10-2 V (10-2 VDC) [4] 1-5 V (1-5 VDC) [5] 5-1 V (5-1 VDC) [6] 	<p>Record the type of analogue input signals to input 53 and 60. You can choose between voltage and current and whether you want the signals to be normal or inverse.</p> <p>If both inputs are used for reference signals, the total reference signal is the sum of both. (See p. 68). The sum is registered with a sign.</p> <p>If you are using the PID controller without the PULSE INPUT, terminal 17 (parameter 401), one of the analogue inputs must be used for the feedback signal.</p> <p>If you are using remote current control (para. 102), one of the inputs must be used to set current limit.</p> <p>Naturally these choices block use of the same type as reference signal.</p>
<p>413 Terminal 60 Analogue input current (Input # 60 ana)</p>	<p>Value:</p> <ul style="list-style-type: none"> No operation (no operation) *) [0] ★ 0-20 mA (0-20 mA) [1] 4-20 mA (4-20 mA) [2] 20- 0 mA (20-0 mA) [3] 20- 4 mA (20-4 mA) [4] 	<p>If you are using remote current control (para. 102), one of the inputs must be used to set current limit.</p> <p>Naturally these choices block use of the same type as reference signal.</p>
<p>*) If terminal 53 and/or terminal 60 are not used, "no operation" should be selected in parameters 412 and 413 to avoid the risk of a reference fault.</p>		

★ = Factory setting. Text in () = Display text.
The figures in [] are used in bus communication.

414 Time out (Time out)	Value: 0 - 99 OFF ★100 OFF	If one of the “live zero” signals has been selected (e.g. 4-20 mA) and this is less than 2 mA, a fault message and a required operating status after expiry of the programmed interval are activated.
415 Time out function (Time out act.)	Value: ★ Freeze (freeze) Stop (stop) Jogging (jog) Max. speed (max)	<div style="display: flex; align-items: flex-start;"> <div style="margin-right: 10px;"> [0] [1] [2] [3] </div> <div> <p>The required operating status is selected in parameter 415.</p> <p>The VLT®’s reference can be frozen to the current value, go to stop, go to the jogging frequency entered in parameter 203, or go to the maximum frequency in parameter 202.</p> <p>The function is not active for local speed reference (para. 004) when open loop or slip compensation is selected (para 101).</p> </div> </div>

★ = Factory setting. Text in () = Display text.
 The figures in [] are used in bus communication.

500 Address (Address)	Value: 01- 99 ★01	Specify an address of each unit. If the master (PLC or PC) addresses 00, the message is written to all connected VLT [®] frequency converters simultaneously (broadcast). The unit will in this case not give a reply to the master. If the number of units is over 31, a repeater must be used. Parameter 500 can not be changed via the serial bus, RS 485.																																																																							
501 Baud rate (Baud rate)	Value: 300, 600, 1200, 2400, 4800, ★9600	<p>This parameter sets the speed at which data is transferred. It is defined as the number of bits transferred per second. The VLT[®] frequency converter's transmission speed must be set equivalent to the PC/PLC's transmission speed. Parameter 501 cannot be selected via the serial bus, RS485.</p> <p>The data transmission time itself, determined by the baud rate setting, is only part of the total communication time. The total time to send a telegram to the VLT[®] frequency converter and receive an answer is between 320 ms and 480 ms.</p>																																																																							
502 Data read-out (Data readout)	<table style="width: 100%; border-collapse: collapse;"> <tr><td style="width: 5%;">0</td><td style="width: 60%;">★ Reference (reference %)</td><td style="width: 35%;">-----%</td></tr> <tr><td>1</td><td>Frequency (frequency Hz)</td><td>----Hz</td></tr> <tr><td>2</td><td>Display / Feedback (feedback unit)</td><td>----"unit"</td></tr> <tr><td>3</td><td>Current (current A)</td><td>----A</td></tr> <tr><td>4</td><td>Torque (torque %)</td><td>----%</td></tr> <tr><td>5</td><td>Power (power kW)</td><td>----kW</td></tr> <tr><td>6</td><td>Power (power HP)</td><td>----HP</td></tr> <tr><td>7</td><td>Energy (energy kWh)</td><td>----kWh</td></tr> <tr><td>8</td><td>Output voltage (output volt. V)</td><td>----V</td></tr> <tr><td>9</td><td>DC voltage (DC bus V)</td><td>----V</td></tr> <tr><td>10</td><td>Motor term (ETR (MOT) %)</td><td>----%</td></tr> <tr><td>11</td><td>VLT[®] term. % (ETR (VLT) %)</td><td>----%</td></tr> <tr><td>12</td><td>Digital input (DIG. INP.CODE) binary code</td><td></td></tr> <tr><td>13</td><td>Analogue input 1 (analog in 53) in terminal 53</td><td></td></tr> <tr><td>14</td><td>Analogue input 2 (analog in 60) in terminal 60</td><td></td></tr> <tr><td>15</td><td>Warning parameter (warning code) binary code</td><td></td></tr> <tr><td>16</td><td>Control word (control word)</td><td></td></tr> <tr><td>17</td><td>Status word (status word)</td><td></td></tr> <tr><td>18</td><td>Alarm parameter (alarm code) binary code</td><td></td></tr> </table>	0	★ Reference (reference %)	-----%	1	Frequency (frequency Hz)	----Hz	2	Display / Feedback (feedback unit)	----"unit"	3	Current (current A)	----A	4	Torque (torque %)	----%	5	Power (power kW)	----kW	6	Power (power HP)	----HP	7	Energy (energy kWh)	----kWh	8	Output voltage (output volt. V)	----V	9	DC voltage (DC bus V)	----V	10	Motor term (ETR (MOT) %)	----%	11	VLT [®] term. % (ETR (VLT) %)	----%	12	Digital input (DIG. INP.CODE) binary code		13	Analogue input 1 (analog in 53) in terminal 53		14	Analogue input 2 (analog in 60) in terminal 60		15	Warning parameter (warning code) binary code		16	Control word (control word)		17	Status word (status word)		18	Alarm parameter (alarm code) binary code		<p><i>Function:</i> This parameter can only be read and is used to read off displays, status reports, warnings and alarms via the serial bus, RS485. The individual data values are read using index reading (byte 4 = 1), and the index number of the required data value is stated in bytes 14-19 as shown below. The possible range is 000.00-018.00. Example of reading of index number 12: 012.00.</p> <table border="1" style="margin-left: auto; margin-right: auto;"> <tr><td>Index</td><td>0</td><td>1</td><td>2</td><td>0</td><td>0</td><td>2</td></tr> <tr><td>Byte</td><td>14</td><td>15</td><td>16</td><td>17</td><td>18</td><td>19</td></tr> </table> <p>Also see description of parameter group 5. The data values cannot be read in the display for para. 502. Description of choices: <u>Index 0-11:</u> 12 process data, which can also be read off in "display mode" (see p. 59). The stated unit is not read, but only the value. Index 0 (reference) is only external references, i.e. pulse input (terminal 17), analogue inputs (terminals 53 and 60) and bus reference (parameter 516).</p>	Index	0	1	2	0	0	2	Byte	14	15	16	17	18	19
0	★ Reference (reference %)	-----%																																																																							
1	Frequency (frequency Hz)	----Hz																																																																							
2	Display / Feedback (feedback unit)	----"unit"																																																																							
3	Current (current A)	----A																																																																							
4	Torque (torque %)	----%																																																																							
5	Power (power kW)	----kW																																																																							
6	Power (power HP)	----HP																																																																							
7	Energy (energy kWh)	----kWh																																																																							
8	Output voltage (output volt. V)	----V																																																																							
9	DC voltage (DC bus V)	----V																																																																							
10	Motor term (ETR (MOT) %)	----%																																																																							
11	VLT [®] term. % (ETR (VLT) %)	----%																																																																							
12	Digital input (DIG. INP.CODE) binary code																																																																								
13	Analogue input 1 (analog in 53) in terminal 53																																																																								
14	Analogue input 2 (analog in 60) in terminal 60																																																																								
15	Warning parameter (warning code) binary code																																																																								
16	Control word (control word)																																																																								
17	Status word (status word)																																																																								
18	Alarm parameter (alarm code) binary code																																																																								
Index	0	1	2	0	0	2																																																																			
Byte	14	15	16	17	18	19																																																																			

★ = Factory setting. Text in () = Display text.
 The figures in [] are used in bus communication.

502
Data read-out
 (Data readout)
 (Continued)

Index 12:
 A decimal value to be converted to an 8-bit binary code.

Example:

Decimal	16							
Binary	0	0	0	1	0	0	0	0
Terminal	33	32	29	27	19	18	17	16

Index 13/14:
 Decimal value between 0 and 1023, where 0 corresponds to 0% and 1023 to 100% of the selected input signal, e.g. 0-10 V.

Index 15:
 Decimal value to be converted to a 16-bit binary code. Each bit represents a warning according to the table below. When a warning is given, the equivalent bit has the value "1".

Bit	Warning
0	Current limit
1	No motor
2	Reference fault
3	Motor overloaded
4	Inverter overloaded
5	Frequency warning low
6	Frequency warning high
7	Current warning low
8	Current warning high
9	EEPROM fault
10	24 V fault
11	Over current
12	Voltage warning high
13	Voltage warning low
14	Overvoltage
15	Undervoltage

A further description of warnings is given on pp. 124-125.

Index 16:
 Decimal value to be converted to a 16-bit binary code. Each bit represents a control command according to the table on p. 75. When a control command is activated, the equivalent bit has the value "1".

Index 17:
 Decimal value to be converted to a 16-bit binary code. Each bit represents a status report according to the table on p. 77. When a status report is activated, the equivalent bit has the value "1".

502

Data read-out

(Data readout)

(Continued)

Index 18:

A decimal value to be converted to a 16-bit binary code. Each bit represents an alarm according to the table below. When an alarm is given, the equivalent bit has the value "1".

Bit	Alarm
0	Trip locked
1	Control card or option card fault
2	Current limit
3	Not used
4	Not used
5	Auto optimization
6	Motor overloaded
7	Inverter overloaded
8	Inverter fault
9	Undervoltage
10	Overvoltage
11	Overcurrent
12	Ground fault
13	DC supply fault
14	Over temperature
15	Thermistor input activated, see parameter 400/terminal 16

A further description of alarms is given on pp. 124-125.

503 Coasting (Coast)	Value: Digital (digital) [0] Bus (bus) [1] Logic and (and) [2] ☆ Logic or (or) [3]	<i>Function:</i> The parameters are used to determine priority of control commands from serial bus communication (control word p. 75) in relation to the same control commands to the digital inputs.															
504 Q-stop (Q-stop)	Value: Digital (digital) [0] Bus (bus) [1] Logic and (and) [2] ☆ Logic or (or) [3]	<i>Description of choices:</i> <u>Digital</u> is selected if the control command is only to be activated via a digital input. <u>Bus</u> is selected if the control command is only to be activated via a bit in the control word (serial bus communication). <u>Logic and</u> is selected if the control command is only to be activated when the signal is active from both the control word and digital input. Active signal "1".															
505 DC-brake (DC brake)	Value: Digital (digital) [0] Bus (bus) [1] Logic and (and) [2] ☆ Logic or (or) [3]	<table border="1" style="width: 100%; border-collapse: collapse; text-align: center;"> <thead> <tr> <th>Digital input</th> <th>Control word</th> <th>Contr.command</th> </tr> </thead> <tbody> <tr><td>0</td><td>0</td><td>0</td></tr> <tr><td>0</td><td>1</td><td>0</td></tr> <tr><td>1</td><td>0</td><td>0</td></tr> <tr><td>1</td><td>1</td><td>1</td></tr> </tbody> </table>	Digital input	Control word	Contr.command	0	0	0	0	1	0	1	0	0	1	1	1
Digital input	Control word	Contr.command															
0	0	0															
0	1	0															
1	0	0															
1	1	1															
506 Start (Start)	Value: Digital (digital) [0] Bus (bus) [1] Logic and (and) [2] ☆ Logic or (or) [3]	<table border="1" style="width: 100%; border-collapse: collapse; text-align: center;"> <thead> <tr> <th>Digital input</th> <th>Control word</th> <th>Contr.command</th> </tr> </thead> <tbody> <tr><td>0</td><td>0</td><td>0</td></tr> <tr><td>0</td><td>1</td><td>1</td></tr> <tr><td>1</td><td>0</td><td>1</td></tr> <tr><td>1</td><td>1</td><td>1</td></tr> </tbody> </table>	Digital input	Control word	Contr.command	0	0	0	0	1	1	1	0	1	1	1	1
Digital input	Control word	Contr.command															
0	0	0															
0	1	1															
1	0	1															
1	1	1															
507 Direction (Direction)	Value: Digital (digital) [0] Bus (bus) [1] Logic and (and) [2] ☆ Logic or (or) [3]	<p><u>Logic or</u> is selected if the control command is to be activated when the signal is active from either the control word or digital input. Active signal "1".</p> <table border="1" style="width: 100%; border-collapse: collapse; text-align: center;"> <thead> <tr> <th>Digital input</th> <th>Control word</th> <th>Contr.command</th> </tr> </thead> <tbody> <tr><td>0</td><td>0</td><td>0</td></tr> <tr><td>0</td><td>1</td><td>1</td></tr> <tr><td>1</td><td>0</td><td>1</td></tr> <tr><td>1</td><td>1</td><td>1</td></tr> </tbody> </table>	Digital input	Control word	Contr.command	0	0	0	0	1	1	1	0	1	1	1	1
Digital input	Control word	Contr.command															
0	0	0															
0	1	1															
1	0	1															
1	1	1															
508 Reset (Reset)	Value: Digital (digital) [0] Bus (bus) [1] Logic and (and) [2] ☆ Logic or (or) [3]	<p><i>Note:</i> Parameters 503-505 concern stop functions, see example re parameter 503 (free-wheeling) below. Active stop signal "0". Parameter 503 = <u>Logic and</u></p> <table border="1" style="width: 100%; border-collapse: collapse; text-align: center;"> <thead> <tr> <th>Digital input</th> <th>Control word</th> <th>Contr.command</th> </tr> </thead> <tbody> <tr><td>0</td><td>0</td><td>Free-wheeling</td></tr> <tr><td>0</td><td>1</td><td>Motor running</td></tr> <tr><td>1</td><td>0</td><td>Motor running</td></tr> <tr><td>1</td><td>1</td><td>Motor running</td></tr> </tbody> </table>	Digital input	Control word	Contr.command	0	0	Free-wheeling	0	1	Motor running	1	0	Motor running	1	1	Motor running
Digital input	Control word	Contr.command															
0	0	Free-wheeling															
0	1	Motor running															
1	0	Motor running															
1	1	Motor running															
509 Setup select (Setup select)	Value: Digital (digital) [0] Bus (bus) [1] Logic and (and) [2] ☆ Logic or (or) [3]	<p>Parameter 503 = <u>Logic or</u></p> <table border="1" style="width: 100%; border-collapse: collapse; text-align: center;"> <thead> <tr> <th>Digital input</th> <th>Control word</th> <th>Contr.command</th> </tr> </thead> <tbody> <tr><td>0</td><td>0</td><td>Free-wheeling</td></tr> <tr><td>0</td><td>1</td><td>Free-wheeling</td></tr> <tr><td>1</td><td>0</td><td>Free-wheeling</td></tr> <tr><td>1</td><td>1</td><td>Motor running</td></tr> </tbody> </table>	Digital input	Control word	Contr.command	0	0	Free-wheeling	0	1	Free-wheeling	1	0	Free-wheeling	1	1	Motor running
Digital input	Control word	Contr.command															
0	0	Free-wheeling															
0	1	Free-wheeling															
1	0	Free-wheeling															
1	1	Motor running															
510 Digital speed select (speed select)	Value: Digital (digital) [0] Bus (bus) [1] Logic and (and) [2] ☆ Logic or (or) [3]	<table border="1" style="width: 100%; border-collapse: collapse; text-align: center;"> <thead> <tr> <th>Digital input</th> <th>Control word</th> <th>Contr.command</th> </tr> </thead> <tbody> <tr><td>0</td><td>0</td><td>Free-wheeling</td></tr> <tr><td>0</td><td>1</td><td>Free-wheeling</td></tr> <tr><td>1</td><td>0</td><td>Free-wheeling</td></tr> <tr><td>1</td><td>1</td><td>Motor running</td></tr> </tbody> </table>	Digital input	Control word	Contr.command	0	0	Free-wheeling	0	1	Free-wheeling	1	0	Free-wheeling	1	1	Motor running
Digital input	Control word	Contr.command															
0	0	Free-wheeling															
0	1	Free-wheeling															
1	0	Free-wheeling															
1	1	Motor running															

☆ = Factory setting. Text in () = Display text.
 The figures in [] are used in bus communication

511 Bus jogging 1 (Bus jog 1)	Value: 0.0 - f_{RANGE} ★10,0	<i>Function:</i> Two fixed speeds set in Hz equivalent to JOGGING frequency in parameter 203. Bus jogging 1 and 2 can only be activated via the control word when serial bus communication is used, see also description of the control word's bit 08 and 09, p. 75 .
512 Bus jogging 2 (Bus jog 2)	Value: 0.0 - f_{RANGE} ★10,0	<i>Function:</i> Two fixed speeds set in Hz equivalent to JOGGING frequency in parameter 203. Bus jogging 1 and 2 can only be activated via the control word when serial bus communication is used, see also description of the control word's bit 08 and 09, p. 75 .
513 Catch-up / slow-down value (Catchup/slowdn)	Value: 0.0 - 100% ★ 0,0	<i>Function:</i> The VLT® frequency converter's output frequency can be reduced or increased via the control word's bit 11 and 12 by the value set as a percentage of the current output frequency. See also description of the control word's bit 11 and 12, p. 76 .
514 Bus bit 4 (Bus bit 4)	Value: ★ Q-stop (Q-stop) [0] DC-brake (DC-brake) [1]	<i>Function:</i> Bit 4 of the control word (see table p. 75) can be used for either quick stop via alternative ramp-down or DC brake.
515 Bus bit 11/12 (Bus bit 11/12)	Value: ★ Catch-up/slow-down (catch / slow) [0] Selection of digital reference (Dig spd type) [1]	<i>Function:</i> Bit 11/12 of the control word can either be used for "catch-up/slow-down" or for selection of digital reference (see description, p. 76).
516 Bus reference (Bus reference)	Value: -100.00% - +100.00% ★0.00	<i>Function:</i> Is used to receive the desired reference as a percentage of f_{MAX} via serial communication. The following is inserted to the telegram. Parameter no.: 516 Bytes 9-12 Data: Required ref. Bytes 13-18 Full stop: Position Byte 19

★ = Factory setting. Text in () = Display text.
 The figures in [] are used in bus communication

517
Store data values
(Store data)

Value:
★ Off (OFF)
On (ON)

Function:
[0] Data values changed via serial bus communication are not saved automatically when the mains voltage is switched off, and therefore parameter 517 must be used to save changed data values.
[1]

Description of choices:

When “to” is selected, it takes approx. 10 sec. to save all parameters’ data values, and parameter 517 then automatically takes the value “from”. Only the data values in the active menu setup are saved, i.e. the save function must be performed in each of the setups used.

Note:

The save function can only be activated when the VLT[®] frequency converter has stopped.

★ = Factory setting. Text in () = Display text.
The figures in [] are used in bus communication

600
Operation data
(Operation data)

- Value:
 * 0 Total operation hours (tot.hrs xxxx) *)
 1 Running hours (run hrs xxxx) *)
 2 kWh (energy xxxx)
 3 Number of cut-ins (pow.ups xxxx)
 4 Number of overheatings (ov.temp xxxx)
 5 Number of overvoltages (ov. volt xxxx)

Function:
 [Index 000.00-005.00]
 Display of most important operation data.
Description of choices:
 Display range: Total number of operation hours/running hours/kWh is 0.0-99999 (under 10000 with 1 decimal).
 Number of cut-ins/number of overheatings/number of overvoltages is 0-99999.
 Serial communication: Total number of operation hours/running hours/kWh returned as floating comma values.
 Number of cut-ins/number of overheatings/number of overvoltages returned as whole figures.
 Total number of operation hours/running hours/kWh reset automatically after manual initialization.
 NB: The stated data is saved every 8 hours. kWh can be reset via parameter 011.
 Operation hours can be reset via parameter 012.
 Number of cut-ins/number of overheatings/number of overvoltages saved as they occur.

601
Data log
(Data log)

	0	1	2	3	4	-	-	19
Digital input [0]								
Control word [1]								
Status word [2]								
Reference % [3]								
Frequency out [4]								
Phase current [5]								
D.C. voltage [6]								

Function:
 (Index 000.00-019.06)
 Logging of data for the last few seconds of operation.
Description of choices:
Digital inputs stated in hex code (0-FF).
Control word stated in hex code (0-FFFF) for bus operation RS 485, see p. 75.
Status word stated in hex code (0-FFFF) for bus operation RS 485, see p. 77.
Reference states the control signal as a percentage (0-100%).
Frequency out states the unit's output frequency in Hz (0.0-999.9).
Phase current is the unit's output current in A (0.0-999.0).
D.C. voltage states the intermediate circuit voltage in [VDC] (0-999).

★ = Factory setting. Text in () = Display text.
 The figures in [] are used in bus communication

601
Data log

(Data log)
(Continued)

		0	1	2	3	4	-	-	19
Digital input	[0]								
Control word	[1]								
Status word	[2]								
Reference %	[3]								
Frequency out	[4]								
Phase current	[5]								
D.C. voltage	[6]								

20 log values (0-19) are given. The lowest number (0) contains the newest/last stored data value, and the highest log number (19) contains the oldest data value. The data values are logged every 160 ms for as long as the start signal is active. The data log contains the last 20 log values (approx. 3.2 s) before a stop signal is given (start not active), or a trip. However, it is possible to scroll through the log values. The data log is reset during start-up (on mains connection).

602
Fault memory

(Alarm memory)

		0	1	2	3	4	-	-	7
Fault code	[0]								
Time	[1]								
Value	[2]								

Function:
(Index 000.00-007.02)
Storage of data on trip.
Description of choices:
Fault code indicates the reason for a trip by a figure code between 1 and 15:

Fault code	Alarm
1	Inverter fault
2	Overvoltage
3	Undervoltage
4	Over-current
5	Earth fault
6	Excess temperature
7	Inverter overloaded
8	Motor overloaded
9	Current limit
10	Trip locked
11	Control card or option card fault
13	Auto-optimization fault
14	DC supply fault
15	Thermistor input activated, see parameter 400/terminal 16

Time states the value of the total number of operatin hours on trip. Display range 0.0-999.9.

Value states e.g. at what voltage or current a trip has taken place. Display range 0.0-999.9.

On serial communication, the fault code is returned as a whole number. Time and value are returned as floating decimal values.

8 log values are given (0-7). The lowest log number (0) contains the newest/last stored data value, and the highest log number (7) contains the oldest data value.

An alarm can only be represented once. The fault log is reset after manual initialization.

Irrespective of which log set is being read, the display will automatically shift to log number 0 if a new trip occurs.

★ = Factory setting. Text in () = Display text.
The figures in [] are used in bus communication

603
Type plate
(Name plate)

Value	
★ 0 Type (VLT3xxx)	
1 Unit voltage (xxx V)	
2 Software type	
Process	[1]
HVAC	[2]
Profibus Proc	[3]
Profibus HVAC	[4]
Synchron Opt	[5]
Modbus+Proc	[6]
Modbus+HVAC	[7]
3 Software version (vx.x)	

Function:
The unit's key data can be read off via the display or bus (RS 485).
Description of choices:
Type indicates unit size and basic function (e.g. VLT® type 3006 or VLT® type 3508).
Unit voltage indicates the voltage for which the unit has been built or has been set to (para. 650).
Software type indicates whether the software is standard or special.
Software version indicates the version number.

604
Operation mode
(Operation mode)

Value	
★ Run normal (run normal)	[0]
Run with inverter disable (run inv disable)	[1]
Control card test (control card test)	[2]
Initialize (Initialize)	[3]

Function:
In addition to the normal function, the parameter can be used for 2 different tests. There is also a possibility of manual initialization of all parameters (except paras. 501, 600 and 602).
Description of choices:

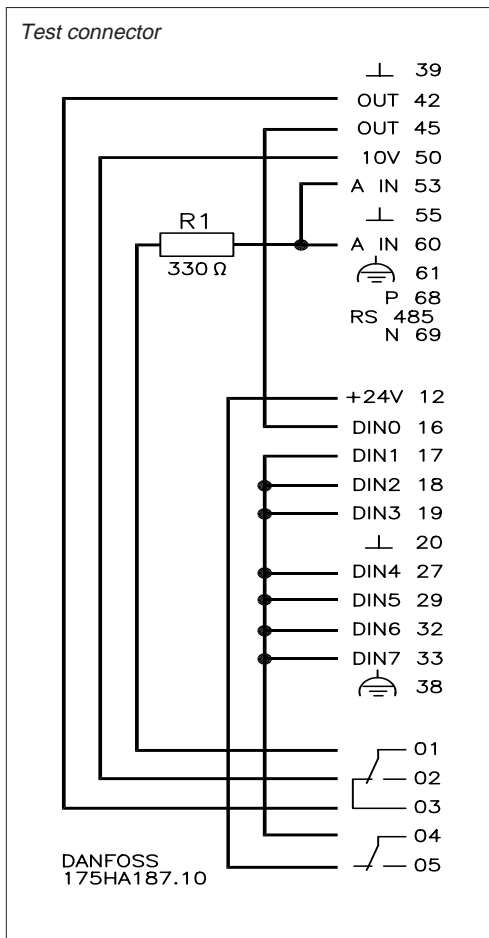

Normal function is used in normal operation with a motor in the selected application.
Function with inverter disabled is selected for control of the control signal's influence on the control card and its functions without the inverter driving the motor.
Control card test is selected for control of the control card's analogue, digital inputs; analogue, digital and relay outputs; and the control voltage of +10 V. This test requires connection of a test connector with internal connections.
The following procedure is used:
1) Press Stop.
2) Insert test connector in the pins.
3) Select control card test in para. 604.
4) Disconnect mains voltage and wait for light in display to disappear.
5) Connect mains voltage.
6) Press Start.
The test will now run through three stages with an OK or fault report depending on the result. If there is a fault report, the control card must be replaced.
Initialization is selected for factory setting of the unit without resetting of paras. 500, 501, 600 and 602.
Procedure:
1) Select initialization.
2) Press Menu.
3) Disconnect mains voltage and wait for light in display to disappear.
4) Connect mains voltage.

★ = Factory setting. Text in () = Display text.
The figures in [] are used in bus communication

605
Personal display select
 (Display select)

Value:

★ Standard display (standard disp.)	[0]
Reference % (reference %)	[1]
Frequency Hz (frequency Hz)	[2]
Feedback unit (feedbk 'unit')	[3]
Current A (current A)	[4]
Torque % (torque %)	[5]
Power kW (power kW)	[6]
HP power (power HP)	[7]
Energy kWh (energy kWh)	[8]
Output voltage VLT (out/volt V)	[9]
DC voltage VLT (DC bus)	[10]
VLT therm % (ETR (VLT) %)	[11]
Motor therm % (ETR (MOT) %)	[12]
Running hours (run hours)	[13]
Input status "binary code" (input status)	[14]

Function:
 You can have two different display read-outs in the display at the same time. The extra read-out selected in this parameter will be shown in line 2 of the display.

Description of choices:
 Standard display is selected for normal reading of e.g. the frequency in Hz in line 1, indication of "frequency" in line 2 and indication of status of operation in line 3. The other data values are selected to read another operation value in line 2, so that the aforementioned frequency in line 1 and current in line 2 simultaneously is possible. There are 14 different data values to select between.

Note that to be able to see both lines simultaneously, the display must be in Display mode.

650
VLT type
 (VLT type)

Function:
 Used to indicate which unit the control card is placed in, in cases where the control card cannot decide for itself, or to select voltage range in multi-voltage units if the factory setting deviates from what is required.

Description of choices:
 The parameter is used to select the correct VLT® type/size/voltage for VLT® types 3060-3250 and VLT® types 3575-3800, which are multi-voltage units. If the factory-set voltage does not correspond to the voltage in the application for which the unit is used, the following procedure is used.

- 1) Select the required VLT® type/size/voltage.
- 2) Select parameter 604, data value initialization.
- 3) Disconnect mains voltage and wait for the light in the display to disappear.
- 4) Connect mains voltage.

Note that during start-up the display shows the selected new data.

★ = Factory setting. Text in () = Display text.
 The figures in [] are used in bus communication.

Display messages

Status messages

Status messages appear in the third line of the display, see example below:



50.0 Hz
FREQUENCY
START LOCAL

LOCAL STOP (ENAB STP LOC):

“Local” or “local with external stop” has been selected in parameter 003, and “stop” has been activated on the keyboard.

VLT® ready, local (UNIT RDY LOC):

“Local” or “local with external stop” has been selected in parameter 003, “free-wheeling stop” in parameter 404, and there is 0 V to terminal 27.

Local start ok (START LOKAL):

Local operation ok (RUN OK LOCAL):

“Local” or “local with external stop” has been selected in parameter 003, and the VLT® frequency converter is running at the set speed reference (parameter 004).

Local jogging (JOG LOCAL):

“Local” or “local with external stop” has been selected in parameter 003, and “jog” has been activated on the keyboard.

Local ramp operation (RAMP LOCAL):

“Local” or “local with external stop” has been selected in parameter 003, and the output frequency changes according to the set ramp times.

Stop (ENAB STOP):

“Remote control” has been selected in parameter 003, and the VLT® frequency converter has been stopped via the keyboard or digital input.

VLT® ready (UNIT READY):

“Remote control” has been selected in parameter 003, “free-wheeling stop” in parameter 404, and there is 0 V to terminal 27.

Start ok (START OK):

Operation ok (RUN OK):

“Remote control” has been selected in parameter 003, and the VLT® frequency converter is running at the speed reference.

Jogging (JOGGING):

“Remote control” has been selected in parameter 003, “jogging” in parameter 405, and there is 24 V to terminal 29.

Ramp operation (RAMPING):

“Remote control” has been selected in parameter 003, and the output frequency changes according to the set ramp times.

Freeze reference (FREEZE.):

“Remote control” has been selected in parameter 003, “freeze reference” in parameter 400, 401 or 405, and the respective input (16, 17 or 29) has been activated.

Auto optimization (ADPT.TUNING)

Adaptive motor tuning is active.

The following status messages are only found when serial communication is used (RS485):

OFF 2 (OFF 2):

Bit 01 in the control word is “0”, see p. 77.

OFF 3 (OFF 3):

Bit 02 in the control word is “0”, see p. 77.

Start disabled (START INHIB.):

Bit 06 in the status word is “1”, see p. 78.

Reference locked (HOLD):

Bit 05 in the control word is “0”, see p. 76.

Display messages

Warnings

Warnings appear in the third line of the display, see the example below:

Voltage low
(VOLTAGE LOW)

Voltage low (VOLTAGE LOW)

The intermediate circuit voltage (d.c.) is below the control card's warning limit, see table p. 125. The inverter is still active.

Voltage high (VOLTAGE HIGH):

The intermediate circuit voltage (d.c.) is above the control card's warning limit, see table p. 125. The inverter is still active.

Undervoltage (UNDERVOLTAGE):

The intermediate circuit voltage is below the inverter's undervoltage limit, see table p. 125. The inverter has stopped, and after the time in parameter 311 there will be a trip.

Overvoltage (OVERVOLTAGE):

The intermediate circuit voltage is above the inverter's overvoltage limit, see table p. 124. The inverter has stopped, and after the time in parameter 311 there will be a trip.

Current limit (CURRENT LIMIT):

The motor current is higher than the value in parameter 209.

Overcurrent (OVER CURRENT):

The inverter's peak current limit (approx. 250% of rated current) has been exceeded, and after 7-11 sec. there will be a trip.

Reference faults (REF. FAULT):

A fault to the analogue input signal (terminal 53 or 60) when a signal type with "live" zero" has been selected (4-20 mA, 1-5 V or 2-10 V). The warning is activated when the signal level is below half of the zero level (4 mA, 1 V or 2 V).

No motor (NO MOTOR):

The motor check function (para. 313)

detects that no motor is connected to the VLT® frequency converter's output.

Frequency warning low (LO FREQ WARN):

The output frequency is lower than the value in parameter 210.

Frequency warning high (HI FREQ WARN):

The output frequency is higher than the value in parameter 211.

Current warning low (LO CURR WARN):

The output current is lower than the value in parameter 212.

Current warning high (HI CURR WARN):

The output current is higher than the value in parameter 213.

Display messages

Warnings (Continued)

Motor overloaded (MOTOR TIME):

According to the electronic thermal motor protection, the motor is too hot. The warning only appears if “warning” has been selected in parameter 315. See curve p. 130.

Inverter overloaded (INVERT TIME):

The electronic thermal inverter protection reports that the VLT® frequency converter is close to cutting out due to overload (current too high for too long). The counter for electronic thermal inverter protection has reached 98% (100% gives trip).

24 V fault (NO 24 VOLT):

24 V voltage supply from power section to control card is absent.

EEPROM fault (EEPROM ERROR):

EEPROM fault, data changes are not saved when the mains voltage is switched off.

Voltage limits:

VLT® 3000 Series	3x200/230 V [VDC]	3x380/415 V [VDC]	3x440/500 V [VDC]	VLT® 3060-3250 [VDC]
Undervoltage	210	400	460	470
Voltage warning low	235	440	510	480
Voltage warning high (Brake option used, parameter 300)	370 (395)	665 (705)	800 (845)	790 (820)
Overvoltage	410	730	880	850

The voltages stated are the VLT®'s intermediate circuit voltage, the equivalent mains voltage is the intermediate circuit voltage divided by $\sqrt{2}$.

Display messages

Reset messages

Reset messages appear in the second line of the display, and alarm messages appear in the third line of the display, see example below:

ALARM
TRIP
UNDERVOLTAGE

Automatic restart (AUTO START):
When “automatic reset” is selected as reset function, the message states that the VLT® frequency converter is trying to restart automatically after cutting out. The restart time depends on parameter 312.

Trip (TRIP):

The VLT® frequency converter has cut out, and manual reset is required. Manual reset can be the reset key on the keyboard, a digital input (terminal 16, 17 or 27) or bit 07 in the control word (RS485).

Trip locked (TRIP LOCK):

The VLT® frequency converter has cut out and can only be reset after the mains voltage is switched off. After the mains voltage is cut back in, manual reset is required.

Alarm messages

Alarm messages

Undervoltage (UNDER VOLTAGE): Fault code 3

The intermediate circuit voltage is below the inverter’s undervoltage limit, see table p. 125.

Overvoltage (OVER VOLTAGE): Fault code 2

The intermediate circuit voltage is above the inverter’s overvoltage limit, see table p. 125.

Current limit (CURRENT LIMIT): Fault code 9

The motor current has exceeded the value in parameter 209 for longer than permitted in parameter 310.

Overcurrent (OVER CURRENT): Fault code 4

The inverter’s peak current limit (approx. 250% of rated current) has been exceeded for more than 7-11 sec. (trip locked).

Earth fault (GROUND FAULT): Fault code 5

Discharge from the output phases to earth, either in the cable between the VLT® frequency converter and motor or in the motor (trip locked).

Overtemperature (OVER TEMP.): Fault code 6

An excess temperature has been measured inside the VLT® frequency converter, making a cooling off period necessary before reset is possible. (Trip locked).

Inverter overloaded (OVER LOAD): Fault code 7

The electronic thermal inverter protection reports that the VLT® frequency converter has cut out due to overload (excessive current for too long). The electronic thermal inverter protection counter has reached 100%.

Motor overloaded (MOTOR TRIP): Fault code 8 and 15

According to the electronic thermal motor protection, the motor is too hot. The alarm only comes if “trip” has been selected in parameter 315. See curve p. 130.

Inverter fault (INVERTER FAULT): Fault code 1

A fault in the VLT® frequency converter’s power section, contact Danfoss.

Display messages

Alarm messages (continued)

Auto optimization ok (TUNING OK):
Auto optimization has taken place.

**Auto optimization fault
(TUNING. FAULT): Fault code 13**
The reasons for auto optimization fault can be the following:
The connected motor is very small or very large in relation to the VLT® frequency converter.
The motor is loaded more than 50%.
The connected motor is a special motor, e.g. a synchronous motor.
The fault can be due to electrical noise, e.g. no or poor earth connection to the VLT® frequency converter.
The reason can also be attempts at auto optimization on a very small motor in relation to the VLT® frequency converter (5-6 undersizes).

EXCEPT fault::

**EXCEPT
XXXX ERROR
PC=XXXX**

Error messages

- If disabled keypad is pressed:
KEY DISABLED
Indicates factory setup.
Change parameter 001 to setup 1-4.
Or the key is disabled (parameters 006-009).
- If data change only possible when the frequency converter is stopped is attempted: **ONLY ON STOP**
- If data change is attempted with open LOCK-switch: **PROG.LOCKED**
- If data change is attempted out of allowed range: **LIMIT**

Start-up test:

The VLT® frequency converter performs a self-test of the control card when the mains voltage is connected, giving the following message:

**TESTING
CONTROL CARD
FAULT_XXXX**

The reason for the fault message is a fault on the control card or possible option card. Contact Danfoss.

Galvanic isolation - Earth leakage current

Galvanic isolation (PELV)

The galvanic isolation of the VLT® frequency converter is tested according to VDE 0106/0160 (PELV).

Galvanic isolation is present when voltage-flashover between two current circuits is prevented when exposed to a pre-determined test voltage.

Galvanic isolation of the VLT® frequency-converter control circuits is achieved by using signal and power isolation transformers and leakage paths with a minimum width of 10.4 mm.

The galvanic isolation can be shown in three locations (see drawing below), namely:

1. Power supply (SMPS) incl. signal

2. Gate drivers controlling the IGBT's (trigger transformers)
3. Current transducers (Hall effect current transformers)

Components, as well as the assembled frequency converter, are tested according to VDE 0106/0160. Selected components, e.g. signal transformers, are tested with 3 kV a.c. for 1 second, and the assembled frequency converter is tested with 2.5 kV d.c and 2.4 kV a.c.

On request, Danfoss will provide a test certificate to confirm that the galvanic isolation is in accordance with VDE 0106/0160.

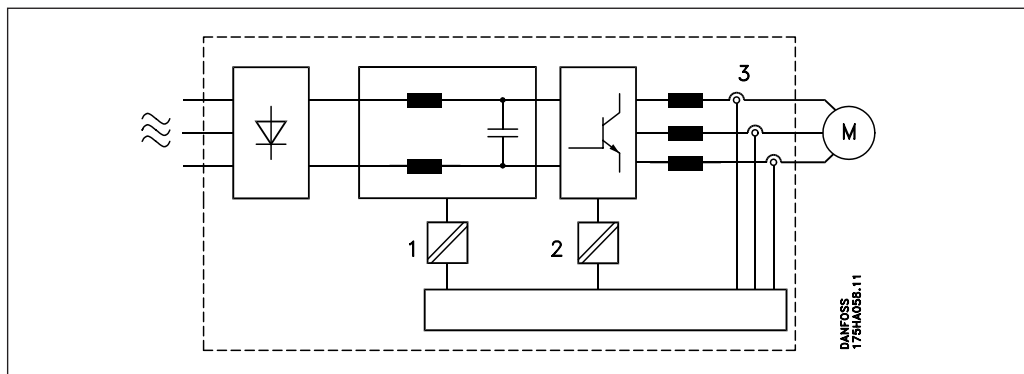

Earth leakage current

The earth leakage current is primarily caused by the capacitance between conductor and the screen of the motor cable. When an RFI filter is used this contributes an additional leakage current, as the filter circuit is connected to earth through capacitors.

This size of the leakage current to ground depends on the following:

- Length of motor cable
- Switching frequency
- With/without RFI filter
- Motor earthed on site or not
- Motor cable with/without screen

This leakage current is of importance to safety during handling/operation of the frequency converter when an earth connection between the frequency converter and the ground is missing.

Note: Never operate the frequency converter without an effective earth connection complying with local regulations for high leakage current (> 3.5 mA).

Never operate on ELCB's where local regulations do not permit it due to possible DC component in the leakage current.

Any ELCB relays used must be:

- Suitable to protect equipment with a direct current element in the earth current (3-phase bridge rectifier)
- Suitable for power-up with pulsing, short discharge.
- Suitable for high discharge current.

Extreme running conditions

Extreme running conditions

Short circuit

By means of current measurement in each of the three motor phases the VLT® 3000 Series is protected against short circuits.

A short circuit between two output phases will cause overcurrent in the inverter. However, all transistors in the inverter are turned off individually when the short-circuit current exceeds the permitted value.

After 5-10 seconds the driver card turns off the inverter and the frequency converter will display a fault code.

Earth fault

In case of an earth fault in a motor phase the inverter is turned off within 5-10 ms.

Switching on the output

The frequency converter output to the motor can be cut in/out without any limit. It is not possible to damage the VLT® frequency converter in any way by cutting in/out on the output, although fault messages can occur.

Catching a spinning motor (flying start)

The frequency converter is able to control a spinning load without stopping it or tripping first, e.g. after a mains failure or when a contactor is used on the output with a large inverter load.

It performs this with a speed search when cutting in on a spinning motor (see parameter 305).

Motor-generated overvoltage

The voltage on the DC link can be increased when the motor acts as a generator. This takes place in two cases:

1. The load runs the motor (at constant output frequency from the frequency converter), i.e. energy is supplied from the load.
2. During deceleration ("ramp-down"), if the moment of inertia is high, the friction load is low and/or the ramp-down time is short.

The control unit attempts to correct the ramp if possible.

The inverter turns off to protect the transistors and the d.c. bus capacitors when a certain d.c. voltage level is reached.

Mains drop-out

During a mains drop-out the VLT® frequency converter will continue to operate until the DC link voltage drops below the minimum stop level, which is typically 15% below the VLT® frequency converter's lowest rated supply voltage.

The time before inverter stop depends on mains voltage before drop-out, and the load of the motor.

Ride-through and/or flying start can be programmed.

Static overload

When the VLT® frequency converter is overloaded (the current limit I_{LIM} is reached) the control will reduce the output frequency f_M in an attempt to reduce the load. If the reduction of output frequency does not reduce the load then the control unit's final trip is released when the output frequency has reached below 0.5 Hz.

Running-in current limit can be limited (0 - 60 sec.) by parameter 310.

du/dt and peak voltage on motor - Acoustic noise

du/dt and peak voltage on motor

When a transistor in the inverter is activated, the voltage applied to the motor will rise by a du/dt ratio determined by

- the motor cable (type, cross-section, length, screened/unscreened)
- Inductors

The self-inductance will cause an overshoot U_{PEAK} in the motor voltage before it stabilizes at a level determined by the voltage in the intermediate circuit.

Both the du/dt ratio and the peak voltage U_{PEAK} influence the lifetime of the motor. Too high values will primarily affect motors without phase coil insulation.

With short (few metres) motor cable, the du/dt ratio will be very high but the peak voltage very low. At long (100 metres) motor cable du/dt will decrease and U_{PEAK} will increase.

To ensure a reasonable lifetime of the motor, the VLT® 3000 Series has as standard built-in motor coils which ensure a

low du/dt ratio value even with very short motor cable.

Note:

When using very small motors without phase coil insulation it is recommended to mount a clamp filter or an LC-filter in series after the VLT®.

Clamp filter, code no. 175H5147 (fits all units in the VLT® types 3002 - 3052).

Typical values for the du/dt ratio and the peak voltage U_{PEAK} measured on the terminals of the frequency converter between two phases (30 m screened motor cable):

VLT® type 3002 - 3052:

- du/dt ~ 200 - 300 V/μs
- U_{PEAK} ~ 800 - 1100 V

VLT® type 3060 - 3250:

- du/dt ~ 2000 - 2100 V/μs
- U_{PEAK} ~ 900 - 950 V measured with 20 m unscreened motor cable

Acoustic noise

The acoustic noise from the frequency converter is generated from 3 sources:

1. D.C. (DC link) and AC coils (motor coils).
2. RFI filter (acoustic noise increases with the length of the motor cable).
3. Built-in fan.

Below are the typical values measured at a distance of 1 metre from the unit and at full load:

VLT® type	3002	3003	3004	3006	3008	3011	3016	3022	3032	3042	3052
IP 00 (dBA)	38	38	38	53	57	-	-	-	-	-	-
IP 20/21 (dBA)	38	38	38	53 (60)	57 (55)	60 (59)	61 (63)	62 (64)	67	63	67
IP 54 (dBA)	38	59	57	57 (58)	57 (58)	63 (66)	63 (66)	67 (66)	67	66	72

(): 200 V units

VLT® type	3060		3075		3100		3125		3150		3200		3250	
	CT	VT	CT	VT	CT	VT	CT	VT	CT	VT	CT	VT	CT	VT
IP 21 (dBA)	63,5	68,8	68,8	72,5	67,6	68,2	68,2	68,9	68,9	70,0	71,3	73,8	73,9	74,4
IP 54 (dBA)	63,9	68,2	68,2	72,0	67,3	68,0	68,0	68,5	68,5	69,6	73,4	75,4	75,2	75,4

All units with built-in RFI filter and 100 m screened motor cable.

For VLT® 3011-52 the values will decrease by approx. 2 dBA for units without RFI filter.

Thermal motor protection

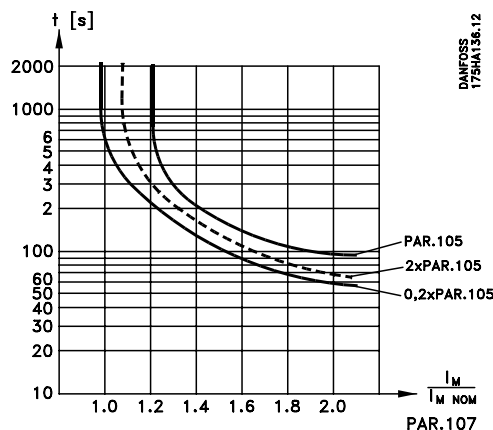

The motor temperature is calculated on the basis of the motor current, output frequency and time. See also description of parameter 315.

Derating

Derating

- Derating for ambient temperature
- Derating for air pressure
- Derating for low running speed
- Derating for installing long motor cables or larger cable cross-section

Derating for ambient temperature

The ambient temperature ($T_{AMB,MAX}$) is the maximum temperature allowed. The average ($T_{AMB,AVG}$) over 24 hours must be at least 5 °C lower in accordance with VDE 160 5.2.1.1.

If the VLT® frequency converter is operated at temperatures above 40 °C (45 °C in CT), then a derating of the continuous output current is necessary.

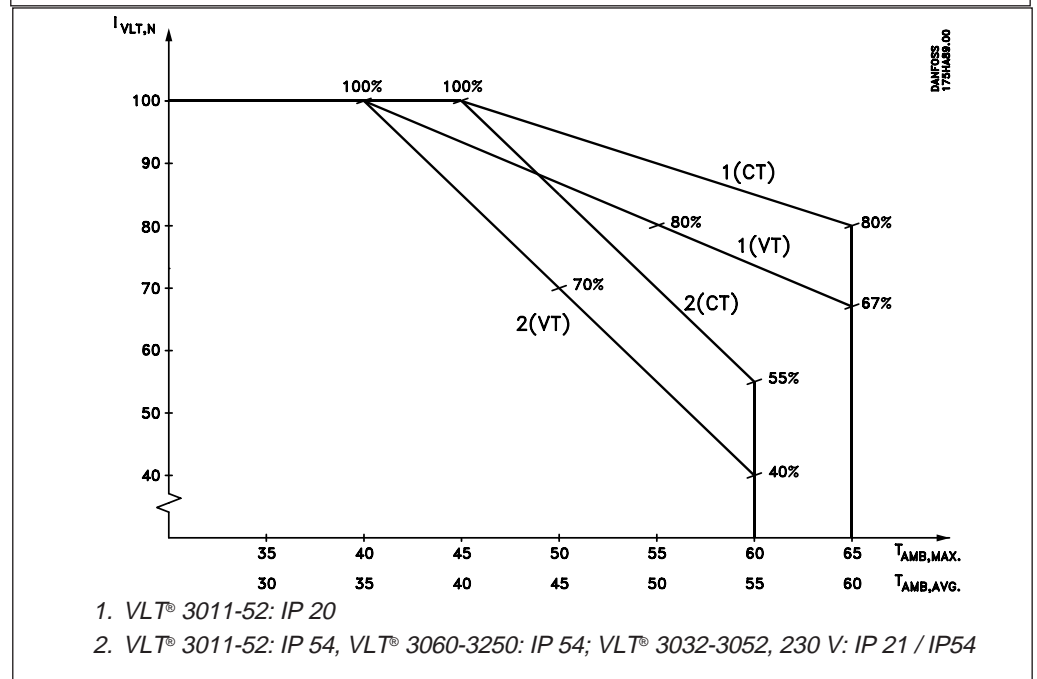
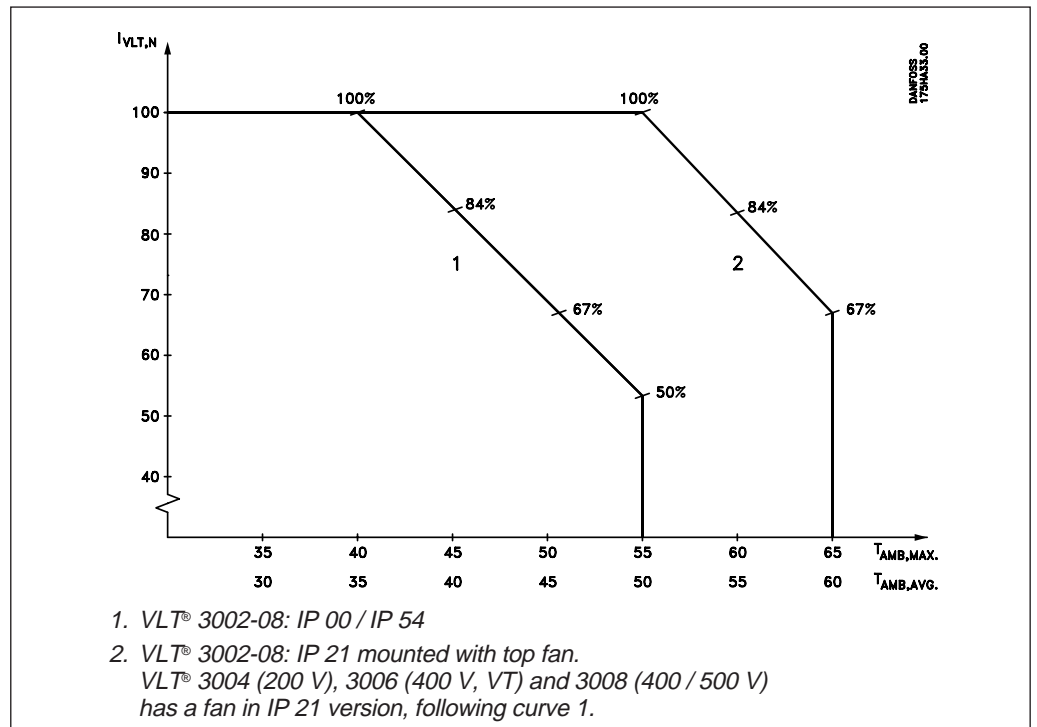

Derating

Derating for air pressure

Below 1000 m altitude no derating is necessary.

Above 1000 m the ambient temperature (t_{AMB}) or max. output current ($I_{VLT,MAX}$) must be derated according to the graph below:

1. Derating of output current versus altitude at $t_{AMB} = \text{max. } 40\text{ }^{\circ}\text{C}$.
2. Derating of max. t_{AMB} versus altitude at 100% output current.

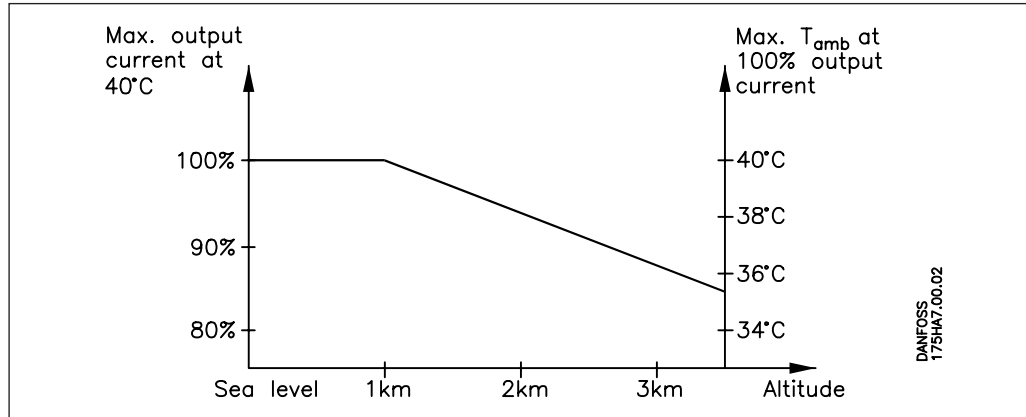

Motor derating for running at low speed

When a centrifugal pump or fan is controlled by the VLT® Series 3000 it is not necessary to reduce the output current at low speed because of the load charac-

teristic for centrifugal pumps/fans. Motors running constant load torque applications at low speed must be derated or force-cooled (see graph).

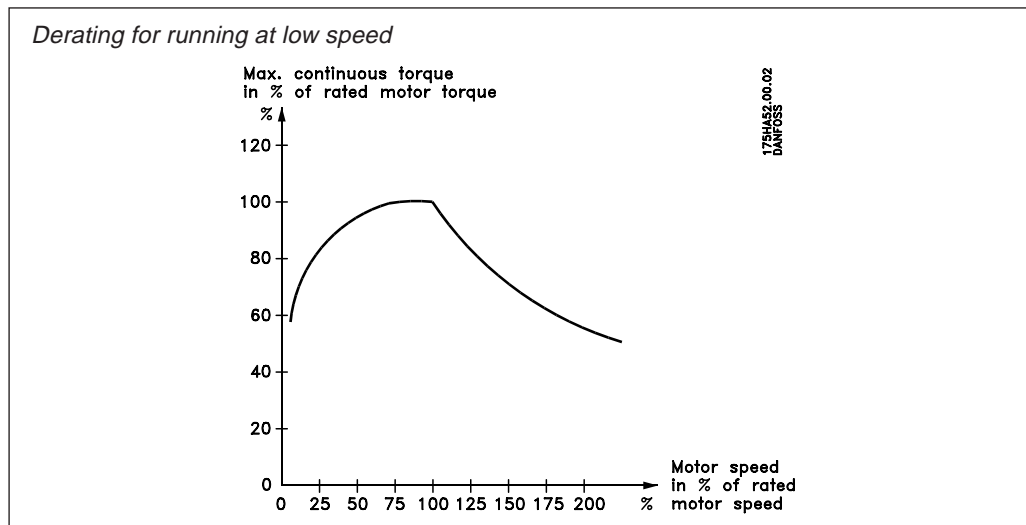

Derating for higher switching frequencies

Applies only to VLT® types 3002-52 as the maximum switching frequency is 4.5 kHz set in the VLT® types 3060-3250.

A higher switching frequency (para. 224) results in greater loss and stronger heat formation in the frequency converter's transistors and motor coils.

The frequency converter therefore automatically derates the maximum permitted constant output current $I_{VLT,N}$ when the switching frequency exceeds 4.5 kHz. Linear reduction is performed down to 60% at 14 kHz (see graph).

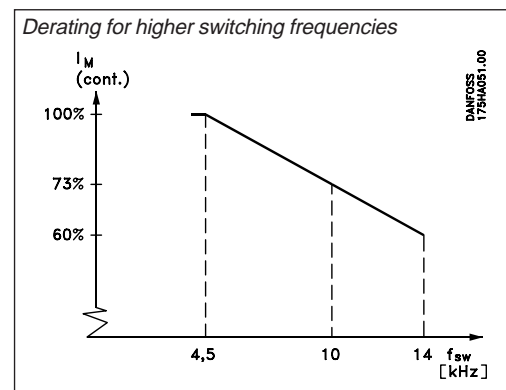

Derating - EMC

Derating for installing long motor cables or larger cable cross-section

The VLT® 3002-3052 is tested with 300 m unscreened cable and 150 m screened cable (for types 3002-3004 this only applies to $f_{\text{SWITCH}} \leq 4.5$ kHz. At $f_{\text{SWITCH}} > 4.5$ kHz, max. 40 m).

The VLT® 3000 Series is designed to run with a motor cable of a rated cross-section. If a cable with a larger cross-section is to be used it is recommended to reduce the output current by 5% for each step the cable cross-section is increased. (Higher cable cross-section gives increased capacity to earth and thereby increased earth current).

EMC testresults

EMC testresults

Emission:

Subsequent test results have been obtained using a system with a VLT® frequency converter (with options, if relevant), a screened control cable and control box with potentiometer, screened motor cable and motor.

Standard	Switching frequency	VLT type		VLT		
		3002-3008 3002-3004	380-500 V 200 V	3011-3052 3006-3022		
EN55014	4.5 kHz 14 kHz	yes ¹ yes ¹		ye ^{1,4} ye ^{1,4}		1
EN55011 Class A Gr.1	4.5 kHz 14 kHz	yes ^{1,2} yes ¹		ye ¹ ye ¹		1
EN55011 Class B Gr.1	4.5 kHz 14 kHz	yes ^{1,3} yes ^{1,3}		ye ^{1,3,4} ye ^{1,3,4}		1, 3

- ¹ Using the RFI option/module
- ² Without the RFI option/module the cable borne part of EN55011 class A gr. 1 (150kHz-30MHz) is complied with.
- ³ Radiated emission (30MHz-1GHz) in accordance with EN55011 class A group 1.
- ⁴ Using the brake module, please contact Danfoss.

With the purpose of minimising the cable-borne interference to the mains supply and the radiated interference from the frequency converter system, the motor cables should be kept as short as possible. According to experience, most installations represent only a slight risk of any interference from radiation.

Immunity

In order to document immunity towards interference from electrical phenomena external, the following immunity test has been made on a system consisting of a

VLT® frequency converter (with options, if relevant), a screened control cable and control box with potentiometer, screened motor cable and motor.

Fault criteria and test were in accordance with EN50082-2 and IEC 22G/21/CDV.

The tests were made using the following standards:

IEC 1000-4-2 (IEC 801-2/1991):

Electrostatic discharges (ESD)

Simulation of electrostatic discharges from human beings.

IEC 1000-4-3 (IEC 801-3):

Incoming electromagnetic field radiation

Simulation of the effects of radar and radio communication equipment as well as mobile communications equipment.

IEC 1000-4-4 (IEC 801-4):

Burst transients

Simulation of interference brought about by coupling with a contactor, relays or similar devices.

IEC 1000-4-5:

Surge transients

Simulation of transients brought about e.g. by lightning that strikes near installations.

ENV50141:

Cable-borne HF

Simulation of the effect of radio transmission equipment coupled to connection cables.

VDE0160 class W2 test pulse:

Mains transients

Simulation of high-energy transients brought about by main fuse breakage, coupling with phase-compensation batteries, etc.

VLT® 3002-3008 380-500V, VLT® 3002-3004 200V

Basic standard	Burst IEC 1000-4-4	Surge IEC 1000-4-5		ESD IEC 1000-4-2	Radiated tromagn. IEC 10
Acceptance criterion	B	B		B	A
Port connection	CM	DM	CM		
Line	OK	OK	OK	-	-
Motor	OK	-	-	-	-
Brake	OK	-	-	-	-
Control lines	OK	-	OK	-	-
PROFIBUS option	OK	-	-	-	-
Signal interface < 3 m	OK	-	-	-	-
Enclosure	-	-	-	OK	OK

Basic specification:

Line	2kV/5kHz/DCN	2kV/2Ω	4kV/12Ω	-	-
Motor	2kV/5kHz/CCC	-	-	-	-
Brake	2kV/5kHz/CCC	-	-	-	-
Control lines	2kV/5kHz/CCC	-	2kV/2 Ω*	-	-
PROFIBUS option	2kV/5kHz/CCC	-	-	-	-
Signal interface < 3 m	1kV/5kHz/CCC	-	-	-	-
Enclosure	-	-	-	8 kV AD 6 kV CD	10V

Acceptance criteria according to: IEC 22G/21/CDV, EN50082-2, 175R0740

DM: Differential mode

CM: Common mode

CCC: Capacitive clamp coupling

DCN: Direct coupling network

* Injection on cable shield

** 2,3 x \hat{U}_N : max. testpulse 1250 V peak

EMC testresults

Immunity

VLT® 3011-3052 380-500V, VLT® 3006-3022 200V

Basic standard	Burst IEC 1000-4-4	Surge IEC 1000-4-5		ESD IEC 1000-4-2	Radiated elec- tromagn. field IEC 1000-4-3
		DM	CM		
Acceptance criterion	B	B		B	A
Port connection	CM	DM	CM		
Line	OK	OK	OK	-	-
Motor	OK	-	-	-	-
Brake	OK	-	-	-	-
Control lines	OK	-	OK	-	-
PROFIBUS option	OK	-	-	-	-
Signal interface < 3 m	OK	-	-	-	-
Enclosure	-	-	-	OK	OK

Line	2kV/5kHz/DCN	2kV/2Ω	4kV/12Ω	-	-
Motor	2kV/5kHz/CCC	-	-	-	-
Brake	2kV/5kHz/CCC	-	-	-	-
Control lines	2kV/5kHz/CCC	-	2kV/2 Ω*	-	-
PROFIBUS option	2kV/5kHz/CCC	-	-	-	-
Signal interface < 3 m	1kV/5kHz/CCC	-	-	-	-
Enclosure	-	-	-	8 kV AD 6 kV CD	10V/m

Acceptance criteria according to: IEC 22G/21/CDV, EN50082-2, 175R0740

DM: Differential mode

* Injection on cable shield

CM: Common mode

** 2,3 x \hat{U}_N : max. testpulse 1250 V peak

CCC: Capacitive clamp coupling

DCN: Direct coupling network

VLT® 3060-3250 380-500V, VLT® 3032-3052 200V

Basic standard	Burst IEC 1000-4-4	Surge IEC 1000-4-5		ESD IEC 1000-4-2	Radiated elec- tromagn. field IEC 1000-4-3
		DM	CM		
Acceptance criterion	B	B		B	A
Port connection	CM	DM	CM		
Line	OK	OK	OK	-	-
Motor	OK	-	-	-	-
Control lines	OK	-	OK	-	-
PROFIBUS option	OK	-	-	-	-
Signal interface < 3 m	OK	-	-	-	-
Enclosure	-	-	-	OK	OK

Line	4kV/5Hz/CCC	1kV/2Ω	2kV/12Ω	-	-
Motor	2kV/5Hz/CCC	-	-	-	-
Control lines	2kV/5Hz/CCC	-	2kV/2Ω*	-	-
PROFIBUS option	2kV/5Hz/CCC	-	-	-	-
Signal interface < 3 m	1kV/5Hz/CCC	-	-	-	-
Enclosure	-	-	-	8 kV AD 6 kV CD	10V/m

Acceptance criteria according to: IEC 22G/21/CDV, EN50082-2, 175R0740

DM: Differential mode

* Injection on cable shield

CM: Common mode

** 2,3 x \hat{U}_N : max. testpulse 1350 V peak

CCC: Capacitive clamp coupling

DCN: Direct coupling network

Vibration and shock - Air humidity

Vibration and shock

The VLT® 3000 Series is tested according to a procedure based on the following standards:

- IEC 68-2-6: *Vibration (sinusoidal) - 1970*
- IEC 68-2-34: *Random vibration wide band-general requirement*
- IEC 68-2-35: *Random vibration wide band-reproducibility high*
- IEC 68-2-36: *Random vibration wide band-reproducibility medium*

VLT® 3002-3008 meet the requirements equal to conditions when mounted close to or directly on heavy production equipment.

VLT® 3011-3052 meet the requirements equal to conditions when mounted directly on wall or floor and in panels in factory buildings.

Air humidity

The VLT® frequency converter has been designed to meet the IEC 68-2.3 standard. The VDE 160, 5.2.1.2./7.2.1/ DIN 40040, class E, 40 °C, IP 54, is obtained according to IEC 68-2-30.

An occasional light dew is tolerated on internal insulating surfaces during operation.

The IP 54 versions can tolerate more moisture, because less dust and dirt are deposited on the insulating surfaces, and the enclosure allows no moisture inside.

Efficiency

Efficiency

To reduce energy consumption it is very important to optimise the efficiency of a system. The efficiency of each single element in the system should be as high as possible.

Efficiency of the VLT® 3000 Series (η_{VLT})
The load on the frequency converter has little effect on its efficiency. In general the efficiency at rated motor frequency $f_{M,N}$ is the same whether the motor supplies a 100% rated shaft torque or only 75%.

The variable switching frequency influences the losses in the VLT® 3000 Series. The efficiency will drop a little when the switching frequency is set to a value higher than 4.5 kHz.

Efficiency of the motor (η_{MOTOR})
The efficiency of a motor connected to the frequency converter is dependent on the sine shape of the current. In general we can say that efficiency is just as good as at mains operation. The motor efficiency depends on the make of the motor.

Normally the motor efficiency drops when the load is lower than rated torque, compared to operation on the mains.

In the range 75-100% of rated torque the efficiency of the motor will be almost constant both when operated by the frequency converter and when running directly on the mains.

In general the internal switching frequency does not affect the efficiency of small motors. Motors from 11 kW and upwards achieve better efficiency (1-2%). The efficiency is improved, because the sine shape of the motor current is near perfect at high switching frequency.

System efficiency (η_{SYSTEM})

To calculate the system efficiency you can multiply the efficiency of the units of the VLT® 3000 Series (η_{VLT}) by the efficiency of the motor (η_{MOTOR}):

$$\eta_{SYSTEM} = \eta_{VLT} \times \eta_{MOTOR}$$

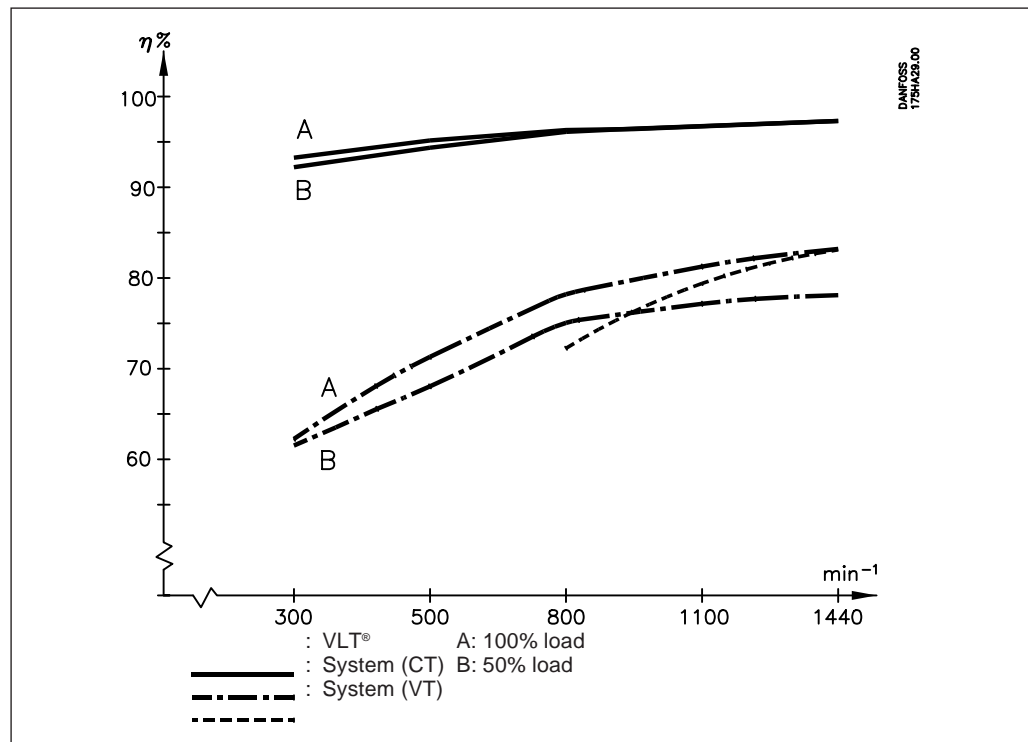

Mains supply interference / harmonics

A frequency converter takes up a non-sinusoidal current, which will increase the input current I_{RMS} . A non-sinusoidal current can be transformed by means of a Fourier analysis and split up into sine wave currents with different frequencies, this means different harmonic currents I_N with 50 Hz as the basic frequency:

Harmonic currents	I_1	I_5	I_7
Hz	50 Hz	250 Hz	350 Hz

The harmonic currents do not contribute directly to the power consumption, but increase the heat losses in the installation (transformer, cables). Therefore, in plants with a rather high percentage of rectifier load, it is important to maintain harmonics at a low level to avoid overload of the transformer and high temperature in the

cables.

Some of the harmonics might disturb communication equipment connected to the same transformer or cause resonances in connection with power-factor correction equipment.

Due to the above it is important to suppress these harmonics. The most common method is to mount coils in the mains supply to the frequency converter or in the intermediate circuit of the frequency converter. Coils in the intermediate circuit give the advantage of a lower voltage drop compared to the coils in the mains connection.

As standard the VLT® series 3000 has coils in the intermediate circuit for effective suppression of the harmonic currents.

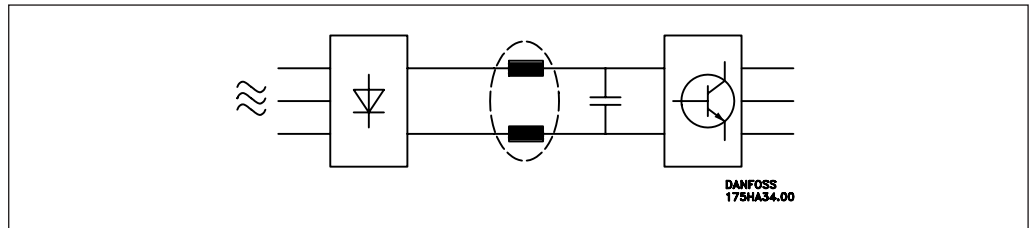

Harmonic currents compared to the RMS input current:

	Input current
I_{RMS}	1.0
I_1	0.9
I_5	0.4
I_7	0.2
I_{11-49}	< 0.1

The value of I_1 is equivalent to the power factor.

The voltage distortion of the mains supply depends on the size of the harmonic currents multiplied by the internal impedance for the relevant frequency.

The total voltage distortion THD is calculated on the individual voltage harmonics according to the following formula:

$$THD\% = \sqrt{U^1 + U^5 + \dots + U^N} \quad (U_N\% \text{ of } U)$$

Power factor

The power factor is the ratio between power (kW) and total (kVA).

Power factor for 3-phased supply

$$= \frac{\sqrt{3} \times V \times I_1 \times \cos\phi_1}{\sqrt{3} \times V \times I_{RMS}}$$

$$\text{Power factor} = \frac{I_1 \times \cos\phi_1}{I_{RMS}}$$

$$\cos\phi_1 \approx 1 \Rightarrow \text{power factor} \approx \frac{I_1}{I_{RMS}}$$

The power factor indicates the frequency converter's load on the supply mains. The lower the power factor, the higher (I_{RMS}) for the same kW.

Furthermore, a high power factor indicates that the different harmonic currents are low.

$$I_{RMS} = \sqrt{I_1^2 + I_5^2 + I_7^2 + \dots + I_n^2}$$

Fault messages

Fault messages

Inverter fault

The VLT® power section is defective.

Overvoltage

The voltage of the VLT® frequency converter's intermediate circuit (DC-voltage) is too high. Possible reasons: line voltage too high, transients on the line voltage, or regenerative motor operation.

Note: When the VLT® frequency converter is stopped, repeated transients are charging the intermediate circuit, as it supplies no power to the motor.

- If the fault indication is given when the speed is reduced, you can increase the ramp-down time. If this is not possible, the application may require a VLT® frequency converter with brake.

If the fault indication is given in other situations, the problem will be due to the mains supply.

Undervoltage

The voltage of the VLT® frequency converter's intermediate circuit (DC-voltage) is too low. Possible reasons: line voltage too low or defect in the VLT® frequency converter's charging circuit/rectifier.

- Check whether the line voltage is OK.

Overcurrent

The peak current limit of the inverter has been reached. This may be due to a short-circuit in the output of the VLT® frequency converter.

- Check the motor and the motor cable for ground failure.

Ground fault

Ground failure on the VLT® frequency converter output. Another reason might be that the motor cable is too long.

- Consult the data sheets for permitted cable length.
Check the motor and the motor cable for earth leakage.

Over-temp

The temperature inside the VLT® frequency converter is too high. Possible reasons: the ambient temperature is too high (max. 40/45 °C), the VLT® frequency converter's cooling ribs are covered, or the VLT® frequency converter's fan is defective.

- Reduce the ambient temperature by increasing the ventilation.
Uncover/clean the cooling ribs.
Replace the fan.

Overload

The electronic VLT® protection is active. This means that the motor has consumed more than 105% of rated VLT® frequency converter current for too long.

- Reduce the motor load. If this is not possible the application may require a larger VLT® frequency converter.

Motor trip

The electronic motor protection is active. This means that the current consumed by the motor at low speed has been too high for too long.

- The motor has been loaded excessively at low speed.
If the load cannot be changed, you must exchange the motor for a bigger one, or provide extra cooling of the existing motor.
If so, the electronic motor protection can be de-activated in parameter 315.

Electrostatic discharge

Electrostatic discharge (ESD)

Important! Many electronic components are sensitive to static electricity. Even voltages so low that they cannot be felt, seen or heard can impair components or damage them completely.

Electronic discharge can, among other things, result in the following:

- Drastic reduction in component operating life
- Periodic faults - as a rule concurrently with varying temperature, vibration or varying load.
- Faults that are difficult to trace and that cannot be located by testing.

It is therefore important to take static electricity into account when servicing electronic equipment.

When performing field service on Danfoss VLT[®] frequency converters the following precautions must be taken:

- A portable ESD field service kit consisting of a wrist strap and a conductive mat must be used.
- The portable ESD field service kit must be connected to the same potential as the VLT[®] frequency converter.
- Replaced defective control cards must be placed in antistatic packing. The packing from the new card could be used for this purpose.

Use the flow charts

The fault location procedure on the following flow charts takes as its starting point the main faults affecting the motor, i.e.

- Motor runs unevenly
- Motor does not run
- Motor does not brake

The flow chart layout is generally in a form applicable to all VLT[®] frequency converters, although at certain points it is necessary to distinguish between some of the types.

Fault location

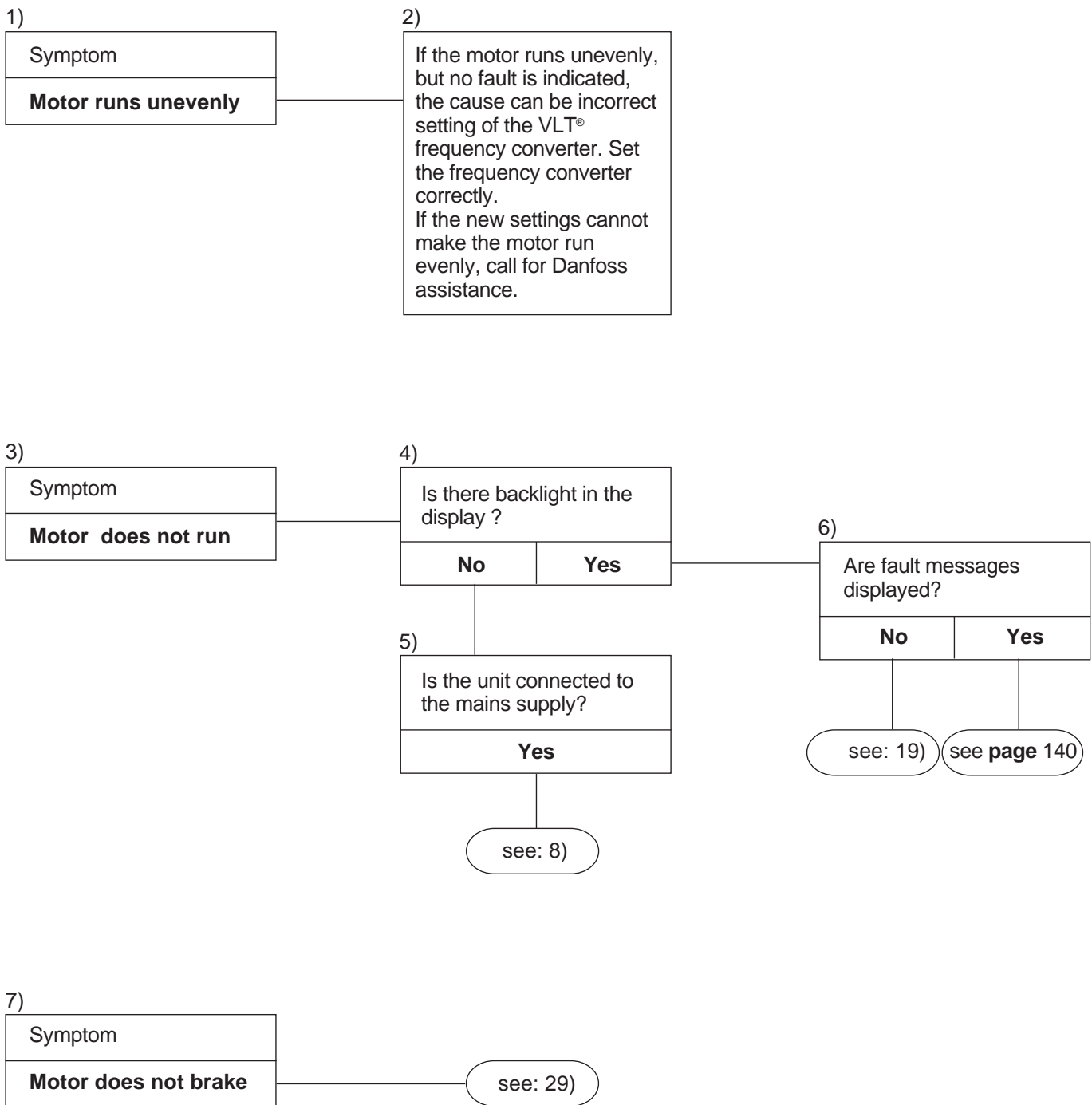

Fault location

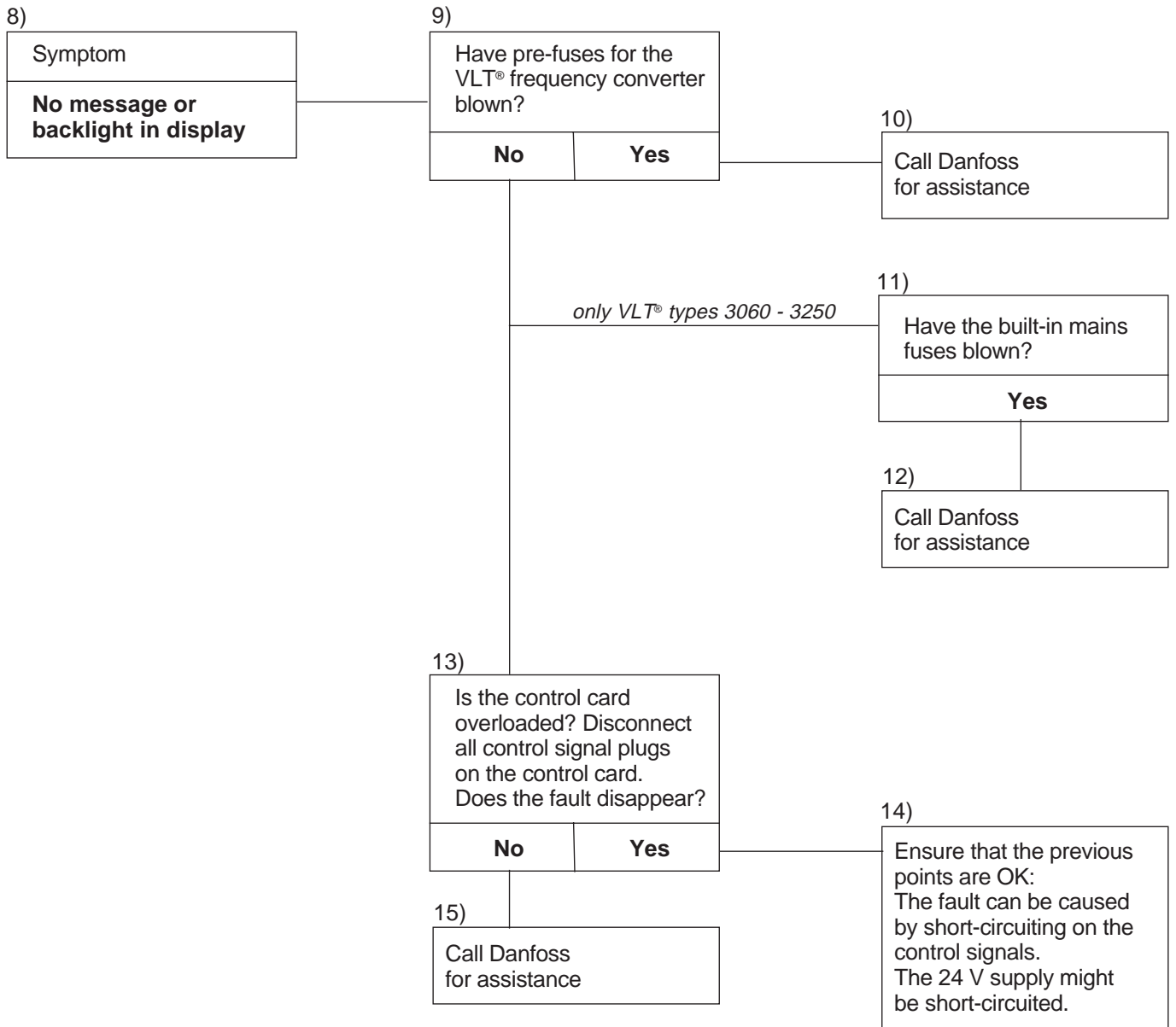

Fault location

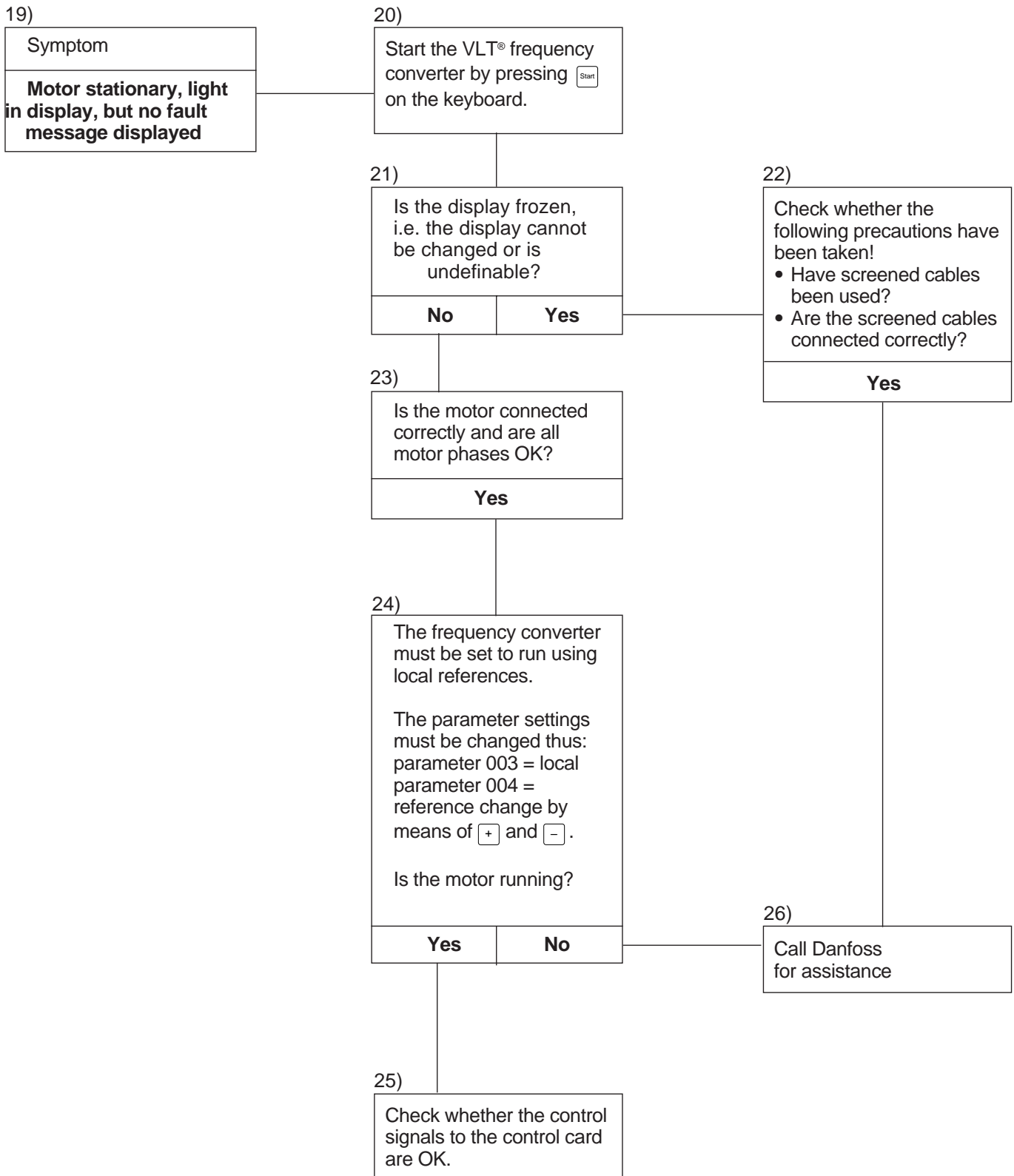

Fault location

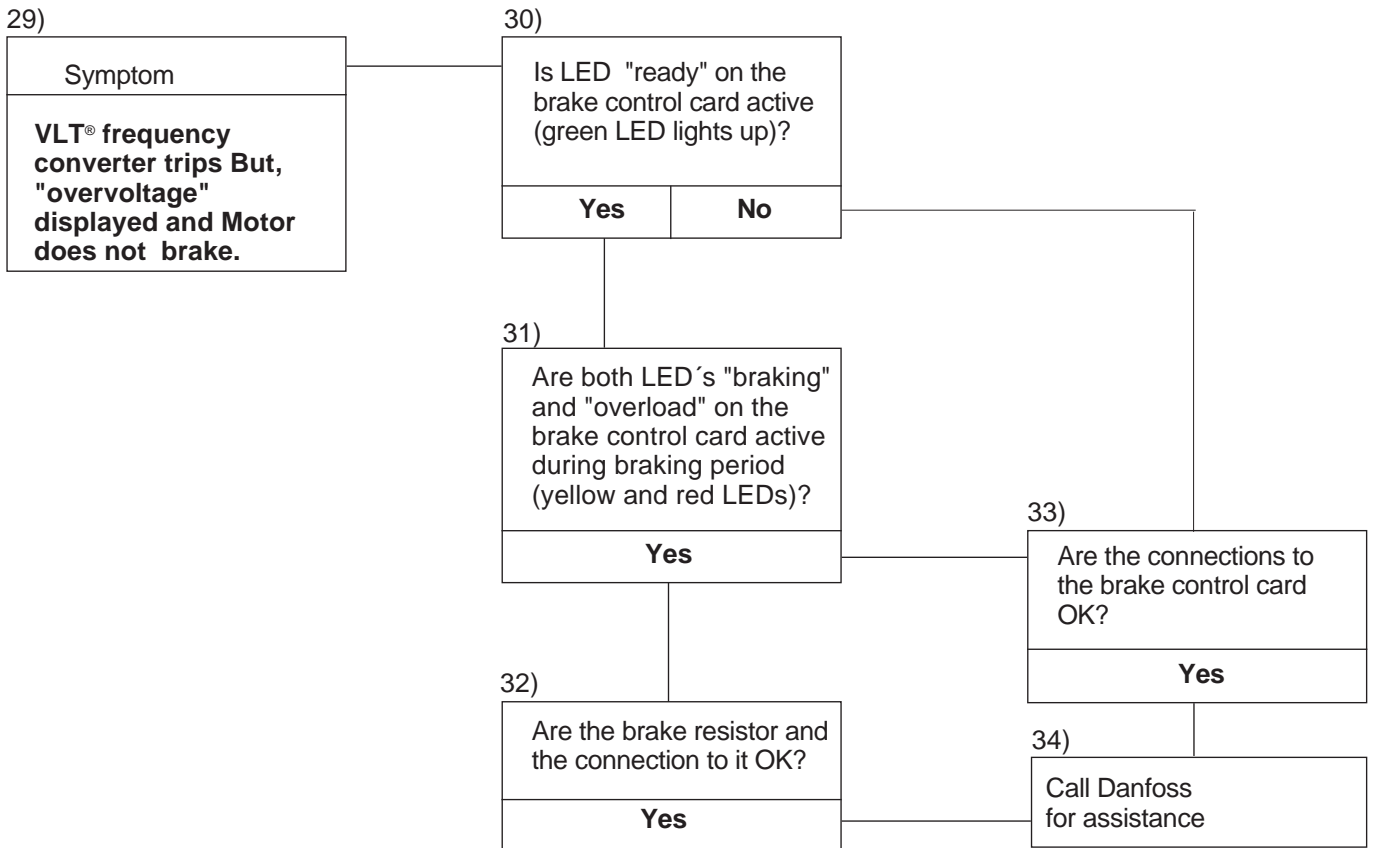

Accessories

External mounting of display

The control panel can be mounted externally using an optional adaptor and cable.

The length of the cable is 3 metres, which is enough to mount the control panel in a cabinet cover.

The enclosure at the cabinet cover is IP 54.

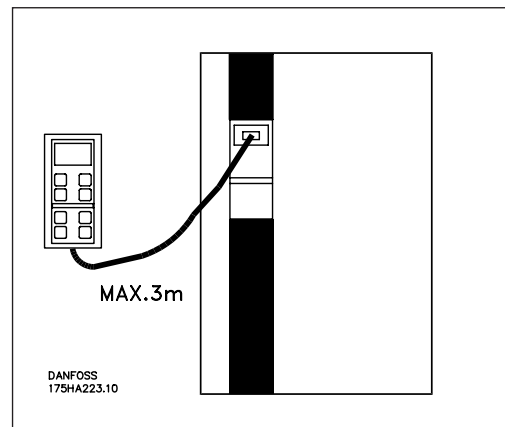

Connection of brake resistors

Danfoss can supply brake resistors suiting every size of VLT® frequency converters.

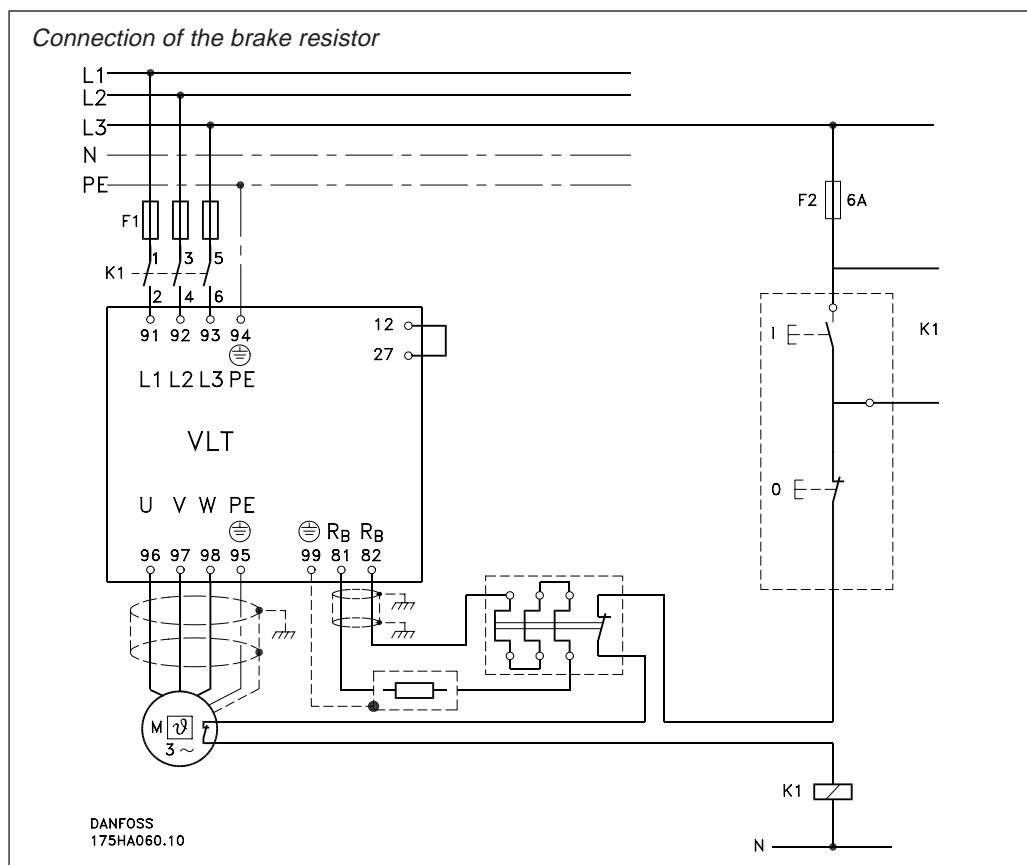

Connection of option cards

Beside the control card of the VLT® frequency converter you will see a free space. This space is used for option cards.

Mount the option card using the groove in the right-hand side of the aluminium tray, and the two screws.

The electrical connection between the option card and the standard control card is done by means of the plugs FK1 - FK4.

The number of option cards is increasing and the functions of specific option cards will be described in a separate manual.

Accessories

DANFOSS
175HA1.00

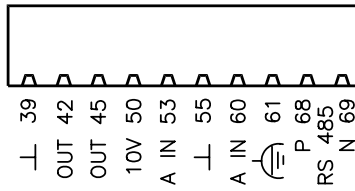
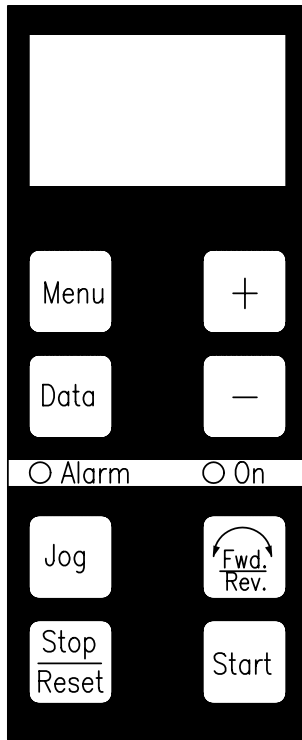

ORDERING NO.

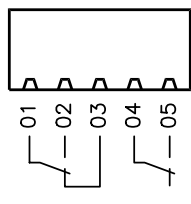
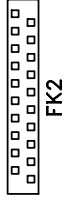
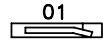
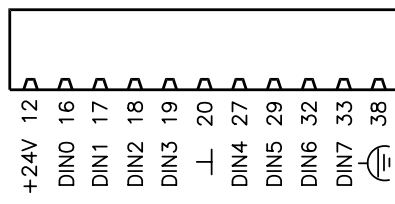

Accessories

Mounting of bonding plate for UL approval

Insert the bonding plate into the cover as shown.

Attach the bonding plate's ground wire with the ground screw marked GND. The GND screw is located to the right of the mains terminal block.

Mount the bottom cover to the control.

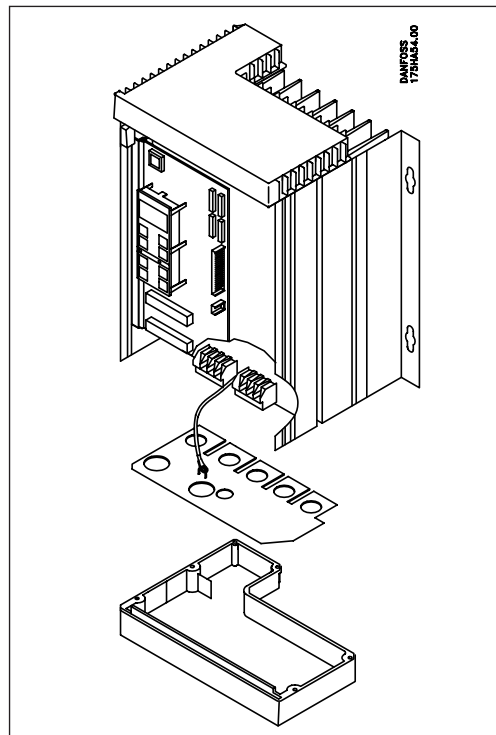

Mounting of fan option

Unplug the ribbon connector, the small cable and the card ground wire. Remove the control card and the shield together.

Place the fan option on the extrusion, making sure that the fan-option mounting holes are aligned with the enclosure.

The next card has a two-pin molex connector placed as shown. Plug the fan cable into the molex connector.

Replace the control card carefully, and plug in the ribbon connector, the small cable and the card's ground wire.

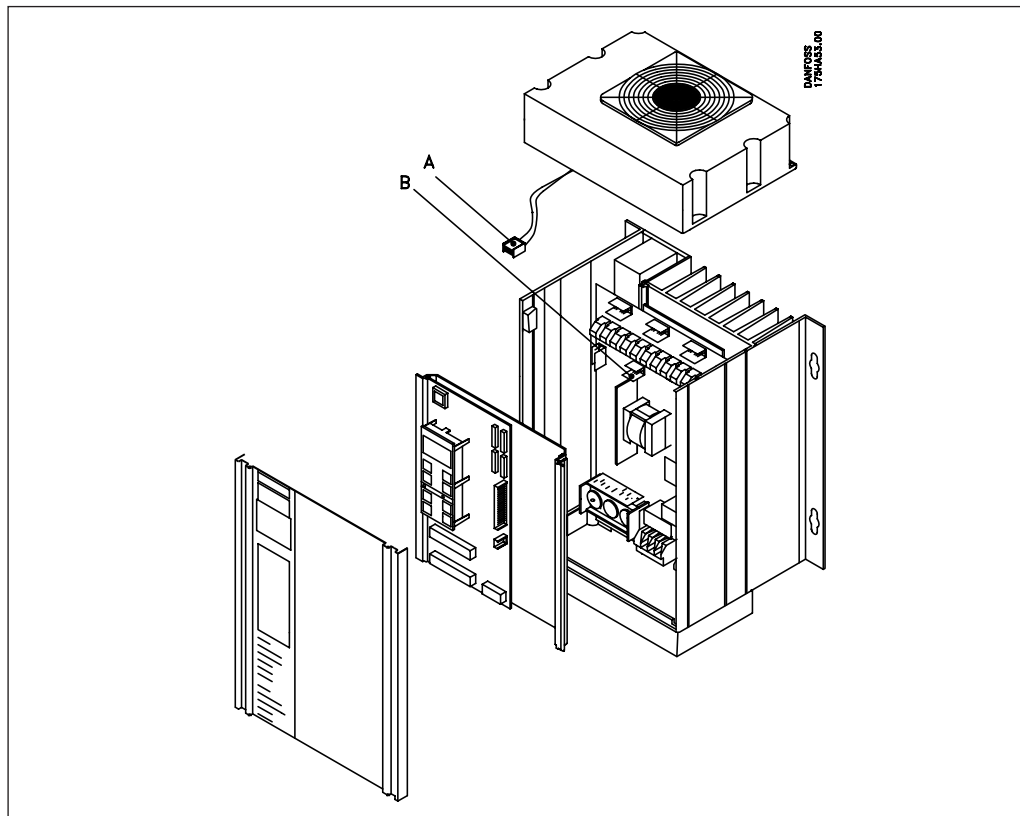

Factory settings

Operation and display:

000	LANGUAGE ^{S)} SETUP SELECTION, OPERATION
001	SETUP OPERATIO ^{S)} SETUP 1
002	MENU SET COPY DO NOT COPY
003	LOCAL / REMOTE ^{S)} REMOTE
004	LOCAL SPEED ^{S)}
005	VALUE AT MAX ^{S)}
006	LOCAL RESET ^{S)} ENABLE
007	LOCAL STOP ^{S)} ENABLE
008	LOCAL FWD/REV ^{S)} DISABLE
009	LOCAL JOG ^{S)} DISABLE
010	LOC REFERENCE ^{S)} ENABLE
011	ENERGY COUNTER ^{S)} NO RESET
012	HOOR COUNTER ^{S)} NO RESET
014	POWER -UP MODE ^{S)} LOK=STOP
015	SETUP PROGRAM ^{S)} SETUP=P001

Load and motor:

100	LOAD ^{4,S)} CT COMPENSATED
101	SPEED CONTROL ^{4,S)} SLIP COMPENSATED
102	SET CUR.LIMIT ^{S)} PREPROGRAMMED VALUE
103	MOTOR POWER DEPENDING ON UNIT
104	MOTOR VOLTAGE DEPENDING ON UNIT
105	MOTOR FREQ DEPENDING ON UNIT
106	AUTO MOTOR SET OFF
107	MOTOR CURRENT ^{4,S)} DEPENDING ON UNIT
108	MOTOR MAG. AMP ^{4,S)} DEPENDING ON UNIT
109	START VOLTAGE ^{4,S)} DEPENDING ON UNIT
110	START COMP. ^{4,S)} DEPENDING ON UNIT
111	U/f RATIO ^{4,S)} DEPENDING ON UNIT
112	SLIP COMP. ^{4,S)} DEPENDING ON UNIT
113	NEG SLIP COMP. ^{4,S)} DEPENDING ON UNIT
114	FEED BACK TYPE ^{S)} CURRENT 20 mA
115	DIS VLU@MIN FB ^{S)} 0
116	DIS VLU@MAX FB ^{S)} 100
117	DISPLAY UNIT ^{S)} %
119	FEED FWD FACTR ^{4,S)} 100%
120	CONTRL RANGE ^{4,S)} 100%
121	PROPRT/L GAIN ^{4,S)} 0,01
122	INTEGRAL TIME ^{4,S)} OFF
123	DIFFERNTL TIME ^{4,S)} OFF
124	LOWPASS FILTER ^{4,S)} 0
125	FEEDBACK FACTR ^{4,S)} 100

References and limits:

200	FREQ RANGE 0-120 Hz
201	MIN. FREQUENCY ^{4,S)} 0
202	MAX. FREQUENCY ^{4,S)} DEPENDING ON UNIT
203	JOG FREQUENCY ^{4,S)} 10
204	DIG. REF. TYPE ^{4,S)} SUM
205	REF. 1 DIGITAL ^{4,S)} 0
206	REF. 2 DIGITAL ^{4,S)} 0
207	REF. 3 DIGITAL ^{4,S)} 0
208	REF. 4 DIGITAL ^{4,S)} 0
209	CURRENT LIMIT ^{4,S)} DEPENDING ON UNIT
210	LO FREQ. WARN ^{4,S)} 0
211	HI FREQ. WARN ^{4,S)} 132 Hz
212	LO CURR. WARN ^{4,S)} 0
213	HI CURR. WARN ^{4,S)} $I_{VLT,MAX}$ (FROM 209)
214	RAMP TYPE ^{4,S)} LINEAR
215	RAMP UP TIME ^{4,S)} DEPENDING ON UNIT
216	RAMP DOWN TIME ^{4,S)} DEPENDING ON UNIT
217	ALT. UP RAMP ^{4,S)} DEPENDING ON UNIT
218	ALT.DOWN RAMP ^{4,S)} DEPENDING ON UNIT
219	FREQ 1 BYPASS ^{4,S)} f_{RANGE}
220	FREQ 2 BYPASS ^{4,S)} f_{RANGE}
221	FREQ 3 BYPASS ^{4,S)} f_{RANGE}
222	FREQ 4 BYPASS ^{4,S)} f_{RANGE}
223	BYPASS B. WIDTH ^{4,S)} 0
224	CARRIER FREQ ^{4,S)} 4.5
225	VAR. CARR.FREQ. ^{4,S)} OFF
230	BRAKE OFF FREQ ^{4,S)} 3 Hz
231	BRAKE ON FREQ. ^{4,S)} 3 Hz
232	CURR. MIN VALUE ^{4,S)} DEPENDING ON VLT [®]
233	CURR DLAY TIME ^{4,S)} 0.1

⁴⁾ Available in all 4 setups.

^{S)} Can be changed in start mode (running motor).

^{*)} Where "Depends on VLT[®]" is stated, the factory setting parameters are shown on the tables on the following pages.

Factory settings

Functions and timers:

300	BRAKE OPTION ^{S)} NOT APPLIED
301	START FREQ ^{4,S)} 0
302	START DELAY ^{4,S)} 0
303	HI START TORQ ^{4,S)} 0
304	POWER FAIL ^{S)} STOP
305	FLYING START ⁴⁾ DISABLE
306	DC-BRAKING TIME ^{4,S)} 0
307	DC-BRK ON FREQ ^{4,S)} 0
308	DC BRK VOLTAGE ^{4,S)} <i>DEPENDING ON UNIT</i>
309	RESET MODE ^{S)} MANUAL RESET
310	TRIP DLY @ C.LIM ^{S)} OFF
311	TRIP DLY @ FAULT ^{S)} <i>DEPENDING ON UNIT</i>
312	AUTO RESTART T ^{S)} MAX. 5
313	MOTOR CHECK ^{S)} OFF
314	MOTOR PRE-HEAT ^{S)} OFF
315	MOTOR THERMAL ^{4,S)} OFF
316	RELAY ON DELAY ^{S)} 0
317	RELAY OFF DELA ^{S)} 0

Inputs and outputs:

400	INPUT 16 ^{S)} RESET
401	INPUT 17 ^{S)} FREEZE REF.
402	INPUT 18 ^{S)} START
403	INPUT 19 ^{S)} REVERSING
404	INPUT 27 ^{S)} MTR. COAST
405	INPUT 29 ^{S)} JOGGING
406	INPUT 32/33 ^{S)} 4 SETUP EXT.
407	OUTPUT 42 ^{S)} 0- _I MAX = 0-20mA
408	OUTPUT 45 ^{S)} 0- _I MAX = 0-20mA
409	RELAY 01 ^{S)} READY-MOT.OK
410	RELAY 04 ^{S)} UNIT READY REMOTE CONTROL
411	ANALOG REFTYPE ^{S)} LINEAR BETWEEN MIN. AND MAX.
412	INPUT # 53 ANA. ^{4,S)} 0-±10 V
413	INPUT # 60 ANA. ^{4,S)} 0-20 mA
414	TIME OUT ^{4,S)} OFF
415	TIME OUT ACT. ^{4,S)} FREEZE

Serial data interface:

500	ADDRESS 1
501	BAUD RATE 9600
502	DATA READOUT ^{S)} REFERENCE
503	COAST ^{S)} LOGIC OR
504	Q-STOP ^{S)} LOGIC OR
505	DC-BRAKE ^{S)} LOGIC OR
506	START ^{S)} LOGIC OR
507	DIRECTION ^{S)} DIGITAL
508	RESET ^{S)} LOGIC OR
509	SETUP SELECT ^{S)} LOGIC OR
510	SPEED SELECT ^{S)} LOGIC OR
511	BUS JOG 1 ^{S)} 10
512	BUS JOG 2 ^{S)} 10
513	CATCHUP/SLOWDN ^{S)} 0
514	BUS BIT 4 ^{S)} Q-STOP
515	BUS BIT 11/12 ^{S)} CATCH / SLOW
516	BUS REFERENCE ^{S)} 0
517	STORE DATA ^{S)} OFF

Service and diagnostics:

600	OPERATION DATA ^{S)} TOT. HRS
601	DATA LOG ^{S)}
602	ALARM MEMORY ^{S)}
603	NAMEPLATE ^{S)}
604	OPERATION MODE ^{S)} RUN NORMAL
605	DISPLAY SELECT ^{S)} STANDARD DISPLAY
650	VLT® TYPE

⁴⁾ Available in all 4 setups.

^{S)} Can be changed in start mode (running motor).

*) Where "Depends on VLT®" is stated, the factory setting parameters are shown on the tables on the following pages.



Factory settings

380/415 V

	3002	3003	3004	3006	3008	3011	3016	3022	3032	3042	3052	3060	3075	3100	3125	3150	3200	3250
Parameter																		
103 Motor power	0.75	1.5	2.2	4	5.5	7.5	11	15	22	30	37	45	55	75	90	110	132	160
104 Motor voltage	380	380	380	380	380	380	380	380	380	380	380	380	380	380	380	380	380	380
105 Motor frequency	50	50	50	50	50	50	50	50	50	50	50	50	50	50	50	50	50	50
107 Motor current	2	3.7	5.3	9.1	12.2	15.8	22.8	31.1	42.8	59.3	72	86.2	106.3	134.1	166.8	197.8	230	272.4
108 Motor magnetizing current	1.1	2	2.4	3.6	4.6	5.4	8.6	10.2	13.1	20	20.3	28	34.5	40.1	53.6	60.3	67.8	77.5
109 Start voltage	40	39.1	36.8	35.6	35.4	35.2	35	34.9	34.9	36.8	36.2	36.8	36.7	36.7	36.7	36.7	36.7	36.7
110 Start compensation	16	5	5	2.3	1.6	1.19	0.7	0.46	0.28	0.21	0.23	0	0	0	0	0	0	0
111 U/F ratio	6.84	6.94	7.03	7.13	7.13	7.18	7.2	7.28	7.3	7.32	7.22	7.33	7.31	7.3	7.3	7.3	7.3	7.3
112 Slip compensation	4.86	3.8	3.2	2.6	2.08	1.72	1.24	1.14	0.84	0.74	0.52	0.56	0.52	0.36	0.32	0.28	0.26	0.24
113 Negative slip comp.	4.86	3.8	3.2	2.6	2.08	1.72	1.24	1.14	0.84	0.74	0.52	0.56	0.52	0.36	0.32	0.28	0.26	0.24
202 Max. frequency	50	50	50	50	50	50	50	50	50	50	50	50	50	50	50	50	50	50
209 Current limit	3.5	6.6	9	16	20.8	25.6	38.4	51.2	70.4	97.6	116.8	129	158	209	252	308	365	453
215 Ramp-up time	1	1	1	1	10	10	10	15	15	15	15	30	30	30	30	30	30	30
216 Ramp-down time	1	1	1	1	10	10	10	15	15	15	15	30	30	30	30	30	30	30
217 Alt. ramp-up time	1	1	1	1	10	10	10	15	15	15	15	30	30	30	30	30	30	30
218 Alt. ramp-down time	1	1	1	1	10	10	10	15	15	15	15	30	30	30	30	30	30	30
232 Current, min. value	0.6	1	1.2	1.8	2.3	2.7	4.3	5.1	6.6	10	10.2	14	17.3	20.1	26.8	30.2	33.9	38.8
308 D.C. brake voltage	28	25	28	21	14	13	11	12	11	21	20	20	0.0	0.0	0.0	0.0	0.0	0.0
311 Trip delay at inverter fault	2	2	2	2	9	9	9	12	12	12	12	0	0	0	0	0	0	0

	3002	3003	3004	3006	3008	3011	3016	3022	3032	3042	3052	3060	3075	3100	3125	3150	3200	3250
Parameter																		
103 Motor power	0.75	1.5	2.2	4	5.5	7.5	11	15	22	30	37	55	75	90	110	132	160	200
104 Motor voltage	460	460	460	460	460	460	460	460	460	460	460	460	460	460	460	460	460	460
105 Motor frequency	60	60	60	60	60	60	60	60	60	60	60	60	60	60	60	60	60	60
107 Motor current	1.8	3.4	4.8	7.6	10.0	13.7	20.0	25.0	35.5	48.5	61.8	84.7	110.8	137.8	163.4	190.0	225.0	285
108 Motormagnetizingcurrent	1.1	2.2	3.4	4	4.8	6.0	9.3	10.6	11.1	16.2	20.8	29.5	33.1	44.3	49.8	56.0	64.0	79
109 Start voltage	49.1	46.3	45.8	45.2	45.0	44.9	44.7	44.3	43.8	44.6	44.5	47.0	47.0	47.0	47.0	47.0	47.0	47.0
110 Start compensation	12.30	8.40	5	2.8	1.5	0.85	0.85	0.75	0.51	0.31	0.32	0	0	0	0	0	0	0
111 U/F ratio	7.30	7.30	7.10	7.40	7.46	7.30	7.40	7.30	7.30	7.40	7.40	7.50	7.40	7.50	7.50	7.50	7.50	7.50
112 Slip compensation	3.33	2.50	2.67	2.50	1.08	1.42	1.75	1.13	0.52	0.60	0.62	0.30	0.30	0.27	0.23	0.22	0.20	0.18
113 Negative slip comp.	3.33	2.50	2.67	2.50	1.08	1.42	1.75	1.13	0.52	0.60	0.62	0.30	0.30	0.27	0.23	0.22	0.20	0.18
202 Max. frequency	60.0	60.0	60.0	60.0	60.0	60.0	60.0	60.0	60.0	60.0	60.0	60.0	60.0	60.0	60.0	60.0	60.0	60.0
209 Current limit	3.4	5.4	.7.	13.1	17.6	23.2	34.7	44.6	67.2	86.4	104.0	116.0	144.0	186.0	234.0	270.0	360.0	453.0
215 Ramp-up time	1	1	1	1	15	15	15	15	15	15	15	30	30	30	30	30	30	30
216 Ramp-down time	1	1	1	1	15	15	15	15	15	15	15	30	30	30	30	30	30	30
217 Alt. ramp-up time	1	1	1	1	15	15	15	15	15	15	15	30	30	30	30	30	30	30
218 Alt. ramp-down time	1	1	1	1	15	15	15	15	15	15	15	30	30	30	30	30	30	30
232 Current, min. value	0.6	1.1	1.7	2.0	2.4	3.0	4.7	5.3	5.6	8.1	10.4	14.8	16.6	22.2	24.9	28.0	32.0	39.5
308 D.C. brake voltage	24	23	19	23	16	11	9	9	9	9	9	0	0	0	0	0	0	0
311 Trip delay at inverter fault	2	2	5	7	7	7	7	8	8	12	12	0	0	0	0	0	0	0

Factory settings

200/230 V

	3002	3003	3004	3006	3008	3011	3016	3022	3032	3042	3052
Parameter											
103 Motor power	0.75	1.5	2.2	4	5.5	7.5	11	15	22	30	37
104 Motor voltage	200	200	200	200	200	200	200	200	230	230	230
105 Motor frequency	50	50	50	50	50	50	50	50	60	60	60
107 Motor current	3.8	7.8	10.0	17.2	25.0	32.0	46.0	57.2	80.0	104.0	130.0
108 Motor magnetizing current	2.4	3.2	4.6	6.8	8.8	10.0	14.4	21.6	28.8	27.1	37.4
109 Start voltage	21.3	20.2	19.3	19.4	19.5	19.4	19.4	19.5	22.3	21.9	22.2
110 Start compensation	4.2	2.10	1.86	0.79	0.50	0.35	0.21	0.11	0.00	0.00	0.00
111 U/F ratio	3.75	3.70	3.80	3.80	3.80	3.80	3.80	3.80	3.70	3.65	3.70
112 Slip compensation	4.6	2.56	2.80	1.60	2.00	1.90	1.80	1.66	0.75	0.37	0.42
113 Negative slip comp.	4.6	2.56	2.80	1.60	2.00	1.90	1.80	1.66	0.75	0.37	0.42
202 Max frequency	50	50	50	50	50	50	50	50	60	60	60
209 Current limit	6.7	12.5	17.0	30.0	40.0	51.2	73.6	97.6	120.0	156.0	195.0
215 Ramp-up time	1	1	1	10	10	10	10	10	30	30	30
216 Ramp-down time	1	1	1	10	10	10	10	10	30	30	30
217 Alt. ramp-up time	1	1	1	10	10	10	10	10	30	30	30
218 Alt. ramp-down time	1	1	1	10	10	10	10	10	30	30	30
232 Current, min. value	1.2	1.6	2.3	3.4	4.4	5.0	7.2	10.8	14.4	13.6	18.7
308 D.C. brake voltage	22	16	21	17	14	11	10	10	0.0	0.0	0.0
311 Trip delay at inverter fault	2	2	2	6	6	6	6	6	0	0	0

Index

A		D		Frequency bypass 2 96	
About this manual 5		Danfoss VLT® frequency		Frequency bypass 3 96	
Acoustic noise 130		converter and CE-labelling 52		Frequency bypass 4 96	
Adaptive motor tuning 91		Data mode 61		Frequency bypassband width 96	
Address 113		Data read-out 113, 114		Frequency range 94	
Advanced VLT® protection 11		Data udlæsning 115		Function diagrams 17	
Advanced motor protection 11		Data value of aparameter 65		Functions and timers 98	
Air humidity 137		DC brake cut-infrequency 99		Functions and timersGroup 3.. 72	
Alarm messages 126		DC brake voltage 99			
Alarm mode 61		DC braking time 99		G	
Alternative ramp-down time 96		Derating 131		Galvanic isolation 11	
Alternative ramp-up time 96		Derating - EMC 133		Galvanic isolation(PELV) 128	
Analogue reference type 111		Description of terminals 31, 32		General 45	
Available documentation 5		Different modes,different		Group description 66	
Avoid unwanted data change 64		information 61		Groups 70	
		Differentiation time 93			
B		Digital reference 1 94		H	
Base VLT® 3100-3250 40		Digital reference 2 94		Heat emission from the VLT® 3000 44	
Baud rate 113		Digital reference 3 94		High starting torque 98	
Binary input 16 101		Digital reference 4 94		How to use this manual 5	
Binary input 18 103		Digital reference type 94			
Binary input 19 104		Dimensions 29		I	
Binary input 29 106		Direction of rotation 50		If the factory setting has been	
Binary input 32/33 107, 108		Display mode 61		changed 7	
Brake cable 56		Display layout 61		In most cases 6	
Brake module 14		Display messages 125		Initialization 63	
Brake option 98		Display unit 93		Initialization viaparameter 604 63	
Bus bit 11/12 117		Display value 84		Inputs and outputs 101	
Bus bit 4 117		Display valueat min. feedback 92		Inputs and outputsGroup 4.. 72	
Bus jogging 1 117		du/dt and peak voltage on motor .. 130		Integral time 93	
Bus jogging 2 117				Intermediate circuit 8	
Bus reference 117				Internal mounting	
		E		panel in mounting cabinet IP54 30	
C		Earth leakage current 128		Introduction 8	
Cable access: 42		Earthing: 53		Inverter 8	
Cables 53		Effective radio frequency		IP 00 28	
Capacitors in the intermediate circuit 8		interference suppression 11		IP 20 28	
Carrier frequency 96		Effektfaktor 139		IP 21 29	
Catch-up / slow-down value 117		Efficiency 138		IP 21 / IP 54 30	
Changing a data value: text 65		Electrical installation 45		IP 54 29	
Choice of frequency converter size 12		Electrical safety 2			
Clamp module 14		Electrostatic discharge (ESD) 141		J	
Coils in the intermediate circuit 8		EMC installation 55		JOG frequency(JOG frequency) 94	
Compliance with EMC		Error messages 127			
directive 89/336/EEC 53		EXCEPT fault:: 127		K	
Connecting ofbrake resistors 146		External mounting of the		Keys for local operation 60	
Connection examples 32		control panel 60		Keys for programming 60	
Connection ofoption cards 146		External operation 6			
Constant torque CT 10		Extreme running conditions 129		L	
Control accuracy 10				Language select 82	
Control cables 56		F		LC module 14	
Control card 8		Factory programmedU/f		LC motor filter 14	
Control principle 8		characteristics 10		Leaving DATA mode 65	
Control: 31		factory setting 7		Load 88	
Controller range 93		Factory-settings 149, 150		Load and motor 88	
Cooling 43		Fault location 142		Load and motorGroup 1.. 66	
Current limit 95		Fault messages 140		Local jogging 85	
Current limit control 89		Feedback type 92		Local reset 84	
		FF factor 93		Local reversing 85	
		Flying start 98		Local start/stop 84	
		For experienced Danfoss VLT users 5		Local reference 85	
		For first-time Danfoss VLT® users 5		Local reference(Local speed) 84	
		Frequency bypass 1 96			

Index

Continued

"LOCK" switch	64	Q	Quadratic torque VT	10	U	U/f ratio	92
Long motor cables	11	Quick set-up	6	Use the flow charts	141		
Low disturbance on the mains 1	1						
Low pass filter	93						
M		R	Radio interference in general	54	V	Ventilation of VLT® units when	
Mains and motor connection for		Ramp type	95	panel-mounted	44		
VLT® types 3002-30	46	Ramp-down time	96	Vibration and shock	137		
Mains and motor connection for		Ramp-up time	96	VLT type	122		
VLT® types 3032-305	47	Rectifier	8	VLT® 3002-3052	40		
Mains failure	98	References and limits	94	VLT® 3060-3250	40		
Mains supply	8, 23	References and limitsGroup 2..	71	VLT® 3100-3250	40		
Mains supply interference /		Relay OFF-delay	100	Voltage Vector Control (VVC)	9		
harmonics	139	Relay ON-delay	100				
Manual initialization	63	Relay output 01	110	W			
Max. auto restart time	100	Relay output 04	111	Warning	2		
Max. frequency	94	Reset	116	Warning current high	95		
Mechanical installation	40, 55	Reset energy counter	85	Warning current low	95		
Menu mode	61	Reset hour counter	85	Warning frequency high	95		
Menu build-up	65	Reset messages	126	What is CE-labelling?	3, 51		
Min. frequency	94	Reset mode	99	Which one to choose?	12		
Motor cable	56	RFI module	14				
Motor check	100	RFI module IP21	30				
Motor coils	8	RFI option	14				
Motor connection	50	RFI-LC module	14				
Motor current	91						
Motor frequency	90	S					
Motor power	90	Serial communication	113				
Motor pre-heat	100	Serial data interfaceGroup 5..	73				
Motor thermal protection	100	Service and diagnosis, Group 6.. ..	81				
Motor voltage	90	Signal output 42	109				
Motormagnetizingcurrent	91	Signal output 45	110				
Mounting cabinet IP54	30	Sizing	12				
Mounting of fan option	148	Slip compensation	92				
Mounting of bonding plate for UL		Software version:	1				
approval	148	Speed control	89				
		Start	116				
N		Start compensation	92				
Negativ slip compensation	92	Start delay	98				
		Start frequency	98				
O		Start voltage	91				
Operation and display	82	Start-up	6				
Operation and displayGroup 0..	66	Start-up test:	127				
Operation place	83	Status messages	123				
Output	8	Store data values	118				
P		T					
Parallel connection of motors	50	Technical data	23				
Parameter description	82, 83	Technology	9				
PARAMETER MODE	61	Terminal 53Analogue input voltage	111				
Parameter numbering	65	Terminal 60Analogue input current	111				
Personal display select	122	The control panel	60				
Pre-fuses	45	Thermal motor protection	130				
Product range	14	These rules concern your safety	2				
Programmable control inputs		Time out	64				
and signal outputs in 4	11	Time out function	112				
Programming keys	6	Time out (Time out)	112				
Proportional gain	93	Travelling the menu	65				
Protected against mains		Travelling through the menu	65				
disturbance	11	Trip delay at current limit	99				
		Trip delay at inverter fault	100				

