

ENGINEERING
TOMORROW

Danfoss

Operating Guide

VLT® Servo Drive System ISD 510/DSD 510

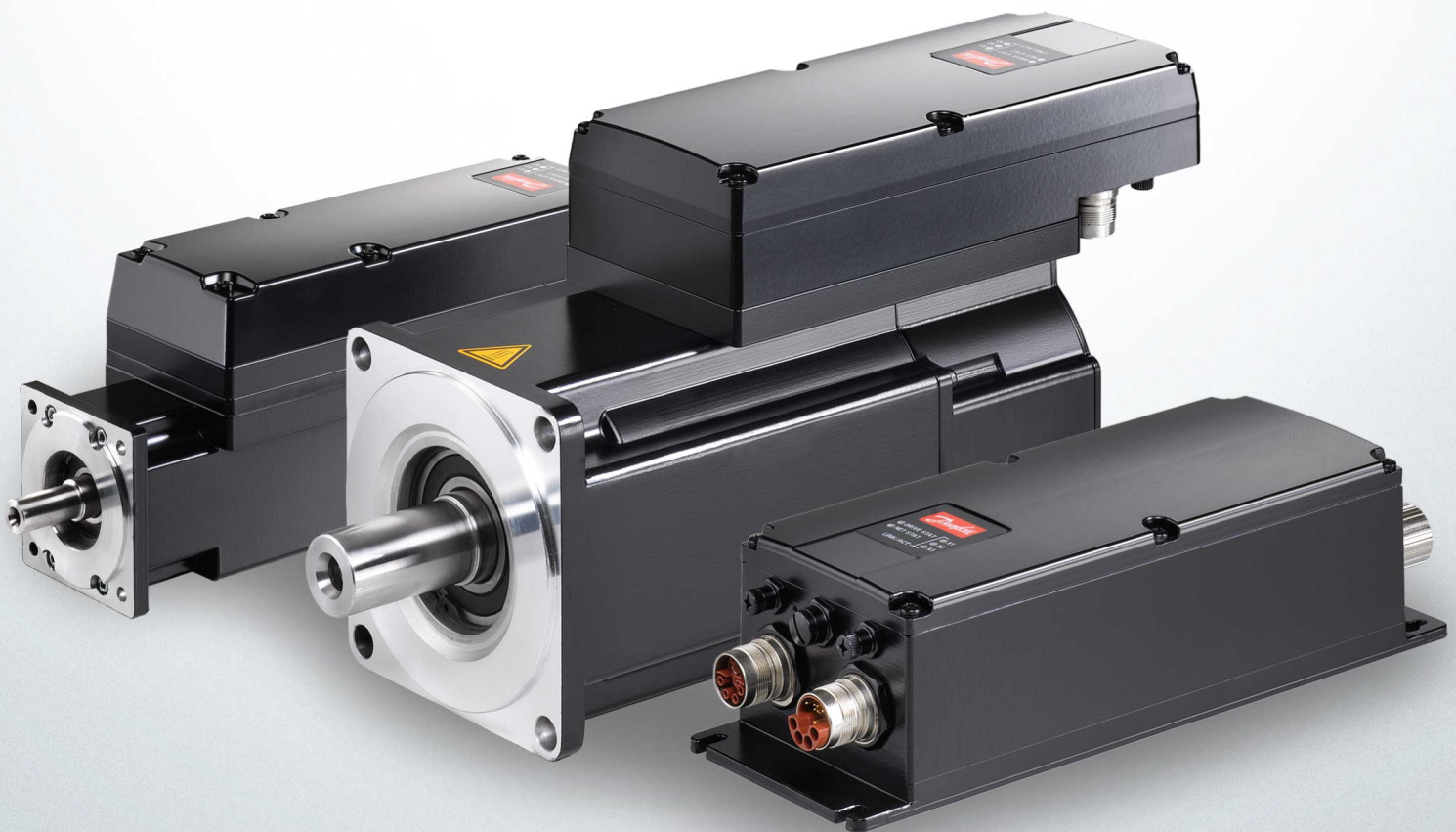



Danfoss A/S

6430 Nordborg
Denmark

CVR nr.: 20 16 57 15

Telephone: +45 7488 2222

Fax: +45 7449 0949

EU DECLARATION OF CONFORMITY

Danfoss A/S
Danfoss Drives A/S

declares under our sole responsibility that the

Product category: Frequency Converter

Type designation(s): ISD510

ISD510xT01C5D6xxxxxxxxxxxxxxxxxxxxxxxxxxxxxxxx, ISD510xT02C1D6xxxxxxxxxxxxxxxxxxxxxxxxxxxxxxxx,
ISD510xT02C9D6xxxxxxxxxxxxxxxxxxxxxxxxxxxxxxxx, ISD510xT03C8D6xxxxxxxxxxxxxxxxxxxxxxxxxxxxxxxx
ISD510xT05C2D6xxxxxxxxxxxxxxxxxxxxxxxxxxxxxxxx, ISD510xT06C0D6xxxxxxxxxxxxxxxxxxxxxxxxxxxxxxxx
ISD510xT11C2D6xxxxxxxxxxxxxxxxxxxxxxxxxxxxxxxx

Covered by this declaration is in conformity with the following directive(s), standard(s) or other normative document(s), provided that the product is used in accordance with our instructions.

Low Voltage Directive 2014/35/EU

EN61800-5-1:2007 Adjustable speed electrical power drive systems – Part 5-1: Safety requirements – Electrical, thermal and energy.

EMC Directive 2014/30/EU



EN61800-3:2004 + A1:2012 Adjustable speed electrical power drive systems – Part 3: EMC requirements and specific test methods.

RoHS Directive 2011/65/EU including amendment 2015/863.

EN63000: 2018 Technical documentation for the assessment of electrical and electronic products with respect to the restriction of hazardous substances

Machine Directive 2006/42/EC

EN61800-5-2:2007 Adjustable speed electrical power drive systems – Part 5-2: Safety requirements – Functional.

Date: 2020.12.07 Place of Issue:	Issued by	Date: 2020.12.07 Place of issue:	Approved by
Bruchsal, DE	 Signature: Name: Christian Schröder Title: Head PM Motion Drives	Merano, IT	 Signature: Name: Andrea Perin Title: Head of Motion Unit

Danfoss only vouches for the correctness of the English version of this declaration. In the event of the declaration being translated into any other language, the translator concerned shall be liable for the correctness of the translation



Danfoss A/S

6430 Nordborg
Denmark
CVR nr.: 20 16 57 15

Telephone: +45 7488 2222
Fax: +45 7449 0949

EU DECLARATION OF CONFORMITY

Danfoss A/S
Danfoss Drives A/S

declares under our sole responsibility that the product **VLT® Decentral Servo Drive DSD 510**

Product category: Frequency converters

Type designation(s):

DSD510xC08A0D6xxxxxxxxxxxxxxxxxxxxxxxxxxxxxxxx

Covered by this declaration is in conformity with the following directive(s), standard(s) or other normative document(s), provided that the product is used in accordance with our instructions.

Low Voltage Directive 2014/35/EU

EN61800-5-1:2007

Adjustable speed electrical power drive systems – Part 5-1:
Safety requirements – Electrical, thermal and energy.

EMC Directive 2014/30/EU

EN61800-3:2004 + A1:2012

Adjustable speed electrical power drive systems – Part 3: EMC
requirements and specific test methods.

RoHS Directive 2011/65/EU including amendment 2015/863.



EN63000:2018

Technical documentation for the assessment of electrical and
electronic products with respect to the restriction of
hazardous substances.

Machine Directive 2006/42/EU

EN61800-5-2: 2007

Adjustable speed electrical power drives systems – Part 5-2:
Safety requirements - Functional.

Date: 2020.12.07 Place of issue:	Issued by 	Date: 2020.12.07 Place of issue:	Approved by 
Bruchsal, DE	Signature: Name: Christian Schröder Title: Head PM Motion Drives	Merano, IT	Signature: Name: Andrea Perin Title: Head of Motion Unit

Danfoss only vouches for the correctness of the English version of this declaration. In the event of the declaration being translated into any other language, the translator concerned shall be liable for the correctness of the translation

Contents

1	Introduction	16
1.1	Purpose of the Operating Guide	16
1.2	Additional Resources	16
1.3	Copyright	16
1.4	Approvals and Certifications	16
1.5	Firmware Updates	18
1.6	Terminology	18
2	Safety	20
2.1	Safety Symbols	20
2.2	Important Safety Warnings	20
2.3	Safety Instructions and Precautions	22
2.3.1	Operational Safety	22
2.4	Qualified Personnel	23
2.5	Due Diligence	23
2.6	Intended Use	23
2.6.1	Prohibited Application Areas	23
2.7	Foreseeable Misuse	24
2.8	Service and Support	24
3	System Description	25
3.1	Overview of the ISD 510/DSD 510 System	25
3.1.1	Application Examples	26
3.2	VLT® Integrated Servo Drive ISD 510	27
3.2.1	Overview of the ISD 510 Servo Drive	27
3.2.2	Motor and Flange Sizes	27
3.2.3	ISD 510 Servo Drive Types	27
3.2.4	Motor Components	28
3.2.4.1	Shaft	28
3.2.4.2	Brake (Optional)	29
3.2.4.3	Cooling	29
3.2.4.4	Thermal Protection	29
3.2.4.5	Built-in Feedback Devices	29
3.2.5	Drive Components	29
3.2.5.1	Connectors on the ISD 510 Servo Drives	29
3.3	VLT® Decentral Servo Drive DSD 510	30
3.3.1	Overview of the DSD 510 Servo Drive	30

3.3.2	DSD 510 Servo Drive Types	30
3.3.3	Connectors on the DSD 510 Servo Drives	31
3.4	Power Supply Module (PSM 510)	32
3.4.1	Overview	32
3.5	Decentral Access Module (DAM 510)	33
3.5.1	Overview	33
3.6	Auxiliary Capacitors Module (ACM 510)	34
3.6.1	Overview	34
3.7	Expansion Module EXM 510	35
3.8	Local Control Panel (LCP)	37
3.8.1	Overview of the Local Control Panel	37
3.8.2	Layout of the Local Control Panel	37
3.8.2.1	A: Display area	37
3.8.2.2	B: Display menu keys	39
3.8.2.3	C: Navigation keys and indicator lights (LEDs)	39
3.8.2.4	D: Operation keys and reset	40
3.9	Cables	40
3.9.1	Hybrid Cable	40
3.9.1.1	Minimum Bending Radius for Hybrid Cable	41
3.9.2	Motor and Feedback Cable	42
3.9.2.1	Minimum Bending Radius for Motor Cable	42
3.9.2.2	Minimum Bending Radius for Feedback Cable	42
3.9.3	I/O and/or Encoder Cable	43
3.9.4	Fieldbus Extension Cable	43
3.9.5	LCP Cable	43
3.10	Cable Layout and Routing	43
3.10.1	Standard Cabling Concept for 2 Lines	43
3.11	Software	44
3.12	Fieldbus	44
3.12.1	EtherCAT®	45
3.12.2	Ethernet POWERLINK®	46
3.12.3	PROFINET®	46
4	Mechanical Installation	48
4.1	Items Supplied	48
4.2	Transport	48
4.3	Inspection on Receipt	48
4.4	Safety Measures during Installation	48

4.5	Installation Environment	48
4.5.1	Overview	48
4.5.2	ISD 510/DSD 510 Servo Drive	49
4.5.3	System Modules	49
4.6	Preparation for Installation	49
4.6.1	ISD 510/DSD 510 Servo Drive	49
4.6.2	System Modules	49
4.6.3	Drilling Templates	50
4.7	Installation Procedure	50
4.7.1	Space Requirements for ISD 510 Servo Drive	50
4.7.1.1	Minimum Distance for M23 Straight Connector on ISD 510	50
4.7.1.2	Minimum Distance for M23 Angled Connector on ISD 510	51
4.7.2	Space Requirements for DSD 510 Servo Drive	51
4.7.2.1	Minimum Distance for M23 Straight Connector on DSD 510	52
4.7.2.2	Minimum Distance for M23 Angled Connector on DSD 510	52
4.7.3	Space Requirements for System Modules	52
4.7.4	Installation Aids and Tools Required	54
4.7.5	Fitting Instructions for ISD 510 Servo Drive	54
4.7.5.1	Overview	54
4.7.5.2	Clamping the ISD 510 Servo Drive	54
4.7.5.3	Coupling the ISD 510 Servo Drive	55
4.7.5.4	Tightening Torques for Fixing Screws	56
4.7.6	Fitting Instruction for DSD 510 Servo Drive	56
4.7.6.1	Clamping the DSD 510 Servo Drive	56
4.7.7	Fitting Instructions for System Modules	57
5	Electrical Installation	61
5.1	Warnings for Electrical Installation	61
5.2	Electrical Environmental Conditions	61
5.3	EMC-Compliant Installation	62
5.4	Grounding	62
5.4.1	Grounding for Electrical Safety	62
5.4.2	Grounding for EMC-Compliant Installation	62
5.5	Mains Supply Requirements	64
5.5.1	Fuses	64
5.5.2	Circuit Breakers	64
5.6	Auxiliary Supply Requirements	65
5.6.1	Fuses	65

5.7	Safety Supply Requirements	65
5.8	UL Requirements	66
5.9	Connecting the ISD 510/DSD 510 Servo Drive	66
5.9.1	Electrical Installation Warnings for ISD 510/DSD 510 Servo Drive	66
5.9.2	General Instructions for Cable Installation	66
5.9.3	Connecting Hybrid Cables	67
5.9.4	Disconnecting Hybrid Cables	69
5.9.5	Connecting Cables to Ports X3, X4, and X5	69
5.9.5.1	Cable Routing Recommendations	69
5.9.5.2	Connecting I/O and/or Encoder Cables to Port X3	70
5.9.5.3	Connecting the LCP Cable to Port X5	71
5.9.5.4	Connecting the 3rd Ethernet Device Cable to Port X3	72
5.9.6	Disconnecting Cables from Ports X3, X4, and X5	72
5.10	Connecting the Power Supply Module PSM 510	72
5.10.1	AC Line Choke	72
5.10.1.1	Connecting 1 PSM 510 to the AC Choke	73
5.10.1.2	Connecting 2 PSM 510 Modules to the AC Choke	73
5.10.1.3	Connecting 2 PSM 510 Modules to the AC Choke with System Splitting	74
5.10.2	Connecting the Cables on the Power Supply Module PSM 510	75
5.10.2.1	Connecting the Cables on the Top of the Power Supply Module PSM 510	75
5.10.2.2	Connecting the Cables on the Bottom of the Power Supply Module PSM 510	76
5.11	Connecting the Decentral Access Module (DAM 510)	77
5.11.1	Connecting the Cables on the Top of the Decentral Access Module DAM 510	77
5.11.2	Connecting the Feed-In Cable	77
5.12	Connecting the Auxiliary Capacitors Module ACM 510	79
5.13	Connecting the Expansion Module EXM 510	79
5.14	Connecting the Brake Resistor on the PSM 510	80
6	Commissioning	83
6.1	Warnings for Commissioning	83
6.2	Pre-Commissioning Checklist	83
6.3	EtherCAT® ID Assignment	83
6.4	Ethernet POWERLINK® ID Assignment	83
6.4.1	Overview	83
6.4.2	Single Device ID Assignment	83
6.4.2.1	Setting the Node ID Directly on a Servo Drive or on the System Modules	83
6.4.2.2	Setting the Node ID for a Single Servo Drive via the Power Supply Module (PSM 510) or Decentral Access Module (DAM 510) via the LCP	84
6.4.3	Multiple Device ID Assignment	84

6.4.3.1	Setting the Node IDs of all Servo Drives and System Modules on a Decentral Access Module (DAM 510)/ Power Supply Module (PSM 510) Line	84
6.5	PROFINET® ID Assignment	85
6.6	Power-Up Time	85
6.7	System Module Charging Time	86
6.8	Switching on the ISD 510/DSD 510 System	86
6.8.1	Procedure for Switching on the ISD 510/DSD 510 System	86
6.9	Libraries	86
6.10	Programming with Automation Studio™	87
6.10.1	Requirements for Programming with Automation Studio™	87
6.10.2	Creating an Automation Studio™ Project	87
6.10.3	Including the Servo Motion Libraries into an Automation Studio™ Project	87
6.10.4	Constants within the DDS_Drive Library	88
6.10.5	Instantiating AXIS_REF_DDS in Automation Studio™	89
6.10.6	Instantiating PSM_REF in Automation Studio™	90
6.10.7	Instantiating DAM_REF in Automation Studio™	90
6.10.8	Instantiating ACM_REF in Automation Studio™	90
6.10.9	Importing a Servo Drive into Automation Studio™	91
6.10.9.1	Version V3.0.90	91
6.10.9.2	Version V4.x	91
6.10.10	Importing PSM 510, DAM 510 and ACM 510 into Automation Studio™	92
6.10.10.1	Version V3.0.90	92
6.10.10.2	Version V4.x	92
6.10.11	I/O Configuration and I/O Mapping	93
6.10.12	Setting the PLC Cycle Time	95
6.10.13	Connecting to the PLC	95
6.11	Programming with TwinCAT®	96
6.11.1	Requirements for Programming with TwinCAT®	96
6.11.2	Creating a TwinCAT® Project	96
6.11.3	Including the TwinCAT® Library into a TwinCAT® Project	96
6.11.4	Constants within the DDS_Drive Library	88
6.11.5	Instantiating AXIS_REF_DDS in TwinCAT®	98
6.11.6	Instantiating PSM_REF in TwinCAT®	99
6.11.7	Instantiating DAM_REF in TwinCAT®	99
6.11.8	Instantiating ACM_REF in TwinCAT®	99
6.11.9	Adding a PLC Project to TwinCAT® System Manager	99
6.11.10	Importing Devices to TwinCAT®	99
6.11.11	I/O Configuration and I/O Mapping	102

6.11.12 Attaching the Input and Output Variables to the Physical Data Points	103
6.11.13 Transferring the Mappings back to the PLC Program	104
6.11.14 Setting the PLC Cycle Time in TwinCAT® PLC Control	105
6.11.15 Configuration as a TwinCAT® NC Axis	105
6.11.15.1 I/O Configuration for Servo Drives used as NC Axes	105
6.11.16 Connecting to the PLC	106
6.12 Programming Guidelines for Automation Studio™ and TwinCAT®	106
6.13 Programming with SIMOTION SCOUT®	106
6.13.1 Requirements for Programming with SIMOTION SCOUT®	106
6.13.2 Connecting to the PLC	107
6.13.3 Creating a SIMOTION SCOUT® Project	107
6.13.4 Including the Servo Motion Libraries into a SIMOTION SCOUT® Project	107
6.13.5 Importing Devices into SIMOTION SCOUT®	109
6.13.6 Assigning IP Configuration and Device Name	110
6.13.7 Creating a Sync Domain	113
6.13.8 Configuring a Topology	116
6.13.9 Defining Send Clock and Update Time	117
6.13.9.1 Configuring the Send Clock Time	117
6.13.9.2 Configuring the Update Time	117
6.13.10 Accessing Inputs and Outputs	118
6.13.11 Programming using the Danfoss VLT® Servo Motion Library	119
6.13.12 Instantiating AXIS_REF_DDS in SIMOTION SCOUT®	119
6.13.13 Instantiating PSM_REF in SIMOTION SCOUT®	119
6.13.14 Instantiating DAM_REF in SIMOTION SCOUT®	119
6.13.15 Instantiating ACM_REF in SIMOTION SCOUT®	120
6.13.16 Global Compiler Settings	120
6.13.17 Assigning Tasks	121
6.14 Programming Guidelines for SIMOTION SCOUT®	123
6.15 Programming with TIA	123
6.15.1 Requirements for Programming with TIA	123
6.15.2 Creating a TIA Project	124
6.15.3 Including the Servo Motion Libraries into a TIA Project	124
6.15.4 Importing Devices into TIA	125
6.15.5 Creating a Network	126
6.16 Programming Guidelines for TIA	130
6.17 VLT® Servo Toolbox Software	131
6.17.1 Overview	131
6.17.2 System Requirements	131

6.17.3	Installing the VLT® Servo Toolbox Software	132
6.17.4	VLT® Servo Toolbox Communication	132
6.17.4.1	Overview	132
6.17.4.2	Firewall	132
6.17.4.3	Indirect Communication	132
6.17.4.4	Direct Communication	135
6.17.5	VLT® Servo Toolbox Commissioning	138
6.17.5.1	Step 1: Opening the Main Window	138
6.17.5.2	Step 2: Connecting to Network	139
6.17.5.3	Step 3: Scanning for Devices	140
6.18	Motion Library	140
6.18.1	Function Blocks	140
6.18.2	Simple Programming Template	140
7	Operation	141
7.1	Operating Modes	141
7.1.1	Motion Functions	141
7.2	Operating Status Indicators	142
7.2.1	Operating LEDs on the ISD 510/DSD 510 Servo Drive	142
7.2.2	Operating LEDs on the PSM 510	143
7.2.3	Operating LEDs on the DAM 510	144
7.2.4	Operating LEDs on the ACM 510	145
8	Functional Safety Concept	147
8.1	Functional Description	147
8.2	Safety Precautions	147
8.3	Qualified Personnel for Working with Functional Safety	148
8.4	Applied Standards and Compliance	148
8.5	Abbreviations and Conventions	148
8.6	Installation	149
8.6.1	Protective Measures	150
8.7	Application Example	150
8.8	Commissioning Test	150
8.8.1	Commissioning Test using Libraries	151
8.8.2	Commissioning Test using PROFINET® Devices	152
8.9	Operation of the STO Function	153
8.9.1	Error Codes	153
8.9.2	Fault Reset	153
8.10	Functional Safety Characteristic Data	153

8.11	Maintenance, Security, and User Accessibility	154
9	Diagnostics	155
9.1	Faults	155
9.2	Troubleshooting	155
9.2.1	Troubleshooting for the ISD 510/DSD 510 Servo Drives	155
9.2.1.1	Drive not Running/Starting Slowly	155
9.2.1.2	Drive Hums and Draws High Current	155
9.2.1.3	Drive Stops Suddenly and Restart is not Possible	155
9.2.1.4	Motor Rotating in Wrong Direction	156
9.2.1.5	Motor not Generating Expected Torque	156
9.2.1.6	Drive Screaming	156
9.2.1.7	Uneven Running	156
9.2.1.8	Vibration	156
9.2.1.9	Unusual Running Noises	156
9.2.1.10	Drive Speed Drops Sharply under Load	157
9.2.1.11	Brake not Releasing	157
9.2.1.12	Holding Brake not Holding the Servo Drive	157
9.2.1.13	Delayed Brake Engagement	157
9.2.1.14	Noises when Power-Off Brake is Engaged	157
9.2.1.15	LEDs not Lighting Up	157
9.2.1.16	Drive Protection Trips Immediately	157
9.2.2	Troubleshooting for the Servo System	158
9.2.2.1	LCP Display is Dark/Not Functioning	158
9.2.2.2	Open Power Fuses or Circuit Breaker Trip	158
9.2.2.3	DC-link Voltage Too Low (Error 0x3220/0x104)	158
9.2.2.4	Current Overload Trip (Error 0x2396/0x15C)	158
9.2.2.5	High Cont. Power Overload (Error 0x2313/0x161)	159
9.2.2.6	Continuous Power Overload (Error 0x2314/0x162)	159
9.2.2.7	AUX Overcurrent (Error 0x2391/0x125)	159
9.2.2.8	AUX Overvoltage (Error 0x3292/0x133)	159
9.2.2.9	AUX Undervoltage (Error 0x3294/0x135)	159
9.2.2.10	Mains Phase Loss (Error 0x3130/0x12F)	160
9.2.2.11	Generic Application Error (Error 0x1000/ 0x100)	160
9.2.2.12	Grounding Fault	160
9.2.2.13	Brake Resistor Error	160
9.2.2.14	Brake Chopper Error	160
9.2.2.15	Internal Fan Error	160

9.3	Error Codes for ISD 510/DSD 510 Servo System	161
9.3.1	No error (0x0000 / 0x0)	161
9.3.2	Generic application error (0x1000 / 0x100)	161
9.3.3	Overcurrent Trip (0x2310 / 0x101)	161
9.3.4	High cont. current overload (0x2311 / 0x15F)	161
9.3.5	Continuous current overload (0x2312 / 0x160)	161
9.3.6	High cont. power overload (0x2313 / 0x161)	162
9.3.7	Continuous power overload (0x2314 / 0x162)	162
9.3.8	Overcurrent short circuit (0x2320 / 0x163)	162
9.3.9	Ground fault (0x2330 / 0x151)	162
9.3.10	AUX overcurrent (0x2391 / 0x125)	162
9.3.11	AUX user limit current (0x2393 / 0x127)	162
9.3.12	AUX user limit current warning (0x2394 / 0x128)	163
9.3.13	AUX supply failure (0x2395 / 0x129)	163
9.3.14	Current overload trip (0x2396 / 0x15C)	163
9.3.15	Power overload trip (0x2397 / 0x12B)	163
9.3.16	Thermal overload motor (0x239B / 0x102)	163
9.3.17	Mains phase loss (0x3130 / 0x12F)	164
9.3.18	DC link overvoltage (0x3210 / 0x103)	164
9.3.19	DC link undervoltage (0x3220 / 0x104)	164
9.3.20	DC link charging error (0x3230 / 0x152)	164
9.3.21	DC Link unbalanced (0x3280 / 0x153)	164
9.3.22	UAUX high voltage (0x3291 / 0x132)	164
9.3.23	UAUX overvoltage (0x3292 / 0x133)	165
9.3.24	UAUX low voltage (0x3293 / 0x134)	165
9.3.25	UAUX undervoltage (0x3294 / 0x135)	165
9.3.26	DC link high voltage (0x3295 / 0x136)	165
9.3.27	DC link low voltage (0x3296 / 0x137)	165
9.3.28	UAUX charging error (0x3297 / 0x154)	166
9.3.29	DC link shutdown error (0x3298 / 0x165)	166
9.3.30	UAUX shutdown error (0x3299 / 0x155)	166
9.3.31	UAUX undervoltage hardware (0x329A / 0x156)	166
9.3.32	Device overtemperature (0x4210 / 0x157)	166
9.3.33	Device under temperature (0x4220 / 0x138)	167
9.3.34	Overtemperature: Control card (0x4291 / 0x106)	167
9.3.35	Overtemperature: Power card (0x4292 / 0x107)	167
9.3.36	Inrush overtemperature DC link (0x4293 / 013C)	167
9.3.37	Inrush overtemperature AUX line (0x4294 / 0x13D)	167

9.3.38	Overtemperature: Motor (0x4310 / 0x108)	167
9.3.39	Charge switch failure voltage (0x5121 / 0x158)	168
9.3.40	EE Checksum Error (parameter missing) (0x5530 / 0x10A)	168
9.3.41	Parameter error (0x6320 / 0x10B)	168
9.3.42	Conf par ver (0x6382 / 0x15D)	168
9.3.43	Configuration parameters limits error (0x6383 / 0x164)	168
9.3.44	Power EEprom configuration error (0x6384 / 0x166)	169
9.3.45	Brake chopper failure (0x7111 / 0x141)	169
9.3.46	Brake chopper overcurrent (0x7112 / 0x167)	169
9.3.47	Brake chopper module overload (0x7181 / 0x142)	169
9.3.48	External brake chopper overload (0x7182 / 0x143)	169
9.3.49	Brake mains voltage too high (0x7183 / 0x159)	170
9.3.50	Internal position sensor error (0x7320 / 0x10C)	170
9.3.51	External position sensor error (0x7380 / 0x10D)	170
9.3.52	Following error (0x8611 / 0x10E)	170
9.3.53	Homing error on entering homing mode (0x8693 / 0x10F)	171
9.3.54	Homing error on start homing method (0x8694 / 0x110)	171
9.3.55	Homing error distance (0x8695 / 0x111)	171
9.3.56	Mechanical brake failure (0xFF01 / 0x112)	171
9.3.57	Short circuit in mechanical brake control (0xFF02 / 0x113)	171
9.3.58	External interface power failure (0xFF0A / 0x114)	171
9.3.59	Fan feedback inconsistent (0xFF21 / 0x145)	172
9.3.60	Fan lifetime critical (0xFF22 / 0x15A)	172
9.3.61	Timing violation 1 (0xFF60 / 0x115)	172
9.3.62	Timing violation 2 (0xFF61 / 0x116)	172
9.3.63	Timing violation 3 (0xFF62 / 0x117)	172
9.3.64	Timing violation 4 (0xFF63 / 0x118)	172
9.3.65	Timing violation 5 (0xFF64 / 0x119)	173
9.3.66	Timing violation 6 (0xFF65 / 0x11A)	173
9.3.67	Timing violation 7 (0xFF66 / 0x168)	173
9.3.68	Timing violation 8 (0xFF67 / 0x16B)	173
9.3.69	Timing violation 9 (0xFF68 / 0x16C)	173
9.3.70	Firmware: Package description mismatch (0xFF70 / 0x11B)	173
9.3.71	Firmware: Power cycle needed (0xFF71 / 0x11C)	174
9.3.72	Firmware: Update started (0xFF72 / 0x11D)	174
9.3.73	Firmware: Update invalid (0xFF73 / 0x15B)	174
9.3.74	STO active while drive enabled (0xFF80 / 0x11E)	174
9.3.75	STO mismatch (0xFF81 / 0x11F)	174

9.3.76	P_STO error (0xFF85 / 0x120)	175
9.3.77	Guide value reversed (0xFF90 / 0x121)	175
9.3.78	Guide value implausible (0xFF91 / 0x122)	175
9.3.79	Sign of life error (0xFF95 / 0x14E)	175
10 Maintenance, Decommissioning, and Disposal		176
10.1	Warnings	176
10.2	Maintenance Tasks	176
10.3	Inspection during Operation	177
10.3.1	ISD 510/DSD 510 Servo Drives	177
10.3.2	System Modules	177
10.4	Repair	177
10.5	ISD 510/DSD 510 Servo Drive Replacement	177
10.5.1	Dismounting the ISD 510/DSD 510 Servo Drive	177
10.5.2	Fitting and Commissioning the ISD 510/DSD 510 Servo Drive	177
10.6	System Module Replacement	177
10.6.1	Dismounting the System Modules	177
10.6.2	Fitting and Commissioning the System Modules	179
10.7	Cable Replacement	180
10.7.1	Overview	180
10.7.2	Feed-In Cable Replacement	180
10.7.2.1	Disconnecting the Feed-In Cable	180
10.7.2.2	Replacing the Feed-In Cable	180
10.7.2.3	Connecting the Feed-In Cable	180
10.7.3	Loop Cable Replacement	180
10.7.3.1	Disconnecting the Loop Cable	180
10.7.3.2	Replacing the Loop Cable	181
10.7.3.3	Connecting the Loop Cable	181
10.8	Fuse Replacement in Decentral Access Module (DAM 510)	181
10.9	Fan Replacement	182
10.10	Product Returns	183
10.11	Recycling	183
10.12	Disposal	183
11 Specifications		184
11.1	Nameplates	184
11.1.1	Nameplate on ISD 510/DSD 510 Servo Drive	184
11.1.2	Nameplate on the System Modules	185
11.1.2.1	Example Nameplate on the Front of the System Modules	185

11.1.2.2	Example Nameplate on the Side of the System Modules	186
11.2	Characteristic Data	186
11.2.1	Characteristic Data for ISD 510 Servo Drive without Brake	186
11.2.2	Characteristic Data for ISD 510 Servo Drive with Brake	188
11.2.3	Characteristic Data for DSD 510 Servo Drive	188
11.2.4	Characteristic Data for Power Supply Module (PSM 510)	189
11.2.5	Characteristic Data for Decentral Access Module (DAM 510)	190
11.2.6	Characteristic Data for Auxiliary Capacitors Module (ACM 510)	190
11.3	Dimensions	191
11.3.1	ISD 510 Servo Drive Flange Dimensions	191
11.3.2	Dimensions of ISD 510 Servo Drive	191
11.3.3	Dimensions of DSD 510 Servo Drive	194
11.3.4	Dimensions of Power Supply Module (PSM 510)	194
11.3.5	Dimensions of Decentral Access Module (DAM 510)	195
11.3.6	Dimensions of Auxiliary Capacitors Module (ACM 510)	195
11.3.7	Dimensions of Expansion Module (EXM 510)	196
11.4	Motor Overload Protection	197
11.5	Motor Overtemperature Protection	197
11.6	Hybrid Cable Protection	197
11.7	Permitted Forces on the ISD 510 Servo Drive Shaft	197
11.8	Connectors on the ISD 510/DSD 510 Servo Drive	198
11.8.1	X1 and X2: Hybrid Connector (M23)	198
11.8.2	X3: 3rd Ethernet Connector (M8, 4 pole)	199
11.8.3	X4: I/O and/or Encoder Connector (M12, 8 pole)	200
11.8.4	X5: LCP Connector (M8, 6 pole)	201
11.8.5	X6: Standard/HIPERFACE DSL Motor Connector	201
11.8.6	X7: Motor Feedback Connector	202
11.9	Connectors on the System Modules	203
11.9.1	Backlink Connector	203
11.9.2	Brake Connectors	205
11.9.2.1	Brake Resistor Connector on PSM 510	205
11.9.3	Ethernet Connectors	205
11.9.3.1	Ethernet Connectors on PSM 510 and ACM 510	205
11.9.3.2	Ethernet Connectors on DAM 510	206
11.9.4	I/O Connectors	206
11.9.4.1	I/O Connector on PSM 510/ACM 510	206
11.9.5	UAUX Connector	206
11.9.5.1	24/48 V Cable Cross Sections for PSM 510	207

11.9.6 LCP Connector (M8, 6-pole)	207
11.9.7 AC Mains Connector	208
11.9.7.1 Mains Cable Cross-Sections for PSM 510	208
11.9.8 Relay Connector	208
11.9.8.1 Relay Connector on PSM 510/ACM 510	209
11.9.9 STO Connectors	209
11.9.9.1 STO Connectors on PSM 510	209
11.9.9.2 STO Connectors on the DAM 510	210
11.9.10 UDC Connector	212
11.9.11 AUX Connector	212
11.9.12 External Encoder Connectors	213
11.9.13 Expansion Module Connector	214
11.9.13.1 Cable Cross Sections for EXM 510	215
11.10 General Specifications and Environmental Data	215
11.10.1 ISD 510/DSD 510 Servo Drive	215
11.10.2 System Modules	216
11.11 Protection Ratings	217
11.11.1 Protection Ratings for ISD 510 Servo Drive	217
11.11.2 Protection Ratings for DSD 510 Servo Drive	217
11.12 Cables	217
11.12.1 Hybrid Cable PE	217
11.13 Storage	218

1 Introduction

1.1 Purpose of the Operating Guide

The purpose of this operating guide is to describe the VLT® Integrated Servo Drive ISD 510/DSD 510 System.

This operating guide contains information about:

- Installation
- Commissioning
- Programming
- Operation
- Troubleshooting
- Service and Maintenance

This operating guide is intended for use by qualified personnel. Read the operating guide in full to use the servo system safely and professionally, and pay particular attention to the safety instructions and general warnings.

This operating guide is an integral part of the servo system and also contains important service information. Therefore always keep this operating guide available with the servo system.

Compliance with the information in the manual is a prerequisite for:

- Trouble-free operation
- Recognition of product liability claims

Therefore, read this operating guide before working with the VLT® Integrated Servo Drive ISD 510/DSD 510 system.

1.2 Additional Resources

Table 1: Additional Resources

Manual	Description
VLT® Integrated Servo Drive System ISD 510, DSD 510 Operating Instructions	Information about the installation, commissioning, and operation of the ISD 510/DSD 510 servo system.
VLT® Servo Drive System ISD 510, DSD 510, MSD 510 (VLT® Flexmotion™) Design Guide	Information about the setup of the ISD 510/DSD 510 servo system and detailed technical data.
VLT® Servo Drive System ISD 510, DSD 510, MSD 510 (VLT® Flexmotion™) Programming Guide	Information about the programming of the ISD 510, DSD 510, and MSD 510 servo systems.

1.3 Copyright





VLT® and ISD® are Danfoss registered trademarks.

1.4 Approvals and Certifications

The VLT® Servo Drive Systems ISD 510, DSD 510, MSD 510 comply with the standards and directives detailed in [Table 2](#).

Table 2: Product and System Approvals and Certifications

Certification	Description
IEC/EN 61800-3	Adjustable speed electrical power drive systems. Part 3: EMC requirements and specific test methods.
IEC/EN 61800-5-1	Adjustable speed electrical power drive systems. Part 5-1: Safety requirements - Electrical, thermal, and energy.
IEC/EN 61800-5-2	Adjustable speed electrical power drive systems. Part 5-2: Safety requirements - Functional.
IEC/EN 61508-1	Functional safety of electrical/electronic/programmable electronic safety-related systems.

Certification	Description
	Part 1: General requirements.
IEC/EN 61508-2	Functional safety of electrical/electronic/programmable electronic safety-related systems. Part 2: Requirements for electrical/electronic/programmable electronic safety-related systems.
EN ISO 13849-1	Safety of machinery - Safety-related parts of control systems. Part 1: General principles for design.
EN ISO 13849-2	Safety of machinery - Safety-related parts of control systems. Part 2: Validation.
IEC/EN 60204-1	Safety of machinery - Electrical equipment of machines. Part 1: General requirements.
IEC/EN 62061	Safety of machinery - Functional safety of safety-related electrical, electronic, and programmable electronic control systems.
IEC/EN 61326-3-1	Electrical equipment for measurement, control, and laboratory use - EMC requirements. Part 3-1: Immunity requirements for safety-related systems and for equipment intended to perform safety-related functions (functional safety) - General industrial applications.
IEC/EN 60529	Degrees of protection provided by enclosures (IP Code).
UL 508C	UL Standard for Safety for Power Conversion Equipment. (Only applies to ISD 510 servo drive sizes 1 and 2.) 
UL 61800-5-1	Adjustable speed electrical power drive systems. Part 5-1: Safety requirements - Electrical, thermal, and energy. ISD 510 servo drive sizes 3 and 4 and DSD 510:  MSD 510: 
CSA C22.2 No. 274-13 (2013)	Standard specifying requirements for adjustable speed drives with respect to electrical, thermal, and energy safety considerations. Applies to ISD 510 sizes 1 and 2.
CSA C22.2 No. 274-17 (2017)	Standard specifying requirements for adjustable speed drives with respect to electrical, thermal, and energy safety considerations. Applies to: <ul style="list-style-type: none"> • ISD 510 sizes 3 and 4 • DSD 510 • MSD 510
CE	

Certification	Description
2014/30/EU	Electromagnetic Compatibility (EMC) Directive.
2014/35/EU	Low Voltage Directive (LVD).
(2011/65/EU) amended (EU) 2015/863	Restriction of Hazardous Substances (RoHS).
2006/42/EC	Machinery Directive (MD).
EtherCAT®	Ethernet for Control Automation Technology. Ethernet-based fieldbus system.
Ethernet POWER-LINK®	Ethernet-based fieldbus system.
PROFINET RT/IRT®	Ethernet-based fieldbus system.
PLCopen®	Technical specification. Function blocks for motion control (formerly Part 1 and Part 2) Version 2.0 March 17, 2011.

1.5 Firmware Updates

Updates to the firmware, VLT® Servo Toolbox software, and PLC libraries may be available. When updates are available, they can be downloaded from the Danfoss website (<http://drives.danfoss.com>). Use the VLT® Servo Toolbox software or the PLC libraries to install the firmware on the servo drives or on the PSM 510 and DAM 510.

1.6 Terminology

Table 3: Terminology

Term	Description
ACM 510	Auxiliary Capacitors Module
DAM 510	Decentral Access Module that connects the Danfoss decentral servo drives (ISD 510 and DSD 510) to the servo system via a hybrid cable.
DSD 510	Decentral Servo Drive
DSD 510 system components	Includes DSD 510 servo drives, PSM 510, DAM 510, and the optional ACM 510 and EXM 510.
EXM 510	Expansion module for splitting system modules between 2 control cabinets.
Feed-in cable	Hybrid cable for connection from the DAM 510 to the 1st servo drive.
ISD 510	Integrated Servo Drive
ISD 510 system components	Includes ISD 510 servo drives, PSM 510, DAM 510, and the optional ACM 510 and EXM 510.
LCP	Local Control Panel
Loop cable	Hybrid cable for connecting servo drives in daisy-chain format.
PLC	Programmable Logic Controller (external device for controlling the servo system).
PSM 510	Power Supply Module that generates a 565–680 V DC supply.
System modules	Includes PSM 510, DAM 510, and the optional ACM 510.
V_{IN} PSM	Input of PSM 510 (V AC).

Term	Description
V _{OUT} PSM	Output of PSM 510 (V DC).

2 Safety

2.1 Safety Symbols

The following symbols are used in this guide:

⚠ WARNING ⚠

Indicates a potentially hazardous situation that could result in death or serious injury.

⚠ CAUTION ⚠

Indicates a potentially hazardous situation that could result in minor or moderate injury. It can also be used to alert against unsafe practices.

NOTICE

Indicates important information, including situations that can result in damage to equipment or property.

2.2 Important Safety Warnings

The following safety instructions and precautions relate to the ISD 510/DSD 510 servo system. Read the safety instructions carefully before starting to work in any way with the servo system or its components. Pay particular attention to the safety instructions in the relevant sections of this manual.

⚠ WARNING ⚠

HAZARDOUS SITUATION

If the ISD 510/DSD 510 system components, or the bus lines are incorrectly connected, there is a risk of death, serious injury, or damage to the unit.

- Always comply with the instructions in this manual and national and local safety regulations.

⚠ WARNING ⚠

HIGH VOLTAGE

The servo system contains components that operate at high voltage when connected to the electrical supply network. There are no indicators on the components that indicate the presence of mains supply. Incorrect installation, commissioning, or maintenance may lead to death or serious injury.

- Installation, commissioning, and maintenance may only be performed by qualified personnel.

⚠ WARNING ⚠

LEAKAGE/GROUNDING CURRENT HAZARD

Leakage/grounding currents are >3.5 mA. Improper grounding of the ISD 510/DSD 510 servo drives and the system modules may result in death or serious injury.

- For reasons of operator safety, use a certified electrical installer to ground the system correctly in accordance with the applicable local and national electrical standards and directives, and the instructions in this manual.

⚠ W A R N I N G ⚠

DISCHARGE TIME

The servo system contains DC-link capacitors that remain charged for some time after the mains supply is switched off at the Power Supply Module (PSM 510). Failure to wait the specified time after power has been removed before performing service or repair work could result in death or serious injury.

- To avoid electrical shock, fully disconnect the Power Supply Module (PSM 510) from the mains and wait for the capacitors to fully discharge before carrying out any maintenance or repair work on the servo system or its components.

Minimum waiting time (minutes)
15

⚠ D A N G E R ⚠

- Risque du choc électrique. Une tension dangereuse peut être présentée jusqu'à 15 min après avoir coupé l'alimentation.

⚠ W A R N I N G ⚠

UNINTENDED START

The servo system contains servo drives, the PSM 510, and DAM 510 that are connected to the electrical supply network and can start running at any time. This may be caused by a fieldbus command, a reference signal, or clearing a fault condition. Servo drives and all connected devices must be in good operating condition. A deficient operating condition may lead to death, serious injury, damage to equipment, or other material damage when the unit is connected to the electrical supply network.

- Take suitable measures to prevent unintended starts.

⚠ W A R N I N G ⚠

UNINTENDED MOVEMENT

Unintended movement may occur when parameter changes are carried out immediately, which may result in death, serious injury, or damage to equipment.

- When changing parameters, take suitable measures to ensure that unintended movement cannot pose any danger.

⚠ C A U T I O N ⚠

DANGER OF BURNS

The surface of the servo drives can reach high temperatures of over 90°C during operation.

- Do not touch the servo drives until they have cooled down.

N O T I C E

RCD COMPATIBILITY

The servo system contains components that can cause a DC current in the protective earthing conductor, which may result in malfunction in any devices connected to the system.

- Where a residual current-operated protective (RCD) or monitoring (RCM) device is used for protection in case of direct or indirect contact, use a type B RCD or RCM device on the supply side of the system components.

NOTICE

CONNECTING/DISCONNECTING HYBRID CABLES

Never connect or disconnect the hybrid cable to or from the servo drives when the servo system is connected to mains or auxiliary supply, or when voltage is still present. Doing so damages the electronic circuitry. Ensure that the mains supply is disconnected and the required discharge time for the DC-link capacitors has elapsed before disconnecting or connecting the hybrid cables to the PSM 510.

- To avoid electrical shock, fully disconnect the PSM 510 from the mains and wait for the discharge time to elapse before disconnecting or connecting the hybrid cables or disconnecting cables from the PSM 510.

2.3 Safety Instructions and Precautions

Compliance with the safety instructions and precautions is necessary at all times.

- Orderly and proper transport, storage, fitting, and installation, as well as careful operation and maintenance, are essential for the trouble-free and safe operation of the servo system and its components.
- Only suitably trained and qualified personnel may work on the servo system and its components or in its vicinity.
- Only use accessories and spare parts approved by Danfoss.
- Comply with the specified ambient conditions.
- The information in this manual about the use of available components is provided solely by way of examples of applications and suggestions.
- The plant engineer or system engineer is personally responsible for checking the suitability of the supplied components and the information provided in this manual for the specific application concerned:
 - For compliance with the safety regulations and standards relevant to the specific application.
 - For implementing the necessary measures, changes, and extensions.
- Commissioning the servo system or its components is not allowed until it has been ascertained that the machine, system, or plant in which they are installed conforms to the statutory provisions, safety regulations, and standards that apply to the application in the country of use.
- Operation is only allowed in compliance with the national EMC regulations for the application concerned.
- Compliance with the limit values specified by national regulations is the responsibility of the producer of the plant, system, or machine.
- Compliance with the specifications, connection conditions, and installation conditions in this manual is mandatory.
- The safety regulations and safety provisions of the country in which the equipment is used must be observed.
- To protect the user against electrical shock and to protect the servo system against overload, protective grounding is obligatory and must be performed in accordance with local and national regulations.

2.3.1 Operational Safety

Operational safety

- Safety-related applications are only allowed if they are explicitly and unambiguously mentioned in this manual.
- All applications that can cause hazards to people or damage to property are safety-related applications.
- The stop functions implemented in the software of the PLC do not interrupt the mains supply to the Power Supply Module (PSM 510). Therefore, they must not be used for electrical safety for the servo system.
- The servo system can be brought to a stop by a software command or a zero speed setpoint, however DC voltage remains present on the servo drives and/or mains voltage in the PSM 510. Also, when the system is stopped, it may start up again on its own if the circuitry is defective or after the elimination of a temporary overload, a problem with the supply voltage, or a problem with the system. If personal safety considerations (for example, risk of personal injury caused by contact with moving machine parts after an unintended start) make it necessary to ensure that an unintended start cannot occur, these stop functions are not sufficient. In this case, ensure that the servo system is detached from the mains network, and prevent unintended motor starting, for example by using the Safe Torque Off function.

- The servo system may start running unintentionally during parameter configuration or programming. If this poses a risk to personal safety (for example, risk of personal injury due to contact with moving machine parts), prevent unintended motor starting, for example by using the Safe Torque Off function, or by safe disconnection of the servo drives.
- In addition to the L1, L2, and L3 supply voltage inputs on the PSM 510, the servo system has other supply voltage inputs, including external auxiliary voltage. Before commencing repair work, check that all supply voltage inputs have been switched off and that the necessary discharge time for the DC-link capacitors has elapsed.

2.4 Qualified Personnel

Installation, commissioning, and maintenance may only be carried out by qualified personnel. For the purposes of this manual and the safety instructions in this manual, qualified personnel are trained personnel who are authorized to fit, install, commission, ground, and label equipment, systems, and circuits in accordance with the standards for safety technology and who are familiar with the safety concepts of automation engineering.

Additionally, the personnel must be familiar with all the instruction and safety measures described in this manual. They must have suitable safety equipment and be trained in first aid.

2.5 Due Diligence

The operator and/or fabricator must ensure that:

- The servo system and its components are used only as intended.
- The components are operated only in a perfect operational condition.
- The operating instructions are always available near the servo system in complete and readable form.
- The servo system and its components are fitted, installed, commissioned, and maintained only by adequately qualified and authorized personnel.
- These personnel are regularly instructed on all relevant matters of occupational safety and environmental protection, as well as the contents of the operating instructions and the instructions it contains.
- The product markings and identification markings applied to the components, as well as safety and warning instructions, are not removed and are always kept in a legible condition.
- The national and international regulations regarding the control of machinery and equipment, that are applicable at the place of use of the servo system, are complied with.
- The users always have all current information relevant to their interests about the servo system and its use and operation.

2.6 Intended Use

The components of the servo system are intended to be installed in machines used in industrial environments in accordance with local laws and standards.

NOTICE

- In a domestic environment, this product may cause radio interferences, in which case supplementary mitigation measures may be required.

To ensure that the product is used as intended, the following conditions must be fulfilled before use:

- Everyone who uses Danfoss products in any manner must read and understand the corresponding safety regulations and the description of the intended use.
- Do not alter hardware from its original state.
- Do not reverse-engineer software products or alter their source code.
- Do not install or operate damaged or faulty products.
- Ensure that the products are installed in conformance with the regulations mentioned in the documentation.
- Observe any specified maintenance and service intervals.
- Comply with all protective measures.
- Only fit or install the components described in this operating guide. Third-party devices and equipment may be used only in consultation with Danfoss.

2.6.1 Prohibited Application Areas

The servo system **may not** be used in the following application areas:

- Areas with potentially explosive atmospheres.
- Mobile or portable systems.
- Floating or airborne systems.
- Inhabited facilities.
- Sites where radioactive materials are present.
- Areas with extreme temperature variations or in which the maximum rated temperatures may be exceeded.
- Under water.

2.7 Forseeable Misuse

Any use not expressly approved by Danfoss constitutes misuse. This also applies to failure to comply with the specified operating conditions and applications. Danfoss assumes no liability of any sort for damage attributable to improper use.

2.8 Service and Support

Contact the local service representative for service and support.

3 System Description

3.1 Overview of the ISD 510/DSD 510 System

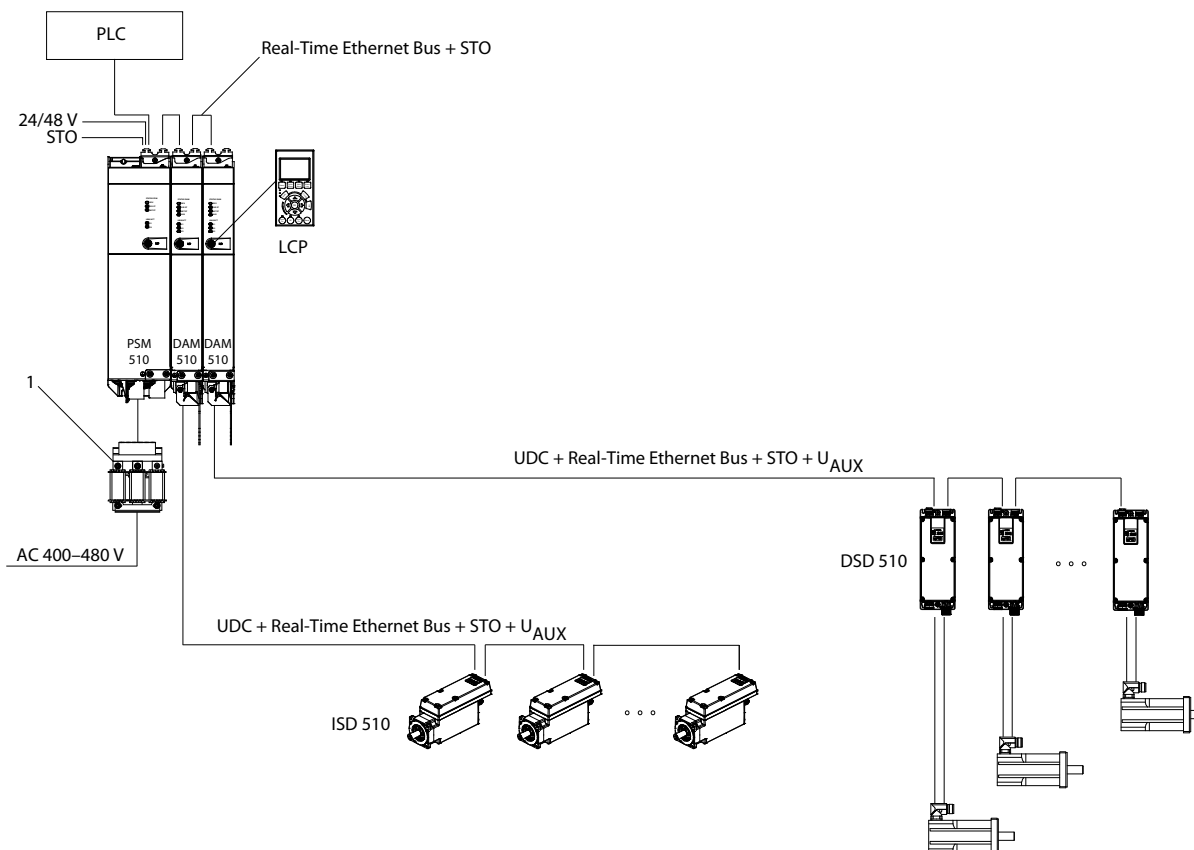

e30b9796.10

Illustration 1: Overview of the VLT® Integrated Servo Drive ISD 510/DSD 510 System

1	AC line choke
---	---------------

The VLT® Servo Drive System ISD 510/DSD 510 is a high-performance decentral servo motion solution. In this decentral system, the ISD 510/DSD 510 servo drives are operated in a DC group and controlled by a PLC. The decentralization of the drive unit offers benefits in mounting, installation, and operation.

Hybrid cables are used to connect the ISD 510/DSD 510 servo drives, making installation fast and simple. These hybrid cables contain the DC-link supply, the Real-Time Ethernet, U_{AUX} , and STO signals.

The ISD 510/DSD 510 system is designed to accommodate various servo drives and consists of:

- VLT® Integrated Servo Drive ISD® 510.
- VLT® Decentral Servo Drive DSD 510.
- A central power supply: Power Supply Module (PSM 510).
- Decentral Access Module (DAM 510).
- Auxiliary Capacitors Module (ACM 510), optional
- Expansion Module (EXM 510), optional
- Cabling infrastructure.
- Blind caps
- Software

- Firmware for the servo drive
- Firmware for the PSM 510, DAM 510, and ACM 510
- PC software tool: VLT® Servo Toolbox
- PLC libraries
 - DanfossMotion library for ISD 510/DSD 510 system for AutomationStudio™.
 - DanfossMotion library for ISD 510/DSD 510 system for TwinCAT® 2 and 3.
 - DanfossMotion library for ISD 510/DSD 510 system for SIMOTION SCOUT® and TiA Portal.

The system modules PSM 510, DAM 510, and ACM 510 are mounted to a backplate located in the control cabinet. DC link and the control voltage supply are integrated in the backplate. The 'click and lock' backplate concept offers easy mounting and installation. The ISD 510 servo drives are self-contained distributed drives, whereby the drive electronics is housed together with the motor in the same casing. The DSD 510 servo drives are decentral servo drives for mounting close to the servo motor.

There are 2 versions of the ISD 510/DSD 510 servo drive:

Version	ISD 510/DSD 510
Standard	With 2 hybrid connectors (M23) that connect power and communication signals from a hybrid cable.
Advanced	As standard plus 3 additional interfaces for external encoder or I/Os, fieldbus devices, and for the local control panel (LCP) to be connected directly.

The motion control is integrated into the servo drive so that the motion sequences can take place independently. This reduces the required computing power of the central PLC and offers a highly flexible drive concept. Danfoss offers libraries for various IEC 61131-3 programmable PLCs. Due to the standardized and certified fieldbus interfaces of the devices, any PLC with an EtherCAT® master functionality, or Ethernet POWERLINK® or PROFINET® managing node functionality according to the standards can be used.

N O T I C E

- The ISD 510/DSD 510 servo drives cannot be used in servo systems from other manufacturers without changing the cabling infrastructure.
- Drives from other manufacturers cannot be used in the ISD 510/DSD 510 system when using Danfoss hybrid cables.
- Size 1 and 2 ISD 510 servo drives cannot be combined on the same line with size 3 and 4 ISD 510 servo drives and DSD 510 servo drives.
- Only the components described in this manual may be fitted or installed. Third-party devices and equipment may be used only in consultation with Danfoss.
- Contact Danfoss for further information.

3.1.1 Application Examples

There are numerous potential areas of application for the servo system as per the following examples.

Beverage machines

- Labeling
- Capping
- Filling
- PET blow-moulding
- Digital bottle printing

Food and beverage packaging machines:

- Flow wrapping
- Bag maker
- Tray sealing
- Shrink wrapping

Industrial and pharmaceutical packaging machines:

- Palletization
- Top loader
- Cartoning
- Tube filling
- Blister machine
- Liquid filling
- Solid dosing

3.2 VLT® Integrated Servo Drive ISD 510

3.2.1 Overview of the ISD 510 Servo Drive

ISD is the abbreviation of integrated servo drive, which is a compact drive with an integrated permanent magnet synchronous motor (PMSM). This means that the entire power drive system consisting of motor, position sensor, mechanical brake, and also power and control electronics is integrated into 1 housing. Additional circuits, such as low voltage supply, bus drivers, and functional safety are implemented within the servo drive electronics. All ISD 510 servo drives have 2 hybrid connectors (M23) that connect power and communication signals from a hybrid cable. The advanced version has 3 additional interfaces for external encoder or I/Os, fieldbus devices, and for the local control panel (LCP) to be connected directly.

LEDs on the top of the ISD 510 servo drive show the current status. Data transfer takes place via Real-Time Ethernet.

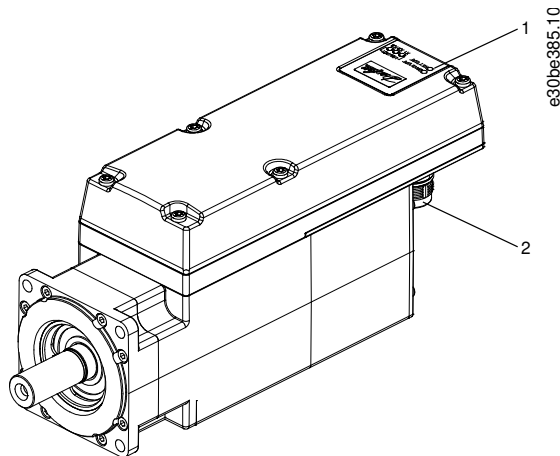

1	Operating LEDs
2	Connectors

3.2.2 Motor and Flange Sizes

Table 4: Motor and Flange Sizes

	Size 1, 1.5 Nm	Size 2, 2.1 Nm	Size 2, 2.9 Nm	Size 2, 3.8 Nm	Size 3, 5.2 Nm	Size 3, 6.0 Nm	Size 4, 11.2 Nm	Size 4, 13.0 Nm ⁽¹⁾
Flange size	76 mm	84 mm			110 mm		138 mm	–

¹ In preparation

3.2.3 ISD 510 Servo Drive Types

NOTICE

- The Drive Configurator shows the valid configuration of servo drive variants. Only valid combinations are shown. Therefore, not all variants detailed in the type code are visible.

Table 5: Type Code ISD 510

1-3	4-6	7	8	9-12	13-14	15-17	18-20	21-22	23-25	26	27-30	31-32	33-35	36	37	38	39-40
ISD	510		T		D6					T		SX					

Table 6: Legend to Type Code

[01-03]	Product group	[18-20]	Drive feedback	[33-35]	Motor speed
ISD	VLT® Integrated Servo Drive	FRX	Resolver	N46	Rated speed 4600 RPM
[04-06]	Product variant	FS1	Single-turn feedback 17 bit	N40	Rated speed 4000 RPM
510	ISD® 510	FM1	Multi-turn feedback 17 bit	N30	Rated speed 3000 RPM
[07]	Hardware configuration	[21-22]	Bus system	N29	Rated speed 2900 RPM
A	Advanced	PL	Ethernet POWERLINK®	N24	Rated speed 2400 RPM
S	Standard	EC	EtherCAT®	N20	Rated speed 2000 RPM
[08]	Drive torque	PN	PROFINET®	[36]	Mechanical brake
T	Torque	[23-25]	Firmware	X	Without brake
[09-12]	Torque	SXX	Standard	B	With brake
01C5	1.5 Nm	SC0	Customized	[37]	Motor shaft
02C1	2.1 Nm	[26]	Safety	S	Standard smooth shaft
02C9	2.9 Nm	T	Safe Torque Off (STO)	K	Standard fitted key
03C8	3.8 Nm	[27-30]	Flange size	[38]	Motor sealing
05C2	5.2 Nm	F076	76 mm	X	Without sealing
06C0	6.0 Nm	F084	84 mm	S	With sealing
11C2	11.2 Nm	F108	108 mm	[39-40]	Surface coating
13C0	13.0 Nm ⁽¹⁾	F138	138 mm	SX	Standard
[13-14]	DC voltage	[31-32]	Flange type	CX	Customized
D6	600 V DC-link voltage	SX	Standard		
[15-17]	Drive enclosure	C0	Customized		
E54	IP54				
E67	IP67 (shaft IP65)				

¹ In preparation

3.2.4 Motor Components

3.2.4.1 Shaft

The shaft transfers the motor force (torque) to the machine coupled to the shaft. The shaft material is C45+C or equivalent according to EN 10277-2. Depending on the mounting position, the ISD 510 servo drives can be sealed by a shaft seal (optional) to achieve IP65 on the A-side of the motor (see [11.11.1 Protection Ratings for ISD 510 Servo Drive](#) for further information).

3.2.4.2 Brake (Optional)

The optional mechanical holding brake is designed as a single-disc brake. The emergency stop function can be initiated at most once every 3 minutes and up to 2000 times in total, depending on the load.

The effective holding torque is:

- Size 1: 2.5 Nm
- Size 2: 5.3 Nm
- Size 3: 14.5 Nm
- Size 4: 25 Nm

The brake operates as a holding brake according to the fail-safe principle **closed when no current**. It is powered from the 24 V DC auxiliary supply. This enables low-backlash load holding when no current is present.

Electrical data: Power consumption:

- Size 1: 1.5 W
- Size 2: 1.8 W
- Size 3: 3.5 W
- Size 4: 5 W

N O T I C E

- Do not misuse the holding brake as a working brake because this causes increased wear, resulting in premature failure.
- Using ISD 510 servo drives with brakes can reduce the number of drives allowed, depending on the total length of each hybrid line.

3.2.4.3 Cooling

The ISD 510 servo drives are self-cooling. Cooling (heat dispersal) is primarily via the flange, with a small amount dispersed by the housing.

3.2.4.4 Thermal Protection

Thermal sensors monitor the maximum allowable temperature of the motor winding and switch the motor off if the limit of 150 °C is exceeded. Thermal sensors are also present in the drive to protect the electronics against overtemperature. An error message is sent via Real-Time Ethernet to the higher-level PLC and is also shown on the LCP.

3.2.4.5 Built-in Feedback Devices

The built-in feedback device measures the rotor position. There are 3 feedback variants available:

- Resolver
- BiSS-B 17 bit single-turn encoder
- BiSS-B 17 bit multi-turn encoder

Data/type	Resolver	Single-turn encoder	Multi-turn encoder
Signal	Sin/cos	BiSS-B	BiSS-B
Accuracy	±10 arcmin	±1.6 arcmin	±1.6 arcmin
Resolution	14 bit	17 bit	17 bit
Maximum number of turns	–	–	4096 (12 bit)

3.2.5 Drive Components

3.2.5.1 Connectors on the ISD 510 Servo Drives

This section details all possible connections for the standard and advanced servo drive.

There are 5 connectors on the ISD 510 servo drives.

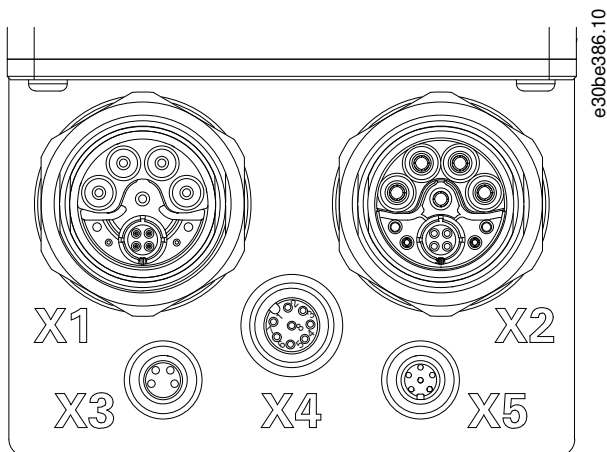

Illustration 2: Connectors on the ISD 510 Servo Drive

Table 7: Connectors on the ISD 510 Servo Drive

Connector	Description
X1	M23 connector for feed-in or loop hybrid cable input
X2	M23 connector for loop hybrid cable output or fieldbus extension cable
X3 (advanced version only)	M8 connector for Ethernet cable (minimum CAT5, shielded)
X4 (advanced version only)	M12 connector for I/O and/or encoder cable (shielded)
X5 (advanced version only)	M8 connector for LCP cable (shielded)

NOTICE

- Detailed information on each of the connectors can be found in [11.8 Connectors on the ISD 510/DSD 510 Servo Drive](#).

3.3 VLT® Decentral Servo Drive DSD 510

3.3.1 Overview of the DSD 510 Servo Drive

DSD is the abbreviation of decentral servo drive, which is a servo drive for mounting close to the servo motor. In this way, the servo motor has no impact to the DSD 510 servo drive from a thermal point of view.

The DSD 510 servo drive extends the selection of a decentral servo drive concept. It delivers rated power up to 4.5 kW and can be used with a wide range of permanent magnet servo motors and motor feedback encoders.

LEDs on the top of the DSD 510 servo drive show the current status. Data transfer takes place via Real-Time Ethernet.

3.3.2 DSD 510 Servo Drive Types

NOTICE

- The Drive Configurator shows the valid configuration of servo drive variants. Only valid combinations are shown. Therefore, not all variants detailed in the type code are visible.

Table 8: Type Code DSD 510

1-3	4-6	7	8-12	13-14	15-17	18-20	21-22	23-25	26	27-28	29-30	31-38	39-40
DSD	510		C08A0	D6	E67			SXX	T	F2		XXXXXXXX	

Table 9: Legend to Type Code

[01–03]	Product group	[18–20] (continued)	Drive feedback (continued)
DSD	VLT® Decentral Servo Drive	FHD	HIPERFACE DSL ⁰
[04–06]	Product variant	[21–22]	Bus system
510	DSD 510	PL	Ethernet POWERLINK®
[07]	Hardware configuration	EC	EtherCAT®
A	Advanced	PN	PROFINET®
S	Standard	[23–25]	Firmware
[08–12]	Current rating	SXX	Standard
C08A0	8.0 A _{rms}	[26]	Safety
[13–14]	DC voltage	T	Safe Torque Off (STO)
D6	600 V DC-link voltage	[27–28]	Frame size
[15–17]	Protection rating	F2	(F2) Frame size 2
E67	IP67	[29–30]	Motor connection
[18–20]	Drive feedback	S1	(S1) Single plug version motor side
FXX	Without feedback/Sensorless ⁰	S2	(S2) Dual plug version motor side
FRX	Resolver	[31–38]	Reserved
FS1	BiSS single-turn feedback 17 bit	–	Reserved
FM1	BiSS multi-turn feedback 17 bit	[39–40]	Surface coating
FE1	EnDat 2.1	SX	Standard
FE2	EnDat 2.2	CX	Customized
FHF	HIPERFACE		

3.3.3 Connectors on the DSD 510 Servo Drives

The DSD 510 servo drives have the same X1-X5 connectors as the ISD 510 servo drives (see [3.2.5.1 Connectors on the ISD 510 Servo Drives](#)). In addition to the X1-X5 connectors, the DSD 510 servo drives have 2 further connectors: X6 and X7.

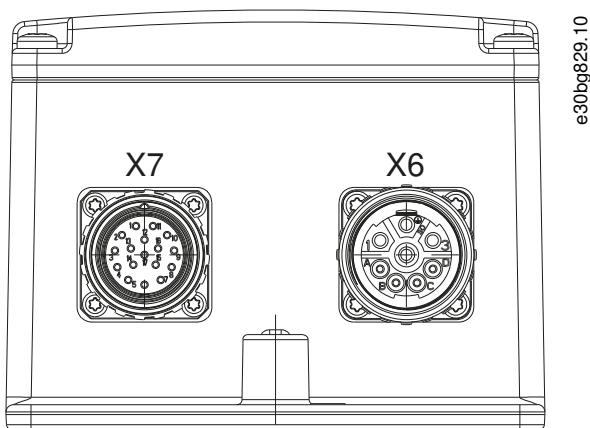

Illustration 3: X6 and X7 Connectors on the DSD 510 Servo Drive

Table 10: Connectors on the DSD 510 Servo Drive

Connector	Description
X6	M23 8-pole motor power connector
X7	M23 17-pole motor feedback connector

The maximum cable length from the DSD 510 to the motor is 5 m.

NOTICE

- The DSD 510 servo drives are available with single plug version for specifications HIPERFACE DSL, EnDat 2.2, and sensorless. This plug is for a hybrid cable containing both the motor and the feedback cables.
- All other specifications use the double plug version with separate motor and feedback cables.

3.4 Power Supply Module (PSM 510)

3.4.1 Overview

PSM is the abbreviation for Power Supply Module. It is the power supply to the servo system. The PSM 510 supplies a DC power voltage and guarantees high-density output. The DC-link and 24/48 V DC are distributed via the backlink in the backplates to all system modules. The PSM 510 can be controlled via Ethernet-based fieldbus.

LEDs on the front of the PSM 510 show the operating status and warnings.

NOTICE

- The system modules are designed for use within a control cabinet. If the STO function is used, the cabinet must be rated at least IP54.
- The PSM 510 has a protection rating of IP20 according to IEC/EN 60529 (except connectors, which are IP00).
- The PSM 510 may be damaged if exposed to fluids.

All power cables are wired into the PSM 510, therefore at least 1 PSM 510 is required for each system.

The PSM 510 also performs service functions, such as voltage measuring, and is cooled by an internal fan.

The PSM 510 is available in 3 power sizes and delivers an output power of 10 kW, 20 kW, or 30 kW with 200% overload capacity for 3 seconds. To achieve an output power of up to 60 kW, 2 PSM 510 modules can be used in parallel.

An example type code for the PSM 510 is: MSD510PSM510F2P10C0D6E20PLSXXXXXXXXXXXXX.

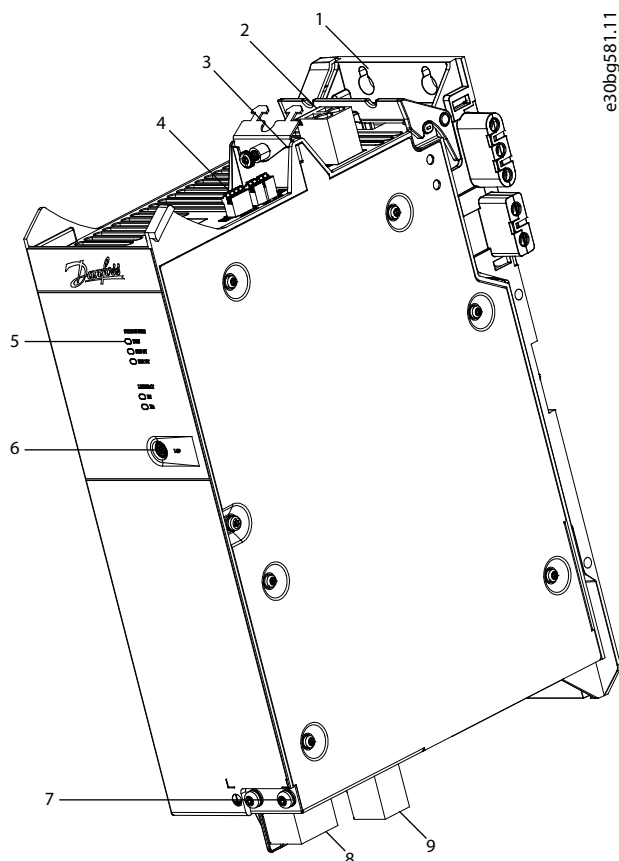

Illustration 4: PSM 510

1	Backplate	6	LCP connector
2	24/48 V input connector	7	PE screw
3	Cable relief and shielding	8	AC mains supply connector
4	Connectors: I/O, STO, relay, and Ethernet	9	Internal/external brake resistor connector
5	Operating LEDs		

3.5 Decentral Access Module (DAM 510)

3.5.1 Overview

DAM is the abbreviation for Decentral Access Module. The DAM 510 is a central interface/gateway to the decentral servo system. It is used to connect the Danfoss VLT® Integrated Servo Drives ISD 510 and VLT® Decentral Servo Drives DSD 510 to the servo system via a hybrid feed-in cable.

The DAM 510 supplies the decentral servo drives with DC-link, U_{AUX} , STO, and the Ethernet-based fieldbus via the hybrid feed-in cable. The DAM 510 provides functions, such as:

- Overcurrent protection of the hybrid cable
- Overvoltage protection
- Charging circuit of the DC-link
- External encoder connection
- DC-link capacitance buffer for the decentral servo drives

The DAM 510 can be controlled via Ethernet-based fieldbus.

LEDs on the front of the DAM 510 show the operating status and warnings.

NOTICE

- The system modules are designed for use within a control cabinet. If the STO function is used, the cabinet must be rated at least IP54.
- The DAM 510 has a protection rating of IP20 according to IEC/EN 60529 (except connectors, which are IP00).
- The DAM 510 can be damaged if exposed to fluids.

An example type code for the DAM 510 is: MSD510DAM510F1C015AD6E20PLSXXXXXXXXXXXXX.

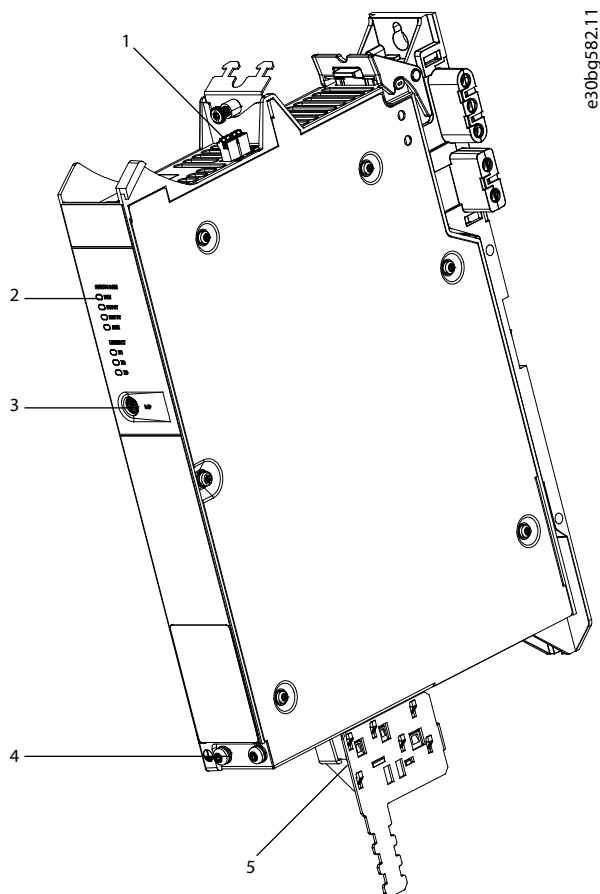

Illustration 5: DAM 510

1	Connectors: STO, Ethernet, and external encoder	4	PE screw
2	Operating LEDs	5	Connectors: UDC, AUX, STO out, and Ethernet
3	LCP connector		

3.6 Auxiliary Capacitors Module (ACM 510)

3.6.1 Overview

ACM is the abbreviation for Auxiliary Capacitors Module. The ACM 510 can be connected to the ISD 510 system to store energy, enabling a controlled machine stop in emergency situations.

NOTICE

- The ACM 510 has a protection rating of IP20 according to IEC/EN 60529 (except connectors, which are IP00).
- The ACM 510 can be damaged if exposed to fluids.

An example type code for the ACM 510 is: MSD510ACM510F1E00C8D6E20PLSXXXXXXXXXXXXXX.

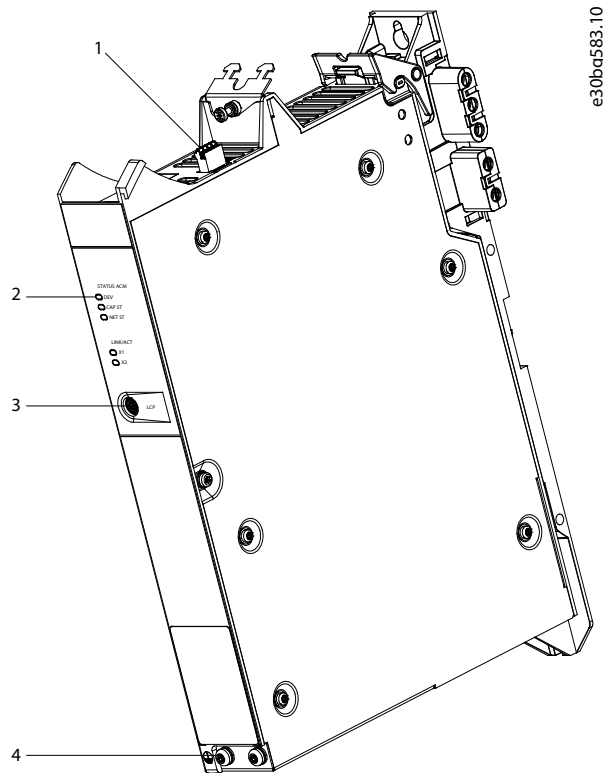

Illustration 6: ACM 510

1	Connectors: I/O, relay, and Ethernet	3	LCP connector
2	Operating LEDs	4	PE screw

3.7 Expansion Module EXM 510

The EXM 510 supports modular machine setup by splitting the system modules into 2 control cabinets. The maximum length of the cable between the EXM 510 modules is 5 m.

See [5.13 Connecting the Expansion Module EXM 510](#) for further information.

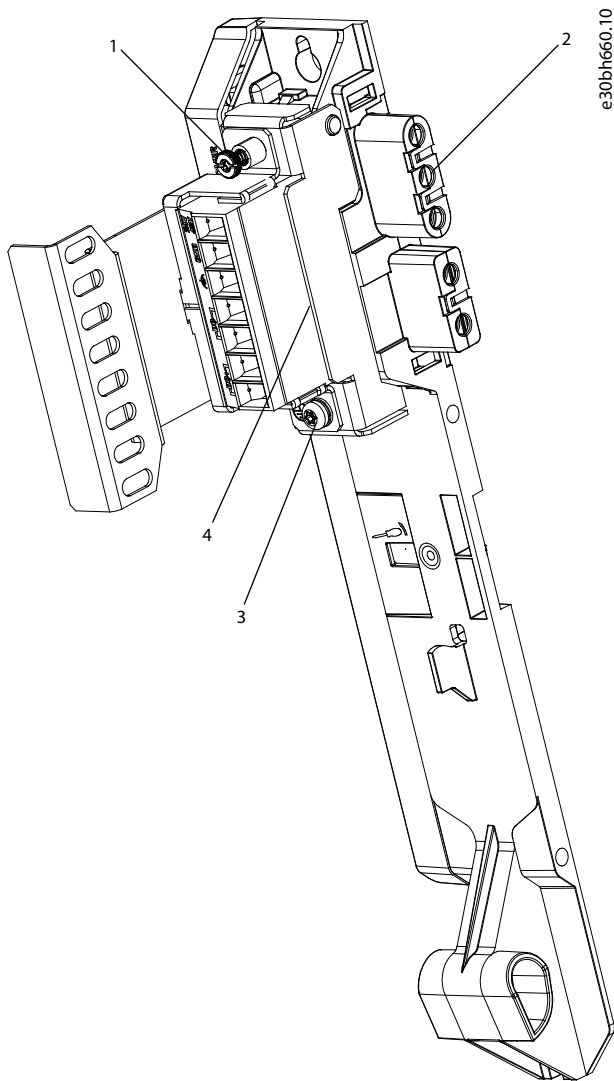

Illustration 7: EXM 510

1	EMC Shielding Plate	3	PE screw
2	Backplate	4	Expansion connector

NOTICE

- The system modules are designed for use within a control cabinet. If the STO function is used, the cabinet must be rated at least IP54.
- The EXM 510 has a protection rating of IP20 according to IEC/EN 60529.
- The EXM 510 may be damaged if exposed to fluids.

An example type code for the EXM 510 is:

MSD510EXM510F1C062AD6E20XXXXXXXXXXXXXXXXXX

3.8 Local Control Panel (LCP)

3.8.1 Overview of the Local Control Panel

The LCP is the graphical user interface that can be connected to the PSM 510, DAM 510, and ACM 510 for diagnostic and operating purposes using an optional cable (M8 to LCP D-SUB extension cable). The LCP is available as an option and can also be connected to the advanced version servo drives using the same optional cable.

The LCP display provides the operator with a quick view of the state of the ISD 510/DSD 510 servo drive or module, depending on which device it is connected to. The display shows parameters and alarms/errors and can be used for commissioning and troubleshooting. It can also be used to perform simple functions, for example activating and deactivating the output lines on the Decentral Access Module.

The LCP can be mounted on the front of the control cabinet and then connected to the modules via SUB-D cables.

3.8.2 Layout of the Local Control Panel

The local control panel is divided into 4 functional groups:

- A: Display area
- B: Display menu keys
- C: Navigation keys and indicator lights (LEDs)
- D: Operation keys and reset

To adjust the display contrast, press [Status] and the [Δ]/[▽] keys.

3.8.2.1 A: Display area

The values in the display area differ depending on whether the LCP is connected to a Danfoss servo drive or system module.

The display area is activated when the servo drive or module it is connected to receives power from the mains supply, a DC bus terminal, or U_{AUX}.

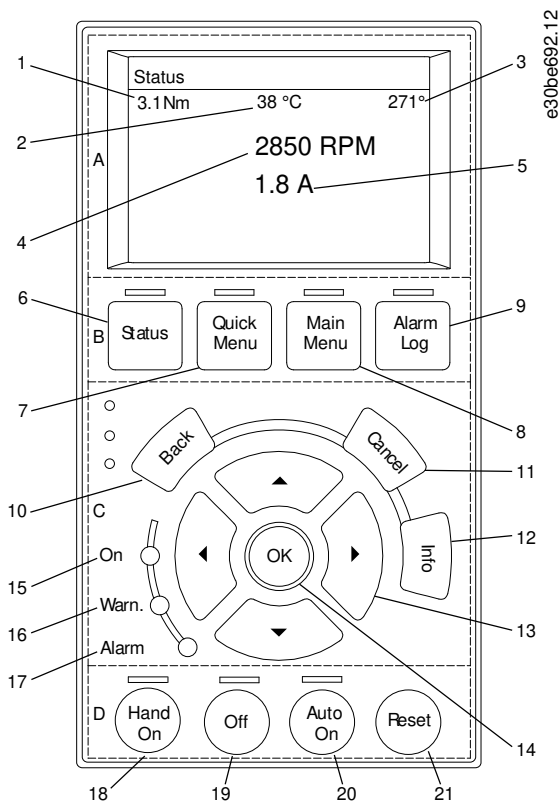

Illustration 8: Display Area when Connected to an ISD 510 Servo Drive

1	Actual torque
2	Temperature drive module

3	Position
4	Speed
5	Current

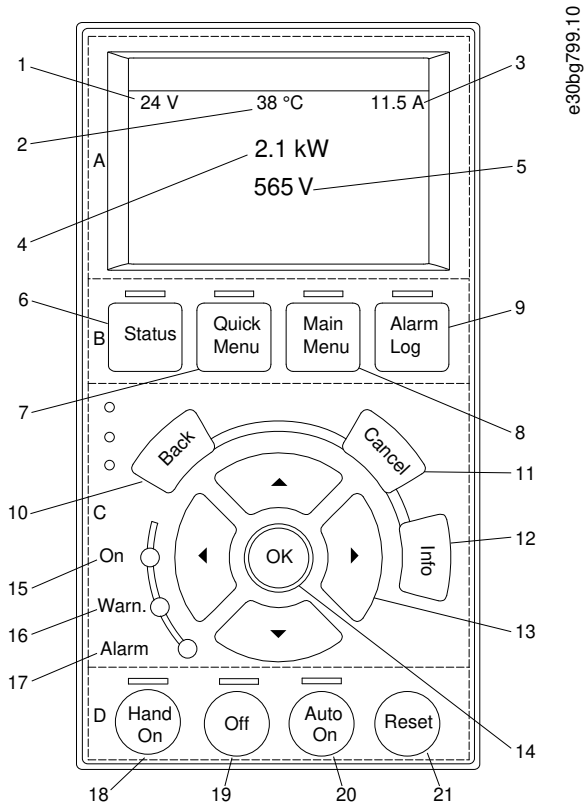

Illustration 9: Display Area when Connected to the PSM 510 and DAM 510

1	U_{AUX} line voltage
2	Temperature power board
3	Actual UDC (current)
4	Power consumption
5	Actual UDC (voltage)

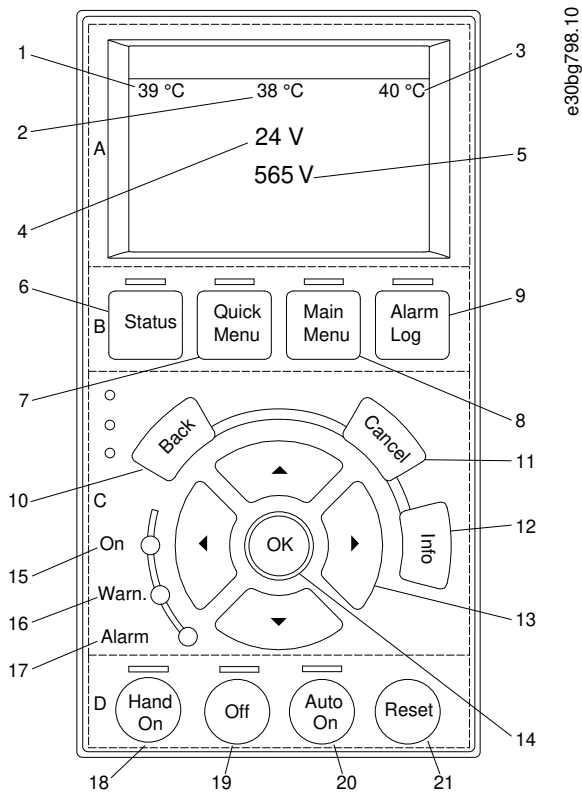

Illustration 10: Display Area when Connected to the ACM 510

1	Temperature power board
2	Temperature capacitor bank 1
3	Temperature capacitor bank 2
4	U_{AUX} line voltage
5	Actual UDC (voltage)

3.8.2.2 B: Display menu keys

Menu keys are used for menu access for parameter set-up, toggling through status display modes during normal operation, and viewing fault log data.

Table 11: Display Menu Keys

	Key	Function
6	Status	Shows operational information.
7	Quick Menu	Allows access to parameters.
8	Main Menu	Allows access to parameters.
9	Alarm Log	Shows the last 10 alarms.

3.8.2.3 C: Navigation keys and indicator lights (LEDs)

Navigation keys are used for moving the display cursor and provide operation control in local operation. There are also 3 status LEDs in this area.

Table 12: Navigation Keys

	Key	Function
10	Back	Reverts to the previous step or list in the menu structure.
11	Cancel	Cancels the last change or command as long as the display mode is not changed.
12	Info	Press for a definition of the function being shown.
13	Navigation keys	Use the 4 navigation keys to move between items in the menu.
14	OK	Use to access parameter groups or to enable a selection.

Table 13: Indicator Lights (LEDs)

	LED	Color	Function
15	On	Green	The <i>On</i> LED activates when the servo drive or module it is connected to receives power from U _{AUX} .
16	Warn	Yellow	When warning conditions are met, the yellow <i>Warn</i> LED activated and text appears in the display area identifying the problem.
17	Alarm	Red	A fault condition causes the red <i>Alarm</i> LED to flash and an alarm text is shown.

3.8.2.4 D: Operation keys and reset

The operation keys are located at the bottom of the LCP.

Table 14: Operation Keys and Reset

	Key	Function
18	Hand On	Enables the connected ISD 510/DSD 510 servo drive or PSM 510 to be controlled via the LCP. Switching between <i>Hand On</i> and <i>Auto On</i> modes is only possible in certain states (see the VLT® Servo Drive System ISD 510, DSD 510, MSD 510 (VLT® Flexmotion™) Programming Guide for further information).
19	Off	Puts the ISD 510/DSD 510 servo drive into state <i>Switch on Disabled</i> and the PSM 510 into state <i>Standby</i> . This only works in <i>Hand On</i> mode. <i>Off</i> mode enables transition from <i>Hand On</i> mode to <i>Auto On</i> mode.
20	Auto On	Puts the system in remote operational mode. In <i>Auto On</i> mode, the device is controlled by fieldbus (PLC). Switching between <i>Auto On</i> and <i>Hand On</i> modes is only possible when the drive is in state <i>Switch on Disabled</i> and/or the PSM 510 is in state <i>Standby</i> .
21	Reset	Resets the ISD 510/DSD 510 servo drive or PSM 510 after a fault has been cleared. The reset is only possible when in <i>Hand On</i> mode.

3.9 Cables

3.9.1 Hybrid Cable

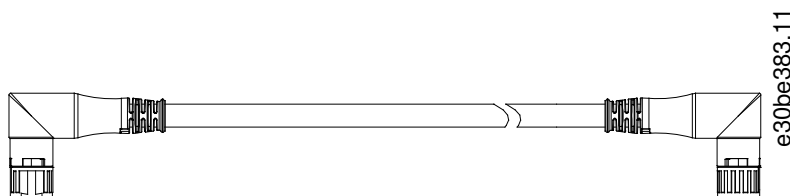

Illustration 11: Hybrid Loop Cable

Pre-configured hybrid cables are used to connect the ISD 510/DSD 510 servo drives to the Decentral Access Module (DAM 510). There are 2 types of hybrid cables that are available with both angled and straight M23 connectors:

- Feed-in cable for connecting the 1st ISD 510/DSD 510 servo drive of a group to the connection point on the Decentral Access Module (DAM 510).
- Loop cable for connecting the ISD 510/DSD 510 servo drives in daisy-chain format in an application.

Both these cables are provided by Danfoss and are available in various lengths. See the **VLT® Servo Drive System ISD 510, DSD 510, MSD 510 (VLT® Flexmotion™) Design Guide** for further information.

Both ends of the loop cable are fitted with M23 connectors.

The feed-in cable is fitted with an M23 connector at the output end for connection to the 1st ISD 510/DSD 510 servo drive. At the input end it is pigtailed and the connectors are mounted on the corresponding terminals on the Decentral Access Module (DAM 510).

Table 15: Hybrid Cables

Cable type	Shielded/unshielded	Notes
Feed-in cable	Shielded	Hybrid cable (overall shield with additional fieldbus and safety section shield).
Loop cable		

NOTICE

- Hybrid cables are available in 2 cross-sections: 2.5 mm² (15 A) and 4 mm² (25 A for CE and UL, 20 A for CSA).
- See the **VLT® Servo Drive System ISD 510, DSD 510, MSD 510 (VLT® Flexmotion™) Design Guide** for further information.

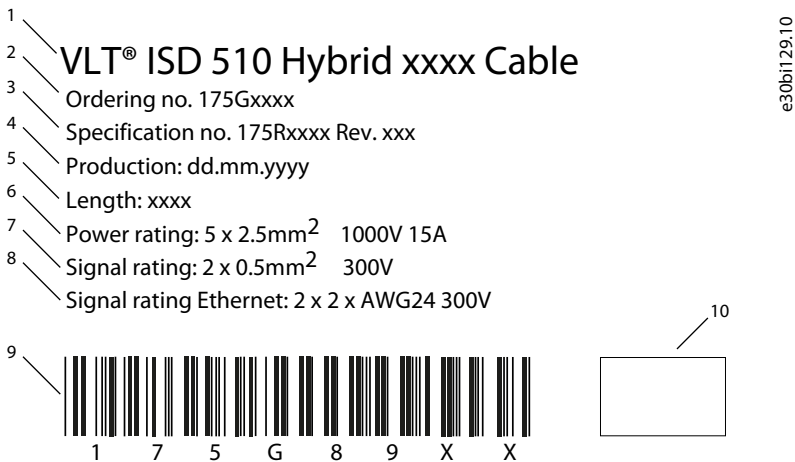

Illustration 12: Example of a Hybrid Cable Nameplate

1	Cable type	6	Power rating
2	Ordering code	7	Signal rating
3	Revision of specification	8	Signal rating for Ethernet
4	Manufacturing date	9	Barcode
5	Length	10	Manufacturer logo

3.9.1.1 Minimum Bending Radius for Hybrid Cable

The maximum number of bending cycles is 5 million at 7.5 x cable diameter (15.6 mm).

- Permanently flexible: 12 x cable diameter
- Permanently installed: 5 x cable diameter

3.9.2 Motor and Feedback Cable

Pre-configured motor and feedback cables are used to connect the DSD 510 servo drive to a PM motor. Both ends of the cable are fitted with M23 connectors.

These cables are provided by Danfoss and are available in 2.5 m and 5 m lengths (see the **VLT® Servo Drive System ISD 510, DSD 510, MSD 510 (VLT® Flexmotion™) Design Guide** for further information).

The maximum length between the DSD 510 and the motor is 5 m.

There are different types of cables available according to the feedback and motor variant used. Refer to the following tables for details of the abbreviations used in the descriptions.

Table 16: Motor and Feedback Cable Types

Ordering number	Description
175G8945	Motor Cable DSD M01 CT01 2.5 m OR
175G8946	Motor Cable DSD M01 CT01 5.0 m OR
175G8947	Feedback Cable DSD M01 CT03 RES 2.5 m GN
175G8948	Feedback Cable DSD M01 CT03 RES 5.0 m GN
175G8949	Feedback Cable DSD M01 CT04 ENC 2.5 m GN
175G8950	Feedback Cable DSD M01 CT04 ENC 5.0 m GN

Table 17: Connector Types (CT)

Type	Variant	Description
CT0	–	M23
CT0	1	Motor standard with HIPERFACE DSL
CT0	2	Reserved
CT0	3	M23 Resolver
CT0	4	M23 Encoder

Table 18: Motor/Cable Configuration

M01	AKM Pinout
M02	–

Table 19: Cable Colors

OR	Orange
GN	Green

3.9.2.1 Minimum Bending Radius for Motor Cable

The maximum number of bending cycles is 5 million at 7.5 x cable diameter (14.8 mm).

- Permanently flexible: 10 x cable diameter
- Permanently installed: 5 x cable diameter

3.9.2.2 Minimum Bending Radius for Feedback Cable

The maximum number of bending cycles is 5 million at 7.5 x cable diameter (11.7 mm).

- Permanently flexible: 7.5 x cable diameter
- Permanently installed: 5 x cable diameter

3.9.3 I/O and/or Encoder Cable

This cable connects the I/O and/or encoder to the ISD 510/DSD 510 servo drive (X4 connector). The cable is not included with the servo drives.

I/O and/or encoder cables with M12 connectors can be used for the ISD 510/DSD 510 system if they comply with the form factor defined in IEC 61076-2-101.

3.9.4 Fieldbus Extension Cable

Cable length: 2 m

Maximum length to next port: 100 m

If this cable is not used, fit the M23 blind cap to the X2 female connector on the last ISD 510/DSD 510 servo drive in the application.

3.9.5 LCP Cable

The LCP cable connects the LCP to the advanced ISD 510/DSD 510 servo drive and the system modules via an M8 connector.

The LCP cable can be purchased from Danfoss (see the **VLT® Servo Drive System ISD 510, DSD 510, MSD 510 (VLT® Flexmotion™) Design Guide** for further information and ordering numbers).

3.10 Cable Layout and Routing

The ISD 510/DSD 510 servo drives are interconnected by hybrid loop cables. A hybrid feed-in cable with quick-release connectors provides the supply voltage from the Decentral Access Module (DAM 510) to the 1st servo drive.

Routing in drag chains

The hybrid cable is compatible with drag chains and therefore suitable for use in moving systems. The number of bending cycles is dependent on individual conditions and must therefore be determined in advance for each application, see [3.9.1 Hybrid Cable](#) for further information.

3.10.1 Standard Cabling Concept for 2 Lines

This cabling concept is for 2 lines, without redundancy for ISD 510/DSD 510 servo drives in an application. For each additional line of servo drives, 1 additional DAM 510 is required. For cabling concepts with only 1 line, only 1 DAM 510 is required.

NOTICE

- For cabling with redundancy, see the **VLT® Servo Drive System ISD 510, DSD 510, MSD 510 (VLT® Flexmotion™) Design Guide**.

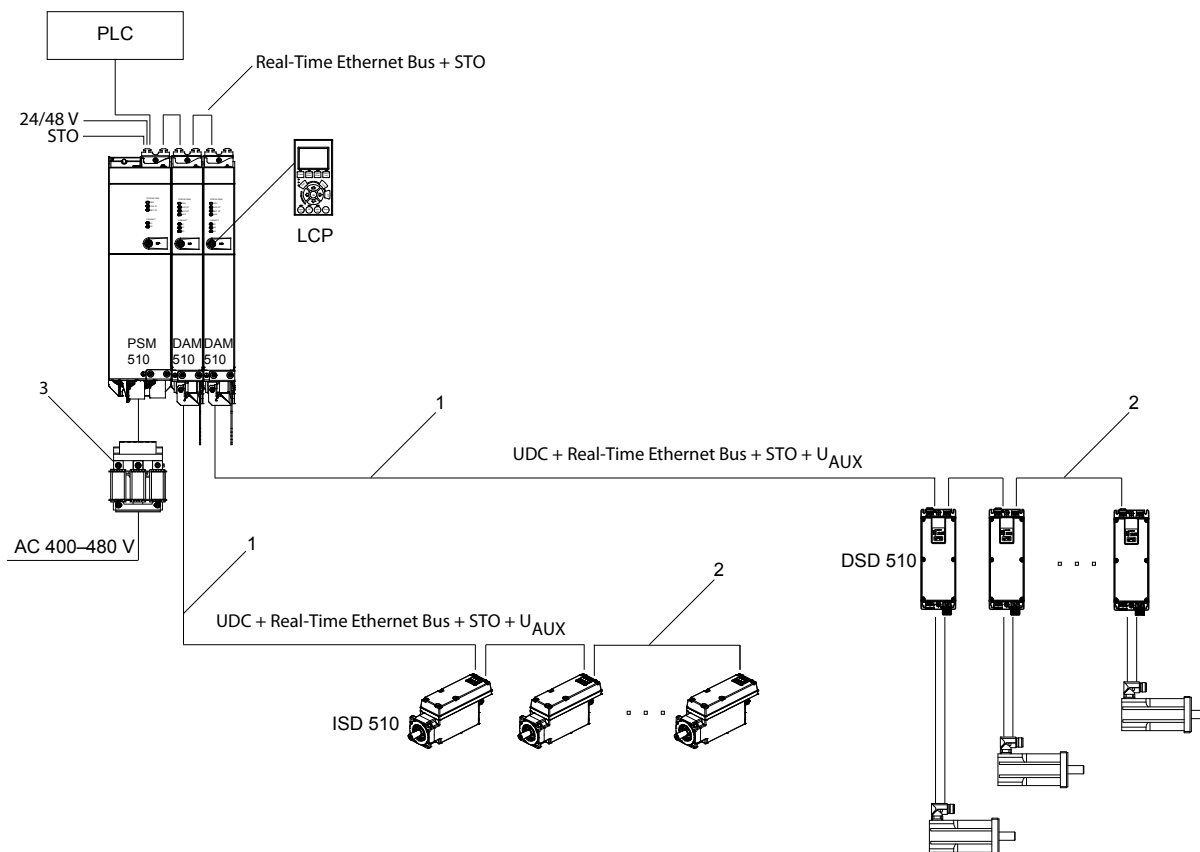

e30bg794.10

Illustration 13: Standard Cabling Concept for 2 Lines

1	M23 feed-in cable	3	AC line choke
2	M23 loop cable		

3.11 Software

The software for the servo system comprises:

- The firmware of the ISD 510/DSD 510 that is already installed on the device.
- The firmware of the system modules that is already installed on the modules.
- A package of PLC libraries for Automation Studio™ for operating the ISD 510/DSD 510 servo drives and the system modules (see [6.10.2 Creating an Automation Studio™ Project](#) for further information).
- A PLC library for TwinCAT® 2 and 3 for operating the ISD 510/DSD 510 servo drives and the system modules (see [6.11.2 Creating a TwinCAT® Project](#) for further information).
- A PLC library for SIMOTION SCOUT® for operating the ISD 510/DSD 510 servo drives and the system modules (see [6.13.3 Creating a SIMOTION SCOUT® Project](#)).
- A PLC library for TIA Portal for operating the ISD 510/DSD 510 servo drives and the system modules.
- VLT® Servo Toolbox: A Danfoss PC-based software tool for commissioning and debugging the devices.

3.12 Fieldbus

The servo system has an open system architecture realized by fast Ethernet (100BASE-T) based communication. The system supports EtherCAT®, Ethernet POWERLINK®, and PROFINET® fieldbuses. See the **VL^T® Servo Drive System ISD 510, DSD 510, MSD 510 (VL^T® Flexmotion™) Programming Guide** for further information.

In productive environments, communication to the devices always takes place via a PLC that acts as a master. The ISD 510/DSD 510 servo drives and the system modules can be controlled by these communication methods:

- Using the VLT® Servo Motion libraries (available for TwinCAT®, Automation Studio™, SIMOTION SCOUT®, and TiA Portal).
- Using the NC axis functionality of TwinCAT® (ISD 510/DSD 510 only).
- Using the CANopen® CiA DS 402 standard by reading and writing to objects.
- Using application class 1 (AC1) and 4 (AC4), PROFINET® only.

The ISD 510/DSD 510 servo drives and the system modules can be operated with the following cycle times.

- EtherCAT® and Ethernet POWERLINK® fieldbuses:
 - 400 µs and multiples of it (for example, 800 µs and 1200 µs).
 - 500 µs and multiples of it (for example, 1 ms).
- PROFINET® fieldbus
 - 500 µs and multiples of it (for example, 1 ms).

When the cycle time is a multiple of 400 µs and 500 µs, the time base of 500 µs is used.

The ISD 510/DSD 510 servo drives and the system modules are certified for fieldbuses according to the corresponding rules and regulations. The servo drives conform to the CANopen® CiA DS 402 Drive Profile.

3.12.1 EtherCAT®

The ISD 510/DSD 510 servo drives and the system modules support the following EtherCAT® protocols:

- CANopen over EtherCAT® (CoE)
- File Access over EtherCAT® (FoE)
- Ethernet over EtherCAT® (EoE)

The ISD 510/DSD 510 servo drives and the system modules support distributed clocks. To compensate for the failure of a communication cable section in the system, cable redundancy is available for all fieldbuses. See the **VLT® Servo Drive System ISD 510, DSD 510, MSD 510 (VLT® Flexmotion™) Design Guide** for further information.

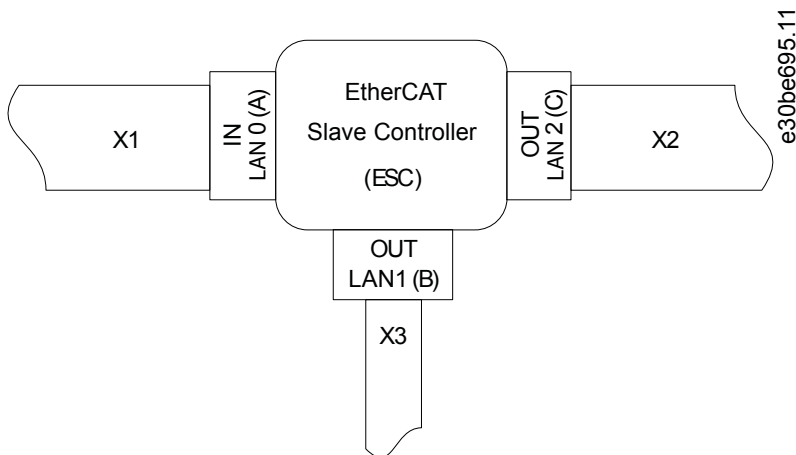

Illustration 14: EtherCAT™ Port Assignment for the ISD 510/DSD 510 Servo Drive

<p>X1</p> <p>X2</p>	<p>M23 hybrid cable connector to Decentral Access Module (DAM 510) or previous servo drive.</p> <p>M23 hybrid cable connector to the next servo drive.</p>	<p>X3</p> <p>M8 Ethernet cable connector to other EtherCAT® slaves, for example EtherCAT® encoder.</p> <p>The connector is only available on the advanced servo drives.</p>
---------------------	--	---

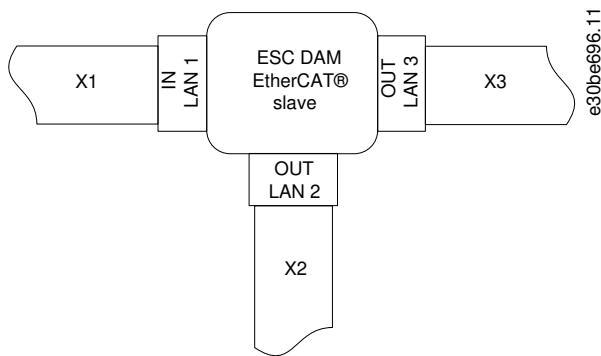

Illustration 15: EtherCAT™ Port Assignment for the Decentral Access Module (DAM 510)

X1	RJ45 cable connector to the previous slave.	X3	RJ45 cable connector to the PLC (cable redundancy) or next slave.
X2	RJ45 to M23 hybrid feed-in cable to the 1st ISD 510/DSD 510 servo drive.		

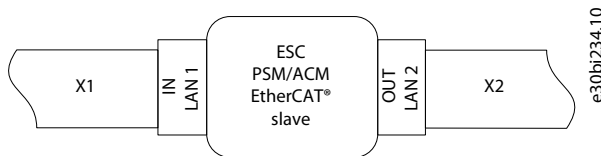

Illustration 16: EtherCAT™ Port Assignment for the Power Supply Module (PSM 510), Auxiliary Capacitors Module (ACM 510), and ISD 510/DSD 510 Servo Drives

X1	RJ45 cable connector to the PLC or previous slave.
X2	RJ45 cable connector to the PLC (cable redundancy) or next slave.

3.12.2 Ethernet POWERLINK®

The ISD 510/DSD 510 servo drives and the system modules are certified according to DS 301 V1.1.0 and support the following features:

- Work as controlled node
- Can be operated as multiplexed stations
- Support of cross-communication
- Ring redundancy supported for media redundancy

Specific ports are not assigned for Ethernet POWERLINK®.

3.12.3 PROFINET®

The ISD 510/DSD 510 servo drive and system modules support PROFINET® conformance class C as per IEC 61158-5-10:2014, IEC 61158-6-10:2014, IEC 61784-2:2014, and IEC 61784-5-3:2013. All the system components (servo drives and system modules) act as I/O devices in a PROFINET® network.

The following features are supported:

- I/O-Device - Device that is being controlled by I/O-Controller
- Dynamic module configuration
- Net load class II
- Ring redundancy (MRP) as client

PROFINET® fieldbus devices are always connected as network components via switches that are integrated in the fieldbus device. There are 2 ports on the ISD 510/DSD 510 servo drives, the PSM 510, and the ACM 510. There are 3 ports on the DAM 510. Only 2 can be used for Isochronous Real-Time (IRT) protocol, whereas all 3 can be used for Real-Time (RT) protocol. If the DAM 510 with IRT is

ordered, a RJ45 cover will be mounted to the X3 OUT port. Remove this cover to enable use of the X3 OUT port required for switching to RT protocol.

The wiring concept for the use of multiple DAM 510 modules in a single application is shown in [Illustration 17](#).

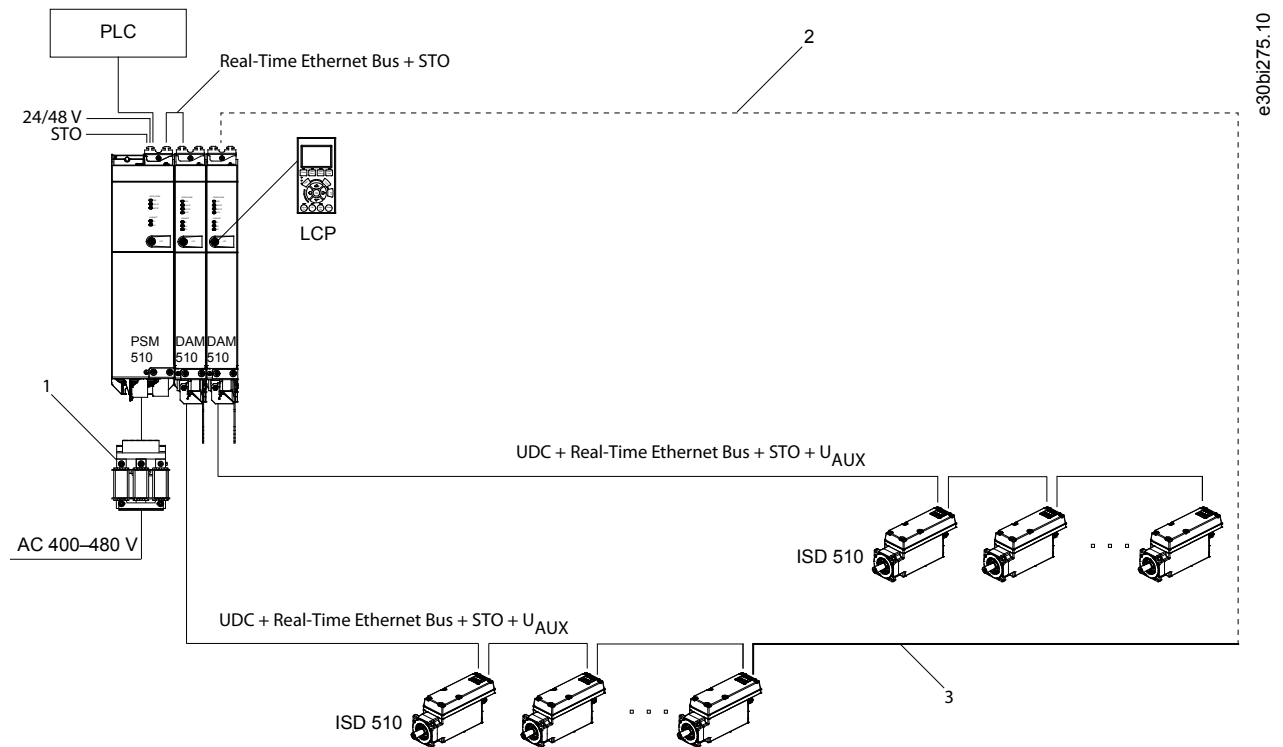

Illustration 17: Wiring Concept for Multiple DAM 510 Modules

1	AC line choke	3	Fieldbus extension cable
2	Customer cable		

4 Mechanical Installation

4.1 Items Supplied

The items supplied for the ISD 510/DSD 510 servo systems are:

- ISD 510/DSD 510 servo drives
- Power Supply Module (PSM 510) including connectors
- Decentral Access Module (DAM 510) including connectors
- Auxiliary Capacitors Module (ACM 510) including connectors, optional
- Expansion Module (EXM 510), optional
- Local control panel (LCP), optional
- This operating guide
- Feed-in (hybrid) cable
- Loop (hybrid) cable
- LCP cable, optional
- Fieldbus extension cable, optional
- Blind caps for connectors M8, M12, and M23

The packaging unit depends on the number of servo drives delivered. Save the packaging for use in the event of product return.

4.2 Transport

- Always use means of transport and lifting gear with sufficient load capacity to transport the servo system components.
- Avoid vibration during transport.
- Avoid heavy impacts and blows.

4.3 Inspection on Receipt

Procedure

1. After receiving the delivery, immediately check whether the items supplied match the shipping documents. Danfoss does not honor claims for faults registered later.
2. Register a complaint immediately with the carrier if there is visible transport damage.
3. Register a complaint immediately with the responsible Danfoss representative if there are visible defects or the delivery is incomplete.

4.4 Safety Measures during Installation

Always observe the safety instructions in this manual during installation. Pay particular attention to ensuring that the following points are always observed:

- Installation may only be performed by qualified personnel.
- Installation must be performed with due care and attention.
- All safety regulations and protective measures must be complied with, and the environmental conditions must be observed.
- The manual is read and understood.

4.5 Installation Environment

4.5.1 Overview

The installation must provide the following environmental conditions to allow the ISD 510/DSD 510 system to be operated safely and efficiently.

Contact Danfoss if it is not possible to comply with these environmental conditions.

4.5.2 ISD 510/DSD 510 Servo Drive

- The allowable operating ambient temperature range and vibration levels must not be exceeded. (See [11.10.1 ISD 510/DSD 510 Servo Drive](#).)
- The allowable relative humidity range is 3–93%, non-condensing.
- Unrestricted ventilation must be available.
- The mounting structure must be suitable for the application, for example, adequately rigid and able to cope with temperatures over 90 °C.

4.5.3 System Modules

The environmental conditions for the PSM 510, DAM 510, and ACM 510 are:

- The allowable operating ambient temperature range and vibration levels must not be exceeded (see [11.10.2 System Modules](#)).
- The allowable relative humidity range is 5–93%, non-condensing.
- The minimum space required above and below the system modules is detailed in [4.7.3 Space Requirements for System Modules](#).

4.6 Preparation for Installation

4.6.1 ISD 510/DSD 510 Servo Drive

Make the following preparations to ensure that the servo system can be installed reliably and effectively.

Always fit couplings and other transfer components in accordance with local regulations.

Procedure

1. Provide a suitable mounting arrangement for the application. This depends on the type, weight, and power size of the ISD 510/DSD 510 servo drives.
2. For the ISD 510 servo drives, seat the motor flange flush against the mounting surface before fixing the servo drive. Misalignment shortens the life of the bearings and the coupling components and reduces heat transfer from the servo drive.
3. For the DSD 510 servo drives, seat the bottom side of the DSD 510 to the mounting surface before fixing the servo drive. Misalignment reduces heat transfer from the servo drive.
4. Provide contact protection according to local regulations if hot surfaces can be expected during operation.
5. Ground the servo drive.

4.6.2 System Modules

Make the following preparations to ensure that the servo system can be installed reliably and effectively.

Always fit the system modules in accordance with local regulations.

Procedure

1. Provide a suitable mounting arrangement for the application. This depends on the type and weight of the modules.
2. To avoid misalignment, ensure that the backplates are perfectly level.
3. To ensure sufficient cooling, pay attention to the specified minimum space requirements.
4. Ground the modules.

4.6.3 Drilling Templates

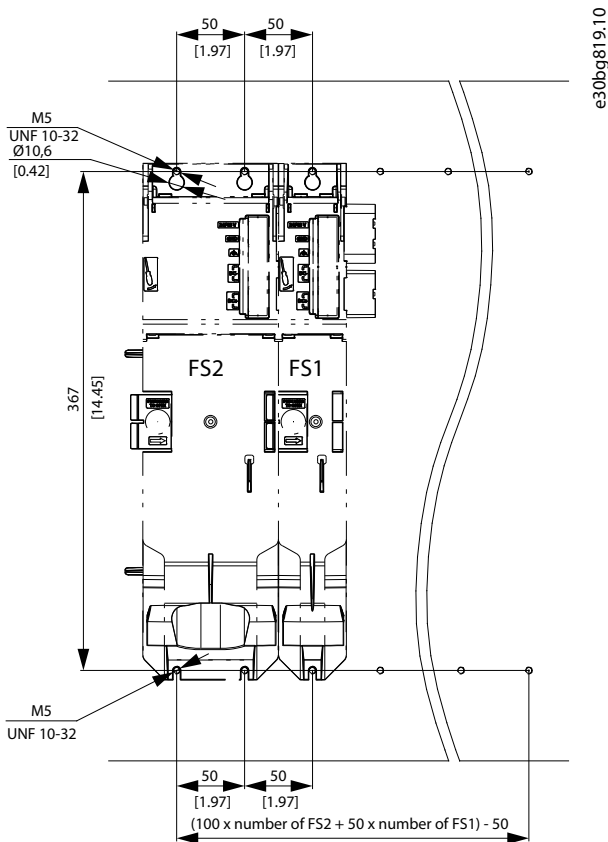

Illustration 18: Drilling templates for 50 mm and 100 mm System Modules

4.7 Installation Procedure

4.7.1 Space Requirements for ISD 510 Servo Drive

In addition to its own dimensions, the ISD 510 servo drive needs space for the hybrid cable.

[4.7.1.1 Minimum Distance for M23 Straight Connector on ISD 510](#) shows the straight connector installed on a size 2 ISD 510 servo drive.

[4.7.1.2 Minimum Distance for M23 Angled Connector on ISD 510](#) shows the angled connector installed on a size 2 ISD 510 servo drive.

The illustrations show the minimum distance from the servo drive to the next object, and the minimum allowable bending radius R_{min} for permanently installed cable. For cable installation, allow the height of the connector plus an additional 30 mm for the cable. The minimum distance is measured from the electronic housing as this is the same for all motor variants.

4.7.1.1 Minimum Distance for M23 Straight Connector on ISD 510

The minimum distance for the straight connector is calculated as follows:

$$0.5 \times \text{cable diameter} + \text{connector height} + R_{min} = 7.8 \text{ mm} + 112 \text{ mm} + 78 \text{ mm} = 197.8 \text{ mm} \approx 200 \text{ mm}$$

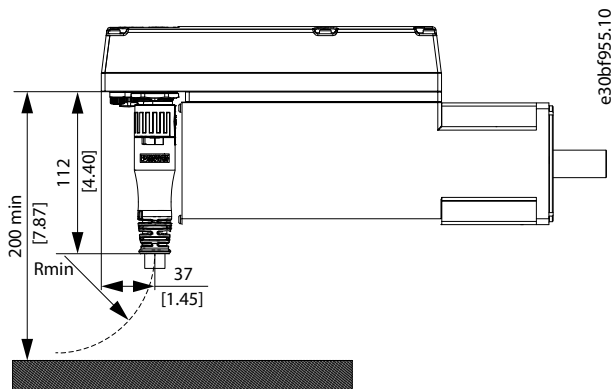

Illustration 19: Minimum Distance for M23 Straight Connector

4.7.1.2 Minimum Distance for M23 Angled Connector on ISD 510

The minimum distance for the angled connector is calculated as follows:

$$0.5 \times \text{cable diameter} + \text{connector length measured from electronic housing} + R_{\min} = 7.8 \text{ mm} + 51.4 \text{ mm} + 78 \text{ mm} = 137.8 \text{ mm} \approx 140 \text{ mm}$$

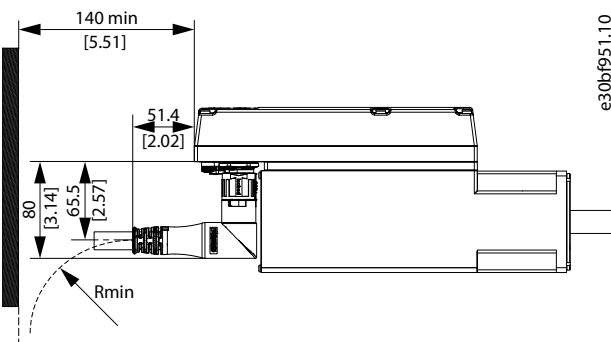

Illustration 20: Minimum Distance for M23 Angled Connector

4.7.2 Space Requirements for DSD 510 Servo Drive

In addition to its own dimensions, the DSD 510 servo drive needs space for the hybrid cable.

[4.7.2.1 Minimum Distance for M23 Straight Connector on DSD 510](#) shows the straight connector installed on a DSD 510 servo drive.

[4.7.2.2 Minimum Distance for M23 Angled Connector on DSD 510](#) shows the angled connector installed on a DSD 510 servo drive.

The illustrations show the minimum distance from the servo drive to the next object, and the minimum allowable bending radius R_{\min} for permanently installed cable. For cable installation, allow the height of the connector plus an additional 30 mm for the cable.

4.7.2.1 Minimum Distance for M23 Straight Connector on DSD 510

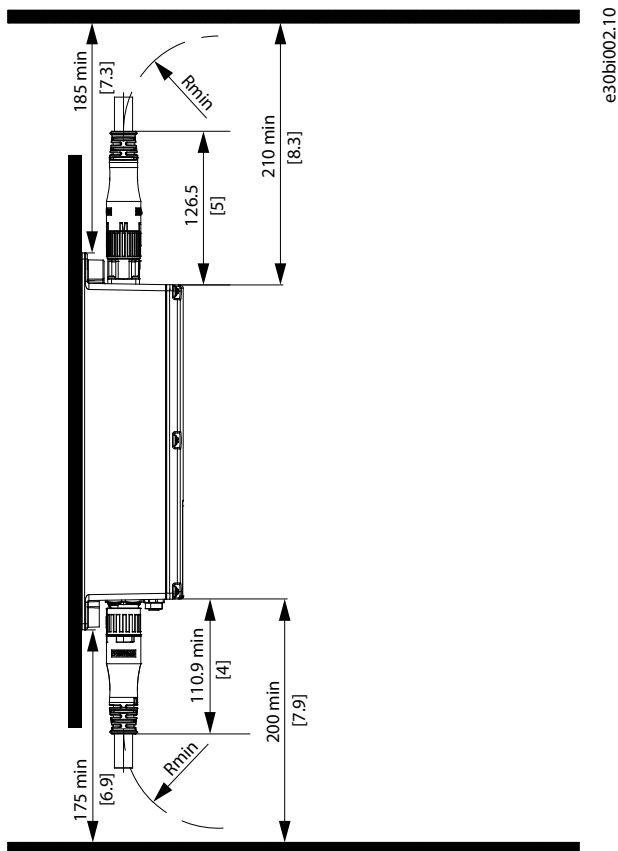

Illustration 21: Minimum Distance for M23 Straight Connector

4.7.2.2 Minimum Distance for M23 Angled Connector on DSD 510

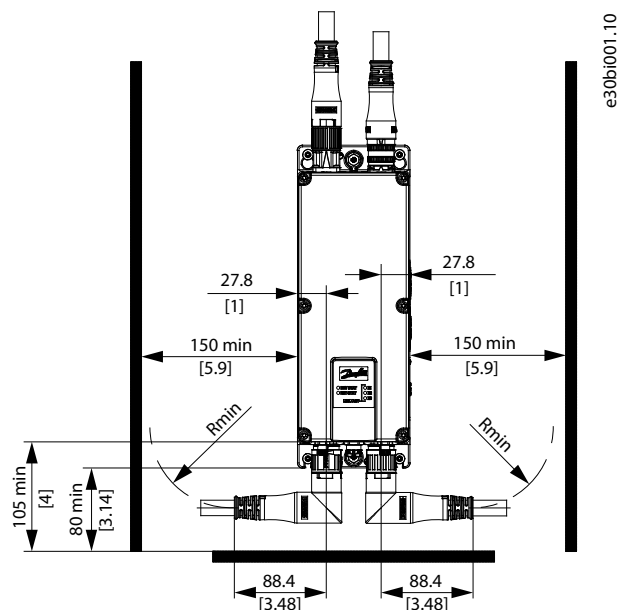

Illustration 22: Minimum Distance for M23 Angled Connector

4.7.3 Space Requirements for System Modules

The modules can be mounted next to each other but require a minimum space at the top and bottom for cooling.

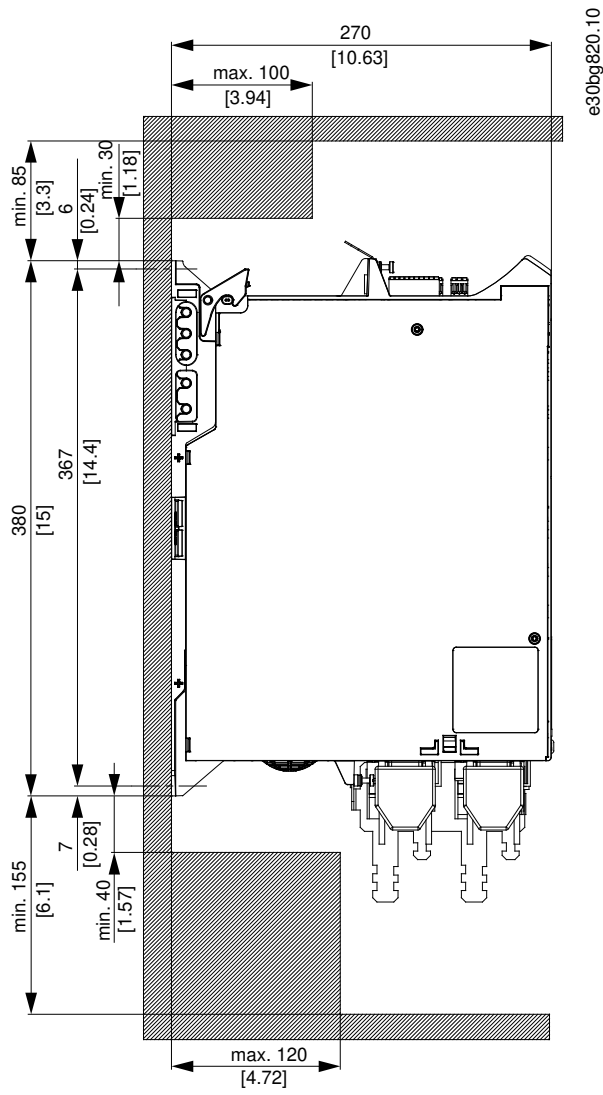

Illustration 23: Minimum Space Required at the Top and Bottom

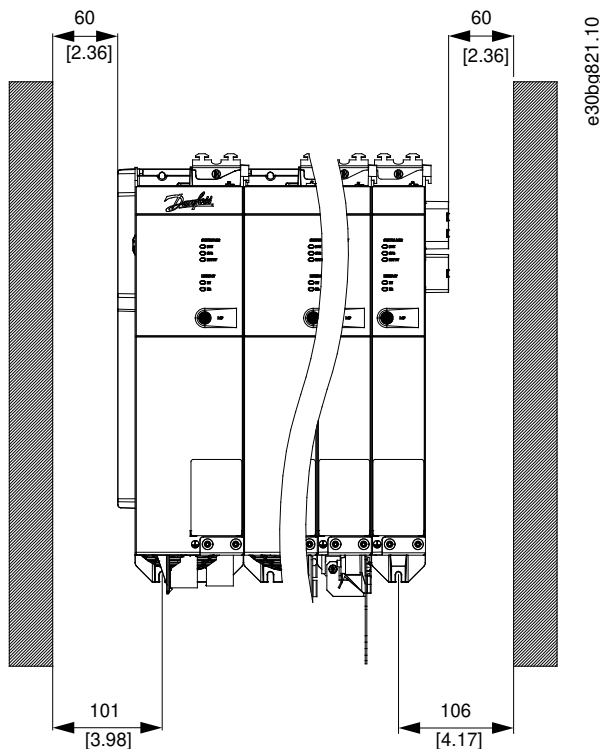

Illustration 24: Minimum Space Required at the Sides

4.7.4 Installation Aids and Tools Required

For installation of the ISD 510 servo drives, the tools corresponding to the fixings screws (not included) are required.

4.7.5 Fitting Instructions for ISD 510 Servo Drive

4.7.5.1 Overview

The ISD 510 servo drives are delivered with an M23 transport protection cap. The M23 blind cap used for IP protection must be ordered separately. The advanced version of the ISD 510 servo drive is delivered additionally with M8 and M12 blind caps. These blind caps prevent contamination of the servo drive and are necessary to achieve the relevant IP protection rating. Always mount these caps if the connector is not used.

NOTICE

- Ensure the machine surface that comes in contact with the servo drive flange is unpainted in order to guarantee good thermal behavior of the servo drive. The surface contact must also provide sufficient grounding protection.

4.7.5.2 Clamping the ISD 510 Servo Drive

Observe the following fitting instructions to ensure the reliable and effective fitting of the ISD 510 servo drive.

Procedure

1. Check the counterface of the motor mount and ensure that it has sufficient heat dispersion capacity. An unpainted surface is mandatory.
2. Remove the protective end cap from the shaft.
3. Fix the servo drive with 4 screws using the 4 mounting holes provided for this purpose in the machine unit as shown.
 - Always use the designated mounting holes in the mounting flange to fix the servo drive.
 - Do not modify the mounting holes.
 - Always use all 4 mounting holes. The motor may run unevenly if fewer mounting holes are used.

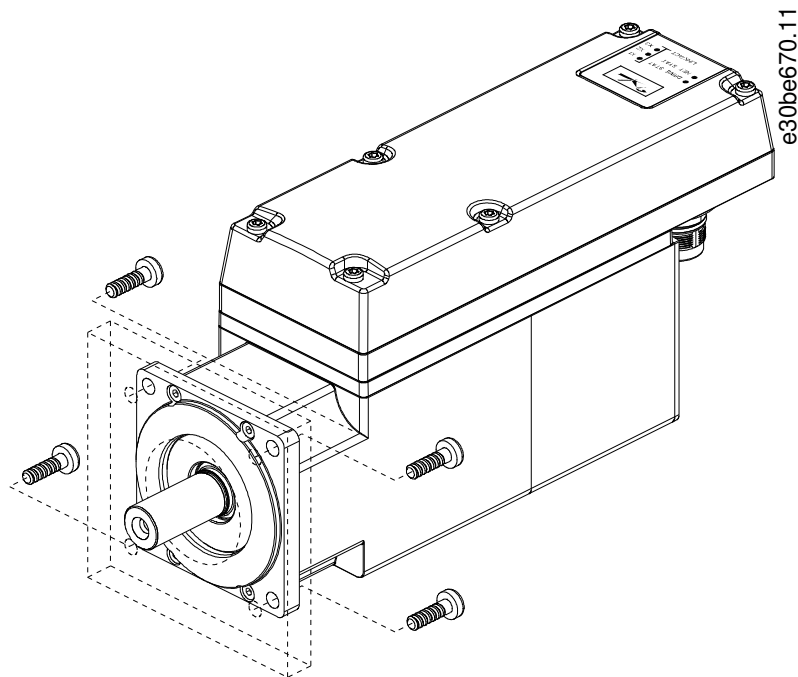

Illustration 25: Mounting of Size 1, 1.5 Nm, Size 2, 2.9 Nm, Size 2, 3.8 Nm, Size 3, and Size 4 ISD 510 Servo Drives

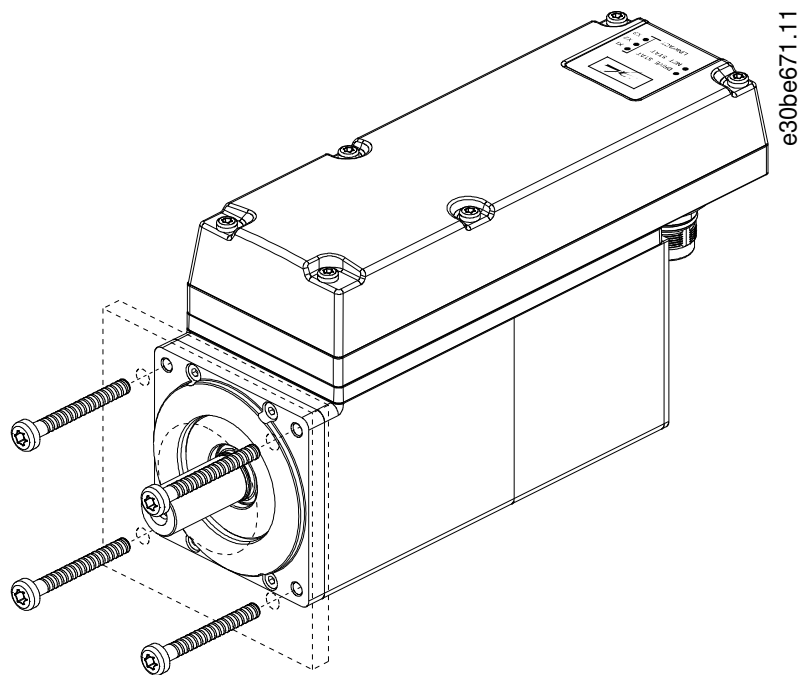

Illustration 26: Mounting of Size 2, 2.1 Nm ISD 510 Servo Drives

4.7.5.3 Coupling the ISD 510 Servo Drive

Observe the following safety warnings before coupling the ISD 510 servo drive.

NOTICE

- Do not machine the shaft.
- Do not use the ISD 510 servo drive if the shaft does not match the coupling arrangement.

N O T I C E

DO NOT USE EXCESSIVE FORCE DURING THE FITTING PROCEDURE:

- Do not exceed the specified vibration limits.
- Do not exceed the specified permitted forces.

Procedure

1. Align the clamping set to the axis of the ISD 510 servo drive.
2. Insert the shaft in the clamping set.
3. Screw the clamping set together.

4.7.5.4 Tightening Torques for Fixing Screws

Always tighten the screws uniformly and crosswise.

Servo drive size	Thread type/ hole size	Maximum thread length	Tightening torque
Size 1, 1.5 Nm	Ø 5.8 mm	–	5 Nm
Size 2, 2.1 Nm	M6 pitch 1 mm	23 mm	6 Nm
Size 2, 2.9 Nm	Ø 7 mm	–	6 Nm
Size 2, 3.8 Nm	Ø 7 mm	–	6 Nm
Size 3, 5.2 Nm	Ø 9 mm	–	14 Nm
Size 3, 6.0 Nm	Ø 9 mm	–	14 Nm
Size 4, 11.2 Nm	Ø 11 mm	–	28 Nm
Size 4, 13.0 Nm	In preparation	–	In preparation

N O T I C E

- The fixing screws are not supplied and must be selected according to the machine fixings.

4.7.6 Fitting Instruction for DSD 510 Servo Drive

4.7.6.1 Clamping the DSD 510 Servo Drive

Observe the following fitting instructions to ensure the reliable and effective fitting of the DSD 510 servo drive.

Procedure

1. Check the mounting surface and ensure that it has sufficient heat dispersion capacity. An unpainted surface is mandatory.
2. Drill the holes for mounting the DSD 510 (see [11.3.3 Dimensions of DSD 510 Servo Drive](#)).
3. Mount the DSD 510 to the mounting plate using M5 screws.
 - The tightening torque is 3 Nm
 - Always use all 4 mounting holes.

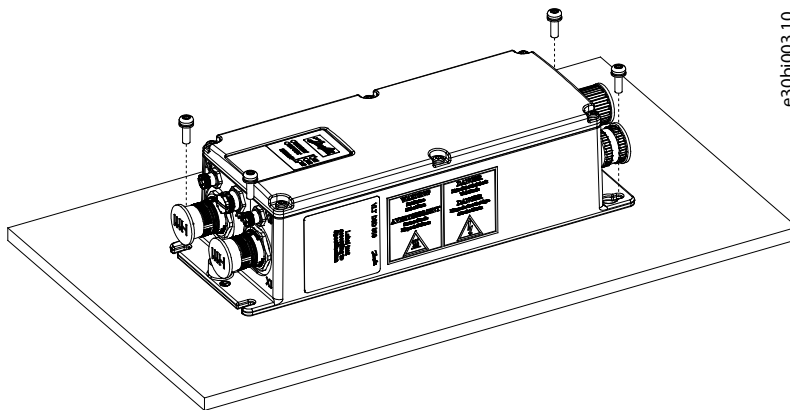

e30bi003.10

Illustration 27: Mounting of DSD 510 Servo Drive

4.7.7 Fitting Instructions for System Modules

NOTICE

- Mount the system module with the highest output power next to the PSM 510. Mount the remaining system modules in descending order of output power.

Procedure

1. Drill the holes for mounting the backplate as per the drilling template (see [4.6.3 Drilling Templates](#)).
2. Connect the backplates and the end cap via the click and lock method.

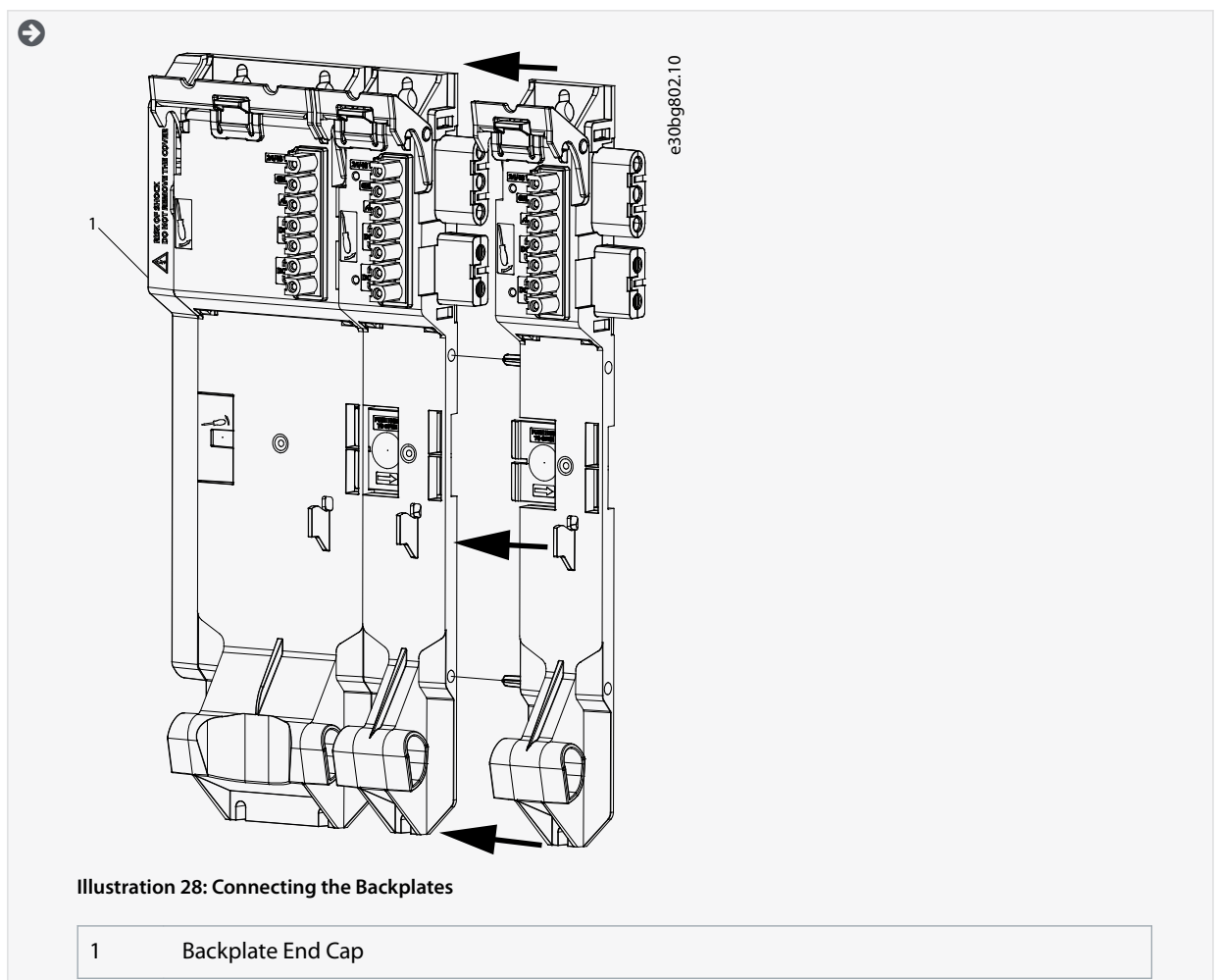
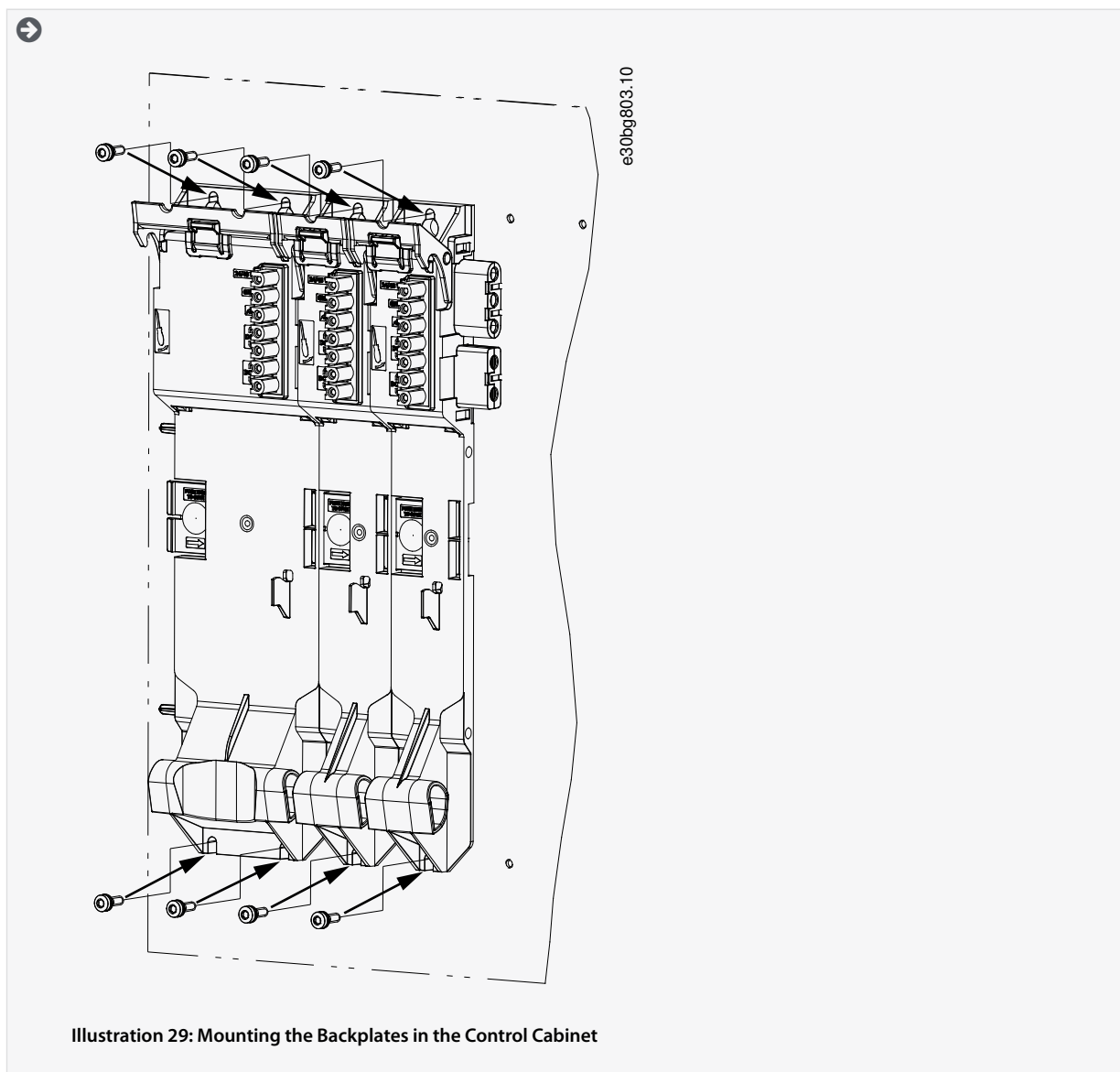

Illustration 28: Connecting the Backplates

1 Backplate End Cap

3. Mount the backplates to the mounting plate in the control cabinet using M5 screws with a minimum head diameter or washer diameter of 9.5 mm. The tightening torque is 3 Nm.



4. Slide the module onto the carrier at the bottom of the backplate.
5. Press the 1st module onto the backlink connector at the top of the backplate.

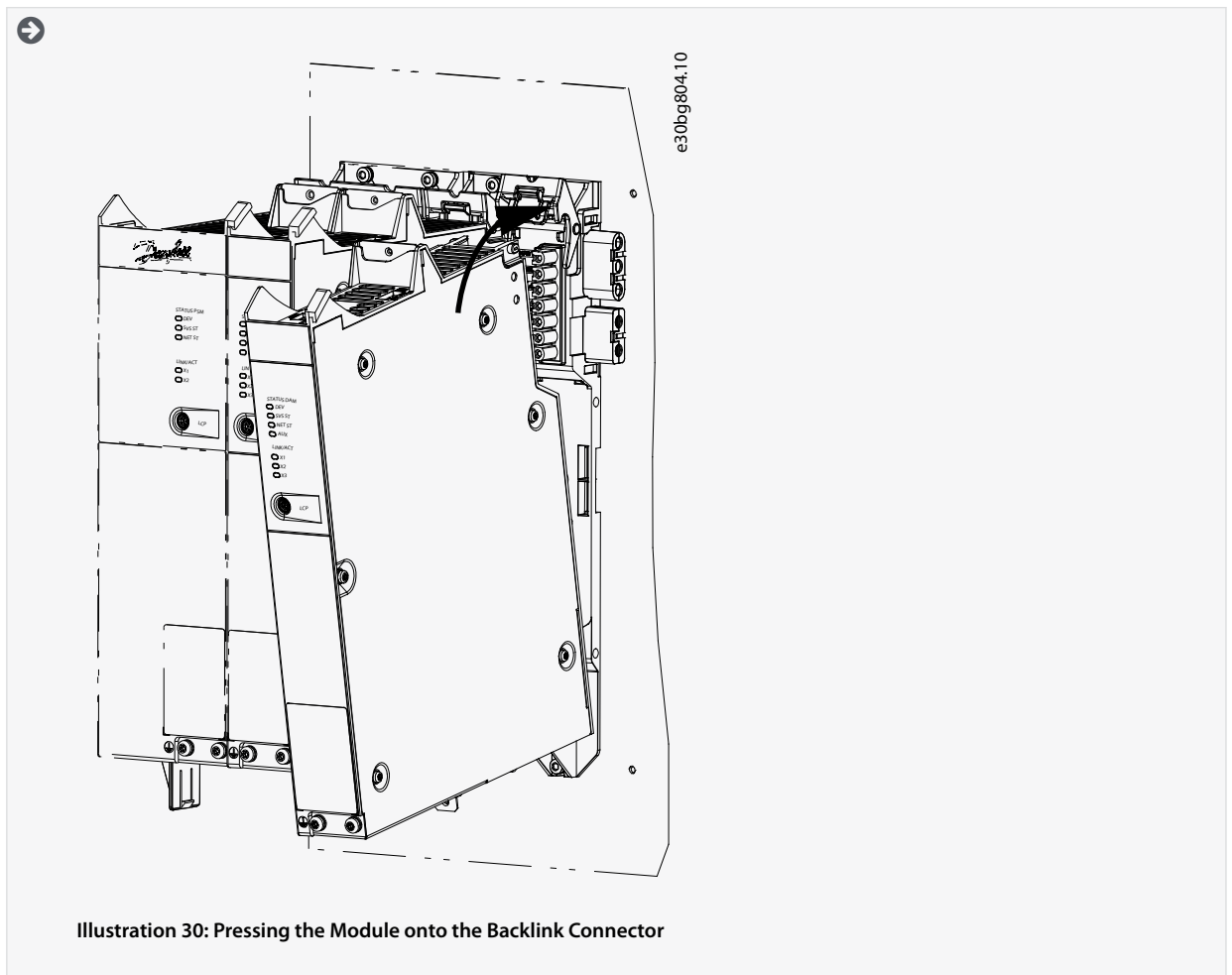

- To secure the module, pull down the holding clamp ([1] in [Illustration 31](#)) at the top of the backplate.

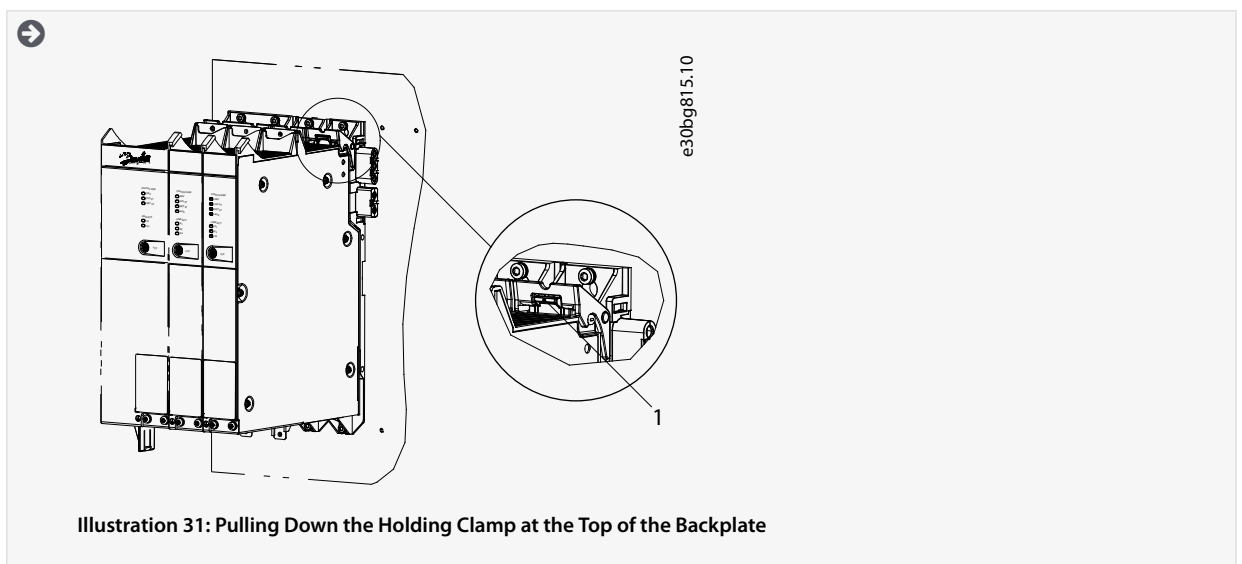

- Repeat steps 4, 5, and 6 for the remaining modules, ensuring that the lip at the left side of the 2nd module is inside the guiding groove at the right side of the 1st module ([1] in [Illustration 32](#)).

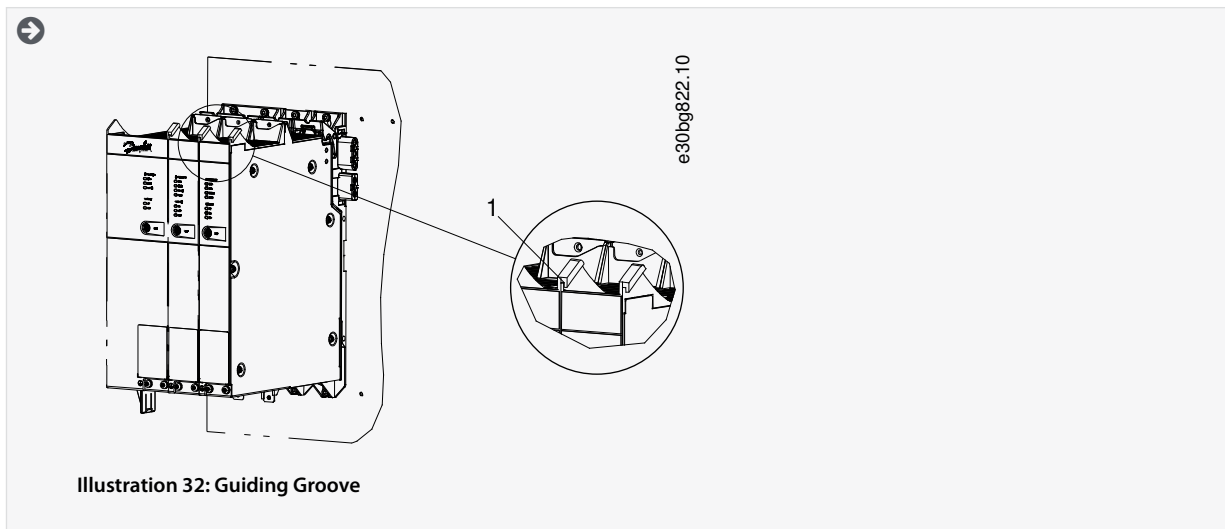

5 Electrical Installation

5.1 Warnings for Electrical Installation

During electrical installation, observe the relevant local and national regulations in addition to the information in this manual.

⚠ WARNING ⚠

LEAKAGE/GROUNDING CURRENT HAZARD

Leakage/grounding currents are >3.5 mA. Improper grounding of the ISD 510/DSD 510 servo drives and the system modules may result in death or serious injury.

- For reasons of operator safety, use a certified electrical installer to ground the system correctly in accordance with the applicable local and national electrical standards and directives, and the instructions in this manual.

⚠ WARNING ⚠

HIGH VOLTAGE

The servo system contains components that operate at high voltage when connected to the electrical supply network. There are no indicators on the components that indicate the presence of mains supply. Incorrect installation, commissioning, or maintenance may lead to death or serious injury.

- Installation, commissioning, and maintenance may only be performed by qualified personnel.

⚠ WARNING ⚠

HIGH VOLTAGE

Potentially lethal voltage is present on the connectors that may lead to death or serious injury.

- Before working on the power connectors (disconnecting or connecting the cable), disconnect the PSM 510 from the mains and wait for the discharge time to elapse.

5.2 Electrical Environmental Conditions

Compliance with the following electrical environmental conditions is necessary to enable safe and effective operation of the servo system:

- Only for use in TN-S, TN-C, TN-CS, TT (not corner earthed) supply earthing system
- Prospective short-circuit current: 5 kA
- Protective class I
- Grounded 3-phase mains network, 400–480 V AC $\pm 10\%$
- 3-phase frequency 44–66 Hz
- 3-phase lines and PE line
- External supply for auxiliary voltage, 24–48 V DC (PELV) $\pm 10\%$
- AC choke (see [5.10.1 AC Line Choke](#))
- Observe the national statutory provisions.
- The leakage current is >3.5 mA.

NOTICE

RCD COMPATIBILITY

The servo system contains components that can cause a DC current in the protective earthing conductor, which may result in malfunction in any devices connected to the system.

- Where a residual current-operated protective (RCD) or monitoring (RCM) device is used for protection in case of direct or indirect contact, use a type B RCD or RCM device on the supply side of the system components.

NOTICE

- The PSM 510, DAM 510, and ACM 510 (optional) must be mounted in a control cabinet.

5.3 EMC-Compliant Installation

To achieve an EMC-compliant installation, follow the instructions provided in [5.4.2 Grounding for EMC-Compliant Installation](#) and the steps defined for connecting the ISD 510/DSD 510 servo drives, PSM 510, DAM 510, and ACM 510.

5.4 Grounding

5.4.1 Grounding for Electrical Safety

- Ground the DSD 510 servo drives with the PE wire of the feed-in cable. There is a dedicated PE screw on the front and another on the back of the DSD 510 servo drive.

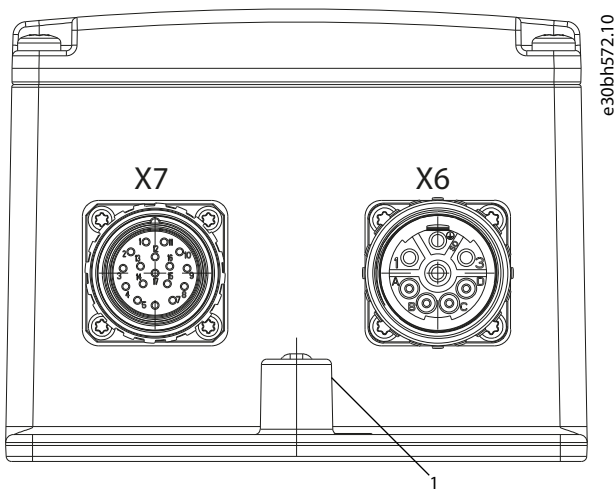

Illustration 33: Grounding the DSD 510 Servo Drive

1	PE Screw
---	----------

- Ensure that the machine frame has a proper electrical connection to the ISD 510 and DSD 510 servo drives:
 - For ISD 510: Use the flange surface on the front side. Ensure PE connection on that part of the machine.
 - For DSD 510: Use the PE screw shown in [Illustration 33](#).
- For the ISD 510/DSD 510 servo drives, ensure a minimum ground wire cross-section of at least 10 mm² (minimum 70 °C, Cu) or 2 separate ground wires both complying with the dimensioning rules. See EN/IEC 61800-5-1 for further information.
- Use a dedicated ground wire for input power and control wiring.
- Do not ground the modules in daisy-chain format.
- Keep the ground wire connections as short as possible.
- Follow the wiring requirements in this manual.
- **For system modules:**
 To comply with CE requirements, ensure a minimum ground wire cross-section of at least 16 mm² (minimum 70 °C, Cu).
 To comply with UL requirements, ensure a minimum ground wire cross-section of at least 6 AWG (minimum 60 °C, Cu).
 If a PSM 510 module with 10 kW is used, the cable cross-section can be reduced to:
 - 10 mm² (minimum 70 °C, Cu) to comply with CE requirements
 - 8 AWG (minimum 60 °C, Cu) to comply with UL requirements

5.4.2 Grounding for EMC-Compliant Installation

- Establish electrical contact between the cable shield and the enclosure using the I/O shielding plate on each module.

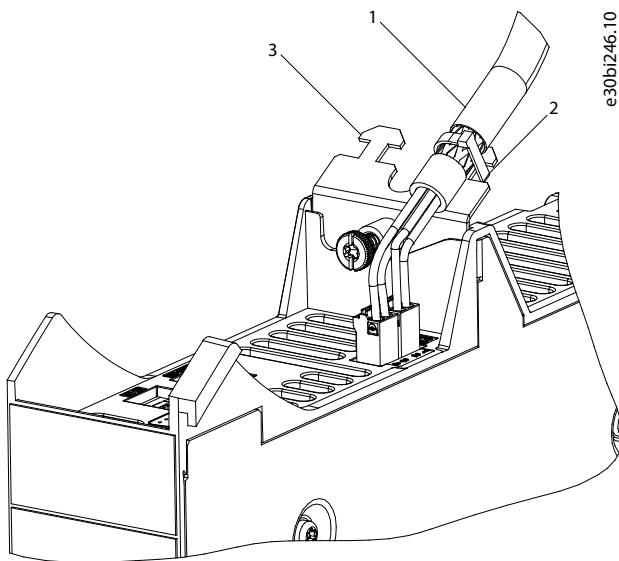

e30bi246.10

Illustration 34: Cable Shielding on the Top of the System Modules

1	Cable	3	I/O shielding plate
2	Cable tie		

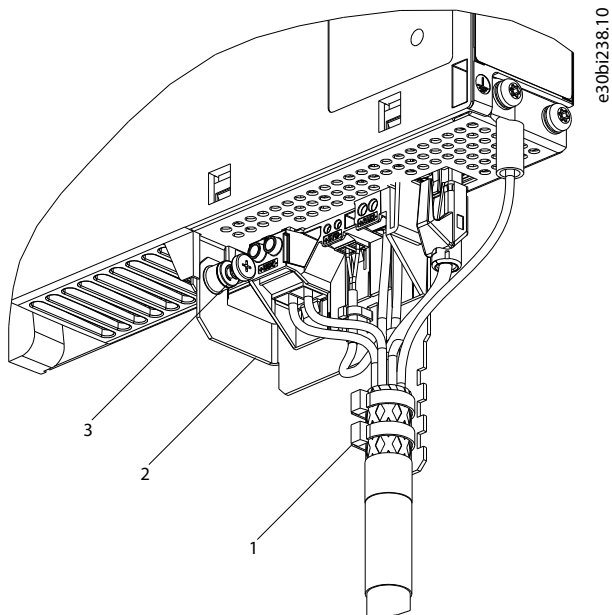

e30bi238.10

Illustration 35: Cable Shielding on the Bottom of the System Modules

1	Cable tie	3	PE screw
2	EMC metal shielding plate		

- Use a cable with a shielding that has a high-coverage to reduce electrical interference.
- Do not use pigtailed to connect the shielding. A 360° wire connection is recommended.

N O T I C E

POTENTIAL EQUALIZATION

- There is a risk of electrical interference when the ground potential between the servo system and the machine is different. Install equalizing cables between them. The recommended cable cross-section is 16 mm².

N O T I C E

EMC INTERFERENCE

- Use shielded cables for control wiring and separate cables for power and control wiring. Failure to isolate power and control wiring can result in unintended behavior or reduced performance.
- Ensure a minimum clearance of 200 mm between signal and power cables.
- Only cross cables at 90°.

5.5 Mains Supply Requirements

Ensure that the supply has the following properties:

- TN-S, TN-C, TN-CS, TT (not corner earthed) supply earthing system.
- Prospective short-circuit current: 5 kA.
- Protective class I.
- Grounded 3-phase mains network, 400–480 V AC ±10%.
- 3-phase lines and PE line.
- 3-phase frequency: 44–66 Hz
- Maximum input current for 1 PSM 510 at 30 kW: 55 A_{rms}

5.5.1 Fuses

N O T I C E

- Use fuses on the supply side of the Power Supply Module PSM 510 that comply with CE and UL requirements (see [Table 20](#)).
- When 2 PSM 510 modules are used, each PSM 510 must have its own dedicated set of fuses.

Table 20: Fuses

Model and power rating	CE Compliance (IEC 60364)	UL Compliance (NEC 2014)
	Maximum fuse type	Maximum fuse type
PSM 510 (10 kW)	gG 25 A	30 A (class T or J only)
PSM 510 (20 kW)	gG 50 A	50 A (class T or J only)
PSM 510 (30 kW)	gG 63 A	80 A (class T or J only)

5.5.2 Circuit Breakers

Use a type B or type C circuit breaker with a capacity of 1.5 times the rated current of PSM 510 to fulfill CE requirements.

N O T I C E

- Circuit breakers are not allowed in installations where C-UL is required. Only UL recommended fuses are allowed.

5.6 Auxiliary Supply Requirements

Supply the Power Supply Module (PSM 510) with a power supply unit with an output range of 24–48 V DC ±10%. The output ripple of the power supply unit must be <math><250\text{ mV}_{pp}</math>. Only use supply units that conform to the PELV specification. Refer to the **VLT® Servo Drive System ISD 510, DSD 510, MSD 510 (VLT® Flexmotion™) Design Guide** for power rating shell diagrams.

N O T I C E

- Only use supply units that conform to the PELV specification.
- Use a supply that is CE-marked according to the standards EN 61000-6-2 and EN 61000-6-4 or similar for industrial use.
- The secondary circuit must be supplied from an external isolated source.

The power supply unit must be dedicated to the ISD 510/DSD 510 servo system, meaning that the supply is used exclusively for powering the PSM 510. The maximum cable length between the supply unit and the PSM 510 is 3 m.

5.6.1 Fuses

UL listed fuses are recommended to protect the wiring on 24–48 V DC.

Table 21: Fuses

CE Compliance (IEC 60364)	UL Compliance (NEC 2014)
Maximum fuse type	Maximum fuse type
50 A ⁽¹⁾	63 A ⁽²⁾

¹ If the maximum current is lower, a fuse with lower current rating can be used. Rating of IEC fuses: according to 100% of maximum current. Use a time delay fuse rated according to the DC voltage used.

² If the maximum current is lower, a fuse with lower current rating can be used. Rating of UL fuses: according to 125% of maximum current. Use a time delay fuse rated according to the DC voltage used.

5.7 Safety Supply Requirements

Supply the STO line with a 24 V DC supply with the following properties:

- Output range: 24 V DC ±10%
- Maximum current: 1 A

Use a 24 V supply unit that is CE marked for industrial use. Ensure that the supply fulfills the PELV specification and is only used for the system safety input.

A common supply for auxiliary and safety supply can be used, provided the only connection point of the 2 circuits is near to the supply. This is intended to avoid interference due to a common voltage drop. The maximum cable length between the 24 V supply unit and the servo system is 3 m.

The safety supply can be looped from PSM 510 to the other system modules except for ACM 510. The cable for this is not provided. For further information, see [8.6 Installation](#).

N O T I C E

- Ensure reinforced isolation between safety signals and other signals, supplies (mains supply), and exposed conductive parts.

5.8 UL Requirements

N O T I C E

- Integral solid-state short-circuit protection does not provide branch circuit protection. Branch circuit protection must be provided in accordance with the National Electrical Code/Canadian Electrical Code, and any additional local codes or equivalent.
- Suitable for use on a circuit capable of delivering not more than 5000 rms symmetrical amperes, 480 V maximum when protected by maximum 80 A class J or T fuses.
- To meet the UL (Underwriters Laboratories) regulations, use a UL-approved copper cable with a minimum heat-resistance of 60 °C. Use Class 1 wire only. For PSM 510 rated 30 kW and EXM 510, use a minimum heat resistance of 75 °C.
- Control Circuit Overcurrent Protection is required.

5.9 Connecting the ISD 510/DSD 510 Servo Drive

5.9.1 Electrical Installation Warnings for ISD 510/DSD 510 Servo Drive

⚠ W A R N I N G ⚠

HIGH VOLTAGE

Potentially lethal voltage is present on the connectors that may lead to death or serious injury.

- Before working on the power or signal connectors (disconnecting or connecting the cable), or performing any maintenance work, disconnect the Power Supply Module (PSM 510) from the mains and wait for the discharge time to elapse.

⚠ W A R N I N G ⚠

DISCHARGE TIME

The servo system contains DC-link capacitors that remain charged for some time after the mains supply is switched off at the Power Supply Module (PSM 510). Failure to wait the specified time after power has been removed before performing service or repair work could result in death or serious injury.

- To avoid electrical shock, fully disconnect the Power Supply Module (PSM 510) from the mains and wait for the capacitors to fully discharge before carrying out any maintenance or repair work on the servo system or its components.

Minimum waiting time (minutes)
15

5.9.2 General Instructions for Cable Installation

Avoid mechanical tension for all cables, especially regarding the range of motion of the installed servo drive.

Secure all cables in accordance with regulations and depending on conditions on site. Ensure that cables cannot come loose, even after prolonged operation.

If the X3, X4, and X5 connectors are not used, always mount the corresponding blind cap.

N O T I C E

- Never connect or disconnect the hybrid cables to or from the servo drive when the supply voltage is present. Doing so damages the electronic circuitry. Observe the discharge time for the DC-link capacitors.
- Do not forcefully connect or fit the connectors. Incorrect connection causes permanent damage to the connector.

Table 22: Tightening Torques

Connector	Tightening Torque [Nm]
M8	0.2
M12	0.4

Connector	Tightening Torque [Nm]
M23	0.8

5.9.3 Connecting Hybrid Cables

Procedure

1. Align the female connector of the M23 feed-in cable to the male input connector (X1) of the 1st ISD 510/DSD 510 servo drive.
2. Fully rotate the threaded ring of the cable connector counterclockwise. Use the marking OPEN as a reference for the cable connector.
3. Ensure the marking OPEN on the cable connector is facing the servo drive.
4. Press the connector towards the electronic housing on the servo drive until the sealing on the connector is entirely covered.
5. Tighten the M23 feed-in cable connector by rotating the threaded ring clockwise out of the flat area around the OPEN marking.

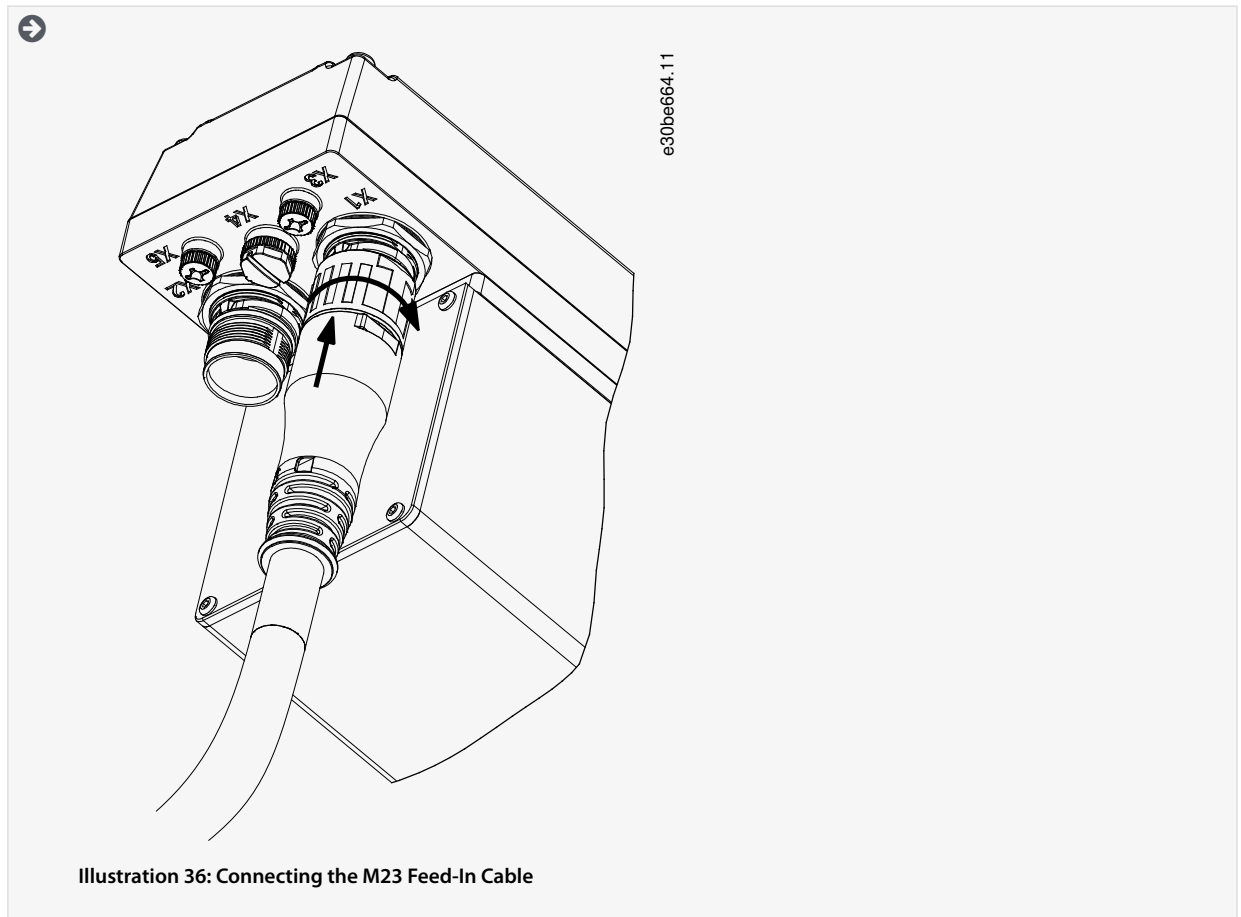

6. To add more servo drives in daisy-chain format, connect the male connector of the loop cable to the female connector (X2) of the 1st servo drive.
7. Connect the female connector of the loop cable to the male connector (X1) of the next servo drive, and so on.
8. Tighten the threaded rings by hand as described in step 5.
9. Ensure that there is no mechanical tension on the cables.

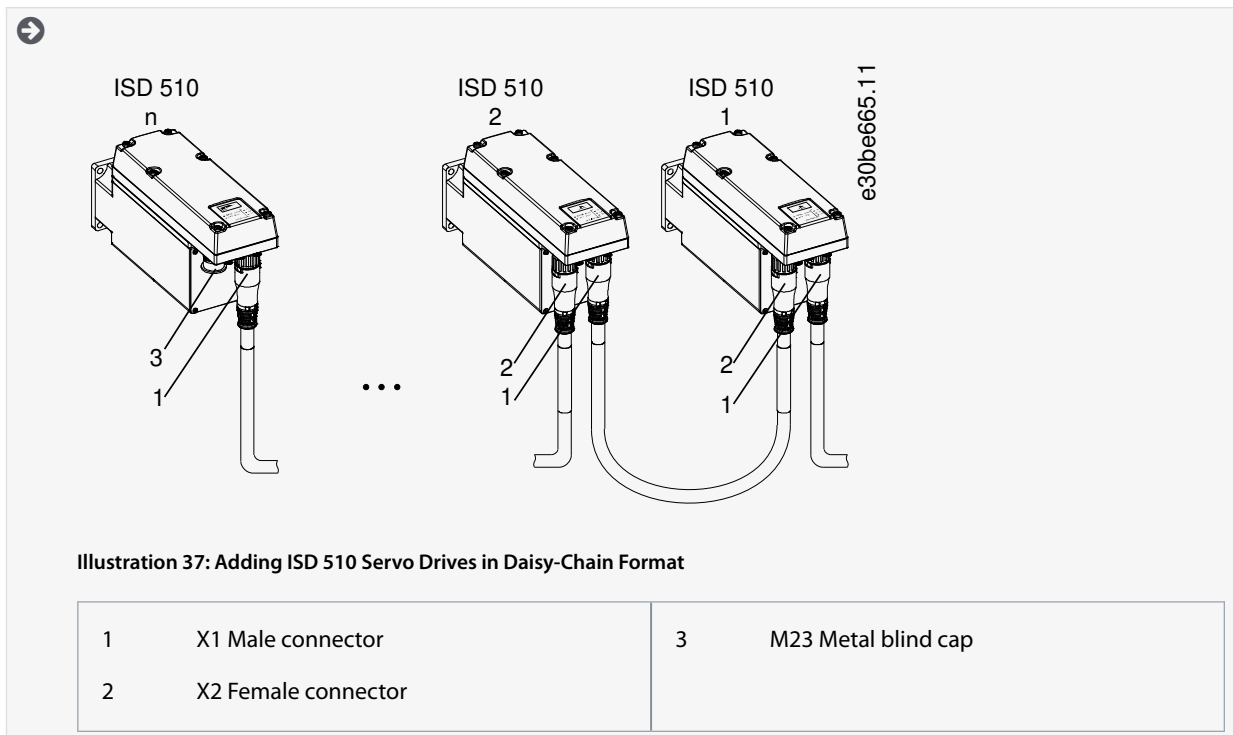

Illustration 37: Adding ISD 510 Servo Drives in Daisy-Chain Format

10. Screw the M23 metal blind cap onto the unused M23 female output connector (X2) on the last servo drive in the servo system.
11. Tighten the metal blind cap until the sealing on the connector is covered.

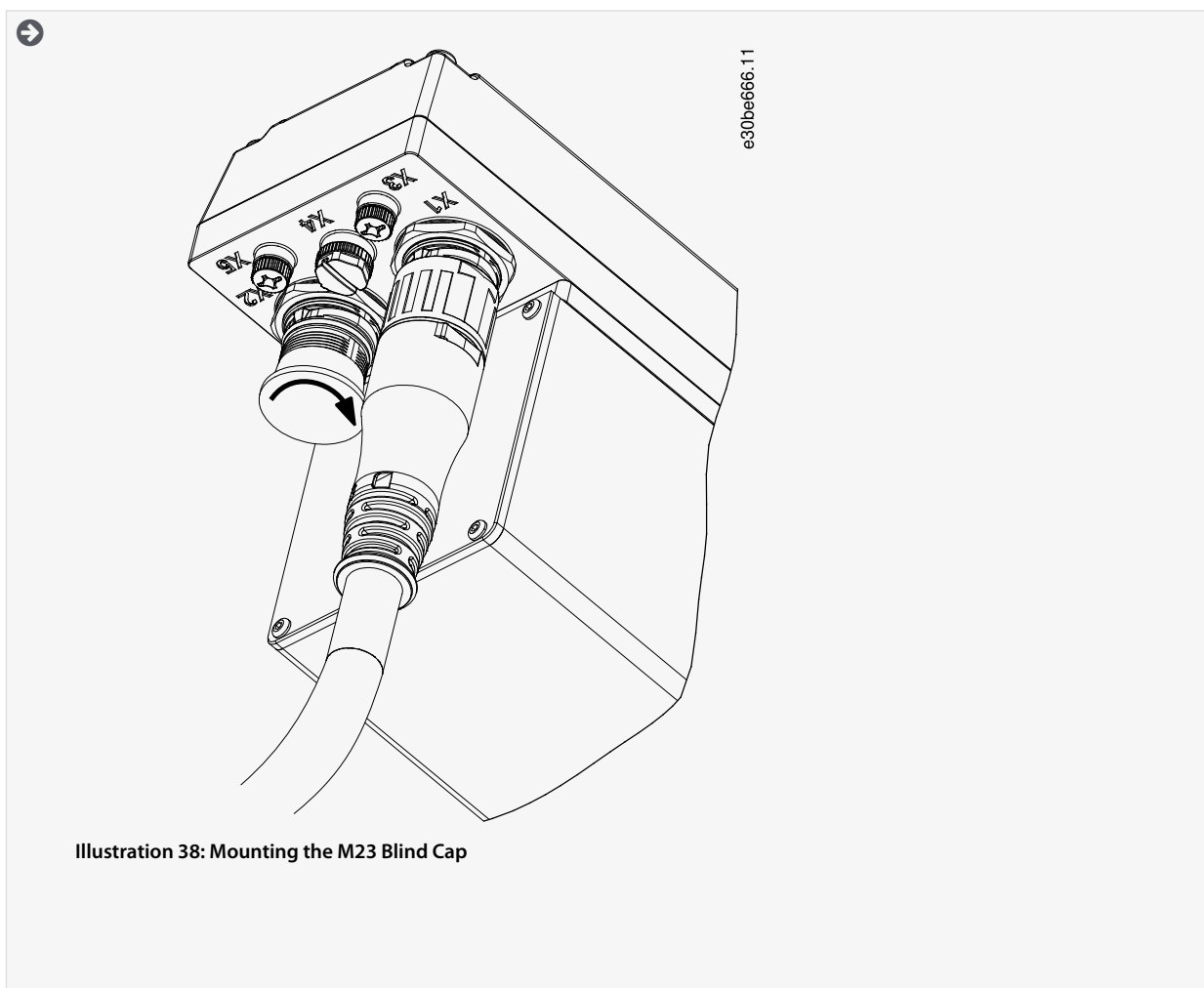

Illustration 38: Mounting the M23 Blind Cap

⚠ CAUTION ⚠**RISK OF INJURY AND/OR EQUIPMENT DAMAGE**

Failure to use the M23 metal blind cap may result in injury to the operator and/or damage to the ISD 510/DSD 510 servo drive.

- Always fit the M23 metal blind cap as described in steps 10 and 11.

NOTICE

- An angled version of the M23 connector is also available. The procedure for connecting the angled M23 connector is the same as for the straight connector.

5.9.4 Disconnecting Hybrid Cables

Procedure

1. Disconnect the Power Supply Module (PSM 510) from its power source (mains network and U_{AUX}).
2. Wait for the minimum discharge time to elapse.
3. Remove the connector of the feed-in cable from the Decentral Access Module (DAM 510).
4. Rotate the threaded ring on the feed-in cable connector on the servo drive counterclockwise until the marking OPEN on the cable connector is facing the servo drive.
5. Pull the connector away from the electronic housing.
6. Protective blind caps are provided for the X1 and X2 connectors. Mount the blind caps after removing the corresponding connector.

5.9.5 Connecting Cables to Ports X3, X4, and X5

5.9.5.1 Cable Routing Recommendations

Avoid mechanical tension for all cables, especially regarding the range of motion of the installed servo drive.

Secure all cables in accordance with regulations and depending on conditions on site. Ensure that cables cannot come loose, even after prolonged operation.

5.9.5.2 Connecting I/O and/or Encoder Cables to Port X3

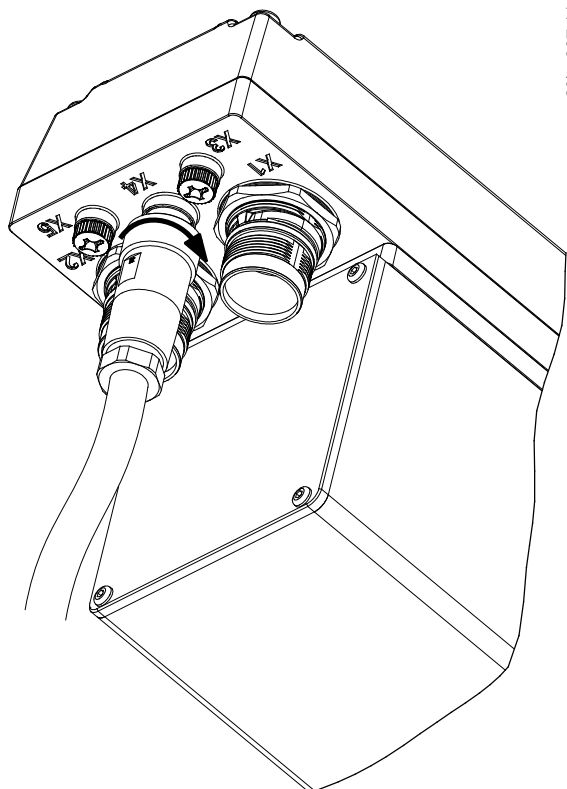

e30be667.11

Illustration 39: Connecting the I/O and/or Encoder Cable

Procedure

1. Align the connector on the cable (not supplied) with the connector marked X4 on the servo drive.
2. Press the connector towards the electronic housing of the servo drive and tighten the threaded ring of the connector by turning it clockwise. The maximum tightening torque is 0.4 Nm.

5.9.5.3 Connecting the LCP Cable to Port X5

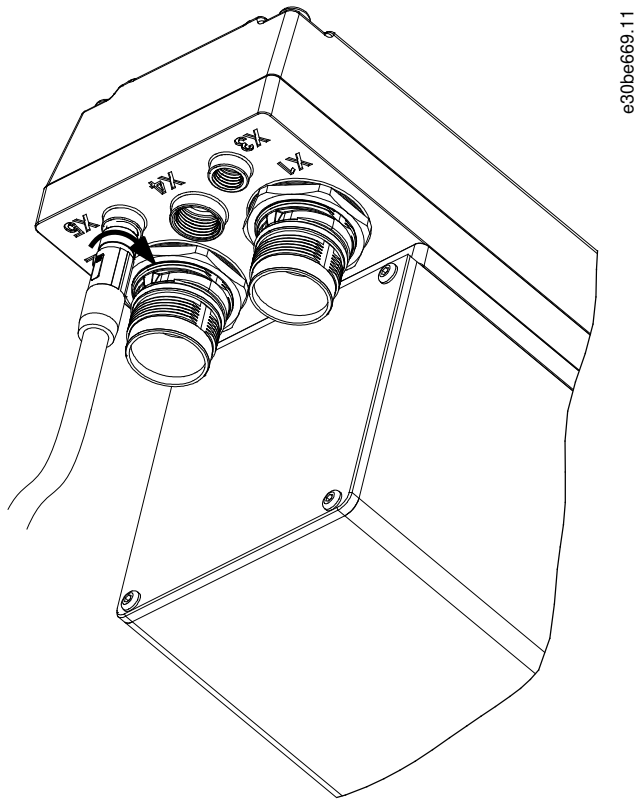

Illustration 40: Connecting the LCP Cable

Procedure

1. Align the connector on the LCP cable (not supplied) with the LCP connector marked X5 on the ISD 510/DSD 510 servo drive.
2. Press the connector towards the electronic housing of the servo drive and tighten the threaded ring of the connector by turning it clockwise. The maximum tightening torque is 0.2 Nm.

The LCP cable can be ordered as an accessory.

5.9.5.4 Connecting the 3rd Ethernet Device Cable to Port X3

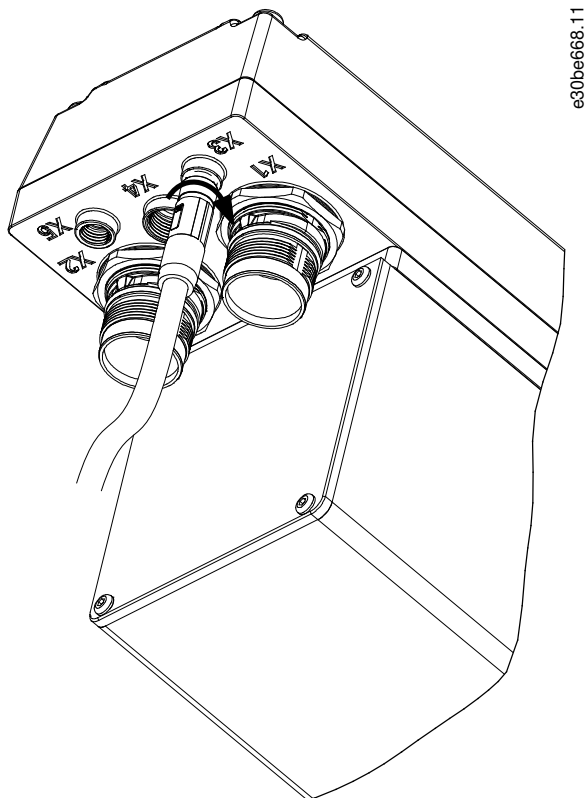

Illustration 41: Connecting the 3rd Ethernet Device Cable

Procedure

1. Align the connector on the cable with the Ethernet connector marked X3 on the ISD 510/DSD 510 servo drive.
2. Press the connector towards the electronic housing of the servo drive and tighten the threaded ring by turning it clockwise. The maximum tightening torque is 0.2 Nm.

5.9.6 Disconnecting Cables from Ports X3, X4, and X5

1. Loosen the threaded ring of the connector by turning it counterclockwise.
2. Disconnect the cable from the servo drive.
3. Protective blind caps are provided for the X3, X4, and X5 connectors. Mount the blind caps after removing the respective connector.

5.10 Connecting the Power Supply Module PSM 510

5.10.1 AC Line Choke

It is mandatory to use a 3-phase AC line choke (see [5.10.1.1 Connecting 1 PSM 510 to the AC Choke](#) and [5.10.1.2 Connecting 2 PSM 510 Modules to the AC Choke](#)).

Table 23: Line Choke Characteristics for 1 PSM 510

Model	Minimum I _{rms} [A]	U _{rms} [V]	Inductance [mH]
PSM 510 (10 kW)	20	500	Minimum: 0.47 Maximum: 1.47
PSM 510 (20 kW)	40	500	Minimum: 0.47 Maximum: 1.47
PSM 510 (30 kW)	60	500	0.47 ±10%

If 2 PSM 510 modules are installed in parallel, use an AC choke as specified in [Table 24](#). See [5.10.1.2 Connecting 2 PSM 510 Modules to the AC Choke](#) for further information.

Table 24: Line Choke Characteristics for 2 PSM 510 installed in parallel

Model	Minimum I_{rms} [A]	U_{rms} [V]	Inductance [mH]
PSM 510 (2 x 30 kW)	125	500	0.24 ±10%

Danfoss recommends mounting the AC line choke close to the PSM 510.

The maximum cable length depends on the cross-section, and the required voltage and current at the DC-link.

If the AC line chokes are mounted away from the PSM 510, the maximum cable distance is 5 m.

5.10.1.1 Connecting 1 PSM 510 to the AC Choke

Connect the PSM 510 to the electric grid with the correct AC choke for the power size of the PSM 510.

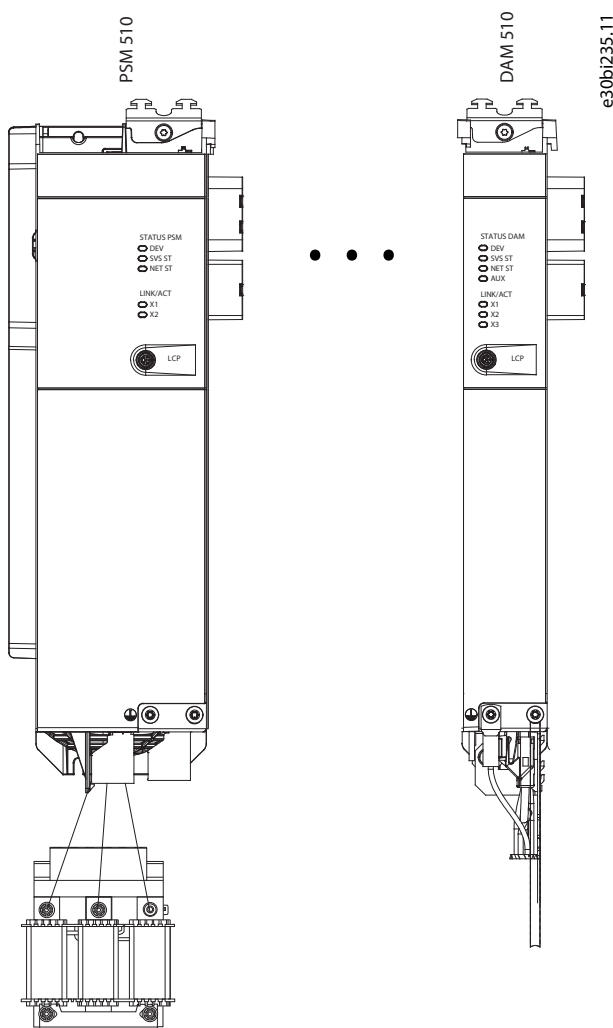

Illustration 42: Connecting 1 PSM 510 to the AC Choke

5.10.1.2 Connecting 2 PSM 510 Modules to the AC Choke

Connect the PSM 510 modules to the same AC choke as shown in [Illustration 43](#).

Ensure the choke used is the correct size based on the combined power of the PSM 510 modules.

When 2 PSM 510 modules are used, the wiring between the AC line choke and each PSM 510 must be the same length within a tolerance of 0.5 m.

Connect each PSM 510 to the AC choke directly. Parallel wiring is not permitted.

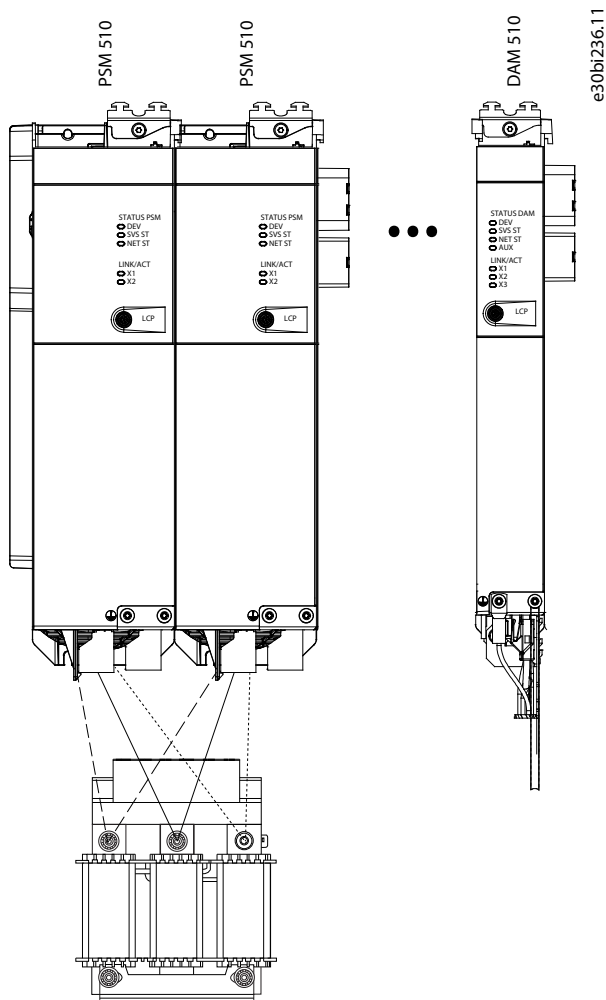

Illustration 43: Connecting 2 PSM 510 Modules to the AC Choke

5.10.1.3 Connecting 2 PSM 510 Modules to the AC Choke with System Splitting

Connect the PSM 510 modules to the same AC choke regardless of the load position (for example, before or after the system splitting) as shown in [Illustration 44](#).

Ensure the choke used is the correct size based on the combined power of the PSM 510 modules.

When 2 PSM 510 modules are used, the wiring between the AC line choke and each PSM 510 must be the same length within a tolerance of 0.5 m.

Connect each PSM 510 to the AC choke directly. Parallel wiring is not permitted.

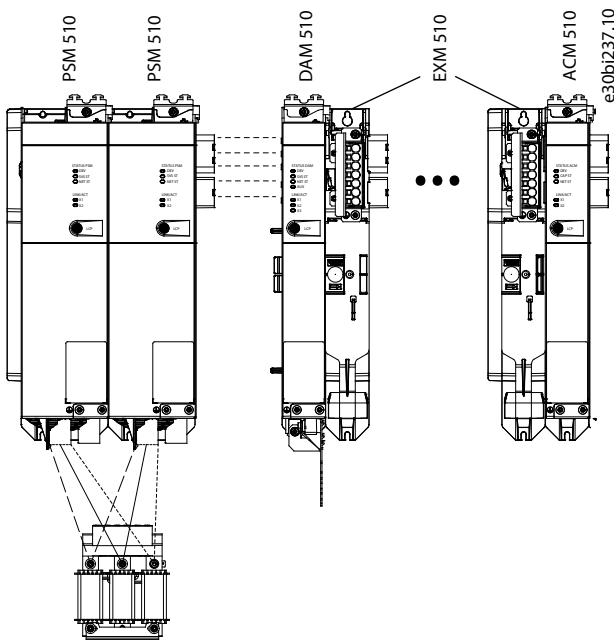

Illustration 44: Connecting 2 PSM 510 Modules to the AC Choke with System Splitting

If 2 AC chokes are used (1 per PSM 510) and both PSM 510 modules are mounted at the same side of the system splitting, the setup is permitted with derating equal to the AC choke's tolerance referred to 60 kW. For example, 10% derating is 54 kW.

If 2 AC chokes are used (1 per PSM 510) where 1 PSM 510 module is mounted before the splitting and 1 after the splitting, the loads must be balanced equally. Otherwise, the derating of both PSM 510 modules is equal to the AC choke's tolerance. For example, tolerance 10% + 10% means -20% derating.

If 2 AC chokes are used (1 per PSM 510) and 1 PSM 510 module is mounted before the splitting and 1 after the splitting and half of the loads are set before the system splitting and half are set after the system splitting, the setup is permitted with derating equal to the AC choke's tolerance referred to 60 kW. For example, 10% derating is 54 kW.

NOTICE

- Further information on the EXM 510 module and wiring can be found in [11.9.13 Expansion Module Connector](#).

5.10.2 Connecting the Cables on the Power Supply Module PSM 510

5.10.2.1 Connecting the Cables on the Top of the Power Supply Module PSM 510

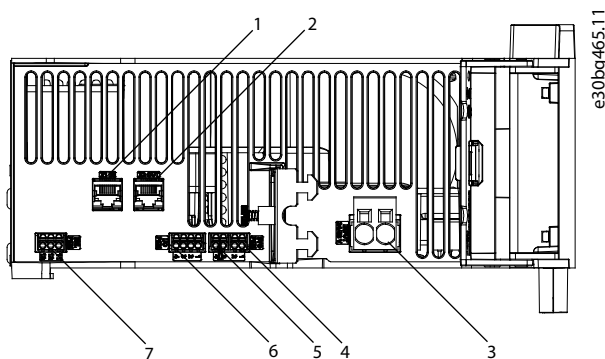

Illustration 45: Connectors on the Top of PSM 510

1	Ethernet connector IN (X1 IN)	5	STO connector OUT (STO PSM)
2	Ethernet connector OUT (X2 OUT)	6	I/O connector (I/O PSM)
3	24/48 V IN connector (INPUT 24/48 V)	7	Relay connector (REL PSM)
4	STO connector IN (STO PSM)		

Procedure

1. Connect the Ethernet cable from the PLC to the Ethernet input connector (X1 IN) [1].
2. Connect the Ethernet cable from the Ethernet output connector (X2 OUT) [2] to the next module.
3. Insert the wires into the 24/48 V IN (INPUT 24/48 V) connector.
4. Insert the 24/48 V IN connector [3].
5. Insert the wires into the STO connector IN (STO PSM) connector.
6. Insert the STO connector IN connector [4].
7. Insert the wires into the STO connector OUT (STO PSM) connector.
8. Insert the STO connector OUT connector [5].
9. If I/Os are required, insert the wires into the I/O connector and insert the connector (I/O PSM) [6].
10. If a relay is required, insert the wires into the relay connector and insert the connector (REL PSM) [7].

5.10.2.2 Connecting the Cables on the Bottom of the Power Supply Module PSM 510

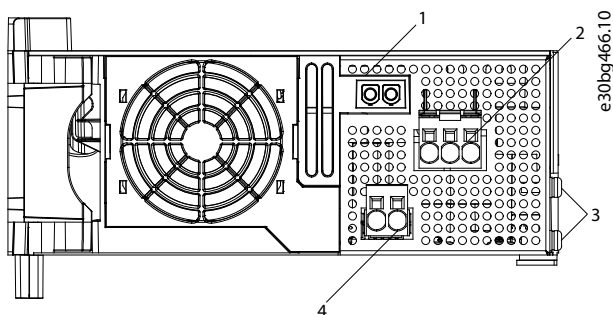

Illustration 46: Connectors on the Bottom of PSM 510

1	Holder for internal brake resistor connector when not in use	3	PE screws
2	AC mains supply connector	4	Internal/external brake resistor connector

Procedure

1. Insert the wires into the AC mains supply connector.
2. Insert the AC mains supply connector [2].
3. If an external brake resistor is required:
 - a. Unplug the internal brake resistor connector [4] and insert the external brake connector in its place.
 - b. Plug the internal brake resistor connector to the internal brake connector holder [1].
4. Connect the PSM 510 to PE using one of the PE screws on the front side [3] and a PE wire. The tightening torque is 3 Nm.

5.11 Connecting the Decentral Access Module (DAM 510)

5.11.1 Connecting the Cables on the Top of the Decentral Access Module DAM 510

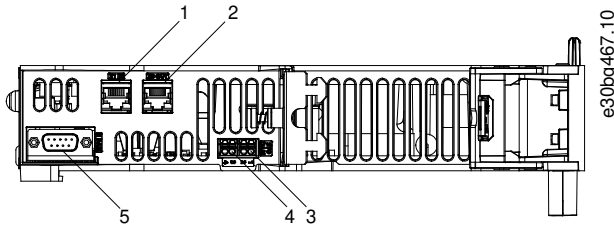

Illustration 47: Connectors on the Top of DAM 510

1	Ethernet connector IN (X1 IN)	4	STO connector OUT (STO DAM)
2	Ethernet connector OUT (X3 OUT)	5	External encoder connector (E DAM)
3	STO connector IN (STO DAM)		

Procedure

1. Connect the Ethernet cable from the output of the previous module to the input connector (X1 IN) [1].
2. Insert the wires from the STO output of the previous module into the 24 V IN (STO input) connector, see [11.9.9.2.1 STO Connectors on the Top of DAM 510](#).
3. Insert the 24 V IN (STO connector IN (STO DAM)) connector [3] into the DAM 510.
4. If required, connect the external encoder connector [5].

5.11.2 Connecting the Feed-In Cable

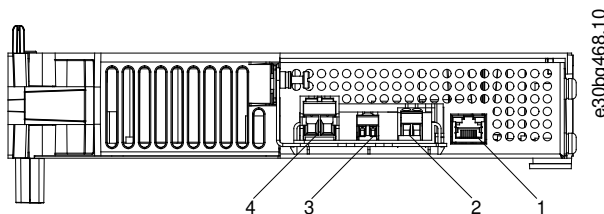

Illustration 48: Connectors on the Bottom of DAM 510

1	Ethernet connector	3	STO out connector
2	AUX connector	4	UDC connector

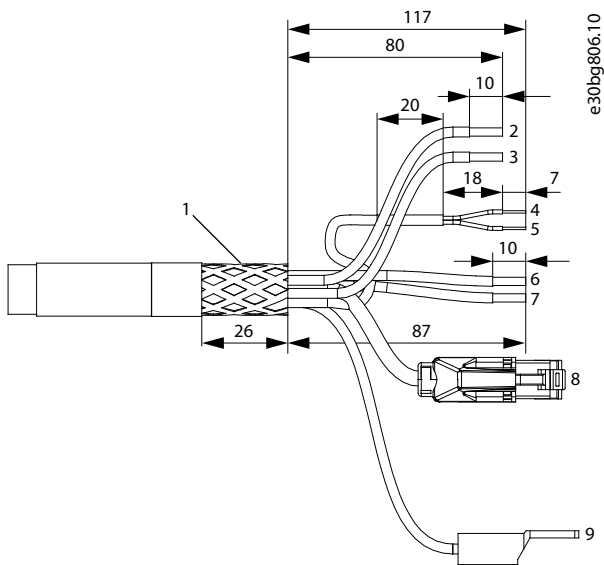

Illustration 49: Feed-In Cable

1	Shielded area	6	AUX+ (red, 2.5 mm ²)
2	UDC+ (black, 2.5 mm ² /4 mm ²)	7	AUX- (blue, 2.5 mm ²)
3	UDC- (gray, 2.5 mm ² /4 mm ²)	8	Ethernet/fieldbus (green, RJ45 connector)
4	STO+ (pink, 0.5 mm ²)	9	PE (yellow/green, 2.5 mm ² /4 mm ² , fork lug)
5	STO- (gray, 0.5 mm ²)		

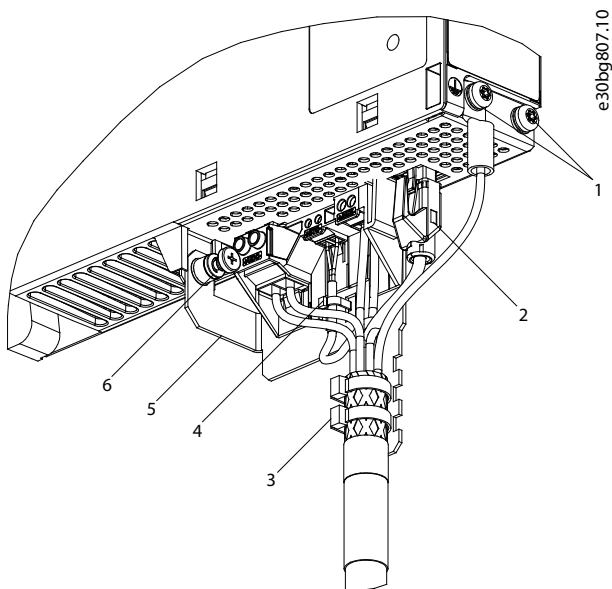

Illustration 50: Connecting the Feed-In Cable

1	Feed-in cable PE screws	4	Cable tie for STO cable
2	Bus connector	5	EMC plate
3	Cable tie for feed-in cable	6	EMC plate screw

Procedure

1. Insert the wires into the UDC, AUX, and STO connectors.
2. Secure the feed-in cable using the cable ties [3], ensuring that the shielded area is positioned exactly under the cable tie.
3. Secure the STO cable using the cable tie [4], ensuring that the shielded area is positioned exactly under the cable tie.
4. Insert the connectors on the feed-in cable into their corresponding terminal block on the DAM 510.
5. Tighten the screw on the EMC plate [6]. The tightening torque is 3 Nm.
6. Insert the RJ45 bus connector [2].
7. Connect the DAM 510 to PE using one of the PE screws on the front side [1] and a PE wire. The tightening torque is 3 Nm.

5.12 Connecting the Auxiliary Capacitors Module ACM 510

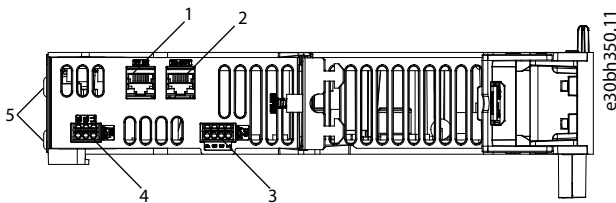

Illustration 51: Connectors on the Top of ACM 510

1	Ethernet connector IN (X1 IN)	3	I/O connector (I/O ACM)
2	Ethernet connector OUT (X2 OUT)	4	Relay connector (REL ACM)

Procedure

1. Connect the Ethernet cable from the output of the previous system module to the input connector (X1 IN) [1].
2. If I/Os are required, insert the wires into the I/O connector (I/O ACM) and insert the connector [3].
3. If a relay is required, insert the wires into the relay connector (REL ACM) and insert the connector [4].
4. Connect the ACM 510 to PE using one of the PE screws on the front side [5] and a PE wire.. The tightening torque is 3 Nm.

5.13 Connecting the Expansion Module EXM 510

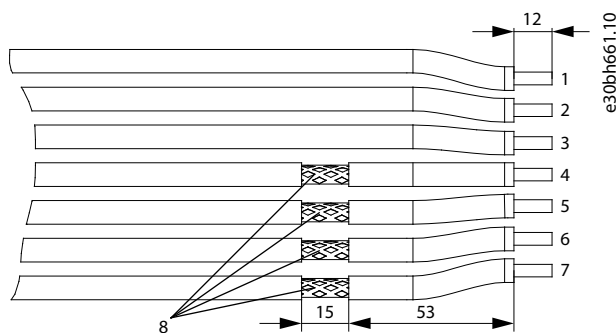

Illustration 52: Expansion Module Cable

1	24/48 V	5	DC-
2	GND	6	DC+
3	Functional earth	7	DC+
4	DC-	8	Shielded area

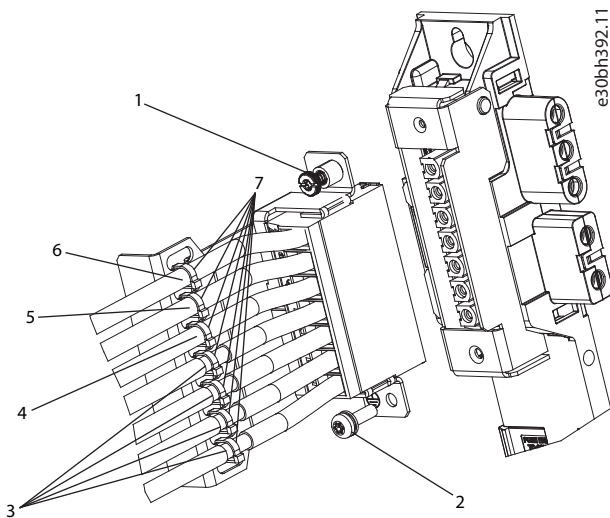

Illustration 53: Connecting the Expansion Module EXM 510

1	EMC shielding plate screw	5	GND cable
2	PE screw	6	24/48 V cable
3	DC cables	7	Cable tie
4	Functional earth cable		

NOTICE

- If 2 separate backlinks are used (connected via 1 or 2 pairs of EXM 510 modules), the 2 grounding bars must be also connected together with a 16 mm² (6 AWG) cable cross-section.
- For cable cross sections see [11.9.13.1 Cable Cross Sections for EXM 510](#).

Procedure

1. Insert wires [3], [4], [5], and [6] into the expansion connector.
2. Secure the DC cables [3] using the cable tie [7], ensuring that the shielded area is positioned exactly under the cable tie.
3. Secure the cables [4], [5], and [6] using the cable ties [7].
4. Plug the connectors into the backplate.
5. Tighten the screw on the EMC shielding plate [1]. The tightening torque is 3 Nm.
6. Connect the EXM 510 to PE using the PE screw [2] and a PE wire. The tightening torque is 3 Nm.

5.14 Connecting the Brake Resistor on the PSM 510

The PSM 510 is connected to the internal brake resistor as shown in [Illustration 54](#).

Alternatively, the PSM 510 can be connected to an external brake resistor. In this case, the internal brake resistor on the PSM 510 must remain unconnected and the connector can be placed in the internal brake resistor connector holder.

Paralleling or series of brake resistors is not permitted.

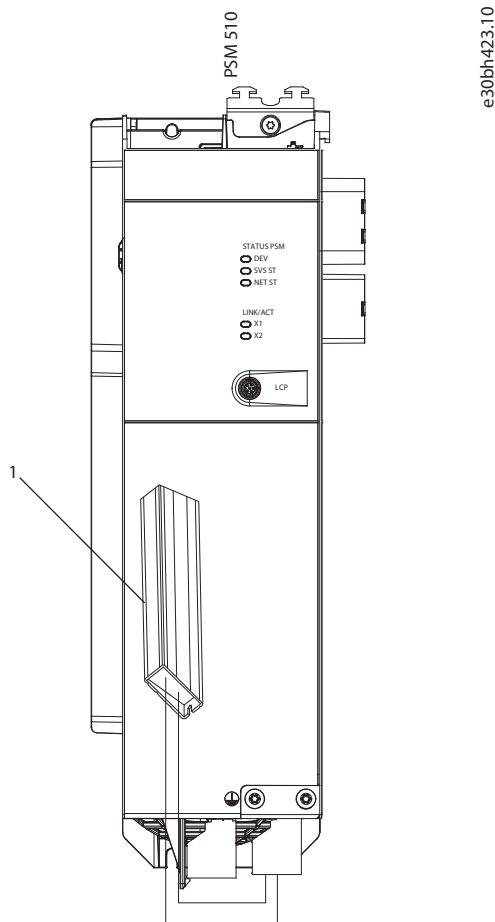

Illustration 54: Connection of Internal Brake Resistor on 1 PSM 510

1	Internal brake resistor
---	-------------------------

When using 2 PSM 510 modules, connect each PSM 510 to its own internal brake resistor as shown in [Illustration 55](#) (factory setting). Alternative permitted configurations for 2 PSM 510 modules:

- 1 PSM 510 is connected to the internal brake resistor and the other is connected to an external brake resistor.
- Both PSM 510 modules are connected to an external brake resistor. In this case, the internal brake resistor on the PSM 510 must remain unconnected and the connector can be placed in the internal brake resistor connector holder (see [5.10.2.2 Connecting the Cables on the Bottom of the Power Supply Module PSM 510](#)).

Paralleling or series of brake resistors is not permitted.

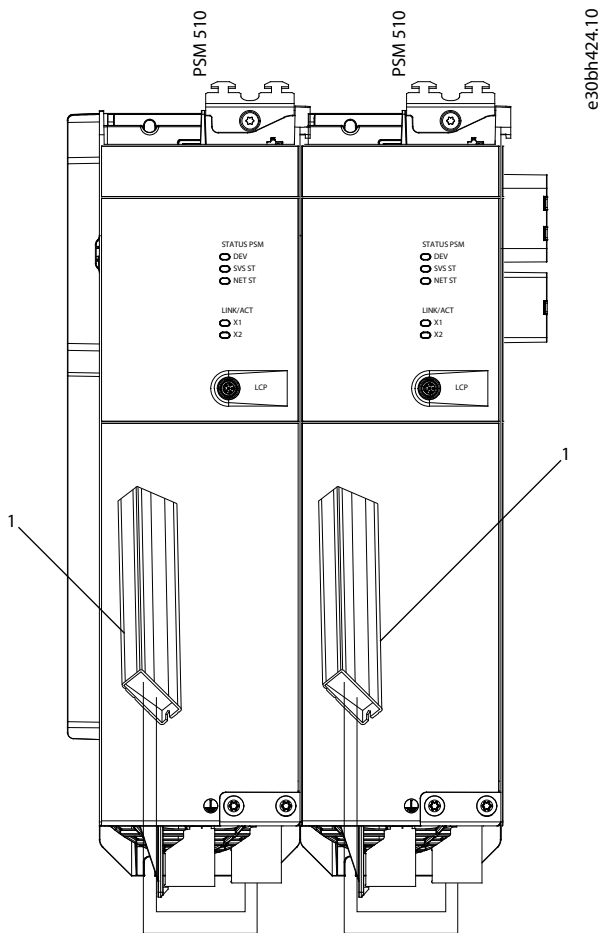

Illustration 55: Connection of Brake Resistor on 2 PSM 510 Modules in Parallel

1	Internal brake resistor
---	-------------------------

6 Commissioning

6.1 Warnings for Commissioning

⚠ WARNING ⚠

UNINTENDED START

The servo system contains servo drives, the PSM 510, and DAM 510 that are connected to the electrical supply network and can start running at any time. This may be caused by a fieldbus command, a reference signal, or clearing a fault condition. Servo drives and all connected devices must be in good operating condition. A deficient operating condition may lead to death, serious injury, damage to equipment, or other material damage when the unit is connected to the electrical supply network.

- Take suitable measures to prevent unintended starts.

6.2 Pre-Commissioning Checklist

Always complete these checks before initial commissioning and before commencing operation after extended downtime or storage.

Procedure

1. Check that all the threaded connectors of mechanical and electrical components are firmly tightened.
2. Check that the free circulation of cooling air (inlet and outlet) is assured.
3. Check that the electrical connections are correct.
4. Ensure that contact protection is in place for rotating parts and surfaces that can become hot.
5. If using the STO functionality, conduct the functional safety concept commissioning test (see [8.8 Commissioning Test](#)).

6.3 EtherCAT® ID Assignment

EtherCAT® needs no special ID assignment (IP address). Special ID assignment is only required when using indirect communication via the VLT® Servo Toolbox software.

6.4 Ethernet POWERLINK® ID Assignment

6.4.1 Overview

Ethernet POWERLINK® master communication must not be active when using the VLT® Servo Toolbox to assign IDs to the devices. ID assignment via the VLT® Servo Toolbox is only possible when acyclic Ethernet POWERLINK® communication is used. If Ethernet POWERLINK® cyclic communication is already started, perform a power cycle to stop it.

Detach the PLC and carry out a power cycle before setting IDs. Alternatively, in the POWERLINK® interface, restart the PLC in *Service Mode* while parameter *Basic Ethernet in Service Mode* is set to *Basic Ethernet enabled*.

6.4.2 Single Device ID Assignment

When assigning an ID to a single device, use the *Device Information* window in the VLT® Servo Toolbox (see the **VLT® Servo Drive System ISD 510, DSD 510, MSD 510 (VLT® Flexmotion™) Programming Guide** for further information).

Setting an ID to a device can also be done via the LCP.

6.4.2.1 Setting the Node ID Directly on a Servo Drive or on the System Modules

All IP-related parameters are located in parameter group *12-0* IP Settings*. According to the Ethernet POWERLINK® standard, the IP address is fixed to 192.168.100.xxx. The last number is the value in parameter *12-60 Node ID*. For parameter *12-02 Subnet Mask*, the IP address is fixed to 255.255.255.0 and cannot be changed.

Procedure

1. Attach the LCP to the servo drive or system module for which the *Node ID* should be changed.
2. Press the *Hand On* button for >1 s to make the LCP the controlling interface.
3. Press the *Main Menu* button then scroll down to submenu *12-** Ethernet* and press *OK*.
4. Scroll down to submenu *12-6* Ethernet POWERLINK* and press *OK*.
5. Change the PSM 510/DAM 510 node ID to the desired value (1–239).
6. Press *OK* to confirm the selection then wait for the ID assignment procedure to complete.

7. Carry out a power cycle to ensure that all ID changes are in effect and operational on the fieldbus.

6.4.2.2 Setting the Node ID for a Single Servo Drive via the Power Supply Module (PSM 510) or Decentral Access Module (DAM 510) via the LCP

It is also possible to change the *Node ID* of a servo drive when the LCP is connected to the PSM 510 or DAM 510. This functionality is contained in parameter group *54-*** ID Assignment* in subgroup *54-1* Manual*.

Procedure

1. Attach the LCP to the PSM 510/DAM 510 that is connected to the servo drives and system modules for which the *Node ID* should be changed.
2. Press the *Hand On* button for >1 s to make the LCP the controlling interface for the PSM 510/DAM 510.
3. Press the *Main Menu* button then scroll down to submenu *12-** Ethernet* and press *OK*.
4. Scroll down to submenu *12-6* Ethernet POWERLINK* and press *OK*.
5. Change the PSM 510/DAM 510 node ID to the desired value (1–239) by pressing the *OK* button.
6. Return to the *Main Menu* and select parameter *54-*** ID Assignment*.
7. Select parameter *54-1* Manual*.
8. PSM 510 only: In parameter *54-01 Epl id assignment line*, select either Ethernet port X1 or X2. The PSM 510 will assign IDs to the selected device via the selected port and the fieldbus network. On DAM 510 port, X2 will be used automatically.
9. Select parameter *54-12 Epl ID assignment start id* then select a valid value (1–239). The value will be assigned to the device at the specified position index. The PSM 510/DAM 510 connected to the LCP is at position 0 and the 1st reachable device on the selected port is position index 1 and so on.
10. Select parameter *54-14 Manual Epl ID assignment start* and change the status from *[0] ready* to *[1] start*.
11. Press *OK* to confirm the selection then wait for the ID assignment procedure to complete.
12. Check that the ID assignment was completed successfully using parameters:
 - a. Parameter *54-15 Epl ID assignment state*
 - b. Parameter *54-16 Epl ID assignment error code*
 - c. Parameter *54-17 Epl ID assignment device count*
13. Carry out a power cycle to ensure that all ID changes are in effect and operational on the fieldbus.

If an error occurs during ID assignment, the detected error is shown on the LCP. The following errors may be reported:

- Invalid NMT state
- Invalid comment
- Invalid Ethernet port
- Invalid node ID
- ID assignment failed
- Duplicate MAC address
- Invalid SW version
- Incomplete assignment
- No device found
- Internal error

6.4.3 Multiple Device ID Assignment

When assigning IDs to several devices (for example, when setting up a new network), use the VLT® Servo Toolbox subtool *DAM ID assignment* (see the **VLT® Servo Drive System ISD 510, DSD 510, MSD 510 (VLT® Flexmotion™) Programming Guide** for further information).

Setting the IDs of all the servo drives connected to a Decentral Access Module (DAM 510) or Power Supply Module (PSM 510) at the same time can also be done via the LCP when it is connected to the DAM 510/PSM 510.

6.4.3.1 Setting the Node IDs of all Servo Drives and System Modules on a Decentral Access Module (DAM 510)/Power Supply Module (PSM 510) Line

The automatic PSM 510/DAM 510 ID assignment is used for automatically setting the *Node IDs* on all servo drives and system modules for a specified PSM 510/DAM 510 line. This functionality is contained in parameter group *54-*** ID Assignment* in subgroup *54-0* Automatic*.

Procedure

1. Attach the LCP to the PSM 510/DAM 510 that is connected to the servo drives and system modules for which the *Node ID* should be changed.
2. Press the *Hand On* button for >1 s to make the LCP the controlling interface for the PSM 510/DAM 510.
3. Press the *Main Menu* button then scroll down to submenu *12-** Ethernet* and press *OK*.
4. Scroll down to submenu *12-6* Ethernet POWERLINK* and press *OK*.
5. Change the PSM 510/DAM 510 node ID to the desired value (1–239) by pressing the *OK* button.
6. Return to the *Main Menu* and select parameter *54-** ID Assignment*.
7. Select parameter *54-0* Automatic*.
8. PSM 510 only: In parameter *54-01 Epl id assignment line*, select either Ethernet port X1 or X2. The PSM 510 will assign IDs to the selected device via the selected port and the fieldbus network. On DAM 510 port, X2 will be used automatically.
9. Select parameter *54-02 Epl ID assignment start id* then select a valid value (1–239). The value will be assigned to the device at the specified position index. The PSM 510/DAM 510 connected to the LCP is at position 0 and the 1st reachable device on the selected port is position index 1 and so on.
10. Select parameter *54-03 Automatic Epl ID assignment start* and change the status from *[0] ready* to *[1] start*.
11. Press *OK* to confirm the selection then wait for the ID assignment procedure to complete.
12. Check that the ID assignment was completed successfully using parameters:
 - a. Parameter *54-04 Epl ID assignment state*
 - b. Parameter *54-05 Epl ID assignment error code*
 - c. Parameter *54-06 Epl ID assignment device count*
13. Carry out a power cycle to ensure that all ID changes are in effect and operational on the fieldbus.

If an error occurs during ID assignment, the detected error is shown on the LCP. The following errors may be reported:

- Invalid NMT state
- Invalid comment
- Invalid Ethernet port
- Invalid node ID
- ID assignment failed
- Duplicate MAC address
- Invalid SW version
- Incomplete assignment
- No device found
- Internal error

6.5 PROFINET® ID Assignment

Each PROFINET® device needs a device name and an IP address. The IP address and the device name are assigned by the I/O controller, when the connection to the I/O device is established.

The IP address assignment is also required when using indirect communication via the VLT® Servo Toolbox software (see the **VLT® Servo Drive System ISD 510, DSD 510, MSD 510 (VLT® Flexmotion™) Programming Guide** for further information).

The IP address and the device name can also be assigned using PRONETA, a free tool that supports in the analysis and configuration of PROFINET® networks.

6.6 Power-Up Time

The maximum power-up time for the system modules is 15 s. This means the time from supplying the system with auxiliary voltage to the module being initialized completely.

The power-up time stated is an indicative time. The exact status of the module can be seen via the statusword.

N O T I C E

- Do not operate any of the system modules until they are all powered up correctly.
- If 2 PSM 510 modules are mounted in parallel, power up both PSM 510 modules simultaneously (within a maximum delay of 1 second).

6.7 System Module Charging Time

The charging time of the system is determined by the longest charging time of each individual system module. The exact status of each module can be seen via the statusword.

N O T I C E

- Do not operate any of the system modules or decentral drives until they are charged up completely. Wait until PSM 510, DAM 510, and ACM 510 are in state *Operation enabled*, before bringing the ISD 510/DSD 510 into state *Operation enabled*.

Table 25: DC-Link (UDC) Charging Time for PSM 510, DAM 510, and ACM 510

Specification	Unit	PSM 510	DAM 510	ACM 510
UDC charging time	s	2.0	2.0	3.5

6.8 Switching on the ISD 510/DSD 510 System

Complete the cabling of the servo system before applying power to the ISD 510/DSD 510 servo drives. This cabling provides the supply voltage and the communication signals for the servo system. This is a fundamental requirement for operation of the ISD 510/DSD 510 servo drives.

The servo system can be switched on in 2 ways:

- If the Power Supply Module (PSM 510) is supplied with mains, STO, and U_{AUX} , communication to the PSM 510 internal controller is established and DC-link and U_{AUX} are automatically passed on via the backlink to the DAM 510 and then passed on further to the connected servo drives.
- If the Power Supply Module (PSM 510) is only powered by U_{AUX} , then the PSM 510, DAM 510, and servo drive control units are running.

6.8.1 Procedure for Switching on the ISD 510/DSD 510 System

Procedure

1. Switch on U_{AUX} power to enable communication to the PSM 510, DAM 510, and ISD 510/DSD 510 servo drives to be established.
2. Switch on the mains.
3. Set the PSM 510 to state *Normal operation*.
4. Set the DAM 510 to state *Normal operation*.

Now the PSM 510, DAM 510 and the ISD 510/DSD 510 servo drives are ready for operation.

6.9 Libraries

The libraries provided for the ISD 510 system can be used in:

- TwinCAT® V2 and V3
- SIMOTION SCOUT® V5.2:
 - C240 from V4.4
 - D410-2 from V4.4
 - D425-2 from V4.4
 - D435-2 from V4.4
 - D445-2 from V4.4

- D455-2 from V4.4
- P320 from V4.4
- Automation Studio™ environment (version 3.0.90 and 4.x, supported platform SG4) to easily integrate the functionality without the need for special motion run-time on the controller.
- TiA from V15

The provided function blocks conform to the PLCopen® standard. Knowledge of the underlying fieldbus communication and/or the CANopen® CiA DS 402 profile is not necessary.

The library contains:

- Function blocks for controlling and monitoring the ISD 510/DSD 510 servo drives and the system modules.
- Function blocks for all available motion commands of the ISD 510/DSD 510 servo drives.
- Function blocks for controlling and monitoring the PSM 510, DAM 510, and ACM 510.
- Function blocks and structures for creating *Basic CAM* profiles.
- Function blocks and structures for creating *Labeling CAM* profiles.

6.10 Programming with Automation Studio™

6.10.1 Requirements for Programming with Automation Studio™

The following files are required to integrate the ISD 510/DSD 510 servo drives and the system modules into an Automation Studio™ project:

- Package of libraries for the ISD 510 servo system: Danfoss_VLT_ServoMotion_V_x_y_z.zip
- XDD file (XML Device Description) for the standard ISD 510 servo drive: 0x0300008D_ISD510_S.xdd
- XDD file (XML Device Description) for the advanced ISD 510 servo drive: 0x0300008D_ISD510_A.xdd
- XDD file (XML Device Description) for the standard DSD 510 servo drive: 0x0300008D_DSD510_S.xdd
- XDD file (XML Device Description) for the advanced DSD 510 servo drive: 0x0300008D_DSD510_A.xdd
- XDD file (XML Device Description) for the Power Supply Module (PSM 510): 0x0300008D_PSM.xdd
- XDD file (XML Device Description) for the Decentral Access Module (DAM 510): 0x0300008D_DAM.xdd
- XDD file (XML Device Description) for the Auxiliary Capacitors Module (ACM 510): 0x0300008D_ACM.xdd

6.10.2 Creating an Automation Studio™ Project

The procedures described in this chapter apply to Automation Studio™ Versions 3.0.90 and V4.x unless otherwise specified.

Information on how to install Automation Studio™ can be found in detail in the Automation Studio™ help. Open the B&R Help Explorer and go to [Automation software → Software Installation → Automation Studio].

Information on how to create a project in Automation Studio™ can be found in detail in the Automation Studio™ help.

V3.0.90:

Open the B&R Help Explorer and go to [Automation Software → Getting Started → Creating programs with Automation Studio → First project with X20 CPU].

V4.x:

Open the B&R Help Explorer and go to [Automation Software → Getting Started → Creating programs with Automation Studio → Example project for a target system with CompactFlash].

6.10.3 Including the Servo Motion Libraries into an Automation Studio™ Project

Procedure

1. In the *Logical View*, open the menu entry [File → Import...].
2. In the next window, select the Danfoss_VLT_ServoMotion_V_x_y_z.zip file (according to the location on the hard drive).
3. Click on *Open*.
4. Assign the libraries to the CPU in the next window.
5. Click on *Finish*. Now the libraries are integrated into the Automation Studio™ project.

A new folder containing the ISD libraries is created during integration:

- DDS_Drive

- Contains program organization units (POUs) defined by PLCopen® (name starting with MC_) and POUs defined by Danfoss (name starting with DD_). The Danfoss POUs provide additional functionality for the axis.
- It is possible to combine POUs defined by PLCopen® with POUs defined by Danfoss.
- The names of the POUs that target the servo drive all end with _DDS.
- DDS_PSM
 - Contains POUs defined by Danfoss (name starting with DD_) and provide the functionality for the Power Supply Module (PSM).
 - The names of the POUs that target the PSM all end with _PSM.
- DDS_DAM
 - Contains POUs defined by Danfoss (name starting with DD_) and provide the functionality for the Decentral Access Module (DAM).
 - The names of the POUs that target the DAM all end with _DAM.
- DDS_ACM
 - Contains POUs defined by Danfoss (name starting with DD_) and provide the functionality for the Auxiliary Capacitors Module (ACM).
 - The names of the POUs that target the ACM all end with _ACM.
- DDS_BasCam
 - Contains POUs for the creation of basic CAMs.
- DDS_LabCam
 - Contains POUs for the creation of labeling CAMs.
- DDS_Intern
 - Contains POUs that are needed internally for the libraries.
 - Do not use these POUs in an application.

When integrating the DDS_Drive package, some standard libraries are integrated automatically, unless they are already part of the project.

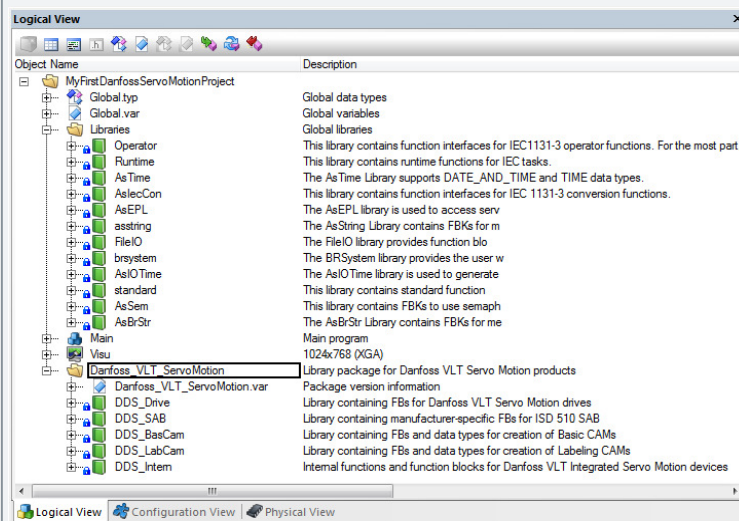

e30bg337.10

Illustration 56: Standard Libraries

NOTICE

– Do not remove these libraries otherwise the Danfoss servo motion libraries will not work.

6.10.4 Constants within the DDS_Drive Library

Inside the library, the following lists of constants are defined:

- Danfoss_VLT_ServoMotion
 - Contains the version information of the library.
- DDS_AxisErrorCodes
 - Constants for error codes of the axis.
 - Error codes can be read using the function block *MC_ReadAxisError_DDS* and/or *DD_ReadAxisWarning_DDS*.
- DDS_AxisTraceSignals
 - Constants for the trace signals of the axis.
 - Intended to be used with the function block *DD_Trace_DDS*.
- DDS_BasCam
 - Constants for the creation of basic CAMs.
- DDS_CamParsingErrors
 - Constants for parsing problems of a CAM.
 - Error reason is returned by function block *MC_CamTableSelect_DDS*.
- DDS_FB_ErrorConstants
 - Constants for errors inside POU's.
 - The reason is given in an output *ErrorInfo.ErrorID* that is available in all POU's.
- DDS_Intern
 - Constants which are needed internally for the library.
 - They are not intended to be used in an application.
- DDS_LabCam
 - Constants for the creation of labeling CAMs.
- DDS_SdoAbortCodes
 - Constants for errors concerning reading and writing of parameters.
 - The reason is given in an output *AbortCode* that is available in several POU's.
- PSM_ErrorCodes
 - Constants for error codes of the Power Supply Module (PSM 510).
 - Error codes can be read using the function block *DD_ReadPsmError_PSM* and/or *DD_ReadPsmWarning_PSM*.
- PSM_TraceSignals
 - Constants for the trace signals of the Power Supply Module (PSM 510).
 - Intended to be used with the function block *DD_Trace_PSM*.
- DAM_ErrorCodes
 - Constants for error codes of the Decentral Access Module (DAM 510).
 - Error codes can be read using the function block *DD_ReadDamError_DAM* and/or *DD_ReadDamWarning_DAM*.
- DAM_TraceSignals
 - Constants for the trace signals of the Decentral Access Module (DAM 510).
 - Intended to be used with the function block *DD_Trace_DAM*.
- ACM_ErrorCodes
 - Constants for error codes of the Auxiliary Capacitors Module (ACM 510).
 - Error codes can be read using the function block *DD_ReadAcmError_ACM* and/or *DD_ReadAcmWarning_ACM*.
- ACM_TraceSignals
 - Constants for the trace signals of the Auxiliary Capacitors Module (ACM 510).
 - Intended to be used with the function block *DD_Trace_ACM*.

6.10.5 Instantiating AXIS_REF_DDS in Automation Studio™

Procedure

1. Create 1 instance of function block *AXIS_REF_DDS* (located in folder *DDS_Drive*) for every servo drive that has to be controlled or monitored.
2. To create a link to the physical servo drive, link each instance of *AXIS_REF_DDS* to 1 physical servo drive. This makes it the logical representation of 1 physical servo drive.
 - Open the *Logical View*.
 - Initialize each instance with its node number and the slot name it is connected to (for example, IF3).
 - Initialize each instance of a drive with its *DriveType*.

Example

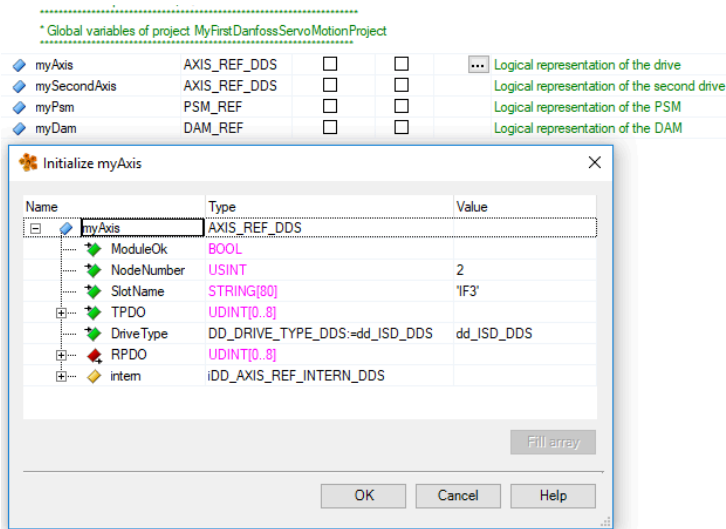

Illustration 57: Instantiation of *AXIS_REF_DDS* and Setting of Initial Values

6.10.6 Instantiating *PSM_REF* in Automation Studio™

Procedure

1. Create 1 instance of function block *PSM_REF* (located in folder *DDS_PSM*) for every Power Supply Module (PSM) that has to be controlled or monitored.
2. To create a link to the physical PSM, link each instance of *PSM_REF* to 1 physical PSM. This makes it the logical representation of 1 physical PSM.
 - Open the *Logical View*.
 - Initialize each instance with its node number and the slot name it is connected to (for example, IF3).

6.10.7 Instantiating *DAM_REF* in Automation Studio™

Procedure

1. Create 1 instance of function block *DAM_REF* (located in folder *DDS_DAM*) for every Decentral Access Module (DAM) that has to be controlled or monitored.
2. To create a link to the physical DAM, link each instance of *DAM_REF* to 1 physical DAM. This makes it the logical representation of 1 physical DAM.
 - Open the *Logical View*.
 - Initialize each instance with its node number and the slot name it is connected to (for example, IF3).

6.10.8 Instantiating *ACM_REF* in Automation Studio™

Procedure

1. Create 1 instance of function block *ACM_REF* (located in folder *DDS_ACM*) for every Auxiliary Capacitors Module (ACM) that has to be controlled or monitored.
2. To create a link to the physical ACM, link each instance of *ACM_REF* to 1 physical ACM. This makes it the logical representation of 1 physical ACM.
 - Open the *Logical View*.

- Initialize each instance with its node number and the slot name it is connected to (for example, IF3).

6.10.9 Importing a Servo Drive into Automation Studio™

NOTICE

- For each physical servo drive, add 1 entry to the *Physical View* of Automation Studio™.

6.10.9.1 Version V3.0.90

Procedure

1. Select the menu entry [Tools → Import Fieldbus Device...].
2. Select the XDD file (for example, *0x0300008D_ISD510_S.xdd* or *0x0300008D_ISD510_A.xdd*) from its location on the hard drive. This import only needs to be done once per project. The device is then known to Automation Studio™.
3. Now add the servo drive to the Ethernet POWERLINK® interface of the controller in the *Physical View*:
 - Right-click on the controller in the *Physical View* and select [Open POWERLINK].
 - Right-click on the interface and select *Insert...*
 - In the *Select controller module* window, select the servo drive in the group *POWERLINK Devices*.
 - Click on *Next*.
 - In the next window, enter the node number of the servo drive.

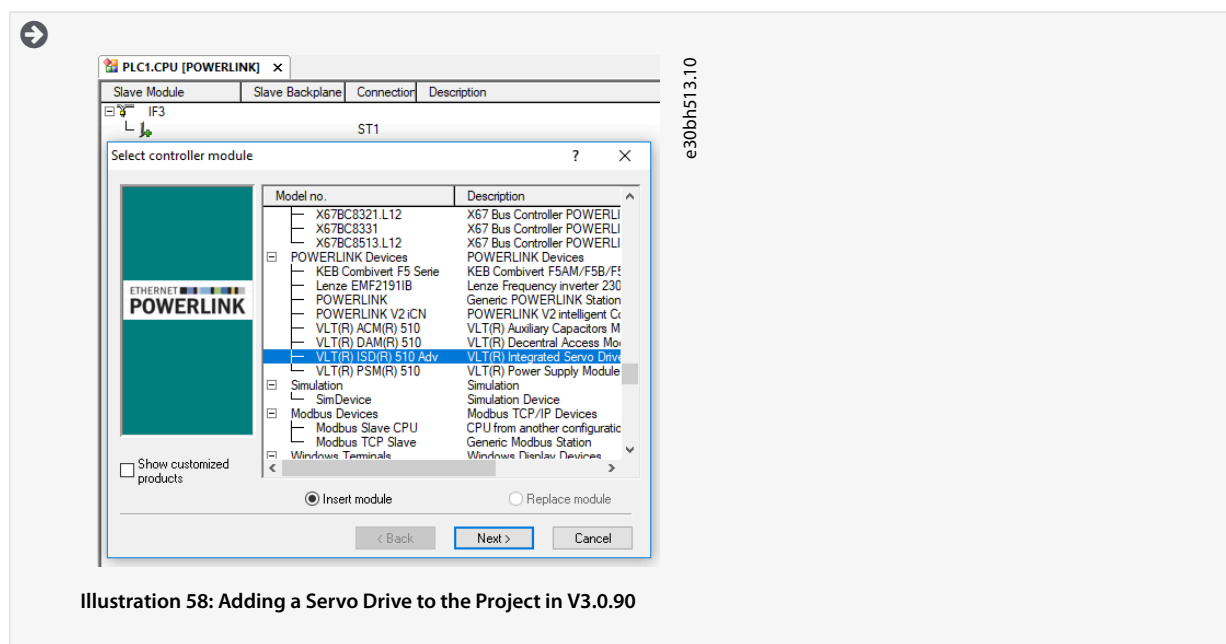

Illustration 58: Adding a Servo Drive to the Project in V3.0.90

6.10.9.2 Version V4.x

Procedure

1. Select the menu entry [Tools → Import Fieldbus Device...].
2. Select the XDD file (for example, *0x0300008D_ISD510_S.xdd* or *0x0300008D_ISD510_A.xdd*) from its location on the hard drive. The device is then known to Automation Studio™.
3. Now add the servo drive to the Ethernet POWERLINK® interface of the controller in the *Physical View*:
 - Select the menu entry [Open → System Designer] to show the *System Designer*.
 - To add a hardware module to the *Physical View* or *System Designer*, select the servo drive in the group *POWERLINK* in the *Hardware Catalog* toolbox.
 - Drag the selected module to the desired position to connect it to the selected hardware module, network interface, or slot.
 - To change the node number, right-click on the device and select [Node Number → Change Node Number].

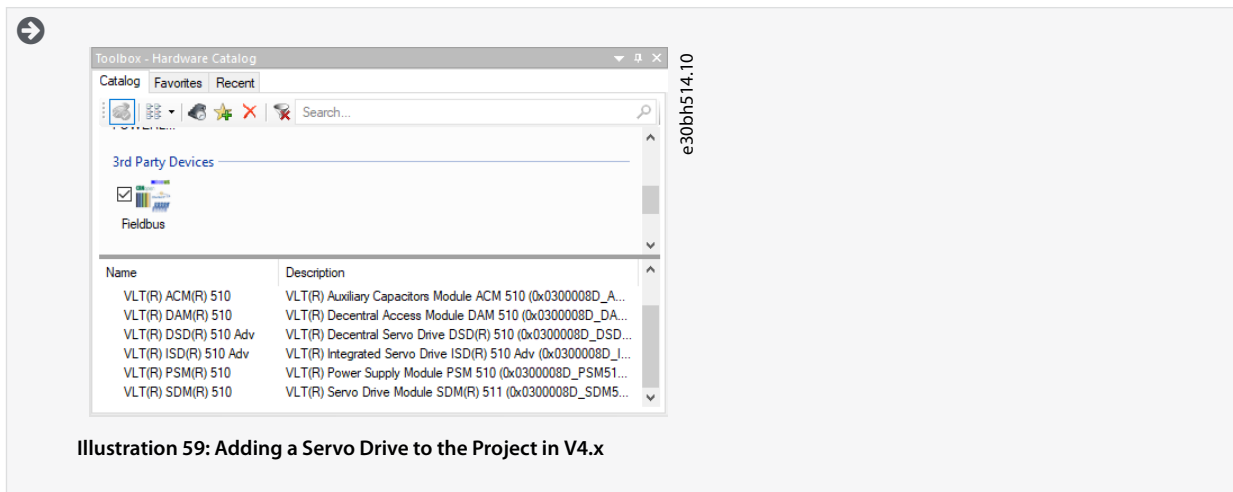

Illustration 59: Adding a Servo Drive to the Project in V4.x

6.10.10 Importing PSM 510, DAM 510 and ACM 510 into Automation Studio™

NOTICE

- For each physical Power Supply Module (PSM 510), Decentral Access Module (DAM 510), and Auxiliary Capacitors Module (ACM 510), add 1 entry to the *Physical View* of Automation Studio™.

6.10.10.1 Version V3.0.90

Procedure

1. Select the menu entry [Tools → Import Fieldbus Device...].
2. Select the XDD file for the PSM 510, DAM 510, or ACM 510 from its location on the hard drive. This import only needs to be done once per project. The device is then known to Automation Studio™.
 - Power Supply Module (PSM 510): *0x0300008D_PSM.xdd*
 - Decentral Access Module (DAM 510): *0x0300008D_DAM.xdd*
 - Auxiliary Capacitors Module (ACM 510): *0x0300008D_ACM.xdd*
3. Now add the PSM 510, DAM 510, or ACM 510 to the Ethernet POWERLINK® interface of the controller in the *Physical View*:
 - Right-click on the controller in the *Physical View* and select [Open POWERLINK].
 - Right-click on the interface and select *Insert...*
 - In the *Select controller module* window, select the PSM 510, DAM 510, or ACM 510 in the group *POWERLINK Devices*.
 - Click on *Next*.
 - In the next window, enter the node number of the PSM 510, DAM 510, or ACM 510.

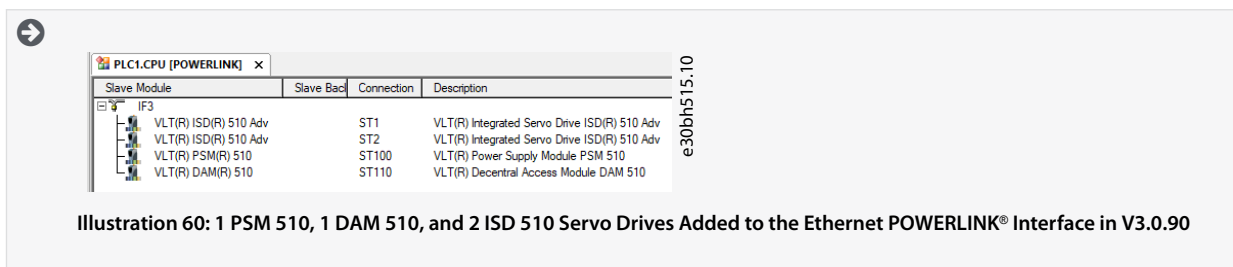

Illustration 60: 1 PSM 510, 1 DAM 510, and 2 ISD 510 Servo Drives Added to the Ethernet POWERLINK® Interface in V3.0.90

6.10.10.2 Version V4.x

Procedure

1. Select the menu entry [Tools → Import Fieldbus Device...].
2. Select the XDD file for the PSM 510, DAM 510, or ACM 510 from its location on the hard drive. The device is then known to Automation Studio™.

- Power Supply Module (PSM 510): *0x0300008D_PSM.xdd*
 - Decentral Access Module (DAM 510): *0x0300008D_DAM.xdd*
 - Auxiliary Capacitors Module (ACM 510): *0x0300008D_ACM.xdd*
3. Now add the PSM 510, DAM 510, or ACM 510 to the Ethernet POWERLINK® interface of the controller in the *Physical View*:
- Select the menu entry [Open → System Designer] to show the *System Designer*.
 - To add a hardware module to the *Physical View* or *System Designer*, select the PSM 510, DAM 510, or ACM 510 in the group *POWERLINK* in the *Hardware Catalog* toolbox.
 - Drag the selected module to the desired position to connect it to the selected hardware module, network interface, or slot.
 - To change the node number, right-click on the device and select [Node → Change Node Number].
- PSM: Danfoss_VLT_R_PSM
DAM: Danfoss_VLT_R_DAM
ACM: Danfoss_VLT_R_ACM

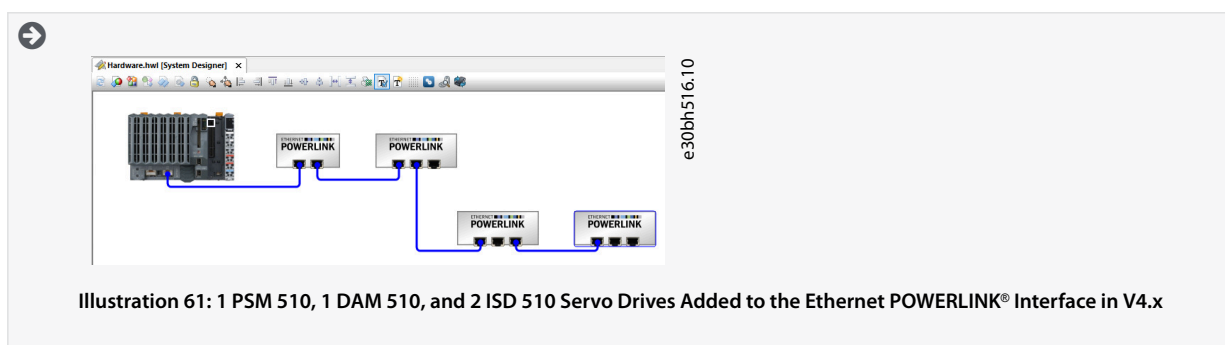

6.10.11 I/O Configuration and I/O Mapping

Procedure

1. Parameterize the I/O configuration of the ISD 510/DSD 510 servo drives so that the library has access to all necessary objects.
 - Right-click on the entry of the ISD 510/DSD 510 servo drive and select *Open I/O Configuration* in V3.0.90 and *Configuration* in V4.x.
 - In the *Channels* section, change the *Cyclic transmission* of the following objects:
All sub-indexes of object 0x5050 (Lib pdo rx_I5050 ARRAY[]) to *Write*.
All sub-indexes of object 0x5051 (Lib pdo tx_I5051 ARRAY[]) to *Read*.
2. Parameterize the I/O configuration of the Power Supply Module (PSM 510), Decentral Access Module (DAM 510), and Auxiliary Capacitors Module (ACM 510) so that the library has access to all necessary objects.
 - Right-click on the entry of the PSM/DAM/ACM and select *Open I/O Configuration* in V3.0.90 and *Configuration* in V4.x.
 - In the *Channels* section, change the *Cyclic transmission* of the following objects:
All sub-indexes of object 0x5050 (Lib pdo rx_I5050 ARRAY[]) to *Write*.
All sub-indexes of object 0x5051 (Lib pdo tx_I5051 ARRAY[]) to *Read*.

These settings configure the cyclic communication with the device. These parameters are required for the library to work.

N O T I C E

- It is possible to use copy and paste to apply the same I/O configuration to multiple devices of the same type.

3. Set *Module supervised* to *off* for the servo drives and the PSM/DAM/ACM. The parameter is found in the I/O configuration of the device.

Name	Value	Description
Lib pdo rx_I5050_ARRAY		
Lib PdoRx1_I5050_S01		
Cyclic transmission	Write	
Datatype	UDINT	UNSIGNED32
Init value		Set at bootup (clear to pre)
Lib PdoRx2_I5050_S02		
Cyclic transmission	Write	
Datatype	UDINT	UNSIGNED32
Init value		Set at bootup (clear to pre)
Lib PdoRx3_I5050_S03		
Cyclic transmission	Write	
Datatype	UDINT	UNSIGNED32
Init value		Set at bootup (clear to pre)
Lib PdoRx4_I5050_S04		
Lib PdoRx5_I5050_S05		
Lib PdoRx6_I5050_S06		
Lib PdoRx7_I5050_S07		
Lib PdoRx8_I5050_S08		
Lib PdoRx9_I5050_S09		
Lib pdo tx_I5051_ARRAY		
Lib PdoTx1_I5051_S01		
Cyclic transmission	Read	
Datatype	UDINT	UNSIGNED32
Init value		Set at bootup (clear to pre)
Lib PdoTx2_I5051_S02		
Cyclic transmission	Read	
Datatype	UDINT	UNSIGNED32
Init value		Set at bootup (clear to pre)
Lib PdoTx3_I5051_S03		
Cyclic transmission	Read	
Datatype	UDINT	UNSIGNED32
Init value		Set at bootup (clear to pre)
Lib PdoTx4_I5051_S04		
Lib PdoTx5_I5051_S05		
Lib PdoTx6_I5051_S06		
Lib PdoTx7_I5051_S07		
Lib PdoTx8_I5051_S08		
Lib PdoTx9_I5051_S09		

Illustration 62: I/O Configuration of an ISD 510 Device

Channel Name	Data Type	Task Class	PV or Channel Name	Inverse	Simulate
ModuleOk	BOOL				
Lib PdoRx1_I5050_S01	UDINT				<input checked="" type="checkbox"/>
Lib PdoRx2_I5050_S02	UDINT				<input checked="" type="checkbox"/>
Lib PdoRx3_I5050_S03	UDINT				<input checked="" type="checkbox"/>
Lib PdoRx4_I5050_S04	UDINT				<input checked="" type="checkbox"/>
Lib PdoRx5_I5050_S05	UDINT				<input checked="" type="checkbox"/>
Lib PdoRx6_I5050_S06	UDINT				<input checked="" type="checkbox"/>
Lib PdoRx7_I5050_S07	UDINT				<input checked="" type="checkbox"/>
Lib PdoRx8_I5050_S08	UDINT				<input checked="" type="checkbox"/>
Lib PdoRx9_I5050_S09	UDINT				<input checked="" type="checkbox"/>
Lib PdoTx1_I5051_S01	UDINT				<input checked="" type="checkbox"/>
Lib PdoTx2_I5051_S02	UDINT				<input checked="" type="checkbox"/>
Lib PdoTx3_I5051_S03	UDINT				<input checked="" type="checkbox"/>
Lib PdoTx4_I5051_S04	UDINT				<input checked="" type="checkbox"/>
Lib PdoTx5_I5051_S05	UDINT				<input checked="" type="checkbox"/>
Lib PdoTx6_I5051_S06	UDINT				<input checked="" type="checkbox"/>
Lib PdoTx7_I5051_S07	UDINT				<input checked="" type="checkbox"/>
Lib PdoTx8_I5051_S08	UDINT				<input checked="" type="checkbox"/>
Lib PdoTx9_I5051_S09	UDINT				<input checked="" type="checkbox"/>

Illustration 63: I/O Mapping after Successful Configuration

- Map the inputs and outputs of the instance of the *AXIS_REF_DDS* function block and the physical data points of the ISD 510 servo drive (here *myAxis* is an instance of *AXIS_REF_DDS*):

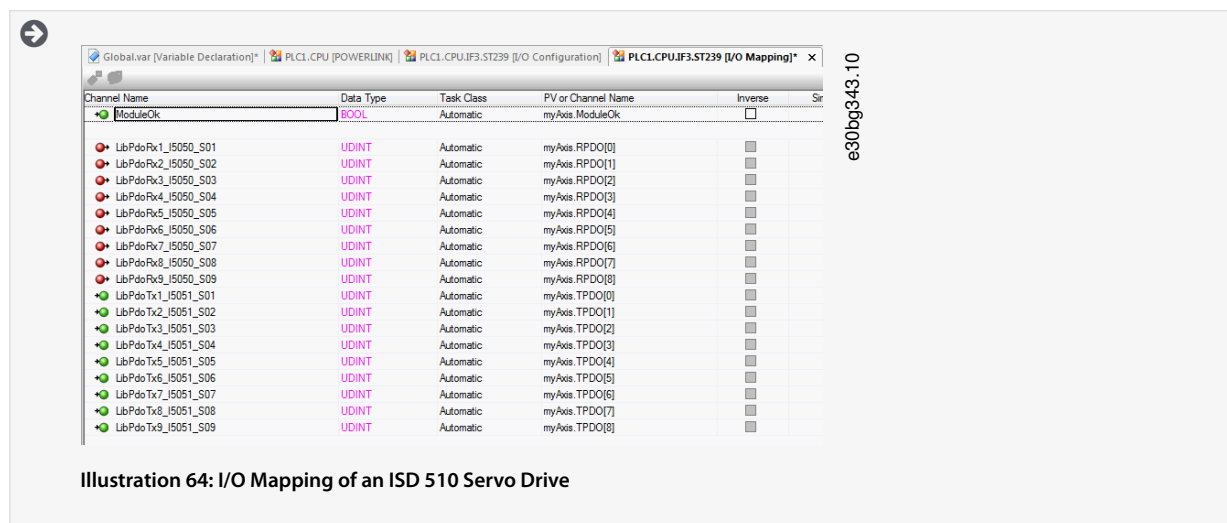

Illustration 64: I/O Mapping of an ISD 510 Servo Drive

- Map the inputs and outputs of the instance of the *PSM_REF*, *DAM_REF*, and *ACM_REF* function blocks and the physical data points of the PSM/DAM/ACM accordingly.

6.10.12 Setting the PLC Cycle Time

The minimum cycle time is 400 μ s. The servo system devices can run Ethernet POWERLINK® cycle times in multiples of 400 μ s and multiples of 500 μ s. The devices are automatically parameterized by the PLC on start-up, depending on the Ethernet POWERLINK® configuration of the physical interface. The Ethernet POWERLINK® configuration can be accessed by right-clicking [CPU → Open IF3 POWERLINK Configuration] in the *Physical View* for V3.0.90 or [PLK → Configuration] for V4.x.

NOTICE

– Ensure that the task cycle times of the PLC program and Ethernet POWERLINK® are the same. Otherwise, data could be lost and performance reduced.

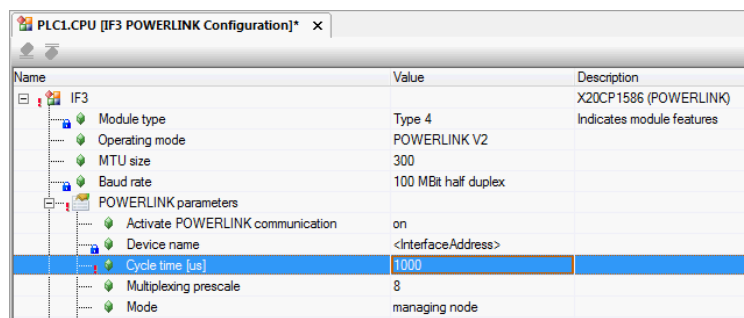

Illustration 65: Ethernet POWERLINK® Configuration Window to Parameterize Ethernet POWERLINK® Cycle Time

Procedure for setting the PLC time in Automation Studio™

- Right-click [CPU → Open Software Configuration] for V3.0.90 and [CPU → Configuration → Timing] for V4.x in the *Physical View*.
- Ensure that the PLC cycle time is the same as the Ethernet POWERLINK® cycle time.

6.10.13 Connecting to the PLC

Information on how to connect to the PLC can be found in detail in the Automation Studio™ Help.

Version V3.0.90:

Open the *B&R Help Explorer* and go to [Automation Software → Getting Started → Creating programs with Automation Studio → First project with X20 CPU → Configure online connection].

Version V4.x:

Open the *B&R Help Explorer* and go to [Automation Software → Getting Started → Creating programs in Automation Studio → Example project for a target system with CompactFlash].

6.11 Programming with TwinCAT®

6.11.1 Requirements for Programming with TwinCAT®

To integrate the ISD 510/DSD 510 servo drives and the PSM 510, DAM 510, or ACM 510 into a TwinCAT® project, the following files are required:

- Library for the ISD 510 servo system: *Danfoss_VLT_ServoMotion_V_x_y_z.lib*
- ESI file (EtherCAT® Slave Information) for the standard ISD 510 servo drive: *Danfoss_ISD510_S.xml*
- ESI file (EtherCAT® Slave Information) for the advanced ISD 510 servo drive: *Danfoss_ISD510_A.xml*
- ESI file (EtherCAT® Slave Information) for the standard DSD 510 servo drive: *Danfoss_DSD510_S.xml*
- ESI file (EtherCAT® Slave Information) for the advanced DSD 510 servo drive: *Danfoss_DSD510_A.xml*
- ESI file (EtherCAT® Slave Information) for the Power Supply Module: *Danfoss_PSM510.xml*
- ESI file (EtherCAT® Slave Information) for the Decentral Access Module: *Danfoss_DAM510.xml*
- ESI file (EtherCAT® Slave Information) for the Auxiliary Capacitor Module: *Danfoss_ACM510.xml*

6.11.2 Creating a TwinCAT® Project

Information on how to install TwinCAT® can be found in detail in the Beckhoff Information System (<https://infosys.beckhoff.com/>). Open the information system and select [TwinCAT 2 → TwinCAT Quick Start → Installation].

Information on how to create a project in TwinCAT® can be found in detail in the Beckhoff Information System (<https://infosys.beckhoff.com/>). Open the information system and select [TwinCAT 2 → TwinCAT Quick Start or TwinCAT 2 → TX1200 TwinCAT PLC → TwinCAT PLC Control].

6.11.3 Including the TwinCAT® Library into a TwinCAT® Project

Procedure

1. In the *Resources* tab of TwinCAT® PLC Control, open the *Library Manager*.
2. In the upper left area of the *Library Manager* window, right-click and select *Additional Library...*
3. Select the *Danfoss_VLT_ServoMotion_V_x_y_z* file (according to the location on the hard drive).
4. Click on *Open*. Now the libraries are integrated into the TwinCAT® PLC control project.

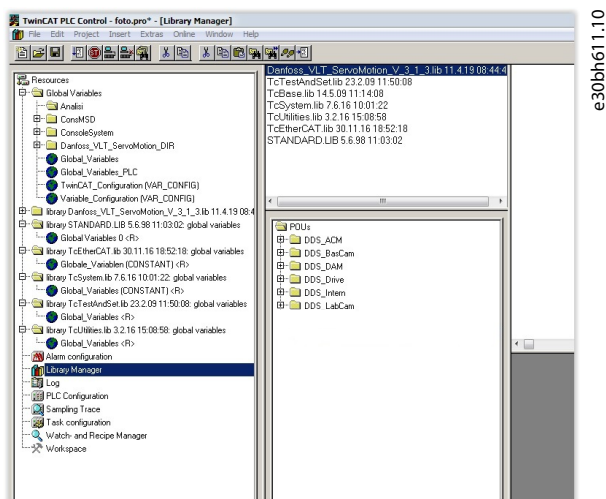

Illustration 66: Library Manager after Including the ServoMotion Library

Inside the library, the POUs are organized into folders:

- **DDS_Drive**
 - Contains program organization units (POUs) defined by PLCopen® (name starting with MC_) and POUs defined by Danfoss (name starting with DD_). The Danfoss POUs provide additional functionality for the axis.
 - It is possible to combine POUs defined by PLCopen® with POUs defined by Danfoss.

- The names of the POU's that target the servo drives all end with `_DDS`.
- `DDS_PSM`
 - Contains POU's defined by Danfoss (name starting with `DD_`) and provide the functionality for the Power Supply Module (PSM 510).
 - The names of the POU's that target the PSM 510 all end with `_PSM`.
- `DDS_DAM`
 - Contains POU's defined by Danfoss (name starting with `DD_`) and provide the functionality for the Decentral Access Module (DAM 510).
 - The names of the POU's that target the DAM 510 all end with `_DAM`.
- `DDS_ACM`
 - Contains POU's defined by Danfoss (name starting with `DD_`) and provide the functionality for the Auxiliary Capacitors Module (ACM 510).
 - The names of the POU's that target the ACM 510 all end with `_ACM`.
- `DDS_BasCam`
 - Contains POU's for the creation of basic CAMs.
- `DDS_LabCam`
 - Contains POU's for the creation of labeling CAMs.
- `DDS_Intern`
 - Contains POU's that are needed internally for the libraries.
 - Do not use these POU's in an application.

When integrating the VLT® Integrated Servo Drive library, some standard libraries are integrated automatically, unless they are already part of the project.

N O T I C E

- Do not remove these libraries otherwise the DDS libraries will not work.

6.11.4 Constants within the DDS_Drive Library

Inside the library, the following lists of constants are defined:

- `Danfoss_VLT_ServoMotion`
 - Contains the version information of the library.
- `DDS_AxisErrorCodes`
 - Constants for error codes of the axis.
 - Error codes can be read using the function block `MC_ReadAxisError_DDS` and/or `DD_ReadAxisWarning_DDS`.
- `DDS_AxisTraceSignals`
 - Constants for the trace signals of the axis.
 - Intended to be used with the function block `DD_Trace_DDS`.
- `DDS_BasCam`
 - Constants for the creation of basic CAMs.
- `DDS_CamParsingErrors`
 - Constants for parsing problems of a CAM.
 - Error reason is returned by function block `MC_CamTableSelect_DDS`.
- `DDS_FB_ErrorConstants`
 - Constants for errors inside POU's.
 - The reason is given in an output `ErrorInfo.ErrorID` that is available in all POU's.
- `DDS_Intern`

- Constants which are needed internally for the library.
- They are not intended to be used in an application.
- DDS_LabCam
 - Constants for the creation of labeling CAMs.
- DDS_SdoAbortCodes
 - Constants for errors concerning reading and writing of parameters.
 - The reason is given in an output *AbortCode* that is available in several POU's.
- PSM_ErrorCodes
 - Constants for error codes of the Power Supply Module (PSM 510).
 - Error codes can be read using the function block *DD_ReadPsmError_PSM* and/or *DD_ReadPsmWarning_PSM*.
- PSM_TraceSignals
 - Constants for the trace signals of the Power Supply Module (PSM 510).
 - Intended to be used with the function block *DD_Trace_PSM*.
- DAM_ErrorCodes
 - Constants for error codes of the Decentral Access Module (DAM 510).
 - Error codes can be read using the function block *DD_ReadDamError_DAM* and/or *DD_ReadDamWarning_DAM*.
- DAM_TraceSignals
 - Constants for the trace signals of the Decentral Access Module (DAM 510).
 - Intended to be used with the function block *DD_Trace_DAM*.
- ACM_ErrorCodes
 - Constants for error codes of the Auxiliary Capacitors Module (ACM 510).
 - Error codes can be read using the function block *DD_ReadAcmError_ACM* and/or *DD_ReadAcmWarning_ACM*.
- ACM_TraceSignals
 - Constants for the trace signals of the Auxiliary Capacitors Module (ACM 510).
 - Intended to be used with the function block *DD_Trace_ACM*.

6.11.5 Instantiating AXIS_REF_DDS in TwinCAT®

Procedure

1. Create 1 instance of function block *AXIS_REF_DDS* (located in folder *DDS_Drive*) for the ISD 510 servo drive that has to be controlled or monitored.
2. Repeat step 1 for each additional servo drive.

Example

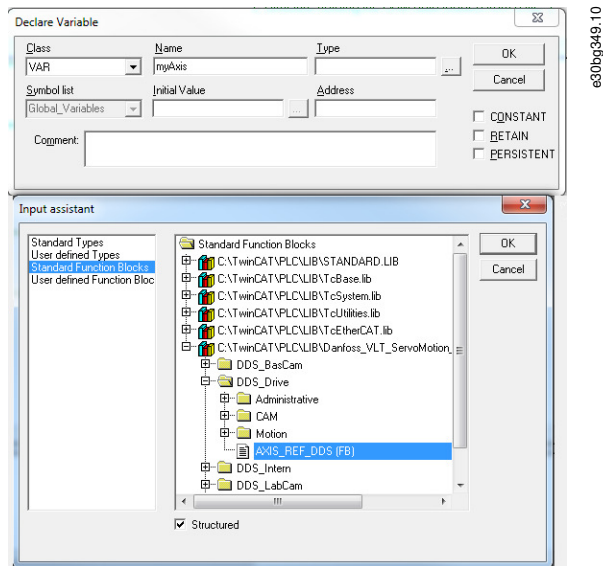

Illustration 67: Instantiation of AXIS_REF_DDS

6.11.6 Instantiating PSM_REF in TwinCAT®

Procedure

1. Create 1 instance of function block *PSM_REF* (located in folder *DDS_PSM*) for each Power Supply Module that has to be controlled or monitored.
2. Repeat step 1 for each additional PSM 510.

6.11.7 Instantiating DAM_REF in TwinCAT®

Procedure

1. Create 1 instance of function block *DAM_REF* (located in folder *DDS_DAM*) for each Decentral Access Module that has to be controlled or monitored.
2. Repeat step 1 for each additional DAM 510.

6.11.8 Instantiating ACM_REF in TwinCAT®

Procedure

1. Create 1 instance of function block *ACM_REF* (located in folder *DDS_ACM*) for each Auxiliary Capacitors Module that has to be controlled or monitored.
2. Repeat step 1 for each additional ACM 510.

6.11.9 Adding a PLC Project to TwinCAT® System Manager

To create a link between the TwinCAT® PLC Control project and the TwinCAT® System Manager, connect the saved project, especially the inputs and outputs, to the TwinCAT® System Manager:

Procedure

1. To add the project information to the TwinCAT® System Manager, right-click on *PLC-Configuration* and select *Append PLC project....*
2. In the *Insert IEC 1131 Project* window, select the project information file according to the location on the hard drive. The file has the same name as the PLC project, but with the file extension *.tpy*.
3. Click on *Open*.

6.11.10 Importing Devices to TwinCAT®

The following procedure is an example of how to import an ISD 510 servo drive to TwinCAT®.

Procedure

1. Copy the ESI file *Danfoss ISD 510 S.xml* into the folder *TwinCAT Installation Folder\Io\EtherCAT* on the hard drive. This only needs to be done once per project. The TwinCAT® System Manager automatically searches for ESI files at this location on the hard drive during start-up.
2. To add an EtherCAT® master, right-click on [I/O-Configuration → I/O Devices] and select *Append Device...*
3. In the following window, select [EtherCAT → EtherCAT] and click on *OK*.

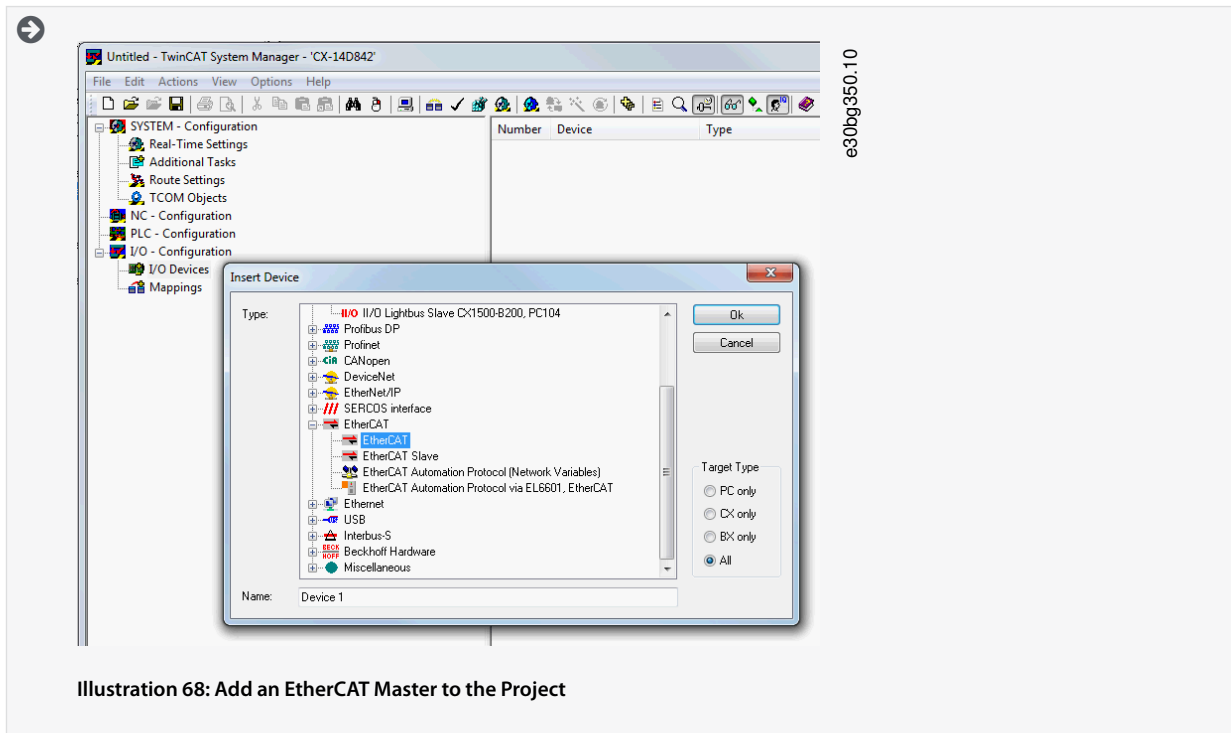

Illustration 68: Add an EtherCAT Master to the Project

4. Select *Device 1 (EtherCAT)* and select the correct *Network Adapter* on the right side of the window in the *Adapter* tab.
5. To add a Power Supply Module, right-click on *Device 1 (EtherCAT)* and select *Append Box...*
6. In the *Insert EtherCAT Device* window, select [Danfoss GmbH → VLT® FlexMotion → VLT® Power Supply Module PSM 510] and click on *OK*.
7. To add a Decentral Access Module, right-click on *Device 1 (EtherCAT)* and select *Append Box...*
8. In the *Insert EtherCAT Device* window, select [Danfoss GmbH → VLT® FlexMotion → VLT® Decentral Access Module] and click on *OK*.
9. To add an Auxiliary Capacitors Module, right-click on *Device 1 (EtherCAT)* and select *Append Box...*
10. In the *Insert EtherCAT Device* window, select [Danfoss GmbH → VLT® FlexMotion → VLT® Auxiliary Capacitors Module] and click on *OK*.
11. To add a servo drive to the Decentral Access Module DAM 510, right-click on *Box 1 (VLT® Decentral Access Module)* and select *Append Box...*
12. In the *Insert EtherCAT Device* window, select [Danfoss GmbH → VLT® FlexMotion → VLT® ISD 510 Integrated Servo Drive Standard] and click on *OK*.



Illustration 69: Add a Servo Drive to the Project

The screenshot shows the TwinCAT System Manager interface for a project named 'MyFirstFlexMotionProject.tsm'. The tree view is expanded to show the 'I/O - Configuration' section. Under 'I/O Devices', there is a 'Device 1 (EtherCAT)' which contains several sub-items: 'Device 1-Image', 'Device 1-Image-Info', 'Inputs', 'Outputs', 'InfoData', 'Box 1 (VLT® Power Supply Module PSM 510)', 'Box 2 (VLT® Decentral Access Module DAM 510)', 'Module 1 (Library PDO)', 'WcState', 'InfoData', 'Drive 1 (VLT® Integrated Servo Drive ISD(R) 510 Adv)', and 'Drive 2 (VLT® Integrated Servo Drive ISD(R) 510 Adv)'. The 'Mappings' section is also visible at the bottom of the tree.

Illustration 70: TwinCAT System Manager after Appending the PLC Project and Adding a Decentral Access Module and 2 ISD 510 Servo Drives

13. Answer the question if the servo drive is used as an NC axis with No. If the servo drive is to be used as an NC axis, see [6.11.15 Configuration as a TwinCAT® NC Axis](#).

NOTICE

- Add 1 entry to the EtherCAT® master of the TwinCAT System Manager for each physical servo drive, PSM 510, DAM 510, and ACM 510. Add the servo drive to the correct DAM 510 line.

6.11.11 I/O Configuration and I/O Mapping

When connecting >1 ISD 510/DSD 510 servo drive, connect port C (X2) of the previous servo drive to port A (X1) of the next servo drive. Also carry out the port assignment for the Decentral Access Module (DAM 510).

If the hardware setup is already present, the TwinCAT® System Manager *Scan devices* function can be used to automatically add the connected devices to the configuration in the correct order.

Using the TwinCAT® System Manager, configure the ISD 510/DSD 510 servo drive so that the PDO mapping matches the requirements of the library.

Procedure (Example for an ISD 510 servo drive)

1. Click on the ISD 510 servo drive entry.
2. Select the *Slots* tab on the right side of the window.
3. Remove the current PDO configuration by selecting the entry *Module 1 (CSV PDO)* in the *Slot* box.
4. Click on X.
5. Select *Library PDO* in the *Module* box.
6. Click on <.

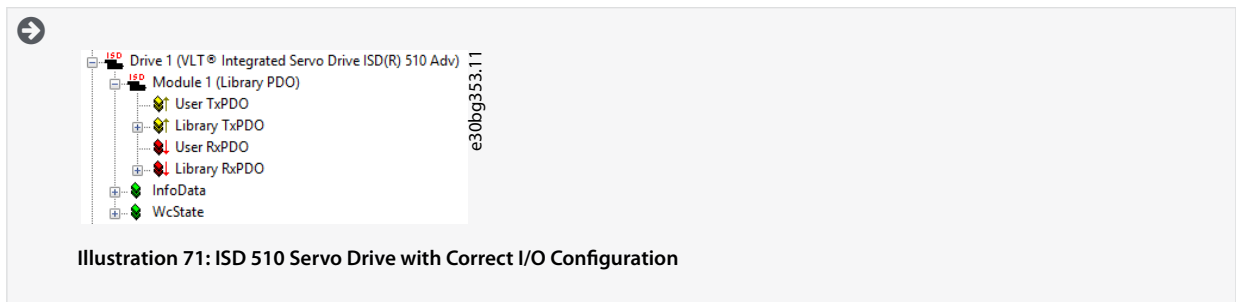

Illustration 71: ISD 510 Servo Drive with Correct I/O Configuration

6.11.12 Attaching the Input and Output Variables to the Physical Data Points

Use the TwinCAT® System Manager to attach the input and output variables of the PLC program to the physical inputs and outputs of the device. This ensures that the library has access to all necessary objects.

⚠ WARNING ⚠

- Repeat steps 2–22 for Box 1 (VLT® Power Supply Module) and the instance *myPSM*.
- Repeat steps 2–22 for Box 2 (VLT® Decentral Access Module) and the instance *myDAM*.

Procedure

1. Select *Library TxPDO* via menu [I/O-Configuration → I/O Devices → Device1 (EtherCAT) → Box 1 (VLT Decentral Access Module) → Drive 1 (VLT ISD 510 Integrated Servo Drive) → Module 1 (Library PDO) → Library TxPDO].
2. Select all entries *Lib pdo tx1* to *Lib pdo tx9* on the right side of the window.

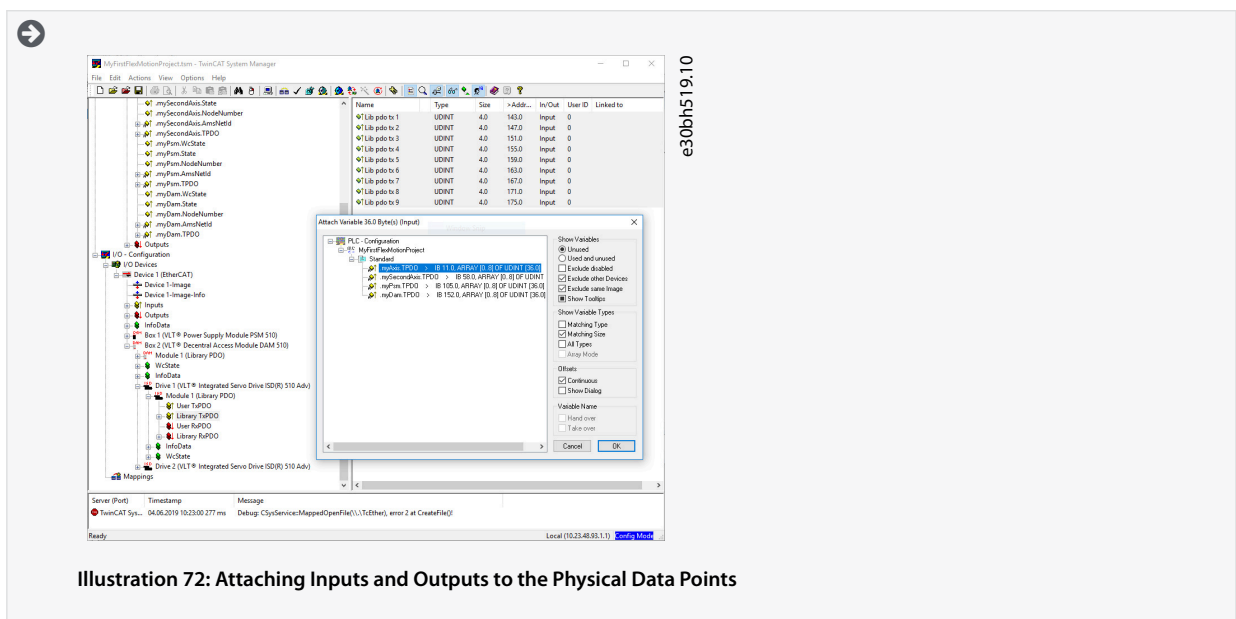

Illustration 72: Attaching Inputs and Outputs to the Physical Data Points

3. Right-click and select *Change Multi Link....*
4. In the *Attach Variable 36.0 Byte(s) (Input)* window, select [PLC-Configuration → MyFirstFlexMotionProject → Standard → .myAxis.TPDO]. Ensure that the *Matching Size* option is selected in the *Attach Variable* window.
5. Click on *OK*.

6. Click on library *RxPDO* via menu [I/O-Configuration → I/O Devices → Device1 (EtherCAT™) → Box1 (VLT™ Decentral Access Module) → Drive2 (VLT™ ISD 510 Integrated Servo Drive) → Module1 (Library PDO) → Library RxPDO].
7. Select all entries *Lib pdo rx1* to *Lib pdo rx9* on the right side of the window.
8. Right-click and select *Change Multi Link...*
9. In the *Attach Variable 36.0 Byte(s) (Output)* window, select [PLC-Configuration → MyFirstIsd510Project → Standard → .myAxis.RPDO].
10. Click on *OK*.
11. Right-click on *WcState* via menu [I/O-Configuration → I/O Devices → Device1 (EtherCAT™) → Box1 (VLT™ Decentral Access Module) → Drive2 (VLT™ ISD 510 Integrated Servo Drive) → WcState] and select *Change Link...*
12. In the *Attach Variable State (Input)* window, select [PLC-Configuration → MyFirstIsd510Project → Standard → .myAxis.WcState].
13. Click on *OK*.
14. Right-click on *State* via menu [I/O-Configuration → I/O Devices → Device1 (EtherCAT™) → Box1 (VLT™ Decentral Access Module) → Drive2 (VLT™ ISD 510 Integrated Servo Drive) → InfoData] and select *Change Link...*
15. In the *Attach Variable State (Input)* window, select [PLC-Configuration → MyFirstIsd510Project → Standard → .myAxis.State].
16. Click on *OK*.
17. Right-click on *netId* via menu [I/O-Configuration → I/O Devices Device1 (EtherCAT→) → Box1 (VLT® Decentral Access Module) → Drive2 (VLT→ ISD 510 Integrated Servo Drive) → InfoData → AdsAddr] and select *Change Link...*
18. In the *Attach Variable netId (Input)* window, select [PLC-Configuration → MyFirstIsd510Project → Standard → .myAxis.AmsNetId].
19. Click on *OK*.
20. Right-click on *Port* via [I/O-Configuration → I/O Devices → Device1 (EtherCAT→) → Box1 (VLT→ Decentral Access Module) → Drive2 (VLT→ ISD 510 Integrated Servo Drive) → InfoData → AdsAddr] and select *Change Link...*
21. In the *Attach Variable port (Input)* window, select [PLC-Configuration → MyFirstIsd510Project → Standard → .myAxis.NodeNumber].
22. Click on *OK*.

6.11.13 Transferring the Mappings back to the PLC Program

To transfer the mappings back to the PLC program, select *Activate Configuration...* in menu item *Actions*.

After a rebuild in TwinCAT® PLC Control, the TwinCAT® configuration is according to [Illustration 73](#) (here *myAxis* and *mySecondAxis* are instances of *AXIS_REF_DDS*, *myPSM* is an instance of *PSM_REF*, and *myDAM* is an instance of *DAM_REF*). The concrete addresses can be different.

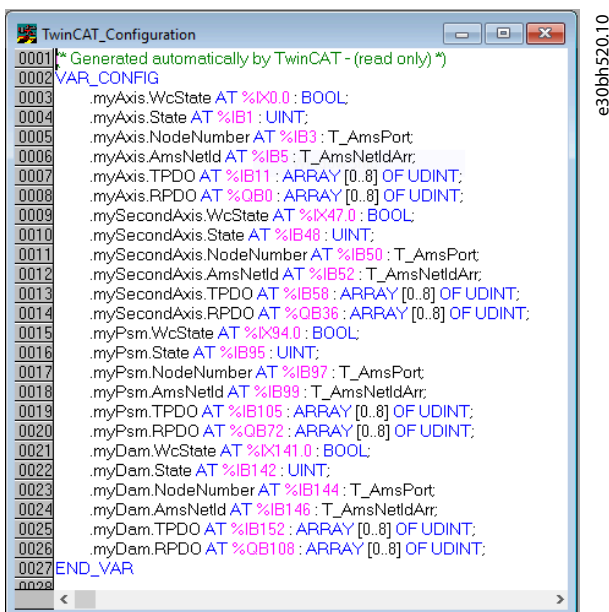

```

0001 | * Generated automatically by TwinCAT - (read only) *)
0002 | VAR_CONFIG
0003 |   myAxis.WcState AT %IX0.0 : BOOL;
0004 |   myAxis.State AT %IB1 : UINT;
0005 |   myAxis.NodeNumber AT %IB3 : T_AmsPort;
0006 |   myAxis.AmsNetId AT %IB5 : T_AmsNetIdArr;
0007 |   myAxis.TPDO AT %IB11 : ARRAY [0..8] OF UDINT;
0008 |   myAxis.RPDO AT %QB0 : ARRAY [0..8] OF UDINT;
0009 |   mySecondAxis.WcState AT %IX47.0 : BOOL;
0010 |   mySecondAxis.State AT %IB48 : UINT;
0011 |   mySecondAxis.NodeNumber AT %IB50 : T_AmsPort;
0012 |   mySecondAxis.AmsNetId AT %IB52 : T_AmsNetIdArr;
0013 |   mySecondAxis.TPDO AT %IB58 : ARRAY [0..8] OF UDINT;
0014 |   mySecondAxis.RPDO AT %QB36 : ARRAY [0..8] OF UDINT;
0015 |   myPsm.WcState AT %IX94.0 : BOOL;
0016 |   myPsm.State AT %IB95 : UINT;
0017 |   myPsm.NodeNumber AT %IB97 : T_AmsPort;
0018 |   myPsm.AmsNetId AT %IB99 : T_AmsNetIdArr;
0019 |   myPsm.TPDO AT %IB105 : ARRAY [0..8] OF UDINT;
0020 |   myPsm.RPDO AT %QB72 : ARRAY [0..8] OF UDINT;
0021 |   myDam.WcState AT %IX141.0 : BOOL;
0022 |   myDam.State AT %IB142 : UINT;
0023 |   myDam.NodeNumber AT %IB144 : T_AmsPort;
0024 |   myDam.AmsNetId AT %IB146 : T_AmsNetIdArr;
0025 |   myDam.TPDO AT %IB152 : ARRAY [0..8] OF UDINT;
0026 |   myDam.RPDO AT %QB108 : ARRAY [0..8] OF UDINT;
0027 | END_VAR
0028 |
  
```

Illustration 73: TwinCAT® Configuration: I/O Mapping of 2 Servo Drives, 1 PSM 510, and 1 DAM 510

NOTICE

- Connect the PSM 510, DAM 510, and ACM 510 to 1 SYNC unit and the ISD 510/DSD 510 servo drives to another. This protects against interruptions in communication to the PSM 510 and DAM 510 if the U_{AUX} supply to the servo drives is switched off due to an error.

6.1.1.14 Setting the PLC Cycle Time in TwinCAT® PLC Control

The minimum cycle time is 400 μ s. The ISD 510 devices can run EtherCAT® cycle times in multiples of 400 μ s or 500 μ s. The devices are automatically parameterized by the PLC on start-up, depending on the EtherCAT® configuration of the physical interface. To access the system base time, select [SYSTEM-Configuration → Real-Time Settings] in the TwinCAT® System Manager. Multiples of this base time can then be used as EtherCAT® cycle times.

NOTICE

- Set the task cycle time of the PLC program to be the same as the EtherCAT® cycle time. Otherwise data may be lost and performance reduced.

Procedure

1. Double-click *Task configuration* in the *Resources* tab.
2. Ensure that the PLC cycle time is the same as the EtherCAT® cycle time.

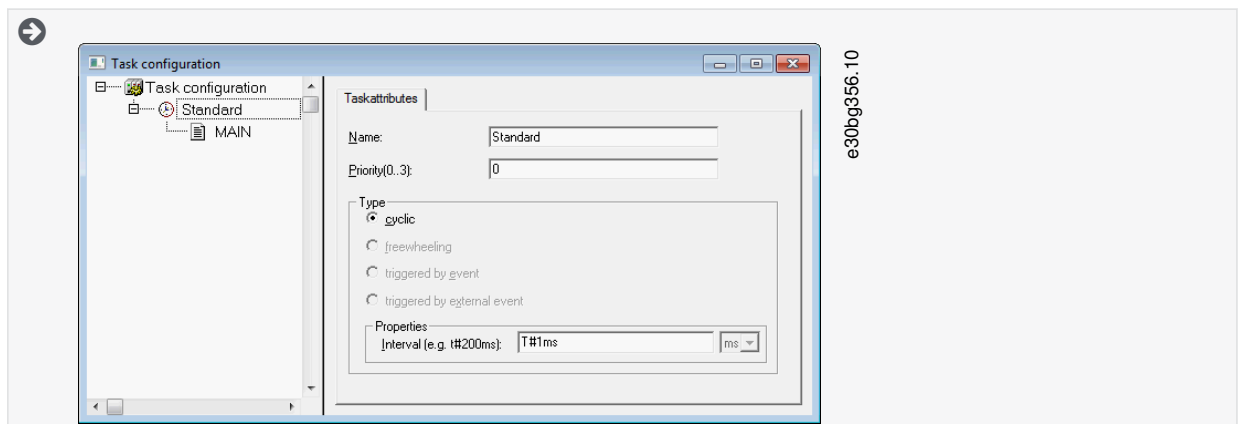

e30bg356.10

Illustration 74: Task Configuration to Parameterize the PLC Cycle Time

NOTICE

– After changing the task cycle time in *TwinCAT® PLC Control*, carry out a *ReScan* of the PLC configuration inside the *TwinCAT® System Manager* to update the settings. Afterwards, activate the configuration in the PLC.

6.1.1.15 Configuration as a TwinCAT® NC Axis

The servo drives can be used with the built-in NC functionality of TwinCAT®.

Everything that is related to the PSM 510 and DAM 510 must be done as described in [6.1.1.2 Creating a TwinCAT® Project](#).

Procedure

1. In addition to the *Danfoss_VLT_ServoMotion_V_x_y_z.lib* file, include the *TcMC2.lib* file.
2. Create 1 instance of *AXIS_REF* (instead of *AXIS_REF_DDS*) for each ISD 510/DSD 510 servo drive that is used as an NC axis.
3. Append the PLC project into the TwinCAT® System Manager, import the devices, and add them to TwinCAT®, however in the last step, answer the question if the servo drive is used as an NC axis with *Yes*. Then an NC task is created automatically.

6.1.1.15.1 I/O Configuration for Servo Drives used as NC Axes

In the TwinCAT® System Manager, select a different I/O Configuration for the servo drives used as NC axes.

Procedure

1. Depending on the mode of operation to be used, select either the slot *CSP PDO* or *CSV PDO*. Per default, *CSV PDO* is mapped and pre-selected. Map the following variables if the VLT® Integrated Servo Drive servo drive is required to work with *CSP PDO*:
 - In the *Settings* Tab of the NC Axis, select [NC-Configuration → NC-Task 1 SAF → Axes → Axis 1]. Click on the *Link To (all Types)...* button and select the desired servo drive.
2. In the same tab, select the preferred *Unit*.
3. Depending on the selected unit, adjust the *Scaling Factor* for the axis encoder via menu [NC-Configuration → NC-Task 1 SAF → Axes → Axis 1 → Axis 1_Enc] in the *Parameter* tab. Example: When the unit *Degrees* is selected, the scaling factor is $360^\circ/2^{20} = 0.00034332275390625$.
4. Set the *Reference Velocity* in the *Parameter* tab via menu [NC-Configuration → NC-Task 1 SAF → Axes → Axis 1 → Axis 1_Enc].
5. Set the *Output Scaling Factor (Velocity)* to 125.
6. Test the functionality and the configuration in the *Online* tab of the axis.

6.11.16 Connecting to the PLC

Information on how to connect to the PLC can be found in detail in the Beckhoff Information System .

Open the information system and go to [TwinCAT 2 → TwinCAT System Manager → Operation → Controls → Choose Target System].

6.12 Programming Guidelines for Automation Studio™ and TwinCAT®

Recommendations for implementation:

- Initialize parameters that usually do not change only once at the beginning of the program. In Automation Studio™, use the *_INIT* section.
- Call up function blocks that provide status or error information with *Enable* input at the beginning of the program.
- Use 1 instance of the function block *MC_Power_DDS* for every axis to control its power stage. Call up this function block in every PLC cycle.
- Use 1 instance of the function block *DD_Power_PSM* for every PSM 510 to control the DC-link voltage on the output. Call up this function block in every PLC cycle.
- Use 1 instance of the function block *DD_Power_DAM* for every DAM 510 to control the DC-link voltage on the output. Call up this function block in every PLC cycle.
- Use 1 instance of the function block *DD_Power_ACM* for every ACM 510 to control the connection between the DC-link and the ACM 510. Call up this function block in every PLC cycle.
- Call up function blocks that execute (motion) commands at the end of the program.
- Do not use any POU's from the library (folder) *DDS_Intern*.
- Do not change the reference to the axis on a function block while it is busy.

N O T I C E

- The full parameter list can be found in the **VLT® Servo Drive System ISD 510, DSD 510, MSD 510 (VLT® Flexmotion™) Programming Guide**.

6.13 Programming with SIMOTION SCOUT®

6.13.1 Requirements for Programming with SIMOTION SCOUT®

The following files are required to integrate the servo system modules into a SIMOTION SCOUT® project. In the filename, 2.xx represents the version number and *yyyymmdd* represents the date.

Table 26: Required Files

System Module	File required
Whole servo system	Package of libraries for the ISD 510 servo system: Danfoss_VLT_ServoMotion_V_x_y_z.zip
	Online Help file(.chm): Programming with SIMOTION SCOUT®

System Module	File required
Servo Drive Module SDM 511/ SDM 512	GSDML file (General station description): GSDML-V2.xx-Danfoss-SDM-yyyymmdd.xml
Integrated Servo Drive ISD 510	GSDML file (General station description): GSDML-V2.xx-Danfoss-ISD-yyyymmdd.xml
Decentral Servo Drive DSD 510	GSDML file (General station description): GSDML-V2.xx-Danfoss-DSD-yyyymmdd.xml
Power Supply Module PSM 510	GSDML file (General station description): GSDML-V2.xx-Danfoss-PSM-yyyymmdd.xml
Decentral Access Module DAM 510	GSDML file (General station description): <ul style="list-style-type: none"> • GSDML-V2.xx-Danfoss-DAM-2Port-IRT-yyyymmdd.xml • GSDML-V2.xx-Danfoss-DAM-3Port-RT-yyyymmdd.xml
Auxiliary Capacitors Module ACM 510	GSDML file (General station description): GSDML-V2.xx-Danfoss-ACM-yyyymmdd.xml

6.13.2 Connecting to the PLC

Information on how to connect to the PLC can be found in detail in the SIMOTION SCOUT® Help.

Open SIMOTION SCOUT® and go to [Help → Help Topics → Getting Started with SIMOTION SCOUT → Download the project to the target system → Connect to selected target devices → Go online].

6.13.3 Creating a SIMOTION SCOUT® Project

Information on how to install SIMOTION SCOUT® can be found in detail in the SIMOTION SCOUT® Configuration Manual.

NOTICE

- SIMATIC STEP 7 V5.5 or higher with HF11 must be installed to create a project.

Information on how to create a project in SIMOTION SCOUT® can be found in detail in the SIMOTION SCOUT® online help. Open SIMOTION SCOUT® and go to [Help → Help Topics → Getting started with SIMOTION SCOUT → Create SIMOTION device and configure PG/PC communication connection].

6.13.4 Including the Servo Motion Libraries into a SIMOTION SCOUT® Project

The folder LIBRARIES in the Project tab contains these libraries:

- DDS_Drive
 - Contains program organization units (POUs) defined by PLCopen® (name starting with MC_) and POU's defined by Danfoss (name starting with DD_). The Danfoss POU's provide additional functionality for the servo drive.
 - It is possible to combine POU's defined by PLCopen® with POU's defined by Danfoss.
 - The names of the POU's that target the servo drive all end with _DDS.
- DDS_PSM
 - Contains POU's defined by Danfoss (name starting with DD_) and provide the functionality for the Power Supply Module (PSM 510).
 - The names of the POU's that target the PSM 510 all end with _PSM.
- DDS_DAM

- Contains POU's defined by Danfoss (name starting with DD_) and provide the functionality for the Decentral Access Module (DAM 510).
- The names of the POU's that target the DAM 510 all end with _DAM.
- DDS_ACM
 - Contains POU's defined by Danfoss (name starting with DD_) and provide the functionality for the Auxiliary Capacitors Module (ACM 510).
 - The names of the POU's that target the ACM 510 all end with _ACM.
- DDS_BasCam
 - Contains POU's for the creation of basic CAMs.
- DDS_LabCam
 - Contains POU's for the creation of labeling CAMs.
- DDS_Intern
 - Contains POU's that are needed internally for the libraries.
 - Do not use these POU's in an application.

When integrating the DDS_Drive package, some standard libraries are integrated automatically, unless they are already part of the project.

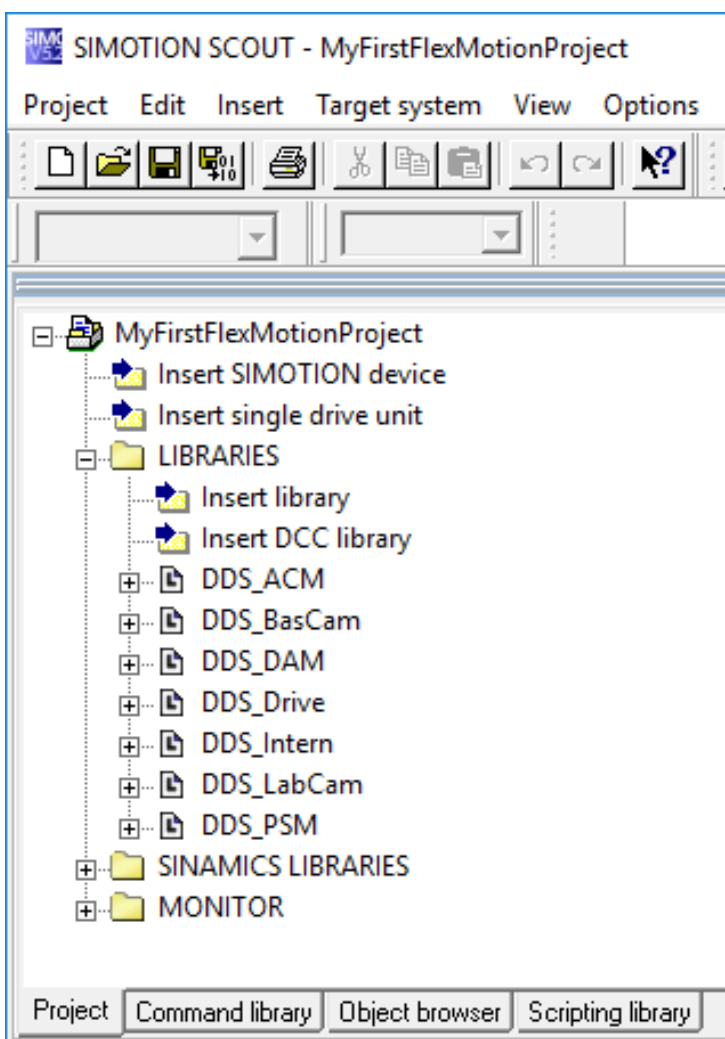

e30bg359.11

Illustration 75: Project Tree after Including Danfoss Servo Motion Libraries

NOTICE

- Do not remove or rename these libraries.

Procedure

1. Extract the files from the *Danfoss_VLT_ServoMotion_V_x_y_z.zip* file (according to the location on the hard drive).

The *DDS_Xxxx.xml* file and *XML_DDS_Xxxx* folder must be located together in the same folder to import the library.

2. In the *Project* tab, right-click on *LIBRARIES* and select [Export/import → Import folders/objects].

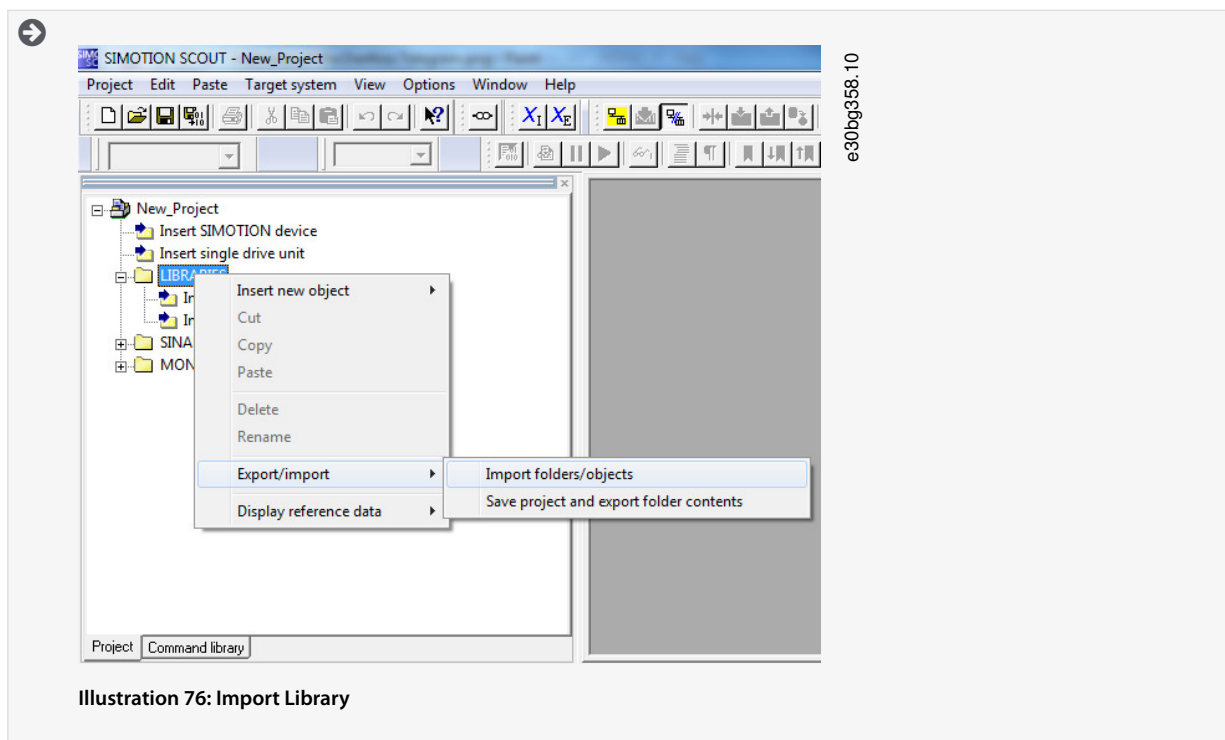

3. Select file *DDS_Intern.xml* according to the location on the hard drive.
4. Click on *OK*. Now the library is integrated into the SIMOTION SCOUT® project.
5. Repeat steps 2–4 for *DDS_BasCam.xml*, *DDS_Drive.xml*, *DDS_LabCam.xml*, *DDS_PSM.xml*, *DDS_DAM.xml*, and *DDS_ACM.xml*.

6.13.5 Importing Devices into SIMOTION SCOUT®

NOTICE

- For each physical servo drive, PSM 510, DAM 510, or ACM 510, add 1 entry to the PROFINET® Ethernet network in the *HW Config* tool.

Procedure

1. Open the *HW Config* tool.
2. Select [Options → Install GSD File...].
3. To add a servo drive, select the xml file (according to the location on the hard drive) and click on *Install*. In the filename, *2.xx* represents the version number and *yyyymmdd* represents the date.
 - GSDML-V2.xx-Danfoss-ISD-yyyymmdd.xml
 - GSDML-V2.xx-Danfoss-DSD-yyyymmdd.xml
4. Repeat steps 2 and 3 for:
 - Power Supply Module (PSM 510): *GSDML-V2.xx-Danfoss-PSM-yyyymmdd.xml*
 - Decentral Access Module (DAM 510):

GSDML-V2.xx-Danfoss-DAM-2Port-IRT-yyyymmdd.xml

GSDML-V2.xx-Danfoss-DAM-3Port-RT-yyyymmdd.xml

- Auxiliary Capacitors Module (ACM 510): *GSDML-V2.xx-Danfoss-ACM-yyyymmdd.xml*

5. Drag the device *Danfoss Drive Servo IRT* on to an existing PROFINET® Ethernet network.

➔ Find the servo drive device named *Danfoss Drive Servo IRT* by expanding the *PROFINET IO* entry in the hardware catalog on the right side of the screen and selecting [Additional Field Devices → Drives → VLT® FlexMotion]. If the device is not visible, update the hardware catalog by selecting [Options → Update catalog].

6. Expand *Drive Object 1* and folder *Profile* in the hardware catalog on the right side of the screen and drag the *Danfoss Telegram* to the free slot of *Drive Object 1* at the bottom of the screen.

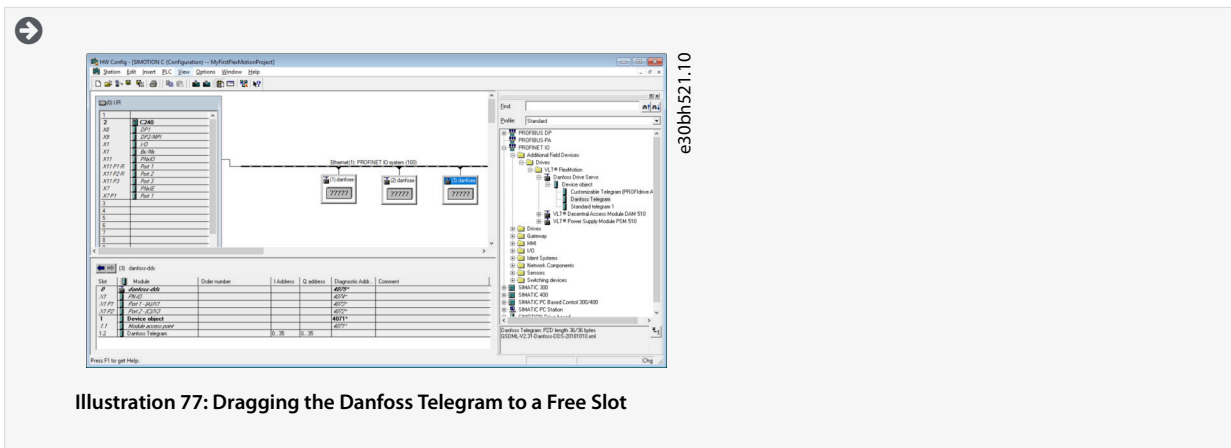

Illustration 77: Dragging the Danfoss Telegram to a Free Slot

- To set the communication parameters, double-click on the icon depicting the servo drive in the main window showing the Ethernet network.
- In the *General* tab, enter a name in field *Device name*.
- In the *General* tab, click on the *Ethernet...* button to set the IP address of the servo drive and then click on *OK*.
- Repeat steps 6–9 for:
 - Power Supply Module (PSM 510): *VLT PSM IRT*
 - Decentral Access Module (DAM 510): *VLT DAM IRT*
 - Auxiliary Capacitors Module (ACM 510): *VLT ACM IRT*

6.13.6 Assigning IP Configuration and Device Name

NOTICE

- If more than 1 servo drive is used in the same PROFINET® network, each servo drive must have a different name and IP address.
- The IP address assignment is also required when using indirect communication via the VLT® Toolbox software (see the **VLT® Servo Drive System ISD 510, DSD 510, MSD 510 (VLT® Flexmotion™) Programming Guide** for further information).

Procedure

- Open menu [PLC → Ethernet → Edit Ethernet Node].
- In the next window, click on *Browse*.

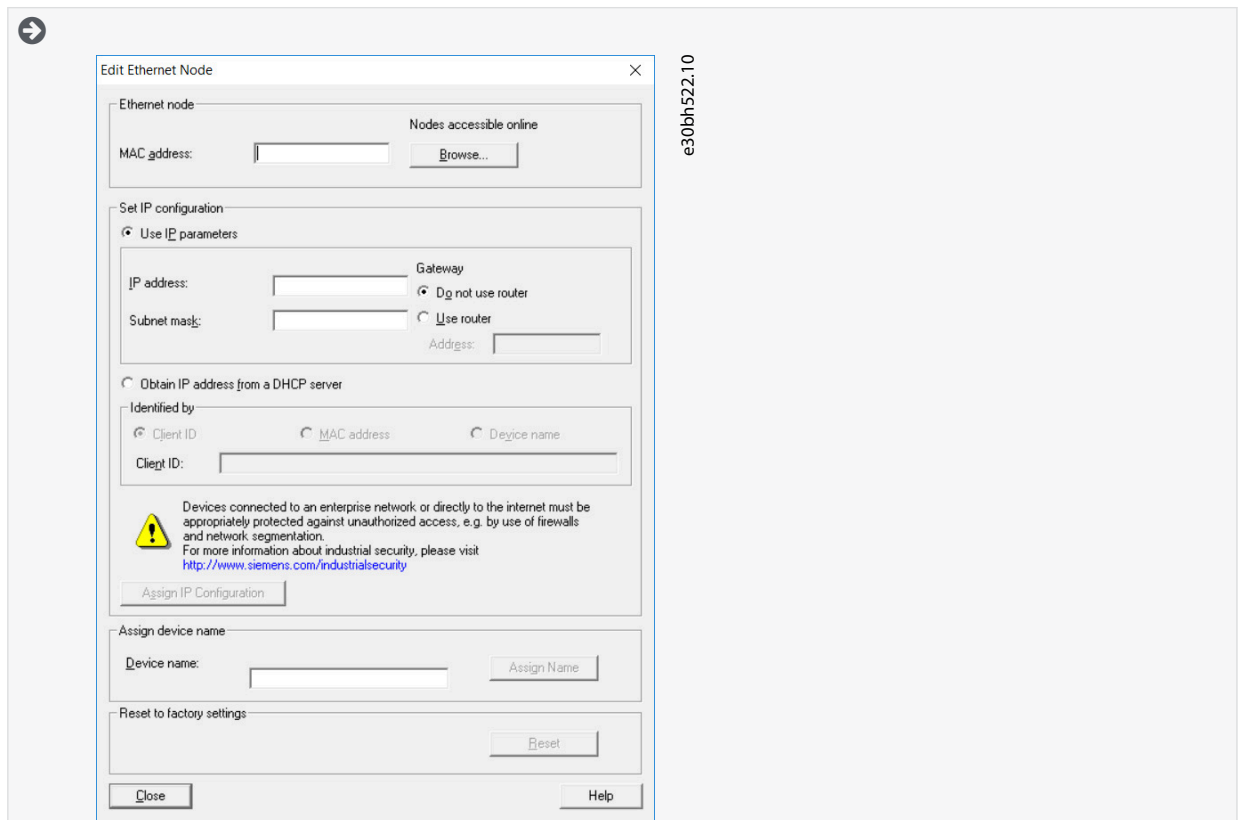

Illustration 78: Edit Ethernet Node

All accessible Ethernet nodes are shown in this window.

The ISD 510 servo drives are listed under device type *VLT® ISD 510*.

The DSD 510 servo drives are listed under device type *VLT® DSD 510*.

3. Select the desired servo drive and click on *OK* (use the *Flash* button to identify the specific servo drive).

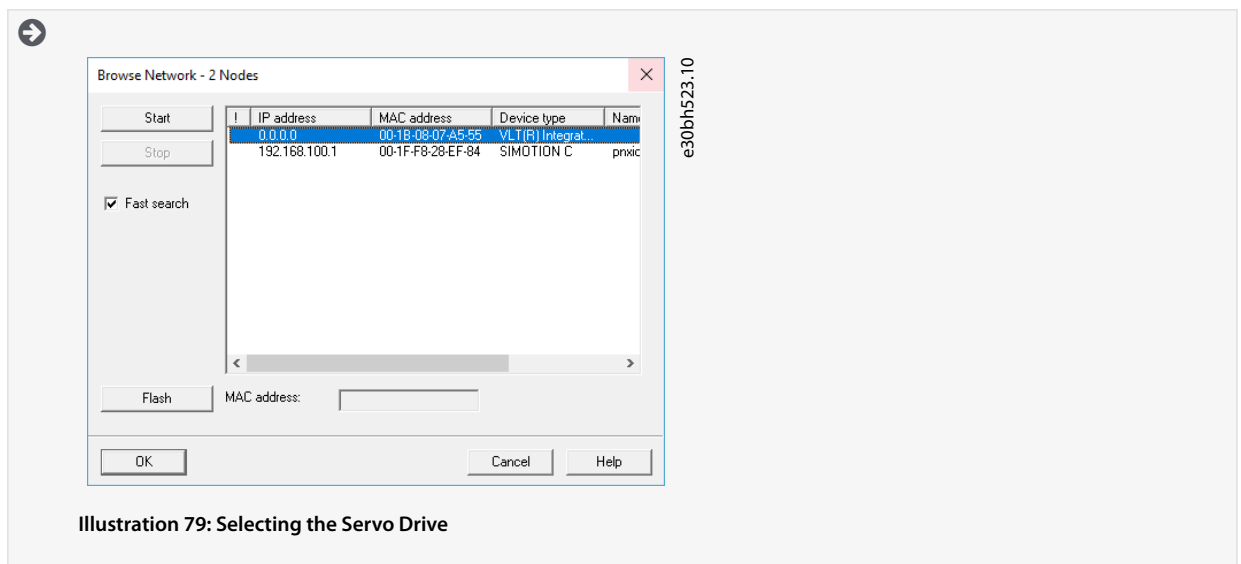

Illustration 79: Selecting the Servo Drive

4. In the *Edit Ethernet Node* window, select the option *Use IP parameters*.
5. Enter the *IP address* and *Subnet mask* and click on *Assign IP configuration*.

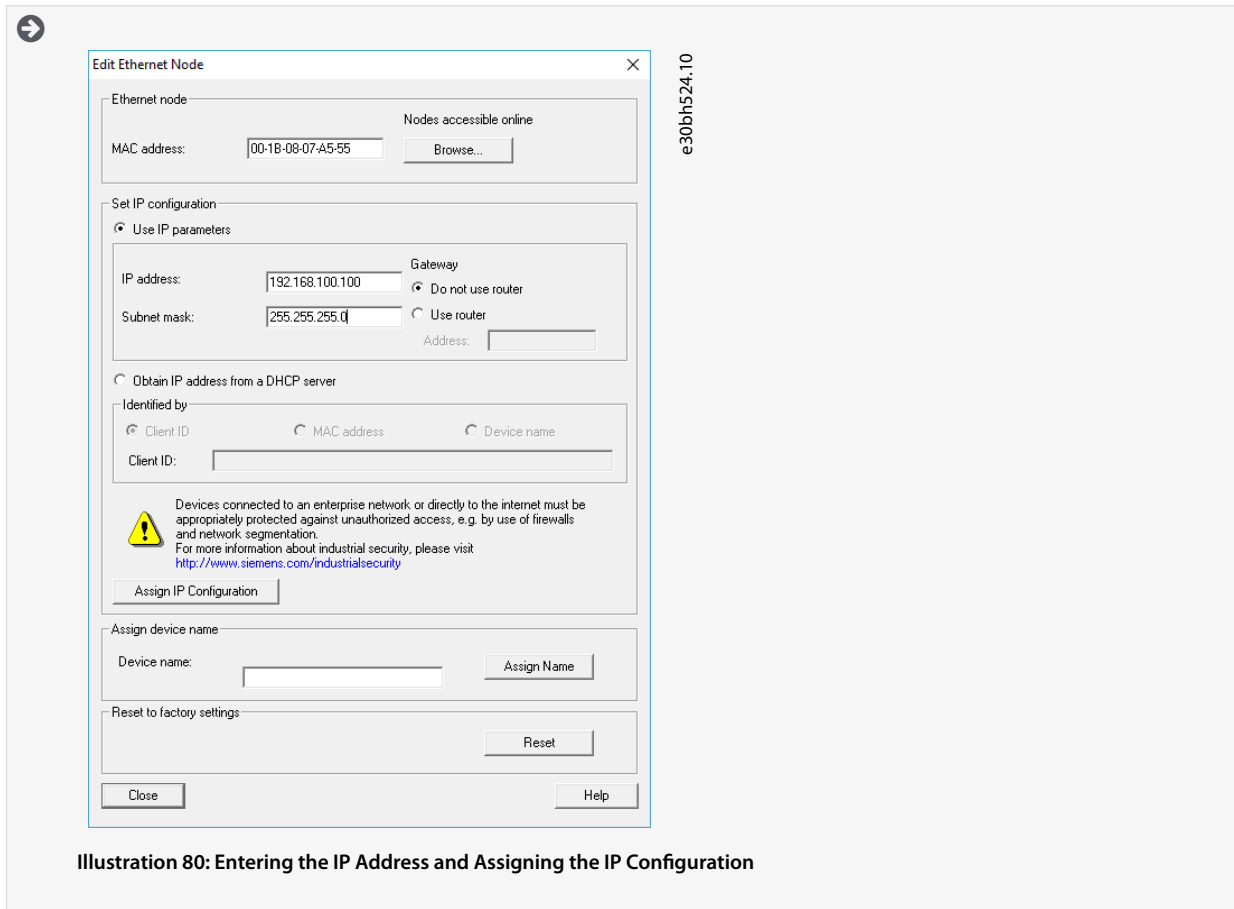
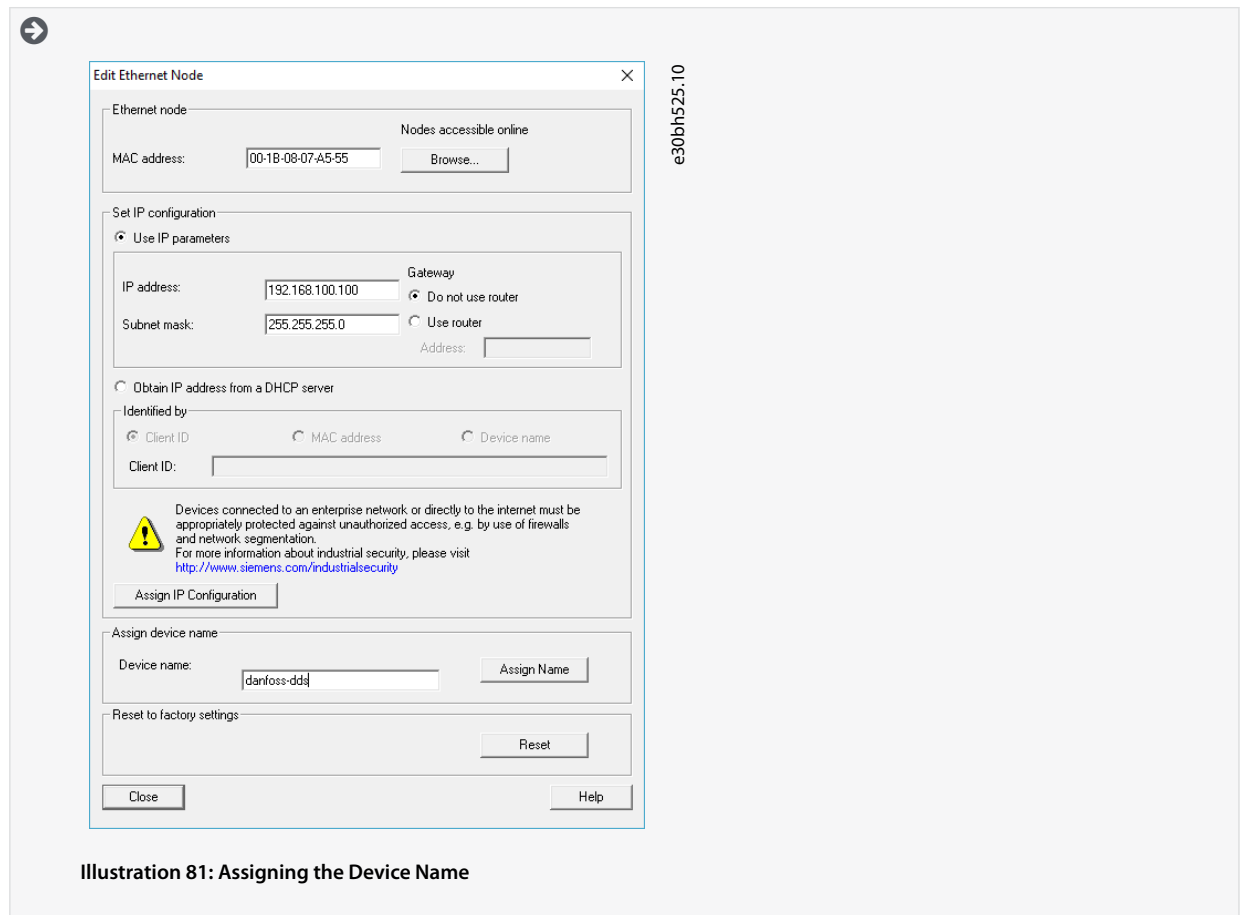

Illustration 80: Entering the IP Address and Assigning the IP Configuration

6. Enter the device name that was previously selected and click on *Assign Name* and then *Close*.



6.13.7 Creating a Sync Domain

A sync domain is a group of PROFINET® devices synchronized to a common cycle clock. One device has the role of the sync master (clock generator). All other devices are sync slaves.

NOTICE

- All devices that exchange data via Isochronous Real-Time (IRT) must belong to the same sync domain.

Procedure

1. Open the *HW Config* tool.
2. Select the station with the PROFINET® devices to be involved in IRT communication.
3. Select the PROFINET® I/O interface in the section *Station/I/O system*.
4. Select the menu [Edit → PROFINET IO → Domain management].

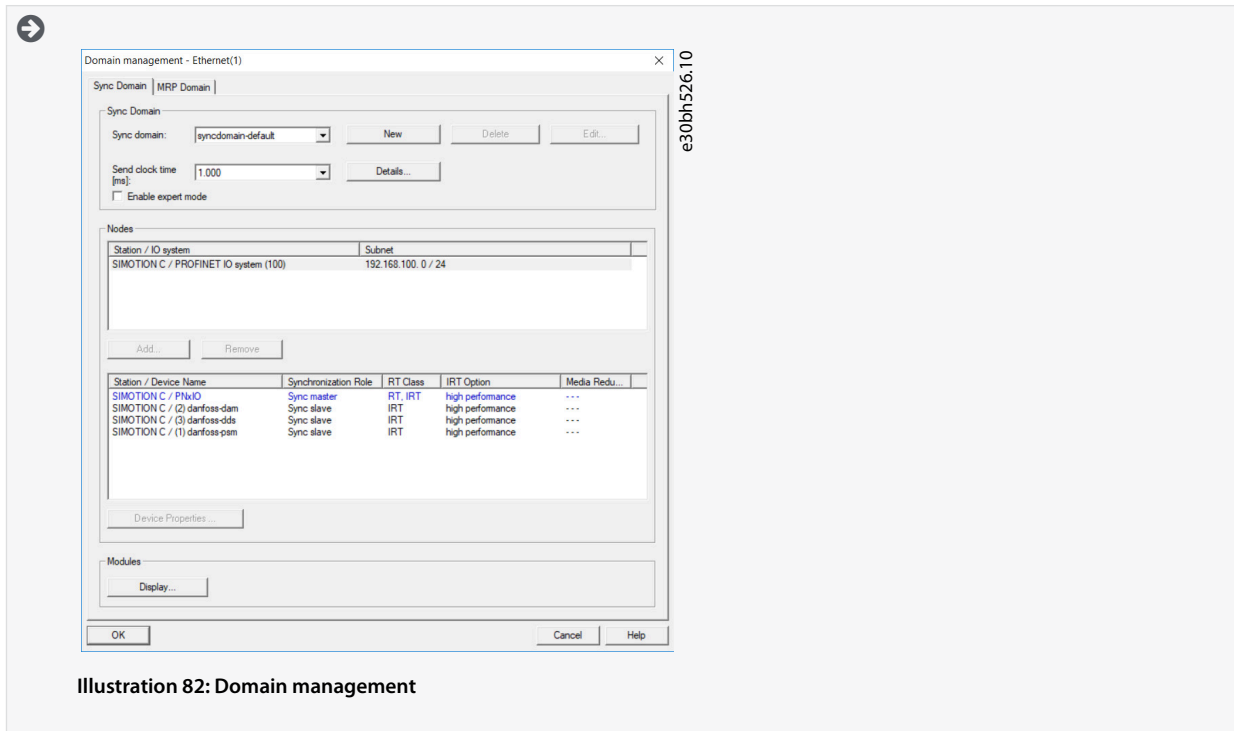

Illustration 82: Domain management

5. In the *Sync Domain* tab, select the station in the upper field of the *Nodes* section.
6. In the lower field of the *Nodes* section, double-click on the device that should be configured as the sync master.
7. When the *Device properties* window opens, select *Sync master* as *Synchronization role* and click on *OK*.

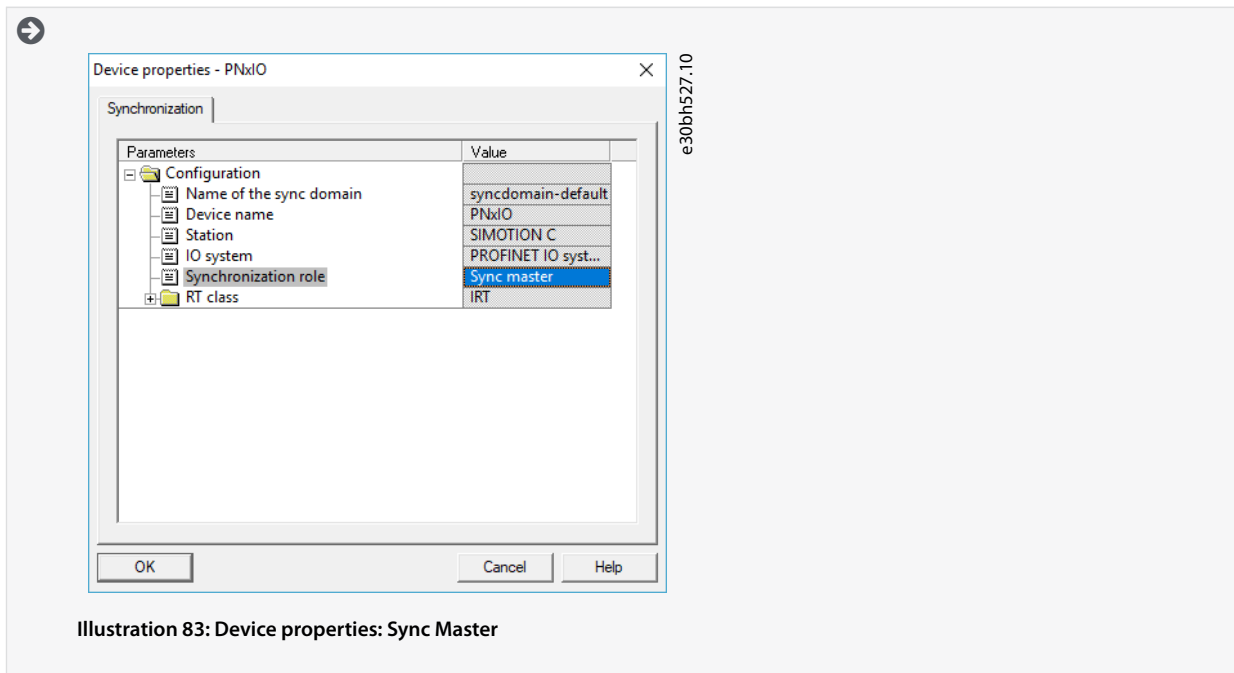

Illustration 83: Device properties: Sync Master

8. In the *Domain management* window, select all devices to be configured as sync slaves in the *Nodes* section (keep the *CTRL* key depressed to select >1 device).
9. Click on the *Device Properties* button.
10. In the *Device Properties* window, select *Sync slave* as *Synchronization role* and click on *OK*.

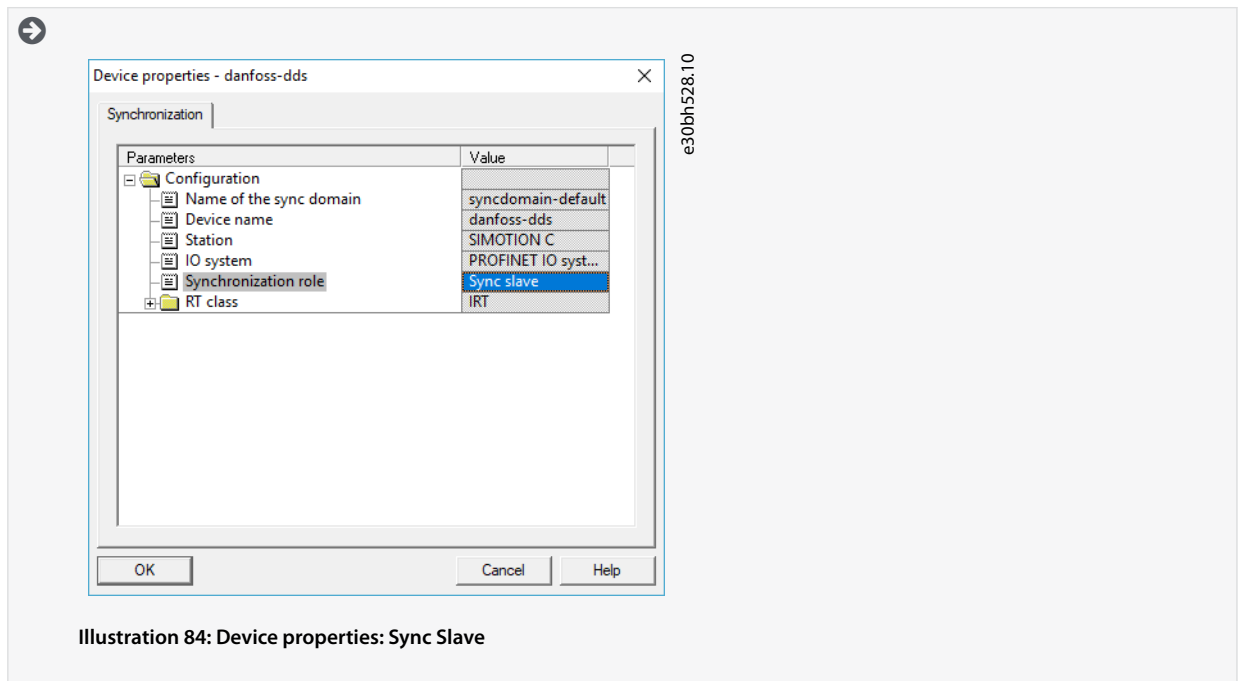

Illustration 84: Device properties: Sync Slave

11. In the *Domain management* window, click on *OK*.
12. Select the station with the PROFINET® devices.
13. Select the menu [Edit → Object Properties].
14. In the next window, open the *Isochronous Tasks* tab, select the isochronous mode for I/O data change, and click on *OK*.

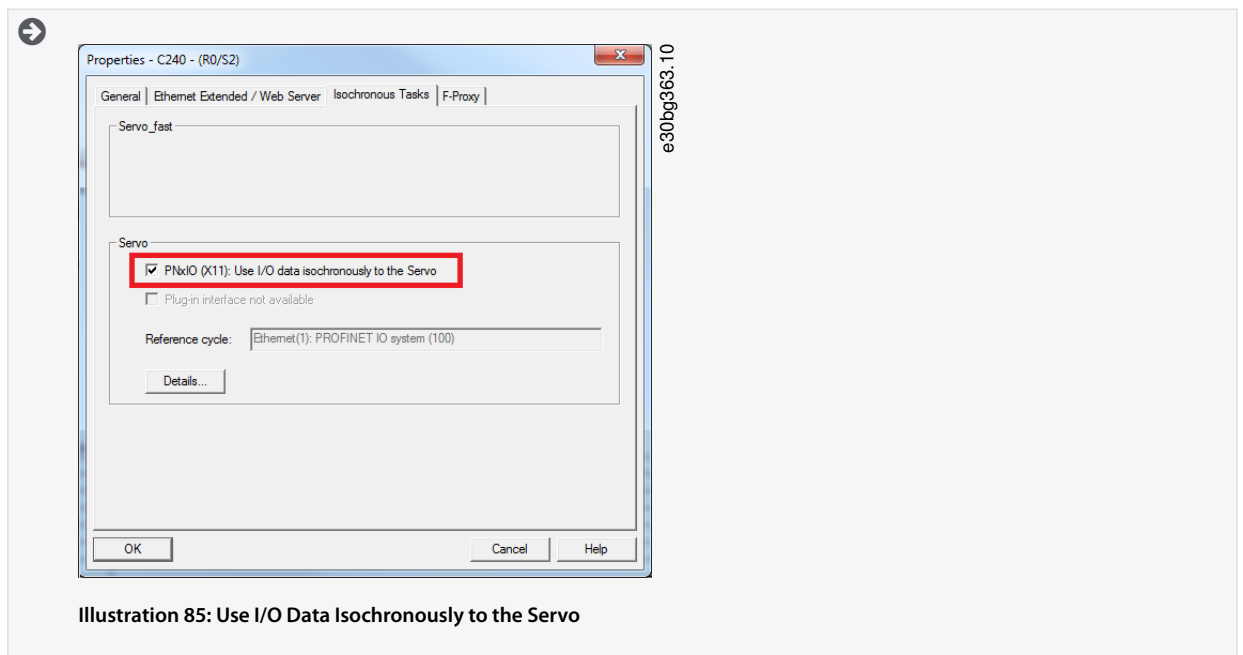
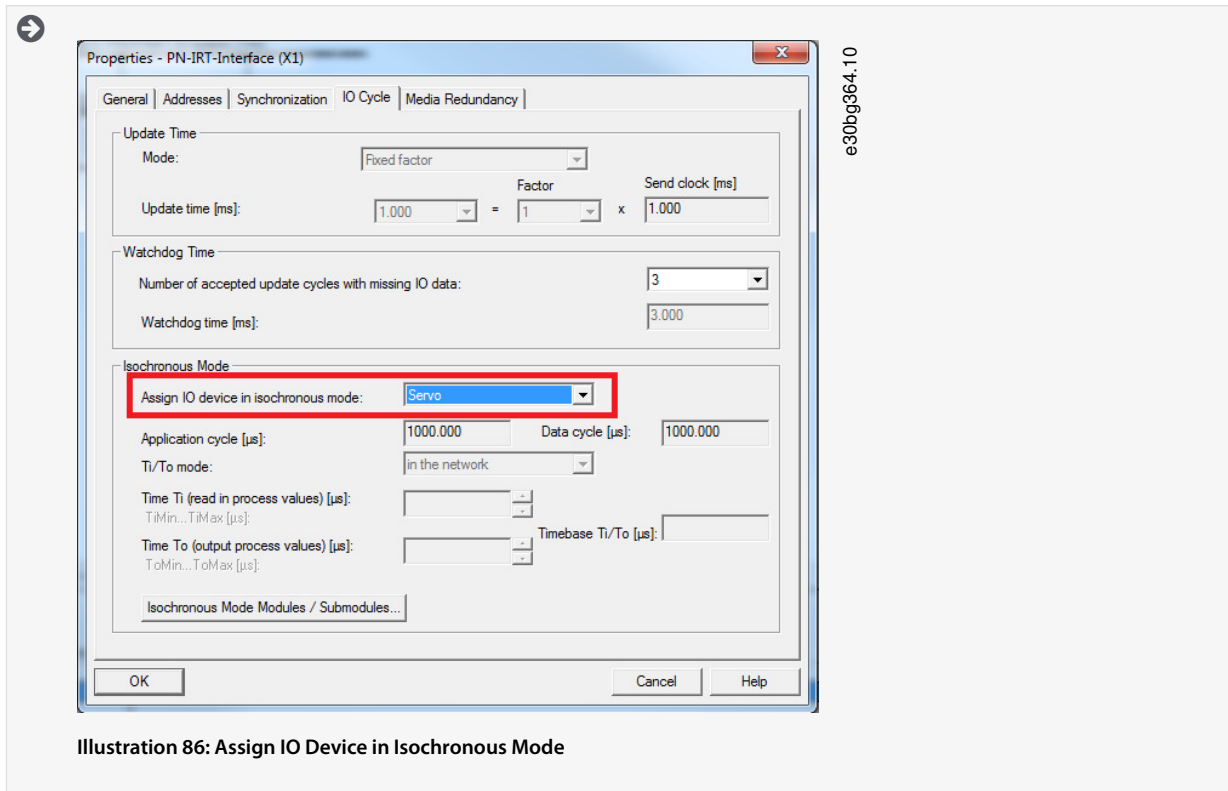

Illustration 85: Use I/O Data Isochronously to the Servo

15. Click on the VLT® ISD 510 IRT device.
16. Double-click on the *PN-IRT-Interface* in the *Module*.
17. In the next window, open the *IO Cycle* tab and set field *Assign IO device in isochronous mode* to *Servo*.



6.13.8 Configuring a Topology

The topology must be configured and parameterized.

Procedure

1. Open the *HW Config* tool.
2. Select the path for the PROFINET® I/O system or PROFINET® module, for example a DanfossISD 510 series.
3. Select the menu [Edit → PROFINET IO → Topology].
4. In the next window, select the *Graphic view* tab.

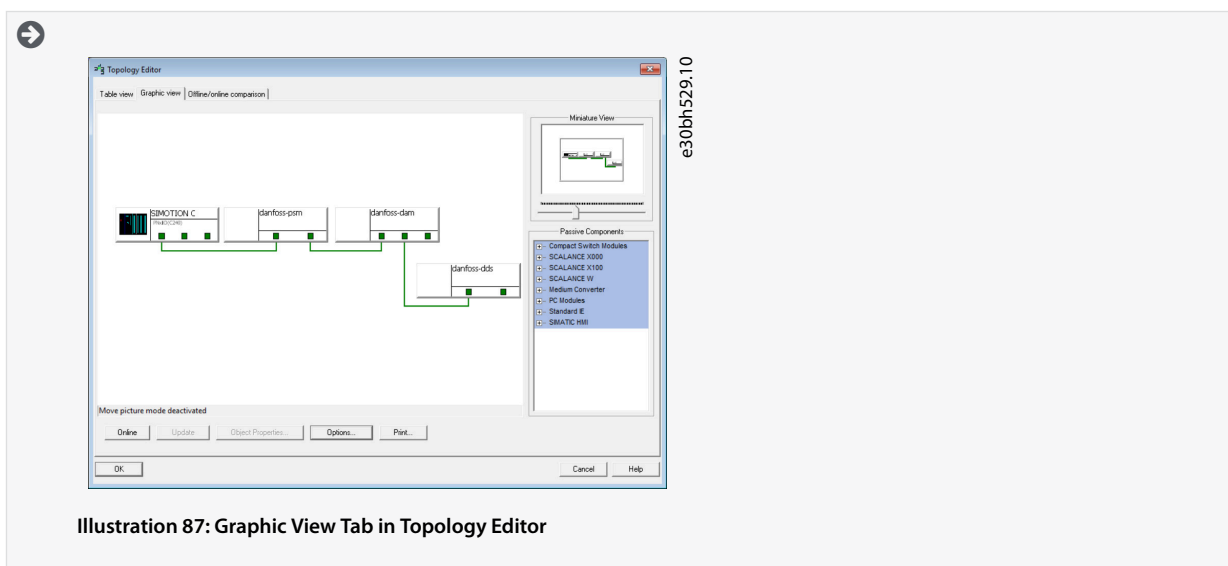

5. Connect the PROFINET® device with the station. Establish connections between ports by holding down the left mouse button and drawing a line between the 2 ports.
6. Once all connections are made, click on *OK*.

6.13.9 Defining Send Clock and Update Time

6.13.9.1 Configuring the Send Clock Time

Procedure

1. Open the *HW Config* tool.
2. Select the station with the PROFINET® devices to be involved in IRT communication, for example PNxIO.
3. Select the menu [Edit → PROFINET IO → Domain management].
4. In the next window, open the *Sync Domain* tab and in the *Send clock time [ms]* field, select an appropriate time for the process, for example 1.000 ms, then click on *OK*.

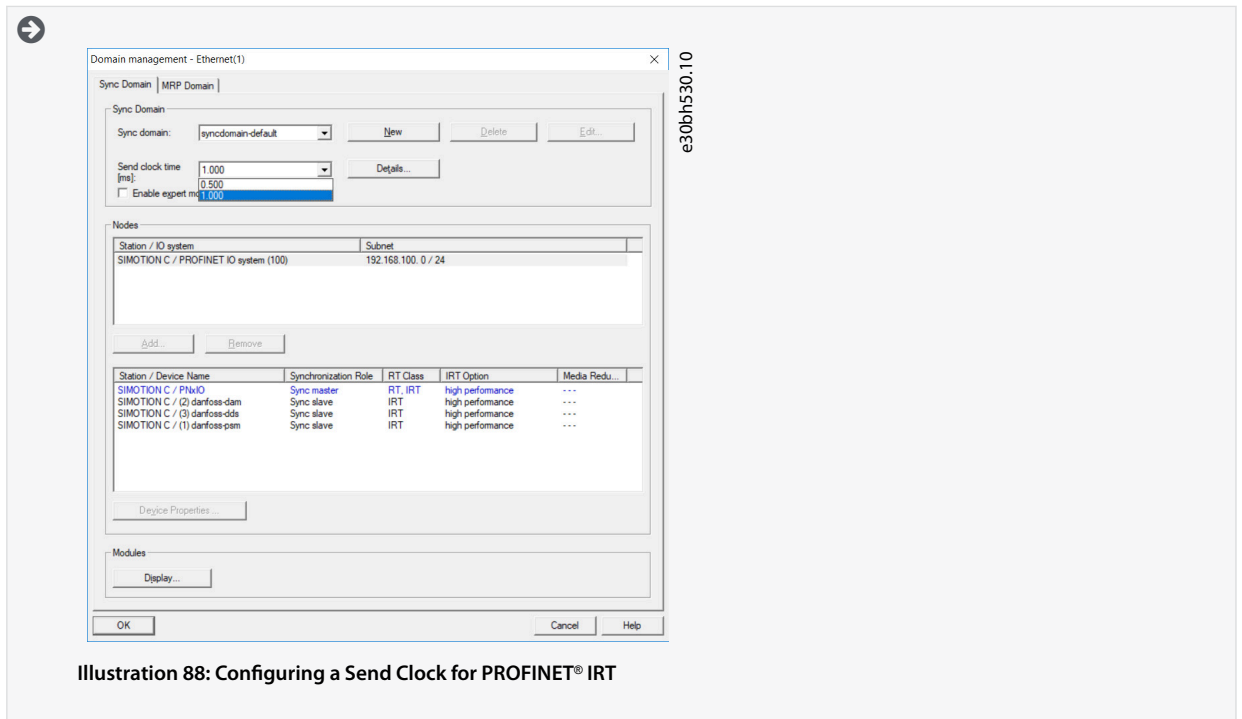

Illustration 88: Configuring a Send Clock for PROFINET® IRT

6.13.9.2 Configuring the Update Time

Procedure

1. Open the *HW Config* tool.
2. Select the path for the PROFINET® I/O system.
3. Select the menu [Edit → Object properties].
4. In the next window, open the *Update Time* tab, highlight the I/O device and click on the *Edit* button.
5. In the next window (*Edit Update Time/Mode*), select the *Update Time* and click on *OK*.

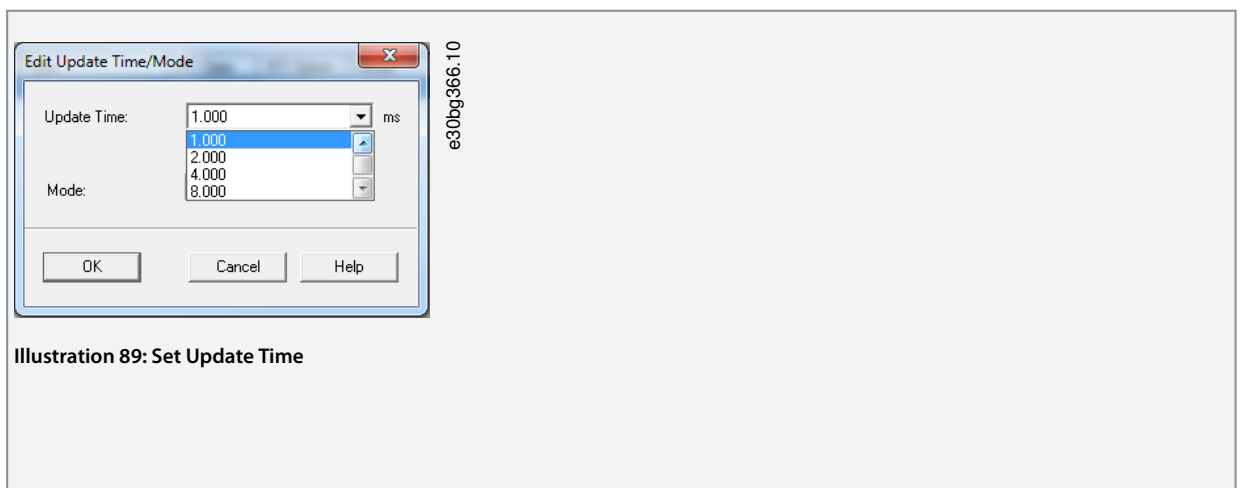

Illustration 89: Set Update Time

NOTICE

- The system cycle clocks of the PLC program must be the same as the PROFINET® send clock, otherwise data may be lost and performance reduced.

6.13.10 Accessing Inputs and Outputs

SIMOTION SCOUT® provides access to the device inputs and outputs of the SIMOTION device via the process image of cyclic tasks using I/O variables.

Procedure

1. Open the *Project* tab and double-click on the *ADDRESS LIST* element in the device subtree, for example *C240 [C240 PN]*.

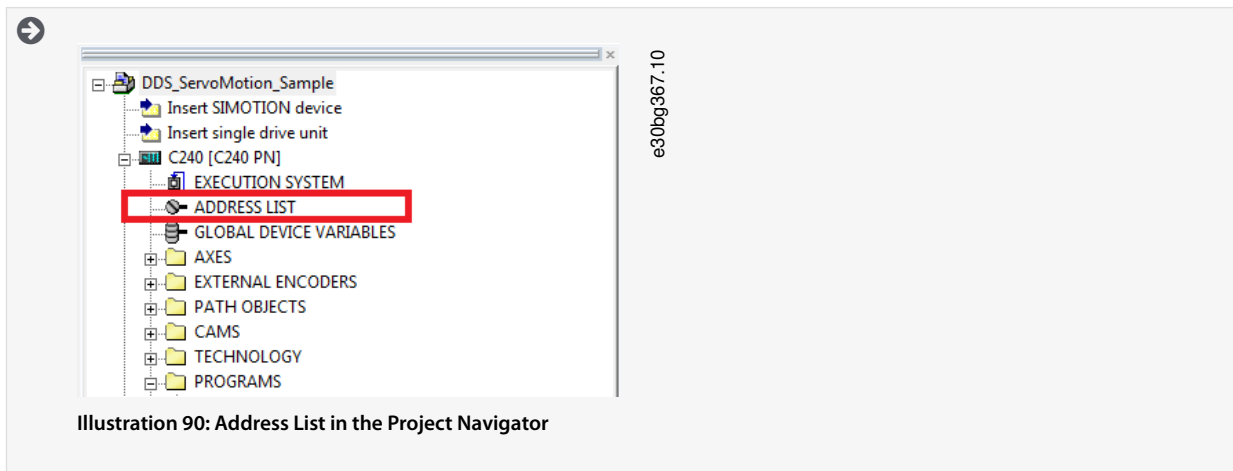

2. In the next window (detailed view), create 1 variable for incoming and outgoing PPO data for each device.

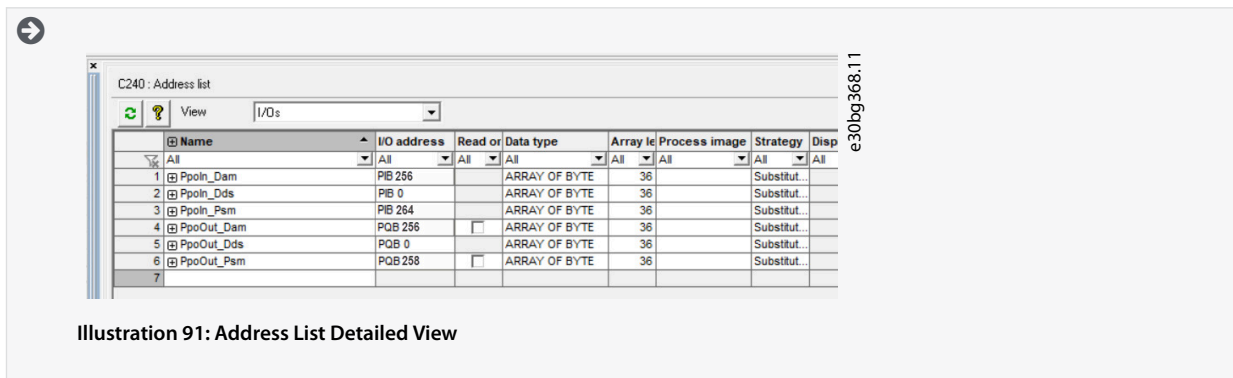

3. Set the following properties for each variable:

- Name (of the I/O variable)
- I/O address
- Data type: ARRAY OF BYTE
- Array length: 36
- Process image: IPOSynchronousTask

NOTICE

- The I/O address must fit the configuration of the device in the *HW Config* tool.
- I/O variables can only be created in offline mode.

6.13.11 Programming using the Danfoss VLT® Servo Motion Library

Before using data types, functions, or function blocks from libraries, the following construct must be used in the interface section:

USELIB DDS_BasCam, DDS_Drive, DDS_LabCam, DDS_PSM, DDS_DAM, DDS_ACM;

More information on how to use data types, functions, and function blocks from libraries can be found in detail in the online help for SIMOTION SCOUT®. Open the SIMOTION SCOUT® and go to [Help → Help Topics → Programming → Integration of ST in SIMOTION → Using libraries → Using data types, functions and function blocks from libraries].

N O T I C E

- Do not use the POU's, Constants, and User-Defined Data Types (UDT) that start with *iDD_* in an application.

6.13.12 Instantiating AXIS_REF_DDS in SIMOTION SCOUT®

Create 1 instance of *AXIS_REF_DDS* (located in folder *DDS_Drive*) for every servo drive that has to be controlled or monitored. Each instance of *AXIS_REF_DDS* is the logical representation of 1 physical servo drive.

N O T I C E

- The instance of the *AXIS_REF_DDS* structure must be created as a global variable (variable in the interface section of a unit declared with *VAR_GLOBAL*).

In the *AXIS_REF_DDS* structure, only assign the variable *InputLogAddress* once at the beginning of the application program for each axis. This is to specify the input logical base address of the I/O module from the HW Config. For this initialization, use the system function *_getLogicalAddressOfVariable()*. Only assign the variable *InputLogAddress* once in the 1st PLC cycle for initialization.

In the *AXIS_REF_DDS* structure, assign the variable *Quality* at the beginning of the application program for each axis in every cycle. Use the system function *_quality.<I/Ovariable>*, whereby *<I/Ovariable>* is the variable containing the cyclic data that was assigned in the *ADDRESS LIST*. Carry out this assignment in every PLC cycle.

Call the function *DD_UpdateProcessInput_DDS* at the beginning of the application program for each device in every cycle. Call the function *DD_UpdateProcessOutput_DDS* at the end of the application program for each device in every cycle.

N O T I C E

- Only create instructions and other program parts between the calls of *DD_UpdateProcessInput* and *DD_UpdateProcessOutput*.

6.13.13 Instantiating PSM_REF in SIMOTION SCOUT®

Create 1 instance of *PSM_REF* (located in folder *DDS_PSM*) for every Power Supply Module (PSM 510) that has to be controlled or monitored. Each instance of *PSM_REF* is the logical representation of 1 physical PSM.

N O T I C E

- The instance of the *PSM_REF* structure must be created as a global variable (variable in the interface section of a unit declared with *VAR_GLOBAL*).

In the *PSM_REF* structure, assign the variable *Quality* at the beginning of the application program for each Power Supply Module in every cycle. Use the system function *_quality.<I/Ovariable>*, whereby *<I/Ovariable>* is the variable containing the cyclic data that was assigned in the *ADDRESS LIST*. Carry out this assignment in every PLC cycle.

Call the function *DD_UpdateProcessInput_PSM* at the beginning of the application program for each device in every cycle. Call the function *DD_UpdateProcessOutput_PSM* at the end of the application program for each device in every cycle.

N O T I C E

- Only create instructions and other program parts between the calls of *DD_UpdateProcessInput* and *DD_UpdateProcessOutput*.

6.13.14 Instantiating DAM_REF in SIMOTION SCOUT®

Create 1 instance of *DAM_REF* (located in folder *DDS_DAM*) for every Decentral Access Module (DAM 510) that has to be controlled or monitored. Each instance of *DAM_REF* is the logical representation of 1 physical DAM.

N O T I C E

- The instance of the *DAM_REF* structure must be created as a global variable (variable in the interface section of a unit declared with *VAR_GLOBAL*).

In the *DAM_REF* structure, assign the variable *Quality* at the beginning of the application program for each Decentral Access Module in every cycle. Use the system function *_quality.</Ovariable>*, whereby *</Ovariable>* is the variable containing the cyclic data that was assigned in the *ADDRESS LIST*. Carry out this assignment in every PLC cycle.

Call the function *DD_UpdateProcessInput_DAM* at the beginning of the application program for each device in every cycle. Call the function *DD_UpdateProcessOutput_DAM* at the end of the application program for each device in every cycle.

N O T I C E

- Only create instructions and other program parts between the calls of *DD_UpdateProcessInput* and *DD_UpdateProcessOutput*.

6.13.15 Instantiating *ACM_REF* in SIMOTION SCOUT®

Create 1 instance of *ACM_REF* (located in folder *DDS_ACM*) for every Auxiliary Capacitors Module (ACM 510) that has to be controlled or monitored. Each instance of *ACM_REF* is the logical representation of 1 physical ACM.

N O T I C E

- The instance of the *ACM_REF* structure must be created as a global variable (variable in the interface section of a unit declared with *VAR_GLOBAL*).

In the *ACM_REF* structure, assign the variable *Quality* at the beginning of the application program for each Auxiliary Capacitors Module in every cycle. Use the system function *_quality.</Ovariable>*, whereby *</Ovariable>* is the variable containing the cyclic data that was assigned in the *ADDRESS LIST*. Carry out this assignment in every PLC cycle.

Call the function *DD_UpdateProcessInput_ACM* at the beginning of the application program for each device in every cycle. Call the function *DD_UpdateProcessOutput_ACM* at the end of the application program for each device in every cycle.

N O T I C E

- Only create instructions and other program parts between the calls of *DD_UpdateProcessInput* and *DD_UpdateProcessOutput*.

6.13.16 Global Compiler Settings

Activate the global compiler settings *Permit language extensions*.

Procedure

1. Open the menu [Options → Settings].
2. In the next window, select the *Compiler* tab.
3. Activate the checkbox *Permit language extensions* and click on *OK*.

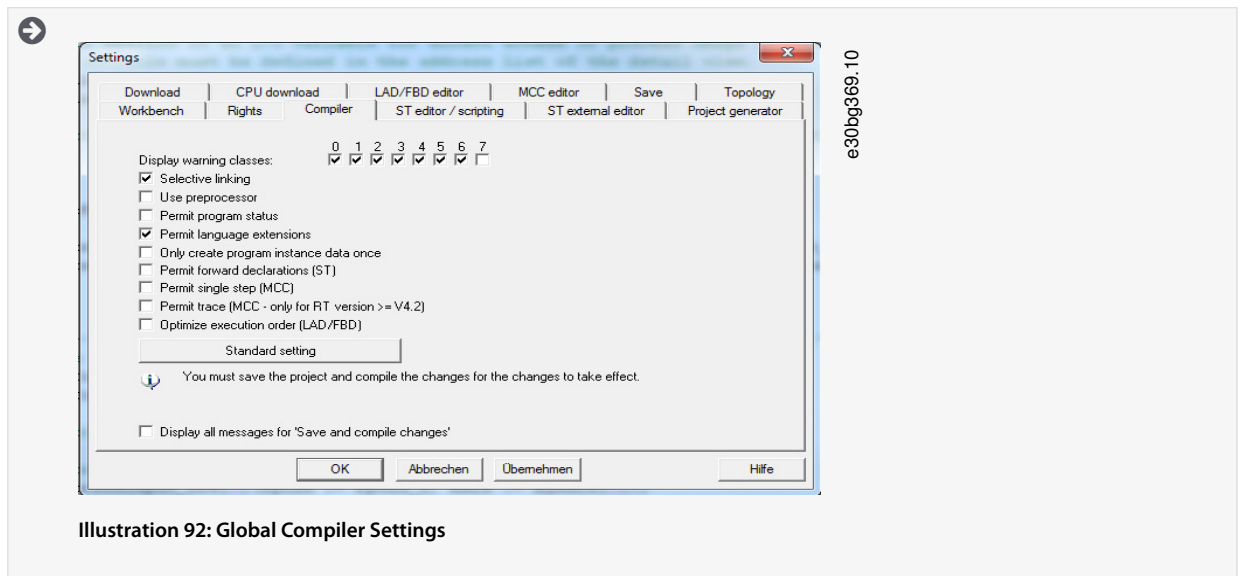

Illustration 92: Global Compiler Settings

6.13.17 Assigning Tasks

To guarantee synchronous operation, the application must use a *Synchronous Task* and a *Peripheral Fault Task* to evaluate the alarms.

Procedure

1. Open the *Project* tab.
2. Double-click on *EXECUTION SYSTEM* in the device subtree.



Illustration 93: Execution System in the Project Navigator

3. In the next window, expand entry *Execution levels* and then select *OperationLevels* and then *SynchronousTask* in the tree structure.
4. In the *SynchronousTask* window, activate checkbox *Use task in execution system*.
5. Click on the new entry *IPOSynchronousTask* in the tree structure.
6. In the *Program assignment* area at the left side of the *Synchronous Task* window, assign the program by selecting it and clicking on the [Programs used section on the right side.

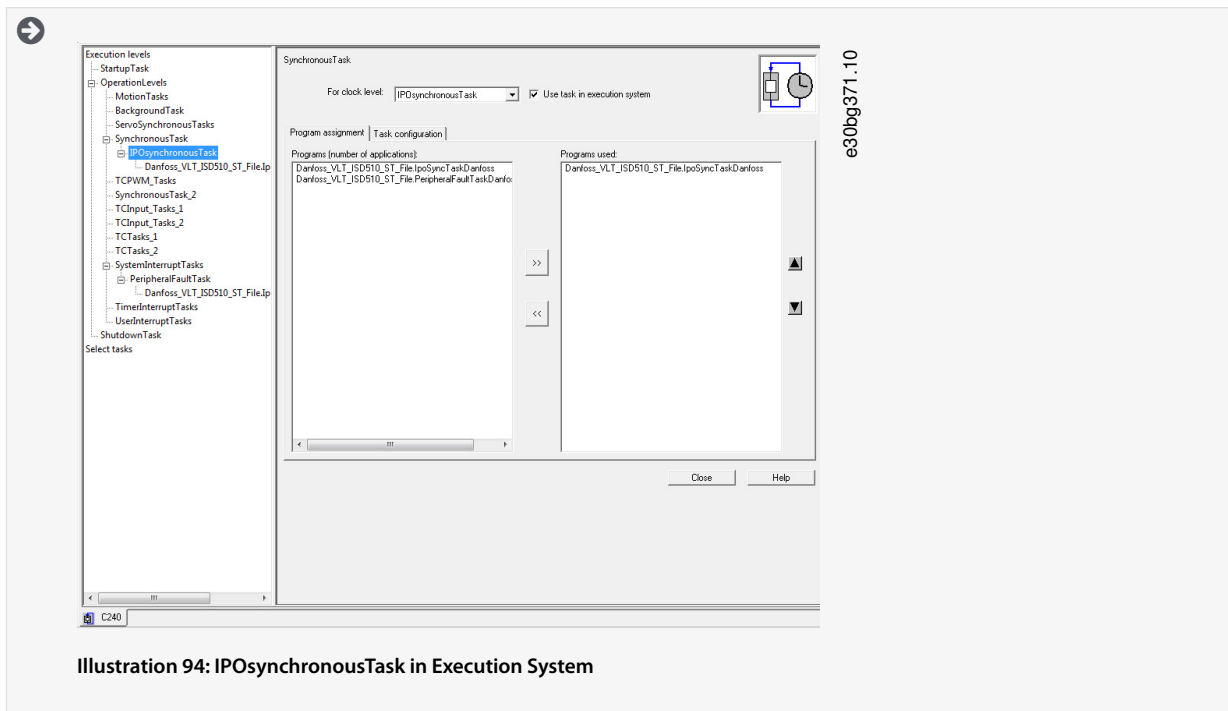

Illustration 94: IPOsynchronousTask in Execution System

7. In the *Task configuration* tab, set the *Number of level overflows in the IPO cycle clock* to 1 and the *IPOsynchronousTask / IPO cycle clock* to 50%.

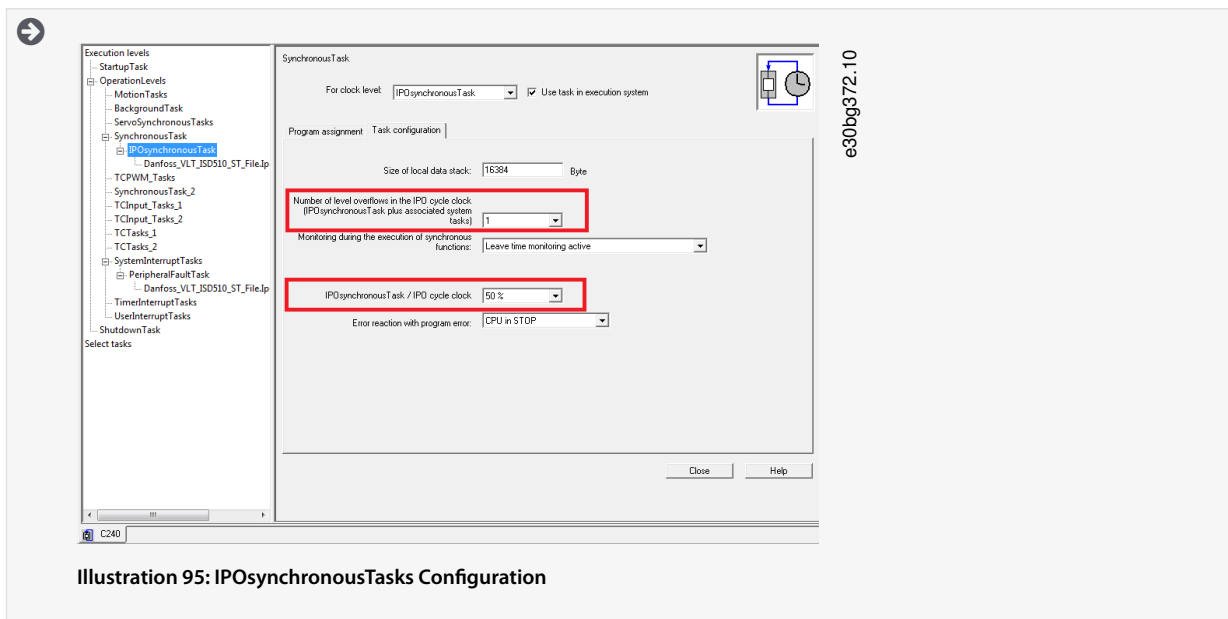

Illustration 95: IPOsynchronousTasks Configuration

8. Expand entry *SystemInterruptTasks* in the tree structure and select the new entry *PeripheralFaultTask*.
9. In the *PeripheralFaultTask* window, activate checkbox *Use task in execution system*.
10. In the *Program assignment* area at the left side of the *PeripheralFaultTask* window, assign the program by selecting it and clicking on the [$>>$] button. The program will then be moved to the *Programs used* section on the right side.
11. Click on *Close* to save and compile the settings.

6.14 Programming Guidelines for SIMOTION SCOUT®

Recommendations for implementation:

- Only assign the variable *InputLogAddress* in the *AXIS_REF_DDS* structure once for each axis at the beginning of the program. Use the system function *_getLogicalAddressOfIoVariable* to get this address from the I/O variable of the address list. Use the input address of the module as the I/O variable. Only assign this variable in the 1st PLC cycle for initialization.
- Initialize parameters that usually do not change only once at the beginning of the program.
- Only assign the variable *Quality* in the *AXIS_REF_DDS* structure once for each axis at the beginning of the program. Use the system function *_quality.var-name*. Carry out this check for every PLC cycle.
- Call up the function blocks *DD_UpdateProcessInput_DDS* and *DD_UpdateProcessOutput_DDS* for every axis to update the process image partition of inputs and outputs. Call up these function blocks in every PLC cycle.
- Only create instructions and other program parts between calling up function blocks *DD_UpdateProcessInput_DDS* and *DD_UpdateProcessOutput_DDS*.
- Call up function blocks that provide status or error information with *Enable input* at the beginning of the program.
- Use 1 instance of function block *MC_Power_DDS* for every axis to control its power stage. Call up this function block in every PLC cycle.
- Use 1 instance of function block *DD_Power_PSM* for every PSM 510 to control the DC-link voltage on the output lines. Call up this function block in every PLC cycle.
- Use 1 instance of function block *DD_Power_DAM* for every DAM 510 to control the DC-link voltage on the output lines. Call up this function block in every PLC cycle.
- Use 1 instance of function block *DD_Power_ACM* for every ACM 510 to control the DC-link voltage on the output lines. Call up this function block in every PLC cycle.
- Call up function blocks that execute (motion) commands at the end of the program.
- Do not use any UDTs, POUs, enumerations, or constants starting with the prefix *iDD_*.
- Do not change the reference to the axis on a function block while it is busy.

6.15 Programming with TIA

6.15.1 Requirements for Programming with TIA

The following files are required to integrate the servo system modules into a TIA project. In the filename, 2.xx represents the version number and *yyyymmdd* represents the date.

Table 27: Required Files

System Module	File required
Whole servo system	Package of libraries for the ISD 510 servo system: <i>Danfoss_VLT_ServoMotion_V_x_y_z.zalxx</i> .
ISD 510 servo drive	GSDML file (General station description): <i>GSDML-V2.xx-Danfoss-ISD-yyyymmdd.xml</i>
DSD 510 servo drive	GSDML file (General station description): <i>GSDML-V2.xx-Danfoss-DSD-yyyymmdd.xml</i>
Power Supply Module PSM 510	GSDML file (General station description): <i>GSDML-V2.xx-Danfoss-PSM-yyyymmdd.xml</i>
Decentral Access Module DAM 510	GSDML file (General station description): <ul style="list-style-type: none"> • <i>GSDML-V2.xx-Danfoss-DAM-2Port-IRT-yyyymmdd.xml</i> • <i>GSDML-V2.xx-Danfoss-DAM-3Port-RT-yyyymmdd.xml</i>
Auxiliary Capacitors Module ACM 510	GSDML file (General station description): <i>GSDML-V2.xx-Danfoss-ACM-yyyymmdd.xml</i>

6.15.2 Creating a TIA Project

NOTICE

- TIA V15 or higher must be installed to create a project.

Information on how to create a project in TIA can be found in detail in the TIA online help. Open TIA and go to [Help → Information System → Editing projects → Creating and managing projects].

6.15.3 Including the Servo Motion Libraries into a TIA Project

The folder *LIBRARIES* in the *Project* tab contains these libraries:

- DDS_Drive
 - Contains program organization units (POUs) defined by PLCopen® (name starting with MC_) and POUs defined by Danfoss (name starting with DD_). The Danfoss POUs provide additional functionality for the servo drive.
 - It is possible to combine POUs defined by PLCopen® with POUs defined by Danfoss.
 - The names of the POUs that target the servo drive all end with _DDS.
- DDS_PSM
 - Contains POUs defined by Danfoss (name starting with DD_) and provide the functionality for the Power Supply Module (PSM 510).
 - The names of the POUs that target the PSM 510 all end with _PSM.
- DDS_DAM
 - Contains POUs defined by Danfoss (name starting with DD_) and provide the functionality for the Decentral Access Module (DAM 510).
 - The names of the POUs that target the DAM 510 all end with _DAM.
- DDS_ACM
 - Contains POUs defined by Danfoss (name starting with DD_) and provide the functionality for the Auxiliary Capacitors Module (ACM 510).
 - The names of the POUs that target the ACM 510 all end with _ACM.
- DDS_BasCam
 - Contains POUs for the creation of basic CAMs.
- DDS_LabCam
 - Contains POUs for the creation of labeling CAMs.
- DDS_Intern
 - Contains POUs that are needed internally for the libraries.
 - Do not use these POUs in an application.

When integrating the DDS_Drive package, some standard libraries are integrated automatically, unless they are already part of the project.

NOTICE

- Do not remove or rename these libraries.

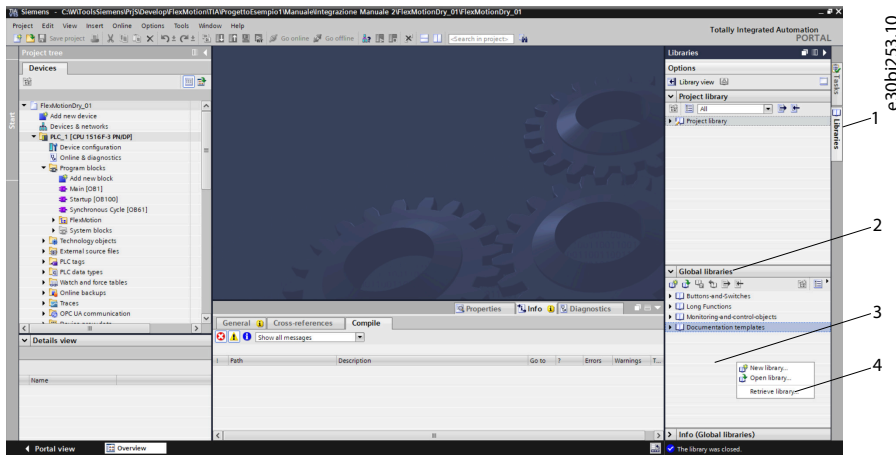

Illustration 96: Including the Servo Motion Libraries

Procedure

1. Expand the *Libraries* window [1], then select and expand the *Global libraries* section [2].
2. Right-click on the empty area [3] then select menu entry *Retrieve library...* [4].
3. Select the *Danfoss_VLT_ServoMotion_V_x_y_z.zal1x* file (according to the location on the hard drive).

6.15.4 Importing Devices into TIA

NOTICE

- For each physical servo drive, PSM 510, DAM 510, or ACM 510, add 1 entry to the PROFINET® Ethernet network in the *Hardware Catalog*.

Procedure

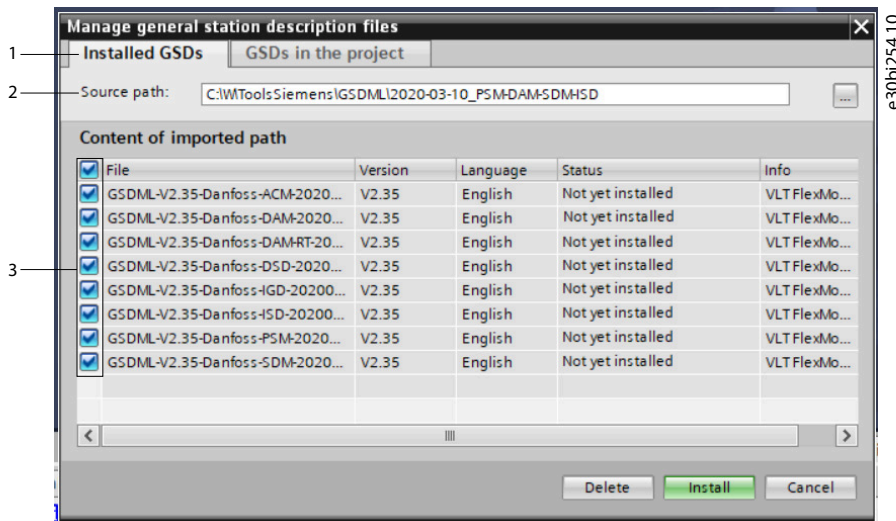

1. Open the *Hardware Catalog*.
2. Select [Options → Manage general station description files]
3. In tab *Installed GSDs* [1], select the Source path [2] where the files are located.
4. To add a servo drive, select one of the xml files [3] and click on *Install*. In the filename, *2.xx* represents the version number and *yyyymmdd* represents the date.
 - GSDML-V2.xx-Danfoss-ISD-yyyymmdd.xml
 - GSDML-V2.xx-Danfoss-DSD-yyyymmdd.xml
5. Repeat steps 2 and 3 for:

- Power Supply Module (PSM 510): *GSDML-V2.xx-Danfoss-PSM-yyyyymmdd.xml*
- Decentral Access Module (DAM 510):
 - GSDML-V2.xx-Danfoss-DAM-2Port-IRT-yyyyymmdd.xml*
 - GSDML-V2.xx-Danfoss-DAM-3Port-RT-yyyyymmdd.xml*
 - GSDML-V2.xx-Danfoss-DAM-yyyyymmdd.xml*
- Auxiliary Capacitors Module (ACM 510): *GSDML-V2.xx-Danfoss-ACM-yyyyymmdd.xml*

6.15.5 Creating a Network

Procedure

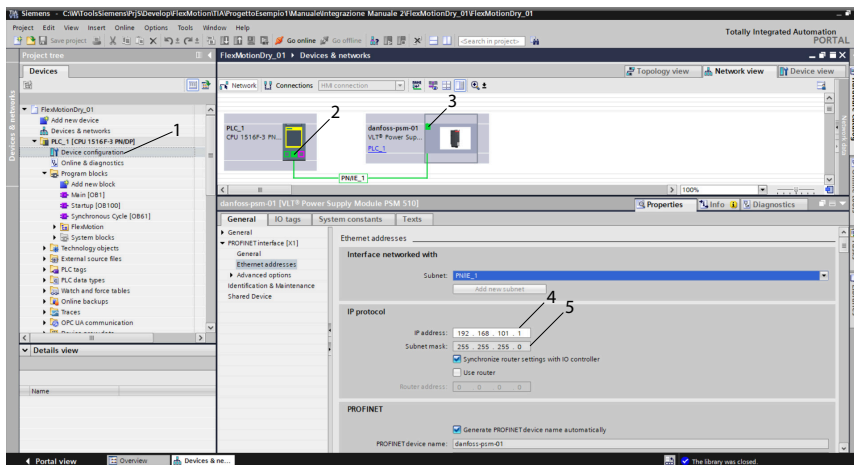

e30bi255.10

1. In the *Devices* window, select *Device configuration* [1] and add a PSM.
2. Assign the PSM to the PLC_1 by dragging the middle square under the PLC icon [2] onto the square at top left of the PSM icon [3]. The PN/IE_1 network is created automatically.
3. Assign the PROFINET device name, IP address, and subnet mask to the PSM:
 - Right-click on the PSM icon.
 - Select the tab *General*.
 - Select *PROFINET interface [X1]* and then *Ethernet addresses*.
 - Enter the IP address 192.168.101.1 [4].
 - Enter the Subnet mask 255.255.255.0 [5].
4. Repeat steps 1–3 to add a DAM 510, ACM 510, ISD 510, or DSD 510.
5. In the *Devices & networks* window, select *Topology view* [1] and connect the devices by dragging and dropping the icons.

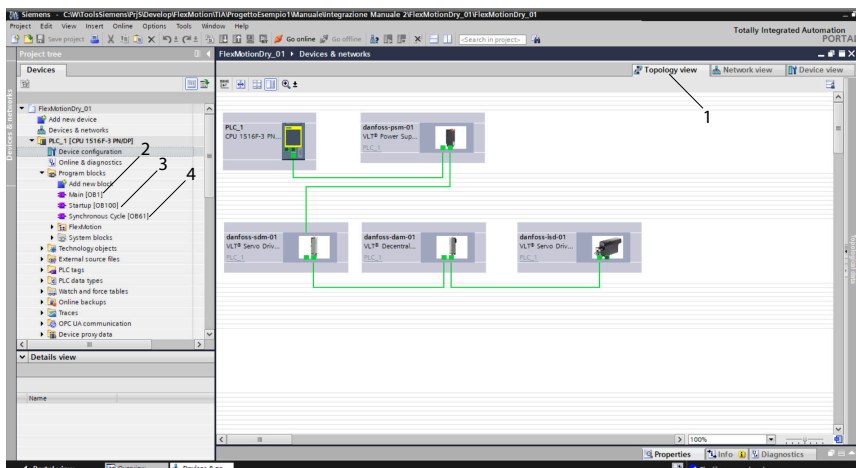

e30bi256.10

6. Remove any existing *MAIN [OB1]* operation block:

- In the *Project Tree*, expand the *Program blocks* entry.
 - Right-click on operation block *Main [OB1]* [2] then select *Delete* in the drop-down menu.
7. Add a new *MAIN [OB1]* operation block [2] and create operation blocks for *Startup [OB100]* [3], and *Synchronous Cycle [OB61]* [4]:
- In the *Project Tree*, expand the *Program blocks* entry.
 - Double-click on *Add new block*.
 - In the *Add new block* window, select *Organization block*.
 - Select organization block *MAIN [OB1]* from the list.
 - Set the language to *SCL* and activate the radio button *Automatic*.
 - Click on *OK*.
 - Repeat for *Startup [OB100]* and *Synchronous Cycle [OB61]*.
8. Verify SyncDomain:
- Open *Network view* [1] and select the Ethernet subnet [2] in which the sync domain is set up.
 - Open the Ethernet subnet properties.
 - In the local navigation [4], select entry [Domain management → Sync domains → Sync-Domain_1].
 - In the field *Sync Domain* [5], change the name as desired.
 - In the field *Send clock* [6], select the desired value from the drop-down menu.
 - Activate the *Default domain* checkbox [7] to make this sync domain the default domain.

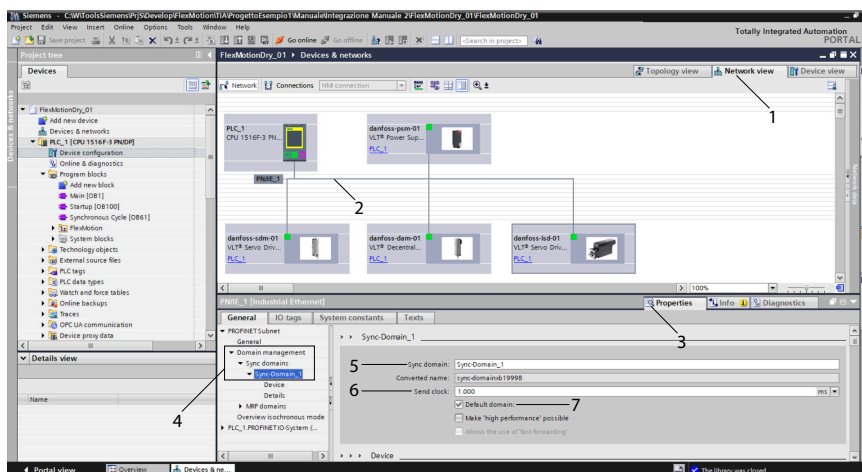

e30bi257.10

9. Verify that all system components have the *Sync slave* role:

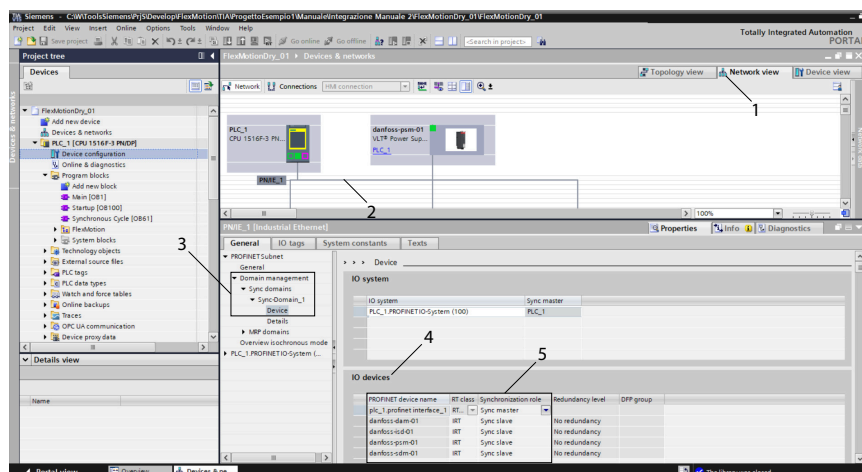

e30bi258.10

- Open *Network view* [1] and select the Ethernet subnet in which the sync domain is set up.
- Open the Ethernet subnet [2] properties.

- In the local navigation [3], select entry [Domain management → Sync domains → Sync-Domain_1 → Device].
- Select the IO devices.
- Verify that all system components are present and set to *Sync slave*.

10. Select the telegram properties of each system component:

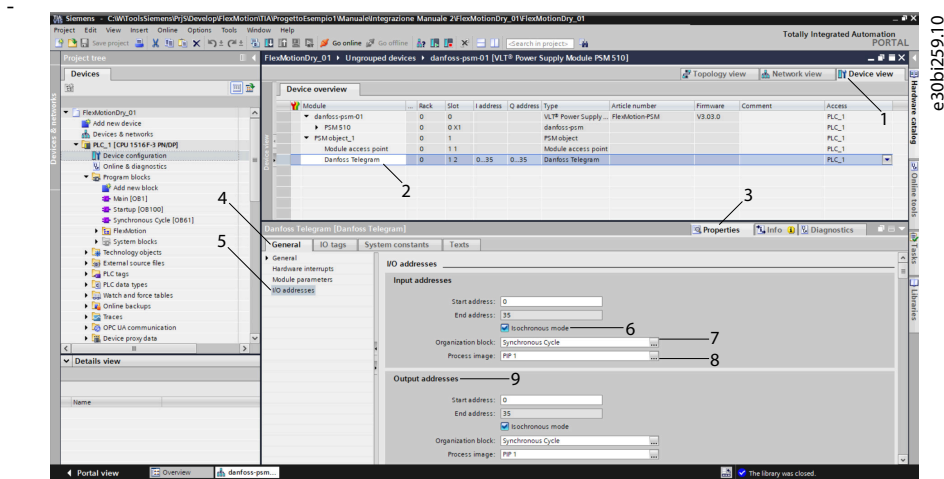

- Open *Device view* [1].
- Select *Danfoss Telegram* [2].
- In the *Properties* window [3], select the *General* tab [4] and then entry *I/O addresses* [5].
- In the *Input addresses* section, activate the checkbox for *Isochronous mode* [6] then set field *Organization block* [7] to *Synchronous Cycle* and field *Process image* [8] to *PIP 1*.
- Repeat these settings in the *Output addresses* section [9].
- Repeat this procedure for each system component.

11. Activate the isochronous mode for each system component:

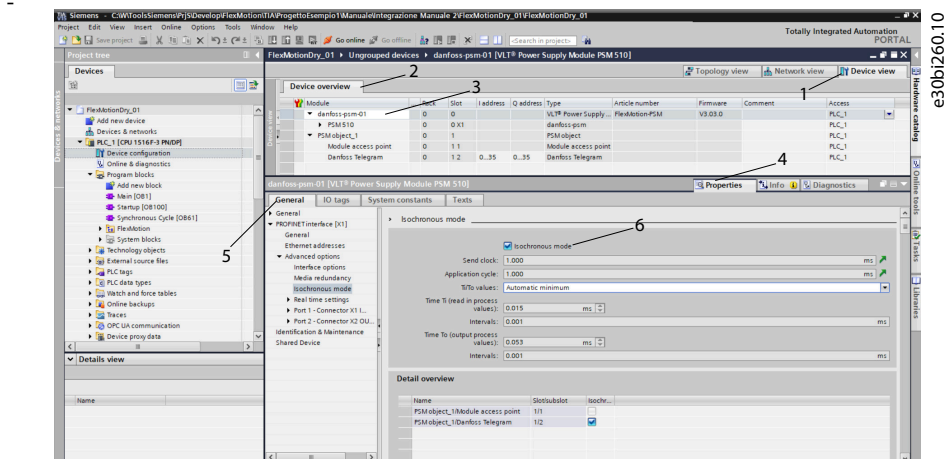

- Open *Device view* [1].
- In section *Device overview* [2], click on *danfoss-psm-01* [3].
- In the *Properties* window [4], select the *General* tab [5] and then menu entries [*PROFINET interface [X1] → Advanced options → Isochronous mode*].
- Activate the checkbox for *Isochronous mode* [6].
- Repeat these settings for each system component.

12. Create the globalData Block *FlexMotion_Data* in which a structure for each system component will be allocated.

FlexMotion_Data		
	Name	Data type
1	Static	
2	▶ Psm01	*PSM_REF*
3	▶ Dam01	*DAM_REF*
4	▶ Sdm01	*AXIS_REF_DDS*
5	▶ Isd_01	*AXIS_REF_DDS*

e30bi261.10

13. In operation block *Startup [OB100]*, check that the module access points have been allocated correctly:

- Expand *Program blocks* in the *Devices* tab.
- Double-click on *Startup [OB100]*.
- Type the settings in the screenshot ensuring that the module access points names match the name assigned automatically by TIA. These can be found by opening menu [PLC tags → Show all tags] and then selecting the *System constants* tab.

```

1 #Counter := #Counter + 1;
2
3 // PSM
4 // =====
5 "FlexMotion_Data".Psm01.HwIdSubmodule := "danfoss-sdm-01-Device_object_1-Module_access_point";
6
7 // DAM
8 // =====
9 "FlexMotion_Data".Dam01.HwIdSubmodule := "danfoss-dam-01-DAM_object_1_1";
10
11 // SDM
12 // =====
13 "FlexMotion_Data".Sdm01.HwIdSubmodule := "danfoss-sdm-01-Device_object_1-Module_access_point";
14
15 // ISD
16 // =====
17 "FlexMotion_Data".Isd_01.HwIdSubmodule := "danfoss-isd-01-Device_object_1-Module_access_point";
18

```

e30bi262.10

14. Define the input and output telegram address for each system component by creating a tag table:

- Select menu [PLC tags → FlexMotion], to open the FlexMotion_Telegram window.
- Define the address of the incoming and outgoing telegram for each system component.

FlexMotion_Telegram							
	Name	Data type	Address	Retain	Acces...	Writa...	Visibl...
1	▶ Psm01_In	*DD_PPO_D...	%I0.0	<input type="checkbox"/>	<input checked="" type="checkbox"/>	<input checked="" type="checkbox"/>	<input checked="" type="checkbox"/>
2	▶ Psm01_Out	*DD_PPO_DDS*	%Q0.0	<input type="checkbox"/>	<input checked="" type="checkbox"/>	<input checked="" type="checkbox"/>	<input checked="" type="checkbox"/>
3	▶ Dam01_In	*DD_PPO_DDS*	%I36.0	<input type="checkbox"/>	<input checked="" type="checkbox"/>	<input checked="" type="checkbox"/>	<input checked="" type="checkbox"/>
4	▶ Dam01_Out	*DD_PPO_DDS*	%Q36.0	<input type="checkbox"/>	<input checked="" type="checkbox"/>	<input checked="" type="checkbox"/>	<input checked="" type="checkbox"/>
5	▶ Sdm01_In	*DD_PPO_DDS*	%I72.0	<input type="checkbox"/>	<input checked="" type="checkbox"/>	<input checked="" type="checkbox"/>	<input checked="" type="checkbox"/>
6	▶ Sdm01_Out	*DD_PPO_DDS*	%Q72.0	<input type="checkbox"/>	<input checked="" type="checkbox"/>	<input checked="" type="checkbox"/>	<input checked="" type="checkbox"/>
7	▶ Isd01_In	*DD_PPO_DDS*	%I108.0	<input type="checkbox"/>	<input checked="" type="checkbox"/>	<input checked="" type="checkbox"/>	<input checked="" type="checkbox"/>
8	▶ Isd01_Out	*DD_PPO_DDS*	%Q108.0	<input type="checkbox"/>	<input checked="" type="checkbox"/>	<input checked="" type="checkbox"/>	<input checked="" type="checkbox"/>
9	<Add new>			<input type="checkbox"/>	<input checked="" type="checkbox"/>	<input checked="" type="checkbox"/>	<input checked="" type="checkbox"/>

e30bi263.10

15. In operation block *Synchronous Cycle [OB61]*, enter the telegram read instructions as per the example below.

```

3 // Read telegrams
4 // =====
5 #Result_01 := SYNC_PI(PART := "PIP 1", FLADDR => #FLAddr_01);
6
7 □ "DD_UpdateProcessInput_PSM" (PpoIn:="Psm01_In".Ppo,
8   [                               Psm:="FlexMotion_Data".Psm01);
9
10 □ "DD_UpdateProcessInput_DAM" (PpoIn:="Dam01_In".Ppo,
11   [                               Dam:="FlexMotion_Data".Dam01);
12
13
14 □ "DD_UpdateProcessInput_DDS" (PpoIn:="Sdm01_In".Ppo,
15   [                               Axis:="FlexMotion_Data".Sdm01);
16
17 □ "DD_UpdateProcessInput_DDS" (PpoIn:="Isd01_In".Ppo,
18   [                               Axis:="FlexMotion_Data".Isd_01);
19

```

e30bi264.10

16. In operation block *Synchronous Cycle [OB61]*, enter the telegram write instructions as per the example below.

```

26
27 // Write telegrams
28 // =====
29 □ "DD_UpdateProcessOutput_PSM" (Output=>"Psm01_Out".Ppo,
30   [                               Psm:="FlexMotion_Data".Psm01);
31
32 □ "DD_UpdateProcessOutput_DAM" (Output=>"Dam01_Out".Ppo,
33   [                               Dam:="FlexMotion_Data".Dam01);
34
35 □ "DD_UpdateProcessOutput_DDS" (Output=>"Sdm01_Out".Ppo,
36   [                               Axis:="FlexMotion_Data".Sdm01);
37
38 □ "DD_UpdateProcessOutput_DDS" (Output=>"Isd01_Out".Ppo,
39   [                               Axis:="FlexMotion_Data".Isd_01);
40
41 #Result_02 := SYNC_PO(PART := "PIP 1", FLADDR => #FLAddr_02);
42

```

e30bi265.10

6.16 Programming Guidelines for TIA

Recommendations for implementation:

- Only assign the *HwldSubmodule* variable in the appropriate structure of each device present at the beginning of the program. Use the constant that is created automatically by TIA in menu [PLC tags → Show all tags → System Constants], for example, *danfoss-isd-01~Device_object_1~Module_access_point*. Only assign this variable in the 1st PLC cycle for initialization. The structures to be used for each type of device are:
 - ISD 510: *AXIS_REF_DDS*
 - DSD 510: *AXIS_REF_DDS*
 - PSM 510: *PSM_REF*
 - DAM 510: *DAM_REF*
 - ACM 510: *ACM_REF*
- Initialize parameters that usually do not change only once at the beginning of the program.
- Call the appropriate functions for each device present in every PLC cycle:
 - ISD 510: *DD_UpdateProcessInput_DDS* and *DD_UpdateProcessOutput_DDS*
 - DSD 510: *DD_UpdateProcessInput_DDS* and *DD_UpdateProcessOutput_DDS*
 - SDM 511/SDM 512: *DD_UpdateProcessInput_DDS* and *DD_UpdateProcessOutput_DDS*
 - PSM 510: *DD_UpdateProcessInput_PSM* and *DD_UpdateProcessOutput_PSM*
 - DAM 510: *DD_UpdateProcessInput_DAM* and *DD_UpdateProcessOutput_DAM*
 - ACM 510: *DD_UpdateProcessInput_ACM* and *DD_UpdateProcessOutput_ACM*
- Only create instructions and other program parts between calling up function blocks *DD_UpdateProcessInput_xxx* and *DD_UpdateProcessOutput_xxx*.
- Call up function blocks that provide status or error information with *Enable input* at the beginning of the program.

- Use 1 instance of function block *MC_Power_DDS* for every axis to control its power stage. Call up this function block in every PLC cycle.
- Use 1 instance of function block *DD_Power_PSM* for every PSM 510 to control the DC-link voltage on the output lines. Call up this function block in every PLC cycle.
- Use 1 instance of function block *DD_Power_DAM* for every DAM 510 to control the DC-link voltage on the output lines. Call up this function block in every PLC cycle.
- Use 1 instance of function block *DD_Power_ACM* for every ACM 510 to control the DC-link voltage on the output lines. Call up this function block in every PLC cycle.
- Call up function blocks that execute (motion) commands at the end of the program.
- Do not use any UDTs, POUs, enumerations, or constants starting with the prefix *iDD_*.
- Do not change the reference to the axis on a function block while it is busy.

6.17 VLT® Servo Toolbox Software

6.17.1 Overview

The VLT® Servo Toolbox is a standalone PC software designed by Danfoss. It is used for parameterization and diagnostics of the system modules. It is also possible to operate the devices in a non-productive environment.

N O T I C E

- The VLT® Servo Toolbox software must be allowed for every firewall profile (private/public/domain).

The VLT® Servo Toolbox contains several subtools that provide various functionalities.

Table 28: Important Subtools

Subtool	Description
Scope	For visualization of the tracing functionality of the servo drives, the Power Supply Module (PSM 510), the Decentral Access Module (DAM 510), and the Auxiliary Capacitors Module (ACM 510).
Parameter list	For reading/writing parameters.
Firmware update	For updating the firmware on the devices.
Drive control	For operating the servo drives for testing purposes.
PSM control	For operating the Power Supply Module (PSM 510) for testing purposes.
DAM control	For operating the Decentral Access Module (DAM 510) for testing purposes.
ACM control	For operating the Auxiliary Capacitors Module (ACM 510) for testing purposes.
CAM editor	For designing CAM profiles for the servo drives.
Configuration parameter	For setting up the motor and feedback parameters, and PID settings.
Drive commissioning	For motor feedback adjustment and inertia measurement.

The detailed description of the VLT® Servo Toolbox functionality and the full parameter lists can be found in the **VLT® Servo Drive System ISD 510, DSD 510, MSD 510 (VLT® Flexmotion™) Programming Guide**.

6.17.2 System Requirements

To install the VLT® Servo Toolbox software, the PC must meet the following requirements:

- Supported hardware platforms: 32-bit, 64-bit.
- Supported operating systems: Windows 7, Windows 8.1, Windows 10.
- .NET framework version: 4.7.

- Minimum hardware requirements: 512 MB RAM, Intel Pentium 4 with 2.6 GHz or equivalent, 20 MB hard disk space.
- Recommended hardware requirements: Minimum 1 GB RAM, Intel Core i5/i7 or compatible.

6.17.3 Installing the VLT® Servo Toolbox Software

Administrator rights are required to install the software with the Windows operating system. If necessary, contact your system administrator.

Procedure

1. Check that your system meets the system requirements specified in [6.17.2 System Requirements](#).
2. Download the VLT® Servo Toolbox installation file from the Danfoss website.
3. Right-click on the .exe file and select *Run as administrator*.
4. Follow the on-screen instructions to complete the installation process.

6.17.4 VLT® Servo Toolbox Communication

6.17.4.1 Overview

This chapter describes the Ethernet-specific network interface settings needed by the VLT® Servo Toolbox. There are 2 basic communication methods: direct communication and indirect communication. Their particular network settings are described in the respective subchapters.

Read and perform the steps with care. Incorrect network configurations can lead to loss of connectivity of a network interface.

6.17.4.2 Firewall

Depending on the firewall settings and the fieldbus used, the messages sent and received by the VLT® Servo Toolbox may be blocked by the firewall on the VLT® Servo Toolbox host system. This may lead to a loss of communication and the inability to communicate with the devices on the fieldbus. Therefore, ensure that the VLT® Servo Toolbox is allowed to communicate through the firewall on the VLT® Servo Toolbox host system. Inappropriate changes to firewall settings may lead to security issues.

NOTICE

- When using a dedicated network interface, the VLT® Servo Toolbox must be allowed to communicate specifically through this network interface.

6.17.4.3 Indirect Communication

6.17.4.3.1 Overview

Communication between ISD 510/DSD 510 devices and the VLT® Servo Toolbox through a PLC is called indirect communication. Ethernet-based fieldbus communication (marked A in the graphic) takes place between the PLC and the ISD 510/DSD 510 devices. However, there is non-fieldbus communication between the PLC and the VLT® Servo Toolbox host system.

In the scenario shown, the PLC has the master function and uses cyclic communication with the devices. Therefore, not all functionalities of the VLT® Servo Toolbox, for example the drive control, can be used.

The restrictions when using indirect communication are detailed in the **VLT® Servo Drive System ISD 510, DSD 510, MSD 510 (VLT® Flexmotion™) Programming Guide**.

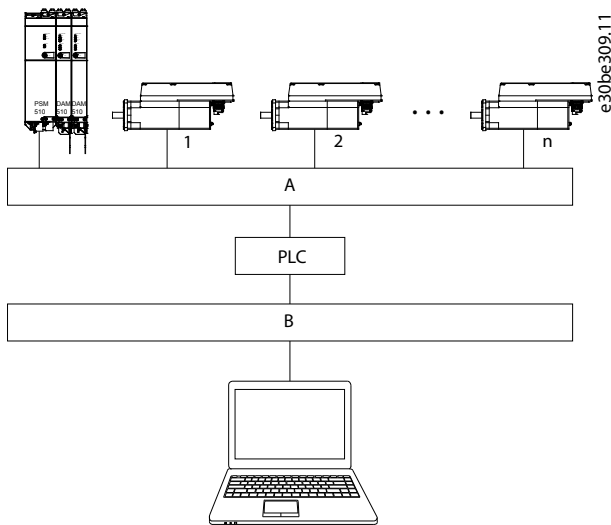

Illustration 97: Logical View of Indirect Ethernet-based Fieldbus Communicaton (Communication via PLC)

A	Fieldbus
B	VLT® Servo Toolbox host system

NOTICE

- The logical view only shows the connectivity from a high-level software perspective and does not reflect the actual physical topology of the network.

6.17.4.3.2 Network Settings for Indirect Communication

Any network interface can be used to communicate through a PLC. A dedicated network interface is not required.

When establishing the communication through a PLC, the VLT® Servo Toolbox configures a routing table using the selected Network Address Translation (NAT). Adding a route to the Windows routing table requires administrator privileges. Therefore, administrator credentials may be requested when initializing the connection.

6.17.4.3.3 Enabling Indirect Communication

Carry out the following steps to enable indirect communication.

NOTICE

When observing the network packets via Wireshark®, checksum offloading often causes confusion as the network packets to be transmitted are handed over to Wireshark® before the checksums have been calculated. Wireshark® shows these empty checksums as invalid, even though the packets contain valid checksums when they leave the network hardware later. Use 1 of these 2 methods to avoid this checksum offloading problem:

- Turn off the checksum offloading in the network driver if possible.
- Turn off the checksum validation of the specific protocol in the Wireshark® preferences.

Disable IPv6 on the network interfaces used for communication on the PC:

Procedure

1. Open the *Network and Sharing Center*.
2. Select *Change adapter settings*.
3. Right-click on the network interface used for fieldbus communication and select *Properties*.
4. If the TCP/IPv6 is available for the network interface, disable it.

6.17.4.3.4 Additional Settings for Indirect Communication with EtherCAT®

Set the IP address of the EtherCAT® Master:

Procedure

1. Open the TwinCAT® System Manager.
2. Select [I/O-Configuration → I/O Devices → Device1 (EtherCAT®)] and check the IP-address in the *Adapter* tab. The IP-address of the PLC's network adapter may not be a link-local address (so not in the range of 169.254.0.1 to 169.254.255.254).
3. If necessary, change the IP-address inside the IPv4 Protocol properties according to the given operating system. This can be done on the controller locally or via *Remote Desktop*.

6.17.4.3.5 Activating the IP Routing in the EtherCAT® Master

The procedure described here may vary depending on the type of PLC and operating system installed.

Procedure

1. Open the TwinCAT® System Manager.
2. Click on *Advanced Settings...* via menu [I/O-Configuration → I/O Devices → Device1 (EtherCAT)] in the *EtherCAT* tab.
3. Select *EoE Support* in the *Advanced Settings* window.
4. Enable *Connect to TCP/IP Stack* in the *Windows Network* section.
5. Enable *IP Enable Router* in the *Windows IP Routing* section.
6. Reboot the PLC for the changes to take effect.

6.17.4.3.6 Setting the IP Address of the EtherCAT® Slave

The procedure for setting the IP Address of the EtherCAT® slave is valid for:

- ISD 510/DSD 510 servo drives
- Power Supply Module (PSM 510)
- Decentral Access Module (DAM 510)
- Auxiliary Capacitors Module (ACM 510)

N O T I C E

- The last number of the IP address is the ID that is used in the VLT® Servo Toolbox to identify the device.

Procedure

1. Open the TwinCAT® System Manager.
2. Click on *Advanced Settings...* under [I/O-Configuration → I/O Devices → Device1 (EtherCAT) → Box 1 (VLT® Decentral Access Module → Drive 2 (VLT® Integrated Servo Drive ISD 510))] in the EtherCAT® tab.
3. Select [Mailbox → EoE] in the *Advanced Settings* window.
4. Enable *Virtual Ethernet Port* and enter a valid IP-address.
5. Each slave in the configuration requires an IP-address. This address is reassigned with every transition from *INIT* to *Pre-Operational* state of the slave state machine. The IP communication of the slaves is deactivated per default.

6.17.4.3.7 Additional Settings for Indirect Communication with PROFINET®

6.17.4.3.7.1 Overview

Each PROFINET™ device needs a device name and an IP address. The IP address and the device name are assigned by the I/O controller, when the connection to the I/O device is established.

For the automatic detection of accessible nodes via a PG/PC interface with TCP/IP, connect the nodes to the same physical Ethernet subnet as the PG/PC. If a node is located in a different physical Ethernet subnet, the IP address of the sought node can be specified.

To reach further nodes, accessible nodes provide the capability of adding IP addresses and subnets to the PG/PC interface. The new IP addresses and subnets are then added to the Ethernet interface of the PG/PC.

6.17.4.3.7.2 Adding IP Addresses and Subnets

Procedure

1. Open SIMOTION SCOUT®.
2. Select the menu [Project → Accessible nodes].
3. If accessible nodes are found in another subnet, the *Add IP addresses / subnet masks* window is displayed and shows them.

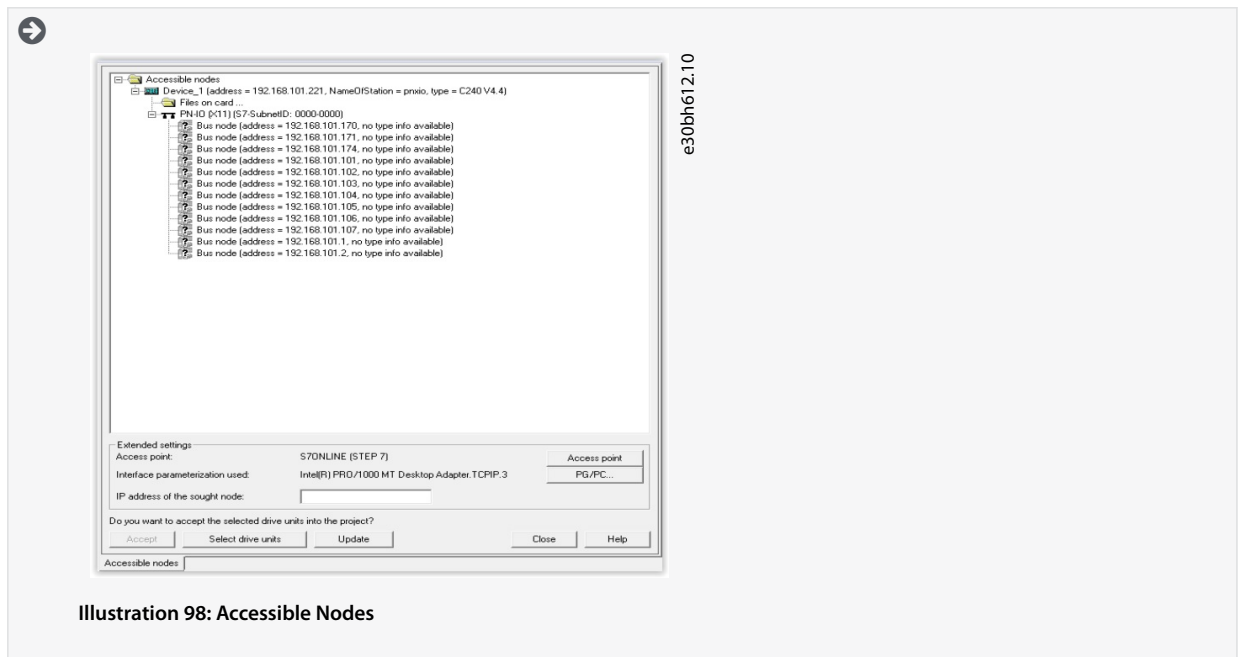

Illustration 98: Accessible Nodes

4. Click on Yes to accept the addresses.
5. The IP address/subnet mask is now added.

NOTICE

- If >1 Danfoss servo drive is used in the same PROFINET® network, each servo drive must have a different name and IP address.
- The last number of the IP address is the ID that is used in the VLT® Servo Toolbox software to identify the device.
- When the *Accessible nodes* tab is closed, the addresses are retained. The newly added addresses are only discarded when SIMOTION SCOUT® is closed.

NOTICE

- IP addresses and subnets can also be added using PRONETA.

6.17.4.4 Direct Communication

6.17.4.4.1 Overview

For Ethernet-based fieldbus communication (direct communication), the VLT® Servo Toolbox must use a dedicated network interface on the VLT® Servo Toolbox host system. Do not use this network interface simultaneously for any other communication.

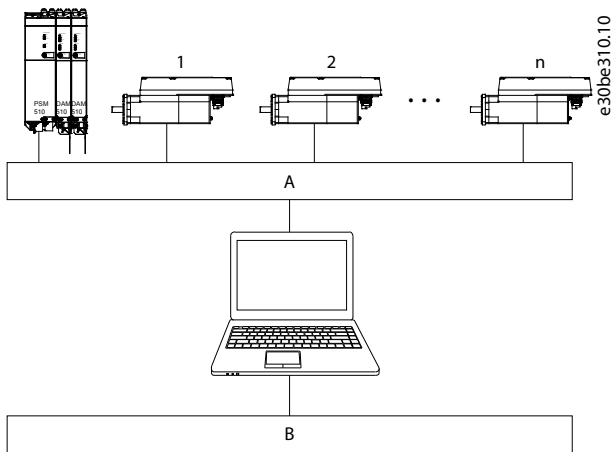

Illustration 99: Logical View of Direct Ethernet-based Fieldbus Communication

A	Ethernet-based fieldbus communication
B	VLT® Servo Toolbox host system

⚠ WARNING ⚠

- The logical view only shows the connectivity from a high-level software perspective and does not reflect the actual physical topology of the network.

6.17.4.4.2 Network Settings for Direct Communication with Ethernet POWERLINK®

Disable all network protocols except TCP/IPv4 on the network interface used for direct Ethernet POWERLINK® communication. This prevents other PC software or the operating system using this network interface for other tasks, such as file and printer sharing and network discovery. Disabling these protocols reduces the number of non-relevant packets sent over the network interface and thus reduces the overall network load.

6.17.4.4.3 Disabling Unused Protocols on the Network Interface on the PC

Procedure

1. Open the *Network and Sharing Center*.
2. On the left, click on *Change adapter settings*.
3. Right-click on the network interface used for fieldbus communication and select *Properties*.
4. Uncheck all checkboxes except the one for *Internet Protocol Version 4 (TCP/IPv4)*.
5. Disable the *IPv4 Checksum offload* on the network interfaces as described in [6.17.4.3.3 Enabling Indirect Communication](#).

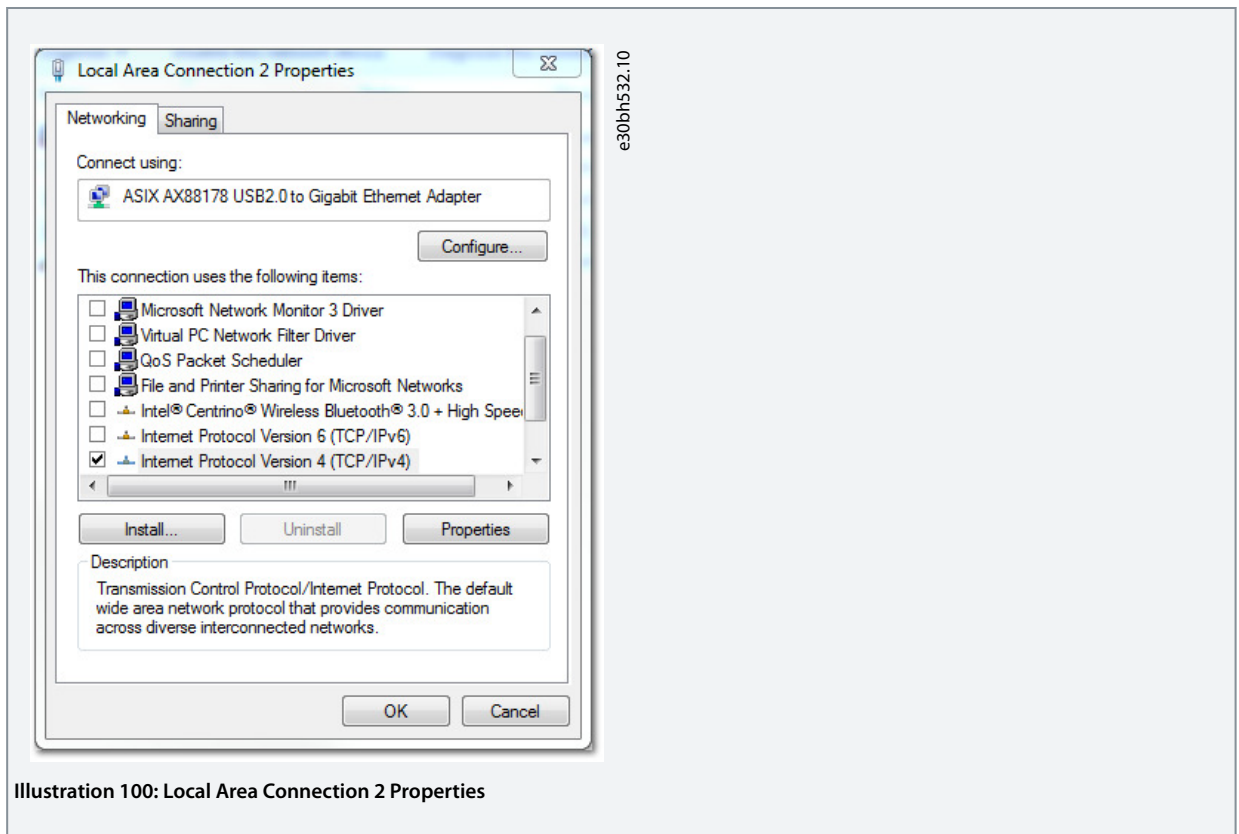

Illustration 100: Local Area Connection 2 Properties

6.17.4.4.4 Setting the Correct Ethernet POWERLINK® Master IP Address

Procedure

1. Open the *Network and Sharing Center*.
2. On the left, click on *Change adapter settings*.
3. Right-click on the network interface used for fieldbus communication and select *Properties*.
4. Click on *Internet Protocol Version 4 (TCP/IPv4)* (the checkbox must be checked) and then click on *Properties*.
5. Select *Use the following IP address* and use 192.168.100.240 as the IP address and 255.255.255.0 as the subnet mask. Leave all other fields empty.

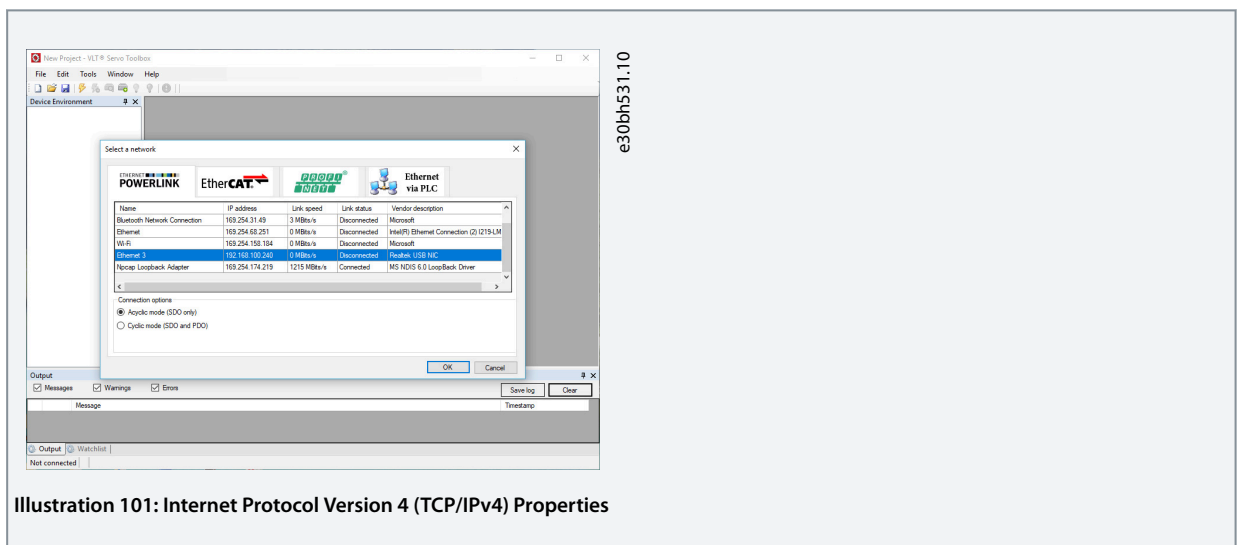

Illustration 101: Internet Protocol Version 4 (TCP/IPv4) Properties

6.17.4.4.5 Network Settings for Direct Communication with EtherCAT®

Disable all network protocols except TCP/IPv4 on the network interface used for direct EtherCAT® communication. This prevents other PC software or the operating system using this network interface for other tasks, such as file and printer sharing and network

discovery. Disabling these protocols reduces the number of non-relevant packets sent over the network interface and thus reduces the overall network load.

6.17.5 VLT® Servo Toolbox Commissioning

6.17.5.1 Step 1: Opening the Main Window

The *Main Window* is the basis for all VLT® Servo Toolbox functionalities. It consists of the following components:

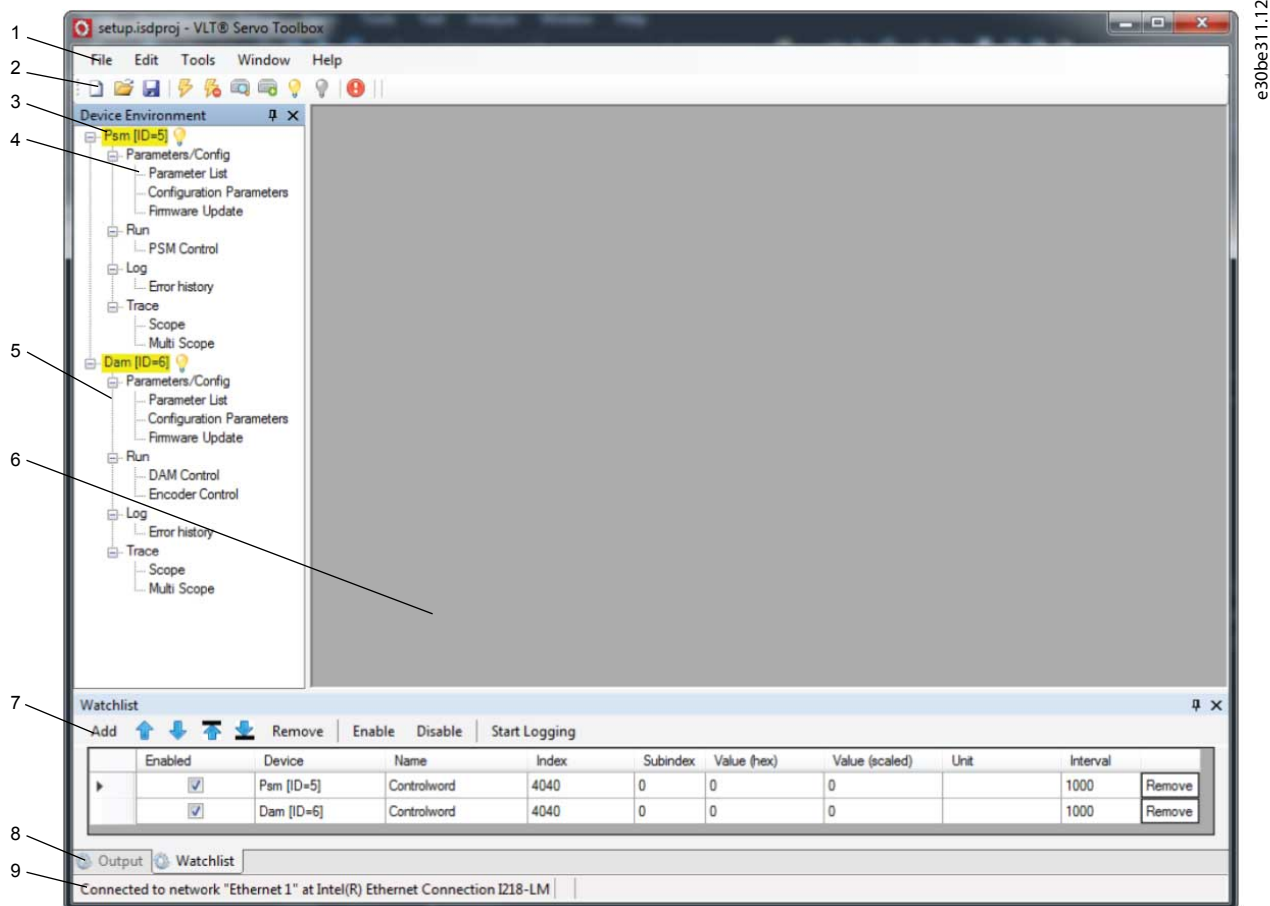

Illustration 102: Main Window

Table 29: Main Window Description

Legend number	Name	Description
1	Menu bar	Contains the general functionalities for saving and loading projects, managing connections, showing and changing settings, managing open subtools, and showing help contents.
2	Tool bar	Contains shortcuts for saving and loading projects, connecting to and disconnecting from networks, automatic searching for online devices, and manually adding devices.
3	Online status and state information	<p>Online devices are indicated by a glowing light bulb next to the device ID.</p> <ul style="list-style-type: none"> An online device is a logical device for which a physical device exists that the VLT® Servo Toolbox is connected to. The color indicates the state of the device and is device-specific.

Legend number	Name	Description
	Offline status and state information	Offline devices are indicated by a gray light bulb next to the device ID. <ul style="list-style-type: none"> An offline device is a logical device without a corresponding physical device. An offline device can represent a saved device configuration or state, for example for offline analysis or troubleshooting. It also contains pre-configured parameter values to be written to a physical device.
4	Available subtools	A subtool is opened by double-clicking on its name in the <i>Device Environment</i> , or by selecting the entry and pressing the <i>Enter</i> key on the keyboard.
5	Device environment	The <i>Device Environment</i> section of the <i>Main Window</i> lists all logical devices managed by the VLT® Servo Toolbox, visualizes their states, and serves as the user interface for accessing the device functionalities. The <i>Device Environment</i> window lists all available subtools for each added device. See the VLT® Servo Drive System ISD 510, DSD 510, MSD 510 (VLT® Flexmotion™) Programming Guide for further information on the subtools.
6	Workspace	This is the space for hosting the subtools and its size depends on the <i>Main Window</i> size. The subtools can be maximized, minimized, horizontally or vertically aligned, or cascaded.
7	Watchlist window	Evaluates the parameter values of 1 or more devices by cyclically reading them from the devices. Allows parameter values to be logged and saved to a text file. It is also possible to modify/write values in the watchlist.
8	Output window	Shows operating information, warnings, and errors. Depending on the user settings, shows messages of up to 3 different logging levels (high, medium, and low). Used for showing advanced error and warning information.
9	Status strip	Shows the communication state of the VLT® Servo Toolbox. If connected to a network, it shows the used hardware interface (for example, network adapter) and the network name.

6.17.5.2 Step 2: Connecting to Network

Pre-configure the appropriate communication settings to connect to a network (see [6.17.4.1 Overview](#)).

Procedure

1. In the *Main Window* toolbar, click on the *Connect to bus* icon to open the *Connect to Network* window.
2. Select the fieldbus type and the network interface to connect to.
3. Click on *OK* to connect.
4. Verify that the connection is successful by checking the status strip at the bottom of the *Main Window*.

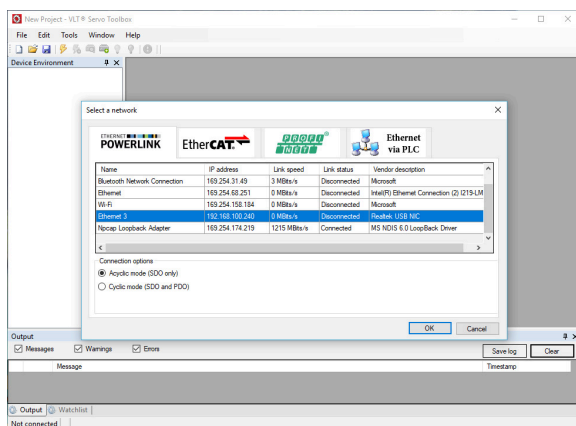

e30b1531_10

Illustration 103: Connect to Network Window (Ethernet POWERLINK®)

6.17.5.3 Step 3: Scanning for Devices

Procedure

1. After verifying that the VLT® Servo Toolbox is connected to the selected network, click on the *Scan for Devices* icon in the toolbar to trigger the device scan procedure.

N O T I C E

- If connected to an Ethernet POWERLINK® network in cyclic mode, select the scan range (minimum and maximum IDs) in the next window to reduce the time needed for scanning. In all other cases, the complete ID range is scanned.

2. When the scan is complete, a list of available devices is shown in the *Select Devices* window. Select the devices to be added to the *Device Environment* and click on *OK*.
3. All selected devices appear in the *Device Environment* window and automatically go online (indicated by a glowing light bulb next to each device name).

6.18 Motion Library

6.18.1 Function Blocks

The PLC library provides function blocks that support the functionality of the servo system and comply with this standard: PLCopen® Technical Specification Function blocks for motion control (Formerly Part 1 and Part 2) Version 2.0 March 17, 2011.

In addition to the PLCopen® functionality, Danfoss offers further functions for the servo system.

The following PLCopen® characteristics apply to all function blocks:

- Commanding (using the inputs)
- Signaling (behaviour of the outputs)
- General calling conventions

N O T I C E

- See the **VLT® Servo Drive System ISD 510, DSD 510, MSD 510 (VLT® Flexmotion™) Programming Guide** for further information on the available function blocks and their behavior.

6.18.2 Simple Programming Template

TwinCAT®:

A basic sample PLC application for starting up the servo system with 1 Power Supply Module (PSM 510), 1 Decentral Access Module (DAM 510), and 2 axes is provided. The project *DDS_ServoMotion_SampleProject* can be downloaded from the Danfoss website.

Automation Studio™:

Detailed information on how to open the sample project within the ISD package in Automation Studio™ can be found in the Automation Studio™ Help. Open the B&R Help Explorer and go to [Programming → Examples → Adding sample programs] and follow the instructions for library samples.

PROFINET®

The project *DDS_ServoMotion_SampleProject* is a basic sample PLC (C240PN) application for starting up the servo system with 1 Power Supply Module (PSM 510), 1 Decentral Access Module (DAM 510), and 2 axes.

7 Operation

7.1 Operating Modes

The ISD 510/DSD 510 servo drives implement several modes of operation. The behavior of the servo drive depends on the activated mode of operation. It is possible to switch between the modes while the servo drive is enabled. The supported modes of operation are according to CANopen® CiA DS 402 and there are also ISD-specific modes of operation. All supported modes of operation are available for EtherCAT®, Ethernet POWERLINK®, and PROFINET®. The various modes of operation are described in detail in the **VLT® Servo Drive System ISD 510, DSD 510, MSD 510 (VLT® Flexmotion™) Programming Guide**.

Inertia measurement mode	This mode measures the inertia of an axis. It is used to measure the inertia of the servo drive and the external load, and to optimize the control loop settings. The friction effects are eliminated automatically.
Profile velocity mode	In profile velocity mode, the servo drive is operated under velocity control and executes a movement with constant speed. Additional parameters, such as acceleration and deceleration, can be parameterized.
Profile position mode	In profile position mode, the servo drive is operated under position control and executes absolute and relative movements. Additional parameters, such as velocity, acceleration, and deceleration, can be parameterized.
Profile torque mode	In profile torque mode, the servo drive is operated under torque control and executes a movement with constant torque. Linear ramps are used. Additional parameters, such as torque ramp and maximum velocity, can be parameterized.
Homing mode	In homing mode, the application reference position of the servo drive can be set. Several homing methods, such as homing on actual position, homing on block, limit switch, or home switch, are available.
CAM mode	In CAM mode, the servo drive executes a synchronized movement based on a master axis. The synchronization takes place by means of a CAM profile that contains slave positions corresponding to master positions. CAMs can be designed graphically with the DDS Toolbox software, or can be parameterized via the PLC. The guide value can be provided by an external encoder, virtual axis, or the position of another axis.
Gear mode	In gear mode, the servo drive executes a synchronized movement based on a master axis by using a gear ratio between the master and the slave position. The guide value can be provided by an external encoder, virtual axis, or the position of another axis.
Cyclic synchronous position mode	In cyclic synchronous position mode, the trajectory generator of the position is located in the control device, not in the servo drive.
Cyclic synchronous velocity mode	In cyclic synchronous velocity mode, the trajectory generator of the velocity is located in the control device, not in the servo drive.
AC1	In application class 1 (AC1) mode a main setpoint (for example speed setpoint) is used to control the servo drive in PROFINET® IO. Speed control is handled entirely within the servo drive.
AC4	Application class 4 (AC4) defines an interface between the speed setpoint interface and actual position value interface, where speed control is executed on the servo drive and position control on the controller. The motion control for multiple axes is performed centrally, for example by numerical control (NC). The position control loop is closed by the fieldbus. Clock synchronization is required to synchronize the clocks for the position control in the controller and for the speed control in the drives (PROFINET® with IRT).

7.1.1 Motion Functions

Function	Description
Digital CAM switch	This functionality controls whether the digital output is enabled or disabled, depending on the axis position. It performs a function comparable to switches on a motor shaft. Forward and backward movements of the axis position are allowed. On and off compensation and hysteresis can be parameterized.
Touch probe	This functionality stores the position actual value at a rising or falling edge of the configured digital input.

Function	Description
Guide value	The guide value is used in all synchronous modes of operation (CAM mode and Gear mode). It is used as the master position within the synchronous modes.

7.2 Operating Status Indicators

The operating status of the ISD 510/DSD 510 servo drive, PSM 510, DAM 510, and ACM 510 is indicated via the LEDs on each device.

7.2.1 Operating LEDs on the ISD 510/DSD 510 Servo Drive

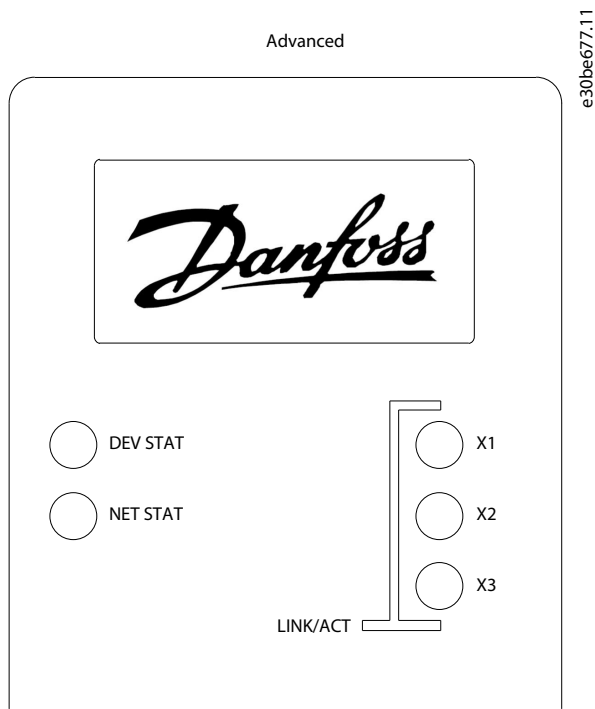

Illustration 104: Operating LEDs on the ISD 510/DSD 510 Servo Drive

Table 30: Operating LEDs on the ISD 510/DSD 510 Servo Drive

LED	Color	Flash status	Description
DEV STAT	Green	On	Servo drive is in state <i>Operation enabled</i>
		Flashing	Auxiliary voltage is applied.
	Red	On	Servo drive is in <i>Fault</i> or <i>Fault reaction active</i> state.
		Flashing	DC-link voltage is not applied.
NET STAT	Green/red	Fieldbus dependent	Network status of the device (see corresponding fieldbus standard).
Link/ACT X1	Green	–	Link/activity status of <i>Hybrid In</i> (X1)
		On	Ethernet link established.
		Flashing	Ethernet link established and active.
		Off	No link.
Link/ACT X2	Green	–	Link/activity status of <i>Hybrid Out</i> (X2)
		On	Ethernet link established.

LED	Color	Flash status	Description
		Flashing	Ethernet link established and active.
		Off	No link.
Link/ACT X3 (1)	Green	–	Link/activity status of the Ethernet port (X3).
		On	Ethernet link established.
		Flashing	Ethernet link established and active.
		Off	No link.

¹ Only for advanced servo drive with POWERLINK® or EtherCAT®.

7.2.2 Operating LEDs on the PSM 510

STATUS PSM

DEV

SVS ST

NET ST

e30bg576.11

LINK/ACT

X1

X2

Illustration 105: Operating LEDs on PSM 510

Table 31: Operating LEDs on PSM 510

LED	Color	Flash status	Description
DEV	Green	On	Device is in state <i>Operation enabled</i> .
		Flashing	Device is in state <i>Standby</i> or <i>Power-up</i> .
	Red	On	Device is in state <i>Fault</i> or <i>Fault reaction active</i> .
		Flashing	Input mains is not applied.
SVS ST	Green	On	24 V safety supply is applied.
		Off	24 V safety supply is not applied.
NET ST	Green	On	Connected.
	Orange	On	Online.
	Red	Flashing	Initialization.
		On	Initialization failed or other error.

LED	Color	Flash status	Description
LINK/ACT X1 (Link/activity status of <i>In</i>)	Green	On	Ethernet link established.
		Flashing	Ethernet link established and active.
		Off	No link.
LINK/ACT X2 (Link/activity status of <i>Out</i>)	Green	On	Ethernet link established.
		Flashing	Ethernet link established and active.
		Off	No link.

7.2.3 Operating LEDs on the DAM 510

STATUS DAM

DEV

SVS ST

NET ST

AUX

e30bg577.11

LINK/ACT

X1

X2

X3

Illustration 106: Operating LEDs on DAM 510



Table 32: Operating LEDs on DAM 510

LED	Color	Flash status	Description
DEV	Green	On	Device is in state <i>Operation enabled</i> .
		Flashing	Device is in state <i>Standby</i> or <i>Power-up</i> .
	Red	On	Device is in state <i>Fault</i> or <i>Fault reaction active</i> .
		Flashing	DC-link is not applied at the input.
SVS ST	Green	On	24 V safety supply is applied.
		Off	24 V safety supply is not applied.
NET ST	Green	On	Connected.
	Orange	On	Online.
	Red	Flashing	Initialization.
		On	Initialization failed or other error.
AUX	Green	On	Auxiliary voltage is applied to the output connector.

LED	Color	Flash status	Description
(State of the auxiliary voltage)		Off	Auxiliary voltage is not applied to the output connector.
	Red	On	Auxiliary voltage undervoltage detected in the hardware.
LINK/ACT X1 (Link/activity of <i>In</i>)	Green	On	Ethernet link established.
		Flashing	Ethernet link established and active.
		Off	No link.
LINK/ACT X2 (Link/activity status of <i>Hybrid Out</i>)	Green	On	Ethernet link established.
		Flashing	Ethernet link established and active.
		Off	No link.
LINK/ACT X3 (Link/activity status of <i>Out</i>)	Green	On	Ethernet link established.
		Flashing	Ethernet link established and active.
		Off	No link.

7.2.4 Operating LEDs on the ACM 510

STATUS ACM

-  DEV
-  CAP ST
-  NET ST

e30bg578.10

LINK/ACT



-  X1
-  X2

Illustration 107: Operating LEDs on ACM 510

Table 33: Operating LEDs on ACM 510

LED	Color	Flash status	Description
DEV	Green	On	Device is in state <i>Operation enabled</i> .
		Flashing	Device is in state <i>Standby</i> or <i>Power-up</i> .
	Red	On	Device is in state <i>Fault</i> or <i>Fault reaction active</i> .
		Flashing	DC-link is not applied at the input.
CAP ST	Green	On	Capacitors fully charged.
		Flashing	Capacitors charging/discharging.

LED	Color	Flash status	Description
		Off	Capacitors discharged.
NET ST	Green	On	Connected.
	Orange	On	Online.
	Red	Flashing	Initialization.
On		Initialization failed or other error.	
LINK/ACT X1 (Link/activity of <i>In</i>)	Green	On	Ethernet link established.
		Flashing	Ethernet link established and active.
		Off	No link.
LINK/ACT X2 (Link/activity status of <i>Out</i>)	Green	On	Ethernet link established.
		Flashing	Ethernet link established and active.
		Off	No link.

8 Functional Safety Concept

8.1 Functional Description

The servo system integrates the safety function Safe Torque Off (STO). The safety function is available in daisy-chain format, which is possible between all system components except for ACM 510 (cables are not included). The hybrid cable passes the STO signal from the Decentral Access Module (DAM 510) to all ISD 510/DSD 510 servo drives in the chain. Once STO is activated (safe state), no torque is generated on the ISD 510 servo drives, or on any motors connected to DSD 510. Reset of the safety function and diagnostics can be carried out via the PLC.

NOTICE

- Use the STO function when performing mechanical work on the servo system or affected area of a machine to avoid a mechanical hazard. However, the STO function does not provide electrical safety.

8.2 Safety Precautions

⚠ WARNING ⚠

UNCONTROLLED MOVEMENT

External forces on the motor could cause an uncontrolled and hazardous movement that could result in death or serious injury.

- Equip the motor with additional measures for preventing uncontrolled and hazardous movement, for example mechanical brakes.

⚠ WARNING ⚠

RISK OF ELECTRICAL SHOCK

The STO function does **not** isolate mains voltage to the servo system or auxiliary circuits. Failure to isolate the mains voltage supply and wait for the specified discharge time to elapse could result in death or serious injury.

- Only perform work on electrical parts of the servo system or the ISD 510/DSD 510 servo drives after isolating the mains voltage supply and waiting for the discharge time to elapse.

⚠ WARNING ⚠

RISK OF RESIDUAL ROTATION

Due to failures in the power semiconductor of the drive, a residual rotation can result from a fault that could result in death or serious injury. The rotation can be calculated to angle = $360^\circ / (\text{number of poles})$.

- Take this residual rotation into consideration and ensure that it does not pose a safety risk.

⚠ WARNING ⚠

LED STATUS RELIABILITY

Status indicators (LEDs) are not reliable for safety functions.

- Only use status indicators for general diagnostics during commissioning and troubleshooting.

NOTICE

- After installing the STO function, perform a commissioning test. A passed commissioning test is mandatory after initial installation and after each change to the safety installation (see [8.8 Commissioning Test](#)).

NOTICE

- If required, implement a manual reset function according to EN ISO 13849-1. For automatic restart without manual reset, observe the requirements detailed in paragraph 6.3.3.2.5 of EN ISO 12100:2010 or equivalent standard.

N O T I C E

- Carry out a risk assessment to select the correct stop category for each stop function in accordance with EN 60204-1.
- When designing the machine application, consider timing and distance for coast to stop (Stop Category 0 or STO). See EN 60204-1 for further information.
- All signals connected to the STO must be supplied by a PELV supply.

8.3 Qualified Personnel for Working with Functional Safety

The STO function can only be installed, programmed, commissioned, maintained, and decommissioned by qualified personnel. Qualified personnel for the functional safety concept are qualified electrical engineers, or persons who have received training from qualified electrical engineers and are suitably experienced to operate devices, systems, plant, and machinery in accordance with the general standards and guidelines for safety technology.

Furthermore, they must:

- Be familiar with the basic regulations concerning health and safety/accident prevention.
- Have read and understood the safety guidelines given in this manual.
- Have a good knowledge of the generic and specialist standards applicable to the specific application.

Users of power drive systems (safety-related) (PDS(SR)) are responsible for:

- Hazard and risk analysis of the application.
- The overall safety of the application.
- Identifying safety functions required and allocating SIL or PL to each of the functions, other subsystems, and the validity of signals and commands from them.
- Designing appropriate safety-related control systems, such as hardware, software, and parameterization.

8.4 Applied Standards and Compliance

Use of the STO function requires that all provisions for safety, including relevant laws, regulations, and guidelines, are satisfied.

The integrated STO function complies with the following standards:

- IEC 60204-1: 2016 Stop Category 0 – uncontrolled stop
- EN 60204-1: 2018 Stop Category 0 – uncontrolled stop
- IEC/EN 61508: 2010 SIL 2
- IEC 61800-5-2: 2016 SIL 2
- EN 61800-5-2: 2017 SIL 2
- IEC 62061: 2005 and A1: 2012 and A2: 2015
- EN 62061: 2005 and Cor.:2010 and A1: 2013 and A2: 2015
- IEC/EN 62061: 2015 SIL CL2
- EN ISO 13849-1: 2015 Category 3, PL d
- EN ISO 13849-2: 2014

8.5 Abbreviations and Conventions

Table 34: Safety-related Abbreviations and Conventions

Abbreviation	Reference	Description
Cat.	EN ISO 13849-1	Category B, 1–4
DC	–	Diagnostic coverage
FIT	–	Failure in time Failure rate: 1E-9/hour
HFT	EN IEC 61508	Hardware fault tolerance

Abbrevia- tion	Reference	Description
		HFT = n means that n + 1 faults may lead to a loss of the safety function.
MTTF _D	EN ISO 13849-1	Mean time to failure – dangerous Unit: years
PFH	EN IEC 61508	Probability of dangerous failures per hour Take this value into account if the safety device is operated in high demand mode or in continuous operating mode, where the frequency of demands for operation made on a safety-related system occurs more than once per year.
PL	EN ISO 13849-1	Performance level A discrete level used to specify the capability of safety-related parts of a system to perform safety-oriented functions under foreseeable conditions. Levels: a–e.
SFF	EN IEC 61508	Safe Failure Fraction [%] Proportion of safe failures and detected dangerous failures of a safety function or a subsystem as a percentage of all possible failures.
SIL	EN IEC 61508 EN IEC 62061	Safety Integrity Level
STO	EN IEC 61800-5-2	Safe Torque Off

8.6 Installation

Only Danfoss cables can be used for the installation of the servo system, however cables from other suppliers can be used for the user connection to the STO terminal **STO DAM (Pins 1 and 2)** on the Decentral Access Module (DAM 510).

N O T I C E

- If the application does not require the Safe Torque Off (STO) functionality, build a bridge by connecting +24 V from the connector **STO 1 IN: +24 V** to **STO 1 IN: +STO**, and from **STO 1 IN: –24 V** to **STO 1 IN: –STO**.

Safety relays that have a plus and minus switching output signal can be directly connected to the servo system to activate STO. The example in [Illustration 108](#) shows the basic connection to be made for the STO function. A suitable safety device to switch it off is not supplied by Danfoss. The STO is activated by opening STO+ and STO–.

Table 35: Activation of STO Function

STO+	STO–	STO function
24 V	GND	STO deactivated
Open	GND	STO activated
24 V	Open	STO activated
Open	Open	STO activated

N O T I C E

- Do not exceed 30 V at the STO inputs.
- STO is activated if the plus input is between –3 V and +3 V.
- STO is deactivated if the plus input is between +21.6 V and +26.4 V.

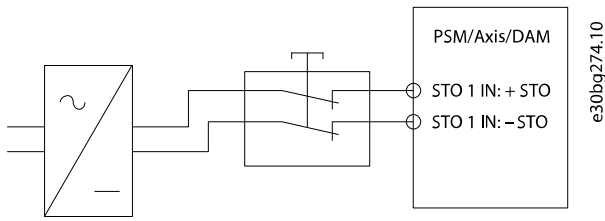

Illustration 108: Safety Relay with Plus and Minus Switching Output

Signals with test pulses must not have test pulses of >1 ms. Longer pulses may lead to reduced availability of the servo system.

8.6.1 Protective Measures

- Install the ISD 510/DSD 510 system components with a protective rating of less than IP54 in an IP54 cabinet as per IEC 60529 or in an equivalent environment. In special applications, higher IP protection may be necessary.
- If external influences can affect the motor axis, for example suspended loads, use additional measures, such as a safety holding brake, to eliminate hazards.

8.7 Application Example

An example of an application that can be put in Safe Torque Off mode by a safety circuit is shown in [Illustration 109](#). The safety circuits can be remote from each other and are not supplied from the VLT® Servo Drive System ISD 510/DSD 510. Select the safety switch devices in accordance with the requirements of the application.

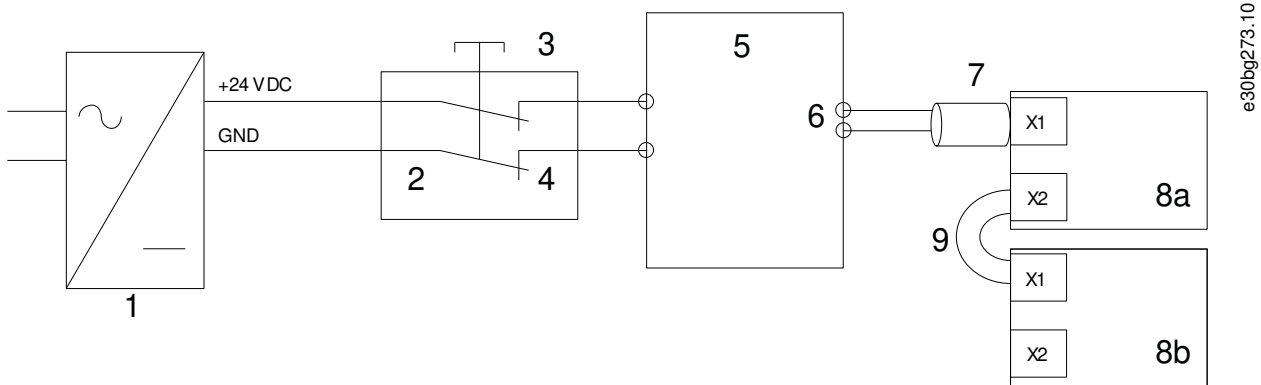

Illustration 109: Application Example: Safe Torque Off Function

1	24 V DC supply	6	Hybrid cable
2	Safety device	7	Feed-in cable
3	Emergency stop button	8a	Servo drive
4	Safety device contacts	8b	Servo drive
5	Decentral Access Module (DAM 510)	9	Loop cable

8.8 Commissioning Test

NOTICE

- Perform a commissioning test for the whole servo system after installation of the STO function, after every change to the installed function, or after a safety fault.

There are 2 ways to implement the commissioning test depending on the method used to program the PLC, however the steps of the test are the same:

- Using the Danfoss Library or the TwinCAT® Library.
- Bit-wise readout of the status.

8.8.1 Commissioning Test using Libraries

Depending on the application, 1 or both of the following libraries are required to program the commissioning test:

- Danfoss Library
 - MC_ReadAxisInfo_DDS
 - MC_ReadStatus_DDS
 - MC_ReadAxisError_DDS
 - MC_Reset_DDS
- TwinCAT® Library
 - MC_ReadStatus
 - MC_ReadAxisError
 - MC_Reset

Table 36: Commissioning Test using Libraries

	Test steps	Reason for the test step	Expected result for Danfoss library	Expected result for Twin-CAT® library
1	Run the application (all the servo drives are enabled).	Check that the application can run.	Application runs as expected.	Application runs as expected.
2	Stop the application.	–	All servo drives are at speed 0 RPM.	All servo drives are at speed 0 RPM.
3	Disable all the servo drives.	–	All servo drives are disabled.	All servo drives are disabled.
4	Enable STO.	Check that STO can be activated without error.	<i>MC_ReadAxisInfo_DDS</i> output <i>SafeTorqueOff</i> = True for all servo drives on the corresponding line.	–
5	Disable STO.	Check that STO can be deactivated without error. No reset is required.	<i>MC_ReadAxisInfo_DDS</i> output <i>SafeTorqueOff</i> = False for all servo drives on the corresponding line.	–
6	Run the application (all the servo drives are enabled).	–	Application runs as expected.	Application runs as expected.
7	Enable STO.	Check that errors are generated correctly when STO is activated while the servo drives are running.	Motors are torque free. Motors coast and stop after some time. <i>MC_ReadAxisInfo_DDS</i> output <i>SafeTorqueOff</i> = True and <i>MC_ReadStatus_DDS</i> output <i>ErrorStop</i> = True and <i>MC_ReadAxisError_DDS</i> output <i>AxisErrorID</i> = 0xFF80 on all enabled servo drives.	Motors are torque free. Motors coast and stop after some time. For enabled motors: <i>MC_ReadStatus</i> output <i>ErrorStop</i> = True and <i>MC_ReadAxisError</i> output <i>AxisErrorID</i> = 0xFF80 on all enabled servo drives.
8	Try to run the application (enable 1 or more servo drives).	Checks that the STO function is working correctly.	Application does not run.	Application does not run.

	Test steps	Reason for the test step	Expected result for Danfoss library	Expected result for Twin-CAT® library
9	Disable STO.	Check that the STO start is still inhibited by the error signal.	<i>MC_ReadAxisInfo_DDS</i> output <i>SafeTorqueOff</i> = False and <i>MC_ReadStatus_DDS</i> output <i>ErrorStop</i> = True	<i>MC_ReadStatus</i> output <i>ErrorStop</i> = True
10	Try to run the application (enable 1 or more servo drives).	Check whether reset is required.	Application does not run.	Application does not run.
11	Send a reset signal via <i>MC_Reset(_DDS)</i> .	–	<i>MC_ReadAxisInfo_DDS</i> output <i>SafeTorqueOff</i> = False and <i>MC_ReadStatus_DDS</i> output <i>ErrorStop</i> = False	<i>MC_ReadStatus</i> output <i>ErrorStop</i> = False
12	Try to run the application (all servo drives are enabled).	–	Application runs as expected.	Application runs as expected.

8.8.2 Commissioning Test using PROFINET® Devices

Table 37: Commissioning Test using PROFINET® Devices

	Test steps	Reason for the test step	Expected result
1	Run the application (all the servo drives are enabled).	Check that the application can run.	Application runs as expected.
2	Stop the application.	–	All servo drives are at speed 0 RPM.
3	Disable all the servo drives.	–	All servo drives are disabled.
4	Enable STO.	Check that STO can be activated without error.	No errors are present. The successful STO activation can be checked on the LEDs on the devices.
5	Disable STO.	Check that STO can be deactivated without error. No reset is required.	No errors are present. The STO status can be checked on the LEDs on the devices.
6	Run the application (all the servo drives are enabled).	–	Application runs as expected.
7	Enable STO.	Check that errors are generated correctly when STO is activated while the servo drives are running.	Motors are torque free. Motors coast and stop after some time. Error 0x11E is shown in object 0x603F on all servo drives.
8	Try to run the application (enable 1 or more servo drives).	Checks that the STO function is working correctly.	Application does not run.
9	Disable STO.	Check that the STO start is still inhibited by the error signal.	Error 0x11E is shown in object 0x603F on all servo drives.
10	Try to run the application (enable 1 or more servo drives).	Check whether reset is required.	Application does not run.

	Test steps	Reason for the test step	Expected result
11	Send a reset signal via the PLC.	–	STO error 0x11E is cleared in all servo drives.
12	Try to run the application (all servo drives are enabled).	–	Application runs as expected.

8.9 Operation of the STO Function

The STO function does not require any parameterization and is always enabled.

The ISD 510/DSD 510 servo drive provides STO status signals via the fieldbus.

All signals transmitted via the fieldbus are not part of the safety function and can only be used for operational purposes.

See the **VLT® Servo Drive System ISD 510, DSD 510, MSD 510 (VLT® Flexmotion™) Programming Guide** for:

- General information on how to access and map data objects.
- Information on a library provided to simplify the use of the fieldbus functions.

If STO is activated when the servo drive is disabled, and no attempt is made to enable the servo drive while STO is active, it is not necessary to reset the STO function after reapplying supply to the STO terminals.

If STO is activated when the servo drive is enabled, an error code is issued.

8.9.1 Error Codes

If bit 3 of the statusword is set, this indicates any faults that occur on the servo drive. If the fault occurred because of the STO circuit, the cause of the fault can be found in object 0x603F.

Table 38: Error Codes

Error code	PROFINET® error code	Classification	Description	Reset
0xFF80	0x11E	Fault	STO activated while the servo drive was enabled, or an attempt to enable the servo drive was made while STO was activated.	Reset via the PLC.
0xFF81	0x11F	Safety fault	Servo drive internal diagnostic fault.	Carry out a power cycle.
0xFF85	0x120	Safety fault	Internal STO supply on the power card is not within limits.	Carry out a power cycle.

Error code 0xFF80/0x11E can be a normal status of the application. In this case, the servo drive requires a reset signal from the PLC. To use the STO function in an application that requires a control guard (see ISO 12100 for details), this reset information can be given automatically by the PLC. All servo drives on the same line will display this fault at the same time. Carry out a check on the PLC to compare the fault of all servo drives on 1 line.

Error code 0xFF81/0x11F means that there is a fault on the servo drive that can only be reset by carrying out a power cycle. Complete the commissioning test after the power cycle. Operation of the servo system can only be resumed if the test is completed successfully. If error code 0xFF81/0x11F or 0xFF85/0x120 is issued again, contact Danfoss Service.

8.9.2 Fault Reset

To reset faults, change bit 7 of the controlword from 0 to 1. See the **VLT® Servo Drive System ISD 510, DSD 510, MSD 510 (VLT® Flexmotion™) Programming Guide** for further information.

8.10 Functional Safety Characteristic Data

Table 39: Functional Safety Characteristic Data

Data	ISD 510/DSD 510	PSM 510	DAM 510
General information			
Response time (from switching on the input until torque generation is disabled)	<100 ms		

Data	ISD 510/DSD 510	PSM 510	DAM 510
Lifetime	20 years		
Data for EN/ISO 13849-1			
Performance level (PL)	d	–	–
Category	3	–	–
Mean time to dangerous failure (MTTF _D)	>5000 years	–	–
Diagnostic coverage (DC)	60%	–	–
Data for EN/ISO 61508 and EN/IEC 62061			
Safety integrity level (SIL)	2	–	–
Probability of failure per hour (PFH)	$<4 \times 10^{-9}/h$	0/h	0/h
Safe failure fraction (SFF)	>95%	100%	100%
Subsystem classification	Type A		
Functional test interval	1 year		

N O T I C E

- The PSM 510, DAM 510, and ACM 510 do not contribute to the dangerous failure rate of the Danfoss system and can therefore be excluded from safety-related calculations.

8.11 Maintenance, Security, and User Accessibility

Maintenance: Test the STO safety function at least once per year as follows:

- Remove the STO input voltage.
- Verify that the motors stop running.
- Verify that no unexpected error codes appear.

Security: If security risks exist, take suitable measures to prevent them.

User accessibility: Restrict access to the ISD 510/DSD 510 servo drives and other system components if access to them could result in safety risks.

9 Diagnostics

9.1 Faults

If faults occur during the operation of the ISD 510/DSD 510 system, check:

- The LEDs on the servo drives for general problems relating to communication or device status.
- The LEDs on the PSM 510 and DAM 510 for general problems with communication, auxiliary supply, or STO voltage.
- The error codes.

The error codes can be read using the VLT® Servo Toolbox software, the LCP, or the PLC. The LCP only shows faults relating to the device it is connected to.

NOTICE

- If the fault cannot be eliminated by 1 of the measures listed in the troubleshooting tables, notify Danfoss Service.

Have the following information available to enable Danfoss to provide help quickly and effectively:

- Type number
- Error code
- Firmware version
- System setup (for example, number of servo drives, system modules, and lines).
- System status when the fault occurred.
- Ambient conditions.

9.2 Troubleshooting

9.2.1 Troubleshooting for the ISD 510/DSD 510 Servo Drives

9.2.1.1 Drive not Running/Starting Slowly

Possible Cause

- Bearing wear.
- Incorrect parameter settings.
- Incorrect control loop parameters.
- Incorrect torque settings.

Troubleshooting

- Check the bearings and the shaft.
- Check the parameter settings.

9.2.1.2 Drive Hums and Draws High Current

Possible Cause

- Drive defective.

Troubleshooting

- Contact Danfoss.

9.2.1.3 Drive Stops Suddenly and Restart is not Possible

Possible Cause

- No drive communication.
- Servo drive in error mode.

Troubleshooting

- Check the fieldbus connection and the LEDs on the servo drive.

9.2.1.4 Motor Rotating in Wrong Direction

Possible Cause

- Mirror mode activated.

Troubleshooting

- Check the parameter settings.

9.2.1.5 Motor not Generating Expected Torque

Possible Cause

- Drive defective.
- Parameter error.

Troubleshooting

- Check the parameter settings.
- Contact Danfoss.

9.2.1.6 Drive Screaming

Possible Cause

- Incorrect calibration.
- Faulty current measurement.
- Incorrect control loop parameters.

Troubleshooting

- Check the parameter settings.
- Contact Danfoss.

9.2.1.7 Uneven Running

Possible Cause

- Defective bearing.

Troubleshooting

- Check the shaft.

9.2.1.8 Vibration

Possible Cause

- Defective bearing.
- Incorrect control loop parameters.

Troubleshooting

- Check the shaft.
- Check the parameter settings.

9.2.1.9 Unusual Running Noises

Possible Cause

- Defective bearing.
- Defects on connected mechanics.
- Incorrect control loop parameters.

Troubleshooting

- Check the shaft.
- Check for loose mechanical components on the connected mechanics.
- Check the parameter settings.

9.2.1.10 Drive Speed Drops Sharply under Load

Possible Cause

- Drive is running at current limit.
- Drive is running with incorrect parameters.

Troubleshooting

- Check the application.
- Check the parameter settings.

9.2.1.11 Brake not Releasing

Possible Cause

- Defective brake control.
- Incorrect mechanical brake parameters.

Troubleshooting

- Check the parameter settings.
- Contact Danfoss.

9.2.1.12 Holding Brake not Holding the Servo Drive

Possible Cause

- Mechanical brake defective.
- Shaft load exceeds the holding torque of the brake.

Troubleshooting

- Contact Danfoss.

9.2.1.13 Delayed Brake Engagement

Possible Cause

- Software error.

Troubleshooting

- Contact Danfoss.

9.2.1.14 Noises when Power-Off Brake is Engaged

Possible Cause

- Mechanical brake damaged.

Troubleshooting

- Contact Danfoss.

9.2.1.15 LEDs not Lighting Up

Possible Cause

- No power supply.

Troubleshooting

- Check the power supply.

9.2.1.16 Drive Protection Trips Immediately

Possible Cause

- Short circuit.
- Incorrect control loop parameters.

Troubleshooting

- Check the wiring.
- Contact Danfoss.

9.2.2 Troubleshooting for the Servo System

9.2.2.1 LCP Display is Dark/Not Functioning

This fault applies to the ISD 510/DSD 510 servo drives, PSM 510, DAM 510, and ACM 510.

Possible Causes

- Missing input power.
- Missing or open fuses or circuit breaker tripped.
- No power to the LCP.
- Incorrect contrast setting.
- Display is defective.

Troubleshooting

Table 40: Fault, LCP Display is Dark/Not Functioning

Possible cause	Possible solution
Missing input power.	Check the input power source.
Missing or open fuses or circuit breaker tripped.	Check the fuses and circuit breaker.
No power to the LCP.	<ul style="list-style-type: none"> • Check the LCP cable for proper connection or damage. • Replace any faulty LCP or connection cables.
Incorrect contrast setting.	Press [Status] + [▲]/[▼] to adjust the contrast.
Display is defective.	Replace the faulty LCP or connection cable.

9.2.2.2 Open Power Fuses or Circuit Breaker Trip

This fault applies to the PSM 510 and DAM 510.

Possible Causes

- Phase-to-phase short.
- Short on backlink.
- Short on hybrid cable.
- Short on EXM 510 connector or cable.
- Short on ISD 510/DSD 510 connector.

Troubleshooting

- Check the cabling
- Check for loose connections.

9.2.2.3 DC-link Voltage Too Low (Error 0x3220/0x104)

This fault applies to all system modules.

Possible Cause

- Incorrect mains input supply.

Troubleshooting

- Check that the supply voltage matches the allowed specification.

9.2.2.4 Current Overload Trip (Error 0x2396/0x15C)

This fault applies to the PSM 510 and the DAM 510.

Possible Causes

- The sum of the servo drive current exceeds the maximum rating of the DAM 510.
- The sum of the system modules' current exceeds the maximum rating of the PSM 510.
- Short on backlink.

Troubleshooting

- Check the servo drive current consumption.
- Avoid simultaneous acceleration of all servo drives.
- Decrease the acceleration value.

9.2.2.5 High Cont. Power Overload (Error 0x2313/0x161)

This fault applies to the PSM 510.

Possible Causes

- The PSM 510 was operating at over 140% of the nominal power rating for too long.

Troubleshooting

- Check the current consumption.

9.2.2.6 Continuous Power Overload (Error 0x2314/0x162)

This fault applies to the PSM 510.

Possible Causes

- The PSM 510 was operating at 100–140% of the nominal power rating for too long.

Troubleshooting

- Check the current consumption.

9.2.2.7 AUX Overcurrent (Error 0x2391/0x125)

This fault applies to the DAM 510.

Possible Causes

- The servo drives are consuming more power on the U_{AUX} line than allowed.

Troubleshooting

- Check the number of attached servo drives with the shell diagrams in the **VLT® Servo Drive System ISD 510, DSD 510, MSD 510 (VLT® Flexmotion™) Design Guide**.
- Avoid simultaneous lifting of the servo drive brakes.

9.2.2.8 AUX Overvoltage (Error 0x3292/0x133)

This fault applies to the DAM 510.

Possible Causes

- Incorrect U_{AUX} supply.

Troubleshooting

- Check that the supply matches the auxiliary supply requirements.

9.2.2.9 AUX Undervoltage (Error 0x3294/0x135)

This fault applies to the PSM 510, DAM 510, and ACM 510.

Possible Causes

- Incorrect U_{AUX} supply.
- Incorrect current dimensioning of the supply equipment.

Troubleshooting

- Check that the supply matches the auxiliary supply requirements.
- Check that the output power of the supply is sufficient.

9.2.2.10 Mains Phase Loss (Error 0x3130/0x12F)

This fault applies to the PSM 510.

Possible Causes

- A phase is missing on the supply side.
- The voltage imbalance is too high.

Troubleshooting

- Check the supply voltages and supply currents to the device.

9.2.2.11 Generic Application Error (Error 0x1000/ 0x100)

This error is valid for PSM 510, DAM 510, ACM 510, and ISD 510/DSD 510.

Possible Causes

- A generic error has occurred in the application.

Troubleshooting

- Contact Danfoss.

9.2.2.12 Grounding Fault

This fault applies to the PSM 510, DAM 510, and ACM 510.

Possible Causes

- Grounding fault.
- When 2 PSM510 modules are mounted in parallel and the maximum delay time for power-up is exceeded (see [6.6 Power-Up Time](#)).

Troubleshooting

- Check for proper grounding and loose connections.
- Check the hybrid cables for short circuits or leakage currents.
- Check the EXM 510 connection and cable.

9.2.2.13 Brake Resistor Error

This fault applies to the PSM 510.

Possible Causes

- Faulty brake resistor.
- Internal/external brake resistor not connected.

Troubleshooting

- Remove the power to the device, wait for the discharge time to elapse, then replace the brake resistor.

9.2.2.14 Brake Chopper Error

This fault applies to the PSM 510.

Possible Causes

- Faulty brake chopper.
- Brake chopper power exceeds the power cycle limit.
- Incorrect parameterization.

Troubleshooting

- Check the parameterization of the brake chopper.
- Check the brake chopper connection.
- Measure the resistance of the brake chopper and compare it with the parameter settings.

9.2.2.15 Internal Fan Error

This fault applies to PSM 510.

Possible Causes

- Fan is not mounted.
- Fan is blocked.

Troubleshooting

- Check if the fan is blocked.
- Check the fan cables for proper connection or damage.

9.3 Error Codes for ISD 510/DSD 510 Servo System

9.3.1 No error (0x0000 / 0x0)

This error code is valid for PSM 510, DAM 510, ACM 510, and ISD 510/DSD 510.

Table 41: No error (0x0000 / 0x0)

Code	PROFINET® code	Name	Severity (warning/error/trip lock)	Description	LCP name
0x0000	0x0	No error	Error	No error.	–

9.3.2 Generic application error (0x1000 / 0x100)

This error is valid for PSM 510, DAM 510, ACM 510, and ISD 510/DSD 510.

Table 42: Generic err (0x1000 / 0x100)

Code	PROFINET® code	Name	Severity (warning/error/trip lock)	Description	LCP name
0x1000	0x100	Generic application error	Error	Generic application error.	generic err

9.3.3 Overcurrent Trip (0x2310 / 0x101)

This error is valid for ISD 510/DSD 510.

Table 43: Overcurr out (0x2310 / 0x101)

Code	PROFINET® code	Name	Severity (warning/error/trip lock)	Description	LCP name
0x2310	0x101	Overcurrent trip	Error	Overcurrent trip on output.	overcurr trip

9.3.4 High cont. current overload (0x2311 / 0x15F)

This error is valid for DAM 510 and ISD 510/DSD 510.

Table 44: High current overload (0x2311 / 0x15F)

Code	PROFINET® code	Name	Severity (warning/error/trip lock)	Description	LCP name
0x2311	0x15F	High cont. current overload	Error	High continuous current overload error.	High curr ovld

9.3.5 Continuous current overload (0x2312 / 0x160)

This error is valid for DAM 510 and ISD 510/DSD 510.

Table 45: Continuous current overload (0x2312 / 0x160)

Code	PROFINET® code	Name	Severity (warning/error/trip lock)	Description	LCP name
0x2312	0x160	Continuous current overload	Error	Continuous current overload error.	cont curr ovld

9.3.6 High cont. power overload (0x2313 / 0x161)

This error is valid for PSM 510.

Table 46: High cont. power overload (0x2313 / 0x161)

Code	PROFINET® code	Name	Severity (warning/error/trip lock)	Description	LCP name
0x2313	0x161	High cont. power overload	Warning, error	High continuous power overload error.	high pwr ovld

9.3.7 Continuous power overload (0x2314 / 0x162)

This error is valid for PSM 510.

Table 47: Continuous power overload (0x2314 / 0x162)

Code	PROFINET® code	Name	Severity (warning/error/trip lock)	Description	LCP name
0x2314	0x162	Continuous power overload	Warning, error	Continuous power overload error.	cont pwr ovld

9.3.8 Overcurrent short circuit (0x2320 / 0x163)

This error is valid for PSM 510 and DAM 510.

Table 48: Overcurrent short circuit (0x2320 / 0x163)

Code	PROFINET® code	Name	Severity (warning/error/trip lock)	Description	LCP name
0x2320	0x163	Overcurrent short circuit	Trip lock	Overcurrent short circuit error.	over curr short

9.3.9 Ground fault (0x2330 / 0x151)

This error is valid for PSM 510, DAM 510, and ISD 510/DSD 510.

Table 49: Ground fault (0x2330 / 0x151)

Code	PROFINET® code	Name	Severity (warning/error/trip lock)	Description	LCP name
0x2330	0x151	Ground fault	Warning, error	Discharge from output phases to ground.	ground fault

9.3.10 AUX overcurrent (0x2391 / 0x125)

This error is valid for DAM 510.

Table 50: AUX overcurr (0x2391 / 0x125)

Code	PROFINET® code	Name	Severity (warning/error/trip lock)	Description	LCP name
0x2391	0x125	AUX overcurrent	Error	Current on the AUX line has reached the overcurrent limit.	AUX overcurr

9.3.11 AUX user limit current (0x2393 / 0x127)

This error is valid for DAM 510.

Table 51: AUX user limit current (0x2393 / 0x127)

Code	PROFINET® code	Name	Severity (warning/error/trip lock)	Description	LCP name
0x2393	0x127	AUX user limit current	Error	Current on the AUX line has reached the user-defined limit for fault.	AUX curr limit

9.3.12 AUX user limit current warning (0x2394 / 0x128)

This error is valid for PSM 510 and DAM 510.

Table 52: AUX user limit current warning (0x2394 / 0x128)

Code	PROFINET® code	Name	Severity (warning/error/trip lock)	Description	LCP name
0x2394	0x128	AUX user limit current warning	Warning	Current on the AUX line has reached the user-defined limit for warning.	AUX curr warn

9.3.13 AUX supply failure (0x2395 / 0x129)

This error is valid for DAM 510.

Table 53: AUX supply failure (0x2395 / 0x129)

Code	PROFINET® code	Name	Severity (warning/error/trip lock)	Description	LCP name
0x2395	0x129	AUX supply failure	Error	AUX supply failure indicated by hardware circuit..	AUX supply fail

9.3.14 Current overload trip (0x2396 / 0x15C)

This error is valid for DAM 510 and ISD 510/DSD 510.

Table 54: Current overload trip (0x2396 / 0x15C)

Code	PROFINET® code	Name	Severity (warning/error/trip lock)	Description	LCP name
0x2396	0x15C	Current overload trip	Error	Current overload trip error.	curr ovld trip

9.3.15 Power overload trip (0x2397 / 0x12B)

This error is valid for PSM 510.

Table 55: Power overload trip (0x2397 / 0x12B)

Code	PROFINET® code	Name	Severity (warning/error/trip lock)	Description	LCP name
0x2397	0x12B	Power overload trip	Error	Power overload trip error.	pwr ovld trip

9.3.16 Thermal overload motor (0x239B / 0x102)

This error is valid for ISD 510/DSD 510.

Table 56: Thermal overload motor (0x239B / 0x102)

Code	PROFINET® code	Name	Severity (warning/error/trip lock)	Description	LCP name
0x239B	0x102	Thermal overload motor	Warning, error	Thermal overload motor error.	therm ovld motor

9.3.17 Mains phase loss (0x3130 / 0x12F)

This error is valid for PSM 510.

Table 57: Mains phase loss (0x3130 / 0x12F)

Code	PROFINET™ code	Name	Severity (warning/error/trip lock)	Description	LCP name
0x3130	0x12F	Mains phase loss	Error	Mains phase loss detected. This occurs when a phase on mains is missing, or when the mains is imbalanced.	phase loss

9.3.18 DC link overvoltage (0x3210 / 0x103)

This error is valid for PSM 510, DAM 510, ACM 510, and ISD 510/DSD 510.

Table 58: DC link overvoltage (0x3210 / 0x103)

Code	PROFINET® code	Name	Severity (warning/error/trip lock)	Description	LCP name
0x3210	0x103	DC link overvoltage	Error	DC-link voltage exceeds limit.	UDC overvolt

9.3.19 DC link undervoltage (0x3220 / 0x104)

This error is valid for PSM 510, DAM 510, ACM 510, and ISD 510/DSD 510.

Table 59: DC link undervoltage (0x3220 / 0x104)

Code	PROFINET® code	Name	Severity (warning/error/trip lock)	Description	LCP name
0x3220	0x104	DC link undervoltage	Error	DC-link voltage below limit in <i>Operation enabled</i> state.	UDC undervolt

9.3.20 DC link charging error (0x3230 / 0x152)

This error is valid for PSM 510, DAM 510, ACM 510, and ISD 510/DSD 510.

Table 60: DC link charging error (0x3230 / 0x152)

Code	PROFINET® code	Name	Severity (warning/error/trip lock)	Description	LCP name
0x3230	0x152	DC link charging error	Error	DC-link charging error. The maximum time limit to charge the DC-link has been exceeded.	UDC charging

9.3.21 DC Link unbalanced (0x3280 / 0x153)

This error is valid for PSM 510, DAM 510, and ACM 510.

Table 61: DC Link unbalanced (0x3280 / 0x153)

Code	PROFINET™ code	Name	Severity (warning/error/trip lock)	Description	LCP name
0x3280	0x153	DC Link unbalanced	Trip lock	DC-link voltage is unbalanced. This fault indicates an internal malfunction of the DC-link.	UDC unbalance

9.3.22 UAUX high voltage (0x3291 / 0x132)

This error is valid for PSM 510, DAM 510, and ACM 510.

Table 62: UAUX high voltage (0x3291 / 0x132)

Code	PROFINET® code	Name	Severity (warning/error/trip lock)	Description	LCP name
0x3291	0x132	U _{AUX} high voltage	Warning	U _{AUX} above warning limit.	UAUX high volt

9.3.23 UAUX overvoltage (0x3292 / 0x133)

This error is valid for DAM 510.

Table 63: UAUX overvoltage (0x3292 / 0x133)

Code	PROFINET® code	Name	Severity (warning/error/trip lock)	Description	LCP name
0x3292	0x133	U _{AUX} overvoltage	Error	U _{AUX} above overvoltage limit.	UAUX overvolt

9.3.24 UAUX low voltage (0x3293 / 0x134)

This error is valid for PSM 510, DAM 510, and ACM 510.

Table 64: UAUX low voltage (0x3293 / 0x134)

Code	PROFINET® code	Name	Severity (warning/error/trip lock)	Description	LCP name
0x3293	0x134	U _{AUX} low voltage	Warning	U _{AUX} below warning limit.	UAUX low volt

9.3.25 UAUX undervoltage (0x3294 / 0x135)

This error is valid for PSM 510, DAM 510, and ACM 510.

Table 65: UAUX undervoltage (0x3294 / 0x135)

Code	PROFINET® code	Name	Severity (warning/error/trip lock)	Description	LCP name
0x3294	0x135	U _{AUX} undervoltage	Error	U _{AUX} below undervoltage limit.	UAUX undervolt

9.3.26 DC link high voltage (0x3295 / 0x136)

This error is valid for PSM 510, DAM 510, and ACM 510.

Table 66: DC link high voltage (0x3295 / 0x136)

Code	PROFINET® code	Name	Severity (warning/error/trip lock)	Description	LCP name
0x3295	0x136	DC link high voltage	Warning	The DC-link voltage is higher than the high-voltage warning limit.	UDC high volt

9.3.27 DC link low voltage (0x3296 / 0x137)

This error is valid for PSM 510, DAM 510, and ACM 510.

Table 67: UDC low voltage (0x3296 / 0x137)

Code	PROFINET® code	Name	Severity (warning/error/trip lock)	Description	LCP name
0x3296	0x137	DC link low voltage	Warning	The DC-link voltage is lower than the low-voltage warning limit.	UDC low volt

9.3.28 UAUX charging error (0x3297 / 0x154)

This error is valid for DAM 510.

Table 68: UAUX charging error (0x3297 / 0x154)

Code	PROFINET® code	Name	Severity (warning/error/trip lock)	Description	LCP name
0x3297	0x154	U _{AUX} charging error	Error	Load error when U _{AUX} is charging. The maximum time limit to charge the AUX line has been exceeded.	UAUX charg err

9.3.29 DC link shutdown error (0x3298 / 0x165)

This error is valid for DAM 510.

Table 69: DC link shutdown error (0x3298 / 0x165)

Code	PROFINET® code	Name	Severity (warning/error/trip lock)	Description	LCP name
0x3298	0x165	DC link shutdown error	Error	Error when UDC is in shutdown phase.	UDC shutdwn err

9.3.30 UAUX shutdown error (0x3299 / 0x155)

This error is valid for DAM 510.

Table 70: UAUX shutdown error (0x3299 / 0x155)

Code	PROFINET® code	Name	Severity (warning/error/trip lock)	Description	LCP name
0x3299	0x155	U _{AUX} shutdown error	Error	Error when U _{AUX} is in shutdown phase.	UAUX shtdwn err

9.3.31 UAUX undervoltage hardware (0x329A / 0x156)

This error is valid for PSM 510, DAM 510, and ACM 510.

Table 71: UAUX undervoltage hardware (0x329A / 0x156)

Code	PROFINET® code	Name	Severity (warning/error/trip lock)	Description	LCP name
0x329A	0x156	U _{AUX} undervoltage hardware	Error	U _{AUX} undervoltage detected by hardware circuit.	AUX undervol HW

9.3.32 Device overtemperature (0x4210 / 0x157)

This error is valid for PSM 510, DAM 510, and ACM 510.

Table 72: Device overtemperature (0x4210 / 0x157)

Code	PROFINET® code	Name	Severity (warning/error/trip lock)	Description	LCP name
0x4210	0x157	Device overtemperature	Warning, error	Triggered when the maximum temperature of the main device component is exceeded. PSM: Thyristor rectifier module. DAM: Maximum temperature of both high side and low side IGBTs.	overtemp device

9.3.33 Device under temperature (0x4220 / 0x138)

This error is valid for PSM 510, DAM 510, and ACM 510.

Table 73: Device under temperature (0x4220 / 0x138)

Code	PROFINET® code	Name	Severity (warning/error/trip lock)	Description	LCP name
0x4220	0x138	Device under temperature	Error	The device is too cold to operate.	undertemp device

9.3.34 Overtemperature: Control card (0x4291 / 0x106)

This error is valid for PSM 510, DAM 510, ACM 510, and ISD 510/DSD 510.

Table 74: Overtemperature: Control card (0x4291 / 0x106)

Code	PROFINET® code	Name	Severity (warning/error/trip lock)	Description	LCP name
0x4291	0x106	Overtemperature: Control card	Error	Maximum temperature of control card exceeded.	overtemp CC

9.3.35 Overtemperature: Power card (0x4292 / 0x107)

This error is valid for PSM 510, DAM 510, and ACM 510.

Table 75: Overtemperature: Power card (0x4292 / 0x107)

Code	PROFINET® code	Name	Severity (warning/error/trip lock)	Description	LCP name
0x4292	0x107	Overtemperature: Power card	Warning, error	Maximum temperature of power card exceeded.	overtemp PC

9.3.36 Inrush overtemperature DC link (0x4293 / 013C)

This error is valid for PSM 510, DAM 510, and ACM 510.

Table 76: Inrush overtemperature DC link (0x4293 / 0x13C)

Code	PROFINET® code	Name	Severity (warning/error/trip lock)	Description	LCP name
0x4293	0x13C	Inrush overtemperature: DC link	Error	Inrush fault. Too many transitions into state <i>Operation enabled</i> in a short time period.	UDC inrush

9.3.37 Inrush overtemperature AUX line (0x4294 / 0x13D)

This error is valid for DAM 510.

Table 77: Inrush overtemperature AUX line (0x4294 / 0x13D)

Code	PROFINET® code	Name	Severity (warning/error/trip lock)	Description	LCP name
0x4294	0x13D	Inrush overtemperature AUX line	Error	Inrush fault. Too many power-ups of the AUX voltage have occurred within a short time period.	UAUX inrush

9.3.38 Overtemperature: Motor (0x4310 / 0x108)

This error is valid for ISD 510/DSD 510.

Table 78: Overtemperature: Motor (0x4310 / 0x108)

Code	PROFINET® code	Name	Severity (warning/error/trip lock)	Description	LCP name
0x4310	0x108	Overtemperature: Motor	Error	Overtemperature on motor.	overtemp motor

9.3.39 Charge switch failure voltage (0x5121 / 0x158)

This error is valid for PSM 510.

Table 79: Charge switch failure voltage (0x5121 / 0x158)

Code	PROFINET® code	Name	Severity (warning/error/trip lock)	Description	LCP name
0x5121	0x158	Charge switch failure voltage	Trip lock	Indicates a malfunction of the internal charge circuit.	Chg switch fail

9.3.40 EE Checksum Error (parameter missing) (0x5530 / 0x10A)

This error is valid for ISD 510/DSD 510.

Table 80: EE Checksum Error (parameter missing) (0x5530 / 0x10A)

Code	PROFINET® code	Name	Severity (warning/error/trip lock)	Description	LCP name
0x5530	0x10A	EE Checksum Error (parameter missing)	Trip lock	EEPROM checksum error or missing device parameter.	eprom err

9.3.41 Parameter error (0x6320 / 0x10B)

This error is valid for PSM 510, DAM 510, ACM 510, and ISD 510/DSD 510.

Table 81: Param err (0x6320 / 0x10B)

Code	PROFINET® code	Name	Severity (warning/error/trip lock)	Description	LCP name
0x6320	0x10B	Parameter error	Trip lock	A parameter has an invalid value.	param err

9.3.42 Conf par ver (0x6382 / 0x15D)

This error is valid for PSM 510, DAM 510, ACM 510, and ISD 510/DSD 510.

Table 82: Configuration parameters version error (0x6382 / 0x15D)

Code	PROFINET® code	Name	Severity (warning/error/trip lock)	Description	LCP name
0x6382	0x15D	Configuration parameters version error	Trip lock	Configuration parameter set version mismatch: parameter set is not valid for this device.	conf par ver

9.3.43 Configuration parameters limits error (0x6383 / 0x164)

This error is valid for PSM 510, DAM 510, and ACM 510.

Table 83: Configuration parameters limits error (0x6383 / 0x164)

Code	PROFINET® code	Name	Severity (warning/error/trip lock)	Description	LCP name
0x6383	0x164	Configuration parameters limits error	Trip lock	≥1 parameter in the configuration parameter set is out of limits: the parameter set is not valid for this device.	conf par lim

9.3.44 Power EEprom configuration error (0x6384 / 0x166)

This error is valid for PSM 510, DAM 510, ACM 510, and ISD 510/DSD 510.

Table 84: Power EEprom configuration error (0x6384 / 0x166)

Code	PROFINET® code	Name	Severity (warning/error/trip lock)	Description	LCP name
0x6384	0x166	Power Eeprom configuration error	Trip lock	The power device Eeprom is corrupt or incompatible with this control board.	conf par EEPROM

9.3.45 Brake chopper failure (0x7111 / 0x141)

This error is valid for PSM 510.

Table 85: Brake chopper failure (0x7111 / 0x141)

Code	PROFINET® code	Name	Severity (warning/error/trip lock)	Description	LCP name
0x7111	0x141	Brake chopper failure	Warning, error	The brake chopper is monitored during operation. A brake failure has been detected by the brake check function.	brake ch fail

9.3.46 Brake chopper overcurrent (0x7112 / 0x167)

This error is valid for PSM 510.

Table 86: Brake chopper overcurrent (0x7112 / 0x167)

Code	PROFINET® code	Name	Severity (warning/error/trip lock)	Description	LCP name
0x7112	0x167	Brake chopper overcurrent	Trip lock	The brake chopper current exceeds the limit.	brake ch overcurr

9.3.47 Brake chopper module overload (0x7181 / 0x142)

This error is valid for PSM 510.

Table 87: Brake resistor maximum power limit (0x7181 / 0x142)

Code	PROFINET® code	Name	Severity (warning/error/trip lock)	Description	LCP name
0x7181	0x142	Brake chopper module overload	Warning, error	The power load of the brake chopper is monitored during operation. This error appears when the maximum power limit of the brake chopper module is reached.	mod ovl

9.3.48 External brake chopper overload (0x7182 / 0x143)

This error is valid for PSM 510.

Table 88: External brake chopper overload (0x7182 / 0x143)

Code	PROFINET® code	Name	Severity (warning/error/trip lock)	Description	LCP name
0x7182	0x143	External brake chopper overload	Warning, error	The power load of the brake chopper is monitored during operation. Depending on the configuration of <i>external brake chopper power monitoring</i> this warning or fault appears when the configured nominal external brake chopper power is reached.	ext brake ch ovl

9.3.49 Brake mains voltage too high (0x7183 / 0x159)

This error is valid for PSM 510.

Table 89: Brake mains voltage too high (0x7183 / 0x159)

Code	PROFINET® code	Name	Severity (warning/error/trip lock)	Description	LCP name
0x7183	0x159	Brake mains voltage too high	Warning	The mains voltage is too high. Due to this, the brake chopper could be activated continuously depending on the value entered in parameter <i>brake chopper start level</i> .	brake ch high volt

9.3.50 Internal position sensor error (0x7320 / 0x10C)

This error is valid for ISD 510/DSD 510.

Table 90: Internal position sensor error (0x7320 / 0x10C)

Code	PROFINET® code	Name	Severity (warning/error/trip lock)	Description	LCP name
0x7320	0x10C	Internal position sensor error	Trip lock	Absolute position sensor error.	int sensor err

9.3.51 External position sensor error (0x7380 / 0x10D)

This error is valid for DAM 510 and ISD 510/DSD 510.

Table 91: External position sensor error (0x7380 / 0x10D)

Code	PROFINET® code	Name	Severity (warning/error/trip lock)	Description	LCP name
0x7380	0x10D	External position sensor error	Error	External encoder data could not be read.	ext sensor err

9.3.52 Following error (0x8611 / 0x10E)

This error is valid for ISD 510/DSD 510.

Table 92: Following error (0x8611 / 0x10E)

Code	PROFINET® code	Name	Severity (warning/error/trip lock)	Description	LCP name
0x8611	0x10E	Following error	Warning, error	A following error has occurred.	following err

9.3.53 Homing error on entering homing mode (0x8693 / 0x10F)

This error is valid for ISD 510/DSD 510.

Table 93: Homing error on entering homing mode (0x8693 / 0x10F)

Code	PROFINET® code	Name	Severity (warning/error/trip lock)	Description	LCP name
0x8693	0x10F	Homing error on entering homing mode	Warning	Could not enter homing mode (for example velocity not 0).	Homing mode fail

9.3.54 Homing error on start homing method (0x8694 / 0x110)

This error is valid for ISD 510/DSD 510.

Table 94: Homing error on start homing method (0x8694 / 0x110)

Code	PROFINET® code	Name	Severity (warning/error/trip lock)	Description	LCP name
0x8694	0x110	Homing error on start homing method	Warning	Could not start homing method (for example drive not in standstill).	Homing method fail

9.3.55 Homing error distance (0x8695 / 0x111)

This error is valid for ISD 510/DSD 510.

Table 95: Homing error distance (0x8695 / 0x111)

Code	PROFINET® code	Name	Severity (warning/error/trip lock)	Description	LCP name
0x8695	0x111	Homing error distance	Warning	Homing distance reached.	Homing distance

9.3.56 Mechanical brake failure (0xFF01 / 0x112)

This error is valid for ISD 510/DSD 510.

Table 96: Mechanical brake failure (0xFF01 / 0x112)

Code	PROFINET® code	Name	Severity (warning/error/trip lock)	Description	LCP name
0xFF01	0x112	Mechanical brake failure	Trip lock	No brake or wire failure.	brake mech fail

9.3.57 Short circuit in mechanical brake control (0xFF02 / 0x113)

This error is valid for ISD 510/DSD 510.

Table 97: Short circuit in mechanical brake control (0xFF02 / 0x113)

Code	PROFINET® code	Name	Severity (warning/error/trip lock)	Description	LCP name
0xFF02	0x113	Short circuit in mechanical brake control	Trip lock	Short circuit in brake control.	brake mech short

9.3.58 External interface power failure (0xFF0A / 0x114)

This error is valid for ISD 510/DSD 510.

Table 98: External interface power failure (0xFF0A / 0x114)

Code	PROFINET® code	Name	Severity (warning/error/trip lock)	Description	LCP name
0xFF0A	0x114	External interface power failure	Error	External interface power supply failure.	ext IF pwr fail

9.3.59 Fan feedback inconsistent (0xFF21 / 0x145)

This error is valid for PSM 510.

Table 99: Fan feedback inconsistent (0xFF21 / 0x145)

Code	PROFINET® code	Name	Severity (warning/error/trip lock)	Description	LCP name
0xFF21	0x145	Fan feedback inconsistent	Warning	Internal fan fault. Internal fan not running/mounted.	fan feedback

9.3.60 Fan lifetime critical (0xFF22 / 0x15A)

This error is valid for PSM 510.

Table 100: Fan lifetime critical (0xFF22 / 0x15A)

Code	PROFINET® code	Name	Severity (warning/error/trip lock)	Description	LCP name
0xFF22	0x15A	Fan lifetime critical	Warning	The theoretical lifetime of the fan has been exceeded.	fan lifetime

9.3.61 Timing violation 1 (0xFF60 / 0x115)

This error is valid for ISD 510/DSD 510.

Table 101: Timing violation 1 (0xFF60 / 0x115)

Code	PROFINET® code	Name	Severity (warning/error/trip lock)	Description	LCP name
0xFF60	0x115	Timing violation 1	Trip lock	Contact Danfoss.	timing err 1

9.3.62 Timing violation 2 (0xFF61 / 0x116)

This error is valid for ISD 510/DSD 510.

Table 102: Timing violation 2 (0xFF61 / 0x116)

Code	PROFINET® code	Name	Severity (warning/error/trip lock)	Description	LCP name
0xFF61	0x116	Timing violation 2	Trip lock	Contact Danfoss.	timing err 2

9.3.63 Timing violation 3 (0xFF62 / 0x117)

This error is valid for ISD 510/DSD 510.

Table 103: Timing violation 3 (0xFF62 / 0x117)

Code	PROFINET® code	Name	Severity (warning/error/trip lock)	Description	LCP name
0xFF62	0x117	Timing violation 3	Trip lock	Contact Danfoss.	timing err 3

9.3.64 Timing violation 4 (0xFF63 / 0x118)

This error is valid for ISD 510/DSD 510.

Table 104: Timing violation 4 (0xFF63 / 0x118)

Code	PROFINET® code	Name	Severity (warning/error/trip lock)	Description	LCP name
0xFF63	0x118	Timing violation 4	Trip lock	Contact Danfoss.	timing err 4

9.3.65 Timing violation 5 (0xFF64 / 0x119)

This error is valid for ISD 510/DSD 510.

Table 105: Timing violation 5 (0xFF64 / 0x119)

Code	PROFINET® code	Name	Severity (warning/error/trip lock)	Description	LCP name
0xFF64	0x119	Timing violation 5	Trip lock	Contact Danfoss.	timing err 5

9.3.66 Timing violation 6 (0xFF65 / 0x11A)

This error is valid for ISD 510/DSD 510.

Table 106: Timing violation 6 (0xFF65 / 0x11A)

Code	PROFINET® code	Name	Severity (warning/error/trip lock)	Description	LCP name
0xFF65	0x11A	Timing violation 6	Trip lock	Contact Danfoss.	timing err 6

9.3.67 Timing violation 7 (0xFF66 / 0x168)

This error is valid for ISD 510/DSD 510.

Table 107: Timing violation 7 (0xFF66 / 0x168)

Code	PROFINET® code	Name	Severity (warning/error/trip lock)	Description	LCP name
0xFF66	0x168	Timing violation 7	Trip lock	Contact Danfoss.	timing err 7

9.3.68 Timing violation 8 (0xFF67 / 0x16B)

This error is valid for ISD 510/DSD 510.

Table 108: Timing violation 8 (0xFF67 / 0x16B)

Code	PROFINET® code	Name	Severity (warning/error/trip lock)	Description	LCP name
0xFF67	0x16B	Timing violation 8	Trip lock	Contact Danfoss.	timing err 8

9.3.69 Timing violation 9 (0xFF68 / 0x16C)

This error is valid for ISD 510/DSD 510.

Table 109: Timing violation 9 (0xFF68 / 0x16C)

Code	PROFINET® code	Name	Severity (warning/error/trip lock)	Description	LCP name
0xFF68	0x16C	Timing violation 9	Trip lock	Contact Danfoss.	timing err 9

9.3.70 Firmware: Package description mismatch (0xFF70 / 0x11B)

This error is valid for PSM 510, DAM 510, ACM 510, and ISD 510/DSD 510.

Table 110: Firmware: Package description mismatch (0xFF70 / 0x11B)

Code	PROFINET® code	Name	Severity (warning/error/trip lock)	Description	LCP name
0xFF70	0x11B	Firmware: Package description mismatch	Trip lock	The firmware found does not match the package description.	FW pack err

9.3.71 Firmware: Power cycle needed (0xFF71 / 0x11C)

This error is valid for PSM 510, DAM 510, ACM 510, and ISD 510/DSD 510.

Table 111: Firmware: Power cycle needed (0xFF71 / 0x11C)

Code	PROFINET® code	Name	Severity (warning/error/trip lock)	Description	LCP name
0xFF71	0x11C	Firmware: Power cycle needed	Warning, error	The firmware update transfer is completed but a power cycle is required before the new firmware is active.	need power-cycle

9.3.72 Firmware: Update started (0xFF72 / 0x11D)

This error is valid for PSM 510, DAM 510, ACM 510, and ISD 510/DSD 510.

Table 112: Firmware: Update started (0xFF72 / 0x11D)

Code	PROFINET® code	Name	Severity (warning/error/trip lock)	Description	LCP name
0xFF72	0x11D	Firmware: Update started	Warning, error	Firmware update is in progress. Warning changes to error when an attempt is made to enable the device in this state.	FW update

9.3.73 Firmware: Update invalid (0xFF73 / 0x15B)

This error is valid for PSM 510 and DAM 510.

Table 113: Firmware: Update invalid (0xFF73 / 0x15B)

Code	PROFINET® code	Name	Severity (warning/error/trip lock)	Description	LCP name
0xFF73	0x15B	Firmware: Update invalid	Error	Invalid or corrupted firmware package update. Last valid firmware package has been loaded.	FW upd invalid

9.3.74 STO active while drive enabled (0xFF80 / 0x11E)

This error is valid for ISD 510/DSD 510.

Table 114: STO active while drive enabled (0xFF80 / 0x11E)

Code	PROFINET® code	Name	Severity (warning/error/trip lock)	Description	LCP name
0xFF80	0x11E	STO active while drive enabled	Error	STO activated while drive was enabled or tried to enable while STO active.	STO active

9.3.75 STO mismatch (0xFF81 / 0x11F)

This error is valid for ISD 510/DSD 510.

Table 115: STO mismatch (0xFF81 / 0x11F)

Code	PROFINET® code	Name	Severity (warning/error/trip lock)	Description	LCP name
0xFF81	0x11F	STO mis-match	Trip lock	Dual diagnosis of STO voltage not plausible.	STO mismatch

9.3.76 P_STO error (0xFF85 / 0x120)

This error is valid for ISD 510/DSD 510.

Table 116: P_STO error (0xFF85 / 0x120)

Code	PROFINET® code	Name	Severity (warning/error/trip lock)	Description	LCP name
0xFF85	0x120	P_STO error	Trip lock	P_STO voltage on the power card exceeds the limits.	P_STO error

9.3.77 Guide value reversed (0xFF90 / 0x121)

This error is valid for ISD 510/DSD 510.

Table 117: Guide value reversed (0xFF90 / 0x121)

Code	PROFINET® code	Name	Severity (warning/error/trip lock)	Description	LCP name
0xFF90	0x121	Guide value reversed	Error	Position guide value went backwards while the servo drive was in CAM mode.	guide val rev

9.3.78 Guide value implausible (0xFF91 / 0x122)

This error is valid for ISD 510/DSD 510.

Table 118: Guide value implausible (0xFF91 / 0x122)

Code	PROFINET® code	Name	Severity (warning/error/trip lock)	Description	LCP name
0xFF91	0x122	Guide value implausible	Error	Increments between succeeding values too large.	guide val impl

9.3.79 Sign of life error (0xFF95 / 0x14E)

This error is valid for ISD 510/DSD 510.

Table 119: Sign of life error (0xFF95 / 0x14E)

Code	PROFINET® code	Name	Severity (warning/error/trip lock)	Description	LCP name
0xFF95	0x14E	Sign of life error	Error	PROFINET® sign of life error.	PNIO SOL error

10 Maintenance, Decommissioning, and Disposal

10.1 Warnings

⚠ WARNING ⚠

HIGH VOLTAGE

Potentially lethal voltage is present on the connectors that may lead to death or serious injury.

- Before working on the power or signal connectors (disconnecting or connecting the cable), or performing any maintenance work, disconnect the Power Supply Module (PSM 510) from the mains and wait for the discharge time to elapse.

⚠ WARNING ⚠

DISCHARGE TIME

The servo system contains DC-link capacitors that remain charged for some time after the mains supply is switched off at the Power Supply Module (PSM 510). Failure to wait the specified time after power has been removed before performing service or repair work could result in death or serious injury.

- To avoid electrical shock, fully disconnect the Power Supply Module (PSM 510) from the mains and wait for the capacitors to fully discharge before carrying out any maintenance or repair work on the servo system or its components.

Minimum waiting time (minutes)
15

10.2 Maintenance Tasks

The ISD 510/DSD 510 servo drives are largely maintenance free. Only the shaft seal on the ISD 510 (if used) is subject to wear. The maintenance tasks must be performed by qualified personnel. No other tasks are required.

Table 120: Overview of Maintenance Tasks

Component	Maintenance task	Maintenance interval	Instruction
Servo drive	Carry out a visual inspection.	Every 6 months	Check for any abnormalities on the surface of the servo drive.
Shaft seal on the ISD 510	Check the condition and check for leakage.	Every 6 months ¹⁾	If damaged, replace the shaft seal.
Flange connection on the ISD 510	Measure the resistance.	Every 12 months.	Measure the resistance of the flange connection on the ISD 510.
Hybrid cable	Check for damage and wear.	Every 6 months	If damaged or worn: Replace the hybrid cable.
Mechanical holding brake (optional)	Check the brake.	Every 6 months	Ensure that the brake can achieve the holding torque.
Functional safety	Perform a system power cycle and check the STO function.	Every 12 months	Activate STO and check the status with the PLC.
System modules	Check the fan.	Every 12 months	Check that the fan can turn and remove any dust or dirt.
	Carry out a visual inspection	Every 6 months	Check for any abnormalities on the surface of the module.

¹ A shorter interval may be necessary depending on the application. Contact Danfoss for more information.

Operating Guide

10.3 Inspection during Operation

10.3.1 ISD 510/DSD 510 Servo Drives

Carry out regular inspections during operation. Check the ISD 510/DSD 510 servo drives at regular intervals for anything unusual. Pay particular attention to:

- Unusual noises (ISD 510/DSD 510 only).
- Overheated surfaces (temperatures up to 100 °C can occur in normal operation).
- Uneven running (ISD 510/DSD 510 only).
- Strong vibrations.
- Loose fastenings.
- Condition of electrical wiring and cables.
- Poor heat dispersion.

10.3.2 System Modules

Carry out regular inspections during operation. Check:

- The cooling vents are not blocked.
- The fan is not making any unusual noises.
- The condition of electrical wiring and cables.

10.4 Repair

Always contact the local Danfoss sales company for information about the repair policy.

10.5 ISD 510/DSD 510 Servo Drive Replacement

10.5.1 Dismounting the ISD 510/DSD 510 Servo Drive

Procedure

1. Disconnect the supply and wait for the discharge time to elapse.
2. Disconnect the electrical cables.
3. Dismount the servo drive.
4. Replace the servo drive with a servo drive of the same type. See the **VLT® Servo Drive System ISD 510, DSD 510, MSD 510 (VLT® Flexmotion™) Design Guide** for part numbers.

10.5.2 Fitting and Commissioning the ISD 510/DSD 510 Servo Drive

Procedure

1. Check if preparation is required (see [4.6.1 ISD 510/DSD 510 Servo Drive](#)).
2. Fit the servo drive (see [4.7.5.2 Clamping the ISD 510 Servo Drive](#)).
3. Connect the hybrid cables (see [5.9.3 Connecting Hybrid Cables](#)).
4. Connect the I/O and/or encoder cables (see [5.9.5.2 Connecting I/O and/or Encoder Cables to Port X3](#)).
5. Configure the servo drive parameters according to the fieldbus used (see [6.3 EtherCAT® ID Assignment](#) and [6.4 Ethernet POWERLINK® ID Assignment](#)).
6. Conduct a test run.

10.6 System Module Replacement

10.6.1 Dismounting the System Modules

1. Disconnect the mains and all auxiliary supplies from the PSM 510 and wait for the discharge time to elapse.
2. Disconnect the EMC plate on the bottom of the system modules. Do not dismount the connectors from the EMC plate.

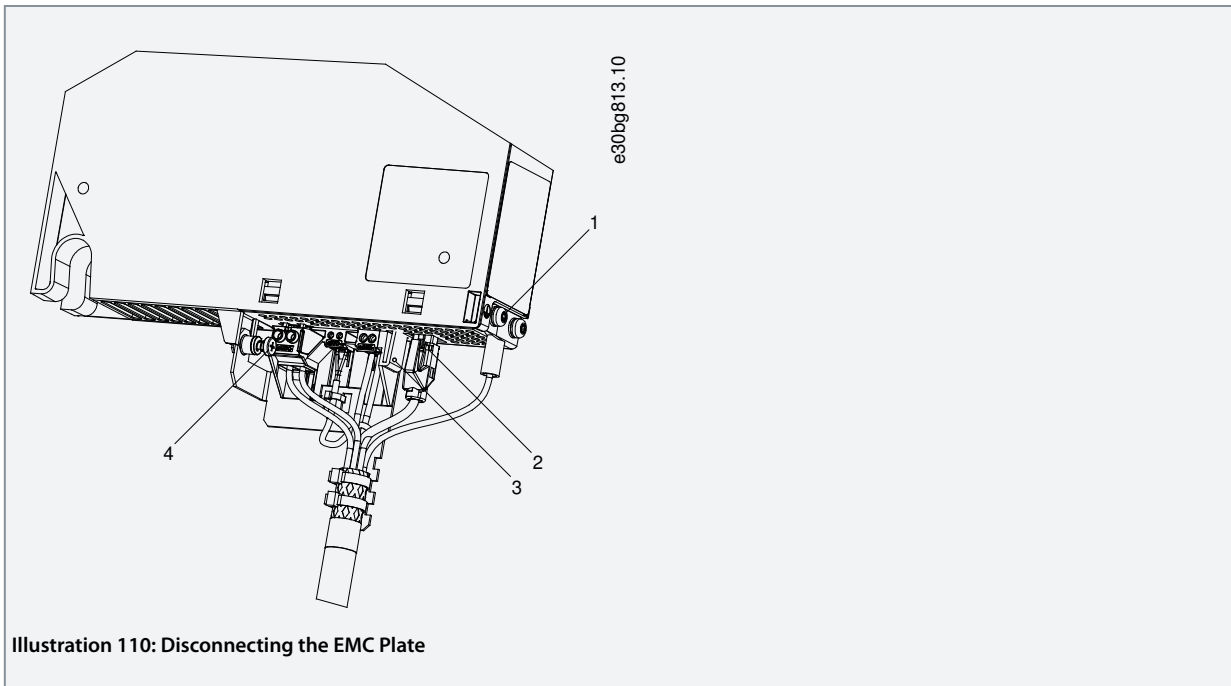

- Unplug the RJ45 connector [2] (only on DAM 510).
- Unscrew the screw [4] on the EMC plate.
- Press the clip [3] to release the EMC plate.
- Unscrew the PE screw [1].

3. Disconnect the I/O shielding plate on the top of the system modules:

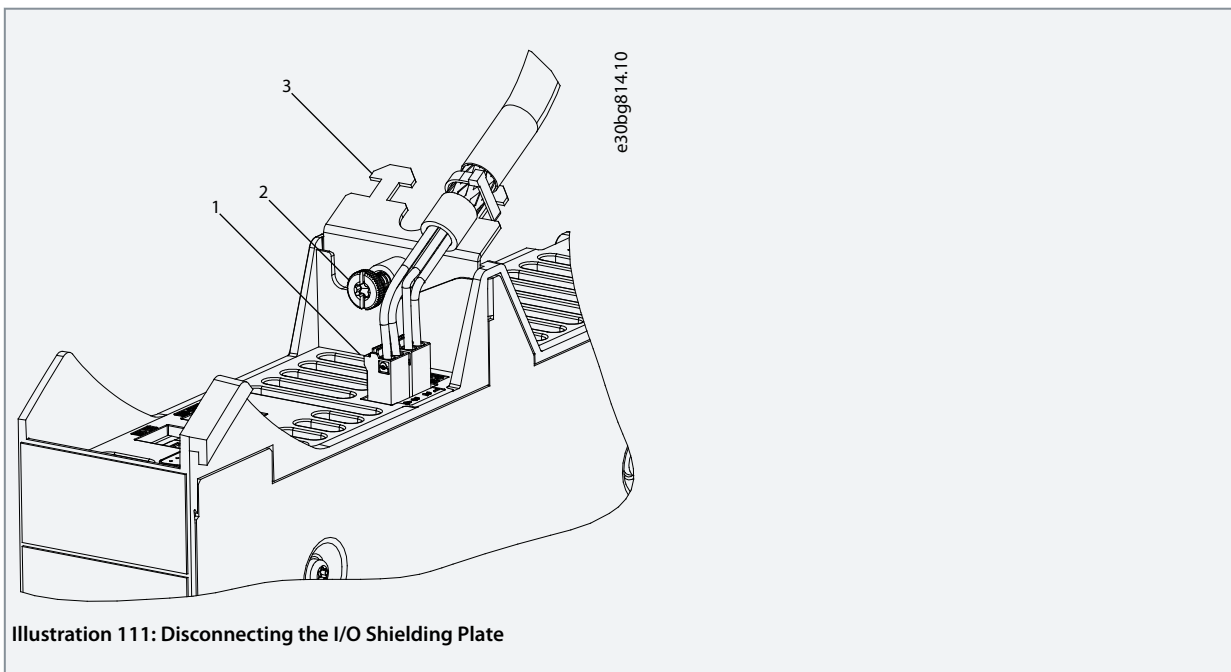

- Unplug the top connectors [1].
- Unscrew the screw [2] on the I/O shielding plate [3].
- Pull the I/O shielding plate upwards to remove it.

4. Release the securing clamp [1] at the top of the module.

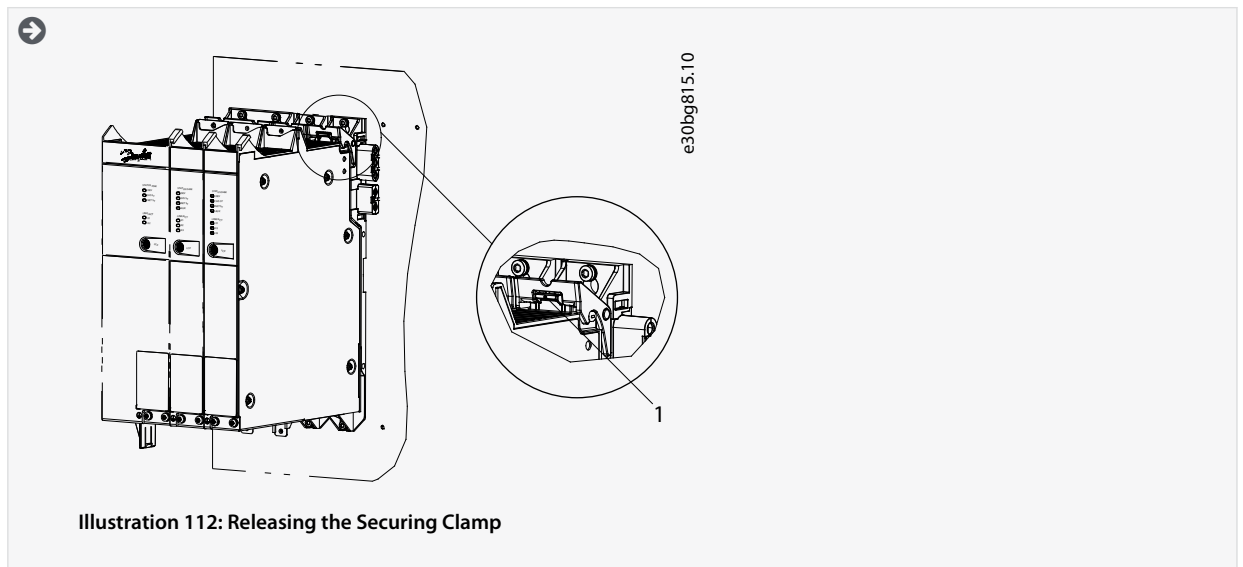

5. Tilt the module forward and remove it from the backplate.

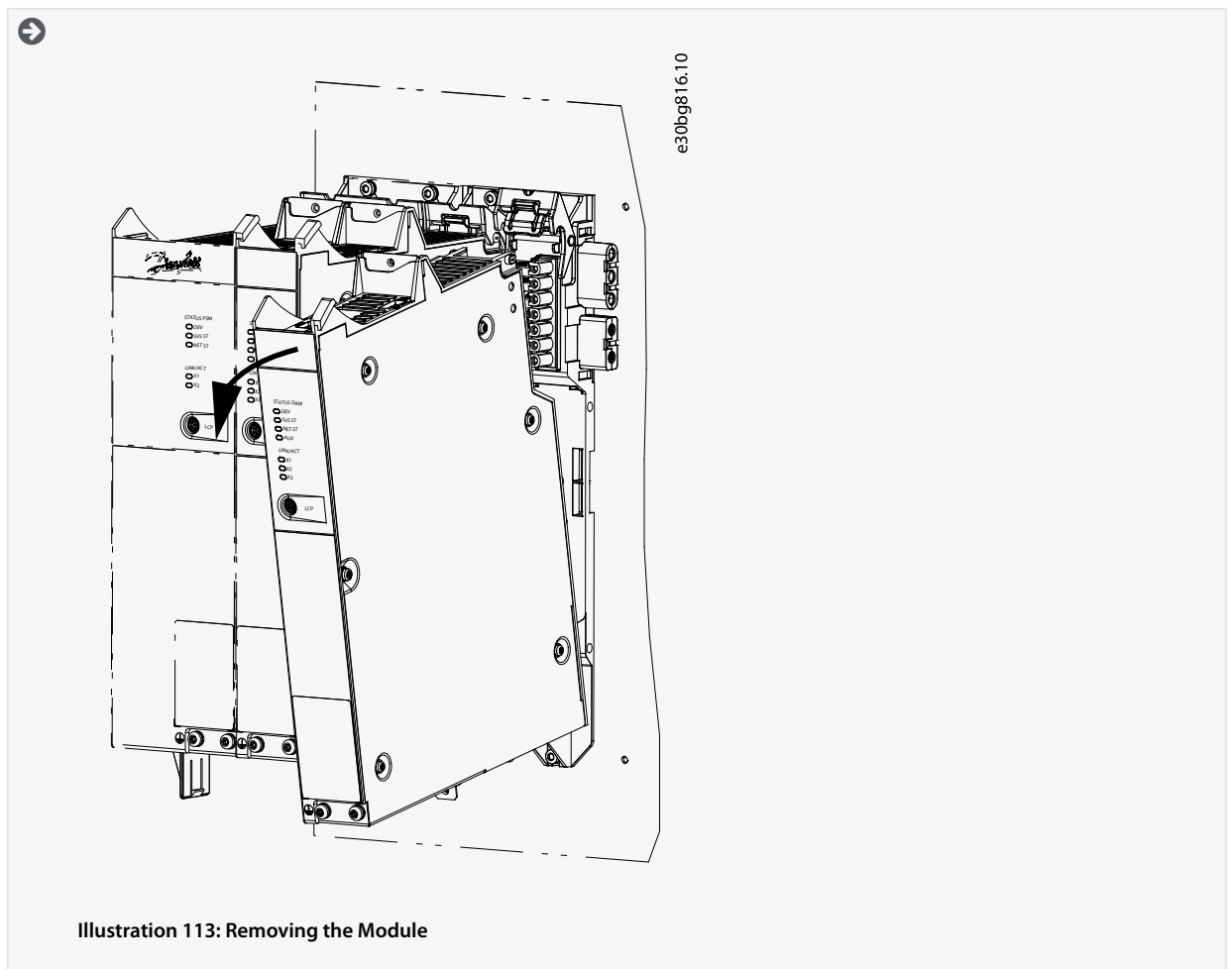

10.6.2 Fitting and Commissioning the System Modules

1. Check if preparation is required (see [4.6.2 System Modules](#)).
2. Fit the system modules (see [4.7.7 Fitting Instructions for System Modules](#)).
3. Connect the electrical cables (see chapter **Electrical Installation**).
4. Switch the system on (see [6.8 Switching on the ISD 510/DSD 510 System](#)).

Operating Guide

5. Configure the system module's parameters according to the fieldbus used (see [6.3 EtherCAT® ID Assignment](#) , [6.4 Ethernet POWERLINK® ID Assignment](#), and [6.5 PROFINET® ID Assignment](#)).
6. Conduct a test run.

10.7 Cable Replacement

10.7.1 Overview

Replace the cables when the rated number of bending cycles has been reached or the cable is damaged.

NOTICE

- Do not forcefully connect or fit the connectors. Incorrect connection causes permanent damage to the connectors.

10.7.2 Feed-In Cable Replacement

10.7.2.1 Disconnecting the Feed-In Cable

Procedure

1. Disconnect the Power Supply Module (PSM 510) from its power source (mains network and all auxiliary supplies).
2. Wait for the necessary discharge time to elapse.
3. Disconnect any cables connected to the X3, X4, or X5 ports on the ISD 510/DSD 510 servo drive for easier access to the feed-in cable.
4. Disconnect the PE wire from the PE screw on the Decentral Access Module (DAM 510).
5. Disconnect the Ethernet connector.
6. Remove the EMC plate from the DAM 510.
7. Open the cable binder holding the STO cable.
8. Open the cable binder holding the feed-in cable on the DAM 510.
9. Loosen the feed-in cable connectors on the DAM 510.
10. Disconnect the feed-in cable from the DAM 510.
11. Loosen the threaded ring of the connector on the servo drive.
12. Disconnect the feed-in cable from the servo drive.

10.7.2.2 Replacing the Feed-In Cable

Replace the feed-in cable with a cable of identical type and length. See the **VLT® Servo Drive System ISD 510, DSD 510, MSD 510 (VLT® Flexmotion™) Design Guide** for part numbers.

10.7.2.3 Connecting the Feed-In Cable

1. Connect the female connector of the feed-in cable to the male connector of the 1st servo drive.
2. Turn the threaded rings of the connectors hand tight.
3. Ensure that there is no mechanical tension on the cables.
4. Insert the feed-in cable wires into the correct connector on the EMC plate at the bottom of the Decentral Access Module (DAM 510).
5. Secure the feed-in cable with a cable binder.
6. Secure the STO cable with a cable binder.
7. Mount the EMC plate on the DAM 510.
8. Connect the Ethernet connector to the DAM 510.
9. Connect the PE wire to the PE screw on the DAM 510.
10. Reconnect any cables that were connected to the X3, X4, or X5 ports.

10.7.3 Loop Cable Replacement

10.7.3.1 Disconnecting the Loop Cable

Procedure

1. Disconnect the Power Supply Module (PSM 510) from its power source (mains network) and all auxiliary supplies.

Operating Guide

2. Wait for the necessary discharge time to elapse.
3. Disconnect any cables connected to the X3, X4, or X5 ports on both ISD 510/DSD 510 servo drives for easier access to the loop cable.
4. Loosen the threaded rings of the loop cable connectors on both servo drives.
5. Disconnect the loop cable from the servo drives.

10.7.3.2 Replacing the Loop Cable

Replace the loop cable with a cable of identical type and length. See the **VLT® Servo Drive System ISD 510, DSD 510, MSD 510 (VLT® Flexmotion™) Design Guide** for part numbers.

10.7.3.3 Connecting the Loop Cable

1. Connect the male connector of the loop cable to the female connector on the servo drive.
2. Connect the female connector of the loop cable to the male connector on the adjacent servo drive.
3. Turn the threaded rings hand tight on both servo drives.
4. Ensure that there is no mechanical tension on the cables.
5. Tighten the threaded rings of the connectors on both servo drives.
6. Reconnect any cables that were connected to the X3, X4, or X5 ports on both servo drives.

10.8 Fuse Replacement in Decentral Access Module (DAM 510)

If a single fuse blows, replace all the fuses with fuses from the same batch (fuse CAT number 5012006.25, SIBA).

Procedure

1. Remove the screws [1] and remove the cover.

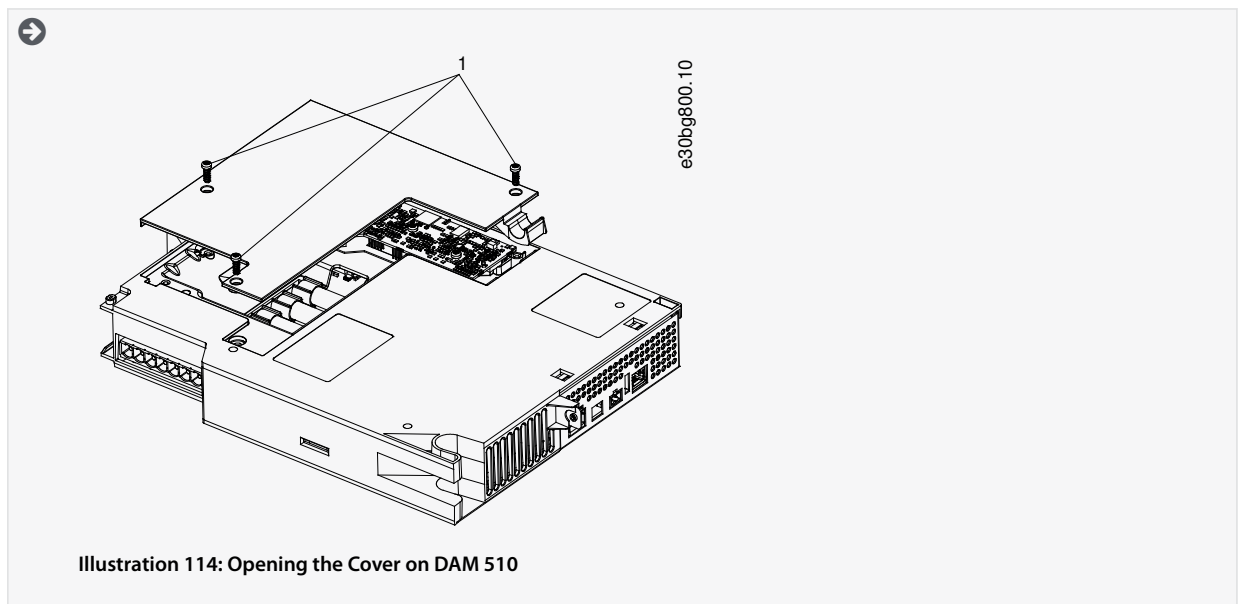

2. Use a screwdriver to remove the fuses and replace them with the same number of identical type fuses (see [5.5.1 Fuses](#)).

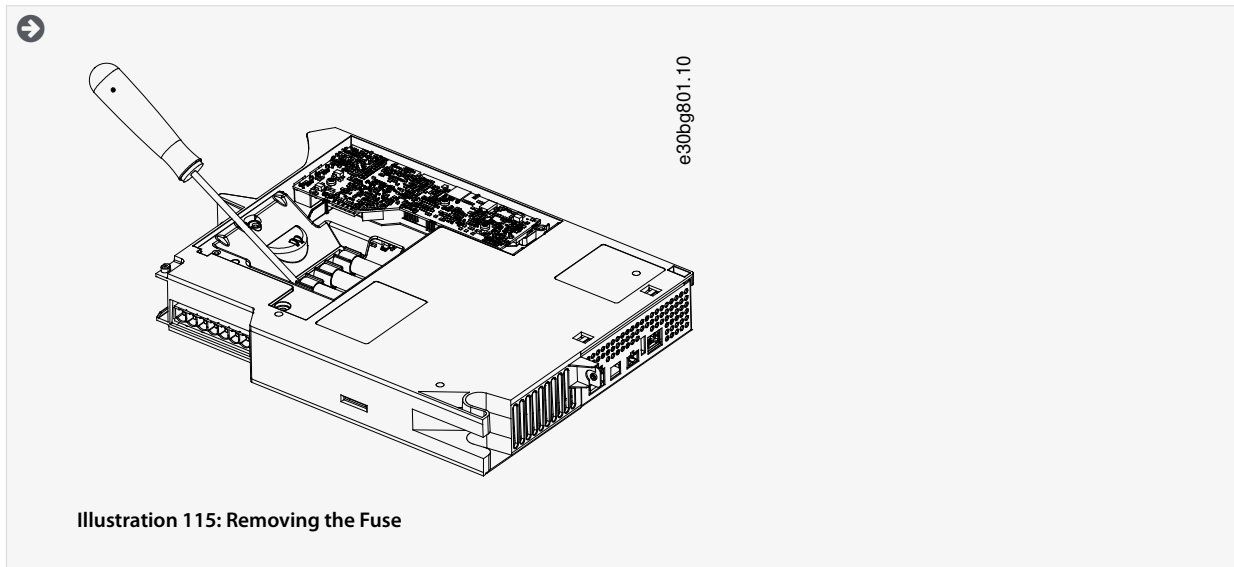

Illustration 115: Removing the Fuse

3. Replace the cover and tighten the screws. The tightening torque is 2 Nm.

10.9 Fan Replacement

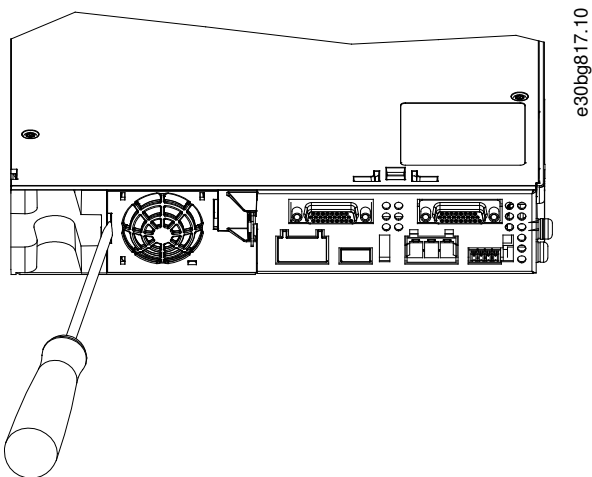

Illustration 116: Fan Replacement on 50 mm Modules

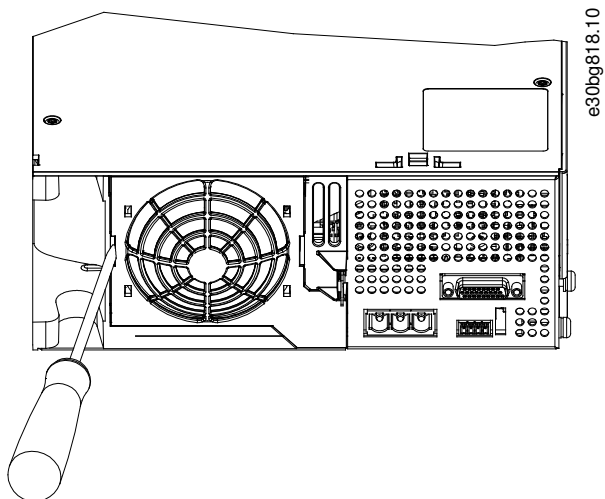

Illustration 117: Fan Replacement on 100 mm Modules

NOTICE

- See the **VLT® Servo Drive System ISD 510, DSD 510, MSD 510 (VLT® Flexmotion™) Design Guide** for further information on fan types.

Procedure

1. Use a screwdriver as a lever to release the fan holder.
2. Remove the fan.
3. Replace the fan with an identical type fan.

10.10 Product Returns

Danfoss products can be returned for disposal at no charge. A prerequisite for this is that they are free of deposits, such as oil, grease, or other types of contamination that hampers disposal. Furthermore, foreign materials or third-party components cannot be included with the returned product.

Ship the products free on board to the local Danfoss sales company.

10.11 Recycling

Take metals and plastics to recycling stations.

The servo drives and system modules are classified as electronic waste, and the packaging is classified as packaging waste.

10.12 Disposal

Devices containing electronic components cannot be disposed of as normal domestic waste.

Dispose of the servo drives and system modules as hazardous waste, electrical waste, recyclable waste, and so on, in accordance with applicable local regulations.

11 Specifications

11.1 Nameplates

11.1.1 Nameplate on ISD 510/DSD 510 Servo Drive

Check the nameplate and compare it with the order data. Use the part number for reference. The part number uniquely identifies the drive type.

Ensure that the nameplate is clearly legible.

The servo drives can be identified externally only by the original Danfoss nameplate.

The following data is shown on the servo drive nameplate:

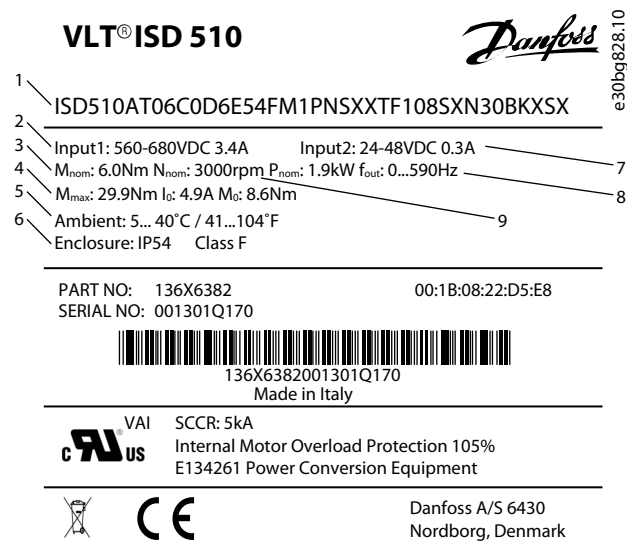

Illustration 118: Example of a Nameplate on the ISD 510 Servo Drive

1	Typecode	6	Protection rating
2	Supply voltage	7	Auxiliary input voltage
3	Nominal torque	8	Output frequency
4	Maximum torque	9	Rated speed
5	Ambient temperature range		



Illustration 119: Example of a Nameplate on the DSD 510 Servo Drive

1	Typecode	6	Protection rating
2	Supply voltage	7	Output frequency
3	Output voltage	8	Peak power
4	Maximum voltage	9	Peak current
5	Ambient temperature range		

11.1.2 Nameplate on the System Modules

11.1.2.1 Example Nameplate on the Front of the System Modules

Ensure that the nameplate is clearly legible.

The following data is shown on the nameplate on the front of the system modules:

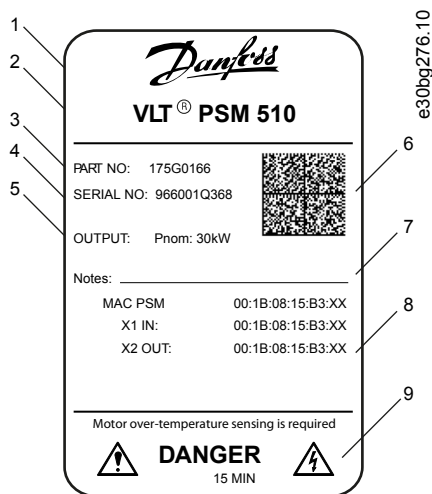

Illustration 120: Example Nameplate on the Front of the System Modules

1	Danfoss logo	6	Data matrix
2	System module name	7	Notes
3	Part number	8	MAC addresses
4	Serial number	9	Warning symbols
5	Output		

11.1.2.2 Example Nameplate on the Side of the System Modules

The following data is shown on the nameplate on the side of the system modules:

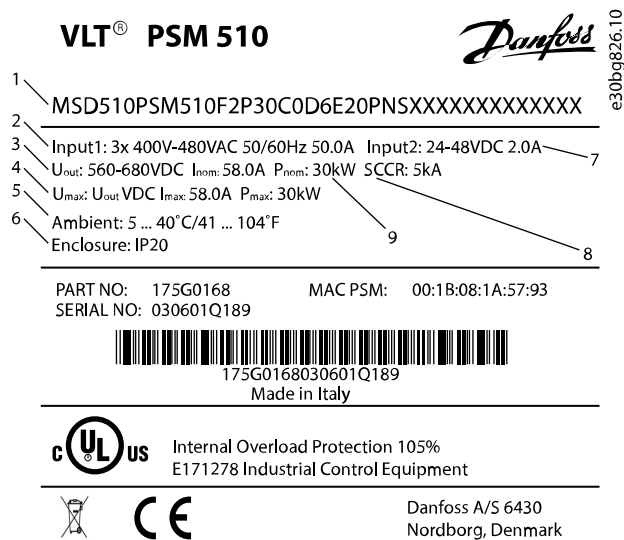

Illustration 121: Example Nameplate on the Side of the System Modules for PSM 510

1	Type code	6	Protection rating: IP20 according to IEC/EN 60529 (except connectors which are IP00)
2	Supply voltage	7	U _{AUX} supply
3	Output voltage	8	Short-circuit current rating
4	Maximum power	9	Rated power
5	Ambient temperature range		

11.2 Characteristic Data

11.2.1 Characteristic Data for ISD 510 Servo Drive without Brake

Table 121: Characteristic Data for Servo Drive without Brake

Specifications	Unit	Size 1, 1.5 Nm	Size 2, 2.1 Nm	Size 2, 2.9 Nm	Size 2, 3.8 Nm	Size 3, 5.2 Nm	Size 3, 6.0 Nm	Size 4, 11.2 Nm	Size 4, 13.0 Nm ⁽¹⁾
Rated speed n_N	RPM	4600	4000	2900	2400	3000	3000	2000	–
Rated torque M_N	Nm	1.5	2.1	2.9	3.8	5.2	6.0	11.2	–
Rated current I_N	A DC	1.4	1.7		1.8	3.6	3.4	4.7	–

Specifications	Unit	Size 1, 1.5 Nm	Size 2, 2.1 Nm	Size 2, 2.9 Nm	Size 2, 3.8 Nm	Size 3, 5.2 Nm	Size 3, 6.0 Nm	Size 4, 11.2 Nm	Size 4, 13.0 Nm ⁽¹⁾
Rated power P_N	kW [hp]	0.72 [0.98]	0.88 [1.20]		0.94 [1.28]	1.6 [2.18]	1.9 [2.58]	2.3 [3.13]	–
Standstill (stall) torque M_0	Nm	2.3	2.8	3.6	4.6	6.6	8.6	13.3	–
Standstill (stall) cur- rent I_0	A DC	2.1	2.3	2.1	2.2	4.6	4.9	5.6	–
Peak torque M_{max}	Nm	6.1	7.8	10.7	12.7	21.6	29.9	38.6	–
Peak current (rms value) I_{max}	A DC	5.7	6.4			17.7	19.8	21.2	–
Rated volt- age	V DC	565–680 ±10%							
Inductance L_{ph-ph}	mH	18.5	26.8	32.6	33.9	11.9	11.4	18.0	–
Resistance R_{ph-ph}	Ω	9.01	7.78	8.61	8.64	2.35	2.10	2.26	–
Voltage con- stant EMK	V/ krpm	70.6	80.9	111.0	132.0	92.7	112.0	158.8	–
Torque con- stant K_t	Nm/A	1.10	1.26	1.72	2.04	1.22	1.51	1.82	–
Inertia	Kgm ²	0.000085	0.00015	0.00021	0.00027	0.00062	0.00091	0.0024	–
Protective measures	–	Overload, short-circuit, and ground fault protection.							
Maximum output fre- quency	Hz	590							
Shaft diame- ter	mm [inch]	14 [0.55]	19 [0.75]			24 [0.94]		32 [1.26]	
Pole pairs	–	4	5						
Flange size	mm [inch]	76 [2.99]	84 [3.31]			108 [4.25]		138 [5.43]	
Functional safety	–	STO							
Cooling	–	Via flange							
Mounting	–	Via flange							
Weight	kg [lbs]	3.5 [7.7]	4.0 [8.8]	5.0 [11.0]	6.0 [13.2]	8.3 [18.3]	10.0 [22.0]	13.8 [30.4]	–

¹ In preparation

11.2.2 Characteristic Data for ISD 510 Servo Drive with Brake

Table 122: Characteristic Data for Servo Drive with Brake

Specifications	Unit	Size 1, 1.5 Nm	Size 2, 2.1 Nm	Size 2, 2.9 Nm	Size 2, 3.8 Nm	Size 3, 5.2 Nm	Size 3, 6.0 Nm	Size 4, 11.2 Nm	Size 4, 13.0 Nm ⁽¹⁾
Brake inertia	Kgm ²	0.0000012		0.0000068		0.000021		0.000072	–
Brake weight	kg [lbs]	0.34 [0.75]		0.63 [1.39]		1.1 [2.42]		2.0 [4.41]	–

¹ In preparation

11.2.3 Characteristic Data for DSD 510 Servo Drive

Table 123: Characteristic Data for DSD 510

Specifications	Unit	DSD 510
Input		
DC-link	V DC	565–680 ±10%
DC-link capacitance	µF	10
U _{AUX}	V DC	24/48 ±10%
U _{AUX} current consumption (at 24 V DC)	A DC	1
U _{AUX} current consumption (at 48 V DC)	A DC	0.5
Output		
Output number of phases	–	3
Output voltage	V AC	V _{IN} PSM
Rated current I _N	A DC	12.0 with mounting plate ⁽¹⁾ , 8.0 standalone
Rated power P _N	kW [hp]	4.4 [5.9] with mounting plate
Peak current (rms value) I _{max}	A rms	21.0
Nominal switching frequency	kHz	4/5
Possible switching frequency	kHz	8/10
Derating of nominal and peak current with 8 kHz switching frequency	%	62.5
Derating of nominal and peak current with 10 kHz switching frequency	%	55
Protective measures	–	Overload, short-circuit, and ground fault protection.
Maximum output frequency	Hz	590
Functional safety	–	STO
Cooling	–	Via mounting surface
Mounting	–	Screw-mounted via base
Number of motor connectors	–	1

Specifications	Unit	DSD 510
Weight	kg [lbs]	2.85 [6.28]
Dimensions (W x H x D)	mm	107.8 x 330.5 x 84

¹ Dimensions: 470 x 270 x 10 mm [18.5 x 10.6 x 0.4 inch]

11.2.4 Characteristic Data for Power Supply Module (PSM 510)

Table 124: Characteristic Data for PSM 510

Definition	Unit	Power size 1	Power size 2	Power size 3
Input				
Mains input voltage	V AC	400–480 ±10%, 3-phase (see 5.2 Electrical Environmental Conditions)		
Input current @ U _{MIN}	A	20	34	50
Input power	VA	12.5	22	32
U _{AUX} input voltage	V DC	24/48 ±10%		
U _{AUX} current consumption at 24 V DC	A DC	2.0		
U _{AUX} current consumption at 48 V DC	A DC	1.0		
Output				
DC-link voltage	V DC	565–680 ±10%		
DC-link capacitance	µF	1800		
Rated current I _N	A	20	40	60
Rated power P _N	kW	10	20	30
Peak power P _{max} t <3.0 s)	kW	20	40	60
Internal brake resistor⁽¹⁾				
Peak power P _{max}	kW	8		
Rated power P _N	W	150		
Nominal resistance	Ω	15		
External brake resistor				
Peak power P _{max}	kW	60		
Rated power P _N	kW	7.5		
Minimum resistance	Ω	10		
General				
Protective measures	–	Overload, short-circuit, and ground fault protection		
Line filter in accordance with EN 61800-3	–	Category C3		
Cooling	–	Integrated fan		

Definition	Unit	Power size 1	Power size 2	Power size 3
Mounting	–	Wall-mounted on backplate using backlink connector		
Weight	kg	6		
Dimensions (W x H x D)	mm	137.3 x 406.3 x 270		

¹ An external brake resistor can be connected.

11.2.5 Characteristic Data for Decentral Access Module (DAM 510)

Table 125: Characteristic Data for DAM 510

Definition	Unit	Power size 1	Power size 2
Input			
DC-link	V DC	565–680 ±10%	
DC-link capacitance	µF	660	
Maximum input current	A DC	15	24
U _{AUX}	V DC	24/48 ±10%	
U _{AUX} current consumption at 24 V DC	A DC	0.5	
U _{AUX} current consumption at 48 V DC	A DC	0.3	
Output			
Output voltage	V DC	V _{OUT PSM}	
Output current DC-link	A DC	15	25
Peak current DC-link (rms value) t < 1.0 s	A _{rms}	30 for < 1 s	48 for < 1 s
Output current U _{AUX}	A DC	15	
General			
Protective measures	–	Overload, short-circuit, and ground fault protection	
Cooling	–	Natural convection	
Mounting	–	Wall-mounted on backplate using backlink connector	
Weight	kg	3.05	
Dimensions (W x H x D)	mm	84.3 x 471 x 270	

11.2.6 Characteristic Data for Auxiliary Capacitors Module (ACM 510)

Table 126: Characteristic Data for ACM 510

Definition	Unit	Value
DC-link	V DC	565–680 ±10%
DC-link capacitance	µF	2750
U _{AUX}	V DC	24/48 ±10%
U _{AUX} current consumption at 24 V DC	A DC	0.5

Definition	Unit	Value
U _{AUX} current consumption at 48 V DC	A DC	0.3
Cooling	–	Natural convection
Mounting	–	Wall-mounted on backplate using backlink connector
Weight	kg	3.54
Dimensions (W x H x D)	mm	84 x 371 x 270

11.3 Dimensions

11.3.1 ISD 510 Servo Drive Flange Dimensions

Size	Flange thickness [mm]
Size 1, 1.5 Nm	7
Size 2, 2.1 Nm	–
Size 2, 2.9 Nm	8
Size 2, 3.8 Nm	8
Size 3, 5.2 Nm	10.8
Size 3, 6.0 Nm	10.8
Size 4, 11.2 Nm	13.8
Size 4, 13.0 Nm ⁽¹⁾	–

¹ In preparation

11.3.2 Dimensions of ISD 510 Servo Drive

All dimensions are in mm (in).

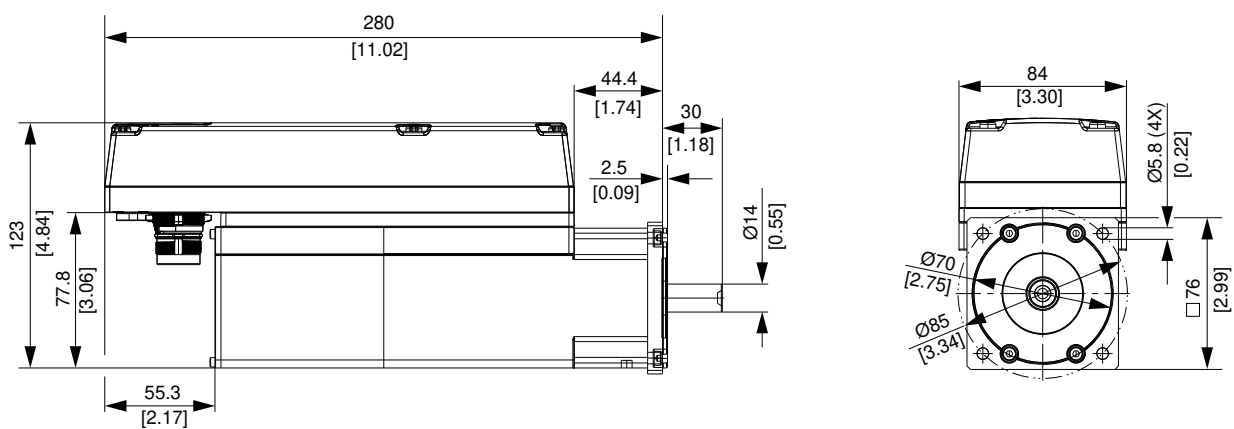

e30be438.10

Illustration 122: Dimensions of ISD 510 Size 1, 1.5 Nm

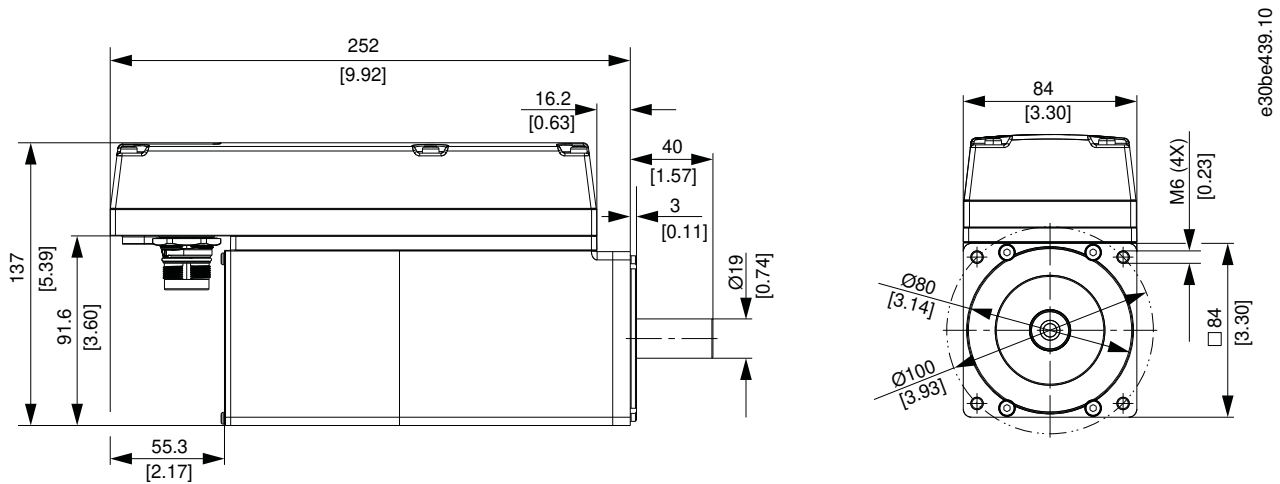

Illustration 123: Dimensions of ISD 510 Size 2, 2.1 Nm

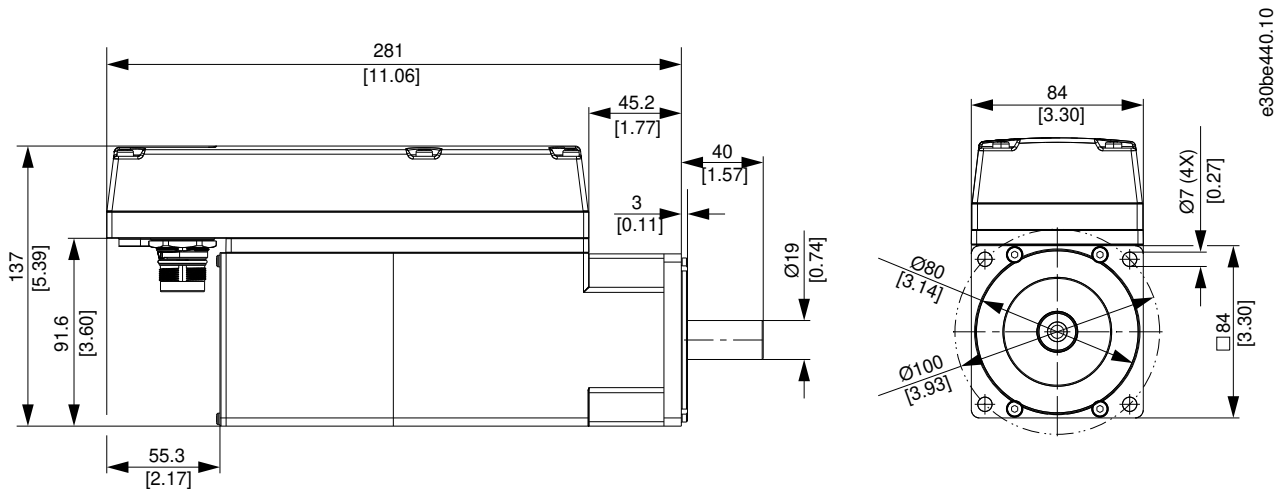

Illustration 124: Dimensions of ISD 510 Size 2, 2.9 Nm

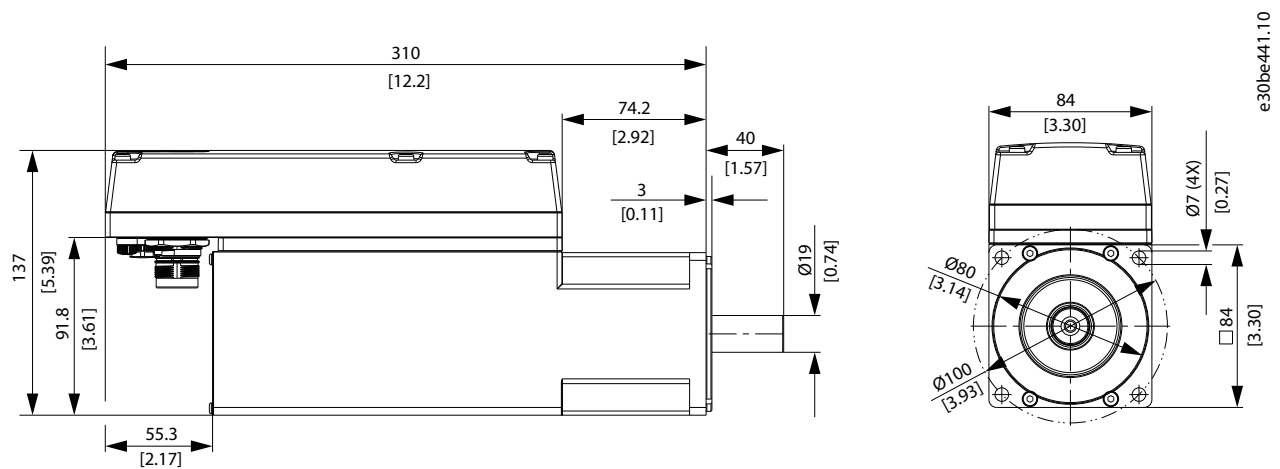

Illustration 125: Dimensions of ISD 510 Size 2, 3.8 Nm

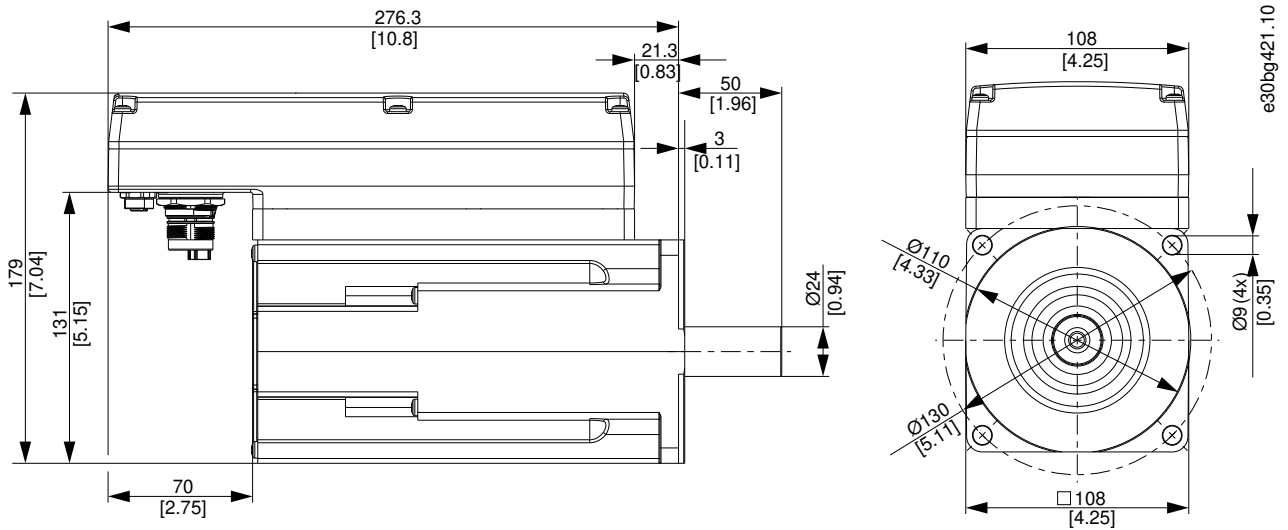

Illustration 126: Dimensions of ISD 510 Size 3, 5.2 Nm

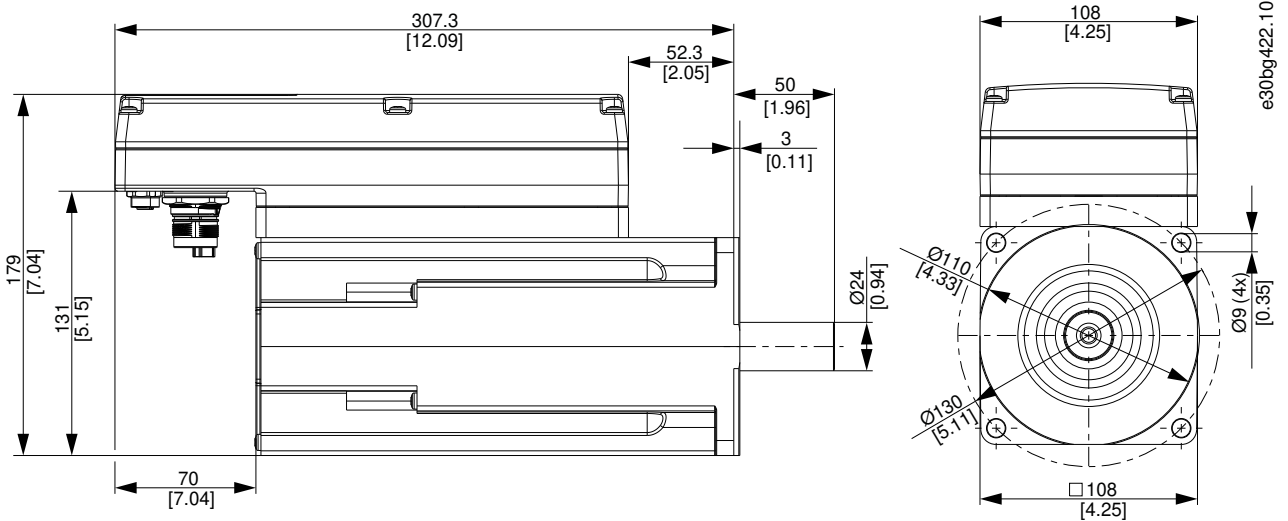

Illustration 127: Dimensions of ISD 510 Size 3, 6.0 Nm

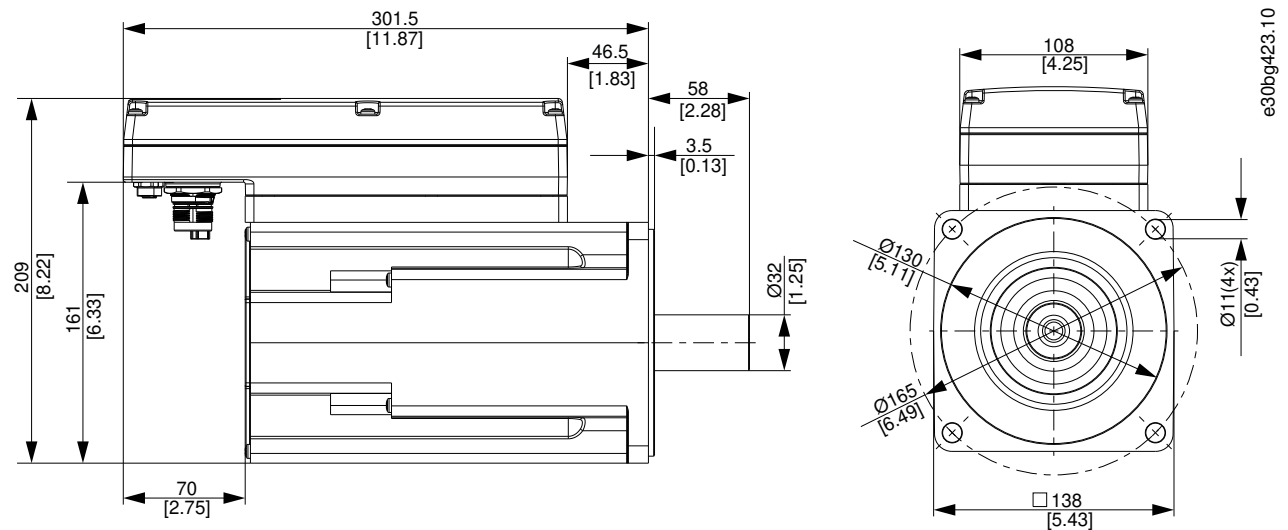

Illustration 128: Dimensions of ISD 510 Size 4, 11.2 Nm

11.3.3 Dimensions of DSD 510 Servo Drive

All dimensions are in mm (in).

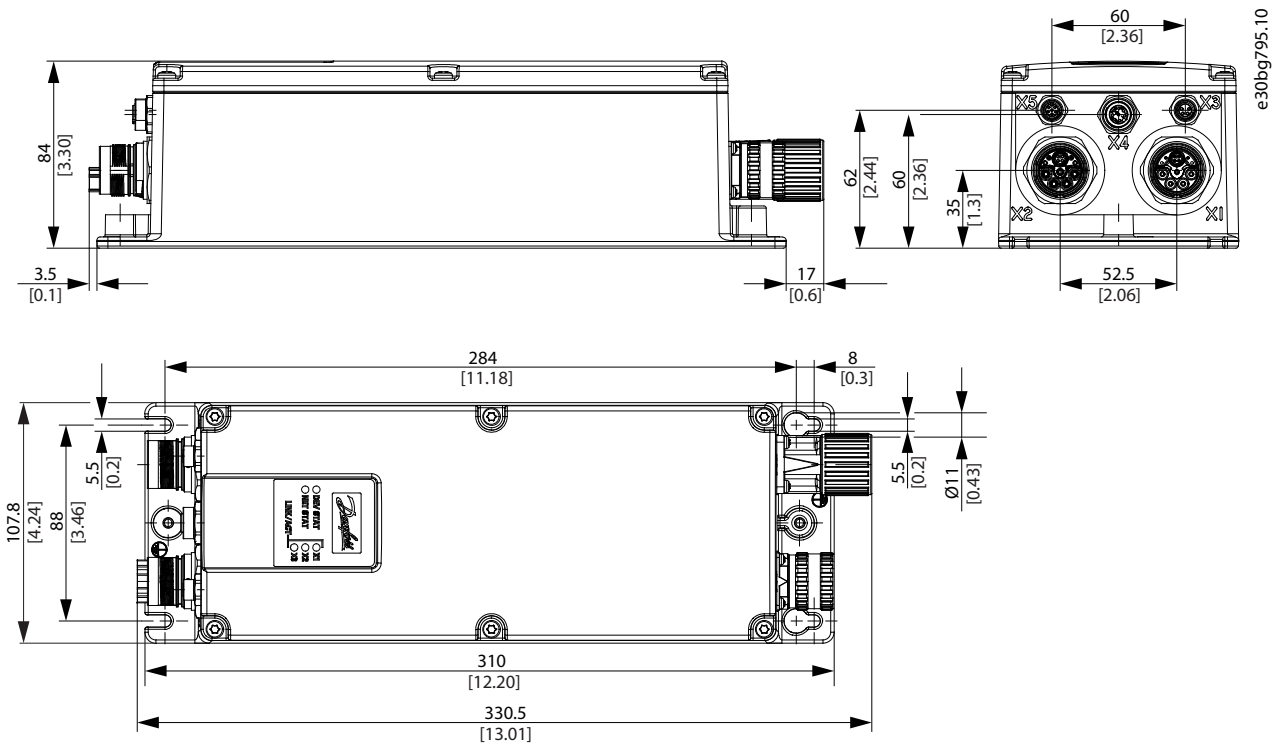

Illustration 129: Dimensions of DSD 510 Servo Drive

11.3.4 Dimensions of Power Supply Module (PSM 510)

All dimensions are in mm (in).

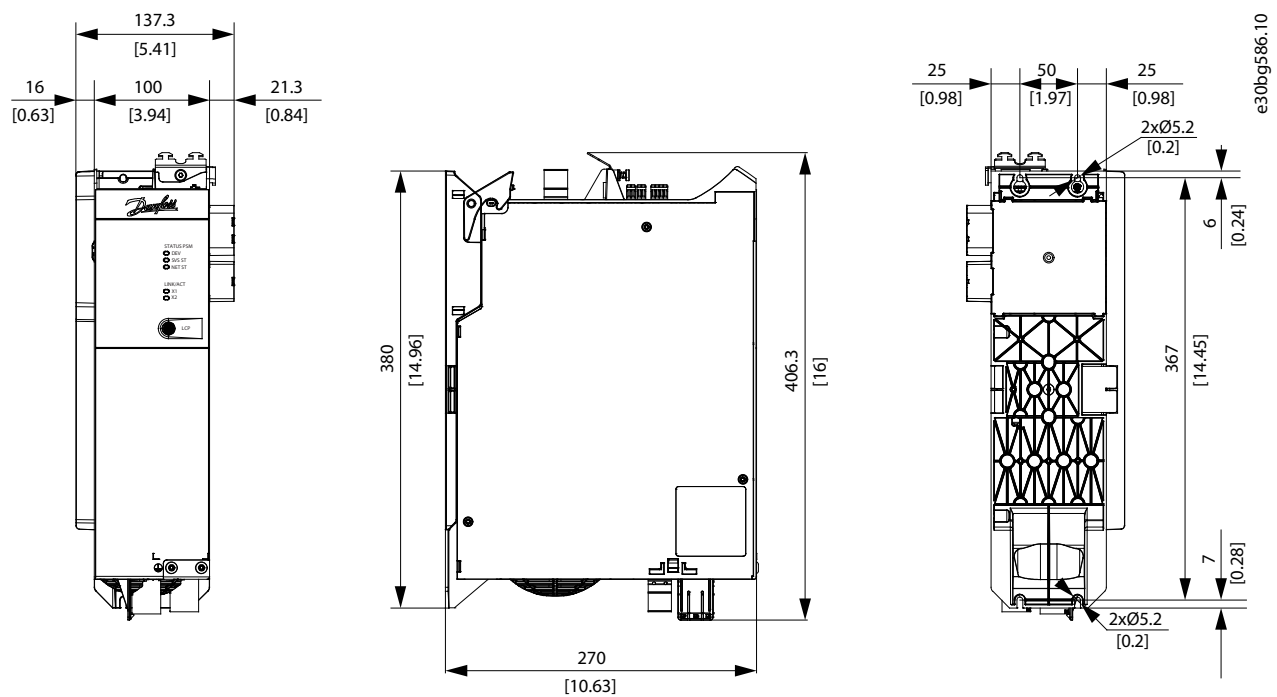

Illustration 130: Dimensions of PSM 510

11.3.5 Dimensions of Decentral Access Module (DAM 510)

All dimensions are in mm (in).

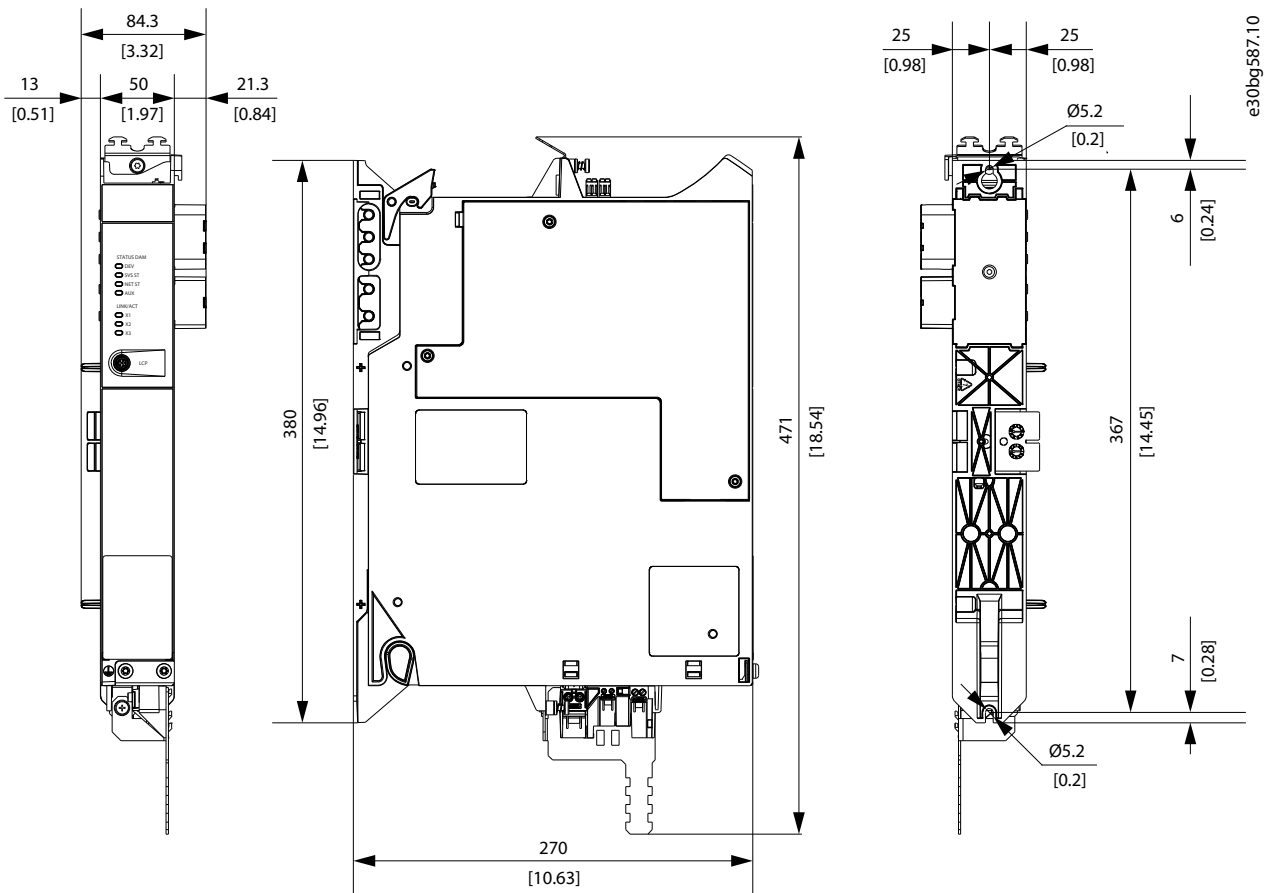

Illustration 131: Dimensions of DAM 510

11.3.6 Dimensions of Auxiliary Capacitors Module (ACM 510)

All dimensions are in mm (in).

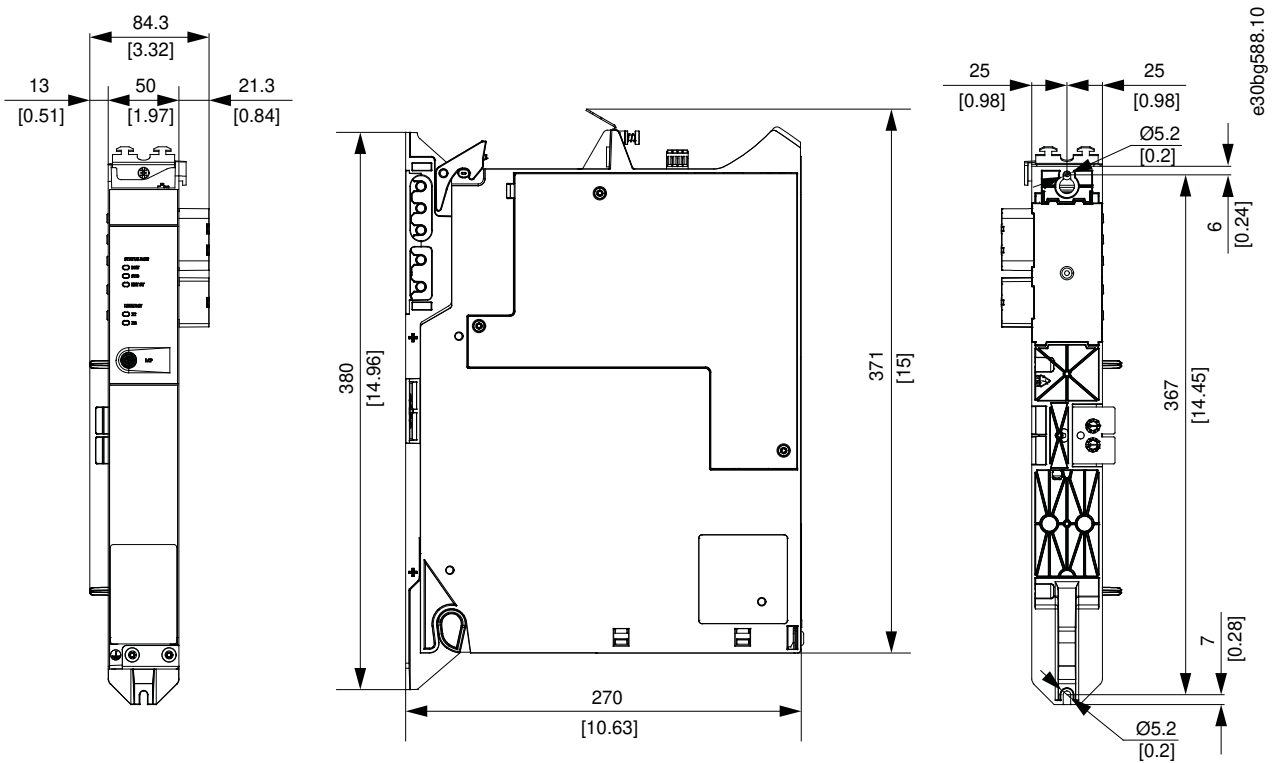

Illustration 132: Dimensions of ACM 510

11.3.7 Dimensions of Expansion Module (EXM 510)

All dimensions are in mm (in).

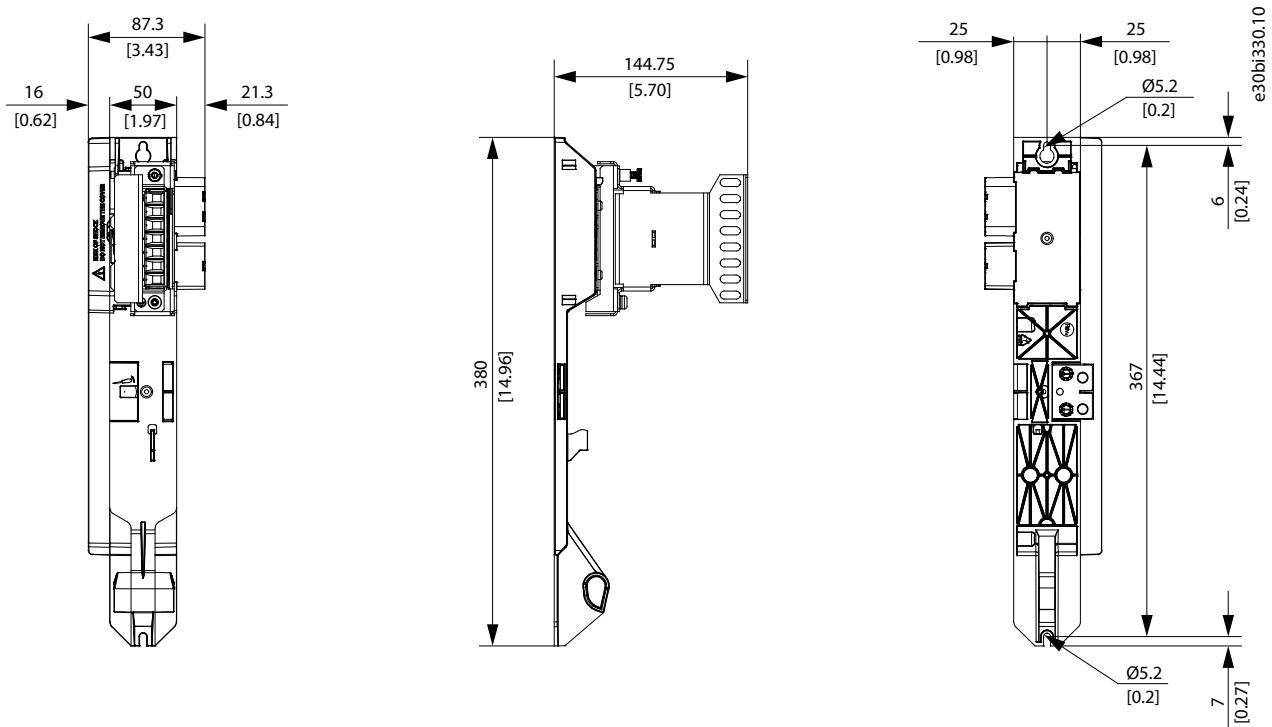

Illustration 133: Dimensions of EXM 510

11.4 Motor Overload Protection

NOTICE

- Internal motor overload protection operates at 105% of the motor full load current.
- Instruct DSD 510 with nominal motor current (full load current according to the motor technical label) to use the protection properly.

DSD 510 incorporates internal overload protection in the following multiples of current setting:

Table 127: Multiples of Current Setting

Multiple of current setting	Maximum trip time
7.2	20 s
1.5	8 min
1.2	2 hrs

11.5 Motor Overtemperature Protection

The internal motor overload protection implemented does not have thermal memory retention or speed sensitivity.

NOTICE

- Internal motor overtemperature protection is not incorporated in DSD 510, so motor overtemperature sensing is required. DSD 510 has an input for motor temperature sensor.
- A temperature sensor is integrated in ISD 510.

NOTICE

- Use a motor with reinforced insulation between the thermistor and the motor windings (tested with 4300 V DC and 8000 V_{peak} impulse).

11.6 Hybrid Cable Protection

The AUX 24/48 V has 3 levels of protection:

- Software (seconds timing range): The control boards opens the 24/48 V AUX if an overload is present (>15 A).
- Hardware (microseconds timing range): Opens automatically if a short circuit of >36 A is present.
- Hardware: A 20 A non-replaceable SMD (surface-mounted device) fuse in case the first 2 protective measures fail.

11.7 Permitted Forces on the ISD 510 Servo Drive Shaft

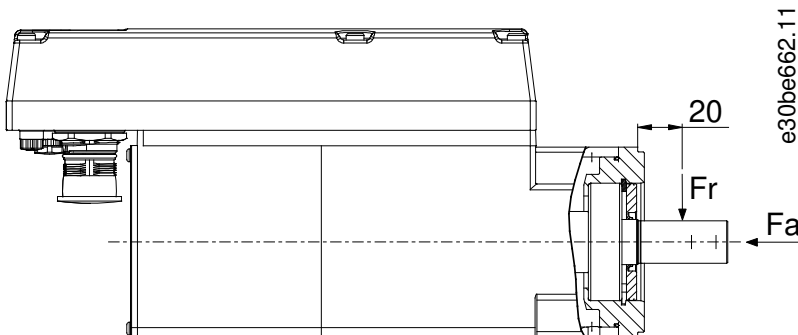

Illustration 134: Permitted Forces

The maximum axial and radial load while assembling the motor and for any mechanical device connected to the shaft, must not exceed the values shown in [Table 128](#). The shaft must be loaded slowly and in a constant manner. Avoid pulsating loads.

N O T I C E

- The bearing could be permanently damaged if the maximum permitted forces are exceeded.

Table 128: Maximum Load Ratings

Motor size	Maximum radial force (Fr) in N	Maximum axial force (Fa) in N
Size 1	450	1050
Size 2	900	1700
Size 3	830	1740
Size 4	1940	2200

The maximum radial load ratings are based on the following assumptions:

- The servo drives are operated with peak torque of the longest member of the frame size.
- Fully reversed load is applied to the end of the smallest diameter standard mounting shaft extension.
- Infinite life with standard 99% reliability.
- Safety factor = 2

11.8 Connectors on the ISD 510/DSD 510 Servo Drive

11.8.1 X1 and X2: Hybrid Connector (M23)

The hybrid cable provides the supply (mains and auxiliary), the communication lines, and the safety supply for each line of servo drives. Input and output connectors are connected inside the servo drive.

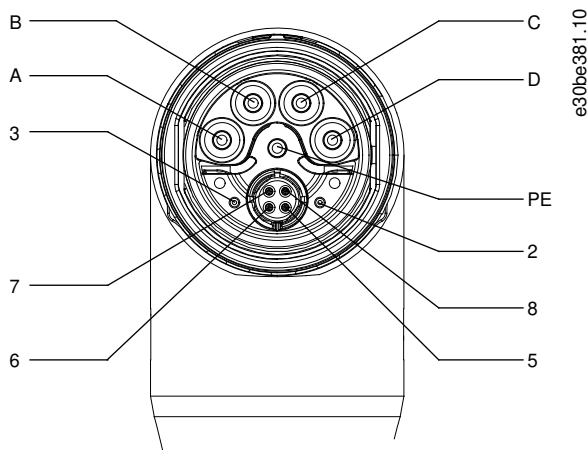

Illustration 135: Pin Assignment of X1 Male Hybrid Connector (M23)

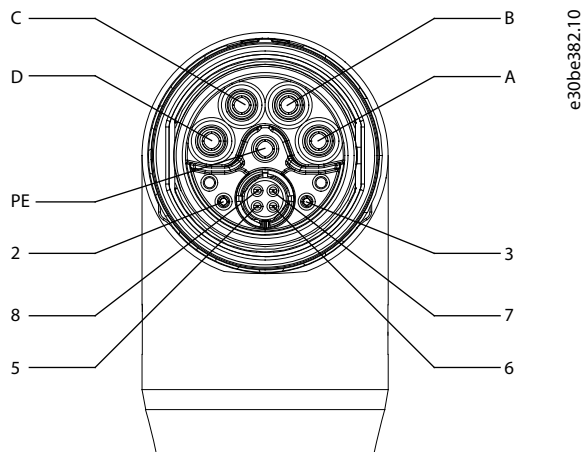

Illustration 136: Pin Assignment of X2 Female Hybrid Connector (M23)

Table 129: Pin Assignment of X1 and X2 Hybrid Connectors (M23)

Pin	Description	Notes	Rating/parameter
A	UDC-	Negative DC supply	Operating voltage: 565–680 V DC, maximum 778 V Negative DC supply (maximum -15 A/25 A)
B	UDC+	Positive DC supply	Operating voltage: 565–680 V DC, maximum 778 V Positive DC supply (maximum 15 A/25 A)
C	AUX+	Auxiliary supply	24-48 V DC±10%, 15 A Absolute maximum 55 V DC
D	AUX-	Auxiliary supply ground	
PE	PE	PE connector	15 A
2	STO+	Safety supply	24 V DC ±10%, 1 A
3	STO-	Safety supply ground	
5	TD+	Positive Ethernet transmit	According to standard 100BASE-T
6	RD-	Positive Ethernet receive	
7	TD-	Negative Ethernet transmit	
8	RD+	Negative Ethernet receive	

11.8.2 X3: 3rd Ethernet Connector (M8, 4 pole)

The ISD 510/DSD 510 advanced servo drives have an additional fieldbus port (X3) for connecting a device that communicated via the selected fieldbus.

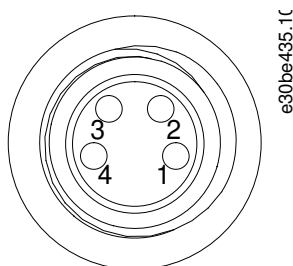

Illustration 137: Pin Assignment of X3 3rd Ethernet Connector (M8, 4 pole)

Table 130: Pin Assignment of X3 3rd Ethernet Connector (M8, 4 pole)

Pin	Description	Notes	Rating/parameter
1	TD+	Positive Ethernet transmit	According to standard 100BASE-T
2	RD+	Positive Ethernet receive	
3	RD-	Negative Ethernet receive	
4	TD-	Negative Ethernet transmit	

11.8.3 X4: I/O and/or Encoder Connector (M12, 8 pole)

The X4 connector is available on the ISD 510/DSD 510 advanced servo drives and can be configured as:

- Digital output
- Digital input
- Analog input
- 24 V supply
- External encoder interface (SSI or BiSS)

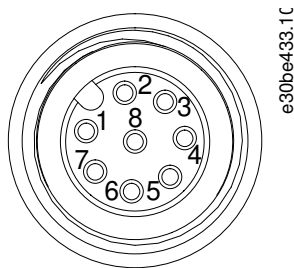

Illustration 138: Pin Assignment of X4 M12 I/O and/or Encoder Connector

Table 131: Pin Assignment of X4 M12 I/O and/or Encoder Connector

Pin	Description	Notes	Rating/parameter
1	Digital output	Switched 24 V as digital output or supply (24 V/150 mA)	Nominal voltage: 24 V ±15% Maximum current: 150 mA Maximum switching frequency: 100 Hz
2	Ground	Ground isolated	-
3	Input 1	Analog/Digital input	Digital input: Nominal voltage: 0-24 V Bandwidth: ≲ 100 kHz Analog input: Nominal voltage: 0-10 V Input impedance: 5.46 kΩ Bandwidth: ≲ 25 kHz
4	/SSI CLK	Negative SSI/BiSS clock out	SSI: Bus speed: 0.5 Mbit with 25 m cable BiSS: Fulfills the RS485 specification. Maximum cable length (SSI & BiSS): 25 m
5	SSI DAT	Positive SSI/BiSS data in	
6	SSI CLK	Positive SSI/BiSS clock out	
7	Input 2	Analog/Digital input	Digital input: Nominal voltage: 0-24 V Bandwidth: ≲ 100 kHz

Pin	Description	Notes	Rating/parameter
			Analog input: Nominal voltage: 0-10 V Input impedance: 5.46 kΩ Bandwidth: ≤ 25 kHz
8	/SSI DAT	Negative SSI/BiSS data in	SSI: Bus speed: 0.5 Mbit with 25 m cable BiSS: Fulfills the RS485 specification. Maximum cable length (SSI & BiSS): 25 m

11.8.4 X5: LCP Connector (M8, 6 pole)

The X5 connector is used to connect the LCP directly to the ISD 510/DSD 510 advanced servo drives via a cable.

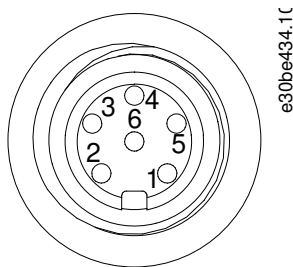

Illustration 139: Pin Assignment of X5 LCP Connector (M8, 6 pole)

Table 132: Pin Assignment of X5 LCP Connector

Pin	Description	Notes	Rating/parameter
1	Not connected	–	–
2	/LCP RST	Reset	Active at ≤ 0.5 V
3	LCP RS485	Positive RS485 signal	Speed: 38.4 kBd The levels fulfill the RS485 specification.
4	/LCP RS485	Negative RS485 signal	
5	GND	GND	–
6	VCC	5 V supply for LCP	5 V ±10% at 120 mA maximum load

11.8.5 X6: Standard/HIPERFACE DSL Motor Connector

The standard/HIPERFACE DSL motor connector is an M23 female connector.

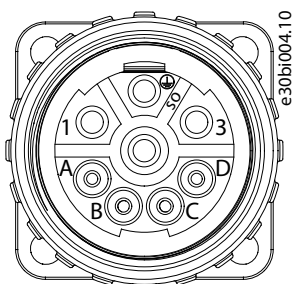

Illustration 140: Pin Assignment of X6 Motor Connector

Table 133: Pin Assignment of X6 Motor Connector

Pin	Description	Notes	Rating/parameter
1	U	Motor phase U	Nominal voltage: 400–480 V ±10% (see 11.2.3 Characteristic Data for DSD 510 Servo Drive) Conductor cross-section: 2.5 mm ²
PE	PE	Protective earth	
3	W	Motor phase W	
4	V	Motor phase V	
A	Brake+	Used to connect the motor's mechanical brake (if present).	Nominal voltage: 24 V Maximum (peak) voltage: 48 V ±10% Conductor cross-section: 0.75 mm ²
B	Brake–		
C	Data– ⁽¹⁾	HIPERFACE DSL negative line	–
D	Data+ ⁽¹⁾	HIPERFACE DSL positive line	–

¹ The data+/- signals are only present on the HIPERFACE DSL variant, otherwise both are not connected.

11.8.6 X7: Motor Feedback Connector

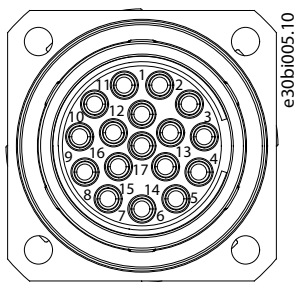

Illustration 141: Pin Assignment of X7 Motor Feedback Connector

Table 134: Pin Assignment of X7 Motor Feedback Connector

Pins	Description	Resolver	BISS B	HIPERFACE	EnDat 2.1 and 2.2	Rating/parameter
1	RESSIN	X	–	X	⁽¹⁾	Resolver positive sine input
2	GND	–	X	X	X	GND
3	RESCOS	X	–	X	⁽¹⁾	Resolver positive cosine input
4	VEE	–	X	X	X	+5/11 V ⁽²⁾
5	RXTX	–	X	X	X	Encoder positive data signal
6	\RESSY	X	–	–	–	Resolver negative exciter output
7	TEMP+	X	X	X	X	Motor temperature sensor input
8	ENC_CLK	–	X	–	–	Encoder positive clock signal
9	\RESSIN	X	–	X	⁽¹⁾	Resolver negative sine input
10	–	–	–	–	–	–
11	\RESCOS	X	–	X	⁽¹⁾	Resolver negative cosine input
12	–	–	–	–	–	–

Pins	Description	Resolver	BISS B	HIPERFACE	EnDat 2.1 and 2.2	Rating/parameter
13	\RXTX	–	X	X	X	Encoder negative data signal
14	TEMP–	X	X	X	X	Motor temperature sensor input
15	\ENC_CLK	–	X	–	–	Encoder negative clock signal
16	–	–	–	–	–	–
17	RESSY	X	–	–	–	Resolver positive exciter output

¹ The SINE and COSINE signals are optional for EnDat

² The supply switched automatically between 5 V and 11 V depending on which feedback type is selected.

11.9 Connectors on the System Modules

11.9.1 Backlink Connector

The backlink connector is located at the top of the backside of all the ISD 510 system modules.

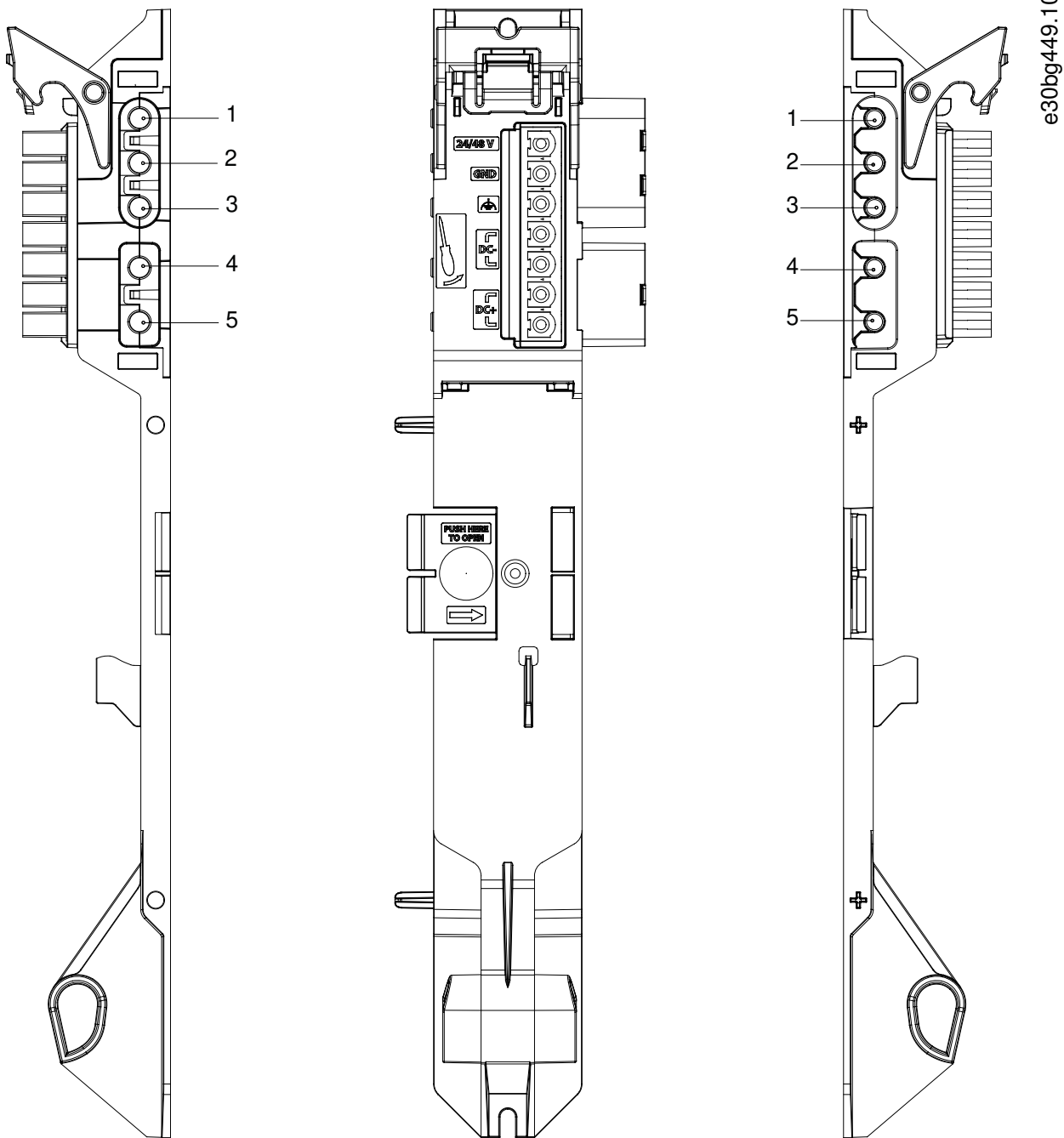

Illustration 142: Pin Assignment of Backlink Connector

Table 135: Pin Assignment of Backlink Connector

Pin	Description
1	24/48 V
2	GND
3	FE: Functional earth
4	DC-
5	DC+

11.9.2 Brake Connectors

Brake connectors are located on the Power Supply Module (PSM 510).

11.9.2.1 Brake Resistor Connector on PSM 510

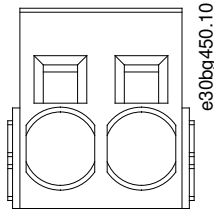

Illustration 143: Brake Connector on PSM 510

Table 136: Pin Assignment of Brake Connector on PSM 510

Pins (left to right)	Description	Notes	Ratings
1	DC+/R+	Used for connecting a brake resistor.	Nominal voltage: 560–800 V DC Maximum brake current: 80 A Conductor cross-section range: 0.75–16 mm ² (AWG 18–AWG 4)
2	R–		

NOTICE

- The maximum length of the brake cable is 30 m (shielded).

11.9.3 Ethernet Connectors

Ethernet connectors are located on all the system modules.

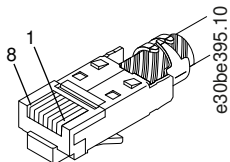

Illustration 144: Ethernet Connector

NOTICE

- Only PELV potential can be connected to the digital inputs and outputs.

11.9.3.1 Ethernet Connectors on PSM 510 and ACM 510

Table 137: Ethernet Connectors on PSM 510 and ACM 510

Connector name	Description	Pins	Ratings
X1 IN	Ethernet IN	1: TX+ 2: TX– 3: RX+ 4: – 5: – 6: RX– 7: – 8: –	According to standard 100BASE-T.
X2 OUT	Ethernet OUT1		

11.9.3.2 Ethernet Connectors on DAM 510

Table 138: Ethernet Connectors on DAM 510

Connector name	Description	Pins	Ratings
X1 IN	Ethernet IN	1: TX+	According to standard 100BASE-T.
X2 OUT	Ethernet OUT1 (connection to hybrid cable)	2: TX-	
X3 OUT	Ethernet OUT2	3: RX+	
		4: -	
		5: -	
		6: RX-	
		7: -	
		8: -	

11.9.4 I/O Connectors

11.9.4.1 I/O Connector on PSM 510/ACM 510

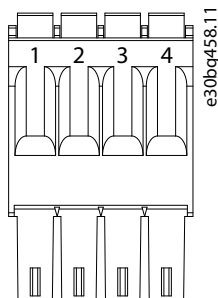

Illustration 145: I/O Connector on PSM 510 (I/O PSM) and ACM 510 (I/O ACM)

Table 139: Pin Assignment of I/O Connector on PSM 510/ACM 510

Pins	Description	Notes	Rating/parameter
1	DIN1-	Digital input	Input voltage: 0–30 V DC High (logic "1") voltage: 15–30 V DC Low (logic "0") voltage: <5 V DC Maximum input signal frequency: 50 Hz Maximum input current at 48 V: 11 mA Maximum input resistance: 4.5 KΩ
2	DIN1+		
3	DIG_OUT-	Digital output	Maximum voltage between terminals: 24 V DC or AC Maximum current: 1 A Maximum output switching frequency: 50 Hz
4	DIG_OUT+		

The conductor cross-section range is 0.2–1.5 mm² (AWG 24–AWG 16).

NOTICE

- Only PELV potential can be connected to the digital inputs and outputs.

11.9.5 UAUX Connector

The U_{AUX} connector is located on the Power Supply Module (PSM 510).

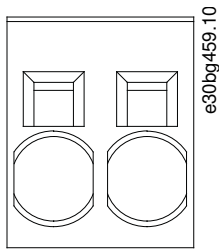

Illustration 146: U_{AUX} Connector

Table 140: Pin Assignment of U_{AUX} Connector

Pins (left to right)	Description	Notes	Rating/parameter
1	24 V AUX	Used for 24–48 V DC input to the Power Supply Module (PSM 510).	Nominal input voltage: 24 V/48 V DC ±10% Nominal current: Depends on the number of servo drives in the application. Maximum current: 50 A Maximum cross-section: 16 mm ² Maximum cable length: 3 m Conductor cross-section range 0.75–16 mm ² , solid or flexible (AWG 18–AWG 4)
2	GND		

NOTICE

- Only PELV potential can be connected to the U_{AUX} input.

11.9.5.1 24/48 V Cable Cross Sections for PSM 510

Minimum cable cross section for CE (minimum 70 °C, Cu)	16 mm ²
Minimum cable cross section for UL (minimum 60 °C, Cu)	4 AWG

11.9.6 LCP Connector (M8, 6-pole)

The LCP connector is located on the front of all the system modules. It is used to connect the LCP directly via a cable.

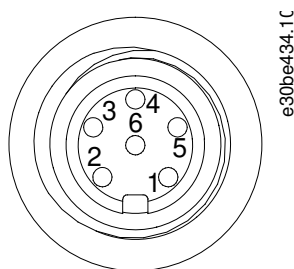

Illustration 147: LCP Connector (M8, 6 pole)

Table 141: Pin Assignment of LCP Connector

Pins	Description	Notes	Rating/parameter
1	Not connected	–	–
2	/LCP RST	Reset	Active at ≤0.5 V
3	LCP RS485	Positive RS485 signal	Speed: 38.4 kBd The levels fulfill the RS485 specification.
4	/LCP RS485	Negative RS485 signal	

Pins	Description	Notes	Rating/parameter
5	GND	GND	–
6	VCC	5 V supply for LCP	5 V ±10% at 120 mA maximum load

NOTICE

– Only PELV potential can be connected to the LCP input.

11.9.7 AC Mains Connector

The AC mains connector is located on the bottom of the Power Supply Module (PSM 510).

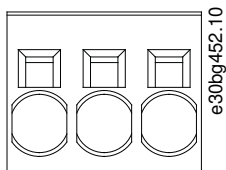

Illustration 148: AC Mains Connector

Table 142: Pin Assignment of AC Mains Connector

Pins (left to right)	Description	Notes	Rating/parameter
1	L3	Used to connect L1/L2/L3	Nominal voltage: 400–480 V AC ±10% Nominal power: 30 kW Maximum cross-section: 16 mm ² (AWG 4) Conductor cross-section range 0.75–16 mm ² , solid or flexible (AWG 18–AWG 4)
2	L2		
3	L1		

11.9.7.1 Mains Cable Cross-Sections for PSM 510

Table 143: Mains Cable Cross-Sections for PSM 510

	PSM 510 (10 kW)	PSM 510 (20 kW)	PSM 510 (30 kW)
Minimum cable cross-section for CE	4 mm ² (minimum 70 °C, Cu)	16 mm ² (minimum 70 °C, Cu)	16 mm ² (minimum 90 °C, Cu)
Minimum cable cross-section for UL	AWG 10 (minimum 60 °C, Cu)	AWG 6 (minimum 60 °C, Cu)	AWG 4 (minimum 75 °C, Cu)

11.9.8 Relay Connector

The relay connector is used for a user-defined reaction and is located as follows:

- Power Supply Module PSM 510: 1 relay connector
- Auxiliary Capacitors Module ACM 510: 1 relay connector

NOTICE

– Only PELV potential can be connected to the relay outputs.

11.9.8.1 Relay Connector on PSM 510/ACM 510

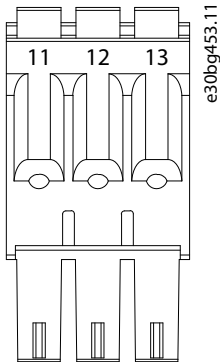

Illustration 149: Relay Connector on PSM 510/ACM 510

Table 144: Pin Assignment of Relay Connector on PSM 510 (REL PSM) and ACM 510 (REL ACM)

Pins	Description	Notes	Rating/parameter
11	NC	Normally closed, 24 V DC	Nominal current: 2 A Conductor cross-section range: 0.2–1.5 mm ² (AWG 24–AWG 16)
12	NO	Normally open, 24 V DC	
13	COM	Common	

11.9.9 STO Connectors

11.9.9.1 STO Connectors on PSM 510

There is 1 input and 1 output STO connector on the Power Supply Module (PSM 510).

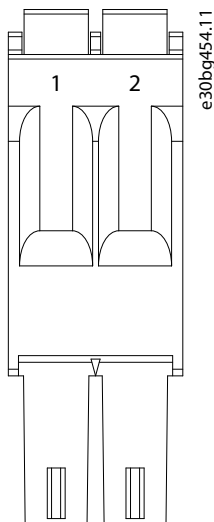

Illustration 150: STO Output Connector on PSM 510

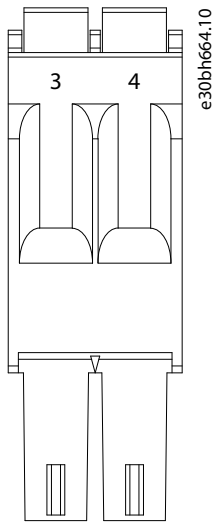

Illustration 151: STO Input Connector on PSM 510

Table 145: Pin Assignment of STO Connectors on PSM 510

Connector name	Pins	Description	Notes	Rating/parameter
STO PSM	1	STO-	Used for STO output voltage to the input of the other system modules.	Nominal voltage: 24 V DC ±10% Nominal current: Depends on the number of servo drives in the application. Maximum current: 1 A Conductor cross-section range: 0.2–1.5 mm ² (AWG 24–AWG 16)
	2	STO+		
	3	STO-	Used for STO input voltage.	
	4	STO+		

N O T I C E

- Only PELV potential can be connected to the STO inputs.

11.9.9.2 STO Connectors on the DAM 510

11.9.9.2.1 STO Connectors on the Top of DAM 510

There is 1 input and 1 output STO connector on the top of the Decentral Access Module (DAM 510).

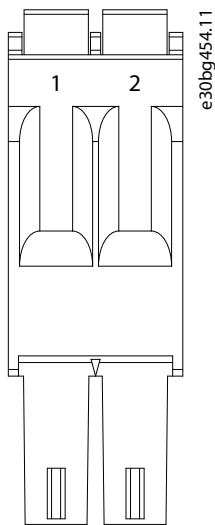

Illustration 152: STO Output Connector on the Top of DAM 510

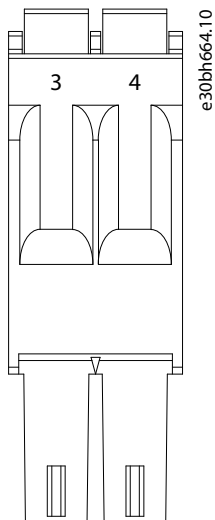

Illustration 153: STO Input Connector on the Top of DAM 510

Table 146: Pin Assignment of STO Connectors on the Top of DAM 510

Connector name	Pins	Description	Notes	Rating/parameter
STO DAM	1	STO-	Used for STO output voltage to the input of the other system modules.	Nominal voltage: 24 V DC $\pm 10\%$ Nominal current: Depends on the number of servo drives in the application. Maximum current: 1 A Conductor cross-section range: 0.2–1.5 mm ² (AWG 24–AWG 16)
	2	STO+		
	3	STO-	Used for STO input voltage.	
	4	STO+		

NOTICE

- Only PELV potential can be connected to the STO inputs.

11.9.9.2.2 STO Connector on the Bottom of DAM 510

There is 1 output STO connector on the bottom of the Decentral Access Module (DAM 510). The output is for the hybrid cable.

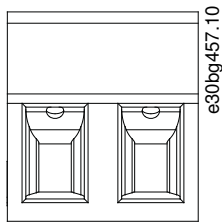

Illustration 154: STO Connector on the Bottom of DAM 510

Table 147: Pin Assignment of STO Connector on the Bottom of DAM 510

Connector name	Pins (left to right)	Description	Notes	Rating/parameter
STO DAM	1	STO+	Used for the STO output from the DAM to the hybrid cable.	Nominal voltage: 24 V DC $\pm 10\%$ Nominal current: Depends on the number of servo drives in the application. Maximum current: 1 A Conductor cross-section range: 0.2–1.5 mm ² (AWG 24–AWG 16) Plug terminal tightening torque: 0.22–0.25 Nm
	2	STO–		

11.9.10 UDC Connector

The UDC connector is located on the bottom of the Decentral Access Module (DAM 510).

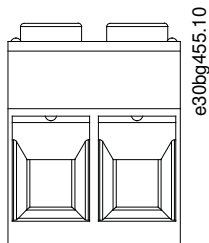

Illustration 155: UDC Connector

Table 148: Pin Assignment of UDC Connector

Pins (left to right)	Description	Notes	Rating/parameter
1	UDC+	Used to connect the DC-link voltage from the Decentral access Module (DAM 510) to the hybrid cable for the ISD line.	Nominal voltage: 560–800 V DC Nominal current: Depends on the number of servo drives in the application. Maximum current: 25 A Conductor cross-section range: 0.2–6 mm ² (AWG 24–AWG 10) Plug terminal tightening torque: 0.5–0.8 Nm
2	UDC–		

11.9.11 AUX Connector

The AUX connector is located on the bottom of the Decentral Access Module (DAM 510).

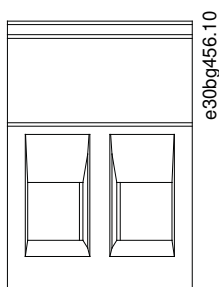

Illustration 156: AUX Connector

Table 149: Pin Assignment of AUX Connector

Pins (left to right)	Description	Notes	Rating/parameter
1	AUX+ (24/48 V)	Used to connect the AUX output from the Decentral access Module (DAM 510) to the hybrid cable for the servo drive line.	Nominal voltage: 24/48 V DC ±10% Nominal current: Depends on the number of servo drives in the application. Maximum current: 15 A Conductor cross-section range: 0.2–2.5 mm ² (AWG 24–AWG 12) Plug terminal tightening torque: 0.5–0.6 Nm
2	AUX– (GND)		

N O T I C E

- Only PELV potential can be connected to the AUX output.

11.9.12 External Encoder Connectors

This connector is used to connect an external encoder to DAM 510. It provides a guide value for CAM mode and Gear mode. The external encoder connector is located on the Decentral Access Module (DAM 510) as follows:

- DAM 510: E DAM

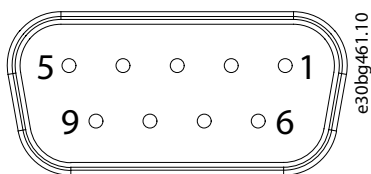

Illustration 157: External Encoder Connector

Table 150: External Encoder Connectors

Connector name	Description	Pins	Ratings/Notes
E DAM	Used to connect the external encoder to DAM 510.	See Table 151 .	Nominal voltage: 24 V DC, isolated (see Table 151) Nominal current: Depends on the number of servo drives in the application. Maximum current: 150 mA (see Table 151) Fulfill the following specifications: <ul style="list-style-type: none"> • BISS/SSI

Table 151: Pin Assignment of External Encoder Connectors (X1/X2)

Pins	Description	Notes SSI/BISS	Notes
1	24 V	24 V DC ±10% (used for powering the encoder)	Maximum current: 150 mA
2	–	–	–
3	–	–	–
4	RS422 RXD	Positive data	Bus speed: SSI: Up to 10 Mhz clock frequency with 30 m cable. BiSS: Fulfills the RS485 specification.
5	RS422 TXD	Positive data	
6	GX	Isolated ground. If encoders are powered externally, the ground of the external supply must be connected to GX.	–
7	–	–	–
8	/RS422 RXD	Negative data	Bus speed: SSI: 0.5 Mbit with 25 m cable. BiSS: Fulfills the RS485 specification.
9	/RS422 TXD	Negative data	

NOTICE

- Only PELV potential can be connected to the external encoder.

11.9.13 Expansion Module Connector

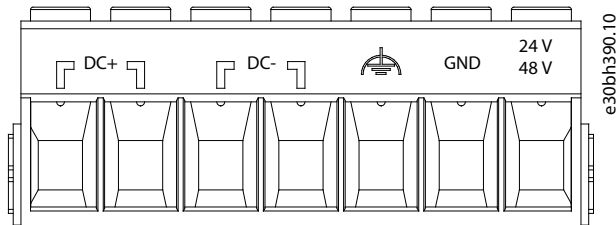

Illustration 158: Expansion Module Connector

Table 152: Pin Assignment of Expansion Module Connector

Pins (left to right)	Description	Note	Rating/parameter
1	DC+	Shield the DC cables using the cable tie on the EXM 510 EMC plate.	Nominal voltage: 560–800 V DC Nominal current: Depends on the number of servo drives in the application. Maximum current: 62 A ⁽¹⁾ Conductor cross-section range: 0.75–16 mm ² , solid or flexible (AWG 18–AWG 4) Only use with ferrule without plastic sleeve with CRIMPFOX 16 S.
2			
3	DC–		
4			
5	FE (functional earth)	–	Use shielded conductors for UDC (DC+, DC–). Plug terminal tightening torque: 1.7–1.8 Nm
6	GND	–	

Pins (left to right)	Description	Note	Rating/parameter
7	24/48 V	–	

¹ The maximum current rating for 1 pair of EXM is 62 A. In systems with 2 PSM 510 modules, 2 pairs of EXM 510 modules can be used to achieve a maximum current rating of 124 A.

11.9.13.1 Cable Cross Sections for EXM 510

Table 153: Minimum Cable Cross Sections for EXM 510 Cables

Cable	CE	UL
DC+/DC–	16 mm ² (minimum 70 °C, Cu)	6 AWG (minimum 75 °C, Cu)
24 V, functional PE	16 mm ² (minimum 70 °C, Cu)	6 AWG (minimum 90 °C, Cu) ⁽¹⁾

¹ Minimum 75 °C is allowed if less than 45 A are measured on the cable.

11.10 General Specifications and Environmental Data

11.10.1 ISD 510/DSD 510 Servo Drive

Table 154: General Specifications and Environmental Conditions for ISD 510/DSD 510

Specification	Value
Vibration test	Random vibration: 7.54 g (2h/axis according to EN 60068-2-64)
	Sinusoidal vibration: 0.7 g (2h/axis according to EN 60068-2-6)
Maximum relative humidity	Storage/transport: 5–93% (non-condensing)
	Stationary use: 15–85% (non-condensing)
Ambient temperature	Operating: 5–40 °C nominal, up to 55 °C with derating
	Transport: –25 to +70 °C
	Storage: –25 to +55 °C
Installation altitude	No limitation up to 1000 m above sea level. Maximum 2000 m above sea level with derating. 9% derating up to 2000 m with normal supply voltage, 3-phase AC 400 V.
EMC standard for emission and immunity	EN 61800-3
EMC immunity functional safety	EN 61800-5-2 Annex E
Pollution degree	2
Overvoltage category	III
IP ratings	See 11.11.1 Protection Ratings for ISD 510 Servo Drive and 11.11.2 Protection Ratings for DSD 510 Servo Drive .

11.10.2 System Modules

Table 155: General Specifications and Environmental Conditions for System Modules

Specification	Value
Protection rating	IP20 according to IEC/EN 60529 (except connectors, which are IP00). <div style="text-align: center; background-color: #cccccc; padding: 5px;">⚠ WARNING ⚠</div> RISK OF ELECTRICAL SHOCK The IP20 rating of the PSM 510, DAM 510, and ACM 510 modules is not fulfilled if the modules are not connected to the backplate. This may result in death or serious injury. - Do not touch the backplate when a module is removed from the backplate.
Vibration test	Random vibration: 1.14 g (2h/axis according to EN 60068-2-64)
	Sinusoidal vibration: 1.0 g (2h/axis according to EN 60068-2-6)
Maximum relative humidity	Storage/transport: 5–95% (non-condensing)
	Stationary use: 5–93% (non-condensing)
Ambient temperature range	Operating: 5–40 °C nominal, up to 55 °C with derating (see Illustration 159)
	Transport: –25 to +55 °C
	Storage: –25 to +55 °C
Installation altitude	Nominal current up to 1000 m above sea level. Derating of output current (1% / 100 m) from 1000 m to 3000 m. Operation above 3000 m is not permitted.
EMC standard for emission and immunity	EN 61800-3
EMC immunity for functional safety	EN 61800-5-2 Annex E
Degree of pollution according to EN 60664-1	2
Overvoltage category according to EN/IEC 61800-5-1	III

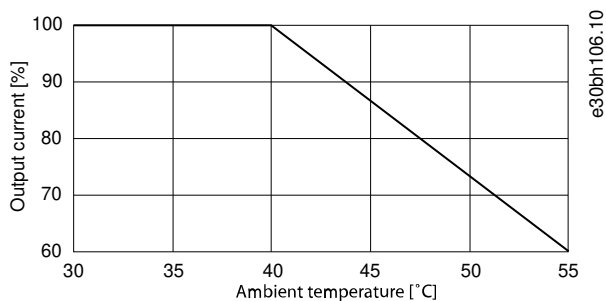

Illustration 159: Derating

11.11 Protection Ratings

11.11.1 Protection Ratings for ISD 510 Servo Drive

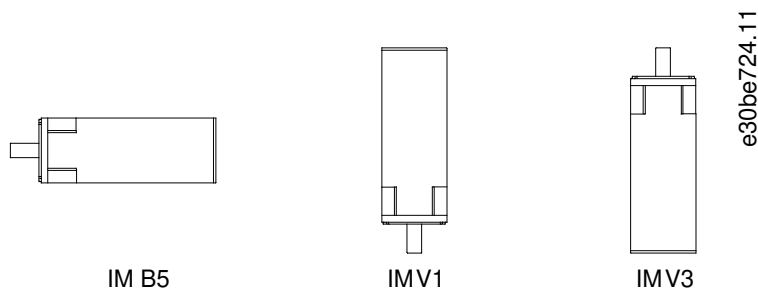

Illustration 160: Mounting Positions

Table 156: Protection ratings for ISD 510 Servo Drive

	Mounting position of servo drive (according to DIN 42 950)	IP rating (according to EN 60529)
Housing	All positions	IP65/IP67
Shaft without shaft seal	IM B5 & IM V1	IP54
	IM V3	IP50
Shaft with shaft seal	IM B5 & IM V1	IP65
	IM V3	IP60

N O T I C E

- Install and connect the ISD 510 servo drives as described in this manual to achieve the ratings detailed in [Table 156](#) in the final application.
- The ISD 510 servo drives are certified by UL as recognized components.

11.11.2 Protection Ratings for DSD 510 Servo Drive

All DSD 510 variants have a protection rating of IP65/IP67.

N O T I C E

- Install and connect the DSD 510 servo drives as described in this manual to achieve the IP65/IP67 rating in the final application.
- The DSD 510 servo drives are certified by UL as recognized components.

11.12 Cables

N O T I C E

- See the [VLT® Servo Drive System ISD 510, DSD 510, MSD 510 \(VLT® Flexmotion™\) Design Guide](#) for cable dimensions and drawings.

11.12.1 Hybrid Cable PE

Table 157: Hybrid Cable PE

Item	Description	Cross section
Hybrid cable PE	Used to connect the PE wire from the hybrid cable to the PE screw on the Decentral Access Module (DAM 510).	Maximum cross-section:

Item	Description	Cross section
		2.5 mm ² /4.0 mm ²

11.13 Storage

Store the servo system components in a dry, dust-free location with low vibration ($v_{\text{eff}} \leq 0.2$ mm/s).

The storage location must be free from corrosive gases.

Avoid sudden temperature changes.

Long-term Storage

To recondition the electrolytic capacitors, servo drives and system components not in service must be connected to a supply source once per year to allow the capacitors to charge and discharge. Otherwise the capacitors could suffer permanent damage.

Index

A

AC mains connector.....	208
AC1 and AC4 operating modes.....	141
ACM_REF	
Automation Studio™.....	90
TwinCAT®.....	99
SIMOTION SCOUT®.....	120
ACM 510 overview.....	34
Altitude	
Servo drive.....	215
System modules.....	216
Ambient temperature	
Servo drive.....	215
System modules.....	216
Application areas.....	26
Approvals.....	16
Automation Studio™	
Requirements.....	87
Project creation.....	87
Programming guidelines.....	106
AUX connector.....	212
AXIS_REF_DDS	
Automation Studio™.....	90
TwinCAT®.....	98
SIMOTION SCOUT®.....	119

B

Backlink connector.....	203
Bending radius	
Hybrid cable.....	41
Motor cable.....	42
Feedback cable.....	42
Brake connector.....	205

C

Cable	
Hybrid.....	41
Feed-in.....	41
Loop.....	41
Encoder.....	43
I/O.....	43
Fieldbus extension.....	43
LCP.....	43
Routing.....	43
Routing recommendations.....	69
Replacement.....	180
Hybrid PE.....	217
Cabling concept for 2 lines.....	43
CAM mode.....	141
Certifications.....	16
Characteristic data	
Functional Safety.....	153
ISD 510 servo drive without brake.....	186
ISD 510 servo drive with brake.....	188
DSD 510 servo drive.....	188
PSM 510.....	189
DAM 510.....	190
ACM 510.....	190
Circuit breakers.....	64, 65
Clamping	

ISD 510 servo drive.....	54
DSD 510 servo drive.....	56
Communication	
VLT® Servo Toolbox.....	132
Indirect.....	132
Direct.....	135
Connecting the 3rd Ethernet device cable.....	72
Connectors	
X1/X2 Hybrid connector.....	198
X3 3rd Ethernet connector.....	199
X4 I/O and/or encoder connector.....	200
X5 LCP connector.....	201
Motor connector: Standard.....	201
Motor feedback.....	202
Backlink.....	203
Brake.....	205
Ethernet.....	205
I/O.....	206
UAUX.....	206
LCP.....	207
AC mains.....	208
Relay.....	208
UDC.....	212
AUX.....	212
External encoder.....	213
Expansion module.....	214
Copyright.....	16
Coupling the ISD 510 servo drive.....	55
Cyclic synchronous position mode.....	141
Cyclic synchronous velocity.....	141

D

DAM_REF	
Automation Studio™.....	90
TwinCAT®.....	99
SIMOTION SCOUT®.....	119
DAM 510 overview.....	33
Dimensions	
ISD 510 servo drive flange.....	191
ISD 510 servo drive.....	191
DSD 510 servo drive.....	194
PSM 510.....	194
DAM 510.....	195
ACM 510.....	195
EXM 510.....	196
Direct communication.....	135
Disconnecting hybrid cables.....	69
Disposal.....	183

E

Electrical environmental conditions.....	61
Electrical installation warnings.....	61
EMC-compliant installation.....	62
Encoder cable.....	43, 70
Environmental conditions	
ISD 510/DSD 510 servo drive.....	49
PSM 510, DAM 510 and ACM 510.....	49
EtherCAT®	
Overview.....	45
ID assignment.....	83
Ethernet connector.....	205

Ethernet POWERLINK®		DSD 510 servo drive.....	217
Overview.....	46	Items supplied.....	48
ID assignment.....	83		
EXM 510		L	
Overview.....	35	LCP	
Connection.....	79	Overview.....	37
Expansion module connector.....	214	Cables.....	43
External encoder connector.....	213	Cable connection.....	71
		Connector on servo drive.....	201
F		Connector on system modules.....	207
Feed-in cable		LEDs	
Overview.....	41	ISD 510/DSD 510 servo drive.....	142
Disconnection.....	180	PSM 510.....	143
Replacement.....	180	DAM 510.....	144
Connection.....	180	ACM 510.....	145
Fieldbus.....	44	Libraries.....	87
Fieldbus extension cable.....	43	Loop cable	
Firewall settings for VLT® Servo Toolbox.....	132	Overview.....	41
Firmware.....	44	Disconnection.....	180
Fitting		Replacement.....	181
ISD 510 servo drive.....	54	Connection.....	181
DSD 510 servo drive.....	56		
System modules.....	57	M	
Function blocks.....	140	Maintenance tasks.....	176
Functional safety concept.....	147	Modes of operation.....	141
Fuses.....	64, 65	Motion functions.....	141
		Motion library.....	140
G		Motor connector.....	201
Gear mode.....	141	Motor feedback connector.....	202
Grounding.....	62	Multiple device ID assignment.....	84
H		N	
Homing mode.....	141	Nameplate	
Humidity		ISD 510/DSD 510 servo drive.....	184
Servo drive.....	215	System modules.....	185
System modules.....	216	NC axis (TwinCAT®).....	105
Hybrid cable			
Overview.....	41	O	
Connection.....	67	Operating modes.....	141
Disconnection.....	69		
Hybrid cable PE.....	217	P	
		PLC cycle time	
I		Automation Studio™.....	95
I/O		TwinCAT®.....	105
Cable.....	43	Product returns.....	183
Cable connection.....	70	Profile position mode.....	141
Configuration Automation Studio™.....	93	Profile torque mode.....	141
Mapping.....	93,102	Profile velocity mode.....	141
Configuration TwinCAT®.....	102	PROFINET®	
Connector.....	206	Overview.....	46
ID assignment		ID assignment.....	85
EtherCAT®.....	83	Programming	
Ethernet POWERLINK®.....	83	Automation Studio™.....	87
PROFINET®.....	85	TwinCAT®.....	96
Indirect communication.....	132	SIMOTION SCOUT®.....	106
Inertia measurement mode.....	141	TIA.....	123
Installation procedure.....	57	Template.....	140
Installation tools.....	54	Programming guidelines	
IP rating		Automation Studio™ and TwinCAT®.....	106
System modules.....	216	SIMOTION SCOUT®.....	123
ISD 510 servo drive.....	217	TIA.....	130

Protection rating		TIA	
System modules.....	216	Requirements.....	123
ISD 510 servo drive.....	217	Programming guidelines.....	130
DSD 510 servo drive.....	217	Tightening torque	
PSM_REF		ISD 510 servo drive.....	56
Automation Studio™.....	90	DSD 510 servo drive.....	56
TwinCAT®.....	99	Tools required for installation.....	54
SIMOTION SCOUT®.....	119	Trademarks.....	16
PSM 510 Overview.....	32	Transport.....	48
Q		TwinCAT®	
Qualified personnel.....	23	Requirements.....	96
R		Project creation.....	96
Recycling.....	183	NC axis.....	105
Relay connector.....	208	Programming guidelines.....	106
Repair.....	177	U	
S		UAUX connector.....	206
Safety during installation.....	48	UDC connector.....	212
Safety instructions.....	22	V	
Safety supply requirements.....	65	Vibration	
Safety warnings.....	20	Servo drive.....	215
Service and support.....	24	System modules.....	216
Servo drive replacement.....	177	VLТ® Servo Toolbox	
SIMOTION SCOUT®		Overview.....	131
Requirements.....	106	Subtools.....	131
Project creation.....	107	PC requirements.....	131
Programming guidelines.....	123	Installation.....	132
Single device ID assignment.....	83	Communication.....	132
Software.....	44	W	
Space requirements		Warnings for electrical installation.....	61
ISD 510 servo drive.....	50	Warnings, safety.....	20
DSD 510 servo drive.....	51	X	
System modules.....	52	X1/X2 connector.....	198
STO connector.....	210	X3 connector.....	199
Storage.....	218	X4 connector.....	200
Switching on the ISD 510/DSD 510 system.....	86	X5 connector.....	201
System module replacement.....	177	X6 connector.....	201
System overview.....	26	X7 connector.....	202
T			
Terminology.....	18		

VLT Servo Drive Systems Glossary

A

A-flange	The A side is the shaft side of the servomotor.
ACM	Auxiliary Capacitors Module.
Ambient temperature	The temperature in the immediate vicinity of the servo system or component.
Automation Studio™	Automation Studio™ is a registered trademark of B&R. It is the integrated software development environment for B&R controllers.
Axial force	The force in newton acting on the rotor axis in the axial direction.

B

B side	The rear side of the servo drive with the plug-and-socket connectors.
B&R	Multi-national company, specializing in factory and process automation software and systems for a wide range of industrial applications.
Bearings	The ball bearings of the servomotor.
Beckhoff®	Beckhoff® is a registered trademark of and licensed by Beckhoff Automation GmbH, Germany.
Brake	Mechanical holding brake on the servo drive.

C

CANopen®	CANopen® is a registered community trademark of CAN in Automation e.V.
CE	European test and certification mark.
CIA DS 402	Device profile for drives and motion control. CIA® is a registered community trademark of CAN in Automation e.V.
Clamping set	A mechanical device, which, for example, can be used to secure gears to a motor shaft.
Connector (M23)	Servo drive hybrid connector.
Cooling	Decentral servo drives are cooled by natural convection (without fans). All system modules except the DAM 510, ACM 510, and EXM 510 are cooled by an internal fan.

D

DAM	Decentral Access Module
DC voltage	A direct constant voltage.
DC-link	Each servo drive has its own DC-link, consisting of capacitors.
DC-link voltage	A DC voltage shared by several servo drives connected in parallel.
DSD	Decentral Servo Drive

E

EPG	Ethernet POWERLINK® Standardization Group.
ETG	EtherCAT® Technology Group
EtherCAT®	EtherCAT® (Ethernet for Control Automation Technology) is an open high-performance Ethernet-based fieldbus system. EtherCAT® is registered trademark and patented technology, licensed by Beckhoff Automation GmbH, Germany.

Ethernet POWERLINK®

Ethernet POWERLINK® is a deterministic real-time protocol for standard Ethernet. It is an open protocol managed by the Ethernet POWERLINK® Standardization Group (EPSSG). It was introduced by Austrian automation company B&R in 2001.

F**Feed-in cable**

Hybrid connection cable between the Decentral Access Module (DAM 510) and ISD 510/DSD 510 servo drive.

Feedback system

The feedback system measures the rotor position.

Fieldbus

Communication bus between controller and servo axis and system modules; in general between controller and field nodes.

Firmware

Software in the unit; runs on the control board.

Function block

Device functionalities are accessible via the engineering environment software.

I**IGBT**

The insulated-gate bipolar transistor is a 3-terminal semiconductor device, primarily used as an electronic switch to combine high efficiency and fast switching.

IRT

Isochronous Real-Time.

ISD

Integrated Servo Drive

ISD servomotor

Designates the ISD servomotor (without the drive electronics).

Installation elevation

Installation elevation above normal sea level, typically associated with a de-rating factor.

L**LCP**

Local control panel.

Loop cable

Hybrid connection cable between 2 decentral servo drives, with 2 M23 connectors.

M**M12 connector**

Connector (X4) for connecting I/O and/or encoder on the B side of the advanced version of the ISD 510/DSD 510 servo drive.

M23 connectors

Connectors (X1 & X2) for connecting the hybrid feed-in and loop cables on the B side of the standard and advanced version of the ISD 510/DSD 510 servo drive.

M8 connectors

Fully functional real-time Ethernet port (X3) on the B side of the advanced version of the ISD 510/DSD 510 servo drive. Connector (X5) for connection of the LCP to the B side of the advanced version of the ISD 510/DSD 510 servo drive.

MSD

Multi-axis Servo Drive

Motor shaft

Rotating shaft on the A side of the servo motor, typically without a key groove.

Multi-turn encoder

Describes an absolute encoder, in which the absolute position remains known after several revolutions.

P**PELV**

Protected extra low voltage is an electricity supply voltage in a range which carries a low risk of dangerous electrical shock.

PLC	A programmable logic controller is a digital computer used for automation of electromechanical processes, such as control of machinery on factory assembly lines.
PLCopen®	The name PLCopen® is a registered trademark and, together with the PLCopen® logos, is owned by the association PLCopen®. PLCopen® is a vendor- and product-independent worldwide association, that defines a standard for industrial control programming.
POU	Program organization unit. This can be a program, function block, or function.
PSM	Power Supply Module.
PWM	Pulse width modulation.
R	
RCCB	Residual current circuit breaker.
RT	Real-time.
Radial force	The force in newton acting at 90° to the longitudinal direction of the rotor axis.
Resolver	A feedback device for servomotors, typically with 2 analog tracks (sine and cosine).
S	
SIL 2	Safety Integrated Level II.
SSI	Synchronous serial interface.
STO	Safe Torque Off function. On activation of STO, the ISD 510 servo drive is no longer able to produce torque in the motor.
Safety (STO)	A servo drive safety circuit that switches off the voltages of the driver components for the IGBTs.
Scope	Scope is part of the DDS Toolbox software and is used for diagnosis. It enables internal signals to be depicted.
Single-turn encoder	Describes an absolute encoder, in which the absolute position for 1 revolution remains known.
Standstill (servo drive)	Power is on, there is no error in the axis, and there are no motion commands active on the axis.
System modules	This term includes the Power Supply Module (PSM 510), the Decentral Access Module (DAM 510), and the optional Auxiliary Capacitors Module (ACM 510).
T	
TwinCAT®	TwinCAT® is a registered trademark of and licensed by Beckhoff Automation GmbH, Germany. It is the integrated software development environment for controllers from Beckhoff.
U	
UAUX	Auxiliary supply, provides power to the control electronics of the ISD 510/DSD 510 servo drives and the Power Supply Module (PSM 510), Decentral Access Module (DAM 510), and Auxiliary Capacitors Module (ACM 510).
V	
VLT® Servo Toolbox	A Danfoss pc software tool used for parameter setting and diagnostics of VLT® Servo Drive systems

W

Wireshark®

Wireshark® is a network protocol analyzer released under the GNU General Public License version 2.

ENGINEERING
TOMORROW



Danfoss A/S
Nordborgvej 81
DK-6430 Nordborg
www.danfoss.com

.....
Danfoss can accept no responsibility for possible errors in catalogues, brochures and other printed material. Danfoss reserves the right to alter its products without notice. This also applies to products already on order provided that such alterations can be made without subsequential changes being necessary in specifications already agreed. All trademarks in this material are property of the respective companies. Danfoss and the Danfoss logotype are trademarks of Danfoss A/S. All rights reserved.
.....

