

# Operating Instructions

## VLT<sup>®</sup> Integrated Servo Drive ISD 410

Contents

<b>1 General Information</b>	<b>5</b>
1.1 Important Safety Warnings	5
1.2 Copyright	5
1.3 Disclaimer	5
1.4 Approvals	5
1.5 Service and Support	5
<b>2 Introduction</b>	<b>6</b>
2.1 System Overview	6
2.2 Terminology	7
2.3 Purpose of the Operating Instructions	7
2.4 Additional Resources	7
<b>3 Safety Instructions</b>	<b>8</b>
3.1 Symbols used in this Manual	8
3.2 General	8
3.3 Safety Instructions and Precautions	8
3.4 Qualified Personnel	10
3.5 Due Diligence	10
3.6 Intended Use	10
3.7 Foreseeable Misuse	11
<b>4 Description</b>	<b>12</b>
4.1 Types	12
4.1.1 Configurations	13
4.2 Motor Components	14
4.2.1 Shaft	14
4.2.2 Brake (Optional)	14
4.2.3 Cooling	14
4.2.4 Winding/Motor	14
4.2.5 Internal Components	14
4.2.6 Angle Position Encoder	15
4.3 Connection Cables/Cabling	16
4.3.1 Layout and Routing	17
4.3.2 Hybrid Cable	17
4.3.3 Sensor Cable	20
4.4 Ports/Connector Pin Assignment	20
<b>5 Installation/Fitting</b>	<b>21</b>
5.1 Transport and Delivery	21

5.1.1 Scope of Delivery	21
5.1.2 Transport	21
5.1.3 Inspection on Receipt	21
5.2 Safety Measures during Installation	21
5.3 Installation Environment	21
5.4 Preparation for Installation	22
5.5 Mechanical Installation	22
5.5.1 Installation and Space Requirements	22
5.5.2 Installation Aids and Tools Required	22
5.5.3 Tightening Torques	22
5.5.4 Fitting Instructions	22
5.6 Electrical Installation	23
5.6.1 Electrical Environmental Conditions	23
5.6.2 Connecting/Disconnecting Hybrid Cables	23
5.6.3 Connecting/Disconnecting Sensor Cables	24
<b>6 Commissioning</b>	<b>25</b>
6.1 Switching on the Servomotors	25
6.2 Connecting the Components	25
6.3 Functional Operation Test (before initial power-up or operation)	25
6.4 Parameter Configuration	25
6.5 Test Run	25
<b>7 Operation</b>	<b>26</b>
7.1 Operating Modes	26
7.1.1 ISD Inertia Measurement Mode	26
7.1.2 Speed Mode	26
7.1.3 ISD Curve Mode	26
7.2 Operating Status Indicators	26
<b>8 ISD Safety Concept</b>	<b>27</b>
8.1 Standards	27
8.2 Functional Description	27
8.3 Activating/Deactivating the Safe Stop Function	28
8.4 Installation	29
8.5 Acceptance Test	30
8.6 Application Examples	31
<b>9 Faults</b>	<b>32</b>
9.1 Troubleshooting	32
<b>10 Maintenance and Repair</b>	<b>33</b>

10.1 Maintenance tasks	33
10.1.1 Replacing the Shaft Seal	33
10.2 Inspection during Operation	33
10.3 Repair	33
10.3.1 Cable Replacement	34
10.3.1.1 Feed Cable Replacement	34
10.3.1.2 Loop Cable Replacement	35
10.4 Servomotor Replacement	35
10.4.1 Dismounting	35
10.4.2 Fitting and Commissioning	35
<b>11 Decommissioning and Disposal</b>	<b>36</b>
11.1 Decommissioning	36
11.2 Dismounting	36
11.3 Product Returns	36
11.4 Recycling and Disposal	37
11.4.1 Recycling	37
11.4.2 Disposal	37
<b>12 Specifications</b>	<b>38</b>
12.1 Nameplate	38
12.2 Storage	38
12.2.1 Long-term Storage	38
12.3 Characteristic Data	39
12.3.1 Servomotor without Brake	39
12.3.2 Servomotor with Brake	40
12.4 Dimensions	41
12.4.1 Servomotor with ISD Flange, without Brake	41
12.4.2 Servomotor with ISD Flange and Brake	42
12.4.3 Servomotor with IEC Flange, without Brake	43
12.4.4 Servomotor with IEC Flange and Brake	44
12.5 Motor Characteristics	45
12.6 Characteristic Curves	45
12.6.1 S1 Duty Cycle (Continuous duty)	45
12.6.2 S3 Service Cycle (Intermittent periodic service)	45
12.6.2.1 Servomotors 175G7801/02/09/10/17/18	46
12.6.2.2 Servomotors 175G7803/04/11/12/19/20	46
12.6.2.3 Servomotors 175G7805/06/13/14/21/22	46
12.6.2.4 Servomotors 175G7807/08/15/16/23/24	46
12.7 General Specifications and Environmental Conditions	47
12.8 Permitted Forces	47

12.8.1 Servomotor without Brake	47
12.8.2 Servomotor with Brake	48
<b>13 Appendix</b>	<b>50</b>
13.1 Glossary	50
<b>Index</b>	<b>52</b>

# 1 General Information

## 1.1 Important Safety Warnings

### **⚠ WARNING**

#### HIGH VOLTAGE

ISD 410 servomotors operate at a high voltage when connected to the electrical supply network. A hazardous voltage is present on the servomotors whenever they are connected to the mains network via the power supply module and the connection box. There are no indicators on the servomotor that indicate the presence of mains voltage. This indication is provided on the connection box. Installation, commissioning and maintenance may only be performed by qualified staff. Incorrect installation, commissioning or maintenance can lead to death or serious injury.

### **⚠ WARNING**

#### UNINTENDED START

A servomotor that is connected to the electrical supply network can start running at any time. This may be caused by an external switch, a CAN bus command, a reference signal, or clearing a fault condition. Servomotors and all connected devices must be in good operating condition. A deficient operating condition may lead to death, serious injury, damage to equipment or other material damage when the device is connected to the electrical supply network. Take suitable measures to prevent unintended starts.

### **⚠ WARNING**

#### DISCHARGE TIME

The DC link capacitors of the servomotors remain charged for some time after the mains supply is switched off at the power supply module.

To avoid electrical shock, fully disconnect the power supply module from the mains before carrying out maintenance. The DC links of the individual ISD servomotors are connected in parallel when they are connected as a group, which increases the discharge time. Wait for at least the time listed below before carrying out maintenance work:

Number	Minimum waiting time (discharge time)
1-60 servomotors	10 minutes
Note: High voltage may be present even if the LED on the ISD connection box is not lit!	

Table 1.1 Discharge Time

## 1.2 Copyright

Disclosure, duplication and sale of this document, as well as communication of its content, are prohibited unless explicitly permitted. Infringement of this prohibition incurs liability for damages. All rights reserved with regard to patents, utility patents and registered designs. ISD is a registered trademark.

## 1.3 Disclaimer

No liability is assumed for any damage or breakdown resulting from:

- Failure to observe the information in the instruction manual
- Unauthorised modifications to the ISD 410 servomotors
- Operator error
- Improper work on or with the ISD 410 servomotors.

## 1.4 Approvals



Illustration 1.1

## 1.5 Service and Support

Contact your local service representative for service and support:

<http://www.danfoss.com/Contact/Worldwide/>

## 2 Introduction

# 2

### 2.1 System Overview

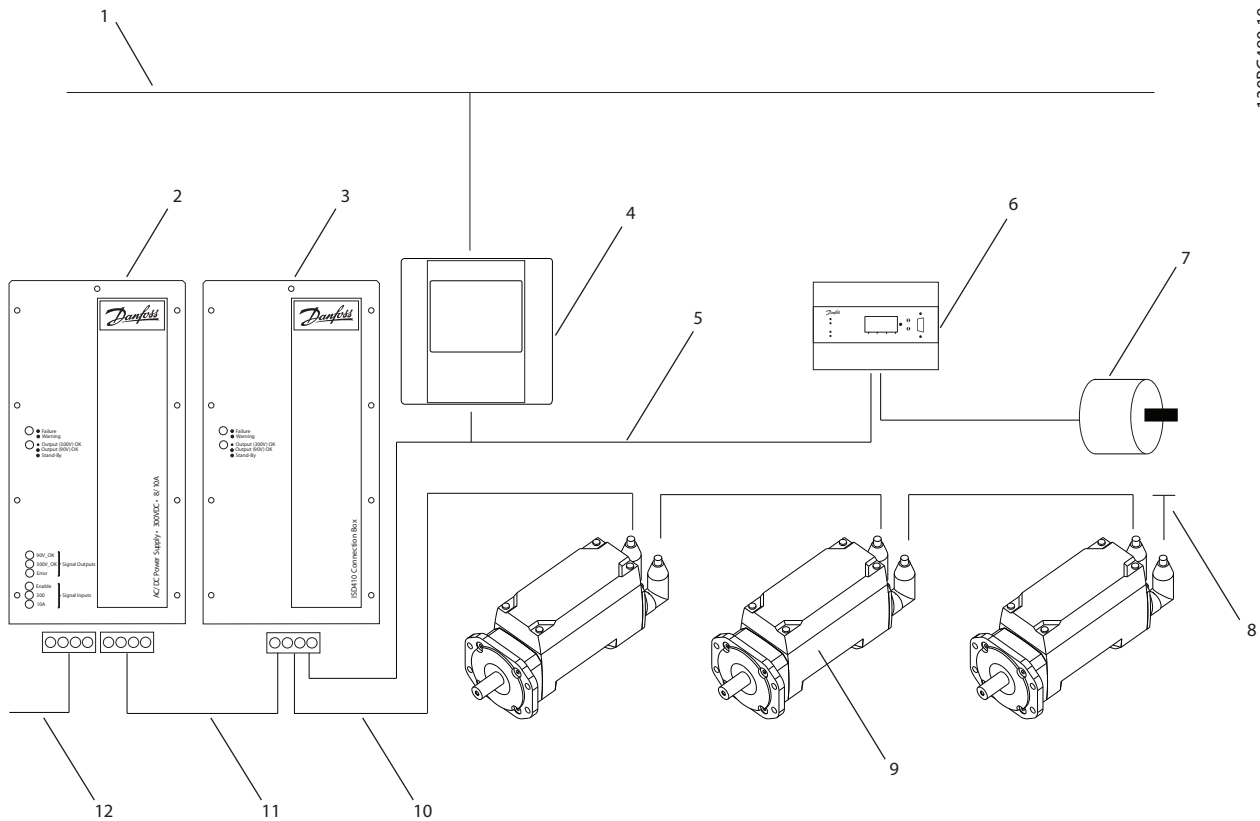

130BC480.10

Illustration 2.1 ISD Servo System with 3 Servomotors

Number	Description	Number	Description
1	Ethernet	7	Master encoder
2	Power supply module	8	Terminating resistor
3	Connection box	9	ISD servo drive
4	Master	10	Hybrid cable (DC & CAN)
5	CAN line	11	DC line
6	Encoder box	12	AC line

Table 2.1 Legend to Illustration 2.1

The servomotors are self-contained distributed drives, which means that the drive electronics is housed together with the motor in the same casing. The motion control software also runs independently in the servomotor; which reduces the load on the higher-level control system.

A master system is needed to control the servomotors. In this system servomotors operated in a DC group are controlled by a master system.

Several motors can be operated in a group using a hybrid cable. This cable carries the DC supply voltage and the CAN bus signals. The ISD 410 servo system is designed to accommodate up to 60 ISD 410 servomotors and consists of:

- 1 power supply module
- 1 connection box
- 1 encoder Box
- Servomotors
- 1 master

**NOTE**

**The ISD 410 servomotors cannot be used in other servo systems from other manufacturers!  
Motors from other manufacturers cannot be used in the Danfoss ISD 410 servo system!**

**2.2 Terminology**

ISD	Integrated Servo Drives
ISD servo system	Complete system including all components.
ISD master	Control system hardware
ISD master system	Control system hardware and software
ISD servo drive	ISD servomotor with hybrid cable

**Table 2.2 Terminology**

**2.3 Purpose of the Operating Instructions**

The purpose of these operating instructions is to describe the Danfoss ISD 410 servomotors exclusively in the context of a Danfoss ISD 410 servo system.

These operating instructions contain information about:

- Installation
- Commissioning
- Operation
- ISD safety concept
- Troubleshooting
- Maintenance and repair

These operating instructions are intended for use by qualified personnel. Read these operating instructions in full in order to use the servo system safely and professionally, and pay particular attention to the safety instructions and general warnings. These operating instructions are an integral part of the ISD 410 servomotor. Keep these operating instructions available with the servo system at all times.

Compliance with the information in the operating instructions is a prerequisite for:

- Trouble-free operation
- Recognition of product liability claims

Therefore, read these operating instructions before working with the servomotor!

The operating instructions also contain important service information. The operating instructions should therefore be kept close to the servomotor.

**2.4 Additional Resources**

Available documents for the ISD 410 servo system:

Document	Contents
VLT® ISD Encoder Box Operating Instructions	Information about the commissioning and operation of the encoder box
VLT® ISD Connection Box Operating Instructions	Information about the commissioning and operation of the connection box
VLT® ISD Power Supply Module Instructions	Information about the commissioning and operation of the power supply module
VLT® ISD 410 Design Guide	Information about the construction and commissioning of the ISD 410 servo system

**Table 2.3 Available Documents for the ISD 410 Servo System**

Technical literature for Danfoss drives is also available online at <http://www.danfoss.com/BusinessAreas/DrivesSolutions/Documentations/Technical+Documentation.htm>.

Firmware updates may be available. When firmware updates are available, they can be downloaded from the [www.danfoss.com](http://www.danfoss.com) website. The ISD Toolbox software is used to install the firmware in the servomotors.



## 3 Safety Instructions

### 3

#### 3.1 Symbols used in this Manual

The following symbols are used in this document.

#### **⚠ WARNING**

Indicates a potentially hazardous situation which, if not avoided, could result in death or serious injury.

#### **⚠ CAUTION**

Indicates a potentially hazardous situation which, if not avoided, may result in minor or moderate injury. It may also be used to alert against unsafe practices.

#### **CAUTION**

Indicates a situation that may result in equipment or property-damage-only accidents.

#### **NOTE**

Indicates highlighted information that should be regarded with attention to avoid mistakes or operate equipment at less than optimal performance.

#### 3.2 General

The following safety instructions and precautions are primarily related to using ISD 410 servomotors in an ISD 410 servo system. The number of servomotors in the servo system is not significant for this.

Read the safety instructions carefully before starting to work in any way with the servomotors.

When working with the servomotors, pay particular attention to the safety instructions in the relevant sections of this instruction manual.

Also observe the safety instructions and precautions in the instruction manuals for the other system components.

#### **⚠ WARNING**

##### HIGH VOLTAGE

ISD 410 servomotors operate at a high voltage when connected to the electrical supply network.

A hazardous voltage is present on the servomotors whenever they are connected to the mains network via the power supply module and the connection box.

There are no indicators on the servomotor that indicate the presence of mains voltage. This indication is provided at the distributor box. Installation, commissioning and maintenance may only be performed by qualified staff. Incorrect installation, commissioning or maintenance can lead to death or serious injury.

#### **⚠ WARNING**

##### HAZARDOUS SITUATION

If the servomotor or the bus lines is/are incorrectly connected, there is a risk of damage to the equipment or personal injury, which may even prove fatal. For this reason, always comply with the instructions in this manual, as well as national and local safety regulations. Read the operating instructions for the other components of the ISD 410 servo system.

#### 3.3 Safety Instructions and Precautions

Read the safety instructions carefully before starting to work in any way with the servomotors. Compliance with the safety instructions and precautions is necessary at all times.

- Orderly and proper transport, storage, fitting and installation, as well as careful operation and maintenance, are essential for the trouble-free and safe operation of this equipment.
- Only suitably trained and qualified staff may work on the equipment or in its vicinity. See *3.4 Qualified Personnel*.
- Use only accessories and spare parts approved by the manufacturer.
- Comply with the specified ambient conditions.
- The information in these operating instructions about the use of available components is provided solely by way of examples of applications and suggestions.
- The plant engineer or system engineer is personally responsible for checking the suitability of the supplied components and the information

provided in this document for the specific application concerned:

- for compliance with the safety regulations and standards relevant to the specific application concerned.
- for implementing the necessary measures, changes and extensions.
- Commissioning the servomotors is not allowed until it has been ascertained that the machine, system or plant in which they are installed conforms to the statutory provisions, safety regulations and standards that apply in the country of use to that application.
- Operation is allowed only in compliance with the national EMC regulations for the application concerned.
- See the *VLT® ISD 410 Design Guide, MG75I* for information regarding EMC-compliant installation of the servomotors.
- Compliance with the limit values specified by national regulations is the responsibility of the producer of the plant, system or machine.
- Compliance with the specifications, connection conditions and installation conditions in this instruction manual is mandatory.
- The safety regulations and safety provisions of the country in which the equipment is used must be observed.
- Care must be taken to ensure that orderly protective earthing of the equipment, which protects the user against the supply voltage and protects the power supply module against overload, is performed in accordance with local and national regulations.
- Overload protection for the servomotor can be programmed using the master system. For more information, see *Programming* in the *VLT® ISD 410 Design Guide, MG75I*.

## **⚠ WARNING**

### **EARTHING HAZARD**

**For reasons of operator safety, the servomotor must be earthed correctly in accordance with national or local electrical regulations and the information in these operating instructions. The earth leakage current is greater than 3.5 mA. Improper earthing of the servomotor may result in death or serious injury.**

### **Operational Safety**

- Safety-related applications are allowed only if they are explicitly and unambiguously mentioned in the *VLT® ISD 410 Design Guide, MG75I*. Otherwise they are not allowed.
- All applications that can give rise to hazards to people or damage to property are safety-related applications.
- The stop functions implemented in the software of the master system do not interrupt the mains voltage supply to the power supply module and are therefore not allowed to be used as safety switches for the servo system.
- The motor can be brought to a stop by a software command or a zero speed setpoint, but DC voltage remains present on the servomotor and/or mains voltage in the power supply module. If personal safety considerations (e.g. risk of personal injury caused by contact with moving machine parts after an unintended start) make it necessary to ensure that an unintended start cannot occur, these stop functions are not sufficient. In this case the servo system must be detached from the mains network or a suitable stop function must be implemented.
- When the servomotor is stopped, it may start up again on its own if the circuitry of the servomotor is defective or after the elimination of a temporary overload, a problem with the supply voltage or a problem with the servomotor. If personal safety considerations (e.g. risk of personal injury caused by contact with moving machine parts after an unintentional start) make it necessary to ensure that an unintended start cannot occur, the normal stop functions of the servomotor are not sufficient. In this case the servo system must be disconnected from the mains network or a suitable stop function must be implemented.
- The servomotor may start running unintentionally during parameter configuration or programming. If this can pose a risk to personal safety (e.g. risk of personal injury due to contact with moving machine parts), unintended motor starting must be prevented, for example by using the Safe Stop function or by safe disconnection of the servomotors.
- Do not disconnect the cables from the servomotor while the servo system is connected to mains voltage. Ensure that the mains supply is disconnected and the required waiting time has elapsed before disconnecting or connecting the hybrid cable or disconnecting cables from the connection box and/or the power supply module.

- In addition to the L1, L2 and L3 supply voltage inputs on the power supply module, the servo system has other supply voltage inputs, including external 24 V DC. Before commencing repair work, check that all supply voltage inputs have been switched off and that the necessary discharge time for the intermediate circuit capacitors has elapsed.
- The supply of power to the servo system must be switched off for repair work. Before disconnecting or connecting the hybrid cable or disconnecting cables from the connection box and/or the power supply module, ensure that the mains supply is disconnected and the necessary discharge time has elapsed.

### **⚠ WARNING**

#### **HIGH VOLTAGE**

The ISD 410 servomotors are electrically powered servo drives with DC link circuits. The capacitors in the DC links hold stored energy even after the supply voltage has been switched off. The total capacitance of the DC link is higher than that of an individual servomotor because the servomotors in the system are configured as a group with their DC links connected in parallel. For this reason, the capacitor discharge times must always be observed without fail.

### **CAUTION**

**Never connect or disconnect the hybrid cable to or from the servomotor when voltage is present. Doing so will damage the electronic circuitry. Observe the discharge time for the DC link capacitors.**

#### 3.4 Qualified Personnel

Installation, commissioning and maintenance of the ISD 410 servo system may only be carried out by qualified personnel.

For the purposes of this document and the safety instructions in this document, qualified staff are trained staff who are authorised to fit, install, commission, earth and label equipment, systems and circuits in accordance with the standards for safety technology and who are familiar with the safety concepts of automation engineering.

Additionally, the personnel must be familiar with all the instructions and safety measures described in these operating instructions.

They must have suitable safety equipment and be trained in first aid.

#### 3.5 Due Diligence

The operator and/or fabricator must ensure that:

- the servomotor is used only as intended
- the servomotor is operated only in a perfect operational condition
- the operating instructions are always available near the servomotor in complete and readable form
- the servomotor is fitted, installed, commissioned and maintained only by adequately qualified and authorised personnel
- these personnel are regularly instructed on all relevant matters of occupational safety and environmental protection, as well as the contents of the operating instructions and in particular the instructions it contains
- the product markings and identification markings applied to the servomotor, as well as safety and warning instructions, are not removed and are always kept in a legible condition
- the national and international regulations regarding the control of machinery and equipment, that are applicable at the place of use of the servo system, are complied with
- the users always have all current information relevant to their interests about the servo system and its use and operation

#### 3.6 Intended Use

The servomotors are intended to be installed in machines used in commercial and industrial environments.

To ensure that the product is used as intended, the following conditions must be fulfilled before using the ISD 410 servomotor:

- Everyone who uses one of our products in any manner must read and understand the corresponding safety regulations and the description of the intended use
- Hardware must be left in its original state, which means that no structural changes may be made to the hardware
- Software products may not be reverse-engineered and their source code may not be altered
- Damaged or faulty products may not be installed or put into service

- It must be ensured that the products are installed in conformance with the regulations mentioned in the documentation
- The specified maintenance and service intervals must be observed
- All protective measures must be complied with
- Only the components described in these operating instructions may be fitted or installed. Third-party devices and equipment may be used only in consultation with Danfoss
- The documentation must be read completely and correctly followed

The servo system **may not** be used in the following application areas:

- Areas with potentially explosive atmospheres
- Mobile or portable systems
- Floating or airborne systems
- Inhabited facilities
- Sites where radioactive materials are present
- Areas with extreme temperature variations or in which the maximum rated temperatures may be exceeded
- Under water

### 3.7 Foreseeable Misuse

Any use not expressly approved by Danfoss constitutes misuse. This also applies to failure to comply with the specified operating conditions and applications.

Danfoss assumes no liability of any sort for damage attributable to improper use.

## 4 Description

The ISD 410 servomotor is a compact drive with a permanent magnet (PM) synchronous motor. The servomotor is an integrated servo drive, which means that the electronic circuitry is integrated in the motor housing. Data transfer takes place by means of the CAN interface integrated in the servo drive. The 300 V DC supply voltage lines and the CAN bus lines are combined in a hybrid cable.

4

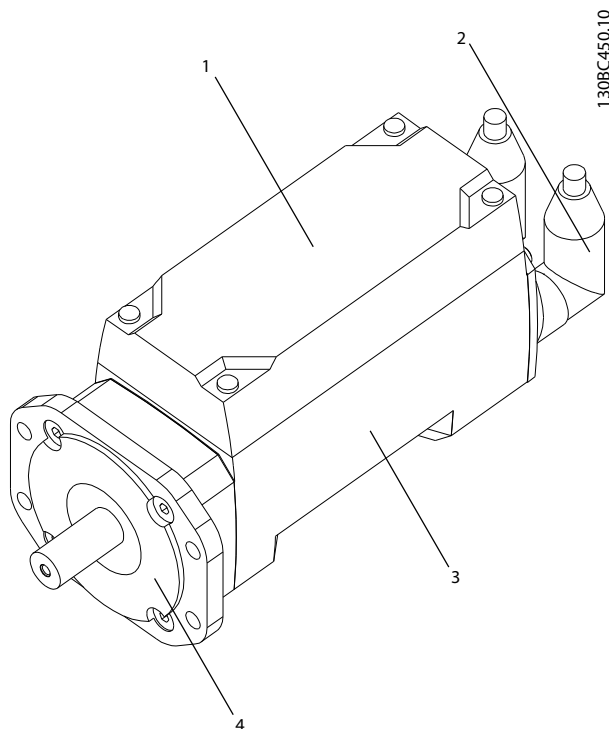

Illustration 4.1 ISD Servomotor

1	Electronics (built in)
2	Connectors
3	Motor
4	A-flange

Table 4.1 ISD Servomotor

### 4.1 Types

The ISD 410 servomotor is available in 2 flange versions. Both versions are available with or without a holding brake.

Type	Description
ISD	Unique flange developed by Danfoss specifically for ISD 410 servomotors
IEC	Standardised flange; rotated such that all 4 screws are outside the protruding contour of the housing

Table 4.2 Overview of Types

The possible configurations with the various types are listed in 4.1.1 Configurations.

All dimensions are listed in 12.4 Dimensions.

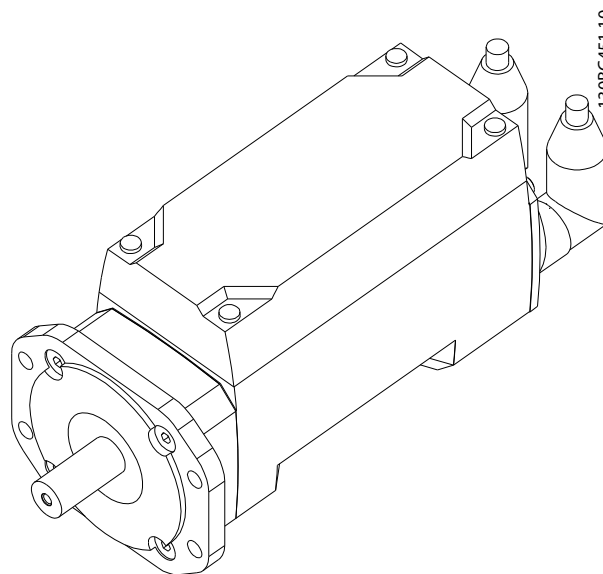

Illustration 4.2 ISD Flange for Servomotor without Brake

Short description for *Illustration 4.2*:

- Without integrated brake (short type)
- ISD flange for horizontal or vertical installation
- Various encoder options

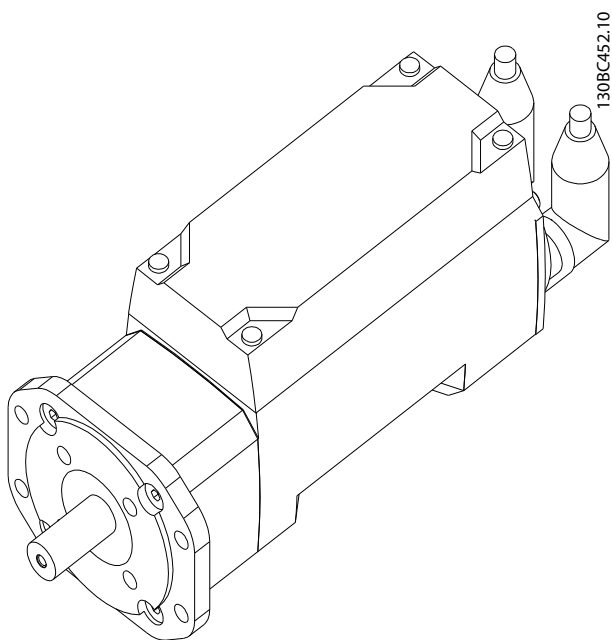

Illustration 4.3 ISD Flange for Servomotor with Brake

Short description for *Illustration 4.3*:

- Integrated brake (long type)
- ISD flange for horizontal or vertical installation
- Various encoder options

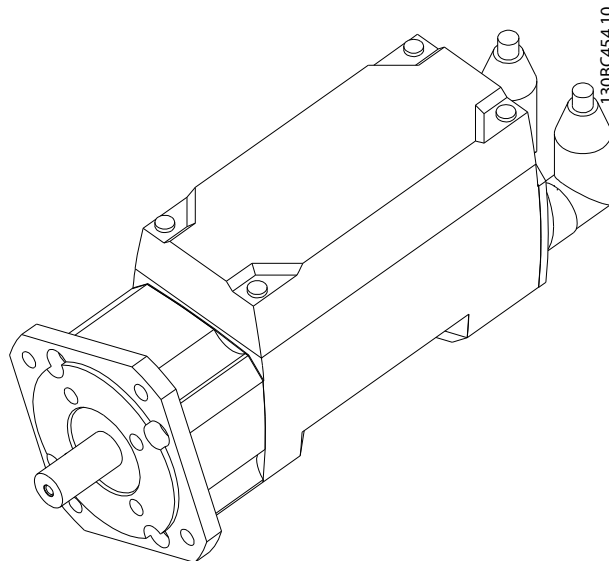

Illustration 4.5 IEC Flange for Servomotor with Brake

Short description for *Illustration 4.5*:

- Integrated brake (long type)
- IEC flange for standardised installation
- Various encoder options

### 4.1.1 Configurations

ISD servomotors can be configured with various encoders and/or brakes, depending on the type.

Flange/ Configuration	ISD without brake	ISD with brake	IEC without brake	IEC with brake
Resolver	X	X	X	X
Single-turn	X	X	X	X
Multi-turn	X	X	X	X
Brake	-	X	-	X

Table 4.3 Configuration/Type

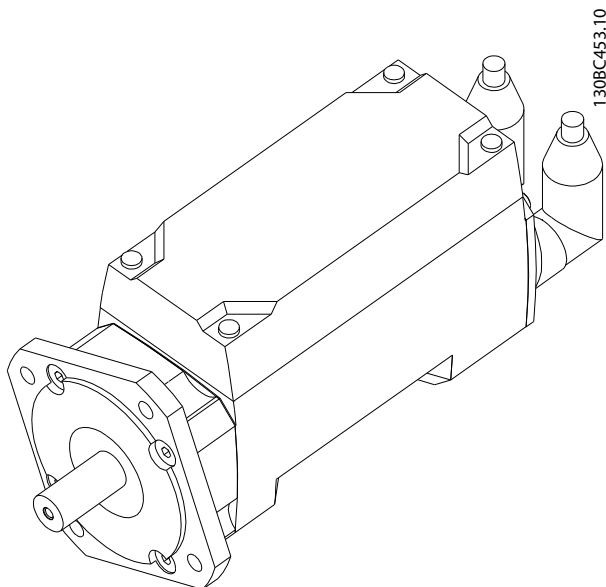

Illustration 4.4 IEC Flange for Servomotor without Brake

Short description for *Illustration 4.4*:

- Without integrated brake (short type)
- IEC flange for standardised installation
- Various encoder options

## 4.2 Motor Components

### 4.2.1 Shaft

The shaft transfers the motor force (torque) to the machine coupled to the shaft.

The torque is transferred by a clamping set.

All servomotor types have a standardised shaft.

Shaft material: St60

ISD servomotors are sealed externally by a shaft seal. The shaft seal is a consumable part (see *10.1 Maintenance tasks*).

## CAUTION

**ISD 410 servomotors are not suitable for installation facing upward with water "standing" on the shaft seal. Consult Danfoss for specific applications.**

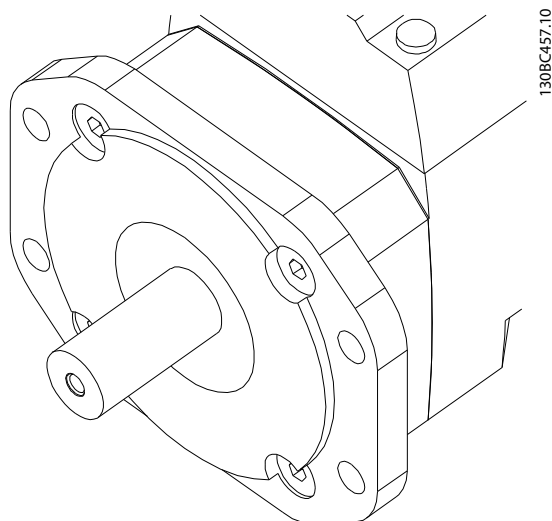

Illustration 4.6 Shaft

### 4.2.2 Brake (Optional)

The optional mechanical power-off brake is designed as a single-disc brake with emergency stop function. The emergency stop function can be initiated at most 20 times per hour and 500 times in total.

The effective holding torque is 9 Nm.

The brake operates according to the fail-safe principle "closed when no current". It is powered from the 300 V DC link.

This enables zero-play load holding when no current is present.

Electrical data: Current consumption 0.056 A at 205 V DC.

## NOTE

**The brake should not be misused as a working brake, as this would cause increased wear, resulting in premature failure.**

### 4.2.3 Cooling

ISD servomotors are self-cooling.

Cooling (heat dispersal) is primarily via the flange, with a small amount dispersed by the housing.

### 4.2.4 Winding/Motor

The winding causes the motor rotor to turn.

There is a choice of two winding and magnet packages. They differ in speed and torque characteristics.

**Winding protection:** A thermal model is used to monitor the maximum allowable power and switch off the motor if it is exceeded. An error message is also sent over the CAN bus to the higher-level master system.

### 4.2.5 Internal Components

#### Power/CAN bus loop input connector

DC link voltage (supply voltage) and CAN bus.

#### Power/CAN bus loop output connector

DC link voltage (supply voltage) and CAN bus for the next servomotor.

#### Sensor I/O (port)

The sensor port includes digital input and output, an analog input and the 24 V DC control voltage and conforms to the PELV specification.

#### Output stage (IGBT)

The output stage converts the intermediate circuit voltage to 3-phase AC voltage that drives the PM motor.

#### Controller (DSP)

Contains the processor that provides all control functions for the ISD servomotor.

#### Resolver

The position controller of the ISD servomotor obtains its data from a resolver. The analog signals from the resolver are processed in the DSP and provided to the controller with a 13 bit resolution.

The positioning accuracy of the servomotor is 0.25° in relation to the motor shaft.

Other encoder systems are optionally available.

## 4.2.6 Angle Position Encoder

Other angle position encoders can be installed in addition to the resolver.

### Single-turn

The single-turn encoder provides the rotor position with a 17 bit resolution. It communicates using the BiSS protocol.

### Multi-turn

The multi-turn encoder provides the rotor position with a resolution of 17 bits per turn. The number of turns is accumulated in a 12-bit counter. This allows a maximum of 4096 turns to be counted. It communicates using the BiSS protocol.

The following table summarises the functions of the individual angle position encoders.

Function	Resolver	Single-turn	Multi-turn
Signal	Analog signal	BiSS	BiSS
Accuracy	±0.25°	±0.028°	±0.028°
Repeatability	±0.1°	–	–
Resolution	Theoretical resolution 13 bits	17 bits	17 bits per turn 12 bits for number of turns

**Table 4.4 Angle Position Encoder Functions**



### 4.3 Connection Cables/Cabling

The ISD servo motors are connected by hybrid cables (loop cables). The hybrid cables contain the 300 V DC supply voltage lines and the CAN bus signal lines.

Hybrid cables are available in various lengths and are designed to be compatible with drag chains.

The loop cables interconnect the servomotors, and a feed cable provides the supply voltage from the connection box to the first servomotor.

4

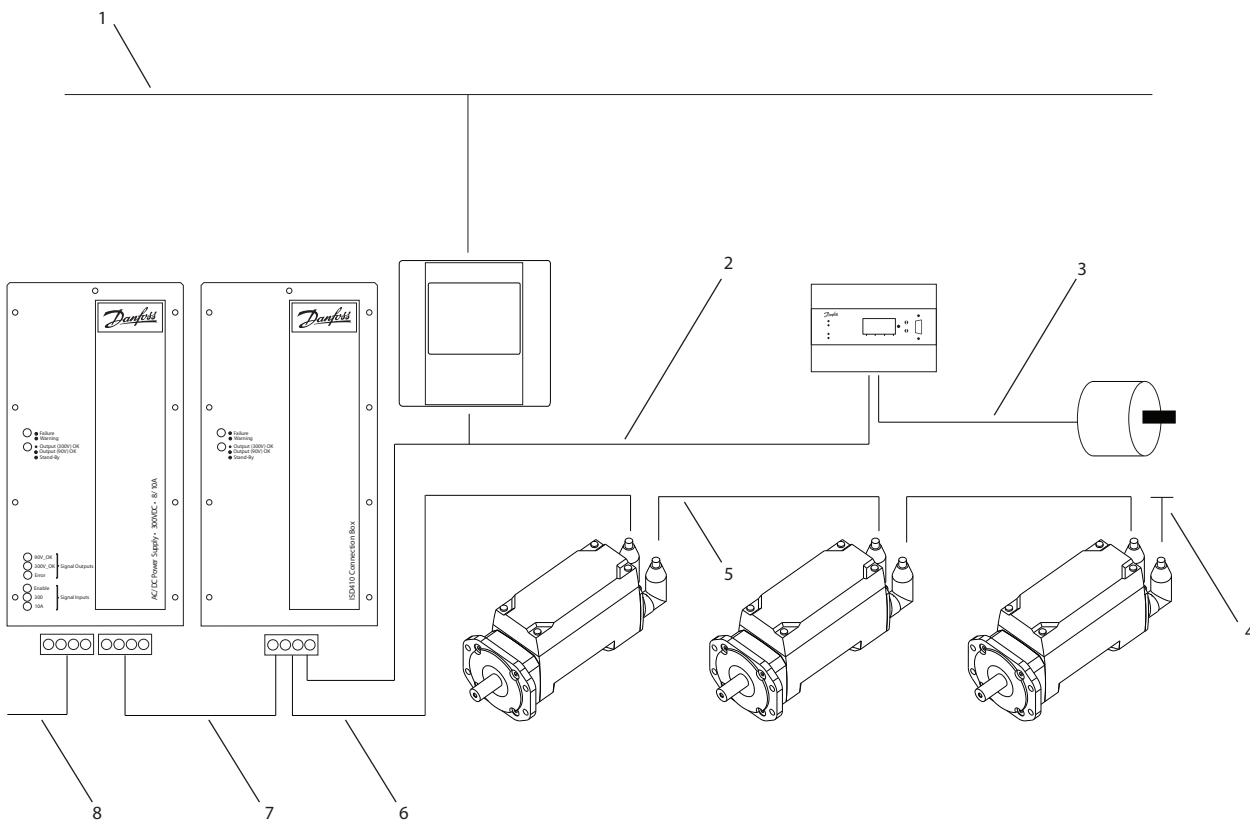

130BC481.10

Illustration 4.7 Motor Daisy-chaining (Looping)

Number	Item	Cable Type/Item	Cable Width	Flexible ?
1	Ethernet	Ethernet cable	4 x 2x 0.27mm <sup>2</sup> , shielded twisted pairs (CAT 5)	X
2	CAN line	CAN cable	4 x 0.25 mm <sup>2</sup>	-
3	Encoder line	Encoder cable	4 x 0.25 mm <sup>2</sup>	-
4	CAN terminator	Connector with terminating resistor	-	-
5	Loop cable	Hybrid cable (DC & CAN)	1 mm <sup>2</sup> /2.5 mm <sup>2</sup>	X (only with 2.5 mm <sup>2</sup> cable)
6	Feed cable	Hybrid cable (DC & CAN)	1 mm <sup>2</sup> /2.5 mm <sup>2</sup>	X (only with 2.5 mm <sup>2</sup> cable)
7	DC cable	Single wire	1.5 mm <sup>2</sup>	-
8	AC feed	Single wire	1.5 mm <sup>2</sup>	-

Table 4.5 Connection Cables

ISD Flange

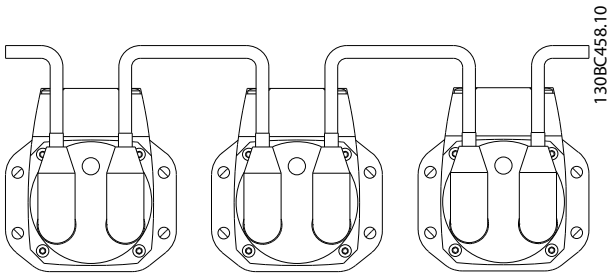

Illustration 4.8 Hybrid Cable Connection for ISD Flange

IEC Flange

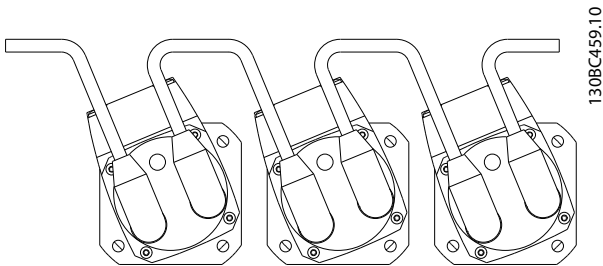

Illustration 4.9 Hybrid Cable Connection for IEC Flange

4.3.2 Hybrid Cable

The ends of the connection cables are fitted with M23 connectors. The feed cable is pigtailed at the input end to allow the individual wires to be connected to the connection box.

Cable Design

	CAN Lines	Power Cable
Rated voltage	600 V (due to enclosure in a common sheath with power wires)	600 V
Test voltage	According to standard	According to standard
Load	<500 mA	Max. 10 A continuous current
Number of wires	2 x 2 twisted pairs	4
Cross section	0.5 mm <sup>2</sup>	1/2.5 mm <sup>2</sup>
Characteristic impedance of data pair	80-200 Ω	-
Colour-coded wires	Data pair: blue/white Supply: red/black	PE: green/yellow Phase: black with printed numbers (1, 2, 3)

Table 4.6 Cable Structure

4.3.1 Layout and Routing

Observe the following instructions for cable layout and routing:

- The total length of the cables in a system may not exceed 100 m (maximum CAN bus length at 500 Kbit/s).
- The cables should generally be routed to keep the cable runs as short as possible.
- Consult Danfoss if the length of the CAN bus exceeds 100 m.

Routing in drag chains

The hybrid cable is compatible with drag chains and therefore suitable for use in moving systems. The number of bending cycles is strongly dependent on individual conditions and must therefore be determined in advance for each application.

4

Loop Cable

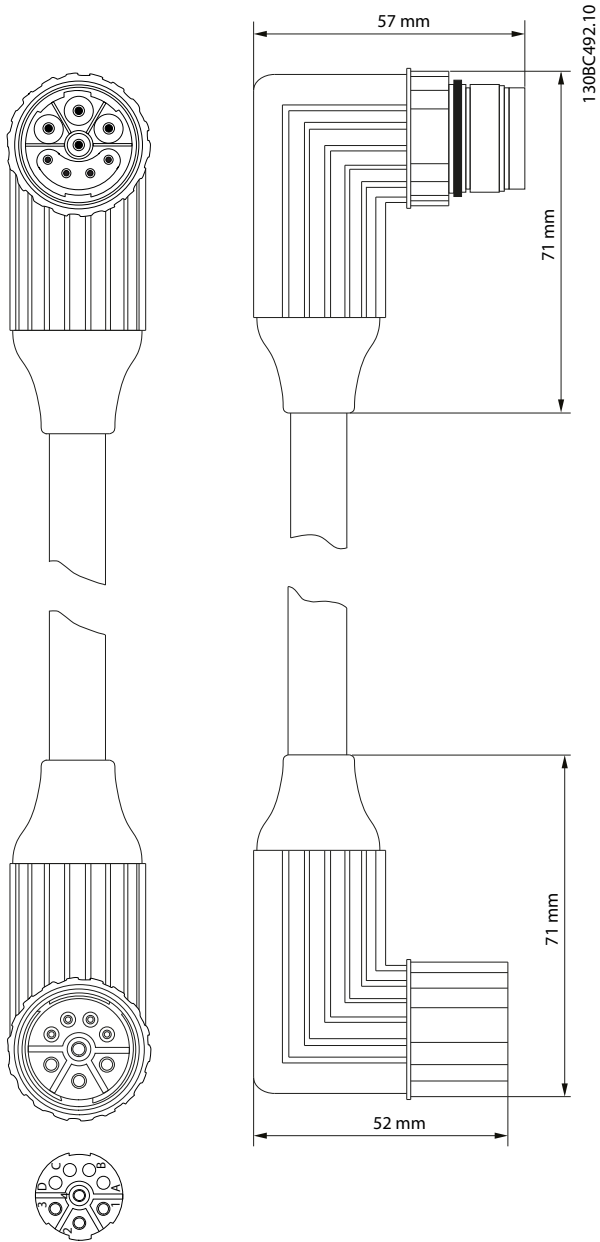

Illustration 4.10 Loop Cable

The connection cable (loop cable) is used to connect servomotors in an application.

Feed Cable

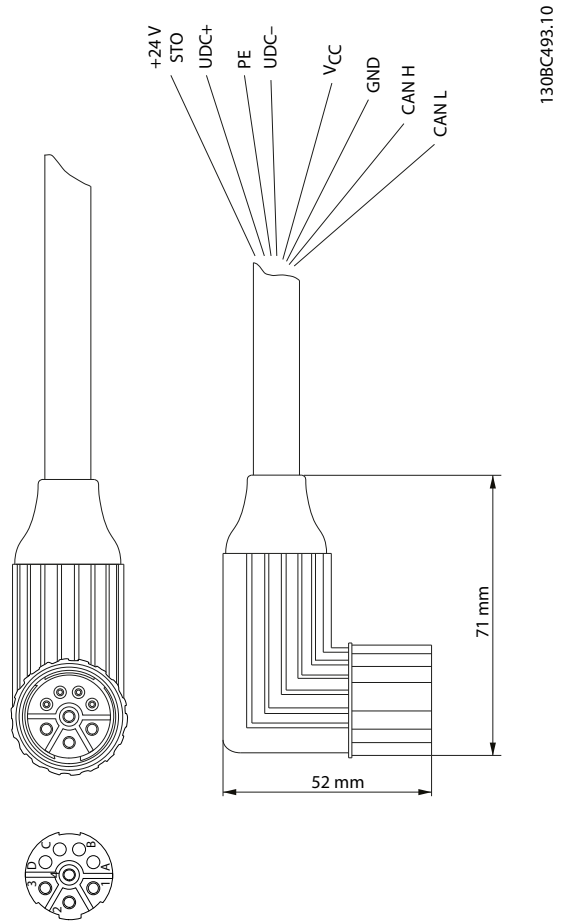

Illustration 4.11 Feed Cable

The feed cable is used to connect the first servomotor of a group to the connection point on the connection box.

Port/Connector (Female end)

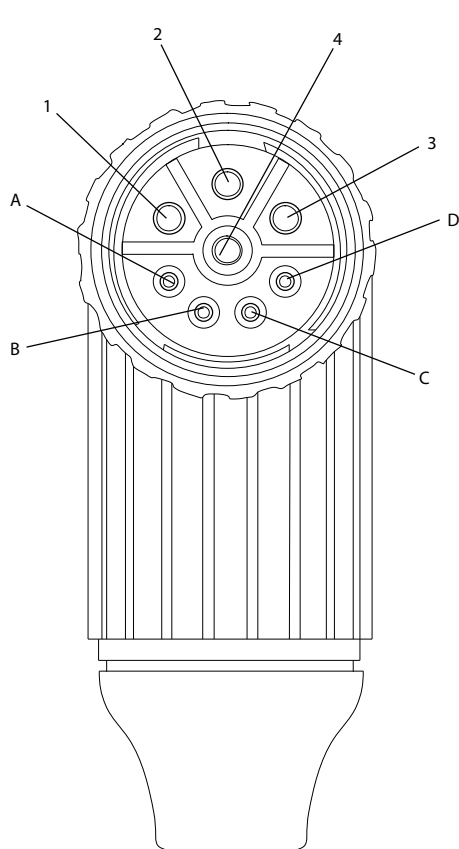

Illustration 4.12 Female Connector

Female end (output): M23, internal thread

Pin	Description	Wire Coding	Ø in mm <sup>2</sup>	Comments
Power				
1	-UDC	1 Black	1/2.5	-
2	PE	Green/Yellow		
3	+UDC	2 Black	-1	STO, referenced to -UDC
4	+24 V Safety (STO)	3 Black		
CAN				
A	CAN GND	Black	0.5	Twisted pair A
B	CAN Low	White		Twisted pair B
C	CAN High	Blue		Twisted pair B
D	CAN V <sub>CC</sub>	Red		Twisted pair A

Table 4.7 M23 Connector/Wire Assignment for Loop Cable and Feed Cable

### 4.3.3 Sensor Cable

The sensor cable is usually supplied with the sensor. Sensors and sensor cables are not included with the servomotors.

### 4.4 Ports/Connector Pin Assignment

Connection and supply voltage cabling for the servomotor is provided by the hybrid cable, which is attached to the B side of the servomotor using threaded connectors.

A sensor cable can also be connected to the B side of the servomotor.

4

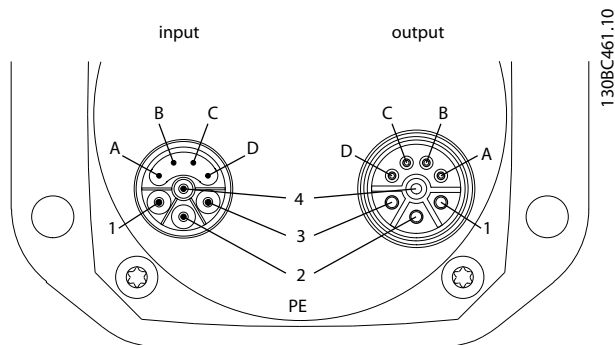

Illustration 4.14 Power and CAN Bus Ports

Pin	Signal	Function
A	CAN GND	CAN earth
B	CAN_L	CAN low
C	CAN_H	CAN high
D	CAN V <sub>cc</sub>	CAN +5 V
1	-UDC	Power earth
2	PE	PE
3	+UDC	+300 V
4	+24 V Safety (STO)	STO, referenced to -UDC

Table 4.9 Power and CAN Bus Ports

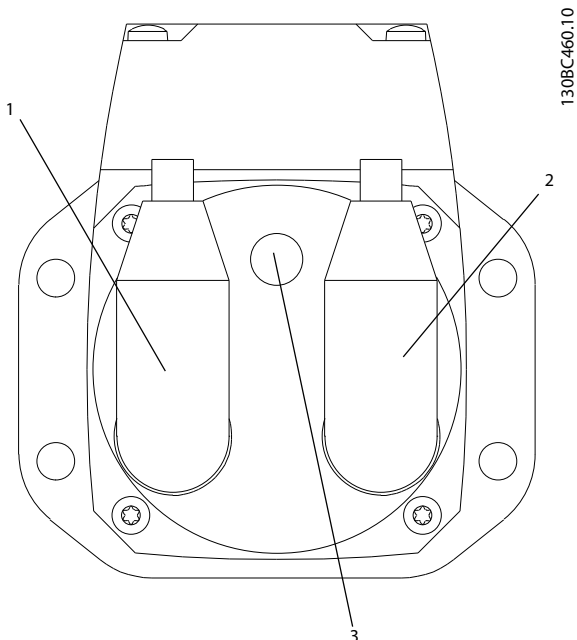

Illustration 4.13 Connectors

No.	Description	Size
1	Power and CAN bus (Input)	M23, external thread
2	Power and CAN bus (Output)	M23, internal thread
3	Sensor (Input)	M12, external thread

Table 4.8 Connectors

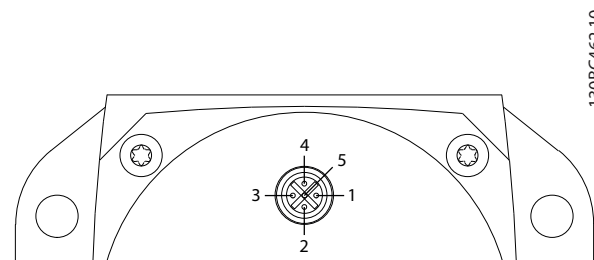

Illustration 4.15 Sensor Port

Pin	Signal	Function
1	PELV+	External sensor supply voltage (PELV)
2	Analog In	Analog input
3	PELV-GND	Earth
4	Digital In	Digital input
5	Digital Out	Digital output

Table 4.10 Sensor Port

## 5 Installation/Fitting

### 5.1 Transport and Delivery

#### 5.1.1 Scope of Delivery

The scope of delivery of the ISD 410 servomotor comprises:

- The servomotor
- These operating instructions
- An installation tool for threaded cable connectors

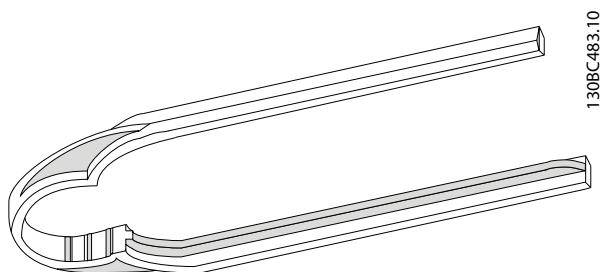

Illustration 5.1 Installation Tool for Threaded Cable Connectors

The packaging unit depends on the number of delivered servomotors. However, operating instructions and an installation tool for threaded cable connectors is supplied for each servomotor.

Save the packaging for use in the event of product return.

#### 5.1.2 Transport

The maximum weight of an individual package is approximately 7 kg. Note:

- Always use means of transport and lifting gear with sufficient load capacity to transport motors
- Avoid vibration during transport of motors
- Avoid heavy impacts and blows

#### 5.1.3 Inspection on Receipt

After receiving the delivery, immediately check whether the scope of delivery matches the shipping documents. Danfoss will not honour claims for faults registered at a later time.

Register a complaint immediately:

- with the carrier in case of visible transport damage;
- with the responsible Danfoss representative in case of visible defects or incomplete delivery.

5

### 5.2 Safety Measures during Installation

Always observe the safety instructions in 3 *Safety Instructions* during installation.

Pay particular attention to ensuring that the following points are observed carefully:

- Installation may only be performed by qualified staff.
- Installation must be performed with due care and attention.
- All safety regulations and protective measures are complied with, and the environmental conditions are observed.
- The documentation is read and understood.

### 5.3 Installation Environment

#### Environmental Conditions

The installation must provide the following environmental conditions to allow the servomotors to be operated safely and efficiently.

- The allowable operating ambient temperature range is not exceeded.
- The relative humidity is  $\leq 85\%$ , non-condensing.
- The vibration level is  $\leq 2 \text{ g}/20 \text{ m/s}^2$  without resonance excitation.
- Unrestricted ventilation is available.
- The mounting structure is suitable for the application, adequately rigid, etc.

Contact Danfoss if it is not possible to comply with these environmental conditions.

## 5.4 Preparation for Installation

The following preparations must be made to allow the servomotors to be installed reliably and effectively.

- Provide a suitable mounting arrangement. The mounting arrangement depends on the design, weight and torque of the servomotor.
- Seat the flange flush against the mounting surface before fixing the servomotor. Misalignment shortens the life of the bearing and the coupling components and reduces heat transfer from the motor.
- Always fit couplings and other transfer components in accordance with regulations.
- Provide contact protection if hot surfaces (100 °C) can be expected during operation.

## 5.5 Mechanical Installation

### 5.5.1 Installation and Space Requirements

In addition to its own dimensions, the servomotor only needs space for the hybrid cable.

The amount of space necessary for installation depends on the tool that is used.

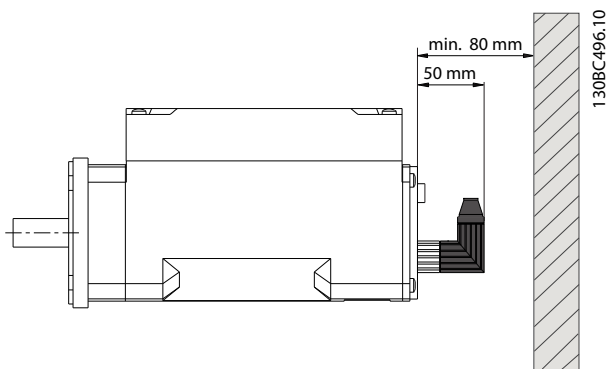

Illustration 5.2 Required Space

### 5.5.2 Installation Aids and Tools Required

For installation the tool or tools corresponding to the fixing screws is needed. The fixing screws are not included with the servomotor.

With each motor, Danfoss supplies a specially designed tool for connecting the hybrid cable. The hybrid cable connector can be tightened quickly and correctly with the aid of this tool.

### 5.5.3 Tightening Torques

See *Table 5.1* for tightening torque values for the fixing screws. Always tighten the fixing screws uniformly and crosswise.

Screw Type	Tightening Torque
M8, standard thread, strength class 8.8 or better	23-25 Nm
M8 x 1, fine thread, strength class 8.8 or better	25-27 Nm

Table 5.1 Tightening Torques

### 5.5.4 Fitting Instructions

#### Clamping

Observe the following fitting instructions to ensure reliable and effective fitting of the servomotor.

- Check the counterface of the motor mount.
  - It must have sufficient heat dispersion capacity; an unpainted surface is recommended.
- Remove the protective end cap from the shaft.
- Fix the servomotor with four screws using the four mounting holes provided for this purpose in the machine unit.
  - Always use the designated mounting holes in the mounting flange to fix the motor.
  - Do not modify the mounting holes.
  - Always use all four mounting holes. The motor may run unevenly if fewer mounting holes are used.

#### Coupling

Use a conventional clamping set to couple the motor shaft to the machine unit.

#### NOTE

**Do not machine the shaft.**  
**Do not use the servomotor if the shaft does not match the coupling arrangement.**

**General instructions**

- Align the clamping set to the axis of the servomotor
- Insert the shaft(s) in the clamping set

**NOTE**

Do not use a hammer for fitting, since this will damage the equipment.

- Screw the clamping set together

**Belt drives**

Fit the belt pulleys for the belt drive in according with the instructions in the original manufacturer's documentation for the belt drive.

If using a belt drive:

- Check the belt tension
- The radial load on the motor shaft may not exceed the maximum allowable radial force (see 12.8 Permitted Forces)

**5.6 Electrical Installation**

For the electrical connection, the relevant local and national regulations must be observed in addition to the information in these operating instructions.

**5.6.1 Electrical Environmental Conditions**

Compliance with the following electrical environmental conditions is necessary to enable safe and effective operation of the servomotor:

- Earthed 3-phase mains network, 400 V AC
- 3-phase frequency 47-53 Hz
- 3-phase lines and PE line
- Observe national statutory provisions
- Observe leakage current

**5.6.2 Connecting/Disconnecting Hybrid Cables**

**⚠ WARNING**

**HIGH VOLTAGE**

Potentially lethal voltage is present on the connectors. Before working on the power connectors (disconnecting or connecting the cable), disconnect the power supply module from the mains and wait for the discharge time to elapse.

**⚠ WARNING**

**DISCHARGE TIME**

The DC link capacitors of the servomotors remain charged for some time after the mains supply is switched off at the power supply module.

To avoid electrical shock, fully disconnect the power supply module from the mains before carrying out maintenance. The DC links of the individual ISD servomotors are connected in parallel when they are connected as a group, which increases the discharge time. Wait for at least the time listed below before carrying out maintenance work:

Number	Minimum waiting time (discharge time)
1-60 servomotors	10 minutes
Note: High voltage may be present even if the LED on the ISD connection box is not lit!	

Table 5.2 Discharge Time

**General instructions for cable installation**

Before installing the cable, note that:

- The female connector of the cable should be connected to the male connector on the servomotor
- The male connector of the cable should be connected to the female connector on the servomotor
- The feed cable is not fitted with a connector on the input end. The cable leads are connected directly to the terminals in the connection box
- Sufficient slack, especially with regard to the range of motion of the installed servomotor, must be provided for all cables
- All cables must be secured in accordance with regulations and depending on conditions on site. It must not be possible for cables to come loose, even after prolonged operation.

**CAUTION**

Never connect or disconnect the hybrid cables to or from the servomotors when the supply voltage is present. Doing so will damage the electronic circuitry. Observe the discharge time for the DC link capacitors.

**NOTE**

Do not forcefully connect or fit the connectors. Incorrect connection will cause permanent damage to the connector.



**Connecting cables**

1. Connect the female connector of the feed cable to the male connector of the first servomotor.
2. To add additional servomotors, connect the male connector of the loop cable to the female connector of the first servomotor.
3. Connect the female connector of the loop cable to the male connector of the next servomotor, and so on.
4. Screw the terminating resistor onto the female connector of the last servomotor.
5. Turn the threaded rings hand tight.
6. Check the cabling again for sufficient slack.
7. Using the Danfoss installation tool, tighten the threaded rings of the connectors.

**Disconnecting cables**

1. Loosen the threaded ring of the connector (use the 13 mm open-end spanner for this if necessary).
2. Disconnect the sensor cable from the servomotor.

**Disconnecting cables**

1. Disconnect the power supply module from its power source (mains network).
2. Wait for the necessary discharge time to elapse.
3. Loosen the connector of the feed cable from the connection box.
4. Loosen the threaded rings of the connectors. Use the Danfoss installation tool for this purpose.
5. Disconnect the hybrid cable (and the sensor cable if present) from the servomotor.

**5.6.3 Connecting/Disconnecting Sensor Cables****Cable routing**

1. Provide sufficient slack for all cables. Especially with regard to the range of motion of the installed servomotor.
2. Secure all cables in accordance with regulations and depending on conditions on site. No cable should come loose, even after prolonged operation.

**Connecting cables**

1. Connect the connectors in the right position.
2. Turn the threaded rings hand tight. Use a standard 13 mm open-end spanner for this purpose.

## 6 Commissioning

### **⚠ WARNING**

#### UNINTENDED START

A servomotor that is connected to the electrical supply network can start running at any time. This may be caused by an external switch, a CAN bus command, a reference signal, or clearing an error condition. Servomotors and all connected devices must be in good operating condition. A deficient operating condition may lead to death, serious injury, damage to equipment or other material damage when the device is connected to the electrical supply network. Take suitable measures to prevent unintended starts.

### 6.1 Switching on the Servomotors

The components of the servo system must be cabled before power is applied to the servomotors. This cabling provides the supply voltage as well as the communication signals for the system. This is a fundamental requirement for operation of the servomotors.

Carefully read the *VLT® ISD 410 Design Guide, MG75I* and the operating instructions for the other ISD components for detailed information.

The information listed below is solely intended as a brief summary.

### 6.2 Connecting the Components

1. Connect the mains supply line to the power supply module and the control terminal strip of the power supply module in accordance with the wiring diagram in the *VLT® ISD 410 Design Guide, MG75I*.
2. Connect the DC supply from the power supply module to the connection box and activate the safety circuit.
3. Connect the feed cable from the connection box to the first servomotor by connecting the cable leads on the connection box and the servomotor using the threaded connectors.
4. Using the loop cables intended for this purpose, connect the other servomotors in the group.
5. Fit a CAN terminating resistor on the last servomotor.
6. Connect the CAN bus to the connection box.
7. Connect the encoder box (if present) to the CAN network.

### 6.3 Functional Operation Test (before initial power-up or operation)

Always check the following items before initial commissioning, before commencing operation after extended downtime, or before commencing operation after motor overhaul:

- Are all threaded connectors of mechanical and electrical components firmly tightened?
- Is the free circulation of cooling air (inlet and outlet) assured?
- Are the devices for protection against overheating (temperature sensor monitoring) operational?
- Are the electrical connections OK?
- Is contact protection in place for rotating parts and surfaces that can become hot?

### NOTE

**The power-off brake may not be misused as a working brake!**

### 6.4 Parameter Configuration

The servomotors are controlled via the CAN interface.

The master software for this purpose is the CoDeSys development system from 3S-Smart Software Solutions GmbH.

Parameter setting can also be carried out via the ISD Toolbox software.

See the *VLT® ISD 410 Design Guide, MG75I* for additional information.

### 6.5 Test Run

After connecting the servomotors, always perform a test run and ensure that the rotation directions have been programmed properly.

## 7 Operation

### 7.1 Operating Modes

The servomotor can be operated in several modes. The options described here are based on the use of a master running under CoDeSys.

It is also possible to operate the servo system under CANopen DS301 or with the aid of CANopen DS402. Consult Danfoss for the latter 2 options.

The various operating modes are described in more detail below.

#### 7.1.1 ISD Inertia Measurement Mode

This mode measures the inertia of an axis. It is used to measure the inertia of the servomotor and the external load, and is needed to optimise the control loop settings. The friction effects are eliminated automatically.

#### 7.1.2 Speed Mode

In speed mode the servomotors are operated exclusively under speed control. For this, the acceleration, maximum speed and delay before motion are specified via the software.

#### 7.1.3 ISD Curve Mode

ISD curve mode is an extended cam profile mode developed by Danfoss that allows several axes to track a machine parameter along a precisely predefined curved path with high accuracy and variable speed.

ISD curve mode functionality is stored in the component library under CoDeSys.

For more information, see the component library documentation and the operating instructions for the Curve Editor.

### 7.2 Operating Status Indicators

The operating status of the ISD servomotors can be displayed using the ISD Toolbox software or CoDeSys.

In addition to the status indication on the connection box, the ISD Toolbox software can be used to query the status of the servomotors. This requires using a laptop computer to establish a connection to the CAN bus network. For this

a CAN dongle is needed, which provides the physical connection between the CAN bus network and the servomotors.

Use the ISD Toolbox software to display individual servomotors directly in order to obtain information about them.

Another option is to use CoDeSys on the master controller to read out parameters related to the servomotors. For information about this, read the description of CoDeSys programming.

## 8 ISD Safety Concept

### NOTE

It is the responsibility of the user to install and use the safe stop function correctly. Observe the following:

- Read and understand the safety regulations regarding occupational health and safety.
- Ensure that the basic and special provisions regarding the safety functions in the descriptions in this and more detailed documents are understood
- A sufficiently familiarity with general and safety-related standards relevant to the specific application is required
- Carry out a hazard and risk analysis
- Demonstrate the safety of the overall system

Read and understand the detailed safety instructions in *3 Safety Instructions*.

Only PELV power supply units may be used.

Safety circuitry must always be wired and operated using conductors and original accessories intended for this purpose. Only original Danfoss cables may be used for cabling between the drives and between the connection box and a drive. Using any other cable will defeat the safe stop function as described in the standards listed below.

The safe stop function of the servo drive is used for synchronous ISD motors. In the event of several concurrent faults, in very rare cases a residual rotation of 22.5° may occur. It must be ensured that this residual rotation cannot create a hazard.

Pulsed semiconductor outputs may not be used with safety devices. The safe stop function can be used when it is necessary to perform mechanical work on the machine. This function does not provide electrical safety in the sense of the VDE regulations. The supply voltage of the drives is not disconnected by this function.

The machine manufacturer is responsible for taking additional safety measures. The holding torques of the servo drive and the optional brake do not constitute safety functions. If hazards are present, additional measures must be taken, such as protective fences, barriers and exclusion of persons from hazard areas.

### **⚠ WARNING**

#### UNCONTROLLED SERVMOTOR COASTING

Uncontrolled coasting of the servo drive occurs when Category 0 Stop (Safe Torque Off) is used. This depends on the inertia of the external mass driven by the motor. Additional measures must be taken if this is not permissible following a risk analysis. See also the example circuit in *8.6 Application Examples*.

### 8.1 Standards

If the safe stop function accessed via pin 4 of the drive is used, the user must ensure compliance with all regulations and prerequisites for safety, including applicable statutes, standards, directives and guidelines. The safe stop function conforms to the following standards:

- EN 60204-1: 2005 Stop Category 0
- IEC 61508: 1998 SIL 2
- IEC 61800-5-2: 2007 Safe Torque Off (STO) function
- IEC 62061: 2005 SIL CL2
- ISO 13849-1: 2006 Category 3 PL d
- ISO 14118: 2000 (EN 1037) – Prevention of unexpected start

To install and use the safe stop function in accordance with the requirements of Safety Category 3 PL d (ISO 13849-1), the related information and instructions on the proper and safe use of the safe stop function in the connection box operating instructions must be followed.

### 8.2 Functional Description

The ISD 410 servo drive is equipped with the Safe Torque Off function under EN IEC 61800-5-2 and Stop Category 0 under EN 60204-1. Danfoss calls this function "Safe Stop".

It has been developed and tested as suitable for requirements conforming to:

- Category 3 under EN ISO 13849-1
- Performance Level d under EN ISO 13849-1
- SIL 2 under EN IEC 61508 and EN 61800-5-2
- SIL CL 2 under EN 62061

### 8.3 Activating/Deactivating the Safe Stop Function

The safe stop function is activated by removing the 24 V DC voltage from pin 4 (safety) of the servo drive. This causes the internal inverter to be blocked in accordance with the requirements of Category 3. Safe stop can be used to prevent an unexpected start. This means that the 24 V DC voltage must be re-applied to pin 4 of the servo drive to end the safe stop and resume normal operation. After this the drive must be restarted via the CAN bus.

#### NOTE

Servo drives with part numbers 175G7825 and 175G7826 are not suitable for the safe stop function.

#### **⚠ WARNING**

##### RISK ANALYSIS REQUIRED

Before installing and using the safe stop function, a thorough risk analysis of the installation must be carried out in order to ensure that the safe stop function and the safety level achieved are sufficient and suitable. A commissioning test must be performed after the safe stop function is installed. Successful completion of an acceptance test is obligatory for compliance with Category 3 PL under EN ISO 13849-1. The test is described in 8.5 Acceptance Test.

The following technical data applies to the various safety levels:

- Typical response time: 1.14 s
- Maximum response time: 2.14 s The response time is the elapsed time between removal of the 24 V DC voltage and switching off the gate driver of the bridge inverter.

Data for EN ISO 13849-1

- Performance level "d"
- Mean time to dangerous failure (MTTFD): > 62 years
- Diagnostic coverage (DC): 60%
- Category 3
- Lifetime 20 years

Data for EN IEC 62061, EN IEC 61508, EN IEC 61800-5-2

- SIL 2 suitability, SILCL 2:
- Probability of dangerous failure per hour (PFH):  $4.0625 \times 10^{-8}/h$
- Safe Failure Fraction (SFF) >90%
- Hardware fault tolerance (HFT): 1 [0] (1002 [1001D] architecture)

Abbreviation	Reference	Description
Cat.	EN ISO 13849-1	Category 1-4
FIT	–	Failure in Time; failure rate: 1E-9 hours
HFT	IEC 61508	Hardware Fault Tolerance; HFT = n means that n + 1 faults may lead to a loss of the safety function
MTTFd	EN ISO 13849-1	Mean Time to dangerous Failure; Mean time to a dangerous failure: (number of units)/(number of undetected dangerous faults) during the measuring interval under the stated conditions
PFH	IEC 61508	Probability of dangerous failures per hour: This value must be taken into account when the safety device is operated in high demand mode (more than once per year) or in continuous demand mode, with the demand on the safety-related system occurring more than once per year.
PL	EN ISO 13849-1	Performance level; a discrete level used to specify the capability of safety-related parts of a system to perform safety-oriented functions under given conditions. Levels: a-e
SFF	IEC 61508	Safe Failure Fraction [%]; proportion of safe failures and detected dangerous failures of a safety function or a subsystem as a percentage of all possible failures
SIL	EN 61800-5-2	Safety Integrity Level
STO	EN61800-5-2	Safe Torque Off

Table 8.1 Abbreviations

### 8.4 Installation

The safe stop function is available in the servo drive via pin 4 of the M23 connector on the drive.

The safe stop function turns off the supply voltage to the semiconductor switches in the output power stage of the drive. This prevents the generation of a voltage that causes the motor to turn.

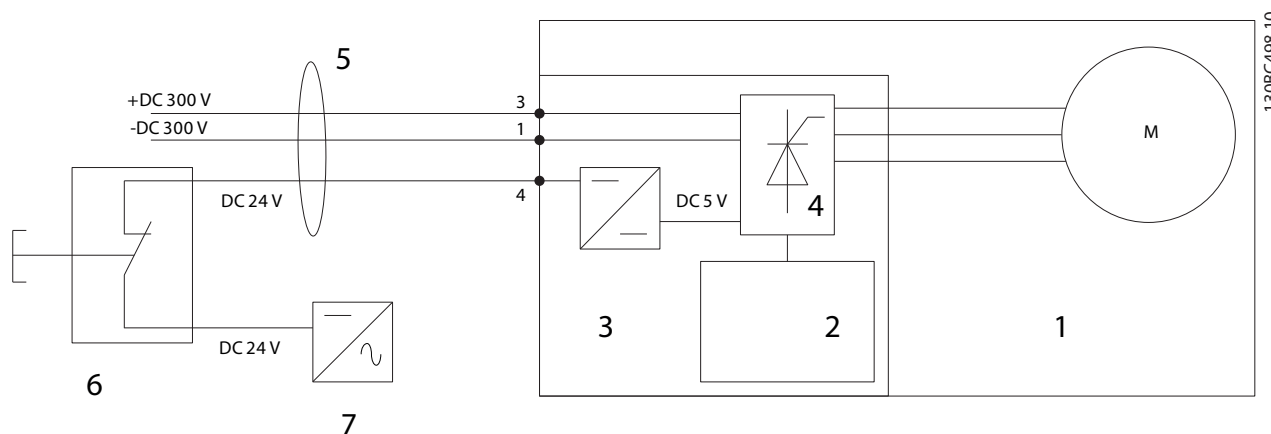

**Illustration 8.1 Essential Functional Modules and Installation Aspects for Achieving Stop Category 0 (EN 60204-1) with category 3 PL (EN ISO 13849-1)**



1	ISD 410 servo drive
2	Control PCB
3	Inverter
4	Output stage
5	Hybrid cable (short-circuit proof)
6	Cat. 3 safety device
7	24 V DC power supply

**Table 8.2 Legend to Illustration 8.1**

When the safe stop function is activated, the drive generates an error message that is sent over the CAN bus as message FF80. The motor coasts to a stop and must be restarted manually.

The safe stop function can be used to stop the servo drive in a hazardous situation. The standard methods for stopping the drive should be used in normal operation situations.

Possible implementation options can be found in *8.6 Application Examples*.

## 8.5 Acceptance Test

### **⚠ WARNING**

#### **COMMISSIONING TEST REQUIRED**

A commissioning test must be performed after installation of the safe stop function and after every change to the installed function. Successful completion of an acceptance test is obligatory for compliance with Category 3 PL d (EN ISO 13849-1).

1. Use the external safety device to disconnect the 24 V DC supply voltage from the STO terminal while the servomotor is being driven (i.e. the mains supply remains intact). The test step is passed if the motor responds by coasting and the power-off brake (if present) is applied. The drive sends the emergency message over the CAN bus.
2. Send a Reset message over the CAN bus to the servo drive and restart the servo drive. The test step is passed if the servomotor remains in safe stop and the holding brake (if present) remains applied. The servo drive sends the emergency message again.
3. Reapply 24 V DC to the STO terminal. The test step is passed if the servomotor remains in coast mode and the holding brake (if present) remains applied.
4. Send a Reset message over the CAN bus to the servo drive and restart the servo drive. The test step is passed if the servomotor starts up again.

The acceptance test is passed if all 4 test steps have been completed successfully.

### 8.6 Application Examples

The figure shows an example of an installation for 2 lines, which can be put in safe stop mode by separate safety circuits. The safety switch devices must be selected by the user in accordance with the requirements.

The figure shows a layout with separate safety circuits for lines 1 and 2. The safety circuits may be remote from each

other. Note that the 2 lines in the example are controlled separately. If the safe stop function is triggered on line 1, line 2 remains in normal operation. The servomotors on this line are not affected. There may still be a hazard from the servomotors on line 2.

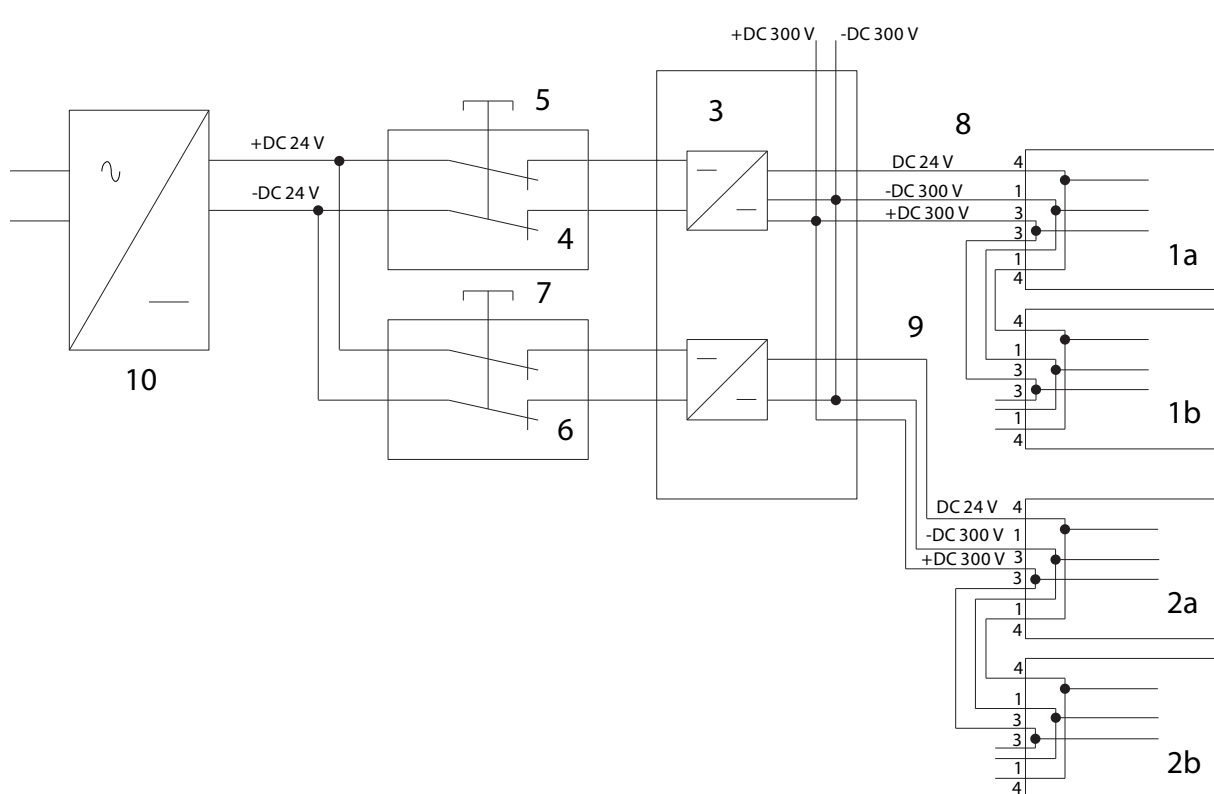

Illustration 8.2 Application Example: Safe Stop Function with 2 Lines

1a/1b	ISD 410 servo drive on line 1
2a/2b	ISD 410 servo drive on line 2
3	Connection box
4	Safety device on line 1
5	Line 1 emergency stop button
6	Safety device on line 2
7	Line 2 emergency stop button
8	Line 1 hybrid cable (short-circuit proof)
9	Line 2 hybrid cable (short-circuit proof)
10	24 V DC power supply

Table 8.3 Legend to Illustration 8.2



## 9 Faults

If faults occur during servo system operation, they are indicated on the front panel of the connection box. See the connection box operating instructions for information on error message codes.

First use *Table 9.1* to check the possible causes of the fault.

### NOTE

**If the fault cannot be eliminated by one of the measures listed, notify Danfoss Service.**

Have the following information available to enable Danfoss to provide help quickly and effectively:

- Type number
- Error message number
- Firmware version

## 9

### 9.1 Troubleshooting

When problems occur in the servo system, they must first be located and properly identified. *Table 9.1* lists potential faults in the servomotor, their possible causes, and actions for correcting the faults.

Fault	Possible Cause	Possible Solution
Motor overheats (high surface temperature)	Excessive load	Check torques
Motor not running	No drive	Check CAN connection
Motor does not run or only starts up slowly or with difficulty	Bearing wear	Check bearings and shaft
Motor hums and draws high current	Motor defective	Contact Danfoss
Motor stops suddenly and does not restart	No drive	Check CAN connection
Wrong motor rotation direction	Parameter error	<ul style="list-style-type: none"> <li>• Check software</li> <li>• Change rotation direction if appropriate</li> </ul>
Motor runs normally, but does not generate the expected torque	Motor defective or parameter error	Contact Danfoss
Motor runs in an uncontrolled manner in one direction at maximum speed	Incorrect setpoints	Check software

Fault	Possible Cause	Possible Solution
Motor runs slowly in one direction, but cannot be controlled by the master	Software error	Check software
Motor screaming	Incorrect calibration or faulty current measurement	Contact Danfoss
Uneven running	Defective bearing	Check shaft
Vibration	Defective bearing	Check shaft
(Unusual) running noises	Defective bearing	Check shaft
Fuses blow, circuit breaker trips or motor protection trips immediately	Short circuit	Contact Danfoss
Motor speed drops sharply under load	At current limit	Check application
Brake does not release	Brake control defective	Contact Danfoss
Holding brake does not hold the servomotor	Mechanical brake defective	Contact Danfoss
Brake engagement delayed	Software error	Contact Danfoss
Noises when power-off brake engaged	Mechanical brake damaged	Contact Danfoss

**Table 9.1 Troubleshooting Overview**

## 10 Maintenance and Repair

### 10.1 Maintenance tasks

The servomotors are largely maintenance free. Only the bearings and the shaft seals are subject to wear.

The maintenance tasks listed in the following table may be performed by the customer. No other tasks are required.

Send the servomotor to Danfoss if it needs to be (fully) overhauled.

Component	Maintenance Task	Maintenance Interval	Instruction
Servomotor	Clean	Regularly or as necessary	Clean the surface with a dry cloth
Bearings	Check for bearing noise	As part of regular operational inspection	Order a new ISD servomotor when the forward motion limit is reached
Shaft seal	Replace shaft seal	Every 2 years	Always replace
Hybrid cable	Check for damage and wear	Every 6 months	If damaged or worn: replace hybrid cable (see chapter 10.3.1 <i>Cable Replacement</i> )
Brake (option)	Danfoss Service	Number of allowed emergency stops exceeded	Inform Danfoss

Table 10.1 Overview of Maintenance Tasks

#### 10.1.1 Replacing the Shaft Seal

#### NOTE

Use only manufacturer spare parts. Danfoss accepts no responsibility for any damage resulting from the use of parts not approved by Danfoss.

The spare parts kit (shaft seal, grease and service instructions) can be ordered under part number 175G7706. A special tool is necessary for fitting the seal. It can be ordered under part number 175G7707 with the first order.

### 10.2 Inspection during Operation

Carry out regular inspections during operation. Check the servomotors at regular intervals for anything unusual.

Pay particular attention to:

- Unusual noises
- Overheated surfaces (temperatures up to 100 °C may occur in normal operation)
- Uneven running
- Strong vibrations
- Loose fastenings
- Condition of electrical wiring and cables
- Poor heat dispersion

In the event of irregularities or problems, see 9.1 *Troubleshooting*.

### 10.3 Repair

#### NOTE

Always return defective servomotors to Danfoss

The repair tasks listed below may be performed by the customer.

#### **⚠ WARNING**

##### HIGH VOLTAGE

Potentially lethal voltage is present on the connectors. Before working on the power connectors (disconnecting or connecting the cable), disconnect the power supply module from the mains and wait for the discharge time to elapse.

## ⚠ WARNING

### DISCHARGE TIME!

The DC link capacitors of the servomotors remain charged for some time after the mains supply is switched off at the power supply module.

To avoid electrical shock, fully disconnect the power supply module from the mains before carrying out maintenance. The DC links of the individual ISD servomotors are connected in parallel when they are connected as a group, which increases the discharge time. Wait for at least the time listed below before carrying out maintenance work:

Number	Minimum waiting time (discharge time)
1-60 servomotors	10 minutes
Note: High voltage may be present even if the LED on the ISD connection box is not lit!	

Table 10.2 Discharge Time

### 10.3.1 Cable Replacement

Hybrid cable replacement is necessary when the rated number of bending cycles has been reached or the cable is damaged. You may replace the cable yourself. Danfoss supplies an installation tool for this purpose with the servomotor.

## CAUTION

Never disconnect or connect the cable from the servomotor with the supply voltage connected. Doing so will damage the electronic circuitry. Observe the discharge time for the DC link capacitors.

## CAUTION

Do not forcefully connect or fit the connectors. Incorrect connection will cause permanent damage to the connector.

### 10.3.1.1 Feed Cable Replacement

Proceed as follows:

#### Disconnecting cables

1. Disconnect the power supply module from its power source (mains network).
2. Wait for the necessary discharge time to elapse.
3. Loosen the feed cable connector on the connection box.
4. Loosen the threaded ring of the connector on the servomotor. Use the Danfoss installation tool for this purpose.
5. Disconnect the feed cable (and the sensor cable if present) from the servomotor.

#### Cable replacement

Replace the feed cable with a cable of identical type and length (see the *VLT® ISD 410 Design Guide, MG75I* for part numbers).

#### Connecting cables

1. Connect the female connector of the feed cable to the male connector of the first servomotor.
2. Turn the threaded rings hand tight.
3. Check the cabling again for sufficient slack.
4. Using the Danfoss installation tool, tighten the threaded rings of the connectors.

### 10.3.1.2 Loop Cable Replacement

Proceed as follows:

#### Disconnecting cables

1. Disconnect the power supply module from its power source (mains network).
2. Wait for the necessary discharge time to elapse.
3. Loosen the loop cable connector on the servomotor.
4. Loosen the threaded rings of the connectors. Use the Danfoss installation tool for this purpose.
5. Disconnect the loop cable (and the sensor cable if present) from the servomotor.

#### Cable replacement

Replace the loop cable with a cable of identical type and length (see the *VLT® ISD 410 Design Guide, MG75I* for part numbers).

#### Connecting cables

1. Connect the male connector of the loop cable to the female connector on the servomotor.
2. Connect the female connector of the loop cable to the male connector on the adjacent servomotor.
3. Turn the threaded rings hand tight.
4. Check the cabling again for sufficient slack.
5. Using the Danfoss installation tool, tighten the threaded rings of the connectors.

## 10.4 Servomotor Replacement

### 10.4.1 Dismounting

The procedure for dismantling the servomotor is the reverse of the fitting procedure described in chapter *5 Installation/Fitting*.

Proceed as follows:

1. Disconnect the power supply and wait for the discharge time to elapse.
2. Disconnect the electrical cables.
3. Dismount the servomotor.
4. Replace the ISD 410 servomotor with an ISD 410 servomotor of the same type (see the *VLT® ISD 410 Design Guide, MG75I* for part numbers).

### 10.4.2 Fitting and Commissioning

The procedure for fitting and commissioning the servomotor is described in *5 Installation/Fitting* and *6 Commissioning*.

Proceed as follows:

1. Fit the servomotor.
2. Connect the electrical cables.
3. Switch on power supply.
4. Configure the servomotor parameters.
5. Conduct a test run.

## 11 Decommissioning and Disposal

### **⚠ WARNING**

#### HIGH VOLTAGE

Potentially lethal voltage is present on the connectors. Before working on the power connectors (disconnecting or connecting the cable), disconnect the power supply module from the mains and wait for the discharge time to elapse.

### **⚠ WARNING**

#### DISCHARGE TIME

The DC link capacitors of the servomotors remain charged for some time after the mains supply is switched off at the power supply module.

To avoid electrical shock, fully disconnect the power supply module from the mains before carrying out maintenance. The DC links of the individual servomotors are connected in parallel when they are connected as a group, which increases the discharge time. Wait for at least the time listed below before carrying out maintenance work:

Number	Minimum waiting time (discharge time)
1-60 servomotors	10 minutes
Note: High voltage may be present even if the LED on the ISD connection box is not lit!	

Table 11.1 Discharge Time

### 11.1 Decommissioning

The procedure for decommissioning the servomotor is the reverse of the installation procedure described in *5 Installation/Fitting*.

Proceed as follows:

1. Disconnect power supply and wait for the discharge time to elapse.
2. Disconnect the electrical cables.

### 11.2 Dismounting

The procedure for dismounting the servomotor is the reverse of the fitting procedure described in *5 Installation/Fitting*.

Proceed as follows:

1. Disconnect power supply and wait for the discharge time to elapse.
2. Disconnect the electrical cables.
3. Dismount the servomotor.

### 11.3 Product Returns

Products we manufactured can be returned to us for disposal at no charge. A prerequisite for this is that they are free of deposits, such as oil, grease or other types of contamination, that hamper disposal.

Furthermore, no unsuitable foreign materials or third-party components may be included with the returned product.

Ship the products FOB to the following address:

Danfoss GmbH  
 Werner-von-Siemens-Strasse 9  
 76646 Bruchsal,  
 Germany

## 11.4 Recycling and Disposal

### 11.4.1 Recycling

Take metals and plastics to recycling stations.

The entire servomotor is classified as electronic waste, and the packaging is classified as packaging waste.

### 11.4.2 Disposal

Devices containing electronic components may not be disposed of as normal domestic waste.

Dispose of servomotors as hazardous waste, electrical waste, recyclable waste, etc. in accordance with applicable local regulations.

## 12 Specifications

### 12.1 Nameplate

Check the nameplate and compare it with the order data. Use the part number for reference.

The part number uniquely identifies the drive type.

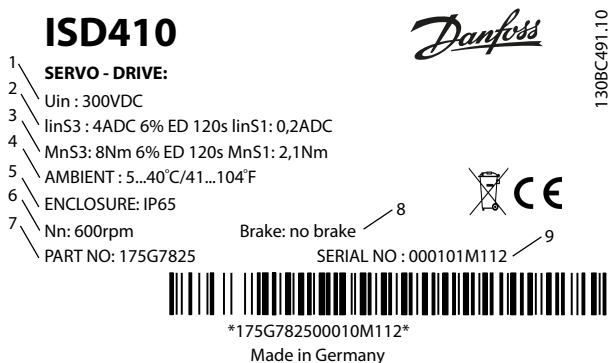

Illustration 12.1 Nameplate

The following data is shown on the nameplate of the ISD motor:

1	Supply voltage	6	Rated speed
2	Current details	7	Part number
3	Power rating	8	Brake option
4	Ambient temperature range	9	Serial number
5	Protection rating	10	

Table 12.1 Legend to Illustration 12.1

Check that the nameplate is clearly legible.

The servomotors can be identified externally only by the original Danfoss nameplate.

### 12.2 Storage

Store the servomotors in a dry, dust-free location with low vibration ( $v_{eff} \leq 0.2$  mm/s).

The storage location must be free from corrosive gases.

Avoid sudden temperature changes.

#### 12.2.1 Long-term Storage

##### NOTE

To recondition the electrolytic capacitors, servomotors not in service must be connected to a supply voltage source once per year to allow the capacitors to charge and discharge, as otherwise the capacitors will suffer permanent damage.

### 12.3 Characteristic Data

#### NOTE

Motors are available with different active components (magnetic packages): Package lengths 50 mm and 70 mm.

#### 12.3.1 Servomotor without Brake

Specifications	Unit	ISD 410											
		01	02	09	10	17	18	05	06	13	14	21	22
Part number 175G78xx		X		X		X		X		X		X	
ISD flange		X		X		X		X		X		X	
IEC flange			X		X		X		X		X		X
Resolver		X	X					X	X				
Single-turn encoder				X	X					X	X		
Multi-turn encoder						X	X					X	X
Power-off brake	Nm	–						–					
Motor package	mm	50						70					
Rated voltage	V <sub>DC</sub>	300						300					
Locked-rotor torque <sup>(1)</sup>	Nm	2.3						2.1					
Rated torque <sup>(1)</sup>	Nm	2.1						1.8					
Peak torque	Nm	8						11					
Locked-rotor current	A DC	0.25						0.3					
Rated current	A DC	0.6						1.1					
Peak current	A DC	3.95						7					
Rated speed	RPM	600						1000					
Max. speed	RPM	1000						1500					
Rated power	W	180						330					
Pole pairs	p	8						8					
Torque coefficient	Nm/A	1.9						1.25					
Voltage coefficient	V/1000 RPM	130						85					
Moment of inertia	kgm <sup>2</sup>	3.5 · 10 <sup>-4</sup>						5.1 · 10 <sup>-4</sup>					
Vibration class		3M7						3M7					
Weight	kg	5.4						6					
Shaft diameter	mm	19						19					
Maximum radial force	N	1200						1200					
Protection type <sup>(2)</sup>		IP54/IP65						IP54/IP65					

**Table 12.2 Characteristic Data for Servomotor without Brake**

(1) Reference conditions: black painted aluminium test flange with dimensions 250 x 250 x 10 mm, max. ambient temperature 40 °C, convection cooling

(2) IP65 not applicable for motors installed with the shaft facing upward



**12.3.2 Servomotor with Brake**

Specifications	Unit	ISD 410											
		03	04	11	12	19	20	07	08	15	16	23	24
<b>Part number 175G78xx</b>													
ISD flange		X		X		X		X		X		X	
IEC flange			X		X		X		X		X		X
Resolver		X	X					X	X				
Single-turn encoder				X	X					X	X		
Multi-turn encoder						X	X					X	X
Power-off brake	Nm	9						9–					
Motor package	mm	50						70					
Rated voltage	V <sub>DC</sub>	300						300					
Locked-rotor torque <sup>(1)</sup>	Nm	2.2						2.0					
Rated torque <sup>(1)</sup>	Nm	2.0						1.7					
Peak torque	Nm	8						11					
Locked-rotor current	A DC	0.3						0.35					
Rated current	A DC	0.65						1.15					
Peak current	A DC	4.0						7.05					
Rated speed	RPM	600						1000					
Max. speed	RPM	1000						1500					
Rated power	W	195						345					
Pole pairs	p	8						8					
Torque coefficient	Nm/A	1.9						1.25					
Voltage coefficient	V/1000 RPM	130						85					
Moment of inertia	kgm <sup>2</sup>	4.2 · 10 <sup>-4</sup>						6.5 · 10 <sup>-4</sup>					
Vibration class		3M7						3M7					
Weight	kg	6.2						6.8					
Shaft diameter	mm	19						19					
Maximum radial force	N	1200						1200					
Protection type <sup>(2)</sup>		IP54/IP65						IP54/IP65					

**12**
**Table 12.3 Characteristic Data for Servomotor with Brake**

(1) Reference conditions: black painted aluminium test flange with dimensions 250 x 250 x 10 mm, max.ambient temperature 40 °C, convection cooling

(2) IP65 not applicable for motors installed with the shaft facing upward

12.4 Dimensions

12.4.1 Servomotor with ISD Flange, without Brake

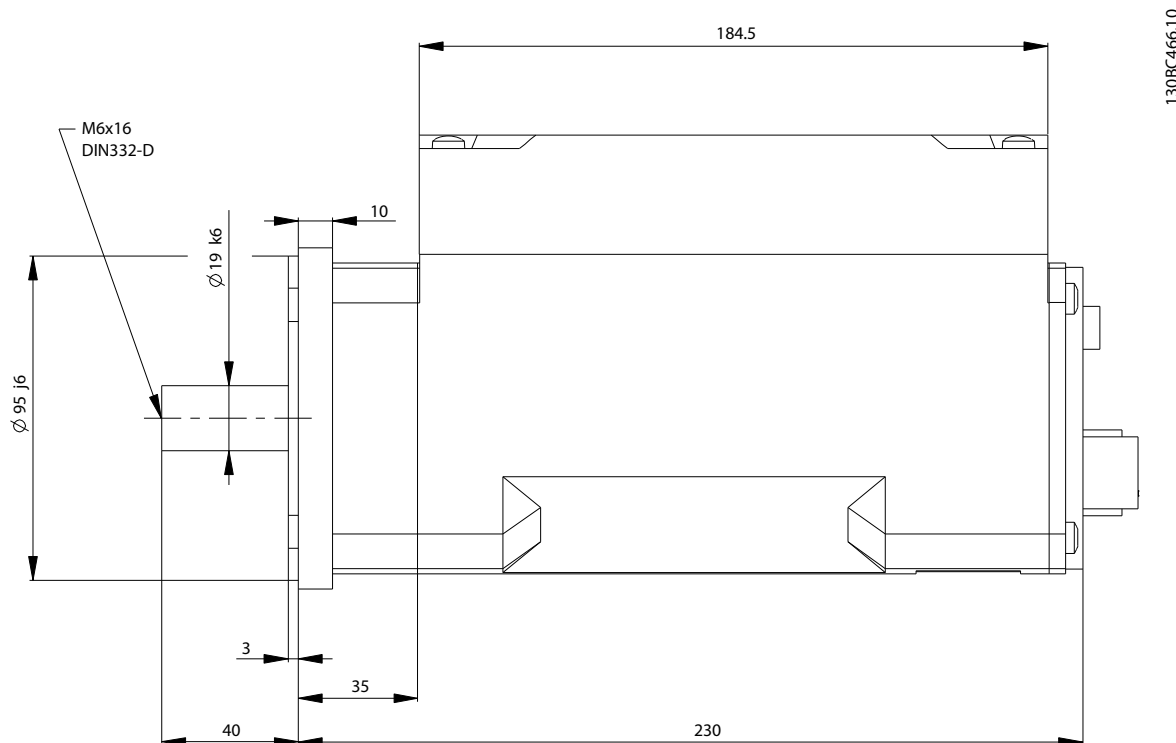

Illustration 12.2 Side View: Servomotor with ISD Flange, without Brake

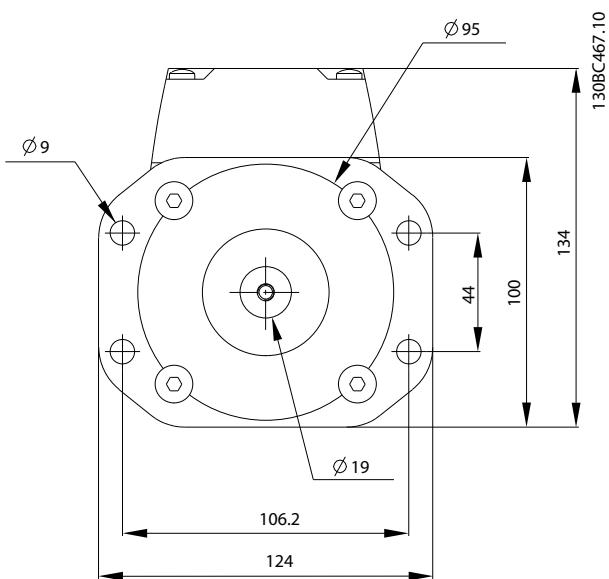

Illustration 12.3 Front View: Servomotor with ISD Flange, without Brake

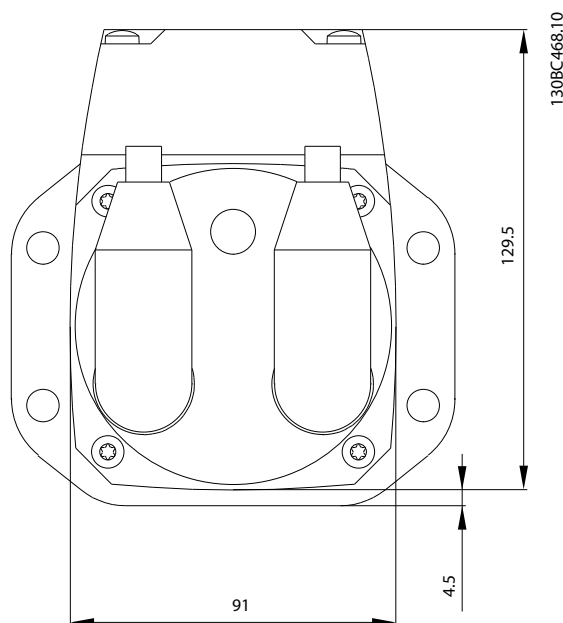

Illustration 12.4 Rear View: Servomotor with ISD Flange, without Brake

12.4.2 Servomotor with ISD Flange and Brake

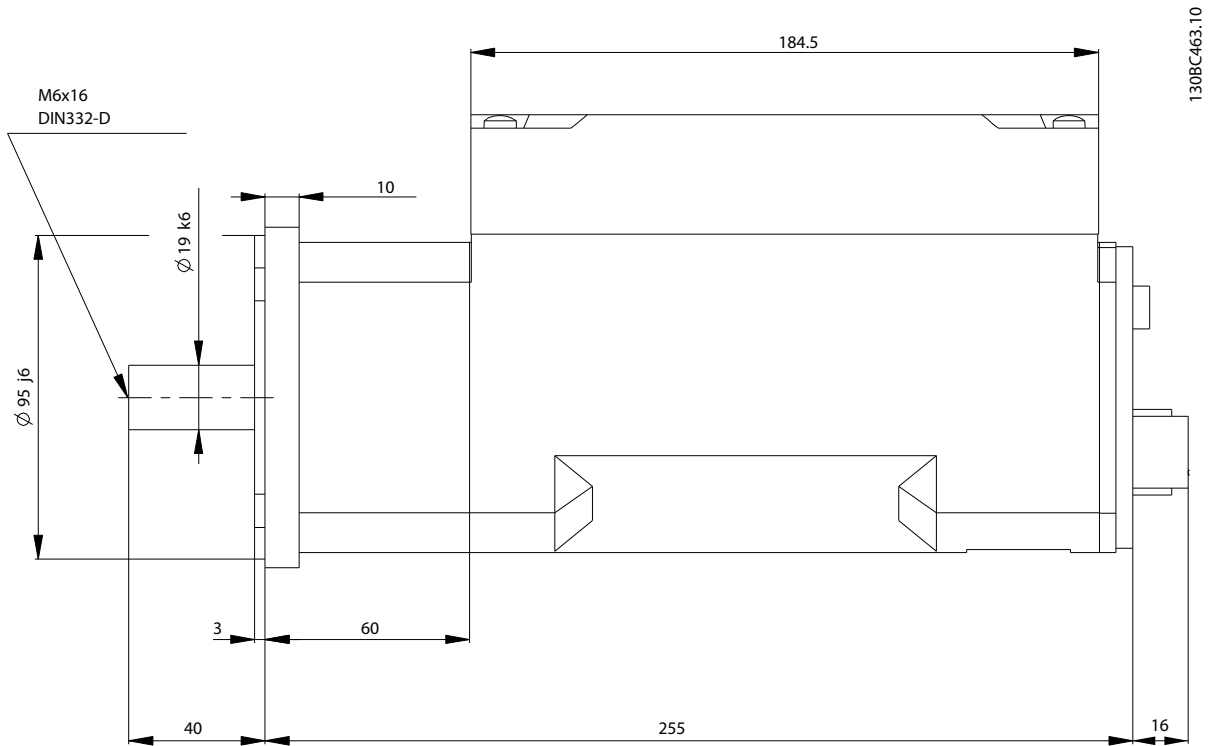

Illustration 12.5 Side View: Servomotor with ISD Flange and Brake

12

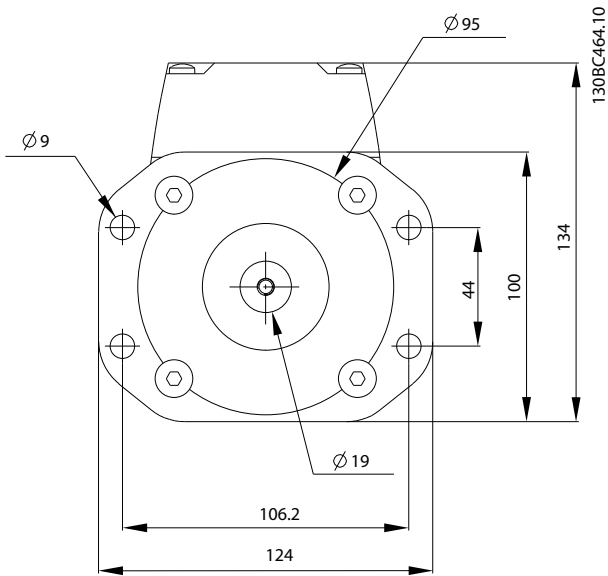

Illustration 12.6 Front View: Servomotor with ISD Flange and Brake

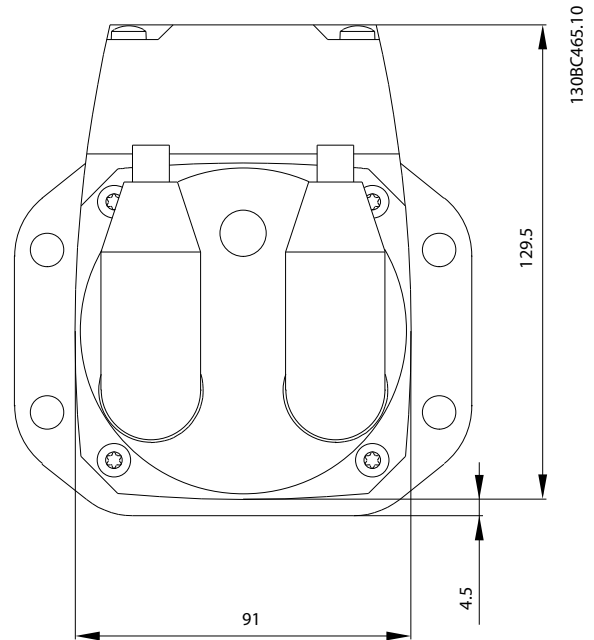

Illustration 12.7 Rear View: Servomotor with ISD Flange and Brake

12.4.3 Servomotor with IEC Flange, without Brake

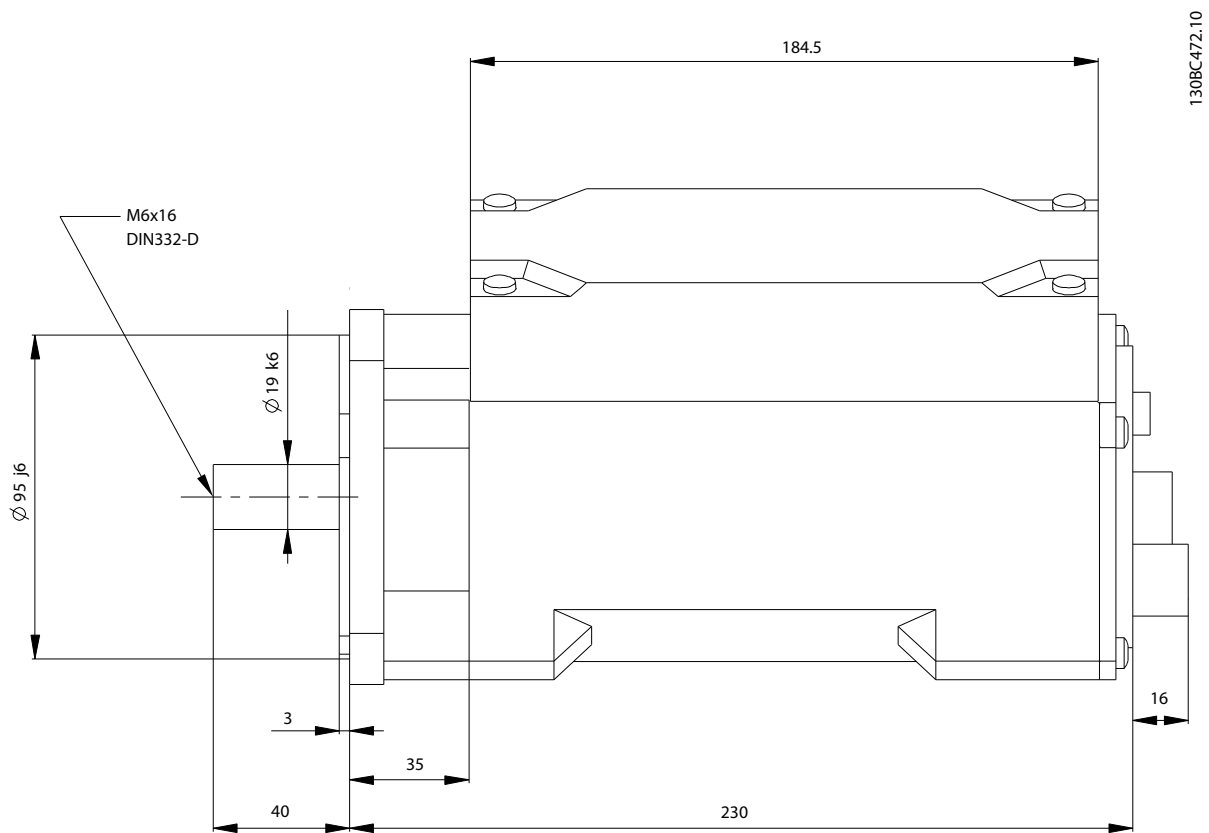

Illustration 12.8 Side View: Servomotor with IEC Flange, without Brake

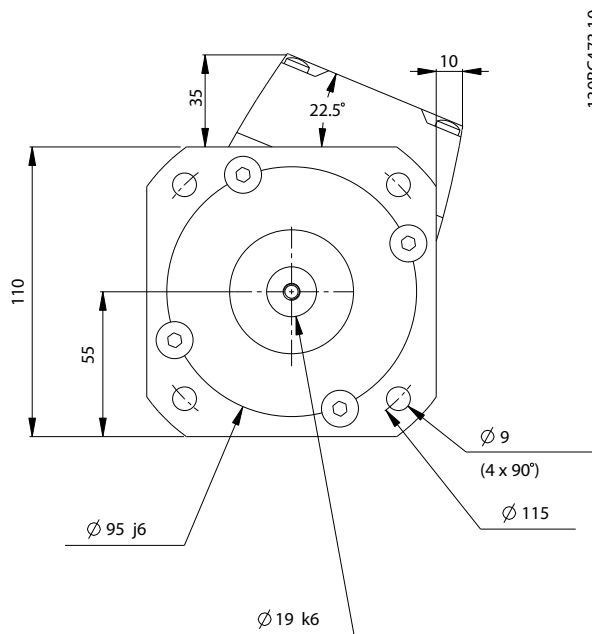

Illustration 12.9 Front View: Servomotor with IEC Flange, without Brake

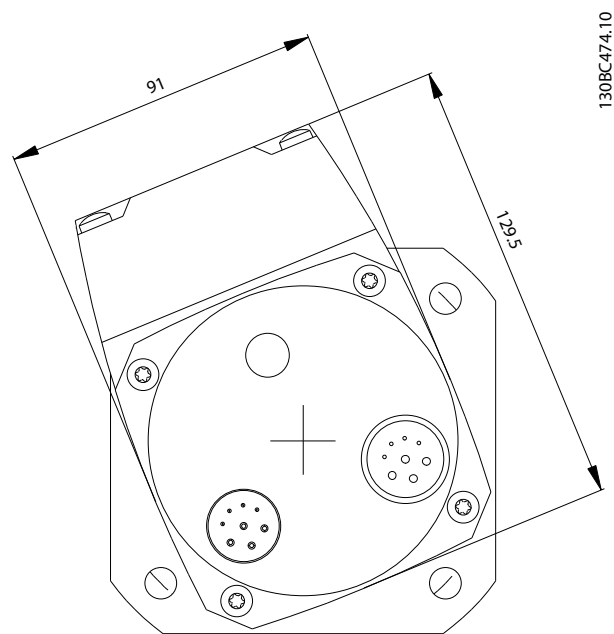
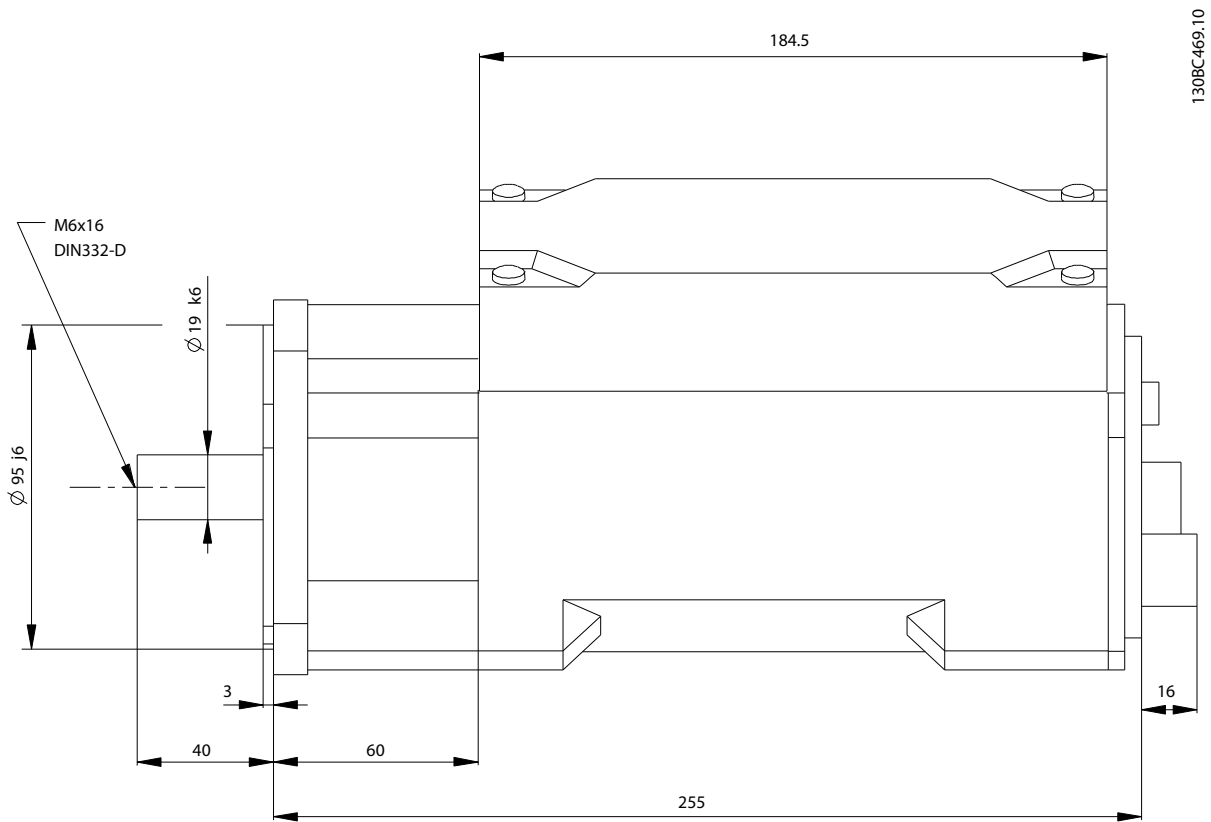

Illustration 12.10 Rear View: Servomotor with IEC Flange, without Brake

12.4.4 Servomotor with IEC Flange and Brake



130BC469.10

Illustration 12.11 Side View: Servomotor with IEC Flange and Brake

12

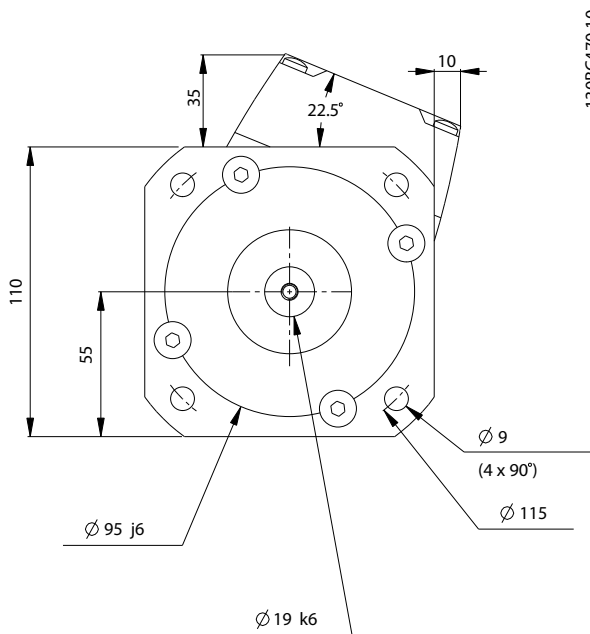

130BC470.10

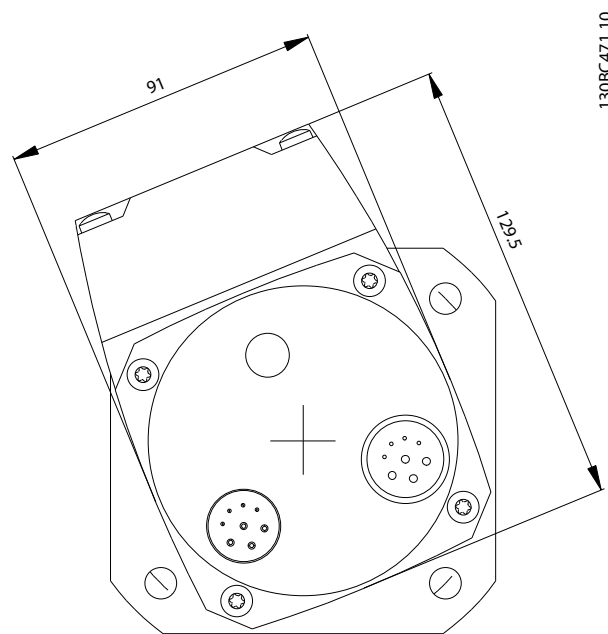

130BC471.10

Illustration 12.12 Front View: Servomotor with IEC Flange and Brake

Illustration 12.13 Rear View: Servomotor with IEC Flange and Brake

## 12.5 Motor Characteristics

The following tables provide a summary of typical characteristics combined with the available torque at a given speed (RPM).

Input protection	12.5 A <sub>eff</sub> in connection box
Supply voltage	300 V DC ±10%
Ripple	V <sub>SS</sub> < 3% (ensured by GP power supply and C battery)
DC link capacitor charging current	Limited by limiting current of upstream power supply
Output frequency	0-200 Hz (1500 RPM with 16-pole motor)
Allowable temperature rise	75 °C with installed ISD servomotor

Table 12.4 General Performance Data

## 12.6 Characteristic Curves

### 12.6.1 S1 Duty Cycle (Continuous duty)

Rated torques apply to continuous operation at an ambient temperature of 25 °C.

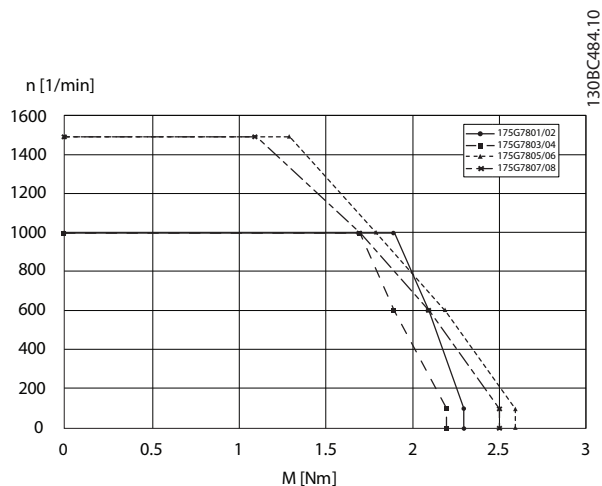

Illustration 12.14 S1 Duty Cycle Characteristic Curve

### 12.6.2 S3 Service Cycle (Intermittent periodic service)

Rated torques apply to intermittent periodic service at an ambient temperature of 25 °C.

S3 service cycle is also called intermittent periodic service. It is characterised by successive load and rest periods. The motor is de-energised during the rest period, with no power dissipation. During the load period the motor temperature rises, and during the rest period the motor cools down.

The load period is defined by the torque to be provided by the motor and the motor speed.

The ratio of the load and rest periods is essential for the thermal profile.

Example:

Mn S3 8 Nm: 6% service cycle S3 120 s – which means 7.2 s run time and 112.8 s rest time

12.6.2.1 Servomotors  
175G7801/02/09/10/17/18

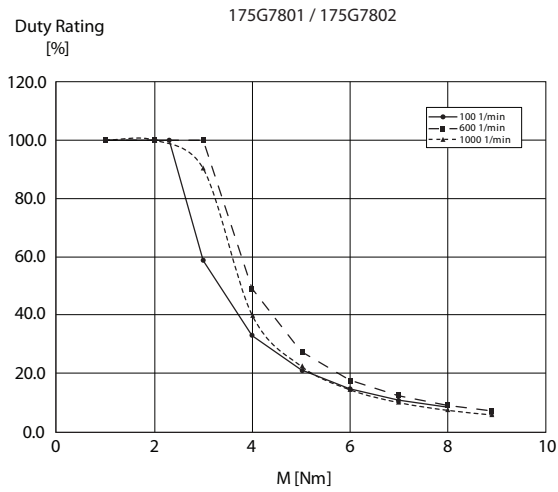

130BC486.10

Illustration 12.15 S3 Characteristic Curve for Servomotors  
175G7801/02/09/10/17/18

12.6.2.3 Servomotors  
175G7805/06/13/14/21/22

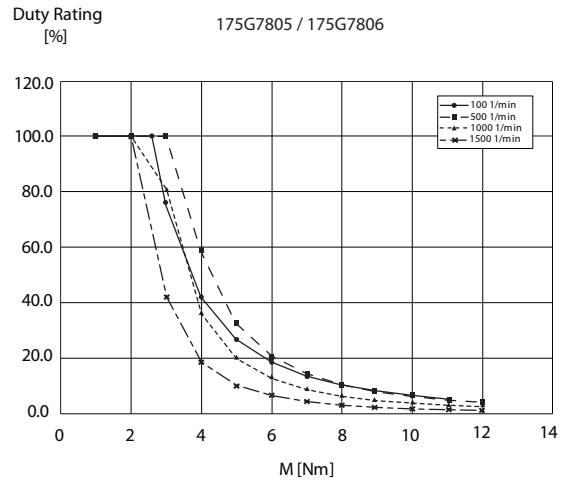

130BC488.10

Illustration 12.17 S3 Characteristic Curve for Servomotors  
175G7805/06/13/14/21/22

12.6.2.2 Servomotors  
175G7803/04/11/12/19/20

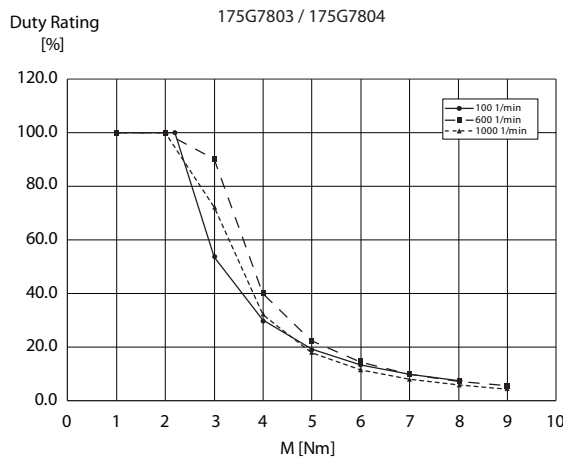

130BC487.10

Illustration 12.16 S3 Characteristic Curve for Servomotors  
175G7803/04/11/12/19/20

12.6.2.4 Servomotors  
175G7807/08/15/16/23/24

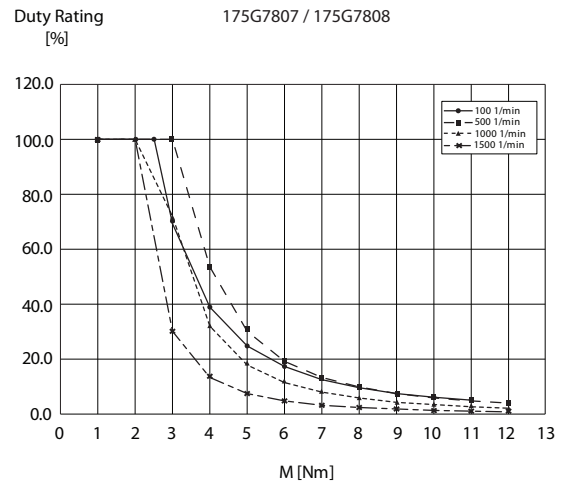

130BC489.10

Illustration 12.18 S3 Characteristic Curve for Servomotors  
175G7807/08/15/16/23/24

## 12.7 General Specifications and Environmental Conditions

Compliance	CE, Low Voltage Directive, IEC 60721-3-3
Ambient temperature range	5–40 °C operating –25 to +70 °C transport –25 to +55 °C storage
EMC class	C2 for interference emission and interference immunity
Thermal class	F (155 °C) in accordance with IEC 34/VDE 0530
Vibration class	3M7
Climate class	3K3
Chemical class	3C2
Relative humidity	15–85% (non condensing)
Installation elevation	No reduction in rated torque or power for installation elevation up to 1000 m (see curve above); derating above 1000 m up to a maximum of 4000 m
Protection rating	IP54; IP65 optional (not for motors installed with shaft facing upward)

**Table 12.5 Ambient Conditions**

## 12.8 Permitted Forces

The 2 bearings absorb the axial and radial forces acting on the internal components of the motor.

### 12.8.1 Servomotor without Brake

The specifications apply to the speed range from 10 RPM to the maximum rated speed.

The figures show the maximum permitted values for the radial and axial forces provided that the other component is 0. Note that the values may differ depending on the choice of shaft material.

See *Table 12.6* for maximum values of combinations of radial and axial forces.

These values apply to all installation positions.

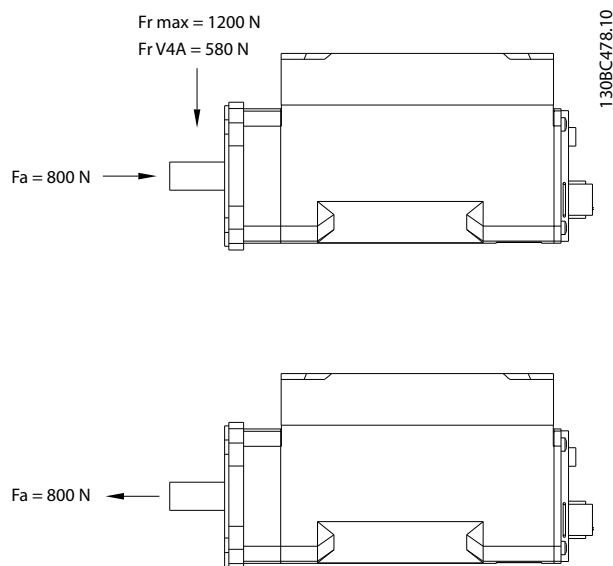

**Illustration 12.19 Permitted Forces (ISD/IEC Servomotor without Brake)**

Radial Force in N	Axial Force in N	Max. Speed in RPM
1200	200	1500
800	500	1500
400	600	1500
200	700	1500

**Table 12.6 Combinations of Permitted Forces (ISD/IEC Servomotor without Brake) for All Installation Positions**



### 12.8.2 Servomotor with Brake

The specifications apply to the speed range from 10 RPM to the maximum rated speed.

The figures show the maximum permitted values for the radial and axial forces provided that the other component is 0. Note that the values may differ depending on the choice of shaft material.

See *Table 12.7*, *Table 12.8* and *Table 12.9* for the maximum values for combinations of radial and axial forces.

#### Horizontal installation

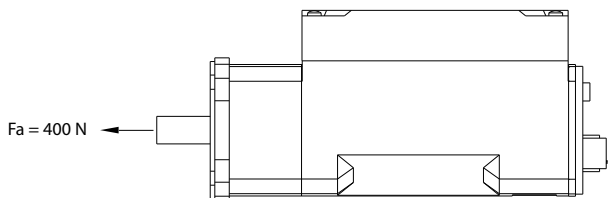
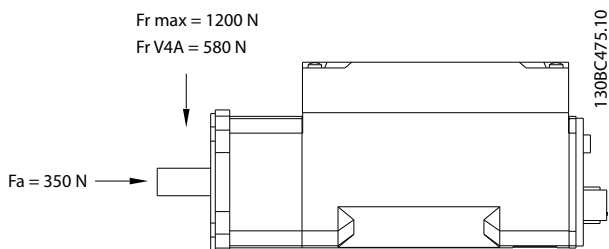

Illustration 12.20 Permitted Forces (ISD/IEC Servomotor with Brake) for Horizontal Installation

Radial Force in N	Axial Force in N	Max. Speed in RPM
1200	200	1500
800	300	1500
400	300	1500
200	350	1500

Table 12.7 Combinations of Permitted Forces (ISD/IEC Servomotor with Brake) for Horizontal Installation

#### Vertical installation with shaft facing upward

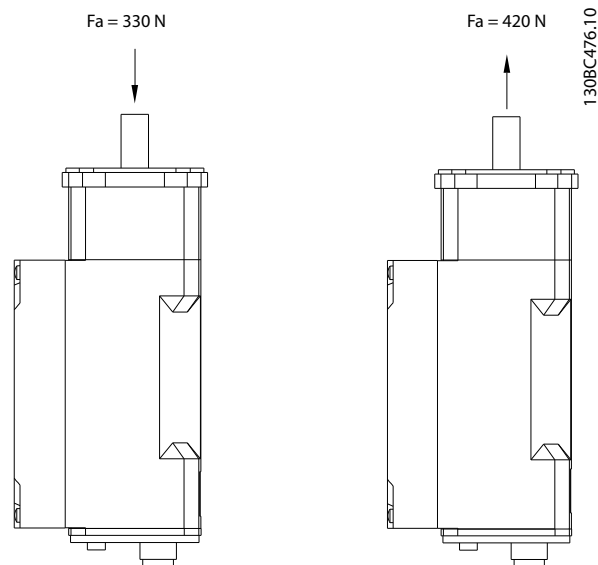

Illustration 12.21 Permitted Forces (ISD/IEC Servomotor with Brake) for Vertical Installation with Shaft Facing Upward

Radial Force in N	Axial Force in N	Max. Speed in RPM
1200	200	1500
800	300	1500
400	300	1500
200	330	1500

Table 12.8 Combinations of Permitted Forces (ISD/IEC Servomotor with Brake) for Vertical Installation with Shaft Facing Upward

Vertical installation with shaft facing downward

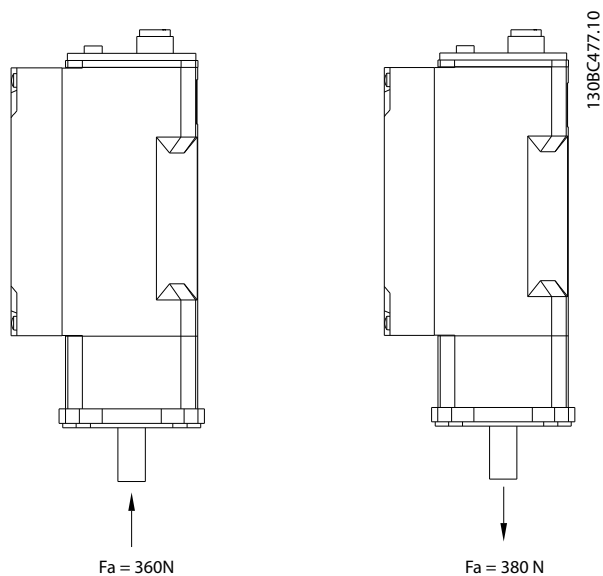

Illustration 12.22 Permitted Forces (ISD/IEC Servomotor with Brake) for Vertical Installation with Shaft Facing Downward

Radial Force in N	Axial Force in N	Max. Speed in RPM
1200	200	1500
800	300	1500
400	300	1500
200	360	1500

Table 12.9 Combinations of Permitted Forces (ISD/IEC Servomotor with Brake) for Vertical Installation with Shaft Facing Downward

## 13 Appendix

### 13.1 Glossary

#### A flange

The A side is the shaft end of the motor.

#### Ambient temperature

The temperature in the immediate vicinity of the servo drive.

#### Axial force

The force in newton-metres acting on the rotor axis in the axial direction.

#### Bearings

The ball bearings of the servo drive.

#### B flange

The B side is the back end with the plug-and-socket connectors.

#### Brake

Power-off brake of the ISD servomotor, attached to the A side of the motor.

#### CAN

Communication Area Network

#### CANopen DS301

A standard that specifies the application layer and communication profile.

#### CANopen DS402

An object-based CAN standard that specifies the device profile for drives and motion control.

#### CE

European test and certification mark.

#### Clamping set

A mechanical device, which, for example, can be used to secure gears to a motor shaft.

#### CoDeSys

Controller Development System; a development environment for programming controller applications, based on IEC 61131-3 and developed by 3S-Smart Software Solutions GmbH.

#### Connection box

The connection box provides the link between the power supply module and the servo drives.

#### Connector (M23)

Servomotor connector.

#### Cooling

ISD servo drives are cooled by convection, which means without fans.

#### CSA

Canadian test and certification mark.

#### DC link

Each servo drive has its own DC link, consisting of capacitors.

#### DC link voltage

A DC voltage shared by several ISD servo drives connected in parallel.

#### DC voltage

A direct constant voltage.

#### DSP

Digital signal processor; processor IC on an ISD control board.

#### Encoder Box

The encoder box allows external encoder signals to be sent to the servo drives over the CAN bus with high precision.

#### Feed cable

Hybrid connection cable between connection box and servo drive, with a connector.

#### Feedback system

Feedback systems for servomotors in general.

#### Fieldbus

Communication bus between controller and servo axis; in general between controller and field nodes.

#### Firmware

Software in the unit; runs on the control board.

#### Flash

Memory IC on the ISD control board; a form of EPROM.

**Function block**

Device functionalities are accessible via CoDeSys function modules.

**Gear ratio**

The speed ratio of the input pinion and the output shaft of the gear unit.

**Gear unit**

External gear unit used to change the output shaft speed and the torque on the motor shaft.

**Hole circle**

The hole patterns of the ISD and IEC flanges.

**IEC flange**

Industry-standard flange

**Installation elevation**

Installation elevation above normal sea level, typically associated with a derating factor.

**ISD**

Integrated servo drive, integrated servomotor solution.

**ISD flange**

This is the standard flange for ISD servo drives; larger than the IEC flange.

**ISD servomotor**

Designates the ISD servomotor with hybrid cable.

**Loop cable**

Hybrid connection cable between two servo drives, with two connectors.

**M12 connector**

Input connector for connecting the sensor on the B side of the servo drive.

**Motor shaft**

Rotating shaft on the A side of the servomotor, typically without a key groove.

**Multi-turn encoder**

Describes a digital absolute encoder, in which the absolute position remains known after several revolutions.

**Nodes**

Nodes are branches within a cam disc function.

**PELV**

Low-voltage directive regarding voltage levels and distances between lines.

**PDO**

Process Data Object (see DS301).

**Planetary gear**

A specific type of gearing, typically used with servomotors.

**Power-off principle**

The brake is normally engaged. It is released by applying a voltage (safety function).

**Power supply module**

The power supply module provides a regulated 300 V DC from 400 V AC.

**Radial force**

The force in newton-metres acting at 90° to the longitudinal direction of the rotor axis.

**Resolver**

A feedback device for servomotors, typically with two analog tracks (sine and cosine).

**Safety**

A servomotor safety circuit that switches off the voltages of the driver components for the IGBTs.

**Scope**

Used for diagnosis. Enables internal signals to be depicted.

**SDO**

Service Data Object (see DS301).

**Segment**

A segment refers to a movement within a curve.

**SIL 2**

Safety Integrated Level II.

**Single-turn encoder**

Describes a digital absolute encoder, in which the absolute position for one revolution remains known.

**Toolbox**

A software tool used for parameter setting and diagnostics of ISD servomotors, the ISD connection box and the ISD encoder box.

**Index**

**A**  
**Angle Position Encoder**..... 15  
**Approvals**..... 5  
**Axial Force**..... 47

**B**  
**Belt Drives**..... 23  
**Brake**..... 14

**C**  
**Cable**  
    Feed..... 18  
    Hybrid..... 17  
    Layout..... 17  
    Loop..... 18  
    Replacement..... 34  
    Replacement Feed Cable..... 34  
    Replacement Loop Cable..... 35  
    Routing..... 17  
    Sensor..... 20  
**Cabling**..... 16  
**CAN Bus Ports**..... 20  
**Characteristic**  
    Curve S1 Duty Cycle..... 45  
    Curves..... 45  
    Curves S3 Service Cycle..... 45  
    Data Of Servomotor..... 39  
**Commissioning**..... 25  
**Components**  
    Connecting Components..... 25  
    Motor..... 14  
**Configuration Of Parameters**..... 25  
**Configurations**..... 13  
**Connection Cables**..... 16  
**Connector Pin Assignment**..... 20  
**Connector, M23**..... 19  
**Cooling**..... 14  
**Copyright**..... 5  
**Curve Mode**..... 26

**D**  
**Decommissioning**..... 36  
**Delivery**  
    Delivery..... 21  
    Scope Of Delivery..... 21  
**Description**..... 12  
**Dimensions**..... 41  
**Discharge Time**..... 5, 34  
**Disclaimer**..... 5

**Dismounting**..... 36  
**Disposal**..... 37  
**Documents**..... 7  
**Due Diligence**..... 10

**E**  
**Electrical**  
    Environmental Conditions..... 23  
    Installation..... 23  
**Encoder**  
    Angle Position..... 15  
    Multi-turn..... 15  
    Single-turn..... 15  
**Environmental Conditions**..... 21, 47

**F**  
**Faults**..... 32  
**Feed Cable**..... 34, 18  
**Forces**..... 47  
**Forseeable Misuse**..... 11  
**Functional Operation Test**..... 25

**G**  
**Glossary**..... 50

**H**  
**High Voltage**..... 5  
**Hybrid**  
    Cable..... 17  
    Cables Connecting/Disconnecting..... 23

**I**  
**Inertia Measurement Mode**..... 26  
**Inspection During Operation**..... 33  
**Installation**  
    Aids And Tools Required..... 22  
    Clamping..... 22  
    Coupling..... 22  
    Electrical..... 23  
    Environment..... 21  
    Mechanical..... 22  
    Preparation For Installation..... 22  
    Safety Measures During Installation..... 21  
    Space Requirements..... 22  
    Tightening Torques..... 22  
**Intended Use**..... 10  
**Internal Components**..... 14  
**Introduction**..... 6  
**ISD Servo System**..... 6

**L**  
**Long-term Storage**..... 38

Loop Cable.....	35, 18	<b>Safety</b>	
<b>M</b>		Discharge Time.....	5, 34
<b>M23 Connector</b> .....	19	During Installation.....	21
<b>Maintenance</b>		High Voltage.....	5
Maintenance.....	33	Instructions.....	8
Replacing Shaft Seal.....	33	Standards.....	27
Tasks.....	33	Unintended Start.....	5
<b>Mechanical Installation</b> .....	22	Warnings.....	8, 5
<b>Modes Of Operation</b> .....	26	<b>Safety Concept</b>	
<b>Monitoring</b> .....	33	Safety Concept.....	27
<b>Motor</b>		Acceptance Test.....	30
Characteristics.....	45	Activating / Deactivating The Safe Stop Function.....	28
Components.....	14	Application Examples.....	31
<b>Multi-turn Encoder</b> .....	15	Functional Description.....	27
		Installation.....	29
<b>N</b>		<b>Sensor</b>	
<b>Nameplate</b> .....	38	Cable.....	20
		Cables Connecting/Disconnecting.....	24
<b>O</b>		Ports.....	20
<b>Operating Modes</b> .....	26	<b>Service</b> .....	5, 32
<b>Operation</b> .....	26	<b>Servo System With 3 Servomotors</b> .....	6
		<b>Servomotor</b>	
<b>P</b>		Characteristic Curves.....	45
<b>Parameter Configuration</b> .....	25	Characteristic Data.....	39
<b>Performance Data</b> .....	45	Dimensions.....	41
<b>Permitted Forces</b> .....	47	Environmental Conditions.....	47
<b>Port, Sensor</b> .....	20	Maintenance And Repair.....	33
<b>Ports</b> .....	20	Performance Data.....	45
<b>Power Ports</b> .....	20	Replacing The Servomotor.....	35
<b>Product Returns</b> .....	36	Safety Concept.....	27
		Startup.....	25
<b>Q</b>		Storage.....	38
<b>Qualified Personnel</b> .....	10	Switching On.....	25
		Test Run.....	25
<b>R</b>		Types.....	12
<b>Radial Force</b> .....	47	<b>Shaft</b> .....	14
<b>Recycling</b> .....	37	<b>Single-turn Encoder</b> .....	15
<b>Repair</b> .....	33	<b>Speed Mode</b> .....	26
<b>Replacing</b>		<b>Startup</b> .....	25
Cables.....	34	<b>Storage</b>	
Servomotor.....	35	Storage.....	38
<b>Returning The Product</b> .....	36	Long-term.....	38
		<b>Support</b> .....	5
<b>S</b>		<b>Symbols</b> .....	8
<b>S1 Duty Cycle Characteristic Curve</b> .....	45	<b>System Overview</b> .....	6
<b>S3 Service Cycle Characteristic Curves</b> .....	45	<b>T</b>	
		<b>Terminology</b> .....	7
		<b>Test Run</b> .....	25
		<b>Test, Functional Operation</b> .....	25
		<b>Tightening Torques</b> .....	22
		<b>Transport</b> .....	21
		<b>Troubleshooting</b> .....	32
		<b>Types, Servomotor</b> .....	12

U  
Unintended Start..... 5

V  
Voltage Warning..... 5

W  
**Warning**  
Discharge Time..... 5, 34  
High Voltage..... 5  
Unintended Start..... 5  
**Winding**..... 14



[www.danfoss.com/drives](http://www.danfoss.com/drives)

---

Danfoss can accept no responsibility for possible errors in catalogues, brochures and other printed material. Danfoss reserves the right to alter its products without notice. This also applies to products already on order provided that such alterations can be made without subsequential changes being necessary in specifications already agreed. All trademarks in this material are property of the respective companies. Danfoss and the Danfoss logotype are trademarks of Danfoss A/S. All rights reserved.

---





