

WL200 Series Inverter Instruction Manual

- Single-phase Input 200V class
- Three-phase Input 400V class

Manual Number: NT353X
November 2015

After read this manual,
Keep it handy for future reference.

Hitachi Industrial Equipment Systems Co., Ltd.

Safety Messages

For the best results with the WL200 Series inverter, carefully read this manual and all of the warning labels attached to the inverter before installing and operating it, and follow the instructions exactly. Keep this manual handy for quick reference.

Definitions and Symbols

A safety instruction (message) includes a "Safety Alert Symbol" and a signal word or phrase such as WARNING or CAUTION. Each signal word has the following meaning:



HIGH VOLTAGE: This symbol indicates high voltage. It calls your attention to items or operations that could be dangerous to you and other persons operating this equipment. Read the message and follow the instructions carefully.



WARNING: indicates a potentially hazardous situation that, if not avoided, can result in serious injury or death.



CAUTION: Indicates a potentially hazardous situation that, if not avoided, can result in minor to moderate injury or serious damage to the product. The situation described in the **CAUTION** may, if not avoided, lead to serious results. Important safety measures are described in CAUTION (as well as WARNING), so be sure to observe them.



Step 1: Indicates a step in a series of action steps required to accomplish a goal. The number of the step will be contained in the step symbol.



NOTE: Notes indicate an area or subject of special merit, emphasizing either the product's capability or common errors in operation or maintenance.



TIP: Tips give a special instruction that can save time or provide other benefits while installing or using the product. The tip calls attention to an idea that may not be obvious to first-time users of the product.

Hazardous High Voltage



HIGH VOLTAGE: Motor control equipment and electronic controllers are connected to hazardous line voltages. When servicing drives and electronic controllers, there may be exposed components with housing or protrusions at or above line potential. Extreme care should be taken to protect against shock.

Stand on an insulating pad and make it a habit to use only one hand when checking components. Always work with another person in case an emergency occurs. Disconnect power before checking controllers or performing maintenance. Be sure equipment is properly grounded. Wear safety glasses whenever working on electronic controllers or rotating machinery.

Caution when using Safe Stop Function

When using Safe Stop function, make sure to check whether the safe stop function properly works when installation (before starting operation). Please carefully refer to Appendix E (Certification in progress)

General Precautions – Read These First!



WARNING: This equipment should be installed, adjusted, and serviced by qualified electrical maintenance personnel familiar with the construction and operation of the equipment and the hazards involved. Failure to observe this precaution could result in bodily injury.



WARNING: The user is responsible for ensuring that all driven machinery, drive train mechanism not supplied by Hitachi Industrial Equipment Systems Co., Ltd., and process line material are capable of safe operation at an applied frequency of 150% of the maximum selected frequency range to the AC motor. Failure to do so can result in destruction of equipment and injury to personnel should a single-point failure occur.



WARNING: For equipment protection, install a ground leakage type breaker with a fast response circuit capable of handling large currents. The ground fault protection circuit is not designed to protect against personal injury.



WARNING: HAZARDOUS OF ELECTRICAL SHOCK. DISCONNECT INCOMING POWER BEFORE WORKING ON THIS CONTROL.



WARNING: Wait at least ten (10) minutes after turning OFF the input power supply before performing maintenance or an inspection. Otherwise, there is the danger of electric shock.



CAUTION: These instructions should be read and clearly understood before working on WL200 series equipment.



CAUTION: Proper grounds, disconnecting devices and other safety devices and their location are the responsibility of the user and are not provided by Hitachi Industrial Equipment Systems Co., Ltd.



CAUTION: Be sure to connect a motor thermal disconnect switch or overload device to the WL200 series controller to assure that the inverter will shut down in the event of an overload or an overheated motor.



HIGH VOLTAGE: Dangerous voltage exists until power light is OFF. Wait at least ten (10) minutes after input power is disconnected before performing maintenance.



WARNING: This equipment has high leakage current and must be permanently (fixed) hard-wire to earth ground via two independent cables.



WARNING: Rotating shafts and above-ground electrical potentials can be hazardous. Therefore, it is strongly recommended that all electrical work conform to the National Electrical Codes and local regulations. Installation, alignment and maintenance should be performed only by qualified personnel.



CAUTION:

- a) Class I motor must be connected to earth ground via low resistive path ($<0.1\Omega$)
- b) Any motor used must be of a suitable rating.
- c) Motors may have hazardous moving path. In this event suitable protection must be provided.



CAUTION: Alarm connection may contain hazardous live voltage even when inverter is disconnected. When removing the front cover for maintenance or inspection, confirm that incoming power for alarm connection is completely disconnected.



CAUTION: Hazardous (main) terminals for any interconnection (motor, contact breaker, filter, etc.) must be inaccessible in the final installation.



CAUTION: This equipment should be installed in IP54 or equivalent (see EN60529) enclosure. The end application must be in accordance with BS EN60204-1. Refer to the section "Choosing a Mounting Location" on page 2–7. The diagram dimensions are to be suitably amended for your application.



CAUTION: Connection to field wiring terminals must be reliably fixed having two independent means of mechanical support. Use a termination with cable support (figure below), or strain relief, cable clamp, etc.

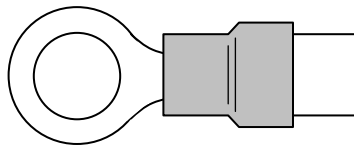

CAUTION: A double-pole disconnection device must be fitted to the incoming main power supply close to the inverter. Additionally, a protection device meet IEC947-1/ IEC947-3 must be fitted at this point (protection device data shown in "Determining Wire and Fuse Sizes" on page 2–15).



NOTE: The above instructions, together with any other requirements highlighted in this manual, must be followed for continue LVD (European Low Voltage Directive) compliance.

Index to Warnings and Cautions in This Manual

Cautions and Warnings for Orientation and Mounting Procedures



HIGH VOLTAGE: Hazard of electrical shock. Disconnect incoming power before working on this control. Wait ten (10) minutes before removing the front cover. ...2-3



HIGH VOLTAGE: Hazard of electrical shock. Never touch the naked PCB (printed circuit board) portions while the unit is powered up. Even for switch portion, the inverter must be powered OFF before you change. ...2-3



WARNING: In the following examples involving a general-purpose inverter, a large peak current flow on the main power supply side, and is able to destroy the converter module. Where such situations are foreseen or the connected equipment must be highly reliable, install an AC reactor between the power supply and the inverter. Also, where influence of indirect lightning strike is possible, install a lightning conductor: ...2-5

1. The unbalance factor of the power supply is 3% or higher.
2. The power supply capacity is at least 10 times greater than the inverter capacity (or the power supply capacity is 500kVA or more).
3. Abrupt power supply changes are expected, due to the conditions such as:
 - a. Several inverters are interconnected with a short bus.
 - b. A thyristor converter and an inverter are interconnected with a short bus.
 - c. An installed phase advance capacitor opens and closes.



WARNING: An inverter run by a private power generator may overheat the generator or suffer from a deformed output voltage waveform of the generator. Generally, the generator capacity should be five times that of the inverter (kVA) in a PWM control system or six times greater in a PAM control system. ...2-5



CAUTION: In the case of important equipment, to shorten the non-operational time of inverter failure, please provide a backup circuit by commercial power supply or spare inverter. ...2-5



CAUTION: Be sure to install the unit on flame-resistant material such as a steel plate. Otherwise, there is the danger of fire. ...2-7



CAUTION: Be sure not to place any flammable materials near the inverter. Otherwise, there is the danger of fire. ...2-7



CAUTION: Be sure not to let the foreign matter enter vent openings in the inverter housing, such as wire clippings, spatter from welding, metal shavings, dust, etc. Otherwise, there is the danger of fire. ...2-7



CAUTION: Be sure to install the inverter in a place that can bear the weight according to the specifications in the text (Chapter 1, Specifications Tables). Otherwise, it may fall and cause injury to personnel. ...2-7



CAUTION: Be sure to install the unit on a perpendicular wall that is not subject to vibration. Otherwise, it may fall and cause injury to personnel. ...2-7



CAUTION: Be sure not to install or operate an inverter that is damaged or has missing parts. Otherwise, it may cause injury to personnel. ...2-7













CAUTION: Be sure to install the inverter in a well-ventilated room that does not have direct exposure to sunlight, a tendency for high temperature, high humidity or dew condensation, high levels of dust, corrosive gas, explosive gas, inflammable gas, grinding-fluid mist, salt damage, etc. Otherwise, there is the danger of fire. ...2-7



CAUTION: Be sure to maintain the specified clearance area around the inverter and to provide adequate ventilation. Otherwise, the inverter may overheat and cause equipment damage or fire. ...2-8

Wiring – Warnings for Electrical Practice and Wire Specifications

-  **WARNING:** "USE 60/75°C Cu wire only" or equivalent. For models WL200-022S, 004H, -007H, -015H, -022H and -030H. ...2-14
-  **WARNING:** "USE 75°C Cu wire only" or equivalent. For models WL200-002S, -004S, -007S, -015S, -055H, -075H, -110H, 150H and -185H. ...2-14
-  **WARNING:** "Open Type Equipment." ...2-14
-  **WARNING:** "Suitable for use on a circuit capable of delivering not more than 100k rms symmetrical amperes, 240V maximum when protected by Class CC, G, J or R fuses or circuit breaker having an interrupting rating not less than 100,000 rms symmetrical amperes, 240 volts maximum." For models with suffix S. ...2-14
-  **WARNING:** "Suitable for use on a circuit capable of delivering not more than 100k rms symmetrical amperes, 480V maximum when protected by Class CC, G, J or R fuses or circuit breaker having an interrupting rating not less than 100,000 rms symmetrical amperes, 480 volts maximum." For models with suffix H. ...2-14
-  **HIGH VOLTAGE:** Be sure to ground the unit. Otherwise, there is a danger of electric shock and/or fire. ...2-14
-  **HIGH VOLTAGE:** Wiring work shall be carried out only by qualified personnel. Otherwise, there is a danger of electric shock and/or fire. ...2-14
-  **HIGH VOLTAGE:** Implement wiring after checking that the power supply is OFF. Otherwise, you may incur electric shock and/or fire. ...2-14
-  **HIGH VOLTAGE:** Do not connect wiring to an inverter operate an inverter that is not mounted according to the instructions given in this manual. Otherwise, there is a danger of electric shock and/or injury to personnel. ...2-14
-  **WARNING:** Make sure the input power to the inverter is OFF. If the drive has been powered, leave it OFF for ten (10) minutes before continuing. ...2-22

Wiring – Cautions for Electrical Practice



CAUTION: Fasten the screws with the specified fastening torque in the table below. ...2-16
Check for any loosening of screws. Otherwise, there is the danger of fire.



CAUTION: Be sure that the input voltage matches the inverter specifications; ...2-20

- Single phase 200V to 240V 50/60Hz (up to 2.2kW) for SFE model
- Three phase 380V to 480V 50/60Hz (up to 18.5kW) for HFE model



CAUTION: Be sure not to power a three-phase-only inverter with single phase power. ...2-20
Otherwise, there is the possibility of damage to the inverter and the danger of fire.



CAUTION: Be sure not to connect an AC power supply to the output terminals. ...2-20
Otherwise, there is the possibility of damage to the inverter and the danger of injury and/or fire.

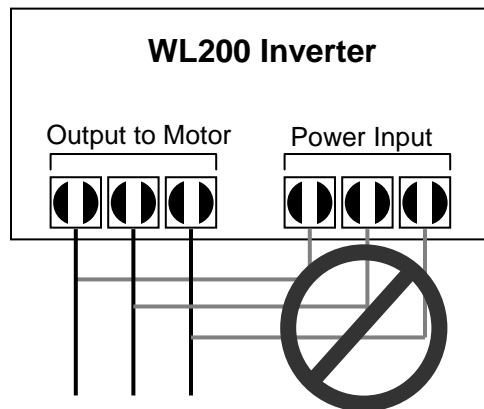

CAUTION: Remarks for using ground fault interrupter breakers in the main power supply: Adjustable frequency inverter with integrated CE-filters and shielded (screened) motor cables have a higher leakage current toward earth GND. Especially at the moment of switching ON this can cause an inadvertent trip of ground fault interrupters. Because of the rectifier on the input side of the inverter there is the possibility to stall the switch-off function through small amounts of DC current. ...2-20
Please observe the following:

- Use only short time-invariant and pulse current-sensitive ground fault interrupters with higher trigger current.
- Other components should be secured with separate ground fault interrupters.
- Ground fault interrupters in the power input wiring of an inverter are not an absolute protection against electric shock.



CAUTION: Be sure to install a fuse in each phase of the main power supply to the inverter. Otherwise, there is the danger of fire. ...2-20







CAUTION: For motor leads, ground fault interrupter breakers and electromagnetic contactors, be sure to size these components properly (each must have the capacity for rated current and voltage). Otherwise, there is the danger of fire. ...2-20



CAUTION: Power terminal assignment is different compared to old models such as L100, L200, X200 series, etc.. Pay attention when wiring the power cable. ...2-21



Powerup Test Caution Messages

-  **CAUTION:** The heat sink fins will have a high temperature. Be careful not to touch them. Otherwise, there is the danger of getting burned. ...2-23
-  **CAUTION:** The operation of the inverter can be easily changed from low speed to high speed. Be sure to check the capability and limitations of the motor and machine before operating the inverter. Otherwise, there is the danger of injury. ...2-23
-  **CAUTION:** If you operate a motor at a frequency higher than the inverter standard default setting (50Hz/60Hz), be sure to check the motor and machine specifications with the respective manufacturer. Only operate the motor at elevated frequencies after getting their approval. Otherwise, there is the danger of equipment damage and/or injury. ...2-23
-  **CAUTION:** Check the following before and during the Powerup test. Otherwise, there is the danger of equipment damage. ...2-23
- Is the shorting bar between the [+1] and [+] terminals installed? DO NOT power or operate the inverter if the jumper is removed.
 - Is the direction of the motor rotation correct?
 - Did the inverter trip during acceleration or deceleration?
 - Were the rpm and frequency meter readings as expected?
 - Were there any abnormal motor vibration or noise?













Warnings for Configuring Drive Parameters

-  **WARNING:** When parameter b012, level of electronic thermal setting, is set to motor FLA rating (Full Load Ampere nameplate rating), the inverter provides solid state motor overload protection at 115% of motor FLA or equivalent. If parameter b012 exceeds the motor FLA rating, the motor may overheat and damaged. Parameter b012, level of electronic thermal setting, is a variable parameter. ...3-46









Cautions for Configuring Drive Parameters

-  **CAUTION:** Be careful to avoid specifying a braking time that is long enough to cause motor overheating. If you use DC braking, we recommend using a motor with a built-in thermistor, and wiring it to the inverter's thermistor input (see "[Thermistor Thermal Protection](#)" on page 4-30). Also refer to the motor manufacturer's specifications for duty-cycle recommendations during DC braking. ...3-26
-  **CAUTION:** Be careful to avoid specifying a braking carrier frequency that is high enough to cause inverter and motor overheating. If you use DC braking, we recommend using a motor with a built-in thermistor, and wiring it to the inverter's thermistor input (see "[Thermistor Thermal Protection](#)" on page 4-30). Also refer to the motor manufacturer's specifications for duty-cycle recommendations during DC braking. ...3-26
-  **CAUTION:** Do not change Debug mode for safety reasons. Otherwise unexpected performances may occur. ...3-95

Warnings for Operations and Monitoring

-  **WARNING:** Be sure to turn ON the input power supply only after closing the front case. While the inverter is energized, be sure not to open the front case. Otherwise, there is the danger of electric shock. ...4-3
-  **WARNING:** Be sure not to operate electrical equipment with wet hands. Otherwise, there is the danger of electric shock. ...4-3
-  **WARNING:** While the inverter is energized, be sure not to touch the inverter terminals even when the motor is stopped. Otherwise, there is the danger of electric shock. ...4-3
-  **WARNING:** If the retry mode is selected, the motor may suddenly restart after a trip stop. Be sure to stop the inverter before approaching the machine (be sure to design the machine so that safety for personnel is secure even if it restarts.) Otherwise, it may cause injury to personnel. ...4-3
-  **WARNING:** If the power supply is cut OFF for a short period of time, the inverter may restart operating after the power supply recovers if the Run command is active. If a restart may pose danger to personnel, so be sure to use a lock-out circuit so that it will not restart after power recovery. Otherwise, it may cause injury to personnel. ...4-3
-  **WARNING:** The Stop Key is effective only when the stop function is enabled. Be sure to enable the Stop Key separately from the emergency stop. Otherwise, it may cause injury to personnel. ...4-3
-  **WARNING:** During a trip event, if the alarm reset is applied and the Run command is present, the inverter will automatically restart. Be sure to apply the alarm reset only after verifying the Run command is OFF. Otherwise, it may cause injury to personnel. ...4-3
-  **WARNING:** Be sure not to touch the inside of the energized inverter or to put any conductive object into it. Otherwise, there is a danger of electric shock and/or fire. ...4-3
-  **WARNING:** If power is turned ON when the Run command is already active, the motor will automatically start and injury may result. Before turning ON the power, confirm that the RUN command is not present. ...4-3
-  **WARNING:** When the Stop key function is disabled, pressing the Stop key does not stop the inverter, nor will it reset a trip alarm. ...4-3
-  **WARNING:** Be sure to provide a separate, hard-wired emergency stop switch when the application warrants it. ...4-3
-  **WARNING:** If the power is turned ON and the Run command is already active, the motor starts rotation and is dangerous! Before turning power ON, confirm that the Run command is not active. ...4-16
-  **WARNING:** After the Reset command is given and the alarm reset occurs, the motor will restart suddenly if the Run command is already active. Be sure to set the alarm reset after verifying that the Run command is OFF to prevent injury to personnel. ...4-29

Cautions for Operations and Monitoring

-  **CAUTION:** The heat sink fins will have a high temperature. Be careful not to touch them. Otherwise, there is the danger of getting burned. ...4-2
-  **CAUTION:** The operation of the inverter can be easily changed from low speed to high speed. Be sure to check the capability and limitations of the motor and machine before operating the inverter. Otherwise, it may cause injury to personnel. ...4-2
-  **CAUTION:** If you operate a motor at a frequency higher than the inverter standard default setting (50Hz/60Hz), be sure to check the motor and machine specifications with the respective manufacturer. Only operate the motor at elevated frequencies after getting their approval. Otherwise, there is the danger of equipment damage. ...4-2
-  **CAUTION:** There is a possibility to damage the inverter or other devices if your application exceeds the maximum current or voltage characteristics of a connection point. ...4-4
-  **CAUTION:** Be sure to turn OFF power to the inverter before changing the jumper wire position. Otherwise, damage to the inverter circuitry may occur. ...4-12
-  **CAUTION:** Be careful not to turn PID clear ON and reset the integrator sum when the inverter is in Run mode (output to motor is ON). Otherwise, this could cause the motor to decelerate rapidly, resulting in a trip. ...4-32
-  **HIGH VOLTAGE:** Dangerous voltage exists even after the Safe Stop is activated. It does *NOT* mean that the main power has been removed. ...4-43
-  **CAUTION:** The digital outputs (relay and/or open collector) available on the drive must not be considered as safety related signals. The outputs of the external safety relay must be used for integration into a safety related control/command circuit. ...4-45

Warnings and Cautions for Troubleshooting and Maintenance



WARNING: Wait at least ten (10) minutes after turning OFF the input power supply before performing maintenance or an inspection. Otherwise, there is the danger of electric shock. ...6-2



WARNING: Make sure that only qualified personnel will perform maintenance, inspection, and part replacement. Before starting to work, remove any metallic objects from your person (wristwatch, bracelet, etc.). Be sure to use tools with insulated handles. Otherwise, there is a danger of electric shock and/or injury to personnel. ...6-2



WARNING: Never remove connectors by pulling on its wire leads (wires for cooling fan and logic P.C.board). Otherwise, there is a danger of fire due to wire breakage and/or injury to personnel. ...6-2



CAUTION: Do not connect the megger to any control terminals such as intelligent I/O, analog terminals, etc. Doing so could cause damage to the inverter. ...6-16



CAUTION: Never test the withstand voltage (HIPOT) on the inverter. The inverter has a surge protector between the main circuit terminals above and the chassis ground. ...6-16



CAUTION: Power terminal assignment is different compared to old models such as L100, L200, X200 series, etc.,. Pay attention when wiring the power cable. ...6-16



HIGH VOLTAGE: Be careful not to touch wiring or connector terminals when working with the inverters and taking measurements. Be sure to place the measurement circuitry components above in an insulated housing before using them. ...6-20

General Warnings and Cautions



WARNING: Never modify the unit. Otherwise, there is a danger of electric shock and/or injury.



CAUTION: Withstand voltage test and insulation resistance tests (HIPOT) are executed before the units are shipped, so there is no need to conduct these tests before operation.



CAUTION: Do not attach or remove wiring or connectors when power is applied. Also, do not check signals during operation.



CAUTION: Be sure to connect the grounding terminal to earth ground.



CAUTION: When inspecting the unit, be sure to wait ten (10) minutes after turning OFF the power supply before opening the cover.



CAUTION: Do not stop operation by switching OFF electromagnetic contactors on the primary or secondary side of the inverter.

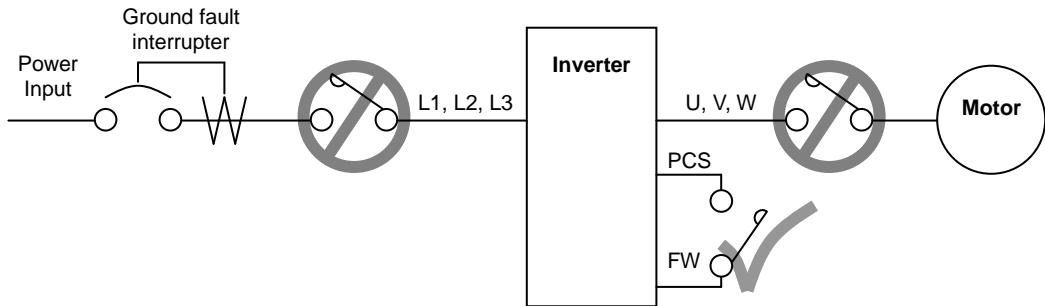

When there has been a sudden power failure while an operation instruction is active, then the unit may restart operation automatically after the power failure has ended. If there is a possibility that such an occurrence may harm humans, then install an electromagnetic contactor (Mgo) on the power supply side, so that the circuit does not allow automatic restarting after the power supply recovers. If the optional remote operator is used and the retry function has been selected, this will also cause automatic restarting when a Run command is active. So, please be careful.



CAUTION: Do not insert leading power factor capacitors or surge absorbers between the output terminals of the inverter and motor.

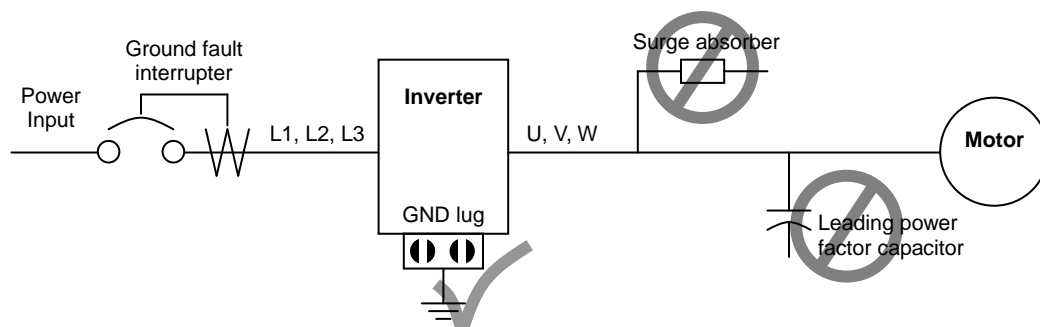

When there has been a sudden power failure while an operation instruction is active, then the unit may restart operation automatically after the power failure has ended. If there is a possibility that such an occurrence may harm humans, then install an electromagnetic contactor (Mgo) on the power supply side, so that the circuit does not allow automatic restarting after the power supply recovers. If the optional remote operator is used and the retry function has been selected, this will also cause automatic restarting when a Run command is active. So, please be careful.



CAUTION: MOTOR TERMINAL SURGE VOLTAGE SUPPRESSION FILTER (For the 400V CLASS)

In a system using an inverter with the voltage control PWM system, a voltage surge caused by the cable constants such as the cable length (especially when the distance between the motor and the inverter is 10m or more) and cabling method may occur at the motor terminals. A dedicated filter of the 400V class for suppressing this voltage surge is available. Be sure to install a filter in this situation.



CAUTION: EFFECTS OF POWER DISTRIBUTION SYSTEM ON INVERTER

In the case below involving a general-purpose inverter, a large peak current can flow on the power supply side, sometimes destroying the converter module:

1. The unbalance factor of the power supply is 3% or higher.
2. The power supply capacity is at least 10 times greater than the inverter capacity (or the power supply capacity is 500kVA or more).
3. Abrupt power supply changes are expected, due to conditions such as:
 - a. Several inverters are interconnected with a short bus.
 - b. A thyristor converter and an inverter are interconnected with a short bus.
 - c. An installed phase advance capacitor opens and closes.

Where these conditions exist or when the connected equipment must be highly reliable, you **MUST** install an input side AC-reactor of 3% (at a voltage drop at rated current) with respect to the supply voltage on the power supply side. Also, where the effects of an indirect lightning strike are possible, install a lightning conductor.



CAUTION: SUPPRESSION FOR NOISE INTERFERENCE FROM INVERTER

The inverter uses many semiconductor switching elements such as transistors and IGBTs. Thus, a radio receiver or measuring instrument located near the inverter is susceptible to noise interference.

To protect the instruments from erroneous operation due to noise interference, they should be used well away from the inverter. It is also effective to shield the whole inverter structure.

The addition of an EMC filter on the input side of the inverter also reduces the effect of noise from the commercial power line on external devices.

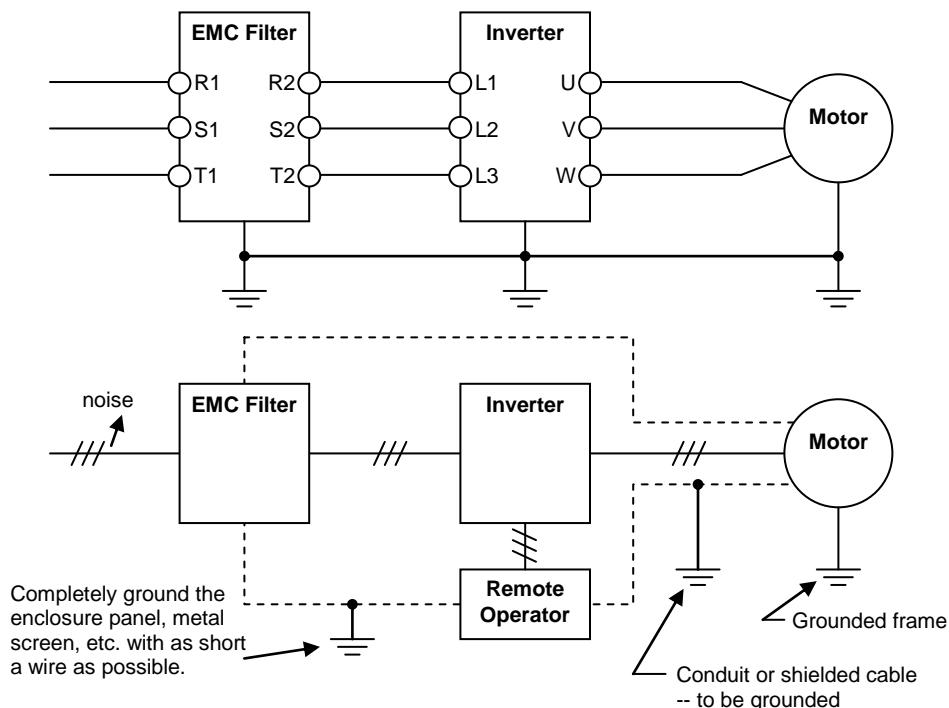
Note that the external dispersion of noise from the power line can be minimized by connecting an EMC filter on the primary side of the inverter.



CAUTION: When the EEPROM error E08 occurs, be sure to confirm the setting values again.



CAUTION: When using normally closed active state settings (C011 to C017) for externally commanded Forward or Reverse terminals [FW] or [RV], the inverter may start automatically when the external system is powered OFF or disconnected from the inverter! So do not use normally closed active state settings for Forward or Reverse terminals [FW] or [RV] unless your system design protects against unintended motor operation.



CAUTION: In all the instrumentations in this manual, covers and safety devices are occasionally removed to describe the details. While operating the product, make sure that the covers and safety devices are placed as they were specified originally and operate it according to the instruction manual.



CAUTION: Do not discard the inverter with household waste. Contact an industrial waste management company in your area who can treat industrial waste without polluting the environment.



UL® Cautions, Warnings and Instructions

Warnings and Cautions for Troubleshooting and Maintenance

The warnings and instructions in this section summarize the procedures necessary to ensure an inverter installation complies with Underwriters Laboratories® guidelines.



WARNING: Use 60/75°C Cu wire only. (for models: WL200-022S, -004H, -007H, -015H, -022H and -030H)



WARNING: Use 75°C Cu wire only. (for models: WL200-002S, -004S, -007S, -015S, -055H, -075H, -110H, 150H and -185H)



WARNING: Suitable for use on a circuit capable of delivering not more than 100,000 rms Symmetrical Amperes, 240 or 480V maximum.



WARNING: When protected by CC, G, J, or R class Fuses, or when Protected By A Circuit Breaker Having An Interrupting Rating Not Less Than 100,000 rms Symmetrical Amperes, 240 or 480 Volts Maximum.



WARNING: Install device in pollution degree 2 environment.



WARNING: Maximum Surrounding Air Temperature 50°C



WARNING: Solid state motor overload protection is provided in each model



WARNING: Integral solid state short circuit protection does not provide branch circuit protection. Branch circuit protection must be provided in accordance with the National Electric Code and any additional local codes



WARNING: Motor over temperature protection is not provided by the drive.

Terminal symbols and Screw size

Inverter Model	Screw Size	Required Torque (N-m)	Wire range
WL200-002S WL200-004S WL200-007S	M3.5	1.0	AWG16 (1.3mm ²)
WL200-015S	M4	1.4	AWG12 (5.3mm ²)
WL200-022S	M4	1.4	AWG10 (5.3mm ²)
WL200-004H WL200-007H WL200-015H WL200-022H	M4	1.4	AWG16 (1.3mm ²)
WL200-030H	M4	1.4	AWG14 (2.1mm ²)
WL200-040H WL200-055H	M4	1.4	AWG12 (3.3mm ²)
WL200-075H WL200-110H	M5	3.0	AWG10 (5.3mm ²)
WL200-150H WL200-185H	M6	3.9 to 5.1	AWG6 (13mm ²)

(For more details, please refer to page 2–15)

Circuit Breaker and Fuse Sizes

CONSTRUCTION DETAILS: (CONT'D)

Distribution fuse and circuit breaker size marking is included in the manual to indicate that the unit shall be connected with a Listed Cartridge Nonrenewable fuse or Inverse time circuit breaker, rated 600 Vac with the current ratings as shown in the table below or Type E Combination Motor Controller marking is included in the manual to indicate that the unit shall be connected with, LS Industrial System Co.,Ltd, Type E Combination Motor Controller MMS Series with the ratings as shown in the table below:

Model No.	Fuse		Inverse Time Circuit Breaker	Type E CMC
	Type	Rating(Maximum A)	Rating (Maximum A)	
WL200-002S	Class J Class CC Class G Class T	10 A, AIC 200 kA	30A	MMS-32H, 240V,40A
WL200-004S		10 A, AIC 200 kA		
WL200-007S		10 A, AIC 200 kA		
WL200-015S		20 A, AIC 200 kA		
WL200-022S		30 A, AIC 200 kA		
WL200-004H		10 A, AIC 200 kA	20A	MMS-32H, 480V,40A or MMS-63H, 480V,52A
WL200-007H		10 A, AIC 200 kA		
WL200-015H		10 A, AIC 200 kA		
WL200-022H		10 A, AIC 200 kA		
WL200-030H		15 A, AIC 200 kA		
WL200-040H		15 A, AIC 200 kA		
WL200-055H		15 A, AIC 200 kA		
WL200-075H		30 A, AIC 200 kA		
WL200-110H		50 A, AIC 200 kA	40A	
WL200-150H		50 A, AIC 200 kA		
WL200-185H		50 A, AIC 200 kA		

Table of Contents

Safety Messages

Hazardous High Voltage	i
Caution when using Safe Stop Function	ii
General Precautions – Read These First!	ii
Index to Warnings and Cautions in This Manual	iv
General Warnings and Cautions	xi
UL® Cautions, Warnings and Instructions	xiv
Terminal symbols and Screw size	xv
Circuit Breaker and Fuse Sizes	xvi
Table of Contents	xvii
Revisions	xix
Contact Information	xx

Chapter 1: Getting Started

Introduction	1-2
WL200 Inverter Specifications	1-4
Introduction to Variable-Frequency Drives	1-15
Frequently Asked Questions	1-20

Chapter 2: Inverter Mounting and Installation

Orientation to Inverter Features	2-2
Basic System Description	2-4
Step-by-Step Basic Installation	2-6
Powerup Test	2-22
Using the Front Panel Keypad	2-24

Chapter 3: Configuring Drive Parameters

Choosing a Programming Device	3-2
Using the Keypad Devices	3-3
"D" Group: Monitoring Functions	3-5
"F" Group: Main Profile Parameters	3-10
"A" Group: Standard Functions	3-11
"B" Group: Fine Tuning Functions	3-43
"C" Group: Intelligent Terminal Functions	3-79
"H" Group: Motor Constants Functions	3-99
"P" Group: Other Parameters	3-100

Chapter 4: Operations and Monitoring

Introduction	4-2
Connecting to PLCs and Other Devices	4-4
Control Logic Signal Specifications	4-6
Intelligent Terminal Listing	4-10
Using Intelligent Input Terminals	4-12
Using Intelligent Output Terminals	4-45
Analog Input Operation	4-77
Analog Output Operation	4-79

Chapter 5: Inverter System Accessories

Introduction.....	5-2
Component Descriptions	5-3

Chapter 6: Troubleshooting and Maintenance

Troubleshooting.....	6-2
Monitoring Trip Events, History, & Conditions.....	6-8
Warning Codes.....	6-11
Restoring Factory Default Settings	6-14
Maintenance and Inspection	6-15
Warranty	6-22

Appendix A: Glossary and Bibliography

Glossary.....	A-2
Bibliography	A-8

Appendix B: Modbus Network Communication

Introduction.....	B-2
Connecting the Inverter to Modbus.....	B-3
Network Protocol Reference.....	B-5
Explanation of function codes	B-10
Modbus Data Listing.....	B-24

Appendix C: Drive Parameter Setting Tables

Introduction.....	C-2
Parameter Settings for Keypad Entry	C-2
List of Parameters.....	C-3

Appendix D: CE-EMC Installation Guidelines

CE-EMC Installation Guidelines	D-2
Hitachi EMC Recommendations.....	D-6

Appendix E: Safety (ISO13849-1)

Introduction.....	E-2
Stop Category defined in EN60204-1.....	E-2
How it works	E-2
Activation.....	E-2
Installation.....	E-3
Wiring example.....	E-4
Components to be combined	E-6
Periodical check (proof test)	E-6
Precautions	E-7

Index

Revisions

Revision History Table

No.	Revision Comments	Date of Issue	Operation Manual No.
1	Initial release.	2015/11	NT353X

Contact Information

Hitachi America, Ltd.
Power and Industrial Division
50 Prospect Avenue
Tarrytown, NY 10591
U.S.A.
Phone: +1-914-631-0600
Fax: +1-914-631-3672

Hitachi Australia Pty. Ltd.
Suite 801, Level 8, 123 Epping Road,
North Ryde, NSW, 2113,
Australia
Phone: +61-2-9888-4100
Fax: +61-2-9888-4188

Hitachi Europe GmbH
Am Seestern 18
D-40547 Dusseldorf
Germany
Phone: +49-211-5283-0
Fax: +49-211-5283-649

Hitachi Industrial Equipment Systems Co., Ltd.
AKS Building, 3, kanda Neribeicho
Chiyoda-ku, Tokyo, 101-0022
Japan
Phone: +81-3-4345-6910
Fax: +81-3-4345-6067

Hitachi Asia Ltd.
Industrial Components & Equipment
Division
No.30 Pioneer Crescent, #10-15 West Park
Bizcentral
Singapore 628560
Phone: +65-6305-7400
Fax: +65-6305-7401

Hitachi Industrial Equipment Systems Co., Ltd.
Narashino Division
1-1, Higashi-Narashino 7-chome
Narashino-shi, Chiba 275-8611
Japan
Phone: +81-47-493-8115
Fax: +81-47-477-4712

Hitachi East Asia Ltd.
6th Floor, North Tower
World Finance Centre, Harbour City
Canton Road, Tsimshatsui, Kowloon
Hong Kong
Phone: +852-2735-9218
Fax: +852-2735-6793



NOTE: To receive technical support for the Hitachi inverter you purchased, contact the Hitachi inverter dealer from whom you purchased the unit, or the sales office or factory contact listed above. Please be prepared to provide the following inverter nameplate information:

1. Model
2. Date of purchase
3. Manufacturing number (MFG No.)
4. Symptoms of any inverter problem

If any inverter nameplate information is illegible, please provide your Hitachi contact with any other legible nameplate items. To reduce unpredictable downtime, we recommend that you stock a spare inverter.

Getting Started



1

In This Chapter...	page
- Introduction	1-2
- WL200 Inverter Specifications	1-4
- Introduction to Variable-Frequency Drives	1-15
- Frequently Asked Questions	1-20

Introduction

Main Features

Congratulation on your purchase of a WL200 Series Hitachi inverter! This inverter drive features state-of-the-art circuitry and components to provide high performance. The housing footprint is exceptionally small, given the size of the corresponding motor. The Hitachi WL200 product line includes more than a dozen inverter models to cover motor sizes from 1/4 horsepower to 25 horsepower, in either 240VAC or 480VAC power input versions.

The main features are:

- 200V and 400V class, 0.2 to 18.5kW inverters
- EU versions available
- EzSQ (simple programming function) integrated
- Built-in RS485 MODBUS RTU as standard, other FieldBus optional
- New current suppressing function
- Sixteen programmable speed levels
- PID control adjusts motor speed automatically to maintain a process variable value
- Password protection to avoid unexpected parameter change

The design in Hitachi inverters overcomes many of the traditional trade-offs between speed, torque and efficiency. The performance characteristics are:

- Continuous operation at 100% torque within a 1:10 speed range (6/60Hz / 5/50Hz) without motor derating.
- Fan has ON/OFF selection to provide longer life for cooling fan.

A full line of accessories from Hitachi is available to complete your motor application:

- Integrated USB port for PC communication
- Digital remote operator keypad
- Integrated brake chopper
- EMC filter (footprint type C1) optional

Inverter Specification Label

The Hitachi WL200 inverters have product labels located on the right side of the housing, as pictured below. Be sure to verify that the specifications on the labels match your power source, and application safety requirements.

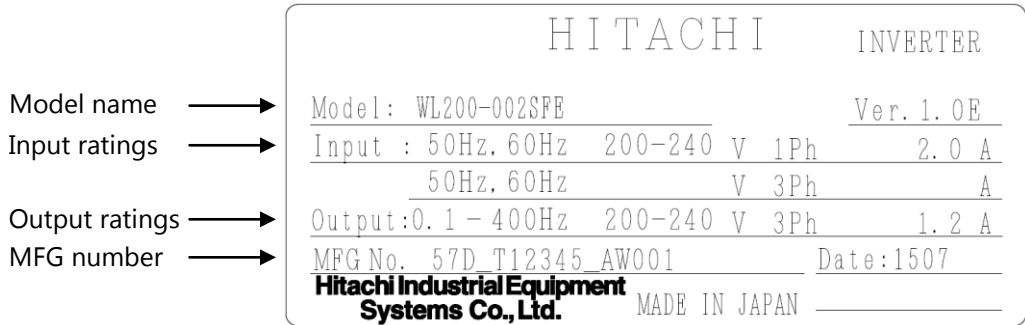

Inverter Model Name

The model number for a specific inverter contains useful information about its operating characteristics. Refer to the model number legend below:

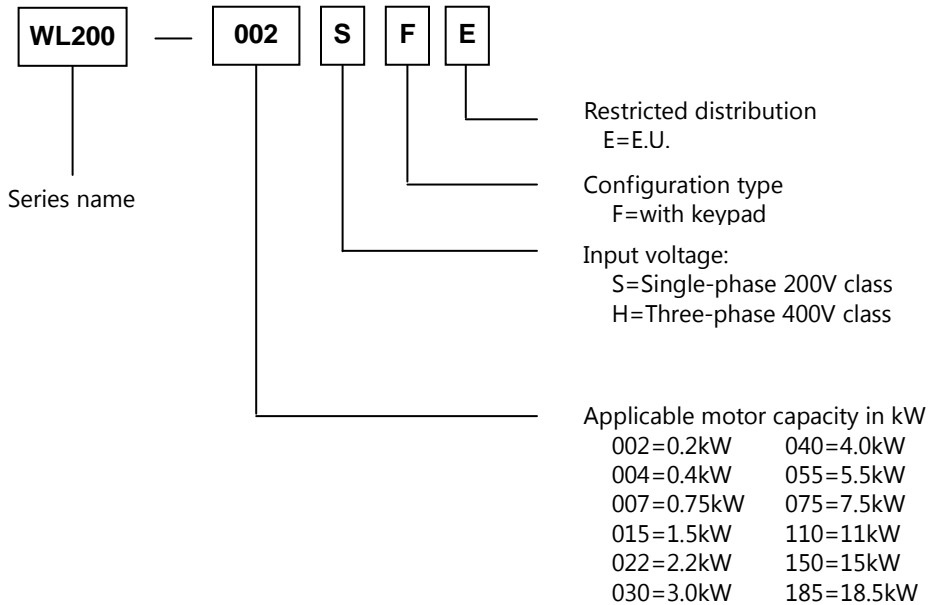

WL200 Inverter Specifications

Model-specific tables for 200V and 400V class inverters

The following tables are specific to WL200 inverters for the 200V and 400V class model groups. Note that "[General Specifications](#)" on page 1-5 apply to both voltage class groups. Footnotes for all specification tables follow the table below.

Item		Single-phase 200V class Specifications				
WL200 inverters, 200V models		002SFE	004SFE	007SFE	015SFE	022SFE
Applicable motor size *2	kW	0.2	0.4	0.75	1.5	2.2
	HP	1/4	1/2	1	2	3
Rated capacity (kVA)	200V	0.4	1.2	1.5	2.8	4.1
	240V	0.5	1.4	1.8	3.4	4.9
Rated input voltage		Single-phase: 200V-15% to 240V +10%, 50/60Hz ±5%				
Rated output voltage *3		Three-phase: 200 to 240V (proportional to input voltage)				
Rated output current (A)		1.2	2.6	3.5	6.0	9.6
Cooling method		Self-cooling				Force ventilation
Weight	Kg	1.0	1.1	1.1	1.6	1.8
	lb	2.2	2.4	2.4	3.1	4.0

Item		Three-phase 400V class Specifications					
WL200 inverters, 400V models		004HFE	007HFE	015HFE	022HFE	030HFE	040HFE
Applicable motor size *2	kW	0.4	0.75	1.5	2.2	3.0	4.0
	HP	1/2	1	2	3	4	5
Rated capacity (kVA)	380V	1.4	1.4	2.9	3.9	5.4	6.2
	480V	1.7	1.8	3.6	5.0	6.8	7.9
Rated input voltage		Three-phase: 380V-15% to 480V +10%, 50/60Hz ±5%					
Rated output voltage *3		Three-phase: 380 to 480V (proportional to input voltage)					
Rated output current (A)		1.5	2.1	4.1	5.4	6.9	8.8
Cooling method		Self-cooling			Force ventilation		
Weight	Kg	1.5	1.5	1.6	1.8	1.9	1.9
	lb	3.3	3.3	3.5	4.0	4.2	4.2

Item		Three-phase 400V class Specifications				
WL200 inverters, 400V models		055HFE	075HFE	110HFE	150HFE	185HFE
Applicable motor size *2	kW	5.5	7.5	11	15	18.5
	HP	7.5	10	15	20	25
Rated capacity (kVA)	380V	8.8	13.2	15.8	25.1	29
	480V	11.1	16.7	20.0	31.6	36.6
Rated input voltage		Three-phase: 380V-15% to 480V +10%, 50/60Hz ±5%				
Rated output voltage *3		Three-phase: 380 to 480V (proportional to input voltage)				
Rated output current (A)		11.1	17.5	23.0	31.0	38.0
Cooling method		Force ventilation				
Weight	Kg	2.1	3.5	3.5	4.7	5.2
	lb	4.6	7.7	7.7	10.4	11.5

General Specifications

The following table applies to all WL200 inverters.

Item		General Specifications		
Protective housing *1		IP20		
Control method		Sinusoidal Pulse Width Modulation (PWM) control		
Carrier frequency		2kHz to 10kHz (derating required depending on the model)(*9)		
Output frequency range *4		0.1 to 400Hz		
Frequency accuracy		Digital command: $\pm 0.01\%$ of the maximum frequency Analog command: $\pm 0.2\%$ of the maximum frequency ($25^{\circ}\text{C} \pm 10^{\circ}\text{C}$)		
Frequency setting resolution		Digital: 0.01Hz; Analog: max. frequency/1000		
Volt./Freq. characteristic		V/f control (constant torque, reduced torque, free-V/F): base freq. 30Hz - 400Hz adjustable		
Overload capacity		60 sec. @120%, 12 sec. @140%		
Acceleration/deceleration time		0.00 to 3600 seconds, linear and S-curve accel/decel, second accel/decel setting available		
Input signal	Freq. setting	Operator panel	Up and Down keys / Value settings	
		External signal *8	0 to 10 VDC (input impedance 10k Ohms), 4 to 20mA (input impedance 100 Ohms), Potentiometer (1k to 2k Ohms, 2W)	
		Via network	RS485 ModBus RTU, other network option	
	FWD/REV run	Operator panel	Run/Stop (Forward/Reverse run change by command)	
		External signal	Forward run/stop, Reverse run/stop	
		Via network	RS485 ModBus RTU, other network option	
	Intelligent input terminal	Seven terminals, sink/source changeable by a short bar	FW (forward run command), RV (reverse run command), CF1 - CF4 (multi-stage speed setting), JG (jog command), DB (external braking), SET (set second motor), 2CH (2-stage accel./decel. command), FRS (free run stop command), EXT (external trip), USP (startup function), CS (commercial power switchover), SFT (soft lock), AT (analog input selection), RS (reset), PTC (thermistor thermal protection), STA (start), STP (stop), F/R (forward/reverse), PID (PID disable), PIDC (PID reset), UP (remote control up function), DWN (remote control down function), UDC (remote control data clear), OPE (operator control), SF1 - SF7 (multi-stage speed setting; bit operation), OLR (overload restriction), BOK (Braking confirmation), LAC (LAD cancellation), ADD (add frequency enable), F-TM (force terminal mode), KHC (Cumulative power clear), MI1 - MI7 (general purpose inputs for EzSQ), AHD (analog command hold), GS1,GS2 (STO inputs, safety related signals), 485 (Starting communication signal), PRG (executing EzSQ program), HLD (retain output frequency), ROK (permission of run command), DISP (display limitation), NO (no function)	
	55 functions assignable			
	Output signal	Intelligent output terminal		43 functions assignable
				RUN (run signal), FA1 - FA5 (frequency arrival signal), OL,OL2 (overload advance notice signal), OD (PID deviation error signal), AL (alarm signal), UV (under-voltage), RNT (run time expired), ONT (power ON time expired), THM (thermal warning), BRK (brake release), BER (brake error), ZS (0Hz detection), ODc (analog voltage input disconnection), OIDc (analog current input disconnection), FBV (PID second stage output), NDc (network disconnect detection), LOG1 - LOG3 (Logic output signals), WAC (capacitor life warning), WAF (cooling fan warning), FR (starting contact), OHF (heat sink overheat warning), LOC (Low load), MO1 - MO3 (general outputs for EzSQ), IRDY (inverter ready), FWR (forward operation), RVR (reverse operation), MJA (major failure), WCO (window comparator O), WCOI (window comparator OI), FREF (frequency command source), REF (run command source), SETM (second motor in operation), EDM (STO performance monitor), OP (option control signal), NO (no function)

Item		General Specifications
Output signal	Monitor output (analog)	Output freq., output current, output voltage, input power, thermal load ratio, LAD freq., heat sink temperature, general output (EzSQ)
	Pulse train output (0 to 10Vdc, 32kHz max.)	[PWM output] Output freq., output current, output voltage, input power, thermal load ratio, LAD freq., heat sink temperature, general output (EzSQ) [Pulse train output] Output frequency, output current
Alarm output contact		ON for inverter alarm (1c contacts, both normally open or closed available.)
Other functions		Free-V/f, manual/automatic torque boost, output voltage gain adjustment, AVR function, reduced voltage start, motor data selection, motor stabilization control, reverse running protection, automatic carrier frequency reduction, energy saving operation, PID function, non-stop operation at instantaneous power failure, brake control, DC injection braking, dynamic braking (BRD), frequency upper and lower limiters, jump frequencies, curve accel and decel (S, U, inversed U), 16-stage speed profile, fine adjustment of start frequency, accel and decel stop, process jogging, frequency calculation, frequency addition, 2-stage accel/decel, stop mode selection, start/end freq., analog input filter, window comparators, input terminal response time, output signal delay/hold function, rotation direction restriction, stop key selection, software lock, safe stop function, scaling function, display restriction, password function, user parameter, initialization, initial display selection, cooling fan control, warning, trip retry, frequency pull-in restart, frequency matching, overload restriction, over current restriction, DC bus voltage AVR
Protective function		Over-current, over-voltage, under-voltage, overload, brake resistor overload, CPU error, memory error, external trip, USP error, ground fault detection at power on, temperature error, internal communication error, driver error, thermistor error, brake error, safe stop, overload at low speed, modbus communication error, option error, EzSQ command error, EzSQ nesting error, EzSQ execution error, EzSQ user trip
Operating environment	Temperature	Operating (ambient): -10 to 40°C(*10), / Storage: -20 to 65°C(*10)
	Humidity	20 to 90% humidity (non-condensing)
	Vibration *11	5.9m/s ² (0.6G), 10 to 55 Hz
	Location	Altitude 1,000m or less, indoors (no corrosive gasses or dust)
Coating color		No painting, [mold: Black (Mansell N1.5)]
Options		Remote operator unit, cables for the units, braking unit, braking resistor, AC reactor, DC reactor, EMC filter, fieldbus
Standards		UL, CE, C-UL C-tick, Functional safety(Certification in progress))

Footnotes for the preceding table and the tables that follow:

- Note1:** The protection method conforms to JIS C 0920 (IEC60529).
- Note2:** Applicable motor size is reference motor. When select motors, take notice so that rated current of motor does not exceed over the inverter's rated current.
- Note3:** The output voltage decreases as the main supply voltage decreases (except when using the AVR function). In any case, the output voltage cannot exceed the input power supply voltage.
- Note4:** To operate the motor beyond 50/60Hz, consult the motor manufacturer for the maximum allowable rotation speed.
- Note5:** For achieving approved input voltage rating categories:
- 460 to 480VAC – Over-voltage category 2
 - 380 to 460VAC – Over-voltage category 3
- To meet the Over-voltage category 3, insert an EN or IEC standard compliant isolation transformer that is earth grounded and star connected (for Low Voltage Directive).
- Note6:** At the rated voltage when using a Hitachi standard 3-phase, 4-pole motor.
- Note7:** The braking torque via capacitive feedback is the average deceleration torque at the shortest deceleration (stopping from 50/60Hz as indicated). It is not continuous regenerative braking torque. The average deceleration torque varies with motor loss. This value decreases when operating beyond 50Hz. If a large regenerative torque is required, the optional regenerative braking unit and a resistor should be used.
- Note8:** The frequency command is the maximum frequency at 9.8V for input voltage 0 to 10VDC, or at 19.6mA for input current 4 to 20mA. If this characteristic is not satisfactory for your application, contact your Hitachi representative.
- Note9:** If the inverter is operated outside the region shown in the graph in the derating curve, the inverter may be damaged or its service life may be shortened. Set **b083** Carrier Frequency Adjustment in accordance with the expected output current level. See derating curve section for the detailed information of the inverter operating range.
- Note10:** The storage temperature refers to the short-term temperature during transportation.
- Note11:** Conforms to the test method specified in JIS JIS C 60068-2-6: 2010(IEC 60068-2-6:2007). For the model types excluded in the standard specifications, contact your Hitachi sales representative.

Signal Ratings

Detailed ratings are in "**Control Logic Signal Specifications**" on page 4-6.

Signal / Contact	Ratings
Built-in power for inputs	24VDC, 100mA maximum
Discrete logic inputs	27VDC maximum
Discrete logic outputs	50mA maximum ON state current, 27 VDC maximum OFF state voltage
Analog output	10bit / 0 to 10VDC, 2mA
Analog input, current	4 to 19.6 mA range, 20mA nominal
Analog input, voltage	0 to 9.8 VDC range, 10VDC nominal, input impedance 10k Ω
+10V analog reference	10VDC nominal, 10mA maximum
Alarm relay contacts	250 VAC, 2.5A (R load) max., 0.2A (I load, P.F.=0.4) max. 100 VAC, 10mA min 30 VDC, 3.0A (R load) max., 0.7A (I load, P.F.=0.4) max.) 5 VDC, 100mA min.

Derating Curves

The maximum available inverter current output is limited by the carrier frequency and ambient temperature. Choosing a higher carrier frequency tends to decrease audible noise, but it also increases the internal heating of the inverter, thus decreasing (derating) the maximum current output capability. Ambient temperature is the temperature just outside the inverter housing—such as inside the control cabinet where the inverter is mounted. A higher ambient temperature decreases (derates) the inverter's maximum current output capacity.

An inverter may be mounted individually in an enclosure or side-by-side with other inverter(s) as shown below. Side-by-side mounting causes greater derating than mounting inverters separately. Graphs for either mounting methods are included in this section. Refer to "Ensure Adequate Ventilation" on page 2-10 for minimum clearance dimensions for both mounting configurations.

Individual mounting

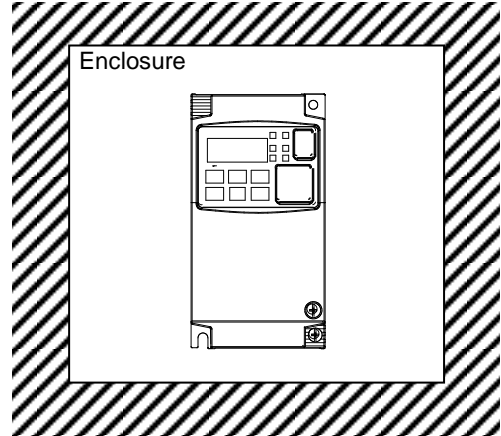

Side-by-side mounting

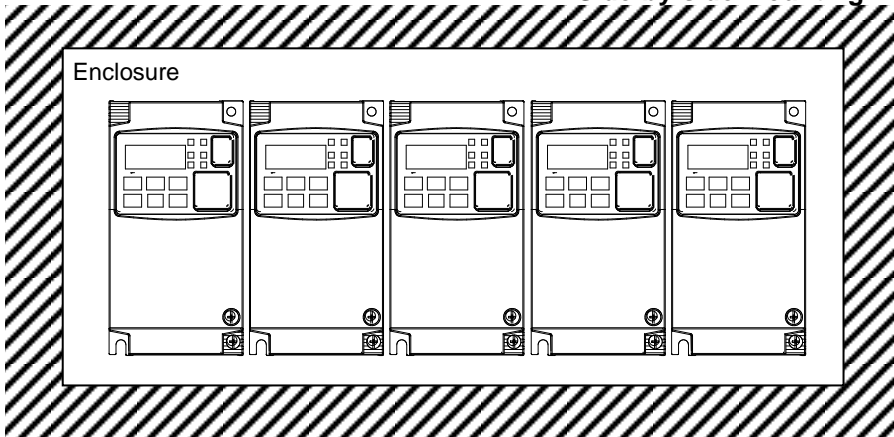

The following table shows which models need derating.

1-ph 200V class	Need derating	3-ph 400V class	Need derating
WL200-002S	—	WL200-004H	—
WL200-004S	—	WL200-007H	—
WL200-007S	✓	WL200-015H	✓
WL200-015S	✓	WL200-022H	—
WL200-022S	—	WL200-030H	—
—	—	WL200-040H	—
—	—	WL200-055H	✓
—	—	WL200-075H	—
—	—	WL200-110H	✓
—	—	WL200-150H	✓
—	—	WL200-185H	✓

✓ : need derating

— : need no derating

Use the following derating curves to help determine the optimal carrier frequency setting for your inverter and find the output current derating. Be sure to use the proper curve for your particular WL200 inverter model number.

Legend for Graphs:

- Ambient temperature 40°C max., individual mounting
- Ambient temperature 50°C max., individual mounting
- . - . - . - . Ambient temperature 40°C max., side-by-side mounting

Derating curves:

Models need no derating

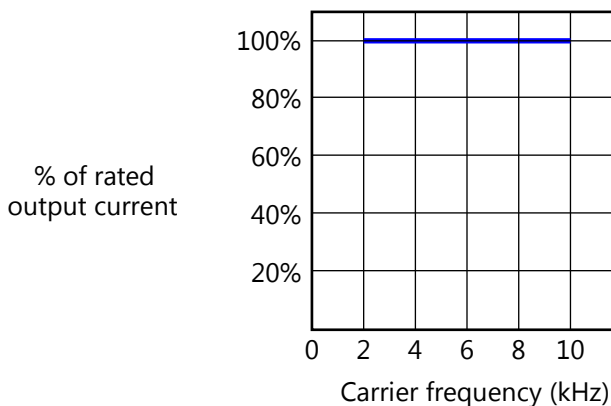

Derating curves, continued...

Models need derating

WL200-007S

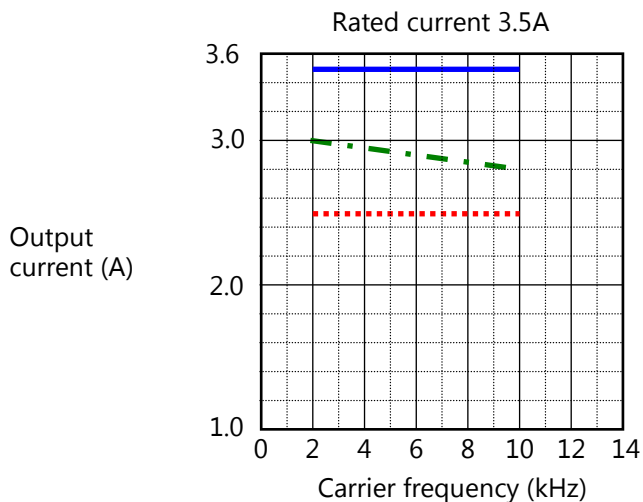

WL200-015S

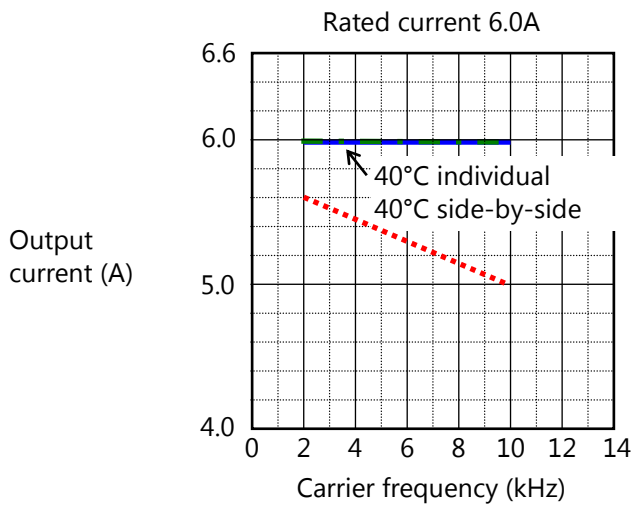

Derating curves, continued...

WL200-015H

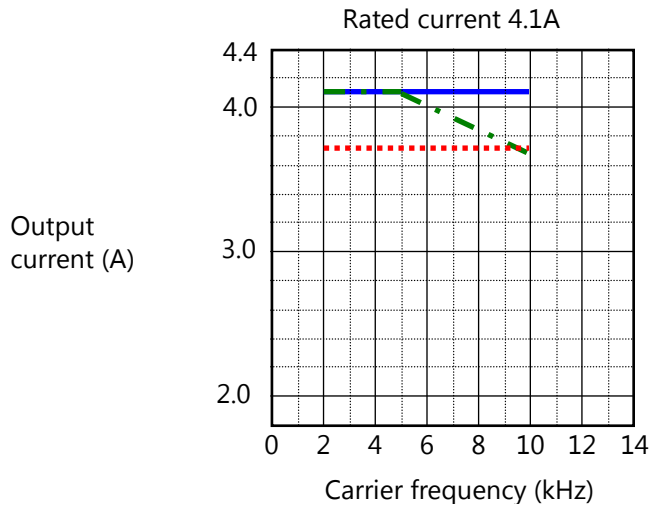

WL200-055H

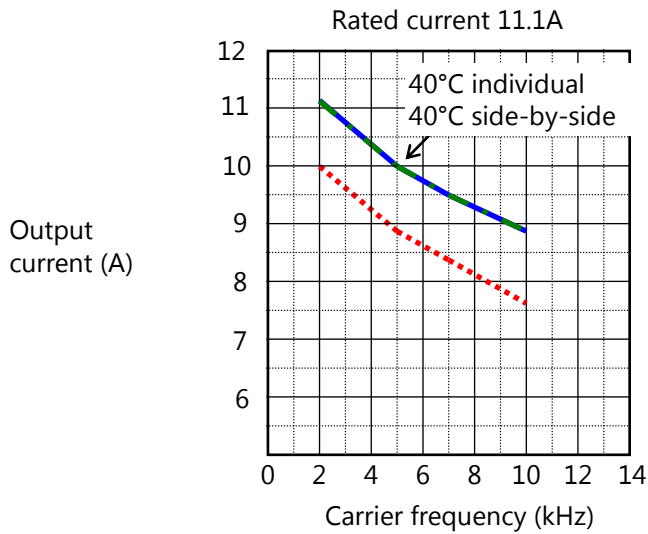

Derating curves, continued...

WL200-110H

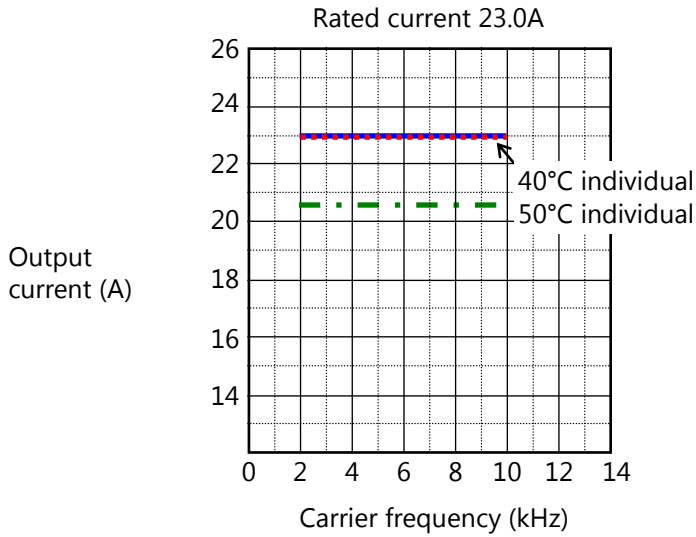

WL200-150H

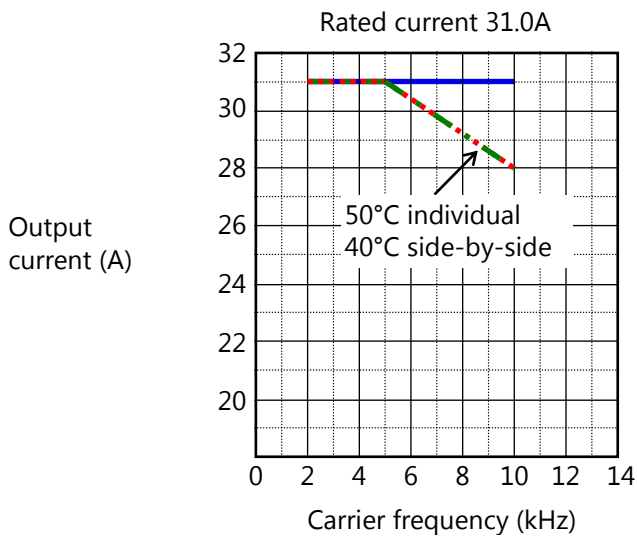

Derating curves, continued...

WL200-185H

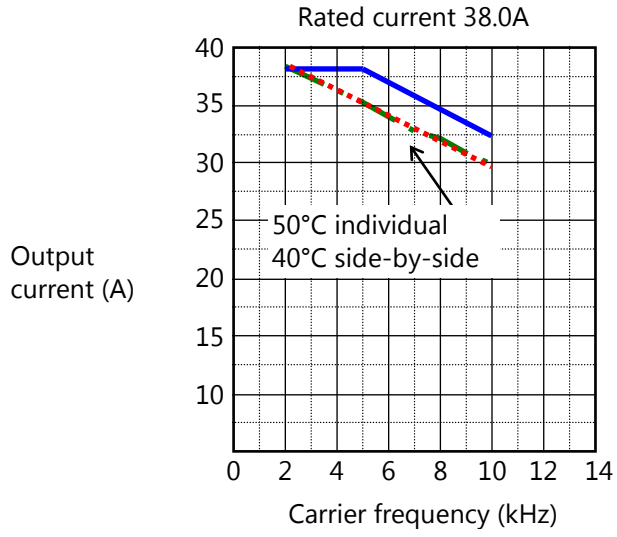

Introduction to Variable-Frequency Drives

The Purpose of Motor Speed Control for Industry

Hitachi inverters provide speed control for 3-phase AC induction motors. You connect AC power to the inverter, and connect the inverter to the motor. Many applications benefit from a motor with variable speed, in several ways:

- Energy savings – HVAC
- Need to coordinate speed with an adjacent process – textile and printing presses
- Need to control acceleration and deceleration
- Sensitive loads – elevators, food processing, pharmaceuticals

What is an Inverter

The term *inverter* and *variable-frequency drive* are related and somewhat interchangeable. An electronic motor drive for an AC motor can control the motor's speed by *varying the frequency* of the power sent to the motor.

An inverter, in general, is a device that converts DC power to AC power. The figure below shows how the variable-frequency drive employs an internal inverter. The drive first converts incoming AC power to DC through a rectifier bridge, creating an internal DC bus voltage. Then the inverter circuit converts the DC back to AC again to power the motor. The special inverter can vary its output frequency and voltage according to the desired motor speed.

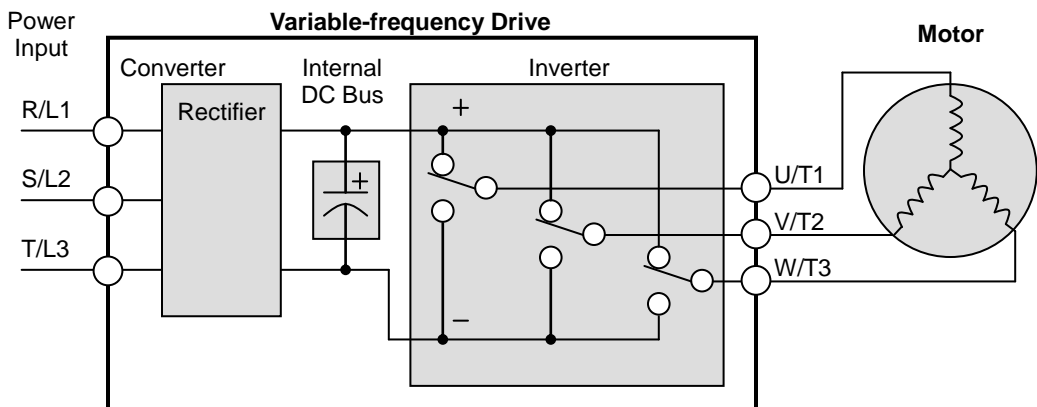

The simplified drawing of the inverter shows three double-throw switches. In Hitachi inverters, the switches are actually IGBTs (insulated gate bipolar transistors). Using a commutation algorithm, the microprocessor in the drive switches the IGBTs on and off at a very high speed to create the desired output waveforms. The inductance of the motor windings helps smooth out the pulses.

Torque and Constant Volts/Hertz Operation

In the past, AC variable speed drives used an open loop (scalar) technique to control speed. The constant-volts-hertz operation maintains a constant ratio between the applied voltage and the applied frequency. With these conditions, AC induction motors inherently delivered constant torque across the operating speed range. For some applications, this scalar technique was adequate.

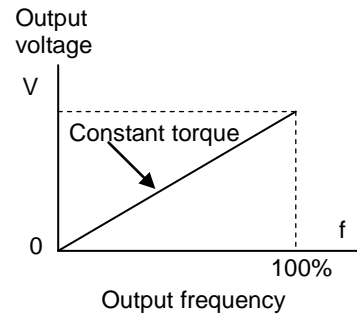

Today, with the advent of sophisticated microprocessors and digital signal processors (DSPs), it is possible to control the speed and torque of AC induction motors with unprecedented accuracy. The WL200 utilizes these devices to perform complex mathematical calculations required to achieve superior performance. You can choose various torque curves to fit the needs of your application. Constant torque applies the same torque level across the frequency (speed) range. *Variable torque*, also called *reduced torque*, lowers the torque delivered at mid-level frequencies. A torque boost setting will add additional torque in the lower half of the frequency range for the constant and variable torque curves. With the *free-setting torque* curve feature, you can specify a series of data points that will define a custom torque curve to fit your application.

Inverter Input and Three-phase Power

The Hitachi WL200 Series of inverters includes two sub-groups: the 200V class and the 400V class inverters. The drive described in this manual may be used in either the United States or Europe, although the exact voltage level for commercial power may be slightly different from country to country. Accordingly, a 200V class inverter requires (nominal) 200 to 240VAC, and 400V class inverter requires from 380 to 480VAC.

The 200V class inverters having a suffix of -SF accept single-phase 200V class input voltage only. All 400V class inverters require three-phase power supply.



TIP: If your application only has single phase power available, refer to WL200 inverter of 3HP or less (European version with a suffix of -SFE); they can accept single phase input power. Note: Larger models may be able to accept single-phase with derating. Contact your Hitachi distributor for assistance.

The common terminology for single phase power is line (L) and Neutral (N). Three-phase power connections are usually labeled Line 1 [R/L1], Line 2 [S/L2] and Line 3 [T/L3]. In any case, the power source should include an earth ground connection. That ground connection will need to connect to the inverter chassis and to the motor frame (see "Wire the Inverter Output to Motor" on page 2-21).

Inverter Output to the Motor

The AC motor must be connected only to the inverter's output terminals. The output terminals are uniquely labeled (to differentiate them from the input terminals) with the designations U/T1, V/T2, and W/T3. This corresponds to typical motor lead connection designations T1, T2, and T3. It is often not necessary to connect a particular motor lead for a new application. The consequence of swapping any two of the three connections is the reversal of the motor direction. In applications where reversed rotation could cause equipment damage or personnel injury, be sure to verify direction of rotation before attempting full-speed operation.

For safety to personnel, you must connect the motor chassis ground to the ground connection at the bottom of the inverter housing.

Notice the three connections to the motor do not include one marked "Neutral" or "Return". The motor represents a balanced "Y" impedance to the inverter, so there is no need for a separate return. In other words, each of the three "Hot" connections serves also as a return for the other connections, because of their phase relationship.

The Hitachi inverter is a rugged and reliable device. The intention is for the inverter to assume the role of controlling power to the motor during all normal operations. Therefore, this manual instructs you not to switch off power to the inverter *while the motor is running* (unless it is an emergency stop). Also, do not install or use disconnect switches in the wiring from the inverter to the motor (except thermal disconnect). Of course, safety-related devices such as fuses must be in the design to break power during a malfunction, as required by NEC and local codes.

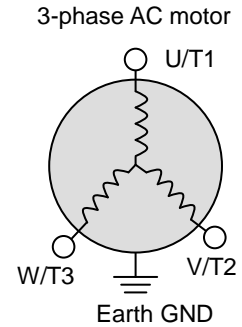

Intelligent Functions and Parameters

Much of this manual is devoted to describing how to use inverter functions and how to configure inverter parameters. The inverter is micro-processor-controlled, and has many independent functions. The microprocessor has an on-board EEPROM for parameter storage. The inverter's front panel keypad provides access to all functions and parameters, which you can access through other devices as well. The general name for all these devices is the *digital operator*, *integrated operator*, or *digital operator panel*. Chapter 2 will show you how to get a motor running, using a minimal set of function commands or configuring parameters.

The optional read/write programmer will let you read and write inverter EEPROM contents from the programmer. This feature is particularly useful for OEMs who need to duplicate a particular inverter's settings in many other inverters in assembly-line fashion.

Braking

In general, braking is a force that attempts to slow or stop motor rotation. So it is associated with motor deceleration, but may also occur even when the load attempts to drive the motor faster than the desired speed (overhauling). If you need the motor and load to decelerate quicker than their natural deceleration during coasting, we recommend installing a braking resistor. The dynamic braking unit (built into WL200) sends excess motor energy into a resistor to slow the motor and load (See "[Introduction](#)" on page 5-2 and "[Dynamic Braking Selection Tables](#)" on page 5-5 for more information). For loads that continuously overhaul the motor for extended periods of time, the WL200 may not be suitable (contact your Hitachi distributor).

The inverter parameters include acceleration and deceleration, which you can set to match the needs of the application. For a particular inverter, motor, and load, there will be a range of practically achievable accelerations and decelerations.

Velocity Profiles

The WL200 inverter is capable of sophisticated speed control. A graphical representation of that capability will help you understand and configure the associated parameters. This manual makes use of the velocity profile graph used in industry (shown at right). In the example, *acceleration* is a ramp to a set speed, and *deceleration* is a decline to a stop.

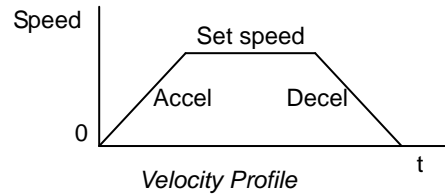

Acceleration and deceleration settings specify the time required to go from a stop to maximum frequency (or vice versa). The resulting slope (speed change divided by time) is the acceleration or deceleration. An increase in output frequency uses the acceleration slope, while a decrease uses the deceleration slope. The accel or decel time a particular speed change depends on the starting and ending frequencies.

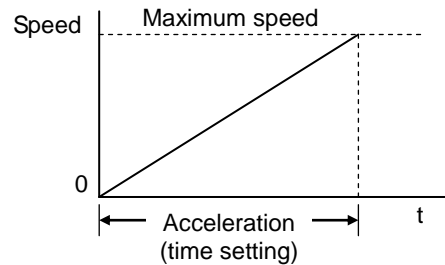

However, the slope is constant, corresponding to the full-scale accel or decel time setting. For example, the full-scale acceleration setting (time) may be 10 seconds – the time required to go from 0 to 60Hz.

The WL200 inverter can store up to 16 preset speeds. And, it can apply separate acceleration and deceleration transitions from any preset to any other preset speed. A multi-speed profile (shown at right) uses two or more preset speeds, which you can select via intelligent input terminals. This external control can apply any preset speed at any time.

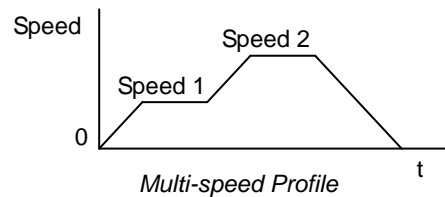

Alternatively, the selected speed is infinitely variable across the speed range. You can use the potentiometer control on the keypad for manual control. The drive accepts analog 0-10VDC signals and 4-20 mA control signals as well.

The inverter can drive the motor in either direction. Separate FW and RV commands select the direction of rotation. The motion profile example shows a forward motion followed by a reverse motion of shorter duration. The speed presets and analog signals control the magnitude of the speed, while the FWD and REV commands determine the direction before the motion starts.

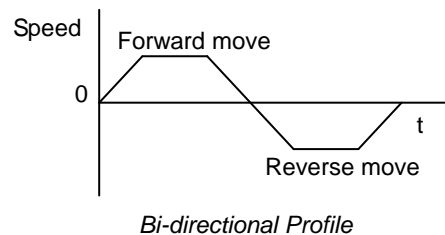

NOTE: The WL200 can move loads in both directions. However, it is not designed for use in servo-type applications that use a bipolar velocity signal that determines direction.

Frequently Asked Questions

- Q.** What is the main advantage in using an inverter to drive a motor, compared to alternative solutions?
- A.** An inverter can vary the motor speed with very little loss of efficiency, unlike mechanical or hydraulic speed control solutions. The resulting energy savings usually pays for the inverter in a relatively short time.
- Q.** The term “inverter” is a little confusing, since we also use “drive” and “amplifier” to describe the electronic unit that controls a motor. What does “inverter” mean?
- A.** The term *inverter*, *drive*, and *amplifier* are used somewhat interchangeably in industry. Nowadays, the term *drive*, *variable-frequency drive*, *variable-speed drive*, and *inverter* are generally used to describe electronic, microprocessor-based motor speed controllers. In the past, *variable-speed drive* also referred to various mechanical means to vary speed. *Amplifier* is a term almost exclusively used to describe drives for servo or stepper motors.
- Q.** Although the WL200 inverter is a variable speed drive, can I use it in a fixed-speed application?
- A.** Yes, sometimes an inverter can be used simply as a “soft-start” device, providing controlled acceleration and deceleration to a fixed speed. Other functions of the WL200 may be useful in such applications, as well. However, using a variable speed drive can benefit many types of industrial and commercial motor applications, by providing controlled acceleration and deceleration, high torque at low speeds, and energy savings over alternative solutions.
- Q.** Can I use an inverter and AC induction motor in a positioning application?
- A.** That depends on the required precision, and the slowest speed the motor must turn and still deliver torque. The WL200 inverter will deliver full torque while turning the motor at 6Hz (180RPM). DO NOT use an inverter if you need the motor to stop and hold the load position without the aid of a mechanical brake (use a servo or stepper motion control system).
- Q.** Can the inverter be controlled and monitored via a network?
- A.** Yes. WL200 inverters have built-in ModBus communications. See Appendix B for more information on network communications.
- Q.** Why does the manual or other documentation use terminology such as “200V class” instead of naming the actual voltage, such as “230 VAC”?
- A.** A specific inverter model is set at the factory to work across a voltage range particular to the destination country for that model. The model specifications are on the label on the side of the inverter.



NOTE: The European 200V class inverter is for single phase input (-SFE).

- Q.** Why doesn't the motor have a neutral connection as a return to the inverter?
- A.** The motor theoretically represents a "balanced Y" load if all three stator windings have the same impedance. The Y connection allows each of the three wires to alternatively serve as input or return on alternate half-cycle.
- Q.** Does the motor need a chassis ground connection?
- A.** Yes, for several reasons. Most importantly, this provides protection in the event of a short in the motor that puts a hazardous voltage on its housing. Secondly, motors exhibit leakage current that increase with aging. Lastly, a grounded chassis generally emits less electrical noise than an ungrounded one.
- Q.** What type of motor is compatible with the Hitachi inverters?
- A. Motor type** – It must be a three-phase AC induction motor. Use an inverter-grade motor that has at least 800V insulation for 200V class inverters, or 1600V insulation for 400V class.
- Motor size** – In practice, it's better to find the right size motor for your application; then look for the inverter to match the motor.



NOTE: There may be other factors that will affect motor selection, including heat dissipation, motor operating speed profile, enclosure type, and cooling method.

- Q.** How many poles should the motor have?
- A.** Hitachi inverters can be configured to operate motors with 2, 4, 6, or 8 poles. The greater the number of the poles, the slower the top motor speed will be, but it will have higher torque at the base speed.
- Q.** Will I be able to add dynamic (resistive) braking to my Hitachi WL200 drive after the initial installation?
- A.** Yes, the WL200 inverter already has a dynamic braking circuit built in. Just add the resistor sized to meet the braking requirements. For more information, contact your nearest Hitachi representative.

- Q.** How will I know if my application will require resistive braking?
- A.** For new applications, it may be difficult to tell before you actually test a motor/drive solution. In general, some application can rely on system losses such as friction to serve as the deceleration force, or otherwise can tolerate a long decel time. These applications will not need dynamic braking. However, applications with a combination of a high-inertia load and a required short decel time will need dynamic braking. This is a physics question that may be answered either empirically or through extensive calculations.
- Q.** Several options related to electrical noise suppression are available for the Hitachi inverters. How can I know if my application requires any of these options?
- A.** The purpose of these noise filters is to reduce the inverter electrical noise so the operation of nearby electrical devices is not affected. Some applications are governed by particular regulatory agencies, and noise suppression is mandatory. In those cases, the inverter must have the corresponding noise filter installed. Other applications may not need noise suppression, unless you notice electrical interference with the operation of other devices.
- Q.** The WL200 features a PID control. PID loops are usually associated with chemical processes, heating, or process industries in general. How could the PID loop feature be useful in my application?
- A.** You will need to determine the particular main variable in your application the motor affects. That is the process variable (PV) for the motor. Over time, a faster motor speed will cause a faster change in the PV than a slow motor speed will. By using the PID loop feature, the inverter commands the motor to run at the optimal speed required to maintain the PV at the desired value for current conditions. Using the PID loop feature will require an additional sensor and other wiring, and is considered an advanced application.

Inverter Mounting and Installation



2

In This Chapter...	page
- Orientation to Inverter Features	2-2
- Basic System Description	2-4
- Step-by-Step Basic Installation.....	2-6
- Powerup Test	2-22
- Using the Front Panel Keypad	2-24

Orientation to Inverter Features

Unpacking and Inspection

Please take a few moments to unpack your new WL200 inverter and perform these steps:

1. Look for any damage that may have occurred during transportation.
2. Verify the contents of the box include:
 - a. One WL200 inverter
 - b. One WL200 Basic manual
3. Inspect the specifications label on the side of the inverter. Make sure it matches the product part number you ordered.

Main Physical Features

The WL200 Series inverters vary in size according to the current output rating and motor size for each model number. All feature the same basic Keypad and connector interface for consistent ease of use. The inverter construction has a heat sink at the back of the housing. The larger models include a fan to enhance heat sink performance. The mounting holes are predrilled in the heat sink for your convenience. Smaller models have two mounting holes, while larger ones have four. Be sure to use all the mounting holes provided.

Never touch the heat sink during or just after operation; it can be very hot.

The electronics housing and front panel are built onto the front of the heat sink.

Inverter Keypad – The inverter uses a digital operator interface, or keypad. The four-digit display can show a variety of performance parameters. LEDs indicate whether the display units are Hertz or Amperes. Other LEDs indicate Power (external), and Run/Stop mode and Program/Monitor Mode status. Membrane keys Run and Stop/Reset control monitor operation. The ESC, SET, Δ and ∇ keys allow an operator to navigate to the inverter's functions and parameter values. The SET key is used when changing a parameter.

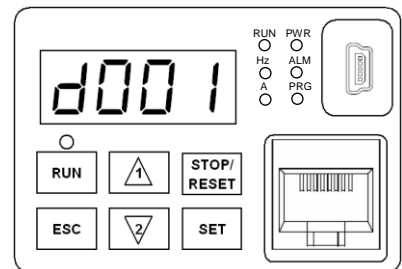
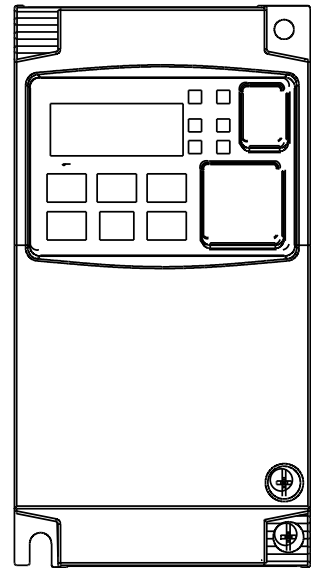

Power Wiring Access – First, ensure no power source is connected to the inverter. If power has been connected, verify that the Power LED is OFF and then wait ten minutes after power down to proceed. After removing the terminal cover and front housing cover, the housing partitions that cover the power and motor wiring exits will be able to slide upward as shown below.

Notice the four wire exit slots in the housing partition. This helps keep the power and motor wiring (to the left) separated from the signal-level logic or analog wiring (to the right).

Remove the housing partition and as shown as set them aside in a secure place while wiring. Be sure to replace them afterward. Never operate the inverter with the partition removed or the front housing cover removed.

The power input and motor 3-phase wiring connect to the lower row of the terminals. The upper row of power terminals connect to optional braking units or DC link choke.

The following section in this chapter will describe system design and guide you through a step-by-step installation process. After the section on wiring, this chapter will show how to use the front panel keys to access functions and edit parameters.

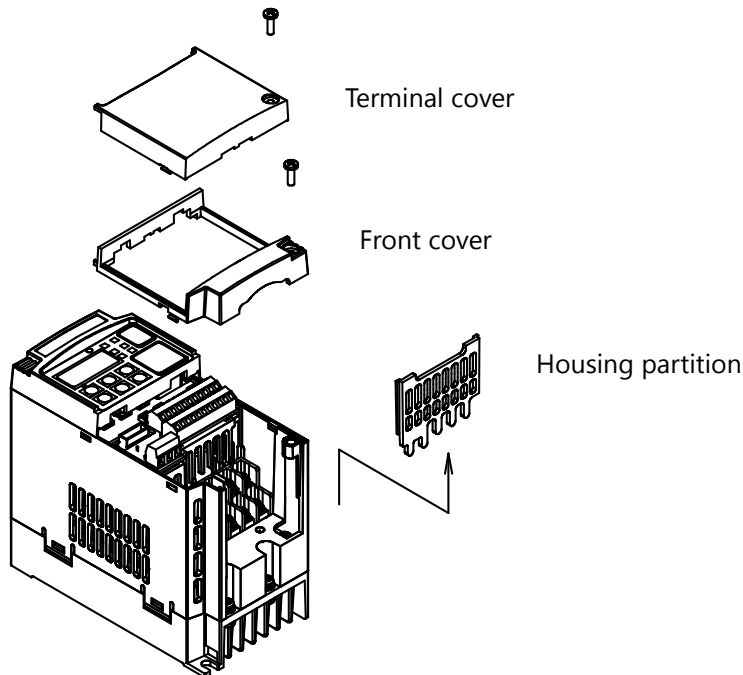

HIGH VOLTAGE: Hazard of electrical shock. Disconnect incoming power before working on this control. Wait ten (10) minutes before removing the front cover.



HIGH VOLTAGE: Hazard of electrical shock. Never touch the naked PCB (printed circuit board) portions while the unit is powered up. Even for switch portion, the inverter must be powered OFF before you change.

Basic System Description

A motor control system will obviously include a motor and inverter, as well as a circuit breaker or fuses for safety. If you are connecting a motor to the inverter on a test bench just to get started, that's all you may need for now. But a system can also have a variety of additional components. Some can be for noise suppression, while others may enhance the inverter's braking performance. The figure and table below show a system with all the **optional** components you might need in your finished application.

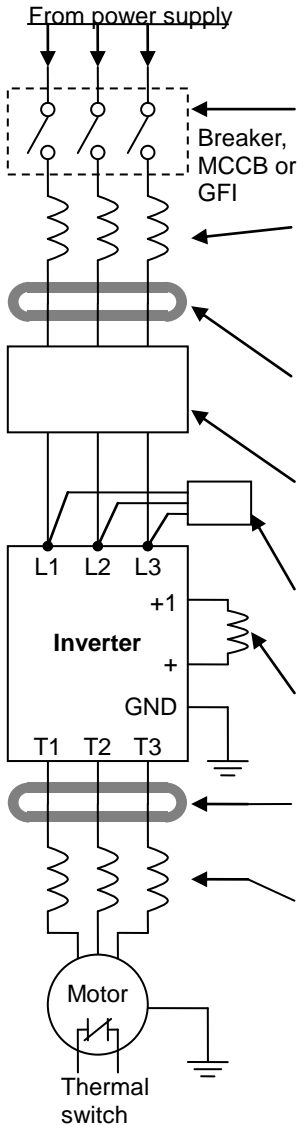

Name	Function
Breaker / disconnect	A molded-case circuit breaker (MCCB), ground fault interrupter (GFI), or a fused disconnect device. NOTE: The installer must refer to the NEC and local codes to ensure safety and compliance.
Input-side AC Reactor	This is useful in suppressing harmonics induced on the power supply lines and for improving the power factor. WARNING: Some applications must use an input-side AC Reactor to prevent inverter damage. See Warning on next page.
Radio noise filter	Electrical noise interference may occur on nearby equipment such as a radio receiver. This magnetic choke filter helps reduce radiated noise (can also be used on output).
EMC filter (for CE applications, see Appendix D)	Reduces the conducted noise on the power supply wiring between the inverter and the power distribution system. Connect to the inverter primary (input) side.
Radio noise filter (use in non-CE applications)	This capacitive filter reduces radiated noise from the main power wires in the inverter input side.
DC link choke	Suppress harmonics generated by the inverter. However, it will not protect the input diode bridge rectifier.
Radio noise filter	Electrical noise interference may occur on nearby equipment such as a radio receiver. This magnetic choke filter helps reduce radiated noise (can also be used on input).
Output-side AC Reactor	This reactor reduces the vibration in the motor caused by the inverter's switching waveforms, by smoothing the waveform to approximate commercial power quality. It is also useful to reduce harmonics when wiring from the inverter to the motor is more than 10m in length.
LCR filter	Sine wave shaping filter for output side.



NOTE: Note that some components are required for regulatory agency compliance (see chapter 5 and Appendix D).



WARNING: In the following examples involving a general-purpose inverter, a large peak current flow on the main power supply side, and is able to destroy the converter module. Where such situations are foreseen or the connected equipment must be highly reliable, install an AC reactor between the power supply and the inverter. Also, where influence of indirect lightning strike is possible, install a lightning conductor:

1. The unbalance factor of the power supply is 3% or higher.
 2. The power supply capacity is at least 10 times greater than the inverter capacity (or the power supply capacity is 500kVA or more).
 3. Abrupt power supply changes are expected, due to conditions such as:
 - a. Several inverters are interconnected with a short bus.
 - b. A thyristor converter and an inverter are interconnected with a short bus.
 - c. An installed phase advance capacitor opens and closes.
-



WARNING: An inverter run by a private power generator may overheat the generator or suffer from a deformed output voltage waveform of the generator. Generally, the generator capacity should be five times that of the inverter (kVA) in a PWM control system or six times greater in a PAM control system.



CAUTION: In the case of important equipment, to shorten the non-operational time of inverter failure, please provide a backup circuit by commercial power supply or spare inverter.

Step-by-Step Basic Installation

This section will guide you through the following basic steps of installation:

Step	Activity	Page
1	Choose a mounting location in compliance with the Warnings and Cautions. See NOTE below.	2-7
2	Check the mounting location for adequate ventilation	2-8
3	Cover the inverter's ventilation openings to prevent debris from entering.	2-8
4	Check the inverter dimensions for footprint and mounting hole locations.	2-9
5	Study the Cautions, Warnings, wire and fuse sizes, and terminal torque specifications before wiring the inverter.	2-14
6	Connect wiring for the inverter power input.	2-17
7	Wire the inverter output to the motor.	2-21
8	Uncover the inverter's ventilation openings applied in Step 3.	2-22
9	Perform the Powerup Test. (This step includes several sub steps.)	2-22
10	Make observations and check your installation.	2-35



NOTE: If the installation is in an EU country, study the EMC installation guidelines in Appendix D.

Choosing a Mounting Location

 **Step 1:** Study the following caution messages associated with mounting the inverter. This is the time when mistakes are most likely to occur that will result in expensive rework, equipment damage, or personal injury.



CAUTION: Be sure to install the unit on flame-resistant material such as steel plate. Otherwise, there is the danger of fire.



CAUTION: Be sure not to place any flammable materials near the inverter. Otherwise, there is the danger of fire.



CAUTION: Be sure not to let the foreign matter enter vent openings in the inverter housing, such as wire clippings, spatter from welding, metal shavings, dust, etc. Otherwise, there is the danger of fire.



CAUTION: Be sure to install the inverter in a place that can bear the weight according to the specifications in the text (Chapter 1, Specifications Tables). Otherwise, it may fall and cause injury to personnel.



CAUTION: Be sure to install the unit on a perpendicular wall that is not subject to vibration. Otherwise, it may fall and cause injury to personnel.



CAUTION: Be sure not to install or operate an inverter that is damaged or has missing parts. Otherwise, it may cause injury to personnel.



CAUTION: Be sure to install the inverter in a well-ventilated room that does not have direct exposure to sunlight, a tendency for high temperature, high humidity or dew condensation, high levels of dust, corrosive gas, explosive gas, inflammable gas, grinding-fluid mist, salt damage, etc. Otherwise, there is the danger of fire.

Ensure Adequate Ventilation

Step 2: To summarize the caution messages – you will need to find a solid, non-flammable, vertical surface that is in a relatively clean and dry environment. In order to ensure enough room for air circulation around the inverter to aid in cooling, it is recommended to maintain the specified clearance and the inverter specified in the below diagram.

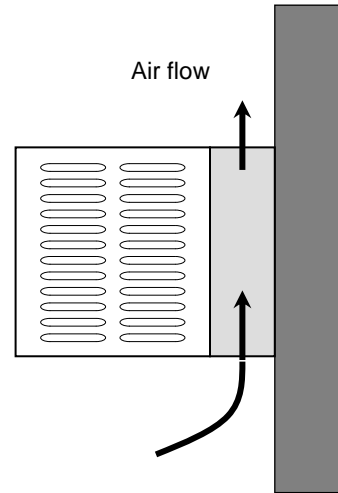
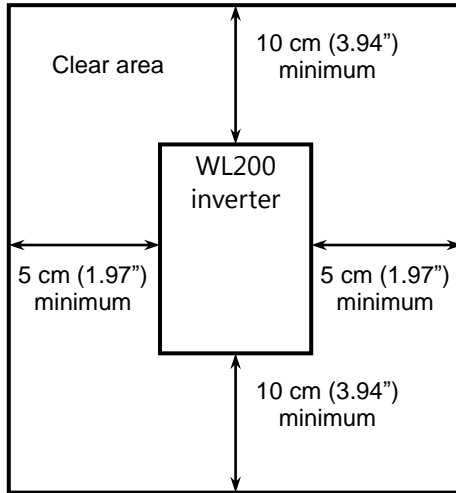

CAUTION: Be sure to maintain the specified clearance area around the inverter and to provide adequate ventilation. Otherwise, the inverter may overheat and cause equipment damage or fire.

Keep Debris Out of Inverter Vents

Step 3: Before proceeding to the wiring section, it's a good time to *temporarily* covers the inverter's ventilation openings. Paper and masking tape are all that is needed. This will prevent harmful debris such as wire clippings and metal shavings from entering the inverter during installation.

Please observe this checklist while mounting the inverter:

1. The ambient temperature must be in the range of -10 to 50°C (using derating).
2. Keep any other heat-producing equipment as far away from the inverter as possible.
3. When installing the inverter in an enclosure, maintain the clearance around the inverter and verify that its ambient is within specification when the enclosure door is closed.
4. Do not remove the front housing at any time during operation.

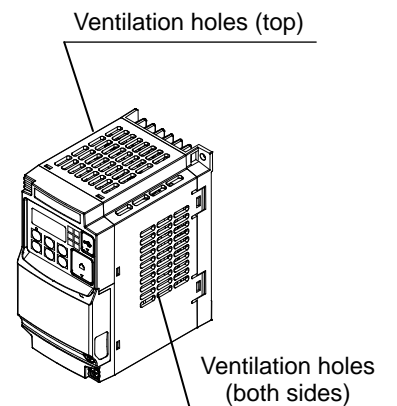

Check Inverter Dimensions

Step 4: Locate the applicable drawing on the following pages for your inverter. Dimensions are given in millimeters (inches) format.

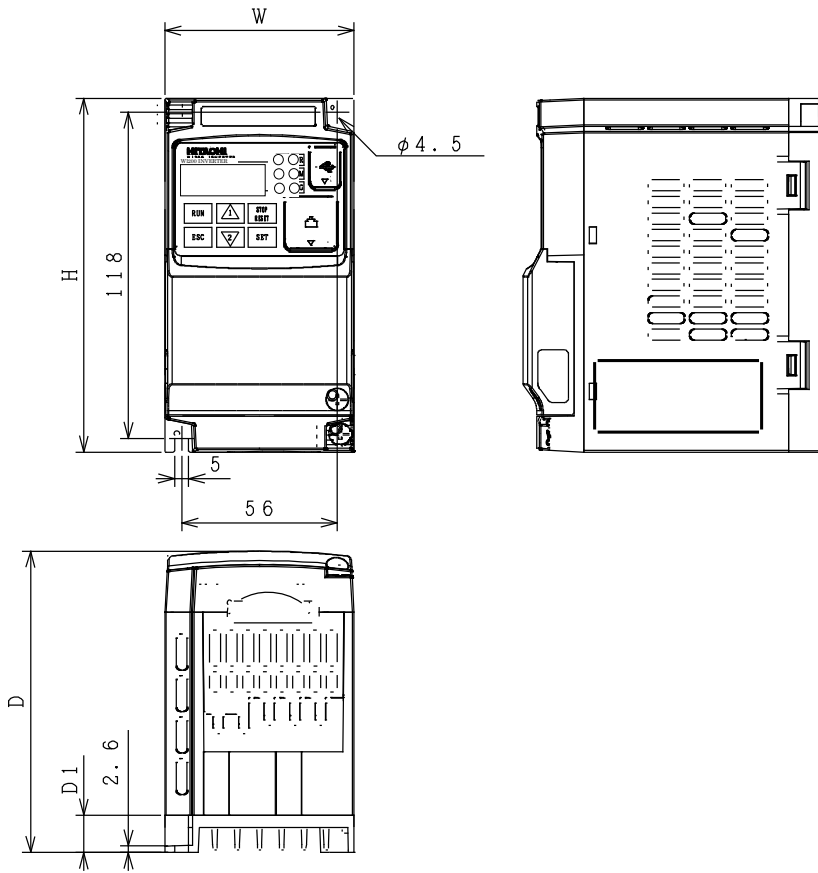

Power	Type	W (mm)	H (mm)	D (mm)	D1 (mm)
Single-phase 200V	WL200-002SF	68	128	109	13.5
	WL200-004SF				
	WL200-007SF			1225	27



NOTE: Some inverter housing require two mounting screws, while other requires four. Be sure to use lock washers or other means to ensure screws do not loosen due to vibration.

Dimensional drawings, continued...

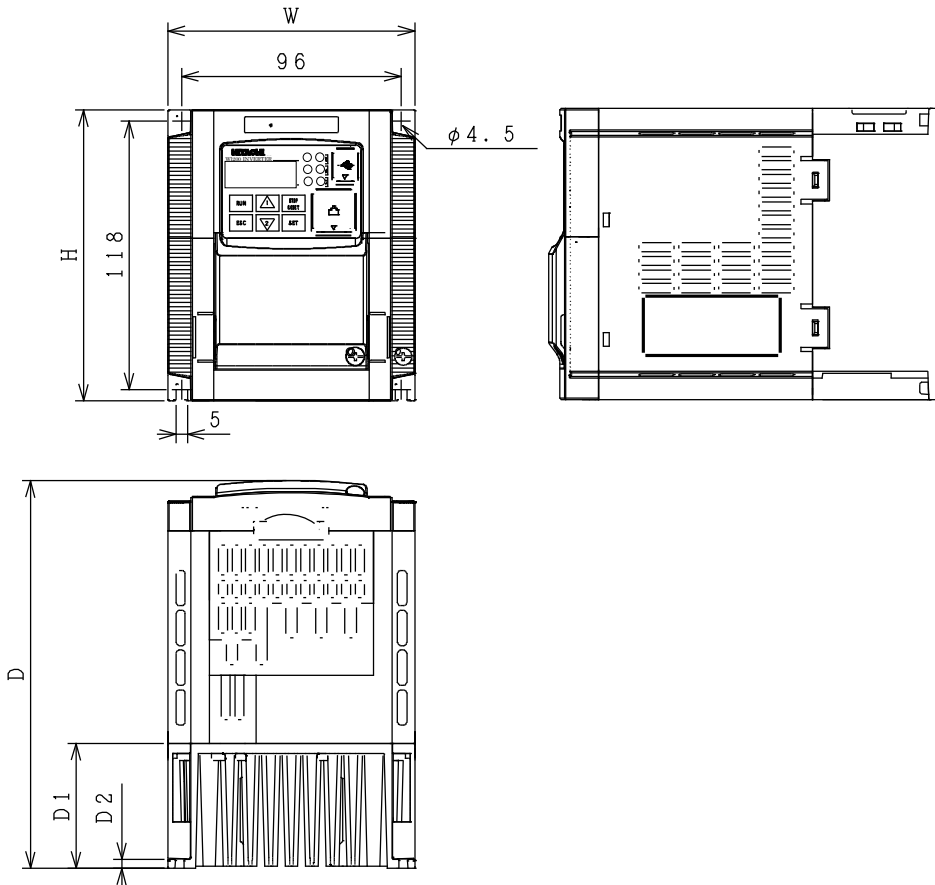

Power	Type	W (mm)	H (mm)	D (mm)	D1 (mm)
Single-phase 200V	WL200-015SF WL200-022SF	108	128	1705	55
3-phase 400V	WL200-004HF WL200-007HF	108	128	1435	28
	WL200-015HF WL200-022HF WL200-030HF WL200-040HF			1705	55

Dimensional drawings, continued...

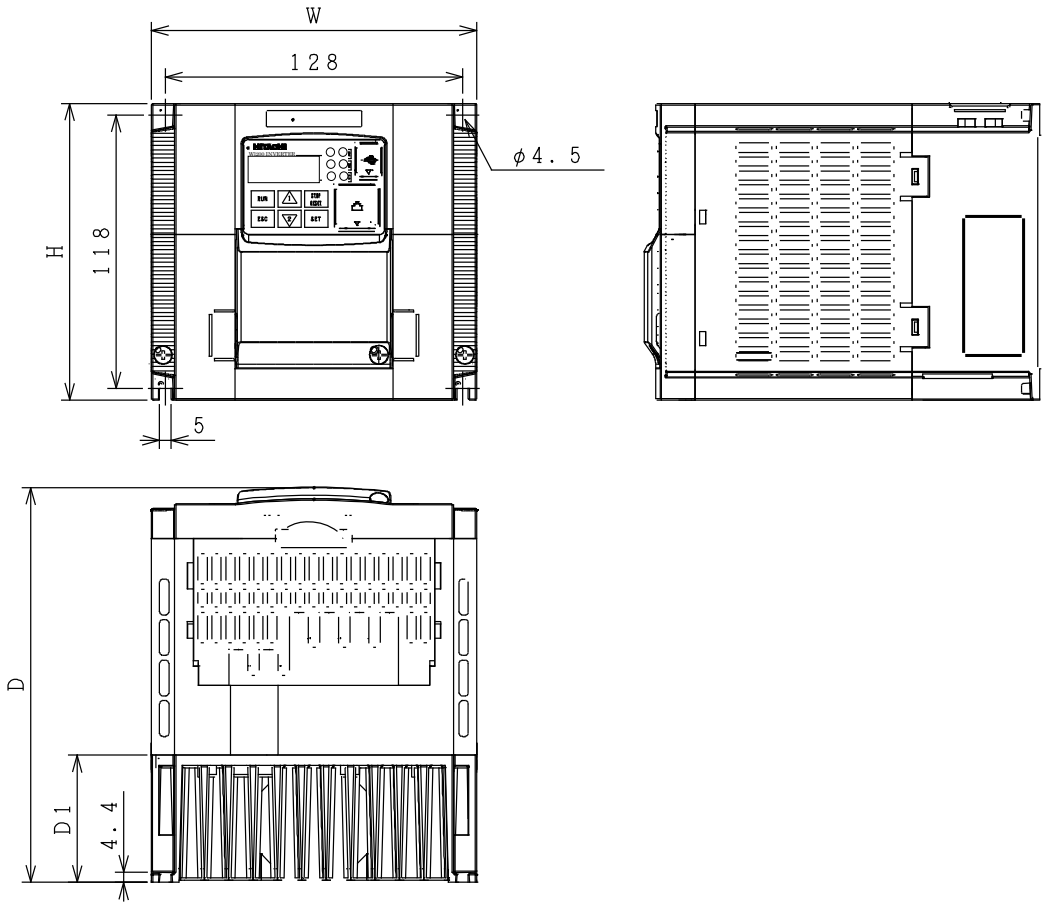

Power	Type	W (mm)	H (mm)	D (mm)	D1 (mm)
3-phase 400V	WL200-055HF	140	128	1705	55

Dimensional drawings, continued...

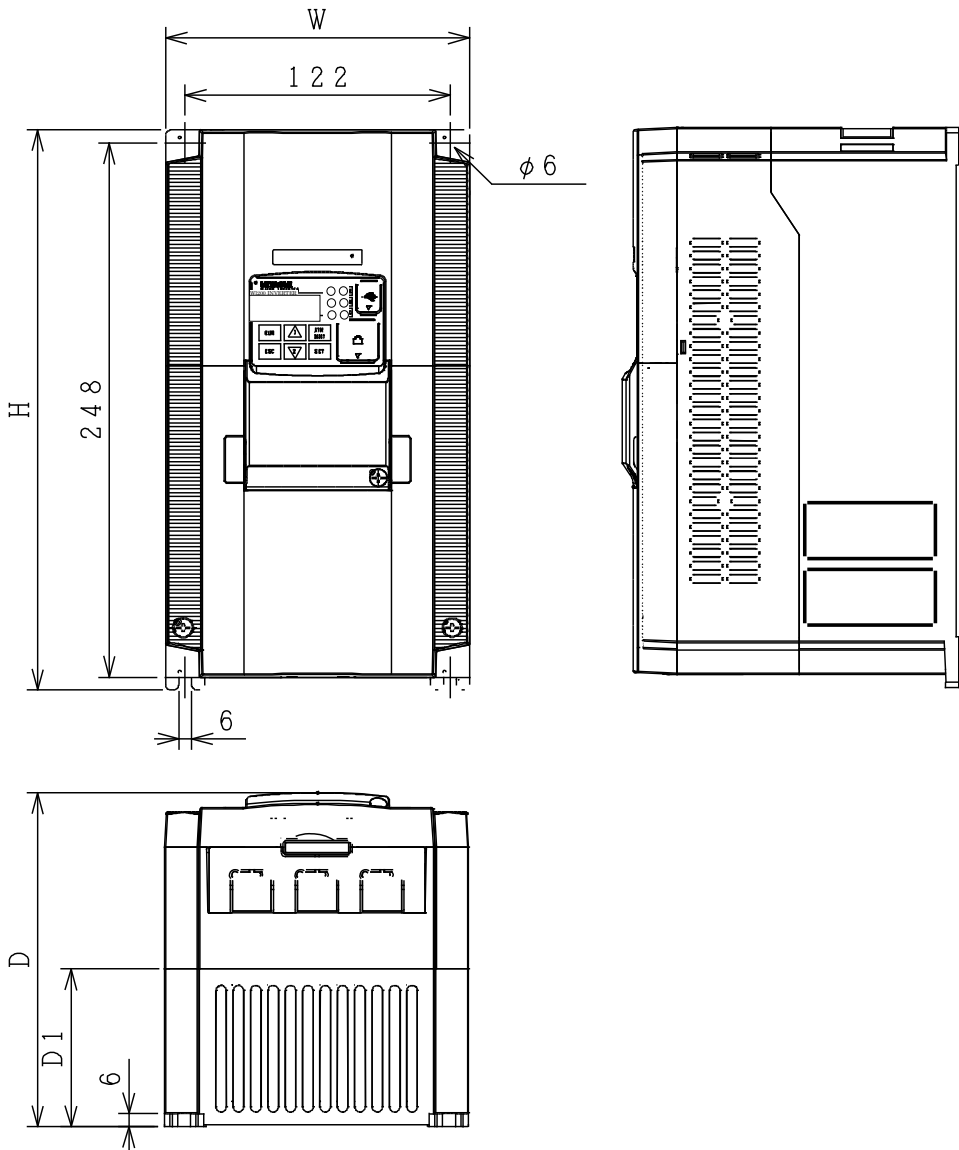

Power	Type	W (mm)	H (mm)	D (mm)	D1 (mm)
3-phase 400V	WL200-075HF WL200-110HF	140	260	155	73.3

Dimensional drawings, continued...

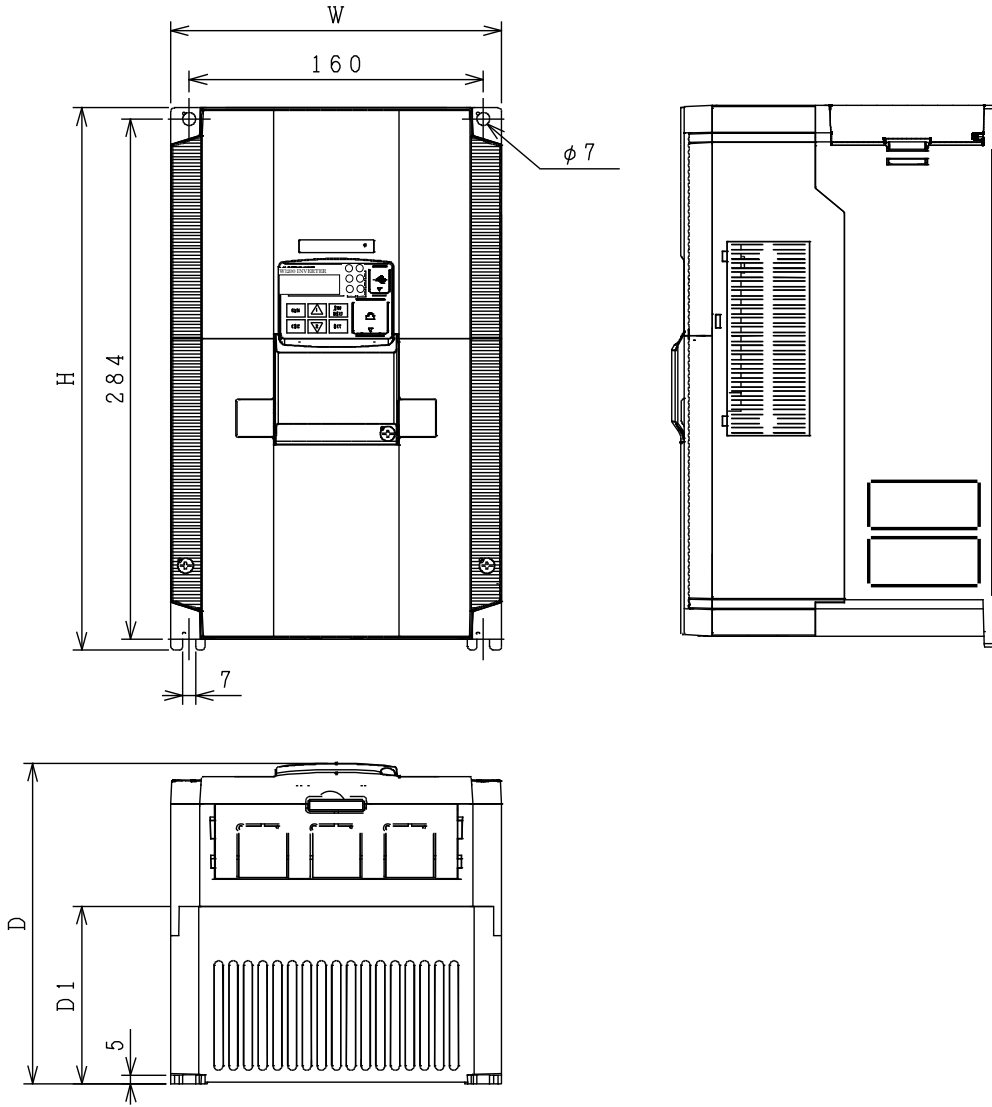

Power	Type	W (mm)	H (mm)	D (mm)	D1 (mm)
3-phase 400V	WL200-150HF WL200-185HF	180	296	175	97

Prepare for Wiring



Step 5: It is very important to perform the wiring steps carefully and correctly. Before proceeding, please study the caution and warning message here below.



WARNING: Use 60/75°C Cu wire only. (for models: WL200-022S, -007H, -015H, -022H, -030H and -040H)



WARNING: Use 75°C Cu wire only. (for models: WL200-002S, -004S, -007S, -015S, -055H, -075H, -110H, -150H and -185H)



WARNING: "Open Type Equipment."



WARNING: "Suitable for use on a circuit capable of delivering not more than 100k rms symmetrical amperes, 240V maximum when protected by Class CC, G, J or R fuses or circuit breaker having an interrupting rating not less than 100,000 rms symmetrical amperes, 240 volts maximum." For models with suffix S.



WARNING: "Suitable for use on a circuit capable of delivering not more than 100k rms symmetrical amperes, 480V maximum when protected by Class CC, G, J or R fuses or circuit breaker having an interrupting rating not less than 100,000 rms symmetrical amperes, 480 volts maximum." For models with suffix H.



HIGH VOLTAGE: Be sure to ground the unit. Otherwise, there is a danger of electric shock and/or fire.



HIGH VOLTAGE: Wiring work shall be carried out only by qualified personnel. Otherwise, there is a danger of electric shock and/or fire.



HIGH VOLTAGE: Implement wiring after checking that the power supply is OFF. Otherwise, you may incur electric shock and/or fire.



HIGH VOLTAGE: Do not connect wiring to an inverter or operate an inverter that is not mounted according to the instructions given in this manual. Otherwise, there is a danger of electric shock and/or injury to personnel.

Determining Wire and Fuse Sizes

The maximum motor current in your application determines the recommended wire size. The following table gives the wire size in AWG. The "Power Lines" column applies to the inverter input power, output wires to the motor, the earth ground connection, and any other components shown in the "Basic System Description" on page 2-4. The "Signal Lines" column applies to any wire connecting to the two green connectors just inside the front cover panel.

Motor Output		Inverter Model	Wiring		Applicable equipment
kW	HP		Power Lines	Signal Lines	Fuse (UL-rated, class J, CC, G, T 600V)
0.2	¼	WL200-002SFE	AWG16 / 1.3mm ² (75°C only)	18 to 28 AWG / 0.14 to 0.75 mm ² shielded wire (see Note 4)	10A
0.4	½	WL200-004SFE			
0.75	1	WL200-007SFE			
1.5	2	WL200-015SFE	AWG12 / 3.3mm ² (75°C only)		20A
2.2	3	WL200-022SFE	AWG10 / 5.3mm ²		30A
0.4	½	WL200-004HFE	AWG16 / 1.3mm ²		10A
0.75	1	WL200-007HFE			
1.5	2	WL200-015HFE			
2.2	3	WL200-022HFE			
3.0	4	WL200-030HFE	AWG14 / 2.1mm ²		15A
4.0	5	WL200-040HFE	AWG12 / 3.3mm ²		
5.5	7.5	WL200-055HFE	AWG12 / 3.3mm ² (75°C only)		30A
7.5	10	WL200-075HFE	AWG10 / 5.3mm ² (75°C only)		
11	15	WL200-110HFE	AWG6 / 13mm ² (75°C only)	50A	
15	20	WL200-150HFE			
18.5	25	WL200-185HFE			

Note 1: Field wiring must be made by a UL-Listed and CSA-certified closed-loop terminal connector sized for the wire gauge involved. Connector must be fixed by using the crimping tool specified by the connector manufacturer.

Note 2: Be sure to consider the capacity of the circuit breaker to be used.

Note 3: Be sure to use a larger wire gauge if power line length exceeds 66ft. (20m).

Note 4: Use 18 AWG / 0.75mm² wire for the alarm signal wire ([AL0], [AL1], [AL2] terminals).

Note 5: Type E Combination Motor Controller marking is to indicate that the unit shall be connected with, LS Industrial System Co., Ltd, Type E Combination Motor Controller MMS Series.

Terminal Dimensions and Torque Specs

The terminal screw dimensions for all WL200 inverters are listed in table below. This information is useful in sizing spade lug or ring lug connectors for wire terminations.



CAUTION: Fasten the screws with the specified fastening torque in the table below. Check for any loosening of screws. Otherwise, there is the danger of fire.

Types	Screw Diameter	Width (mm)	Tightening Torque (N•m)
WL200-002S,004S,007S	M3.5	7.6	1.0
WL200-015S,022S	M4	10	1.4
WL200-004H,007H,015H,022H,030H,040H,055H	M5	13	3.0
WL200-075H,110H	M6	17.5	3.9 to 5.1

Wire the Inverter Input to a Supply

Step 6: In this step, you will connect wiring to the input of the inverter. First, you must determine whether the inverter model you have required three-phase power only, or single-phase power only. All models have the same power connection terminals [R/L1], [S/L2], and [T/L3]. So you must refer to the specifications label (on the side of the inverter) for the acceptable power source types! For inverters that can accept single-phase power and are connected that way, terminal [S/L2] will remain unconnected. Note the use of ring lug connectors for a secure connection.

Single-phase 200V 0.2 to 0.75kW

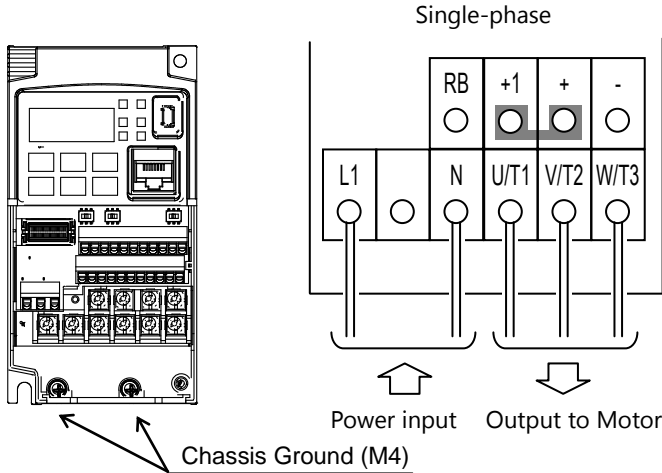

Single-phase 200V 1.5 to 2.2kW

Three-phase 400V 0.4 to 4.0kW

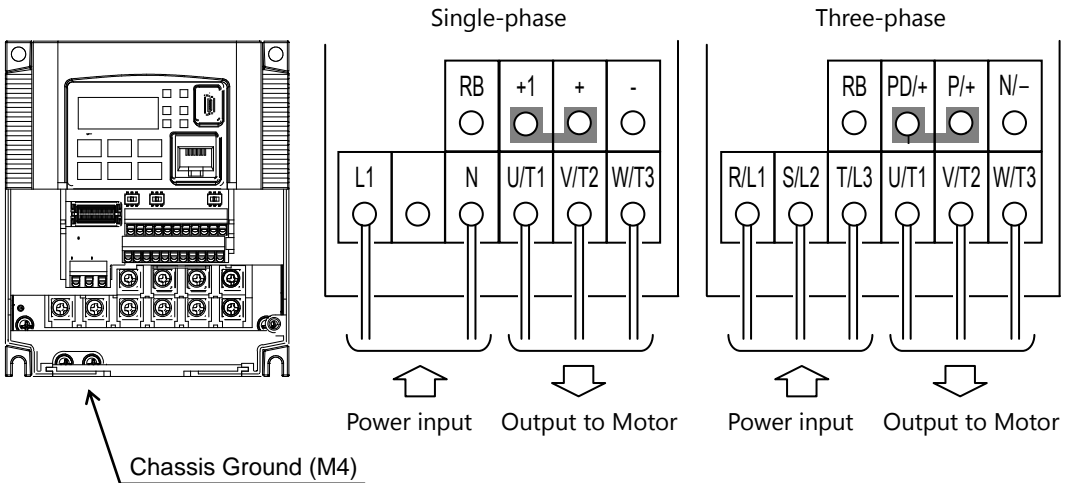

Three-phase 400V 5.5kW

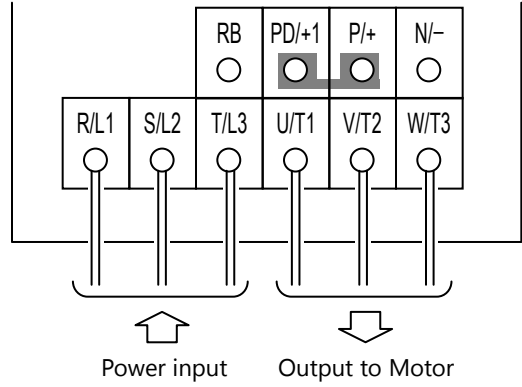
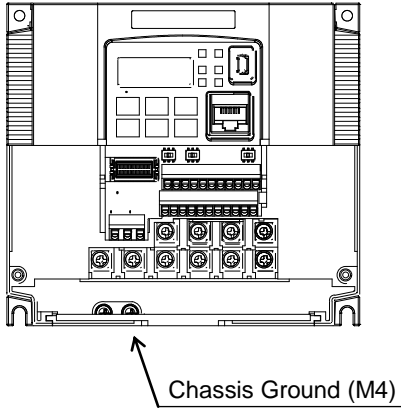

Three-phase 400V 7.5, 11kW

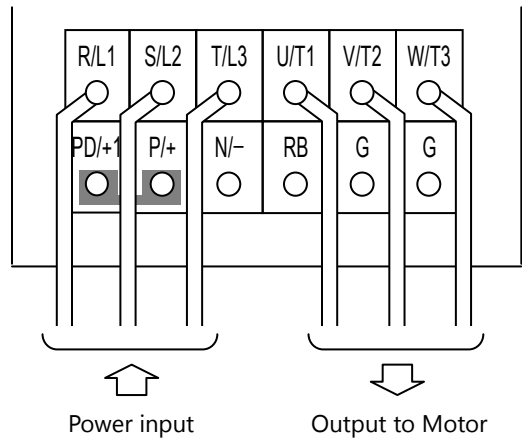
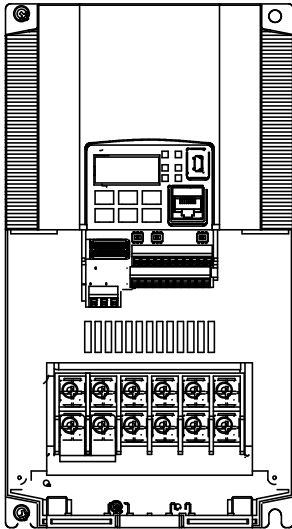

Three-phase 400V 15, 18.5kW

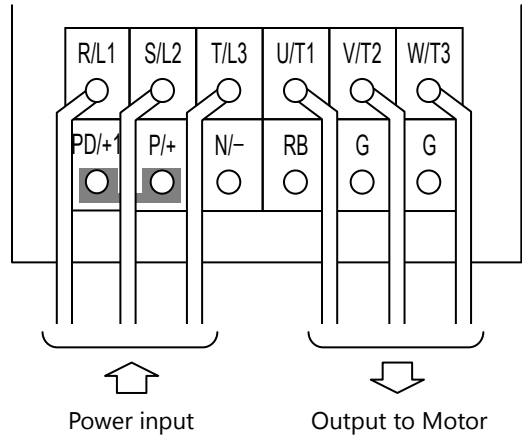
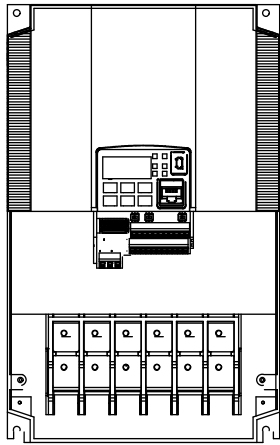

NOTE: An inverter powered by a portable power generator may receive a distorted power waveform, overheating the generator. In general, the generator capacity should be five times that of the inverter (kVA).



CAUTION: Be sure that the input voltage matches the inverter specifications:

- Single-phase 200 to 240 V 50/60 Hz (0.2kW to 2.2kW) for SFE models
- Three-phase 380 to 480 V 50/60Hz (0.4kW to 18.5kW) for HFE models



CAUTION: Be sure not to power a three-phase-only inverter with single-phase power. Otherwise, there is the possibility of damage to the inverter and the danger of fire.



CAUTION: Be sure not to connect an AC power supply to the output terminals. Otherwise, there is the possibility of damage to the inverter and the danger of injury and/or fire.

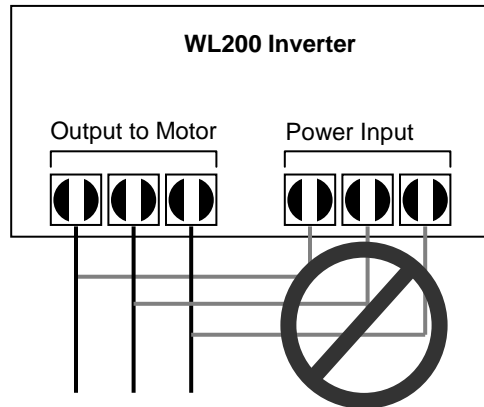

CAUTION: Remarks for using ground fault interrupter breakers in the main power supply: Adjustable frequency inverter with integrated CE-filters and shielded (screened) motor cables have a higher leakage current toward earth GND. Especially at the moment of switching ON this can cause an inadvertent trip of ground fault interrupters. Because of the rectifier on the input side of the inverter there is the possibility to stall the switch-off function through small amounts of DC current.

Please observe the following:

- Use only short time-invariant and pulse current-sensitive ground fault interrupters with higher trigger current.
- Other components should be secured with separate ground fault interrupters.
- Ground fault interrupters in the power input wiring of an inverter are not an absolute protection against electric shock.



CAUTION: Be sure to install a fuse in each phase of the main power supply to the inverter. Otherwise, there is the danger of fire.



CAUTION: For motor leads, ground fault interrupter breakers and electromagnetic contactors, be sure to size these components properly (each must have the capacity for rated current and voltage). Otherwise, there is the danger of fire.

Wire the Inverter Output to Motor



Step 7: The process of motor selection is beyond the scope of this manual. However, it must be an AC induction motor with three phases. It should also come with a chassis ground lug. If the motor does not have three power input leads, stop the installation and verify the motor type. Other guidelines for wiring the motor include:

- Use an inverter-grade motor for maximum motor life (1600V insulation).
- For standard motors, use the AC reactor accessory if the wiring between the inverter and motor exceeds 10 meters in length.

Simply connect the motor to the terminals [U/T1], [V/T2], and [W/T3] as shown in page 2-17 to 2-19. This is a good time to connect the chassis ground lug on the drive as well. The motor chassis ground must also connect to the same point. Use a star ground (single-point) arrangement, and never daisy-chain the grounds (point-to-point).

- Check the mechanical integrity of each wire crimp and terminal connection.
- Replace the housing partition that covers access to the power connections.



CAUTION: Power terminal assignment is different compared to old models such as L100, L200, X200 series, etc.,. Pay attention when wiring the power cable.

Logic Control Wiring

After completing the initial installation and powerup test in this chapter, you may need to wire the logic signal connector for your application. For new inverter users/applications, we highly recommend that you first complete the powerup test in this chapter without adding any logic control wiring. Then you will be ready to set the required parameters for logic control as covered in Chapter 4, Operations and Monitoring.



IMPORTANT!: Please be sure to set the motor nameplate data into the appropriate parameters to ensure proper operation and protection of the motor:

- * b012 is the motor overload protection value
- * A082 is the motor voltage selection
- * H003 is the motor kW capacity
- * H004 is the number of motor poles

Please refer to the appropriate pages in this guide and the Instruction Manual for further details.

Uncover the Inverter Vents

Step 8: After mounting and wiring the inverter, remove any temporary covers from the inverter housing. This includes material over the side ventilation holes.



WARNING: Make sure the input power to the inverter is OFF. If the drive has been powered, leave it OFF for ten (10) minutes before continuing.

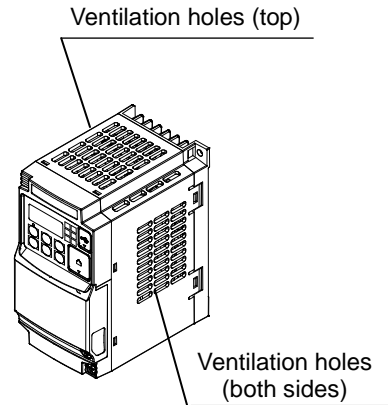

Powerup Test

Step 9: After wiring the inverter and motor, you're ready to do a powerup test. The procedure that follows is designed for the first-time use of the drive. Please verify the following conditions before conducting the powerup test:

- You have followed all the steps in this chapter up to this step.
- The inverter is new, and is securely mounted to a non-flammable vertical surface.
- The inverter is connected to a power source and a motor.
- No additional wiring of the inverter connectors or terminals has been done.
- The power supply is reliable, and the motor is a known working unit, and the motor nameplate ratings match the inverter ratings.
- The motor is securely mounted, and is not connected to any load.

Goals for the Powerup Test

If there are any exceptions to the above conditions at this step, please take a moment to take any measures necessary to reach this basic starting point. The specific goals of this powerup test are:

1. Verify that the wiring to the power supply and motor is correct.
2. Demonstrate that the inverter and motor are generally compatible.
3. Get an introduction to the use of the built-in operator keypad.

The powerup test gives you an important starting to ensure a safe and successful application of the Hitachi inverter. We highly recommend performing this test before proceeding to the other chapters in this manual.

Pre-test and Operational Precautions

The following instructions apply to the powerup test, or to any time the inverter is powered and operating. Please study the following instructions and messages before proceeding with the powerup test.

1. The power supply must have fusing suitable for the load. Check the fuse size chart presented in Step 5, if necessary.
2. Be sure you have access to a disconnect switch for the drive input power if necessary. However, do not turn OFF power during inverter operation unless it is an emergency.
3. Turn the keypad potentiometer to the minimum position (full counter-clockwise).



CAUTION: The heat sink fins will have a high temperature. Be careful not to touch them. Otherwise, there is the danger of getting burned.



CAUTION: The operation of the inverter can be easily changed from low speed to high speed. Be sure to check the capability and limitations of the motor and machine before operating the inverter. Otherwise, there is the danger of injury.



CAUTION: If you operate a motor at a frequency higher than the inverter standard default setting (50Hz/60Hz), be sure to check the motor and machine specifications with the respective manufacturer. Only operate the motor at elevated frequencies after getting their approval. Otherwise, there is the danger of equipment damage and/or injury.



CAUTION: Check the following before and during the Powerup test. Otherwise, there is the danger of equipment damage.

- Is the shorting bar between the [+1] and [+] terminals installed? DO NOT power or operate the inverter if the jumper is removed.
 - Is the direction of the motor rotation correct?
 - Did the inverter trip during acceleration or deceleration?
 - Were the rpm and frequency meter readings as expected?
 - Were there any abnormal motor vibration or noise?
-

Powering the Inverter

If you have followed all the steps, cautions and warnings up to this point, you're ready to apply power. After doing so, the following events should occur:

- The *POWER* LED will illuminate.
- The numeric (7-segment) LEDs will display a test pattern, then stop at **0.0**.
- The *Hz* LED will be ON.

If the motor starts running unexpectedly or any other problem occurs, press the STOP key. Only if necessary should you remove power to the inverter as a remedy.



NOTE: If the inverter has been previously powered and programmed, the LEDs (other than the *POWER* LED) may illuminate differently than as indicated above. If necessary, you can initialize all parameters to the factory default settings. See "Restoring Factory Default Settings" on page 6-14.

Using the Front Panel Keypad

Please take a moment to familiarize yourself with the keypad layout shown in the figure below. The display is used in programming the inverter's parameters, as well as monitoring specific parameter values during operation.

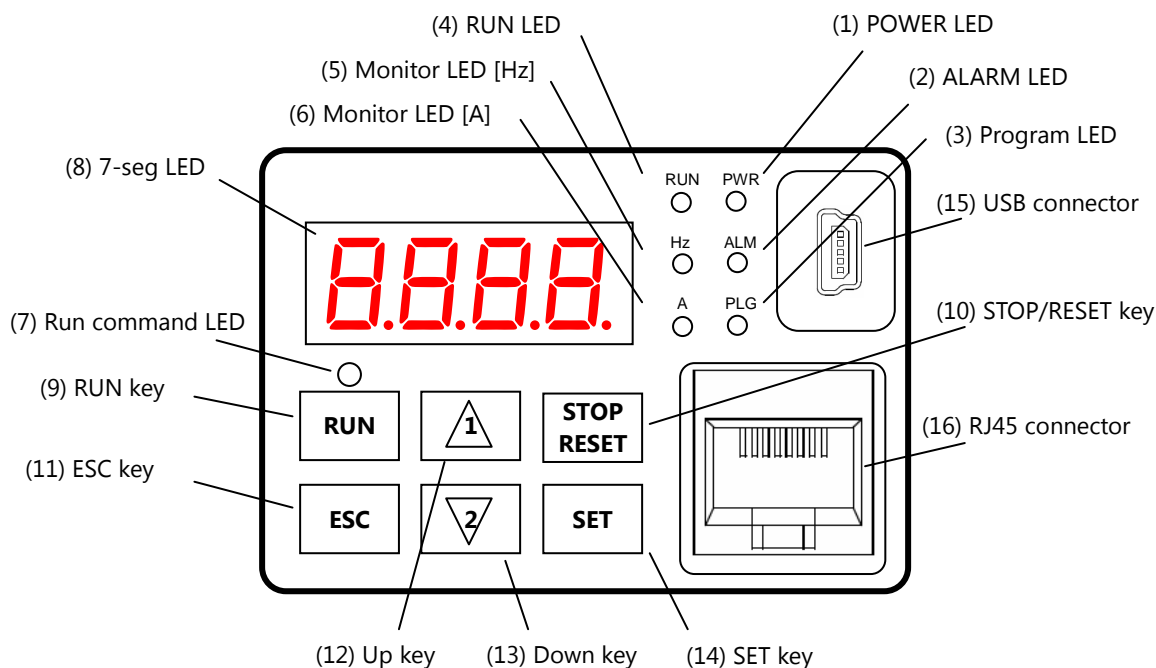

Key and Indicator Legend

Items	Contents
(1) POWER LED	Turns ON (Green) while the inverter is powered up.
(2) ALARM LED	Turns ON (Red) when the inverter trips.
(3) Program LED	Turns ON (Green) when the display shows changeable parameter. Blinks when there is a mismatch in setting.
(4) RUN LED	Turns ON (Green) when the inverter is driving the motor.
(5) Monitor LED [Hz]	Turns ON (Green) when the displayed data is frequency related.
(6) Monitor LED [A]	Turns ON (Green) when the displayed data is current related.
(7) Run command LED	Turns ON (Green) when a Run command is set to the operator. (Run key is effective.)
(8) 7-seg LED	Shows each parameter, monitors etc.
(9) Run key	Makes inverter run.
(10) Stop/reset key	Makes inverter decelerates to a stop. Reset the inverter when it is in trip situation
(11) ESC key	Go to the top of next function group, when a function mode is shown Cancel the setting and return to the function code, when a data is shown Moves the cursor to a digit left, when it is in digit-to-digit setting mode Pressing for 1 second leads to display data of 000 I , regardless of current display.
(12) Up key (13) Down key	Increase or decrease the data. Pressing the both keys at the same time gives you the digit-to-digit edit.
(14) SET key	Go to the data display mode when a function code is shown Stores the data and go back to show the function code, when data is shown. Moves the cursor to a digit right, when it is in digit-to-digit display mode
(15) USB connector	Connect USB connector (mini-B) for using PC communication
(16) RJ45 connector	Connect RJ45 jack for remote operator. (RS422 only)

Keys, Modes, and Parameters

The purpose of the keypad is to provide a way to change modes and parameters. The term function applies to both monitoring modes and parameters. These are all accessible through function codes that are primary 4-character codes. The various functions are separated into related groups identifiable by the left-most character, as the table shows.

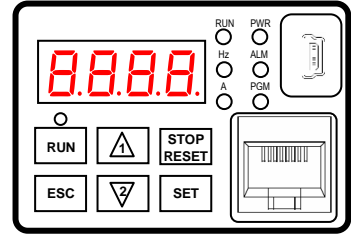

Function Group	Type (Category) of Function	Mode to Access	PRG LED Indicator
"D"	Monitoring functions	Monitor	○
"F"	Main profile parameters	Program	●
"A"	Standard functions	Program	●
"B"	Fine tuning functions	Program	●
"C"	Intelligent terminal functions	Program	●
"H"	Motor constant related functions	Program	●
"P"	Pulse train input, torque, EzSQ, and communication related functions	Program	●
"U"	User selected parameters	Program	●
"E"	Error codes	—	—

You can see from the following page how to monitor and/or program the parameters.

Keypad Navigation Map

The WL200 Series inverter drives have many programmable functions and parameters. Chapter 3 will cover these in detail, but you need to access just a few items to perform the powerup test. The menu structure makes use of function codes and parameter codes to allow programming and monitoring with only a 4-digit display and keys and LEDs. So, it is important to become familiar with the basic navigation map of parameters and functions in the diagram below. You may later use this map as a reference.

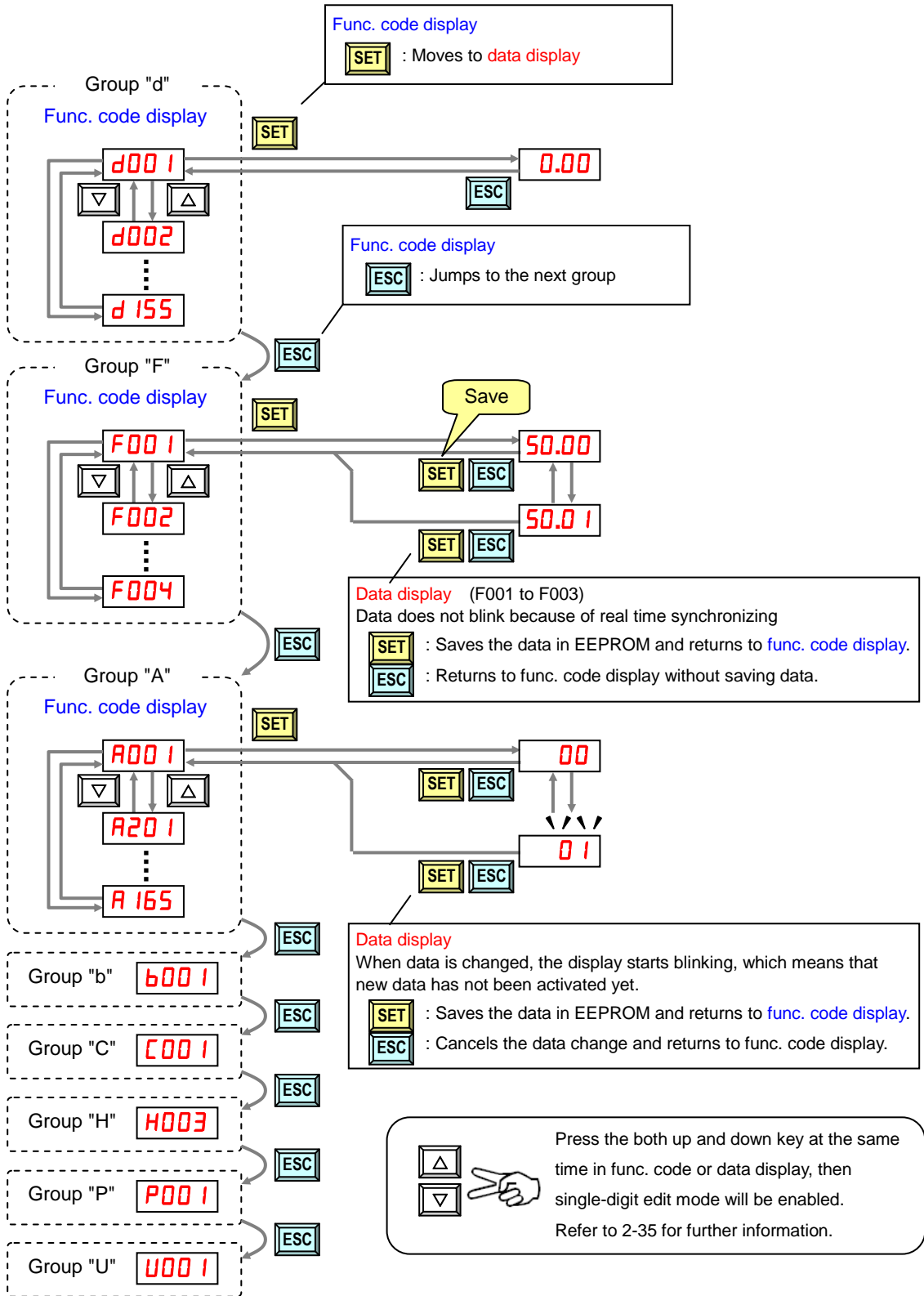

NOTE: Pressing the [ESC] key will make the display go to the top of next function group, regardless the display contents. (e.g. **A02 1** → [ESC] → **b00 1**)

[Setting example]

After power ON, changing from 0.00 display to change the **b003** (carrier frequency) data.

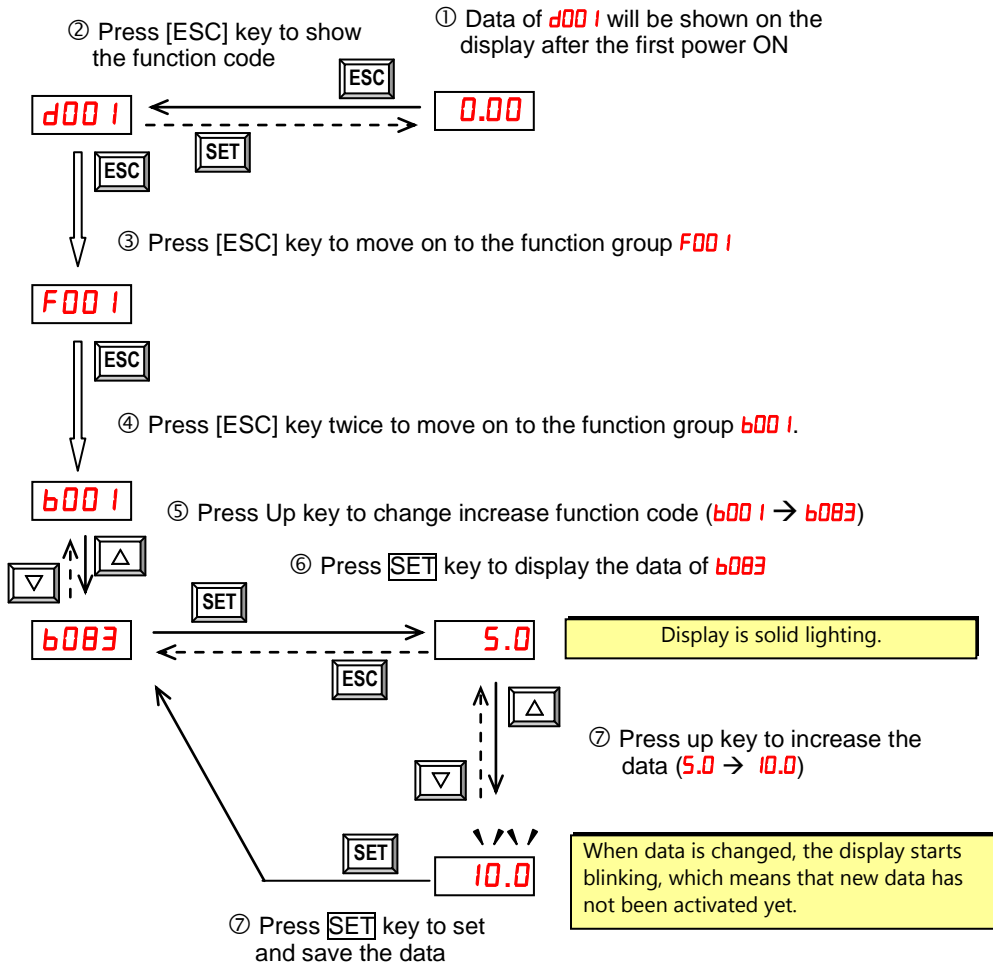

- [SET] :Fix and stores the data and moves back to the function code
- [ESC] :Cancels the change and moves back to the function code

Function code **dxxx** are for monitor and not possible to change.

Function codes **Fxxx** other than **F004** are reflected on the performance just after changing the data (before pressing [SET] key), and there will be no blinking.



	When a function code is shown...	When a data is shown...
[ESC] key	Move on to the next function group	Cancels the change and moves back to the function code
[SET] key	Move on to the data display	Fix and stores the data and moves back to the function code
[Δ] key	Increase function code	Increase data value
[▽] key	Decrease function code	Decrease data value

Note

Keep pressing the [ESC] key for more than 1 second leads to d001 display, regardless the display situation. But note that the display will circulates while keep pressing the [ESC] key because of the original function of the key. (e.g. **F001** → **A001** → **b001** → **C001** → ... → displays **50.00** after 1 second)

Selecting Functions and Editing Parameters

To prepare to run the motor in the powerup test, this section will show how to configure the necessary parameters:

1. Select the digital operator as the source of motor speed command (**A001=02**).
2. Select the digital operator as the source of the RUN command (**A002=02**).
3. Set the motor base frequency (**A003**) and AVR voltage of the motor (**A082**).
4. Set the motor current for proper thermal protection (**b012**).
5. Set the number of poles for the motor (**H004**).

The following series of programming tables are designed for successive use. Each table uses the previous table's final state as the starting point. Therefore, start with the first and continue programming until the last one. If you get lost or concerned that some of the other parameters setting may be incorrect, refer to "Restoring Factory Default Settings" on page 6-14.

Prepare to Edit Parameters – This sequence begins with powering ON the inverter, then it shows how to navigate to the "A" Group parameters for subsequent settings. You can also refer to the "Keypad Navigation Map" on page 2-25 for orientation throughout the steps.

Action	Display	Func./Parameter
Turn ON the inverter		Inverter output frequency displayed (0Hz in stop mode)
Press the key		"d" group selected
Press the key 2 times		"A" group selected

1. Select the digital operator for Speed Command – The inverter output frequency can be set from several sources, including an analog input, memory setting, or the network, for example. The powerup test uses the keypad as the speed control source for your convenience. Note that the default setting depends on the country.

Action	Display	Func./Parameter
(Starting point)		"A" Group selected Speed command source setting
Press the key		00...Potentiometer of ext. operator 01...Control terminals 02...Digital operator (F001) 03...ModBus network etc.
Press the / key to select		02...Digital operator (selected)
Press the key to store		Stores parameter, returns to "A001"

2. Select the digital operator for RUN Command –

To RUN command causes the inverter to accelerate the motor to the selected speed. The Run command can arrive from various sources, including the control terminals, the Run key on the keypad or the network. In the figure to the right, notice the Run Key Enable LED, just above the Run key. If the LED is ON, the Run key is already selected as the source, and you may skip this step. Note that the default setting depends on the country.

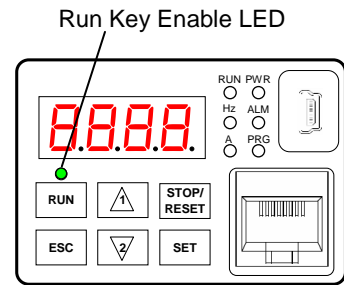

If the Potentiometer Enable LED is OFF, follow these steps below (the table resumes action from the end of the previous table).

Action	Display	Func./Parameter
(Starting point)	A001	Speed command source setting
Press the ▲ key two times	A002	Run command source setting
Press the SET key	01	01 ...Control terminal 02 ...Digital operator 03 ...ModBus network input etc.
Press the ▲ / ▼ key to select	02	02 ... Digital operator (selected)
Press the SET key to store	A002	Stores parameter, returns to "A002"



NOTE: After completing the steps above, the Run Key Enable LED will be ON. This does not mean the motor is trying to run; it means that the RUN key is now enabled. DO NOT press the RUN key at this time – complete the parameter setup first.

3. Set the Motor Base Frequency and AVR voltage of the motor – The motor is designed to operate at a specific AC frequency. Most commercial motors are designed for 50/60 Hz operation. First, check the motor specifications. Then follow the steps below to verify the setting or correct it for your motor. DO NOT set it greater than 50/60 Hz unless the motor manufacturer specifically approves operation at the higher frequency.

Action	Display	Func./Parameter
(Starting point)	A002	Run command source setting
Press the △ key two times	A003	Base frequency setting
Press the SET key	50.0	Default value for the base frequency = 50 Hz
Press the △ / ▽ key to select	60.0	Set to your motor specs (your display may be different)
Press the SET key	A003	Store parameter, returns to "A003"



CAUTION: If you operate a motor at a frequency higher than the inverter standard default setting (50Hz/60Hz), be sure to check the motor and machine specifications with the respective manufacturer. Only operate the motor at elevated frequencies after getting their approval. Otherwise, there is the danger of equipment damage.

Set the AVR Voltage Setting – The inverter has an Automatic Voltage Regulation (AVR) function. It adjusts the output voltage to match the motor's nameplate voltage rating. The AVR smoothes out fluctuation in the input power source, but note that it does not boost the voltage in the event of a brown-out. Use the AVR setting (**A0B2**) that most closely matches the one for your motor.

- 200V class: 200 / 215 / 220 / 230 / 240 VAC
- 400V class: 380 / 400 / 415 / 440 / 460 / 480 VAC

To set the motor voltage, follow the steps on the following table.

Action	Display	Func./Parameter
(Starting point)	A003	Base frequency setting
Press the △ key and hold until →	A0B2	AVR voltage select
Press the SET key	230 or 400	Default value for AVR voltage: 200V class = 230VAC 400V class = 400VAC
Press the △ / ▽ key to select	215	Set to your motor specs (your display may be different)
Press the SET key	A0B2	Store parameter, returns to "A0B2"

4. Set the Motor Current – The inverter has thermal overload protection that is designed to protect the inverter and motor from overheating due to an excessive load. The inverter's uses the motor's current rating to calculate the time-based heating effect. This protection depends on using correct current rating for your motor. The level of electronic thermal setting, parameter **b0 12**, is adjustable from 20% to 100% of the inverter's rated current. A proper configuration will also help prevent unnecessary inverter trip events.

Read the motor's current rating on its manufacturer's nameplate. Then follow the steps below to configure the inverter's overload protection setting.

Action	Display	Func./Parameter
(Starting point)	A0B2	AVR voltage select
Press the ESC key	b001	First "B" Group parameter selected
Press the △ key and hold until →	b012	Level of electronic thermal setting
Press the SET key	5.4	Default value will be 100% of inverter rated current
Press the △ / ▽ key to select	4.0	Set to your motor specs (your display may be different)
Press the SET key	b012	Store parameter, returns to "b012"

5. Set the Number of Motor Poles – The motor's internal winding arrangement determines its number of magnetic poles. The specification label on the motor usually indicates the number of poles. For proper operation, verify the parameter setting matches the motor poles. Many industrial motors have four poles, corresponding to the default setting in the inverter (**H004**).

Follow the steps in the table below to verify the motor poles setting and change if necessary (the table resumes action from the end of the previous table.)

Action	Display	Func./Parameter
(Starting point)	60 12	Level of electronic thermal setting
Press the ESC key two times	H003	"H" Group selected
Press the Δ key two times	H004	Motor poles parameter
Press the SET key.	H004	2 = 2 poles 4 = 4 poles (default) 6 = 6 poles ⋮ 48 = 48 poles
Press the Δ / ▽ key to select	4	Set to your motor specs (your display may be different)
Press the SET key.	H004	Store parameter, returns to "H004"

This step concludes the parameter setups for the inverter. You are almost ready to run the motor for the first time!



TIP: If you became lost during any of these steps, first observe the state of the PRG LED. Then study the "[Keypad Navigation Map](#)" on page 2-25 to determine the current state of the keypad controls and display. As long as you do not press the SET key, no parameter will be changed by keypad entry errors. Note that power cycling the inverter causes it to power up Monitor Mode, displaying the value for **d001** (output frequency).

The next section will show you how to monitor a particular parameter from the display. Then you will be ready to run the motor.

Monitoring Parameters with the Display

After using the keypad for parameter editing, it's a good idea to switch the inverter from Program Mode to Monitor Mode. The PRG LED will be OFF, and the Hertz or Ampere LED indicates the display units.

For the powerup test, monitor the motor speed indirectly by viewing the inverter's output frequency. The output frequency must not be confused with base frequency (50/60 Hz) of the motor, or the carrier frequency (switching frequency of the inverter, in the kHz range). The monitoring functions are in the "D" list, located near the top left of the "[Keypad Navigation Map](#)" on page 2-25.

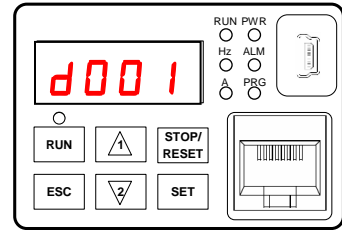

Output frequency (speed) set – Resuming keypad operation from the previous table, follow the steps below.

Action	Display	Func./Parameter
(Starting point)	H004	Motor poles parameter
Press the ESC key four times	F001	F001 is selected
Press the SET key.	9.00	Set frequency displayed

Running the Motor

If you have programmed all the parameters up to this point, you're ready to run the motor! First, review this checklist:

1. Verify the power LED is ON. If not, check the power connections.
2. Verify the Run Key Enable LED is ON. If it is OFF, check the **A002** setting.
3. Verify the PRG LED is OFF. If it is ON, review the instructions above.
4. Make sure the motor is disconnected from any mechanical load.
5. Now, press the RUN key on the keypad. The RUN LED will turn ON.
6. Press the [**△**] key for a few seconds. The motor should start turning.
7. Press the STOP key to stop the motor rotation.

Single-Digit Edit Mode

If a target function code or data is far from current data, using the single-digit edit mode makes it quicker. Pressing the up key and down key at the same time leads you to go into the digit-to-digit changing mode.

While in Single-digit edit mode (single digit is blinking):

[SET] : Move cursor to right or set the func.code/data (lowest digit only)

[ESC] : Move cursor to left.

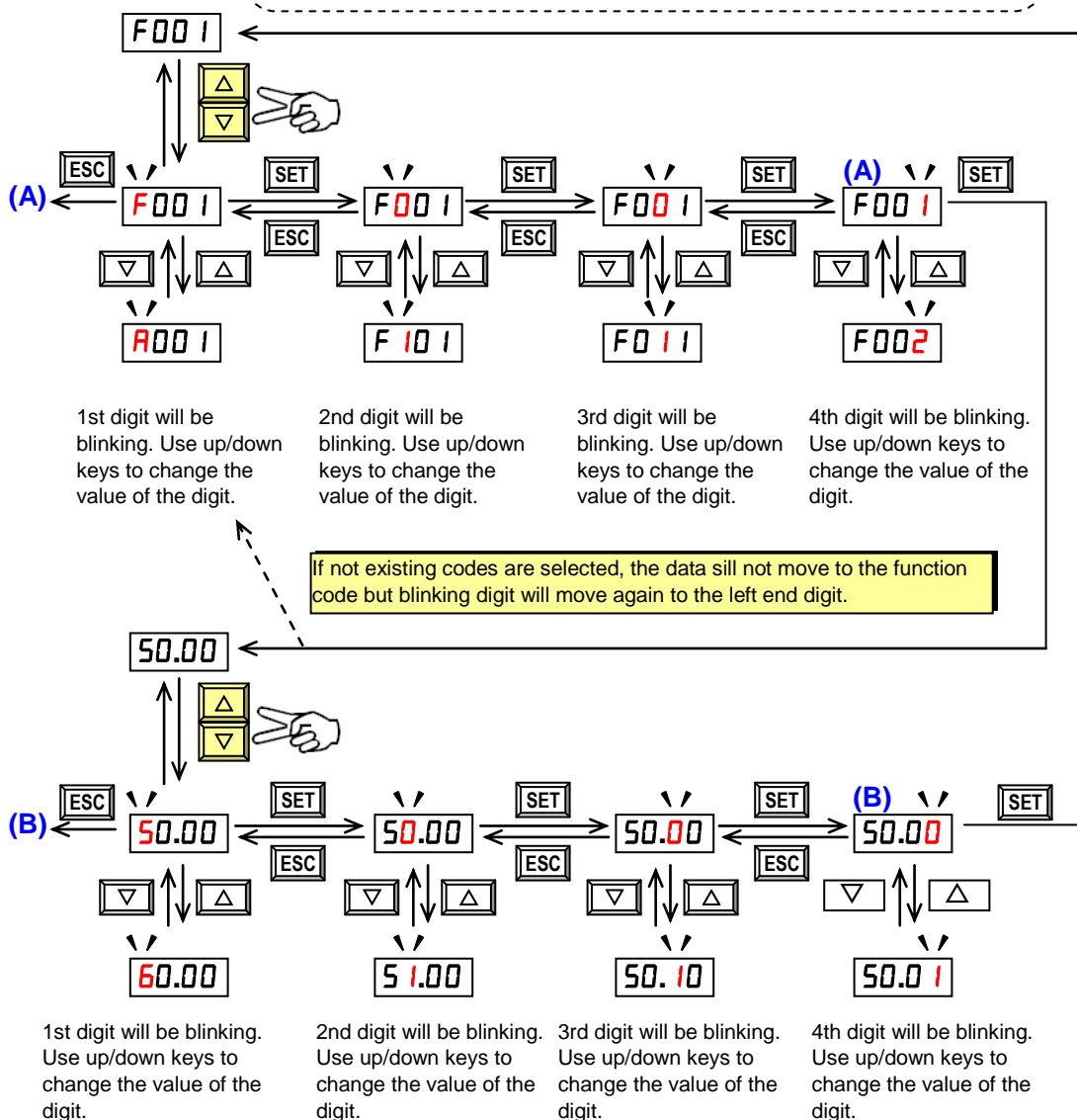

(Note) When pressing [ESC] with cursor on the highest digit, the cursor will jump to the lowest digit. ((A) and (B) in above figure.)



(Note) When pressing up key and down key at the same time in single-digit edit mode, the single-digit edit mode is disabled and goes back to normal mode.

Powerup Test Observations and Summary



Step 10: Reading this section will help you make some useful observations when first running the motor.

Error Codes – If the inverter displays an error code (format is “E xx”), see “[Monitoring Trip Events, History, & Conditions](#)” on page 6–8 to interpret and clear the error.

Acceleration and Deceleration – The WL200 inverter has programmable acceleration and deceleration value. The test procedure left these at the default value, 10 seconds. You can observe this by setting the frequency **F001** at about half speed before running the motor. Then press RUN, and the motor will take 5 seconds to reach a steady speed. Press the STOP key to see a 5 second deceleration to a STOP.

State of Inverter at Stop – If you adjust the motor’s speed to zero, the motor will slow to a near stop, and the inverter turns the outputs OFF. The high-performance WL200 can rotate at a very slow speed with high torque output, but not zero (must use servo systems with position feedback for that feature). This characteristic means you must use a mechanical brake for some applications.

Interpreting the Display – First, refer to the output frequency display readout. The maximum frequency setting (parameter **A004**) defaults to 50 Hz for your application.

Example: Suppose a 4-pole motor is rated for 60 Hz operation, so the inverter is configured to output 60 Hz at full scale. Use the following formula to calculate the rpm.

$$\text{Speed in RPM} = \frac{\text{Frequency} \times 60}{\text{Pairs of poles}} = \frac{\text{Frequency} \times 120}{\# \text{ of poles}} = \frac{60 \times 120}{4} = 1800 \text{ RPM}$$

The theoretical speed for the motor is 1800 RPM (speed of torque vector rotation). However, the motor cannot generate torque unless its shaft turns at a slightly different speed. This difference is called slip. So it’s common to see a rated speed of approximately 1750 RPM on a 60 Hz, 4-pole motor. Using a tachometer to measure shaft speed, you can see the difference between the inverter output frequency and the actual motor speed. The slip increases slightly as the motor’s load increases. This is why the inverter output value is called “frequency”, since it is not exactly equal to motor speed.

Run/Stop Versus Monitor/Program Modes – The Run LED on the inverter is ON in Run Mode, and OFF in Stop Mode. The Program LED is ON when the inverter is in Program Mode, and OFF for Monitor Mode. All four mode combinations are possible. The diagram to the right depicts the modes and the mode transitions via keypad.

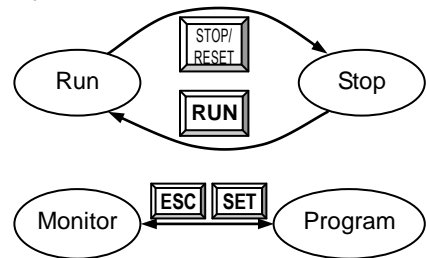

NOTE: Some factory automation devices such as PLCs have alternative Run/Program modes; the device is in either one mode or the other. In the Hitachi inverter, however, Run Mode alternates with Stop Mode, and Program Mode alternates with Monitor Mode. This arrangement lets you program some value while the inverter is operating – providing flexibility for maintenance personnel.

Configuring Drive Parameters



3

In This Chapter...	page
- Choosing a Programming Device	3-2
- Using the Keypad Devices	3-3
- “D” Group: Monitoring Functions	3-5
- “F” Group: Main Profile Parameters	3-10
- “A” Group: Standard Functions	3-11
- “B” Group: Fine Tuning Functions	3-43
- “C” Group: Intelligent Terminal Functions	3-79
- “H” Group: Motor Constants Functions	3-99
- “P” Group: Other Parameters	3-100

Choosing a Programming Device

Introduction

Hitachi variable frequency drives (inverters) use the latest electronics technology for getting the right AC waveform to the motor at the right time. The benefits are many, including energy savings and higher machine output or productivity. The flexibility required to handle a broad range of applications has required ever more configurable options and parameters – inverter are now a complex industrial automation component. And this can make a product seem difficult to use, but the goal of this chapter is to make this easier for you.

As the powerup test in Chapter 2 demonstrated, you do not have to program very many parameters to run the motor. In fact, most applications would benefit only from programming just a few, specific parameters. This chapter will explain the purpose of each set of parameters, and help you choose the ones that are important to your application.

If you are developing a new application for the inverter and a motor, finding the right parameters to change is mostly an exercise in optimization. Therefore, it is okay to begin running the motor with a loosely tuned system. By making specific, individual changes and observing their effects, you can achieve a finely tuned system.

Introduction of Inverter Programming

The front panel keypad is the first and best way to get to know the inverter's capabilities. Every function or programmable parameter is accessible from the keypad.

Using the Keypad Devices

The WL200 Series inverter front keypad contains all the elements for both monitoring and programming parameters. The keypad layout is pictured below. All other programming devices for the inverter have a similar key arrangement and function.

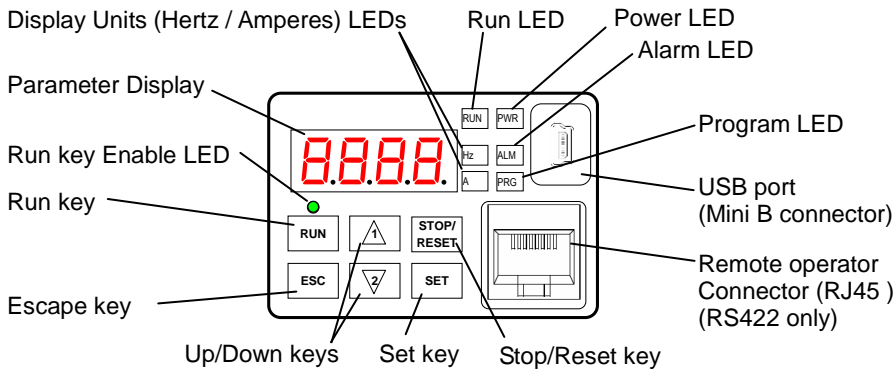

Key and Indicator Legend

- **Run LED** – ON when the inverter output is ON and the motor is developing torque (Run Mode), and OFF when the inverter output is OFF (Stop Mode).
- **Program LED** – This LED is ON when the inverter is ready for parameter editing (Program Mode). It is OFF when the parameter display is monitoring data (Monitor Mode).
- **Run Key Enable LED** – This LED is ON when the inverter is ready to respond to the Run key, OFF when the Run key is disabled.
- **Run Key** – Press this key to run the motor (the Run Enable LED must be ON first). Parameter **F004**, Keypad Run Key Routing, determines whether the Run key generates a Run FWD or Run REV command.
- **Stop/Reset Key** – Press this key to stop the motor when it is running (uses the programmed deceleration rate). This key will also reset an alarm that has tripped.
- **Parameter Display** – A 4-digit, 7-segment display for parameters and function codes.
- **Display Units, Hertz/Amperes** – One of these LEDs will be ON to indicate the units associated with the parameter display.
- **Power LED** – This is ON when the power input to the inverter is ON.
- **Alarm LED** – ON when an inverter trip is active (alarm relay contact will be closed).
- **Escape Key** – This key is used to escape from the current situation.
- **Up/Down keys** – Use these keys alternatively to move up or down the lists of parameter and functions shown in the display, and increment/decrement values.
- **Set key** – This key is used to navigate through the lists of parameters and functions for setting and monitoring parameter values. When the unit is in Program Mode and you have edited a parameter value, press the Set key to write the new value to the EEPROM.

Operational Modes

The RUN and PRG LEDs tell just part of the story; Run Mode and Program Modes are independent modes, not opposite modes. In the state diagram to the right, Run alternates with Stop, and Program Mode alternates with Monitor Mode. This is a very important ability, for it shows that a technician can approach a running machine and change some parameters without shutting down the machine.

The occurrence of a fault during operation will cause the inverter to enter Trip Mode as shown. An event such as an output overload will cause the inverter to exit the Run Mode and turn OFF its output to the motor. In the Trip Mode, any request to run the motor is ignored. You must clear the error by pressing the Stop/Reset switch. See ["Monitoring Trip Events, History, & Conditions"](#) on page 6-8.

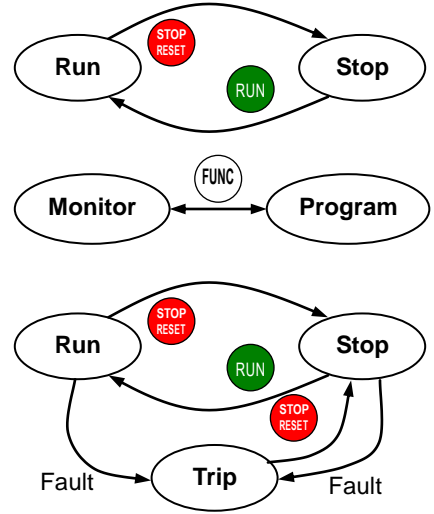

Run Mode Edit

The inverter can be in Run Mode (inverter output is controlling motor) and still allow you to edit certain parameters. This is useful in applications that must run continuously, you need some inverter parameter adjustment.

The parameter tables in this chapter have a column titled "Run Mode Edit". An Ex mark **X** means the parameter cannot be edited; a Check mark **✓** means the parameter can be edited. The Software Lock Setting (parameter **b03 I**) determines when the Run Mode access permission is in effect and access permission in other conditions, as well. It is the responsibility of the user to choose a useful and safe software lock setting for the inverter operating conditions and personnel. Please refer to ["Software Lock Mode"](#) on page 3-54 for more information.

	Run Mode Edit	
	X	
	✓	

Control Algorithms

The motor control program in the WL200 inverter has two sinusoidal PWM switching algorithms. The intent is that you select the best algorithm for the motor and load characteristics of your application. Both algorithms generate the frequency output in a unique way.

Once configured, the algorithm is the basis for other parameter settings as well (see ["Torque Control Algorithms"](#) on page 3-21). Therefore, choose the best algorithm early in your application design process.

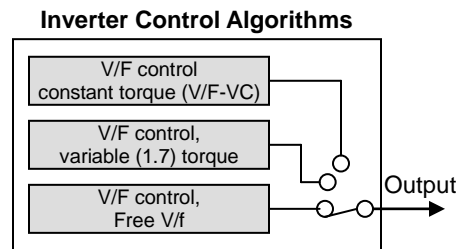

"D" Group: Monitoring Functions

You can access important parameter values with the "D" Group monitoring functions, whether the inverter is in Run Mode or Stop Mode. After selecting the function code number for the parameter you want to monitor, press the Set key once to show the value on the display. In functions **d005** and **d006**, the intelligent terminals use individual segments of the display to show ON/OFF status.

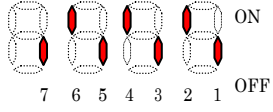
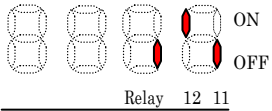
"d" Function			Run Mode Edit	Units
Func. Code	Name	Description		
d001	Output frequency monitor	Real time display of output frequency to motor from 0.0 to 400.0Hz If b163 is set 01, output frequency (F001) can be changed by up/down key with d001 monitoring.	-	Hz
d002	Output current monitor	Filtered display of output current to motor, range is 0 to 655.3 ampere	-	A
d003	Rotation direction monitor	Three different indications: "F"...Forward "o"...Stop "r"...Reverse	-	-
d004	Process variable (PV), PID feedback monitor	Displays the scaled PID process variable (feedback) value (A075 is scale factor), 0.00 to 9999.00	-	% times constant
d005	Intelligent input terminal status	Displays the state of the intelligent input terminals:  Terminal numbers	-	-
d006	Intelligent output terminal status	Displays the state of the intelligent output terminals:  Relay 12 11	-	-
d007	Scaled output frequency monitor	Displays the output frequency scaled by the constant in b086 . Decimal point indicates range: 0 to 3999	-	Hz times constant
d013	Output voltage monitor	Voltage of output to motor, Range is 0.0 to 600.0V	-	V
d014	Input power monitor	Displays the input power, range is 0 to 999.9 kW	-	KW

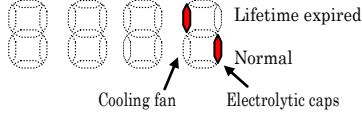
"d" Function			Run Mode Edit	Units
Func. Code	Name	Description		
d015	Watt-hour monitor	Displays watt-hour of the inverter, range is 0.0 to 999.9/ 1000. to 9999./ 1000 to 9999 (10,000 to 99,900)/ [100 to [999 (10,0000 to 999,9000)	-	
d016	Elapsed RUN time monitor	Displays total time the inverter has been in RUN mode in hours. Range is 0. to 9999./ 1000 to 9999 (10,000 to 99,900)/ [100 to [999 (10,0000 to 99,9000)	-	hours
d017	Elapsed power-on time monitor	Displays total time the inverter has been powered up in hours. Range is 0. to 9999./ 1000 to 9999 (10,000 to 99,900)/ [100 to [999 (10,0000 to 99,9000)	-	hours
d018	Heat sink temperature monitor	Temperature of the cooling fin, range is -20 to 150	-	°C
d022	Life check monitor	Displays the state of lifetime of electrolytic capacitors on the PWB and cooling fan. 	-	-
d023	Program counter monitor [EzSQ]	Range is 0 to 1024	-	-
d024	Program number monitor [EzSQ]	Range is 0 to 9999	-	-
d025	User monitor 0 [EzSQ]	Result of EzSQ execution, range is -2147483647 to 2147483647	-	-
d026	User monitor 1 [EzSQ]	Result of EzSQ execution, range is -2147483647 to 2147483647	-	-
d027	User monitor 2 [EzSQ]	Result of EzSQ execution, range is -2147483647 to 2147483647	-	-
d050	Dual monitor	Displays two different data configured in b 160 and b 161 .	-	-
d062	Frequency source monitor	Displays the frequency source 0 ...Operator 1 to 15 ...Multi-speed freq. 1 to 15 16 ...Jog frequency 18 ...Modbus network 19 ...Option 21 ...Potentiometer 23 ...Calculate function output 24 ...EzSQ 25 ...[O] input 26 ...[OI] input 27 ...[O] + [OI]	-	-
d063	Run source monitor	1 ...Terminal 2 ...Operator 3 ...Modbus network 4 ...Option	-	-

"d" Function			Run Mode	Edit	Units
Func. Code	Name	Description			
d 102	DC bus voltage monitor	Voltage of inverter internal DC bus, range is 0.0 to 999.9	-		V
d 103	BRD load ratio monitor	Usage ratio of integrated brake chopper, range is 0.0 to 100.0%	-		%
d 104	Electronic thermal monitor	Accumulated value of electronic thermal detection, range is from 0.0 to 100.0%	-		%
d 130	Analog input [O] monitor	Displays [O] input value, range is 0 to 1023	-		-
d 131	Analog input [OI] monitor	Displays [OI] input value, range is 0 to 1023	-		-
d 153	PID deviation monitor	Displays the scaled PID deviation (A075 is scale factor), range is -9999.00 to 9999.00	-		% times constant
d 155	PID output monitor	Displays PID output, range is -100.00 to 100.00%	-		%

Trip Event and History Monitoring

The trip event and history monitoring feature lets you cycle through related information using the keypad. See “[Monitoring Trip Events, History, & Conditions](#)” on page 6–8 for more details.

“d” Function			Run Mode Edit	Units
Func. Code	Name	Description		
d080	Trip counter	Number of trip events, Range is 0. to 65530	–	events
d081	Trip monitor 1	Displays trip event information: <ul style="list-style-type: none"> • Error code • Output frequency at trip point • Motor current at trip point • DC bus voltage at trip point • Cumulative inverter operation time at trip point • Cumulative power-ON time at trip point 	–	–
d082	Trip monitor 2		–	–
d083	Trip monitor 3		–	–
d084	Trip monitor 4		–	–
d085	Trip monitor 5		–	–
d086	Trip monitor 6		–	–
d090	Warning monitor	Displays the warning code	–	–

Local Monitoring with keypad connected

The WL200 inverter's serial port may be connected to an external digital operator. During those times, the inverter keypad keys will not function (except for the Stop key). However, the inverter's 4-digit display still provides the Monitor Mode function, displaying any of the parameters **d001** to **d050**. Function **b150**, Monitor Display Select for Networked Inverter, determines the particular **d00x** parameter displayed. Refer to the previous table.

When monitoring the inverter with external keypad connected, please note the following:

- The inverter display will monitor **d00x** functions according to **b150** setting when a device is already connected to the inverter's serial port at inverter powerup.
- When external keypad is connected, the inverter keypad will also display error codes for inverter trip events. Use the Stop key or inverter Reset function to clear the error. Refer to "[Error Codes](#)" on page 6-8 to interpret the error codes.
- The Stop key can be disabled, if you prefer, by using function **b087**.

"F" Group: Main Profile Parameters

The basic frequency (speed) profile is defined by parameters contained in the "F" Group as shown to the right. The set running frequency is in Hz, but acceleration and deceleration are specified in the time duration of the ramp (from zero to maximum frequency, or from maximum frequency to zero). The motor direction parameter determines whether the keypad Run key produces a FWD or REV command. This parameter does not affect the intelligent terminal [FW] and [REV] functions, which you configure separately.

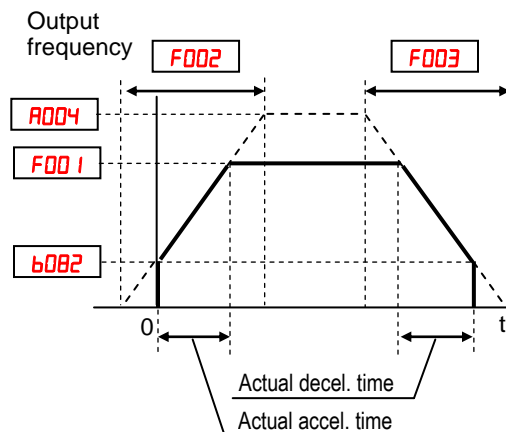

Acceleration 1 and Deceleration 1 are the standard default accel and decel values for the main profile. Accel and decel values for an alternative profile are specified by using parameters **Ax92** through **Ax93**. The motor direction selection (**FOO4**) determines the direction of rotation as commanded only from the keypad. This setting applies to any motor profile (1st or 2nd) in use at t particular time. When [LAC] is ON, acceleration and deceleration time become 0.00 second and target frequency is set into the output frequency immediately.

"F" Function			Run Mode Edit	Defaults	
Func. Code	Name	Description		Initial data	Units
FOO1	Output frequency setting	Standard default target frequency that determines constant motor speed, range is 0.00 / start frequency to maximum frequency (FOO4)	✓	0.00	Hz
FOO2	Acceleration time (1)	Standard default acceleration, range is 0.00 to 3600.00 sec.	✓	10.00	sec.
F202	Acceleration time (1), 2 nd motor		✓	10.00	sec.
FOO3	Deceleration time (1)	Standard default deceleration, range is 0.00 to 3600.00 sec.	✓	10.00	sec.
F203	Deceleration time (1), 2 nd motor		✓	10.00	sec.
FOO4	Keypad RUN key routing	Two options; select codes: 00 ...Forward 01 ...Reverse	✗	00	-

Acceleration and deceleration can be set via EzSQ as well via the following parameter.

"P" Function			Run Mode Edit	Defaults	
Func. Code	Name	Description		Initial data	Units
P031	Acceleration/Deceleration setting source selection	Two options; select codes: 00 ...Via operator 03 ...Via EzSQ	✗	00	-

"A" Group: Standard Functions

The inverter provides flexibility in how you control Run/Stop operation and set the output frequency (motor speed). It has other control sources that can override the **A001** / **A002** settings. Parameter **A001** sets the source selection for the inverter's output frequency. Parameter **A002** selects the Run command source (for FW or RV Run commands). The default settings use the input terminals.

"A" Function			Run Mode Edit	Defaults	
Func. Code	Name	Description		Initial data	Units
A001	Frequency source	Eight options; select codes: 00 ...POT on ext. operator 01 ...Control terminal 02 ...Function F001 setting 03 ...Modbus network input 04 ...Option 07 ...via EzSQ 10 ...Calculate function output	✗	01	–
A201	Frequency source, 2 nd motor	Eight options; select codes: 00 ...POT on ext. operator 01 ...Control terminal 02 ...Function F001 setting 03 ...Modbus network input 04 ...Option 07 ...via EzSQ 10 ...Calculate function output	✗	01	–
A002	Run command source	Four options; select codes: 01 ...Control terminal 02 ...Run key on keypad, or digital operator 03 ...Modbus network input 04 ...Option	✗	01	–
A202	Run command source, 2 nd motor	Four options; select codes: 01 ...Control terminal 02 ...Run key on keypad, or digital operator 03 ...Modbus network input 04 ...Option	✗	01	–

Frequency Source Setting – For parameter **A001**, the following table provides a further description of each option, and a reference to other page(s) for more information.

Code	Frequency Source	Refer to page(s)...
00	POT on ext. operator – The range of rotation of the knob matches the range defined by b082 (start frequency) to A004 (max. frequency), when external operator is used	–
01	Control terminal – The active analog input signal on analog terminals [O] or [OI] sets the output frequency	3-15, 3-16, 3-39, 3-79, 4-77
02	Function F001 setting – The value in F001 is a constant, used for the output frequency	3-10
03	Modbus network input – The network has a dedicated register for inverter output frequency	B-26
04	Option – Select when an option card is connected and use the frequency source from the option	(manual of each option)
07	Via EzSQ – The frequency source can be given by the EzSQ function, when it is used	(EzSQ manual)
10	Calculate function output – The Calculated function has user-selectable analog input sources (A and B). The output can be the sum, difference, or product (+, -, x) of the two outputs.	3-40

Run Command Source Setting – For parameter **A002**, the following table provides a further description of each option, and a reference to other page(s) for more information.

Code	Run Command Source	Refer to page(s)...
01	Control terminal – The [FW] or [RV] input terminals control Run/Stop operation	4–16
02	Keypad Run key – The Run and Stop keys provide control	2–24
03	Modbus network input – The network has a dedicated coil for Run/Stop command and a coil for FW/RV	8–24
04	Option – Select when an option card is connected and use the frequency source from the option	(manual of each option)

A001/A002 Override Sources – The inverter allows some sources to override the setting for output frequency and Run command in **A001** and **A002**. This provides flexibility for applications that occasionally need to use a different source, leaving the standard settings in **A001/A002**.

The inverter has other control sources that can temporarily override the parameter **A001** setting, forcing a different output frequency source. The following table lists all frequency source setting methods and their relative priority (“1” is the highest priority).

Priority	A001 Frequency Source Setting Method	Refer to page...
1	[CF1] to [CF4] Multi-speed terminals	4–17
2	[OPE] Operator Control intelligent input	4–35
3	[F-TM] intelligent input	4–40
4	[AT] terminal	4–28
5	A001 Frequency source setting	3–11

The inverter also has other control sources that can temporarily override the parameter **A002** setting, forcing a different Run command source. The following table lists all Run command setting methods and their relative priority (“1” is the highest priority).

Priority	A002 Run Command Setting Method	Refer to page...
1	[OPE] Operator Control intelligent input	4–35
2	[F-TM] intelligent input	4–40
3	A002 Run command source setting	3–11

Basic Parameter Settings

These settings affect the most fundamental behavior of the inverter – the outputs to the motor. The frequency of the inverter's AC output determines the motor speed. You may select from three different sources for the reference speed. During application development you may prefer using the potentiometer, but you may switch to an external source (control terminal setting) in the finished application, for example.

The base frequency and maximum frequency settings interact according to the graph below (left). The inverter output operation follows the constant V/f curve until it reaches the full-scale output voltage at the base frequency. This initial straight line is the constant-torque part of the operating characteristic. The horizontal line over to the maximum frequency serves to let the motor run faster, but at a reduced torque. This is the constant-power operating range. If you want the motor to output constant torque over its entire operating range (limited to the motor nameplate voltage and frequency rating), then set the base frequency and maximum frequency equal as shown (below right).

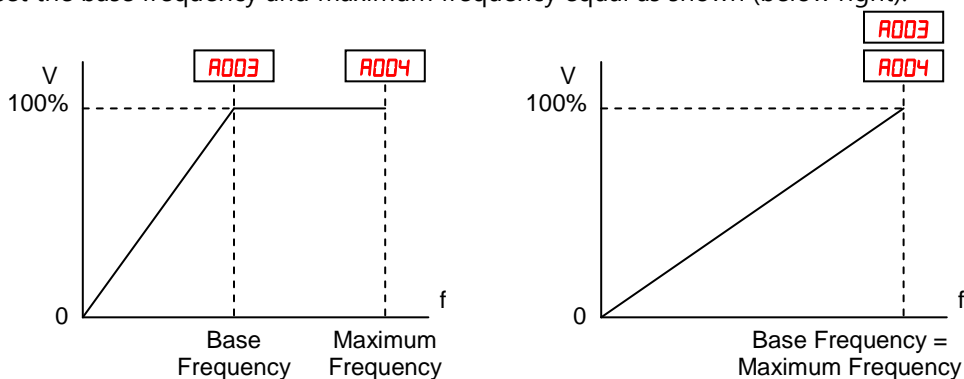

NOTE: The "2nd motor" settings in the table in this chapter store an alternate set of parameters for a second motor. The inverter can use the 1st set or 2nd set of parameters to generate the output frequency to the motor.

Func. Code	"A" Function		Run Mode Edit	Defaults	
	Name	Description		Initial data	Units
A003	Base frequency	Settable from 30.0 Hz to the maximum frequency(A004)	✗	50.0	Hz
A203	Base frequency, 2 nd motor	Settable from 30.0 Hz to the 2 nd maximum frequency(A204)	✗	50.0	Hz
A004	Maximum frequency	Settable from the base frequency to 400.0 Hz	✗	50.0	Hz
A204	Maximum frequency, 2 nd motor	Settable from the 2 nd base frequency to 400.0 Hz	✗	50.0	Hz

Analog Input Settings

The inverter has the capability to accept an external analog input that can command the output frequency to the motor. Voltage input (0-10 V) and current input (4-20mA) are available on separate terminals ([O] and [OI] respectively). Terminal [L] serves as signal ground for the two analog inputs. The analog input settings adjust the curve characteristics between the analog input and the frequency output.

Adjusting [O-L] characteristics – In the graph to the right, **AD 13** and **AD 14** select the active portion of the input voltage range. Parameters **AD 11** and **AD 12** select the start and end frequency of the converted output frequency range, respectively. Together, these four parameters define the major line segment as shown. When the line does not begin at the origin (**AD 11** and **AD 13** > 0), then **AD 15** defines whether the inverter outputs 0Hz or the **AD 11**-specified frequency when the analog input value is less than the **AD 13** setting. When the input voltage is greater than the **AD 14** ending value, the inverter outputs the ending frequency specified by **AD 12**.

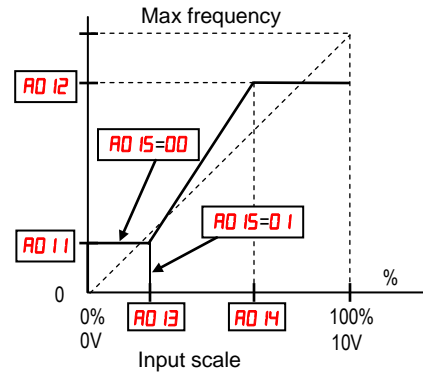

Adjusting [OI-L] characteristics – In the graph to the right, **A 103** and **A 104** select the active portion of the input current range. Parameters **A 101** and **A 102** select the start and end frequency of the converted output frequency range, respectively. Together, these four parameters define the major line segment as shown. When the line does not begin at the origin (**A 101** and **A 103** > 0), then **A 105** defines whether the inverter outputs 0Hz or the **A 101**-specified frequency when the analog input value is less than the **A 103** setting. When the input voltage is greater than the **A 104** ending value, the inverter outputs the ending frequency specified by **A 102**.

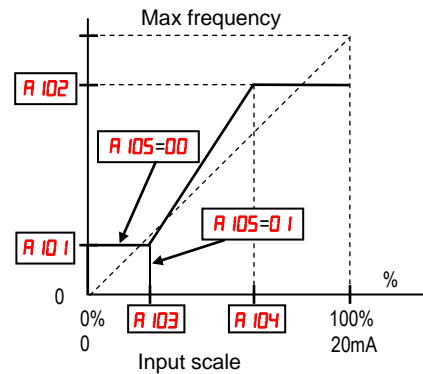

If [AT] is not assigned to any of the intelligent input terminal, inverter recognizes the input [O]+[OI].

Adjusting [VR-L] characteristics – This is used when an optional operator is used. Refer to parameters **A 161** to **A 165** for the details.

Func. Code	"A" Function		Run Mode Edit	Defaults	
	Name	Description		Initial data	Units
AO05	[AT] selection	Three options; select codes: 00 ...Select between [O] and [OI] at [AT] (ON=OI, OFF=O) 02 ...Select between [O] and external POT at [AT] (ON=POT, OFF=O) 03 ...Select between [OI] and external POT at [AT] (ON=POT, OFF=OI)	✗	00	–
AO11	[O] input active range start frequency	The output frequency corresponding to the analog input range starting point, range is 0.00 to 400.00	✗	0.00	Hz
AO12	[O] input active range end frequency	The output frequency corresponding to the analog input range ending point, range is 0.00 to 400.00	✗	0.00	Hz
AO13	[O] input active range start voltage	The starting point (offset) for the active analog input range, range is 0. to 100.	✗	0.	%
AO14	[O] input active range end voltage	The ending point (offset) for the active analog input range, range is 0. to 100.	✗	100.	%
AO15	[O] input start frequency enable	Two options; select codes: 00 ...Use offset (AO11 value) 01 ...Use 0Hz	✗	01	–
AO16	Analog input filter	Range n = 1 to 31, 1 to 30 : ×2ms filter 31: 500ms fixed filter with ±0.1kHz hys.	✗	8.	Spl.

AO16: External Frequency Filter Time Constant – This filter smooths the analog input signal for the inverter's output frequency reference.

- **AO16** sets the filter range from n= 1 to **30**. This is a simple moving average calculation, where n (number of samples) is variable.
- **AO16=31** is a special value. It configures the inverter to use a movable deadband feature. Initially the inverter uses the 500ms of filter time constant. Then, the deadband is employed for each subsequent average of 16 samples. The deadband works by ignoring small fluctuations in each new average: less than ±0.1Hz change. When a 30-sample average exceeds this deadband, then the inverter applies that average to the output frequency reference, and it also becomes the new deadband comparison point for subsequent sample averages.

The example graph below shows a typical analog input waveform. The filter removes the noise spikes. When a speed change (such as level increase) occurs, the filter naturally has a delayed response. Due to the deadband feature (**AO16=31**), the final output changes only when the 30-sample average moves past the deadband threshold.



TIP: The deadband feature is useful in applications that require a very stable output frequency but use an analog input for the speed reference. Example application: A grinding machine uses a remote potentiometer for operator speed input. After a setting change, the grinder maintains a very stable speed to deliver a uniform finished surface.

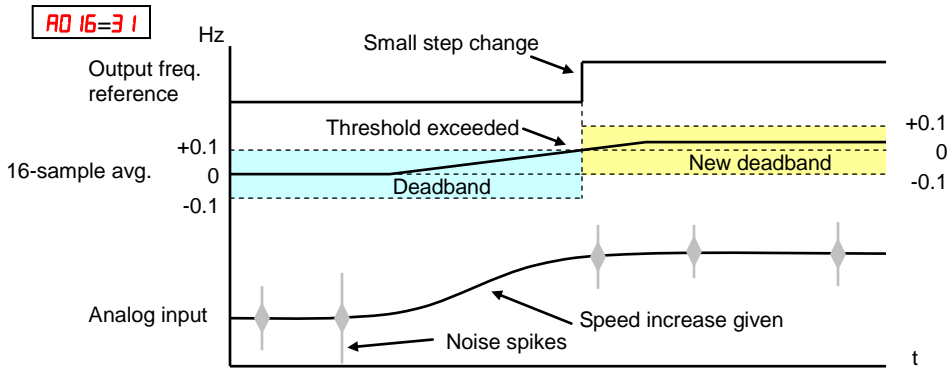

EzSQ Related Settings

The WL200 series inverter has capability to execute EzSQ program like SJ700 series inverters. Parameters **AD 17** is for the EzSQ performance. Please refer to the EzSQ section for the detailed explanation.

Multi-speed and Jog Frequency Settings

Multi-speed – The WL200 inverter has the capability to store and output up to 16 preset frequencies to the motor (**A020** to **A035**). As in traditional motion terminology, we call this *multi-speed profile* capability. These preset frequencies are selected by means of digital inputs to the inverter. The inverter applies the current acceleration or deceleration setting to change from the current output frequency to the new one. The first multi-speed setting is duplicated for the second motor settings (the remaining 15 multi-speeds apply only to the first motor).

Func. Code	"A" Function		Run Mode Edit	Defaults	
	Name	Description		Initial data	Units
A019	Multi-speed operation selection	Select codes: 00 ...Binary operation (16 speeds selectable with 4 terminals) 01 ...Bit operation (8 speeds selectable with 7 terminals)	✗	00	–
A020	Multi-speed freq. 0	Defines the first speed of a multi-speed profile, range is 0.00 / start frequency to 400.00Hz	✓	6.00	Hz
A220	Multi-speed freq. 0, 2 nd motor		✓	6.00	Hz
A021 to A035	Multi-speed freq. 1 to 15 (for both motors)	Defines 15 more speeds, range is 0.00 / start frequency to 400.00Hz. A021 =Speed 1 to A035 =Speed15	✓	0.00	Hz
C169	Multistage speed/position determination time	Set range is 0. to 200. (x 10ms)	✗	0.	ms

There are two ways for speed selection, which are "binary operation" and "bit operation".

For binary operation (**A019=00**), you can select 16 speeds by combination of 4 digital inputs. And for bit operation (**A019=01**), you can select 8 speeds by using 7 digital inputs. Please refer to the following figures for detailed explanation.

(1) Binary operation ("1"=ON)

Speed	Param.	CF4	CF3	CF2	CF1
Speed 0	RD20	0	0	0	0
Speed 1	RD21	0	0	0	1
Speed 2	RD22	0	0	1	0
Speed 3	RD23	0	0	1	1
Speed 4	RD24	0	1	0	0
Speed 5	RD25	0	1	0	1
Speed 6	RD26	0	1	1	0
Speed 7	RD27	0	1	1	1
Speed 8	RD28	1	0	0	0
Speed 9	RD29	1	0	0	1
Speed 10	RD30	1	0	1	0
Speed 11	RD31	1	0	1	1
Speed 12	RD32	1	1	0	0
Speed 13	RD33	1	1	0	1
Speed 14	RD34	1	1	1	0
Speed 15	RD35	1	1	1	1

(2) Bit operation ("1"=ON, "X"=regardless the condition (ON or OFF))

Speed	Param.	SF7	SF6	SF5	SF4	SF3	SF2	SF1
Speed 0	RD20	0	0	0	0	0	0	0
Speed 1	RD21	X	X	X	X	X	X	1
Speed 2	RD22	X	X	X	X	X	1	0
Speed 3	RD23	X	X	X	X	1	0	0
Speed 4	RD24	X	X	X	1	0	0	0
Speed 5	RD25	X	X	1	0	0	0	0
Speed 6	RD26	X	1	0	0	0	0	0
Speed 7	RD27	1	0	0	0	0	0	0

Jog Frequency – The jog speed setting is used whenever the Jog command is active. The jog speed setting range is arbitrarily limited to 10 Hz, to provide safety during manual operation. The acceleration to the jog frequency is instantaneous, but you can choose from three modes for the best method for stopping the jog operation.

Func. Code	"A" Function		Run Mode Edit	Defaults	
	Name	Description		Initial data	Units
A038	Jog frequency	Defines limited speed for jog, range is from start frequency to 9.99 Hz	✓	6.00	Hz
A039	Jog stop mode	Define how end of jog stops the motor; six options: 00 ...Free-run stop (invalid during run) 01 ...Controlled deceleration (invalid during run) 02 ...DC braking to stop(invalid during run) 03 ...Free-run stop (valid during run) 04 ...Controlled deceleration (valid during run) 05 ...DC braking to stop(valid during run)	✗	04	–

Note 1: For jogging operation, turn JG terminal ON at first and then turn FW or RV terminal on.

Note 2: When jogging stop mode A039=02 or 05, DC braking data is needed.

Note 3: During jogging operation, frequency can be set with output frequency setting F001.

Torque Control Algorithms

The inverter generates the motor output according to the V/f algorithm selected. Parameter **A044** selects the inverter algorithm for generating the frequency output, as shown in the diagram to the right (**A244** for 2nd motor). The factory default is **00** (constant torque).

Review the following description to help you choose the best torque control algorithm for your application.

The built-in V/f curves are oriented toward developing constant torque or variable torque characteristics (see graphs below). You can select either constant torque or reduced torque V/f control.

Constant and Variable (Reduced) Torque – The graph at right shows the constant torque characteristic from 0Hz to the base frequency **A003**. The voltage remains constant for output frequencies higher than the base frequency.

Inverter Torque Control Algorithms

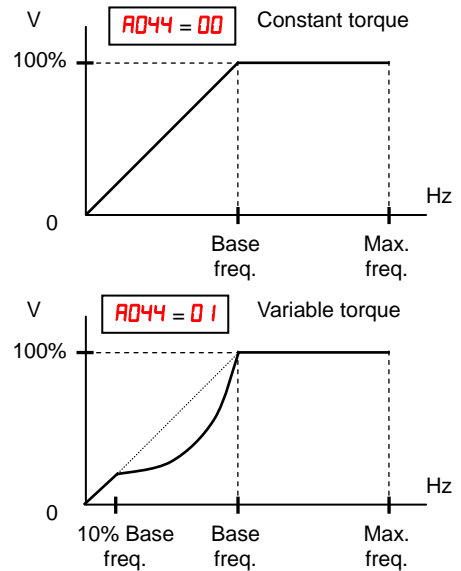
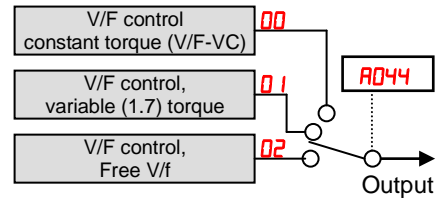

The graph above (right) shows the variable (reduced) torque curve, which has a constant torque characteristic from 0Hz to 10% of the base frequency. This helps to achieve higher torque at low speed with reduced torque curve at higher speeds.

Free V/F Control – The free V/F setting function allows you to set arbitrary V/F characteristics by specifying the voltages and frequencies (**b 100** to **b 113**) for the seven points on the V/F characteristic curve.

The free V/F frequencies 1 to 7 set by this function must always be in the collating sequence of "1<2<3<4<5<6<7".

Since all the free V/F frequencies are set to 0Hz as default (factory setting), specify their arbitrary values (being set with free-setting V/F frequency 7). The inverter does not operate the free V/F characteristics with the factory setting.

Enabling the free V/F characteristics setting function disables the torque boost selection (**A04 I/A24 I**), base frequency setting (**A003/A203**), and maximum frequency setting (**A004/A204**) automatically. (The inverter regard the value of free-setting V/F frequency 7 (**b 112**) as the maximum frequency.)

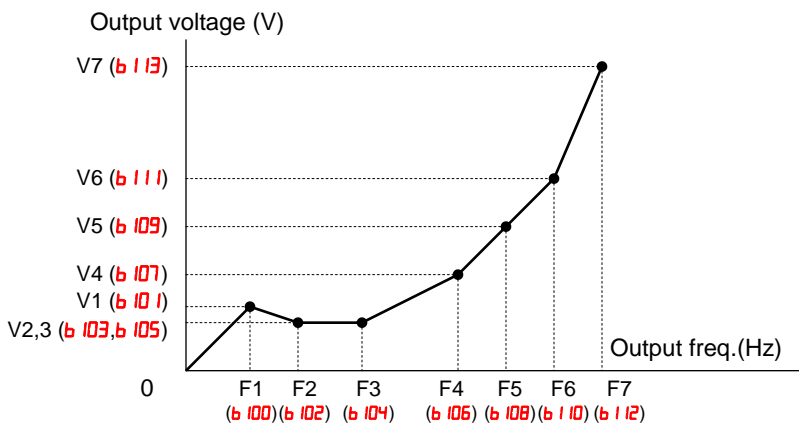

Item	Code	Set range	Remarks
Free-setting V/F freq. (7)	b 112	0 to 400 (Hz)	Setting of the output freq. at each breakpoint of the V/F characteristic curve
Free-setting V/F freq. (6)	b 110	Free-setting V/F freq.5 to freq.7 (Hz)	
Free-setting V/F freq. (5)	b 108	Free-setting V/F freq.4 to freq.6 (Hz)	
Free-setting V/F freq. (4)	b 106	Free-setting V/F freq.3 to freq.5 (Hz)	
Free-setting V/F freq. (3)	b 104	Free-setting V/F freq.2 to freq.4 (Hz)	
Free-setting V/F freq. (2)	b 102	Free-setting V/F freq.1 to freq.3 (Hz)	
Free-setting V/F freq. (1)	b 100	0 to Free-setting V/F freq.2 (Hz)	
Free-setting V/F volt. (7)	b 113	0.0 to 800.0 (V)	Setting of the output voltage at each breakpoint of the V/F characteristic curve *1)
Free-setting V/F volt. (6)	b 111		
Free-setting V/F volt. (5)	b 109		
Free-setting V/F volt. (4)	b 107		
Free-setting V/F volt. (3)	b 105		
Free-setting V/F volt. (2)	b 103		
Free-setting V/F volt. (1)	b 101		

*1) Even if the voltage higher than input is set as a free-setting V/F voltage 1 to 7, the inverter output voltage cannot exceed the inverter input voltage or that specified by the AVR voltage selection. Carefully note that selecting an inappropriate control system (V/F characteristics) may result in overcurrent during motor acceleration or deceleration or vibration of the motor or other machine driven by the inverter.

Manual Torque Boost – The Constant and Variable Torque algorithms feature an adjustable *torque boost* curve. When the motor load has a lot of inertia or starting friction, you may need to increase the low frequency starting torque characteristics by boosting the voltage above the normal V/f ratio (shown at right). The function attempts to compensate for voltage drop in the motor primary winding in the low speed range.

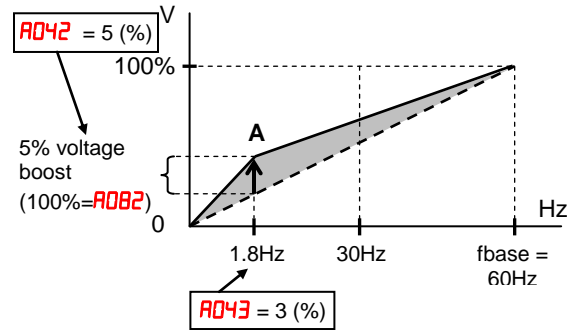

The boost is applied from zero to the base frequency. You set the breakpoint of the boost (point **A** on the graph) by using parameters **RO42** and **RO43**. The manual boost is calculated as an addition to the standard V/f curve.

Be aware that running the motor at a low speed for a long time can cause motor overheating. This is particularly true when manual torque boost is ON, or if the motor relies on a built-in fan for cooling.

Voltage gain – Using parameter **RO45** you can modify the voltage gain of the inverter (see graph at right). This is specified as a percentage of the full scale output voltage. The gain can be set from 20% to 100%. It should be adjusted in accordance with the motor specifications. Gain can be changed even during operation in V/f mode

Refrain from change the setting value suddenly (within 10%). Inverter may overvoltage trip due to the rapid change of output voltage.

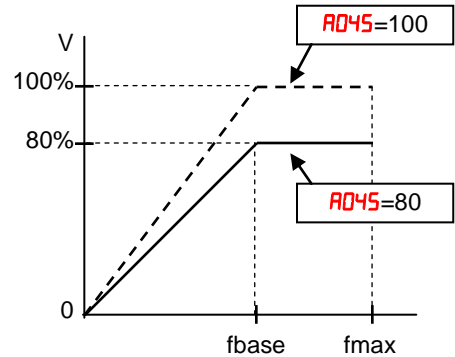

Voltage compensation gain and slip compensation gain – Using parameters **A046** and **A047**, you can obtain better performance under automatic torque boost mode (**A041=01**). See following table for the concept of adjustment, including other parameters.

Symptom	Adjustment	Adjust item
Motor torque is not enough at low speed (The motor does not rotate at low speed)	Increase the voltage setting for manual torque boost, step by step	A042 / A242
	Increase the voltage compensation gain for automatic torque boost, step by step	A046 / A246
	Increase the slip compensation gain for automatic torque boost, step by step	A047 / A247
	Reduce carrier frequency	b083
Motor speed decreases (stalls) when a load is given to the motor	Increase the slip compensation gain for automatic torque boost, step by step	A047 / A247
Motor speed increases when a load is given to the motor	Decrease the slip compensation gain for automatic torque boost, step by step	A047 / A247
The inverter trips due to overcurrent when a load is given to the motor	Decrease the voltage setting for manual torque boost, step by step	A042 / A242
	Decrease the voltage compensation gain for automatic torque boost, step by step	A046 / A246
	Decrease the slip compensation gain for automatic torque boost, step by step	A047 / A247

"A" Function			Run Mode Edit	Defaults	
Func. Code	Name	Description		Initial data	Units
A041	Torque boost select	Two options: 00 ...Manual torque boost	✗	00	–
A241	Torque boost select, 2 nd motor	01 ...Automatic torque boost	✗	00	–
A042	Manual torque boost value	Can boost starting torque between 0 and 20% above normal V/f curve, range is 0.0 to 20.0%	✓	1.0	%
A242	Manual torque boost value, 2 nd motor		✓	1.0	%
A043	Manual torque boost frequency	Sets the frequency of the V/f breakpoint A in graph (top of previous page) for torque boost, range is 0.0 to 50.0%	✓	5.0	%
A243	Manual torque boost frequency, 2 nd motor		✓	5.0	%
A044	V/f characteristic curve	Four available V/f curves; 00 ...Constant torque 01 ...Reduced torque (1.7) 02 ...Free V/F	✗	00	–
A244	V/f characteristic curve, 2 nd motor		✗	00	–
A045	V/f gain	Sets voltage gain of the inverter, range is 20. to 100.%	✓	100.	%
A245	V/f gain, 2 nd motor		✓	100.	%
A046	Voltage compensation gain for automatic torque boost	Sets voltage compensation gain under automatic torque boost, range is 0. to 255.	✓	100.	–
A246	Voltage compensation gain for automatic torque boost, 2 nd motor		✓	100.	–
A047	Slip compensation gain for automatic torque boost	Sets slip compensation gain under automatic torque boost, range is 0. to 255.	✓	100.	–
A247	Slip compensation gain for automatic torque boost, 2 nd motor		✓	100.	–

DC Braking (DB) Settings

Normal DC braking performance – The DC braking feature can provide additional stopping torque when compared to a normal deceleration to a stop. DC braking is particularly useful at low speeds when normal deceleration torque is minimal.

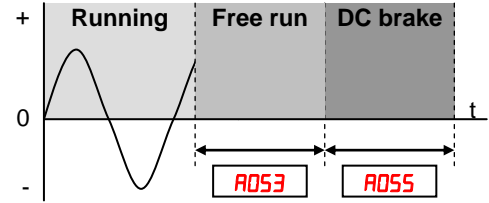

When you set **A051** to **01** (Enable during stop), and the RUN command (FW/RV signal) turns OFF, the inverter injects a DC voltage into the motor windings during deceleration below a frequency you can specify (**A052**).

The braking power (**A054**) and duration (**A055**) can both be set. You can optionally specify a wait time before DC braking (**A053**), during which the motor will free run.

DC Braking – Frequency Detection – You can instead set DC braking to operate during RUN mode only, by setting **A051** to **02** (Frequency detection). In this case DC braking operates when the output frequency comes down to the one you specified in **A052** while the RUN command is still active. Refer to the graphs figures below.

External DB and Internal DC braking are invalid during the frequency detection mode.

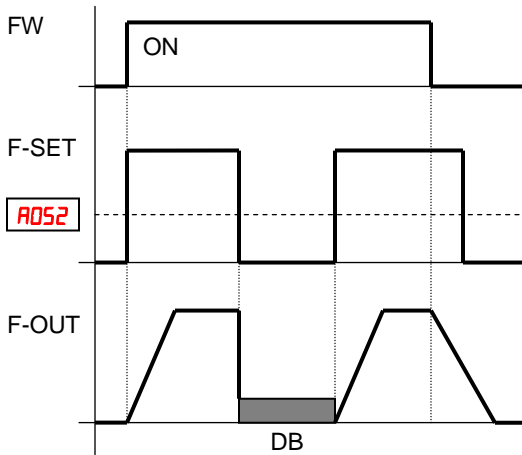

Ex.1) Step change in F-SET.

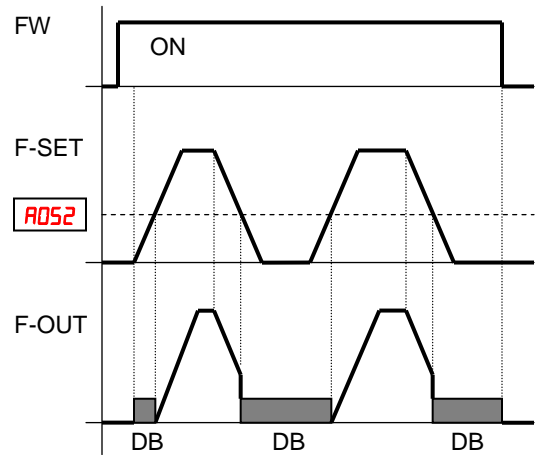

Ex.2) Analog change in F-SET.

Example 1, (above left) shows the performance with **A051=02** with a step-changing frequency reference. In this case, when the reference goes to 0, the inverter immediately starts DC braking because the set point drops below the value specified in **A052**. DC braking continues until the set point exceeds **A052**. There will be no DC braking at next downward transition because the FW input is OFF.

Example 2, (above right) shows a gradually changing frequency reference, for example by analog input. In this case, there will be a DC braking period at starting because the frequency set point is lower than the value specified in **A052**.



CAUTION: Be careful to avoid specifying a braking time that is long enough to cause motor overheating. If you use DC braking, we recommend using a motor with a built-in thermistor, and wiring it to the inverter's thermistor input (see "[Thermistor Thermal Protection](#)" on page 4-30). Also refer to the motor manufacturer's specifications for duty-cycle recommendations during DC braking.

DC braking performance at start can also be set separately ([A057](#) and [A058](#)).
And carrier frequency of DC braking performance can also be set separately ([A059](#)).



CAUTION: Be careful to avoid specifying a braking carrier frequency that is high enough to cause inverter and motor overheating. If you use DC braking, we recommend using a motor with a built-in thermistor, and wiring it to the inverter's thermistor input (see "[Thermistor Thermal Protection](#)" on page 4-30). Also refer to the motor manufacturer's specifications for duty-cycle recommendations during DC braking.

Func. Code	"A" Function		Run Mode Edit	Defaults	
	Name	Description		Initial data	Units
A051	DC braking enable	Three options; select codes: 00 ...Disable 01 ...Enable during stop 02 ...Frequency detection	✗	00	–
A052	DC braking frequency	The frequency at which DC braking begins, range is from the start frequency (b002) to 60.00Hz	✗	0.50	Hz
A053	DC braking wait time	The delay from the end of controlled deceleration to start of DC braking (motor free runs until DC braking begins), range is 0.0 to 5.0 sec.	✗	0.0	sec.
A054	DC braking force for deceleration	Level of DC braking force, settable from 0 to 70%	✗	50.	%
A055	DC braking time for deceleration	Sets the duration for DC braking, range is from 0.0 to 60.0 seconds	✗	0.5	sec.
A056	DC braking / edge or level detection for [DB] input	Two options; select codes: 00 ...Edge detection 01 ...Level detection	✗	01	–
A057	DC braking force at start	Level of DC braking force at start, settable from 0 to 70%	✗	0.	%
A058	DC braking time at start	Sets the duration for DC braking, range is from 0.0 to 60.0 seconds	✗	0.0	sec.
A059	Carrier frequency during DC braking	Carrier frequency of DC braking performance, range is from 2.0 to 10.0kHz	✗	2.0	kHz

Frequency-related Functions

Frequency Limits – Upper and lower limits can be imposed on the inverter output frequency. These limits will apply regardless of the source of the speed reference. You can configure the lower frequency limit to be greater than zero as shown in the graph. The upper limit must not exceed the rating of the motor or capability of the machinery. The maximum frequency setting (*A004/A204*) takes precedence over frequency upper limit (*A061/A261*).

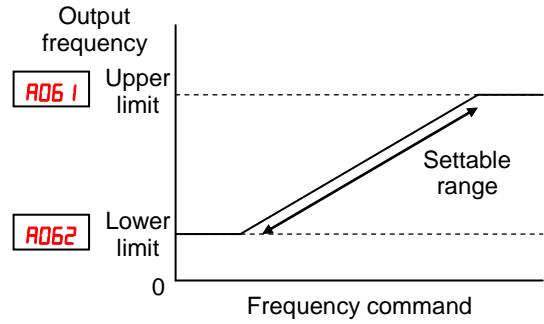

Func. Code	"A" Function		Run Mode Edit	Defaults	
	Name	Description		Initial data	Units
<i>A061</i>	Frequency upper limit	Sets a limit on output frequency less than the maximum frequency (<i>A004/A204</i>). Range is from frequency lower limit (<i>A062/A262</i>) to maximum frequency (<i>A004/A204</i>).	✗	0.00	Hz
<i>A261</i>	Frequency upper limit, 2nd motor	0.00 setting is disabled >0.00 setting is enabled	✗	0.00	Hz
<i>A062</i>	Frequency lower limit	Sets a limit on output frequency greater than zero. Range is start frequency (<i>b082</i>) to frequency upper limit (<i>A061/A261</i>)	✗	0.00	Hz
<i>A262</i>	Frequency lower limit, 2nd motor	0.00 setting is disabled >0.00 setting is enabled	✗	0.00	Hz

Jump Frequencies – Some motors or machines exhibit resonances at particular speed(s), which can be destructive for prolonged running at those speeds. The inverter has up to three *jump frequencies* as shown in the graph. The hysteresis around the jump frequencies causes the inverter output to skip around the sensitive frequency values.

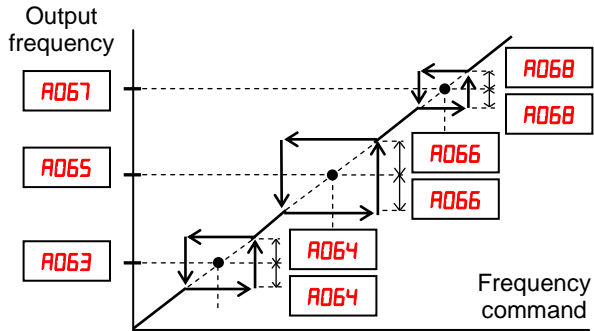

"A" Function			Run Mode Edit	Defaults	
Func. Code	Name	Description		Initial data	Units
A063 A065 A067	Jump freq. (center) 1 to 3	Up to 3 output frequencies can be defined for the output to jump past to avoid motor resonances (center frequency) Range is 0.00 to 400.00 Hz	✗	0.00	Hz
A064 A066 A068	Jump freq. width (hysteresis) 1 to 3	Defines the distance from the center frequency at which the jump around occurs Range is 0.00 to 10.00 Hz	✗	0.50	Hz

Acceleration stop/Deceleration stop – The acceleration stop and deceleration stop frequency setting allows you to make the inverter wait, upon starting the motor or upon decelerating the motor, until the motor slip becomes less when the motor load causes a large moment of inertia. Use this function if the inverter trips because of overcurrent when starting or decelerating the motor. This function operates with every acceleration and deceleration pattern, regardless the acceleration and deceleration curve selection (**A097** and **A098**). Instead of setting **A069**, **A070**, **A154** and **A155**, acceleration and deceleration can be held by intelligent input configured as "**B3**:HLD".

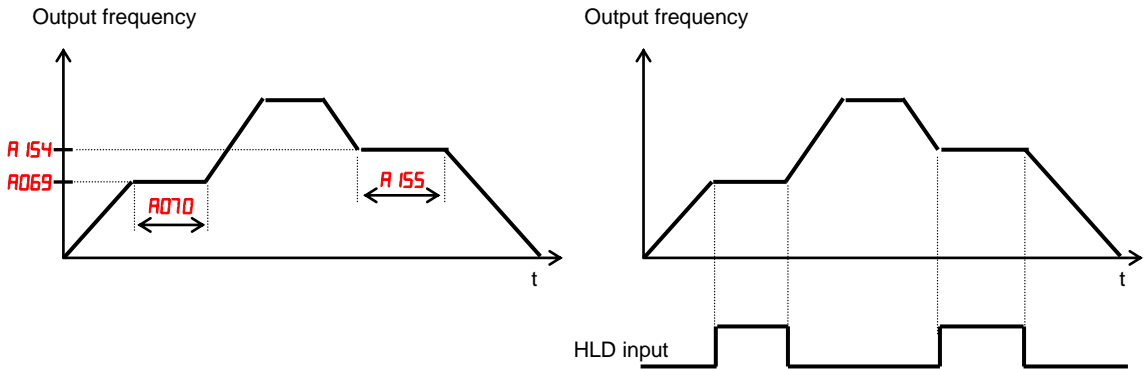

"A" Function			Run Mode Edit	Defaults	
Func. Code	Name	Description		Initial data	Units
A069	Acceleration hold frequency	Sets the frequency to hold acceleration, range is 0.00 to 400.00Hz	✗	0.00	Hz
A070	Acceleration hold time	Sets the duration of acceleration hold, range is 0.0 to 60.0 seconds	✗	0.0	sec.
A154	Deceleration hold frequency	Sets the frequency to hold deceleration, range is 0.00 to 400.00Hz	✗	0.00	Hz
A155	Deceleration hold time	Sets the duration of deceleration hold, range is 0.0 to 60.0 seconds	✗	0.0	sec.

PID Control

When enabled, the built-in PID loop calculates an ideal inverter output value to cause a loop feedback process variable (PV) to move closer in value to the set point (SP). The frequency command serves as the SP. The PID loop algorithm will read the analog input for the process variable (you specify the current or voltage input) and calculate the output.

Func. Code	Name	"A" Function Description	Run Mode Edit	Defaults	
				Initial data	Units
A071	PID enable	Enables PID function, three option codes: 00 ...PID Disable 01 ...PID Enable 02 ...PID Enable with reverse output	✗	00	–
A072	PID proportional gain	Proportional gain has a range of 0.00 to 25.00	✓	1.00	–
A073	PID integral time constant	Integral time constant has a range of 0.0 to 3600.0 seconds	✓	1.0	sec.
A074	PID derivative time constant	Derivative time constant has a range of 0.0 to 100.00 seconds	✓	0.00	sec.
A075	PV scale conversion	Process Variable (PV), scale factor (multiplier), range of 0.01 to 99.99	✗	1.00	–
A076	PV source	Selects source of Process Variable (PV), option codes: 00 ...[OI] terminal (current in) 01 ...[O] terminal (voltage in) 02 ...Modbus network 10 ...Calculate function output	✗	00	–
A077	Reverse PID action	Two option codes: 00 ...PID input = SP-PV 01 ...PID input = -(SP-PV)	✗	00	–
A078	PID output limit	Sets the limit of PID output as percent of full scale, range is 0.0 to 100.0%	✗	0.0	%
A079	PID feed forward selection	Selects source of feed forward gain, option codes: 00 ...Disabled 01 ...[O] terminal (voltage in) 02 ...[OI] terminal (current in)	✗	00	–
A156	PID sleep function action threshold	Sets the threshold for the action, set range 0.0 to 400.0 Hz	✗	0.00	Hz
A157	PID sleep function action delay time	Sets the delay time for the action, set range 0.0 to 25.5 sec	✗	0.0	sec.



NOTE: The setting **A073** for the integrator is the integrator's time constant T_i , not the gain. The integrator gain $K_i = 1/T_i$. When you set **A073** = 0, the integrator is disabled.

In standard operation, the inverter uses a reference source selected by parameter **F00 1** for the output frequency, which may be a fixed value (**F00 1**), a variable set by the front panel potentiometer, or value from an analog input (voltage or current). To enable PID operation, set **A07 1=0 1**. This causes the inverter to calculate the target freq, or setpoint.

A calculated target frequency can have a lot of advantages. It lets the inverter adjust the motor speed to optimize some other process of interest, potentially saving energy as well. Refer to the figure below. The motor acts upon the external process. To control that external process, the inverter must monitor the process variable. This requires wiring a sensor to either the analog input terminal [O] (voltage) or terminal [OI] (current).

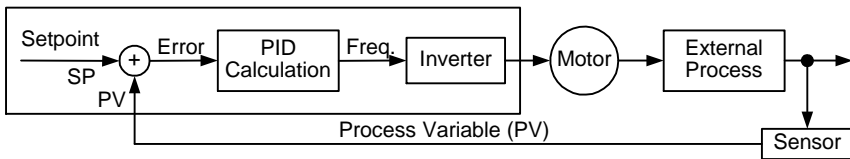

When enabled, the PID loop calculates the ideal output frequency to minimize the loop error. This means we no longer command the inverter to run at a particular frequency, but we specify the ideal value for the process variable. That ideal value is called the setpoint, and is specified in the units of the external process variable. For a pump application it may be gallons/minute, or it could be air velocity or temperature for an HVAC unit. Parameter **A07 5** is a scale factor that relates the external process variable units to motor frequency. The figure below is a more detailed diagram of the function.

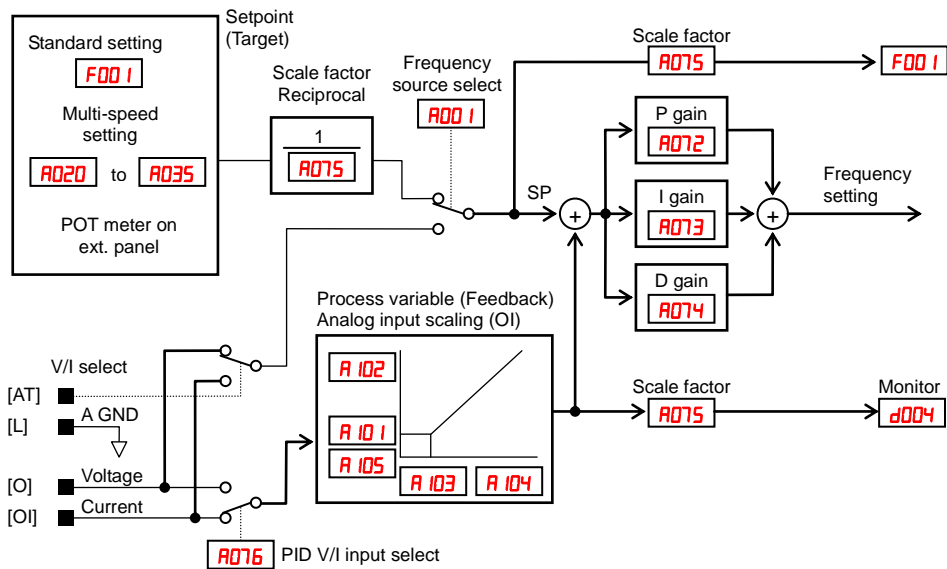

PID Loop Configuration

The inverter's PID loop algorithm is configurable for various applications.

PID Output Limit – The PID loop controller has a built-in output limit function. This function monitors the difference between the PID setpoint and the loop output (inverter output frequency), measured as a percentage of the full scale range of each. The limit is specified by parameter **A078**.

- When the difference $|\text{Setpoint} - \text{loop output}|$ is smaller than or equal to the **A078** limit value, the loop controller operates in its normal linear range.
- When the difference $|\text{Setpoint} - \text{loop output}|$ is larger than the **A078** limit value, the loop controller changes the output frequency as needed so that the difference does not exceed the limit.

The diagram below shows PID setpoint changes and the related output frequency behavior when a limit value in **A078** exists.

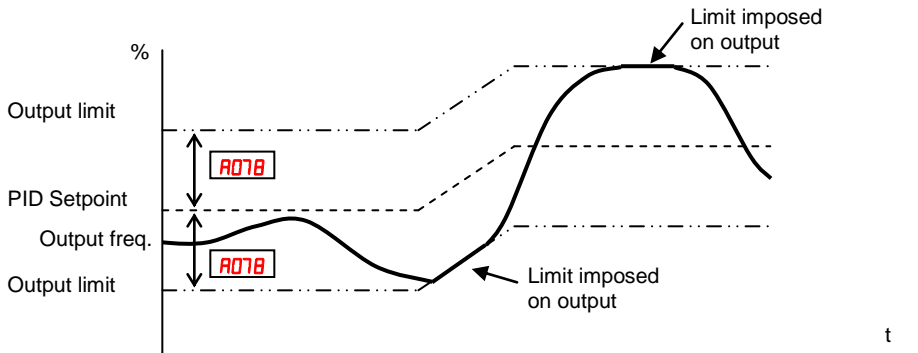

Deviation (error) Inversion – In typical heating loops or ventilation loops, an increase in energy into the process results in an *increasing* PV. In this case, the Loop Error = $(SP - PV)$. For cooling loops, an increase in energy into the process results in a *decreasing* PV. In this case, the Loop Error = $-(SP - PV)$. Use **A077** to configure the error term.

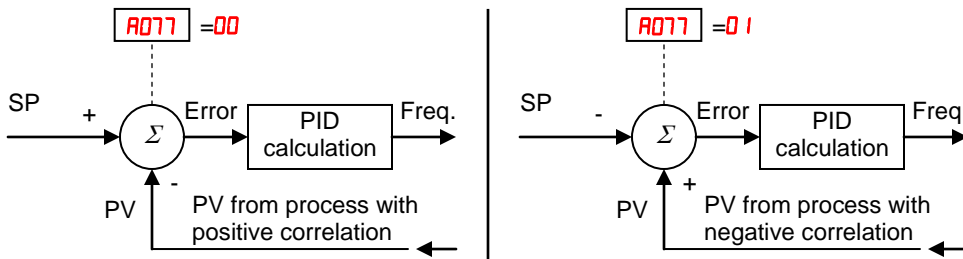

PID deviation output – If PID deviation "ε" exceeds the value in **C044**, output signal configured as **04** (OD) is activated.

PID feedback comparison output – If PID feedback is out of the range between **C052** and **C053** output signal configured as **31** (FBV) is activated.

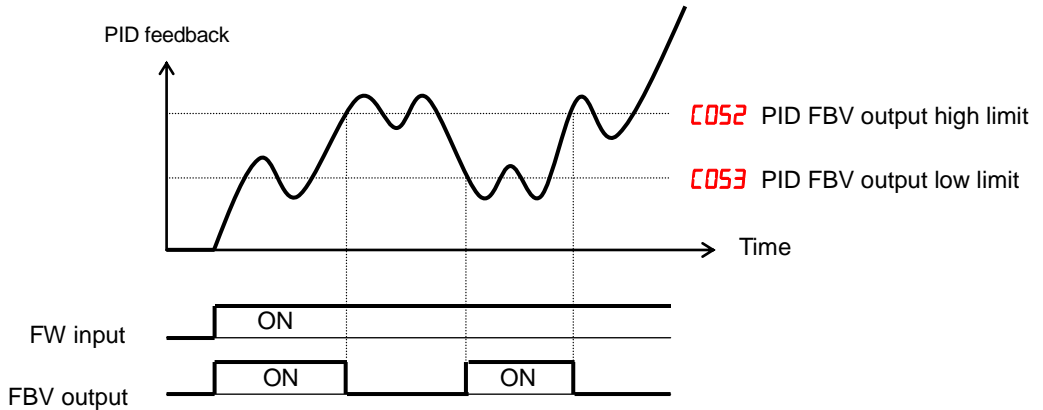

PID scaling – When PID scale parameter (**A075**) is set, following variables are scaled.

(monitored) = (variable) × (**A075**)

d004	d154	F001	A011	A012	A020	A220	A021
A022	A023	A024	A025	A026	A027	A028	A029
A030	A031	A032	A033	A034	A035	A101	A102
A145							

PID Sleep Function

The inverter shuts off the output when the PID output becomes less than the specified value (**A156**) in case of PID is set enabled, or shuts off when the frequency command becomes less than the specified value in case of PID is set disabled. And if the PID output or frequency command exceeds the specified value (**A156**) for a specified period (**A157**), inverter automatically restarts the operation. This is the PID sleep function.

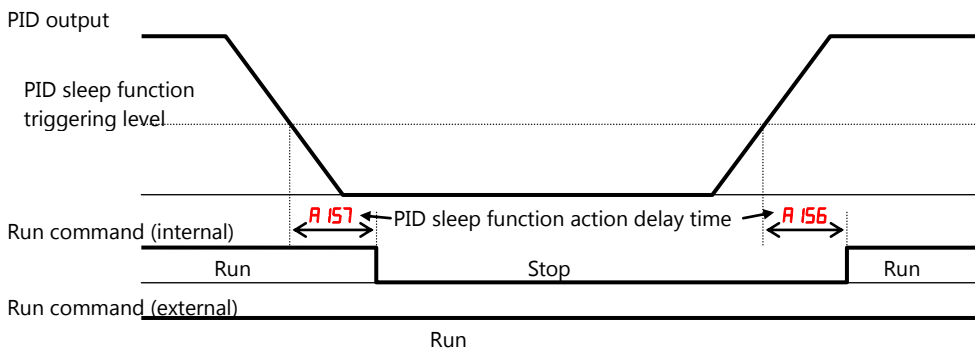

- ✓ PID Sleep function is always enabled, even the PID function is disabled.

Automatic Voltage Regulation (AVR) Function

The automatic voltage regulation (AVR) feature keeps the inverter output waveform at relatively constant amplitude during power input fluctuations. This can be useful if the installation is subject to input voltage fluctuations. However, the inverter cannot boost its motor output to a voltage higher than the power input voltage. If you enable this feature, be sure to select the proper voltage class setting for your motor.

Func. Code	"A" Function		Run Mode Edit	Defaults	
	Name	Description		Initial data	Units
A0B1	AVR function select	Automatic (output) voltage regulation, selects from three type of AVR functions, three option codes: 00 ...AVR enabled 01 ...AVR disabled 02 ...AVR enabled except during deceleration	✗	02	–
A2B1	AVR function select, 2 nd motor		✗	02	–
A0B2	AVR voltage select	200V class inverter settings:200/215/220/230/240	✗	230/ 400	V
A2B2	AVR voltage select, 2 nd motor	400V class inverter settings:380/400/415/440/460/480	✗	230/ 400	V
A0B3	AVR filter time constant	Define the time constant of the AVR filter, range is 0.000 to 10.000 sec.	✗	0.300	sec.
A0B4	AVR deceleration gain	Gain adjustment of the braking performance, range is 50 to 200%	✗	100.	%

Note: The motor behave as generator during deceleration and the energy is regenerated to the drive. As a result, the DC voltage in the inverter increases and cause over-voltage trip when exceeding the OV level. When the voltage is set high, deceleration time can be set shorter thanks to the energy consumption due to the incensement of loss in inverter. In order to set deceleration time shorter without over-voltage trip, please try to set AVR off during deceleration or to tune the AR filter time constant and AVR deceleration gain.

Energy Savings Mode / Optional Accel/Decel

Energy Saving Mode – This function allows the inverter to deliver the minimum power necessary to maintain speed at any given frequency. This works best when driving variable torque characteristic loads such as fans and pumps. Parameter **A0B5=0 1** enables this function and **A0B6** controls the degrees of its effect. A setting of 0.0 yields slow response but high accuracy, while a setting of 100 will yield a fast response with lower accuracy.

Func. Code	"A" Function		Run Mode Edit	Defaults	
	Name	Description		Initial data	Units
A0B5	Energy-saving operation mode	Two option codes: 00 ...Normal operation 0 1 ...Energy-saving operation	✗	00	–
A0B6	Energy-saving mode tuning	Range is 0.0 to 100 %.	✓	50.0	%

The acceleration time is controlled so that the output current below the level set by the Overload Restriction Function if enabled (Parameters **b02 1**, **b022**, and **b023**). If Overload Restriction is not enabled, then the current limit used is 150% of the inverter's rated output current.

The deceleration time is controlled so that the output current is maintained below 150% of the inverter's rated current, and the DC bus voltage is maintained below the OV Trip level (400V or 800V).



NOTE: If the load exceeds the rating of the inverter, the acceleration time may be increased.



NOTE: If using a motor with a capacity that is one size smaller than the inverter rating, enable the Overload Restriction function (**b02 1**) and set the Overload Restriction Level (**b022**) to 1.5 times the motor nameplate current.



NOTE: Be aware that the acceleration and deceleration times will vary, depending on the actual load conditions during each individual operation of the inverter.



NOTE: When analog input is a source of frequency command, be sure to set analog filter **A0 16=3 1** (500ms). Otherwise, there can be the case that this energy saving function doesn't work well.

Second Acceleration and Deceleration Functions

The WL200 inverter features two-stage acceleration and deceleration ramps. This gives flexibility in the profile shape. You can specify the frequency transition point, the point at which the standard acceleration (**F002**) or deceleration (**F003**) changes to the second acceleration (**A092**) or deceleration (**A093**). Or, you can use intelligent input [2CH] to trigger this transition. These profile options are also available for the second motor settings. Select a transition method via **A094** as depicted below. Be careful not to confuse the *second acceleration/deceleration settings* with settings for the *second motor*!

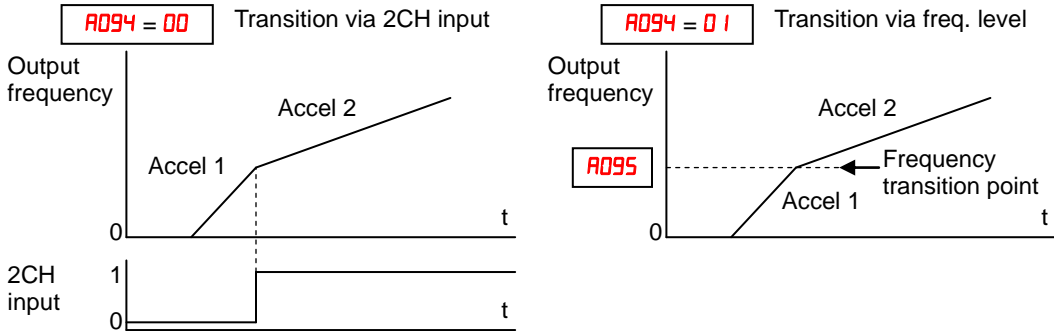

Func. Code	"A" Function		Run Mode Edit	Defaults	
	Name	Description		Initial data	Units
A092	Acceleration time (2)	Duration of 2 nd segment of acceleration, range is: 0.00 to 3600.00 sec.	✓	10.00	sec.
A292	Acceleration time (2), 2 nd motor		✓	10.00	sec.
A093	Deceleration time (2)	Duration of 2 nd segment of deceleration, range is: 0.00 to 3600.00 sec.	✓	10.00	sec.
A293	Deceleration time (2), 2 nd motor		✓	10.00	sec.
A094	Select method to switch to Acc2/Dec2 profile	Three options for switching from 1st to 2nd accel/decel: 00 ...2CH input from terminal 01 ...Transition frequency 02 ...Forward and reverse	✗	00	-
A294	Select method to switch to Acc2/Dec2 profile, 2 nd motor		✗	00	-
A095	Acc1 to Acc2 frequency transition point	Output frequency at which Accel1 switches to Accel2, range is 0.00 to 400.00 Hz	✗	0.00	Hz
A295	Acc1 to Acc2 frequency transition point, 2 nd motor		✗	0.00	Hz
A096	Dec1 to Dec2 frequency transition point	Output frequency at which Decel1 switches to Decel2, range is 0.00 to 400.00 Hz	✗	0.00	Hz
A296	Dec1 to Dec2 frequency transition point, 2 nd motor		✗	0.00	Hz



NOTE: For **A095** and **A096** (and for 2nd motor settings), if you set a very rapid Acc1 or Dec1 time (less than 1.0 second), the inverter may not be able to change rates to Acc2 or Dec2 before reaching the target frequency. In that case, the inverter decreases the rate of Acc1 or Dec1 in order to achieve the second ramp to the target frequency.

Accel/Decel

Standard acceleration and deceleration is linear. The inverter CPU can also calculate an S-curve acceleration or deceleration curve as shown. This profile is useful for favoring the load characteristics in particular applications.

Curve settings for acceleration and deceleration are independently selected. To enable the S-curve, use function **A097** (acceleration) and **A098** (deceleration).

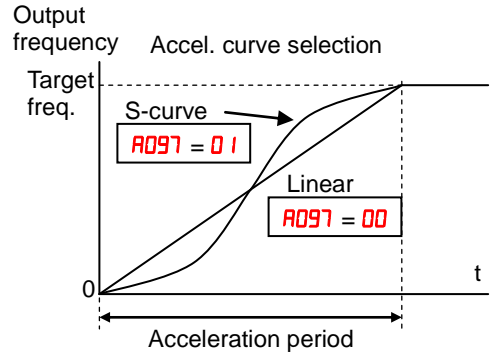

Func. Code	"A" Function		Run Mode Edit	Defaults	
	Name	Description		Initial data	Units
A097	Acceleration curve selection	Set the characteristic curve of Acc1 and Acc2, five options: 00...linear 01...S-curve 02...U-curve 03...Inverse U-curve	✘	01	—
A098	Deceleration curve selection	Set the characteristic curve of Dec1 and Dec2, options are same as above (A097)	✘	01	—
A131	Acceleration curve constant	Range is 01 to 10.	✘	02	—
A132	Deceleration curve constant	Range is 01 to 10.	✘	02	—

See next page for the details.

(1) Acceleration / deceleration pattern summary

Setting	00	01	02	03
Curve	Linear	S-curve	U-curve	Inverse U-curve
A097 (Accel. pattern)				
A098 (Decel. pattern)				
Remarks	Standard pattern.	Effective for preventing the collapse of cargo carried by lift or conveyor for example.	Effective for the tension control of winding machine, to prevent cutting the object to be wound, for example.	

(2) A131 Curve constant (swelling)

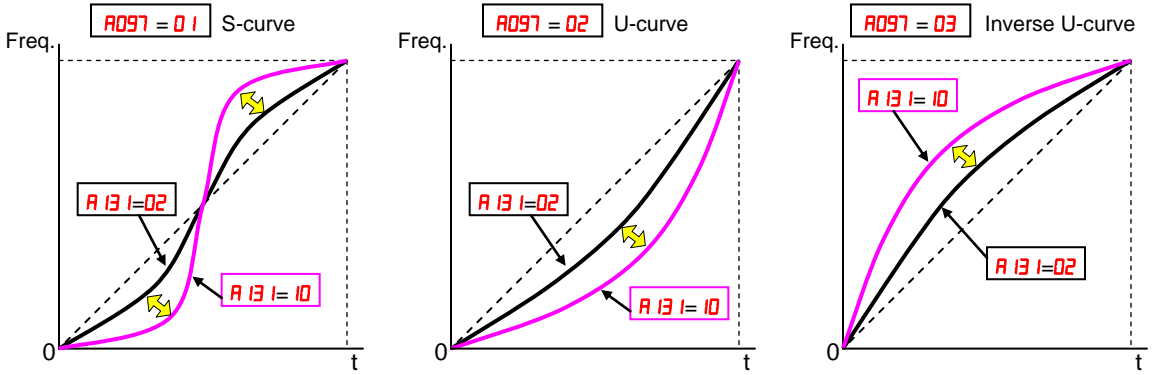

Large A131 value will result in a big swelling. A132 is the same concept as above.

Additional Analog Input Settings

Input Range Settings – The parameters in the following table adjust the input characteristics of the analog current input. When using the inputs to command the inverter output frequency, these parameters adjust the starting and ending ranges for the current, as well as the output frequency range. Related characteristic diagrams are located in “[Analog Input Settings](#)” on page 3-15.

Analog sampling setting is the value specified in **AD 16**.

Func. Code	“A” Function		Run Mode Edit	Defaults	
	Name	Description		Initial data	Units
A 101	[OI] input active range start frequency	The output frequency corresponding to the analog input range starting point, range is 0.00 to 400.00 Hz	✗	0.00	Hz
A 102	[OI] input active range end frequency	The output frequency corresponding to the current input range ending point, range is 0.00 to 400.00 Hz	✗	0.00	Hz
A 103	[OI] input active range start current	The starting point (offset) for the current input range, range is 0. to 100.%	✗	20.	%
A 104	[OI] input active range end current	The ending point (offset) for the current input range, range is 0. to 100.%	✗	100.	%
A 105	[OI] input start frequency select	Two options; select codes: 00 ...Use offset (A 101 value) 01 ...Use 0Hz	✗	00	–

Refer to parameter **AD 11** to **AD 15** for analog voltage input.

Analog Input Calculate Function – The inverter can mathematically combine two input sources into one value. The Calculate function can either add, subtract, or multiply the two selected sources. This provides the flexibility needed by various applications. You can use the result for the output frequency setting (use **A00 I= 10**) or for the PID Process Variable (PV) input (use **A075=03**).

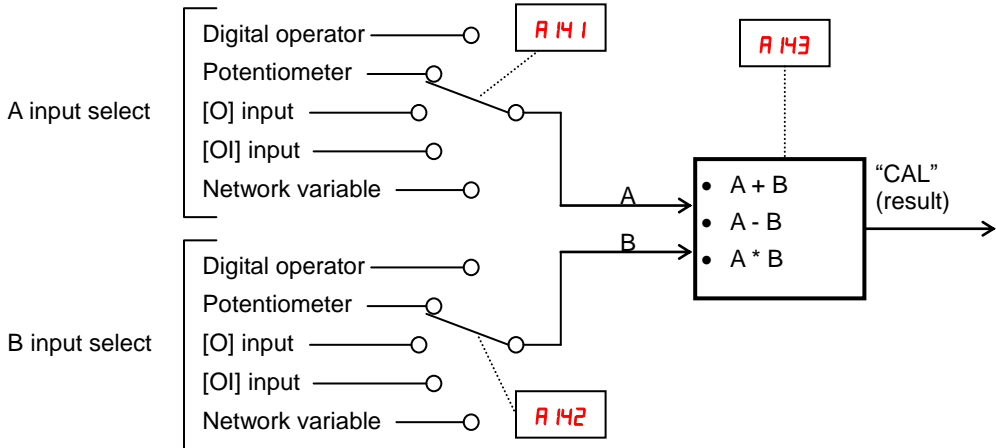

"A" Function			Run Mode Edit	Defaults	
Func. Code	Name	Description		Initial data	Units
A 141	A input select for calculate function	Six options: 00 ...Operator 01 ...VR 02 ...Terminal [O] input 03 ...Terminal [OI] input 04 ...RS485 05 ...Option	✗	02	–
A 142	B input select for calculate function		✗	03	–
A 143	Calculation symbol	Calculates a value based on the A input source (A 141 selects) and B input source (A 142 selects). Three options: 00 ...ADD (A input + B input) 01 ...SUB (A input - B input) 02 ...MUL (A input * B input)	✗	00	–

Add Frequency – The inverter can add or subtract an offset value to the output frequency setting which is specified by **ADD 1** (will work with any of the five possible sources). The ADD Frequency is a value you can store in parameter **A 145**. The ADD Frequency is summed with or subtracted from the output frequency setting only when the [ADD] terminal is ON. Function **A 146** selects whether to add or subtract. By configuring an intelligent input as the [ADD] terminal, your application can selectively apply the fixed value in **A 145** to offset (positively or negatively) the inverter output frequency in real time.

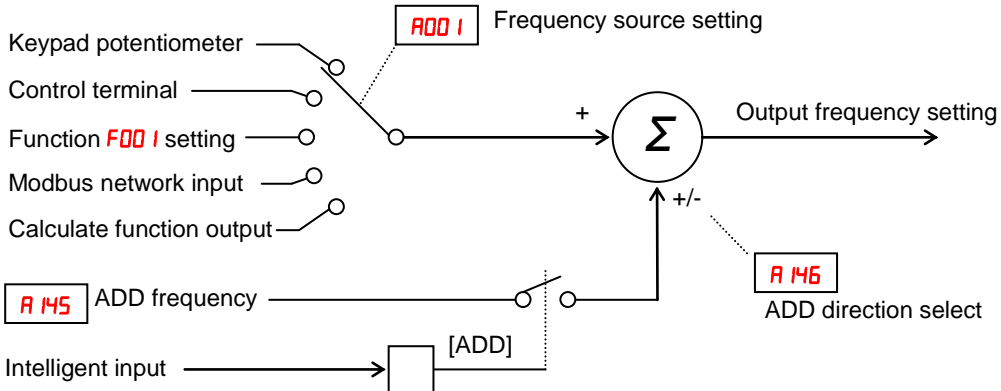

"A" Function			Run Mode Edit	Defaults	
Func. Code	Name	Description		Initial data	Units
A 145	ADD frequency	An offset value that is applied to the output frequency when the [ADD] terminal is ON. Range is 0.00 to 400.00 Hz	✘	0.00	Hz
A 146	ADD direction select	Two options: 00 ...Plus (adds A 145 value to the output frequency setting) 01 ...Minus (subtracts A 145 value from the output frequency setting)	✘	00	–

Input Range Settings – The parameters in the following table adjust the input characteristics of the VR (POT meter on external operator) input. When using the inputs to command the inverter output frequency, these parameters adjust the starting and ending ranges for the current, as well as the output frequency range. Related characteristic diagrams are located in “[Analog Input Settings](#)” on page 3-15.

Analog sampling setting is the value specified in [AO 16](#).

Func. Code	"A" Function		Run Mode Edit	Defaults	
	Name	Description		Initial data	Units
A 161	[VR] input active range start frequency	The output frequency corresponding to the analog input range starting point, range is 0.00 to 400.00 Hz	✗	0.00	Hz
A 162	[VR] input active range end frequency	The output frequency corresponding to the current input range ending point, range is 0.00 to 400.00 Hz	✗	0.00	Hz
A 163	[VR] input active range start %	The starting point (offset) for the current input range, range is 0. to 100.%	✗	0.	%
A 164	[VR] input active range end %	The ending point (offset) for the current input range, range is 0. to 100.%	✗	100.	%
A 165	[VR] input start frequency select	Two options; select codes: 00 ...Use offset (A 161 value) 01 ...Use 0Hz	✗	01	–

Refer to parameter [AO 11](#) to [AO 15](#) for analog voltage input.

“B” Group: Fine Tuning Functions

The “B” Group of functions and parameters adjust some of the more subtle but useful aspects of motor control and system configuration.

Automatic Restart Mode

The restart mode determines how the inverter will resume operation after a fault causes a trip event. The five options provide advantages for your applications. Frequency matching allows the inverter to read the motor speed by virtue of its residual magnetic flux and restart the output at the corresponding frequency. The inverter can attempt a restart a certain number of times depending on the particular trip event:

- Over-current trip, restart up to 3 times
- Over-voltage trip, restart up to 3 times

When the inverter reaches the maximum number of restarts (3), you must power cycle the inverter to reset its operation.

Other parameters specify the allowable under-voltage level and the delay time before restarting. The proper settings depend on the typical fault conditions for your application, the necessity of restarting the process in unattended situations, and whether restarting is always say.

Power failure < allowable power fail Time (b022), Inverter resumes

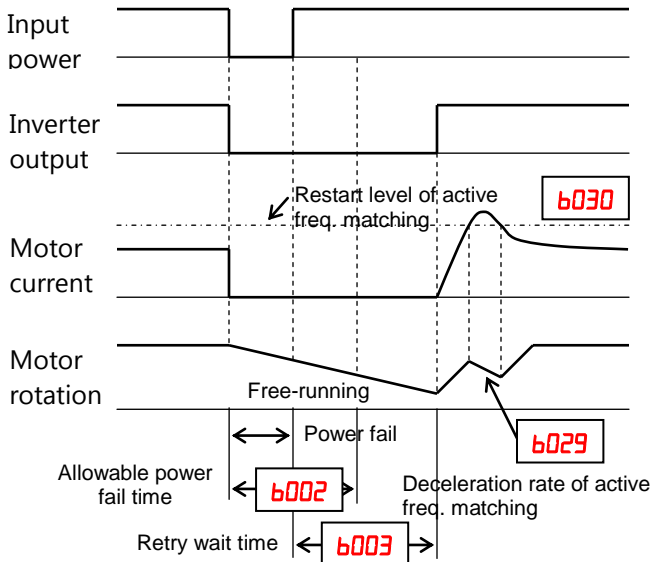

If the actual power failure time is shorter than the **b002** set value, inverter resumes from the set frequency in **b011**.

The resumption mode is called “active frequency matching” and the inverter performs reduced voltage start to avoid over-current trip.

If the motor current exceeds the **b030** set value during this period, the inverter decelerates according to the **b029** set value and helps to reduce the motor current.

When the motor current is less than **b030**, the inverter increases motor speed toward the set speed. The inverter continues this retry process until the motor speed comes to the previous set speed.

Overload restriction (**b021** to **b028**) is not valid when active frequency matching is activated.

If the actual power failure time is longer than the **b002** set value, the inverter does not resume and the motor will coast to stop.

Automatic restart (retry) related parameters.

Func. Code	"b" Function		Run Mode Edit	Defaults	
	Name	Description		Initial data	Units
b001	Restart mode on power failure / under-voltage trip	Select inverter restart method, Five option codes: 00 ...Alarm output after trip, no automatic restart 01 ...Restart at 0Hz 02 ...Resume operation after frequency matching 03 ...Resume previous freq. after freq. matching, then decelerate to stop and display trip info 04 ...Resume operation after active freq. matching	×	00	–
b002	Allowable under-voltage power failure time	The amount of time a power input under-voltage can occur without tripping the power failure alarm. Range is 0.3 to 25 sec. If under-voltage exists longer than this time, the inverter trips, even if the restart mode is selected.	×	1.0	sec.
b003	Retry wait time before motor restart	Time delay after under-voltage condition goes away, before the inverter runs motor again. Range is 0.3 to 100.0 seconds.	×	1.0	sec.
b004	Instantaneous power failure / under-voltage trip alarm enable	Three option codes: 00 ...Disable 01 ...Enable 02 ...Disable during stop and decelerates to a stop	×	00	–
b005	Number of restarts on power failure / under-voltage trip events	Two option codes: 00 ...Restart 16 times 01 ...Always restart	×	00	–
b007	Restart frequency threshold	Restart the motor from 0Hz if the frequency becomes less than this set value during the motor is coasting, range is 0.00 to 400.00Hz	×	0.00	Hz
b008	Restart mode on over voltage / over current trip	Select inverter restart method, Five option codes: 00 ...Alarm output after trip, no automatic restart 01 ...Restart at 0Hz 02 ...Resume operation after frequency matching 03 ...Resume previous freq. after active freq. matching, then decelerate to stop and display trip info 04 ...Resume operation after active freq. matching	×	00	–
b010	Number of retry on over voltage / over current trip	Range is 1 to 3 times	×	3	times
b011	Retry wait time on over voltage / over current trip	Range is 0.3 to 100.0 sec.	×	1.0	sec.

Active Frequency Matching Restart

Goal of the active frequency matching is the same as normal frequency matching. Difference is the method. Please select the suitable one for your application.

Func. Code	"b" Function		Run Mode Edit	Defaults	
	Name	Description		Initial data	Units
b028	Current level of active freq. matching	Sets the current level of active freq. matching restart, range is 0.2*inverter rated current to 1.5*inverter rated current, resolution 0.1	✗	Rated current	A
b029	Deceleration rate of active freq. matching	Sets the deceleration rate when active freq. matching restart, range is 0.1 to 3000.0, resolution 0.1	✗	0.5	sec.
b030	Start freq. of active freq. matching	Three option codes: 00 ...freq at previous shutoff 01 ...start from max. Hz 02 ...start from set frequency	✗	00	-

Electronic Thermal Overload Alarm Setting

The thermal overload detection protects the inverter and motor from overheating due to an excessive load. It uses a current/inverse time curve to determine the trip point.

First, use **b0 13** to select the torque characteristic that matches your load. This allows the inverter to utilize the best thermal overload characteristic for your application.

The torque developed in a motor is directly proportional to the current in the windings, which is also related to the heat generated (and temperature, over time).

Therefore, you must set the thermal overload threshold in terms of current (amperes) for parameter **b0 12**. The range is 20% to 100% of the rated current for each inverter model. If the current exceeds the level you specify, the inverter will trip and log an event (error **E05**) in the history table. The inverter turns the motor output OFF when tripped. Separate settings are available for the second motor (if applicable) as shown in the following table.

Func. Code	"b" Function		Run Mode Edit	Defaults	
	Name	Description		Initial data	Units
b0 12	Level of electronic thermal	Set a level between 20% and 100% for the rated inverter current.	✗	Rated current	A
b2 12	Level of electronic thermal, 2 nd motor		✗	Rated current	A
b0 13	Electronic thermal characteristic	Select from three curves, option codes: 00 ...Reduced torque 01 ...Constant torque 02 ...Free setting	✗	01	–
b2 13	Electronic thermal characteristic, 2 nd motor		✗	01	–
b0 15	Free setting electronic thermal ~freq.1	Range is 0 to 400Hz	✗	0.	Hz
b0 16	Free setting electronic thermal ~current1	Range is 0 to inverter rated current Amps	✗	0.00	A
b0 17	Free setting electronic thermal ~freq.2	Range is 0 to 400Hz	✗	0.	Hz
b0 18	Free setting electronic thermal ~current2	Range is 0 to inverter rated current Amps	✗	0.00	A
b0 19	Free setting electronic thermal ~freq.3	Range is 0 to 400Hz	✗	0.	Hz
b020	Free setting electronic thermal ~current3	Range is 0 to inverter rated current Amps	✗	0.00	A



WARNING: When parameter **b0 12**, level of electronic thermal setting, is set to motor FLA rating (Full Load Ampere nameplate rating), the inverter provides solid state motor overload protection at 115% of motor FLA or equivalent. If parameter **b0 12** exceeds the motor FLA rating, the motor may overheat and be damaged. Parameter **b0 12**, level of electronic thermal setting, is a variable parameter.

Electronic thermal characteristic – The characteristic curve is unique, but reduction rate depending on frequency is selected in **b0 13**.

• **Reduced Torque (b0 13=00)**

Example: WL200-022S** (Rated current 9.6A = b012), Base FQ=60Hz

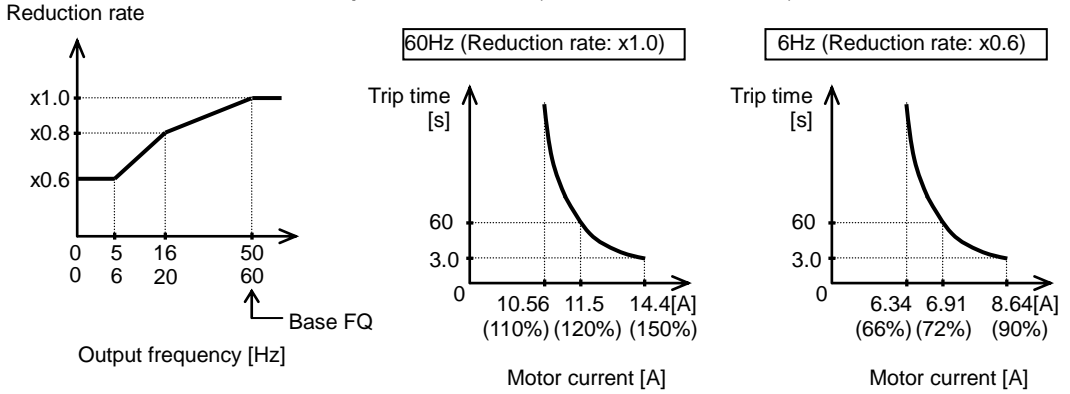

• **Constant Torque (b0 13=0 1)**

Example: WL200-022S** (Rated current 9.6A = b012), Base FQ=60Hz

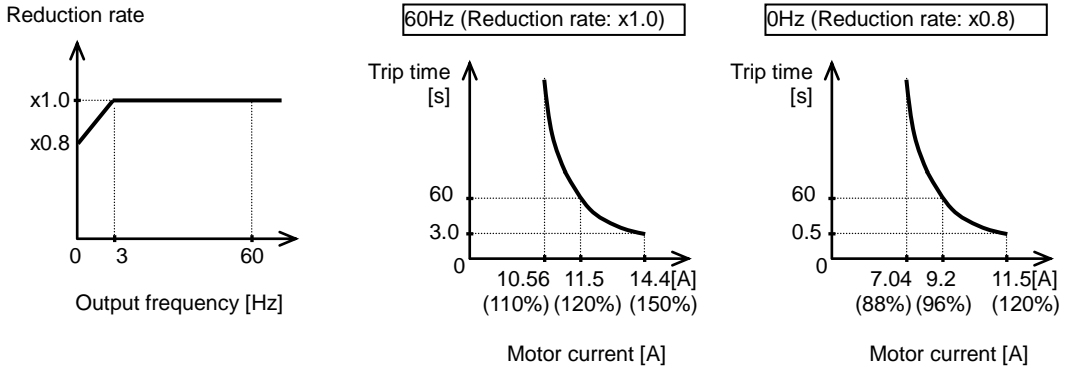

• **Free setting (b0 13=02)**

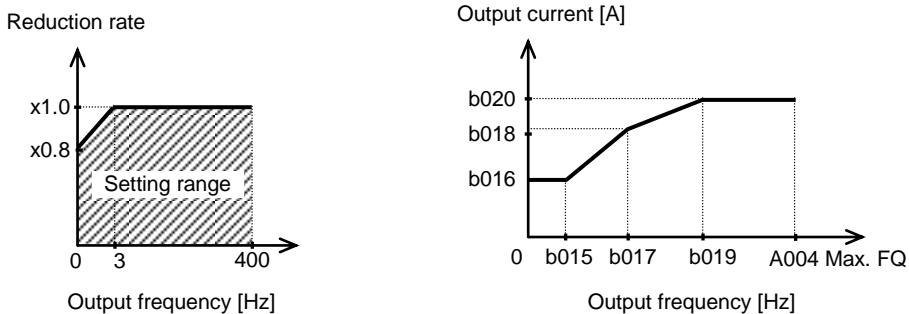

Electronic Thermal Warning Output – You can configure this function so that the inverter outputs a warning signal before the electronic thermal protection operates against motor overheat. You can also set the threshold level to output a warning signal with the electronic thermal warning level setting in function “**C06 I**”.

To output the warning signal, assign parameter “**I3**” (THM) to one of the intelligent output terminals [11] to [12] (**C02 I** to **C022**), or to the relay output terminal (**C026**).

Electronic Thermal Subtraction Function

Electronic thermal is separated into for the motor and for the inverter when **b9 I0=0 I** to **03**. It depends on plural pattern / rate and becomes able to subtract electronic thermal integrated value from in consideration of the heat production of the motor then.

Subtraction rates in each pattern are defined by **b9 I1/b9 I2**. Please set the large value with enough margins for the characteristic of the application motor.

Thermal accumulation gain for the motor can be defined by **b9 I3** in case of **b9 I0=0 I** to **03**. If it is set to 100%, accumulation is same as in case of **b9 I0=00**. Please note that when **b9 I3** is small, the time to trip gets longer and it means that the protection is delayed.

Func. Code	“b” Function		Run Mode Edit	Defaults	
	Name	Description		Initial data	Units
b9 I0	Electronic thermal subtraction function select	Four option codes: 00 ...OFF 0 I ...Linear subtraction: pre-fixed ratio 02 ...Linear subtraction: ratio set in b9 I1 03 ...Subtraction with first-order lag filter: ratio set in b9 I2	✗	00	–
b9 I1	Thermal subtraction time	This function is valid when b9 I0=02 Range is 0.10 to 100000.00 s Out of warranty when setting less than initial value (600.00[s])	✗	600.00	sec.
b9 I2	Thermal subtraction time constant	This function is valid when b9 I0=03 Range is 0.10 to 100000.00 s Out of warranty when setting less than initial value (120.00[s])	✗	120.00	sec.
b9 I3	Thermal accumulation gain	Range is 1.0 to 200.0 % Out of warranty when setting less than initial value (100.0[%])	✗	100.0	%

Subtraction function of electronic thermal for motor – Electronic thermal subtraction function select (**b9 10**) is prepared to be able to select from 3 patterns of subtraction rate. When **b900=00**, subtraction is invalid.

- **b9 10=01**

When output current is less than thermal count level, subtracted constantly with fixed rate as max value thermal counter (trip level) down to 0 in 10 minutes.

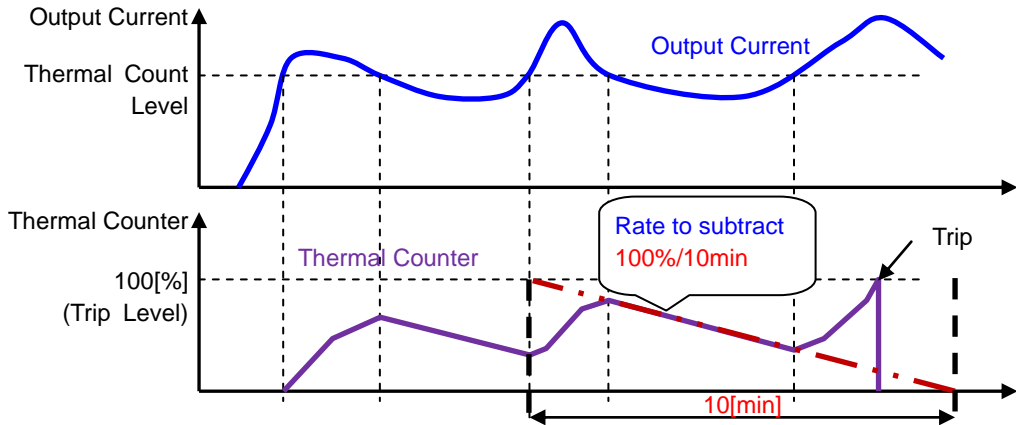

- **b9 10=02**

When output current is less than thermal count level, subtracted constantly with fixed rate as max value thermal counter (trip level) down to 0 within the time defined with thermal subtraction time (**b9 11**).

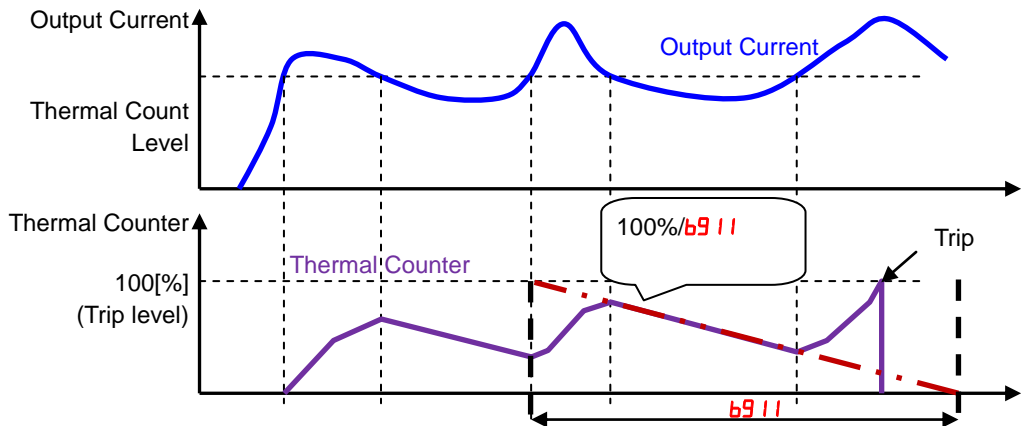

- b9 10=03**
 When output current is less than thermal count level, subtracted with the value equal to thermal counter value multiplied with linear filter of time constant (b9 12) and target as 0. (when output current keeps to be less than thermal count level, thermal counter becomes 0 within a time approximately 5 times b9 12)

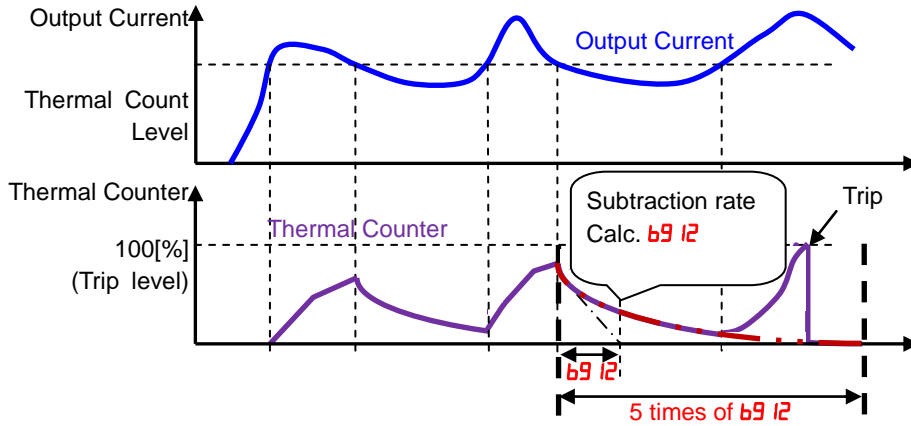

Electronic Thermal Accumulation Gain – Only for accumulation for motor electronic thermal protection, value to accumulate is multiplied with electronic thermal accumulation gain (b9 13) instead of standard value. When b9 10=00 and common to inverter protection, b913 is void.

Electronic Thermal Function for inverter – When electronic thermal protection subtraction selection (**b9 10**) is set other than 0, electronic thermal protection for inverter and motor are separated. Electronic thermal protection for inverter in this case is as described below.

- Thermal protection characteristics for inverter is fixed (Identical to the electronic thermal protection of constant torque characteristics with thermal level **b0 12** of rated current (**b0 12**=rated current, **b0 13=0 1**))
- Characteristics are independent from **b0 12** to **b020** setting therefore. (only for electronic thermal protection for Motor is valid)
- Error code for inverter’s electronic thermal protection is E38 (inverter thermal protection). (Error code for motor electronic thermal protection remains to be E05) E38 trip cannot be reset for 10 seconds, identical to E05.
- Subtraction is invalid for inverter electronic thermal protection. When **b910=0**, electronic thermal protection for inverter and motor is common. Following table is summary of electronic thermal protection according to **b910** setting

Characteristics of electronic thermal protection for inverter according to **b9 10** setting

Item	b9 10(Electronic thermal subtraction function select)			
	00	01	02	03
Characteristics	Common to motor	Characteristics for inverter thermal protection is fixed (Identical to the constant torque characteristics with thermal level b012 of rated current)		
b0 12 to b020	Valid	Invalid		
Subtraction	Not available			
Error Code	E05	E38 (Inverter Electronic Thermal Protection)		

Characteristics of electronic thermal protection for motor according to **b9 10** setting

Item	b9 10(Electronic thermal subtraction function select)			
	00	01	02	03
Characteristics	Common to inverter	Not common with inverter when subtraction valid		
b0 12 to b020	Valid	Valid (only for motor)		
Subtraction	Not available	Subtraction max to zero in 10 minutes.	Subtraction max to zero in the time defined by b9 11	Subtraction with time constant set in b9 12
Error Code	E05			

Current limitation Related Functions

Overload Restriction: b022 – If the inverter’s output current exceeds a preset current level you specify during acceleration or constant speed, the overload restriction feature automatically reduces the output frequency during powering drive (and can increase the speed during regeneration) to restrict the overload. This feature does not generate an alarm or trip event. You can instruct the inverter to apply overload restriction only during constant speed, thus allowing higher currents for acceleration. Or, you may use the same threshold for both acceleration and constant speed.

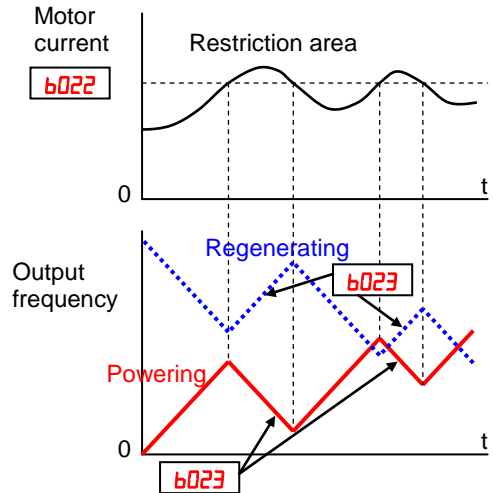

You can specify two types of overload restriction operation by setting functional items **b021**, **b022**, **b023**, and **b024**, **b025**, **b026** separately. To switch between these two is done by assigning "39 (OLR)" to an intelligent input terminal and make it ON/OFF.

When the inverter detects an overload, it must decelerate the motor to reduce the current until it is less than the threshold. You can choose the rate of deceleration that the inverter uses to lower the output current.

Over-current Trip Suppression: b027 – The Over-current Trip Suppression function monitors the motor current and actively changes the output frequency profile to maintain the motor current within the limits. Although "LAD" refers to "linear acceleration / deceleration", the inverter only "STOPS" the acceleration and deceleration ramp so that it will not cause an over-current trip event.

b027 = 0 1/02 OC LAD STOP = Enabled

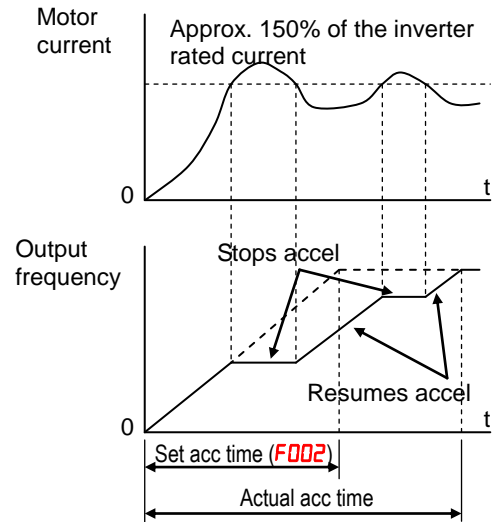

The graph at right shows an inverter output profile that starts acceleration to a constant speed. At two different points during the acceleration, motor current increases and exceeds the fixed level of Over-current Trip Suppression level.

When the Over-current Trip Suppression feature is enabled by **b027 = 0 1/02**, the inverter stops the acceleration ramp in each case until the motor current level is again less than the threshold value, which is approximately 150% of the rated current of the inverter. Exceptionally 200% of rated current, about 004SFE/004HFE.

When using the Over-current Trip Suppression feature, please note the following:

- When the feature is enabled (**b027 = 01/02**), the actual acceleration may be longer than the value set by parameters **F002/F202** in some cases.
- The Over-current Trip Suppression feature does not operate by maintaining a constant motor current, so it does not prevent Over-current trip events completely. Over-current trip event may happen during extreme acceleration or by the short-circuit states for example.
- When **b027** is set to "02...Enable with voltage reduction", the Over-current Trip Suppression function raises the effect by reducing output voltage after an acceleration and deceleration halt.

"b" Function			Run Mode Edit	Defaults	
Func. Code	Name	Description		Initial data	Units
b021	Overload restriction operation mode	Select the operation mode during overload conditions, four options, option codes: 00 ...Disabled 01 ...Enabled for acceleration and constant speed	✗	01	-
b221	Overload restriction operation mode, 2 nd motor	02 ...Enabled for constant speed only 03 ...Enabled for acceleration and constant speed, increase speed at regen.	✗	01	-
b022	Overload restriction level	Sets the level of overload restriction, between 20% and 150% of the rated current of the inverter, setting resolution is 1% of rated current	✗	Rated current x 1.2	A
b222	Overload restriction level, 2 nd motor		✗	Rated current x 1.2	A
b023	Deceleration rate at overload restriction	Sets the deceleration rate when inverter detects overload, range is 0.1 to 3000.0, resolution 0.1	✗	1.0	sec.
b223	Deceleration rate at overload restriction, 2 nd motor		✗	1.0	sec.
b024	Overload restriction operation mode 2	Select the operation mode during overload conditions, four options, option codes: 00 ...Disabled 01 ...Enabled for acceleration and constant speed 02 ...Enabled for constant speed only 03 ...Enabled for acceleration and constant speed, increase speed at regen.	✗	01	-
b025	Overload restriction level 2	Sets the level of overload restriction, between 20% and 150% of the rated current of the inverter, setting resolution is 1% of rated current	✗	Rated current x 1.2	A
b026	Deceleration rate 2 at overload restriction	Sets the deceleration rate when inverter detects overload, range is 0.1 to 3000.0, resolution 0.1	✗	1.0	sec.
b027	OC suppression selection	Three option codes: 00 ...Disabled 01 ...Enabled 02 ...Enabled with voltage reduction	✗	00	-

Software Lock Mode

The software lock function keeps personnel from accidentally changing parameters in the inverter memory. Use **b03 1** to select from various protection levels.

The table below lists all combinations of **b03 1** option codes and the ON/OFF state of the [SFT] input. Each Check ✓ or Ex ✗ indicates whether the corresponding parameter(s) can be edited. The Standard Parameters column below shows access in permitted for some lock modes. These refer to the parameter tables throughout this chapter, each of which includes a column titled *Run Mode Edit* as shown to the right.

	Run Mode Edit	
	✗	
	✓	

The marks (Check ✓ or Ex ✗) under the “Run Mode Edit” column title indicate whether access applies to each parameter as defined in the table below. In some lock modes, you can edit only **F00 1** and the Multi-speed parameter group that includes **A020, A220, A02 1-A035**, and **A038** (Jog). However, it does not include **A0 19**, Multi-speed operation selection. The editing access to **b03 1** itself is unique, and is specified in the right-most two columns below.

b03 1 Lock Mode	[SFT] Intelligent Input	Standard Parameters		F00 1 and Multi-Speed	b03 1	
		Stop	Run	Stop and Run	Stop	Run
00	OFF	✓	Run mode edit access	✓	✓	✗
	ON	✗	✗	✗	✓	✗
01	OFF	✓	Run mode edit access	✓	✓	✗
	ON	✗	✗	✓	✓	✗
02	(ignored)	✗	✗	✗	✓	✗
03	(ignored)	✗	✗	✓	✓	✗
10	(ignored)	✓	High level access	✓	✓	✓



NOTE: Since the software lock function **b03 1** is always accessible, this feature is not the same as password protection used in other industrial control devices. So if you want to use password function, use parameter **b037** together with the **b03 1**. See page 3-77 for detailed explanation of the password function.

"b" Function			Run Mode Edit	Defaults	
Func. Code	Name	Description		Initial data	Units
b031	Software lock mode selection	Prevents parameter changes, in five options, option codes: 00 ...all parameters except b031 are locked when [SFT] terminal is ON 01 ...all parameters except b031 and output frequency F001 are locked when [SFT] terminal is ON 02 ...all parameters except b031 are locked 03 ...all parameters except b031 and output frequency F001 are locked 10 ...High level access including b031 <i>See appendix C for the accessible parameters in this mode.</i>	✘	01	-



NOTE: To disable parameter editing when using **b031** lock modes **00** and **01**, assign the [SFT] function to one of the intelligent input terminals. See "Software Lock" on page 4-27.

Motor Cable Length Parameter

To achieve higher motor control performance, the WL200 inverter has the Motor Cable Length Parameter setting **b033**. Normally there is no need to adjust this parameter, however in case of long motor cable and/or shielded cable, where there is a comparatively higher earth capacitance, set this parameter higher to achieve better motor control performance.

Note that the parameter is indicative and no formula to calculate the suitable value. Normally, longer the motor cable, bigger the set value. Please adjust depending on your system.

For 15 and 18.5kW inverter, it is not needed to set **b033**.

"b" Function			Run Mode Edit	Defaults	
Func. Code	Name	Description		Initial data	Units
b033	Motor cable length parameter	Set range is 5 to 20.	✔	10.	-

Run/power ON warning time

Inverter outputs the operation time over (RNT) or the plug-in time over (ONT) signal when the time specified as the run/power ON warning time (**b034**) is exceeded.

Func. Code	"b" Function		Run Mode Edit	Defaults	
	Name	Description		Initial data	Units
b034	Run/power ON warning time	Range is, 0. : Warning disabled 1. to 9999. : 10 to 99,990 hrs (unit: 10) 1000 to 6553 : 100,000 to 655,350 hrs (unit: 100)	✕	0.	hours

(1) Operation time over (RNT) signal

To use this signal function, assign function "11 (RNT)" to one of the intelligent output terminals [11] to [12] (**C021** to **C022**), or to the alarm relay output (**C026**). Specify the run/power-ON warning time (**b034**).

(2) Plug-in time over (ONT) signal

To use this signal function, assign function "12 (ONT)" to one of the intelligent output terminals [11] to [12] (**C021** to **C022**), or to the alarm relay output (**C026**). Specify the run/power-ON warning time (**b034**).

Rotation restriction related parameter

Rotation direction restriction: b035 – The rotation direction restriction function allows you to restrict the direction of the motor rotation. This function is effective regardless of the specification of operation command input device (e.g., control terminal or integrated operator). If an operation command to drive the motor in a restricted direction is given, the inverter (display) shows (**0000**).

Func. Code	"b" Function		Run Mode Edit	Defaults	
	Name	Description		Initial data	Units
b035	Rotation direction restriction	Three option codes: 00 ...No restriction 01 ...Reverse rotation is restricted 02 ...Forward rotation is restricted	✕	00	–

Reduced voltage start

The reduced voltage start function enables you to make the inverter increase the output voltage gradually when starting the motor.

Set a small value for the reduced voltage start selection (**b036**) if you intend to increase the start torque. On the other hand, setting a small value will cause the inverter to perform full-voltage starting and to easily trip because of overcurrent.

Func. Code	Name	Description	Run Mode Edit	Defaults	
				Initial data	Units
b036	Reduced voltage start selection	Set range, 0 (disabling the function), 1 (approx. 6ms) to 255 (approx. 1.5s)	✗	2	-

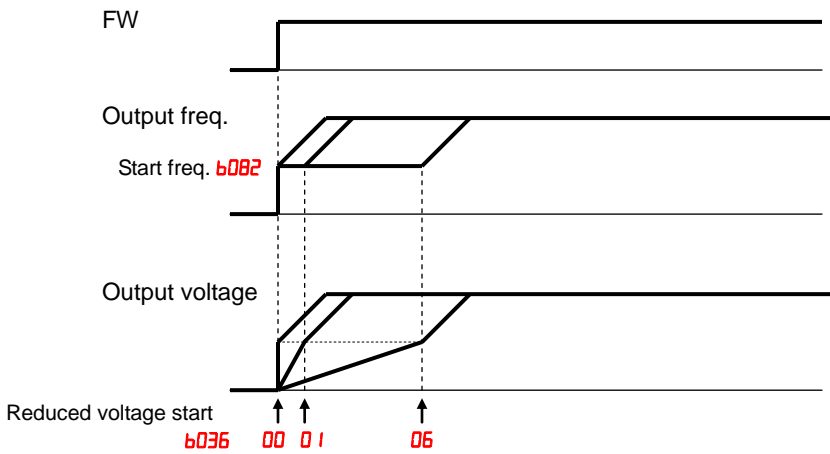

Display related parameters

Function code display restriction: b037 – The function code display restriction allows you to arbitrarily switch the display mode or the display content on the integrated operator.

Func. Code	"b" Function		Run Mode Edit	Defaults	
	Name	Description		Initial data	Units
b037	Function code display restriction	Six option codes: 00...Full display 01...Function-specific display 02...User setting (and b037) 03...Data comparison display 04...Basic display 05...Monitor display only	X	00	–

(1) Function-specific display mode (b037=01)

If a specific function has not been selected, the monitor does not show the parameters concerning the specific function. Following table lists the details of display conditions.

No.	Displayed conditions		Displayed func. codes when condition fulfilled.
1	2nd motor	C001...C007=08	F202, F203, A201 to A204, A220, A244, A245, A261, A262, A281, A282, A292 to A296, b212, b213, b221 to b223, C241, H203, H204, H206
2	EzSQ	A017=01,02	d023 to d027, P100 to P131
5	Free V/F control	A044=02 OR C001...C007=08 AND A244=02	b100 to b113
6	Free setting of electronic-thermal	b013=02 OR C001...C007=08 AND b213=02	b015 to b020
7	VC or VP ^{1.7} control	A044=00,01	A041 to A043, A046, A047
8	VC or VP ^{1.7} control for 2nd motor	C001...C007=08 AND A244=00,01	A241 to A243, A246, A247
9	DC breaking	A051=01,02 OR C001...C007=07	A052 to A059
10	PID	A071=01,02	d004, d153, d155, A072 to A079, A156, A157, C044, C052, C053
11	EzCOM	C096=01,02	C098 to C100, P140 to P155
12	Curving accel/deceleration	A097, A098=01...03	A131, A132, A150 to A153
13	Controlled deceleration	b050=01,02,03	b051 to b054
14	Breaking	b120=01	b121 to b127
15	Decel. overvoltage. suppress	b130=01,02	b131 to b134

(2) User setting display mode (**b037=02**)

The monitor displays only the codes and items that are arbitrarily assigned to user parameters (**U001** to **U032**), except codes **d001**, **F001** and **b037**.

Refer to User parameter (**U001** to **U032**) section for the detail.

(3) Data comparison display mode (**b037=03**)

The monitor displays only the parameters that have been changed from the factory settings. All monitoring indications **dxxx** and code **F001**, **b190**, **b191** are always displayed.

(4) Basic display mode (**b037=04**)

The monitor displays basic parameters. (The monitor display is the factory setting.) The following table lists the parameters that can be displayed in basic display mode.

No.	Code displayed	Item
1	d001 to d155	Monitoring indication
2	F001	Output frequency setting
3	F002	Acceleration time (1)
4	F003	Deceleration time (1)
5	F004	Keypad Run key routing
6	R001	Frequency source
7	R002	Run command source
8	R003	Base frequency
9	R004	Maximum frequency
10	R005	[AT] selection
11	R020	Multi-speed frequency 0
12	R021	Multi-speed frequency 1
13	R022	Multi-speed frequency 2
14	R023	Multi-speed frequency 3
15	R044	V/F characteristic curve selection
16	R045	V/F gain
17	R085	Energy saving operation mode
18	b001	Restart mode on power failure / under volt. trip
19	b002	Allowable under-voltage power failure time
20	b008	Restart mode on over volt. / over current trip
21	b011	Retry wait time on over volt. / over current trip
22	b037	Function code display restriction
23	b083	Carrier frequency
24	b084	Initialization mode (parameters or trip history)
25	b130	Decel. overvoltage suppression enable
26	b131	Decel. overvoltage suppression level
27	b180	Initialization trigger
28	b190	Password A setting
29	b191	Password A for authentication
30	C021	Output [11] function
31	C022	Output [12] function
32	C036	Alarm relay active state

Initial display selection: b038 – The initial display selection function allows you to specify data displayed on the integrated operator on powerup. The table below lists the display items selectable. (The factory setting is 01 [d001].)

Panel display selection: b150 – When an external operator is connected to WL200 via RS-422 port, the display is locked and shows only one parameter configured by b150.

Automatic return to the initial display: b164 – 10 min. after the last key operation, display returns to the initial parameter set by b038.

Frequency conversion coefficient setting: b086 – By setting b086, converted output frequency is monitored in d007. ($d007 = d001 \times b086$)

Frequency set in monitoring: b163 – If 01 is set in b163, frequency can be changed by up/down key in monitor display d001 and d007.

Action selection in case of external operator disconnection: b165 – When an external operator is disconnected, the inverter behaves according to b165 setting.

Func. Code	"b" Function		Run Mode Edit	Defaults	
	Name	Description		Initial data	Units
b038	Initial display selection	000 ...Func. code that SET key pressed last displayed.(*) 00 1 to 030 ... d00 1 to d030 displayed 20 1 ... F00 1 displayed 202 ...B display of LCD operator	✗	001	–
b086	Frequency scaling conversion factor	Specify a constant to scale the displayed frequency for d007 monitor, range is 0.01 to 99.99	✗	1.00	–
b 150	Display ex.operator connected	When an external operator is connected via RS-422 port, the built-in display is locked and shows only one "d" parameter configured in: d00 1 to d050	✗	001	–
b 160	1st parameter of Dual Monitor	Set any two "d" parameters in b 160 and b 16 1 , then they can be monitored in d050 . The two parameters are switched by up/down keys. Set range: d00 1 to d027	✗	001	–
b 16 1	2nd parameter of Dual Monitor		✗	002	–
b 163	Frequency set in monitoring	Two option codes: 00 ...Freq. set disabled 0 1 ...Freq. set enabled	✓	00	–
b 164	Automatic return to the initial display	10 min. after the last key operation, display returns to the initial parameter set by b038 . Two option codes: 00 ...Disable 0 1 ...Enable	✓	00	–
b 165	Ex. operator com. loss action	Five option codes: 00 ...Trip 0 1 ...Trip after deceleration to a stop 02 ...Ignore 03 ...Coasting (FRS) 04 ...Decelerates to a stop	✓	02	–

(*) note: If the power is off with displaying "000" after the set, **b038** comes when power is on again.

User Parameter Registration

Parameter group "U" is the user parameter. Any function code can be chosen to register on this parameter up to 32. When display mode is set to be "user parameter" (**b037 = 02**) then is **U001** to **U032** and **d001**, **F001**, **b037** are displayed.

Func. Code	"b" Function		Run Mode Edit	Defaults	
	Name	Description		Initial data	Units
b037	Function code display restriction	Six option codes: 00 ...Full display 01 ...Function-specific display 02 ...User setting (and b037) 03 ...Data comparison display 04 ...Basic display 05 ...Monitor display only	✗	00	-
U001 to U032	User parameters 1 to 32	Set range, "no", d001 to P192	✓		-

Automatic User Parameter Registration

The automatic user parameter setting function allows you to make the inverter automatically record changed function codes in **U001** to **U032**. You can use the stored function codes as a history of data change. To enable this function, select "**01**" (enabling automatic user parameter setting) for the **b039**.

When any data is changed and SET key is pressed, the function code will be stored in **U001** to **U032** sequentially.

The latest data is in **U001**, and the oldest one is in **U032**.

Stored function codes in **U001** to **U032** are not duplicated. If duplicated function code is changed, old existing function code is deleted. If number of changed function code exceeds 32, the oldest one in **U032** is deleted.

Func. Code	"b" Function		Run Mode Edit	Defaults	
	Name	Description		Initial data	Units
b039	Automatic user parameter registration	Two option codes: 00 ...Disable 01 ...Enable	✗	00	-
U001 to U032	User parameters 1 to 32	Set range, "no", d001 to P192	✓		-

Controlled Stop Operation at Power Loss

Controlled stop operation at power loss helps avoid tripping or free-running (coasting) of the motor when power is lost while in run mode. The inverter controls the internal DC bus voltage while decelerating the motor, and brings the motor to a controlled stop.

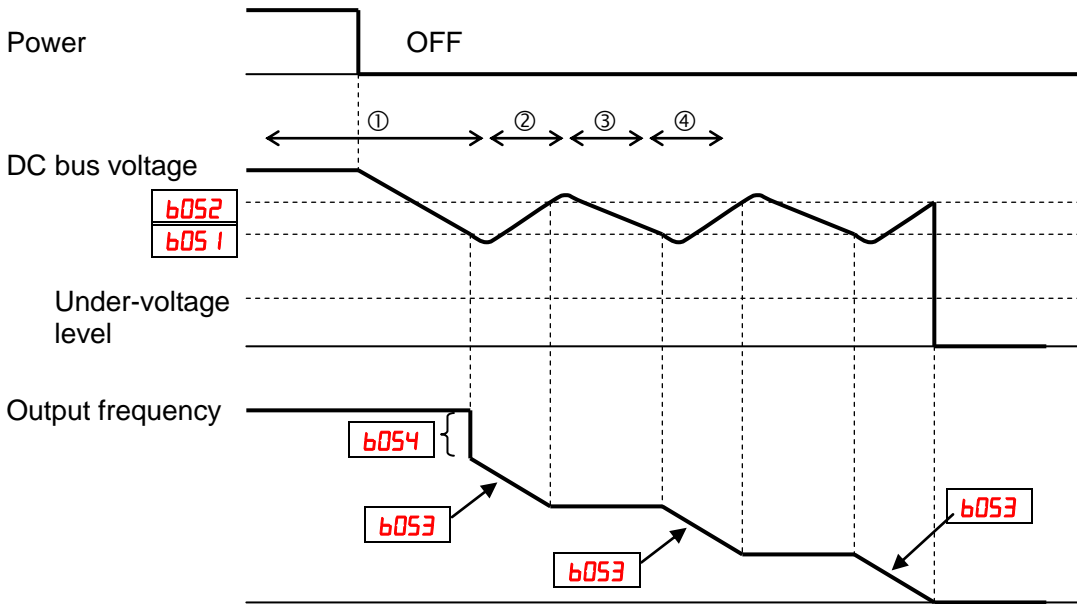

Should power be lost while the inverter is in run mode, this function will have the following effect:

- ① When the internal DC bus voltage of the inverter comes down to the set level of **b051**, the inverter decreases the output frequency by the amount set in **b054**. (During this interval the DC bus voltage rises due to regeneration, so does not reach the UV level.)
- ② The inverter then continues deceleration according to the value set in **b053**. If the DC bus voltage rises up to the set value of **b052**, the inverter stops deceleration to avoid OV tripping.
- ③ During this interval, the DC bus voltage decreases again due to lack of input power.
- ④ When the DC bus voltage comes down to the set value of **b051**, the inverter starts deceleration according to the set value of **b053** again. This process will be repeated as needed until the motor is brought to a stop.

"b" Function			Run Mode Edit	Defaults	
Func. Code	Name	Description		Initial data	Units
b050	Controlled deceleration on power loss	Four option codes: 00 ...Trips 01 ...Decelerates to a stop 02 ...Decelerates to a stop with DC bus voltage controlled 03 ...Decelerates to a stop with DC bus voltage controlled, then restart	✗	00	–
b051	DC bus voltage trigger level of ctrl. decel.	Setting of DC bus voltage to start controlled decel. operation. Range is 0.0 to 1000.0	✗	220.0/ 440.0	V
b052	Over-voltage threshold of ctrl. decel.	Setting the OV-LAD stop level of controlled decel. operation. Range is 0.0 to 1000.0	✗	360.0/ 720.0	V
b053	Deceleration time of ctrl. decel.	Range is 0.01 to 3600.00	✗	1.00	sec.
b054	Initial freq. drop of ctrl. decel.	Setting of initial freq. drop. Range is 0.0 to 10.0 Hz	✗	0.0	Hz



NOTE: If the DC bus voltage comes down to the UV level during this operation, the inverter trips with under-voltage and motor will free-run (coast) to a stop.



NOTE: If the set value of **b052** < **b051**, then the inverter internally swaps the **b052** and **b051** values. However the displayed values are not changed.



NOTE: This function cannot be interrupted until it is completed. So if the power is restored during this operation, wait until the operation is done (motor stops) and then give the run command.

Window Comparator, Analog disconnection

The window comparator function outputs signals when the values of analog inputs O and OI are within the maximum and minimum limits specified for the window comparator. You can monitor analog inputs with reference to arbitrary levels (to find input terminal disconnection and other errors).

You can specify a hysteresis width for the maximum-limit and minimum-limit levels of the window comparator. You can also specify limit levels and a hysteresis width individually for analog inputs O and OI.

You can fix the analog input data to be applied to an arbitrary value when WCO or WCOI is output. For this purpose, specify a desired value as the operation level at O/OI disconnection (b070/b071/b072). When "no" is specified, the analog input data is reflected as input.

Output values of ODc and OIDc are the same as those of WCO and WCOI, respectively.

Func. Code	"b" Function		Run Mode Edit	Defaults	
	Name	Description		Initial data	Units
b060	Maximum-limit level of window comparator (O)	Set range, {Min.-limit level (b061) + hysteresis width (b062)x2} to 100 % (Minimum of 0%)	✓	100.	%
b061	Minimum-limit level of window comparator (O)	Set range, 0 to {Max.-limit level (b060) - hysteresis width (b062)x2} % (Maximum of 0%)	✓	0.	%
b062	Hysteresis width of window comparator (O)	Set range, 0 to {Max.-limit level (b060) - Min.-limit level (b061)}/2 % (Maximum of 10%)	✓	0.	%
b063	Maximum-limit level of window comparator (OI)	Set range, {Min.-limit level (b064 + hysteresis width (b065)x2} to 100 % (Minimum of 0%)	✓	100.	%
b064	Minimum-limit level of window comparator (OI)	Set range, 0 to {Max.-limit level (b063) - hysteresis width (b065)x2} % (Maximum of 0%)	✓	0.	%
b065	Hysteresis width of window comparator (OI)	Set range, 0 to {Max.-limit level (b063) - Min.-limit level (b064)}/2 % (Maximum of 10%)	✓	0.	%
b070	Operation level at O disconnection	Set range, 0 to 100%, or "no" (ignore)	✗	no	-
b071	Operation level at OI disconnection	Set range, 0 to 100%, or "no" (ignore)	✗	no	-

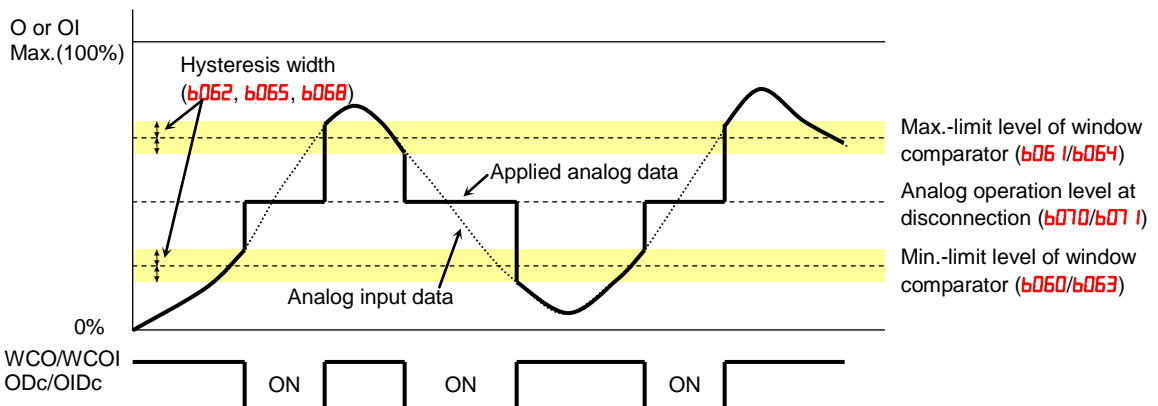

Ambient Temperature Setting

Sets the ambient temperature where the inverter is installed, so to calculate internally the lifetime of cooling fan. Incorrect data will result in an incorrect calculation result.

Func. Code	"b" Function		Run Mode Edit	Defaults	
	Name	Description		Initial data	Units
b075	Ambient temperature setting	Set range is, -10 to 50 °C	✓	40	°C

Watt-hour related

When the watt-hour monitoring function is selected, the inverter displays the watt-hour value of electric power given to the inverter. You can also convert the value to be displayed to gain data by setting the cumulative input power display gain setting (**b079**). Value displayed by function **d015** is expressed as follows:

$$d015 = \frac{\text{Watt-hour (kWh)}}{\text{Watt-hour gain setting (b079)}}$$

The watt-hour input gain can be set within the range 1 to 1000 in step of 1.

You can clear the watt-hour data by specifying "01" for the watt-hour clearance function (**b078**) and pressing the STR key. You can also clear the watt-hour data at an intelligent input terminal by assigning parameter "53" (KHC: watt-hour clearance) to the terminal.

When the watt-hour display gain setting (**b078**) is set to "1000", the watt-hour data up to 999000 (kWh) can be displayed.

Func. Code	"b" Function		Run Mode Edit	Defaults	
	Name	Description		Initial data	Units
b078	Watt-hour clearance	Two option codes: 00 ...OFF 01 ...ON (press STR then clear)	✓	00	-
b079	Watt-hour display gain	Set range is, 1. to 1000.	✓	1.	-

Carrier frequency (PWM) related

Carrier frequency adjustment: `b0B3` – The internal *switching frequency* of the inverter circuitry (also called the *chopper frequency*). It is called the carrier frequency because the lower AC power frequency of the inverter “rides” the carrier. The faint, high-pitched sound you hear when the inverter is in Run Mode is characteristic of switching power supplies in general. The carrier frequency is adjustable from 2.0kHz to 10kHz. The audible sound decreases at the higher frequencies, but RFI noise and leakage current may be increased. Refer to the specification derating curves in Chapter 1 to determine the maximum allowable carrier frequency setting for your particular inverter and environmental conditions. Refer also to `b0B9` for automatic carrier frequency reduction.



NOTE: The carrier frequency setting must stay within specified limits for inverter-motor applications that must comply with particular regulatory agencies. For example, European CE-approved application requires the carrier to be 3kHz or less.

Automatic carrier frequency reduction: `b0B9` – The automatic carrier frequency reduction automatically reduces the carrier frequency according to the increase in output current. To enable this function, specify “01” for automatic carrier frequency reduction selection (`b0B9`).

When the output current increases to 72%, 84%, or 96% of the rated current, this function reduces the carrier frequency to 9, 6, or 3 kHz, respectively. This function restores the original carrier frequency when the output decreases to 5% lower than each reduction start level.

The rate of carrier frequency reduction is 2kHz per second. The maximum limit of carrier frequency change by this function is the value specified for the carrier frequency setting (`b0B3`); the minimum limit is 3 kHz.

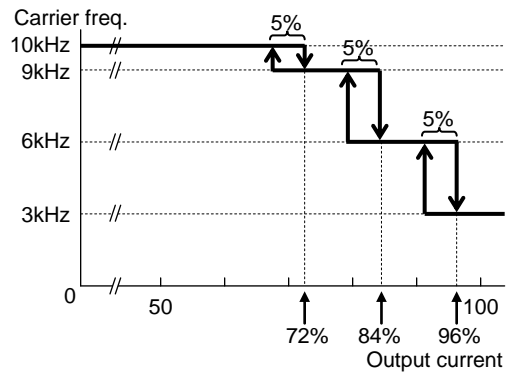

Note: If 3 kHz or less freq. has been specified for `b0B3`, this function is disabled regardless of the setting of `b0B9`.

[Remark: Above graph is for schematic concept and the profile is a subject to change reflecting the temperature test.]

"b" Function			Run Mode Edit	Defaults	
Func. Code	Name	Description		Initial data	Units
<code>b0B3</code>	Carrier frequency	Sets the PWM carrier (internal switching frequency), range is 2.0 to 10.0 kHz	✗	2.0	kHz
<code>b0B9</code>	Automatic carrier frequency reduction	Three option codes: <code>00</code> ...Disabled <code>01</code> ...Enabled, depending on the output current <code>02</code> ...Enabled, depending on the heat-sink temperature	✗	01	–

Miscellaneous Settings

The miscellaneous settings include initialization modes, and others. This section covers some of the most important settings you may need to configure.

Start frequency adjustment: **b082** – When the inverter starts to run, the output frequency does not ramp from 0Hz. Instead, it steps directly to the *start frequency* (**b082**), and the ramp proceeds upward from there.

Initialization related: **b084, b085, b094, b180** – These functions allow you to restore the factory default settings. Please refer to “[Restoring Factory Default Settings](#)” on page 6–14.

Stop key enable function: **b087** – This function allows you to decide whether the stop key on the integrated operator is enabled or not.

Dynamic Braking related functions: **b090, b095, b096,** – These parameters are for using the internal brake chopper so to get more regeneration torque of the motor.

Cooling Fan Control: **b092** – You can select the performance of the cooling fan (if your inverter model includes a fan). This function controls whether the cooling fan stops or keeps on running after the inverter stops the motor. This can result in an additional energy saving and extends fan life.

Func. Code	"b" Function		Run Mode Edit	Defaults	
	Name	Description		Initial data	Units
b082	Start frequency	Sets the starting frequency for the inverter output, range is 0.01 to 9.99 Hz	✗	0.50	Hz
b084	Initialization mode (parameters or trip history)	Select initialized data, five option codes: 00 ...Initialization disabled 01 ...Clears Trip history 02 ...Initializes all Parameters 03 ...Clears Trip history and initializes all parameters 04 ...Clears Trip history and initializes all parameters and EzSQ program	✗	00	–
b085	Country for initialization	Select default parameter values for country on initialization, two option codes: 00 ...area A 01 ...area B	✗	01	–
b087	STOP key enable	Select whether the STOP key on the keypad is enabled, three option codes: 00 ...Enabled 01 ...Disabled always 02 ...Disabled for stop	✗	00	–

Func. Code	"b" Function		Run Mode Edit	Defaults	
	Name	Description		Initial data	Units
b090	Dynamic braking usage ratio	Selects the rate of use (in %) of the regenerative braking resistor per 100 sec. intervals, range is 0.0 to the value calculated by the value of b097 . If the connected resistor's allowable range is narrower than above range, the resistor's range is prior. 0%: Function disabled >0%: Enabled, per value	✗	0.0	%
b092	Cooling fan control	Selects when the fan is ON during inverter operation, three options: 00 ...Fan is always ON 01 ...Fan is ON during run, OFF during stop (5 minute delay from ON to OFF) 02 ...Fan is temperature controlled	✗	01	-
b093	Clear elapsed time of cooling fan	Two option codes: 00 ...Count 01 ...Clear	✗	00	-
b094	Initialization target data	Select initialized parameters, four option codes: 00 ...All parameters 01 ...All parameters except in/output terminals and communication. 02 ...Only registered parameters in Uxxx . 03 ...All parameters except registered parameters in Uxxx and b037 .	✗	00	-
b095	Dynamic braking control (BRD) selection	Three option codes: 00 ...Disable 01 ...Enable during run only 02 ...Enable always	✗	00	-
b096	BRD activation level	Range is: 330 to 380V (200V class) 660 to 760V (400V class)	✗	360/ 720	V
b097	BRD resistor	Set the value of the resistor connected to the inverter. By this setting, upper limit of b090 as the inverter hardware is calculated automatically. Range is minimum connectable resistor R_{bmin} to 600.0Ω	✗	Min. resistance	Ω
b180	Initialization trigger (*)	This is to perform initialization by parameter input with b084 , b085 and b094 . Two option codes: 00 ...Initialization disable 01 ...Perform initialization	✗	00	-

(*) Note: When 01 is set on **b180**, and SET key is pressed, initialization starts immediately and there is not any way to restore the previous parameter setting. WL200 doesn't have a method to trigger the initialization by key action as the other Hitachi inverter models have.

Stop Mode / Restart Mode Configuration: b09 I/b088 – You can configure how the inverter performs a standard stop (each time Run FWD and REV signals turn OFF). Setting **b09 I** determines whether the inverter will control the deceleration, or whether it will perform a free-run stop (coast to a stop). When using the free-run stop selection, it is imperative to also configure how you want the inverter to resume control of motor speed. Setting **b088** determines whether the inverter will ensure the motor always resumes at 0 Hz, or whether the motor resumes from its current coasting speed (also called *active frequency matching*). The run command may turn OFF briefly, allowing the motor to coast to a slower speed from which normal operation can resume.

In most applications a controlled deceleration is desirable, corresponding to **b09 I=00**. However, applications such as HVAC fan control will often use a free-run stop (**b09 I=0 I**). This practice decreases dynamic stress on system components, prolonging system life. In this case, you will typically set **b088=0 I** in order to resume from the current speed after a free-run stop (see diagram down below: active frequency matching resume). Note that using the default setting, **b088=00**, can cause trip events when the inverter attempts to force the load quickly to zero speed.



NOTE: Other events can cause (or be configured to cause) a free-run stop, such as power loss (see “[Automatic Restart Mode](#)” on page 3-43), or an intelligent input terminal [FRS] signal. If all free-run stop behavior is important to your application (such as HVAC), be sure to configure each event accordingly.

An additional parameter further configures all instances of a free-run stop. Parameter **b003**, Retry Wait Time Before Motor Restart, sets the minimum time the inverter will free-run. For example, if **b003** = 4 seconds (and **b091**=**01**) and the cause of the free-run stop lasts 10 seconds, the inverter will free-run (coast) for a total of 14 seconds before driving the motor again.

The figure at below right describes how active frequency matching resume operates. After waiting the time set in **b003**, the inverter tries to catch the speed of the motor shaft and outputs the speed set in **b030**. At this time, if the motor current rises up to the value set in **b028**, the inverter decreases the frequency according to the deceleration time set in **b029**, and finally comes to the required speed. Following are the related parameters for this control.

Code	Parameter contents
b028	Current level of active frequency matching
b029	Deceleration rate of active frequency matching
b030	Start freq. of active freq. matching
b088	Restart mode after FRS
b091	Stop mode selection

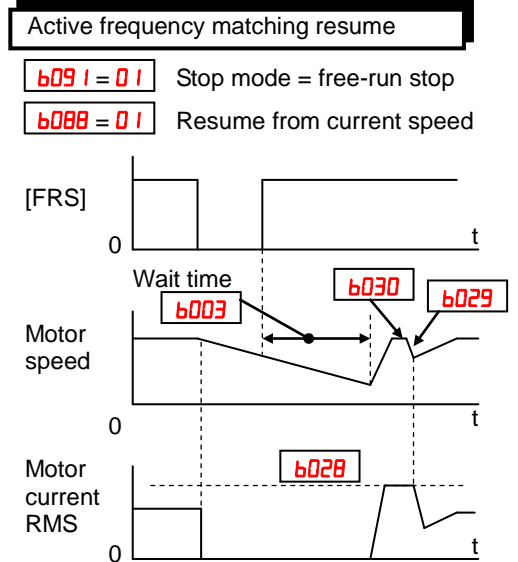
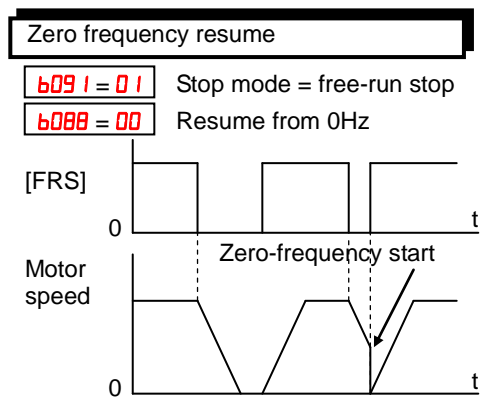

Func. Code	Name	Description	Run Mode Edit	Defaults	
				Initial data	Units
b088	Restart mode after FRS	Selects how the inverter resumes operation when free-run stop (FRS) is cancelled, three options: 00 ...Restart from 0Hz 01 ...Restart from frequency detected from real speed of motor (freq. matching) 02 ...Restart from frequency detected from real speed of motor (active freq. matching)	✘	00	-
b091	Stop mode selection	Select how the inverter stops the motor, two option codes: 00 ...DEC (decelerate to stop) 01 ...FRS (free-run to stop)	✘	00	-

Free-V/F Settings Related

Please refer to page 3-21 for detailed explanation of the function.

Func. Code	"b" Function		Run Mode Edit	Defaults	
	Name	Description		Initial data	Units
b 100	Free V/F setting, freq.1	Set range, 0 to value of b 102	✗	0.	Hz
b 101	Free V/F setting, voltage.1	Set range, 0.0 to 800.0V	✗	0.0	V
b 102	Free V/F setting, freq.2	Set range, value of b 100 to b 104	✗	0.	Hz
b 103	Free V/F setting, voltage.2	Set range, 0.0 to 800.0V	✗	0.0	V
b 104	Free V/F setting, freq.3	Set range, value of b 102 to b 106	✗	0.	Hz
b 105	Free V/F setting, voltage.3	Set range, 0.0 to 800.0V	✗	0.0	V
b 106	Free V/F setting, freq.4	Set range, value of b 104 to b 108	✗	0.	Hz
b 107	Free V/F setting, voltage.4	Set range, 0.0 to 800.0V	✗	0.0	V
b 108	Free V/F setting, freq.5	Set range, value of b 108 to b 110	✗	0.	Hz
b 109	Free V/F setting, voltage.5	Set range, 0.0 to 800.0V	✗	0.0	V
b 110	Free V/F setting, freq.6	Set range, value of b 108 to b 112	✗	0.	Hz
b 111	Free V/F setting, voltage.6	Set range, 0.0 to 800.0V	✗	0.0	V
b 112	Free V/F setting, freq.7	Set range, b 110 to 400	✗	0.	Hz
b 113	Free V/F setting, voltage.7	Set range, 0.0 to 800.0V	✗	0.0	V

Brake Control Function Related

The brake control function allows you to make the inverter control an external brake used for a lift or other machines. To enable this function, specify "01" (enabling the brake control function) for the Brake Control Enable (b 120). This function operates as described below.

- (1) When the inverter receives an operation command, it starts the output and accelerates the motor up to the Brake Release Frequency Setting.
- (2) After the Brake Release Frequency Setting is reached, the inverter waits for the braking wait time (b 121), and then outputs the brake release signal (BOK). However, if the inverter output current has not reached the brake release current (b 126), the inverter does not output the brake release signal, but trips and outputs a brake error signal (BER).
- (3) When the braking confirmation signal (BOK) has been assigned to an intelligent input terminal (that is, when "44" is specified for one of "C001" to "C007"), the inverter waits for the Brake Wait Time for Confirmation (b 124) without accelerating the motor after receiving the brake release signal. If the inverter does not receive the braking confirmation signal within the braking confirmation time (b 124), it trips with the braking error signal (BER) output. When the braking confirmation signal (BOK) has not been assigned to any intelligent input terminal, the Brake Wait Time for Confirmation (b 124) is invalid. In such cases, the inverter proceeds to the operation described in item (4) after the output of the brake release signal.
- (4) After the input of the braking confirmation signal (or the output of the brake release signal [when the BOK signal function is disabled]), the inverter waits for the Brake Wait Time for Acceleration (b 122), and then starts accelerating the motor up to the set acceleration frequency.
- (5) When the operation command is turned off, the inverter decelerates the motor down to the braking frequency (b 125), and then turns off the brake release signal (BRK).

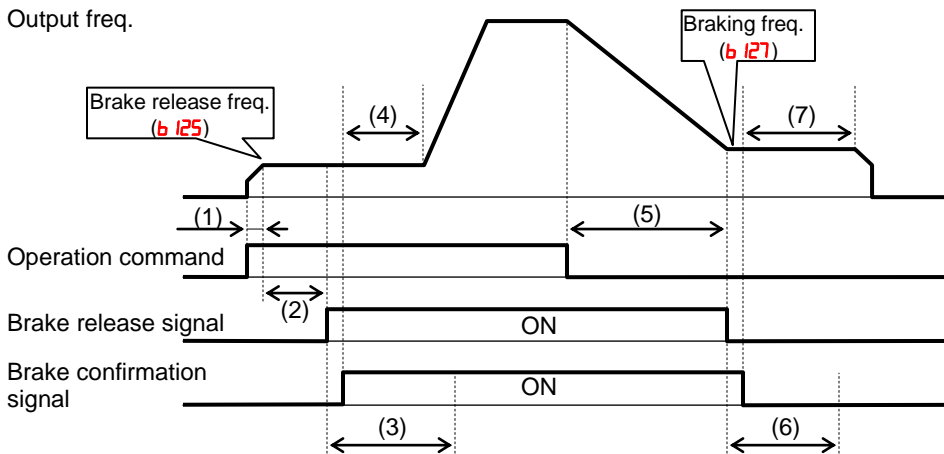

- (1) Time to reach Brake release freq.
- (2) Brake Wait Time for Release (b 121)
- (3) Brake Wait Time for Confirmation (b 124)
- (4) Brake Wait Time for Acceleration (b 122)
- (5) Time to decelerate down to Braking freq
- (6) Brake Wait Time for Confirmation (b 124)
- (7) Brake Wait Time for Stopping (b 123)

- (6) When the braking confirmation signal (BOK) has been assigned to an intelligent input terminal (that is, when "44" is specified for one of "C00 1" to "C00 7"), the inverter waits, after turning off the brake release signal, until the braking confirmation is turned off at least for the Brake Wait Time for Confirmation (b 124) without decelerating the motor. If the braking confirmation signal is not turned off within the Brake Wait Time for Confirmation (b 124), the inverter trips with the braking error signal (BER) output. When the braking confirmation signal (BOK) has not been assigned to any intelligent input terminal, the Brake Wait Time for Confirmation (b 124) is invalid. In such cases, the inverter proceeds to the operation described in item (7) after the brake release signal is turned off.
- (7) After the braking confirmation signal (or the brake release signal [when the BOK signal function is disabled]) is turned off, the inverter waits for the Brake Wait Time for Stopping (b 123), and then starts decelerating the motor down to 0Hz.



NOTE: The above timing chart shows the operation on the assumption that the braking confirmation signal "44" (BOK) is assigned to one of the terminal 1 to 7 (C00 1 to C00 7). If the BOK signal is not assigned to any terminal, the Brake Wait Time for Acceleration (b 122) begins when the brake release signal is turned on, and the Brake Wait Time for Stopping (b 123) begins when the brake release signal is turned off.

When using the brake control function, assign the following signal functions to intelligent input and output terminals as needed.

- (1) To input a signal indicating that the brake is released from the external brake to the inverter, assign the braking confirmation signal (44: BOK) to one of the terminal 1 to 7 (C00 1 to C00 7)
- (2) Assign the brake release signal (19: BRK), which is a brake-releasing command, to one of the output terminal 11 to 12 (C02 1 to C02 2). To output a signal when braking is abnormal, assign the brake error signal (20: BER) to an output terminal.

Func. Code	"b" Function		Run Mode Edit	Defaults	
	Name	Description		Initial data	Units
b 120	Brake control enable	Two option codes: 00...Disable 01...Enable 02...Enable (same as 01)	×	00	—
b 121	Brake Wait Time for Release	Set range: 0.00 to 5.00 sec	×	0.00	sec.
b 122	Brake Wait Time for Acceleration	Set range: 0.00 to 5.00 sec	×	0.00	sec.
b 123	Brake Wait Time for Stopping	Set range: 0.00 to 5.00 sec	×	0.00	sec.
b 124	Brake Wait Time for Confirmation	Set range: 0.00 to 5.00 sec	×	0.00	sec.
b 125	Brake release freq.	Set range: 0 to 400Hz	×	0.00	sec.
b 126	Brake release current	Set range: 0 to 150% of inverter rated current	×	Rated current	A
b 127	Braking freq. setting	Set range: 0 to 400Hz	×	0.00	Hz

DC Bus AVR (Automatic Voltage Regulation) for Deceleration Settings

This function is to achieve stable DC bus voltage in case of deceleration. DC bus voltage rises due to regeneration during deceleration. When this function is activated (**b 130=01** or **02**), inverter controls the deceleration time so that the DC bus voltage not to go up to the overvoltage trip level, and leads to the trip-less operation during deceleration.

Please note that the actual deceleration time can be longer in this case.

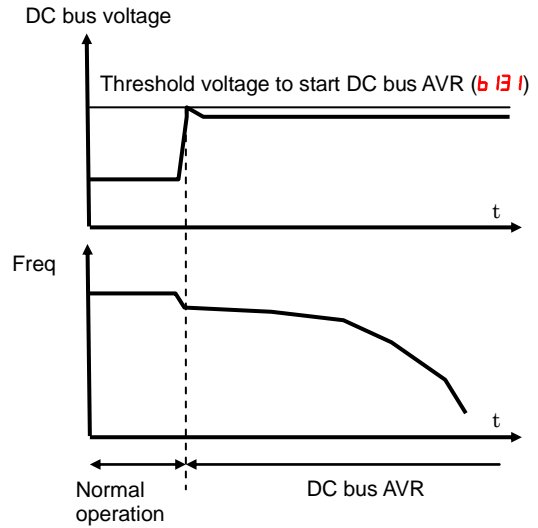

Func. Code	Name	"b" Function Description	Run Mode Edit	Defaults	
				Initial data	Units
b 130	Deceleration overvoltage suppression enable	00...Disabled 01...Enabled 02...Enabled with accel.	✗	00	-
b 131	Decel. overvoltage. suppress level	DC bus voltage of suppression. Range is: 200V class...330 to 395 400V class...660 to 790	✗	380 /760	V
b 132	Decel. overvoltage. suppress const.	Accel. rate when b130=02. Set range: 0.10 to 30.00 sec.	✗	1.00	sec.
b 133	Decel. overvoltage. suppress proportional gain	Proportional gain when b130=01. Range is: 0.00 to 5.00	✓	0.20	-
b 134	Decel. overvoltage. suppress integral time	Integration time when b130=01. Range is: 0.00 to 150.0	✓	1.0	sec.

STO (Safe Torque Off) Setting

Please refer to the appendix E for detailed information.

Func. Code	"b" Function		Run Mode Edit	Defaults	
	Name	Description		Initial data	Units
b 145	GS input mode	Two option codes: 00 ...No trip (Hardware shutoff only) 01 ...E37 trip 02 ...E98/E99 trip/ display -5-- . With external fault detection 03 ...E99 trip/ display -5-- . Without external fault detection 04 ...Display -5-- . With external fault detection 05 ...Display input status. Without external fault detection 06 ...Display input status. With external fault detection	X	00	-

Data Read/Write selection

By setting b166 to "01", both Read and Write function by WOP are inhibited. This function is different from "software lock function".

Func. Code	"b" Function		Run Mode Edit	Defaults	
	Name	Description		Initial data	Units
b 166	Data Read/Write selection	Two option codes: 00 ...Read/Write enable 01 ...both Read, Write disable	X	00	-

Password Function

The WL200 inverter has password function to prevent from changing parameters or to hide a part of parameters. There are two passwords for **b037** (Function Code Display Restriction) and **b031** (Software Lock) corresponding to password A and password B.

If password is forgotten, there is no way to delete password. Please be careful to set password.

◆ Overview of password function (Example of password A)

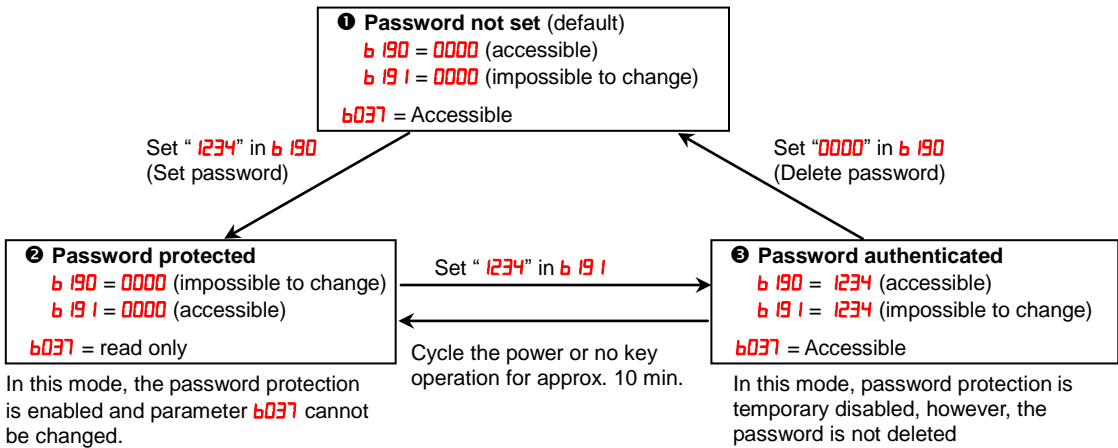

◆ Function Code Display Restriction Function and Software Lock Function

Target of password	Function description	Applied parameters for setting password
Function Code Display Restriction b037 (password A)	Depending on the value in b037 , a part of function codes are not displayed. (Displayed parameters can be changed.)	b190, b191
Software Lock b031 (password B)	Depending on the value in b031 , all or a part of parameters cannot be changed. (All the function codes and data are displayed.)	b192, b193

◆ How to Set Password

- (1) Set parameter **b037** and/or **b031** depending on your demand
- (2) Set password in **b190** and/or **b192** ("0000" is not available.)

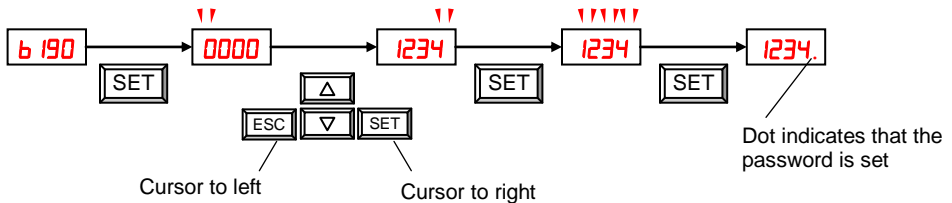

- (3) Password has been set and locked.
Parameter **b037** and/or **b031** cannot be changed.

◆ How to authenticate Password

For a person who knows the password, unlock password protection as follows.

(4) Set password in **b 19 1** and/or **b 193**.

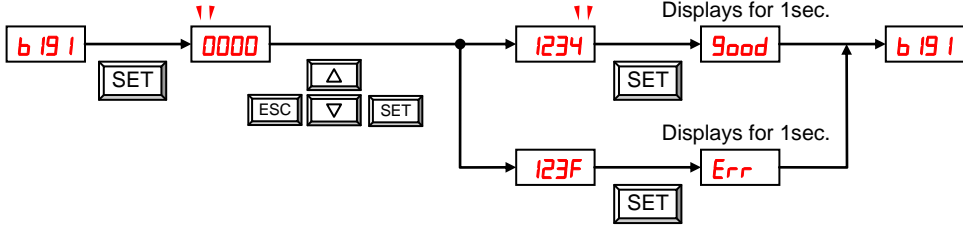

(5) If entered password is matched, "Good (Good)" is displayed for 1 second and password protection is unlocked temporary. If cycling the power or no key operation lasts 10 min., password protection is enabled again automatically. If entered password is unmatched, "Err (Error)" is displayed and protection is not unlocked.

◆ How to change Password

(6) Make password authentication as above (4).

(7) Set new password in **b 190** and/or **b 192**

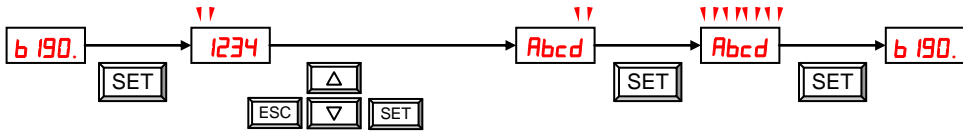

(8) After changing the password, password protection is enabled automatically.

◆ How to delete Password

(9) Make password authentication as above (4).

(10) Set "0000" in **b 190** and/or **b 192**

(11) Password has been deleted and all the password information are cleared

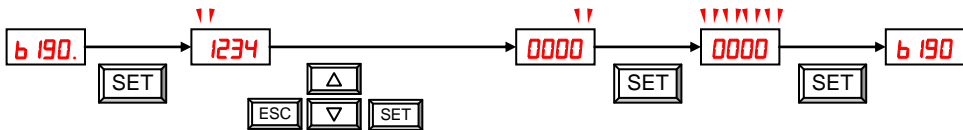

"C" Group: Intelligent Terminal Functions

The seven input terminals [1], [2], [3], [4], [5], [6], and [7] can be configured for any of 56 different functions. The next two tables show how to configure the seven terminals. The inputs are logical, in that they are either OFF or ON. We define these states as OFF=0, and ON=1.

The inverter comes with default options for the seven terminals. These settings are initially unique, each one having its own setting. You can use any option on any terminal, and even use the same option twice to create a logical OR (though usually not required).



NOTE: Terminals [3] and [4] have the ability to be logical inputs, and to be safety inputs in case of safe stop function is selected.



NOTE: Terminal [5] has the ability to be a logical input, and to be an analog input for a thermistor device when PTC function (option code 19) is assigned to that terminal.

Input Terminal Configuration

Functions and Options – The *function codes* in the following table let you assign one of 56 options to any of the seven logic inputs for the WL200 inverters. The functions **C001** through **C007** configure the terminals [1] through [7] respectively. The “value” of these particular parameters is not a scalar value, but it is a discrete number that selects one option from many available *options*.

For example, if you set function **C001=00**, you have assigned option **00** (Forward Run) to terminal [1]. The option codes and the specifics of how each one works are in Chapter 4.

Func. Code	"C" Function		Run Mode Edit	Defaults	
	Name	Description		Initial data	Units
C001	Input [1] function	Select input terminal function, 56 options (see next section)	×	00 [FW]	–
C002	Input [2] function		×	01 [RV]	–
C003	Input [3] function [GS1 assignable]		×	12 [EXT]	–
C004	Input [4] function [GS2 assignable]		×	18 [RS]	–
C005	Input [5] function [PTC assignable]		×	02 [CF1]	–
C006	Input [6] function		×	03 [CF2]	–
C007	Input [7] function		×	06 [JG]	–

The input logic conversion is programmable for each of the seven inputs default to normally open (active high), but you can select normally closed (active low) in order to invert the sense of the logic.

"C" Function			Run Mode Edit	Defaults	
Func. Code	Name	Description		Initial data	Units
C011	Input [1] active state	Select logic conversion, two option codes: 00 ...normally open [NO] 01 ...normally closed [NC]	✗	00	–
C012	Input [2] active state		✗	00	–
C013	Input [3] active state		✗	00	–
C014	Input [4] active state		✗	00	–
C015	Input [5] active state		✗	00	–
C016	Input [6] active state		✗	00	–
C017	Input [7] active state		✗	00	–



NOTE: An input terminal configured for option code **1B** ([RS] Reset command) cannot be configured for normally closed operation.

Note: This response time is disregarded when power-on or reset. For example, when the power is up when FW terminal is on, then the operation starts regardless this response time as soon as the internal reset process is completed.

"C" Function			Run Mode Edit	Defaults	
Func. Code	Name	Description		Initial data	Units
C160	Input [1] response time	Sets response time of each input terminal, set range: 0 (x 2 [ms]) to 200 (x 2 [ms]) (0 to 400 [ms])	✗	1.	–
C161	Input [2] response time		✗	1.	–
C162	Input [3] response time		✗	1.	–
C163	Input [4] response time		✗	1.	–
C164	Input [5] response time		✗	1.	–
C165	Input [6] response time		✗	1.	–
C166	Input [7] response time		✗	1.	–

Intelligent Input Terminal Overview

Each of the seven intelligent terminals may be assigned any of the options in the following table. When you program one of the option codes for terminal assignments **C001** to **C007**, the respective terminal assumes the function role of that option code. The terminal functions have a symbol or abbreviation that we use to label a terminal using that function. For example, the "Forward Run" command is [FW]. The physical label on the terminal block connector is simply **1, 2, 3, 4, 5, 6, or 7**. However, schematic examples in this manual also use the terminal symbol (such as [FW]) to show the assigned option. The option codes for **C011** to **C017** determine the active state of the logical input (active high or active low).

Input Function Summary Table – This table shows all intelligent input functions at a glance. Detailed description of these functions, related parameters and settings, and example wiring diagrams are in “Using Intelligent Input Terminals” on page 4-12.

Input Function Summary Table				
Option Code	Terminal Symbol	Function Name	Description	
00	FW	FORWARD Run/Stop	ON	Inverter is in Run Mode, motor runs forward
			OFF	Inverter is in Stop Mode, motor stops
01	RV	Reverse Run/Stop	ON	Inverter is in Run Mode, motor runs reverse
			OFF	Inverter is in Stop Mode, motor stops
02	CF1	Multi-speed Select, Bit 0 (LSB)	ON	Binary encoded speed select, Bit 0, logical 1
			OFF	Binary encoded speed select, Bit 0, logical 0
03	CF2	Multi-speed Select, Bit 1	ON	Binary encoded speed select, Bit 1, logical 1
			OFF	Binary encoded speed select, Bit 1, logical 0
04	CF3	Multi-speed Select, Bit 2	ON	Binary encoded speed select, Bit 2, logical 1
			OFF	Binary encoded speed select, Bit 2, logical 0
05	CF4	Multi-speed Select, Bit 3 (MSB)	ON	Binary encoded speed select, Bit 3, logical 1
			OFF	Binary encoded speed select, Bit 3, logical 0
06	JG	Jogging	ON	Inverter is in Run Mode, output to motor runs at jog parameter frequency
			OFF	Inverter is in Stop Mode
07	DB	External DC braking	ON	DC braking will be applied during deceleration
			OFF	DC braking will not be applied
08	SET	Set (select) 2nd Motor Data	ON	The inverter uses 2nd motor parameters for generating frequency output to motor
			OFF	The inverter uses 1st (main) motor parameters for generating frequency output to motor
09	2CH	2-stage Acceleration and Deceleration	ON	Frequency output uses 2nd-stage acceleration and deceleration values
			OFF	Frequency output uses standard acceleration and deceleration values
11	FRS	Free-run Stop	ON	Causes output to turn OFF, allowing motor to free run (coast) to stop
			OFF	Output operates normally, so controlled deceleration stop motor
12	EXT	External Trip	ON	When assigned input transitions OFF to ON, inverter latches trip event and displays E 12
			OFF	No trip event for ON to OFF, any recorded trip events remain in history until reset
13	USP	Unattended Start Protection	ON	On powerup, the inverter will not resume a Run command (mostly used in the US)
			OFF	On powerup, the inverter will resume a Run command that was active before power loss
14	CS	Commercial power source switchover	ON	Motor can be driven by commercial power
			OFF	Motor is driven via the inverter
15	SFT	Software Lock	ON	The keypad and remote programming devices are prevented from changing parameters
			OFF	The parameters may be edited and stored
16	AT	Analog Input Voltage/Current Select	ON	Refer to “Analog Input Settings” on page3-15.
			OFF	
18	RS	Reset Inverter	ON	The trip condition is reset, the motor output is turned OFF, and powerup reset is asserted
			OFF	Normal power-ON operation

Input Function Summary Table

Option Code	Terminal Symbol	Function Name	Description	
19	PTC	PTC thermistor Thermal Protection (C005 only)	ANLG	When a thermistor is connected to terminal [5] and [L], the inverter checks for over-temperature and will cause trip event and turn OFF output to motor
			OPEN	A disconnect of the thermistor causes a trip event, and the inverter turns OFF the motor
20	STA	Start (3-wire interface)	ON	Starts the motor rotation
			OFF	No change to present motor status
21	STP	Stop (3-wire interface)	ON	Stops the motor rotation
			OFF	No change to present motor status
22	F/R	FWD, REV (3-wire interface)	ON	Selects the direction of motor rotation: ON = FWD. While the motor is rotating, a change of F/R will start a deceleration, followed by a change in direction
			OFF	Selects the direction of motor rotation: OFF = REV. While the motor is rotating, a change of F/R will start a deceleration, followed by a change in direction
23	PID	PID Disable	ON	Temporarily disables PID loop control. Inverter output turns OFF as long as PID Enable is active (AD7 I=0 I)
			OFF	Has no effect on PID loop operation, which operates normally if PID Enable is active (AD7 I=0 I)
24	PIDC	PID Reset	ON	Resets the PID loop controller. The main consequence is that the integrator sum is forced to zero
			OFF	No effect on PID controller
27	UP	Remote Control UP Function (motorized speed pot.)	ON	Accelerates (increases output frequency) motor from current frequency
			OFF	Output to motor operates normally
28	DWN	Remote Control Down Function (motorized speed pot.)	ON	Decelerates (decreases output frequency) motor from current frequency
			OFF	Output to motor operates normally
29	UDC	Remote Control Data Clearing	ON	Clears the UP/DWN frequency memory by forcing it to equal the set frequency parameter F001. Setting C 10 I must be set= 00 to enable this function to work
			OFF	UP/DWN frequency memory is not changed
31	OPE	Operator Control	ON	Forces the source of the output frequency setting AD0 I and the source of the Run command AD02 to be from the digital operator
			OFF	Source of output frequency set by AD0 I and source of Run command set by AD02 is used
32	SF1	Multi-speed Select, Bit operation Bit 1	ON	Bit encoded speed select, Bit 1, logical 1
			OFF	Bit encoded speed select, Bit 1, logical 0
33	SF2	Multi-speed Select, Bit operation Bit 2	ON	Bit encoded speed select, Bit 2, logical 1
			OFF	Bit encoded speed select, Bit 2, logical 0
34	SF3	Multi-speed Select, Bit operation Bit 3	ON	Bit encoded speed select, Bit 3, logical 1
			OFF	Bit encoded speed select, Bit 3, logical 0
35	SF4	Multi-speed Select, Bit operation Bit 4	ON	Bit encoded speed select, Bit 4, logical 1
			OFF	Bit encoded speed select, Bit 4, logical 0
36	SF5	Multi-speed Select, Bit operation Bit 5	ON	Bit encoded speed select, Bit 5, logical 1
			OFF	Bit encoded speed select, Bit 5, logical 0
37	SF6	Multi-speed Select, Bit operation Bit 6	ON	Bit encoded speed select, Bit 6, logical 1
			OFF	Bit encoded speed select, Bit 6, logical 0

Input Function Summary Table

Option Code	Terminal Symbol	Function Name	Description	
38	SF7	Multi-speed Select, Bit operation Bit 7	ON	Bit encoded speed select, Bit 7, logical 1
			OFF	Bit encoded speed select, Bit 7, logical 0
39	OLR	Overload Restriction Source Changeover	ON	Perform overload restriction
			OFF	Normal operation
44	BOK	Brake confirmation	ON	Brake wait time (b 124) is valid
			OFF	Brake wait time (b 124) is not valid
46	LAC	LAD cancellation	ON	Set ramp times are ignored. Inverter output immediately follows the freq. command.
			OFF	Accel. and/or decel. is according to the set ramp time
50	ADD	ADD frequency enable	ON	Adds the A 145 (add frequency) value to the output frequency
			OFF	Does not add the A 145 value to the output frequency
51	F-TM	Force Terminal Mode	ON	Force inverter to use input terminals for output frequency and Run command sources
			OFF	Source of output frequency set by A001 and source of Run command set by A002 is used
53	KHC	Clear watt-hour data	ON	Clear watt-hour data
			OFF	No action
56	MI1	General purpose input (1)	ON	General purpose input (1) is made ON under EzSQ
			OFF	General purpose input (1) is made OFF under EzSQ
57	MI2	General purpose input (2)	ON	General purpose input (2) is made ON under EzSQ
			OFF	General purpose input (2) is made OFF under EzSQ
58	MI3	General purpose input (3)	ON	General purpose input (3) is made ON under EzSQ
			OFF	General purpose input (3) is made OFF under EzSQ
59	MI4	General purpose input (4)	ON	General purpose input (4) is made ON under EzSQ
			OFF	General purpose input (4) is made OFF under EzSQ
60	MI5	General purpose input (5)	ON	General purpose input (5) is made ON under EzSQ
			OFF	General purpose input (5) is made OFF under EzSQ
61	MI6	General purpose input (6)	ON	General purpose input (6) is made ON under EzSQ
			OFF	General purpose input (6) is made OFF under EzSQ
62	MI7	General purpose input (7)	ON	General purpose input (7) is made ON under EzSQ
			OFF	General purpose input (7) is made OFF under EzSQ
65	AHD	Analog command hold	ON	Analog command is held
			OFF	Analog command is not held
77	GS1	GS1 input (C003 only)	ON	EN60204-1 related signals: Signal input of "Safe torque off" function.
			OFF	
78	GS2	GS2 input (C004 only)	ON	
			OFF	
81	485	Start EzCOM	ON	Starts EzCOM
			OFF	No execution
82	PRG	Executing EzSQ program	ON	Executing EzSQ program
			OFF	No execution
83	HLD	Retain output frequency	ON	Retain the current output frequency
			OFF	No retention
84	ROK	Permission of Run command	ON	Run command permitted
			OFF	Run command is not permitted
86	DISP	Display limitation	ON	Only a parameter configured in b038 is shown
			OFF	All the monitors can be shown
255	no	No function	ON	(input ignored)

Output Terminal Configuration

The inverter provides configuration for logic (discrete) and analog outputs, shown in the table below.

"C" Function			Run Mode Edit	Defaults	
Func. Code	Name	Description		Initial data	Units
C021	Output [11] function [EDM assignable]	44 programmable functions available for logic (discrete) outputs (see next section)	✗	00 [RUN]	–
C022	Output [12] function		✗	01 [FA1]	–
C026	Alarm relay function		✗	05 [AL]	–
C027	[EO] terminal selection (Pulse/PWM output)	11 programmable functions: 00 ...Output frequency (PWM) 01 ...Output current (PWM) 03 ...Output frequency (Pulse train) 04 ...Output voltage (PWM) 05 ...Input power (PWM) 06 ...Electronic thermal load ratio (PWM) 07 ...LAD frequency (PWM) 08 ...Output current (Pulse train) 10 ...Heat sink temperature (PWM) 12 ...General output (PWM) 16 ...Option(PWM)	✗	07	–
C028	[AM] terminal selection (Analog voltage output 0...10V)	9 programmable functions: 00 ...Output frequency 01 ...Output current 04 ...Output voltage 05 ...Input power 06 ...Electronic thermal load ratio 07 ...LAD frequency 10 ...Heat sink temperature 13 ...General output 16 ...Option	✗	07 [LAD]	–
C030	Digital current monitor reference value	Current with digital current monitor output at 1,440Hz Range is 20% to 150% of rated current	✓	Rated current	A

The output logic conversion is programmable for terminal [11], [12] and the alarm relay terminal. The open-collector output terminal [11] and [12] defaults to normally open (active low), but you can select normally closed (active high) for the terminal in order to invert the sense of the logic. You can invert the logical sense of the alarm relay output as well.

"C" Function			Run Mode Edit	Defaults	
Func. Code	Name	Description		Initial data	Units
C031	Output [11] active state	Select logic conversion, two option codes: 00 ...normally open [NO] 01 ...normally closed [NC]	✗	00	–
C032	Output [12] active state		✗	00	–
C036	Alarm relay active state		✗	01	–

You can also adjust the output with ON/OFF delays.

"C" Function			Run Mode Edit	Defaults	
Func. Code	Name	Description		Initial data	Units
C130	Output [11] on delay	Set range is 0.0 to 100.0 sec.	✗	0.0	Sec.
C131	Output [11] off delay		✗	0.0	Sec.
C132	Output [12] on delay		✗	0.0	Sec.
C133	Output [12] off delay		✗	0.0	Sec.
C140	Relay output on delay		✗	0.0	Sec.
C141	Relay output off delay		✗	0.0	Sec.



NOTE: If you are using the output terminal OFF delay feature (any of **C145**, **C149** > 0.0 sec.), the [RS] (reset) terminal affects the ON-to-OFF transition slightly. Normally (with using OFF delays), the [RS] input causes the motor output and the logic outputs to turn OFF together, immediately. However, when any output uses an OFF delay, then after the [RS] input turns ON, that output will remain ON for an additional 1 sec. period (approximate) before turning OFF.

Output Function Summary Table – This table shows all functions for the logical outputs (terminals [11], [12] and [AL]) at a glance. Detailed descriptions of these functions, related parameters and settings, and example wiring diagrams are in “Using Intelligent Output Terminals” on page 4-45.

Output Function Summary Table				
Option Code	Terminal Symbol	Function Name	Description	
00	RUN	Run Signal	ON	When the inverter is in Run Mode
			OFF	When the inverter is in Stop Mode
01	FA1	Frequency Arrival Type 1-Constant Speed	ON	When output to motor is at the set frequency
			OFF	When output to motor is OFF, or in any acceleration or deceleration ramp
02	FA2	Frequency Arrival Type 2-Over frequency	ON	When output to motor is at or above the set freq., even if in accel (C042) or decel (C043) ramps
			OFF	When output to motor is OFF, or at a level below the set frequency
03	OL	Overload Warning Signal 1	ON	When output current is more than the set threshold (C041) for the overload signal
			OFF	When output current is less than the set threshold for the deviation signal
04	OD	Output Deviation for PID Control	ON	When PID error is more than the set threshold for the deviation signal
			OFF	When PID error is less than the set threshold for the deviation signal
05	AL	Alarm Signal	ON	When an alarm signal has occurred and has not been cleared
			OFF	When no alarm has occurred since the last cleaning of alarm(s)
06	FA3	Frequency Arrival Type 3-Set frequency	ON	When output to motor is at the set frequency, during accel (C042) and decel (C043).
			OFF	When output to motor is OFF, or is not at a level of the set frequency
09	UV	Under-voltage	ON	Inverter is in Under-voltage
			OFF	Inverter is not in Under-voltage
11	RNT	Run Time Expired	ON	Total running time of the inverter exceeds the specified value
			OFF	Total running time of the inverter does not exceed the specified value
12	ONT	Power ON time Expired	ON	Total power ON time of the inverter exceeds the specified value
			OFF	Total power ON time of the inverter does not exceed the specified value
13	THM	Thermal Warning	ON	Accumulated thermal count exceeds the C061 set value
			OFF	Accumulated thermal count does not exceed the C061 set value
19	BRK	Brake Release Signal	ON	Output for brake release
			OFF	No action for brake
20	BER	Brake Error Signal	ON	Brake error has occurred
			OFF	Brake performance is normal
21	ZS	Zero Hz Speed Detection Signal	ON	Output frequency falls below the threshold specified in C063
			OFF	Output frequency is higher than the threshold specified in C063

Output Function Summary Table

Option Code	Terminal Symbol	Function Name	Description	
24	FA4	Frequency Arrival Type 4-Over frequency	ON	When output to motor is at or above the set freq., even if in accel (C045) or decel (C046) ramps
			OFF	When output to motor is OFF, or at a level below the set frequency
25	FA5	Frequency Arrival Type 5-Set frequency	ON	When output to motor is at the set frequency, during accel (C045) and decel (C046).
			OFF	When output to motor is OFF, or is not at a level of the set frequency
26	OL2	Overload Warning Signal 2	ON	When output current is more than the set threshold (C111) for the overload signal
			OFF	When output current is less than the set threshold for the deviation signal
27	ODc	Analog Voltage Input Disconnect Detection	ON	When the [O] input value < b070 setting (signal loss detected)
			OFF	When no signal loss is detected
28	OIDc	Analog Current input Disconnect Detection	ON	When the [OI] input value < b071 setting (signal loss detected)
			OFF	When no signal loss is detected
31	FBV	PID Second Stage Output	ON	Transitions to ON when the inverter is in RUN Mode and the PID Process Variable (PV) is less than the Feedback Low Limit (C053)
			OFF	Transitions to OFF when the PID Process Variable (PV) exceeds the PID High Limit (C052), and transitions to OFF when the inverter goes from Run Mode to Stop Mode
32	NDc	Network Disconnect Detection	ON	When the communications watchdog timer (period specified by C077) has time out
			OFF	When the communications watchdog timer is satisfied by regular communications activity
33	LOG1	Logic Output Function 1	ON	When the Boolean operation specified by C143 has a logical "1" result
			OFF	When the Boolean operation specified by C143 has a logical "0" result
34	LOG2	Logic Output Function 2	ON	When the Boolean operation specified by C146 has a logical "1" result
			OFF	When the Boolean operation specified by C146 has a logical "0" result
35	LOG3	Logic Output Function 3	ON	When the Boolean operation specified by C149 has a logical "1" result
			OFF	When the Boolean operation specified by C149 has a logical "0" result
39	WAC	Capacitor Life Warning Signal	ON	Lifetime of internal capacitor has expired.
			OFF	Lifetime of internal capacitor has not expired.
40	WAF	Cooling Fan Warning Signal	ON	Lifetime of cooling fan has expired.
			OFF	Lifetime of cooling fan has not expired.
41	FR	Starting Contact Signal	ON	Either FW or RV command is given to the inverter
			OFF	No FW or RV command is given to the inverter, or both are given to the inverter
42	OHF	Heat Sink Overheat Warning	ON	Temperature of the heat sink exceeds a specified value (C064)
			OFF	Temperature of the heat sink does not exceed a specified value (C064)

Output Function Summary Table

Option Code	Terminal Symbol	Function Name	Description	
43	LOC	Low load detection	ON	Motor current is less than the specified value (C039)
			OFF	Motor current is not less than the specified value (C039)
44	MO1	General Output 1	ON	General output 1 is ON
			OFF	General output 1 is OFF
45	MO2	General Output 2	ON	General output 2 is ON
			OFF	General output 2 is OFF
46	MO3	General Output 3	ON	General output 3 is ON
			OFF	General output 3 is OFF
50	IRDY	Inverter Ready Signal	ON	Inverter can receive a run command
			OFF	Inverter cannot receive a run command
51	FWR	Forward Rotation	ON	Inverter is driving the motor in forward direction
			OFF	Inverter is not driving the motor in forward direction
52	RVR	Reverse Rotation	ON	Inverter is driving the motor in reverse direction
			OFF	Inverter is not driving the motor in reverse direction
53	MJA	Major Failure Signal	ON	Inverter is tripping with major failure
			OFF	Inverter is normal, or is not tripping with major failure
54	WCO	Window Comparator for Analog Voltage Input	ON	Analog voltage input value is inside of the window comparator
			OFF	Analog voltage input value is outside of the window comparator
55	WCOI	Window Comparator for Analog Current Input	ON	Analog current input value is inside of the window comparator
			OFF	Analog current input value is outside of the window comparator
58	FREF	Frequency Command Source	ON	Frequency command is given from the operator
			OFF	Frequency command is not given from the operator
59	REF	Run Command Source	ON	Run command is given from the operator
			OFF	Run command is not given from the operator
60	SETM	2 nd Motor Selection	ON	2 nd motor is being selected
			OFF	2 nd motor is not being selected
62	EDM	STO (Safe Torque Off) Performance Monitor (Output terminal 11 only)	ON	STO is being performed
			OFF	STO is not being performed
63	OPO	Option card output	ON	(output terminal for option card)
			OFF	(output terminal for option card)
255	no	Not used	ON	-
			OFF	-

Output Function Adjustment Parameters

The following parameters work in conjunction with the intelligent output function, when configured.

Low Load Detection output – The output mode parameter (C038) sets the mode of the detection at which the low load detection signal [LOC] turns ON. Two kinds of modes can be selected. The detection level parameter (C039) is to set the level of the low load.

This function is for generating an early warning logic output, without causing either a trip event or a restriction of the motor current (those effects are available on other functions).

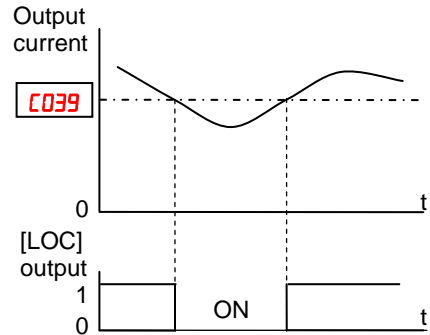

"C" Function			Run Mode Edit	Defaults	
Func. Code	Name	Description		Initial data	Units
C038	Output mode of low current detection	Two option codes: 00...During acceleration, deceleration and constant speed 01...During constant speed only	X	01	-
C039	Low current detection level	Set the level of low load detection, range is 0.0 to 1.5*inverter rated current	✓	Rated current	A

Overload Warning Output –The overload warning level parameter (C041/C241/C111) sets the motor current level at which the overload warning signal [OL/OL2] turns ON. The range of setting is from 0% to 150% of the rated current for the inverter. This function is for generating an early warning logic output, without causing either a trip event or a restriction of the motor current (those effects are available on other functions).

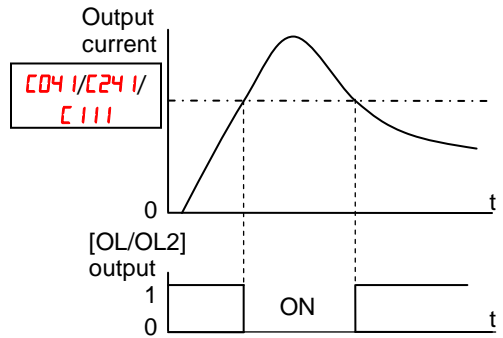

Processing cycle of overload warning signal [OL/OL2] can be selected from 40ms or 2ms by C901. Overload warning filter time constant (C902) and overload warning hysteresis (C903) are enable only when C901=01. Overload warning signal is turned off when output current is lower than “overload warning level (C041/C241/C111) – overload warning hysteresis (C903)”.

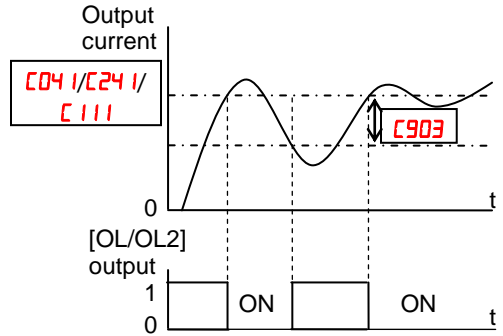

"C" Function			Run Mode Edit	Defaults	
Func. Code	Name	Description		Initial data	Units
C040	Output mode of overload warning	Two option codes: 00...During accel., decel. and constant speed 01...During constant speed only	✗	01	–
C041	Overload warning level	Sets the overload warning signal level between 0% and 200% (from 0 to two time the rated current of the inverter)	✓	Rated current x 1.15	A
C241	Overload warning level, 2 nd motor	Sets the overload warning signal level between 0% and 200% (from 0 to two time the rated current of the inverter)	✓	Rated current x 1.15	A
C111	Overload warning level 2	Sets the overload warning signal 2 level between 0% and 200% (from 0 to two time the rated current of the inverter)	✓	Rated current x 1.15	A
C901	Overload warning processing cycle select	Two option codes: 00...40ms 01...2ms	✗	00	–
C902	Overload warning filter time constant	Set the filter time constant for output current detection used for judgement of overload warning. Range is 0 to 9999 ms	✗	0	msec.
C903	Overload warning hysteresis	Set the hysteresis for overload warning signal. Range is 0 to 50% of the rated current of the inverter	✗	10.00	%

Frequency Arrival Output – The frequency arrival signals, [FA1] to [FA5], are intended to indicate when the inverter output has reached (arrived at) the target frequency. You can adjust the timing of the leading and trailing edges of the signal via two parameters specified to acceleration and deceleration ramps, **C042/C045** and **C043/C046**. Refer also to chapter 4.

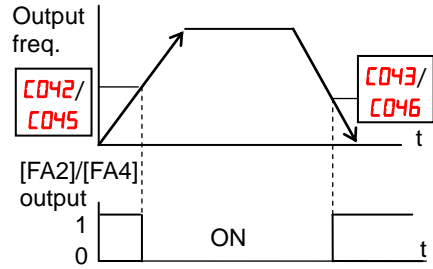

"C" Function			Run Mode Edit	Defaults	
Func. Code	Name	Description		Initial data	Units
C042	Frequency arrival setting for acceleration	Sets the frequency arrival setting threshold for [FA2]/[FA3] during acceleration, range is 0.00 to 400.00 Hz	✗	0.00	Hz
C043	Frequency arrival setting for deceleration	Sets the frequency arrival setting threshold for [FA2]/[FA3] during deceleration, range is 0.00 to 400.00 Hz	✗	0.00	Hz
C045	Frequency arrival setting 2 for acceleration	Sets the frequency arrival setting threshold for [FA4]/[FA5] during acceleration, range is 0.00 to 400.00 Hz	✗	0.00	Hz
C046	Frequency arrival setting 2 for deceleration	Sets the frequency arrival setting threshold for [FA4]/[FA5] during deceleration, range is 0.00 to 400.00 Hz	✗	0.00	Hz

PID FBV Output – The Error for the PID loop is the magnitude (absolute value) of the difference between the Set point (desired value) and Process Variable (actual value). The PID output deviation signal [OD] (output terminal function option code **04**) indicates when the error magnitude has exceeded a magnitude defined by **C044**.

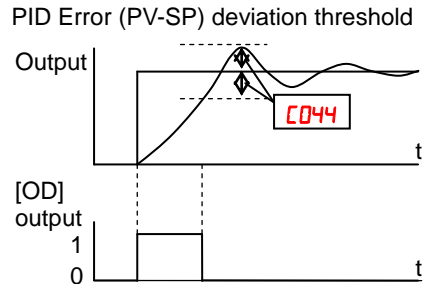

Func. Code	Name	Description		Initial data	Units
C044	PID deviation level	Sets the allowable PID loop error magnitude (absolute value), SP-PV, range is 0.0 to 100%	✗	3.0	%

Electronic Thermal Warning Output – Please refer to page 3-48 for detailed information.

"C" Function			Run Mode Edit	Defaults	
Func. Code	Name	Description		Initial data	Units
C061	Electronic thermal warning level	Set range is 0 to 100% Setting 0 means disabled.	✗	90.	%

Zero speed detection Output – The inverter outputs the 0Hz speed detection signal when the inverter output frequency falls below the threshold frequency specified in the zero speed detection level (**C063**).

To use this function, assign parameter "2 I" to one of the intelligent output terminals [11], [12] (**C021**, **C022**), or to the alarm relay output terminal (**C026**).

"C" Function			Run Mode Edit	Defaults	
Func. Code	Name	Description		Initial data	Units
C063	Zero speed detection level	Set range is 0.00 to 100.00Hz	✗	0.00	Hz

Heat Sink Overheat Warning Output – The inverter monitors the temperature of its heat sink, and outputs the heat sink overheat warning (OHF) signal when the temperature exceeds the heat sink overheat warning level specified in parameter **C064**.

"C" Function			Run Mode Edit	Defaults	
Func. Code	Name	Description		Initial data	Units
C064	Heat sink overheat warning	Set range is 0 to 110 °C	✗	100.	°C

Network Communications Settings

The following table lists parameters that configure the inverter's serial communications terminal. The settings affect how the inverter communication with a Modbus network (for networked inverter applications). The settings cannot be edited via the network, in order to ensure network reliability. Refer to Appendix B for more information on controlling any monitoring your inverter from a network.

Func. Code	"C" Function		Run Mode Edit	Defaults	
	Name	Description		Initial data	Units
C071	Communication speed	Eight option codes: 03 ...2,400 bps 04 ...4,800 bps 05 ...9,600 bps 06 ...19,200 bps 07 ...38,400 bps 08 ...57,600 bps 09 ...76,800 bps 10 ...115,200 bps	✗	05	baud
C072	Modbus address	Set the address of the inverter on the network. Range is 1 to 247	✗	1.	–
C074	Communication parity	Three option codes: 00 ...No parity 01 ...Even parity 02 ...Odd parity	✗	00	–
C075	Communication stop bit	Two option codes: 1 ...1 bit 2 ...2 bit	✗	1	bit
C076	Communication error select	Selects inverter response to communications error. Five options: 00 ...Trip 01 ...Decelerate to a stop and trip 02 ...Disable 03 ...Free run stop (coasting) 04 ...Decelerates to a stop	✗	02	–
C077	Communication error time-out	Sets the communications watchdog timer period. Range is 0.00 to 99.99 sec 0.0 = disabled	✗	0.00	sec.
C078	Communication wait time	Time the inverter waits after receiving a message before it transmits. Range is 0. to 1000. ms	✗	0.	msec.
C096	Communication selection	Three option codes; 01 ...Modbus-RTU 03 ...EzCOM 03 ...EzCOM<Administrator>	✗	00	–

Analog Input Signal Calibration Settings

The functions in the following table configure the signals for the analog input terminals. Note that these settings do not change the current/voltage or sink/source characteristics – only the zero and span (scaling) of the signals.

These parameters are already adjusted before the shipment, and therefore it is not recommended to do the adjustment at the customer.

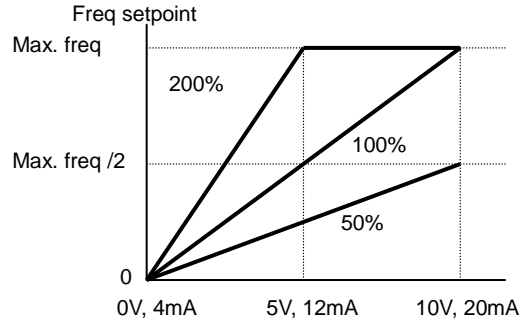

Func. Code	"C" Function		Run Mode Edit	Defaults	
	Name	Description		Initial data	Units
C081	O input span calibration	Scale factor between the external frequency command on terminals L-O (voltage input) and the frequency output, range is 0.0 to 200.0%	✓	100.0	%
C082	OI input span calibration	Scale factor between the external frequency command on terminals L-OI (voltage input) and the frequency output, range is 0.0 to 200.0%	✓	100.0	%
C085	Thermistor input (PTC) span calibration	Scale factor of PTC input. Range is 0.0 to 200.0%	✓	100.0	%



NOTE: When you restore factory default settings, the values will change to those listed above. Be sure to manually reconfigure the values for your application, if needed, after restoring factory defaults.

Miscellaneous Functions

The following table contains miscellaneous functions not in other function groups.

Func. Code	"C" Function		Run Mode Edit	Defaults	
	Name	Description		Initial data	Units
C091	Debug mode enable *	Displays debug parameters. Two option codes: 00 ...Disable 01 ...Enable <Do not set> (for factory use)	✓	00	–
C101	Up/Down memory mode selection	Controls speed setpoint for the inverter after power cycle. Two option codes: 00 ...Clear last frequency (return to default frequency F001) 01 ...Keep last frequency adjusted by UP/DWN	✗	00	–
C102	Reset selection	Determines response to Reset input [RS]. Four option codes: 00 ...Cancel trip state at input signal ON transition, stops inverter if in Run Mode 01 ...Cancel trip state at signal OFF transition, stops inverter if in Run Mode 02 ...Cancel trip state at input ON transition, no effect if in Run Mode 03 ...Clear the memories only related to trip status	✓	00	–
C103	Restart mode after reset	Determines the restart mode after reset is given, three option codes: 00 ...Start with 0 Hz 01 ...Start with freq. matching 02 ...Start with active freq. matching	✗	00	–
C104	UP/DWN clear mode	Freq. set value when UDC signal is given to the input terminal, two option codes: 00 ...0 Hz 01 ...Original setting (in the EEPROM memory at power on)	✗	00	–



CAUTION: Do not change the debug mode for safety reasons. Otherwise unexpected performances may occur.

Analog Output Calibration Related Functions

These functions are for adjustment of analog output EO and AM. The outputs are adjusted at factory before the shipment, and therefore basically no need to adjust at the customer. But in case you need to change the gain depending on your system (i.e. analog meter specification), you can use these functions for the adjustment.

"C" Function			Run Mode Edit	Defaults	
Func. Code	Name	Description		Initial data	Units
C 105	EO gain adjustment	Set range is 50 to 200%	✓	100.	%
C 106	AM gain adjustment	Set range is 50 to 200%	✓	100.	%
C 109	AM bias adjustment	Set range is 0 to 100%	✓	0.	%

Output Logic and Timing

Logic Output Function – The inverter has a built-in logic output feature. Select any two operands out of all intelligent output options except LOG1 to LOG3 and their operator out of AND, OR, or XOR (exclusive OR). The terminal symbol for the new output is [LOG]. Use **C021**, **C022** or **C026** to route the logical result to terminal [11], [12] or the relay terminals. LOG1-LOG3, no, OPO cannot be the operand.

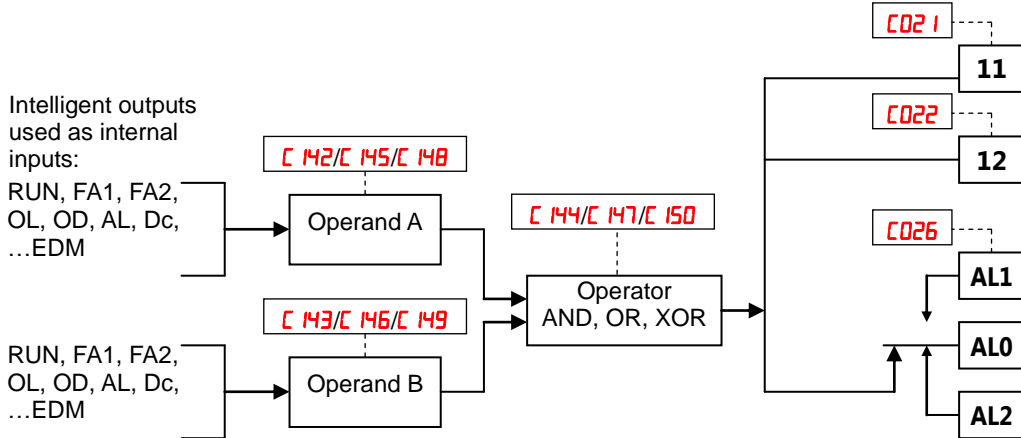

The following table shows all four possible input combinations with each of the three available logic operations.

Operand		Operator		
A	B	AND	OR	XOR
0	0	0	0	0
0	1	0	1	1
1	0	0	1	1
1	1	1	1	0

"C" Function			Run Mode Edit	Defaults	
Func. Code	Name	Description		Initial data	Units
C 142	Logic output 1 operand A	- All the programmable functions available for logic (discrete) outputs except LOG1 to LOG3, OPO, no	✘	00	-
C 143	Logic output 1 operand B			00	-
C 144	Logic output 1 operator	Applies a logic function to calculate [LOG] output state, Three options: 00 ...[LOG] = A AND B 01 ...[LOG] = A OR B 02 ...[LOG] = A XOR B	✘	00	-
C 145	Logic output 2 operand A	- All the programmable functions available for logic (discrete) outputs except LOG1 to LOG3, OPO, no	✘	00	-
C 146	Logic output 2 operand B			00	-
C 147	Logic output 2 operator	Applies a logic function to calculate [LOG] output state, Three options: 00 ...[LOG] = A AND B 01 ...[LOG] = A OR B 02 ...[LOG] = A XOR B	✘	00	-
C 148	Logic output 3 operand A	- All the programmable functions available for logic (discrete) outputs except LOG1 to LOG3, OPO, no	✘	00	-
C 149	Logic output 3 operand B			00	-
C 150	Logic output 3 operator	Applies a logic function to calculate [LOG] output state, Three options: 00 ...[LOG] = A AND B 01 ...[LOG] = A OR B 02 ...[LOG] = A XOR B	✘	00	-

Other Functions

To avoid the miss-input of the multi-speed due to the time rug, waiting time to fix the multi-speed can be set by **C 169**. When input is detected, data is fixed after the time defined with **C 169**.

“H” Group: Motor Constants Functions

The “H” Group parameters configure the inverter for the motor characteristics. You must manually set **H003** and **H004** values to match the motor. Parameter **H006** is factory-set. If you want to reset the parameters to the factory default settings, use the procedure in “[Restoring Factory Default Settings](#)” on page 6-14. Use **A044** to select the torque control algorithm as shown in the diagram.

Inverter Torque Control Algorithms

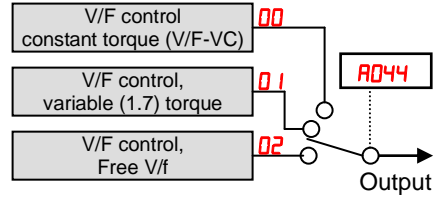

Func. Code	“H” Function		Run Mode Edit	Defaults	
	Name	Description		Initial data	Units
H003	Motor capacity	Twelve selections: 0.1/0.2/0.4/0.75/1.5/2.2/3.7/ 5.5/7.5/11/15/18.5	✗	Specified by the capacity of each inverter model	kW
H203	Motor capacity, 2 nd motor		✗		kW
H004	Motor poles setting	Twenty four selections: 2 / 4 / 6 / 8 / 10 / 12 / 14 / 16 / 18 / 20 / 22 / 24 / 26 / 28 / 30 / 32 / 34 / 36 / 38 / 40 / 42 / 44 / 46 / 48	✗	4	poles
H204	Motor poles setting, 2 nd motor		✗	4	poles
H006	Motor stabilization constant	Motor constant (factory set), range is 0 to 255	✓	100.	–
H206	Motor stabilization constant, 2 nd motor		✓	100.	–

"P" Group: Other Parameters

P group parameters are for other functionality such as option error related, EzSQ related, and communication (CompoNet, DeviceNet, EtherNet, ProfiBus, CAN Open, and CC-Link) related.

Option Card Error

You can select how the inverter reacts when an error results from a built-in option card.

"P" Function			Run Mode Edit	Defaults	
Func. Code	Name	Description		Initial data	Units
P001	Reaction when option card error occurs	Two option codes: 00 ...Inverter trips 01 ...Ignores the error (Inverter continues operation)	✘	00	-

EzSQ User Parameter and other options Related Settings

Please refer to EzSQ manual, manual of each option and appendix B for the detailed description of the function.

"P" Function			Run Mode Edit	Defaults	
Func. Code	Name	Description		Initial data	Units
P044	Communication watchdog timer (for option)	Set range is 0.00 to 99.99s	✘	1.00	Sec.
P045	Inverter action on communication error (for option)	00 ...Tripping 01 ...Tripping after decelerating and stopping the motor 02 ...Ignoring errors 03 ...Stopping the motor after free-running 04 ...Decelerating and stopping the motor	✘	00	-
P046	DeviceNet polled I/O: Output instance number	0 to 20	✘	01	-
P048	Inverter action on communication idle mode	00 ...Tripping 01 ...Tripping after decelerating and stopping the motor 02 ...Ignoring errors 03 ...Stopping the motor after free-running 04 ...Decelerating and stopping the motor	✘	00	-
P049	Motor poles setting for RPM	0/2/4/6/8/10/12/14/16/18/20/22/24/26/28/30/32/34/36/38/40/42/44/46/48	✘	0	poles
P100 to P131	EzSQ user parameter U(00) to U(31)	Each set range is 0 to 65535	✔	0.	-

Func. Code	"P" Function		Run Mode Edit	Defaults	
	Name	Description		Initial data	Units
P 140	EzCOM number of data	1 to 5	✓	5.	–
P 141	EzCOM destination 1 address	1 to 247	✓	1.	–
P 142	EzCOM destination 1 register	0000 to FFFF	✓	0000	–
P 143	EzCOM source 1 register	0000 to FFFF	✓	0000	–
P 144	EzCOM destination 2 address	1 to 247	✓	2.	–
P 145	EzCOM destination 2 register	0000 to FFFF	✓	0000	–
P 146	EzCOM source 2 register	0000 to FFFF	✓	0000	–
P 147	EzCOM destination 3 address	1 to 247	✓	3.	–
P 148	EzCOM destination 3 register	0000 to FFFF	✓	0000	–
P 149	EzCOM source 3 register	0000 to FFFF	✓	0000	–
P 150	EzCOM destination 4 address	1 to 247	✓	4.	–
P 151	EzCOM destination 4 register	0000 to FFFF	✓	0000	–
P 152	EzCOM source 4 register	0000 to FFFF	✓	0000	–
P 153	EzCOM destination 5 address	1 to 247	✓	5.	–
P 154	EzCOM destination 5 register	0000 to FFFF	✓	0000	–
P 155	EzCOM source 5 register	0000 to FFFF	✓	0000	–
P 160 to P 169	Option I/F command register to write 1 to 10	0000h to FFFFh	✓	0000	–
P 170 to P 179	Option I/F command register to read 1 to 10	0000h to FFFFh	✓	0000	–
P 180	Profibus Node address	0. to 125.	✗	0.	–
P 181	Profibus Clear Node address	00...Clear 01...Hold previous time value	✗	00	–
P 182	Profibus Map selection	00...PPO type 01...Conventional 02...Flexible Mode Format Selection	✗	00	–
P 192	DeviceNet MAC ID	0 to 63	✗	63	–

Operations and Monitoring



4

In This Chapter...	page
- Introduction	4-2
- Connecting to PLCs and Other Devices	4-4
- Control Logic Signal Specifications	4-6
- Intelligent Terminal Listing	4-10
- Using Intelligent Input Terminals	4-12
- Using Intelligent Output Terminals	4-45
- Analog Input Operation	4-77
- Analog Output Operation	4-79

Introduction

The previous material in Chapter 3 gave a reference listing of all the programmable functions of the inverter. We suggest that you first scan through the listing of inverter functions to find a general familiarity. This chapter will build on that knowledge in the following ways:

- 1. Related functions** – Some parameters interact with or depend on the settings in other functions. This chapter lists “required settings” for a programmable function to serve as a cross-reference and an aid in showing how function interacts.
- 2. Intelligent terminals** – Some functions rely on an input signal on a control logic connector terminal, or generate output signals in other cases.
- 3. Electrical interfaces** – This chapter shows how to make connections between the inverter and other electrical devices.
- 4. PID Loop Operation** – The WL200 has a built-in PID loop that calculates the optimal inverter output frequency to control an external process. This chapter shows the parameters and input/output terminals associated with PID loop operation.
- 5. Multiple motors** – A single WL200 inverter may be used with two or more motors in some types of applications. This chapter shows the electrical connections and inverter parameters involved in multiple-motor applications.

The topics in this chapter can help you decide the features that are important to your application, and how to use them. The basic installation covered in Chapter 2 concluded with the powerup test and running the motor. Now, this chapter starts from that point and shows how to make the inverter part of a larger control or automation system.

Caution Messages for Operating Procedures

Before continuing, please read the following Caution messages.



CAUTION: The heat sink fins will have a high temperature. Be careful not to touch them. Otherwise, there is the danger of getting burned.



CAUTION: The operation of the inverter can be easily changed from low speed to high speed. Be sure to check the capability and limitations of the motor and machine before operating the inverter. Otherwise, it may cause injury to personnel.



CAUTION: If you operate a motor at a frequency higher than the inverter standard default setting (50Hz/60Hz), be sure to check the motor and machine specifications with the respective manufacturer. Only operate the motor at elevated frequencies after getting their approval. Otherwise, there is the danger of equipment damage.

Warning Messages for Operating Procedures



WARNING: Be sure to turn ON the input power supply only after closing the front case. While the inverter is energized, be sure not to open the front case. Otherwise, there is the danger of electric shock.



WARNING: Be sure not to operate electrical equipment with wet hands. Otherwise, there is the danger of electric shock.



WARNING: While the inverter is energized, be sure not to touch the inverter terminals even when the motor is stopped. Otherwise, there is the danger of electric shock.



WARNING: If the retry mode is selected, the motor may suddenly restart after a trip stop. Be sure to stop the inverter before approaching the machine (be sure to design the machine so that safety for personnel is secure even if it restarts.) Otherwise, it may cause injury to personnel.



WARNING: If the power supply is cut OFF for a short period of time, the inverter may restart operating after the power supply recovers if the Run command is active. If a restart may pose danger to personnel, so be sure to use a lock-out circuit so that it will not restart after power recovery. Otherwise, it may cause injury to personnel.



WARNING: The Stop Key is effective only when the stop function is enabled. Be sure to enable the Stop Key separately from the emergency stop. Otherwise, it may cause injury to personnel.



WARNING: During a trip event, if the alarm reset is applied and the Run command is present, the inverter will automatically restart. Be sure to apply the alarm reset only after verifying the Run command is OFF. Otherwise, it may cause injury to personnel.



WARNING: Be sure not to touch the inside of the energized inverter or to put any conductive object into it. Otherwise, there is a danger of electric shock and/or fire.



WARNING: If power is turned ON when the Run command is already active, the motor will automatically start and injury may result. Before turning ON the power, confirm that the RUN command is not present.



WARNING: When the Stop key function is disabled, pressing the Stop key does not stop the inverter, nor will it reset a trip alarm.



WARNING: Be sure to provide a separate, hard-wired emergency stop switch when the application warrants it.

Connecting to PLCs and Other Devices

Hitachi inverters (drives) are useful in many types of applications. During installation, the inverter keypad (or other programming device) will facilitate the initial configuration. After installation, the inverter will generally receive its control commands through the control logic connector or serial interface from another controlling device. In a simple application such as single-conveyor speed control, a Run/Stop switch and potentiometer will give the operator all the required control. In a sophisticated application, you may have a *programmable logic controller* (PLC) as the system controller, with several connections to the inverter.

It is not possible to cover all the possible types of application in this manual. It will be necessary for you to know the electrical characteristics of the devices you want to connect to the inverter. Then, this section and the following sections on I/O terminal functions can help you quickly and safely connect those devices to the inverter.



CAUTION: There is a possibility to damage the inverter or other devices if your application exceeds the maximum current or voltage characteristics of a connection point.

The connections between the inverter and other devices rely on the electrical input/output characteristics at both ends of each connection, shown in the diagram to the right. The inverter's configurable inputs accept either a sourcing or sinking output from an external device (such as PLC). This chapter shows the inverter's internal electrical component(s) at each I/O terminal. In some cases, you will need to insert a power source in the interface wiring.

In order to avoid equipment damage and get your application running smoothly, we recommend drawing a schematic of each connection between the inverter and the other device. Include the internal components of each device in the schematic, so that it makes a complete circuit loop.

After making the schematic, then:

1. Verify that the current and voltage for each connection is within the operating limits of each device.
2. Make sure that the logic sense (active high or active low) of any ON/OFF connection is correct.
3. Check the zero and span (curve end points) for analog connections, and be sure the scale factor from input to output is correct.
4. Understand what will happen at the system level if any particular device suddenly loses power, or powers up after other devices.

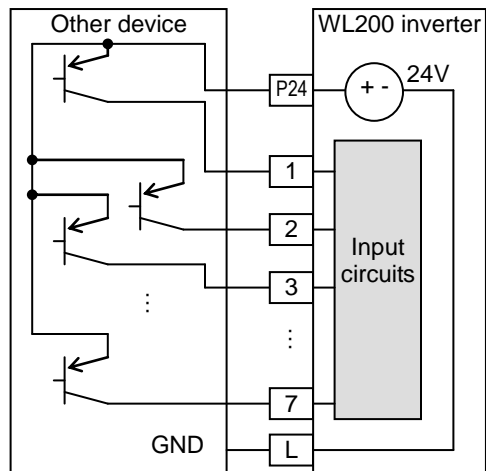
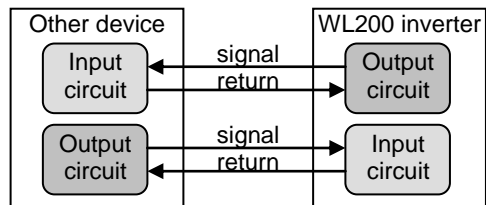

Example Wiring Diagram

The schematic diagram below provides a general example of logic connector wiring, in addition to basic power and motor wiring converted in Chapter 2. The goal of this chapter is to help you determine the proper connections for the various terminals shown below for your application needs.

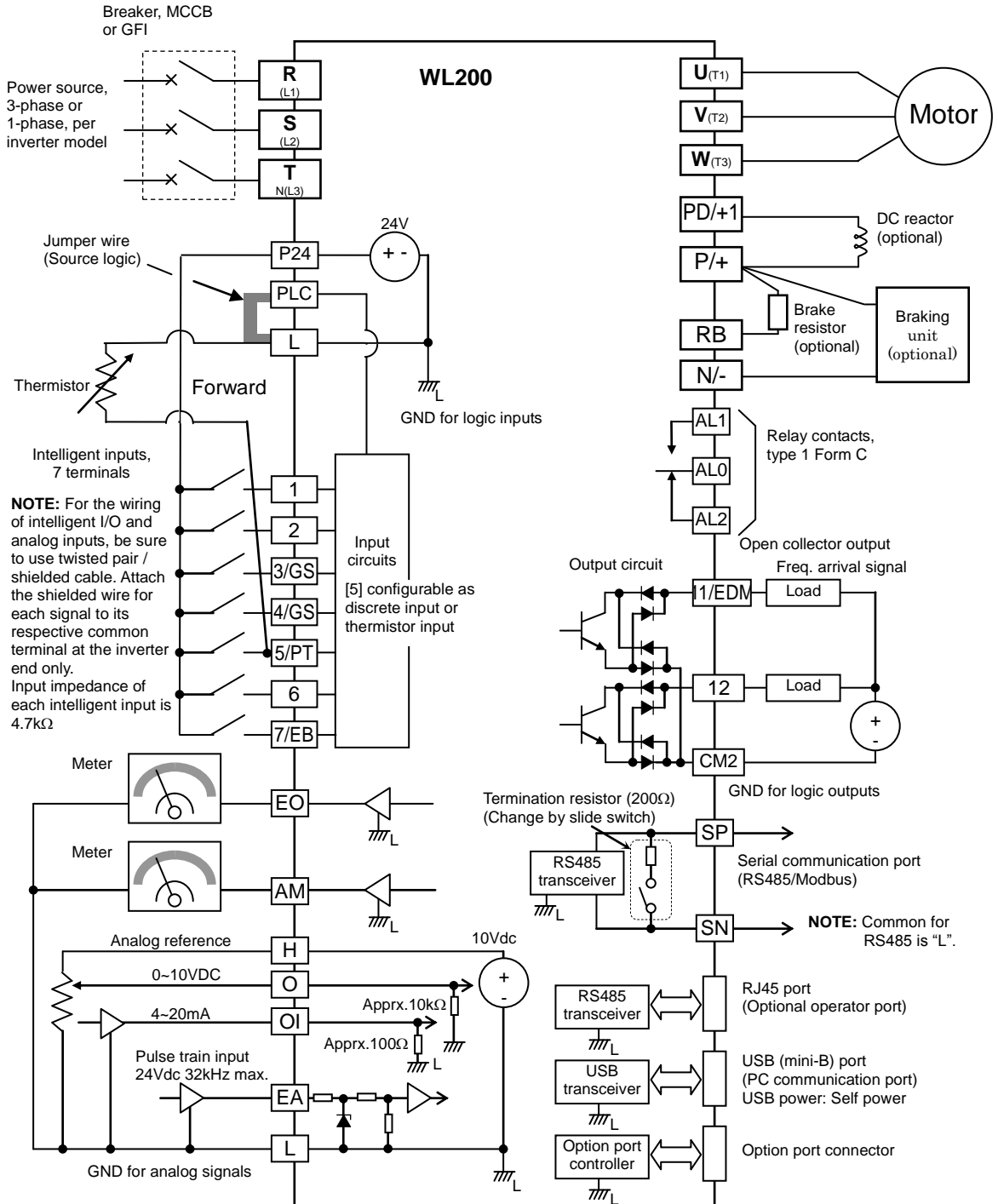

Control Logic Signal Specifications

The control logic connectors are located just behind the front housing cover. The relay contacts are just to the left of the logic connectors. Connector labeling is shown below.

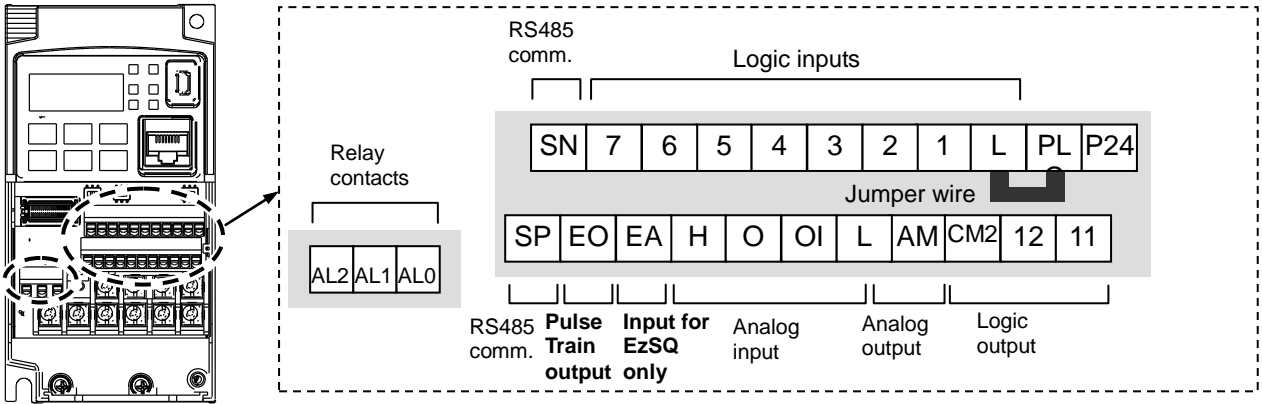

Terminal Name	Description	Ratings
P24	+24V for logic inputs	24VDC, 100mA. (do not short to terminal L)
PLC	Intelligent input common	To change to sink type, remove the jumper wire between [PLC] and [L], and connect it between [P24] and [PLC]. In this case, connecting [L] to [1] to [7] makes each input ON. Please remove the jumper wire when using external power supply.
1 2 3/GS1 4/GS2 5/PTC 6 7	Discrete logic inputs (Terminal [3],[4] and [5] have dual function. See following description and related pages for the details.)	27VDC max. (use PLC or an external supply referenced to terminal L)
GS1(3)	Safe stop input GS1	Functionality is based on ISO13849-1
GS2(4)	Safe stop input GS2	See appendix for the details.
PTC(5)	Motor thermistor input	Connect motor thermistor between PTC and L terminal to detect the motor temperature. Set 19 in C005 .
L (in upper row) *1	GND for logic inputs	Sum of input [1] to [7] currents (return)
11/EDM	Discrete logic outputs [11] (Terminal [11] has dual function. See following description and related pages for the details.)	50mA max. ON state current, 27 VDC max. OFF state voltage Common is CM2 In case the EDM is selected, the functionality is based on ISO13849-1 4VDC max. ON state voltage depression
12	Discrete logic outputs [12]	50mA max. ON state current, 27 VDC max. OFF state voltage Common is CM2
CM2	GND for logic output	100 mA: [11], [12] current return
AM	Analog voltage output	0 to 10VDC 2mA maximum
EO	Pulse train output	10VDC 2mA maximum 32kHz maximum
L (in bottom row) *2	GND for analog signals	Sum of [OI], [O], and [H] currents (return)

Terminal Name	Description	Ratings
OI	Analog current input	4 to 19.6 mA range, 20 mA nominal, input impedance 250 Ω
O	Analog voltage input	0 to 9.8 VDC range, 10 VDC nominal, input impedance 10 kΩ
H	+10V analog reference	10VDC nominal, 10mA max.
SP, SN	Serial communication terminal	For RS485 Modbus communication.
AL0	Relay common contact	250VAC, 2.5A (R load) max. 250VAC, 0.2A (I load, P.F.=0.4) max.
AL1 *3	Relay contact, normally open	100VAC, 10mA min. 30VDC, 3.0A (R load) max.
AL2 *3	Relay contact, normally closed	30VDC, 0.7A (I load, P.F.=0.4) max. 5VDC, 100mA min.

Note 1: The two terminals [L] are electrically connected together inside the inverter.

Note 2: We recommend using [L] logic GND (to the right) for logic input circuits and [L] analog GND (to the left) for analog I/O circuits.

Note 3: Default relay N.O./N.C. configuration is reversed. See page 4-54.

Wiring sample of control logic terminal (sink logic)

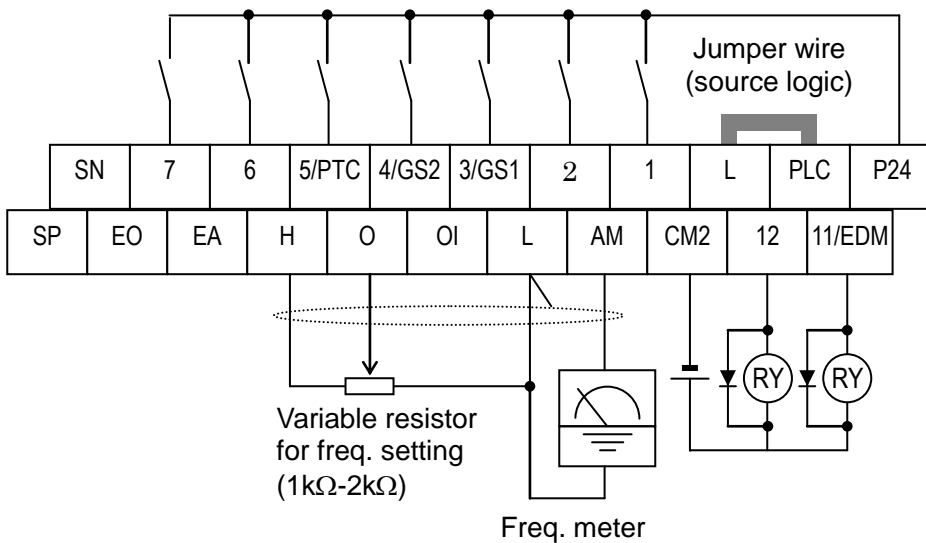

Note: If relay is connected to intelligent output, install a diode across the relay coil (reverse-biased) in order to suppress the turn-off spike.

Caution for intelligent terminals setting

In turning on power when the inputs to the intelligent terminals become the following operations, the set data might be initialized.

Please ensure not becoming the following operations, in changing the function allocation of the intelligent input terminal.

- 1) Turning on power while [Intelligent input terminal 1/2/3 are ON] and [Intelligent input terminal 4/5/6/7 are OFF].
- 2) After 1)'s condition, turning off power.
- 3) After 2)'s condition, turning on power while [Intelligent input terminal 2/3/4 are ON] and [Intelligent input terminal 1/5/6/7 are OFF].

Sink/source logic of intelligent input terminals

Sink or source logic is switched by a jumper wire as below.

Sink logic

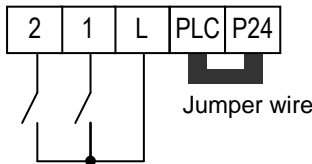

Source logic

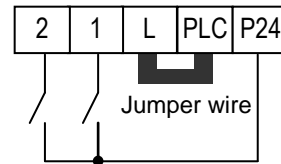

Wire size for control and relay terminals

Use wires within the specifications listed below. For safe wiring and reliability, it is recommended to use ferrules, but if solid or stranded wire is used, stripping length should be 8mm.

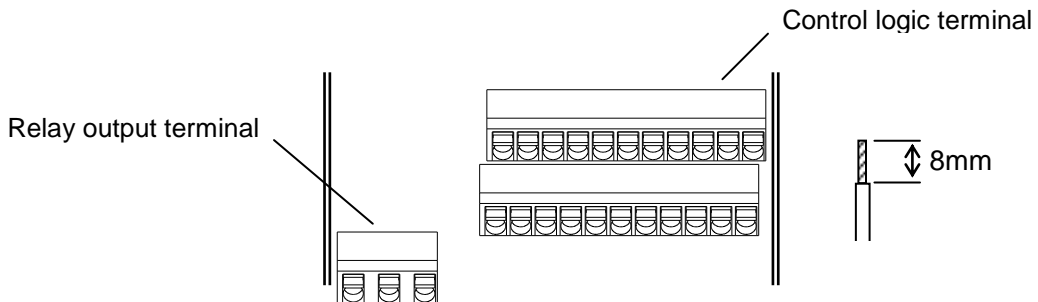

	Solid mm ² (AWG)	Stranded mm ² (AWG)	Ferrule mm ² (AWG)
Control logic terminal	0.2 to 1.5 (AWG 24 to 16)	0.2 to 1.0 (AWG 24 to 17)	0.25 to 0.75 (AWG 24 to 18)
Relay terminal	0.2 to 1.5 (AWG 24 to 16)	0.2 to 1.0 (AWG 24 to 17)	0.25 to 0.75 (AWG 24 to 18)

Recommended ferrule

For safe wiring and reliability, it is recommended to use following ferrules.

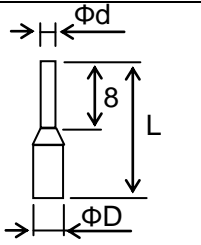
Wire size mm ² (AWG)	Model name of ferrule *	L [mm]	Φd [mm]	ΦD [mm]	
0.25 (24)	AI 0.25-8YE	12.5	0.8	2.0	
0.34 (22)	AI 0.34-8TQ	12.5	0.8	2.0	
0.5 (20)	AI 0.5-8WH	14	1.1	2.5	
0.75 (18)	AI 0.75-8GY	14	1.3	2.8	

* Supplier: Phoenix contact

Crimping pliers: CRIPMFOX UD 6-4 or CRIMPFOX ZA 3

How to connect?

- (1) Push down an orange actuating lever by a slotted screwdriver (width 2.5mm max.).
- (2) Plug in the conductor.
- (3) Pull out the screwdriver then the conductor is fixed.

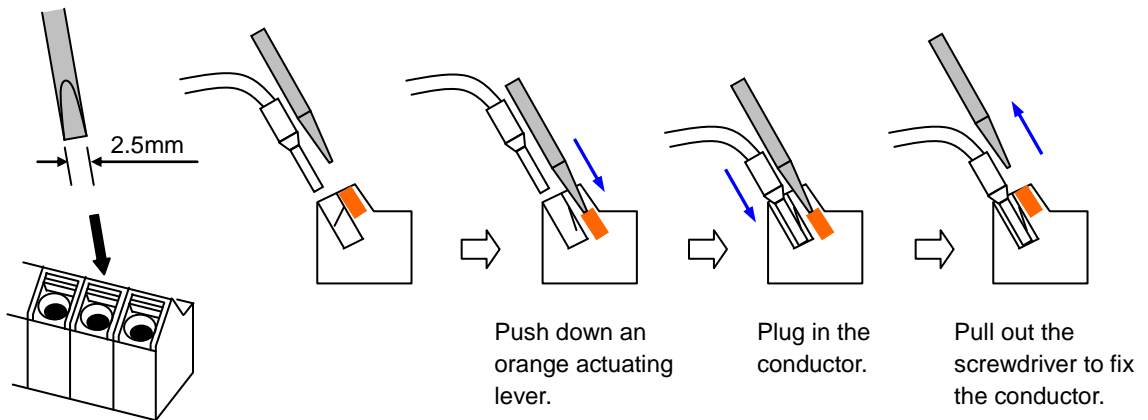

Intelligent Terminal Listing

Intelligent Inputs

Use the following table to locate pages for intelligent input material in this chapter.

Input Function Summary Table			
Symbol	Code	Function Name	Page
FW	00	Forward Run/Stop	4-16
RV	01	Reverse Run/Stop	4-16
CF1	02	Multi-speed Select, Bit 0 (LSB)	4-17
CF2	03	Multi-speed Select, Bit 1	4-17
CF3	04	Multi-speed Select, Bit 2	4-17
CF4	05	Multi-speed Select, Bit 3 (MSB)	4-17
JG	06	Jogging	4-19
DB	07	External DC braking	4-20
SET	08	Set (select) 2nd Motor Data	4-21
2CH	09	2-stage Acceleration and Deceleration	4-22
FRS	11	Free-run Stop	4-23
EXT	12	External Trip	4-24
USP	13	Unattended Start Protection	4-25
CS	14	Commercial power source switchover	4-26
SFT	15	Software Lock	4-27
AT	16	Analog Input Voltage/Current Select	4-28
RS	18	Reset Inverter	4-29
PTC	19	PTC thermistor Thermal Protection	4-30
STA	20	Start (3-wire interface)	4-31
STP	21	Stop (3-wire interface)	4-31
F/R	22	FWD, REV (3-wire interface)	4-31
PID	23	PID Disable	4-32
PIDC	24	PID Reset	4-32
UP	27	Remote Control UP Function	4-33
DWN	28	Remote Control Down Function	4-33
UDC	29	Remote Control Data Clearing	4-33
OPE	31	Operator Control	4-35
SF1 to SF7	32 to 38	Multi-speed Select, Bit operation Bit 1 to 7	4-36
OLR	39	Overload Restriction Source Changeover	4-37
BOK	44	Brake confirmation	4-37
LAC	46	LAD cancellation	4-38
ADD	50	Add frequency enable	4-39
F-TM	51	Force Terminal Mode	4-40
KHC	53	Clear watt-hour data	4-40
MI1 to MI7	56 to 62	General purpose input (1) to (7)	4-41
AHD	65	Analog command hold	4-42
GS1	77	STO1 input (Safety related signal)	4-43
GS2	78	STO2 input (Safety related signal)	4-43
485	81	Starting communication signal	B-20
PRG	82	Executing EzSQ program	4-43
HLD	83	Retain output frequency	4-43
ROK	84	Permission of Run command	4-44
DISP	86	Display limitation	4-44
NO	255	No assign	

Intelligent Outputs

Use the following table to locate pages for intelligent output material in this chapter.

Input Function Summary Table			
Symbol	Code	Function Name	Page
RUN	00	Run Signal	4-48
FA1	01	Frequency Arrival Type 1-Constant Speed	4-49
FA2	02	Frequency Arrival Type 2-Over frequency	4-49
OL	03	Overload Warning Signal	4-51
OD	04	PID Deviation error signal	4-52
AL	05	Alarm Signal	4-53
FA3	06	Frequency Arrival Type 3-Set frequency	4-49
UV	09	Under-voltage	4-55
RNT	11	Run Time Expired	4-56
ONT	12	Power ON time Expired	4-56
THM	13	Thermal Warning	4-57
BRK	19	Brake Release Signal	4-58
BER	20	Brake Error Signal	4-58
ZS	21	Zero Hz Speed Detection Signal	4-59
FA4	24	Frequency Arrival Type 4-Over frequency	4-49
FA5	25	Frequency Arrival Type 5-Set frequency	4-49
OL2	26	Overload Warning Signal 2	4-51
ODc	27	Analog Voltage Input Disconnect Detection	4-60
OIDc	28	Analog Voltage Output Disconnect Detection	4-60
FBV	31	PID Second Stage Output	4-61
NDc	32	Network Disconnect Detection	4-64
LOG1 to LOG3	33 to 35	Logic Output Function 1 to 3	4-65
WAC	39	Capacitor Life Warning Signal	4-66
WAF	40	Cooling Fan Warning Signal	4-66
FR	41	Starting Contact Signal	4-67
OHF	42	Heat Sink Overheat Warning	4-68
LOC	43	Low load detection	4-69
MO1 to MO3	44 to 46	General Output 1 to 3	4-69
IRDY	50	Inverter Ready Signal	4-70
FWR	51	Forward Operation	4-71
RVR	52	Reverse Operation	4-71
MJA	53	Major Failure Signal	4-72
WCO	54	Window Comparator for Analog Voltage Input	4-73
WCOI	55	Window Comparator for Analog Current Input	4-73
FREF	58	Frequency Command Source	4-74
REF	59	Run Command Source	4-74
SETM	60	2 nd Motor in operation	4-75
EDM	62	STO (Safe Torque Off) Performance Monitor (Output terminal 11 only)	4-76
OP	63	Option control signal	
no	255	Not used	

Using Intelligent Input Terminals

Terminals [1], [2], [3], [4], [5], [6] and [7] are identical, programmable inputs for general use. The input circuits can use the inverter's internal (isolated) +24V field supply or an external power supply. This section describes input circuits operation and how to connect them properly to switches or transistor outputs on field devices.

The WL200 inverter features selectable *sinking* or *sourcing* inputs. These terms refer to the connection to the external switching device—it either *sinks* current (from the input to GND) or *sources* current (from a power source) into the input. Note that the sink/source naming convention may be different in your particular country or industry. In any case, just follow the wiring diagrams in this section for your application.

The inverter has a jumper wire for configuring the choice of sinking or sourcing inputs. To access it, you must remove the front cover of the inverter housing. In the figure to the top right, the jumper wire is shown as attached to the logic terminal block (connector). For EU and version (suffix -xFE), it is originally located as source type logic. If you need to change to the sink type connection, remove the jumper wire and connect it as shown in the figure at the bottom right.

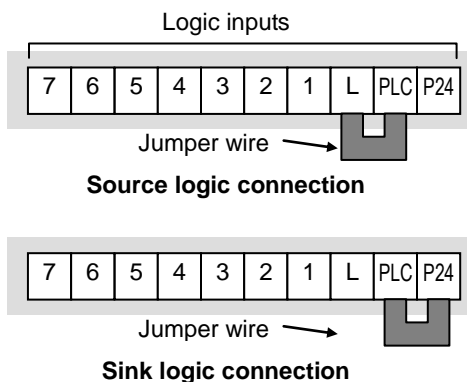

CAUTION: Be sure to turn OFF power to the inverter before changing the jumper wire position. Otherwise, damage to the inverter circuitry may occur.

[PLC] Terminal Wiring – The [PLC] terminal (Programmable Logic Control terminal) is named to include various devices that can connect to the inverter's logic inputs. In the figure to the right, note the [PLC] terminal and the jumper wire. Locating the jumper wire between [PLC] and [L] sets the input logic source type, which is the default setting for EU and US versions. In this case, you connect input terminal to [P24] to make it active. If instead you locate the jumper wire between [PLC] and [P24], the input logic will be sink type. In this case, you connect the input terminal to [L] to make it active.

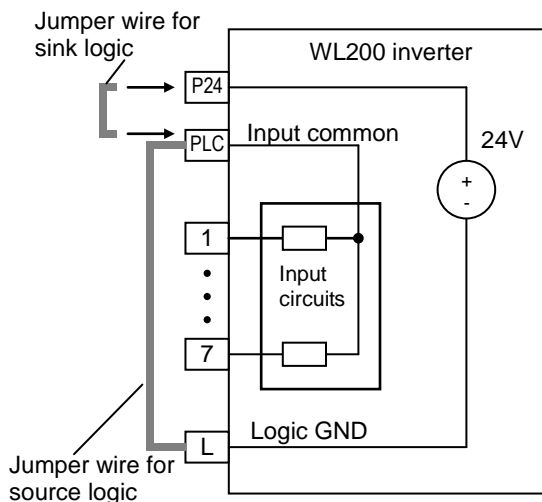

The wiring diagram on the following pages show the four combinations of using sourcing or sinking inputs, and using the internal or an external DC supply.

The two diagrams below input wiring circuits using the inverter's internal +24V supply. Each diagram shows the connection for simple switches, or for a field device with transistor outputs. Note that in the lower diagram, it is necessary to connect terminal [L] only when using the field device with transistors. Be sure to use the correct connection of the jumper wire shown for each wiring diagram.

Sinking Inputs, Internal Supply

Jumper wire = [PLC] – [P24] position

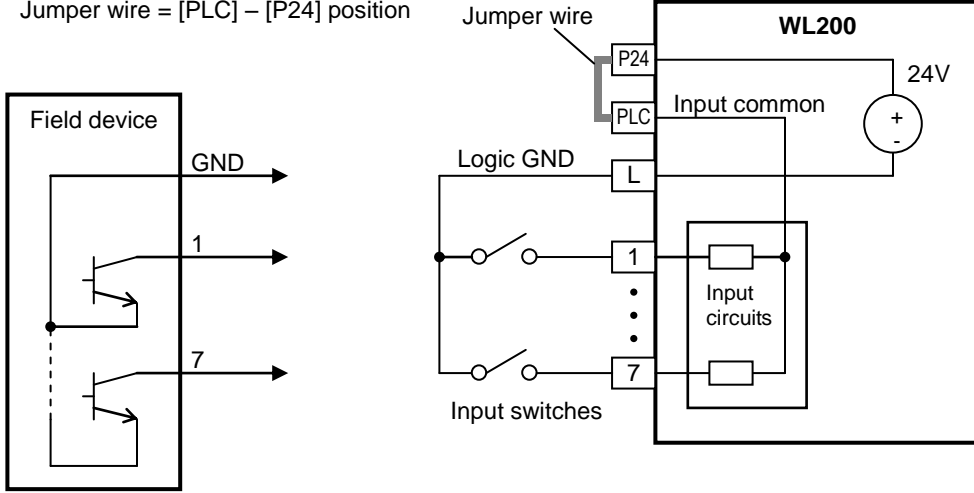

Open collector outputs,
NPN transistors

Sourcing Inputs, Internal Supply

Jumper wire = [PLC] – [L] position

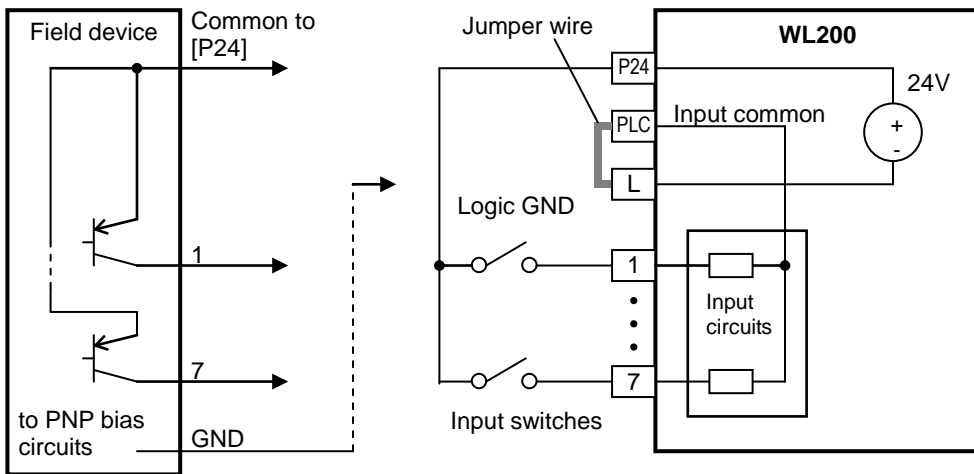

PNP transistor
sourcing outputs

The two diagrams below show input wiring circuits using an external supply. If using the "Sinking Inputs, External Supply" in below wiring diagram, be sure to remove the jumper wire, and use a diode (*) with the external supply. This will prevent a power supply contention in case the jumper wire is accidentally placed in the incorrect position. For the "Sourcing Inputs, External Supply", please connect the jumper wire as drawn in the diagram below.

Sinking Inputs, External Supply

Jumper wire = Removed

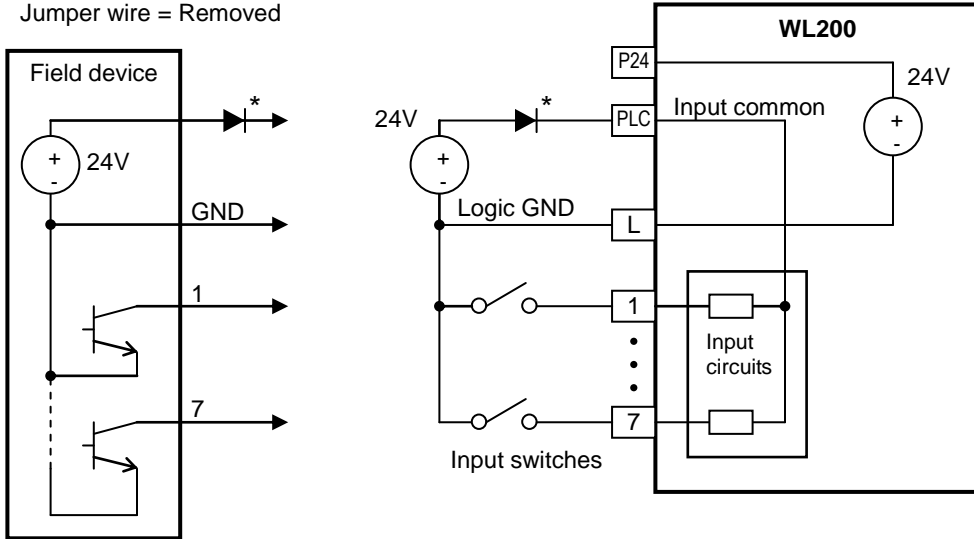

Open collector outputs,
NPN transistors

* Note: If the external power supply to GND is (optionally) connected to [L], then install the above diode.

Sourcing Inputs, External Supply

Jumper wire = Removed

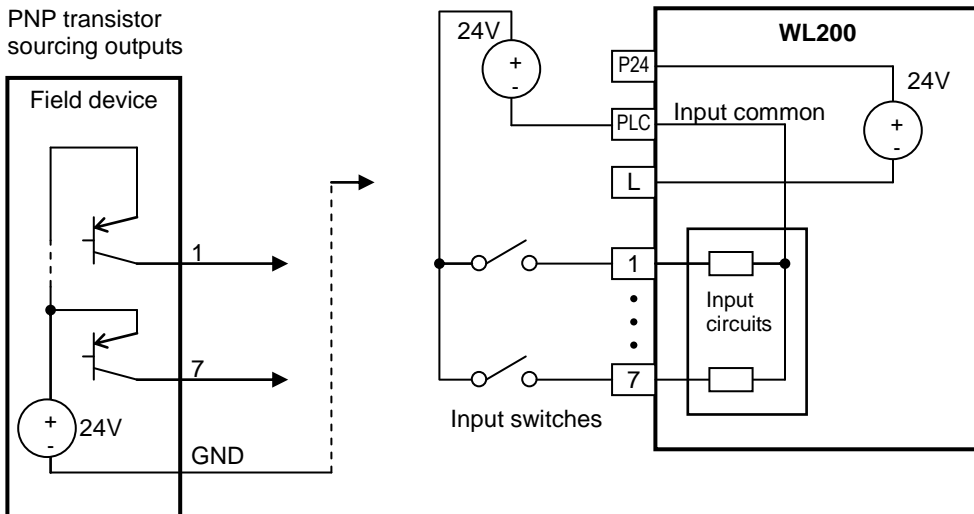

PNP transistor
sourcing outputs

The inverter control section can be powered externally with 24 Vdc as shown below. This will allow you to read and write parameters using the keypad or via communication (such as Modbus/RTU or with optional fieldbus communication cards).

NOTE: You CANNOT use the ProDriveNext programming software when powering the inverter in this way! It will also not be possible to drive a motor.

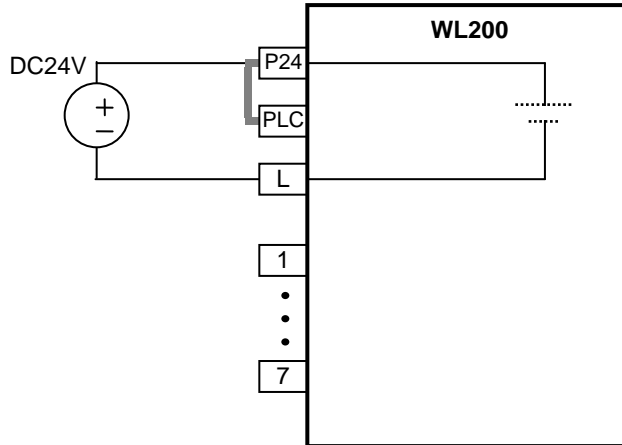

By having ability inverter doesn't block the current flowing into itself when it is not powered. This may cause the closed circuit when two or more inverters are connected to common I/O wiring as shown below to result in unexpected turning the on the input. To avoid this closed circuit, please put the diode (rated:50V/0.1A) in the path as described below.

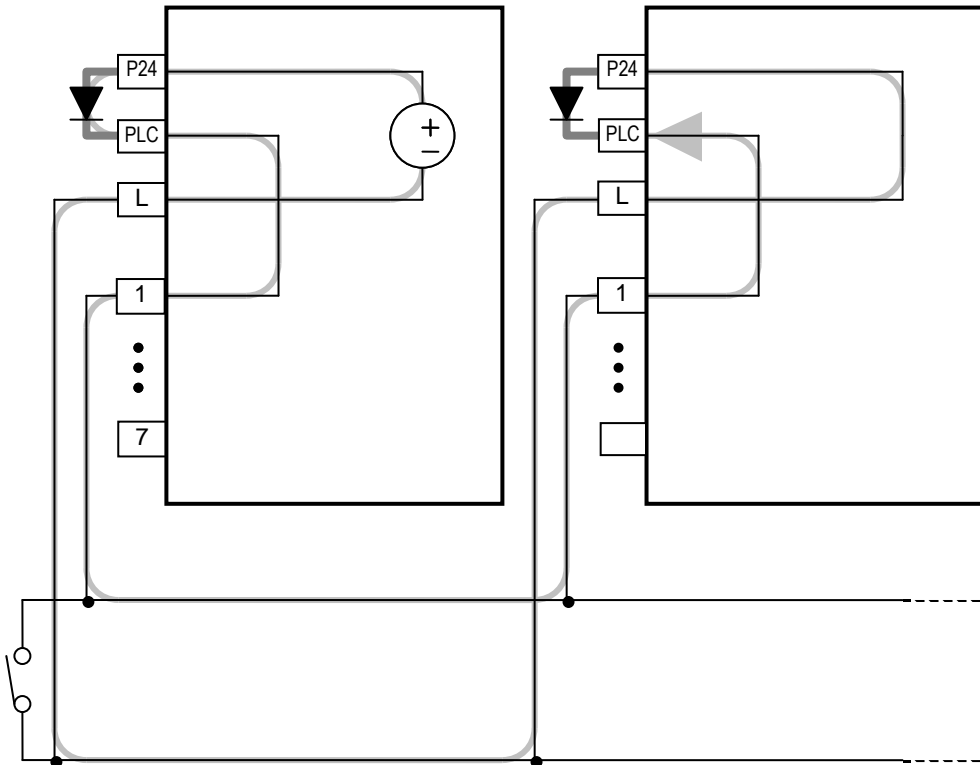

Forward Run/Stop and Reverse Run/Stop Commands:

When you input the Run command via the terminal [FW], the inverter executes the Forward Run command (high) or Stop command (low). When you input the Run command via the terminal [RV], the inverter executes the Reverse Run command (high) or Stop command (low).

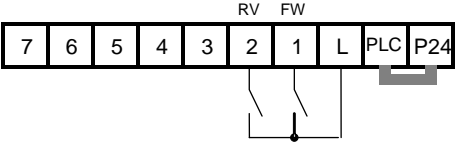
Option Code	Terminal Symbol	Function Name	State	Description
00	FW	Forward Run/Stop	ON	Inverter is in Run Mode, motor runs forward
			OFF	Inverter is in Stop Mode, motor stops
01	RV	Reverse Run/Stop	ON	Inverter is in Run Mode, motor runs reverse
			OFF	Inverter is in Stop Mode, motor stops
Valid for inputs		C001 to C007		Example (default input configuration shown—see page 3-79):
Required settings		A002 = 01		
Notes: <ul style="list-style-type: none"> When the Forward Run and Reverse Run commands are active at the same time, the inverter enters the Stop Mode. When a terminal associated with either [FW] or [RV] function is configured for <i>normally closed</i>, the motor starts rotation when that terminal is disconnected or otherwise has no input voltage. 				
				 <p>See I/O specs on page 4-6.</p>



NOTE: The parameter **F004**, Keypad Run Key Routing, determines whether the single Run key issues a Run FWD command or Run REV command. However, it has no effect on the [FW] and [RV] input terminal operation.



WARNING: If the power is turned ON and the Run command is already active, the motor starts rotation and is dangerous! Before turning power ON, confirm that the Run command is not active.

Multi-Speed Select ~ Binary Operation

The inverter can store up to 16 different target frequencies (speeds) that the motor output uses for steady-state run condition. These speeds are accessible through programming four of the intelligent terminals as binary-encoded inputs [CF1] to [CF4] per the table to the right. These can be any of the six inputs, and in any order. You can use fewer inputs if you need eight or fewer speeds.

Multi-speed	Input Function			
	CF4	CF3	CF2	CF1
Speed 0	0	0	0	0
Speed 1	0	0	0	1
Speed 2	0	0	1	0
Speed 3	0	0	1	1
Speed 4	0	1	0	0
Speed 5	0	1	0	1
Speed 6	0	1	1	0
Speed 7	0	1	1	1
Speed 8	1	0	0	0
Speed 9	1	0	0	1
Speed 10	1	0	1	0
Speed 11	1	0	1	1
Speed 12	1	1	0	0
Speed 13	1	1	0	1
Speed 14	1	1	1	0
Speed 15	1	1	1	1



NOTE: When choosing a subset of speeds to use, always start at the top of the table, and with the least-significant bit: [CF1], [CF2], etc.

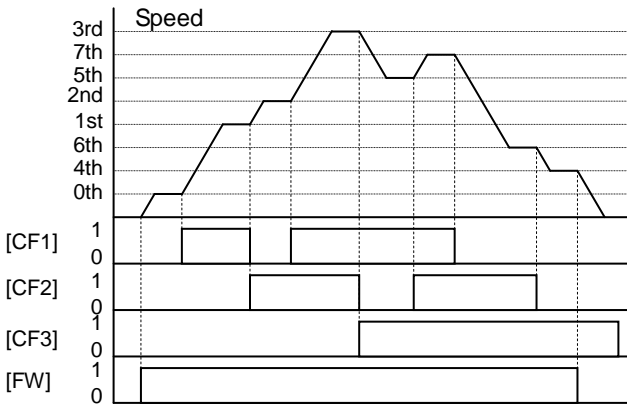

The example with eight speeds in the figure below shows how input switches configured for [CF1]–[CF3] functions can change the motor speed in real time.

NOTE: Speed 0 depends on **AO01** parameter value.

Option Code	Terminal Symbol	Function Name	State	Description
02	CF1	Multi-speed Select, Bit 0 (LSB)	ON	Binary encoded speed select, Bit 0, logical 1
			OFF	Binary encoded speed select, Bit 0, logical 0
03	CF2	Multi-speed Select, Bit 1	ON	Binary encoded speed select, Bit 1, logical 1
			OFF	Binary encoded speed select, Bit 1, logical 0
04	CF3	Multi-speed Select, Bit 2	ON	Binary encoded speed select, Bit 2, logical 1
			OFF	Binary encoded speed select, Bit 2, logical 0
05	CF4	Multi-speed Select, Bit 3 (MSB)	ON	Binary encoded speed select, Bit 3, logical 1
			OFF	Binary encoded speed select, Bit 3, logical 0
Valid for inputs		C001 to C007		Example (some CF inputs require input configuration; some are default inputs):
Required settings		F001, AO01=02, AO20 to AO35		
Notes: <ul style="list-style-type: none"> When programming the multi-speed settings, be sure to press the SET key each time and then set the next multi-speed setting. Note that when the key is not pressed, no data will be set. When a multi-speed setting more than 50Hz (60Hz) is to be set, it is necessary to program the maximum frequency AO04 high enough to allow that speed 				

See I/O specs on page 4-6.

While using the multi-speed capability, you can monitor the present frequency with monitor function **d00 I** during each segment of a multi-speed operation.



NOTE: When using the Multi-speed Select settings [CF1] to [CF4], do not display parameter **F00 I** or change the value of **F00 I** while the inverter is in Run Mode (motor running). If it is necessary to check the value of **F00 I** during Run Mode, please monitor **d00 I** instead of **F00 I**.

There are two ways to program the speeds into the registers **A020** to **A035**:

1. Standard keypad programming:
 - a. Select each parameter **A020** to **A035**.
 - b. Press the **SET** key to view the parameter value.
 - c. Use the **△** and **▽** keys to edit the value.
 - d. Use the **SET** key to save the data to memory.
2. Programming using the CF switches. Set the speed by following these steps:
 - a. Turn the Run command OFF (Stop Mode).
 - b. Turn inputs ON to select desired Multi-speed. Display the value of **F00 I** on the digital operator.
 - c. Set the desired output frequency by pressing the **△** and **▽** keys.
 - d. Press the **SET** key once to store the set frequency. When this occurs, **F00 I** indicates the output frequency of Multi-speed n.
 - e. Press the **SET** key once to confirm that the indication is the same as the set frequency.
 - f. Repeat operations in 2. a) to 2. e) to set the frequency of other Multi-speeds. It can be set also by parameters **A020** to **A035** in the first procedure 1. a) to 1. d).

Jogging Command

The Jog input [JG] is used to command the motor to rotate slowly in small increments for manual operation. The speed is limited to 9.99 Hz. The frequency for the jogging operation is set by parameter **A038**. Jogging does not use an acceleration ramp, so we recommend setting the jogging frequency **A038** to 5 Hz or less to prevent tripping.

When the terminal [JG] is turned ON and the Run command is issued, the inverter outputs the programmed jog frequency to the motor. To enable the Run key on the digital operator for jog input, set the value 01 (terminal mode) in **A002** (Run command source).

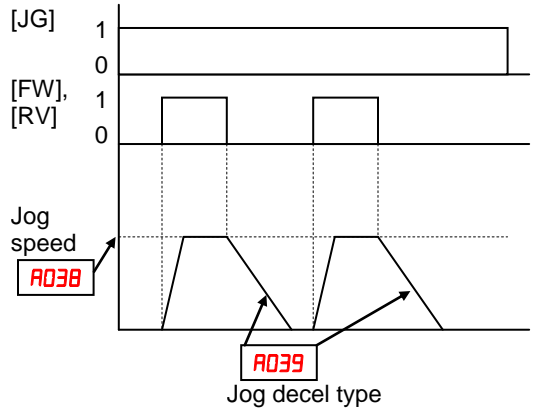

The type of deceleration used to end a motor jog operation is selectable by programming function **A039**. The options are:

- **00** valid during operation, Free-run stop (coasting)
- **01** valid during operation, Deceleration (normal level) and stop
- **02** valid during operation, Use DC braking and stop
- **03** invalid during operation, Free-run stop (coasting)
- **04** invalid during operation, Deceleration (normal level) and stop
- **05** invalid during operation, Use DC braking and stop

Option Code	Terminal Symbol	Function Name	State	Description
06	JG	Jogging	ON	Inverter is in Run Mode, output to motor runs at jog parameter frequency
			OFF	Inverter is in Stop Mode
Valid for inputs			C001 to C007	
Required settings			A002=01, A038>b082, A038>0, A039	
<p>Notes:</p> <ul style="list-style-type: none"> • No jogging operation is performed when the set value of jogging frequency A038 is smaller than the start frequency b082, or the value is 0Hz. • Be sure to stop the motor when switching the function [JG] ON or OFF. 				
<p>Example (default input configuration shown—see page 3-79):</p> <p>See I/O specs on page 4-6.</p>				

External Signal for DC Braking

When the terminal [DB] is turned ON, the DC braking feature is enabled. Set the following parameters when the external DC braking terminal [DB] is to be used:

- **A053** – DC braking delay time setting. The range is 0.1 to 5.0 seconds.
- **A054** – DC braking force setting. The range is 0 to 100%.

The scenarios to the right help show how DC braking works in various situations.

1. Scenario 1 – The [FW] or [RV] terminal is ON. When [DB] is ON, DC braking is applied. When [DB] is OFF again, the output frequency ramps to the prior level.
2. Scenario 2 – The Run command is applied from the operator keypad. When the [DB] terminal is ON, DC braking is applied. When the [DB] terminal is OFF again, the inverter output remains OFF.
3. Scenario 3 – The Run command is applied from the operator keypad. When the [DB] terminal is ON, DC braking is applied after the delay time set by **A053** expires. The motor is in a free-running (coasting) condition. When the [DB] terminal is OFF again, the inverter output remains OFF.

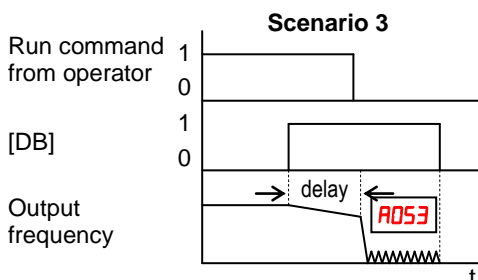
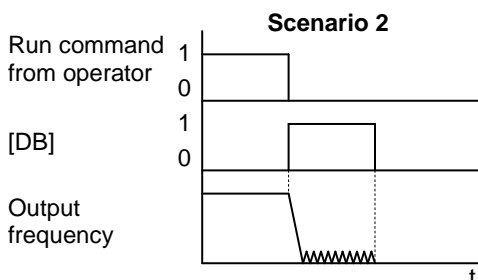
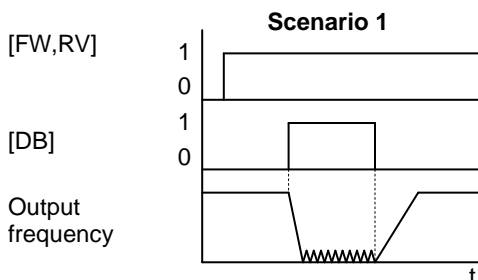

Option Code	Terminal Symbol	Function Name	State	Description
07	DB	External DC Braking	ON	Applies DC injection braking during deceleration
			OFF	Does not apply DC injection braking during deceleration
Valid for inputs		C001 to C007		Example (requires input configuration—see page 3-79):
Required settings		A053, A054		
Notes:				
<ul style="list-style-type: none"> • Do not use the [DB] input continuously or for a long time when the DC braking force setting A054 is high (depends on the motor application). • Do not use the [DB] feature for continuous or high duty cycle as a holding brake. The [DB] input is designed to improve stopping performance. Use a mechanical brake for holding a stop position. 				<p>The diagram shows a terminal block with terminals 7, 6, 5, 4, 3, 2, 1, L, PLC, and P24. Terminal 2 is labeled 'DB' and is connected to terminal 1. Terminal 1 is connected to terminal L. Terminal L is connected to terminal PLC. Terminal PLC is connected to terminal P24.</p>
				See I/O specs on page 4-6.

Set Second Motor

If you assign the [SET] function to an intelligent input terminal, you can select between two sets of motor parameters. The second parameters store an alternate set of motor characteristics. When the terminal [SET] is turned ON, the inverter will use the second set of parameters to generate the frequency output to the motor. When changing the state of the [SET] input terminal, the change will not take effect until the inverter is stopped.

When you turn ON the [SET] input, the inverter operates per the second set of parameters. When the terminal is turned OFF, the output function returns to the original settings (first set of motor parameters). Refer to “[2nd Motor Selection](#)” on page 4-75 for details.

Parameters	SET		Parameters	SET	
	Stop	Run		Stop	Run
F002/F202			R08 I/A28 I	✓	-
F003/F203	✓	-	R082/A282	✓	-
R00 I/A20 I	✓	-	R092/A292	✓	-
R002/A202	✓	-	R093/A293	✓	-
R003/A203	✓	-	R094/A294	✓	-
R004/A204	✓	-	R095/A295	✓	-
R020/A220	✓	-	R096/A296	✓	-
R04 I/A24 I	✓	-	b0 12/b2 12	✓	-
R042/A242	✓	-	b0 13/b2 13	✓	-
R043/A243	✓	-	b02 1/b22 1	✓	-
R044/A244	✓	-	b022/b222	✓	-
R045/A245	✓	-	b023/b223	✓	-
R046/A246	✓	-	C04 I/C24 I	✓	-
R047/A247	✓	-	H003/H203	✓	-
R06 I/A26 I	✓	-	H004/H204	✓	-
R062/A262	✓	-	H006/H206	✓	-

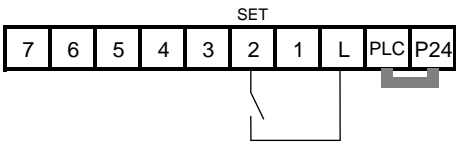
Option Code	Terminal Symbol	Function Name	State	Description
08	SET	Set (select) 2nd Motor data	ON	causes the inverter to use the 2nd set of motor parameters for generating the frequency output to motor
			OFF	causes the inverter to use the 1st (main) set of motor parameters for generating the frequency output to motor
Valid for inputs		C00 I to C007		Example (requires input configuration—see page 3-79): 
Required settings		(none)		
Notes:				
<ul style="list-style-type: none"> If the terminal state is changed while the inverter is running, the inverter continues using the current set of parameters until the inverter is stopped. 				See I/O specs on page 4-6.

Two Stage Acceleration and Deceleration

When terminal [2CH] is turned ON, the inverter changes the rate of acceleration and deceleration from the initial settings (**F002** and **F003**) to use the second set of acceleration/ deceleration values. When the terminal is turned OFF, the inverter is returned to the original acceleration and deceleration time (**F002** acceleration time 1, and **F003** deceleration time 1). Use **A092** (acceleration time 2) and **A093** (deceleration time 2) to set the second stage acceleration and deceleration times.

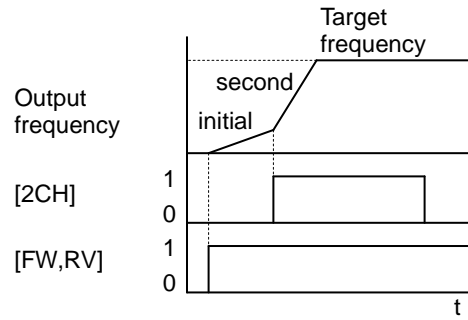

In the graph shown above, the [2CH] becomes active during the initial acceleration. This causes the inverter to switch from using acceleration 1 (**F002**) to acceleration 2 (**A092**).

Option Code	Terminal Symbol	Function Name	State	Description
09	2CH	Two-stage Acceleration and Deceleration	ON	Frequency output uses 2nd-stage acceleration and deceleration values
			OFF	Frequency output uses the initial acceleration 1 and deceleration 1 values
Valid for inputs		C001 to C007		Example (requires input configuration—see page 3-79):
Required settings		A092, A093, A094=00		
Notes: <ul style="list-style-type: none"> Function A094 selects the method for second stage acceleration. It must be set = 00 to select the input terminal method in order for the [2CH] terminal assignment to operate. 				
<div style="text-align: center;"> <p>Terminal block diagram for 2CH. The block has terminals 7, 6, 5, 4, 3, 2, 1, L, PLC, and P24. A switch is connected to terminal 5. Terminal 1 is labeled 'L', 'PLC', and 'P24'.</p> </div> <p>See I/O specs on page 4-6.</p>				

Free-run Stop

When the terminal [FRS] is turned ON, the inverter stops the output and the motor enters the free-run state (coasting). If terminal [FRS] is turned OFF, the output resumes sending power to the motor if the Run command is still active. The free-run stop feature works with other parameters to provide flexibility in stopping and starting motor rotation.

In the figure below, parameter **b088** selects whether the inverter resumes operation from 0 Hz (left graph) or the current motor rotation speed (right graph) when the [FRS] terminal turns OFF. The application determines the best setting.

Parameter **b003** specifies a delay time before resuming operation from a free-run stop. To disable this feature, use a zero delay time.

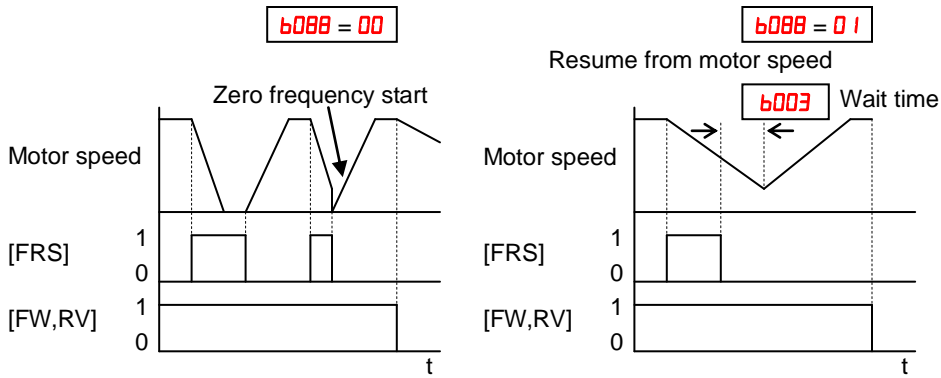

Option Code	Terminal Symbol	Function Name	State	Description
11	FRS	Free-run Stop	ON	Causes output to turn OFF, allowing motor to free run (coast) to stop
			OFF	Output operates normally, so controlled deceleration and stops motor
Valid for inputs		c001 to c007		Example (requires input configuration—see page 3-79): <div style="text-align: center;"> </div>
Required settings		b003, b088, c011 to c017		
Notes: <ul style="list-style-type: none"> When you want the [FRS] terminal to be active low (normally closed logic), change the setting (c011 to c017) that corresponds to the input (c001 to c007) that is assigned the [FRS] function. 				
				See I/O specs on page 4-6.

External Trip

When the terminal [EXT] is turned ON, the inverter enters the trip state, indicates error code **E 12**, and stops the output. This is a general purpose interrupt type feature, and the meaning of the error depends on what you connect to the [EXT] terminal. Even if the [EXT] input is turned OFF, the inverter remains in the trip state. You must reset the inverter or cycle power to clear the error, returning the inverter to the Stop Mode.

In the graph below, the [EXT] input turns ON during normal Run Mode operation. The inverter lets the motor free-run to a stop, and the alarm output turns ON immediately. When the operator initiates a Reset command, the alarm and error are cleared. When the Reset is turned OFF, the motor begins rotation since the Run command is already active.

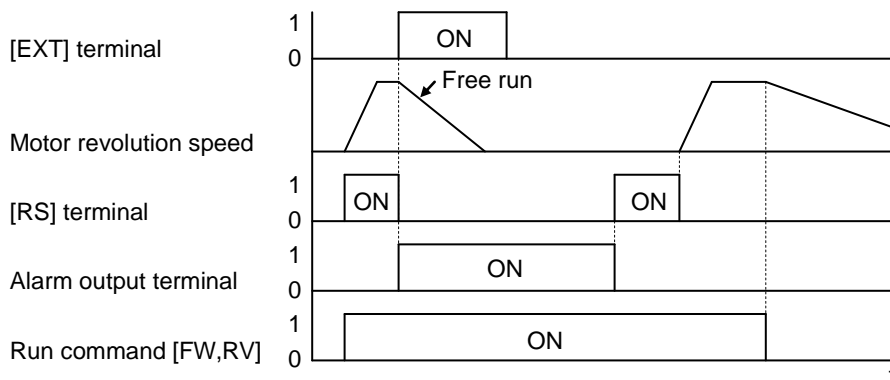

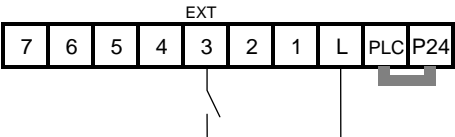
Option Code	Terminal Symbol	Function Name	State	Description
E 12	EXT	External Trip	ON	When assigned input transitions OFF to ON, inverter latches trip event and displays E 12
			OFF	No trip event for ON to OFF, any recorded trip events remain in history until Reset.
Valid for inputs		C001 to C007	Example (default input configuration shown—see page 3-79): 	
Required settings		(none)		
Notes:		<ul style="list-style-type: none"> If the USP (Unattended Start Protection) feature is in use, the inverter will not automatically restart after canceling the EXT trip event. In that case, it must receive either another Run command (OFF-to- ON transition), a keypad Reset command, or an [RS] intelligent terminal input signal. 		
				See I/O specs on page 4-6.

Unattended Start Protection

If the Run command is already set when power is turned ON, the inverter starts running immediately after powerup. The Unattended Start Protection (USP) function prevents that automatic startup, so that the inverter *will not* run without outside intervention. When [USP] is active and you need to reset an alarm and resume running, either turn the Run command OFF, or perform a reset operation by the terminal [RS] input or the keypad Stop/reset key.

In the figure below, the [USP] feature is enabled. When the inverter power turns ON, the motor does not start, even though the Run command is already active. Instead, it enters the USP trip state, and displays **E 13** error code. This requires outside intervention to reset the alarm by turning OFF the Run command per this example (or applying a reset). Then the Run command can turn ON again and start the inverter output.

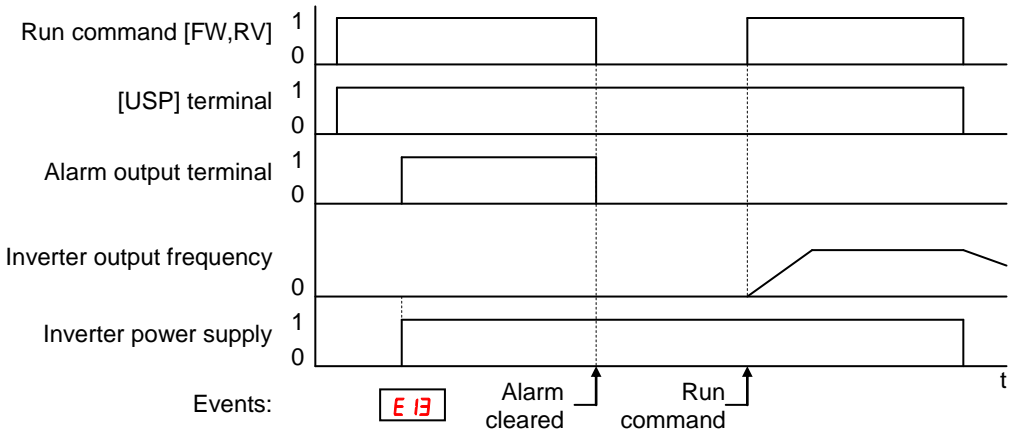

Option Code	Terminal Symbol	Function Name	State	Description
E 13	USP	Unattended Start Protection	ON	On powerup, the inverter will not resume a Run command (mostly used in the US)
			OFF	On powerup, the inverter will resume a Run command that was active before power loss
Valid for inputs		E 001 to E 007		Example (requires input configuration—see page 3-79):
Required settings		(none)		
Notes:				<p>See I/O specs on page 4-6.</p>
<ul style="list-style-type: none"> Note that when a USP error occurs and it is canceled by a reset from a [RS] terminal input, the inverter restarts running immediately. Even when the trip state is canceled by turning the terminal [RS] ON and OFF after an under voltage protection E 09 occurs, the USP function will be performed. When the running command is active immediately after the power is turned ON, a USP error will occur. When this function is used, wait for at least three (3) seconds after the powerup to generate a Run command. 				

Commercial power source switchover

The commercial power source switching function allows you to switch the power supply (between the inverter and commercial power supply) to your system of which the load causes a considerable moment of inertia. You can use the inverter to accelerate and decelerate the motor in the system and the commercial power supply to drive the motor for constant speed operation.

To use this function, assign parameter "14 (CS)" to one of the intelligent input terminal [1] to [7] (C001 to C007). When the [CS] is turned OFF with an operation command is being given, the inverter waits for the retry wait time before motor starts (b003), adjusts the output frequency to the speed of the free-running motor, and then accelerates the motor with the adjusted frequency.

Mechanically interlock the MC3 and MC2 contacts with each other. Otherwise you may damage the drive.

If the earth leakage breaker (ELB) trips because of a ground fault, the commercial power will be disabled. Therefore, contact a backup power supply from the commercial power line circuit (ELBC) to your system if needed.

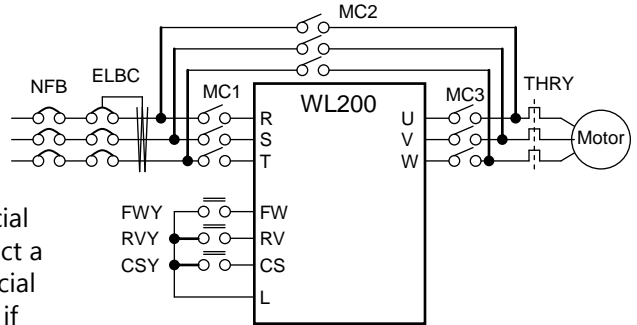

Use weak-current type relays for FWY, RVY, and CSY. The figures below show the sequence and timing of operations for reference.

Switching from inverter to commercial power

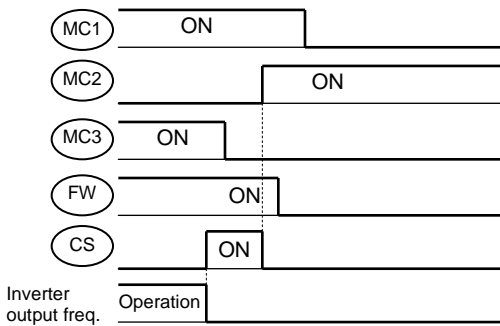

Switching from commercial power to inverter

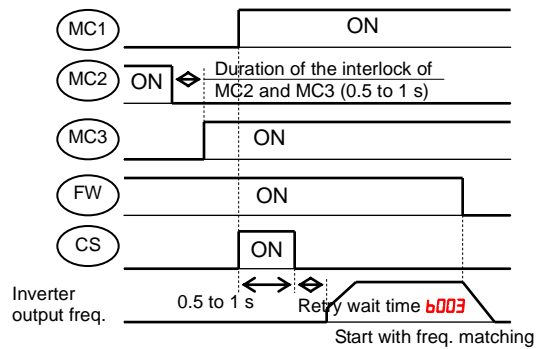

If the inverter trips because of overcurrent when it starts the motor with frequency matching, increase the retry wait time before motor starts (b003).

Option Code	Terminal Symbol	Function Name	State	Description
14	CS	Commercial power source switchover	ON OFF	
Valid for inputs		C001 to C007		
Required settings		b003, b007		
Notes:				
inverter may start the motor with 0 Hz if:				
<ul style="list-style-type: none"> the motor speed is no more than half of the base frequency, or the voltage induced on the motor is attenuated quickly. 				

Software Lock

When the terminal [SFT] is turned ON, the data of all the parameters and functions (except the output frequency, depending on the setting of **b03 l**) is locked (prohibited from editing). When the data is locked, the keypad keys cannot edit inverter parameters. To edit parameters again, turn OFF the [SFT] terminal input.

Use parameter **b03 l** to select whether the output frequency is excluded from the lock state or is locked as well.

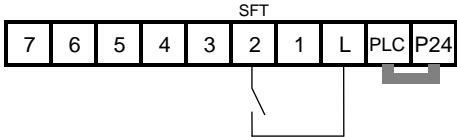
Option Code	Terminal Symbol	Function Name	State	Description
IS	SFT	Software Lock	ON	The keypad and remote programming devices are prevented from changing parameters
			OFF	The parameters may be edited and stored
Valid for inputs		C00 l to C007		Example (requires input configuration—see page 3-79):
Required settings		b03 l (excluded from lock)		
Notes:				 <p>See I/O specs on page 4-6.</p>
<ul style="list-style-type: none"> When the [SFT] terminal is turned ON, only the output frequency can be changed. Software lock can include the output frequency by setting b03 l. Software lock by the operator is also possible without the [SFT] terminal being used (b03 l). 				

Analog Input Current/Voltage Select

The [AT] terminal selects whether the inverter uses the voltage [O] or current [OI] input terminals for external frequency control. When intelligent input [AT] is ON, you can set the output frequency by applying a current input signal at [OI]-[L]. When the [AT] input is OFF, you can apply a voltage input signal at [O]-[L] to set the output frequency. Note that you must also set parameter **A001 = 01** to enable the analog terminal set for controlling the inverter frequency.

Option Code	Terminal Symbol	Function Name	State	Description																		
16	AT	Analog Input Voltage/Current Select	ON	See the table down below																		
			OFF																			
Valid for inputs		C001 to C007		Example (requires input configuration—see page 3-79):																		
Required settings		A001 = 01																				
<p>Notes:</p> <ul style="list-style-type: none"> If the [AT] option is not assigned to any intelligent input terminal, then inverter recognizes [AT] = OFF in following table. <p>Combination of A005 setting and [AT] input for analog input activation.</p> <table border="1"> <thead> <tr> <th>A005</th> <th>[AT] Input</th> <th>Analog Input Configuration</th> </tr> </thead> <tbody> <tr> <td rowspan="2">00</td> <td>ON</td> <td>[OI]</td> </tr> <tr> <td>OFF</td> <td>[O]</td> </tr> <tr> <td rowspan="2">02</td> <td>ON</td> <td>Keypad Pot</td> </tr> <tr> <td>OFF</td> <td>[O]</td> </tr> <tr> <td rowspan="2">03</td> <td>ON</td> <td>Keypad Pot</td> </tr> <tr> <td>OFF</td> <td>[OI]</td> </tr> </tbody> </table> <ul style="list-style-type: none"> Be sure to set the frequency source setting A001=01 to select the analog input terminals. 					A005	[AT] Input	Analog Input Configuration	00	ON	[OI]	OFF	[O]	02	ON	Keypad Pot	OFF	[O]	03	ON	Keypad Pot	OFF	[OI]
A005	[AT] Input	Analog Input Configuration																				
00	ON	[OI]																				
	OFF	[O]																				
02	ON	Keypad Pot																				
	OFF	[O]																				
03	ON	Keypad Pot																				
	OFF	[OI]																				
<p>See I/O specs on page 4-6.</p>																						

Reset Inverter

The [RS] terminal causes the inverter to execute the reset operation. If the inverter is in Trip Mode, the reset cancels the Trip state. When the signal [RS] is turned ON and OFF, the inverter executes the reset operation. The minimum pulse width for [RS] must be 12 ms or greater. The alarm output will be cleared within 30 ms after the onset of the Reset command.

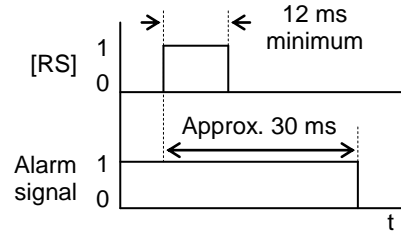

WARNING: After the Reset command is given and the alarm reset occurs, the motor will restart suddenly if the Run command is already active. Be sure to set the alarm reset after verifying that the Run command is OFF to prevent injury to personnel.

Option Code	Terminal Symbol	Function Name	State	Description
1B	RS	Reset Inverter	ON	The motor output is turned OFF, the Trip Mode is cleared (if it exists), and powerup reset is applied
			OFF	Normal power ON operation
Valid for inputs		C001 to C007		Example (default input configuration shown—see page 3-79):
Required settings		(none)		
<p>Notes:</p> <ul style="list-style-type: none"> While the control terminal [RS] input is ON, the keypad displays alternating segments. After RS turns OFF, the display recovers automatically. Pressing the Stop/Reset key of the digital operator can generate a reset operation only when an alarm occurs. 				
<p>See I/O specs on page 4-6.</p> <p>The diagram shows a terminal block with terminals labeled 7, 6, 5, 4, 3, 2, 1, L, PLC, and P24. A switch is connected to terminal 4. Terminal 1 is connected to terminal L. The label 'RS' is positioned above terminals 4 and 3.</p>				
<ul style="list-style-type: none"> A terminal configured with the [RS] function can only be configured for normally open operation. The terminal cannot be used in the normally closed contact state. When input power is turned ON, the inverter performs the same reset operation as it does when a pulse on the [RS] terminal occurs. The Stop/Reset key on the inverter is only operational for a few seconds after inverter powerup when a hand-held remote operator is connected to the inverter. If the [RS] terminal is turned ON while the motor is running, the motor will be free running (coasting). If you are using the output terminal OFF delay feature (any of C145, C147, C149 > 0.0 sec.), the [RS] terminal affects the ON-to-OFF transition slightly. Normally (without using OFF delays), the [RS] input causes the motor output and the logic outputs to turn OFF together, immediately. However, when any output uses an OFF delay, then after the [RS] input turns ON, that output will remain ON for an additional 1 sec. period (approximate) before turning OFF. 				

Thermistor Thermal Protection

Motors that are equipped with a thermistor can be protected from overheating. Input terminal [5] has the unique ability to sense a thermistor resistance. When the resistance value of the thermistor connected to terminal [PTC] (5) and [L] is more than $3\text{ k}\Omega \pm 10\%$, the inverter enters the Trip Mode, turns OFF the output to the motor, and indicates the trip status **E35**. Use this function to protect the motor from overheating.

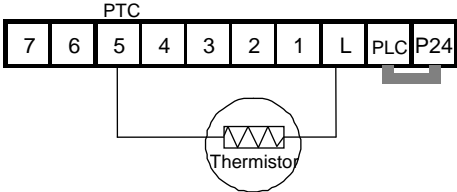
Option Code	Terminal Symbol	Function Name	State	Description
19	PTC	Thermistor Thermal Protection	ON	When a thermistor is connected to terminals [5] and [L], the inverter checks for over-temperature and will cause trip (E35) and turn OFF the output to the motor
			OFF	An open circuit in the thermistor causes a trip, and the inverter turns OFF the output
Valid for inputs		E005 only		Example (requires input configuration—see page 3-79): 
Required settings		(none)		
Notes:				
<ul style="list-style-type: none"> Be sure the thermistor is connected to terminals [5] and [L]. If the resistance is above the threshold the inverter will trip. When the motor cools down enough, the thermistor resistance will change enough to permit you to clear the error. Press the STOP/Reset key to clear the error. 				

Three-wire Interface Operation

The 3-wire interface is an industry standard motor control interface. This function uses two inputs for momentary contact start/stop control, and a third for selecting forward or reverse direction. To implement the 3-wire interface, assign **20** [STA] (Start), **21** [STP] (Stop), and **22** [F/R] (Forward/Reverse) to three of the intelligent input terminals. Use a momentary contact for Start and Stop. Use a selector switch, such as SPST for the Forward/Reverse input. Be sure to set the operation command selection **A002=01** for input terminal control of motor.

If you have a motor control interface that needs logic-level control (rather than momentary pulse control), use the [FW] and [RV] inputs instead.

Option Code	Terminal Symbol	Function Name	State	Description
20	STA	Start Motor	ON	Start motor rotation on momentary contact (uses acceleration profile)
			OFF	No change to motor operation
21	STP	Stop Motor	ON	No change to motor operation
			OFF	Stop motor rotation on momentary contact (use deceleration profile)
22	F/R	Forward/Reverse	ON	Select reverse direction of rotation
			OFF	Select forward direction of rotation
Valid for inputs		C001 to C007		Example (requires input configuration—see page 3-79):
Required settings		A002 = 01		
<p>Notes:</p> <ul style="list-style-type: none"> The STP logic is inverted. Normally the switch will be closed, so you open the switch to stop. In this way, a broken wire causes the motor to stop automatically (safe design). When you configure the inverter for 3-wire interface control, the dedicated [FW] terminal is automatically disabled. The [RV] intelligent terminal assignment is also disabled. 				
				<p>See I/O specs on page 4-6.</p>

The diagram below shows the use of 3-wire control. STA (Start Motor) is an edge-sensitive input; an OFF-to-ON transition gives the Start command. The control of direction is level-sensitive, and the direction may be changed at any time. STP (Stop Motor) is also a level-sensitive input.

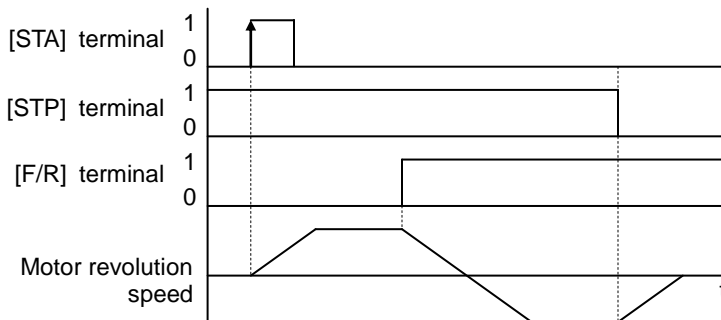

PID ON/OFF and PID Clear

The PID loop function is useful for controlling motor speed to achieve constant flow, pressure, temperature, etc. in many process applications. The PID Disable function temporarily suspends PID loop execution via an intelligent input terminal. It overrides the parameter **A07 I** (PID Enable) to stop PID execution and return to normal motor frequency output characteristics. The use of PID Disable on an intelligent input terminal is optional. Of course, any use of the PID loop control requires setting PID Enable function **A07 I=0 I**.

The PID Clear function forces the PID loop integrator sum = 0. So, when you turn ON an intelligent input configured as [PIDC], the integrator sum is reset to zero. This is useful when switching from manual control to PID loop control and the motor is stopped.

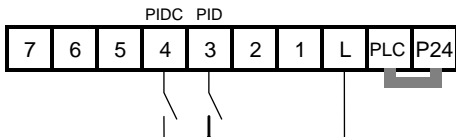

CAUTION: Be careful not to turn PID Clear ON and reset the integrator sum when the inverter is in Run Mode (output to motor is ON). Otherwise, this could cause the motor to decelerate rapidly, resulting in a trip.

Option Code	Terminal Symbol	Function Name	State	Description
23	PID	PID Disable	ON	Disables PID loop execution
			OFF	Allows PID loop execution
24	PIDC	PID Clear	ON	Force the value of the integrator to zero
			OFF	No change in PID loop execution
Valid for inputs		C00 I to C007		Example (requires input configuration—see page 3-79): 
Required settings		A07 I		
Notes: <ul style="list-style-type: none"> • The use of [PID] and [PIDC] terminals are optional. Use A07 I=0 I if you want PID loop control enabled all the time. • Do not enable/disable PID control while the motor is running (inverter is in Run Mode). • Do not turn ON the [PIDC] input while the motor is running (inverter is in Run Mode). 				
				See I/O specs on page 4-6.

Remote Control Up and Down Functions

The [UP] [DWN] terminal functions can adjust the output frequency for remote control while the motor is running. The acceleration time and deceleration time of this function is same as normal operation ACC1 and DEC1 (2ACC1,2DEC1). The input terminals operate according to these principles:

- Acceleration - When the [UP] contact is turned ON, the output frequency accelerates from the current value. When it is turned OFF, the output frequency maintains its current value at that moment.
- Deceleration - When the [DWN] contact is turned ON, the output frequency decelerates from the current value. When it is turned OFF, the output frequency maintains its current value at that moment.

In the graph below, the [UP] and [DWN] terminals activate while the Run command remains ON. The output frequency responds to the [UP] and [DWN] commands.

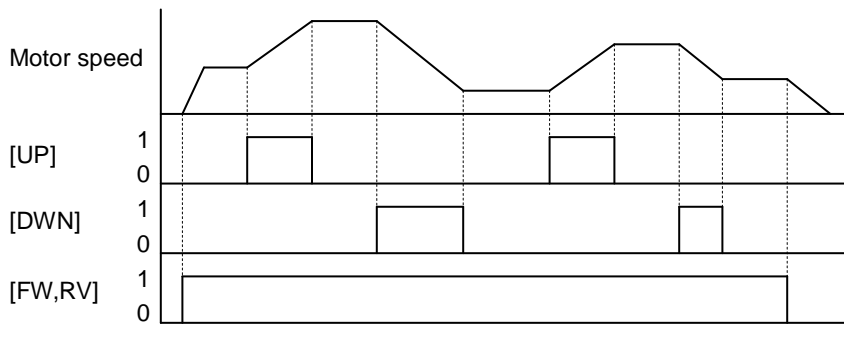

It is possible for the inverter to retain the frequency set from the [UP] and [DWN] terminals through a power loss. Parameter **C101** enables/disables the memory. If disabled, the inverter retains the last frequency before an UP/DWN adjustment. Use the [UDC] terminal to clear the memory and return to the original set output frequency.

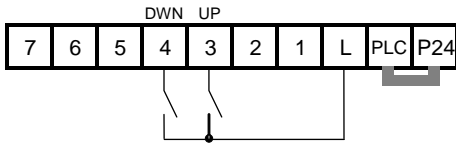
Option Code	Terminal Symbol	Function Name	State	Description
27	UP	Remote Control UP Function (motorized speed pot.)	ON	Accelerates (increases output frequency) motor from current frequency
			OFF	Output to motor operates normally
28	DWN	Remote Control DOWN Function (motorized speed pot.)	ON	Decelerates (increases output frequency) motor from current frequency
			OFF	Output to motor operates normally
29	UDC	Remote Control Data Clear	ON	Clears the Up/Down frequency memory
			OFF	No effect on Up/Down memory
Valid for inputs		C001 to C007		Example (requires input configuration—see page 3-79): 
Required settings		A001 = 02		
Notes: <ul style="list-style-type: none"> • This feature is available only when the frequency command source is programmed for operator control. Confirm A001 is set to 02. • This function is not available when [JG] is in use. • The range of output frequency is 0 Hz to the value in A004 (maximum frequency setting). • This setting modifies the inverter speed from using F001 output frequency setting as a starting point. 				
				See I/O specs on page 4-6.

Force Operation from Digital Operator

This function permits a digital operator interface to override the following two settings in the inverter:

- **ADD 1** - Frequency source
- **ADD 2** - Run command source

When using the [OPE] terminal input, typically **ADD 1** and **ADD 2** are configured for sources other than the digital operator interface for the output frequency and Run command sources, respectively. When the [OPE] input is ON, then user has immediate command of the inverter, to start or stop the motor and to set the speed.

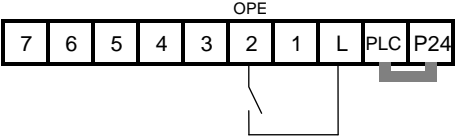
Option Code	Terminal Symbol	Function Name	State	Description
31	OPE	Force Operation from Digital Operator	ON	Forces the operator interface to override: ADD 1 - Frequency Source Setting, and ADD 2 - Run Command Source Setting
			OFF	Parameters ADD 1 and ADD 2 are in effect again, for the frequency source and the Run command source, respectively
Valid for inputs		C001 to C007		Example (requires input configuration—see page 3-79): 
Required settings		ADD 1 (set not equal to 00) ADD 2 (set not equal to 02)		
Notes: <ul style="list-style-type: none"> • When changing the [OPE] state during Run Mode (inverter is driving the motor), the inverter will stop the motor before the new [OPE] state takes effect. • If the [OPE] input turns ON and the digital operator gives a Run command while the inverter is already running, the inverter stops the motor. Then the digital operator can control the motor. 				

See I/O specs on page 4-6.

Multi-Speed Select ~Bit Operation

The inverter can store up to 16 different target frequencies (speeds) that the motor output uses for steady-state run condition. These speeds are accessible through programming seven of the intelligent terminals as bit-encoded inputs [SF1] to [SF7] per the table to the right. These can be any of the seven inputs, and in any order. You can use fewer inputs if you need eight or fewer speeds.

Multi-speed	Input Function						
	SF7	SF6	SF5	SF4	SF3	SF2	SF1
Speed 0	A020	0	0	0	0	0	0
Speed 1	A021	X	X	X	X	X	1
Speed 2	A022	X	X	X	X	1	0
Speed 3	A023	X	X	X	1	0	0
Speed 4	A024	X	X	X	1	0	0
Speed 5	A025	X	X	1	0	0	0
Speed 6	A026	X	1	0	0	0	0
Speed 7	A027	1	0	0	0	0	0

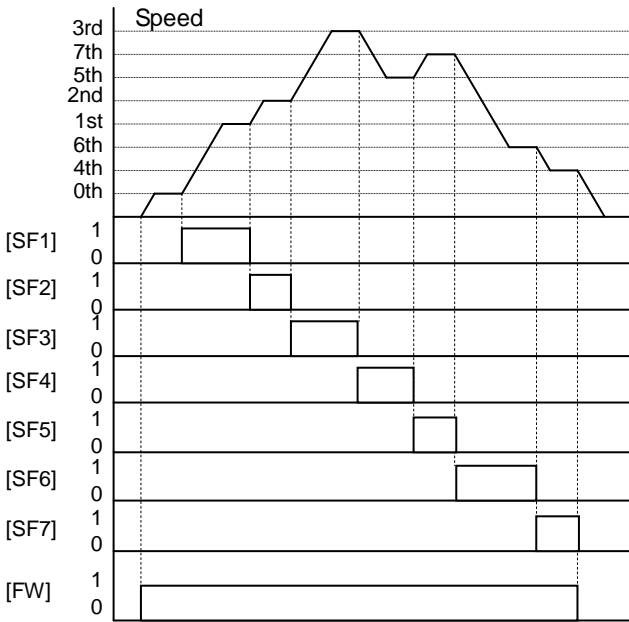

The example with eight speeds in the figure below shows how input switches configured for [SF1]–[SF7] functions can change the motor speed in real time.

NOTE: Speed 0 depends on **A001** parameter value.

Option Code	Terminal Symbol	Function Name	State	Description
32 to 38	SF1 to SF7	Multistage Speed ~Bit Operation	ON OFF	Makes multistage speed by combination of the inputs.
Valid for inputs	C001 to C007		Example (requires input configuration—see page 3-79):	
Required settings	F001 , A001=02 , A020 to A035			
Notes:				
<ul style="list-style-type: none"> When programming the multi-speed settings, be sure to press the SET key each time and then set the next multi-speed setting. Note that when the key is not pressed, no data will be set. When a multi-speed setting more than 50Hz (60Hz) is to be set, it is necessary to program the maximum frequency A004 high enough to allow that speed 				
<div style="text-align: center;"> </div> <p>See I/O specs on page 4-6.</p>				

Overload Restriction Source Changeover

This function allows you to change the parameter sets of overload restriction. Please refer to "Current limitation Related Functions" on page 3-52 for details.

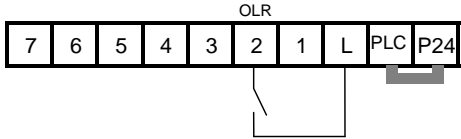
Option Code	Terminal Symbol	Function Name	State	Description
39	OLR	Overload restriction source changeover	ON	Parameter sets b024, b025, b026 are enabled.
			OFF	Parameter sets b021, b022, b023 are enabled.
Valid for inputs		C001 to C007		Example (requires input configuration—see page 3-79): 
Required settings		b021 to b026		
Notes:				
				See I/O specs on page 4-6.

Brake Confirmation

This function is for brake performance. Please refer to "Brake Control Function Related" on page 3-73 for details.

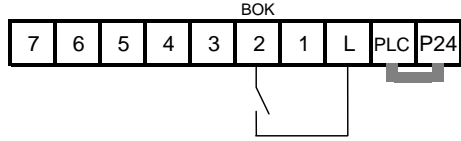
Option Code	Terminal Symbol	Function Name	State	Description
44	BOK	Brake confirmation	ON	Brake confirmation signal is being given
			OFF	Brake confirmation signal is not given
Valid for inputs		C001 to C007		Example (requires input configuration—see page 3-79): 
Required settings		b120 to b127, C021 to C022		
Notes:				
				See I/O specs on page 4-6.

LAD Cancellation

This function is for canceling the set ramp time and changes the output speed immediately according to the set speed. Please refer to page 3-10 for details.

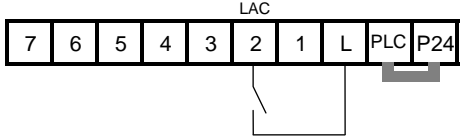
Option Code	Terminal Symbol	Function Name	State	Description
46	LAC	LAD cancellation	ON	Disabling the set ramp time and inverter output immediately follows the speed command.
			OFF	Accelerates and decelerates according to the set ramp time
Valid for inputs		C001 to C007		Example (requires input configuration—see page 3-79): 
Required settings				
Notes:				
				See I/O specs on page 4-6.

Add Frequency Enable

The inverter can add or subtract an offset value to the output frequency setting which is specified by **A001** (will work with any of the five possible sources). The ADD Frequency is a value you can store in parameter **A145**. The ADD Frequency is summed with or subtracted from the output frequency setting only when the [ADD] terminal is ON. Function **A146** selects whether to add or subtract. By configuring an intelligent input as the [ADD] terminal, your application can selectively apply the fixed value in **A145** to offset (positively or negatively) the inverter output frequency in real time.

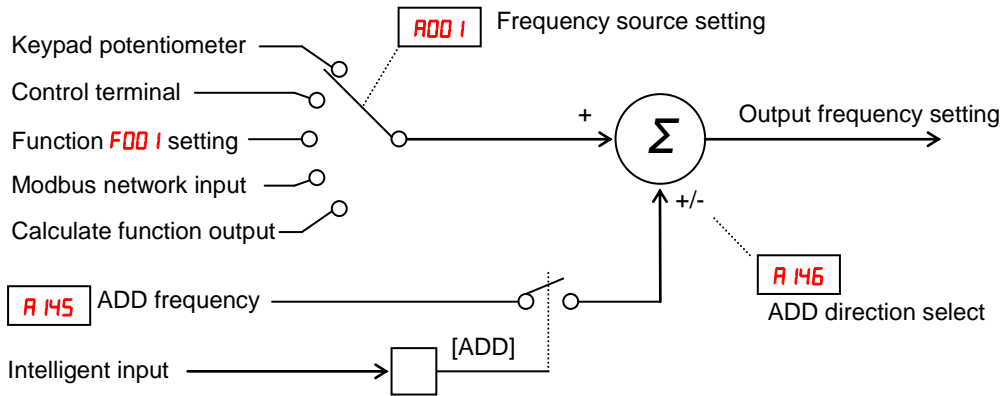

Option Code	Terminal Symbol	Function Name	State	Description
50	ADD	ADD Frequency Enable	ON	Applies the A145 Add Frequency value to the output frequency
			OFF	Does not apply the Add frequency. The output frequency retains its normal value
Valid for inputs		C001 to C007		Example (requires input configuration—see page 3-79):
Required settings		A001, A145, A146		
Notes: <ul style="list-style-type: none"> A001 may specify any source; the Add Frequency will be added to or subtracted from that value to yield output frequency value. 				
				See I/O specs on page 4-6.

Force Terminal Mode

The purpose of this intelligent input is to allow a device to force the inverter to allow control of the following two parameters via the control terminals:

- **ADD 1** - Frequency source setting (**DI** = control terminals [FW] and [RV])
- **ADD 2** - Run command source setting (**DI** = control terminals [O] or [OI])

Some applications will require one or both settings above to use a source other than the terminals. You may prefer to normally use the inverter's keypad and potentiometer, or to use the Modbus network for control, for example. However, an external device can turn ON the [F-TM] input to force the inverter to (temporarily) allow control (frequency source and Run command) via control terminals. When the [F-TM] input is OFF, then the inverter uses the regular sources specified by **ADD 1** and **ADD 2** again.

Option Code	Terminal Symbol	Function Name	State	Description
51	F-TM	Force Terminal Mode	ON	Forces ADD 1=DI (frequency source setting = control terminal), and ADD 2=DI (Run command source setting = control terminal)
			OFF	Inverter applies the user setting for ADD 1 and ADD 2 normally
Valid for inputs		C001 to C007		Example (requires input configuration—see page 3-79): <div style="text-align: center;"> </div>
Required settings				
Notes:				
<ul style="list-style-type: none"> • When changing the [F-TM] state during Run Mode (inverter is driving the motor), the inverter will stop the motor before the new [F-TM] state takes effect. 				See I/O specs on page 4-6.

Clearance of cumulative power data

This function is to clear the cumulative input power data.

Option Code	Terminal Symbol	Function Name	State	Description
53	KHC	Clear watt-hour data	ON	Clear the cumulative power data
			OFF	Does not clear the data
Valid for inputs		C001 to C007		Example (requires input configuration—see page 3-79): <div style="text-align: center;"> </div>
Required settings				
Notes:				
				See I/O specs on page 4-6.

General Purpose Input (1) to (7)

These functions are used with EzSQ function. Refer to a manual of EzSQ for the details.

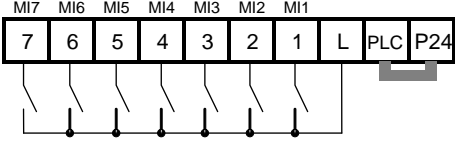
Option Code	Terminal Symbol	Function Name	State	Description
56 to 62	MI1 to MI7	General purpose input (1) to (7)	ON	General purpose input is made ON
			OFF	General purpose input is made OFF
Valid for inputs		<i>C001</i> to <i>C007</i>		Example (requires input configuration—see page 3-79):
Required settings				
Notes:				
				 <p>See I/O specs on page 4-6.</p>

Analog Command Hold

This function allows you to make the inverter hold the analog command input via the external analog input terminal when the [AHD] terminal is made ON.

While the [AHD] is turned ON, the up/down function can be used based on the analog signal held by this function as reference data.

When "01" is specified for Up/down memory mode selection (C101), the result of up/down processing can be stored in memory.

If the inverter power is turned on or the [RS] terminal turned off with the [AHD] terminal left turned on, the data held immediately before power on or turning off the [RS] terminal will be used.

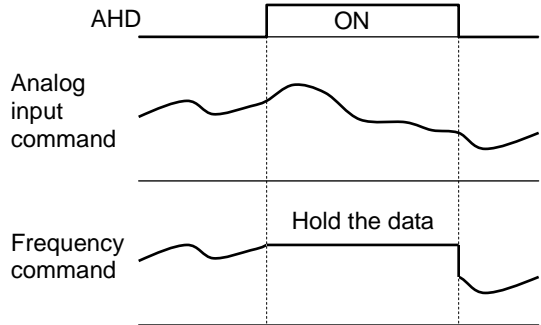

NOTE: Set frequency remains when the inverter is switched with [SET] terminal with [AHD] on. Turn [AHD] terminal off to re-hold the set frequency.



NOTE: Frequent use of this function may result in a shorter in memory component of the inverter.

Option Code	Terminal Symbol	Function Name	State	Description
65	AHD	Analog command hold	ON	Hold the analog input value
			OFF	Does not hold the analog input value
Valid for inputs		C001 to C007		Example (requires input configuration—see page 3-79):
Required settings				
Notes:				
				See I/O specs on page 4-6.

Safe Stop Related Signals

The function is based on European norm, EN60204-1, EN954-1. Please refer to the relevant pages for the detailed explanation.

Option Code	Terminal Symbol	Function Name	State	Description
77 78	STO1	Safety related signals	ON	
	STO2		OFF	
Refer to Safe Stop section (Appendix E Safety)				



HIGH VOLTAGE: Dangerous voltage exists even after the Safe Stop is activated. It does NOT mean that the main power has been removed.

Executing EzSQ program

Option Code	Terminal Symbol	Function Name	State	Description
82	PRG	Executing EzSQ program	ON	
			OFF	
Refer to EzSQ manual				

Retain output frequency

This function allows you to retain output frequency.

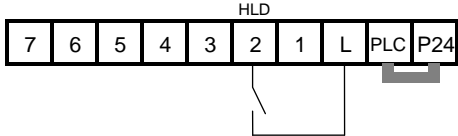
Option Code	Terminal Symbol	Function Name	State	Description
83	HLD	Retain output frequency	ON	
			OFF	
Valid for inputs		C001 to C007		Example (requires input configuration—see page 3-79): 
Required settings				
Notes:				
See I/O specs on page 4-6.				

Permission of Run command

This function allows you to accept run command.

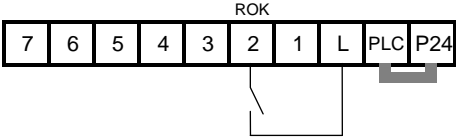
Option Code	Terminal Symbol	Function Name	State	Description
B4	ROK	Permission of Run command	ON	Run command can be accepted
			OFF	Run command is ignored
Valid for inputs		C001 to C007		Example (requires input configuration—see page 3-79): 
Required settings				
Notes:				
				See I/O specs on page 4-6.

Display limitation

This function is to show only the contents of initial display set by **b03B**.

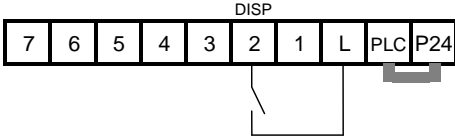
Option Code	Terminal Symbol	Function Name	State	Description
B6	DISP	Display limitation	ON	
			OFF	
Valid for inputs		C001 to C007		Example (requires input configuration—see page 3-79): 
Required settings				
Notes:				
				See I/O specs on page 4-6.

Using Intelligent Output Terminals

The intelligent output terminals are programmable in a similar way to the intelligent input terminals. The inverter has several output functions that you can assign individually to two physical logic outputs. One of the outputs is an open-collector transistor, and the other output is the alarm relay (form C – normally open and normally closed contacts). The relay is assigned the alarm function by default, but you can assign it to any of the functions that the open-collector output uses.



CAUTION: The digital outputs (relay and/or open collector) available on the drive must not be considered as safety related signals. The outputs of the external safety relay must be used for integration into a safety related control/command circuit

Sinking Outputs, Open Collector

The open-collector transistor output can handle up to 50mA. We highly recommend that you use an external power source as shown at the right. It must be capable of providing at least 50mA to drive the output at full load. To drive loads that require more than 50mA, use external relay circuits as shown below right.

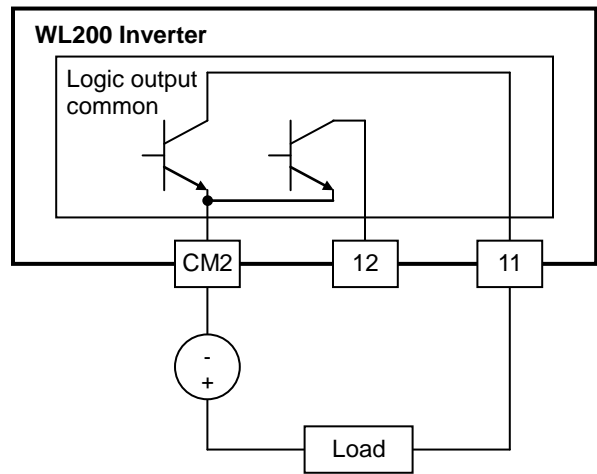

Sinking Outputs, Open Collector

If you need output current greater than 50mA, use the inverter output to drive a small relay. Be sure to use a diode across the coil of the relay as shown (reverse-biased) in order to suppress the turn-off spike, or use a solid-state relay.

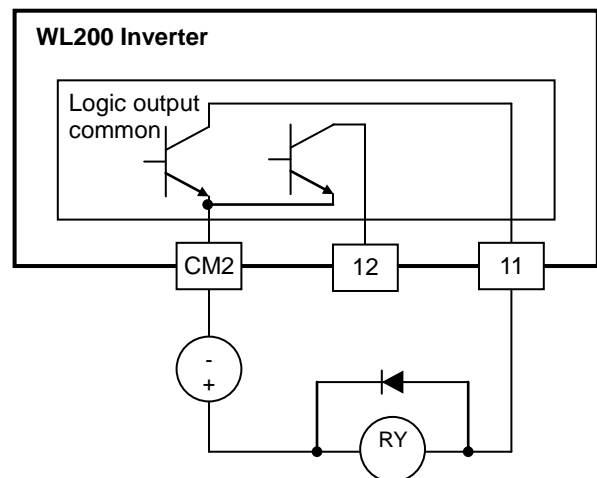

Internal Relay Output

The inverter has an internal relay output with normally open and normally closed contacts (Type 1 form C). The output signal that controls the relay is configurable; the Alarm Signal is the default setting. Thus, the terminals are labeled [AL0], [AL1], [AL2], as shown to the right. However, you can assign any one of the nine intelligent outputs to the relay. For wiring purposes, the general terminal functions are:

- [AL0] – Common contact
- [AL1] – Normally open contact
- [AL2] – Normally closed contact

The relay itself can be configured as “normally open or closed.” Parameter **C036**, Alarm Relay Active State, is the setting. This setting determines whether or not the relay coil is energized when its output signal is OFF:

- **C036=00** – “Normally open” (relay coil is **de-energized** when output signal is OFF)
- **C036=01** – “Normally closed” (relay coil is **energized** when the output signal is OFF)

Since the relay already has normally open [AL1] and normally closed [AL2] contacts, the purpose of the ability to invert the relay coil’s active state may not be obvious. *It allows you to determine whether or not an inverter power loss causes the relay to change state.* The default relay configuration is the Alarm Signal (**C026=05**), as shown to the right. And, **C036=01** sets the relay to “normally closed” (relay coil normally energized). The reason for this is that a typical system design will require an inverter power loss to assert an alarm signal to external devices.

The relay can be used for other intelligent output signals, such as the Run Signal (set **C026=00**). For these remaining output signal types, the relay coil typically must NOT change state upon inverter power loss (set **C036=00**). The figure to the right shows the relay settings for the Run Signal output.

If you assign the relay an output signal other than the Alarm Signal, the inverter can still have an Alarm Signal output. In this case, you can assign it to terminal [11], providing an open collector output.

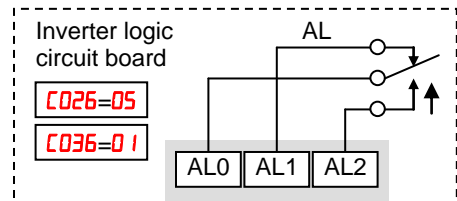
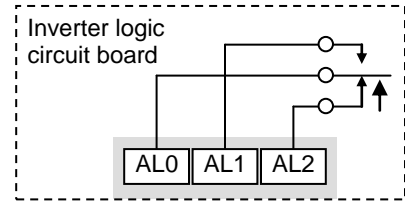

Relay shown with inverter power ON, Alarm Signal OFF

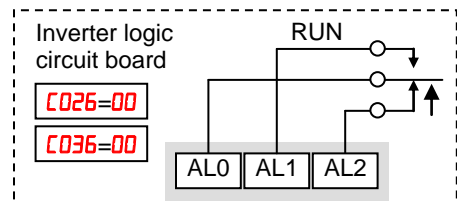

Relay shown with inverter power ON, Run Signal OFF

Output Signal ON/OFF Delay Function

Intelligent outputs including terminals [11], [12] and the output relay have configurable signal transition delays. Each output can delay either the OFF-to-ON or ON-to-OFF transitions, or both. Signal transition delays are variable from 0.1 to 100.0 seconds. This feature is useful in applications that must tailor inverter output signals to meet timing requirements of certain external devices.

The timing diagram below shows a sample output signal (top line) and the results of various ON/OFF delay configurations.

- **Original signal** - This example signal waveform consists of three separate pulses named "A," "B," and "C."
- **...with ON delay** - Pulse A is delayed by the duration of the ON delay time. Pulses B and C do not appear at the output, because they are shorter than the ON delay.
- **...with OFF delay** - Pulse A is lengthened by the amount of the OFF delay time. The separation between pulses B and C does not appear at the output, because it is shorter than the OFF delay time.
- **...with ON/OFF delays** - Pulse A is delayed on both leading and trailing edges by the amounts of the ON and OFF delay times, respectively. Pulses B and C do not appear at the output, because they are shorter than the ON delay time.

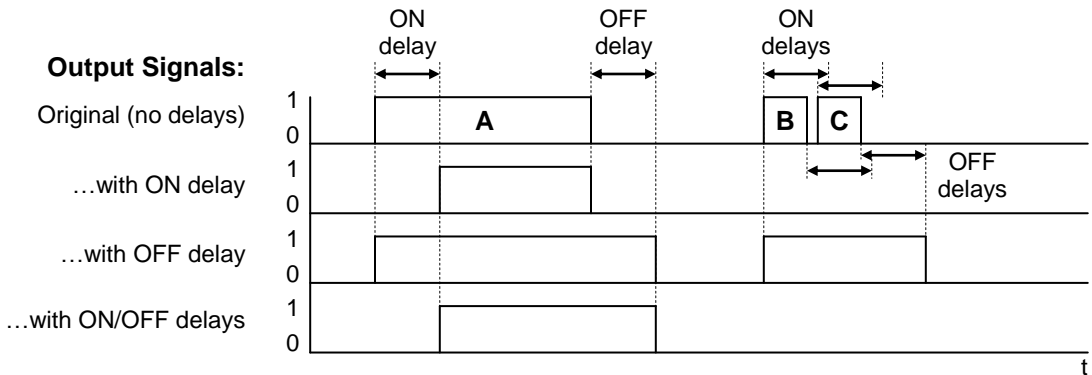

Func.	Description	Range	Default
C 130	Output [11] ON delay	0.0 to 100.0 sec.	0.0
C 131	Output [11] OFF delay	0.0 to 100.0 sec.	0.0
C 132	Output [12] ON delay	0.0 to 100.0 sec.	0.0
C 133	Output [12] OFF delay	0.0 to 100.0 sec.	0.0
C 140	Output relay ON delay	0.0 to 100.0 sec.	0.0
C 141	Output relay OFF delay	0.0 to 100.0 sec.	0.0

Use of the ON/OFF signal delay functions is optional. Note that any of the intelligent output assignments in this section can be combined with ON/OFF signal timing delay configurations.

Run Signal

When the [RUN] signal is selected as an intelligent output terminal, the inverter outputs a signal on that terminal when it is in Run Mode. The output logic is active low, and is the open collector type (switch to ground).

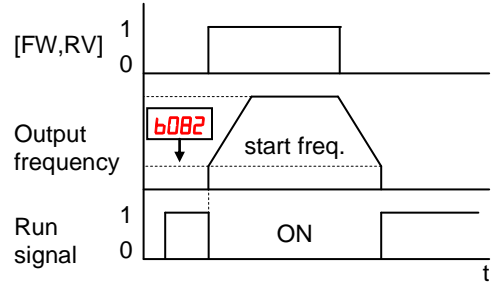

Option Code	Terminal Symbol	Function Name	State	Description
00	RUN	Run Signal	ON	when inverter is in Run Mode
			OFF	when inverter is in Stop Mode
Valid for outputs		C021, C022, C026		Example for terminal [11] (default output configuration shown – see page 3-84):
Required settings		(none)		
<p>Notes:</p> <ul style="list-style-type: none"> The inverter outputs the [RUN] signal whenever the inverter output exceeds the start frequency specified by parameter b082. The start frequency is the initial inverter output frequency when it turns ON. The example circuit for terminal [11] drives a relay coil. Note the use of a diode to prevent the negative going turn-off spike generated by the coil from damaging the inverter's output transistor. 				
<p>Example for terminal [AL0], [AL1], [AL2] (requires output configuration – see page 4-46 and 3-84):</p> <p>Example for terminal [AL0], [AL1], [AL2] (requires output configuration – see page 4-46 and 3-84):</p>				
See I/O specs on page 4-6.				

Frequency Arrival Signals

The *Frequency Arrival* group of outputs helps coordinate external systems with the current velocity profile of the inverter. As the name implies, output [FA1] turns ON when the output frequency arrives at the standard set frequency (parameter **F00 I**). Output [FA2] relies on programmable accel/ decel thresholds for increased flexibility. For example, you can have an output turn ON at one frequency during acceleration, and have it turn OFF at a different frequency during deceleration. All transitions have hysteresis to avoid output chatter if the output frequency is near one of the thresholds.

Option Code	Terminal Symbol	Function Name	State	Description
01	FA1	Frequency Arrival Type 1 – Constant Speed	ON	when output to motor is at the constant frequency
			OFF	when output to motor is OFF, or in any acceleration or deceleration ramp
02	FA2	Frequency Arrival Type 2 – Over frequency	ON	when output to motor is at or above the set frequency thresholds for, even if in acceleration or decel ramps
			OFF	when output to motor is OFF, or during accel or decel before the respective thresholds are crossed
06	FA3	Frequency Arrival Type 3 – Set frequency	ON	when output to motor is at the set frequency
			OFF	when output to motor is OFF, or in any acceleration or deceleration ramp
24	FA4	Frequency Arrival Type 4 – Over frequency (2)	ON	when output to motor is at or above the set frequency thresholds for, even if in acceleration or decel ramps
			OFF	when output to motor is OFF, or during accel or decel before the respective thresholds are crossed
25	FA5	Frequency Arrival Type 5 – Set frequency (2)	ON	when output to motor is at the set frequency
			OFF	when output to motor is OFF, or in any acceleration or deceleration ramp

Valid for outputs C021, C022, C026

Required settings C042, C043, C045, C046,

Notes:

- For most applications you will need to use only one type of frequency arrival outputs (see examples). However, it is possible assign both output terminals to output functions [FA1] and [FA2]
- For each frequency arrival threshold, the output anticipates the threshold (turns ON early) by 1.5Hz
- The output turns OFF as the output frequency moves away from the threshold, delayed by 0.5Hz
- The example circuit for terminal [11] drives a relay coil. Note the use of a diode to prevent the negative going turn-off spike generated by the coil from damaging the inverter's output transistor

Example for terminal [12] (default output configuration shown – see page 3-84):

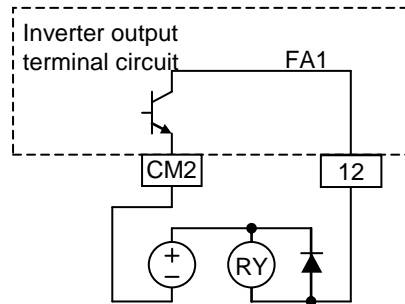

Example for terminal [AL0], [AL1], [AL2] (requires output configuration – see page 4-46 and 3-84):

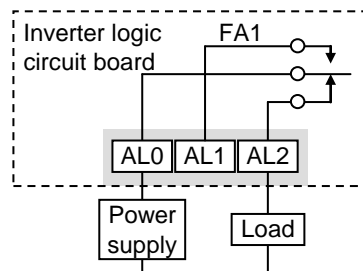

See I/O specs on page 4-6.

Frequency arrival output [FA1] uses the standard output frequency (parameter **F00 I**) as the threshold for switching. In the figure to the right, Frequency Arrival [FA1] turns ON when the output frequency gets within *Fon* Hz below or *Foff* Hz above the target constant frequency, where *Fon* is 1% of the set maximum frequency and *Foff* is 2% of the set maximum frequency. This provides hysteresis that prevents output chatter near the threshold value. The hysteresis effect causes the output to turn ON slightly *early* as the speed approaches the threshold. Then the turn-OFF point is slightly *delayed*. Note the active low nature of the signal, due to the open collector output.

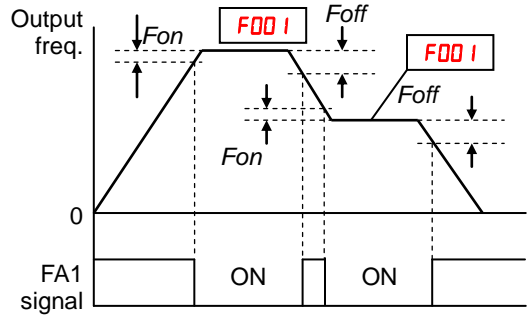

Fon=1% of max. frequency
Foff=2% of max. frequency

Frequency arrival output [FA2/FA4] works the same way; it just uses two separate thresholds as shown in the figure to the right. These provide for separate acceleration and deceleration thresholds to provide more flexibility than for [FA1]. [FA2/FA4] uses **C042/C045** during acceleration for the ON threshold, and **C043/C046** during deceleration for the OFF threshold. This signal also is active low. Having different accel and decel thresholds provides an asymmetrical output function. However, you can use equal ON and OFF thresholds, if desired.

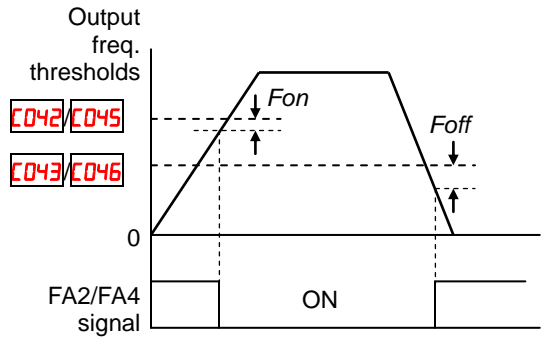

Fon=1% of max. frequency
Foff=2% of max. frequency

Frequency arrival output [FA3/FA5] works also the same way, only difference is arriving at set frequency.

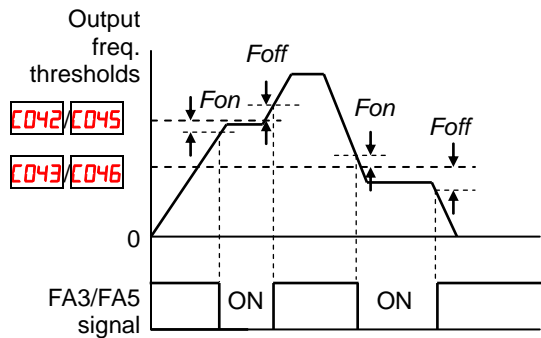

Fon=1% of max. frequency
Foff=2% of max. frequency

Overload Warning Signal

When the output current exceeds a preset value, the [OL] terminal signal turns ON. The parameter **C041** and **C111** set the overload threshold. (Two thresholds can be set.) The overload detection circuit operates during powered motor operation and during regenerative braking. The output circuits use open-collector transistors, and are active low. Please refer to "Overload Warning Output" on page 3-90 for details.

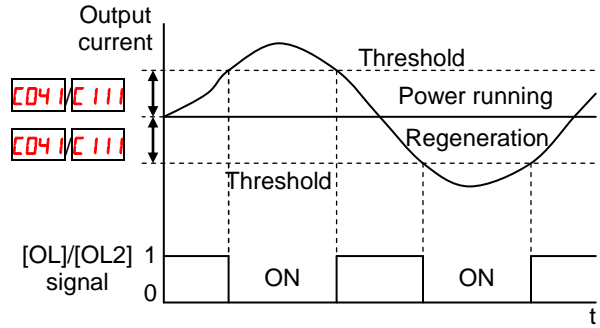

Option Code	Terminal Symbol	Function Name	State	Description
03	OL	Overload Warning Signal 1	ON	when output current is more than the set threshold for the overload signal
			OFF	when output current is less than the set threshold for the overload signal
26	OL2	Overload Warning Signal 2	ON	(Same as above)
			OFF	(Same as above)
Valid for outputs		C021, C022, C026		Example for terminal [11] (requires output configuration – see page 3-84):
Required settings		C041, C111		
<p>Notes:</p> <ul style="list-style-type: none"> The default value is 100%. To change the level from the default, set C041 (overload level) and/or C111 (overload level (2)). The example circuit for terminal [11] drives a relay coil. Note the use of a diode to prevent the negative-going turn-off spike generated by the coil from damaging the inverter's output transistor. 				
<p>Example for terminal [AL0], [AL1], [AL2] (requires output configuration – see page 4-46 and 3-84):</p> <p>The diagram shows an inverter logic circuit board with terminals AL0, AL1, and AL2. A power supply is connected to AL0, and a load is connected to AL1 and AL2. The OL signal is shown as an active-low output from the board.</p>				
See I/O specs on page 4-6.				

Output Deviation for PID Control

The PID loop error is defined as the magnitude (absolute value) of the difference between the Setpoint (target value) and the Process Variable (actual value). When the error magnitude exceeds the preset value for **C044**, the [OD] terminal signal turns ON. Refer to "PID Control" on page 3-30.

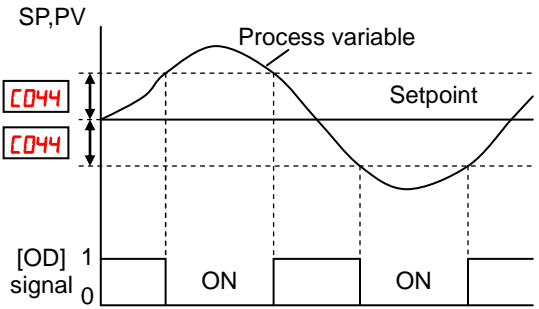

Option Code	Terminal Symbol	Function Name	State	Description
04	OD	Output Deviation for PID Control	ON	When PID error is more than the set threshold for the deviation signal.
			OFF	when PID error is less than the set threshold for the deviation signal
Valid for outputs		C021, C022, C026		Example for terminal [11] (requires output configuration – see page 3-84):
Required settings		C044		
Notes:				<div data-bbox="754 730 1159 1033" data-label="Diagram"> </div> <p>Example for terminal [AL0], [AL1], [AL2] (requires output configuration – see page 4-46 and 3-84):</p> <div data-bbox="775 1149 1138 1420" data-label="Diagram"> </div> <p>See I/O specs on page 4-6.</p>
<ul style="list-style-type: none"> The default difference value is set to 3%. To change this value, change parameter C044 (deviation level). The example circuit for terminal [11] drives a relay coil. Note the use of a diode to prevent the negative-going turn-off spike generated by the coil from damaging the inverter's output transistor. 				

Alarm Signal

The inverter alarm signal is active when a fault has occurred and it is in the Trip Mode (refer to the diagram at right). When the fault is cleared the alarm signal becomes inactive.

We must make a distinction between the alarm *signal* [AL] and the alarm relay *contacts* [AL0], [AL1] and [AL2]. The signal [AL] is a logic function, which you can assign to the open collector output terminals [11], [12], or the relay outputs.

The most common (and default) use of the relay is for [AL], thus the labeling of its terminals. Use an open collector output (terminal [11] or [12]) for a low-current logic signal interface or to energize a small relay (50 mA maximum). Use the relay output to interface to higher voltage and current devices (10 mA minimum).

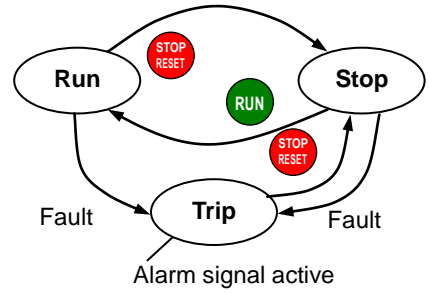

Option Code	Terminal Symbol	Function Name	State	Description
05	AL	Alarm Signal	ON	when an alarm signal has occurred and has not been cleared
			OFF	when no alarm has occurred since the last clearing of alarm(s)
Valid for outputs			C021, C022, C026	
Required settings			C031, C032, C036	
<p>Notes:</p> <ul style="list-style-type: none"> By default, the relay is configured as normally closed (C036=0). Refer to the next page for an explanation. In the default relay configuration, an inverter power loss turns ON the alarm output. The alarm signal remains ON as long as the external control circuit has power. When the relay output is set to normally closed, a time delay of less than 2 seconds occurs after powerup before the contact is closed. Terminals [11] and [12] are open collector outputs, so the electric specifications of [AL] are different from the contact output terminals [AL0], [AL1], [AL2]. This signal output has the delay time (300 ms nominal) from the fault alarm output. The relay contact specifications are in "Control Logic Signal Specifications" on page 4-6. The contact diagrams for different conditions are on the next page. 				
				<p>Example for terminal [11] (requires output configuration – see page 3-84):</p>
				<p>Example for terminal [AL0], [AL1], [AL2] (default output configuration shown – see page 4-46 and 3-84):</p>
				See I/O specs on page 4-6.

The alarm relay output can be configured in two main ways:

- Trip/Power Loss Alarm** – The alarm relay is configured as normally closed (**C036=0 1**) by default, shown below (left). An external alarm circuit that detects broken wiring also as an alarm connects to [AL0] and [AL1]. After powerup and short delay (< 2 seconds), the relay energizes and the alarm circuit is OFF. Then, either an inverter trip event or an inverter power loss will de-energize the relay and open the alarm circuit
- Trip Alarm** – Alternatively, you can configure the relay as normally open (**C036=00**), shown below (right). An external alarm circuit that detects broken wiring also as an alarm connects to [AL0] and [AL2]. After powerup, the relay energizes only when an inverter trip event occurs, opening the alarm circuit. However, in this configuration, an inverter power loss does not open the alarm circuit.

Be sure to use the relay configuration that is appropriate for your system design. Note that the external circuits shown assume that a closed circuit = no alarm condition (so that a broken wire also causes an alarm). However, some systems may require a closed circuit = alarm condition. In that case, then use the opposite terminal [AL1] or [AL2] from the ones shown.

N.C. contacts (C036=0 1)		N.O. contacts (C036=00)																																	
During normal operation	When an alarm occurs or when power is OFF	During normal operation or when power is OFF	When an alarm occurs																																
<table border="1"> <thead> <tr> <th>Power</th> <th>Run Mode</th> <th>AL0-AL1</th> <th>AL0-AL2</th> </tr> </thead> <tbody> <tr> <td>ON</td> <td>Normal</td> <td>Closed</td> <td>Open</td> </tr> <tr> <td>ON</td> <td>Trip</td> <td>Open</td> <td>Closed</td> </tr> <tr> <td>OFF</td> <td>-</td> <td>Open</td> <td>Closed</td> </tr> </tbody> </table>	Power	Run Mode	AL0-AL1	AL0-AL2	ON	Normal	Closed	Open	ON	Trip	Open	Closed	OFF	-	Open	Closed		<table border="1"> <thead> <tr> <th>Power</th> <th>Run Mode</th> <th>AL0-AL1</th> <th>AL0-AL2</th> </tr> </thead> <tbody> <tr> <td>ON</td> <td>Normal</td> <td>Open</td> <td>Closed</td> </tr> <tr> <td>ON</td> <td>Trip</td> <td>Closed</td> <td>Open</td> </tr> <tr> <td>OFF</td> <td>-</td> <td>Open</td> <td>Closed</td> </tr> </tbody> </table>	Power	Run Mode	AL0-AL1	AL0-AL2	ON	Normal	Open	Closed	ON	Trip	Closed	Open	OFF	-	Open	Closed	
Power	Run Mode	AL0-AL1	AL0-AL2																																
ON	Normal	Closed	Open																																
ON	Trip	Open	Closed																																
OFF	-	Open	Closed																																
Power	Run Mode	AL0-AL1	AL0-AL2																																
ON	Normal	Open	Closed																																
ON	Trip	Closed	Open																																
OFF	-	Open	Closed																																

Under-voltage Signal

The inverter outputs the under-voltage signal during under-voltage.

To output the under-voltage signal, assign function "09 (UV)" to one of the intelligent output terminals [11] to [12], or to the relay output terminal.

Option Code	Terminal Symbol	Function Name	State	Description
09	UV	Under-voltage signal	ON	Inverter is during under-voltage
			OFF	Inverter is not during under-voltage
Valid for outputs		C02 I, C022, C026		Example for terminal [11] (requires output configuration – see page 3-84):
Required settings		C06 I		
<p>Notes:</p> <ul style="list-style-type: none"> The example circuit for terminal [11] drives a relay coil. Note the use of a diode to prevent the negative-going turn-off spike generated by the coil from damaging the inverter's output transistor. 				
				<p>Example for terminal [AL0], [AL1], [AL2] (requires output configuration – see page 4-46 and 3-84):</p>
				See I/O specs on page 4-6.

Running Time and Power On Time Over Signal

The inverter outputs the operation time expiration signal and power on time expiration signal.

To enable this function, assign " **11** (RNT)", and/or " **12** (ONT)" to intelligent output terminals.

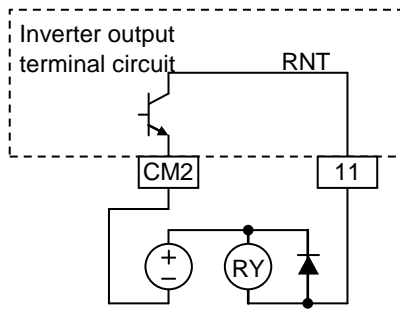
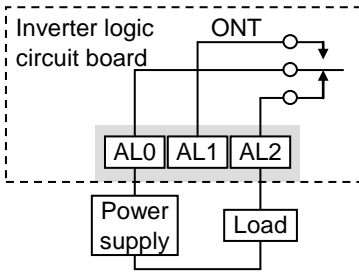
Option Code	Terminal Symbol	Function Name	State	Description
11	RNT	Run time expiration signal	ON	Accumulated operation time of the inverter exceeds the set value of b034
			OFF	Accumulated operation time of the inverter does not exceed the set value of b034
12	ONT	Power ON time expiration signal	ON	Accumulated power on time of the inverter exceeds the set value of b034
			OFF	Accumulated power on time of the inverter does not exceed the set value of b034
Valid for outputs		C021, C022, C026		Example for terminal [11] (requires output configuration – see page 3-84): 
Required settings		b034		
Notes:		<ul style="list-style-type: none"> The example circuit for terminal [11] drives a relay coil. Note the use of a diode to prevent the negative-going turn-off spike generated by the coil from damaging the inverter's output transistor. 		
				Example for terminal [AL0], [AL1], [AL2] (requires output configuration – see page 4-46 and 3-84): 
				See I/O specs on page 4-6.

Electronic Thermal Warning Signal Output

You can configure this function so that the inverter outputs a warning signal before the electronic thermal protection operates against motor overheat. You can also set the threshold level to output a warning signal with the electronic thermal warning level setting (C06 I).

To output the warning signal, assign function "13 (THM)" to one of the intelligent output terminals [11] to [12], or to the relay output terminal.

Option Code	Terminal Symbol	Function Name	State	Description
13	THM	Thermal warning signal output	ON	Accumulated thermal level exceeds the electronic thermal warning level (C06 I)
			OFF	Accumulated thermal level does not exceed the electronic thermal warning level (C06 I)
Valid for outputs		C02 I, C022, C026		Example for terminal [11] (requires output configuration – see page 3-84):
Required settings		C06 I		
Notes: <ul style="list-style-type: none"> The example circuit for terminal [11] drives a relay coil. Note the use of a diode to prevent the negative-going turn-off spike generated by the coil from damaging the inverter's output transistor. 				<p>Example for terminal [11] (requires output configuration – see page 3-84):</p>
				<p>Example for terminal [AL0], [AL1], [AL2] (requires output configuration – see page 4-46 and 3-84):</p> <p>See I/O specs on page 4-6.</p>

External Brake Related Output Signals

These signals are used with brake control function.

To output the warning signals, assign function "19 (BRK)" and "20 (BER)" to the intelligent output terminals [11] and [12], or to the relay output terminal.

Refer to "Brake Control Function Related" on page 3-73 for details.

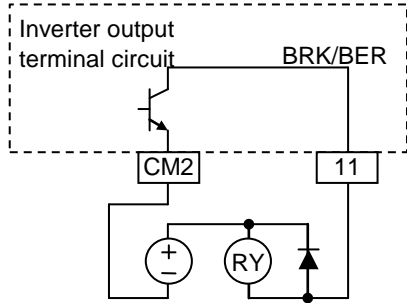
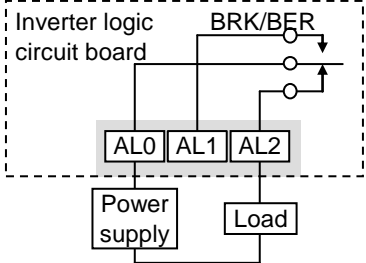
Option Code	Terminal Symbol	Function Name	State	Description
19	BRK	Brake release signal	ON	Brake is ready to be released
			OFF	Brake is not ready to be released
20	BER	Brake error signal	ON	Brake error has occurred
			OFF	Brake is working properly
Valid for outputs		C021, C022, C026		Example for terminal [11] (requires output configuration – see page 3-84):
Required settings		b 120 to b 127		
<p>Notes:</p> <ul style="list-style-type: none"> The example circuit for terminal [11] drives a relay coil. Note the use of a diode to prevent the negative-going turn-off spike generated by the coil from damaging the inverter's output transistor. 				
<p>Example for terminal [AL0], [AL1], [AL2] (requires output configuration – see page 4-46 and 3-84):</p> 				
				
See I/O specs on page 4-6.				

Zero Hz Speed Detection Signal

The inverter outputs the 0Hz speed detection signal when the inverter output frequency falls below the threshold level (C063).

To use this function, assign "2 1 (ZS)" to one of the intelligent output terminals.

Option Code	Terminal Symbol	Function Name	State	Description
2 1	ZS	Zero Hz speed detection signal	ON	Output frequency is less than C063
			OFF	Output frequency is not less than C063
Valid for outputs		C02 1, C022, C026		Example for terminal [11] (requires output configuration – see page 3-84):
Required settings		C063		
Notes: <ul style="list-style-type: none"> The example circuit for terminal [11] drives a relay coil. Note the use of a diode to prevent the negative-going turn-off spike generated by the coil from damaging the inverter's output transistor. 				
				Example for terminal [AL0], [AL1], [AL2] (requires output configuration – see page 4-46 and 3-84):
				See I/O specs on page 4-6.

Analog Input Disconnect Detect

This feature is useful when the inverter receives a speed reference from an external device. Upon input signal loss at either the [O] or [OI] terminal, the inverter normally just decelerates the motor to a stop. However, the inverter can use the intelligent output terminal [Dc] to signal other devices that a signal loss has occurred.

Voltage signal loss at [O] terminal - Parameter **b0B2** is the Start Frequency Adjustment. It sets the beginning (minimum) output frequency when the speed reference source is greater than zero. If the analog input at terminal [O] is less than the Start Frequency, the inverter turns ON the [ODc] output to indicate a signal loss condition.

Current signal loss at [OI] terminal - The [OI] terminal accepts a 4mA to 20mA signal, with 4mA representing the beginning of the input range. If the input current falls below 4mA, the inverter applies a threshold to detect signal loss.

Note that a signal loss is not an inverter trip event. When the analog input value is again above the **b0B2** value, the [Dc] output turns OFF. There is no error condition to clear.

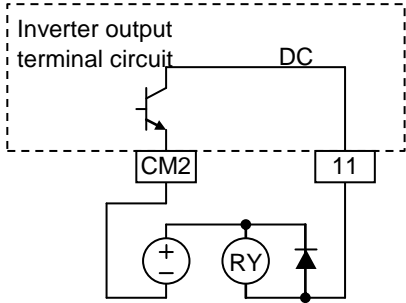
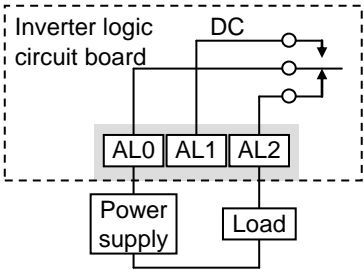
Option Code	Terminal Symbol	Function Name	State	Description
27	ODc	Analog voltage Input Disconnect Detect	ON	when signal loss is detected on [O] input
			OFF	when no signal loss is detected on [O] input
28	OIDc	Analog current Input Disconnect Detect	ON	when signal loss is detected on [OI] input
			OFF	when no signal loss is detected on [OI] input
Valid for outputs		C021, C022, C026		Example for terminal [11] (requires output configuration – see page 3-84):
Required settings		A001=01, b0B2		
<p>Notes:</p> <ul style="list-style-type: none"> The [Dc] output can indicate an analog signal disconnect when the inverter is in Stop Mode, as well as Run Mode. The example circuit for terminal [11] drives a relay coil. Note the use of a diode to prevent the negative-going turn-off spike generated by the coil from damaging the inverter's output transistor. 				
<p>Example for terminal [AL0], [AL1], [AL2] (requires output configuration – see page 4-46 and 3-84):</p> 				
				
See I/O specs on page 4-6.				

PID Second Stage Output

The inverter has a built-in PID loop feature for *two-stage control*, useful for certain applications such as building ventilation or heating and cooling (HVAC). In an ideal control environment, a single PID loop controller (stage) would be adequate. However, in certain conditions, the maximum output energy from the first stage is not enough to maintain the Process Variable (PV) at or near the Setpoint (SP). And, the output of the first stage is in saturation. A simple solution is to add a second stage, which puts an additional and constant amount of energy into the system under control. When sized properly, the boost from the second stage brings the PV toward the desired range, allowing the first stage PID control to return to its linear range of operation.

The two-stage method of control has some advantages for particular applications.

- The second stage is only ON in adverse conditions, so there is an energy savings during normal conditions.
- Since the second stage is simple ON/OFF control, it is less expensive to add than just duplicating the first stage.
- At powerup, the boost provided by the second stage helps the process variable reach the desired setpoint sooner than it would if the first stage acted alone.
- Even though the second stage is simple ON/OFF control, when it is an inverter you can still adjust the output frequency to vary the boost it provides.

Refer to the example diagram below. Its two stages of control are defined as follows:

- Stage 1 - Inverter #1 operating in PID loop mode, with motor driving a fan
- Stage 2 - Inverter #2 operating as an ON/OFF controller, with motor driving a fan

Stage #1 provides the ventilation needs in a building most of the time. On some days, there is a change in the building's air volume because large warehouse doors are open. In that situation, Stage #1 alone cannot maintain the desired air flow (PV sags under SP). Inverter #1 senses the low PV and its PID Second Stage Output at [FBV] terminal turns ON. This gives a Run FWD command to Inverter #2 to provide the additional air flow.

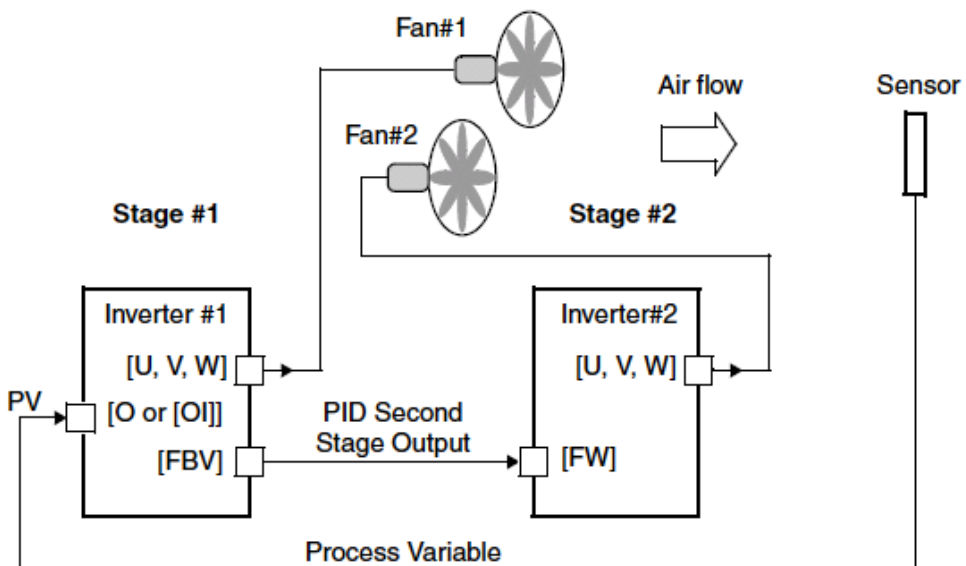

To use the PID Second Stage Output feature, you will need to choose upper and lower limits for the PV, via **C053** and **C052** respectively. As the timing diagram below shows, these are the thresholds Stage #1 inverter uses to turn ON or OFF Stage #2 inverter via the [FBV] output. The vertical axis units are percent (%) for the PID setpoint, and for the upper and lower limits. The output frequency, in Hz, is superimposed onto the same diagram.

When the system control begins, the following events occur (in sequence in the timing diagram):

1. Stage #1 inverter turns ON via the [FW] Run command.
2. Stage #1 inverter turns ON the [FBV] output, because the PV is below the PV low limit **C053**. So, Stage #2 is assisting in loop error correction from the beginning.
3. The PV rises and eventually exceeds the PV high limit **C052**. Stage #1 inverter then turns OFF the [FBV] output to Stage #2, since the boost is no longer needed.
4. When the PV begins decreasing, only Stage #1 is operating, and it is in the linear control range. This region is where a properly configured system will operate most often.
5. The PV continues to decrease until it crosses under the PV low limit (apparent external process disturbance). Stage #1 inverter turns ON the [FBV] output, and Stage #2 inverter is assisting again.
6. After the PV rises above the PV low limit, the [FW] Run command to Stage #1 inverter turns OFF (as in a system shutdown).
7. Stage #1 inverter enters Stop Mode and automatically turns OFF the [FBV] output, which causes Stage #2 inverter to also stop.

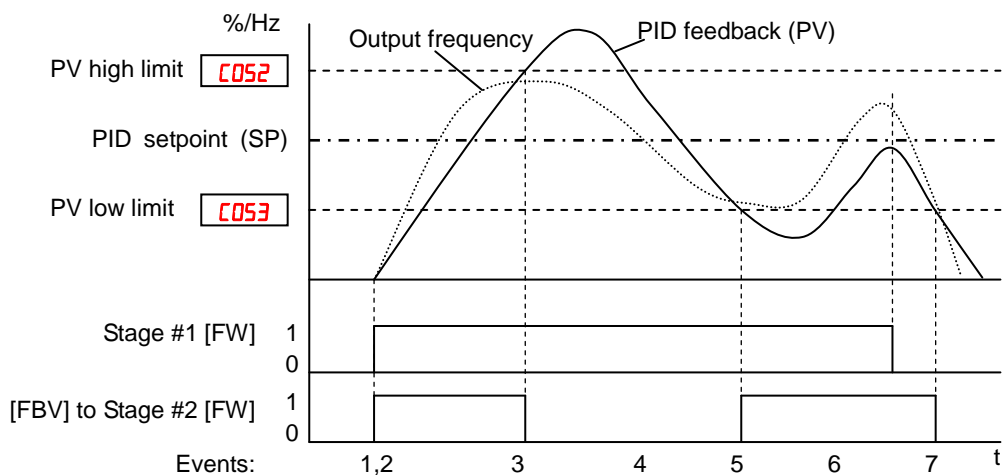

The terminal [FBV] configuration table is on the following page.

Option Code	Terminal Symbol	Function Name	State	Description
31	FBV	Feedback Value Check	ON	<ul style="list-style-type: none"> Transitions to ON when the inverter is in RUN Mode and the PID Process Variable (PV) is less than the Feedback Low Limit (C053)
			OFF	<ul style="list-style-type: none"> Transitions to OFF when the PID Feedback Value (PV) exceeds the PID High Limit (C052) Transitions to OFF when the inverter goes from Run Mode to Stop Mode

Valid for outputs C021, C022, C026

Required settings A076, C052, C053

Notes:

- The [FBV] is designed for implementing two-stage control. The PV high limit and PV low limit parameters, C052 and C053, do not function as process alarm thresholds. Terminal [FBV] does not provide a PID alarm function.
- The example circuit for terminal [11] drives a relay coil. Note the use of a diode to prevent the negative-going turn-off spike generated by the coil from damaging the inverter's output transistor.

Example for terminal [11] (requires output configuration – see page 3-84):

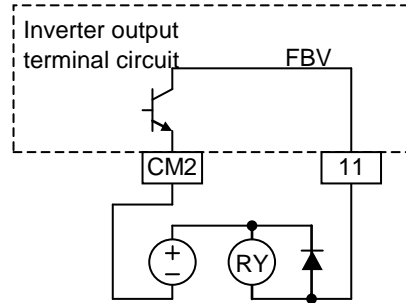

Example for terminal [AL0], [AL1], [AL2] (requires output configuration – see page 4-46 and 3-84):

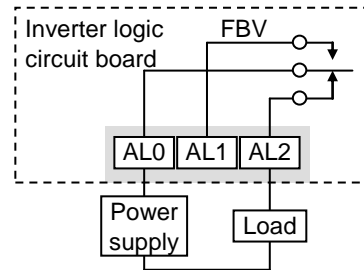

See I/O specs on page 4-6.

Communication signal Disconnect Detection

This signal function is enabled only when Modbus-RTU has been selected for the communication. If a reception timeout occurs, the inverter continues to output the communication line disconnection signal until it receives the next data.

Specify the limit time for reception timeout by setting the communication trip time (**C077**).

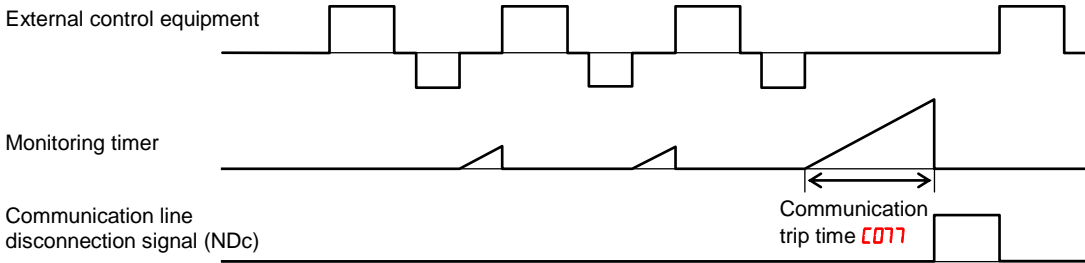

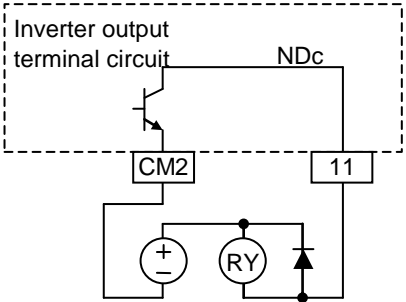
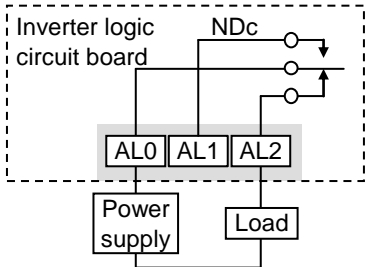
Option Code	Terminal Symbol	Function Name	State	Description
32	Ndc	Communication signal disconnect detection	ON	When there is a disconnection in communication
			OFF	When there is no disconnection in communication
Valid for outputs		C021, C022, C026		Example for terminal [11] (requires output configuration – see page 3-84): 
Required settings		C077		
Notes: <ul style="list-style-type: none"> The example circuit for terminal [11] drives a relay coil. Note the use of a diode to prevent the negative-going turn-off spike generated by the coil from damaging the inverter's output transistor. 				
				Example for terminal [AL0], [AL1], [AL2] (requires output configuration – see page 4-46 and 3-84): 
				See I/O specs on page 4-6.

Logic Output Function

The inverter has a built-in logic output feature. Select any two operands out of all intelligent output options except LOG1 to LOG3 and their operator out of AND, OR, or XOR (exclusive OR). The terminal symbol for the new output is [LOG]. Use **C021**, **C022** or **C026** to route the logical result to terminal [11], [12] or the relay terminals.

Intelligent outputs used as internal inputs:

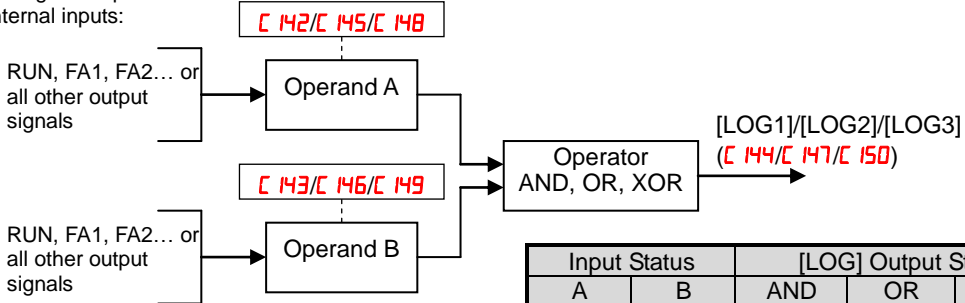

Input Status		[LOG] Output State		
A	B	AND	OR	XOR
0	0	0	0	0
0	1	0	1	1
1	0	0	1	1
1	1	1	1	0

Option Code	Terminal Symbol	Function Name	State	Description
33	LOG1	Logic Output Function	ON	when the Boolean operation specified by C144 / C145 / C147 has a logical "1" result
34	LOG2		OFF	when the Boolean operation specified by C144 / C145 / C147 has a logical "0" result
35	LOG3			
Valid for outputs		C021, C022, C026		Example for terminal [11] (requires output configuration – see page 3-84):
Required settings		C141 to C150		
Notes:				<p>Example for terminal [AL0], [AL1], [AL2] (requires output configuration – see page 4-46 and 3-84):</p> <p>See I/O specs on page 4-6.</p>

Lifetime Warning Output Function

Capacitor life warning signal - The inverter checks the operating life of the capacitors on the internal circuit board on the basis of the internal temperature and cumulative power on time. You can also monitor the state of the capacitor life warning signal [WAC] in **d022**. If the [WAC] signal is given out, it is recommended to replace the main PCB and control PCB.

Cooling fan warning signal - The inverter gives out the cooling fan speed-drop signal [WAF] when it detects the rotation speed of the cooling fan drops down to approx. 75% of the full speed. If "01" has been selected for the cooling fan control (**b092**), the inverter will not give out the [WAF] signal even when the cooling fan is stopped. If the signal is given out, check the cooling fan cover for clogging. You can also monitor the state of [WAF] signal in **d022**.

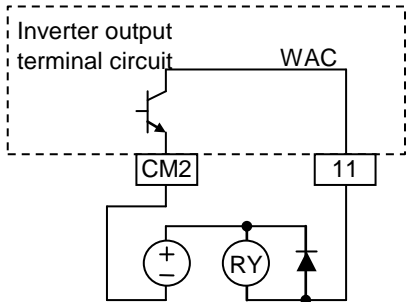
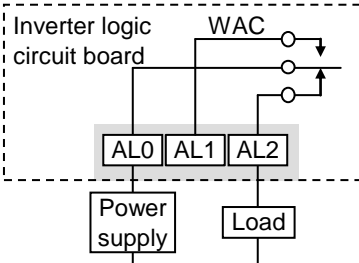
Option Code	Terminal Symbol	Function Name	State	Description
39	WAC	Capacitor life warning signal	ON	Calculated lifetime of the electrolytic capacitor is expired
			OFF	Electrolytic capacitor is normal
40	WAF	Cooling fan warning signal	ON	Calculated lifetime of the cooling fan is expired
			OFF	Cooling fan is normal
Valid for outputs	C021, C022, C026			Example for terminal [11] (requires output configuration – see page 3-84): 
Required settings				
Notes:				
				Example for terminal [AL0], [AL1], [AL2] (requires output configuration – see page 4-46 and 3-84): 
				See I/O specs on page 4-6.

Starting Contact Signal

The inverter gives out the starting contact signal [FR] while it is receiving an operational command. The FR signal is given out, regardless the setting of the run command source setting (**A002**). If the forward operation [FW] and reverse operation [RV] are given at the same time, the inverter stops the motor operation.

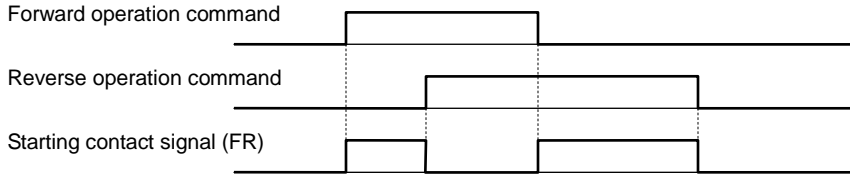

Option Code	Terminal Symbol	Function Name	State	Description
41	FR	Starting contact signal	ON	Either [FW] or [RV] is given
			OFF	Both [FW] and [RV] is given at the same time, or no operation command is given
Valid for outputs		C021, C022, C026		Example for terminal [11] (requires output configuration – see page 3-84):
Required settings				
Notes:				<p>The diagram shows a dashed box labeled 'Inverter output terminal circuit'. It contains a relay symbol labeled 'FR' connected to terminal '11'. Below this, a power source (battery symbol) is connected to a relay symbol labeled 'RY', which is also connected to terminal '11'.</p>
				<p>Example for terminal [AL0], [AL1], [AL2] (requires output configuration – see page 4-46 and 3-84):</p> <p>The diagram shows a dashed box labeled 'Inverter logic circuit board'. It contains three terminals labeled 'AL0', 'AL1', and 'AL2'. 'AL0' is connected to a 'Power supply'. 'AL1' and 'AL2' are connected to a 'Load'. The 'FR' signal is also shown as an output from the board.</p>
				See I/O specs on page 4-6.

Heat Sink Overheat Warning

The inverter monitors the temperature of its internal heatsink, and gives out the heat sink overheat warning signal [OHF] when the temperature exceeds the overheat warning level (C064).

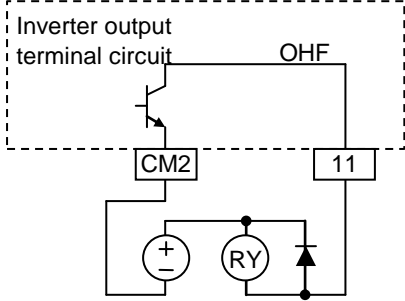
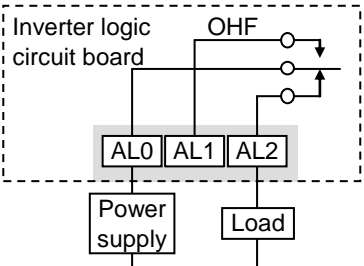
Option Code	Terminal Symbol	Function Name	State	Description
42	OHF	Heat sink overheat warning	ON	Heat sink temperature exceeds the C064 set level
			OFF	Heat sink temperature does not exceed the C064 set level
Valid for outputs			C021, C022, C026	
Required settings			C064	
Notes:			<p>Example for terminal [11] (requires output configuration – see page 3-84):</p>  <p>Example for terminal [AL0], [AL1], [AL2] (requires output configuration – see page 4-46 and 3-84):</p>  <p>See I/O specs on page 4-6.</p>	

Low Load Detection Signal

The low load detection signal output indicates the general status of the inverter output current. When the output current becomes less than the value specified by **C039**, the [LOC] output turns ON.

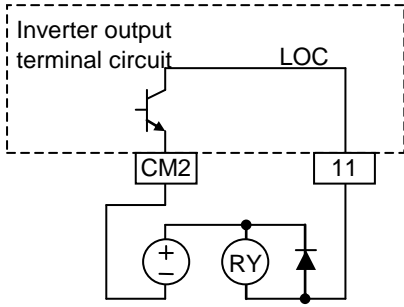
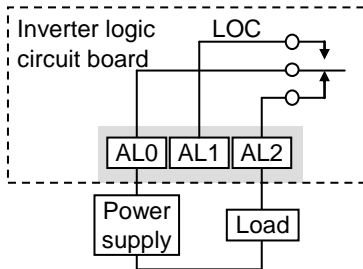
Option Code	Terminal Symbol	Function Name	State	Description
43	LOC	Low load detection	ON	When the output current becomes less than the value specified by C039
			OFF	When the output current is more than the value specified by C039
Valid for outputs		C021, C022, C026		Example for terminal [11] (requires output configuration – see page 3-84): 
Required settings		C038, C039		
Notes:				
				Example for terminal [AL0], [AL1], [AL2] (requires output configuration – see page 4-46 and 3-84): 
				See I/O specs on page 4-6.

General Output (1) to (3)

The functions are for EzSQ. Refer to a manual of EzSQ for detailed description.

Option Code	Terminal Symbol	Function Name	State	Description
44	MO1	General input (1)	ON	Each general output is turned on
45	MO2	General input (2)		
46	MO3	General input (3)		
Valid for outputs		C021, C022, C026		
Required settings				
Notes: Refer to a manual of EzSQ for detailed explanation.				

Inverter Ready Signal

The inverter outputs the inverter ready signal [IRDY] when it is ready for operation (i.e. when it can receive an operational command).

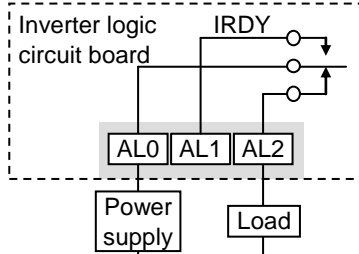
Option Code	Terminal Symbol	Function Name	State	Description
50	IRDY	Inverter ready signal	ON	The inverter is ready to accept the operation command
			OFF	The inverter is not ready to accept the operation command
Valid for outputs		C021, C022, C026		Example for terminal [11] (requires output configuration – see page 3-84):
Required settings		C038, C039		
<p>Notes:</p> <ul style="list-style-type: none"> The inverter can recognize only the operation command is given while the [IRDY] signal is given out If the [IRDY] signal is not given out, check whether the input power supply voltage (connect to the R, S, and T terminals) is within the range of specification 				
<p>Example for terminal [AL0], [AL1], [AL2] (requires output configuration – see page 4-46 and 3-84):</p>  <p>See I/O specs on page 4-6.</p>				

Forward Rotation, Reverse Rotation Signals

Forward Rotation signal- The inverter continues to output the forward rotation signal [FWR] while it is driving the motor for forward operation. The [FWR] signal is turned off while the inverter is driving the motor for reverse operation or stopping the motor.

Reverse Rotation signal - The inverter continues to output the forward rotation signal [RVR] while it is driving the motor for reverse operation. The [RVR] signal is turned off while the inverter is driving the motor for forward operation or stopping the motor.

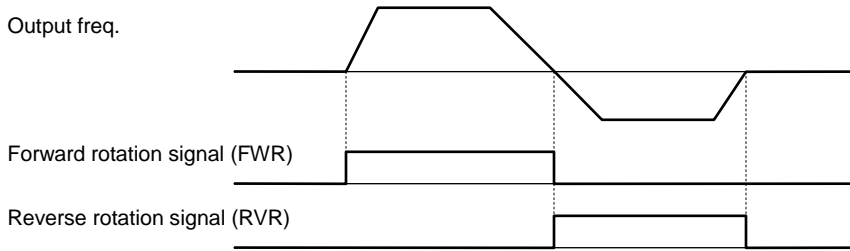

Option Code	Terminal Symbol	Function Name	State	Description
S1	FWR	Forward rotation	ON	Inverter is driving the motor for forward operation
			OFF	Inverter is driving the motor for reverse operation, or the motor is stopped
S2	RVR	Reverse rotation	ON	Inverter is driving the motor for reverse operation
			OFF	Inverter is driving the motor for forward operation, or the motor is stopped
Valid for outputs		C021, C022, C026		Example for terminal [11] (requires output configuration – see page 3-84):
Required settings				
Notes:				<p>Example for terminal [AL0], [AL1], [AL2] (requires output configuration – see page 4-46 and 3-84):</p> <p>See I/O specs on page 4-6.</p>

Major Failure Signal

The inverter gives out the major failure signal in addition to an alarm signal when it trips because of one of the errors listed in note down below.

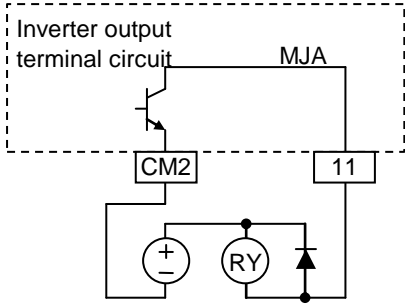
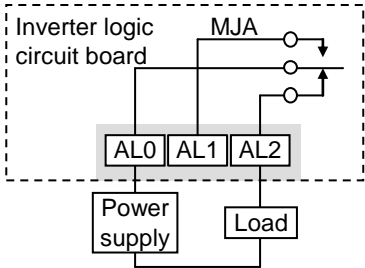
Option Code	Terminal Symbol	Function Name	State	Description
53	MJA	Major failure signal	ON	
			OFF	
Valid for outputs			<i>C021, C022, C026</i>	
Required settings				
Notes:				
The output applies to the tripping caused by hardware as shown below.				
No.	Error code	Description		
1	<i>E08.*</i>	EEPROM error		
2	<i>E10.*</i>	CT error		
3	<i>E11.*</i>	CPU error		
4	<i>E14.*</i>	Ground-fault at power ON		
5	<i>E22.*</i>	CPU error		
6	<i>E25.*</i>	Main Circuit Error		
<p>Example for terminal [11] (requires output configuration – see page 3-84):</p>  <p>Example for terminal [AL0], [AL1], [AL2] (requires output configuration – see page 4-46 and 3-84):</p>  <p>See I/O specs on page 4-6.</p>				

Window Comparator for Analog Inputs

The window comparator function outputs signals when the value of analog inputs [O] and [OI] are within the maximum and minimum limits specified for the window comparator. You can monitor analog inputs with reference to arbitrary levels (to find input terminal disconnection and other errors).

Refer to “[Window Comparator, Analog disconnection](#)” on page 3-65 for details.

Option Code	Terminal Symbol	Function Name	State	Description
54	WCO	Window comparator for analog voltage input	ON	[O] input is inside of the window comparator
			OFF	[O] input is outside of the window comparator
55	WCOI	Window comparator for analog current input	ON	[OI] input is inside of the window comparator
			OFF	[OI] input is outside of the window comparator
Valid for outputs		C021, C022, C026		Example for terminal [11] (requires output configuration – see page 3-84):
Required settings		b060 to b065, b070, b071		
<p>Notes:</p> <ul style="list-style-type: none"> Output values of ODc and OIDc are the same as those of WCO and WCOI, respectively. 				
				<p>The diagram shows an inverter output terminal circuit connected to terminal 11. The circuit includes a transistor, a diode, a resistor labeled RY, and a power source. The output of the inverter is connected to terminal 11 through a diode and a resistor.</p>
				<p>Example for terminal [AL0], [AL1], [AL2] (requires output configuration – see page 4-46 and 3-84):</p> <p>The diagram shows an inverter logic circuit board connected to a power supply and a load. The board has terminals AL0, AL1, and AL2, and a WCO output. The power supply is connected to the board, and the load is connected to the WCO output.</p>
				See I/O specs on page 4-6.

Frequency Command Source, Run Command Source

Frequency Command Source signal - The inverter outputs the frequency command source signal [FREF] while frequency command can be given by operator (**A001 = 02**). The [FREF] signal is turned off while frequency command cannot be given by operator

Run Command Source signal - The inverter outputs the frequency command source signal [REF] while run command can be given by operator (**A002 = 02**). The [REF] signal is turned off while run command cannot be given by operator

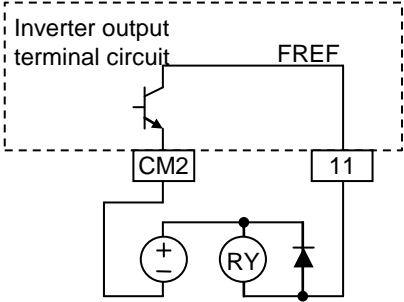
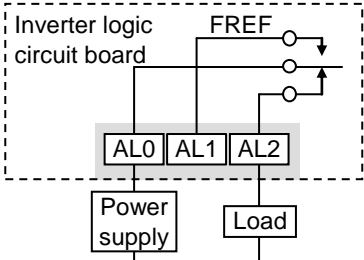
Option Code	Terminal Symbol	Function Name	State	Description
58	FREF	Frequency command source	ON	Frequency command source is via operator
			OFF	Frequency command source is not via operator
59	REF	Run command source	ON	Run command source is via operator
			OFF	Run command source is not via operator
Valid for outputs		C021, C022, C026		Example for terminal [11] (requires output configuration – see page 3-84): 
Required settings				
Notes:				
				Example for terminal [AL0], [AL1], [AL2] (requires output configuration – see page 4-46 and 3-84): 
				See I/O specs on page 4-6.

2nd Motor Selection

This function allows you to switch the inverter setting to control two different types of motors. To use this function, assign function "08" to one of the input terminal and make it on or off. When 2nd motor parameters are selected, output signal [SETM] turns on.

No.	Codes	Description	No.	Codes	Description
1	F202	Acceleration time (1)	15	A261	Frequency upper limit
2	F203	Deceleration time (1)	16	A262	Frequency lower limit
3	A201	Frequency source	17	A281	AVR function select
4	A202	Run command source	18	A282	AVR voltage select
5	A203	Base frequency	19	A292	Acceleration time (2)
6	A204	Maximum frequency	20	A293	Deceleration time (2)
7	A220	Multi-speed frequency 0	21	A294	Select method to switch to Acc2/Dec2 profile
8	A241	Torque boost select	22	A295	Acc1 to Acc2 frequency transition point
9	A242	Manual torque boost value	23	A296	Dec1 to Dec2 frequency transition point
10	A243	Manual torque boost freq.	24	C241	Overload warning level
11	A244	V/f characteristic curve	25	H203	Motor capacity
12	A245	V/f gain	26	H204	Motor poles
13	A246	Voltage comp. gain for automatic torque boost	27	H206	Motor stabilization constant
14	A247	Slip comp. gain for automatic torque boost			

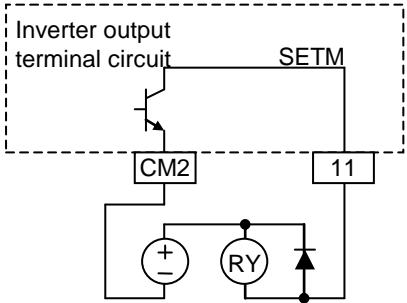
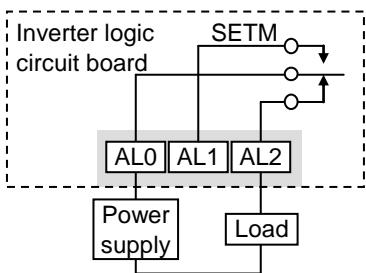
Option Code	Terminal Symbol	Function Name	State	Description
60	SETM	2 nd motor selection	ON	2 nd motor parameter sets are selected
			OFF	1 st motor parameter sets are selected
Valid for outputs		C021		Example for terminal [11] (requires output configuration – see page 3–84): 
Required settings				
Notes:				
				Example for terminal [AL0], [AL1], [AL2] (requires output configuration – see page 4–46 and 3–84): 
				See I/O specs on page 4-6.

STO (Safe Torque Off) Performance Monitor

This signal is specific for Safe Stop function.

Option Code	Terminal Symbol	Function Name	State	Description
62	EDM	STO (Safe Torque Off) Performance Monitor (Output terminal 11 only)	ON	
			OFF	
Valid for outputs		CO2 I		Dedicated to terminal [11]:
Required settings				
Notes:				

Analog Input Operation

The WL200 inverters provide for analog input to command the inverter frequency output value. The analog input terminal group includes the [L], [OI], [O], and [H] terminals on the control connector, which provide for Voltage [O] or Current [OI] input. All analog input signals must use the analog ground [L].

If you use either the voltage or current analog input, you must select one of them using the logic input terminal function [AT] analog type. Refer to the table on next page showing the activation of each analog input by combination of **ADD5** set parameter and [AT] terminal condition. The [AT] terminal function is covered in "Analog Input Current/Voltage Select" on page 4-28. Remember that you must also set **ADD 1 = 0 1** to select analog input as the frequency source.

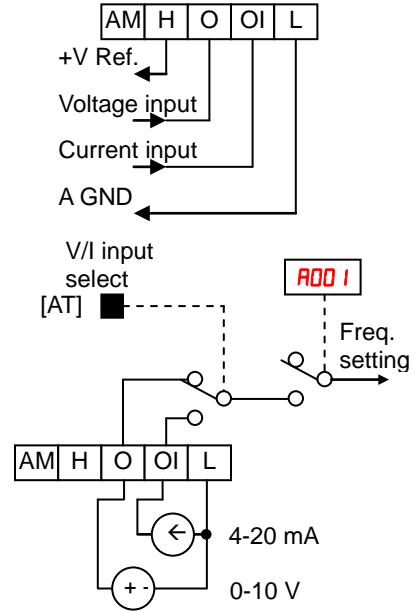

NOTE: If no logic input terminal is configured for the [AT] function, then inverter recognizes that [AT]=OFF and MCU recognizes [O]+[OI] as analog input.

Using an external potentiometer is a common way to control the inverter output frequency (and a good way to learn how to use the analog inputs). The potentiometer uses the built-in 10V reference [H] and the analog ground [L] for excitation, and the voltage input [O] for the signal. By default, the [AT] terminal selects the voltage input when it is OFF. Take care to use the proper resistance for the potentiometer, which is 1 to 2 k Ω , 2 Watts.

Voltage Input – The voltage input circuit uses terminals [L] and [O]. Attach the signal cable's shield wire only to terminal [L] on the inverter. Maintain the voltage within specifications (do not apply negative voltage).

Current Input – The current input circuit uses terminals [OI] and [L]. The current comes from a *sourcing* type transmitter; a *sinking* type will not work! This means the current must flow into terminal [OI], and terminal [L] is the return back to the transmitter. The input impedance from [OI] to [L] is 100 Ohms. Attach the cable shield wire only to terminal [L] on the inverter.

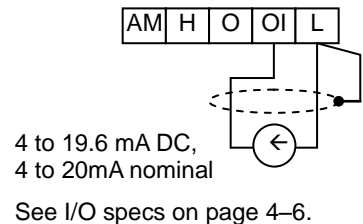
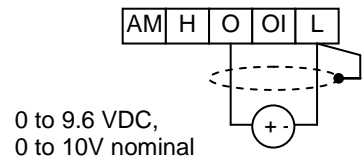
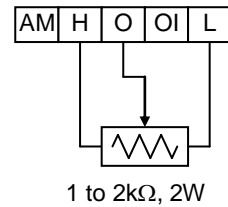

The following table shows the available analog input settings. Parameter **A005** and the input terminal [AT] determine the External Frequency Command input terminals that are available, and how they function. The analog inputs [O] and [OI] use terminal [L] as the reference (signal return).

A005	[AT] Input	Analog Input Configuration
00	ON	[O]
	OFF	[OI]
02	ON	[O]
	OFF	Integrated POT on external panel
03	ON	[OI]
	OFF	Integrated POT on external panel

Other Analog Input-related topics:

- "Analog Input Settings"
- "Additional Analog Input Settings"
- "Analog Signal Calibration Settings"
- "Analog Input Current/Voltage Select"
- "ADD Frequency Enable"
- "Analog Input Disconnect Detect"

Analog Output Operation

In inverter applications it is useful to monitor the inverter operation from a remote location or from the front panel of an inverter enclosure. In some cases, this requires only a panel-mounted volt meter. In other cases, a controller such as a PLC may provide the inverter's frequency command, and require inverter feedback data (such as output frequency or output current) to confirm actual operation. The analog output terminal [AM] serves these purposes.

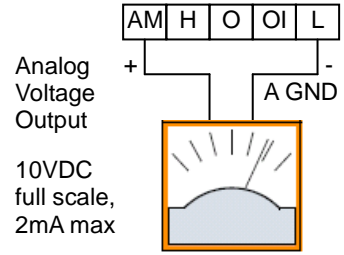

Analog Voltage Output

10VDC full scale, 2mA max

See I/O specs on page 4-6.

The inverter provides an analog voltage output on terminal [AM] with terminal [L] as analog GND reference. The [AM] can output inverter frequency or current output value. Note that the voltage range is 0 to +10V (positive-going only), regardless of forward or reverse motor rotation. Use **C028** to configure terminal [AM] as indicated below.

Func.	Code	Description
C028	00	Inverter output frequency
	01	Inverter output current
	03	Digital output frequency
	04	Inverter output voltage
	05	Inverter input power
	06	Electronic Thermal Load
	07	LAD frequency
	08	Digital current monitor
	10	Cooling fin temperature
	12	General purpose
	16	Option

The [AM] signal offset and gain are adjustable, as indicated below.

Func.	Description	Range	Default
C 106	[AM] output gain	0. to 255.	100.
C 109	[AM] output offset	0.0 to 10.0	0.0

The graph below shows the effect of the gain and offset setting. To calibrate the [AM] output for your application (analog meter), follow the steps below:

1. Run the motor at the full scale speed, or most common operating speed.
 - a. If the analog meter represents output frequency, adjust offset (**C 109**) first, and then use **C 106** to set the voltage for full scale output.
 - b. If [AM] represents motor current, adjust offset (**C 109**) first, and then use **C 106** to set the voltage for full scale output. Remember to leave room at the upper end of the range for increased current when the motor is under heavier loads.

AM output offset adjustment

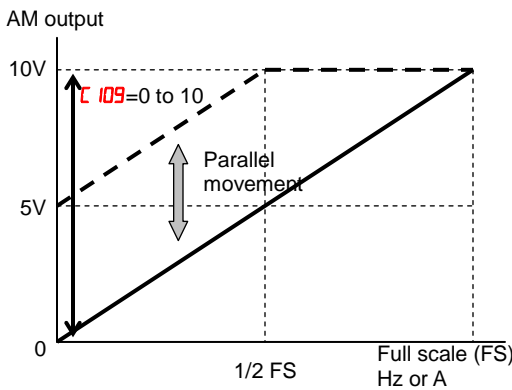

AM output gain adjustment

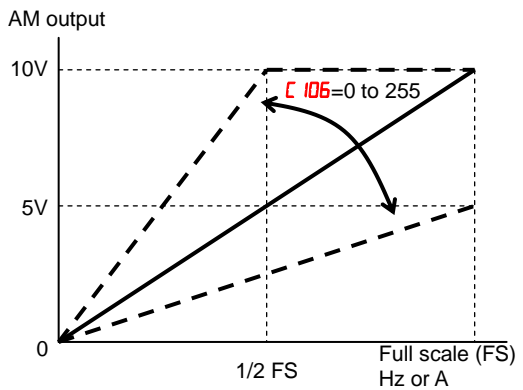

NOTE: As mentioned above, first adjust the offset, and then adjust the gain. Otherwise the required performance cannot be obtained because of the parallel movement of the offset adjustment.

Inverter System Accessories



In This Chapter...	page
- Introduction.....	5-2
- Component Descriptions.....	5-3

Introduction

A motor control system will obviously include a motor and inverter, as well as fuses for safety. If you are connecting a motor to the inverter on a test bench just to get started, that's all you may need for now. But a fully developed system can also have a variety of additional components. Some can be for noise suppression, while others may enhance the inverter's braking performance. The figure below shows a system with several possible optional components, and the table gives part number information.

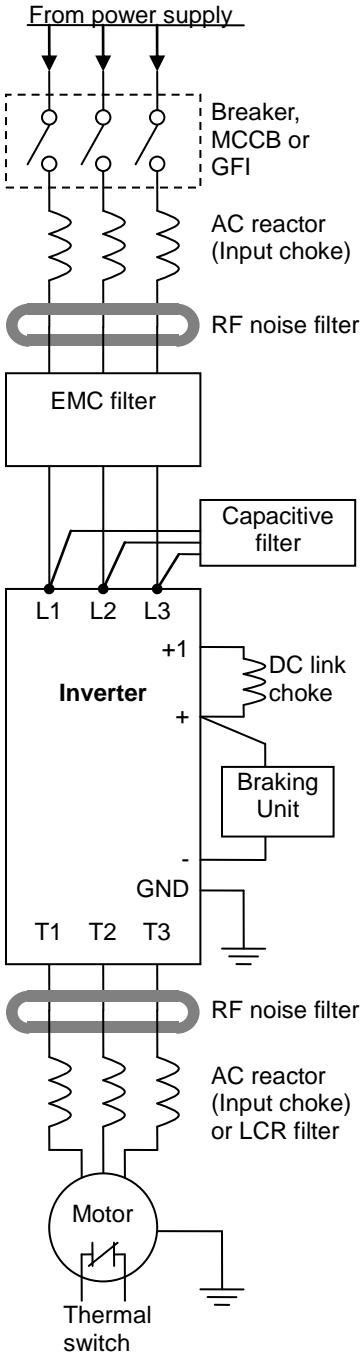

Name	Part No. Series	
	EU, Japan	USA
AC reactor, input side	ALI-xxx2	HRL-x
RF noise filter, input side	ZCL-xxx	ZCL-xxx
EMC filter (for CE)	Refer to Appendix D "CE-EMC Installation Guidelines".	
Capacitive filter	CFI-x	CFI-x
DC link choke	DCL-x-xx	HDC-xxx
Braking resistor	JRB-xxx-x SRB-xxx-x	JRB-xxx-x SRB-xxx-x
Braking resistor NEMA-rated	—	HRB-x, NSRBx00-x NJRb-xxx
Braking unit	BRD-xxx	BRD-xxx
RF noise filter, output side	ZCL-xxx	ZCL-xxx
AC reactor, output side	ACL-x2-xxx	HRL-xxx
LCR filter	Combination: ACL-x2-xxx LPF-xxx R-2-xxx	HRL-xxC



NOTE: The Hitachi part number series for accessories includes different sizes of each part type, specified by the -x suffix. Hitachi product literature can help match size and rating of your inverter to the proper accessory size.

Each inverter accessory comes with its own printed instruction manual. Please refer to those manuals for complete installation details. This chapter gives only an overview of these optional system devices.

Component Descriptions

AC Reactors, Input Side

This is useful in suppressing harmonics induced on the power supply lines, or when the main power voltage imbalance exceeds 3% (and power source capacity is more than 500 kVA), or to smooth out line fluctuations. It also improves the power factor.

In the following cases for a general-purpose inverter, a large peak current flow on the main power supply side, and is able to destroy the inverter module:

- If the unbalanced factor of the power supply is 3% or higher
- If the power supply capacity is at least 10 times greater than the inverter capacity (the power supply capacity is 500 kVA or more)
- If abrupt power supply changes are expected

Examples of these situations include:

1. Several inverters are connected in parallel, sharing the same power bus
2. A thyristor converter and an inverter are connected in parallel, sharing the same power bus
3. An installed phase-advance (power factor correction) capacitor opens and closes

Where these conditions exist or when the connected equipment must be highly reliable, you **MUST** install an input-side AC reactor of 3% (at a voltage drop at rated current) with respect to the supply voltage on the power supply side. Also, where the effects of an indirect lightning strike are possible, install a lightning conductor.

Example calculation:

$$V_{RS} = 205V, V_{ST} = 203V, V_{TR} = 197V,$$

where V_{RS} is R-S line voltage, V_{ST} is S-T line voltage, V_{TR} is T-R line voltage

Unbalance factor of voltage =

$$\frac{\text{Max. line voltage (min.)} - \text{Mean Line voltage}}{\text{Meanline voltage}} \times 100$$

$$= \frac{V_{RS} - (V_{RS} + V_{ST} + V_{TR})/3}{(V_{RS} + V_{ST} + V_{TR})/3} \times 100 = \frac{205 - 202}{202} \times 100 = 1.5\%$$

Please refer to the documentation that comes with the AC reactor for installation instructions.

AC Reactors, Output Side

This reactor reduces the vibrations in the motor caused by the inverter's switching waveforms, by smoothing the waveforms to approximate commercial power quality. It is also useful to reduce the reflected voltage wave phenomenon when wiring from the inverter to the motor is more than 10m in length. Please refer to the documentation that comes with the AC reactor for installation instructions.

Zero-phase Reactor (RF Noise Filter)

The zero-phase reactor helps reduce radiated noise from the inverter wiring. It can be used on the input or output side of the inverter. The example zero-phase reactor shown to the right comes with a mounting bracket. The wiring must go through the opening to reduce the RF component of the electrical noise. Loop the wires three times (four turns) to attain the full RF filtering effect. For larger wire sizes, place multiple zero-phase reactors (up to four) side-by-side for a greater filtering effect.



ZCL-xxx

Dynamic Braking Selection Tables

The WL200 series inverter models have internal braking units. Additional stopping torque is available by adding external resistors. The required braking torque depends on your particular application. Other tables in this section will help you choose the proper resistor.

200V Class		Performance without resistor		Performance at Minimum Resistance			Min. Resistance at 100% Braking Duty Cycle	
WL200 Model Number	HP	Integrated Resistor	Braking Torque (%)	Min. Resistance (Ohms)	Braking Torque (%)	Max. Braking Duty Cycle (%)	Min. Resistance at 100% Braking Duty Cycle (Ohms)	Braking Torque (%)
002	1/4	N.A.	50	100	200	10	317	150
004	1/2	N.A.	50	100	200	10	317	100
007	1	N.A.	50	50	200	10	159	100
015	2	N.A.	50	50	200	10	159	100
022	3	N.A.	50	50	150	10	159	50

400V Class		Performance without resistor		Performance at Minimum Resistance			Min. Resistance at 100% Braking Duty Cycle	
WL200 Model Number	HP	Integrated Resistor	Braking Torque (%)	Min. Resistance (Ohms)	Braking Torque (%)	Max. Braking Duty Cycle (%)	Min. Resistance at 100% Braking Duty Cycle (Ohms)	Braking Torque (%)
004	1/2	N.A.	50	180	150	10	570	100
007	1	N.A.	50	180	150	10	570	100
015	2	N.A.	50	180	150	10	570	100
022	3	N.A.	50	180	150	10	570	60
030	4	N.A.	20	100	100	10	317	60
040	5	N.A.	20	100	100	10	317	50
055	7.5	N.A.	20	100	100	10	317	40
075	10	N.A.	20	70	80	10	222	40
110	15	N.A.	20	70	80	10	222	30
150	20	N.A.	15	70	60	10	222	20
185	25	N.A.	15	35	60	10	111	20

Troubleshooting and Maintenance



6

In This Chapter...	page
- Troubleshooting	6-2
- Monitoring Trip Events, History, & Conditions	6-8
- Restoring Factory Default Settings	6-14
- Maintenance and Inspection	6-15
- Warranty	6-22

Troubleshooting

Safety Messages

Please read the following safety messages before troubleshooting or performing maintenance on the inverter and motor system.



WARNING: Wait at least ten (10) minutes after turning OFF the input power supply before performing maintenance or an inspection. Otherwise, there is a danger of electric shock.



WARNING: Make sure that only qualified personnel will perform maintenance, inspection, and part replacement. Before starting to work, remove any metallic objects from your person (wristwatch, bracelet, etc.). Be sure to use tools with insulated handles. Otherwise, there is a danger of electric shock and/or injury to personnel.



WARNING: Never remove connectors by pulling on its wire leads (wires for cooling fan and logic P.C.board). Otherwise, there is a danger of fire due to wire breakage and/or injury to personnel.

General Precautions and Notes

- Always keep the unit clean so that dust or other foreign matter does not enter the inverter.
- Take special care in regard to breaking wires or making connection mistakes.
- Firmly connect terminals and connectors.
- Keep electronic equipment away from moisture and oil. Dust, steel filings and other foreign matter can damage insulation, causing unexpected accidents, so take special care.

Inspection Items

This chapter provides instructions or checklists for these inspection items:

- Daily inspection
- Periodical inspection (approximately once a year)
- Insulation resistance (Megger) test (approximately once two years)

Troubleshooting Tips

The table below lists typical symptoms and the corresponding solution(s).

1. Inverter does not power up.

Possible Cause(s)	Corrective Action
Power cable is incorrectly wired.	Check input wiring
Short bar or DCL between [P] and [PD] is disconnected.	Install short bar or DCL between [P] and [PD] terminal.
Power cable is breaking.	Check input wiring.

2. Motor does not start.

Possible Cause(s)	Corrective Action
Incorrect RUN command source is selected.	Check RUN command source (A002) for correct source. Ex. Terminal (digital input) : 01 Operator (RUN key) : 02
Incorrect frequency source is selected.	Check frequency source (A001) for correct source. Ex. Terminal (analog input) : 01 Operator (F001) : 02
Frequency setting is 0Hz.	If frequency source is terminal (A001=01), check analog voltage or current signal at [O] or [OI] terminals. If frequency source is operator (A001=02), set frequency in F001. Depending on frequency source, input proper frequency reference. If frequency source is multi-speed operation, set frequency in A020 to A035 and A220.
RUN command is not set to input terminal.	If RUN command source is terminal (A002=01), set "forward" (00:FW) or "reverse" (01:RV) to any input terminals. In case of 3-wire control, set "3-wire start" (20:STA), "3-wire stop" (21:STP) and "3-wire FW/RV" (22:F/R) to any input terminals.
"Multi-speed input(s) (02 to 05:CF1 to CF4)" is (are) set to input terminal(s) and active.	Deactivate the input(s).
Both FW and RV input are active.	If RUN command source is FW/RV input, activate either FW or RV input.
Rotation direction restriction (b035) is enabled.	Check b035.
Incorrect input wiring or short bar position	Wire inputs correctly and/or install short bar. (ON/OFF status of inputs are monitored in d005.)
Incorrect analog input or variable resistor wiring	Wire correctly. In case of analog voltage or variable resistor input, check voltage between [O] and [L] terminal. In case of analog current, check current between current source and [OI] terminal.
RUN command source is operator, but input terminal is set to "Force terminal" and active.	Deactivate the input.
RUN command source is terminal, but input terminal is set to "Force operator" and active.	Deactivate the input.
Inverter is in trip status. (With ALARM LED and "Exxx" indication)	Reset inverter by STOP/RESET key and check error code.
Safety function is enabled and either GS1 or GS2 input is inactive.	If safety function is used, activate both GS1 and GS2. If not, disable safety function by dip switch.

Possible Cause(s)	Corrective Action
"18:RS", "14:CS" or "11:FRS" is set to input terminal and the input is active.	Deactivate the input.
"84:ROK" is set to input terminal and the input is not active.	Activate the input.
Cable between inverter and motor or internal cable of motor is breaking.	Check the wiring.
Excess load.	Remove excess load.
Motor is locked.	Unlock the motor.

3. Motor does not accelerate to command speed.

Possible Cause(s)	Corrective Action
Bad connection of analog wiring.	Check the wiring. In case of analog voltage or variable resistor input, check voltage between [O] and [L] terminal. In case of analog current, check current between current source and [OI] terminal.
Overload restriction or OC suppression function works.	Check the function level.
Max. frequency (A004) or upper limit (A061/A261) is lower than as expected.	Check the value.
Acceleration time is excessive.	Change acceleration time (F002/A092/A292).
"Multi-speed input(s) (02 to 05:CF1 to CF4)" is (are) set to input terminal(s) and active.	Deactivate the input(s).
"06:JG " is set to input terminal and the input is active.	Deactivate the input.
Excess load.	Remove excess load.
Motor is locked.	Unlock the motor.
Over fluxing	Refer to Note.1.

4. Inverter does not respond to changes in frequency setting from operator.

Possible Cause(s)	Corrective Action
Incorrect frequency source is selected.	Check frequency source (A001=02).
"51:F-TM" is set to input terminal and the input is active.	Deactivate the input.

5. A part of function codes is not displayed.

Possible Cause(s)	Corrective Action
"Function code display restriction" (b037) is enabled.	Set 00 (all display) to b037.
"86:DISP" is set to input terminal and the input is active.	Deactivate the input.

6. Operator (keypad) does not respond.

Possible Cause(s)	Corrective Action
"86:DISP" is set to input terminal and the input is active.	Deactivate the input.

7. Parameter data does not change.

Possible Cause(s)	Corrective Action
Inverter is in RUN status.	Stop the inverter, make sure the motor stops and try again. If "RUN mode edit" is enabled, a part of function codes can be changed in RUN status.
Software lock function (b031) is enabled.	Disable software lock function.

8. Motor rotates reverse direction with forward command.

Possible Cause(s)	Corrective Action
Incorrect power wiring.	Exchange any two of U/T1, V/T2 or W/T3.
Incorrect logic of direction signal in 3-wire operation.	Check the logic of input set as "22:F/R".

9. Motor rotates reverse direction with RUN key of keypad.

Possible Cause(s)	Corrective Action
Keypad RUN key routing (F004) is incorrectly set.	Check F004.

10. Overcurrent trip (E03)

Possible Cause(s)	Corrective Action
Acceleration time is short.	Change acceleration time (F002/A092/A292). Enable "acceleration hold" function (A069,A070)
Excess load.	Remove excess load. Enable torque boost function. Set free V/f in V/F characteristic curve selection (A044/A244=02)
Overload restriction (b021) is disabled (00).	Enable overload restriction (b021=01/02/03).

When the inverter trips due to Overcurrent (E03), despite overload restriction is enabled (b021=01/02/03).

Overload restriction level (b022/b025) is high.	Set overload restriction level (b022/b025) lower.
Deceleration rate at overload restriction (b023/b026) is too short.	Set deceleration rate at overload restriction (b023/b026) longer.
Over fluxing	Refer to Note.1.

11. STOP/RESET key does not respond.

Possible Cause(s)	Corrective Action
STOP/RESET key disabled.	Check "STOP key enable" function. (b087)
Deceleration overvoltage suppression (b130) or controlled deceleration on power loss (b050) function is enabled.	Check b130 and b050.

12. Sound noise of motor or machine.

Possible Cause(s)	Corrective Action
Carrier frequency is low.	Set carrier frequency (b083) higher. (This could cause electric noise and leak current higher.)
Machine frequency and motor frequency are resonated.	Change output frequency slightly. If resonating in accel/deceleration, use jump frequency function (A063-68) to avoid machine frequency.
Over excitation	Set base frequency (A003/A203) and AVR voltage (A082/A282) according to motor rating. If not improved, reduce V/f gain (A045/A245) slightly or change V/f curve (A044/A244) as free V/f.

13. Overload trip (E05).

Possible Cause(s)	Corrective Action
Improper electronic thermal level	Check electronic thermal setting (b012/b013)
Over fluxing	Refer to Note.1.

14. Over voltage trip (E07).

Possible Cause(s)	Corrective Action
Short deceleration time	Change deceleration time. (F003/F203/A093/A293)
Overvoltage suppression during deceleration (b130) is disabled (00).	Enable overvoltage suppression (b130=01/02).

When the inverter trips due to over voltage, despite over voltage suppression is enabled.

Improper overvoltage suppression proportional gain (b134) or integral time (135).	Check overvoltage suppression proportional gain (b134) and integral time (b135).
Overvoltage suppression level (b131) is high.	Set Overvoltage suppression level (b131) lower. (Lower limit of parameter b131 must be (input voltage) $\times\sqrt{2}\times 1.1$.)

15. Thermistor error trip (E35).

Possible Cause(s)	Corrective Action
Thermistor is set to input [5] and DC24V is supplied.	Check setting of input terminal [5] (C005).

16. Unstable output frequency.

Possible Cause(s)	Corrective Action
Improper parameters	Set output frequency slightly smaller or bigger value than power source frequency. Change motor stabilization constant (H006/H206).
Load variation is excessive.	Change motor and inverter to one size bigger.
Power voltage variation is excessive.	Check power source.
Over fluxing	Refer to Note.1.

17. Output torque is not sufficient.

Possible Cause(s)	Corrective Action
Improper parameters [Acceleration]	Increase torque boost (A042/A242-A043/A243)
	Reduce carrier frequency (A083).
	Change torque boost select (A041/A241) to automatic.
Improper parameters [Deceleration]	Increase deceleration time (F003/F203/A093/A293).
	Disable AVR function (A081/A281).
	Install dynamic braking resistor or regenerative braking unit.

18. If cable to operator is disconnected, inverter will trip or stop.

Possible Cause(s)	Corrective Action
Improper setting of b165.	Set ex.operator com loss action (b165) to 02.

19. No response over Modbus communication.

Possible Cause(s)	Corrective Action
New parameter is not updated.	If C071, C074 or C075 is changed, cycle power or reset inverter by turning RS terminal ON and OFF.
Incorrect setting of RUN command source (A002/A202).	Set RUN command source (A002/A202) to 03.
Incorrect setting of Frequency source (A001/A201).	Set frequency source (A001/A201) to 03.
Incorrect setting of com. speed.	Check communication speed (A071).
Incorrect setting or duplication of Modbus address.	Check Modbus address (A072).
Incorrect setting of com. parity.	Check communication parity (A074).
Incorrect setting of com. stop bit.	Check communication stop bit (A075).
Incorrect wiring.	Check communication wiring at SP,SN terminals.

20. When inverter starts, ECB (Earth leakage Circuit Breaker) trips.

Possible Cause(s)	Corrective Action
Leak current of inverter is excessive.	Reduce carrier frequency (A083). Increase current sensor level of ECB or replace ECB with another one having higher current sensor level.

21. DC braking doesn't work

Possible Cause(s)	Corrective Action
DC braking force for deceleration (A054) isn't set. (Defaults (0.))	Set DC braking force for deceleration (A054).
DC braking time for deceleration (A055) isn't set. (Defaults (0.0))	Set DC braking time for deceleration (A055).

22. Under-voltage error

Possible Cause(s)	Corrective Action
Decrease in input voltage due to capacity shortage of electric source.	Make capacity of electric source larger.

23. TV or radio near inverter receives noises

Possible Cause(s)	Corrective Action
The radiation noise generated by the inverter.	Put away those devices from the inverter as far as possible.

Note.

Set the parameter A041 from 01 to 00 and try. Take a guess motor constant about the connected motor either Europe or Japanese. Change parameter setting H003 to another and cut & try. If the motor constant is closer to Japanese, set the parameter setting b085 from 01 to 00. Change the current parameter setting H003 to another value anyway. Then, change the parameter setting H003 to your thinking value cut & try.

Monitoring Trip Events, History, & Conditions

Fault Detection and Clearing

The microprocessor in the inverter detects a variety of fault conditions and captures the event, recording it in a history table. The inverter output turns OFF, or "trips" similar to the way a circuit breaker trips due to an over-current condition. Most faults occur when the motor is running (refer to the diagram to the right). However, the inverter could have an internal fault and trip in Stop Mode.

In either case, you can clear the fault by pressing the Stop/Reset key. Additionally, you can clear the inverter's cumulative trip history by performing the procedure "[Restoring Factory Default Settings](#)" on page 6-14 (setting **b084=00** will clear the trip history but leave inverter settings intact).

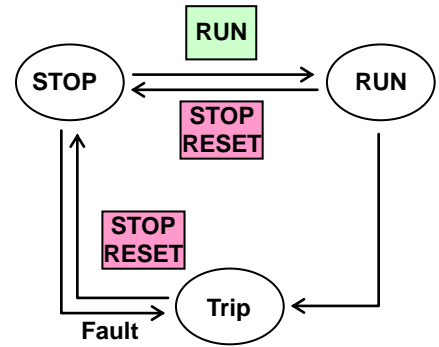

Error Codes

An error code will appear on the display automatically when a fault causes the inverter to trip. The following table lists the cause associated with the error.

Error Code	Name	Cause(s)
E01	Over-current event while at constant speed	The inverter output was short-circuited, or the motor shaft is locked or has a heavy load. These conditions cause excessive current for the inverter, so the inverter output is turned OFF. Setting in dual-voltage motor is wrong.
E02	Over-current event during deceleration	
E03	Over-current event during acceleration	
E04	Over-current event during other conditions	
E05	Overload protection	When a motor overload is detected by the electronic thermal function, the inverter trips and turns OFF its output.
E06	Braking resistor overload protection	When the BRD operation rate exceeds the setting of "b090", this protective function shuts off the inverter output and displays the error code.
E07	Over-voltage protection	When the DC bus voltage exceeds a threshold, due to regenerative energy from the motor.
E08	EEPROM error	When the built-in EEPROM memory has problems due to noise or excessive temperature, the inverter trips and turns OFF its output to the motor.
E09	Under-voltage error	A decrease of internal DC bus voltage below a threshold results in a control circuit fault. This condition can also generate excessive motor heat or cause low torque. The inverter trips and turns OFF its output.
E10	Current detection error	If an error occurs in the internal current detection system, the inverter will shut off its output and display the error code.

Error Code	Name	Cause(s)
E11	CPU error	A malfunction in the built-in CPU has occurred, so the inverter trips and turns OFF its output to the motor.
E12	External trip	A signal on an intelligent input terminal configured as EXT has occurred. The inverter trips and turns OFF the output to the motor.
E13	USP	When the Unattended Start Protection (USP) is enabled, an error occurred when power is applied while a Run signal is present. The inverter trips and does not go into Run Mode until the error is cleared.
E14	Ground fault	The inverter is protected by the detection of ground faults between the inverter output and the motor upon during powerup tests. This feature protects the inverter, and does not protect humans.
E15	Input over-voltage	The inverter tests for input over-voltage after the inverter has been in Stop Mode for 100 seconds. If an over-voltage condition exists, the inverter enters a fault state. After the fault is cleared, the inverter can enter Run Mode again.
E19	Inverter thermal detection system error	When the thermal sensor in the inverter module is not connected.
E21	Inverter thermal trip	When the inverter internal temperature is above the threshold, the thermal sensor in the inverter module detects the excessive temperature of the power devices and trips, turning the inverter output OFF.
E22	CPU communication error	When communication between two CPU fails, inverter trips and displays the error code.
E25	Main circuit error (*3)	The inverter will trip if the power supply establishment is not recognized because of a malfunction due to noise or damage to the main circuit element.
E30	Driver error	An internal inverter error has occurred at the safety protection circuit between the CPU and main driver unit. Excessive electrical noise may be the cause. The inverter has turned OFF the IGBT module output.
E35	Thermistor	When a thermistor is connected to terminals [5] and [L] and the inverter has sensed the temperature is too high, the inverter trips and turns OFF the output.
E36	Braking error	When "01" has been specified for the Brake Control Enable (b120), the inverter will trip if it cannot receive the braking confirmation signal within the Brake Wait Time for Confirmation (b124) after the output of the brake release signal.
E37	Safe Stop	Safe stop signal is given.
E38	Low-speed overload protection	If overload occurs during the motor operation at a very low speed, the inverter will detect the overload and shut off the inverter output.
E40	Operator connection	When the connection between inverter and operator keypad failed, inverter trips and displays the error code.
E41	Modbus communication error	When "trip" is selected (C076=00) as a behavior in case of communication error, inverter trips when timeout happens.
E43	EzSQ invalid instruction	The program stored in inverter memory has been destroyed, or the PRG terminal was turned on without a program downloaded to the inverter.









Error Code	Name	Cause(s)
<i>E44</i>	EzSQ nesting count error	Subroutines, if-statement, or for-next loop are nested in more than eight layers
<i>E45</i>	EzSQ instruction error	Inverter found the command which cannot be executed.
<i>E50</i> to <i>E59</i>	EzSQ user trip (0 to 9)	When user –defined trip happens, inverter trips and displays the error code.
<i>E60</i> to <i>E69</i>	Option error	The inverter detects errors in the option board mounted in the optional slot. For details, refer to the instruction manual for the mounted option board.

Warning Codes

If set parameter is conflicted to other parameters, warning code is displayed as follows.

Warning Code	Warning condition		
H001	Frequency upper limit (A061)	>	Max. Frequency (A004)
H002	Frequency lower limit (A062)	>	Max. Frequency (A004)
H005	Output Frequency setting (F001) Multi-speed freq. 0 (A020)	>	Max. Frequency (A004)
H015	Output Frequency setting (F001) Multi-speed freq. 0 (A020)	>	Frequency upper limit (A061)
H025	Frequency lower limit (A062)	>	Output Frequency setting (F001) Multi-speed freq. 0 (A020)
H031	Start frequency (A082)	>	Frequency upper limit (A061)
H032	Start frequency (A082)	>	Frequency lower limit (A062)
H035	Start frequency (A082)	>	Output Frequency setting (F001) Multi-speed freq. 0 (A020)
H036	Start frequency (A082)	>	Multi-speed freq. 1-15 (A021-A035)
H037	Start frequency (A082)	>	Jogging frequency (A038)
H085	Output Frequency setting (F001) Multi-speed freq. 0 (A020)	=	Jump frequency (A063/A063/A063±A064/A066/A068)
H086	Multi-speed freq. 1-15 (A021-A035)		
H091	Free setting V/f frequency 7	>	Frequency upper limit (A061)
H092	Free setting V/f frequency 7	>	Frequency lower limit (A062)
H095	Free setting V/f frequency 7	>	Output Frequency setting (F001) Multi-speed freq. 0 (A020)
H201	Frequency upper limit (A261)	>	Max. Frequency (A204)
H202	Frequency lower limit (A262)	>	Max. Frequency (A204)
H205	Output Frequency setting (F001) Multi-speed freq. 0 (A220)	>	Max. Frequency (A204)
H215	Output Frequency setting (F001) Multi-speed freq. 0 (A220)	>	Frequency upper limit (A261)
H225	Frequency lower limit (A262)	>	Output Frequency setting (F001) Multi-speed freq. 0 (A220)
H231	Start frequency (A082)	>	Frequency upper limit (A261)
H232	Start frequency (A082)	>	Frequency lower limit (A262)
H235	Start frequency (A082)	>	Output Frequency setting (F001) Multi-speed freq. 0 (A220)
H285	Output Frequency setting (F001) Multi-speed freq. 0 (A220)	=	Jump frequency (A063/A063/A063±A064/A066/A068)
H291	Free setting V/f frequency 7	>	Frequency upper limit (A261)
H292	Free setting V/f frequency 7	>	Frequency lower limit (A262)
H295	Free setting V/f frequency 7	>	Output Frequency setting (F001) Multi-speed freq. 0 (A220)

Other indications

Display	Name	Descriptions
 Rotating	Reset	RS input is ON or STOP/RESET key is pressed.
	Under-voltage	If input voltage is under the allowed level, inverter shuts off output and wait with this indication.
	Waiting to restart	This indication is displayed after tripping before restarting.
	Restricted operation command	Commanded RUN direction is restricted in b035.
	Trip history initializing	Trip history is being initialized.
	No data (Trip monitor)	No trip/waning data exists.
 Blinking	Communication error	Communication between inverter and digital operator fails.
	Auto-tuning completed	Auto-tuning is completed properly.
	Auto-tuning error	Auto-tuning fails.



NOTE: Reset is not allowed in 10 second after trip.

NOTE: When error E08, E14 and E30 occur, reset operation by RS terminal or STOP/RESET key is not accepted. In this case, reset by cycling power. If still same error occurs, perform initialization.

Trip History and Inverter Status

We recommend that you first find the cause of the fault before clearing it. When a fault occurs, the inverter stores important performance data at the moment of the fault. To access the data, use the monitor function (dxxx) and select **d0B1** details about the present fault. The previous 5 faults are stored in **d0B2** to **d0B6**. Each error shifts **d0B1**-**d0B5** to **d0B2**-**d0B6**, and writes the new error to **d0B1**.

The following Monitor Menu map shows how to access the error codes. When fault(s) exist, you can review their details by first selecting the proper function: **d0B1** is the most recent, and **d0B6** is the oldest.

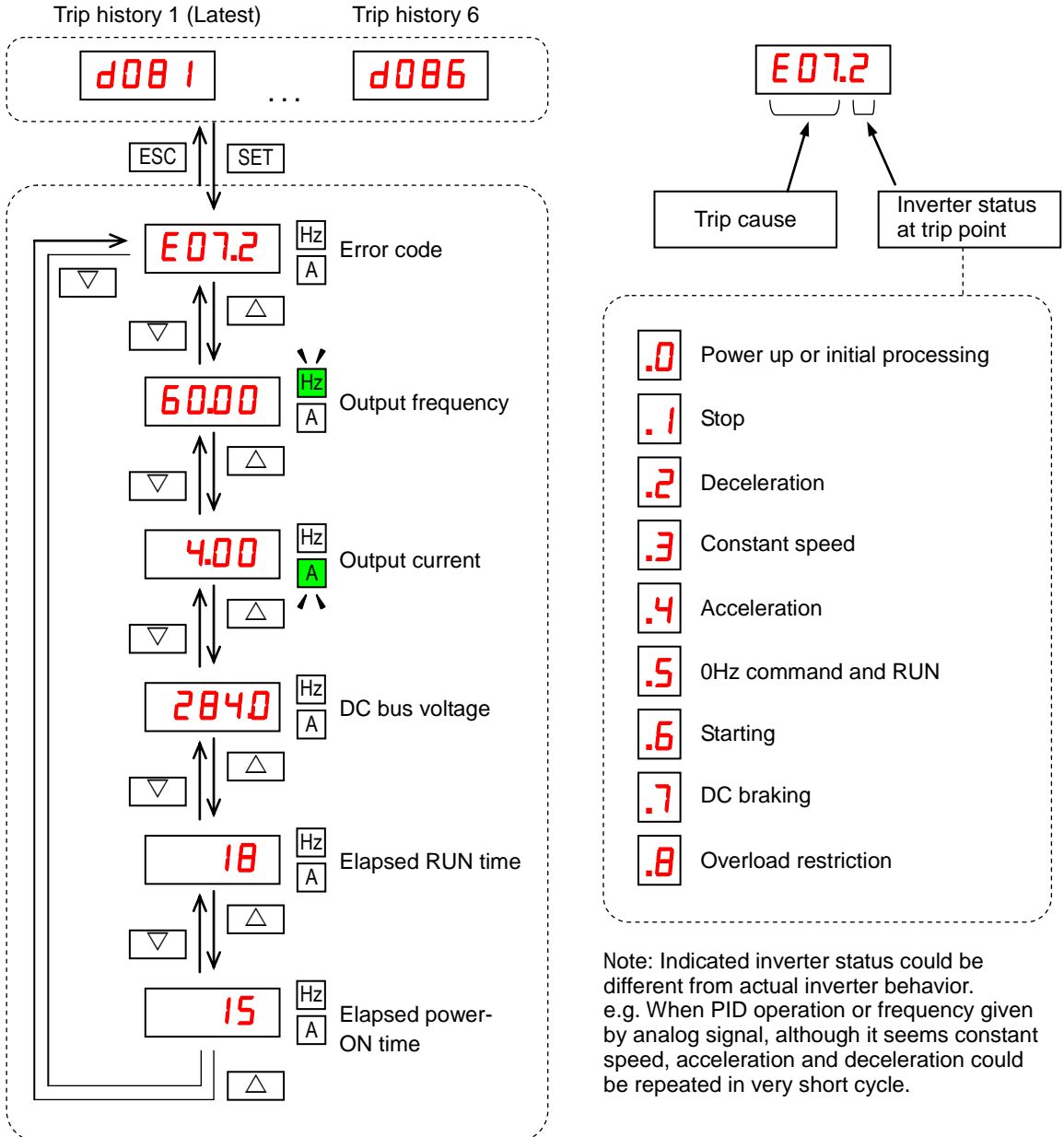

Restoring Factory Default Settings

You can restore all inverter parameters to the original factory (default) settings according to area of use. After initializing the inverter, use the powerup test in Chapter 2 to get the motor running again. To initialize the inverter, follow the steps below.

- (1) Select initialization mode in **b084**.
 - (2) If **b084=02, 03** or **04**, select initialization target data in **b094**.
 - (3) If **b084=02, 03** or **04**, select country code in **b085**.
 - (4) Set **01** in **b180**.
-
- (5) The following display appears for a few seconds, and initialization is completed with **d001** displayed.
-

Display during initialization

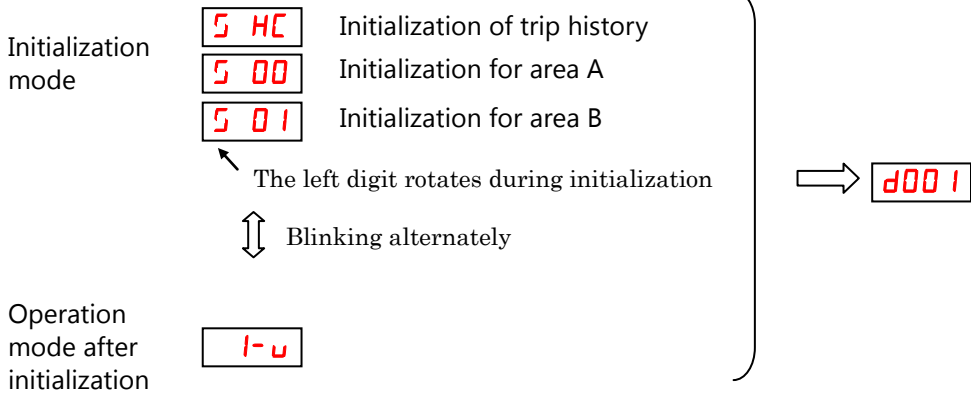

"b" Function		
Func. Code	Name	Description
b084	Initialization mode (parameters or trip history)	Select initialized data, five option codes: 00 ...Initialization disabled 01 ...Clears Trip history 02 ...Initializes all Parameters 03 ...Clears Trip history and initializes all parameters 04 ...Clears Trip history and initializes all parameters and EzSQ program
b094	Initialization target data setting	Select initialized parameters, four option codes: 00 ...All parameters 01 ...All parameters except in/output terminals and communication. 02 ...Only registered parameters in Uxxx . 03 ...All parameters except registered parameters in Uxxx and b037 .
b085	Initial value select	Select default parameter values: 00 ...area A 01 ...area B
b180	Initialization trigger	This is to perform initialization by parameter input with b084, b085 and b094 . Two option codes: 00 ...Initialization disable 01 ...Perform initialization

Data of b084 is not saved in EEPROM to avoid unintentional initializing.

Maintenance and Inspection

Daily and Yearly Inspection Chart

Item Inspected		Check for...	Inspection Cycle		Inspection Method	Criteria
			Daily	Year		
Overall	Ambient environment	Extreme temperatures & humidity	✓		Thermometer, hygrometer	Ambient temperature between -10 to 50°C, Humidity 90% or less non-condensing
	Major devices	Abnormal noise & vib.	✓		Visual and aural	Stable environment for electronic controls
	Power supply voltage	Voltage tolerance	✓		Digital volt meter, measure between inverter terminals [L1], [L2], [L3]	200V class: 50/60 Hz 200 to 240V (-15/+10%) 400V class: 50/60 Hz 380 to 460V (-15/+10%)
Main circuit	Ground Insulation	Adequate resistance		✓	Refer to Page 6–16	5 MΩ or greater
	Mounting	No loose screws		✓	Torque wrench	M3.5: 1.0Nm M4: 1.4Nm M5: 3.0 M6: 3.9 to 5.1Nm M8: 5.9 to 8.8Nm
	Components	Overheating		✓	Thermal trip events	No trip events
	IGBT	Resistance value		✓	Refer to Page 6–17	
	Terminal block	Secure connections		✓	Visual	No abnormalities
	Smoothing capacitors	Leaking, swelling	✓		Visual	No abnormalities
	Relay(s)	Chattering		✓	Aural	Single click when switching ON or OFF
Control circuit	Function	Voltage balance between phases		✓	Measure voltage between U,V,W	Difference must be 2% or less.
		Protection circuit		✓	e.g. Input Ex.trip signal and check inverter behavior and alarm signal.	Functions properly.
	Overall	No odor, discoloring, corrosion		✓	Visual	No abnormalities
	Capacitor	Leaking, swelling	✓		Visual	Undistorted appearance
Cooling	Cooling fan	Noise	✓		Power down, manually rotate	Rotation must be smooth
		Dust	✓		Visual	Vacuum to clean
		Mounting	✓		Visual	Mounted firmly
	Heat sink	Dust	✓		Visual	Vacuum to clean
Display	LEDs	Legibility			Visual	All LED segments work

Note 1: The life of a capacitor is affected by the ambient temperature. See page 6–21.

Note 2: Designed life of a cooling fan is 10 years. However, it is affected by the ambient temperature and other environmental conditions.

Note 3: The inverter must be cleaned periodically. If dust accumulates on the fan and heat sink, it can cause overheating of the inverter.

Megger test

The megger is a piece of test equipment that uses a high voltage to determine if insulation degradation has occurred. For inverters, it is important that the power terminals be isolated from the Earth GND terminal via the proper amount of insulation.

The circuit diagram below shows the inverter wiring for performing the megger test. Just follow the steps to perform the test:

1. Remove power from the inverter and wait at least 10 minutes before proceeding.
2. Open the front housing panel to access the power wiring.
3. Remove all wires to terminals [R, S, T, PD/+1, P/+, N/-, U, V, and W]. Most importantly, the input power and motor wires will be disconnected from the inverter.
4. Use a bare wire and short terminals [R, S, T, PD/+1, P/+, N/-, U, V, and W] together as shown in the diagram.
5. Connect the megger to the inverter Earth GND and to the shorted power terminals as shown. Then perform the megger test at 500 VDC and verify 5M Ω or greater resistance.

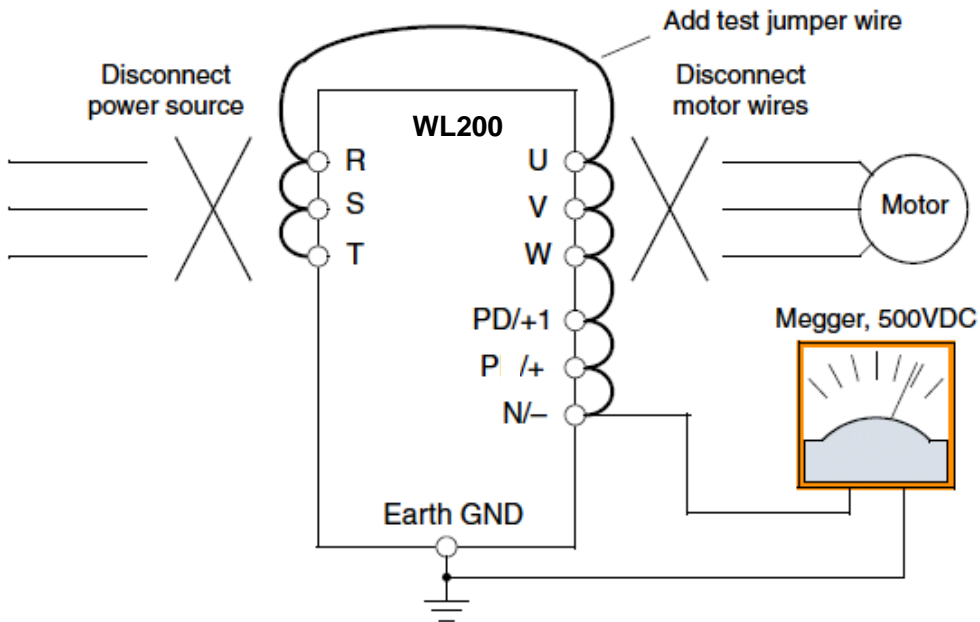

6. After completing the test, disconnect the megger from the inverter.
7. Reconnect the original wires to terminals [R, S, T, PD/+1, P/+, N/-, U, V, and W].



CAUTION: Do not connect the megger to any control circuit terminals such as intelligent I/O, analog terminals, etc. Doing so could cause damage to the inverter.



CAUTION: Never test the withstand voltage (HIPOT) on the inverter. The inverter has a surge protector between the main circuit terminals above and the chassis ground.



CAUTION: Power terminal assignment is different compared to old models such as L100, L200, X200 series, etc.. Pay attention when wiring the power cable.

IGBT Test Method

The following procedure will check the inverter transistors (IGBTs) and diodes:

1. Disconnect input power to terminals [R, S, and T] and motor terminals [U, V, and W].
2. Disconnect any wires from terminals [+] and [-] for regenerative braking.
3. Use a Digital Volt Meter (DVM) and set it for 1Ω resistance range. You can check the status of the charging state of terminals [R, S, T, U, V, W, +, and -] of the inverter and the probe of the DVM by measuring the charging state.

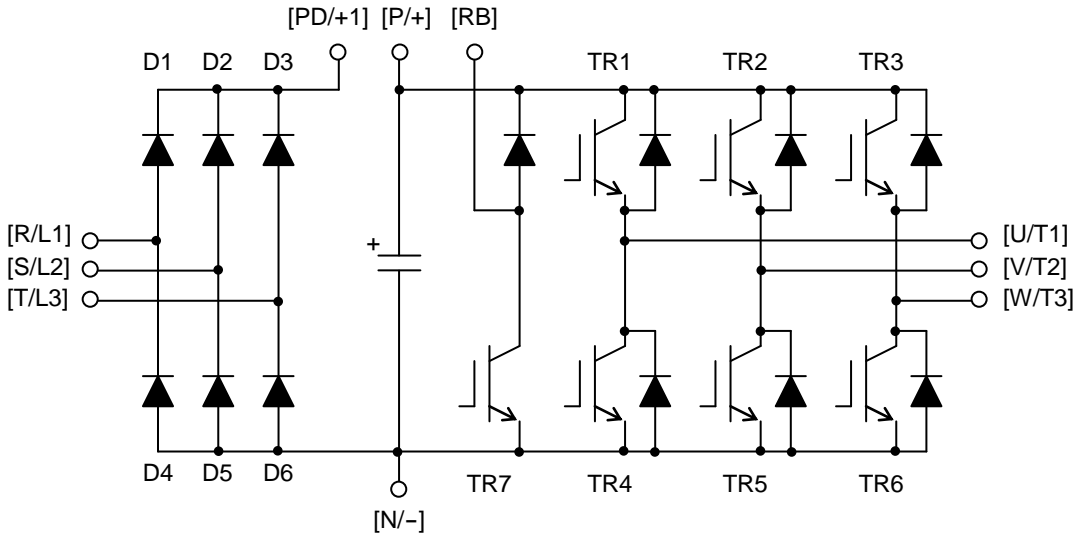

Table Legend Almost infinite resistance: $\cong \infty \Omega$ Almost zero resistance: $\cong 0 \Omega$

Part	DVM		Measured Value	Part	DVM		Measured Value	Part	DVM		Measured Value
	-	+			-	+			-	+	
D1	[R]	[+1]	$\cong \infty \Omega$	D5	[S]	[-]	$\cong 0 \Omega$	TR4	[U]	[-]	$\cong 0 \Omega$
	[+1]	[R]	$\cong 0 \Omega$		[-]	[S]	$\cong \infty \Omega$		[-]	[U]	$\cong \infty \Omega$
D2	[S]	[+1]	$\cong \infty \Omega$	D6	[T]	[-]	$\cong 0 \Omega$	TR5	[V]	[-]	$\cong 0 \Omega$
	[+1]	[S]	$\cong 0 \Omega$		[-]	[T]	$\cong \infty \Omega$		[-]	[V]	$\cong \infty \Omega$
D3	[T]	[+1]	$\cong \infty \Omega$	TR1	[U]	[+]	$\cong \infty \Omega$	TR6	[W]	[-]	$\cong 0 \Omega$
	[+1]	[T]	$\cong 0 \Omega$		[+]	[U]	$\cong 0 \Omega$		[-]	[W]	$\cong \infty \Omega$
D4	[R]	[-]	$\cong 0 \Omega$	TR2	[V]	[+]	$\cong \infty \Omega$	TR7	[RB]	[+]	$\cong \infty \Omega$
	[-]	[R]	$\cong \infty \Omega$		[+]	[V]	$\cong 0 \Omega$		[+]	[RB]	$\cong 0 \Omega$
				TR3	[W]	[+]	$\cong \infty \Omega$		[RB]	[-]	$\cong \infty \Omega$
					[+]	[W]	$\cong 0 \Omega$		[-]	[RB]	$\cong \infty \Omega$



NOTE: The resistance values for the diodes or the transistors will not be exactly the same, but they will be close. If you find a significance difference, a problem may exist.



NOTE: Before measuring the voltage between [+] and [-] with the DC current range, confirm that the smoothing capacitor is discharged fully, then execute the tests.

General Inverter Electrical Measurements

The following table specifies how to measure key system electrical parameters. The diagrams on the next page show inverter-motor systems and the location of measurement points for these parameters.

Parameter	Circuit location of measurement	Measuring instrument	Notes	Reference Value
Supply voltage E_1	E_R – across L1 and L2 E_S – across L2 and L3 E_T – across L3 and L1 Single phase E_1 – across L1 and N	Moving-coil type voltmeter or rectifier type voltmeter	Fundamental wave effective value	Commercial supply voltage 200V class: 200–240V, 50/60 Hz 400V class: 380–460V, 50/60 Hz
Supply current I_1	I_r – L1 I_s – L2 I_t – L3 Single phase $I_1 = L1$			
Supply power W_1	W_{11} – across L1 and L2 W_{12} – across L2 and L3 Single phase W_1 – across L1 and N		Total effective value	—
Supply power factor Pf_1	$Pf_1 = \frac{W_1}{\sqrt{3} \times E_1 \times I_1} \times 100\%$			—
Output voltage E_o	E_U – across U and V E_V – across V and W E_W – across W and U	Rectifier type voltmeter	Total effective value	—
Output current I_o	I_U – U I_V – V I_W – W	Moving-coil type ammeter	Total effective value	—
Output power W_o	W_{O1} – across U and V W_{O2} – across V and W	Electronic type wattmeter	Total effective value	—
Output power factor Pf_o	Calculate the output power factor from the output voltage E, output current I, and output power W. $Pf_o = \frac{W_1}{\sqrt{3} \times E_o \times I_o} \times 100\%$			—

Note 1: Use a meter indicating a fundamental wave effective value for voltage, and meters indicating total effective values for current and power.

Note 2: The inverter output has a distorted waveform, and low frequencies may cause erroneous readings. However, the measuring instruments and methods listed above provide comparably accurate results.

Note 3: A general-purpose digital volt meter (DVM) is not usually suitable to measure a distorted waveform (not pure sinusoid).

The figures below show measurement locations for voltage, current, and power measurements listed in the table on the previous page. The voltage to be measured is the fundamental wave effective voltage. The power to be measured is the total effective power.

Single-phase Measurement Diagram

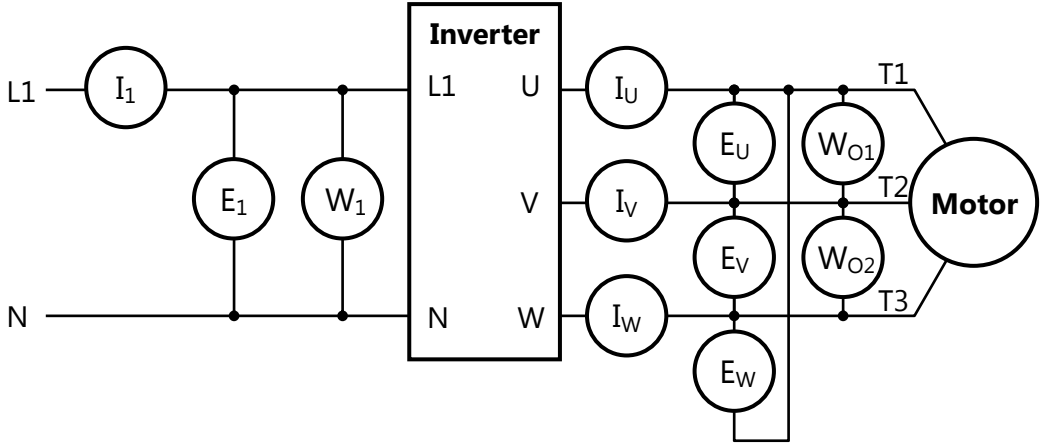

Three-phase Measurement Diagram

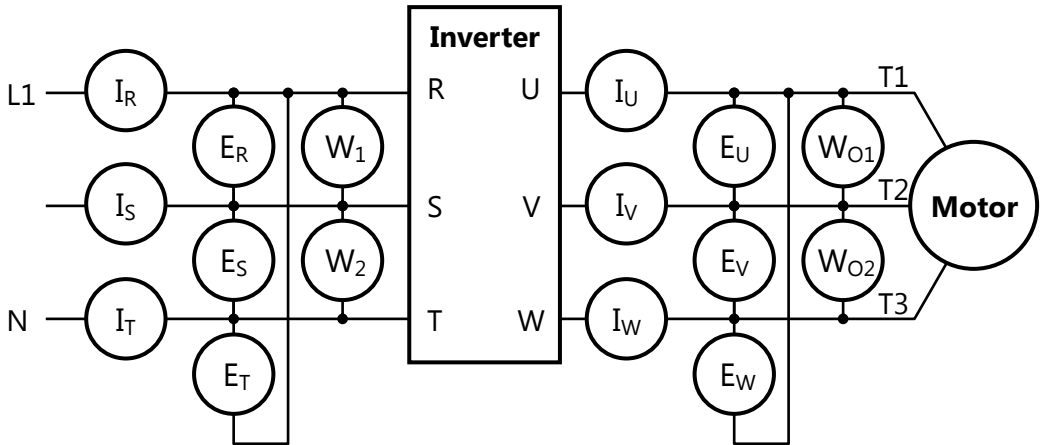

Inverter Output Voltage Measurement Techniques

Taking voltage measurements around drives equipment requires the right equipment and a safe approach. You are working with high voltages and high-frequency switching waveforms that are not pure sinusoids. Digital voltmeters will not usually produce reliable readings for these waveforms. And, it is usually risky to connect high voltage signals to oscilloscopes. The inverter output semiconductors have some leakage, and no-load measurements produce misleading results. So, we highly recommend using the following circuits to measure voltage for performing the equipment inspections.

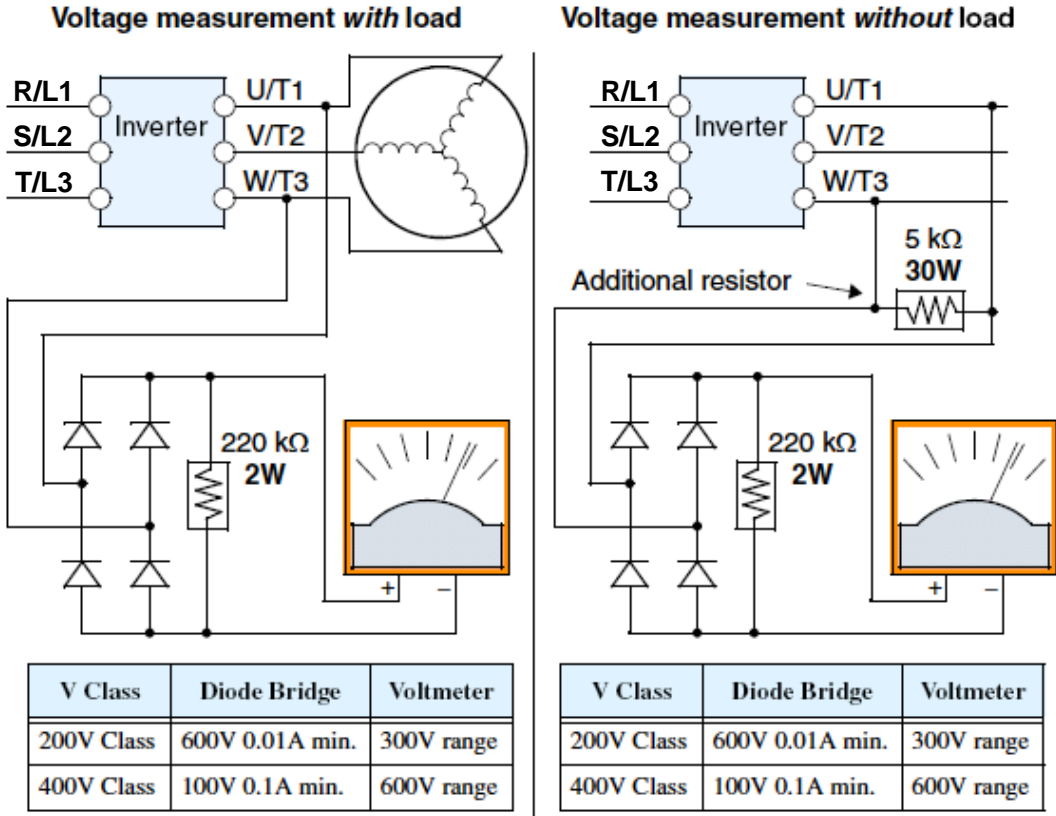

HIGH VOLTAGE: Be careful not to touch wiring or connector terminals when working with the inverters and taking measurements. Be sure to place the measurement circuitry components above in an insulated housing before using them.

Capacitor Life Curves

The DC bus inside the inverter uses a large capacitor as shown in the diagram below. The capacitor handles high voltage and current as it smooths the power for use by the inverter. So, any degradation of the capacitor will affect the performance of the inverter.

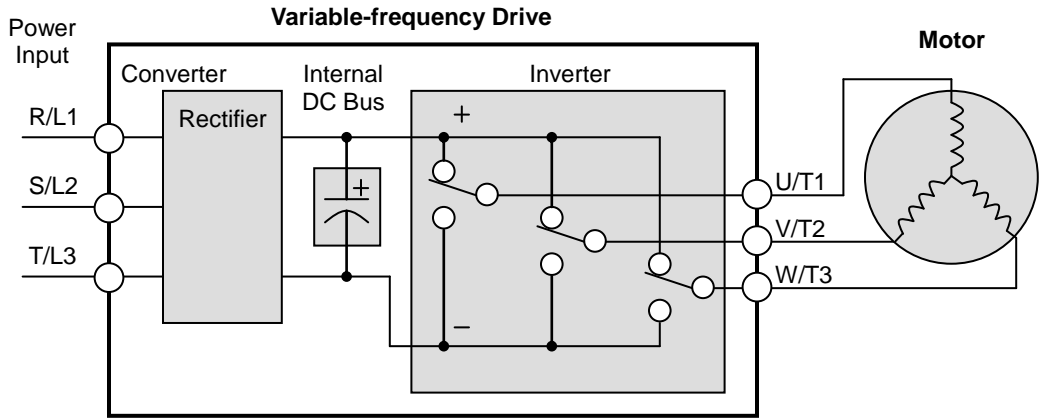

Capacitor life is reduced in higher ambient temperatures, as the graph below demonstrates. Under the condition of average ambient temperature 40°C, 80% load, 24 hours operation, the lifetime is 10 years. Be sure to keep the ambient temperature at acceptable levels, and perform maintenance inspections on the fan, heat sink, and other components. If the inverter is installed on a cabinet, the ambient temperature is the temperature inside the cabinet.

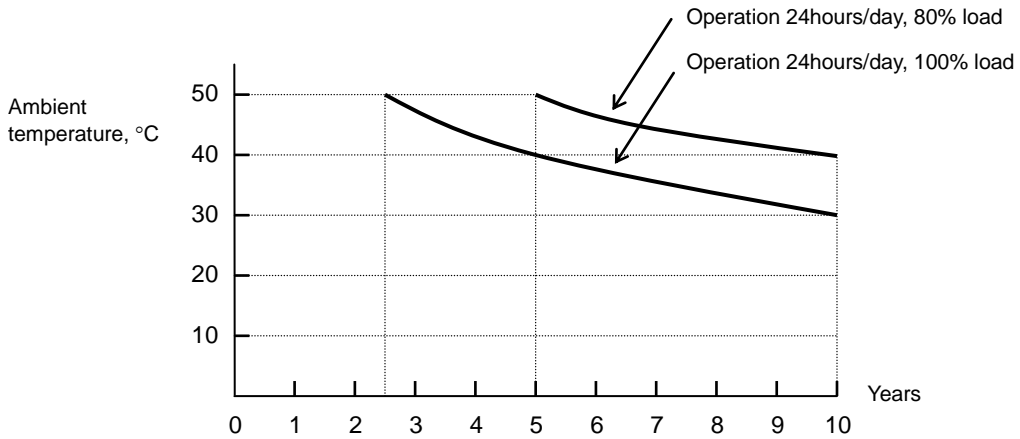

Warranty

Warranty Terms

The warranty period under normal installation and handling conditions shall be two (2) years from the date of manufacture, or one (1) year from the date of installation, whichever occurs first. The warranty shall cover the repair or replacement, at Hitachi's sole discretion, of ONLY the inverter that was installed.

- 1.** Service in the following cases, even within the warranty period, shall be charged to the purchaser:
 - a.** Malfunction or damage caused by mis-operation or modification or improper repair
 - b.** Malfunction or damage caused by a drop after purchase and transportation
 - c.** Malfunction or damage caused by fire, earthquake, flood, lightning, abnormal input voltage, contamination, or other natural disasters
 - d.** If the preset parameter setting (such as b911 to b913, etc.) is out of specifications.
- 2.** When service is required for the product at your work site, all expenses associated with field repair shall be charged to the purchaser.
- 3.** Always keep this manual handy; please do not lose it. Please contact your Hitachi distributor to purchase replacement or additional manuals.

Glossary and Bibliography



In This Appendix...	page
- Glossary.....	A-2
- Bibliography	A-8

Glossary

- Ambient Temperature** The air temperature in the chamber containing a powered electronic unit. A unit's heat sinks rely on a lower ambient temperature in order to dissipate heat away from sensitive electronics.
- Arrival Frequency** The arrival frequency refers to the set output frequency of the inverter for the constant speed setting. The arrival frequency feature turns on an output when the inverter reaches the set constant speed. The inverter has various arrival frequencies and pulsed or latched logic options.
- Base Frequency** The power input frequency for which an AC induction motor is designed to operate. Most motors will specify a 50 to 60 Hz value. The Hitachi inverters have a programmable base frequency, so you must ensure that parameter matches the attached motor. The term *base frequency* helps differentiate it from the carrier frequency. See also *Carrier Frequency* and *Frequency Setting*.
- Braking Resistor** An energy-absorbing resistor that dissipates energy from a decelerating load. Load inertia causes the motor to act as a generator during deceleration. For the X200 inverter models, the braking unit and braking resistor are optional (external) components. See also *Four-quadrant Operation* and *Dynamic Braking*.
- Break-away Torque** The torque a motor must produce to overcome the static friction of a load, in order to start the load moving.
- Carrier Frequency** The frequency of the constant, periodic, switching waveform that the inverter modulates to generate the AC output to the motor. See also *PWM*.
- CE** A regulatory agency for governing the performance of electronic products in Europe. Drive installations designed to have CE approval must have particular filter(s) installed in the application.
- Choke** An inductor that is tuned to react at radio frequencies is called a "choke," since it attenuates (chokes) frequencies above a particular threshold. Tuning is often accomplished by using a movable magnetic core. In variable-frequency drive systems, a choke positioned around high-current wiring can help attenuate harmful harmonics and protect equipment. See also *Harmonics*.
- DC Braking** The inverter DC braking feature stops the AC commutation to the motor, and sends a DC current through the motor windings in order to stop the motor. Also called "DC injection braking," it has little effect at high speed, and is used as the motor is nearing a stop.
- Deadband** In a control system, the range of input change for which there is no perceptible change in the output. In PID loops, the error term may have a dead band associated with it. Deadband may or may not be desirable; it depends on the needs of the application.

Diode	A semiconductor device that has a voltage-current characteristic that allows current to flow only in one direction, with negligible leakage current in the reverse direction. See also <i>Rectifier</i> .
Duty Cycle	<ol style="list-style-type: none">1. The percent of time a square wave of fixed frequency is ON (high) versus OFF (low).2. The ratio of operating time of a device such as a motor to its resting time. This parameter usually is specified in association with the allowable thermal rise for the device.
Dynamic Braking	For the WL200 inverter models, the braking unit and braking resistor are optional (external) components. The dynamic braking feature shunts the motor-generated EMF energy into a special braking resistor. The added dissipation (braking torque) is effective at higher speeds, having a reduced effect as the motor nears a stop.
EDM	[<i>Functional Safety Related Term</i>] External Device Monitoring, the output signal from inverter to external device in order to feed back the status that the both safety path working properly. Safety certificate is issued based on the condition that this EDM signal is interfaced to certified external device to avoid restarting or to inform in case of failure in safety path.
Error	In process control, the error is the difference between the desired value or setpoint (SP) and the actual value of the process variable (PV). See also <i>Process Variable</i> and <i>PID Loop</i> .
EMI	Electromagnetic Interference - In motor/drive systems, the switching of high currents and voltages creates the possibility of generating radiated electrical noise that may interfere with the operation of nearby sensitive electrical instruments or devices. Certain aspects of an installation, such as long motor lead wire lengths, tend to increase the chance of EMI. Hitachi provides accessory filter components you can install to decrease the level of EMI.
Four-quadrant operation	Referring to a graph of torque versus direction, a four-quadrant drive can turn the motor either forward or reverse, as well as decelerate in either direction (see also <i>reverse torque</i>). A load that has a relatively high inertia and must move in both directions and change directions rapidly requires four-quadrant capability from its drive.
Free-run Stop	A method of stopping a motor, caused when the inverter simply turns OFF its motor output connections. This may allow the motor and load to coast to a stop, or a mechanical brake may intervene and shorten the deceleration time.
Frequency Setting	While frequency has a broad meaning in electronics, it typically refers to motor speed for variable-frequency drives (inverters). This is because the output frequency of the inverter is variable, and is proportional to the attained motor speed. For example, a motor with a base frequency of 60 Hz can be speed controlled with an inverter output varying from 0 to 60 Hz. See also <i>Base Frequency</i> , <i>Carrier Frequency</i> , and <i>Slip</i> .

Harmonics	<p>A <i>harmonic</i> is a whole number multiple of a base of fundamental frequency. The square waves used in inverters produce high frequency harmonics, even though the main goal is to produce lower-frequency sine waves. These harmonics can be harmful to electronics (including motor windings) and cause radiated energy that interferes with nearby electronic devices. Chokes, line reactors, and filters are sometimes used to suppress the transmission of harmonics in an electrical system. See also <i>Choke</i>.</p>
Horsepower	<p>A unit of physical measure to quantify the amount of work done per unit of time. You can directly convert between horsepower and Watts as measurements of power.</p>
IGBT	<p>Insulated Gate Bipolar Transistor(IGBT) – A semiconductor transistor capable of conducting very large currents when in saturation and capable of withstanding very high voltages when it is OFF. This high-power bipolar transistor is the type used in Hitachi inverters.</p>
Inertia	<p>The natural resistance a stationary object to being moved by an external force. See also <i>Momentum</i>.</p>
Intelligent Terminal	<p>A configurable input or output logic function on the Hitachi inverters. Each terminal may be assigned one of several functions.</p>
Inverter	<p>A device that electronically changes DC to AC current through an alternating process of switching the input to the output, inverted and non-inverted. A variable speed drive such as the Hitachi WL200 is also called an inverter, since it contains three inverter circuits to generate 3-phase output to the motor.</p>
Isolation Transformer	<p>A transformer with 1:1 voltage ratio that provides electrical isolation between its primary and secondary windings. These are typically used on the power input side of the device to be protected. An isolation transformer can protect equipment from a ground fault or other malfunction of nearby equipment, as well as attenuate harmful harmonics and transients on the input power.</p>
Jogging Operation	<p>Usually done manually, a jog command from an operator's panel requests the motor/drive system to run indefinitely in a particular direction, until the machine operator ends the jog operation.</p>
Jump Frequency	<p>A jump frequency is a point on the inverter output frequency range that you want the inverter to skip around. This feature may be used to avoid a resonant frequency, and you can program up to three jump frequencies in the inverter.</p>
Line Reactor	<p>A three-phase inductor generally installed in the AC input circuit of an inverter to minimize harmonics and to limit short-circuit current.</p>
Momentum	<p>The physical property of a body in motion that causes it to remain in motion. In the case of motors, the rotor and attached load are rotating and possesses angular momentum.</p>

Motor Load	In motor terminology, motor load consists of the inertia of the physical mass that is moved by the motor and the related friction from guiding mechanisms. See also <i>Inertia</i> .
Multi-speed Operation	The ability of a motor drive to store preset discrete speed levels for the motor, and control motor speed according to the currently selected speed preset. The Hitachi inverters have 16 preset speeds.
NEC	The National Electric Code is a regulatory document that governs electrical power and device wiring and installation in the United States.
NEMA	The National Electric Manufacturer's Association. NEMA Codes are a published series of device ratings standards. Industry uses these to evaluate or compare the performance of devices made by various manufacturers to a known standard.
Open-collector Outputs	A common logic-type discrete output that uses an NPN transistor that acts as a switch to a power supply common, usually ground. The transistor's <i>collector</i> is <i>open</i> for external connection (not connected internally). Thus, the output <i>sinks</i> external load current to ground.
Power Factor	A ratio that expresses a phase difference (timing offset) between current and voltage supplied by a power source to a load. A perfect power factor = 1.0 (no phase offset). Power factors less than one cause some energy loss in power transmission wiring (source to load).
PID Loop	Proportional - Integral-Derivative - A mathematical model used for process control. A process controller maintains a process variable (PV) at a setpoint (SP) by using its PID algorithm to compensate for dynamic conditions and vary its output to drive the PV toward the desired value. For variable-frequency drives, the process variable is the motor speed. See also <i>Error</i> .
Process Variable	A physical property of a process that is of interest because it affects the quality of the primary task accomplished by the process. For an industrial oven, temperature is the process variable. See also PID Loop and Error.
Proof Test	[Functional Safety Related Term] The test to be carried out periodically to confirm the proper working of safety path. Safety certificate is issued based on the condition that this proof test is carried out at least once a year.
PWM	Pulse-width modulation: A type of AC adjustable frequency drive that accomplishes frequency and voltage control at the output section (inverter) of the drive. The drive output voltage waveform is at a constant amplitude, and by "chopping" the waveform (pulsewidth-modulating), the average voltage is controlled. The chopping frequency is sometimes called the Carrier Frequency.

Reactance	The impedance of inductors and capacitors has two components. The resistive part is constant, while the reactive part changes with applied frequency. These devices have a complex impedance (complex number), where the resistance is the real part and the reactance is the imaginary part.
Rectifier	An electronic device made of one or more diodes that converts AC power into DC power. Rectifiers are usually used in combination with capacitors to filter (smooth) the rectified waveform to closely approximate a pure DC voltage source.
Regenerative Braking	A particular method of generating reverse torque to a motor, an inverter will switch internally to allow the motor to become a generator and will either store the energy internally, deliver the braking energy back to the main power input, or dissipate it with a resistor.
Regulation	The quality of control applied to maintain a parameter of interest at a desired value. Usually expressed as a percent (\pm) from the nominal, motor regulation usually refers to its shaft speed.
Reverse Torque	The torque applied in the direction opposite to motor shaft rotation. As such, reverse torque is a decelerating force on the motor and its external load.
Rotor	The windings of a motor that rotate, being physically coupled to the motor shaft. See also <i>Stator</i> .
Saturation Voltage	For a transistor semiconductor device, it is in saturation when an increase in input current no longer results in an increase in the output current. The saturation voltage is the voltage drop across the device. The ideal saturation voltage is zero.
Sensorless Vector Control	A technique used in some variable-frequency drives (featured in some other Hitachi inverter model families) to rotate the force vector in the motor without the use of a shaft position sensor (angular). Benefits include an increase in torque at the lowest speed and the cost savings from the lack of a shaft position sensor.
Setpoint (SP)	The <i>setpoint</i> is the desired value of a process variable of interest. See also <i>Process Variable (PV)</i> and <i>PID Loop</i> .
Single-phase power	An AC power source consisting of Hot and Neutral wires. An Earth Ground connection usually accompanies them. In theory, the voltage potential on Neutral stays at or near Earth Ground, while Hot varies sinusoidally above and below Neutral. This power source is named Single Phase to differentiate it from three-phase power sources. Some Hitachi inverters can accept single phase input power, but they all output three-phase power to the motor. See also <i>Three-phase</i> .
Slip	The difference between the theoretical speed of a motor at no load (determined by its inverter output waveforms) and the actual speed. Some slip is essential in order to develop torque to the load, but too much will cause excessive heat in the motor windings and/or cause the motor to stall.

Squirrel Cage	A “nick-name” for the appearance of the rotor frame assembly for an AC induction motor.
Stator	The windings in a motor that are stationary and coupled to the power input of the motor. See also <i>Rotor</i> .
Tachometer	<ol style="list-style-type: none">1. A signal generator usually attached to the motor shaft for the purpose of providing feedback to the speed controlling device of the motor.2. A speed-monitoring test meter that may optically sense shaft rotation speed and display it on a readout.
Thermal Switch	An electromechanical safety device that opens to stop current flow when the temperature at the device reaches a specific temperature threshold. Thermal switches are sometimes installed in the motor in order to protect the windings from heat damage. The inverter can use thermal switch signals to trip (shut down) if the motor overheats. See also <i>Trip</i> .
Thermistor	A type of temperature sensor that changes its resistance according to its temperature. The sensing range of thermistors and their ruggedness make them ideal for motor overheating detection. Hitachi inverters have built-in thermistor input circuits, which can detect an overheated motor and shut off (trip) the inverter output.
Three-phase power	An AC power source with three Hot connections that have phase offsets of 120 degrees is a 3-phase power source. Usually, Neutral and Earth Ground wires accompany the three Hot connections. Loads may be configured in a delta or Y configuration. A Y-connected load such as an AC induction motor will be a balanced load; the currents in all the Hot connections are the same. Therefore, the Neutral connection is theoretically zero. This is why inverters that generate 3-phase power for motors do not generally have a Neutral connection to the motor. However, the Earth Ground connection is important for safety reasons, and is provided.
Torque	The rotational force exerted by a motor shaft. The units of measurement consist of the distance (radius from shaft center axis) and force (weight) applied at that distance. Units are usually given as pound-feet, ounce-inches, or Newton-meters.
Transistor	A solid state, three-terminal device that provides amplification of signals and can be used for switching and control. While transistors have a linear operating range, inverters use them as high-powered switches. Recent developments in power semiconductors have produced transistors capable of handling high voltages and currents, all with high reliability. The saturation voltage has been decreasing, resulting in less heat dissipation. Hitachi inverters use state-of-the-art semiconductors to provide high performance and reliability in a compact package. See also <i>IGBT</i> and <i>Saturation Voltage</i> .

Trip Event

An event that causes the inverter to stop operation is called a “trip” event (as in *tripping* a circuit breaker). The inverter keeps a history log of trip events. They also require an action to clear.

Watt Loss

A measure of the internal power loss of a component, the difference between the power it consumes and what its output delivers. An inverter’s watt loss is the input power minus the power delivered to the motor. The watt loss is typically highest when an inverter is delivering its maximum output. Therefore, watt loss is usually specified for a particular output level. Inverter watt loss specifications are important when designing enclosures.

Bibliography

Title	Author and Publisher
Variable Speed Drive Fundamentals, 2nd Ed.	Phipps, Clarence A. The Fairmont Press, Inc. / Prentice-Hall, Inc. 1997
Electronic Variable Speed Drives	Brumbach, Michael E. Delmar Publishers 1997 ISBN 0-8273-6937-9
Hitachi Inverter Technical Guide Book	Published by Hitachi, Ltd. Japan 1995 Publication SIG-E002

Modbus Network Communication

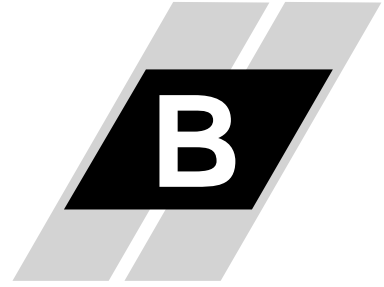

In This Appendix...	page
- Introduction.....	B-2
- Connecting the Inverter to Modbus	B-3
- Network Protocol Reference.....	B-5
- Explanation of function codes.....	B-10
- Modbus Data Listing.....	B-24

Introduction

WL200 Series inverters have built-in RS-485 serial communications, featuring the Modbus RTU protocol. The inverters can connect directly to existing factory networks or work with new networked applications, without any extra interface equipment. The specifications are in the following table.

If any network option card connected, Modbus cannot work.

Item	Specifications	User-selectable
Transmission speed	2400 / 4800 / 9600 / 19.2k / 38.4k / 57.6k / 76.8k / 115.2k bps	✓
Communication mode	Asynchronous	✗
Character code	Binary	✗
LSB placement	Transmits LSB first	✗
Electrical interface	RS-485 differential transceiver	✗
Data bits	8-bit (Modbus RTU mode)	✗
Parity	None / even / odd	✓
Stop bits	1 or 2 bits	✓
Startup convention	One-way start from host device	✗
Wait time for response	0 to 1000 msec.	✓
Connections	Station address numbers from 1 to 32	✓
Connector	Terminal connector	–
Error check	Overrun, Framing block check code, CRC-16, or horizontal parity	–
Cable length	500m maximum	

The network diagram below shows a series of inverters communicating with a host computer. Each inverter must have a unique address, from 1 to 32, on the network. In a typical application, a host computer or controller is the master and each of the inverter(s) or other devices is a slave.

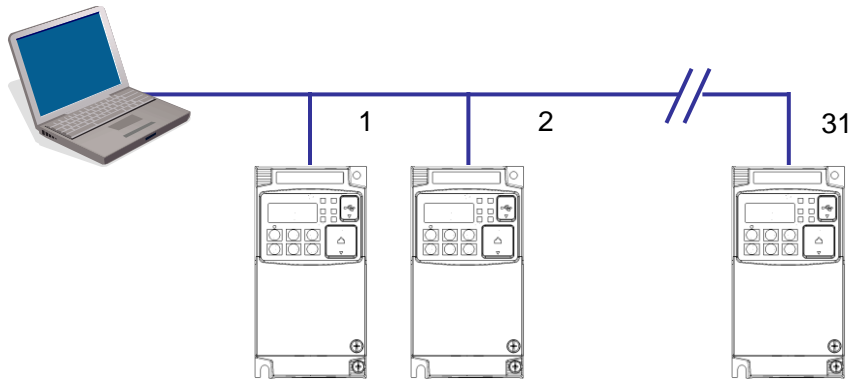

Connecting the Inverter to Modbus

Modbus connector is in control terminal block as below. Note that RJ45 connector (RS-422) is used for external operator only.

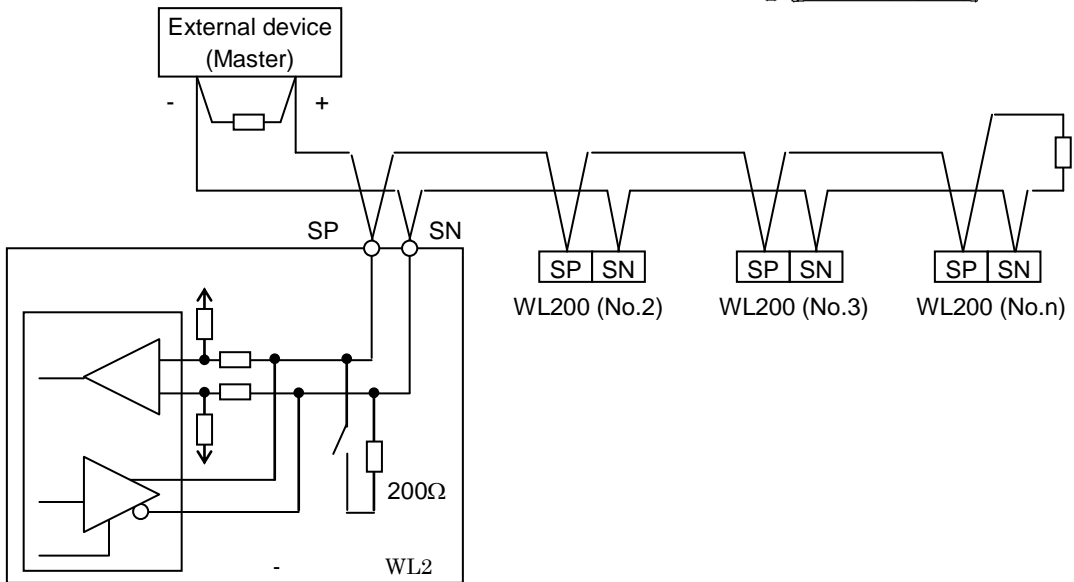
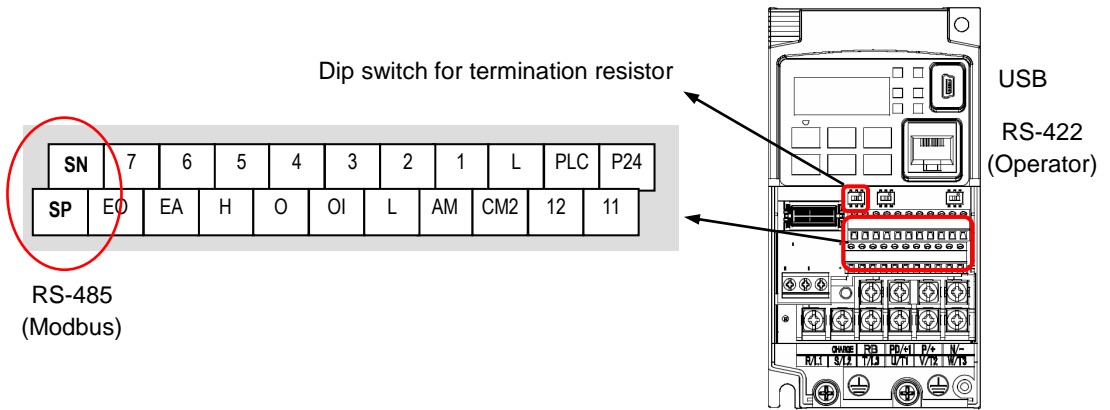

Terminate Network Wiring - The RS-485 wiring must be terminated at each physical end to suppress electrical reflections and help decrease transmission errors. WL200 has a built-in 200Ω resistor activated by a dip switch. Select termination resistors that match the characteristic impedance of the network cable. The diagram above shows a network with the needed termination resistor at each end.

Inverter Parameter Setup - The inverter has several settings related to Modbus communications. The table below lists them together. The *Required* column indicates which parameters *must* be set properly to allow communications. You may need to refer to the host computer documentation in order to match some of its settings.

Func. Code	Name	Required	Settings
A001	Frequency source	✓	00...Keypad potentiometer 01...Control terminal 02...Function F001 setting 03...Modbus network input 10...Calculate function output
A002	Run command source	✓	01...Control terminal 02...Run key on keypad, or digital operator 03... Modbus network input
C071	Communication speed	✓	03 2400 bps 04...4800 bps 05 9600 bps 06 19.2k bps 07...38.4k bps 08...57.6k bps 09...76.8k bps 10...115.2k bps
C072	Modbus Address	✓	Network address, range is 1 to 247
C074	Communication parity	✓	00...No parity 01...Even parity 02...Odd parity
C075	Communication stop bit	✓	Range is 1 or 2
C076	Communication error select	–	00...Trip (Error code E60) 01...Decelerate to a stop and trip 02...Disable 03...Free run stop (coasting) 04...Decelerate to a stop
C077	Communication error time-out	–	Comm. Watchdog timer period, range is 0.00 to 99.99 sec.
C078	Communication wait time	✓	Time the inverter waits after receiving a message before it transmits. Range is 0. to 1000. ms



NOTE: When you change any of the parameters above, the inverter power must be rebooted in order to activate new parameters. Instead of rebooting, turning ON/OFF of reset terminal works as same.

Network Protocol Reference

Transmission procedure

The transmission between the external control equipment and the inverter takes the procedure below.

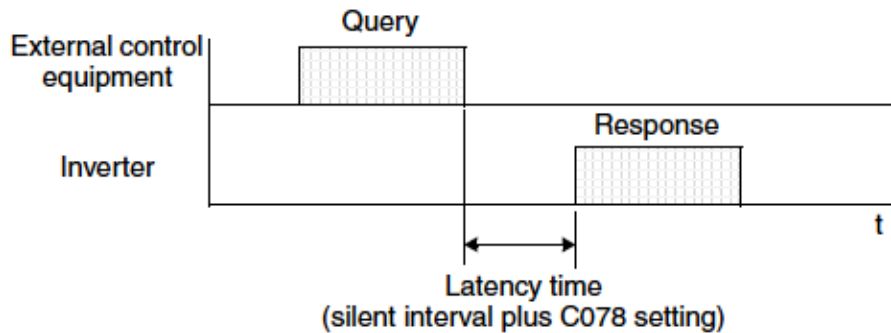

- Query - A frame sent from the external control equipment to the inverter
- Response - A frame returned from inverter to the external control equipment

The inverter returns the response only after the inverter receives a query from the external control equipment and does not output the response positively. Each frame is formatted (with commands) as follows:

Frame Format
Header (silent interval)
Slave address
Function code
Data
Error check
Trailer (silent interval)

Message Configuration: Query

Slave address:

- This is a number of 1 to 32 assigned to each inverter (slave). (Only the inverter having the address given as a slave address in the query can receive the query.)
- When slave address "0" is specified, the query can be addressed to all inverters simultaneously. (Broadcasting)
- In broadcasting, you cannot call and loop back data.
- Slave Address 1-247 in Modbus specification. When master address the slave 250-254, broadcast toward specific slave address. Slave doesn't answer back. And this function is valid for the write command (05h, 06h, 0Fh, 10h)

Slave address	Broadcast to
250 (Fah)	Broadcast to Slave address 01to 09
251 (FBh)	Broadcast to Slave address 10 to 19
252 (FCh)	Broadcast to Slave address 20 to 29
253 (FDh)	Broadcast to Slave address 30 to 39
254 (FEh)	Broadcast to Slave address 40 to 247

Data:

- A function command is set here.
- The data format used in the WL200 series is corresponding to the Modbus data format below.

Name of Data	Description
Coil	Binary data that can be referenced and changed (1 bit long)
Holding Register	16-bit data that can be referenced and changed

Function code:

Specify a function you want to make the inverter execute. Function codes available to the WL200 series are listed below.

Function Code	Function	Maximum data size (bytes available per message)	Maximum number of data elements available per message
0 1 h	Read Coil Status	4	32 coils (in bits)
0 3 h	Read Holding Resistor	32	16 registers (in bytes)
0 5 h	Write in Coil	2	1 coil (in bits)
0 6 h	Write in Holding Register	2	1 register (in bytes)
0 8 h	Loopback Test	–	–
0 F h	Write in Coils	4	32 coils (in bits)
1 0 h	Write in Registers	32	16 registers (in bytes)
1 7 h	Read/Write Holding Register	32	16 registers (in bytes)

Error check:

Modbus-RTU uses CRC (Cyclic Redundancy Check) for error checking.

- The CRC code is 16-bit data that is generated for 8-bit blocks of arbitrary length.
- The CRC code is generated by a generator polynomial CRC-16 ($X^{16} + X^{15} + X^2 + 1$).

Header and trailer (silent interval):

Latency is the time between the reception of a query from the master and transmission of a response from the inverter.

- 3.5 characters (24 bits) are always required for latency time. If the latency time shorter than 3.5 characters, the inverter returns no response.
- The actual transmission latency time is the sum of silent interval (3.5 characters long) + C078 (transmission latency time).

Message Configuration: Response

Transmission time required:

- A time period between reception of a query from the master and transmission of a response from the inverter is the sum of the silent interval (3.5 characters long) + C078 (transmission latency time).
- The master must provide a time period of the silent interval (3.5 characters long or longer) before sending another query to an inverter after receiving a response from the inverter.

Normal response:

- When receiving a query that contains a function code of Loopback (08h), the inverter returns a response of the same content of the query.
- When receiving a query that contains a function code of Write in Register or Coil (05h, 06h, 0Fh, or 10h), the inverter directly returns the query as a response.
- When receiving a query that contains a function code of Read Register or Coil (01h or 03h), the inverter returns, as a response, the read data together with the same slave address and function code as those of the query.

Response when an error occurs:

- When finding any error in a query (except for a transmission error), the inverter returns an exception response without executing anything.
- You can check the error by the function code in the response. The function code of the exception response is the sum of the function code of the query and 80h.
- The content of the error is known from the exception code.

Field Configuration
Slave address
Function code
Exception code
CRC-16

Exception Code	Description
0 1 h	The specified function is not supported.
0 2 h	The specified function is not found.
0 3 h	The format of the specified data is not acceptable.
2 1 h	The data to be written in a holding register is outside the inverter.
2 2 h	The specified functions are not available to the inverter. <ul style="list-style-type: none"> • Function to change the content of a register that cannot be changed while the inverter is in service • Function to submit an ENTER command during running (UV) • Function to write in a register during tripping (UV) • Function to change the I/O terminal configuration which is not allowed. • Function to change active state of RS (reset) terminal • Function to write in a register during auto-tuning • Function to write in a register locked by password
2 3 h	The register (or coil) to be written in is read-only

No response occurs:

In the cases below, the inverter ignores a query and returns no response.

- When receiving a broadcasting query
- When detecting a transmission error in reception of a query
- When the slave address set in the query is not equal to the slave address of the inverter
- When a time interval between data elements constituting a message is shorter than 3.5 characters
- When the data length of the query is invalid
- When broadcast message received.



NOTE: Provide a timer in the master and make the master retransmit the same query when no response is made within a preset time period after the preceding query was sent.

Explanation of function codes

Read Coil Status [01h]:

This function reads the status (ON/OFF) of selected coils. An example follows below.

- Read intelligent input terminals [1] to [7] of an inverter having a slave address "8".
- This example assumes the intelligent input terminals have terminal states listed below.

Item	Data						
Intelligent input terminal	[1]	[2]	[3]	[4]	[5]	[6]	[7]
Coil number	0007h	0008h	0009h	000Ah	000Bh	000Ch	000Dh
Coil Status	ON	OFF	ON	OFF	OFF	OFF	ON

Query:

No.	Field Name	Example (Hex)
1	Slave address *1	08
2	Function code	01
3	Coil start address *4 (high order)	00
4	Coil start address *4 (low order)	06
5	Number of coils (high order *2)	00
6	Number of coils (low order *2)	07
7	CRC-16 (high order)	9D
8	CRC-16 (low order)	50

Response:

No.	Field Name	Example (Hex)
1	Slave address	08
2	Function code	01
3	Data size (in bytes)	01
4	Coil data *3	45
5	CRC-16 (high order)	93
6	CRC-16 (low order)	E7

Note 1: Broadcasting is disabled.

Note 2: When 0 or more than 31 is specified as a number of coils, error code "03h" is returned.

Note 3: Data is transferred by the specified number of data bytes (data size).

Note 4: The PDU Coils are addressed starting at zero. Therefore coils numbered 1-31 are addressed as 0-30. Coil address value (transmitted on Modbus line) is 1 less than the Coil Number.

- The data set in the response shows terminal state of coils 0007h to 000Dh.
- Data "45h = 01000101b" indicates the following assuming coil 7 is the LSB.

Item	Data						
Coil Number	000Dh	000Ch	000Bh	000Ah	0009h	0008h	0007h
Coil Status	ON	OFF	OFF	OFF	ON	OFF	ON

- When a read coil is outside the defined coils, the final coil data to be transmitted contains "0" as the status of the coil outside the range.
- When the Read Coil Status command cannot be executed normally, see the exception response.

Read Holding Register [03h]:

This function reads the contents of the specified number of consecutive holding registers (of specified register addresses). An example follows below.

- Reading Trip monitor 1 factor and trip frequency, current, and voltage from an inverter having a slave address "1".
- This example assumes the previous three trip factors are as follows:

WL200 Command	d081 (factor)	d081 (inverter status)	d081 (frequency)	d081 (output current)	d081 (DC-bus Voltage)
Register Number	0012h	0013h	0015h	0016h	0017h
Trip factor	Over-Current (E03)	Accelerating (4)	9.90Hz	3.00A	284V

Query:

No.	Field Name	Example (Hex)
1	Slave address *1	01
2	Function code	03
3	Register start address *3 (high order)	00
4	Register start address *3 (low order)	11
5	Number of holding registers (high order)	00
6	Number of holding registers (low order)	06
7	CRC-16 (high order)	95
8	CRC-16 (low order)	CD

Response:

No.	Field Name	Example (Hex)
1	Slave address	01
2	Function code	03
3	Data size (in bytes) *2	0C
4	Register data 1 (high order)	00
5	Register data 1 (low order)	03
6	Register data 2 (high order)	00
7	Register data 2 (low order)	04
8	Register data 3 (high order)	00
9	Register data 3 (low order)	00
10	Register data 4 (high order)	03
11	Register data 4 (low order)	DE
12	Register data 5 (high order)	01
13	Register data 5 (low order)	2C
14	Register data 6 (high order)	01
15	Register data 6 (low order)	1C
16	CRC-16 (high order)	C6
17	CRC-16 (low order)	B8

Note 1: Broadcasting is disabled.

Note 2: Data is transferred by the specified number of data bytes (data size). In this case, 6 bytes are used to return the content of three holding registers.

Note 3: The PDU Register Number are addressed starting at zero. Therefore register numbered "0012h" are addressed as "0011h". Register address value (transmitted on Modbus line) is 1 less than the Register Number.

The data set in the response is as follows:

Response Buffer	4-5		6-7		8-9	
Register Number	12+0 (high order)	12+0 (low order)	12+1 (high order)	12+1 (low order)	12+2 (high order)	12+2 (low order)
Register Data	0003h		0004h		00h	00h
Trip data	Trip factor (E03)		Inverter status (4)		Not used	
Response Buffer	10-11		12-13		14-15	
Register Number	12+3 (high order)	12+3 (low order)	12+4 (high order)	12+4 (low order)	12+5 (high order)	12+5 (low order)
Register Data	03DE		012Ch		011Ch	
Trip data	Frequency (9.90Hz)		Output current (3.00A)		DC-bus voltage (284V)	

When the Read Holding Register command cannot be executed normally, refer to the exception response.

Write in Coil [05h]:

This function writes data in a single coil. Coil status changes are as follows:

Data	Coil Status	
	OFF to ON	ON to OFF
Change data (high order)	FFh	00h
Change data (low order)	00h	00h

An example follows (note that to command the inverter, set A002=03):

- Sending a RUN command to an inverter having slave address "8"
- This example writes in coil number "1."

Query:

No.	Field Name	Example (Hex)
1	Slave address *1	08
2	Function code	05
3	Coil start address *2 (high order)	00
4	Coil start address *2 (low order)	00
5	Change data (high order)	FF
6	Change data (low order)	00
7	CRC-16 (high order)	8C
8	CRC-16 (low order)	A3

Response:

No.	Field Name	Example (Hex)
1	Slave address	08
2	Function code	05
3	Coil start address *2 (high order)	00
4	Coil start address *2 (low order)	00
5	Change data (high order)	FF
6	Change data (low order)	00
7	CRC-16 (high order)	8C
8	CRC-16 (low order)	A3

Note 1: No response is made for a broadcasting query.

Note 2: The PDU Coils are addressed starting at zero. Therefore coils numbered 1-31 are addressed as 0-30. Coil address value (transmitted on Modbus line) is 1 less than the Coil Number.

When writing in a selected coil fails, see the exception response.

Write in Holding Register [06h]:

This function writes data in a specified holding register. An example follows:

- Write "50.00Hz" as the first Multi-speed 0 (A020) in an inverter having slave address "5".
- This example uses change data "5000(1388h)" to set "50.00Hz" as the data resolution of the register "1217h" holding the first Multi-speed 0 (A020) is 0.01Hz

Query:

No.	Field Name	Example (Hex)
1	Slave address *1	08
2	Function code	06
3	Register start address *2 (high order)	12
4	Register start address *2 (low order)	16
5	Change data (high order)	13
6	Change data (low order)	88
7	CRC-16 (high order)	60
8	CRC-16 (low order)	B9

Response:

No.	Field Name	Example (Hex)
1	Slave address	08
2	Function code	06
3	Register start address *2 (high order)	12
4	Register start address *2 (low order)	16
5	Change data (high order)	13
6	Change data (low order)	88
7	CRC-16 (high order)	60
8	CRC-16 (low order)	B9

Note 1: No response is made for a broadcasting query.

Note 2: The PDU Register Number are addressed starting at zero. Therefore register numbered "1217h" are addressed as "1216h". Register address value (transmitted on Modbus line) is 1 less than the Register Number.

When writing in a selected holding register fails, see the exception response.

Loopback Test [08h]:

This function checks a master-slave transmission using any test data. An example follows:

- Send test data to an inverter having slave address "1" and receiving the test data from the inverter (as a loopback test).

Query:

No.	Field Name	Example (Hex)
1	Slave address *1	01
2	Function code	08
3	Test subcode (high order)	00
4	Test subcode (low order)	00
5	Data (high order)	Any
6	Data (low order)	Any
7	CRC-16 (high order)	CRC
8	CRC-16 (low order)	CRC

Response:

No.	Field Name	Example (Hex)
1	Slave address *1	01
2	Function code	08
3	Test subcode (high order)	00
4	Test subcode (low order)	00
5	Data (high order)	Any
6	Data (low order)	Any
7	CRC-16 (high order)	CRC
8	CRC-16 (low order)	CRC

Note 1: Broadcasting is disabled.

When test subcode is for echo (00h, 00h) only and not available to the other commands.

Write in Coils [0Fh]:

This function writes data in consecutive coils. An example follows:

- Change the state of intelligent input terminal [1] to [5] of an inverter having a slave address "8".
- This example assumes the intelligent input terminals have terminal states listed below.

Item	Data						
Intelligent input terminal	[1]	[2]	[3]	[4]	[5]	[6]	[7]
Coil number	0007h	0008h	0009h	000Ah	000Bh	000Ch	000Dh
Coil Status	ON	ON	ON	OFF	ON	OFF	OFF

Query:

No.	Field Name	Example (Hex)
1	Slave address *1	08
2	Function code	0F
3	Coil start address *3 (high order)	00
4	Coil start address *3 (low order)	06
5	Number of coils (high order)	00
6	Number of coils (low order)	07
7	Byte number *2	02
8	Change data (high order)	17
9	Change data (low order)	00
10	CRC-16 (high order)	82
11	CRC-16 (low order)	52

Response:

No.	Field Name	Example (Hex)
1	Slave address	08
2	Function code	0F
3	Coil start address *3 (high order)	00
4	Coil start address *3 (low order)	06
5	Number of coils (high order)	00
6	Number of coils (low order)	07
7	CRC-16 (high order)	F4
8	CRC-16 (low order)	91

Note 1: No response is made for a broadcasting query.

Note 2: The change data is a set of high-order data and low-order data. So when the size (in bytes) of data to be changed is an odd start coil number ("7"), add "1" to the data size (in bytes) to make it an even number.

Note 3: The PDU Coils are addressed starting at zero. Therefore coils numbered 1-31 are addressed as 0-30. Coil address value (transmitted on Modbus line) is 1 less than the Coil Number.

Write in Holding Registers [10h]:

This function writes data in consecutive holding registers. An example follows:

- Write "3000 seconds" as the first acceleration time 1 (F002) in an inverter having a slave address "8".
- This example uses change data "300000(493E0h)" to set "3000 seconds" as the data resolution of the registers "1103h" and "1104h" holding the first acceleration time 1 (F002) is 0.01 second.

Query:

No.	Field Name	Example (Hex)
1	Slave address *1	08
2	Function code	10
3	Start address *3 (high order)	11
4	Start address *3 (low order)	02
5	Number of holding registers (high order)	00
6	Number of holding registers (low order)	02
7	Byte number *2	04
8	Change data 1 (high order)	00
9	Change data 1 (low order)	04
10	Change data 2 (high order)	93
11	Change data 2 (low order)	E0
12	CRC-16 (high order)	B0
13	CRC-16 (low order)	03

Response:

No.	Field Name	Example (Hex)
1	Slave address	08
2	Function code	10
3	Start address *3 (high order)	11
4	Start address *3 (low order)	02
5	Number of holding registers (high order)	00
6	Number of holding registers (low order)	02
7	CRC-16 (high order)	E5
8	CRC-16 (low order)	AD

Note 1: No response is made for a broadcasting query.

Note 2: This is not the number of holding registers. Specify the number of bytes of data to be changed.

Note 3: The PDU Register Number are addressed starting at zero. Therefore register numbered "1103h" are addressed as "1102h". Register address value (transmitted on Modbus line) is 1 less than the Register Number.

When writing in selected holding registers fails, see the exception response.

Read/Write Holding Registers [17h]:

This function is to read and write data in consecutive holding registers. An example follows:

- Write "50.00Hz" as the set frequency (F001) in an inverter having a slave address "1" and then to read out the output frequency (d001).

Query:

No.	Field Name	Example (Hex)
1	Slave address *1	01
2	Function code	17
3	Start address to read *3 (high order)	10
4	Start address to read *3 (low order)	01
5	Number of holding registers to read (high order)	00
6	Number of holding registers to read (low order)	01
7	Start address to write *3 (high order)	00
8	Start address to write *3 (low order)	01
9	Number of holding registers to write (high order)	00
10	Number of holding registers to write (low order)	01
11	Byte number to write*2	02
12	Change data 1 (high order)	13
13	Change data 1 (low order)	88
14	CRC-16 (high order)	5D
15	CRC-16 (low order)	2C

Response:

No.	Field Name	Example (Hex)
1	Slave address	01
2	Function code	17
3	Byte number n	02
4	Register Data 1 (high order)	13
5	Register Data 1 (low order)	88
6	CRC-16 (high order)	B0
7	CRC-16 (low order)	E2

Note 1: Register address value (transmitted on Modbus line) is 1 less than the Register Number.

When writing in selected holding registers fails, see the exception response.

Exception Response:

When sending a query (excluding a broadcasting query) to an inverter, the master always requests a response from the inverter. Usually, the inverter returns a response according to the query. However, when finding an error in the query, the inverter returns an exception response. The exception response consists of the fields shown below.

Field Configuration
Slave address
Function code
Exception code
CRC-16

The content of each field is explained below. The function code of the exception response is the sum of the function code of the query and 80h. The exception code indicates the factor of the exception response.

Function Code	
Query	Exception Response
01 h	81 h
03 h	83 h
05 h	85 h
06 h	86 h
0F h	8F h
10 h	90 h

Exception Code	
Code	Description
01 h	The specified function is not supported.
02 h	The specified function is not found.
03 h	The format of the specified data is not acceptable.
21 h	The data to be written in a holding register is outside the inverter.
22 h	The specified functions are not available to the inverter. <ul style="list-style-type: none"> • Function to change the content of a register that cannot be changed while the inverter is in service • Function to submit an ENTER command during running (UV) • Function to write in a register during tripping (UV) • Function to change the I/O terminal configuration which is not allowed. • Function to change active state of RS (reset) terminal • Function to write in a register locked by password
23 h	The register (or coil) to be written in is read-only

Store New Register Data (ENTER command)

After being written in a selected holding register by the Write in Holding Register command (06h) or in selected holding registers by the Write in Holding Registers command (10h), new data is temporary and still outside the storage element of the inverter. If power to the inverter is shut off, this new data is lost and the previous data returns. There are following two methods to store this new data in the storage element of the inverter.

1) ENTER command:

- Write any data in all memory (of a holding register at 0900h) by the Write in Holding Register command [06h].



NOTE: The ENTER command takes much time to run. You can check its progress by monitoring the Data Writing signal (of a coil at 0049h).



NOTE: The service life of the storage element of the inverter is limited (to about 100,000 write operations). Frequent use of the ENTER command may shorten its service life.

2) EEPROM write mode:

- Inverter transfers the EEPROM mode write when the data "1" is written into holding register of EEPROM write mode (0902h) with the command [06h] to write data to registers.
- After the inverter transferred the EEPROM write mode, the data changing with the command [06h] to write data to registers is written into both volatile memory (RAM) and nonvolatile memory (EEPROM). The EEPROM write mode is removed simultaneously.
- After the inverter transferred the EEPROM write mode, when the inverter receive exclusive of the command [06h] to write data to registers, the EEPROM write mode is removed.

* The difference between ENTER command and EEPROM write mode

ENTER command

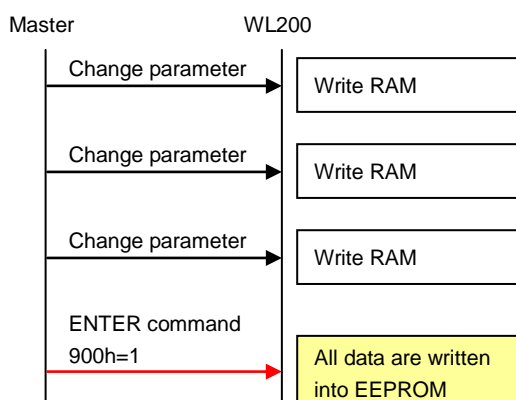

EEPROM write mode

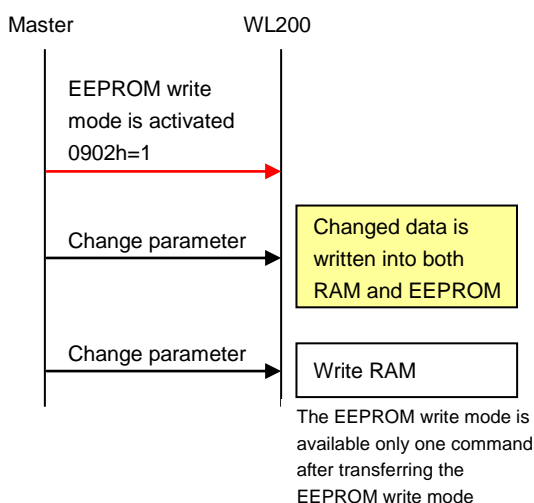

EzCOM (Peer-to-Peer communication)

- Besides standard Modbus-RTU communication (slave), WJ200 supports Peer-to-Peer communication between multiple inverters.
- The max. number of inverter in the network is up to 247 (32 without repeater).
- One administrator inverter is necessary in the network, and the other inverters behave as master or slave.
- Be sure to set station No.1 as an administrator inverter, which controls master inverter according to user setting. The others will be slave inverters. An admin. inverter is fixed, but a master inverter always turns by rotation. For this reason, an admin. inverter can be a master or a slave.
- A master inverter is able to write data to any holding register of designated slave inverter. The max. number of holding register is up to 5. After writing data completed, a master inverter will be shift to the next inverter.
- The max. number of master inverter is 8.

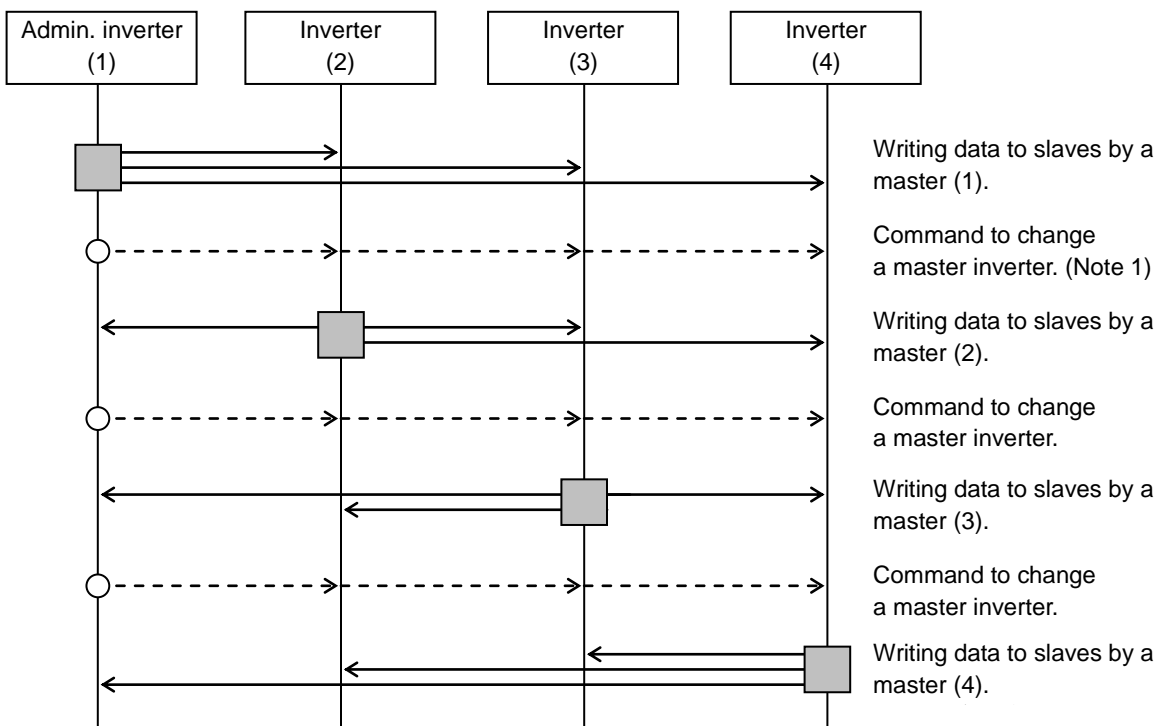

- Note 1:** The command to change a master is issued by an admin. inverter automatically, which users do not have to take care.
- Note 2:** The command to change a master from 01 to 02 is issued after the data is sent from master inverter 01 to slave and silent interval plus communication wait time (C078) passed.
- Note 3:** Administrative inverter issues the next command to change a master after the data from master inverters is sent and silent interval plus communication wait time (C078) passed. In case the data from master inverter cannot be received within the communication timeout (C077), then the inverter timeouts and the behaves according to the communication error selection.
- Note 4:** Please set the communication timeout as it is valid (C077=0.01 to 99.99). If it is disabled (C077=0.0), EzCOM function is interrupted in case the data from master inverter was not received. In case it is interrupted, please turn on/off the power or reset (reset terminal on/off).

Func. code	Name	Data/Range	For	Description
C072	Modbus address	1 to 247	ALL	Network address
C076	Selection of the operation after communication error	00	ALL	tripping
		01	ALL	tripping after decelerating and stopping the motor
		02	ALL	ignoring errors
		03	ALL	stopping the motor after free-running
		04	ALL	decelerating and stopping the motor
C077	Communication timeout limit	0.00	ALL	Disabled
		0.01 to 99.99	ALL	[sec.]
C078	Communication wait time	0. to 1000.	ALL	[ms]
C096	Communication selection	00	-	Modbus-RTU
		01	B	EzCOM
		02	A	EzCOM < Admin. inverter >
C098	EzCOM start adr. of master	01 to 08	A	
C099	EzCOM end adr. of master	01 to 08	A	
C100	EzCOM starting trigger	00	A	Input terminal (Note 7)
		01	A	Always
P140	EzCOM the number of data	1 to 5	M	
P141	EzCOM destination 1 address	1 to 247	M	
P142	EzCOM destination 1 register	0000 to FFFF	M	
P143	EzCOM source 1 register	0000 to FFFF	M	
P144	EzCOM destination 2 address	1 to 247	M	
P145	EzCOM destination 2 register	0000 to FFFF	M	
P146	EzCOM source 2 register	0000 to FFFF	M	
P147	EzCOM destination 3 address	1 to 247	M	
P148	EzCOM destination 3 register	0000 to FFFF	M	
P149	EzCOM source 3 register	0000 to FFFF	M	
P150	EzCOM destination 4 address	1 to 247	M	
P151	EzCOM destination 4 register	0000 to FFFF	M	
P152	EzCOM source 4 register	0000 to FFFF	M	
P153	EzCOM destination 5 address	1 to 247	M	
P154	EzCOM destination 5 register	0000 to FFFF	M	
P155	EzCOM source 5 register	0000 to FFFF	M	
C001 to C007	Input terminal function	81	A	485: start EzCOM

Which parameters to be set?

- ALL : Set all inverters in the network.
- A : Set admin. inverter (address=1) only.
- B : Set all inverters except admin. inverter.
- M : Set master inverters configured in C098 to C099 of admin. inverter.

Note 5: Address of Administrative inverter is to be set 01 (C072=01).

Note 6: When selection of operation after communication error is set other than "ignoring errors (C076=02)", EzCOM function is interrupted in case of communication timeout on administrative inverter. In this case, please power off/on or reset (on/off RES terminal) to recover.

- Note 7:** If EzCOM starting trigger is set as input terminal (C100=00), be sure to configure 81 in one of input terminals.
- Note 8:** If EzCOM starting trigger is set as always (C100=01), administrative inverter starts to send the data immediately after power on. In case the establishment of the inverter to be assigned as master of delays and fail to receive the command to change the master, the data cannot be sent from master and administrative inverter time-outs. When C100=01 selected, please be sure to power up the administrative inverter at last after reconfirming the establishment of inverters other than administrative inverters.
- Note 9:** Although slave addresses are set in a master inverter, data is sent as broadcast address (00). If a slave inverter receives data to another slave, it will be ignored.
- Note 10:** As EzCOM source and destination register, please set the number minus one from the value listed in the table in "modbus data listing".
- Note 11:** Be sure to avoid to set "08FFh (EEPROM writing)" and "0901h (EEPROM write mode)"
- Note 12:** If above parameter is changed, the inverter power must be rebooted in order to activate new parameters. Instead of rebooting, turning ON/OFF of reset terminal works as same.

Basic function (in case the number of data is 1 (P140=1))

- A master inverter sends data in holding register P143 of the master to a slave inverter of address P141 and overwrites on holding register P142.
- A master inverter is changed to the next inverter, and repeats same procedure according to setting of new master inverter.

Modbus Data Listing

Modbus Coil List

The following tables list the primary coils for the inverter interface to the network. The table legend is given below.

- **Coil Number** - The network *register address offset* for the coil. The coil data is a single bit (binary) value.
- **Item** - The functional name of the coil
- **R/W** - The read-only (R) or read-write (R/W) access permitted to the inverter data
- **Setting** - The meaning of each of the states of the coils

Coil No.	Item	R/W	Setting
0000h	(Unused)	-	(Inaccessible)
0001h	Operation command	R/W	1: Run, 0: Stop (valid when A002 = 03)
0002h	Rotation direction command	R/W	1: Reverse rotation, 0: Forward rotation (valid when A002 = 03)
0003h	External trip (EXT)	R/W	1: Trip
0004h	Trip reset (RS)	R/W	1: Reset
0005h	(Reserved)	-	-
0006h	(Reserved)	-	-
0007h	Intelligent input terminal [1]	R/W	1: ON, 0: OFF (*1)
0008h	Intelligent input terminal [2]	R/W	1: ON, 0: OFF (*1)
0009h	Intelligent input terminal [3]	R/W	1: ON, 0: OFF (*1)
000Ah	Intelligent input terminal [4]	R/W	1: ON, 0: OFF (*1)
000Bh	Intelligent input terminal [5]	R/W	1: ON, 0: OFF (*1)
000Ch	Intelligent input terminal [6]	R/W	1: ON, 0: OFF (*1)
000Dh	Intelligent input terminal [7]	R/W	1: ON, 0: OFF (*1)
000Eh	(Reserved)	-	-
000Fh	Operation status	R	1: Run, 0: Stop (interlocked to "d003")
0010h	Rotation direction	R	1: Reverse rotation, 0: Forward rotation (interlocked to "d003")
0011h	Inverter ready	R	1: Ready, 0: Not ready
0012h	(Reserved)	-	-
0013h	RUN (running)	R	1: Tripping, 0: Normal
0014h	FA1 (constant-speed reached)	R	1: ON, 0: OFF
0015h	FA2 (set frequency overreached)	R	1: ON, 0: OFF
0016h	OL (overload warning (1))	R	1: ON, 0: OFF
0017h	OD (output deviation for PID control)	R	1: ON, 0: OFF
0018h	AL (alarm signal)	R	1: ON, 0: OFF
0019h	FA3 (set frequency reached)	R	1: ON, 0: OFF
001Ah	(Reserved)	R	1: ON, 0: OFF
001Bh	(Reserved)	-	-
001Ch	UV (under-voltage)	R	1: ON, 0: OFF
001Dh	(Reserved)	R	1: ON, 0: OFF
001Eh	RNT (operation time over)	R	1: ON, 0: OFF
001Fh	ONT (plug-in time over)	R	1: ON, 0: OFF
0020h	THM (thermal alarm signal)	R	1: ON, 0: OFF
0021h	(Reserved)	-	-
0022h	(Reserved)	-	-
0023h	(Reserved)	-	-
0024h	(Reserved)	-	-
0025h	(Reserved)	-	-
0026h	BRK (brake release)	R	1: ON, 0: OFF
0027h	BER (brake error)	R	1: ON, 0: OFF
0028h	ZS (0 Hz detection signal)	R	1: ON, 0: OFF
0029h	(Reserved)	R	1: ON, 0: OFF
002Ah	(Reserved)	R	1: ON, 0: OFF
002Bh	FA4 (set frequency overreached 2)	R	1: ON, 0: OFF
002Ch	FA5 (set frequency reached 2)	R	1: ON, 0: OFF
002Dh	OL2 (overload warning (2))	R	1: ON, 0: OFF

Coil No.	Item	R/W	Setting
002Eh	ODc (Analog O disconnection detection)	-	1: ON, 0: OFF
002Fh	OIDc (Analog OI disconnection detection)	-	1: ON, 0: OFF
0030h	(Reserved)	-	-
0031h	(Reserved)	-	-
0032h	FBV (PID feedback comparison)	R	1: ON, 0: OFF
0033h	NDC (communication train disconnection)	R	1: ON, 0: OFF
0034h	LOG1 (logical operation result 1)	R	1: ON, 0: OFF
0035h	LOG2 (logical operation result 2)	R	1: ON, 0: OFF
0036h	LOG3 (logical operation result 3)	R	1: ON, 0: OFF
0037h	(Reserved)	-	-
0038h	(Reserved)	-	-
0039h	(Reserved)	-	-
003Ah	WAC (capacitor life warning)	R	1: ON, 0: OFF
003Bh	WAF (cooling-fan speed drop)	R	1: ON, 0: OFF
003Ch	FR (starting contact signal)	R	1: ON, 0: OFF
003Dh	OHF (heat sink overheat warning)	R	1: ON, 0: OFF
003Eh	LOC (low-current indication signal)	R	1: ON, 0: OFF
003Fh	M01 (general output 1)	R	1: ON, 0: OFF
0040h	M02 (general output 2)	R	1: ON, 0: OFF
0041h	M03 (general output 3)	R	1: ON, 0: OFF
0042h	(Reserved)	-	-
0043h	(Reserved)	-	-
0044h	(Reserved)	-	-
0045h	IRDY (inverter ready)	R	1: ON, 0: OFF
0046h	FWR (forward rotation)	R	1: ON, 0: OFF
0047h	RVR (reverse rotation)	R	1: ON, 0: OFF
0048h	MJA (major failure)	R	1: ON, 0: OFF
0049h	Data writing in progress	R	1: Writing in progress, 0: Normal status
004Ah	CRC error	R	1: Error detected, 0: No error (*2)
004Bh	Overrun	R	1: Error detected, 0: No error (*2)
004Ch	Framing error	R	1: Error detected, 0: No error (*2)
004Dh	Parity error	R	1: Error detected, 0: No error (*2)
004Eh	Sum check error	R	1: Error detected, 0: No error (*2)
004Fh	(Reserved)	-	-
0050h	WCO (window comparator O)	R	1: ON, 0: OFF
0051h	WCOI (window comparator OI)	R	1: ON, 0: OFF
0052h	(Reserved)	-	-
0053h	OPDc (option disconnection)	R	1: ON, 0: OFF
0054h	FREF (FQ command source)	R	1: Operator, 0: Others
0055h	REF (RUN command source)	R	1: Operator, 0: Others
0056h	SETM (2nd motor selected)	R	1: 2nd motor selected, 0: 1st motor selected
0057h	(Reserved)	-	-
0058h	EDM (Gate suppress monitor)	R	1: ON, 0: OFF
0059h-	(Unused)	R	inaccessible

- *1 Normally, this coil is turned on when the corresponding intelligent input terminal on the control circuit terminal block is turned on or the coil itself is set to on. In this regard, the operation of the intelligent input terminal has priority over the operation of the coil. If disconnection of the communication train has disabled the master system from turning off the coil, turn the corresponding intelligent input terminal on the control circuit block on and off. This operation turns off the coil.
- *2 Communication error data is retained until an error reset command is input. (The data can be reset during the inverter operation.)

Modbus Holding Registers

The following tables list the holding registers for the inverter interface to the network. The table legend is given below.

- **Register No.** - The network *register address offset* for the value. Some values have a high-byte and low-byte address.
- **Function name** - The standard functional name of the parameter or function for the inverter
- **Function code** - The inverter's reference code for the parameter or function (same as inverter keypad display)
- **R/W** - The read-only(R) or read-write access(R/W) permitted to the data in the inverter
- **Monitoring and setting items** - The numerical range for the network value that is sent and/or received



TIP: The network values are binary integers. Since these values cannot have an embedded decimal point, for many parameters it represents the actual value (in engineering units) multiplied by a factor of 10 or 100. Network communications must use the listed range for network data. The inverter automatically divides received values by the appropriate factor in order to establish the decimal point for internal use. Likewise, the network host computer must apply the same factor when it needs to work in engineering units. However, when sending data to the inverter, the network host computer must scale values to the integer range listed for network communications.

- **Data resolution** - This is the quantity represented by the LSB of the network value, in engineering units. When the network data range is greater than the inverter's internal data range, this 1-bit resolution will be fractional.

List of resistors (frequency setting and status)

Register No.	Function name	Function code	R/W	Monitoring and setting items	Data resolution
0000h	(Unused)	-	-	Inaccessible	
0001h	(Reserved)	-	R	-	-
0002h	Frequency setting	F001	R/W	0 to 40000 (valid when A001 = 03)	0.01 [Hz]
0003h	Inverter status A	-	R	0: Initial status 2: Stopping 3: Running 4: Free-run stop 5: Jogging 6: DC braking 7: Retrying 8: Tripping 9: Under-voltage (UV)	-
0004h	Inverter status B	-	R	0: Stopping, 1: Running, 2: Tripping	-
0005h	Inverter status C	-	R	0: --- 1: Stopping 2: Decelerating 3: Constant-speed operation 4: Accelerating 5: Forward rotation 6: Reverse rotation 7: Switching from fwd. to rev. rotation, 8: Switching from rev. to fwd. rotation, 9: Starting fwd. 10: Starting rev.	-
0006h	PID feedback	-	R/W	0 to 10000	0.01 [%]
0007h to 0010h	(Reserved)	-	R	-	-

Register No.	Function name	Function code	R/W	Monitoring and setting items	Data resolution
0011h	Trip Counter	d080	R	0 to 65530	1 [time]
0012h	Trip info. 1 (factor)	d081	R	See the list of inverter trip factors below	-
0013h	Trip info. 1 (inverter status)			See the list of inverter trip factors below	-
0014h	(Reserved)			-	-
0015h	Trip info. 1 (frequency)			0 to 40000	0.01[Hz]
0016h	Trip info. 1 (current)			Output current at tripping	0.01[A]
0017h	Trip info. 1 (voltage)			DC input voltage at tripping	1[V]
0018h	Trip info. 1 (running time) (high)			Cumulative running time at tripping	1[h]
0019h	Trip info. 1 (running time) (low)				
001Ah	Trip info. 1 (power-on time) (high)				
001Bh	Trip info. 1 (power-on time) (low)				
0012h	Trip info. 2 (factor)	d082	R	See the list of inverter trip factors below	-
0013h	Trip info. 2 (inverter status)			See the list of inverter trip factors below	-
0014h	(Reserved)			-	-
0015h	Trip info. 2 (frequency)			0 to 40000	0.01[Hz]
0016h	Trip info. 2 (current)			Output current at tripping	0.01[A]
0017h	Trip info. 2 (voltage)			DC input voltage at tripping	1[V]
0018h	Trip info. 2 (running time) (high)			Cumulative running time at tripping	1[h]
0019h	Trip info. 2 (running time) (low)				
001Ah	Trip info. 2 (power-on time) (high)				
001Bh	Trip info. 2 (power-on time) (low)				
0012h	Trip info. 3 (factor)	d083	R	See the list of inverter trip factors below	-
0013h	Trip info. 3 (inverter status)			See the list of inverter trip factors below	-
0014h	(Reserved)			-	-
0015h	Trip info. 3 (frequency)			0 to 40000	0.01[Hz]
0016h	Trip info. 3 (current)			Output current at tripping	0.01[A]
0017h	Trip info. 3 (voltage)			DC input voltage at tripping	1[V]
0018h	Trip info. 3 (running time) (high)			Cumulative running time at tripping	1[h]
0019h	Trip info. 3 (running time) (low)				
001Ah	Trip info. 3 (power-on time) (high)				
001Bh	Trip info. 3 (power-on time) (low)				
0012h	Trip info. 4 (factor)	d084	R	See the list of inverter trip factors below	-
0013h	Trip info. 4 (inverter status)			See the list of inverter trip factors below	-
0014h	(Reserved)			-	-
0015h	Trip info. 4 (frequency)			0 to 40000	0.01[Hz]
0016h	Trip info. 4 (current)			Output current at tripping	0.01[A]
0017h	Trip info. 4 (voltage)			DC input voltage at tripping	1[V]
0018h	Trip info. 4 (running time) (high)			Cumulative running time at tripping	1[h]
0019h	Trip info. 4 (running time) (low)				
001Ah	Trip info. 4 (power-on time) (high)				
001Bh	Trip info. 4 (power-on time) (low)				
0012h	Trip info. 5 (factor)	d085	R	See the list of inverter trip factors below	-
0013h	Trip info. 5 (inverter status)			See the list of inverter trip factors below	-
0014h	(Reserved)			-	-
0015h	Trip info. 5 (frequency)			0 to 40000	0.01[Hz]
0016h	Trip info. 5 (current)			Output current at tripping	0.01[A]
0017h	Trip info. 5 (voltage)			DC input voltage at tripping	1[V]
0018h	Trip info. 5 (running time) (high)			Cumulative running time at tripping	1[h]
0019h	Trip info. 5 (running time) (low)				
001Ah	Trip info. 5 (power-on time) (high)				
001Bh	Trip info. 5 (power-on time) (low)				
0012h	Trip info. 6 (factor)	d086	R	See the list of inverter trip factors below	-
0013h	Trip info. 6 (inverter status)			See the list of inverter trip factors below	-
0014h	(Reserved)			-	-
0015h	Trip info. 6 (frequency)			0 to 40000	0.01[Hz]
0016h	Trip info. 6 (current)			Output current at tripping	0.01[A]
0017h	Trip info. 6 (voltage)			DC input voltage at tripping	1[V]
0018h	Trip info. 6 (running time) (high)			Cumulative running time at tripping	1[h]
0019h	Trip info. 6 (running time) (low)				
001Ah	Trip info. 6 (power-on time) (high)				
001Bh	Trip info. 6 (power-on time) (low)				

Register No.	Function name	Function code	R/W	Monitoring and setting items	Data resolution
004Eh	Programming error monitoring	d090	R	Warning code	-
004Fh to 006Ch	(Reserved)	-	-	-	-
006Dh to 08Efh	(Reserved)	-	-	-	-
0900h	Writing to EEPROM	-	W	0: Motor constant recalculation 1: Save all data in EEPROM Other: Motor constant recalculation and save all data in EEPROM	-
0901h	(Unused)	-	-	Inaccessible	-
0902h	EEPROM write mode	-	W	0 (invalid) 1 (valid)	
0903h to 1000h	(Unused)	-	-	Inaccessible	-

Note 1: Assume that the rated current of the inverter is "1000".

Note 2: If a number not less than "1000" (100.0 seconds) is specified, the second value after the decimal point will be ignored.

Note 3: 0902h setting is referred for one time when following 06H command is executed.

List of inverter trip factors

Upper part of trip factor code (indicating the factor)		Lower part of trip factor code (indicating the inverter status)	
Name	Code	Name	Code
No trip factor	0	Resetting	0
Over-current event while at constant speed	1	Stopping	1
Over-current event during deceleration	2	Decelerating	2
Over-current event during acceleration	3	Constant-speed operation	3
Over-current event during other conditions	4	Accelerating	4
Overload protection	5	Operating at zero frequency	5
Braking resistor overload protection	6	Starting	6
Overvoltage protection	7	DC braking	7
EEPROM error	8	Overload restricted	8
Under-voltage protection	9		
Current detection error	10		
CPU error	11		
External trip	12		
USP error	13		
Ground-fault protection	14		
Input overvoltage protection	15		
Thermistor thermal protection	19		
Inverter thermal trip	21		
CPU error	22		
Main circuit error	25		
Driver error	30		
Thermistor error	35		
Braking error	36		
Safe Stop	37		
Low-speed overload protection	38		
Operator connection	40		
Modbus communication error	41		
Easy sequence error (invalid instruction)	43		
Easy sequence error (invalid nesting count)	44		
Easy sequence execution error 1	45		
Easy sequence user trip 0 to 9	50 to 59		
Option error 0 to 9	60 to 69		

List of registers (monitoring)

Register No.	Function name	Function code	R/W	Monitoring and setting items	Data resolution
1001h	(Reserved)	-	-	-	-
1002h	Output frequency monitor	d001	R	0 to 40000	0.01 [Hz]
1003h	Output current monitor	d002	R	0 to 65530	0.01 [A]
1004h	Rotation direction monitoring	d003	R	0: Stopping 1: Forward rotation 2: Reverse rotation	0.1 [Hz]
1005h	Process variable (PV), PID feedback monitoring	d004 (high)	R	0 to 1000000	0.1
1006h		d004 (low)			
1007h	Intelligent input terminal status	d005	R	2 [^] 0: Terminal 1 to 2 [^] 6: Terminal 7	1 bit
1008h	Intelligent output terminal status	d006	R	2 [^] 0: Terminal 11 2 [^] 1: Terminal 12 2 [^] 2: Relay Terminal	1 bit
1009h	Scaled output frequency monitor	d007 (high)	R	0 to 399600	0.01
100Ah		d007 (low)			
100Bh to 1010h	(Reserved)	-	-	-	-
1011h	Output voltage monitor	d013	R	0 to 6000	0.1 [V]
1012h	Power monitor	d014	R	0 to 1000	0.1 [kW]
1013h	Watt-hour monitor	d015 (high)	R	0 to 9999000	0.1
1014h		d015 (low)			
1015h	Elapsed RUN time monitor	d016 (high)	R	0 to 999900	1 [h]
1016h		d016 (low)			
1017h	Elapsed power-on time monitor	d017 (high)	R	0 to 999900	1 [h]
1018h		d017 (low)			
1019h	Heat sink temperature monitor	d018	R	-200 to 1500	0.1 [°C]
101Ah to 101Ch	(Reserved)	-	-	-	-
101Dh	Life-check monitor	d022	R	2 [^] 0: Capacitor on main circuit board 2 [^] 1: cooling-fan	1 bit
101Eh	EzSQ program counter	d023	R	0 to 1024	1
101Fh	EzSQ program number	d024	R	0 to 9999	1
1020h to 1025h	(Reserved)	-	-	-	-
1026h	DC voltage monitoring (across P and N)	d102	R	0 to 10000	0.1 [V]
1027h	BRD load factor monitoring	d103	R	0 to 1000	0.1 [%]
1028h	Electronic thermal overload monitoring	d104	R	0 to 1000	0.1 [%]
1029h to 102Dh	(Reserved)	-	-	-	-
102Eh	User monitor 1	d025(high)	R	-2147483647 to 2147483647	1
102Fh		d025(low)	R		
1030h	User monitor 2	d026(high)	R	-2147483647 to 2147483647	1
1031h		d026(low)	R		
1032h	User monitor 3	d027(high)	R	-2147483647 to 2147483647	1
1033h		d027(low)	R		
1034h to 1058h	(Reserved)	-	-	-	-

Register No.	Function name	Function code	R/W	Monitoring and setting items	Data resolution
1059h	Frequency source monitor	d062	R	0 (Operator) 23 (Calculate function output) 1-15 (1-15 Multi-speed) 24 (EzSQ) 16 (Jog frequency) 25 ([O] input) 18 (Modbus communication) 26 ([OI] input) 19 (Option) 27 ([O] + [OI] input) 21 (Potentiometer. available with OPE-SR or OPE-SRmini)	-
105Ah	Run command source monitor	d063	R	1 (Control terminal) 3 (Modbus network) 2 (Operator) 4 (Option)	-
105Bh to 118Dh	(Unused)	-	-	Inaccessible	-
108Eh	Analog input O monitor	d130	R	0 to 1023	1
108Fh	Analog input OI monitor	d131	R	0 to 1023	1
1090h to 10ADh	(Unused)	-	-	Inaccessible	-
10AEh	PID deviation monitor	d153(high)	R	-999900 to 999900	0.01[%]
10AFh		d153(low)	R		
10B0h to 10B1h	(Unused)	-	-	Inaccessible	-
10B2h	PID output monitor	d155(high)	R	-999900 to 999900	0.01[%]
10B3h		d155(low)	R		
10B4h to 1102h	(Unused)	-	-	Inaccessible	-

List of registers (function modes)

Parameter group F

Register No.	Function name	Function code	R/W	Monitoring and setting items	Data resolution
1103h	Acceleration time (1)	F002 (high)	R/W	0 to 360000	0.01 [sec.]
1104h		F002 (low)			
1105h	Deceleration time (1)	F003 (high)	R/W	0 to 360000	0.01 [sec.]
1106h		F003 (low)			
1107h	Keypad Run key routing	F004	R/W	0 (forward rotation) 1 (reverse rotation)	-
1108h to 1200h	(Unused)	-	-	Inaccessible	-

Parameter group A

Register No.	Function name	Function code	R/W	Monitoring and setting items	Data resolution
1201h	Frequency source	A001	R/W	0 (keypad potentiometer) 3 (Modbus) 4 (option) 1 (control circuit terminal block) 7 (easy sequence) 2 (digital operator) 10 (operation function result)	-
1202h	Run command source (*)	A002	R/W	1 (control circuit terminal block) 3 (Modbus) 2 (digital operator) 4 (option)	-
1203h	Base frequency	A003	R/W	300 to "maximum frequency"	0.1 [Hz]
1204h	Maximum frequency	A004	R/W	300 to 4000(10000)	0.1 [Hz]
1205h	[AT] selection	A005	R/W	0 (switching between O and OI terminals) 2 (switching between O terminal and keypad potentiometer) 3 (switching between OI terminal and keypad potentiometer)	-
1206h to 120Ah	(Reserved)	-	-	-	-
120Bh	(Reserved)	-	-	-	-
120Ch	[O] input active range start frequency	A011	R/W	0 to 40000	0.01 [Hz]
120Dh	(Reserved)	-	-	-	-
120Eh	[O] input active range end frequency	A012	R/W	0 to 40000	0.01 [Hz]
120Fh	[O] input active range start voltage	A013	R/W	0 to "[O]-[L] input active range end voltage"	1 [%]
1210h	[O] input active range end voltage	A014	R/W	"[O]-[L] input active range start voltage" to 100	1 [%]
1211h	[O] input start frequency select	A015	R/W	0 (external start frequency) 1 (0 Hz)	-
1212h	Analog input filter.	A016	R/W	1 to 30 or 31 (500 ms filter ±0.1 Hz with hysteresis)	1
1213h	EzSQ selection	A017	R/W	0 (disabling) 2 (Always) 1 (PRG terminal)	-
1214h	(Reserved)	-	-	-	-

(*) After changing the setting, keep the time 40ms or longer before actually give run command

Register No.	Function name	Function code	R/W	Monitoring and setting items	Data resolution
1215h	Multi speed operation selection	A019	R/W	0 (binary) 1 (bit)	-
1216h	(Reserved)	-	-	-	-
1217h	Multi-speed freq. 0	A020	R/W	0 or "start frequency" to "maximum frequency"	0.01 [Hz]
1218h	(Reserved)	-	R/W	-	-
1219h	Multi-speed freq. 1	A021	R/W	0 or "start frequency" to "maximum frequency"	0.01 [Hz]
121Ah	(Reserved)	-	R/W	-	-
121Bh	Multi-speed freq. 2	A022	R/W	0 or "start frequency" to "maximum frequency"	0.01 [Hz]
121Ch	(Reserved)	-	R/W	-	-
121Dh	Multi-speed freq. 3	A023	R/W	0 or "start frequency" to "maximum frequency"	0.01 [Hz]
121Eh	(Reserved)	-	R/W	-	-
121Fh	Multi-speed freq. 4	A024	R/W	0 or "start frequency" to "maximum frequency"	0.01 [Hz]
1220h	(Reserved)	-	R/W	-	-
1221h	Multi-speed freq. 5	A025	R/W	0 or "start frequency" to "maximum frequency"	0.01 [Hz]
1222h	(Reserved)	-	R/W	-	-
1223h	Multi-speed freq. 6	A026	R/W	0 or "start frequency" to "maximum frequency"	0.01 [Hz]
1224h	(Reserved)	-	R/W	-	-
1225h	Multi-speed freq. 7	A027	R/W	0 or "start frequency" to "maximum frequency"	0.01 [Hz]
1226h	(Reserved)	-	-	-	-
1227h	Multi-speed freq. 8	A028	R/W	0 or "start frequency" to "maximum frequency"	0.01 [Hz]
1228h	(Reserved)	-	-	-	-
1229h	Multi-speed freq. 9	A029	R/W	0 or "start frequency" to "maximum frequency"	0.01 [Hz]
122Ah	(Reserved)	-	-	-	-
122Bh	Multi-speed freq. 10	A030	R/W	0 or "start frequency" to "maximum frequency"	0.01 [Hz]
122Ch	(Reserved)	-	-	-	-
122Dh	Multi-speed freq. 11	A031	R/W	0 or "start frequency" to "maximum frequency"	0.01 [Hz]
122Eh	(Reserved)	-	-	-	-
122Fh	Multi-speed freq. 12	A032	R/W	0 or "start frequency" to "maximum frequency"	0.01 [Hz]
1230h	(Reserved)	-	-	-	-
1231h	Multi-speed freq. 13	A033	R/W	0 or "start frequency" to "maximum frequency"	0.01 [Hz]
1232h	(Reserved)	-	-	-	-
1233h	Multi-speed freq. 14	A034	R/W	0 or "start frequency" to "maximum frequency"	0.01 [Hz]
1234h	(Reserved)	-	-	-	-
1235h	Multi-speed freq. 15	A035	R/W	0 or "start frequency" to "maximum frequency"	0.01 [Hz]
1236h to 1237h	(Reserved)	-	-	-	-
1238h	Jog frequency	A038	R/W	0, "Start frequency" to 999	0.01 [Hz]
1239h	Jog stop mode	A039	R/W	0 (free-running after jogging stops [disabled during operation]) 3 (free-running after jogging stops [enabled during operation]) 1 (deceleration and stop after jogging stops [disabled during operation]) 4 (deceleration and stop after jogging stops [enabled during operation]) 2 (DC braking after jogging stops [disabled during operation]) 5 (DC braking after jogging stops [enabled during operation])	-
123Ah	(Reserved)	-	-	-	-
123Bh	Torque boost method selection	A041	R/W	0 (manual torque boost) 1 (automatic torque boost)	-
123Ch	Manual torque boost value	A042	R/W	0 to 200	0.1 [%]
123Dh	Manual torque boost frequency	A043	R/W	0 to 500	0.1 [%]

Register No.	Function name	Function code	R/W	Monitoring and setting items	Data resolution
123Eh	V/F characteristic curve selection, 1st motor	A044	R/W	0 (VC) 2 (free V/f) 1 (VP)	-
123Fh	V/f gain	A045	R/W	20 to 100	1 [%]
1240h	Voltage compensation gain setting for automatic torque boost, 1st motor	A046	R/W	0 to 255	1 [%]
1241h	Slippage compensation gain setting for automatic torque boost, 1st motor	A047	R/W	0 to 255	1 [%]
1242h to 1244h	(Reserved)	-	-	-	-
1245h	DC braking enable	A051	R/W	0 (disabling) 2 (output freq < [A052]) 1 (enabling)	-
1246h	DC braking frequency	A052	R/W	0 to 6000	0.01 [Hz]
1247h	DC braking wait time	A053	R/W	0 to 50	0.1 [sec.]
1248h	DC braking force during deceleration	A054	R/W	0 to 70	1 [%]
1249h	DC braking time for deceleration	A055	R/W	0 to 600	0.1 [sec.]
124Ah	DC braking/edge or level detection for [DB] input	A056	R/W	0 (edge operation) 1 (level operation)	-
124Bh	DC braking force for starting	A057	R/W	0 to 70	1 [%]
124Ch	DC braking time for starting	A058	R/W	0 to 600	0.1 [sec.]
124Dh	DC braking carrier frequency setting	A059	R/W	20 to 100	0.1 [kHz]
124Eh to 124Fh	(Reserved)	-	-	-	-
1250h	Frequency upper limit	A061	R/W	0 or "maximum frequency limit" to "maximum frequency"	0.01 [Hz]
1251h	(Reserved)	-	-	-	-
1252h	Frequency lower limit	A062	R/W	0 or "maximum frequency limit" to "maximum frequency"	0.01 [Hz]
1253h	(Reserved)	-	-	-	-
1254h	Jump freq. (center) 1	A063	R/W	0 to 40000	0.01 [Hz]
1255h	Jump freq. width (hysteresis) 1	A064	R/W	0 to 1000	0.01 [Hz]
1256h	(Reserved)	-	-	-	-
1257h	Jump freq. (center) 2	A065	R/W	0 to 40000	0.01 [Hz]
1258h	Jump freq. width (hysteresis) 2	A066	R/W	0 to 1000	0.01 [Hz]
1259h	(Reserved)	-	-	-	-
125Ah	Jump freq. (center) 3	A067	R/W	0 to 40000	0.01 [Hz]
125Bh	Jump freq. width (hysteresis) 3	A068	R/W	0 to 1000	0.01 [Hz]
125Ch	(Reserved)	-	-	-	-
125Dh	Acceleration hold frequency	A069	R/W	0 to 40000	0.01 [Hz]
125Eh	Acceleration hold time	A070	R/W	0 to 600	0.1 [sec.]
125Fh	PID Function Enable	A071	R/W	0 (disabling) 2 (enabling inverted-data output) 1 (enabling)	-
1260h	PID proportional gain	A072	R/W	0 to 2500	0.10
1261h	PID integral time constant	A073	R/W	0 to 36000	0.1 [sec.]
1262h	PID derivative gain	A074	R/W	0 to 10000	0.01 [sec.]
1263h	PV scale conversion	A075	R/W	1 to 9999	0.01
1264h	PV source	A076	R/W	0 (input via OI) 3 (pulse train frequency input) 1 (input via O) 10 (operation result output) 2 (external communication)	-
1265h	Reverse PID	A077	R/W	0 (disabling) 1 (enabling)	-
1266h	PID output limiter	A078	R/W	0 to 1000	0.1 [%]

Register No.	Function name	Function code	R/W	Monitoring and setting items	Data resolution
1267h	PID feed forward selection	A079	R/W	0 (disabled) 2 (OI input) 1 (O input)	-
1268h	(Reserved)	-	-	-	-
1269h	AVR function select	A081	R/W	0 (always on) 2 (off during 1 (always off) deceleration)	-
126Ah	AVR voltage select	A082	R/W	200 V class: 400 V class: 0 (200) 5 (380) 1 (215) 6 (400) 2 (220) 7 (415) 3 (230) 8 (440) 4 (240) 9 (460) 10 (480)	-
126Bh	AVR filter time constant	A083	R/W	0 to 10000	0.001[sec.]
126Ch	AVR deceleration gain	A084	R/W	50 to 200	1[%]
126Dh	Energy-saving operation mode	A085	R/W	0 (normal operation) 1 (energy-saving operation)	-
126Eh	Energy-saving mode tuning	A086	R/W	0 to 1000	0.1 [%]
126Fh to 1273h	(Reserved)	-	-	-	-
1274h	Acceleration time (2)	A092 (high)	R/W	0 to 360000	0.01 [sec.]
1275h		A092 (low)	R/W		
1276h	Deceleration time (2)	A093 (high)	R/W	0 to 360000	0.01 [sec.]
1277h		A093 (low)	R/W		
1278h	Select method to switch to Acc2/Dec2 profile	A094	R/W	0 (switching by 2CH terminal) 1 (switching by setting) 2 (Forward and reverse)	-
1279h	(Reserved)	-	-	-	-
127Ah	Acc1 to Acc2 frequency transition point	A095	R/W	0 to 40000	0.01 [Hz]
127Bh	(Reserved)	-	-	-	-
127Ch	Dec1 to Dec2 frequency transition point	A096	R/W	0 to 40000	0.01 [Hz]
127Dh	Acceleration curve selection	A097	R/W	0 (linear) 2 (U curve) 1 (S curve) 3 (inverted-U curve)	-
127Eh	Deceleration curve setting	A098	R/W	0 (linear) 2 (U curve) 1 (S curve) 3 (inverted-U curve)	-
127Fh to 1281h	(Reserved)	-	-	-	-
1282h	[OI] input active range start frequency	A101	R/W	0 to 40000	0.01 [Hz]
1283h	(Reserved)	-	-	-	-
1284h	[OI] input active range end frequency	A102	R/W	0 to 40000	0.01 [Hz]
1285h	[OI] input active range start current	A103	R/W	0 to "[OI]-[L] input active range end current"	1 [%]
1286h	[OI] input active range end current	A104	R/W	"[OI]-[L] input active range start current" to 100	1 [%]
1287h	[OI] input start frequency select	A105	R/W	0 (external start frequency) 1 (0 Hz)	-
1288h to 12A4h	(Reserved)	-	-	-	-
12A5h	Acceleration curve constant	A131	R/W	1 (smallest swelling) to 10 (largest swelling)	-
12A6h	Deceleration curve constant	A132	R/W	1 (smallest swelling) to 10 (largest swelling)	-
12A7h to 12AEh	(Reserved)	-	-	-	-

Register No.	Function name	Function code	R/W	Monitoring and setting items	Data resolution
12AFh	Operation-target frequency selection 1	A141	R/W	0 (digital operator) 3 (input via OI) 1 (keypad potentiometer) 4 (external communication) 2 (input via O) 5 (option)	-
12B0h	Operation-target frequency selection 2	A142	R/W	0 (digital operator) 3 (input via OI) 1 (keypad potentiometer) 4 (external communication) 2 (input via O) 5 (option)	-
12B1h	Operator selection	A143	R/W	0 (addition: A141 + A142) 1 (subtraction: A141 - A142) 2 (multiplication: A141 x A142)	-
12B2h to 12B3	(Reserved)	-	-	-	-
12B4h	Frequency to be added	A145	R/W	0 to 40000	0.01 [Hz]
12B5h	Sign of the frequency to be added	A146	R/W	00 (frequency command + A145) 01 (frequency command - A145)	-
12B6h to 12BDh	(Reserved)	-	-	-	-
12BDh	Deceleration hold frequency	A154	R/W	0 to 40000	0.01 [Hz]
12BFh	Deceleration hold time	A155	R/W	0 to 600	0.1 [sec.]
12C0h	(Reserved)	-	-	-	-
12C1h	PID sleep function triggering level	A156	R/W	0 to 40000	0.01 [Hz]
12C2h	PID sleep function action delay time	A157	R/W	0 to 255	0.1 [sec.]
12C3h to 12C6h	(Reserved)	-	-	-	-
12C7h	[VR] input active range start frequency	A161	R/W	0 to 40000	0.01 [Hz]
12C8h	(Reserved)	-	-	-	-
12C9h	[VR] input active range end frequency	A162	R/W	0 to 40000	0.01 [Hz]
12CAh	[VR] input active range start %	A163	R/W	0 to 100	1 [%]
12CBh	[VR] input active range end %	A164	R/W	0 to 100	1 [%]
12CCh	[VR] input start frequency select	A165	R/W	0(start frequency A161) / 1(0Hz)	-
12CDh to 1300h	(Unused)	-	-	Inaccessible	-

Parameter group B

Register No.	Function name	Function code	R/W	Monitoring and setting items	Data resolution
1301h	Restart mode on power failure / under-voltage trip	b001	R/W	0 (tripping) 1 (starting with 0 Hz) 2 (starting with matching frequency) 3 (tripping after deceleration and stopping with matching frequency) 4 (restarting with active matching frequency)	-
1302h	Allowable under-voltage power failure time	b002	R/W	3 to 250	0.1 [sec.]
1303h	Retry wait time before motor restart	b003	R/W	3 to 1000	0.1 [sec.]
1304h	Instantaneous power failure/under-voltage trip alarm enable	b004	R/W	0 (disabling) 2 (disabling during stopping and decelerating to stop) 1 (enabling)	-
1305h	Number of restarts on power failure/under-voltage trip events	b005	R/W	0 (16 times) 1 (unlimited)	-
1306h to 1307h	(Reserved)	-	-	-	-
1307h	Restart frequency threshold	b007	R/W	0 to 40000	0.01 [Hz]
1309h	Restart mode on over voltage / over current	b008	R/W	0 (tripping) 3 (tripping after deceleration and stopping with matching frequency) 1 (starting with 0 Hz) 2 (starting with matching frequency) 4 (restarting with active matching frequency)	-
130Ah	(Reserved)	-	-	-	-
130Bh	Number of retry on over voltage / over current	b010	R/W	1 to 3	1 [time]
130Ch	Retry wait time on over voltage / over current	b011	R/W	3 to 1000	0.1 [sec.]
130Dh	Level of electronic thermal	b012	R/W	200 to 1000	0.1 [%]
130Eh	Electronic thermal characteristic	b013	R/W	0 (reduced-torque characteristic) 1 (constant-torque characteristic) 2 (free setting)	-
130Fh	(Reserved)	-	-	Inaccessible	-
1310h	Free setting, electronic thermal frequency (1)	b015	R/W	0 to 400	1 [Hz]
1311h	Free setting, electronic thermal current (1)	b016	R/W	0 to Rated current	0.1 [A]
1312h	Free setting, electronic thermal frequency (2)	b017	R/W	0 to 400	1 [Hz]
1313h	Free setting, electronic thermal current (2)	b018	R/W	0 to Rated current	0.1 [A]
1314h	Free setting, electronic thermal frequency (3)	b019	R/W	0 to 400	1 [Hz]
1315h	Free setting, electronic thermal current (3)	b020	R/W	0 to Rated current	0.1 [A]
1316h	Overload restriction operation mode	b021	R/W	0 (disabling) 1 (enabling during acceleration and constant-speed operation) 2 (enabling during constant-speed operation) 3 (enabling during acceleration and constant-speed operation [speed increase at regeneration])	-
1317h	Overload restriction level	b022	R/W	200 to 1500	0.1 [%]
1318h	Deceleration rate at overload restriction	b023	R/W	1 to 30000	0.1 [sec.]

Register No.	Function name	Function code	R/W	Monitoring and setting items	Data resolution
1319h	Overload restriction operation mode (2)	b024	R/W	0 (disabling) 1 (enabling during acceleration and constant-speed operation) 2 (enabling during constant-speed operation) 3 (enabling during acceleration and constant-speed operation [speed increase at regeneration])	-
131Ah	Overload restriction level 2	b025	R/W	200 to 1500	0.1 [%]
131Bh	Deceleration rate at overload restriction (2)	b026	R/W	1 to 30000	0.1 [sec.]
131Ch	Overcurrent suppression enable	b027	R/W	0 (disabling) 1 (enabling without voltage reduction) 2 (enabling with voltage reduction)	-
131Dh	Current level of active freq. matching	b028	R/W	100 to 1500	0.1 [%]
131Eh	Deceleration rate of active freq. matching	b029	R/W	1 to 30000	0.1 [sec.]
131Fh	Start freq. of active frequency matching	b030	R/W	0 (frequency at the last shutoff) 1 (maximum frequency) 2 (set frequency)	-
1320h	Software lock mode selection	b031	R/W	0 (disabling change of data other than "b031" when SFT is on) 1 (disabling change of data other than "b031" and frequency settings when SFT is on) 2 (disabling change of data other than "b031") 3 (disabling change of data other than "b031" and frequency settings) 10 (enabling data changes during operation)	-
1321h	(Reserved)	-	-	-	-
1322h	Motor cable length parameter	b033	R/W	5 to 20	-
1323h	Run/power-on warning time	b034 (high)	R/W	0 to 65535	1 [10h]
1324h		b034 (low)	R/W		
1325h	Rotation direction restriction	b035	R/W	0 (Enable for both direction) 1 (Enable for forward only) 2 (Enable for reverse only)	-
1326h	Reduced voltage start selection	b036	R/W	0 (minimum reduced voltage start time) to 255 (maximum reduced voltage start time)	-
1327h	Function code display restriction	b037	R/W	0 (full display) 3 (data comparison display) 1 (function-specific display) 4 (basic display) 2 (user setting) 5 (monitor display)	-
1328h	Initial display selection	b038	R/W	0 (last displayed) 1 to 30 (d001 to d030)201 (F001) 202 (B display of LCD operator)	-
1329h	Automatic user parameter registration	b039	R/W	0 (disabling) 1 (enabling)	-
132Ah to 1333h	(Reserved)	-	-	-	-
1334h	Controlled deceleration on power loss	b050	R/W	0 (disabling) 1 (enabling) 2 (nonstop operation at momentary power failure (no restoration)) 3 (nonstop operation at momentary power failure (restoration to be done))	-
1335h	DC bus voltage trigger level of ctrl. decel.	b051	R/W	0 to 10000	0.1 [V]

Register No.	Function name	Function code	R/W	Monitoring and setting items	Data resolution
1336h	Over-voltage threshold of ctrl. decel.	b052	R/W	0 to 10000	0.1 [V]
1337h	Deceleration time of ctrl. decel.	b053 (high)	R/W	1 to 360000	0.01 [sec.]
1338h		b053 (low)	R/W		
1339h	Initial freq. drop of ctrl. decel.	b054	R/W	0 to 1000	0.01 [Hz]
133Ah to 133Eh	(Reserved)	-	-	-	-
133Fh	Maximum-limit level of window comparators O	b060	R/W	0. to 100. (lower limit : b061 + b062 *2) (%)	1 [%]
1340h	Minimum-limit level of window comparators O	b061	R/W	0. to 100. (lower limit : b060 - b062*2) (%)	1 [%]
1341h	Hysteresis width of window comparators O	b062	R/W	0. to 10. (lower limit : b061 - b062 / 2) (%)	1 [%]
1342h	Maximum-limit level of window comparators OI	b063	R/W	0. to 100. (lower limit : b064 + b066 *2) (%)	1 [%]
1343h	Minimum-limit level of window comparators OI	b064	R/W	0. to 100. (lower limit : b063 - b066 *2) (%)	1 [%]
1344h	Hysteresis width of window comparators OI	b065	R/W	0. to 10. (lower limit : b063 - b064 / 2) (%)	1 [%]
1345h to 1348h	(Reserved)	-	-	-	-
1349h	Operation level at O disconnection	b070	R/W	0 to 100 (%) or 255 (no)	1 [%]
134Ah	Operation level at OI disconnection	b071	R/W	0 to 100 (%) or 255 (no)	1 [%]
134Bh to 134Dh	(Reserved)	-	-	-	-
134Eh	Ambient temperature	b075	R/W	-10 to 50	1 [°C]
134Fh to 1350	(Reserved)	-	-	-	-
1351h	Cumulative input power data clearance	b078	R/W	Clearance by setting "1"	-
1352h	Watt-hour display gain	b079	R/W	1 to 1000	1
1353h to 1354h	(Reserved)	-	-	-	-
1355h	Start frequency	b082	R/W	1 to 999	0.01 [Hz]
1356h	Carrier frequency	b083	R/W	20 to 100	0.1 [kHz]
1357h	Initialization mode (parameters or trip history)	b084	R/W	0 (initialization disabled) 1 (clearing the trip history) 2 (initializing the data) 3 (clearing the trip history and initializing the data) 4 (clearing the trip history and initializing the data and EzSQ program)	-
1358h	Country code for initialization	b085	R/W	0 (area A) 1 (area B)	-
1359h	Frequency scaling conversion factor	b086	R/W	1 to 9999	0.01
135Ah	STOP key enable	b087	R/W	0 (enabling) 1 (disabling) 2 (disabling only stop)	-
135Bh	Restart mode after FRS	b088	R/W	0 (starting with 0 Hz) 1 (starting with matching frequency) 2 (starting with active matching frequency)	-
135Ch	Automatic carrier frequency reduction	b089	R/W	0 (disabling) 1 (enabling (output current controlled)) 2 (enabling (fin temperature controlled))	-
135Dh	Dynamic braking usage ratio	b090	R/W	0 to 1000	0.1 [%]

Register No.	Function name	Function code	R/W	Monitoring and setting items	Data resolution
135Eh	Stop mode selection	b091	R/W	0 (deceleration until stop) 1 (free-run stop)	-
135Fh	Cooling fan control	b092	R/W	0 (always operating the fan) 1 (during inverter operation) 2 (control by temperature)	-
1360h	Clear elapsed time of cooling fan	b093	R/W	0 (count) 1 (clear)	-
1361h	Initialization target data	b094	R/W	0 to 3	-
1362h	Dynamic braking control	b095	R/W	0 (disabling) 1 (enabling [disabling while the motor is stopped]) 2 (enabling [enabling also while the motor is stopped])	-
1363h	Dynamic braking activation level	b096	R/W	330 to 380, 660 to 760	1. [V]
1364h	BRD resistor value	b097	R/W	Minimum resistance to 6000	0.1[Ω]
1365h to 1366h	(Reserved)	-	-	-	-
1367h	Free-setting V/f frequency (1)	b100	R/W	0. to "free-setting V/f frequency (2)"	1 [Hz]
1368h	Free-setting V/f voltage (1)	b101	R/W	0. to 8000	0.1 [V]
1369h	Free-setting V/f frequency (2)	b102	R/W	0. to "free-setting V/f frequency (3)"	1 [Hz]
136Ah	Free-setting V/f voltage (2)	b103	R/W	0. to 8000	0.1 [V]
136Bh	Free-setting V/f frequency (3)	b104	R/W	0. to "free-setting V/f frequency (4)"	1 [Hz]
136Ch	Free-setting V/f voltage (3)	b105	R/W	0. to 8000	0.1 [V]
136Dh	Free-setting V/f frequency (4)	b106	R/W	0. to "free-setting V/f frequency (5)"	1 [Hz]
136Eh	Free-setting V/f voltage (4)	b107	R/W	0. to 8000	0.1 [V]
136Fh	Free-setting V/f frequency (5)	b108	R/W	0. to "free-setting V/f frequency (6)"	1 [Hz]
1370h	Free-setting V/f voltage (5)	b109	R/W	0. to 8000	0.1 [V]
1371h	Free-setting V/f frequency (6)	b110	R/W	0. to "free-setting V/f frequency (7)"	1 [Hz]
1372h	Free-setting V/f voltage (6)	b111	R/W	0. to 8000	0.1 [V]
1373h	Free-setting V/f frequency (7)	b112	R/W	0. to 400.	1 [Hz]
1374h	Free-setting V/f voltage (7)	b113	R/W	0. to 8000	0.1 [V]
1375h to 137Ah	(Reserved)	-	-	-	-
137Bh	Brake Control Enable	b120	R/W	0 (disabling) 1 (enabling) 2 (enabling)	-
137Ch	Brake Wait Time for Release	b121	R/W	0 to 500	0.01 [sec.]
137Dh	Brake Wait Time for Acceleration	b122	R/W	0 to 500	0.01 [sec.]
137Eh	Brake Wait Time for Stopping	b123	R/W	0 to 500	0.01 [sec.]
137Fh	Brake Wait Time for Confirmation	b124	R/W	0 to 500	0.01 [sec.]
1380h	Brake Release Frequency	b125	R/W	0 to 40000	0.01 [Hz]
1381h	Brake Release Current	b126	R/W	0 to 1500	0.1 [%]
1382h	Braking frequency	b127	R/W	0 to 40000	0.01 [Hz]
1383h	(Reserved)	-	-	-	-
1384h	(Reserved)	-	-	-	-
1385h	Deceleration overvoltage suppression enable	b130	R/W	0 (disabling) 2 (enabling with acceleration) 1 (enabling)	-
1386h	Decel. overvolt. suppress level	b131	R/W	200 V class: 330 to 390 (V) 400 V class: 660 to 780 (V)	1 [V]
1387h	Decel. overvolt. suppress const.	b132	R/W	10 to 3000	0.01 [sec.]
1388h	Decel. overvolt. suppress proportional gain	b133	R/W	0 to 500	0.01
1389h	Decel. overvolt. suppress Integral time	b134	R/W	0 to 1500	0.1 [sec.]
138Ah to 1393h	(Reserved)	-	-	-	-

Register No.	Function name	Function code	R/W	Monitoring and setting items		Data resolution
1394h	GS input mode	b145	R/W	0 (no Trip)	1 (Trip)	-
1395h to 1399h	(Reserved)	-	-	-	-	-
139Ah	Display ex.operator connected	b150	R/W	1 to 50		-
139Bh to 13A2h	(Reserved)	-	-	-	-	-
13A3h	1st parameter of Dual Monitor	b160	R/W	1 to 27		-
13A4h	2nd parameter of Dual Monitor	b161	R/W	1 to 27		-
13A5h	(Reserved)	-	-	-	-	-
13A6h	Freq. set in monitoring	b163	R/W	0 (disabling)	1 (enabling)	-
13A7h	Automatic return to the initial display	b164	R/W	0 (disabling)	1 (enabling)	-
13A8h	Ex. operator com. loss action	b165	R/W	0 (tripping) 1 (tripping after decelerating and stopping the motor) 2 (ignoring errors)	3 (stopping the motor after free-running) 4 (decelerating and stopping the motor)	-
13A9h	Data Read/Write select	b166	R/W	0 (Read/Write OK)	1 (Protected)	-
13AAh to 13B6h	(Reserved)	-	-	-	-	-
13B7h	Initialization trigger	b180	R/W	0 (disabling)	1 (enabling)	-
13B8h to 13C5h	(Unused)	-	-	Inaccessible		-
13C6h	Electronic thermal subtraction function selection	b910	R/W	0 (OFF) 1 (Linear subtraction: pre-fixed ratio)	2 (Linear subtraction: ratio set in b911) 3 (Subtraction with first-order lag filter: ratio set in b912)	-
13C7h	Thermal subtraction time	b911(high)	R/W	10 to 1000000		0.01 [sec.]
13C8h		b911(low)	R/W			
13C9h	Thermal subtraction time constant	b912(high)	R/W	10 to 1000000		0.01 [sec.]
13CAh		b912(low)	R/W			
13CBh	Thermal accumulation gain	b913	R/W	10 to 2000		0.1[%]
13CCh to 1400h	(Unused)	-	-	Inaccessible		-

Parameter group C

Register No.	Function name	Function code	R/W	Monitoring and setting items			Data resolution
1401h	Input [1] function	C001	R/W	0 (FW) 1 (RV) 2 (CF1)	22 (F/R) 23 (PID) 24 (PIDC)	51 (F-TM) 53 (KHC) 56 (MI1)	-
1402h	Input [2] function	C002	R/W	3 (CF2) 4 (CF3) 5 (CF4)	27 (UP) 28 (DWN) 29 (UDC)	57 (MI2) 58 (MI3) 59 (MI4)	-
1403h	Input [3] function	C003	R/W	6 (JG) 7 (DB)	31 (OPE) 32 (SF1)	60 (MI5) 61 (MI6)	-
1404h	Input [4] function	C004	R/W	8 (SET) 9 (2CH) 11 (FRS)	33 (SF2) 34 (SF3) 35 (SF4)	62 (MI7) 65 (AHD) 77 (GS1)	-
1405h	Input [5] function	C005	R/W	12 (EXT) 13 (USP) 14 (CS)	36 (SF5) 37 (SF6) 38 (SF7)	78 (GS2) 81 (485) 82 (PRG)	-
1406h	Input [6] function	C006	R/W	15 (SFT) 16 (AT)	39 (OLR) 44 (BOK)	83 (HLD) 84 (ROK)	-
1407h	Input [7] function	C007	R/W	18 (RS) 20 (STA) 21 (STP)	46 (LAC) 50 (ADD)	86 (DISP) 255 (no)	-
1408h to 140Ah	(Reserved)	-	-	Inaccessible			-
140Bh	Input [1] active state	C011	R/W	0 (NO)	1 (NC)		-
140Ch	Input [2] active state	C012	R/W	0 (NO)	1 (NC)		-
140Dh	Input [3] active state	C013	R/W	0 (NO)	1 (NC)		-
140Eh	Input [4] active state	C014	R/W	0 (NO)	1 (NC)		-
140Fh	Input [5] active state	C015	R/W	0 (NO)	1 (NC)		-
1410h	Input [6] active state	C016	R/W	0 (NO)	1 (NC)		-
1411h	Input [7] active state	C017	R/W	0 (NO)	1 (NC)		-
1412h to 1414h	(Reserved)	-	-	Inaccessible			-
1415h	Output [11] function	C021	R/W	0 (RUN) 1 (FA1) 2 (FA2) 3 (OL) 4 (OD) 5 (AL) 6 (FA3) 9 (UV)	25 (FA5) 26 (OL2) 27 (Odc) 28(OIDc) 31 (FBV) 32 (NDc) 33 (LOG1) 34 (LOG2)	45 (M02) 46 (M03) 50 (IRDY) 51 (FWR) 52 (RVR) 53 (MJA) 54 (WCO) 55 (WCO)	-
1416h	Output [12] function	C022	R/W	11 (RNT) 12 (ONT) 13 (THM) 19 (BRK) 20 (BER) 21 (ZS) 24 (FA4)	35 (LOG3) 39 (WAC) 40 (WAF) 41 (FR) 42 (OHF) 43 (LOC) 44 (M01)	58 (FREF) 59 (REF) 60 (SETM) 62 (EDM) 63 (OPO) 255 (no)	-
1421h to 1423h	(Reserved)	-	-				-
141Ah	Alarm relay function	C026	R/W	Same as the settings of C021 and C022			-

Register No.	Function name	Function code	R/W	Monitoring and setting items	Data resolution
141Bh	[EO] terminal selection	C027	R/W	0 (output frequency) 1 (output current) 3 (digital output frequency) 4 (output voltage) 5 (input power) 6 (electronic thermal overload) 7 (LAD frequency) 8 (digital current monitoring) 10 (heat sink temperature) 12 (general-purpose output YA0) 16 (option)	-
141Ch	[AM] terminal selection	C028	R/W	0 (output frequency) 1 (output current) 4 (output voltage) 5 (input power) 6 (electronic thermal overload) 7 (LAD frequency) 10 (heat sink temperature) 13 (general-purpose output YA1) 16 (option)	-
141Dh	(Reserved)	-	-	-	-
141Eh	Digital current monitor reference value	C030	R/W	200 to 1500	0.1 [%]
141Fh	Output [11] active state	C031	R/W	0 (NO) 1 (NC)	-
1420h	Output [12] active state	C032	R/W	0 (NO) 1 (NC)	-
1421h to 1423h	(Reserved)	-	-	-	-
1424h	Alarm relay active state	C036	R/W	0 (NO) 1 (NC)	-
1425h	(Reserved)	-	-	-	-
1426h	Output mode of low current detection	C038	R/W	0 (output during acceleration/deceleration and constant-speed operation) 1 (output only during constant-speed operation)	-
1427h	Low current detection level	C039	R/W	0 to 1500	0.1 [%]
1428h	Overload signal output mode	C040	R/W	0 (output during acceleration/deceleration and constant-speed operation) 1 (output only during constant-speed operation)	-
1429h	Overload warning level	C041	R/W	0 to 1500	0.1 [%]
142Ah	(Reserved)	-	-	-	-
142Bh	Frequency arrival setting for accel.	C042	R/W	0 to 40000	0.01 [Hz]
142Ch	(Reserved)	-	-	-	-
142Dh	Frequency arrival setting for decel.	C043	R/W	0 to 40000	0.01 [Hz]
142Eh	PID deviation level	C044	R/W	0 to 1000	0.1 [%]
142Fh	(Reserved)	-	-	-	-
1430h	Frequency arrival setting 2 for accel.	C045	R/W	0 to 40000	0.01 [Hz]
1431h	(Reserved)	-	-	-	-
1432h	Frequency arrival setting 2 for decel.	C046	R/W	0 to 40000	0.01 [Hz]
1433h to 1437h	(Reserved)	-	-	-	-
1438h	Maximum PID feedback data	C052	R/W	0 to 1000	0.1 [%]
1439h	Minimum PID feedback data	C053	R/W	0 to 1000	0.1 [%]
143Ah to 1440h	(Reserved)	-	-	-	-
1441h	Electronic thermal warning level	C061	R/W	0 to 100	1 [%]
1442h	(Reserved)	-	-	-	-
1443h	Zero speed detection level	C063	R/W	0 to 10000	0.01 [Hz]

Register No.	Function name	Function code	R/W	Monitoring and setting items	Data resolution
1444h	Heat sink overheat warning level	C064	R/W	0 to 110	1 [°C]
1445h to 144Ah	(Reserved)	-	-	-	-
144Bh	Communication speed	C071	R/W	3 (2400bps) 4 (4800bps) 5 (9600bps) 6 (19.2kbps) 7 (38.4kbps) 8 (57.6kbps) 9 (76.8kbps) 10 (115.2kbps)	-
144Ch	Modbus address	C072	R/W	1. to 247.	-
144Dh	(Reserved)	-	-	-	-
144Eh	Communication parity	C074	R/W	0 (no parity) 1 (even parity) 2 (odd parity)	-
144Fh	Communication stop bit	C075	R/W	1 (1 bit) 2 (2 bits)	-
1450h	Selection of the operation after communication error	C076	R/W	0 (tripping) 1 (tripping after decelerating and stopping the motor) 2 (ignoring errors) 3 (stopping the motor after free-running) 4 (decelerating and stopping the motor)	-
1451h	Communication timeout limit	C077	R/W	0 to 9999	0.01 [sec.]
1452h	Communication wait time	C078	R/W	0 to 1000	1 [msec.]
1453h to 1454h	(Reserved)	-	-	-	-
1455h	[O] input span calibration	C081	R/W	0 to 2000	0.1
1456h	[OI] input span calibration	C082	R/W	0 to 2000	0.1
1457h to 1458h	(Reserved)	-	-	-	-
1459h	Thermistor input tuning	C085	R/W	0 to 2000	0.1
145Ah to 145Eh	(Reserved)	-	-	-	-
145Fh	Debug mode enable	C091	R	0/1	-
1460h to 1463h	(Reserved)	-	-	-	-
1464h	Communication selection	C096	R/W	0 (Modbus-RTU) 1 (EzCOM) 2 (EzCOM <administrator>)	-
1465h	(Reserved)	-	-	-	-
1466h	EzCOM start adr. of master	C098	R/W	1 to 8	1
1467h	EzCOM end adr. of master	C099	R/W	1 to 8	1
1468h	EzCOM starting trigger	C100	R/W	0(Input terminal) 1(Always)	-
1469h	Up/Down memory mode selection	C101	R/W	0 (not storing the frequency data) 1 (storing the frequency data)	-
146Ah	Reset mode selection	C102	R/W	0 (resetting the trip when RS is on) 1 (resetting the trip when RS is off) 2 (enabling resetting only upon tripping [resetting when RS is on]) 3 (resetting only trip)	-
146Bh	Restart mode after reset	C103	R/W	0 (starting with 0 Hz) 1 (starting with matching frequency) 2 (restarting with active matching frequency)	-
146Ch	UP/DWN clear mode	C104	R/W	0 (0Hz) 1 (EEPROM data)	-
146Dh	FM gain adjustment	C105	R/W	50 to 200	1 [%]
146Eh	AM gain adjustment	C106	R/W	50 to 200	1 [%]
146Fh	(Reserved)	-	-	Inaccessible	1 [%]
1471h	AM bias adjustment	C109	R/W	0 to 100	1 [%]
1472h	(Reserved)	-	-	-	1 [%]

Parameter group H

Register No.	Function name	Function code	R/W	Monitoring and setting items	Data resolution
1503h	Motor capacity, 1st motor	H003	R/W	0 (0.1kW) 8 (3.0kW) 1 (0.2kW) 9 (3.7kW) 2 (0.4kW) 10 (4.0kW) 3 (0.55kW) 11 (5.5kW) 4 (0.75kW) 12 (7.5kW) 5 (1.1kW) 13 (11.0kW) 6 (1.5kW) 14 (15.0kW) 7 (2.2kW) 15 (18.5kW)	-
1504h	Motor poles setting, 1st motor	H004	R/W	0 (2 poles) 12 (26 poles) 1 (4 poles) 13 (28 poles) 2 (6 poles) 14 (30 poles) 3 (8 poles) 15 (32 poles), 4 (10 poles) 16 (34 poles) 5 (12 poles) 17 (36 poles) 6 (14 poles) 18 (38 poles) 7 (16 poles), 19 (40 poles), 8 (18 poles) 20 (42 poles) 9 (20 poles) 21 (44 poles) 10 (22 poles) 22 (46 poles) 11 (24 poles), 23 (48 poles)	-
1505h to 1506h	(Reserved)	-	-	-	-
1507h	Motor stabilization constant, 1st motor	H006	R/W	0 to 255	1
1508h to 1600h	(Unused)	-	-	Inaccessible	-

Parameter group P

Register No.	Function name	Function code	R/W	Monitoring and setting items	Data resolution
1601h	Operation mode on expansion card error	P001	R/W	0 (tripping) 1 (continuing operation)	-
1602h to 161Eh	(Reserved)	-	-	-	-
161Fh	Accel/decel time input selection	P031	R/W	0 (digital operator) 3 (easy sequence)	-
1620h to 162Dh	(Reserved)	-	-	-	-
162Eh	Communication watchdog timer	P044	R/W	0 to 9999	0.01 [sec.]
162Fh	Inverter action on communication error	P045	R/W	0 (tripping) 3 (stopping the motor after free-running) 1 (tripping after decelerating and stopping the motor) 4 (decelerating and stopping the motor) 2 (ignoring errors)	-
1630h	DeviceNet polled I/O: Output instance number	P046	R/W	0 to 20	-
1631h	(Reserved)	-	-	-	-
1632h	Inverter action on communication idle mode	P048	R/W	0 (tripping) 3 (stopping the motor after free-running) 1 (tripping after decelerating and stopping the motor) 4 (decelerating and stopping the motor) 2 (ignoring errors)	-
1633h	Motor poles setting for RPM	P049	R/W	0 (0 pole) 13 (26 poles) 1 (2 poles) 14 (28 poles) 2 (4 poles), 15 (30 poles) 3 (6 poles) 16 (32 poles) 4 (8 poles) 17 (34 poles) 5 (10 poles) 18 (36 poles) 6 (12 poles) 19 (38 poles) 7 (14 poles) 20 (40 poles), 8 (16 poles), 21 (42 poles) 9 (18 poles) 22 (44 poles) 10 (20 poles) 23 (46 poles) 11 (22 poles) 24 (48 poles) 12 (24 poles)	-
1634h to 1665h	(Reserved)	-	-	-	-
1666h	EzSQ user parameter U (00)	P100	R/W	0 to 65530	1
1667h	EzSQ user parameter U (01)	P101	R/W	0 to 65530	1
1668h	EzSQ user parameter U (02)	P102	R/W	0 to 65530	1
1669h	EzSQ user parameter U (03)	P103	R/W	0 to 65530	1
166Ah	EzSQ user parameter U (04)	P104	R/W	0 to 65530	1
166Bh	EzSQ user parameter U (05)	P105	R/W	0 to 65530	1
166Ch	EzSQ user parameter U (06)	P106	R/W	0 to 65530	1
166Dh	EzSQ user parameter U (07)	P107	R/W	0 to 65530	1
166Eh	EzSQ user parameter U (08)	P108	R/W	0 to 65530	1
166Fh	EzSQ user parameter U (09)	P109	R/W	0 to 65530	1
1670h	EzSQ user parameter U (10)	P110	R/W	0 to 65530	1
1671h	EzSQ user parameter U (11)	P111	R/W	0 to 65530	1
1672h	EzSQ user parameter U (12)	P112	R/W	0 to 65530	1
1673h	EzSQ user parameter U (13)	P113	R/W	0 to 65530	1
1674h	EzSQ user parameter U (14)	P114	R/W	0 to 65530	1
1675h	EzSQ user parameter U (15)	P115	R/W	0 to 65530	1

Register No.	Function name	Function code	R/W	Monitoring and setting items	Data resolution
1676h	EzSQ user parameter U (16)	P116	R/W	0 to 65530	1
1677h	EzSQ user parameter U (17)	P117	R/W	0 to 65530	1
1678h	EzSQ user parameter U (18)	P118	R/W	0 to 65530	1
1679h	EzSQ user parameter U (19)	P119	R/W	0 to 65530	1
167Ah	EzSQ user parameter U (20)	P120	R/W	0 to 65530	1
167Bh	EzSQ user parameter U (21)	P121	R/W	0 to 65530	1
167Ch	EzSQ user parameter U (22)	P122	R/W	0 to 65530	1
167Dh	EzSQ user parameter U (23)	P123	R/W	0 to 65530	1
167Eh	EzSQ user parameter U (24)	P124	R/W	0 to 65530	1
167Fh	EzSQ user parameter U (25)	P125	R/W	0 to 65530	1
1680h	EzSQ user parameter U (26)	P126	R/W	0 to 65530	1
1681h	EzSQ user parameter U (27)	P127	R/W	0 to 65530	1
1682h	EzSQ user parameter U (28)	P128	R/W	0 to 65530	1
1683h	EzSQ user parameter U (29)	P129	R/W	0 to 65530	1
1684h	EzSQ user parameter U (30)	P130	R/W	0 to 65530	1
1685h	EzSQ user parameter U (31)	P131	R/W	0 to 65530	1
1686h to 168Dh	(Reserved)	-	-	-	-
168Eh	EzCOM number of data	P140	R/W	1 to 5	
168Fh	EzCOM destination 1 address	P141	R/W	1 to 247	
1690h	EzCOM destination 1 register	P142	R/W	0000 to FFFF	
1691h	EzCOM source 1 register	P143	R/W	0000 to FFFF	
1692h	EzCOM destination 2 address	P144	R/W	1 to 247	
1693h	EzCOM destination 2 register	P145	R/W	0000 to FFFF	
1694h	EzCOM source 2 register	P146	R/W	0000 to FFFF	
1695h	EzCOM destination 3 address	P147	R/W	1 to 247	
1696h	EzCOM destination 3 register	P148	R/W	0000 to FFFF	
1697h	EzCOM source 3 register	P149	R/W	0000 to FFFF	
1698h	EzCOM destination 4 address	P150	R/W	1 to 247	
1699h	EzCOM destination 4 register	P151	R/W	0000 to FFFF	
169Ah	EzCOM source 4 register	P152	R/W	0000 to FFFF	
169Bh	EzCOM destination 5 address	P153	R/W	1 to 247	
169Ch	EzCOM destination 5 register	P154	R/W	0000 to FFFF	
169Dh	EzCOM source 5 register	P155	R/W	0000 to FFFF	
169Eh to 16A1h	(Reserved)	-	-	-	-
16A2h	Option I/F command register to write 1	P160	R/W	0000 to FFFF	-
16A3h	Option I/F command register to write 2	P161	R/W	0000 to FFFF	-
16A4h	Option I/F command register to write 3	P162	R/W	0000 to FFFF	-
16A5h	Option I/F command register to write 4	P163	R/W	0000 to FFFF	-
16A6h	Option I/F command register to write 5	P164	R/W	0000 to FFFF	-
16A7h	Option I/F command register to write 6	P165	R/W	0000 to FFFF	-
16A8h	Option I/F command register to write 7	P166	R/W	0000 to FFFF	-
16A9h	Option I/F command register to write 8	P167	R/W	0000 to FFFF	-
16AAh	Option I/F command register to write 9	P168	R/W	0000 to FFFF	-

Register No.	Function name	Function code	R/W	Monitoring and setting items	Data resolution
16ABh	Option I/F command register to write 10	P169	R/W	0000 to FFFF	-
16ACh	Option I/F command register to read 1	P170	R/W	0000 to FFFF	-
16ADh	Option I/F command register to read 2	P171	R/W	0000 to FFFF	-
16AEh	Option I/F command register to read 3	P172	R/W	0000 to FFFF	-
16AFh	Option I/F command register to read 4	P173	R/W	0000 to FFFF	-
16B0h	Option I/F command register to read 5	P174	R/W	0000 to FFFF	-
16B1h	Option I/F command register to read 6	P175	R/W	0000 to FFFF	-
16B2h	Option I/F command register to read 7	P176	R/W	0000 to FFFF	-
16B3h	Option I/F command register to read 8	P177	R/W	0000 to FFFF	-
16B4h	Option I/F command register to read 9	P178	R/W	0000 to FFFF	-
16B5h	Option I/F command register to read 10	P179	R/W	0000 to FFFF	-
16B6h	Profibus Node address	P180	R/W	0 to 125	-
16B7h	Profibus Clear Node address	P181	R/W	0 (clear) 1 (not clear)	-
16B8h	Profibus Map selection	P182	R/W	0 (PPO) 2 (flexible mode format selection) 1 (conventional)	-
16B9h to 16C1h	(Reserved)	-	-	-	-
16C2h	DeviceNet MAC ID	P192	R/W	0 to 63	-
16C3h to 1E00h	(Unused)	-	-	Inaccessible	-
1E01h	Coil data 1	-	R/W	2 ¹ : coil number 0010h to 2 ¹⁵ : coil number 001Fh	-
1E02h	Coil data 2	-	R/W	2 ¹ : coil number 0020h to 2 ¹⁵ : coil number 002Fh	-
1E03h	Coil data 3	-	R/W	2 ¹ : coil number 0030h to 2 ¹⁵ : coil number 003Fh	-
1E04h	Coil data 4	-	R/W	2 ¹ : coil number 0040h to 2 ¹⁵ : coil number 004Fh	-
1E05h	Coil data 5	-	R/W	2 ¹ : coil number 0050h to 2 ¹⁵ : coil number 005Fh	-
1E06h to 1F18h	(Reserved)	-	-	-	-
1E19h to 1F00h	(Unused)	-	-	Inaccessible	-
1F01h	Coil data 0	-	R/W	2 ¹ : coil number 0001h to 2 ¹⁵ : coil number 000Fh	-
1F02h to 1F1Dh	(Reserved)	-	-	(note: 2)	-
1F1Eh to 2102h	(Unused)	-	-	Inaccessible	-

Note 1: above registers (coil data 0 to 5) are consisted with 16 coil data. EzCOM communication (inverter to inverter) doesn't support coil, but only register is supported, in case of need to access coil, please use above registers.

Note 2: Be sure not to write into above 1F02h to 1F1Dh.

List of registers (2nd control settings)

Register No.	Function name	Function code	R/W	Monitoring and setting items	Data resolution
2103h	Acceleration time (1), 2nd motor	F202 (high)	R/W	0 to 360000	0.01 [sec.]
2104h		F202 (low)	R/W		
2105h	Deceleration time (1), 2nd motor	F203 (high)	R/W	0 to 360000	0.01 [sec.]
2106h		F203 (low)	R/W		
2107h to 2200h	(Unused)	-	-	Inaccessible	-

List of registers (function modes for the 2nd control settings)

Register No.	Function name	Function code	R/W	Monitoring and setting items	Data resolution
2201h	Frequency source, 2nd motor	A201	R/W	0 (keypad potentiometer) 1 (control circuit terminal block) 2 (digital operator) 3 (Modbus) 4 (option) 7 (easy sequence) 10 (operation function result)	-
2202h	Frequency source, 2nd motor	A202	R/W	1 (control circuit terminal block) 2 (digital operator) 3 (Modbus) 4 (option)	-
2203h	Base frequency, 2nd motor	A203	R/W	300 to "maximum frequency, 2nd motor"	0.1 [Hz]
2204h	Maximum frequency, 2nd motor	A204	R/W	300 to 4000	0.1 [Hz]
2205h to 2216h	(Reserved)	-	-	-	-
2217h	Multispeed frequency setting, 2nd motor	A220	R/W	0 or "start frequency" to "maximum frequency, 2nd motor"	0.01 [Hz]
2218h to 223Ah	(Reserved)	-	-	Inaccessible	-
223Bh	Torque boost method selection, 2nd motor	A241	R/W	0 (manual torque boost) 1 (automatic torque boost)	-
223Ch	Manual torque boost value, 2nd motor	A242	R/W	20 to 200	1 [%]
223Dh	Manual torque boost frequency, 2nd motor	A243	R/W	0 to 255	1 [%]
223Eh	V/F characteristic curve selection, 2nd motor	A244	R/W	0 (VC) 1 (VP) 2 (free V/f)	-
223Fh	V/f gain, 2nd motor	A245	R/W	20 to 100	1 [%]
2240h	Voltage compensation gain setting for automatic torque boost, 2nd motor	A246	R/W	0 to 255	1
2241h	Slippage compensation gain setting for automatic torque boost, 2nd motor	A247	R/W	0 to 255	1
2242h to 224Fh	(Reserved)	-	-	-	-
2250h	Frequency upper limit, 2nd motor	A261	R/W	0 or "2nd minimum frequency limit" to "maximum frequency, 2nd motor"	0.01 [Hz]
2251h	(Reserved)	-	-	-	-
2252h	Frequency lower limit, 2nd motor	A262	R/W	0 or "start frequency" to "maximum frequency, 2nd motor limit"	0.01 [Hz]
2253h to 2268h	(Reserved)	-	-	-	-
2269h	AVR function select, 2nd motor	A281	R/W	0 (always on) 1 (always off) 2 (off during deceleration)	-

Register No.	Function name	Function code	R/W	Monitoring and setting items	Data resolution
226Ah	AVR voltage select, 2nd motor	A282	R/W	200 V class: 0 (200) 1 (215) 2 (220) 3 (230) 4 (240) 400 V class: 5 (380) 6 (400) 7 (415) 8 (440) 9 (460) 10 (480)	
226Bh to 226Eh	(Reserved)	-	-	-	-
226Fh	Acceleration time (2), 2nd motor	A292 (high)	R/W	1 to 360000	0.01 [sec.]
2270h		A292 (low)	R/W		
2271h	Deceleration time (2), 2nd motor	A293 (high)	R/W	1 to 360000	0.01 [sec.]
2272h		A293 (low)	R/W		
2273h	Select method to switch to Acc2/Dec2, 2nd motor	A294	R/W	0 (switching by 2CH terminal) 1 (switching by setting) 2 (Forward and reverse)	-
2274h	(Reserved)	-	-	-	-
2275h	Acc1 to Acc2 frequency transition point, 2nd motor	A295	R/W	0 to 40000	0.01 [Hz]
2276h	(Reserved)	-	-	-	-
2277h	Dec1 to Dec2 frequency transition point, 2nd motor	A296	R/W	0 to 40000	0.01 [Hz]
2278h to 230Bh	(Reserved)	-	-	-	-
230Ch	Level of electronic thermal, 2nd motor	b212	R/W	200 to 1000	0.1 [%]
230Dh	Electronic thermal characteristic, 2nd motor	b213	R/W	0 (reduced-torque characteristic) 1 (constant-torque characteristic) 2 (free setting)	-
230Eh to 2315h	(Reserved)	-	-	-	-
2316h	Overload restriction operation mode, 2nd motor	b221	R/W	0 (disabling) 1 (enabling during acceleration and constant-speed operation) 2 (enabling during constant-speed operation) 3 (enabling during acceleration and constant-speed operation [speed increase at regeneration])	-
2317h	Overload restriction level, 2nd motor	b222	R/W	100 to 1500	0.1 [%]
2318h	Deceleration rate at overload restriction, 2nd motor	b223	R/W	1 to 30000	0.1 [sec.]
2319h to 2428h	(Unused)	-	-	Inaccessible	-
2429h	Overload warning level 2, 2nd motor	C241	R/W	0 to 1500	0.1 [%]
242Ah to 2502h	(Unused)	-	-	Inaccessible	-

Register No.	Function name	Function code	R/W	Monitoring and setting items	Data resolution
2503h	Motor capacity, 2nd motor	H203	R/W	0 (0.1kW) 8 (3.0kW) 1 (0.2kW) 9 (3.7kW) 2 (0.4kW) 10 (4.0kW) 3 (0.55kW) 11 (5.5kW) 4 (0.75kW) 12 (7.5kW) 5 (1.1kW) 13 (11.0kW) 6 (1.5kW) 14 (15.0kW) 7 (2.2kW) 15 (18.5kW)	-
2504h	Motor poles setting, 2nd motor	H204	R/W	0 (2 poles) 12 (26 poles) 1 (4 poles) 13 (28 poles) 2 (6 poles) 14 (30 poles) 3 (8 poles) 15 (32 poles), 4 (10 poles) 16 (34 poles) 5 (12 poles) 17 (36 poles) 6 (14 poles) 18 (38 poles) 7 (16 poles), 19 (40 poles), 8 (18 poles) 20 (42 poles) 9 (20 poles) 21 (44 poles) 10 (22 poles) 22 (46 poles) 11 (24 poles), 23 (48 poles)	-
2505h to 2506h	(Reserved)	-	-	-	-
2507h	Motor stabilization constant, 2nd motor	H206	R/W	0 to 255	1
2508h-	(Unused)	-	-	Inaccessible	-

Drive Parameter Setting Tables

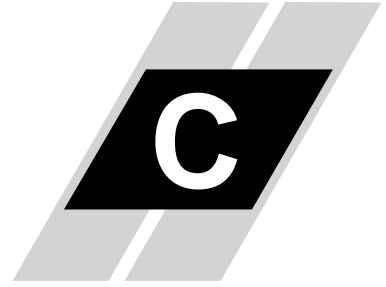

In This Appendix...	page
- Introduction	C-2
- Parameter Settings for Keypad Entry	C-2
- List of Parameters	C-3

Introduction

This appendix lists the user-programmable parameters for the WL200 series inverters and the default values for European and U.S. product types. The right-most column of the tables is blank, so you can record values you have changed from the default. This involves just a few parameters for most applications. This appendix presents the parameters in a format oriented toward the keypad on the inverter.

Parameter Settings for Keypad Entry

WL200 series inverters provide many functions and parameters that can be configured by the user. We recommend that you record all parameters that have been edited, in order to help in troubleshooting or recovery from a loss of parameter data.

Inverter model

WL200

MFG. No.

} This information is printed on the specification label located on the right side of the inverter

List of Parameters

Monitoring functions



NOTE: Parameters marked with "✓" in A column are accessible even in inverter running. Parameters marked with "✓" in B column are accessible even in inverter running when in the high level access mode, which means that b031 is set to "10".

* Please change from "04 (Basic display)" to "00 (Full display)" in parameter **b037** (Function code display restriction), in case some parameters cannot be displayed.

IMPORTANT

Please be sure to set the motor nameplate data into the appropriate parameters to ensure proper operation and protection of the motor:

- b012 is the motor overload protection value
- A082 is the motor voltage selection
- H003 is the motor kW capacity
- H004 is the number of motor poles

Please refer to the appropriate pages in this guide and the Instruction Manual for further details.

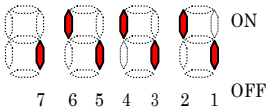
Func. Code	Name	Description	A	B	Units	Page
d001	Output frequency monitor	Real time display of output frequency to motor from 0.0 to 400.0Hz If b163 is set 01, output frequency (f001) can be changed by up/down key with d001 monitoring.	✓	✓	Hz	3-5
d002	Output current monitor	Filtered display of output current to motor, range is 0 to 655.3 ampere	-	-	A	
d003	Rotation direction monitor	Three different indications: "F"...Forward "s"...Stop "r"...Reverse	-	-	-	
d004	Process variable (PV), PID feedback monitor	Displays the scaled PID process variable (feedback) value (r075 is scale factor), 0.00 to 9999.00	-	-	% times constant	
d005	Intelligent input terminal status	Displays the state of the intelligent input terminals:  Terminal numbers	-	-	-	

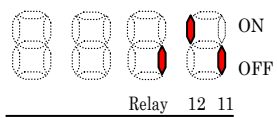
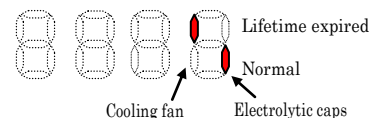
Func. Code	Name	Description	A	B	Units	Page
d006	Intelligent output terminal status	Displays the state of the intelligent output terminals: 	-	-	-	3-5
d007	Scaled output frequency monitor	Displays the output frequency scaled by the constant in b086 . Decimal point indicates range: 0 to 3999	✓	✓	Hz times constant	
d013	Output voltage monitor	Voltage of output to motor, Range is 0.0 to 600.0V	-	-	V	
d014	Input power monitor	Displays the input power, range is 0 to 999.9 kW	-	-	KW	3-6
d015	Watt-hour monitor	Displays watt-hour of the inverter, range is 0.0 to 999.9/ 1000. to 9999./ 1000 to 9999 (10,000 to 99,900)/ 100 to 999 (10,000 to 99,9000)	-	-		
d016	Elapsed RUN time monitor	Displays total time the inverter has been in RUN mode in hours. Range is 0. to 9999./ 1000 to 9999 (10,000 to 99,900)/ 100 to 999 (10,000 to 99,9000)	-	-	hours	
d017	Elapsed power-on time monitor	Displays total time the inverter has been powered up in hours. Range is 0. to 9999./ 1000 to 9999 (10,000 to 99,900)/ 100 to 999 (10,000 to 99,9000)	-	-	hours	
d018	Heat sink temperature monitor	Temperature of the cooling fin, range is -20 to 150	-	-	°C	
d022	Life check monitor	Displays the state of lifetime of electrolytic capacitors on the PWB and cooling fan. 	-	-	-	
d023	Program counter monitor [EzSQ]	Range is 0 to 1024	-	-	-	
d024	Program number monitor [EzSQ]	Range is 0 to 9999	-	-	-	
d025	User monitor 0 [EzSQ]	Result of EzSQ execution, range is -2147483647 to 2147483647	-	-	-	
d026	User monitor 1 [EzSQ]	Result of EzSQ execution, range is -2147483647 to 2147483647	-	-	-	
d027	User monitor 2 [EzSQ]	Result of EzSQ execution, range is -2147483647 to 2147483647	-	-	-	
d050	Dual monitor	Displays two different data configured in b160 and b161 .	-	-	-	

Func. Code	Name	Description	A	B	Units	Page
d062	Frequency source monitor	Displays the frequency source 0 ...Operator 1 to 15 ...Multi-speed freq. 1 to 15 16 ...Jog frequency 18 ...Modbus network 19 ...Option 21 ...Potentiometer 23 ...Calculate function output 24 ...EzSQ 25 ...[O] input 26 ...[OI] input 27 ...[O] + [OI]	-	-	-	3-6
d063	Run source monitor	1 ...Terminal 2 ...Operator 3 ...Modbus network 4 ...Option	-	-	-	
d080	Trip counter	Number of trip events, Range is 0. to 65530	-	-	events	3-8
d081	Trip monitor 1		-	-	-	
d082	Trip monitor 2	Displays trip event information: <ul style="list-style-type: none"> Error code 	-	-	-	
d083	Trip monitor 3	<ul style="list-style-type: none"> Output frequency at trip point 	-	-	-	
d084	Trip monitor 4	<ul style="list-style-type: none"> Motor current at trip point DC bus voltage at trip point 	-	-	-	
d085	Trip monitor 5	<ul style="list-style-type: none"> Cumulative inverter operation time at trip point 	-	-	-	
d086	Trip monitor 6	<ul style="list-style-type: none"> Cumulative power-ON time at trip point 	-	-	-	
d090	Warning monitor	Displays the warning code	-	-	-	
d102	DC bus voltage monitor	Voltage of inverter internal DC bus, range is 0.0 to 999.9	-	-	V	3-7
d103	BRD load ratio monitor	Usage ratio of integrated brake chopper, range is 0.0 to 100.0%	-	-	%	
d104	Electronic thermal monitor	Accumulated value of electronic thermal detection, range is from 0.0 to 100.0%	-	-	%	
d130	Analog input [O] monitor	Displays [O] input value, range is 0 to 1023	-	-	-	
d131	Analog input [OI] monitor	Displays [OI] input value, range is 0 to 1023	-	-	-	
d153	PID deviation monitor	Displays the scaled PID deviation (d075 is scale factor), range is -9999.00 to 9999.00	-	-	% times constant	
d155	PID output monitor	Displays PID output, range is -100.00 to 100.00%	-	-	%	

Main Profile Parameters



NOTE: Parameters marked with "✓" in A column are accessible even in inverter running.

Parameters marked with "✓" in B column are accessible even in inverter running when in the high level access mode, which means that b031 is set to "10".

Func. Code	Name	Description	A	B	Initial data	Units	Page
F001	Output frequency setting	Standard default target frequency that determines constant motor speed, range is 0.00 / start frequency to maximum frequency (F004)	✓	✓	0.00	Hz	3-10
F002	Acceleration time (1)	Standard default acceleration, range is 0.00 to 3600.00 sec.	✓	✓	10.00	sec.	
F202	Acceleration time (1), 2 nd motor		✓	✓	10.00	sec.	
F003	Deceleration time (1)	Standard default deceleration, range is 0.00 to 3600.00 sec.	✓	✓	10.00	sec.	
F203	Deceleration time (1), 2 nd motor		✓	✓	10.00	sec.	
F004	Keypad RUN key routing	Two options; select codes: 00 ...Forward 01 ...Reverse	✗	✗	00	-	

Standard Functions



NOTE: Parameters marked with "✓" in A column are accessible even in inverter running.

Parameters marked with "✓" in B column are accessible even in inverter running when in the high level access mode, which means that b031 is set to "10".

Func. Code	Name	Description	A	B	Initial data	Units	Page
A001	Frequency source	Eight options; select codes: 00 ...POT on ext. operator 01 ...Control terminal 02 ...Function F001 setting 03 ...Modbus network input	✗	✗	01	–	3-11
A201	Frequency source, 2 nd motor	04 ...Option 07 ...via EzSQ 10 ...Calculate function output	✗	✗	01	–	
A002	Run command source	Four options; select codes: 01 ...Control terminal 02 ...Run key on keypad, or digital operator	✗	✗	01	–	3-14
A202	Run command source, 2 nd motor	03 ...Modbus network input 04 ...Option	✗	✗	01	–	
A003	Base frequency	Settable from 30.0 Hz to the maximum frequency(A004)	✗	✗	50.0	Hz	3-14
A203	Base frequency, 2 nd motor	Settable from 30.0 Hz to the 2 nd maximum frequency(A204)	✗	✗	50.0	Hz	
A004	Maximum frequency	Settable from the base frequency to 400.0 Hz	✗	✗	50.0	Hz	
A204	Maximum frequency, 2 nd motor	Settable from the 2 nd base frequency to 400.0 Hz	✗	✗	50.0	Hz	
A005	[AT] selection	Three options; select codes: 00 ...Select between [O] and [OI] at [AT] (ON=OI, OFF=O) 02 ...Select between [O] and external POT at [AT] (ON=POT, OFF=O) 03 ...Select between [OI] and external POT at [AT] (ON=POT, OFF=OI)	✗	✗	00	–	3-15
A011	[O] input active range start frequency	The output frequency corresponding to the analog input range starting point, range is 0.00 to 400.00	✗	✓	0.00	Hz	
A012	[O] input active range end frequency	The output frequency corresponding to the analog input range ending point, range is 0.00 to 400.00	✗	✓	0.00	Hz	
A013	[O] input active range start voltage	The starting point (offset) for the active analog input range, range is 0. to 100.	✗	✓	0.	%	
A014	[O] input active range end voltage	The ending point (offset) for the active analog input range, range is 0. to 100.	✗	✓	100.	%	

Func. Code	Name	Description	A	B	Initial data	Units	Page
AD 15	[O] input start frequency enable	Two options; select codes: 00 ...Use offset (AD 11 value) 01 ...Use 0Hz	✗	✓	01	-	3-15
AD 16	Analog input filter	Range n = 1 to 31, 1 to 30 : ×2ms filter 31: 500ms fixed filter with ±0.1kHz hys.	✗	✓	8.	Spl.	
AD 17	EzSQ function select	Select codes: 00 ...Disable 01 ...Activate by PRG terminal 02 ...Activate always	✓	✓	00	-	3-17
AD 19	Multi-speed operation selection	Select codes: 00 ...Binary operation (16 speeds selectable with 4 terminals) 01 ...Bit operation (8 speeds selectable with 7 terminals)	✗	✗	00	-	3-18
AD20	Multi-speed freq. 0	Defines the first speed of a multi-speed profile, range is 0.00 / start frequency to 400.00Hz	✓	✓	6.00	Hz	
A220	Multi-speed freq. 0, 2 nd motor		✓	✓	6.00	Hz	
AD21 to AD35	Multi-speed freq. 1 to 15 (for both motors)	Defines 15 more speeds, range is 0.00 / start frequency to 400.00Hz. AD21 =Speed 1 to AD35 =Speed15	✓	✓	0.00	Hz	3-18
AD38	Jog frequency	Defines limited speed for jog, range is from start frequency to 9.99 Hz	✓	✓	6.00	Hz	
AD39	Jog stop mode	Define how end of jog stops the motor; six options: 00 ...Free-run stop (invalid during run) 01 ...Controlled deceleration (invalid during run) 02 ...DC braking to stop(invalid during run) 03 ...Free-run stop (valid during run) 04 ...Controlled deceleration (valid during run) 05 ...DC braking to stop(valid during run)	✗	✓	04	-	
AD41	Torque boost select	Two options: 00 ...Manual torque boost 01 ...Automatic torque boost	✗	✗	00	-	3-21
A241	Torque boost select, 2 nd motor		✗	✗	00	-	
AD42	Manual torque boost value	Can boost starting torque between 0 and 20% above normal V/f curve, range is 0.0 to 20.0%	✓	✓	1.0	%	
A242	Manual torque boost value, 2 nd motor		✓	✓	1.0	%	
AD43	Manual torque boost frequency	Sets the frequency of the V/f breakpoint A in graph (top of previous page) for torque boost, range is 0.0 to 50.0%	✓	✓	5.0	%	
A243	Manual torque boost frequency, 2 nd motor		✓	✓	5.0	%	

Func. Code	Name	Description	A	B	Initial data	Units	Page
A044	V/f characteristic curve	Four available V/f curves; 00 ...Constant torque	✗	✗	00	–	3–21
A244	V/f characteristic curve, 2 nd motor	01 ...Reduced torque (1.7) 02 ...Free V/F	✗	✗	00	–	
A045	V/f gain	Sets voltage gain of the inverter, range is 20. to 100.%	✓	✓	100.	%	
A245	V/f gain, 2 nd motor		✓	✓	100.	%	
A046	Voltage compensation gain for automatic torque boost	Sets voltage compensation gain under automatic torque boost, range is 0. to 255.	✓	✓	100.	–	
A246	Voltage compensation gain for automatic torque boost, 2 nd motor		✓	✓	100.	–	
A047	Slip compensation gain for automatic torque boost	Sets slip compensation gain under automatic torque boost, range is 0. to 255.	✓	✓	100.	–	
A247	Slip compensation gain for automatic torque boost, 2 nd motor		✓	✓	100.	–	
A051	DC braking enable	Three options; select codes: 00 ...Disable 01 ...Enable during stop 02 ...Frequency detection	✗	✓	00	–	3–25
A052	DC braking frequency	The frequency at which DC braking begins, range is from the start frequency (b0B2) to 60.00Hz	✗	✓	0.50	Hz	
A053	DC braking wait time	The delay from the end of controlled deceleration to start of DC braking (motor free runs until DC braking begins), range is 0.0 to 5.0 sec.	✗	✓	0.0	sec.	
A054	DC braking force for deceleration	Level of DC braking force, settable from 0 to 70%	✗	✓	50.	%	
A055	DC braking time for deceleration	Sets the duration for DC braking, range is from 0.0 to 60.0 seconds	✗	✓	0.5	sec.	
A056	DC braking / edge or level detection for [DB] input	Two options; select codes: 00 ...Edge detection 01 ...Level detection	✗	✓	01	–	
A057	DC braking force at start	Level of DC braking force at start, settable from 0 to 70%	✗	✓	0.	%	
A058	DC braking time at start	Sets the duration for DC braking, range is from 0.0 to 60.0 seconds	✗	✓	0.0	sec.	
A059	Carrier frequency during DC braking	Carrier frequency of DC braking performance, range is from 2.0 to 10.0kHz	✗	✓	2.0	kHz	

Func. Code	Name	Description	A	B	Initial data	Units	Page
A061	Frequency upper limit	Sets a limit on output frequency less than the maximum frequency (A004/A204).	✗	✓	0.00	Hz	3-27
A261	Frequency upper limit, 2nd motor	Range is from frequency lower limit (A062/A262) to maximum frequency (A004/A204). 0.00 setting is disabled >0.00 setting is enabled	✗	✓	0.00	Hz	
A062	Frequency lower limit	Sets a limit on output frequency greater than zero. Range is start frequency (b082) to frequency upper limit (A061/A261)	✗	✓	0.00	Hz	
A262	Frequency lower limit, 2nd motor	0.00 setting is disabled >0.00 setting is enabled	✗	✓	0.00	Hz	
A063 A065 A067	Jump freq. (center) 1 to 3	Up to 3 output frequencies can be defined for the output to jump past to avoid motor resonances (center frequency) Range is 0.00 to 400.00 Hz	✗	✓	0.00	Hz	3-28
A064 A066 A068	Jump freq. width (hysteresis) 1 to 3	Defines the distance from the center frequency at which the jump around occurs Range is 0.00 to 10.00 Hz	✗	✓	0.50	Hz	
A069	Acceleration hold frequency	Sets the frequency to hold acceleration, range is 0.00 to 400.00Hz	✗	✓	0.00	Hz	3-29
A070	Acceleration hold time	Sets the duration of acceleration hold, range is 0.0 to 60.0 seconds	✗	✓	0.0	sec.	
A071	PID enable	Enables PID function, three option codes: 00 ...PID Disable 01 ...PID Enable 02 ...PID Enable with reverse output	✗	✓	00	-	3-30
A072	PID proportional gain	Proportional gain has a range of 0.00 to 25.00	✓	✓	1.00	-	
A073	PID integral time constant	Integral time constant has a range of 0.0 to 3600.0 seconds	✓	✓	1.0	sec.	
A074	PID derivative time constant	Derivative time constant has a range of 0.00 to 100.00 seconds	✓	✓	0.00	sec.	
A075	PV scale conversion	Process Variable (PV), scale factor (multiplier), range of 0.01 to 99.99	✗	✓	1.00	-	
A076	PV source	Selects source of Process Variable (PV), option codes: 00 ...[O] terminal (current in) 01 ...[O] terminal (voltage in) 02 ...Modbus network 10 ...Calculate function output	✗	✓	00	-	
A077	Reverse PID action	Two option codes: 00 ...PID input = SP-PV 01 ...PID input = -(SP-PV)	✗	✓	00	-	
A078	PID output limit	Sets the limit of PID output as percent of full scale, range is 0.0 to 100.0%	✗	✓	0.0	%	

Func. Code	Name	Description	A	B	Initial data	Units	Page
A079	PID feed forward selection	Selects source of feed forward gain, option codes: 00 ...Disabled 01 ...[O] terminal (voltage in) 02 ...[OI] terminal (current in)	✗	✓	00	-	3-30
A081	AVR function select	Automatic (output) voltage regulation, selects from three type of AVR functions, three option codes: 00 ...AVR enabled 01 ...AVR disabled 02 ...AVR enabled except during deceleration	✗	✗	02	-	3-34
A281	AVR function select, 2 nd motor		✗	✗	02	-	
A082	AVR voltage select	200V class inverter settings:200/215/220/230/240	✗	✗	230/ 400	V	
A282	AVR voltage select, 2 nd motor	400V class inverter settings:380/400/415/440/460/480	✗	✗	230/ 400	V	
A083	AVR filter time constant	Define the time constant of the AVR filter, range is 0.000 to 10.000 sec.	✗	✓	0.300	sec.	3-35
A084	AVR deceleration gain	Gain adjustment of the braking performance, range is 50 to 200%	✗	✓	100.	%	
A085	Energy-saving operation mode	Two option codes: 00 ...Normal operation 01 ...Energy-saving operation	✗	✗	00	-	
A086	Energy-saving mode tuning	Range is 0.0 to 100 %.	✓	✓	50.0	%	
A092	Acceleration time (2)	Duration of 2 nd segment of acceleration, range is: 0.00 to 3600.00 sec.	✓	✓	10.00	sec.	3-36
A292	Acceleration time (2), 2 nd motor		✓	✓	10.00	sec.	
A093	Deceleration time (2)	Duration of 2 nd segment of deceleration, range is: 0.00 to 3600.00 sec.	✓	✓	10.00	sec.	
A293	Deceleration time (2), 2 nd motor		✓	✓	10.00	sec.	
A094	Select method to switch to Acc2/Dec2 profile	Three options for switching from 1st to 2nd accel/decel: 00 ...2CH input from terminal 01 ...Transition frequency 02 ...Forward and reverse	✗	✗	00	-	
A294	Select method to switch to Acc2/Dec2 profile, 2 nd motor		✗	✗	00	-	
A095	Acc1 to Acc2 frequency transition point	Output frequency at which Accel1 switches to Accel2, range is 0.00 to 400.00 Hz	✗	✗	0.00	Hz	
A295	Acc1 to Acc2 frequency transition point, 2 nd motor		✗	✗	0.00	Hz	
A096	Dec1 to Dec2 frequency transition point	Output frequency at which Decel1 switches to Decel2, range is 0.00 to 400.00 Hz	✗	✗	0.00	Hz	
A296	Dec1 to Dec2 frequency transition point, 2 nd motor		✗	✗	0.00	Hz	
A097	Acceleration curve selection	Set the characteristic curve of Acc1 and Acc2, five options: 00 ...linear 01 ...S-curve 02 ...U-curve 03 ...Inverse U-curve	✗	✗	01	-	3-37

Func. Code	Name	Description	A	B	Initial data	Units	Page
A098	Deceleration curve selection	Set the characteristic curve of Dec1 and Dec2, options are same as above (A097)	✗	✗	01	–	3-37
A101	[OI] input active range start frequency	The output frequency corresponding to the analog input range starting point, range is 0.00 to 400.00 Hz	✗	✓	0.00	Hz	3-39
A102	[OI] input active range end frequency	The output frequency corresponding to the current input range ending point, range is 0.00 to 400.00 Hz	✗	✓	0.00	Hz	
A103	[OI] input active range start current	The starting point (offset) for the current input range, range is 0. to 100.%	✗	✓	20.	%	
A104	[OI] input active range end current	The ending point (offset) for the current input range, range is 0. to 100.%	✗	✓	100.	%	
A105	[OI] input start frequency select	Two options; select codes: 00 ...Use offset (A101 value) 01 ...Use 0Hz	✗	✓	00	–	
A131	Acceleration curve constant	Range is 01 to 10.	✗	✓	02	–	3-37
A132	Deceleration curve constant	Range is 01 to 10.	✗	✓	02	–	
A141	A input select for calculate function	Six options: 00 ...Operator 01 ...VR 02 ...Terminal [O] input	✗	✓	02	–	3-40
A142	B input select for calculate function	03 ...Terminal [OI] input 04 ...RS485 05 ...Option	✗	✓	03	–	
A143	Calculation symbol	Calculates a value based on the A input source (A141 selects) and B input source (A142 selects). Three options: 00 ...ADD (A input + B input) 01 ...SUB (A input - B input) 02 ...MUL (A input * B input)	✗	✓	00	–	3-40
A145	ADD frequency	An offset value that is applied to the output frequency when the [ADD] terminal is ON. Range is 0.00 to 400.00 Hz	✗	✓	0.00	Hz	3-41
A146	ADD direction select	Two options: 00 ...Plus (adds A145 value to the output frequency setting) 01 ...Minus (subtracts A145 value from the output frequency setting)	✗	✓	00	–	
A154	Deceleration hold frequency	Sets the frequency to hold deceleration, range is 0.00 to 400.00Hz	✗	✓	0.00	Hz	3-29
A155	Deceleration hold time	Sets the duration of deceleration hold, range is 0.0 to 60.0 seconds	✗	✓	0.0	sec.	

Func. Code	Name	Description	A	B	Initial data	Units	Page
A 156	PID sleep function action threshold	Sets the threshold for the action, set range 0.0 to 400.0 Hz	✗	✓	0.00	Hz	3-30
A 157	PID sleep function action delay time	Sets the delay time for the action, set range 0.0 to 25.5 sec	✗	✓	0.0	sec.	
A 161	[VR] input active range start frequency	The output frequency corresponding to the analog input range starting point, range is 0.00 to 400.00 Hz	✗	✓	0.00	Hz	3-42
A 162	[VR] input active range end frequency	The output frequency corresponding to the current input range ending point, range is 0.00 to 400.00 Hz	✗	✓	0.00	Hz	
A 163	[VR] input active range start %	The starting point (offset) for the current input range, range is 0. to 100.%	✗	✓	0.	%	
A 164	[VR] input active range end %	The ending point (offset) for the current input range, range is 0. to 100.%	✗	✓	100.	%	
A 165	[VR] input start frequency select	Two options; select codes: 00 ...Use offset (A 161 value) 01 ...Use 0Hz	✗	✓	01	-	

Fine Tuning Functions

Func. Code	Name	Description	A	B	Initial data	Units	Page
b001	Restart mode on power failure / under-voltage trip	Select inverter restart method, Five option codes: 00 ...Alarm output after trip, no automatic restart 01 ...Restart at 0Hz 02 ...Resume operation after frequency matching 03 ...Resume previous freq. after freq. matching, then decelerate to stop and display trip info 04 ...Resume operation after active freq. matching	✗	✓	00	-	3-43
b002	Allowable under-voltage power failure time	The amount of time a power input under-voltage can occur without tripping the power failure alarm. Range is 0.3 to 25 sec. If under-voltage exists longer than this time, the inverter trips, even if the restart mode is selected.	✗	✓	1.0	sec.	
b003	Retry wait time before motor restart	Time delay after under-voltage condition goes away, before the inverter runs motor again. Range is 0.3 to 100.0 seconds.	✗	✓	1.0	sec.	
b004	Instantaneous power failure / under-voltage trip alarm enable	Three option codes: 00 ...Disable 01 ...Enable 02 ...Disable during stop and decelerates to a stop	✗	✓	00	-	
b005	Number of restarts on power failure / under-voltage trip events	Two option codes: 00 ...Restart 16 times 01 ...Always restart	✗	✓	00	-	
b007	Restart frequency threshold	Restart the motor from 0Hz if the frequency becomes less than this set value during the motor is coasting, range is 0.00 to 400.00Hz	✗	✓	0.00	Hz	
b008	Restart mode on over voltage / over current trip	Select inverter restart method, Five option codes: 00 ...Alarm output after trip, no automatic restart 01 ...Restart at 0Hz 02 ...Resume operation after frequency matching 03 ...Resume previous freq. after active freq. matching, then decelerate to stop and display trip info 04 ...Resume operation after active freq. matching	✗	✓	00	-	
b010	Number of retry on over voltage / over current trip	Range is 1 to 3 times	✗	✓	3	times	
b011	Retry wait time on over voltage / over current trip	Range is 0.3 to 100.0 sec.	✗	✓	1.0	sec.	

Func. Code	Name	Description	A	B	Initial data	Units	Page
b012	Level of electronic thermal	Set a level between 20% and 100% for the rated inverter current.	✗	✓	Rated current	A	3-46
b212	Level of electronic thermal, 2 nd motor		✗	✓	Rated current	A	
b013	Electronic thermal characteristic	Select from three curves, option codes: 00 ...Reduced torque	✗	✓	01	-	
b213	Electronic thermal characteristic, 2 nd motor	01 ...Constant torque 02 ...Free setting	✗	✓	01	-	
b015	Free setting electronic thermal ~freq.1	Range is 0 to 400Hz	✗	✓	0.	Hz	
b016	Free setting electronic thermal ~current1	Range is 0 to inverter rated current Amps	✗	✓	0.00	A	
b017	Free setting electronic thermal ~freq.2	Range is 0 to 400Hz	✗	✓	0.	Hz	
b018	Free setting electronic thermal ~current2	Range is 0 to inverter rated current Amps	✗	✓	0.00	A	
b019	Free setting electronic thermal ~freq.3	Range is 0 to 400Hz	✗	✓	0.	Hz	
b020	Free setting electronic thermal ~current3	Range is 0 to inverter rated current Amps	✗	✓	0.00	A	
b021	Overload restriction operation mode	Select the operation mode during overload conditions, four options, option codes: 00 ...Disabled	✗	✓	01	-	3-52
b221	Overload restriction operation mode, 2 nd motor	01 ...Enabled for acceleration and constant speed 02 ...Enabled for constant speed only 03 ...Enabled for acceleration and constant speed, increase speed at regen.	✗	✓	01	-	
b022	Overload restriction level	Sets the level of overload restriction, between 20% and 150% of the rated current of the inverter, setting resolution is 1% of rated current	✗	✓	Rated current x 1.2	A	
b222	Overload restriction level, 2 nd motor		✗	✓	Rated current x 1.2	A	
b023	Deceleration rate at overload restriction	Sets the deceleration rate when inverter detects overload, range is 0.1 to 3000.0, resolution 0.1	✗	✓	1.0	sec.	
b223	Deceleration rate at overload restriction, 2 nd motor		✗	✓	1.0	sec.	
b024	Overload restriction operation mode 2	Select the operation mode during overload conditions, four options, option codes: 00 ...Disabled 01 ...Enabled for acceleration and constant speed 02 ...Enabled for constant speed only 03 ...Enabled for acceleration and constant speed, increase speed at regen.	✗	✓	01	-	

Func. Code	Name	Description	A	B	Initial data	Units	Page
b025	Overload restriction level 2	Sets the level of overload restriction, between 20% and 150% of the rated current of the inverter, setting resolution is 1% of rated current	✗	✓	Rated current x 1.2	A	3-52
b026	Deceleration rate 2 at overload restriction	Sets the deceleration rate when inverter detects overload, range is 0.1 to 3000.0, resolution 0.1	✗	✓	1.0	sec.	
b027	OC suppression selection	Three option codes: 00...Disabled 01...Enabled 02...Enabled with voltage reduction	✗	✓	00	-	
b028	Current level of active freq. matching	Sets the current level of active freq. matching restart, range is 0.2*inverter rated current to 1.5*inverter rated current, resolution 0.1	✗	✓	Rated current	A	3-45
b029	Deceleration rate of active freq. matching	Sets the deceleration rate when active freq. matching restart, range is 0.1 to 3000.0, resolution 0.1	✗	✓	0.5	sec.	
b030	Start freq. of active freq. matching	Three option codes: 00...freq at previous shutoff 01...start from max. Hz 02...start from set frequency	✗	✓	00	-	
b031	Software lock mode selection	Prevents parameter changes, in five options, option codes: 00...all parameters except b031 are locked when [SFT] terminal is ON 01...all parameters except b031 and output frequency F001 are locked when [SFT] terminal is ON 02...all parameters except b031 are locked 03...all parameters except b031 and output frequency F001 are locked 10...High level access including b031 <i>See the row "A" and "B" for the accessible parameters in this mode.</i>	✗	✓	01	-	3-54
b033	Motor cable length parameter	Set range is 5 to 20.	✓	✓	10.	-	3-55
b034	Run/power ON warning time	Range is, 0.:Warning disabled 1. to 9999.: 10 to 99,990 hrs (unit: 10) 1000 to 6553: 100,000 to 655,350 hrs (unit: 100)	✗	✓	0.	hours	3-56

Func. Code	Name	Description	A	B	Initial data	Units	Page
b035	Rotation direction restriction	Three option codes: 00 ...No restriction 01 ...Reverse rotation is restricted 02 ...Forward rotation is restricted	✗	✗	00	–	3–56
b036	Reduced voltage start selection	Set range, 0 (disabling the function), 1 (approx. 6ms) to 255 (approx. 1.5s)	✗	✓	2	–	3–57
b037	Function code display restriction	Six option codes: 00 ...Full display 01 ...Function-specific display 02 ...User setting (and b037) 03 ...Data comparison display 04 ...Basic display 05 ...Monitor display only	✗	✓	00	–	3–58
b038	Initial display selection	000 ...Func. code that SET key pressed last displayed.(*) 001 to 030 ... d001 to d030 displayed 201 ... F001 displayed 202 ...B display of LCD operator	✗	✓	001	–	3–60
b039	Automatic user parameter registration	Two option codes: 00 ...Disable 01 ...Enable	✗	✓	00	–	3–62
b050	Controlled deceleration on power loss	Four option codes: 00 ...Trips 01 ...Decelerates to a stop 02 ...Decelerates to a stop with DC bus voltage controlled 03 ...Decelerates to a stop with DC bus voltage controlled, then restart	✗	✗	00	–	3–63
b051	DC bus voltage trigger level of ctrl. decel.	Setting of DC bus voltage to start controlled decel. operation. Range is 0.0 to 1000.0	✗	✗	220.0/ 440.0	V	
b052	Over-voltage threshold of ctrl. decel.	Setting the OV-LAD stop level of controlled decel. operation. Range is 0.0 to 1000.0	✗	✗	360.0/ 720.0	V	
b053	Deceleration time of ctrl. decel.	Range is 0.01 to 3600.00	✗	✗	1.00	sec.	
b054	Initial freq. drop of ctrl. decel.	Setting of initial freq. drop. Range is 0.0 to 10.0 Hz	✗	✗	0.0	Hz	
b060	Maximum-limit level of window comparator (O)	Set range, {Min.-limit level (b061) + hysteresis width (b062)x2} to 100 % (Minimum of 0%)	✓	✓	100.	%	3–65
b061	Minimum-limit level of window comparator (O)	Set range, 0 to {Max.-limit level (b060) - hysteresis width (b062)x2} % (Maximum of 0%)	✓	✓	0.	%	
b062	Hysteresis width of window comparator (O)	Set range, 0 to {Max.-limit level (b060) - Min.-limit level (b061)/2} % (Maximum of 10%)	✓	✓	0.	%	
b063	Maximum-limit level of window comparator (OI)	Set range, {Min.-limit level (b064) + hysteresis width (b065)x2} to 100 % (Minimum of 0%)	✓	✓	100.	%	
b064	Minimum-limit level of window comparator (OI)	Set range, 0 to {Max.-limit level (b063) - hysteresis width (b065)x2} % (Maximum of 0%)	✓	✓	0.	%	

Func. Code	Name	Description	A	B	Initial data	Units	Page
b065	Hysteresis width of window comparator (OI)	Set range, 0 to {Max.-limit level (b063) - Min.-limit level (b064)} / 2 % (Maximum of 10%)	✓	✓	0.	%	3-65
b070	Operation level at O disconnection	Set range, 0 to 100%, or "no" (ignore)	✗	✓	no	-	
b071	Operation level at OI disconnection	Set range, 0 to 100%, or "no" (ignore)	✗	✓	no	-	
b075	Ambient temperature setting	Set range is, -10 to 50 °C	✓	✓	40	°C	3-66
b078	Watt-hour clearance	Two option codes: 00 ...OFF 01 ...ON (press STR then clear)	✓	✓	00	-	3-66
b079	Watt-hour display gain	Set range is, 1. to 1000.	✓	✓	1.	-	
b082	Start frequency	Sets the starting frequency for the inverter output, range is 0.01 to 9.99 Hz	✗	✓	0.50	Hz	3-68
b083	Carrier frequency	Sets the PWM carrier (internal switching frequency), range is 2.0 to 10.0 kHz	✗	✓	2.0	kHz	3-67
b084	Initialization mode (parameters or trip history)	Select initialized data, five option codes: 00 ...Initialization disabled 01 ...Clears Trip history 02 ...Initializes all Parameters 03 ...Clears Trip history and initializes all parameters 04 ...Clears Trip history and initializes all parameters and EzSQ program	✗	✗	00	-	6-14
b085	Country for initialization	Select default parameter values for country on initialization, two option codes: 00 ...area A 01 ...area B	✗	✗	01	-	
b086	Frequency scaling conversion factor	Specify a constant to scale the displayed frequency for d007 monitor, range is 0.01 to 99.99	✓	✓	1.00	-	3-60
b087	STOP key enable	Select whether the STOP key on the keypad is enabled, three option codes: 00 ...Enabled 01 ...Disabled always 02 ...Disabled for stop	✗	✓	00	-	3-68
b088	Restart mode after FRS	Selects how the inverter resumes operation when free-run stop (FRS) is cancelled, three options: 00 ...Restart from 0Hz 01 ...Restart from frequency detected from real speed of motor (freq. matching) 02 ...Restart from frequency detected from real speed of motor (active freq. matching)	✗	✓	00	-	3-70

Func. Code	Name	Description	A	B	Initial data	Units	Page
b089	Automatic carrier frequency reduction	Three option codes: 00 ...Disabled 01 ...Enabled, depending on the output current 02 ...Enabled, depending on the heat-sink temperature	✗	✗	01	–	3–67
b090	Dynamic braking usage ratio	Selects the rate of use (in %) of the regenerative braking resistor per 100 sec. intervals, range is 0.0 to the value calculated by the value of b097 . If the connected resistor's allowable range is narrower than above range, the resistor's range is prior. 0%: Function disabled >0%: Enabled, per value	✗	✓	0.0	%	3–68
b091	Stop mode selection	Select how the inverter stops the motor, two option codes: 00 ...DEC (decelerate to stop) 01 ...FRS (free-run to stop)	✗	✓	00	–	3–70
b092	Cooling fan control (NOTE 1)	Selects when the fan is ON during inverter operation, three options: 00 ...Fan is always ON 01 ...Fan is ON during run, OFF during stop (5 minute delay from ON to OFF) 02 ...Fan is temperature controlled	✗	✓	01	–	3–68
b093	Clear elapsed time of cooling fan (NOTE 1)	Two option codes: 00 ...Count 01 ...Clear	✗	✗	00	–	
b094	Initialization target data	Select initialized parameters, four option codes: 00 ...All parameters 01 ...All parameters except in/output terminals and communication. 02 ...Only registered parameters in Uxxx . 03 ...All parameters except registered parameters in Uxxx and b037 .	✗	✗	00	–	6–14
b095	Dynamic braking control (BRD) selection	Three option codes: 00 ...Disable 01 ...Enable during run only 02 ...Enable always	✗	✓	00	–	
b096	BRD activation level	Range is: 330 to 380V (200V class) 660 to 760V (400V class)	✗	✓	360/ 720	V	3–68
b097	BRD resistor	Set the value of the resistor connected to the inverter. By this setting, upper limit of b090 as the inverter hardware is calculated automatically. Range is minimum connectable resistor R_{bmin} to 600.0 Ω	✗	✓	Min. resistance	Ω	

Func. Code	Name	Description	A	B	Initial data	Units	Page
b 100	Free V/F setting, freq.1	Set range, 0 to value of b 102	✗	✗	0.	Hz	3-72
b 101	Free V/F setting, voltage.1	Set range, 0.0 to 800.0V	✗	✗	0.0	V	
b 102	Free V/F setting, freq.2	Set range, value of b 100 to b 104	✗	✗	0.	Hz	
b 103	Free V/F setting, voltage.2	Set range, 0.0 to 800.0V	✗	✗	0.0	V	
b 104	Free V/F setting, freq.3	Set range, value of b 102 to b 106	✗	✗	0.	Hz	
b 105	Free V/F setting, voltage.3	Set range, 0.0 to 800.0V	✗	✗	0.0	V	
b 106	Free V/F setting, freq.4	Set range, value of b 104 to b 108	✗	✗	0.	Hz	
b 107	Free V/F setting, voltage.4	Set range, 0.0 to 800.0V	✗	✗	0.0	V	
b 108	Free V/F setting, freq.5	Set range, value of b 108 to b 110	✗	✗	0.	Hz	
b 109	Free V/F setting, voltage.5	Set range, 0.0 to 800.0V	✗	✗	0.0	V	
b 110	Free V/F setting, freq.6	Set range, value of b 108 to b 112	✗	✗	0.	Hz	
b 111	Free V/F setting, voltage.6	Set range, 0.0 to 800.0V	✗	✗	0.0	V	
b 112	Free V/F setting, freq.7	Set range, b 110 to 400	✗	✗	0.	Hz	
b 113	Free V/F setting, voltage.7	Set range, 0.0 to 800.0V	✗	✗	0.0	V	
b 120	Brake control enable	Two option codes: 00 ...Disable 01 ...Enable 02 ...Enable (same as 01)	✗	✓	00	-	3-73
b 121	Brake Wait Time for Release	Set range: 0.00 to 5.00 sec	✗	✓	0.00	sec.	
b 122	Brake Wait Time for Acceleration	Set range: 0.00 to 5.00 sec	✗	✓	0.00	sec.	
b 123	Brake Wait Time for Stopping	Set range: 0.00 to 5.00 sec	✗	✓	0.00	sec.	
b 124	Brake Wait Time for Confirmation	Set range: 0.00 to 5.00 sec	✗	✓	0.00	sec.	
b 125	Brake release freq.	Set range: 0 to 400Hz	✗	✓	0.00	sec.	
b 126	Brake release current	Set range: 0 to 150% of inverter rated current	✗	✓	Rated current	A	
b 127	Braking freq. setting	Set range: 0 to 400Hz	✗	✓	0.00	Hz	
b 130	Deceleration overvoltage suppression enable	00 ...Disabled 01 ...Enabled 02 ...Enabled with accel.	✗	✓	00	-	3-75
b 131	Decel. overvoltage. suppress level	DC bus voltage of suppression. Range is: 200V class...330 to 395 400V class...660 to 790	✗	✓	380 /760	V	

Func. Code	Name	Description	A	B	Initial data	Units	Page
b 132	Decel. overvoltage. suppress const.	Accel. rate when b130=02. Set range: 0.10 to 30.00 sec.	✗	✓	1.00	sec.	3-75
b 133	Decel. overvoltage. suppress proportional gain	Proportional gain when b130=01. Range is: 0.00 to 5.00	✓	✓	0.20	-	
b 134	Decel. overvoltage. suppress integral time	Integration time when b130=01. Range is: 0.00 to 150.0	✓	✓	1.0	sec.	
b 145	GS input mode	Two option codes: 00 ...No trip (Hardware shutoff only) 01 ...E37 trip 02 ...E98/E99 trip/ display -5-- . With external fault detection 03 ...E99 trip/ display -5-- . Without external fault detection 04 ...Display -5-- . With external fault detection 05 ...Display input status. Without external fault detection 06 ...Display input status. With external fault detection	✗	✓	00	-	3-76
b 150	Display ex.operator connected	When an external operator is connected via RS-422 port, the built-in display is locked and shows only one "d" parameter configured in: d001 to d050	✓	✓	001	-	3-60
b 160	1st parameter of Dual Monitor	Set any two "d" parameters in b 160 and b 161 , then they can be monitored in d050 . The two parameters are switched by up/down keys. Set range: d001 to d027	✓	✓	001	-	
b 161	2nd parameter of Dual Monitor		✓	✓	002	-	
b 163	Frequency set in monitoring	Two option codes: 00 ...Freq. set disabled 01 ...Freq. set enabled	✓	✓	00	-	3-60
b 164	Automatic return to the initial display	10 min. after the last key operation, display returns to the initial parameter set by b038 . Two option codes: 00 ...Disable 01 ...Enable	✓	✓	00	-	
b 165	Ex. operator com. loss action	Five option codes: 00 ...Trip 01 ...Trip after deceleration to a stop 02 ...Ignore 03 ...Coasting (FRS) 04 ...Decelerates to a stop	✓	✓	02	-	
b 166	Data Read/Write selection	Two option codes: 00 ...Read/Write enable 01 ...both Read, Write disable	✗	✓	00	-	3-76
b 180	Initialization trigger	This is to perform initialization by parameter input with b084 , b085 and b094 . Two option codes: 00 ...Initialization disable 01 ...Perform initialization	✗	✗	00	-	6-14

Func. Code	Name	Description	A	B	Initial data	Units	Page
b 190	Password Settings A	0000(Invalid Password) 0001-FFFF>Password)	✗	✗	0000	–	3-77
b 191	Password authentication A	0000-FFFF	✗	✗	0000	–	
b 192	Password Settings B	0000(Invalid Password) 0001-FFFF>Password)	✗	✗	0000	–	
b 193	Password authentication B	0000-FFFF	✗	✗	0000	–	
b9 10	Electronic thermal subtraction function select	Four option codes: 00 ...OFF 01 ...Linear subtraction: pre-fixed ratio 02 ...Linear subtraction: ratio set in b9 11 03 ...Subtraction with first-order lag filter: ratio set in b9 12	✗	✓	00	–	3-48
b9 11	Thermal subtraction time	This function is valid when b9 10=02 Range is 0.10 to 100000.00 s Out of warranty when setting less than initial value (600.00[s])	✗	✓	600.00	sec.	
b9 12	Thermal subtraction time constant	This function is valid when b9 10=03 Range is 0.10 to 100000.00 s Out of warranty when setting less than initial value (120.00[s])	✗	✓	120.00	sec.	
b9 13	Thermal accumulation gain	Range is 1.0 to 200.0 % Out of warranty when setting less than initial value (100.0[%])	✗	✓	100.0	%	

(NOTE 1) Invalid for the models without cooling fan.

Intelligent Terminal Functions

Func. Code	Name	Description	A	B	Initial data	Units	Page
C001	Input [1] function	Select input terminal function, 56 options (see "Intelligent Inputs" on page 4-10)	✗	✓	00 [FW]	-	3-79
C002	Input [2] function		✗	✓	01 [RV]	-	
C003	Input [3] function [GS1 assignable]		✗	✓	12 [EXT]	-	
C004	Input [4] function [GS2 assignable]		✗	✓	18 [RS]	-	
C005	Input [5] function [PTC assignable]		✗	✓	02 [CF1]	-	
C006	Input [6] function		✗	✓	03 [CF2]	-	
C007	Input [7] function		✗	✓	06 [JG]	-	
C011	Input [1] active state	Select logic conversion, two option codes: 00...normally open [NO] 01...normally closed [NC]	✗	✓	00	-	3-79
C012	Input [2] active state		✗	✓	00	-	
C013	Input [3] active state		✗	✓	00	-	
C014	Input [4] active state		✗	✓	00	-	
C015	Input [5] active state		✗	✓	00	-	
C016	Input [6] active state		✗	✓	00	-	
C017	Input [7] active state		✗	✓	00	-	
C021	Output [11] function [EDM assignable]	44 programmable functions available for logic (discrete) outputs (see "Intelligent Outputs" on page 4-11)	✗	✓	00 [RUN]	-	3-84
C022	Output [12] function		✗	✓	01 [FA1]	-	
C026	Alarm relay function		✗	✓	05 [AL]	-	
C027	[EO] terminal selection (Pulse/PWM output)	11 programmable functions: 00...Output frequency (PWM) 01...Output current (PWM) 03...Output frequency (Pulse train) 04...Output voltage (PWM) 05...Input power (PWM) 06...Electronic thermal load ratio (PWM) 07...LAD frequency (PWM) 08...Output current (Pulse train) 10...Heat sink temperature (PWM) 12...General output (PWM) 16...Option(PWM)	✗	✓	07	-	3-84

Func. Code	Name	Description	A	B	Initial data	Units	Page
C028	[AM] terminal selection (Analog voltage output 0...10V)	9 programmable functions: 00 ...Output frequency 01 ...Output current 04 ...Output voltage 05 ...Input power 06 ...Electronic thermal load ratio 07 ...LAD frequency 10 ...Heat sink temperature 13 ...General output 16 ...Option	✗	✓	07 [LAD]	-	3-84
C030	Digital current monitor reference value	Current with digital current monitor output at 1,440Hz Range is 20% to 150% of rated current	✓	✓	Rated current	A	
C031	Output [11] active state	Select logic conversion, two option codes: 00 ...normally open [NO] 01 ...normally closed [NC]	✗	✓	00	-	
C032	Output [12] active state		✗	✓	00	-	
C036	Alarm relay active state		✗	✓	01	-	
C038	Output mode of low current detection	Two option codes: 00 ...During acceleration, deceleration and constant speed 01 ...During constant speed only	✗	✓	01	-	3-89
C039	Low current detection level	Set the level of low load detection, range is 0.0 to 1.5*inverter rated current	✓	✓	Rated current	A	
C040	Output mode of overload warning	Two option codes: 00 ...During accel., decel. and constant speed 01 ...During constant speed only	✗	✓	01	-	3-90
C041	Overload warning level	Sets the overload warning signal level between 0% and 200% (from 0 to two time the rated current of the inverter)	✓	✓	Rated current x 1.15	A	
C241	Overload warning level, 2 nd motor	Sets the overload warning signal level between 0% and 200% (from 0 to two time the rated current of the inverter)	✓	✓	Rated current x 1.15	A	
C042	Frequency arrival setting for acceleration	Sets the frequency arrival setting threshold for the output frequency during acceleration, range is 0.00 to 400.00 Hz	✗	✓	0.00	Hz	3-91
C043	Frequency arrival setting for deceleration	Sets the frequency arrival setting threshold for the output frequency during deceleration, range is 0.00 to 400.00 Hz	✗	✓	0.00	Hz	
C044	PID deviation level	Sets the allowable PID loop error magnitude (absolute value), SP-PV, range is 0.0 to 100%	✗	✓	3.0	%	
C045	Frequency arrival setting 2 for acceleration	Sets the frequency arrival setting threshold for [FA4]/[FAS] during acceleration, range is 0.00 to 400.00 Hz	✗	✓	0.00	Hz	3-91

Func. Code	Name	Description	A	B	Initial data	Units	Page
C046	Frequency arrival setting 2 for deceleration	Sets the frequency arrival setting threshold for [FA4]/[FA5] during deceleration, range is 0.00 to 400.00 Hz	✗	✓	0.00	Hz	3-91
C052	PID FBV output high limit	When the PV exceeds this value, the PID loop turns OFF the PID second stage output, range is 0.0 to 100 %	✗	✓	100.0	%	4-61
C053	PID FBV output low limit	When the PV goes below this value, the PID loop turns ON the PID second stage output, range is 0.0 to 100 %	✗	✓	0.0	%	
C061	Electronic thermal warning level	Set range is 0 to 100% Setting 0 means disabled.	✗	✓	90.	%	3-92
C063	Zero speed detection level	Set range is 0.00 to 100.00Hz	✗	✓	0.00	Hz	3-92
C064	Heat sink overheat warning	Set range is 0 to 110 °C	✗	✓	100.	°C	3-92
C071	Communication speed	Eight option codes: 03 ...2,400 bps 04 ...4,800 bps 05 ...9,600 bps 06 ...19,200 bps 07 ...38,400 bps 08 ...57,600 bps 09 ...76,800 bps 10 ...115,200 bps	✗	✓	05	baud	3-93
C072	Modbus address	Set the address of the inverter on the network. Range is 1 to 247	✗	✓	1.	-	
C074	Communication parity	Three option codes: 00 ...No parity 01 ...Even parity 02 ...Odd parity	✗	✓	00	-	
C075	Communication stop bit	Two option codes: 1 ...1 bit 2 ...2 bit	✗	✓	1	bit	
C076	Communication error select	Selects inverter response to communications error. Five options: 00 ...Trip 01 ...Decelerate to a stop and trip 02 ...Disable 03 ...Free run stop (coasting) 04 ...Decelerates to a stop	✗	✓	02	-	
C077	Communication error time-out	Sets the communications watchdog timer period. Range is 0.00 to 99.99 sec 0.0 = disabled	✗	✓	0.00	sec.	
C078	Communication wait time	Time the inverter waits after receiving a message before it transmits. Range is 0. to 1000. ms	✗	✓	0.	msec.	

Func. Code	Name	Description	A	B	Initial data	Units	Page
C081	O input span calibration	Scale factor between the external frequency command on terminals L-O (voltage input) and the frequency output, range is 0.0 to 200.0%	✓	✓	100.0	%	3-94
C082	OI input span calibration	Scale factor between the external frequency command on terminals L-OI (voltage input) and the frequency output, range is 0.0 to 200.0%	✓	✓	100.0	%	
C085	Thermistor input (PTC) span calibration	Scale factor of PTC input. Range is 0.0 to 200.0%	✓	✓	100.0	%	
C091	Debug mode enable	Displays debug parameters. Two option codes: 00 ...Disable 01 ...Enable <Do not set> (for factory use)	✓	✓	00	-	3-95
C096	Communication selection	Three option codes; 01 ...Modbus-RTU 03 ...EzCOM 03 ...EzCOM<Administrator>	✗	✗	00	-	3-93
C098	EzCOM start adr. of master	1 to 8	✗	✗	1.	-	B-20
C099	EzCOM end adr. of master	1 to 8	✗	✗	1.	-	
C100	EzCOM starting trigger	00 ...Input terminal 01 ...Always	✗	✗	00	-	
C101	Up/Down memory mode selection	Controls speed setpoint for the inverter after power cycle. Two option codes: 00 ...Clear last frequency (return to default frequency F001) 01 ...Keep last frequency adjusted by UP/DWN	✗	✓	00	-	3-95
C102	Reset selection	Determines response to Reset input [RS]. Four option codes: 00 ...Cancel trip state at input signal ON transition, stops inverter if in Run Mode 01 ...Cancel trip state at signal OFF transition, stops inverter if in Run Mode 02 ...Cancel trip state at input ON transition, no effect if in Run Mode 03 ...Clear the memories only related to trip status	✓	✓	00	-	
C103	Restart mode after reset	Determines the restart mode after reset is given, three option codes: 00 ...Start with 0 Hz 01 ...Start with freq. matching 02 ...Start with active freq. matching	✗	✓	00	-	

Func. Code	Name	Description	A	B	Initial data	Units	Page
C 104	UP/DWN clear mode	Freq. set value when UDC signal is given to the input terminal, two option codes: 00 ...0 Hz 01 ...Original setting (in the EEPROM memory at power on)	✗	✓	00	-	3-95
C 105	EO gain adjustment	Set range is 50 to 200%	✓	✓	100.	%	3-96
C 106	AM gain adjustment	Set range is 50 to 200%	✓	✓	100.	%	
C 109	AM bias adjustment	Set range is 0 to 100%	✓	✓	0.	%	
C 111	Overload warning level 2	Sets the overload warning signal 2 level between 0% and 200% (from 0 to two time the rated current of the inverter)	✓	✓	Rated current x 1.15	A	3-90
C 130	Output [11] on delay	Set range is 0.0 to 100.0 sec.	✗	✓	0.0	Sec.	3-84
C 131	Output [11] off delay		✗	✓	0.0	Sec.	
C 132	Output [12] on delay		✗	✓	0.0	Sec.	
C 133	Output [12] off delay		✗	✓	0.0	Sec.	
C 140	Relay output on delay		✗	✓	0.0	Sec.	
C 141	Relay output off delay		✗	✓	0.0	Sec.	
C 142	Logic output 1 operand A	All the programmable functions available for logic (discrete) outputs except LOG1 to LOG3, OPO, no	✗	✓	00	-	3-97
C 143	Logic output 1 operand B		✗	✓	00	-	
C 144	Logic output 1 operator	Applies a logic function to calculate [LOG] output state, Three options: 00 ...[LOG] = A AND B 01 ...[LOG] = A OR B 02 ...[LOG] = A XOR B	✗	✓	00	-	
C 145	Logic output 2 operand A	All the programmable functions available for logic (discrete) outputs except LOG1 to LOG3, OPO, no	✗	✓	00	-	
C 146	Logic output 2 operand B		✗	✓	00	-	
C 147	Logic output 2 operator	Applies a logic function to calculate [LOG] output state, Three options: 00 ...[LOG] = A AND B 01 ...[LOG] = A OR B 02 ...[LOG] = A XOR B	✗	✓	00	-	
C 148	Logic output 3 operand A	All the programmable functions available for logic (discrete) outputs except LOG1 to LOG3, OPO, no	✗	✓	00	-	
C 149	Logic output 3 operand B		✗	✓	00	-	

Func. Code	Name	Description	A	B	Initial data	Units	Page
C 150	Logic output 3 operator	Applies a logic function to calculate [LOG] output state, Three options: 00 ...[LOG] = A AND B 01 ...[LOG] = A OR B 02 ...[LOG] = A XOR B	✗	✓	00	-	3-97
C 160	Input [1] response time	Sets response time of each input terminal, set range: 0 (x 2 [ms]) to 200 (x 2 [ms]) (0 to 400 [ms])	✗	✓	1.	-	3-79
C 161	Input [2] response time		✗	✓	1.	-	
C 162	Input [3] response time		✗	✓	1.	-	
C 163	Input [4] response time		✗	✓	1.	-	
C 164	Input [5] response time		✗	✓	1.	-	
C 165	Input [6] response time		✗	✓	1.	-	
C 166	Input [7] response time		✗	✓	1.	-	
C 169	Multistage speed/position determination time	Set range is 0. to 200. (x 10ms)	✗	✓	0.	msec.	3-98
C 901	Overload warning processing cycle select	Two option codes: 00 ...40ms 01 ...2ms	✗	✓	00	-	3-90
C 902	Overload warning filter time constant	Set the filter time constant for output current detection used for judgement of overload warning. Range is 0 to 9999 ms	✗	✓	0	msec.	
C 903	Overload warning hysteresis	Set the hysteresis for overload warning signal. Range is 0 to 50% of the rated current of the inverter	✗	✓	10.00	%	

Motor Constants Functions

Func. Code	Name	Description	A	B	Initial data	Units	Page
H003	Motor capacity	Twelve selections: 0.1/0.2/0.4/0.75/1.5/2.2/3.7/ 5.5/7.5/11/15/18.5	✗	✗	Specified by the capacity of each inverter model	kW	3-99
H203	Motor capacity, 2 nd motor		✗	✗		kW	
H004	Motor poles setting	Twenty four selections: 2 / 4 / 6 / 8 / 10 / 12 / 14 / 16 / 18 / 20 / 22 / 24 / 26 / 28 / 30 / 32 / 34 / 36 / 38 / 40 / 42 / 44 / 46 / 48	✗	✗	4	poles	
H204	Motor poles setting, 2 nd motor		✗	✗	4	poles	
H006	Motor stabilization constant	Motor constant (factory set), range is 0 to 255	✓	✓	100.	-	
H206	Motor stabilization constant, 2 nd motor		✓	✓	100.	-	

Expansion Card Functions

Func. Code	Name	Description	A	B	Initial data	Units	Page
P001	Reaction when option card error occurs	Two option codes: 00 ...Inverter trips 01 ...Ignores the error (Inverter continues operation)	✗	✓	00	–	3–100
P031	Acceleration/Deceleration setting source selection	00 ...Via operator 03 ...Via EzSQ	✗	✗	00	–	3–10
P044	Communication watchdog timer (for option)	Set range is 0.00 to 99.99s	✗	✗	1.00	Sec.	3–100
P045	Inverter action on communication error (for option)	00 ...Tripping 01 ...Tripping after decelerating and stopping the motor 02 ...Ignoring errors 03 ...Stopping the motor after free-running 04 ...Decelerating and stopping the motor	✗	✗	00	–	
P046	DeviceNet polled I/O: Output instance number	0 to 20	✗	✗	01	–	
P048	Inverter action on communication idle mode	00 ...Tripping 01 ...Tripping after decelerating and stopping the motor 02 ...Ignoring errors 03 ...Stopping the motor after free-running 04 ...Decelerating and stopping the motor	✗	✗	00	–	
P049	Motor poles setting for RPM	0/2/4/6/8/10/12/14/16/18/20/22/24/26/28/30/32/34/36/38/40/42/44/46/48	✗	✗	0	poles	
P100 to P131	EzSQ user parameter U(00) to U(31)	Each set range is 0 to 65535	✓	✓	0.	–	
P140	EzCOM number of data	1 to 5	✓	✓	5.	–	
P141	EzCOM destination 1 address	1 to 247	✓	✓	1.	–	
P142	EzCOM destination 1 register	0000 to FFFF	✓	✓	0000	–	
P143	EzCOM source 1 register	0000 to FFFF	✓	✓	0000	–	
P144	EzCOM destination 2 address	1 to 247	✓	✓	2.	–	
P145	EzCOM destination 2 register	0000 to FFFF	✓	✓	0000	–	
P146	EzCOM source 2 register	0000 to FFFF	✓	✓	0000	–	
P147	EzCOM destination 3 address	1 to 247	✓	✓	3.	–	
P148	EzCOM destination 3 register	0000 to FFFF	✓	✓	0000	–	

Func. Code	Name	Description	A	B	Initial data	Units	Page
P 149	EzCOM source 3 register	0000 to FFFF	✓	✓	0000	–	3–100
P 150	EzCOM destination 4 address	1 to 247	✓	✓	4.	–	
P 151	EzCOM destination 4 register	0000 to FFFF	✓	✓	0000	–	
P 152	EzCOM source 4 register	0000 to FFFF	✓	✓	0000	–	
P 153	EzCOM destination 5 address	1 to 247	✓	✓	5.	–	
P 154	EzCOM destination 5 register	0000 to FFFF	✓	✓	0000	–	
P 155	EzCOM source 5 register	0000 to FFFF	✓	✓	0000	–	
P 160 to P 169	Option I/F command register to write 1 to 10	0000h to FFFFh	✓	✓	0000	–	
P 170 to P 179	Option I/F command register to read 1 to 10	0000h to FFFFh	✓	✓	0000	–	
P 180	Profibus Node address	0. to 125.	✗	✗	0.	–	
P 181	Profibus Clear Node address	00 ...Clear 01 ...Hold previous time value	✗	✗	00	–	
P 182	Profibus Map selection	00 ...PPO type 01 ...Conventional 02 ...Flexible Mode Format Selection	✗	✗	00	–	
P 192	DeviceNet MAC ID	0 to 63	✗	✗	63	–	

User setting parameters

Func. Code	Name	Description	A	B	Initial data	Units	Page
U001 to U032	User parameters 1 to 32	Set range, " no ", d001 to P 192	✓	✓	no	–	3–62

CE-EMC Installation Guidelines



In This Appendix...	page
- CE-EMC Installation Guidelines	D-2
- Hitachi EMC Recommendations	D-6

CE-EMC Installation Guidelines

You are required to satisfy the EMC directive (2004/108/EC) when using a WL200 inverter in an EU country.

To satisfy the EMC directive and to comply with standard, you need to use a dedicated EMC filter suitable for each model, and follow the guidelines in this section. Following table shows the compliance condition for reference.

Table 1. Condition for the compliance

Model	Cat.	Carrier f	Motor cable
All WL200 series	C1	2kHz	20m (Shielded)

Table 2. Applicable EMC filter

Input class	Inverter model	Filter model (Schaffner)
1-ph. 200V class	WL200-002SFE	FS24828-8-07
	WL200-004SFE	
	WL200-007SFE	
	WL200-015SFE	FS24828-27-07
	WL200-022SFE	
3-ph. 400V class	WL200-004HFE	FS24830-6-07
	WL200-007HFE	
	WL200-015HFE	
	WL200-022HFE	FS24830-12-07
	WL200-030HFE	
	WL200-040HFE	FS24830-15-07
	WL200-055HFE	
	WL200-075HFE	FS24830-29-07
	WL200-110HFE	
	WL200-150HFE	FS24830-48-07
WL200-185HFE		

WL200-185H needs to be installed in a metal cabinet and add ferrite core at the input cable to meet category C1. Unless otherwise category C2.

Important notes

1. Input choke or other equipment is required if necessary to comply with EMC directive from the harmonic distortion point of view (IEC 61000-3-2 and 4).
2. If the motor cable length exceeds 20m, use output choke to avoid unexpected problem due to the leakage current from the motor cable (such as malfunction of the thermal relay, vibration of the motor, etc..).
3. As user you must ensure that the HF (high frequency) impedance between adjustable frequency inverter, filter, and ground is as small as possible.
 - Ensure that the connections are metallic and have the largest possible contact areas (zinc-plated mounting plates).
4. Avoid conductor loops that act like antennas, especially loops that encompass large areas.
 - Avoid unnecessary conductor loops.
 - Avoid parallel arrangement of low-level signal wiring and power-carrying or noise-prone conductors.
5. Use shielded wiring for the motor cable and all analog and digital control lines.
 - Allow the effective shield area of these lines to remain as large as possible; i.e., do not strip away the shield (screen) further away from the cable end than absolutely necessary.
 - With integrated systems (for example, when the adjustable frequency inverter is communicating with some type of supervisory controller or host computer in the same control cabinet and they are connected at the same protective ground), connect the shields of the control lines to protective ground at both ends. With distributed systems (for example the communicating supervisory controller or host computer is not in the same control cabinet and there is a distance between the systems), we recommend connecting the shield of the control lines only at the end connecting to the adjustable frequency inverter. If possible, route the other end of the control lines directly to the cable entry section of the supervisory controller or host computer. The shield conductor of the motor cables always must be connected to protective ground at both ends.
 - To achieve a large area contact between shield and protective ground, use a PG screw with a metallic shell, or use a metallic mounting clip.
 - Use only cable with braided, tinned copper mesh shield (type "CY") with 85% coverage.
 - The shielding continuity should not be broken at any point in the cable. If the use of reactors, contactors, terminals, or safety switches in the motor output is necessary, the unshielded section should be kept as short as possible.
 - Some motors have a rubber gasket between terminal box and motor housing. Very often, the terminal boxes, and particularly the threads for the metal PG screw connections, are painted. Make sure there is always a good metallic connection between the shielding of the motor cable, the metal PG screw connection, the terminal box, and the motor housing. If necessary, carefully remove paint between conducting surfaces.

6. Take measures to minimize interference that is frequently coupled in through installation cables.
 - Separate interfering cables with 0.25m minimum from cables susceptible to interference. A particularly critical point is laying parallel cables over longer distances. If two cables intersect (one crosses over the other), the interference is smallest if they intersect at an angle of 90°. Cables susceptible to interference should therefore only intersect motor cables, intermediate circuit cables, or the wiring of a rheostat at right angles and never be laid parallel to them over longer distances.
 7. Minimize the distance between an interference source and an interference sink (interference- threatened device), thereby decreasing the effect of the emitted interference on the interference sink.
 - You should use only interference-free devices and maintain a minimum distance of 0.25 m from the adjustable frequency inverter.
 8. Follow safety measures in the filter installation.
 - If using external EMC filter, ensure that the ground terminal (PE) of the filter is properly connected to the ground terminal of the adjustable frequency inverter. An HF ground connection via metal contact between the housings of the filter and the adjustable frequency inverter, or solely via cable shield, is not permitted as a protective conductor connection. The filter must be solidly and permanently connected with the ground potential so as to preclude the danger of electric shock upon touching the filter if a fault occurs.
- To achieve a protective ground connection for the filter:
- Ground the filter with a conductor of at least 10 mm² cross-sectional area.
 - Connect a second grounding conductor, using a separate grounding terminal parallel to the protective conductor. (The cross section of each single protective conductor terminal must be sized for the required nominal load.)

Installation for WL200 series (example of SFE models)

Model HFx (3-ph. 400V class) is the same concept for the installation.

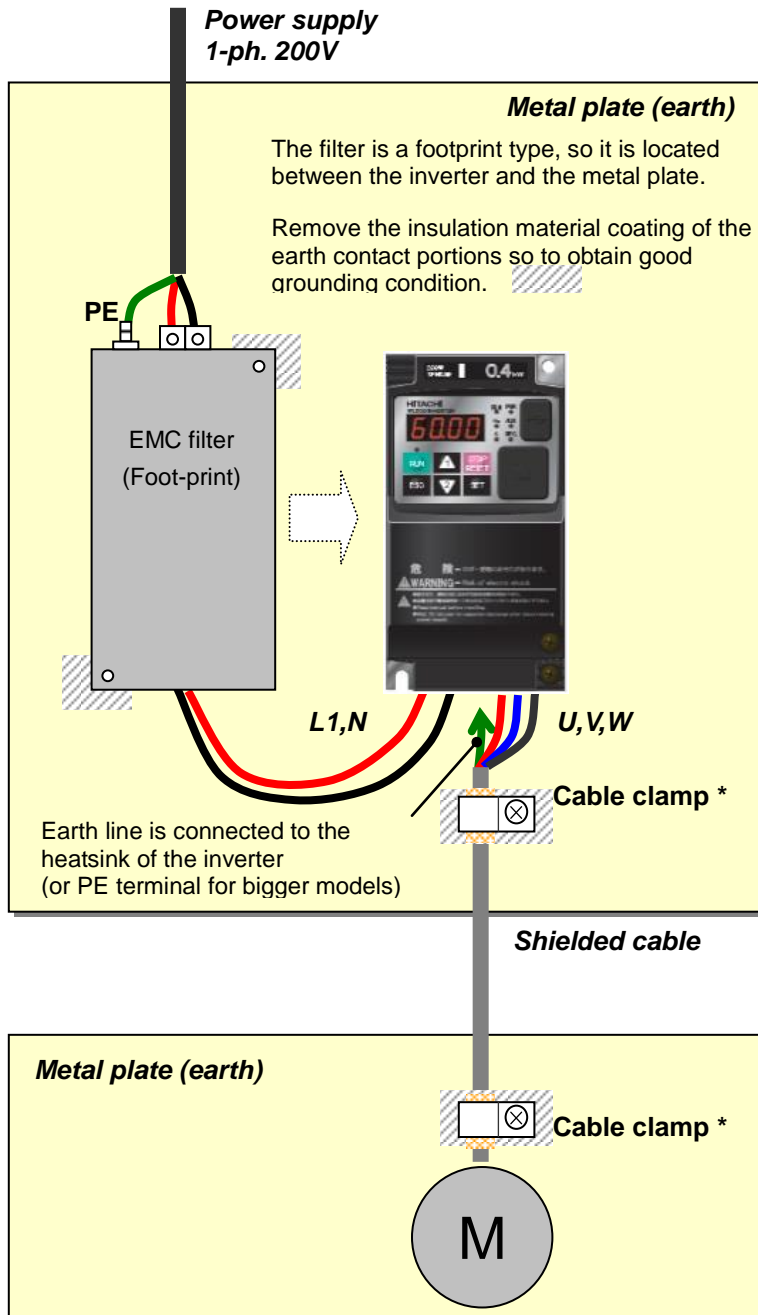

*) Both earth portions of the shielded cable must be connected to the earth point by cable clamps.

Input choke or equipment to reduce harmonic current is necessary for CE marking (IEC 61000-3-2 and IEC61000-3-4) from the harmonic current point of view, even conducted emission and radiated emission passed without the input choke.

Hitachi EMC Recommendations



WARNING: This equipment should be installed, adjusted, and serviced by qualified personal familiar with construction and operation of the equipment and the hazards involved. Failure to observe this precaution could result in bodily injury.

Use the following checklist to ensure the inverter is within proper operating ranges and conditions.

1. The power supply to WL200 inverters must meet these specifications:
 - Voltage fluctuation $\pm 10\%$ or less
 - Voltage imbalance $\pm 3\%$ or less
 - Frequency variation $\pm 4\%$ or less
 - Voltage distortion THD = 10% or less
2. Installation measure:
 - Use a filter designed for WL200 inverter. Refer to the instruction of the applicable external EMC filter.
3. Wiring:
 - Shielded wire (screened cable) is required for motor wiring, and the length must be 20 meter or less.
 - If the motor cable length exceeds the value shown above, use output choke to avoid unexpected problem due to the leakage current from the motor cable.
 - The carrier frequency setting must be 2 kHz to satisfy EMC requirements.
 - Separate the power input and motor wiring from the signal/process circuit wiring.
4. Environmental conditions—when using a filter, follow these guidelines:
 - Ambient temperature: -10 to 40 °C (Derating is required)
 - Humidity: 20 to 90% RH (non-condensing)
 - Vibration: 5.9 m/sec² (0.6 G) 10 to 55Hz
 - Location: 1000 meters or less altitude, indoors (no corrosive gas or dust)

Safety

(ISO13849-1)

*Be available in future



In This Appendix...	page
- Introduction	E-2
- Stop Category defined in EN60204-1	E-2
- How it works	E-2
- Activation	E-2
- Installation	E-3
- Wiring example	E-4
- Components to be combined	E-6
- Periodical check (proof test)	E-6
- Precautions	E-7

Introduction

The Gate Suppress function can be utilized to perform a safe stop according to the EN60204-1, stop category 0 (Uncontrolled stop by power removal) (as STO function of IEC/EN61800-5-2). It is designed to meet the requirements of the ISO13849-1 Cat.3 PLd, IEC61508 SIL2 and IEC/EN61800-5-2 SIL2 only in a system in which EDM signal is monitored by an "External Device Monitor".

Stop Category defined in EN60204-1

Category 0: Uncontrolled stop by immediate (< 200 ms) shut-down of the power supply to the actuators.

(as STO function of IEC/EN61800-5-2)

Category 1: Controlled stop by interrupting the power supply to the actuator level if, for example, the hazardous movement has been brought to a standstill (time-delayed shut-down of the power supply).

(as SS1 function of IEC/EN61800-5-2)

Category 2: Controlled stop. The power supply to the drive element is not interrupted. Additional measures to EN 1037 (protection from unexpected restart) are necessary.

(as SS2 function of IEC/EN61800-5-2)

How it works

Interrupting the current to GS1 or GS2, for example removing the link between either GS1 or GS2 and PLC or both GS1/GS2 and PLC disables the drive output, i.e. the power supply to the motor is cut by stopping the switching of the output transistors in a safe way. EDM output is activated when GS1 and GS2 are given to the drive.

Always use both inputs to disable the drive. EDM output conducts when both GS1 and GS2 circuits are working properly. If for any reason only one channel is opened, the drive output is stopped but the EDM output is not activated. In this case the Safe Disable input wiring must be checked.

Activation

Turning on the safety switch automatically assign the GS1 input and GS2 input automatically.

To assign EDM (External Device Monitor) output, please turn the EDM function switch on. EDM output is automatically assigned on intelligent output terminal 11.

(When safety switch or EDM switch is turned off, the intelligent input and output terminal assigned on will be set as "no" function, and contact will remain normally off.)

Always use both inputs to disable the drive. If for any reason only one channel is opened, the drive output is stopped but the EDM output is not activated. In this case the Safe Disable input wiring must be checked.

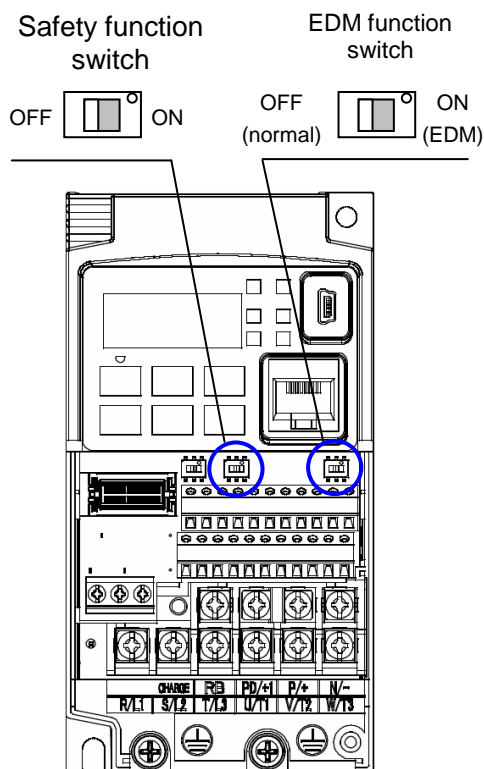

Installation

According to the safety standard listed above, please install referring to the example. Please be sure to use the both GS1 and GS2, and construct the system that GS1 and GS2 are both turned off when safety input is given to the inverter. Be sure to carry out the proof test when installation is ready before operation.

When the Gate Suppress function is utilized, connect the drive to a safety certified interrupting device utilizing EDM output signal to reconfirm both safety inputs GS1 and GS2.

item	Function code	data	description
Input [3] and [4] function	C003	77	GS1: Safety input 1 (note 1)
	C004	78	GS2 : Safety input 2 (note 1)
Input [3] and [4] active state	C013	01	NC: Normally Closed (note 1)
	C014	01	NC: Normally Closed (note 1)
Output [11] function	C021	62	EDM : External Device Monitor (note2)
Output [11] active state	C031	00	NO: Normally Open (note 2)
GS input mode	b145	00	Output is shut off by hardware. No trip.
		01	Output is shut off by hardware, and then, trip. (note3) (note4)

Note 1) They are automatically set when safety switch is turned ON, cannot be changed.

Note 2) Those are automatically assigned when EDM switch is turned ON, cannot be changed.

Note 3) Inverter trips with "E37". When competing with external trip (E12), E37 has priority.

Note 4) While the drive is the trip status "E037" and either GS1 or GS2 is activated, on the safety by is not guaranteed.

Wiring example

When the Gate Suppress function is utilized, connect the drive to a safety certified interrupting device utilizing EDM output signal to reconfirm both safety inputs GS1 and GS2.

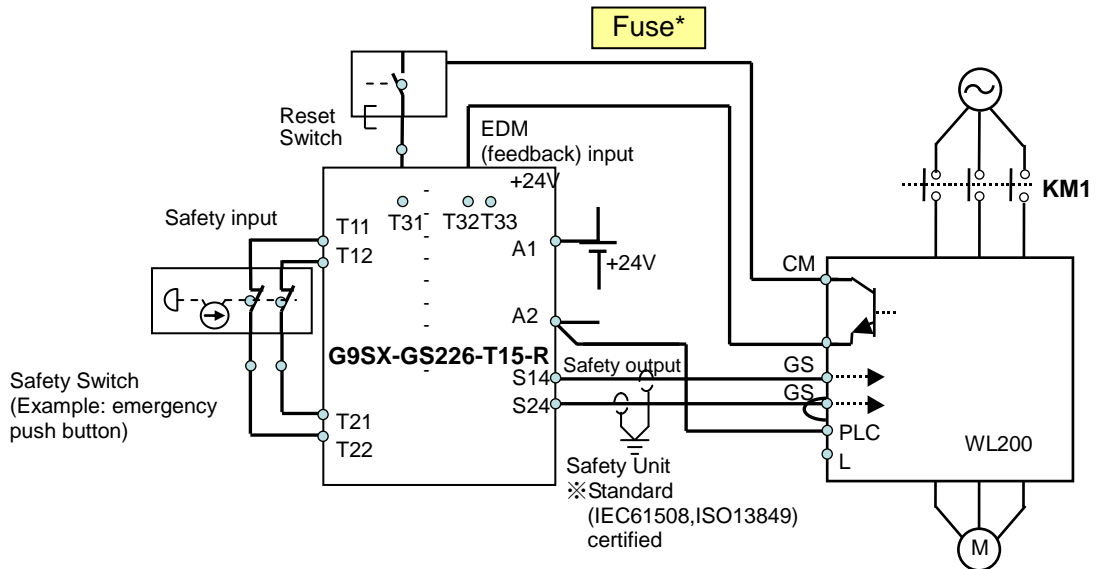

(*) Specification of the fuse:

The arch extinguishing fuse with rated voltage AC250V, rated current 100mA complies to either IEC6127 -2/-3/-4

example)

SOC EQ series AC250V, 100Ma (UL, SEMKO, BSI)

Little 216 series AC250V, 100mA (CCC, UL, CSA, SEMKO, CE, VDE)

Any external signal voltage connected to the WL200 must be from a SELV Power Supply.

By pressing the emergency stop button, the current to GS1 and GS2 is shut off, and the inverter output is shut off. By this, motor is free-running. This behavior is according to the stop category 0 defined in EN60204.

Note 1: Above is the example to use the intelligent input terminal with source logic. When it is used with sink logic, the wiring is to be modified.

Note 2: The wire for safety relay and emergency input signal are to be shielded coaxial cable for example RS174/U (produced by LAPP) by MIL-C17, or KX2B by NF C 93-550 with diameter 2.9mm with less than 2 meters. Please be sure to ground the shielding.

Note 3: All the inductance related parts such as relay and contactor are required to contain the over-voltage protection circuit.

 Inverter doesn't block the current flowing into itself when it is not powered. This may cause the closed circuit when two or more inverters are connected to common I/O wiring as shown below to result in unexpected turning the on the input. This may lead to dangerous situation. To avoid this closed circuit, please put the diode (rated:50V/0.1A) in the path as described below.

 IF the protection diodes used when the units are in wired parallel are only single diodes then their condition would be checked as part of the proof test.

By having ability inverter doesn't block the current flowing into itself when it is not powered. This may cause the closed circuit when two or more inverters are connected to common I/O wiring as shown below to result in unexpected turning the on the input. To avoid this closed circuit, please put the diode (rated:50V/0.1A) in the path as described below.

In case of Source logic

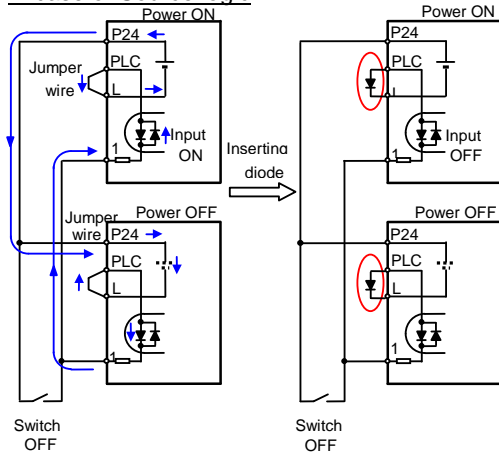

The current loop cause turn the input ON even the switch is off when diode is not inserted.

The current loop is to be prevented by inserting diode instead of short bar.

In case of Sink logic

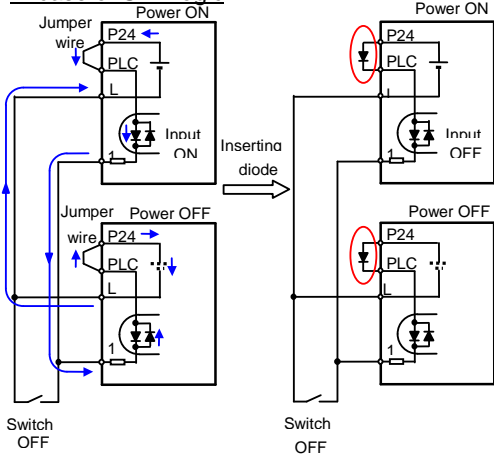

The current loop cause turn the input ON even the switch is off when diode is not inserted.

The current loop is to be prevented by inserting diode instead of short bar.

Components to be combined

Followings are the example of the safety devices to be combined.

Series	Model	Norms to comply	reference certificate
GS9A	301	ISO13849-2 cat4, SIL3	06.06.2007
G9SX	GS226-T15-RC	IEC61508 SIL1-3	04.11.2004
NE1A	SCPU01-V1	IEC61508 SIL3	27.09.2006

The configuration of and components used in any circuit other than an appropriately pre approved safety module that interfaces with the WL200 GS1/GS2 and EDM ports **MUST** be at least equivalent to Cat. 3 PLd under ISO 13849-1:2006 in order to be able to claim an overall Cat. 3 PLd for the WL200 and external circuit combination.

The EMI level that the external module has been assessed to must be at least equivalent to that of Annex E in IEC 62061.

Periodical check (proof test)

Proof test is essential to be able to reveal any dangerous undetected failures after a period of time, in this case 1 year. Carrying out this proof test at least one a year is the condition to comply the ISO13849-1 PLd.

Terminal	Status			
	current OFF	current ON	current OFF	current ON
GS1	current OFF	current ON	current OFF	current ON
GS2	current OFF	current OFF	current ON	current ON
EDM	conducted	not conducted	not conducted	not conducted
(output)	forbidden	forbidden	forbidden	Allowed

- To activate (give current to) GS1 and GS2 simultaneously and separately to see output is allowed and EDM is conducting - To activate (give current to) both GS1 and GS2 to see output is allowed and EDM is not conducting
- To activate (give current to) GS1, not to activate GS2 and see output is forbidden and EDM is not conducting
- To activate (give current to) GS2, not to activate GS1 and see output is forbidden and EDM is not conducting
- To deactivate (interrupt current to) both GS1 and GS2 to see output is forbidden and EDM is conducting

Be sure to carry out the proof test when installation is ready before operation.



IF the protection diodes used when the units are in wired parallel are only single diodes then their condition would be checked as part of the proof test. Check to reconfirm the diodes are not damaged when proof test is done.

Precautions



1. To assure, that the Safe Disable function appropriately fulfills the safety requirements of the application, a throughout risk assessment for the whole safety system has to be carried out.
2. The Safe Disable function does not cut the power supply to the drive and does not provide electrical isolation. Before any installation or maintenance work is done, the drives power supply must be switched off and place a tag/lock-out.
3. The wiring distance for the Safe Disable inputs should be shorter than 30 m.
4. The time from opening the Safe Disable input until the drive output is switched off is less than 10 ms. To assure, that the Safe Disable function appropriately fulfills the safety requirements of the application, a throughout risk assessment for the whole safety system has to be carried out.

Index

2

2CH 4-22

A

A Group parameters 3-11
 AC reactors 5-3
 Acceleration 1-19, 3-10
 characteristic curves 3-37
 second function 3-36
 stop 3-29
 two stage 4-22
 Accessories 5-2
 Active frequency matching restart 3-45
 ADD 4-39
 Add frequency 3-41
 enable 4-39
 AHD 4-42
 AL 4-53
 Alarm signal 4-46, 4-53
 Algorithm torque control 3-4, 3-99
 Ambient temperature 2-8, A-2
 setting 3-66
 Analog
 command hold 4-42
 current input disconnect detect 4-60
 disconnect detect 4-60
 voltage input disconnect detect 4-60
 Analog input
 adjusting characteristics 3-15
 calibration settings 3-94
 current 4-77
 operation 4-77
 range settings 3-39, 3-42
 settings 3-15, 3-39
 voltage 4-77
 voltage/current select 4-28
 Analog output
 calibration related function 3-96
 operation 4-79
 Arrival frequency A-2
 AT 4-28
 Automatic
 restart mode 3-43
 user parameter registration 3-62
 Automatic voltage regulation 2-30, 3-34

B

B Group parameters 3-43
 Base frequency 2-30, A-2
 setting 3-14
 BER 4-58
 Bibliography A-8
 BOK 4-37
 Brake
 confirmation 4-37
 control function related 3-73
 error signal 4-58
 release signal 4-58
 Braking 1-18
 dynamic 5-5
 resistor A-2
 settings 3-25
 Break-away torque A-2
 BRK 4-58

Index-2

- C**
- C Group parameters 3-79
 - Calcurate function 3-40
 - Capacitor life
 - curve 6-21
 - warning signal 4-66
 - Carrier frequency A-2
 - (PWM)related 3-67
 - adjustment 3-67
 - automatic reduction 3-67
 - Cautions
 - general xi
 - index to iv
 - inverter mounting 2-7
 - operating procedures 4-2
 - CE approval A-2
 - CE-EMC guidelines D-2
 - CF1 4-17
 - CF2 4-17
 - CF3 4-17
 - CF4 4-17
 - Choke 2-4, 5-3, A-2
 - Clear watt-hour data 4-40
 - Commercial power source switchover 4-26
 - Communication signal disconnect
 - detection 4-64
 - Components to be combined E-6
 - Constant
 - torque 3-21
 - voltage/hertz operation 1-16
 - Contact Information xxi
 - Control algorithms 3-21
 - Controlled stop operation at
 - power loss 3-63
 - Cooling fan warning signal 4-66
 - CS 4-26
 - Current
 - input 4-77
 - limitation related functions 3-52
 - overload 2-31, 3-46
 - Current/voltage input select 4-28
- D**
- D Group parameters 3-5
 - Data Read/Write selection 3-76
 - DB 4-20
 - DC braking 3-25, A-2
 - (DB)settings 3-25
 - frequency detection 3-25
 - DC Braking 4-20
 - DC Bus AVR 3-75
 - Deadband A-2
 - Deceleration 1-19, 3-10
 - characteristic curves 3-37
 - second function 3-36
 - stop 3-29
 - two stage 4-22
 - Default settings
 - listing C-3
 - restoring 6-14
 - Delay function output circuits 4-47
 - Digital operator 2-24, 3-3
 - Dimensions
 - inverter 2-9
 - terminals 2-16
 - Diode A-3
 - Disconnect defect analog input 4-60
 - DISP 4-44
 - Display
 - limitation 4-44
 - related paramerters 3-58
 - Duty cycle A-3
 - DWN 4-34
 - Dynamic braking 1-18, A-3
 - related function 3-68
- E**
- Edit mode 2-34
 - Editing parameters 2-24, 2-28
 - EDM 4-76, A-3
 - EEPROM write mode B-19
 - Electronic thermal
 - characteristic 3-47
 - characteristic curve 3-47
 - subtraction 3-48
 - warning output 3-48, 4-57
 - warring output 3-92
 - EMC
 - filter xiii
 - installation guidelines D-2
 - installation recommendations D-6
 - EMI A-3
 - Energy savings mode 3-35
 - ENTER command B-19
 - Environmentl
 - specs 1-7
 - Executing EzSQ program 4-43
 - EXT 4-24
 - External
 - DC braking 4-20
 - frequency filter time constant 3-16
 - trip 4-24
 - EzCOM B-20
 - EzSQ related parameter settings 3-101

F	<ul style="list-style-type: none"> F Group parameters 3-10 F/R..... 4-31 FA1 to FA5 4-49 Factory default settings restoring 6-14 Fan control 3-68 Fan outlet 2-8 FAQ 1-20 FBV 4-63 Features 1-2, 2-2 Feedback value check 4-63 Ferrule 4-9 Filters noise suppressions 5-2 Fine-tuning functions 3-43 Force <ul style="list-style-type: none"> operation from digital operator 4-35 terminal mode 4-40 Forward <ul style="list-style-type: none"> reverse 4-31 rotation 4-71 run/stop 4-16 Four-quadrant operation A-3 FR 4-67 Free-run stop 4-23, A-3 Free-V/F settings related 3-22, 3-72 FREF 4-74 Frequency <ul style="list-style-type: none"> command source 4-74 limits 3-27 setting A-3 source setting 3-11 Frequency arrival <ul style="list-style-type: none"> output 3-91 signals 4-49 Frequently asked questions 1-20 FRS 4-23 F-TM 4-40 Fuse size xvi, 2-15 FW 4-16 FWR..... 4-71
G	<ul style="list-style-type: none"> General input(1) to (3) 4-69 General purpose input(1) to (7)..... 4-41 Glossary of terms..... A-2
H	<ul style="list-style-type: none"> H Group parameters 3-99 Harmonics A-4 Heat sink overheat warning 4-68 Heat sink overheat warning output 3-92 History of trip events..... 3-8
	<ul style="list-style-type: none"> HLD..... 4-43 Horsepower A-4 How to connect? 4-9
I	<ul style="list-style-type: none"> IGBT 1-15, A-4 <ul style="list-style-type: none"> measurements techniques..... 6-20 procedures 6-15 test method 6-17 unpacking..... 2-2 Inertia A-4 Initialization 6-14 <ul style="list-style-type: none"> codes 3-68 related 3-68 Input <ul style="list-style-type: none"> circuits..... 4-5, 4-12 function summary table 3-81 terminal configuration 3-79 Inspection electrical measurements ... 6-18 Installation <ul style="list-style-type: none"> for WL200 series D-5 instructions 2-6 Insulation test 6-16 Integral gain 3-30 Intelligent input..... 4-10 <ul style="list-style-type: none"> overview 3-80 terminals..... 3-79, 4-12 Intelligent output 4-11 <ul style="list-style-type: none"> terminals..... 3-84, 4-45 Intelligent terminals <ul style="list-style-type: none"> definition..... A-4 functions..... 3-79 index..... 4-10 Inverter 1-15, A-4 <ul style="list-style-type: none"> dimensions 2-9 programming..... 3-2 ready signal 4-70 IRDY..... 4-70 Isolation transformer A-4
J	<ul style="list-style-type: none"> JG 4-19 Jog frequency..... 3-20 <ul style="list-style-type: none"> settings 3-18 Jogging..... 4-19 Jogging operation..... A-4 Jump frequencies 3-28, A-4

- K**
 - Keypad..... 2-2, 3-2
 - connected 3-9
 - features 2-24, 3-3
 - navigation..... 2-25
 - navigation trip events..... 6-8
 - KHC 4-40
- L**
 - LAC..... 4-38
 - LAD cancellation 4-38
 - LEDs 2-24, 2-25, 3-3
 - Line reactor A-4
 - Linear accel/decel..... 3-37
 - LOC..... 4-69
 - LOG1 to LOG3..... 4-65
 - Logic output
 - function..... 3-97, 4-65
 - terminals 3-84, 4-6
 - Low load detection..... 4-69
 - output..... 3-89
- M**
 - Main profile parameters 3-10
 - Maintenance procedures 6-15
 - Major failure signal 4-72
 - Manual torque boost..... 3-23
 - Maximum frequency setting 3-14
 - Megger test 6-16
 - MI1 to MI7..... 4-41
 - MJA 4-72
 - MO1 to MO3..... 4-69
 - Modbus
 - coil list..... B-24
 - data listing B-24
 - exception response B-18
 - explanation of function codes B-10
 - introduction B-2
 - message configuration query B-6
 - message configuration response B-8
 - protocol reference B-5
 - store new register data B-19
 - Modbus holding registers B-26
 - Model number
 - convention..... 1-3
 - on nameplate..... 1-3
 - Model-specs table..... 1-4
 - Momentum..... A-4
 - Monitor mode 2-25, 3-4, 6-8
 - Monitoring
 - function..... 3-5
 - parameters..... 2-33
 - Motor
 - cable length parameter 3-55
 - constants 3-99
 - load A-5
 - poles..... 1-21, 2-32, 3-99
 - speed..... 2-35
 - wiring 2-21
 - Mounting
 - clearance for ventilation..... 2-8
 - dimensions..... 2-9
 - location..... 2-7
 - Multi-speed
 - binary operation..... 4-17
 - bit operation..... 4-36
 - operation..... A-5
 - profiles..... 1-19
 - settings 3-18
 - N**
 - Nameplate 1-3
 - Navigation
 - map 2-25
 - Navigational
 - trip events 6-13
 - NDc..... 4-64
 - NEC..... A-5
 - NEMA definition..... A-5
 - Network communications
 - error code..... 6-10
 - Network communications 1-20, B-2
 - Modbus data listing..... B-24
 - parameter settings..... B-4
 - protocol reference..... B-5
 - settings 3-93
 - termination resistor B-3

O	<ul style="list-style-type: none"> OD 4-52 ODc 4-60 OHF 4-68 OIDc 4-60 OL 4-51 OL2 4-51 OLR 4-37 ONT 4-56 OPE 4-35 Open collector outputs 4-45, A-5 Operational <ul style="list-style-type: none"> components 2-7 modes 3-4 precautions 2-23 Operational components 1-2 Orientation 2-2 Other <ul style="list-style-type: none"> analog input related topics 4-78 functions 3-98 Output <ul style="list-style-type: none"> adjustment parameters 3-89 circuits 4-5 curcuits 4-45 deyay function 4-47 deviation for PID control 4-52 frequency 2-33 function summary table 3-86 logic and timing 3-97 motor 1-17 overload 3-46 setting 3-10 terminal configuration 3-84 Over-current trip 3-43 <ul style="list-style-type: none"> error code 6-8 suppression 3-52 Overload <ul style="list-style-type: none"> configuration 3-46 error code 6-8 restriction 3-52 restriction source changeover 4-37 warning output 4-51 warring output 3-90 Override source settings 3-12 Over-voltage trip 3-43 <ul style="list-style-type: none"> error code 6-8
P	<ul style="list-style-type: none"> P Group parameters 3-100 Parameter editing 2-24, 2-28 <ul style="list-style-type: none"> listing C-3 setting 1-18, 2-25 Password function 3-77 Periodical check E-6 Permission <ul style="list-style-type: none"> of run command 4-44 PID 4-32 <ul style="list-style-type: none"> clear 4-32 control 3-30 deviation output 3-33 disable 4-32 error 4-52, A-3 error inversion 3-32 feedback comparison output 3-33 loop 1-22, A-5 loop configuration 3-32 output limit 3-32 scalling 3-33 second stage output 4-61 settings 3-30 sleep function 3-33 PIDC 4-32 PLC connecting 4-4 Poles of motor 1-21, 2-32, 3-99 Potentiometer 3-11 Potentiometer 2-28 Power <ul style="list-style-type: none"> factor A-5 on time expiration signal 4-56 Power test observations <ul style="list-style-type: none"> acceleration and deceleration 2-35 error codes 2-35 interpreting the display 2-35 inverter at stop 2-35 monitor/program modes 2-35 run/stop vs monitor/program <ul style="list-style-type: none"> modes 2-35 speed (RPM) 2-35 Powering the inverter 2-23 Powerup fail 3-43 Powerup test 2-22 Powerup test observations 2-35 Powerup unattended start 4-25 <ul style="list-style-type: none"> error code 6-9 Pre-test 2-23 Preventative maintenance 6-15 PRG 4-43 Process variable A-5 Program <ul style="list-style-type: none"> mode 3-4 Program mode 2-25, 2-33 Programming device 3-2 Proof test A-5 Proportional gain 3-30 PTC 4-30 PV source setting 3-30 PWM A-5

- R**
- Ratings label 1-3
 - Reactance A-6
 - Recommended ferrule 4-9
 - Rectifier A-6
 - Reduced torque..... 3-21
 - Reduced voltage start 3-57
 - REF 4-74
 - Regenerative braking..... A-6
 - Regulation A-6
 - Relay
 - alarm signal contacts 4-53
 - as intelligent output 4-46
 - Remote control 4-33
 - data clear 4-34
 - down function..... 4-34
 - up function 4-34
 - Reset
 - inverter 4-29
 - Restart mode configuration 3-70
 - Retain output frequency 4-43
 - Reverse
 - rotation 4-71
 - run/stop 4-16
 - torque A-6
 - Revision History xx
 - RF noise filter 5-4
 - RNT 4-56
 - ROK 4-44
 - Rotation
 - direction restriction..... 3-56
 - restriction related paramerter 3-56
 - Rotor A-6
 - RPM..... 2-35
 - RS 4-29
 - Run
 - command source 4-74
 - command source
 - setting 2-29, 3-12, 4-35
 - mode 2-33, 3-4
 - signal 4-46, 4-48
 - time expiration signal 4-56
 - RUN..... 4-48
 - Run mode edit..... 3-4, 3-54, 4-27
 - Running the motor..... 2-33
 - RV..... 4-16
 - RVR..... 4-71
- S**
- Safety
 - how it works..... E-2
 - installation..... E-3
 - message i
 - precaution..... E-7
 - related signals 4-43
 - wiring example E-4
 - Saturation voltage A-6
 - Scaling 3-60
 - S-curve accel/decel 3-37
 - Second
 - accel and decel 3-36
 - motor..... 4-21
 - motor selection..... 4-75
 - stage output 4-61
 - Sensorless vector control..... A-6
 - Service warranty..... 6-22
 - SET 4-21
 - Set (select)2nd motor data 4-21
 - SETM 4-75
 - Setpoint..... A-6
 - SF1 to SF7 4-36
 - SFT 4-27
 - Single-phase power..... A-6
 - Sink/source input configuration 4-12
 - Slip
 - compensation gain..... 3-24
 - definition..... A-6
 - Software lock..... 3-4, 3-54, 4-27
 - Specifications
 - control logic signals 1-8, 4-6
 - general 1-6
 - inverter 1-4
 - inverter label 1-3
 - Speed
 - command..... 2-28
 - control..... 1-15, 1-19, 4-17
 - Squirrel cage A-7
 - STA..... 4-31
 - Standard functions..... 3-11
 - Start
 - contact signal 4-67
 - frequency adjustment 3-68
 - motor..... 4-31
 - Stator A-7
 - STO(Safe Torque Off)
 - performance monitor 4-76
 - setting..... 3-76
 - STO1 4-43
 - STO2 4-43
 - Stop
 - enable function 3-68
 - mode configuration 3-70
 - motor..... 4-31
 - STP..... 4-31
 - Supply wiring 2-15
 - Symbol definitions..... i
 - System description 2-4

- T**
- Tachometer.....A-7
 - technical support.....xxi
 - Term definition.....A-2
 - Terminal/program source configuration.....3-13
 - Terminals
 - listing.....4-10
 - torque specs.....xv, 2-16
 - Termination resistor network.....B-3
 - Thermal
 - switch.....A-7
 - trip error code6-9
 - Thermistor
 - definitionA-7
 - error code6-9
 - thermal protection.....4-30
 - THM4-57
 - Three-phase power
 - definitionA-7
 - motor phase connections1-16
 - wiring precautions.....2-14
 - Three-wire interface operation4-31
 - Torque1-16, A-7
 - boost.....3-23
 - control algorithm3-4, 3-21, 3-99
 - specs terminals.....xv, 2-16
 - Transistor.....A-7
 - Transmission procedureB-5
 - Trip alarm4-54
 - Trip events.....4-29
 - clearing6-8
 - definitionA-8
 - history6-13
 - Trip events.....3-8
 - monitoring.....6-8
 - Trip/power loss alarm4-54
 - Troubleshooting tips.....6-3
 - Two-stage acceleration and deceleration.....4-22
- U**
- UDC.....4-34
 - UL instructionsxiv
 - Unattended start protection4-25
 - error code6-9
 - Uncover the inverter vents2-22
 - Under-voltage
 - error code.....6-8
 - signal4-55
 - trip.....3-43
 - Unpacking2-2
- UP**4-34
- Up/down function.....4-33
- User parameter registration3-62
- USP4-25, 6-9
- UV4-55
- V**
- V/f control3-21
 - Variable frequency drives introduction1-15
 - Variable torque3-21
 - Velocity profiles.....1-19
 - Ventilation2-8
 - Voltage compensation gain3-24
 - Voltage gain3-23
 - Voltage input.....3-15, 4-77
- W**
- WAC.....4-66
 - WAF4-66
 - Warning
 - codes6-11
 - generalxi
 - index to.....iv
 - operating procedures.....4-3
 - troubleshooting6-2
 - Warranty.....6-22
 - Watt hour related.....3-66
 - Watt lossA-8
 - WCO4-73
 - WCOI.....4-73
 - Window comparator analog disconnection.....3-65
 - Window comparator for analog
 - current input.....4-73
 - voltage input4-73
 - Wire size control relay terminals.....4-8
 - Wiring
 - analog inputs.....4-77
 - gaugexv, 2-15
 - inverter output.....2-21
 - logic connectors2-21, 4-7
 - power input2-17
 - precautions2-14
 - relay contacts4-7
 - sample control logic terminal4-7
 - system diagram.....4-5
- Z**
- Zero Hz speed detection signal.....4-59
 - Zero speed detection output3-92
 - Zero-phase reactor5-4
 - ZS.....4-59

