

Goodrive800 Pro Series Inverter Unit

Software Manual



No.	Change description	Version	Release date
1	First release.	V1.0	June 2022

Preface

Thank you for choosing INVT Goodrive800 Pro series engineering variable-frequency drive (VFD).

For ease of use, read the manual carefully before using Goodrive800 Pro series product.

As an upgrade product of Goodrive800 series engineering VFD, Goodrive800 Pro series engineering VFD inherits the high reliability feature of Goodrive800 platform but optimizes the upgrade, structure, and components, achieving unit modularization, flexible cabinet configuration, more compact structure, easier installation and maintenance, and optimum protection.

- Excellent speed and torque control performance
- Modular design, as flexible as building blocks, which makes the project integration simple and efficient
- Long-life component selection and fast fault recovery design to ensure efficient process control
- Ergonomic design to make installation and maintenance easier
- Enriched expansion capability to support various protection options

Goodrive800 Pro series engineering VFD can be widely used in:

Metallurgy: Such as high-speed wire rod and hot strip rolling equipment, wide and thick plate equipment, cold rolling equipment, pickling lines, annealing lines, galvanizing line, color coating lines, non-ferrous metal alloy manufacturing equipment, and non-ferrous metal rolling equipment.

Petroleum: All-electric oil drilling rigs, large well repair machines, large oil machinery and equipment electric-drive power transformation, oilfield water injection equipment and other heavy oil equipment.

Paper making: Paper making joint equipment, including flow box, net section, press section, drying section, sizing, hard calendering, coating, super calender, rewinder and other continuous production lines.

Port and other large lifting equipment: Such as shore-side container overhead cranes, tire-type (orbital) container gantry cranes, grab unloaders, grab gantry cranes, large shipbuilding gantry cranes, and large metallurgical casting cranes.

Others: Such as unit test benches, military equipment, oil and gas transmission, and mining transmission equipment.

Goodrive800-51 series is the inverter unit of Goodrive800 Pro series. If not otherwise specified, the inverter unit in this manual refers to the inverter unit of Goodrive800 Pro series, that is, Goodrive800-51 series product. The rated power of a single inverter unit is 355kW–720kW, and the max. parallel power can be 4100kW. The inverter unit consists of fuse, bus capacitor, IGBT, output reactor, and other components. It is compact in structure and easy to integrate and maintain.

You are reading Goodrive800 Pro Series Inverter Unit Software Manual. Read through this manual carefully before installation to ensure the VFD is installed and operated in a proper manner to give full play to its excellent performance and powerful functions. If you have any question about the function and performance of the product, please consult our technical support.

If the product is ultimately used for military affairs or weapon manufacture, comply with the export control regulations in the Foreign Trade Law of the People's Republic of China and complete related formalities.

To continuously improve the performance of the product to meet higher application requirements, we reserve the right to continuously improve the product and accordingly the product manual, which may be made without prior notice. We have the final interpretation of the manual content.

Contents

- Preface**..... i
- Contents**..... ii
- 1 Safety precautions**..... 1
 - 1.1 Safety declaration1
 - 1.2 Safety definition.....1
 - 1.3 Warning symbols1
 - 1.4 Safety guidelines2
 - 1.4.1 Delivery and installation2
 - 1.4.2 Commissioning and running3
 - 1.4.3 Maintenance and component replacement3
 - 1.4.4 Disposal.....3
- 2 Quick startup** 4
 - 2.1 Safety notes.....4
 - 2.2 Unpacking inspection4
 - 2.3 Checking before use4
 - 2.4 Environment checking5
 - 2.5 Checking after installation5
- 3 System instruction**..... 6
 - 3.1 System topology6
 - 3.2 Parallel connection6
- 4 Keypad operation guidelines**..... 8
 - 4.1 Keypad introduction8
 - 4.2 Keypad display.....10
 - 4.2.1 Displaying stopped-state parameters10
 - 4.2.2 Displaying running-state parameters.....10
 - 4.2.3 Displaying fault information10
 - 4.2.4 Editing function codes.....10
 - 4.3 Operation procedure.....11
 - 4.3.1 Modifying function codes.....11
 - 4.3.2 Setting a password for the VFD12
 - 4.3.3 Viewing VFD status.....12
- 5 Function description**..... 13
 - 5.1 Inverter unit basic functions13
 - 5.1.1 What this section describes13
 - 5.1.2 Common commissioning procedure of the inverter unit.....13
 - 5.1.3 Space voltage vector control mode15
 - 5.1.4 Vector control mode21
 - 5.1.5 Torque control.....27
 - 5.1.6 Motor parameter autotuning.....29
 - 5.1.7 Motor overload protection.....36
 - 5.1.8 Start/stop control37
 - 5.1.9 Frequency setting45
 - 5.1.10 Analog input51
 - 5.1.11 Analog output.....53
 - 5.1.12 Digital input56
 - 5.1.13 Digital output.....64

5.1.14 Run at wobbling frequency.....	68
5.1.15 HMI.....	69
5.1.16 Enhanced functions.....	74
5.1.17 PID control.....	77
5.1.18 Simple PLC and multi-step speed running.....	83
5.1.19 Protection function.....	89
5.1.20 Encoder parameters.....	93
5.1.21 Master/slave control.....	96
5.1.22 Hoisting.....	98
5.1.23 Fault handling.....	100
6 Fault Information.....	104
6.1 Indications of alarms and faults.....	104
6.2 Fault reset.....	104
6.3 Fault history.....	104
6.4 Faults and solutions.....	104
6.4.1 VFD fault.....	104
6.4.2 Unit fault.....	108
6.4.3 Other status.....	109
6.5 Analysis on common faults.....	110
6.5.1 Motor fails to work.....	110
6.5.2 Motor vibrates.....	111
6.5.3 Overvoltage.....	111
6.5.4 Undervoltage.....	112
6.5.5 Motor overheating.....	112
6.5.6 VFD overheating (Check if the fan is running reversely).....	113
6.5.7 Motor stalls during ACC.....	113
6.5.8 Overcurrent.....	114
7 Communication.....	115
7.1 Modbus protocol.....	115
7.1.1 Modbus protocol instruction.....	115
7.1.2 Application of Modbus.....	115
7.1.3 RTU command codes and communication data.....	118
7.1.4 Common communication faults.....	128
7.1.5 Related function codes.....	128
7.2 PROFIBUS protocol.....	129
7.2.1 System configuration.....	129
7.2.2 PROFIBUS-DP Networking.....	131
7.2.3 Fault Information.....	137
7.2.4 Related function codes.....	137
7.3 PROFINET protocol.....	139
7.3.1 Communication settings.....	139
7.3.2 Packet format.....	139
7.3.3 PROFINET IO communication.....	140
7.3.4 Mission message (from the master station to the VFD).....	141
7.3.5 PKW zone.....	143
7.3.6 Related function codes.....	144
7.4 CANopen protocol.....	146
7.5 DEVICE-NET (Reserved).....	147
7.6 Ethernet communication.....	147
8 Parameter list.....	148

P00 group--Basic functions.....	148
P01 group--Start and stop control.....	151
P02 group--Parameters of motor 1.....	152
P03 group--Vector control	154
P04 group--Space voltage vector.....	158
P05 group--Input terminals	161
P06 group--Output terminals.....	165
P07 group--Human-machine interface	168
P08 group--Enhanced functions	171
P09 group-- PID control.....	176
P10 group--Simple PLC and multi-step speed control.....	177
P11 group--Protection parameters	179
P12 group--Parameters of motor 2.....	181
P13 group--Parameters of motor 3.....	183
P14 group--Parameters of motor 4.....	186
P15 group--SM control	188
P16 group--Encoders.....	189
P17 Display--Overall status display	190
P18 Display--Unit status display	192
P19 group--Fault information	195
P20 group--Serial communication	198
P21 group--PROFIBUS PROFIBUS/CANopen/PROFINET function	199
P22 group--Ethernet communication	201
P23 group--Master/slave control	202
P24 group--Hoisting	203
P29 group--Factory parameters.....	204
9 Derated application	205
9.1 Capacity	205
9.2 Derating	205

1 Safety precautions

1.1 Safety declaration

Read this manual carefully and follow all safety precautions before moving, installing, operating and servicing the product. Otherwise, equipment damage or physical injury or death may be caused.

We shall not be liable or responsible for any equipment damage or physical injury or death caused due to your or your customers' failure to follow the safety precautions.

1.2 Safety definition

Danger: Severe personal injury or even death can result if related requirements are not followed.





Warning: Personal injury or equipment damage can result if related requirements are not followed.

Note: Actions taken to ensure proper running.





Trained and qualified professionals: People operating the equipment must have received professional electrical and safety training and obtained the certificates, and must be familiar with all steps and requirements of equipment installing, commissioning, running and maintaining and capable to prevent any emergencies.

1.3 Warning symbols

Warnings caution you about conditions that can result in severe injury or death and/or equipment damage and advice on how to prevent dangers. The following table lists the warning symbols in this manual.

Symbol	Accessory	Description
	Danger	Severe personal injury or even death can result if related requirements are not followed.
	Warning	Personal injury or equipment damage can result if related requirements are not followed.
	Electrostatic sensitive	The PCBA may be damaged if related requirements are not followed.
	Hot sides	Do not touch. The inverter unit base may become hot.
	Electric shock	As high voltage still presents in the bus capacitor after power off, wait for at least 25 minutes (depending on the warning symbols on the machine) after power off to prevent electric shock.
Note	Note	Actions taken to ensure proper running.

1.4 Safety guidelines

	<ul style="list-style-type: none"> Only trained and qualified professionals are allowed to carry out related operations. Do not perform wiring, inspection or component replacement when power supply is applied. Ensure all the input power supplies have been disconnected before wiring or inspection, and wait for at least the time designated on the Goodrive800 Pro series product or until the DC bus voltage is less than 36V. The minimum waiting time is listed in the following. <table border="1" style="margin-left: auto; margin-right: auto;"> <thead> <tr> <th colspan="2">Inverter unit model</th> <th>Minimum waiting time</th> </tr> </thead> <tbody> <tr> <td>380V</td> <td>>355kW</td> <td>25 minutes</td> </tr> <tr> <td>690V</td> <td>>400kW</td> <td>25 minutes</td> </tr> </tbody> </table>	Inverter unit model		Minimum waiting time	380V	>355kW	25 minutes	690V	>400kW	25 minutes
Inverter unit model		Minimum waiting time								
380V	>355kW	25 minutes								
690V	>400kW	25 minutes								
	<ul style="list-style-type: none"> Do not refit the Goodrive800 Pro series product unless authorized; otherwise fire, electric shock or other injury may result. 									
	<ul style="list-style-type: none"> The base may become hot when the Goodrive800 Pro series product is running. Do not touch. Otherwise, you may get burnt. 									
	<ul style="list-style-type: none"> The electrical parts and components inside the Goodrive800 Pro series product are electrostatic sensitive. Take measurements to prevent electrostatic discharge when performing related operations. 									

1.4.1 Delivery and installation

	<ul style="list-style-type: none"> Do not install the inverter unit on inflammables. In addition, prevent the inverter unit from contacting or adhering to inflammables. Do not run the inverter unit if it is damaged or incomplete. Do not contact the inverter unit with damp objects or body parts. Otherwise, electric shock may result. 								
Note	<ul style="list-style-type: none"> Select appropriate tools for inverter unit delivery and installation to ensure the safe and proper running and avoid physical injury or death. To ensure personal safety, take mechanical protective measures like wearing safety shoes and working uniforms. Protect the inverter unit against physical shock or vibration during the delivery and installation. Do not carry the inverter unit only by its front cover as the cover may fall off. The installation site must be away from children and other public places. Prevent the screws, cables and other conductive parts from falling into the inverter unit. As inverter unit leakage current caused during running may exceed 3.5mA, ground properly and ensure the grounding resistance is less than 10Ω. The conductivity of PE grounding conductor must meet the following requirements: <table border="1" style="margin-left: auto; margin-right: auto;"> <thead> <tr> <th>Power cable conductor cross-sectional area <i>S</i> (mm²)</th> <th>Grounding conductor cross-sectional area</th> </tr> </thead> <tbody> <tr> <td>$S \leq 16$</td> <td><i>S</i></td> </tr> <tr> <td>$16 < S \leq 35$</td> <td>16</td> </tr> <tr> <td>$35 < S$</td> <td><i>S</i>/2</td> </tr> </tbody> </table> <ul style="list-style-type: none"> (+) and (-) are the DC bus input terminals, while U, V, and W are the output terminals. Connect the input power and motor cables properly; otherwise, the inverter unit may be damaged. 	Power cable conductor cross-sectional area <i>S</i> (mm ²)	Grounding conductor cross-sectional area	$S \leq 16$	<i>S</i>	$16 < S \leq 35$	16	$35 < S$	<i>S</i> /2
Power cable conductor cross-sectional area <i>S</i> (mm ²)	Grounding conductor cross-sectional area								
$S \leq 16$	<i>S</i>								
$16 < S \leq 35$	16								
$35 < S$	<i>S</i> /2								



1.4.2 Commissioning and running

	<ul style="list-style-type: none"> • Cut off all power supplies connected to the inverter unit before terminal wiring, and wait for at least the time designated on the inverter unit after disconnecting the power supplies. • High voltage presents inside the inverter unit during running. Do not carry out any operation on the inverter unit during running except for keypad setup. For products at voltage class of 4 or 6, the control terminals form extra-low voltage circuits. Therefore, you need to prevent the control terminals from connecting to accessible terminals of other devices. • Before turning on the power supply, check the cable connection status. • Prevent anyone from directly touching the energized part of the cabinet door. Pay special attention to safety when handling shields that are made of metal sheets. • Do not do any withstand voltage testing during unit connection. Disconnect the motor cable before performing any insulation and voltage withstand tests for the motor or motor cable. • Do not open the cabinet door since high voltage presents inside the Goodrive800 Pro series product during running.
<p>Note</p>	<ul style="list-style-type: none"> • Do not switch on or switch off the input power supplies of the inverter unit frequently. • If the inverter unit has been stored for a long time without use, perform checking and carry out pilot run for the inverter unit before using it again. • Close the inverter unit front cover before running; otherwise, electric shock may occur.

1.4.3 Maintenance and component replacement

	<ul style="list-style-type: none"> • Only trained and qualified professionals are allowed to perform maintenance, inspection, and component replacement for the inverter unit. • Cut off all power supplies connected to the inverter unit before terminal wiring, and wait for at least the time designated on the inverter unit after disconnecting the power supplies. • During maintenance and component replacement, take measures to prevent screws, cables and other conductive matters from falling into the internal of the inverter unit.
<p>Note</p>	<ul style="list-style-type: none"> • Use proper torque to tighten screws. • During maintenance and component replacement, keep the inverter unit and its parts and components away from combustible materials and ensure they have no combustible materials adhered. • Do not carry out insulation voltage-endurance test on the inverter unit, or measure the control circuits of the inverter unit with a megohmmeter. • During maintenance and component replacement, take proper anti-static measures on the inverter unit and its internal parts.

1.4.4 Disposal

	<ul style="list-style-type: none"> • The inverter unit contains heavy metals. Dispose of a scrap inverter unit as industrial waste.
	<ul style="list-style-type: none"> • Dispose of a scrap product separately at an appropriate collection point but not place it in the normal waste stream.

2 Quick startup

2.1 Safety notes

	<p>Equipment can tip over if transported incorrectly or with disallowed means of transport. Serious injury, property damage, or even death may result.</p> <ul style="list-style-type: none"> • Only trained and qualified professionals are allowed to carry out the operations mentioned in this chapter. Please carry out operations according to instructions presented in chapter 1.4.1 Delivery and installation. Ignoring these safety precautions may lead to physical injury or death, or device damage. • Ensure the rectifier unit power has been disconnected before installation. If the rectifier unit has been powered on, disconnect the rectifier unit power and wait for at least the time specified on the rectifier unit, and ensure the POWER indicator is off. You are recommended to use a multimeter to check and ensure the rectifier unit DC bus voltage is below 36V. • The equipment installation must be designed and done according to applicable local laws and regulations. We do not assume any liability whatsoever for any equipment installation which breaches local laws or regulations. If recommendations given by us are not followed, the rectifier unit may experience problems that the warranty does not cover. • Only trained and qualified professionals are allowed to carry out related operations. • Do not perform wiring, inspection or component replacement when power supply is applied. Ensure all the input power supplies have been disconnected before wiring or inspection, and wait for at least the time designated on the Goodrive800 Pro series product or until the DC bus voltage is less than 36V.
---	--

2.2 Unpacking inspection

Check the following after receiving the product.

1. Whether the packing box is damaged or dampened.
2. Whether the model identifier on the exterior surface of the packing box is consistent with the purchased model.
3. Whether the interior surface of the packing box is abnormal, for example, in wet condition, or whether the enclosure of the VFD is damaged or cracked.
4. Whether the VFD nameplate is consistent with the model identifier on the exterior surface of the packing box.
5. Whether the accessories (including the manual, keypad, and expansion card) inside the packing box are complete.

If any problems are found, contact the local INVT dealer or office.

2.3 Checking before use

Check the following before using the VFD.

1. Mechanical type of the load to be driven by the VFD to verify whether the VFD will be overloaded during work. Whether the power class of the VFD needs to be increased.
2. Whether the actual running current of the motor is less than the rated current of the VFD.

- | |
|---|
| 3. Whether the grid voltage is within the voltage range allowed by the VFD. |
| 4. Whether the requirements of communication method to be used is met. |

2.4 Environment checking

Check the following before installing the VFD:

- | |
|---|
| 1. Whether the actual ambient temperature exceeds 40°C. If yes, the current is derated by 2% for every increase of 1°C. Do not use the VFD when the ambient temperature exceeds 50°C. |
| 2. Whether the actual ambient temperature is lower than -10°C. If the temperature is lower than -10°C, use heating devices. |
| 3. Whether the altitude of the application site exceeds 1000m. When the installation site altitude exceeds 1000 m, the current is derated by 1% for every increase of 100m. |
| 4. Whether the actual environment humidity exceeds 90%, or condensation occurs. If yes, take additional protective measures. |
| 5. Whether there is direct sunlight or biological invasion in the environment where the VFD is to be used. If yes, take additional protective measures. |
| 6. Whether there is dust or inflammable and explosive gas in the environment where the VFD is to be used. If yes, take additional protective measures. |

2.5 Checking after installation

Check the following after the VFD installation is complete.

- | |
|---|
| 1. Whether the input power cables and motor cables meet the current-carrying capacity requirements of the actual load. |
| 2. Whether correct accessories are selected for the VFD, the accessories are correctly and properly installed, and the installation cables meet the capacity carrying requirements of all components (including the reactor, input filter, output reactor, output filter, DC reactor, braking unit and braking resistor). |
| 3. Whether the VFD is installed on non-flammable materials and the heat-radiating accessories (such as the reactor and braking resistor) are away from flammable materials. |
| 4. Whether all control cables and power cables are run separately and the routing complies with EMC requirement. |
| 5. Whether all grounding systems are properly grounded. |
| 6. Whether all the installation clearances of the VFD meet the requirements in the manual. |
| 7. Whether the external connection terminals of the VFD are tightly fastened and the torque is appropriate. |
| 8. Take additional protective measure to prevent the screws, cables and other conductive parts from falling into the VFD. |

3 System instruction

3.1 System topology

GD800 Pro multi-drive typical topology consists of rectifier (basic rectifier, regenerative rectifier, active rectifier), inverter and brake, as shown in the following figure. The module can be expanded through the parallel connection of control units. The control unit and PLC are connected through the bus, which realizes the centralized control and enables the host controller debugging and monitoring functions through Ethernet.

Figure 3-1 GD800 Pro multi-drive typical topology

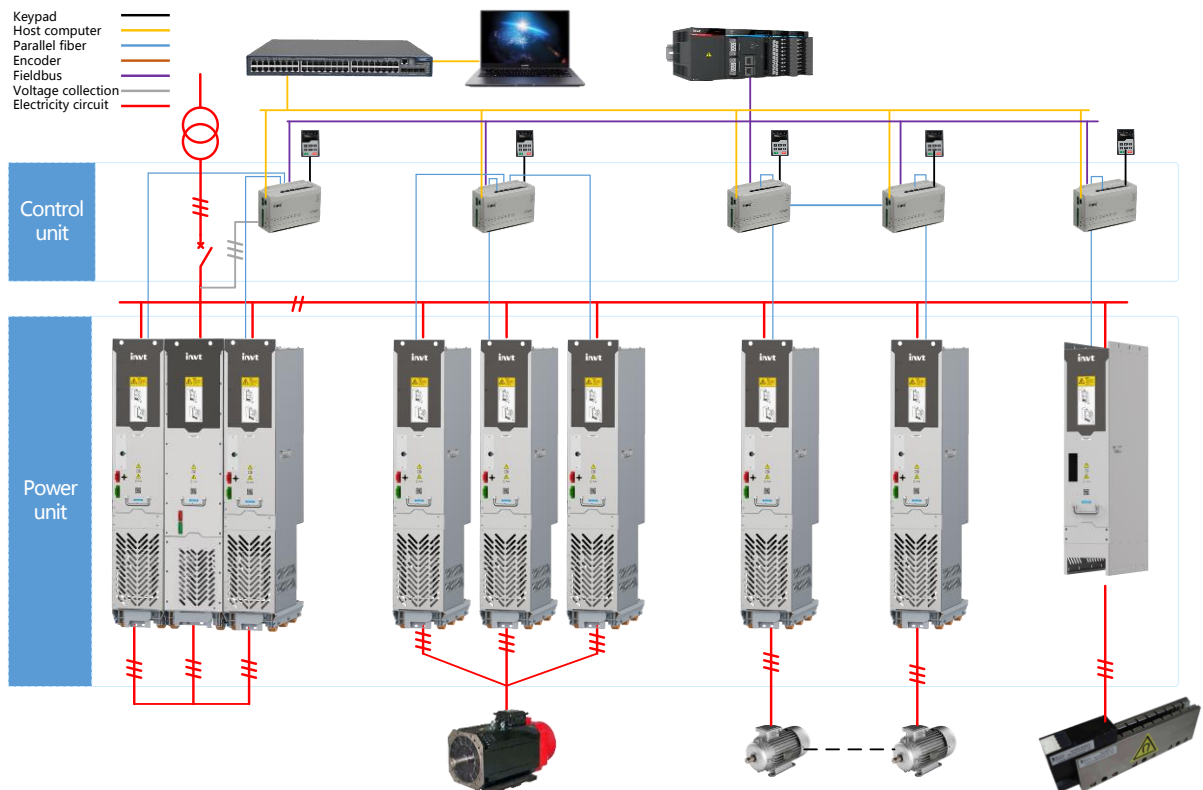

3.2 Parallel connection

Inverter units can be paralleled through the control interface of ICU inverter unit. One control unit supports a maximum of 6 inverter units installed in parallel. GD800 Pro Series A8i inverter unit can be used directly in parallel as it is equipped with output reactors as standard. For units in other sizes, an output reactor should be equipped for parallel use.

Figure 3-2 Inverter unit in parallel

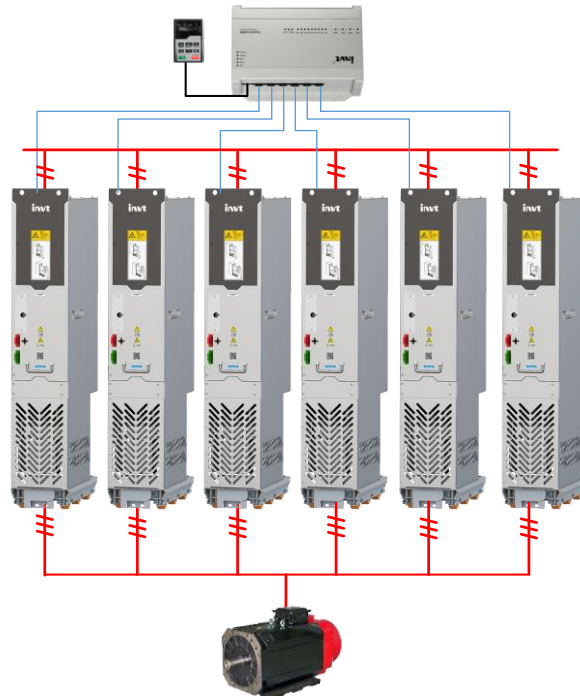

Note: Inverter units of different sizes cannot be used in parallel.

4 Keypad operation guidelines

4.1 Keypad introduction

The keypad is a vital HMI device for operation control, parameter display and parameter setting for Goodrive800 Pro series VFDs.

Figure 4-1 Keypad diagram



No.	Item	Description		
1	Status indicator	RUN/TUNE	VFD running status indicator. Off: The VFD is stopped. Blinking: The VFD is autotuning parameters. On: The VFD is running.	
		FWD/REV	Forward or reverse running indicator Off: The VFD is running forward. On: The VFD is running reversely.	
		LOCAL/REMOT	Indicates whether the VFD is controlled through the keypad, terminals, or communication. Off: The VFD is controlled through the is in keypad. Blinking: The VFD is controlled through terminals. On: The VFD is controlled through remote communication.	
		TRIP	Fault indicator On: The VFD is in fault state. Off: The VFD is in normal state. Blinking: The VFD is in overload pre-alarm state.	
2	Unit indicator	Unit displayed currently		
			Hz	Frequency unit
			RPM	Rotation speed unit
			A	Current unit
			%	Percentage
	V	Voltage unit		

No.	Item	Description					
3	Digital display zone	Five-digit LED displays various monitoring data and alarm codes such as the frequency setting and output frequency.					
		Display	Means	Display	Means	Display	Means
			0		1		2
			3		4		5
			6		7		8
			9		A		b
			C		d		E
			F		H		I
			L		N		n
			O		P		r
			S		t		U
	V		.		-		
4	Keys		Programming key	Press it to enter or exit level-1 menus or delete a parameter.			
			Confirmation key	Press it to enter menus in cascading mode or confirm the setting of a parameter.			
			Up key	Press it to increase data or move upward.			
			Down key	Press it to decrease data or move downward.			
			Right-shifting key	Press it to select display parameters rightward in the interface for the VFD in stopped or running state or to select digits to change during parameter setting.			
			Run key	Press it to run the VFD when using the keypad for control.			
			Stop/Reset key	Press it to stop the VFD that is running. The function of this key is restricted by P07.04. In fault alarm state, this key can be used for reset in any control modes.			
			Multifunction shortcut key	The function is determined by P07.02.			
		+	Combination	When RUN key and STOP/RST key are pressed simultaneously, the VFD will coast to stop.			

4.2 Keypad display

The keypad displays information such as the stopped-state parameters, running-state parameters, and fault status, and allows you to modify function codes.

The keypad display has a priority. The communication failure between keypad and main control board has the highest priority, followed by the fault code, C.oFF, then P.oFF, and finally the normal running parameters. i.e.:

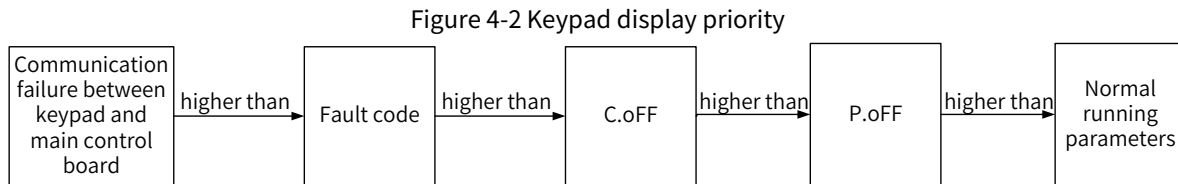

4.2.1 Displaying stopped-state parameters

When the VFD is in stopped state, the keypad displays stopped-state parameters, as shown in Figure 4-3.

In the stopped state, various kinds of parameters can be displayed. You can determine which parameters are displayed by setting function code P07.07. For details, see the description of P07.07.

In stopped state, there are 13 parameters that can be selected for display, including the set frequency, bus voltage, input terminal status, output terminal status, PID reference value, PID feedback value, torque setting, AI1 value, AI2 value, AI3 value, S8 pulse frequency, PLC and the present step of multi-step speed, pulse counting.

You can press **»/SHIFT** to shift selected parameters from left to right or press **QUICK/JOG** (P07.02=2) to shift selected parameters from right to left.

4.2.2 Displaying running-state parameters

After receiving a valid running command, the VFD enters the running state, and the keypad displays running-state parameters, with the **RUN/TUNE** indicator on. The on/off state of the **FWD/REV** indicator is determined by the current running direction. As shown in Figure 4-3.

In running state, there are 24 parameters that can be selected for display, including running frequency, set frequency, bus voltage, output voltage, output current, running speed, output power, output torque, PID reference value, PID feedback value, input terminal status, output terminal status, torque setting, counting value, motor overload percentage, PLC and the current step of multi-step speed, AI1, AI2, AI3, high-speed pulse S8 frequency, VFD overload percentage, ramp reference value, linear speed, AC input current.

You can press **»/SHIFT** to shift selected parameters from left to right or press **QUICK/JOG** (P07.02=2) to shift selected parameters from right to left.

4.2.3 Displaying fault information

After detecting a fault signal, the VFD enters the fault alarm state immediately, the fault code blinks on the keypad, and the **TRIP** indicator is on. You can perform fault reset by using the **STOP/RST** key, control terminals, or communication commands.

If the fault persists, the fault code is continuously displayed.

4.2.4 Editing function codes

You can press the PRG/ESC key to enter the editing mode in stopped, running, or fault alarm state (if a user password is used, see the description of P07.00). The editing mode contains two levels of menus in the following sequence: Function code group or function code number → Function code setting. You can press

the DATA/ENT key to enter the function parameter display interface. In the function parameter display interface, you can press the **DATA/ENT** key to save parameter settings or press the **PRG/ESC** key to exit the parameter display interface.

Figure 4-3 Status display

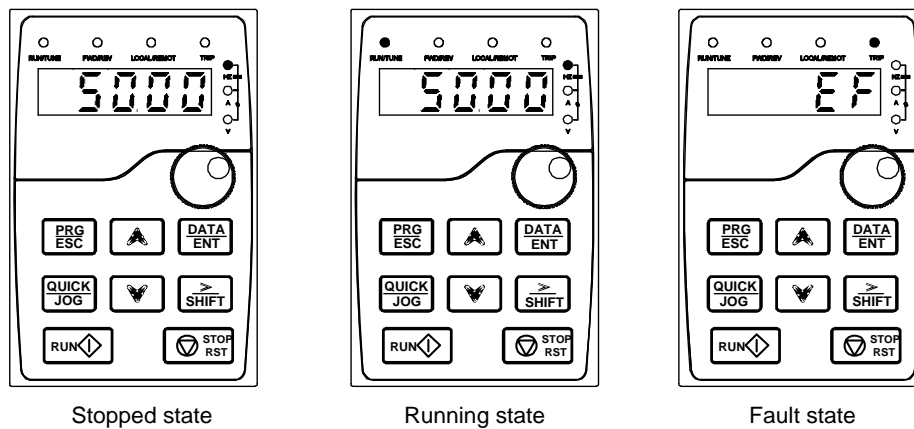

4.3 Operation procedure

You can operate the VFD by using the keypad. For details about function code descriptions, see the function code list.

4.3.1 Modifying function codes

The VFD provides three levels of menus, including:

- Function code group number (level-1 menu)
- Function code number (level-2 menu)
- Function code setting (level-3 menu)

Note: When performing operations on the level-3 menu, you can press the **PRG/ESC** or **DATA/ENT** key to return to the level-2 menu. If you press the **DATA/ENT** key, the set value of the parameter is saved to the control board first, and then the level-2 menu is returned, displaying the next function code. If you press the **PRG/ESC** key, the level-2 menu is returned directly, without saving the set value of the parameter, and the current function code is displayed.

If you enter the level-3 menu but the parameter does not have a digit blinking, the parameter cannot be modified due to either of the following reasons:

1. It is read only. Read-only parameters include actual detection parameters and running record parameters.
2. It cannot be modified in running state and can be modified only in stopped state.

Example: Change the value of P00.01 from 0 to 1.

5 Function description

5.1 Inverter unit basic functions

5.1.1 What this section describes

This section describes the internal function modules of the inverter unit.

	<ul style="list-style-type: none"> • Ensure that all terminals have been securely connected. • Ensure that the motor power matches the inverter unit.
---	---

5.1.2 Common commissioning procedure of the inverter unit

The common commissioning procedure is as follows (taking motor 1 as an example).

Figure 5-1 Common commissioning procedure of the inverter unit

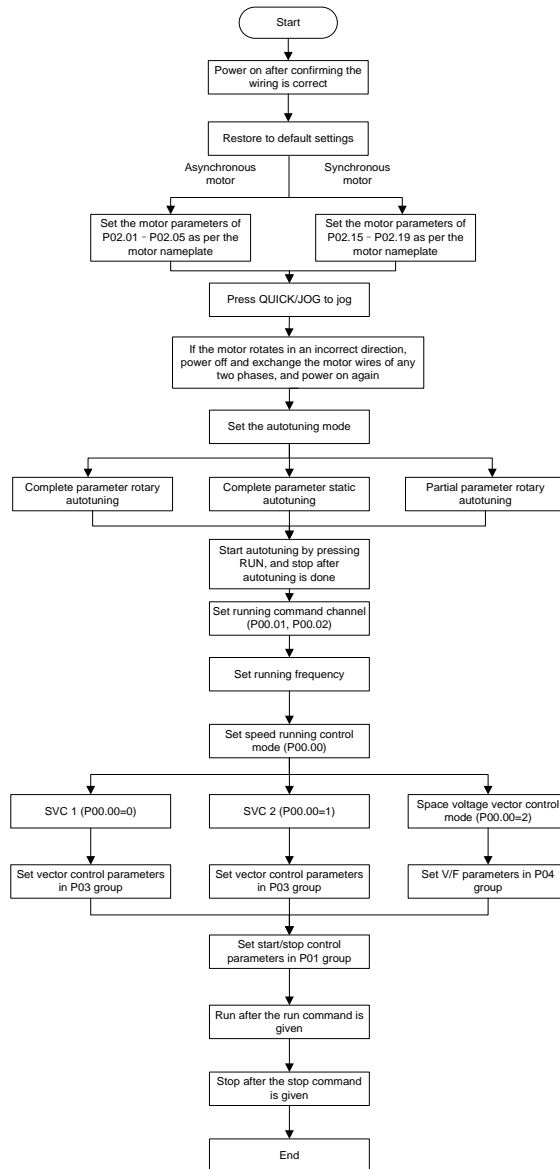

Note: If a fault occurred, find out the fault cause according to "fault tracking".

The running command channel can be set through terminal commands in addition to P00.01 and P00.02.

Channel of running commands P00.01	Multifunction terminal function 36 Switch the running command channel to keypad	Multifunction terminal function 37 Switch the running command channel to terminal	Multifunction terminal function 38 Switch the running command channel to communication
Keypad	/	Terminal	Communication
Terminal	Keypad	/	Communication
Communication	Keypad	Terminal	/

Note: "/" indicates this multifunction terminal is invalid under present reference channel.

Related parameter list:

Function code	Name	Description	Default
P00.00	Speed control mode	0: Sensorless vector control (SVC) mode 0 (for AM, SM) 1: SVC mode 1 (for AM) 2: Space voltage vector control mode 3: Closed-loop vector control mode	2
P00.01	Channel of running commands	0: Keypad (the indicator is off) 1: Terminal (the indicator blinks) 2: Communication (the indicator is on)	0
P00.02	Communication mode of running commands	0: MODBUS 1: PROFIBUS/CANopen/PROFINET 2: Ethernet 3: Reserved 4: DEVICE_NET (Reserved)	0
P00.15	Motor parameter autotuning	0: No operation 1: Rotary autotuning 2: Static autotuning 3: Simple autotuning	0
P00.18	Function parameter restore	0: No operation 1: Restore default values 2: Clear fault records Note: After the selected operation is performed, the function code is automatically restored to 0. Restoring the default values may delete the user password. Exercise caution when using this function.	0
P02.00	Type of motor 1	0: Asynchronous motor (AM) 1: Synchronous motor (SM)	0
P02.01	Rated power of AM 1	0.1–3000.0kW	Model depended
P02.02	Rated frequency of AM 1	0.01Hz–P00.03 (Max. output frequency)	50.00Hz
P02.03	Rated speed of AM 1	1–36000rpm	Model depended
P02.04	Rated voltage of AM 1	0–1200V	Model depended

Function code	Name	Description	Default
P02.05	Rated current of AM 1	0.8–6000.0A	Model depended
P02.15	Rated power of SM 1	0.1–3000.0kW	Model depended
P02.16	Rated frequency of SM 1	0.01Hz–P00.03 (Max. output frequency)	50.00Hz
P02.17	Number of pole pairs of SM 1	1–50	2
P02.18	Rated voltage of SM 1	0–1200V	Model depended
P02.19	Rated current of SM 1	0.8–6000.0A	Model depended
P05.01–P05.08	Function selection of multifunction digital input terminals (S1–S8)	36: Switch the running command channel to keypad 37: Switch the running command channel to terminal 38: Switch the running command channel to communication	/

5.1.3 Space voltage vector control mode

The inverter unit provides the space voltage control function. The space voltage control mode can be used in cases where mediocre control precision is enough and in cases where a VFD needs to drive multiple motors.

- V/F curve

The VFD provides multiple V/F curve modes to meet different requirements. You can select V/F curves or set V/F curves as required.

Function code	Name	Description	Setting range	Default
P04.00	V/F curve setting of motor 1 and 3	0: Straight-line V/F curve 1: Multi-point V/F curve 2: Torque-down V/F curve (power of 1.3) 3: Torque-down V/F curve (power of 1.7) 4: Torque-down V/F curve (power of 2.0) 5: Customized V/F curve (V/F separation)	0–5	0

The function code defines the V/F curve of motor 1 and motor 3 to meet the needs of different loads.

Specific V/F curve:

- Straight-line V/F curve (P04.00=0): For the load featuring constant moment, such as conveyor belt which runs in straight line, as the whole running process requires constant moment, it is recommended to adopt the straight line V/F curve.
- Power index V/F curve (P04.00=2/3/4): For the load featuring decreasing moment, such as fan and water pumps, as there is a power (square or cube) relation between its actual torque and speed): is recommended to adopt the V/F curve corresponding to the power of 1.3, 1.7 or 2.0.

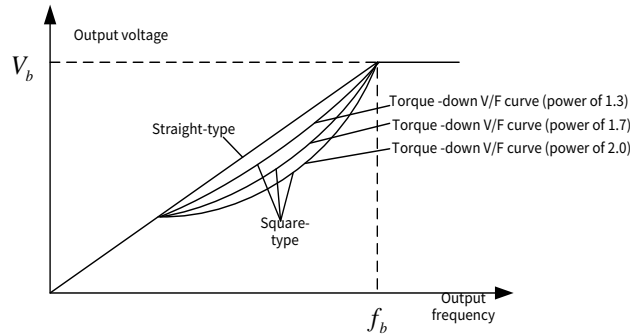

Multi-point V/F curves. You can change the V/F curves output by the inverter unit by setting the voltage and frequency of the three points in the middle. A whole curve consists of five points starting from (0Hz, 0V) and ending at (motor fundamental frequency, motor rated voltage). During setting, follow the rule: $0 \leq f_1 \leq f_2 \leq f_3 \leq \text{Motor fundamental frequency}$, and $0 \leq V_1 \leq V_2 \leq V_3 \leq \text{Motor rated voltage}$.

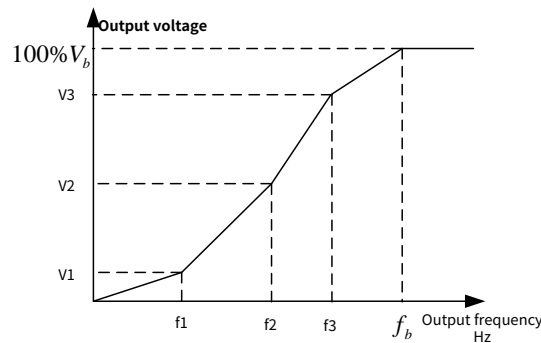

Function code	Name	Description	Setting range	Default
P04.03	V/F frequency point 1 of motor 1 and 3	0.00Hz-P04.05	0.00-P04.05	0.00Hz
P04.04	V/F voltage point 1 of motor 1 and 3	0.0%-110.0% (of the rated voltage of motor 1)	0.0-110.0	0.0%
P04.05	V/F frequency point 2 of motor 1 and 3	P04.03-P04.07	P04.03-P04.07	0.00Hz
P04.06	V/F voltage point 2 of motor 1 and 3	0.0%-110.0% (of the rated voltage of motor 1)	0.0-110.0	0.0%
P04.07	V/F frequency point 3 of motor 1 and 3	P04.05-P02.02 (rated frequency of AM 1) or P04.05-P02.16 (rated frequency of SM 1)	P04.05-Rated frequency of motor 1	0.00Hz
P04.08	V/F voltage point 3 of motor 1 and 3	0.0%-110.0% (of the rated voltage of motor 1)	0.0-110.0	0.0%

Customized V/F (V/F separation P04.00=5); in this mode, V can be separated from F and F can be adjusted through the frequency setting channel set by P00.06 or the voltage setting channel set by P04.27 to change the characteristics of the curve.

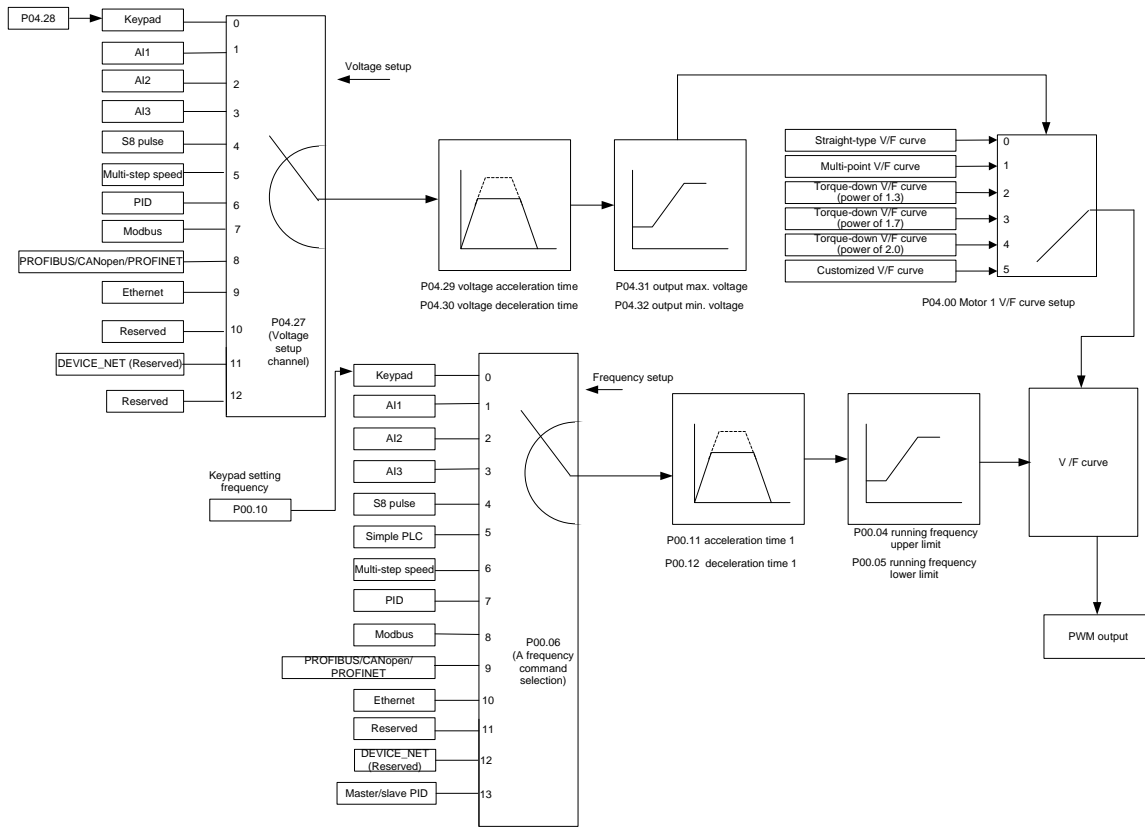

The V/F curve separation can be applied in various variable-frequency power sources. However, exercise caution when setting parameters as improper settings may cause equipment damage.

Function code	Name	Description	Setting range	Default
P04.27	Voltage setting channel	0: Keypad (The output voltage is determined by P04.28.) 1: AI1 2: AI2 3: AI3 4: HDI 5: Multi-step speed running (The setting is determined by group P10.) 6: PID 7: Modbus communication 8: PROFIBUS/CANopen/PROFINET communication 9: Ethernet communication 10: Reserved 11: DEVICE_NET (Reserved) 12-14: Reserved	0-14	0

The function code is used to select the output voltage setting channel at V/F curve separation.

Note: 100% corresponds to the motor rated voltage.

Function code	Name	Description	Setting range	Default
P04.28	Voltage set through keypad	0.0%–100.0%	0.0–100.0	100.0%

The function code is the voltage digital setting when "keypad" is selected (P04.27=0) as the voltage setting channel.

Function code	Name	Description	Setting range	Default
P04.29	Voltage increase time	0.0–3600.0s	0.0–3600.0	5.0s
P04.30	Voltage decrease time	0.0–3600.0s	0.0–3600.0	5.0s

Voltage increase time means the time needed for the VFD to accelerate from 0V to the motor rated frequency.

Voltage decrease time means the time needed for the VFD to decelerate from the rated output frequency to 0V.

Function code	Name	Description	Setting range	Default
P04.31	Max. output voltage	P04.32 –100.0% (of the motor rated voltage)	P04.32–100.0	100.0%
P04.32	Min. output voltage	0.0%–P04.31 (motor rated voltage)	0.0–P04.31	0.0%

The function codes are used to set the upper and lower limits of output voltage.

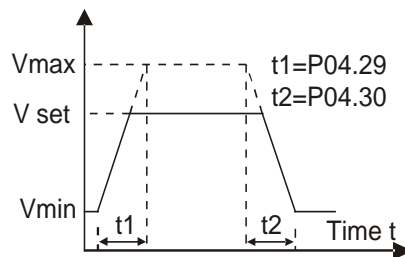

- Torque boost

The torque boost function can effectively compensate for the low-speed torque performance in space voltage control. Automatic torque boost has been set by default, which enables the inverter unit to adjust the torque boost value based on actual load conditions.

Function code	Name	Description	Setting range	Default
P04.01	Torque boost of motor 1 and 3	0.0%–10.0% (of the rated voltage of motor 1)	0.0–10.0	0.0%
P04.02	Torque boost cut-off of motor 1 and 3	0.0%–50.0% (of the rated frequency of motor 1)	0.0–50.0	20.0%

The function code defines the torque boost function of motor 1 and motor 3 to meet the needs of different loads.

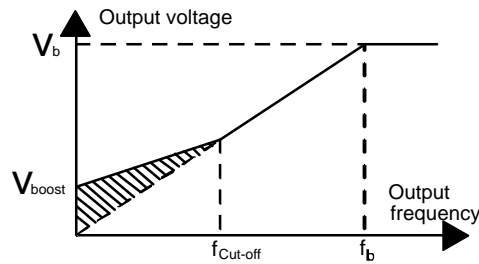

In order to compensate for low-frequency torque characteristics, you can make some boost compensation for the output voltage. P04.01 is relative to the max. output voltage V_b . When torque boost is set to 0.0%, the VFD uses automatic torque boost.

P04.02 defines the percentage of cut-off frequency of manual torque boost to the rated motor frequency f_b . Torque boost can improve the low-frequency torque characteristics of V/F.

You need to select torque boost based on the load. For example, larger load requires larger torque boost. However, if torque boost is too large, the motor may encounter low-frequency vibration or overcurrent, and even run at over-excitation, which may cause motor overheating and decreased efficiency. If such a situation occurs, reduce the torque boost value.

Torque boost cut-off threshold: Below this frequency threshold, torque boost is valid; exceeding this threshold will invalidate torque boost.

- V/F slip compensation gain

Space voltage vector control belongs to an open-loop mode. Sudden motor load changes cause motor speed fluctuation. In cases where strict speed requirements must be met, you can set the slip compensation gain to compensate for the speed change caused by load fluctuation through inverter unit internal output adjustment, and thus improve the rigidity of the mechanical characteristics of the motor.

Function code	Name	Description	Setting range	Default
P04.09	V/F slip compensation gain of motor 1 and 3	0.0–200.0%	0.0–200.0	0.0%

You need to calculate the rated slip frequency of the motor when using the slip compensation function. Rated slip frequency = (Rated synchronous rotation speed of motor – Rated rotation speed of motor) x (Number of motor pole pairs)/60. 100.0% corresponds to the rated slip frequency Δf of the motor.

- Oscillation control

Motor oscillation often occurs in space voltage vector control in large-power driving applications. To solve this problem, the inverter unit provides two oscillation factor function codes. You can set the function codes based on the oscillation occurrence frequency to eliminate such phenomenon.

Function code	Name	Description	Setting range	Default
P04.10	Low-frequency oscillation control factor of motor 1 and 3	0–100	0–100	10
P04.11	High-frequency oscillation control factor of motor 1 and 3	0–100	0–100	10

Function code	Name	Description	Setting range	Default
P04.12	Oscillation control threshold of motor 1 and 3	0.00Hz–P00.03 (Max. output frequency)	0.00–P00.03	30.00 Hz

Note: A greater value indicates better control effect. However, if the value is too large, the inverter unit output current may be too large.

- Multiple motors

P04 group includes V/F parameters of four motors which can be displayed simultaneously and will be valid to the selected motor. The motor can be selected by the channels defined in the function code P08.31.

Function code	Name	Description	Setting range	Default
P04.13	V/F curve setting of motor 2 and 4	0: Straight-line V/F curve 1: Multi-point V/F curve 2: Torque-down V/F curve (power of 1.3) 3: Torque-down V/F curve (power of 1.7) 4: Torque-down V/F curve (power of 2.0) 5: Customized V/F curve (V/F separation)	0–5	0
P04.14	Torque boost of motor 2 and 4	0.0%: (automatic) 0.1%–10.0%	0.0–10.0	0.0%
P04.15	Torque boost cut-off of motor 2 and 4	0.0%–50.0% (of the rated frequency of motor 2)	0.0–50.0	20.0%
P04.16	V/F frequency point 1 of motor 2 and 4	0.00Hz–P04.18	0.00–P04.18	0.00Hz
P04.17	V/F voltage point 1 of motor 2 and 4	0.0%–110.0% (of the rated voltage of motor 2)	0.0–110.0	0.0%
P04.18	V/F frequency point 2 of motor 2 and 4	P04.16–P04.20	P04.16–P04.20	0.00Hz
P04.19	V/F voltage point 2 of motor 2 and 4	0.0%–110.0% (of the rated voltage of motor 2)	0.0–110.0	0.0%
P04.20	V/F frequency point 3 of motor 2 and 4	P04.18–P12.02 (rated frequency of AM 2) or P04.18–P12.16 (rated frequency of SM 2)	P04.18–P12.02 or P04.18–P12.16	0.00Hz
P04.21	V/F voltage point 3 of motor 2 and 4	0.0%–110.0% (of the motor rated voltage)	0.0–110.0	0.0%
P04.22	V/F slip compensation gain of motor 2 and 4	0.0–200.0%	0.0–200.0	0.0%
P04.23	Low-frequency oscillation control factor of motor 2 and 4	0–100	0–100	10

Function code	Name	Description	Setting range	Default
P04.24	High-frequency oscillation control factor of motor 2 and 4	0–100	0–100	10
P04.25	Oscillation control threshold of motor 2 and 4	0.00Hz–P00.03 (Max. output frequency)	0.00Hz–P00.03	30.00 Hz

The function codes define the V/F setting method of motor 2 and 4 to meet the needs of different loads. For details, see P04.00–P04.12.

- Energy-saving run

During actual running, the inverter unit can search for the max. efficiency point to keep the multi-drive system to run in the most efficient state to save energy.

Function code	Name	Description	Setting range	Default
P04.26	Energy-saving run	0: Disable 1: Automatic energy-saving run	0–1	0

Note:

- This function is generally used in light load or no-load cases.
- This function is no applicable to the cases where sudden load changes often occur.

- EPS function

EPS function is mainly used in power supply applications to achieve voltage compensation during heavy load operation. It compensates the voltage drop of transformer or reactor, and keeps the output voltage stable.

Function code	Name	Description	Setting range	Default
P04.33	Feedforward voltage compensation coefficient	0.00–100.0 (Compensation of the voltage drop of transformer or reactor)	0.00–100.0	0.00
P04.34	Feedforward voltage limit	0.0–80.0% (Limit of feedforward voltage compensation. 100.0% corresponds to the motor rated voltage.)	0.00–80.0	0.0%
P04.35	EPS enabling selection	0: Disable 1: Enable	0–1	0

5.1.4 Vector control mode

AMs feature high order, nonlinearity, strong coupling and multi-variables, which increase difficulty to control AMs during actual application. The vector control technology solves this situation as follows: measures and controls the stator current vector of the AM, and then decomposes the stator current vector into exciting current (current component that generates internal magnet field) and torque current (current component that generates torque) based on field orientation principle, and therefore controls the

amplitude values and phase positions of the two components (namely, controls the stator current vector of the AM) to realize decoupled control on exciting current and torque current, thus achieving high-performance speed regulation of the AM.

The VFD uses the sensor-less vector control algorithm, which can be used to drive AMs and permanent-magnet SMs simultaneously. As the core algorithm of vector control is based on accurate motor parameter models, the accuracy of motor parameters affects vector control performance. It is recommended to enter accurate motor parameters and autotune motor parameters before executing vector control.

As the vector control algorithm is complicated, exercise caution before modifying vector control function parameters.

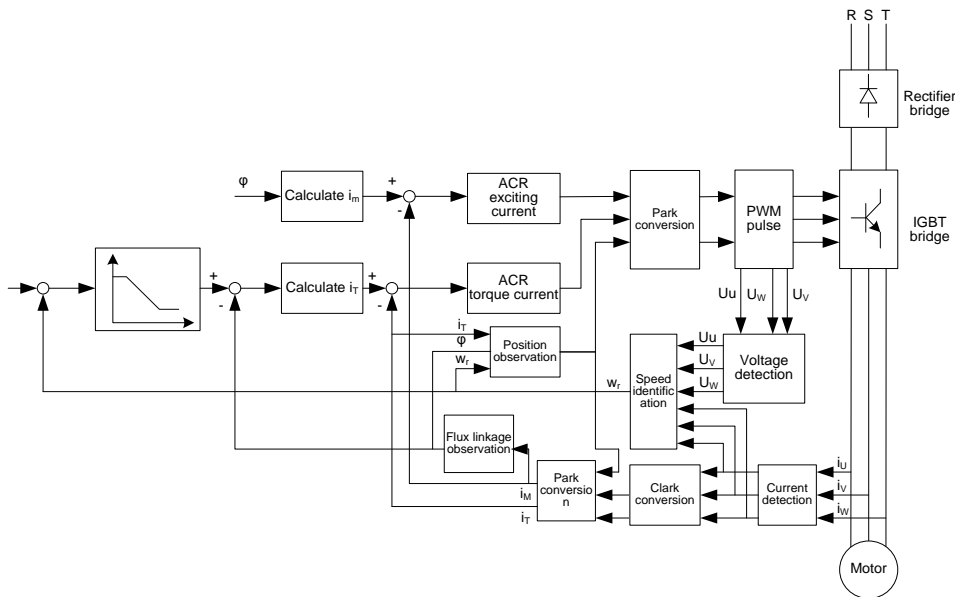

Function code	Name	Description	Setting range	Default
P03.00	Speed-loop proportional gain 1		0–200.0	10.0
P03.01	Speed-loop integral time 1		0.001–10.000s	0.500s
P03.02	Low-point frequency for switching		0.00Hz–P03.05	5.00Hz
P03.03	Speed-loop proportional gain 2		0–200.0	10.0
P03.04	Speed-loop integral time 2		0.001–10.000s	0.500s
P03.05	High-point frequency for switching		P03.02–P00.03 (Max. frequency)	10.00Hz

The parameters P03.00–P03.05 are applicable only to vector control mode. Below the switching frequency 1 (P03.02), the speed-loop PI parameters are: P03.00 and P03.01. Above the switching frequency 2 (P03.05), the speed-loop PI parameters are: P03.03 and P03.04. PI parameters are obtained according to the linear change of two groups of parameters. See the following figure:

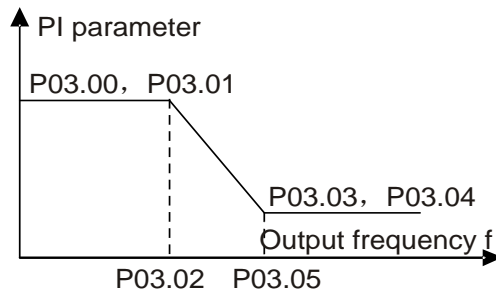

The speed loop dynamic response characteristics of vector control can be adjusted by setting the proportional coefficient and integral time of speed regulator. Increasing proportional gain or reducing integral time can accelerate dynamic response of speed loop; however, if the proportional gain is too large or integral time is too small, system oscillation and overshoot may occur; if proportional gain is too small, stable oscillation or speed offset may occur.

PI parameters have a close relationship with the inertia of the system. Adjust PI parameters depending on different loads to meet various demands.

Function code	Name	Description	Setting range	Default
P03.06	Speed-loop output filter	0-8 (corresponding to 0-2 ⁸ /10ms)	0-8	0

The function code is used to set the filter time of the speed loop.

Function code	Name	Description	Setting range	Default
P03.07	Electromotive slip compensation coefficient of vector control	50-200%	50-200	100%
P03.08	Braking slip compensation coefficient of vector control	50-200%	50-200	100%

Slip compensation coefficient is used to adjust the slip frequency of the vector control and improve the speed control accuracy of the system. Adjusting the parameter properly can control the speed steady-state error.

Function code	Name	Description	Setting range	Default
P03.09	Current-loop proportional coefficient P	0-65535	0-65535	1000
P03.10	Current-loop integral coefficient I	0-65535	0-65535	1000
P08.19	High-frequency current-loop proportional coefficient	0-20000	0-20000	1000
P08.20	High-frequency current-loop integral coefficient	0-20000	0-20000	1000

Note:

- P03.09 and P03.10 impact the dynamic response speed and control accuracy of the system. Generally do not need to modify the two function parameters.

- In the closed-loop vector control mode (P00.00=3), when the frequency is lower than the motor rated frequency, the current-loop PI parameters are P03.09 and P03.10; and when the frequency is higher than the motor rated frequency, the current-loop PI parameters are P08.19 and P08.20.
- **Applicable to SVC mode 0 (P00.00=0) only.**

Function code	Name	Description	Setting range	Default
P03.11	Torque setting method	0: Torque control invalid 1: Keypad (P03.12) 2: AI1 3: AI2 4: AI3 5: S8 pulse frequency 6: Multi-step torque 7: MODBUS communication 8: PROFIBUS/CANopen/PROFINET communication 9: Ethernet communication 10: Reserved 11: DEVICE_NET communication 12: Internal setting of the slave (transmit from the master) 13: PID control 14-15: Reserved	0-15	0

The function code is used to enable the torque control mode and set the torque setting method.

Note:

- For setting methods 2-15, 100% corresponds to triple the motor rated current.
- Part of above methods are available only when corresponding expansion cards are configured.

Function code	Name	Description	Setting range	Default
P03.12	Torque set through keypad	-300.0%-300.0% (of the motor rated current)	-300.0-300.0	50.0%

When P03.11=1, the torque is set on the keypad.

Function code	Name	Description	Setting range	Default
P03.13	Torque reference filter time	0.000-10.000s	0.000-10.000	0.100s

The function code is used to set the torque reference filter time.

Function code	Name	Description	Setting range	Default
P03.14	Setting source of forward rotation upper-limit frequency in torque control	0: Keypad (Set P03.16 for P03.14, and set P03.17 for P03.15) 1: AI1 2: AI2	0-13	0
P03.15	Setting source of reverse rotation upper-limit frequency in torque control	3: AI3 4: S8 Pulse frequency 5: Multi-step setting 6: MODBUS communication	0-13	0

Function code	Name	Description	Setting range	Default
		7: PROFIBUS/CANopen/PROFINET communication 8: Ethernet communication 9: Reserved 10: DEVICE_NET communication (reserved) 11-13: Reserved		

Note: For setting methods 1-13, 100% corresponds to the maximum frequency.

Function code	Name	Description	Setting range	Default
P03.16	Forward rotation upper-limit frequency set through keypad in torque control	0.00Hz-P00.03	0.00-P00.03	50.00 Hz
P03.17	Reverse rotation upper-limit frequency set through keypad in torque control	0.00 Hz-P00.03	0.00-P00.03	50.00Hz

The function code is used to set the frequency upper limits. 100% corresponds to the max. frequency. P03.16 sets the value for P03.14, and P03.17 sets the value for P03.15.

Function code	Name	Description	Setting range	Default
P03.18	Setting source of electromotive torque upper limit	0: Keypad (Set P03.20 for P03.18, and set P03.21 for P03.19) 1: AI1 2: AI2 3: AI3 4: S8 pulse frequency	0-12	0
P03.19	Setting source of braking torque upper limit	5: MODBUS communication 6: PROFIBUS/CANopen/PROFINET communication 7: Ethernet communication 8: Reserved 9: DEVICE_NET communication (reserved) 10-12: Reserved	0-12	0

The function code is used to set the source of electromotive torque upper limit.

Note: For setting sources 1-12, 100% corresponds to three times the rated motor current.

Function code	Name	Description	Setting range	Default
P03.20	Electromotive torque upper limit set through keypad	0.0-300.0% (of the motor rated current)	0.0-300.0	180.0%
P03.21	Braking torque upper limit set through keypad	0.0-300.0% (of the motor rated current)	0.0-300.0	180.0%

The function code is used to set the torque upper limit via keypad.

Function code	Name	Description	Setting range	Default
P03.22	Weakening coefficient in constant power zone	0.01–2.00	0.01–2.00	1.00
P03.23	Lowest weakening point in constant power zone	10%–100%	10–100	10%

P03.22 is only valid for the vector mode 1 and closed-loop vector mode.

The function code is used when the motor is in flux-weakening control.

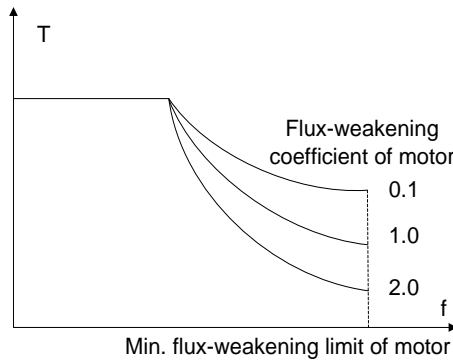

The function codes P03.22 and P03.23 are valid at constant power. The motor enters the flux-weakening state when the motor runs above the rated speed. Change the flux-weakening curvature by modifying the flux-weakening control coefficient. The larger the coefficient, the steeper the curve, the smaller the coefficient, the smoother the curve.

Function code	Name	Description	Setting range	Default
P03.24	Max. voltage limit	0.0–120.0% (of the motor rated voltage)	0.0–120.0	103.0%
P03.25	Pre-exciting time	0.000–10.000s	0.000–10.000	0.000s
P03.26	Flux-weakening proportional gain	0–8000	0–8000	1200
P03.31	Speed observer filter coefficient	0–6	0–6	0

P03.24: It sets the max. output voltage of the VFD. Set the value according to onsite conditions.

P03.25: Pre-exciting is performed for the motor when the VFD starts up. A magnetic field is built up inside the motor to improve the torque performance during the start process.

P03.26: It is used when the AM is in flux-weakening control. The running performance of the motor can be improved by adjusting the parameters properly.

P03.24–P03.26 are invalid to vector control mode 1 and space voltage vector control.

P03.31 is applicable to the large-power motor in vector mode 1, which can be enhanced appropriately in frequency band oscillation.

Function code	Name	Description	Setting range	Default
P03.27	Speed display selection in vector control	0: Display the actual value 1: Display the set value	0–1	0

The function code is used to set the speed display selection in vector control.

Function code	Name	Description	Setting range	Default
P03.28	Motor temperature compensation enabling	0: Disable 1: Motoring temperature compensating rotor resistance 2: Enabling online identification of rotor resistance (only valid in the closed-loop vector control of AM)	0-2	0
P03.29	Starting temperature of motor temperature compensation	0-60.0°C	0-60.0	40.0°C
P03.30	Motor temperature compensation coefficient	0.0-200.0%	0.0-200.0	100.0%

This function are used to compensate the impact on rotor resistance variation at different temperature. A motor temperature sensor must be installed to use this function.

5.1.5 Torque control

The inverter unit supports torque control and speed control. Speed control aims to stabilize the speed to keep the set speed consistent with the actual running speed, meanwhile, the max. load-carrying capacity is restricted by the torque limit. Torque control aims to stabilize the torque to keep the set torque consistent with the actual output torque, meanwhile, the output frequency is restricted by the upper and lower limits.

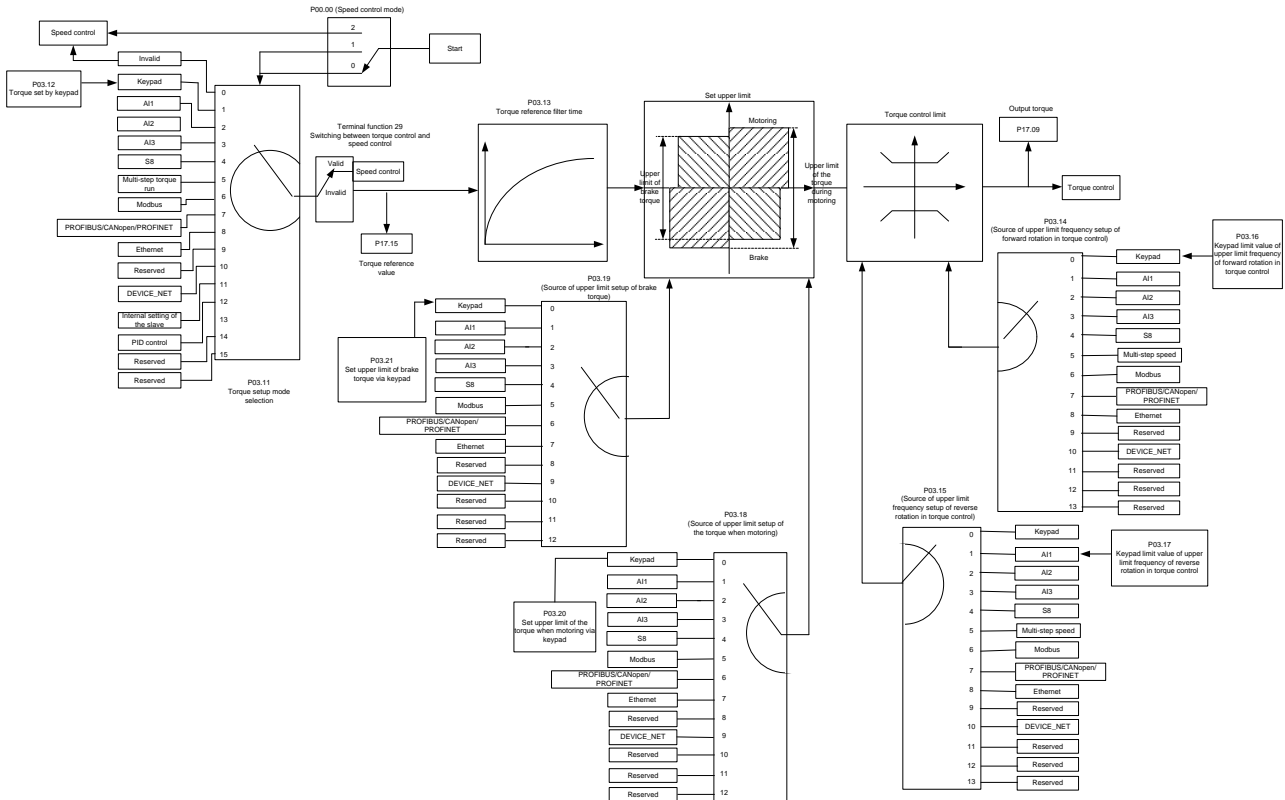



Function code	Name	Description	Setting range	Default
P00.00	Speed control mode	0: Sensorless vector control (SVC) mode 0 1: Sensorless vector control (SVC)	0-3	2

Function code	Name	Description	Setting range	Default
		mode 1 2: Space voltage vector control mode 3: Closed-loop vector control mode		
P05.01– P05.08	Function selection of multifunction digital input terminals (S1–S8)	29: Switch between speed control and torque control	/	/
P03.11	Torque setting method	0: Torque control invalid 1: Keypad (P03.12) 2: AI1 3: AI2 4: AI3 5: S8 pulse frequency 6: Multi-step torque 7: MODBUS communication 8: PROFIBUS/CANopen/PROFINET communication 9: Ethernet communication 10: Reserved 11: DEVICE_NET communication 12: Internal setting of the slave (transmit from the master) 13: PID control 14–15: Reserved	0–15	0
P03.12	Torque set through keypad	-300.0%–300.0% (of the motor rated current)	-300.0– 300.0	50.0%
P03.13	Torque reference filter time	0.000–10.000s	0.000– 10.000	0.100s
P03.14	Setting source of forward rotation upper-limit frequency in torque control	0: Keypad (Set P03.16 for P03.14, and set P03.17 for P03.15) 1: AI1 2: AI2	0–13	0
P03.15	Setting source of reverse rotation upper-limit frequency in torque control	3: AI3 4: S8 Pulse frequency 5: Multi-step setting 6: MODBUS communication 7: PROFIBUS/CANopen/PROFINET communication 8: Ethernet communication 9: Reserved 10: DEVICE_NET communication (reserved) 11–13: Reserved	0–13	0
P03.16	Forward rotation upper-limit frequency set through keypad in torque control	0.00Hz–P00.03	0.00– P00.03	50.00 Hz
P03.17	Reverse rotation upper-limit frequency set through keypad in torque control	0.00 Hz–P00.03	0.00– P00.03	50.00Hz

Function code	Name	Description	Setting range	Default
P03.18	Setting source of electromotive torque upper limit	0: Keypad (Set P03.20 for P03.18, and set P03.21 for P03.19) 1: AI1	0-12	0
P03.19	Setting source of braking torque upper limit	2: AI2 3: AI3 4: S8 pulse frequency 5: MODBUS communication 6: PROFIBUS/CANopen/PROFINET communication 7: Ethernet communication 8: Reserved 9: DEVICE_NET communication (reserved) 10-12: Reserved	0-12	0
P03.20	Electromotive torque upper limit set through keypad	0.0-300.0% (of the motor rated current)	0.0-300.0	180.0%
P03.21	Braking torque upper limit set through keypad	0.0-300.0% (of the motor rated current)	0.0-300.0	180.0%
P17.09	Output torque load coefficient	Displays the present output torque of the VFD. 100% corresponds to the motor rated torque. The positive value is the motoring state while the negative value is the generating state. -250.0-250.0%	-250.0-250.0	0.0%
P17.15	Torque reference value	Relative to the percentage of the rated torque of the present motor, displaying the torque reference. -300.0%-300.0% (of the motor rated current)	-300.0-300.0	0.0%

5.1.6 Motor parameter autotuning

	<ul style="list-style-type: none"> Check the safety conditions surrounding the motor and load machineries before autotuning as physical injury may occur due to sudden start of motor during autotuning. Although the motor does not run during static autotuning, the motor is still supplied with power. Do not touch the motor during autotuning; otherwise, electric shock may occur. Do not touch the motor before autotuning is completed.
	<ul style="list-style-type: none"> If the motor has been connected to a load, do not carry out rotary autotuning. Otherwise, the inverter unit may malfunction or mechanical device may be damaged. If rotary autotuning is carried out on a motor which has been connected to a load, incorrect motor parameter settings and motor action exceptions may occur. Disconnect from the load to carry out autotuning if necessary.

The inverter unit can drive both asynchronous motors and synchronous motors, and it supports four sets of motor parameters, which can be switched over by multifunction digital input terminals or communication modes.

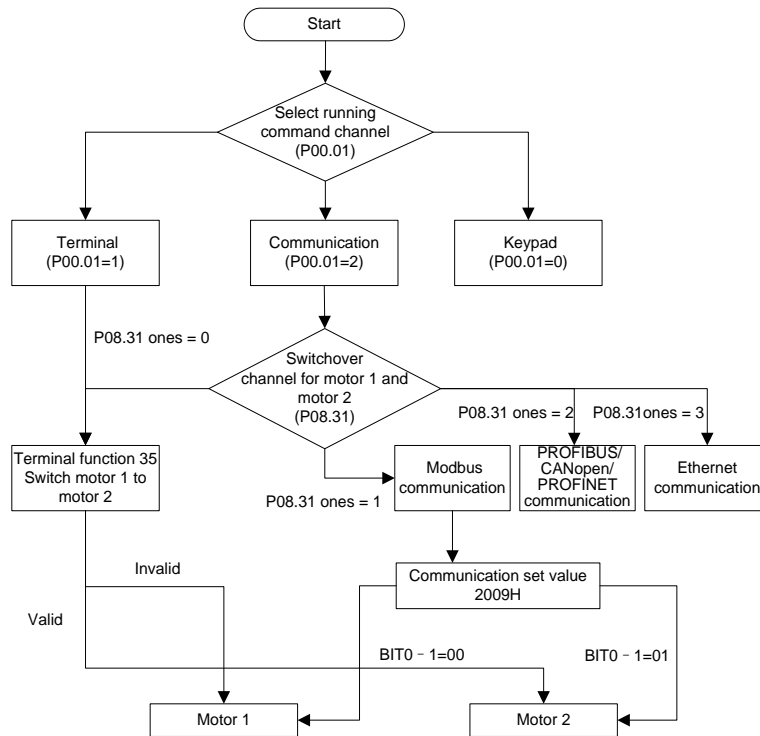

The control performance of the inverter unit is based on accurate motor models. Therefore, you need to carry out motor parameter autotuning before running a motor for the first time (taking motor 1 as an example).

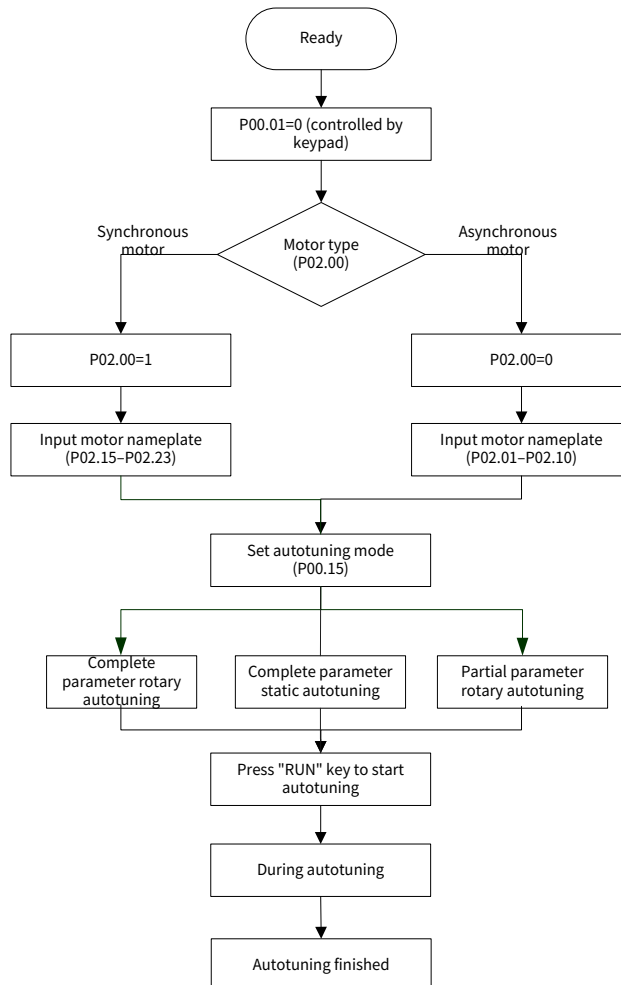

Note:

- Motor parameters must be set correctly according to the motor nameplate.
- After entering P00.15, you can press the RUN key to enter autotuning and press the STOP key to exit autotuning.
- If rotary autotuning is selected during motor autotuning, disconnect the motor from the load to put the motor in static and no-load state. Otherwise, the motor parameter autotuning results may be incorrect. In addition, autotune P02.06–P02.10 for AMs and autotune P02.20–P02.23 for SMs.
- If static autotuning is selected for motor autotuning, there is no need to disconnect the motor from the load, but the control performance may be impacted as only a part of the motor parameters have been autotuned. In addition, autotune P02.06–P02.10 for AMs and autotune P02.20–P02.22 for SMs. P02.23 can be obtained through calculation.

Counter-emf constant can be calculated through from the parameters on the motor nameplate through the following three methods.

Method 1: If the nameplate provides the counter-emf coefficient K_e , perform the calculation as follows:

$$E = (K_e * n_N * 2\pi) / 60$$

Method 2: If the nameplate provides the counter-emf E' (V/1000r/min), perform the calculation as follows:

$$E = E' * n_N / 1000$$

Method 3: If both parameters are not given in the nameplate, perform the calculation as follows:

$$E = P / (\sqrt{3} * I)$$

In the formula, " n_N " is the rated speed, " P " is the rated power, and " I " is the rated current.

- Static autotuning: when the present motor is motor 1, only P02.06, P02.07, P02.08 are autotuned; when the present motor is motor 2, only P12.06, P12.07 and P12.08 are autotuned; when the present motor is motor 3, only P13.06, P13.07 and P13.08 are autotuned; when the present motor is motor 4, only P14.06, P14.07 and P14.08 are autotuned.
- Motor autotuning can be carried out on the present motor only. If you need to perform autotuning on the other motor, switch the motor through selecting motor 1–4 by setting P08.31 and corresponding functions.
- In addition, you need to configure a motor according to the standard motor configuration of the VFD. If the power of the motor is greatly different from that of the standard motor configuration, the control performance of the VFD degrades significantly.

Related parameter list:

5.1.6.1 Common parameters

Function code	Name	Description	Default
P00.01	Channel of running commands	0: Keypad 1: Terminal 2: Communication	0
P00.15	Motor parameter autotuning	0: No operation 1: Rotary autotuning 2: Static autotuning 3: Simple autotuning	0
P05.01–P05.08	Function selection of multifunction digital input terminals (S1–S8)	43: Motor group 1 44: Motor group 2	/

Function code	Name	Description	Default
P08.31	Motor switchover selection	0: Terminal 1: MODBUS communication 2: PROFIBUS/CANopen/PROFINET communication	0

5.1.6.2 Parameters of motor 1

Function code	Name	Description	Default
P02.00	Type of motor 1	0: Asynchronous motor (AM) 1: Synchronous motor (SM)	0
P02.01	Rated power of AM 1	0.1–3000.0kW	Model depended
P02.02	Rated frequency of AM 1	0.01Hz–P00.03 (Max. output frequency)	50.00Hz
P02.03	Rated speed of AM 1	1–36000rpm	Model depended
P02.04	Rated voltage of AM 1	0–1200V	Model depended
P02.05	Rated current of AM 1	0.8–6000.0A	Model depended
P02.06	Stator resistance of AM 1	0.0001–6.5535Ω	Model depended
P02.07	Rotor resistance of AM 1	0.0001–6.5535Ω	Model depended
P02.08	Leakage inductance of AM 1	0.01–655.35mH	Model depended
P02.09	Mutual inductance of AM 1	0.01–655.35mH	Model depended
P02.10	No-load current of AM 1	0.1–6553.5A	Model depended
P02.15	Rated power of SM 1	0.1–3000.0kW	Model depended
P02.16	Rated frequency of SM 1	0.01Hz–P00.03 (Max. output frequency)	50.00Hz
P02.17	Number of pole pairs of SM 1	1–50	2
P02.18	Rated voltage of SM 1	0–1200V	Model depended
P02.19	Rated current of SM 1	0.8–6000.0A	Model depended
P02.20	Stator resistance of SM 1	0.0001–6.5535Ω	Model depended
P02.21	Direct-axis inductance of SM 1	0.01–655.35mH	Model depended
P02.22	Quadrature-axis inductance of SM 1	0.01–655.35mH	Model depended
P02.23	Counter-emf of SM 1	0–10000V	300V

Function code	Name	Description	Default
P02.24	Initial pole angle of SM 1	0.00–359.99	0.00
P02.25	Pole position amplitude gain of SM 1	0.50–1.50	1.00
P02.26	Phase-C pole position offset of SM1	0–9999	2230
P02.27	Phase-D pole position offset of SM1	0–9999	2230

5.1.6.3 Parameters of motor 2

Function code	Name	Description	Default
P12.00	Type of motor 2	0: Asynchronous motor (AM) 1: Synchronous motor (SM)	0
P12.01	Rated power of AM 2	0.1–3000.0kW	Model depended
P12.02	Rated frequency of AM 2	0.01Hz–P00.03 (Max. output frequency)	50.00Hz
P12.03	Rated speed of AM 2	1–36000rpm	Model depended
P12.04	Rated voltage of AM 2	0–1200V	Model depended
P12.05	Rated current of AM 2	0.8–6000.0A	Model depended
P12.06	Stator resistance of AM 2	0.0001–6.5535Ω	Model depended
P12.07	Rotor resistance of AM 2	0.0001–6.5535Ω	Model depended
P12.08	Leakage inductance of AM 2	0.01–655.35mH	Model depended
P12.09	Mutual inductance of AM 2	0.01–655.35mH	Model depended
P12.10	No-load current of AM 2	0.1–6553.5A	Model depended
P12.15	Rated power of SM 2	0.1–3000.0kW	Model depended
P12.16	Rated frequency of SM 2	0.01Hz–P00.03 (Max. output frequency)	50.00Hz
P12.17	Number of pole pairs of SM 2	1–50	2
P12.18	Rated voltage of SM 2	0–1200V	Model depended
P12.19	Rated current of SM 2	0.8–6000.0A	Model depended
P12.20	Stator resistance of SM 2	0.0001–6.5535Ω	Model depended

Function code	Name	Description	Default
P12.21	Direct-axis inductance of SM 2	0.01–655.35mH	Model depended
P12.22	Quadrature-axis inductance of SM 2	0.01–655.35mH	Model depended
P12.23	Counter-emf constant of SM 2	0–10000V	300V
P12.24	Initial pole angle of SM 2	0.00–359.99	0.00
P12.25	Pole position amplitude gain of SM2	0.50–1.50	1.00
P12.26	Phase-C pole position offset of SM2	0–9999	2230
P12.27	Phase-D pole position offset of SM2	0–9999	2230

5.1.6.4 Parameters of motor 3

Function code	Name	Description	Default
P13.00	Type of motor 3	0: Asynchronous motor (AM) 1: Synchronous motor (SM)	0
P13.01	Rated power of AM 3	0.1–3000.0kW	Model depended
P13.02	Rated frequency of AM 3	0.01Hz–P00.03 (Max. output frequency)	50.00Hz
P13.03	Rated speed of AM 3	1–36000rpm	Model depended
P13.04	Rated voltage of AM 3	0–1200V	Model depended
P13.05	Rated current of AM 3	0.8–6000.0A	Model depended
P13.06	Stator resistance of AM 3	0.0001–6.5535Ω	Model depended
P13.07	Rotor resistance of AM 3	0.0001–6.5535Ω	Model depended
P13.08	Leakage inductance of AM 3	0.01–655.35mH	Model depended
P13.09	Mutual inductance of AM 3	0.01–655.35mH	Model depended
P13.10	No-load current of AM 3	0.1–6553.5A	Model depended
P13.15	Rated power of SM 3	0.1–3000.0kW	Model depended
P13.16	Rated frequency of SM 3	0.01Hz–P00.03 (Max. output frequency)	50.00Hz
P13.17	Number of pole pairs of SM 3	1–50	2

Function code	Name	Description	Default
P13.18	Rated voltage of SM 3	0–1200V	Model depended
P13.19	Rated current of SM 3	0.8–6000.0A	Model depended
P13.20	Stator resistance of SM 3	0.0001–6.5535Ω	Model depended
P13.21	Direct-axis inductance of SM 3	0.01–655.35mH	Model depended
P13.22	Quadrature-axis inductance of SM 3	0.01–655.35mH	Model depended
P13.23	Counter-emf constant of SM 3	0–10000V	300V
P13.24	Initial pole angle of SM 3	0.00–359.99	0.00
P13.25	Pole position amplitude gain of SM 3	0.50–1.50	1.00
P13.26	Phase-C pole position offset of SM3	0–9999	2230
P13.27	Phase-D pole position offset of SM3	0–9999	2230

5.1.6.5 Parameters of motor 4

Function code	Name	Description	Default
P14.00	Type of motor 4	0: Asynchronous motor (AM) 1: Synchronous motor (SM)	0
P14.01	Rated power of AM 4	0.1–3000.0kW	Model depended
P14.02	Rated frequency of AM 4	0.01Hz–P00.03 (Max. output frequency)	50.00Hz
P14.03	Rated speed of AM 4	1–36000rpm	Model depended
P14.04	Rated voltage of AM 4	0–1200V	Model depended
P14.05	Rated current of AM 4	0.8–6000.0A	Model depended
P14.06	Stator resistance of AM 4	0.0001–6.5535Ω	Model depended
P14.07	Rotor resistance of AM 4	0.0001–6.5535Ω	Model depended
P14.08	Leakage inductance of AM 4	0.01–655.35mH	Model depended
P14.09	Mutual inductance of AM 4	0.01–655.35mH	Model depended
P14.10	No-load current of AM 4	0.1–6553.5A	Model depended

Function code	Name	Description	Default
P14.15	Rated power of SM 4	0.1–3000.0kW	Model depended
P14.16	Rated frequency of SM 4	0.01Hz–P00.03 (Max. output frequency)	50.00Hz
P14.17	Number of pole pairs of SM 4	1–50	2
P14.18	Rated voltage of SM 4	0–1200V	Model depended
P14.19	Rated current of SM 4	0.8–6000.0A	Model depended
P14.20	Stator resistance of SM 4	0.0001–6.5535Ω	Model depended
P14.21	Direct-axis inductance of SM 4	0.01–655.35mH	Model depended
P14.22	Quadrature-axis inductance of SM 4	0.01–655.35mH	Model depended
P14.23	Counter-emf constant of SM 4	0–10000V	300V
P14.24	Initial pole angle of SM 4	0.00–359.99	0.00
P14.25	Pole position amplitude gain of SM 4	0.50–1.50	1.00
P14.26	Phase-C pole position offset of SM4	0–9999	2230
P14.27	Phase-D pole position offset of SM4	0–9999	2230

5.1.7 Motor overload protection

Function code	Name	Description	Setting range	Default
P02.29	Overload protection of motor 1	0: No protection 1: Common motor (with low-speed compensation) 2: Frequency-variable motor (without low-speed compensation)	0–2	2

0: No protection

1: Common motor protection (with low-speed compensation). As the cooling effect of a common motor is degraded at low speed running, the corresponding electronic thermal protection value needs to be adjusted properly, the low compensation indicates lowering the overload protection threshold of the motor whose running frequency is lower than 30Hz.

2: Variable-frequency motor protection (without low speed compensation). Because the heat dissipation function for a variable-frequency motor is not impacted by the rotation speed, it is not necessary to adjust the protection value at low speed running.

Function code	Name	Description	Setting range	Default
P02.30	Overload protection coefficient of motor 1	20.0%–120.0%	20.0–120.0	100.0%

Motor overload multiples $M = I_{out} / (I_n * K)$

“ I_n ” is rated motor current, “ I_{out} ” is VFD output current, “ K ” is motor overload protection coefficient.

A smaller value of “ K ” indicates a bigger value of “ M ” .

When $M=116\%$, protection is performed after motor overload lasts for 1 hour; when $M=200\%$, protection is performed after motor overload lasts for 60 seconds; and when $M \geq 400\%$, protection is performed immediately.

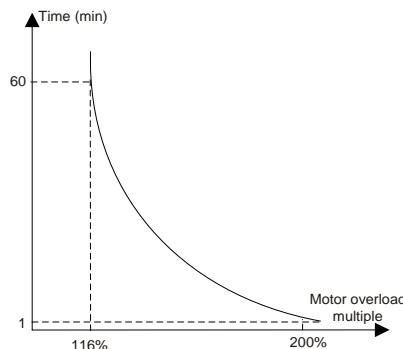

5.1.8 Start/stop control

The start/stop control of the inverter unit involves three states: start after a running command is given at power-on; start after power-off restart is effective; start after automatic fault reset. The three start/stop control states are described in the following.

There are three start modes for the inverter unit, which are start at starting frequency, start after DC braking, and start after speed tracking. You can select the proper start mode based on actual conditions.

For large-inertia load, especially in cases where reversal may occur, you can choose to start after DC braking or start after speed tracking.

Note: It is recommended to drive SMs in direct start mode.

- Logic diagram for start after a running command is given at power-on

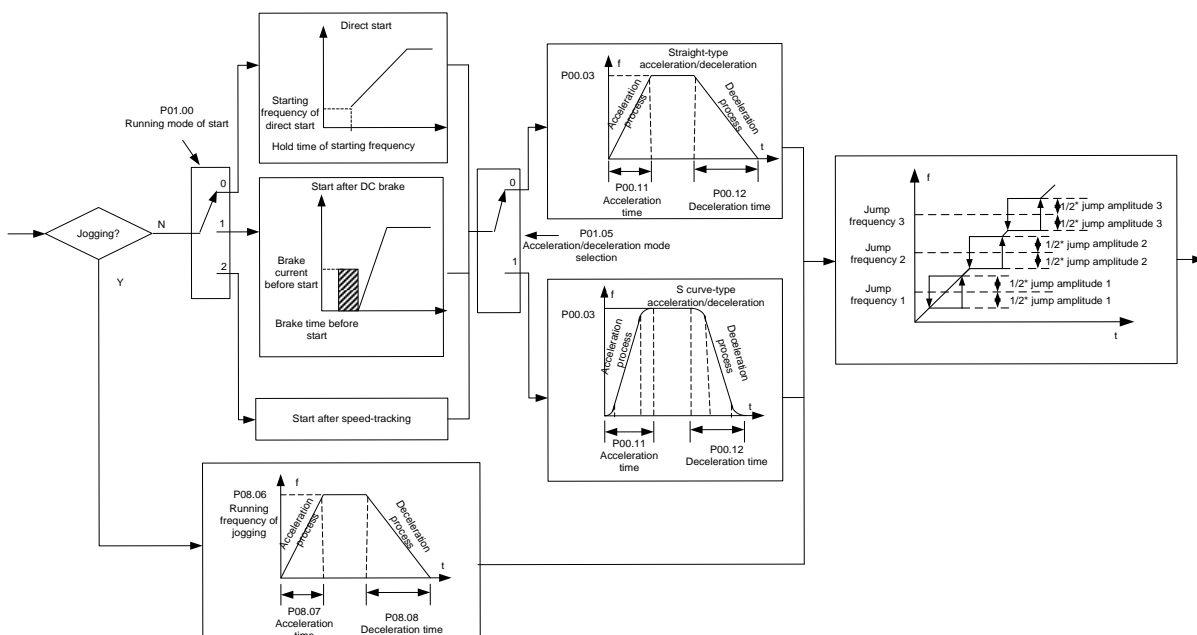

- Logic diagram for start after power-off restart is effective

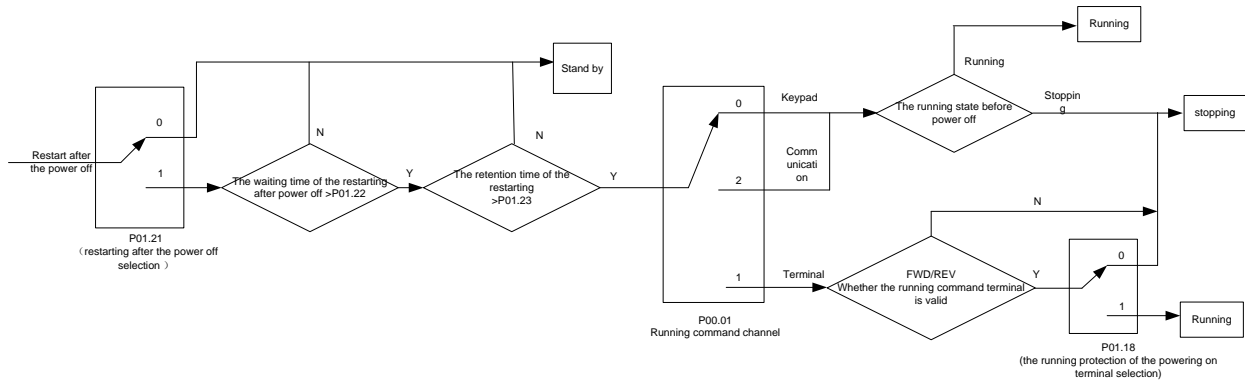

- Logic diagram for start after automatic fault reset

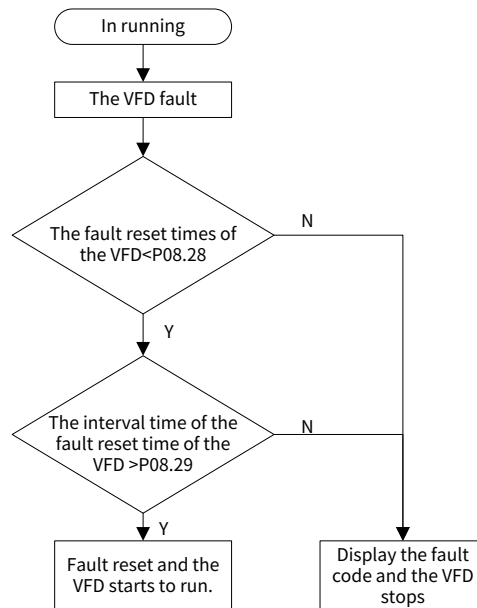

Function code	Name	Description	Setting range	Default
P01.00	Start mode	0: Direct start 1: Start after DC braking 2: Start after rotating speed tracking	0-2	0

0: Direct start. Start from the starting frequency P01.01.

1: Start after DC braking. Start the motor from the starting frequency after DC braking (Set the parameters P01.03 and P01.04). It is suitable in cases where reverse rotation may occur to the small inertia load during starting.

2: Start after rotating speed tracking. The VFD automatically tracks the rotating speed and direction of the motor, and start the rotating motor smoothly. It is suitable in cases where reverse rotation may occur to the large inertia load during starting.

Function code	Name	Description	Setting range	Default
P01.01	Starting frequency of direct start	0.00-50.00Hz	0.00-50.00	0.50Hz

The function code indicates the initial frequency during VFD start.

Function code	Name	Description	Setting range	Default
P01.02	Starting frequency hold time	0.0–60.0s	0.0–60.0	0.0s

Setting a proper starting frequency can increase the torque during VFD start. During the hold time of the starting frequency, the output frequency of the VFD is the starting frequency. And then, the VFD runs from the starting frequency to the set frequency. If the set frequency is lower than the starting frequency, the VFD stops running and keeps in the standby state. The starting frequency is not limited in the lower limit frequency.

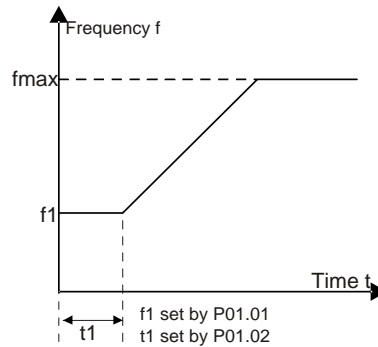

Function code	Name	Description	Setting range	Default
P01.03	Braking current before start	0.0–100.0% (of the motor rated current)	0.0–100.0	0.0%
P01.04	Braking time before start	0.0–60.0s	0.0–60.0	0.0s

The VFD performs DC braking with the braking current before start and it speeds up after the DC braking time. If the set DC braking time is 0, DC braking is invalid.

Stronger braking current indicates larger braking power. The DC braking current before start is a percentage of the VFD rated current.

Function code	Name	Description	Setting range	Default
P01.05	ACC/DEC mode	0: Linear type 1: S curve	0–1	0

The function code is used to indicate the changing mode of the frequency during start and running.

0: Linear type. The output frequency increases or decreases linearly.

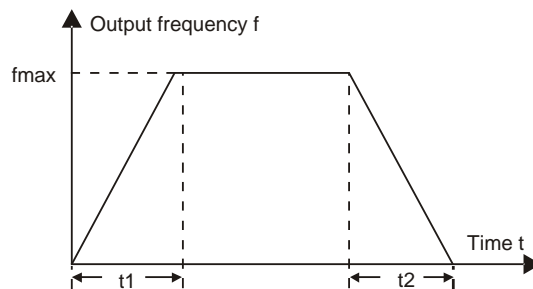

1: S curve. The output frequency increases or decreases according to the S curve.

The S curve is generally applied to elevators, conveyors, and other application scenarios where smoother start or stop is required.

Function code	Name	Description	Setting range	Default
P01.06	S curve starting segment proportion	0.0–50.0% (ACC/DEC time)	0.0–50.0	30.0%
P01.07	S curve ending segment proportion	0.0–50.0% (ACC/DEC time)	0.0–50.0	30.0%

The curvature of S curve is determined by the ACC range, ACC/DEC time, starting time, and ending time.

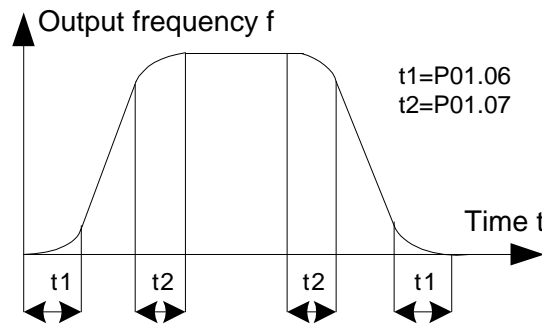

Function code	Name	Description	Setting range	Default
P01.08	Stop mode	0: Decelerate to stop 1: Coast to stop	0–1	0

0: Decelerate to stop. When a stop command takes effect, the VFD lowers output frequency based on the DEC mode and the defined DEC time; when the frequency drops to 0Hz, the VFD stops.

1: Coast to stop. After a stop command takes effect, the VFD stops output immediately; and the load coasts to stop according to mechanical inertia.

Function code	Name	Description	Setting range	Default
P01.09	Starting frequency of DC braking for stop	0.00Hz–P00.03 (Max. output frequency)	0.00–P00.03	0.00Hz
P01.10	Wait time before DC braking for stop	0.0–60.0s	0.0–50.0	0.0s
P01.11	DC braking current for stop	0.0–100.0% (of the motor rated current)	0.0–100.0	0.0%
P01.12	DC braking time for stop	0.0–60.0s	0.0–50.0	0.0s
P15.13	Short-circuit braking current	0.0–150.0% (relative to the VFD)	0.0–150.0	0.0%
P15.14	Hold time of short-circuit braking for start	0.0–50.0s	0.0–50.0	0.0s
P15.15	Hold time of short-circuit braking for stop	0.0–50.0s	0.0–50.0	0.0s

When P01.09 is set to a non-zero value, the DC braking for stop and short-circuit braking are valid. The short-circuit braking (P15.13) has a higher priority than the DC braking for stop. The DC braking for stop can only be executed after the short-circuit braking is completed.

DC braking:

Starting frequency of DC braking for stop: During the deceleration to stop, the VFD starts DC braking for stop when running frequency reaches the starting frequency determined by P01.09.

Wait time before braking: The VFD blocks the output before starting DC braking. After this wait time, DC braking is started so as to prevent overcurrent caused by DC braking at high speed.

DC braking current for stop: It indicates the applied DC braking energy. Stronger current indicates greater DC braking effect.

DC braking time for stop: It indicates the hold time of DC braking. If the time is 0, DC braking is invalid, and the VFD decelerates to stop within the specified time.

Short-circuit braking:

For SM control, when the VFD starts in direct start mode (P01.00=0), set P15.14 to a non-zero value to enter short-circuit braking.

During stop, if the running frequency of VFD is lower than the starting frequency of brake for stop, set P15.13 to a non-zero value to enter short-circuit braking for stop, and then carry out DC braking in the time set by P01.12.

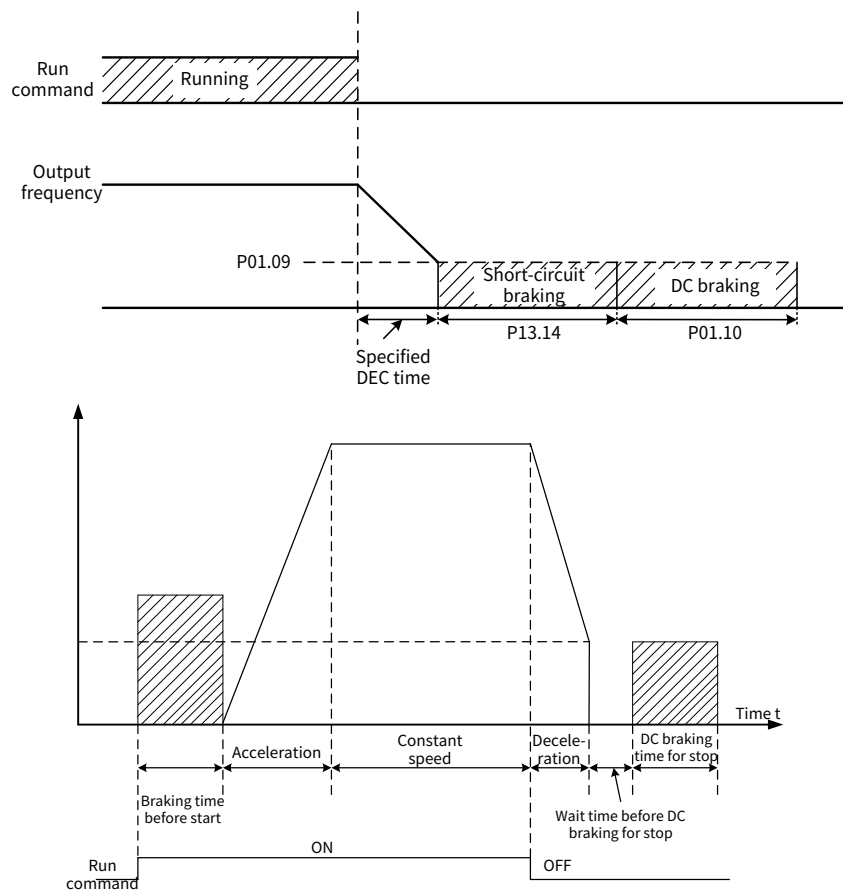

Function code	Name	Description	Setting range	Default
P01.13	FWD/REV running deadzone time	0.0–3600.0s	0.0–3600.0	0.0s

Function code	Name	Description	Setting range	Default
P01.14	FWD/REV running switching mode	0: Switch at zero frequency 1: Switch at the starting frequency 2: Switch after the speed reaches the stop speed with a delay (reserved)	0-2	0

The function code is used to set the shifting mode between forward running and reverse running.

This function code indicates the transition time specified in P01.13 during FWD/REV rotation switching. See the following figure:

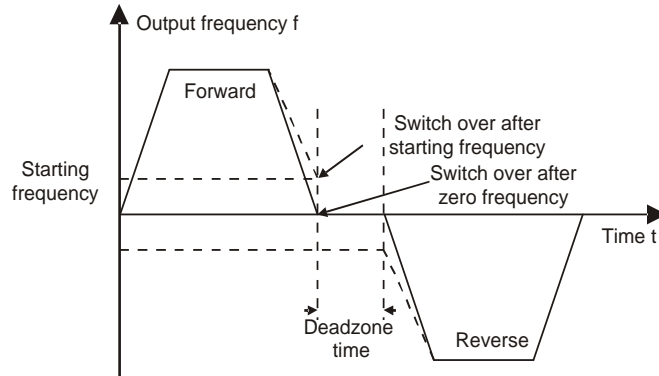

Function code	Name	Description	Setting range	Default
P01.15	Stop speed	0.00-100.00Hz	0.00-100.0	0.50 Hz
P01.16	Stop speed detection mode	0: Detect by the speed setting 1: Detect by speed feedback	0-1	0
P01.17	Feedback speed detection time	0.0-100.0 s	0.0-100.0	0.5s

The function code is used to set the stop speed detection mode.

0: Detect by the speed setting (without speed delay). This is the only detection method in space voltage vector mode.

1: Detect by speed feedback (valid only for vector control)

When P01.16 is set to 1, if the feedback frequency is less than or equal to the set value of P01.15 and it is detected within the time set in P01.17, the VFD will coast to stop immediately; Otherwise, the VFD stops after the time set by P01.17.

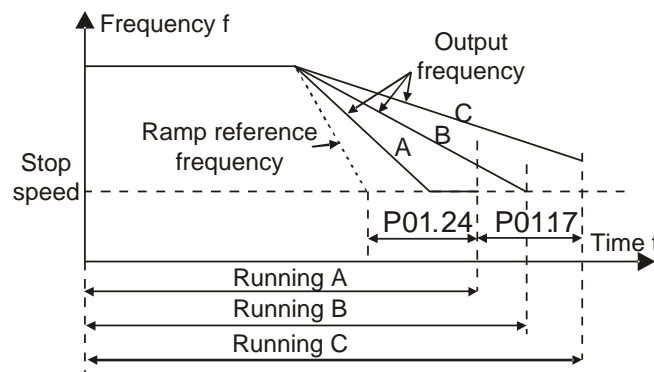

Function code	Name	Description	Setting range	Default
P01.18	Terminal-based running command protection at power-on	0: The terminal running command is invalid at power-on 1: The terminal running command is valid at power-on	0-1	0

When the channel of running commands is terminal control, the system detects the state of the running terminal during power-on.

0: The terminal running command is invalid at power-on. Even the running command is considered as valid during power-on, the VFD does not run and it keeps the protection state until the running command is canceled and enabled again.

1: The terminal running command is valid at power-on. If the running command is considered as valid during power-on, the VFD is started automatically after the initialization.

Note: Exercise caution before using this function. Otherwise, serious result may follow.

Function code	Name	Description	Setting range	Default
P01.19	Action selected when running frequency less than frequency lower limit (valid when frequency lower limit greater than 0)	0: Run at the frequency lower limit 1: Stop 2: Sleep	0-2	0

The function code determines the running state of the VFD when the set frequency is lower than the lower-limit one.

The VFD coasts to stop when the set frequency is lower than the lower-limit one. If the set frequency exceeds the lower limit one again and it lasts for the time set by P01.20, the VFD resumes the running state automatically.

Function code	Name	Description	Setting range	Default
P01.20	Wake-up-from-sleep delay	0.0-3600.0s (valid when P01.19 is 2)	0.0-3600.0	0.0s

The function code determines the wake-up-from-sleep delay time. When the running frequency of the VFD is lower than the lower limit, the VFD becomes standby.

When the set frequency exceeds the lower limit one again and it lasts for the time set by P01.20, the VFD runs automatically.

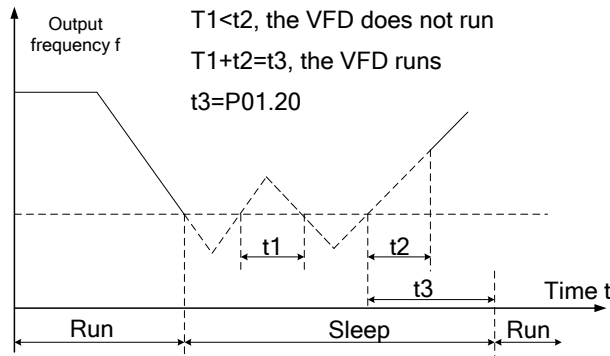

Function code	Name	Description	Setting range	Default
P01.21	Power-off restart selection	0: Disable 1: Enable	0-1	0

The function code indicates whether the VFD automatically runs after re-power on.

0: Disable

1: Enable. If the restart condition is met, the VFD will run automatically after waiting the time defined by P01.22.

Function code	Name	Description	Setting range	Default
P01.22	Wait time for restart after power-off	0.0-3600.0s (valid when P01.21 is 1)	0.0-3600.0	1.0s

The function code indicates the wait time before the automatic running of the VFD that is re-powered on.

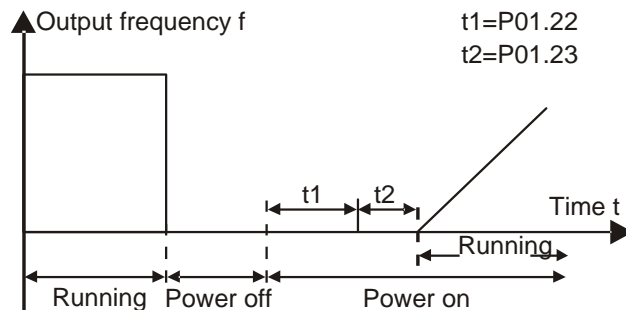

Function code	Name	Description	Setting range	Default
P01.23	Start delay	0.0-60.0s	0.0-60.0	0.0s

After a VFD running command is given, the VFD is in standby state and restarts with the delay defined by P01.23 to implement brake release.

Function code	Name	Description	Setting range	Default
P01.24	Stop speed delay	0.0-60.0s	0.0-60.0	0.0s

The function code is used to set the delay time of stop speed of the VFD. When the actual output frequency of the VFD is equal to P01.15 and it lasts over the time set by P01.24, the VFD will stop.

Function code	Name	Description	Setting range	Default
P01.25	VFD type	0: Common VFD 1: Four-quadrant VFD	0-1	1

The function code is used to select the VFD type for accurate positioning during speed tracking.

Jump frequency

The VFD can avoid mechanical resonance points by setting jump frequencies. The VFD supports the setting of three jump frequencies. If the jump frequency points are set to 0, this function is invalid.

When the set frequency is within the range of jump frequency, the VFD runs at the boundary of jump frequency.

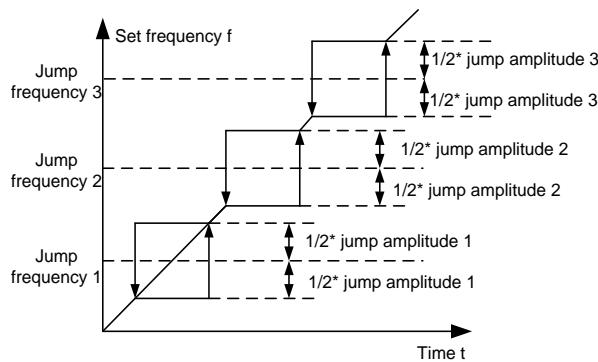

Function code	Name	Description	Setting range	Default
P08.09	Jump frequency 1	0.00-P00.03 (Max. output frequency)	0.00-P00.03	0.00Hz
P08.10	Jump frequency amplitude 1	0.00-P00.03 (Max. output frequency)	0.00-P00.03	0.00Hz
P08.11	Jump frequency 2	0.00-P00.03 (Max. output frequency)	0.00-P00.03	0.00Hz
P08.12	Jump frequency amplitude 2	0.00-P00.03 (Max. output frequency)	0.00-P00.03	0.00Hz
P08.13	Jump frequency 3	0.00-P00.03 (Max. output frequency)	0.00-P00.03	0.00Hz
P08.14	Jump frequency amplitude 3	0.00-P00.03 (Max. output frequency)	0.00-P00.03	0.00Hz

5.1.9 Frequency setting

The inverter unit supports multiple types of frequency reference modes, which can be categorized into: main reference channel and auxiliary reference channel.

There are two main reference channels, namely frequency reference channel A and frequency reference channel B. These two channels support simple arithmetical operation between each other, and they can be switched dynamically by setting multifunction terminals.

There are three input modes for auxiliary reference channel: keypad **UP/DOWN** key input, terminal **UP/DOWN** switch input, and digital potentiometer input. These input modes are all equivalent to the internal auxiliary reference, namely input **UP/DOWN** reference. By setting function codes, you can enable the corresponding reference mode and the impact made on the VFD frequency reference by this reference mode.

The VFD actual reference is comprised of the main reference channel and auxiliary reference channel.

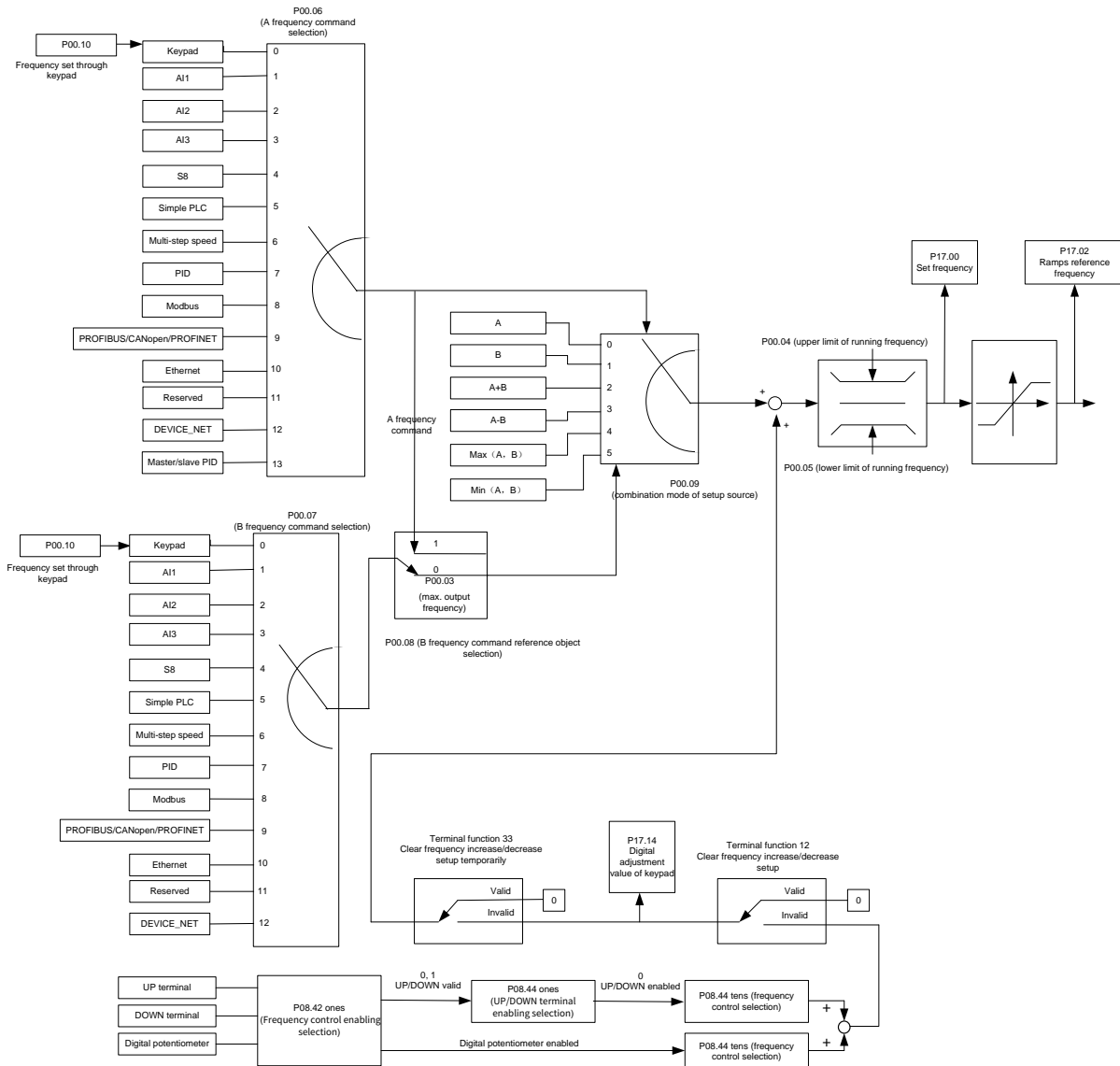

Function code	Name	Description	Setting range	Default
P00.03	Max. output frequency	Max (P00.04,10.00)-630.00Hz	Max (P00.04,10.00)-630.00	50.00Hz

Used to set the max. output frequency of the VFD. Pay attention to the function code because it is the foundation of the frequency setting and the speed of acceleration (ACC) and deceleration (DEC).

Function code	Name	Description	Setting range	Default
P00.04	Upper limit of running frequency	P00.05-P00.03 (Max. frequency)	P00.05-P00.03	50.0Hz

The upper limit of the running frequency is the upper limit of the output frequency of the VFD, which is lower than or equal to the max. output frequency.

When the set frequency is higher than the upper limit of the running frequency, the upper limit of the running frequency is used for running.

Function code	Name	Description	Setting range	Default
P00.05	Lower limit of running frequency	0.00Hz-P00.04 (Upper limit of running frequency)	0.00-P00.04	0.00 Hz

The lower limit of the running frequency is the lower limit of the output frequency of the VFD,
 When the set frequency is lower than the lower limit of the running frequency, the lower limit of the running frequency is used for running.

Note: Max. output frequency ≥ Upper limit of frequency ≥ Lower limit of frequency

Function code	Name	Description	Setting range	Default
P00.06	Setting channel of A frequency command	0: Keypad 1: AI1	0-13	0
P00.07	Setting channel of B frequency command	2: AI2 3: AI3 4: S8 pulse 5: Simple PLC program 6: Multi-step speed running 7: PID control 8: Modbus communication 9: PROFIBUS/CANopen/PROFINET (expansion card) 10: Ethernet communication 11-14: Reserved	0-13	1

0: Keypad

Modify the value P00.10 (set frequency by keypad) to set the frequency by keypad.

1: AI1

2: AI2

3: AI3

Set the frequency by analog input terminals. The VFD provides 3 channel analog input terminals, among which AI1/AI2 is the voltage/current option (0-10V/0-20mA) and can be shifted by jumpers while AI3 is the voltage input (-10V-+10V).

Note: When 0-20mA input is selected for AI1/AI2, the corresponding voltage of 20mA is 10V.

100.0% of the analog input setting corresponds to Max. output frequency (P00.03) and -100.0% corresponds to the max output frequency (P00.03).

4: S8 pulse

Set the frequency by high-speed pulse terminals. The VFD provides 1 channel high-speed pulse input in the range of 0.00-50.00kHz.

100.0% of the high-speed pulse input setting corresponds to Max. output frequency (P00.03) in forward direction and -100.0% corresponds to Max. output frequency (P00.03) in reverse direction.

Note: The pulse setting can be only input by S8. Set P05.00 (S8 input type) to pulse input and P05.46 (S8 pulse input function) to frequency setting input.

5: Simple PLC program

When P00.06 or P00.07 is equal to 5, the VFD runs at simple PLC program mode. Set parameters of P10 group (Simple PLC and multi-step speed control group) to select corresponding running frequency, running

direction, time of acceleration and deceleration, and duration. Please refer to the description of P10 group functions.

6: Multi-step speed running

When P00.06 or P00.07 is equal to 6, the VFD runs at multi-step speed mode. Set multi-step speed terminals by P05 to select the current running step and select the current running frequency by parameters of P10.

When P00.06 or P00.07 is not equal to 6, the multi-step speed setting has the priority, but the set step can be only 1–15. When P00.06 or P00.07 is equal to 6, the set step is 0–15.

7: PID control

When P00.06 or P00.07 is equal to 7, the running mode of the VFD is process PID control. It is necessary to set P09 (PID control). The running frequency of the VFD is the value after PID effect. As for PID preset source, preset value and feedback source, refer to the description of P09 PID functions.

8: Modbus communication

Set the frequency by Modbus communication. Please see the description of P20 group.

9: PROFIBUS/CANopen/PROFINET (expansion card)

Set the frequency by PROFIBUS/CANopen/PROFINET communication.

Please see the description of P21 group for PROFIBUS communication. PROFIBUS communication card is required.

Please see the description of P21 group for CANopen communication. CANopen communication card is required.

Please see the description of P21 group for PROFINET communication. PROFINET communication card is required.

10: Ethernet communication

Set the frequency by Ethernet communication. Please see the description of P22 group. Ethernet communication card is required.

11–14: Reserved

Note: A frequency and B frequency cannot be set to the same frequency reference mode.

Function code	Name	Description	Setting range	Default
P00.08	Reference object of B frequency command	0: Max. output frequency 1: A frequency command	0–1	0

The function code is used to select the reference object of B frequency command.

0: Max. output frequency: 100% of B frequency setting corresponds to Max. output frequency.

1: A frequency command: 100% of B frequency setting corresponds to Max. output frequency. If it is necessary to adjust on basis of A frequency command, select this setting.

Function code	Name	Description	Setting range	Default
P00.09	Combination mode of setting source	0: A 1: B 2: (A+B) 3: (A-B) 4: Max(A, B) 5: Min(A, B)	0–5	0

The function code is used to set the combination mode of setting source.

- 0: A. The present frequency is set to A frequency command.
- 1: B. The present frequency is set to B frequency command.
- 2: A+B. The present frequency is set to A+B frequency command.
- 3: A-B. The present frequency is set to A-B frequency command.
- 4: Max(A, B). Take the larger value between A and B frequency commands as the set frequency.
- 5: Min(A, B). Take the smaller value between A and B frequency commands as the set frequency.

Note: The combination can be shifted by terminal functions (P05).

Function code	Name	Description	Setting range	Default
P00.10	Frequency set through keypad	0.00 Hz–P00.03 (Max. output frequency)	0.00–P00.03	50.00Hz

When A and B frequency commands select the keypad for setting, the value of the function code is the original setting one of the frequency data of the VFD.

Note: A frequency and B frequency cannot be set to the same frequency reference mode.

The inverter unit supports switchover between different channels, and the rules for channel switchover are shown in the following.

Present reference channel (P00.09)	Multifunction terminal function 13 (Switch from channel A to channel B)	Multifunction terminal function 14 (Switch from combined setting to channel A)	Multifunction terminal function 15 (Switch from combined setting to channel B)
A	B	/	/
B	A	/	/
A+B	/	A	B
A-B	/	A	B
Max(A, B)	/	A	B
Min(A, B)	/	A	B

Note: "/" indicates this multifunction terminal is invalid under present reference channel.

Related parameter list:

Function code	Name	Description	Default
P00.03	Max. output frequency	P00.04–400.00Hz	50.00Hz
P00.04	Upper limit of running frequency	P00.05Hz–P00.03	50.00Hz
P00.05	Lower limit of running frequency	0.00Hz–P00.04	0.00Hz
P00.06	Setting channel of A frequency command	0: Keypad 1: AI1	0
P00.07	Setting channel of B frequency command	2: AI2 3: AI3 4: Reserved 5: Simple PLC program 6: Multi-step speed running 7: PID control 8: Modbus communication 9: PROFIBUS/CANopen/PROFINET	15

Function code	Name	Description	Default
		communication 10: Ethernet communication 11: Reserved 12: DEVICE_NET communication (expansion card) 13: Master/slave PID output 14-15: Reserved	
P00.08	Reference object of B frequency command	0: Max. output frequency 1: A frequency command	0
P00.09	Combination mode of setting source	0: A 1: B 2: (A+B) 3: (A-B) 4: Max(A, B) 5: Min(A, B)	0
P05.01- P05.04	Function selection of multifunction digital input terminals (S1-S4)	10: Increase frequency setting (UP) 11: Decrease frequency setting (DOWN) 12: Clear the frequency increase/decrease setting 13: Switch between A setting and B setting 14: Switch between combination setting and A setting 15: Switch between combination setting and B setting 14: Switch between combination setting and A setting 15: Switch between combination setting and B setting	/

When setting the auxiliary frequency inside the inverter unit through multi-function terminal UP (10) and DOWN (11), you can increase/decrease the frequency quickly by setting P08.44 (UP terminal frequency incremental change rate) and P08.45 (DOWN terminal frequency decremental change rate).

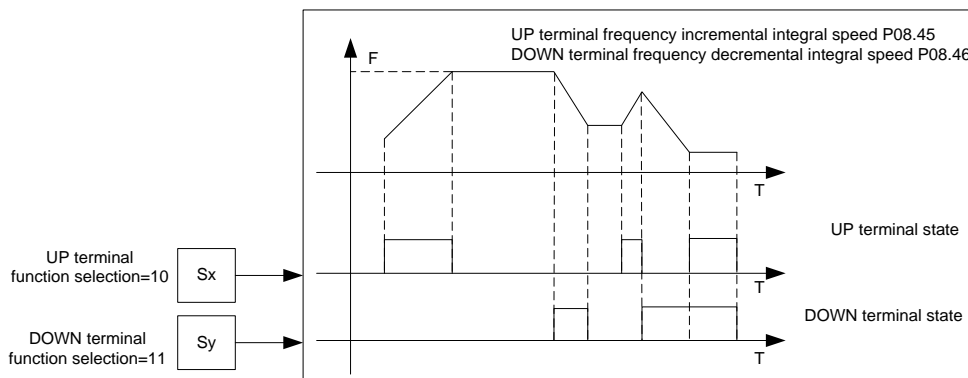

Function code	Name	Description	Default
P08.43	Keypad digital potentiometer integral rate	0.01-10.00s	0.10s

Function code	Name	Description	Default
P08.44	UP/DOWN terminal control setting	0x000–0x221 Ones place: Frequency setting selection 0: The setting made through UP/DOWN is valid. 1: The setting made through UP/DOWN is invalid. Tens place: Frequency control selection 0: Valid only when P00.06=0 or P00.07=0 1: Valid for all frequency setting methods 2: Invalid for multi-step speed running when multi-step speed running has the priority Hundreds place: Action selection for stop 0: Setting is valid. 1: Valid during running, cleared after stop 2: Valid during running, cleared after a stop command is received	0x000
P08.45	Frequency increment change rate of the UP terminal	0.01–50.00Hz/s	0.50 Hz/s
P08.46	Frequency reduce rate of the DOWN terminal	0.01–50.00Hz/s	0.50 Hz/s

5.1.10 Analog input

The inverter unit carries three analog input terminals, among which AI1 and AI2 are 0–10V/0–20mA, and AI3 is -10–10V. Whether AI1 uses voltage input or current input can be set by J3, and whether AI2 uses voltage input or current input can be set by J4. Each input can be filtered separately, and the corresponding reference curve can be set by adjusting the reference corresponds to the max. value and min. value.

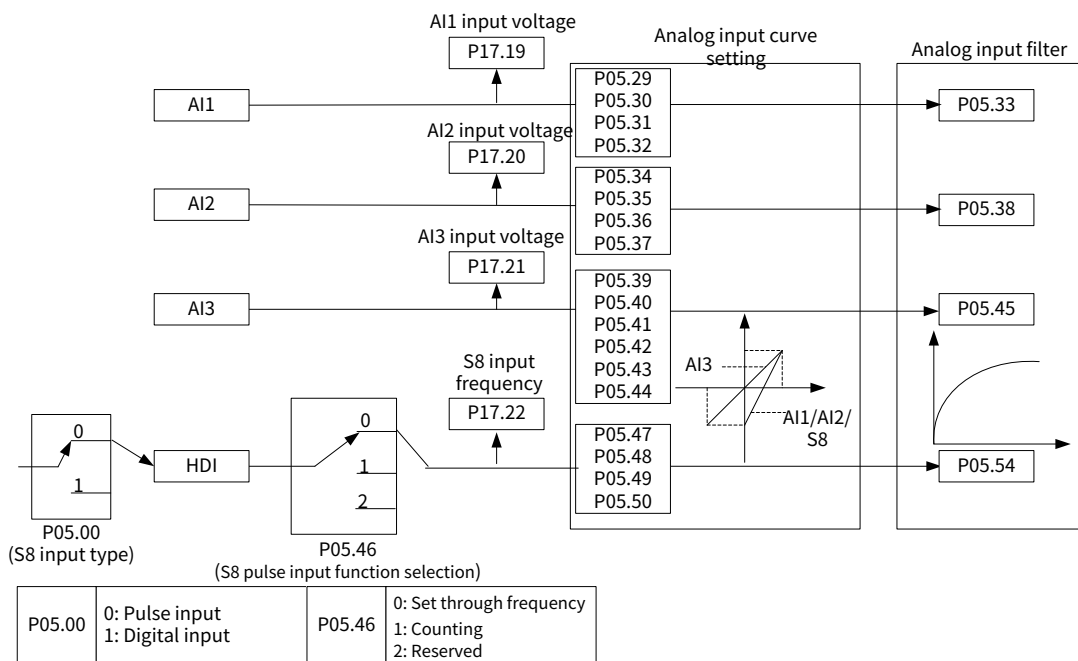

Related parameter list:

Function code	Name	Description	Setting range	Default
P05.29	AI1 lower limit	0.00V–P05.31	0.00–P05.31	0.00V
P05.30	Corresponding setting of AI1 lower limit	-100.0%–100.0%	-100.0–100.0	0.0%
P05.31	AI1 upper limit	P05.29–10.00V	P05.29–10.00	10.00V
P05.32	Corresponding setting of AI1 upper limit	-100.0%–100.0%	-100.0–100.0	100.0%
P05.33	AI1 input filter time	0.000s–10.000s	0.000–10.000	0.030s
P05.34	AI2 lower limit	0.00V–P05.36	0.00–P05.36	0.00V
P05.35	Corresponding setting of AI2 lower limit	-100.0%–100.0%	-100.0–100.0	0.0%
P05.36	AI2 upper limit	P05.34–10.00V	P05.34–10.00	10.00V
P05.37	Corresponding setting of AI2 upper limit	-100.0%–100.0%	-100.0–100.0	100.0%
P05.38	AI2 input filter time	0.000s–10.000s	0.000–10.000	0.030s
P05.39	AI3 lower limit	-10.00V–P05.41	P05.41–10.00	-10.00V
P05.40	Corresponding setting of AI3 lower limit	-100.0%–100.0%	-100.0–100.0	-100.0%
P05.41	AI3 middle value	P05.39–P05.43	P05.39–P05.43	0.00V
P05.42	Corresponding setting of AI3 middle value	-100.0%–100.0%	-100.0–100.0%	0.0%
P05.43	AI3 upper limit	P05.41–10.00V	P05.41–10.00	10.00V
P05.44	Corresponding setting of AI3 upper limit	-100.0%–100.0%	-100.0–100.0	100.0%
P05.45	AI3 input filter time	0.000s–10.000s	0.000–10.000	0.100s

Used to define the relationship between the analog input voltage and its corresponding setting. When the analog input voltage exceeds the range from the upper limit to the lower limit, the upper limit or lower limit is used.

When the analog input is current input, 0mA–20mA current corresponds to 0V–10V voltage.

In different applications, 100.0% of the analog setting corresponds to different nominal values. See the descriptions of each application section for details.

The following figure illustrates the cases of several settings:

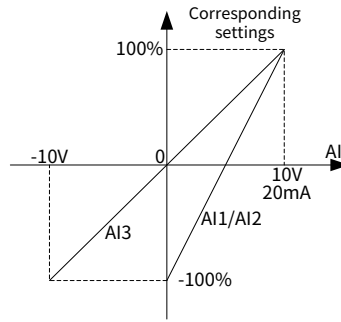

Input filter time: to adjust the sensitivity of analog input. Increasing the value properly can enhance analog input anti-interference but may reduce the sensitivity of analog input.

Note: AI1 and AI2 support the 0–10V/0–20mA input. When AI1 and AI2 select the 0–20mA input, the corresponding voltage of 20mA is 10V. AI3 supports the -10–+10V input.

5.1.11 Analog output

The inverter unit carries two analog output terminals (0–10V/0–20mA) and one high-speed pulse output terminal. Analog output signals can be filtered separately, and the proportional relation can be adjusted by setting the max. value, min. value, and the percentage of their corresponding output. Analog output signal can output motor speed, output frequency, output current, motor torque and motor power at a certain proportion. Output current 100% corresponds to twice the inverter rated current.

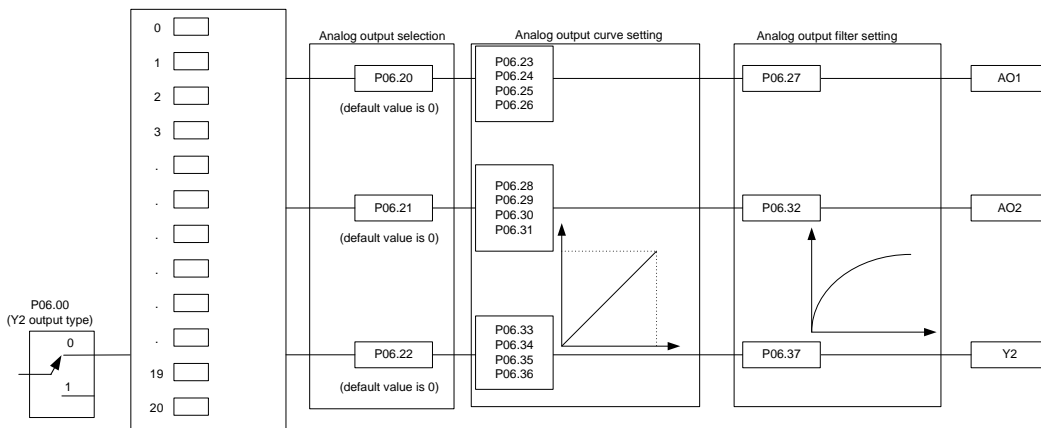

Function code	Name	Description	Setting range	Default
P06.20	AO1 output	0: Running frequency	0–30	0
P06.21	AO2 output	1: Set frequency	0–30	0
		2: Ramp reference frequency		
		3: Rotational speed		
		4: Output current (relative to the VFD)		
		5: Output current (relative to the motor)		
		6: Output voltage		
		7: Output power		
		8: Set torque		
		9: Output torque		
		10: AI1 input		
		11: AI2 input		
		12: AI3 input		
		13: S8 pulse input		
		14: Value 1 set through Modbus communication		

Function code	Name	Description	Setting range	Default
		15: Value 2 set through Modbus communication 16: Value 1 set through PROFIBUS/CANopen/PROFINET communication 17: Value 2 set through PROFIBUS/CANopen/PROFINET communication 18: Value 1 set through Ethernet communication 19: Value 2 set through Ethernet communication 20: Torque current reference 21: Reserved 22: Torque current (relative to the motor rated current) 23: Exciting current (relative to the motor rated current) 24: PID reference 25: PID feedback 26-30: Reserved		

AO output relationship description:

(The min. value and max. value of the output correspond to 0.% and 100.00% of the pulse or analog default output. The actual output voltage or pulse frequency corresponds to the actual percentage, which can be set through function codes.)

Setting	Function	Description
0	Running frequency	0–Max. output frequency
1	Set frequency	0–Max. output frequency
2	Ramp reference frequency	0–Max. output frequency
3	Rotational speed	0–Synchronous speed corresponding to max. output frequency
4	Output current (relative to the inverter unit)	0–Twice the inverter unit rated current
5	Output current (relative to motor)	0–Twice the motor rated current
6	Output voltage	0–1.5 times the inverter unit rated voltage
7	Output power	0–Twice the motor rated power
8	Set torque value (bipolar)	0–Twice the motor rated current. A negative value corresponds to 0.0% by default.
9	Output torque (absolute value)	0–±(Twice the motor rated torque)
10	AI1 input	0–10V/0–20mA
11	AI2 input	0–10V/0–20mA
12	AI3 input	-10V–10V
13	S8 pulse input	0.00–50.00kHz
14	Value 1 set through Modbus communication	-1000–1000, 1000 corresponding to 100.0%
15	Value 2 set through Modbus communication	-1000–1000, 1000 corresponding to 100.0%
16	Value 1 set through PROFIBUS/CANopen/PROFINET	-1000–1000, 1000 corresponding to 100.0%

Setting	Function	Description
	communication	
17	Value 2 set through PROFIBUS/CANopen/PROFINET communication	-1000-1000, 1000 corresponding to 100.0%
18	Value 1 set through Ethernet communication	-1000-1000, 1000 corresponding to 100.0%
19	Value 2 set through Ethernet communication	-1000-1000, 1000 corresponding to 100.0%
20	Torque current reference	0-Twice the motor rated current
21	Reserved	
22	Torque current (relative to the motor rated current)	0-Twice the motor rated current
23	Exciting current (relative to the motor rated current)	0-Twice the motor rated current
24	PID reference	
25	PID feedback	
26-30	Reserved	

Related parameter list:

Function code	Name	Description	Setting range	Default
P06.23	AO1 output lower limit	-100.0%-100.0%	-100.0-100.0	0.0%
P06.24	AO1 output corresponding to lower limit	0.00V-10.00V	0.00-10.00	0.00V
P06.25	AO1 output upper limit	-100.0%-100.0%	-100.0-100.0	100.0%
P06.26	AO1 output corresponding to upper limit	0.00V-10.00V	0.00-10.00	10.00V
P06.27	AO1 output filter time	0.000s-10.000s	0.000-10.000	0.000s
P06.28	AO2 output lower limit	-100.0%-100.0%	-100.0-100.0	0.0%
P06.29	AO2 output corresponding to lower limit	-10.00V-10.00V	-10.00-10.00	0.00V
P06.30	AO2 output upper limit	-100.0%-100.0%	-100.0-100.0	100.0%
P06.31	AO2 output corresponding to upper limit	-10.00V-10.00V	-10.00-10.00	10.00V
P06.32	AO2 output filter time	0.000s-10.000s	0.000-10.000	0.000s

The function codes define the relationship between the output value and analog output. When the output value exceeds the allowed range, the output uses the lower limit or upper limit.

When the analog output is current output, 1mA equals 0.5V.

In different cases, the corresponding analog output of 100% of the output value is different. See each application for detailed information.

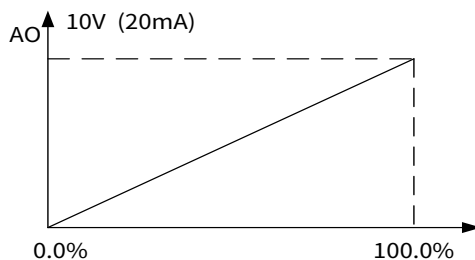

5.1.12 Digital input

The inverter unit carries eight programmable digital input terminals and one open collector input terminal. The function of all the digital input terminals can be programmed through function codes. Open collector input terminal can be set to act as high-speed pulse input terminal or common digital input terminal; if it is set to act as a high-speed pulse input terminal (HDI), you can also set HDI high-speed pulse input to serve as the frequency reference, counting input, or length pulse input.

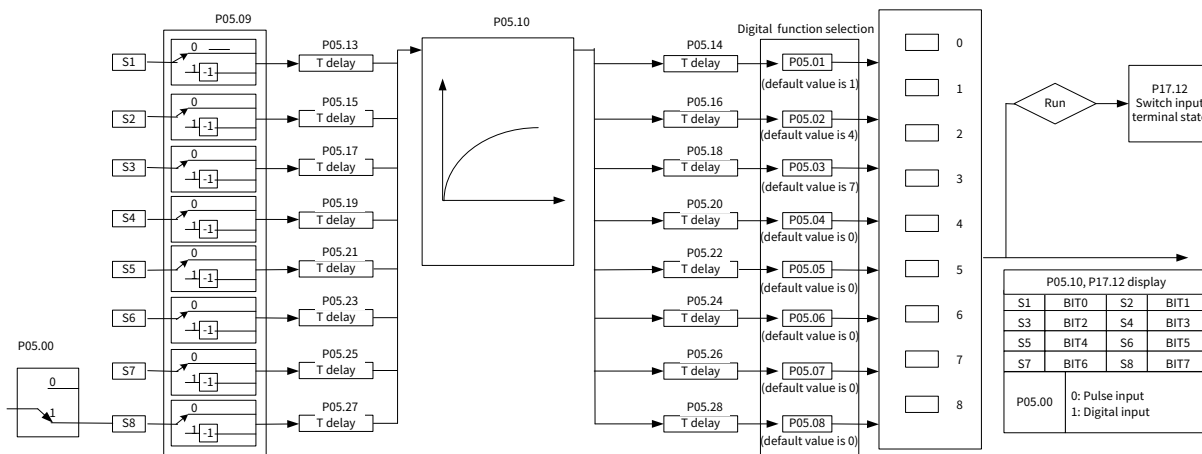

This parameter is used to set the corresponding function of digital multi-function input terminals.

Note: Two different multifunction input terminals cannot be configured with a same function.

- Terminal functions

Function code	Name	Description	Setting range	Default
P05.00	S8 input type	0: Pulse input 1: Digital input	0-1	0

The function code is used to set the S8 input type.

Function code	Name	Description	Setting range	Default
P05.01	Function of S1 terminal	0: No function 1: Run forward	0-79	1
P05.02	Function of S2 terminal	2: Run reversely 3: Three-wire running control	0-79	4
P05.03	Function of S3 terminal	4: Jog forward 5: Jog reversely	0-79	7
P05.04	Function of S4 terminal	6: Coast to stop 7: Reset faults	0-79	0

Function code	Name	Description	Setting range	Default
P05.05	Function of S5 terminal	8: Pause running 9: External fault input	0-79	0
P05.06	Function of S6 terminal	10: Increase frequency setting (UP) 11: Decrease frequency setting (DOWN)	0-79	0
P05.07	Function of S7 terminal	12: Clear the frequency increase/decrease setting 13: Switch between A setting and B setting	0-79	0
P05.08	Function of S8 terminal	14: Switch between combination setting and A setting 15: Switch between combination setting and B setting 16: Multi-step speed terminal 1 17: Multi-step speed terminal 2 18: Multi-step speed terminal 3 19: Multi-step speed terminal 4 20: Pause multi-step speed running 21: ACC/DEC time selection 1 22: ACC/DEC time selection 2 23: Simple PLC stop reset 24: Pause simple PLC 25: Pause PID control 26: Pause wobbling frequency (stopped at the present frequency) 27: Reset wobbling frequency (returned to the center frequency) 28: Counter reset 29: Switch between speed control and torque control 30: Disable ACC/DEC 31: Trigger the counter 32: Length reset (reserved) 33: Clear the frequency increase/decrease setting temporarily 34: DC braking 35: Reserved 36: Switch the running command channel to keypad 37: Switch the running command channel to terminal 38: Switch the running command channel to communication 39: Pre-exciting command 40: Clear electricity consumption 41: Keep electricity consumption 42: Switch the setting source of braking torque upper limit to keypad 43: Motor group 1	0-60	0

Function code	Name	Description	Setting range	Default
		44: Motor group 2 45: Anti-sag protection input (reserved) 46: Safe stop 1 (SS1) 47: Safe speed limit (SLS) 48-60: Reserved		

This parameter is used to set the corresponding function of digital multi-function input terminals.

Note: Two different multifunction input terminals cannot be configured with a same function.

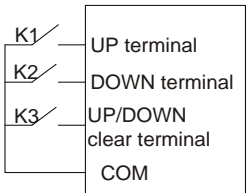
Setting	Function	Description
0	No function	The inverter unit does not act even if there is signal input. Set unused terminals to "no function" to avoid misaction.
1	Run forward	External terminals are used to control the forward/reverse running of the inverter unit.
2	Run reversely	
3	Three-wire running control	The terminal is used to determine the three-wire running control of the inverter unit. For details, see the description for P05.12.
4	Jog forward	For details about frequency of jogging running and ACC/DEC time of jogging running, see the description for P08.06, P08.07, and P08.08.
5	Jog reversely	
6	Coast to stop	The inverter unit blocks output, and the motor stop process is uncontrolled by the inverter unit. This mode is applied in the scenarios with large-inertia loads and without stop time requirements. Its definition is the same as P01.08, and it is mainly used in remote control.
7	Fault reset	External fault reset function, same as the reset function of the STOP/RST key on the keypad. You can use this function to reset faults remotely.
8	Pause running	The inverter unit decelerates to stop, however, all the run parameters are in memory state, such as PLC parameter, wobbling frequency, and PID parameter. After this signal disappears, the inverter unit restores to the state before the stop.
9	External fault input	When an external fault signal is transmitted to the inverter unit, the inverter unit reports a fault and stops.
10	Increase frequency setting (UP)	Used to change the frequency increase/decrease command when the frequency is given by external terminals.
12	Decrease frequency setting (DOWN)	
12	Clear the frequency increase/decrease setting	 <p>The terminal used to clear frequency increase/decrease setting can clear the frequency value of auxiliary channel set by UP/DOWN, thus restoring the reference</p>

Setting	Function	Description																				
		frequency to the frequency given by main reference frequency command channel.																				
13	Switch between A setting and B setting	The function is used to switch between the frequency setting channels.																				
14	Switch between combination setting and A setting	A frequency reference channel and B frequency reference channel can be switched by function 13; the combination channel set by P00.09 and the A frequency reference channel can be switched by function 14; the combination channel set by P00.09 and the B frequency reference channel can be switched by function 15.																				
15	Switch between combination setting and B setting																					
16	Multi-step speed terminal 1	A total of 16-step speeds can be set by combining digital states of these four terminals. Note: Multi-step speed 1 is the LSB, and multi-step speed 4 is the MSB.																				
17	Multi-step speed terminal 2																					
18	Multi-step speed terminal 3																					
19	Multi-step speed terminal 4	<table border="1"> <thead> <tr> <th>Multi-step speed 4</th> <th>Multi-step speed 3</th> <th>Multi-step speed 2</th> <th>Multi-step speed 1</th> </tr> </thead> <tbody> <tr> <td>BIT3</td> <td>BIT2</td> <td>BIT1</td> <td>BIT0</td> </tr> </tbody> </table>	Multi-step speed 4	Multi-step speed 3	Multi-step speed 2	Multi-step speed 1	BIT3	BIT2	BIT1	BIT0												
Multi-step speed 4	Multi-step speed 3	Multi-step speed 2	Multi-step speed 1																			
BIT3	BIT2	BIT1	BIT0																			
20	Pause multi-step speed running	The multi-step speed selection function can be screened to keep the set value in the present state.																				
21	ACC/DEC time selection 1	The status of the two terminals can be combined to select four groups of ACC/DEC time.																				
22	ACC/DEC time selection 2	<table border="1"> <thead> <tr> <th>Terminal 1</th> <th>Terminal 2</th> <th>ACC/DEC time</th> <th>Parameter</th> </tr> </thead> <tbody> <tr> <td>OFF</td> <td>OFF</td> <td>ACC/DEC time 1</td> <td>P00.11/P00.12</td> </tr> <tr> <td>ON</td> <td>OFF</td> <td>ACC/DEC time 2</td> <td>P08.00/P08.01</td> </tr> <tr> <td>OFF</td> <td>ON</td> <td>ACC/DEC time 3</td> <td>P08.02/P08.03</td> </tr> <tr> <td>ON</td> <td>ON</td> <td>ACC/DEC time 4</td> <td>P08.04/P08.05</td> </tr> </tbody> </table>	Terminal 1	Terminal 2	ACC/DEC time	Parameter	OFF	OFF	ACC/DEC time 1	P00.11/P00.12	ON	OFF	ACC/DEC time 2	P08.00/P08.01	OFF	ON	ACC/DEC time 3	P08.02/P08.03	ON	ON	ACC/DEC time 4	P08.04/P08.05
Terminal 1	Terminal 2	ACC/DEC time	Parameter																			
OFF	OFF	ACC/DEC time 1	P00.11/P00.12																			
ON	OFF	ACC/DEC time 2	P08.00/P08.01																			
OFF	ON	ACC/DEC time 3	P08.02/P08.03																			
ON	ON	ACC/DEC time 4	P08.04/P08.05																			
23	Simple PLC stop reset	Used to clear the previous PLC state memory information and restart the simple PLC process.																				
24	Pause simple PLC	Used to pause the simple PLC. When the function is revoked, the simple PLC resumes the running.																				
25	Pause PID control	PID is ineffective temporarily, and the inverter unit maintains the present frequency output.																				
26	Pause wobbling frequency (stop at current frequency)	The inverter unit pauses at current output. When the function is revoked, it continues wobbling-frequency operation at current frequency.																				
27	Reset wobbling frequency (back to center frequency)	The set frequency of the inverter unit restores to center frequency.																				
28	Reset the counter	The counter is cleared.																				
29	Switch between speed control and torque control	The inverter unit switches from torque control to speed control, or vice versa.																				
30	Disable ACC/DEC	Used to ensure the inverter unit is not impacted by external signals (except for stop command), and maintains the present output frequency.																				
31	Trigger the counter	Used to enable the counter to count pulses.																				
32	Length reset	Used to clear the length counting value. Reserved																				
33	Clear the frequency increase/decrease setting	When the terminal is closed, the frequency value set by UP/DOWN can be cleared to restore the reference																				

Setting	Function	Description																				
	temporarily	frequency to the frequency given by frequency command channel; when the terminal is opened, it restores to the frequency value after frequency increase/decrease setting.																				
34	DC braking	In the process of decelerating to stop, after the command becomes valid, the VFD will decrease to P01.09 (starting frequency of braking for stop) and then begin DC braking immediately. The braking time is not limited by P01.12 (DC braking time at stopping).																				
35	Brake feedback	After the brake control is enabled by setting P24.04, the input terminal receives the brake feedback signal. If the brake feedback signal is incorrect, the VFD reports Brake action fault (FAE).																				
36	Switch the running command channel to keypad	When the function is enabled, the running command channel is switched to keypad. When the function is disabled, the running command channel is restored to the previous setting.																				
37	Switch the running command channel to terminal	When the function is enabled, the running command channel is switched to terminal. When the function is disabled, the running command channel is restored to the previous setting.																				
38	Switch the running command channel to communication	When the function is enabled, the running command channel is switched to communication. When the function is disabled, the running command channel is restored to the previous setting.																				
39	Pre-exciting command	When the function is enabled, motor pre-exciting is started until the function becomes invalid.																				
40	Clear power consumption quantity	When the function is enabled, the power consumption quantity of the inverter unit is cleared.																				
41	Keep power consumption quantity	When the function is enabled, the present operation of the inverter unit does not impact the power consumption quantity.																				
42	Switch the setting source of braking torque upper limit to keypad	<table border="1"> <thead> <tr> <th>Terminal 1</th> <th>Terminal 2</th> <th>Motor selection</th> <th>Parameter</th> </tr> </thead> <tbody> <tr> <td>OFF</td> <td>OFF</td> <td>Motor 1</td> <td>Parameters of group P02</td> </tr> <tr> <td>ON</td> <td>OFF</td> <td>Motor 2</td> <td>Parameters of group P12</td> </tr> <tr> <td>OFF</td> <td>ON</td> <td>Motor 3</td> <td>Parameters of group P13</td> </tr> <tr> <td>ON</td> <td>ON</td> <td>Motor 4</td> <td>Parameters of group P14</td> </tr> </tbody> </table>	Terminal 1	Terminal 2	Motor selection	Parameter	OFF	OFF	Motor 1	Parameters of group P02	ON	OFF	Motor 2	Parameters of group P12	OFF	ON	Motor 3	Parameters of group P13	ON	ON	Motor 4	Parameters of group P14
		Terminal 1	Terminal 2	Motor selection	Parameter																	
		OFF	OFF	Motor 1	Parameters of group P02																	
		ON	OFF	Motor 2	Parameters of group P12																	
		OFF	ON	Motor 3	Parameters of group P13																	
ON	ON	Motor 4	Parameters of group P14																			
The torque upper limit is set through the keypad when the command is valid.																						
43	Motor group 1	The status of the two terminals can be combined to select four groups of motor parameters.																				
44	Motor group 2																					
45	Anti-snag protection input	When the function is enabled, the VFD can be forced to stop at the fastest speed.																				

Setting	Function	Description
46	Safe stop 1 (SS1)	When the function is enabled, the VFD stops at the deceleration time set in P24.17.
47	Safe speed limit (SLS)	When the function is enabled, the VFD limits the speed at the frequency and deceleration time set in P24.15 and P24.16.
48-63	Reserved	

● Terminal parameters

Function code	Name	Description	Setting range	Default
P05.09	Input terminal polarity	0x00-0xFF	0x00-0xFF	0x00

The function code is used to set the polarity of input terminals.

When a bit is 0, the input terminal is positive;

when a bit is 1, the input terminal is negative.

BIT7	BIT6	BIT5	BIT4	BIT3	BIT2	BIT1	BIT0
S8	S7	S6	S5	S4	S3	S2	S1

Function code	Name	Description	Setting range	Default
P05.10	Digital input filter time	0.000-1.000s	0.000-1.000	0.010s

The function code is used to specify the filter time of S1-S8 terminal sampling. In strong interference cases, increase the value to avoid maloperation.

Function code	Name	Description	Setting range	Default
P05.11	Virtual terminal setting	0x00-0xFF (0: Disable; 1: Enable) BIT0: S1 virtual terminal BIT1: S2 virtual terminal BIT2: S3 virtual terminal BIT3: S4 virtual terminal BIT4: S5 virtual terminal BIT5: S6 virtual terminal BIT6: S7 virtual terminal BIT7: S8 virtual terminal	0x00-0xFF	0x00

Specifies whether to enable the virtual input terminals in communication mode.

Function code	Name	Description	Setting range	Default
P05.12	Terminal control mode	0: Two-wire control mode 1 1: Two-wire control mode 2 2: Three-wire control mode 1 3: Three-wire control mode 2	0-3	0

The function code is used to set the mode of terminal control.

0: Two-wire control 1, the enabling consistent with the direction. This mode is widely used. The defined FWD/REV terminal command determines the motor rotation direction.

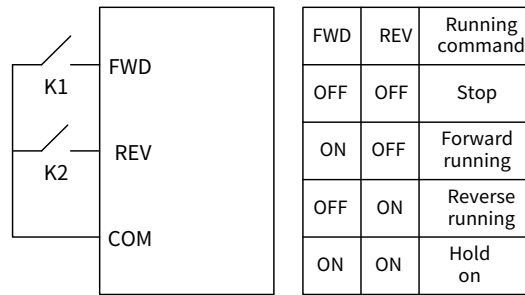

1: Two-wire control 2, the enabling separated from the direction. In this mode, FWD is the enabling terminal. The direction depends on the defined REV state.

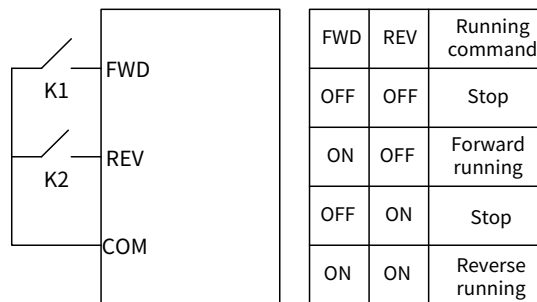

2: Three-wire control 1. This mode defines Sin as the enabling terminal, and the running command is generated by FWD, while the direction is controlled by REV. During running, the Sin terminal needs to be closed, and terminal FWD generates a rising edge signal, then the VFD starts to run in the direction set by the state of terminal REV; the VFD needs to be stopped by disconnecting terminal Sin.

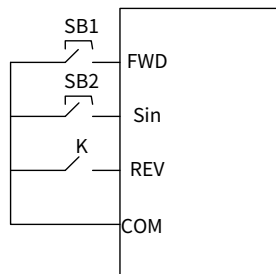

The direction control is as follows during running:

Sin	REV	Previous direction	Present direction
ON	OFF→ON	FWD run	REV run
		REV run	FWD run
ON	ON→OFF	REV run	FWD run
		FWD run	REV run
ON→OFF	ON	Decelerate to stop	
	OFF		

Sin: Three-wire control; FWD: Forward running; REV: Reverse running

3: Three-wire control 2. This mode defines Sin as the enabling terminal, and the running command is generated by FWD or REV, but the direction is controlled by both FWD and REV. During running, the Sin terminal needs to be closed, and terminal FWD or REV generates a rising edge signal to control the running and direction of the VFD; the VFD needs to be stopped by disconnecting terminal Sin.

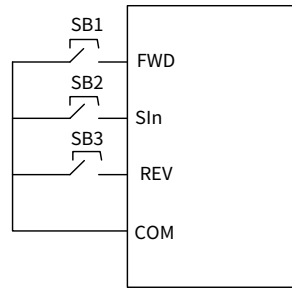

Sin	FWD	REV	Running direction
ON	OFF→ON	ON	FWD run
		OFF	FWD run
ON	ON	OFF→ON	REV run
	OFF		REV run
ON→OFF			Decelerate to stop

Sin: Three-wire control; FWD: Forward running; REV: Reverse running

Note: For two-wire controlled running mode, when the FWD/REV terminal is valid, if the VFD stops due to a stop command given by another source, the VFD does not run again after the stop command disappears even if the control terminal FWD/REV is still valid. To make the VFD run, you need to trigger FWD/REV again, for example, PLC single-cycle stop, fixed-length stop, and valid STOP/RST stop during terminal control. (See P07.04.)

Function code	Name	Description	Setting range	Default
P05.13	S1 switch-on delay	0.000–50.000s	0.000–50.000	0.000s
P05.14	S1 switch-off delay	0.000–50.000s	0.000–50.000	0.000s
P05.15	S2 switch-on delay	0.000–50.000s	0.000–50.000	0.000s
P05.16	S2 switch-off delay	0.000–50.000s	0.000–50.000	0.000s
P05.17	S3 switch-on delay	0.000–50.000s	0.000–50.000	0.000s
P05.18	S3 switch-off delay	0.000–50.000s	0.000–50.000	0.000s
P05.19	S4 switch-on delay	0.000–50.000s	0.000–50.000	0.000s
P05.20	S4 switch-off delay	0.000–50.000s	0.000–50.000	0.000s
P05.21	S5 switch-on delay	0.000–50.000s	0.000–50.000	0.000s
P05.22	S5 switch-off delay	0.000–50.000s	0.000–50.000	0.000s
P05.23	S6 switch-on delay	0.000–50.000s	0.000–50.000	0.000s
P05.24	S6 switch-off delay	0.000–50.000s	0.000–50.000	0.000s
P05.25	S7 switch-on delay	0.000–50.000s	0.000–50.000	0.000s
P05.26	S7 switch-off delay	0.000–50.000s	0.000–50.000	0.000s
P05.27	S8 switch-on delay	0.000–50.000s	0.000–50.000	0.000s
P05.28	S8 switch-off delay	0.000–50.000s	0.000–50.000	0.000s

Used to specify the delay time corresponding to the electrical level changes when the programmable input terminals switch on or switch off.

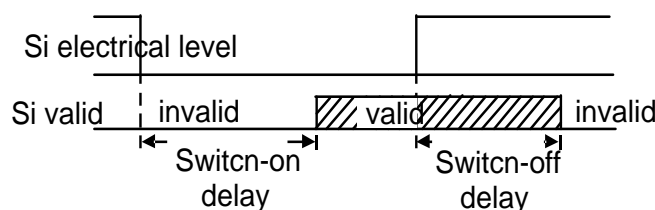

Function code	Name	Description	Setting range	Default
P05.46	S8 pulse input function selection	0: Input set through frequency 1: Counting (reserved) 2: Length (reserved)	0–2	0

- High-speed pulse terminal function

The function code is used to select function when the S8 terminal is used as pulse input.

0: Frequency setting input. The high-speed pulse can be used as input of frequency, torque, PID reference, and PID feedback. The corresponding relationship is determined by the function codes of P05.47–P05.51.

Function code	Name	Description	Setting range	Default
P05.47	S8 lower limit frequency	0.00 kHz–P05.49	0.00–P05.49	0.00kHz
P05.48	Corresponding setting of S8 lower limit frequency	-100.0%–100.0%	-100.0–100.0	0.0%
P05.49	Upper limit of S8 pulse frequency	P05.47–50.00kHz	P05.47–50.00	50.00kHz
P05.50	Corresponding setting of S8 upper limit frequency	-100.0%–100.0%	-100.0–100.0	100.0%
P05.51	S8 pulse frequency input filter time	0.000s–10.000s	0.000–10.000	0.100s

The function codes define the corresponding relations when the pulse is the setting input.

5.1.13 Digital output

The VFD carries two groups of relay output terminals, one open collector Y output terminal and one high-speed pulse output (HDO) terminal. The function of all the digital output terminals can be programmed through function codes, of which the high-speed pulse output terminal HDO can also be set to high-speed pulse output or digital output by function code.

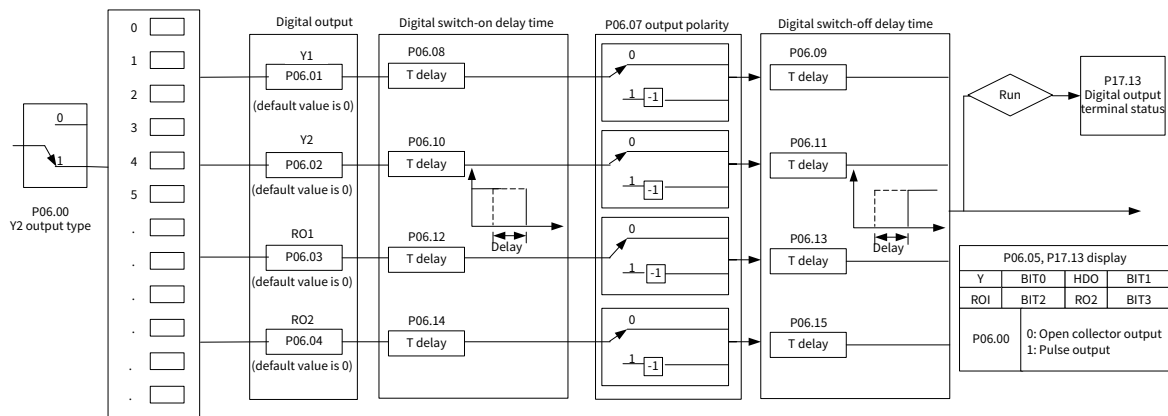

- Terminal functions

Function code	Name	Description	Setting range	Default
P06.00	Y2 output type	0: Open collector output 1: Open collector high-speed pulse output	0–1	0

Used to select the Y2 output type.

Function code	Name	Description	Setting range	Default
P06.01	Y1 output	0: Invalid	0-63	0
P06.02	Y2 output selection	1: Running	0-63	0
P06.03	RO1 output	2: Running forward	0-63	1
P06.04	RO2 output	3: Running reversely	0-63	5
P06.05	RO3 output	4: Jogging	0-63	0
P06.06	RO4 output	5: VFD in fault 6: Frequency level detection FDT1 7: Frequency level detection FDT2 8: Frequency reached 9: Running in zero speed 10: Upper limit frequency reached 11: Lower limit frequency reached 12: Ready for running 13: Pre-exciting 14: Overload pre-alarm 15: Underload pre-alarm 16: Simple PLC stage completed 17: Simple PLC cycle completed 18: Set counting value reached 19: Designated counting value reached 20: External fault is valid 21: Length reached (reserved) 22: Running time reached 23: Modbus communication virtual terminal output 24: PROFIBUS/CANopen/PROFINET communication virtual terminal output 25: Ethernet communication virtual terminal output 26: Bus voltage established 27: Brake control 28-63: Reserved	0-63	0

The following table lists the function code options. A same output terminal function can be repeatedly selected.

Setting	Function	Description
0	Invalid	The output terminal does not have any function.
1	Running	When the inverter unit works properly and there is frequency output, it outputs the ON signal.
2	Running forward	When the inverter runs forward and there is frequency output, it outputs the ON signal.

Setting	Function	Description
3	Running reversely	When the inverter unit runs reversely and there is frequency output, it outputs the ON signal.
4	Jogging	When the inverter unit jogs and there is frequency output, it outputs the ON signal.
5	Inverter unit fault	When the inverter unit encounters a fault, it outputs the ON signal.
6	Frequency level detection FDT1	(Refer to the descriptions for P08.32–P08.33.)
7	Frequency level detection FDT2	(Refer to the descriptions for P08.34–P08.35.)
8	Frequency reached	(Refer to the description for P08.36.)
9	Running in zero speed	When both the inverter unit output frequency and reference frequency are zero, it outputs the ON signal.
10	Upper limit frequency reached	The ON signal is output when the running frequency reaches the upper limit frequency.
11	Lower limit frequency reached	The ON signal is output when the running frequency reaches the lower limit frequency.
12	Ready for running	When the main circuit and control circuit powers are established, the inverter unit protection functions do not act, and the inverter unit is ready to run, it outputs the ON signal.
13	Pre-exciting	When the inverter unit is pre-exciting, it outputs the ON signal.
14	Overload pre-alarm	When the pre-alarm time elapsed if the inverter unit pre-alarm threshold is reached, it outputs the ON signal. For details, see the descriptions for P11.08–P11.10.
15	Underload pre-alarm	When the pre-alarm time elapsed if the inverter unit pre-alarm threshold is reached, it outputs the ON signal. For details, see the descriptions for P11.11–P11.12.
16	Simple PLC stage completed	When the present state of the simple PLC is completed, it outputs a signal.
17	Simple PLC cycle completed	When a single cycle of the simple PLC is completed, it outputs a signal.
18	Set counting value reached	The output is valid when the detected counting value exceeds the value set by P08.25.
19	Designated counting value reached	The output is valid when the detected counting value exceeds the value set by P08.26.
20	External fault is valid	Output is valid when the external fault (EF) occurs.
21	Length reached	(reserved)
22	Running time reached	The output is valid after the running time of the VFD exceeds the time set in P08.27.
23	Modbus communication virtual terminal output	A signal is output based on the value set through Modbus communication. When the value is 1, the ON signal is output; when the value is 0, the OFF signal is output.
24	PROFIBUS/CANopen/PRO FINET communication virtual terminal output	Output corresponding signal based on the set value of PROFIBUS. When the value is 1, the ON signal is output; when the value is 0, the OFF signal is output.

Setting	Function	Description
25	Ethernet communication virtual terminal output	A signal is output based on the value set through Ethernet communication. When the value is 1, the ON signal is output; when the value is 0, the OFF signal is output.
26	DC bus voltage established	The output is valid when the bus voltage is above the inverter undervoltage.
27	Brake control	When the brake control is selected via P24.04, the brake control signal is output (ON: brake release; OFF: Brake).
28-63	Reserved	/

● Terminal parameters

Function code	Name	Description	Setting range	Default
P06.07	Output terminal polarity selection	0x00-0x3F RO4, RO3, RO2, RO1, HDO, Y1 in sequence	0x00-0x3F	0x00

The function code is used to set the polarity of output terminals.

When a bit is 0, the output terminal is positive; when a bit is 1, the output terminal is negative.

BIT5	BIT4	BIT3	BIT2	BIT1	BIT0
RO4	RO3	RO2	RO1	Y2	Y1

Note: When either STO terminals H1 and H2 are active, RO4 can only be set to positive polarity.

Function code	Name	Description	Setting range	Default
P06.08	Y1 switch-on delay	0.000-50.000s	0.000-50.000	0.000s
P06.09	Y1 switch-off delay	0.000-50.000s	0.000-50.000	0.000s
P06.10	Y2 switch-on delay	0.000-50.000s (valid when P06.00 is 1)	0.000-50.000	0.000s
P06.11	Y2 switch-off delay	0.000-50.000s (valid when P06.00 is 1)	0.000-50.000	0.000s
P06.12	RO1 switch-on delay	0.000-50.000s	0.000-50.000	0.000s
P06.13	RO1 switch-off delay	0.000-50.000s	0.000-50.000	0.000s
P06.14	RO2 switch-on delay	0.000-50.000s	0.00-50.000	0.000s
P06.15	RO2 switch-off delay	0.000-50.000s	0.00-50.000	0.000s
P06.16	RO3 switch-on delay	0.000-50.000s	0.000-50.000	0.000s
P06.17	RO3 switch-off delay	0.000-50.000s	0.000-50.000	0.000s
P06.18	RO4 switch-on delay	0.000-50.000s	0.00-50.000	0.000s
P06.19	RO4 switch-off delay	0.000-50.000s	0.00-50.000	0.000s

Note: When either STO terminals H1 and H2 are active, RO4 delay is invalid.

The function codes specify the delay time corresponding to the electrical level changes when the programmable output terminals switch on or switch off.

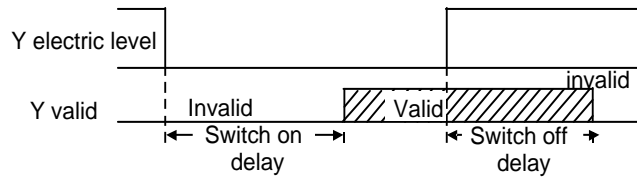

● High-speed pulse terminal function

Function code	Name	Description	Setting range	Default
P06.00	Y2 output type	0: Open collector output 1: Open collector high-speed pulse output	0-1	0
P06.22	Y2 pulse output selection	0-47: See section Analog output for details	0-47	0
P06.33	Y2 output lower limit	-100.0%-100.0%	-100.0-100.0	0.0%
P06.34	Y2 output corresponding to lower limit	0.00-50.00kHz	0.00-50.00	0.00kHz
P06.35	Y2 output upper limit	-100.0%-100.0%	-100.0-100.0	100.0%
P06.36	Y2 output corresponding to upper limit	0.00-50.00kHz	0.00-50.00	50.00kHz
P06.37	Y2 output filter time	0.000s-10.000s	0.000-10.000	0.000s

The function codes define the relationship between the output value and high-speed pulse output. When the output value exceeds the allowed range, the output uses the lower limit or upper limit.

5.1.14 Run at wobbling frequency

Wobbling frequency is mainly applied in the scenarios where transverse movement and winding functions are needed such as textile and chemical fiber industries. The typical working process is shown as follows.

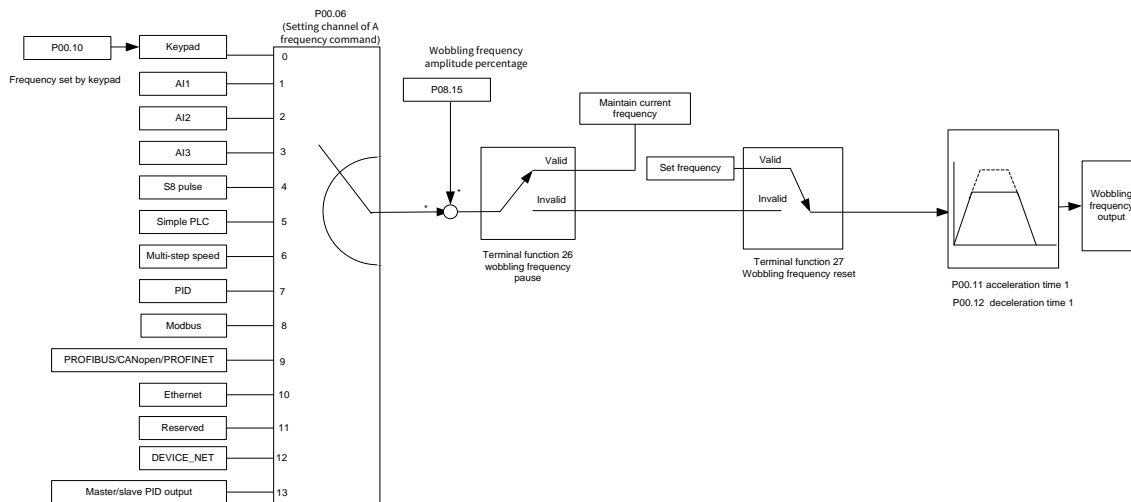

Function code	Name	Description	Setting range	Default
P05.01–P05.08	Digital input function selection	26: Pause wobbling frequency (stopped at the present frequency) 27: Reset wobbling frequency (returned to the center frequency)	/	
P08.15	Wobbling frequency amplitude percentage	0.0–100.0% (of the set frequency)	0.0–100.0	0.0%
P08.16	Amplitude of sudden jump frequency	0.0–50.0% (of the amplitude of wobbling frequency)	0.0–50.0	0.0%
P08.17	Rise time of wobbling frequency	0.1–3600.0s	0.1–3600.0	5.0s
P08.18	Fall time of wobbling frequency	0.1–3600.0s	0.1–3600.0	5.0s

Wobbling frequency function means that the VFD output frequency swings up and down with the set frequency as the center. The following figure shows the relation between running frequency and time, where the amplitude of wobbling frequency is set by P08.15. When P08.15 is set to 0, the wobbling frequency does not work.

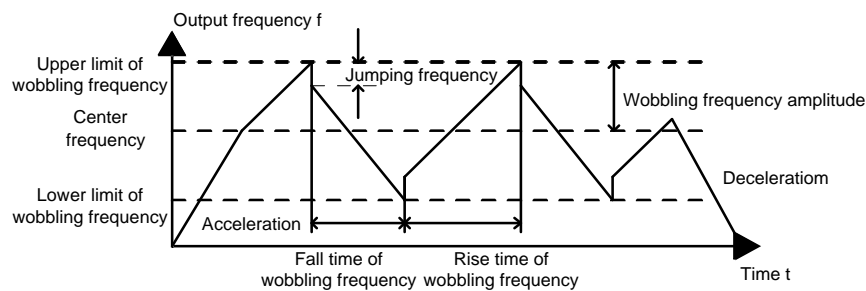

Amplitude of wobbling frequency: wobbling frequency is restricted by the upper limit and lower limit frequency.

The amplitude of wobbling frequency is relative to the center frequency (set frequency): amplitude of wobbling frequency (AW) = center frequency × wobbling frequency amplitude percentage (P08.15)

Sudden jump frequency = AW × amplitude of sudden jump frequency (P08.16) P08.16 indicates the value that the sudden jump frequency relative to the amplitude of wobbling frequency when the VFD runs at wobbling frequency.

Rise time of wobbling frequency: time taken to run from the lower limit frequency of the wobbling frequency to the upper limit frequency.

Fall time of wobbling frequency: time taken to run from the upper limit frequency of the wobbling frequency to the lower limit frequency.

5.1.15 HMI

Function code	Name	Description	Setting range	Default
P07.00	User password	0–65535	0–65535	0

When you set the function code to a non-zero number, password protection is enabled.

If you set the function code to 00000, the previous user password is cleared and password protection is disabled.

After the user password is set and takes effect, you cannot enter the parameter menu if you enter an incorrect password. Please remember your password and save it in a secure place.

After you exit the function code editing interface, the password protection function is enabled within 1 minute. If password protection is enabled, "0.0.0.0.0" is displayed when you press the PRG/ESC key again to enter the function code editing interface. You need to enter the correct user password to enter the interface.

Note: Restoring the default values may delete the user password. Exercise caution when using this function.

Function code	Name	Description	Setting range	Default
P07.01	Parameter copy	0: No operation 1: Upload parameters from the local address to the keypad 2: Download parameters (including motor parameters) from the keypad to the local address 3: Download parameters (excluding motor parameters) from the keypad to the local address 4: Download parameters (only including motor parameters) from the keypad to the local address	0-4	0

Used to set the parameter copy mode.

Note: After any operation among 1-4 is complete, the parameter restores to 0. The upload and download functions are not applicable to group P29.

Function code	Name	Description	Setting range	Default
P07.02	Function of QUICK/JOG	0: No function 1: Jog 2: Switch between states 3: Switch between forward and reverse rotating 4: Clear the UP/DOWN setting 5: Coast to stop 6: Switch command channels in sequence 7: Quick commissioning mode (based on non-factory parameter settings)	0-7	1

The function code is used to select the function of the QUICK/JOG key.

0: No function

1: Jogging Press QUICK/JOG to begin the jogging running.

2: Switch displayed function codes from right to left by Press QUICK/JOG to shift the displayed function code from right to left.

3: Switch between forward and reverse rotations. Press QUICK/JOG to shift the direction of the frequency commands. This function is only valid in the keypad command channels.

- 4: Clear the UP/DOWN setting. Press **QUICK/JOG** to clear the set values of UP/DOWN.
- 5: Coast to stop. Press **QUICK/JOG** to coast to stop.
- 6: Switch command channels in sequence Press **QUICK/ JOG** to switch command channels in sequence.
- 7: Quick commissioning mode (based on non-factory parameter settings)

Note: When **QUICK/JOG is used to shift between forward rotation and reverse rotation, the VFD does not record the state after shifting during power off. The VFD will run according to the running direction set by P00.13 during next power on.**

Function code	Name	Description	Setting range	Default
P07.03	Sequence of switching running-command channels by pressing QUICK	0: Keypad→Terminal→Communication 1: Keypad←→Terminal 2: Keypad←→Communication 3: Terminal←→Communication	0-3	0

When P07.02=6, set the sequence of switching running-command channels by pressing this key.

Function code	Name	Description	Setting range	Default
P07.04	Stop function validity of STOP/RST	0: Valid only for keypad control 1: Valid both for keypad and terminal control 2: Valid both for keypad and communication control 3: Valid for all control modes	0-3	0

Used to specify the stop function validity of **STOP/RST**. For fault reset, **STOP/RST** is valid in any conditions.

Function code	Name	Description	Setting range	Default
P07.05	Selection 1 of parameters to be displayed in the running state	BIT0: Running frequency (Hz on) BIT1: Set frequency (Hz blinking) BIT2: Bus voltage (V on) BIT3: Output voltage (V on) BIT4: Output current (A on) BIT5: Running speed (rpm on) Bit 6: Output power (% on) Bit 7: Output torque (% on) Bit 8: PID reference value (% blinking) Bit 9: PID feedback value (% on) BIT10: Input terminal status BIT11: Output terminal status Bit 12: Set torque (% on) Bit 13: Pulse count value BIT14: Reserved Bit 15: PLC and current step number of multi-step speed	0x0000- 0xFFFF	0x03FF
P07.06	Selection 2 of parameters to be displayed in the running state	Bit 0: AI1 (V on) Bit 1: AI1 (V on) Bit 2: AI3 (V on) Bit3-Bit4: Reserved Bit5: High-speed pulse S8 frequency	0x0000- 0xFFFF	0x0000

Function code	Name	Description	Setting range	Default
		Bit6: Reserved Bit7: Motor overload percentage (% on) Bit8: VFD overload percentage (% on) Bit9: Ramp frequency reference (Hz on) Bit10: Linear speed Bit11-15: Reserved		

The function code P07.06 determines parameter display at VFD running state. The value is a 16-bit binary number. If a bit is 1, the parameter corresponding to this bit can be viewed through **>>/SHIFT** during running. If this bit is 0, the parameter corresponding to this bit is not displayed. When setting P07.05 and P07.06, convert the binary number to a hex number before the input to the function code.

P07.05	BIT15	BIT14	BIT13	BIT12	BIT11	BIT10	BIT9	BIT8
	PLC and actual step of multi-step speed	Reserved	Pulse count value	Torque set value	Output terminal status	Input terminal status	PID feedback value	PID reference value
P07.06	BIT7	BIT6	BIT5	BIT4	BIT3	BIT2	BIT1	BIT0
	Output torque	Output power	Rotational speed	Output current	Output voltage	Bus voltage	Set frequency	Running frequency
P07.06	BIT15	BIT16	BIT13	BIT12	BIT11	BIT10	BIT9	BIT8
	Reserved	Reserved	Reserved	Reserved	Reserved	Linear speed	Ramp frequency reference	VFD overload percentage
P07.06	BIT7	BIT6	BIT5	BIT4	BIT3	BIT2	BIT1	BIT0
	Motor overload percentage	Reserved	High-speed pulse S8 frequency	Reserved	Reserved	A13 value	A12 value	A11 value

Function code	Name	Description	Setting range	Default
P07.07	Selection of parameters to be displayed in the stop state	BIT0: Set frequency (Hz on, blinking slowly) BIT1: Bus voltage (V on) BIT2: Input terminal state BIT3: Output terminal state BIT4: PID reference value (% blinking) BIT5: PID feedback value (% on) BIT6: Set torque (% on) BIT7: A11 (V on) BIT8: A12 (V on) BIT9: A13 (V on) BIT10: Reserved BIT11: Reserved BIT12: High-speed pulse S8 frequency BIT13: Reserved BIT14: PLC and actual step of multi-step speed BIT15: Pulse count value	0x0000-0xFFFF	0x00FF

The setting method of P07.07 is the same with that of P07.06. The function code P07.07 determines the parameter display at VFD stopped state.

BIT15	BIT14	BIT13	BIT12	BIT11	BIT10	BIT9	BIT8
Pulse count value	PLC and actual step of multi-step speed	Reserved	High-speed pulse S8 frequency	Reserved	Reserved	AI3 value	AI2 value
BIT7	BIT6	BIT5	BIT4	BIT3	BIT2	BIT1	BIT0
AI1 value	Torque set value	PID feedback value	PID reference value	Output terminal status	Input terminal status	Bus voltage	Set frequency

Function code	Name	Description	Setting range	Default
P07.08	Frequency display coefficient	0.01-10.00	0.01-10.00	1.00
P07.09	Rotational speed display coefficient	0.1-999.9%	0.1-999.9%	100.0%
P07.10	Linear speed display coefficient	0.1-999.9%	0.1-999.9%	1.0%

Display frequency = Running frequency * P07.08

Mechanical rotation speed = 120 * (Displayed running frequency * P07.09 / (Number of motor pole pairs))

Linear speed = (Mechanical rotation speed) * P07.10.

Function code	Name	Description	Setting range	Default
P07.11	Rectifier bridge temperature	-20-120.0°C		
P07.12	Inverter temperature	-20-120.0°C		
P07.13	Control board software version	1.00-655.35		
P07.14	Local accumulative running time	0-65535h		

The parameters above are read-only.

Function code	Name	Description	Setting range	Default
P07.15	VFD electricity consumption MSB	0-65535kWh (*1000)		
P07.16	VFD electricity consumption LSB	0.0-999.9kWh		

Used to display the electricity consumption of the VFD.

VFD electricity consumption = P07.15 * 1000 + P07.16.

Function code	Name	Description	Setting range	Default
P07.17	VFD model	0: Heavy overload application 1: Light overload application 2: No overload application		

Function code	Name	Description	Setting range	Default
P07.18	VFD rated power	0.4–6000.0kW		
P07.19	VFD rated voltage	50–1200V		
P07.20	VFD rated current	0.1–6000.0A		
P07.21	Factory bar code 1	0x0000–0xFFFF		
P07.22	Factory bar code 2	0x0000–0xFFFF		
P07.23	Factory bar code 3	0x0000–0xFFFF		
P07.24	Factory bar code 4	0x0000–0xFFFF		
P07.25	Factory bar code 5	0x0000–0xFFFF		
P07.26	Factory bar code 6	0x0000–0xFFFF		

The parameters above are read-only.

5.1.16 Enhanced functions

- Multiple groups of ACC/DEC time

Function code	Name	Description	Setting range	Default
P00.11	ACC time 1	0.0–3600.0s	0.0–3600.0	Model depended
P00.12	DEC time 1	0.0–3600.0s	0.0–3600.0	Model depended
P08.00	ACC time 2	0.0–3600.0s	0.0–3600.0	Model depended
P08.01	DEC time 2	0.0–3600.0s	0.0–3600.0	Model depended
P08.02	ACC time 3	0.0–3600.0s	0.0–3600.0	Model depended
P08.03	DEC time 3	0.0–3600.0s	0.0–3600.0	Model depended
P08.04	ACC time 4	0.0–3600.0s	0.0–3600.0	Model depended
P08.05	DEC time 4	0.0–3600.0s	0.0–3600.0	Model depended

ACC time means the time needed if the VFD speeds up from 0Hz to the max. output frequency (P00.03).

DEC time means the time needed if the VFD speeds down from the max. output frequency (P00.03) to 0Hz.

The inverter unit has four groups of ACC/DEC time, which can be selected by P05. The factory default ACC/DEC time of the VFD is the first group.

- Jogging function

Function code	Name	Description	Setting range	Default
P08.06	Running frequency of jog	0.00Hz–P00.03 (Max. output frequency)	0.00–P00.03	5.00Hz

The function code is used to define the reference frequency during jogging.

Function code	Name	Description	Setting range	Default
P08.07	ACC time for jogging	0.0–3600.0s	0.0–3600.0	Model depended
P08.08	DEC time for jogging	0.0–3600.0s	0.0–3600.0	Model depended

ACC time for jogging means the time needed for the VFD to accelerate from 0Hz to the max. output frequency (P00.03).

DEC time for jogging means the time needed for the VFD to decelerate from the max. output frequency (P00.03) to 0Hz.

● Counters

Function code	Name	Description	Setting range	Default
P08.25	Set counting value	P08.26–65535	P08.26–65535	0
P08.26	Designated counting value	0–P08.25	0–P08.25	0

The counter works through the S8 terminal input pulse signal.

When the counting value reaches the designated counting value, the multifunction digital output terminal outputs the signal of "Designated counting value reached" and the counting continues. When the counting value reaches the set counting value, the multifunction digital output terminal outputs the signal of "Set counting value reached" and the counting is cleared. The counter will restart counting at next pulse arrival.

P08.26 should not be greater than P08.25.

The function is shown in the following figure:

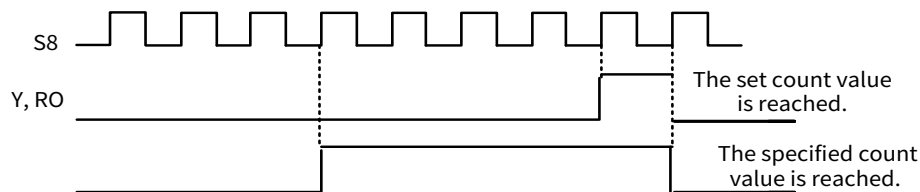

Function code	Name	Description	Setting range	Default
P08.27	Set running time	0–65535min	0–65535	0min

The function code is used to preset the running time of the VFD. When the last continuous running time achieves the set time, the multi-function digital output terminal will output the signal of "Running time reached".

● Auto fault reset

Function code	Name	Description	Setting range	Default
P08.28	Auto fault reset count	0–10	0–10	0
P08.29	Auto fault reset interval	0.1–100.0s	0.1–100.0	1.0s

Auto fault reset count: When the VFD uses automatic fault reset, it is used to set the number of automatic fault reset times. When the number of continuous reset times exceeds the value, the VFD reports a fault and stops.

Auto fault reset interval: Time interval from when a fault occurred to when automatic fault reset takes effect.

- FDT function

Function code	Name	Description	Setting range	Default
P08.32	FDT1 electrical level detection value	0.00Hz-P00.03 (Max. output frequency)	0.00-P00.03	50.00Hz
P08.33	FDT1 lagging detection value	0.0-100.0% (FDT1 electrical level)	0.0-100.0	5.0%
P08.34	FDT2 electrical level detection value	0.00Hz-P00.03 (Max. output frequency)	0.00-P00.03	50.00Hz
P08.35	FDT2 lagging detection value	0.0-100.0% (FDT2 electrical level)	0.0-100.0	5.0%

When the output frequency exceeds the corresponding frequency of FDT electrical level, the multifunction digital output terminal continuously outputs the signal of "Frequency level detection FDT". The signal is invalid only when the output frequency decreases to a value lower than the frequency corresponding to (FDT electrical level—FDT lagging detection value).

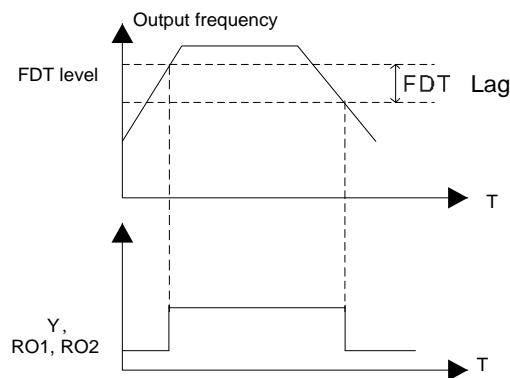

Function code	Name	Description	Setting range	Default
P08.36	Detection value for frequency being reached	0.0-P00.03 (Max. output frequency)	0.0-P00.03	0.00Hz

When the output frequency is within the detection range, the multifunction digital output terminal outputs the signal of "Frequency reached".

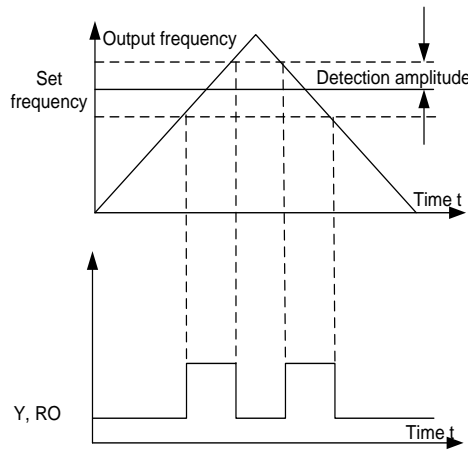

5.1.17 PID control

PID control, a common mode for process control, is mainly used to adjust the inverter unit output frequency or output voltage through performing scale-division, integral and differential operations on the difference between feedback signal of controlled variables and signal of the target, thus forming a negative feedback system to keep the controlled variables above the target. It is applicable to flow control, pressure control, temperature control, and so on. The following is the basic schematic block diagram for output frequency regulation.

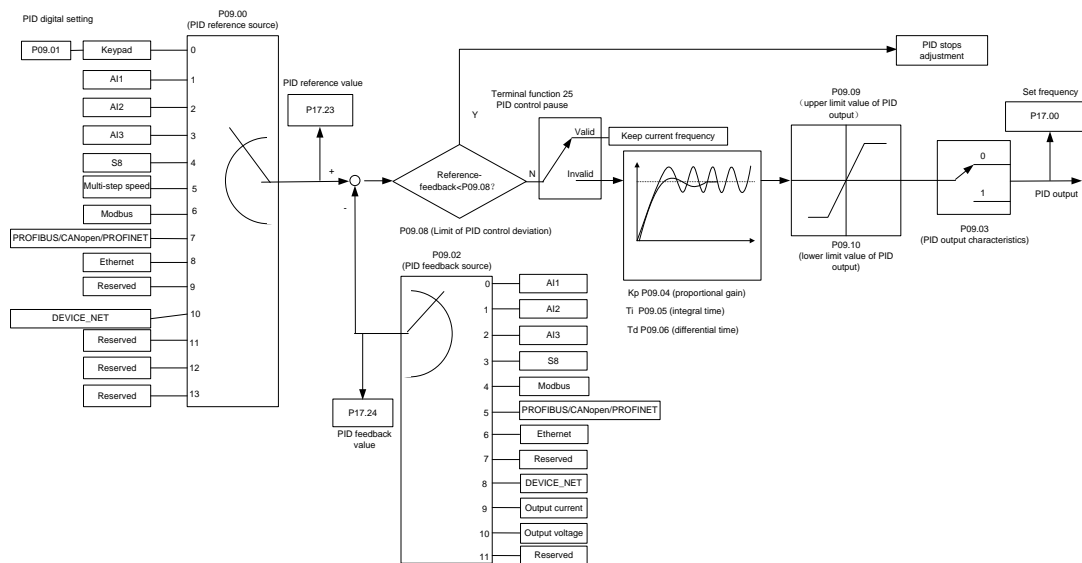

Introduction to the working principles and control methods for PID control:

Proportional control (Kp): When the feedback is different from the reference, the output will be proportional to the difference. If such a difference is constant, the regulating variable will also be constant. Proportional control can respond to feedback changes rapidly, however, it cannot eliminate the difference by itself. A larger proportional gain indicates a faster regulating speed, but a too large gain will result in oscillation. To solve this problem, set the integral time to a large value and the differential time to 0, run the system only with proportional control, and then change the reference to observe the difference (that is, static difference) between the feedback signal and reference. If the static difference occurs in the direction of reference change (such as reference increase, where the feedback is always less than the reference after system stabilizes), continue increasing the proportional gain; otherwise, decrease the proportional gain. Repeat this process until the static difference becomes small.

Integral time (Ti): When feedback is different from reference, the output regulating variable accumulates continuously, if the difference persists, the regulating variable will increase continuously until difference

disappears. The integral regulator can be used to eliminate static difference. However, too large regulation may lead to repetitive overshoot, which will cause system instability and oscillation. The feature of oscillation caused by strong integral effect is that the feedback signal fluctuates up and down based on the reference variable, and fluctuation range increases gradually until oscillation occurs. The integral time parameter is generally regulated gradually from large to small until the stabilized system speed fulfills the requirement.

Differential time (Td): When the difference between feedback and reference changes, there is output of the regulating variable that is proportional to the difference variation rate, and this regulating variable is only related to the direction and magnitude of the difference change rather than the direction and magnitude of the difference itself. Differential control is used to control the feedback signal variation based on the change trend. Exercise caution before using the differential regulator since it may enlarge the system interferences, especially those with high change frequency.

When the frequency command selection (P00.06, P00.07) is 7 or the voltage setting channel selection (P04.27) is 6, the inverter unit is process PID controlled.

5.1.17.1 General procedures for PID parameter setup

1. Determine proportional gain P.

When determining proportional gain P, first, remove the integral term and derivative term of PID by making $T_i=0$ and $T_d=0$ (see PID parameter setup for details), thus turning PID into pure proportional control. Set the input to 60%–70% of the max. allowable value, and increase proportional gain P gradually from 0 until system oscillation occurred, and then in turn, decrease proportional gain P gradually from current value until system oscillation disappears, record the proportional gain P at this point and set the proportional gain P of PID to 60%–70% of current value. This is the entire commissioning procedure of proportional gain P.

2. Determine integral time T_i .

After proportional gain P is determined, set the initial value of integral time T_i to a large value, and decrease T_i gradually until system oscillation occurs. Then in reverse, increase T_i until system oscillation disappears. Record the value of T_i at this point. Set the integral time constant T_i of PID to 150%–180% of this value. This is the commissioning procedure of integral time constant T_i .

3. Determine derivative time T_d .

The differential time T_d is generally set to 0.

If you need to set T_d to another value, the setting method is similar to that for P and T_i , namely, set T_d to 30% of the value when there is no oscillation.

4. Empty system load, perform load-carrying joint debugging, and then adjust PID parameters until fulfilling the requirement.

5.1.17.2 How to fine-tune PID

After setting the parameters controlled by PID, you can adjust these parameters by the following means.

Control overshoot: When overshoot occurred, shorten the derivative time (T_d) and prolong integral time (T_i).

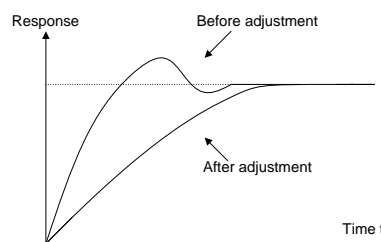

Stabilize the feedback value as fast as possible: When overshoot occurred, shorten integral time (T_i) and prolong derivative time (T_d) to stabilize control as fast as possible.

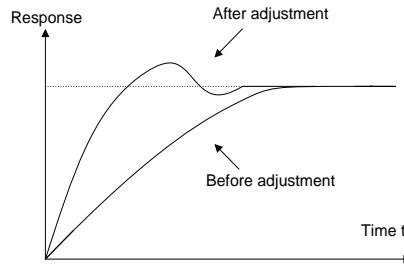

Control long-term vibration: If the cycle of periodic vibration is longer than the set value of integral time (Ti), it indicates the integral action is too strong, prolong the integral time (Ti) to control vibration.

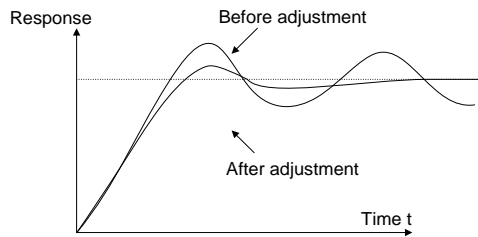

Control short-term vibration: If the vibration cycle is as short almost the same as the set value of differential time (Td), it indicates the differential action is too strong. Shorten the differential time (Td) to control vibration. When the differential time (Td) is set to 0.00 (namely no differential control), and there is no way to control vibration, decrease the proportional gain.

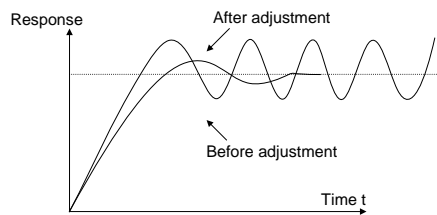

Related parameters

Function code	Name	Description	Setting range	Default
P09.00	PID reference source	0: P09.01 1: AI1 2: AI2 3: AI3 4: S8 pulse 5: Multi-step running 6: MODBUS communication 7: PROFIBUS/CANopen/PROFINET communication 8: Ethernet communication 9: Reserved 10: DEVICE_NET 11-13: Reserved	0-13	0

The function code determines the target given channel during the PID process. When the frequency command selection (P00.06, P00.07) is 7 or the voltage setting channel selection (P04.27) is 6, the VFD is process PID controlled.

The set target of process PID is a relative value, for which 100% equals 100% of the feedback signal of the controlled system.

The system always performs calculation by using a relative value (0-100.0%).

Note:

- Multi-step speed reference can be realized by setting parameters of P10 group.
- The reference sources PROFIBUS communication, Ethernet communication, CANopen communication, and DEVICE_NET are available only when corresponding expansion cards are configured.

Function code	Name	Description	Setting range	Default
P09.01	PID digital setting	-100.0%–100.0%	-100.0–100.0	0.0%

When P09.00=0, the parameter is set on the keypad.

Function code	Name	Description	Setting range	Default
P09.02	PID feedback source	0: AI1 1: AI2 2: AI3 3: S8 pulse 4: MODBUS communication 5: PROFIBUS/CANopen/PROFINET communication 6: Ethernet communication 7: Reserved 8: DEVICE_NET (Reserved) 9: Output Current 10: Output voltage 11: Reserved	0–11	P09.02

The function code is used to select PID feedback channel.

Note: The reference channel and feedback channel cannot be duplicate. Otherwise, effective PID control cannot be achieved.

Function code	Name	Description	Setting range	Default
P09.03	PID output characteristics selection	0: PID output is positive. 1: PID output is negative.	0–1	0

The function code is used to select PID output characteristics.

0: PID output is positive. When the feedback signal is greater than the PID reference value, the output frequency of the VFD will decrease to balance the PID. Example: PID control on strain during unwinding.

1: PID output is negative. When the feedback signal is greater than the PID reference value, the output frequency of the VFD will increase to balance the PID. Example: PID control on strain during unwinding.

Function code	Name	Description	Setting range	Default
P09.04	Proportional gain (Kp)	0.00–100.0	0.00–100.0	1.00

The function is applied to the proportional gain P of PID input.

P determines the strength of the whole PID adjuster. The larger the value of P, the stronger the adjustment intensity. The value 100 indicates that when the difference between the PID feedback value and given value

is 100%, the range within which the PID regulator can regulate the output frequency command is the max. frequency (ignoring integral function and differential function).

Function code	Name	Description	Setting range	Default
P09.05	Integral time (Ti)	0.00-10.00s	0.00-10.00	1.00s

Used to determine the speed of the integral adjustment on the deviation of PID feedback and reference from the PID regulator.

When the deviation of PID feedback and reference is 100%, the integral adjuster works continuously during the time (ignoring proportional and differential function) to achieve the max. output frequency (P00.03) or the max. voltage (P04.31). Shorter integral time indicates stronger adjustment.

Function code	Name	Description	Setting range	Default
P09.06	Differential time (Td)	0.00-10.00s	0.00-10.00	0.00s

Used to determine the strength of the change ratio adjustment on the deviation of PID feedback and reference from the PID regulator.

If the PID feedback changes 100% during the time, the adjustment of the differential regulator (ignoring proportional and integral function) is the max. output frequency (P00.03) or the max. voltage (P04.31). Longer differential time indicates stronger adjustment.

Function code	Name	Description	Setting range	Default
P09.07	Sampling cycle (T)	0.001-1.000s	0.001-1.000	0.001s

Used to indicate the sampling cycle of feedback. The regulator calculates in each sampling cycle. A longer sampling cycle indicates slower response.

Function code	Name	Description	Setting range	Default
P09.08	PID control deviation limit	0.0-100.0%	0.0-100.0	0.0%

The output of the PID system is relative to the max. deviation of the closed loop reference. As shown in the following figure, the PID regulator stops regulating in the range of deviation limit. Set the function parameter properly to adjust the accuracy and stability of the PID system.

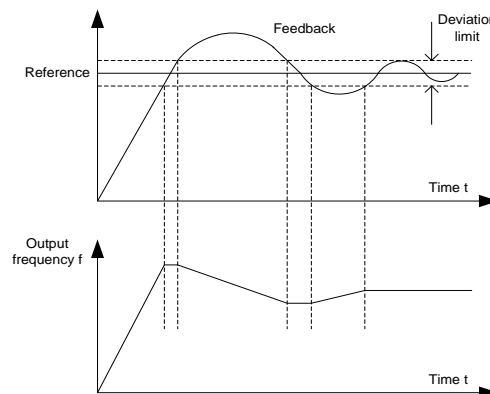

Function code	Name	Description	Setting range	Default
P09.09	PID output upper limit	P09.10-100.0% (Max. frequency or voltage)	P09.10-100.0	100.0%
P09.10	PID output lower limit	-100.0%-P09.09 (Max. frequency or voltage)	-100.0-P09.09	0.0%

The function code is used to set the upper and lower limits of PID regulator output values. 100.0% corresponds to the max. output frequency (P00.03) or max. voltage (P04.31).

Function code	Name	Description	Setting range	Default
P09.11	Feedback offline detection value	0.0-100.0%	0.0-100.0	0.0%
P09.12	Feedback offline detection time	0.0-3600.0s	0.0-3600.0	1.0s

Used to set the PID feedback offline detection value. When the feedback value is smaller than or equal to the feedback offline detection value, and the duration exceeds the value specified by P09.12, the VFD reports "PID feedback offline fault" and the keypad displays PIDE.

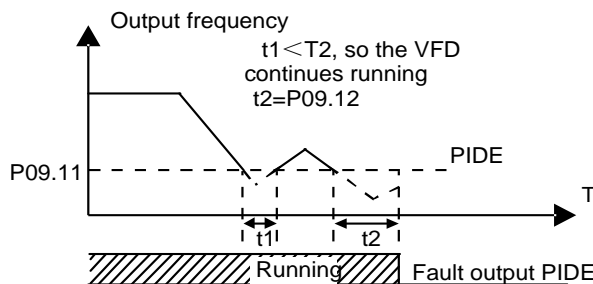

Function code	Name	Description	Setting range	Default
P09.13	PID control selection	0x00-0x11 LED ones place: 0: Continue integral control after the frequency reaches upper/lower limit 1: Stop integral control after the frequency reaches upper/lower limit Hundreds place: Reserved	0x00-0x11	0x00

LED ones place:

0: Continue integral control after the frequency reaches upper/lower limit: the integration responses the changes between the reference and feedback unless it reaches the internal integral limit. When the size between the reference and feedback changes, it needs more time to offset the impact of continuous working integration and the integration can change with the trend.

1: Stop integral control after the frequency reaches upper/lower limit: if the integration keeps stable and the size between the reference and feedback changes, the integration will change along with the trend quickly.

Related parameter list:

Function code	Name	Setting range	Default
P09.00	PID reference source	0-13	0
P09.01	PID digital setting	-100.0-100.0	0.0%

Function code	Name	Setting range	Default
P09.02	PID feedback source	0-11	0
P09.03	PID output characteristics selection	0-1	0
P09.04	Proportional gain (Kp)	0.00-100.0	1.00
P09.05	Integral time (Ti)	0.01-10.00	0.10s
P09.06	Differential time (Td)	0.00-10.00	0.00s
P09.07	Sampling cycle (T)	0.00-100.0	0.010s
P09.08	PID control deviation limit	0.0-100.0	0.0%
P09.09	PID output upper limit	P09.10-100.0	100.0%
P09.10	PID output lower limit	-100.0-P09.09	0.0%
P09.11	Feedback offline detection value	0.0-100.0%	0.0%
P09.12	Feedback offline detection time	0.0-3600.0	1.0s
P09.13	PID control selection	00-11	0x00
P17.00	Set frequency	0.00Hz-P00.03	0.00Hz
P17.23	PID reference value	-100.0-100.0%	0.0%
P17.24	PID feedback value	-100.0-100.0%	0.0%

5.1.18 Simple PLC and multi-step speed running

- Simple PLC

A simple PLC is a multi-step speed generator, and the inverter unit can change the running frequency and direction automatically based on the run time to fulfill process requirements. Previously, such function was realized with external PLC, while now, the inverter unit itself can achieve this function.

The inverter unit can realize 16-step speed control, and provide four groups of ACC/DEC time for you to choose.

After the set PLC completes one cycle (or one step), one ON signal can be output by the multifunction relay.

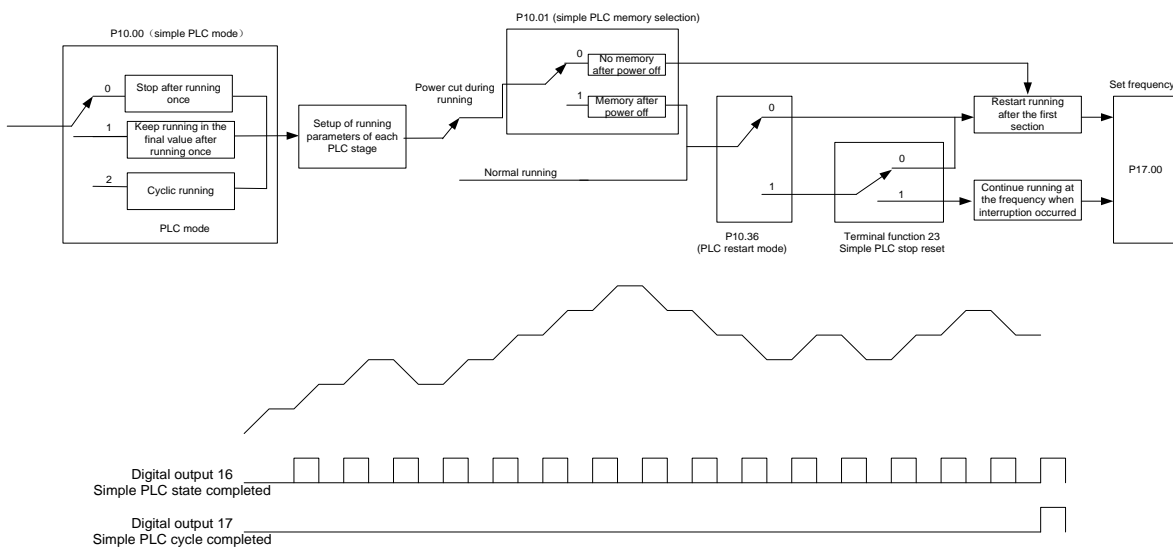

Function code	Name	Description	Setting range	Default
P10.00	Simple PLC mode	0: Stop after running once 1: Keep running with the final value after running once 2: Cyclic running	0-2	0

The function code is used to set simple PLC mode.

0: Stop after running once. The VFD stops automatically after running for one cycle, and it can be started only after receiving the running command.

1: Keep running in the final value after running for one cycle. The VFD keeps the running frequency and direction of the last section after a single cycle.

2: Cyclic running. The VFD enters the next cycle after completing one cycle until receiving the stop command.

Function code	Name	Description	Setting range	Default
P10.01	Simple PLC memory selection	0: Without memory at power failure 1: With memory after power off	0-1	0

The function code is used to set the simple PLC memory mode at power off.

0: Without memory at power failure

1: Memory at power-off. The PLC memories its running stage and running frequency before power-off.

Function code	Name	Description	Setting range	Default
P10.02	Multi-step speed 0	-100.0-100.0%	-100.0-100.0	0.0%
P10.03	Running time of step 0	0.0-6553.5 s(min)	0.0-6553.5	0.0 s(min)
P10.04	Multi-step speed 1	-100.0-100.0%	-100.0-100.0	0.0%
P10.05	Running time of step 1	0.0-6553.5 s(min)	0.0-6553.5	0.0 s(min)
P10.06	Multi-step speed 2	-100.0-100.0%	-100.0-100.0	0.0%
P10.07	Running time of step 2	0.0-6553.5 s(min)	0.0-6553.5	0.0 s(min)
P10.08	Multi-step speed 3	-100.0-100.0%	-100.0-100.0	0.0%
P10.09	Running time of step 3	0.0-6553.5 s(min)	0.0-6553.5	0.0 s(min)
P10.10	Multi-step speed 4	-100.0-100.0%	-100.0-100.0	0.0%
P10.11	Running time of step 4	0.0-6553.5 s(min)	0.0-6553.5	0.0 s(min)
P10.12	Multi-step speed 5	-100.0-100.0%	-100.0-100.0	0.0%
P10.13	Running time of step 5	0.0-6553.5 s(min)	0.0-6553.5	0.0 s(min)

Function code	Name	Description	Setting range	Default
P10.14	Multi-step speed 6	-100.0–100.0%	-100.0–100.0	0.0%
P10.15	Running time of step 6	0.0–6553.5 s(min)	0.0–6553.5	0.0 s(min)
P10.16	Multi-step speed 7	-100.0–100.0%	-100.0–100.0	0.0%
P10.17	Running time of step 7	0.0–6553.5 s(min)	0.0–6553.5	0.0 s(min)
P10.18	Multi-step speed 8	-100.0–100.0%	-100.0–100.0	0.0%
P10.19	Running time of step 8	0.0–6553.5 s(min)	0.0–6553.5	0.0 s(min)
P10.20	Multi-step speed 9	-100.0–100.0%	-100.0–100.0	0.0%
P10.21	Running time of step 9	0.0–6553.5 s(min)	0.0–6553.5	0.0 s(min)
P10.22	Multi-step speed 10	-100.0–100.0%	-100.0–100.0	0.0%
P10.23	Running time of step 10	0.0–6553.5 s(min)	0.0–6553.5	0.0 s(min)
P10.24	Multi-step speed 11	-100.0–100.0%	-100.0–100.0	0.0%
P10.25	Running time of step 11	0.0–6553.5 s(min)	0.0–6553.5	0.0 s(min)
P10.26	Multi-step speed 12	-100.0–100.0%	-100.0–100.0	0.0%
P10.27	Running time of step 12	0.0–6553.5 s(min)	0.0–6553.5	0.0 s(min)
P10.28	Multi-step speed 13	-100.0–100.0%	-100.0–100.0	0.0%
P10.29	Running time of step 13	0.0–6553.5 s(min)	0.0–6553.5	0.0 s(min)
P10.30	Multi-step speed 14	-100.0–100.0%	-100.0–100.0	0.0%
P10.31	Running time of step 14	0.0–6553.5 s(min)	0.0–6553.5	0.0 s(min)
P10.32	Multi-step speed 15	-100.0–100.0%	-100.0–100.0	0.0%
P10.33	Running time of step 15	0.0–6553.5 s(min)	0.0–6553.5	0.0 s(min)

The setting 100.0% corresponds to the max. output frequency (P00.03).

When simple PLC operation is selected, it is required to set P10.02–P10.33 to determine the running frequency and direction of each step.

Note: The symbol of multi-step speed determines the running direction of simple PLC, and the negative value means reverse running.

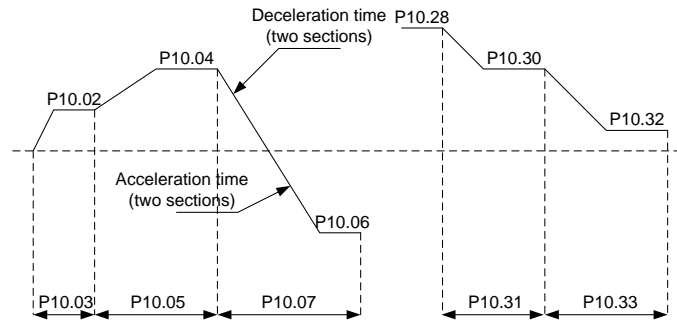

Multi-step speed can be set continuously in the range of -fmax~fmax.

The VFD can set 16-step speeds, which are selectable by multi-step speed terminals 1-4, corresponding to multi-step speed 0 to multi-step speed 15.

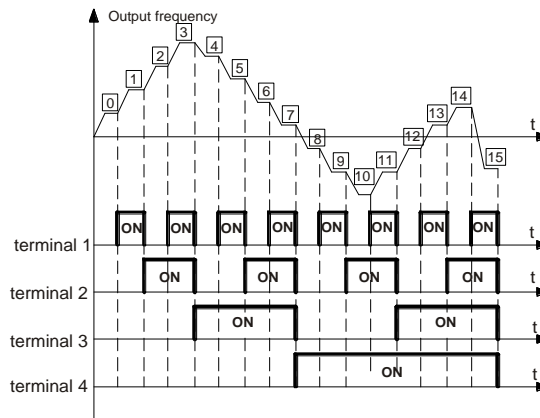

When S1, S2, S3, and S4 are OFF, the frequency input mode is set by P00.06 or P00.07. When S1, S2, S3, and S4 are not all OFF, the VFD runs at multi-step speed and the multi-step speed has the priority over the keypad, analog values, high-speed pulse, PLC and communication frequency input. Select at most 16-step speed via the the combined codes of S1, S2, S3 and S4.

The start-up and stop of multi-step speed is determined by the function code P00.01. The relationship between the terminals of S1, S2, S3 and S4 and the multi-step speed is shown as follows:

Step	S1	S2	S3	S4
0	OFF	OFF	OFF	OFF
1	ON	OFF	OFF	OFF
2	OFF	ON	OFF	OFF
3	ON	ON	OFF	OFF
4	OFF	OFF	ON	OFF
5	ON	OFF	ON	OFF
6	OFF	ON	ON	OFF
7	ON	ON	ON	OFF
8	OFF	OFF	OFF	ON
9	ON	OFF	OFF	ON
10	OFF	ON	OFF	ON
11	ON	ON	OFF	ON
12	OFF	OFF	ON	ON
13	ON	OFF	ON	ON
14	OFF	ON	ON	ON
15	ON	ON	ON	ON

Function code	Name	Description	Setting range	Default
P10.34	ACC/DEC time of steps 0-7 of simple PLC	0x0000-0xFFFF	0x0000-0xFFFF	0x0000
P10.35	ACC/DEC time of steps 8-15 of simple PLC	0x0000-0xFFFF	0x0000-0xFFFF	0x0000

The description is as follows:

Function code	Binary		Step	ACC/DEC time 1	ACC/DEC T2	ACC/DEC T3	ACC/DEC T4
P10.34	BIT1	BIT0	0	00	01	10	11
	BIT3	BIT2	1	00	01	10	11
	BIT5	BIT4	2	00	01	10	11
	BIT7	BIT6	3	00	01	10	11
	BIT9	BIT8	4	00	01	10	11
	BIT11	BIT10	5	00	01	10	11
	BIT13	BIT12	6	00	01	10	11
P10.35	BIT15	BIT14	7	00	01	10	11
	BIT1	BIT0	8	00	01	10	11
	BIT3	BIT2	9	00	01	10	11
	BIT5	BIT4	10	00	01	10	11
	BIT7	BIT6	11	00	01	10	11
	BIT9	BIT8	12	00	01	10	11
	BIT11	BIT10	13	00	01	10	11
BIT13	BIT12	14	00	01	10	11	
BIT15	BIT14	15	00	01	10	11	

Select corresponding acceleration/deceleration time, and then convert 16-bit binary number into decimal number, finally, and then set corresponding function codes.

Function code	Name	Description	Setting range	Default
P10.36	PLC restart mode	0: Restart from step 1 1: Resume from the paused step	0-1	0

The function code is used to set the PLC restart mode.

0: Restart from the first step, namely if the VFD stops during running (caused by stop command, fault or power down), it will run from the first step after restart.

1: Continue running from the step frequency when interruption occurred, namely if the VFD stops during running (caused by stop command or fault), it will record the running time of current step, and enters this step automatically after restart, then continue running at the frequency defined by this step in the remaining time.

Function code	Name	Description	Setting range	Default
P10.37	Multi-step time unit	0: second 1: minute	0-1	0

The function code is used to set the time unit.

0: Second. The running time of each step is counted in seconds.

1: Minute. The running time of each step is counted in minutes.

- Multi-step speed running

You can set parameters to enable the inverter unit to run at multiple steps. The inverter unit supports setting 16-step speeds, which are selectable by multi-step speed terminals 1–4, corresponding to multi-step speed 0 to multi-step speed 15.

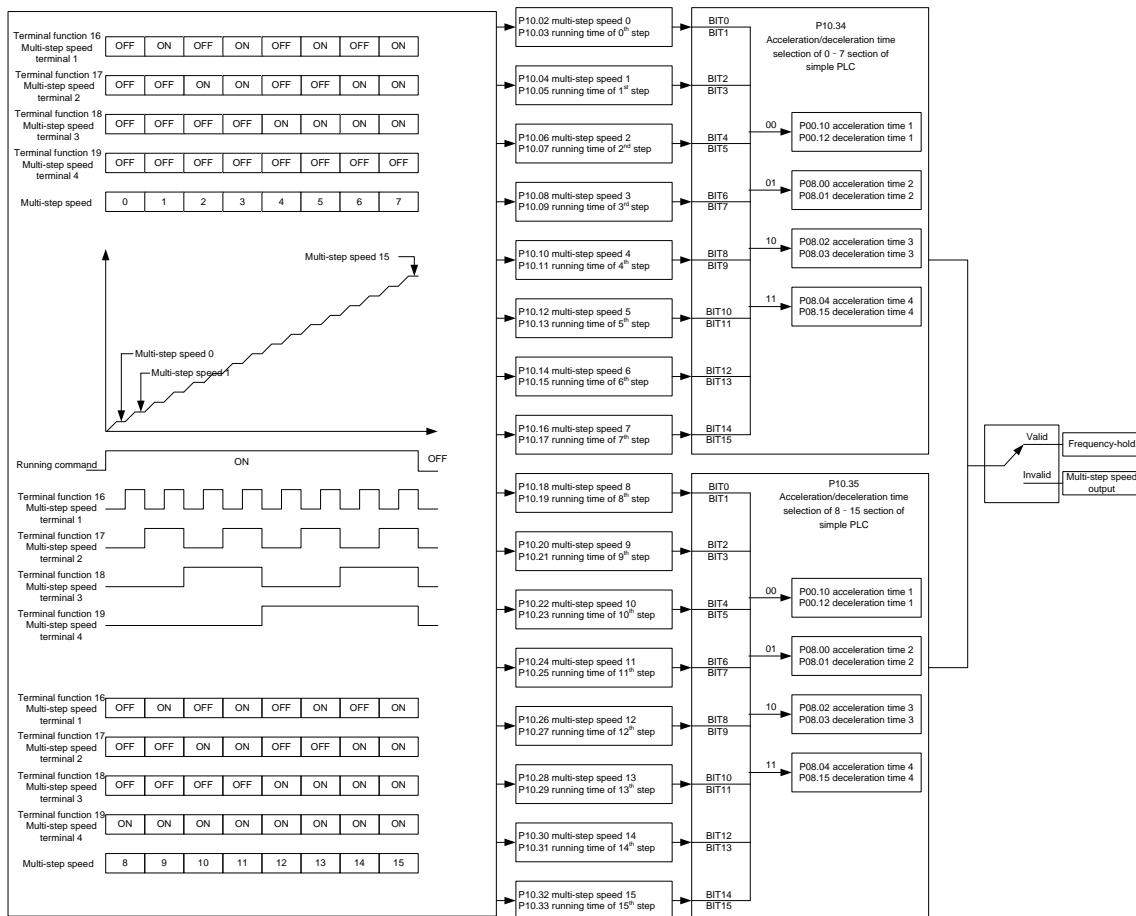

Related parameter list:

Function code	Name	Description
P05.01–P05.08	Digital input function selection	16: Multi-step speed terminal 1 17: Multi-step speed terminal 2 18: Multi-step speed terminal 3 19: Multi-step speed terminal 4 20: Pause multi-step speed running 23: Simple PLC stop reset 24: Pause simple PLC 25: Pause PID control
P06.01–P06.06	Digital output function selection	16: Simple PLC stage reached 17: Simple PLC cycle reached
P10.00–P10.37	Simple PLC and multi-step speed control	/
P17.00	Set frequency	0.00Hz–P00.03 (Max. output frequency)
P17.27	Present step of simple PLC	Used to display the present step of the simple PLC function.

5.1.19 Protection function

Function code	Name	Description	Setting range	Default
P11.00	Protection against phase loss	LED ones place: 0: Protection against input phase loss disabled 1: Protection against input phase loss enabled LED tens place: 0: Protection against output phase loss disabled 1: Protection against output phase loss enabled	Ones place: 0-1 Tens place: 0-1	0x11

The function code is used to enable protection against phase loss.

Function code	Name	Description	Setting range	Default
P11.01	Frequency drop at transient power-off	0: Disable 1: Enable	0-1	0

The function code is used to enable the frequency decrease at sudden power loss.

Function code	Name	Description	Setting range	Default
P11.02	Frequency drop rate at transient power-off	0.00Hz/s-P00.03 (Max. frequency)/s	0.00-P00.03	10.00Hz/s

If the bus voltage drops to the sudden frequency decreasing point due to the power loss of the grid, the VFD begins to decrease the running frequency according to P11.02 to make the motor in power generation state. The feedback power can maintain the bus voltage to ensure the continuous running of the VFD until the recovery of power.

Voltage class	380V	660V
Frequency decrease at sudden power failure	460V	800V

Note:

- Adjusting the parameter properly can prevent the stop caused by the VFD protection during shifting the grid.
- This function can be enabled only when the input phase loss protection function is disabled.

Function code	Name	Description	Setting range	Default
P11.03	Overvoltage stalling protection	0: Disable 1: Enable	0-1	0

The function code is used to enable the protection against overvoltage stalling.

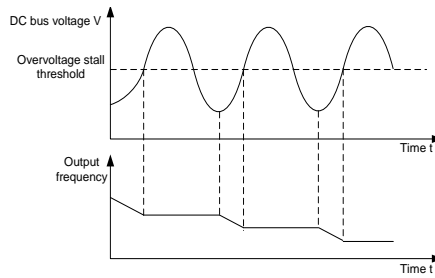

Function code	Name	Description	Setting range	Default
P11.04	Overvoltage stalling protection voltage	120–150% (100% corresponds to 1.414 times the VFD rated voltage)	120–150	140%
P13.34	Overvoltage stalling voltage loop Kp	Proportional coefficient of DC bus voltage loop regulator	0–200	60
P13.35	Overvoltage stalling voltage loop Ki	Integral coefficient of DC bus voltage loop regulator	0–200	60
P13.36	Overvoltage stalling current loop Kp	Proportional coefficient of current loop regulator during overvoltage stall	0–500	60
P13.37	Overvoltage stalling current loop Ki	Integral coefficient of current loop regulator during overvoltage stall	0–500	250

The function codes are used to set the protection against overvoltage stalling and regulation coefficient during overvoltage stalling.

Function code	Name	Description	Setting range	Default
P11.05	Current limit action	0: Disabled 1: Always enabled	0–1	1
P11.06	Automatic current limit threshold	50.0–200.0% (100% corresponds to rated current))	50.0–200.0	Heavy overload: 160.0% Light overload: 120.0%
P11.07	Frequency drop rate during current limit	0.00–50.00Hz/s	0.00–50.00	10.00Hz/s

During accelerated running, as the load is too large, the actual acceleration rate of motor is lower than that of output frequency, if no measures are taken, the VFD may trip due to overcurrent during acceleration.

Current-limit protection function detects output current during running, and compares it with the current-limit level defined by P11.06, if it exceeds the current-limit level, the VFD will run at stable frequency during accelerated running, or run in decreased frequency during constant-speed running; if it exceeds the current-limit level continuously, the VFD output frequency will drop continuously until reaching lower limit frequency. When the output current is detected to be lower than the current-limit level again, it will continue accelerated running.

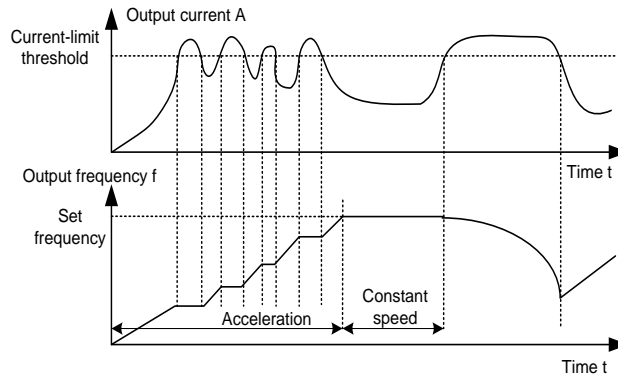

Function code	Name	Description	Setting range	Default
P11.08	Pre-alarm selection for VFD/motor OL/UL	<p>LED ones place:</p> <p>0: Motor OL/UL pre-alarm, relative to motor rated current.</p> <p>1: VFD OL/UL pre-alarm, relative to the VFD rated current</p> <p>Tens place:</p> <p>0: The VFD continues running after overload/underload alarm.</p> <p>1: The VFD continues running after underload alarm, and stops running after overload fault.</p> <p>2: The VFD continues to work for an OL alarm but stops running for a UL fault.</p> <p>3: The VFD stops running for an OL/UL alarm.</p> <p>LED hundreds place:</p> <p>0: Detect all the time.</p> <p>1: Detect during constant speed running.</p>	<p>Ones place: 0-1</p> <p>Tens place: 0-3</p> <p>Hundreds place: 0-1</p>	0x000
P11.09	Overload pre-alarm detection threshold	0-200%	0-200	<p>Heavy overload: 150%</p> <p>Light overload: 120%</p>
P11.10	Overload pre-alarm detection time	0.1-60.0s	0.1-60.0	1.0s
P11.11	Underload pre-alarm detection threshold	0%- P11.09	0-P11.09	50%
P11.12	Underload pre-alarm detection time	0.1-60.0s	0.1-60.0	1.0s

If the VFD or motor output current is larger than the overload pre-alarm detection level (P11.09), and the duration exceeds the overload pre-alarm detection time (P11.10), overload pre-alarm signal will be outputted.

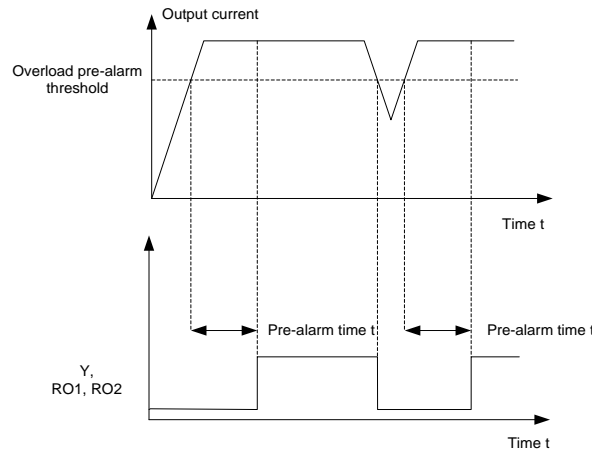

Underload pre-alarm signal will be outputted if the output current of the VFD or motor is lower than underload pre-alarm detection level (P11.11), and the duration exceeds underload pre-alarm detection time (P11.12).

Note: The underload pre-alarm detection threshold (P11.11) should be smaller than the overload pre-alarm detection threshold (P11.09).

Function code	Name	Description	Setting range	Default
P11.13	Output terminal action during undervoltage and automatic reset	LED ones place: 0: Act upon an undervoltage fault 1: Do not act upon an undervoltage fault LED tens place: 0: Act during automatic reset 1: Do not act during the automatic reset period	Ones place: 0-1 Tens place: 0-1	0x00

The function code is used to set the action of fault output terminals at undervoltage and fault reset (Y1-Y3, RO1-RO8 are set to 5: VFD in fault).

Function code	Name	Description	Setting range	Default
P11.14	Speed deviation detection value	0.0-50.0%	0.0-50.0	10.0%
P11.15	Speed deviation detection time	0.0-10.0s (No speed deviation protection for the value=0.0)	0.0-10.0	1.0s

Used to set the speed deviation detection time.

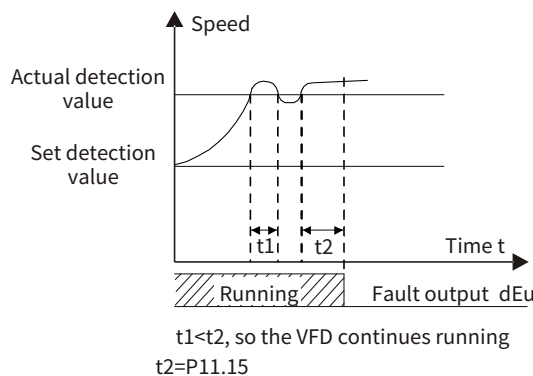

Function code	Name	Description	Setting range	Default
P11.16	Unit validity selection	0x00–0x3F	0x00–0x3F	0x3F

Each bit stands for a unit. If BIT0 is 1, unit 1 is valid.

BIT5	BIT4	BIT3	BIT2	BIT1	BIT0
Unit 6	Unit 5	Unit 4	Unit 3	Unit 2	Unit 1

The function code is restricted by P18.60. The unit specified by the function code is valid only when the bit specified by P18.60 is 1.

Function code	Name	Description	Setting range	Default
P11.17	Motor overtemp protection selection	0: Disable 1: Enable	0–1	0
P11.18	Motor overtemperature protection threshold	0.0–150.0°C	0–150.0	100.0°C
P11.19	Motor temperature detection	0: Invalid 1: PT100 2: NTC (Reserved) 3: PTC (Reserved)	0–3	0

The function codes are used to enable the motor overtemperature protection.

Motor temperature is detected only when P11.19 is set to a non-zero value.

When P11.17=1, the VFD reports the motor overtemperature fault (OH) if the detected motor temperature exceeds the value set by P11.18.

5.1.20 Encoder parameters

Function code	Name	Description	Setting range	Default
P16.00	Encoder type selection	0: Incremental encoder 1: UVW encoder 2: Sin/Cos encoder 3: Resolver-type encoder	0–3	0

The function code is used to select an encoder type.

Note: An expansion card is required.

Function code	Name	Description	Setting range	Default
P16.01	Encoder pulse count	0–8192	0–8192	1024

The function code is used to set the encoder pulse number per rotation.

Function code	Name	Description	Setting range	Default
P16.02	Encoder direction	Ones place: AB direction 0: Forward	Ones place: 0–1	0x000

Function code	Name	Description	Setting range	Default
		1: Reverse Tens place: Z pulse direction 0: Not inverse 1: Inverse Hundreds place: 0: UVW forward 1: UVW reverse	Tens place: 0-1 Hundreds place: 0-1	

Note: Please set the encoder pulse number correctly under the closed loop vector control mode (P16.01); otherwise, the motor will not run properly. If it still cannot run properly after parameter setting of the encoder, change the encoder direction (P16.02).

Function code	Name	Description	Setting range	Default
P16.03	Encoder disconnection detection time	0.0-100.0s	0.0-100.0	1.0s
P16.04	Detection time of encoder reversal	0.0-100.0s	0.0-100.0	1.0s
P16.05	Filter times of encoder detection	Bit0-3: Low-speed filter time Bit4-7: High-speed filter time	0x00-0x99	0x33

P16.03 defines encoder offline detection time. When the offline time exceeds the set time, the VFD will alarm encoder offline fault (ENCIO).

P16.04 defines encoder reverse detection time. When the reverse detection time exceeds the set time, the VFD will alarm encoder reverse fault (ENCID).

Note: Adjusting above parameters will influence the flexibility of encoder fault protection and sometimes abnormal actions may occur, so adjust carefully.

Function code	Name	Description	Setting range	Default
P16.06	Speed ratio between motor and encoder	0.000-65.535	0.000-65.535	1.000

The function code is used to set the speed ratio between motor and encoder. Set the value according to the actual conditions.

Function code	Name	Description	Setting range	Default
P16.07	Control parameters of SM	Bit0: Enable Z pulse calibration Bit1: Enable encoder angle calibration Bit2: Enable SVC speed measurement Bit3: Resolver speed measurement mode Bit4: Z pulse capture mode Bit12: Clear the Z pulse arrival signal after stop Bit15: =0: Without Z pulse autotuning =1: With Z pulse autotuning	0x0000-0xFFFF	0x0003
P16.08	Initial angle of Z pulse	0.00-359.99	0.00-359.99	0.00

The function code is used to define the initial angle of Z pulse.

Function code	Name	Description	Setting range	Default
P16.09	Enable Z pulse offline detection	0: Disable 1: Enable	0-1	0

The function code is used to enable Z pulse offline detection.

Function code	Name	Description	Setting range	Default
P16.10	Autotuning pole initial angle	0-2 1: Rotary autotuning 2: Static autotuning (suitable for resolver-type encoder feedback) (reserved)	0-2	0

When P16.10 is set to 1 or 2, the keypad displays "-RUN-". Press RUN key to start the magnetic pole initial angle autotuning. The keypad displays "-END-" when the autotuning is completed.

When P16.00 is set to 2 or 3: for motor 1, P02.24 and P16.08 are autotuned; for motor 2, P12.24 and P16.08 are autotuned; for motor 3, P13.24 and P16.08 are autotuned; for motor 4, P14.24 and P16.08 are autotuned.

When P16.00 is set to 1: for motor 1, P02.24 and P16.17 are autotuned; for motor 2, P12.24 and P16.17 are autotuned; for motor 3, P13.24 and P16.17 are autotuned; for motor 4, P14.24 and P16.17 are autotuned.

The pole initial angle obtained through rotary autotuning is accurate. Rotary autotuning is recommended in most cases, in which the motor needs to be decoupled from the load.

Function code	Name	Description	Setting range	Default
P16.11	Actual frequency of encoder	The function code is used to display the actual frequency of encoder. -3276.8-3276.7Hz	-3276.8-3276.7	0.0Hz
P16.12	Encoder position count value	The function code is used to display the encoder position count value. 0-65535	0-65535	0
P16.13	Encoder Z pulse count value	The function code is used to display the encoder Z pulse count value. 0-65535	0-65535	0
P16.14	Rotor identification value	The function code is used to display the rotor identification value. 0.0000-6.5535Ω	0.0000-6.5535	0.0000Ω
P16.15	Z pulse angle of SM	The function code is used to display the magnetic pole angle of Z pulse. 0-359.99	0.00-359.99	0.00
P16.16	UVW signal state	The function code is used to display the UVW signal state. 0-65535	0-65535	0

Function code	Name	Description	Setting range	Default
P16.17	Initial angle of U pulse	0.00-359.99	0.00-359.99	0.00

The function code is used to display the magnetic pole angle of UVW encoder U pulse rising edge.

5.1.21 Master/slave control

The inverter unit supports the master/slave control function, which means that multiple inverter units can carry the same load. Master/slave control can be applied to speed synchronization and power balance.

Function code	Name	Description	Setting range	Default
P23.00	Master/slave mode	0: Master/slave control is invalid. 1: The local device is the master. 2: The local device is the slave.	0-2	0

The function code is used to select the master/slave control mode.

Function code	Name	Description	Setting range	Default
P23.01	Master/slave communication data selection	0: Optical-fiber communication power balance 1: Optical-fiber communication expansion (reserved)	0-1	0

The function code is used to select the master/slave communication data selection.

0: Optical fiber power balance. Generally available for load-connection applications. The output current of the master and slave can be the same.

1: Optical-fiber communication expansion. The power capacity of the VFD can be expanded.

2: Reserved

Function code	Name	Description	Setting range	Default
P23.02	Master/slave communication mode	0: Optical fiber 1: Reserved	0-1	0

The function code is used to enable the master to send data to the slave. When P23.02=0, the master will send data to the slave.

Function code	Name	Description	Setting range	Default
P23.03	Master power balancing control mode	0: Master/slave mode 0. (Both the master and slave use speed control, and power balancing is performed by droop control. The droop quantity is set by P08.30.) 1: Master/slave mode 1. (The master and slave must be in the same type of vector control. When the master is in speed control, the slave is forced into torque control.) 2-3: Reserved	0-3	0

0: Master/slave mode 0

The reference signal sent by the master to the slave is the master ramp reference frequency.

1: Master/slave mode 1

The reference signal sent by the master to the slave is the master torque current reference.

Function code	Name	Description	Setting range	Default
P23.04	Reference frequency source gain of the slave	0.0–500.0%	0.0–500.0%	100.0%

During master-slave control, slave reference signal=master frequency * P23.04, facilitating the users adjusting the speed relation of the master and slave.

Function code	Name	Description	Setting range	Default
P23.05	Reference torque source gain of the slave	0.0–500.0%	0.0–500.0%	100.0%

During master-slave control, slave reference torque current reference=master torque current reference * P23.05, facilitating the users adjusting the torque relation of the master and slave.

Function code	Name	Description	Setting range	Default
P23.06	Slave fault auto bypass enabling	0: Disable 1: Enable	0–1	0

When P23.06=0, the slave is not bypassed at slave failure. When P23.06=1, the slave is automatically bypassed at slave failure.

Function code	Name	Description	Setting range	Default
P23.07	Slave bypassing	0: Not bypass 1: Bypass	0–1	0

When P23.07=0, the slave is not bypassed. When P23.07=1, the slave is bypassed.

Function code	Name	Description	Setting range	Default
P23.08	Slave count/ slave number	0–65535	0–65535	0

If there are multiple slaves, number them automatically with the ring fiber.

Function code	Name	Description	Setting range	Default
P23.09	Slave fault information	0–1	0–1	0

0: Slave is not faulty; 1: Slave is faulty

Function code	Name	Description	Setting range	Default
P08.30	Frequency decrease ratio in drop control	0.00–30.00Hz	0.00–30.000	0.00Hz

The output frequency of the VFD changes as the load changes. The function code is mainly used to balance the power when several motors drive a same load.

5.1.22 Hoisting

Function code	Name	Description	Setting range	Default
P24.00	Pre torque input signal source	0: Invalid 1: AI1 2: AI2 3: AI3 4: MODBUS communication 5: Reserved 6: PROFIBUS/CANopen/PROFINET communication 7: Internal setting 8-10: Reserved	0-10	0

The pre-torque signal is mainly used for pre-torque compensation, which can output the torque corresponding to the load weight in advance to avoid backward pulling or slipping at startup, and improve the comfortability of mechanical startup.

Note: The pre-torque signal source input should not share the same analog input source as the speed command (P00.01, P00.02).

Function code	Name	Description	Setting range	Default
P24.01	Pre torque offset	-100.0-100.0%	-100.0-100.0	0.0%
P24.02	Drive-side gain	0.000-7.000	0.000-7.000	1.000
P24.03	Braking-side gain	0.000-7.000	0.000-7.000	1.000

When the mechanical hoisting starts, the pre-torque output can be used to achieve fast balance load, reducing the start impact and improving the comfortability. The pre-torque compensation is valid only when P24.00 is set to a non-zero value.

For hoisting with additional load, the pre-torque offset should be calculated to compensate the impact from the additional weight on pre-torque. For hoisting without additional load, compensate the pre-torque directly.

Pre-torque compensation= $K \times (\text{pre-torque input signal} - \text{pre-torque offset})$. At motoring state, $K=P24.02$. At generating state, $K=P24.03$. The pre-torque direction is determined by the BIT0 of P24.04.

Function code	Name	Description	Setting range	Default
P24.04	Pre-torque direction and braking control	Ones place: 0: Forward 1: Reverse Tens place: 0: Braking control invalid 1: Braking control Valid	Ones place: 0-1 Tens place: 0-1	0x00

The function code is used to set the pre-torque direction and braking control.

Function code	Name	Description	Setting range	Default
P24.05	Brake release delay	0.000-5.000s	0.000-5.000	0.000s

The brake release delay indicates the time from when the VFD starts to when the brake release command is output. This parameter is set to make the VFD enter the running state before the brake release to prevent the motor from slipping at startup, thus improving the comfortability.

Function code	Name	Description	Setting range	Default
P24.06	Brake closing frequency	0.00–50.00Hz	0.00–50.00	0.00Hz
P24.07	Brake closing delay	0.000–5.000s	0.000–5.000	0.000s

Brake closing delay indicates the time from when the VFD output frequency reaches P24.09 to when the brake closing command is output. This parameter is set to improve the comfortability at stop.

Function code	Name	Description	Setting range	Default
P24.08	Brake feedback detection time	0.000–20.000s	0.000–20.000	1.000s

When the brake control is valid and the digital input terminal is set to brake feedback detection, the VFD reports a brake feedback fault (FAE) if the brake action error lasts over the time set by P24.08.

Function code	Name	Description	Setting range	Default
P24.09	Torque verification	0: Invalid 1: Through current percentage 2: Through torque percentage	0–2	0
P24.10	Keypad setting value during torque verification	0.0–100.0% (of the rated motor current/torque. 0.0%: Torque verification is invalid.)	0.0–100.0	0.0%
P24.11	Torque verification fault detection time	0.000–10.000s	0.000–10.000	0.500s

When the torque verification is enabled at VFD running state, the output torque or current (selected by P24.09) is smaller than P24.10, and the duration is longer than the P24.11, the VFD will stop due to torque verification fault and displays the torque verification fault (TCE) on the keypad.

Note: The torque verification can be enabled only when the brake control is valid.

Function code	Name	Description	Setting range	Default
P24.12	Anti-sag protection braking torque	0.0–300.0% (of the motor rated current)	0.0–300.0	0.0%
P24.13	Braking torque ACC/DEC time	0.000–10.000s	0.000–10.000	0.2000s
P24.14	Braking torque end frequency	0.00–30.00Hz	0.00–30.000	0.10Hz

Anti-sag indicates that the VFD outputs reserve torque so that the motor can stop at the fastest speed.

P24.12 is used to set the braking torque.

P24.13 is used to set the braking torque ACC/DEC time. A greater value indicates a faster braking speed. When the motor decelerates to the braking torque end frequency (P24.14), the VFD stops.

Note: The VFD also stops when the motor is braked to reverse rotation.

Function code	Name	Description	Setting range	Default
P24.15	Safe speed limit frequency	0.00–30.00Hz	0.00–30.000	1.00Hz
P24.16	DEC time at safe speed limit	0.0–100.0s	0.0–100.0	2.0s

When the safe speed limit (SLS) terminal is valid, the motor decelerates from the current frequency to the safety speed limit frequency, and the deceleration time at the safety speed limit is set by P24.16.

Function code	Name	Description	Setting range	Default
P24.17	DEC time at safe stop 1	0.0–100.0s	0.0–100.0	5.0s

When the safe stop 1 (SS1) is enabled, the motor stops at the deceleration time set in P24.17.

5.1.23 Fault handling

The following provides fault handling information.

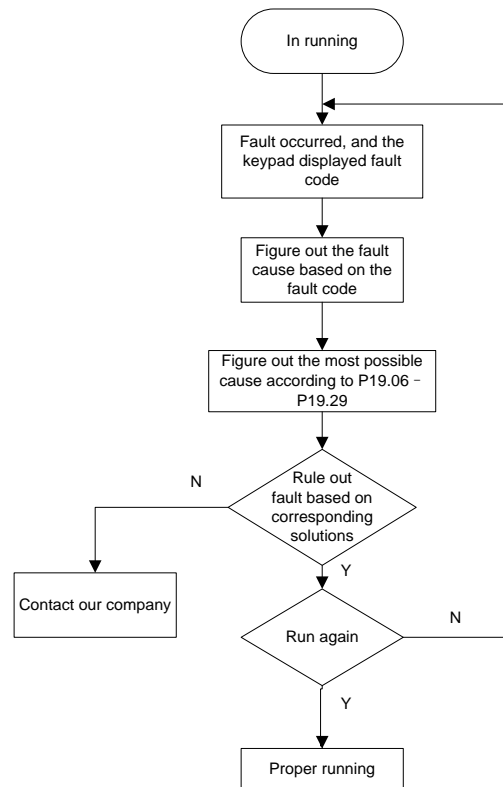

Related parameter list:

Function code	Name	Description	Default
P19.00	Present fault type	0: No fault	0
P19.01	Last fault type	1–3: Reserved	/
P19.02	2nd-last fault type	4: Overcurrent during acceleration (oC1)	/
P19.03	3rd-last fault type	5: Overcurrent during deceleration (oC2)	/
P19.04	4th-last fault type	6: Overcurrent during constant speed running (oC3)	/
P19.05	5th-last fault type		/

Function code	Name	Description	Default
		7: Overvoltage during acceleration (ov1) 8: Overvoltage during deceleration (ov2) 9: Overvoltage during constant speed running (ov3) 10: Bus undervoltage(Lv) 11: Motor overload (oL1) 12: VFD overload (oL2) 13: Phase loss on input side (SPI) 14: Phase loss on output side (SPo) 15: Reserved 16: Reserved 17: External fault (EF) 18: RS485 communication fault (E-485) 19: Current detection fault (ItE) 20: Motor autotuning fault (tE) 21: EEPROM operation error (EEP) 22: PID feedback offline fault (PIde) 23: Braking unit fault (bCE) 24: Running time reached (END) 25: Electronic overload (oL3) 26: Keypad communication error (PCE) (reserved) 27: Parameter upload to keypad error (UPE) 28: Parameter download from keypad error (dNE) 29: PROFIBUS communication fault (E-dP) 30: Ethernet communication fault (E-NET) 31: CANopen communication fault (E-CAN) 32: To-ground short-circuit fault 1 (Eth1) (reserved) 33: (Reserved) 34: Speed deviation fault (dEU) 35: Mal-adjustment fault (STE) 36: Underload fault (LL) 37: Encoder disconnection fault (ENC1o) 38: Encoder reversal fault (ENC1d) 39: STO fault (E-STo) 40: Brake action fault (FAE) 41: Master/slave communication fault (E- FSC) (Main control board FPGA) 42: Slave fault (E-SLE) (DSP) 43: DSP-FPGA communication fault (dF_CE) 44: Control power fault (CPoE) (Main control board DSP) 45: Motor overtemperature fault (oH) 46: Torque verification failure (tCE) Unit fault: m.n m.01: Unit phase-U Vce check fault (m. oUt1)	

Function code	Name	Description	Default
		(Unit FPGA) m.02: Unit phase-V Vce check fault (m. oUt2) (Unit FPGA) m.03: Unit phase-W Vce check fault (m. oUt3) (Unit FPGA) m.04: Unit hardware overcurrent fault (m. oC) (Unit FPGA) m.05: Unit current check fault (m. ItE) (Unit DSP) m.06: Unit current imbalance fault (m. IbC) (Unit DSP) m.07: Unit rectifier bridge overheating fault (m. oH1) (Main control board DSP) m.08: Unit IGBT overheating fault (m. oH2) (Main control board DSP) m.09: Unit fan overheating fault (m. EF1) (Unit DSP) m.10: Unit filter module overheating fault (m. EF2) (Unit DSP) m.11: Unit input phase loss (m.EF3) (Unit DSP) m.12: Unit bus overvoltage fault (m. oV) (Unit DSP) m.13: Unit bus undervoltage fault (m. Lv) (Main control board DSP) m.14: Unit downstream communication fault (m.dn-C) (Unit FPGA) m.15: Unit upstream communication fault (m.UP-C) (Main control board FPGA) m.16: Unit power down (m.PEr) (Unit DSP)	
P19.06	Running frequency at present fault		0.00HZ
P19.07	Ramp reference frequency at present fault		0.00HZ
P19.08	Output current at present fault		0V
P19.09	Output current at present fault		0.0A
P19.10	Bus voltage at present fault		0.0V
P19.11	Max. temperature at present fault		0.0°C
P19.12	Input terminal status at present fault		0
P19.13	Output terminal status at present fault		0
P19.14	Running frequency at last fault		0.00HZ
P19.15	Ramp reference frequency at last fault		0.00HZ
P19.16	Output voltage at last fault		0V
P19.17	Output current at last fault		0.0A
P19.18	Bus voltage at last fault		0.0V
P19.19	Max. temperature at last fault		0.0°C
P19.20	Input terminal status at last fault		0
P19.21	Output terminal status at last fault		0
P19.22	Running frequency at 2nd-last fault		0.00HZ

Function code	Name	Description	Default
P19.23		Ramp reference frequency at 2nd-last fault	0.00HZ
P19.24		Output voltage at 2nd-last fault	0V
P19.25		Output current at 2nd-last fault	0.0A
P19.26		Bus voltage at 2nd-last fault	0.0V
P19.27		Max. temperature at 2nd-last fault	0.0°C
P19.28		Input terminal status at 2nd-last fault	0
P19.29		Output terminal status at 2nd-last fault	0

6 Fault Information

The chapter tells you how to reset faults and check faults history. A complete list of alarms and fault information as well as possible causes and corrective measures are presented in this chapter.

	<ul style="list-style-type: none"> Only trained and qualified professionals are allowed to carry out the operations mentioned in this chapter. Please carry out operations according to instructions presented in chapter 1 “Safety precautions” .
---	---

6.1 Indications of alarms and faults

The fault is indicated by indicators. See "Keypad operation guidelines". When the **TRIP** indicator is on, the alarm or fault code displayed in the keypad indicates the VFD is in exception state. This chapter covers most of the alarms and faults, and their possible causes and corrective measures. If you cannot find out the alarm or fault causes, contact local INVT office.

6.2 Fault reset

The VFD can be reset by pressing the keypad key **STOP/RST**, digital inputs, or by cutting off the VFD power. After faults are removed, the motor can be started again.

6.3 Fault history

The function codes from P19.00 to P19.05 record the types of the last six faults. The function codes P19.06–P19.17, P19.22–P19.33, P19.38–P19.49 record the running data of the PWM rectifier at the last three faults.

6.4 Faults and solutions

Do as follows if the VFD encounters a fault:

1. Check whether there is any exception on the keypad. If yes, contact the local INVT office.
2. If no, check function group P07 to view the fault record parameters and understand the actual condition.
3. See the following table for a detailed solution and check for exceptions.
4. Rectify the fault or ask for help.
5. Ensure the fault has been rectified, perform fault reset, and run the VFD again.

6.4.1 VFD fault

Fault code	Fault type	Possible cause	Solution
ov1	Overvoltage during acceleration	Exception occurred to input voltage; Large energy feedback.	Check the input power; Check whether load DEC time is too short; or the motor starts during rotating; or additional dynamic brake components is required.
ov2	Overvoltage during deceleration		
ov3	Overvoltage during constant speed running		
oC1	Overcurrent during acceleration	ACC/DEC is too fast; The voltage of the grid is too	Increase ACC/DEC time; Check the input power;

Fault code	Fault type	Possible cause	Solution
oC2	Overcurrent during deceleration	low;	Select the VFD with larger power;
oC3	Overcurrent during constant speed running	VFD power is too small; Load transient or exception occurred; To-ground short circuit or output phase loss occurred; Strong external interference sources.	Check whether the load is short circuited (to-ground short circuit or line-to-line short circuit) or the rotation is not smooth; Check the output wiring; Check if there is strong interference.
Lv	Bus undervoltage fault	The voltage of the grid is too low.	Check the grid input power.
oL1	Motor overload	The grid voltage is too low; The motor rated current is set incorrectly; The motor stall occurs or the load transient is too large.	Check the grid voltage; Reset the motor rated current; Check the load and adjust the torque boost quantity.
oL2	VFD overload	ACC is too fast; The motor in rotating is restarted; The grid voltage is too low; Load is too large.	Increase ACC time; Avoid restart after stop; Check the grid voltage; Select the VFD with larger power; Select a proper motor.
SPI	Input phase loss	Phase loss or violent fluctuation occurred on input R, S, T.	Check the input power; Check the installation wiring.
SPo	Phase loss on output side	Phase loss occurred to U, V, W output (or the three phases of motor is asymmetrical).	Check the output wiring; Check the motor and cable.
EF	External fault	SI external faulty input terminal action.	Check external device input.
E_485	RS485 communication fault	Baud rate is set improperly; Communication line fault; Incorrect communication address; Communication suffers from strong interference.	Set proper baud rate; Check the wiring of communication interfaces; Set the communication address correctly; Replace or change the wiring to enhance the anti-interference capacity.
ItE	Current detection fault	Poor contact of the connector of control board; Hall component is damaged; Exception occurred to amplification circuit.	Check the connector and re-plug; Replace the hall component; Replace the main control board.
tE	Motor-autotuning fault	The motor capacity does not match the VFD capacity; Motor parameter is set improperly; The parameters gained from autotuning deviate sharply from the standard	Change the VFD model; Set proper motor type and nameplate parameters; Empty the motor load and carry out autotuning again; Check the motor wiring and parameter setup;

Fault code	Fault type	Possible cause	Solution
		parameters; Autotuning timeout.	Check whether the upper limit frequency is larger than 2/3 of the rated frequency.
EEP	EEPROM operation error	Error in reading or writing control parameters; EEPROM is damaged.	Press STOP/RST for reset; Change the main control board.
PidE	PID feedback offline fault	PID feedback offline; PID feedback source disappears.	Check PID feedback signal wires; Check PID feedback source.
bCE	Braking unit fault	Fault occurred to the brake circuit or the braking pipe is damaged; Resistance of the external braking resistor is small.	Check the braking unit, and replace with new braking pipe; Increase the brake resistance.
ENd	Running time reached	The actual running time of the VFD is longer than the internal set running time.	Ask for the supplier and adjust the set running time.
oL3	Electronic overload fault	The VFD reports overload pre-alarm according to the setting.	Check the load and the overload pre-alarm points.
PCE	Keypad communication fault	Keypad cable connected improperly or disconnected; Keypad cable too long, causing strong interference; Keypad or mainboard communication circuit error.	Check the keypad cable to determine whether a fault occurs; Check for and remove the external interference source; Replace the hardware and seek maintenance services.
UPE	Parameter upload error	Keypad cable connected improperly or disconnected; Keypad cable too long, causing strong interference; Keypad or mainboard communication circuit error.	Check for and remove the external interference source; Replace the hardware and seek maintenance services; Replace the hardware and seek maintenance services.
dNE	Parameter download error	Keypad cable connected improperly or disconnected; Keypad cable too long, causing strong interference; Data storage error occurred to the keypad.	Check for and remove the external interference source; Replace the hardware and seek maintenance services; Re-back up the data on the keypad.
E_dP	PROFIBUS communication fault	Communication address is not correct; The matching resistance is not set well; The master GSD file is not set up; The peripheral interference is too large.	Check the related settings; Check the surrounding environment, and eliminate interference effects.
E_NEt	Ethernet communication fault	The address of Ethernet is set improperly;	Check the related settings; Check the communication mode

Fault code	Fault type	Possible cause	Solution
		The communication mode is set improperly; The peripheral interference is too large.	selection; Check the surrounding environment, and eliminate interference effects.
E_CAN	CANopen communication fault	Line contact is poor; The matching resistor is not switched on; Communication baud rates do not match; The peripheral interference is too large.	Check the line: switch on the matching resistor; Set the same baud rate; Check the surrounding environment, and eliminate interference effects.
EtH1	To-ground short-circuit fault 1	The output of the VFD is short circuited to the ground; There is a fault in the current detection circuit.	Check whether the motor wiring is normal; Replace the hall component; Replace the main control board.
dEU	Speed deviation fault	The load is too heavy or stalled.	Check the load to ensure it is proper, and increase the detection time; Check whether the control parameters are set properly.
STE	Mal-adjustment fault	SM control parameters are set incorrectly; Autotuned parameters are not accurate; The VFD is not connected to the motor.	Check the load and ensure the load is normal; Check whether control parameters are set correctly; Increase the mal-adjustment detection time.
LL	Underload fault	The VFD reports underload pre-alarm according to the setting.	Check the load and the underload pre-alarm points.
ENClo	Encoder offline fault	In closed-loop vector control, the encoder signal cables is disconnected; Encoder is damaged.	Check the encoder wiring and re-connect the cables; Check for encoder output.
ENCId	Encoder reversal fault	In closed-loop vector control, the encoder is disconnected or damaged; VFD wiring is improper.	Check the encoder wiring and adjust the wiring.
E_STo	STO fault	STO terminal is disconnected.	Check the external controller.
FAE	Brake action fault	Brake feedback action error.	Check the external contactor.
E_ASC	Master/slave communication fault	The address is set improperly; The communication mode is set improperly; The communication cable is not connected properly.	Check the related settings; Check the communication mode selection; Check the wiring and adjust the wiring.
E_SLE	Slave fault	Fault occurring to the slave.	Check slave settings and ambient environment.
dF_CE	DSP-FPGA communication fault	DSP-FPGA communication fault occurred; Control board is faulty.	Ask for service.

Fault code	Fault type	Possible cause	Solution
CPoE	Control power fault	The working voltage of switch power is too low.	Check whether the switch power is normal; and whether the power board is normal.
oH	Motor overtemperature fault	Long-time overload running or exception occurred; The temperature detection resistance is abnormal; Motor overtemperature protection threshold is set improperly.	Check the motor, and perform maintenance on the motor; Check whether the temperature sensor is proper; Reset the motor overtemperature protection threshold.
tCE	Torque verification fault	The motor load is disconnected with the VFD.	Ensure the wiring between the motor and the VFD is in good conditions; Decrease the torque verification point for light motor load.
P.oFF	VFD power-off status	Bus voltage is lower than the undervoltage point.	Check that the main power is disconnected.

6.4.2 Unit fault

Fault code	Fault type	Possible cause	Solution
m. oUt1	Unit phase-U Vce check fault	The corresponding IGBT inside the unit is damaged; Strong interference; External short circuit.	Ask for technical support; Check for and remove the external interference source; Check the external circuit and eliminate the load fault.
m.oUt2	Unit phase-V Vce check fault		
m. oUt3	Unit phase-W Vce check fault		
m.oC	Unit hardware overcurrent fault	The IGBT inside the unit is damaged; The inverter acceleration is too fast; Short circuit occurred to the output side of the unit.	Ask for technical support; Update the parameter settings and restart; Check the external circuit of the unit and eliminate the fault.
m.ltE	Unit current detection fault	The unit current detection parts is damaged; Interference exists.	Ask for technical support; Check for and remove the external interference source.
m.lbC	Unit current imbalance fault	The three phase current amplitude difference of the power unit is too large and severely affect the system operating performance.	Check the input power; Check the installation wiring.
m.oH1	Unit rectifier bridge overheating fault	Instantaneous overcurrent occurred to the rectifier;	See solutions for overcurrent
m.oH2	Unit IGBT overheating fault	Three-phase output have interphase or the grounding is short circuited; Air duct is blocked or fan is damaged Ambient temperature is too high; Control board cables or plugs are loose	Re-wiring; Dredge the vent duct or replace the fan; Lower the ambient temperature;

Fault code	Fault type	Possible cause	Solution
		Auxiliary power supply is damaged, and undervoltage occurred for drive voltage; The short through of bridge arm of power modules occurred; Control board is abnormal.	Check and reconnect the control board; Ask for technical support.
m. EF1	Unit fan overheating fault	Fan is not powered on; Fan is overheated.	Check the power supply; Clean the air duct of the inverter.
m. EF2	Unit filter module overheating fault	The unit is continuously running in overload; The air duct is blocked by foreign objects.	Check the inverter load and reduce the load power; Clean the air duct of the inverter.
m.EF3	Unit input phase loss	SI external faulty input terminal action.	Check external device input.
m.ov	Unit bus overvoltage fault	The grid voltage is too high.	Check the input power.
m.Lv	Unit bus undervoltage fault	The grid voltage is too low.	Check the input power.
m.dn_C	Unit downstream communication fault	The address settings between the master and the slave is not consistent; The communication mode is set improperly for the slave; The communication cable is not connected properly.	Check the related settings; Check the communication mode selection; Check the wiring and adjust the wiring.
m.UP_C	Unit upstream communication fault	The address settings between the master and the slave is not consistent; The communication mode is set improperly for the master; The communication cable is not connected properly.	Check the related settings; Check the communication mode selection; Check the wiring and adjust the wiring.
m.PEr	Unit power supply detection fault	The working voltage of switch power is too low.	Ask for technical support.

6.4.3 Other status

Displayed code	Status type	Possible cause	Solution
m.CoFF	Unit optical-fiber communication fault	The optical fiber is not connected properly or the optical fiber is damaged.	Check the optical fiber or replace a new optical fiber.
PoFF	Power on failure	The optical fiber is normal but the bus voltage is too low.	Check the grid conditions.
	Communication failure between keypad and main control board	The keypad is not connected properly.	Check the installation environment of the keypad.

6.5 Analysis on common faults

6.5.1 Motor fails to work

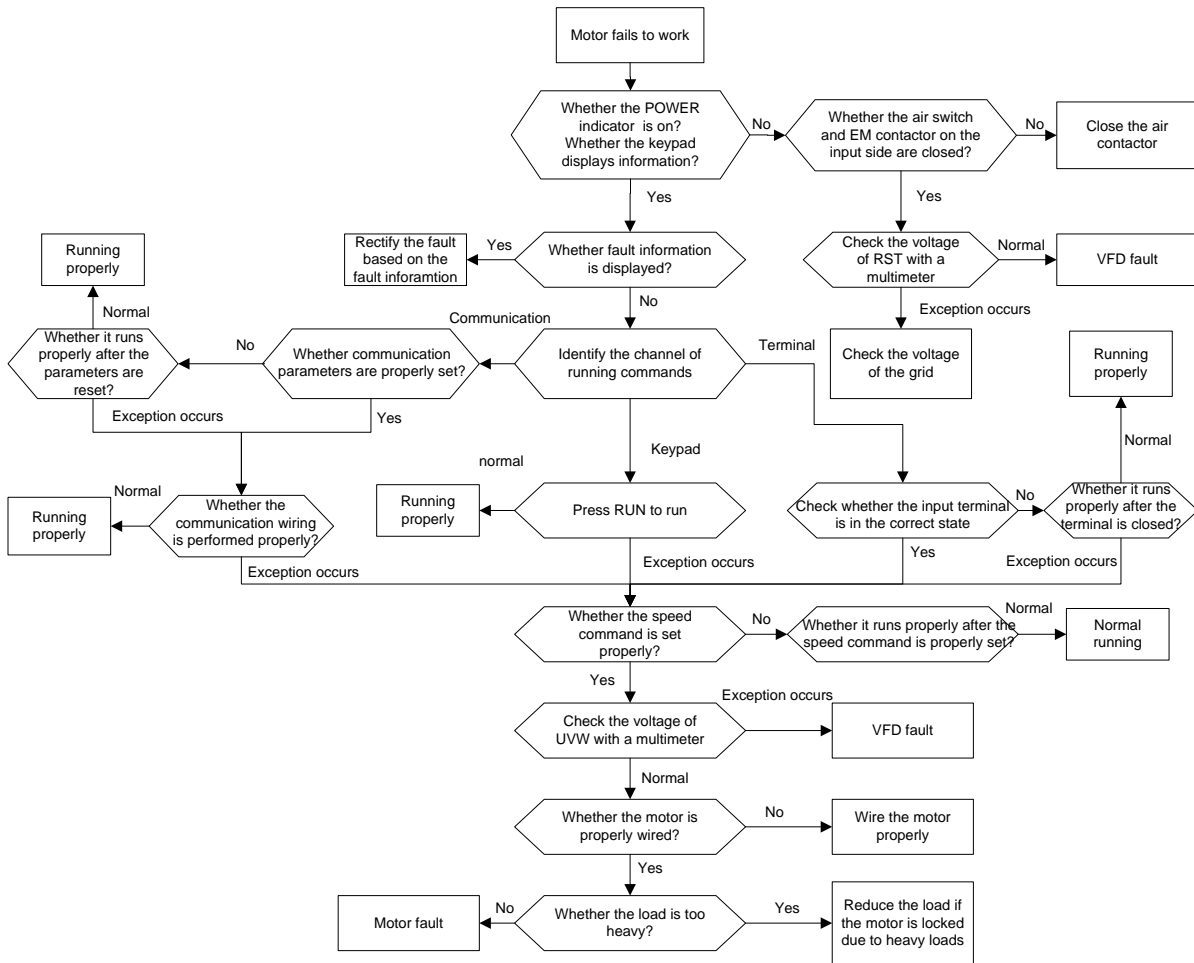

6.5.2 Motor vibrates

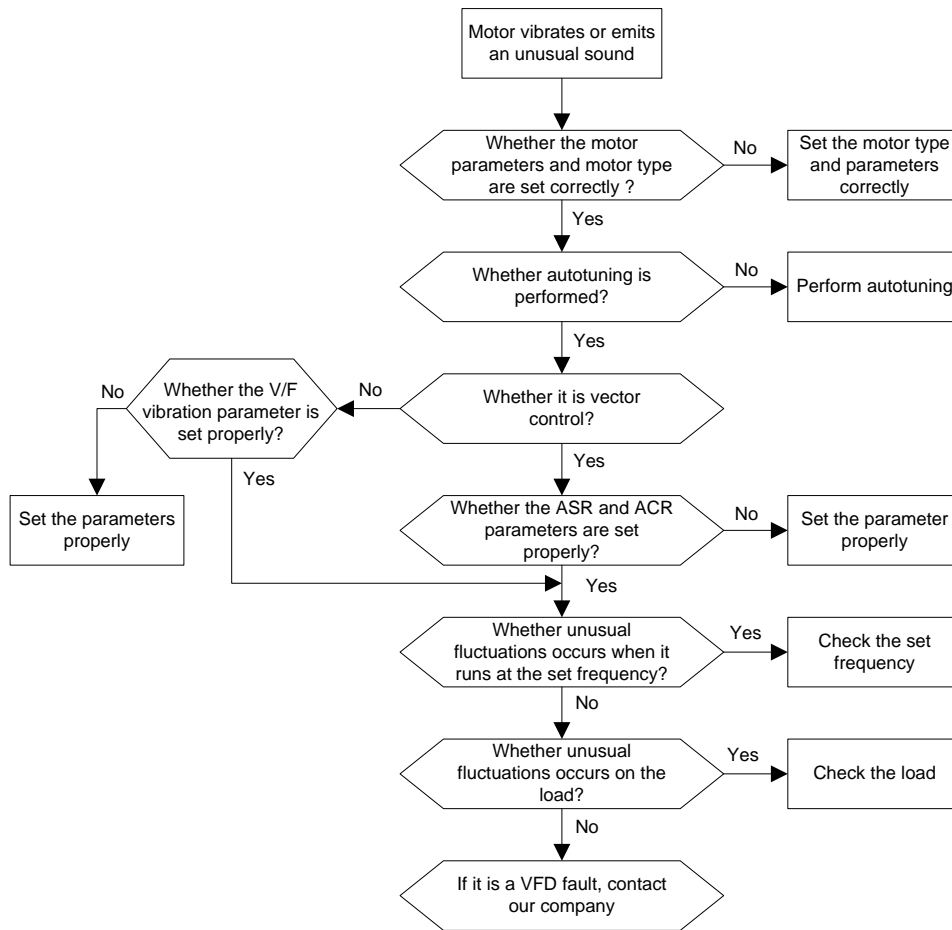

6.5.3 Overvoltage

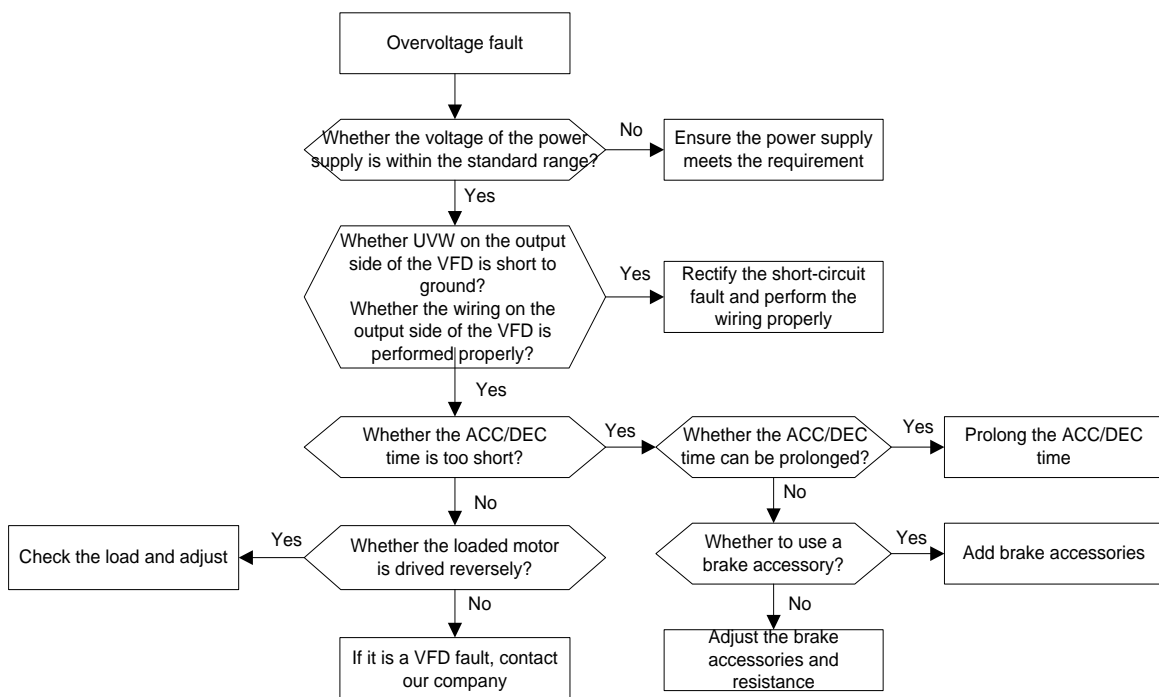

6.5.4 Undervoltage

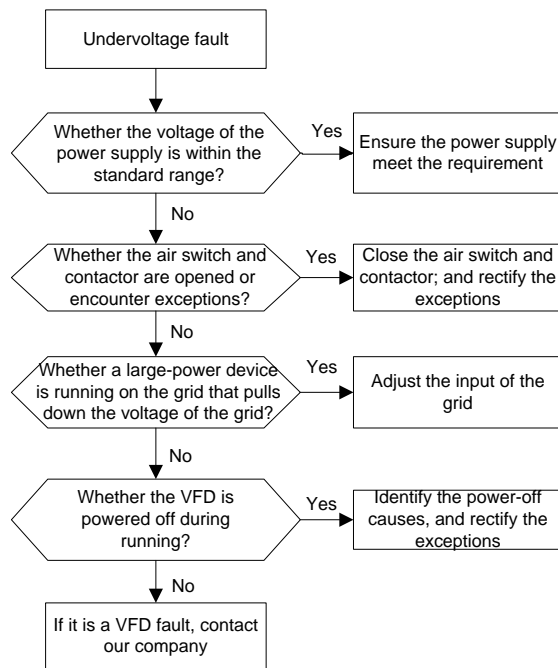

6.5.5 Motor overheating

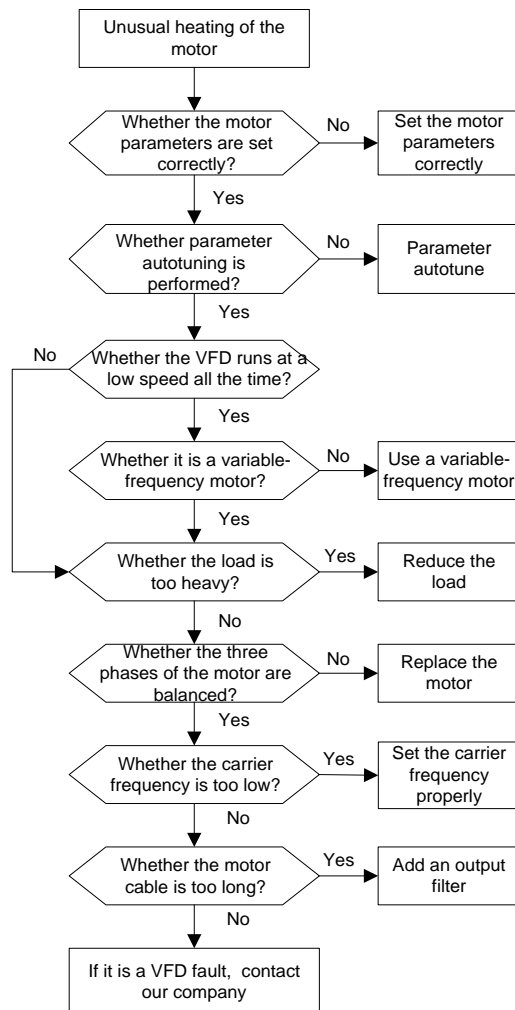

6.5.6 VFD overheating (Check if the fan is running reversely)

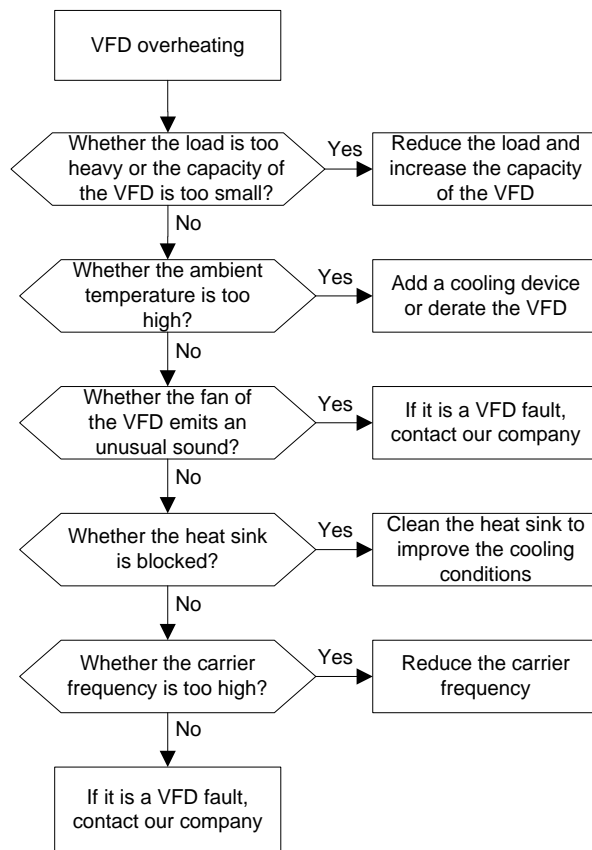

6.5.7 Motor stalls during ACC

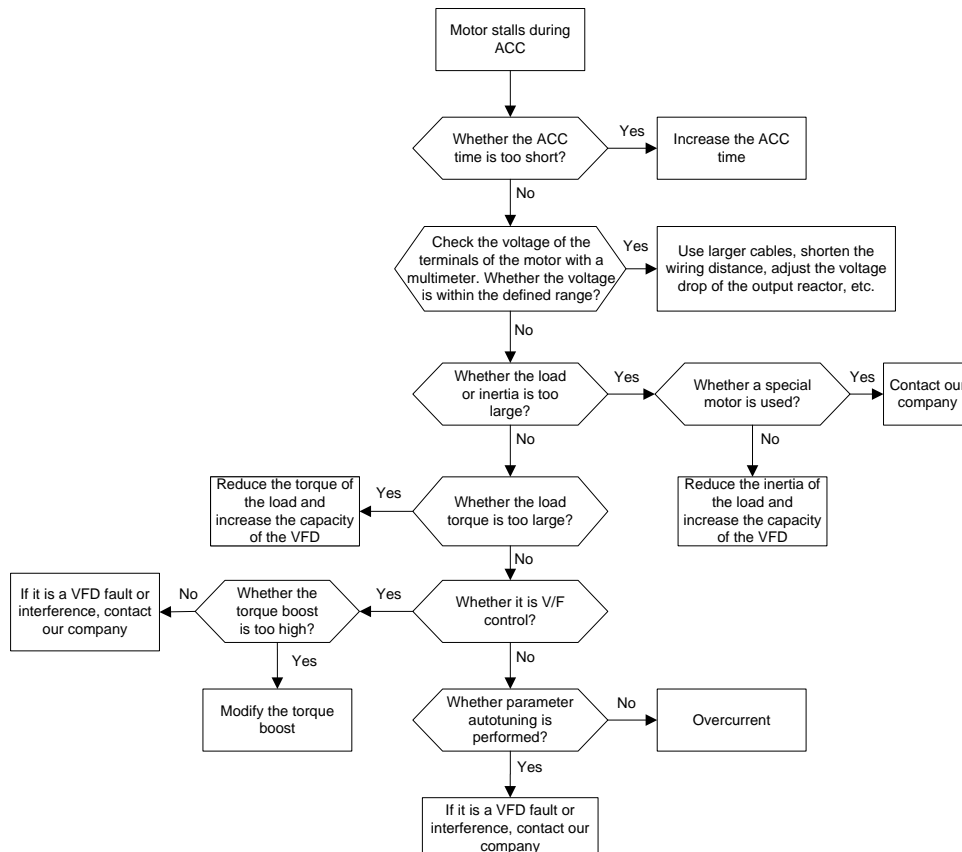

6.5.8 Overcurrent

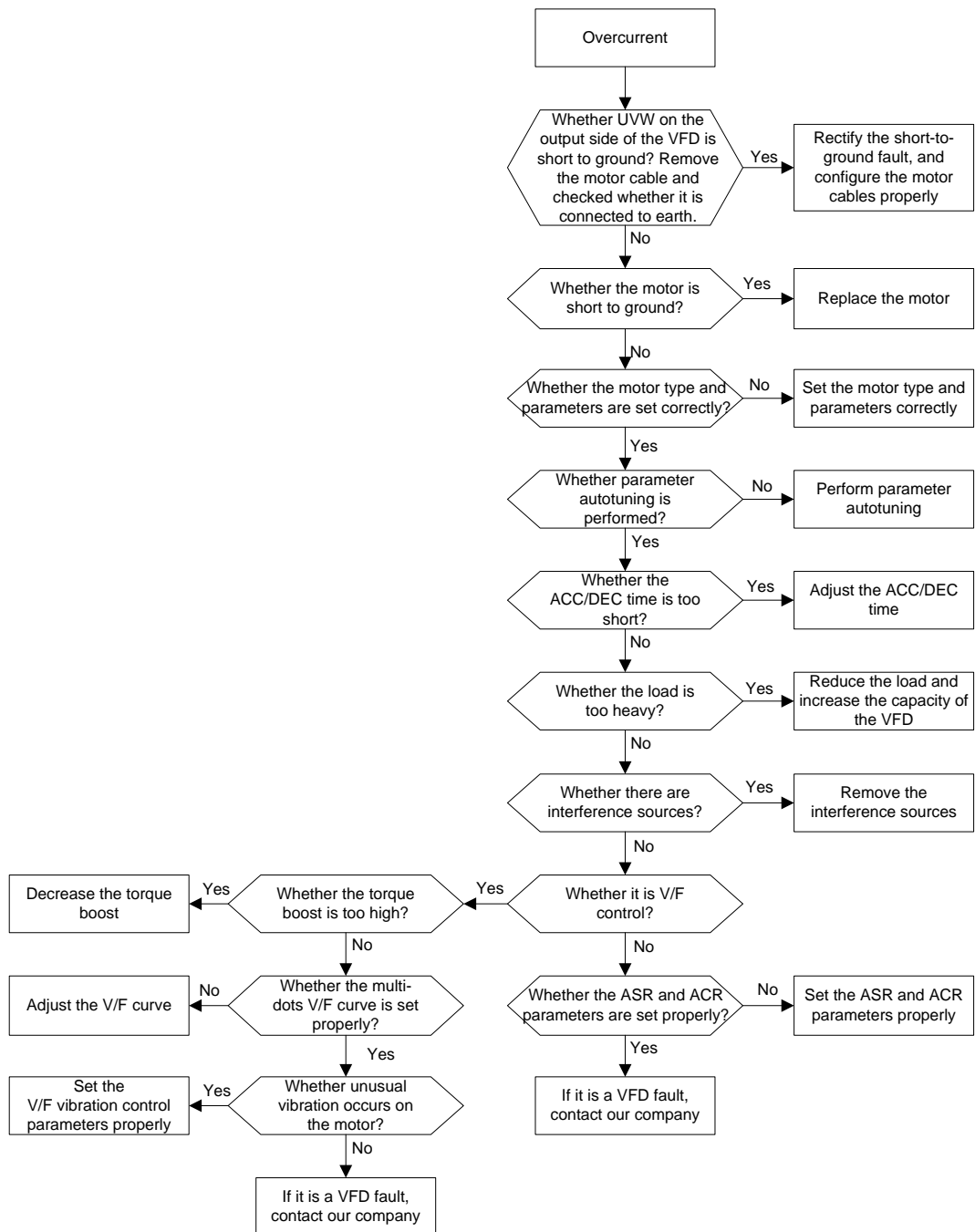

7 Communication

7.1 Modbus protocol

This chapter describes the communication of the VFD.

The VFD provides RS485 communication interfaces and adopts the master-slave communication based on the international standard Modbus communication protocol. You can implement centralized control (setting commands for controlling the VFD, modifying the running frequency and related function code parameters, and monitoring the working state and fault information of the VFD) through PC/PLC, upper control computer, or other devices to meet specific application requirements.

7.1.1 Modbus protocol instruction

Modbus a software protocol, a common language used in electronic controllers. By using this protocol, a controller can communicate with other devices through transmission lines. It is a general industrial standard. With this standard, control devices produced by different manufacturers can be connected to form an industrial network and be monitored in a centralized way.

The Modbus protocol provides two transmission modes, namely American Standard Code for Information Interchange (ASCII) and remote terminal units (RTU). On one Modbus network, all the device transmission modes, baud rates, data bits, check bits, end bits, and other basic parameters must be set consistently.

A Modbus network is a control network with one master and multiple slaves, that is, on one Modbus network, there is only one device serving as the master, and other devices are the slaves. The master can communicate with any single slave or with all slaves. For separate access commands, a slave needs to return a response. For broadcasted information, slaves do not need to return responses.

7.1.2 Application of Modbus

The VFD uses Modbus RTU mode and communicates through RS485 interfaces.

7.1.2.1 RS485

RS485 interfaces work in half-duplex mode and transmit data signals in the differential transmission way, which is also referred to as balanced transmission. An RS485 interface uses a twisted pair, where one wire is defined as A (+), and the other B (-). Generally, if the positive electrical level between the transmission drives A and B ranges from +2V to +6V, the logic is "1"; and if it ranges from -2V to -6V, the logic is "0".

On the VFD terminal block, the 485+ terminal corresponds to A, and 485- corresponds to B.

The communication baud rate (P20.01) indicates the number of bits sent in a second, and the unit is bit/s (bps). A higher baud rate indicates faster transmission and poorer anti-interference capability. When a twisted pair of 0.56mm (24 AWG) is used, the maximum transmission distance varies according to the baud rate, as described in the following table.

Baud rate	Max. transmission distance	Baud rate	Max. transmission distance
2400BPS	1800m	9600BPS	800m
4800BPS	1200m	19200BPS	600m

In long-distance RS485 communication, it is recommended that you use shielded cables, and use the shielding layer as the ground wire.

When there are fewer devices and the transmission distance is short, the whole network works well without terminal load resistors. The performance, however, degrades as the distance increases. Therefore, it is recommended that you use a 120 Ω terminal resistor when the transmission distance is long.

7.1.2.2 RTU mode

(1) RTU communication frame structure

When a controller is set to use the RTU communication mode on a Modbus network, every byte (8 bits) in the message includes 2 hexadecimal characters (each includes 4 bits). Compared with the ASCII mode, the RTU mode can send more data at the same baud rate.

Code system

- 1 start bit
- 7 or 8 data bits; the minimum valid bit is transmitted first. Each frame domain of 8 bits includes 2 hexadecimal characters (0–9, A–F).
- 1 odd/even check bit; this bit is not provided if no check is needed.
- 1 end bit (with check performed), 2 bits (without check)

Error detection domain

- Cyclic redundancy check (CRC)

The following table describes the data format.

11-bit character frame (Bits 1 to 8 are data bits)

Start bit	BIT1	BIT2	BIT3	BIT4	BIT5	BIT6	BIT7	BIT8	Check bit	Stop bit
-----------	------	------	------	------	------	------	------	------	-----------	----------

10-bit character frame (Bits 1 to 7 are data bits)

Start bit	BIT1	BIT2	BIT3	BIT4	BIT5	BIT6	BIT7	Check bit	Stop bit
-----------	------	------	------	------	------	------	------	-----------	----------

In a character frame, only the data bits carry information. The start bit, check bit, and stop bit are used to facilitate the transmission of the data bits to the destination device. In practical applications, you must set the data bits, parity check bits, and stop bits consistently.

In RTU mode, the transmission of a new frame always starts from an idle time (the transmission time of 3.5 bytes). On a network where the transmission rate is calculated based on the baud rate, the transmission time of 3.5 bytes can be easily obtained. After the idle time ends, the data domains are sent in the following sequence: slave address, operation command code, data, and CRC check character. Each byte sent in each domain includes 2 hexadecimal characters (0–9, A–F). The network devices always monitor the communication bus. After receiving the first domain (address information), each network device identifies the byte. After the last byte is sent, a similar transmission interval (with a minimum length of 3.5 bytes) is used to indicate that the frame transmission ends. Then, the transmission of a new frame starts.

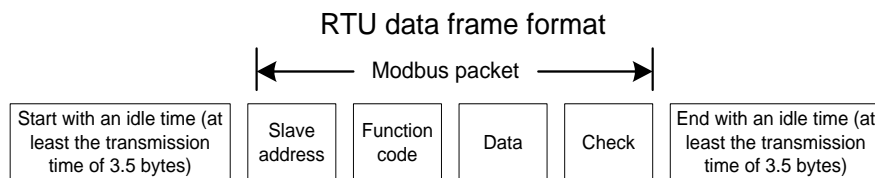

The information of a frame must be sent in a continuous data flow. If there is an interval greater than the transmission time of 1.5 bytes before the transmission of the entire frame is complete, the receiving device deletes the incomplete information, and mistakes the subsequent byte for the address domain of a new frame. Similarly, if the transmission interval between two frames is shorter than the transmission time of 3.5 bytes, the receiving device mistakes it for the data of the last frame. The CRC check value is incorrect due to the disorder of the frames, and thus a communication fault occurs.

The following table describes the standard structure of an RTU frame.

START (frame header)	T1-T2-T3-T4 (time gap with a min. length of 3.5 bytes)
ADDR (slave address domain)	Communication address: 0–247 (decimal system) (0 is the broadcast address)
CMD (function domain)	03H: read slave parameters 06H: write slave parameters
Data domain DATA (N-1) ... DATA (0)	Data of 2×N bytes, main content of the communication as well as the core of data exchanging.
CRC CHK LSB	Detection value: CRC (16 bits)
CRC CHK MSB	
END (frame tail)	T1-T2-T3-T4 (time gap with a min. length of 3.5 bytes)

(2) RTU communication frame error check modes

During the transmission of data, errors may occur due to various factors. Without check, the data receiving device cannot identify data errors and may make an incorrect response. The incorrect response may cause severe problems. Therefore, the data must be checked.

The check is implemented as follows: The sender calculates the to-be-sent data based on a specific algorithm to obtain a result, appends the result at the end of the message, and sends them together. After receiving the message, the receiver calculates the data based on the same algorithm to obtain a result, and compares the result with that sent by the sender. If the results are the same, the message is correct. Otherwise, the message is considered wrong.

The error check of a frame includes two parts, namely bit check on individual bytes (that is, odd/even check bit using the check bit in the character frame), and whole data check (CRC check).

Bit check on individual bytes (odd/even check)

You can select the bit check mode as required, or you can choose not to perform the check, which will affect the check bit setting of each byte.

Definition of even check: Before the data is sent, an even check bit is added to indicate whether the number of "1" in the to-be-sent data is odd or even. If it is even, the check bit is set to "0"; and if it is odd, the check bit is set to "1".

Definition of odd check: Before the data is sent, an odd check bit is added to indicate whether the number of "1" in the to-be-sent data is odd or even. If it is odd, the check bit is set to "0"; and if it is even, the check bit is set to "1".

For example, the data bits to be sent are "11001110", including five "1". If the even check is applied, the even check bit is set to "1"; and if the odd check is applied, the odd check bit is set to "0". During the transmission of the data, the odd/even check bit is calculated and placed in the check bit of the frame. The receiving device performs the odd/even check after receiving the data. If it finds that the odd/even parity of the data is inconsistent with the preset information, it determines that a communication error occurs.

CRC

A frame in the RTU format includes an error detection domain based on the CRC calculation. The CRC domain checks all the content of the frame. The CRC domain consists of two bytes, including 16 binary bits. It is calculated by the transmitter and added to the frame. The receiver calculates the CRC of the received frame, and compares the result with the value in the received CRC domain. If the two CRC values are not equal to each other, errors occur in the transmission.

During CRC, 0xFFFF is stored first, and then a process is invoked to process a minimum of 6 contiguous bytes in the frame based on the content in the current register. CRC is valid only for the 8-bit data in each character. It is invalid for the start, end, and check bits.

During the generation of the CRC values, the "exclusive or" (XOR) operation is performed on the each 8-bit

character and the content in the register. The result is placed in the bits from the least significant bit (LSB) to the most significant bit (MSB), and 0 is placed in the MSB. Then, LSB is detected. If LSB is 1, the XOR operation is performed on the current value in the register and the preset value. If LSB is 0, no operation is performed. This process is repeated for 8 times. After the last bit (8th bit) is detected and processed, the XOR operation is performed on the next 8-bit byte and the current content in the register. The final values in the register are the CRC values obtained after operations are performed on all the bytes in the frame.

The calculation adopts the international standard CRC check rule. You can refer to the related standard CRC algorithm to compile the CRC calculation program as required.

The following example is a simple CRC calculation function for your reference (using the C programming language):

```
unsigned int crc_cal_value(unsigned char*data_value,unsigned char data_length)
{
    int i;
    unsigned int crc_value=0xffff;
    while(data_length--)
    {
        crc_value^=*data_value++;
        for(i=0;i<8;i++)
        {
            if(crc_value&0x0001)
                crc_value=(crc_value>>1)^0xa001;
            else
                crc_value=crc_value>>1;
        }
    }
    return(crc_value);
}
```

In the ladder logic, CKSM uses the table look-up method to calculate the CRC value according to the content in the frame. The program of this method is simple, and the calculation is fast, but the ROM space occupied is large. Use this program with caution in scenarios where there are space occupation requirements on programs.

7.1.3 RTU command codes and communication data

7.1.3.1 Command code 03H, reading N words (continuously up to 16 words)

The command code 03H is used by the master to read data from the VFD. The count of data to be read depends on the "data count" in the command. A maximum of 16 pieces of data can be read. The addresses of the read parameters must be contiguous. Each piece of data occupies 2 bytes, that is, one word. The command format is presented using the hexadecimal system (a number followed by "H" indicates a hexadecimal value). One hexadecimal value occupies one byte.

The 03H command is used to read information including the parameters and running status of the VFD.

For example, to read two contiguous data content pieces from 0004H from the VFD with the address of 01H (that is, to read content from data addresses 0004H and 0005H), the frame structure is as follows:

RTU master command (from the master to the VFD)

START	T1-T2-T3-T4 (transmission time of 3.5 bytes)
ADDR (address)	01H
CMD (command code)	03H
Start address MSB	00H
Start address LSB	04H
Data count MSB	00H
Data count LSB	02H
CRC LSB	85H
CRC MSB	CAH
END	T1-T2-T3-T4 (transmission time of 3.5 bytes)

The value in START and END is "T1-T2-T3-T4 (transmission time of 3.5 bytes)", indicating that the RS485 needs to stay idle for at least the transmission time of 3.5 bytes. An idle time is required to distinguish on message from another to ensure that the two messages are not regarded as one.

ADDR=01H means the command message is sent to the VFD with the address of 01H and ADDR occupies one byte.

CMD=03H means the command message is sent to read data from the VFD and CMD occupies one byte.

"Start address" means reading data from the address and it occupies two bytes with the MSB on the left and LSB on the right.

"Data count" indicates the count of data to be read (unit: word). "Start address" is "0004H" and "Data count" is 0002H, indicating that data is to be read from the data addresses of 0004H and 0005H.

CRC check occupies two bytes, with the LSB on the left, and MSB on the right.

RTU slave response (from the VFD to the master)

START	T1-T2-T3-T4 (transmission time of 3.5 bytes)
ADDR	01H
CMD	03H
Number of bytes	04H
MSB of data in 0004H	13H
LSB of data in 0004H	88H
MSB of data in 0005H	00H
LSB of data in 0005H	00H
CRC LSB	7EH
CRC MSB	9DH
END	T1-T2-T3-T4 (transmission time of 3.5 bytes)

The definition of the response information is described as follows:

"ADDR" is "01H", indicating that the message is sent by the VFD whose address is 01H. The ADDR information occupies one byte.

"CMD" is "03H", indicating that the message is a response of the VFD to the 03H command of the master for reading data. The CMD information occupies one byte.

"Number of bytes" indicates the number of bytes between a byte (not included) and the CRC byte (not included). The value "04" indicates that there are four bytes of data between "Number of bytes" and "CRC LSB", that is, "MSB of data in 0004H", "LSB of data in 0004H", "MSB of data in 0005H", and "LSB of data in 0005H".

A piece of data contains two bytes, with the MSB on the left and LSB on the right. From the response, the data in 0004H is 1388H, and that in 0005H is 0000H.

CRC check occupies two bytes, with the LSB on the left, and MSB on the right.

7.1.3.2 Command code 06H, writing a word

This command is used by the master to write data to the VFD. One command can be used to write only one piece of data. It is used to modify the parameters and running mode of the VFD.

For example, if the master writes 5000 (1388H) to 0004H of the VFD whose address is 02H, the frame structure is as follows.

RTU master command (from the master to the VFD)

START	T1-T2-T3-T4 (transmission time of 3.5 bytes)
ADDR	02H
CMD	06H
MSB of data writing address	00H
LSB of data writing address	04H
MSB of to-be-written data	13H
LSB of to-be-written data	88H
CRC LSB	C5H
CRC MSB	6EH
END	T1-T2-T3-T4 (transmission time of 3.5 bytes)

RTU slave response (from the VFD to the master)

START	T1-T2-T3-T4 (transmission time of 3.5 bytes)
ADDR	02H
CMD	06H
MSB of data writing address	00H
LSB of data writing address	04H
MSB of to-be-written data	13H
LSB of to-be-written data	88H
CRC LSB	C5H
CRC MSB	6EH
END	T1-T2-T3-T4 (transmission time of 3.5 bytes)

Note: The sections 7.1.3.1 and 7.1.3.2 mainly describe the command formats. For the detailed application, see the examples in section 7.1.3.7.

7.1.3.3 Command code 08H, diagnosis

Sub-function code description:

Sub-function code	Description
0000	Returned data based on query information

For example, to query about the circuit detection information about the VFD whose address is 01H, the query and return strings are the same, and the format is described as follows.

RTU master command

START	T1-T2-T3-T4 (transmission time of 3.5 bytes)
ADDR	01H
CMD	08H
Sub-function code MSB	00H
Sub-function code LSB	00H
MSB of to-be-written data	12H
LSB of to-be-written data	ABH
CRC CHK LSB	ADH
CRC CHK MSB	14H
END	T1-T2-T3-T4 (transmission time of 3.5 bytes)

RTU slave response

START	T1-T2-T3-T4 (transmission time of 3.5 bytes)
ADDR	01H
CMD	08H
Sub-function code MSB	00H
Sub-function code LSB	00H
MSB of to-be-written data	12H
LSB of to-be-written data	ABH
CRC CHK LSB	ADH
CRC CHK MSB	14H
END	T1-T2-T3-T4 (transmission time of 3.5 bytes)

7.1.3.4 Data address definition

This section describes the address definition of communication data. The addresses are used for controlling the running, obtaining the state information, and setting related function parameters of the VFD.

- **Function code address format rules**

The address of a function code consists of two bytes, with the MSB on the left and LSB on the right. The MSB ranges from 00 to ffH, and the LSB also ranges from 00 to ffH. The MSB is the hexadecimal form of the group number before the dot mark, and LSB is that of the number behind the dot mark. Take P05.06 as an example: The group number is 05, that is, the MSB of the parameter address is the hexadecimal form of 05; and the number behind the dot mark is 06, that is, the LSB is the hexadecimal form of 06. Therefore, the function code address is 0506H in the hexadecimal form. For P10.01, the parameter address is 0A01H.

Function code	Name	Description	Setting range	Default	Modify
P10.00	Simple PLC mode	0: Stop after running once 1: Keep running with the final value after running once 2: Cyclic running	0-2	0	<input type="radio"/>
P10.01	Simple PLC memory selection	0: Without memory at power failure 1: With memory after power off	0-1	0	<input type="radio"/>

Note: P29 group is the factory parameters which cannot be read or changed. Some parameters cannot be changed when the VFD is in the running state and some parameters cannot be changed in any state. The setting range, unit and related descriptions should be paid attention to when modifying the function codes.

Besides, EEPROM is stocked frequently, which may shorten the usage time of EEPROM. For users, some functions are not necessary to be stocked on the communication mode. The needs can be met on by changing the value in RAM. Changing the MSB of the function code form 0 to 1 can also realize the function. For example, the function code P00.07 is not stocked into EEPROM. Only by changing the value in RAM can set the address to 8007H. This address can only be used in writing RAM other than reading. If it is used to read, it is an invalid address.

- **Address description of other Modbus functions**

In addition to modifying the parameters of the VFD, the master can also control the VFD, such as starting and stopping the VFD, and monitoring the running status of the VFD.

The following table lists other function parameters.

Function	Address	Data description	R/W
Communication-based control command	2000H	0001H: Run forward	W/R
		0002H: Run reversely	

Function	Address	Data description	R/W
		0003H: Jog forward	
		0004H: Jog reversely	
		0005H: Stop	
		0006H: Coast to stop (in emergency)	
		0007H: Fault reset	
		0008H: Jogging stop	
Communication-based setting address	2001H	Communication-based frequency setting (0-Fmax; unit: 0.01 Hz)	W/R
	2002H	PID reference (0-1000, in which 1000 corresponds to 100.0%)	
	2003H	PID feedback (0-1000, in which 1000 corresponds to 100.0%)	W/R
	2004H	Torque setting (-3000-3000, in which 1000 corresponds to 100.0% of the motor rated current)	W/R
	2005H	Upper limit setting of forward running frequency (0-Fmax; unit: 0.01 Hz)	W/R
	2006H	Upper limit setting of reverse running frequency (0-Fmax; unit: 0.01Hz)	W/R
	2007H	Upper limit of the electromotive torque (0-3000, in which 1000 corresponds to 100.0% of the motor rated current)	W/R
	2008H	Braking torque upper limit. (0-3000, in which 1000 corresponds to 100.0% of the VFD rated current)	W/R
	2009H	Special CW Bit0-1: = 00: Motor1 =01: Motor2 =10: Motor 3 =11: motor 4 Bit2: =1: Torque control =0: Speed control	W/R
	200AH	Virtual input terminal command (0x0000-0x00FF)	W/R
	200BH	Virtual output terminal command (0x00-0x3F)	W/R
	200CH	Voltage setting (used when V/F separation is implemented) (0-1000, 1000 corresponding to 100.0% of the motor rated voltage)	W/R
	200DH	AO setting 1 (-1000-+1000, in which 1000 corresponding to 100.0%)	W/R
	200EH	AO setting 2 (-1000-+1000, in which 1000 corresponding to 100.0%)	W/R
VFD status word 1	2100H	0001H: Forward running	R
		0002H: Reverse running	
		0003H: Stopped	
		0004H: Faulty	
		0005H: POFF	
VFD status word 2	2101H	Bit0: = 0: Bus voltage not established =1: Bus voltage established Bi1-2: = 00: Motor1 =01: Motor2 =10: Motor 3 =11: motor 4 Bit3: =0: AM =1: SM Bit4: = 0: No pre-alarm upon overload =1:	R

Function	Address	Data description	R/W
		overload pre-alarm Bit5: =0: Braking =1: Brake released	
VFD fault code	2102H	See the description of fault types.	R
VFD identification code	2103H	GD800-----0x010F	R
Running frequency	3000H	Compatible with CHF100A and CHV100 communication addresses	R
Set frequency	3001H		R
Bus voltage	3002H		R
Output voltage	3003H		R
Output current	3004H		R
Rotational speed	3005H		R
Output power	3006H		R
Output torque	3007H		R
Closed-loop setting	3008H		R
Closed-loop feedback	3009H		R
Input IO status	300AH		R
Output IO status	300BH		R
Analog input 1	300CH		R
Analog input 2	300DH		R
Analog input 3	300EH		R
Analog input 4	300FH		R
Read input of high-speed pulse 1	3010H		R
Read high speed pulse 2 input	3011H		R
Read the actual step of multi-step speed	3012H		R
External length value	3013H		R
External counting value	3014H		R
Torque setting	3015H		R
VFD identification code	3016H		R
Fault code	5000H		R

The Read/Write (R/W) characteristics indicate whether a function parameter can be read and written. For example, "Communication-based control command" can be written, and therefore the command code 06H is used to control the VFD. The R characteristic indicates that a function parameter can only be read, and W indicates that a function parameter can only be written.

Note: Some parameters in the preceding table are valid only after they are enabled. Take the running and stop operations as examples, you need to set "Running command channel" (P00.01) to "Communication", and set "Communication mode of running commands" (P00.02) to MODBUS For another example, when modifying "PID reference", you need to set "PID reference source" (P09.00) to MODBUS communication.

The following table describes the encoding rules of device codes (corresponding to the identification code 2103H of the VFD).

8 MSBs	Meaning	8 LSBs	Meaning
0x01	Goodrive	0x0E	Goodrive800 Pro series PMW rectifier
		0x0F	Goodrive800 Pro series VFD or inverter

Note: A device code consists of 16 bits, with 8 MSBs and 8 LSBs. The 8 MSBs indicate the model series, and the 8 LSBs indicate the derivative model.

7.1.3.5 Fieldbus scale

In practical applications, communication data is represented in the hexadecimal form, but hexadecimal values cannot represent decimals. For example, 50.12 Hz cannot be represented in the hexadecimal form. In such cases, multiply 50.12 by 100 to obtain an integer 5012, and then 50.12 can be represented as 1394H in the hexadecimal form (5012 in the decimal form).

In the process of multiplying a non-integer by a multiple to obtain an integer, the multiple is referred to as a fieldbus scale.

The fieldbus scale depends on the number of decimal places in the value specified in "Setting range" or "Default". If there are n (for example, 1) decimal places in the value, the fieldbus scale m (then $m=10^n$) is the result of 10 to the power of n. Take the following table as an example.

Function code	Name	Description	Setting range	Default	Modify
P01.20	Wake-up-from-sleep delay	0.0–3600.0s (valid when P01.19=2)	0.0–3600.0	0.0s	<input type="radio"/>
P01.21	Power-off restart selection	0: Disable 1: Enable	0–1	0	<input type="radio"/>

If "Setting range" or "Default value" contains one decimal, the fieldbus scale is 10. If the value received by the host controller is 50, "Delay of auto fault reset" of the rectifier is 5.0 ($5.0=50/10$).

To set "Wake-up-from-sleep delay" to 5.0s through Modbus communication, you need first to multiply 5.0 by 10 according to the scale to obtain an integer 50, that is, 32H in the hexadecimal form, and then send the following write command:

01 06 01 14 00 32 49 E7
 VFD Write Parameter Parameter CRC
 address command address data

After receiving the command, the VFD converts 50 into 5.0 based on the fieldbus scale, and then sets "Wake-up-from-sleep delay" to 5.0s.

For another example, after the host controller sends the "Wake-up-from-sleep delay" parameter read command, the master receives the following response from the VFD:

01 03 02 00 32 39 91
 VFD Read 2-byte Parameter CRC
 address command data data

The parameter data is 0032H, that is, 50, and therefore 5.0 is obtained based on the fieldbus scale ($50/10=5.0$). In this case, the master identifies that "Wake-up-from-sleep delay" is 5.0s.

7.1.3.6 Error message response

Operation errors may occur in communication-based control. For example, some parameters can only be read, but a write command is sent. In this case, the VFD returns an error message response.

Error message responses are sent from the VFD to the master. The following table lists the codes and definitions of the error message responses.

Code	Name	Meaning
01H	Invalid command	The command code received by the host controller is not allowed to be executed. The possible causes are as follows: <ul style="list-style-type: none"> The function code is applicable only on new devices and is not implemented on this device. The slave is in faulty state when processing this request.

Code	Name	Meaning
02H	Invalid data address	For the VFD, the data address in the request of the host controller is not allowed. In particular, the combination of the register address and the number of the to-be-sent bytes is invalid.
03H	Invalid data value	The received data domain contains a value that is not allowed. The value indicates the error of the remaining structure in the combined request. Note: It does not mean that the data item submitted for storage in the register includes a value unexpected by the program.
04H	Operation failure	The parameter is set to an invalid value in the write operation. For example, a function input terminal cannot be set repeatedly.
05H	Incorrect password	The password entered in the password verification address is different from that is specified by P07.00.
06H	Incorrect data frame	The data frame sent from the host controller is incorrect in the length, or in the RTU format, the value of the CRC check bit is inconsistent with the CRC value calculated by the lower computer.
07H	Parameter read-only	The parameter to be modified in the write operation of the host controller is a read-only parameter.
08H	Parameter cannot be modified in running	The parameter to be modified in the write operation of the host controller cannot be modified during the running of the VFD.
09H	Password protection	If the host controller does not provide the correct password to unlock the system to perform a read or write operation, the error of "system being locked" is reported.

When returning a response, the slave uses a function code domain and fault address to indicate whether it is a normal response (no error) or exception response (an error occurs). In a normal response, the slave returns the corresponding function code and data address or sub-function code. In an exception response, the slave returns a code that is equal to a normal code, but the first bit is logic 1.

For example, if the master sends a request message to a slave for reading a group of function code address data, the following code is generated:

0 0 0 0 0 1 1 (03H in the hexadecimal form)

In a normal response, the slave returns the same code. In an exception response, the slave returns the following code:

1 0 0 0 0 1 1 (83H in the hexadecimal form)

In addition to the modification of the code, the slave returns a byte of exception code that describes the cause of the exception. After receiving the exception response, the typical processing of the master is to send the request message again or modify the command based on the fault information.

For example, to set the "Channel of running commands" (P00.01, the parameter address is 0000H) to 03 for the VFD whose address is 01H, the command is as follows:

01 **06** **00 01** **00 03** **98 0B**
VFD Write Parameter Parameter CRC
address command address data

However, the "Running command channel" ranges from 0 to 2. The value 3 is out of the setting range. In this case, the VFD returns an error message response as shown in the following:

01 **86** **04** **43 A3**
VFD Exception Error CRC
address response code code

The exception response code 86H (generated based on the highest-order bit "1" of the write command 06H) indicates that it is an exception response to the write command (06H). The error code is 04H, which indicates "Operation failure".

7.1.3.7 Read/Write operation examples

For the formats of the read and write commands, see section 7.1.3.1 and 7.1.3.2.

(1) Example of reading command 03H

Example 1: Read state word 1 of the VFD whose address is 01H. According to the table of other Modbus function addresses, the parameter address of state word 1 of the VFD is 2100H.

The read command transmitted to the VFD is as follows:

<u>01</u>	<u>03</u>	<u>21 00</u>	<u>00 01</u>	<u>8E 36</u>
VFD address	Read command	Parameter address	Data quantity	CRC

Assume that the following response is returned:

<u>01</u>	<u>03</u>	<u>02</u>	<u>00 03</u>	<u>F8 45</u>
VFD address	Read command	Number of bytes	Data content	CRC

The data content returned by the VFD is 0003H, which indicates that the VFD is in the stopped state.

Example 2: View information about the VFD whose address is 03H, including "Present fault type" (P19.00) to "5th-last fault type" (P19.05) of which the parameter addresses are 1900H to 1905H (contiguous 6 parameter addresses starting from 1300H).

The command transmitted to the VFD is as follows:

<u>03</u>	<u>03</u>	<u>07 1B</u>	<u>00 06</u>	<u>B5 59</u>
VFD address	Read command	Start address	6 parameters in total	CRC

Assume that the following response is returned:

<u>03</u>	<u>03</u>	<u>0C</u>	<u>00 23</u>	<u>00 23</u>	<u>00 23</u>	<u>00 23</u>	<u>00 23</u>	<u>00 23</u>	<u>00 23</u>	<u>5F D2</u>
VFD address	Read command	Number of bytes	Most recent fault type	Last fault type	2nd-last fault type	3rd-last fault type	4th-last fault type	5th-last fault type	CRC	

From the returned data, we can see that all the fault types are 0023H, that is, 35 in the decimal form, which means the maladjustment fault (STE).

(2) Example of writing command 06H

Example 1: Set the VFD whose address is 03H to be forward running. Refer to the table of other function parameters, the address of "Communication-based control command" is 2000H, and 0001H indicates forward running, as shown in the following table.

Function	Address	Data description	R/W
Communication-based control command	2000H	0001H: Run forward	R/W
		0002H: Run reversely	
		0003H: Jog forward	
		0004H: Jog reversely	
		0005H: Stop	
		0006H: Coast to stop (in emergency)	
		0007H: Fault reset	
		0008H: Jogging stop	

The command transmitted from the master is as follows:

03 06 20 00 00 01 42 28
 VFD Write Parameter Forward CRC
 address command address running

If the operation is successful, the following response is returned (same as the command sent from the master):

03 06 20 00 00 01 42 28
 VFD Write Parameter Forward CRC
 address command address running

Example 2: Set the max. output frequency to 100 Hz for the VFD with the address of 03H.

Function code	Name	Description	Setting range	Default	Modify
P00.03	Max. output frequency	P00.04-400.00Hz	P00.04-400.00	50.00Hz	⊙

See the figures behind the radix point, the fieldbus ratio value of max. output frequency (P00.03) is 100. 100Hz timed by 100 is 10000 and the corresponding hex is 2710H.

The command transmitted from the master is as follows:

03 06 00 03 27 10 62 14
 VFD Write Parameter Parameter CRC
 address command address data

If the operation is successful, the following response is returned (same as the command sent from the master):

03 06 00 03 27 10 62 14
 VFD Write Parameter Parameter CRC
 address command address data

Note: In the preceding command description, spaces are added to a command just for explanatory purposes. In practical applications, no space is required in the commands.

(3) Example of Modbus communication commissioning

A PC is used as the host, an RS232-RS485 converter is used for signal conversion, and the PC serial port used by the converter is COM1 (an RS232 port). The host controller commissioning software is the serial port commissioning assistant Commix, which can be downloaded from the Internet. Download a version that can automatically execute the CRC check function. The following figure shows the interface of Commix.

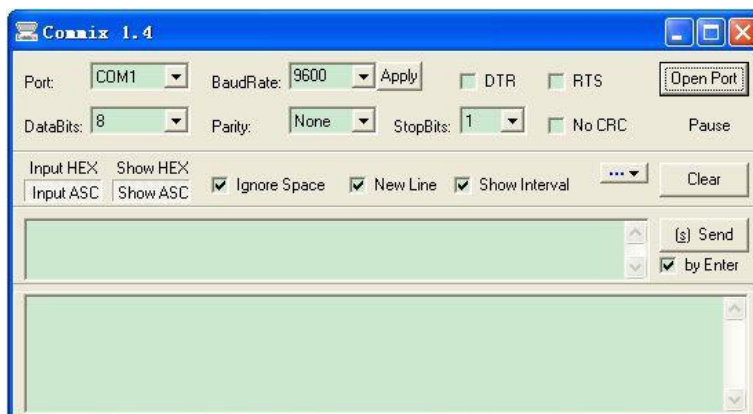

First, set the serial port to **COM1**. Then, set the baud rate consistently with P20.01. The data bits, check bits, and end bits must be set consistently with P20.02. If the RTU mode is selected, you need to select the

hexadecimal form **Input HEX**. To set the software to automatically execute the CRC function, you need to select **ModbusRTU**, select **CRC16 (MODBUSRTU)**, and set the start byte to **1**. After the auto CRC check function is enabled, do not enter CRC information in commands. Otherwise, command errors may occur due to repeated CRC check.

The commissioning command to set the VFD whose address is 03H to be forward running is as follows:

03
VFD
address
06
Write
command
20 00
Parameter
address
00 01
Forward running
42 28
CRC

Note:

- **Set the address (P20.00) of the VFD to 03.**
- **Set "Channel of running commands" (P00.01) to "Communication", and set "Communication channel of running commands" (P00.02) to the Modbus channel.**
- **Click "Send". If the line configuration and settings are correct, a response transmitted by the VFD is received as follows:**

7.1.4 Common communication faults

Common communication faults include the following:

- No response is returned.
- The VFD returns an exception response.

Possible causes of no response include the following:

- The serial port is set incorrectly. For example, the adapter uses the serial port COM1, but COM2 is selected for the communication.
- The settings of the baud rates, data bits, end bits, and check bits are inconsistent with those set on the VFD.
- The positive pole (+) and negative pole (-) of the RS485 bus are connected reversely.

7.1.5 Related function codes

Function code	Name	Description	Setting range	Default
P20.00	Local communication address	1-247; 0 indicates a broadcast address	1-247	1
P20.01	Communication baud rate	0: 1200BPS 1: 2400BPS 2: 4800BPS 3: 9600BPS 4: 19200BPS 5: 38400BPS	0-5	4
P20.02	Data bit check	0: No check (N, 8, 1) for RTU 1: Even check (E, 8, 1) for RTU 2: Odd check (O, 8, 1) for RTU 3: No check (N, 8, 2) for RTU 4: Even check (E, 8, 2) for RTU 5: Odd check (O, 8, 2) for RTU	0-5	1
P20.03	Communication response delay	0-200ms	0-200	5

Function code	Name	Description	Setting range	Default
P20.04	Communication timeout time	0.0 (invalid); 0.1–60.0s	0.0–60.0	0.0s
P20.05	Transmission error processing	0: Report an alarm and coast to stop 1: Keep running without reporting an alarm 2: Stop in enabled stop mode without reporting an alarm (applicable only to communication mode) 3: Stop in enabled stop mode without reporting an alarm (applicable to any mode)	0–3	0
P20.06	Communication processing action	0x00–0x11 LED ones place: 0: Respond to write operations 1: Not respond to write operations LED tens place: 0: Disabled 1: Enabled	0x00–0x11	0x00

7.2 PROFIBUS protocol

PROFIBUS is an international open fieldbus standard that can implement data exchange between various automation components. It is widely applicable to automation in various industries, such as the manufacturing, process, building, transportation, and power industries. It provides effective solutions for implementing integrated automation and intelligentization of field devices.

PROFIBUS consists of three mutually compatible components, namely PROFIBUS-Decentralised Peripherals (DP), PROFIBUS-Process Automation (PA), and PROFIBUS-Fieldbus Message Specification (FMS). It adopts the master/slave mode and is generally used for periodic data exchange between VFD devices.

The transmission media of a PROFIBUS field bus are twisted pairs (complying with the RS-485 standard), paired cables, or optical cables. The baud rate ranges from 9.6kbit/s to 12Mbit/s. The maximum length of a fieldbus cable must be within the range of 100 meters to 1200 meters, and the specific length depends on the selected transmission rate (see the chapter of "Technical Data"). A maximum of 31 nodes can be connected to one PROFIBUS network segment when no repeater is used. If repeaters are used, a maximum of 127 nodes (including the repeaters and master nodes) can be connected.

In PROFIBUS communication, tokens are transmitted between master nodes or by master nodes to slave nodes. Single-master or multi-master systems are supported. The node to respond to the command of a master is selected by the master node, generally a programmable logic controller (PLC). For cyclic master/slave user data transmission and non-cyclic master-master data transmission, a master can also transmit commands to multiple nodes in broadcast mode. When the broadcast mode is adopted, the nodes do not need to transmit feedback signals to the master. On PROFIBUS networks, nodes cannot communicate with each other.

The PROFIBUS protocol is described in details in the EN50170 standard. For details, refer to the EN50170 standard.

7.2.1 System configuration

- System configuration

Master station and VFD should be configured so that the master station can communicate with the communication card after correctly installing EC-TX103 communication card.

Each PROFIBUS subsidiary station on the PROFIBUS bus need to have "device description document" named GSD file which used to describe the characteristics of PROFIBUS-DP devices. The software we provided for the user includes VFD related GSD files (device data files) information, users can obtain type definition file (GSD) of master machines from local INVT agent.

Parameter number	Parameter name	Optional setting	Default	Remarks
0	Module type	Read only	PROFIBUS-DP	This parameter shows communication module type detected by VFD; users can not adjust this parameter. If this parameter is not defined, communication between the communication card and VFD cannot be established.
1	Node address	0-99	2	In PROFIBUS network, each device corresponds to a unique node address, you can use the node address selection switch to define node address, but you cannot adjust the parameter by yourself and the parameter is only used to display the node address.
2	Baud rate setting	0: 9.6kbit/s 1: 19.2kbit/s 2: 45.45kbit/s 3: 93.75kbit/s 4: 187.5kbit/s 5: 500kbit/s 6: 1.5Mbit/s 7: 3Mbit/s 8: 6Mbit/s 9: 9Mbit/s 10: 12Mbit/s	6	
3	PZD2	0-65535	0	
4	PZD3	0-65535	0	
...	...	0-65535	0	
10	PZD12	0-65535	0	

- GSD file

Each PROFIBUS subsidiary station on the PROFIBUS bus need to have "device description document" named GSD file which used to describe the characteristics of PROFIBUS-DP devices. GSD file contains all defined parameters, including the supported baud rate, information length, amount of input/output data, meaning of diagnostic data.

A CD-ROM will be offered in which contains GSD file of the EC-TX103 communication card (expansion name is .gsd) for fieldbus adapter. Users can copy GSD file to relevant subdirectory of configuration tools, please refer to relevant system configuration software instructions to know specific operations and PROFIBUS system configuration.

7.2.2 PROFIBUS-DP Networking

- PROFIBUS-DP

PROFIBUS-DP is a distributed I/O system, which enables master machine to use a large number of peripheral modules and field devices. Data transmission shows cycle: master machine read input information from subsidiary machine then give feedback signal. EC-TX103 communication card supports PROFIBUS-DP protocol.

- Service access point

PROFIBUS-DP has access to PROFIBUS data link layer (Layer 2) services through service access point SAP. Every independent SAP has clearly defined function. Please refer to relevant PROFIBUS user manual to know more about service access point information. PROFIDRIVE - Variable speed drive adopts PROFIBUS model or EN50170 standards (PROFIBUS protocol).

- PROFIBUS -DP information frame data structure

PROFIBUS-DP bus mode allows rapid data exchange between master station and VFD. Adopting master-slave mode dealing with VFD access, VFD is always subsidiary station, and each has definite address. PROFIBUS periodic transmission messages use 16 words (16 bit) transmission, the structure shown in the following figure.

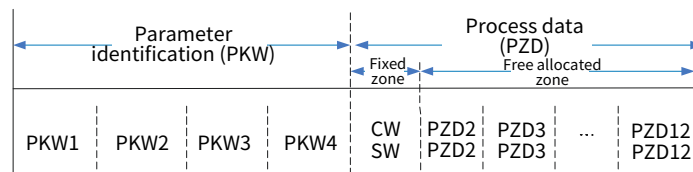

Parameter zone:

PKW1-Parameter identification

PKW2-array index number

PKW3-parameter value 1

PKW4-parameter value 2

Process data:

CW-control word

SW-status word

PZD-process data (user defined)

(From master to slave output **【reference value】** , from slave to master input **【actual value】**)

PZD zone (process data zone)

The PZD zone in a communication packet is designed for controlling and monitoring a VFD. The master and slave stations always process the received PZD with the highest priority. The processing of PZD takes priority over that of PKW, and the master and slave nodes always transmit the latest valid data on the interfaces.

Control word (CW) and status word (SW)

Using CWs is the basic method of the fieldbus system to control the VFD. A CW is transmitted by the fieldbus master node to the VFD. In this case, the adapter module functions as a gateway. The VFD responds to the bit code information of the CW and feeds state information back to the master through an SW.

Reference value: The VFD may receive control information in multiple channels, including analog and digital input terminals, VFD control panel, and communication modules (such as RS485 and CH-PA01 adapter modules). To enable the control over the VFD through PROFINET, you need to set the communication module as the controller of the VFD.

Actual value: An actual value is a 16-bit word that includes information about VFD operation. The monitoring function is defined through VFD parameters. The conversion scale of an integer transmitted as an actual value from the VFD to the master depends on the set function.

Note: The VFD always checks the bytes of a CW and reference value.

Mission message (from the master station to the VFD)

Control word (CW): The first word of PZD is control word (CW) of VFD.

Control word

Bit	Name	Value	Status/description
0-7	COMMAND BYTE Communication-based control command	1	Forward running
		2	Reverse running
		3	Jog forward
		4	Jog reversely
		5	Decelerate to stop
		6	Coast to stop (emergency stop)
		7	Fault reset
		8	Jog stop
		9	Pre-exciting
8	WRITE ENABLE	1	Write enabling (mainly PKW1-PKW4)
9-10	MOTOR GROUP SELECTION	00	MOTOR GROUP 1 SELECTION
		01	MOTOR GROUP 2 SELECTION
		02	MOTOR GROUP 3 SELECTION
		03	MOTOR GROUP 4 SELECTION
11	TORQUE CONTROL SELECTION	1	Enabling torque control
		0	Disable torque control
13	PRE-EXCIATION	1	Pre-excitation enable
		0	Pre-excitation disable
14	Reserved	1	
		0	
15	HEARTBEAT REF	1	Heartbeat enable
		0	Heartbeat disable

Reference value (REF): The second to twelfth words (PZD2-PZD12) in a PZD task packet are the main reference values. The following table shows the reference values of the inverter.

Bit	Name	function selection
Received PZD2	0: Disable 1: Set frequency (0-Fmax (Unit: 0.01Hz))	0
Received PZD3	2: PID reference (0-1000, in which 1000 corresponds to 100.0%) 3: PID feedback (0-1000, in which 1000 corresponds to 100.0%)	0
Received PZD4	4: Torque setting (-3000+3000, in which 1000 corresponds to 100.0% of the motor rated current)	0
Received PZD5	5: Setting of the upper limit of forward running frequency (0-Fmax, unit: 0.01 Hz)	0
Received PZD6	6: Setting of the upper limit of reverse running frequency (0-Fmax, unit: 0.01 Hz)	0
Received PZD7	7: Upper limit of the electromotive torque (0-3000, in which 1000 corresponds to 100.0% of the motor rated current)	0

Bit	Name	function selection
Received PZD8	8: Upper limit of braking torque (0–2000, in which 1000 corresponds to 100% of the motor rated current)	0
Received PZD9	9: Virtual input terminal command (0x00–0xFF) 10: Virtual output terminal command (0x00–0x0F)	0
Received PZD10	11: Voltage setting (special for V/F separation) (0–1000, in which 1000 corresponds to 100% of the motor rated voltage)	0
Received PZD11	12: AO output setting 1 (-1000–+1000, in which 1000 corresponds to 100.0%) 13: AO output setting 2 (-1000–+1000, in which 1000 corresponds to 100.0%)	0
Received PZD12	14: External ACC time (0–3600.0s) 15: External DEC time (0–3600.0s) 16: Pre-torque setting (-100.0%–100.0%)	0

Response message (from the VFD to the master station)

Status word (SW): The first word of PZD response message is status word (SW) of VFD, the definition of SW is as follows:

Status word

Bit	Name	Value	Status/description
0–7	RUN STATUS BYTE	1	Running forward
		2	Running reversely
		3	VFD stop
		4	VFD in fault
		5	VFD POFF status
8	DC VOLTAGE ESTABLISH	1	Ready for running
		0	Not ready for running
9–10	MOTOR GROUP FEEDBACK	0	Feedback of motor 1
		1	Feedback of motor 2
		2	Feedback of motor 3
		3	Feedback of motor 4
11	MOTOR TYPE FEEDBACK	1	Synchronous motor (SM)
		0	Asynchronous motor (AM)
12	OVERLOAD ALARM	1	Pre-alarm upon overload
		0	No pre-alarm upon overload
13	Braking control	1	Brake release
		0	Braking
14	Reserved	1	
		0	
15	HEARTBEAT FEEDBACK	1	Enable
		0	Disable

Actual value (ACT): The second to twelfth words (PZD2–PZD12) in a PZD task packet from the rectifier unit are the main actual values.

Actual SW

Bit	Name	function selection
Sent PZD2	0: Disable	0

Bit	Name	function selection
Sent PZD3	1: Running frequency (x100, Hz)	0
Sent PZD4	2: Set frequency (x100, Hz)	0
Sent PZD5	3: Bus voltage (x10, V)	0
Sent PZD6	4: Output voltage (×1, V)	0
Sent PZD7	5: Output current (x10, A)	0
Sent PZD8	6: Actual output torque (x10, %)	0
Sent PZD9	7: Actual output power (x10, %)	0
Sent PZD10	8: Rotation speed of running (x1, RPM)	0
Sent PZD11	9: Linear speed of running (x1, m/s)	0
Sent PZD12	10: Ramp reference frequency	0
	11: Fault code	
	12: AI1 input (*100, V)	
	13: AI2 input (*100, V)	
	14: AI3 input (*100, V)	
	15: Motor temperature (*10, °C)	
	16: Module temperature (*10, °C)	
	17: S8 frequency value (*100, kHz)	
	18: PG card speed (signed)	
	19: Terminal input status	
	20: Terminal output status	
	21: PID reference (x100, %)	
	22: PID feedback (x100, %)	
23: Motor rated torque		

PKW zone (parameter identification marks PKW1-value zone): PKW zone describes treatment of parameter identification interface, PKW interface is a mechanism which determine parameters transmission between two communication partners, such as reading and writing parameter values.

Structure of PKW zone

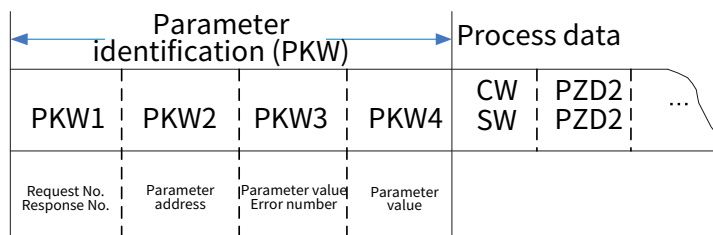

Parameter identification zone

In the process of periodic PROFIBUS-DP communication, PKW zone is composed of four words (16 bit), each word is defined as follows:

The first word PKW1 (16 bit)		
Bit 15-00	Task or response identification marks	0-7
The second word PKW2 (16 bit)		
Bit 15-00	Basic parameter address	0-247
The third word PKW3 (16 bit)		
Bit 15-00	Parameter value (MSB) or return error code value	00
The fourth word PKW4 (16 bit)		
Bit 15-00	Parameter value (LSB)	0-65535

Note: If the master node requests the value of a parameter, the values in PKW3 and PKW4 of the packet that the master node transmits to the VFD are no longer valid.

Task request and response: When transmitting data to a slave node, the master node uses a request number, and the slave node uses a response number to accept or reject the request.

The definition of task identification flag PKW1 is as follows:

Request No. (from the master to a slave)		Response signal	
Request No.	Function	Acceptance	Rejection
0	No task.	0	-
1	Requesting the value of a parameter	1, 2	3
2	Modifying a parameter value (one word) [modifying the value only on RAM]	1	3 or 4
3	Modifying a parameter value (two words) [modifying the value only on RAM]	2	3 or 4
4	Modifying a parameter value (one word) [modifying the value on both RAM and EEPROM]	1	3 or 4
5	Modifying a parameter value (two words) [modifying the value on both RAM and EEPROM]	2	3 or 4

Requests 2, 3, and 5 are not supported currently.

The definition of response identification flag PKW1 is as follows:

Response No. (from a slave to the master)	
Response No.	Function
0	No response
1	Transmitting the value of a parameter (one word)
2	Transmitting the value of a parameter (two words)
3	The task cannot be executed and one of the following error number is returned: 0: Invalid parameter number 1: Parameter values cannot be changed (read-only parameter) 2: Out of set value range 3: Incorrect sub-index number 4: Setting is not allowed (reset only) 5: Invalid data type 6: The task could not be implemented due to operational state 7: Request is not supported 8: Request cannot be completed due to communication error 9: Fault occurs during the write operation to fixed storage zone 10: Request failed due to timeout 11: Parameter cannot be assigned to PZD 12: Control word bit cannot be allocated 13: Other faults
4	No parameter modification rights

PKW examples:

Example 1: Reading the value of a parameter

You can set PKW1 to 1 and PKW2 to 10 to read a frequency set through keypad (the address of the frequency set through keypad is 10), and the value is returned in PKW4.

Request (from the master station to the VFD):

	PKW1		PKW2		PKW3		PKW4		CW		PZD2		PZD3		...	PZD12	
Request	00	01	00	10	00	00	00	00	xx	xx	xx	xx	xx	xx	...	xx	xx

0010: Parameter address
 0001: Request for parameter value reading

Response (from the VFD to the master station):

	PKW1		PKW2		PKW3		PKW4		CW		PZD2		PZD3		...	PZD12	
Response	00	01	00	10	00	00	50	00	xx	xx	xx	xx	xx	xx	...	xx	xx

5000: Parameter value in address 10
 0001: Response (parameter value updated)

Example 2: Modifying the value of a parameter (on both RAM and EEPROM)

You can set PKW1 to 4 and PKW2 to 10 to modify a frequency set through keypad (the address of the frequency set through keypad is 10), and the value to be modified (50.00) is in PKW4.

Request (from the master station to the VFD):

	PKW1		PKW2		PKW3		PKW4		CW		PZD2		PZD3		...	PZD12	
Request	00	04	00	10	00	00	50	00	xx	xx	xx	xx	xx	xx	...	xx	xx

5000: Parameter address in address 10
 0004: Request for parameter value modifying

Response (from the VFD to the master station):

	PKW1		PKW2		PKW3		PKW4		CW		PZD2		PZD3		...	PZD12	
Response	00	01	00	10	00	00	50	00	xx	xx	xx	xx	xx	xx	...	xx	xx

0001: Response (parameter value updated)

Examples for PZD: Transmission of PZD area is achieved through VFD function code. Please see INVT VFD user manual for relevant function code.

Example 1: Reading process data of the VFD

In this example, PZD3 is set to "8: Rotating speed of the running" through the VFD parameter P15.14. This operation sets the parameter forcibly. The setting remains until the parameter is set to another option.

Response (from the VFD to the master station):

	PKW1		PKW2		PKW3		PKW4		CW		PZD2		PZD3		...	PZD12	
Response	xx	xx	xx	xx	xx	xx	xx	xx	xx	xx	xx	xx	00	0A	...	xx	xx

Example 2: Writing process data into the VFD

In this example, PZD3 is set to "2: PID reference" through the VFD parameter P15.03. The parameter specified in each request frame is updated with the information contained in PZD3 until another parameter is specified.

Request (from the master station to the VFD):

	PKW1		PKW2		PKW3		PKW4		CW		PZD2		PZD3		...	PZD12	
Response	xx	xx	xx	xx	xx	xx	xx	xx	xx	xx	xx	xx	00	00	...	xx	xx

Then the content of PZD3 is traction reference within each request frame until a parameter is reselected.

7.2.3 Fault Information

An EC-TX103 communication card is equipped with two fault indicators. The following figure and table show the indicator details.

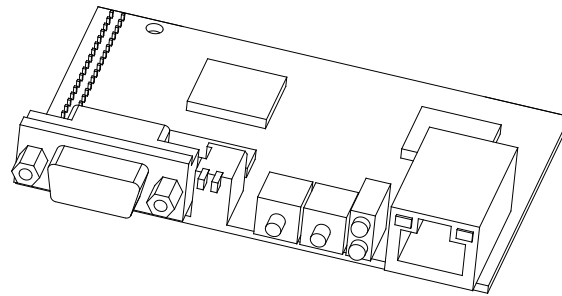

LED No.	Name	Color	Function
1	Online	Green	On--The module is online and data exchange can be performed. Off--The module is not in the online state.
2	Offline/Fault	Red	On--The module is offline and data exchange cannot be performed. Off--The module is not in the offline state. It blinks at the frequency of 1 Hz when a configuration error occurs: The length of the user parameter data set during the module initialization is different from that during the network configuration. It blinks at the frequency of 2 Hz when user parameter data is incorrect: The length or content of the user parameter data set during the module initialization is different from that during the network configuration. It blinks at the frequency of 4 Hz when an error occurs in the ASIC initialization of PROFIBUS communication. It is off when the diagnosis function is disabled.

7.2.4 Related function codes

Function code	Name	Description	Setting range	Default
P21.00	Module type	0: PROFIBUS/CANopen 1: DEVICE-NET	0-1	0
P21.01	PROFIBUS/CANopen Module address	0-127	0-127	2
P21.02	Received PZD2	0: Disable	0-20	0
P21.03	Received PZD3	1: Set frequency (0-Fmax (Unit: 0.01Hz))	0-20	0
P21.04	Received PZD4	2: PID reference (0-1000, in which 1000 corresponds to 100.0%)	0-20	0
P21.05	Received PZD5	3: PID feedback (0-1000, in which 1000 corresponds to 100.0%)	0-20	0
P21.06	Received PZD6	4: Torque setting (-3000+3000, in which	0-20	0
P21.07	Received PZD7		0-20	0
P21.08	Received PZD8		0-20	0

Function code	Name	Description	Setting range	Default
P21.09	Received PZD9	1000 corresponds to 100.0% of the motor rated current)	0-20	0
P21.10	Received PZD10		0-20	0
P21.11	Received PZD11		0-20	0
P21.12	Received PZD12	5: Setting of the upper limit of forward running frequency (0-Fmax, unit: 0.01 Hz) 6: Setting of the upper limit of reverse running frequency (0-Fmax, unit: 0.01 Hz) 7: Upper limit of the electromotive torque (0-3000, in which 1000 corresponds to 100.0% of the motor rated current) 8: Upper limit of braking torque (0-2000, in which 1000 corresponds to 100% of the motor rated current) 9: Virtual input terminal command (0x00-0xFF) 10: Virtual output terminal command (0x00-0x3F) 11: Voltage setting (special for V/F separation) (0-1000, in which 1000 corresponding to 100.0% of the motor rated voltage) 12: AO output setting 1 (-1000+1000, in which 1000 corresponds to 100.0%) 13: AO output setting 2 (-1000+1000, in which 1000 corresponds to 100.0%) 14: External ACC time (0-3600.0s) 15: External DEC time (0-3600.0s) 16: Pre-torque setting (-100.0%-100.0%) 17-20: Reserved	0-20	0
P21.13	Sent PZD2	0: Disable	0-23	0
P21.14	Sent PZD3	1: Running frequency (x100, Hz)	0-23	0
P21.15	Sent PZD4	2: Set frequency (x100, Hz)	0-23	0
P21.16	Sent PZD5	3: Bus voltage (x10, V)	0-23	0
P21.17	Sent PZD6	4: Output voltage (×1, V)	0-23	0
P21.18	Sent PZD7	5: Output current (x10, A)	0-23	0
P21.19	Sent PZD8	6: Actual output torque (x10, %)	0-23	0
P21.20	Sent PZD9	7: Actual output power (x10, %)	0-23	0
P21.21	Sent PZD10	8: Rotation speed of running (x1, RPM)	0-23	0
P21.22	Sent PZD11	9: Linear speed of running (x1, m/s)	0-23	0
P21.23	Sent PZD12	10: Ramp reference frequency 11: Fault code 12: AI1 input (*100, V) 13: AI2 input (* 100, V) 14: AI3 input (*100, V) 15: Motor temperature (*10, °C) 16: Module temperature (*10, °C) 17: S8 frequency value (*100, kHz) 18: PG card speed (signed) 19: Terminal input status 20: Terminal output status	0-23	0

Function code	Name	Description	Setting range	Default
		21: PID reference (x100, %) 22: PID feedback (x100, %) 23: Motor rated torque		
P21.24	Temporary variable 1 for PZD sending	0-65535	0-65535	0
P21.25	DP communication timeout time	0.0 (invalid), 0.1-60.0s	0.0-60.0	0.0s

7.3 PROFINET protocol

7.3.1 Communication settings

The communication card can only be used as a PROFINET slave, and function codes should to be set in the VFD before communication. See the following steps.

1. Set the communication timeout time

The communication timeout time is 0 by default and the timeout detection is disabled. Users can set the timeout time as required and the timeout detection is activated upon timeout time setting. **Note:** The timeout detection is only for PROFINET communication.

2. Set control mode

To enable the VFD control through PROFINET communication, set the control mode to PROFINET communication control. To be specific, set P00.01=2 and P00.02=1 to control VFD start and stop. In brief, if a certain value need to be set through PROFINET communication, modify the corresponding function code for PROFINET communication control. See Appendix 1 for related function codes.

3. GSD file

There must be a device description file on each PROFINET slave node on the PROFINET bus. The device description file must be which describes the PROFINET device characteristics. The GSD file contains all defined parameters of the device, such as the supported information length, and input and output data count.

7.3.2 Packet format

Table 7-1 describes the structure of an RT frame (non-synchronous).

Table 7-1 RT frame structure

Data header	Ethernet type	VLAN	Ethernet type	Frame identifier	RT user data	Period counter	Data status	Transmission status	FCS
	2 bytes	2 bytes	2 bytes	2 bytes	36-1440 bytes	2 bytes	1 byte	1 byte	4 bytes
	0x8100		0x8892						
	VLAN flag					APDU status			
Data header									
7-byte preamble		1-byte synchronization information		6-byte source MAC address		6-byte destination MAC address			

Table 7-2 describes the IRT communication protocol and the structure of IRT frame (synchronous).

Table 7-2 IRT frame structure

Data header				Ethernet type	VLAN	Ethernet type	Frame identifier	IRT user data	FCS
7-byte preamble	1-byte synchronization information	6-byte source MAC address	6-byte destination MAC address	2 bytes	2 bytes	2 bytes	2 bytes	36-1440 bytes	4 Byte

7.3.3 PROFINET IO communication

The communication card supports 16-word input/output. Figure 7-1 shows the packet format for transmitting data with the VFD.

Figure 7-1 Packet structure

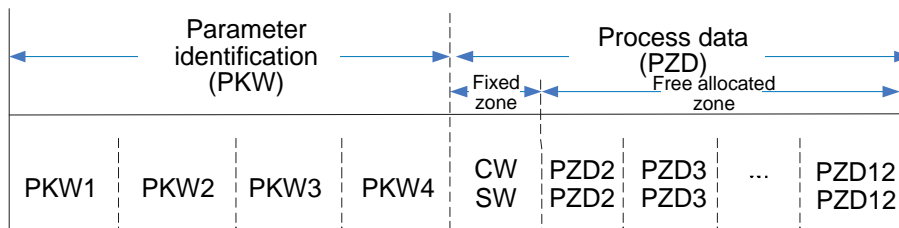

By using the 32 inputs/outputs, you can set the reference parameters of VFD, monitor the state values, transmit control commands, monitor the running state, and read/write the function parameters. For specific operations, see the following description.

1. Parameter zone:

PKW1-Parameter identification

PKW2-array index number

PKW3-parameter value 1

PKW4-parameter value 2

2. Process data:

CW-control word(from the master to a slave)

SW-status word(from a slave to the master)

PZD-process data (user defined)

(From master to slave output **【reference value】** , from slave to master input **【actual value】**)

PZD zone (process data zone)

The PZD zone in a communication packet is designed for controlling and monitoring a VFD. The master and slave stations always process the received PZD with the highest priority. The processing of PZD takes priority over that of PKW, and the master and slave nodes always transmit the latest valid data on the interfaces.

3. Control word (CW) and status word (SW)

Using CWs is the basic method of the fieldbus system to control the VFD. A CW is transmitted by the fieldbus master node to the VFD. In this case, the adapter module functions as a gateway. The VFD responds to the bit code information of the CW and feeds state information back to the master through an SW.

Reference value: The VFD may receive control information in multiple channels, including analog and digital input terminals, VFD control panel, and communication modules (such as RS485 and CH-PA01 adapter modules). To enable the control over the VFD through PROFINET, you need to set the communication module as the controller of the VFD.

Actual value: An actual value is a 16-bit word that includes information about VFD operation. The monitoring function is defined through VFD parameters. The conversion scale of an integer transmitted as an actual value from the VFD to the master depends on the set function. For more description, see the related VFD operation manual.

Note: The VFD always checks the bytes of a CW and reference value.

7.3.4 Mission message (from the master station to the VFD)

The first word of PZD is the control word (CW) of inverter. The CW definition is described as following:

Control word

Bit	Name	Value	Status/description
0-7	COMMAND BYTE Communication-based control command	1	Forward running
		2	Reverse running
		3	Jog forward
		4	Jog reversely
		5	Decelerate to stop
		6	Coast to stop (emergency stop)
		7	Fault reset
		8	Jog stop
		9	Pre-exciting
8	WRITE ENABLE	1	Write enabling (mainly PKW1-PKW4)
9-10	MOTOR GROUP SELECTION	00	MOTOR GROUP 1 SELECTION
		01	MOTOR GROUP 2 SELECTION
		02	MOTOR GROUP 3 SELECTION
		03	MOTOR GROUP 4 SELECTION
11	TORQUE CONTROL SELECTION	1	Enabling torque control
		0	Disable torque control
13	PRE-EXCIATION	1	Pre-excitation enable
		0	Pre-excitation disable
14	Reserved	1	
		0	
15	HEARTBEAT REF	1	Heartbeat enable
		0	Heartbeat disable

Reference value (REF): The second to twelfth words (PZD2-PZD12) in a PZD task packet are the main reference values. The following table shows the reference values of the inverter.

Bit	Name	function selection
Received PZD2	0: Disable 1: Set frequency (0-Fmax (Unit: 0.01Hz))	0
Received PZD3	2: PID reference (0-1000, in which 1000 corresponds to 100.0%) 3: PID feedback (0-1000, in which 1000 corresponds to 100.0%)	0
Received PZD4	4: Torque setting (-3000-+3000, in which 1000 corresponds to 100.0% of the motor rated current)	0
Received PZD5	5: Setting of the upper limit of forward running frequency (0-Fmax, unit: 0.01 Hz)	0
Received PZD6	6: Setting of the upper limit of reverse running frequency (0-Fmax, unit: 0.01 Hz)	0
Received PZD7	7: Upper limit of the electromotive torque (0-3000, in which 1000 corresponds to 100.0% of the motor rated current)	0

Bit	Name	function selection
Received PZD8	8: Upper limit of braking torque (0–2000, in which 1000 corresponds to 100% of the motor rated current)	0
Received PZD9	9: Virtual input terminal command (0x00–0xFF) 10: Virtual output terminal command (0x00–0x0F)	0
Received PZD10	11: Voltage setting (special for V/F separation) (0–1000, in which 1000 corresponds to 100% of the motor rated voltage)	0
Received PZD11	12: AO output setting 1 (-1000–+1000, in which 1000 corresponds to 100.0%)	0
Received PZD12	13: AO output setting 2 (-1000–+1000, in which 1000 corresponds to 100.0%) 14: External ACC time (0–3600.0s) 15: External DEC time (0–3600.0s) 16: Pre-torque setting (-100.0%–100.0%)	0

Response message (from the VFD to the master station)

Status word (SW): The first word of PZD response message is status word (SW) of VFD, the definition of SW is as follows:

Status word

Bit	Name	Value	Status/description
0–7	RUN STATUS BYTE	1	Running forward
		2	Running reversely
		3	VFD stop
		4	VFD in fault
		5	VFD POFF status
8	DC VOLTAGE ESTABLISH	1	Ready for running
		0	Not ready for running
9–10	MOTOR GROUP FEEDBACK	0	Feedback of motor 1
		1	Feedback of motor 2
		2	Feedback of motor 3
		3	Feedback of motor 4
11	MOTOR TYPE FEEDBACK	1	Synchronous motor (SM)
		0	Asynchronous motor (AM)
12	OVERLOAD ALARM	1	Pre-alarm upon overload
		0	No pre-alarm upon overload
13	Brake control	1	Brake release
		0	Brake
14	Reserved	1	
		0	
15	HEARTBEAT FEEDBACK	1	Enable
		0	Disable

Actual value (ACT): The second to twelfth words (PZD2–PZD12) in a PZD task packet from the rectifier unit are the main actual values.

Actual SW

Bit	Name	function selection
Sent PZD2	0: Disable	0

Bit	Name	function selection
Sent PZD3	1: Running frequency (x100, Hz) 2: Set frequency (x100, Hz)	0
Sent PZD4	3: Bus voltage (x10, V) 4: Output voltage (×1, V)	0
Sent PZD5	5: Output current (x10, A) 6: Actual output torque (x10, %)	0
Sent PZD6	7: Actual output power (x10, %) 8: Rotation speed of running (x1, RPM)	0
Sent PZD7	9: Linear speed of running (x1, m/s) 10: Ramp reference frequency	0
Sent PZD8	11: Fault code	0
Sent PZD9	12: AI1 input (*100, V) 13: AI2 input (* 100, V) 14: AI3 input (* 100, V)	0
Sent PZD10	15: Motor temperature (*10, °C) 16: Module temperature (*10, °C)	0
Sent PZD11	17: S8 frequency value (*100, kHz)	0
Sent PZD12	18: PG card speed (signed) 19: Terminal input status 20: Terminal output status 21: PID reference (x100, %) 22: PID feedback (x100, %) 23: Motor rated torque	0

7.3.5 PKW zone

PKW zone (parameter identification marks PKW1–value zone): PKW zone describes treatment of parameter identification interface, PKW interface is a mechanism which determine parameters transmission between two communication partners, such as reading and writing parameter values.

Figure 7-2 Parameter identification zone

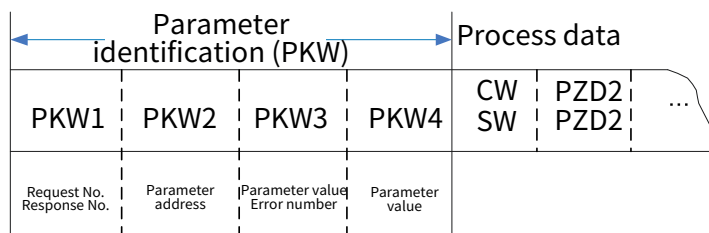

In the process of periodic communication, PKW zone is composed of four words (16 bit), each word is defined as follows:

The first word PKW1 (16 bit)		
Bit 15–00	Task or response identification marks	0–7
The second word PKW2 (16 bit)		
Bit 15–00	Basic parameter address	0–247
The third word PKW3 (16 bit)		
Bit 15–00	Parameter value (MSB) or return error code value	00
The fourth word PKW4 (16 bit)		
Bit 15–00	Parameter value (LSB)	0–65535

Note: If the master node requests the value of a parameter, the values in PKW3 and PKW4 of the packet that the master node transmits to the VFD are no longer valid.

Task request and response: When transmitting data to a slave node, the master node uses a request number, and the slave node uses a response number to accept or reject the request.

Table 7-3 Task identification flag PKW1

Request (from the master to a slave)		Response signal	
Request No.	Function	Acceptance	Rejection
0	No task.	0	—
1	Requesting the value of a parameter	1,2	3
2	Modifying a parameter value (one word) [modifying the value only on RAM]	1	3 or 4
3	Modifying a parameter value (two words) [modifying the value only on RAM]	2	3 or 4
4	Modifying a parameter value (one word) [modifying the value on both RAM and EEPROM]	1	3 or 4
5	Modifying a parameter value (two words) [modifying the value on both RAM and EEPROM]	2	3 or 4

Note: Requests 2, 3, and 5 are not supported currently.

Table 7-4 Response identification flag PKW1

Response (from a slave to the master)	
Response No.	Function
0	No response
1	Transmitting the value of a parameter (one word)
2	Transmitting the value of a parameter (two words)
3	The task cannot be executed and one of the following error number is returned: 0: Invalid parameter number 1: Parameter values cannot be changed (read-only parameter) 2: Out of set value range 3: Incorrect sub-index number 4: Setting is not allowed (reset only) 5: Invalid data type 6: The task could not be implemented due to operational state 7: Request is not supported 8: Request cannot be completed due to communication error 9: Fault occurs during the write operation to fixed storage zone 10: Request failed due to timeout 11: Parameter cannot be assigned to PZD 12: Control word bit cannot be allocated 13: Other faults
4	No parameter modification rights

7.3.6 Related function codes

Function code	Name	Description	Setting range	Default
P21.00	Module type	0: PROFIBUS/CANopen/PROFINET 1: Reserved	0-1	0
P21.01	PROFIBUS/CANopen/ PROFINET module address	0-127	0-127	2

Function code	Name	Description	Setting range	Default
P21.02	Received PZD2	0: Disable	0–20	0
P21.03	Received PZD3	1: Set frequency (0–Fmax (Unit: 0.01Hz))	0–20	0
P21.04	Received PZD4	2: PID reference (0–1000, in which 1000 corresponds to 100.0%)	0–20	0
P21.05	Received PZD5	3: PID feedback (0–1000, in which 1000 corresponds to 100.0%)	0–20	0
P21.06	Received PZD6	4: Torque setting (-3000–+3000, in which 1000 corresponds to 100.0% of the motor rated current)	0–20	0
P21.07	Received PZD7	5: Setting of the upper limit of forward running frequency (0–Fmax, unit: 0.01 Hz)	0–20	0
P21.08	Received PZD8	6: Setting of the upper limit of reverse running frequency (0–Fmax, unit: 0.01 Hz)	0–20	0
P21.09	Received PZD9	7: Upper limit of the electromotive torque (0–3000, in which 1000 corresponds to 100.0% of the motor rated current)	0–20	0
P21.10	Received PZD10	8: Upper limit of braking torque (0–2000, in which 1000 corresponds to 100% of the motor rated current)	0–20	0
P21.11	Received PZD11	9: Virtual input terminal command. Range: 0x000–0x0FF	0–20	0
P21.12	Received PZD12	10: Virtual output terminal command. Range: 0x00–0x3F	0–20	0
		11: Voltage setting (special for V/F separation) (0–1000, in which 1000 corresponds to 100% of the motor rated voltage)		
		12: AO output setting 1 (-1000–+1000, in which 1000 corresponds to 100.0%)		
		13: AO output setting 2 (-1000–+1000, in which 1000 corresponds to 100.0%)		
		14: External ACC time (0–3600.0s)		
		15: External DEC time (0–3600.0s)		
		16: Pre-torque setting (-100.0%–100.0%)		
		17–20: Reserved		
P21.13	Sent PZD2	0: Invalid	0–23	0
P21.14	Sent PZD3	1: Running frequency (*100, Hz)	0–23	0
P21.15	Sent PZD4	2: Set frequency (*100, Hz)	0–23	0
P21.16	Sent PZD5	3: Bus voltage (*10, V)	0–23	0
P21.17	Sent PZD6	4: Output voltage (*1, V)	0–23	0
P21.18	Sent PZD7	5: Output current (x10, A)	0–23	0
P21.19	Sent PZD8	6: Actual output torque (x10, %)	0–23	0

Function code	Name	Description	Setting range	Default
P21.20	Sent PZD9	7: Actual output power (x10, %)	0-23	0
P21.21	Sent PZD10	8: Rotation speed of running (x1, RPM)	0-23	0
P21.22	Sent PZD11	9: Linear speed of running (x1, m/s)	0-23	0
P21.23	Sent PZD12	10: Ramp reference frequency 11: Fault code 12: AI1 input (*100, V) 13: AI2 input (*100, V) 14: AI3 input (*100, V) 15: Motor temperature (*10, °C) 16: Module temperature (*10, °C) 17: S8 frequency value (*100, kHz) 18: PG card speed (signed) 19: Terminal input status 20: Terminal output status 21: PID reference (x100, %) 22: PID feedback (x100, %) 23: Motor rated torque	0-23	0
P21.24	Temporary variable 1 for PZD sending	0-65535	0-65535	0
P21.25	DP/PN communication timeout time	0.0 (invalid); 0.1-60.0s	0.0-60.0	0.0s
P21.41	Output length	PROFINET output length	0-32	32
P21.42	Input length	PROFINET input length	0-32	32
P22.01	IP address 1	0-255	0-255	192
P22.02	IP address 2	0-255	0-255	168
P22.03	IP address 3	0-255	0-255	0
P22.04	IP address 4 (PN address)	0-255	0-255	1

7.4 CANopen protocol

See *EC-TX105 CANopen communication card* operation manual.

Function code	Name	Description	Setting range	Default
P21.29	CANopen communication baud rate	0: 1000k 1: 800k 2: 500k 3: 250k 4: 125k 5: 100k 6: 50k 7: 20k	0-7	2
P21.30	CANopen communication timeout time	0.0 (invalid); 0.1-100.0s	0.1-100.0	0.0s
P21.31	CANopen communication protocol	0: Common control protocol 1: Internal master/slave communication protocol	0-1	0

Function code	Name	Description	Setting range	Default
P21.32	External ACC/DEC enabling	0: Disable 1: Enable	0-1	0

7.5 DEVICE-NET (Reserved)

7.6 Ethernet communication

With the host controller, all parameters in the VFD can be easily set, uploaded, downloaded, while the waveforms of up to 100+ messages can be easily monitored in real time.

Goodrive800 Pro series VFD can save the waveform information of 0.2 seconds before the last stop failure, which can be extracted by the software of the host controller for fault cause analysis.

Function code	Name	Description	Setting range	Default
P22.00	Ethernet communication rate	0: Self adaptive 1: 100M full duplex 2: 100M half duplex 3: 10M full duplex 4: 10M half duplex	0-4	0
P22.01	IP address 1	0-255	0-255	192
P22.02	IP address 2	0-255	0-255	168
P22.03	IP address 3	0-255	0-255	0
P22.04	IP address 4	0-255	0-255	1
P22.05	Subnet mask 1	0-255	0-255	255
P22.06	Subnet mask 2	0-255	0-255	255
P22.07	Subnet mask 3	0-255	0-255	255
P22.08	Subnet mask 4	0-255	0-255	0
P22.09	Gateway 1	0-255	0-255	192
P22.10	Gateway 2	0-255	0-255	168
P22.11	Gateway 3	0-255	0-255	1
P22.12	Gateway 4	0-255	0-255	1

8 Parameter list

The function parameters are divided into groups by function, and each group includes several function codes (each function code identifies a function parameter). A three-level menu style is applied to function codes. For example, "P00.08" indicates the 8th function code in the P00 group. The P29 group consist of factory function parameters, which are user inaccessible.

The function group numbers correspond to the level-1 menus, the function codes correspond to the level-2 menus, and the function parameters correspond to the level-3 menus.

The content of the function code table is as follows:

Column 1 "Function code ": Code of the function group and parameter.

Column 2 "Name": Full name of the function parameter.

Column 3 "Description": Detailed description of the function parameter.

Column 4 "Setting range": Setting range of the function parameter

Column 5 "Default": Initial value set in factory/

Column 6 "Modify": Whether the parameter can be modified, and conditions for the modification.

"○" indicates that the value of the parameter can be modified when the VFD is in stopped or running state.

"◉" indicates that the value of the parameter cannot be modified when the VFD is in running state.

"●" indicates that the value of the parameter is detected and recorded, and cannot be modified.

(The VFD automatically checks and constrains the modification of parameters, which helps prevent incorrect modifications.)

The parameters adopt the decimal system (DEC). If the hexadecimal system is adopted, all bits are mutually independent on data during parameter editing, and the setting ranges at some bits can be hexadecimal (0-F).

"Default" indicates the factory setting of the function parameter. If the value of the parameter is detected or recorded, the value cannot be restored to the factory setting.

To better protect parameters, the VFD provides the password protection function. After a password is set (that is, P07.00 is set to a non-zero value), "0. 0. 0. 0. 0." is displayed when you press the **PRG/ESC** key to enter the function code editing interface. You need to enter the correct user password to enter the interface. For the factory parameters, you need to enter the correct factory password to enter the interface. (You are not advised to modify the factory parameters. Incorrect parameter setting may cause operation exceptions or even damage to the VFD.) If password protection is not in locked state, you can change the password any time. You can set P07.00 to 0 to cancel the user password. When P07.00 is set to a non-zero value during power-on, parameters are prevented from being modified by using the user password function.

When you modify function parameters through serial communication, the user password protection function is also applicable and compliant with the same rule.

P00 group--Basic functions

Function code	Name	Description	Setting range	Default	Modify
P00.00	Speed control mode	0: Sensorless vector control (SVC) mode 0 (for AM, SM) 1: SVC mode 1 (for AM) 2: V/F control	0-3	2	◉

Function code	Name	Description	Setting range	Default	Modify
		3: Closed-loop vector control mode Note: AM-asynchronous motor SM-synchronous motor			
P00.01	Channel of running commands	0: Keypad (the indicator is off) 1: Terminal (the indicator blinks) 2: Communication (the indicator is on)	0-2	0	<input type="radio"/>
P00.02	Communication mode of running commands	0: MODBUS 1: PROFIBUS/CANopen/PROFINET 2: Ethernet 3: Reserved 4: DEVICE_NET (Reserved) Note: The options 1, 2, 3, and 4 are add-on functions and are available only when corresponding expansion cards are configured.	0-4	0	<input type="radio"/>
P00.03	Max. output frequency	P00.04-400.00Hz	P00.04-400.00	50.00Hz	<input checked="" type="radio"/>
P00.04	Upper limit of running frequency	P00.05-P00.03 (Max. frequency)	P00.05-P00.03	50.00Hz	<input checked="" type="radio"/>
P00.05	Lower limit of running frequency	0.00Hz-P00.04 (Upper limit of running frequency)	0.00-P00.04	0.00Hz	<input checked="" type="radio"/>
P00.06	Setting channel of A frequency command	0: Keypad 1: AI1 2: AI2 3: AI3 4: S8 pulse 5: Simple PLC program 6: Multi-step speed running 7: PID control 8: MODBUS communication 9: PROFIBUS/CANopen/PROFINET communication (expansion card) 10: Ethernet communication (expansion card) 11: Reserved 12: DEVICE_NET communication (Reserved) 13: Master/slave PID output	0-13	0	<input type="radio"/>
P00.07	Setting channel of B frequency command	0: Keypad 1: AI1 2: AI2 3: AI3 4: S8 pulse 5: Simple PLC program	0-13	1	<input type="radio"/>

Function code	Name	Description	Setting range	Default	Modify
		6: Multi-step speed running 7: PID control 8: MODBUS communication 9: PROFIBUS/CANopen/PROFINET communication 10: Ethernet communication (expansion card) 11: Reserved 12: DEVICE_NET communication (Reserved) 13: Master/slave PID output			
P00.08	Reference object of B frequency command	0: Max. output frequency 1: A frequency command	0-1	0	<input type="radio"/>
P00.09	Combination mode of setting source	0: A 1: B 2: (A+B) 3: (A-B) 4: Max(A, B) 5: Min(A, B)	0-5	0	<input type="radio"/>
P00.10	Frequency set through keypad	0.00Hz-P00.03 (Max. output frequency)	0.00-P00.03	50.00Hz	<input type="radio"/>
P00.11	ACC time 1	0.0-3600.0s	0.0-3600.0	Model depended	<input type="radio"/>
P00.12	DEC time 1	0.0-3600.0s	0.0-3600.0	Model depended	<input type="radio"/>
P00.13	Running direction	0: Run at the default direction. 1: Run at the opposite direction. 2: Disable reverse running	0-2	0	<input type="radio"/>
P00.14	Carrier frequency	1.0-8.0kHz	1.0-8.0	Model depended	<input type="radio"/>
P00.15	Motor parameter autotuning	0: No operation 1: Rotary autotuning 2: Static autotuning 3: Simple autotuning	0-3	0	<input checked="" type="radio"/>
P00.16	AVR function selection	0: Invalid 1: Valid during the whole procedure	0-1	1	<input type="radio"/>
P00.17	VFD application type	0: Heavy overload application 1: Light overload application 2: No overload application	0-2	0	<input checked="" type="radio"/>
P00.18	Function parameter restore	0: No operation 1: Restore default values 2: Clear fault records	0-2	0	<input checked="" type="radio"/>

P01 group--Start and stop control

Function code	Name	Description	Setting range	Default	Modify
P01.00	Start mode	0: Direct start 1: Start after DC braking 2: Start after rotating speed tracking	0-2	0	☉
P01.01	Starting frequency of direct start	0.00-50.00Hz	0.00-50.00	0.50Hz	☉
P01.02	Starting frequency hold time	0.0-60.0s	0.0-60.0	0.0s	☉
P01.03	Braking current before start	0.0-100.0%	0.0-100.0	0.0%	☉
P01.04	Braking time before start	0.0-60.0s	0.0-60.0	0.0s	☉
P01.05	ACC/DEC mode	0: Linear type 1: S curve	0-1	0	☉
P01.06	S curve starting segment proportion	0.0-50.0% (ACC/DEC time)	0.0-50.0	30.0%	☉
P01.07	S curve ending segment proportion	0.0-50.0% (ACC/DEC time)	0.0-50.0	30.0%	☉
P01.08	Stop mode	0: Decelerate to stop 1: Coast to stop	0-1	0	○
P01.09	Starting frequency of DC braking for stop	0.00-P00.03 (Max. output frequency)	0.00-P00.03	0.00Hz	○
P01.10	Wait time before DC braking for stop	0.0-60.0s	0.0-60.0	0.0s	○
P01.11	DC braking current for stop	0.0-100.0%	0.0-100.0	0.0%	○
P01.12	DC braking time for stop	0.0-60.0s	0.0-60.0	0.0s	○
P01.13	FWD/REV running deadzone time	0.0-3600.0s	0.0-3600.0	0.0s	○
P01.14	FWD/REV running switching mode	0: Switch at zero frequency 1: Switch at the starting frequency 2: Switch after the speed reaches the stop speed with a delay (reserved)	0-2	0	☉
P01.15	Stop speed	0.00-100.00Hz	0.00-100.0	0.50Hz	☉
P01.16	Stop speed detection mode	0: Detect by the set speed (unique in V/F mode) 1: Detect by the feedback speed	0-1	0	☉

Function code	Name	Description	Setting range	Default	Modify
P01.17	Feedback speed detection time		0.0-100.0	0.5s	☉
P01.18	Terminal-based running command protection at power-on	0: The terminal running command is invalid at power-on 1: The terminal running command is valid at power-on	0-1	0	○
P01.19	Action selected when running frequency less than frequency lower limit (valid when frequency lower limit greater than 0)	0: Run at the frequency lower limit 1: Stop 2: Sleep	0-2	0	☉
P01.20	Wake-up-from-sleep delay	0.0-3600.0s (valid when P01.19=2)	0.0-3600.0	0.0s	○
P01.21	Power-off restart selection	0: Disable 1: Enable	0-1	0	○
P01.22	Wait time for restart after power-off	0.0-3600.0s (valid when P01.21=1)	0.0-3600.0	1.0s	○
P01.23	Start delay	0.0-60.0s	0.0-60.0	0.0s	○
P01.24	Stop speed delay	0.0-60.0s	0.0-60.0	0.0s	○
P01.25	VFD type (for speed tracking)	0: Common VFD 1: Four-quadrant VFD	0-1	1	○

P02 group--Parameters of motor 1

Function code	Name	Description	Setting range	Default	Modify
P02.00	Type of motor 1	0: Asynchronous motor (AM) 1: Synchronous motor (SM)	0-1	0	☉
P02.01	Rated power of AM 1	0.1-3000.0kW	0.1-3000.0	Model depended	☉
P02.02	Rated frequency of AM 1	0.01Hz-P00.03 (Max. output frequency)	0.01-P00.03	50.00Hz	☉
P02.03	Rated speed of AM 1	1-36000rpm	1-36000	Model depended	☉
P02.04	Rated voltage of AM 1	0-1200V	0-1200	Model depended	☉
P02.05	Rated current of AM 1	0.8-6000.0A	0.8-6000.0	Model depended	☉
P02.06	Stator resistance of AM 1	0.0001-6.5535Ω	0.0001-6.5535	Model depended	○

Function code	Name	Description	Setting range	Default	Modify
P02.07	Rotor resistance of AM 1	0.0001–6.5535Ω	0.0001–6.5535	Model depended	<input type="radio"/>
P02.08	Leakage inductance of AM 1	0.01–655.35mH	0.01–655.35	Model depended	<input type="radio"/>
P02.09	Mutual inductance of AM 1	0.01–655.35mH	0.01–655.35	Model depended	<input type="radio"/>
P02.10	No-load current of AM 1	0.1–6553.5A	0.1–6553.5	Model depended	<input type="radio"/>
P02.11	Magnetic saturation coefficient 1 of iron core of AM 1	0.0–100.0%	0.0–100.0	88.0%	<input checked="" type="radio"/>
P02.12	Magnetic saturation coefficient 2 of iron core of AM 1	0.0–100.0%	0.0–100.0	81.0%	<input checked="" type="radio"/>
P02.13	Magnetic saturation coefficient 3 of iron core of AM 1	0.0–100.0%	0.0–100.0	75.0%	<input checked="" type="radio"/>
P02.14	Magnetic saturation coefficient 4 of iron core of AM 1	0.0–100.0%	0.0–100.0	50.0%	<input checked="" type="radio"/>
P02.15	Rated power of SM 1	0.1–3000.0kW	0.1–3000.0	Model depended	<input checked="" type="radio"/>
P02.16	Rated frequency of SM 1	0.01Hz–P00.03 (Max. output frequency)	0.01–P00.03	50.00Hz	<input checked="" type="radio"/>
P02.17	Number of pole pairs of SM 1	1–50	1–50	2	<input checked="" type="radio"/>
P02.18	Rated voltage of SM 1	0–1200V	0–1200	Model depended	<input checked="" type="radio"/>
P02.19	Rated current of SM 1	0.8–6000.0A	0.8–6000.0	Model depended	<input checked="" type="radio"/>
P02.20	Stator resistance of SM 1	0.0001–6.5535Ω	0.0001–6.5535	Model depended	<input type="radio"/>
P02.21	Direct-axis inductance of SM 1	0.01–655.35mH	0.01–655.35	Model depended	<input type="radio"/>
P02.22	Quadrature-axis inductance of SM 1	0.01–655.35mH	0.01–655.35	Model depended	<input type="radio"/>
P02.23	Counter-emf of SM 1	0–10000V	0–10000	300V	<input type="radio"/>

Function code	Name	Description	Setting range	Default	Modify
P02.24	Initial pole angle of SM 1	0.00–359.99	0.00–35999	0.00	☉
P02.25	Pole position amplitude gain of SM 1	0.50–1.50	0.50–1.50	1.00	○
P02.26	Phase-C pole position offset of SM1	0–9999	0–9999	2230	○
P02.27	Phase-D pole position offset of SM1	0–9999	0–9999	2230	○
P02.28	Identification current of SM 1 (Reserved)	0%–50% (of the motor rated current)	0–50	10%	●
P02.29	Overload protection of motor 1	0: No protection 1: Common motor (with low-speed compensation) 2: Frequency-variable motor (without low-speed compensation)	0–2	2	☉
P02.30	Overload protection coefficient of motor 1	20.0%–120.0%	20.0–120.0	100.0%	○
P02.31	Parameter display of motor 1	0: Display based on motor type 1: Display all	0–1	0	○
P02.32	SM reactive current Kp	Reactive current proportional coefficient	0–1000	60	○
P02.33	SM reactive current Ki	Reactive current integral coefficient	0–1000	60	○
P02.34–P02.35	Reserved				

P03 group--Vector control

Function code	Name	Description	Setting range	Default	Modify
P03.00	Speed-loop proportional gain 1	0–200.0	0–200.0	10.0	○
P03.01	Speed-loop integral time 1	0.001–10.000s	0.001–10.000	0.500s	○
P03.02	Low-point frequency for switching	0.00Hz–P03.05	0.00–P03.05	5.00Hz	○
P03.03	Speed-loop proportional gain 2	0–200.0	0–200.0	10.0	○

Function code	Name	Description	Setting range	Default	Modify
P03.04	Speed-loop integral time 2	0.001–10.000s	0.001–10.000	0.500s	<input type="radio"/>
P03.05	High-point frequency for switching	P03.02–P00.03 (Max. frequency)	P03.02–P00.03	10.00Hz	<input type="radio"/>
P03.06	Speed-loop output filter	0–8 (corresponding to 0–2 ⁸ /10ms)	0–8	0	<input type="radio"/>
P03.07	Electromotive slip compensation coefficient of vector control	50%–200%	50–200	100%	<input type="radio"/>
P03.08	Braking slip compensation coefficient of vector control	50%–200%	50–200	100%	<input type="radio"/>
P03.09	Current-loop proportional coefficient P	0–65535	0–65535	1000	<input type="radio"/>
P03.10	Current-loop integral coefficient I	0–65535	0–65535	1000	<input type="radio"/>
P03.11	Torque setting method	0: Torque control invalid 1: Keypad (P03.12) 2: AI1 (100% corresponding to three times the motor rated current) 3: AI2 (Same as the above) 4: AI3 (same as the above) 5: S8 pulse frequency (same as the above) 6: Multi-step torque (same as the above) 7: MODBUS communication (same as the above) 8: PROFIBUS/CANopen/PROFINET communication (same as the above) 9: Ethernet communication (same as the above) 10: Reserved 11: DEVICE_NET communication 12: Internal setting of the slave (transmit from the master) 13: PID control 14: Reserved 15: Reserved	0–15	0	<input type="radio"/>
P03.12	Torque set through keypad	-300.0%–300.0% (of the motor rated current)	-300.0–300.0	50.0%	<input type="radio"/>

Function code	Name	Description	Setting range	Default	Modify
P03.13	Torque reference filter time	0.000–10.000s	0.000–10.000	0.100s	<input type="radio"/>
P03.14	Setting source of forward rotation upper-limit frequency in torque control	0: Keypad (P03.16) 1: AI1 (100% corresponding to the max. frequency) 2: AI2 (same as the above) 3: AI3 (same as the above) 4: S8 Pulse frequency (same as the above) 5: Multi-step setting (same as the above) 6: MODBUS communication (same as the above) 7: PROFIBUS/CANopen/PROFINET communication (same as the above) 8: Ethernet communication (same as the above) 9: Reserved 10: DEVICE_NET communication (same as the above) 11: Reserved 12: Reserved 13: Reserved	0–13	0	<input type="radio"/>
P03.15	Setting source of reverse rotation upper-limit frequency in torque control	0: Keypad (P03.17) 1: AI1 (100% corresponding to the max. frequency) 2: AI2 (same as the above) 3: AI3 (same as the above) 4: S8 Pulse frequency (same as the above) 5: Multi-step setting (same as the above) 6: MODBUS communication (same as the above) 7: PROFIBUS/CANopen/PROFINET communication (same as the above) 8: Ethernet communication (same as the above) 9: Reserved 10: DEVICE_NET communication 11: Reserved 12: Reserved 13: Reserved	0–13	0	<input type="radio"/>
P03.16	Forward rotation	0.00Hz–P00.03	0.00–P00.03	50.00 Hz	<input type="radio"/>

Function code	Name	Description	Setting range	Default	Modify
	upper-limit frequency set through keypad in torque control				
P03.17	Reverse rotation upper-limit frequency set through keypad in torque control	0.00Hz-P00.03	0.00-P00.03	50.00Hz	<input type="radio"/>
P03.18	Setting source of electromotive torque upper limit	0: Keypad (P03.20) 1: AI1 (100% corresponding to triple the motor rated current) 2: AI2 (same as the above) 3: AI3 (same as the above) 4: S8 pulse frequency (same as the above) 5: MODBUS communication (same as the above) 6: PROFIBUS/CANopen/PROFINET communication (same as the above) 7: Ethernet communication (same as the above) 8: Reserved 9: DEVICE_NET communication (above) 10-12: Reserved	0-12	0	<input type="radio"/>
P03.19	Setting source of braking torque upper limit	0: Keypad (P03.21) 1: AI1 (100% corresponding to triple the motor rated current) 2: AI2 (same as the above) 3: AI3 (same as the above) 4: Pulse frequency S8 (same as the above) 5: MODBUS communication (same as the above) 6: PROFIBUS/CANopen/PROFINET communication (same as the above) 7: Ethernet communication (same as the above) 8: Reserved 9: DEVICE_NET communication (above) 10-12: Reserved	0-12	0	<input type="radio"/>

Function code	Name	Description	Setting range	Default	Modify
P03.20	Electromotive torque upper limit set through keypad	0.0–300.0% (of the motor rated current)	0.0–300.0	180.0%	<input type="radio"/>
P03.21	Braking torque upper limit set through keypad	0.0–300.0% (of the motor rated current)	0.0–300.0	180.0%	<input type="radio"/>
P03.22	Weakening coefficient in constant power zone	0.01–2.00	0.01–2.00	1.00	<input type="radio"/>
P03.23	Lowest weakening point in constant power zone	10%–100%	10–100	10%	<input type="radio"/>
P03.24	Max. voltage limit	0.0–120.0%	0.0–120.0	103.0%	<input checked="" type="radio"/>
P03.25	Pre-exciting time	0.000–10.000s	0.000–10.000	0.000s	<input type="radio"/>
P03.26	Flux-weakening proportional gain	0–8000	0–8000	1200	<input type="radio"/>
P03.27	Speed display selection in vector control	0: Display the actual value 1: Display the set value	0–1	0	<input type="radio"/>
P03.28	Rotor resistance compensation enabling	0: Disable 1: Motoring temperature compensating rotor resistance 2: Enabling online identification of rotor resistance	0–2	0	<input checked="" type="radio"/>
P03.29	Starting temperature of motor temperature compensation	0–60.0°C	0–60.0	40.0°C	<input checked="" type="radio"/>
P03.30	Motor temperature compensation coefficient	0.0–200.0%	0.0–200.0	100.0%	<input checked="" type="radio"/>
P03.31	Speed observer filter coefficient	0–6	0–6	0	<input checked="" type="radio"/>

P04 group--Space voltage vector

Function code	Name	Description	Setting range	Default	Modify
P04.00	V/F curve setting	0: Straight-line V/F curve	0–5	0	<input checked="" type="radio"/>

Function code	Name	Description	Setting range	Default	Modify
	of motor 1 and 3	1: Multi-point V/F curve 2: Torque-down V/F curve (power of 1.3) 3: Torque-down V/F curve (power of 1.7) 4: Torque-down V/F curve (power of 2.0) 5: Customized V/F curve (V/F separation)			
P04.01	Torque boost of motor 1 and 3	0.0%: (automatic) 0.1%–10.0%	0.0–10.0	0.0%	<input type="radio"/>
P04.02	Torque boost cut-off of motor 1 and 3	0.0%–50.0% (of the rated frequency of motor 1, 3)	0.0–50.0	20.0%	<input type="radio"/>
P04.03	V/F frequency point 1 of motor 1 and 3	0.00Hz–P04.05	0.00–P04.05	0.00Hz	<input type="radio"/>
P04.04	V/F voltage point 1 of motor 1 and 3	0.0%–110.0% (of the rated voltage of motor 1)	0.0–110.0	0.0%	<input type="radio"/>
P04.05	V/F frequency point 2 of motor 1 and 3	P04.03–P04.07	P04.03–P04.07	0.00Hz	<input type="radio"/>
P04.06	V/F voltage point 2 of motor 1 and 3	0.0%–110.0% (of the rated voltage of motor 1)	0.0–110.0	0.0%	<input type="radio"/>
P04.07	V/F frequency point 3 of motor 1 and 3	P04.05–P02.02 (Rated frequency of motor 1)	P04.05–P02.02	0.00Hz	<input type="radio"/>
P04.08	V/F voltage point 3 of motor 1 and 3	0.0%–110.0% (of the rated voltage of motor 1)	0.0–110.0	0.0%	<input type="radio"/>
P04.09	V/F slip compensation gain of motor 1 and 3	0.0–200.0%	0.0–200.0	100.0%	<input type="radio"/>
P04.10	Low-frequency oscillation control factor of motor 1 and 3	0–100	0–100	10	<input type="radio"/>
P04.11	High-frequency oscillation control factor of motor 1 and 3	0–100	0–100	10	<input type="radio"/>
P04.12	Oscillation control threshold of motor 1 and 3	0.00Hz–P00.03 (Max. output frequency)	0.00–P00.03	30.00 Hz	<input type="radio"/>

Function code	Name	Description	Setting range	Default	Modify
P04.13	V/F curve setting of motor 2 and 4	0: Straight-line V/F curve 1: Multi-point V/F curve 2: Torque-down V/F curve (power of 1.3) 3: Torque-down V/F curve (power of 1.7) 4: Torque-down V/F curve (power of 2.0) 5: Customized V/F curve (V/F separation)	0-5	0	<input checked="" type="radio"/>
P04.14	Torque boost of motor 2 and 4	0.0%: (automatic) 0.1%-10.0%	0.0-10.0	0.0%	<input type="radio"/>
P04.15	Torque boost cut-off of motor 2 and 4	0.0%-50.0% (of the rated frequency of motor 2)	0.0-50.0	20.0%	<input type="radio"/>
P04.16	V/F frequency point 1 of motor 2 and 4	0.00Hz-P04.18	0.00-P04.18	0.00Hz	<input type="radio"/>
P04.17	V/F voltage point 1 of motor 2 and 4	0.0%-110.0% (of the rated voltage of motor 2)	0.0-110.0	0.0%	<input type="radio"/>
P04.18	V/F frequency point 2 of motor 2 and 4	P04.16-P04.20	P04.16-P04.20	0.00Hz	<input type="radio"/>
P04.19	V/F voltage point 2 of motor 2 and 4	0.0%-110.0% (of the rated voltage of motor 2)	0.0-110.0	0.0%	<input type="radio"/>
P04.20	V/F frequency point 3 of motor 2 and 4	P04.18-P12.02 (of the rated frequency of motor 2)	P04.18-P12.02	0.00Hz	<input type="radio"/>
P04.21	V/F voltage point 3 of motor 2 and 4	0.0%-110.0% (of the rated voltage of motor 2)	0.0-110.0	0.0%	<input type="radio"/>
P04.22	V/F slip compensation gain of motor 2 and 4	0.0-200.0%	0.0-200.0	100.0%	<input type="radio"/>
P04.23	Low-frequency oscillation control factor of motor 2 and 4	0-100	0-100	10	<input type="radio"/>
P04.24	High-frequency oscillation control factor of motor 2 and 4	0-100	0-100	10	<input type="radio"/>
P04.25	Oscillation control	0.00Hz-P00.03 (Max. output frequency)	0.00-P00.03	30.00 Hz	<input type="radio"/>

Function code	Name	Description	Setting range	Default	Modify
	threshold of motor 2 and 4				
P04.26	Energy-saving run	0: Disable 1: Automatic energy-saving run	0–1	0	☉
P04.27	Voltage setting channel (during V/F separation)	0: Keypad (The output voltage is determined by P04.28.) 1: AI1 2: AI2 3: AI3 4: S8 pulse 5: Multi-step speed running (The setting is determined by group P10.) 6: PID 7: MODBUS communication 8: PROFIBUS/CANopen/PROFINET communication 9: Ethernet communication 10: Reserved 11: DEVICE_NET 12–14: Reserved	0–14	0	○
P04.28	Voltage set through keypad	0.0%–100.0%	0.0–100.0	100.0%	○
P04.29	Voltage increase time	0.0–3600.0s	0.0–3600.0	5.0s	○
P04.30	Voltage decrease time	0.0–3600.0s	0.0–3600.0	5.0s	○
P04.31	Max. output voltage	P04.32 –100.0% (of the motor rated voltage)	P04.32–100.0	100.0%	☉
P04.32	Min. output voltage	0.0%–P04.31 (motor rated voltage)	0.0–P04.31	0.0%	☉
P04.33	Feedforward voltage compensation coefficient	0.00–100.0 (Compensation of the voltage drop of transformer or reactor)	0.00–100.0	0.00	○
P04.34	Feedforward voltage limit	0.0–80.0% (Limit of feedforward voltage compensation. 100.0% corresponds to the motor rated voltage.)	0.0–80.0	0.0%	○
P04.35	EPS enabling selection	0: Disable 1: Enable	0–1	0	☉

P05 group--Input terminals

Function code	Name	Description	Setting range	Default	Modify
P05.00	S8 input type	0: Pulse input 1: Digital input	0–1	0	☉

Function code	Name	Description	Setting range	Default	Modify
P05.01	Function of S1 terminal	0: No function	0-63	0	☉
P05.02	Function of S2 terminal	1: Forward running			
P05.03	Function of S3 terminal	2: Reverse running			
P05.04	Function of S4 terminal	3: Three-wire running control			
P05.05	Function of S5 terminal	4: Jog forward			
P05.06	Function of S6 terminal	5: Jog reversely			
P05.07	Function of S7 terminal	6: Coast to stop			
P05.08	Function of S8 terminal	7: Fault reset	0-63	0	☉
		8: Pause running			
		9: External fault input			
		10: Increase frequency setting (UP)			
		11: Decrease frequency setting (DOWN)			
		12: Clear the frequency increase/decrease setting			
		13: Switch between A setting and B setting			
		14: Switch between combination setting and A setting			
		15: Switch between combination setting and B setting			
		16: Multi-step speed terminal 1			
		17: Multi-step speed terminal 2			
		18: Multi-step speed terminal 3			
		19: Multi-step speed terminal 4			
		20: Pause multi-step speed running			
		21: ACC/DEC time selection 1			
		22: ACC/DEC time selection 2			
		23: Simple PLC stop reset			
		24: Pause simple PLC			
		25: Pause PID control			
		26: Pause wobbling frequency (stopped at the present frequency)			
		27: Reset wobbling frequency (returned to the center frequency)			
		28: Counter reset			
		29: Disable torque control			
		30: Disable ACC/DEC			
		31: Trigger the counter			
		32: Length reset (reserved)			
		33: Clear the frequency increase/decrease setting temporarily			
		34: DC braking			
		35: Brake feedback			
		36: Switch the running command channel to keypad			
		37: Switch the running command			

Function code	Name	Description	Setting range	Default	Modify
		channel to terminal 38: Switch the running command channel to communication 39: Pre-exciting command 40: Clear electricity consumption 41: Keep electricity consumption 42: Switch setting source of braking torque upper limit 43: Motor group 1 44: Motor group 2 45: Anti-sag protection input 46: Safe stop 1 (SS1) 47: Safe speed limit (SLS) 48-63: Reserved			
P05.09	Input digital polarity	0x0000-0x00FF	0x0000-0x00FF	0x0000	○
P05.10	Input digital filter time	0.000-1.000s	0.000-1.000	0.010s	○
P05.11	Virtual terminal setting	0x00-0xFF (0: Disable; 1: Enable) BIT0: S1 virtual terminal BIT1: S2 virtual terminal BIT2: S3 virtual terminal BIT3: S4 virtual terminal BIT4: S5 virtual terminal BIT5: S6 virtual terminal BIT6: S7 virtual terminal BIT7: S8 virtual terminal	0x00-0xFF	0x00	◎
P05.12	Terminal control mode	0: Two-wire control mode 1 1: Two-wire control mode 2 2: Three-wire control mode 1 3: Three-wire control mode 2	0-3	0	◎
P05.13	S1 switch-on delay	0.000-60.000s	0.000-60.000	0.000s	○
P05.14	S1 switch-off delay	0.000-60.000s	0.000-60.000	0.000s	○
P05.15	S2 switch-on delay	0.000-60.000s	0.000-60.000	0.000s	○
P05.16	S2 switch-off delay	0.000-60.000s	0.000-60.000	0.000s	○
P05.17	S3 switch-on delay	0.000-60.000s	0.000-60.000	0.000s	○
P05.18	S3 switch-off delay	0.000-60.000s	0.000-60.000	0.000s	○
P05.19	S4 switch-on delay	0.000-60.000s	0.000-60.000	0.000s	○
P05.20	S4 switch-off delay	0.000-60.000s	0.000-60.000	0.000s	○

Function code	Name	Description	Setting range	Default	Modify
P05.21	S5 switch-on delay	0.000–60.000s	0.000–60.000	0.000s	<input type="radio"/>
P05.22	S5 switch-off delay	0.000–60.000s	0.000–60.000	0.000s	<input type="radio"/>
P05.23	S6 switch-on delay	0.000–60.000s	0.000–60.000	0.000s	<input type="radio"/>
P05.24	S6 switch-off delay	0.000–60.000s	0.000–60.000	0.000s	<input type="radio"/>
P05.25	S7 switch-on delay	0.000–60.000s	0.000–60.000	0.000s	<input type="radio"/>
P05.26	S7 switch-off delay	0.000–60.000s	0.000–60.000	0.000s	<input type="radio"/>
P05.27	S8 switch-on delay	0.000–60.000s	0.000–60.000	0.000s	<input type="radio"/>
P05.28	S8 switch-off delay	0.000–60.000s	0.000–60.000	0.000s	<input type="radio"/>
P05.29	AI1 lower limit	0.00V–P05.31	0.00–P05.31	0.00V	<input type="radio"/>
P05.30	Corresponding setting of AI1 lower limit	-100.0%–100.0%	-100.0–100.0	0.0%	<input type="radio"/>
P05.31	AI1 upper limit	P05.29–10.00V	P05.29–10.00	10.00V	<input type="radio"/>
P05.32	Corresponding setting of AI1 upper limit	-100.0%–100.0%	-100.0–100.0	100.0%	<input type="radio"/>
P05.33	AI1 input filter time	0.000s–10.000s	0.000–10.000	0.100s	<input type="radio"/>
P05.34	AI2 lower limit	0.00V–P05.36	0.00–P05.36	0.00V	<input type="radio"/>
P05.35	Corresponding setting of AI2 lower limit	-100.0%–100.0%	-100.0–100.0	0.0%	<input type="radio"/>
P05.36	AI2 upper limit	P05.34–10.00V	P05.34–10.00	10.00V	<input type="radio"/>
P05.37	Corresponding setting of AI2 upper limit	-100.0%–100.0%	-100.0–100.0	100.0%	<input type="radio"/>
P05.38	AI2 input filter time	0.000s–10.000s	0.000–10.000	0.100s	<input type="radio"/>
P05.39	AI3 lower limit	-10.00V–P05.41	-10.00–P05.41	-10.00V	<input type="radio"/>
P05.40	Corresponding setting of AI3 lower limit	-100.0%–100.0%	-100.0–100.0	-100.0%	<input type="radio"/>
P05.41	AI3 middle value	P05.39–P05.43	P05.39–P05.43	0.00V	<input type="radio"/>
P05.42	Corresponding setting of AI3 middle value	-100.0%–100.0%	-100.0–100.0	0.0%	<input type="radio"/>

Function code	Name	Description	Setting range	Default	Modify
P05.43	AI3 upper limit	P05.41–10.00V	P05.41–10.00	10.00V	<input type="radio"/>
P05.44	Corresponding setting of AI3 upper limit	-100.0%–100.0%	-100.0–100.0	100.0%	<input type="radio"/>
P05.45	AI3 input filter time	0.000s–10.000s	0.000–10.000	0.100s	<input type="radio"/>
P05.46	S8 pulse input function selection	0: Input set through frequency 1: Counting 2: Length (reserved)	0–2	0	<input checked="" type="radio"/>
P05.47	S8 lower limit frequency	0.00kHz–P05.49	0.00–P05.49	0.00kHz	<input type="radio"/>
P05.48	Corresponding setting of S8 lower limit frequency	-100.0%–100.0%	-100.0–100.0	0.0%	<input type="radio"/>
P05.49	Upper limit of S8 pulse frequency	P05.47–50.00kHz	P05.47–50.00	50.00kHz	<input type="radio"/>
P05.50	Corresponding setting of S8 upper limit frequency	-100.0%–100.0%	-100.0–100.0	100.0%	<input type="radio"/>
P05.51	S8 pulse frequency input filter time	0.000s–10.000s	0.000–10.000	0.100s	<input type="radio"/>
P05.52–P05.59	Reserved				

P06 group—Output terminals

Function code	Name	Description	Setting range	Default	Modify
P06.00	Y2 output type	0: Open collector output 1: Pulse output	0–1	0	<input checked="" type="radio"/>
P06.01	Y1 output	0: Disable	0–63	0	<input type="radio"/>
P06.02	Y2 output selection	1: Running 2: Running forward	0–63	0	<input type="radio"/>
P06.03	RO1 output	3: Running reversely 4: Jogging	0–63	0	<input type="radio"/>
P06.04	RO2 output	5: VFD in fault	0–63	0	<input type="radio"/>
P06.05	RO3 output	6: Frequency level detection FDT1 7: Frequency level detection FDT2	0–63	0	<input type="radio"/>
P06.06	RO4 output	8: Frequency reached 9: Running in zero speed 10: Upper limit frequency reached 11: Lower limit frequency reached 12: Ready for running 13: Pre-exciting	0–63	0	<input type="radio"/>

Function code	Name	Description	Setting range	Default	Modify
		14: Overload pre-alarm 15: Underload pre-alarm 16: Simple PLC stage completed 17: Simple PLC cycle completed 18: Set counting value reached 19: Designated counting value reached 20: External fault is valid 21: Length reached (reserved) 22: Running time reached 23: Modbus communication virtual terminal output 24: PROFIBUS/CANopen/PROFINET communication virtual terminal output 25: Ethernet communication virtual terminal output 26: Bus voltage established 27: Brake control 28-63: Reserved			
P06.07	Output terminal polarity selection	0x00-0x3F	0x00-0x3F	0x00	○
P06.08	Y1 switch-on delay	0.000-60.000s	0.000-60.000	0.000s	○
P06.09	Y1 switch-off delay	0.000-60.000s	0.000-60.000	0.000s	○
P06.10	Y2 switch-on delay	0.000-60.000s	0.000-60.000	0.000s	○
P06.11	Y2 switch-off delay	0.000-60.000s	0.000-60.000	0.000s	○
P06.12	RO1 switch-on delay	0.000-60.000s	0.000-60.000	0.000s	○
P06.13	RO1 switch-off delay	0.000-60.000s	0.000-60.000	0.000s	○
P06.14	RO2 switch-on delay	0.000-60.000s	0.000-60.000	0.000s	○
P06.15	RO2 switch-off delay	0.000-60.000s	0.000-60.000	0.000s	○
P06.16	RO3 switch-on delay	0.000-60.000s	0.000-60.000	0.000s	○
P06.17	RO3 switch-off delay	0.000-60.000s	0.000-60.000	0.000s	○
P06.18	RO4 switch-on delay	0.000-60.000s	0.000-60.000	0.000s	○
P06.19	RO4 switch-off delay	0.000-60.000s	0.000-60.000	0.000s	○

Function code	Name	Description	Setting range	Default	Modify
P06.20	AO1 output	0: Running frequency	0-30	0	<input type="radio"/>
P06.21	AO2 output	1: Set frequency	0-30	0	<input type="radio"/>
P06.22	Y2 pulse output selection	2: Ramp reference frequency	0-30	0	<input type="radio"/>
		3: Rotational speed			
		4: Output current (relative to the VFD)			
		5: Output current (relative to the motor)			
		6: Output voltage			
		7: Output power			
		8: Set torque			
		9: Output torque			
		10: AI1 input			
		11: AI2 input			
		12: AI3 input			
		13: S8 pulse frequency input			
		14: Value 1 set through MODBUS communication			
		15: Value 2 set through MODBUS communication			
		16: Value 1 set through PROFIBUS/CANopen/PROFINET communication	0-30	0	<input type="radio"/>
		17: Value 2 set through PROFIBUS/CANopen/PROFINET communication			
		18: Value 1 set through Ethernet communication			
		19: Value 2 set through Ethernet communication			
		20: Torque current reference			
		21: Reserved			
		22: Torque current (relative to the motor rated current)			
		23: Exciting current (relative to the motor rated current)			
		24: PID reference			
		25: PID feedback			
		26-30: Reserved			
P06.23	AO1 output lower limit	0.0%-100.0%	0.0-100.0	0.0%	<input type="radio"/>
P06.24	AO1 output corresponding to lower limit	0.00V-10.00V	0.00-10.00	0.00V	<input type="radio"/>
P06.25	AO1 output upper limit	0.0%-100.0%	0.0%-100.0	100.0%	<input type="radio"/>
P06.26	AO1 output corresponding	0.00V-10.00V	0.00-10.00	10.00V	<input type="radio"/>

Function code	Name	Description	Setting range	Default	Modify
	to upper limit				
P06.27	AO1 output filter time	0.000s–10.000s	0.000–10.000	0.000s	<input type="radio"/>
P06.28	AO2 output lower limit	-100.0%–100.0%	-100.0–100.0	0.0%	<input type="radio"/>
P06.29	AO2 output corresponding to lower limit	-10.00V–10.00V	-10.00–10.00	0.00V	<input type="radio"/>
P06.30	AO2 output upper limit	-100.0%–100.0%	-100.0–100.0	100.0%	<input type="radio"/>
P06.31	AO2 output corresponding to upper limit	-10.00V–10.00V	-10.00–10.00	10.00V	<input type="radio"/>
P06.32	AO2 output filter time	0.000s–10.000s	0.000–10.000	0.000s	<input type="radio"/>
P06.33	Y2 output lower limit	0.0%–100.0%	0.0–100.0%	0.00%	<input type="radio"/>
P06.34	Pulse frequency Y2 output corresponding to lower limit	0.00–50.00kHz	0.00–50.00	0.0kHz	<input type="radio"/>
P06.35	Y2 output upper limit	0.0%–100.0%	0.0–100.0%	100.0%	<input type="radio"/>
P06.36	Pulse frequency Y2 output corresponding to upper limit	0.00–50.00kHz	0.00–50.00	50.00kHz	<input type="radio"/>
P06.37	Y2 output filter time	0.000s–10.000s	0.000–10.000	0.000s	<input type="radio"/>
P06.38–P06.49	Reserved				

P07 group--Human-machine interface

Function code	Name	Description	Setting range	Default	Modify
P07.00	User password	0–65535	0–65535	0	<input type="radio"/>
P07.01	Parameter copy	0: No operation 1: Upload parameters from the local address to the keypad 2: Download parameters (including motor parameters) from the keypad to the local address 3: Download parameters (excluding groups P02, P12, P13 and P14) from the keypad to the local address 4: Download parameters (only	0–4	0	<input checked="" type="radio"/>

Function code	Name	Description	Setting range	Default	Modify
		including groups P02, P12, P13 and P14) from the keypad to the local address Note: After any operation among 1-4 is complete, the parameter restores to 0. The upload and download functions are not applicable to group P29.			
P07.02	QUICK/JOG key function selection	0: No function 1: Jog 2: Switch between states 3: Switch between forward and reverse rotating 4: Clear the UP/DOWN setting 5: Coast to stop 6: Switch command channels in sequence 7: Quick commissioning mode (based on non-factory parameter settings)	0-7	1	☉
P07.03	Sequence of switching running-command channels by pressing QUICK	0: Keypad→Terminal→Communication 1: Keypad←→Terminal 2: Keypad←→Communication 3: Terminal←→Communication	0-3	0	○
P07.04	Stop function validity of STOP/RST	0: Valid only for keypad control 1: Valid both for keypad and terminal control 2: Valid both for keypad and communication control 3: Valid for all control modes	0-3	0	○
P07.05	Selection 1 of parameters to be displayed in the running state	0x0000-0xFFFF BIT0: Running frequency (Hz on) BIT1: Set frequency (Hz blinking) BIT2: Bus voltage (V on) BIT3: Output voltage (V on) BIT4: Output current (A on) BIT5: Running speed (rpm on) Bit 6: Output power (% on) Bit 7: Output torque (% on) Bit 8: PID reference value (% blinking) Bit 9: PID feedback value (% on) BIT10: Input terminal status BIT11: Output terminal status Bit 12: Set torque (% on) Bit 13: Pulse count value Bit 14: Length value (reserved)	0x0000-0xFFFF	0x03FF	○

Function code	Name	Description	Setting range	Default	Modify
		Bit 15: PLC and current step number of multi-step speed			
P07.06	Selection 2 of parameters to be displayed in the running state	0x0000–0xFFFF Bit 0: AI1 (V on) Bit 1: AI1 (V on) Bit 2: AI3 (V on) BIT3: Reserved BIT4: Reserved BIT5: High-speed pulse S8 frequency BIT6: Reserved Bit7: Motor overload percentage (% on) Bit8: VFD overload percentage (% on) Bit9: Ramp frequency reference (Hz on) BIT10: Linear speed BIT11–15: Reserved	0x0000–0xFFFF	0x0000	
P07.07	Selection of parameters to be displayed in the stop state	0x0000–0xFFFF BIT0: Set frequency (Hz on, blinking slowly) BIT1: Bus voltage (V on) BIT2: Input terminal state BIT3: Output terminal state BIT4: PID reference value (% blinking) BIT5: PID feedback value (% on) BIT6: Set torque (% on) BIT7: AI1 (V on) BIT8: AI2 (V on) Bit 9: AI3 (V on) BIT10: Reserved Bit 11: Reserved BIT12: High-speed pulse S8 frequency BIT13: Reserved BIT14: PLC and actual step of multi-step speed BIT15: Pulse count value	0x0000–0xFFFF	0x00FF	○
P07.08	Frequency display coefficient	0.01–10.00 Display frequency = Running frequency * P07.08	0.01–10.00	1.00	○
P07.09	Rotational speed display coefficient	0.1–999.9% Mechanical rotation speed = 120 × (Displayed running frequency × P07.09)/(Number of motor pole pairs)	0.1–999.9	100.0%	○
P07.10	Linear speed display coefficient	0.1–999.9% Linear speed = (Mechanical rotation speed) * P07.10	0.1–999.9	1.0%	○

Function code	Name	Description	Setting range	Default	Modify
P07.11	Rectifier bridge temperature	-20~120.0°C			●
P07.12	Inverter module temperature	-20~120.0°C			●
P07.13	Control board software version	1.00~655.35			●
P07.14	Local accumulative running time	0~65535h			●
P07.15	VFD electricity consumption MSB	0~65535kWh (*1000)			●
P07.16	VFD electricity consumption LSB	0.0~999.9kWh			●
P07.17	VFD application type	0: Heavy overload 1: Light overload 2: No overload			●
P07.18	VFD rated power	0.4~6000.0kW			●
P07.19	VFD rated voltage	50~1200V			●
P07.20	VFD rated current	0.1~6000.0A			●
P07.21	Factory bar code 1	0x0000~0xFFFF			●
P07.22	Factory bar code 2	0x0000~0xFFFF			●
P07.23	Factory bar code 3	0x0000~0xFFFF			●
P07.24	Factory bar code 4	0x0000~0xFFFF			●
P07.25	Factory bar code 3	0x0000~0xFFFF			●
P07.26	Factory bar code 4	0x0000~0xFFFF			●

P08 group--Enhanced functions

Function code	Name	Description	Setting range	Default	Modify
P08.00	ACC time 2	0.0~3600.0s	0.0~3600.0	Model depended	○
P08.01	DEC time 2	0.0~3600.0s	0.0~3600.0	Model depended	○
P08.02	ACC time 3	0.0~3600.0s	0.0~3600.0	Model depended	○
P08.03	DEC time 3	0.0~3600.0s	0.0~3600.0	Model depended	○

Function code	Name	Description	Setting range	Default	Modify
P08.04	ACC time 4	0.0–3600.0s	0.0–3600.0	Model depended	<input type="radio"/>
P08.05	DEC time 4	0.0–3600.0s	0.0–3600.0	Model depended	<input type="radio"/>
P08.06	Running frequency of jog	0.00–P00.03 (Max. output frequency)	0.00–P00.03	5.00Hz	<input type="radio"/>
P08.07	ACC time for jogging	0.0–3600.0s	0.0–3600.0	Model depended	<input type="radio"/>
P08.08	DEC time for jogging	0.0–3600.0s	0.0–3600.0	Model depended	<input type="radio"/>
P08.09	Jump frequency 1	0.00–P00.03 (Max. output frequency)	0.00–P00.03	0.00Hz	<input type="radio"/>
P08.10	Jump frequency amplitude 1	0.00–P00.03 (Max. output frequency)	0.00–P00.03	0.00Hz	<input type="radio"/>
P08.11	Jump frequency 2	0.00–P00.03 (Max. output frequency)	0.00–P00.03	0.00Hz	<input type="radio"/>
P08.12	Jump frequency amplitude 2	0.00–P00.03 (Max. output frequency)	0.00–P00.03	0.00Hz	<input type="radio"/>
P08.13	Jump frequency 3	0.00–P00.03 (Max. output frequency)	0.00–P00.03	0.00Hz	<input type="radio"/>
P08.14	Jump frequency amplitude 3	0.00–P00.03 (Max. output frequency)	0.00–P00.03	0.00Hz	<input type="radio"/>
P08.15	Wobbling frequency amplitude percentage	0.0–100.0% (of the set frequency)	0.0–100.0	0.0%	<input type="radio"/>
P08.16	Amplitude of sudden jump frequency	0.0–50.0% (of the amplitude of wobbling frequency)	0.0–50.0	0.0%	<input type="radio"/>
P08.17	Rise time of wobbling frequency	0.1–3600.0s	0.1–3600.0	5.0s	<input type="radio"/>
P08.18	Fall time of wobbling frequency	0.1–3600.0s	0.1–3600.0	5.0s	<input type="radio"/>
P08.19	High-frequency current-loop proportional coefficient	0–20000	0–20000	1000	<input type="radio"/>
P08.20	High-frequency current-loop integral coefficient	0–20000	0–20000	1000	<input type="radio"/>
P08.21	Pulse per rotation of axis	1–10000	1–10000	1	<input type="radio"/>
P08.22	Axis perimeter (reserved)	0.01–100.00cm	0.01–100.0	10.00cm	<input type="radio"/>

Function code	Name	Description	Setting range	Default	Modify
P08.23	Open-loop 0Hz output selection	0: Output without voltage 1: Output with voltage 2: Output with the DC braking current	0-2	0	<input type="radio"/>
P08.24	Length calibration coefficient (reserved)	0.001-1.000	0.001-1.000	1.000	<input type="radio"/>
P08.25	Set counting value	P08.26-65535	P08.26-65535	0	<input type="radio"/>
P08.26	Designated counting value	0-P08.25	0-P08.25	0	<input type="radio"/>
P08.27	Set running time	0-65535min	0-65535	0min	<input type="radio"/>
P08.28	Auto fault reset count	0-10	0-10	0	<input type="radio"/>
P08.29	Auto fault reset interval	0.1-100.0s	0.1-100.0	1.0s	<input type="radio"/>
P08.30	Frequency decrease ratio in drop control	0.00-30.00Hz	0.00-30.000	0.00Hz	<input type="radio"/>
P08.31	Motor switchover selection	0: Terminal 1: MODBUS communication 2: PROFIBUS/CANopen communication	0-2	0	<input checked="" type="radio"/>
P08.32	FDT1 electrical level detection value	0.00-P00.03 (Max. output frequency)	0.00-P00.03	50.00Hz	<input type="radio"/>
P08.33	FDT1 lagging detection value	0.0-100.0% (FDT1 electrical level)	0.0-100.0	5.0%	<input type="radio"/>
P08.34	FDT2 electrical level detection value	0.00-P00.03 (Max. output frequency)	0.00-P00.03	50.00Hz	<input type="radio"/>
P08.35	FDT2 lagging detection value	0.0-100.0% (FDT2 electrical level)	0.0-100.0	5.0%	<input type="radio"/>
P08.36	Detection value for frequency being reached	0.0-P00.03 (Max. output frequency)	0.0-P00.03	0.00Hz	<input type="radio"/>
P08.37	Enabling dynamic braking	0: Disable 1: Enable	0-1	0	<input type="radio"/>
P08.38	Dynamic braking threshold voltage	200.0-2000.0V	200.0-2000.0	For 220V: 380.0V For 380V: 700.0V For 660V: 1120.0V	<input type="radio"/>
P08.39	Cooling-fan running mode	0: Normal mode 1: Permanent running after power-on	0-1	0	<input type="radio"/>

Function code	Name	Description	Setting range	Default	Modify
P08.40	PWM selection	<p>Ones place: PWM mode</p> <p>0: PWM mode 1, 3PH modulation and 2PH modulation</p> <p>1: PWM mode 2, 3PH modulation</p> <p>Tens place: Low-frequency carrier frequency selection</p> <p>0: Reduce carrier frequency at a low frequency</p> <p>1: Do not reduce carrier frequency at a low frequency</p>	0x00–0x11	0x01	☉
P08.41	Overmodulation selection	<p>Ones place: Overmodulation selection</p> <p>0: Disable</p> <p>1: Enable</p> <p>Tens place: Deepened overmodulation coefficient</p> <p>0–9</p>	0x00–0x91	0x01	○
P08.42	Keypad digit control setting	<p>0x0000–0x1223</p> <p>Ones place: Frequency control enabling selection</p> <p>0: Controls through both the \wedge/\vee key and digital potentiometer are valid.</p> <p>1: Only control through the \wedge/\vee key is valid.</p> <p>2: Only control through the digital potentiometer is valid.</p> <p>3: Controls through the \wedge/\vee key and digital potentiometer are invalid.</p> <p>Tens place: Frequency control selection</p> <p>0: Valid only when P00.06=0 or P00.07=0</p> <p>1: Valid for all frequency setting methods</p> <p>2: Invalid for multi-step speed running when multi-step speed running has the priority</p> <p>Hundreds place: Action selection for stop</p> <p>0: Setting is valid.</p> <p>1: Valid during running, cleared after stop</p> <p>2: Valid during running, cleared after a stop command is received</p> <p>LED thousands place: Integral function of the \wedge/\vee key and digital</p>	0x0000–0x1223	0x0000	○

Function code	Name	Description	Setting range	Default	Modify
		potentiometer 0: Enable the integral function 1: Disable the integral function			
P08.43	Keypad digital potentiometer integral rate	0.01-10.00s	0.01-10.00	0.10s	○
P08.44	UP/DOWN terminal control setting	0x000-0x221 LED ones place: Frequency control enabling selection 0: The setting made through UP/DOWN is valid. 1: The setting made through UP/DOWN is invalid. Tens place: Frequency control selection 0: Valid only when P00.06=0 or P00.07=0 1: Valid for all frequency setting methods 2: Invalid for multi-step speed running when multi-step speed running has the priority Hundreds place: Action selection for stop 0: Setting is valid. 1: Valid during running, cleared after stop 2: Valid during running, cleared after a stop command is received	0x000-0x221	0x000	○
P08.45	Frequency increment integral time of the UP terminal	0.01-50.00s	0.01-50.00	0.50s	○
P08.46	Frequency increment integral time of the DOWN terminal	0.01-50.00s	0.01-50.00	0.50s	○
P08.47	Action selection at power-off during frequency setting	0x000-0x111 Ones place: Action selection at power-off during frequency adjusting through digitals. 0: Save the setting at power-off. 1: Clear the setting at power-off. Tens place: Action selection at power-off during frequency adjusting through MODBUS communication	0x000-0x111	0x000	○

Function code	Name	Description	Setting range	Default	Modify
		0: Save the setting at power-off. 1: Clear the setting at power-off. Hundreds place: Action selection at power-off during frequency adjusting through other communication methods 0: Save the setting at power-off. 1: Clear the setting at power-off.			
P08.48	Initial electricity consumption MSB	0-59999kWh	0-59999	0kWh	<input type="radio"/>
P08.49	Initial electricity consumption LSB	0.0-999.9kWh	0-999.9	0.0kWh	<input type="radio"/>
P08.50	Magnetic flux braking coefficient	100-150 0: Disable	0-150	0	<input type="radio"/>
P08.51	VFD input power factor	0.00-1.00	0.00-1.00	0.56	<input type="radio"/>

P09 group-- PID control

Function code	Name	Description	Setting range	Default	Modify
P09.00	PID reference source	0: P09.01 1: AI1 2: AI2 3: AI3 4: S8 pulse 5: Multi-step running 6: MODBUS communication 7: PROFIBUS/CANopen/PROFINET communication 8: Ethernet communication 9: Reserved 10: DEVICE_NET 11: Reserved 12: Reserved 13: Reserved	0-13	0	<input type="radio"/>
P09.01	PID digital setting	-100.0%-100.0%	-100.0-100.0	0.0%	<input type="radio"/>
P09.02	PID feedback source	0: AI1 1: AI2 2: AI3 3: S8 pulse 4: MODBUS communication 5: PROFIBUS/CANopen/PROFINET communication	0-11	0	<input type="radio"/>

Function code	Name	Description	Setting range	Default	Modify
		6: Ethernet communication 7: Reserved 8: DEVICE_NET (Reserved) 9: Output Current 10: Output voltage 11: Reserved			
P09.03	PID output characteristics selection	0: PID output is positive. 1: PID output is negative.	0-1	0	<input type="radio"/>
P09.04	Proportional gain (Kp)	0.00-100.0	0.00-100.0	1.00	<input type="radio"/>
P09.05	Integral time (Ti)	0.01-10.00s	0.01-10.00	0.10s	<input type="radio"/>
P09.06	Differential time (Td)	0.00-10.00s	0.00-10.00	0.00s	<input type="radio"/>
P09.07	Sampling cycle (T)	0.00-100.00s	0.00-100.0	0.10s	<input type="radio"/>
P09.08	PID control deviation limit	0.0-100.0%	0.0-100.0	0.0%	<input type="radio"/>
P09.09	PID output upper limit	P09.10-100.0% (Max. frequency or voltage)	P09.10-100.0	100.0%	<input type="radio"/>
P09.10	PID output lower limit	-100.0%-P09.09 (Max. frequency or voltage)	-100.0-P09.09	0.0%	<input type="radio"/>
P09.11	Feedback offline detection value	0.0-100.0%	0.0-100.0%	0.0%	<input type="radio"/>
P09.12	Feedback offline detection time	0.0-3600.0s	0.0-3600.0	1.0s	<input type="radio"/>
P09.13	PID control selection	0x00-0x11 LED ones place: 0: Continue integral control after the frequency reaches upper/lower limit 1: Stop integral control after the frequency reaches upper/lower limit Hundreds place: Reserved	0x00-0x11	0x00	<input type="radio"/>
P09.14-P09.16	Reserved				

P10 group--Simple PLC and multi-step speed control

Function code	Name	Description	Setting range	Default	Modify
P10.00	Simple PLC mode	0: Stop after running once 1: Keep running with the final value after running once 2: Cyclic running	0-2	0	<input type="radio"/>

Function code	Name	Description	Setting range	Default	Modify
P10.01	Simple PLC memory selection	0: Without memory at power off 1: With memory after power off	0-1	0	<input type="radio"/>
P10.02	Multi-step speed 0	-100.0-100.0%	-100.0-100.0	0.0%	<input type="radio"/>
P10.03	Running time of step 0	0.0-6553.5s (min)	0.0-6553.5	0.0s (min)	<input type="radio"/>
P10.04	Multi-step speed 1	-100.0-100.0%	-100.0-100.0	0.0%	<input type="radio"/>
P10.05	Running time of step 1	0.0-6553.5s (min)	0.0-6553.5	0.0s (min)	<input type="radio"/>
P10.06	Multi-step speed 2	-100.0-100.0%	-100.0-100.0	0.0%	<input type="radio"/>
P10.07	Running time of step 2	0.0-6553.5s (min)	0.0-6553.5	0.0s (min)	<input type="radio"/>
P10.08	Multi-step speed 3	-100.0-100.0%	-100.0-100.0	0.0%	<input type="radio"/>
P10.09	Running time of step 3	0.0-6553.5s (min)	0.0-6553.5	0.0s (min)	<input type="radio"/>
P10.10	Multi-step speed 4	-100.0-100.0%	-100.0-100.0	0.0%	<input type="radio"/>
P10.11	Running time of step 4	0.0-6553.5s (min)	0.0-6553.5	0.0s (min)	<input type="radio"/>
P10.12	Multi-step speed 5	-100.0-100.0%	-100.0-100.0	0.0%	<input type="radio"/>
P10.13	Running time of step 5	0.0-6553.5s (min)	0.0-6553.5	0.0s (min)	<input type="radio"/>
P10.14	Multi-step speed 6	-100.0-100.0%	-100.0-100.0	0.0%	<input type="radio"/>
P10.15	Running time of step 6	0.0-6553.5s (min)	0.0-6553.5	0.0s (min)	<input type="radio"/>
P10.16	Multi-step speed 7	-100.0-100.0%	-100.0-100.0	0.0%	<input type="radio"/>
P10.17	Running time of step 7	0.0-6553.5s (min)	0.0-6553.5	0.0s (min)	<input type="radio"/>
P10.18	Multi-step speed 8	-100.0-100.0%	-100.0-100.0	0.0%	<input type="radio"/>
P10.19	Running time of step 8	0.0-6553.5s (min)	0.0-6553.5	0.0s (min)	<input type="radio"/>
P10.20	Multi-step speed 9	-100.0-100.0%	-100.0-100.0	0.0%	<input type="radio"/>
P10.21	Running time of step 9	0.0-6553.5s (min)	0.0-6553.5	0.0s (min)	<input type="radio"/>
P10.22	Multi-step speed 10	-100.0-100.0%	-100.0-100.0	0.0%	<input type="radio"/>
P10.23	Running time of step 10	0.0-6553.5s (min)	0.0-6553.5	0.0s (min)	<input type="radio"/>

Function code	Name	Description	Setting range	Default	Modify
P10.24	Multi-step speed 11	-100.0–100.0%	-100.0–100.0	0.0%	<input type="radio"/>
P10.25	Running time of step 11	0.0–6553.5s (min)	0.0–6553.5	0.0s (min)	<input type="radio"/>
P10.26	Multi-step speed 12	-100.0–100.0%	-100.0–100.0	0.0%	<input type="radio"/>
P10.27	Running time of step 12	0.0–6553.5s (min)	0.0–6553.5	0.0s (min)	<input type="radio"/>
P10.28	Multi-step speed 13	-100.0–100.0%	-100.0–100.0	0.0%	<input type="radio"/>
P10.29	Running time of step 13	0.0–6553.5s (min)	0.0–6553.5	0.0s (min)	<input type="radio"/>
P10.30	Multi-step speed 14	-100.0–100.0%	-100.0–100.0	0.0%	<input type="radio"/>
P10.31	Running time of step 14	0.0–6553.5s (min)	0.0–6553.5	0.0s (min)	<input type="radio"/>
P10.32	Multi-step speed 15	-100.0–100.0%	-100.0–100.0	0.0%	<input type="radio"/>
P10.33	Running time of step 15	0.0–6553.5s (min)	0.0–6553.5	0.0s (min)	<input type="radio"/>
P10.34	ACC/DEC time of steps 0–7 of simple PLC	0x0000–0xFFFF	0x0000–0xFFFF	0x0000	<input type="radio"/>
P10.35	ACC/DEC time of steps 8–15 of simple PLC	0x0000–0xFFFF	0x0000–0xFFFF	0x0000	<input type="radio"/>
P10.36	PLC restart mode	0: Restart from step 1 1: Resume from the paused step	0–1	0	<input checked="" type="radio"/>
P10.37	Multi-step time unit	0: second 1: minute	0–1	0	<input checked="" type="radio"/>

P11 group--Protection parameters

Function code	Name	Description	Setting range	Default	Modify
P11.00	Protection against phase loss	0x00–0x11 LED ones place: 0: Protection against input phrase loss disabled 1: Protection against input phrase loss enabled LED tens place: 0: Protection against output phrase loss disabled 1: Output phrase loss protection enabled	0x00–0x11	0x11	<input type="radio"/>

Function code	Name	Description	Setting range	Default	Modify
P11.01	Frequency drop at transient power-off	0: Disable 1: Enable	0-1	0	<input type="radio"/>
P11.02	Frequency drop rate at transient power-off	0.00Hz-P00.03 (Max. output frequency)/s	0.00-P00.03	10.00Hz/s	<input type="radio"/>
P11.03	Overvoltage stalling protection	0: Disable 1: Enable	0-1	0	<input type="radio"/>
P11.04	Overvoltage stalling protection voltage	120-150% (corresponds to 1.414 times the VFD rated voltage)	120-150%	140%	<input type="radio"/>
P11.05	Current limit action	0: Disabled 1: Always enabled	0-1	1	<input checked="" type="radio"/>
P11.06	Automatic current limit threshold	50.0-200.0%	50.0-200.0	Heavy overload: 160.0% Light overload: 120.0%	<input checked="" type="radio"/>
P11.07	Frequency drop rate during current limit	0.00-50.00Hz/s	0.00-50.00	10.00Hz/s	<input checked="" type="radio"/>
P11.08	Pre-alarm selection for VFD/motor OL/UL	0x000-0x131 LED ones place: 0: Motor OL/UL pre-alarm, relative to motor rated current. 1: VFD OL/UL pre-alarm, relative to the VFD rated current Tens place: 0: The VFD continues running after overload/underload alarm. 1: The VFD continues running after underload alarm, and stops running after overload fault. 2: The VFD continues to work for an OL alarm but stops running for a UL fault. 3: The VFD stops running for an OL/UL alarm. LED hundreds place: 0: Detect all the time. 1: Detect during constant speed running.	0x000-0x131	0x000	<input type="radio"/>
P11.09	Overload pre-alarm detection threshold	P11.11-200%	P11.11-200	Heavy overload: 150% Light overload: 120%	<input type="radio"/>

Function code	Name	Description	Setting range	Default	Modify
P11.10	Overload pre-alarm detection time	0.1-60.0s	0.1-60.0	1.0s	<input type="radio"/>
P11.11	Underload pre-alarm detection threshold	0%- P11.09	0-P11.09	50%	<input type="radio"/>
P11.12	Underload pre-alarm detection time	0.1-60.0s	0.1-60.0	1.0s	<input type="radio"/>
P11.13	Fault output terminal action upon fault occurring	0x00-0x11 LED ones place: 0: Act upon an undervoltage fault 1: Do not act upon an undervoltage fault Tens place: 0: Act during automatic reset 1: Do not act during the automatic reset period	0x00-0x11	0x00	<input type="radio"/>
P11.14	Speed deviation detection value	0.0-50.0%	0.0-50.0	10.0%	<input type="radio"/>
P11.15	Speed deviation detection time	0.0-10.0s (No speed deviation protection for the value=0.0)	0.0-10.0	1.0s	<input type="radio"/>
P11.16	Unit validity selection	0x00-0x3F	0x00-0x3F	0x3F	<input checked="" type="radio"/>
P11.17	Motor overtemp protection selection	0: Disable 1: Enable	0-1	0	<input type="radio"/>
P11.18	Motor overtemperature protection threshold	0-150.0°C	0-150.0	100.0°C	<input checked="" type="radio"/>
P11.19	Motor temperature detection	0: Invalid 1: PT100 2: NTC (Reserved) 3: PTC (Reserved)	0-3	0	<input type="radio"/>
P11.20	Reserved				

P12 group--Parameters of motor 2

Function code	Name	Description	Setting range	Default	Modify
P12.00	Type of motor 2	0: Asynchronous motor (AM) 1: Synchronous motor (SM)	0-1	0	<input checked="" type="radio"/>
P12.01	Rated power of AM 2	0.1-3000.0kW	0.1-3000.0	Model depended	<input checked="" type="radio"/>
P12.02	Rated frequency of AM 2	0.01Hz-P00.03 (Max. output frequency)	0.01-P00.03	50.00Hz	<input checked="" type="radio"/>

Function code	Name	Description	Setting range	Default	Modify
P12.03	Rated speed of AM 2	1-36000rpm	1-36000	Model depended	☉
P12.04	Rated voltage of AM 2	0-1200V	0-1200	Model depended	☉
P12.05	Rated current of AM 2	0.8-6000.0A	0.8-6000.0	Model depended	☉
P12.06	Stator resistance of AM 2	0.0001-6.5535Ω	0.0001-6.5535	Model depended	○
P12.07	Rotor resistance of AM 2	0.0001-6.5535Ω	0.0001-6.5535	Model depended	○
P12.08	Leakage inductance of AM 2	0.01-655.35mH	0.01-655.35	Model depended	○
P12.09	Mutual inductance of AM 2	0.01-655.35mH	0.01-655.35	Model depended	○
P12.10	No-load current of AM 2	0.1-6553.5A	0.1-6553.5	Model depended	○
P12.11	Magnetic saturation coefficient 1 of iron core of AM 2	0.0-100.0%	0.0-100.0	88%	☉
P12.12	Magnetic saturation coefficient 2 of iron core of AM 2	0.0-100.0%	0.0-100.0	81%	☉
P12.13	Magnetic saturation coefficient 3 of iron core of AM 2	0.0-100.0%	0.0-100.0	75%	☉
P12.14	Magnetic saturation coefficient 4 of iron core of AM 2	0.0-100.0%	0.0-100.0	50%	☉
P12.15	Rated power of SM 2	0.1-3000.0kW	0.1-3000.0	Model depended	☉
P12.16	Rated frequency of SM 2	0.01Hz-P00.03 (Max. output frequency)	0.01-P00.03	50.00Hz	☉
P12.17	Number of pole pairs of SM 2	1-50	1-50	2	☉
P12.18	Rated voltage of SM 2	0-1200V	0-1200	Model depended	☉
P12.19	Rated current of SM 2	0.8-6000.0A	0.8-6000.0	Model depended	☉
P12.20	Stator resistance of SM 2	0.0001-6.5535Ω	0.0001-6.5535	Model depended	○

Function code	Name	Description	Setting range	Default	Modify
P12.21	Direct-axis inductance of SM 2	0.01-655.35mH	0.01-655.35	Model depended	<input type="radio"/>
P12.22	Quadrature-axis inductance of SM 2	0.01-655.35mH	0.01-655.35	Model depended	<input type="radio"/>
P12.23	Counter-emf constant of SM 2	0-10000V	0-10000	300	<input type="radio"/>
P12.24	Initial pole angle of SM 2	0.00-359.99	0.00-359.99	0.00	<input checked="" type="radio"/>
P12.25	Pole position amplitude gain of SM 2	0.50-1.50	0.50-1.50	1.00	<input type="radio"/>
P12.26	Phase-C pole position offset of SM2	0-9999	0-9999	2230	<input type="radio"/>
P12.27	Phase-D pole position offset of SM2	0-9999	0-9999	2230	<input type="radio"/>
P12.28	Identification current of SM 2 (reserved)	0%-50% (of the motor rated current)	0-50	10%	<input checked="" type="radio"/>
P12.29	Overload protection of motor 2	0: No protection 1: Common motor (with low-speed compensation) 2: Frequency-variable motor (without low-speed compensation)	0-2	2	<input checked="" type="radio"/>
P12.30	Overload protection coefficient of motor 2	20.0%-120.0%	20.0-120.0	100.0%	<input type="radio"/>
P12.31	Parameter display of motor 2	0: Display based on motor type 1: Display all	0-1	0	<input type="radio"/>
P12.32- P12.37	Reserved				

P13 group--Parameters of motor 3

Function code	Name	Description	Setting range	Default	Modify
P13.00	Type of motor 3	0: Asynchronous motor (AM) 1: Synchronous motor (SM)	0-1	0	<input checked="" type="radio"/>
P13.01	Rated power of AM 3	0.1-3000.0kW	0.1-3000.0	Model depended	<input checked="" type="radio"/>
P13.02	Rated frequency of AM 3	0.01Hz-P00.03 (Max. output frequency)	0.01-P00.03	50.00Hz	<input checked="" type="radio"/>

Function code	Name	Description	Setting range	Default	Modify
P13.03	Rated speed of AM 3	1-36000rpm	1-36000	Model depended	☉
P13.04	Rated voltage of AM 3	0-1200V	0-1200	Model depended	☉
P13.05	Rated current of AM 3	0.8-6000.0A	0.8-6000.0	Model depended	☉
P13.06	Stator resistance of AM 3	0.0001-6.5535Ω	0.0001-6.5535	Model depended	○
P13.07	Rotor resistance of AM 3	0.0001-6.5535Ω	0.0001-6.5535	Model depended	○
P13.08	Leakage inductance of AM 3	0.01-655.35mH	0.01-655.35	Model depended	○
P13.09	Mutual inductance of AM 3	0.01-655.35mH	0.01-655.35	Model depended	○
P13.10	No-load current of AM 3	0.1-6553.5A	0.1-6553.5	Model depended	○
P13.11	Magnetic saturation coefficient 1 of iron core of AM 3	0.0-100.0%	0.0-100.0	88%	☉
P13.12	Magnetic saturation coefficient 2 of iron core of AM 3	0.0-100.0%	0.0-100.0	81%	☉
P13.13	Magnetic saturation coefficient 3 of iron core of AM 3	0.0-100.0%	0.0-100.0	75%	☉
P13.14	Magnetic saturation coefficient 4 of iron core of AM 3	0.0-100.0%	0.0-100.0	50%	☉
P13.15	Rated power of SM 3	0.1-3000.0kW	0.1-3000.0	Model depended	☉
P13.16	Rated frequency of SM 3	0.01Hz-P00.03 (Max. output frequency)	0.01-P00.03	50.00Hz	☉
P13.17	Number of pole pairs of SM 3	1-50	1-50	2	☉
P13.18	Rated voltage of SM 3	0-1200V	0-1200	Model depended	☉
P13.19	Rated current of SM 3	0.8-6000.0A	0.8-6000.0	Model depended	☉
P13.20	Stator resistance of SM 3	0.0001-6.5535Ω	0.0001-6.5535	Model depended	○

Function code	Name	Description	Setting range	Default	Modify
P13.21	Direct-axis inductance of SM 3	0.01-655.35mH	0.01-655.35	Model depended	<input type="radio"/>
P13.22	Quadrature-axis inductance of SM 3	0.01-655.35mH	0.01-655.35	Model depended	<input type="radio"/>
P13.23	Counter-emf constant of SM 3	0-10000V	0-10000	300V	<input type="radio"/>
P13.24	Initial pole angle of SM 3	0.00-359.99	0.00-359.99	0.00	<input checked="" type="radio"/>
P13.25	Pole position amplitude gain of SM 3	0.50-1.50	0.50-1.50	1.00	<input type="radio"/>
P13.26	Phase-C pole position offset of SM3	0-9999	0-9999	2230	<input type="radio"/>
P13.27	Phase-D pole position offset of SM3	0-9999	0-9999	2230	<input type="radio"/>
P13.28	Identification current of SM 3 (reserved)	0%-50% (of the motor rated current)	0-50	10%	<input checked="" type="radio"/>
P13.29	Overload protection of motor 3	0: No protection 1: Common motor (with low-speed compensation) 2: Frequency-variable motor (without low-speed compensation)	0-2	2	<input checked="" type="radio"/>
P13.30	Overload protection coefficient of motor 3	20.0%-120.0%	20.0-120.0	100.0%	<input type="radio"/>
P13.31	Parameter display of motor 3	0: Display based on motor type 1: Display all	0-1	0	<input type="radio"/>
P13.32- P13.33	Reserved				
P13.34	Overvoltage stalling voltage loop Kp	Proportional coefficient of DC bus voltage loop regulator	0-200	60	<input type="radio"/>
P13.35	Overvoltage stalling voltage loop Ki	Integral coefficient of DC bus voltage loop regulator	0-200	60	<input type="radio"/>
P13.36	Overvoltage stalling current loop Kp	Proportional coefficient of current loop regulator during overvoltage stall	0-500	60	<input type="radio"/>
P13.37	Overvoltage stalling current loop Ki	Integral coefficient of current loop regulator during overvoltage stall	0-500	250	<input type="radio"/>

P14 group--Parameters of motor 4

Function code	Name	Description	Setting range	Default	Modify
P14.00	Type of motor 4	0: Asynchronous motor (AM) 1: Synchronous motor (SM)	0-1	0	<input checked="" type="radio"/>
P14.01	Rated power of AM 4	0.1-3000.0kW	0.1-3000.0	Model depended	<input checked="" type="radio"/>
P14.02	Rated frequency of AM 4	0.01Hz-P00.03 (Max. output frequency)	0.01-P00.03	50.00Hz	<input checked="" type="radio"/>
P14.03	Rated speed of AM 4	1-36000rpm	1-36000	Model depended	<input checked="" type="radio"/>
P14.04	Rated voltage of AM 4	0-1200V	0-1200	Model depended	<input checked="" type="radio"/>
P14.05	Rated current of AM 4	0.8-6000.0A	0.8-6000.0	Model depended	<input checked="" type="radio"/>
P14.06	Stator resistance of AM 4	0.0001-6.5535Ω	0.0001-6.5535	Model depended	<input type="radio"/>
P14.07	Rotor resistance of AM 4	0.0001-6.5535Ω	0.0001-6.5535	Model depended	<input type="radio"/>
P14.08	Leakage inductance of AM 4	0.01-655.35mH	0.01-655.35	Model depended	<input type="radio"/>
P14.09	Mutual inductance of AM 4	0.01-655.35mH	0.01-655.35	Model depended	<input type="radio"/>
P14.10	No-load current of AM 4	0.1-6553.5A	0.1-6553.5	Model depended	<input type="radio"/>
P14.11	Magnetic saturation coefficient 1 of iron core of AM 4	0.0-100.0%	0.0-100.0	88%	<input checked="" type="radio"/>
P14.12	Magnetic saturation coefficient 2 of iron core of AM 4	0.0-100.0%	0.0-100.0	81%	<input checked="" type="radio"/>
P14.13	Magnetic saturation coefficient 3 of iron core of AM 4	0.0-100.0%	0.0-100.0	75%	<input checked="" type="radio"/>
P14.14	Magnetic saturation coefficient 4 of iron core of AM 4	0.0-100.0%	0.0-100.0	50%	<input checked="" type="radio"/>
P14.15	Rated power of SM 4	0.1-3000.0kW	0.1-3000.0	Model depended	<input checked="" type="radio"/>
P14.16	Rated frequency of SM 4	0.01Hz-P00.03 (Max. output frequency)	0.01-P00.03	50.00Hz	<input checked="" type="radio"/>

Function code	Name	Description	Setting range	Default	Modify
P14.17	Number of pole pairs of SM 4	1-50	1-50	2	☉
P14.18	Rated voltage of SM 4	0-1200V	0-1200	Model depended	☉
P14.19	Rated current of SM 4	0.8-6000.0A	0.8-6000.0	Model depended	☉
P14.20	Stator resistance of SM 4	0.0001-6.5535Ω	0.0001-6.5535	Model depended	○
P14.21	Direct-axis inductance of SM 4	0.01-655.35m	0.01-655.35	Model depended	○
P14.22	Quadrature-axis inductance of SM 4	0.01-655.35mH	0.01-655.35	Model depended	○
P14.23	Counter-emf constant of SM 4	0-10000V	0-10000	300	○
P14.24	Initial pole angle of SM 4	0.00-359.99	0.00-359.99	0.00	☉
P14.25	Pole position amplitude gain of SM 4	0.50-1.50	0.50-1.50	1.00	○
P14.26	Phase-C pole position offset of SM4	0-9999	0-9999	2230	○
P14.27	Phase-D pole position offset of SM4	0-9999	0-9999	2230	○
P14.28	Identification current of SM 4 (reserved)	0%-50% (of the motor rated current)	0-50	10%	●
P14.29	Overload protection of motor 4	0: No protection 1: Common motor (with low-speed compensation) 2: Frequency-variable motor (without low-speed compensation)	0-2	2	☉
P14.30	Overload protection coefficient of motor 4	20.0%-120.0%	20.0-120.0	100.0%	○
P14.31	Parameter display of motor 4	0: Display based on motor type 1: Display all	0-1	0	○
P14.32-P14.37	Reserved				

P15 group--SM control

Function code	Name	Description	Setting range	Default	Modify
P15.00	Reduction coefficient of pull-in current	0.0%–100.0% (of the motor rated current)	0.0–100.0	80.0%	☉
P15.01	Detection mode of initial pole	0: Source current 1: High frequency superimposition (reserved) 2: Pulse superposition	0–2	0	☉
P15.02	Pull-in current 1	0.0%–100.0% (of the motor rated current)	0.0–100.0	10.0%	○
P15.03	Pull-in current 2	0.0%–100.0% (of the motor rated current)	0.0–100.0	10.0%	○
P15.04	Switch-over frequency of pull-in current	0.0%–80.0% (of the rated frequency)	0.0–80.0	20.0%	○
P15.05	High frequency overlay frequency (reserved)	200Hz–1000Hz	200–1000	500Hz	☉
P15.06	Pulse superposition voltage	0.0–150.0% (of the motor rated voltage)	0.0–150.0	50.0%	☉
P15.07	Reserved	0.0–6553.5	0.0–6553.5	0.0	○
P15.08	Control parameter 1	0X0000–0xFFFF	0X0000–0xFFFF	0X0000	○
P15.09	Control parameter 2	0.00–50.00	0.00–50.00	2.00	○
P15.10	Reserved	0–65535	0–65535	0	○
P15.11	Maladjustment detection time	0.0–10.0s	0.0–10.0	0.5s	○
P15.12	High frequency compensation coefficient	0.0–100.0%	0.0–100.0	0.0%	○
P15.13	Short-circuit braking current	0.0–150.0% (relative to the VFD)	0.0–150.0	0.0%	○
P15.14	Hold time of short-circuit braking for start	0.0–50.0s	0.0–50.0	0.0s	○
P15.15	Hold time of short-circuit braking for stop	0.0–50.0s	0.0–50.0	0.0s	○
P15.16–P15.18	Reserved				

P16 group--Encoders

Function code	Name	Description	Setting range	Default	Modify
P16.00	Encoder type selection	0: Incremental encoder 1: UVW encoder 2: Sin/Cos encoder 3: Resolver-type encoder	0-3	0	☉
P16.01	Encoder pulse count	0-8192	0-8192	1024	☉
P16.02	Encoder direction	0x00-0x11 Ones place: 0: AB forward 1: AB reverse Tens place: 0: Not reverse Z pulse (reserved) 1: Reverse Z pulse (reserved) Hundreds place: 0: UVW forward 1: UVW reverse	0x00-0x11	0x00	☉
P16.03	Encoder disconnection detection time	0.0-100.0s	0.0-100.0	1.0s	○
P16.04	Detection time of encoder reversal	0.0-100.0s	0.0-100.0	1.0s	○
P16.05	Filter times of encoder detection	Bit0-3: Low-speed filter time Bit4-7: High-speed filter time	0x00-0x99	0x33	○
P16.06	Speed ratio between motor and encoder	0.000-65.535	0-65.535	1.000	○
P16.07	Control parameters of SM	Bit0: Enable Z pulse calibration Bit1: Enable encoder angle calibration Bit2: Enable SVC speed measurement Bit3: Resolver speed measurement mode Bit4: Z pulse capture mode Bit12: Clear the Z pulse arrival signal after stop Bit15: =0: Without Z pulse autotuning =1: With Z pulse autotuning	0x0000-0xffff	0x0003	○
P16.08	Initial angle of Z pulse	0.00-359.99	0.00-359.99	0.00	○
P16.09	Enable Z pulse offline detection	0: Disable 1: Enable	0-1	0	○

Function code	Name	Description	Setting range	Default	Modify
P16.10	Autotuning pole initial angle	0-2 1: Rotary autotuning 2: Static autotuning (suitable for resolver-type encoder feedback) (reserved)	0-2	0	☉
P16.11	Actual frequency of encoder	-327.68-327.67Hz	-327.68-327.67	0.00Hz	●
P16.12	Encoder position count value	0-65535	0-65535	0	●
P16.13	Encoder Z pulse count value	0-65535	0-65535	0	●
P16.14	Rotor identification value	0.0000-6.5535Ω	0.0000-6.5535	0.0000	●
P16.15	Z pulse angle of SM	0.00-359.99	0.00-359.99	0.00	●
P16.16	UVW signal state	0-65535	0-65535	0	●
P16.17	Initial angle of U pulse	0.00-359.99	0.00-359.99	0.00	○
P16.18- P16.30	Reserved				

P17 group--Overall status display

Function code	Name	Description	Setting range	Default	Modify
P17.00	Set frequency	0.00Hz-P00.03		0.00Hz	●
P17.01	Output frequency	0.00Hz-P00.03		0.00Hz	●
P17.02	Ramp reference frequency	0.00Hz-P00.03		0.00Hz	●
P17.03	Output voltage	0-1200V		0V	●
P17.04	Output current	0.0-5000.0A		0.0A	●
P17.05	Motor rotation speed	0-65535RPM		0RPM	●
P17.06	Torque current	-5000.0-5000.0A		0.0A	●
P17.07	Exciting current	-5000.0-5000.0A		0.0A	●
P17.08	Motor power load coefficient	-300.0 -300.0% (of the motor rated power)		0.0%	●
P17.09	Output torque load coefficient	-250.0-250.0%		0.0%	●
P17.10	Estimated motor frequency	0.00-P00.03		0.00Hz	●
P17.11	DC bus voltage	0.0-2000.0V		0V	●

Function code	Name	Description	Setting range	Default	Modify
P17.12	Digital input terminal status	0x0000–0xFFFF		0x0000	●
P17.13	Digital output terminal status	0x0000–0xFFFF		0x0000	●
P17.14	Digital adjustment value	0.00Hz–P00.03		0.00Hz	●
P17.15	Torque reference value	-300.0%–300.0% (of the motor rated current)		0.0%	●
P17.16	Linear speed	0–65535		0	●
P17.17	Length value	0–65535		0	●
P17.18	Count value	0–65535		0	●
P17.19	AI1 input voltage	0.00–10.00V		0.00V	●
P17.20	AI2 input voltage	0.00–10.00V		0.00V	●
P17.21	AI3 input voltage	-10.00–10.00V		0.00V	●
P17.22	S8 input frequency	0.00–50.00kHz		0.00kHz	●
P17.23	PID reference value	-100.0–100.0%		0.0%	●
P17.24	PID feedback value	-100.0–100.0%		0.0%	●
P17.25	Motor power factor	-1.00–1.00		0.0	●
P17.26	Duration of this run	0–65535min		0min	●
P17.27	Simple PLC and actual step of multi-step speed	0–15		0	●
P17.28	ASR controller output	-300.0%–300.0% (of the motor rated current)		0.0%	●
P17.29	Magnetic pole angle of SM	0.0–360.0		0.0	●
P17.30	Phase compensation of SM	-180.0–180.0		0.0	●
P17.31	High-frequency superposition current of SM	0.0%–200.0% (of the motor rated current)		0.0	●
P17.32	Flux linkage	0.0%–200.0%		0.0%	●
P17.33	Exciting current reference	-3000.0–3000.0A		0.0A	●
P17.34	Torque current reference	-3000.0–3000.0A		0.0A	●

Function code	Name	Description	Setting range	Default	Modify
P17.35	AC incoming current	0.0–5000.0A		0.0A	●
P17.36	Output torque	-30000–30000Nm		0Nm	●
P17.37	Motor overload count value	0–100 (When the value=100, OL1 is reported)		0	●
P17.38	Present fault code	0–65535		0	●
P17.39	DP command display	0–65535		0	●
P17.40–P17.41	Reserved				
P17.42	Motor temperature display	-200.0–200.0°C		0.0°C	●
P17.43	External master frequency	0.00Hz–P00.03		0.00Hz	●
P17.44	External master torque	-300.0%–300.0% (of the motor rated current)		0.0%	●
P17.45	External master command	0–65535		0	●
P17.46	Speed tracking frequency	-3276.7–3276.7Hz		0.0Hz	●

P18 group--Unit status display

Function code	Name	Description	Setting range	Default	Modify
P18.00	Current of unit 1	0.0–2000.0A		0.0A	●
P18.01	Bus voltage of unit 1	0.0–2000.0V		0.0V	●
P18.02	Rectifier bridge temperature of unit 1	-20–120.0°C		0.0°C	●
P18.03	IGBT temperature of unit 1	-20–120.0°C		0.0°C	●
P18.04	Reserved				
P18.05	Fault code of unit 1	0x0000–0xffff		0x0000	●
P18.06–P18.07	Reserved				
P18.08	DSP version of unit 1	1.00–655.35		1.00	●
P18.09	FPGA version of unit 1	1.00–655.35		1.00	●
P18.10	Current of unit 2	0.0–2000.0A		0.0A	●
P18.11	Bus voltage of unit 2	0.0–2000.0V		0.0V	●

Function code	Name	Description	Setting range	Default	Modify
P18.12	Rectifier bridge temperature of unit 2	-20.0-120.0°C		0.0°C	●
P18.13	IGBT temperature of unit 2	-20.0-120.0°C		0.0°C	●
P18.14	Reserved				
P18.15	Fault code of unit 2	0x0000-0xffff		0x0000	●
P18.16- P18.17	Reserved				
P18.18	DSP version of unit 2	1.00-655.35		1.00	●
P18.19	FPGA version of unit 2	1.00-655.35		1.00	●
P18.20	Current of unit 3	0.0-2000.0A		0.0A	●
P18.21	Bus voltage of unit 3	0.0-2000.0V		0.0V	●
P18.22	Rectifier bridge temperature of unit 3	-20.0-120.0°C		0.0°C	●
P18.23	IGBT temperature of unit 3	-20.0-120.0°C		0.0°C	●
P18.24	Reserved				
P18.25	Fault code of unit 3	0x0000-0xffff		0x0000	●
P18.26- P18.27	Reserved				
P18.28	DSP version of unit 3	1.00-655.35		1.00	●
P18.29	FPGA version of unit 3	1.00-655.35		1.00	●
P18.30	Current of unit 4	0.0-2000.0A		0.0A	●
P18.31	Bus voltage of unit 4	0.0-2000.0V		0.0V	●
P18.32	Rectifier bridge temperature of unit 4	-20.0-120.0°C		0.0°C	●
P18.33	IGBT temperature of unit 4	-20.0-120.0°C		0.0°C	●
P18.34	Reserved				
P18.35	Fault code of unit 4	0x0000-0xffff		0x0000	●
P18.36- P18.37	Reserved				

Function code	Name	Description	Setting range	Default	Modify
P18.38	DSP version of unit 4	1.00–655.35		1.00	●
P18.39	FPGA version of unit 4	1.00–655.35		1.00	●
P18.40	Current of unit 5	0.0–2000.0A		0.0A	●
P18.41	Bus voltage of unit 5	0.0–2000.0V		0.0V	●
P18.42	Rectifier bridge temperature of unit 5	-20–120.0°C		0.0°C	●
P18.43	IGBT temperature of unit 5	-20–120.0°C		0.0°C	●
P18.44	Reserved				
P18.45	Fault code of unit 5	0x0000–0xffff		0x0000	●
P18.46– P18.47	Reserved				
P18.48	DSP version of unit 5	1.00–655.35		1.00	●
P18.49	FPGA version of unit 5	1.00–655.35		1.00	●
P18.50	Current of unit 6	0.0–2000.0A		0.0A	●
P18.51	Bus voltage of unit 6	0.0–2000.0V		0.0V	●
P18.52	Rectifier bridge temperature of unit 6	-20.0–120.0°C		0.0°C	●
P18.53	IGBT temperature of unit 6	-20.0–120.0°C		0.0°C	●
P18.54	Reserved				
P18.55	Fault code of unit 6	0x0000–0xffff		0x0000	●
P18.56– P18.57	Reserved				
P18.58	DSP version of unit 6	1.00–655.35		1.00	●
P18.59	FPGA version of unit 6	1.00–655.35		1.00	●
P18.60	Valid unit count	0x00–0x3F		0x00	●
P18.61	Unit rated power	0.1–3000.0kW		0.1KW	●
P18.62	Unit rated current	0.0–2000.0A		0.0A	●
P18.63	FPGA version of main control board	1.00–655.35		1.00	●

Function code	Name	Description	Setting range	Default	Modify
P18.64–P18.69	Reserved				

P19 group--Fault information

Function code	Name	Description	Setting range	Default	Modify
P19.00	Present fault type	0: No fault 1–3: Reserved 4: Overcurrent during acceleration (oC1) 5: Overcurrent during deceleration (oC2) 6: Overcurrent during constant speed running (oC3) 7: Overvoltage during acceleration (ov1) 8: Overvoltage during deceleration (ov2) 9: Overvoltage during constant speed running (ov3) 10: Bus undervoltage(Lv) 11: Motor overload (oL1) 12: VFD overload (oL2) 13: Phase loss on input side (SPI) 14: Phase loss on output side (SPo) 15: Reserved 16: Reserved 17: External fault (EF) 18: RS485 communication fault (E-485) 19: Current detection fault (ItE) 20: Motor autotuning fault (tE) 21: EEPROM operation error (EEP) 22: PID feedback offline fault (PIdE) 23: Braking unit fault (bCE) 24: Running time reached (END) 25: Electronic overload (oL3) 26: Keypad communication error (PCE) (reserved) 27: Parameter upload to keypad error (UPE) 28: Parameter download from keypad error (dNE) 29: PROFIBUS communication fault (E-dP) 30: Ethernet communication fault (E-NET)			●

Function code	Name	Description	Setting range	Default	Modify
		31: CANopen communication fault (E-CAN) 32: To-ground short-circuit fault 1 (EtH1) (reserved) 33: Reserved 34: Speed deviation fault (dEU) 35: Mal-adjustment fault (STE) 36: Underload fault (LL) 37: Encoder disconnection fault (ENC1o) 38: Encoder reversal fault (ENC1d) 39: STO fault (E-STo) 40: Brake action fault (FAE) 41: Master/slave communication fault (E- FSC) (Main control board FPGA) 42: Slave fault (E-SLE) (DSP) 43: DSP-FPGA communication fault (dF_CE) 44: Control power fault (CPoE) (Main controller DSP) 45: Motor overtemperature fault (oH) 46: Torque verification failure (tCE) Unit fault: m.n m.01: Unit phase-U Vce check fault (m. oUt1) (Unit FPGA) m.02: Unit phase-V Vce check fault (m. oUt2) (Unit FPGA)			
P19.01	Last fault type	m.03: Unit phase-W Vce check fault (m. oUt3) (Unit FPGA)			●
P19.02	2nd-last fault type	m.04: Unit hardware overcurrent fault (m. oC) (Unit FPGA)			●
P19.03	3rd-last fault type	m.05: Unit current check fault (m. ItE) (Unit DSP)			●
P19.04	4th-last fault type	m.06: Unit current imbalance fault (m. IbC) (Unit DSP)			●
P19.05	5th-last fault type	m.07: Unit rectifier bridge overheating fault (m. oH1) (Main control board DSP) m.08: Unit IGBT overheating fault (m. oH2) (Main control board DSP) m.09: Unit fan overheating fault (m. EF1) (Unit DSP) m.10: Unit filter module overheating fault (m.EF2) (Unit			●

Function code	Name	Description	Setting range	Default	Modify
		DSP) m.11: Unit input phase loss (m.EF3) (Unit DSP) m.12: Unit bus overvoltage fault (m.oV) (Unit DSP) m.13: Unit bus undervoltage fault (m. Lv) (Main control board DSP) m.14: Unit downstream communication fault (m.dn-C) (Unit FPGA) m.15: Unit upstream communication fault (m.UP-C) (Main control FPGA) m.16: Unit power down (m.PEr) (Unit DSP)			
P19.06	Running frequency at present fault			0.00Hz	●
P19.07	Ramp reference frequency at present fault			0.00Hz	●
P19.08	Output current at present fault			0.0V	●
P19.09	Output current at present fault			0.0A	●
P19.10	Bus voltage at present fault			0.0V	●
P19.11	Max. temperature at present fault			0.0°C	●
P19.12	Input terminal status at present fault			0	●
P19.13	Output terminal status at present fault			0	●
P19.14	Running frequency at last fault			0.00Hz	●
P19.15	Ramp reference frequency at last fault			0.00Hz	●
P19.16	Output voltage at last fault			0V	●
P19.17	Output current at last fault			0.0A	●
P19.18	Bus voltage at last fault			0.0V	●

Function code	Name	Description	Setting range	Default	Modify
P19.19	Max. temperature at last fault			0.0°C	●
P19.20	Input terminal status at last fault			0	●
P19.21	Output terminal status at last fault			0	●
P19.22	Running frequency at 2nd-last fault			0.00Hz	●
P19.23	Ramp reference frequency at 2nd-last fault			0.00Hz	●
P19.24	Output voltage at 2nd-last fault			0V	●
P19.25	Output current at 2nd-last fault			0.0A	●
P19.26	Bus voltage at 2nd-last fault			0.0V	●
P19.27	Max. temperature at 2nd-last fault			0.0°C	●
P19.28	Input terminal status at 2nd-last fault			0	●
P19.29	Output terminal status at 2nd-last fault			0	●

P20 group--Serial communication

Function code	Name	Description	Setting range	Default	Modify
P20.00	Local communication address	1-247; 0 indicates a broadcast address	1-247	1	○
P20.01	Communication baud rate	0: 1200BPS 1: 2400BPS 2: 4800BPS 3: 9600BPS 4: 19200BPS 5: 38400BPS	0-5	4	○
P20.02	Data bit check	0: No check (N, 8, 1) for RTU 1: Even check (E, 8, 1) for RTU 2: Odd check (O, 8, 1) for RTU 3: No check (N, 8, 2) for RTU	0-5	1	○

Function code	Name	Description	Setting range	Default	Modify
		4: Even check (E, 8, 2) for RTU 5: Odd check (O, 8, 2) for RTU			
P20.03	Communication response delay	0–200ms	0–200	5ms	<input type="radio"/>
P20.04	Communication timeout time	0.0 (invalid), 0.1–60.0s	0.0–60.0	0.0s	<input type="radio"/>
P20.05	Transmission error processing	0: Report an alarm and coast to stop 1: Keep running without reporting an alarm 2: Stop in enabled stop mode without reporting an alarm (applicable only to communication mode) 3: Stop in enabled stop mode without reporting an alarm (applicable to any mode)	0–3	0	<input type="radio"/>
P20.06	Communication processing action	0x00–0x11 LED ones place: 0: Respond to write operations 1: Not respond to write operations LED tens place: 0: Disabled 1: Enabled	0x00–0x11	0x00	<input type="radio"/>
P20.07–P20.09	Reserved				

P21 group--PROFIBUS PROFIBUS/CANopen/PROFINET function

Function code	Name	Description	Setting range	Default	Modify
P21.00	Module type	0: PROFIBUS/CANopen/PROFINET 1: Reserved	0–1	0	<input checked="" type="radio"/>
P21.01	PROFIBUS/CANopen/PROFINET module address	0–127	0–127	2	<input checked="" type="radio"/>
P21.02	Received PZD2	0: Disable	0–20	0	<input type="radio"/>
P21.03	Received PZD3	1: Set frequency (0–Fmax (Unit: 0.01Hz)) 2: PID reference (0–1000, in which 1000 corresponds to 100.0%) 3: PID feedback (0–1000, in which 1000 corresponds to 100.0%) 4: Torque setting (-3000–+3000, in which 1000 corresponds to 100.0% of the motor rated current) 5: Setting of the upper limit of forward running frequency (0–	0–20	0	<input type="radio"/>
P21.04	Received PZD4		0–20	0	<input type="radio"/>
P21.05	Received PZD5		0–20	0	<input type="radio"/>
P21.06	Received PZD6		0–20	0	<input type="radio"/>
P21.07	Received PZD7		0–20	0	<input type="radio"/>
P21.08	Received PZD8		0–20	0	<input type="radio"/>
P21.09	Received PZD9		0–20	0	<input type="radio"/>
P21.10	Received PZD10		0–20	0	<input type="radio"/>
P21.11	Received PZD11		0–20	0	<input type="radio"/>
P21.12	Received PZD12		0–20	0	<input type="radio"/>

Function code	Name	Description	Setting range	Default	Modify
		Fmax, unit: 0.01 Hz) 6: Setting of the upper limit of reverse running frequency (0–Fmax, unit: 0.01 Hz) 7: Upper limit of the electromotive torque (0–3000, in which 1000 corresponds to 100.0% of the motor rated current) 8: Upper limit of braking torque (0–2000, in which 1000 corresponds to 100% of the motor rated current) 9: Virtual input terminal command. Range: 0x000–0x0FF 10: Virtual output terminal command. Range: 0x00–0x3F 11: Voltage setting (special for V/F separation) (0–1000, in which 1000 corresponds to 100% of the motor rated voltage) 12: AO output setting 1 (-1000–+1000, in which 1000 corresponds to 100.0%) 13: AO output setting 2 (-1000–+1000, in which 1000 corresponds to 100.0%) 14: External ACC time (0–3600.0s) 15: External DEC time (0–3600.0s) 16: Pre-torque setting (-100.0%–100.0%) 17–20: Reserved			
P21.13	Sent PZD2	0: Invalid	0–23	0	○
P21.14	Sent PZD3	1: Running frequency (*100, Hz)	0–23	0	○
P21.15	Sent PZD4	2: Set frequency (*100, Hz)	0–23	0	○
P21.16	Sent PZD5	3: Bus voltage (*10, V)	0–23	0	○
P21.17	Sent PZD6	4: Output voltage (*1, V)	0–23	0	○
P21.18	Sent PZD7	5: Output current (x10, A)	0–23	0	○
P21.19	Sent PZD8	6: Actual output torque (x10, %)	0–23	0	○
P21.20	Sent PZD9	7: Actual output power (x10, %)	0–23	0	○
P21.21	Sent PZD10	8: Rotation speed of running (x1, RPM)	0–23	0	○
P21.22	Sent PZD11	9: Linear speed of running (x1, m/s)	0–23	0	○
P21.23	Sent PZD12	10: Ramp reference frequency 11: Fault code 12: AI1 input (*100, V) 13: AI2 input (*100, V) 14: AI3 input (*100, V) 15: Motor temperature (*10, °C) 16: Module temperature (*10, °C)	0–23	0	○

Function code	Name	Description	Setting range	Default	Modify
		17: S8 frequency value (*100, kHz) 18: PG card speed (signed) 19: Terminal input status 20: Terminal output status 21: PID reference (x100, %) 22: PID feedback (x100, %) 23: Motor rated torque			
P21.24	Temporary variable 1 for PZD sending	0-65535	0-65535	0	<input type="radio"/>
P21.25	DP communication timeout time	0.0 (invalid), 0.1-60.0s	0.0-60.0	0.0s	<input type="radio"/>
P21.26- P21.28	Reserved				
P21.29	CANopen communication baud rate	0: 1000k 1: 800k 2: 500k 3: 250k 4: 125k 5: 100k 6: 50k 7: 20k	0-7	2	<input checked="" type="radio"/>
P21.30	CANopen communication timeout time	0.0 (invalid), 0.1-60.0s	0.0-60.0	0.0s	<input checked="" type="radio"/>
P21.31	Reserved				
P21.32	External ACC/DEC enabling	0: Disable 1: Enable	0-1	0	<input checked="" type="radio"/>
P21.33- P21.40	Reserved				
P21.41	Output length	PROFINET output length	0-32	32	<input checked="" type="radio"/>
P21.42	Input length	PROFINET input length	0-32	32	<input checked="" type="radio"/>

P22 group--Ethernet communication

Function code	Name	Description	Setting range	Default	Modify
P22.00	Ethernet communication rate	0: Self adaptive 1: 100M full duplex 2: 100M half duplex 3: 10M full duplex 4: 10M half duplex	0-4	0	<input checked="" type="radio"/>
P22.01	IP address 1	0-255	0-255	192	<input checked="" type="radio"/>
P22.02	IP address 2	0-255	0-255	168	<input checked="" type="radio"/>
P22.03	IP address 3	0-255	0-255	0	<input checked="" type="radio"/>

Function code	Name	Description	Setting range	Default	Modify
P22.04	IP address 4	0-255	0-255	1	☉
P22.05	Subnet mask 1	0-255	0-255	255	☉
P22.06	Subnet mask 2	0-255	0-255	255	☉
P22.07	Subnet mask 3	0-255	0-255	255	☉
P22.08	Subnet mask 4	0-255	0-255	0	☉
P22.09	Gateway 1	0-255	0-255	192	☉
P22.10	Gateway 2	0-255	0-255	168	☉
P22.11	Gateway 3	0-255	0-255	1	☉
P22.12	Gateway 4	0-255	0-255	1	☉
P22.13- P22.14	Reserved				

P23 group--Master/slave control

Function code	Name	Description	Setting range	Default	Modify
P23.00	Master/slave mode	0: Master/slave control is invalid. 1: The local device is the master. 2: The local device is the slave.	0-2	0	☉
P23.01	Master/slave communication data selection	0: Power balance mode 1: Expansion mode (reserved)	0-1	0	☉
P23.02	Master/slave communication mode	0: Optical fiber 1: Reserved	0-1	0	☉
P23.03	Master power balancing control mode	0: Master/slave mode 0. (Both the master and slave use speed control, and power balancing is performed by droop control. The droop quantity is set by P08.30.) 1: Master/slave mode 1. (The master and slave must be in the same type of vector control. When the master is in speed control, the slave is forced into torque control.) 2-3: Reserved	0-3	0	☉
P23.04	Reference frequency source gain of the slave	0.0-500.0%	0.0-500.0%	100.0%	○
P23.05	Reference torque source gain of the slave	0.0-500.0%	0.0-500.0%	100.0%	○
P23.06	Slave fault auto bypass enabling	0: Disable 1: Enable	0-1	0	☉
P23.07	Slave bypassing	0: Not bypass 1: Bypass	0-1	0	○

Function code	Name	Description	Setting range	Default	Modify
P23.08	Slave count/ slave number	0-65535	0-65535	0	●
P23.09	Slave fault information	0-65535	0-65535	0	●
P23.10- P23.19	Reserved				

P24 group--Hoisting

Function code	Name	Description	Setting range	Default	Modify
P24.00	Pre torque input signal source	0: Disable 1: AI1 2: AI2 3: AI3 4: RS485 communication 5: Reserved 6: PROFIBUS/CANopen/PROFINET communication 7: Internal setting 8-10: Reserved	0-10	0	◎
P24.01	Pre torque offset	-100.0-100.0%	-100.0- 100.0	0.0%	○
P24.02	Drive-side gain	0.000-7.000	0.000-7.000	1.000	○
P24.03	Braking-side gain	0.000-7.000	0.000-7.000	1.000	○
P24.04	Pre-torque direction and braking control	0x00-0x11 Ones place: 0: Forward 1: Reverse Tens place: 0: Braking control invalid 1: Braking control valid	0x00-0x11	0x00	◎
P24.05	Brake release delay	0.000-5.000s	0.000-5.000	0.000s	◎
P24.06	Brake closing frequency	0.00-50.00Hz	0.00-50.00	0.00Hz	◎
P24.07	Brake closing delay	0.000-5.000s	0.000-5.000	0.000s	◎
P24.08	Brake feedback detection time	0.000-20.000s	0.000- 20.000	1.000s	◎
P24.09	Torque verification	0: Invalid 1: Through current percentage 2: Through torque percentage	0-2	0	◎
P24.10	Keypad setting value during torque verification	0.0-100.0% (of the rated motor current/torque. 0.0%: Torque verification is invalid.)	0.0-100.0	0.0%	◎

Function code	Name	Description	Setting range	Default	Modify
P24.11	Torque verification fault detection time	0.000–10.000s	0.000–10.000	0.500S	☉
P24.12	Anti-sag protection braking torque	0.0–300.0% (of the motor rated current)	0.0–300.0%	0	☉
P24.13	Braking torque ACC time	0.000–10.000s	0.000–10.000	0.200s	☉
P24.14	Braking torque end frequency	0.00–30.00Hz	0.00–30.000	0.10Hz	☉
P24.15	Safe speed limit frequency	0.00–30.00Hz	0.00–30.000	1.00Hz	☉
P24.16	DEC time at safe speed limit	0.0–100.0s	0.0–100.0	2.0s	☉
P24.17	DEC time at safe stop 1	0.0–100.0s	0.0–100.0	5.0s	☉
P24.18–P24.19	Reserved				

P29 group--Factory parameters

Function code	Name	Description	Setting range	Default	Modify
P29.00	Factory password	0–65535	0–65535	*****	●

9 Derated application

9.1 Capacity

Choose a VFD model based on the rated current and power of the motor. To endure the rated power of the motor, the rated output current of the VFD must be larger or equal to the rated current of the motor. The rated power of the VFD must be higher or equal to that of the motor.

Note:

- The maximum allowable shaft power of the motor is limited to 1.5 times the rated power of the motor. If the limit is exceeded, the VFD automatically restricts the torque and current of the motor. This function effectively protects the input shaft against overload.
- The rated capacity is the capacity at the ambient temperature of 40°C.
- You need to check and ensure that the power flowing through the common DC connection in the common DC system does not exceed the rated power of the motor.

9.2 Derating

If the ambient temperature at the VFD installation site exceeds 40°C, the VFD installation site altitude exceeds 1000m, a cover with heat dissipation vents is used, or the carrier frequency is higher than the recommended (for the recommended frequency, see P00.14), the VFD needs to be derated.

Your Trusted Industry Automation Solution Provider



Shenzhen INVT Electric Co., Ltd.

Address: INVT Guangming Technology Building, Songbai Road, Matian,
Guangming District, Shenzhen, China

INVT Power Electronics (Suzhou) Co., Ltd.

Address: No. 1 Kunlun Mountain Road, Science & Technology Town,
Gaoxin District, Suzhou, Jiangsu, China

Website: www.invt.com



INVT mobile website



INVT e-manual



6 6 0 0 1 - 0 0 9 8 7