

Goodrive800 Pro Series Basic Rectifier Unit

Hardware Manual



No.	Change description	Version	Release date
1	First release.	V1.0	Feb 2022

Preface

Thank you for choosing INVT Goodrive800 Pro series engineering variable-frequency drive (VFD).

For ease of use, read the manual carefully before using Goodrive800 Pro series product.

As an upgrade product of Goodrive800 series engineering VFD, Goodrive800 Pro series engineering VFD inherits the high reliability feature of Goodrive800 platform but optimizes the upgrade, structure, and components, achieving unit modularization, flexible cabinet configuration, more compact structure, easier installation and maintenance, and optimum protection.

- ◆ Excellent speed and torque control performance
- ◆ Modular design, as flexible as building blocks, which makes the project integration simple and efficient
- ◆ Long-life component selection and fast fault recovery design to ensure efficient process control
- ◆ Ergonomic design to make installation and maintenance easier
- ◆ Enriched expansion capability to support various protection options

Goodrive800 Pro series engineering VFD can be widely used in:

Metallurgy: Such as high-speed wire rod and hot strip rolling equipment, wide and thick plate equipment, cold rolling equipment, pickling lines, annealing lines, galvanizing line, color coating lines, non-ferrous metal alloy manufacturing equipment, and non-ferrous metal rolling equipment.

Petroleum: All-electric oil drilling rigs, large well repair machines, large oil machinery and equipment electric-drive power transformation, oilfield water injection equipment and other heavy oil equipment.

Paper making: Paper making joint equipment, including flow box, net section, press section, drying section, sizing, hard calendering, coating, super calender, rewinder and other continuous production lines.

Port and other large lifting equipment: Such as shore-side container overhead cranes, tire-type (orbital) container gantry cranes, grab unloaders, grab gantry cranes, large shipbuilding gantry cranes, and large metallurgical casting cranes.

Others: Such as unit test benches, military equipment, oil and gas transmission, and mining transmission equipment.

Goodrive800-71 series is the basic rectifier unit of Goodrive800 Pro series. If not otherwise specified, the basic rectifier unit in this manual refers to the basic rectifier unit of Goodrive800 Pro series, that is, Goodrive800-71 series product. The rated power of a single unit is 356kW–929kW, and the max. parallel power can be 5183kW. The basic rectifier unit consists of input reactor, semi-controlled rectifier bridge and DC fuse. It is compact in structure and easy to integrate and maintain, reducing cabinet footprint.

This manual is Goodrive800 Pro series basic rectifier unit hardware manual, presenting safety precautions, product information, mechanical and electrical installation, and precautions related to daily maintenance. Read through this manual carefully before installation to ensure the VFD is installed and operated in a proper manner to give full play to its excellent performance and powerful functions. If you have any question about the function and performance of the product, please consult our technical support.

If the product is ultimately used for military affairs or weapon manufacture, comply with the export control regulations in the Foreign Trade Law of the People's Republic of China and complete related formalities.

To continuously improve the performance of the product to meet higher application requirements, we reserve the right to continuously improve the product and accordingly the product manual, which may be made without prior notice. We have the final interpretation of the manual content.

Contents

Preface i

Contents ii

1 Safety precautions1

 1.1 Safety declaration 1

 1.2 Safety definition 1

 1.3 Warning symbols 1

 1.4 Safety guidelines 2

 1.4.1 Delivery and installation 2

 1.4.2 Commissioning and running 3

 1.4.3 Maintenance and component replacement 3

 1.4.4 Disposal 3

2 Product overview4

 2.1 Product specifications 4

 2.2 Product nameplate and model 5

 2.3 Product ratings 6

 2.4 Overload capability 7

 2.5 Hardware principles 7

 2.5.1 Basic principles 7

 2.5.2 Six-pulse rectification 9

 2.5.3 Twelve-pulse rectification 10

 2.6 Product structure 10

 2.7 System configuration 12

 2.8 Electrical model selection 12

 2.8.1 Breaker 12

 2.8.2 AC fuse 13

 2.8.3 Built-in DC fuse 13

3 Mechanical installation14

 3.1 Safety notes 14

 3.2 Installation environment 14

 3.3 Installation procedure 15

 3.3.1 Unpacking inspection 15

 3.3.2 Transportation 16

 3.3.3 Unpacking 16

 3.3.4 Lifting 17

 3.3.5 Installation 20

 3.3.6 Fastening torque 29

 3.3.7 Checklist 29

4 Electrical installation31

 4.1 Safety notes 31

 4.2 Insulation inspection 31

 4.3 EMC regulations 32

 4.3.1 Power cable 33

 4.3.2 Control cable 33

 4.3.3 Wiring suggestions 34

 4.3.4 Shielded cable connection 36

 4.4 Electrical wiring 37

 4.4.1 Wiring procedure 37

 4.4.2 Isolated grid (IT grid) application 37

 4.4.3 Main circuit wiring 38

 4.4.4 Control circuit wiring 39

 4.4.5 Electrical installation checklist 40

5 Maintenance and inspection41

 5.1 Periodical inspection 41

 5.1.1 Overview 41

5.1.2 Required tools.....	41
5.1.3 Maintenance cycle	41
5.2 Replacement of wearing parts	43
5.2.1 Cooling fan	43
5.2.2 DC fuse.....	44
5.2.3 Basic rectifier unit.....	45
Appendix A Technical data	47
A.1 Derated application	47
A.1.1 Capacity	47
A.1.2 Derating	47
A.2 Grid specifications	48
A.3 Application standards	48
A.3.1 CE marking.....	48
A.3.2 EMC compliance declaration	48
A.4 EMC regulations.....	48
A.4.1 VFD category of C2.....	49
A.4.2 VFD category of C3.....	49
Appendix B Dimension drawings	50
B.1 Installation dimensions.....	50

1 Safety precautions

1.1 Safety declaration

Read this manual carefully and follow all safety precautions before moving, installing, operating and servicing the product. Otherwise, equipment damage or physical injury or death may be caused.

We shall not be liable or responsible for any equipment damage or physical injury or death caused due to your or your customers' failure to follow the safety precautions.

1.2 Safety definition

Danger: Severe personal injury or even death can result if related requirements are not followed.





Warning: Personal injury or equipment damage can result if related requirements are not followed.

Note: Actions taken to ensure proper running.





Trained and qualified professionals: People operating the equipment must have received professional electrical and safety training and obtained the certificates, and must be familiar with all steps and requirements of equipment installing, commissioning, running and maintaining and capable to prevent any emergencies.

1.3 Warning symbols

Warnings caution you about conditions that can result in severe injury or death and/or equipment damage and advice on how to prevent dangers. The following table lists the warning symbols in this manual.

Symbol	Name	Description
	Danger	Severe personal injury or even death can result if related requirements are not followed.
	Warning	Personal injury or equipment damage can result if related requirements are not followed.
	Electrostatic sensitive	The PCBA may be damaged if related requirements are not followed.
	Hot sides	Do not touch. The rectifier unit base may become hot.
	Electric shock	As high voltage still presents in the bus capacitor after power off, wait for at least 15 minutes (depending on the warning symbols on the machine) after power off to prevent electric shock.
Note	Note	Actions taken to ensure proper running.

1.4 Safety guidelines

	<ul style="list-style-type: none"> Only trained and qualified professionals are allowed to carry out related operations. Do not perform wiring, inspection or component replacement when power supply is applied. Ensure all the input power supplies have been disconnected before wiring or inspection, and wait for at least the time designated on the Goodrive800 Pro series product or until the DC bus voltage is less than 36V. The minimum waiting time is listed in the following. <table border="1" style="margin-left: auto; margin-right: auto;"> <thead> <tr> <th colspan="2">Rectifier unit model</th> <th>Minimum waiting time</th> </tr> </thead> <tbody> <tr> <td>380V</td> <td>>356kW</td> <td>15 minutes</td> </tr> <tr> <td>690V</td> <td>>487kW</td> <td>15 minutes</td> </tr> </tbody> </table>	Rectifier unit model		Minimum waiting time	380V	>356kW	15 minutes	690V	>487kW	15 minutes
Rectifier unit model		Minimum waiting time								
380V	>356kW	15 minutes								
690V	>487kW	15 minutes								
	<ul style="list-style-type: none"> Do not refit the Goodrive800 Pro series product unless authorized; otherwise fire, electric shock or other injury may result. 									
	<ul style="list-style-type: none"> The base may become hot when the Goodrive800 Pro series product is running. Do not touch. Otherwise, you may get burnt. 									
	<ul style="list-style-type: none"> The electrical parts and components inside the Goodrive800 Pro series product are electrostatic sensitive. Take measurements to prevent electrostatic discharge when performing related operations. 									

1.4.1 Delivery and installation

	<ul style="list-style-type: none"> Do not install the rectifier unit on inflammables. In addition, prevent the rectifier unit from contacting or adhering to inflammables. Do not run the rectifier unit if it is damaged or incomplete. Do not contact the rectifier unit with damp objects or body parts. Otherwise, electric shock may result. 								
Note	<ul style="list-style-type: none"> Select appropriate tools for rectifier unit delivery and installation to ensure the safe and proper running and avoid physical injury or death. To ensure personal safety, take mechanical protective measures like wearing safety shoes and working uniforms. Protect the rectifier unit against physical shock or vibration during the delivery and installation. Do not carry the rectifier unit only by its front cover as the cover may fall off. The installation site must be away from children and other public places. Prevent the screws, cables and other conductive parts from falling into the rectifier unit. As rectifier unit leakage current caused during running may exceed 3.5mA, ground properly and ensure the grounding resistance is less than 10Ω. The conductivity of PE grounding conductor must meet the following requirements: <table border="1" style="margin-left: auto; margin-right: auto;"> <thead> <tr> <th>Power cable conductor cross-sectional area S (mm²)</th> <th>Grounding conductor cross-sectional area (mm²)</th> </tr> </thead> <tbody> <tr> <td>S ≤ 16</td> <td>S</td> </tr> <tr> <td>16 < S ≤ 35</td> <td>16</td> </tr> <tr> <td>35 < S</td> <td>S/2</td> </tr> </tbody> </table> <ul style="list-style-type: none"> R, S, and T are the power input terminals, while U, V, and W are the DC bus output terminals. Connect the input power cables and output busbars properly; otherwise, the rectifier unit may be damaged. 	Power cable conductor cross-sectional area S (mm ²)	Grounding conductor cross-sectional area (mm ²)	S ≤ 16	S	16 < S ≤ 35	16	35 < S	S/2
Power cable conductor cross-sectional area S (mm ²)	Grounding conductor cross-sectional area (mm ²)								
S ≤ 16	S								
16 < S ≤ 35	16								
35 < S	S/2								



1.4.2 Commissioning and running

	<ul style="list-style-type: none"> • Cut off all power supplies connected to the rectifier unit before terminal wiring, and wait for at least the time designated on the rectifier unit after disconnecting the power supplies. • High voltage presents inside the rectifier unit during running. Do not carry out any operation on the rectifier unit during running except for keypad setup. For products at voltage class of 4 or 6, the control terminals form extra-low voltage circuits. Therefore, you need to prevent the control terminals from connecting to accessible terminals of other devices. • Before turning on the power supply, check the cable connection status. • Prevent anyone from directly touching the energized part of the cabinet door. Pay special attention to safety when handling shields that are made of metal sheets. • Do not do any withstand voltage testing during unit connection. Disconnect the motor cable before performing any insulation and voltage withstand tests for the motor or motor cable. • Do not open the cabinet door since high voltage presents inside the Goodrive800 Pro series product during running.
<p>Note</p>	<ul style="list-style-type: none"> • Do not switch on or switch off the input power supplies of the rectifier unit frequently. • If the rectifier unit has been stored for a long time without use, perform checking and carry out pilot run for the rectifier unit before using it again. • Close the rectifier unit front cover before running; otherwise, electric shock may occur.

1.4.3 Maintenance and component replacement

	<ul style="list-style-type: none"> • Only trained and qualified professionals are allowed to perform maintenance, inspection, and component replacement for the rectifier unit. • Cut off all power supplies connected to the rectifier unit before terminal wiring, and wait for at least the time designated on the rectifier unit after disconnecting the power supplies. • During maintenance and component replacement, take measures to prevent screws, cables and other conductive matters from falling into the internal of the rectifier unit.
<p>Note</p>	<ul style="list-style-type: none"> • Use proper torque to tighten screws. • During maintenance and component replacement, keep the rectifier unit and its parts and components away from combustible materials and ensure they have no combustible materials adhered. • Do not carry out insulation voltage-endurance test on the rectifier unit, or measure the control circuits of the rectifier unit with a megohmmeter. • During maintenance and component replacement, take proper anti-static measures on the rectifier unit and its internal parts.

1.4.4 Disposal

	<ul style="list-style-type: none"> • The rectifier unit contains heavy metals. Dispose of a scrap rectifier unit as industrial waste.
	<ul style="list-style-type: none"> • Dispose of a scrap product separately at an appropriate collection point but not place it in the normal waste stream.

2 Product overview

2.1 Product specifications

Table 2-1 Product specifications

Description		Specifications
Power input	Input voltage (V)	380–480VAC 3PH $\pm 10\%$, $-15\% < 1\text{min}$; Rated voltage: 380V 520–690VAC 3PH $\pm 10\%$, $-15\% < 1\text{min}$; Rated voltage: 690V
	Input current (A)	See 2.3 Product ratings.
	Input frequency (Hz)	50Hz or 60Hz; Allowed range: 47–63Hz
Power output	Output voltage (V)	Input voltage * 1.35
	Output current (A)	See 2.3 Product ratings.
	Output power (kW)	See 2.3 Product ratings.
Environment condition	Working temperature	$-10^{\circ}\text{C} - +50^{\circ}\text{C}$; Derating is required when the ambient temperature exceeds 40°C .
	Relative humidity	5%–95%, no condensation
	Installation altitude	Below 1000m (Derating is required when the altitude exceeds 1000m. Derate by 1% for every increase of 100m.)
Mechanical data	Anti-vibration performance	Compliant with 3M4 vibration level in GB/T4798.3
	IP rating	For the module: IP00 For the cabinet: IP20 (Optional: IP23 and IP42)
	Safety performance	Compliant with EN 61800-5-1
	Cooling method	Forced air cooling
Protection functions	Protection functions	Including functions of protection against short circuit, overcurrent, overload, overvoltage, undervoltage, overtemperature, and phase loss

2.2 Product nameplate and model

Figure 2-1 Product nameplate

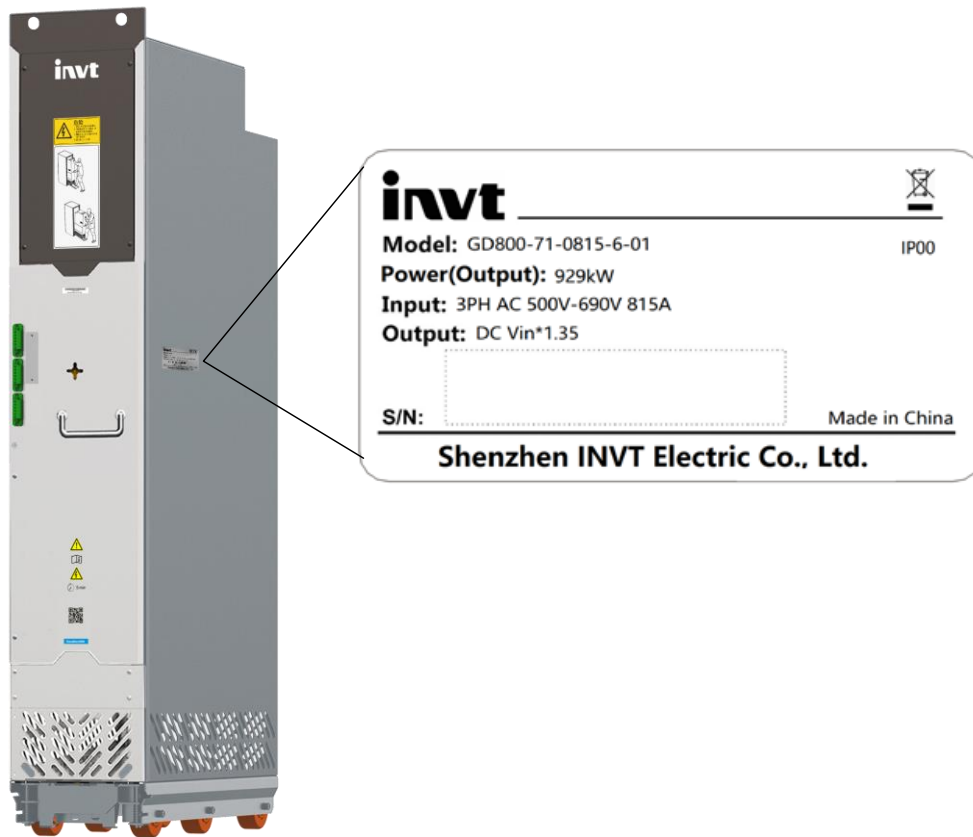

Note: The preceding nameplate is a standard product nameplate example. The marking varies slightly depending on the model.

The model designation code contains basic product information such as rated current and rated voltage. You can find the model designation code on the product nameplate.

Figure 2-2 Product model

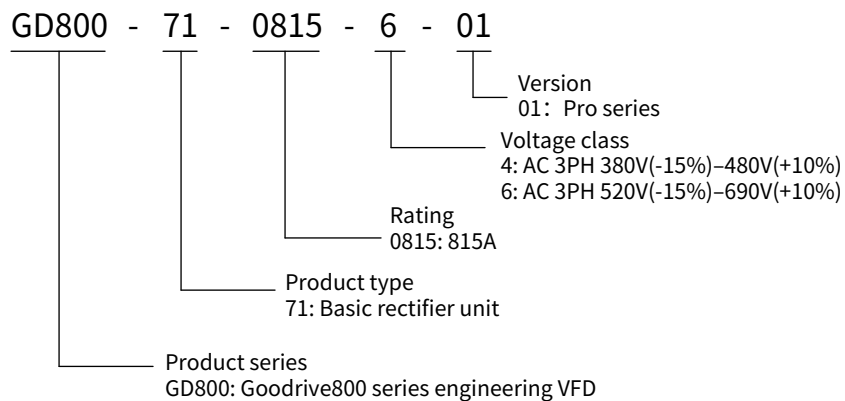

Note: The preceding model is only an example of GD800-71 models.

2.3 Product ratings

Table 2-2 AC 3PH 380V (-15%)–480V(+10%)

Model GD800-71...	Rating					Light overload application		Heavy overload application		Structure	Heat dissipation	Air volume
	I _N	I _N	I _{max}	S _N	P _N	I _{Ld}	P _{Ld}	I _{hd}	P _{Hd}			
	A (AC)	A (DC)	A (DC)	kVA	kW(DC)	A (DC)	kW(DC)	A (DC)	kW(DC)		kW	m ³ /h
6-pulse												
0718-4-01	718	879	1142	497	475	844	456	659	356	D8T	2.8	1500
0980-4-01	980	1200	1560	680	648	1154	623	901	487	D8T	3	1500
1336-4-01	1336	1635	2126	926	883	1570	848	1226	662	2*D8T	5.6	3000
1822-4-01	1822	2232	2902	1263	1205	2143	1157	1670	902	2*D8T	6	3000
2734-4-01	2734	3348	4353	1895	1808	3214	1736	2504	1352	3*D8T	9	4500
3645-4-01	3645	4464	5804	2525	2411	4285	2314	3339	1803	4*D8T	12	6000
4556-4-01	4556	5580	7254	3156	3013	5357	2893	4174	2254	5*D8T	15	7500
5467-4-01	5467	6696	8705	3788	3616	6428	3471	5009	2705	6*D8T	18	9000
12-pulse												
1336-4-01	1336	1635	2126	926	883	1570	848	1226	662	2*D8T	5.6	3000
1822-4-01	1822	2232	2902	1263	1205	2143	1157	1670	902	2*D8T	6	3000
2674-4-01	2674	3273	4255	1852	1767	3142	1697	2455	1325	4*D8T	11.2	6000
3645-4-01	3645	4464	5804	2525	2408	4285	2314	3339	1803	4*D8T	12	6000
4008-4-01	4008	4906	6377	2777	2649	4709	2543	3679	1987	6*D8T	16.8	9000
5467-4-01	5467	6696	8705	3788	3616	6428	3471	5009	2705	6*D8T	18	9000

Table 2-3 AC 3PH 520V(-15%)–690V(+10%)

Model GD800-71...	Rating					Light overload application		Heavy overload application		Structure	Heat dissipation	Air volume
	I _N	I _N	I _{max}	S _N	P _N	I _{Ld}	P _{Ld}	I _{hd}	P _{Hd}			
	A (AC)	A (DC)	A (DC)	kVA	kW (DC)	A (DC)	kW(DC)	A (DC)	kW (DC)		kW	m ³ /h
6-pulse												
0570-6-01	570	698	907	682	650	670	624	523	487	D8T	2.5	1500
0815-6-01	815	998	1297	974	929	958	892	748	697	D8T	2.8	1500
1061-6-01	1061	1299	1688	1268	1210	1247	1161	974	907	2*D8T	5	3000
1515-6-01	1515	1854	2411	1810	1727	1780	1658	1391	1295	2*D8T	5.6	3000
2273-6-01	2273	2782	3617	2716	2591	2671	2488	2087	1944	3*D8T	8.4	4500
3031-6-01	3031	3710	4823	3622	3456	3561	3317	2782	2592	4*D8T	11.2	6000

Model GD800-71...	Rating					Light overload application		Heavy overload application		Structure	Heat dissipation	Air volume
	I_N	I_N	I_{max}	S_N	P_N	I_{Ld}	P_{Ld}	I_{hd}	P_{hd}			
	A (AC)	A (DC)	A (DC)	kVA	kW (DC)	A (DC)	kW(DC)	A (DC)	kW (DC)			
3788-6-01	3788	4636	6027	4527	4319	4451	4146	3477	3239	5*D8T	14	7500
4546-6-01	4546	5564	7233	5433	5183	5341	4976	4173	3887	6*D8T	16.8	9000
12-pulse												
1061-6-01	1061	1299	1688	1268	1210	1247	1161	974	907	2*D8T	5	3000
1515-6-01	1515	1854	2411	1810	1727	1780	1658	1391	1295	2*D8T	5.6	3000
2122-6-01	2122	2597	3376	2536	2419	2493	2323	1948	1814	4*D8T	10	6000
3031-6-01	3031	3710	4823	3622	3456	3561	3317	2782	2592	4*D8T	11.2	6000
4546-6-01	4546	5564	7233	5433	5183	5341	4976	4173	3887	6*D8T	16.8	9000

Note:

- I_N indicates the rated current for continuous running when no overload occurs at 40°C, while I_{max} indicates the max. output current.
- Light overload application: I_{Ld} indicates the continuous running current at light overload. Every 5 minutes, the overload with the current of $110% \cdot I_{Ld}$ can last for 1 minutes at 40°C.
- Heavy overload application: I_{hd} indicates the continuous running current at heavy overload. Every 5 minutes, the overload with the current of $150% \cdot I_{hd}$ can last for 1 minutes at 40°C.

2.4 Overload capability

Based on the light overload continuous run current (I_{Ld}), the basic rectifier unit can keep running for 60s at 110% of the rated current. See Figure 2-3.

Figure 2-3 Light overload application

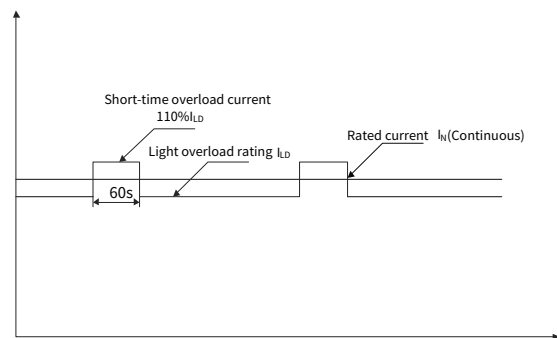
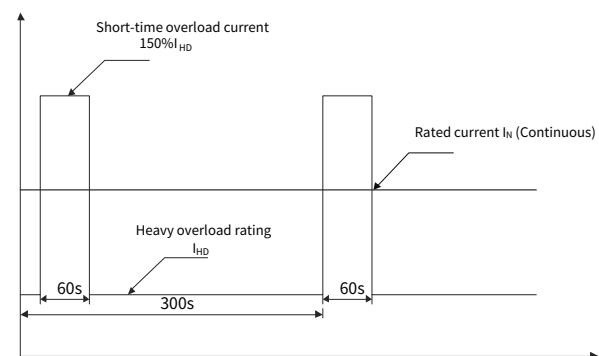

Figure 2-4 Heavy overload application



2.5 Hardware principles

2.5.1 Basic principles

The basic rectifier unit converts 3PH AC voltage into intermediate DC voltage, and the intermediate DC voltage can supply the subsequent inverter modules. It can connect to one or multiple inverter modules.

The basic rectifier unit is equipped with AC reactors to suppress AC voltage and current harmonics. The

thyristor rectifier bridge has the controllability characteristic, which can gradually boost the bus voltage by controlling the thyristor switch-on through the conduction angle. In this way, there is no need to add additional precharge circuit.

The basic rectifier unit mainly consists of input reactor, semi-controlled rectifier bridge, energy storage capacitor and DC fuse. Figure 2-5 shows the simplified main circuit.

Figure 2-5 Simplified main circuit

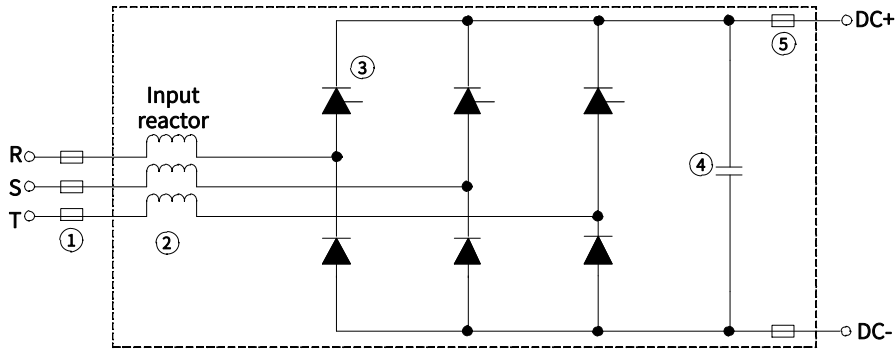

No.	Name	Description
1	AC fuse	To protect against overload and short-circuit on the basic rectifier unit side.
2	AC input reactor	To suppress AC voltage and current harmonics.
3	Basic rectifier module	To convert AC current to DC current.
4	Bus capacitor	To filter out the AC part from the bus voltage.
5	DC fuse	To prevent backend device short circuit from causing machine burndown.

Note: The AC fuse is not a component of the basic rectifier unit. You can choose to configure AC fuses according to the actual application requirements.

When the system is switched on and started, and the three-phase AC power is connected to the basic rectifier unit, and then the control board detects the three-phase input line voltage and controls the trigger signal of the three-phase rectification to make the system enter the rectification state. The rectification of three phases is triggered in turn. The rectification is triggered from the negative zero-crossing point of the line voltage of each phase, and then gradually shifted to the left according to the moving rule (the width of the triggered pulse train does not exceed 120°). Thus the effect of gradually boosting the bus voltage is achieved by switching to a higher line voltage by means of phase shifting. Subsequently, DC bus voltage is provided to downstream inverter side. Figure 2-6 shows the basic rectifier unit working principles.

Figure 2-6 Basic rectification principles

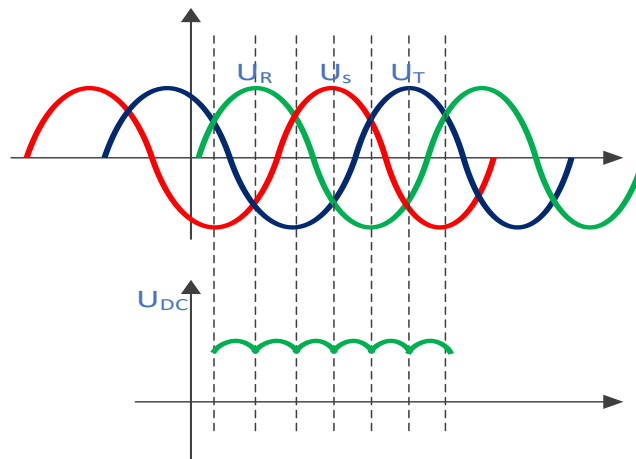

2.5.2 Six-pulse rectification

Six-pulse basic rectification can meet most common rectification applications, in which there is no demanding requirements on harmonics. Figure 2-7 shows how a single basic rectifier unit works.

Figure 2-7 Simplified main circuit of a single six-pulse rectifier unit

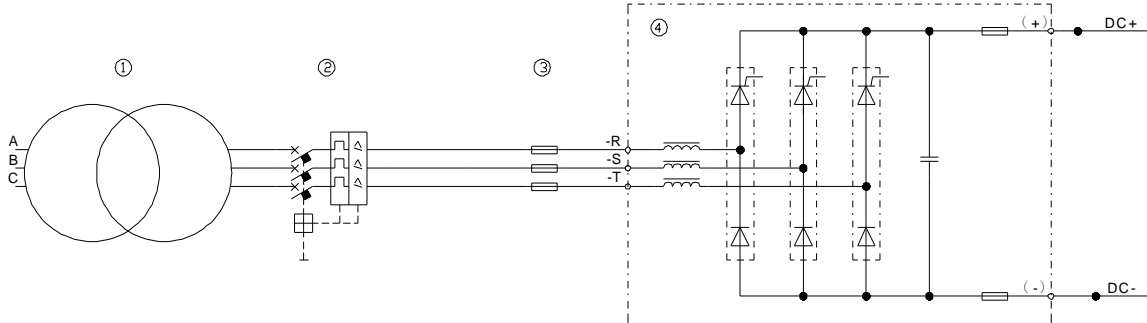

No.	Name
1	Grid transformer
2	Breaker
3	AC fuse
4	Basic rectifier unit

The basic rectifier unit supports parallel use. Multiple basic rectifier units can be connected in parallel, as shown in Figure 2-8.

Figure 2-8 Simplified main circuit of parallel six-pulse rectifier units

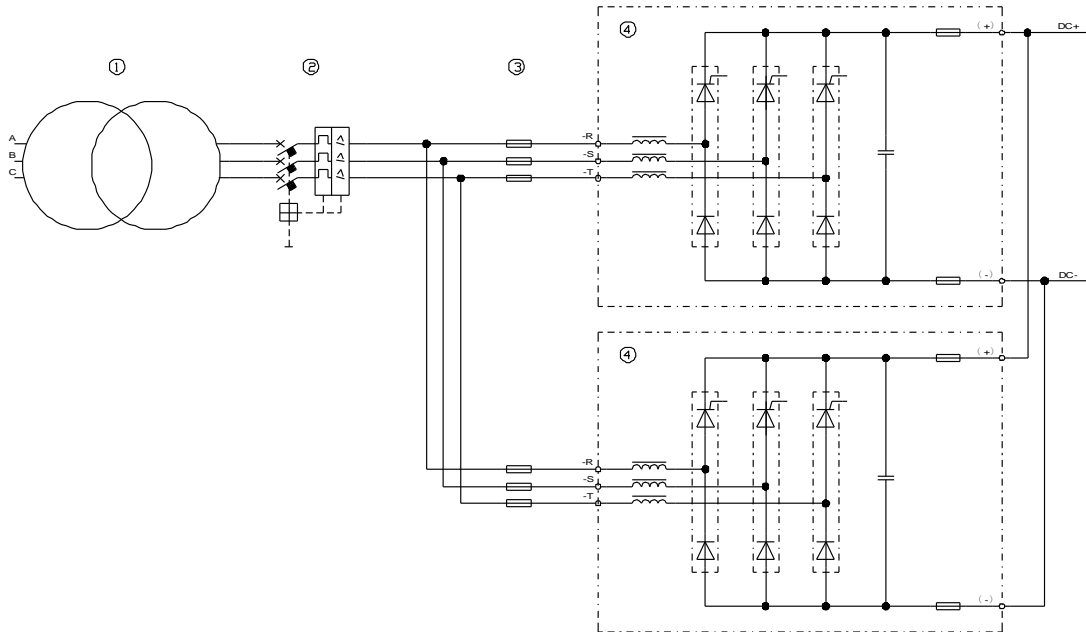

No.	Name
1	Grid transformer
2	Breaker
3	AC fuse
4	Basic rectifier unit

2.5.3 Twelve-pulse rectification

The basic rectifier unit is a high-power device, which is required to minimize the harmonic impact on the power supply system from the view of engineering design. The requirements can be met by using twelve-pulse rectification at a relatively low cost, while the transformer selects two windings with a phase difference of 30°. See Figure 2-9.

Figure 2-9 Simplified main circuit of twelve-pulse rectifier units

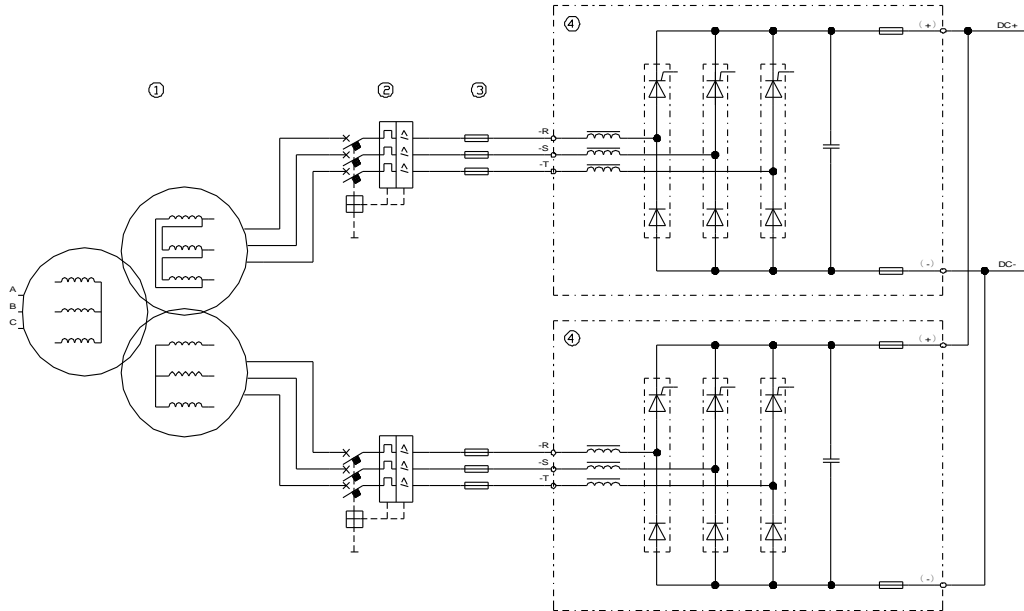

No.	Name
1	Phase shifting transformer
2	Frame breaker
3	Fuse
4	Basic rectifier unit

2.6 Product structure

Figure 2-10 shows the basic rectifier unit structure (taking GD800-71-0815-6-01 for example).

Figure 2-10 Basic rectifier unit structure

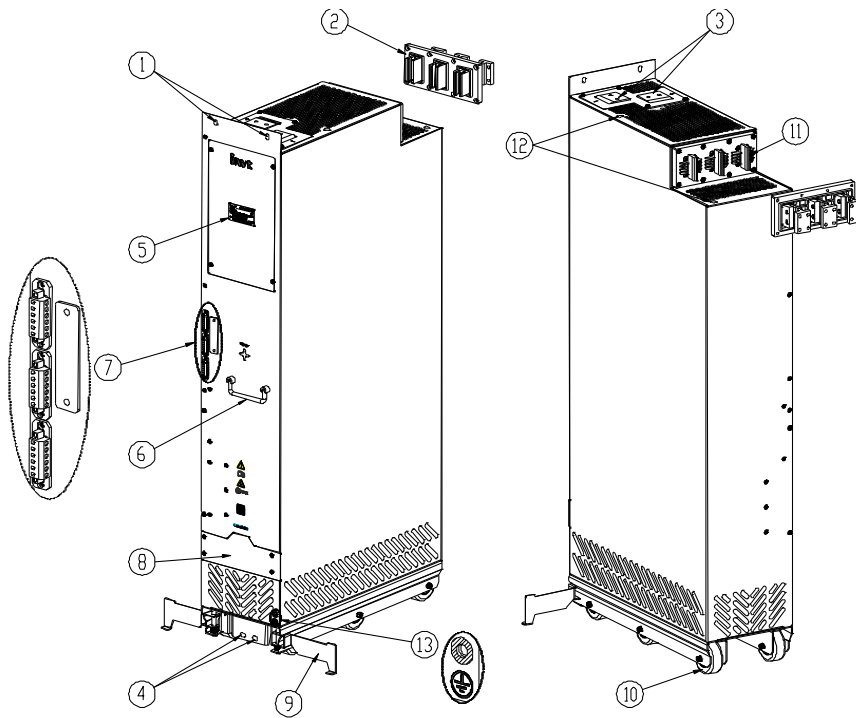

No.	Description
1	Module top fixing hole
2	Female connector, mounted and fixed to the cabinet
3	(+) and (-) bus output copper bar
4	Module bottom fixing hole
5	Warning marking
6	Handle
7	User terminals on the and control boards
8	Fan cover plate
9	Anti-tipping stand
10	Pulley
11	RST AC input terminals
12	Lifting hole
13	Module grounding point

2.7 System configuration

Figure 2-11 shows the typical topology in which the basic rectifier unit works with three inverter units.

Figure 2-11 System configuration

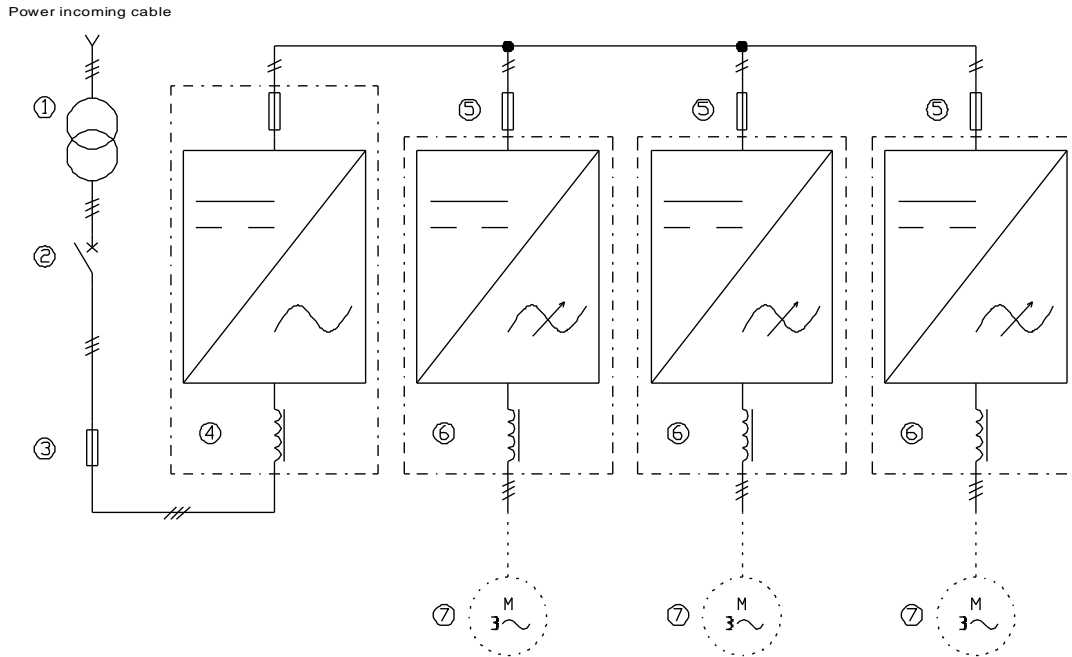

No.	Description
1	Grid transformer, secondary-side short circuit impedance $\geq 5\%$
2	Breaker
3	AC fuse
4	Basic rectifier unit
5	DC fuse
6	Inverter unit
7	Motor

2.8 Electrical model selection

2.8.1 Breaker

A breaker can effectively prevent the overload of the variable-frequency equipment and break the fault current generated by the phase-to-phase or to-ground short circuit, and at the same time it has the function of isolation so as to avoid electric shock accidents during maintenance.

Table 2-4 Breaker model selection

Power supply module	Structure	Recommended specification	Recommended breaker (ABB)	Qty
GD880-71-0718-4-01	D8T	1000V 800A	T6 S800	1
GD880-71-0980-4-01	D8T	1000V 1250A	T7 S1250M	1
GD880-71-1336-4-01	2*D8T	1000V 1600A	T7 S1600M	1
GD880-71-1822-4-01	2*D8T	1000V 2000A	E3S2000 R2000	1
GD880-71-2734-4-01	3*D8T	1000V 3200A	E3S3200 R3200	1

Power supply module	Structure	Recommended specification	Recommended breaker (ABB)	Qty
GD880-71-3645-4-01	4*D8T	1000V 4000A	E4S4000 R4000	1
GD880-71-4556-4-01	5*D8T	1000V 5000A	E6H6300 R5000	1
GD880-71-5467-4-01	6*D8T	1000V 6300A	E6H6300 R6300	1
GD880-71-0570-6-01	D8T	1000V 800A	T6 S800	1
GD880-71-0815-6-01	D8T	1000V 1000A	T7 S1000M	1
GD880-71-1061-6-01	2*D8T	1000V 1250A	T7 S1250M	1
GD880-71-1515-6-01	2*D8T	1000V 2000A	E3S3200 R2000	1
GD880-71-2273-6-01	3*D8T	1000V 2500A	E3S3200 R2500	1
GD880-71-3031-6-01	4*D8T	1000V 3200A	E3S3200 R3200	1
GD880-71-3788-6-01	5*D8T	1000V 4000A	E4S4000 R4000	1
GD880-71-4546-6-01	6*D8T	1000V 5000A	E6H6300 R5000	1

2.8.2 AC fuse

An AC fuse protects the rectifier unit and input power cable in case of short circuit, avoiding thermal overload. See the following table to select AC fuses.

Table 2-5 AC fuse model selection

Power supply module	Structure	Voltage (V)	Current (A)	Qty
GD800-71-0718-4-01	D8T	690V	1000A	3
GD800-71-0980-4-01	D8T	690V	1250A	3
GD800-71-0570-6-01	D8T	690V	1000A	3
GD800-71-0815-6-01	D8T	690V	1250A	3

2.8.3 Built-in DC fuse

A DC fuse protects the rectifier unit and DC bus in case of short circuit, avoiding thermal overload. The same brand replacement principle should be followed. See the following table for selection.

Table 2-6 DC fuse model selection





Power supply module	Structure	Voltage (V)	Current (A)	Qty
GD800-71-0653-4-01	D8T	1250V	900A	4
GD800-71-0980-4-01	D8T	1250V	900A	4
GD800-71-0570-6-01	D8T	1250V	900A	2
GD800-71-0815-6-01	D8T	1250V	900A	4





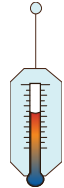

3 Mechanical installation

3.1 Safety notes

	<p>Equipment can tip over if transported incorrectly or with disallowed means of transport. Serious injury, property damage, or even death may result.</p> <ul style="list-style-type: none"> • Only trained and qualified professionals are allowed to carry out the operations mentioned in this chapter. Please carry out operations according to instructions presented in 1.4.1 Delivery and installation. Ignoring these safety precautions may lead to physical injury or death, or device damage. • Ensure the rectifier unit power has been disconnected before installation. If the rectifier unit has been powered on, disconnect the rectifier unit power and wait for at least the time specified on the rectifier unit, and ensure the POWER indicator is off. You are recommended to use a multimeter to check and ensure the rectifier unit DC bus voltage is below 36V. • The equipment installation must be designed and done according to applicable local laws and regulations. We do not assume any liability whatsoever for any equipment installation which breaches local laws or regulations. If recommendations given by us are not followed, the rectifier unit may experience problems that the warranty does not cover. • Only trained and qualified professionals are allowed to carry out related operations. • Do not perform wiring, inspection or component replacement when power supply is applied. Ensure all the input power supplies have been disconnected before wiring or inspection, and wait for at least the time designated on the Goodrive800 Pro series product or until the DC bus voltage is less than 36V.
---	--

3.2 Installation environment

Environment	Condition		
<p>Ambient temperature</p> 	<ul style="list-style-type: none"> • -10–+50°C. • When the ambient temperature exceeds 40°C, derate 1% for every increase of 1°C. • Do not use the rectifier unit when the ambient temperature exceeds 50°C. • To improve reliability, do not use the rectifier unit in the places where the temperature changes rapidly. • When the rectifier unit is used in a closed space, such as control cabinet, use a cooling fan or air conditioner for cooling, preventing the internal temperature from exceeding the temperature required. • When the temperature is too low, if you want to use the rectifier unit that has been idled for a long time, install an external heating device before the use to eliminate the freeze inside the rectifier unit. Otherwise, the rectifier unit may be damaged. 		
<p>Relative humidity (RH)</p> 	<p>RH: less than 90%</p>	 <p>Condensation is not allowed.</p>	 <p>The max. RH cannot exceed 60% in the environment with corrosive gases.</p>

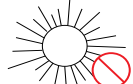
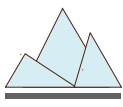
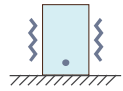
Environment	Condition			
Running environment	Install the rectifier unit in a place:			
	 Away from electromagnetic radiation sources	 Away from oil mist, corrosive gases, or combustible gases	 Without the chance for foreign objects such as metal powder, dust, oil and water to fall into the rectifier unit	 Do not install the rectifier unit onto combustible objects.
	 Without radioactive substances or combustible objects	 Without hazard gases and liquids	 With low salt content	 Without direct sunlight
Altitude		<ul style="list-style-type: none"> • Lower than 1000 meters • When the altitude exceeds 1000m, derate by 1% for every additional 100m. • When the installation site altitude exceeds 3000m, consult the local INVT dealer or office. 		
Vibration		The max. ACC speed cannot exceed 5.8m/s ² (0.6g).		

3.3 Installation procedure

The installation procedure is as follows:

- Perform unpacking inspection. For details, see 3.3.1 Unpacking inspection.
- Transport before unpacking. For details, see 3.3.2 Transportation.
- Unpack. For details, see 3.3.3 Unpacking.
- Lift the modules. For details, see 3.3.4 Lifting.
- Install the modules. For details, see 3.3.5 Installation.

3.3.1 Unpacking inspection

After receiving the product, perform the following steps to ensure the product use safety.

- Step 1 Before unpacking, check whether the product package is intact—whether the package is damaged, dampened, soaked, or deformed.
- Step 2 Check whether the nameplate and label on the product body are consistent with the model ordered.
- Step 3 After unpacking, check whether the interior surface of the packing box is abnormal, for example, in wet condition, and whether the equipment enclosure is damaged or cracked.
- Step 4 Check whether the parts (including the complete equipment of unit, keypad, and manual) inside the packing box are complete.

3.3.2 Transportation

The basic rectifier unit is shipped in a wooden box with pallets, which are heavy as a whole and must be carried with a lifting tool, such as a forklift and crane; operators must be professionally trained; the unit must be transported in strict accordance with the allowed ways marked on the box, and not allowed to be transported upside down or on the sides.

Figure 3-1 Transportation requirements

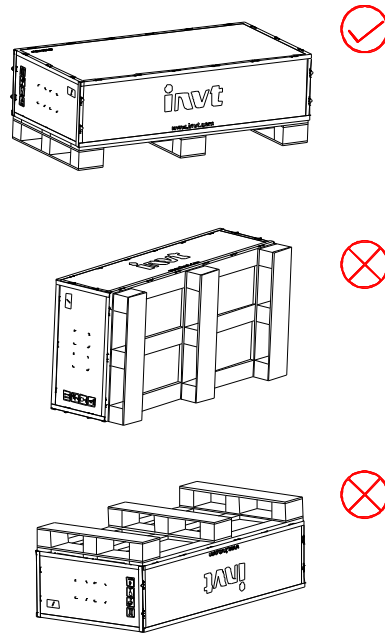

When transported with a forklift, the basic rectifier unit must be fixed to the pallets and transported together, which means you are not allowed to remove the pallets to transport the unit. If the forklift's fork tines are too short, it may cause the unit/cabinet to tip over, resulting in serious injury, property damage or even death.

When transported with a crane, the basic rectifier unit must be fixed to the pallets and lifted together.

Figure 3-2 Transportation means

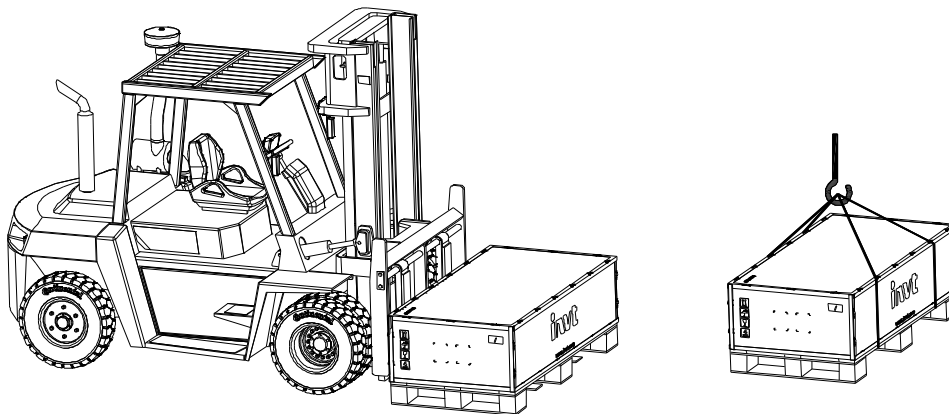

3.3.3 Unpacking

The unit is delivered in the wooden box padded with EPE.

To remove the packing, do as follows:

- Step 1 Place the well-packed unit in an empty and flat place.

- Step 2 Use tools such as a pry bar or large one-piece screwdriver to remove the wooden box cover and the steel tongue nails of the surrounding boards.
- Step 3 Remove the surrounding boards and EPE filling materials from the wooden box.
- Step 4 Cut off the plastic windings.
- Step 5 Take out of the unit.
- Step 6 Ensure that the unit is intact without any damage.

Dispose of or recycle packaging in accordance with local regulations.

Figure 3-3 Unpacking

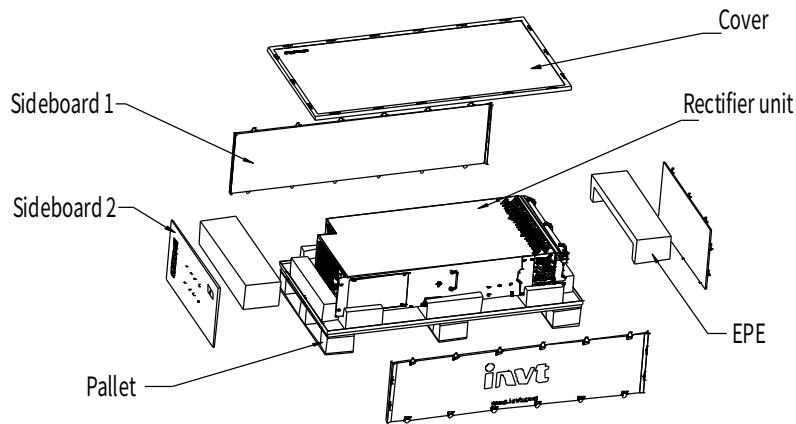

3.3.4 Lifting

Attach the required lifting ring to the locations shown in the figure, use the sling to slowly lift the unit end, move the unit until it is completely lifted, place it vertically in the empty and flat place, and then unfold the anti-tipping stand at the lower front of the unit. Figure 3-4 shows the anti-tipping stand location.

Figure 3-4 Unit lifting

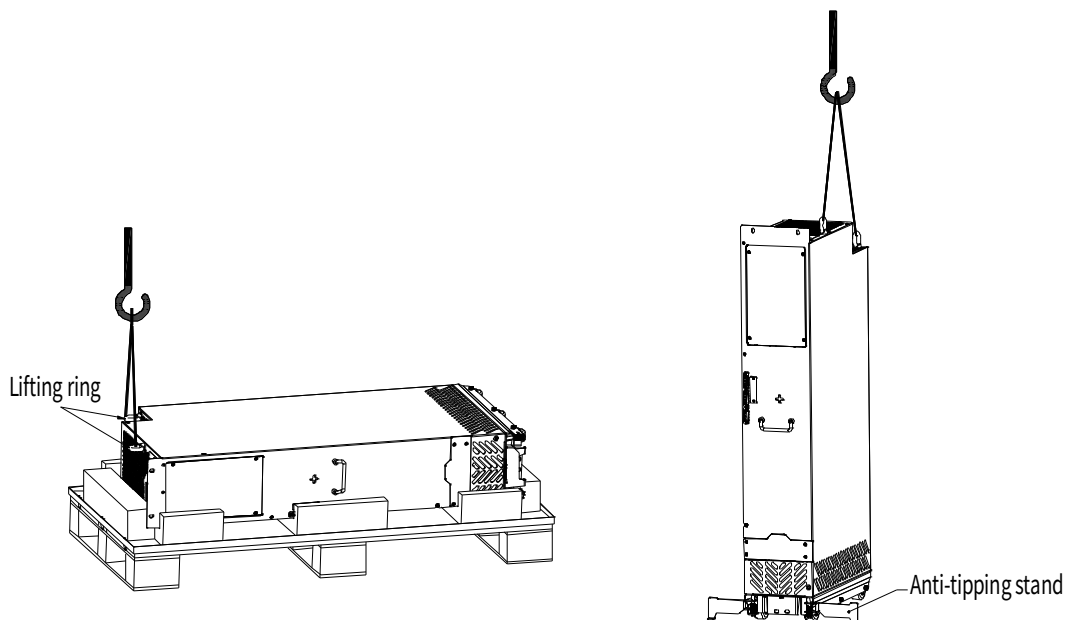

Note: Use the lifting ring on the top of unit for lifting and moving. Never apply force to the positive or negative bus terminals.

Figure 3-5 Unit top structure

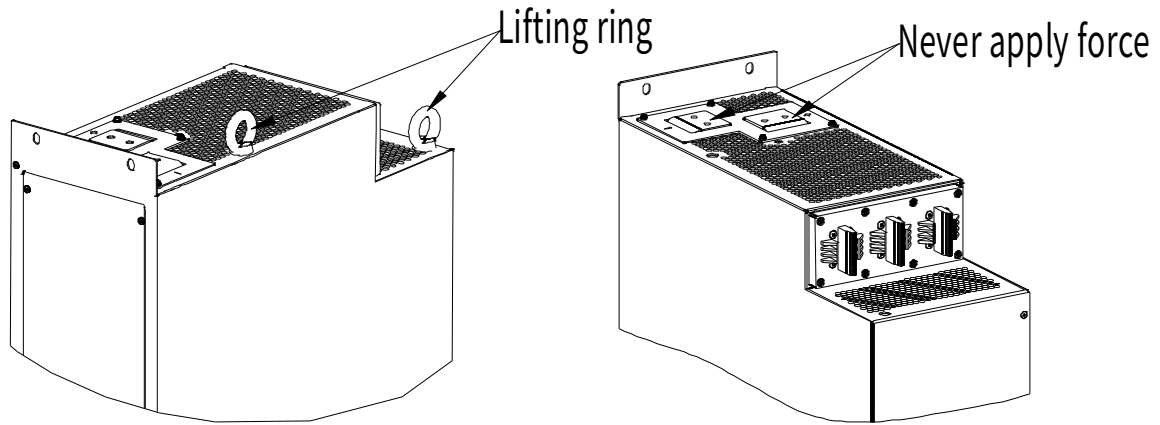

The basic rectifier unit has a high center of gravity and must be placed on a flat and solid ground with sufficient support strength and a tilt angle of less than 5°. Failure to comply with this requirement will cause the unit to tip over or topple over, which may result in serious injury or property damage.

Figure 3-6 Unit placing requirements

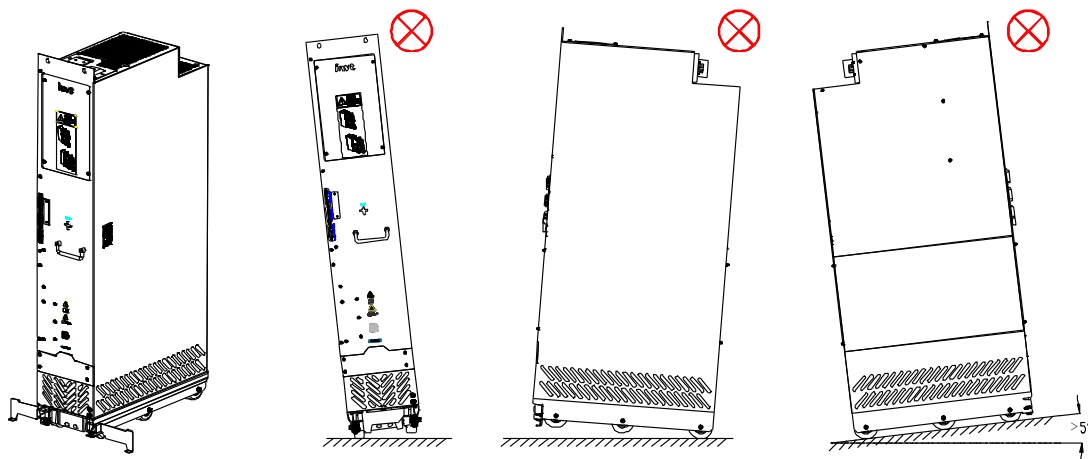

Note the following to fold or unfold the anti-tipping stand:

- To unfold the anti-tipping stand, pull down the anti-tipping stand to press the spring, wrap it around the restraining pin and rotate it 180° to snap into the slot as shown in Figure 3-8.
- To fold the anti-tipping stand, rotate the anti-tipping stand in the slot by 180° to restore the pressed spring back to its original state to clamp the anti-tipping stand, as shown in Figure 3-9.

The restraint of the pin ensures that the anti-tipping stand will not unfold due to shaking. The anti-tipping stand folds, as shown in Figure 3-7.

Figure 3-7 Unit bottom structure

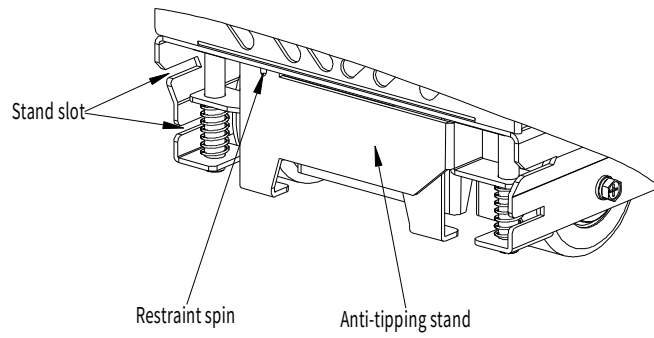

Figure 3-8 Unfolding the anti-tipping stand

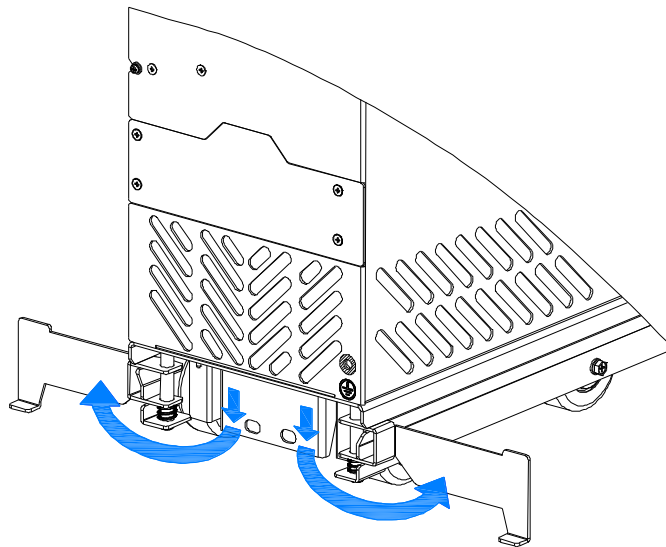
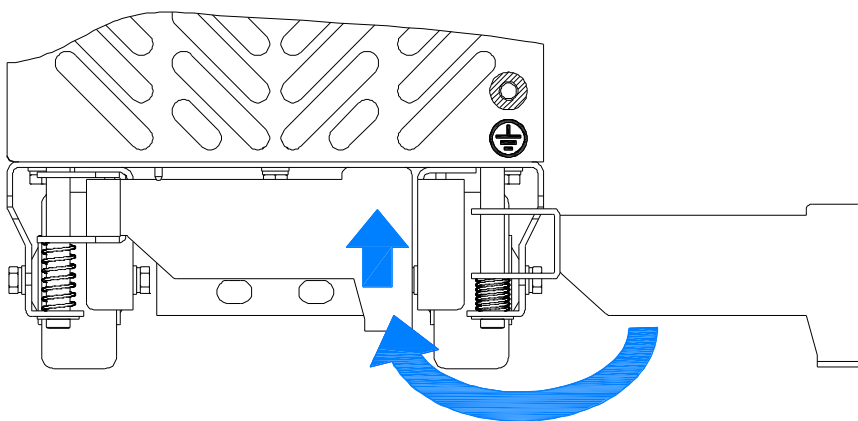

Figure 3-9 Folding the anti-tipping stand



3.3.5 Installation

3.3.5.1 Installation space and heat dissipation

To ensure that the units are installed reliably and in good heat dissipation, pay attention to the following:

- The unit must be installed and used in a cabinet.
- A minimum ventilation clearance must be kept from the top and bottom of each unit to ensure good heat dissipation. For details, see Figure 3-10.
- Both sides of each unit are designed with air baffle and sealing sponge for isolation to prevent the hot air at the unit top outlet from circulating inside the cabinet and ensure that the heat of the unit is discharged from the heat dissipation holes at the cabinet top outlet cover. See Figure 3-10.

Figure 3-10 Installation space requirements

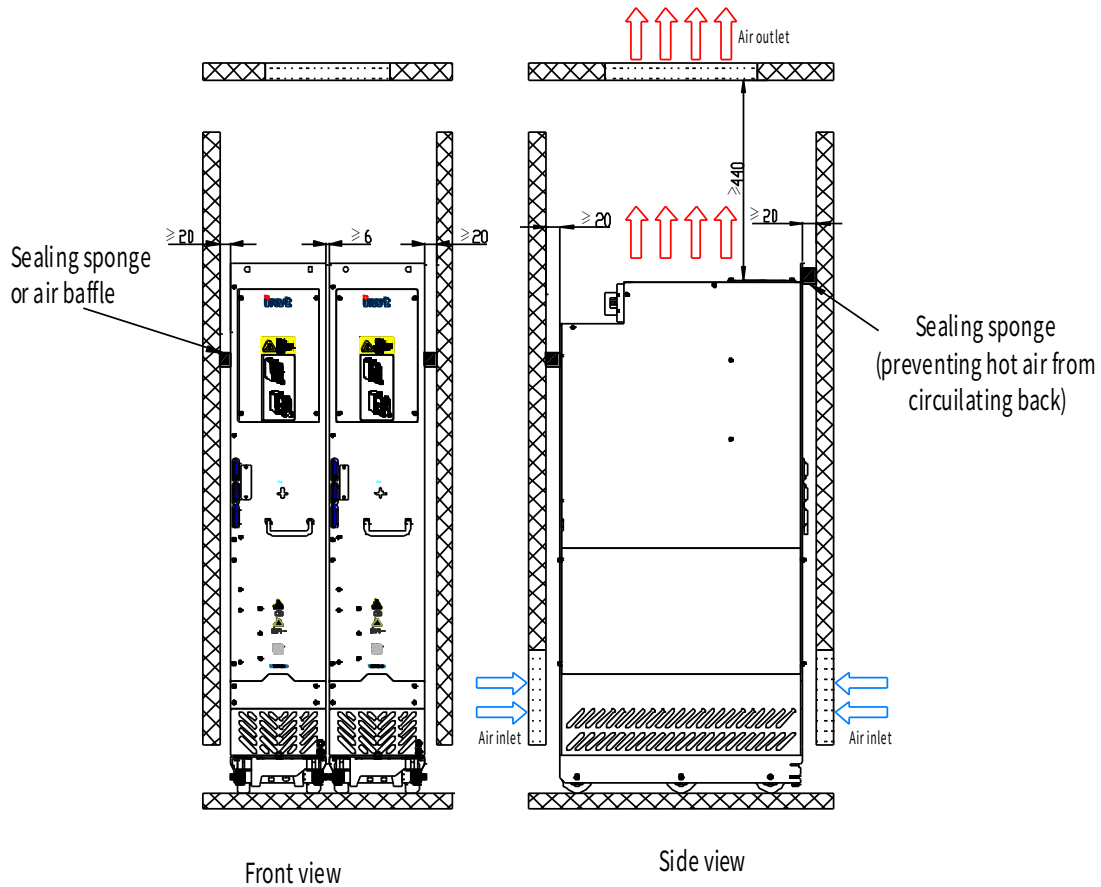

To ensure good heat dissipation of the units, design the air inlet and outlet as follows:

Air inlet area formula: $S_{in} = (1.5 \sim 2.0) \times (S_{module1} + S_{module2} + S_{module3} + \dots + S_{moduleN})$

S: System ventilation area

S_{module} : Each module ventilation area (cm²)

Air outlet area formula: $S_{out} = (1.2 \sim 1.5) \times S_{in}$

For details about the air volumes required by the units, see Table 3-1.

Table 3-1 Ventilation areas and actual air volumes of units

No.	Frame size	Ventilation area S_{in} (cm ²)	Actual air volume (CFM)
1	D8T	706	880
2	2*D8T	1412	1760
3	3*D8T	2118	2640



- Violation of the requirements in 3.3.5.1 Installation space and heat dissipation will shorten the unit life and may result in unit failure or malfunction.

3.3.5.2 Cabinet requirements

It is recommended that the cabinet adopts the nine-fold profile cabinet (PS cabinet). Before mounting the VFD, install two bottom support crossbeams, a mounting bracket, and a mounting rail in the cabinet, and design the mounting crossbeam for VFD fixing, and reserve fixing holes on the mounting crossbeam (see B.1 Installation dimensions for the specific location and size).

Fix the bottom support crossbeams and mounting bracket. See Figure 3-11.

- (1) Use eight M8 cage nuts to fix the two bottom support crossbeams to the base of the nine-fold profile cabinet frame. (For the support crossbeams, $T \geq 2.0\text{mm}$, firmly installed)
- (2) Fix the mounting bracket to the nine-fold profile cabinet frame base with six M5 self-tapping screws, as shown in the following figure.
- (3) If you use another type of cabinet but not nine-fold profile cabinet, the fixing holes for the mounting bracket need to be drilled and assembled on site.

Figure 3-11 Bottom mounting bracket diagram

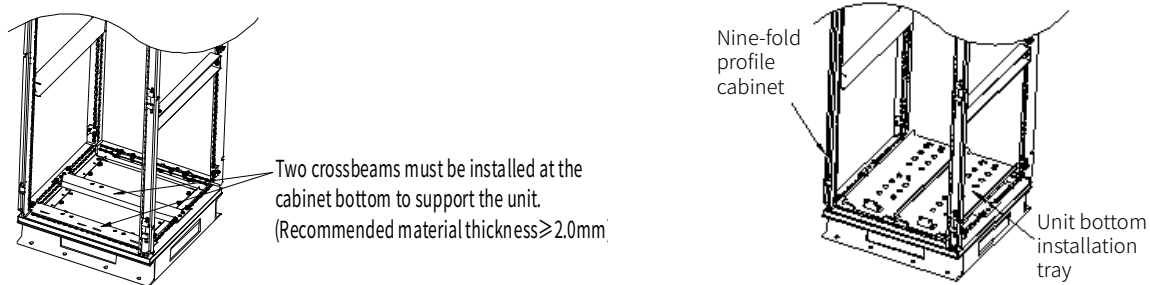

3.3.5.3 Layout and mounting for one D8T unit

Figure 3-12 shows the 400mm-wide cabinet layout for one D8T unit.

Figure 3-12 400mm-wide cabinet layout for one D8T unit

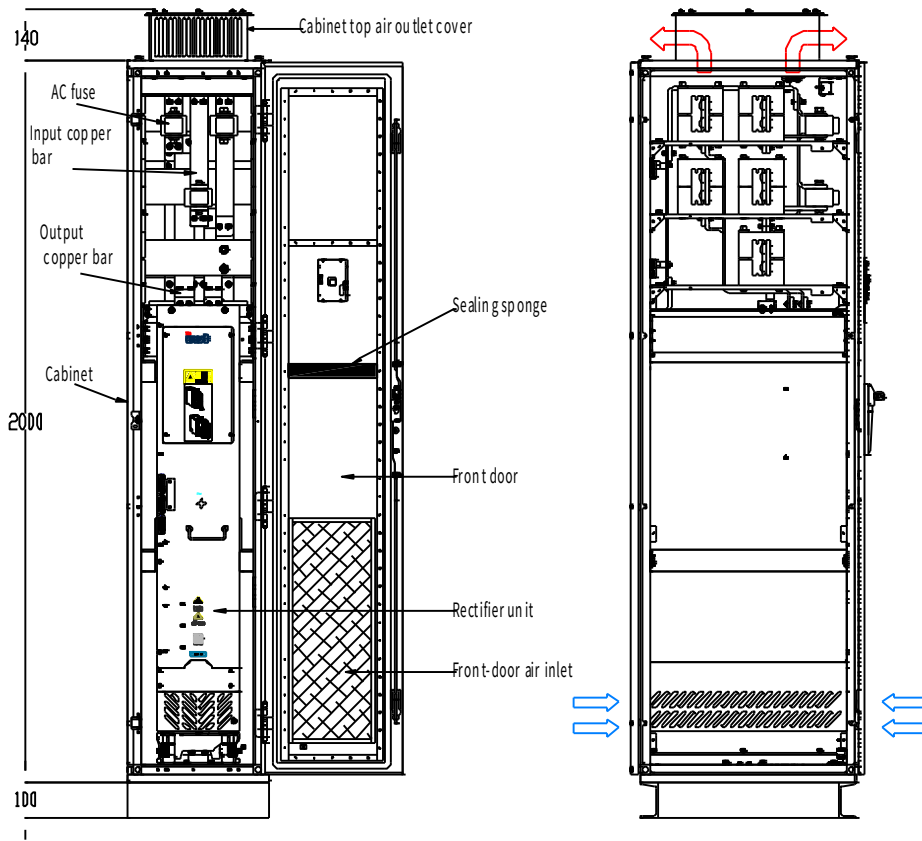
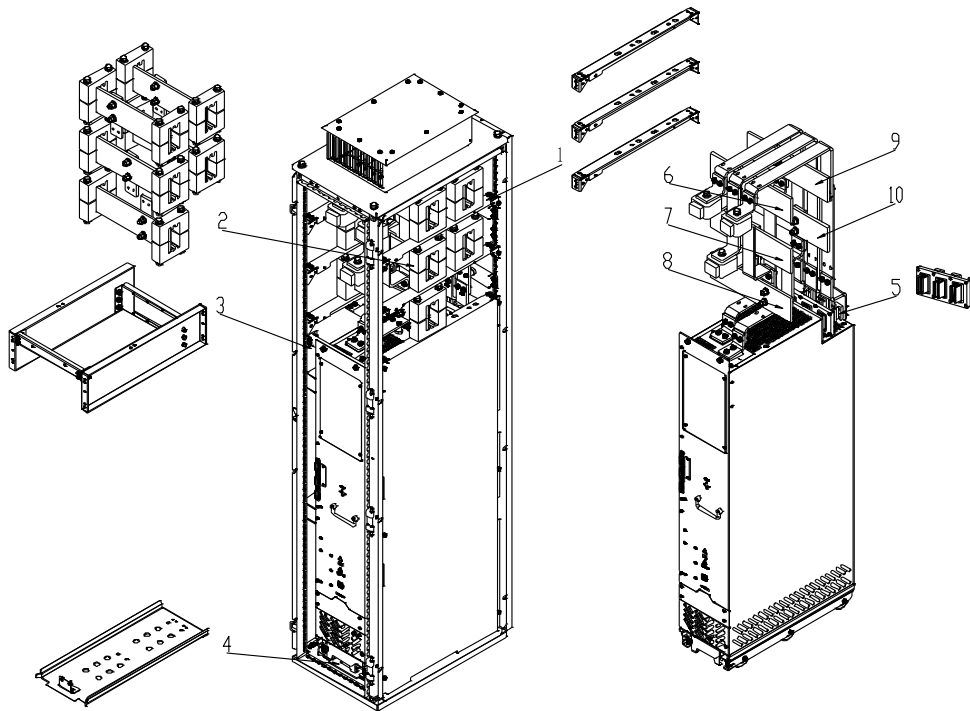

Figure 3-13 shows the installation of one D8T unit in a 400mm-wide cabinet.

Figure 3-13 Installing one D8T unit in a 400mm-wide cabinet



No.	Name
1	Busbar clamp support
2	Busbar and busbar clamp

No.	Name
3	Unit top fixed assembly (air baffle included)
4	Unit bottom fixed plate
5	Fast connector female end
6	Copper busbar of R
7	Copper busbar of S
8	Copper busbar of T
9	Copper busbar of (+)
10	Copper busbar of (-)

3.3.5.4 Layout and mounting for two D8T units

Figure 3-14 shows the installation of two D8T units in a 600mm-wide cabinet.

Figure 3-14 600mm-wide cabinet layout for two D8T units

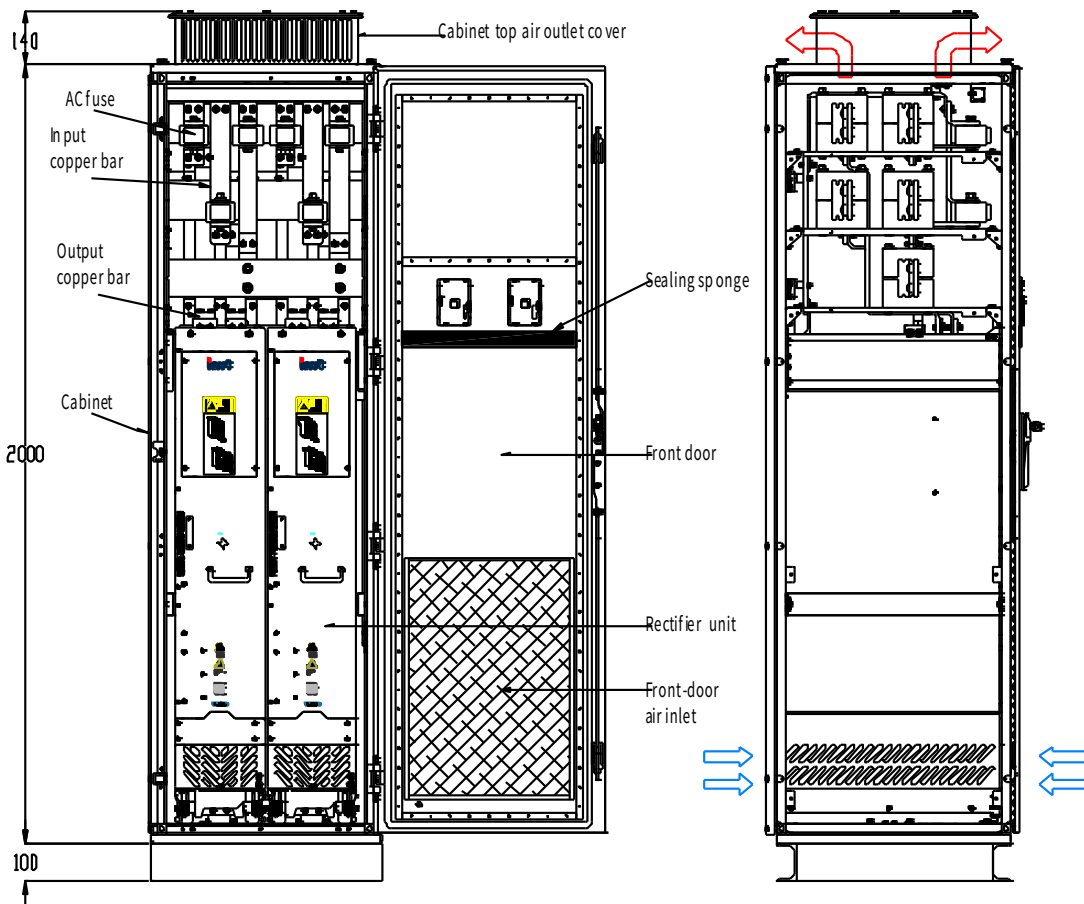
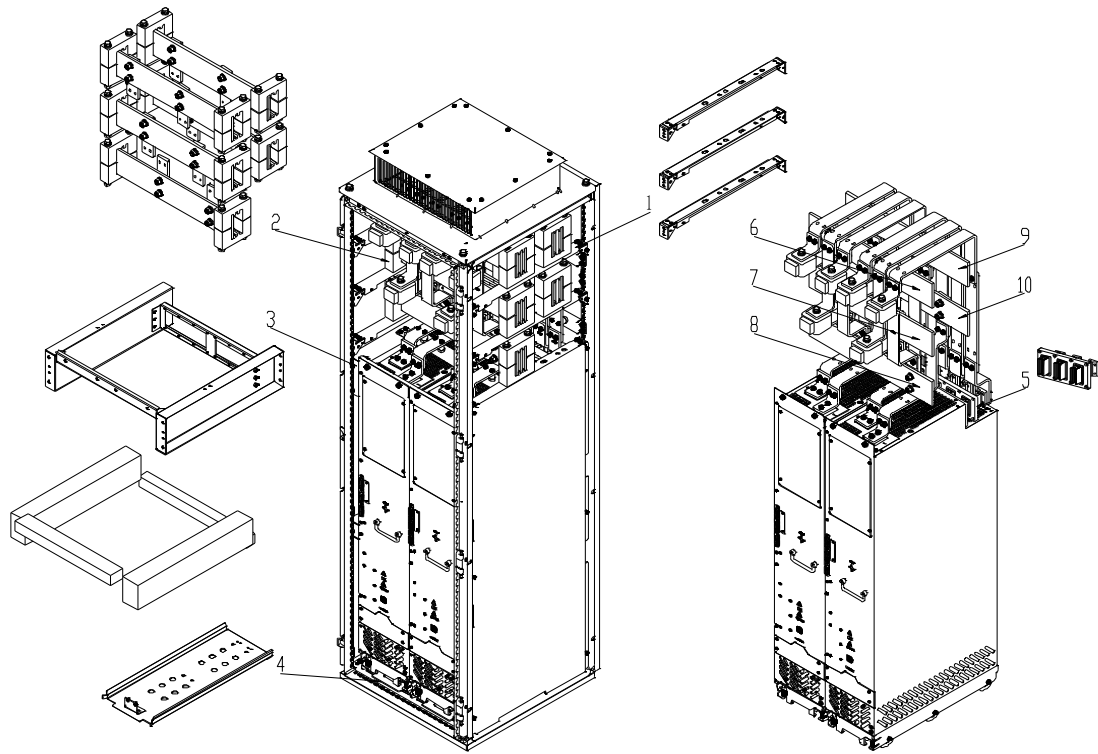

Figure 3-15 shows the installation of two D8T units in a 600mm-wide cabinet.

Figure 3-15 Installing two D8T units in a 600mm-wide cabinet



No.	Name
1	Busbar clamp support
2	Busbar and busbar clamp
3	Unit-top fixing assembly
4	Unit bottom fixed plate
5	Fast connector female end
6	Copper busbar of R
7	Copper busbar of S
8	Copper busbar of T
9	Copper busbar of (+)
10	Copper busbar of (-)

Note: A 40x40 sealing sponge must be used at the position corresponding to the air baffle in the front/back door panel, which prevents air duct reflow.

3.3.5.5 Layout and mounting for three D8T units

Figure 3-16 shows the 800mm-wide cabinet layout for three D8T units.

Figure 3-16 800mm-wide cabinet layout for three D8T units

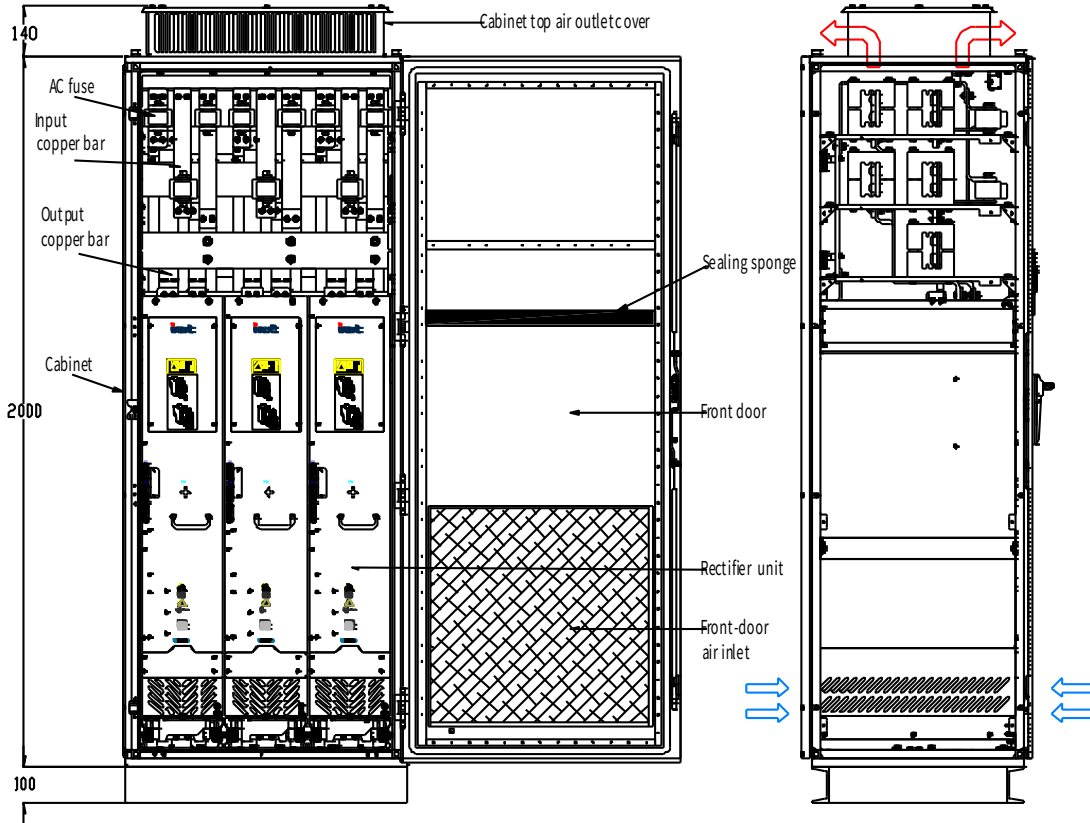
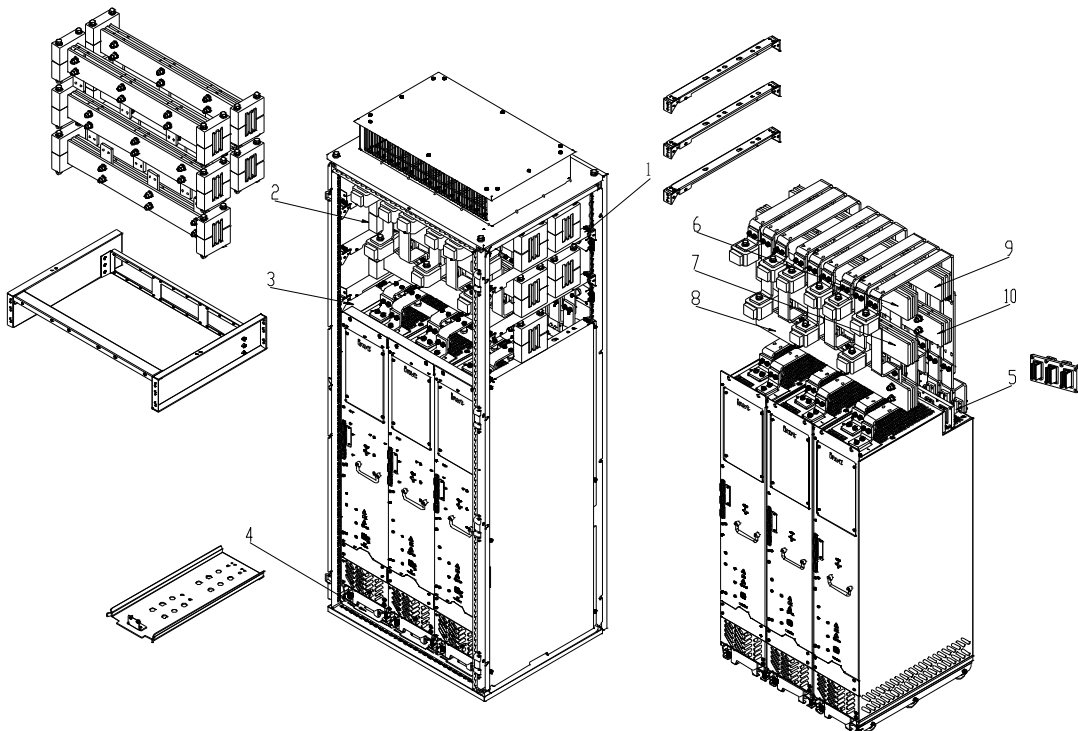

Figure 3-17 shows the installation of three D8T units in an 800mm-wide cabinet.

Figure 3-17 Installing three D8T units in an 800mm-wide cabinet



No.	Name
1	Busbar clamp support
2	Busbar and busbar clamp
3	Unit top fixed assembly (air baffle included)
4	Unit bottom fixed plate
5	Fast connector female end
6	Copper busbar of R
7	Copper busbar of S
8	Copper busbar of T
9	Copper busbar of (+)
10	Copper busbar of (-)

3.3.5.6 Unit installation and replacement

The installation procedure is as follows:

Step 1 Insert the unit entry/exit guide rail into the slot of the cabinet front bottom beam. See Figure 3-18.

Step 2 Push the unit into the cabinet.

(1) Align the unit casters to the rail. See Figure 3-19.

Figure 3-18 Unit entry/exit guide rail placement

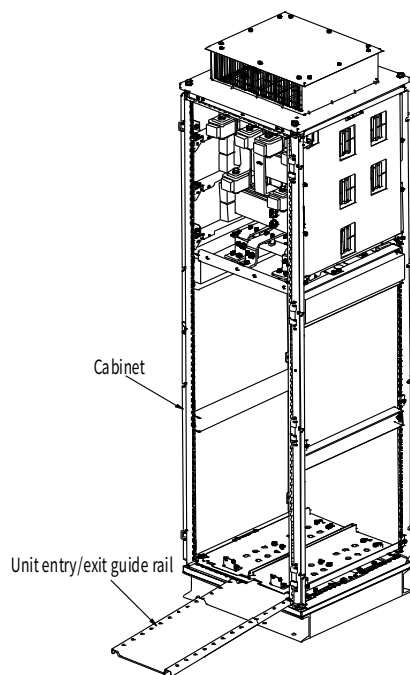
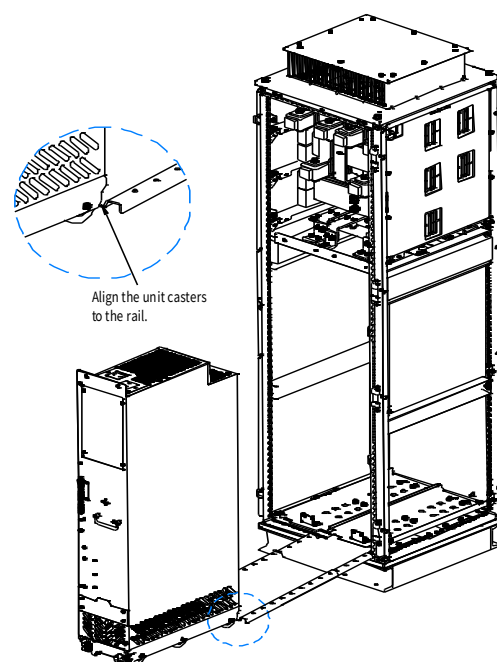

Figure 3-19 Unit placement



(2) Push the unit into the cabinet slowly. See Figure 3-20.

Note:

- Since the basic rectifier unit barycenter is too high, use the auxiliary rope for mounting to prevent the unit from rollover during the push-in or push-out.
- When pushing in/out the unit, use one foot to apply force to the bottom of the unit while holding the handle to prevent the unit from tipping over, falling over, hitting or injury. See Figure 3-20.
- When installing or replacing the unit, wear gloves and safety shoes to prevent against scratching or smashing.

Figure 3-20 Pushing the basic rectifier unit into the cabinet

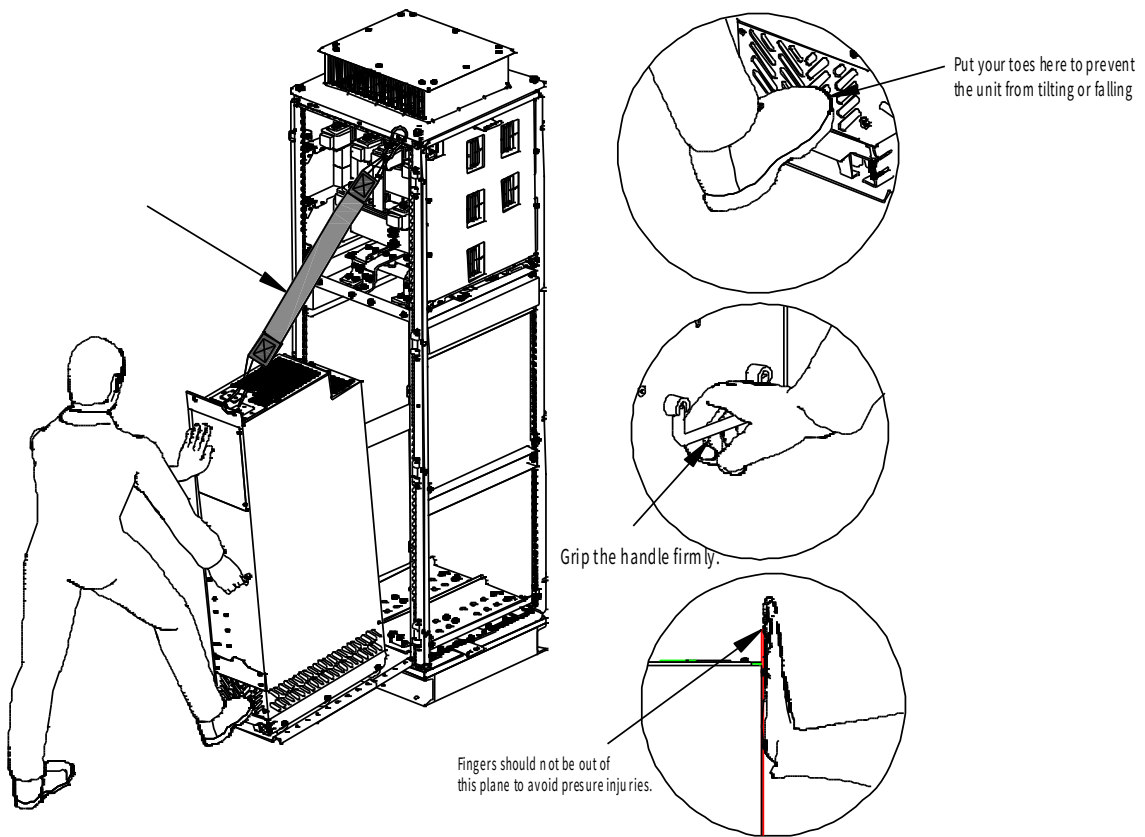

(3) Ensure that the unit is pushed into place. See Figure 3-21.

Figure 3-21 Checking whether the unit is pushed into place

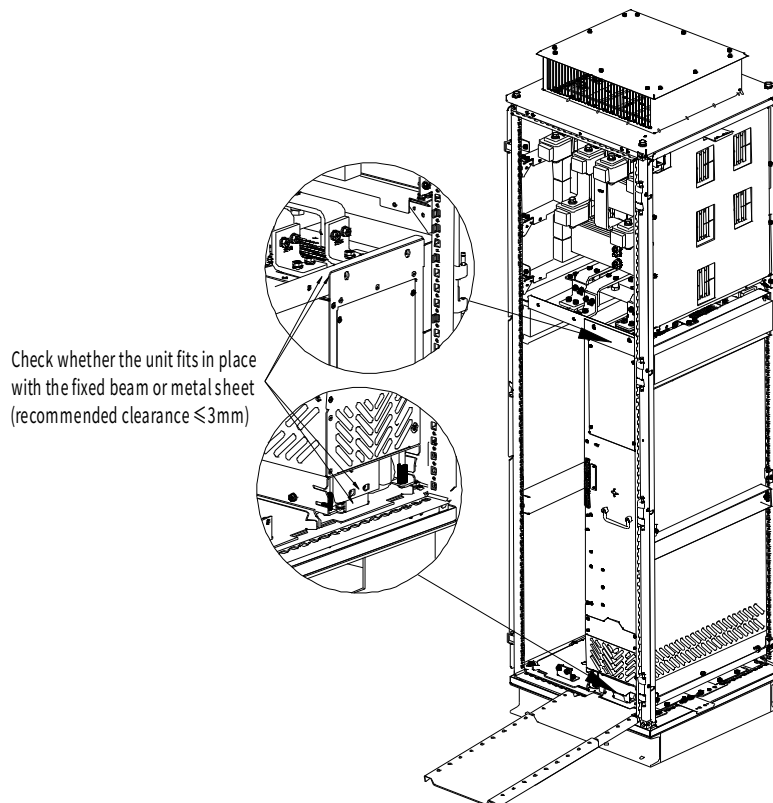

(4) After confirming that the unit is pushed into place, install the unit fixing screws and remove the unit entry/exit guide rail.

Figure 3-22 Unit fixing

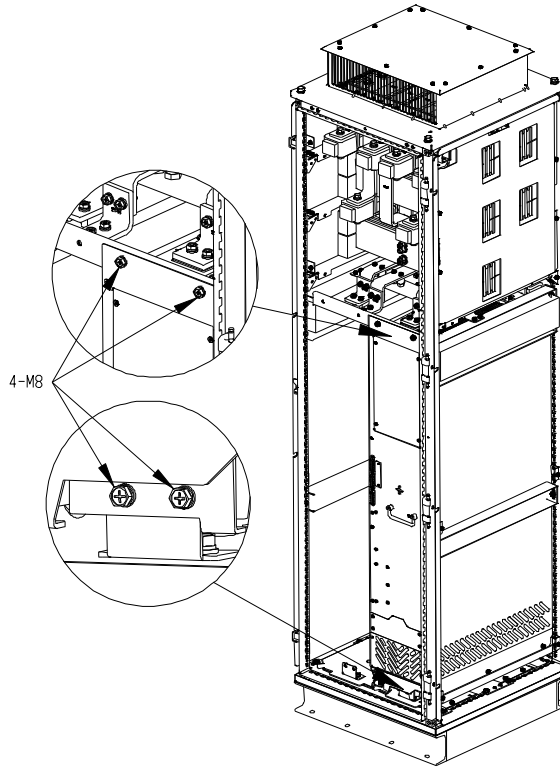

3.3.5.7 Keypad installation

The basic rectifier unit is equipped with an externally installed keypad (as shown in Figure 3-23), which is used with a keypad bracket that can be fixed to the cabinet door or external support sheet metal, and the keypad bracket mounting structure is shown in Figure 3-24.

Figure 3-23 LED keypad structure

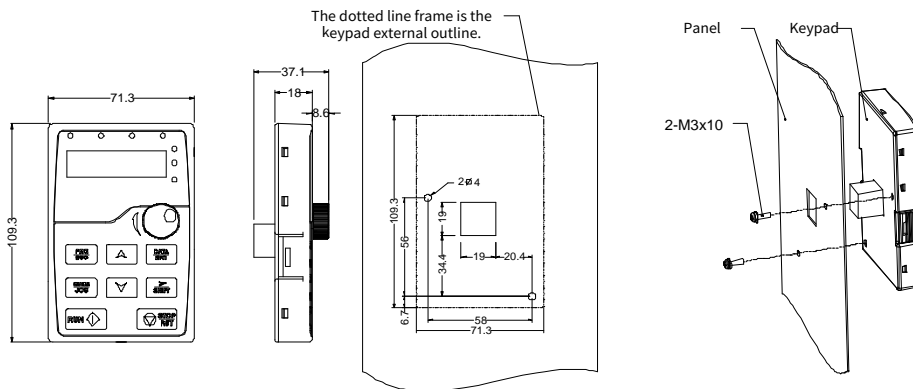

Dimensions of installing the keypad without a bracket

Figure 3-24 Installing the keypad bracket

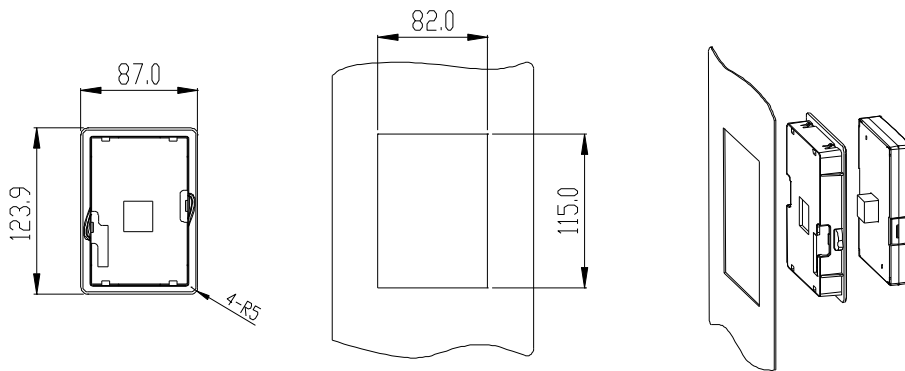

3.3.6 Fastening torque

You need the following tools to install the basic rectifier unit:

- Standard toolbox, including screwdrivers, nut wrenches, socket wrenches.
- Torque wrenches with torques from 1.5 N · m to 100 N · m.
- Socket wrench extension bars, 400 mm long.

The unit installation involves conductive components (AC input connectors, DC bus connectors, and cable terminals) and other component connections (grounding terminals, protective ground terminals, and fixing screws), and the screw tightening torques must meet the requirements in the following table.

Table 3-2 Recommended values of screw thread tightening torque

Screw/Bolt	Strength grade	Recommended torque (N · m)
M4	4.8	1.5
M5	5.8	3
M6	5.8	5
M8	5.8	11
M10	4.8	22
M12	4.8	39

3.3.7 Checklist

No.	Operation	Completion	Compliant
1	Installed the beam for unit fixing in the nine-fold profile cabinet.	<input type="checkbox"/>	<input type="checkbox"/>
2	Installed the bottom tray for unit fixing in the nine-fold profile cabinet.	<input type="checkbox"/>	<input type="checkbox"/>
3	Installed the copper bars of the unit in the cabinet.	<input type="checkbox"/>	<input type="checkbox"/>
4	Assembled the installation guide rail (optional part) and installed it in the cabinet.	<input type="checkbox"/>	<input type="checkbox"/>
5	In the cooperation of two people, aligned the unit casters with the installation guide rail and pushed the unit to the cabinet. (See Figure 3-18 and 3-19. The auxiliary rope for installation has been used to prevent the unit from side tipping during the push-in or push-out.)	<input type="checkbox"/>	<input type="checkbox"/>
6	Removed the auxiliary rope for mounting, and ensured	<input type="checkbox"/>	<input type="checkbox"/>

No.	Operation	Completion	Compliant
	that the unit was pushed into place.		
7	Inserted screws into the fixing holes at the unit front top and bottom to fix the unit to the cabinet. (See Figure 3-22.)	<input type="checkbox"/>	<input type="checkbox"/>
8	Installed the (+) and (-) bus copper bars.	<input type="checkbox"/>	<input type="checkbox"/>
9	Remove the mounting rail when you ensure the mounting is secure.	<input type="checkbox"/>	<input type="checkbox"/>
10	Checked the screw tightening state.	<input type="checkbox"/>	<input type="checkbox"/>

4 Electrical installation

4.1 Safety notes

	<ul style="list-style-type: none"> • All safety precautions in this manual must be read and followed. Only trained and qualified professionals are allowed to carry out the operations mentioned in this chapter. • All work on electrical equipment must comply with the following: <ul style="list-style-type: none"> ♦ The power is off. ♦ Re-power on must not occur. ♦ Wait for at least the time designated on the unit, and ensure the voltage between (+) and (-) is lower than 36V through measurement. ♦ The equipment is well grounded. ♦ Live parts have been shielded or isolated. • All installation work can be performed only in power-off (no voltage) state since high voltage is present in the unit internal during the running. • Do not perform wiring, inspection or component replacement when power supply is applied. Before wiring or inspection, ensure all the input power supplies have been disconnected, and wait for at least 15 minutes or until the DC bus voltage is lower than 36V. • If the auxiliary control power of the unit is supplied externally, disconnecting the circuit break device cannot disconnect the entire power supply. The unit control system may be live even if not started. Please refer to the electrical schematic diagram for inspection to avoid personal injury caused by contacting the live part of the unit. • If the safety device on a current branch trips, check the unit for the fault cause, rectify the fault, and replace the damaged parts.
---	---

4.2 Insulation inspection

Basic rectifier unit

Before delivery, each unit has been tested for insulation of the main circuit to the housing. Moreover, there is voltage limiting circuit inside the unit, and the circuit will automatically cut off the test voltage of the withstand voltage test. Do not carry out insulation withstand test on the unit, or measure the control circuit of the unit with a megohmmeter.

Input power cable

Check the insulation conditions of the input power cable of the unit according to the local regulations before connecting it.

Motor and motor cable

Check the motor and motor cable insulation status as follows:

- Step 1 Ensure that the motor cable has been connected to the motor.
- Step 2 Remove the motor cable from the U, V, and W output terminals of the unit.
- Step 3 Measure the insulation resistance between the motor cable and each phase of the motor and the protective ground with a 1kV DC megohmmeter.
Insulation resistance must be greater than 1M Ohm.

4.3 EMC regulations

General knowledge of electromagnetic compatibility

EMC is short for electromagnetic compatibility, which refers to the ability of a device or system to function properly in its electromagnetic environment and not constitute an unbearable electromagnetic disturbance to anything in that environment. EMC includes two aspects: electromagnetic interference and electromagnetic immunity.

Electromagnetic interference can be divided into two categories according to the transmission paths: conducted interference and radiation interference.

Conducted interference propagates along any conductor. Therefore, any conductor, such as wire, transmission line, inductor, and capacitor, is a transmission channel for conducted interference.

Radiated interference is in the form of electromagnetic waves that propagate with energy that is inversely proportional to the square of the distance.

Electromagnetic interference must have three conditions or three elements at the same time: interference source, transmission channel, and sensitive receiver, each of which is indispensable. The solution of EMC problem mainly focuses the three elements. For users, the solution of EMC problem is mainly in transmission channels because the equipment as interference source or receiver cannot be changed.

Different electric and electronic devices have different EMC capacities because of adopting different EMC standards or classes.

General EMC guidelines on variable-frequency regulation system wiring

The following introduces general EMC guidelines on VFDs in several aspects including noise control, site wiring and grounding for reference in site installation, with consideration of ECM characteristics of VFDs where the input current and output voltage harmonics are relatively small but the voltage is high and the current is large.

1. Noise control

All the connections to the VFD control terminals must use shielded wires. The shield layer of wire must be grounded near the VFD entrance. The ground mode is 360-degree loop connection formed by cable clips. It is not allowed to connect the twisted shield layer to the ground of the VFD, which greatly decreases or loses the shield effect.

2. Site wiring

Power supply wiring: The shield layer of power supply incoming cables of the VFD shall be grounded reliably. It is not allowed to route the power cables and control cables in parallel.

Device categorization: There are different electric devices in the same distribution system, which have different ability of emitting and withstanding electromagnetic noise. Therefore, it needs to categorize these devices into strong noise device and noise sensitive device. The same kind of devices needs to be placed in the same area, and the distance between devices in different categories needs to be more than 20cm.

Wiring in the control cabinet: During wiring, signal cables and power cables need to be arranged in different areas. It is not allowed to arrange them in parallel or in interlaced state at a close distance (less than 20cm) or tie them together. If the signal cables have to cross the power cables, they need to be arranged in 90 degree angle.

3. Grounding

The VFD must be grounded safely and reliably in operation. Grounding has the priority in all EMC methods because it does not only ensure the safety of equipment and persons, but also it is the simplest, most effective and lowest-cost solution for EMC problems.

Three categories of grounding: special pole grounding, common pole grounding and series-wound grounding. Different control system needs to use special pole grounding, different devices in the same

control system needs to use common pole grounding, and different devices connected by the same power cables needs to use series-wound grounding.

This section introduces general EMC guidelines on VFDs in several aspects including noise control, site wiring and grounding for reference in site installation.

4.3.1 Power cable

To meet the EMC requirements stipulated in the CE standards, you must use symmetrical shielded cables as motor cables.

Four-core cables can be used as input cables, but symmetrical shielded cables are recommended. Compared with four-core cables, symmetrical shielded cables can reduce electromagnetic radiation as well as the current and loss of the motor cables.

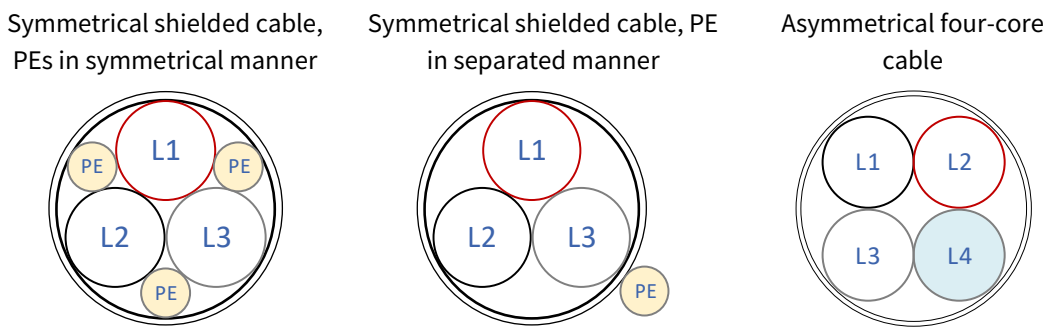

Power cables must meet the following requirements:

- The sizes of the input power cables and motor cables must comply with local regulations.
- The input power cables and motor cables must be able to carry the corresponding load currents.
- The maximum temperature margin of the motor cables in continuous operation cannot be lower than 70°C.
- PE grounding conductor conductivity must be as good as possible to reduce the grounding resistance to achieve better impedance continuity. If the electrical conductivity of the motor cable shield layer does not meet the requirements, a separate PE conductor must be used.

To effectively restrict the emission and conduction of radio frequency (RF) interference, the conductivity of the shielded cable must at least be 1/10 of the conductivity of the phase conductor. This requirement can be well met by a copper or aluminum shield layer. The following figure shows the minimum requirement on motor cables of a rectifier. The cable must consist of a layer of spiral-shaped copper strips. The denser the shield layer is, the more effectively the electromagnetic interference is restricted.

Figure 4-1 Cable cross section

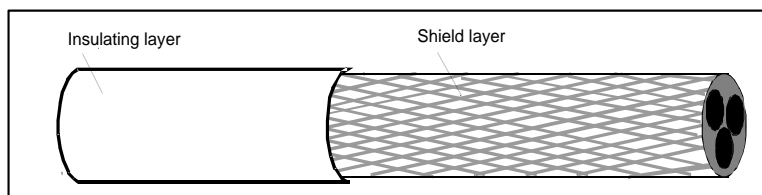

Note: Check the insulation conditions of the input power cable of a rectifier according to the local regulations before connecting it.

4.3.2 Control cable

All analog signal cables, communication cables, and encoder cables must be shielded cables.

Analog signal cables need to be double-shielded twisted-pair cables (as shown in figure a). Use one separate

shielded twisted pair for each signal. Do not use the same ground wire for different analog signals.

Communication cables and encoder cables need to be single-shielded twisted-pair cables (as shown in figure b). The shield layer of cable is connected to the system PE by means of a 360-degree connection or twisting into a single bundle, and the exposed shield layer is wrapped with insulating tape to prevent interference introduced by the shield layer in contact with other equipment and structural components.

The keypad needs to be connected by using a network cable. In complicated electromagnetic environments, a shielded network cable is recommended.

Figure 4-2 Control cable

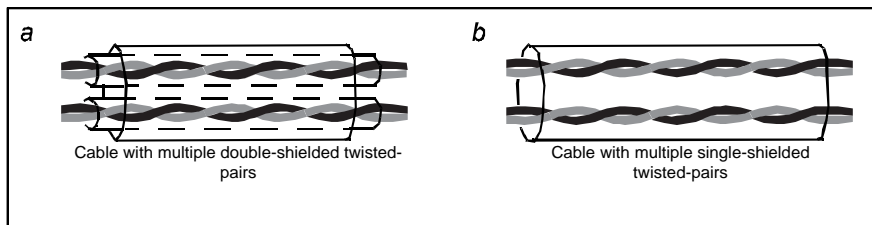

Note: Analog signals and digital signals cannot share a same cable, and their cables must be routed separately.

4.3.3 Wiring suggestions

Motor cables and input cables in a drive system are interference cables, while communication cables, encoder cables, analog signals, and high-speed signal cables are sensitive cables. It is recommended that you arrange the motor cables, input power cables, and control cables separately in different trays, reducing electromagnetic interference caused by the du/dt of the rectifier output to other cables. The general cable arrangement rules are shown in Figure 4-3. The recommended values for the spacing between sensitive and interference cables are shown in the following table.

Figure 4-3 General cable arrangement rules

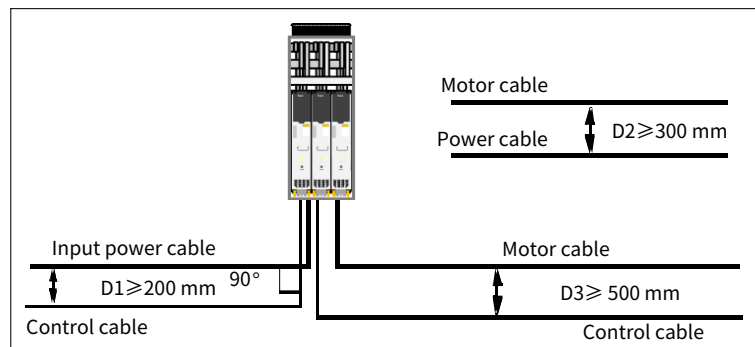

Table 4-1 Recommended values for the spacing between sensitive and interference cables

D1	D2	D3
≥200mm	≥300mm	≥500mm

Note:

- The motor cables of different VFDs/inverters can be arranged in parallel, but motor cables must be arranged far away from sensitive cables.
- Analog signals and digital signals cannot share a same cable, and their cables must be routed separately.
- If a control cable and power cable must cross each other, ensure that the angle between them is 90 degrees.

Figure 4-4 Routing sensitive and interference cables

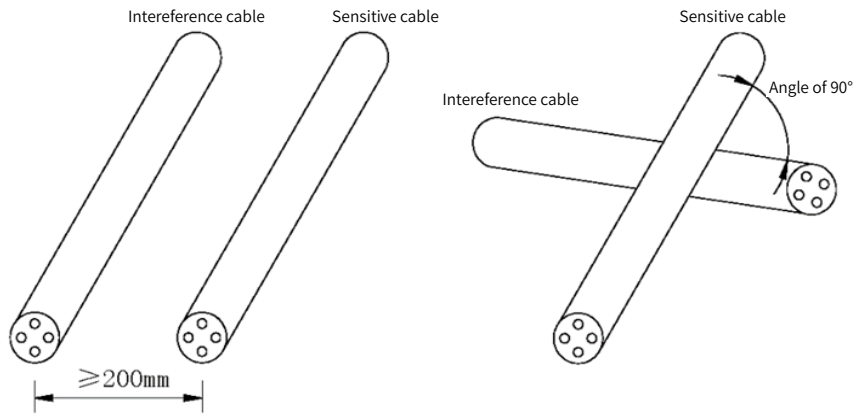

The cable trays must be connected properly and well grounded. Aluminum trays can implement local equipotential.

For inputs of such as relay signals and other non-differential signals, non-twisted pair cables can be used, and the wiring should minimize the loop area and a pair of signal lines should be routed as close as possible.

Figure 4-5 Non-differential signal wiring loop

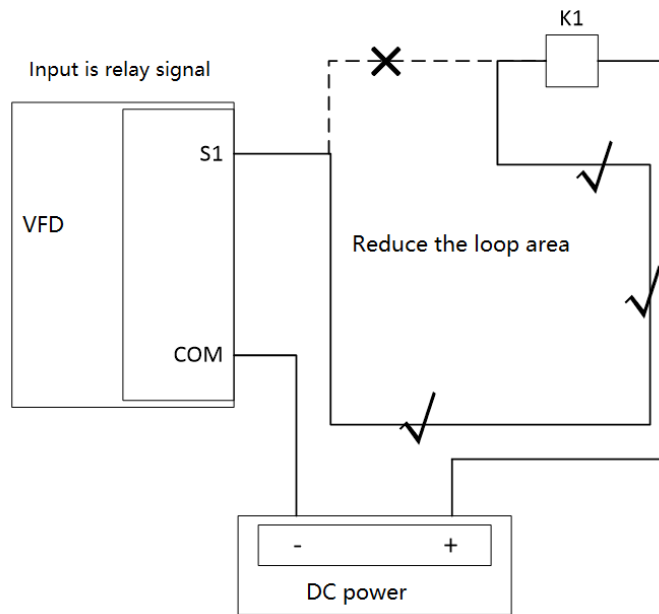

When laying multiple types of cables, the cables should always be routed along the alignment grooves or metal pipes in equipotential connection, with different types of cables separated as much as possible. You can better improve electromagnetic compatibility by using metal spacers to isolate different types of cables in the same metal groove or metal pipe.

Figure 4-6 Routing multiple types of cable

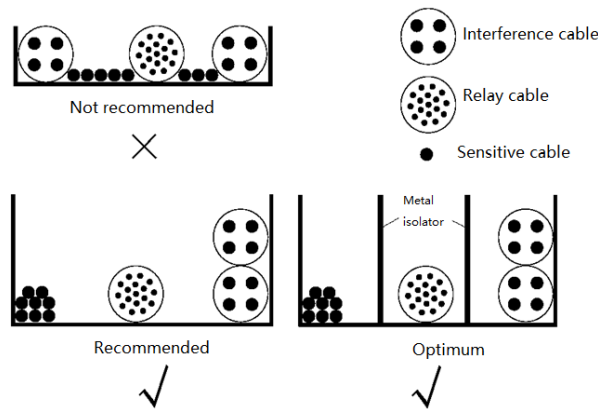

4.3.4 Shielded cable connection

The shield layer of signal cable is grounded at both ends, of which the grounding points must be the same. That is, if the shield layer at the upper computer side is connected to PE, the shield layer at the drive side is also connected to PE; if the shield layer at the upper computer side is connected to GND, the shield layer at the drive side is also connected to GND. It is recommended to connect the both ends of the shield layer to PE, which is the housing.

The unshielded part of the control cable that is shielded should be as short as possible, and the shield layer is connected to the nearest PE end. If the cable is stripped too long, the core is susceptible to interference of signals, especially analog, communication, and encoder signals.

Figure 4-7 Control cable shield connection

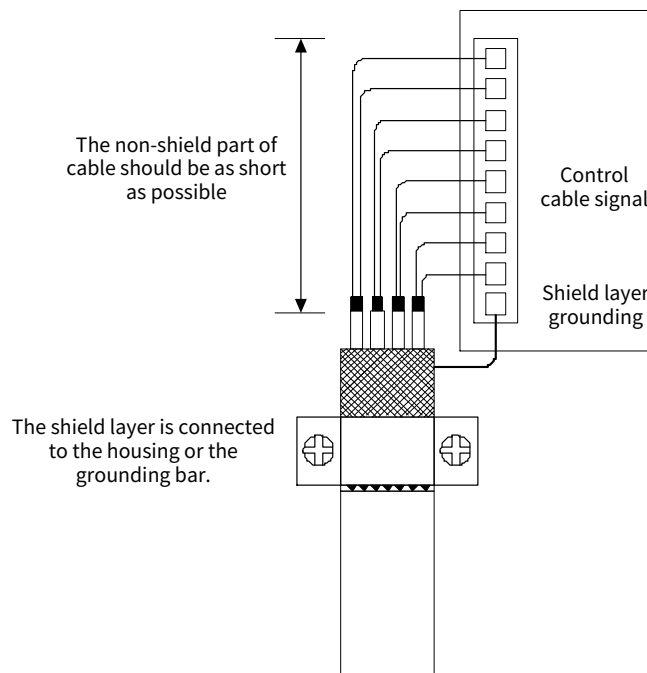

The shield layers of the input power and output motor cables should have large contact with the shield board inside the installation cabinet to achieve good EMC shield effect. The specific installation and fixing method can be referred to the following diagram.

Figure 4-8 Power cable shield connection

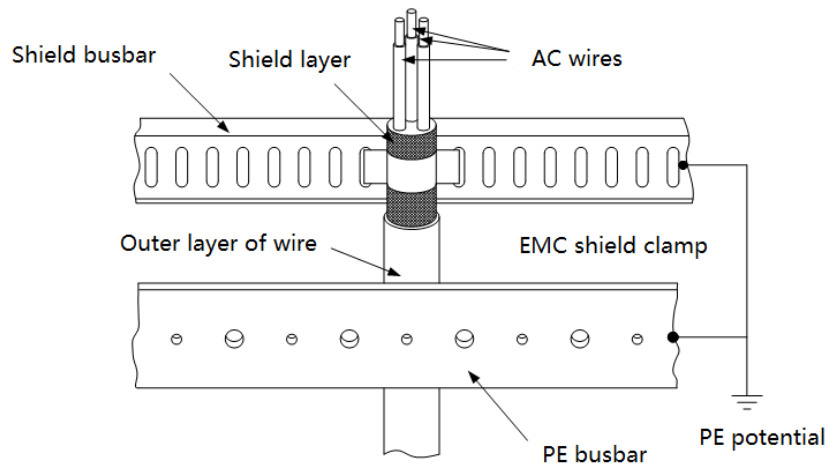

4.4 Electrical wiring

4.4.1 Wiring procedure

Step 1 Connect the ground wire of the input power cable to the grounding terminal (PE) of the rectifier unit, connect the three-phase input cable to the R, S and T terminals and tighten up.

Step 2 Connect signal cables to target positions based on requirements.

Step 3 Check whether the connection is correct and reliable.

4.4.2 Isolated grid (IT grid) application

When running the basic rectifier unit on an isolated grid (IT grid), the two screws on the varistor board should be removed, as shown in Figure 4-9.

Figure 4-9 Basic rectifier unit wiring

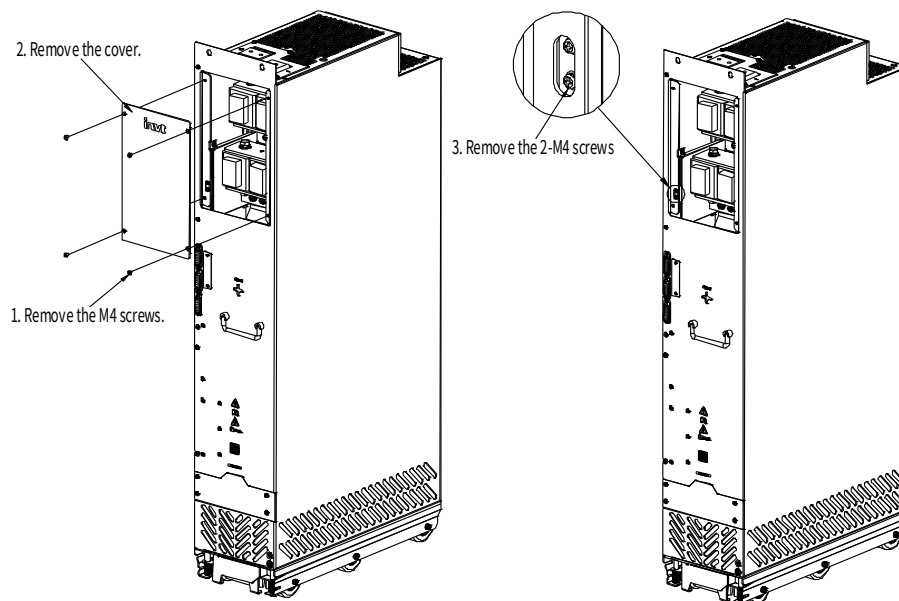

4.4.3 Main circuit wiring

4.4.3.1 Main circuit wiring diagrams

Figure 4-10 Basic rectifier unit wiring

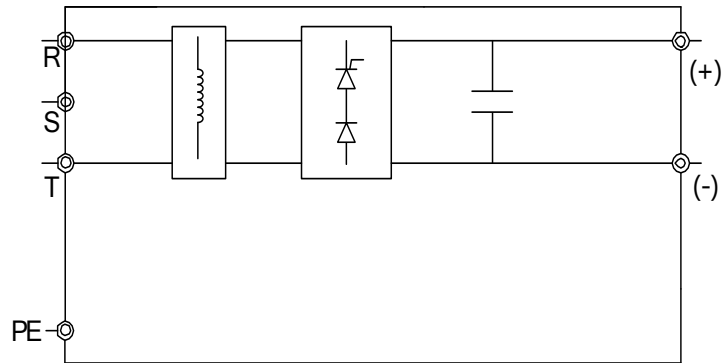

4.4.3.2 Main circuit wiring terminals

Figure 4-11 Structural position description

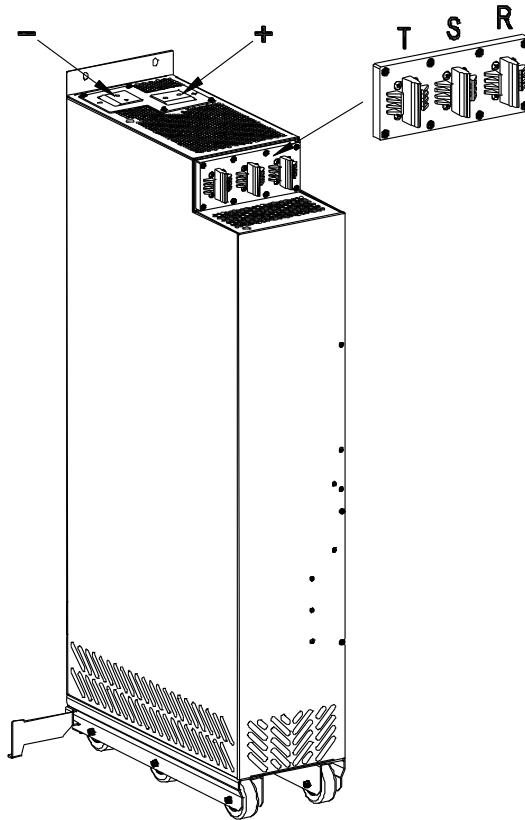

4.4.3.3 Screw tightening

Figure 4-12 Screw installation requirements

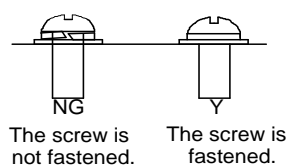

4.4.4 Control circuit wiring

4.4.4.1 Control circuit wiring

Figure 4-13 Control circuit wiring

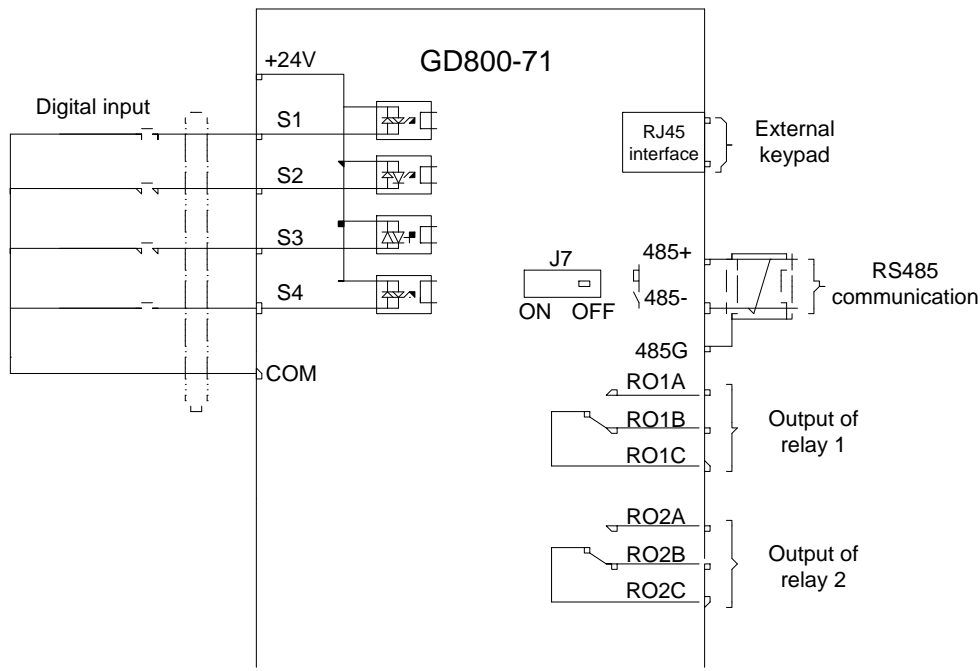

4.4.4.2 Control circuit terminals

Figure 4-14 Control circuit terminals

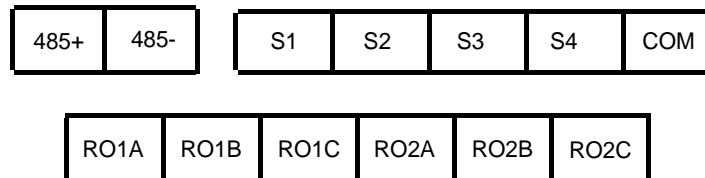

Category	Terminal	Name	Description
Digital input	S1	Digital input 1	1. Input impedance: 3.3kΩ 2. Voltage input range: 12–30V 3. Supporting bidirectional input of NPN and PNP
	S2	Digital input 2	
	S3	Digital input 3	
	S4	Digital input 4	
	COM	Digital common terminal	
Relay output	RO1A	NO contact of relay 1	1. Contact capacity: AC250V/3A, DC30V/1A 2. Cannot be used as high frequency digital output
	RO1B	NC contact of relay 1	
	RO1C	Common contact of relay 1	
	RO2A	NO contact of relay 2	
	RO2B	NC contact of relay 2	
	RO2C	Common contact of relay 2	
Communication	485+	RS485 communication	RS485 communication terminals, using the Modbus protocol You can choose whether to connect the 120Ω terminal resistor through J7.
	485-		

4.4.5 Electrical installation checklist

No.	Operation	Completion	Compliant
1	Checked the input and output power wiring and ensured the wiring positions and voltages were correct.	<input type="checkbox"/>	<input type="checkbox"/>
2	Ensured that the input and output power wiring was correct and fastened.	<input type="checkbox"/>	<input type="checkbox"/>
3	Ensured that the input and output power cable carrying capacity selection was correct.	<input type="checkbox"/>	<input type="checkbox"/>
4	Ensured that routing the input and output power cables that were shielded complied with EMC regulations.	<input type="checkbox"/>	<input type="checkbox"/>
5	Checked the external auxiliary power wiring and ensured the wiring positions and voltages are correct.	<input type="checkbox"/>	<input type="checkbox"/>
6	Routed the control power cables and power cables separately, complying with EMC regulations.	<input type="checkbox"/>	<input type="checkbox"/>

5 Maintenance and inspection

5.1 Periodical inspection

5.1.1 Overview

Only trained and qualified professionals are allowed to maintain the equipment.

Before operating the interior of the equipment:

- Disconnect the power to the equipment (note that no switch/breaker installed in the cabinet can disconnect the power to the equipment).
- Wait 15 minutes for the DC circuit capacitor to discharge.
- Ensure that the DC bus voltage is lower than 36V.

5.1.2 Required tools

These tools are used to remove and install devices, screws, and other components during maintenance and repair.

- A set of torque wrench or sleeve
- A set of open-end wrench or sleeve
- A set of hexagonal wrench
- A medium-sized straight screwdriver and a small-sized straight screwdriver
- A medium-sized cross screwdriver
- Cart

Table 5-1 Screw thread tightening torque (Fastener grade: 4.8; unit: N.m)

Screw thread specification	Copper bar connection	Metal sheet connection
M5	30	20
M6	45	30
M8	110	85
M10	220	164
M12	390	285
M16	980	710

5.1.3 Maintenance cycle

Little maintenance is required when the VFD is installed in an environment that meets requirements. The following table describes the routine maintenance periods recommended by us.

Maintenance cycle	Maintenance work description
Once per 6–12 months (based on the site installation environment)	Check according to the following table
Once per 6–12 months (based on the site installation environment)	Heat sink inspection and cleaning
Once per year (VFD stored without use)	Capacitor aging
Once per year	Air filter check. Replace it when necessary.
Every 6 years	Replace the fans for the filter and power units.
Every 10 years	Capacitor replacement

Little maintenance is required when the rectifier is installed in an environment that meets requirements.

The following table describes the routine maintenance periods recommended by INVT.

Check scope		Item	Method	Criterion
Ambient environment		Check the temperature, and humidity, and whether there is vibration, dust, gas, oil spray, and water droplets in the environment.	Visual inspection, and use instruments for measurement.	The requirements stated in this manual are met.
		Check whether there are foreign matters, such as tools, or dangerous substances placed nearby.	Visual inspection	There are no tools or dangerous substances placed nearby.
Voltage		Check the voltage of the main circuit and control circuit.	Use multimeters or other instruments for measurement.	Comply with the requirements stated in this manual. (Do not use a multimeter to measure the bus voltage.)
Keypad		Check the display of information.	Visual inspection	The characters are displayed properly.
		Check whether characters are not completely displayed.	Visual inspection	The requirements stated in this manual are met.
Main circuit	Common	Check whether the bolts loose or come off.	Screw them up.	No exception occurs.
		Check whether the machine is deformed, cracked, or damaged, or their color changes due to overheating and aging.	Visual inspection	No exception occurs.
		Check whether there are stains and dust attached.	Visual inspection	No exception occurs. Note: Discoloration of copper bars does not mean that they cannot work properly.
	Conductor and wire	Check whether conductors are deformed or color change for overheat.	Visual inspection	No exception occurs.
		Check whether the wire sheaths are cracked or their color changes.	Visual inspection	No exception occurs.
	Terminal block	Check whether there is damage.	Visual inspection	No exception occurs.
	Reactor	Check whether there is unusual vibration sounds or smells.	Auditory, olfactory, and visual inspection	No exception occurs.
	Control circuit	Control PCB and connector	Check whether the screws and connectors loose.	Screw them up.
Check whether there is unusual smell or discoloration.			Olfactory and visual inspection	No exception occurs.
Check whether there are cracks, damage, deformation, or rust.			Visual inspection	No exception occurs.

Check scope		Item	Method	Criterion
		Check whether there is electrolyte leakage or deformation.	Visual inspection, and determine the service life based on the maintenance information.	No exception occurs.
Cooling system	Cooling fan	Check whether there are unusual sounds or vibration.	Auditory and visual inspection, and turn the fan blades with your hand.	The rotation is smooth.
		Check whether the bolts loose.	Screw them up.	No exception occurs.
		Check whether there is decoloration caused due to overheat. Check whether there is dust.	Visual inspection, and determine the service life based on the maintenance information.	No exception occurs.
	Ventilation duct	Check whether there are foreign matters blocking or attached to the cooling fan, air inlets, or air outlets. Check whether there are foreign objects attached.	Visual inspection	No exception occurs.

For more details about maintenance, contact the local INVT office, or visit our website <http://www.invt.com>, and choose **Support > Services**.

5.2 Replacement of wearing parts

5.2.1 Cooling fan

The service life of the cooling fan of the basic rectifier unit is more than 35000 hours. The actual service life of the cooling fan is related to the use of the unit and the temperature in the ambient environment.

You can view the running duration of the unit through P07.14 (Accumulated running time).

The increase of the bearing noise indicates a fan fault. If the unit is applied in a key position, replace the fan once the fan starts to generate unusual noise. You can purchase spares of fans from INVT.

Cooling fan replacement:

	<ul style="list-style-type: none"> Read chapter 1 Safety precautions carefully and follow the instructions to perform operations. Ignoring these safety precautions may lead to physical injury or death, or device damage.
---	--

- Step 1 Stop the unit, disconnect the AC power supply, and wait for a time no shorter than the waiting time designated on the unit.
- Step 2 Remove the fan module front cover from the unit housing.
- Step 3 Remove the fan module connection cable.
- Step 4 Pull out the fan box and remove the fan with a screwdriver.

- Step 5 Install a new fan in the fan box. Insert the fan module connection cable to the connector in reverse sequence. Install the front cover. Ensure that the air direction of the fan is consistent with that of the unit, as shown in Figure 5-1.
- Step 6 Connect to the power.

Figure 5-1 Fan maintenance for the basic rectifier unit

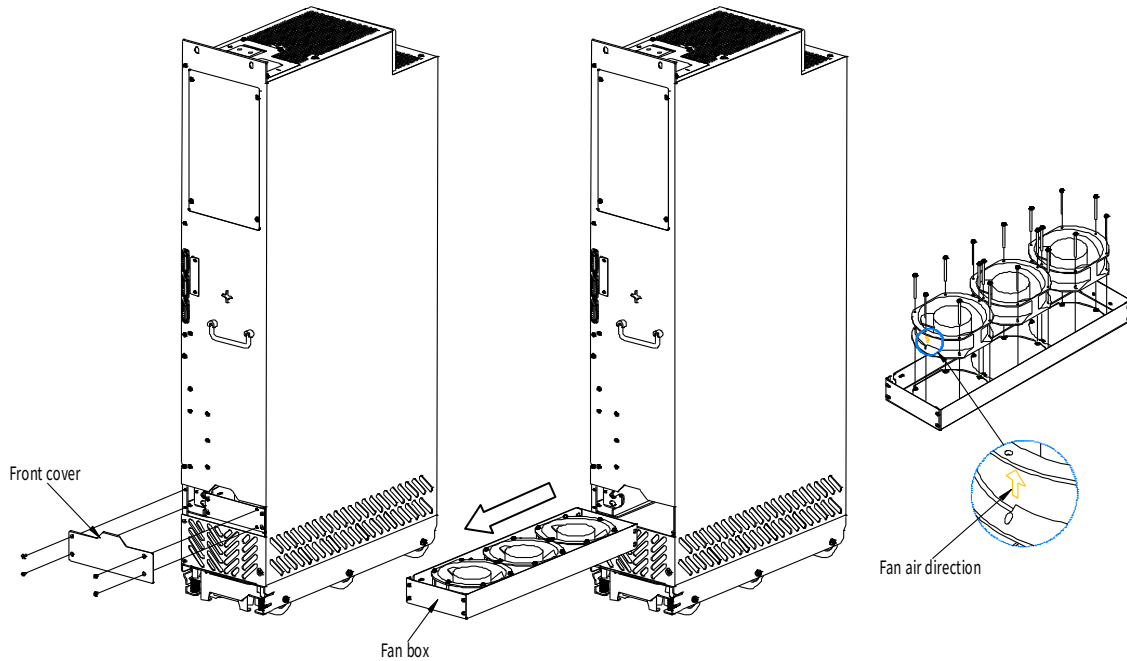

5.2.2 DC fuse

To check and replace the DC fuse of an D8T unit, do as follows:



- Only qualified electricians can perform this task. Read all the safety precautions. Ignoring these safety precautions may lead to physical injury or death, or device damage.

- Step 1 Stop the unit, disconnect the AC power supply, and wait for a time no shorter than the waiting time designated on the unit.
- Step 2 Remove the screws of the protective cover plate of the unit DC fuse and remove the cover plate.
- Step 3 Remove the copper bar fixing screws of the DC fuse assembly and remove the DC fuse assembly. See Figure 5-2.
- Step 4 Check the condition of the fuse and replace it as needed. When replacing it, install the new fuse and copper bar as an assembly and tighten the screws according to the tightening torque table.
- Step 5 Install the protective cover and close the cabinet door.
- Step 6 Connect to the power.

Figure 5-2 Fuse maintenance

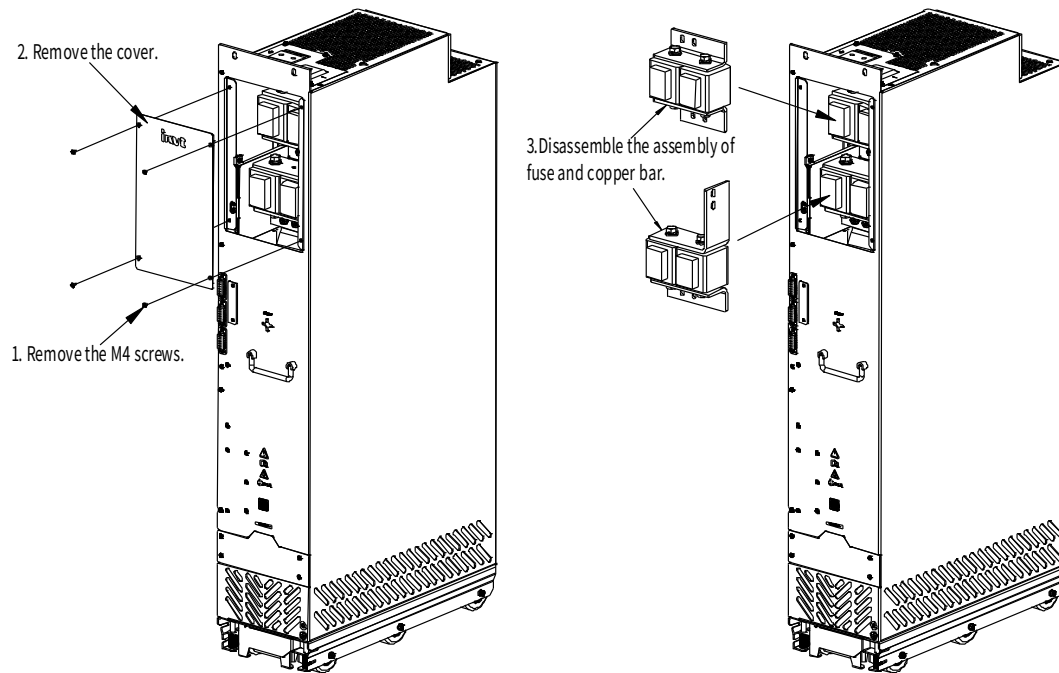

5.2.3 Basic rectifier unit

The unit replacement procedure is as follows:

- Step 1 Stop the machine and disconnect the AC power.
- Step 2 Open the cabinet door and check to ensure there is no voltage in the machine.
- Step 3 Disconnect the external connection cables of the basic rectifier unit.
- Step 4 Disconnect the (+) and (-) DC output copper bars.
- Step 5 Install the unit installation guide rail.
- Step 6 Remove the (four M8) fixing screws from the top and bottom of the unit.
- Step 7 Pull the unit and unfold the anti-tipping stand.
- Step 8 Install the new unit according to 3.3.5.6 Unit installation and replacement.

Figure 5-3 Basic rectifier unit replacement

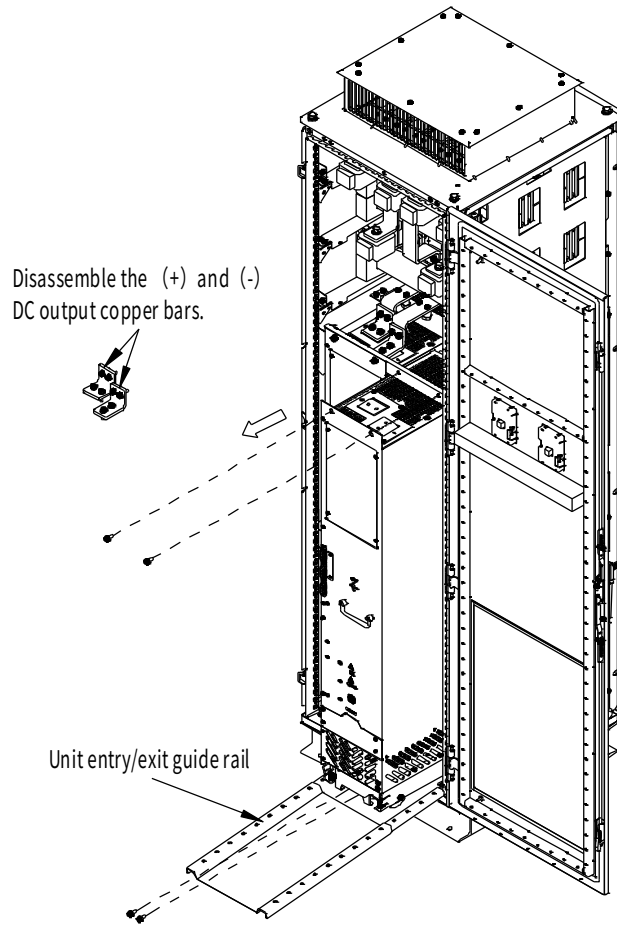

Appendix A Technical data

A.1 Derated application

A.1.1 Capacity

Choose a rectifier model based on the rated current and power of the motor. To endure the rated power of the motor, the rated output current of the rectifier must be larger or equal to the rated current of the motor. The rated power of the rectifier must be higher or equal to that of the motor.

Note:

- The maximum allowable shaft power of the motor is limited to 1.5 times the rated power of the motor. If the limit is exceeded, the rectifier automatically restricts the torque and current of the motor. This function effectively protects the input shaft against overload.
- The rated capacity is the capacity at the ambient temperature of 40°C.
- You need to check and ensure that the power flowing through the common DC connection in the common DC system does not exceed the rated power of the motor.

A.1.2 Derating

If the ambient temperature at the rectifier installation site exceeds 40°C, the rectifier installation site altitude exceeds 1000 m, a cover with heat dissipation vents is used, or the carrier frequency is higher than the recommended (for the recommended frequency, see P00.14), the rectifier needs to be derated.

A.1.2.1 Derating due to temperature

When the temperature ranges from +40°C to +50 °C, the rated output current is derated by 1% for each increased 1 °C. For the actual derating, see the following figure.

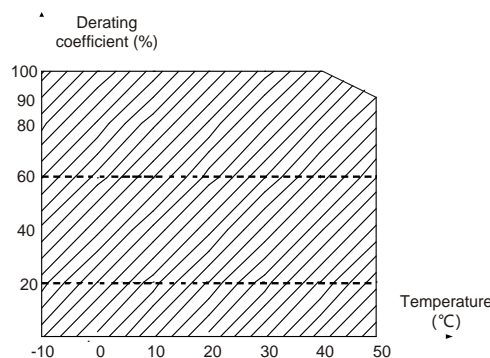

Note: It is not recommended to use the rectifier at an environment with the temperature higher than 50°C. If you do, you shall be held accountable for the consequences caused.

A.1.2.2 Derating due to altitude

When the altitude of the site where the rectifier is installed is lower than 1000 m, the rectifier can run at the rated power. When the altitude exceeds 1000m, derate by 1% for every increase of 100m. When the altitude exceeds 3000m, consult the local INVT dealer or office for details.

A.1.2.3 Derating due to carrier frequency

The carrier frequency of Goodrive800 Pro series basic rectifier unit product varies with power class. The product rated power is defined based on the carrier frequency factory setting. If the carrier frequency exceeds the factory setting, the product power is derated by 10% for each increased 1 kHz.

A.2 Grid specifications

Grid voltage	AC 3PH 380V(-15%)–440V(+10%) AC 3PH 520V(-15%)–690V(+10%)
Short-circuit capacity	According to the definition in IEC 61439-1, the maximum allowable short-circuit current at the incoming end is 100 kA. Therefore, the product is applicable to scenarios where the transmitted current in the circuit is no larger than 100 kA when the VFD runs at the maximum rated voltage.
Frequency	50/60 Hz \pm 5%, with a maximum change rate of 20%/s

A.3 Application standards

The following table describes the standards that our products comply with.

EN/ISO 13849-1	Safety of machinery—Safety-related parts of control systems—Part 1: General principles for design
IEC/EN 60204-1	Safety of machinery. Electrical equipment of machines. Part 1: General requirements
IEC/EN 62061	Safety of machinery—Safety-related functional safety of electrical, electronic, and programmable electronic control systems
IEC/EN 61800-3	Adjustable speed electrical power drive systems. Part 3: EMC requirements and specific test methods
IEC/EN 61800-5-1	Adjustable speed electrical power drive systems—Part 5-1: Safety requirements—Electrical, thermal and energy
IEC/EN 61800-5-2	Adjustable speed electrical power drive systems—Part 5-2: Safety requirements—Function

A.3.1 CE marking

The CE marking on the product nameplate indicates that the product is CE-compliant, meeting the regulations of the European low-voltage directive (2014/35/EU) and EMC directive (2014/30/EU).

A.3.2 EMC compliance declaration

European union (EU) stipulates that the electric and electrical devices sold in Europe cannot generate electromagnetic disturbance that exceeds the limits stipulated in related standards, and can work properly in environments with certain electromagnetic interference. The EMC product standard (EN 61800-3) describes the EMC standards and specific test methods for adjustable speed electrical power drive systems. Our products have been compliant with these regulations.

A.4 EMC regulations

The EMC product standard (EN 61800-3) describes the EMC requirements on VFDs.

Application environment categories:

First environment: Civilian environments, including application scenarios where VFDs are directly connected to the civil power supply low-voltage grids without intermediate transformers.

Second environment: All environments except those in Category I.

VFD categories:

C1: Rated voltage lower than 1000 V, applied to environments of Category I.

C2: Rated voltage lower than 1000 V, non-plug, socket, or mobile devices; power drive systems that must be installed and operated by specialized personnel when applied to the first environment.

Note: The EMC standard IEC/EN 61800-3 no longer restricts the power distribution of VFDs, but it specifies their use, installation, and commissioning. Specialized personnel or organizations must have the necessary skills (including the EMC-related knowledge) for installing and/or performing commissioning on the electrical drive systems.

C3: Rated voltage lower than 1000 V, applied to environments of Category II. They cannot be applied to environments of Category I.

C4: Rated voltage higher than 1000 V, or rated current higher or equal to 400 A, applied to complex systems in the second environment.

A.4.1 VFD category of C2

The induction disturbance limit meets the following stipulations:

- Select the motor and control cables according to the description in the manual.
- Install the rectifier according to the description in the manual.

	<ul style="list-style-type: none"> • Currently in environments in China, the product may generate radio interference, you need to take measures to reduce the interference.
---	--

A.4.2 VFD category of C3

The anti-interference performance of the rectifier meets the requirements of the second environment in the IEC/EN 61800-3 standard.

The induction disturbance limit meets the following stipulations:

- Select the motor and control cables according to the description in the manual.
- Install the rectifier according to the description in the manual.

	<ul style="list-style-type: none"> • Rectifiers of category C3 cannot be applied to civilian low-voltage common grids. When applied to such grids, the rectifier may generate radio frequency electromagnetic interference.
---	--

Appendix B Dimension drawings

B.1 Installation dimensions

Figure B-1 Installation dimensions

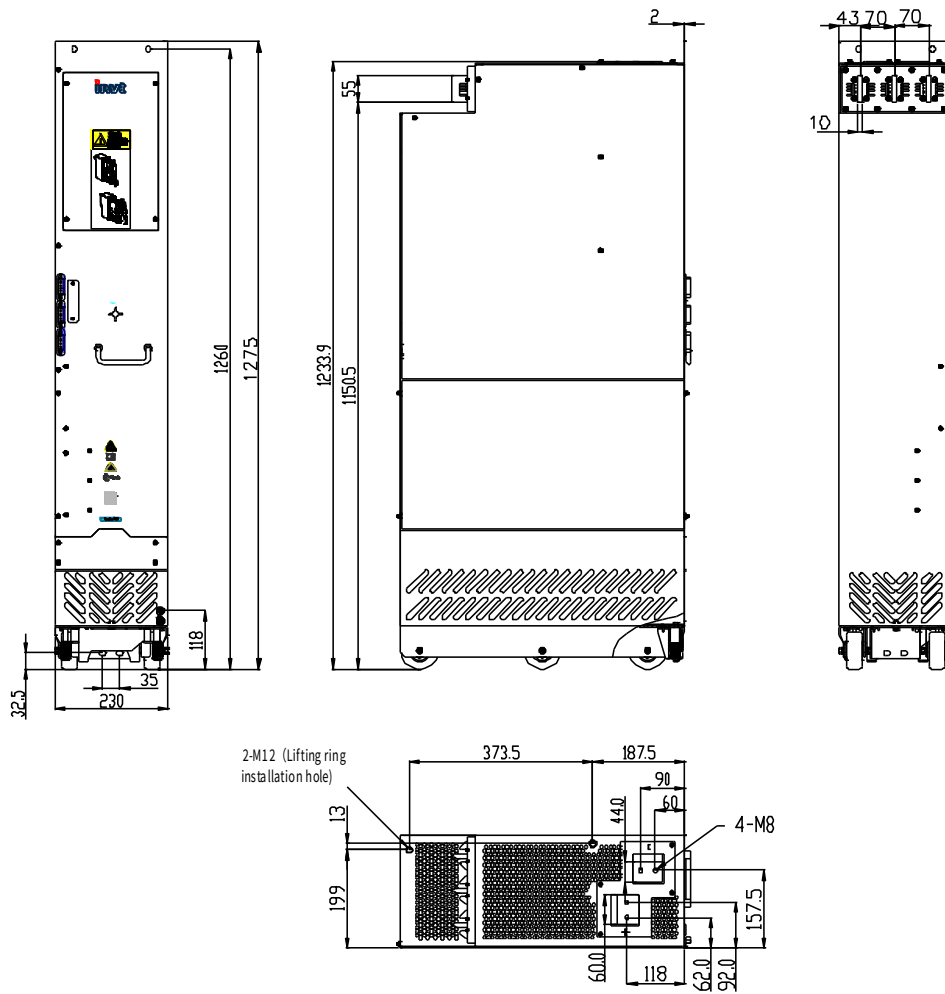

Your Trusted Industry Automation Solution Provider



Shenzhen INVT Electric Co., Ltd.

Address: INVT Guangming Technology Building, Songbai Road, Matian,
Guangming District, Shenzhen, China

INVT Power Electronics (Suzhou) Co., Ltd.

Address: No. 1 Kunlun Mountain Road, Science & Technology Town,
Gaoxin District, Suzhou, Jiangsu, China

Website: www.invt.com



INVT mobile website



INVT e-manual



6 6 0 0 1 - 0 0 9 4 6