



GRAPHIC OPERATION TERMINAL

GOT2000

GOT2000 Series User's Manual (Utility)

- GT27 model
- GT25 model
- GT25 open frame model
- GT25 wide model
- GT25 rugged model
- GT23 model
- GT21 model
- GT21 wide model
- Handy GOT

SAFETY PRECAUTIONS

(Be sure to read these instructions before using this product.)

Before using this product, please read this manual and the relevant manuals introduced in this manual carefully and pay full attention to safety to handle the product correctly.

The precautions given in this manual are concerned with this product.

In this manual, the safety precautions are ranked as "WARNING" and "CAUTION".



Indicates that incorrect handling may cause hazardous conditions, resulting in death or severe injury.



Indicates that incorrect handling may cause hazardous conditions, resulting in minor or moderate injury or property damage.

Note that the  caution level may lead to a serious accident according to the circumstances.

Always follow the instructions of both levels because they are important to personal safety.

Please save this manual to make it accessible when required and always forward it to the end user.

[DESIGN PRECAUTIONS]

WARNING

- Some failures of the GOT, communication unit or cable may keep the outputs on or off.
Some failures of a touch panel may cause malfunction of the input objects such as a touch switch.
An external monitoring circuit should be provided to check for output signals which may lead to a serious accident. Not doing so can cause an accident due to false output or malfunction.
 - Do not use the GOT as the warning device that may cause a serious accident.
An independent and redundant hardware or mechanical interlock is required to configure the device that displays and outputs serious warning.
Failure to observe this instruction may result in an accident due to incorrect output or malfunction.
 - When the GOT backlight has a failure, the GOT status will be as follows. Failure to observe this instruction may result in an accident due to incorrect output or malfunction.
[GT27, GT25, GT23]
The POWER LED blinks (orange/blue), the display section dims, and inputs by a touch switch are disabled.
[GT2105-Q]
The POWER LED blinks (orange/blue), and the display section dims. However, inputs by a touch switch are still available.
[GT2107-W, GT2104-R, GT2104-P, GT2103-P]
The display section dims. However, inputs by a touch switch are still available.
Even if the display section dims, inputs by a touch switch may still be available. This may cause an unintended operation of the touch switch.
For example, if an operator assumes that the display section has dimmed because of the screen save function and touches the display section to cancel the screen save, a touch switch may be activated.
The GOT backlight failure can be checked with a system signal of the GOT. (This system signal is not available on GT2107-W, GT2104-R, GT2104-P, and GT2103-P.)
-

[DESIGN PRECAUTIONS]

WARNING

- The display section of the GOT is an analog-resistive type touch panel.
When multiple points of the display section are touched simultaneously, an accident may occur due to incorrect output or malfunction.
[GT27]
Do not touch three points or more simultaneously on the display section. Doing so may cause an accident due to an incorrect output or malfunction.
[GT25,GT23,GT21]
Do not touch two points or more simultaneously on the display section. Doing so may cause a touch switch near the touched points to operate unexpectedly, or may cause an accident due to an incorrect output or malfunction.
 - When programs or parameters of the controller (such as a PLC) that is monitored by the GOT are changed, be sure to reset the GOT, or turn on the unit again after shutting off the power as soon as possible.
Not doing so can cause an accident due to false output or malfunction.
 - If a communication fault (including cable disconnection) occurs during monitoring on the GOT, communication between the GOT and PLC CPU is suspended and the GOT becomes inoperative.
 - ◇For bus connection (GT27 and GT25 only): The GOT becomes inoperative. Power on the PLC CPU again to reestablish communication.
 - ◇For other than bus connection: The GOT becomes inoperative.A system where the GOT is used should be configured to perform any significant operation to the system by using the switches of a device other than the GOT on the assumption that a GOT communication fault will occur.
Not doing so can cause an accident due to false output or malfunction.
 - To maintain the security (confidentiality, integrity, and availability) of the GOT and the system against unauthorized access, DoS^{*1} attacks, computer viruses, and other cyberattacks from unreliable networks and devices via network, take appropriate measures such as firewalls, virtual private networks (VPNs), and antivirus solutions.
Mitsubishi Electric shall have no responsibility or liability for any problems involving GOT trouble and system trouble by unauthorized access, DoS attacks, computer viruses, and other cyberattacks.
^{*1} DoS: A denial-of-service (DoS) attack disrupts services by overloading systems or exploiting vulnerabilities, resulting in a denial-of-service (DoS) state.
-

[DESIGN PRECAUTIONS]

CAUTION

- Do not bundle the control and communication cables with main-circuit, power or other wiring.
Run the above cables separately from such wiring and keep them a minimum of 100mm apart.
Not doing so noise can cause a malfunction.
 - Do not press the GOT display section with a pointed material as a pen or driver.
Doing so can result in a damage or failure of the display section.
 - When the GOT connects to an Ethernet network, the IP address setting is restricted according to the system configuration.
[GT27, GT25, GT23]
When a GOT2000 series model and a GOT1000 series model are on an Ethernet network, do not set the IP address 192.168.0.18 for the GOTs and the controllers on this network.
Doing so can cause IP address duplication at the GOT startup, adversely affecting the communication of the device with the IP address 192.168.0.18.
The operation at the IP address duplication depends on the devices and the system.
[GT21]
When multiple GOTs are connected to the Ethernet network, do not set the IP address (192.168.3.18) for the GOTs and the controllers in the network.
When one GOT is connected to the Ethernet network, do not set the IP address (192.168.3.18) for the controllers other than the GOT in the network.
Doing so can cause IP address duplication at the GOT startup, adversely affecting the communication of the device with the IP address 192.168.3.18.
The operation at the IP address duplication depends on the devices and the system.
 - When using the Ethernet interfaces, set an IP address for each interface to access a different network.
Turn on the controllers and the network devices to be ready for communication before they communicate with the GOT.
Failure to do so can cause a communication error on the GOT.
 - When the GOT is subject to shock or vibration, or some colors appear on the screen of the GOT, the screen of the GOT might flicker.
-

[MOUNTING PRECAUTIONS]

WARNING

- Be sure to shut off all phases of the external power supply used by the system before mounting or removing the GOT main unit to/from the panel.
Not doing so can cause the unit to fail or malfunction.
 - Be sure to shut off all phases of the external power supply used by the system before mounting or removing the option unit onto/from the GOT. (GT27,GT25 Only)
-

[MOUNTING PRECAUTIONS]

CAUTION

- Use the GOT in the environment that satisfies the general specifications described in this manual. Not doing so can cause an electric shock, fire, malfunction or product damage or deterioration.
 - When mounting the GOT to the control panel, tighten the mounting screws in the specified torque range with a Phillips-head screwdriver No.2.
[GT27, GT25-W, GT2512-S, GT2510-V, GT2508-V, GT23, GT2107-W]
Specified torque range (0.36 N.m to 0.48 N.m)
[GT2505, GT2105-Q]
Specified torque range (0.30 N.m to 0.50 N.m)
[GT2104-R, GT2104-P, GT2103-P]
Specified torque range (0.20 N.m to 0.25 N.m)
Undertightening can cause the GOT to drop, short circuit or malfunction.
Overtightening can cause a drop, short circuit or malfunction due to the damage of the screws or the GOT.
 - When mounting a unit on the GOT, tighten the mounting screws in the following specified torque range.
[GT27, GT25 (except GT25-W)]
When loading the communication unit or option unit other than wireless LAN unit to the GOT, fit it to the connection interface of the GOT and tighten the mounting screws in the specified torque range (0.36 N.m to 0.48 N.m) with a Phillips-head screwdriver No.2.
When loading the wireless LAN unit to the GOT, fit it to the side interface of GOT and tighten the mounting screws in the specified torque range (0.10 N.m to 0.14 N.m) with a Phillips-head screwdriver No.1.
When the GOT is installed vertically, its side interface is positioned on the bottom.
To prevent the falling of the wireless LAN communication unit from the side interface, install or remove the unit while holding it with hands.
[GT25-W]
When mounting the wireless LAN communication unit on the GOT, fit it to the wireless LAN communication unit interface and tighten the mounting screws in the specified torque range (0.10 N.m to 0.14 N.m) with a Phillips-head screwdriver No.1.
[GT2103-P]
When mounting the SD card unit on the GOT, fit it to the side of the GOT and tighten the tapping screws in the specified torque range (0.3 N.m to 0.6 N.m) with a Phillips-head screwdriver No.2.
Under tightening can cause the GOT to drop, short circuit or malfunction.
Overtightening can cause a drop, failure or malfunction due to the damage of the screws or unit.
 - When closing the USB environmental protection cover, note the following points to ensure the IP rating.
[GT27, GT25 (except GT25-W and GT2505-V)]
Push the [PUSH] mark on the latch firmly to fix the cover to the GOT.
[GT2512-WX, GT2510-WX, GT2507-W, GT2505-V, GT2107-W]
Push the USB mark on the latch firmly to fix the cover to the GOT.
[GT2105-Q]
Tighten the lower fixing screws of the cover in the specified torque range (0.36 N.m to 0.48 N.m) to fix the cover to the GOT.
-

[MOUNTING PRECAUTIONS]

CAUTION

- Remove the protective film of the GOT.

When the user continues using the GOT with the protective film, the film may not be removed.

In addition, for the models equipped with the human sensor function, using the GOT with the protective film may cause the human sensor not to function properly.

For GT2512F-S, GT2510F-V, and GT2508F-V, attach an environmental protection sheet dedicated to the open frame model (sold separately) to the display section.

Or, attach a user-prepared environmental protection sheet.

Not doing so may damage or soil the GOT or cause foreign matter to enter the GOT, resulting in a failure or malfunction.

When installing the supplied fittings on GT2512F-S, GT2510F-V, or GT2508F-V, tighten screws in the specified torque range (0.8 N•m to 1.0 N•m).

Meld studs on the control panel to fasten the fittings.

The studs must have strength adequate to withstand a tightening torque of 0.9 N•m or more.

Make sure that no foreign matter such as welding waste is at and around the bases of the studs.

Tighten nuts on the studs in the specified torque range (0.8 N•m to 0.9 N•m) with a wrench for M4 nuts.

Undertightening a screw or nut may cause the GOT to drop, short-circuit, or malfunction.

Overtightening a screw or nut may damage it or the GOT, causing the GOT to drop, short-circuit, or malfunction.

- Do not operate or store the GOT in the environment exposed to direct sunlight, rain, high temperature, dust, humidity, or vibrations.
- Although GT2507T-W is ruggedized for environments such as UV rays, temperatures and vibrations, its operation is not guaranteed in all conditions and environments.
Make sure to use or store the GOT in an appropriate environment.
- When using the GOT in the environment of oil or chemicals, use the protective cover for oil.
Failure to do so may cause failure or malfunction due to the oil or chemical entering into the GOT.
- Do not operate the GOT with its display section frozen.

The water droplets on the display section may freeze at a low temperature.

Touch switches and other input objects may malfunction if the display section is frozen.

[WIRING PRECAUTIONS]

WARNING

- Be sure to shut off all phases of the external power supply used by the system before wiring.
Failure to do so may result in an electric shock, product damage or malfunctions.
 - After installation, wiring, or other work, make sure to attach the back cover to the Handy GOT before turning on the power and starting operation.
Not doing so may cause an electrical shock.
 - The Handy GOT is designed to operate on DC power.
Supply power to the power supply, operation switch, and emergency stop switch within the specifications.
Not doing so may cause a failure due to a reverse power connection.
 - Correctly wire the 24 V DC power cable (terminal) of the Handy GOT and [+]/[-] of the DC power supply equipment as shown in this manual.
Not doing so may cause a failure.
 - Ground the FG terminal of the Handy GOT with a ground resistance of 100 Ω or less by using a drain wire that has a cross-sectional area of 2 mm² or more.
Do not use common grounding with higher voltage systems.
Failure to observe these instructions may cause an electric shock or malfunction.
 - When making a connection cable or installing wiring, make sure that no chips or wire offcuts enter the Handy GOT.
Not doing so may cause a fire, failure or malfunction.
-

[WIRING PRECAUTIONS]

CAUTION

- When grounding the FG terminal and LG terminal of the GOT power supply section, note the following points.
Not doing so may cause an electric shock or malfunction.
[GT27, GT25, GT23, GT2107-W, GT2105-Q]
Make sure to ground the FG terminal and LG terminal of the GOT power supply section solely for the GOT (ground resistance: 100 Ω or less, ground cable diameter: 1.6 mm or more). (GT2705-V, GT25-W, GT2505-V, GT2107-W, and GT2105-Q do not have the LG terminal.)
[GT2104-R, GT2104-P, GT2103-P]
Make sure to ground the FG terminal of the GOT power supply section with a ground resistance of 100 Ω or less. (For GT2104-PMBLS and GT2103-PMBLS, grounding is unnecessary.)
 - When tightening the terminal screws, use the following screwdrivers.
[GT27, GT25, GT23, GT2107-W, GT2105-Q]
Use a Phillips-head screwdriver No. 2.
[GT2104-R, GT2104-P, GT2103-P]
For the usable screwdrivers, refer to the following.
 GOT2000 Series User's Manual (Hardware)
 - Tighten the terminal screws of the GOT power supply section in the following specified torque range.
[GT27, GT25, GT23]
Specified torque range (0.5 N.m to 0.8 N.m)
-

[WIRING PRECAUTIONS]

CAUTION

- For a terminal processing of a wire to the GOT power supply section, use the following terminal.
[GT27, GT25, GT23, GT2107-W, GT2105-Q]
Use applicable solderless terminals for terminal processing of a wire and tighten them with the specified torque.
Not doing so can cause a fire, failure or malfunction.
[GT2104-R, GT2104-P, GT2103-P]
Connect a stranded wire or a solid wire directly, or use a rod terminal with an insulation sleeve.
 - Correctly wire the GOT power supply section after confirming the rated voltage and terminal arrangement of the product.
Not doing so can cause a fire or failure.
 - Tighten the terminal screws of the GOT power supply section in the following specified torque range.
[GT27, GT25, GT23, GT2107-W, GT2105-Q]
Specified torque range (0.5 N.m to 0.8 N.m)
[GT2104-R, GT2104-P, GT2103-P]
Specified torque range (0.22 N.m to 0.25 N.m)
 - Exercise care to avoid foreign matter such as chips and wire offcuts entering the GOT.
Not doing so can cause a fire, failure or malfunction.
 - Some models have an ingress prevention label on their top to prevent foreign matter, such as wire offcuts, from entering the GOT during wiring.
Do not peel this label during wiring.
Before starting system operation, be sure to peel this label because of heat dissipation.
 - Plug the communication cable into the GOT interface or the connector of the connected unit, and tighten the mounting screws and the terminal screws in the specified torque range.
Undertightening can cause a short circuit or malfunction.
Overtightening can cause a short circuit or malfunction due to the damage of the screws or unit.
 - Plug the QnA/ACPU/Motion controller(A series) bus connection cable by inserting it into the connector of the connected unit until it "clicks".
After plugging, check that it has been inserted snugly.
Not doing so can cause a malfunction due to a contact fault.
 - When you use the Handy GOT, run the connected cable in ducts or clamp the cable.
Not doing so can cause the unit or cable to be damaged due to the dangling, motion or accidental pulling of the cables or can cause a malfunction due to a cable connection fault.
 - When you remove a cable from the Handy GOT, do not pull the cable portion.
Doing so can cause the unit or cable to be damaged or can cause a malfunction due to a cable connection fault.
-

[TEST OPERATION PRECAUTIONS]

WARNING

- Before testing the operation of a user-created screen (such as turning on or off a bit device, changing the current value of a word device, changing the set value or current value of a timer or counter, and changing the current value of a buffer memory), thoroughly read the manual to fully understand the operating procedure.

During the test operation, never change the data of the devices which are used to perform significant operation for the system.

False output or malfunction can cause an accident.

[STARTUP/MAINTENANCE PRECAUTIONS]

WARNING

- When power is on, do not touch the terminals.
Doing so can cause an electric shock or malfunction.
 - Correctly connect the battery connector.
Do not charge, disassemble, heat, short-circuit, solder, or throw the battery into the fire.
Doing so will cause the battery to produce heat, explode, or ignite, resulting in injury and fire.
 - Before starting cleaning or terminal screw retightening, always switch off the power externally in all phases.
Not switching the power off in all phases can cause a unit failure or malfunction.
Undertightening can cause a short circuit or malfunction.
Overtightening can cause a short circuit or malfunction due to the damage of the screws or unit.
-

[STARTUP/MAINTENANCE PRECAUTIONS]

CAUTION

- Do not disassemble or modify the unit.
Doing so can cause a failure, malfunction, injury or fire.
 - Do not touch the conductive and electronic parts of the unit directly.
Doing so can cause a unit malfunction or failure.
 - The cables connected to the unit must be run in ducts or clamped.
Not doing so can cause the unit or cable to be damaged due to the dangling, motion or accidental pulling of the cables or can cause a malfunction due to a cable connection fault.
 - When unplugging the cable connected to the unit, do not hold and pull from the cable portion.
Doing so can cause the unit or cable to be damaged or can cause a malfunction due to a cable connection fault.
 - Do not drop the module or subject it to strong shock.
A module damage may result.
 - Do not drop or give an impact to the battery mounted to the unit.
Doing so may damage the battery, causing the battery fluid to leak inside the battery.
If the battery is dropped or given an impact, dispose of it without using.
 - Before touching the unit, always touch grounded metals, etc. to discharge static electricity from human body, etc.
Not doing so can cause the unit to fail or malfunction.
-

[STARTUP/MAINTENANCE PRECAUTIONS]

CAUTION

- Use the battery manufactured by Mitsubishi Electric Corporation.
Use of other batteries may cause a risk of fire or explosion.
 - Dispose of used battery promptly.
Keep away from children. Do not disassemble and do not dispose of in fire.
 - Be sure to shut off all phases of the external power supply before replacing the battery or using the dip switch of the terminating resistor.
Not doing so can cause the unit to fail or malfunction by static electricity.
 - Before cleaning the GOT, be sure to turn off the power.
Before cleaning, check the following items.
 - ◇ Ensure that there are no problems with the installation condition of the GOT to the control panel.
 - ◇ Ensure that there are no damages on the environmental protection sheet (not replaceable).If the environmental protection sheet peels or the cleaning solution enters between the sheet and the display section during cleaning, stop the cleaning immediately.
In such a case, do not use the GOT.
-

[TOUCH PANEL PRECAUTIONS]

CAUTION

- For the analog-resistive film type touch panels, normally the adjustment is not required.
However, the difference between a touched position and the object position may occur as the period of use elapses. When any difference between a touched position and the object position occurs, execute the touch panel calibration.
 - When any difference between a touched position and the object position occurs, other object may be activated.
This may cause an unexpected operation due to incorrect output or malfunction.
-

[PRECAUTIONS FOR USING A DATA STORAGE]

WARNING

- If the SD card is removed from drive A of the GOT while being accessed by the GOT, the GOT may stop processing data for about 20 seconds.
The GOT cannot be operated during this period. The functions that run in the background including a screen updating, alarm, logging, scripts, and others are also interrupted.
Before removing the SD card, check the following items.
[GT27, GT25, GT23(Excluding GT2505 and GT25HS-V)]
Before removing the SD card, check that the SD card access LED is off.
[GT2505, GT25HS-V]
Make sure to turn off the SD card access switch before removing the SD card.
Not doing so may damage the SD card or files.
[GT21]
Disable the SD card access in the GOT utility, and then check that the SD card access LED is off before removing the SD card.
 - Do not remove the data storage from the file server (drive N) that is being accessed by the GOT, or the system operation may be affected.
Before removing the data storage, check the relevant system signal to make sure that the data storage is not being accessed.
-

[PRECAUTIONS FOR USING A DATA STORAGE]

CAUTION

- If the data storage is removed from the GOT while being accessed by the GOT, the data storage and files may be damaged.
Before removing the data storage from the GOT, check the SD card access LED, system signal, or others to make sure that the data storage is not accessed.
 - Turning off the GOT while it accesses the SD card results in damage to the SD card and files.
 - When using the GOT with an SD card inserted, check the following items.
[GT27, GT25, GT23(Excluding GT2505 and GT25HS-V)]
After inserting an SD card into the GOT, make sure to close the SD card cover.
Otherwise, data cannot be read or written.
[GT2505-V, GT25HS-V]
After inserting an SD card into the GOT, make sure to turn on the SD card access switch.
Otherwise, data cannot be read or written.
[GT21]
After inserting an SD card into the SD card unit, make sure to enable the SD card access in the GOT utility.
Otherwise, data cannot be read or written.
 - When removing the SD card from the GOT, make sure to support the SD card by hand as it may pop out.
Not doing so may cause the SD card to drop from the GOT, resulting in a failure or break.
 - When inserting a USB device into a USB interface of the GOT, make sure to insert the device into the interface firmly.
Not doing so may cause the USB device to drop from the GOT, resulting in a failure or break.(GT27, GT25, and GT2107-W)
 - Before removing the data storage from the GOT, follow the procedure for removal on the utility screen of the GOT. After the successful completion dialog is displayed, remove the data storage by hand carefully.
Not doing so may cause the data storage to drop from the GOT, resulting in a failure or break.
-

[PRECAUTIONS FOR USE]

CAUTION

- When you operate the Handy GOT while holding it, slide your hand through the hand strap on the back of the GOT to prevent falling.
The hand strap length is adjustable.
 - When you remove a cable from the Handy GOT, do not pull the cable portion.
Doing so may damage the unit or cable, or cause a malfunction due to a cable connection fault.
 - Do not drop or strike the Handy GOT.
Doing so may damage the GOT.
 - When you carry or operate the Handy GOT, hold its body.
Carrying or operating the Handy GOT while holding its cable may damage the unit or cable.
 - Determine whether to use the emergency stop switch of the Handy GOT according to your risk assessment.
 - If you use a parallel circuit (to avoid entering the emergency stop status while the Handy GOT is removed), the system may not conform to the safety standards.
Check the safety standards required for your system before use.
 - If the Handy GOT is exposed to any impact beyond the general specifications, chattering may occur in the emergency stop switch for its structural reasons.
Check that your use conditions are proper.
 - Do not touch the edges of the touch panel (display section) repeatedly.
Doing so may result in a failure.
 - Do not turn off the GOT while data is being written to the storage memory (ROM) or SD card.
Doing so may corrupt the data, rendering the GOT inoperative.
 - The GOT rugged model uses the environmental protection sheet (not replaceable) with UV protection function on the front surface.
Therefore, it is possible to suppress deterioration of the touch panel or the liquid crystal display panel that may be caused by ultraviolet rays.
Note that if the rugged model is exposed to ultraviolet rays for an extended period of time, the front surface may turn yellow.
If the rugged model is likely to be exposed to ultraviolet rays for an extended period of time, it is recommended to use a UV protective sheet (option).
-

[PRECAUTIONS FOR REMOTE CONTROL]

WARNING

- Remote control is available through a network by using GOT functions, including the SoftGOT-GOT link function, the remote personal computer operation function, the VNC server function, and the GOT Mobile function.

If you remotely operate control equipment using such functions, the field operator may not notice the remote operation, leading to an accident.

In addition, a communication delay or interruption may occur depending on the network environment, and remote control of control equipment cannot be performed normally in some cases.

Before using the above functions to perform remote control, fully grasp the circumstances of the field site and ensure safety.

- When operating the server (GOT) of the GOT Mobile function to disconnect a client, notify the operator of the client about the disconnection beforehand.
Not doing so may cause an accident.
-

[PRECAUTIONS FOR EXCLUSIVE AUTHORIZATION CONTROL]

WARNING

- Before using the GOT network interaction function to prevent simultaneous operations from multiple pieces of equipment, make sure you understand the function.

You can enable or disable the exclusive authorization control of the GOT network interaction function for each screen. (For all screens, the exclusive authorization control is disabled by default.)

Properly determine the screens for which the exclusive authorization control is required, and set the control by screen.

A screen for which the exclusive authorization control is disabled is operable simultaneously from multiple pieces of equipment. Make sure to determine the operation period for each operator, fully grasp the circumstances of the field site, and ensure safety to perform operations.

[DISPOSAL PRECAUTIONS]

CAUTION

- When disposing of this product, treat it as industrial waste.

When disposing of batteries, separate them from other wastes according to the local regulations. (Refer to GOT2000 Series User's Manual (Hardware) for details of the battery directive in the EU member states.)

[TRANSPORTATION PRECAUTIONS]

CAUTION

- When transporting lithium batteries, make sure to treat them based on the transport regulations. (Refer to GOT2000 Series User's Manual (Hardware) for details of the regulated models.)
 - Make sure to transport the GOT main unit and/or relevant unit(s) in the manner they will not be exposed to the impact exceeding the impact resistance described in the general specifications of this manual, as they are precision devices.
Failure to do so may cause the unit to fail. Check if the unit operates correctly after transportation.
 - When fumigants that contain halogen materials such as fluorine, chlorine, bromine, and iodine are used for disinfecting and protecting wooden packaging from insects, they cause malfunction when entering our products.
Please take necessary precautions to ensure that remaining materials from fumigant do not enter our products, or treat packaging with methods other than fumigation (heat method). Additionally, disinfect and protect wood from insects before packing products.
-

CONTENTS

SAFETY PRECAUTIONS	1
INTRODUCTION	25
Manuals for GT Works3	25
Abbreviations, Generic Terms, and Model Icons	27

PART 1 UTILITY FOR GT27/GT25/GT23

CHAPTER 1 UTILITY FUNCTION	36
1.1 Utility Execution	36
1.2 Utility Function List	37
1.3 Utility Display	42
Display operation of main menu	44
Utility basic configuration	46
Basic operation to change the settings	47
CHAPTER 2 GOT BASIC SETTING	49
2.1 Display	50
Display setting	50
Display operation of display	52
Display setting operations	52
2.2 Language	56
Language setting	56
Display operation of language display	56
Setting operation of language	57
2.3 Unique Information	58
Unique information setting	58
Display operation of unique information	58
Setting procedure for unique information	59
2.4 IP Address	60
IP address setting	60
Display operation of IP address	61
Setting procedure for the IP address	62
Precautions	66
2.5 IP Filter Setting	67
IP filter setting	67
Display operation of the IP filter setting	68
Setting procedure for the IP filter	69
2.6 Operation	71
Operation setting	71
Display operation of operation	72
Setting operation of operation	73
2.7 Utility Call Key	74
Utility call key setting	74
Display operation of the utility call key setting	74
Utility call key setting operation	75
2.8 USB Host	77
USB host setting	77

	Display operation of the USB host setting	77
	Setting operation of USB host	78
2.9	Time	80
	Clock synchronization method	80
	Time setting	82
	Adjusting the clock	85
	Broadcasting the clock data	91
	Local time	96
2.10	Controller	99
	Controller setting	99
	Communication detail setting display operation	99
	Controller contents	100
	Controller setting operation	103
	Communication detail setting	108
2.11	Ethernet Communication	116
	Ethernet setting	116
	Display operation of the Ethernet setting	116
	Display contents of Ethernet setting	117
2.12	Transparent Mode	122
	Transparent mode setting	122
	Display operation of the transparent mode setting	122
	Operation the transparent mode	123
2.13	GOT Internal Device Monitor	124
	GOT internal device monitor setting	124
	Display operation of the GOT internal device monitor	124
	Setting procedure for the GOT internal device monitor	125
2.14	Security	126
	Security level authentication	126
2.15	Operator Authentication	128
	Operator management	128
	Password change	148
	Function setting	151
CHAPTER 3 EXTENDED FUNCTION SETTING		157
3.1	SoftGOT-GOT Link Function	158
	SoftGOT-GOT link function setting	158
	Display operation of the SoftGOT-GOT link function setting	159
	SoftGOT-GOT link function setting operation	160
3.2	VNC Server Function	163
	VNC server function setting	163
	Display operation of the VNC server function setting	163
	VNC server function setting operation	164
3.3	Sequence Program Monitor	165
	Sequence program monitor setting	165
	Display operation of the sequence program monitor	166
	Sequence program monitor setting operation	166
3.4	Backup/Restoration	167
	Backup/restoration setting	167
	Display operation of backup/restoration setting	168
	Backup/restoration setting operation	169

3.5	Trigger Backup	171
	Trigger backup setting	171
	Display operation of the trigger backup setting	171
	Trigger backup setting operation	172
	Trigger time setting operation	173
3.6	License Management	174
	License management setting	174
	Display operation of the license management setting	174
	Setting operation of license management	175
3.7	Video/RGB	176
	Video unit setting	176
	Video display setting	178
	RGB display setting	182
3.8	Multimedia	184
	Video unit setting	184
	Video setting	186
	Long time recording setting	189
	Version control	191
	Network setting	194
	Multimedia screen	196
3.9	Wireless LAN Function	199
	Wireless LAN function setting	199
	Display operation of the wireless LAN function setting	199
	Display contents when [Action Mode] is set to [Access point]	200
	Display contents when [Action Mode] is set to [Station]	202
3.10	System Launcher	204
	System launcher setting	204
	Display operation of the system launcher setting	204
	Setting procedure for the system launcher	205
3.11	iQSS Utility	206
	iQSS utility setting	206
	Display operation of the iQSS utility setting	206
	Setting procedure for the iQSS utility	207
3.12	ANDON Connection	208
	ANDON connection setting	208
	Display operation of the ANDON connection setting	208
	Setting procedure for the ANDON connection	209
	Precautions	210
3.13	Ethernet Printer	211
	Ethernet printer setting	211
	Display operation of the Ethernet printer	211
	Procedure for setting an Ethernet printer	212
3.14	Network drive setting	213
	Setting the network drive	213
	Displaying the network drive setting screen	213
	Procedure for setting the network drive	214
CHAPTER 4 MAINTENANCE		215
4.1	Batch Self Check	216
	Batch self check	216

	Display operation of batch self check	216
	Operation of batch self check	217
4.2	USB Device Management	219
	Function of the USB device management	219
	Display operation of the USB device management	219
	USB device status display operation	220
4.3	Screen Cleaning	221
	Screen cleaning function	221
	Display operation of the screen for cleaning	221
	Operation of clean	222
4.4	Touch Panel Calibration	223
	Touch panel calibration setting	223
	Display operation of the touch panel calibration setting	223
	Touch panel calibration operation	224
4.5	System Alarm.	226
	System alarm.	226
	Display operation of system alarm	226
	Operation of system alarm display	227
4.6	Drawing Check.	228
	Drawing check function	228
	Display operation of drawing check.	228
	Drawing check operation	229
4.7	Font Check.	232
	Font check function	232
	Display operation of Font check	232
	Font check operation	233
4.8	Touch Panel Check	234
	Touch panel check function	234
	Display operation of Touch panel check	234
	Touch panel check operations.	235
4.9	I/O Check	236
	I/O check function	236
	Display operation of I/O Check	237
	I/O check operation	238
4.10	Ethernet Status Check	241
	Ethernet status check function	241
	Display operation of Ethernet status check.	241
	Operation of Ethernet status check	242
4.11	GOT Information	243
	GOT information	243
	Display operation of GOT information	243
	Display of GOT information	244
4.12	GOT Mobile Information	245
	GOT Mobile information	245
	Display operation of the GOT Mobile information	245
	Displaying the GOT Mobile information	246
CHAPTER 5 MONITOR		247
5.1	Monitor Screens	247
	Function of monitor screens	248

Display operation of monitor screens	249
--	-----

CHAPTER 6 DATA CONTROL 251

6.1 Data Type and Storage Location	252
6.2 Alarm Information	255
Function of alarm information	255
The display operation of alarm information	255
The display example of alarm information	256
Alarm information operation	257
6.3 Image File Management	262
Function of image file management	262
Display operation of image file management	262
Display example of image file management	263
Operation of image file management	264
6.4 Recipe Information	269
Function of recipe information	269
Display operation of recipe information	271
Example of advanced recipe information display	272
Recipe information operation	273
Precautions	302
6.5 Logging Information	304
Function of logging information	304
Display operation of logging information	304
Example of logging information display	305
Logging information operation	306
Precautions	316
6.6 Operation Log Information	318
Function of operation log information	318
Display operation of operation log information	319
Example of operation log information display	320
Operation log information operation	322
Precautions	340
6.7 File Manager	341
Required system application (extended function)	341
Display operation of the file manager screen	342
Display example of the file manager screen	343
Operations on the file manager screen	344
Precautions	354
6.8 File Print	356
Required system application (extended function)	356
Display operation of the file print	357
Display example of the file print screen	358
Operation of the file print	359
Precautions	362
6.9 Package Data Management	363
Function of package data management	363
Display operation of package data management	363
Display example of package data management	364
Operation of package data management	365
Precautions	373

6.10	Backup/Restore Function	374
	Backup/restore function	374
	Display operation of backup/restoration	374
	Operation of backup/restoration	374
6.11	SRAM management	375
	Function of SRAM management	375
	Display operation of SRAM management	375
	Display example of SRAM management	376
	SRAM management operation	377
6.12	Memory Card Format	381
	Display operation of memory card format	381
	Operating the memory card format	382
6.13	Memory Check	384
	Memory check function	384
	Display operation of memory check	384
	Memory check operation	385
6.14	GOT Data Package Acquisition	387
	GOT data package acquisition function	387
	Display operation of GOT data package acquisition	387
	Display example of GOT data package acquisition	388
	GOT data package acquisition operation	389

CHAPTER 7 BOOTOS AND SYSTEM APPLICATION **391**

7.1	Preparation before Installation	392
7.2	Installation Using Data Storage	393
	Installing when starting the GOT	394
	Installing using the data control function (Utility)	396
7.3	When Installing the Different Version	398

CHAPTER 8 SYSTEM ALARM DISPLAY AND LIST **401**

8.1	Display on the GOT	401
8.2	Error Codes and System Alarm List	403

PART 2 UTILITY FOR GT21

CHAPTER 9 UTILITY FUNCTION **422**

9.1	Utility Execution	422
9.2	Utility Function List	423
9.3	Utility Display	425
	Display operation of main menu	427
	Utility basic configuration	429
	Basic operation of settings change	430

CHAPTER 10 LANGUAGE SETTING **433**

10.1	Display Language Setting	433
	Display language setting function	433
	Language setting operation	433

CHAPTER 11 COMMUNICATION INTERFACE SETTING 435

11.1	Standard I/F	435
	Standard I/F functions	435
	Standard I/F display operation	436
	Display contents of standard I/F	438
	Detail information setting operation	445
	Channel setting operation	448
	Driver setting operation	450
11.2	GOT IP Address Setting (Ethernet models only)	451
	Standard	451
	Display operation of GOT IP address	451
	Setting operation	454
11.3	Ethernet Communication (Ethernet models only)	456
	Setting function for Ethernet communication	456
	Display operation of Ethernet communication	456
	Display contents of Ethernet setting	459
11.4	Communication Monitor	464
	Communication monitor functions	464
	Communication monitor display operation	464
	Screen display content	467
11.5	Ethernet Check (Ethernet models only)	469
11.6	Setting the Transparent Mode	471
11.7	Keyword	472
	Keyword functions	472
	Keyword display operation	472
	Regist	473
	Delete	476
	Clear	478
	Protect	479
11.8	Ethernet Printer	480
	Ethernet printer setting	480
	Display operation of the Ethernet printer	480
	Procedure for setting an Ethernet printer	483

CHAPTER 12 DISPLAY AND OPERATION SETTINGS 485

12.1	Display Settings	486
	Display functions	486
	Display operation of display setting	487
	Display setting operations	489
12.2	Operation Settings (Settings for Operation)	492
	Operation setting functions	492
	Display operation of operation setting	493
	Setting operation of operation	495
	Position correction of the touch panel (touch panel calibration setting)	497
	Setting the utility call keys	499
12.3	Inherent Information	502
	Setting function for inherent information	502
	Display operation of inherent information	502
	Setting operation for inherent information	502

12.4	USB Host	503
	USB host setting	503
	Display operation of the USB host setting	503
	Setting operation of USB host	504
12.5	Setting the storage location for backup and restoration	506
	Backup/restoration setting	506
	Display operation for setting the storage location for backup and restoration	506
	Backup/restoration setting operation	507
12.6	GOT Internal Device Monitor	508
	Setting the GOT internal device monitor	508
	GOT internal device monitor display operation	508
	GOT internal device monitor setting operation	509
12.7	VNC Server Function	510
	VNC server function setting	510
	Display operation of the VNC server function setting	510
	VNC server function setting operation	511
12.8	License Management	512
	License management setting	512
	Display operation of the license management setting	512
	Setting operation of license management	513
12.9	IP filter setting	514
	IP filter setting	514
	Display operation of the IP filter setting	514
	Setting procedure for the IP filter	515

CHAPTER 13 SECURITY LEVEL AND OPERATOR SETTINGS **521**

13.1	Security Level Authentication	521
13.2	Operator Authentication	523
	Operator information management	523
	Password change	532
	Function setting	534
13.3	Login/Logout	536

CHAPTER 14 CLOCK SETTINGS AND BATTERY STATUS DISPLAY **537**

14.1	Time Setting and Display	537
	Time setting and display functions	537
	Clock synchronization method	538
	Time setting	539
	Adjusting the clock	542
	Broadcasting the clock data	546
	Local time	550

CHAPTER 15 CONTROL OF VARIOUS DATA **553**

15.1	Data Storage Location	553
	Data type and storage location	553
	Checking version of BootOS and basic system application	557
15.2	OS information	558
15.3	Resource Data Information	559
	Alarm information	559
	Recipe information	569

	Logging information	580
	Image file management	587
	Operation log information	594
15.4	SD Card Access	600
	Functions of SD card access	600
	Display operation of SD card access	600
	Operation of SD card access	600
15.5	SD Card Format	601
15.6	Clear Data	605
	Clear data functions	605
	Clear data display	605
	Clear data operation	608
15.7	Data Copy	609
	Display operation of data copy	609
	Operation of data copy	611
15.8	Backup and Restoration	614
	Backup and restoration	614
	System configuration	615
	Access range	618
	Precautions	619
	Security and password	622
	Display operation of backup and restoration	628
	Backup operation	629
	Restoration operation	631
	Keyword operations	633
	Errors and corrective actions	634
15.9	USB Device Management	636
	Function of the USB device management	636
	Display operation of the USB device management	636
	USB device status display operation	637
CHAPTER 16 DEBUG		639
16.1	Device Monitor Function	639
	System configuration	639
	Devices that can be monitored	640
	Precautions	640
	Display operation of device monitor	641
	Information displayed on the device monitor screen and key functions	645
	Basic operation of device monitor	647
	Device registration	648
	Quick test	650
16.2	FX List Editor	653
	Display operation of FX list editor	653
	Specifications	656
	Access range	657
	Precautions	658
	Display operation	659
	Operation procedures	662
	Selection and operation of modes	664
	Displaying sequence programs	665

Searching commands/devices	667
Writing commands	669
Changing operands, set values	672
Deleting commands	673
Sequence program all clear	674
PLC diagnostics	675
Parameter setting	676
Keyword	678
List monitor	680
Action for an incorrect key input	682
Error messages and corrective actions	682
16.3 FX3U-ENET-ADP Communication Setting Function	683
Specifications	683
Display operation of FX3U-ENET-ADP communication setting function	684
Setting operation	685
CHAPTER 17 MAINTENANCE	687
<hr/>	
17.1 Touch Panel Calibration	687
17.2 Touch Panel Check	690
17.3 Clean	692
CHAPTER 18 BOOTOS AND SYSTEM APPLICATION	693
<hr/>	
18.1 Preparation before Installation	694
18.2 Installation Using Data Storage	695
Installing when starting the GOT	696
Installing using the data copy function (Utility)	696
CHAPTER 19 ERROR MESSAGE LIST	697
<hr/>	
19.1 GOT Error Messages and Corrective Actions	697
Revisions	698
Warranty	701
Intellectual Property Rights	702

INTRODUCTION

Thank you for choosing Mitsubishi Electric Graphic Operation Terminal (GOT).

Before using the product, read this manual carefully and make sure you understand the functions and performance of the GOT for correct use.

☞ Manuals for GT Works3

☞ Abbreviations, Generic Terms, and Model Icons

Manuals for GT Works3

The electronic manuals related to this product are installed together with the screen design software.

If you need the printed manuals, consult your local sales office.

Manuals for GT Designer3 (GOT2000)

Point

e-Manual refers to the Mitsubishi Electric FA electronic book manuals that can be browsed using a dedicated tool.

e-Manual has the following features:

- Required information can be cross-searched in multiple manuals.
- Other manuals can be accessed from the links in the manual.
- Hardware specifications of each part can be found from the product figures.
- Pages that users often browse can be bookmarked.
- Sample programs can be copied to the engineering tool.

■ Screen design software-related manuals

Manual name	Manual number (Model code)	Format
GT Works3 Installation Instructions	-	PDF
GT Designer3 (GOT2000) Screen Design Manual	SH-081220ENG (1D7ML9)	PDF e-Manual
GT Converter2 Version3 Operating Manual for GT Works3	SH-080862ENG (1D7MB2)	PDF e-Manual
GOT2000 Series MES Interface Function Manual for GT Works3 Version1	SH-081228ENG	PDF e-Manual

■ Connection manuals

Manual name	Manual number (Model code)	Format
GOT2000 Series Connection Manual (Mitsubishi Electric Products) For GT Works3 Version1	SH-081197ENG (1D7MJ8)	PDF e-Manual
GOT2000 Series Connection Manual (Non-Mitsubishi Electric Products 1) For GT Works3 Version1	SH-081198ENG	PDF e-Manual
GOT2000 Series Connection Manual (Non-Mitsubishi Electric Products 2) For GT Works3 Version1	SH-081199ENG	PDF e-Manual
GOT2000 Series Connection Manual (Microcomputers, MODBUS/Fieldbus Products, Peripherals) For GT Works3 Version1	SH-081200ENG	PDF e-Manual
GOT2000 Series Handy GOT Connection Manual For GT Works3 Version1	SH-081867ENG (1D7MS9)	PDF e-Manual

■GT SoftGOT2000 manuals

Manual name	Manual number (Model code)	Format
GT SoftGOT2000 Version1 Operating Manual	SH-081201ENG	PDF e-Manual
MELSOFT GT OPC UA Client Operating Manual	SH-082174ENG	PDF

■GOT2000 series user's manuals

Manual name	Manual number (Model code)	Format
GOT2000 Series User's Manual (Hardware)	SH-081194ENG (1D7MJ5)	PDF e-Manual
GOT2000 Series User's Manual (Utility)	SH-081195ENG (1D7MJ6)	PDF e-Manual
GOT2000 Series User's Manual (Monitor)	SH-081196ENG (1D7MJ7)	PDF e-Manual

■GOT SIMPLE series user's manuals

Manual name	Manual number	Format
GOT SIMPLE Series User's Manual	JY997D52901	PDF e-Manual

■Manuals related to GT Works3 add-on projects

Manual name	Manual number (Model code)	Format
GT Works3 Add-on License for GOT2000 Enhanced Drive Control (Servo) Project Data Manual (Fundamentals)	SH-082072ENG (1D7MV1)	PDF e-Manual
GT Works3 Add-on License for GOT2000 Enhanced Drive Control (Servo) Project Data Manual (Screen Details)	SH-082074ENG (1D7MV3)	PDF e-Manual

Manuals for GT Designer3 (GOT1000)













Refer to the Help and manuals for GT Designer3 (GOT1000).

Abbreviations, Generic Terms, and Model Icons

The following shows the abbreviations, generic terms, and model icons used in this manual.

GOT

■GOT2000 series

Abbreviations and generic terms			Description	Meaning of icon			
				Available	Unavailable		
GT27	GT27-X	GT2715-X	GT2715-XTBA GT2715-XTBD				
		GT27-S	GT2712-S			GT2712-STBA GT2712-STWA GT2712-STBD GT2712-STWD	
	GT2710-S		GT2710-STBA GT2710-STBD				
	GT2708-S		GT2708-STBA GT2708-STBD				
	GT27-V	GT2710-V	GT2710-VTBA GT2710-VTWA GT2710-VTBD GT2710-VTWD				
			GT2708-V			GT2708-VTBA GT2708-VTBD	
		GT2705-V	GT2705-VTBD				
GT25			All GT25 models				
GT25-W	GT2512-WX	GT2512-WXTBD GT2512-WXTSD					
		GT2510-WX			GT2510-WXTBD GT2510-WXTSD		
		GT2507-W			GT2507-WTBD GT2507-WTSD		
		GT2507T-W			GT2507T-WTSD		
	GT25-S	GT2512-S			GT2512-STBA GT2512-STBD		
		GT2512F-S			GT2512F-STNA GT2512F-STND		
	GT25-V	GT2510-V			GT2510-VTBA GT2510-VTWA GT2510-VTBD GT2510-VTWD		
					GT2510F-V	GT2510F-VTNA GT2510F-VTND	
		GT2508-V			GT2508-VTBA GT2508-VTWA GT2508-VTBD GT2508-VTWD		
					GT2508F-V	GT2508F-VTNA GT2508F-VTND	
		GT2505-V			GT2505-VTBD		
	GT25HS-V Handy GOT	GT2506HS-V			GT2506HS-VTBD		
		GT2505HS-V			GT2505HS-VTBD		
GT23	GT23-V	GT2310-V	GT2310-VTBA GT2310-VTBD				
		GT2308-V	GT2308-VTBA GT2308-VTBD				

Abbreviations and generic terms		Description	Meaning of icon	
			Available	Unavailable
GT21		All GT21 models		
GT21-W	GT2107-W	GT2107-WTBD GT2107-WTSD		
GT21-Q	GT2105-Q	GT2105-QTBDS GT2105-QMBDS		
GT21-R	GT2104-R	GT2104-RTBD		
GT21-P	GT2104-P	GT2104-PMBD		
		GT2104-PMBDS		
		GT2104-PMBDS2		
		GT2104-PMBLS		
	GT2103-P	GT2103-PMBD		
		GT2103-PMBDS		
		GT2103-PMBDS2		
		GT2103-PMBLS		
GT SoftGOT2000		GT SoftGOT2000 Version1		

■GOT SIMPLE series

Abbreviations and generic terms		Description	Meaning of icon	
			Available	Unavailable
GS21	GS21-W-N	GS2110-WTBD-N GS2107-WTBD-N		
	GS21-W	GS2110-WTBD GS2107-WTBD		

■GOT1000 series, GOT900 series, and GOT800 series

Abbreviations and generic terms		Description	Meaning of icon	
			Available	Unavailable
GOT1000 Series		GOT1000 Series	-	
GOT900 Series		GOT-A900 Series GOT-F900 Series	-	
GOT800 Series		GOT-800 Series	-	

Communication unit

Abbreviations and generic terms	Description
Bus connection unit	GT15-QBUS GT15-QBUS2 GT15-ABUS GT15-ABUS2 GT15-75QBUSL GT15-75QBUS2L GT15-75ABUSL GT15-75ABUS2L
Serial communication unit	GT15-RS2-9P GT15-RS4-9S GT15-RS4-TE
MELSECNET/H communication unit	GT15-J71LP23-25 GT15-J71BR13
CC-Link IE TSN communication unit	GT25-J71GN13-T2
CC-Link IE Controller Network communication unit	GT15-J71GP23-SX
CC-Link IE Field Network communication unit	GT15-J71GF13-T2
CC-Link communication unit	GT15-J61BT13
Wireless LAN communication unit	GT25-WLAN
Serial multi-drop connection unit	GT01-RS4-M
Connection conversion adapter	GT10-9PT5S
Field network adapter unit	GT25-FNADP
Ethernet communication unit	GT25-J71E71-100
RS-232/485 signal conversion adapter	GT14-RS2T4-9P

Option unit

Abbreviations and generic terms	Description
Printer unit	GT15-PRN
Video input unit	GT27-V4-Z (A set of GT16M-V4-Z and GT27-IF1000)
RGB input unit	GT27-R2 GT27-R2-Z (A set of GT16M-R2-Z and GT27-IF1000)
Video/RGB input unit	GT27-V4R1-Z (A set of GT16M-V4R1-Z and GT27-IF1000)
RGB output unit	GT27-ROUT GT27-ROUT-Z (A set of GT16M-ROUT-Z and GT27-IF1000)
Digital video output unit	GT27-VHOUT
Multimedia unit	GT27-MMR-Z (A set of GT16M-MMR-Z and GT27-IF1000)
Video signal conversion unit	GT27-IF1000
External I/O unit	GT15-DIO GT15-DIOR
Sound output unit	GT15-SOUT
SD card unit	GT21-03SDCD

Option

Abbreviations and generic terms	Description
SD card	NZ1MEM-2GBSD NZ1MEM-4GBSD NZ1MEM-8GBSD NZ1MEM-16GBSD L1MEM-2GBSD L1MEM-4GBSD
Battery	GT11-50BAT GT15-BAT
Protective sheet	GT27-15PSGC GT25-12WPSGC GT25-12PSGC GT25-10WPSGC GT25-10PSGC GT25-08PSGC GT21-07WPSGC GT25T-07WPSVC GT25-05PSGC GT25-05PSGC-2 GT21-05PSGC GT21-04RPSGC-UC GT21-03PSGC-UC GT21-04PSGC-UC GT27-15PSCC GT25-12WPSCC GT25-12PSCC GT25-10WPSCC GT25-10PSCC GT25-08PSCC GT25-05PSCC GT25-05PSCC-2 GT25-12PSCC-UC GT25-10PSCC-UC GT25-08PSCC-UC GT21-07WPSCC GT21-05PSCC GT21-04RPSCC-UC GT21-04PSCC-UC GT21-03PSCC-UC GT16H-60PSC GT14H-50PSC
Antibacterial/antiviral protective sheet	GT25-12PSAC GT25-10PSAC GT25-08PSAC
Environmental protection sheet	GT25F-12ESGS GT25F-10ESGS GT25F-08ESGS
Protective cover for oil	GT20-15PCO GT20-12PCO GT20-10PCO GT20-08PCO GT21-12WPCO GT21-10WPCO GT21-07WPCO GT25T-07WPCO GT25-05PCO GT25-05PCO-2 GT05-50PCO GT21-04RPCO GT10-30PCO GT10-20PCO
USB environmental protection cover	GT25-UCOV GT25-05UCOV GT21-WUCOV

Abbreviations and generic terms	Description
Stand	GT15-90STAND GT15-80STAND GT15-70STAND GT05-50STAND GT25-10WSTAND GT21-07WSTAND GT25T-07WSTAND
Attachment	GT15-70ATT-98 GT15-70ATT-87 GT15-60ATT-97 GT15-60ATT-96 GT15-60ATT-87 GT15-60ATT-77 GT21-04RATT-40
Panel-mounted USB port extension	GT14-C10EXUSB-4S GT10-C10EXUSB-5S
Connector conversion box	GT16H-CNB-42S GT16H-CNB-37S GT11H-CNB-37S
Emergency stop switch guard cover	GT16H-60ESCOV GT14H-50ESCOV
Wall-mounting attachment	GT14H-50ATT

Software

■ Software related to GOT

Abbreviations and generic terms	Description
GT Works3	SW1DND-GTWK3-J, SW1DND-GTWK3-E, SW1DND-GTWK3-C
GT Designer3 Version1	Screen design software GT Designer3 for GOT2000 and GOT1000 series
GT Designer3	Screen design software for GOT2000 series included in GT Works3
GT Designer3 (GOT2000)	
GT Designer3 (GOT1000)	Screen design software for GOT1000 series included in GT Works3
Speech synthesis license	GT Works Text to Speech License (SW1DND-GTVO-M)
Add-on license	GT Works3 add-on license for GOT2000 enhanced drive control (servo) project data (SW1DND-GTSV-MZ)
GENESIS64 Advanced	GENESIS64 server application (GEN64-APP)
GENESIS64 Basic SCADA	GENESIS64 server application (GEN64-BASIC)
GENESIS64	Generic term of GENESIS64 Advanced and GENESIS64 Basic SCADA
GOT Mobile function license for GT SoftGOT2000	License required to use the GOT Mobile function with GT SoftGOT2000 (SGT2K-WEBSKEY-□)
GT Simulator3	Screen simulator GT Simulator3 for GOT2000, GOT1000, and GOT900 series
GT SoftGOT2000	GOT2000 compatible HMI software GT SoftGOT2000
GT OPC UA Client	MELSOFT GT OPC UA Client (SW1DNN-GTOUC-MD)
GT Converter2	Data conversion software GT Converter2 for GOT1000 and GOT900 series
GT Designer2 Classic	Screen design software GT Designer2 Classic for GOT900 series
GT Designer2	Screen design software GT Designer2 for GOT1000 and GOT900 series
DU/WIN	Screen design software FX-PCS-DU/WIN for GOT-F900 series

■ Software related to iQ Works

Abbreviations and generic terms	Description
iQ Works	iQ Platform compatible engineering environment MELSOFT iQ Works
MELSOFT Navigator	Integrated development environment software included in SW□DND-IQWK (iQ Platform compatible engineering environment MELSOFT iQ Works) (□ represents a version.)
MELSOFT iQ AppPortal	SW□DND-IQAPL-M type integrated application management software (□ represents a version.)

Other software

Abbreviations and generic terms		Description
GX Works3		SW□DND-GXW3-E (-EA, -EAZ) type programmable controller engineering software (□ represents a version.)
GX Works2		SW□DNC-GXW2-E (-EA, -EAZ) type programmable controller engineering software (□ represents a version.)
Controller simulator	GX Simulator3	Simulation function of GX Works3
	GX Simulator2	Simulation function of GX Works2
	GX Simulator	SW□D5C-LLT-E (-EV) type ladder logic test tool function software package (SW5D5C-LLT (-V) or later versions) (□ represents a version.)
GX Developer		SW□D5C-GPPW-E (-EV)/SW□D5F-GPPW (-V) type software package (□ represents a version.)
GX LogViewer		SW□DNN-VIEWER-E type software package (□ represents a version.)
MI Configurator		Configuration and monitor tool for Mitsubishi Electric industrial computers (SW□DNNMICONF-M) (□ represents a version.)
PX Developer		SW□D5C-FBDQ-E type FBD software package for process control (□ represents a version.)
MT Works2		Motion controller engineering environment MELSOFT MT Works2 (SW□DND-MTW2-E) (□ represents a version.)
MT Developer		SW□RNC-GSV type integrated start-up support software for motion controller Q series (□ represents a version.)
CW Configurator		Setting/monitoring tools for the C Controller module and MELSECWinCPU (SW□DND-RCCPU-E) (□ represents a version.)
MR Configurator2		SW□DNC-MRC2-E type servo configuration software (□ represents a version.)
MR Configurator		MRZJW□-SETUP type servo configuration software (□ represents a version.)
FR Configurator2		Inverter setup software (SW□DND-FRC2-E) (□ represents a version.)
FR Configurator		Inverter setup software (FR-SW□-SETUP-WE) (□ represents a version.)
NC Configurator2		CNC parameter setting support tool (FCSB1221)
NC Configurator		CNC parameter setting support tool
FX Configurator-FP		Parameter setting, monitoring, and testing software package for FX3U-20SSC-H (SW□D5CFXSSCE) (□ represents a version.)
FX3U-ENET-L Configuration tool		FX3U-ENET-L type Ethernet module setting software (SW1D5-FXENETL-E)
RT ToolBox2		Robot program creation software (3D-11C-WINE)
RT ToolBox3		Robot program creation software (3F-14C-WINE)
MX Component		MX Component Version□ (SW□D5C-ACT-E, SW□D5C-ACT-EA) (□ represents a version.)
MX Sheet		MX Sheet Version□ (SW□D5C-SHEET-E, SW□D5C-SHEET-EA) (□ represents a version.)
CPU Module Logging Configuration Tool		CPU module logging configuration tool (SW1DNN-LLUTL-E)

License key (for GT SoftGOT2000)

Abbreviations and generic terms	Description
License key	GT27-SGTKEY-U

Others

Abbreviations and generic terms	Description
IAI	IAI Corporation
AZBIL	Azbil Corporation
OMRON	OMRON Corporation
KEYENCE	KEYENCE CORPORATION
KOYO EI	KOYO ELECTRONICS INDUSTRIES CO., LTD.
JTEKT	JTEKT Corporation
SHARP	Sharp Corporation
SHINKO	Shinko Technos Co., Ltd.
CHINO	CHINO CORPORATION
TOSHIBA	TOSHIBA CORPORATION
SHIBAURA MACHINE	SHIBAURA MACHINE CO.,LTD.
PANASONIC	Panasonic Corporation
PANASONIC IDS	Panasonic Industrial Devices SUNX Co., Ltd.
HITACHI IES	Hitachi Industrial Equipment Systems Co., Ltd.
HITACHI	Hitachi, Ltd.
HIRATA	Hirata Corporation
FUJI	FUJI ELECTRIC CO., LTD.
MURATEC	Muratec products manufactured by Murata Machinery, Ltd.
YASKAWA	YASKAWA Electric Corporation
YOKOGAWA	Yokogawa Electric Corporation
RKC	RKC INSTRUMENT INC.
ALLEN-BRADLEY	Allen-Bradley products manufactured by Rockwell Automation, Inc.
CLPA	CC-Link Partner Association
GE	GE Intelligent Platforms, Inc.
HMS	HMS Industrial Networks
LS IS	LS Industrial Systems Co., Ltd.
MITSUBISHI INDIA	Mitsubishi Electric India Pvt. Ltd.
ODVA	Open DeviceNet Vendor Association, Inc.
SCHNEIDER	Schneider Electric SA
SICK	SICK AG
SIEMENS	Siemens AG
SCHNEIDER EJH	Schneider Electric Japan Holdings Ltd.
PLC	Programmable controller manufactured by its respective company
Control equipment	Control equipment manufactured by its respective company
Temperature controller	Temperature controller manufactured by its respective company
Indicating controller	Indicating controller manufactured by its respective company
Controller	Controller manufactured by its respective company
TSN Switch	CC-Link IE TSN Class B (Synchronized Realtime Communication) hub certified by CC-Link Partner Association
General-purpose Switch	CC-Link IE TSN Class A (Realtime Communication) hub certified by CC-Link Partner Association
CC-Link IE TSN-equipped module	Generic term for the following CC-Link IE TSN master/local modules and CC-Link IE TSN Plus master/local module <ul style="list-style-type: none"> • RJ71GN11-T2 • RJ71GN11-EIP • FX5-CCLGN-MS

MEMO

PART 1

UTILITY FOR GT27/ GT25/GT23

1 UTILITY FUNCTION

2 GOT BASIC SETTING

3 EXTENDED FUNCTION SETTING

4 MAINTENANCE

5 MONITOR

6 DATA CONTROL

7 BOOTOS AND SYSTEM APPLICATION

8 SYSTEM ALARM DISPLAY AND LIST

1 UTILITY FUNCTION

☞ Page 36 Utility Execution

☞ Page 37 Utility Function List

☞ Page 42 Utility Display

Utility is a function, which carries out connection of GOT and controller, screen display and operation method settings, program/data control and self-check etc.

Refer to the following for the utility function list.

☞ Page 37 Utility Function List

1.1 Utility Execution

For utility execution, utility has to be displayed by installing BootOS and basic system application in the C drive (built in flash memory).

There are following three types for the installing BootOS and basic system application methods.

1) GT Designer3→GOT

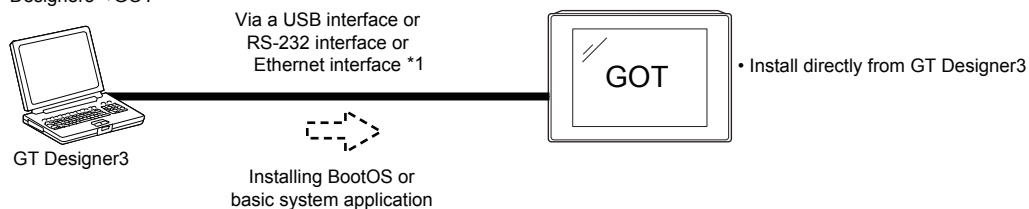

2) GT Designer3 → Data storage → GOT

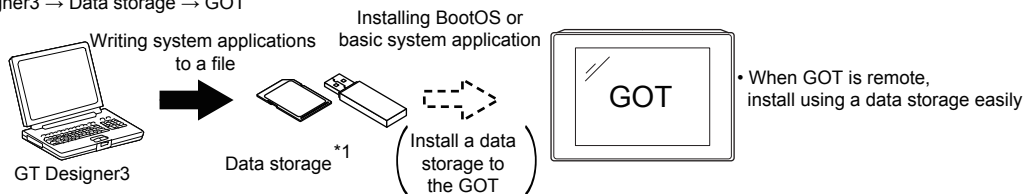

3) GOT → Data storage → GOT

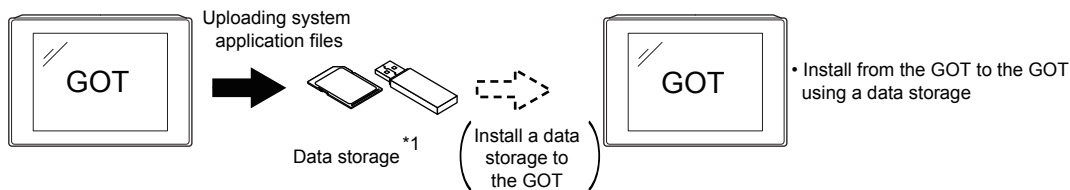

*1 When installing the BootOS and basic system application, standard monitor OS has to be installed in GOT in advance. Refer to the following for the installation which uses GT Designer3.

📖 GT Designer3 (GOT2000) Screen Design Manual

Refer to the following for the installation which uses GOT.

☞ Page 391 BOOTOS AND SYSTEM APPLICATION

1.2 Utility Function List

The items in the following list can be set/operated on the utility screens.

For GT Designer3 of an old version, displayed screens, setting items and others may differ from those described in the manual.

The sequence program monitor (R ladder) will be supported soon.

Item		Functions overview	Applicable GOT			Reference	
			GT27	GT25	GT23		
GOT basic setting	Display	Setting the startup screen display time and screen saving time	○	○	○	☞ Page 50 Display	
		Setting the battery alarm display to ON or OFF	○	○	○		
		Setting the detect level/detect time of human sensor	○	×	×		
		Adjusting brightness	○	○	○		
Language		Switching message languages	○	○	○	☞ Page 56 Language	
Unique information		Setting the GOT ID number	○	○	○	☞ Page 58 Unique Information	
IP address		Setting the GOT IP address, subnet mask, and default gateway Setting the GOT operation when a device with the same IP address as that of the GOT is added to the network afterwards.	○	○	○	☞ Page 60 IP Address	
IP filter setting		Setting IP addresses from which access to the GOT is allowed or blocked	○	○	○	☞ Page 67 IP Filter Setting	
Operation		Setting the buzzer volume and window move buzzer	○	○	○	☞ Page 71 Operation	
		Setting a musical interval for the buzzer sound	○	○	×		
		Setting the key sensitivity and key reaction speed	○	○	○		
		Setting the access switch for the drive A	○	○	○		
Utility call key		Setting the utility call keys	○	○	○	☞ Page 74 Utility Call Key	
USB host		Setting the USB mouse and keyboard	○	○*6	○	☞ Page 77 USB Host	
Time		Displaying and setting the clock current time	○	○	○	☞ Page 80 Time	
Controller	Assign Ethernet I/F	Setting the assign Ethernet I/F	○	○	○	☞ Page 99 Controller	
	Channel - Driver assign	Displaying the communication driver assigned to each channel	○	○	○		
	-	Changing assignment	Changing the assigned communication driver	○	○		○
	5 V power supply	Setting 5 V power supply for channel No. 1	○	○	×		
	Communication detail setting	Setting communication parameters, setting or deleting sequence program protection key words, canceling sequence program protection status (When connecting to FX series CPU)	○	○	○		
Ethernet communication		Displaying the contents of Ethernet setting, changing the host	○	○	○	☞ Page 116 Ethernet Communication	
Transparent mode		Setting the channel No. to be used for the communication for the FA transparent function	○	○	○	☞ Page 122 Transparent Mode	
GOT internal device monitor		Setting whether to use the GOT internal device monitor of the GOT diagnostics function	○	○	○	☞ Page 124 GOT Internal Device Monitor	
Security	Security level authentication	Authenticating security levels	○	○	○	☞ Page 126 Security	

Item			Functions overview	Applicable GOT			Reference
				GT27	GT25	GT23	
Maintenance	Operator authentication	Operator management	Managing operator	○	○	○	Page 128 Operator Authentication
		Password change	Changing a password	○	○	○	
		Function setting	Setting the operator authentication function	○	○	○	
Extended function setting	SoftGOT-GOT link function		Setting the SoftGOT-GOT link function	○	○	×	Page 158 SoftGOT-GOT Link Function
	VNC server function		Setting the VNC server function	○	○	×	Page 163 VNC Server Function
	Sequence program monitor		Starting the sequence program monitor	○	○	×	Page 165 Sequence Program Monitor
	Backup/restoration setting		Setting the backup and restoration	○	○	○	Page 167 Backup/Restoration
	-	Trigger backup setting	Setting the trigger backup	○	○	○	Page 171 Trigger Backup
		-	Trigger time setting	Setting the trigger time	○	○	
	License management		Displaying the screen for registering and releasing the license	○	○	×	Page 174 License Management
	Video/RGB		Displaying the screen for setting the video/RGB I/O unit	○ ^{*3}	×	×	Page 176 Video/RGB
	Multimedia		Displaying the screen for setting the multimedia	○ ^{*3}	×	×	Page 184 Multimedia
	Wireless LAN connection function		Setting the wireless LAN connection function	○	○ ^{*5}	×	Page 199 Wireless LAN Function
	System launcher		Configuring a setting to enable the online module change in the system launcher function	○	○	○	Page 204 System Launcher
	iQSS utility		Setting a drive for a data storage containing the profile data of iQSS-compatible equipment	○	○	×	Page 206 iQSS Utility
	ANDON connection		Setting the IP address of a client targeted for the ANDON connection	○	○	×	Page 208 ANDON Connection
	Ethernet printer		Setting the IP address of the Ethernet printer	○	○	○	Page 211 Ethernet Printer
Network drive setting		Setting the network drive	○	○	×	Page 213 Network drive setting	

Item	Functions overview	Applicable GOT			Reference	
		GT27	GT25	GT23		
Maintenance	Batch self check	Executing various diagnostics collectively and copying the result to a data storage	○	○	○	☞ Page 216 Batch Self Check
	USB device management	Displaying the status of USB device	○	○	○	☞ Page 219 USB Device Management
	Cleaning	Displaying the screen for cleaning the display	○	○	○	☞ Page 221 Screen Cleaning
	Touch panel calibration	Adjusting the touch panel	○	○	○	☞ Page 223 Touch Panel Calibration
	System alarm	Displaying the system alarm	○	○	○	☞ Page 226 System Alarm
	Drawing check	Checking the drawing	○	○	○	☞ Page 228 Drawing Check
	Font check	Checking the font	○	○	○	☞ Page 232 Font Check
	Touch panel check	Checking the touch panel	○	○	○	☞ Page 234 Touch Panel Check
	I/O check	Checking the I/O of RS-232 interface	○	○	○	☞ Page 236 I/O Check
	Ethernet status check	Checking the connection status of Ethernet	○	○	○	☞ Page 241 Ethernet Status Check
	GOT information	Displaying the GOT information	○	○	○	☞ Page 243 GOT Information
GOT Mobile information	Displaying the GOT Mobile function settings	○	○	×	☞ Page 245 GOT Mobile Information	

Item		Functions overview	Applicable GOT			Reference
			GT27	GT25	GT23	
Monitor	System launcher	Starting the system launcher	○	○	○	Page 247 Monitor Screens
	Device monitor	Starting the device monitor	○	○	○	
	Sequence program monitor (Ladder)	Starting the QCPU or LCPU sequence program monitor	○	○	×	
	Sequence program monitor (iQ-R ladder)	Starting the RCPUR sequence program monitor	○	○	×	
	Sequence program monitor (iQ-F ladder)	Starting the FX5CPU sequence program monitor	○	○	×	
	FX ladder monitor	Starting the FX ladder monitor	○	○	×	
	Network monitor	Starting the network monitor	○	○	×	
	Intelligent module monitor	Starting the intelligent module monitor	○	○	×	
	Servo amplifier monitor	Starting the servo amplifier monitor	○	○	×	
	Q motion monitor	Starting the Q motion monitor	○	○	×	
	R motion monitor	Starting the R motion monitor	○	○	×	
	CNC monitor	Starting the CNC monitor	○ ^{*1}	○ ^{*2}	×	
	CNC monitor 2	Starting the CNC monitor 2	○	○ ^{*4}	×	
	Sequence program monitor (SFC)	Starting the SFC monitor	○	○	×	
	Q Motion SFC monitor	Starting the Q motion SFC monitor	○	○	×	
	R Motion SFC monitor	Starting the R motion SFC monitor	○	○	×	
	Log viewer	Starting the log viewer	○	○	×	
	Network status display	Starting the network status display	○	○ ^{*7}	×	
	FX list editor	Starting the FX list editor	○	○ ^{*4}	○	
	CNC machining program edit	Starting the CNC machining program edit	○ ^{*1}	○ ^{*2}	×	
	CNC data I/O	Starting the CNC data I/O	○ ^{*1}	○ ^{*2}	×	
	Motion Program Editor	Starting the motion program editor	○ ^{*1}	○ ^{*8}	×	
	Motion Program I/O	Starting the motion program I/O	○ ^{*1}	○ ^{*8}	×	
	MELSEC-L troubleshooting	Starting the MELSEC-L troubleshooting	○	○	×	
	iQSS utility	Starting the iQSS utility	○	○	×	
	Drive recorder	Starting the drive recorder	○	○	×	
CC-Link IE diagnostics	Starting the CC-Link IE TSN/CC-Link IE Field Network diagnostics	○	○	×		
Servo amplifier graph	Starting the servo amplifier graph	○	○	×		
Vision sensor monitor	Starting the vision sensor monitor	○	○	×		

Item	Functions overview	Applicable GOT			Reference	
		GT27	GT25	GT23		
Data management	Alarm information	Deleting or copying alarm log files	○	○	○	Page 255 Alarm Information
		Converting alarm log files in G2A format → CSV/TXT format	○	○	○	
	Image file management	Deleting/copying image files, changing image file names	○	○	○	Page 262 Image File Management
	Recipe information	Converting recipe files in G2P → CSV/TXT format, deleting/copying/moving/creating recipe files, deleting/moving/changing recipe folder names, writing/reading/verifying record values with the recipe record list, deleting device values	○	○	○	Page 269 Recipe Information
	Logging information	Converting logging files in G2L format → CSV/TXT format	○	○	○	Page 304 Logging Information
		Deleting/copying/moving logging files, changing logging file names	○	○	○	
	Operation log information	Converting operation log files in G20 → CSV/TXT format	○	○	○	Page 318 Operation Log Information
		Deleting, copying, moving, or renaming an operation log file, deleting or creating an operation log folder	○	○	○	
	File manager	Deleting, copying, moving or renaming a folder or file, sorting the list of folders and files, or creating a folder	○	○	○	Page 341 File Manager
	File Print	Printing or previewing a report file	○	○	○	Page 356 File Print
	Package data management	Installing/uploading package data, checking the property	○	○	○	Page 363 Package Data Management
	Backup/restoration	Starting the backup/restoration function	○	○	○	Page 374 Backup/ Restore Function
	SRAM management	Confirming the SRAM user area usage, backing up or restoring the data in the SRAM user area, and initializing the SRAM user area	○	○	○	Page 375 SRAM management
	Memory card format	Formatting a data storage	○	○	○	Page 381 Memory Card Format
Memory check	Write/read check of a data storage and built-in flash memory	○	○	○	Page 384 Memory Check	
GOT data package acquisition	Copying the data stored in the GOT to an SD card in a batch	○	○	○	Page 387 GOT Data Package Acquisition	

*1 Available to GT27-X and GT27-S.

*2 Only available to GT25-S.

*3 GT2705-V does not support.

*4 Not available to GT25-W.

*5 Not available to GT2505-V and GT25HS-V.

*6 Not available to GT25HS-V.

*7 Not available to GT25-W, GT2505-V, and GT2505HS-V.

*8 Available to GT25-S, GT2512-WX, and GT2510-WX.

1.3 Utility Display

To display each setting screen of the utility, the main menu has to be displayed first. Even when the GOT is installed vertically, the utility screen appears horizontally. In the utility main menu, message dialogs appear according to the vertical installation.

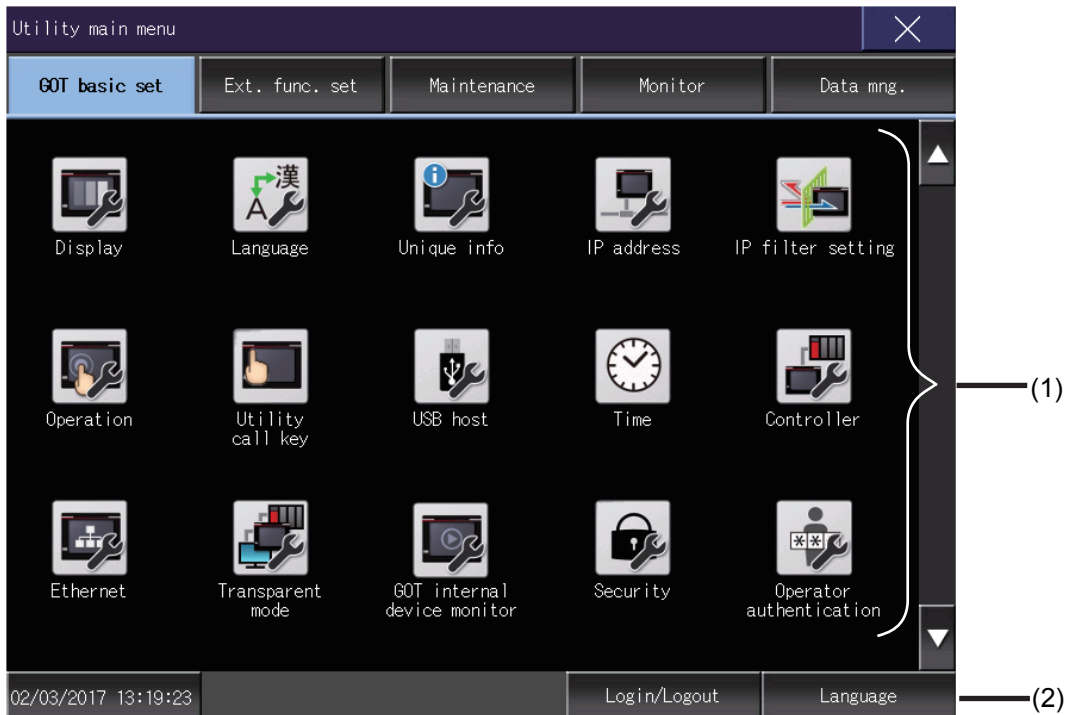

1)Main menu

The menu items that can be set at the GOT utility are displayed.

Touching a menu item in the main menu will display the setting screen or subsequent selection screen for the item.

2)System message switch button

This button switches the language used for the utility or system alarms.

When touching the [Language] button, the Select Language screen is displayed.

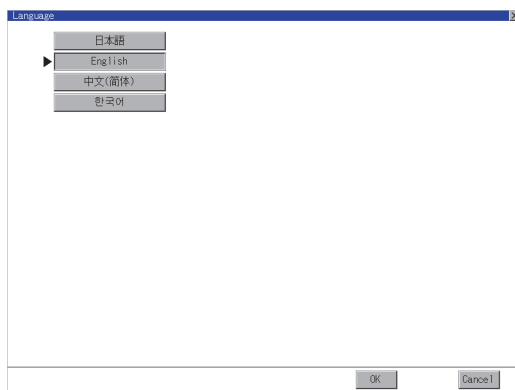

1. Touch the button of the language to be displayed.

2. Touch the [OK] button to restart the GOT for the selected language to take effect in the utility.

To cancel the setting, touch the [Cancel] button to return to the main menu.

When starting the GOT without selecting any language or the selected language and the installed fonts are not matched

- The following screen will be displayed.

Touching the button of a desired language restarts the GOT and the language is switched to the selected one.



- Selectable languages

The system message switch button is displayed only for the selectable languages.

The selectable languages differ depending on the fonts installed in the GOT.

For the relation between the selectable languages and the fonts, refer to the following.

 GT Designer3 (GOT2000) Screen Design Manual

- System language switching using the device

The system language can be switched using the system language switching device set with GT Designer3.

For the setting method of the system language switching device, refer to the following.

 GT Designer3 (GOT2000) Screen Design Manual

Display operation of main menu

The following three types of operation can display the main menu.

(Display the main menu after installing the basic system application from GT Designer3 to the GOT built in flash memory.)

When project data is undownloaded

If the power supply of GOT turns ON, the main menu is displayed automatically after title display.

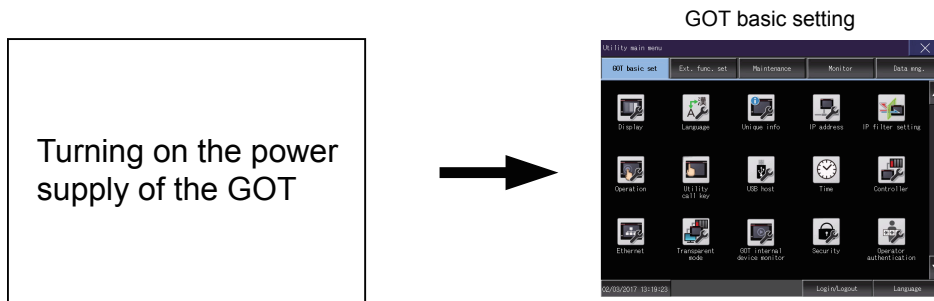

When touching menu call key

If you touch the menu call key while user-created screen is displayed, the main menu is displayed.

The menu call key is set in the position on the GOT screen upper left corner at factory shipment.

Utility call key

Touch a top left corner.

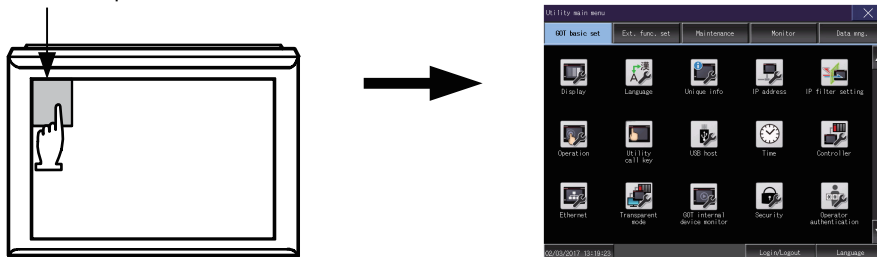

The menu call key can be set by the GOT utility or GT Designer3.

For the setting method of the utility call key, refer to the following.

Page 75 Utility call key setting operation

GT Designer3 (GOT2000) Screen Design Manual

Point

- Prohibited simultaneous 2-point presses

Do not touch 2 points or more on the GOT screen simultaneously. Touching 2 points or more simultaneously may activate a part other than the touched point.

- When setting menu call key to 1-point

When having set [Pressing time] of the menu call key setting screen to other than "0 (s)", keep pressing the touch panel for the period set to [Pressing time] or more before leaving the finger from the touch panel.

For menu call key setting, refer to the following.

Page 75 Utility call key setting operation

When touching special function switch (utility)

If you touch the special function switch (utility) while user-created screen is displayed, the main menu is displayed.

The special function switch (utility) can be set as a touch switch that is displayed on a user-created screen by GT Designer3.

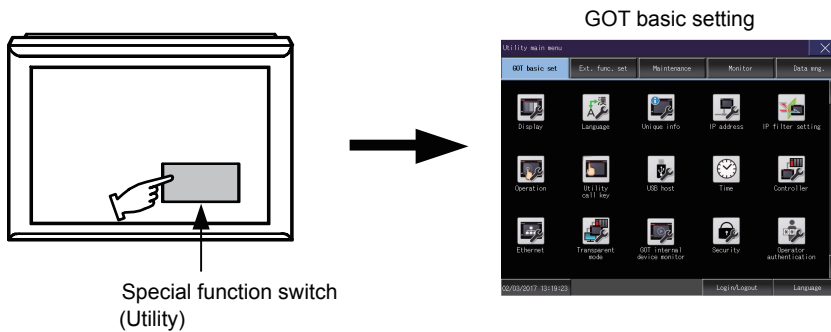

For the details of the special function switch, refer to the following.

GT Designer3 (GOT2000) Screen Design Manual

Locking the utility display by password

When you try to display the utility main menu while the password is set to the GOT by GT Designer3, the display for password input will be appeared.

(Set a password from the common setting menu.)



When the password is not matched, displays the error message.



When touching the [OK] button, the screen returns to the monitor screen.

■Input operation of password

1. Input the password after touching [0] to [9], [A] to [F] key.
2. Define the password by touching [Enter] key, after password input.
3. To correct the input character, touch [Del] key to delete the correcting character and reinput/retype the new character.

■Password input cancel operation

When the [x] button is touched, it returns to the monitor screen.

Refer to the following for the details related to the password setting.

GT Designer3 (GOT2000) Screen Design Manual

Utility basic configuration

The basic configuration of utility is as follows.

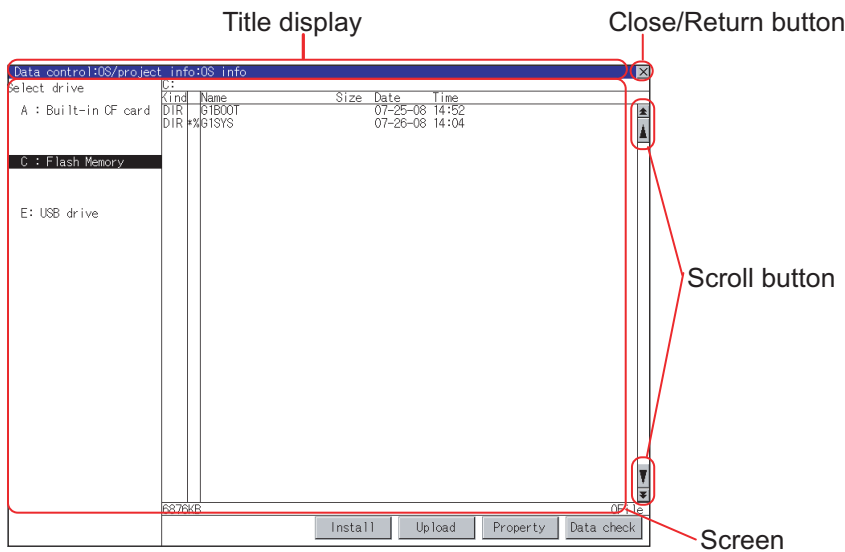

Title display

The screen title name is displayed in title display part.

As the screen is composed of multiple layers, the title including these layers is displayed.

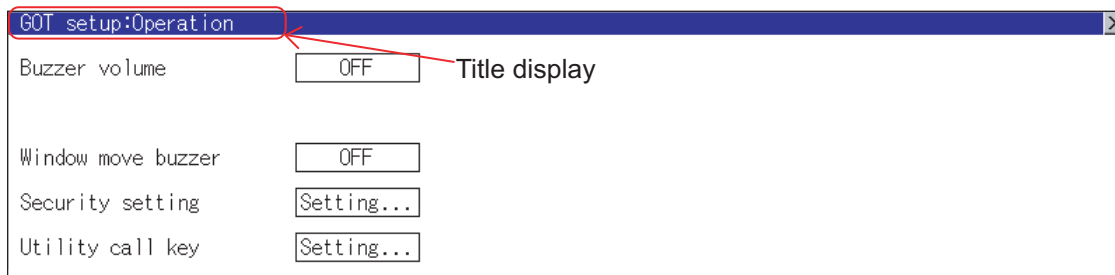

Close/Return button

When a middle screen of the layers is displayed, if the  (Close/return) button in the right corner of screen is touched, returns to the previous screen.

If this button is touched when directly displayed from monitor screen, the screen is closed and returns to monitor screen.

Scroll button

For screens in which the content does not fit on one screen page, there is a right or down scroll button on the screen.

    / Scroll one line/column.

    / Scroll window.

Basic operation to change the settings

Change of setting value

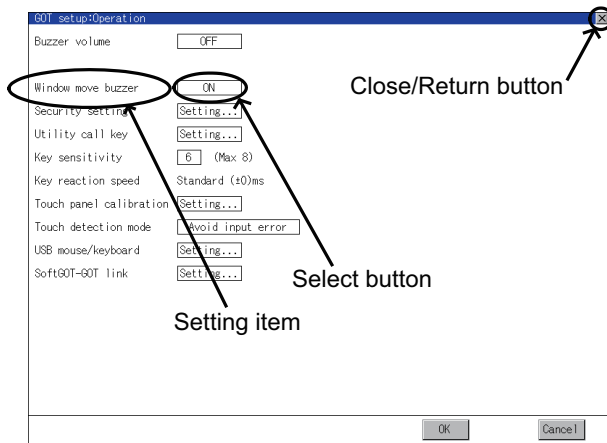

Example: [Operation] screen

■Setting item, select button

Touch a select button to change the setting.

The setting methods differ depending on the setting items.

The following setting methods are available.

- Changing the setting

Touch the select button to change the setting.

- Enter the setting value with a keyboard.

Touch the button to display a keyboard on the GOT screen.

- Move to another setting screen.

Touch the button to move to another setting screen.

For the setting method of each setting item, refer to the setting operation of each setting screen.

■[OK] button, [Cancel] button, [X] (Close/Return) button

Reflect or cancel the changed settings.

[OK] button

Touch this button to reflect the changed settings and return to the previous screen.

Depending on the setting item, the GOT restarts.

[Cancel] button

Touch this button to cancel the changed settings and return to the previous screen.

[X] (Close/Return) button

Touch this button to display the following dialog.

(If no setting is changed, the dialog is not displayed.)

Operate following the message of the dialog.

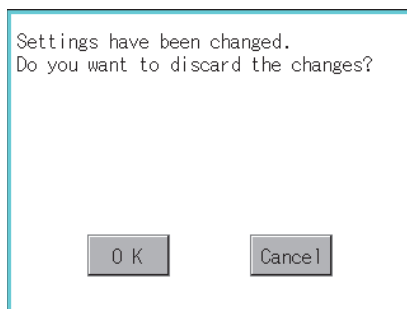

2 GOT BASIC SETTING

- ☞ Page 50 Display
- ☞ Page 56 Language
- ☞ Page 58 Unique Information
- ☞ Page 60 IP Address
- ☞ Page 67 IP Filter Setting
- ☞ Page 71 Operation
- ☞ Page 74 Utility Call Key
- ☞ Page 77 USB Host
- ☞ Page 80 Time
- ☞ Page 99 Controller
- ☞ Page 116 Ethernet Communication
- ☞ Page 122 Transparent Mode
- ☞ Page 124 GOT Internal Device Monitor
- ☞ Page 126 Security
- ☞ Page 128 Operator Authentication

Setting screen for display and setting screen for operation can be displayed from the GOT utility screen. In the setting screen for display and the setting screen for operation, the following settings can be set.

Item	Description	Reference
Display	Opening screen time, screen save time, battery alarm display, human sensor, sensor detect level, sensor detect time, sensor off delay, brightness adjustment mode, brightness adjustment, POWER LED	☞ Page 50 Display
Language	Language setting	☞ Page 56 Language
Unique information	Number setting, GOT name display, GOT description display	☞ Page 58 Unique Information
IP address	Ethernet communication unit, IP address, subnet mask, default gateway, peripheral software port No., transparent port No., behavior of duplicate IPs	☞ Page 60 IP Address
IP filter setting	Settings of the IP filter usage, filtering method, target IP address, and exception IP address	☞ Page 67 IP Filter Setting
Operation	Buzzer sound, musical interval, window move buzzer volume, Key sensitivity, Access switch for the drive A	☞ Page 71 Operation
Utility call key	Call key setting, pressing time setting	☞ Page 74 Utility Call Key
USB host	USB mouse setting, interlock with mouse cursor touch operation, USB keyboard setting, USB keyboard type setting	☞ Page 77 USB Host
Time	Time setting	Current time, GOT internal battery voltage status
	Adjust	Adjust the clock, mode, reference CH No., SNTP IP address, trigger type, specify the time zone of target unit, time zone, time difference from GMT
	Broadcast	Broadcast the clock data, broadcast CH No., trigger type, specify the time zone of target unit, time zone, time difference from GMT
	Local time	Specify time zone, time zone, time difference from GMT
Controller	The setting contents of the communication interface can be checked or changed.	☞ Page 99 Controller
Ethernet communication	The contents of the Ethernet setting can be checked and the host can be changed.	☞ Page 116 Ethernet Communication
Transparent mode	Channel No. setting	☞ Page 122 Transparent Mode
GOT internal device monitor	Setting whether to use the GOT internal device monitor of the GOT diagnostics function	☞ Page 124 GOT Internal Device Monitor
Security	Security level authentication	☞ Page 126 Security
Operator authentication	Operator management, password change function setting	☞ Page 128 Operator Authentication

2.1 Display

Display setting

Configure display settings.

The items which can be set are shown below. When each item part is touched, the respective setting becomes possible.

Item	Description	Setting range
Opening screen time	The title display period at the main unit boot can be set.	0 to 60 seconds ^{*1} <At factory shipment: 0 seconds>
Screen save time	The period from the user stops the touch panel operation till the screen save function starts can be set.	0 to 60 minutes ^{*1} <At factory shipment: 0 minutes>
Battery alarm display	Whether to display system alarm when the voltage of the GOT internal battery has dropped can be specified.	ON/OFF <At factory shipment: OFF>
Human sensor	Screen saver status cancel by human sensor can be set to Effective or Invalid.	Valid/Invalid <At factory shipment: Invalid>
Sensor detect level ^{*2}	The sensor detect level can be set.	0 to 10 <At factory shipment: 10>
Sensor detect time ^{*2}	The time corresponding to the [Sensor detect level] is displayed. (setting is disabled) When the [Sensor detect level] is changed, the corresponding time is reflected by touching [OK] button.	0 to 4 <At factory shipment: 0 seconds>
Sensor off delay	The time period from when the human sensor detects no human movement until the Human Sensor Detection Signal (System Signal 2-1.b5) turns OFF can be set.	0Min 10Sec to 60Min 0Sec <At factory shipment: 0Min 10Sec>
Brightness adjustment mode ^{*3}	The brightness adjustment mode can be set to the standard or low intensity mode.	Standard/Low <At factory shipment: standard>
Brightness adjustment	The brightness can be adjusted.	1 to 32 ^{*4} <Default: 32>
POWER LED ^{*5}	Turning on/off the POWER LED can be set.	Turning on/off <At factory shipment: turning on>

*1 If setting 0, the title screen is not hidden.

The title screen is always displayed for 4 seconds or longer (which changes depending on the project data contents).

*2 The monitoring time corresponding to the sensor detect level (0 to 10) is as follows.

As the sensor detect level becomes greater, the sensitivity of the human sensor becomes higher.

Sensor detect level	10	9	8	7	6	5	4	3	2	1	0
Sensor detect time [s]	0	0.1	0.2	0.4	0.8	1	1.5	2	2.5	3	4

*3 For BootOS version D or earlier, the [Standard] mode is specified.

*4 For GT23, the brightness can be adjusted in 16 levels.

The following table shows the correspondences between values set in the utility and the brightness in 16 levels.

Setting value	1	2	3	4	5	6	7	8	...	25	26	27	28	29	30	31	32
Brightness adjustment (16 levels)	1		2		3		4		...	13		14		15		16	

*5 GT23 does not support.

- Display setting by GT Designer3

Set the title display period and screen save time in [GOT setup] in [Environmental Setting] of GT Designer3. When change a part of the setting, change the setting by the GOT display setting after downloading the project data.

📖 GT Designer3 (GOT2000) Screen Design Manual

- Screen save time

Using the system information function can compulsorily switch the controller to the screen saving status (Forced Screen Saver Disable Signal) or disable the screen save time (Automatic Screen Saver Disable Signal) set with Utility.

📖 GT Designer3 (GOT2000) Screen Design Manual

- Display control by human sensor

The human sensor is a function that releases the GOT from the screen saving mode without the necessity to touch the GOT.

This function releases the GOT from the screen saving mode when the operator has come closer to the GOT.

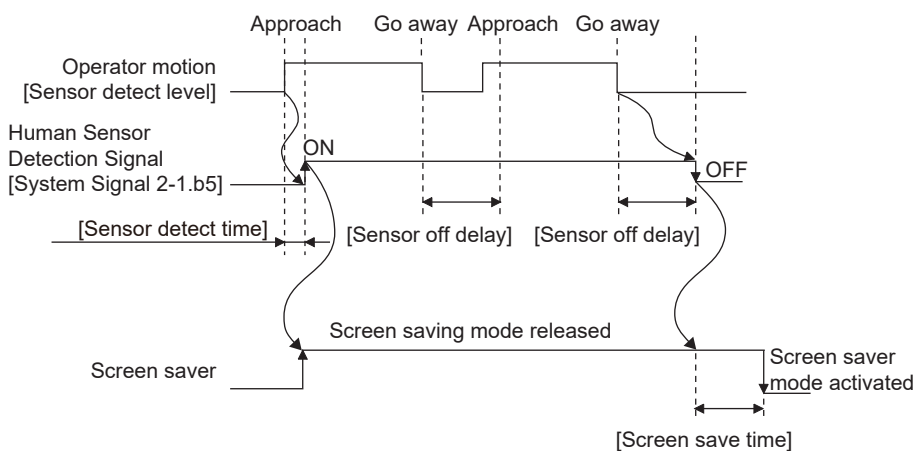

When there is no operator around the GOT for the time set as "Sensor OFF delay", the "Human Sensor Detection Signal" turns OFF.

When the time set as the "Screen save time" elapses after the "Human Sensor Detection Signal" turns OFF, the GOT enters the screen saving mode.

Refer to the following for the Human Sensor Detection Signal (System Signal 2-1.b5).

📖 GT Designer3 (GOT2000) Screen Design Manual

- When setting the human sensor to invalid

Even if setting the human sensor to invalid by the utility, the Human Sensor Detection Signal (System Signal 2-1.b5) turns ON when the human sensor detects human movement.

Unintended operation may result, therefore, if controlling the Forced Screen Saver Enable Signal (System Signal 1-1.b1) and Human Sensor Detection Signal associating them with each other by a sequence program, etc.

When setting the human sensor to invalid, review the related sequence program, etc.

- Restrictions when a backlight failure is detected

When the brightness adjustment mode is set to [Low] mode, the GOT cannot detect the backlight failure.

To detect the backlight failure, set the brightness adjustment mode to [Standard].

- Restrictions on the screen display in the [Low] mode

In the [Low] mode, the screen may flicker, or the screen display may turn off.

If you do not use the GOT in a dark place, set the brightness adjustment mode to [Standard].

- When the utility screen is difficult to see in the [Low] mode

Touch the upper-left corner of the main menu for two seconds to change the mode to the [Standard] mode.

When the utility screen transitions to a user-created screen, the mode is returned to the [Low] mode.

Display operation of display

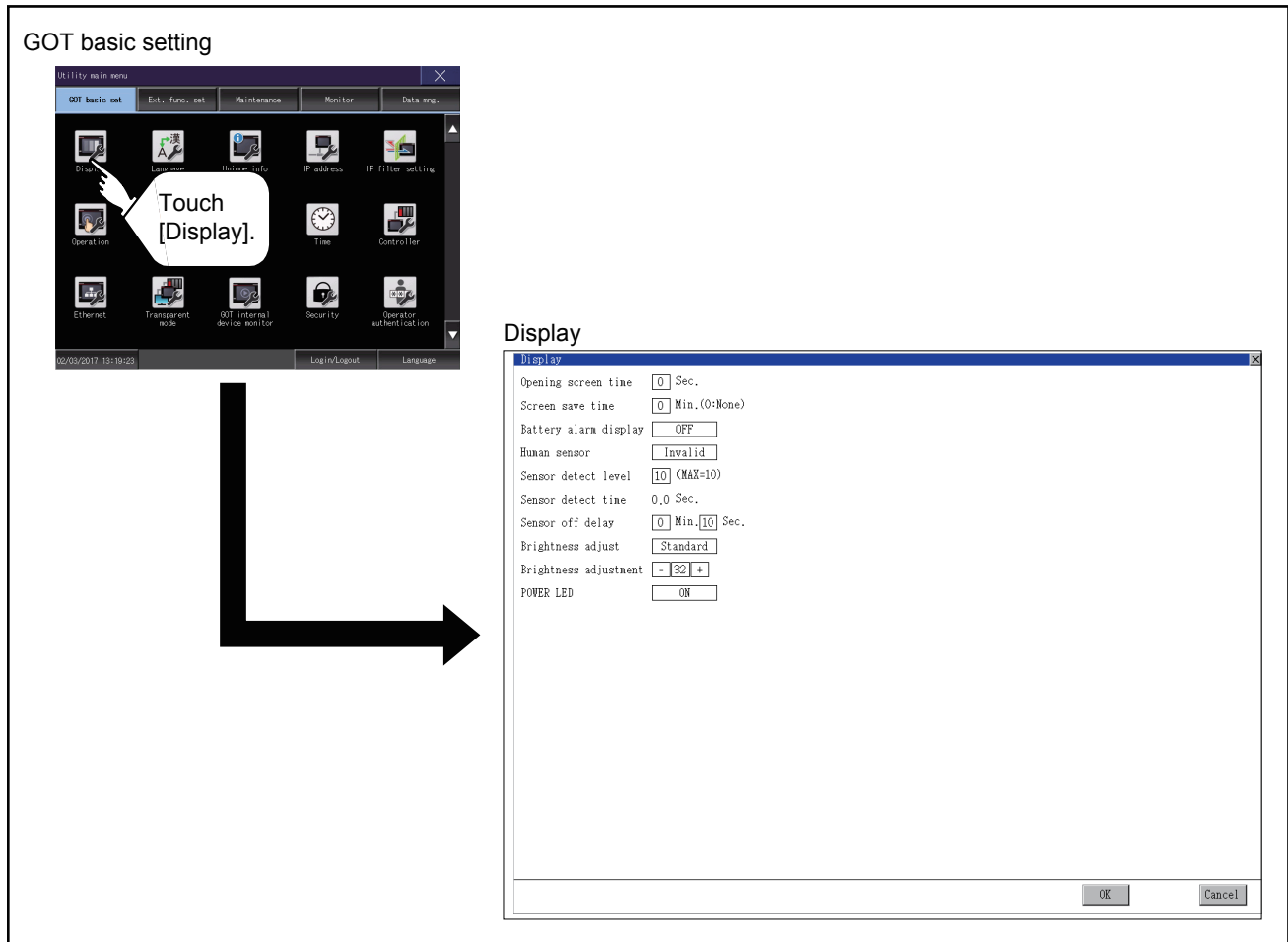

Display setting operations

Opening screen, screen save time

1. Touch the setting item (numeral) to display a software keyboard.
Input a value with the keyboard.

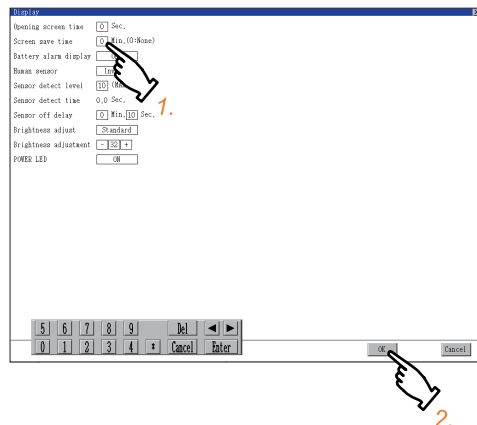

2. Touch the [OK] button to restart the GOT and reflect the setting change.
To cancel the setting change and return to the Main Menu, touch the [Cancel] button.

Battery alarm display

1. Touch the field of the setting to be changed.

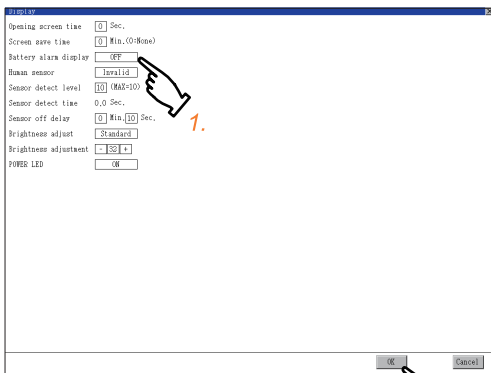

2. Touch the [OK] button to restart the GOT and reflect the setting change.
To cancel the setting change and return to the Main Menu, touch the [Cancel] button.

Human sensor

1. Touch the field of the setting to be changed.

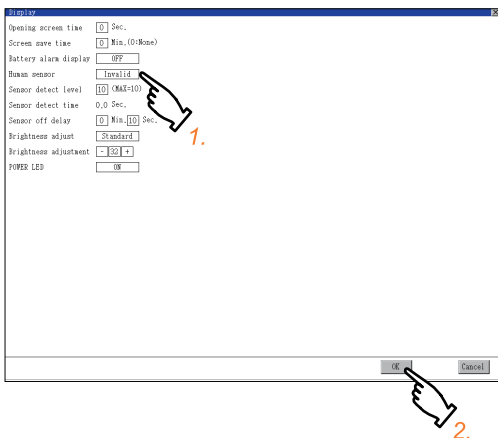

2. Touch the [OK] button to restart the GOT and reflect the setting change.
To cancel the setting change and return to the Main Menu, touch the [Cancel] button.

Sensor detect level, sensor off delay

1. Touch the setting item (numeral) to display a software keyboard.

Input a value with the keyboard.

To move the cursor, touch the ◀ or ▶ button.

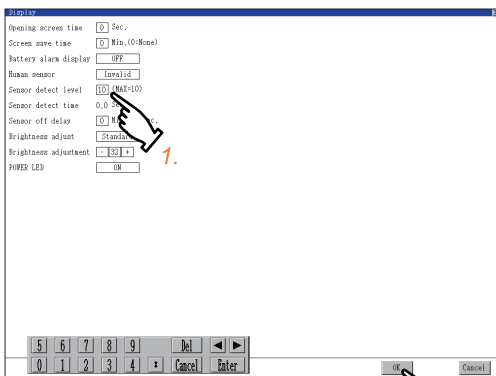

2. Touch the [OK] button to restart the GOT and reflect the setting change.

To cancel the setting change and return to the Main Menu, touch the [Cancel] button.

Brightness adjustment mode

1. Touch the field of the setting to be changed.

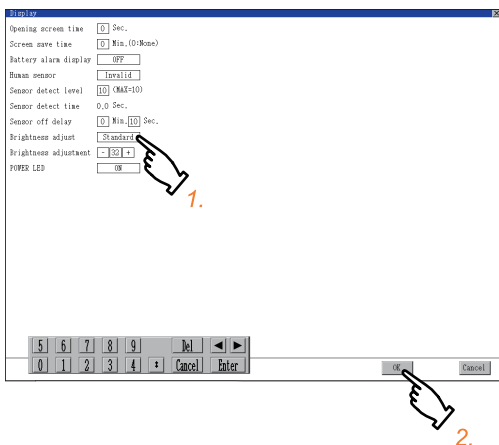

2. Touch the [OK] button to restart the GOT and reflect the setting change.

To cancel the setting change and return to the Main Menu, touch the [Cancel] button.

Brightness adjustment

1. Touch the [+] or [-] key to adjust the brightness.

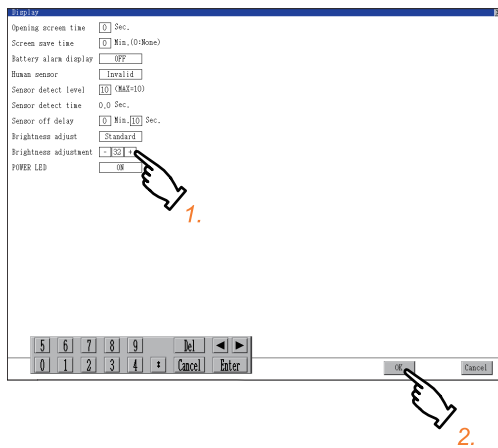

2. If touch the [OK] button, the changed settings are reflected and the screen returns to the [Display] screen. If touch the [Cancel] button, the changed settings are canceled and the screen returns to the [Display] screen.

POWER LED

1. Touch the field of the setting to be changed.

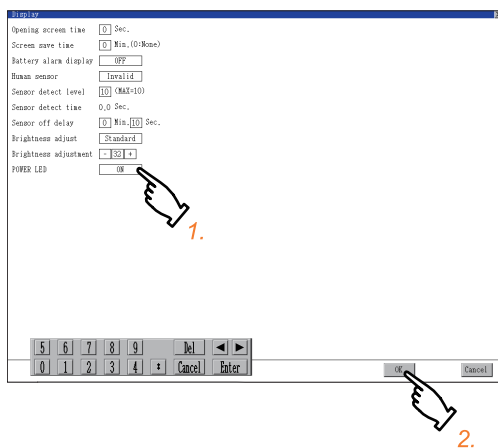

2. Touch the [OK] button to restart the GOT and reflect the setting change. To cancel the setting change and return to the Main Menu, touch the [Cancel] button.

2.2 Language

Language setting

Configure language settings.

Item	Description	Setting range										
Language*1	Confirmation of the current language and switching language can be performed regarding with the language displayed by utility and dialog.	<table border="1"><tr><td>日本語</td><td>(Japanese)</td></tr><tr><td>English</td><td>(English)</td></tr><tr><td>中文(简体)</td><td>(Chinese (Simplified))</td></tr><tr><td>中文(繁體)</td><td>(Chinese (Traditional))</td></tr><tr><td>한국어</td><td>(Korean)</td></tr></table> <p><At factory shipment: User's selection></p>	日本語	(Japanese)	English	(English)	中文(简体)	(Chinese (Simplified))	中文(繁體)	(Chinese (Traditional))	한국어	(Korean)
日本語	(Japanese)											
English	(English)											
中文(简体)	(Chinese (Simplified))											
中文(繁體)	(Chinese (Traditional))											
한국어	(Korean)											

- *1 Only selectable languages are displayed.
The selectable languages differ depending on the fonts installed in the GOT.
For details of the fonts, refer to the following.
 GT Designer3 (GOT2000) Screen Design Manual

Display operation of language display

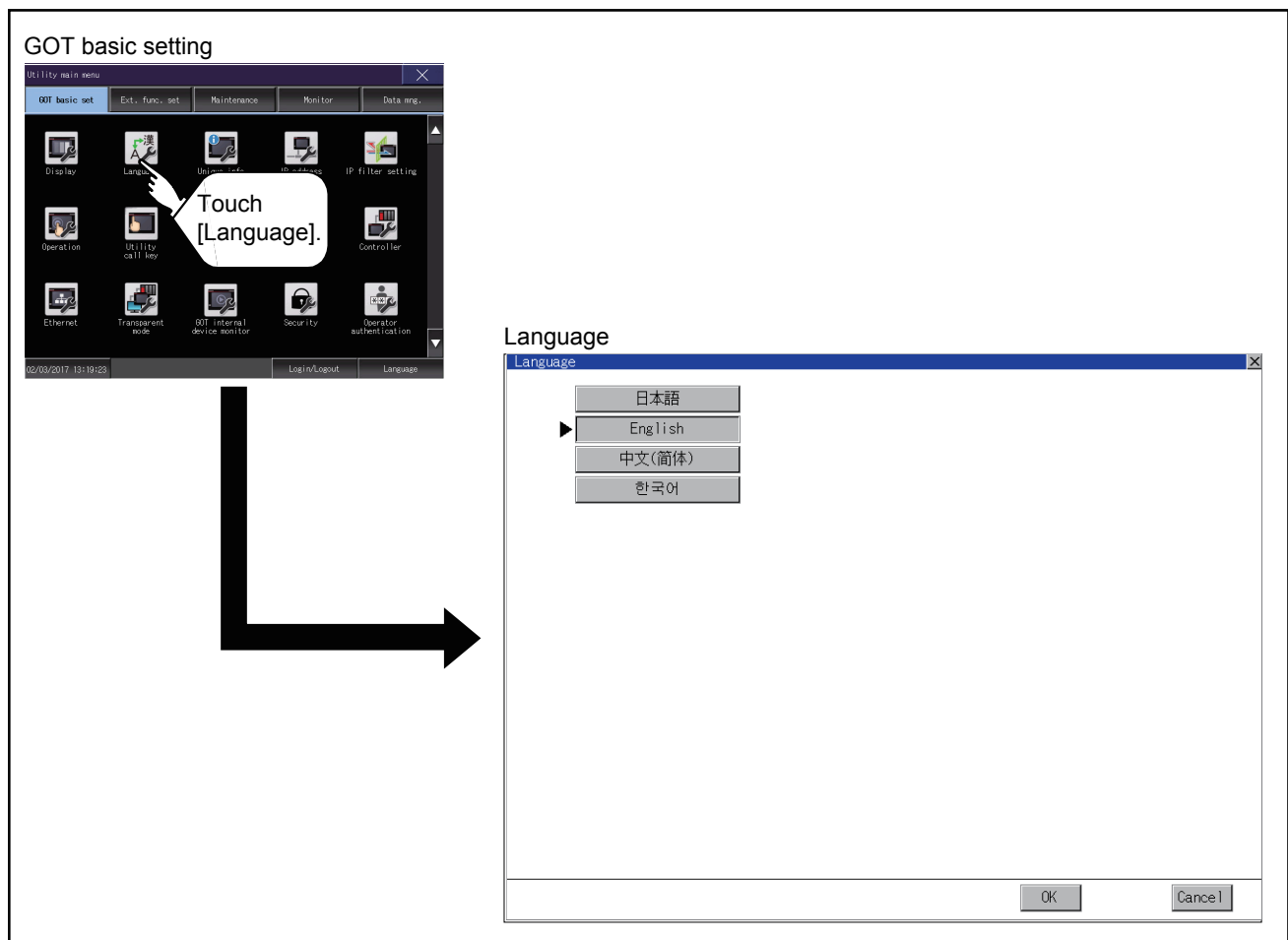

Setting operation of language

Language

1. If touch the language to be displayed, the language is selected.

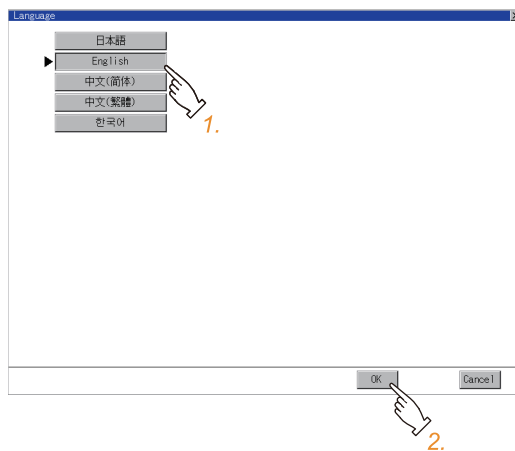

2. If touch the [OK] button, the GOT restarts and operates with the changed settings.

If touch the [Cancel] button, the changed settings are canceled and the screen returns to the Main Menu.

Point

- Selectable languages

The system message switch button is displayed only for the selectable languages.

The selectable languages differ depending on the fonts installed in the GOT.

For the relation between the selectable languages and the fonts, refer to the following.

 GT Designer3 (GOT2000) Screen Design Manual

- System language switching using the device

The system language can be switched using the system language switching device set with GT Designer3.

For the setting method of the system language switching device, refer to the following.

 GT Designer3 (GOT2000) Screen Design Manual

2.3 Unique Information

Unique information setting

Configure unique information settings.

Item	Description	Setting range
GOT ID No.	Set the ID No. as the unique information for the GOT.	0 to 32767 <Default: 0>

Display operation of unique information

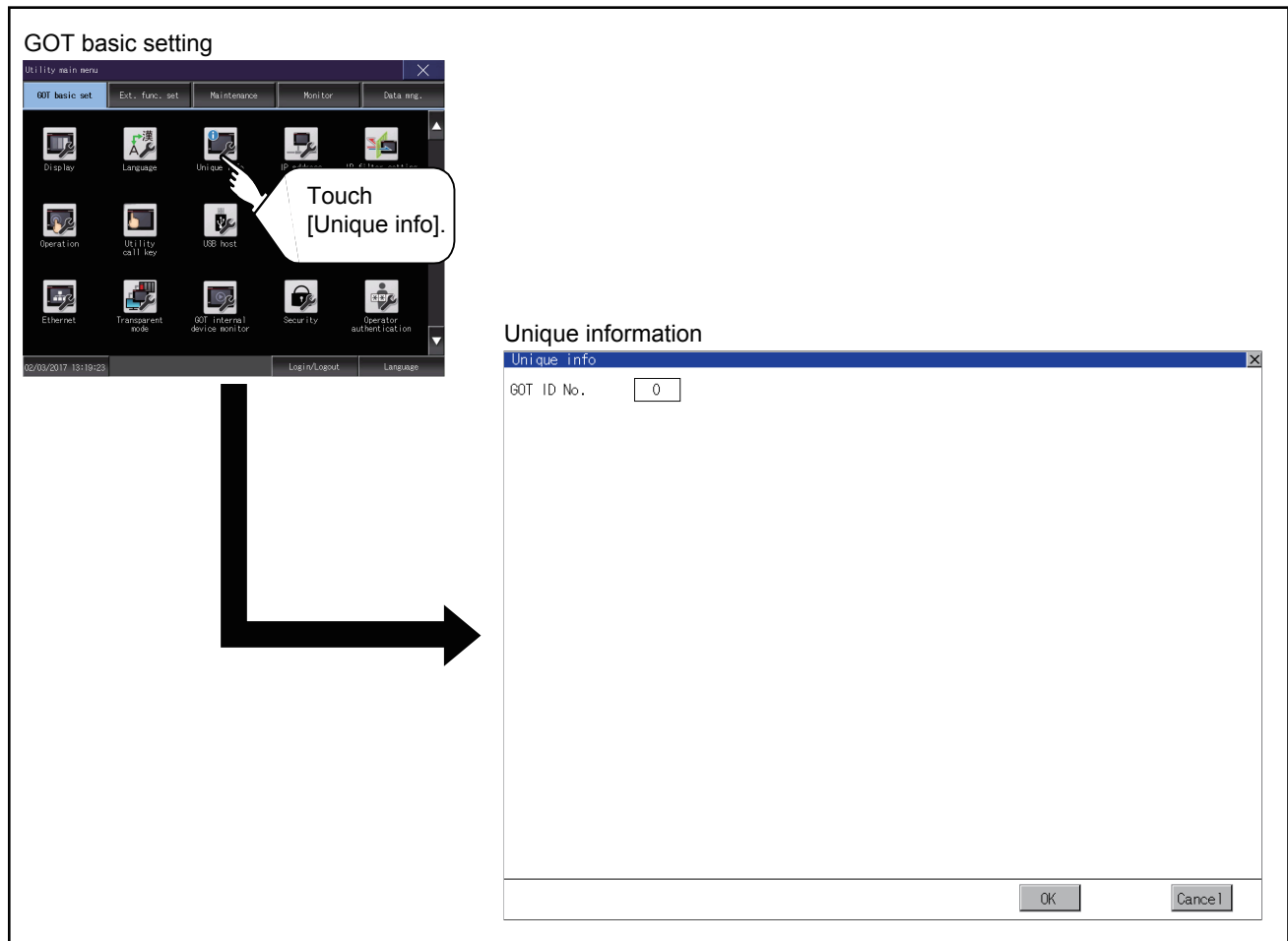

Setting procedure for unique information

GOT ID No.

1. Touch the setting item to display a software keyboard.
Input a value with the keyboard.

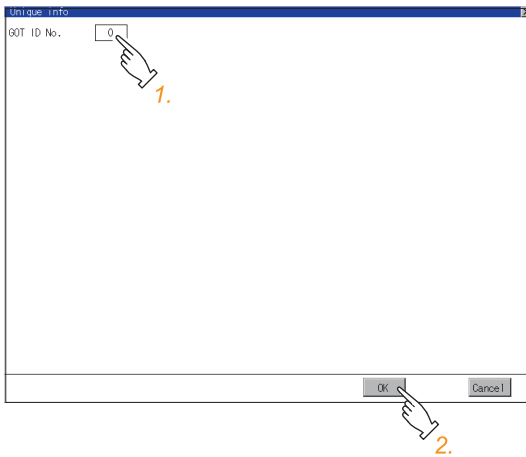

2. Touch the [OK] button to restart the GOT and reflect the setting change.
To cancel the setting change and return to the Main Menu, touch the [Cancel] button.

2.4 IP Address

IP address setting

Set the IP address and others.

Item	Description	Setting range
Ethernet comm. unit	Set whether to use the Ethernet communication unit.	Effective/Invalid <Default: Invalid>
IP Address	Check or set the IP address.	0.0.0.0 to 255.255.255.255 • Ethernet standard port, Ethernet standard port 1 <Default: 192.168.3.18> • Ethernet extension port, Ethernet standard port 2 <Default: 192.168.5.22> • Wireless LAN I/F <Default: 192.168.4.20>
Subnet Mask	Check or set the subnet mask.	0.0.0.0 to 255.255.255.255 <Default: 255.255.255.0>
Default Gateway	Check or set the router address of the default gateway.	0.0.0.0 to 255.255.255.255 <Default: 0.0.0.0>
Per. S/W wireless port No.	Set the port number for the GOT to use peripheral software.	1024 to 5010, 5014 to 49152, 49171 to 65534 <Default: 5014>
Transparent port No.	Set the port number for the GOT to use the FA transparent function.	1024 to 5010, 5014 to 49152, 49171 to 65534 <Default: 5015>
Behavior of duplicate IPs	Set the behavior of the GOT to be performed when a device with the same IP address as the GOT is connected to the network afterwards.	Maintain a network connection (rec)/Do not maintain a network connection <Default: Maintain a network connection (rec)>

Display operation of IP address

The image shows two screenshots from the GOT basic setting utility. The left screenshot is the 'GOT basic setting' main menu, with a callout bubble pointing to the 'IP address' icon and the text 'Touch [IP address]'. A large black arrow points from this menu to the right screenshot. The right screenshot is the 'IP address' configuration window for 'Ethernet extension port'. It contains the following fields:

IP address		
Ethernet standard port	Ethernet extension port	Wireless LAN I/F
IP Address	192 . 168 . 3 . 18	
Subnet Mask	255 . 255 . 255 . 0	
Default Gateway	0 . 0 . 0 . 0	
Per. S/W port No.	5015	
Transparent port No.	5014	
Behavior of duplicate IPs	Maintain a network connection (rec)	

Buttons for 'OK' and 'Cancel' are located at the bottom right of the configuration window.

If the Ethernet setting is changed with applicable GOT special registers (GS), the GOT may not operate with the new Ethernet setting displayed in the utility.

Therefore, restart the GOT to reflect the new setting.

Setting procedure for the IP address

Ethernet standard port, Ethernet standard port 1, and wireless LAN I/F

■ IP address, subnet mask, default gateway, peripheral software port No., and transparent port No.

1. Touch the entry box for the setting item to display a software keyboard.

Input a value with the keyboard.

Example) For GT27

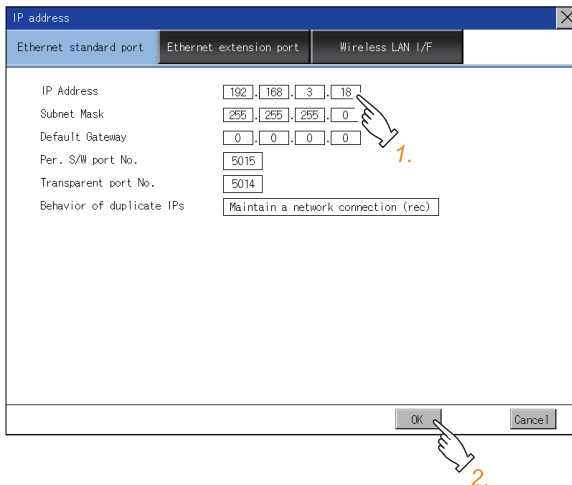

2. Touch the [OK] button to restart the GOT and reflect the setting.

To cancel the setting, touch the [Cancel] button to return to the main menu.

Point

Settings of [Per. S/W port No.] and [Transparent port No.]

You cannot set the same port number for [Per. S/W port No.] and [Transparent port No.].

Set a different port number for each setting item.

■ Behavior of duplicate IPs

This item is settable in [Ethernet standard port] or [Ethernet standard port 1].

1. Touch the selection for the setting item to switch the selection.

This setting determines the behavior of the GOT when a device with the same IP address connects to the network on which the GOT resides.

- [Maintain a network connection (rec)]

Displays a system alarm, and maintains the network connection for the GOT.

- [Do not maintain a network connection]

Disconnects the GOT from the network.

Example) For GT27

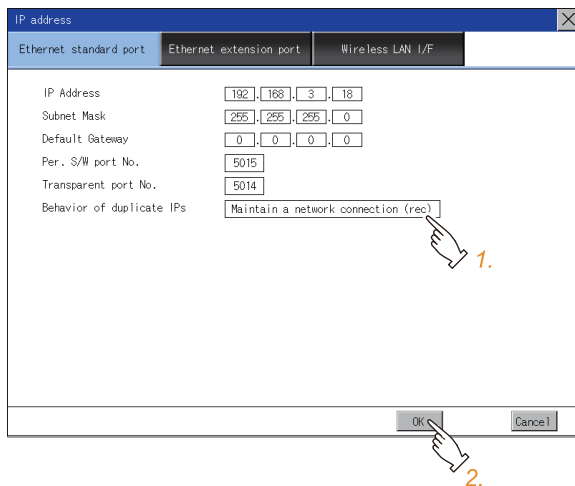

2. Touch the [OK] button to restart the GOT and reflect the setting.

To cancel the setting, touch the [Cancel] button to return to the main menu.

Ethernet extension port and Ethernet standard port 2

■IP address, subnet mask, default gateway, peripheral software port No., and transparent port No.

1. Touch the selection for [Ethernet comm. unit] to switch to [Effective].
2. Touch the entry box for the setting item to display a software keyboard.
Input a value with the keyboard.

Example) For GT27

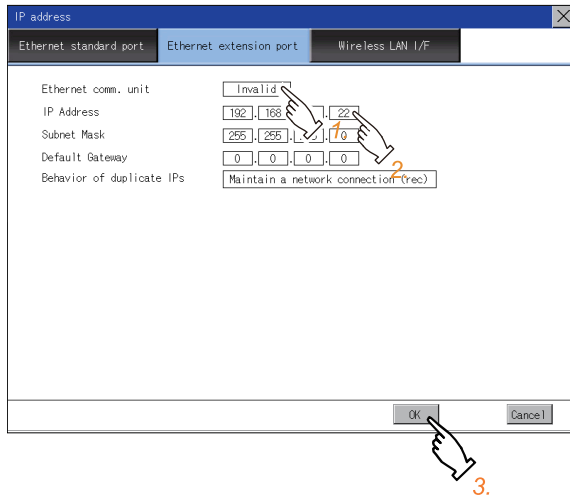

3. Touch the [OK] button to restart the GOT and reflect the setting.
To cancel the setting, touch the [Cancel] button to return to the main menu.

Point

Assignment to an extension interface

The Ethernet extension port is assigned to an unused extension interface with the lowest stage number.
If all extension interfaces are occupied, the Ethernet extension port cannot be assigned.

■ Behavior of duplicate IPs

1. Touch the selection for the setting item to switch the selection.

This setting determines the behavior of the GOT when a device with the same IP address connects to the network on which the GOT resides.

- [Maintain a network connection (rec)]

Displays a system alarm, and maintains the network connection for the GOT.

- [Do not maintain a network connection]

Disconnects the GOT from the network.

Example) For GT27

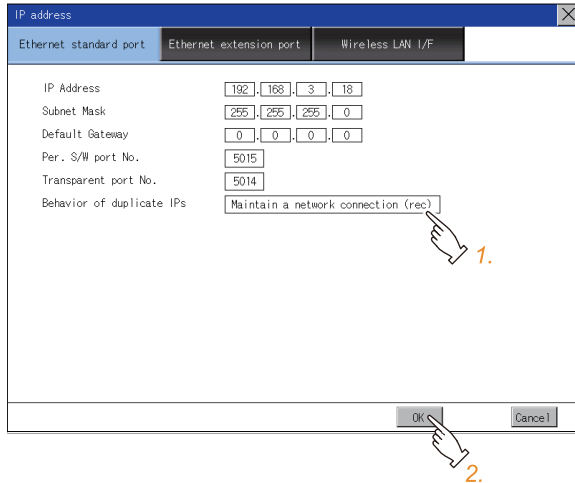

2. Touch the [OK] button to restart the GOT and reflect the setting.

To cancel the setting, touch the [Cancel] button to return to the main menu.

Precautions

IP address setting

Set an IP address for each interface to access a different network.

When the GOT connects to the network on which a device with the same IP address resides

The GOT goes into an offline state, and displays the following dialog.

Example) For GT27

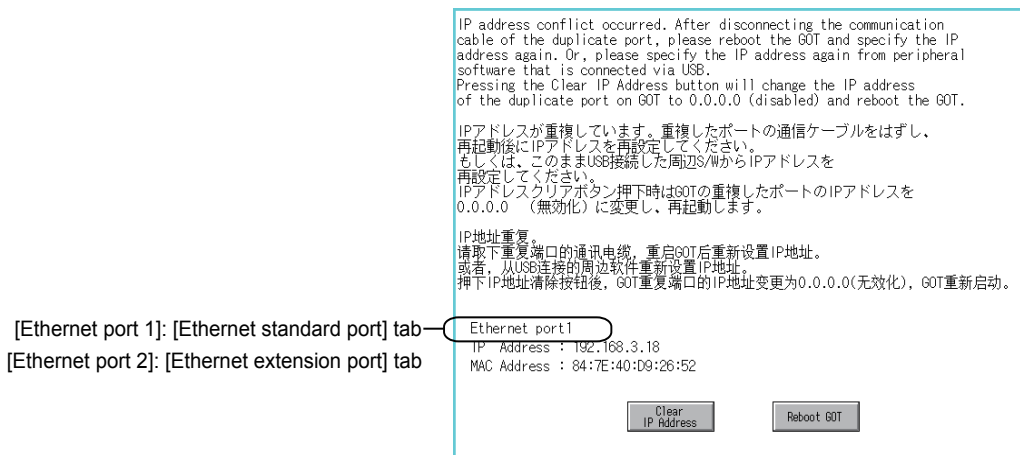

Change the IP address of the GOT or the device.

- When changing the IP address of the device

Specify a new IP address for the device, and touch the [Reboot GOT] button to restart the GOT.

- When changing the IP address of the GOT

Touch the [Clear IP Address] button to clear the GOT IP address.

Then, touch the [Reboot GOT] button to restart the GOT, and specify a new IP address for the GOT.

Selection for [Behavior of duplicate IPs]

When [Do not maintain a network connection] is selected for [Behavior of duplicate IPs], if a device with the same IP address as the GOT connects to the same network, the GOT becomes disconnected from the network.

Thus, incorrect setting of IP addresses or any malicious action may disable the relevant GOT to communicate, affecting the system control.

Make sure to consider the necessity to change the selection for [Behavior of duplicate IPs] before doing so.

Using a switching hub compatible with the Spanning Tree Protocol

For the switching hub port connected with the GOT, configure the setting (PortFast or others) that makes the GOT be ready for communications (forwarding state). Thus, the Spanning Tree Protocol does not cause a delay upon connection.

Without the setting, the Ethernet IP address duplication is detected incorrectly.

Additionally, the GOT may not connect to the Ethernet network correctly.

For the setting that makes the GOT be ready for communications (forwarding state), refer to the user's manual for the switching hub used.

2.5 IP Filter Setting

IP filter setting

IP addresses from which access to the GOT is allowed or blocked can be set.

For the details of the IP filter setting, refer to the following.

 GT Designer3 (GOT2000) Screen Design Manual

Item	Description	Setting range
IP filter usage	You can set whether to use or not the IP filter function.	Yes/No <Default: No>
Access from the following address	You can set whether to allow or block access from the IP addresses that set in the filtering list. <ul style="list-style-type: none">• If [Transmit] is selected Access from the IP addresses that are set for [Target IP address] is blocked. Access from the IP addresses that are set for [Exception IP address] is disallowed.• If [Block] is selected Access from the IP addresses that are set for [Target IP address] is blocked. Access from the IP addresses that are set for [Exception IP address] is allowed.	Transmit/Block <Default: Transmit>
Range	You can set whether to register IP addresses by specifying a range. To specify a range, set the start IP address and the end IP address for [Target IP address].	Selected/Not selected <Default: Not selected>
Target IP address	You can set IP addresses or IP address ranges to be filtered. Up to 32 ranges can be set.	0.0.0.0 to 255.255.255.255 ^{*1} <Default: Blank>
Exception IP address	This item can be set only when [Range] is selected. For an IP address range specified in [Target IP address], set IP addresses excluded from being filtered. Up to 32 addresses can be set for one range specified in [Target IP address].	0.0.0.0 to 255.255.255.255 ^{*1} <Default: Blank>

*1 Leave the boxes blank if you do not set any IP addresses.

Display operation of the IP filter setting

GOT basic setting

Utility main menu

Touch [IP filter setting].

IP filter setting

IP filter usage: Yes

Access from the following address: Transmit

No.	Range	Target IP address	Exception IP address
1	<input checked="" type="checkbox"/>	192.168.0.1 - 192.168.10.10	Not set
2	<input checked="" type="checkbox"/>	192.168.20.1 - 192.168.20.10	Set
3	<input type="checkbox"/>	192.168.30.1	
4	<input type="checkbox"/>		
5	<input type="checkbox"/>		
6	<input type="checkbox"/>		
7	<input type="checkbox"/>		
8	<input type="checkbox"/>		
9	<input type="checkbox"/>		
10	<input type="checkbox"/>		
11	<input type="checkbox"/>		
12	<input type="checkbox"/>		

Default OK Cancel

Setting procedure for the IP filter

Setting IP addresses

1. Touch the down arrow of the [IP filter usage] list box and select [Yes].

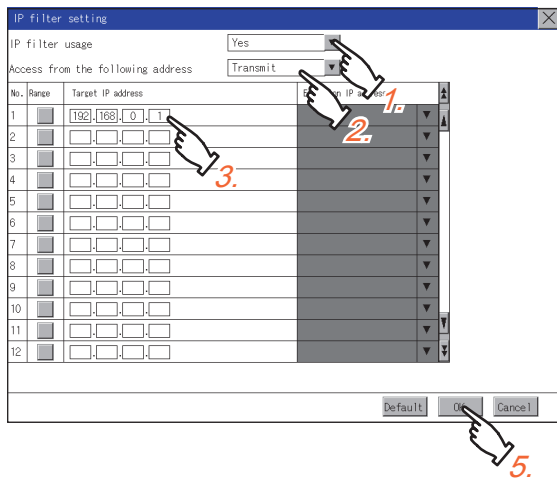

2. Touch the down arrow of the [Access from the following address] list box and select [Transmit] or [Block].
3. Touch a start IP address entry box in the [Target IP address] section in the filtering list to display a software keyboard. Input a value with the keyboard.

4. For specifying an IP address range and setting an IP address excluded from a specified range, refer to the following.

Specifying IP address ranges

☞ Page 69 Specifying IP address ranges

Setting exception IP addresses

☞ Page 70 Setting exception IP addresses

5. Touch the [OK] button to restart the GOT and reflect the setting change.
To cancel the setting change and return to the Main Menu, touch the [Cancel] button.
To change the setting for each item to its default, touch the [Default] button.

■Specifying IP address ranges

1. Touch the checkbox in the filtering list to display the end IP address entry boxes in the [Target IP address] section.

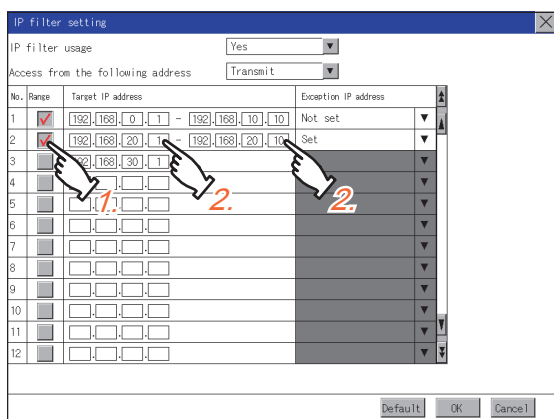

2. In the filtering list, touch any IP address entry box in [Target IP address] to display a software keyboard. Input a value for each box with the keyboard.

■Setting exception IP addresses

[Exception IP address] can be set only when [Range] is selected.

1. Touch the exception IP address display button to open the exception IP address list.

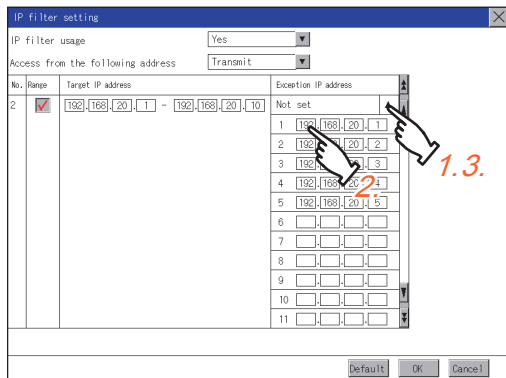

2. Touch an exception IP address entry box to display a software keyboard. Input a value for each box with the keyboard.
3. Touch the exception IP address display button to close the exception IP address list.

2.6 Operation

Operation setting

Setting regarding GOT operation can be set.

The items which can be set are described below. If touch the each item part, the respective setting becomes possible.

Function	Description	Setting range
Buzzer volume setting	Buzzer volume setting can be changed.	OFF/SHORT/LONG <At factory shipment: SHORT>
Musical interval setting	The setting of the musical interval for the buzzer sound can be changed.	1 to 5 <Default: 4>
Window move buzzer volume setting	Whether turn ON/OFF buzzer when move window can be selected.	ON/OFF <At factory shipment: OFF>
Key sensitivity setting	The touch panel sensitivity when touching the GOT screen can be set. E.g. a setting can be changed when double-touch is made when touching the GOT screen only once. (For preventing chattering)	1 to 8 ^{*1} <Default: 6>
Access switch for the drive A	Set whether to access drive A or not while the cover of an SD card interface is open.	Unignore/Ignore <Default: Unignore>

*1 Relation between the [Key sensitivity] setting and reaction speed

The larger the set value in [Key sensitivity] is, the shorter the time taken from touching the touch panel until the GOT responds becomes.
E.g. decrease the value set for [Key sensitivity] when double-touch is made when touching the GOT screen only once. (Decrease the reaction speed.)



Operation setting by GT Designer3

Set buzzer volume and window move buzzer volume by [GOT setup] in [Environmental Setting] of GT Designer3.

When change a part of the setting, change the setting by the GOT display setting after downloading the project data.

GT Designer3 (GOT2000) Screen Design Manual

Display operation of operation

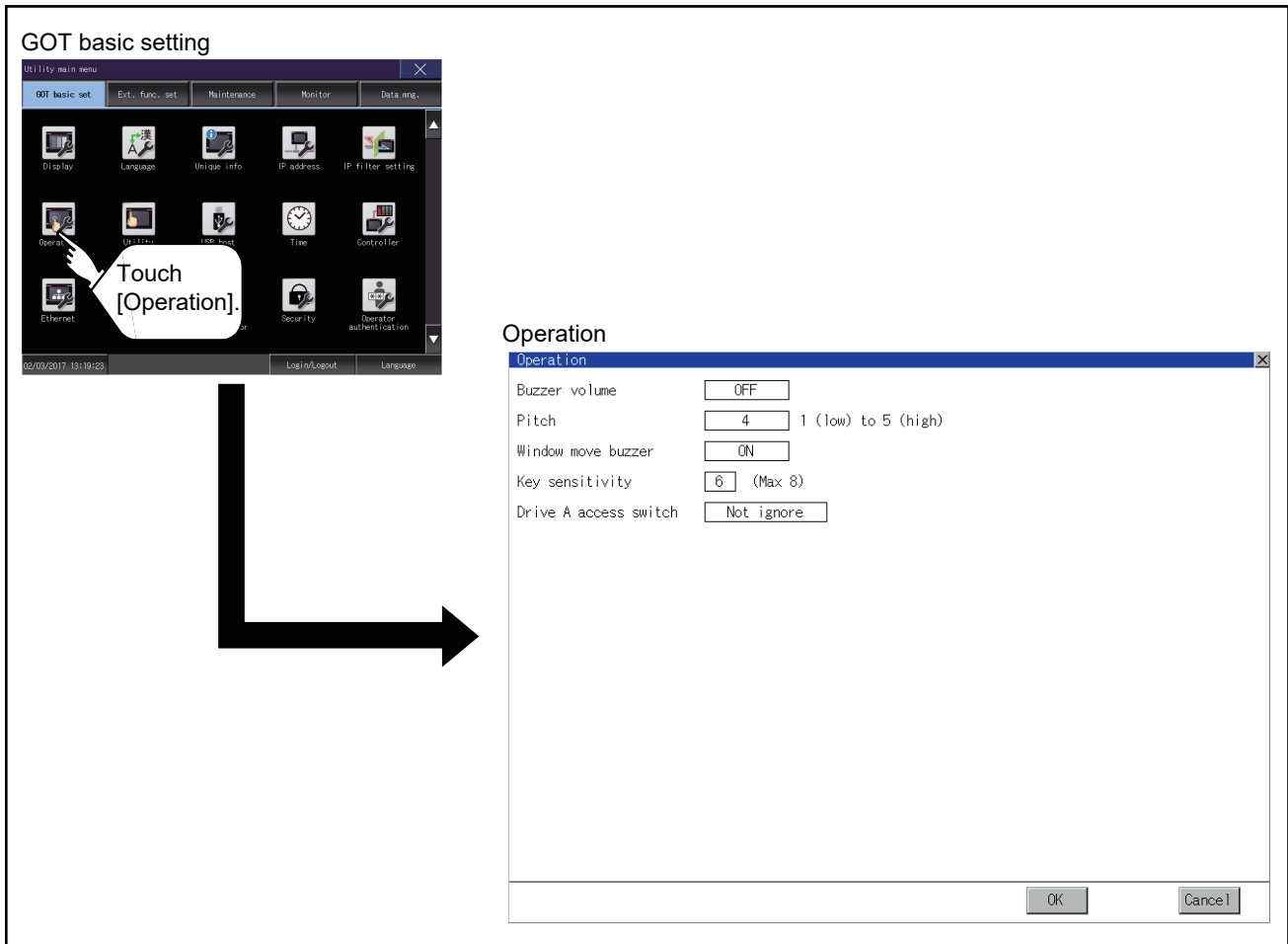

Setting operation of operation

Buzzer sound, musical interval, window move buzzer volume, access switch for the drive A

1. If touch the setup item, the setup contents is changed.

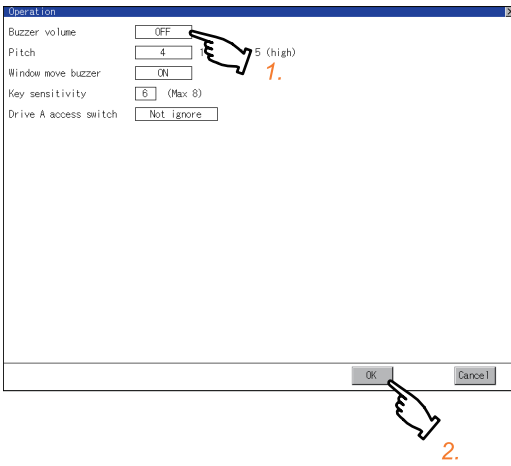

2. If touch the [OK] button, the GOT restarts and operates with the changed settings.
If touch the [Cancel] button, the changed settings are canceled and the screen returns to the Main Menu.

Key sensitivity setting

1. If touching the setting items, keyboard is displayed.
Input numeric with the keyboard.

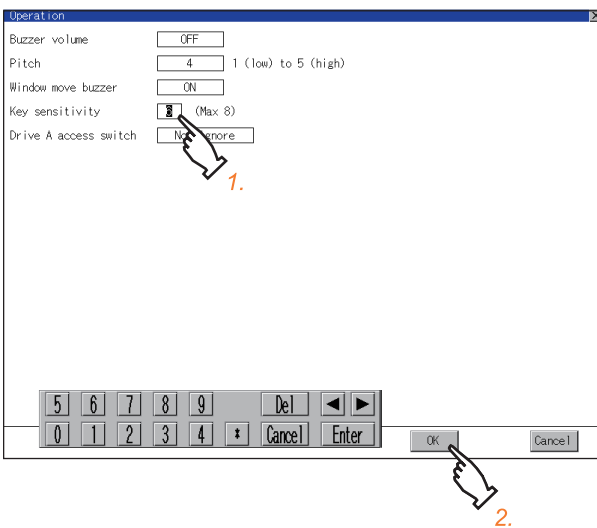

2. If touch the [OK] button, the GOT restarts and operates with the changed settings.
If touch the [Cancel] button, the changed settings are canceled and the screen returns to the Main Menu.

2.7 Utility Call Key

Utility call key setting

The key position for calling the main menu of the utility can be specified.

For the key position, the specification of 1 point from 4 corners on the screen, or no specification, can be set.

(No specification can be set when GT Designer3 is used.)

By keeping pressing the screen, a setting to switch the screen to the utility is available.

This prevents a switching to the utility by an unintentional operation.

Point

Operation setting by GT Designer3

Set the utility call key at [GOT set up] in [Environmental Setting] of GT Designer3.

When change a part of the setting, change the setting by the GOT display setting after downloading the project data.

 GT Designer3 (GOT2000) Screen Design Manual

Display operation of the utility call key setting

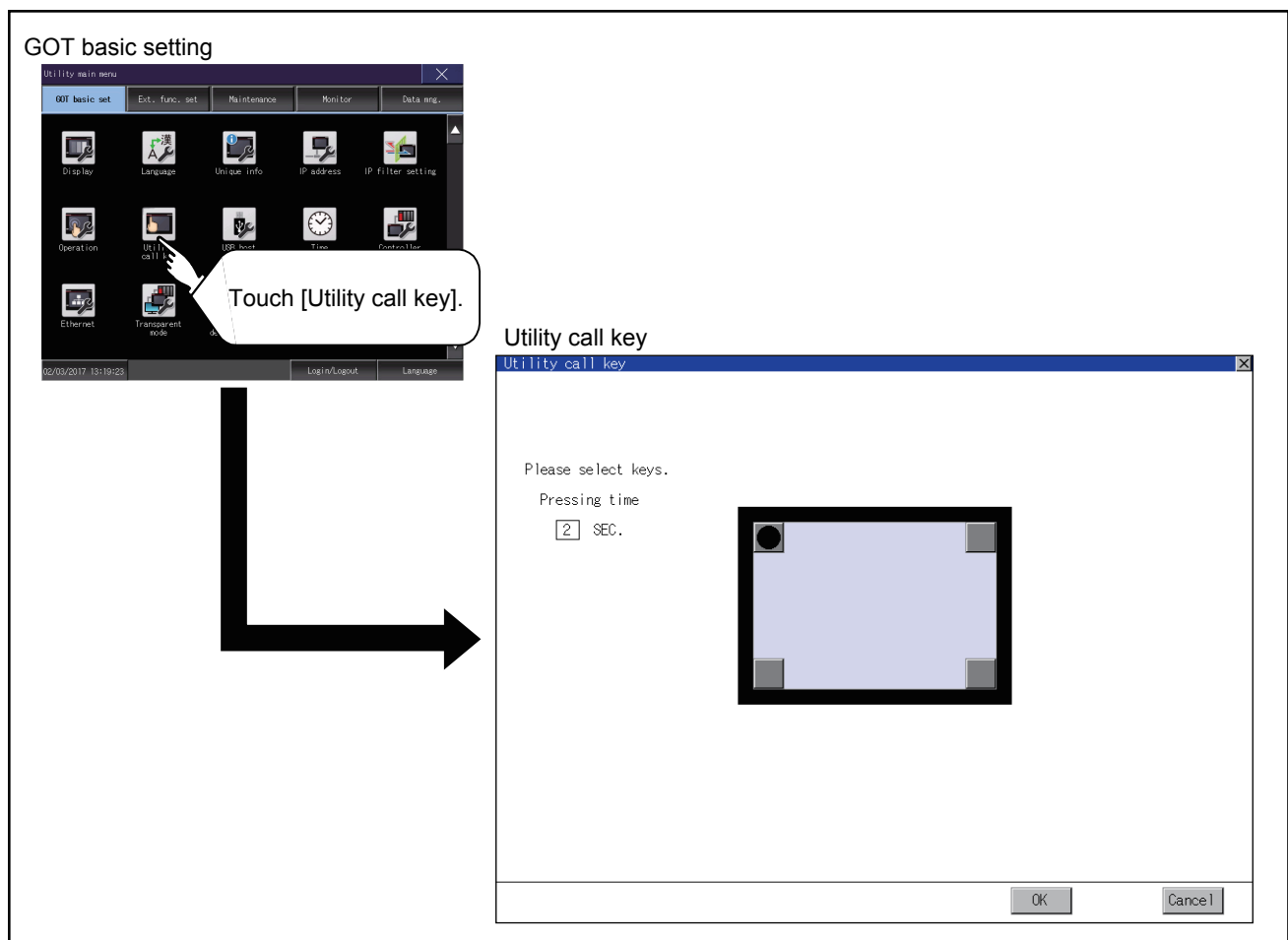

Utility call key setting operation

1. Touch or displayed at the 4 corners of the setting screen. The button repeats  with every touch. Set the corner to be specified as a key position to .

For the key position, up to 1 point can be specified.

When the key position is not specified, displaying the utility with the utility call key is not available.

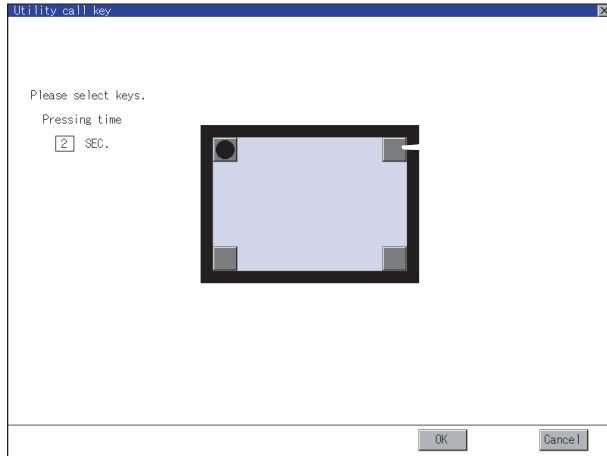

2. When setting 1 point, specify the time to switch to the utility in case of keeping pressing the key position. Touch the time input area.

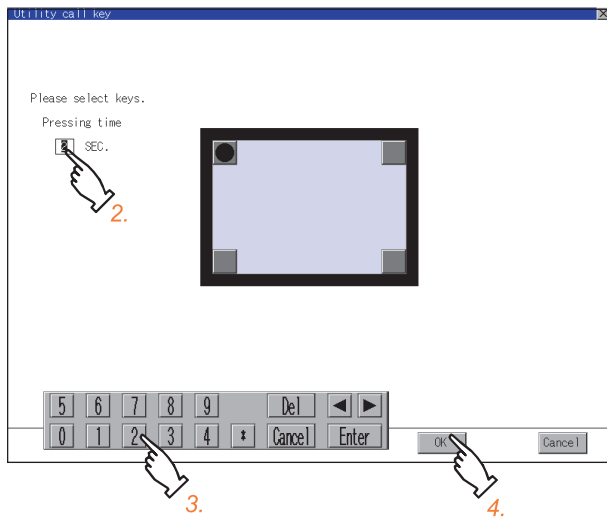

3. Touching the input area displays a keyboard. Input numeric with the keyboard.
4. If touch the [OK] button, the changed settings are reflected and the screen returns to the [Operation] screen. If touch the [Cancel] button, the changed settings are canceled and the screen returns to the [Operation] screen.
5. In the [Operation] screen, touching the [OK]/[Cancel]/[x] button restarts and operates the GOT with the changed settings.

When the utility call key is not specified

The followings are the method for displaying the utility without using the utility call key.

■Changing the project data in GT Designer3

1. Read the project data in GT Designer3.
2. Set either of the followings in GT Designer3.
 - Set the utility call key in the [Display/Operation] tab of the [Environmental Setting] dialog.
 - Set a special function switch to display the utility at the user-created screen.
3. Write the project data whose setting is changed to the GOT.

■Operating the forced start-up of the utility with the GOT

After powering on the GOT, pressing the S.MODE switch during [Booting] displayed on the upper left displays the utility in the screen.

To display the utility on GT2505-V, power on the GOT, and press the lower right of the screen while [Booting] is being displayed on the upper left of the screen.

When restricting the display of the utility, set a password in GT Designer3.

 GT Designer3 (GOT2000) Screen Design Manual

Precautions on using the alarm popup display

When [Display Position Switching] is set to [Switch] in the alarm popup display setting, set either of the following for the utility call key.

Setting the position of the utility call key to the upper-right or lower-left corner

Setting [Pressing Time] of the utility call key to 1 or more seconds

When [Pressing Time] is set to 0 and the key position is set to the lower-left corner, the operation is as described below. If the positions of the key and the alarm popup display overlap, the utility screen appears by switching the display position of the alarm popup display.

For the alarm popup display, refer to the following.

 GT Designer3 (GOT2000) Screen Design Manual

2.8 USB Host

USB host setting

To install and use the USB mouse/keyboard on the GOT, set the USB mouse/keyboard.

Item	Description	Setting range
Use USB mouse	Set whether to use a USB mouse.	YES/NO <Default: YES>
Interlock with mouse cursor touch operation	The mouse cursor can be moved to the touched position.	YES/NO <Default: YES>
Use USB keyboard/USB barcode	Set whether to use a USB keyboard or a USB barcode reader.	YES/NO <Default: YES>
USB keyboard type	Set the USB keyboard type.	Japanese 106 keyboard/English 101 keyboard <Default: Japanese 106 keyboard>

Display operation of the USB host setting

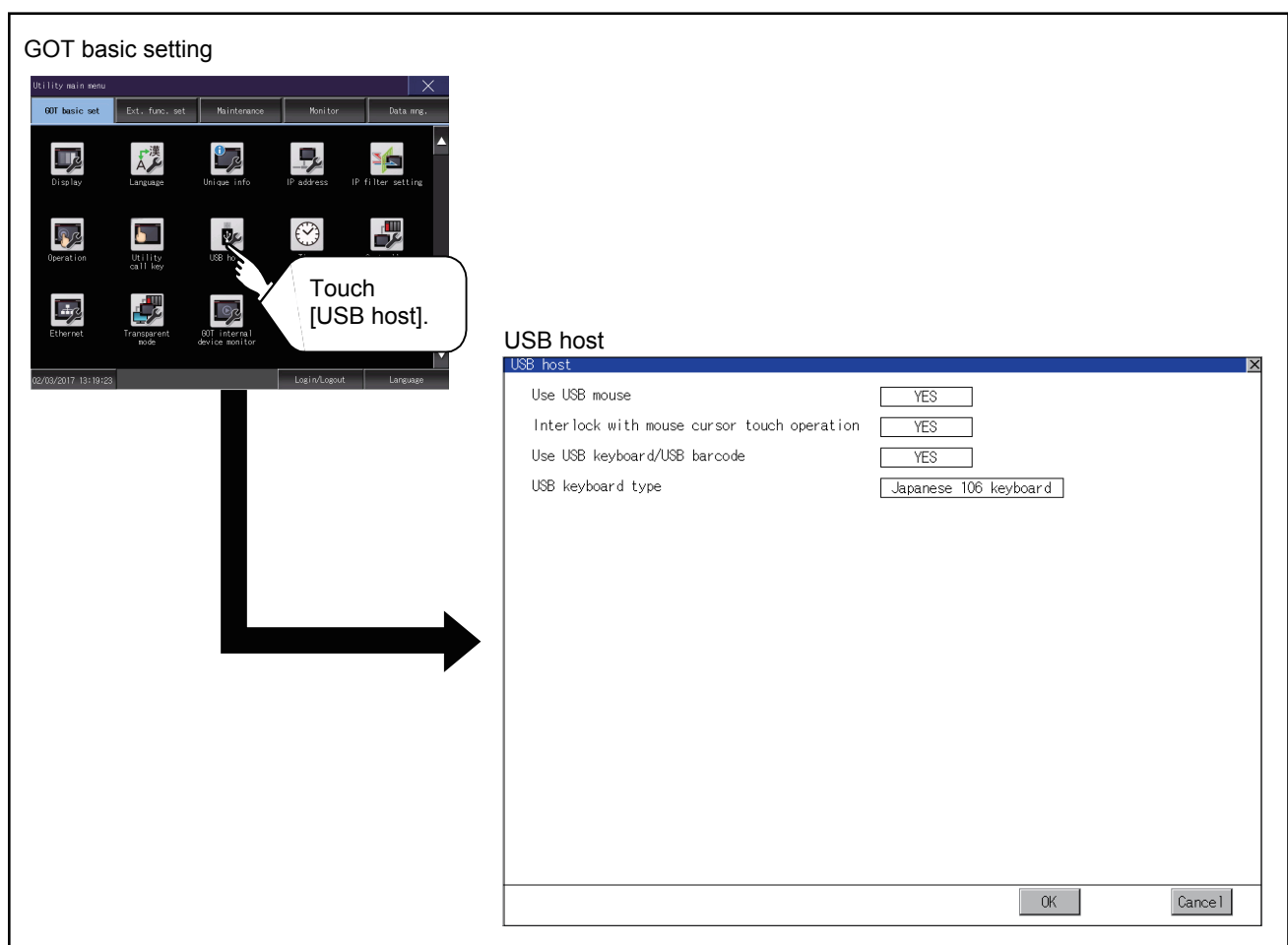

Setting operation of USB host

1. To use a USB mouse, touch the current selection of [Use USB mouse].
Touch the field of the setting to be changed.

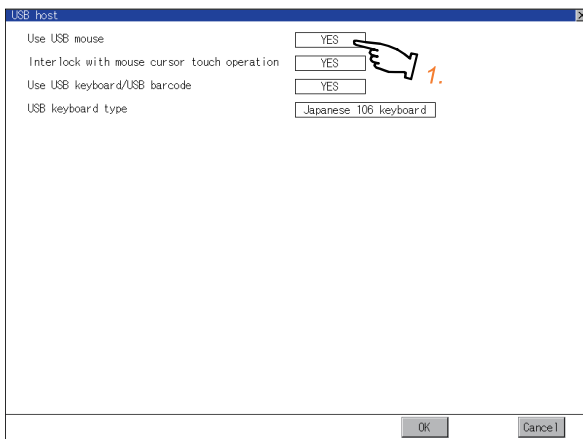

2. To move the mouse cursor to a touched position, touch the current selection of [Interlock with mouse cursor touch operation].
Touch the field of the setting to be changed.

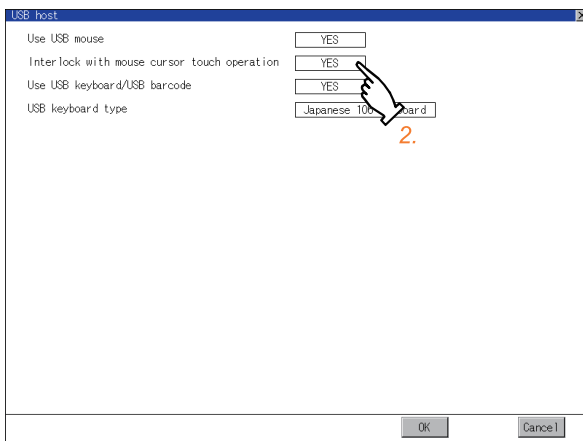

3. To use a USB keyboard or a USB barcode reader, touch the current selection of [Use USB keyboard/USB barcode].
Touch the field of the setting to be changed.

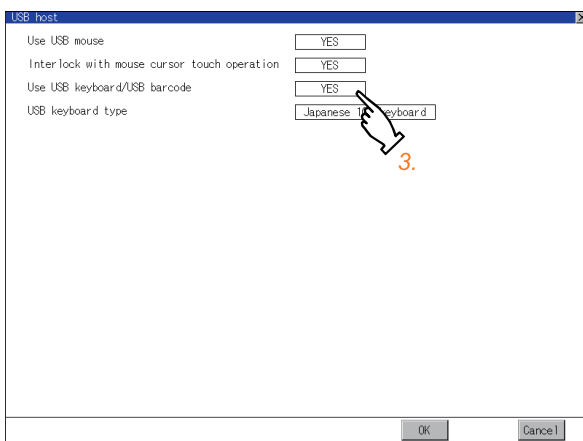

- 4.** To use a USB keyboard, touch the current selection of [USB keyboard type].
Touch the field of the setting to be changed.

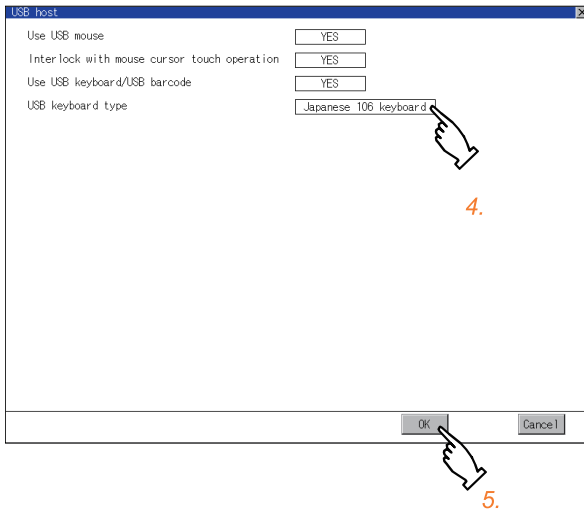

- 5.** Touch the [OK] button to reflect the new settings and return to the [USB Host] screen.
To cancel the new settings, touch the [Cancel] button to return to the [USB Host] screen.
- 6.** In the [Operation] screen, touch the [OK] button, [Cancel] button, or [x] button to restart the GOT to operate with the new settings.

2.9 Time

Clock synchronization method

The following shows the clock synchronization method on the GOT.

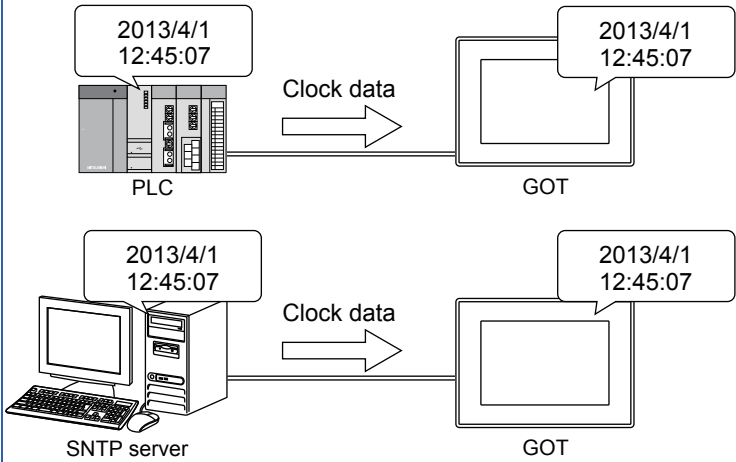
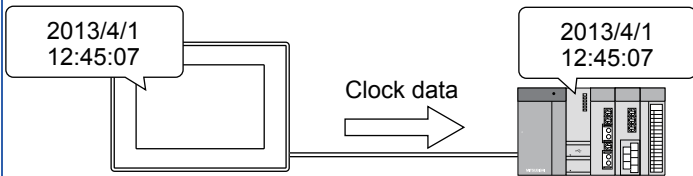
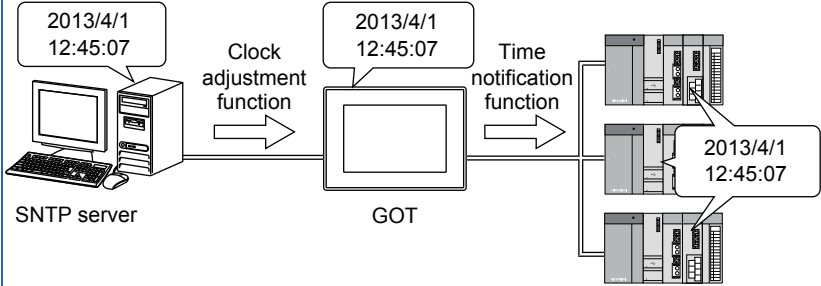
Clock synchronization method	Description
<p>Time setting function</p>	<p>Acquire the clock data of the controller or the SNTP server and change the clock data of the GOT.</p>  <p>When the GOT is powered on, set the clock data of the GOT to that of the controller or the SNTP server. Since the GOT does not have to hold the clock data while the GOT is powered off, no battery is required. (If the GOT needs to hold the clock data at startup, install a battery in the GOT.) To set the controller clock data of the controller, refer to the manual of the controller you use.</p>
<p>Time notification function</p>	<p>Notify the clock data of the GOT to the controller to change that of the controller.</p>  <p>At the timing of the trigger, set the clock data of the controller to that of the GOT. Since the GOT must hold the clock data while the GOT is powered off, a battery is required. Set the clock data of the GOT in the utility.</p>
<p>Using the clock adjustment function and the time notification function together</p>	<p>Acquire the clock data of the controller or the SNTP server by the clock adjustment function. Then change the clock data of other controllers by the time notification function. Then change the clock data of other controllers by the time notification function.</p> 

- When connecting to an external device which does not have clock function

If the GOT is connected to an external device (such as a PLC or microcomputer) that has no clock function, setting [Adjust] or [Broadcast] does not synchronize the clock data between the GOT and external device.

For the list of the PLCs having the clock function, refer to the following.

 GOT2000 Series Connection Manual for the controller used

- Details of the clock synchronization method

For the details of the clock synchronization method, refer to the following.

 GT Designer3 (GOT2000) Screen Design Manual

Time setting

Set the current time.

Point

- Time setting and battery



The GOT built-in battery is not connected to the GOT at factory default.

To use the time notification function, connect the GOT built-in battery and then configure the time setting.

For information on how to connect the GOT built-in battery, refer to the following.

 GOT2000 Series User's Manual (Hardware)

Time setting

Item	Description	Reference
Current time	Carry out the display and setup of GOT clock data.	 Page 83 Current time
GOT internal battery voltage status	Displays GOT internal battery voltage status.	 Page 84 GOT internal battery voltage status

Display operation of the time setting

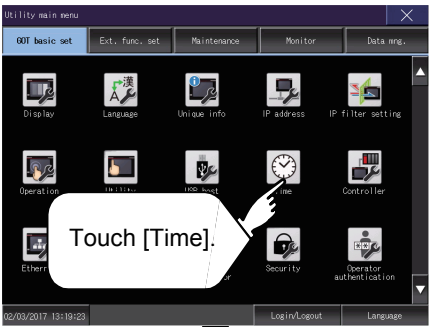

GOT basic setting

Touch [Time].

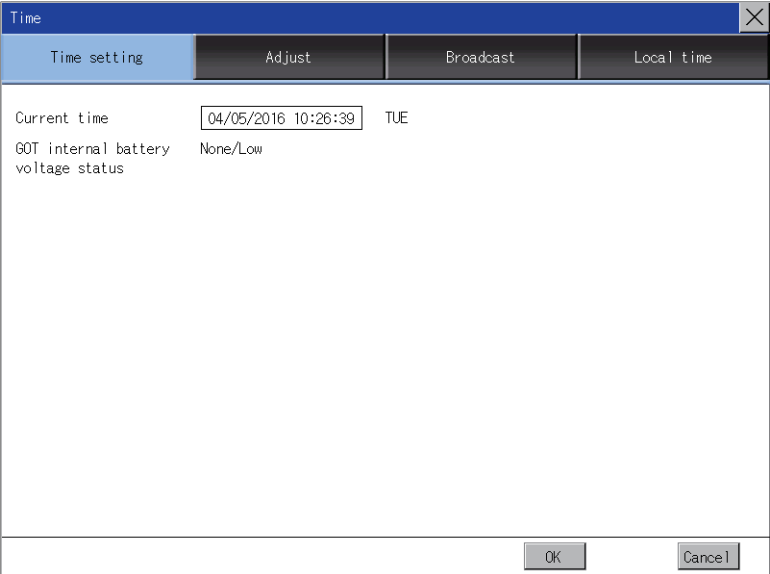

Time (Time setting)

Time setting Adjust Broadcast Local time

Current time 04/05/2016 10:26:39 TUE

GOT internal battery voltage status None/Low

OK Cancel

Setting procedure for the time setting

■ Current time

Carry out the display and setting of GOT clock data.

The setup methods of clock data are shown below.

1. Touch the current date and time to display the keyboard and stop the clock update.

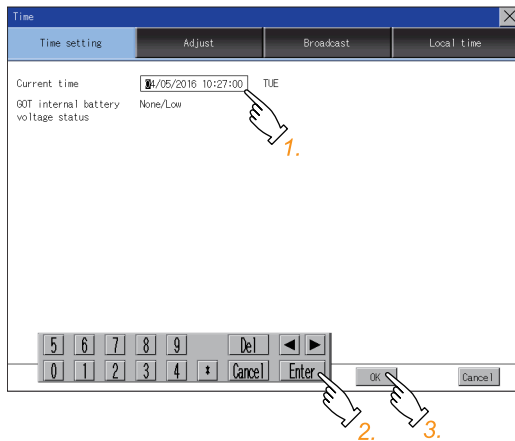

2. Input date and time with the keyboard by referring to the table below.

The input date and time are reflected after step 3 is performed.

The day of the week on the input date is displayed automatically.

The following shows the setting range of the date.

Jan. 1, 2000 to Dec. 31, 2099

Key	Description
[0] to [9]	Input numeric value in cursor position.
◀ ▶	Move the cursor.
[Del]	Move the cursor to the left by one character when [Del] Key is touched while inputting year, month, day, time, minutes, seconds.
[Enter]	Close the keyboard after the input time is displayed in clock display.
[Cancel]	Cancel the input time and returns the time of clock display to the time at which the keyboard was displayed and close the keyboard.

3. To reflect the new setting and return to the Main Menu, touch the [OK] button.

To cancel the new setting and return to the Main Menu, touch the [Cancel] button.

Point

- Time display

The GOT displays the current time to which the local time setting is reflected.

For the local time setting, refer to the following.

☞ Page 96 Local time

- Changing times

If you have changed the present time of the GOT where the time setting function or the time notification function was being used, the new time setting will be written to the PLC.

Thus, you can change the time of the PLC from the GOT even when the time setting function is being used.

For details of [Adjust] and [Broadcast], refer to the following.

📖 GT Designer3 (GOT2000) Screen Design Manual

■GOT internal battery voltage status

Displays battery voltage status.

Display	Status
Normal	Normal
Low/None	Voltage drop or no battery installed

When the battery voltage is low, replace the battery immediately.

Refer to the following for battery replacement procedure.

 GOT2000 Series User's Manual (Hardware)

Adjusting the clock

Synchronize the clock data of the GOT with the clock data of the controller.

Clock adjustment setting

Item	Description	Setting range
Adjust the clock	Set whether to use the clock adjustment function.	Yes (selected)/No (deselected) <Default: No (deselected)>
Mode	Set the clock adjustment mode.*1	External unit/SNTP server <Default: External unit >
Reference CH No.	When selecting [External unit] for [Mode], set a reference channel of the controller.	1 to 4 <Default: 1>
SNTP IP address	When selecting [SNTP server] for [Mode], set the IP address of the SNTP server. Touch the [Connection test] button to check the connection with the SNTP server.	0.0.0.0 to 255.255.255.255 <Default: 0.0.0.0>
Trigger type	Set the trigger type for the clock adjustment.*2 <ul style="list-style-type: none"> When selecting [Sampling] for [Trigger type], set the sampling interval for the clock adjustment. When selecting [Rise] or [Fall] for [Trigger type], information on the device set as a trigger is displayed.*3 	Trigger type: Rise/Fall/Sampling <Default: Sampling> Sampling interval: 1 to 1440 <Default: 60>
Specify the time zone of target unit	Set whether to specify the time zone of the target controller.	Selected/Not selected <Default: Not selected>
Time zone	When selecting [Specify the time zone of target unit], set the time zone.	GMT-12:00 to GMT+13:00/Custom <Default: GMT+9:00>
Time difference from GMT	When selecting [Custom] for [Time zone], set the time difference based on GMT.	Hour: -12 to 13 Minute: 0, 15, 30, or 45 <Default: 0 hour 0 minute>

*1 If you set this item to [SNTP server], set [Time zone] to the time zone of the local time.

 Page 96 Local time

*2 If [Adjust the clock] is deselected or [Trigger Type] is set to [Sampling] in [GOT Setup] in the project data, only [Sampling] is selectable as the trigger type for the clock adjustment in the utility.

*3 If [Adjust the clock] is deselected or [Trigger Type] is set to [Sampling] in [GOT Setup] in the project data, [No setting] is displayed in [Device].

Point

Settings of [Adjust] in the utility

Configure the settings in the utility and in [GOT Setup] on GT Designer3 by the same method.

 GT Designer3 (GOT2000) Screen Design Manual

Display operation of the clock adjustment

GOT basic setting

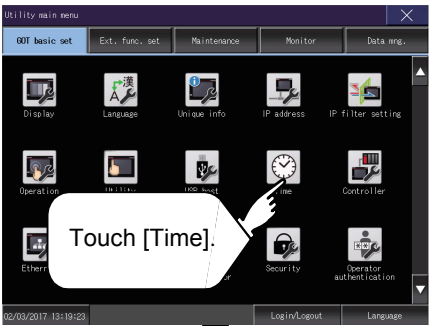

Utility main menu

GOT basic set | Ext. func. set | Maintenance | Monitor | Data reg.

Display | Language | Unique Info | IP address | IP Filter setting

Operation | File | USB boot | **Time** | Controller

Ethernet | Security | Operator authentication

02/03/2017 13:19:23 | Login/Logout | Language

Touch [Time].

Time (Time setting)

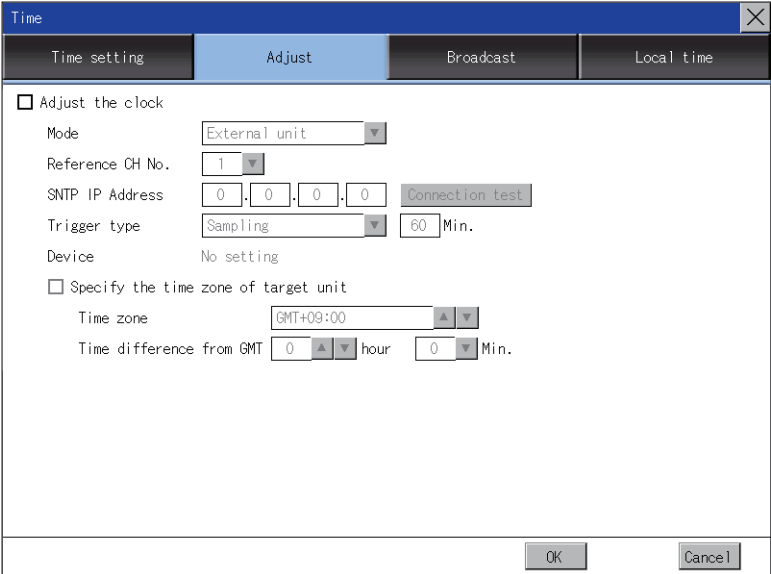

Time

Time setting | **Adjust** | Broadcast | Local time

Adjust the clock

Mode: External unit

Reference CH No.: 1

SNTP IP Address: 0.0.0.0 Connection test

Trigger type: Sampling 60 Min.

Device: No setting

Specify the time zone of target unit

Time zone: GMT+09:00

Time difference from GMT: 0 hour 0 Min.

OK Cancel

Setting procedure for the clock adjustment

■Adjust the clock

1. To synchronize the clock data of the GOT with the clock data of the controller, select [Adjust the clock].

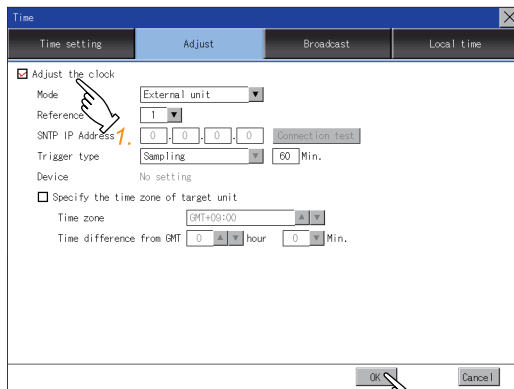

2. Touch the [OK] button to display a restart confirmation dialog.

Restart the GOT to operate with the new setting.

If touch the [Cancel] button, the changed settings are canceled and the screen returns to the Main Menu.

■Mode

1. Touch the setting item and select a setting from the list.

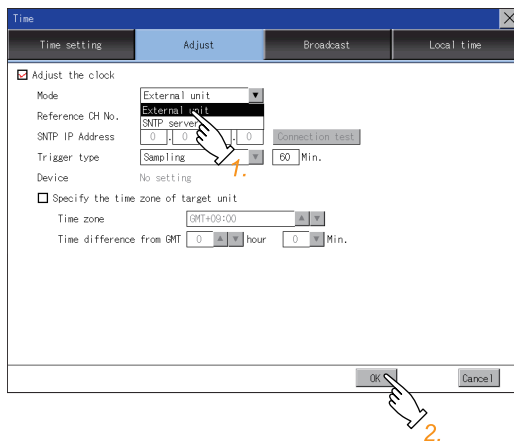

2. Touch the [OK] button to display a restart confirmation dialog.

Restart the GOT to operate with the new setting.

If touch the [Cancel] button, the changed settings are canceled and the screen returns to the Main Menu.

■Reference CH No.

1. Touch the setting item and select a setting from the list.

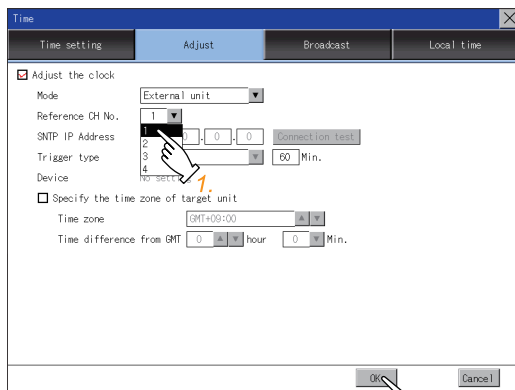

2. Touch the [OK] button to display a restart confirmation dialog.

Restart the GOT to operate with the new setting.

If touch the [Cancel] button, the changed settings are canceled and the screen returns to the Main Menu.

■SNTP IP address

1. Touch the setting item to display a software keyboard.

Input a value for each box with the keyboard.

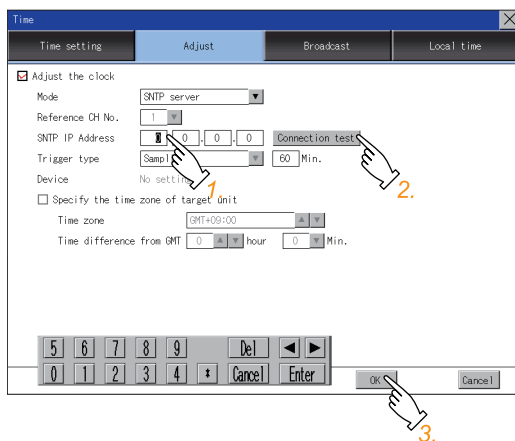

2. Touch the [Connection test] button to check the connection with the SNTP server.

3. Touch the [OK] button to display a restart confirmation dialog.

Restart the GOT to operate with the new setting.

If touch the [Cancel] button, the changed settings are canceled and the screen returns to the Main Menu.

■Trigger type

1. Touch the setting item and select a setting from the list.

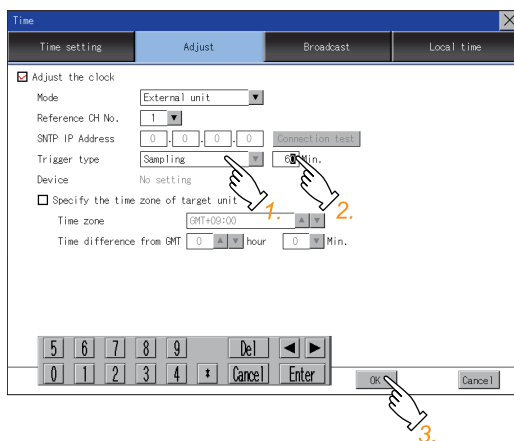

2. If you select [Sampling], set the sampling interval for the clock adjustment. Touch the entry box on the left side of [Min.] to display a software keyboard. Input a value with the keyboard.

3. Touch the [OK] button to display a restart confirmation dialog.

Restart the GOT to operate with the new setting.

If touch the [Cancel] button, the changed settings are canceled and the screen returns to the Main Menu.

■Specify the time zone of target unit

1. To specify the time zone of the target controller, select [Specify the time zone of target unit].

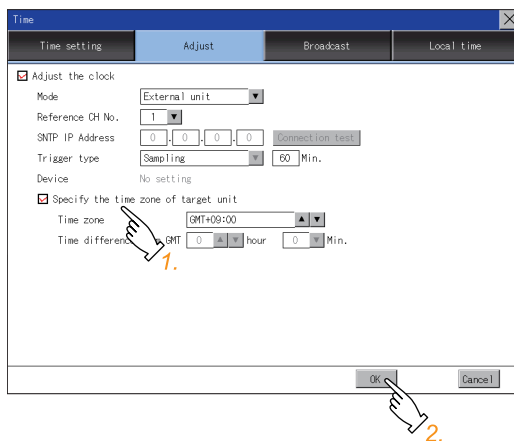

2. Touch the [OK] button to display a restart confirmation dialog.

Restart the GOT to operate with the new setting.

If touch the [Cancel] button, the changed settings are canceled and the screen returns to the Main Menu.

■ Time zone

1. Touch the up or down button on the right side of the time zone entry box to change the setting.

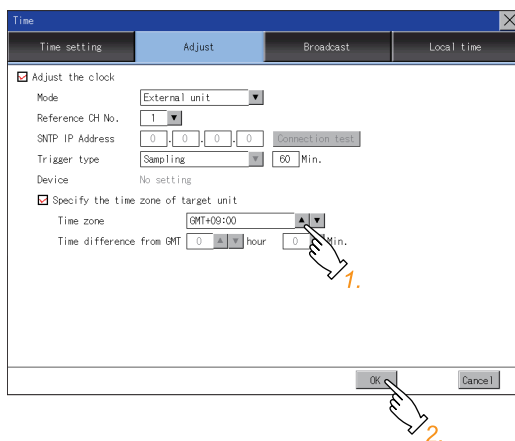

2. Touch the [OK] button to display a restart confirmation dialog.

Restart the GOT to operate with the new setting.

If touch the [Cancel] button, the changed settings are canceled and the screen returns to the Main Menu.

■ Time difference from GMT

1. To change the setting of [hour], touch the up or down button on the left side of [hour].

To change the setting of [Min.], touch the pull-down menu button on the left side of [Min.] and select an item from the list.

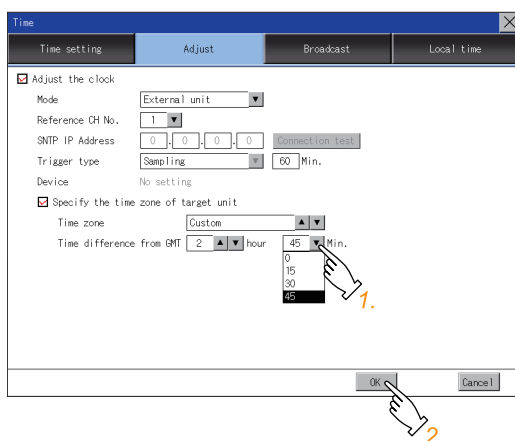

2. Touch the [OK] button to display a restart confirmation dialog.

Restart the GOT to operate with the new setting.

If touch the [Cancel] button, the changed settings are canceled and the screen returns to the Main Menu.

Broadcasting the clock data

Notify the clock data of the GOT to the controller for synchronization with the GOT.

Time notification setting

Item	Description	Setting range
Broadcast the clock data	Set whether to use the time notification function.	Selected/Not selected <Default: Not selected>
Broadcast CH No.	Set a channel used for the time notification.	CH 1, CH 2, CH 3, CH 4 <Default: 1>
Trigger type	Set the trigger type for the time notification. ^{*1} <ul style="list-style-type: none"> When selecting [Sampling] for [Trigger type], set the sampling interval for the time notification. When selecting [Rise] or [Fall] for [Trigger type], information on the device set as a trigger is displayed.^{*2} 	Trigger type: Rise/Fall/Sampling <Default: Sampling> Sampling interval: 1 to 1440 <Default: 60>
Specify the time zone of target unit	Set whether to specify the time zone of the target controller.	Selected/Not selected <Default: Not selected>
Time zone	When selecting [Specify the time zone of target unit], set the time zone.	GMT-12:00 to GMT+13:00/Custom <Default: GMT+9:00>
Time difference from GMT	When selecting [Custom] for [Time zone], set the time difference based on GMT.	Hour: -12 to 13 Minute: 0, 15, 30, or 45 <Default: 0 hour 0 minute>

*1 If [Broadcast the clock data] is deselected or [Trigger Type] is set to [Sampling] in [GOT Setup] in the project data, only [Sampling] is selectable as the trigger type for the time notification in the utility.

*2 If [Broadcast the clock data] is deselected or [Trigger Type] is set to [Sampling] in [GOT Setup] in the project data, [No setting] is displayed for the device.

Point

Settings of [Broadcast] in the utility

Configure the settings in the utility and in [GOT Setup] on GT Designer3 by the same method.

 GT Designer3 (GOT2000) Screen Design Manual

Display operation of the time notification

GOT basic setting

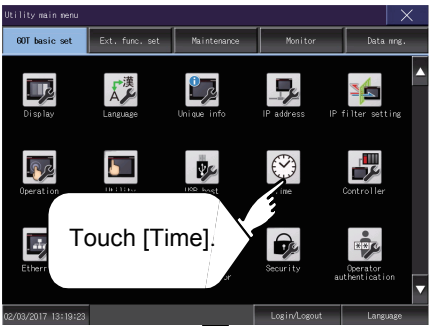

Utility main menu

GOT basic set | Ext. func. set | Maintenance | Monitor | Data reg.

Display | Language | Unique Info | IP address | IP Filter setting

Operation | File | USB host | **Time** | Controller

Ethernet | Security | Operator authentication

02/03/2017 13:19:23 | Login/Logout | Language

Touch [Time].

Time (Broadcast tab)

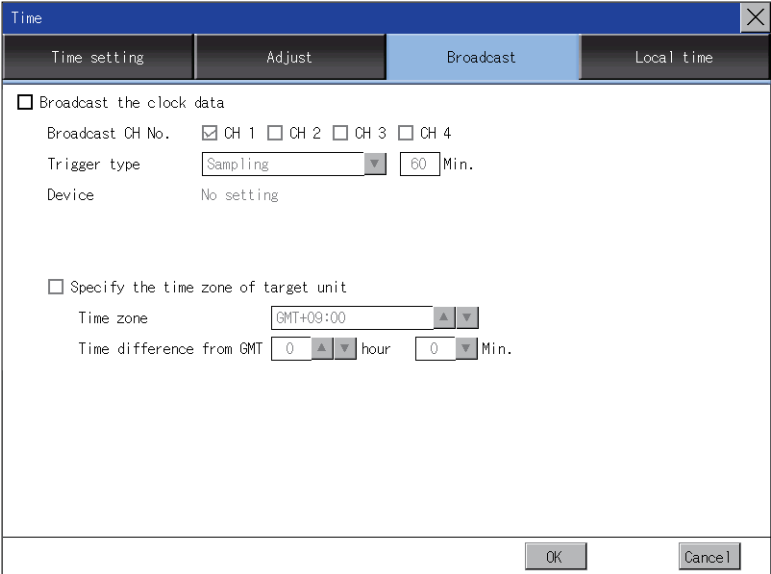

Time

Time setting | Adjust | **Broadcast** | Local time

Broadcast the clock data

Broadcast CH No. CH 1 CH 2 CH 3 CH 4

Trigger type Sampling 60 Min.

Device No setting

Specify the time zone of target unit

Time zone GMT+09:00

Time difference from GMT 0 hour 0 Min.

OK Cancel

Setting procedure for the time notification

■Broadcast the clock data

1. To notify the clock data of the GOT to the controller for synchronization with the GOT, select [Broadcast the clock data].

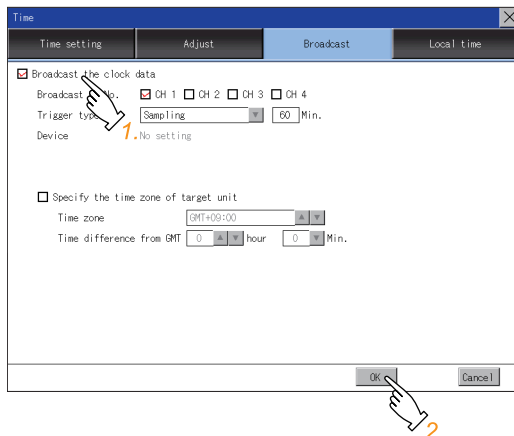

2. Touch the [OK] button to display a restart confirmation dialog.

Restart the GOT to operate with the new setting.

If touch the [Cancel] button, the changed settings are canceled and the screen returns to the Main Menu.

■Broadcast CH No.

1. Touch a channel number to select it.

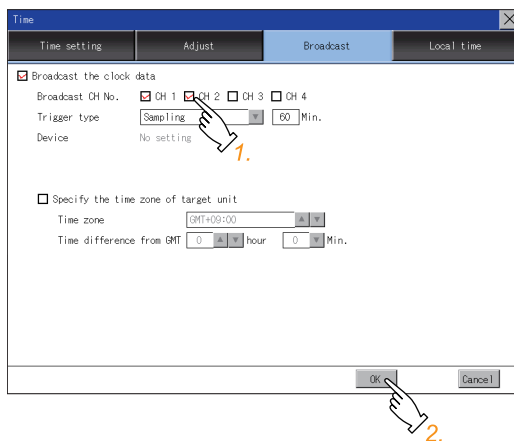

2. Touch the [OK] button to display a restart confirmation dialog.

Restart the GOT to operate with the new setting.

If touch the [Cancel] button, the changed settings are canceled and the screen returns to the Main Menu.

■Trigger type

1. Touch the setting item and select a setting from the list.

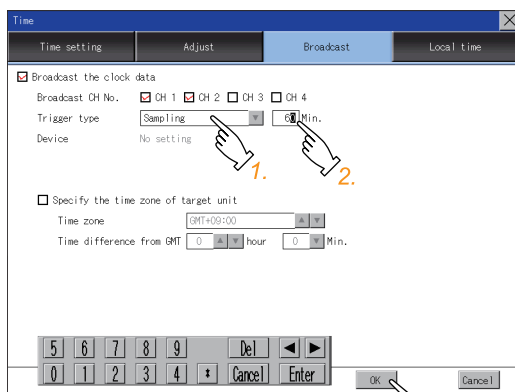

2. If you select [Sampling], set the sampling interval for the time notification. Touch the entry box on the left side of [Min.] to display a software keyboard. Input a value with the keyboard.

3. Touch the [OK] button to display a restart confirmation dialog.

Restart the GOT to operate with the new setting.

If touch the [Cancel] button, the changed settings are canceled and the screen returns to the Main Menu.

■Specify the time zone of target unit

1. To specify the time zone of the target controller, select [Specify the time zone of target unit].

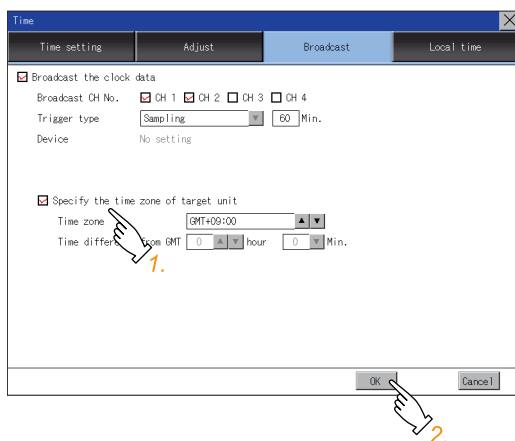

2. Touch the [OK] button to display a restart confirmation dialog.

Restart the GOT to operate with the new setting.

If touch the [Cancel] button, the changed settings are canceled and the screen returns to the Main Menu.

Time zone

1. Touch the up or down button on the right side of the time zone entry box to change the setting.

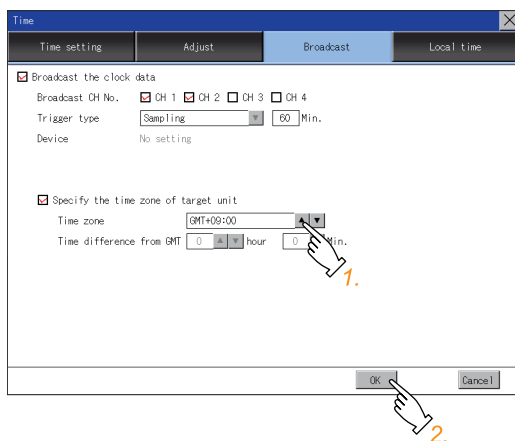

2. Touch the [OK] button to display a restart confirmation dialog.
Restart the GOT to operate with the new setting.

If touch the [Cancel] button, the changed settings are canceled and the screen returns to the Main Menu.

Time difference from GMT

1. To change the setting of [hour], touch the up or down button on the left side of [hour].
To change the setting of [Min.], touch the pull-down menu button on the left side of [Min.] and select an item from the list.

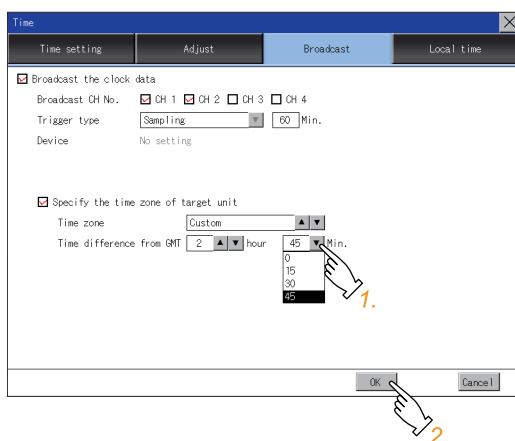

2. Touch the [OK] button to display a restart confirmation dialog.
Restart the GOT to operate with the new setting.

If touch the [Cancel] button, the changed settings are canceled and the screen returns to the Main Menu.

Local time

Set the time zone of the local time in the clock data of the GOT.

Local time setting

Item	Description	Setting range
Specify time zone	Set whether to specify the time zone in the clock data of the GOT.	Selected/Not selected <Default: Not selected>
Time zone	When selecting [Specify time zone], set the time zone.	GMT-12:00 to GMT+13:00/Custom <Default: GMT+9:00>
Time difference from GMT	When selecting [Custom] for [Time zone], set the time difference based on GMT.	Hour: -12 to 13 Minute: 0, 15, 30, or 45 <Default: 0 hour 0 minute>

Display operation of the local time

GOT basic setting

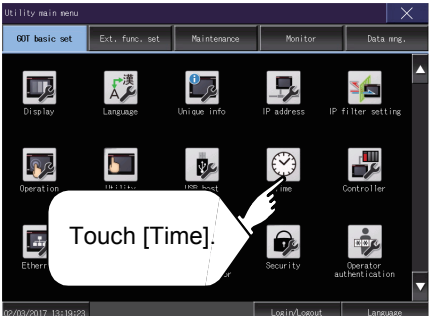

Utility main menu

GOT basic set | Ext. func. set | Maintenance | Monitor | Data mg.

Display | Language | Unique info | IP address | IP filter setting

Operation | Maintenance | Time | Controller

Ethernet | Security | Operator authentication

02/03/2017 13:19:23 | Login/Logout | Language

Touch [Time].

Time (Local time)

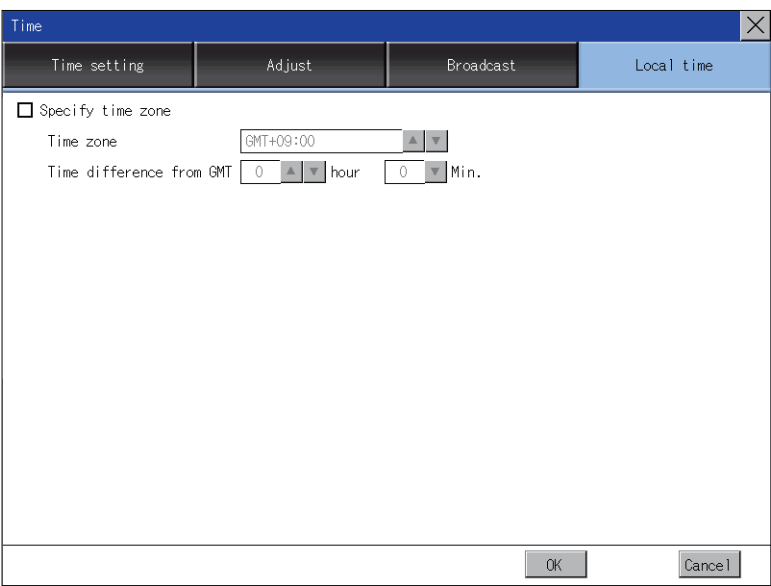

Time

Time setting | Adjust | Broadcast | Local time

Specify time zone

Time zone: GMT+09:00

Time difference from GMT: 0 hour 0 Min.

OK | Cancel

Setting procedure for the local time

■Specify time zone

1. To set the time zone, select [Specify time zone].

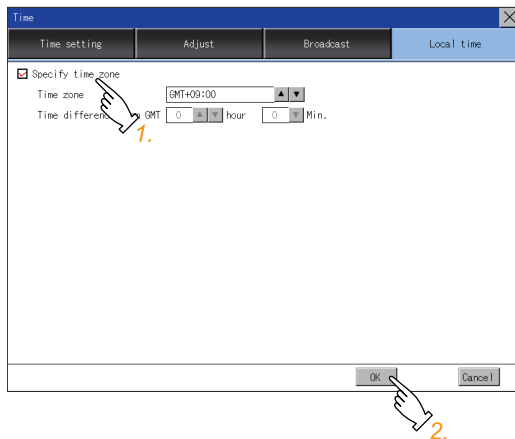

2. Touch the [OK] button to display a restart confirmation dialog.

Restart the GOT to operate with the new setting.

If touch the [Cancel] button, the changed settings are canceled and the screen returns to the Main Menu.

■Time zone

1. Touch the up or down button on the right side of the time zone entry box to change the setting.

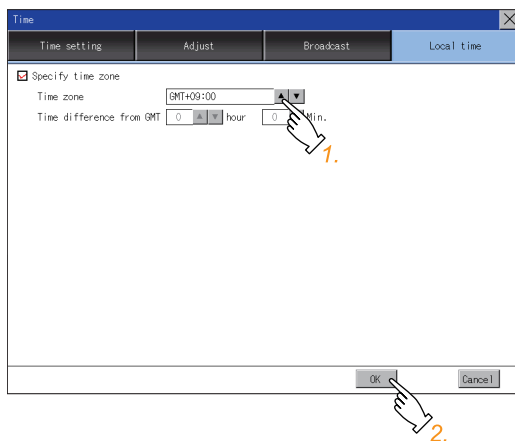

2. Touch the [OK] button to display a restart confirmation dialog.

Restart the GOT to operate with the new setting.

If touch the [Cancel] button, the changed settings are canceled and the screen returns to the Main Menu.

■ Time difference from GMT

1. To change the setting of [hour], touch the up or down button on the left side of [hour].

To change the setting of [Min.], touch the pull-down menu button on the left side of [Min.] and select an item from the list.

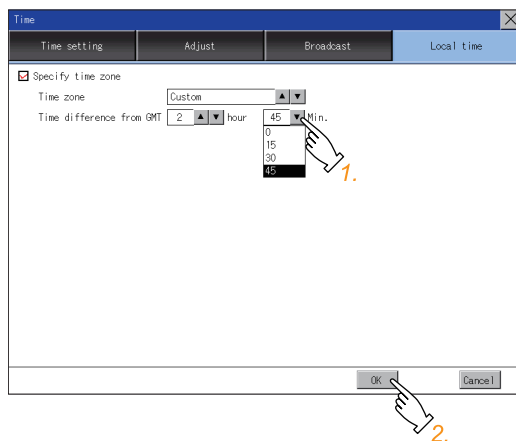

2. Touch the [OK] button to display a restart confirmation dialog.

Restart the GOT to operate with the new setting.

If touch the [Cancel] button, the changed settings are canceled and the screen returns to the Main Menu.

2.10 Controller

Controller setting

Configure controller settings.

The items which can be set are shown below. When each item part is touched, the respective setting becomes possible.

Function	Description
Assign Ethernet I/F	Change the assignment of channel No. and communication driver name of the device connected using the Ethernet interface.
Channel-Driver assign	Change the assignment of channel No. and communication driver name.
Channel no. (Ch No.) setting	Set the channel numbers of the communication interface (Standard interface/Extend interface).
5 V power supply	When connecting a controller to the RS-232 interface, whether to supply 5 V DC power or not to the controller through 9 pins can be selected.
Communication Detail Setting	Set communication parameters of communication devices.

Communication detail setting display operation

GOT basic setting



Controller(For GT27)

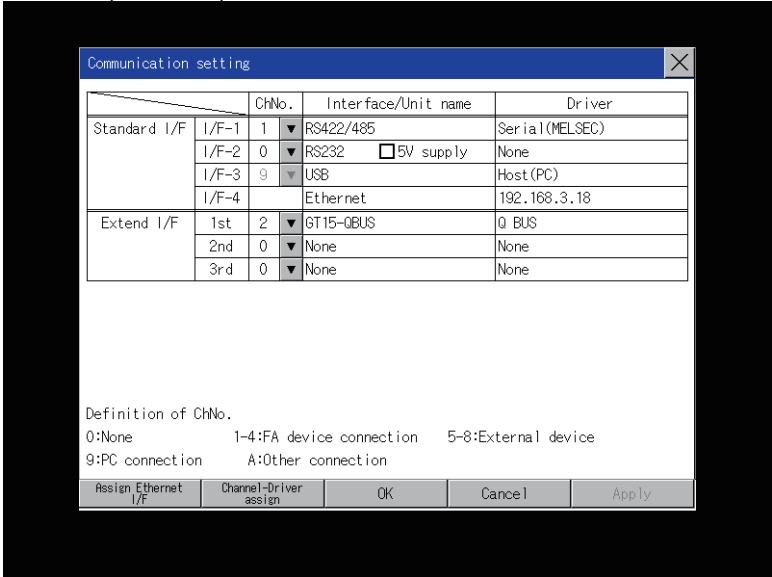

Controller contents

This section describes setting items and display contents for a controller.

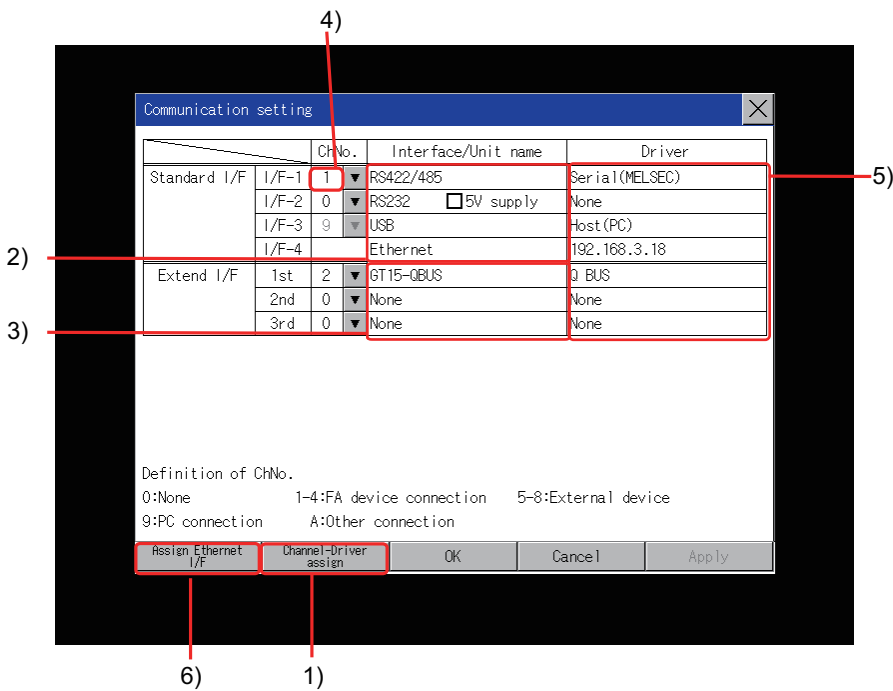

1) Channel-Driver assign

- Assignment of communication drivers to channels

Even without setting [Controller Setting] on GT Designer3, communication with controller is available by assigning channel No. with this function.

Page 104 Channel-Driver assign operation

- Changing the assignment of communication drivers to channels

Without using GT Designer3, the assignment of communication drivers to channels can be changed.

When change a communication driver, the alternative communication driver has to be installed in GOT in advance.

2) Standard interface display box

The standard communication interfaces of the GOT are displayed.

There are the following 4 types.

RS-232	For communicating with a controller
RS-422/485	For communicating with a controller
USB (Device)	For communicating with a personal computer (GT Designer3)
Ethernet	For communicating with a personal computer (GT Designer3) or a controller

3) Extension interface display box

The name of the unit installed in the extension interface is displayed.

(Displays [None] when any unit is not mounted.)

For details of each unit, refer to the following.

GOT2000 Series User's Manual (Hardware)

4)Channel number specification menu box

Set the channel number used for a standard interface or extension interface.

For communication drivers that can be assigned to channels, refer to the following.

5)Communication driver display box

0	Set when the communication interface is not used.
1 to 4	Set when connecting to a controller. (Except a barcode reader, an RFID controller, and a personal computer)
5 to 8 ^{*1,2}	Set when connecting to a barcode reader, an RFID controller or a PC.
9 ^{*1}	Set when connecting to a personal computer (GT Designer3). When the USB interface is used, the channel number is fixed to [9].
A	Set this item when using the following functions. <ul style="list-style-type: none"> • Gateway function • MES interface function • Ethernet download • Report function • Hard copy function (for output to a printer) • Video display function • RGB display function • RGB output function • External I/O function • Operation panel function • Sound output function • Multimedia function • Remote personal computer operation function • VNC server function • Wireless LAN connection function
-	When the Ethernet communication unit is used, the channel number is fixed to [-].

*1 The channels cannot be assigned with the Ethernet I/F assignment.

*2 The same device cannot be used for Ch No.5 to Ch No.8 simultaneously.

For restrictions on external devices, refer to the following.

 GOT2000 Series Connection Manual for the controller used

 GT Designer3 (GOT2000) Screen Design Manual

5)Communication driver display box

Displays the name of the communication driver assigned to a channel or the communication driver set in the controller setting of GT Designer3.

For details on communication drivers to be displayed, refer to the following.

 GOT2000 Series Connection Manual for the controller used

 GT Designer3 (GOT2000) Screen Design Manual

Display [None] in the driver display box in case of the followings.

- The communication driver is not installed.
- In the channel number specification menu box, [0] is set.
- The type of the communication unit mounted on the extension interface does not correspond to the set communication driver.

For how to set the communication driver, refer to the following.

 Page 104 Channel-Driver assign operation

6)Assign Ethernet I/F

The communication settings for the Ethernet connection can be made.

Ethernet I/F Assignment can assign up to four channels per interface.

 Page 103 Assign Ethernet I/F operation

Precautions for communications between GOT and controller

■Installing a communication driver and downloading communication setting data

To communicate with a controller, perform the following to the communication interface

- 1) Install a communication driver (up to four drivers).
- 2) Assign a channel number and the communication driver to the communication interface.
- 3) Download the project data including the setting configured in step 2) above.

Perform 1), 2), 3) by GT Designer3.

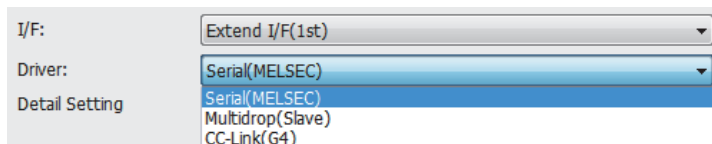

Refer to the following for details.

 GOT2000 Series Connection Manual for the controller used

 GT Designer3 (GOT2000) Screen Design Manual

■When the communication setting data is not downloaded.

The GOT automatically assigns the installed communication driver in the order of 1) to 3) as follows.

(This automatic assignment is applied to the extension interface only.)

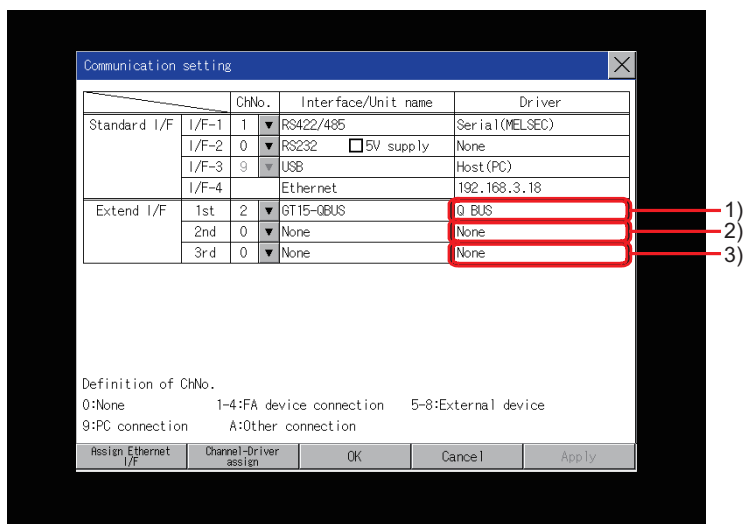

1): ChNo.1, Communication driver installed at 1st

2): ChNo.2, Communication driver installed at 2nd

3): ChNo.3, Communication driver installed at 3rd

- After communication driver is assigned automatically.

When saving the settings to the GOT with [OK] button after the automatic assignment of communication driver, automatic assignment will not be performed at the next time and after.

- Priority against [Controller Setting] of GT Designer3

If download the communication settings to the GOT with GT Designer3 after the automatic assignment, the GOT will operate with the communication settings of GT Designer3. (The GOT operates with the latest communication settings.)

■When the communication driver does not match with the unit that is installed in the GOT

An error is displayed on the GOT when displaying [Communication setting].

If an error is displayed, confirm the combination of the communication driver and communication unit.

Refer to the following manual for the combination.

 GOT2000 Series Connection Manual for the controller used

Controller setting operation

Assign Ethernet I/F operation

The following describes how to operate the Ethernet I/F assign.

The setting operation is same as that of the communication setting screen.

1. Touch the [Assign Ethernet I/F] button in [Communication setting].

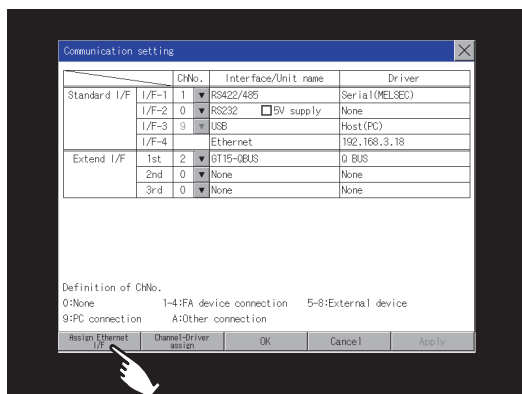

2. After the screen shown below is displayed, touch the channel number specification menu BOX when changing the channel number.

Page 106 Channel number setting operation

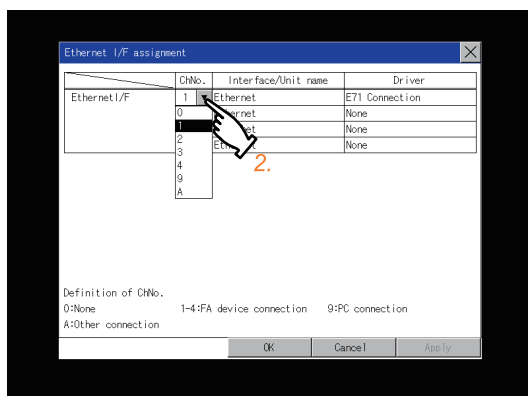

3. For changing the parameter settings, touch the driver display BOX.

Page 108 Communication detail setting

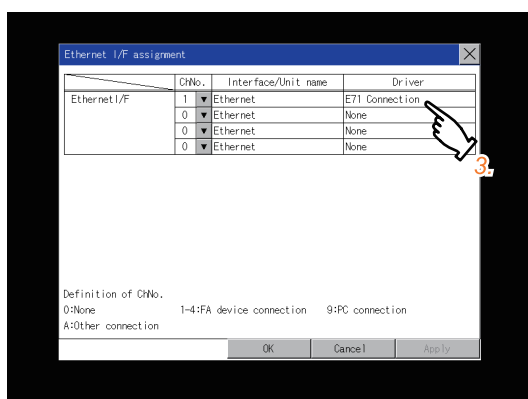

4. If touch the [OK] button, the changed settings are reflected and the screen returns to the [Communication setting] screen.

If touch the [Cancel] button, the changed settings are canceled and the screen returns to the [Communication setting] screen.

5. In the [Communication setting] screen, touching the [OK]/[Cancel]/[x] button restarts and operates the GOT with the changed settings.

Channel-Driver assign operation

The following describes how to operate the Channel-Driver assign.

The following description uses an example of changing the serial communication connection to the direct CPU connection (serial).

Point

Before the operation

The GOT automatically restarts after executing this setting.

If project data has been downloaded, the GOT starts monitoring of the controller after restarting.

Execute this setting after carefully confirming the safety.

1. Install the communication driver [Serial(MELSEC)] to the GOT.

(Download of [Controller Setting] from GT Designer3 is not required.)

After installing communication driver, touch the [Channel Driver assign] button in [Channel-Driver Assign].

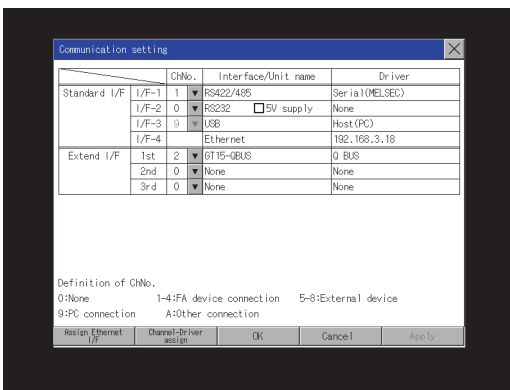

2. Select a communication driver to be assigned for each channel on the screen displayed as below.

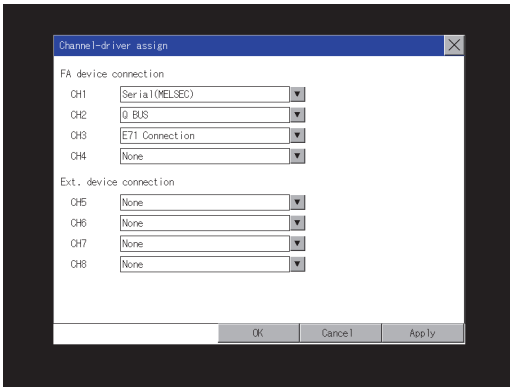

3. As the communication driver ([Serial(MELSEC)]) installed in the GOT is displayed, touch it.

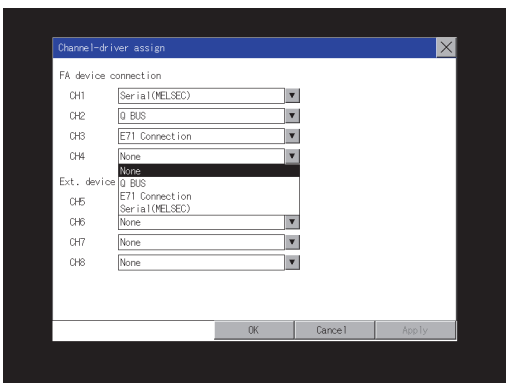

4. The screen returns to the [Channel-Driver assign] screen. If touch the [OK] button, the changed settings are reflected and the screen returns to the [Communication setting] screen.

If touch the [Cancel] button, the changed settings are canceled and the screen returns to the [Communication setting] screen.

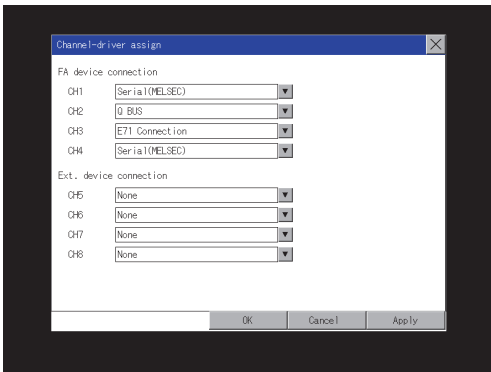

5. Confirm that the selected communication driver ((Serial(MELSEC))) is assigned.

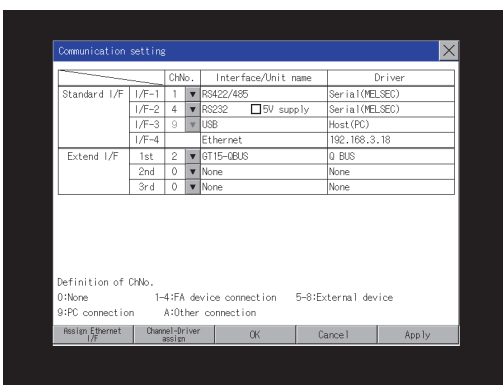

6. After the confirmation, if touch the [OK]/[Cancel]/[*] button, the GOT restarts and operates with the changed settings.

Channel number setting operation

1. Touch channel number specification menu BOX to be set.

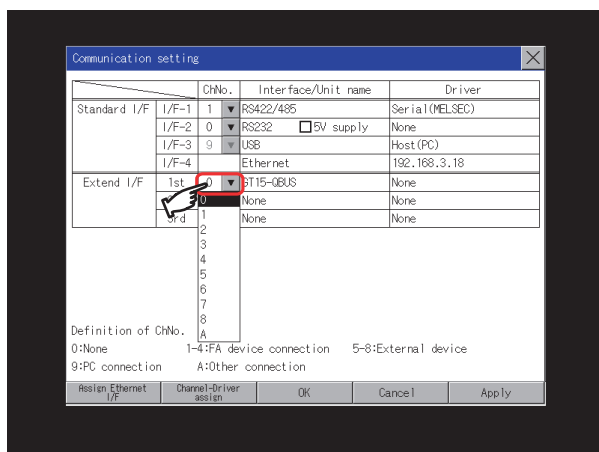

2. The cursor for the channel number specification menu BOX is displayed.

Simultaneously the keyboard for a numerical input is displayed.

3. Input the channel number from the keyboard and touch [Enter] key, and the value is defined.

Simultaneously, the name of the communication driver corresponding to the channel number assigned by GT Designer3 is displayed in the driver display BOX.

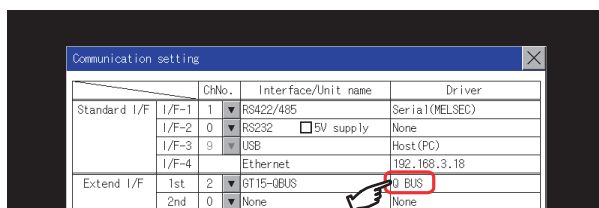

Communication detail setting switching operation

1. If the driver display BOX is touched on the communication setting screen or Ethernet I/F assign screen, the screen switches to the detailed setting screen of the related controller device.

☞ Page 108 Communication detail setting

5V power supply setting operation

When connecting a controller to the RS-232 interface, whether to supply 5 V DC power or not to the controller through 9 pins can be selected.

Thus, it is not necessary to connect an external power supply.

1. Touch [5V supply].

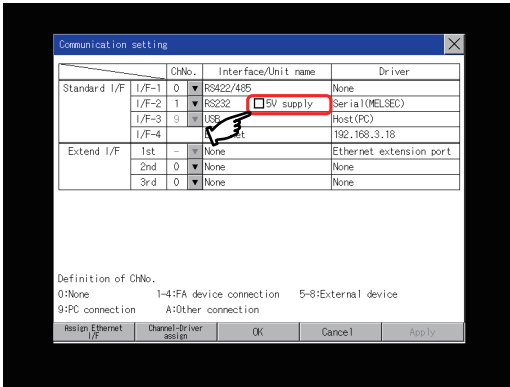

2. Check that the 5V power supply is selected.

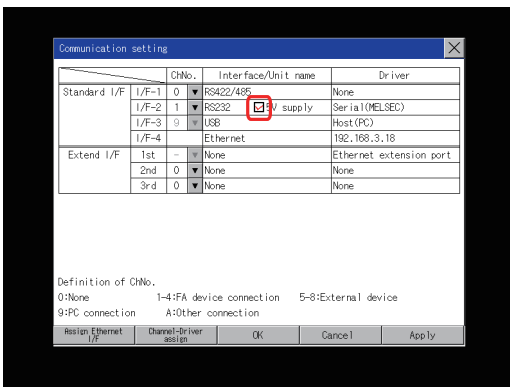

3. If touch the [OK]/[Cancel]/[x] button, the GOT restarts and operates with the changed settings.

Host (PC) settings

The communication driver of [USB] is fixed to [Host(PC)].

Communication detail setting

Communication detail setting

Function	Description
Communication parameters setting	Set various communication parameters of communication devices. The settable parameters differ according to the communication device.
Keyword setting	For the FX series PLCs, key word for protecting program in the PLC can be set.
Key word deleting	For the FX series PLCs, key word for protecting program in the PLC can be deleted.
Key word protection cancel	For the FX series PLCs, the program protection status in the PLC can be cancelled.
Keyword protection	For the FX series PLCs, the cancelled program protection status in the PLC can be returned to the protection status again.

Before setting a keyword

■How to select a keyword protection level

For equipments that are allowed to operate the FX PLC on line, 3 levels of protection level can be set.

When performing monitoring or changing settings with any on-line equipment is required, set password with referring to the following.

- When setting keyword only

Select a protection level by the initial letter of keyword.

All operation protect: Set a keyword with initial letter of "A", "D" to "F", or "0" to "9".

Read/Incorrect write protection: Set a keyword with initial letter of "B".

Incorrect write protect: Set a keyword with initial letter of "C".

- When setting keyword and 2nd keyword

Select a protection level by [Registration condition].

■Monitoring availability at each keyword protection level

Device monitoring availability at each keyword protection level is shown in the following.

Item	When setting keyword only			When setting keyword and 2nd keyword			Keyword not registered or protection canceled
	All operation protect	Read/Incorrect write protection	Incorrect write protect	All on-line operation protect	Read/write protect	Write protect	
Monitoring devices	○	○	○	×	○	○	○
Changing devices	T, C set value and file register (D1000 and the following)	×	×	×	○	○	○
	Other than the above	○	○	○	×	○	○

■Difference between all online operations prohibition and all operations prohibition

When specifying All online operations prohibited, displaying devices and inputting data with a programming tool or GOT are all prohibited.

When all operations are prohibited, displaying devices and inputting data with the GOT are enabled while all operations using a programming tool are prohibited.

Display operation of the communication detail setting

■Communication setting

1. Touch the target communication driver display box to set the communication parameter.

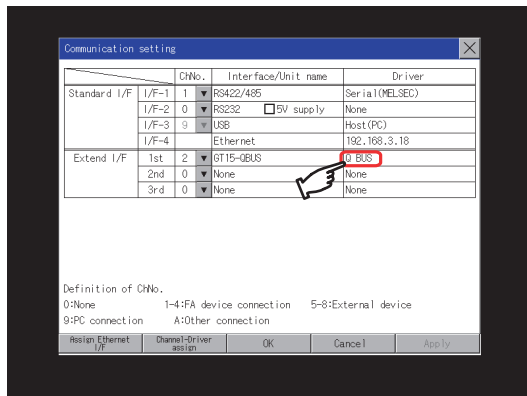

2

Point

Communication using the Ethernet communication unit

If the Ethernet communication unit is assigned to an extension interface, the corresponding communication detail setting cannot be displayed.

2. The screen switches to the detail setting screen.
Set communication parameters from this screen.
Refer to the following for the setting change operation.

☞ Page 47 Basic operation to change the settings

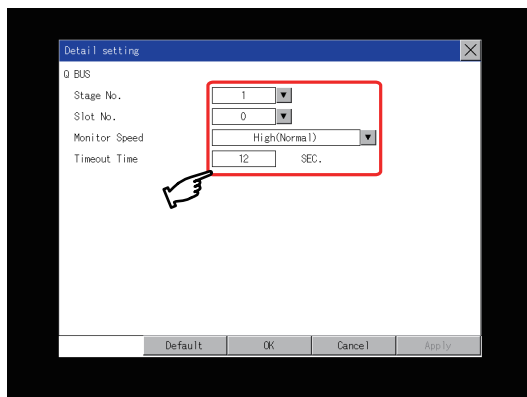

Point

- Communication parameter setting by GT Designer3

Set the communication parameters for each communication driver at [Communication Settings] in [Controller Setting] of GT Designer3.

When change the communication parameters after downloading project data, change the setting at communication detail setting of GOT.

📖 GOT2000 Series Connection Manual for the controller used

📖 GT Designer3 (GOT2000) Screen Design Manual

- For the Ethernet multiple connection

Touch the driver display BOX of the Ethernet connection, and then the communication detail setting screen of Channel No. 1 is displayed.

■Ethernet I/F assignment

Several communication drivers are assigned to an Ethernet interface, whereas only one GOT IP address is assigned to an Ethernet interface.

By changing the settings of one interface, the GOT IP address, GOT port No. download, default gateway and subnet mask settings of other drivers, which are assigned to the same interface, are also changed.

1. Touch the [Assign Ethernet I/F] button in [Communication setting].

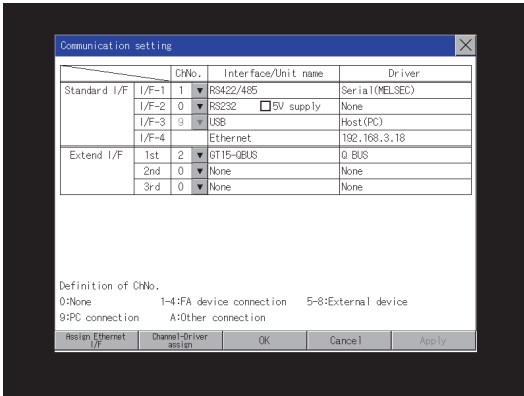

2. Touch the driver display BOX of the communication parameter to be set in the [Ethernet I/F assignment] screen.

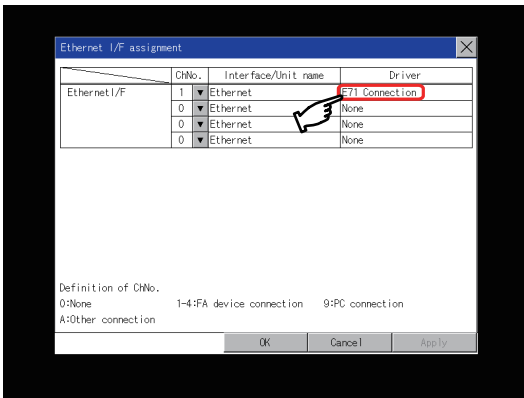

3. The screen switches to the detail setting screen.
 Set communication parameters from this screen.
 Refer to the following for the setting change operation.

☞ Page 47 Basic operation to change the settings

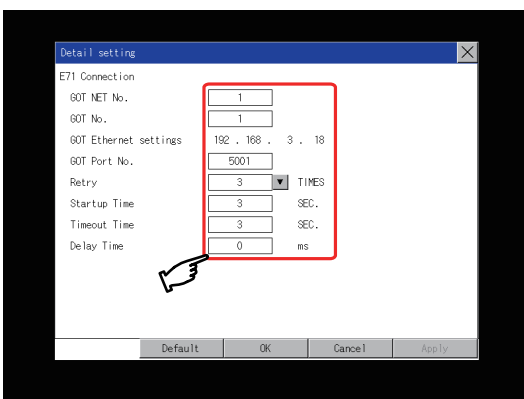

Communication parameter setting by GT Designer3

Set the communication parameters for each communication driver at [Communication Settings] in [Controller Setting] of GT Designer3.

When change the communication parameters after downloading project data, change the setting at communication detail setting of GOT.

 GOT2000 Series Connection Manual for the controller used

 GT Designer3 (GOT2000) Screen Design Manual

Display contents of communication detail setting

What to set in the communication detail setting varies depending on the communication driver type.

This section explains the settings when MELSEC-FX or CC-Link IE TSN is selected as a communication driver.

For setting items other than described in this section, refer to the following.

 GOT2000 Series Connection Manual for the controller used

 GT Designer3 (GOT2000) Screen Design Manual

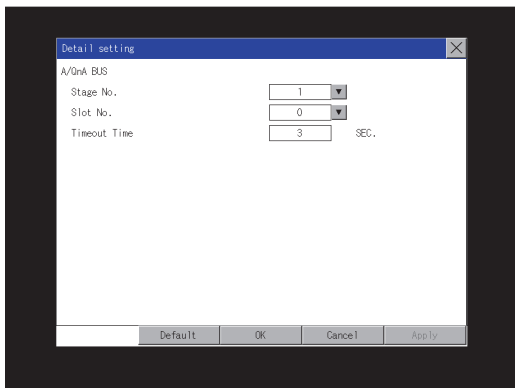

■MELSEC-FX

When MELSEC-FX is selected as a communication driver, the following operations can be performed for a keyword.

Registration

Deletion

Protection delete

Protection

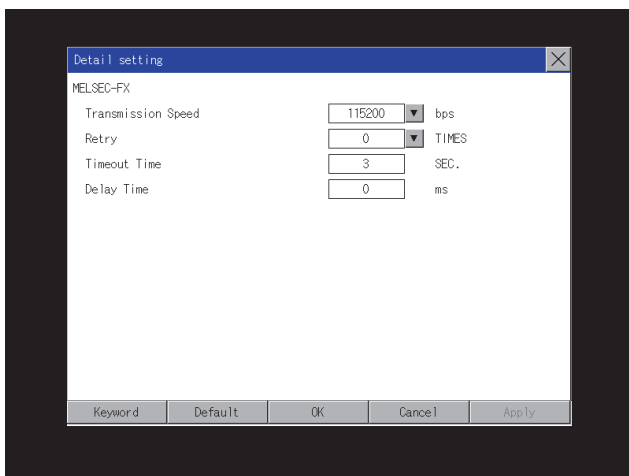

- Registration

Register key words.

1. Touching the [Regist] key pop-up displays the keyboard for inputting a keyword.
2. Input a keyword and touch the [Enter] key, and the registration completes.

Up to 8 characters can be set for keyword with using A to F and 0 to 9.



PLC connected	Setting	
	When registering keyword and 2nd keyword	When registering keyword only
FX CPU compatible with 2nd keyword	[Registration condition] ^{*1} can be selected.	[Registration condition] ^{*1} cannot be selected.
FX CPU not compatible with 2nd keyword	-	

*1 The access restriction can be selected from [Read/Write Protect], [Write Protect], and [All Protect].

For access restriction on each setting, refer to the following manual.

The User's Manual of the FX series PLC you are using

- Deletion

Delete a registered keyword.

1. Touching the [Delete] key pop-up displays the keyboard for inputting a keyword.
2. Input a key word and touch the [Enter] key, and the keyword is deleted.

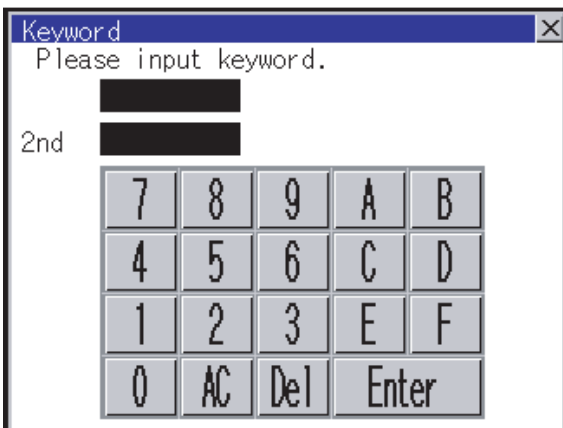

PLC connected	Setting
FX CPU compatible with 2nd keyword	Input a keyword to delete.
FX CPU not compatible with 2nd keyword	Input the keyword to delete only into the keyword. The 2nd keyword will be ignored.

- Protection delete

Delete the protection by key word in order to access to a FX PLC to which a key word is registered.

1. Touching the [Clear] key pop-up displays the keyboard for inputting a keyword.
2. Input a keyword and touch the [Enter] key to delete the protection.

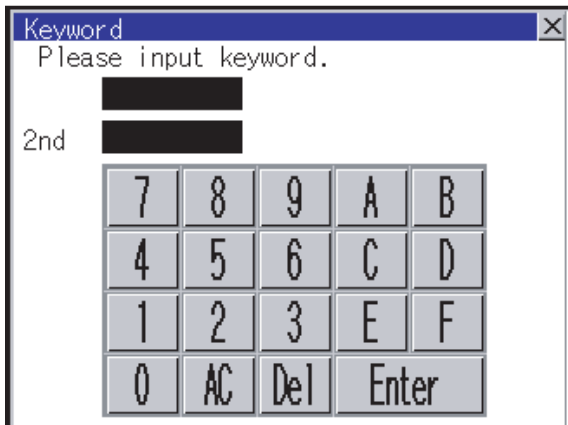

PLC connected	Setting
FX CPU compatible with 2nd keyword	Input a keyword to delete the protection.
FX CPU not compatible with 2nd keyword	Input a keyword to delete only into the keyword. The 2nd keyword will be ignored.

- Protection

Reset the keyword in which protection has been deleted to the protection status.

1. Touch the [Protect] key, and the keyword goes to a protected status.

■CC-Link IE TSN

When CC-Link IE TSN is selected as a communication driver, the following items are settable on the [Detail setting: IP Address] screen.

IP Address

Subnet Mask

Default Gateway

1. Touch the [IP Address] button to display the [Detail setting: IP Address] screen.

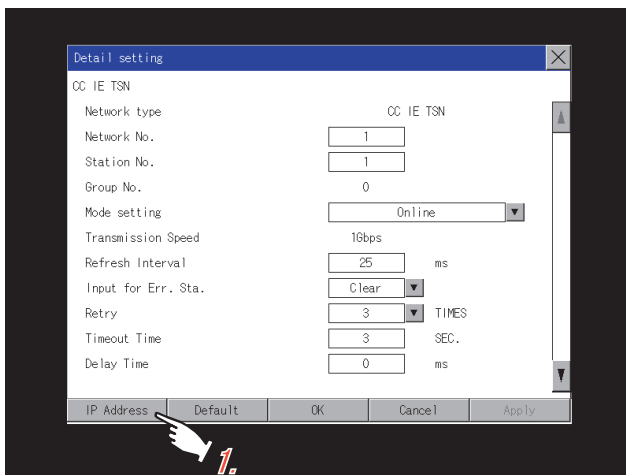

2. Touch the entry box for the setting item to display a software keyboard. Input a value with the keyboard.

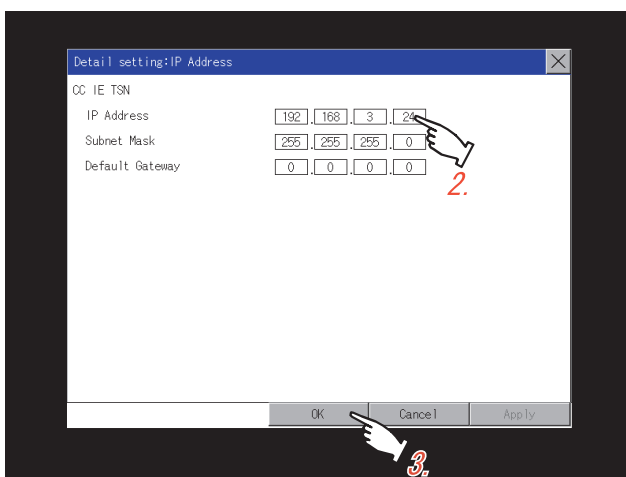

3. Touch the [OK] button to apply the new settings and return to the [Detail setting] screen. To cancel the new settings, touch the [Cancel] button to return to the [Detail setting] screen.

2.11 Ethernet Communication

Ethernet setting

The Ethernet setting, which has been configured with GT Designer3, can be checked.
The host station setting, network number, station number, and IP address are changeable.
For the Ethernet setting, refer to the following.

 GOT2000 Series Connection Manual for the controller used

Display operation of the Ethernet setting

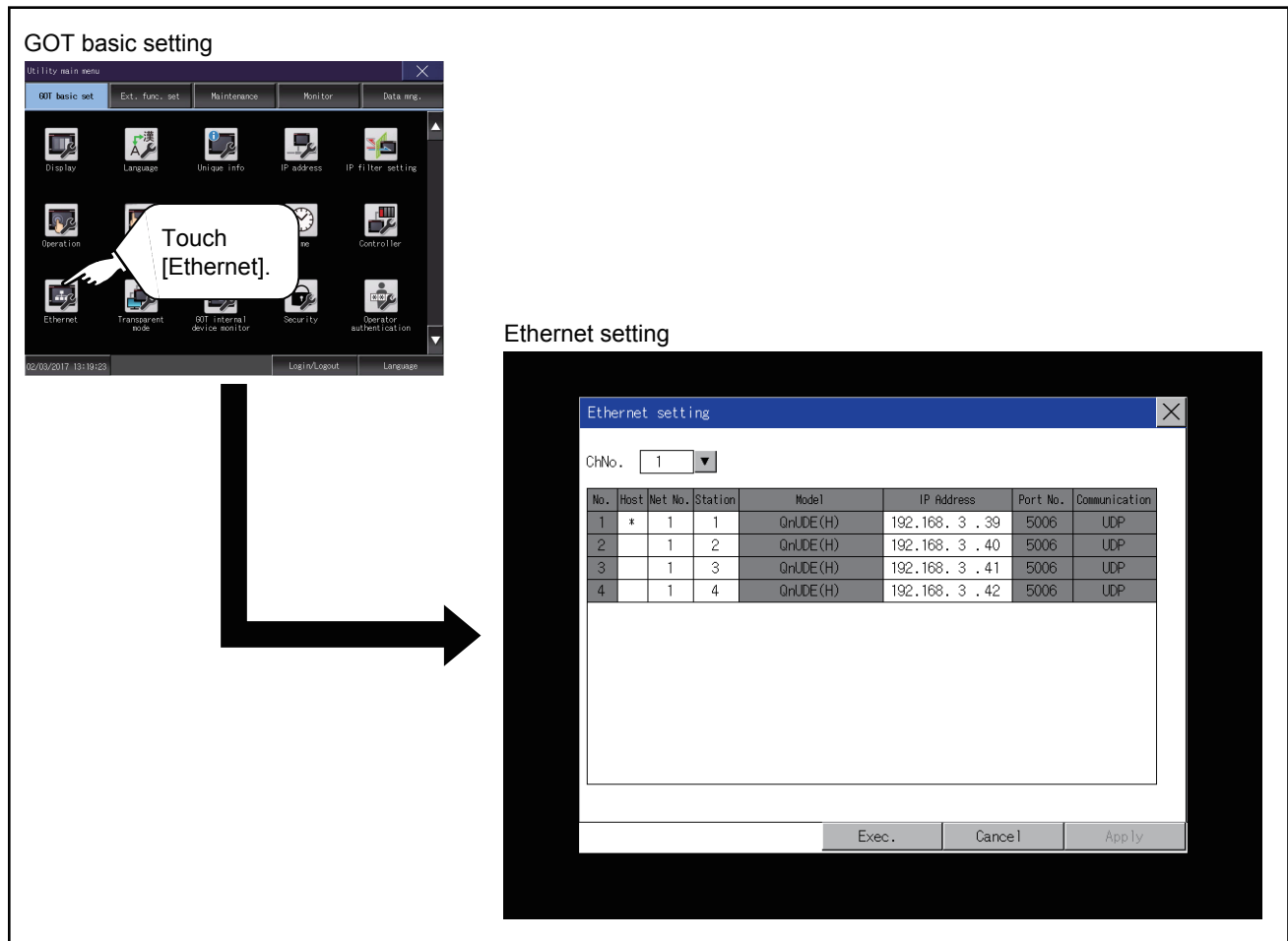

If the Ethernet setting is changed with applicable GOT special registers (GS), the GOT may not operate with the new Ethernet setting displayed in the utility.
Therefore, restart the GOT to reflect the new setting.

Display contents of Ethernet setting

The following describes the setting items and the display contents of the Ethernet setting.

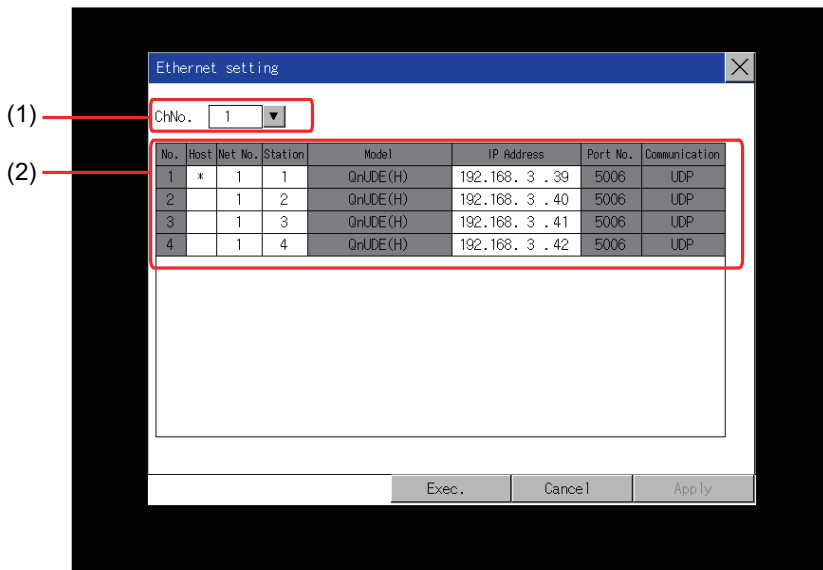

1) Channel select tab

Channels can be switched.

Switching to the channel which does not have the Ethernet setting is not available.

[*] is displayed on the right side of the channel whose setting is changed.

2) Ethernet setting items

The contents of the Ethernet setting configured in GT Designer3 are displayed.

Changing [Host], [Net No.], [Station No.] and [IP Address] are available.

☞ Page 118 Change of host

☞ Page 119 Change of Net No.

☞ Page 120 Change of station No.

☞ Page 121 Change of IP address

Point

- How to cancel the change of the setting in the [Ethernet setting] screen.

Cancel the settings changed in the [Ethernet setting] screen with the [Restore default settings] button.

The changed settings remain until they are canceled with the [Restore default settings] button.

The changed settings are not canceled even if writing the project data or system application to the GOT.

When the project data is written to the GOT without canceling the changed settings, those changed settings are reflected to the Ethernet setting of the written project data.

(If the written project data does not have a channel with same Ethernet settings as that of the channel changed in [Ethernet setting] screen, the changed settings are not reflected.)

Change of host

1. Touch the device to be set as the host.

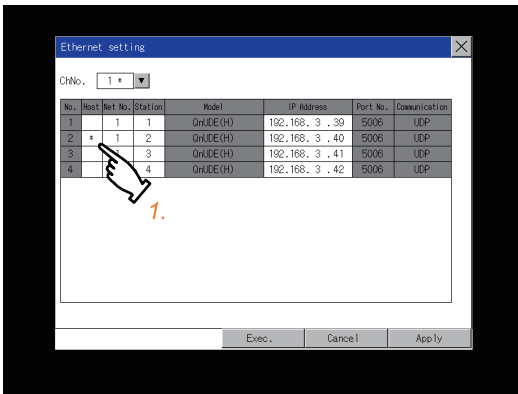

2. Touch the [OK] button to restart the GOT to operate with the changed settings.
Touch the [Cancel] button to cancel the changed settings and return to the [Controller] screen.

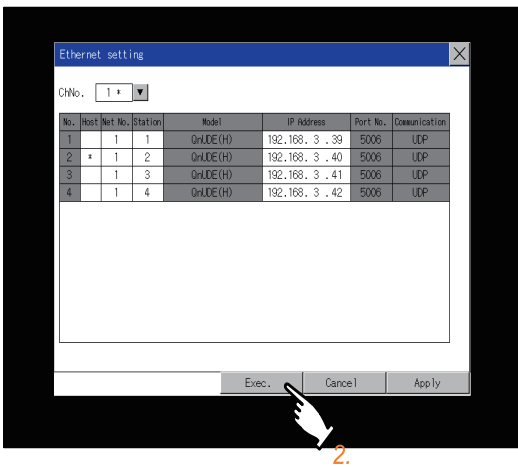

Change of Net No.

1. Touch the Net No. to be changed, and input the network No. to be changed by the numeric keypad displayed.

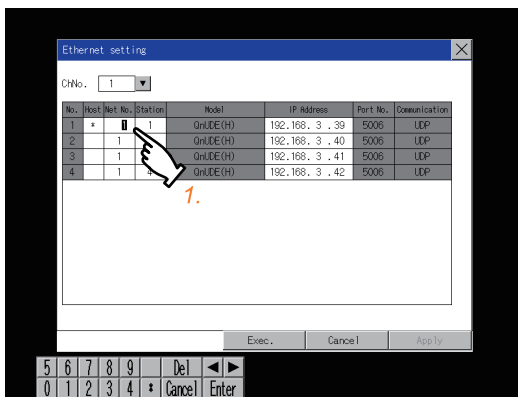

2. Touch the [Enter] button and [OK] button to restart the GOT to operate with the changed settings. Touch the [Cancel] button to cancel the changed settings and return to the [Basic Setting] screen.

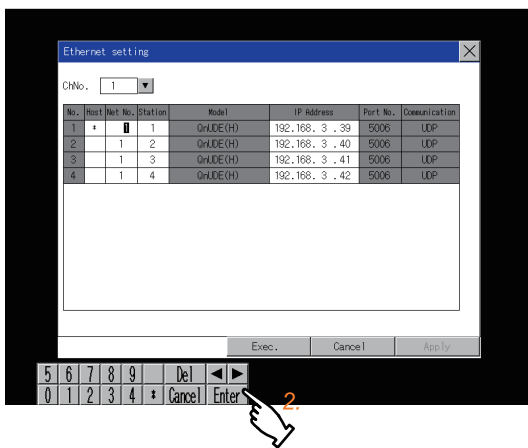

Change of station No.

1. Touch the station No. to be changed, and input the station No. of the destination Ethernet module to be changed by the numeric keypad displayed.

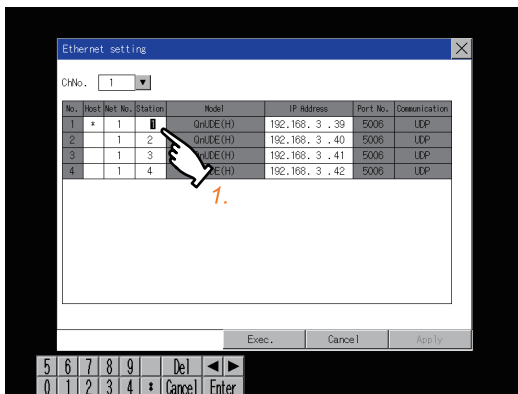

2. Touch the [Enter] button and [OK] button to restart the GOT to operate with the changed settings. Touch the [Cancel] button to cancel the changed settings and return to the [Basic Setting] screen.

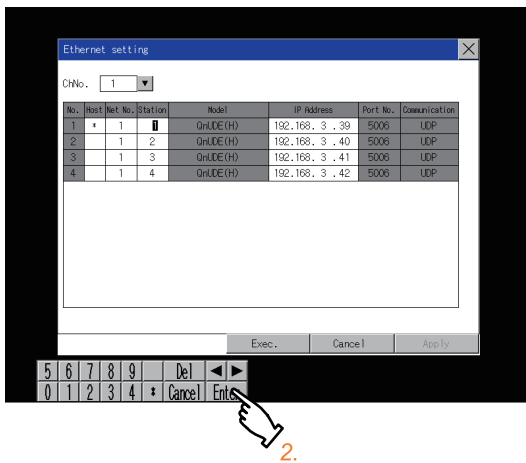

Change of IP address

1. Touch the IP address to be changed, input the destination IP address to be changed by the numeric keypad displayed.

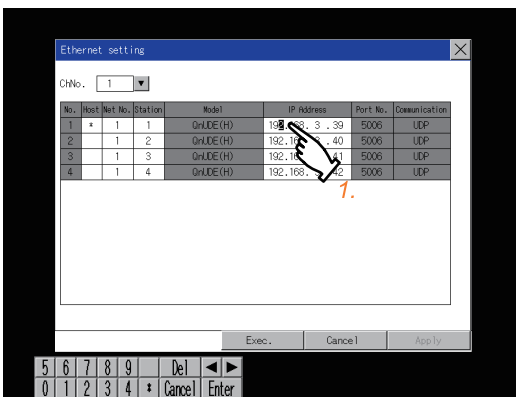

2. Touch the [Enter] button and [OK] button to restart the GOT to operate with the changed settings. Touch the [Cancel] button to cancel the changed settings and return to the [Basic Setting] screen.

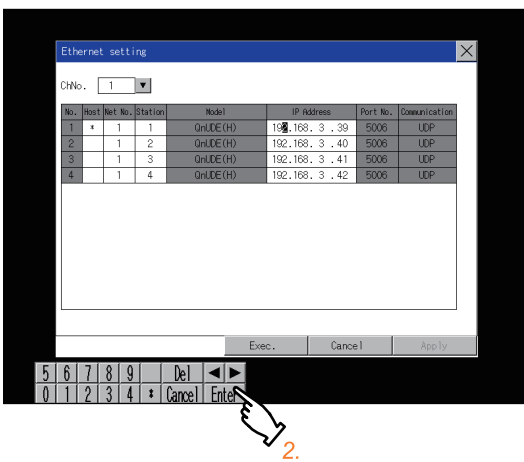

2.12 Transparent Mode

Transparent mode setting

When using the multi-channel function, the channel No. of a controller to which the FA transparent function is executed can be set. For the multi-channel settings, refer to the following.

📖 GOT2000 Series Connection Manual (Mitsubishi Electric Products) For GT Works3 Version1

📖 GT Designer3 (GOT2000) Screen Design Manual

Also, refer to the following for the FA transparent function.

📖 GOT2000 Series Connection Manual (Mitsubishi Electric Products) For GT Works3 Version1

Function	Description	Setting range
ChNo.	The channel No. of a controller to which the FA transparent function is executed can be set.	1/2/3/4 <Default: 1>

Display operation of the transparent mode setting

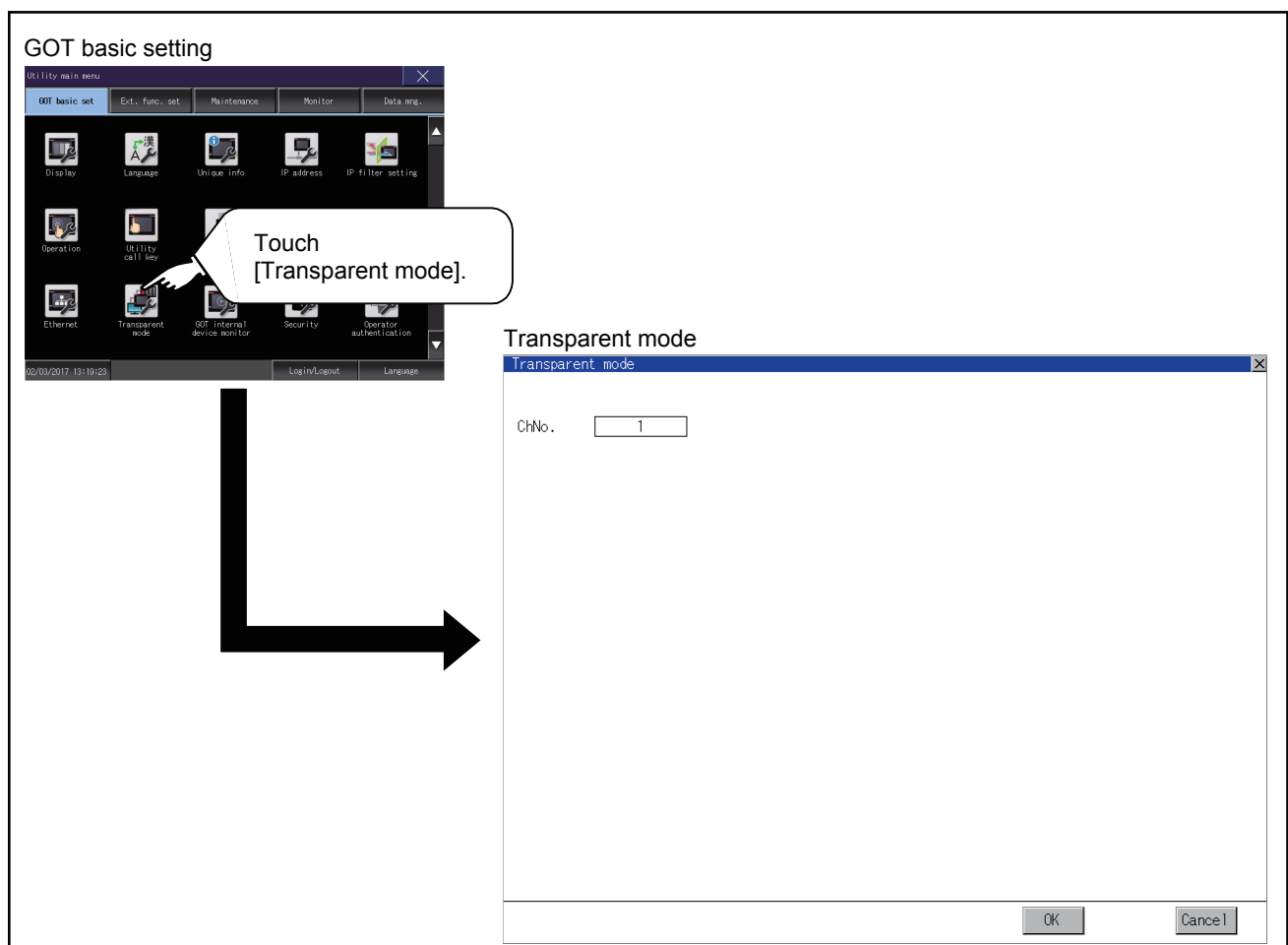

Operation the transparent mode

1. Touching the transparent ChNo. (numerical part) shown below, the keyboard is displayed.
Input numerical value by the keyboard.

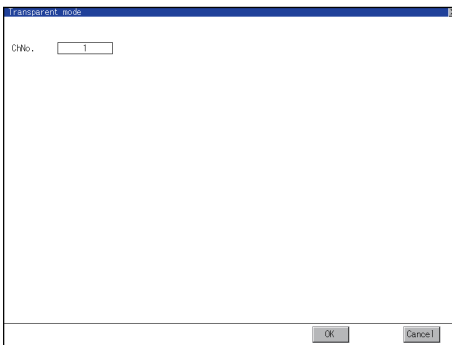

2. If touch the [OK] button, the GOT restarts and operates with the changed settings.
If touch the [Cancel] button, the changed settings are canceled and the screen returns to the Main Menu.

2.13 GOT Internal Device Monitor

GOT internal device monitor setting

Set whether to use the GOT internal device monitor of the GOT diagnostics function.

Item	Description	Setting range
Use GOT internal device monitor of GOT diagnostics	Set whether to use the GOT internal device monitor of the GOT diagnostics function.	Selected/Not selected <Default: Not selected>
Allow GOT internal device change	Set whether to allow the GOT internal device change.	YES/NO <Default: NO>

Display operation of the GOT internal device monitor

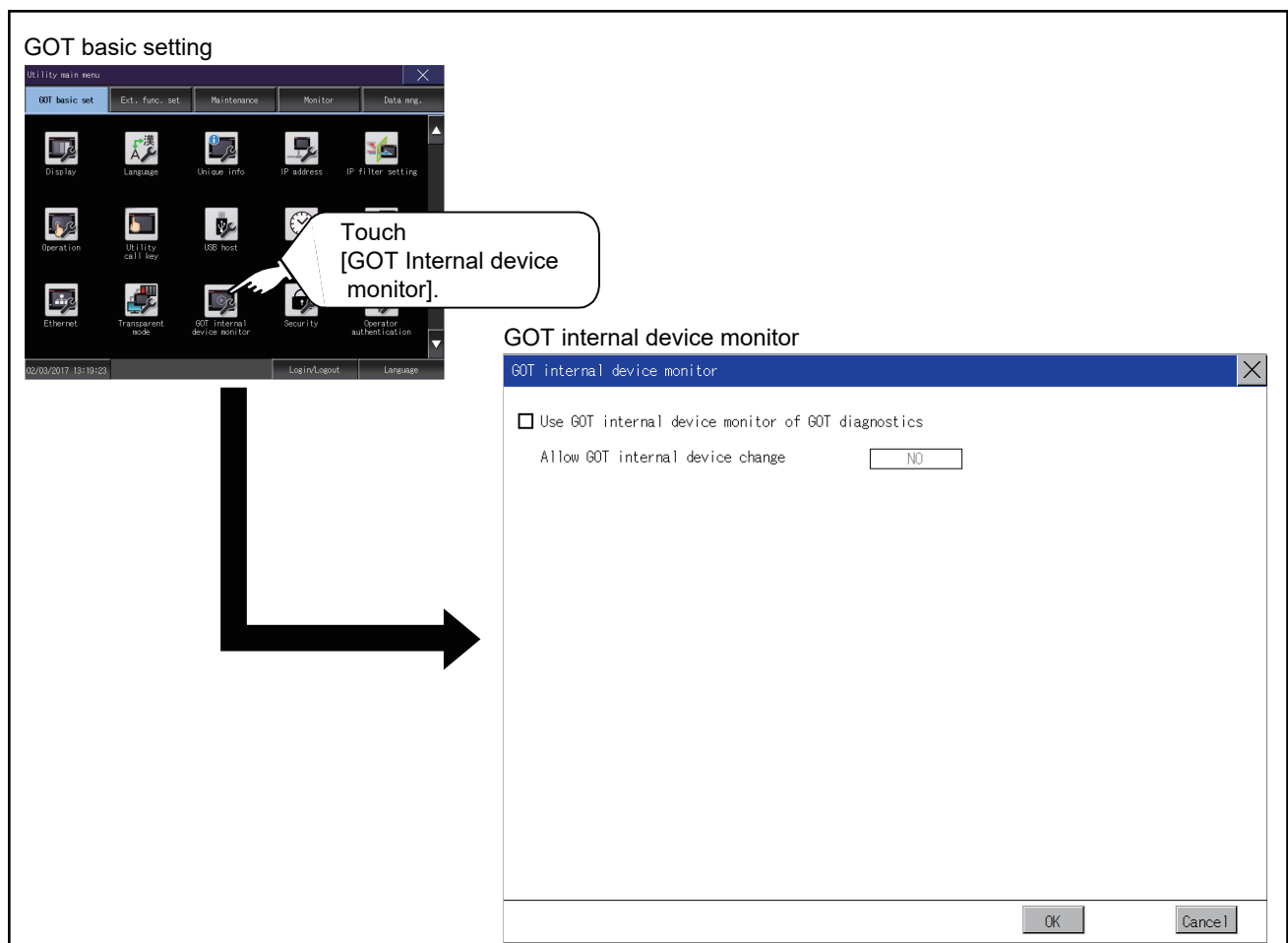

Setting procedure for the GOT internal device monitor

1. To use the GOT internal device monitor of the GOT diagnostics function, select the item shown below.

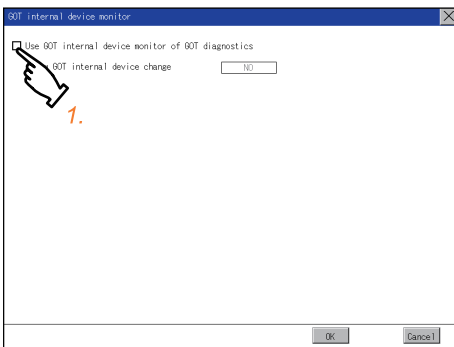

2. To allow the values of the GOT internal devices to be changed, touch the current selection of [Allow GOT internal device change].

Switch between the selections with each touch.

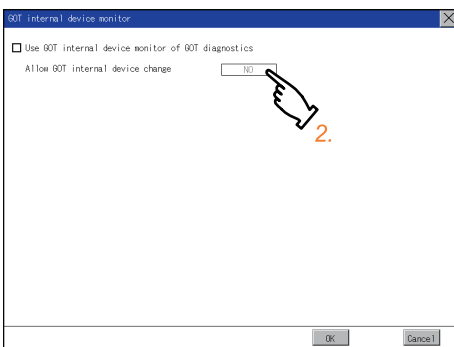

3. Touch the [OK] button to display a restart confirmation dialog.

Restart the GOT to operate with the new setting.

To cancel the new setting, touch the [Cancel] button to return to the main menu.

2.14 Security

Security level authentication

Security level change functions

Authenticates the security level set by each object or screen switch.

Refer to the following for the security level.

- Security level setting
📖 GT Designer3 (GOT2000) Screen Design Manual
- Password setting
📖 GT Designer3 (GOT2000) Screen Design Manual



Restrictions on screen display

The security level change screen cannot be displayed when project data do not exist in GOT.

Change the security level after downloading the project data to GOT.

Display operation of security level

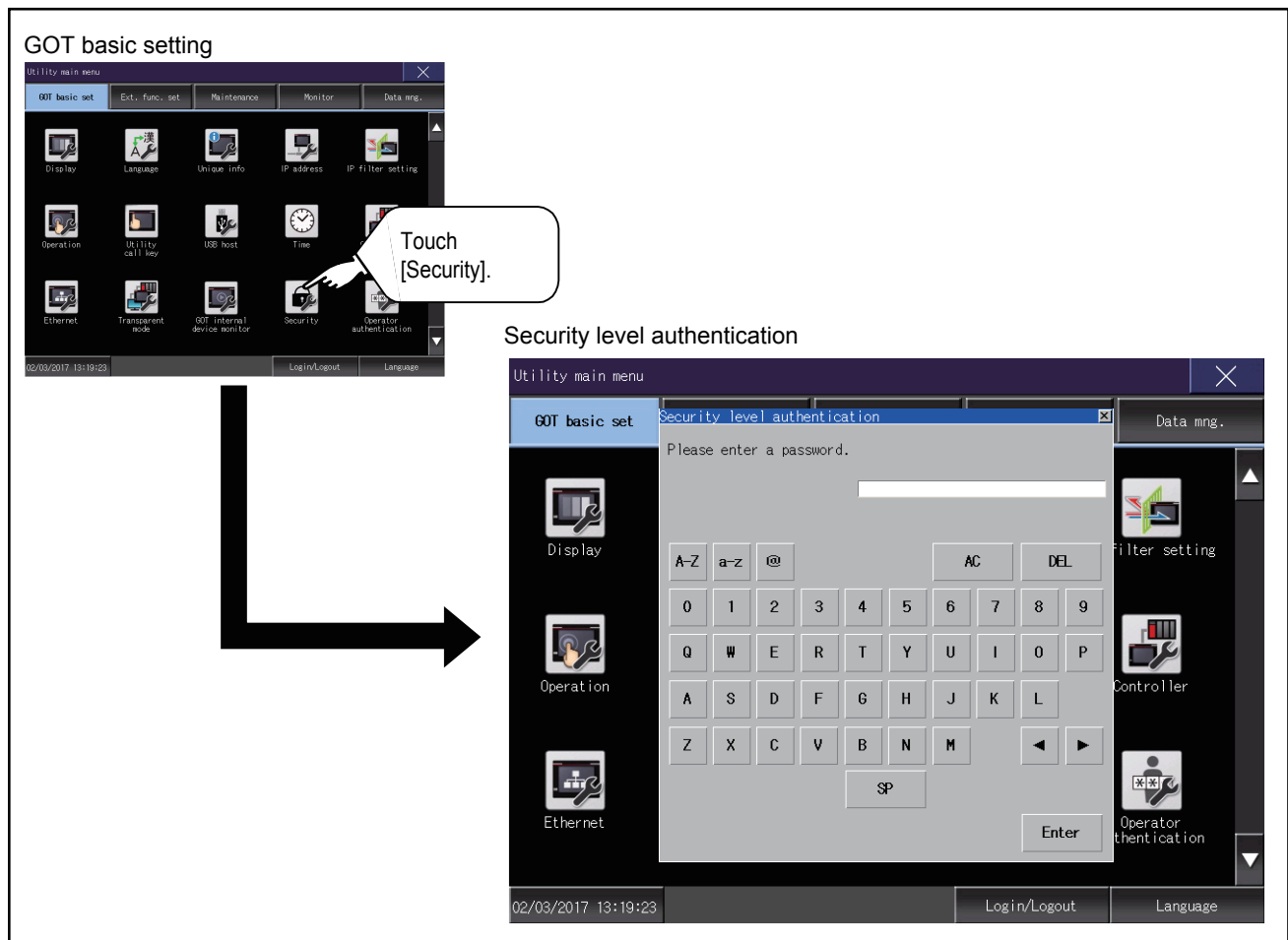

Setting operation of security level

■ Password input operation

1. By touching [0] to [9], [A] to [F] key, the password of the changed security level is input.

When correcting the input character, touch [Del] key to delete the correcting character and input the password again.

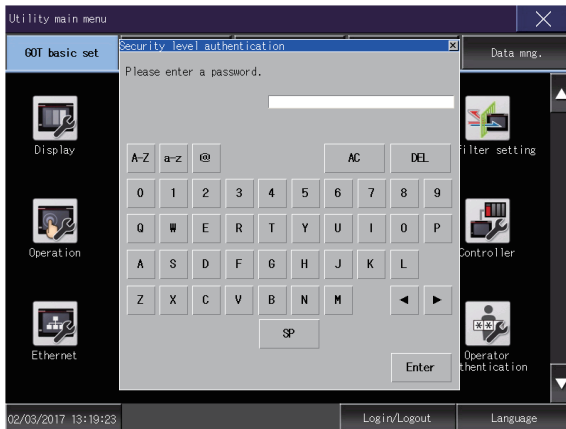

2. After inputting password, touch the [Enter] key.

When the password matches, the normal completion message is displayed.

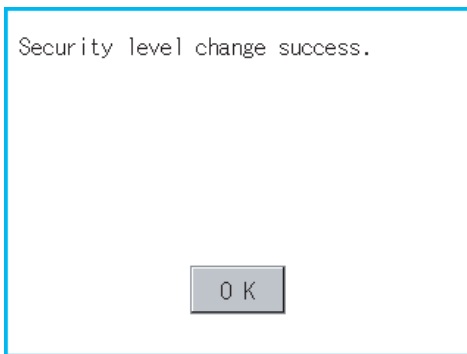

If the password does not match, the error message is displayed.

Touch the [OK] button to return to the password entry screen.

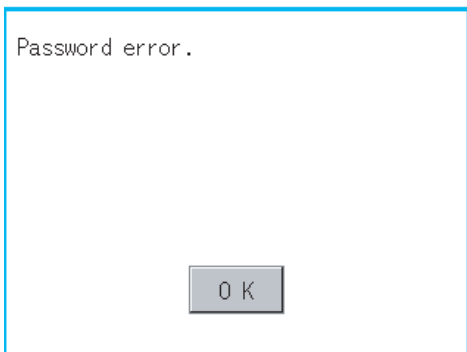

Point

About forgetting to return to the original level after changing security level temporarily

When use GOT after temporarily changing the security level, do not forget to return the security level to the original level.

2.15 Operator Authentication

Operator management

Operator management

■ Operator management function

The function enables displaying a list of the operator information and adding, changing, or deleting the operator information to be used.

A password for operator authentication can be changed when the password is out of date.

Functions for the operator authentication (automatic logout time, authentication method, password expiration date, etc.) can be set.

For the details of the operator authentication functions, refer to the following.

📖 GT Designer3 (GOT2000) Screen Design Manual

Function	Description	Reference
Operator management	Enables adding, editing, deleting, importing, and exporting the operator information.	📖 Page 130 Display operation of operator management 📖 Page 133 Operator management operation
Add operation	Add operator information to the GOT.	📖 Page 135 Add operation
Edit operation	Edit the operator information stored in the GOT. Unlock an operator ID.	📖 Page 139 Edit operation
Deletion	Delete the operator information stored in the GOT.	📖 Page 141 Deletion operation
Undo	Restore the current operator information to the previous saved one.	📖 Page 142 Undo operation
Import operation	Import the operator information that is already exported to a CF card to the GOT.	📖 Page 144 Import operation
Export operation	Export the operator information stored in the data storage.	📖 Page 146 Export operation
Password change	Enables changing passwords to be used for login and logout in/out of the GOT.	📖 Page 148 Export operation
Function setting	Set the following items. <ul style="list-style-type: none">• Operator authentication method• Automatic logout time• Password expiration date• Password expiration prenotification• Start position of the external authentication ID• Number of bytes of the external authentication ID• Sub administrator setting• Displaying uneditable operator information• Security level required to change the function setting• Continuous failure count to block login• Login prohibition time• Continuous failure count to lock an operator ID• Password requirements• Password history	📖 Page 151 Password change operation

■ Administrator and sub administrator

Administrator refers to the account preset in the GOT for management use only.

(Operator name: Administrator, operator ID number: -)

The administrator can register, edit, or delete the operator management information on each operator.

The administrator can also change the function setting for the operator authentication in the utility.

However, the administrator cannot log in as an operator to perform operations on the GOT.

Sub administrator refers to an operator with administrator privileges.

The sub administrator can register, edit, or delete the operator management information on an operator having a lower security level.

The sub administrator can also change the function setting for the operator authentication in the utility.

To enable the use of sub administrators, configure the relevant setting in [Function setting] in the utility.

For the setting, refer to the following.

☞ Page 153 Function setting operation

To grant administrator privileges to an operator, set the operator management information on the operator.

For the details of the operator management information, refer to the following.

☞ Operator information edit screen

(○: Available, ×: Not available)

Settings in the utility		Administrator	Sub administrator		
			When [Allow functionsetting] is selected	When [Allow functionsetting] is deselected	
Operator management	Registering, editing, or deleting the operator management information	○	○*1	○*1	
	Editing the operator management information on the administrator	○	○*2	×	
Function setting	Settings other than the administrator setting	○	○*3	×	
	Administrator setting	Enabling the use of sub administrators	○	×	×
		Displaying uneditable operator information	○	○*2	×
		Allowing the function setting to be changed	○	×	×
	Security level required to change the function setting	○	○*2	×	

*1 A sub administrator can manipulate the operator management information on an operator having a lower security level.

*2 To set this item, a sub administrator must have security level 15.

*3 A sub administrator having a security level lower than the level specified in [Allow function setting] cannot configure the settings.

■ Display operation of operator management

GOT basic setting

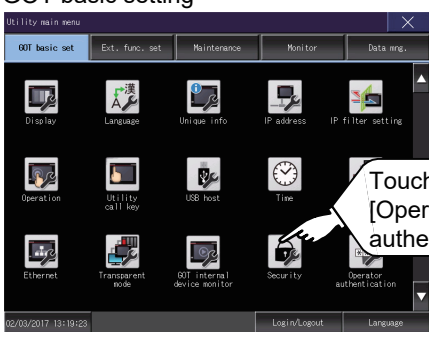

Touch [Operator authentication].

Operator authentication

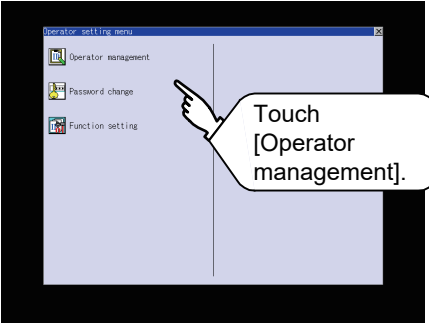

Touch [Operator management].

Operator management

Operator information management

OperatorName	ID	Level	PW Update	Lock status
Administrator	-	-	-	-
Ⓞ Ope0001	1	10	10/17/2019	-
Ope0002	2	5	10/17/2019	✓
Ⓞ Ope0011	3	15	10/17/2019	-
Ⓞ Ope0012	4	10	10/17/2019	-
× Ope0021	5	8	10/17/2019	-

Ⓞ : admin authority
× : disabled

Drive in use

Add Edit Delete Undo
A Import Export Save

■ Display example of operator management

- Operator information management screen

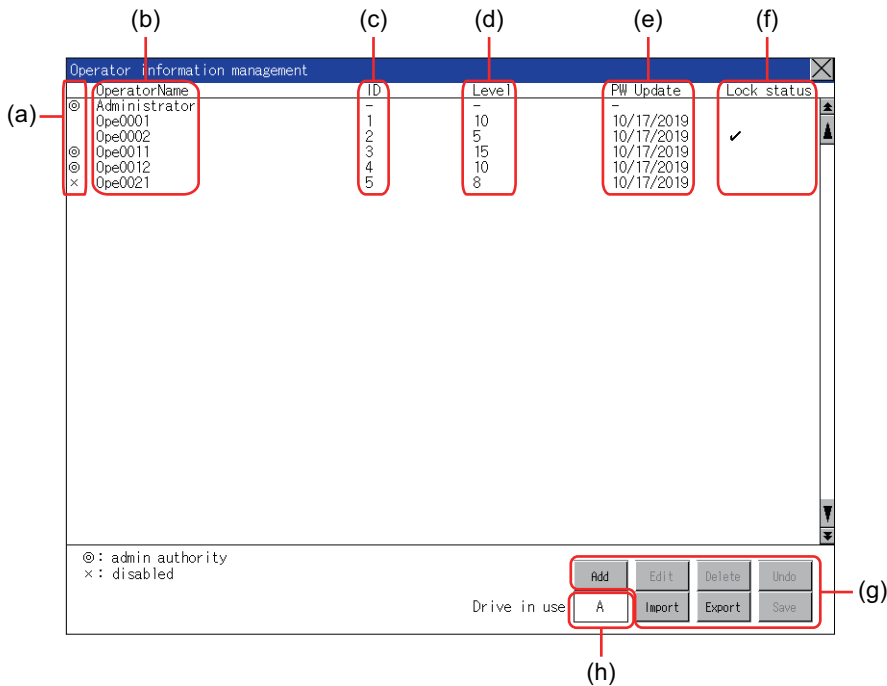

No.	Item	Description
(a)	Status	Displays the operator status. <ul style="list-style-type: none"> • ⊙: Operator with administrator privileges • ×: Operator in the disabled state
(b)	[Operator Name]	Displays operator names.
(c)	[ID]	Displays operator IDs.
(d)	[Level]	Displays security levels for operators.
(e)	[PW Update]	Displays the updated dates of the operators' passwords.
(f)	[Lock status]	Displays a checkmark in the row of the operator whose account is locked after consecutive failed login attempts.
(g)	Operation keys	Execution keys for each function
(h)	Drive in use	Displays and sets the storage location for imported and exported operator information. To switch the drive, touch the key. (A: Built-in SD card/B: USB drive/E: USB drive/F: USB drive/G: USB drive) Only when the drive B, drive E, drive F, or drive G is installed on the GOT, the user can switch the drive.

• Operator information edit screen

Touch the [Add] button or touch the [Edit] button with the operator information selected on the Operator information management screen, and then the Operator information edit screen is displayed.

The operator information can be edited.

No.	Item	Description
(a)	[Operator Name]	Displays the operator name, or input an operator name. Up to 16 alphanumeric characters, symbols, and one-byte spaces can be entered per operatormame.
(b)	[Operator ID]	Displays the operator ID, or input an operator ID. (Setting range: 1 to 32766) The maximum number of registrations depends on the GOT model. • GT27, GT25: 1000 • GT23: 255
(c)	[Level]	Displays the security level of the operator, or input a security level for the operator. (0 to 15)
(d)	[Password]	Input a password. Up to 32 alphanumeric characters, symbols, and one-byte spaces can be entered per password. You are recommended to set an unpredictable password consisting of uppercase and lowercase alphabetic characters, numbers, and symbols.
(e)	[Grant admin authority]	Grants administrator privileges to the operator, which changes the operator to a sub administrator. For the sub administrator privileges, refer to the following. ☞ Page 129 Administrator and sub administrator
(f)	[Make a permanent password]	Sets or does not set a permanent password. When this item is selected, the password does not expire regardless of the set password expiration date.
(g)	[Disable the operator]	Disables the operator account. The disabled operator account is not usable for login. To enable the operator account, deselect this item.
(h)	[Change password at next login]	Prompts for a password change at the next login. This item becomes deselected after the password change. An operator cannot log in with the unchanged password.
(i)	[Use ext. auth. ID]	Uses or does not use the external authentication ID.
(j)	[Ext.auth. ID]	Displays the external authentication ID in hexadecimal or input an external authentication ID in hexadecimal. The setting range is 4 to 32 alphanumeric characters from A to F and 0 to 9. ☞ Page 151 Function setting
(k)	[Unlock]	Unlocks the operator account.

■ Operator management operation

1. Touch [Operator management] in the operator setting menu.

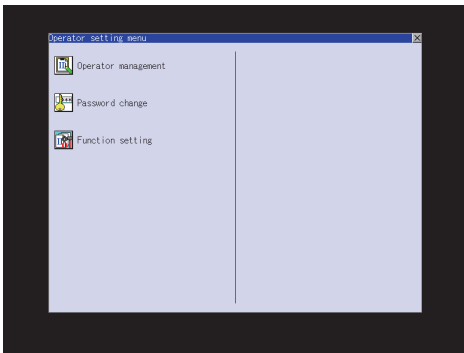

2. The Admin password authentication screen is displayed, and then input the administrator password.

If [Use sub administrator] is selected on the function setting screen, enter the operator name.

Character types to be input can be changed with touching the following buttons.

[A-Z]: Alphabet capital

[a-z]: Alphabet small letter

[0-9]: Numeric

When the input is completed, touch the [Enter] key.



Point

If the administrator password authentication is succeeded in the invalid login state, the invalid login state is cleared.

- 3.** When the administrator password is correctly input, the Operator information management screen is displayed. For operation of operating switches, refer to the following.

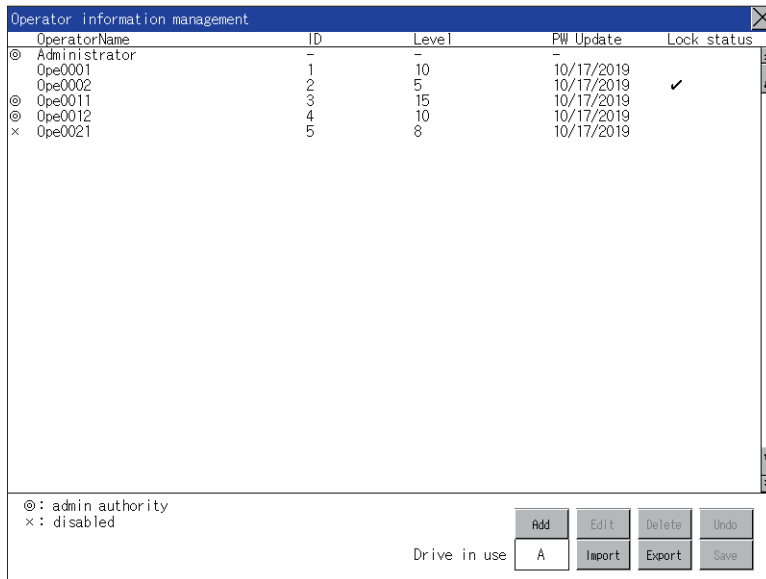

[Add]

☞ Page 135 Add operation

[Edit]

☞ Page 139 Edit operation

[Delete]

☞ Page 141 Deletion operation

[Undo]

☞ Page 142 Undo operation

[Import]

☞ Page 144 Import operation

[Export]

☞ Page 146 Export operation

- 4.** After all settings are completed, touch the [Save] button, and then the settings are saved.

- 5.** If you touch the [x] button without touching the [Save] button, the dialog shown below is displayed.

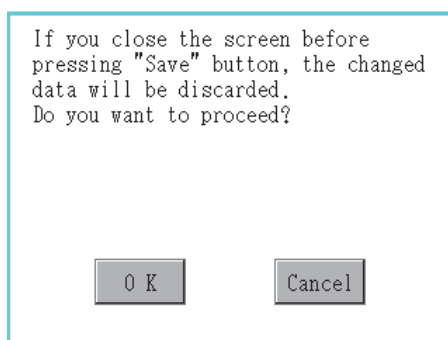

■Add operation

Add operator information to the GOT.

1. Touch the [Add] button.

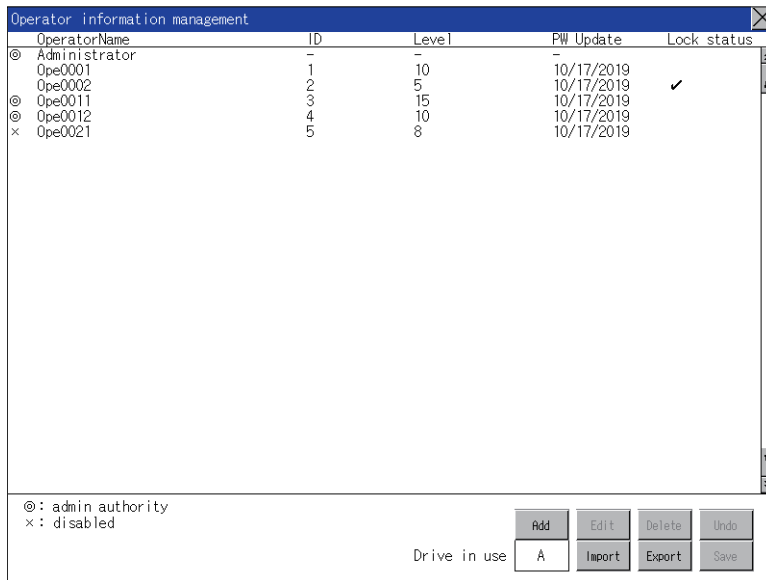

2

2. The Operator information edit screen is displayed, and then touch an item to be edited.

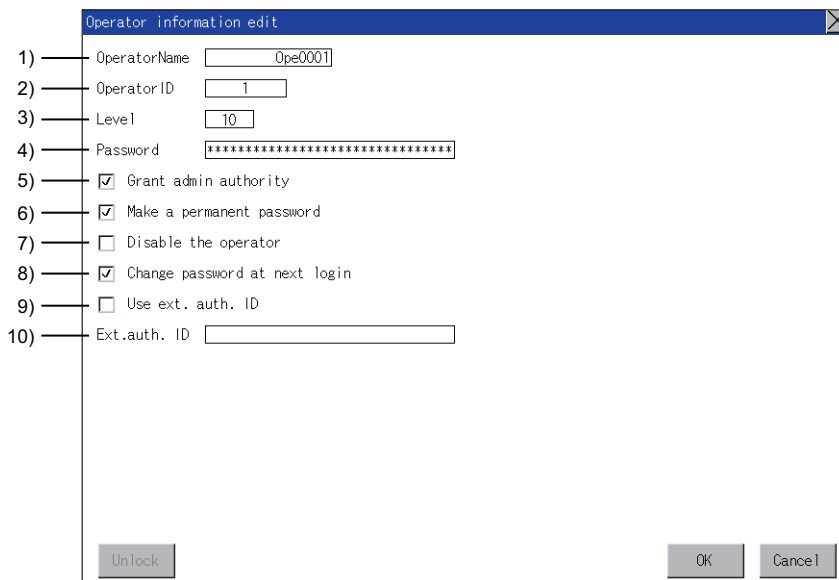

1)[OperatorName]

Touch the OperatorName, and then the Operator name input dialog is displayed. Input an operator name.

Character types to be input can be changed with touching the following buttons.

[A-Z]: Alphabet capital

[a-z]: Alphabet small letter

[0-9]: Numeric

When the input is completed, touch the [Enter] key.



2)[OperatorID]

Touch the Operator ID, and then the Operator ID input dialog is displayed. Input an operator ID.

When the input is completed, touch the [Enter] key.

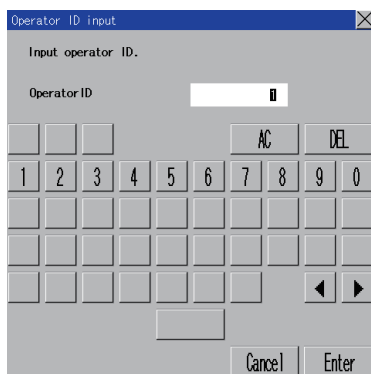

3)[Level]

Touch the level, and then the Operator level input dialog is displayed. Input an operator level.

When the input is completed, touch the [Enter] key.

When the level of the operator being login is changed during editing the operator information, a new level is not reflected until you log out of the GOT once and log in the GOT again.

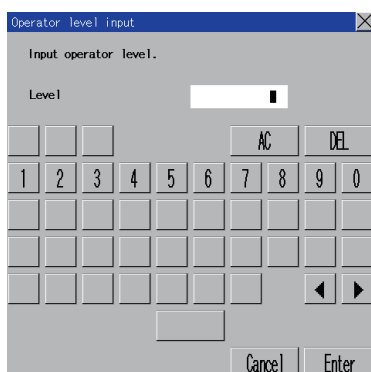

4)[Password]

For changing passwords during editing, touch the password.

The New password input dialog is displayed, and then input a password.

When the input is completed, touch the [Enter] key.

When the password input is completed, the New password input confirmation dialog is displayed. Input the same password.



5)[Grant admin authority]

To grant administrator privileges to the operator, touch the check box to select this item.

: Do not grant

: Grant

For the sub administrator privileges, refer to the following.

Page 129 Administrator and sub administrator

6)[Make a permanent password]

To set a permanent password, touch the check box to select this item.

: Do not set

: Set

7)[Disable the operator]

To disable an operator account, touch the check box to select this item.

: Enable

: Disable

8)[Change password at next login]

To prompt for a password change at the next login, touch the check box to select this item.

: Do not prompt

: Prompt

9)[Use ext. auth. ID]

To use an external authentication ID, touch the check box to select this item.

: Do not use

: Use

10)[Ext.auth. ID]

Touch this item to display an input dialog, and input an external authentication ID in the dialog.

When the input is completed, touch the [Enter] key.

When the authentication method is set to [External auth (serial)] or [External auth (USB)], you can input the external authentication ID with an external authentication device.

3. Touch the [OK] button after all items are input, and then the dialog shown below is displayed and the input operator information is added.

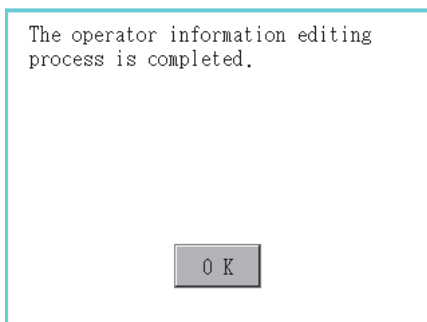

4. Touch the [Cancel] button or the [x] button, and then the dialog box shown below is displayed.

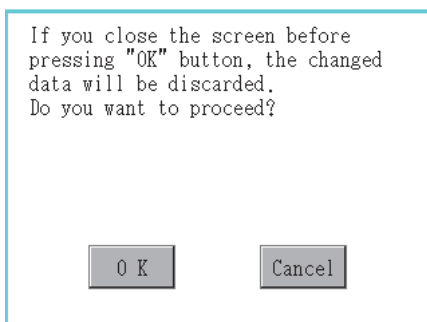

■ Edit operation

Edit the operator information stored in the GOT.

1. Select the operator information to be edited with touching the operator information.

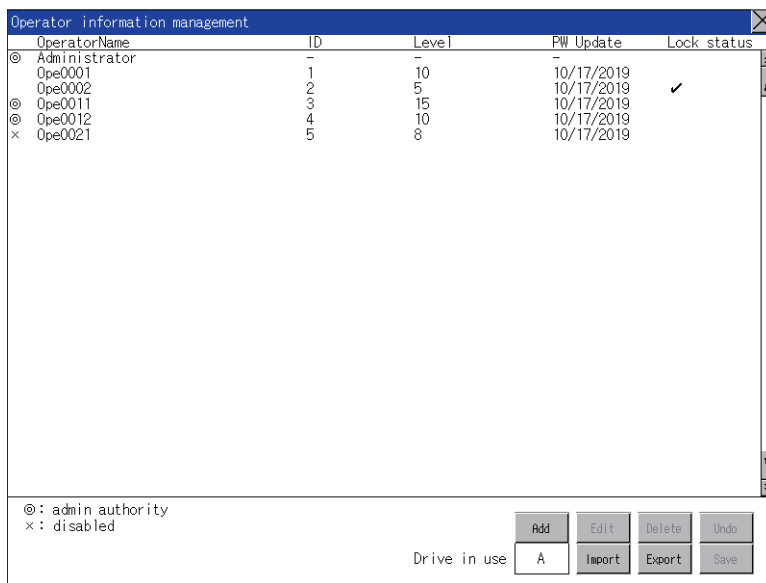

OperatorName	ID	Level	PW Update	Lock status
Administrator	-	-	-	-
Ⓞ Ope0001	1	10	10/17/2019	
Ope0002	2	5	10/17/2019	✓
Ⓞ Ope0011	3	15	10/17/2019	
Ⓞ Ope0012	4	10	10/17/2019	
× Ope0021	5	8	10/17/2019	

Ⓞ: admin authority
×: disabled

Drive in use: A

Buttons: Add, Edit, Delete, Undo, Import, Export, Save

2

2. Touch the [Edit] button.

3. The Operator information edit screen is displayed, and then touch an item to be edited.

For information on how to edit the items, refer to the following.

📖 Page 135 Add operation

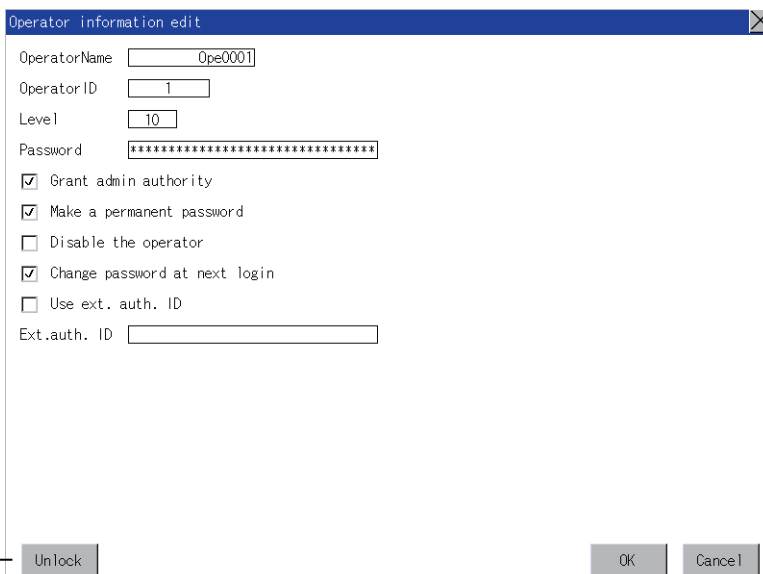

OperatorName: Ope0001

Operator ID: 1

Level: 10

Password: *****

Grant admin authority

Make a permanent password

Disable the operator

Change password at next login

Use ext. auth. ID

Ext.auth. ID: _____

1) — [Unlock] [OK] [Cancel]

- 1)Unlock

To unlock an operator ID, touch the [Unlocked] button.

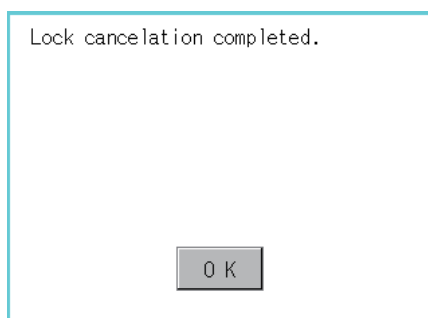

Lock cancelation completed.

[OK]

4. Touch the [OK] button after all items are input, and then the dialog shown below is displayed and the input operator information is changed.

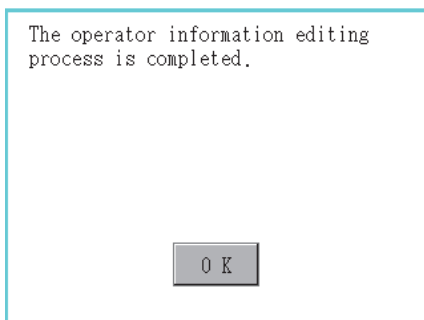

5. Touch the [Cancel] button or the [x] button, and then the dialog box shown below is displayed.

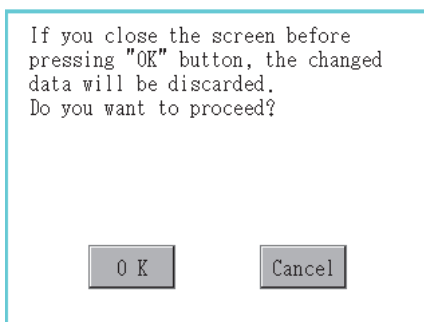

Point 

When GS621.b1 is ON, editing of the disabled operator account is prohibited.

For the details, refer to the following.

 GT Designer3 (GOT2000) Screen Design Manual

Even if GS621.b1 is ON, you can restore the disabled operator account by touching the [Undo] button on the [Operator information management] screen.

For details on the undo operation, refer to the following.

 Page 142 Undo operation

■ Deletion operation

Delete the operator information stored in the GOT.

1. Select the operator information to be deleted with touching the operator information.

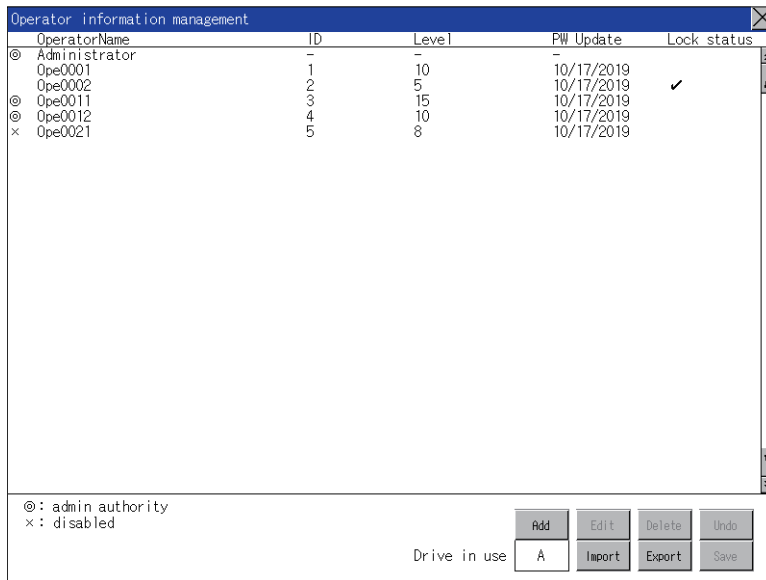

2. Touch the [Delete] button to display the dialog shown below.
To delete the selected operator information, touch the [OK] button.
To cancel the deletion, touch the [Cancel] button.

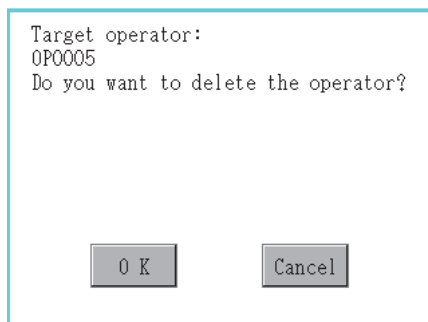

3. When the deletion is completed, the completion dialog is displayed.
Touching the [OK] button closes the dialog box.

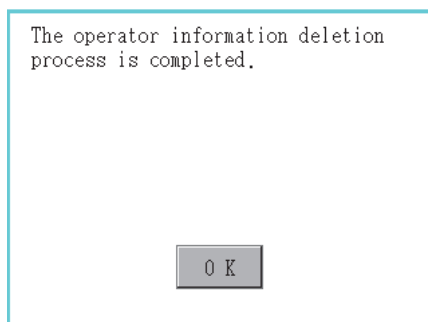

Point

When GS621.b0 is ON, deletion of operator accounts is prohibited.

For the details, refer to the following.

📖 GT Designer3 (GOT2000) Screen Design Manual

Even if GS621.b0 is ON, you can cancel the addition of an operator account by touching the [Undo] button on the [Operator information management] screen.

For details on the undo operation, refer to the following.

👉 Page 142 Undo operation

■ Undo operation

Restore the current operator information to the previous saved one.

1. Touch the [Undo] button.

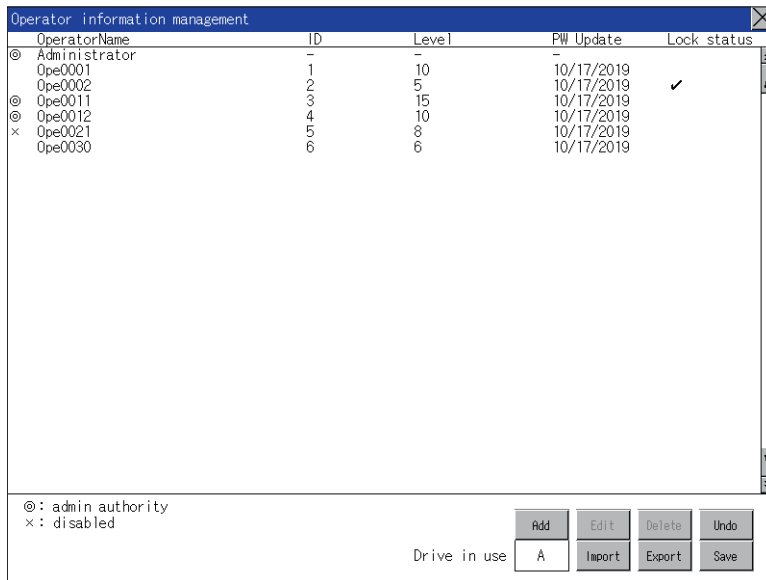

2. The dialog shown below is displayed, and then touch the [OK] button.

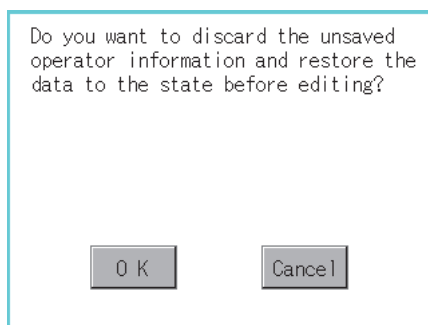

3. The Admin password authentication screen is displayed, and then input the administrator password.

If [Use sub administrator] is selected on the function setting screen, enter the operator name.

Character types to be input can be changed with touching the following buttons.

[A-Z]: Alphabet capital

[a-z]: Alphabet small letter

[0-9]: Numeric

When the input is completed, touch the [Enter] key.

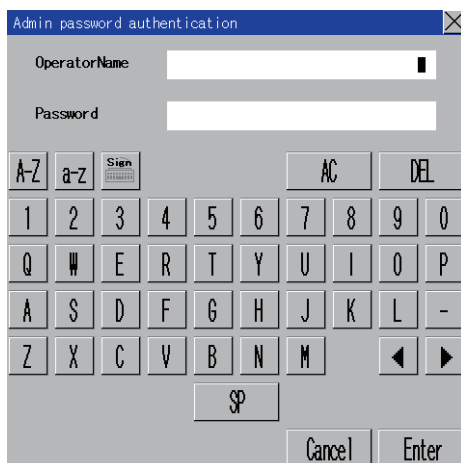

4. When the administrator password is correctly input, the current operator information is restored to the previous saved one.

The screenshot shows a window titled "Operator information management" with a table of operator data. The table has columns for OperatorName, ID, Level, PW Update, and Lock status. Below the table are control buttons for Add, Edit, Delete, Undo, Import, Export, and Save, along with a legend for symbols and a "Drive in use" indicator.

OperatorName	ID	Level	PW Update	Lock status
Administrator	-	-	-	-
Ⓞ Ope0001	1	10	10/17/2019	
Ope0002	2	5	10/17/2019	✓
Ⓞ Ope0011	3	15	10/17/2019	
Ⓞ Ope0012	4	10	10/17/2019	
× Ope0021	5	8	10/17/2019	

Ⓞ : admin authority
× : disabled

Drive in use: A

Buttons: Add, Edit, Delete, Undo, Import, Export, Save

■ Import operation

Import the operator information that is already exported to an SD card to the GOT.

1. Touch the [Import] button.

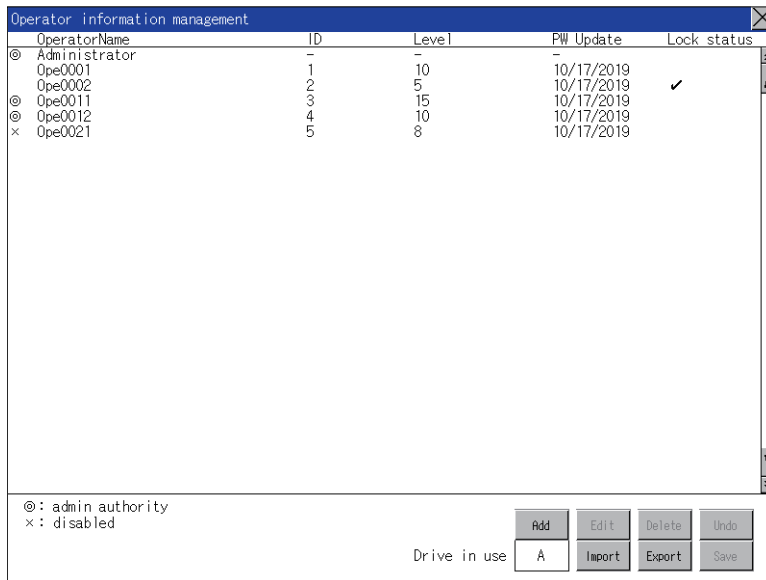

2. The dialog shown below is displayed, and then touch the [OK] button.

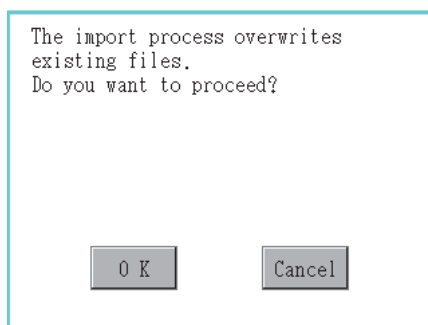

3. When [Delete password history on import] is selected on the function setting screen, the dialog that confirms deleting the password history appears. Click the [OK] button.

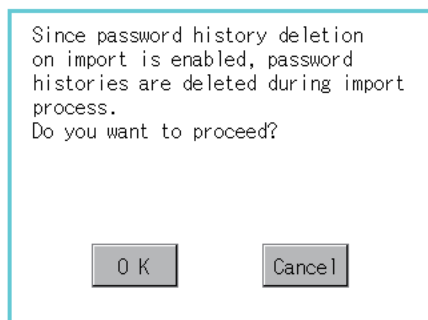

4. The Admin password authentication screen is displayed, and then input the administrator password.

If [Use sub administrator] is selected on the function setting screen, enter the operator name.

Character types to be input can be changed with touching the following buttons.

[A-Z]: Alphabet capital

[a-z]: Alphabet small letter

[0-9]: Numeric

When the input is completed, touch the [Enter] key.

When the administrator password is correctly input, the operator information stored in an SD card is imported to the GOT.



5. The dialog shown below is displayed, and then touch the [OK] button.

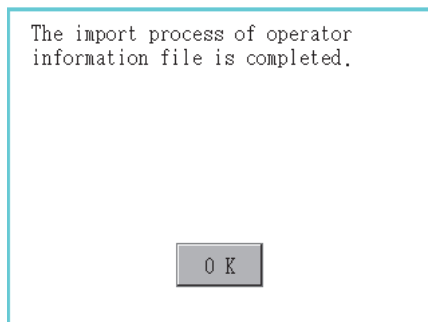

Point

When GS621.b2 is ON, the [Import] button is inactivated.

For the details, refer to the following.

 GT Designer3 (GOT2000) Screen Design Manual

■Export operation

Export the operator information stored in the GOT to an SD card.

1. Touch the [Export] button.

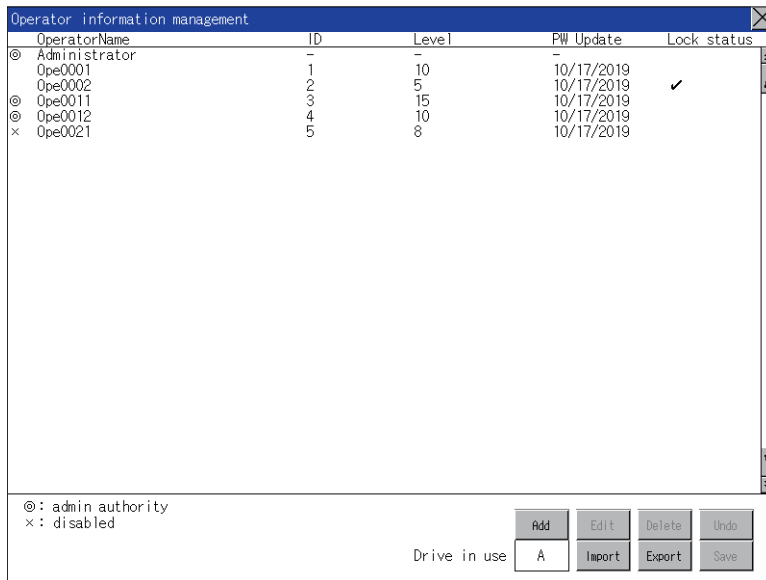

2. The dialog shown below is displayed.

Touch the following buttons according to the output format for the file.

- Binary file: [Binary] button
- CSV file: [CSV] button

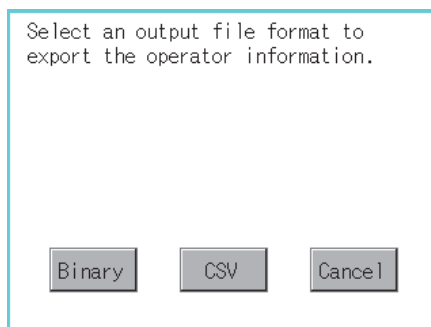

3. The dialog shown below is displayed.

Touch [OK] button, and then the Admin password authentication screen is displayed. Input the administrator password.

If [Use sub administrator] is selected on the function setting screen, enter the operator name.

Character types to be input can be changed with touching the following buttons.

[A-Z]: Alphabet capital

[a-z]: Alphabet small letter

[0-9]: Numeric

When the input is completed, touch the [Enter] key.

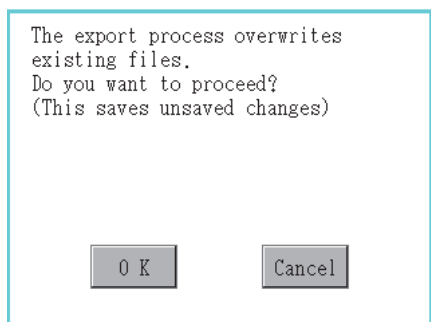

4. When the administrator password is correctly input, the dialog shown below is displayed and the operator information stored in the GOT is exported to an SD card.

(file name: AUTHINF.G2U)

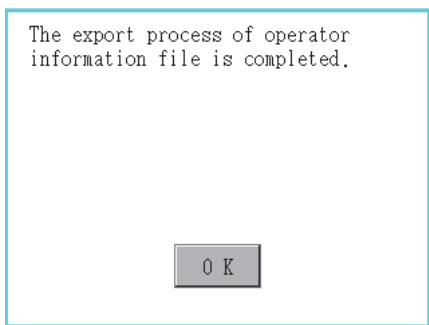

Password change

Password change

■ Password change function

The passwords to be used for the operator authentication can be changed.

For the password change, log into the GOT in advance with the operator name corresponding to the password to be changed.

■ Display operation of password change

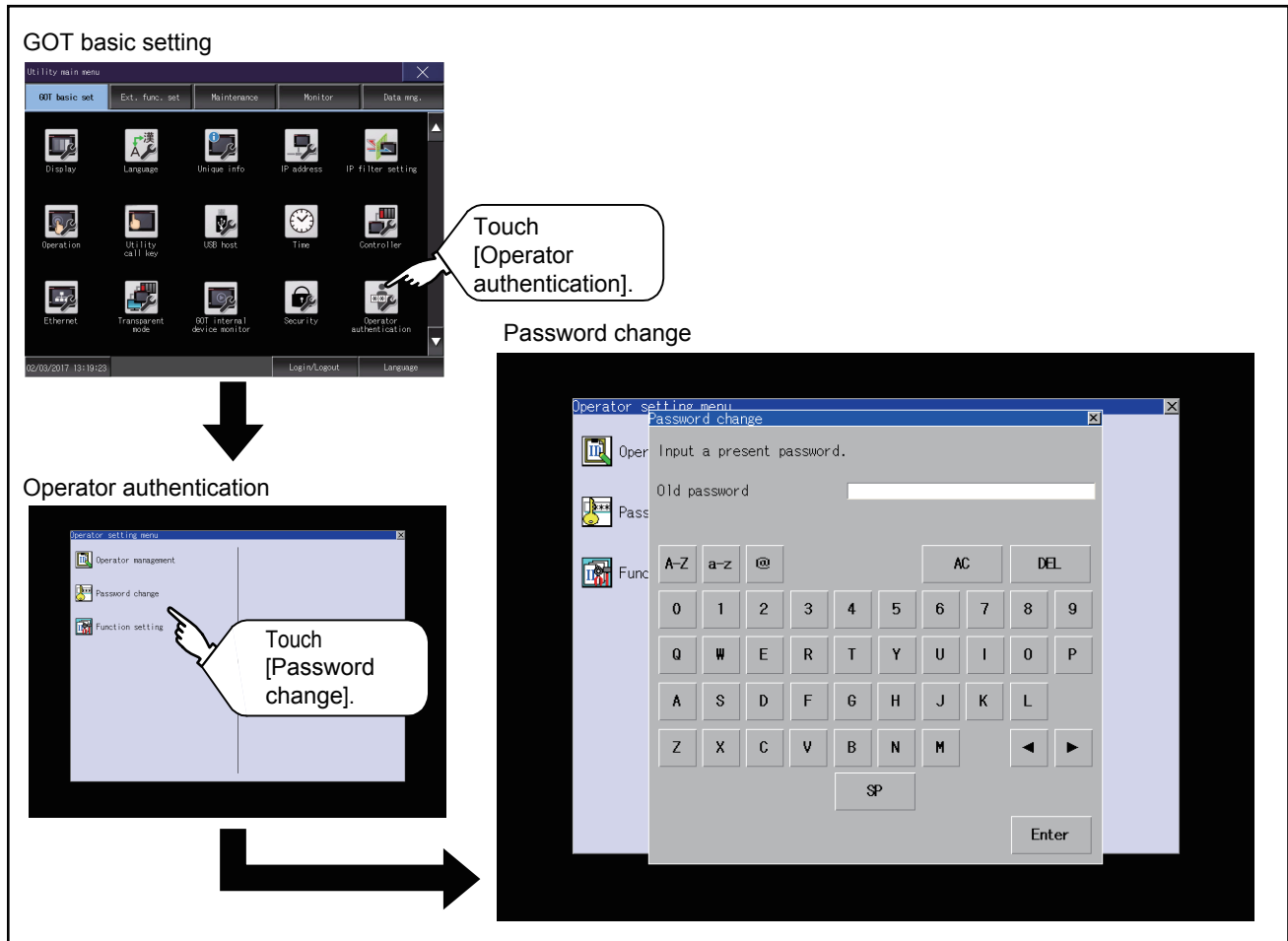

■ Password change operation

1. Log into the GOT with the operator name corresponding to the password to be changed on the Main Menu screen for the utility.

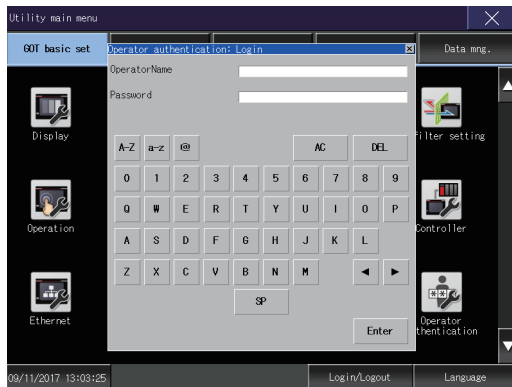

2. Touch [Password change] in the operator setting menu, and then the Password change dialog is displayed.

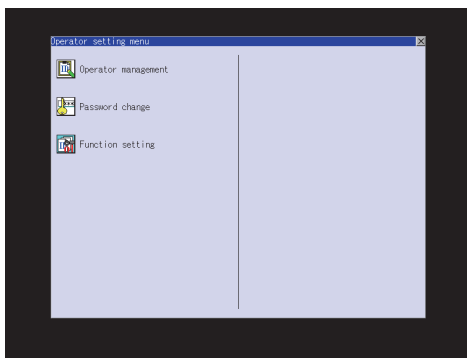

3. Input the current password on the Password change dialog.

Character types to be input can be changed with touching the following buttons.

[A-Z]: Alphabet capital

[a-z]: Alphabet small letter

[0-9]: Numeric

When the input is completed, touch the [Enter] key.



4. Input a new password.

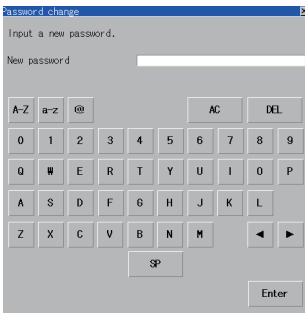

5. After inputting a new password, input the new password again.

6. When the new password is correctly input, the dialog shown below is displayed and the password is changed.

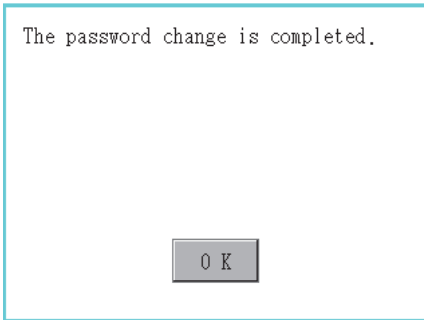

Function setting

Function setting

■Function setting

The functions for the operator information can be set.

The following items can be set.

Setting item	Description	Reference
Auth method	Switch between the authentication methods. ([Operator name + password], [External auth (serial)], [External auth (USB)]) When [External auth (serial)] or [External auth (USB)] is selected, the [Enable operator name/pswd authentication] check box appears.	☞ 1)[Auth method]
Automatic logout time	Set the time period from when the last operation is performed on the GOT until when the automatic logout is performed. (1 to 60 minutes, 0: invalid)	☞ 2)[Automatic logout time]
Password expiration date	Set the item for regularly changing the password to be used for the operator authentication. (1 to 1000 days, 0 is invalid.) When the password is out of date after setting the password, the GOT requests the password change.	☞ 3)[Password expiration date]
Adv. notification	Set the number of days before password expiration to start notifying the password expiration date. (1 to 30 days, 0: invalid)	☞ 4)[Adv. notification]
Initial position input	Set the initial position input (byte count) of external authentication ID from among the data read from the external authentication device. (0 to 1998 bytes)	☞ 5)[Initial position input]
Valid byte count input	Set the valid byte count for external authentication ID. (2 to 16 bytes)	☞ 6)[Valid byte count input]
Admin setting	Set whether to enable the use of sub administrators. Set whether to display editable operators only or display all the operators. Set whether to allow sub administrators to change the function setting. Set the security level of the sub administrator who can edit the function setting.	☞ 7)[Admin setting]
Upon login failure, prohibit login for a set period of time*1	Set the continuous failure count to block login. (3 to 10 times, 0: invalid) Set the prohibition time. (1 to 3600 seconds)	☞ 8)[Continuous failure count] ☞ 9)[Prohibition time]
Upon login failure, lock the operator (individually)	Set the continuous failure count to lock an operator ID. (3 to 10 times, 0: invalid)	☞ 10)[Continuous failure count]
Check password requirements	Set whether to check the number of characters and the character types of a password.	☞ 11)[Set password requirements]
Set minimum length	Set the minimum number of characters of a password. (1 to 32 characters)	
Set character type	Set the character types of a password. <ul style="list-style-type: none"> • [No check]: Does not check the character types of a password. • [[A-Z, a-z]/[1-9, Other]]: Checks if a password contains letters and another type of characters. • [[A-Z, a-z]/1-9/Other]: Checks if a password contains letters, numbers, and another type of characters. • [A-Z/a-z/1-9/Other]: Checks if a password contains uppercase and lowercase letters, numbers, and another type of characters. 	
Set number of histories	Set the number of passwords used. (1 to 5, 0 is invalid.)	☞ 12)[Set password history]
Delete password history on import	Set whether to delete the password history when the operator management information file is imported.	

*1 If the number of login attempts has reached the invalid login count, another login attempt fails for a certain period of time.
To immediately clear the invalid login state without waiting for the prohibition time, perform the administrator password authentication on the operator management screen.

☞ Page 133 Operator management operation

■ Display operation of function setting

The diagram illustrates the steps to reach the function settings for operator authentication. It starts with the 'GOT basic setting' window, where the 'Operator authentication' icon is selected. This leads to the 'Operator authentication' window, where the 'Function settings' icon is selected. Finally, the 'Function setting (1/2)' dialog box is displayed, showing various configuration options.

GOT basic setting

Utility main menu

GOT basic set | Exit, func. set | Maintenance | Monitor | Data reg.

Display | Language | Uniqae info | IP address | IP filter setting

Operation | Utility call flow | USB host | Time | Controller

Ethernet | Transparent mode | GOT internal device monitor | Security | Operator authentication

02/03/2017 13:19:23 | Login/Logout | Language

Touch [Operator authentication].

Operator authentication

Operator setting menu

Operator management

Password change

Function settings

Touch [Function setting].

Function setting

Function setting (1/2)

Auth method

Automatic logout time min(1-60, 0 invalid)

Password expiration date day(1-1000, 0 always)

Adv. notification days (1-30, 0 invalid)

Ext.auth. ID

Initial position input Byte (0-1998) Valid byte count input Byte (2-16)

Admin setting

Use sub administrator

Display operators without edit permission

Allow function setting

Function (2/2) OK Cancel

■Function setting operation

1. Touch [Function setting] in the operator setting menu, and then the Admin password authentication dialog is displayed.

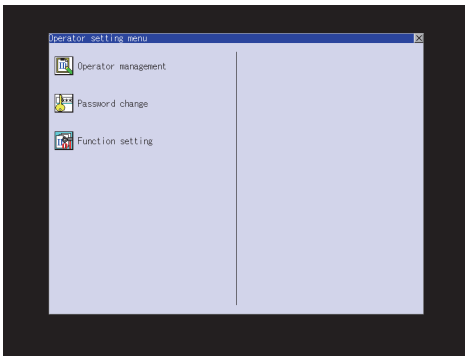

2. Input the administrator password.

If [Use sub administrator] is selected on the function setting screen, enter the operator name.

Character types to be input can be changed with touching the following buttons.

[A-Z]: Alphabet capital

[a-z]: Alphabet small letter

[0-9]: Numeric

When the input is completed, touch the [Enter] key.



3. When the administrator password is correctly input, the Function setting screen is displayed.

Touch an item to be set.

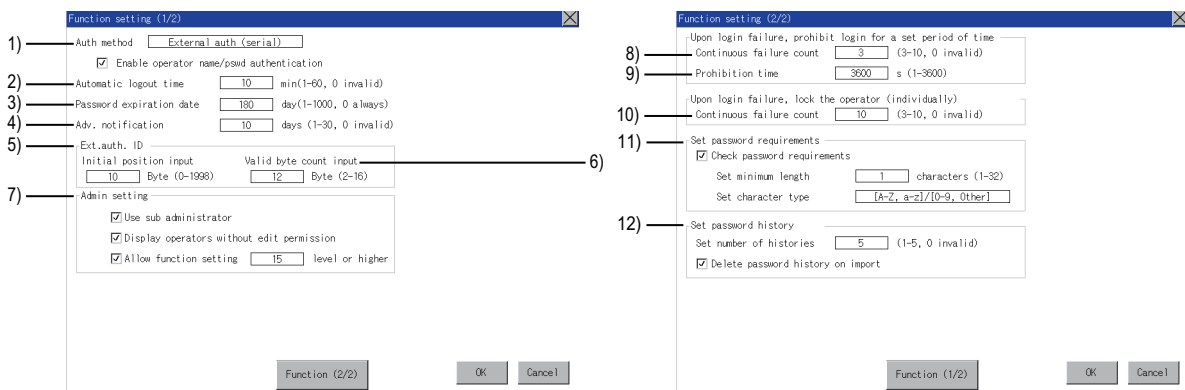

1)[Auth method]

Switch the authentication method.

Touch the current selection to switch the authentication method between [Operator name + password], [External auth (serial)], and [External auth (USB)].

When [External auth (serial)] or [External auth (USB)] is selected, the [Enable operator name/pswd authentication] check box appears.

Select the checkbox to also perform authentication through an operator name and password at login.

2)[Automatic logout time]

Touch the entry box of [Automatic logout time] to display the [Automatic logout time edit] dialog.

Input the time.

After completing the entry, touch the [Enter] key.

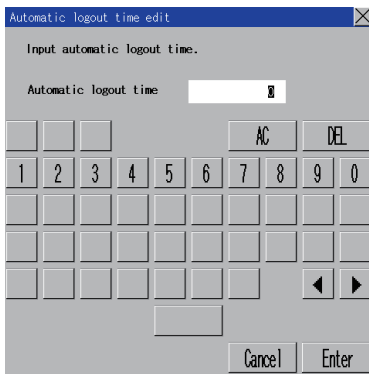

3)[Password expiration date]

Touch the entry box of [Password expiration date] to display the [Password expiration date edit] dialog.

Input the expiration date.

After completing the entry, touch the [Enter] key.

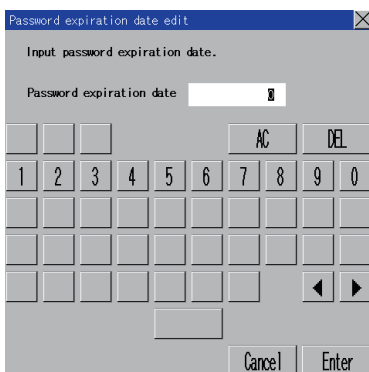

4)[Adv. notification]

Touch the entry box of [Adv. notification] to display the [Enter advance notification days] dialog.

Input the number of days.

After completing the entry, touch the [Enter] key.

5)[Initial position input]

Touch the entry box of [Initial position input] to display the [Ext. auth. ID initial position input] dialog.

Input the start position.

After completing the entry, touch the [Enter] key.

6)[Valid byte count input]

Touch the entry box of [Valid byte count input] to display the [Ext. auth. ID valid byte count input] dialog.

Input the number of bytes.

After completing the entry, touch the [Enter] key.

(Only available when the [External auth (serial)] or [External auth (USB)] is set as the authentication method.)

7)[Admin setting]

To use sub administrators, select [Use sub administrator].

: Do not use

: Use

To display uneditable operator information, select [Display operators without edit permission].

: Do not display

: Display

To allow sub administrators to change the function setting, select [Allow function setting].

: Do not allow

: Allow

Selecting this item displays the [Operator level input] dialog.

Specify the security level required to change the function setting.

After completing the entry, touch the [Enter] key.

When a sub administrator having security level 14 or less logs into the GOT, this setting item is not displayed.

For the authority of the sub administrator, refer to the following.

☞ Page 129 Administrator and sub administrator

8)[Continuous failure count]

Touch the entry box of [Continuous failure count] to display the [Continuous failure count input] dialog.

Input the maximum number of consecutive failed login attempts.

After completing the entry, touch the [Enter] key.

9)[Prohibition time]

Touch the entry box of [Prohibition time] to display the [Prohibition time input] dialog.

Input the prohibition time.

After completing the entry, touch the [Enter] key.

10)[Continuous failure count]

Touch the entry box of [Continuous failure count] to display the [Continuous failure count input] dialog.

Input the maximum number of consecutive failed login attempts.

After completing the entry, touch the [Enter] key.

For information on how to unlock an operator ID, refer to the following.

☞ Page 139 Edit operation

11)[Set password requirements]

To check for password requirements, select [Check password requirements].

: Do not check

: Check

Touch the entry box of [Set minimum length] to display the [Enter minimum password length] dialog.

Input the number of characters.

Touch the entry box of [Set character type] to make a selection.

After completing the entry, touch the [Enter] key.

12)[Set password history]

Touch the entry field of [Set number of histories] to display the [Number of password histories input] dialog.

Enter the number of passwords used.

When the authentication method is set to [External auth (serial)] or [External auth (USB)], and [Enable operator name/pswd authentication] is deselected, this item is disabled.

Set whether to delete the password history by selecting or deselecting [Delete password history on import].

: Do not delete

: Delete

When [Set number of histories] is set to 0, this item is disabled.

Although [Set password history] is disabled, the settings of [Set password history] are retained when the [OK] button is touched.

The settings are enabled when [Set password history] is enabled.

- 4.** After all settings are completed, touch the [OK] button, and then the settings are saved.
If you touch the [X] button without touching the [OK] button, the dialog shown below is displayed

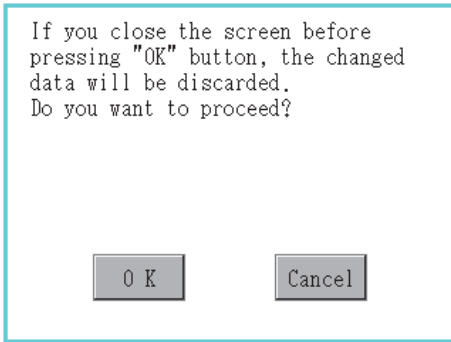

- 5.** The dialog shown below is displayed, and then touch the [OK] button.

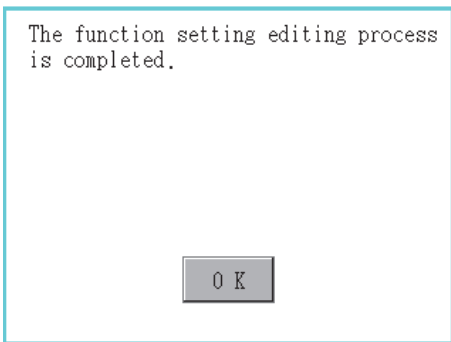

3 EXTENDED FUNCTION SETTING

- ☞ Page 158 SoftGOT-GOT Link Function
- ☞ Page 163 VNC Server Function
- ☞ Page 165 Sequence Program Monitor
- ☞ Page 167 Backup/Restoration
- ☞ Page 171 Trigger Backup
- ☞ Page 174 License Management
- ☞ Page 176 Video/RGB
- ☞ Page 184 Multimedia
- ☞ Page 199 Wireless LAN Function
- ☞ Page 204 System Launcher
- ☞ Page 206 iQSS Utility
- ☞ Page 208 ANDON Connection
- ☞ Page 211 Ethernet Printer
- ☞ Page 213 Network drive setting

You can display the setting screens for the extended functions from the GOT utility.

The following table lists the extended functions and their setting contents in the corresponding screens.

Item	Description	Reference
SoftGOT-GOT link function	Setting the authorization of the SoftGOT-GOT link function, obtaining or releasing the exclusive authorization	☞ Page 158 SoftGOT-GOT Link Function
VNC server function	Setting the authorization guarantee time for the VNC server function	☞ Page 163 VNC Server Function
Sequence program monitor	Specifying the destination location to store sequence programs, setting the ladder editor (iQ-R ladder)	☞ Page 165 Sequence Program Monitor
Backup/restoration	Specifying the destination location to store backup data	☞ Page 167 Backup/Restoration
Trigger backup	Setting the trigger backup	☞ Page 171 Trigger Backup
License management	Registering or deleting a license	☞ Page 174 License Management
Video/RGB	Configuring the video unit settings, video display settings, and RGB display settings	☞ Page 176 Video/RGB
Multimedia	Configuring the video unit settings, video setting, and long time recording settings	☞ Page 184 Multimedia
Wireless LAN	Setting the wireless LAN communication unit, listing the connected stations, and setting the destination access point	☞ Page 199 Wireless LAN Function
System launcher	Configuring a setting to enable the online module change from the system launcher	☞ Page 204 System Launcher
iQSS utility	Setting a drive of the data storage in which profile data of iQSS-compatible devices is stored	☞ Page 206 iQSS Utility
ANDON connection	Setting the IP address of a client targeted for the ANDON connection	☞ Page 208 ANDON Connection
Ethernet printer	Setting the IP address of the Ethernet printer	☞ Page 211 Ethernet Printer
Network drive setting	Setting the network drive	☞ Page 213 Network drive setting

3.1 SoftGOT-GOT Link Function

SoftGOT-GOT link function setting

The authorization of the SoftGOT-GOT link function can be set, and the exclusive authorization can be obtained or released. Only the GOT can obtain the exclusive authorization.

While the GOT has the exclusive authorization, GT SoftGOT2000 cannot obtain the authorization.

For the details of the SoftGOT-GOT link function, refer to the following.

 GT SoftGOT2000 Version1 Operating Manual

Function	Description	Setting range
Exclusive authorization obtained state	The status whether or not the GOT obtains the exclusive authorization is displayed. Obtaining or releasing the exclusive authorization can be executed by the GOT.	Obtain/Release <At GOT startup: Release>
Authorization obtained time	The time length from the last operation of GT SoftGOT2000 after obtaining the authorization until the GOT automatically obtains the authorization can be set.	0 to 3600 seconds <At factory shipment: 60 seconds>
Operating priority guaranteed time	The time period that the authorized equipment (GOT or GT SoftGOT2000) keeps the authorization after the last operation of the authorized equipment can be set. (The unauthorized equipment cannot obtain the authorization until the set time elapses.)	0 to 3600 seconds <At factory shipment: 0 seconds>
Operation status popup notification	When the authorization is not obtained in GT SoftGOT2000/GOT, whether to display or not the information of the authorized side in pop-up can be set.	YES/NO <At GOT startup: NO>

Point

Relationship with the GOT network interaction function setting

The SoftGOT-GOT link function setting is independent of the GOT network interaction function setting. Both of the settings are enabled.

Display operation of the SoftGOT-GOT link function setting

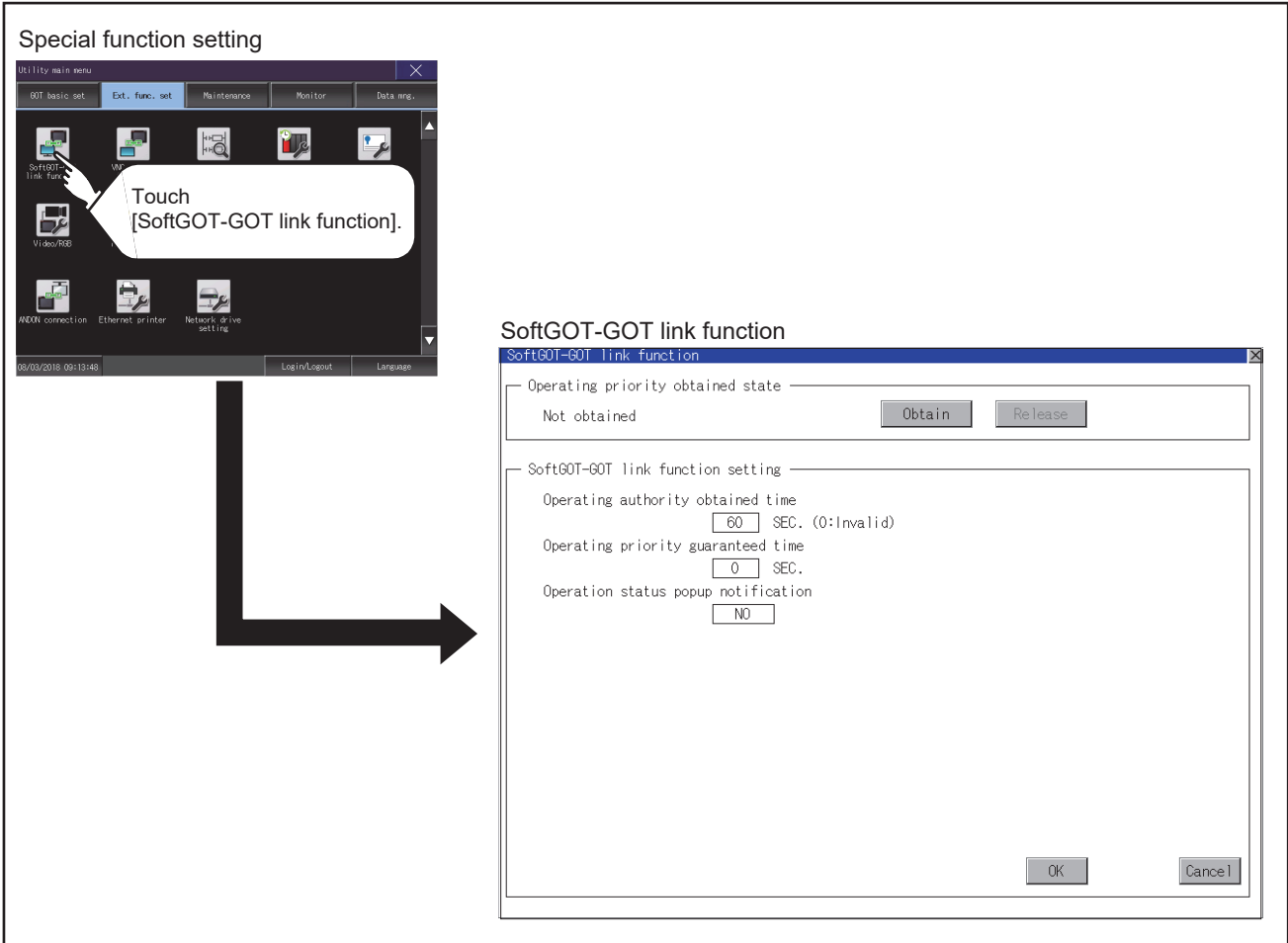

SoftGOT-GOT link function setting operation

Exclusive authorization obtained state

■Obtaining the exclusive authorization

1. Touch the [Obtain] button to display the dialog.

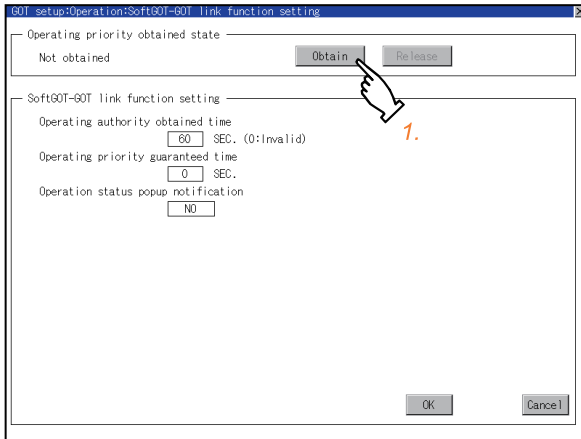

2. Touch the [OK] button to obtain the exclusive authorization.
Touch the [Cancel] button to stop obtaining the exclusive authorization.

■Releasing the exclusive authorization

1. Touch the [Release] button to display the dialog.

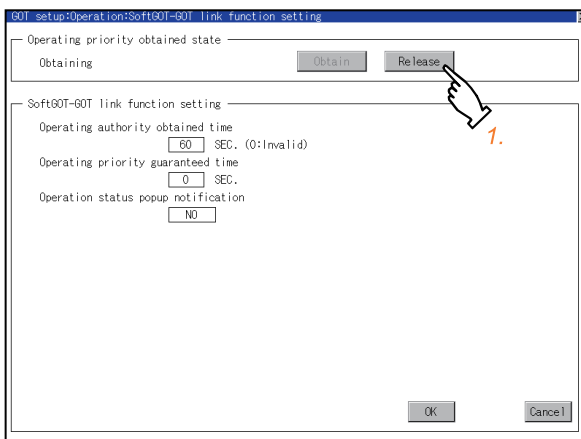

2. Touch the [OK] button to release the exclusive authorization.
Touch the [Cancel] button to stop releasing the exclusive authorization.

Authorization obtained time

1. If touch the select button of the authorization obtained time, a keyboard is displayed.

Enter the authorization obtained time with the keyboard.

When setting to 0 second, the authorization is not automatically obtained by the GOT.

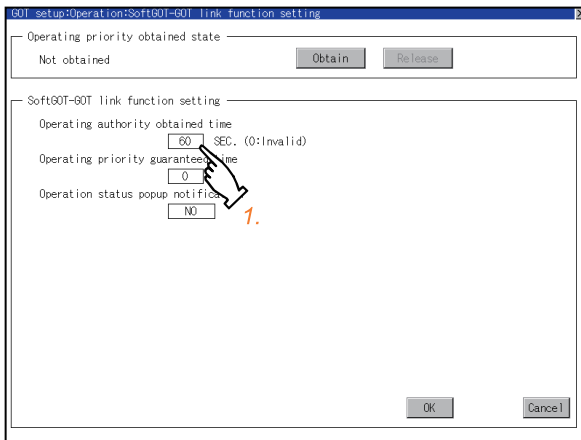

2. If touch the [OK] button, the GOT restarts and operates with the changed settings.

If touch the [Cancel] button, the changed settings are canceled and the screen returns to the [Ext. func. set] screen.

Operating priority guaranteed time

1. If touch the select button of the operating priority guaranteed time, a keyboard is displayed.

Enter the operating priority guaranteed time with the keyboard.

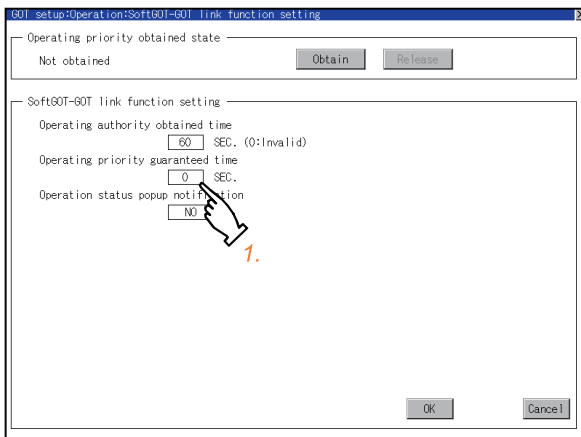

2. If touch the [OK] button, the GOT restarts and operates with the changed settings.

If touch the [Cancel] button, the changed settings are canceled and the screen returns to the [Ext. func. set] screen.

Point

Relation between the authorization obtained time and the operating priority guaranteed time

When the followings are set, the authorization obtained time is prioritized. (After the authorization obtained time is elapsed, the GOT automatically obtains the authorization.)

- 1sec or more is set for the authorization obtained time.
- The authorization guarantee time is set longer than the authorization obtained time.

Operation status popup notification

1. Touch the field of the setting to be changed.

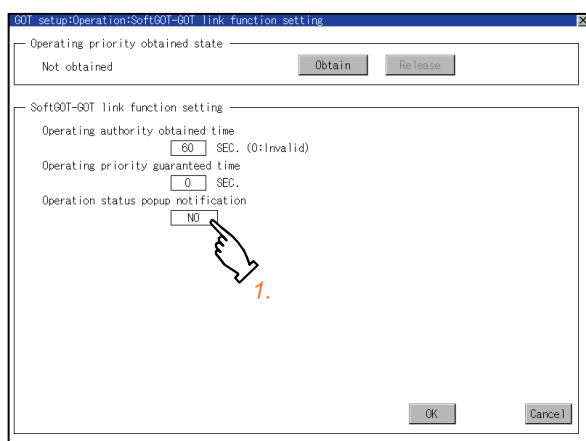

2. If touch the [OK] button, the GOT restarts and operates with the changed settings.

If touch the [Cancel] button, the changed settings are canceled and the screen returns to the [Ext. func. set] screen.

3.2 VNC Server Function

VNC server function setting

In the VNC server function setting, the authorization guarantee time for the VNC server function can be set. For details on the VNC server function, refer to the following.

📖 GT Designer3 (GOT2000) Screen Design Manual

Function	Description	Setting range
Operating priority guaranteed time	The time that the authorized equipment holds the authorization after you operate the authorized equipment can be set. (The unauthorized equipment cannot obtain the authorization until the set time elapses.)	0 to 3600 seconds <At factory shipment: 0 seconds>

3

Point

- Authorization guarantee time cancel signal (GS1792.b8)

When the Authorization guarantee time cancel signal (GS1792.b8) turns on, the authorization guarantee time setting is disabled.

- Relationship with the GOT network interaction function setting

The VNC server function setting is independent of the GOT network interaction function setting. Both of the settings are enabled.

Display operation of the VNC server function setting

The image illustrates the navigation to the VNC server function setting. On the left, the 'Special function setting' window is shown with the 'Ext. func. set' tab selected. A callout bubble points to the 'VNC server function' icon with the text 'Touch [VNC server function]'. A large black arrow points from this icon to the right, where a separate window titled 'VNC server function' is displayed. This window shows the 'Operating priority guaranteed time' set to '0 SEC.' with 'OK' and 'Cancel' buttons at the bottom.

VNC server function setting operation

Operating priority guaranteed time

1. Touch the input field for [Operating priority guaranteed time] to display a keyboard.
Input the authorization guarantee time with the keyboard.

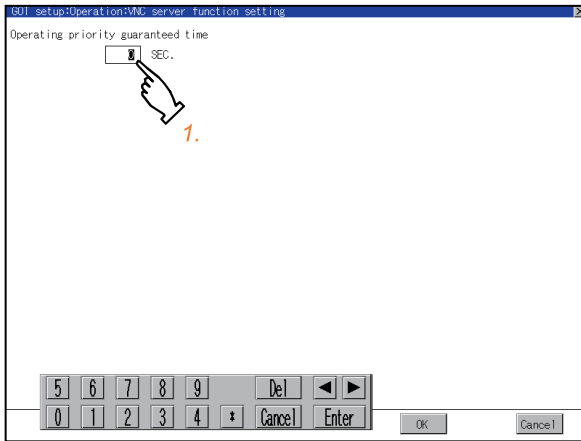

2. If touch the [OK] button, the GOT restarts and operates with the changed settings.
If touch the [Cancel] button, the changed settings are canceled and the screen returns to the [Special function setting] screen.

3.3 Sequence Program Monitor

Sequence program monitor setting

Storage locations and others for data to be used for the sequence program monitor function can be set. Storing a sequence program eliminates the need for reading the program from the PLC CPU at the next GOT startup. This shortens the time required for the execution of the sequence program monitor.

For the details of the sequence program monitor, refer to the following.

 GOT2000 Series User's Manual (Monitor)

Function	Description	Setting range
Data save location	Select the storage location for the sequence program monitor.	A: Built-in SD card B: USB Drive E: USB Drive F: USB Drive G: USB Drive <Default: A: Built-in SD card>
Automatic program read	Select whether to automatically read sequence programs when the sequence program monitor starts from a touch switch or alarm display.	YES/NO <Default: YES>
Priority comment	If both Common comment and Each program comment are set for the same device in a sequence program, select either of the comments to be displayed in the sequence program monitor.	Common comment/Each program comment <Default: Common comment>
Ladder editor (iQ-R ladder)	Select whether to enable or disable the ladder editor of sequence programs (MELSEC iQ-R series).	Invalid/Effective <Default: Invalid>

Sequence program to be saved

The sequence program to be saved is used by the GOT to execute the sequence program monitor.

The sequence program can be saved in the SD card with this function, however it cannot be copied in the personal computer to be referred/edited with GX Developer, etc.

Display operation of the sequence program monitor

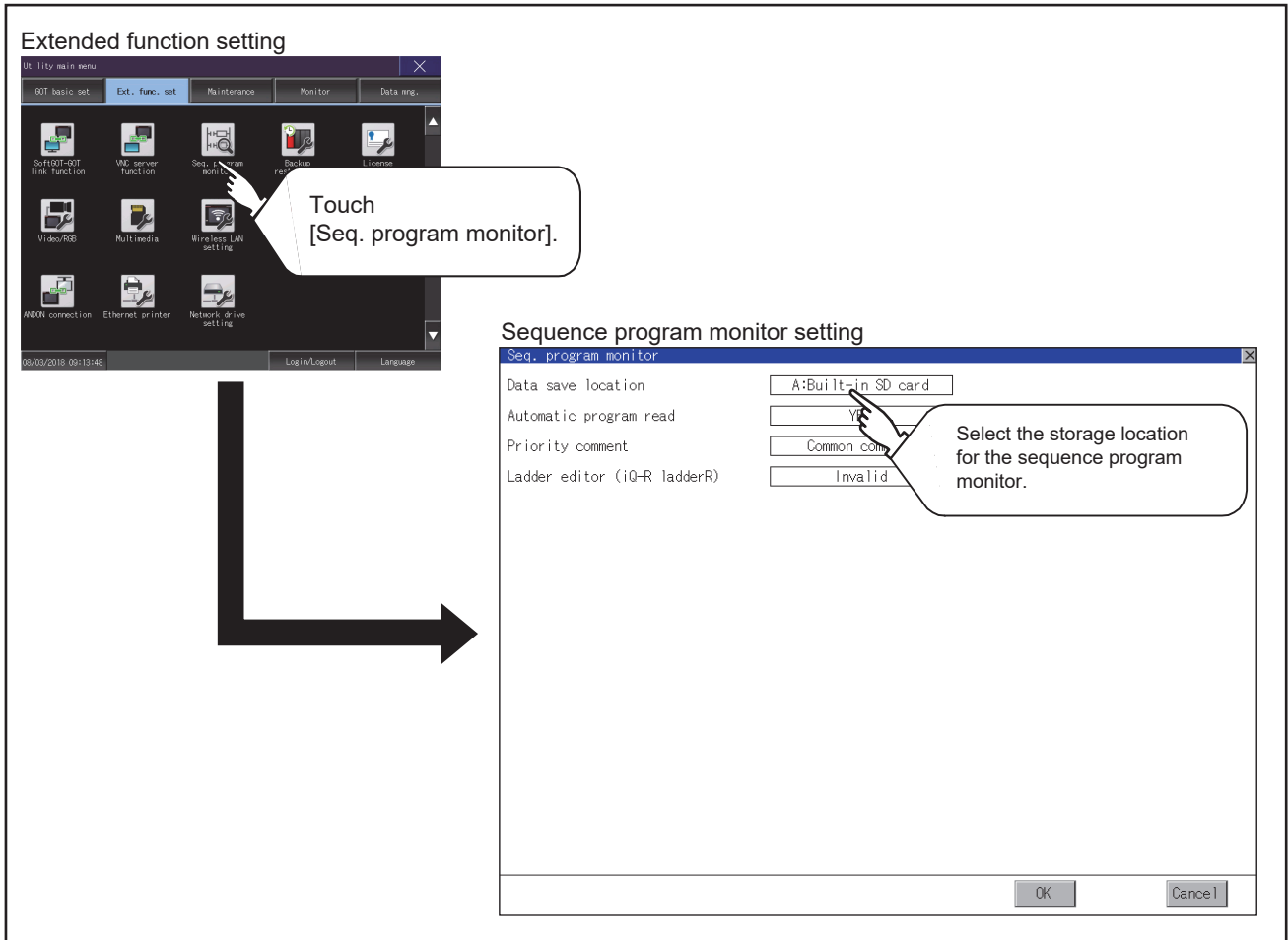

Sequence program monitor setting operation

1. Touch the selection for the setting item to switch the selection.

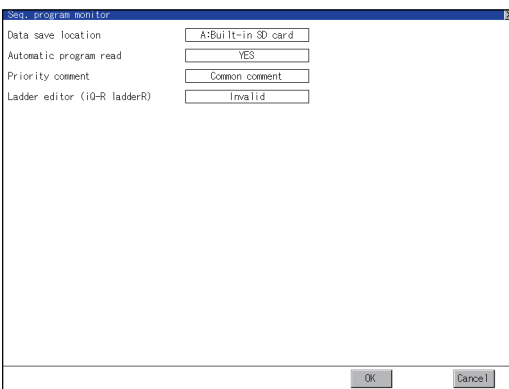

2. Touch the [OK] button to reflect the new setting and return to the [Ext. func. set] screen.
To cancel the setting change, touch the [Cancel] button to return to the [Ext. func. set] screen.

3.4 Backup/Restoration

Backup/restoration setting

The storage location for backup data can be set.

For how to use the backup/restoration, refer to the following.

 GOT2000 Series User's Manual (Monitor)

Set the following items with touching the items on the GOT.

Item	Description	Setting range
Drive for backup setting	The drive for storing backup settings, including parameters and passwords for controllers, can be selected.	A: Built-in SD card B: USB Drive E: USB Drive F: USB Drive G: USB Drive X: Drive <Default: X: Drive>
Drive for backup data	The drive for storing backup data can be selected.	A: Built-in SD card B: USB Drive E: USB Drive F: USB Drive G: USB Drive X: Drive <Default: X: Drive>
Trigger backup setting	The GOT automatically backs up data when triggers (Rise, Time) specified for each backup setting are met.	None/Rise/Time <Default: None>  Page 171 Trigger Backup
Max. of backup data	Set the maximum number of backup data to be stored. (When 0 is specified, the GOT does not check the number of backup data to be stored.)	Setting range: 0 to 50 <Default: 0>
Enable CPU No. setting	Set whether to specify the CPU No. at a backup. (When [YES] is selected, the GOT starts to communicate with only the specified PLC. Therefore the network batch backup/restoration on the multiple PLCs cannot be executed.)	YES/NO <Default: NO>
Retain file register inf. during restor	Set whether to retain the file register information at a restoration.	YES/NO <Default: NO>

Display operation of backup/restoration setting

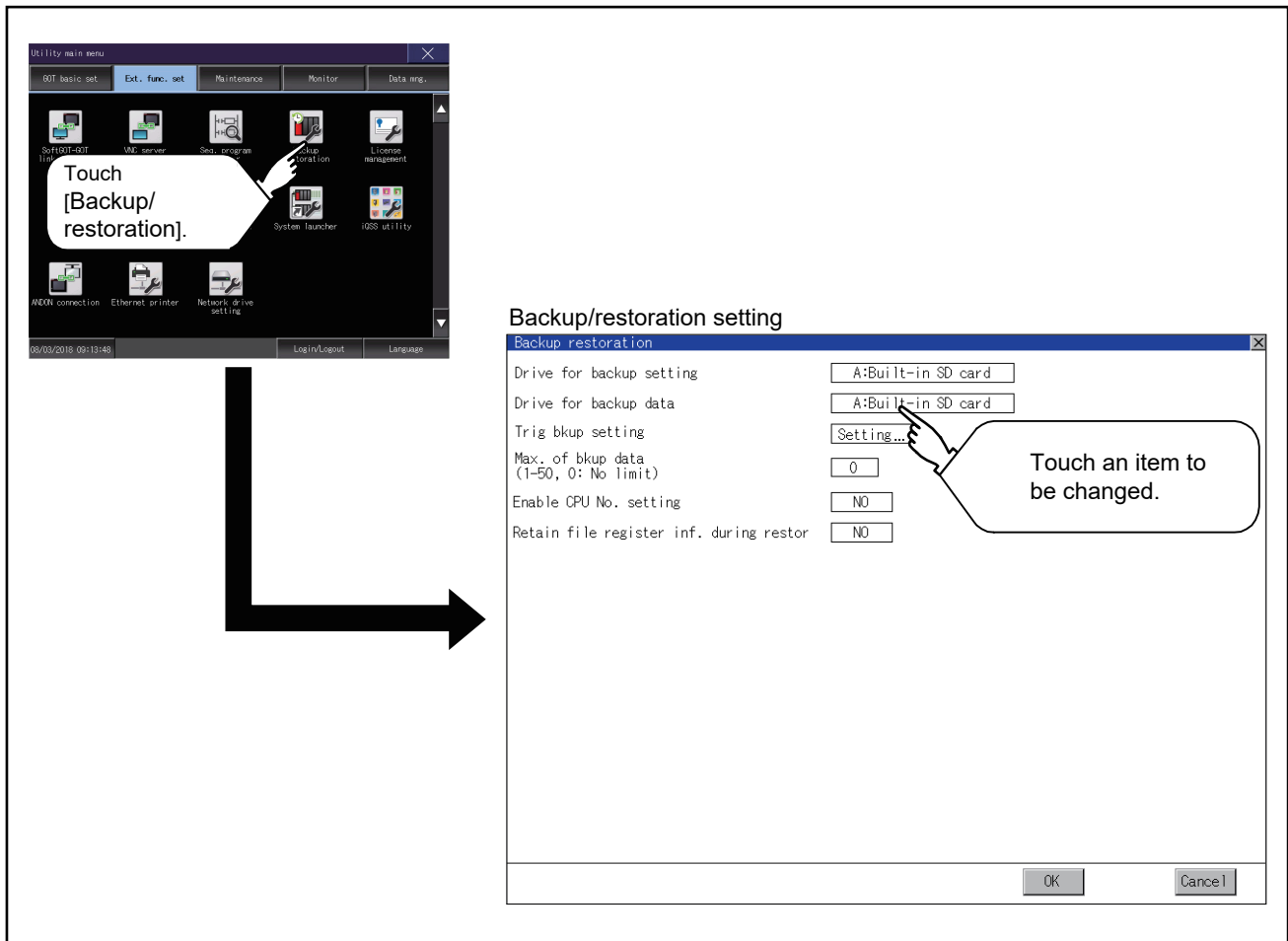

Backup/restoration setting operation

Drive for backup setting, drive for backup data

1. If touch the setup item, the setup contents are changed.

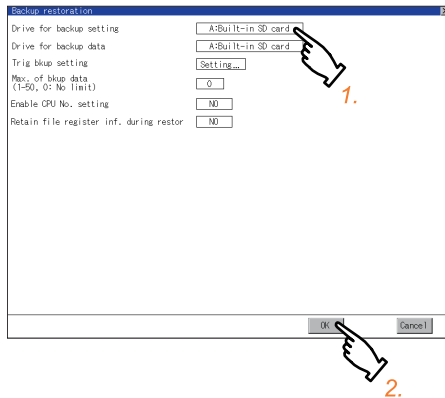

2. If touch the [OK] button, the changed settings are reflected and the screen returns to the [Special function setting] screen.

If touch the [Cancel] button, the changed settings are canceled and the screen returns to the [Special function setting] screen.

Trigger backup setting

For operations of the trigger backup setting, refer to the following.

☞ Page 169 Backup/restoration setting operation

Max. of backup data

1. If touching the setting items, keyboard is displayed.

Input numeric with the keyboard.

Setting range: 0 to 50, Default: 0

(When 0 is specified, the GOT does not check the number of backup data to be stored.)

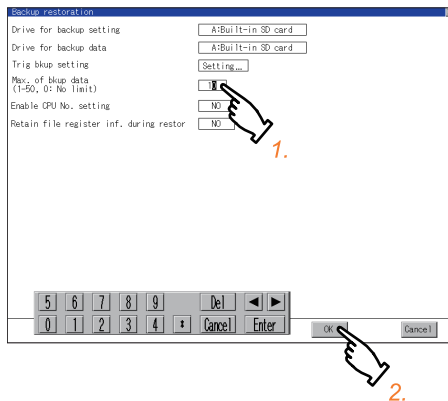

2. If touch the [OK] button, the changed settings are reflected and the screen returns to the [Special function setting] screen.

If touch the [Cancel] button, the changed settings are canceled and the screen returns to the [Special function setting] screen.

Enable CPU No. setting

1. If touch the setup item, the setup contents are changed.

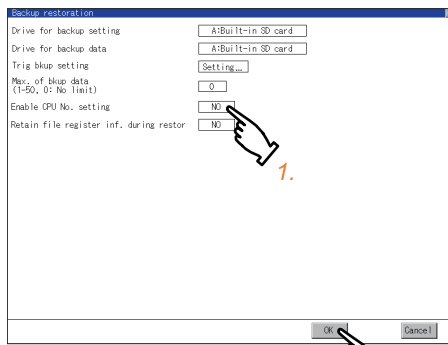

2. If touch the [OK] button, the changed settings are reflected and the screen returns to the [Special function setting] screen.

If touch the [Cancel] button, the changed settings are canceled and the screen returns to the [Special function setting] screen.

Retain file register inf. during restor

1. If touch the setup item, the setup contents are changed.

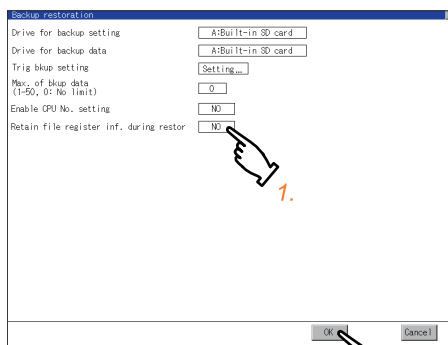

2. If touch the [OK] button, the changed settings are reflected and the screen returns to the [Special function setting] screen.

If touch the [Cancel] button, the changed settings are canceled and the screen returns to the [Special function setting] screen.

3.5 Trigger Backup

Trigger backup setting

When the conditions of the trigger specified for each backup setting (Rise, Time) are met, the GOT automatically backs up data.

For how to use the trigger backup, refer to the following.

GOT2000 Series User's Manual (Monitor)

Display operation of the trigger backup setting

Special function setting

Utility main menu

Touch [Backup/restoration].

Backup/restoration

Touch [Trig bkup setting].

Trigger backup setting

CH No.	Backup setting	Trigger Type	Detail	(*)
1	SYS1BKUP	Time	02:00 Mon Wed Fri	<input type="checkbox"/>
2	SYS2BKUP	None	--	<input type="checkbox"/>
3	SYS3BKUP	Rise	X0100	<input type="checkbox"/>
4	SYS4BKUP	Time	12:00 Tue Thu Sat	<input type="checkbox"/>

(*) Do not check changes. Check changes if Include

Touch an item to be changed.

Trigger backup setting operation

1. Touch a setting item for the trigger type, and then the setting is changed.



None: The GOT does not execute the trigger backup.

Rise: The GOT backs up data when the trigger device turns on.

Time: The GOT backs up data at the specified time.

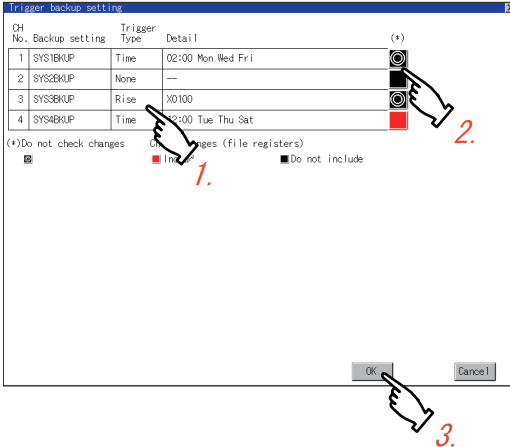

2. Touch a setting item for check changes, and then the setting is changed.



: Backup is executed regardless of whether the backup data has been changed.



: When the backup is executed, the GOT checks if the backup data and the data stored in the file register have been changed after the previous backup. When the data has been changed, the GOT backs up the changed data.



: When the backup is executed, the GOT checks if the backup data has been changed after the previous backup. When the data has been changed, the GOT backs up the changed data. However, the GOT does not check if the data stored in the file register has been changed.

3. When the trigger type is changed, a password input window appears by touching the [OK] button.

Input the password for the backup/restore.

When the password is verified, the settings are reflected, and then the screen returns to the [trigger backup setting] screen.

When the trigger type is not changed, touching the [OK] button reflects the settings.

If touch the [Cancel] button, the changed settings are canceled and the screen returns to the [Backup/restoration] screen.

Point

Precautions for setting

When the trigger type is set to [Rise], set the trigger device with GT Designer3 in advance.

Failure to do so disables the backup setting with [Rise] set.

Trigger time setting operation

1. When the trigger type is set to [Time], touch a setting item for [Detail] and the screen is switched to the trigger time setting screen.

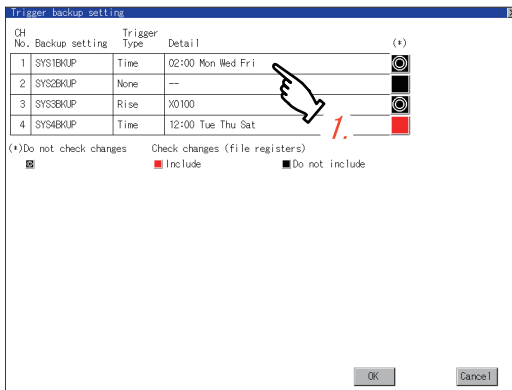

2. In the screen, specify the days and time that the GOT executes the backup.
Day: Select days that the GOT executes the backup by touching displayed items. Multiple days can be selected.
Time: Set the time that the GOT executes the backup by touching the displayed item.

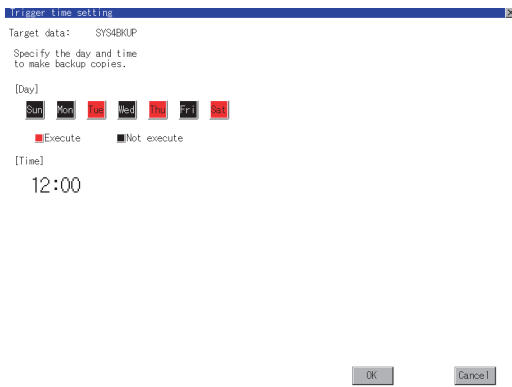

3.6 License Management

License management setting

To use functions which require a license, register the license to the GOT.

To delete the license registered to the GOT, perform the operation also on the license management screen.

Item	Description	Setting range
Remote personal computer operation function (Ethernet)	Register or delete the license for the remote personal computer operation function (Ethernet).	-
VNC server function	Register or delete the license for the VNC server function.	-
MES interface function	Register or delete the license for the MES interface function.	-
GOT Mobile function	Register or delete the license for the GOT Mobile function.	-

You can register or delete licenses for the remote personal computer operation function (Ethernet), the VNC server function, the MES interface function, and the GOT Mobile function independently.

For the details of each function, refer to the following.

GT Designer3 (GOT2000) Screen Design Manual

GOT2000 Series MES Interface Function Manual for GT Works3 Version1

Display operation of the license management setting

The diagram illustrates the navigation process. On the left, the 'Special function setting' screen is shown with a callout 'Touch [License management]' pointing to the 'License management' icon. A large arrow points to the right, where the 'License management' screen is displayed. This screen lists four functions: PC Remote Operation function (Ethernet), VNC server function, MES interface function, and GOT Mobile function. Each function has a 'License number' field (represented by three black boxes) and two buttons: 'Regist' and 'Not reg.'.

Setting operation of license management

When registering a license number for the GOT

1. Touch the license number input area on the license management screen, and then the keyboard appears on the bottom of the screen.

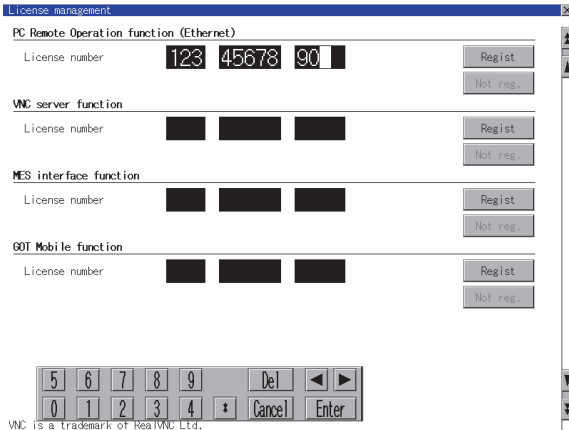

2. Touch the [Register] button to register the input license number.
If the [X] button is touched without touching the [Register] button, the license number is not registered.
3. After a license number is registered, touch the [X] button to close the license management screen.

When releasing a license number for the GOT

1. Touch the [Cancel reg.] button to release the registered license number.

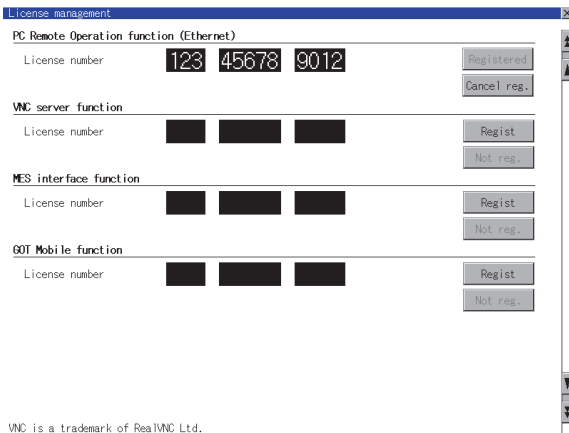

2. Touch the [X] button to close the license management screen.



How to obtain a license number

For how to obtain a license number, consult your local sales office.

3.7 Video/RGB

Video unit setting

Video unit setting

The video input signal and resolution can be selected.

Item	Description	Setting range
Video unit setting	The input signal and resolution can be selected.	Input signal: NTSC format, PAL format <At factory shipment: NTSC format> Resolution: 640 × 480, 720 × 480*1, 768 × 576 <At factory shipment : 640 × 480>

*1 Can be selected only in PAL format

Input signal settings

Set the input signal as follows according to the output format for the video camera or the like connected.

If the settings made differ from these, video images may not be displayed correctly.

Output format for video camera or the like	Input signal setting
NTSC format	NTSC
PAL format	PAL
EIA format	NTSC
CCIR format	PAL

Display operation of the video unit setting

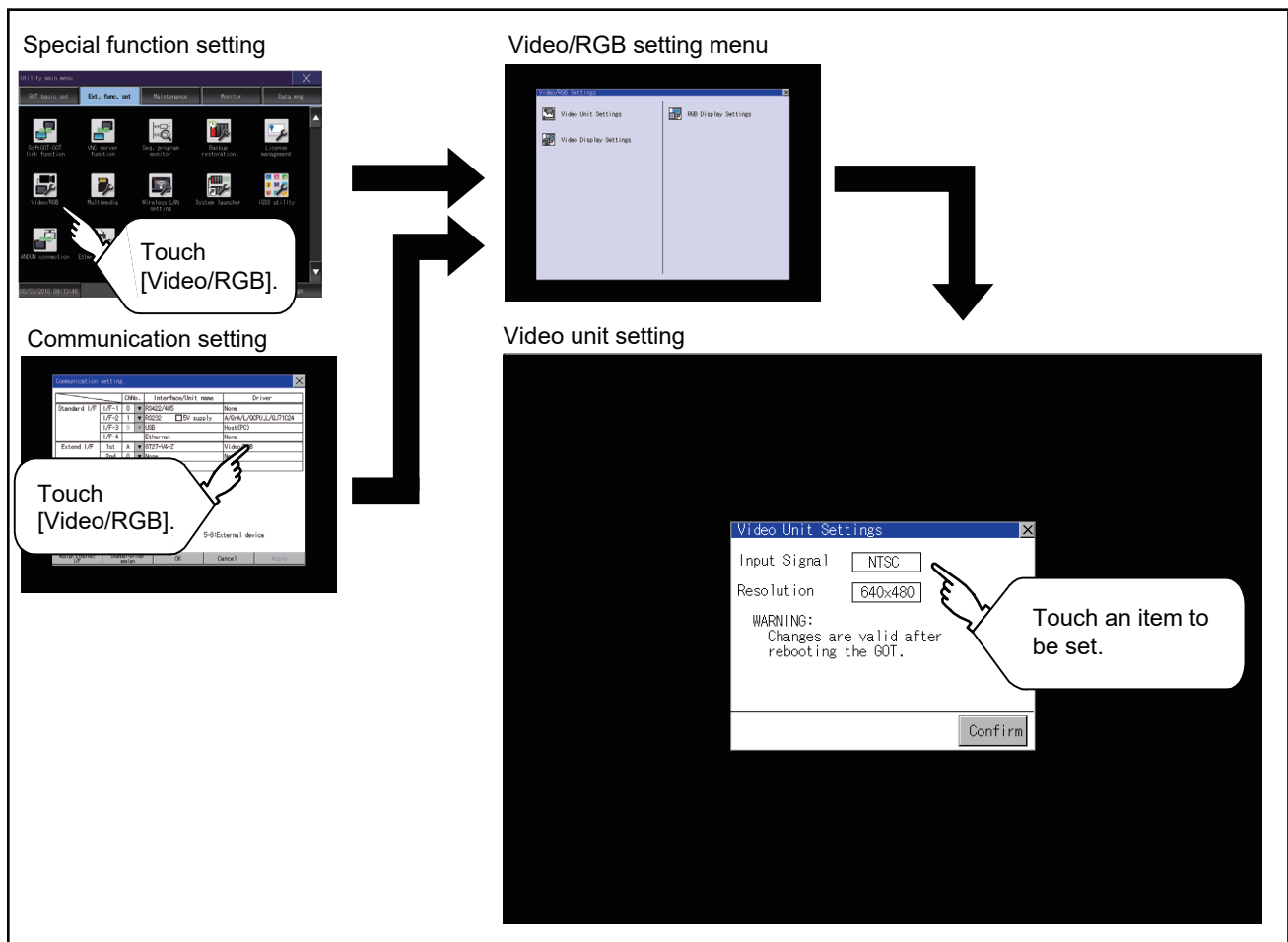

Operating the video unit setting

1. When you touch the setting item, the setting contents change.

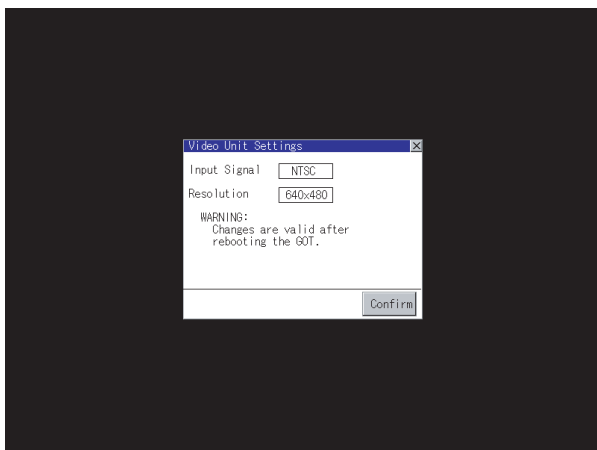

Input signal	PAL, NTSC
Resolution	720×480, 768×576, 640×480

2. When you touch the [Confirm] button, the setting contents are determined.
3. If you touch the [×] button without touching the [Confirm] button, the dialog shown below is displayed.

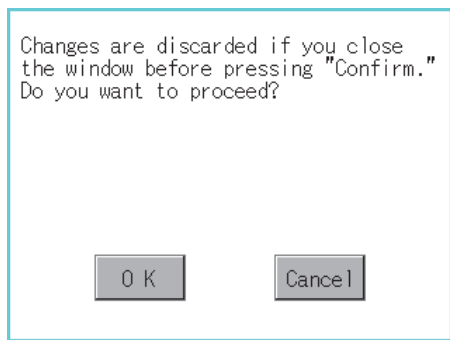

4. After completing the settings for all the items you want to change in [Video Unit Settings], when closing [Video Unit Settings] and [Video/RGB Setting]/[Communication Setting] with the [×] button, the GOT is restarted, and the new setting contents are reflected.

Video display setting

Video display setting

The target for the video settings and the preview channel can be selected and the captive area and image quality can be set.

Item	Description	Setting range
Video Display Setting	The target for the video settings and the preview channel can be selected and the captive area (in the horizontal direction and vertical direction) and image quality (color tone, contrast, brightness, color intensity) can be set. The captive area and image quality can be set for each channel.	Channel 1/2/3/4 <At factory shipment : 1> Captive area Horizontal: -100 to 100 <At factory shipment : 0> Vertical: -100 to 100 <At factory shipment : 0> Image Quality and Color Tone: -100 to 100 <At factory shipment : 0> Contrast: -100 to 100 <At factory shipment : 0> Brightness: -100 to 100 <At factory shipment : 0> Intensity: -100 to 100 <At factory shipment : 0>

Display operation of the video display setting

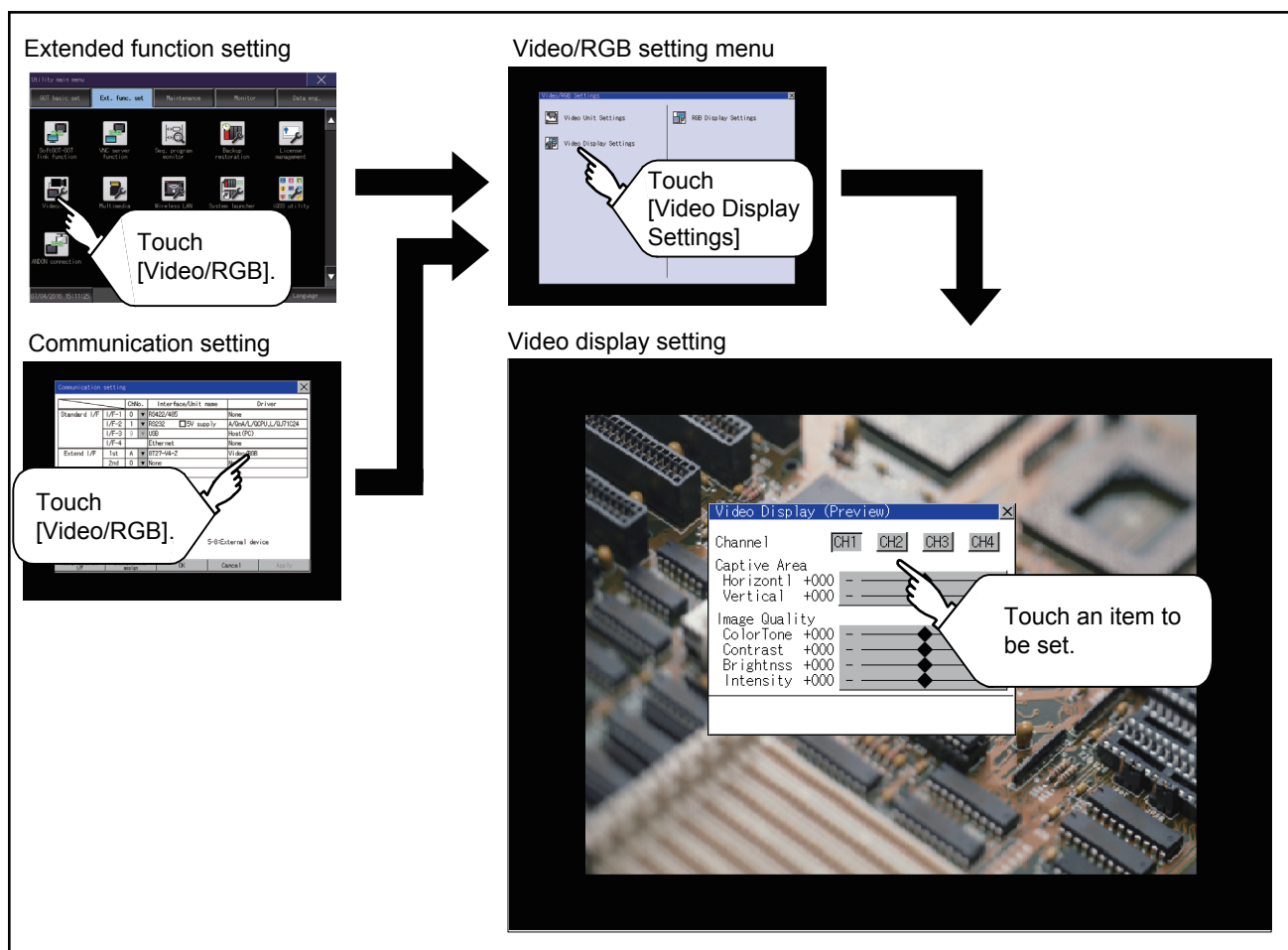

Video display setting operation

1. Select a video channel No. to be displayed.

The video image for the selected channel No. is previewed.

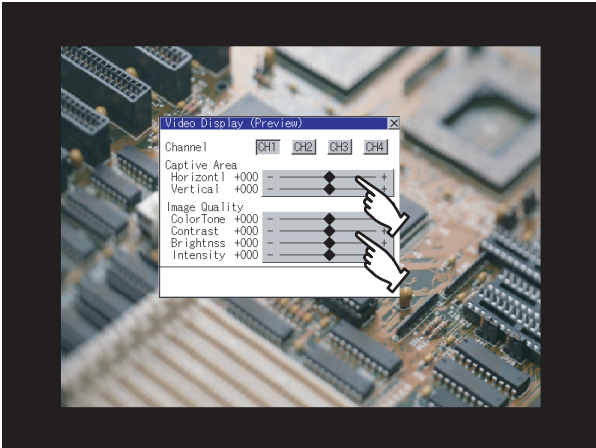

2. To change the captive area or image quality, touch the display section of each item.

Captive Area: Refer to step 3 to step 6.

Image Quality: Refer to step 7 to step 10.

3. The captive area (horizontal direction/vertical direction) for the selected channel No. can be changed.

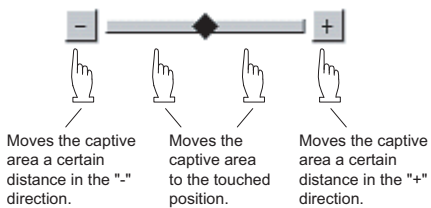

Touching the [Default] button returns to the default status.

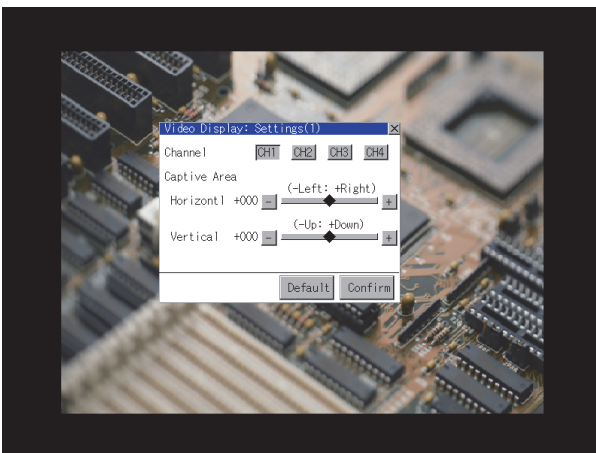

4. When you touch the [Confirm] button, the setting contents are determined.

5. If you touch the [x] button without touching the [Confirm] button, the dialog shown below is displayed.

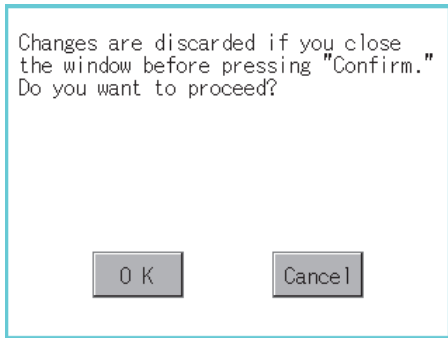

6. After completing all the items to set, if you touch the [x] button, the display returns to the preview screen step1.

7. The image quality (color tone, contrast, brightness, color intensity) for the selected channel No. can be changed.

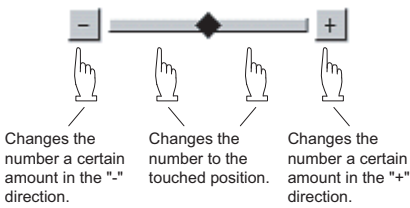

Touching the [Default] button returns to the default status.

When touching the [Copy CH1] button, the image quality (color tone, contrast, brightness, color intensity) for the selected channel No. is matched with the image quality settings for Channel No. 1 ([CH1]).

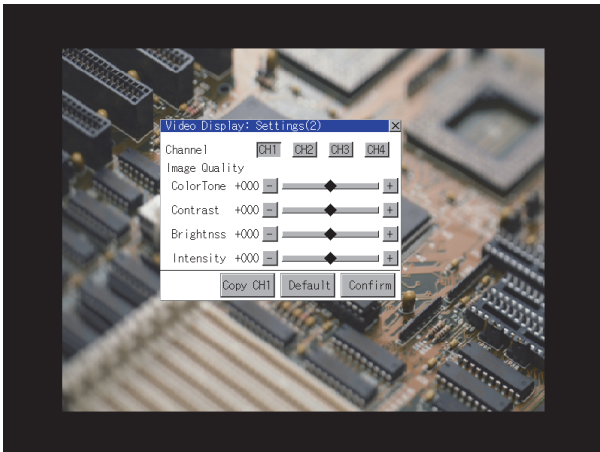

8. When touching the [Confirm] button, the setting contents are determined.

9. If you touch the [x] button without touching the [Confirm] button, the dialog shown below is displayed.

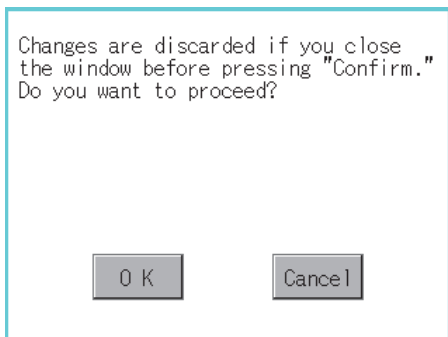

10. After completing all the items to set, if you touch the [x] button, the display returns to the preview screen step1.

11. After completing the settings for all the items you want to change in the video display settings, when closing [Video Display (Preview)] with the [x] button, the display returns to [Video/RGB Setting].

Point 

Precautions for setting

Incorrect settings may disrupt or stop the video image.

(If this happens, returning the settings to their default values restores normal display.)

This phenomenon depends on the video camera or other device connected.

Use setting values that provide proper display.

RGB display setting

RGB display setting

The RGB clock phase and screen position can be set.

Item	Description	Setting range
RGB Display Setting	The following items can be set. <ul style="list-style-type: none"> • Channel to be previewed • Clock phase *1 • Clock phase (extend) *2*3 • Screen position (horizontal) • Screen position (vertical) 	Channel: 1/2 <At factory shipment : 1> ClockPhase: -100 to 100 <At factory shipment : 0> Clock phase (extend): -100 to 100 <At factory shipment : 0> Display position Horizontal: -100 to 100 <At factory shipment : 0> Display position Vertical: -100 to 100 <At factory shipment : 0>

- *1 Adjust this setting when horizontal noise lines appear on the screen.
- *2 Adjust this setting when characters are blotted or contours are unclear.
- *3 Only available to GT27-R2.

Display operation of the RGB display setting

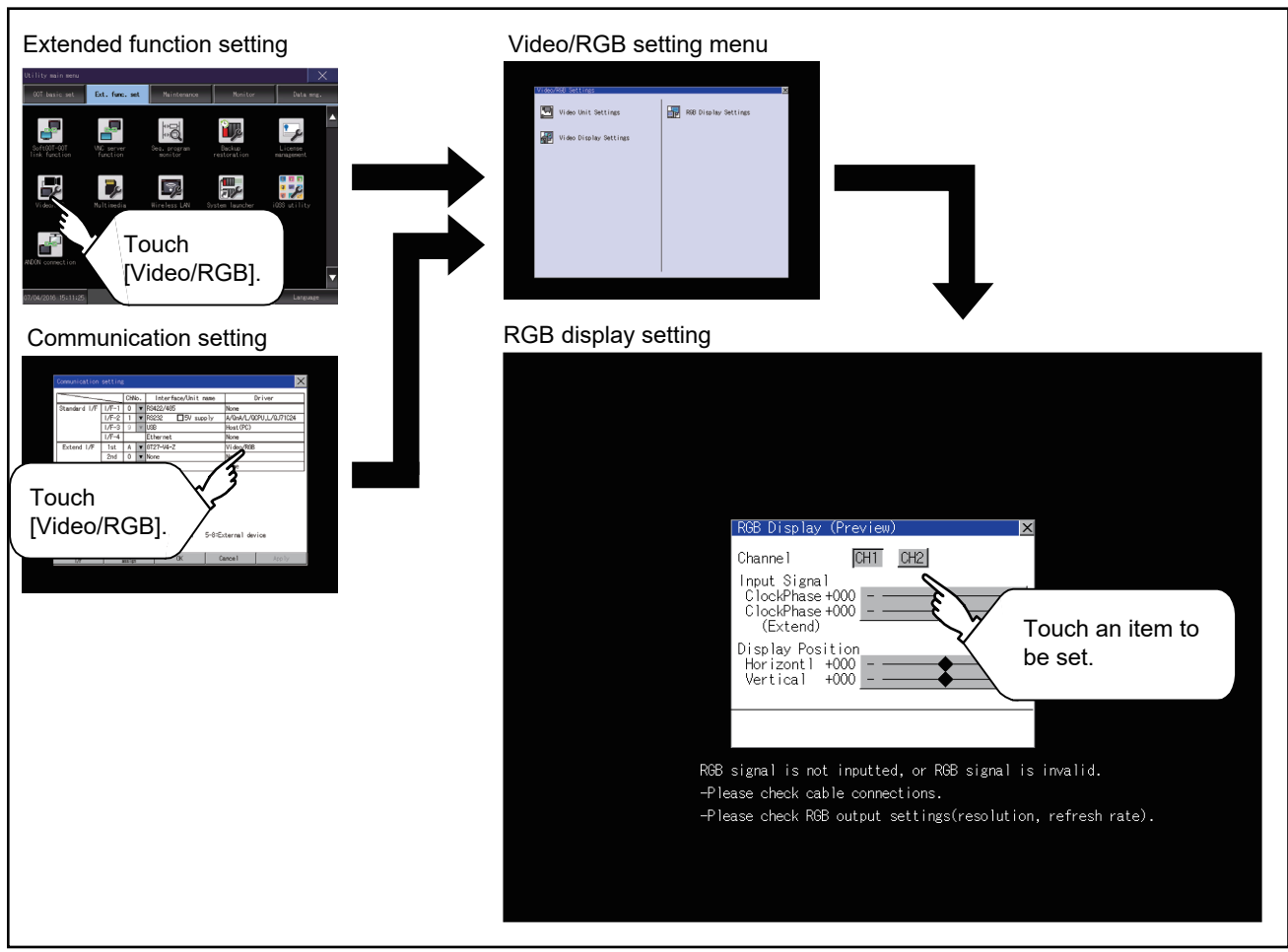

RGB display setting operation

1. Select an RGB channel No. to be displayed.

The RGB image for the selected channel No. is previewed.

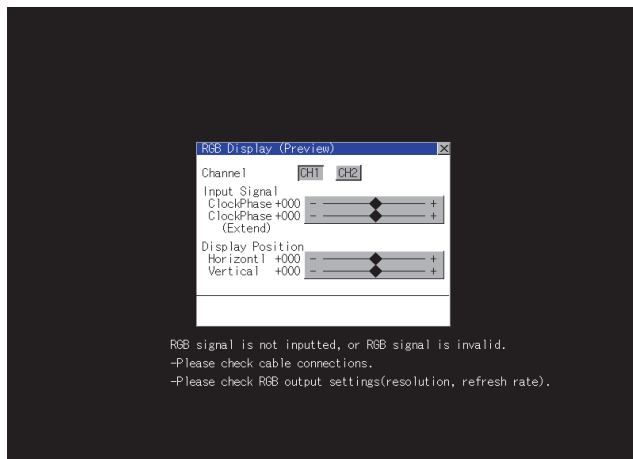

2. The clock phase and screen display position (horizontal direction or vertical direction) can be changed.

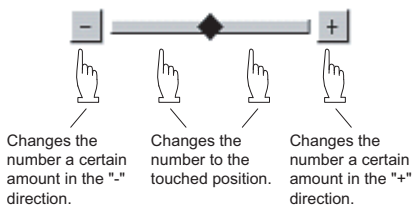

3. When you touch the [Confirm] button, the setting contents are determined.

4. If you touch the [x] button without touching the [Confirm] button, the dialog shown below is displayed.

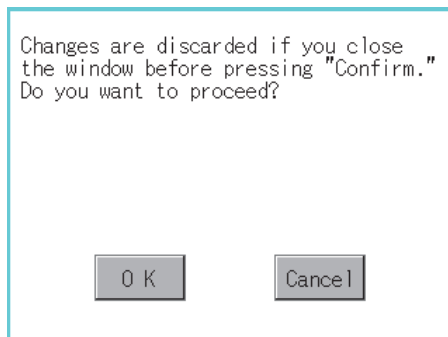

5. After completing all the items to set, if you touch the [x] button, the display returns to [Video/RGB Setting].

Point

Precautions for setting

If the value for [Horizontal] or [Vertical] is too large, RGB display may not be performed or the display may be disrupted or stopped.

If this happens, return the settings to their default values and make settings in the range where RGB display is possible.

3.8 Multimedia

Video unit setting

Video unit setting

The video input signal and resolution can be selected.

Item	Description	Setting range
Video unit setting	The input signal and resolution can be selected.	Input signal: NTSC format, PAL format <At factory shipment: NTSC format> Resolution: 640 × 480 ^{*1} , 768 × 576 ^{*2} <At factory shipment : 640 × 480>

*1 When NTSC format is selected, the resolution is fixed to 640 × 480.

*2 When PAL format is selected, the resolution is fixed to 768 × 576.

Input signal settings

Set the input signal as follows according to the output format for the video camera or the like connected.

If the settings made differ from these, video images may not be displayed correctly.

Output format for video camera or the like	Input signal setting
NTSC format	NTSC
PAL format	PAL
EIA format	NTSC
CCIR format	PAL

Display operation of the video unit setting

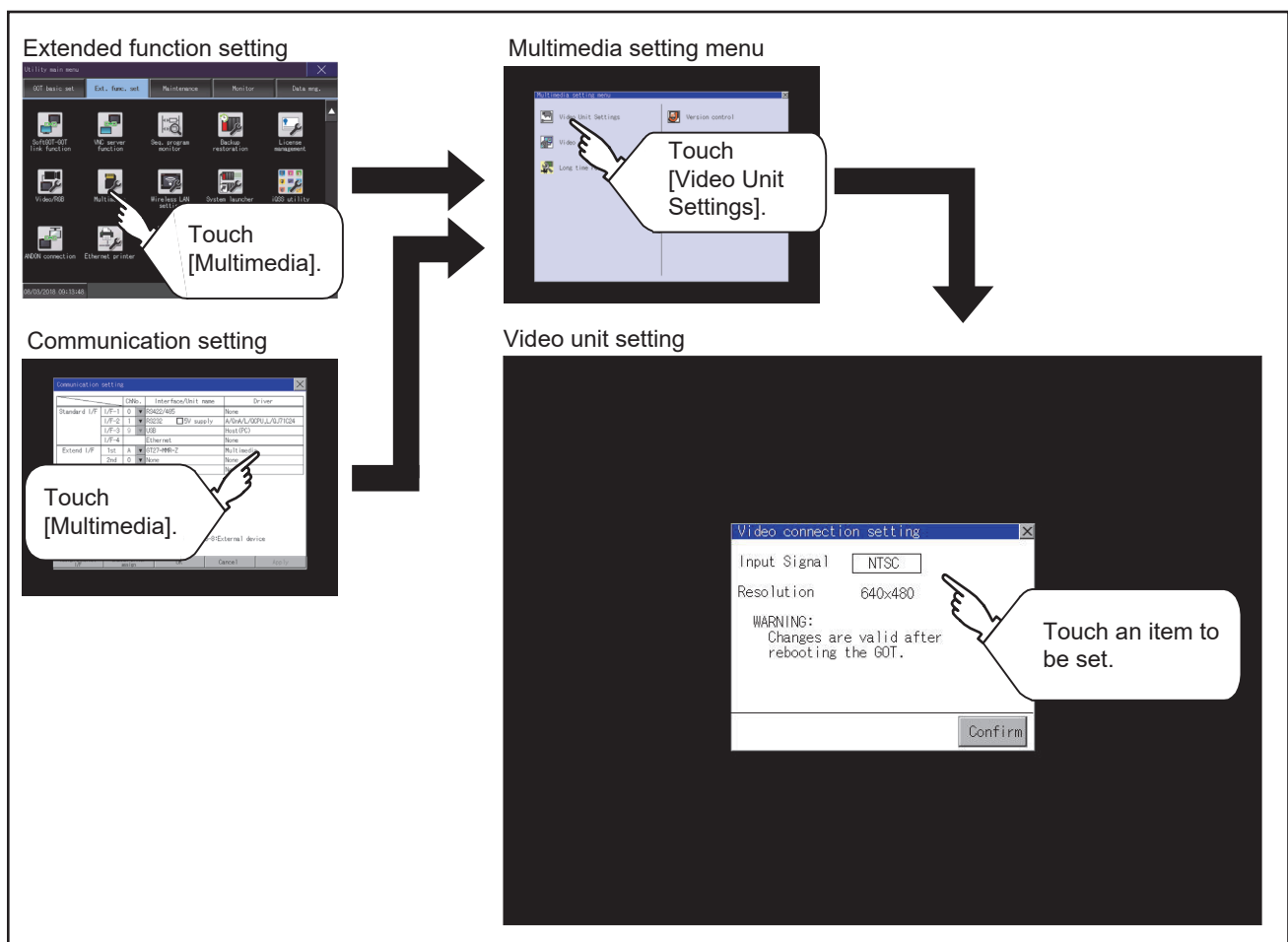

Operating the video unit setting

1. When you touch the setting item, the setting contents change.

Input signal	PAL, NTSC
Resolution	768× 576, 640× 480

Resolution automatically switches to 640 × 480 when NTSC is selected and to 768 × 576 when PAL is selected.

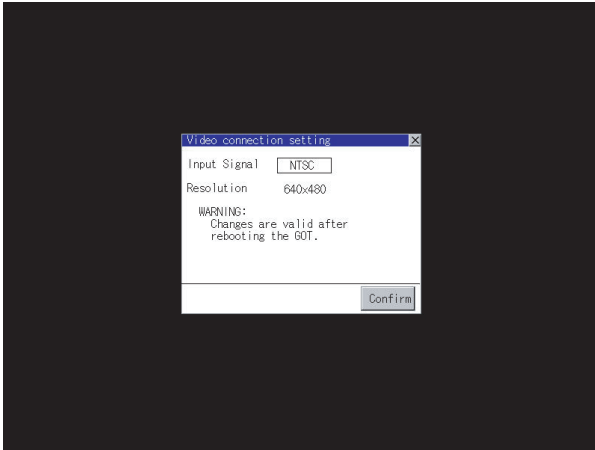

2. When you touch the [Confirm] button, the setting contents are determined.
3. If you touch the [×] button without touching the [Confirm] button, the dialog shown below is displayed.

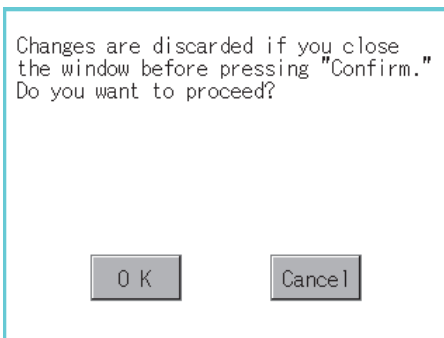

4. After completing the settings for all the items you want to change, close [Video Unit Settings] with the [×] button.
5. When closing [Multimedia Setting] or [Communication Setting] with the [×] button, the new setting contents are reflected.

Video setting

Video setting

The captive area and image quality can be set.

Item	Description	Setting range
Video setting	The captive area (in the horizontal direction and vertical direction) for the video and the image quality (color tone, contrast, brightness, color intensity) can be set.	Captive area Horizontal: -100 to 100 <At factory shipment : 0> Vertical: -100 to 100 <At factory shipment : 0> Image Quality and Color Tone: -100 to 100 <At factory shipment : 0> Contrast: -100 to 100 <At factory shipment : 0> Brightness: -100 to 100 <At factory shipment : 0> Intensity: -100 to 100 <At factory shipment : 0>

Display operation of the video setting

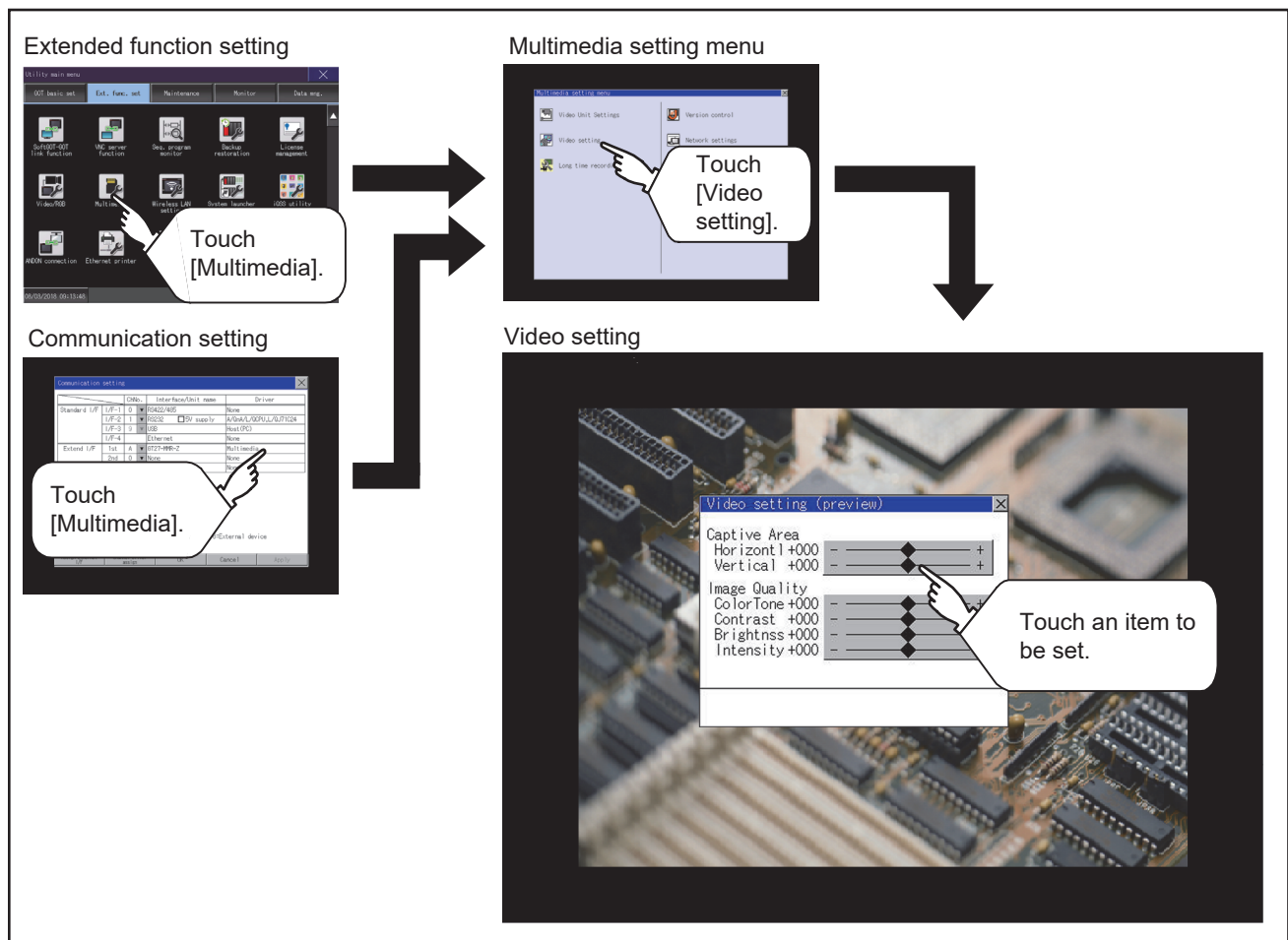

Operation of Video setting

1. To change the captive area or image quality, touch the display section of each item.

Captive Area: Refer to step 2 to step 5.

Image Quality: Refer to step 6 to step 9.

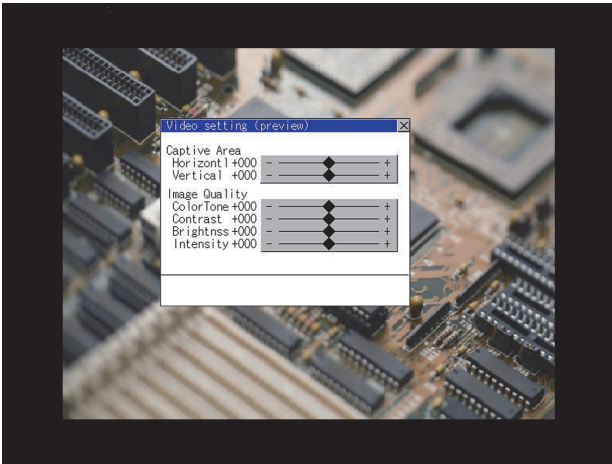

2. The captive area (horizontal direction or vertical direction) can be changed.

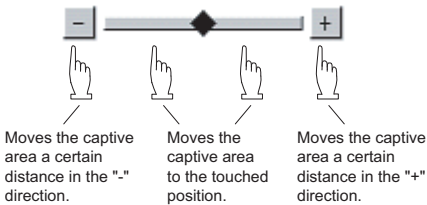

Touching the [Default] button returns to the default status.

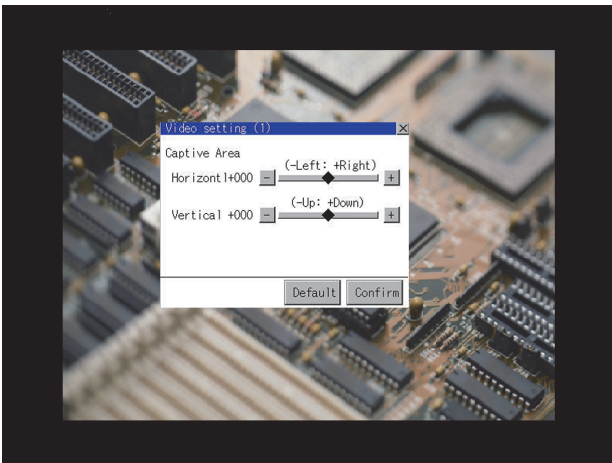

3. When you touch the [Confirm] button, the setting contents are determined.

4. If you touch the [x] button without touching the [Confirm] button, the dialog shown below is displayed.

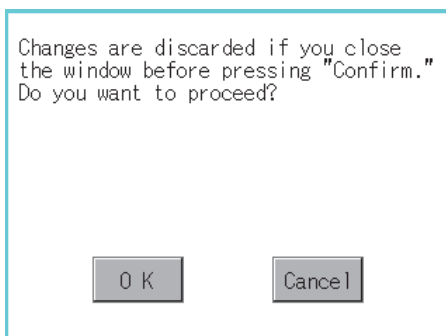

5. After completing all the items to set, if you touch the [x] button, the display returns to the preview screen step 1.

6. The image quality (color tone, contrast, brightness, color intensity) for the selected channel No. can be changed.

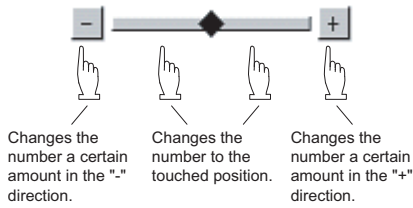

Touching the [Default] button returns to the default status.

When touching the [x] button, the setting contents are determined.

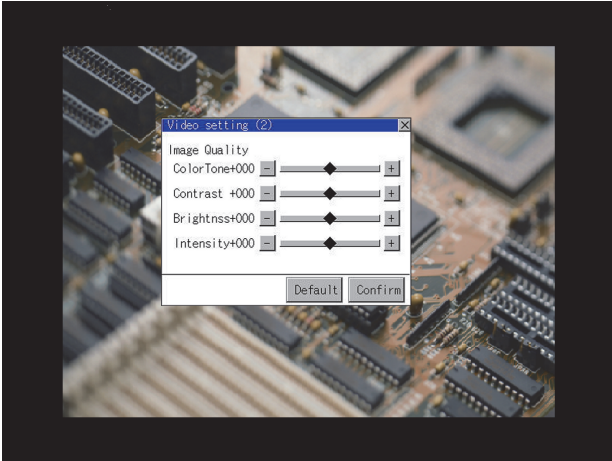

7. If you touch the [x] button without touching the [Confirm] button, the dialog shown below is displayed.

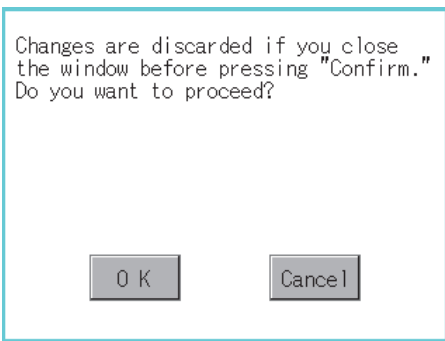

8. After completing all the items to set, if you touch the [x] button, the display returns to the preview screen step1.

9. After completing the settings for all the items you want to change in [Video setting], when closing [Video setting (preview)] with the [x] button, the display returns to [Multimedia Setting].

Point

Precautions for setting

Incorrect settings may disrupt or stop the video image.

(If this happens, returning the settings to their default values restores normal display.)

This phenomenon depends on the video camera or other device connected.

Use setting values that provide proper display.

Long time recording setting

Long time recording setting

In the long time recording settings, the saving method of video files for long time recording can be set.

Item	Description	Setting range
Continuous save	At the long time recording, whether to start recording after deleting all the video files which are previously recorded or to start recording without the deletion can be set.	Valid/Invalid <At factory shipment: Invalid>

Display operation of the long time recording setting

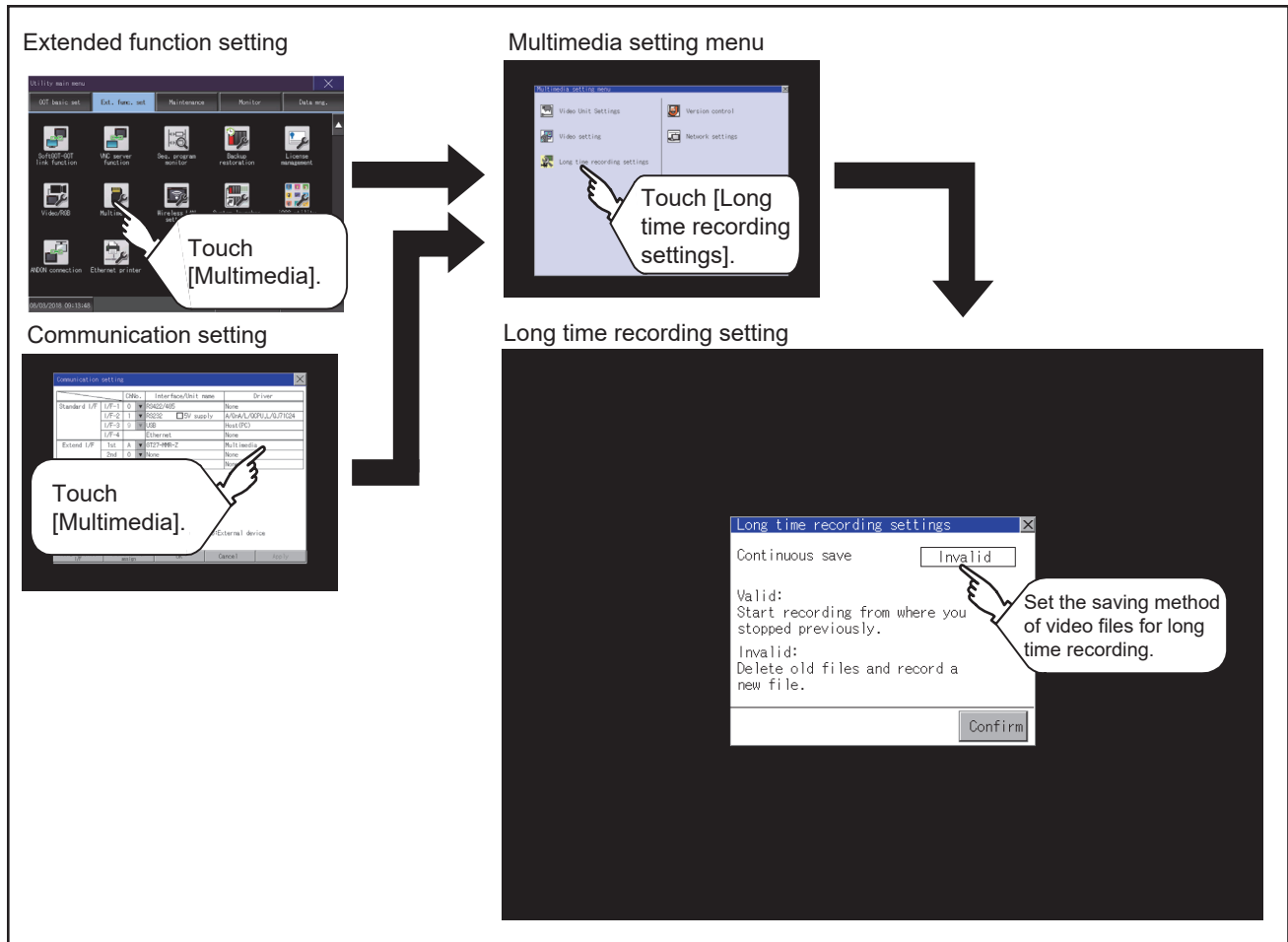

Operating the long time recording settings

1. When you touch the setting item, the setting contents change.

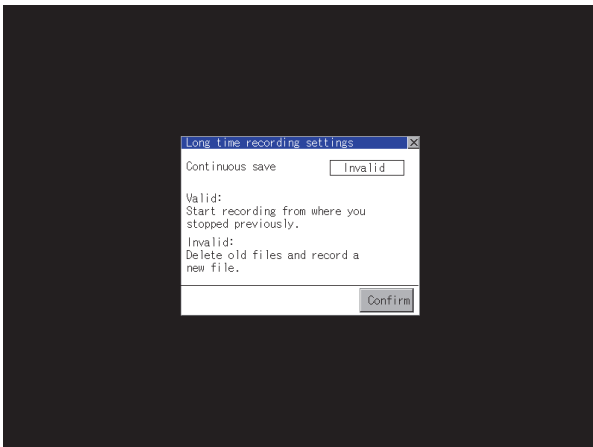

Continuous recording: Valid/Invalid

2. When you touch the [Confirm] button, the setting contents are determined.
3. If you touch the [x] button without touching the [Confirm] button, the dialog shown below is displayed.

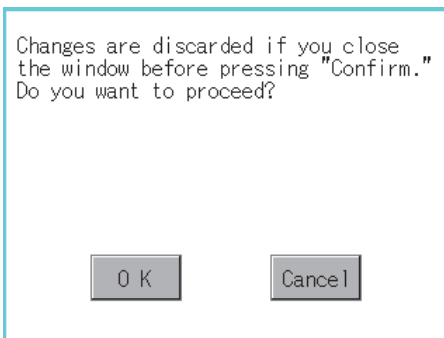

4. After completing the settings for all the items you want to change, close [Long time recording settings] with the [x] button.
5. When closing [Multimedia Setting] or [Communication Setting] with the [x] button, the new setting contents are reflected.

Version control

Perform the version control when updating the software version of the multimedia unit.

Display operation of the version control

To update the software version of the multimedia unit, insert a CF card that contains the update program into the multimedia unit.

Obtain the update program by one of the following methods.

Disk5 folder in GT Works3 DVD-ROM

Contact your local distributor.

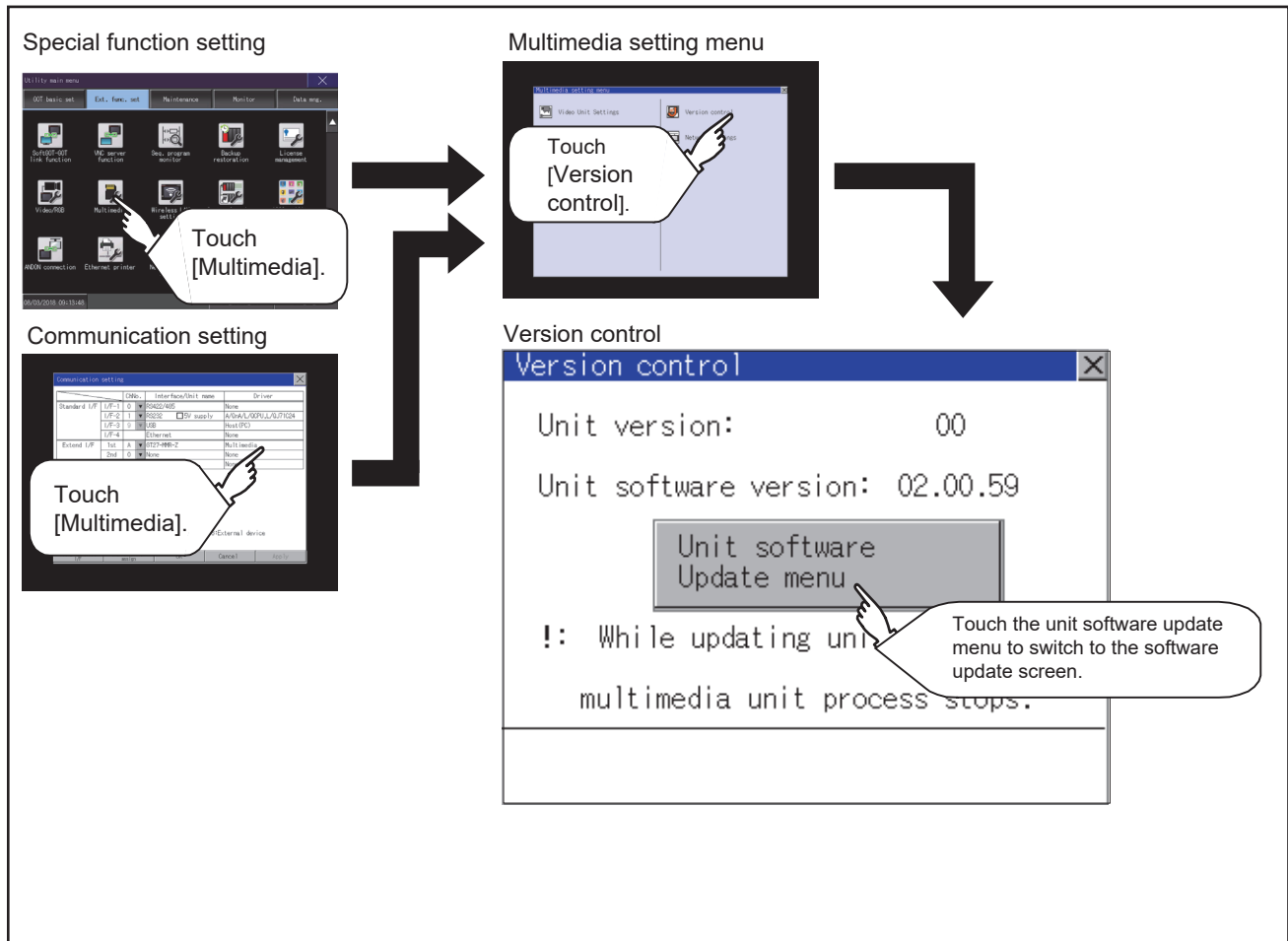

Setting procedure for the version control

1. Check the current software version of the multimedia unit that is displayed in [Unit software version].
Touch the [Unit software Update menu] button to display the update program transfer screen.

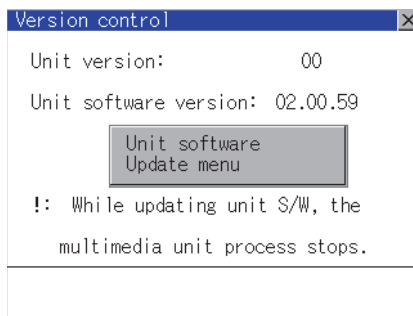

2. Insert a CF card that contains the update program into the multimedia unit.
The update program version appears in [Update software ver] only when this version is newer than the one displayed in [Unit software version].

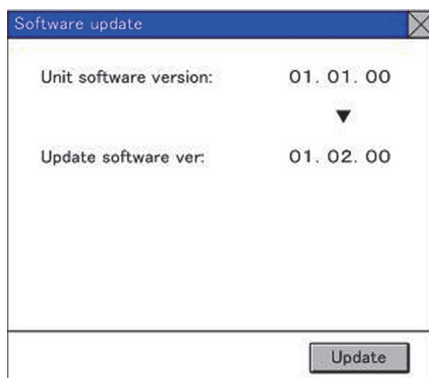

3. To update to the new version, touch the [Update] button.
4. The dialog below appears.

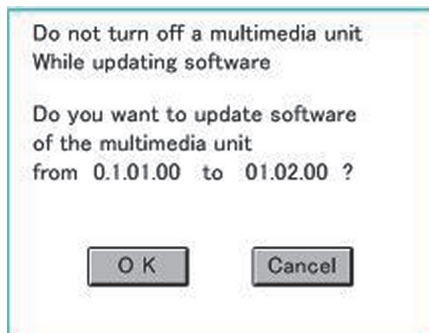

To perform the update, touch the [OK] button.
To cancel the update, touch the [Cancel] button.

- 5.** The dialog below appears during the update.
Do not remove the CF card or power off the GOT while this dialog is being displayed.
Do not turn off the SD card access switch of the multimedia unit.
Doing so causes an improper update of the software.

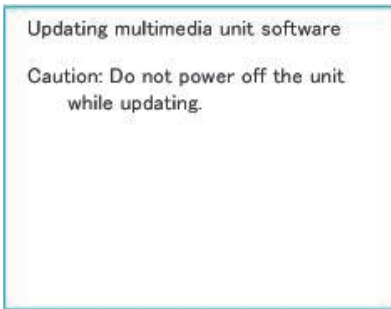

- 6.** After the update is complete, the dialog below appears.

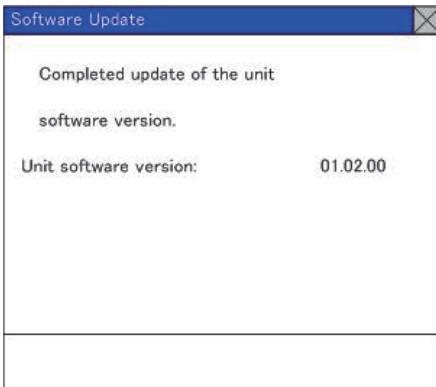

- 7.** If the update terminates abnormally or fails, the dialog below appears.
In such a case, restart the GOT and then perform the update from step 1 again.

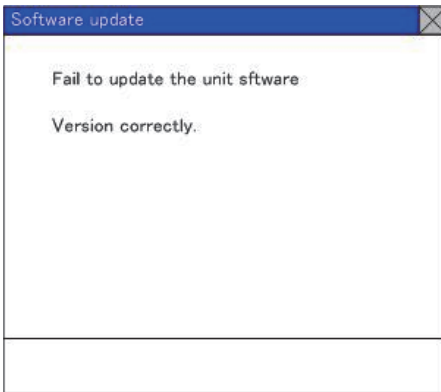

Network setting

Network setting

The network setting is executed when the network connection is made using the Ethernet I/F of the multimedia unit. The following settings can be made in the network setting.

Item	Description	Setting range
MAC address	Displays the MAC address.	-
IP address	Displays and sets the IP address.	0.0.0.0 to 255.255.255.255 <Default: 192.168.3.51>
Default gateway	Displays and sets the router address of the default gateway. For the connection via a router, the setting is required.	0.0.0.0 to 255.255.255.255 <Default: 0.0.0.0>
Subnet mask	Displays and sets the subnet mask. For the connection via a router, the setting is required.	0.0.0.0 to 255.255.255.255 <Default: 255.255.255.0>

Display operation of the network setting

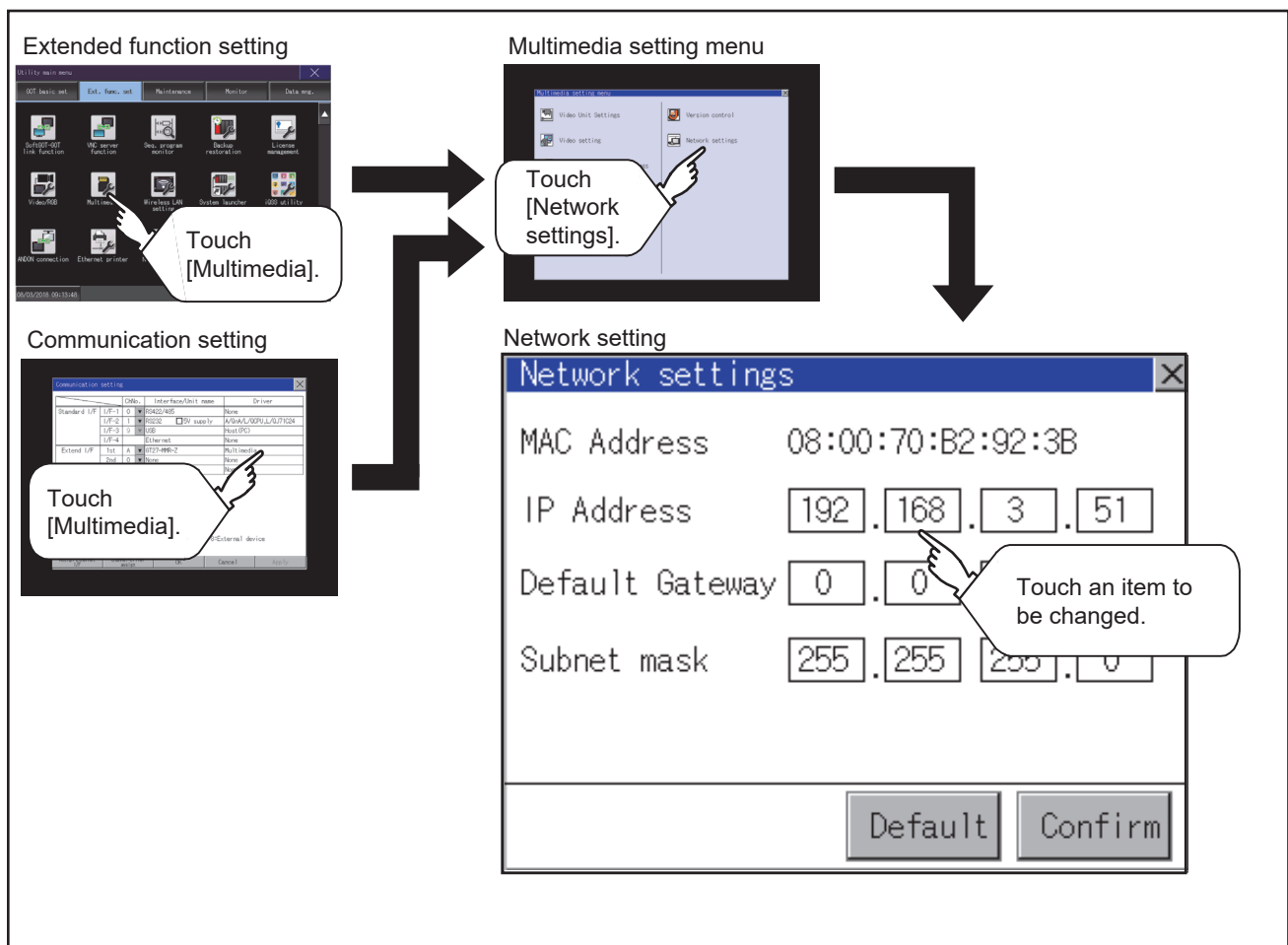

Operating the network setting

The following shows the setting operation of the IP address.

The same setting operation is applied to the default gateway and the subnet mask.

1. Touch the IP address display box.

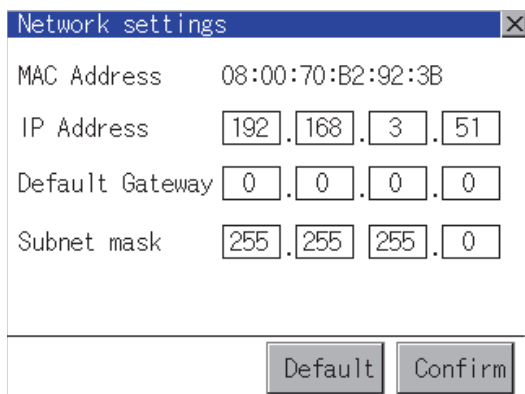

Network settings

MAC Address 08:00:70:B2:92:3B

IP Address 192 . 168 . 3 . 51

Default Gateway 0 . 0 . 0 . 0

Subnet mask 255 . 255 . 255 . 0

Default Confirm

2. The keyboard appears. Enter numerical values.

3. When you touch the [Confirm] button, the setting contents are determined.

If you touch the [Default] button, the setting contents can be returned to the initial values.

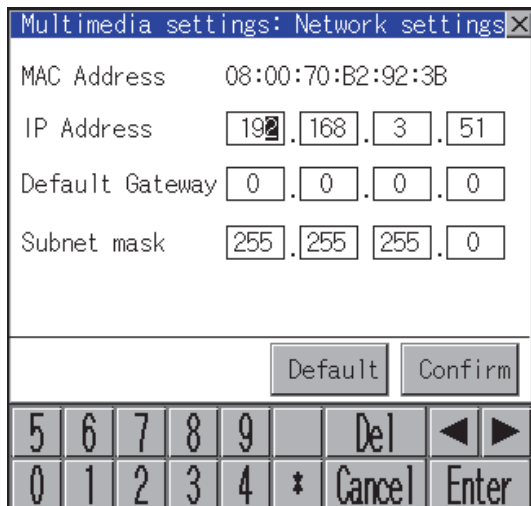

Multimedia settings: Network settings

MAC Address 08:00:70:B2:92:3B

IP Address 192 . 168 . 3 . 51

Default Gateway 0 . 0 . 0 . 0

Subnet mask 255 . 255 . 255 . 0

Default Confirm

5 6 7 8 9 Del ◀ ▶

0 1 2 3 4 * Cancel Enter

4. If you touch the [x] button without touching the [Confirm] button, the dialog shown below is displayed.

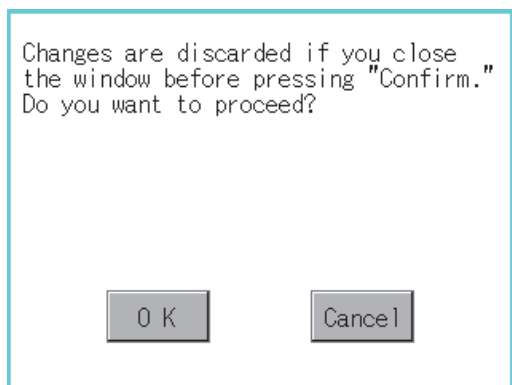

Changes are discarded if you close the window before pressing "Confirm."
Do you want to proceed?

OK Cancel

5. After completing the settings for all the items you want to change in [Network settings], when touching the [x] button, the display returns to [Multimedia setting menu].

Multimedia screen

Display operation of multimedia screen

Create the multimedia screen switch used to display the multimedia screen on the project screen.

Touch the multimedia screen switch so that the screen is switched to the multimedia screen.

The video image, play video and file selection menu can be switched on the multimedia screen.

For details of the procedures for creating the special function switch used to display the multimedia screen, refer to the following.

📖 GT Designer3 (GOT2000) Screen Design Manual



Operation of multimedia screen

■Video image screen

Images taken with a video camera connected to the multimedia unit can be displayed on the GOT screen.

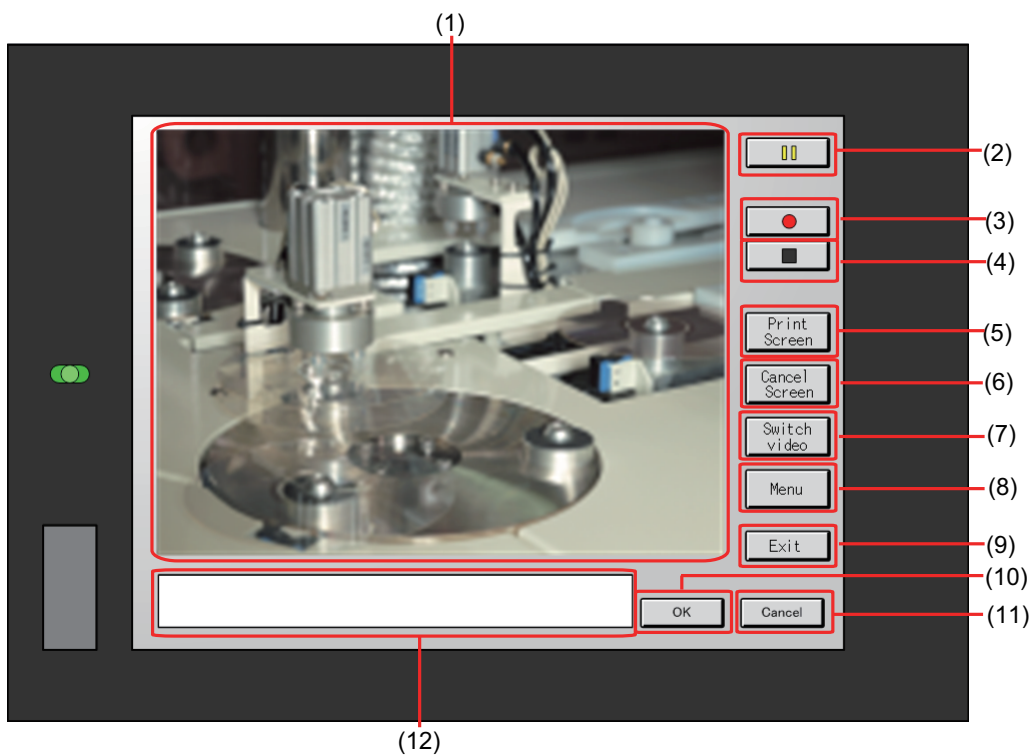
Images taken with a video camera can be recorded.







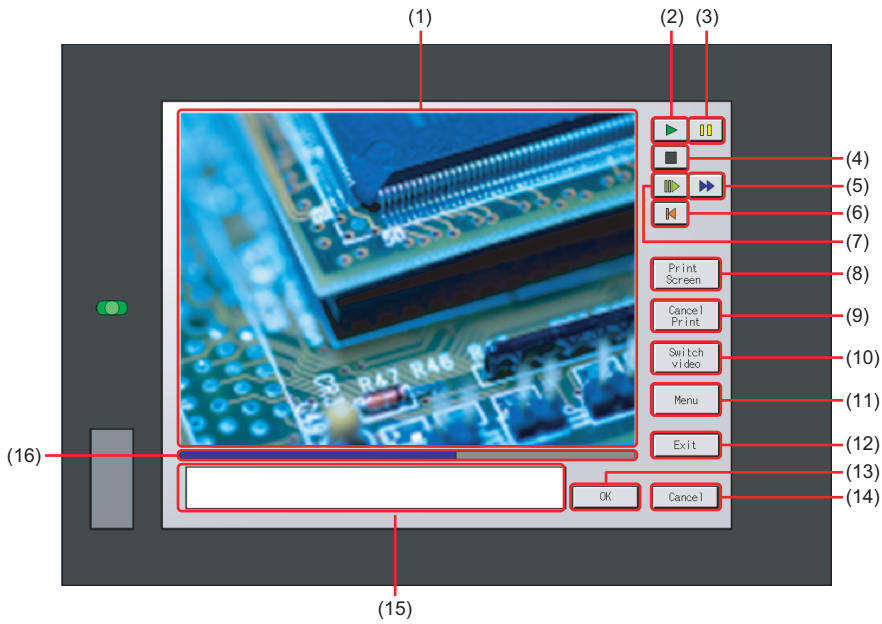

Item	Item	Description
(1)	Image display screen	Screen to display images taken with a video camera
(2)	 button	Button to pause images taken with a video camera
(3)	 button	Button to start recording images taken with a video camera
(4)	 button	Button to stop recording
(5)	[Print Screen] button	Button to start printing the screen*1
(6)	[Cancel Print] button	Button to cancel printing the screen
(7)	[Switch video] button	Button to switch the display to the play video screen
(8)	[Menu] button	Button to switch the screen to the file menu screen
(9)	[Exit] button	Button to exit the multimedia screen and return to the utility screen
(10)	[OK] button	Button to accept messages
(11)	[Cancel] button	Button to stop messages
(12)	Message display screen	Screen to display error messages, etc.

*1 The file is saved to the output destination specified in the hard copy function setting.

■Play video screen

Video files saved in the CF card installed on the multimedia unit can be played and displayed.



Item	Item	Description
(1)	Image display screen	Screen to display images taken with a video camera or to play video taken with a video camera
(2)	 button	Play button for playing video
(3)	 button	Button to pause images or video taken with a video camera
(4)	 button	Button to stop playing
(5)	 button	Button to return to the beginning of video files and to play the video
(6)	 button	Button to return to the beginning of video files and to play the video
(7)	 button	Button to play the video in slow motion
(8)	[Print Screen] button	Button to start printing the screen ^{*1}
(9)	[Cancel Print] button	Button to cancel printing the screen
(10)	[Switch video] button	Button to switch the screen to the video image screen
(11)	[Menu] button	Button to switch the screen to the file menu screen
(12)	[Exit] button	Button to exit the multimedia screen switch and to return to the utility screen
(13)	[OK] button	Button to accept messages
(14)	[Cancel] button	Button to stop messages
(15)	Message display screen	Screen to display the file name and shooting time of the video being played and messages
(16)	Play position display bar	Bar to display the play position of the video

*1 The file is saved to the output destination specified in the hard copy function setting.

■File menu screen

Video files of the CF card installed on the multimedia unit can be searched.

Searched video files can be displayed on the play video screen.

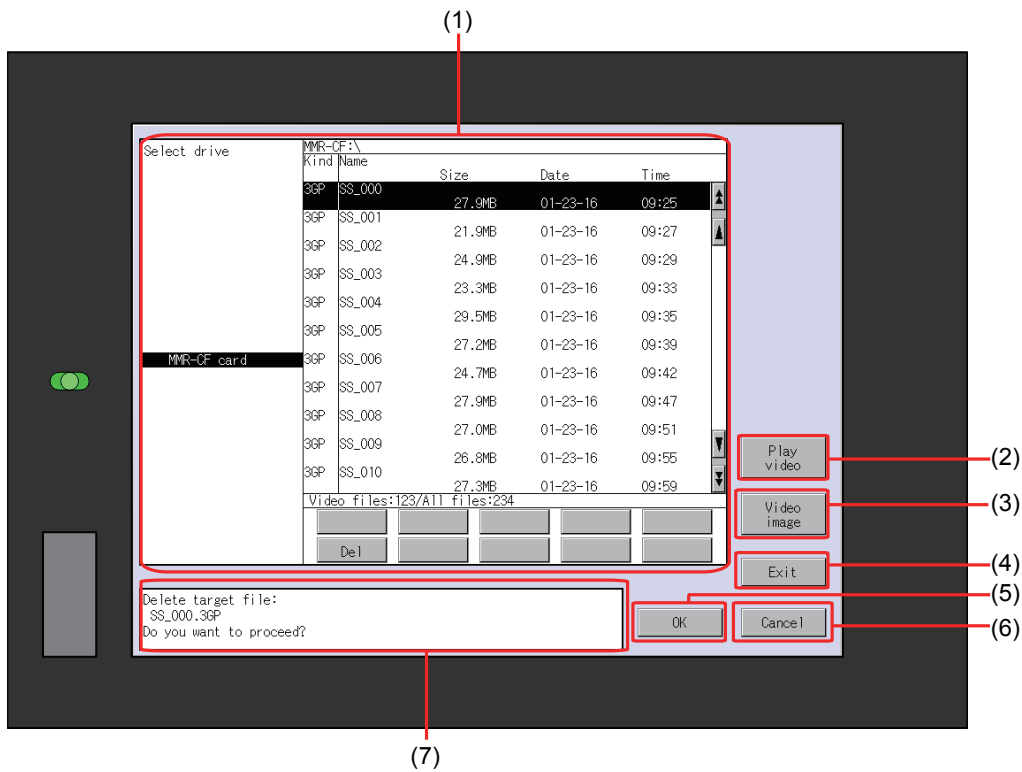

Item	Name	Description
(1)	File menu display screen	Screen to list the video files, display the number of files, and delete a target file in the CF card selected in [Select drive]
(2)	[Play video] button	Button to switch the display to the play video screen
(3)	[Video image] button	Button to switch the screen to the video image screen
(4)	[Exit] button	Button to exit the multimedia screen switch and to return to the utility screen
(5)	[OK] button	Button to accept messages
(6)	[Cancel] button	Button to stop messages
(7)	Message display screen	Screen to display error messages, etc.

3.9 Wireless LAN Function

Wireless LAN function setting

On the GOT, you can enable or disable the wireless LAN function, and check the wireless LAN function setting that is configured with GT Designer3.

For the setting of the wireless LAN function, refer to the following.

📖 GT Designer3 (GOT2000) Screen Design Manual

Display operation of the wireless LAN function setting

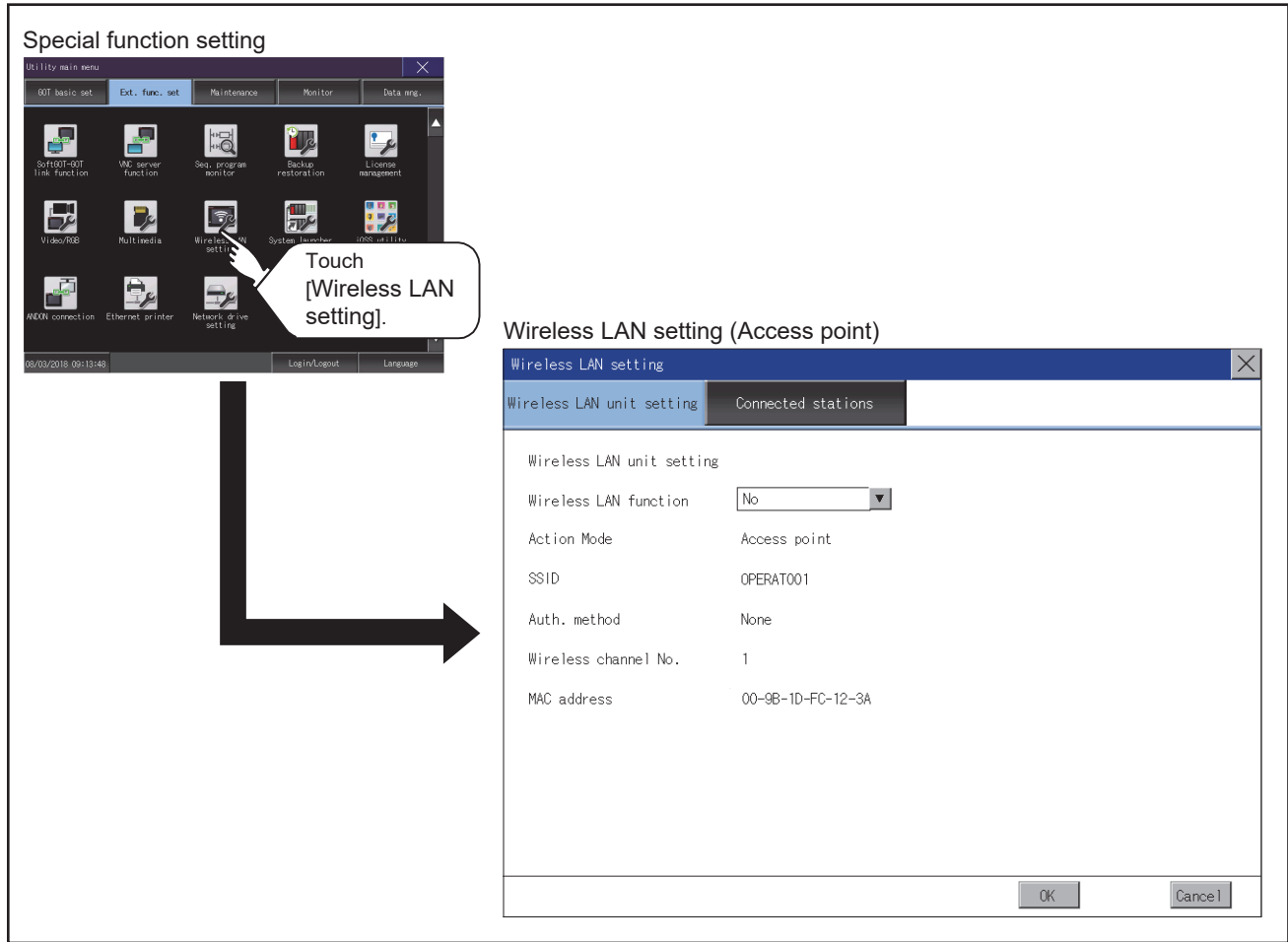

Display contents when [Action Mode] is set to [Access point]

The following describes the setting of the wireless LAN function when [Action Mode] is set to [Access point].

Wireless LAN unit setting

The following describes the setting items and the display contents of the wireless LAN setting.

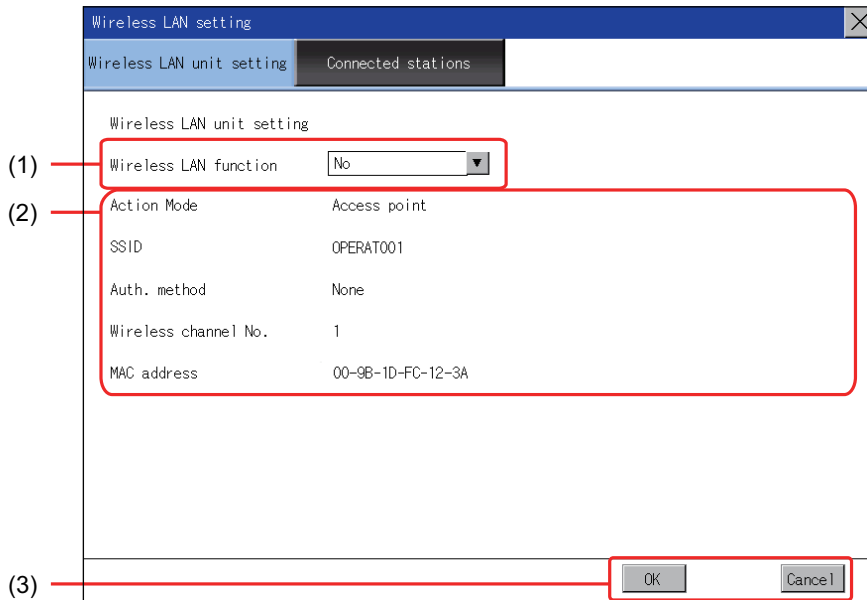

■ Wireless LAN function

Select whether to enable the wireless LAN function.

■ Action mode, SSID, authentication method, wireless channel No., and MAC address

Displays the action mode, SSID, authentication method, and wireless channel number that are set with GT Designer3.

Displays the MAC address of the wireless LAN communication unit that is mounted on the GOT.

■ Setting change

Touch the [OK] button to restart the GOT to operate with the changed settings.

To cancel the setting change and return to the utility main menu, touch the [Cancel] button.

Connected stations

The following describes the display contents of [Connected stations].

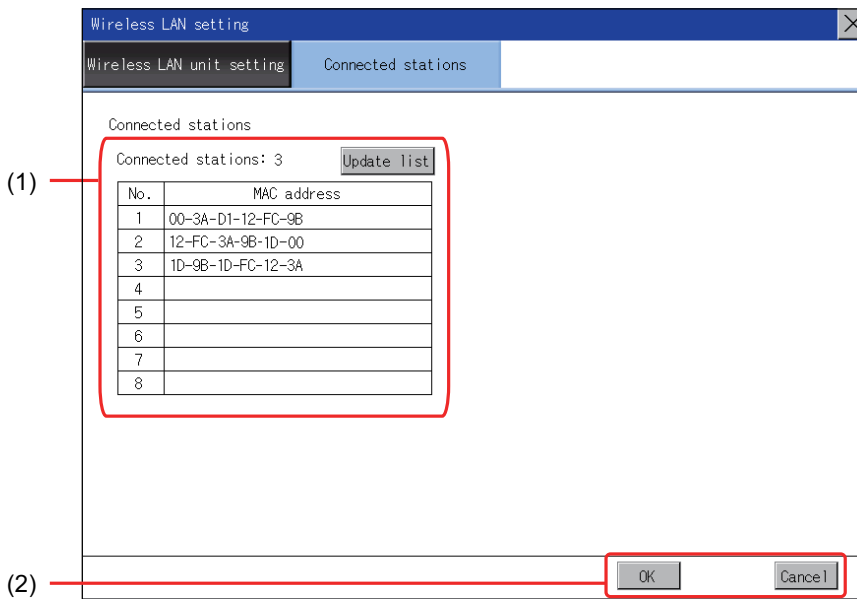

■Connected stations

The number of connected stations and MAC address are displayed.

Touch the [Update list] button to update the number of connected stations and their MAC addresses.

■Changing the settings

Touch the [OK] button to restart the GOT to operate with the changed settings.

To cancel the setting change and return to the utility main menu, touch the [Cancel] button.

Display contents when [Action Mode] is set to [Station]

The following describes the setting of the wireless LAN function when [Action Mode] is set to [Station].

Wireless LAN communication unit setting

The following describes the setting of the wireless LAN function when [Action Mode] is set to [Station].

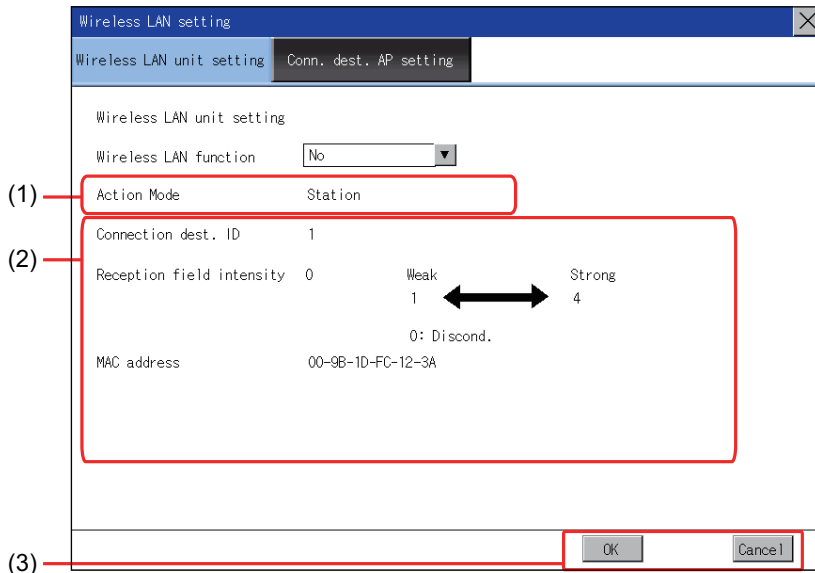

■Wireless LAN function

Select whether to enable the wireless LAN function.

■Action mode, connection destination ID, reception field intensity, and MAC address

Displays the action mode and the connection destination ID that are set with GT Designer3.

Displays the reception field intensity that indicates the connection status between the GOT and the current destination access point.

Displays the MAC address of the wireless LAN communication unit that is mounted on the GOT.

■Setting change

Touch the [OK] button to restart the GOT to operate with the changed settings.

To cancel the setting change and return to the utility main menu, touch the [Cancel] button.

Destination access point setting

The following describes the display contents of [Conn. dest. AP setting].

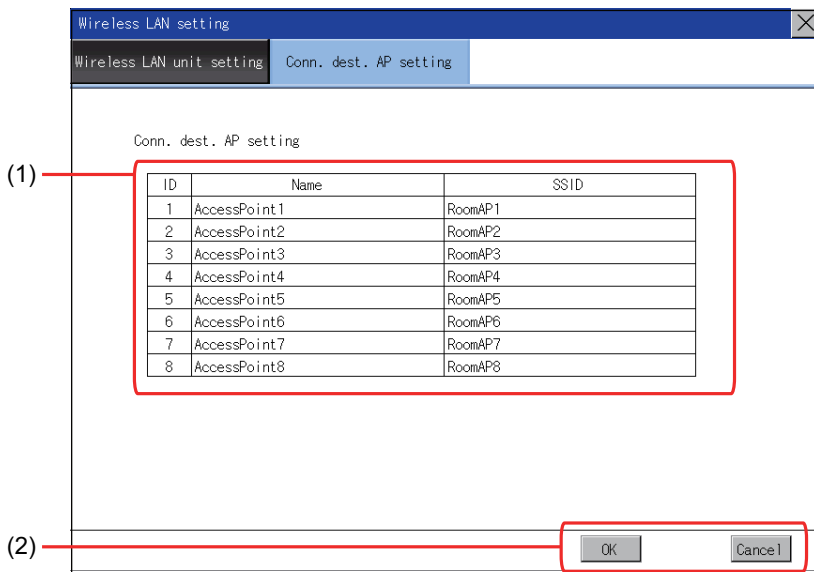

■Connection destination access point setting

Lists the ID numbers, names, and SSIDs of the destination access points that are set with GT Designer3.

■Setting change

Touch the [OK] button to restart the GOT to operate with the changed settings.

To cancel the setting change and return to the utility main menu, touch the [Cancel] button.

3.10 System Launcher

System launcher setting

You can enable or disable the online module change in the system launcher function.

For the details of the system launcher function, refer to the following.

 GOT2000 Series User's Manual (Monitor)

Item	Description	Setting range
Online module change	Enable or disable the online module change in the system launcher function.	Effective/Invalid <Default: Invalid>

Display operation of the system launcher setting

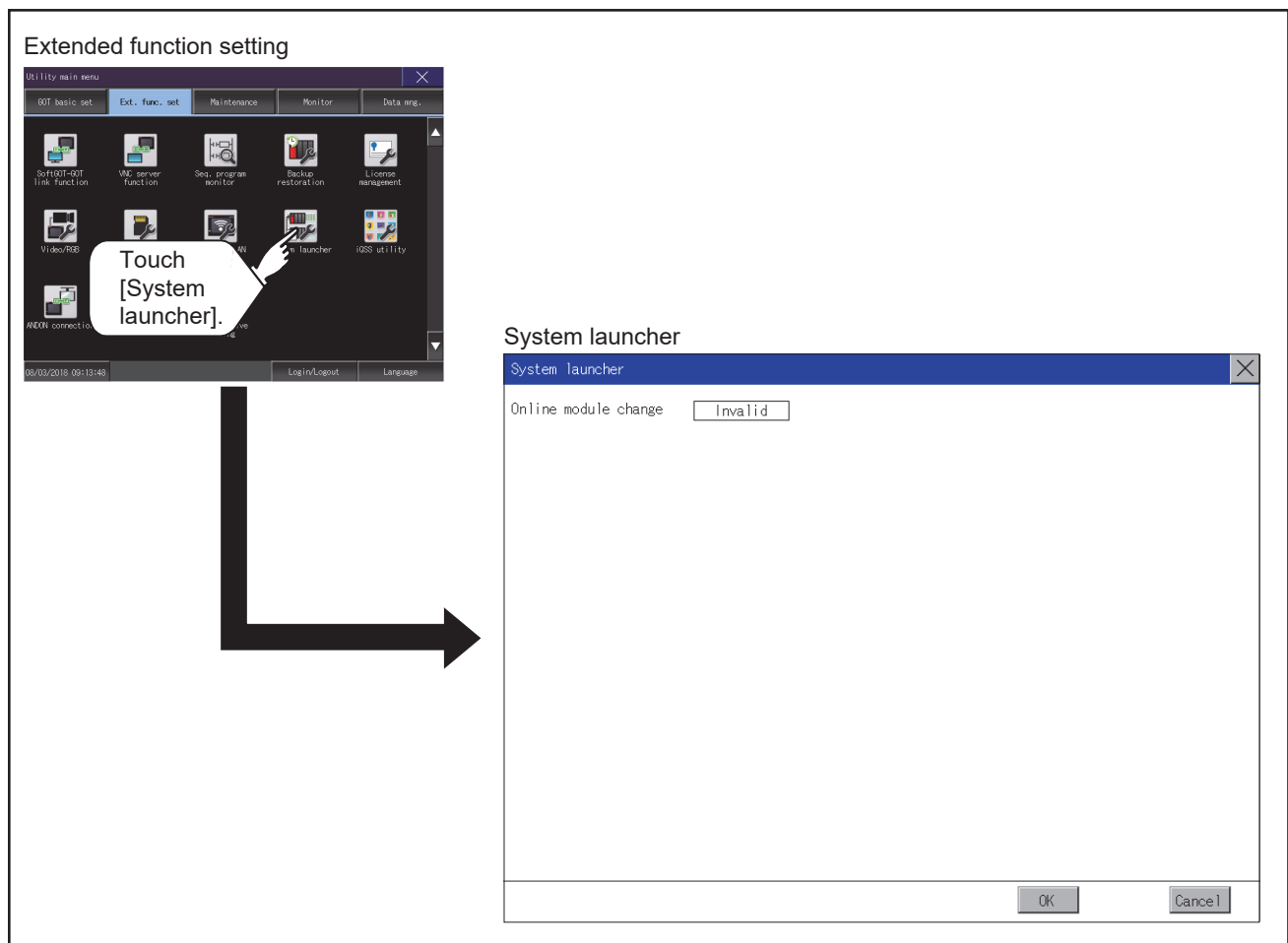

Setting procedure for the system launcher

Online module change

1. Touch the setting item to change the selection.

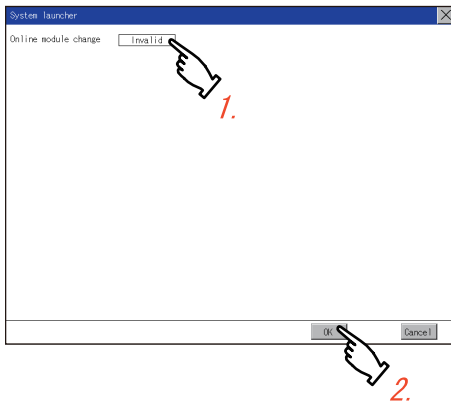

2. Touch the [OK] button to restart the GOT and reflect the setting change.
To cancel the setting change, touch the [Cancel] button to return to the [Ext. func. set] screen.

3.11 iQSS Utility

iQSS utility setting

You can set the drive for a data storage containing the profile data of iQSS-compatible equipment.

For the details of the iQSS utility function, refer to the following.

 GOT2000 Series User's Manual (Monitor)

Item	Description	Setting range
Data save location	Select the drive for a data storage containing profile data.	A:Built-in SD card B:USB drive E:USB drive F:USB drive G:USB drive X:drive <Default: X:drive>

Display operation of the iQSS utility setting

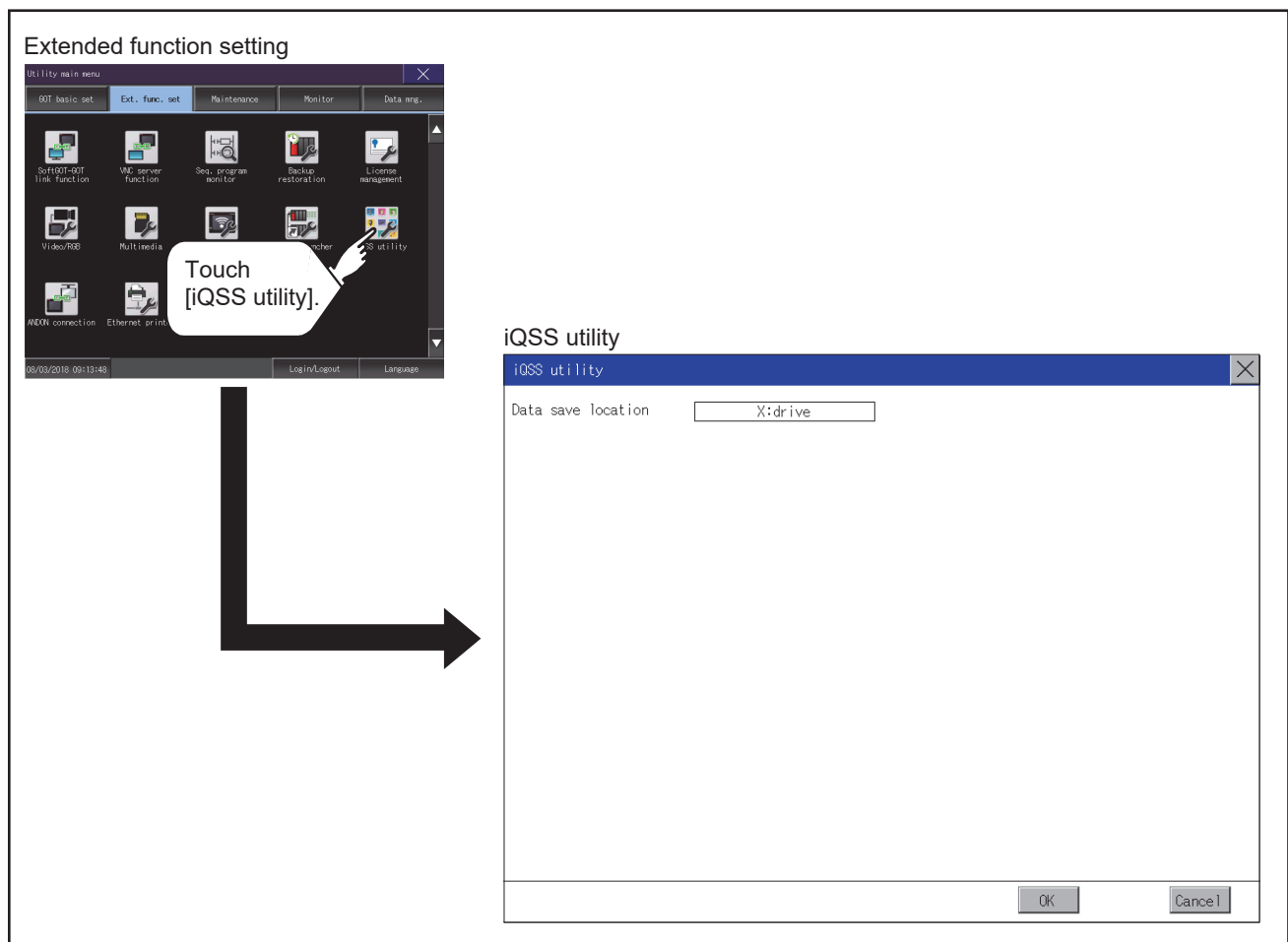

Setting procedure for the iQSS utility

Data save location

1. Touch the setting item to change the selection.

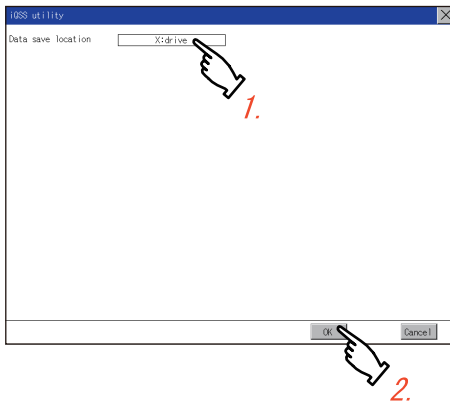

2. Touch the [OK] button to restart the GOT and reflect the setting change.
To cancel the setting change, touch the [Cancel] button to return to the [Ext. func. set] screen.

3.12 ANDON Connection

ANDON connection setting

You can set the IP address of a client that connects to the GOT without the operator name and password-based authentication. (The authentication screen does not appear.)

For the details of the ANDON function, refer to the following.

 GOT2000 Series User's Manual (Monitor)

Item	Description	Setting range
ANDON IP filter usage	Set whether to limit the IP addresses targeted for the ANDON connection.	Yes/No <Default: Yes>
Range	Set whether to set IP addresses by specifying a range. To specify a range, set the start IP address and the end IP address in [Target IP address].	Selected/Not selected <Default: Not selected>
Target IP address	Set the IP addresses or IP address ranges targeted for the ANDON connection. Up to five settings can be made.	0.0.0.0 to 255.255.255.255 ^{*1} <Default: Blank>

*1 Leave the boxes blank if you do not set any IP addresses.

Display operation of the ANDON connection setting

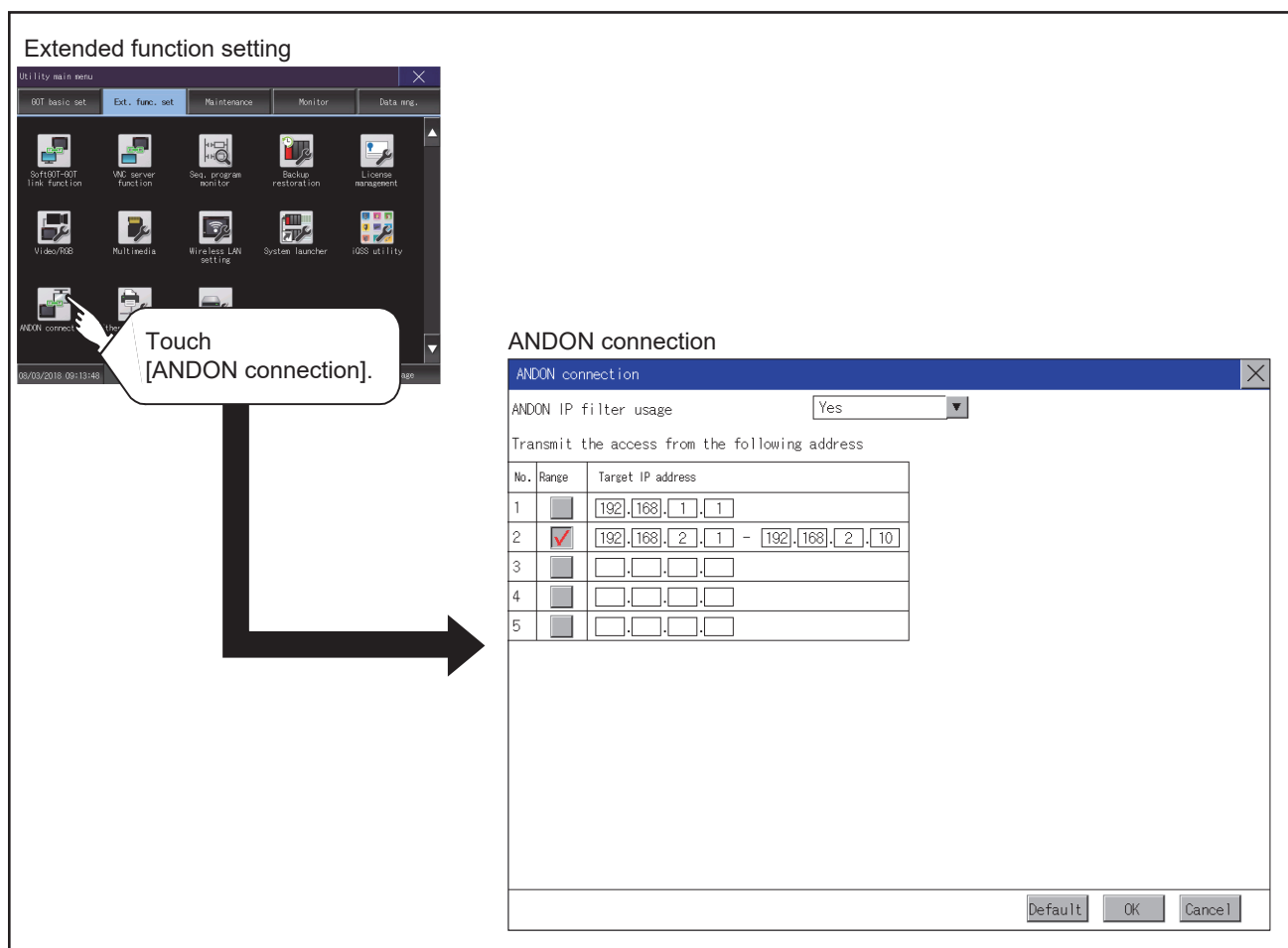

Extended function setting

Utility main menu

GOT basic set. Ext. func. set Maintenance Monitor Data ring.

Software-GOT link function IME server function Sea program monitor Backup restoration License management

Video/RGB Multimedia Wireless LAN setting System launcher iQSS utility

ANDON connect

Touch [ANDON connection].

ANDON connection

ANDON IP filter usage Yes

Transmit the access from the following address

No.	Range	Target IP address
1	<input type="checkbox"/>	192.168.1.1
2	<input checked="" type="checkbox"/>	192.168.2.1 - 192.168.2.10
3	<input type="checkbox"/>	
4	<input type="checkbox"/>	
5	<input type="checkbox"/>	

Default OK Cancel

Setting procedure for the ANDON connection

Setting an IP address

1. Touch the down arrow of the [ANDON IP filter usage] list box, and select [Yes].

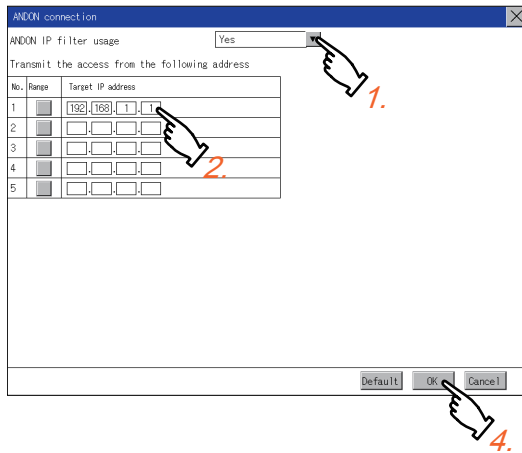

2. Touch a start IP address entry box in the [Target IP address] column to display a software keyboard. Input a value with the keyboard.

3. To specify an IP address range, refer to the following.

☞ Page 209 Specifying an IP address range

4. Touch the [OK] button to display a restart confirmation dialog. Restart the GOT to operate with the new setting. To cancel the setting, touch the [Cancel] button to return to the main menu. To reset each item to its default, touch the [Default] button.

■Specifying an IP address range

1. Touch a checkbox in the [Range] column to display the end IP address entry boxes in the [Target IP address] column.

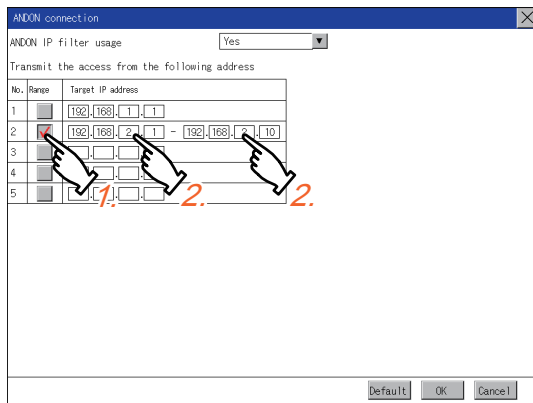

2. Touch any IP address entry box in the [Target IP address] column to display a software keyboard. Input a value with the keyboard.

Precautions

Setting of [ANDON IP filter usage]

If you select [No] for [ANDON IP filter usage], any IP address can access the GOT without the operator name and password-based authentication.

When you use the ANDON connection, make sure to select [Yes] to limit the IP addresses that can access the GOT without the operator name and password-based authentication.

Configuring the IP filter setting

In the IP filter setting, allow the IP addresses targeted for the ANDON connection to access the GOT.

Otherwise, the IP addresses cannot access the GOT using the ANDON connection.

3.13 Ethernet Printer

Ethernet printer setting

Set the IP address of an Ethernet printer.

Item	Description	Setting range
IP address	Set the IP address of the Ethernet printer to be connected.	0.0.0.0 to 255.255.255.255 <Default: 192.168.3.100>

Display operation of the Ethernet printer

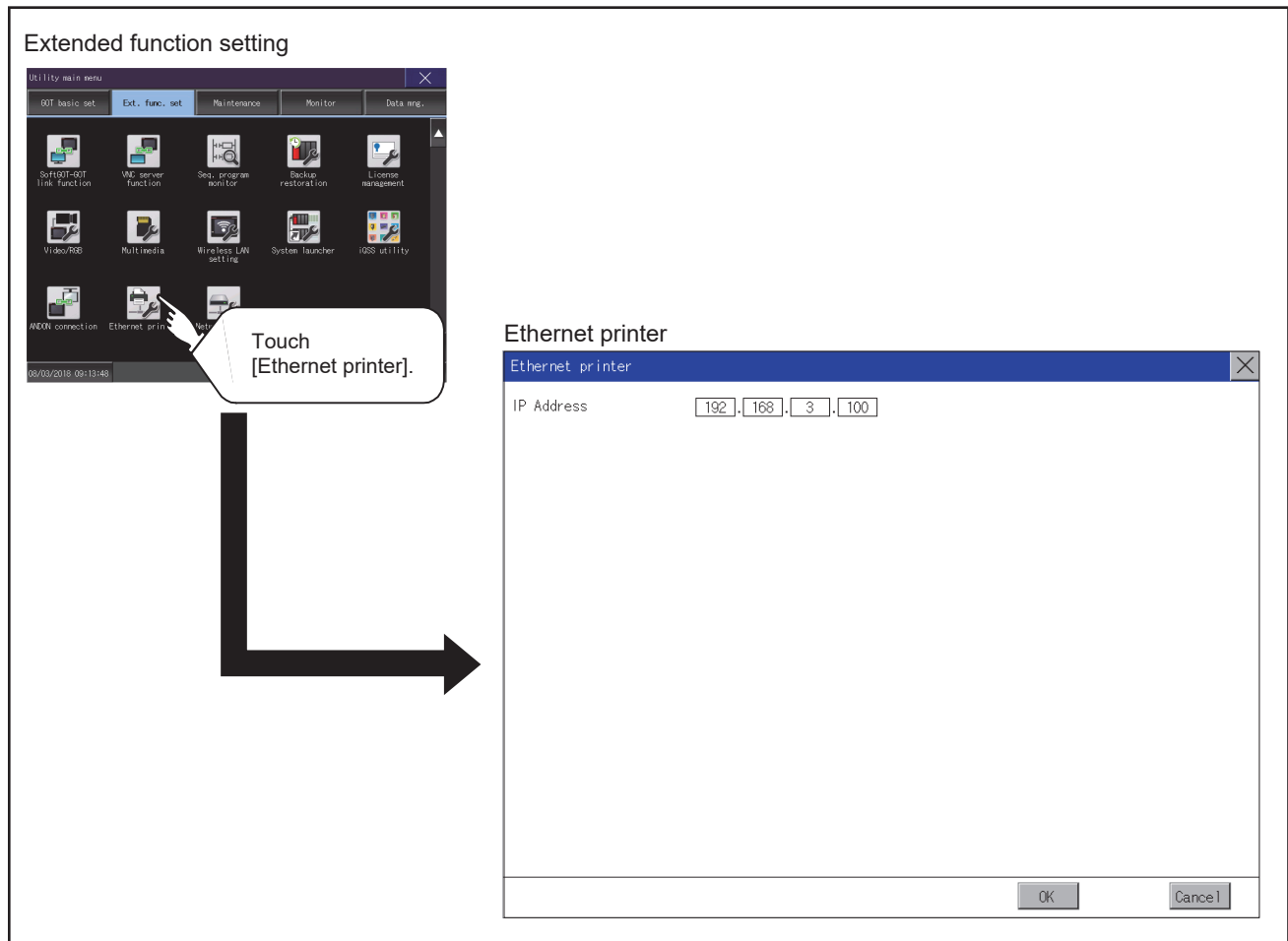

Procedure for setting an Ethernet printer

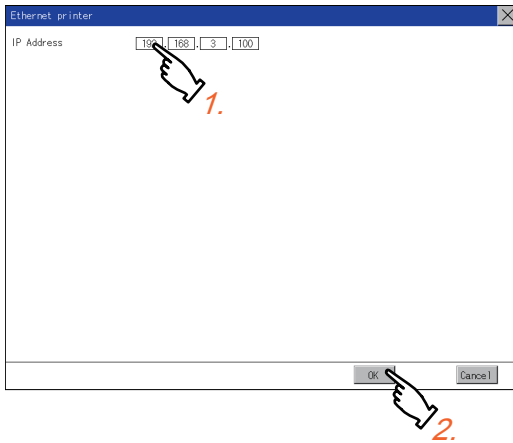

- 1.** Touch the input area of [IP Address] to display a keyboard.
Input values with the keyboard.
- 2.** Touch the [OK] button to reflect the new setting and return to the [Ext. func. set] screen.
To cancel the setting change, touch the [Cancel] button to return to the [Ext. func. set] screen.

3.14 Network drive setting

Setting the network drive

Configure the network drive settings.

Function	Description	Setting range
File server address	Display or change the IP address of the file server.	0.0.0.0 to 255.255.255.255
Share name	Display or change the name of the shared folder on the file server.	Make sure that the number of characters (including delimiters) in the drive path is 60 or less.
Folder path	Display or change the path to a folder in the shared folder.	
User name	Display or change the name of a user that is permitted to access the network drive.	1 to 32 one-byte or two-byte characters
Password	Display or change the password for a user to access the network drive.	1 to 32 one-byte alphanumeric characters and symbols
Drive name	Display the network drive name.	Drive N (fixed)
Communication timeout	Display or change the communication timeout period.	3 to 255 seconds

Displaying the network drive setting screen

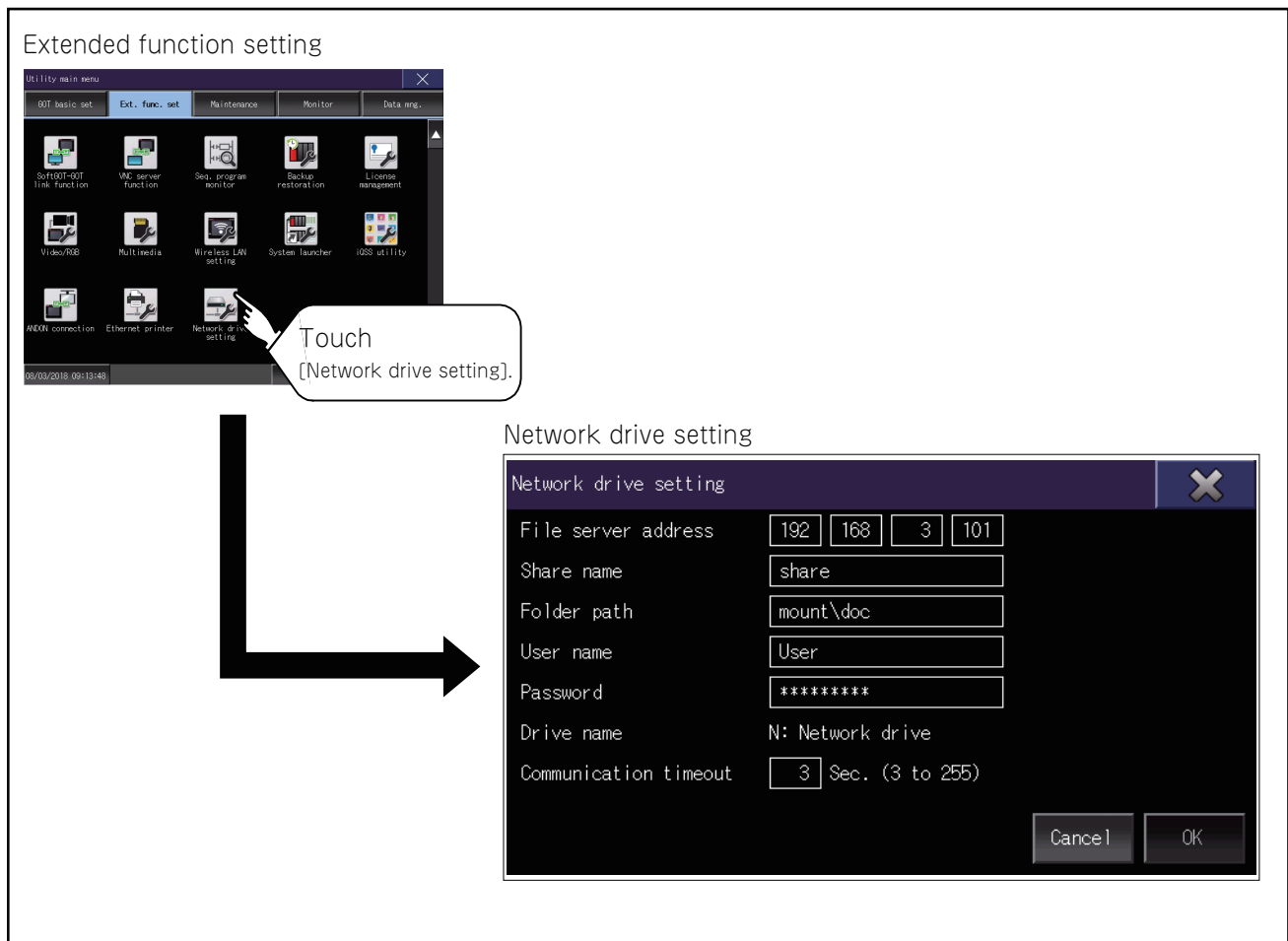

Procedure for setting the network drive

1. Touch a setting item.

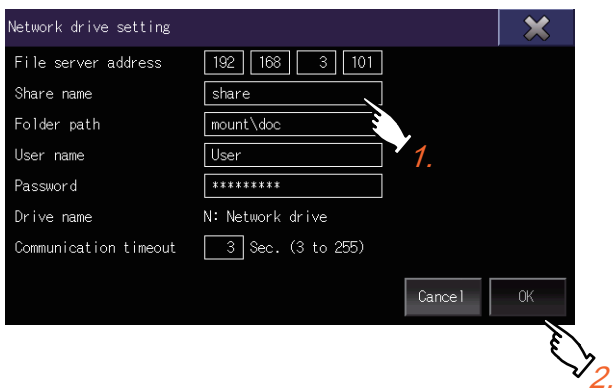

2. Enter values or characters using the software keyboard displayed.
3. Touch the [OK] button to confirm the entry.

4 MAINTENANCE

- ☞ Page 216 Batch Self Check
- ☞ Page 219 USB Device Management
- ☞ Page 221 Screen Cleaning
- ☞ Page 223 Touch Panel Calibration
- ☞ Page 226 System Alarm
- ☞ Page 228 Drawing Check
- ☞ Page 232 Font Check
- ☞ Page 234 Touch Panel Check
- ☞ Page 236 I/O Check
- ☞ Page 241 Ethernet Status Check
- ☞ Page 243 GOT Information
- ☞ Page 245 GOT Mobile Information

The GOT can display the screen for maintenance.

The following describes the functions available as the maintenance.

Item	Description	Reference
Batch self check	This function collects data about energization time, installed system application and others, and can display it in View self check results menu.	☞ Page 216 Batch Self Check
USB device management	This function controls the USB peripheral device connection status in the GOT.	☞ Page 219 USB Device Management
Clean	The screen can be set as not to be effected by touching the screen when clean with clothes.	☞ Page 221 Screen Cleaning
Touch panel calibration	Touch panel reading error can be corrected.	☞ Page 223 Touch Panel Calibration
System alarm	Displays error code and error message when error occurs.	☞ Page 226 System Alarm
Drawing check	Carries out missing bit check, color check and drawing check.	☞ Page 228 Drawing Check
Font check	Displays the character data on the screen to check visually.	☞ Page 232
Touch panel check	Checks whether there are no dead zone area in the Touch key minimum unit (16 dots x 16 dots).	☞ Page 234 Touch Panel Check
I/O check	Carries out RS-232 connecting target confirmation and self-loopback check.	☞ Page 236 I/O Check
Ethernet status check	Sends a ping to check the Ethernet connection status.	☞ Page 241 Ethernet Status Check
GOT information	Displays information of the GOT.	☞ Page 243 GOT Information
GOT Mobile information	Displays the GOT Mobile function settings and the list of clients being connected to the GOT.	☞ Page 245 GOT Mobile Information

4.1 Batch Self Check

The Batch self check collects data about energization time, installed system application and others, and can display it in View self check results menu.

Batch self check

When an export destination of the system status log is specified in the batch self check screen, the data can be logged.

Item	Description
System status log,	Diagnostic data that the GOT system status has been logged

Also, the following information are displayed in View self check results menu.

Item	Description
Start up information	Information at power-on, Information at system start up
System status 1	Installed system application, installation history
System status 2	Communication driver, GOT system configuration information
Communication setting contents	Displays the controller status.
Operation history	Displays the operation history and execution time.
Screen switching history	Displays the screen switching history and execution time.
Clock change history	Displays the time before and after clock change.
System alarm history	Displays the alarm and alarm occurrence time.
CPU error history	Displays the ChNo., error messages and error occurrence time.
GOT start time history	Displays the time GOT was powered on.

Display operation of batch self check

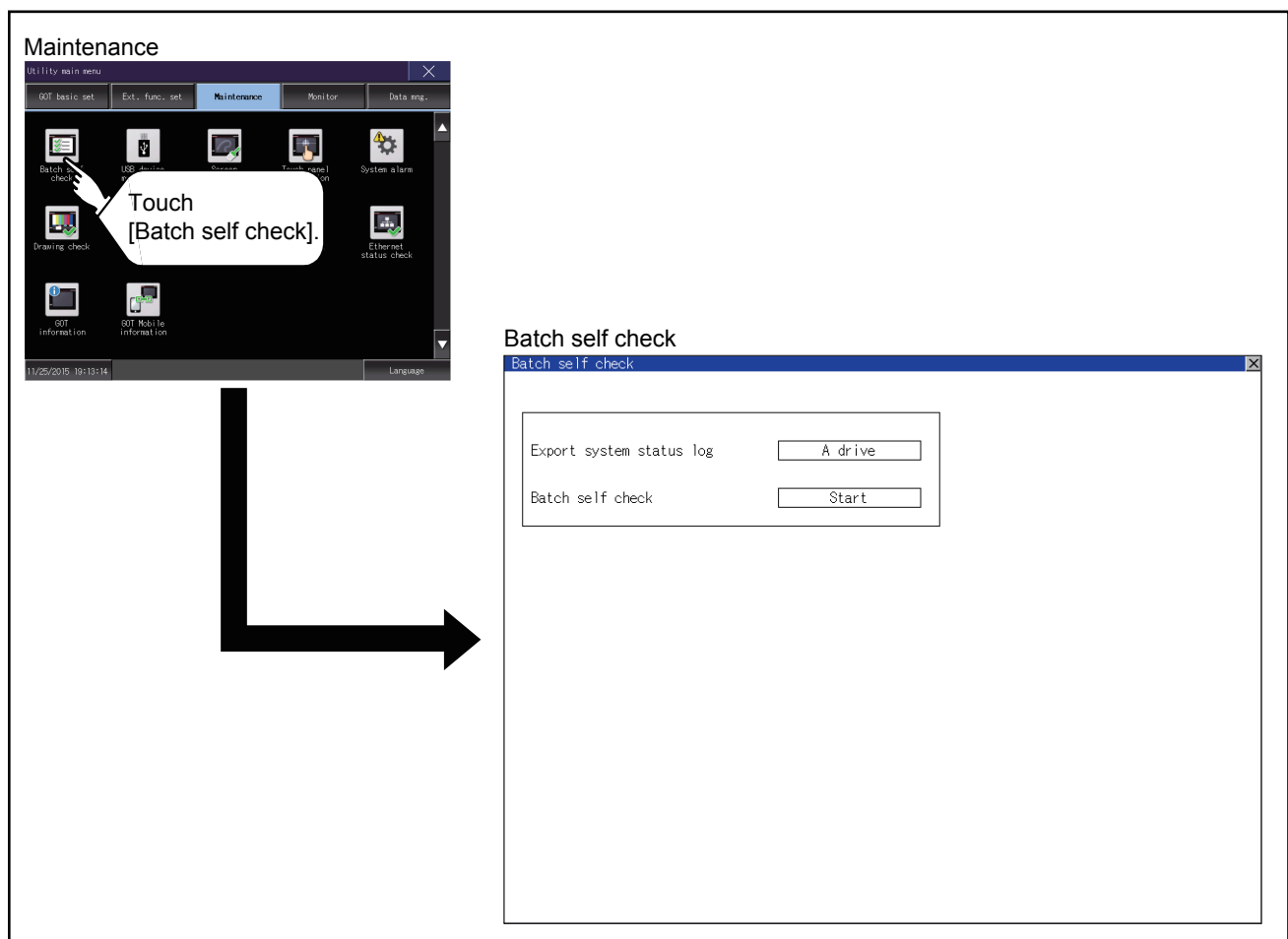

Operation of batch self check

Batch self check

1. Touch the selection of [Export system status log] to switch the set drive. Each touch changes the selection in the following order: [A drive] → [B drive] → [E drive] → [F drive] → [G drive] → [Not exported] → [A drive].

If you select drive A, insert an SD card into the drive. If you select drive B, drive E, drive F, or drive G, install a data storage on the drive.

If the batch self check is started with no SD card or data storage installed, the system status log is not saved.

(The system status log is for manufacturer investigation only. Customers cannot view it.)

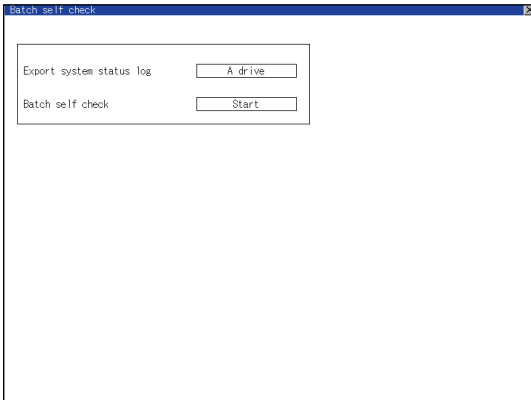

2. Touch the [Start] button to start Batch self check. Touch the [×] button to return to the main menu.

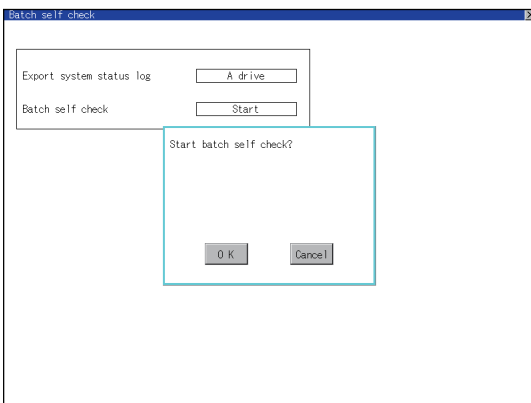

View self check results menu

After completion of Batch self check, the following screen is displayed.

Touch each item to display the details screen.

Touch the [Stop] button to return to the Batch self check screen.

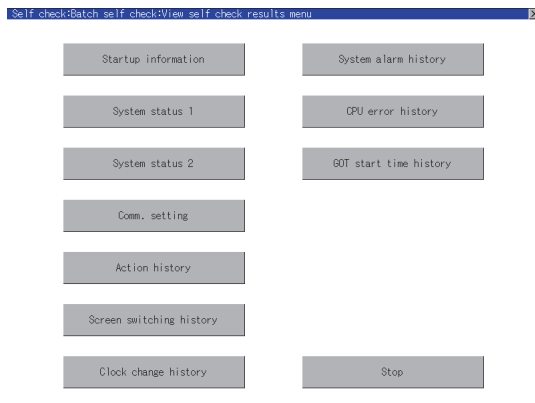

Display example of details screen

Touch the items to display the following screens.

Touch the [x] button to return to the View self check results menu.

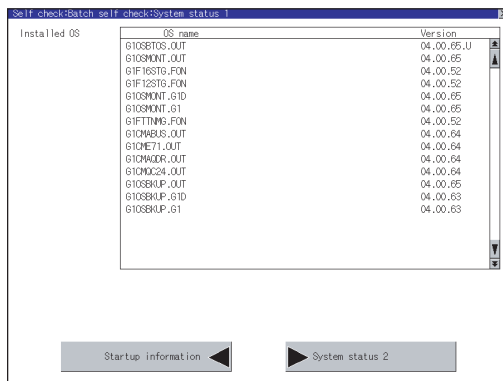

Touch the button in the left bottom of the screen to display the previous screen.

Touch the button in the right bottom of the screen to display the next screen.

4.2 USB Device Management

Function of the USB device management

This function displays a list of the USB peripheral device connection status in the GOT.
Also, this screen is used to remove the USB peripheral device from GOT.

Display operation of the USB device management

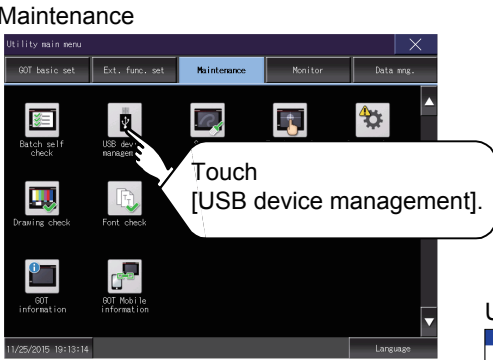

Maintenance

Utility main menu

GOT basic set Ext. func. set Maintenance Monitor Data mg.

Touch [USB device management].

11/25/2015 19:13:14 Language

USB device management

No.	Device	Vendor/product	Drive	Attach
1	USB mass storage	***** *****	B	Stop
2				
3				
4				
5	USB mouse			
6	USB keyboard	***** *****		
7				
8				

USB device status display operation

1. When a USB memory is installed, the [Stop] button is displayed in the [Attach] column. Touch the [Stop] button when removing the USB memory.

No.	Device	Vendor/product	Drive	Attach
1	USB mass storage	XXXXXXXXXXXXXXXXXXXX	B	Stop
2	USB mouse	XXXXXXXXXXXXXXXXXXXX		
3	USB keyboard	XXXXXXXXXXXXXXXXXXXX		
4				
5				
6				
7				
8				

2. Touch the [Stop] button in the [Attach] column to display the following dialog. Touch the [OK] button to remove the USB peripheral device. Touch the [Cancel] button to cancel removing the USB peripheral device.

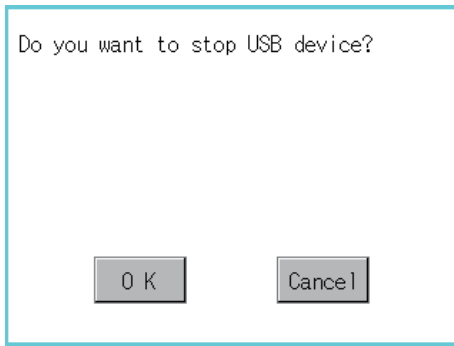

3. When the USB peripheral device is ready to be removed, the following dialog appears. Touch the [OK] button to close the dialog.



4.3 Screen Cleaning

Screen cleaning function

You can display the dedicated screen for cleaning the GOT.

The touch operation is disabled on the dedicated screen, and therefore wiping the GOT display section with a cloth or others does not operate the GOT.

For information on how to clean the GOT, refer to the following.

📖 GOT2000 Series User's Manual (Hardware)

Display operation of the screen for cleaning

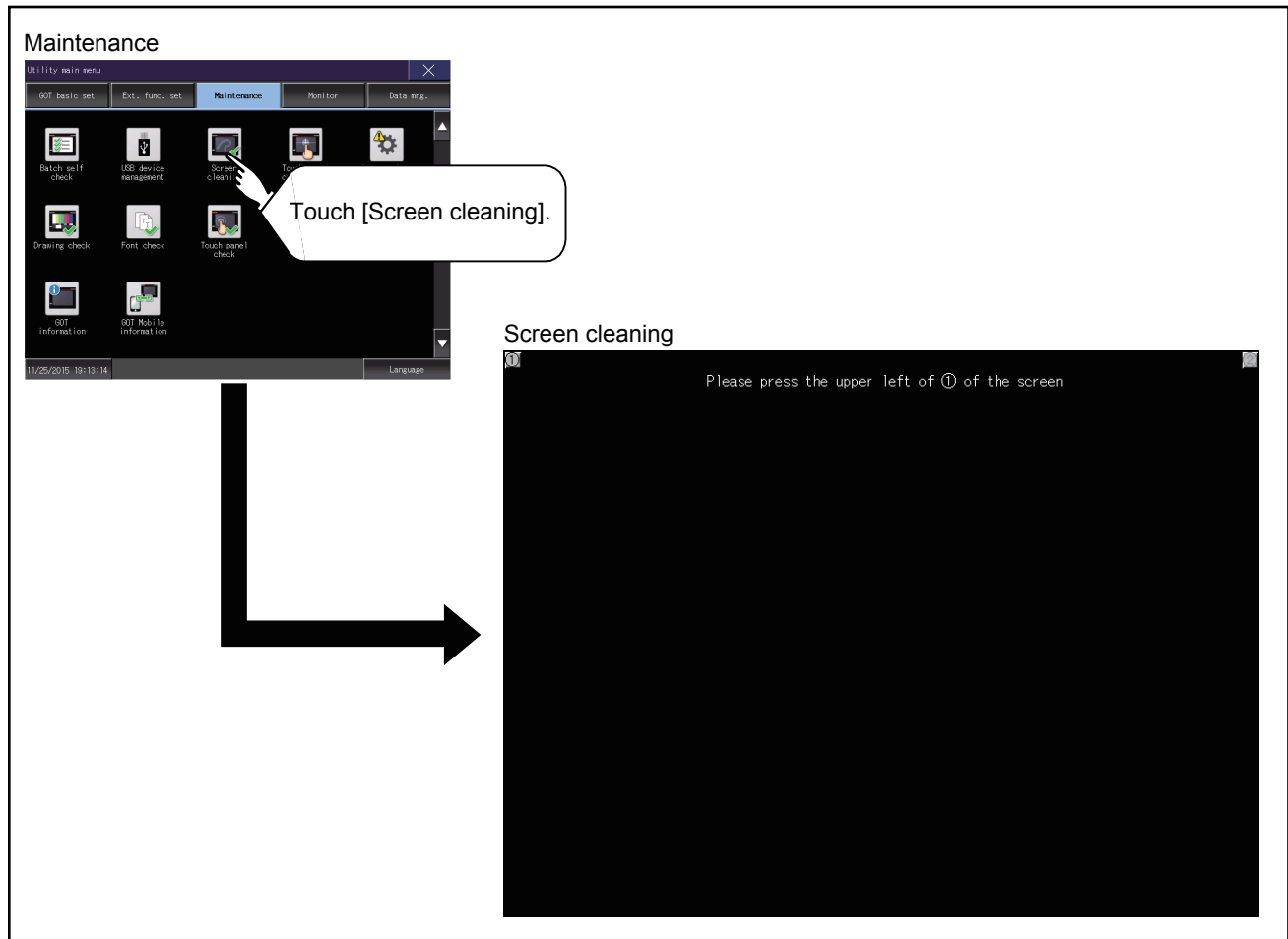

To switch to the utility screen, touch the upper-left corner and then the upper-right corner of the screen.

Operation of clean

After cleaning the screen, touch the screen following the instruction displayed.

After touching the screen, the screen returns to the Main Menu.

The following screen is displayed.



4.4 Touch Panel Calibration

Touch panel calibration setting

Touch panel reading error can be corrected.

Normally the adjustment is not required, however, the difference between a touched position and the object position may occur as the period of use elapses.

When any difference between a touched position and the object position occurs, correct the position with this function.

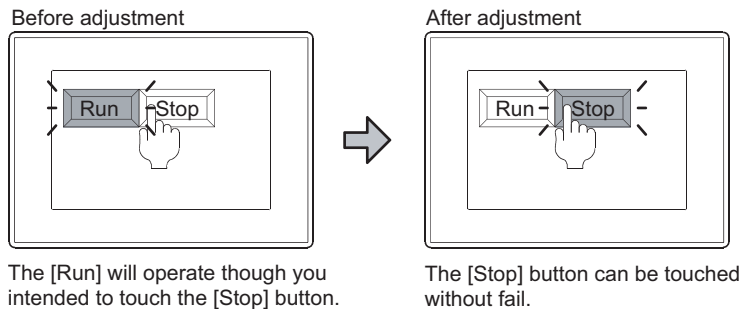

Display operation of the touch panel calibration setting

Maintenance
Utility main menu
GOT basic set, Ext. func. set, Maintenance, Monitor, Data mg.
Touch panel calibration, System alarm, I/O check, Ethernet status check, GOT information, GOT Mobile information
11/25/2015 19:13:14, Language

Example) For GT25
Touch panel calibration

Touch panel calibration

Press on the X mark to calibrate the touch panel.

Note) 1: The positions, where the finger is released, are coordinate setting points.
Note) 2: Calibration can be performed using 4 points being displayed.
Note) 3: Calibration is aborted when the process is left for 10 seconds.

1 / 4
Perform touch panel calibration.

Touch panel calibration operation

Touch the  point displayed on the screen with the finger one by one to make the setting.

Example) For GT25

1. Touch the center of the  displayed on the upper left precisely.



2. Touch the  point displayed on the upper right.



3. Touch the  point displayed on the lower right.

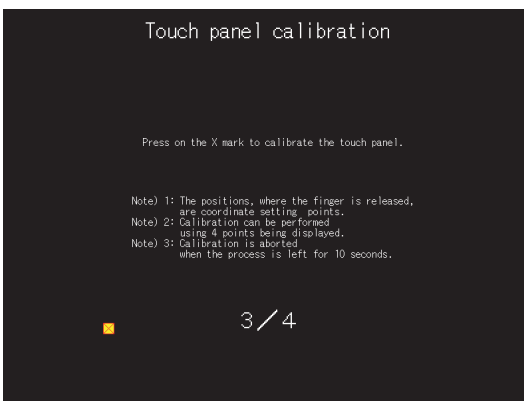

4. Touch the  point displayed on the lower right.



5. Touching the  button displayed on the upper right returns to the previous screen.

When the precise touch could not be made, touch the [Readjustment] button to make the setting from step1 again.

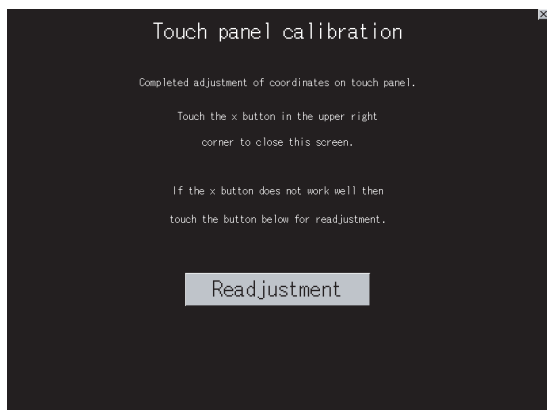

4.5 System Alarm

System alarm

The system alarm function displays the error code and error message when an error occurs in the GOT, GOT Mobile function client, network, or controller.

System alarms can be reset on the System alarm display screen.

For the details of the system alarm, refer to the following.

☞ Page 401 SYSTEM ALARM DISPLAY AND LIST

Display operation of system alarm

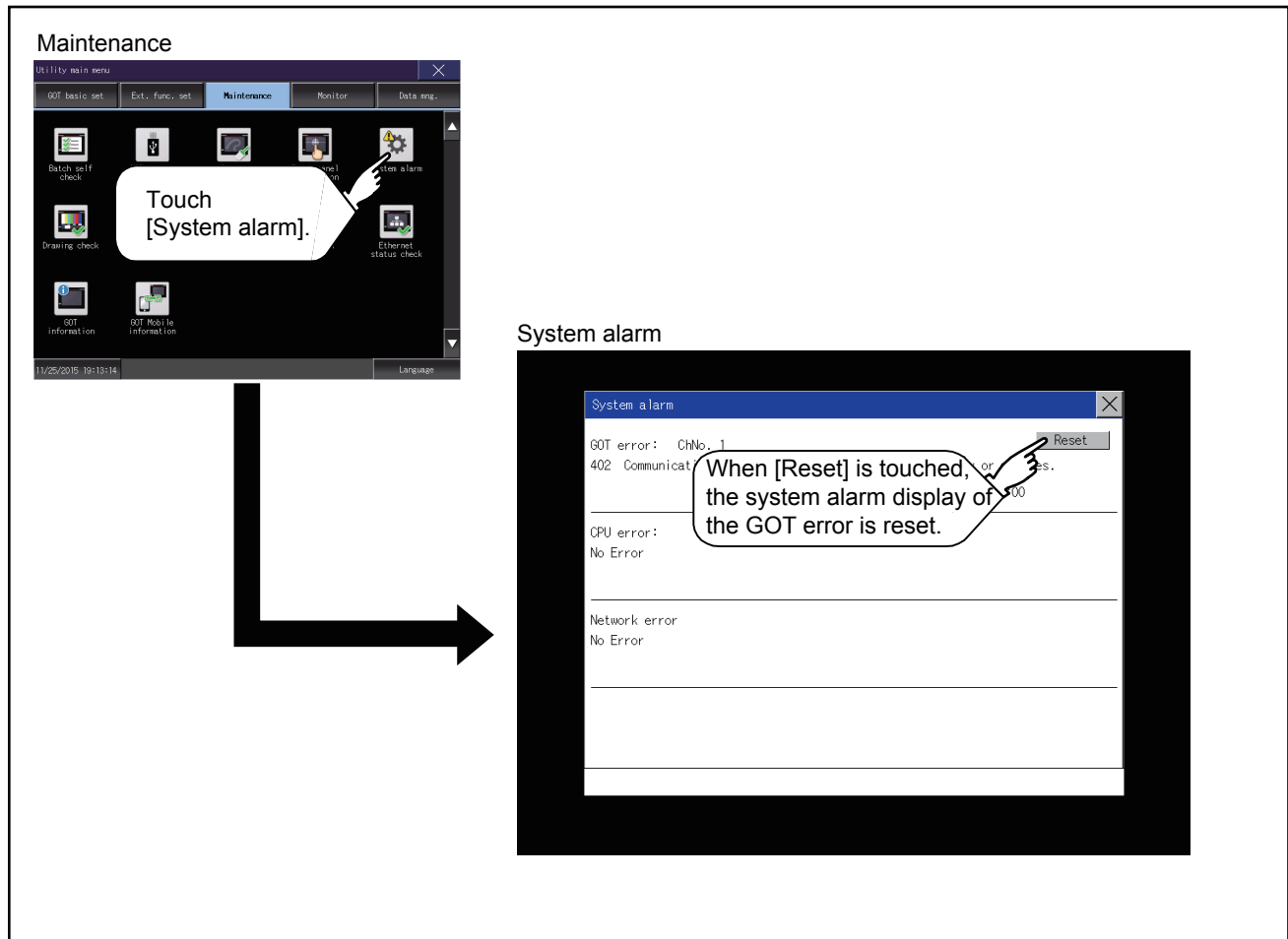

Operation of system alarm display

System alarm display resetting

1. Eliminate each cause of the system alarm being occurred.

Error causes can be identified by the error code, error message and channel No. displayed on the System alarm screen.

 GOT2000 Series User's Manual (Hardware)

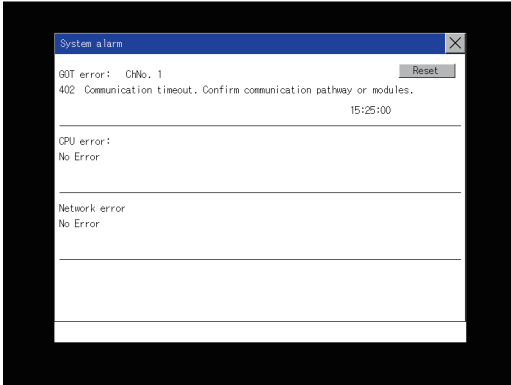

2. A method for resetting system alarm depends on an error.

- GOT error

Touch the [Reset] button to reset system alarms.

- CPU error and Network error

The system alarm is automatically reset after its cause is eliminated.

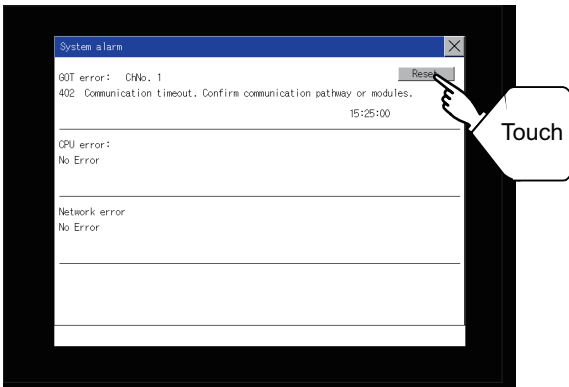

Point

- Before resetting the system alarm display in the GOT error

Eliminate the system alarm cause before resetting the system alarm display in the GOT error.

If not eliminated, the system alarm display in the GOT error will not be reset even after the reset operation.

- Displaying a GOT Mobile error

A GOT Mobile error is displayed as a GOT error.

- Processings with reset operation

The following data in the system information are also reset.

GOT error code (Write device)

GOT error detection signal (System Signal 2-1.b13)

4.6 Drawing Check

Drawing check function

The drawing check function carries out display checks as missing bit check, color check, basic figure display check, move check among screens.

Display operation of drawing check

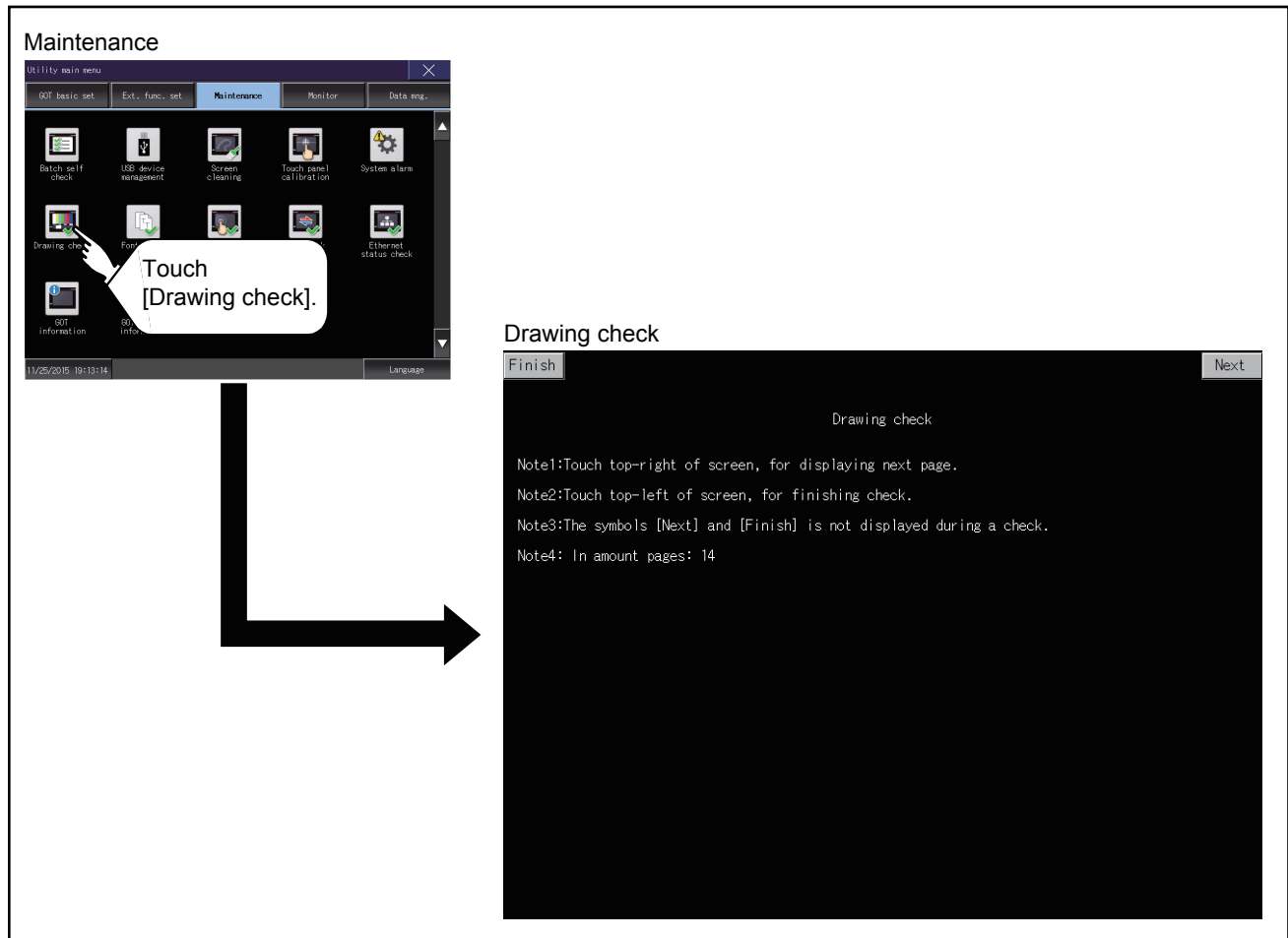

Point

Notes on drawing check

Missing bits is occurred in the following cases.

- There are parts drawn in different color with the filled color.
- There are basic figures or patterns which are not drawn according to the layout and procedure described in the following section.

☞ Page 228 Display operation of drawing check

When missing bits occurs, contact your local Mitsubishi (Electric System) Service.

Drawing check operation

Touch [Drawing check] to display the drawing check screen.

Before execute drawing check

Touching the upper right part of the screen proceeds to the next check in each step during drawing check.

Touching the upper left part of the screen returns to the [Display check] screen.

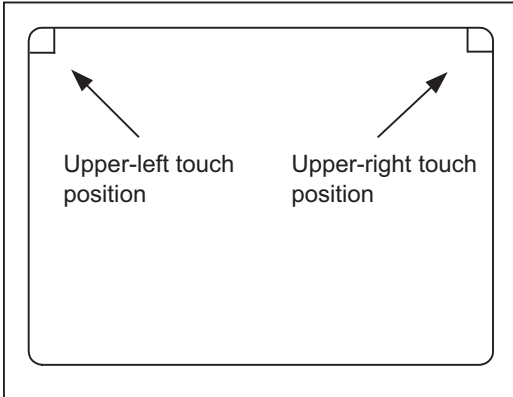

■Missing bit, Color Check

Each touch of the upper-right part of the screen, the entire screen color changes in the following order: blue, black, red, purple, green, light blue, yellow, white, and gray.

Check missing bit and color visually.

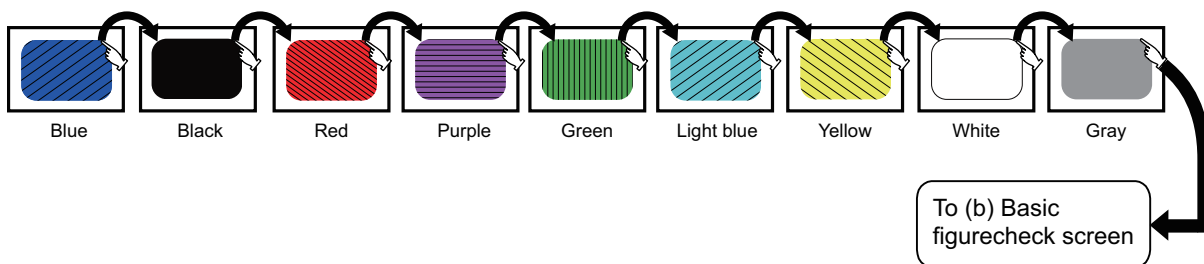

If touch the upper right part of the screen at the final color (white screen), the following 2) Basic figure check screen is displayed.

■Basic figure check

Check whether there is no shape transformation of basic figure or display losses.

The basic figure drawn has 4 types: 1. Filled circle, 2. Line, 3. Rectangle, 4. Ellipse.

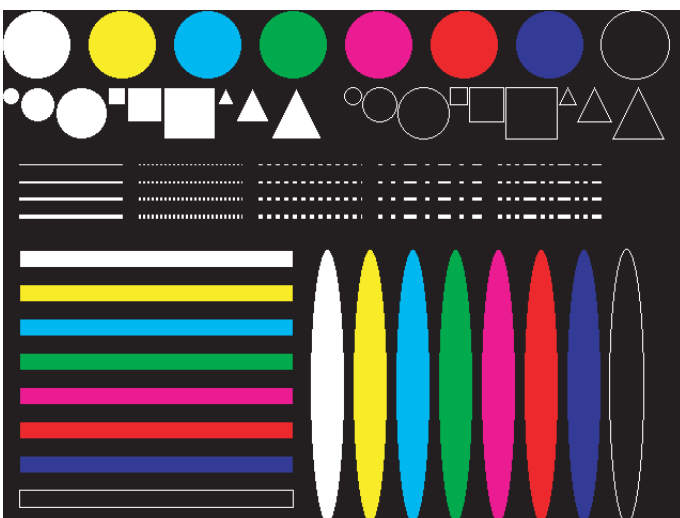

To Pattern 1 of (c) Move check among screen

■ Move check among screens

- Pattern 1: Shape transformation, color check

The drawn figures are displayed in order and at regular intervals.
If the shape and color are displayed visually in order, it is normal.

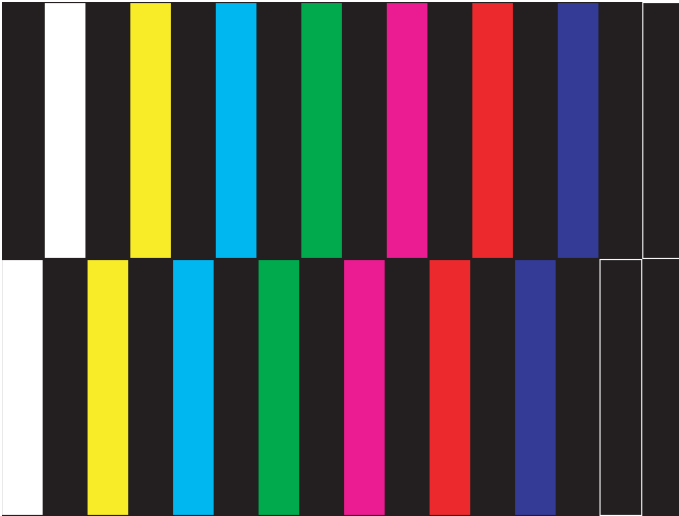

Pattern 1

- Pattern 2: Shape transformation, color check

The drawn figures are displayed in order and at regular intervals.
If the shape and color are displayed visually in order, it is normal.

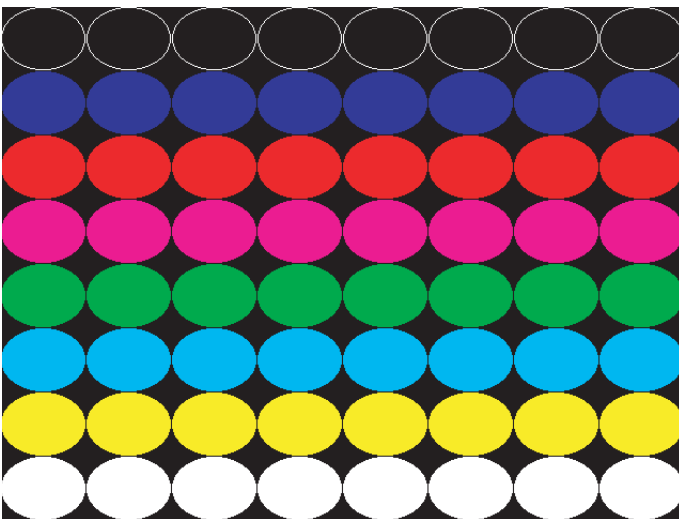

Pattern 2

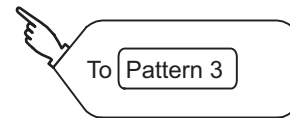
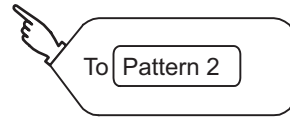

- Pattern 3: Shape transformation, color check

The overlapped shapes of pattern 1 and pattern 2 are displayed.
If the shape and color are displayed visually in order, it is normal.

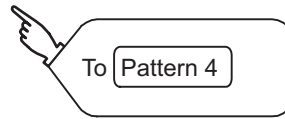
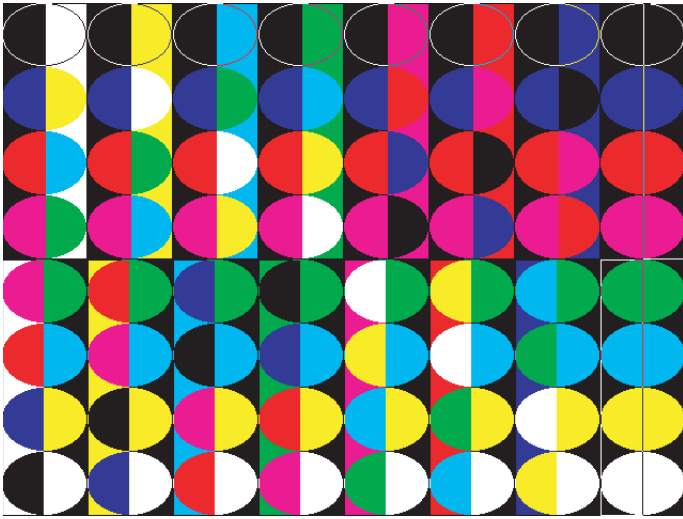

- Pattern 4: Shape check

The drawn figures are displayed in order and at regular intervals.
If the shape and color are displayed visually in order, it is normal.
If touch the upper right part of the screen, returns to [Display check] screen.

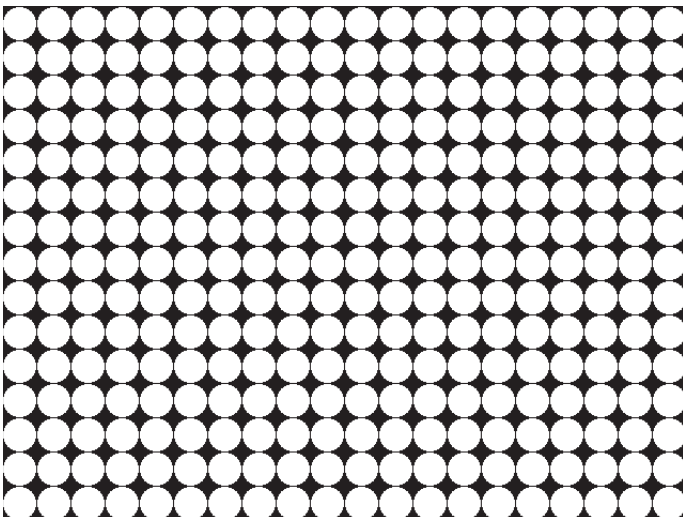

The main screen image after the screen information read and write is executed

4.7 Font Check

Font check function

The font check is a function which confirms fonts installed in GOT. The character data of the font is displayed on the upper left part of the screen one by one.

Display operation of Font check

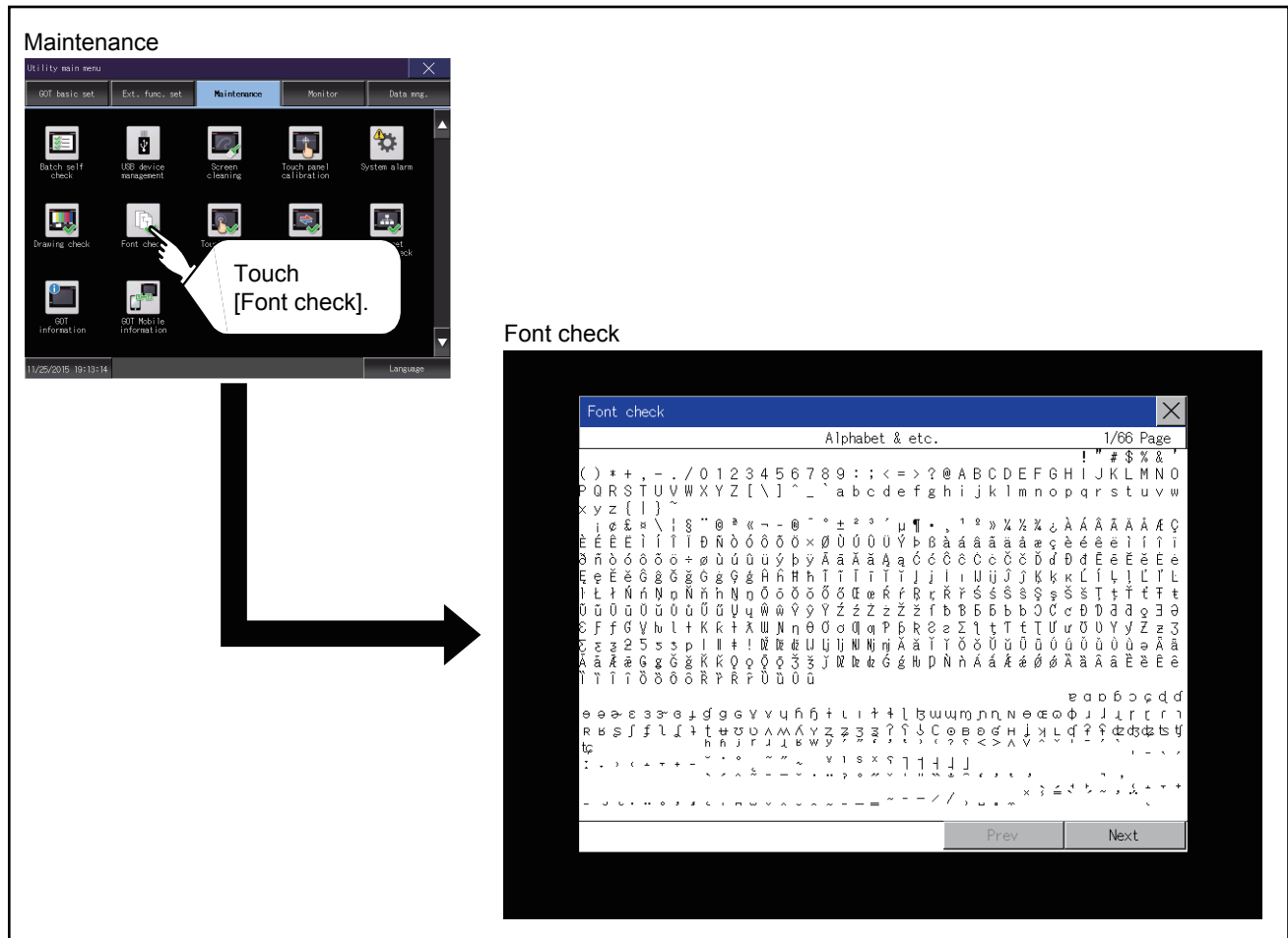

Point

Display operation of Font check

Judged as normal if the following characters are correctly displayed. (UNICODE)

- Alphabetic characters etc.: 0x0000 to 0x04F9 (From basic Latin to Kirill)
- Hangul characters: 0xAC00 to 0xD7A3 (Hangul/Hangul auxiliary)
- Kanji: 0x4E00 to 0x9FA5 (CJK integrated Kanjis)

If the characters above are not displayed correctly, the fonts may not be installed.

Install the system application again.

Font check operation

Touch [Font check] to start the font check.

The character data of the built-in font (in the built-in flash memory) can be checked visually to confirm the font drawings by displaying the character data serially on the screen.

Before executing the font check

To proceed to the next check in each step during the font check, touch the [Next] button at the bottom right of the screen.

To return to the [Display check] screen, touch the [Prev] button at the bottom right of the screen.

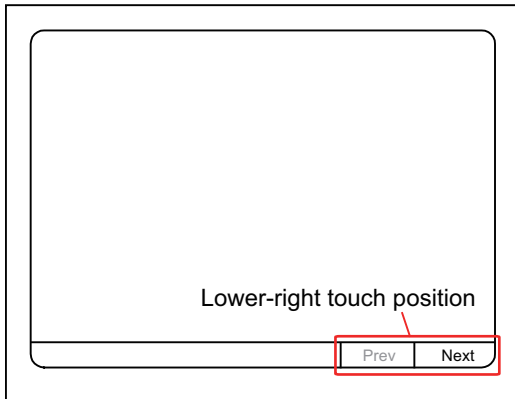

4.8 Touch Panel Check

Touch panel check function

Touch panel check is a function which checks whether there is no dead zone area in touch key minimum unit (16 dots × 16 dots).

Display operation of Touch panel check

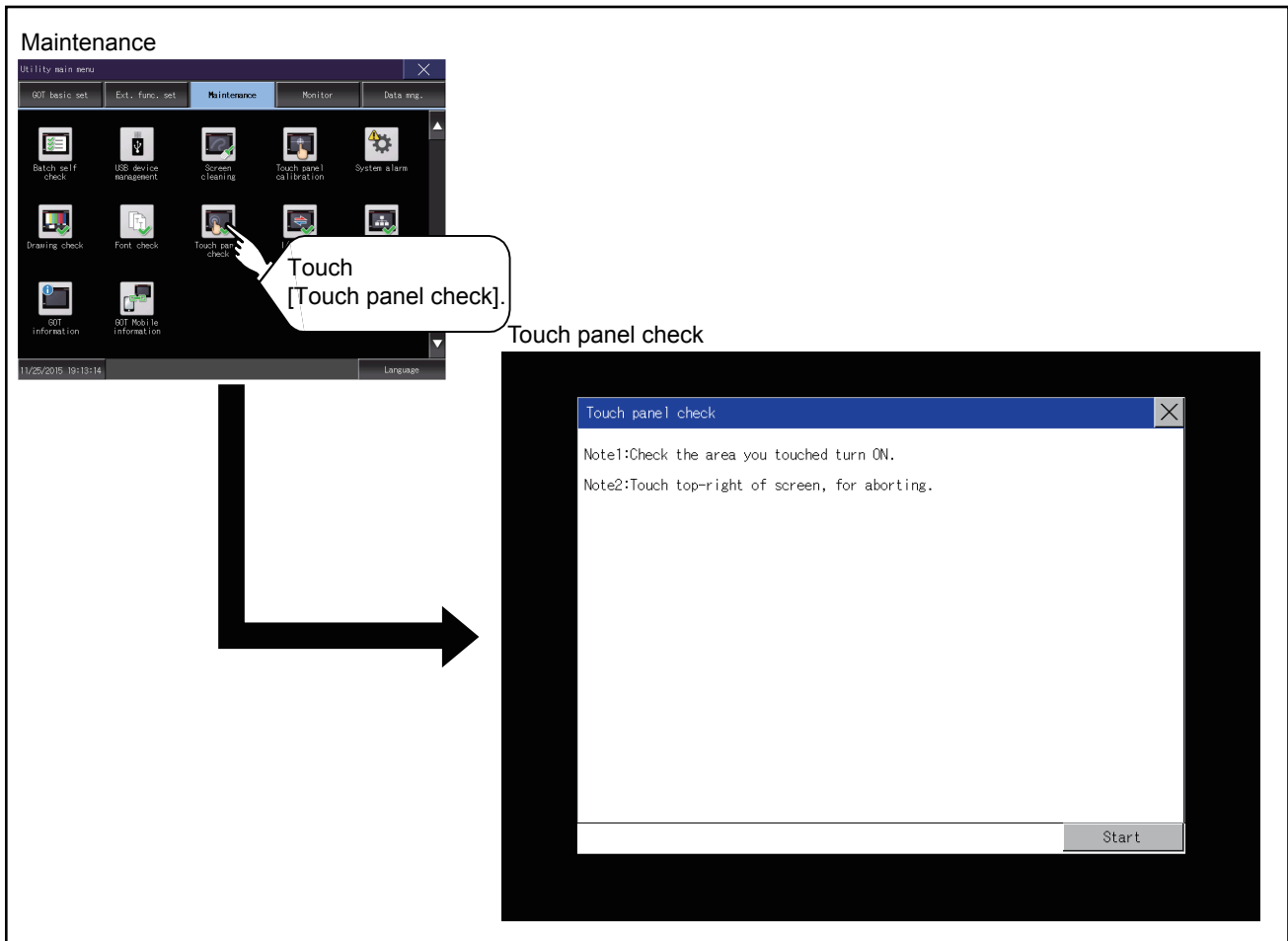

Point

Notes on Touch panel check

If the touched part is not filled with yellow color, there are the following two possible causes.

1. Display part failure
2. Touch panel failure

In that case, contact your local Mitsubishi (Electric System) Service.

Touch panel check operations

Touch [Touch panel check] to display the screen filled with black.

1. Touch a part of the screen.

The touched part becomes a yellow-filled display.

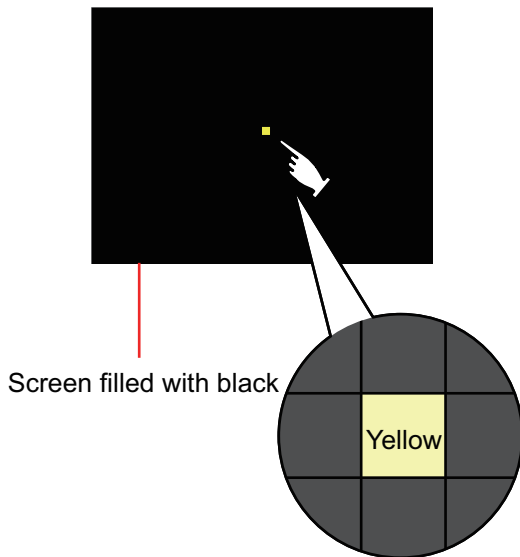

2. To return to the previous screen, touch the upper right part of the screen.

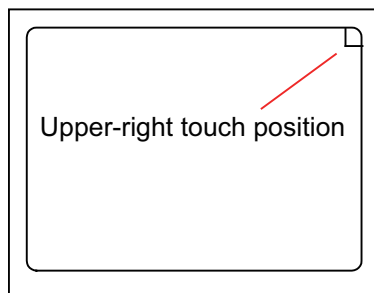

Point

Checking the upper right part of the screen

Only the upper right part of the screen cannot be filled with yellow.

If you can return to the previous screen by touching the upper right part of the screen, the part is judged to be normal.

4.9 I/O Check

I/O check function

The I/O check is a function which checks whether GOT and PLC can communicate with each other.

If I/O check ends normally, the communication interface and the connection cable hardwares are normal.

Before executing the I/O check, write the applicable communication driver from GT Designer3 to the GOT.

Note that the GOT restarts when this function is performed.

Refer to the following for the details related to the installation of the communication driver.

 GT Designer3 (GOT2000) Screen Design Manual

Communication drivers inapplicable to I/O check

When the following communication drivers are used, the I/O check cannot be executed.

Connection type	Communication driver	
Connection to MITSUBISHI ELECTRIC PLC	MELSECNET/H connection	MELSECNET/H
	MELSECNET/10 connection	MELSECNET/H
	CC-Link IE TSN connection	CC-Link IE TSN
	CC-Link IE Controller Network connection	CC-Link IE Controller Network
	CC-Link IE Field Network connection	CC-Link IE Field Network
	CC-Link connection (Intelligent device station)	CC-Link Ver.2(ID)
	Ethernet connection	Ethernet (MITSUBISHI ELECTRIC), Gateway Ethernet (FREQROL (Batch monitor)), Gateway
Connection to FUJI PLC	FUJI PXR/PXG/PXH	
Connection to YASKAWA PLC	YASKAWA GL YASKAWA CP9200(H) YASKAWA CP9300MS (MC compatible) YASKAWA MP2000/MP900/CP9200SH Ethernet (YASKAWA), gateway	
Connection to YOKOGAWA PLC	YOKOGAWA FA500/FA-M3/STARDOM Ethernet (YOKOGAWA), gateway YOKOGAWA GREEN/UT100/UT2000/UTAdvanced	
Connection to ALLEN-BRADLEY PLC	Ethernet(AB), Gateway	
Connection to SIEMENS PLC	SIEMENS S7-200 SIEMENS S7-300/400 Ethernet(SIEMENS S7), gateway	
Microcomputer connection	Microcomputer connection	
Inverter connection	FREQROL 500/700/800,SENSORLESS SERVO	
MODBUS/TCP connection	MODBUS/TCP Master, Gateway	
AZBIL control equipment connection	Azbil SDC/DMC	
Connection to RKC temperature controller	RKC SR Mini HG (MODBUS)	

Display operation of I/O Check

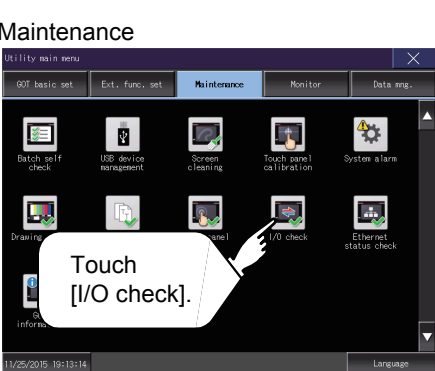

Maintenance

Utility main menu

GO! basic set Ext. func. set Maintenance Monitor Data mg.

Batch self check USB device management Screen cleaning Touch panel calibration System alarm

Drawing I/O check Ethernet status check

11/25/2015 19:13:14 Language

Touch [I/O check].

I/O check(For GT27)

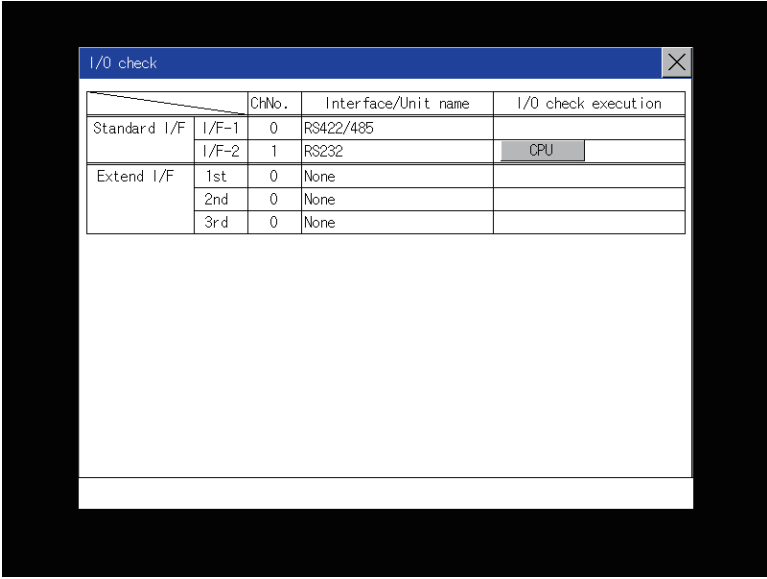

	ChNo.	Interface/Unit name	I/O check execution
Standard I/F	1/F-1	0 RS422/485	
	1/F-2	1 RS232	CPU
Extend I/F	1st	0 None	
	2nd	0 None	
	3rd	0 None	

I/O check operation

Connecting target confirmation

If touch [CPU] button, the connecting target confirmation communication check is carried out.

1. After the CPU communication starts normally, the dialog mentioned right notifying that it is on checking, until the connecting target confirmation communication ends normally.



2. When the connecting target confirmation communication ends, its result is notified by dialog.

If the connecting target confirmation communication ends normally, the dialog notifying of the normal termination mentioned right is displayed.

If touch [OK] button in the dialog after confirming the result, returns to [I/O check].



If the dialog mentioned right is displayed after selecting connecting target confirmation or during CPU communication check, confirm the following.



No misconnection with CPU

 GOT2000 Series Connection Manual for the controller used

No missettings of parameter

 Page 100 Controller contents

Check if the hardware has no problems.

 GOT2000 Series User's Manual (Hardware)

If touch [OK] button in the dialog after confirming the result, returns to [I/O check].

Self-loopback

If touch [Self], the hardware check of RS-232 interface is carried out.

1. For preparation for the self-loopback communication check, insert the connector for self-loopback check (Customer purchased) shown in the diagram right in the RS-232 interface.

For this connector, short 2 and 3 pins, 7 and 8 pins and 4 and 6 pins, respectively.

In the communication setting of the GOT utility, set the channel number for the RS-232 interface to 0 ([None]).

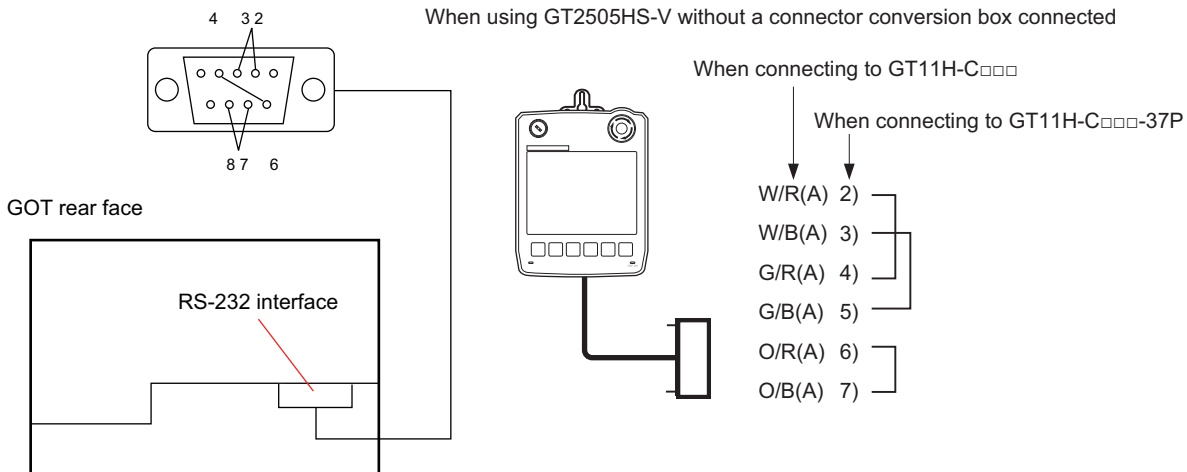

2. After selecting [Self], the transferred data and received data are verified through the self-loopback connector.

When the GOT cannot receive data during data transmission, the following dialog appears.



When this dialog appears, check the following.

- Check if the pins of the connector for self-loopback check are incorrectly shorted.
- Check if the channel number for the RS-232 interface is set to 0 ([None]) in the communication setting of the GOT utility.

☞ Page 100 Controller contents

- Check if the hardware has no problems.

📖 GOT2000 Series User's Manual (Hardware)

3. The following dialog is displayed during a check.

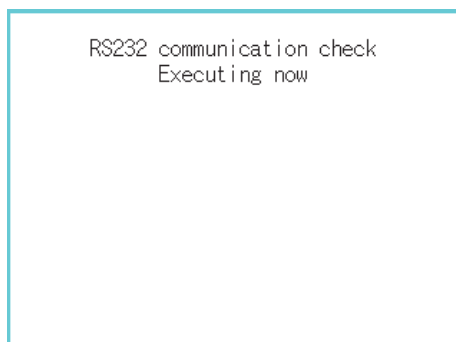

4. If the check is complete, the following dialog appears.



5. If an error occurs, a dialog appears notifying you of an abnormal termination and the byte in error.



When this dialog appears, check the following.

- Check if the hardware has no problems.

 GOT2000 Series User's Manual (Hardware)

4.10 Ethernet Status Check

Ethernet status check function

Ethernet status check is a function that sends a ping to check the connection status with the equipment on the Ethernet.

Display operation of Ethernet status check

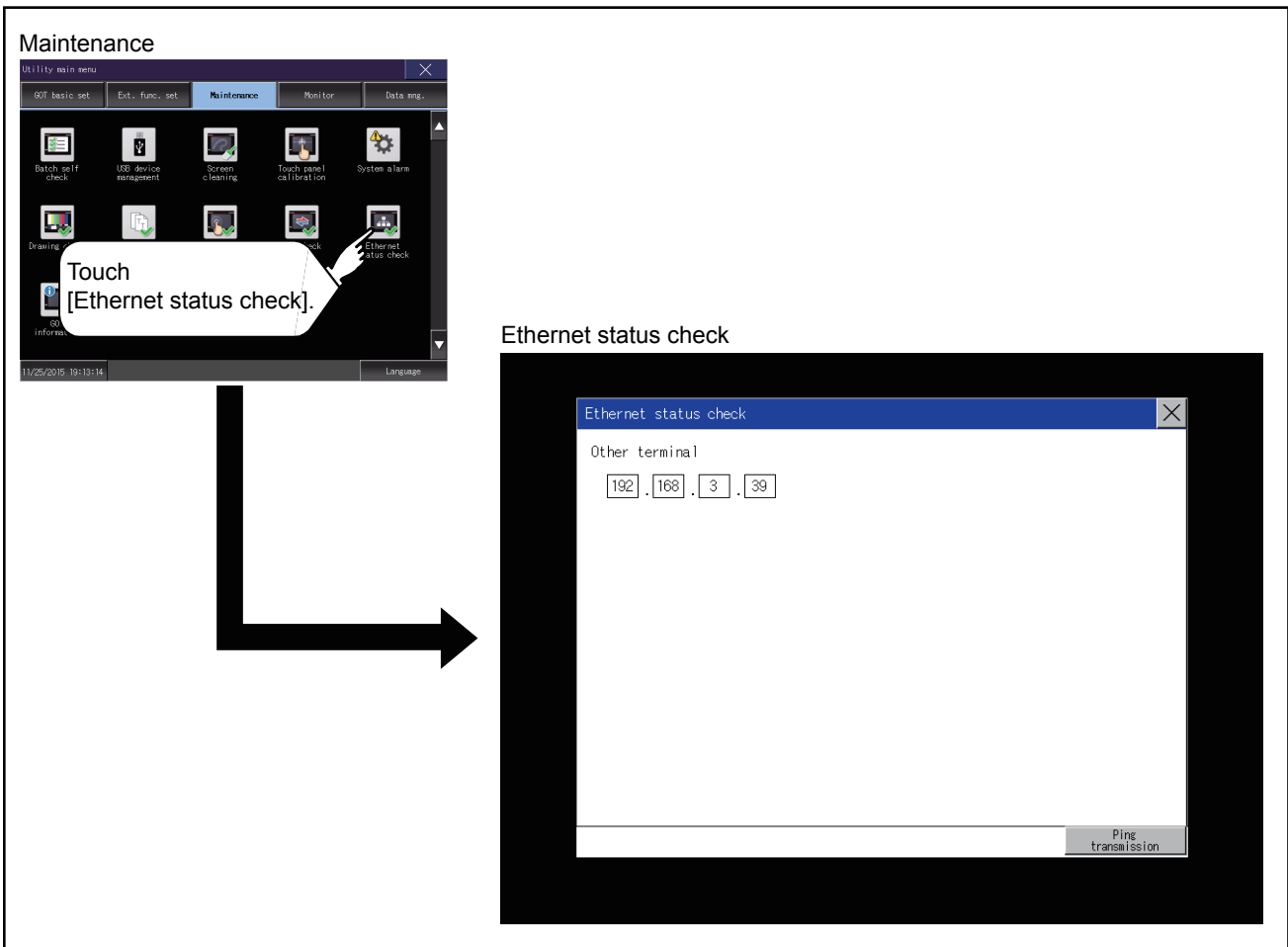

Operation of Ethernet status check

1. If touch the select button of [IP address of the other terminal], a keyboard is displayed.

Enter the IP address of the other terminal with the keyboard.

<Default: 192.168.3.39>

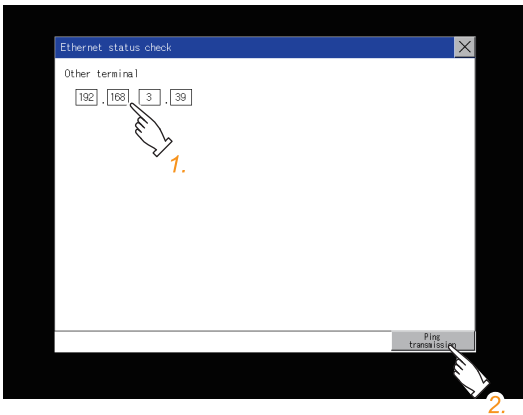

2. If touch the [Ping transmission] button, a ping is sent to the IP address entered in [IP address of the other station].

The result is displayed in the dialog.

The timeout time is about 5sec.

4.11 GOT Information

GOT information

This function displays the following contents of the GOT information.

- Serial number
- MAC address of the Ethernet interface built in the GOT
- MAC address of the Ethernet communication unit
- Hardware version
- Software version at factory default
- CoreOS version
- BootOS version

Display operation of GOT information

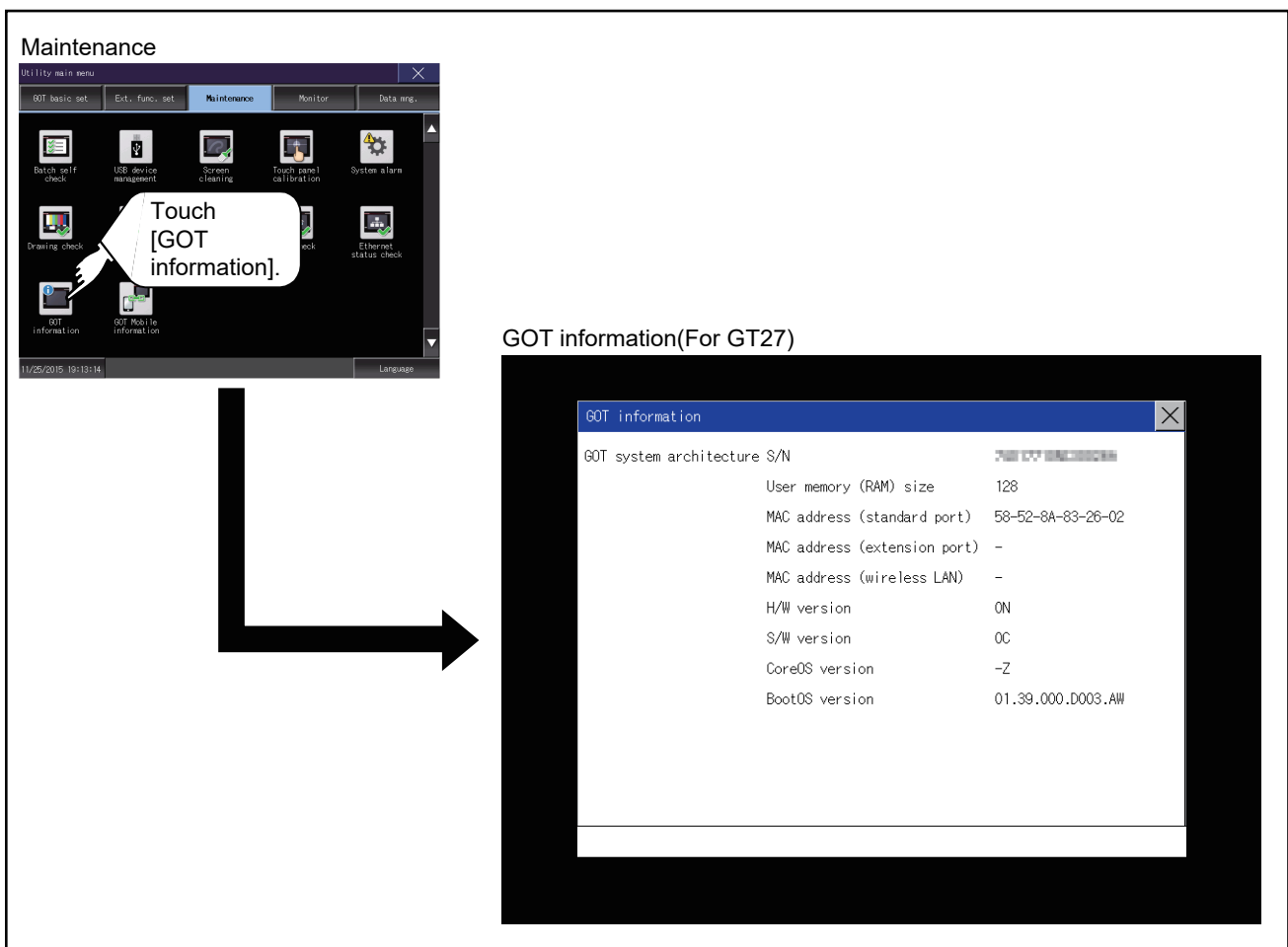

Display of GOT information

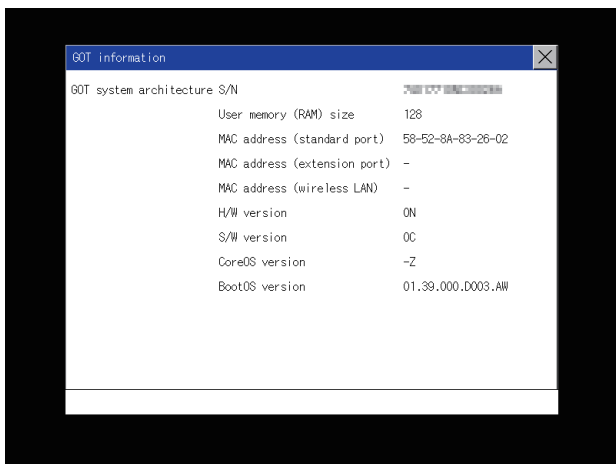

For the models other than GT25-W

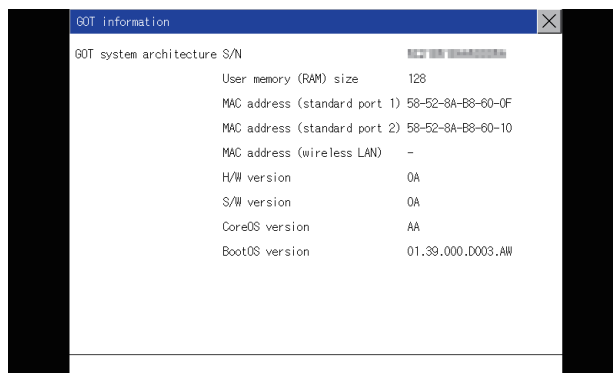

For GT25-W

Item	Description
S/N	Displays the serial number.
User memory (RAM) size	Displays the size of the user area in the built-in RAM of the GOT.
MAC address (standard port)	Displays the MAC address of the Ethernet interface built in the GOT.
MAC address (standard port 1)	
MAC address (standard port 2)	
MAC address (extension port)	Displays the MAC address of the Ethernet communication unit. Displays [-] when the Ethernet communication unit is not mounted.
MAC address (wireless LAN)	Displays the MAC address of the wireless LAN communication unit. Displays [-] when the wireless LAN communication unit is not mounted.
H/W version	Displays the H/W version.
S/W version	Displays the S/W version at factory shipment.
CoreOS version	Displays the CoreOS version.
BootOS version	Displays the BootOS version. 01.17.000.R001.-Z └─┬─┘ BootOS

4.12 GOT Mobile Information

GOT Mobile information

This function displays the GOT Mobile function settings and the list of clients being connected to the GOT.

For the GOT Mobile function settings, refer to the following.

 GT Designer3 (GOT2000) Screen Design Manual

Point

Precautions for remote control

To disconnect a client when operating the server of the GOT Mobile function, be sure to notify the operator of the client before the disconnection.

Not doing so may cause an accident.

Display operation of the GOT Mobile information

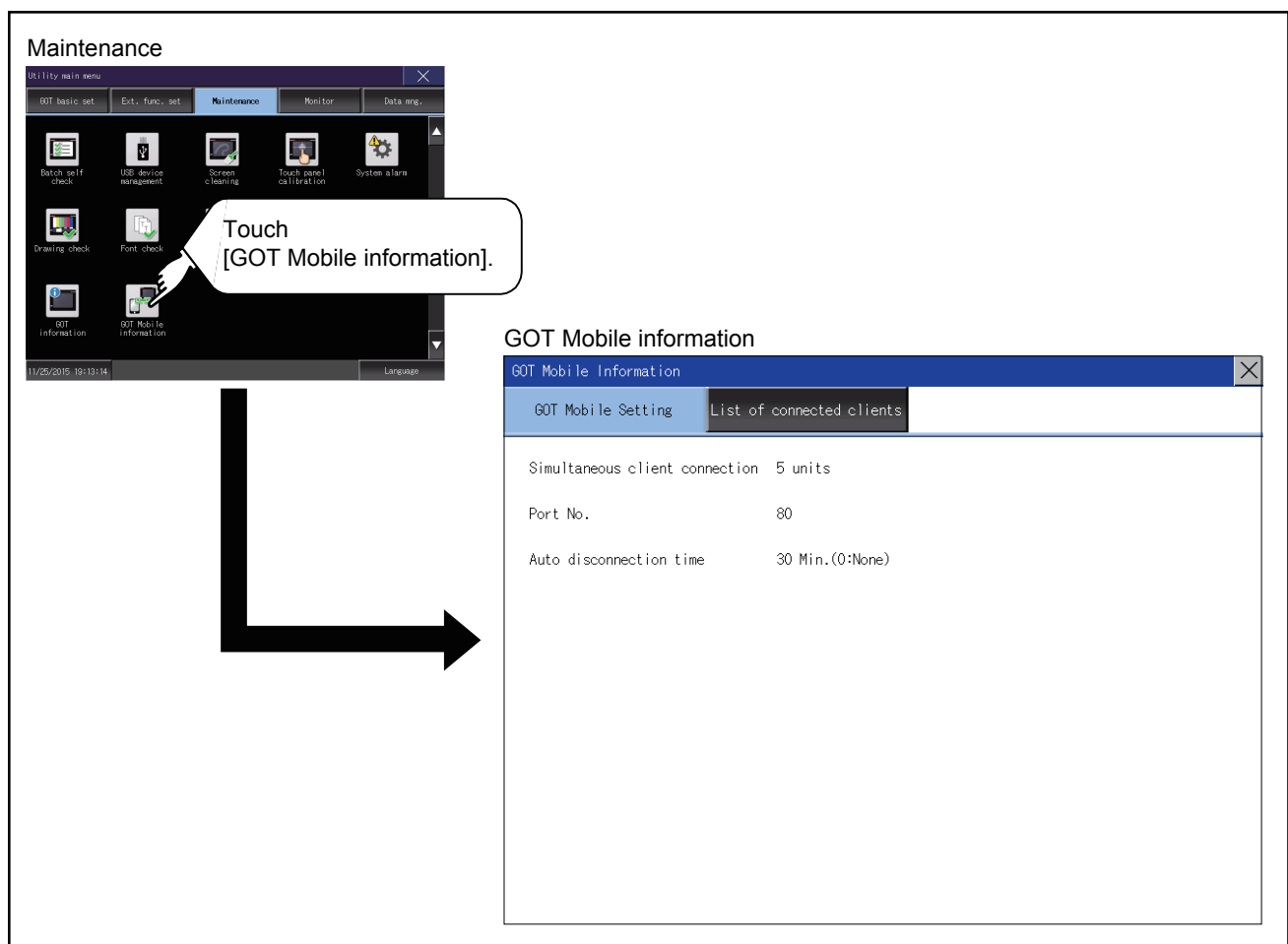

Displaying the GOT Mobile information

GOT Mobile information

You can check the GOT Mobile function settings.

To change the settings, refer to the following.

📖 GT Designer3 (GOT2000) Screen Design Manual

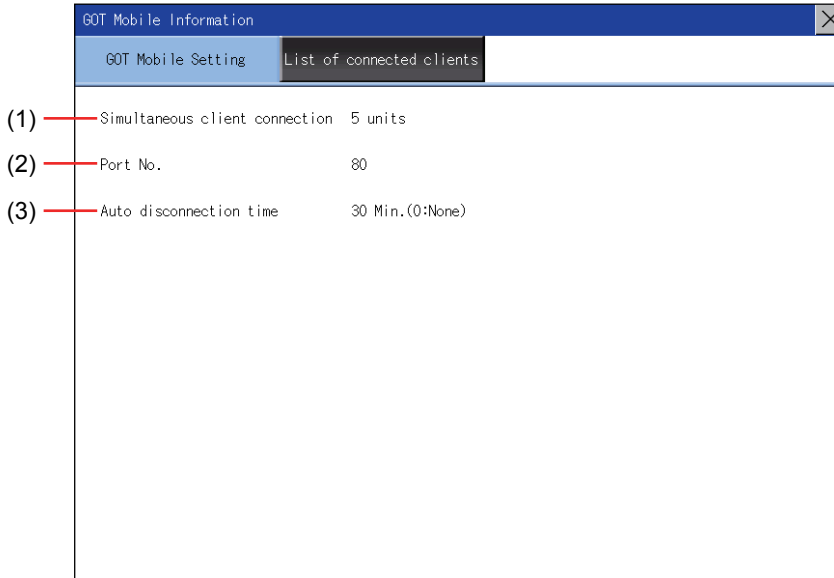

Item	Item	Description
(1)	[Simultaneous client connection]	Maximum number of clients connectable to the GOT simultaneously
(2)	[Port No.]	Port number of the GOT to which clients are connected
(3)	[Auto disconnection time]	Time period until a client is automatically disconnected from the GOT if no operation is performed on the client

List of connected clients

You can check the clients being connected to the GOT.

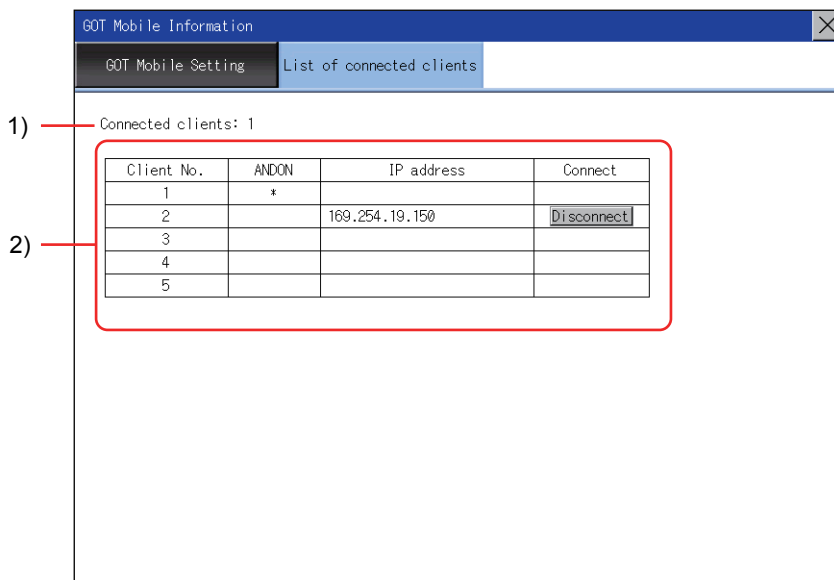

Item	Item	Description
1)	[Connected clients]	Number of clients being connected to the GOT
2)	IP address list	Displays the IP addresses of the clients being connected to the GOT. The IP address is displayed for each client number. A client using the ANDON connection is marked with an asterisk [*] in the [ANDON] column. To disconnect a client, touch the [Disconnect] button in the [Connect] column.

5 MONITOR

 Page 247 Monitor Screens

5.1 Monitor Screens

The monitor screens are designed to confirm the device status of PLC CPU and to make the response for PLC system trouble more efficient.

In this manual, the overview of the monitor screens and the operation procedure until displaying the screen are described.

For display contents and operation procedure of monitor screens, refer to the following manual.

 GOT2000 Series User's Manual (Monitor)

Function of monitor screens

The following shows the functions that can be performed with the monitor screens.

Item	Description
System launcher	Displays the menu for a module selected in the system configuration diagram, and launches a target application from the menu.
Device monitor	Monitors or tests the devices of a PLC CPU and the buffer memory of an intelligent function module.
Sequence program monitor (Ladder)	Monitors the program of a QCPU or LCPU in the ladder format.
Sequence program monitor (iQ-R ladder)	Monitors the program of an RCPU in the ladder format.
Sequence program monitor (iQ-F ladder)	Monitors the program of an FX5CPU in the ladder format.
FX ladder monitor	Monitors the program of a PLC CPU in the ladder format.
Network monitor	Monitors the status of the MELSECNET/H, MELSECNET(II), CC-Link IE TSN, CC-Link IE Controller Network, and CC-Link IE Field Network.
Intelligent module monitor	Monitors the buffer memory of an intelligent function module on a dedicated screen and the signal status of an I/O module. Data change is also available on the dedicated screen.
Servo amplifier monitor	Various monitor functions, parameter change, test operation, etc. of the servo amplifier are available.
Q motion monitor	The servo monitor and the parameter setting of the Motion CPU (Q series) are available.
R motion monitor	The servo monitor and the parameter setting of the Motion CPU (MELSEC iQ-R series) are available.
CNC monitor	The position display monitor, alarm diagnosis monitor, tool compensation parameter, and program monitor, and others, which are equivalent to the MELDAS dedicated display, are available.
CNC monitor 2	Monitors the information required for the operation, setup, diagnosis, and maintenance of the CNC C80 connected to the GOT. Setting and inputting or outputting the data of the CNC C80 are also available.
Sequence program monitor (SFC)	Monitors the program of a PLC CPU in the SFC diagram format (MELSAP3 or MELSAP-L format).
Q Motion SFC monitor	Monitors the motion SFC programs and device values in a Motion CPU (Q series) connected to the GOT.
R Motion SFC monitor	Monitors the motion SFC programs and device values in a Motion CPU (MELSEC iQ-R series) connected to the GOT.
Log viewer	Displays the logging data collected by a high speed data logger module, PLC CPU, or BOX data logger on the GOT, and manages files.
Network status display	Monitors the network status using a communication unit mounted on the GOT.
FX list editor	The sequence program of FXCPU can be list edited.
CNC machining program edit	Editing the machining program of the CNC connected to the GOT is available.
CNC data I/O	Copying, verifying, and deleting the machining programs, parameters, and others of the CNC connected to the GOT is available.
MELSEC-L troubleshooting	Displays the status of a LCPU and the buttons to call up the functions for troubleshooting.
iQSS utility	Monitors iQSS-compatible sensors. Parameter change is also available.
Drive recorder	Reads the data prior to and subsequent to an alarm from a connected servo amplifier, and displays the data (including motor current values and position commands) in waveform or list form on the GOT.
CC-Link IE diagnostics	Performs diagnostics and troubleshooting of the CC-Link IE TSN/CC-Link IE Field Network.
Motion program editor	Lists the motion programs of a Motion CPU (MELSEC iQ-R series). Editing the programs is available.
Motion program I/O	Copying or deleting the G-code programs of a Motion CPU (MELSEC iQ-R series) is available.
Servo amplifier graph	Reads the waveform data measured by a servo amplifier and displays the data in graph form.
Vision sensor monitor	Monitors and controls the vision sensor connected to the GOT.

Display operation of monitor screens

The image shows two screenshots from a software interface. The left screenshot is the 'Monitor' utility main menu, which has a dark background and several icons. A white callout bubble with a hand icon points to the 'Device monitor' icon, containing the text 'Touch the monitor function to be operated'. A large black arrow points from this menu to the right screenshot. The right screenshot is the 'Device monitor' screen, which has a dark green background. At the top, it says 'Device monitor' and '4 screens Quit'. Below that is a 'Selected' dropdown menu. A status bar at the top right shows 'ChNo.1 NetNo.0 St.No.0'. In the center, there is a small dialog box with a table of data:

ChNo	Comm. Driver
1	A/QnA/L/OCPU,L/QJ71C24

At the bottom of the 'Device monitor' screen, there is a row of buttons: Register, Delete, Delete all, Test, Layout, Change comment, Local monitor, and Connect.

MEMO

6 DATA CONTROL

- ☞ Page 252 Data Type and Storage Location
- ☞ Page 255 Alarm Information
- ☞ Page 262 Image File Management
- ☞ Page 269 Recipe Information
- ☞ Page 304 Logging Information
- ☞ Page 318 Operation Log Information
- ☞ Page 341 File Manager
- ☞ Page 356 File Print
- ☞ Page 363 Package Data Management
- ☞ Page 374 Backup/Restore Function
- ☞ Page 375 SRAM management
- ☞ Page 381 Memory Card Format
- ☞ Page 384 Memory Check
- ☞ Page 387 GOT Data Package Acquisition

A system application, project data (screen data), or alarm data which is written in the GOT or data storage can be displayed, and the data can be transferred between the GOT and data storage.

The format of the data storage is also possible.

System screen operation restriction function

The system screen operation restriction function is available to set the GOT special registers (GS) that restrict operation on the file management screen.

GOT special register (GS)	System screen that can be restricted
GS622.b0	<ul style="list-style-type: none"> • Alarm information • Image file management • Recipe information • Logging information • Operation log information • Memory card format
GS622.b1	<ul style="list-style-type: none"> • Package management • GOT data package acquisition
GS622.b2	<ul style="list-style-type: none"> • SRAM management
GS623.b0 to b6	<ul style="list-style-type: none"> • Alarm information • Image file management • Recipe information • Logging information • Operation log information • Memory card format
GS624.b0 to b6	<ul style="list-style-type: none"> • Alarm information • Image file management • Recipe information • Logging information • Operation log information • Memory card format

For details on the GOT special registers (GS), refer to the following.

📖 GT Designer3 (GOT2000) Screen Design Manual

6.1 Data Type and Storage Location

System

The data storage location and transferring (write/read) route for each data type are shown below. Also, the data storage locations are shown below.

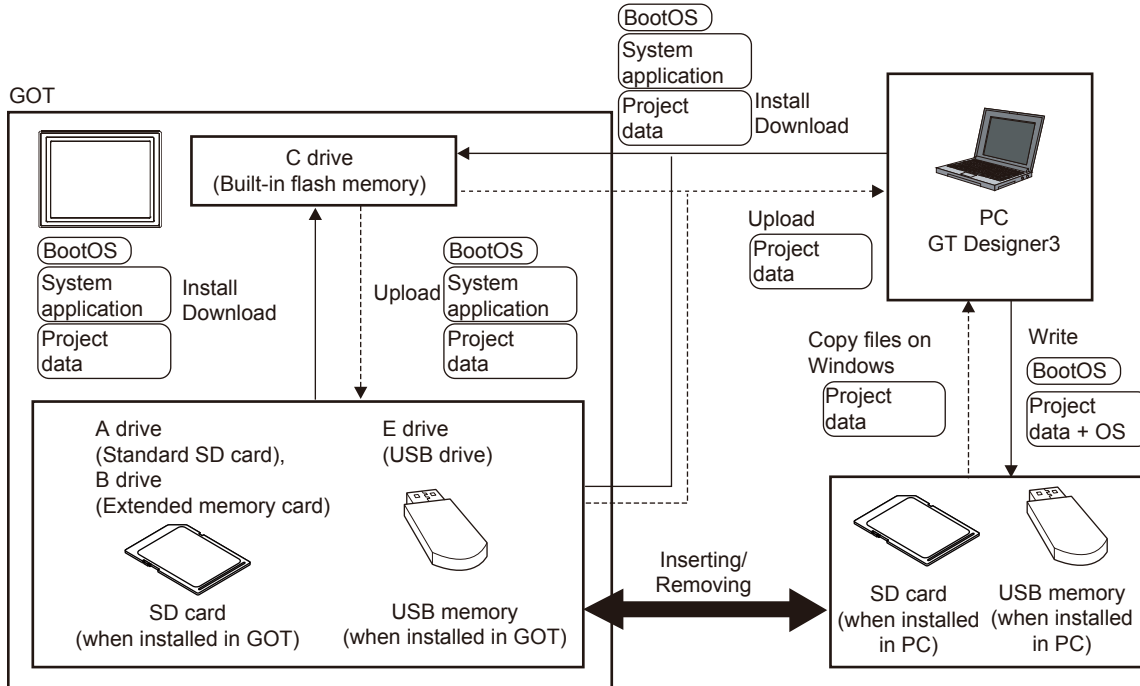

Item	Data type	Storage location
BootOS	BootOS	• Built in flash memory (C drive)
System application ^{*1}	Basic system application	• Built-in SD card (A drive)
	PLC communication driver	• Built in flash memory (C drive) ^{*2}
	System application (Extended function)	
Project data ^{*1}	Project data (Including recipe setting, alarm conditions, time action, and GOT setup.)	• Built-in SD card (A drive) ^{*2} • Built-in flash memory (C drive) ^{*2}

*1 The USB memory can be used from Utility.

☞ Page 396 Installing using the data control function (Utility)

*2 When using the project data stored in the Built-in SD card (A drive) with the GOT, hold the SD card installed to the GOT. For the USB memory, store the project data to the Built-in SD card (A drive) or built-in flash memory (C drive).

At maintenance

GOT

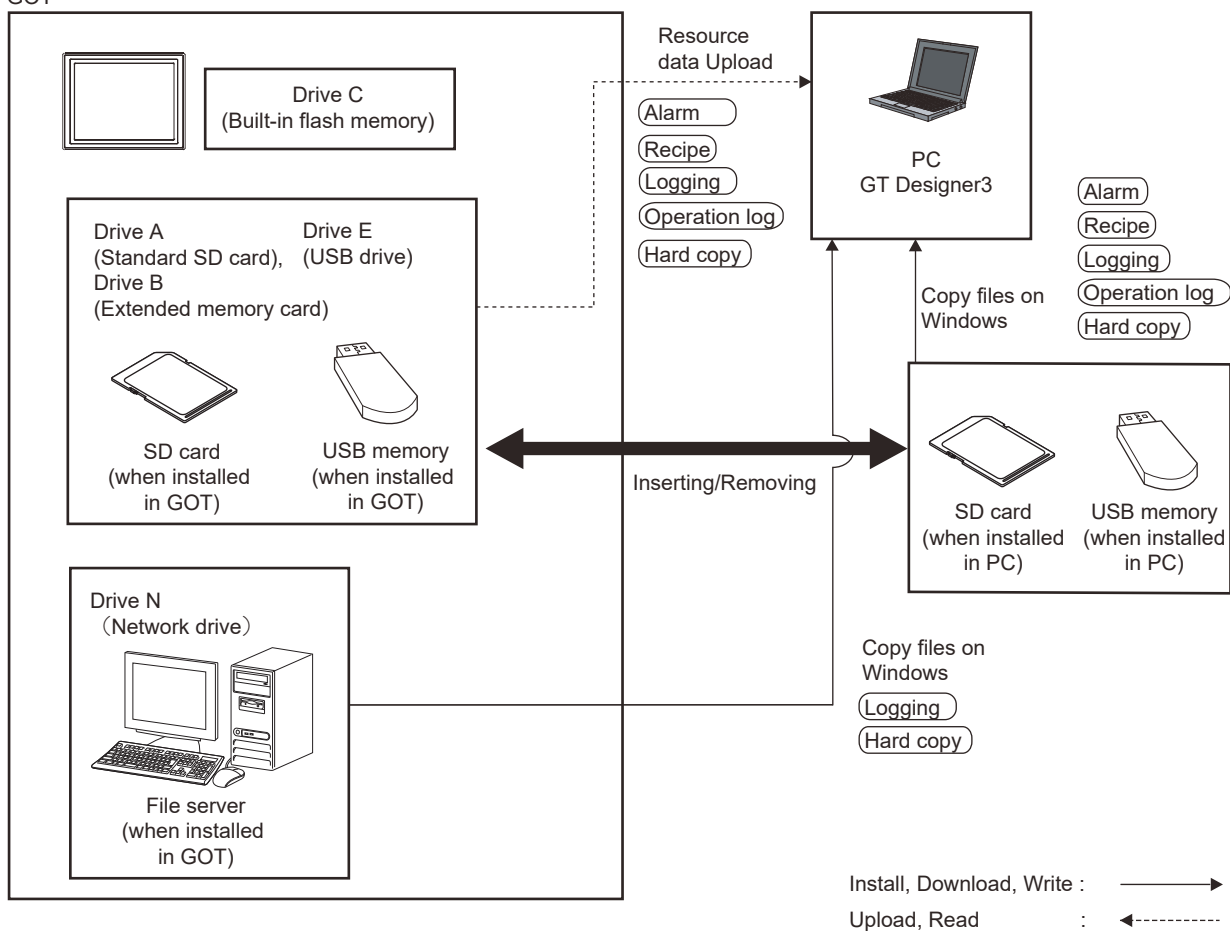

The data in the built-in flash memory (Project data, etc.) can be saved even if the battery voltage becomes low.

Item	Data type	Storage location
Alarm	Alarm log file	<ul style="list-style-type: none"> • Built-in SD card (drive A) • USB drive (drive B) *1 • USB drive (drive E) *1 • USB drive (drive F) *1 • USB drive (drive G) *1 • Network drive (drive N) *2
Recipe	Recipe file	
Logging	Logging file	
Operation Log	Operation log file	
Hard copy	BMP file, JPEG file, PDF file	

*1 The USB memory can be used from Utility.

Page 396 Installing using the data control function (Utility)

*2 Only available for the logging and hard copy functions.

OS version confirmation

Confirm the system application version carefully when installing the BootOS and basic system application.
When the system application is installed, the GOT checks and compares the system application version automatically.

■When install BootOS

When the BootOS to be installed has the older major version, GOT displays the installation disapproving message to cancel the installation so that the older version may not be written.

(Even when the version of the BootOS to be installed has the same or later version, the version information and the dialog box for selecting continue/not continue will be displayed.)

Depending on the installation method, the dialog to be displayed varies.

When installing from the Built-in SD card, the dialog is displayed by the main unit.

When installing from GT Designer3 via USB, RS-232, or Ethernet, the dialog is displayed by GT Designer3.

■When install basic system application, communication driver, or system application (Extended function)

When a basic system application, communication driver, or system application (Extended function) has already been installed, the version information of the system application which has been installed and the dialog for selecting whether to continue the installation or not will be displayed.

Moreover, when the different versions will coexist among all applications (basic system application, communication driver, and system application (Extended function)) by installing the system application, the installation disapproving dialog will be displayed and the installation process is canceled.

■When download project data

The GOT automatically compares the version between the project data to be downloaded and the installed system application.

When the versions are different, the dialog confirming whether to install the system application together is displayed.

When downloading the project data from a data storage, storing the project data and system application beforehand is recommended.

Point

Version confirmation of BootOS by rating plate

Confirm the version of BootOS installed in the GOT at product shipment by rating plate of GOT rear face.

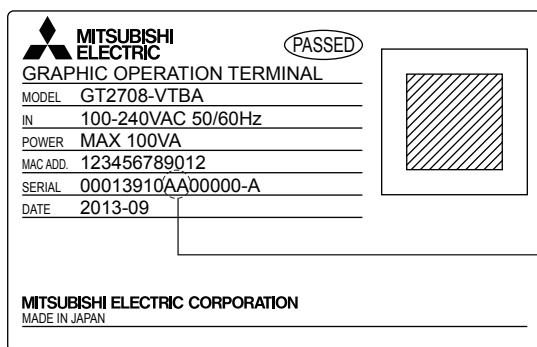

AA

BootOS version
(In case that the BootOS is two digits, only the first digit is written.)

Capacity confirmation of the project data downloading location

When download the project data, confirm the capacity of the user area in the drive to which transferred, the transferred project data size, the transfer size and buffering area size of the system application (Extended function) in advance to judge whether to carry out the download.

The capacities can be confirmed by GT Designer3.

Refer to the following for details.

📖 GT Designer3 (GOT2000) Screen Design Manual

6.2 Alarm Information

Function of alarm information

This function displays the alarm log file stored in each drive (A: Standard SD card, B: USB drive, E: USB drive, F: USB drive, G: USB drive).

The functions below can be carried out for files.

The USB drive only stores log files, and cannot be displayed.

For details on the alarms, refer to the following.

GT Designer3 (GOT2000) Screen Design Manual

Function	Description	Reference
Information display of files and folders	Displays name, data size, creation date and time of file or folder.	Page 256 The display example of alarm information, Page 257 Alarm information operation
G2A → CSV conversion	Converts the G2A file of an advanced alarm log file to a CSV file.	Page 258 G2A → CSV conversion operation, G2A → TXT conversion operation
G2A → TXT conversion	Converts the G2A file of an advanced alarm log file to a Unicode text file.	Page 258 G2A → CSV conversion operation, G2A → TXT conversion operation
Deletion	Deletes the file.	Page 259 Deletion operation
Copy	Copies the file.	Page 260 Copy operation

The display operation of alarm information

Data management

Utility main menu
GOT basic set | Ext. func. set | Maintenance | Monitor | **Data mg.**

Touch [Alarm information].

Alarm information

Select drive: A:\PACKAGE1\

Kind	Name	Size	Date	Time
DIR	..			
DIR	OPEL.LOG		08-02-18	16:17
DIR	REPORT		07-02-18	20:33
<input checked="" type="checkbox"/>	G2A_AAM00001	0.2kB	08-02-18	19:04

Free space: 3.6GB
Drive capacity: 3.7GB

1 files are selected (0.2kB in total)
Number of selectable files in this folder: 1 files

Buttons: Select all files, G2A→CSV, G2A→TXT, Cancel selection, Copy, Move, Rename, CreateFolder, Del

The display example of alarm information

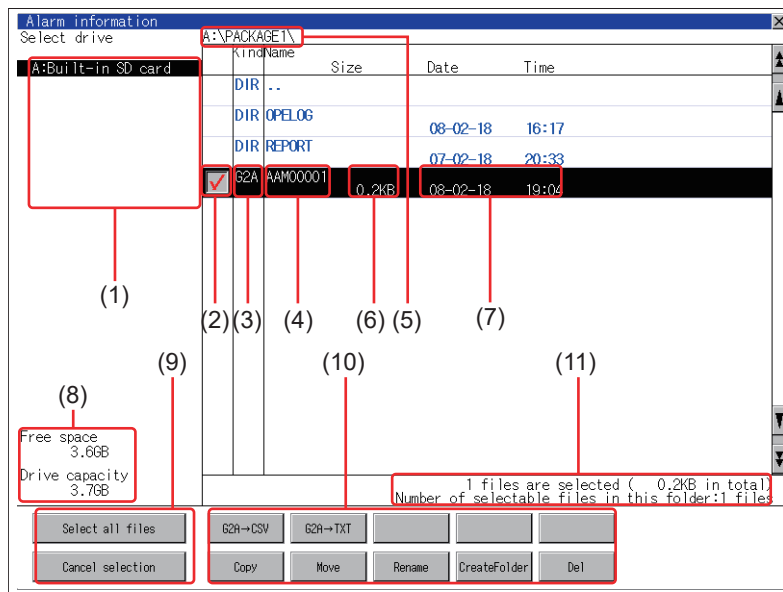

Number	Item	Description
(1)	Select drive	Select a drive to display files or folders. When a USB memory is installed in a drive, the drive is displayed. • SD card: [A: Built-in SD card] • USB memory: [B: USB Drive], [E: USB Drive], [F: USB Drive], and [G: USB Drive]
(2)	Check box	If the check box is selected, up to 512 files can be selected.
(3)	Kind	Indicates whether the displayed name is file or folder. Displays the extension for a file and "DIR" for a folder.
(4)	Name	Displays the file name or folder name. For the long file/folder name, entire part may not be displayed. Confirm the non-displayed part with the [Copy] button, etc. ☞ Page 260 Copy operation After confirmation, touch the [Cancel] button to cancel the operation.
(5)	Path name	Displays the path name of drive /folder which is currently displayed.
(6)	Size	Displays the size of the file displayed in Name.
(7)	Date and time	Displays the creation date and time of each file.
(8)	The size of drive	Displays the size of free area and the entire size of the drive which is selected by drive selection.
(9)	Select all files/Cancel selection	Multiple files can be selected or canceled at once. Touch the [Select all files] button to select all files. If the number of the displayed files exceeds 513, the first 512 files are selected.
(10)	Operation switch	Execution switch of each function.
(11)	Number and size of files	Displays the number of the selected files, the total file size, and the selectable number of files in the folder.

Point

Display of creation date and time

The creation date and time display is not updated even if a file is created or updated while displaying the alarm information display screen.

If close the screen currently displayed (moving the screen to the folder of the upper hierarchy, etc.) and display the screen again, the updated contents are displayed.

Alarm information operation

The display operation of alarm information

1. If touch a drive of [Select drive], the information of the touched drive is displayed.

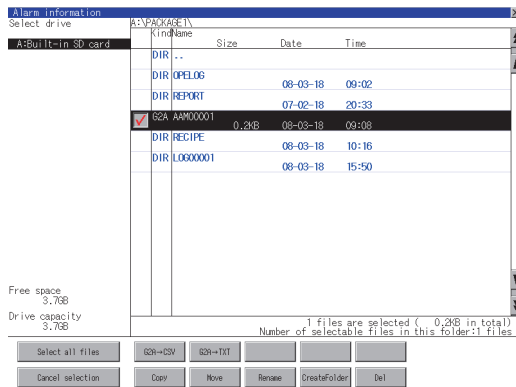

2. If touch a folder name, the information of the touched folder is displayed.
3. If touch a folder of ". .", the information of the folder of the one upper hierarchy is displayed.
4. If touch the button of the scrollbar, the screen scrolls up/down by one line.
If touch the button, the screen scrolls up/down by one screen.
5. Touch the check box to select the file.
6. For operations of G2A → CSV conversion, G2A → TXT conversion, deletion, and copy, refer to the following.
G2A → CSV, G2A → TXT
 Page 258 G2A → CSV conversion operation, G2A → TXT conversion operation
Delete
 Page 259 Deletion operation
Copy
 Page 260 Copy operation
7. If touch the [x] button, the screen is closed.

G2A → CSV conversion operation, G2A → TXT conversion operation

The selected G2A file is converted to a CSV file or Unicode text file.

1. Touch the check box of the G2A file which is to be converted to a CSV file or Unicode text file to select the file.
2. The following dialog box is displayed when touching the following button according to the file type to convert to.
 - CSV file: [G2A → CSV] button
 - Unicode text file: [G2A→TXT] button

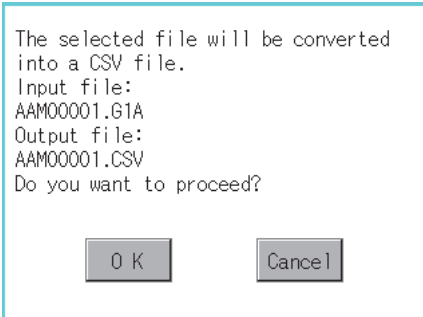

3. Touch the [OK] button.

When the file, whose name is the same, exists in the destination folder, the dialog box showed below appears without starting the conversion.

To overwrite the file, touch the [OK] button.

To cancel the conversion, touch the [Cancel] button.

(Example: Dialog box when the [G2A → CSV] button is touched)

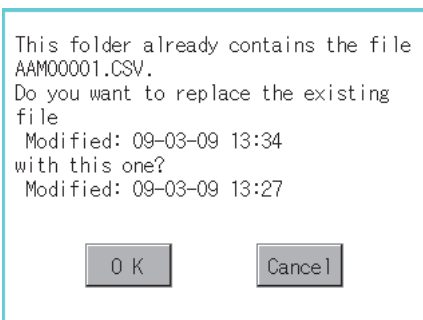

4. The message of completion is displayed in dialog box when conversion is completed.

To close the dialog box, touch the [OK] button.

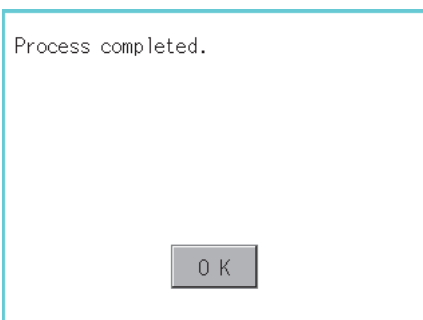

Deletion operation

Deletes the selected file.

1. Touch the check box of the file to delete to select the file.
2. If touch the [Del] button, the dialog box mentioned below is displayed.
If touch the [OK] button, the file is deleted.
If touch the [Cancel] button, the deletion is canceled.

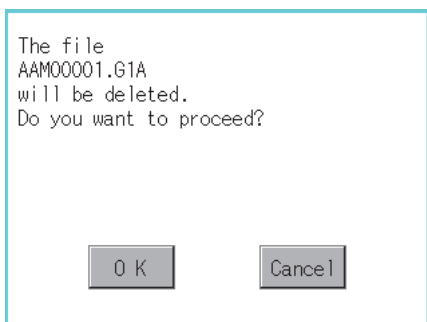

3. When the deletion is completed, the completion dialog box is displayed.
To close the dialog box, touch the [OK] button.

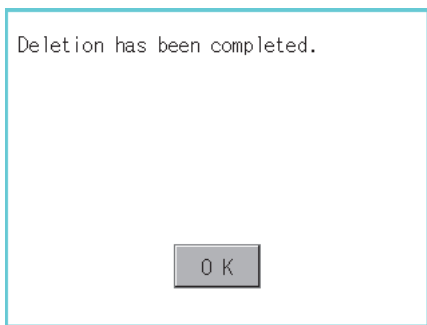

Copy operation

Copies the selected file.

1. Touch the check box of the file to copy to select the file.
2. If touch the [Copy] button, the message [Please select a destination.] is displayed in the following bottom of the screen.

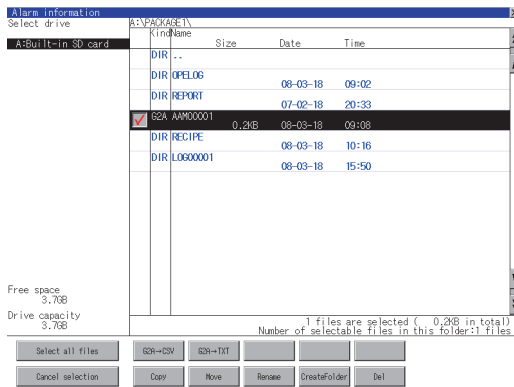

3. If the copy destination folder is touched, the screen display is changed to the folder of copy destination. At this time, it cannot be copied into the same folder where the file exists. Select other folders.
4. If touch the [Exec] button, the dialog box mentioned below is displayed.

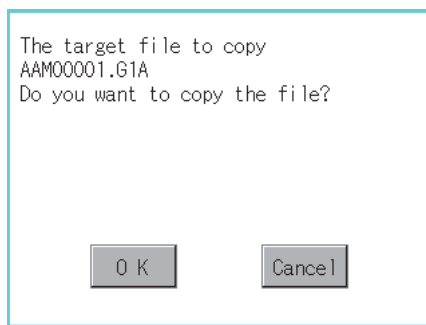

5. Touch the [OK] button. If there is a file of the same name in the copy destination folder, the following dialog is displayed without starting the copy. If touch the [OK] button, overwrites the file. If touch the [Cancel] button, cancels to copy.

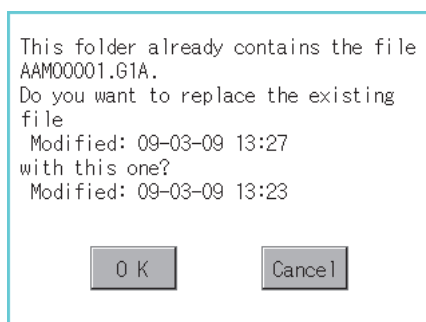

- 6.** When the copy is completed, the dialog box of completion is displayed.
To close the dialog box, touch the [OK] button.

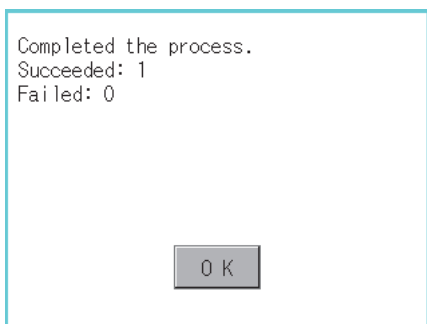

6.3 Image File Management

Function of image file management

Deletes, copies, moves, or renames the image file (BMP file or JPEG file) created by the hard copy function or creates a new folder for such a file.

For details on the hard copy function, refer to the following.

GT Designer3 (GOT2000) Screen Design Manual

Function	Description	Reference
Information display of files and folders	Displays the kind, name, data size, creation date and time of the file or folder.	☞ Page 263 Display example of image file management, ☞ Page 264 Operation of image file management
Deletion	Deletes the file.	☞ Page 265 Deletion operation
Copy	Copies the file.	☞ Page 266 Copy operation
Move	Moves the file.	☞ Page 297 Move operation
Rename	Renames the file.	☞ Page 267 Rename operation
Create Folder	New folder is created.	☞ Page 300 Folder create operation

Display operation of image file management

Data management

Utility main menu

GOT basic set Ext. func. set Maintenance Monitor Data mgmt.

Alarm information Image file management File manager Package management Memory check GOT data diag. acquisition

Touch [Image file management].

Image file management

Image file management

Select drive A:\

Kind	Name	Size	Date	Time
DIR	PACKAGE1		08-03-18	09:08
DIR	HARD_COPY		08-03-18	09:16

Free space 3.76GB
Drive capacity 3.76GB

0 files are selected (0.0KB in total)
Number of selectable files in this folder:0 files

Select all files Cancel selection Copy Rename Del

Display example of image file management

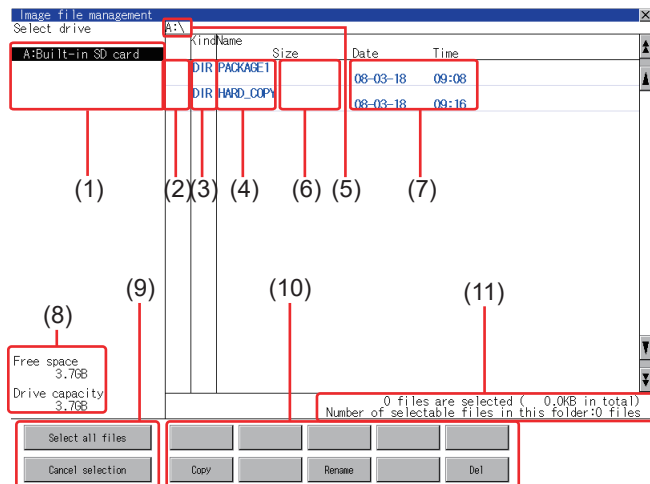

Number	Item	Description
(1)	Select drive	Select a drive to display files or folders. When a USB memory or network drive is used, the following drives are displayed. <ul style="list-style-type: none"> • SD card: [A: Built-in SD card] • USB memory: [B: USB Drive], [E: USB Drive], [F: USB Drive], and [G: USB Drive] • Network drive: [N: Network drive] *1
(2)	Check box	If the check box is selected, up to 512 files can be selected.
(3)	Kind	Indicates whether the displayed name is file or folder. Displays the extension for a file and "DIR" for a folder.
(4)	Name	Displays the file name or folder name. For the long file/folder name, entire part may not be displayed. Confirm the non-displayed part with the [Copy] button, etc. ☞ Page 266 Copy operation After confirmation, touch the [Cancel] button to cancel the operation.
(5)	Path name	Displays the path name of drive /folder which is currently displayed.
(6)	Size	Displays the size of the file displayed in Name.
(7)	Date and time	Displays the creation date and time of each file.
(8)	The size of drive	Displays the size of free area and the entire size of the drive which is selected by drive selection.
(9)	Select all files/Cancel selection	Multiple files can be selected or canceled at once. Touch the [Select all files] button to select all files. If the number of the displayed files exceeds 513, the first 512 files are selected.
(10)	Operation switch	Execution switch of each function.
(11)	Number and size of files	Displays the number of the selected files, the total file size, and the selectable number of files in the folder.

*1 To display the creation date and time of a file or folder using the file server time, set the same time zone for the GOT and file server.

Point

Display of creation date and time

The creation date and time display is not updated even if a file is created or updated while the image file management screen is displayed. To display the updated creation date and time, close the screen currently displayed (by moving to the upper hierarchy folder, etc.) and display the screen again.

Operation of image file management

Display operation of image file management

1. If touch a drive of [Select drive], the information of the touched drive is displayed.

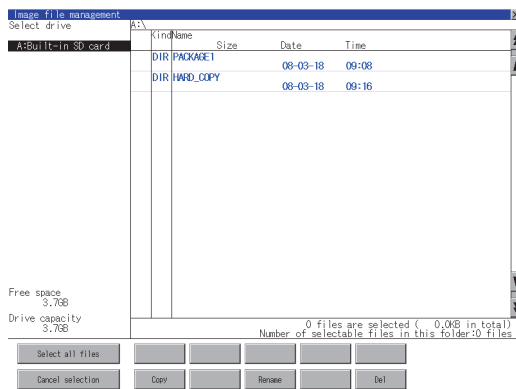

2. If touch a folder name, the information of the touched folder is displayed.
3. If touch a folder of ". .", the information of the folder of the one upper hierarchy is displayed.
4. If touch the ▲▼ button of the scrollbar, the screen scrolls up/down by one line.
5. Touch the check box to select the file.
6. For the operations of the delete, copy, and rename, refer to the following.

Delete

☞ Page 265 Deletion operation

Copy

☞ Page 266 Copy operation

Rename

☞ Page 267 Rename operation

7. If touch the [x] button, the screen is closed.

Deletion operation

Deletes the selected file.

1. Touch the check box of the file to delete to select the file.

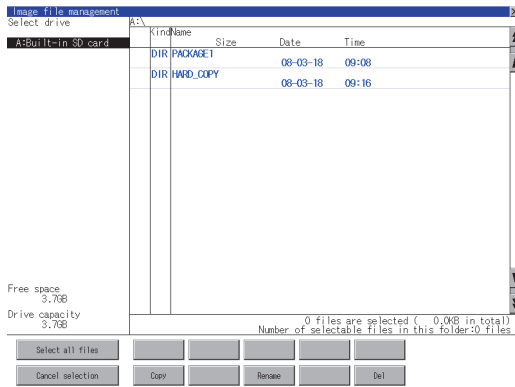

2. If touch the [Del] button, the dialog box mentioned below is displayed.
If touch the [OK] button, the file is deleted.
If touch the [Cancel] button, the deletion is canceled.

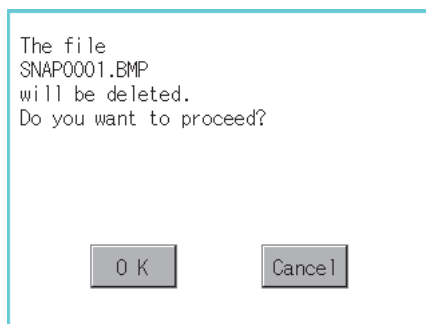

3. When the deletion is completed, the completion dialog box is displayed.
To close the dialog box, touch the [OK] button.

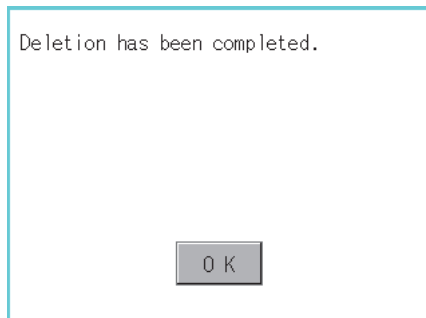

Copy operation

Copies the selected file.

1. Touch the check box of the file to copy to select the file.

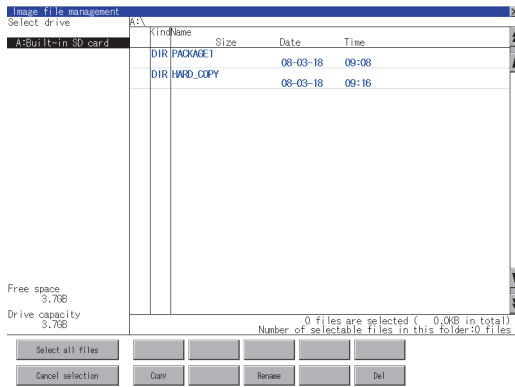

2. If touch the [Copy] button, the message [Please select a destination.] is displayed in the left bottom of the screen.

3. If the copy destination folder is touched, the screen display is changed to the folder of copy destination.

At this time, it cannot be copied into the same folder where the file exists.

Select other folders.

4. If touch the [Exec] button, the dialog box mentioned below is displayed.

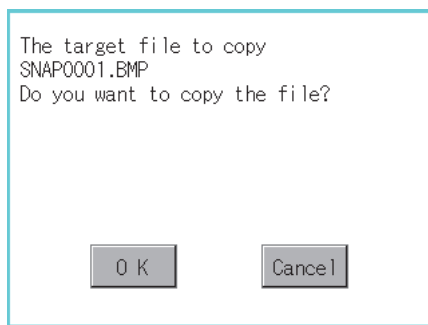

5. Touch the [OK] button.

If there is a file of the same name in the copy destination folder, the following dialog is displayed without starting the copy.

If touch the [OK] button, overwrites the file.

If touch the [Cancel] button, cancels to copy.

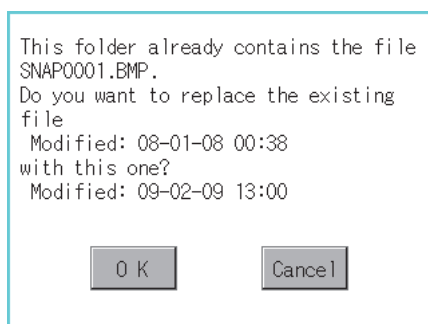

6. When the copy is completed, the dialog box of completion is displayed.
To close the dialog box, touch the [OK] button.

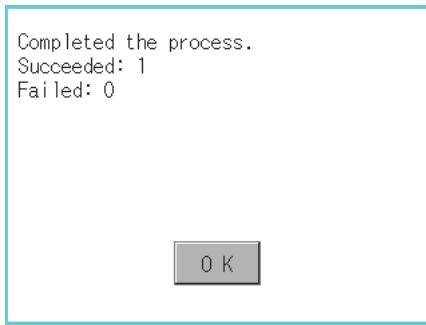

Rename operation

Rename the selected file.

1. Select the check box of the file to be renamed by touching.

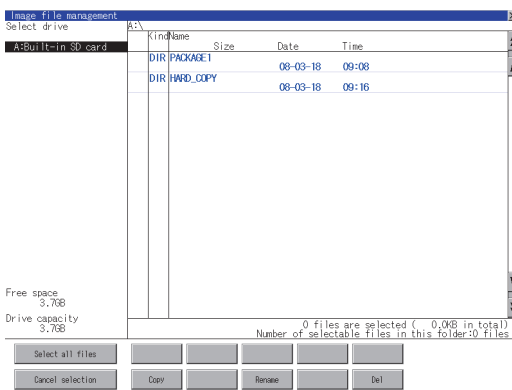

2. Touch the [Rename] button, and then the screen shown below is displayed. Input a new file name.
By touching the following button, input text type is changed.

[A-Z]: Alphabet capital
[0-9]: Numeric/Symbol



3. Touch the [Enter] button, and then the dialog box shown below is displayed.

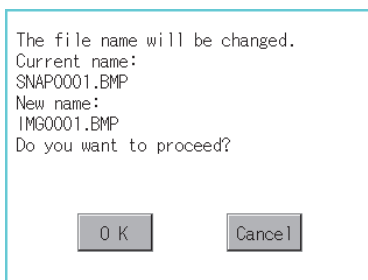

4. Touch the [OK] button, and then renaming the file is started.
5. When renaming the file is completed, a completion dialog box is displayed. To close the dialog box, touch the [OK] button.

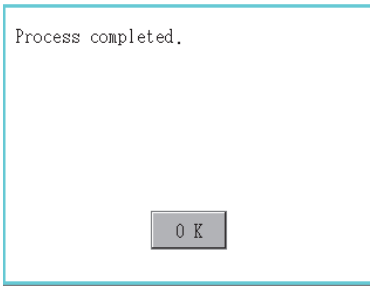

6.4 Recipe Information

Point

Before using recipe information

For writing/reading into/from a controller with this function or editing of recipe files on the personal computer, refer to the following.

Specifications and operating procedure are described.

 GT Designer3 (GOT2000) Screen Design Manual











Function of recipe information

The recipe file used in the recipe function can be copied, deleted, and output in a file.

In addition, it is possible to writing/reading into/from a controller by using this function, without creating the screen to operate the recipe. (Recipe setting of GT Designer3 is required.)

Recipe information

The following table shows the functions that can be operated on the recipe information screen.

Function	Description	Reference
Information display of files and folders	Displays name, data size, creation date and time of file or folder.	 Page 272 Example of advanced recipe information display,  Page 273 Recipe information operation
G2P → CSV conversion	Converts a G2P file of a recipe file to a CSV file.	 Page 274 G2P → CSV conversion operation, G2P → TXT conversion operation
G2P → TXT conversion	Converts a G2P file of a recipe file to a Unicode text file.	 Page 274 G2P → CSV conversion operation, G2P → TXT conversion operation
CSV/TXT → G2P conversion	A CSV file or Unicode text file is converted to a recipe file (G2P file).	 Page 276 CSV/TXT → G2P conversion operation
Operation	Displays the recipe operation window.	 Page 270 Recipe operation window
Copy	Copies the file.	 Page 295 Copy operation
Move	Moves the file.	 Page 297 Move operation
Rename	Renames the file.	 Page 299 Rename operation
Create Folder	Creates a new folder.	 Page 300 Folder create operation
Delete	Deletes a file or folder.	 Page 301 Delete operation

Recipe operation window

This window is a dedicated window for operating recipe files.

The recipe data saved in the SRAM user area cannot be manipulated in the recipe operation window.

The following table shows the functions of the recipe operation window.

Function	Description	Reference
Recipe operation	Displays the recipe operation screen.	<ul style="list-style-type: none"> ☞ Page 273 Recipe information operation ☞ Page 278 Recipe file manipulation ☞ Page 279 Recipe operation
Load recipe	Writes device values of a selected record into controllers.	<ul style="list-style-type: none"> ☞ Page 273 Recipe information operation ☞ Page 278 Recipe file manipulation ☞ Page 279 Recipe operation ☞ Write recipe operation
Save recipe	Reads the device values from controllers into a selected record.	<ul style="list-style-type: none"> ☞ Page 273 Recipe information operation ☞ Page 278 Recipe file manipulation ☞ Page 279 Recipe operation ☞ Read recipe operation
Verify recipe	Verifies the device values of a selected record against those of controllers.	<ul style="list-style-type: none"> ☞ Page 273 Recipe information operation ☞ Page 278 Recipe file manipulation ☞ Page 279 Recipe operation ☞ Verify recipe operation
Update recipe	Reads the selected recipe file and saves the data as a newly-named record.	<ul style="list-style-type: none"> ☞ Page 273 Recipe information operation ☞ Page 278 Recipe file manipulation ☞ Page 279 Recipe operation ☞ Update recipe operation
Copy	Copies a recipe file.	<ul style="list-style-type: none"> ☞ Page 273 Recipe information operation ☞ Page 278 Recipe file manipulation ☞ Page 285 Copy operation
New folder	Creates a new folder.	<ul style="list-style-type: none"> ☞ Page 273 Recipe information operation ☞ Page 278 Recipe file manipulation ☞ Page 287 Create folder operation
New recipe	Creates a new recipe file.	<ul style="list-style-type: none"> ☞ Page 273 Recipe information operation ☞ Page 278 Recipe file manipulation ☞ Page 288 Create recipe operation
Convert	Converts a G2P recipe file to a CSV file or Unicode text file. Or, converts a CSV file or Unicode text file to a G2P recipe file.	<ul style="list-style-type: none"> ☞ Page 273 Recipe information operation ☞ Page 278 Recipe file manipulation ☞ Page 291 Convert operation
Rename	Renames the recipe file.	<ul style="list-style-type: none"> ☞ Page 273 Recipe information operation ☞ Page 278 Recipe file manipulation ☞ Page 293 Rename operation
Delete	Deletes a recipe file.	<ul style="list-style-type: none"> ☞ Page 273 Recipe information operation ☞ Page 278 Recipe file manipulation ☞ Page 294 Delete operation

Display operation of recipe information

Data management

Utility main menu

001 basic set | Exit, func. set | Maintenance | Monitor | Data mgmt.

Alarm information | Image file management | Recipe information | Local backup | Local restore

File manager | Package management | Backup restoration

Memory check | 001 data mgmt. acquisition

11/27/2015 15:40:55 | Language

Touch [Recipe information].

Recipe information

Recipe information

Select drive

A:\PACKAGET\RECIPES\

Kind	Name	Size	Date	Time
DIR	..			
<input checked="" type="checkbox"/>	G2P ARP00001	0.3KB	08-03-18	10:16

Free space: 3.6GB
Drive capacity: 3.7GB

1 files are selected (0.3KB in total)
Number of selectable files in this folder: 1 files

Select all files | G2P→DSV | G2P→TXT | DSV/TXT→G2P | Oper.

Cancel selection | Copy | Move | Rename | CreateFolder | Del

Example of advanced recipe information display

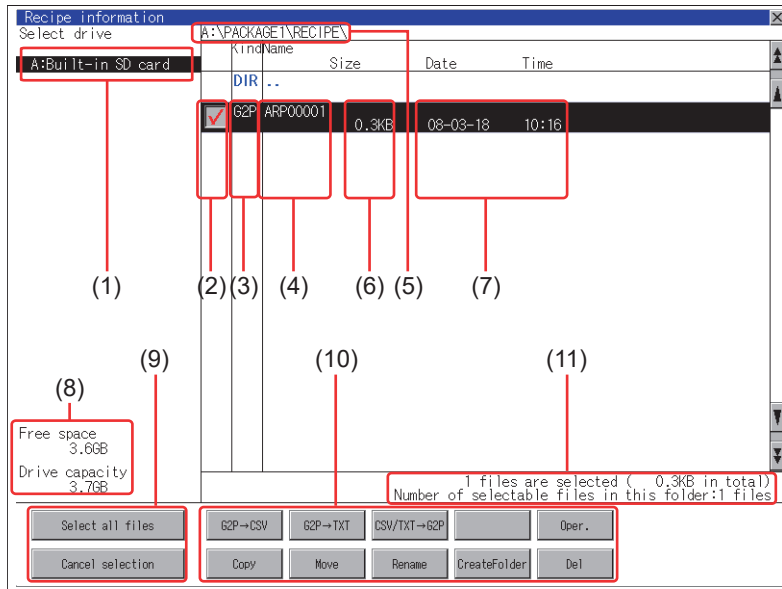

Number	Item	Description
(1)	Select drive	The drive which displays file or folder can be selected. <ul style="list-style-type: none"> • SD card: [A: Built-in SD card] • USB memory: [B: USB Drive], [E: USB Drive], [F: USB Drive], and [G: USB Drive]
(2)	Check box	If the check box is selected, up to 512 files can be selected.
(3)	Kind	Indicates whether the displayed name is file or folder. Displays the extension for a file and "DIR" for a folder.
(4)	Name	Displays the file name or folder name. For the long file/folder name, entire part may not be displayed. Confirm the nondisplayed part with the [Rename] button, etc. Page 299 Rename operation After confirmation, touch the [Cancel] button to cancel the operation.
(5)	Path name	Displays the path name of drive /folder which is currently displayed.
(6)	Size	Displays the size of the file displayed in Name.
(7)	Date and time	Displays the creation date and time of each file.
(8)	The size of drive	Displays the size of free area and the entire size of the drive which is selected by drive selection.
(9)	Select all files/Cancel selection	Multiple files can be selected or canceled at once. Touch the [Select all files] button to select all files. If the number of the displayed files exceeds 513, the first 512 files are selected.
(10)	Operation switch	Execution switch of each function.
(11)	Number and size of files	Displays the number of the selected files, the total file size, and the selectable number of files in the folder.

Point

About the displayed file





The files other than that for recipe are not displayed on the recipe information screen.

Recipe information operation

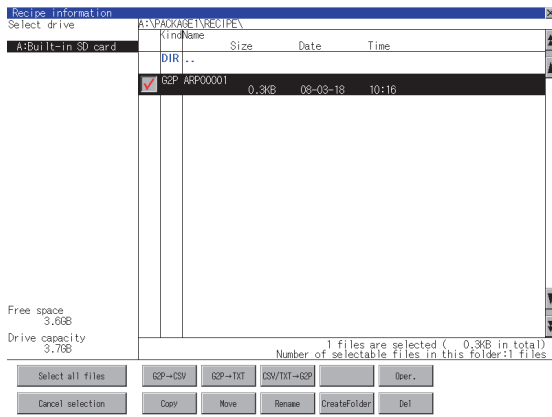
Display operation of recipe information

1. If touch a drive of [Select drive], the information of the touched drive is displayed.



2. If touch a folder name, the information of the touched folder is displayed.
3. If touch a folder of ". .", the information of the folder of the one upper hierarchy is displayed.
4. If touch the   button of the scrollbar, the screen scrolls up/down by one line.
If touch the   button, the screen scrolls up/down by one screen.

5. Touch the check box to select the file.

6. For operation of operating switches, refer to the following.

G2P → CSV, G2P → TXT

 Page 274 G2P → CSV conversion operation, G2P → TXT conversion operation

CSV/TXT → G2P conversion

 Page 276 CSV/TXT → G2P conversion operation

Operation

 Page 278 Recipe file manipulation

Copy

 Page 295 Copy operation

Move

 Page 297 Move operation

Rename

 Page 299 Rename operation

Create Folder

 Page 300 Folder create operation

Delete

 Page 301 Delete operation

7. If touch the [x] button, the screen is closed.

G2P → CSV conversion operation, G2P → TXT conversion operation

A recipe file (G2P file) is converted to a CSV file or Unicode text file that can be displayed/edited on a personal computer. The conversion source file remains intact.

1. Touch the check box of a G2P file which is to be converted to a CSV file or Unicode text file to select the file.

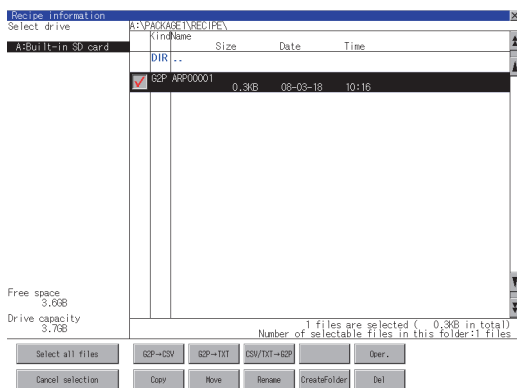

2. Touch the following button in accordance with destination file type.

CSV file:

[G2P → CSV] button

Unicode text file:

[G2L → TXT] button

3. Select the target folder.

(Selecting a folder is not needed for outputting directly below the drive.)

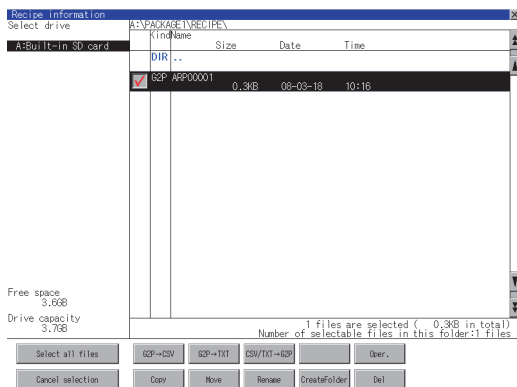

4. If touch the [Exec] button, the dialog box mentioned below is displayed.

Touch the [OK] button.

(While executing, "Processing..." message appears on the screen.)

(Example: Dialog box if the [G2P → CSV] button is touched)

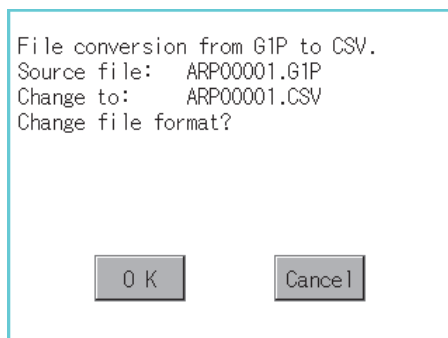

5. When the file, whose name is the same, exists in the destination folder, the dialog box showed below appears without starting the conversion.

To overwrite the file, touch the [OK] button.

To cancel the conversion, touch the [Cancel] button.

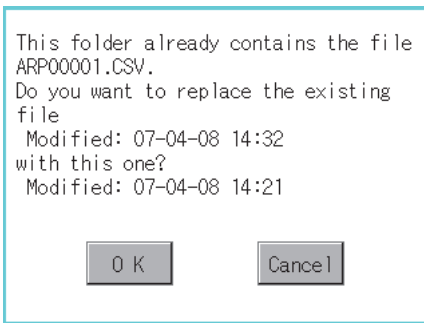

6. The message of completion is displayed in dialog box when conversion is completed.

To close the dialog box, touch the [OK] button.

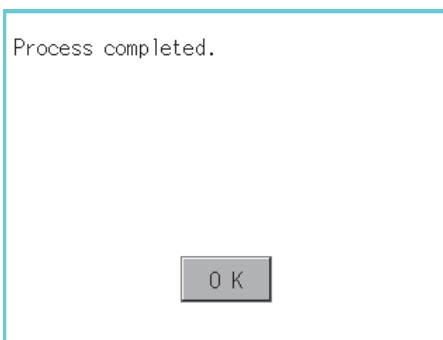

CSV/TXT → G2P conversion operation

A CSV file or Unicode text file is converted to a recipe file (G2P file).

The conversion source file remains intact.

1. To select the file, touch the check box of a CSV file or Unicode text file to be converted to a G2P file.

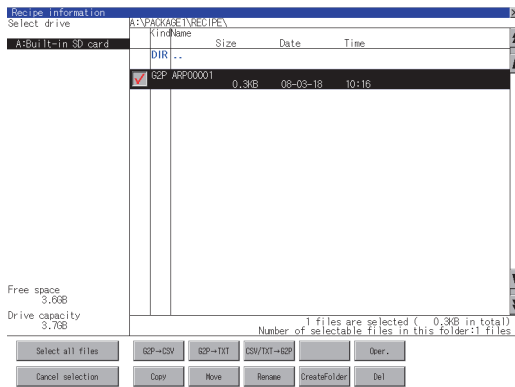

2. Touch the [CSV/TXT → G2P] button to display [Please select destination] at the lower left corner of the screen.

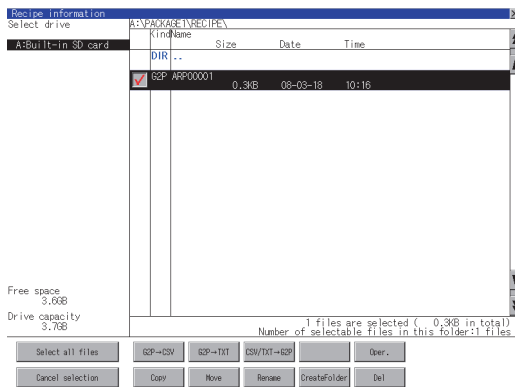

3. Select the target folder.

(Selecting a folder is not needed for outputting directly below the drive.)

4. If touch the [Exec] button, the dialog box mentioned below is displayed.

Touch the [OK] button.

(While executing, "Processing..." message appears on the screen.)

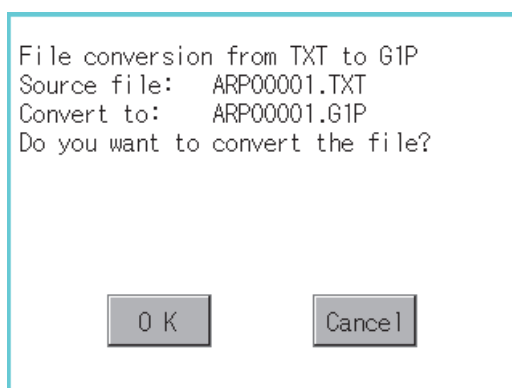

5. When the file, whose name is the same, exists in the destination folder, the dialog box showed below appears without starting the conversion.

To overwrite the file, touch the [OK] button.

To cancel the conversion, touch the [Cancel] button.

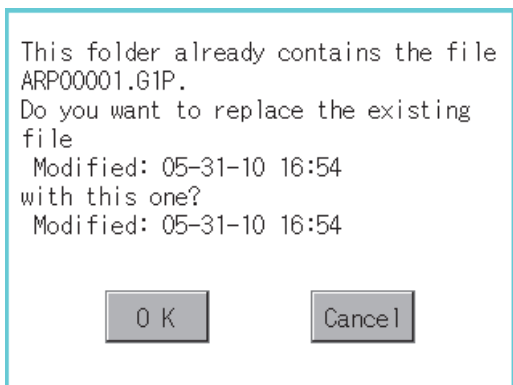

6. The message of completion is displayed in dialog box when conversion is completed.

To close the dialog box, touch the [OK] button.

Recipe file manipulation

Select a recipe file on the recipe file list screen to perform various operations.

1. Touch [DRV] on the recipe file list screen to display the drive selection screen. Select a drive.

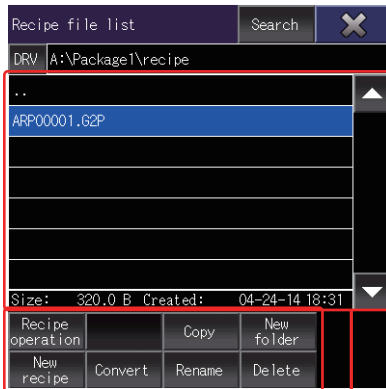

Operation switch File display area

2. Touch a recipe file in the file display area to select the recipe file.
3. To return to the parent folder and display its information, touch a [. .] folder.
4. To scroll the file display area up or down one row, touch the ▲ ▼ button of the scroll bar.
5. To search for a file by keyword or file type, touch the [Search] button to display the search screen.
6. For the operation of the operation switches, refer to the following.

Recipe operation

☞ Page 279 Recipe operation

Copy

☞ Page 285 Copy operation

New folder

☞ Page 287 Create folder operation

New recipe

☞ Page 288 Create recipe operation

Convert

☞ Page 291 Convert operation

Rename

☞ Page 293 Rename operation

Delete

☞ Page 294 Delete operation

7. Touch the [x] button to close the window.

■Recipe operation

To display the recipe operation screen, select a recipe file (G2P file) and touch the [Recipe operation] button.

1. To scroll the file display area up or down one row, touch the ▲▼ button of the scroll bar.



2. To search for a file by record number or record name, touch the [Search] button to display the search screen.
3. Select a record name in the file display area and touch an operation switch to perform the corresponding operation as shown below.

For the operation of the operation switches, refer to the following.

Load recipe

☞ Write recipe operation

Save recipe

☞ Read recipe operation

Verify recipe

☞ Verify recipe operation

Update recipe

☞ Update recipe operation

4. Touch the [x] button to return to the recipe file list screen.

- Write recipe operation

1. Select a record name in the file display area.

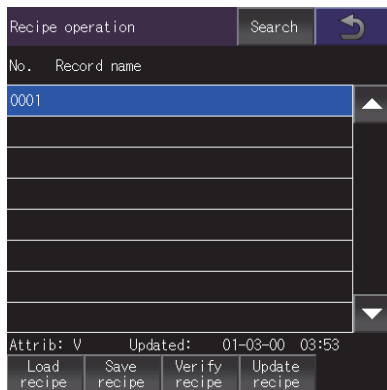

2. Touch the [Load recipe] button on the recipe operation screen to display the dialog shown below.

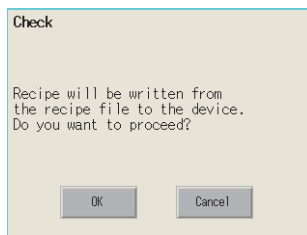

3. To write device values of the selected record into controllers, touch the [OK] button.
To cancel the writing of the values, touch the [Cancel] button.

- Read recipe operation

1. Touch the [Save recipe] button on the recipe operation screen to display the record name screen.

Touch the record name input area to display an input key window.

Enter the name of a record to be created.

To change the character type, touch any of the following buttons.

[A-Z]: Uppercase alphabet

[a-z]: Lowercase alphabet

[@]: Symbols

[0-9]: Numeric characters, A to F

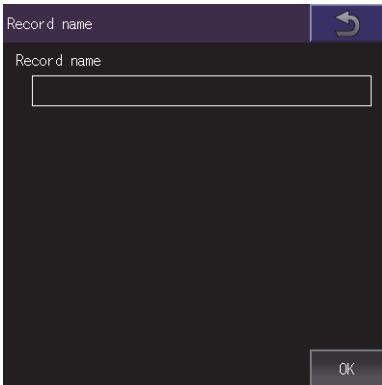

2. Touch the [Enter] button to close the input key window.

3. Touch the [OK] button on the record name screen to display the dialog shown below.

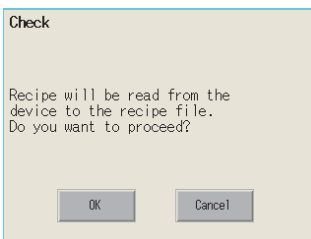

4. To read the device values from controllers into the selected record, touch the [OK] button.

To cancel the reading of the values, touch the [Cancel] button.

- Verify recipe operation

1. Select a record name in the file display area.



2. Touch the [Verify recipe] button on the recipe operation screen to display the dialog shown below.

To verify the recipe file in the GOT against the one in the device, touch the [OK] button.

To cancel the verification, touch the [Cancel] button.



3. When the verification is completes and the recipe file of the GOT and the one of the device match, the dialog shown below appears.

When the recipe file of the GOT and the one of the device do not match, the dialog indicating [Verification NG.] appears.

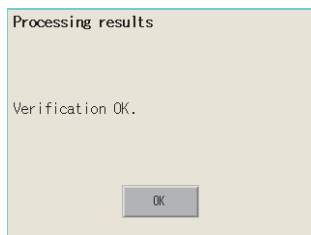

4. Touch the [OK] button to close the dialog.

- Update recipe operation

1. Select a record name in the file display area.

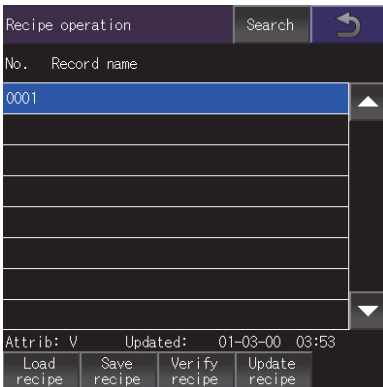

2. Touch the [Update recipe] button on the recipe operation screen to display the record information screen.

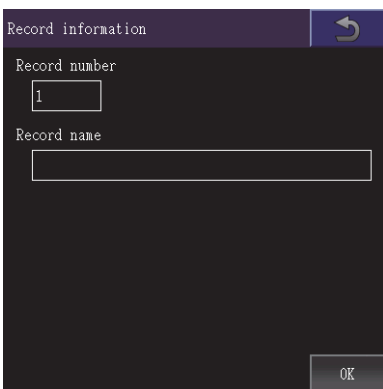

3. Enter a record number in the record number input area.

Touch the record number input area to display the input key window.

4. Touch the record name input area to display the input key window.

Enter the name of a folder to be created.

To change the character type, touch any of the following buttons.

[A-Z]: Uppercase alphabet

[a-z]: Lowercase alphabet

[@]: Symbols

[0-9]: Numeric characters, A to F

5. Touch the [Enter] button to close the input key window.

6. Touch the [OK] button on the record information screen to display the recipe file storage destination screen.

To return to the parent folder and display its information, touch a [. .] folder.

To create a new folder, touch the [New folder] button to display the folder name screen.

New folder

☰ Page 287 Create folder operation

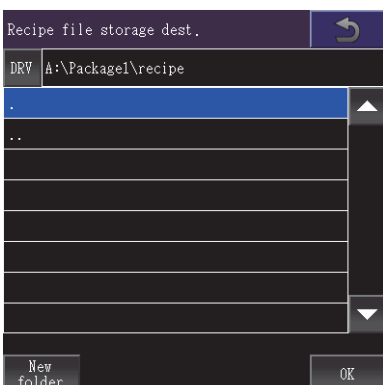

- 7.** Touch the [OK] button on the recipe file storage destination screen to display the file name screen.
Enter a recipe file name in the input area.

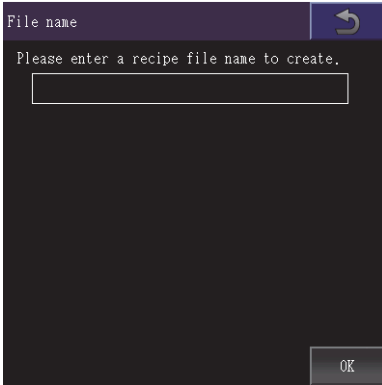

- 8.** Touch the recipe file name input area to display the input key window.
Input a recipe file name.

To change the character type, touch any of the following buttons.

[A-Z]: Uppercase alphabet

[a-z]: Lowercase alphabet

[@]: Symbols

[0-9]: Numeric characters, A to F

- 9.** Touch the [Enter] button to close the input key window.

- 10.** Touch the [OK] button on the file name screen to display the dialog shown below.
To read the device values from controllers into the selected record, touch the [OK] button.
To cancel the reading of the values, touch the [Cancel] button.

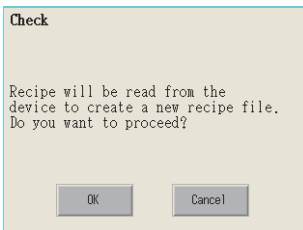

- 11.** If the recipe read destination folder has a file of the same name, the screen shown below appears without reading device values of controllers.

To overwrite the file of the same name, touch the [OK] button.

To cancel the overwriting, touch the [Cancel] button.

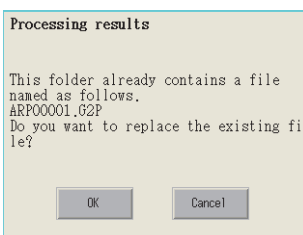

- 12.** When the reading of device values from controllers completes, the completion dialog appears.
Touch the [OK] button to close the dialog.

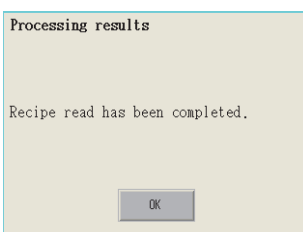

■ Copy operation

A recipe file is copied.

1. Select a file to copy on the recipe file list screen.

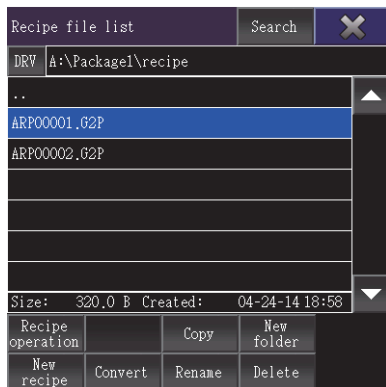

2. Touch the [Copy] button to display the copy destination folder screen.

Select a copy destination folder.

To return to the parent folder and display its information, touch a [. .] folder.

To create a new folder, touch the [New folder] button to display the folder name screen.

New folder

☞ Page 287 Create folder operation

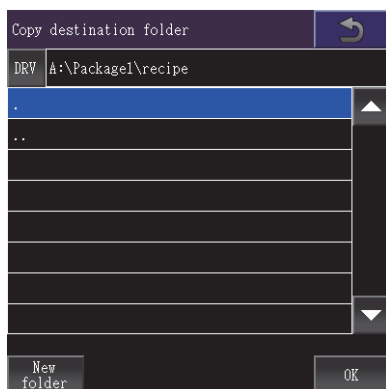

3. Touch the [OK] button on the copy destination folder screen to display the dialog shown below.

Touch the [OK] button.

(The message "Processing" is displayed during processing.)

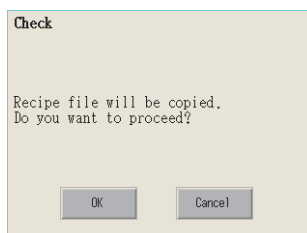

4. If the copy destination folder has a file of the same name, the screen shown below appears without starting the copy.

To overwrite the file of the same name, touch the [OK] button.

To cancel the copy, touch the [Cancel] button.

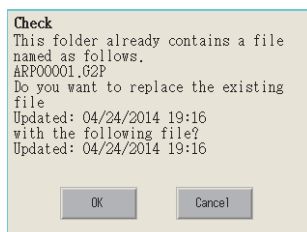

5. When the copy completes, the completion dialog appears.
Touch the [OK] button to close the dialog.



■ Create folder operation

A new folder is created.

1. Touch the [New folder] button on the recipe file list screen.

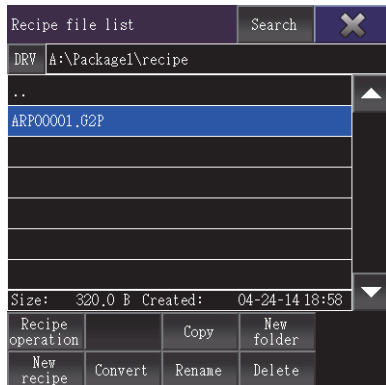

2. In the folder name screen, create a new folder.
Touch the new folder name input area to display the input key window.
Enter the name of a folder to be created.
To change the character type, touch any of the following buttons.

[A-Z]: Uppercase alphabet

[a-z]: Lowercase alphabet

[@]: Symbols

[0-9]: Numeric characters, A to F

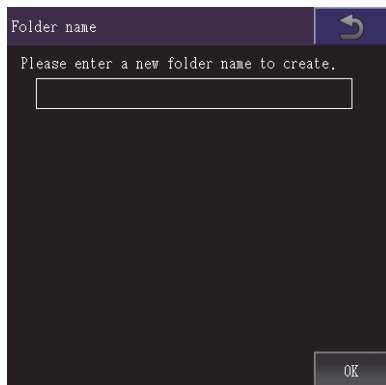

3. Touch the [Enter] button to close the input key window.
4. Touch the [OK] button on the folder name screen to display the dialog shown below and create a folder.
Touch the [OK] button to close the dialog.

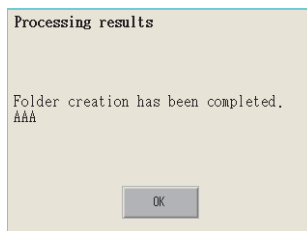

■ Create recipe operation

A new recipe file is created.

1. Touch the [New recipe] button on the recipe file list screen.

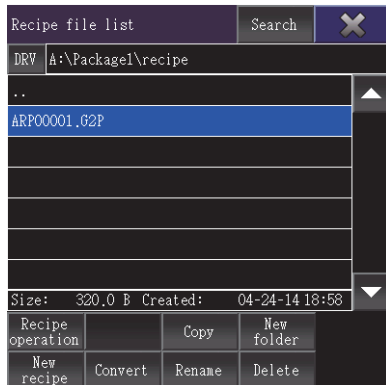

2. The new recipe screen is displayed.

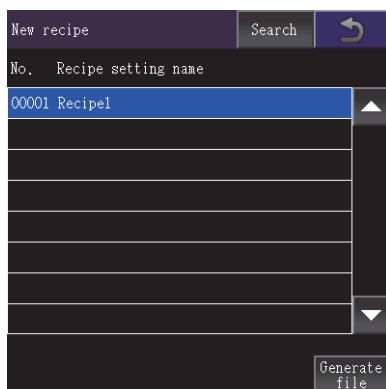

3. Touch the [Generate file] button on the new recipe screen to display the recipe file storage destination screen.

To return to the parent folder and display its information, touch a [. .] folder.

To create a new folder, touch the [New folder] button to display the folder name screen.

New folder

☞ Page 287 Create folder operation

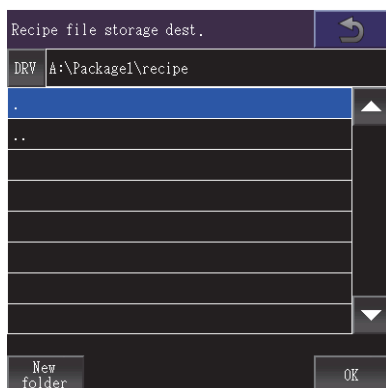

4. Touch the [OK] button on the recipe file storage destination screen to display the file name screen.

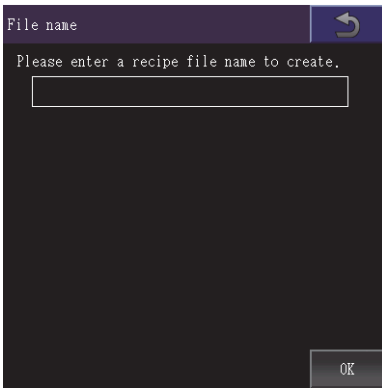

5. Touch the recipe file name input area to display the input key window.

Input a recipe file name.

To change the character type, touch any of the following buttons.

[A-Z]: Uppercase alphabet

[a-z]: Lowercase alphabet

[@]: Symbols

[0-9]: Numeric characters, A to F

6. Touch the [Enter] button to close the input key window.

7. Touch the [OK] button on the file name screen to display the dialog shown below and create a recipe file.

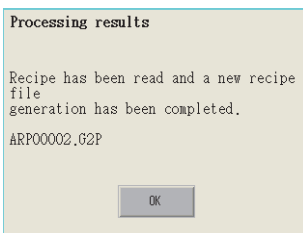

8. If the file storage destination folder has a file of the same name, the screen shown below appears without creating a recipe file.

To overwrite the file of the same name, touch the [OK] button.

To cancel the creation of a recipe file, touch the [Cancel] button.

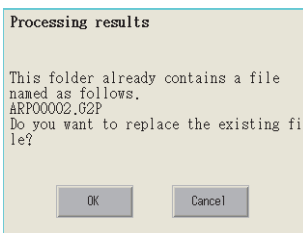

9. Touch the [OK] button to display the recipe operation screen shown below.
Touch an operation switch to perform the corresponding operation as shown below.
For the operation of the operation switches, refer to the following.

Save recipe

☞ Page 279 Recipe operation, Read recipe operation

Update recipe

☞ Page 279 Recipe operation, Update recipe operation

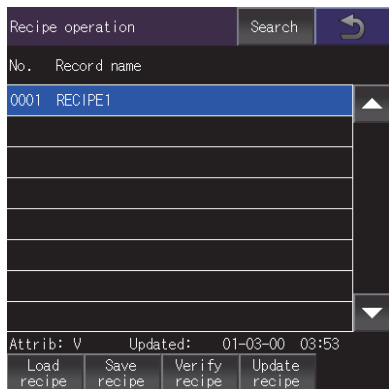

10. Touch the [x] button to return to the new recipe screen.

■ Convert operation

A G2P recipe file is converted to a CSV file or Unicode text file.

Or, a CSV file or Unicode text file is converted to a G2P recipe file.

The conversion source file remains intact.

1. Select a file to be converted on the recipe file list screen.

The screen displayed when the [Convert] button on the recipe file list screen is touched differs depending on the file to be converted.

For G2P recipe files:

The conversion file type screen is displayed.

For CSV files or Unicode text files:

The converted file storage destination screen is displayed.

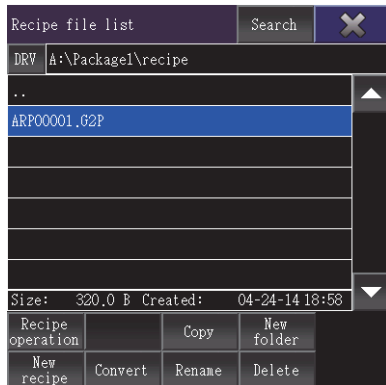

2. For converting a G2P recipe file, touch the [Convert] button on the recipe file list screen to display the conversion file type screen.

Select the file format of a file to be created after the conversion.

- [CSV]

Converts the file to a CSV file.

- [Unicode text]

Converts the file to a Unicode text file.

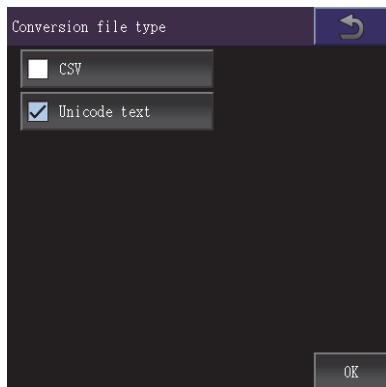

3. Touch the [OK] button on the conversion file type screen or the [Convert] button on the recipe file list screen to display the converted file storage destination screen.

To return to the parent folder and display its information, touch a [. .] folder.

To create a new folder, touch the [New folder] button to display the folder name screen.

New folder

☞ Page 287 Create folder operation

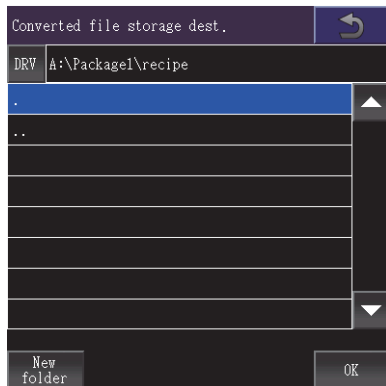

4. Touch the [OK] button on the converted file storage destination screen to display the dialog shown below. Touch the [OK] button to close the dialog.

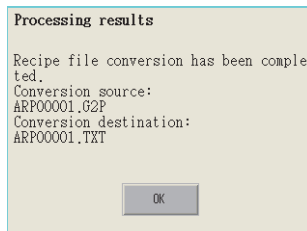

■Rename operation

A recipe file is renamed.

1. Select a file to rename on the recipe file list screen.

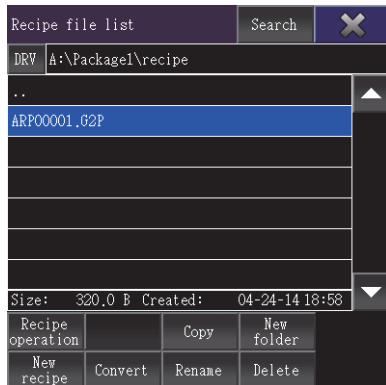

2. Touch the [Rename] button on the recipe file list screen to display the file name screen. Enter the file name to be renamed.

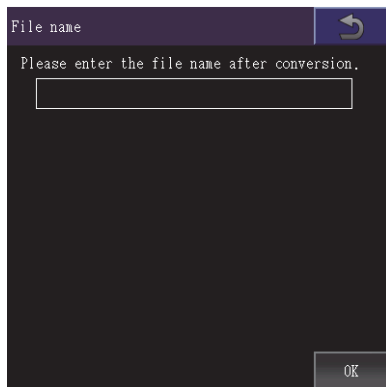

3. Touch the recipe file name input area to display the input key window.

Input a recipe file name.

To change the character type, touch any of the following buttons.

[A-Z]: Uppercase alphabet

[a-z]: Lowercase alphabet

[@]: Symbols

[0-9]: Numeric characters, A to F

4. Touch the [OK] button on the file name screen to display the dialog shown below.

Touch the [OK] button to close the dialog.

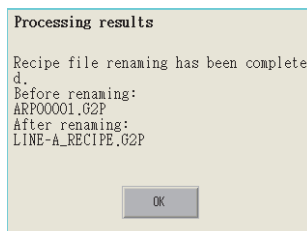

■Delete operation

A recipe file is deleted.

1. Touch a file to delete on the recipe file list screen.

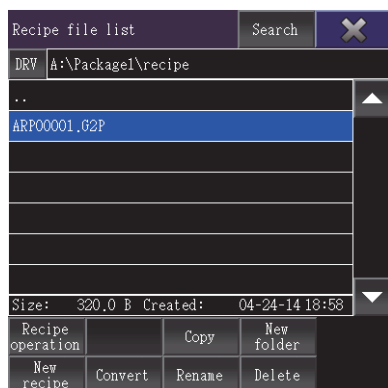

2. Touch the [Delete] button on the recipe file list screen to display the dialog shown below.
To delete the file, touch the [OK] button.
To cancel the deletion, touch the [Cancel] button.

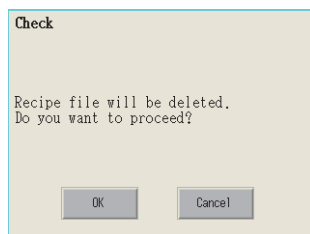

3. When the deletion completes, the completion dialog appears.
Touch the [OK] button to close the dialog.

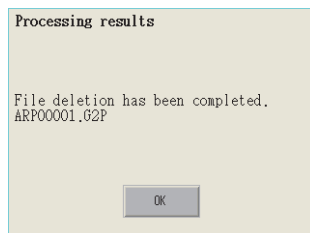

Copy operation

Folders to be used in recipe are copied.

1. Touch the check box of the file to copy to select the file.

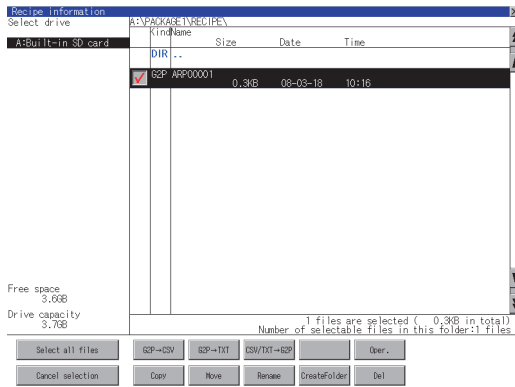

2. Touch the [Copy] button.

3. Select the target folder.

(Selecting a folder is not needed for outputting directly below the drive.)

At this time, it cannot be copied into the same folder where the file exists.

Select other folders.

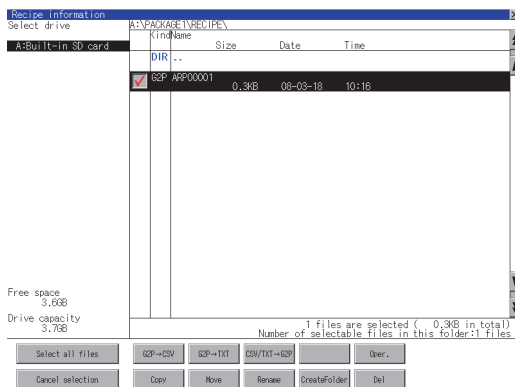

4. If touch the [Exec] button, the dialog box mentioned below is displayed.

Touch the [OK] button.

(While executing, "Processing..." message appears on the screen.)

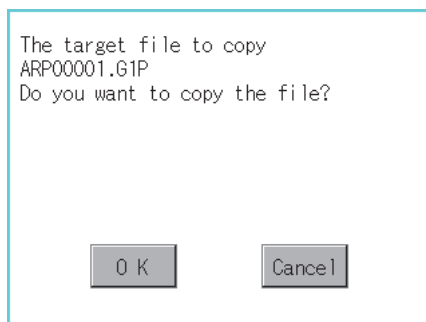

- 5.** If there is a file of the same name in the copy destination folder, the following dialog is displayed without starting the copy.
If touch the [OK] button, overwrites the file.
If touch the [Cancel] button, cancels to copy.

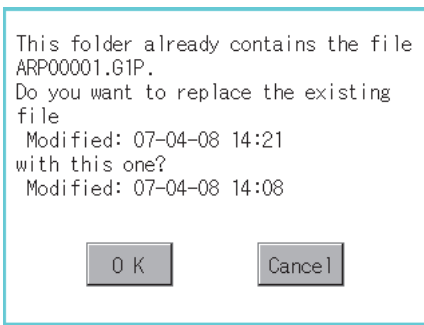

- 6.** When the copy is completed, the dialog box of completion is displayed.
To close the dialog box, touch the [OK] button.

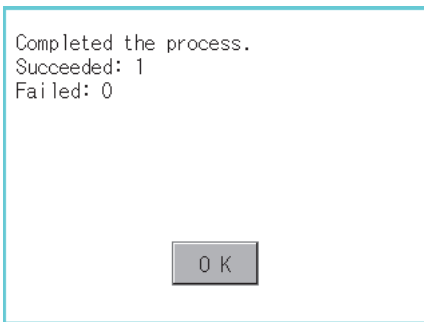

Move operation

Files to be used in recipe are moved.

1. Touch the check box of the file to be moved to select the file.

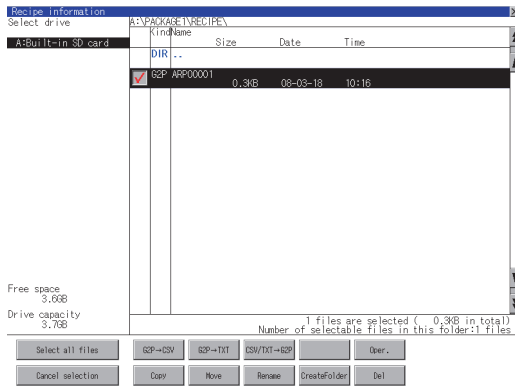

2. Touch the [Move] button.

3. Select the target folder.

(Selecting a folder is not needed for moving directly below the drive.)

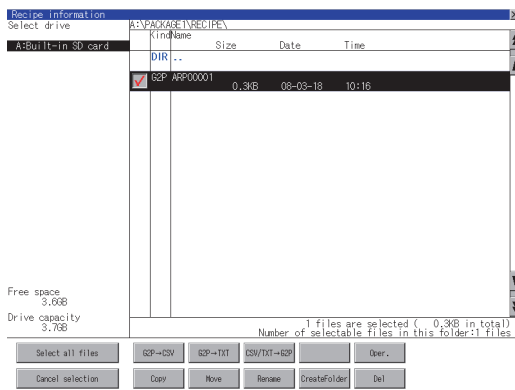

4. If touch the [Exec] button, the dialog box mentioned below is displayed.

Touch the [OK] button.

(While executing, "Processing..." message appears on the screen.)

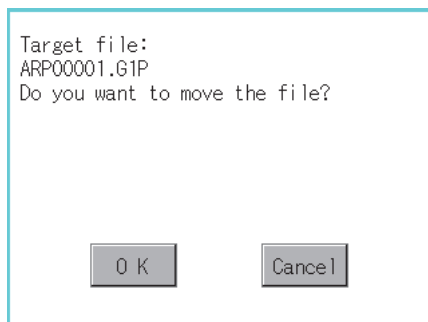

5. When any file with the same name exists in the destination folder, the dialog box shown below appears without starting the movement.

Touching the [OK] button overwrites the file.

If touch the [Cancel] button, cancels moving.

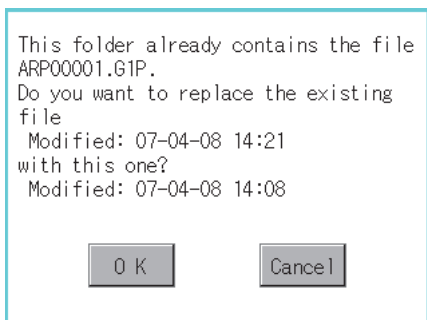

6. When moving is completed, completion dialog box is displayed.

To close the dialog box, touch the [OK] button.

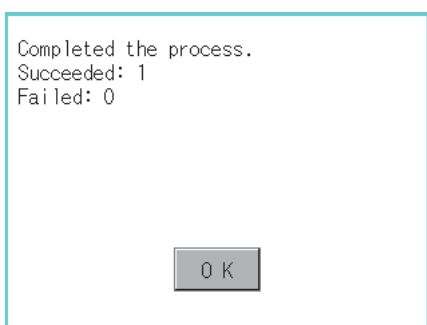

Rename operation

File names to be used in recipe are changed.

1. Select the check box of the file to be renamed by touching.

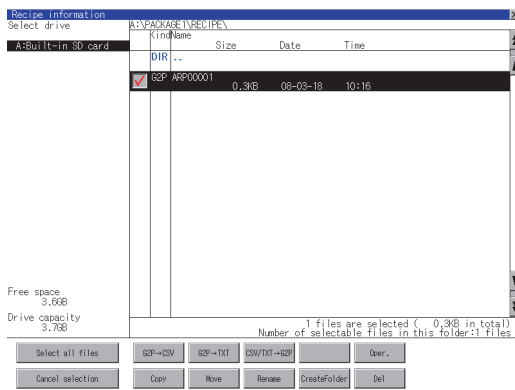

2. Touch the [Rename] button, and then the screen shown below is displayed. Input the file name to be changed. By touching the following button, input text type is changed.

[A-Z]: Alphabet capital

[0-9]: Numeric/Symbol

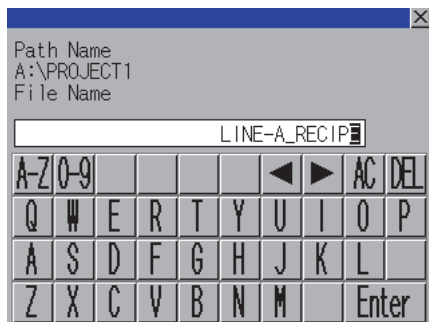

3. Touch the [Enter] button, and then the dialog box shown below is displayed.

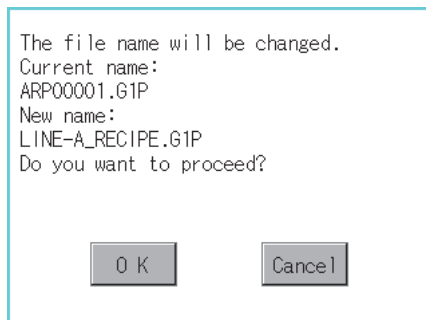

4. Touch the [OK] button, and then renaming the file is started. (While executing, "Processing..." message appears on the screen.)
5. When renaming the file is completed, a completion dialog box is displayed. To close the dialog box, touch the [OK] button.

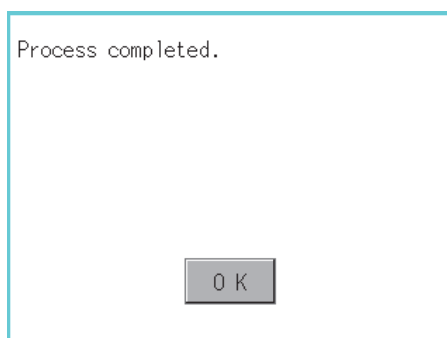

Folder create operation

Folders to be used in recipe are created.

1. Touch the [Create Folder] button.

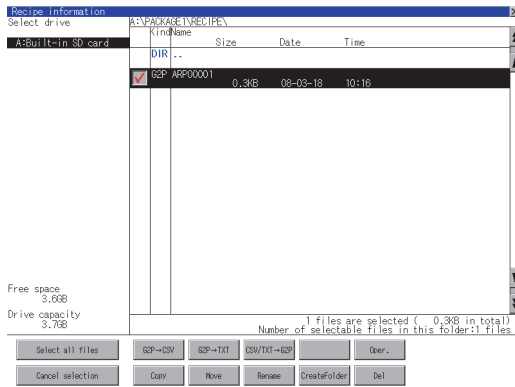

2. The input key window shown below appears, then input the file name to be created. By touching the following button, input text type is changed.

[A-Z]: Alphabet capital
[0-9]: Numeric/Symbol

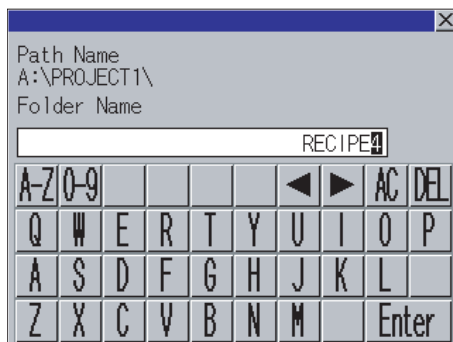

3. Touch the [Enter] button, and then the dialog box shown below is displayed.

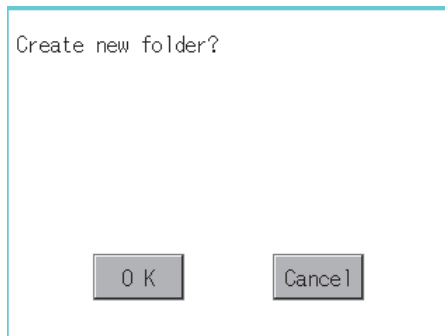

4. If touch the [OK] button, starts creating folder.
5. When creating folder is completed, completion dialog box is displayed. To close the dialog box, touch the [OK] button.

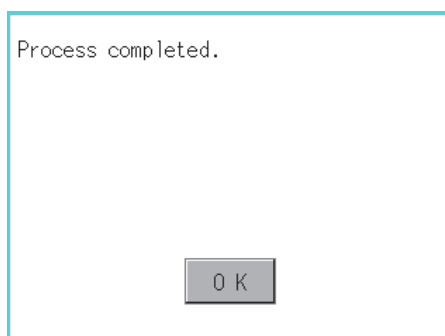

Delete operation

Folders and files to be used on recipe are deleted.

1. Touch the folder to delete or the check box of the file to delete to select the file.

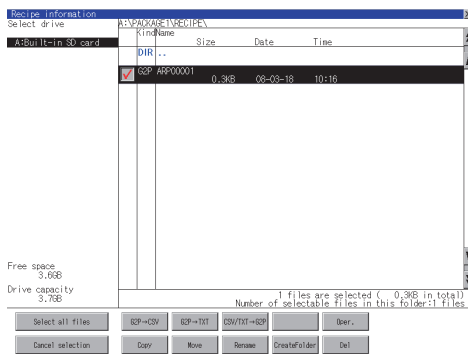

2. If touch the [Del] button, the dialog box mentioned below is displayed.

If touch the [OK] button, the file/folder is deleted.

(While executing, "Processing..." message appears on the screen.)

If touch the [Cancel] button, the deletion is canceled.

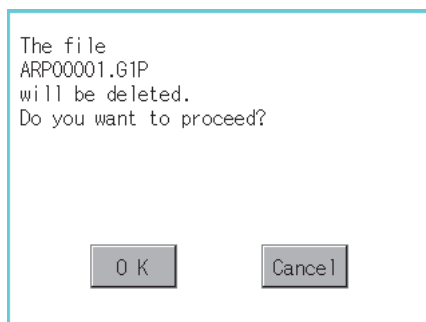

3. When the deletion is completed, the completion dialog box is displayed.

To close the dialog box, touch the [OK] button.

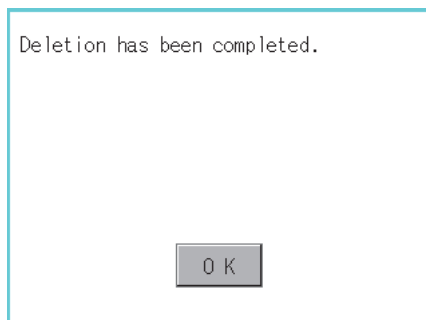

4. When it cannot be deleted, the dialog box showed below appears. (Only when deleting a folder is executed.)

Verify that there is no file in the folder and execute the delete operation again.

📖 Page 302 Precautions



Precautions

When creating or deleting folders or files

Number of characters set for a folder or file name when creating a folder or file

GOT recognizes file location according to path explained below.

Specify folder or file name, and total characters of path cannot exceed 78 characters.

Users only can rename folder or file name.

(Other than folder/file name is automatically printed.)

Example: CSV file path in a data storage

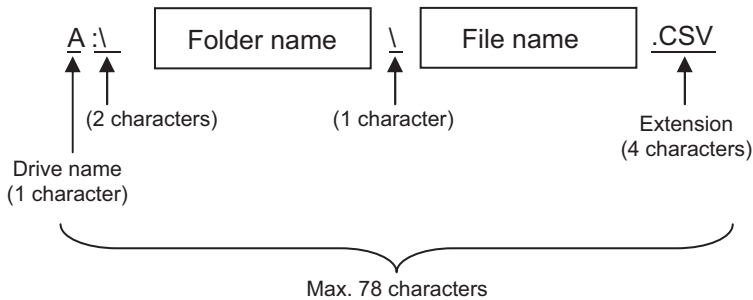

Point

If folder is assigned the hierarchy.

The \ mark is displayed between a folder name and folder name, a folder name and file name. The \ mark is also counted as one character.

Character strings that cannot be set to a folder/file

The following character strings cannot be used as a folder name or a file name. Even small characters of those cannot be used.

• COM1 to COM9	• LPT1 to LPT9	• AUX	• CON
• NUL	• PRN	• CLOCK\$	

In addition, the folder/file name showed below cannot be used.

The folder name which begins with G2

Folder name and file name which begins with . (period)

Folder name and file name which ends with . (period)

Folder name and file name which has only . (one period) or ..(two periods)

For deleting the folder

The folder in which the file exists cannot be deleted.

Delete the folder after having deleted the files.

In addition, on the recipe information screen, the file other than that for recipe is not displayed on the GOT.

When the folder, in which there is no file displayed on the screen, cannot be deleted, confirm whether there is other file in the data storage by using a personal computer, etc.

Available character codes

Although characters other than one-byte alphanumeric characters (ASCII) can be used for a file name, the characters become garbled when the file name is displayed on the file list of the utility screen.

When operating files on the utility screen, use one-byte alphanumeric characters (ASCII) for file names.

Restrictions on the file display area of the recipe file list screen

- Number of files displayed in the folder display area

If the number of the files stored in one folder is 501 or more, the 501st and later files are not displayed.

- Number of characters set for folder and file names at the creation of new folders and files

Specify the folder and file names so that the number of the characters for the path is 84 or less.

If the number of the characters is 85 or more, the 85th and later characters are not displayed.

Precautions for operation

■Precautions during folder/file operation (Create/Delete/Copy/File output, etc)

Even if the cover of the SD card interface is opened while the GOT is processing folders and files, the processing continues to be executed. (Example: Even if the cover of the SD card interface is opened while the GOT is creating a folder, the folder is created.)

Therefore, do not pull out the SD card while the "Processing..." message is on the screen after the cover of the SD card interface is opened.

■While GOT is accessing to other file (Alarm data, etc)

When folder/file processing for the recipe is executed while the GOT is in access to other file (SD card access LED ON), the GOT executes folder/file processing for the recipe after the processing for other file has completed.

Therefore, it may take some time to finish the process of recipe folder/file.(The "Processing..." message is displayed on the screen.)

Point

Estimation of processing time

The process may take time depending on the setting of advanced recipe file to be operated. (The more number of blocks increases, the longer it takes to process recipe folder/file.)

The following shows the reference values for connection to a QCPU using the direct CPU connection (serial).

Device point: 32767 points setting, transmission speed: 115200bps

- When the block setting number is 1: about 17 seconds
- When the block setting number is 2048: about 4 minutes

■Reading or writing the device values of the recipe file moved or renamed

If you move or rename a recipe file, specify the new path or file name in the [Recipe] dialog in GT Designer3.

Write the project data to the GOT afterward.

■Changing a folder or file name

You cannot change only the case of the characters in a folder or file name.

Example)

Before change		After change
JANUARY	————→	january
january	————→	JANUARY
january	————→	January

To change only the case of the characters in a folder or file name, rename the folder or file to a different name, and then rename the folder or file back to its original name with the case changed.

■G2P file to which recipe data is exported

In the recipe operation window, you cannot manipulate a G2P file to which recipe data is exported.

6.5 Logging Information

Function of logging information

Logging files created with the logging function can be copied, deleted or renamed, etc.

Without using a personal computer, you can manage logging files on the GOT.

For details on the logging function, refer to the following.

GT Designer3 (GOT2000) Screen Design Manual

Function	Description	Reference
Information display of files and folders	Displays name, data size, creation date and time of file or folder.	Page 305 Example of logging information display, Page 306 Logging information operation
G2L → CSV conversion	Converts a G2L file of a logging file to a CSV file.	Page 307 G2L → CSV conversion operation, G2L → TXT conversion operation
G2L → TXT conversion	Converts a G2L file of a logging file to a Unicode text file.	Page 307 G2L → CSV conversion operation, G2L → TXT conversion operation
Deletion	Deletes a file or folder.	Page 309 Deletion operation
Copy	Copies the file.	Page 310 Copy operation
Move	Moves the file.	Page 312 Move operation
Rename	Renames the file.	Page 314 Rename operation
Create Folder	New folder is created.	Page 315 Folder create operation

Display operation of logging information

Data management

Utility main menu

60T basic set | Ext. func. set | Maintenance | Monitor | **Data mg.**

Touch [Logging information].

Logging information

Select drive: A:\PACKAGE1\LOG00001\

Kind	Name	Size	Date	Time
DIR	..			
<input checked="" type="checkbox"/>	G2L.LOG00001	0.2KB	08-03-18	11:47
<input type="checkbox"/>	G2L.LOG00001_0000	1.0KB	08-03-18	11:47
<input type="checkbox"/>	G2L.LOG00001_0001	1.3KB	08-03-18	11:46
<input type="checkbox"/>	G2L.LOG00001_0002	1.3KB		
<input type="checkbox"/>	G2L.LOG00001_0003	1.3KB		
<input type="checkbox"/>	G2L.LOG00001_0005	1.3KB	08-03-18	11:47
<input type="checkbox"/>	G2L.LOG00001_0006	1.3KB	08-03-18	11:47

Free space: 3.6GB
Drive capacity: 3.7GB

1 files are selected (0.2KB in total)
Number of selectable files in this folder: 7 files

Buttons: Select all files | G2L→CSV | G2L→TXT | Copy | Move | Rename | CreateFolder | Del

Example of logging information display

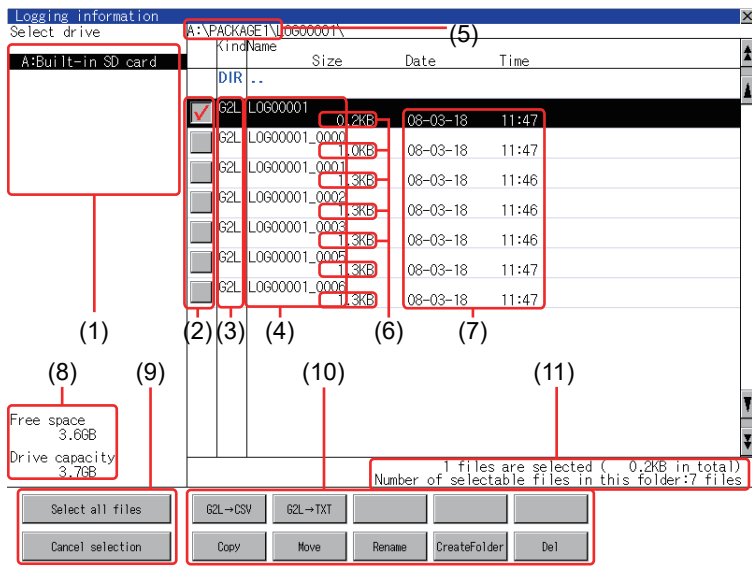

Number	Item	Description
(1)	Select drive	Select a drive to display files or folders. When a USB memory or network drive is used, the following drives are displayed. <ul style="list-style-type: none"> • SD card: [A: Built-in SD card] • USB memory: [B: USB Drive], [E: USB Drive], [F: USB Drive], and [G: USB Drive] • Network drive: [N: Network drive] *1
(2)	Check box	If the check box is selected, up to 512 files can be selected.
(3)	Kind	Indicates whether the displayed name is file or folder. Displays the extension for a file and "DIR" for a folder.
(4)	Name	Displays the file name or folder name. For the long file/folder name, entire part may not be displayed. Confirm the nondisplayed part with the [Rename] button, etc. ☞ Page 314 Rename operation After confirmation, touch the [Cancel] button to cancel the operation.
(5)	Path name	Displays the path name of drive /folder which is currently displayed.
(6)	Size	Displays the size of the file displayed in Name.
(7)	Date and time	Displays the creation date and time of each file.
(8)	The size of drive	Displays the size of free area and the entire size of the drive which is selected by drive selection.
(9)	Select all files/Cancel selection	Multiple files can be selected or canceled at once. Touch the [Select all files] button to select all files. If the number of the displayed files exceeds 513, the first 512 files are selected.
(10)	Operation switch	Execution switch of each function.
(11)	Number and size of files	Displays the number of the selected files, the total file size, and the selectable number of files in the folder.

*1 To display the creation date and time of a file or folder using the file server time, set the same time zone for the GOT and file server.

Point

About the displayed file

The files other than that for logging are not displayed on the logging information screen.

Logging information operation

Display operation of logging information

1. If touch a drive of [Select drive], the information of the touched drive is displayed.

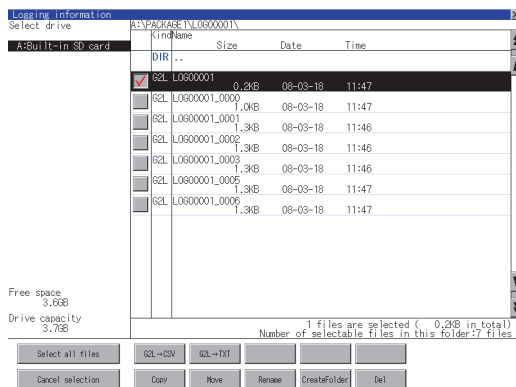

2. If touch a folder name, the information of the touched folder is displayed.
3. If touch a folder of ". .", the information of the folder of the one upper hierarchy is displayed.
4. If touch the ▲▼ button of the scrollbar, the screen scrolls up/down by one line.
If touch the ⬆️⬇️ button, the screen scrolls up/down by one screen.
5. Touch the check box to select the file.
6. For operation of operating switches, refer to the following.
G2L → CSV, G2L → TXT
☞ Page 307 G2L → CSV conversion operation, G2L → TXT conversion operation
Delete
☞ Page 309 Deletion operation
Copy
☞ Page 310 Copy operation
Move
☞ Page 312 Move operation
Rename
☞ Page 314 Rename operation
Create Folder
☞ Page 315 Folder create operation
7. If touch the [x] button, the screen is closed.

G2L → CSV conversion operation, G2L → TXT conversion operation

A logging file (G2L file) is converted to a CSV file or Unicode text file that can be displayed/edited on a personal computer.

1. Touch the check box of a G2L file which is to be converted to a CSV file or Unicode text file to select the file.

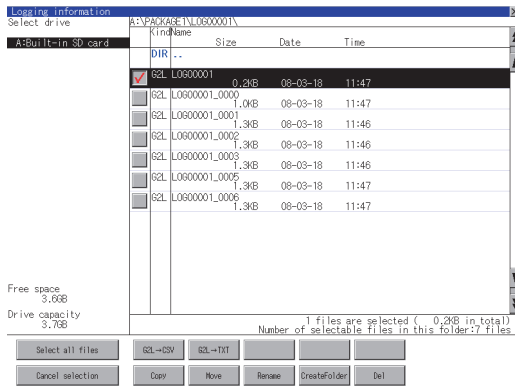

2. Touch the following button in accordance with destination file type.

- CSV file:

[G2L → CSV] button

- Unicode text file:

[G2L → TXT] button

3. Select the target folder.

(Selecting a folder is not needed for outputting directly below the drive.)

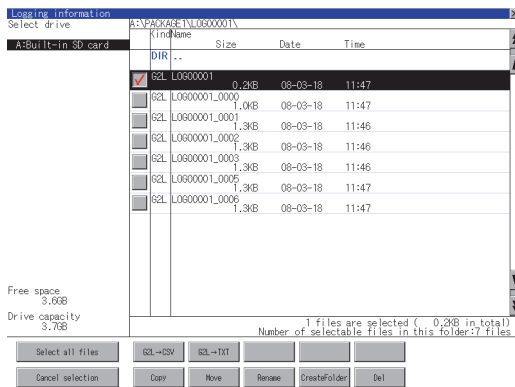

4. If touch the [Exec] button, the dialog box mentioned below is displayed.

Touch the [OK] button.

(While executing, "Processing..." message appears on the screen.)

(Example: Dialog box if the [G2L → CSV] button is touched)

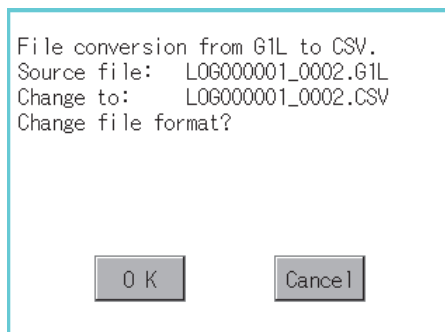

5. When the file, whose name is the same, exists in the destination folder, the dialog box showed below appears without starting the conversion.

To overwrite the file, touch the [OK] button.

To cancel the conversion, touch the [Cancel] button.

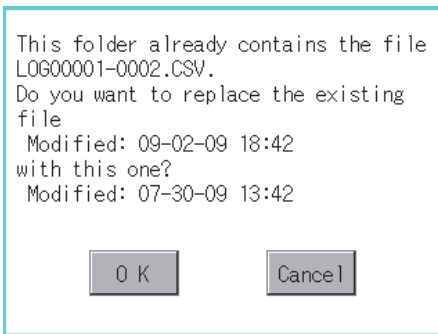

6. The message of completion is displayed in dialog box when conversion is completed.

To close the dialog box, touch the [OK] button.

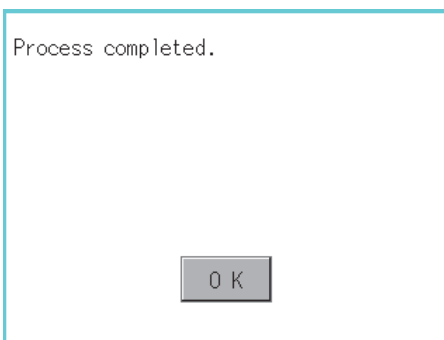

Deletion operation

Folder and file to be used on logging are deleted.

1. Touch the folder to delete or the check box of the file to delete to select the file.

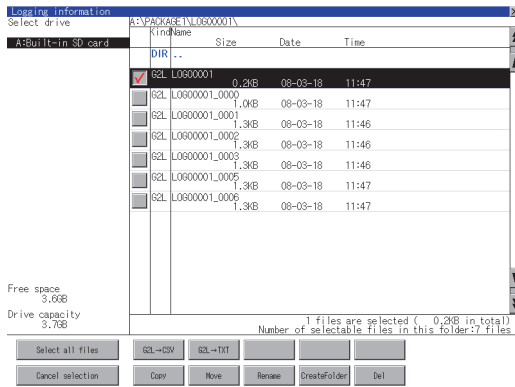

2. If touch the [Del] button, the dialog box mentioned below is displayed.

If touch the [OK] button, the file/folder is deleted.

(While executing, "Processing..." message appears on the screen.)

If touch the [Cancel] button, the deletion is canceled.

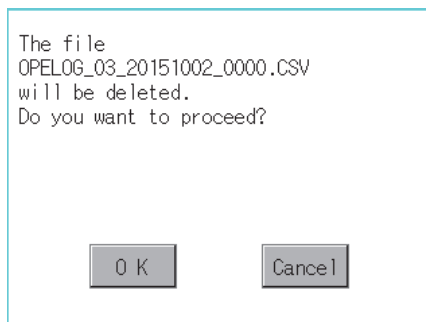

3. When the deletion is completed, the completion dialog box is displayed.

To close the dialog box, touch the [OK] button.

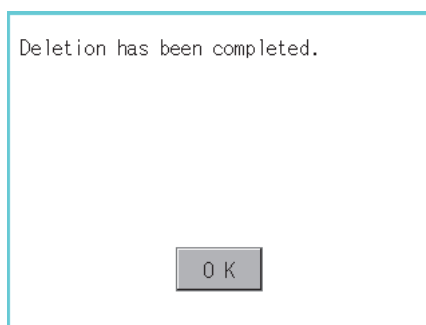

4. When it cannot be deleted, the dialog box showed below appears. (Only when deleting a folder is executed.)

Verify that there is no file in the folder and execute the delete operation again.

Page 316 Precautions



Copy operation

Folder to be used in logging is copied.

1. Touch the check box of the file to copy to select the file.

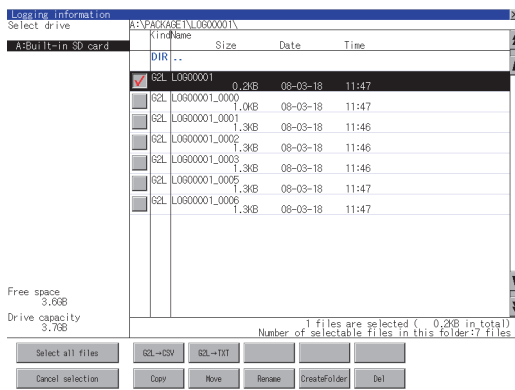

2. Touch the [Copy] button.

3. Select the target folder.

(Selecting a folder is not needed for outputting directly below the drive.)

At this time, it cannot be copied into the same folder where the file exists.

Select other folders.

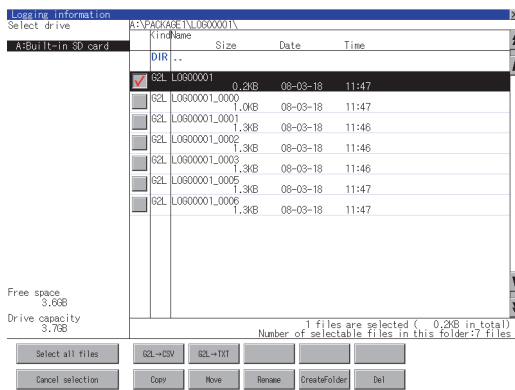

4. If touch the [Exec] button, the dialog box mentioned below is displayed.

Touch the [OK] button.

(While executing, "Processing..." message appears on the screen.)

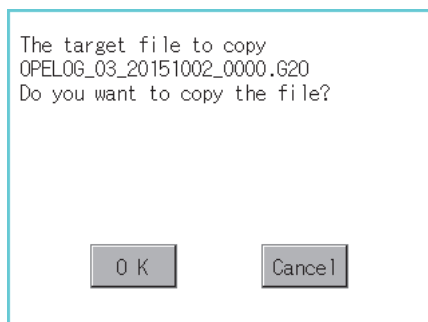

- 5.** If there is a file of the same name in the copy destination folder, the following dialog is displayed without starting the copy.
If touch the [OK] button, overwrites the file.
If touch the [Cancel] button, cancels to copy.

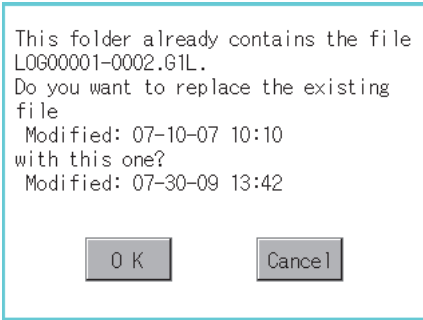

- 6.** When the copy is completed, the dialog box of completion is displayed.
To close the dialog box, touch the [OK] button.

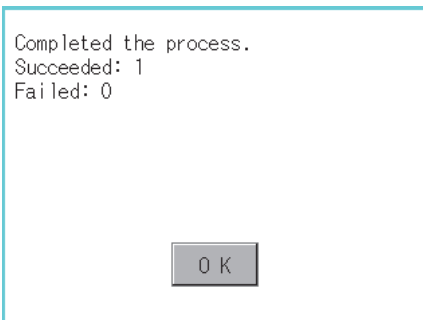

Move operation

An operation log file is moved.

1. Touch the check box of the file to be moved to select the file.

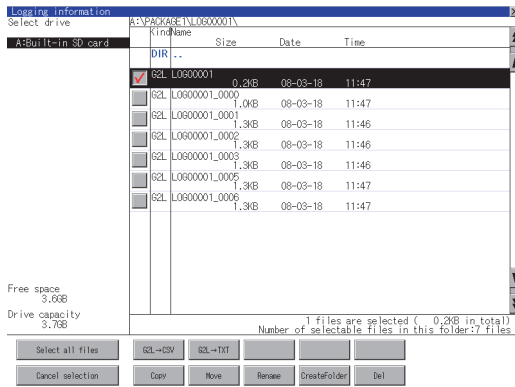

2. Touch the [Move] button.

3. Select the target folder.

(Selecting a folder is not needed for moving directly below the drive.)

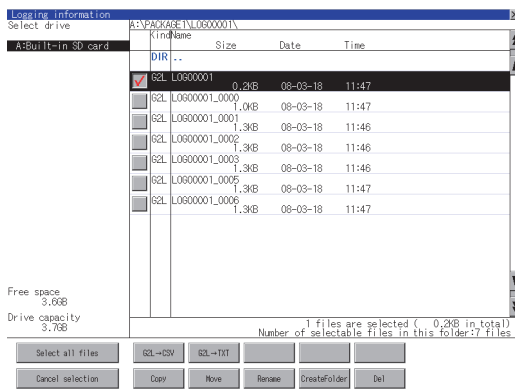

4. If touch the [Exec] button, the dialog box mentioned below is displayed.

Touch the [OK] button.

(While executing, "Processing..." message appears on the screen.)

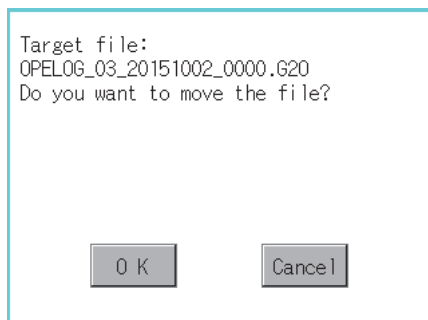

5. When any file with the same name exists in the destination folder, the dialog box shown below appears without starting the movement.

Touching the [OK] button overwrites the file.

If touch the [Cancel] button, cancels moving.

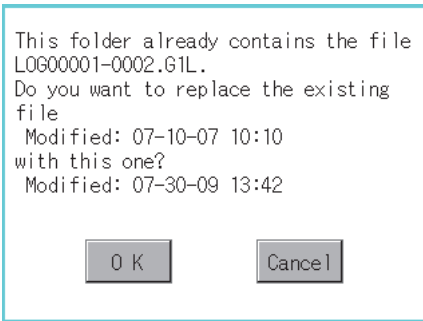

6. When moving is completed, completion dialog box is displayed.

To close the dialog box, touch the [OK] button.

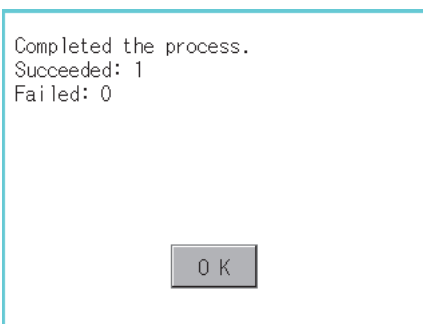

Rename operation

An operation log file is changed.

1. Select the check box of the file to be renamed by touching.

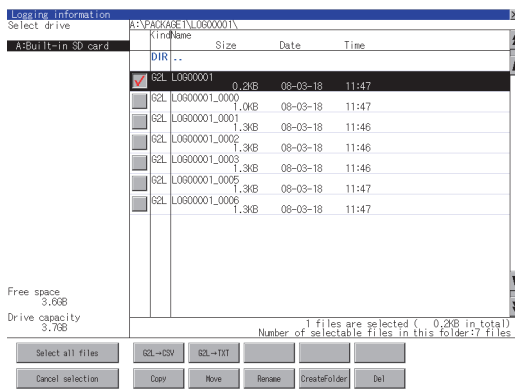

2. Touch the [Rename] button, and then the screen shown below is displayed. Input the file name to be changed. By touching the following button, input text type is changed.

[A-Z]: Alphabet capital

[0-9]: Numeric/Symbol

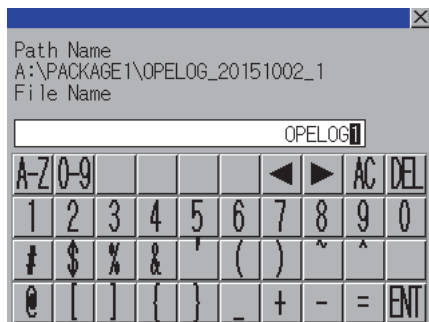

3. Touch the [Enter] button, and then the dialog box shown below is displayed.

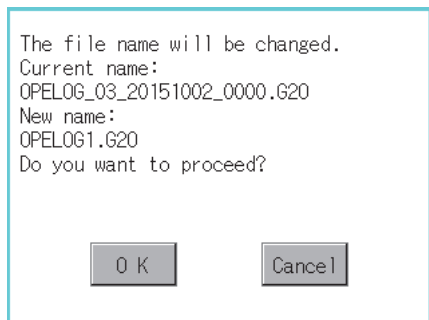

4. Touch the [OK] button, and then renaming the file is started. (While executing, "Processing..." message appears on the screen.)
5. When renaming the file is completed, a completion dialog box is displayed. To close the dialog box, touch the [OK] button.

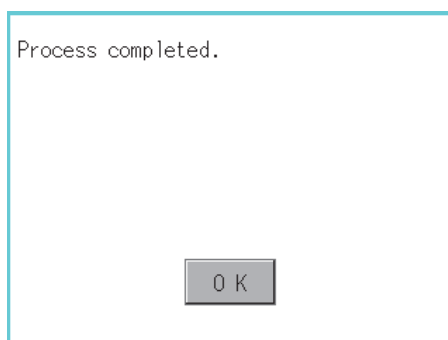

Folder create operation

An operation log folder is created.

1. Touch the [Create Folder] button.

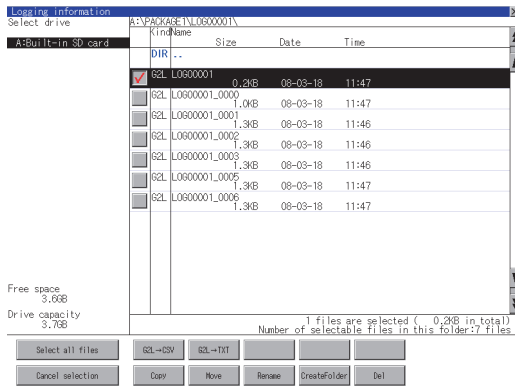

2. The input key window shown below appears, then input the file name to be created. By touching the following button, input text type is changed.

[A-Z]: Alphabet capital
[0-9]: Numeric/Symbol

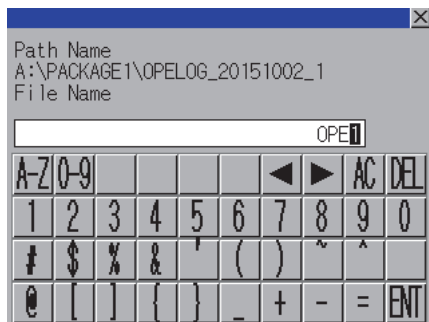

3. Touch the [Enter] button, and then the dialog box shown below is displayed.

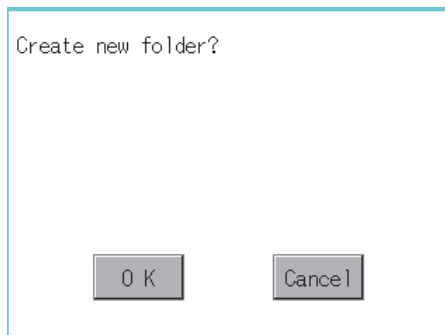

4. If touch the [OK] button, starts creating folder.
5. When creating folder is completed, completion dialog box is displayed. To close the dialog box, touch the [OK] button.

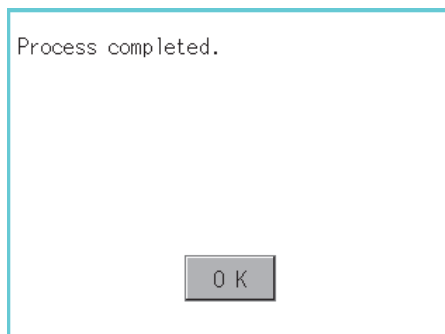

Precautions

When creating or deleting folders or files

Number of characters set for a folder or file name when creating a folder or file

GOT recognizes file location according to path explained below.

Specify folder or file name, and total characters of path cannot exceed 78 characters.

Users only can rename folder or file name.

(Other than folder/file name is automatically printed.)

Example: CSV file path in a data storage

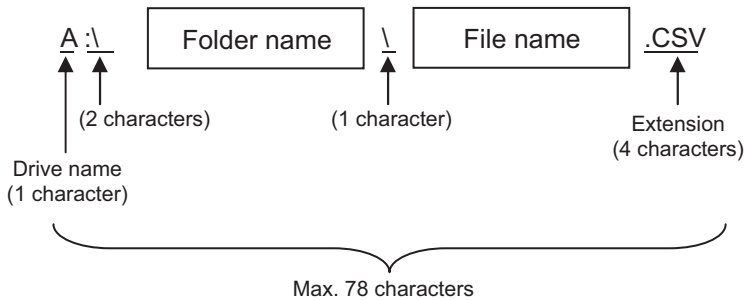

Point

If folder is assigned the hierarchy.

The \ mark is displayed between a folder name and folder name, a folder name and file name. The \ mark is also counted as one character.

Character strings that cannot be set to a folder/file

The following character strings cannot be used as a folder name or a file name. Even small characters of those cannot be used.

• COM1 to COM9	• LPT1 to LPT9	• AUX	• CON
• NUL	• PRN	• CLOCK\$	

In addition, the folder/file name showed below cannot be used.

The folder name which begins with G2

Folder name and file name which begins with . (period)

Folder name and file name which ends with . (period)

Folder name and file name which has only . (one period) or ..(two periods)

For deleting the folder

The folder in which the file exists cannot be deleted.

Delete the folder after having deleted the files.

In addition, on the logging information screen, the files other than logging files are not displayed on GOT.

When the folder, in which there is no file displayed on the screen, cannot be deleted, confirm whether there is other file in the data storage by using a personal computer, etc.

Precautions for operation

■Precautions during folder/file operation (Create/Delete/Copy/File output, etc)

Even if the cover of the SD card interface is opened while the GOT is processing folders and files, the processing continues to be executed. (Example: Even if the cover of the SD card interface is opened while the GOT is creating a folder, the folder is created.)

Therefore, do not pull out the SD card while the "Processing..." message is on the screen after the cover of the SD card interface is opened.

■While GOT is accessing to other file (Alarm data, etc)

When folder/file processing for the logging is executed while the GOT is in access to other files (SD card access LED ON), the GOT executes folder/file processing for the logging after the processing for other files is completed.

Therefore, it may take some time to finish the process of the logging folder/file. (The "Processing..." message is displayed on the screen.)

6.6 Operation Log Information















Function of operation log information

Operation log files created with the operation log function can be copied, deleted or renamed, etc.

Without using a personal computer, you can manage operation log files on the GOT.

For details of the operation log function, refer to the following.

 GT Designer3 (GOT2000) Screen Design Manual

Function	Description	Reference
Information display of files and folders	Displays name, data size, creation date and time of file or folder.	 Page 319 Display operation of operation log information
G2O → CSV conversion	Converts a G2O file of an operation log file to a CSV file.	 Page 323 G2O → CSV conversion operation, G2O → TXT conversion operation
G2O → TXT conversion	Converts a G2O file of an operation log file to a Unicode text file.	 Page 323 G2O → CSV conversion operation, G2O → TXT conversion operation
Deletion	Deletes a file or folder.	 Page 339 Deletion operation
Copy	Copies the file.	 Page 333 Copy operation
Move	Moves the file.	 Page 335 Move operation
Rename	Renames the file.	 Page 337 Rename operation
Create Folder	Creates a folder.	 Page 338 Folder create operation
List	Displays operation logs in a list and allows searching.	 Page 327 List display
Switching the display format	Changes the display format of an operation log.	 Page 329 Display format switching operation
Switching display order	Changes the display order of an operation log.	 Page 329 Display order switching operation
Switching the screen image display	Switches between displaying and hiding the window of the screen image on the operation log list.	 Page 330 Display operation of screen image
Search	Searches an operation log.	 Page 331 Search operation
Changing the date format	Changes the date format used for the [Operation Log Data List] screen and the dialogs displayed from the [Operation Log Data List] screen.	 Page 332 Date format change operation
Latest	Displays the latest operation log in a list.	 Page 325 Latest display

Display operation of operation log information

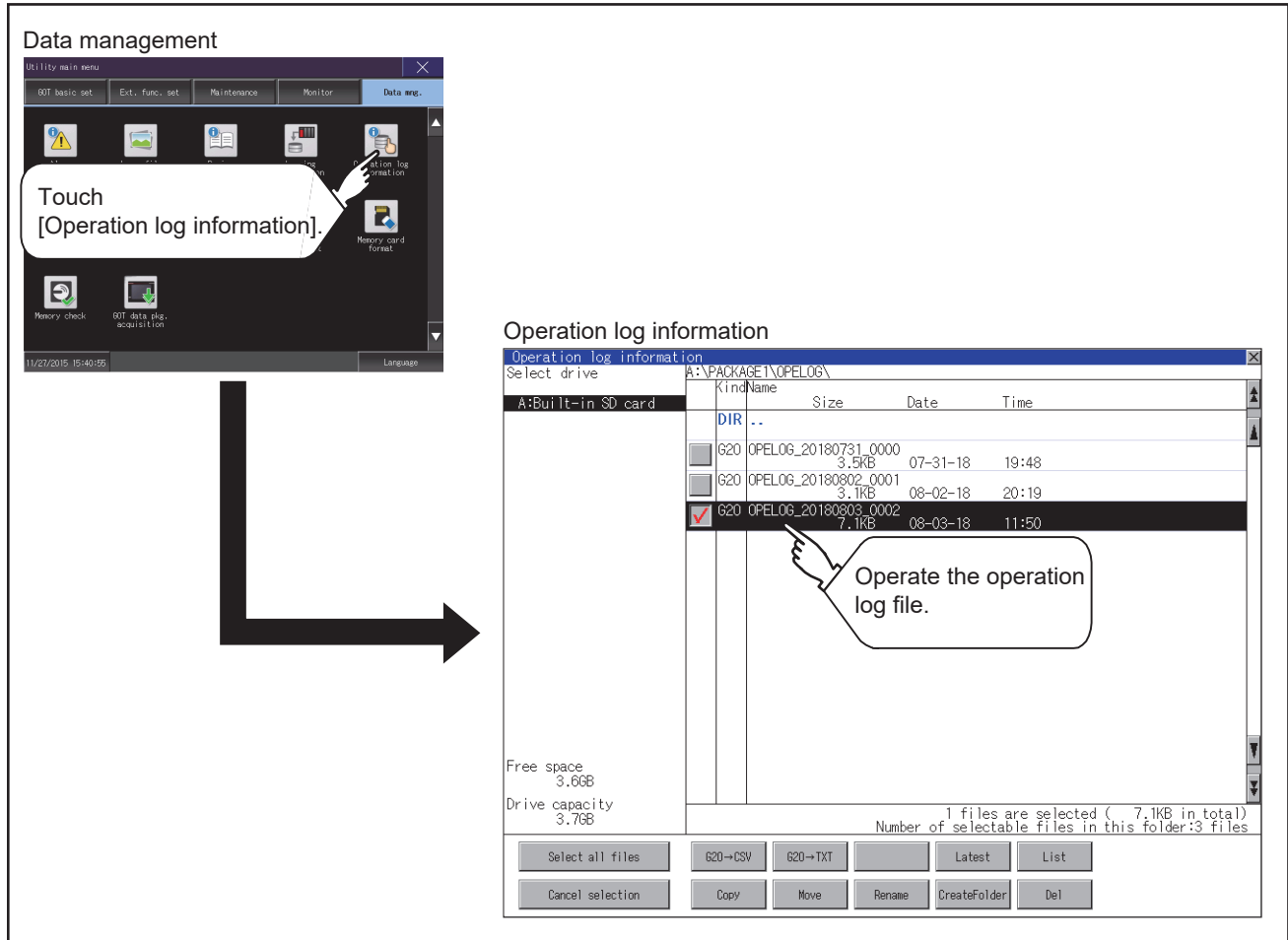

Point

Default display drive when displaying the operation log information screen.
 When [Save to] of the [Environmental Setting] dialog is set in GT Designer3, the default display drive for displaying the operation log information screen is the drive set in GT Designer3.

📖 GT Designer3 (GOT2000) Screen Design Manual

In the following cases, the default display drive is A drive.

- [Save to] is not specified in GT Designer3.
- The drive set as [Save to] in GT Designer3 is not found.

Example of operation log information display

Operation log information screen

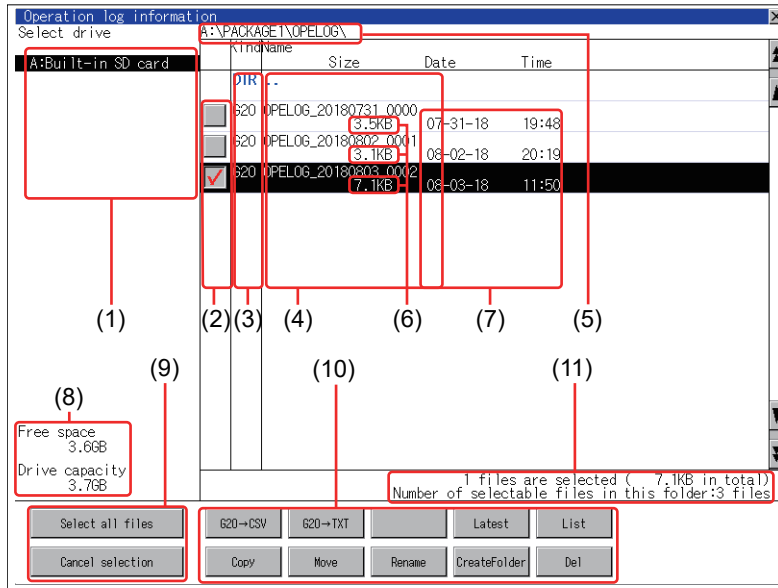

Number	Item	Description
(1)	Select drive	Select a drive to display files or folders. When a USB memory is installed in a drive, the drive is displayed. • SD card: [A: Built-in SD card] • USB memory: [B: USB Drive], [E: USB Drive], [F: USB Drive], and [G: USB Drive]
(2)	Check box	If the check box is selected, up to 512 files can be selected.
(3)	Kind	Indicates whether the displayed name is file or folder. Displays the extension for a file and "DIR" for a folder.
(4)	Name	Displays the file name or folder name. For the long file/folder name, entire part may not be displayed. Confirm the nondisplayed part with the [Rename] button, etc. ☞ Page 337 Rename operation After confirmation, touch the [Cancel] button to cancel the operation.
(5)	Path name	Displays the path name of drive /folder which is currently displayed.
(6)	Size	Displays the size of the file displayed in Name.
(7)	Date and time	Displays the creation date and time of each file.
(8)	The size of drive	Displays the size of free area and the entire size of the drive which is selected by drive selection.
(9)	Select all files/Cancel selection	Multiple files can be selected or canceled at once. Touch the [Select all files] button to select all files. If the number of the displayed files exceeds 513, the first 512 files are selected.
(10)	Operation switch	Execution switch of each function.
(11)	Number and size of files	Displays the number of the selected files, the total file size, and the selectable number of files in the folder.

Point

About the displayed file

The files other than that for operation log are not displayed on the operation log information screen.

Operation log data list screen

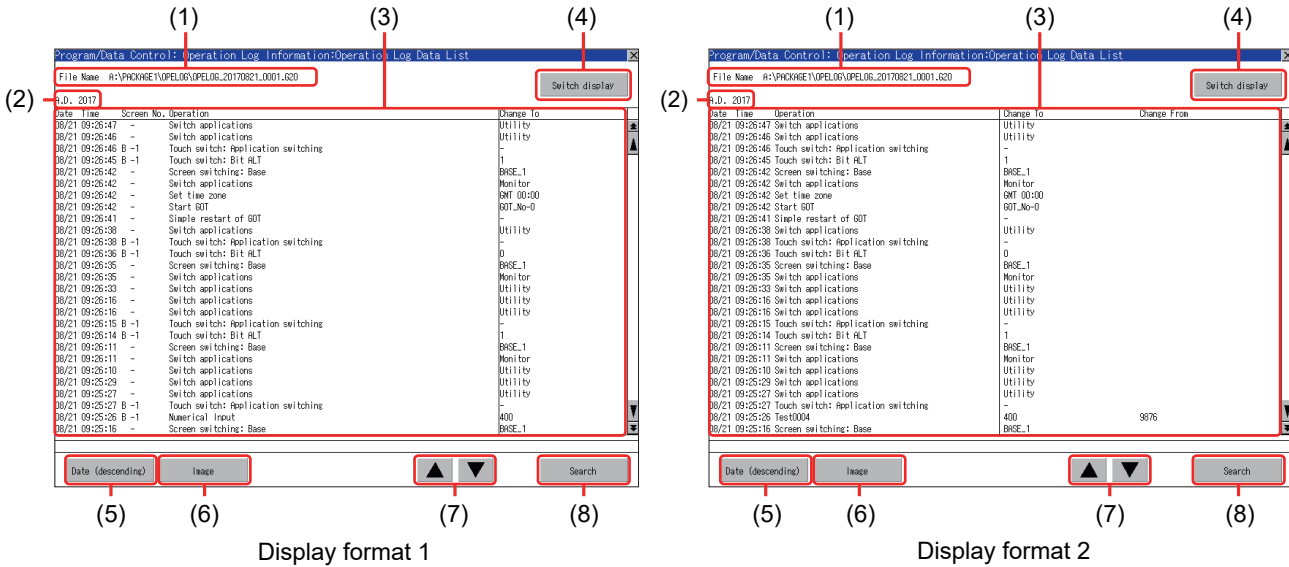

Number	Item	Description
(1)	[File Name]	Displays the file name and path to the displayed operation log file.
(2)	[A.D.]	Displays the year when the operation log file is created.
(3)	[Date]	Displays the operation date.
	[Time]	Displays the operation time.
	[Screen No.]	Displays the operated screen numbers in "screen type-screen number" format. When there is no screen number, - (hyphen) is displayed. The following display formats are used to display the screen types. <ul style="list-style-type: none"> • Base screen: B • Overlap window 1: O1 • Overlap window 2: O2 • Overlap window 3: O3 • Overlap window 4: O4 • Overlap window 5: O5 • Superimpose window 1: S1 • Superimpose window 2: S2 • Dialog: D • Key window: K • Operation panel: P • Mobile screen^{*1}: M
	[Operation] (display format 1)	Displays the operation contents.
	[Operation] (display format 2)	Displays the operation name. For an unnamed operation, the type of the operation is displayed.
	[Change To]	Displays the value after operation.
	[Change From]	Displays the value before operation.
(4)	[Switch display]	Switches between the display format 1 and display format 2. For display format switching operation, refer to the following. <ul style="list-style-type: none"> ☞ Page 329 Display format switching operation
(5)	[Date (descending)], [Date (ascending)]	Changes the display order of an operation logs in ascending or descending order. For display order switching operation, refer to the following. <ul style="list-style-type: none"> ☞ Page 329 Display order switching operation
(6)	[Image]	Displays the window of the screen image corresponding to the operation log in the selected row. For display operation of screen image, refer to the following. <ul style="list-style-type: none"> ☞ Page 330 Display operation of screen image
(7)	▲, ▼	Move the cursor up or down.
(8)	[Search]	Searches the operation for the operation logs by date and time. For search operation for the operation logs, refer to the following. <ul style="list-style-type: none"> ☞ Page 331 Search operation

*1 The display format of the mobile screens are common to base screens (GOT Mobile), overlap windows 1 and 2 (GOT Mobile), and superimpose windows 1 and 2 (GOT Mobile).

Operation log information operation

Display operation of operation log information

1. If touch a drive of [Select drive], the information of the touched drive is displayed.

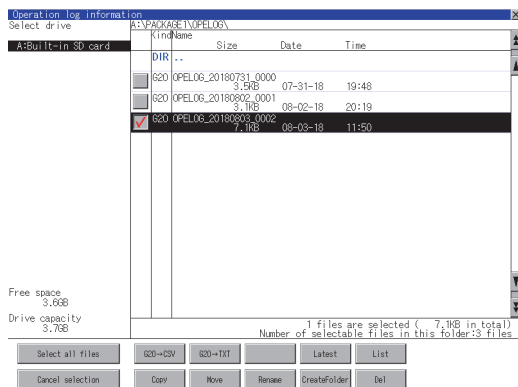

2. If touch a folder name, the information of the touched folder is displayed.
3. If touch a folder of ". .", the information of the folder of the one upper hierarchy is displayed.
4. If touch the button of the scrollbar, the screen scrolls up/down by one line.
If touch the button, the screen scrolls up/down by one screen.
5. Touch the check box to select the file.
6. For operation of operating switches, refer to the following.
 - G2O → CSV, G2O → TXT
 Page 323 G2O → CSV conversion operation, G2O → TXT conversion operation
 - Deletion
 Page 339 Deletion operation
 - Copy
 Page 333 Copy operation
 - Move
 Page 335 Move operation
 - Rename
 Page 337 Rename operation
 - Create Folder
 Page 338 Folder create operation
 - List
 Page 327 List display
 - Latest
 Page 325 Latest display
7. If touch the [x] button, the screen is closed.

Point

Restrictions on the operations of the Operation log information screen

Turning on the Prohibit Operation Log Information Operation signal (GS522.b3) restricts the operations on the Operation log information screen to only the [Latest] and [List] buttons.

For the details, refer to the following.

GT Designer3 (GOT2000) Screen Design Manual

G2O → CSV conversion operation, G2O → TXT conversion operation

An operation log file (G2O file) is converted to a CSV file or Unicode text file that can be displayed/edited on a personal computer.

1. Touch the check box of a G2O file which is to be converted to a CSV file or Unicode text file to select the file.

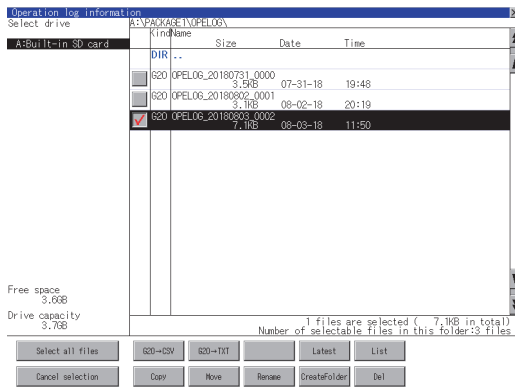

2. Touch the following button in accordance with destination file type.

- CSV file:

[G2O → CSV] button

- Unicode text file:

[G2O → TXT] button

3. Select the target folder.

(Selecting a folder is not needed for outputting directly below the drive.)

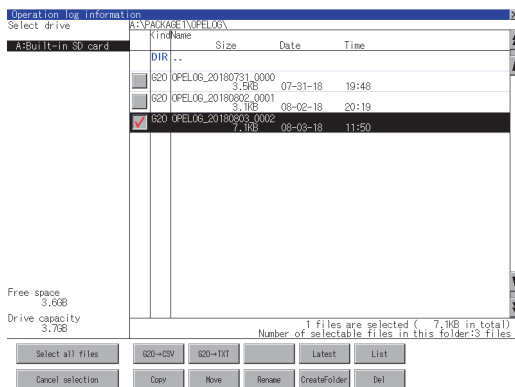

4. If touch the [Exec] button, the dialog box mentioned below is displayed.

Touch the [OK] button.

(While executing, "Processing..." message appears on the screen.)

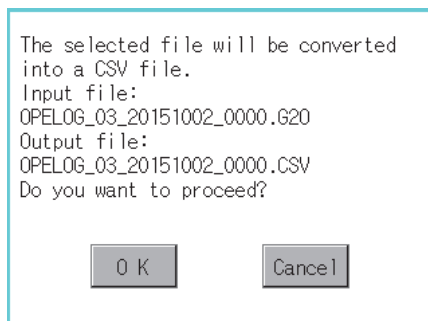

(Example: Dialog box if the [G2O → CSV] button is touched)

5. When the file, whose name is the same, exists in the destination folder, the dialog box showed below appears without starting the conversion.

To overwrite the file, touch the [OK] button.

To cancel the conversion, touch the [Cancel] button.

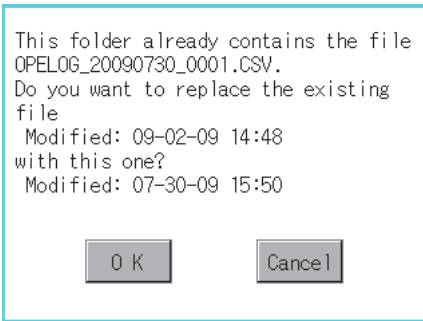

6. The message of completion is displayed in dialog box when conversion is completed.

To close the dialog box, touch the [OK] button.

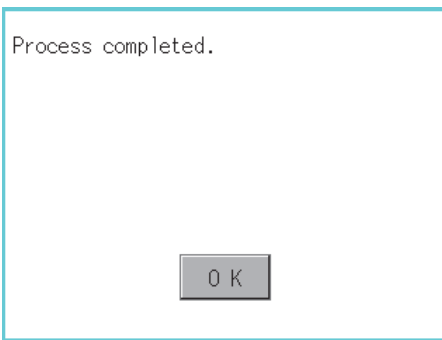

Latest display

The latest operation log files are selected and displayed in a list.

1. If touch the [Latest] button, the latest one in the operation log files is displayed in a list.

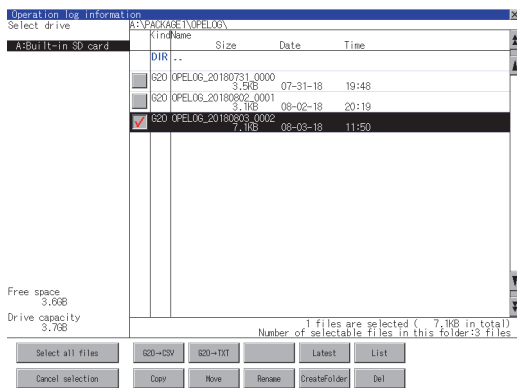

2. Touching the [List] button displays the list. In the list, the following contents can be checked.

Display format	Display item	Description
Display type 1	[Date]	Displays the operation date.
	[Time]	Displays the operation time.
	[Screen No.]	Displays the screen number of the operated screen.
	[Operation]	Displays the operation contents.
	[Change To]	Displays the value after operation.
Display type 2	[Date]	Displays the operation date.
	[Time]	Displays the operation time.
	[Operation]	Displays the operation name. For an unnamed operation, the type of the operation is displayed.
	[Change To]	Displays the value after operation.
	[Change From]	Displays the value before operation.

For operation of operating switches, refer to the following.

Switch display

☞ Page 329 Display format switching operation

☞ Page 329 Display order switching operation

Search

☞ Page 331 Search operation

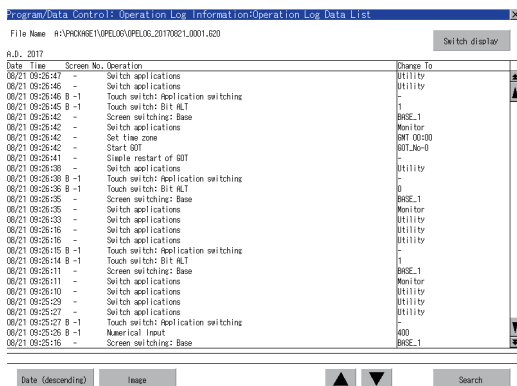

Display format 1

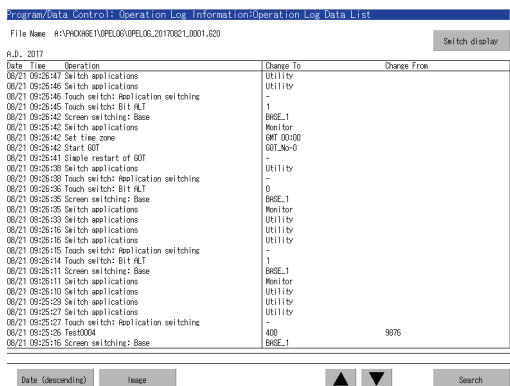

Display format 2

3. For the method for displaying the detail of each operation log, refer to the following.

☞ Page 327 List display

Program/Data Control: Operation Log Information: Operation Log Data List

File Name: R:\PHOENIX\OPEL06\OPEL06.20170821_0001_620

Switch display

R.D., 2017

Date	Time	Screen No.	Operation	Change To	Change From
08/21	09:26:47	-	Switch applications	UI111by	-
08/21	09:26:46	-	Switch applications	UI111by	-
08/21	09:26:46	B-1	Touch switch: Application switching	-	-
08/21	09:26:45	B-1	Touch switch: Bit HLT	1	1
08/21	09:26:45	-	Screen switching: Base	BASE_1	-
08/21	09:26:42	-	Switch applications	Monitor	-
08/21	09:26:42	-	Set time zone	BW 00-00	-
08/21	09:26:42	-	Start B0T	B0T No-0	-
08/21	09:26:41	-	Simple restart of B0T	-	-
08/21	09:26:39	-	Switch applications	UI111by	-
08/21	09:26:38	B-1	Touch switch: Application switching	-	-
08/21	09:26:36	B-1	Touch switch: Bit HLT	0	0
08/21	09:26:35	-	Screen switching: Base	BASE_1	-
08/21	09:26:35	-	Switch applications	Monitor	-
08/21	09:26:33	-	Switch applications	UI111by	-
08/21	09:26:16	-	Switch applications	UI111by	-
08/21	09:26:16	-	Switch applications	UI111by	-
08/21	09:26:15	B-1	Touch switch: Application switching	-	-
08/21	09:26:14	B-1	Touch switch: Bit HLT	1	1
08/21	09:26:11	-	Screen switching: Base	BASE_1	-
08/21	09:26:11	-	Switch applications	Monitor	-
08/21	09:26:10	-	Switch applications	UI111by	-
08/21	09:26:29	-	Switch applications	UI111by	-
08/21	09:26:27	-	Switch applications	UI111by	-
08/21	09:26:27	B-1	Touch switch: Application switching	-	-
08/21	09:26:26	B-1	Numerical Input	400	-
08/21	09:26:16	-	Screen switching: Base	BASE_1	-

Date (descending) Image Search

Display format 1

Program/Data Control: Operation Log Information: Operation Log Data List

File Name: R:\PHOENIX\OPEL06\OPEL06.20170821_0001_620

Switch display

R.D., 2017

Date	Time	Operation	Change To	Change From
08/21	09:26:47	Switch applications	UI111by	-
08/21	09:26:46	Switch applications	UI111by	-
08/21	09:26:46	Touch switch: Application switching	-	-
08/21	09:26:45	Touch switch: Bit HLT	1	1
08/21	09:26:42	Screen switching: Base	BASE_1	-
08/21	09:26:42	Switch applications	Monitor	-
08/21	09:26:42	Set time zone	BW 00-00	-
08/21	09:26:42	Start B0T	B0T No-0	-
08/21	09:26:41	Simple restart of B0T	-	-
08/21	09:26:39	Switch applications	UI111by	-
08/21	09:26:38	Touch switch: Application switching	-	-
08/21	09:26:36	Touch switch: Bit HLT	0	0
08/21	09:26:35	Screen switching: Base	BASE_1	-
08/21	09:26:35	Switch applications	Monitor	-
08/21	09:26:33	Switch applications	UI111by	-
08/21	09:26:16	Switch applications	UI111by	-
08/21	09:26:16	Switch applications	UI111by	-
08/21	09:26:15	Touch switch: Application switching	-	-
08/21	09:26:14	Touch switch: Bit HLT	1	1
08/21	09:26:11	Screen switching: Base	BASE_1	-
08/21	09:26:11	Switch applications	Monitor	-
08/21	09:26:10	Switch applications	UI111by	-
08/21	09:26:29	Switch applications	UI111by	-
08/21	09:26:27	Switch applications	UI111by	-
08/21	09:26:27	Touch switch: Application switching	-	-
08/21	09:26:26	Tex 0004	400	9876
08/21	09:26:16	Screen switching: Base	BASE_1	-

Date (descending) Image Search

Display format 2

List display

Displays operation logs in an operation log file in a list.

1. Touch the check box of the file to display the list to select the file.

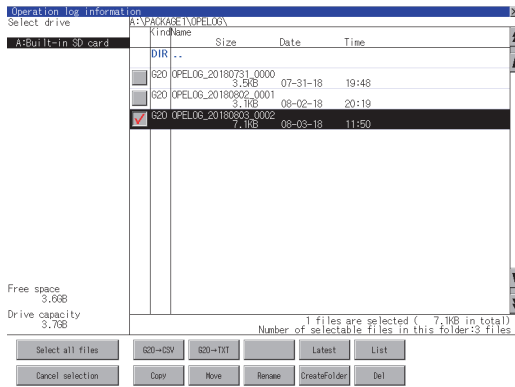

2. Touching the [List] button displays the list. In the list, the following contents can be checked.

Display type	Display item	Description
Display type 1	[Date]	Displays the operation date.
	[Time]	Displays the operation time.
	[Screen No.]	Displays the screen number of the operated screen.
	[Operation]	Displays the performed operation.
	[Change To]	Displays the value after the operation.
Display type 2	[Date]	Displays the operation date.
	[Time]	Displays the operation time.
	[Operation]	Displays the operation name. For an unnamed operation, the type of the operation is displayed.
	[Change To]	Displays the value after operation.
	[Change From]	Displays the value before operation.

For operation of operating switches, refer to the following.

Switch display

☞ Page 329 Display format switching operation

Date (ascending/descending)

☞ Page 329 Display order switching operation

Image

☞ Page 330 Display operation of screen image

Search

☞ Page 331 Search operation

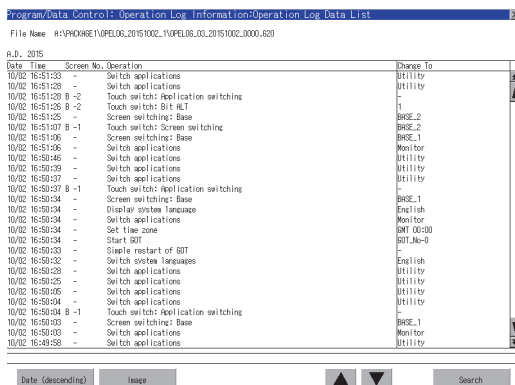

- To display the details of an operation log, touch the row for that operation log to select it. The color of the row is inverted (white black).

Program/Data Control: Operation Log Information/Operation Log Data List

File Name: #1\PK00R61\OPELOG\OPELOG_20170821_0001_020

Sch display

A.D. 2017

Date	Time	Screen No.	Operation	Change To
08/21	08:26:47	-	Switch applications	Utility
08/21	08:26:46	-	Switch applications	Utility
08/21	08:26:46	8 -1	Touch switch: Application switching	-
08/21	08:26:45	8 -1	Touch switch: Bit HLT	1
08/21	08:26:45	-	Screen switching: Base	BASE_1
08/21	08:26:42	-	Switch applications	Monitor
08/21	08:26:42	-	Set time zone	GMT_00:00
08/21	08:26:42	-	Start BOT	BOT_00:0
08/21	08:26:41	-	Simple restart of BOT	-
08/21	08:26:39	-	Switch applications	Utility
08/21	08:26:38	8 -1	Touch switch: Application switching	Utility
08/21	08:26:36	8 -1	Touch switch: Bit HLT	0
08/21	08:26:35	-	Screen switching: Base	BASE_1
08/21	08:26:35	-	Switch applications	Monitor
08/21	08:26:33	-	Switch applications	Utility
08/21	08:26:16	-	Switch applications	Utility
08/21	08:26:16	-	Switch applications	Utility
08/21	08:26:15	8 -1	Touch switch: Application switching	-
08/21	08:26:14	8 -1	Touch switch: Bit HLT	1
08/21	08:26:11	-	Screen switching: Base	BASE_1
08/21	08:26:11	-	Switch applications	Monitor
08/21	08:26:10	-	Switch applications	Utility
08/21	08:26:29	-	Switch applications	Utility
08/21	08:25:27	-	Switch applications	Utility
08/21	08:25:27	8 -1	Touch switch: Application switching	-
08/21	08:25:26	8 -1	Numerical Input	ADD
08/21	08:25:16	-	Screen switching: Base	BASE_1

Search

- Touching the selected row again displays the detailed information for the operation log. Touch the [x] button to close the dialog box.

Date/Time	:10/02/2015 16:50:46	[x]
Function	:AppChng	
Switch applications		
Screen No	:--	
Operation	:	
Operator	:-- (ID:--)	
User ID	:--	
Action No	:--	
Data Type	:--	
Device	:--	
Change To	:Utility	
Change To(Ope.)	:--	
Chng From	:--	
Chng From(Disp)	:--	

■ Display format switching operation

1. Touch the [Switch display] button in the list to switch the screen between the display type 1 and 2.

Date	Time	Screen No.	Operation	Change To	Change From
08/21	09:28:47	-	Switch applications	U1111ty	-
08/21	09:28:46	-	Switch applications	U1111ty	-
08/21	09:28:46	B-1	Touch switch: Application switching	-	-
08/21	09:28:45	B-1	Touch switch: Bit HLT	1	-
08/21	09:28:42	-	Screen switching: Base	BASE_1	-
08/21	09:28:42	-	Switch applications	Monitor	-
08/21	09:28:42	-	Set time zone	GMT_00:00	-
08/21	09:28:42	-	Start GOT	GOT_No-0	-
08/21	09:28:41	-	Simple restart of GOT	-	-
08/21	09:28:38	-	Switch applications	U1111ty	-
08/21	09:28:38	B-1	Touch switch: Application switching	-	-
08/21	09:28:38	B-1	Touch switch: Bit HLT	0	-
08/21	09:28:35	-	Screen switching: Base	BASE_1	-
08/21	09:28:35	-	Switch applications	Monitor	-
08/21	09:28:33	-	Switch applications	U1111ty	-
08/21	09:28:32	-	Switch applications	U1111ty	-
08/21	09:28:16	-	Switch applications	U1111ty	-
08/21	09:28:15	B-1	Touch switch: Application switching	-	-
08/21	09:28:14	B-1	Touch switch: Bit HLT	1	-
08/21	09:28:11	-	Screen switching: Base	BASE_1	-
08/21	09:28:11	-	Switch applications	Monitor	-
08/21	09:28:10	-	Switch applications	U1111ty	-
08/21	09:28:09	-	Switch applications	U1111ty	-
08/21	09:28:07	-	Switch applications	U1111ty	-
08/21	09:28:27	B-1	Touch switch: Application switching	-	-
08/21	09:28:26	B-1	Numerical input	400	9876
08/21	09:28:16	-	Screen switching: Base	BASE_1	-

Display format 1

Display format 2



Operation name display at system language switching

The items appearing in [Operation] of display format 2 depend on the settings on GT Designer3, and thus the display language of the items is not changed with the system language of the GOT.

■ Display order switching operation

1. Touch [Date (ascending)]/[Date (descending)] in the list to switch the display order of operation logs.

[Date (ascending)] and [Date (descending)] are switched every time the button is touched.

The buttons show the current display order.

[Date (ascending)]: Data is displayed in chronological order as collected.

[Date (descending)]: Data is displayed in reverse chronological order as collected.

Date	Time	Screen No.	Operation	Change To
08/21	09:28:47	-	Switch applications	U1111ty
08/21	09:28:46	-	Switch applications	U1111ty
08/21	09:28:46	B-1	Touch switch: Application switching	-
08/21	09:28:45	B-1	Touch switch: Bit HLT	1
08/21	09:28:42	-	Screen switching: Base	BASE_1
08/21	09:28:42	-	Switch applications	Monitor
08/21	09:28:42	-	Set time zone	GMT_00:00
08/21	09:28:42	-	Start GOT	GOT_No-0
08/21	09:28:41	-	Simple restart of GOT	-
08/21	09:28:38	-	Switch applications	U1111ty
08/21	09:28:38	B-1	Touch switch: Application switching	-
08/21	09:28:38	B-1	Touch switch: Bit HLT	0
08/21	09:28:35	-	Screen switching: Base	BASE_1
08/21	09:28:35	-	Switch applications	Monitor
08/21	09:28:33	-	Switch applications	U1111ty
08/21	09:28:32	-	Switch applications	U1111ty
08/21	09:28:16	-	Switch applications	U1111ty
08/21	09:28:15	B-1	Touch switch: Application switching	-
08/21	09:28:14	B-1	Touch switch: Bit HLT	1
08/21	09:28:11	-	Screen switching: Base	BASE_1
08/21	09:28:11	-	Switch applications	Monitor
08/21	09:28:10	-	Switch applications	U1111ty
08/21	09:28:09	-	Switch applications	U1111ty
08/21	09:28:07	-	Switch applications	U1111ty
08/21	09:28:27	B-1	Touch switch: Application switching	-
08/21	09:28:26	B-1	Numerical input	400
08/21	09:28:16	-	Screen switching: Base	BASE_1



- Selected line position after switching the display order

After the display order is switched while lines are selected, the lines still remain selected.

Depending on which line is selected, the selected line may not be displayed on the screen after switching the display order.

- Display order of operation logs in non-chronological order

When the display order of operation logs are switched, the logs are displayed in order as collected, not in order as the date they are collected.

In case that the displayed operation logs are not lined up in time order due to the time change of GOT clock, the displayed logs may not be lined up in order of the log dates even though the operation logs are switched.

■ Display operation of screen image

1. Touch the [Image] button in the list to switch displaying/hiding the window of the screen image corresponding to the operation log in the selected row.

Touch the title bar to move the window of the screen image.

The window of the screen image is displayed until the display of the list is closed.

Touch the [x] button to close the window of the screen image.

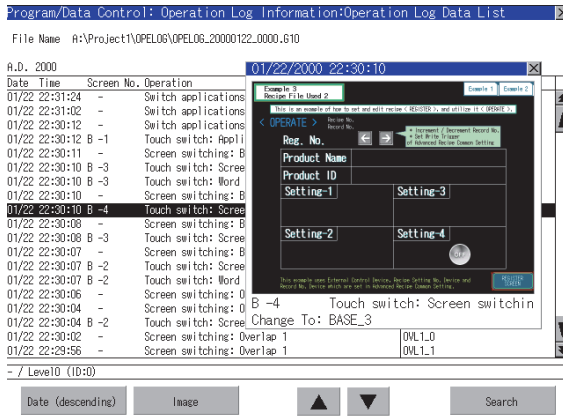

- When the row in the operation log is not selected, or when the row in the operation log, which indicates an error such as data damaged, is selected

The window color of the screen image is a gray.

- Whether to display the screen image or not

Whether the screen image is displayed or not depends on the object type or the operation type.

- Precautions for displaying the screen image

The screen image to be displayed is an object or a shape based on the object data.

Therefore, if the numerical display, the lamp display, and others exist on the screen, the numeric value and the status of the lamp in the actual operation are not displayed.

If the project data when the operation log is collected is different from that currently in operation, the screen image might not be displayed properly.

■ Search operation

1. Touching [Search] in the list enables searching of a log using the following items.

Item: Date

Time

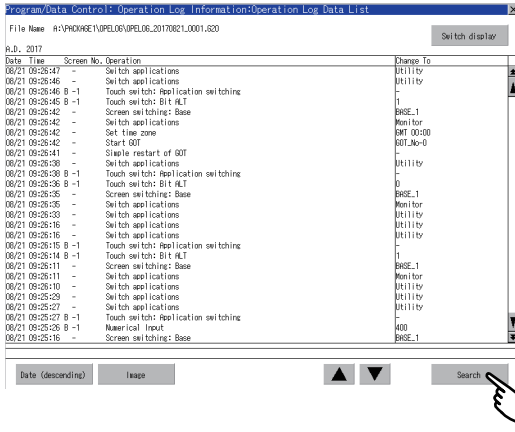

2. Input the date or time to be searched.

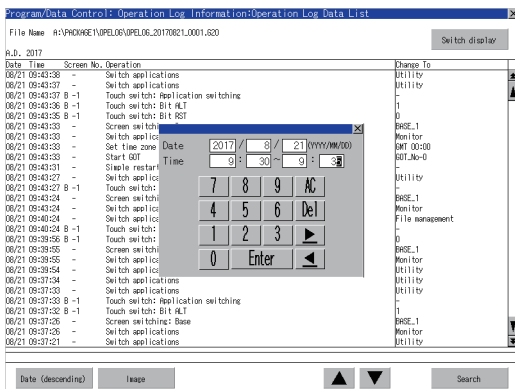

3. Touch the [Enter] button, and then the dialog box shown below is displayed.

Touch the [OK] button.

(When processing is being executed, the "Processing" message is displayed on the screen.)

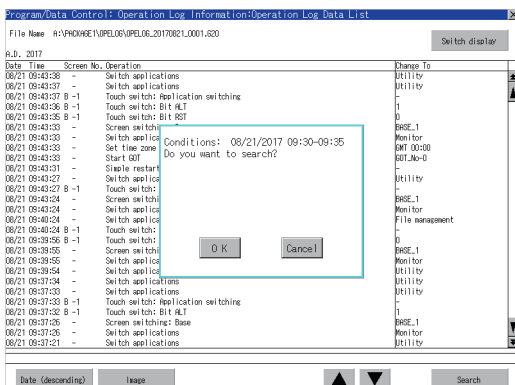

4. The results found are displayed and the dialog box shown below is displayed.

To continue a search, touch the [OK] button.

To stop a search, touch the [Cancel] button.

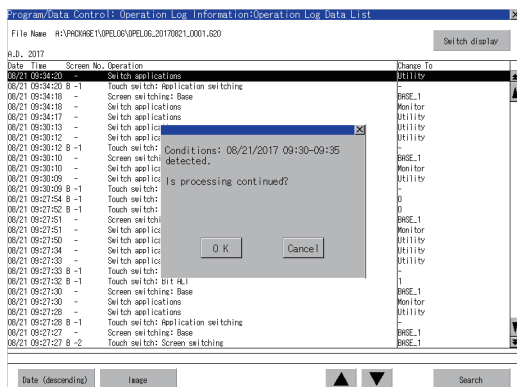

5. When searching is completed, a completion message is displayed in the dialog box.

To close the dialog box, touch the [OK] button.

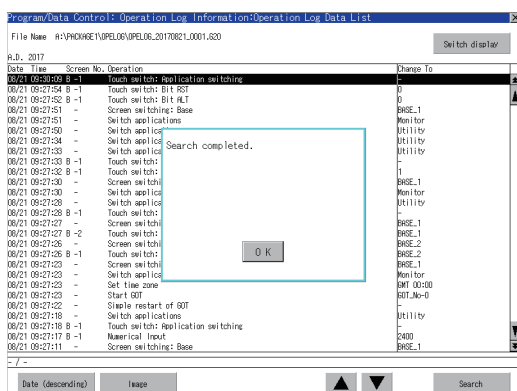

■ Date format change operation

Use GS632 to change the data format for the [Operation Log Data List] screen and the dialogs displayed from the [Operation Log Data List] screen.

For the details, refer to the following.

📖 GT Designer3 (GOT2000) Screen Design Manual

Copy operation

An operation log file is copied.

1. Touch the check box of the file to copy to select the file.

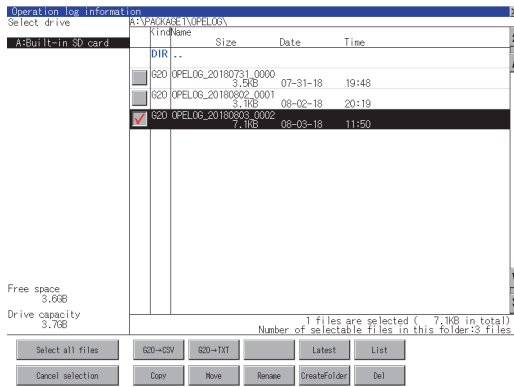

2. Touch the [Copy] button.

3. Select the target folder.

(Selecting a folder is not needed for outputting directly below the drive.)

At this time, it cannot be copied into the same folder where the file exists.

Select other folders.

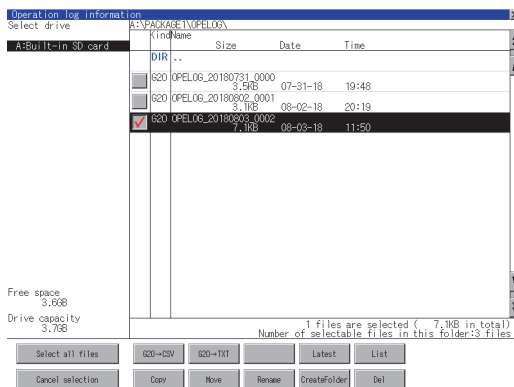

4. If touch the [Exec] button, the dialog box mentioned below is displayed.

Touch the [OK] button.

(While executing, "Processing..." message appears on the screen.)

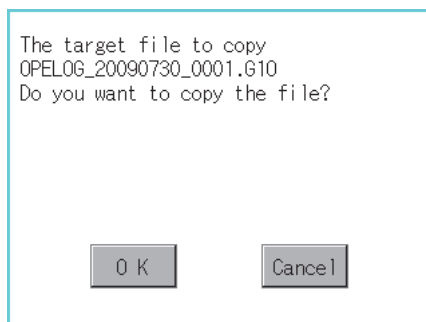

- 5.** If there is a file of the same name in the copy destination folder, the following dialog is displayed without starting the copy.
If touch the [OK] button, overwrites the file.
If touch the [Cancel] button, cancels to copy.

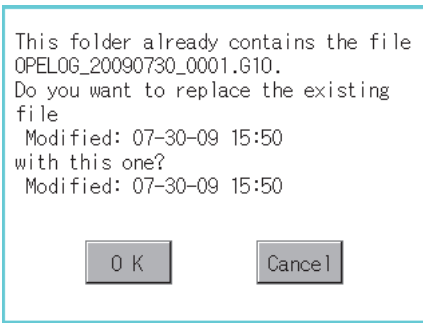

- 6.** When the copy is completed, the dialog box of completion is displayed.
To close the dialog box, touch the [OK] button.

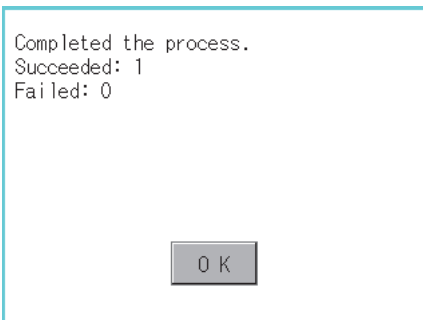

Move operation

An operation log file is moved.

1. Touch the check box of the file to be moved to select the file.

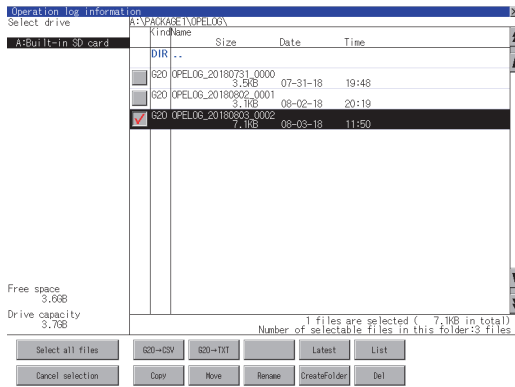

2. Touch the [Move] button.

3. Select the target folder.

(Selecting a folder is not needed for moving directly below the drive.)

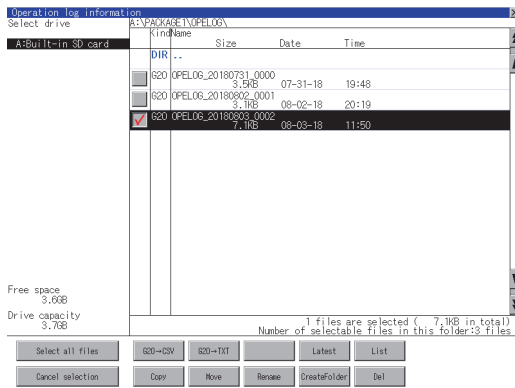

4. If touch the [Exec] button, the dialog box mentioned below is displayed.

Touch the [OK] button.

(While executing, "Processing..." message appears on the screen.)

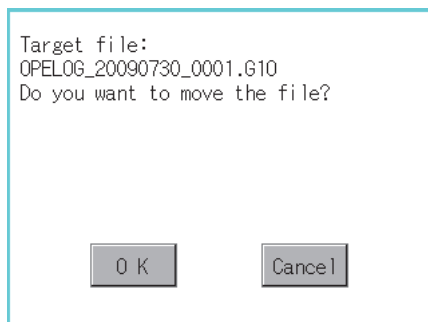

5. When any file with the same name exists in the destination folder, the dialog box shown below appears without starting the movement.

Touching the [OK] button overwrites the file.

If touch the [Cancel] button, cancels moving.

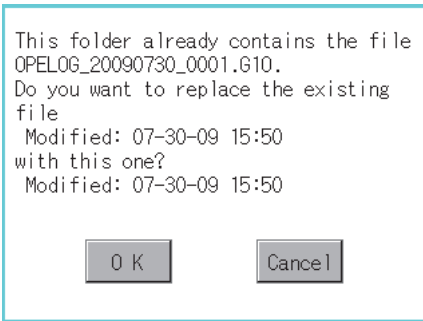

6. When moving is completed, completion dialog box is displayed.

To close the dialog box, touch the [OK] button.

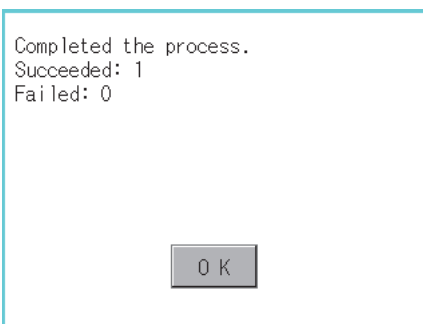

Rename operation

An operation log file is changed.

1. Select the check box of the file to be renamed by touching.

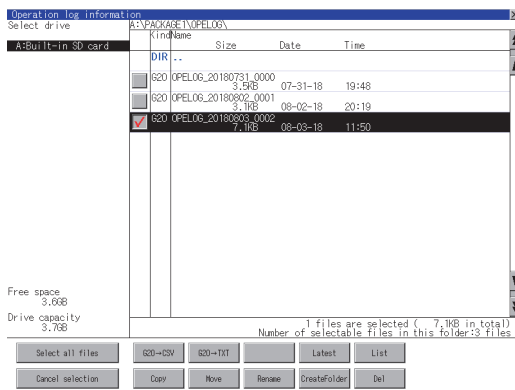

2. Touch the [Rename] button, and then the screen shown below is displayed. Input the file name to be changed. By touching the following button, input text type is changed.

[A-Z]: Alphabet capital
[0-9]: Numeric/Symbol



3. Touch the [Enter] button, and then the dialog box shown below is displayed.

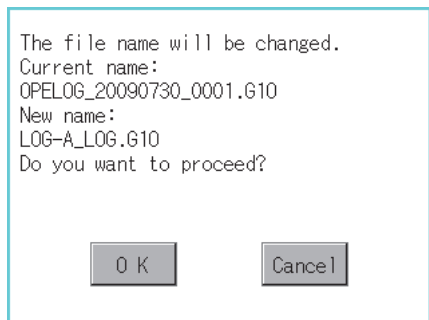

4. Touch the [OK] button, and then renaming the file is started. (While executing, "Processing..." message appears on the screen.)
5. When renaming the file is completed, a completion dialog box is displayed. To close the dialog box, touch the [OK] button.

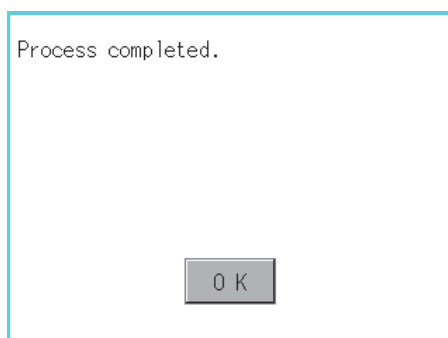

Folder create operation

An operation log folder is created.

1. Touch the [Create Folder] button.

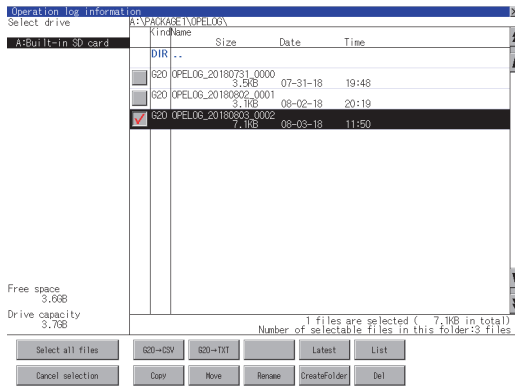

2. The input key window shown below appears, then input the file name to be created. By touching the following button, input text type is changed.

[A-Z]: Alphabet capital
[0-9]: Numeric/Symbol



3. Touch the [Enter] button, and then the dialog box shown below is displayed.

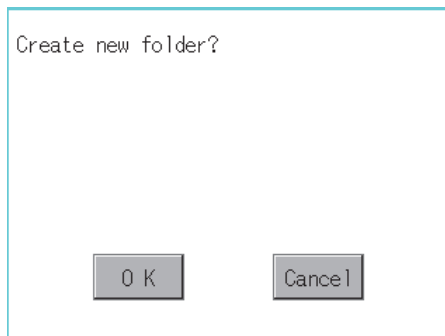

4. If touch the [OK] button, starts creating folder.
5. When creating folder is completed, completion dialog box is displayed. To close the dialog box, touch the [OK] button.

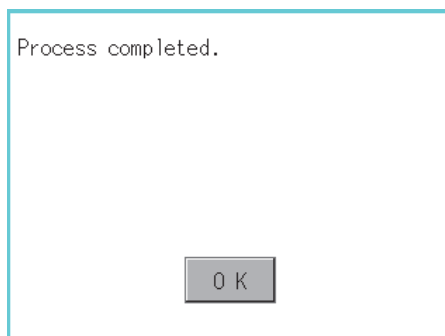

Deletion operation

Folder and file to be used on operation log are deleted.

1. Touch the folder to delete or the check box of the file to delete to select the file.

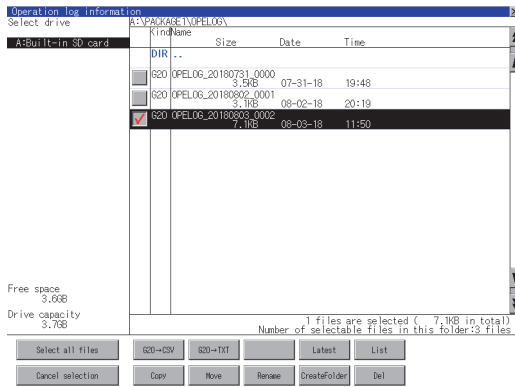

2. If touch the [Del] button, the dialog box mentioned below is displayed.

If touch the [OK] button, the file/folder is deleted.

(While executing, "Processing..." message appears on the screen.)

If touch the [Cancel] button, the deletion is canceled.

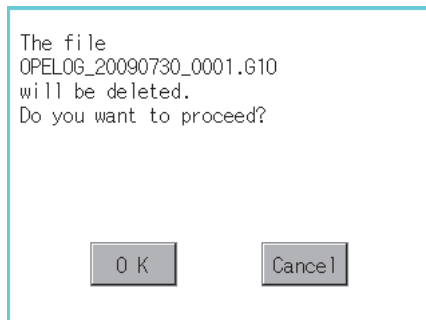

3. When the deletion is completed, the completion dialog box is displayed.

To close the dialog box, touch the [OK] button.

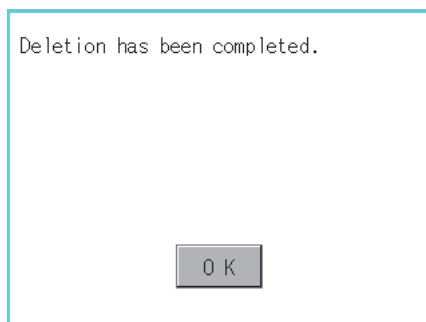

4. When it cannot be deleted, the dialog box showed below appears. (Only when deleting a folder is executed.)

Verify that there is no file in the folder and execute the delete operation again.

Page 340 Precautions

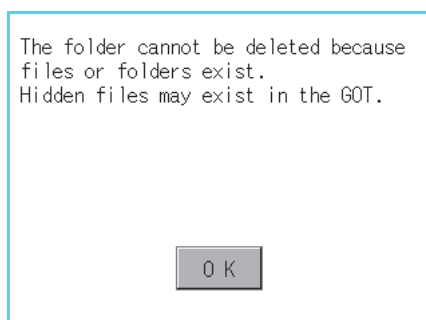

Precautions

When creating or deleting folders or files

Number of characters set for a folder or file name when creating a folder or file

GOT recognizes file location according to path explained below.

Specify folder or file name, and total characters of path cannot exceed 78 characters.

Users only can rename folder or file name.

(Other than folder/file name is automatically printed.)

Example: CSV file path in a data storage

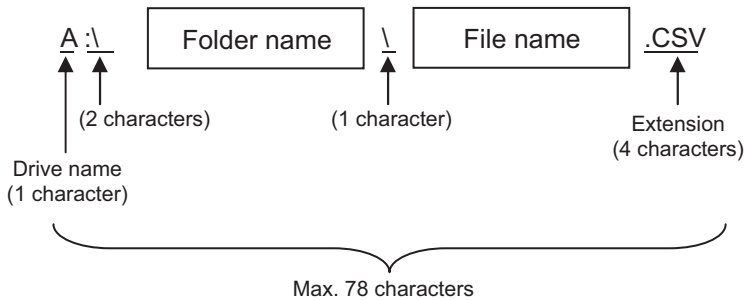

Point

If folder is assigned the hierarchy.

The \ mark is displayed between a folder name and folder name, a folder name and file name. The \ mark is also counted as one character.

Character strings that cannot be set to folder/file

The following character strings cannot be used as a folder name or a file name. Even small characters of those cannot be used.

• COM1 to COM9	• LPT1 to LPT9	• AUX	• CON
• NUL	• PRN	• CLOCK\$	

In addition, the folder/file name showed below cannot be used.

The folder name which begins with G2

Folder name and file name which begins with . (period)

Folder name and file name which ends with . (period)

Folder name and file name which has only . (one period) or ..(two periods)

For deleting the folder

The folder in which the file exists cannot be deleted.

Delete the folder after having deleted the files.

In addition, on the operation log information screen, the file other than that for operation log is not displayed on GOT.

When the folder, in which there is no file displayed on the screen, cannot be deleted, confirm whether there is other file in the data storage by using a personal computer, etc.

Precautions for operation







Precautions during folder/file operation (Create/Delete/Copy/File output, etc)

Even if the cover of the SD card interface is opened while the GOT is processing folders and files, the processing continues to be executed. (Example: Even if the cover of the SD card interface is opened while the GOT is creating a folder, the folder is created.)

Therefore, do not pull out the SD card while the "Processing..." message is on the screen after the cover of the SD card interface is opened.

6.7 File Manager

You can manipulate or sort the folders and files stored in each drive of the GOT.

Function	Description	Reference
Folder and file list	Displays the type, name, size, and updated date and time of each folder or file. The folders and files can be sorted in ascending or descending order.	 Page 342 Display operation of the file manager screen  Page 345 Sorting folders and files
Copy	Copies a folder or file .	 Page 346 Copy
Move	Moves a folder or file.	 Page 348 Move
New folder	Creates a folder.	 Page 350 New folder
Delete	Deletes a folder or file.	 Page 351 Delete
Rename	Renames a folder or file.	 Page 352 Rename

Required system application (extended function)

The system application (extended function) for the file manager is required.

System application (extended function)

Write the package data that contains the system application (extended function) for the file manager to the GOT.

For the communication method with the GOT, refer to the following.

 GT Designer3 (GOT2000) Screen Design Manual

System application (extended function) size

To install a system application (extended function) to the GOT, enough space in the user area is required.

For information on how to check the available space of the user area and each data size, refer to the following.

 GT Designer3 (GOT2000) Screen Design Manual

Display operation of the file manager screen

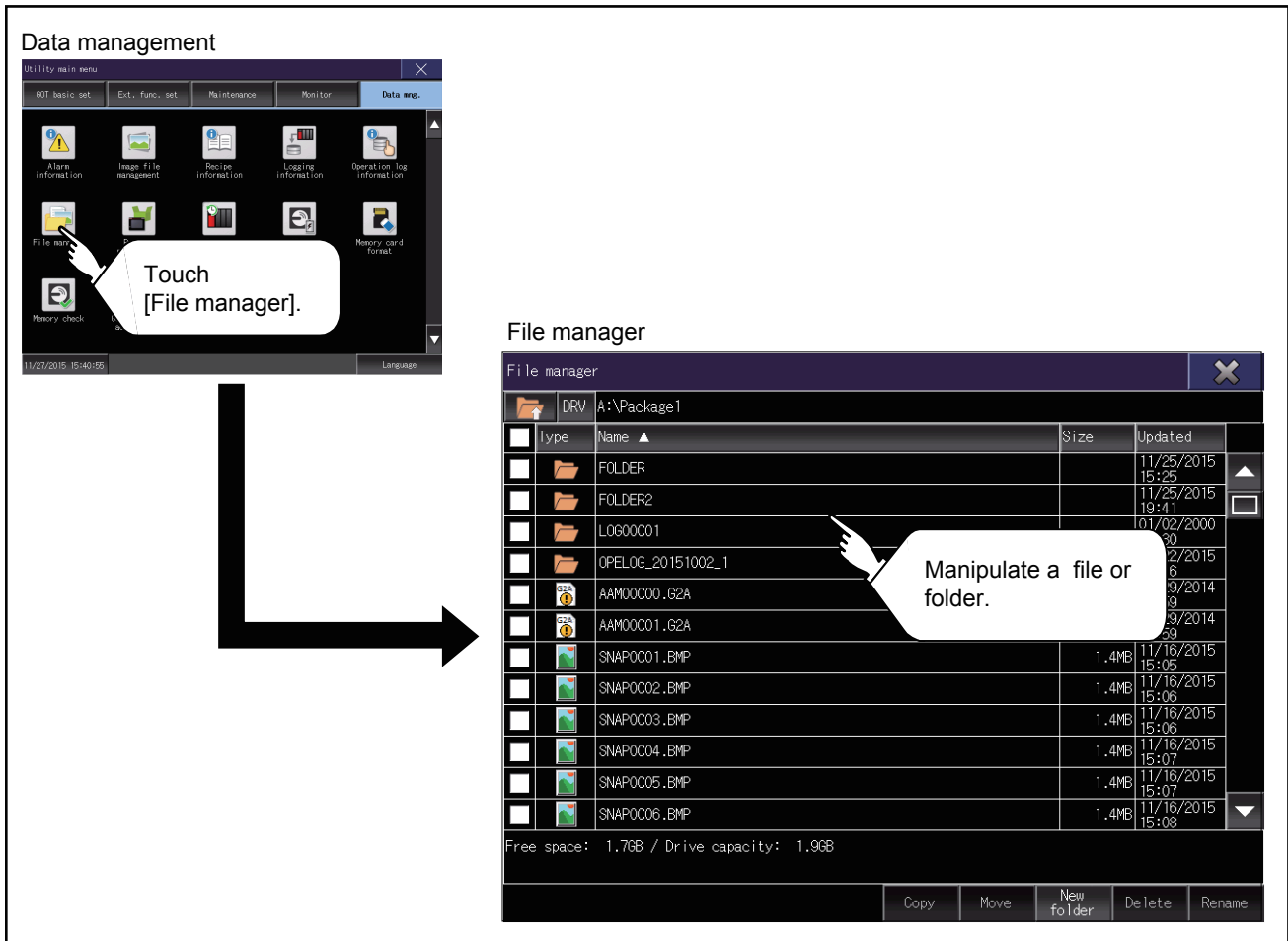

Display example of the file manager screen

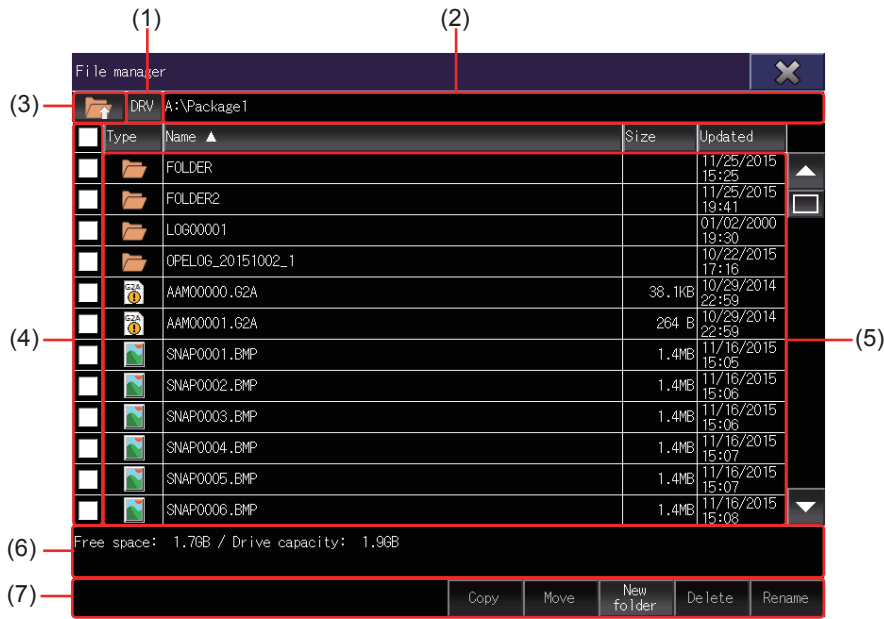

Number	Item	Description
(1)	[DRV] button	Displays the [Select drive] screen to select a target drive. <ul style="list-style-type: none"> • SD card: [A: Built-in SD card] • USB memory: [B: USB Drive], [E: USB Drive], [F: USB Drive], and [G: USB Drive] • Network drive: [N: Network drive]
(2)	Drive and folder path display	Displays the path to the drive or folder that stores the currently listed folders or files.If the number of characters in the path exceeds the limit, only the characters within the limit are displayed.
(3)	Move-to-parent folder button	Moves to the parent folder.
(4)	Check box	Select a checkbox to select a folder or file.To select all folders and files, select the top checkbox.
(5)	Type	Displays the folder and file icons.
	Name	Displays the folder and file names.A long folder or file name does not wrap to the next line, and the portion of the name that lies off the display area is invisible.A folder or file is not listed in the following cases.The full path to the folder or file contains 79 or more characters including delimiters (\).The folder or file name starts with G2 or G1
	Size	Displays the file size.This item is not displayed for folders.
	Updated	Displays the updated date and time of folders and files.
(6)	Drive information	Displays the information of the drive, folders, or files.The following information is displayed.Available space and capacity of the selected driveNumber of selected folders and files, and their total size
(7)	Operation buttons	Execute intended operations.

Operations on the file manager screen

Data display operation

1. Touch the [DRV] button to display the [Select drive] screen.

Select a drive to list the data stored in the drive.

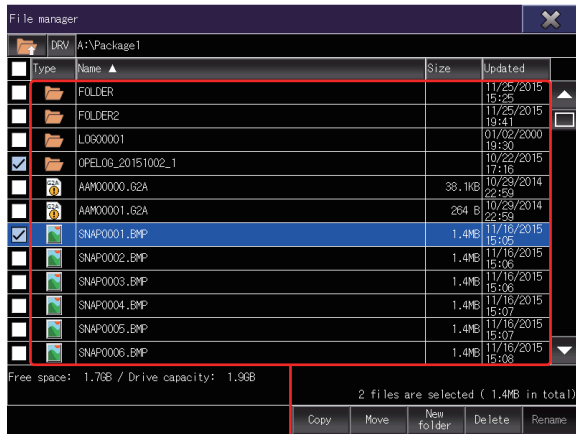

File display area

2. Double-touch a folder name to list the data stored in the folder.
3. Touch the move-to-parent folder button to list the data stored in the parent folder.
4. Scroll through the list by using the scroll bar or sliding the file display area.
5. Touch a checkbox to select a folder or file.
6. For the operation of the operation buttons, refer to the following.
 - ☞ Page 346 Copy
 - ☞ Page 348 Move
 - ☞ Page 350 New folder
 - ☞ Page 351 Delete
 - ☞ Page 352 Rename
7. Touch the [x] button to close the screen.

Sorting folders and files

The folders and files can be sorted in ascending or descending order.

The mark ▲ or ▼ is displayed in the header of the column by which the list is sorted.

The following shows the applicable column headers.

- Type
- Name
- Size
- Updated

Example) When sorting the folders and files alphabetically

1. Touch the [Name] header to sort the folders and files alphabetically in ascending order.

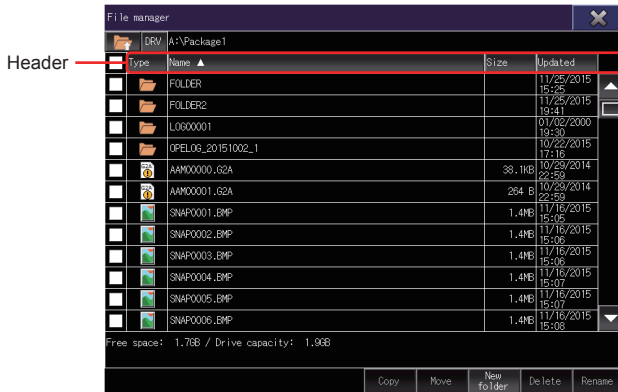

2. Touch the [Name] header again to sort them alphabetically in descending order.

Copy

A selected folder or file is copied.

1. Touch a checkbox to select a folder or file.

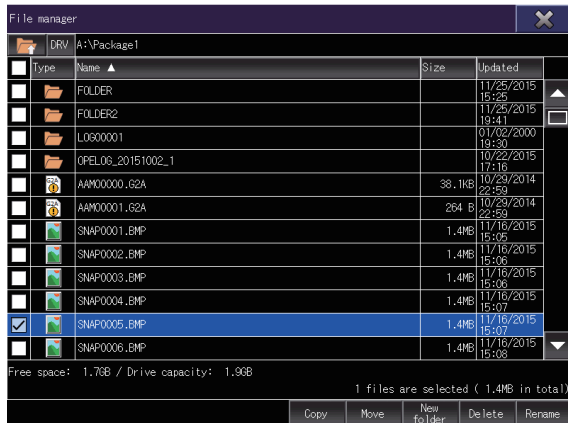

2. Touch the [Copy] button to copy the selected folder or file, switching the display of the operation buttons and the drive information contents.

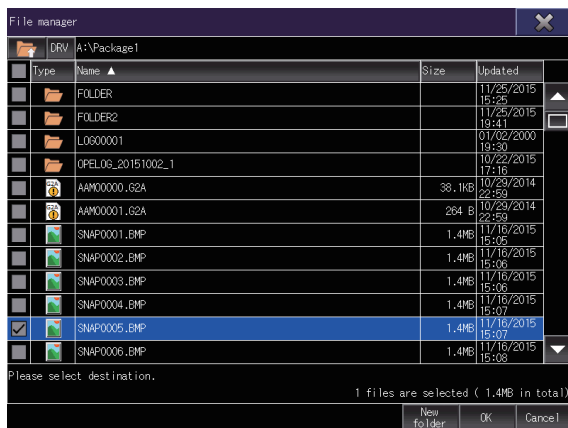

3. Touch a copy destination folder.

You cannot paste the selected folder or file in the same folder. Select a different folder to store.

4. Touch the [OK] button to display a confirmation dialog.

5. Touch the [OK] button to start the copy.

To cancel the copy, touch the [Cancel] button.

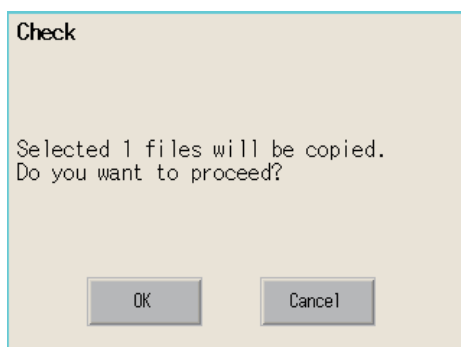

- 6.** If the copy destination folder has a folder or file with the same name, the overwrite confirmation dialog appears. To overwrite the folder or file with the same name, touch the [YES] button. To not to copy the folder or file, touch the [NO] button. To cancel the copy, touch the [Cancel] button.

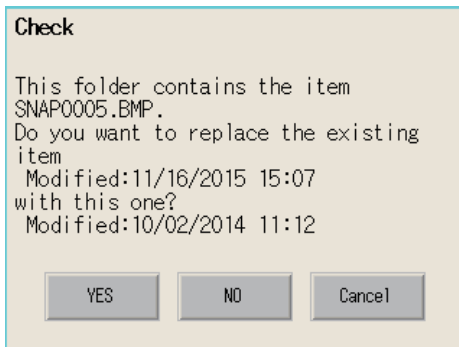

- 7.** If the copy destination folder has multiple folders or files with the same name, another confirmation dialog appears. To perform the same process for the rest of folders or files, touch the [YES] button. To display the overwrite confirmation dialog for the next folder or file, touch the [NO] button.

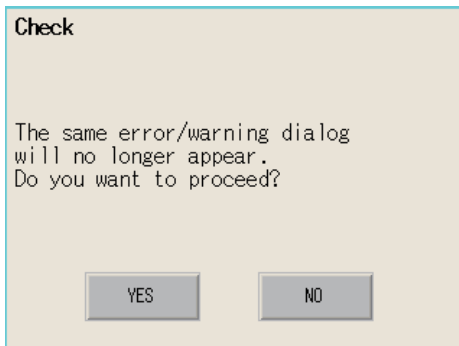

- 8.** Upon completion of the copy process, the confirmation dialog appears saying the numbers of successes and failures. Touch the [OK] button to close the confirmation dialog.

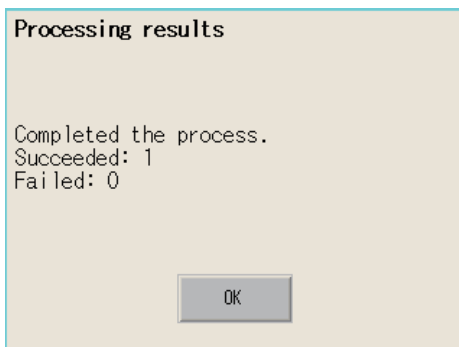

Move

A selected folder or file is moved.

1. Touch a checkbox to select a folder or file.

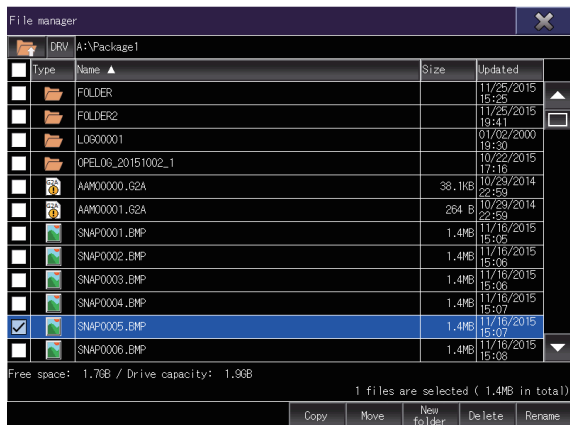

2. Touch the [Move] button to move the selected folder or file, switching the display of the operation buttons and the drive information contents.

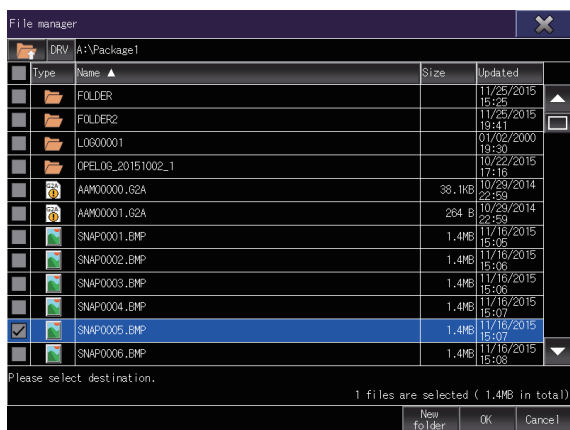

3. Touch a move destination folder.
 4. Touch the [OK] button to display a confirmation dialog.
 5. Touch the [OK] button to start the move.
- To cancel the move, touch the [Cancel] button.

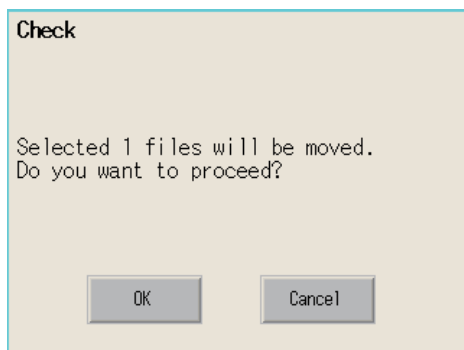

- 6.** If the move destination folder has a folder or file with the same name, the overwrite confirmation dialog appears. To overwrite the folder or file with the same name, touch the [YES] button. To not to move the folder or file, touch the [NO] button. To cancel the move, touch the [Cancel] button.

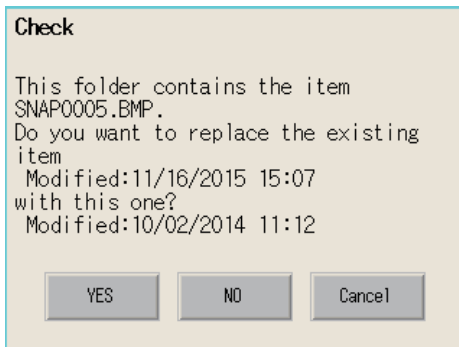

- 7.** If the move destination folder has multiple folders or files with the same name, another confirmation dialog appears. To perform the same process for the rest of folders or files, touch the [YES] button. To display the overwrite confirmation dialog for the next folder or file, touch the [NO] button.

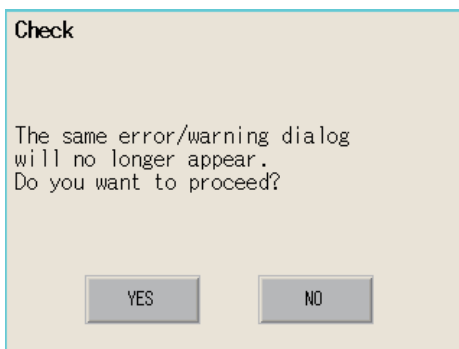

- 8.** Upon completion of the move process, the confirmation dialog appears saying the numbers of successes and failures. Touch the [OK] button to close the confirmation dialog.

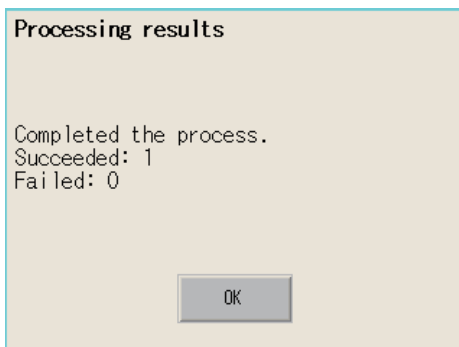

New folder

A folder is created.

1. Touch the [New folder] button to display the [Folder name] screen.

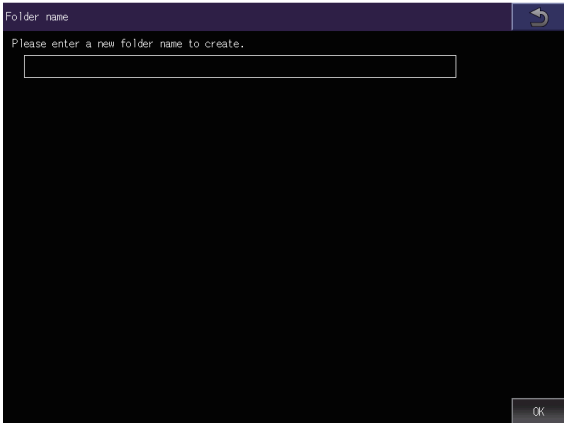

2. Touch the text box to display the key window.

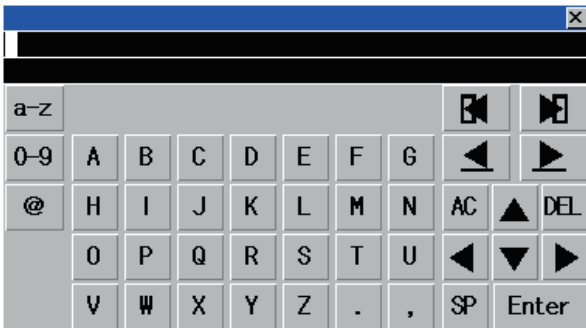

3. Enter a folder name with the key window.

To change the character type, touch any of the following buttons.

[A-Z]: Uppercase alphabet

[a-z]: Lowercase alphabet

[@]: Symbols

[0-9]: Numeric characters, A to F

4. Touch the [Enter] button to confirm the entry.

5. Touch the [OK] button to create the folder.

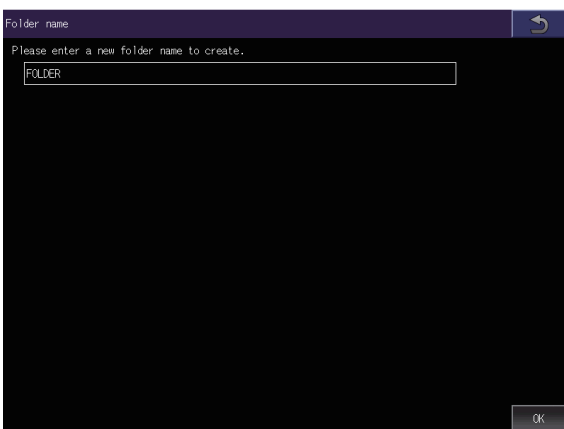

Delete

A selected folder or file is deleted.

1. Touch a checkbox to select a folder or file.

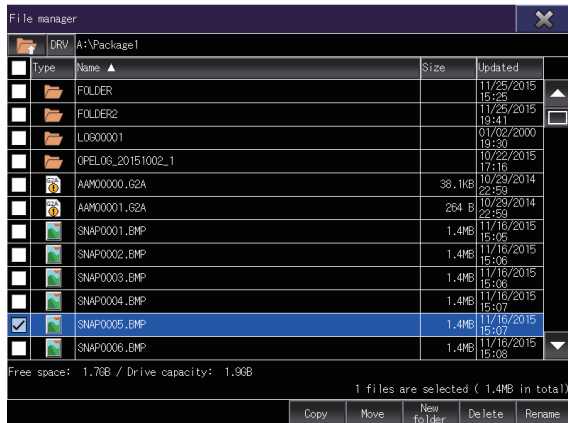

2. Touch the [Delete] button to display a confirmation dialog.

3. Touch the [OK] button to start the deletion.

To cancel the deletion, touch the [Cancel] button.

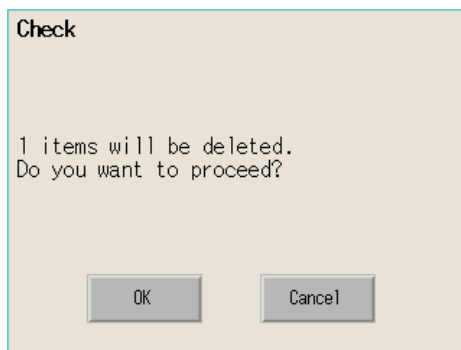

4. Upon completion of the delete process, the confirmation dialog appears saying the numbers of successes and failures.

Touch the [OK] button to close the confirmation dialog.

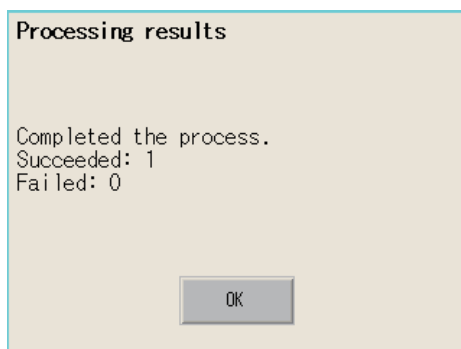

Rename

A selected folder or file is renamed.

1. Touch a checkbox to select a folder or file.

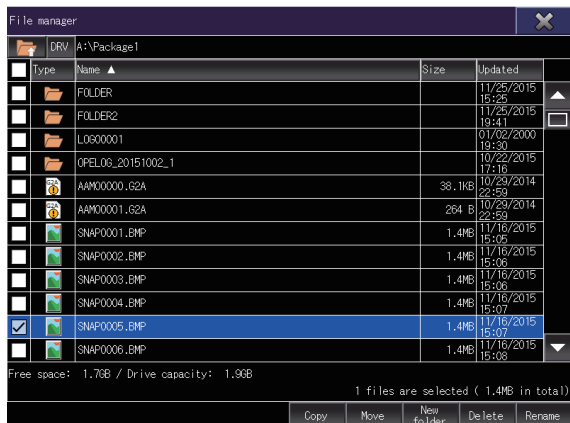

2. Touch the [Rename] button to display the [Folder name] screen or the [File name] screen.

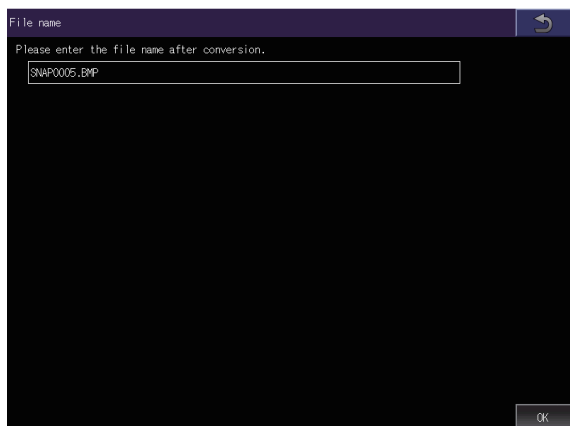

3. Touch the text box to display the key window.

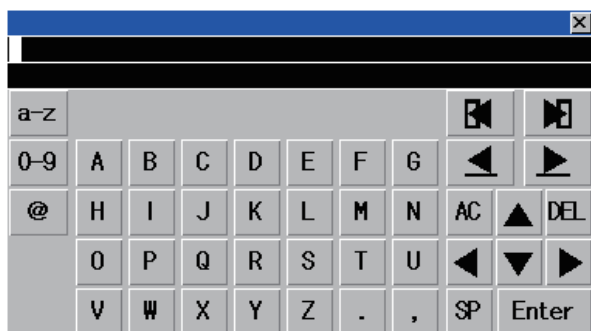

4. Enter a new name with the key window.
To change the character type, touch any of the following buttons.
[A-Z]: Uppercase alphabet
[a-z]: Lowercase alphabet
[@]: Symbols
[0-9]: Numeric characters, A to F
5. Touch the [Enter] button to confirm the entry.

6. Touch the [OK] button to rename the folder or file.

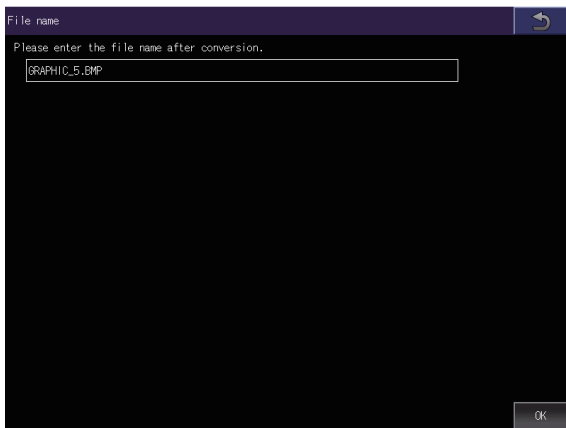

Precautions

When creating or deleting folders or files

■Number of characters in the folder or file name

GOT recognizes file location according to path explained below.

Specify folder or file name, and total characters of path cannot exceed 78 characters.

Users only can rename folder or file name.

(Other than folder/file name is automatically printed.)

Example: CSV file path in a data storage

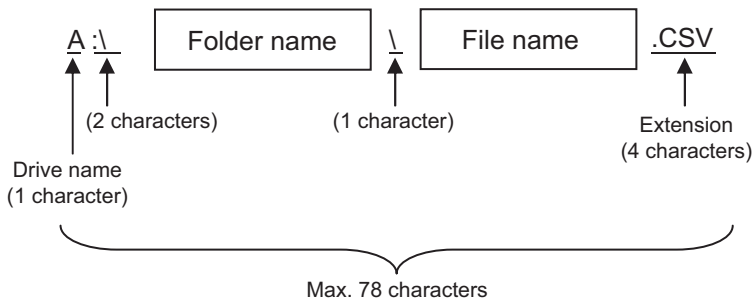

Point

If folder is assigned the hierarchy.

The `\` mark is displayed between a folder name and folder name, a folder name and file name.

The `\` mark is also counted as one character.

■Character strings that cannot be set to a folder/file

The following character strings cannot be used as a folder name or a file name. Even small characters of those cannot be used.

COM1 to COM9, LPT1 to LPT9, AUX, CON, NUL, PRN, CLOCK\$

In addition, the folder/file name showed below cannot be used.

Folder and file names starting with G2 or G1

Folder and file names starting with a period (.)

Folder and file names ending with a period (.)

■Unavailable characters in the folder name

One-byte spaces and the following characters cannot be used in a folder name.

`/ \ ? * : | " < >`

■For deleting the folder

The deletion of a folder is executed even if another function is using a file in the folder.

If such a file is deleted, the function that is using the file may not operate properly.

Do not delete a folder that is set for another function.

■Available character codes

Although characters other than one-byte alphanumeric characters (ASCII) can be entered for a folder or file name, the characters become garbled when the file name is displayed in the file list of the utility screen.

To manipulate folders or files on the utility screen, use one-byte alphanumeric characters (ASCII) for folder and file names.

Precautions for operation

■Precautions during folder/file operation (Create/Delete/Copy/File output, etc)

Even if the cover of the SD card interface is opened while the GOT is processing folders and files, the processing continues to be executed.

Therefore, do not pull out the SD card while the "Processing..." message is on the screen after the cover of the SD card interface is opened.

■While the GOT is accessing another file (such as alarm data)

If you manipulate a folder or file while the GOT is accessing another file, the GOT completes the current process and then executes the manipulation process.

In such a case, the manipulation process may take a longer time than usual.

■Copying or moving a folder

When a folder is copied or moved to another folder with the same name, if the folders contain a file with the same name, the file in the destination folder is automatically replaced.

■Changing a folder or file name

You cannot change only the case of the characters in a folder or file name.

Example)

Before change		After change
JANUARY	→	january
january	→	JANUARY
january	→	January

To change only the case of the characters in a folder or file name, rename the folder or file to a different name, and then rename the folder or file back to its original name with the case changed.

■Maximum number of folders and files displayable in the list

Up to 2000 folders and files stored in the same path are displayable in the list.

If the number of folders and files stored in the same path is 2001 or more, the overflow folders and files are not displayed.

You cannot select or sort the overflow folders and files.

To display all folders and files stored in the same path, reduce the number of folders and files to 2000 or less by deleting unnecessary folders or files, storing folders or files to a different folder, or other methods.

■Copying or moving a file to a folder in which a read-only file with the same name is stored

A read-only file cannot be overwritten.



To copy or move a file to a folder in which a read-only file with the same name is stored, rename the source file before copying or moving it to the folder.

6.8 File Print

Preview or print a report file created with the report function.

For the details of the report function, refer to the following.

 GT Designer3 (GOT2000) Screen Design Manual

Function	Description	Reference
Print file list display	Displays the type, name, data size, and updated date and time of each file.	 Page 358 Display example of the file print screen
Print	Prints the file selected in the list.	 Page 360 Print
Preview	Previews the file selected in the list.	 Page 361 Preview

Required system application (extended function)

The system application (extended function) for the file print is required.

System application (extended function)

Write the package data that contains the following system applications (extended function) to the GOT.

- [File Print]
- [Printer(PictBridge)], [Printer(Serial)], or [Printer(ESC/P-R, PCL5)]
- [Report]

For the communication method with the GOT, refer to the following.

 GT Designer3 (GOT2000) Screen Design Manual

Data size of the system application (extended function)

To install a system application (extended function) to the GOT, enough space in the user area is required.

For information on how to check the available space of the user area and each data size, refer to the following.

 GT Designer3 (GOT2000) Screen Design Manual

Display operation of the file print

Data management

Utility main menu

60T basic set | Ext. func. set | Maintenance | Monitor | **Data mg.**

Alarm information | Image file management | Recipe information | Logging information | Operation log information

File manager | **File print** | 60T basic set

Memory card format | Memory check

05/23/2018 15:38:19 | Language

Touch [File print].

Print file list display

Print file list display

DRV A:\Package1\REPORT

Print	Type	Name ▲	Size	Updated
	Folder	folder1		05/23/2018 15:09
	Folder	folder2		05/23/2018 15:09
	Folder	folder3		05/23/2018 15:09
	Folder	folder4		05/23/2018 15:09
	Folder	folder5		05/23/2018 15:08
	Folder	folder6		05/23/2018 15:08
<input type="checkbox"/>	File	REPORT01_0000.G2R	1013.5KB	05/23/2018 15:07
<input type="checkbox"/>	File	REPORT01_0001.G2R		05/23/2018 15:07
<input type="checkbox"/>	File	REPORT01_0002.G2R		05/23/2018 15:07
<input type="checkbox"/>	File	REPORT01_0003.G2R		05/23/2018 15:07
<input type="checkbox"/>	File	REPORT01_0004.G2R	1013.5KB	05/23/2018 15:07
<input type="checkbox"/>	File	REPORT01_0005.G2R	1013.5KB	05/23/2018 15:07

Free space: 899.8MB / Drive capacity: 971.6MB

Print | Preview | Select all | Cancel all

Preview or print a file.

Display example of the file print screen

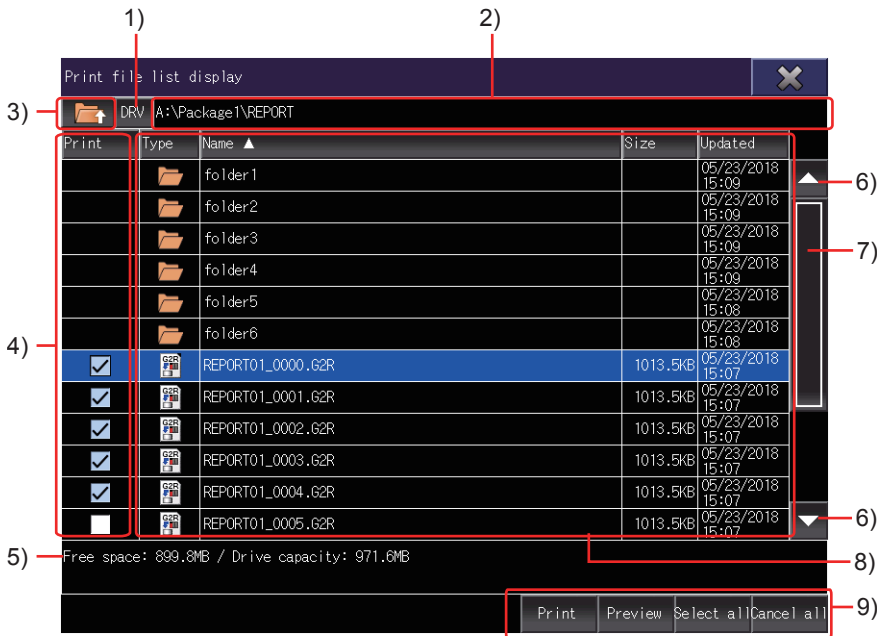

Number	Item	Description
1)	[DRV] button	Displays the [Select drive] screen to select a target drive. <ul style="list-style-type: none"> • SD card: [A: Built-in SD card] • USB memory: [B: USB Drive], [E: USB Drive], [F: USB Drive], and [G: USB Drive] • Network drive: [N: Network drive]
2)	Drive and folder path display	Displays the path to the drive or folder that stores the currently listed folders or files. If the number of characters in the path exceeds the limit, only the characters within the limit are displayed.
3)	Move-to-parent folder button	Moves to the parent folder.
4)	Checkbox to select a file to be printed	Select a checkbox to select a file.
5)	Drive information	Displays the information of the selected file. The following information is displayed. <ul style="list-style-type: none"> • Free space and capacity of the drive • Number of selected files and the total data size
6)	Scroll keys	Scroll the list up or down by row.
7)	Scroll bar	Touch the empty area above or below the scroll bar knob to scroll one page up or down. Alternatively, touch and hold the knob, and slide the knob up or down to scroll the page to the desired position.
8)	Type	Displays the folder and file icons.
	Name	Displays the folder and file names. Up to 2000 folders and files can be displayed. (For GT23: Up to 500 folders and files) Only report files (*.G2R) are listed. The folder or file whose full path contains 79 characters or more is not listed. A long folder or file name does not wrap to the next line, and the portion of the name that lies off the display area is invisible. <p>Swiping up or down scrolls the screen. Double touching a folder name moves to the folder. Touching a file name selects the row.</p>
	Size	Displays files sizes. This item is not displayed for folders.
	Updated	Displays the updated date and time of folders and files.
9)	Operation buttons	<ul style="list-style-type: none"> • [Print]: Prints the selected files. • [Preview]: Previews the selected files. • [Select all]: Selects all files. • [Cancel all]: Deselects all files.

Operation of the file print

Sorting folders and files

The folders and files can be sorted in ascending or descending order.

The mark ▲ or ▼ is displayed in the header of the column by which the list is sorted.

The following shows the applicable column headers.

- Print
- Type
- Name
- Size
- Updated

Example) When sorting the folders and files alphabetically

1. Touch the [Name] header to sort the folders and files alphabetically in ascending order.



2. Touch the [Name] header again to sort them alphabetically in descending order.

Print

Print the selected file.

1. Touch a check box to select the file.



2. Touch the [Print] button to display a confirmation dialog.

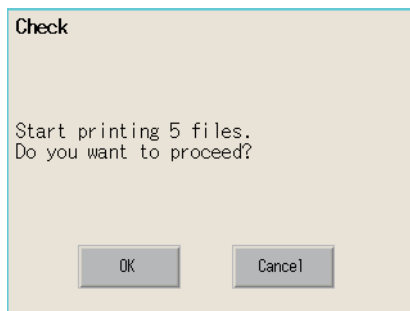

3. Touch the [OK] button to start printing.

Touch the [Cancel] button to cancel the printing job.

4. After the printing starts, a progress dialog appears to display the progress of printing.

Touch the [Cancel] button to abort printing and close the progress dialog.

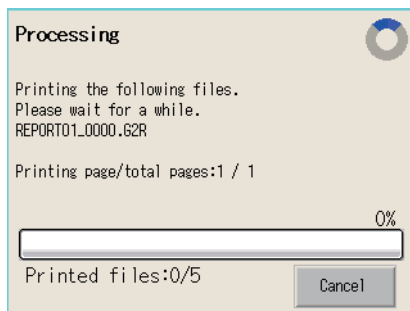

Point

Restriction on printing

Use GS522.b4 to disable printing.

For the details, refer to the following.

GT Designer3 (GOT2000) Screen Design Manual

Preview

Preview the selected file.

1. Touch a row to select the file.



2. Touch the [Preview] button to preview the file.

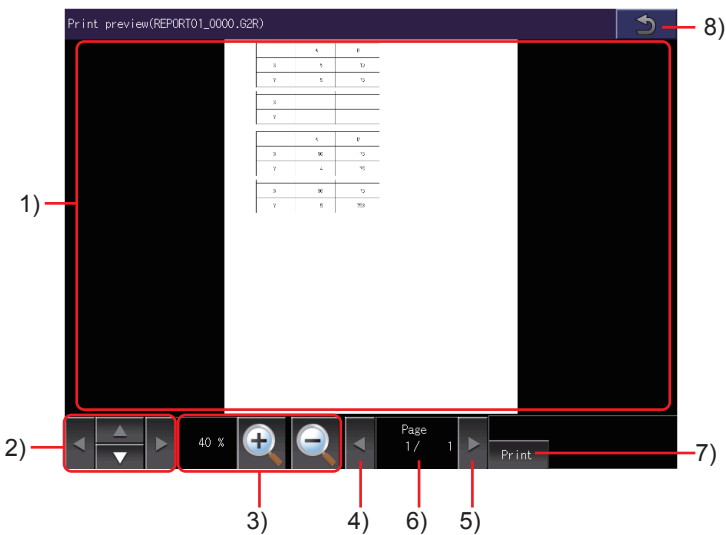

Number	Item	Description
1)	Preview	Print preview For a file exceeding 1000 pages, 1001st and later pages cannot be displayed.
2)	Scroll buttons	Scroll the preview screen up, down, right, or left.
3)	Display magnification	Display magnification of the preview screen Change the display magnification with the zoom in or zoom out button.
4)	Previous page button	Displays the previous page.
5)	Next page button	Displays the next page.
6)	[Page]	Displays the page number of the currently displayed page and the total number of pages. Displays the key window. Enter a page number to be displayed.
7)	[Print] button	Prints the currently displayed file.
8)	Return button	Returns to the print file list display screen.

Precautions

Position of a page break on the preview screen and in the printed file

When the printer type is set to [Serial] and [Output Timing] is set to [At the time of data collection], the position of a page break may differ between the preview screen and the printed file.

Displayable page layout on the preview screen when using a serial printer

For the page layout of a report screen to be previewed, set 70 lines or less and 124 columns or less, when the printer type is [Serial].

Setting the lines and columns above the limit may fail to preview the report screen.

Operating the [Print preview] screen during a page refresh

You cannot perform the following operations on the [Print preview] screen during a page refresh.

- Page turning with the previous or next page button
- Page turning by a flick

For a page turning across multiple pages, touch the current page number and enter a new page number to move to in the key window.

Print preview and the printed output

The print preview and printed output may be inconsistent.

Print a file and check the layout and others of the printed output.

6.9 Package Data Management

Function of package data management

The package data held by each drive (A: Built-in SD card, B: USB drive, C: built-in flash memory, E: USB drive, F: USB drive, G: USB drive) is displayed.

The following operations can be performed.

Function	Description	Reference
Install	All package data written in drive A (Built-in SD card), drive B (USB drive), drive E (USB drive), drive F (USB drive), and drive G (USB drive) can be installed in drive C (Built-in flash memory).	☞ Page 366 Installation operation
Upload	All package data written in drive C (Built-in flash memory) can be uploaded to drive A (Built-in SD card), drive B (USB drive), drive E (USB drive), drive F (USB drive), and drive G (USB drive).	☞ Page 368 Upload operation
Property	The versions of system applications and communication drivers, and other information can be checked.	☞ Page 369 Property operation
Data check	The contents of package data can be checked.	☞ Page 371 Data check operation
Delete all labels	All pieces of label name resolution information can be deleted.	☞ Page 372 Delete all labels operation
Sort out labels	Unused label name resolution information can be deleted.	☞ Page 372 Sort out labels operation

Display operation of package data management

The image shows the 'Data management' utility menu with 'Package management' selected. An arrow points to the 'Package management' window, which displays drive information and operation buttons.

Data management

Utility main menu

OOT basic set | Ext. Func. set | Maintenance | Monitor | Data mgmt.

Alarm information | Image file management | Recipe information | Logging information | Operation log information

File manager | **Package management** | Memory check | OOT data plug acquisition

Touch [Package management].

11/27/2015 15:40:55 | Language

Package management

Select drive: A:\

Kind	Name	Size	Date	Time
DIR	PACKAGE1		08-03-18	11:42
DIR	HARD_COPY		08-21-18	09:31

Free space: 3.6GB
Drive capacity: 3.7GB

0 files are selected (0.0KB in total)
Number of selectable files in this folder: 0 files

Buttons: Install, Upload, Property, Data check, Delete all labels, Sort out labels

Operate the package data.

Display example of package data management

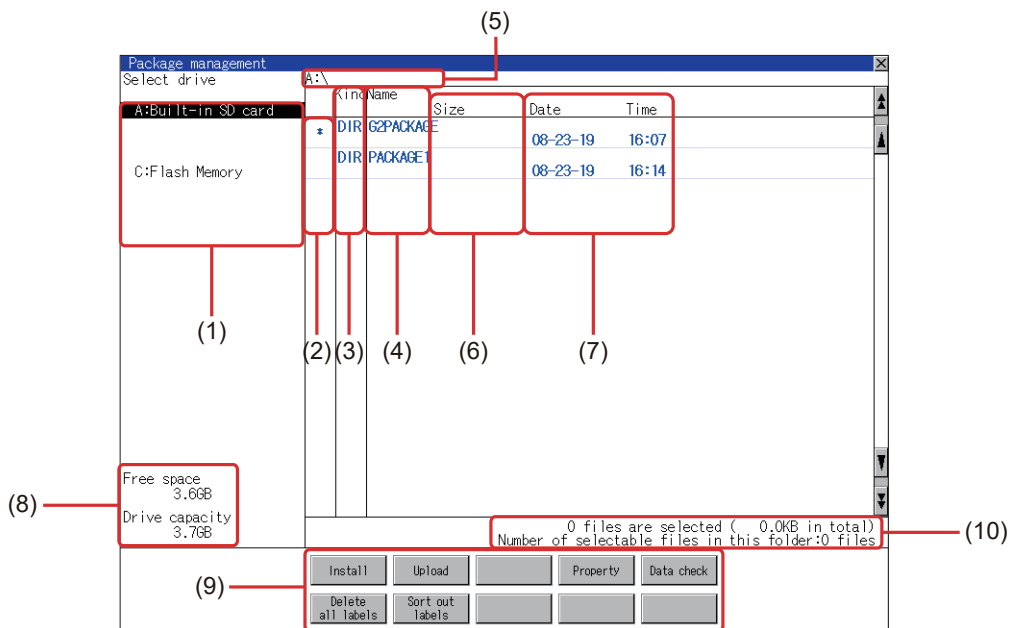

Number	Item	Description
(1)	Select drive	The drive which displays file or folder can be selected. When an SD card or USB memory is not installed, the following drives are not displayed. • SD card: [A: Built-in SD card] • USB memory: [B: USB Drive], [E: USB Drive], [F: USB Drive], and [G: USB Drive]
(2)	Folder which stores the running project	[*] indicates the folder which stores the running project.
(3)	Kind	Indicates whether the displayed name is file or folder. Displays the extension for a file and "DIR" for a folder.
(4)	Name	The file name or folder name which is stored in the selected drive or folder is displayed. When the file name or folder name exceeds 20 characters, the exceeding characters (the 21th character or after) are not displayed.
(5)	Path name	Displays the path name of drive /folder which is currently displayed.
(6)	Size	Displays the size of the file displayed in Name.
(7)	Date and time	Displays the creation date and time of each file.
(8)	The size of drive	Displays the size of free area and the entire size of the drive which is selected by drive selection. Note that this item is not displayed when drive C is selected.
(9)	Operation switch	Execution switch of each function.
(10)	Number and size of files	Displays the number of the selected files, the total file size, and the selectable number of files in the folder.

Operation of package data management

Display operation of package data

1. If touch a drive in [Select drive], the information of the first folder of the touched drive is displayed.

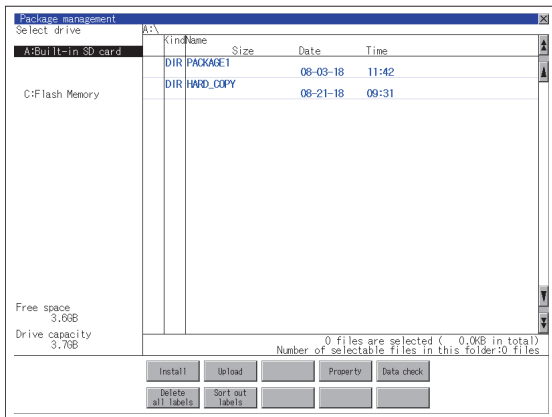

2. If touch a folder name, the information of the touched folder is displayed.
3. If touch a folder of ". .", the information of the folder of the one upper hierarchy is displayed.
4. If touch the ▲▼ button of the scrollbar, the screen scrolls up/down by one line.
If touch the ▲▼ button, the screen scrolls up/down by one screen.
5. If touch a file name, the touched file name is selected and inverted.
6. For the operation of installation, upload, data check, and global labels, refer to the following.

Installation

☞ Page 366 Operation of package data management

Upload

☞ Page 368 Operation of package data management

Property

☞ Page 369 Property operation

Data check

☞ Page 371 Data check operation

Delete all labels

☞ Page 372 Delete all labels operation

Sort out labels

☞ Page 372 Sort out labels operation

7. If touch the [x] button, the screen is closed.

Installation operation

BootOS and OS which are written in drive A (Built-in SD card), drive B (USB drive), drive E (USB drive), drive F (USB drive), and drive G (USB drive) can be installed in GOT.

(The following procedure uses drive A as an example.)

1. Install the data storage to which package data to be installed is written to the GOT.

For installation/removal procedure of data storages, refer to the following.

 GOT2000 Series User's Manual (Hardware)

2. Touch [A:Built-in SD card] in the drive selection.

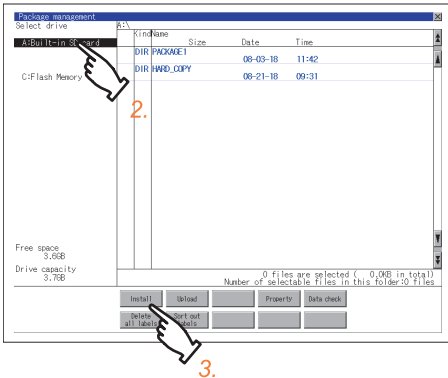

3. Touch the [Install] button.

4. Touch the installation destination drive.

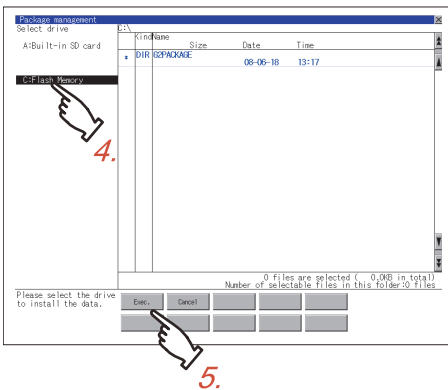

5. Touch the [Exec.] button.

6. In the dialog shown below, touch the [OK] button to start the installation.

To cancel the installation, touch the [Cancel] button.

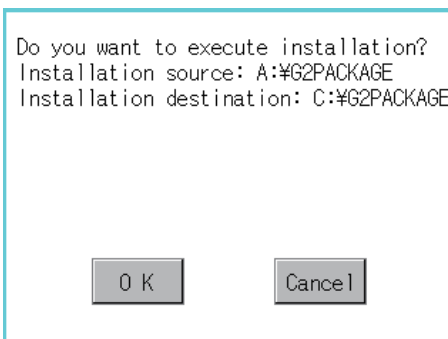

7. If the installation destination drive has package data with the same name, the dialog shown below appears. To delete the package data from the installation destination drive and then start the installation, touch the [OK] button. To cancel the installation, touch the [Cancel] button.

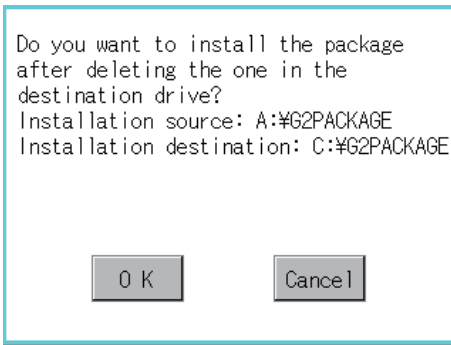

8. When the installation completes, the dialog shown below appears. Touch the [OK] button to restart the GOT.

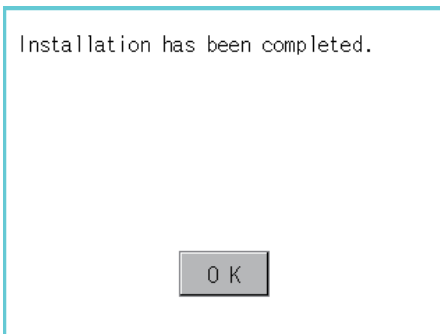

Upload operation

Package data written in drive C (Built-in flash memory) can be uploaded to drive A (Built-in SD card), drive B (USB drive), drive E (USB drive), drive F (USB drive), and drive G (USB drive).

The data storage after uploading can be used for installing the package data on another GOT.

☞ Page 391 BOOTOS AND SYSTEM APPLICATION

(The following procedure uses drive A as an example.)

1. Install the data storage used as the uploading destination to the GOT.

For installation/removal procedure of data storages, refer to the following.

📖 GOT2000 Series User's Manual (Hardware)

2. Touch the upload source drive ([C:Flash Memory]) in [Select drive].

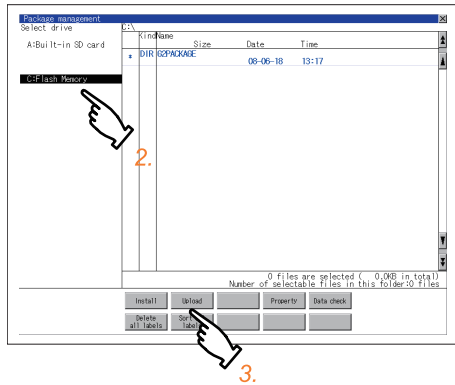

3. Touch the [Upload] button.

4. Touch the upload destination drive.

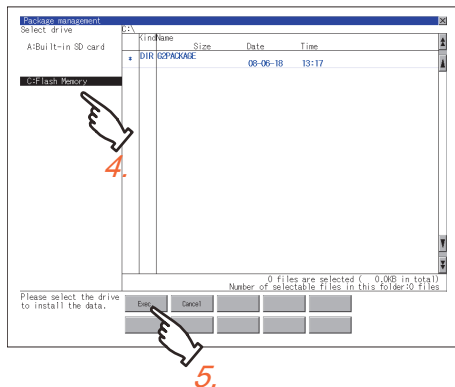

5. Touch the [Exec.] button to start uploading the package.

6. When the upload is completed, the dialog box shown below is displayed.

Touch the [OK] button to close the dialog.

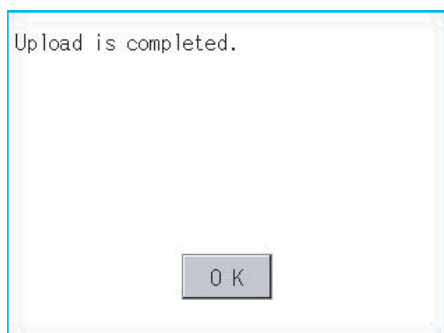

Property operation

The versions of system applications and communication drivers, and other information can be checked.

1. Open a target package folder in the [G2PACKAGE] folder.

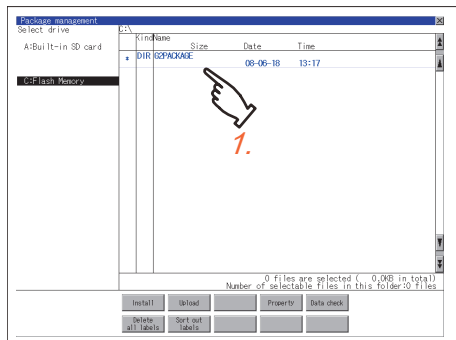

2. Open one of the following folders.

- [G2SYS] folder

System applications (standard functions) and system applications (extended functions) are stored.

- [G2COM] folder

Communication drivers are stored.

- [G2PROJECT] folder

Project data are stored.

- [G2SPC] folder

Special data are stored.

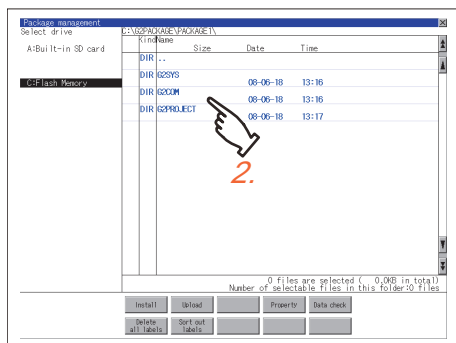

3. Touch the [Property] button to display the properties of the files in the folder.

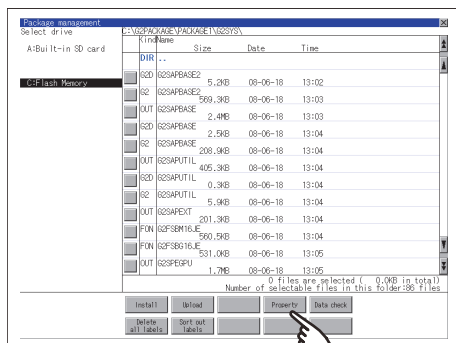

4. Check the properties.

For the [G2SYS] folder, the properties of system applications are displayed. For the [G2COM] folder, the properties of communication drivers are displayed.

- [File Name]:

Displays the file names.

- [Size]:

Displays the file size.

- [Kind]:

Displays the file types.

[Basic]: System application (standard function)

[Extend]: System application (extended function)

[Comm.]: Communication driver

- [Version]:

Displays the file versions.

- [Date Time]:

Displays the date and time of the file creation.

File Name	Size	Kind	Version	Date	Time
System Application Name					
SSAPBASE_GSD	10.0KB	Basic	01.12.000.0005	05-20-15	20:02
Standard System Application Information					
SSAPBASE_GSI	1.0KB	Basic	01.12.000.0005	05-20-15	20:02
Standard System Application Data					
SSAPBASE_OUT	2.4KB	Basic	01.12.000.0005	05-21-15	12:37
Standard System Application					
SSAPBASE_GSD	20.0KB	Basic	01.12.000.0003	05-08-15	15:39
Standard System Application Information					
SSAPBASE_GSI	512.0KB	Basic	01.12.000.0003	05-08-15	15:39
Standard System Application Data					
SSAPUTIL_OUT	1590.0KB	Basic	01.12.000.0005	05-21-15	12:37
Standard System Application(Uni11ty)					
SSAPUTIL_GSD	20.0KB	Basic	01.04.000.R001	07-13-13	11:57
Standard System Application Information(01.1113)					
SSAPUTIL_GSI	200.0KB	Basic	01.04.000.R001	07-13-13	11:57
Standard System Application Data(01.1113)					
SSAPM16_E_FON	570.0KB	Basic	01.03.010.R001	03-11-13	19:35
16dot Standard Mincho Font(Japanese)					
SSAPM16E_FON	540.0KB	Basic	01.03.010.R001	03-11-13	19:35
16dot Standard Gothic Font(Japanese)					
SSAPGPU_OUT	2.0KB	Extend	01.03.010.R001	01-22-14	09:00
Graphic acceleration driver					
SSAPM16_E_FON	170.0KB	Extend	01.10.000.R001	03-05-15	11:30
16dot Standard Extended Mincho Font(Japanese)					
SSAPM16E_FON	160.0KB	Extend	01.03.010.R001	03-11-13	19:35
16dot Standard Extended Gothic Font(Japanese)					
SSAPM12_E_FON	140.0KB	Extend	01.03.010.R001	03-11-13	19:35
12dot Standard Extended Gothic Font(Japanese)					
SSAPM12E_FON	180.0KB	Extend	01.03.010.R001	03-11-13	19:35
16dot Standard Extended Mincho Font(Chinese Simplified)					
SSAPM12E_FON	140.0KB	Extend	01.03.010.R001	03-11-13	19:35
12dot Standard Extended Gothic Font(Chinese Simplified)					
SSAPM16E_FON	290.0KB	Extend	01.03.010.R001	03-11-13	19:35
16dot Standard Extended Gothic Font(Chinese Traditional)					

Property displayed for the [G2SYS] folder

For the [G2PROJECT] folder, the project property and the screen numbers used in the project are displayed.

The project property includes the following information.

- [Date]:

Creation date of the project data

- [Author]:

Creator of the project data

- [GT Designer3 Version]:

Version of GT Designer3 (GOT2000) from which the project data is written

- [System version]:

GOT system version

Property	Value
Date	05-20-15 19:35
Author	3EE
GT Designer3 Version	1.340
System Version	01.12.000
S-1	Base screen 1
S-2	Base screen 2
S-3	Base screen 3
W-1	Overlap window 1
W-2	Overlap window 2
W-3	Superimpose window 1

Property displayed for the [G2PROJECT] folder

For the [G2SPC] folder, the project property and the special data are displayed.

The project property includes the following information.

- [Date]:

Creation date of the project data

- [Author]:

Creator of the project data

- [GT Designer3 Version]:

Version of GT Designer3 (GOT2000) from which the project data is written

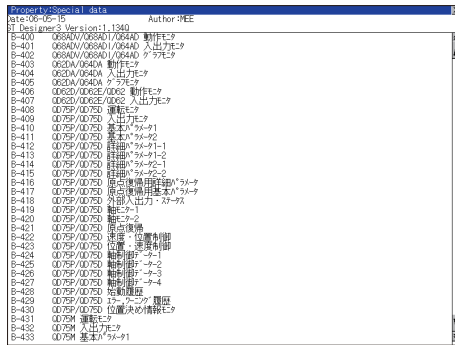

Property displayed for the [G2SPC] folder

Data check operation

The contents of the selected package data are checked.

1. Touch the [Data check] button after selecting the package data for data check.

The data check is executed and the result is displayed by the dialog box shown below.

Dialog at data check normal

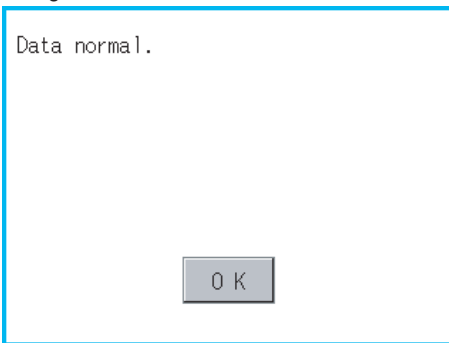

Dialog at data check abnormal

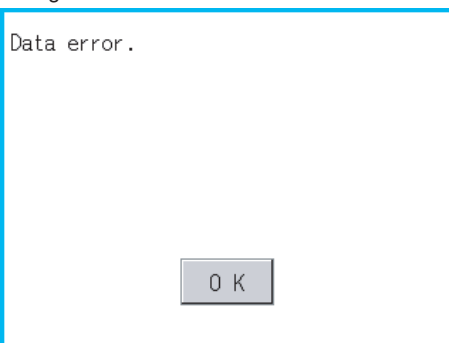

2. To close the dialog box, touch the [OK] button.

Delete all labels operation

All pieces of label name resolution information are deleted.

For the details of the label name resolution information, refer to the following.

 GT Designer3 (GOT2000) Screen Design Manual

1. Touch the [Delete all labels] button to display the dialog shown below.

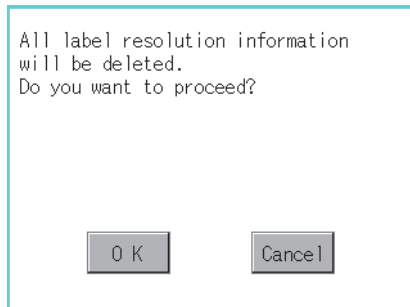

2. To delete all pieces of label name resolution information, touch the [OK] button.
To cancel the deletion and close the dialog, touch the [Cancel] button.

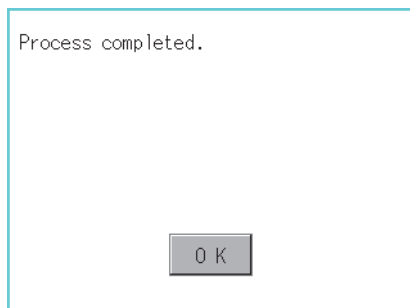

Sort out labels operation

Unused label name resolution information is deleted.

For the details of the label name resolution information, refer to the following.

 GT Designer3 (GOT2000) Screen Design Manual

1. Touch the [Sort out labels] button to display the dialog shown below.

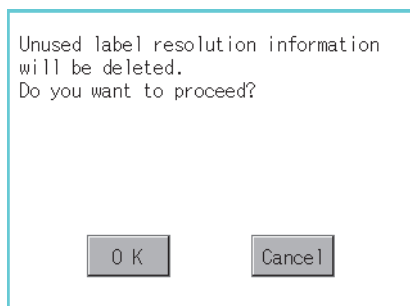

2. To delete unused label name resolution information, touch the [OK] button.
To cancel the deletion and close the dialog, touch the [Cancel] button.

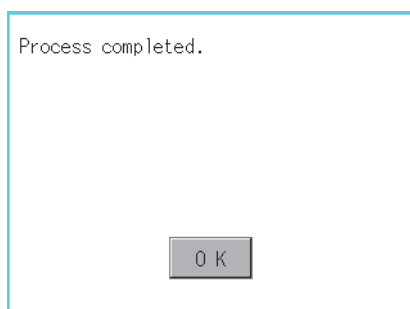

Precautions

Precautions for upload operations

When the project in drive C is protected with a security key, uploading data from drive C to the other drives is not available. For the details of the security key, refer to the following.

 GT Designer3 (GOT2000) Screen Design Manual

6.10 Backup/Restore Function

Backup/restore function

Executing backups, executing restorations, and deleting backup data are possible.

For details on the backup/restoration function, refer to the following.

GOT2000 Series User's Manual (Monitor)

For using the backup/restoration function on GT21, refer to the following.

Page 614 Backup and Restoration

Display operation of backup/restoration

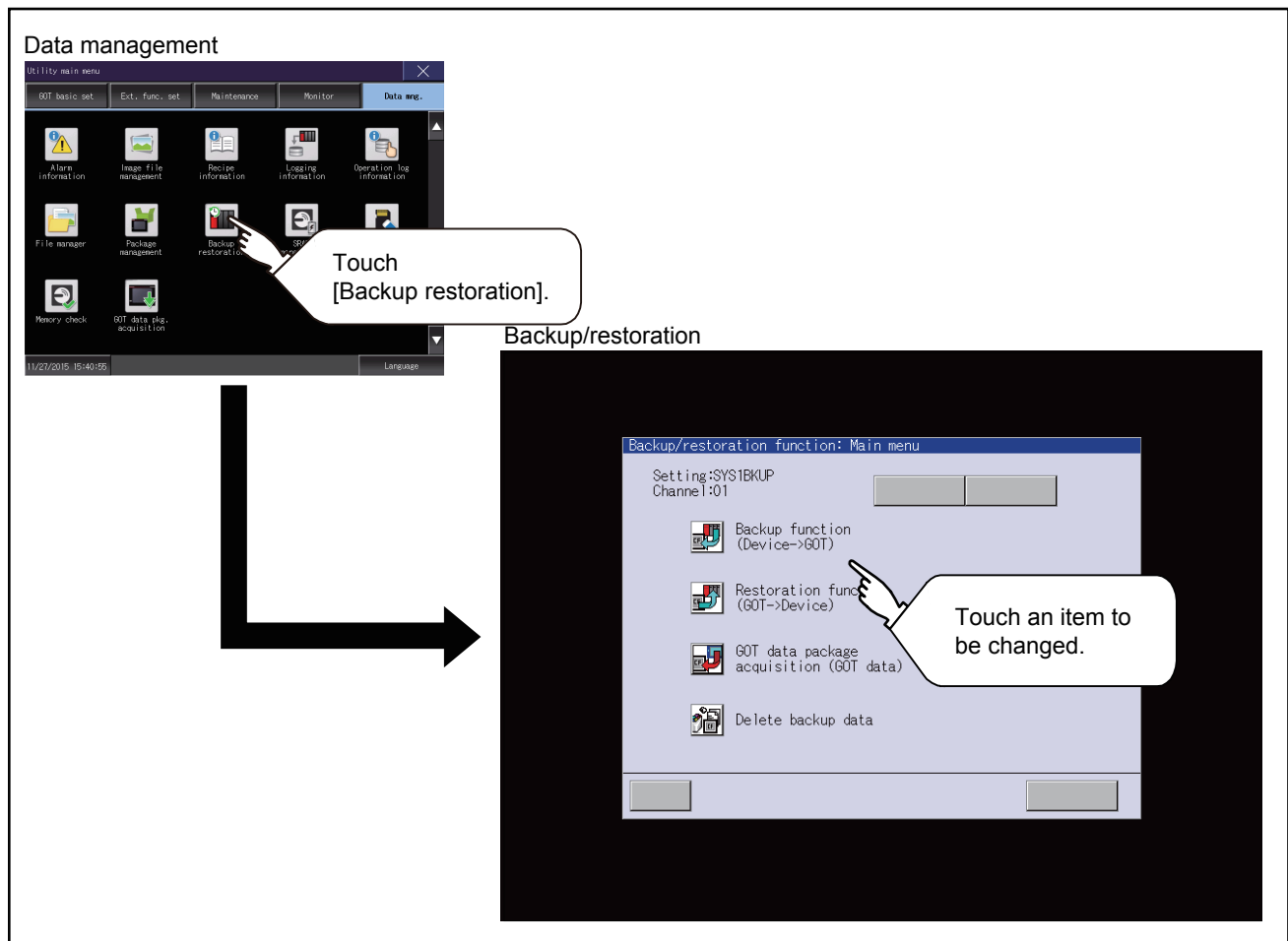

Operation of backup/restoration

Backup/restore data from the controller to GOT, or erase backup data with the backup/restoration.

GOT data package acquisition is also possible.

For details on the backup/restoration function, refer to the following.

GOT2000 Series User's Manual (Monitor)

6.11 SRAM management

Function of SRAM management

The SRAM user area usage can be confirmed, data in the SRAM user area can be backed up or restored, and the SRAM user area is initialized.

For the available functions in the SRAM user area, refer to the following.

📖 GT Designer3 (GOT2000) Screen Design Manual

Display operation of SRAM management

Data management

Utility main menu

Alarm information
 Image File management
 Recipe information
 Logging information
 Operation log information

File manager
 Package management
 Backup restoration
 SRAM management

Memory check
 GOT data plug. acquisition

11/27/2015, 15:40:55 Language

SRAM management

Function name	Setting ID	Setting name	Date	Time
<input type="checkbox"/> User alarm	82	History by Line	09-08-17	13:04
<input type="checkbox"/> User alarm	84	Cumulative Demo.	09-08-17	13:04
<input type="checkbox"/> User alarm	86	Specify Date/Time	09-08-17	13:04
<input type="checkbox"/> User alarm	87	Alarm&Graph&List	09-12-17	09:42
<input type="checkbox"/> User alarm	200	(B-201)	09-08-17	12:48
<input type="checkbox"/> User alarm	313	Overcurrent Alarm	09-12-17	09:42
<input type="checkbox"/> User alarm	314	Manual Event Alarm	09-12-17	09:42
<input type="checkbox"/> User alarm	352	Ladder Monitor	09-12-17	09:42
<input type="checkbox"/> User alarm	400	(B-401)History by Line	09-08-17	12:48
<input type="checkbox"/> User alarm	401	(B-403)Cumulative Demo	09-08-17	12:48
<input type="checkbox"/> User alarm	402	(B-405)Specify Date/Time	09-08-17	12:48
<input type="checkbox"/> Logging	400	(B-406, 601)	09-08-17	12:48
<input type="checkbox"/> Logging	1000	Current Value	09-08-17	13:04

0 item(s) has/have been selected.(0.0KB in total)

SRAM Free space 207.2KB
 SRAM capacity 500KB

Backup/restration
 Free space 3.66B
 Drive capacity 3.76B

Display example of SRAM management

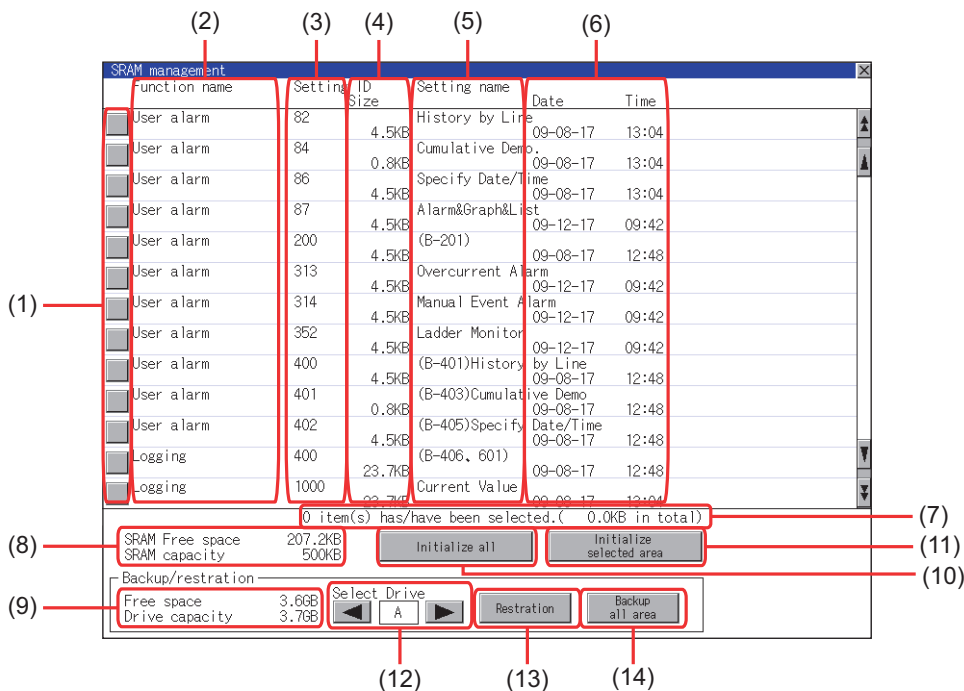

Number	Item	Description
(1)	Check box	Touch the check box to select or clear the item.
(2)	Function name	Displays the functions that use the SRAM in the order of system alarm, user alarm, logging, recipe, and internal device.
(3)	Setting ID	Displays the setting IDs. For the system alarm function, the setting IDs are not displayed.
(4)	Size	Displays the data size.
(5)	Setting name	Displays the setting name. For the setting name, only characters within the display range are displayed.
(6)	Date and time	Displays the creation date and time of each data.
(7)	n item(s) has/have been selected.	Displays the information of the items currently selected.
(8)	SRAM Free space	Displays the current free space size or total space size of the SRAM user area.
(9)	Free space	Displays the current free space size or total space size of the drive selected for [Select drive].
(10)	Initialize all	Initializes all areas of the SRAM user area.
(11)	Initialize selected area	Select each area of the SRAM user area to initialize multiple areas of the SRAM user area.
(12)	Select drive	Switches drives to be used for the data backup or restoration in the SRAM user area. The following drives can be switched only when an SD card or USB memory is installed. • SD card: [A: Built-in SD card] • USB memory: [B: USB Drive], [E: USB Drive], [F: USB Drive], and [G: USB Drive]
(13)	Restoration	Saves data in the selected drive to the SRAM user area.
(14)	Backup all area	Saves data in the SRAM user area to the selected drive.

SRAM management operation

Operation to initialize all or selected areas of the SRAM user area

1. Perform any of the following operations.

- To initialize all areas of the SRAM user area, touch the [Initialize all] button.
- To initialize selected areas of the SRAM user area, select the check box of the area to be initialized, and then touch the [Initialize selected area] button.

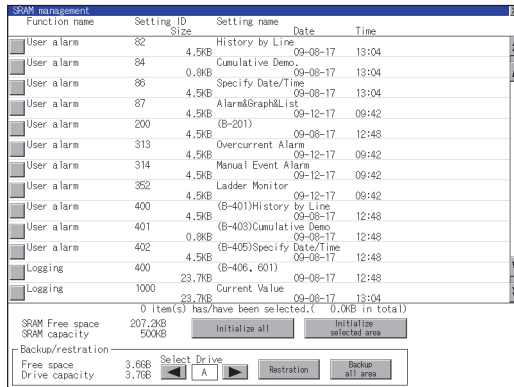

2. The dialog box shown below appears.

Check the description of the dialog box. To initialize the SRAM user area, touch the [OK] button.

To cancel the initialization, touch the [Cancel] button.

(Example: Dialog box if the [Initialize all] button is touched)

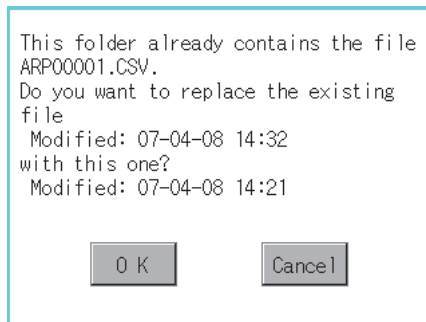

3. When touching the [OK] button in step2, the dialog box shown below appears for recheck.

To start the initialization, touch the [OK] button.

To cancel the initialization, touch the [Cancel] button.

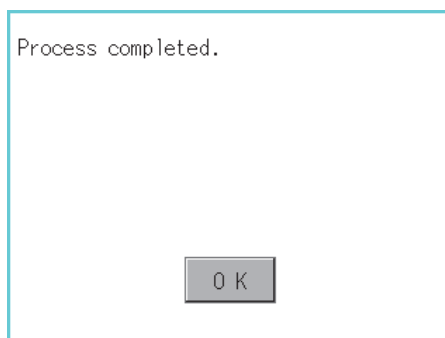

4. The completion dialog box appears when the initialization is completed.

To close the dialog box and restart the GOT, touch the [OK] button.

Operation to restore data

1. To restore data in the SRAM user area to a drive

Select the drive where the data is stored, and then touch the [Restoration] button.

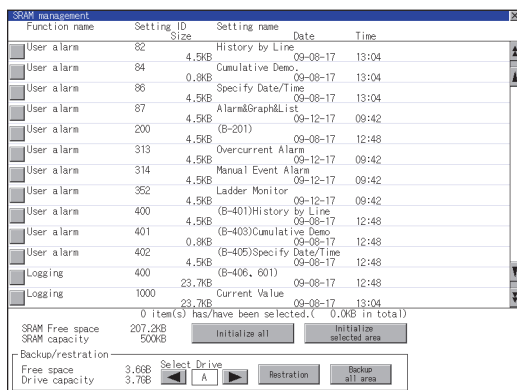

2. The dialog box shown below appears.

Check the description of the dialog box. To restore all data in the SRAM user area, touch the [OK] button.

To cancel the restoration, touch the [Cancel] button.

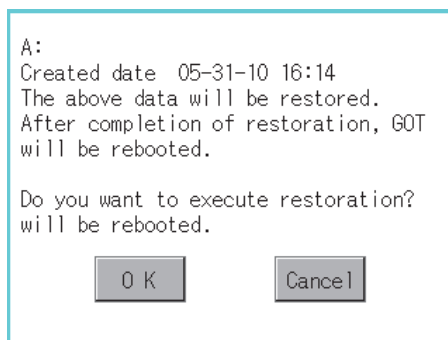

3. When touching the [OK] button in step2, the dialog box shown below appears for recheck.

To start the restoration, touch the [OK] button.

To cancel the restoration, touch the [Cancel] button.

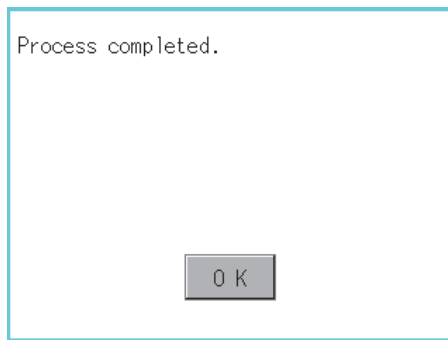

4. The completion dialog box appears when the restoration is completed.

To close the dialog box and restart the GOT, touch the [OK] button.

Operation to back up all data in the SRAM user area

1. To back up data in the SRAM user area to a drive

Select the drive where the data is stored, and then touch the [Backup all area] button.

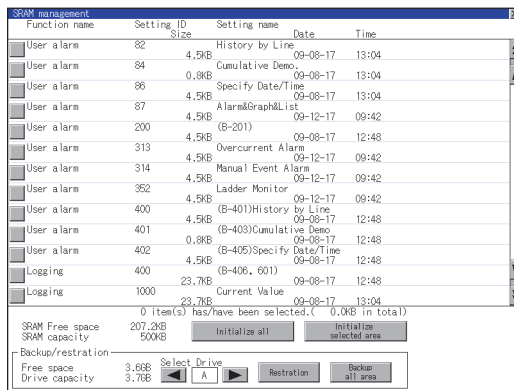

2. The dialog box shown below appears.

Check the description of the dialog box. To back up all data in the SRAM user area, touch the [OK] button.

To cancel the backup, touch the [Cancel] button.

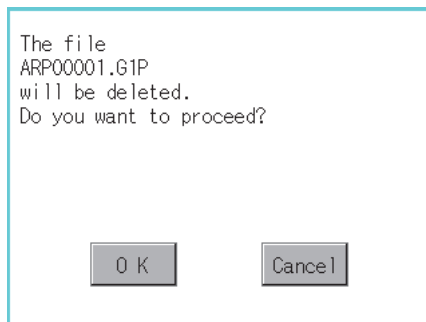

3. When touching the [OK] button in step 2, the dialog box shown below appears for recheck.

To start the backup, touch the [OK] button.

To cancel the backup, touch the [Cancel] button.

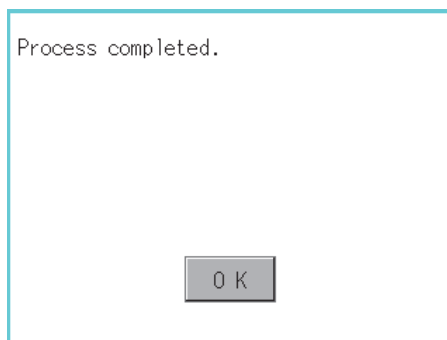

4. When the file, whose name is the same, exists in the destination folder, the dialog box shown below appears without starting the backup.

To overwrite the file, touch the [OK] button.

To cancel the backup, touch the [Cancel] button.



5. The completion dialog box appears when the backup is completed.

To close the dialog box, touch the [OK] button.

6.12 Memory Card Format

The data storage is formatted.

Display operation of memory card format

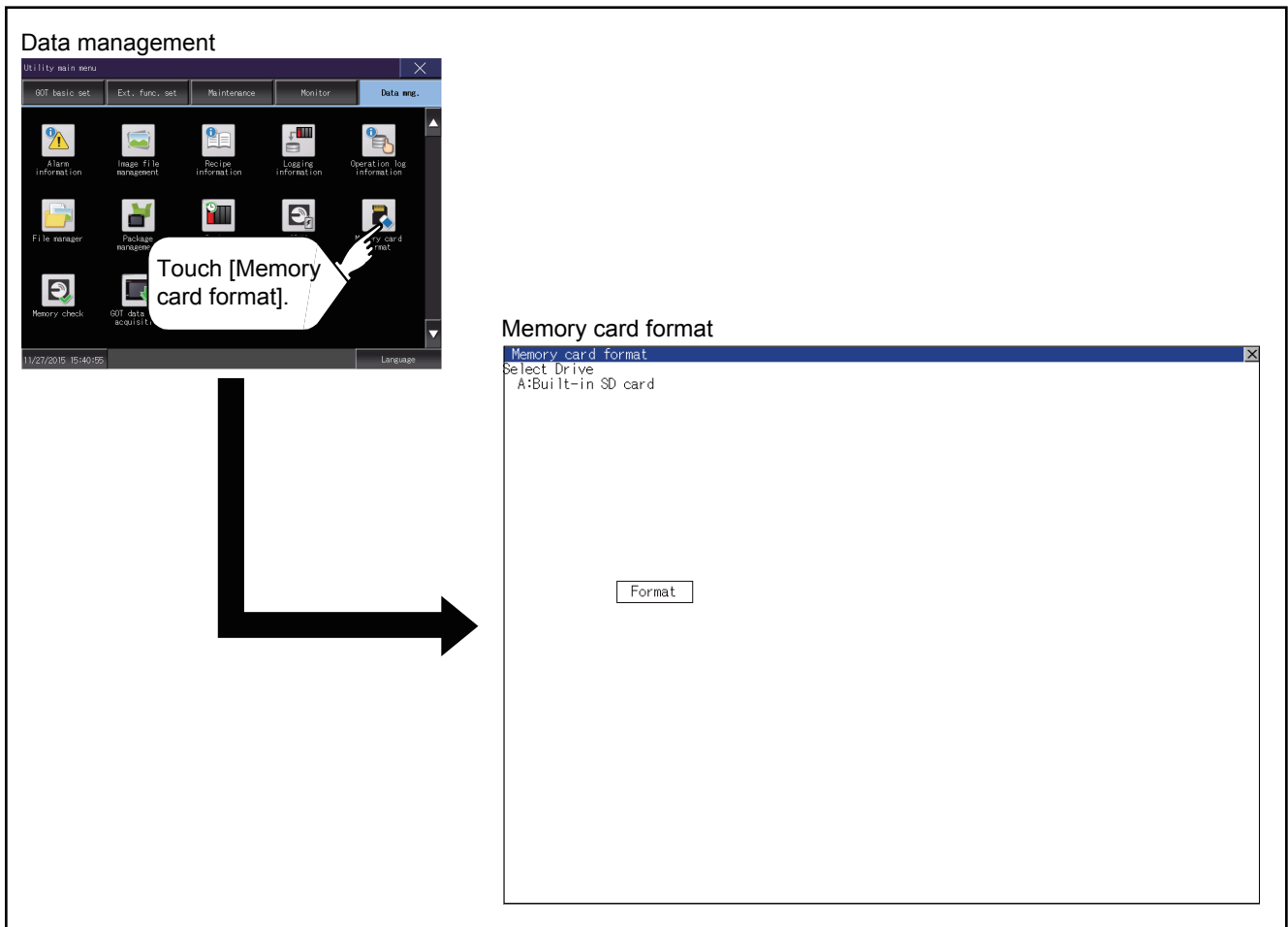

Operating the memory card format

1. Install a data storage to the GOT.

For installation/removal procedure of data storages, refer to the following.

📖 GOT2000 Series User's Manual (Hardware)

2. Touch and select the drive to format by drive selection.
3. If touch the [Format] button, the password input screen is displayed.

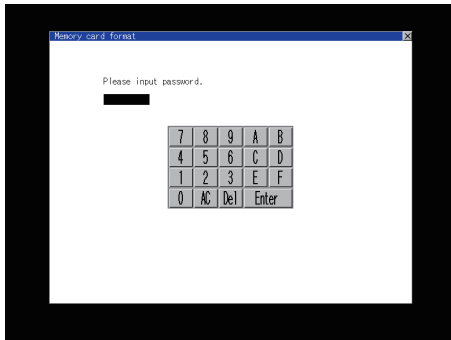

4. Type [1] [1] [1] [1] and touch the [Enter] key. The dialog box shown below will appear. (The password is fixed to 1111.) Confirm the contents of the dialog box, and touch the [OK] button to format of the data storage. To cancel the format of the data storage, touch the [Cancel] button.

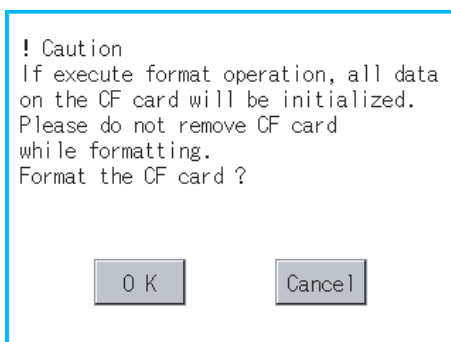

5. If touch the [OK] button by step4, the dialog mentioned below is displayed for reconfirm.

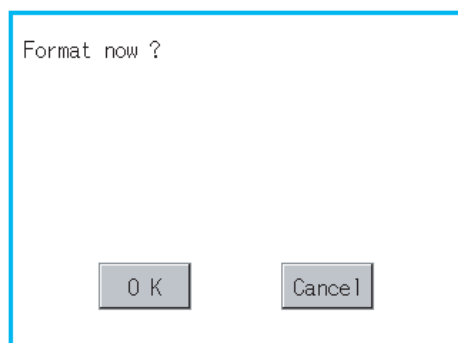

6. Reconfirm whether to format the data storage. Touch the [OK] button to start the format. Touch the [Cancel] button to cancel the format of the data storage.

7. When the formatting is completed, the completion dialog mentioned below is displayed.

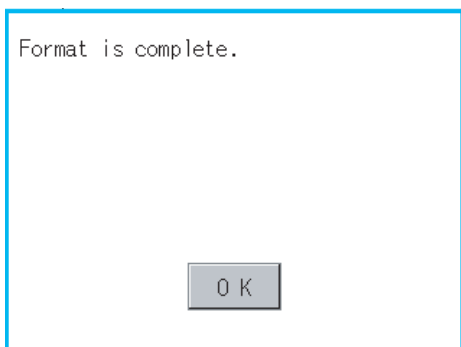

8. To close the dialog box, touch the [OK] button.

Point 

Restrictions on formatting

- When using an unformatted data storage in the GOT, format it by a personal computer. The GOT cannot format the unformatted data storage.
- The format of the GOT does not change the file system (Example: FAT16) of the data storage and inherits the file system before the format.

6.13 Memory Check

Memory check function

Memory check function carries out the write/read check of drive A (Built-in SD card), drive B (USB drive), C (Built-in flash memory), drive E (USB drive), drive F (USB drive), and drive G (USB drive).

Function	Description
A drive memory check	Checks whether the memory (Built-in SD card) of the A drive can be read/written normally.
B drive memory check	Checks whether the memory (USB drive) of the B drive can be read/written normally.
C drive memory check	Checks whether the memory (Built-in flash memory) of the C drive can be read/written normally.
E drive memory check	Checks whether the memory (USB drive) of the E drive can be read/written normally.
F drive memory check	Checks whether the memory (USB drive) of the F drive can be read/written normally.
G drive memory check	Checks whether the memory (USB drive) of the G drive can be read/written normally.

Display operation of memory check

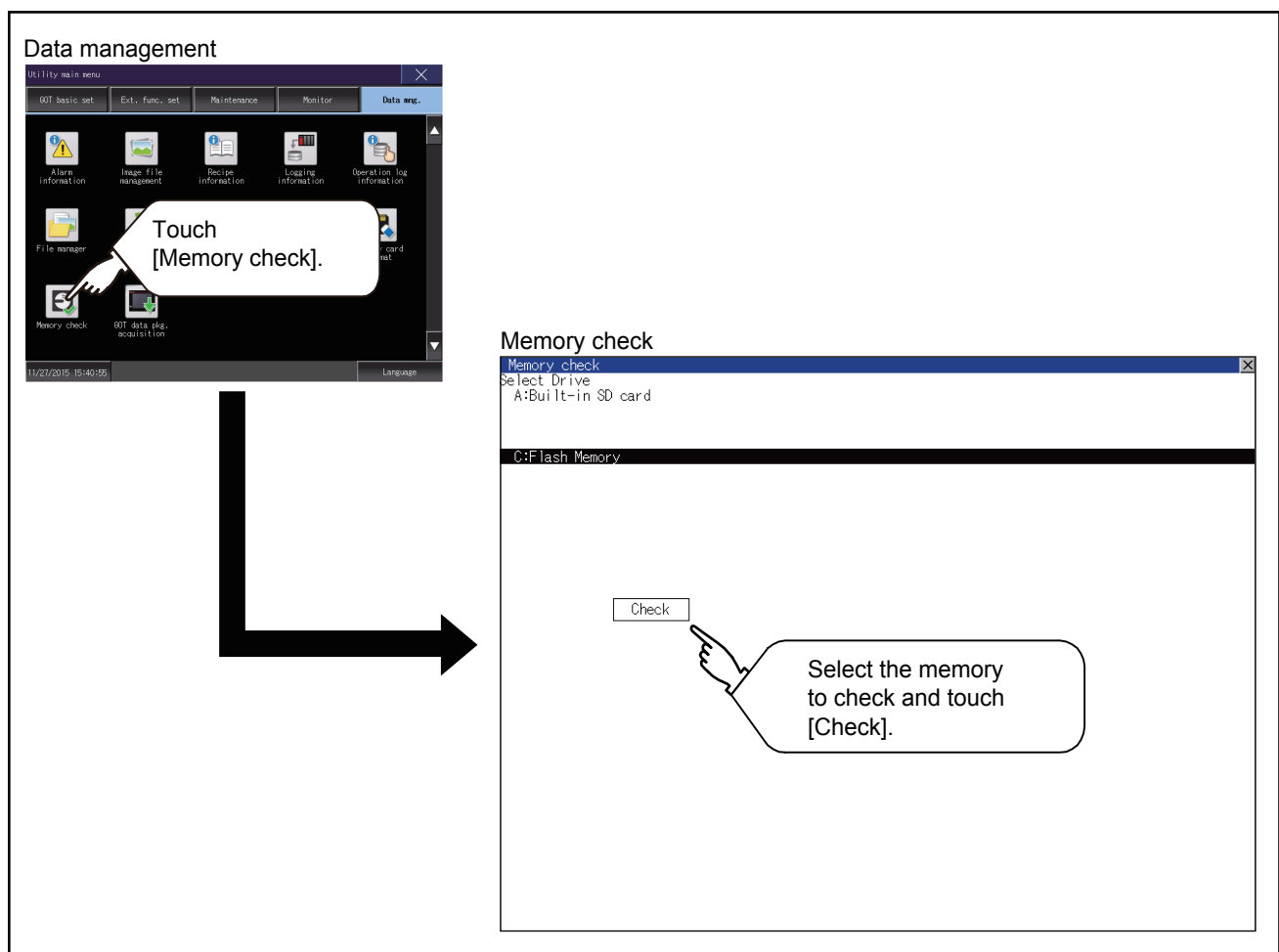

Memory check operation

Carries out write/read check of memory.

Point

When drive is not displayed

When the drive (memory) to check is not displayed, confirm the mounting procedure or memory type with reference to the following.

📖 GOT2000 Series User's Manual (Hardware)

When no faults are found in mounting, etc, a memory failure may be arisen.

Replace the data storage or built-in flash memory (C drive).

For details of built-in flash memory, contact your local Mitsubishi (Electric System) Service.

The following example explains about Memory Check using built-in flash memory (C drive).

For the Built-in SD card (A drive) memory check, install the SD card before carrying out the same key operations as those for the built-in flash memory check. For the USB drive (B drive, E drive, F drive, or G drive) memory check, install the USB memory before carrying out the check operations.

1. Select [Flash Memory] in the Memory check setting screen.

If select the [OK] button, the numeric keyboard window is displayed.

If select [Cancel] button, returns to the initial menu.

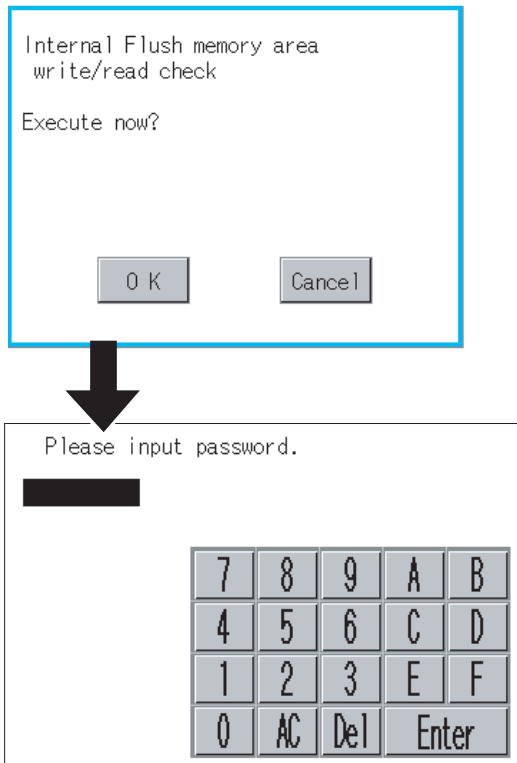

2. Touch to input password ([5] [9] [2] [0]) and touch the [Enter] key.

If touch the [Enter] key,executes read/write check for the built-in flash memory, which is completed in around 10 seconds.

Password chang

The password cannot be changed.

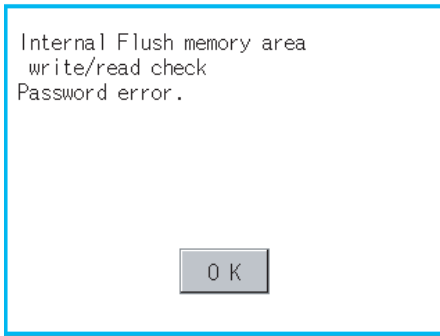

When input password error, the cancel dialog box is displayed.

If touch the [OK], returns to the Memory check screen.

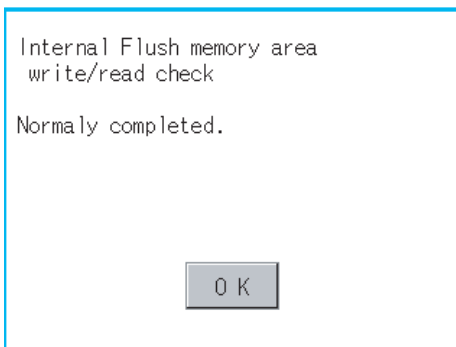
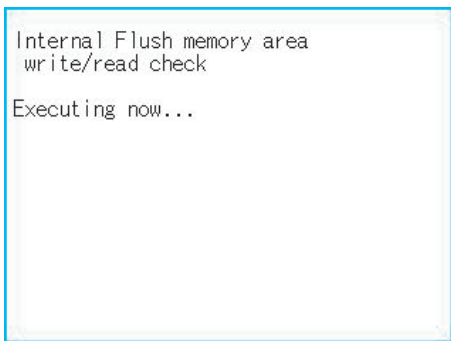

When error is found in memory

When error is found by memory check, the dialog box indicating the area in which the error occurred is displayed.

In case of error, contact your local Mitsubishi (Electric System) Service.

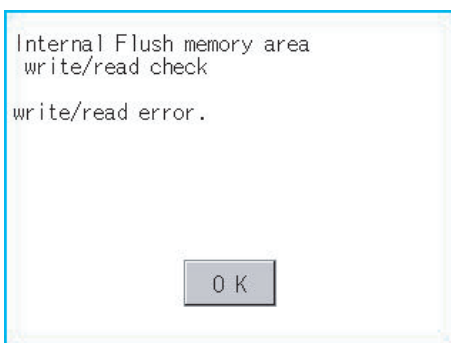

If touch the [OK], returns to the Memory check screen.

6.14 GOT Data Package Acquisition

GOT data package acquisition function

The GOT data package acquisition function copies the following the system applications installed in the GOT and data in the GOT to a data storage.

System application(BootOS, basic system application, communication driver, and system application (Extended function))

Special data

Project data

The copied data can be utilized for backup or creating the same GOT system by installing the data.

For installation function of the GOT, refer to the following.

☞ Page 393 Installation Using Data Storage

The GOT data package acquisition can be executed at the timing of the trigger backup.

For information on the trigger backup, refer to the following.

📖 GOT2000 Series User's Manual (Monitor)

Display operation of GOT data package acquisition

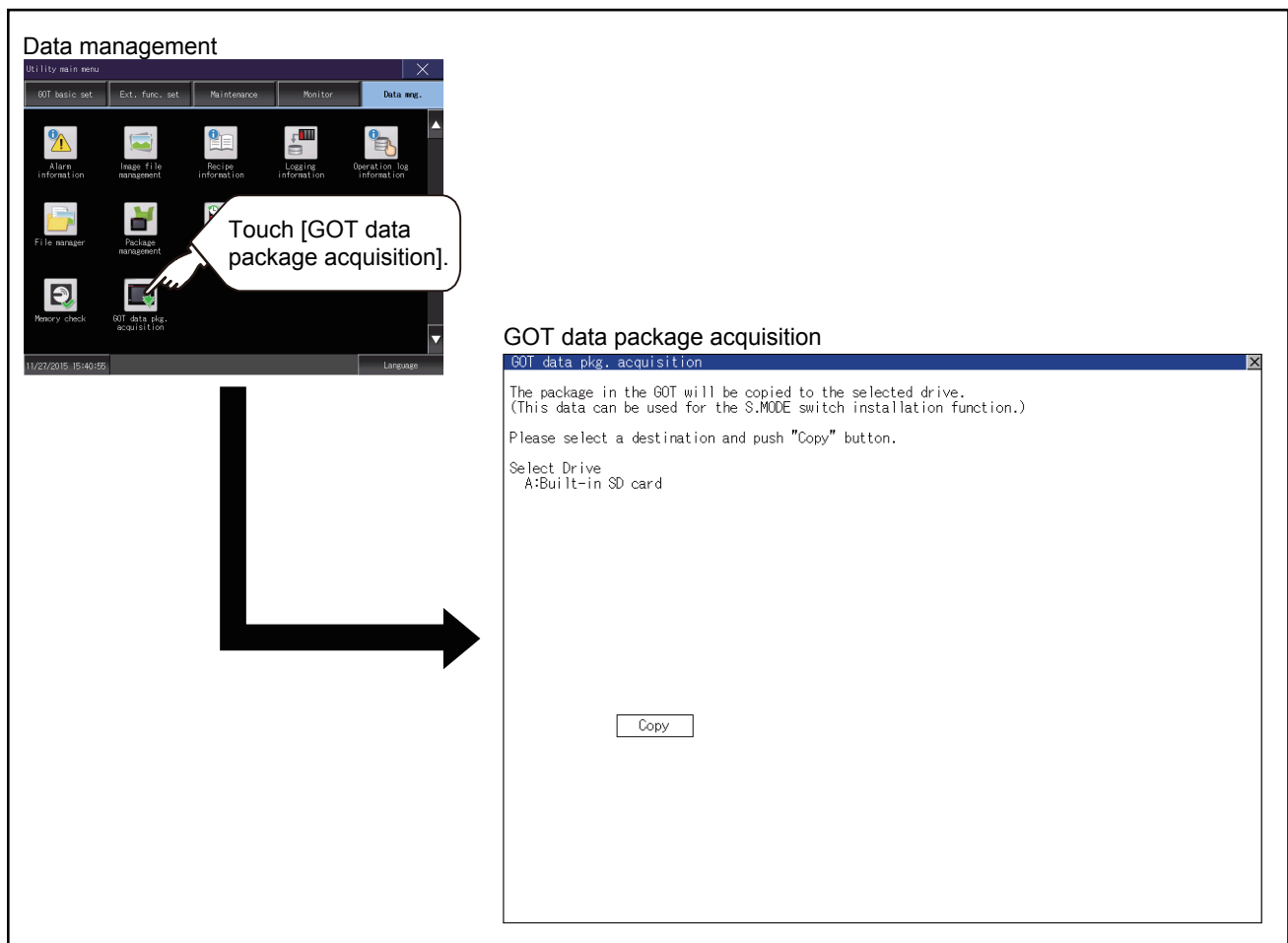

Display example of GOT data package acquisition

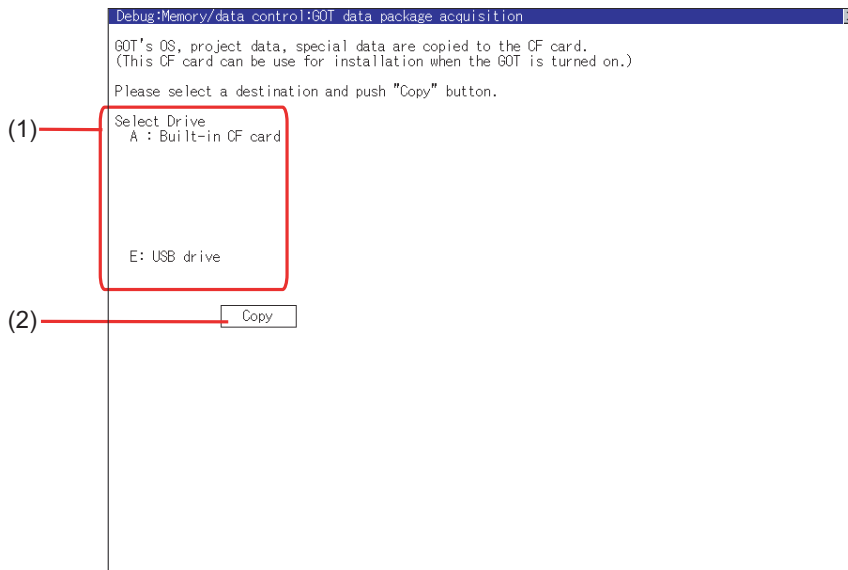

Number	Item	Description
(1)	Select drive	Displays the drive where OS and data can be copied. When an SD card is not installed, [A: Built-in SD card] is not displayed. When a USB memory is installed, the recognized USB drive is displayed. When a USB memory is not installed, no USB drive is recognized and displayed.
(2)	Copy	Touching the button starts copying.

GOT data package acquisition operation

Display operation of GOT data package acquisition

The GOT data package acquisition function copies the system applications installed in the GOT and data in the GOT to a data storage.

(This item explains using the A drive.)

1. Touching the drive name below [Select Drive] inverts the touched drive name.

Touching the [Copy] button starts copying.

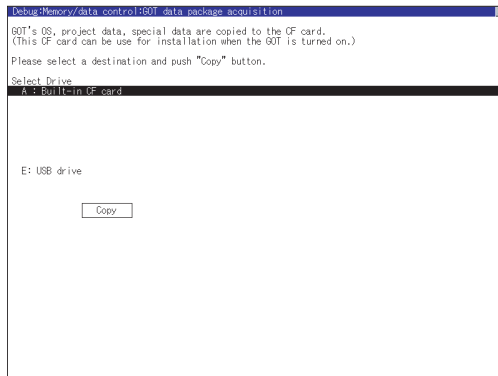

2. The display depends on the status of copy destination and setup.

Operate following the displayed dialog box.

(Example: Dialog box after touching the [Copy] button)

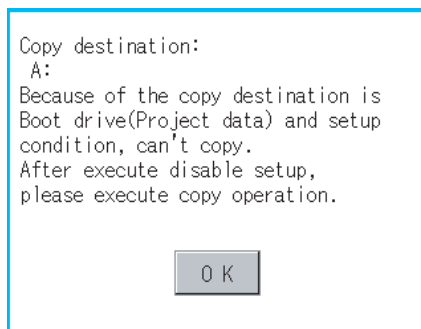

3. After copying the system application and data, the dialog box for notifying the completion appears.

Touching the [OK] button closes the dialog box.

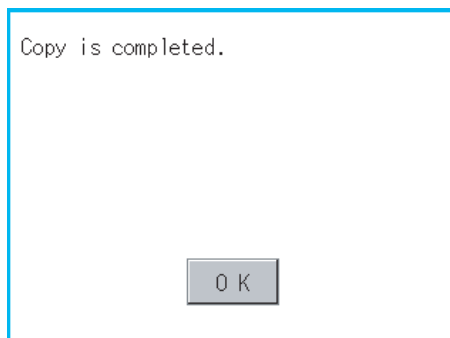

Point

Estimation of processing time

The time required for the processing depends on conditions such as system application, data capacity, and file structure.

(Reference value)

When the capacity is 4 Mbytes: Around 6 seconds

When the capacity is 12 Mbytes: Around 18 seconds

Precautions for operation

■Copying project data

If the Boot source drive and copy destination drive for project data is the same, the project data cannot be copied.

If the drives are the same, cancel the setup.

■When project data are copied to the GOT

If the system application or project data is copied to the GOT using the data storage created with the GOT data package acquisition, the utility setting is also copied.

Check each utility setting after copying to the GOT and change the setting according to need.

■Data storage to be used

When performing the GOT data package acquisition, do not store other data to the data storage.

If doing so, the previous data will be unavailable.

■When a project in drive C is protected with a security key

You cannot copy the project in drive C even by selecting the destination drive and then touching the [Copy] button.

For the details of the security key, refer to the following.

 GT Designer3 (GOT2000) Screen Design Manual

7 BOOTOS AND SYSTEM APPLICATION

☞ Page 392 Preparation before Installation

☞ Page 393 Installation Using Data Storage

☞ Page 398 When Installing the Different Version

To execute the GOT utility, install the BootOS and system applications on the C drive (built-in flash memory) of the GOT, or set the boot drive of the system application to [A: Built-in SD card] and insert an SD card with system applications into the GOT. (BootOS is installed in the GOT at factory shipment. It is not necessary to install BootOS when upgrading of it is unnecessary.) This chapter explains the installation using GOT.

GT Designer3 → Data storage → GOT

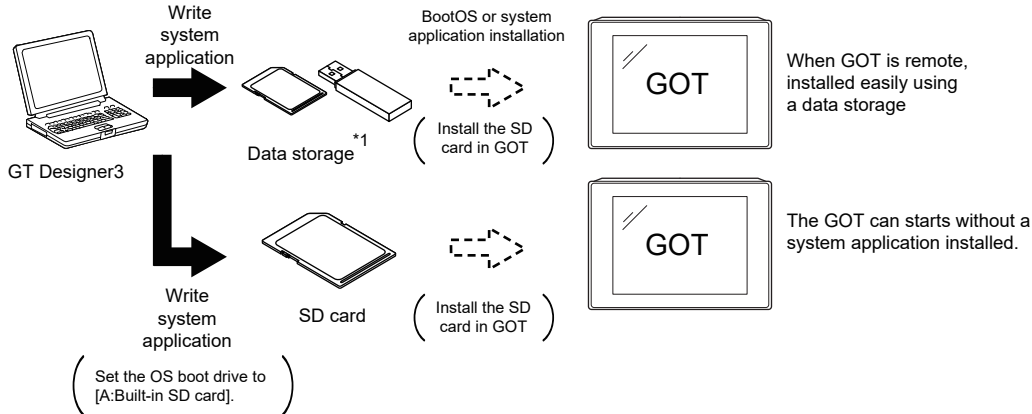

GOT → Data storage → GOT

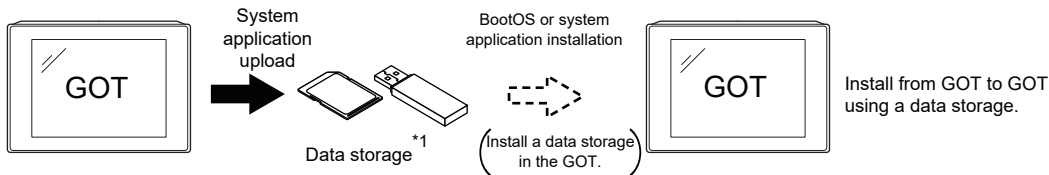

*1 When execute installation with a USB memory, the system applications have to be installed in GOT in advance.

Refer to the following for the installation which uses GT Designer3.

📖 GT Designer3 (GOT2000) Screen Design Manual

The following BootOS and system application are necessary to execute the utility.

- BootOS

Operating system required for control of the GOT and communication between the personal computer and the GOT. It is installed at factory shipment.

(BootOS can be installed from GT Designer3, or the SD card. When the installation has completed, the GOT is initialized to be the factory shipment status. Also, the basic system applications must be pre-installed in the GOT when the BootOS is installed again.)

- Basic system application

System application required for the GOT operations including the monitoring function, installation and deletion of the system application or project data, touch key control, and display of the screen, guidance, user-created screen, and utility screen.

It is not installed in the GOT at factory shipment.

Install it from GT Designer3 or the data storage.

7.1 Preparation before Installation

For the installation using GOT, the data storage that is storing BootOS or the system application is required. There are the following three methods for the installation of BootOS and system application.

To Memory Card] from GT Designer3

📖 GT Designer3 (GOT2000) Screen Design Manual

Uploading from other GOT (BootOS or system application has been installed)

📖 6 DATA CONTROL

Using an SD card that stores data with OS boot drive set to A drive

📖 GT Designer3 (GOT2000) Screen Design Manual

Point

Precautions on writing BootOS, system applications in a data storage

When writing BootOS, system applications or others into the data storage, be sure to execute by the utility of other GOT or GT Designer3.

The installation is not executed properly with the storage to which uploaded from the utility of GOT or copied by software other than GT Designer3.

Note the available capacity of the data storage.

The available capacity of BootOS and system applications can be confirmed by [Write to Memory Card] or [Write Option] of GT Designer3.

[Communicate with Memory Card] dialog

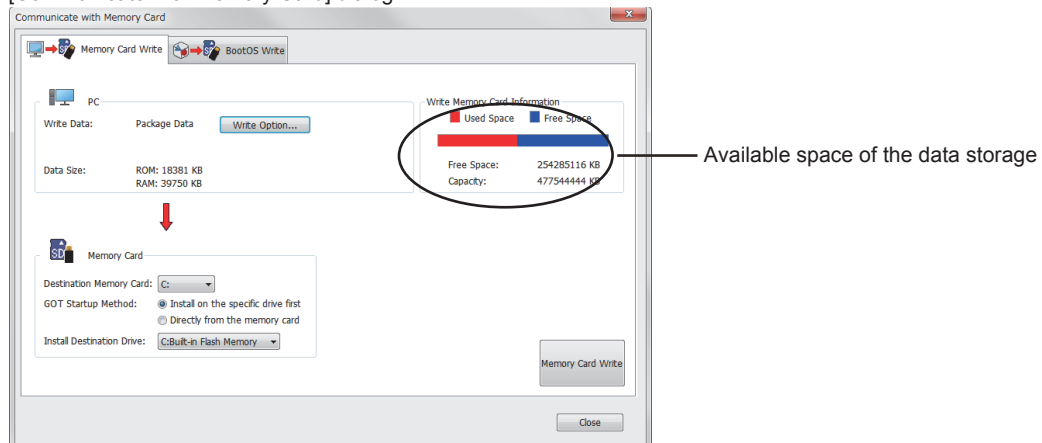

[Write Option] dialog

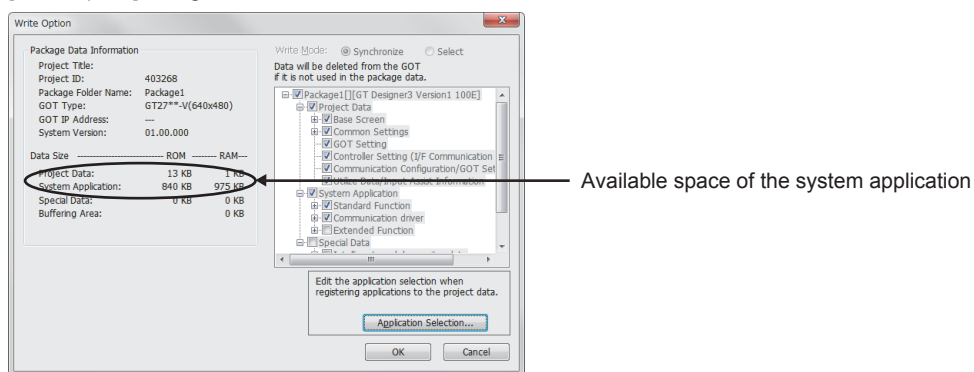

7.2 Installation Using Data Storage

There are the following two types for the installation of BootOS and system applications using a data storage.

Installing when starting the GOT

 Page 394 Installing when starting the GOT

All the system applications and project data stored in the data storage are transferred to the GOT when powering on the GOT.

This installing method is effective in the following cases.

The GOT utility cannot be displayed.

The system application is not installed.

Installing using the data control function (Utility)

 Page 396 Installing using the data control function (Utility)

By operating the utility, select the system application or project data stored in the data storage and transfer them to the GOT.

Point

Precautions on installing BootOS, system applications

- Installing both BootOS and system applications

After completing BootOS installation, install system applications.

When installing BootOS, the built-in flash memory in the GOT is initialized and goes to the status at factory shipment. (All system applications and project data are erased.)

BootOS is installed in the GOT at factory shipment.

It is not necessary to install BootOS when not upgrading it.

- Copying project data using a data storage

After installing BootOS and system applications, download the project data.

At this time, match the version of the system application in the GOT with the version of the system application with which the project data was created.

- When system applications and project data are in the data storage (when using GT Designer3)

For S.MODE switch-pressing installation, after the system application installation has completed, the project data is downloaded.

If installation is performed on GT2505-V by touching the lower right of the screen, the project data is downloaded after the system application installation is complete.

When installing with the utility, install the system application and download the project data from their respective operation screens.

- Installation cannot be interrupted.

Do not perform any of the following during a BootOS or system application installation.

Failure to do so may result in installation failure, causing the GOT malfunction.

- Powering off the GOT
- Pressing the reset button of the GOT
- Opening the cover of the SD card interface
- Removing the data storage

If the installation failure and the GOT malfunction occur, take the following action.

- If BootOS installation failed:

Touch the screen according to the displayed dialog to restart the GOT.

After restarting the GOT, the GOT is initialized to be the factory shipment status.

- If the basic system application installation failed:

Install BootOS.

 Page 394 Installing when starting the GOT

Installing when starting the GOT

The displayed message is different depending on the installation condition of the basic system application in the GOT. When the screen requesting operation is displayed, operate the GOT according to the instructions on the screen.

Point

S.MODE switch-pressing installation function

When the data storage that stores data with the OS boot drive set to the A drive is used, the S.MODE switch-pressing installation function is not available.

Operation procedure

The S.MODE switch is on the back or top of the GOT.

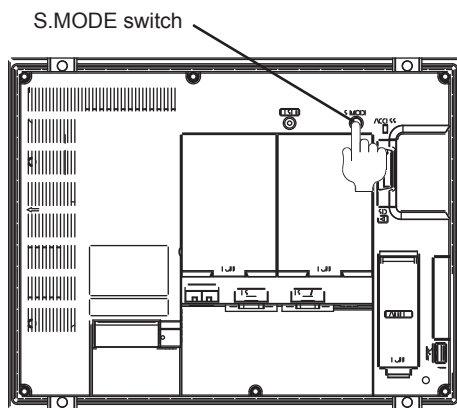

For GT2712

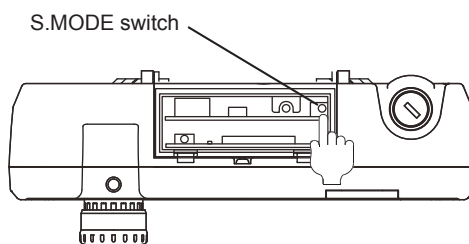

For GT2506HS-V

■When installing with an SD card

1. Power OFF the GOT, and install the SD card where the BootOS, system application or project data is stored in the SD card interface of the GOT.
2. Close the cover of the SD card interface of the GOT.
3. Power on the GOT.

Hold down the S.MODE switch and power on the GOT.

For GT2505-V, power on the GOT while touching the lower right of the screen. (1-point press installation function)

4. The BootOS or system application is installed in the built-in flash memory.

The SD card access LED is lit during the install execution.

Do not pull out the SD card or power OFF the GOT while the SD card access LED is lit.

Now installing BootOS.

5. The GOT restarts automatically after the installation is completed.
(If the system application is already installed, touch the [OK] button to restart the GOT.)

Reboot.

6. After confirming normal restart, confirm that the SD card access LED is not lit, and remove the SD card from the SD card interface of the GOT.

■When installing with USB memory

1. Power off the GOT, and install the USB memory where the BootOS, system application or project data is stored in the USB interface of the GOT.

The BootOS cannot be stored in the USB memory where the system application or project data is stored.

2. Power on the GOT.

While pressing the S.MODE switch, power on the GOT.

When using GT2505-V, while pressing the lower right of the GOT screen, power on the GOT. (1-point press installation function)

3. The BootOS or system application is installed in the built-in flash memory.

The USB memory access LED is lit during the installation execution.

Do not pull out the USB memory or power off the GOT while the USB memory access LED is lit.



Now installing BootOS.

4. The GOT restarts automatically after the installation is completed.

(If the system application is already installed, touch the [OK] button to restart the GOT.)



Reboot.

5. After confirming normal restart, confirm that the USB memory access LED is not lit, and remove the USB memory from the USB interface of the GOT.

For removing methods of the USB memory, refer to the following.

☞ Page 220 USB device status display operation

Installing using the data control function (Utility)

For details of data control function, refer to the following.

☞ Page 251 DATA CONTROL



Precautions on executing data control function

When execute data control function, system application has to be installed in GOT in advance. Thus, this function cannot be used for the initial installation of BootOS, system application after purchasing GOT. Install system application by the following two methods.

- GT Designer3
- Installing when starting the GOT

Operation procedure

■When installing with an SD card

1. Install the SD card where the BootOS, system application or project data is stored in the SD card interface of the GOT.
2. Close the cover of the SD card interface of the GOT.
3. Display the data control function screen (Utility) on the GOT, and install BootOS, system application from the SD card to GOT.

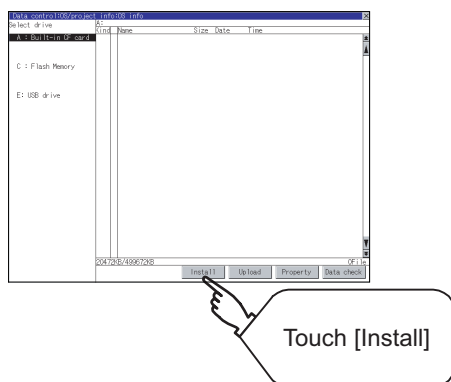

4. The SD card access LED is lit during the install execution. Do not pull out the SD card or open the SD card interface while the SD card access card is lit.

Now installing BootOS.

5. GOT restarts automatically after installation is completed.

Reboot.

6. After confirming normal restart, confirm that the SD card access LED is not lit, and remove the SD card from the SD card interface of the GOT.

■When installing with USB memory

1. Install the USB memory where the BootOS, system application or project data is stored in the USB interface of the GOT.
2. Display the data control function screen (Utility) on the GOT, and install basic system application from the USB drive to GOT.

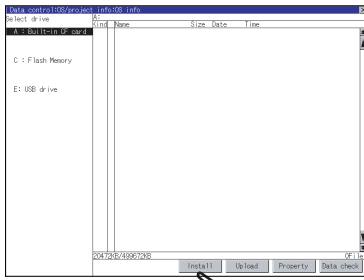

Touch [Install]

3. The USB memory access LED is lit during install execution.
Do not pull out the USB memory or power OFF the GOT while the USB memory access LED is lit.

Now installing BootOS.

4. The GOT restarts automatically after the installation is completed.

Reboot.

5. After confirming normal restart, confirm that the USB memory access LED is not lit.
Display the USB device status screen and remove the USB memory from the USB interface of GOT.

☞ Page 220 USB device status display operation

7.3 When Installing the Different Version

BootOS installation

When installing BootOS, GOT compares the version of the BootOS to be installed with the version of BootOS which is already installed.

If the major version of BootOS to be installed is old, execute the following operations to prevent it from being rewritten.

(When installing from GT Designer3, a message is displayed on the personal computer screen. Follow the instructions in that message.)

■When only BootOS is stored in the data storage

The message indicating disabled installation is displayed.



Touch the [OK] button to cancel the installation.

After canceling installation, restart the GOT.

■When BootOS and system application are stored in the data storage

Skip the BootOS installation and install the system application.

If the system application has already installed in the GOT, the following message is displayed.

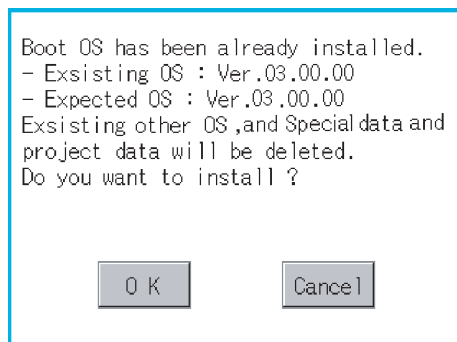

Touch the [OK] button to execute the installation.

Touch the [Cancel] button to cancel the installation.

After executing or canceling installation, restart the GOT.

■When the version is the same or newer regardless of the stored data (BootOS only or BootOS and system application) in the data storage

The version information and a dialog for selecting whether or not to continue installation are displayed.

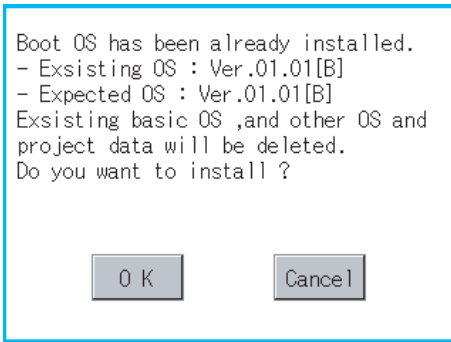

Touch the [OK] button to execute the installation.

Touch the [Cancel] button to cancel the installation.

System application installation

■Version of each system application

Match the version of each system application when installing system applications.

System applications cannot be installed if the version of each system application does not match.

When the installation process is discontinued.		When the installation process is normally executed.	
Basic system application	: 1.1 o. o	Basic system application	: 2. o. o
Communication driver	: 2.1 o. o	Communication driver	: 2. o. o
System application (Extended function)	: 2.1 o. o	System application (Extended function)	: 2. o. o

Please match the number.

■When using package data created with GT Designer3 Version1.122C or later

If package data created with an earlier version of GT Designer3 than 1.122C or later is installed, the GOT ID No. and the communication settings may not be reflected.

To reflect the GOT ID No. and the communication settings, them in the utility.

☞ Page 58 Unique Information

☞ Page 99 Controller

Point

Checking method of BootOS, system application version

Confirm the version of BootOS installed in the GOT at product shipment by rating plate of GOT rear face

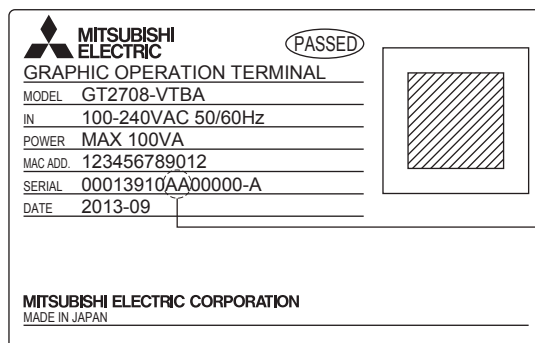

AA
BootOS version
(In case that the BootOS is two digits,
only the first digit is written.)

8 SYSTEM ALARM DISPLAY AND LIST

☞ Page 401 Display on the GOT

☞ Page 403 Error Codes and System Alarm List

This chapter describes the system alarms displayed on the GOT.

8.1 Display on the GOT

The following shows the displayed contents and checking method of the system alarm on the GOT.

Display contents of the system alarm

The display contents differ according to the error source.

Controller error

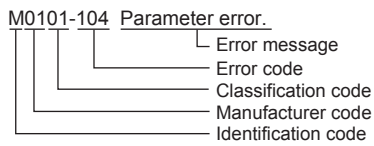

GOT error

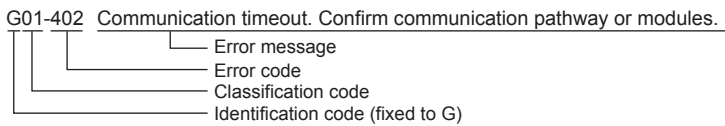

GOT Mobile error

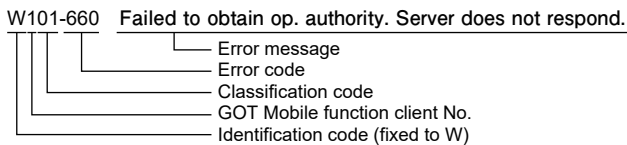

Network error

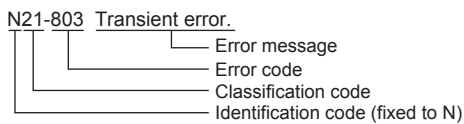

CPU error

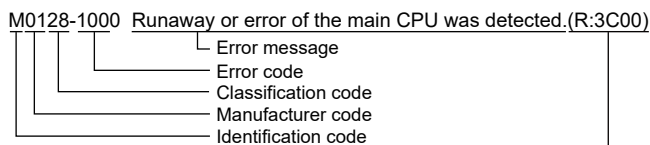

Error code of the CPU*1

*1 Displays the error code of the error occurred in the RCPU or FX5CPU.

How to check system alarms

■Checking method when the system alarm settings are configured on GT Designer3

The system alarm settings can be configured on GT Designer3.

For the details of the settings on GT Designer3 and the display contents, refer to the following.

 GT Designer3 (GOT2000) Screen Design Manual

■Checking method using the utility

When the system alarm settings are not configured on GT Designer3, you can check system alarms using the system alarm display in the utility.

 Page 226 System Alarm

Point

How to check the error code and channel number

You can check the following for the error code and channel number.

- Error code

Error code storage area for the system information function

- Channel No.

GOT special registers (GS262 to GS264)

For details of the system information and GOT special register, refer to the following manual.

 GT Designer3 (GOT2000) Screen Design Manual

8.2 Error Codes and System Alarm List

Error codes displayed on the GOT

The following shows the error codes displayed on the GOT and the relevant manuals.

■GOT error codes and network error codes

Error source	Error code	Description	Channel No. storage destination*1	Reference
Controller	0 to 99 (Value of D9008)	Error code of CPU (ACPU)	GS263	User's Manual of the ACPUs connected to the GOT
	100 to 299	Error code of the following controllers FXCPU*2 Non-Mitsubishi Electric PLC Temperature controller (OMRON temperature controller only)		Manual of the controller connected to the GOT Deal with errors according to the error messages.
GOT*5	300 to 399	Error code of the GOT main unit function	GS262*4	☞ Page 409 System alarm list
	400 to 499	Error code of the GOT communication function		
	500 to 699	Error code of the GOT main unit function		
Network	800 to 999	Error code of network	GS264	
CPU	1000 to 10000 (Value of SD0)	Error code of the CPU (QCPU, LCPU, or QnACPU)	GS263	User's Manual of the QCPU, LCPU, or QnACPU connected to the GOT
		Error code of an RCPUs or Motion CPU (MELSEC iQ-R series)		A system alarm message appears to indicate the code of the error occurring in an RCPUs. ☞ Page 401 Display contents of the system alarm For error handling, check the manual of the RCPUs.
		Error code of an FX5CPU		A system alarm message appears to indicate the code of the error occurring in an FX5CPU. ☞ Page 401 Display contents of the system alarm For error handling, check the manual of the FX5CPU.
Motion CPU	10001 to 10999	Error code of a Motion CPU (Q173D (S)CPU/Q172D (S)CPU/Q170M (S)CPU)		*6
CNC C70	11000 to 11999	Error code of the CNC (Q173NCCPU)		*7
Robot controller	12000 to 12999	Error code of the robot controller		*8
CPU	15000 to 15999	Error code of an RCPUs		*9
	16000	Error code of an FX5CPU		*10
Servo amplifier*3	20016 to 21121	Error code of the servo amplifier		User's Manual of the servo amplifier connected to the GOT

*1 For the details of the GOT special registers (GS262 to GS264), refer to the following.

☞ GT Designer3 (GOT2000) Screen Design Manual

*2 FXCPU has error codes 100 to 109, indicating the status of M8060 to M8069.

(Example) If error code (100) occurs, handle the error according to the M8060 description.

*3 The GOT displays the error code displayed on the servo amplifier (hexadecimal) in decimal + 20000.

Therefore, when referring to the manual of the servo amplifier with the error code displayed on the GOT using the system alarm, subtract 20000 from the GOT error code and convert the last 3 digits into the hexadecimal number.

(Example: When the GOT system alarm shows 20144, the error code of the servo amplifier is 90H.)

*4 Channel No. will not be stored depending on the error code.

For the details of the channel No. storage by error code, refer to the following.

☞ Page 409 System alarm list

*5 With the system alarm related to the file access, you cannot identify the drive where the alarm occurs. However, you can identify the drive by checking the File Access Error signal (b7 to b10) of System signal 2-2.

*6 The GOT displays the error code corresponding to an error occurring in the multiple CPU system.

Check the error details with MT Developer or MT Works2.

For error handling, refer to the manual of the Motion CPU.

- *7 The GOT displays the error code corresponding to an error occurring in the multiple CPU system.
Check the error details with the CNC monitor.
For error handling, refer to the manual of the CNC.
- *8 The GOT displays the error code corresponding to an error occurring in a robot controller in the multiple CPU system or a standalone robot controller.
Check the error details with RT ToolBox2 or RT ToolBox3.
For error handling, refer to the manual of the robot controller.
- *9 The GOT displays the error code corresponding to an error occurring in an RCPU or Motion CPU (MELSEC iQ-R series).
Check the error details with GX Works3 or MT Works2.
For error handling, refer to the manual of the RCPU or Motion CPU (MELSEC iQ-R series).
- *10 The GOT displays the error code corresponding to an error occurring in an FX5CPU.
Check the error details with GX Works3.
For error handling, refer to the manual of the FX5CPU.

■ Controller error codes

Error source	Error code	Description	Channel No. storage destination ^{*1}	Reference
Controller	1 to 32767	Error codes for the controller ^{*2*3}	GS263	Manual of the controller

- *1 For the details of the GOT special registers (GS262 to GS264), refer to the following.
 GT Designer3 (GOT2000) Screen Design Manual
- *2 For the FXCPU, error code 100 to 109 correspond to M8060 to M8069 respectively.
Example) For error code 100, take the corrective action for M8060.
- *3 For the hexadecimal error code of the servo amplifier, the GOT displays the error code in decimal incremented by 2000.
When referring to the manual of servo amplifier by the error code displayed as a GOT system alarm, subtract 20000 from the GOT error code and change its lower three digits to the hexadecimal number.
Example) The GOT system alarm 20144 refers to the servo amplifier error code 90H.

Identification/manufacture/classification code of the system alarm

A system alarm contains an identification code, manufacturer code, and classification code. The identification code indicates the category of the error. The manufacturer code and classification code indicate the area where the error occurred.

The following shows the details of the identification code, manufacturer code, and classification code.

■ Identification code

Identification code	Description
G	GOT error
W	GOT Mobile error
N	Network error (in the network unit that is mounted on the GOT)
M	Mitsubishi Electric controller error
C	Non-Mitsubishi Electric controller, microcomputer, or MODBUS error

■ Manufacturer code

Manufacturer code	Description
01h	Mitsubishi Electric Corporation
20h	Computer, MODBUS
21h	OMRON
22h	KEYENCE
23h	FUJI ELECTRIC (PLC)
24h	FUJI ELECTRIC (Temperature controller)
25h	YASKAWA
26h	YOKOGAWA
27h	PANASONIC, PANASONIC IDS
28h	TOSHIBA
29h	SHIBAURA MACHINE
2Ah	HITACHI IES
2Bh	HITACHI
2Ch	KOYO EI
2Dh	SHARP
2Eh	JTEKT
30h	SHINKO
31h	CHINO
32h	AZBIL
33h	RKC
34h	IAI
36h	ALLEN-BRADLEY
37h	GE IP
38h	LS IS
39h	SICK
3Ah	SIEMENS

■Classification code

The details of the classification code differ according to the identification code and manufacturer code.

Identification code	Manufacturer code	Classification code	Description
G, W	-	00h	Related to the monitor function or object function
		01h	Related to the communication or controllers
		02h	Related to operations
		03h	Related to the file access
N	-	21h	[MELSECNET/H]
		22h	[CC-Link IE Controller Network]
		23h	[CC-Link IE Field Network]
		24h	[CC-Link Ver.2(ID)]
		25h	[PROFIBUS DP]
		26h	[DeviceNet]
		27h	[CC-Link IE Field Network Basic]
		28h	[CC-Link IE TSN]
M	01h	00h	[Serial(MELSEC)]
		01h	[CC-Link(G4)]
		02h	[Multidrop(Slave)]
		03h	[AJ71QC24,MELDAS C6*]
		04h	[AJ71C24/UC24]
		05h	[MELSEC-FX]
		06h	[MELSEC-WS]
		10h	[Ethernet(MITSUBISHI ELECTRIC),Gateway]
		11h	[Ethernet(FX),Gateway]
		20h	[BUS(Q)]
		21h	[MELSECNET/H]
		22h	[CC-Link IE Controller Network]
		23h	[CC-Link IE Field Network]
		24h	[CC-Link Ver.2(ID)]
		25h	[Bus(A/QnA)]
		27h	[CC-Link IE Field Network Basic]
		28h	[CC-Link IE TSN]
		30h	[MELSERVO-J4,J3,J2S/M,JE]
		40h	[Ethernet(MELSERVO),Gateway]
		50h	[FREQROL 500/700/800,SENSORLESS SERVO]
		51h	[FREQROL 800]
		52 h	[FREQROL(batch monitor)]
		60h	[Ethernet(FREQROL),Gateway]
61h	[Ethernet(FREQROL(Batch monitor)), Gateway]		
C	20h	E0h	[MODBUS/RTU Master]
		E1h	[Computer]
		E2h	[MODBUS/RTU Slave]
		25h	[PROFIBUS DP]
		26h	[DeviceNet]
		F0h	[MODBUS/TCP Master,Gateway]
		F1h	[Computer]
		F2h	[Ethernet(SLMP),Gateway]
		F3h	[MODBUS/TCP Slave,Gateway]
		F4h	[OPC]





Identification code	Manufacturer code	Classification code	Description
C	21h	00h	[OMRON SYSMAC]
		10h	[Ethernet(OMRON),Gateway]
		11h	[Ethernet(OMRON NJ/NX), Gateway]
		70h	[OMRON THERMAC/INPANEL NEO]
		71h	[OMRON Digital Temperature Controller]
	22h	00h	[Serial(KEYENCE)]
		10h	[Ethernet(KEYENCE),Gateway]
	23h	00h	[FUJI MICREX-F]
	24h	70h	[FUJI Temperature Controller/Digital Controller]
	25h	00h	[YASKAWA GL]
		01h	[YASKAWA MP2000/MP900/CP9200SH]
		02h	[YASKAWA CP9200(H)]
		03h	[YASKAWA CP9300MS(MC compatible)]
		10h	[Ethernet(YASKAWA),Gateway]
		11h	[Ethernet(YASKAWA MP3000),Gateway]
		12h	[Ethernet(YASKAWA High Speed Ethernet Server), Gateway]
	26h	00h	[YOKOGAWA FA500/FA-M3/STARDOM]
		10h	[Ethernet(YOKOGAWA),Gateway]
		70h	[YOKOGAWA GREEN/UT100/UT2000/UT Advance]
	27h	00h	[Panasonic MEWNET-FP]
		01h	[Panasonic MEWTOCOL-7]
		30h	[Panasonic MINAS-A4]
		31h	[Panasonic MINAS-A5]
	28h	00h	[TOSHIBA PROSEC T/V]
	29h	00h	[SHIBAURA MACHINE TCmini]
	2Ah	00h	[HITACHI IES HIDIC H]
		01h	[HITACHI IES HIDIC H(Protocol2)]
		10h	[Ethernet(HITACHI IES), Gateway]
	2Bh	00h	[HITACHI S10mini/S10V]
		10h	[Ethernet(HITACHI), Gateway]
	2Ch	00h	[KOYO KOSTAC/DL]
	2Dh	00h	[SHARP JW]
	2Eh	00h	[JTECT TOYOPUC-PC]
	2Fh	00h	[Muratec MPC]
		01h	[Muratec MPR]
	30h	70h	[SHINKO TECHNOS CONTROLLER]
	31h	70h	[CHINO MODBUS device]
	32h	70h	[Azbil SDC/DMC]
		71h	[Azbil DMC50]
	33h	70h	[RKC SR Mini HG(MODBUS)]
	34h	90h	[IAI ROBO CYLINDER]
		91h	[IAI X-SEL]
	35h	90h	[Hirata HNC]
	36h	00h	[AB SLC500,AB 1:N]
		01h	[AB MicroLogix]
		02h	[AB Control/CompactLogix]
		03h	[AB MicroLogix(Extended)]
04h		[AB DH485]	
10h		[Ethernet(AB), Gateway]	
11h		[Ethernet(AB Tag), Gateway]	
12h		[Ethernet(AB MicroLogix), Gateway]	
37h	00h	[GE (SNP-X)]	

Identification code	Manufacturer code	Classification code	Description
C	38h	00h	[LS Industrial Systems MASTER-K]
		10h	[Ethernet(LS Industrial Systems XGK), Gateway]
	39h	00h	[SICK Flexi Soft]
	3Ah	00h	[SIEMENS S7-200]
		01h	[SIEMENS S7-300/400]
		10h	[Ethernet(SIEMENS S7),Gateway]
		11h	[Ethernet(SIEMENS OP),Gateway]

System alarm list





The system alarm detected with GOT is shown below.



Error code	Error message	Action	Channel No. storage
300	Project data contains unsupported objects.	Install the latest version of GT Designer3 and write the package data again to the GOT.	×
301	Project data contains unsupported functions.	Install the latest version of GT Designer3 and write the package data again to the GOT.	×
302	Project data contains unsupported settings.	Install the latest version of GT Designer3 and write the package data again to the GOT.	×
303	Set monitor points too large. Decrease setting points.	Decrease the number of objects from the displayed screen. For the number of maximum objects for 1 screen, refer to the following. 📖 GT Designer3 (GOT2000) Screen Design Manual	×
		Place the objects with quantity limit on either of the following screens when outputting a hidden screen's image using the hard copy function. If placed on both screens, the objects will not appear in the outputted file. <ul style="list-style-type: none"> • Displayed monitor screen • Hard copy output target screen 	×
305	Background loading of the system package failed.	Check that the data storage, which stores the package data and GOT project data, is installed and the data is not damaged.	×
306	No project data. Download screen data.	The project data is not downloaded or the screen data is not sufficient. <ul style="list-style-type: none"> • Download the project data or screen data. 	×
307	Monitor device not set	The monitor device of the object is not set. <ul style="list-style-type: none"> • Set the monitor device of the object. 	×
308	No comment data. Download comment.	The comment file does not exist. <ul style="list-style-type: none"> • Create the comment file and download to GOT. 	×
309	Device reading error. Correct device.	The error occurred when reading a continuous device. <ul style="list-style-type: none"> • Correct the device. 	×
310	Project data does not exist or out of range.	Specified base screen / window screen does not exist in the project data. Specified base screen / window screen is out of the permissible area. <ul style="list-style-type: none"> • Specify the existing base screen / window screen. 	×
311	No. of alarm has exceeded upper limit. Delete restored alarm.	The number of alarm histories that can be observed by the alarm history display function has exceeded the maximum points. <ul style="list-style-type: none"> • Delete the restored history to decrease the number of alarm histories. 	×
312	No. of sampling has exceeded upper limit. Delete collected data.	The collection frequency exceeded the upper limit when "Store Memory" and "Accumulate/Average" were set in the scatter graph. <ul style="list-style-type: none"> • Approve "Clear trigger" setup in the scatter graph. • Set the "Operation at frequency over time" to "Initialize and Continue" in scatter graph. 	×
313	Insufficient key window design information. Download extended system application.	Install a system application (extended function) of [Key Window Design Information] on the GOT.	×
315	Device writing error. Correct device.	Error occurred while writing in the device. <ul style="list-style-type: none"> • Correct the device. 	×
316	Cannot display or input operation value. Review expression.	In indirect specification of comment/parts number, the data operation result exceeded the range in which device type can be expressed. <ul style="list-style-type: none"> • Review the data operational expression, in order not exceeding the range in which the device type can be expressed. 	×
317	Too high frequency of data collection. Review conditions.	Data of an object, to which [Collect data only when trigger conditions are satisfied] is set, are collected too frequently, or the number of objects has exceeded the number of objects collectable simultaneously. <ul style="list-style-type: none"> • Set a longer cycle for trigger occurrence to each object. • Make the settings so that 257 or more display triggers of objects, to which [Collect data only when trigger conditions are satisfied] is set, do not occur simultaneously. 	×
318	The sound data with the specified number does not exist.	The sound data with the specified number does not exist in the sound file list. <ul style="list-style-type: none"> • Check the specified number. • Register a sound file with the specified number. 	×
320	Specified object does not exist or out of range.	The part file does not exist. <ul style="list-style-type: none"> • Create the part file and download to GOT. 	×

Error code	Error message	Action	Channel No. storage
322	Dedicated device is out of range. Confirm device range.	The monitored device No. is out of the permissible area of the targeted PLC CPU. • Check the PLC CPU to be monitored and its parameter settings, and set a valid device in GT Designer3.	×
		The specified data type is not supported by the devices of the connected controller. • Check the controller settings and specify a data type supported by the devices of the controller.	
		Consecutive device setting is specified for devices that cannot be specified as consecutive devices. • Change the device so that consecutive device setting can be specified, or do not set consecutive devices. For how to set the devices, refer to the following.  GT Designer3 (GOT2000) Screen Design Manual	
326	The data type of labels/tags do not match. Please check the settings.	The data type of the device assigned to the label or tag is incorrect. • For the usable data types, refer to the following.  GT Designer3 (GOT2000) Screen Design Manual	×
		The data types are inconsistent between the object or others and the label or tag set on the PLC side. • Correct the data type of the object or others according to that of the label or tag set on the PLC side.	
		String-type labels or tags may have not been imported. • If the labels or tags have not been imported, import them with GT Designer3.	
327	Label names have not been resolved. Resolve label names again.	Check the connection status of the PLC and execute the label name resolution again.  GT Designer3 (GOT2000) Screen Design Manual	×
328	There are label/tag settings that can not be monitored. Check the label/tag settings or resolve the label name again.	• The label or tag is set for the PLC which does not support labels. Correct the network No. and station number. • The label name or tag name specified in the project data does not exist on the PLC side. Check if the label name or tag name specified in the project data exists on the PLC side. • The GOT access the label or tag inaccessible from external devices. Enable the access from external devices in the label/tag setting on the PLC side. • When a global label of structure has members to which devices are manually assigned, the GOT fails to perform the label name resolution. Perform operations so that the devices are automatically assigned to the members, or directly set the manually assigned devices as monitor devices. • Label name resolution cannot be performed during the PLC initial processing. Change the title display time of the GOT so as to execute the label name resolution after the PLC initial processing.	×
329	Station numbers cannot be switched when label/ tag devices are used.	Do not perform the station No. switching to the station using labels or tags.	×
330	Insufficient memory media capacity. Confirm M-card capacity.	The available space of the memory card is insufficient. Check the available space of the memory card. For the checking method, refer to the following.  GT Designer3 (GOT2000) Screen Design Manual	×
331	Cannot access the memory card. Please check the memory card (inserted)/ SD card cover/access switch.	No memory card is installed in the drive, the SD card cover is open, or the SD card access switch is turned off. • Install the memory card in the specified drive. • Close the SD card cover to make the SD card accessible. • Turn on the SD card access switch to make the SD card accessible.	×
332	Memory media is not formatted.	Memory card (build-in SD card) is not formatted or formatted incorrectly. Format the memory card.	×
333	Unable to overwrite. Memory card is write-protected.	Memory card (build-in SD card) is write-protected. Cancel the write-protection of memory card.	×
334	Memory media error. Replace memory media.	Memory card (build-in SD card) is faulty. Replace the memory card.	×
336	Access failed because the target file size is too large.	The size of the file that the GOT attempts to access is not supported. • Make sure that the file size does not exceed 2 GB. • For GT27 and GT25, the size of the target file for a hard copy output must be less than 3840 KB. • For GT23, the size of the target file for a hard copy output must be less than 300 KB.	×

Error code	Error message	Action	Channel No. storage
337	File output failed. Confirm output file path.	Either of the following folder or file with the name same as the file to be created exists in the storage destination SD card or USB memory. <ul style="list-style-type: none"> Folder storing data Write-protect file Delete the above folder or file, or change the name of the file to be created.	×
338	Modem is not connected correctly or the power is not turned on.	There is no response to the initializing command because the modem is not connected correctly or the power is not turned on. <ul style="list-style-type: none"> Confirm the modem connection. Turn on the power of the modem. 	×
339	Failed to initialize the modem. Check initialization command.	An error is returned from the modem because the initializing command is invalid. <ul style="list-style-type: none"> Confirm the initializing command of the modem. 	×
340	Printer error or power failure	Printer is faulty or the printer power supply has not been turned on. <ul style="list-style-type: none"> Confirm the printer. Turn on the power supply of the printer. 	×
342	External power is not supplied to external I/O unit	Error occurred at the external I/O interface module. <ul style="list-style-type: none"> If an external power supply (24VDC) is not supplied, supply the external power supply. If an external power supply is supplied, replace the external I/O interface module. 	×
343	External I/O unit installation error. Check if firmly installed.	The external I/O interface module is not installed correctly. <ul style="list-style-type: none"> Install the external I/O interface module correctly. 	×
345	BCD/BIN conversion error Correct data	Any value that cannot be converted to a BCD/BIN value is being displayed/input. <ul style="list-style-type: none"> Change the device data to be displayed to the BCD value. Correct the input value to the 4 digits integer. 	○
346	There are no valid report screen settings.	The specified save destination of the report file is invalid. Check the following report file settings. <ul style="list-style-type: none"> The report screen exists in the report file specified as the save destination. The report file specified as the save destination of a report screen does not specify another report file as its save destination. 	×
351	The specified comment file does not exist.	The comment file was inaccessible at the GOT startup. <ul style="list-style-type: none"> Check that the comment file is in the read source folder. 	×
352	The format of the comment file is invalid.	Reading the comment file has failed due to one of the following causes. <ul style="list-style-type: none"> The format of the comment file is incorrect. The comment file does not have a comment column or comment row. Correct the format of the comment file, and read the file again.	×
353	Failed to read the comment file due to insufficient user area.	The user area does not have enough space for reading comments. <ul style="list-style-type: none"> Reduce the size of the project data by deleting unnecessary data or performing other operations. 	×
359	Thumbnail output is not available.	Thumbnail output is not supported if the output format or output target is set as shown below. Disable thumbnail output and execute the output again. <ul style="list-style-type: none"> The output format is PDF. The output target is one of overlap windows 1 to 5 being displayed. The output target is a hidden window screen. 	×
360	0 divisor division error. Confirm operation expression.	Zero division occurred by the data operational expression. <ul style="list-style-type: none"> Review the data operational expression so that the divisor should not become 0. 	×
361	Specified device No. is out of range.	The entered file number is out of range. <ul style="list-style-type: none"> Check the entered file number, and enter a valid value (1 to 9999). 	×
362	Invalid device value in time action setting	When controllers are controlled with the GOT's time action function, the set No. is out of range, or the set device values regarding the operation settings are out of range or invalid. <ul style="list-style-type: none"> Set valid values. 	×
363	The file number exceeds the limitation. File output failed.	Delete the file that has the largest file No. and unnecessary files.	×
364	Cannot start hard copy. Confirm destination setting.	Check if the output destination specified with the special function switch in which the hard copy start is set and the output destination specified by setting of the hard copy are matched.	×
365	Cannot start hard copy. Output target is not displayed.	The overlap window specified for the output target is not displayed. <ul style="list-style-type: none"> Display the target overlap window and start a hard copy output. 	×
366	Unable to output hard copy. Confirm output target setting.	An invalid setting or screen operation is detected while the image of a screen other than the displayed monitor screen is being output. For the corrective actions, refer to the following manual.  GT Designer3 (GOT2000) Screen Design Manual	×

Error code	Error message	Action	Channel No. storage
367	Cannot start hard copy. Confirm the external control device value.	Invalid values are set for the following external control devices. Set valid values. • Output file format • Output target screen • Number of output target screens	×
368	Unable to output hard copy. The specified screen is invalid.	Correct the settings of the output target screen. A hard copy output is not executed if any of the following applies. • Even one of sequentially numbered screens out of the specified number of screens is missing. • The security level is insufficient. • The screen number of the displayed screen is included.	×
369	Unable to output hard copy. The output screen data size exceeds the user area.	The data size of the output target screen exceeds the user area size (20 MB). • Adjust the number of output target screens and the contents of those screens.	×
370	Upper and lower limit value error. Confirm value setting.	The setting of lower/upper limit value is [Upper limit ≤ Lower limit]. Correct the setting so as to be "Upper limit > Lower limit".	×
372	Cannot display bookmark contents over 1000.	Set the number of bookmarks of the PDF file so that it does not exceed 1000.	×
373	Overflow occurred in 64-bit bitwise operations. Confirm operation expression.	An overflow has occurred in a 64-bit data operation. • Correct the expression for a data operation.	×
380	Insufficient USB drive capacity. Confirm the drive capacity.	Available memory of the extension drive is insufficient. Confirm the available memory of the extension drive, and increase the memory if it is low.	×
381	USB drive is not installed or in a removable state.	Install the extension drive if it is not installed. • Reinstall the extension drive if it is in the removable status.	×
382	USB drive is not formatted.	Extension drive is not formatted or formatted incompatible with GOT. • Reformat the extension drive.	×
383	Unable to overwrite. USB drive is write-protected	Extension driver is write-protected. • Cancel the write-protection of extension drive.	×
384	USB drive error. Replace USB drive.	Extension drive is faulty. • Replace the extension drive.	×
390	Failed to connect to the file server. Exceeded the share limit of the server.	The number of clients connected the shared folder on the file server has exceeded the limit. Disconnect any client or raise the maximum number of connections to the shared folder.	×
391	Failed to connect to the file server. Authentication failed on the server.	The user name and password settings are inconsistent between the GOT and the file server. Correct the user name and password settings.	×
392	Failed to connect to the file server. Cannot find the destination.	The specified shared folder does not exist on the file server. Check that the specified shared folder name is consistent between the GOT and the file server.	×
393	Failed to connect to the file server. Accessed with a locked user.	The specified user name has been locked out on the server. Specify an unlocked user name, or unlock the user name.	×
394	Failed to connect to the file server. An invalid volume was specified.	The hard disk specified as the network drive is inaccessible. Check the settings of the hard disk.	×
395	Cannot use the network drive. File server does not respond (timeout).	• After the GOT is connected to the file server, the IP address of the server or shared folder name is changed, the holder becomes unshared, or the server is turned off. Check if the above conditions have occurred. • The connected file server is not validated. Check if the file server has been validated.	×
396	An unexpected error was detected in the network drive.	An error occurred in the file server. Contact the manufacturer of the file server.	×
401	An error response has been received from the connected device.	• Eliminate the cause of the CPU error. • Review the operating conditions of the CPU, parameters, and others.	○

Error code	Error message	Action	Channel No. storage
402	Communication timeout. Confirm communication pathway or modules.	<p>The time-out error occurred during communicating.</p> <ul style="list-style-type: none"> • Confirm the cable omission, the communication unit mounting status and status of the PLC. <p>Channel No. is not displayed in error code or error message in the case an error occurs when using the multi-channel function.</p> <p>Refer to the following manual to identify the channel No. in error.</p> <p> GOT2000 Series Connection Manual for GT Works3 and a controller used (1.6 Checking for Normal Monitoring)</p> <ul style="list-style-type: none"> • This error may occur when the load of PLC CPU becomes heavier while accessing other stations. In such case, transfer the data of the other station to the host station PLC CPU and monitor them at the host. • Put COM instruction when the PLC scanning is long. • Check if the version of the communication driver supports the controller. <p>For how to check the version of the communication driver, refer to the following.</p> <p> GT Designer3 (GOT2000) Screen Design Manual</p>	○
403	SIO status error. Confirm communication pathway or modules.	<p>Either of the overrun error, parity bit error or flaming error was generated when the RS-422 / RS-232 communication was received.</p> <p>Confirm the cable omission, the communication module mounting status, status of the PLC and the transmission speed of the computer link.</p> <p>Channel No. is not displayed in error code or error message in the case an error occurs when using the multi-channel function.</p> <p>Refer to the following manual to identify the channel No. in error.</p> <p> GOT2000 Series Connection Manual for GT Works3 and a controller used (1.6 Checking for Normal Monitoring)</p>	○
404	Response does not match communication request.	<ul style="list-style-type: none"> • Resolve crosstalk on the line. • Lengthen the communication timeout time. <p>Change the communication timeout time by one of the following methods.</p> <p>Changing the setting in [Detail setting] of the utility.</p> <p> Page 108 Communication detail setting</p> <p>Changing the setting of the communication detail settings in GT Designer3.</p> <p> GOT2000 Series Connection Manual for the controller used</p>	○
406	Specified station access is out of range. Confirm station no.	<ul style="list-style-type: none"> • Station numbers other than master/local station are specified at the CC-Link connection (via G4). • A PLC CPU other than QCPU is accessed. <p>Confirm the station number of the project data.</p>	○
407	Accessed other network. Change network setting.	<ul style="list-style-type: none"> • When monitoring the same network as the GOT <p>The GOT accesses the other networks with the MELSECNET/H, MELSECNET/10 (PLC to PLC network), or CC-Link IE Controller Network connection. Confirm the network number of the project data so as not to access to other networks.</p> <ul style="list-style-type: none"> • When monitoring other networks <p>Reconfigure the [Routing Information Setting] of GT Designer3 or the [Routing Information Setting] of GX Developer.</p> <ul style="list-style-type: none"> • When using GT15-75J71LP23-Z/ GT15-75J71BR13-Z <p>Other networks cannot be monitored.</p> <p>Confirm the network number of the project data so as not to access to other networks.</p>	○
410	Cannot perform operation because of PLC run mode. stop the PLC.	<p>The operation, which could not be performed during RUN of PLC CPU, was performed.</p> <p>Stop the PLC CPU.</p>	○
411	Memory cassette is write-protected. Check the memory cassette.	<p>The memory cassette installed in the PLC CPU is EPROM or E2PROM, and it is in a protected status.</p> <p>Confirm the memory cassette installed in PLC CPU.</p>	○
412	Cannot read/write device protected by keyword. Remove keyword.	<p>The key word is set in PLC CPU.</p> <p>Cancel the key word.</p>	○
413	Unsupported CPU has been accessed.	<ul style="list-style-type: none"> • Check the latest manual to see if the CPU is supported. • Write package data created with the latest version of GT Designer3. • Connect a servo amplifier of the same model as the one specified in GT Designer3. 	○
414	Data cannot be written to a writeprotected device. Please review the settings.	<p>The external write-protection setting of the device is set to the CPU to which data was attempted to be written.</p> <p>Perform one of the following actions.</p> <ul style="list-style-type: none"> • Do not write data to a device to which the external write-protection setting of the device is set. • Write data to the available device again. • Disable the external write-protection setting of the device and write data again. 	○

Error code	Error message	Action	Channel No. storage
415	Failed to write a file to the connected device because the write-protection setting of the device was enabled.	The external write-protection setting of the device is set to the CPU to which a file was attempted to be written. Perform one of the following actions. • Do not write a device initial value file or file register file. • Disable the external write-protection setting of the device and write data again.	○
416	Failed to write to a file because the external operation prohibition setting of the operation history file was enabled.	[Disable clearing operation history] is enabled in the CPU to which a file was attempted to be written. Disable this setting and write the file again.	○
420	E71 specification is ASCII.	[ASCII code] is selected in [Ethernet operations] of the PLC side setting. Select [Binary code].	○
421	E71 is set as read-only. Clear setting.	The Ethernet module on the PLC side is set in read-only. Set the Ethernet module on the PLC side to write-enabled.	○
422	Not communicating between CPU and E71. Confirm CPU error.	PLC CPU error. Communication between PLC CPU and the PLC side Ethernet module impossible. Confirm whether there is error in PLC CPU by GX Developer etc. (Confirm buffer memory)	○
423	Insufficient network table information. Add station no.	The station number set in the project data and the station number set in the switching station No. device do not exist in the Ethernet setting of GT Designer3. • Add the station number set in the project data to the Ethernet setting of GT Designer3. • When using the station No. switching function, check the data of the switching station No. device. When the station number specified in the switching station No. device is not set in the Ethernet setting, add the station number to the Ethernet setting. When the station number does not exist in the system, change the data of the switching station No. device. (Set the station number so that it becomes the same as the station number of the PLC side Ethernet module set in the parameter setting of GX Developer.)	○
424	Same sta. on GOT & project data. Review communication parameter.	The station number set in the GOT's utility is the same as the station number set in the Ethernet setting of GT Designer3 (the station number of the PLC side Ethernet module) or in the project data. Check the following contents so that the multiple station numbers should not be the same. • Check the GOT's station number in the GOT's utility. • Check the station number set in the project data. • Check the station number set in the Ethernet setting. (Set the station number so that it becomes the same as the station number of the PLC side Ethernet module set in the parameter setting of GX Developer.) • When using the station No. switching function, check the data of the switching station No. device.	○
425	A duplicate IP address has been detected. Confirm the setting.	The GOT has the same IP address as another device. Change the IP address of the GOT or the device.	×
430	Wireless LAN unit is not mounted or a hardware error occurred.	The wireless LAN communication unit is not installed on the side interface. Check that the unit is installed properly.	×
431	Connectable access point is not found.	Check the setting for an accessible access point, and the wireless LAN connection setting.	×
432	Wireless LAN connection settings are not specified.	After configuring the wireless LAN connection setting, enable the wireless LAN connection function.  GT Designer3 (GOT2000) Screen Design Manual	×
433	Failed to authenticate the access point.	Check if the authentication method specified in the wireless LAN connection setting is the same as that on the access point side.	×
434	GOT hardware version not supported by wireless LAN connection	Use a GOT with hardware version B or later. For how to check the hardware version, refer to the following.  GOT2000 Series User's Manual (Hardware)	×
440	The label information has been updated.	The label name resolution will be executed automatically. Wait for the completion.	○
441	The specified CPU is updating the label information.	The global label information of the specified CPU will be updated. Wait for the completion.	○
442	Resolving the label information. Do not turn off the power during the process.	The label name resolution is being executed. Wait for the completion.	○

Error code	Error message	Action	Channel No. storage
443	Label names were resolved with the batch method because the firmware version of the programmable controller CPU does not support the split method. It may take time to complete the process.	The firmware of the PLC CPU does not support performing the label name resolution in units of global label blocks. Update the firmware version of the PLC CPU.	○
445	Failed to resolve label names. Resolve label names after completing initial processing of programmable controller CPU or confirm label name settings.	<ul style="list-style-type: none"> Label name resolution cannot be performed during the PLC initial processing. Turn on the GOT after the PLC initial processing, or set the title display time of the GOT so that the GOT is started after the PLC initial processing. The label name specified in the project data does not exist on the PLC side. Check if the label name exists on the PLC side. The GOT accesses the label inaccessible from external devices. Enable the access from external devices in the label setting on the PLC side. When a global label of structure has members to which devices are manually assigned, the GOT fails to perform the label name resolution. Perform operations so that the devices are automatically assigned to the members, or directly set the manually assigned devices as monitor devices. 	○
448	PLC cannot handle as requested. Correct devices.	<ul style="list-style-type: none"> A device outside the range of PLC CPU file registers and the buffer memory was specified. Correct the monitor device by setting file register of the PLC CPU. The label of the PLC CPU is assigned with a device out of the device range. Assign a device within the device range to the label. 	○
449	Dedicated device is out of range. Confirm device range.	<ul style="list-style-type: none"> Check the PLC CPU to be monitored and its parameter settings, and set a valid device in GT Designer3. Set the address for the special function module in the GOT monitor available range. 	○
450	Path has changed or timeout occurred in redundant system.	<p>The path has been switched or timeout occurred in the redundant system.</p> <ul style="list-style-type: none"> Check the PLC CPU to know if the path has been switched. Check the cable connection status, the communication unit installation status, and the PLC CPU status. This error may occur when the load of the PLC CPU becomes heavier when accessing other stations. In such a case, transfer the data of the other stations to the host station PLC CPU and monitor them at the host. Perform one of the following operations if the PLC scanning time is long: COM instruction/Extension of END processing/Setting of the number of processing times for general data/Data update batch processing. 	○
451	MELSEC redundant system settings and current config. do not match.	Change the MELSEC redundant setting in accordance with the actual MELSEC redundant system.	○
452	System (A/B) and system status (control/standby) not determined in redundant system.	<ul style="list-style-type: none"> Set one system as system A or control system and the other system as system B or standby system. Do not specify any connection destination system (request destination module I/O number). 	○
453	The standby system is set in a system other than the MELSEC iQ-R redundant system.	<ul style="list-style-type: none"> When the MELSEC redundant setting is not configured, delete the specified device of the standby system. Configure the redundant system using the MELSEC iQ-R series. 	○
460	Communication unit error	<ul style="list-style-type: none"> Reset the power of the GOT. Replace the unit. Correct the detail settings in the controller setting in GT Designer3. 	○
461	Communication error occurred between option units and the GOT.	<p>Check the following manual for the vibration resistance specifications and the method of mounting the option units. After that, reset the GOT power supply.</p> <p> GOT2000 Series User's Manual (Hardware)</p>	○
470	No routing params. Communication not established with specified sta.	Set routing parameters.	○
471	No IP address info. (Ethernet table) of connection destination.	Set the network information about the destination for [Ethernet setting].	○
480	Communication channel not set. Set channel number on Utility.	<p>Channel (CH.No.1 to 4) to communicate with a controller is not set.</p> <ul style="list-style-type: none"> After setting the Communication Settings on the GT Designer3, download it to the GOT. Change the channel assignment in the Communication Setting on the utility. 	○ ^{*1}
481	Communication unit not mounted to the slot of active channel.	<p>The interface where the channel (CH No.1 to 4) is set does not have a communication unit installed.</p> <ul style="list-style-type: none"> Install a communication unit to the interface where the channel (CH No.1 to 4) is set. Change assignment of the channel (CH No.1 to 4) in the Communication Setting. 	○

Error code	Error message	Action	Channel No. storage
482	Too many same units are mounted. Confirm the no of units.	Units are mounted on the GOT exceeding the maximum number of mountable units. Check the number of units, and remove unnecessary units.	○*1
483	Simultaneous mounting of the units are not allowed.	Two or more units which cannot be mounted on the GOT simultaneously are mounted. Check the mounted units, and remove unnecessary units.	○*1
484	Unit mounted incorrectly. Move the unit to correct position.	The unit is not mounted on the GOT in the correct position. Confirm the mounting position of the unit.	○*1
485	Too many units mounted on GOT. Reduce units.	Units are mounted on the GOT exceeding the maximum number of mountable units. Check the number of units, and remove unnecessary units.	○*1
486	Communication unit not corresponded to set communication driver.	The communication driver set in the Communication Setting and the communication unit installed on the GOT do not match. • Check whether the communication driver set in the Communication Setting is correct. • Check whether any incorrect communication unit has been installed on the GOT.	○*1
487	Please turn on the PLC and the GOT again.	Turn the power of the PLC and GOT on again.	○
488	Too many units mounted on GOT. Reduce units.	Units are mounted on the GOT exceeding the maximum number of mountable units. Check the number of units, and remove unnecessary units.	○*1
489	Inactive channel has been selected at Communication Settings.	Inactive channel No. has been set in the project data. • Check whether any unnecessary channel No. has been set in the project data. • Check whether channel Nos. set in the project data are set in the Communication Settings.	○*1
492	Unusable communication units are mounted.	Unit unusable for GOT is installed. Remove the unusable unit.	○*1
493	Installation of extension units may be inappropriate.	Check if the extension units are securely mounted on the GOT.	×
496	GOT settings do not meet operating conditions of the comm. driver.	• An unavailable IP address has been set. Set the IP address within the range of 0.0.0.1 to 223.255.255.254. • Multiple Ethernet interfaces are set to access the same network. Set an IP address and a subnet mask for each Ethernet interface so that each interface accesses a different network. • Another device uses port No. 61451. Change the port number for the device.	○
497	Failed to start communication driver(s).	Install the communication driver(s) again.	○
500	Warning! Built-in battery voltage is low.	The voltage of the GOT built-in battery is decreased. Replace the GOT built-in battery.	×
510	Clock data input out of range	The value that is input as clock data is out of the input enabled range. In this case, the input value is not accepted. Confirm the input range of the value to be input as clock data, and input the proper value again.	×
511	Detected a decrease in brightness or a failure of the liquid crystal backlight.	The liquid crystal backlight has a decrease in brightness or a failure. If the error is repeatedly detected, consult your local sales office.	×
522	Unnecessary file deleted to create new file.	The old file of different contents has been deleted and a new file has been created. Note that the old file is deleted and the new file is created if the file of the same name with different contents exists when creating files.	×
523	The read alarm log file has a different number of alarm points.	When the alarm settings (including the number of monitored alarms and the hierarchy) are changed, the alarm log file before the change is read, but alarms are collected according to the new settings. An alarm displayed after the change may differ from one before the change. Delete the alarm log file as necessary.	×
525	Unable to read/write alarm log files under different projects.	Unable to read the alarm log file saved by the different project. Confirm the alarm log file and where to store the alarm log file.	×
526	File conversion failed.	The file specified for the file conversion does not exist. Check the settings for specifying a file to be converted.	×
527	Insufficient SRAM capacity.	The capacity for the SRAM user area is insufficient. Confirm the available memory in the SRAM user area.	×
528	Error in SRAM. Failed to write data.	The error may be caused by a failure in the GOT main unit. Contact your local Mitsubishi representative.	×
529	Data error in SRAM. Check the battery life.	Error in SRAM data due to battery voltage low, etc. Confirm the battery status.	×

Error code	Error message	Action	Channel No. storage
532	Cannot access the files. Check the memory card.	Check if the file name is appropriate. The file name contains invalid characters. For the character type and the number of characters available for file names, refer to the following. 📖 GT Designer3 (GOT2000) Screen Design Manual	×
533	Cannot access Files. Check the memory card	Insert a SD card or USB memory. Close the SD card cover to make the SD card accessible. If the SD card or USB memory have unnecessary files, delete the files.	×
535	Cannot open image file.	Check if the target file is stored in the SD card or USB memory.	×
536	Image file error or invalid file format.	<ul style="list-style-type: none"> • Check if the image files in the SD card, USB memory, or drive V are normal. • Check if any image file of invalid format is stored. 	×
537	The display position of the image file is invalid.	If a part containing an image file is used in GOT Graphic Ver.1 and the part lies beyond the top or left of the screen, the image file is not displayed. Adjust the position of the part.	×
562	Install the font appropriate for the specified system language.	No font appropriate for the system language specified at the system language switching is installed. Install the appropriate font.	×
565	Files for the extended system application are missing.	Install again system application (extended function) that you failed to execute.	×
571	Capacity shortage of user memory (RAM)	There is no empty area/space in D drive. Format the D drive in the memory to secure free area.	×
577	Newly readable records do not exist.	The space for reading records is insufficient. Delete unnecessary records.	×
578	The specified record name is invalid. Check the record name.	A blank record with no name and device value does not exist. Set such a blank record in advance.	×
579	Recipe is in process. Cannot operate the recipe file.	Another recipe processing is in progress. After the processing is complete, perform the recipe file operation again.	×
580	Selected recipe setting is not the recipe file operation target.	The specified recipe setting has no G2P recipe file. Specify a G2P file.	×
581	Abnormal Advanced recipe file	Recipe cannot be executed for recipe file with incorrect contents. Take one of the following corrective actions. <ul style="list-style-type: none"> • Delete the recipe file from the SD card or USB memory. • Delete the relevant recipe data with the SRAM management function, and perform the recipe operation again. 	×
582	Cannot generate Advanced recipe file.	Cannot generate recipe file. Confirm the following and execute recipe processing again. <ul style="list-style-type: none"> • Confirm whether the SD card or USB memory is installed. • Close the SD card cover to make the SD card accessible. • Confirm the available memory of the SD card or USB memory. • Check that the SRAM user area has enough free space. 	×
583	Unable to save device value to Advanced recipe file.	Unable to save device value to recipe file. <ul style="list-style-type: none"> • Confirm the write-protection of the SD card or USB memory. • Confirm whether the attribute of saving file is for reading only. 	×
584	Advance recipe file save error	An error has occurred at the time of writing the recipe file or recipe data. Take one of the following corrective actions. <ul style="list-style-type: none"> • If the recipe file is set to be saved in a data storage (SD card or USB memory), do not remove the data storage during the operation. • If the recipe data is set to be saved in the SRAM user area, the GOT physical memory may be corrupted. Consult your local sales office. 	×
585	Advanced recipe file upload error	An error has occurred at the time of writing the recipe file or recipe data. Take one of the following corrective actions. <ul style="list-style-type: none"> • If the recipe file is set to be saved in a data storage (SD card or USB memory), do not remove the data storage during the operation. • If the recipe data is set to be saved in the SRAM user area, the GOT physical memory may be corrupted. Consult your local sales office. 	×
586	Specified Advanced recipe number does not exist.	The recipe of non-existing number is about to be executed. Execute recipe of existing number.	×
587	Specified record number does not exist.	The advanced record of non-existing number is about to be executed. Execute record of existing number.	×
588	Cannot save recipe data to read only record.	Saving recipe is about to be executed to the record of which recipe device value cannot be edited. Make the recipe device value of the record editable with Recipe Setting of GT Designer3 or specify the record of which recipe device value can be edited.	×

Error code	Error message	Action	Channel No. storage
589	Recipe device read/conversion error. The file save destination is not specified.	Saving recipe is about to be executed to the recipe setting that is set for not using file. Specify a different recipe setting in which recipe data is set to be saved.	×
590	Recipe device upload error. Recipe device value does not exist.	You tried to read device values into the recipe setting in which recipe data is set not to be saved. Specify the record of which recipe device value is set.	×
591	Advanced Recipe error. Check recipe data.	The recipe setting is not correct. Confirm the recipe setting of the project data and download it to the GOT again.	×
592	The extension specified to the recipe file is invalid.	Check if the file name is appropriate. The file name contains invalid characters. For the details, refer to the following. 📖 GT Designer3 (GOT2000) Screen Design Manual	×
593	The setting of G1P file of the original diversion is different from the project data.	The settings of the sourcMatch the settings of the advanced recipe file and those of the GOT2000 recipe file, or delete an unnecessary advanced recipe file from the memory card.e advanced recipe file are not matched with those of the GOT2000 recipe file, or incorrect.	×
594	Abnormal device values were detected in the conversion source recipe file.	A value outside the setting range or a character that cannot be converted into a numerical value is included in the device value of the conversion source recipe file or CSV/Unicode text file. Check the file and correct the device value.	×
595	Logging file error.	Logging file error.The setting of G1P file of the original diversion is different from the project data.The setting of G1P file of the original diversion is different from the project data. When collecting data again, delete logging files and management files.	×
596	Logging setting does not exist or setting value error.	Logging setting does not exist or setting value error. Specify an existing logging setting in the historical trend graph setting and the historical data list setting.	×
597	The specified logging ID does not exist.	Check the logging ID in the historical trend graph setting. • Specify an existing logging ID in the Logging ID External Control device. • Select the graph offset function to specify an existing logging ID in the logging setting	×
598	The specified logging setting is incompatible.	• Configure the setting so that the number of logging devices set for the logging ID exceeds that of data lines on the historical trend graph. • Configure the setting so that the data type of the logging device set for the logging ID is the same as that of the device specified in the historical trend graph.	×
601	Printer unit error.	The printer unit is installed incorrectly. The built-in flash memory of the printer unit is broken or the guaranteed life has been elapsed. Check that the printer unit is installed correctly. When the printer unit has been installed correctly, the built-in flash memory is broken or the guaranteed life has been elapsed. Replace the printer unit with new one.	×
602	Video/RGB unit not mounted	Check if the video/RGB input unit is installed. Check if the GOT used supports video/RGB input.	×
603	External I/O unit error	Check if the external I/O unit is correctly installed.	×
604	Sound output unit error	Check if the sound output unit is correctly installed.	×
605	USB device I/F error	The error may be caused by a failure in the GOT. Contact your local Mitsubishi representative.	×
606	Multimedia processing unit is not mounted.	Multimedia unit is installed incorrectly. Check that the multimedia unit is installed correctly.	×
607	Video · RGB input object has too many. Please reduce the number of settings.	Reduce the number of the video/RGB display objects to be displayed simultaneously.	×
608	Hierarchical relationship of video · RGB input object can not be represented correctly.	Make sure that multiple video/RGB display objects do not overlap each other.	×
609	Communication/Option unit is not mounted.	Mount the communication unit or option unit correctly.	×
610	Insufficient memory capacity.	The memory capacity for the MES interface function is insufficient. Delete unnecessary files, and reserve memory.	×
611	Improper job files. Confirm job setting.	The contents for job files are unmatched with the settings for job files. Check if there are mistakes in the settings on the setting screen.	×
612	Cannot access Logging Files Check the memory card	Insert a SD card or USB memory. Close the SD card cover to make the SD card accessible. If the SD card or USB memory have unnecessary files, delete the files.	×

Error code	Error message	Action	Channel No. storage
613	Error in writing logfile	Insert a SD card or USB memory. Close the SD card cover to make the SD card accessible. Check if the SD card or USB memory is writable.	×
614	Error in reading logfile	Insert a SD card or USB memory. Close the SD card cover to make the SD card accessible. Check if the SD card or USB memory is readable.	×
615	Cannot connect to MES Server. Check the Server.	The server does not work normally or the connection path to the server is made up incorrectly. Check the operating conditions of the server. Check the network to the server.	×
616	Cannot connect to SNTP Server. Check the Server.	The settings for the SNTP server are wrong or the network to the SNTP server is made up incorrectly. Check the operating conditions of the STNP server. Check the network to the SNTP server.	×
620	Trial connection has started.	While the license number of the GOT Mobile function is unregistered, the GOT is accessed by information devices. To use the GOT Mobile function in the full version, register the license number on the GOT.	×
621	Failed to start the GOT Mobile function.	Check if the HTTP connection port number is duplicated. (For GT SoftGOT2000, use the set port number, the port number +1, and the port number +2.) Restart the personal computer.	×
622	Cannot display the overlap window having a width wider than the base screen.	Set the width (excluding the frame width) of an overlap window with the title bar equal or less than the width of the base screen.	×
630	Failed to save a video file.	Check the CF card available area, installation status, cancellation of write-protect, format status and number of saved files.	×
631	Failed to save a video file on network.	Check the activation status of personal computer linkage software in file server, the setting of Ethernet FTP function of GOT, the network setting of GOT and file server and the available area of SD card installed in the GOT main unit.	×
632	Error detected during multimedia processing.	Switch off the GOT and check the installation status of multimedia unit, or change the multimedia unit.	×
633	The version of the unit software is not the latest.	Install the latest compatible multimedia unit software using the utility of the GOT.	×
634	No space remaining in the multimedia CF card. Terminating long time recording.	Change the CF card installed on the multimedia unit, or delete unnecessary files.	×
640	An error occurred in a File transfer process.	Correct the settings for the file transfer function (FTP transfer). Check the operating status and network line of the FTP server. For the error details, check GS989 (File Transfer Error No.).  GT Designer3 (GOT2000) Screen Design Manual This system alarm does not occur when GS989 stores error code 600 or higher.	×
641	The license key has not been registered. Confirm your license.	On the GOT, register the license number for the VNC server function, the remote personal computer operation function (Ethernet), the MES interface function, or the GOT Mobile function.	×
643	The version of the DB connection service is not supported by GOT.	Use DB Connection Service Version 1.14Q or later, or Version 2 or later.	×
650	The operator management information file is invalid.	Prepare a normal operator management information file and import it ,or store the operator management information file in a specified location.	×
651	Cannot access the operator management information file.	Check if the destination drive that stores the specified operator management information file is accessible by the GOT.	×
660	Failed to obtain op. authority. Server does not respond.	Make sure that the master GOT has been connected and started. Make sure that the GOT network interaction function is enabled in the master GOT.	×
670	Current alarms exceeded the max no. that can be procd. at a time.	A hundred or more system alarms have occurred simultaneously. Eliminate the cause of the output system alarms and check system alarms again.	×
697	Package writing of the old version is not allowed.	Install the latest version of GT Designer3, and then perform the operation again.	×
698	Insufficient CoreOS version.	Install the latest version of CoreOS.	×
699	Insufficient BootOS version.	Install the latest version of BootOS	×
800	Abnormal module status	A module status error has occurred on the connected network. For the causes and corrective actions, refer to the network manual.	○
801	Abnormal baton passing status	Refer to explanations of SB0047 on the applicable network manual.	○
802	Abnormal cyclic transmission status	Refer to explanations of SB0049 on the applicable network manual.	○

Error code	Error message	Action	Channel No. storage
803	Transient error	Refer to explanations of SB00EE on the applicable network manual.	○
804	The cable on the IN side is disconnected or is not connected.	Refer to explanations of SB0067 on the applicable network manual.	○
805	The cable on the OUT side is disconnected or is not connected.	Refer to explanations of SB0068 on the applicable network manual.	○
820	A duplicate IP address has been detected. Confirm the setting.	Change the IP address of the CC-Link IE TSN communication unit or another device. Do not duplicate the IP address.	○
840	PROFIBUS master is not started.	Turn on the PROFIBUS master module.	○
841	I/O setting of the PROFIBUS master and slaves do not match.	<ul style="list-style-type: none"> • Use the GSD file, a configuration file provided by MITSUBISHI ELECTRIC. (Edit prohibited) • Correct relevant settings, and turn off and then on the GOT. 	○
850	CC-Link switch setting error	<ul style="list-style-type: none"> • Check if the switch settings have no error. • Check error codes stored in SW006A. • Refer to explanations of SB006A on the applicable network manual. 	○
851	Abnormal cyclic transmission status	<p>Check if terminating resistors are connected.</p> <p>Check error codes for the PLC CPU.</p> <p>Check the parameter for the PLC CPU on the master station(specified control station).</p> <p>Check the error status of the master station(specified control station).</p> <p>Refer to explanations of SB006E on the applicable network manual.</p>	○
852	Abnormal host line status	<p>Check if the cable is unplugged or not.</p> <p>Refer to explanations of SB0090 on the applicable network manual.</p>	○
853	Transient error	<p>Check the transient error occurrence status for each station stored in SW0094 to SW0097.</p> <p>Refer to explanations of SB0094.</p>	○
854	Duplicate master stations are set in the same network.	Set only one master station(specified control station) in the network.	○
855	Disconnected.	<p>The GOT is waiting for a request from the master station(specified control station).</p> <p>Check the status of the master station(specified control station).</p>	○
860	Off line or the network power is off.	<ul style="list-style-type: none"> • Check the module status LED indicator. • Turn on the network. • Check that cables are connected properly. • Match the communication speed of the GOT to that of the master equipment. 	○
861	No connections are established.	<ul style="list-style-type: none"> • Check the settings of the master equipment. • Turn on the master equipment. 	○
862	Critical link error	The controller has failed, or has an error disabling network communication. (MAC IDs are duplicated, or Bus-off is detected.) Check the controller.	○
863	Incomplete configuration	The controller setting is not configured, or the setting is inadequate or incorrect. Review the controller setting.	○
864	Unrecoverable fault(s)	The controller has an uncorrectable error.	○
865	Recoverable fault(s)	<p>The error is automatically corrected.</p> <p>If the module status LED indicator does not turn green, the controller may have a failure.</p>	○

*1 When there is an error, "0" is stored to the channel No.

PART 2

UTILITY FOR GT21

9 UTILITY FUNCTION

10 LANGUAGE SETTING

11 COMMUNICATION INTERFACE SETTING

12 DISPLAY AND OPERATION SETTINGS

13 SECURITY LEVEL AND OPERATOR SETTINGS

14 CLOCK SETTINGS AND BATTERY STATUS DISPLAY

15 CONTROL OF VARIOUS DATA

16 DEBUG

17 MAINTENANCE

18 BOOTOS AND SYSTEM APPLICATION

19 ERROR MESSAGE LIST

9 UTILITY FUNCTION

☞ Page 422 Utility Execution

☞ Page 423 Utility Function List

☞ Page 425 Utility Display

Utility is a function, which carries out connection of GOT and controller, screen display and operation method settings, program/data control and self-check etc.

9.1 Utility Execution

For utility execution, utility has to be displayed by installing BootOS and package data in the C drive (built in flash memory). (BootOS is installed in the GOT at factory shipment. It is not necessary to install BootOS when upgrading of it is unnecessary.) There are following two methods for installing BootOS and package data.

1) GT Designer3 → GOT

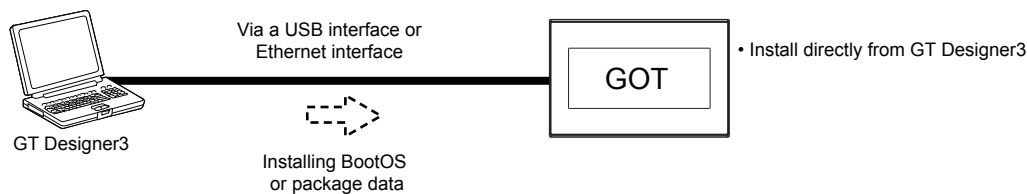

2) GT Designer3 → SD card → GOT

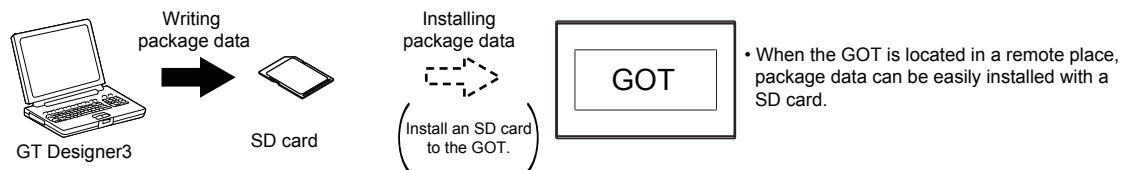

Refer to the following for the installation which uses GT Designer3.

☞ GT Designer3 (GOT2000) Screen Design Manual

For the installation methods of package data with an SD card, refer to the following.

☞ Page 693 BOOTOS AND SYSTEM APPLICATION

9.2 Utility Function List

The items in the following list can be set/operated on the utility screens.

Item	Function overview	Reference	
Language	Switching message languages	☞ Page 433 LANGUAGE SETTING	
Communication setting	standard I/F setting	Assigning channel number and communication driver to communication interface	☞ Page 435 Standard I/F
	GOT IP Address* ¹	Configuring GOT Ethernet setting	☞ Page 451 GOT IP Address Setting (Ethernet models only)
	Ethernet communication* ¹	Displaying the contents of Ethernet setting, changing the host	☞ Page 456 Ethernet Communication (Ethernet models only)
	Comm. Monitor	Checking the serial communication port communication	☞ Page 464 Communication Monitor
	Ethernet check* ¹	Checking the Ethernet communication port communication	☞ Page 469 Ethernet Check (Ethernet models only)
	Transparent setting	Setting the channel No. to be used for the communication for the FA transparent function	☞ Page 471 Setting the Transparent Mode
	Keyword	Setting or deleting sequence program protection key words and canceling sequence program protection status for the FXCPU connection	☞ Page 472 Keyword
	Ethernet printer	Setting the IP address of the Ethernet printer	☞ Page 480 Ethernet Printer
GOT Setup	Display settings	Setting the title display period	☞ Page 486 Display Settings
		Setting the screen save time	
		Adjusting brightness	
	Operation	Setting the buzzer sound	☞ Page 492 Operation Settings (Settings for Operation)
		Setting the window move buzzer	
		Setting the key reaction speed	
		Touch panel calibration	
		Setting the utility call keys	
	Unique information	Setting the GOT ID No.	☞ Page 502 Inherent Information
	USB host	Setting the USB mouse/keyboard (GT2107-W)	☞ Page 503 USB Host
	Backup/restoration setting	Setting the storage location for backup and restoration (GT2107-W)	☞ Page 506 Setting the storage location for backup and restoration
	GOT internal device monitor	Setting the Use/Disuse the GOT internal device monitor of GOTdiagnostics	☞ Page 508 GOT Internal Device Monitor
	VNC server function	Setting the VNC server function (GT2107-W)	☞ Page 510 VNC Server Function
License Management	Display screen for Register or delete the license (GT2107-W)	☞ Page 512 License Management	
IP filter setting* ¹	Setting the IP filter usage, filtering method, target IP address, and exception IP address	☞ Page 514 IP filter setting	
Security setting	Security level authentication	Changing the security level	☞ Page 521 Security Level Authentication
	Operator Authentication	Operator management	☞ Page 523 Operator Authentication
		Password change	
		Function setting	
Login/Logout		☞ Page 536 Login/Logout	
Time setting	Time setting	☞ Page 537 Time Setting and Display	

Item		Function overview	Reference	
Data control	OS information	OS information	☞ Page 558 OS information	
	Resource data	Alarm Information	Deleting or copying alarm log files Converting alarm log files in G2A format → CSV/TXT format	☞ Page 559 Alarm information
		Recipe Information	Converting recipe files in G2P format → CSV/TXT format Converting CSV/TXT format → Recipe files in G2P format Deleting or copying recipe files	☞ Page 569 Recipe information
		Logging Information	Deleting or copying logging files	☞ Page 580 Logging information
		Image File Management	Deleting or copying hard copy files	☞ Page 587 Image file management
		Operation log information	Deleting or copying operation log files Converting operation log files in G2O format → CSV/TXT format	☞ Page 594 Operation log information
	SD card acce	Setting the access permission of the SD card	☞ Page 600 SD Card Access	
	SD card format	Formatting the SD card	☞ Page 601 SD Card Format	
	Clear data	Clearing the project data and resource data on the GOT	☞ Page 605 Clear Data	
	Data copy	Installing or updating package data	☞ Page 609 Data Copy	
	Backup/restore	Backing up or restoring sequence programs, parameters, and setting values	☞ Page 614 Backup and Restoration	
	USB device management	Displaying the status of USB device (GT2107-W)	☞ Page 636 USB Device Management	
Debug	Device monitor	Device monitor of PLC, test function, current value change of the buffer memory and the buffer memory monitor of intelligent module	☞ Page 639 Device Monitor Function	
	FX list editor	Changing parameters and sequence program of FX PLC	☞ Page 653 FX List Editor	
	FX3U-ENET-ADP communication setting function	Configuring the communication setting for FX3U-ENET-ADP stored in the FXCPU	☞ Page 683 FX3U-ENET-ADP Communication Setting Function	
Maintenance	Touch panel calibration	Calibrating the touch panel reading error	☞ Page 687 Touch Panel Calibration	
	Touch panel check	Checking the touch panel operation	☞ Page 690 Touch Panel Check	
	Clean	Displaying the screen for cleaning the display	☞ Page 692 Clean	

*1 Only available to the models with an Ethernet interface.

9.3 Utility Display

To display setting screens for each utility, the main menu has to be displayed first.
(For GT2107-W)

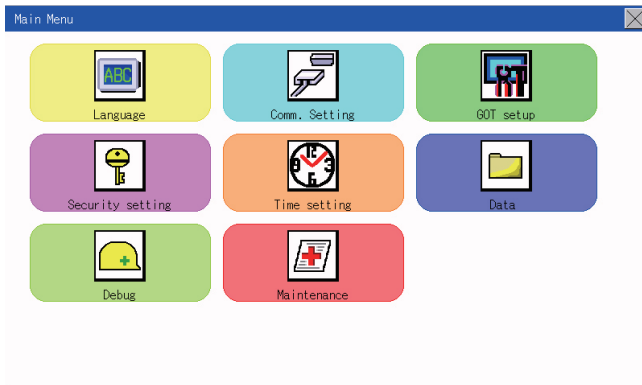

(For GT2105-Q, GT2104-R)

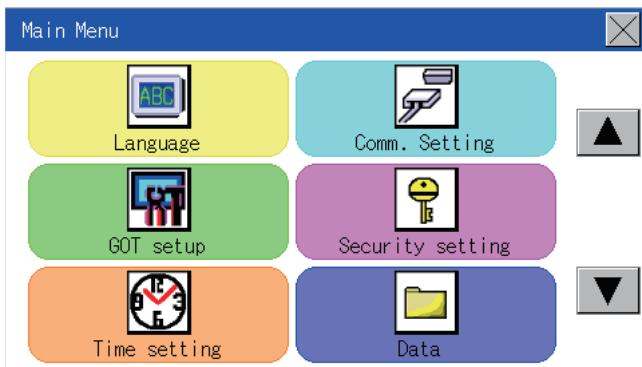

(For GT2104-P, GT2103-P)

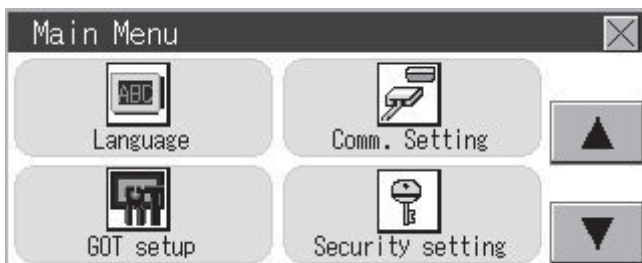

Main menu

The menu items that can be set at the GOT utility are displayed.

Touching a menu item in the main menu will display the setting screen or following selection screen for the item.

System message switch button

This button switches the language used for the utility or system alarms.

Touching the [Language] button displays the Language screen.



1. Touch the language button of a desired language and touch the [OK] button to select the language.
2. Touching the [X] button switches the utility language to the selected language.

Point

- When starting the GOT without selecting any language or the selected language and the installed fonts are not matched

The following screen will be displayed.

Touching the button of a desired language restarts the GOT and the language is switched to the selected one.



- Selectable languages

The system message switch button is displayed only for the selectable languages.

The selectable languages differ depending on the fonts installed in the GOT.

For the relation between the selectable languages and the fonts, refer to the following.

 GT Designer3 (GOT2000) Screen Design Manual

- System language switching using the device

The system language can be switched using the system language switching device set with GT Designer3.

For the setting method of the system language switching device, refer to the following.

 GT Designer3 (GOT2000) Screen Design Manual

Display operation of main menu

The following four types of operation can display the main menu.

(Display the main menu after installing the package data from GT Designer3 to the GOT built in flash memory.)

When project data is undownloaded

After the GOT is turned on, a dialog box for notifying of absence of project data is displayed. After the dialog box is displayed, touch the [OK] button to display the main menu.

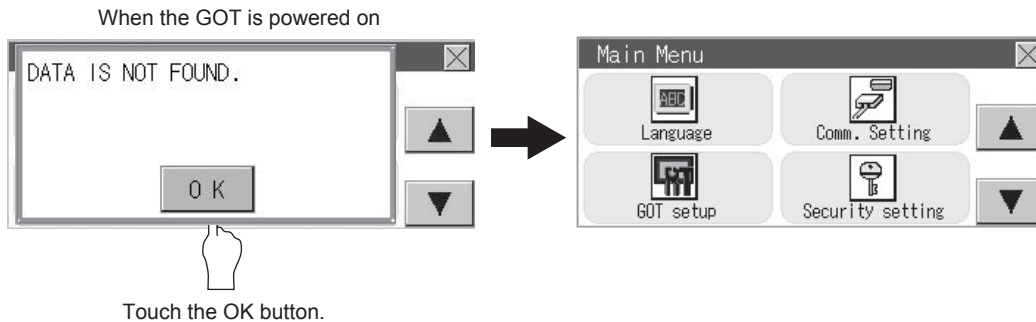

When touching utility call key

If you touch the utility call key while user-created screen is displayed, the main menu is displayed.

The utility call key is set in the position on the GOT screen upper left corner at factory shipment.

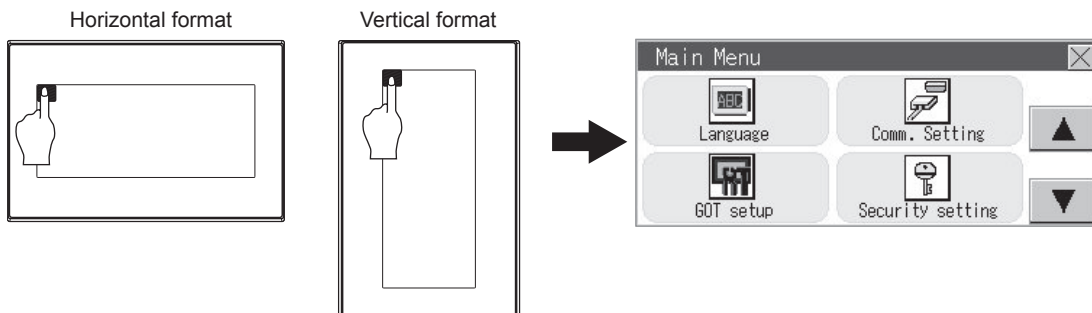

The utility function windows appear in the horizontal format, and this format cannot be changed.

The utility call key can be set by the GOT utility or GT Designer3.

For the setting method of the utility call key, refer to the following.

Page 499 Setting the utility call keys

GT Designer3 (GOT2000) Screen Design Manual

Point

- Prohibited simultaneous 2-point presses

Do not touch 2 points or more on the GOT screen simultaneously. Touching 2 points or more simultaneously may activate a part other than the touched point.

- Press time of the utility call key

When having set [Press time] of the utility call key setting screen to other than "0 (s)", keep pressing the touch panel for the period set to [Press time] or more before leaving the finger from the touch panel.

For utility call key setting, refer to the following.

Page 499 Setting the utility call keys

- When the utility call key is not set

Even when the utility call key is not set (set to the zero point), you can display the main menu by performing the following operation.

Pressing the special function switch set on the user-created screen

Selecting [Utility] from the startup mode selection screen

When touching special function switch (utility)

If you touch the special function switch (utility) while user-created screen is displayed, the main menu is displayed.

The special function switch (utility) can be set as a touch switch that is displayed on a user-created screen by GT Designer3.

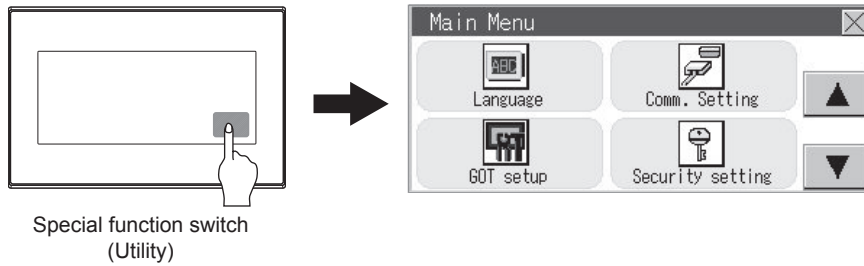

For the details of the special function switch, refer to the following.

GT Designer3 (GOT2000) Screen Design Manual

Point

When limiting the display and operation of the utility

When limiting the display and operating users, set a password to the GOT using GT Designer3. If a user tries to display the main menu of the utility, the password is displayed.

Refer to the following for the details related to the password setting.

GT Designer3 (GOT2000) Screen Design Manual

Utility basic configuration

The basic configuration of utility is as follows.

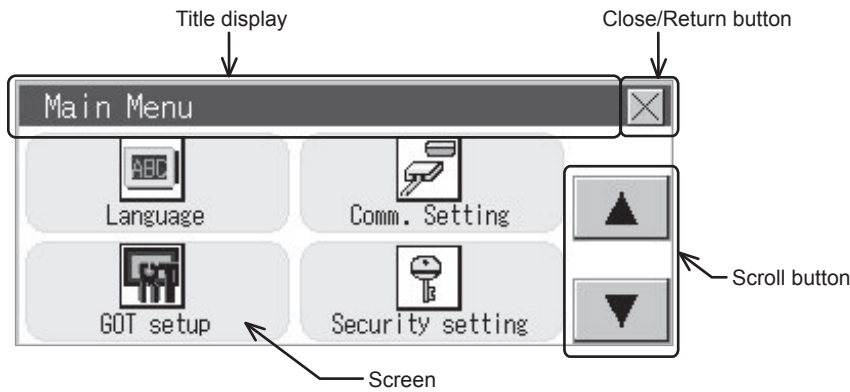

Title display

The screen title name is displayed in title display part.

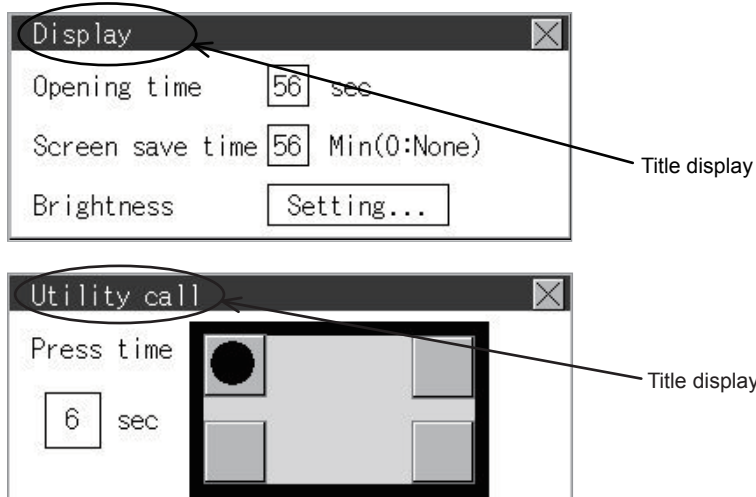

Close/Return button

When a middle screen of the layers is displayed, if the [×] (Close/return) button in the right corner of screen is touched, returns to the previous screen.

If this button is touched when directly displayed from monitor screen, the screen is closed and returns to monitor screen.

Scroll button

For screens in which the content does not fit on one screen page, there is a right or down scroll button on the screen.

▲ ▼ Scroll one line/column.

Basic operation of settings change

Change of setting value

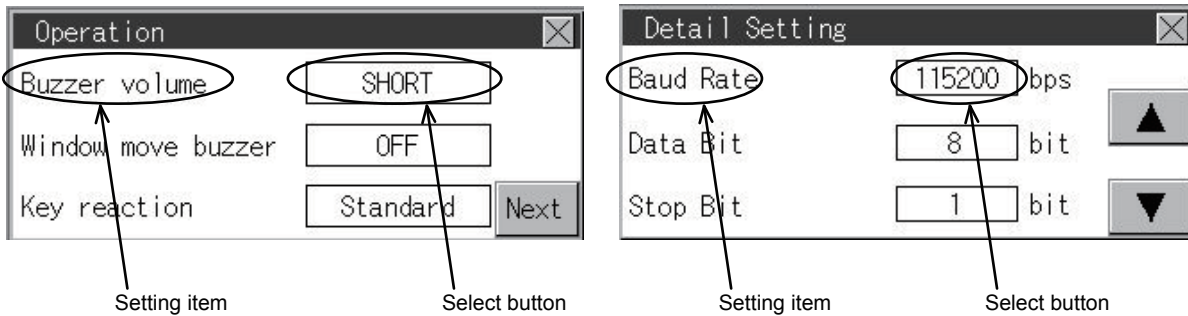

■Setting item, select button

Touch the select button to change the settings.

The setting methods differ depending on the setting items.

The following types of setting method are available.

- Switching the setting value

The button repeats ON  OFF every time it is pressed.

- Enter the setting value with a keyboard.

Use these keys to enter numerical values. Touch the button to display a keyboard on the GOT screen.

For the keyboard operations, refer to the next page.

 Keyboard operations

- Move to another setting screen.

Touch the button to move to each setting screen.

For the setting method of each setting item, refer to the setting operation of each setting screen.

■[×] (Close/Return) button

Reflect or cancel the changed settings.

- [×] (Close/Return) button

Touching this button closes the screen. Depending on the setting item, the GOT restarts.

Touching the [×] button displays the dialog box shown below.

(If no setting is changed, the dialog is not displayed.)

Follow the instruction in the dialog.

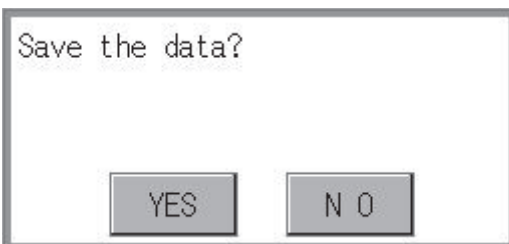

Save message screen

In a setting screen having the [Save] button shown below, touching the [x] button does not show the save message screen shown above and returns to the previous screen when the setting is changed. To save the setting contents, always touch the [Save] button.

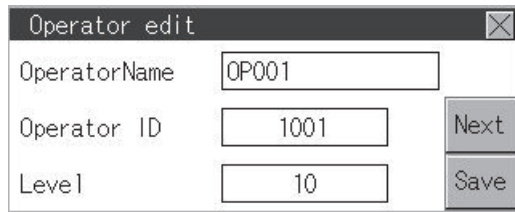

Keyboard operations

1. Touch the numerical value to be changed.
2. The keyboard for entering numerical values and a cursor are displayed.
The display position of the keyboard differs depending on the position of the touched numerical value.
(The keyboard is displayed at a position that does not disturb users to input numerical values.)

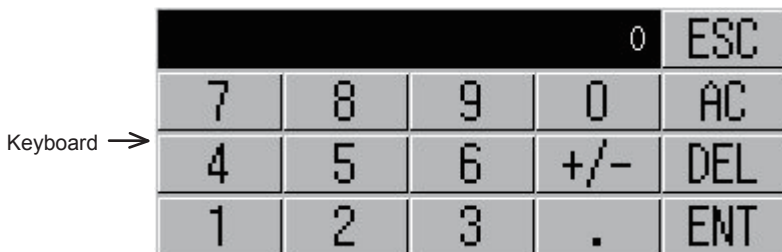
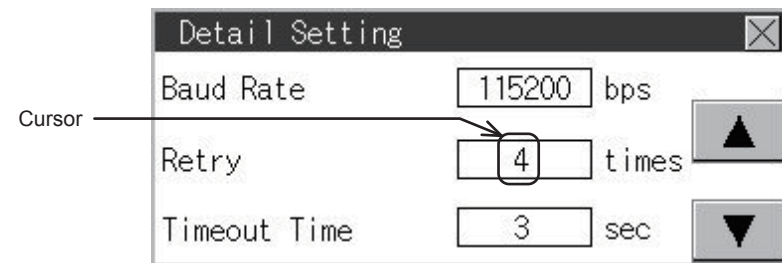

3. Input numerical value by the keyboard.
[0] to [9] Key: Enter numerical values.
[Enter] Key: Completes the numerical value input and closes the keyboard.
[Cancel] Key: Cancels the numerical value input and closes the keyboard.
[Del] Key: Deletes one character.
[AC] Key: Deletes all characters.
4. Touching the [Enter] key completes the numerical value input and closes the keyboard.

10 LANGUAGE SETTING

10.1 Display Language Setting

Display language setting function

This function allows display language selection.
The items which can be set are shown below.

Item	Description	Setting range
Language	Display language in which the utility functions and dialog windows are displayed can be selected or confirmed in this menu	Japanese/English/Chinese

Language setting operation

Language

1. Touch [Language] to bring up the set up screen.

Main menu

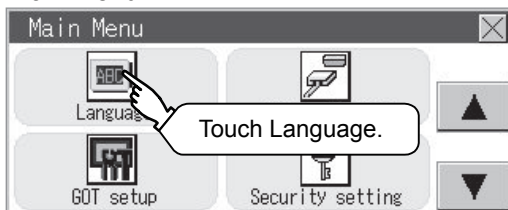

2. Select a display language by touching the corresponding button.

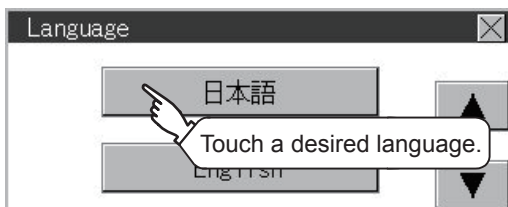

3. After changing the setting, touch the [X] button.
The setting is saved and the setting screen is closed.



- Switching the display language of the utility by devices

Any device can be used for switching the display language of the utility. For details, refer to the following.

 GT Designer3 (GOT2000) Screen Design Manual

When using devices to switch the display language of the utility, it does not change even if the display language is switched from the GOT utility screen.

- Selectable languages

The system message switch button is displayed only for the selectable languages.

The selectable languages differ depending on the fonts installed in the GOT.

For the relation between the selectable languages and the fonts, refer to the following.

 GT Designer3 (GOT2000) Screen Design Manual

11 COMMUNICATION INTERFACE SETTING

- ☞ Page 435 Standard I/F
- ☞ Page 451 GOT IP Address Setting (Ethernet models only)
- ☞ Page 456 Ethernet Communication (Ethernet models only)
- ☞ Page 464 Communication Monitor
- ☞ Page 469 Ethernet Check (Ethernet models only)
- ☞ Page 471 Setting the Transparent Mode
- ☞ Page 472 Keyword
- ☞ Page 480 Ethernet Printer

The following communication interface setting can be configured.

Item		Function overview	Reference
Communication setting	Standard I/F	Assigning channel number and communication driver to communication interface	☞ Page 435 Standard I/F
	GOT IP Address ^{*1}	Configuring GOT Ethernet setting	☞ Page 451 GOT IP Address Setting (Ethernet models only)
	Ethernet communication ^{*1}	Displaying the contents of Ethernet setting, changing the host	☞ Page 456 Ethernet Communication (Ethernet models only)
	Comm.Monitor	Checking the serial communication port communication	☞ Page 464 Communication Monitor
	Ethernet check ^{*1}	Checking the Ethernet communication port communication	☞ Page 469 Ethernet Check (Ethernet models only)
	Transparent mode	Setting the channel No. to be used for the communication for the FA transparent function	☞ Page 471 Setting the Transparent Mode
	Keyword	Setting or deleting sequence program protection key words and canceling sequence program protection status for the FXCPU connection	☞ Page 472 Keyword
	Ethernet Printer	Setting the IP address of the Ethernet printer	☞ Page 480 Ethernet Printer

*1 Only available to Ethernet models.

11.1 Standard I/F

Standard I/F functions

Function	Description
Channel no. display	Displays the channel number (CH No) that has been assigned by drawing software
Communication driver display	Displays the communication driver that has been assigned by drawing software
Communication parameters display	Displays the communication parameters of the controllers that has been assigned by drawing software

Standard I/F display operation

GT2107-W

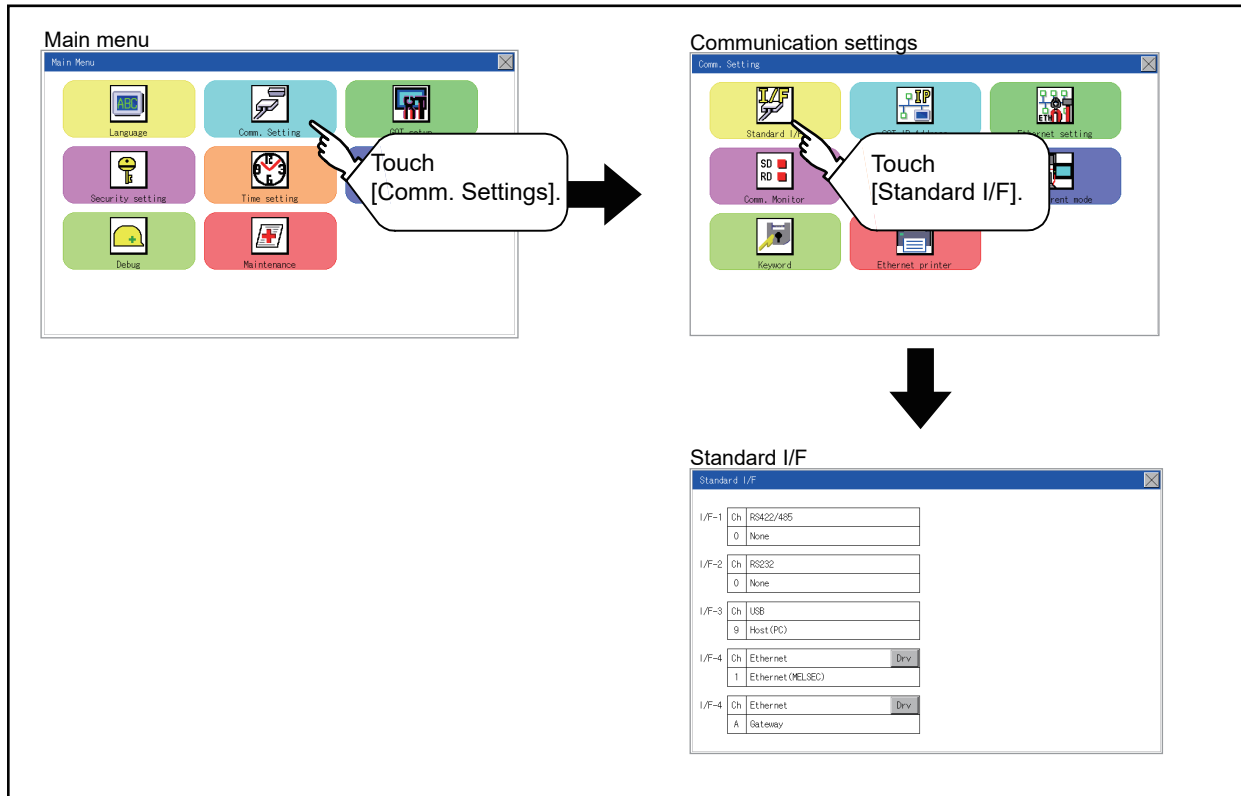

GT2105-Q, GT2104-R

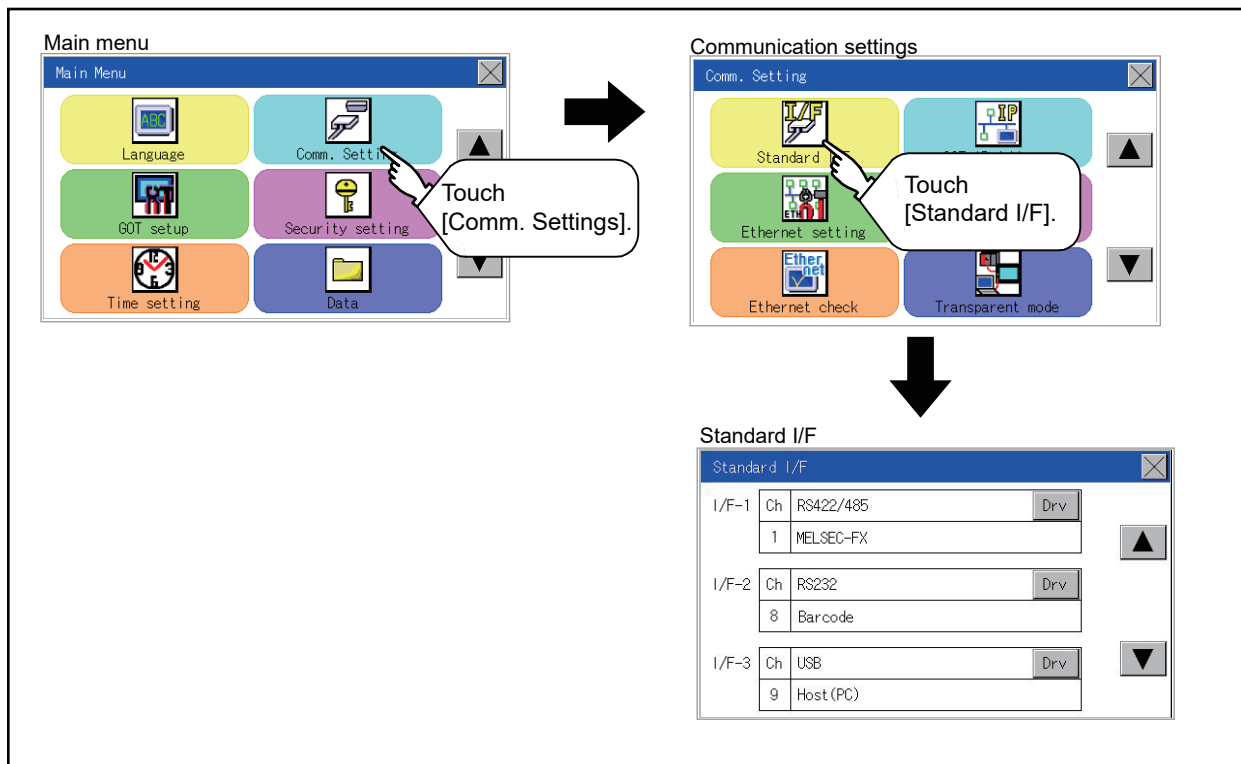

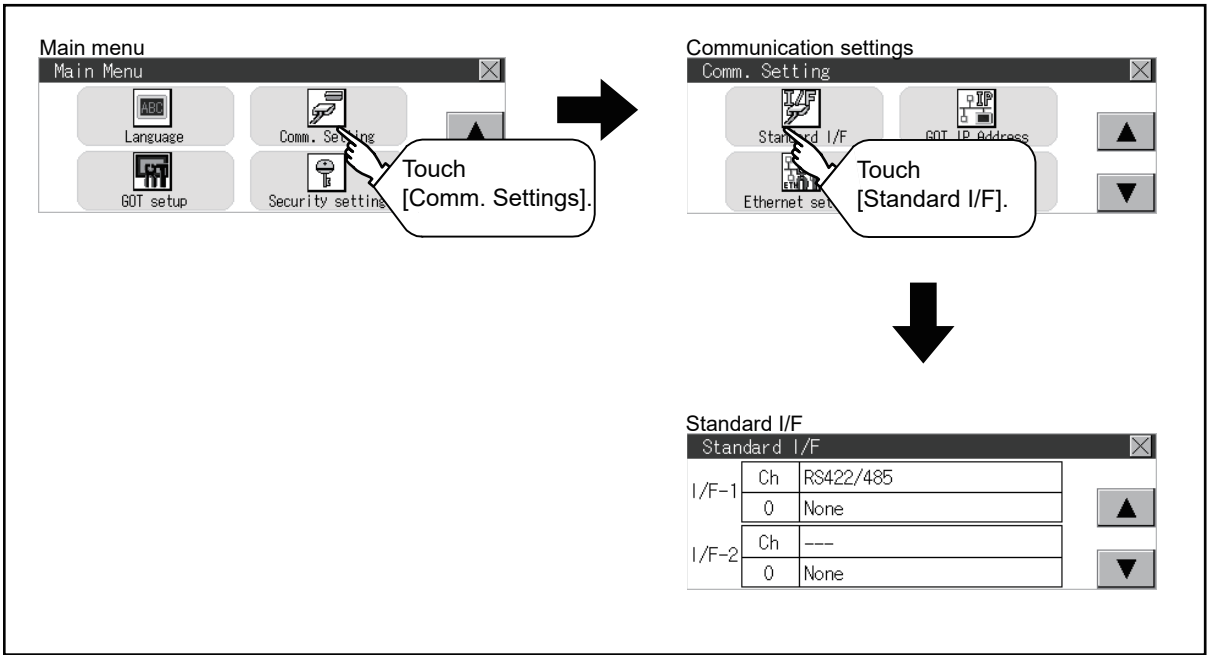

Display contents of standard I/F

Described below are the display items on the standard I/F menu and their functions.

Display item

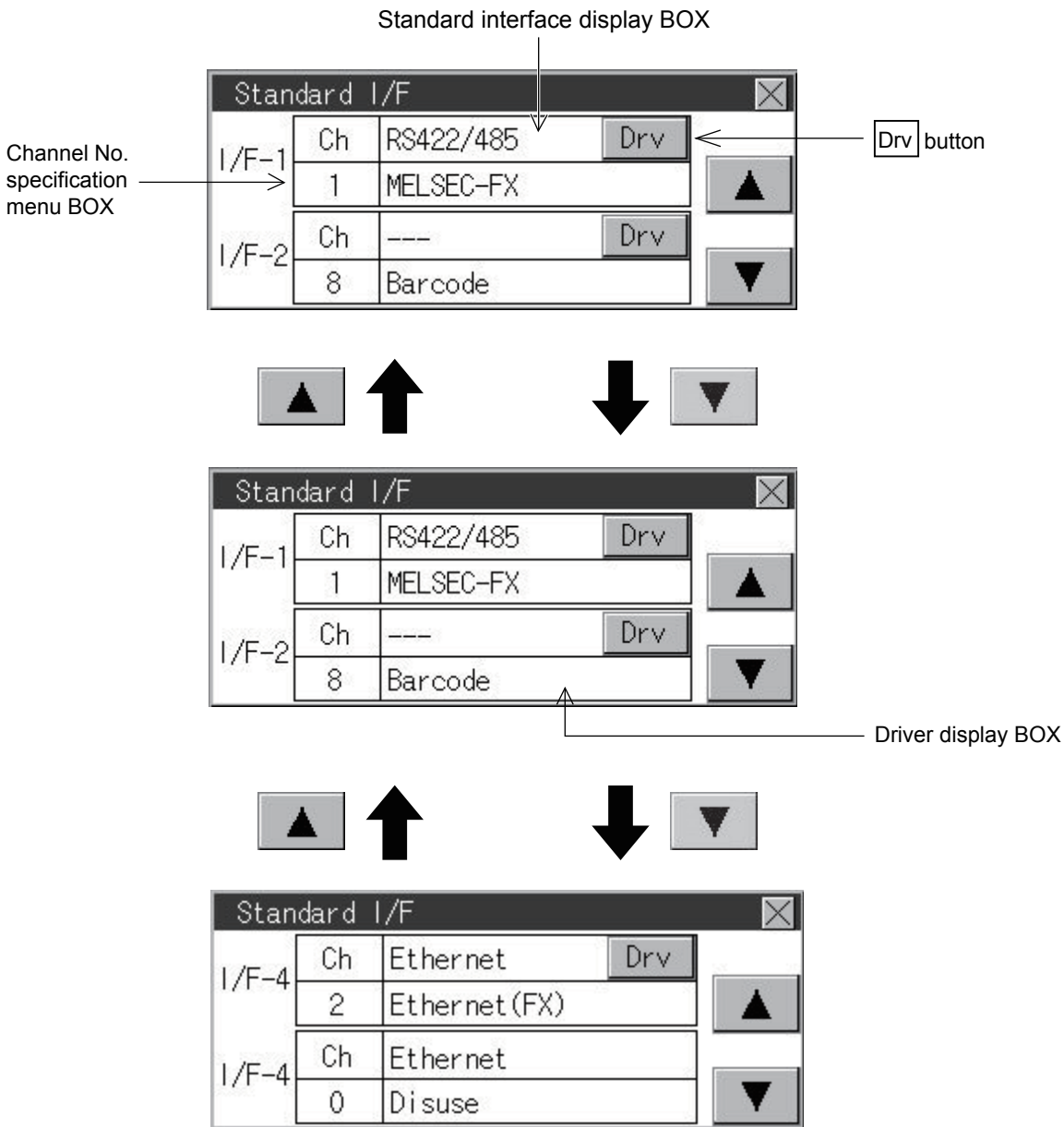

Standard interface display BOX

The standard interface includes the following four types.

Standard I/F-1(RS-422/485, RS-232 or RS-422): For communication with PLC, microcomputer and other equipment

Standard I/F-2(RS-232): For communication with other equipment, bar code reader, RFID and transparent

Standard I/F-3(USB): For communication with PC (drawing software) and transparent

Standard I/F-4(Ethernet): For communication with PC (drawing software) and other equipment

Available standard interfaces differ depending on the GOT model used.

○: Available, ×: Not available

GOT	Standard I/F-1			Standard I/F-2	Standard I/F-3	Standard I/F-4
	RS-422/485	RS-232	RS-422	RS-232	USB	Ethernet
GT2107-WTBD GT2107-WTSD	○	×	×	○	○	○
GT2105-QTBDS GT2105-QMBDS	○	×	×	○	○	×
GT2104-RTBD	○	×	×	○	○	○
GT2104-PMBD	○	×	×	×	○	○
GT2104-PMBDS	○	×	×	○	○	×
GT2104-PMBDS2	×	○	×	○	○	×
GT2104-PMBLS	×	×	○	×	○	×
GT2103-PMBD	○	×	×	×	○	○
GT2103-PMBDS	○	×	×	○	○	×
GT2103-PMBDS2	×	○	×	○	○	×
GT2103-PMBLS	×	×	○	×	○	×

• For GT2107-WTBD, GT2107-WTSD

[GOT front]

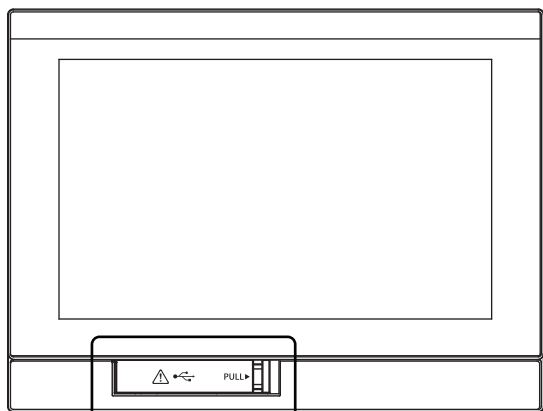

Standard I/F-3(USB)

[GOT back]

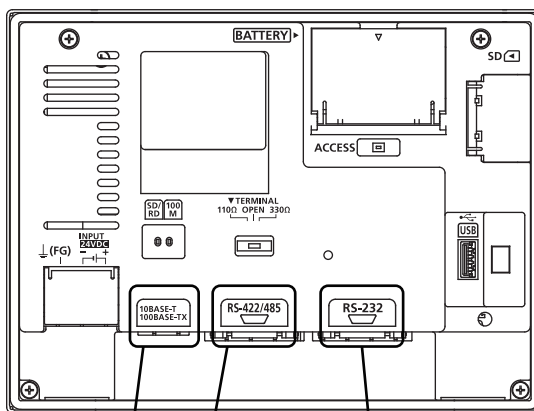

Standard I/F-2(RS-232)
Standard I/F-1(RS-422/485)
Standard I/F-4(Ethernet)

- For GT2105-QTBDS, GT2105-QMBDS

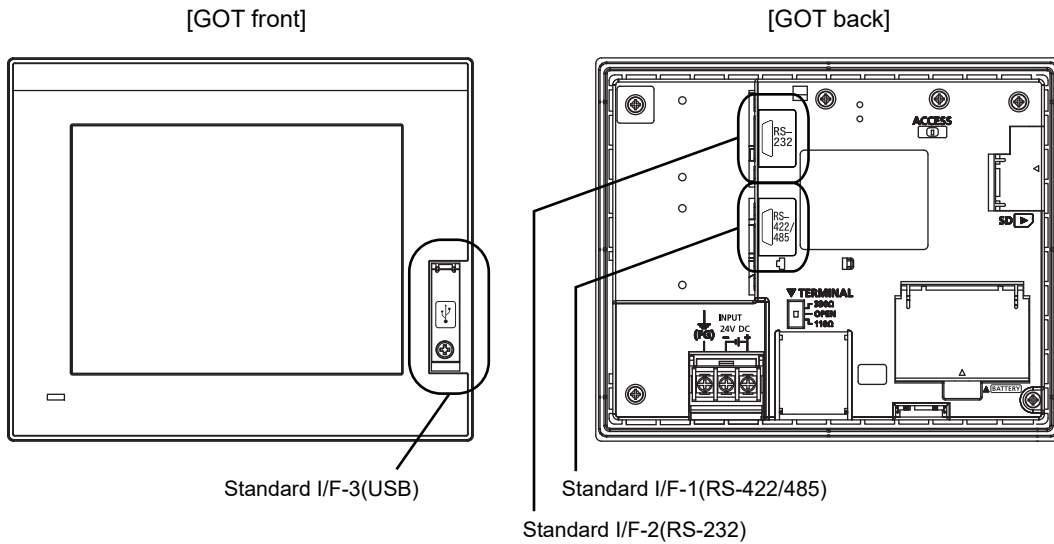

- For GT2104-RTBD

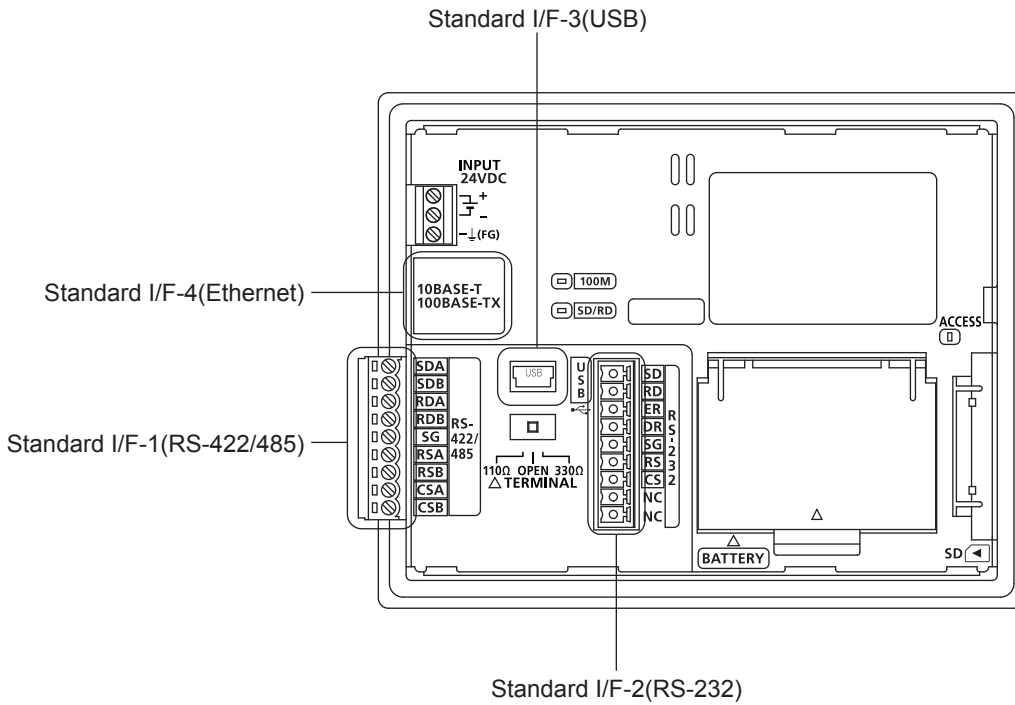

- For GT2104-PMBD

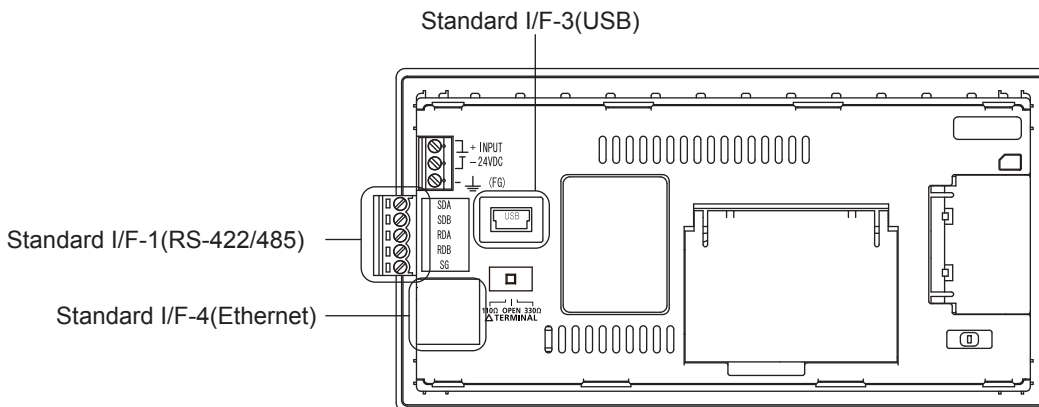

- For GT2104-PMBDS

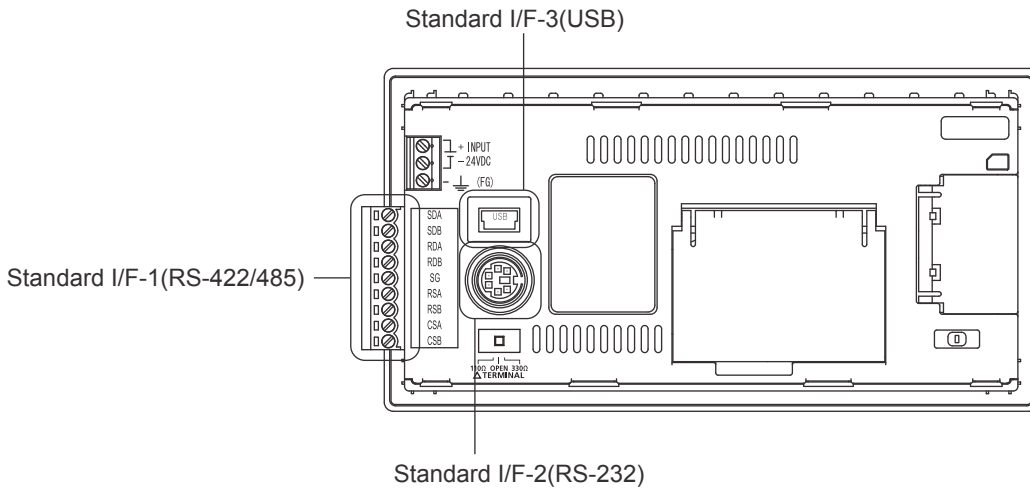

- For GT2104-PMBDS2

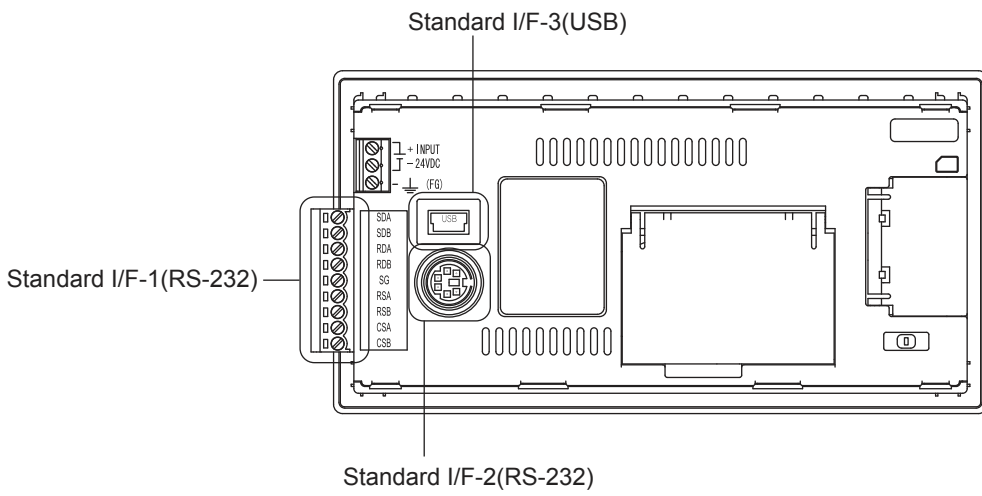

- For GT2104-PMBLS

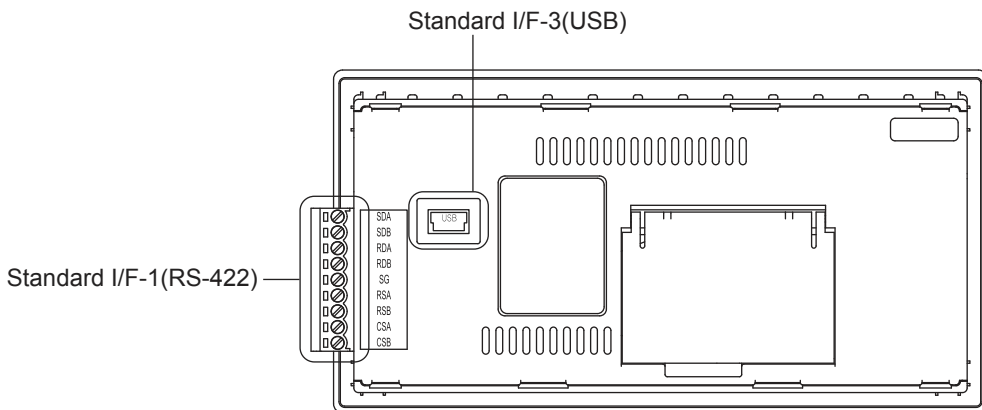

- For GT2103-PMBD

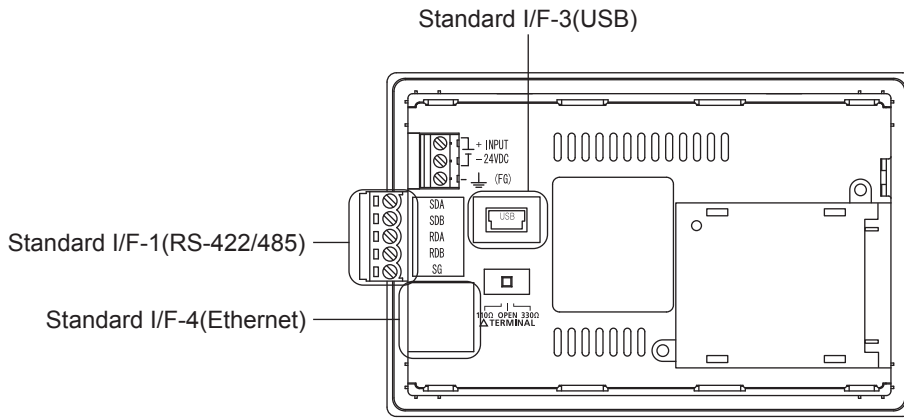

- For GT2103-PMBDS

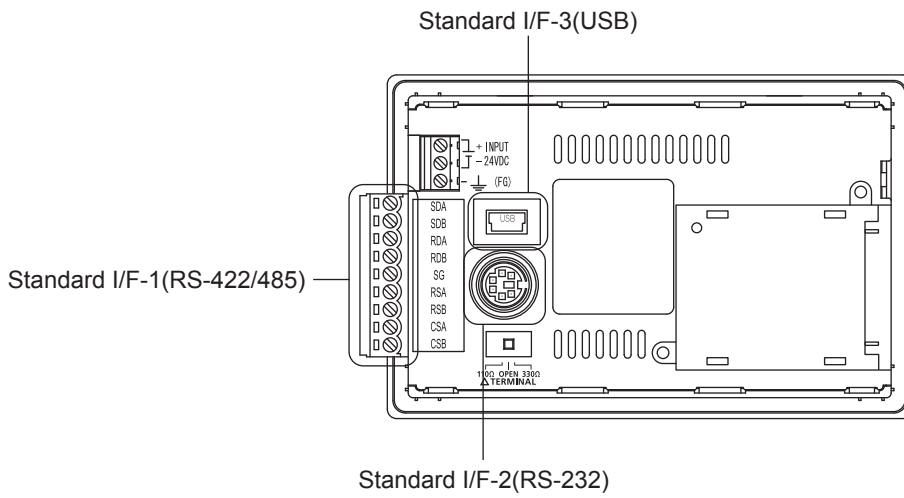

- For GT2103-PMBDS2

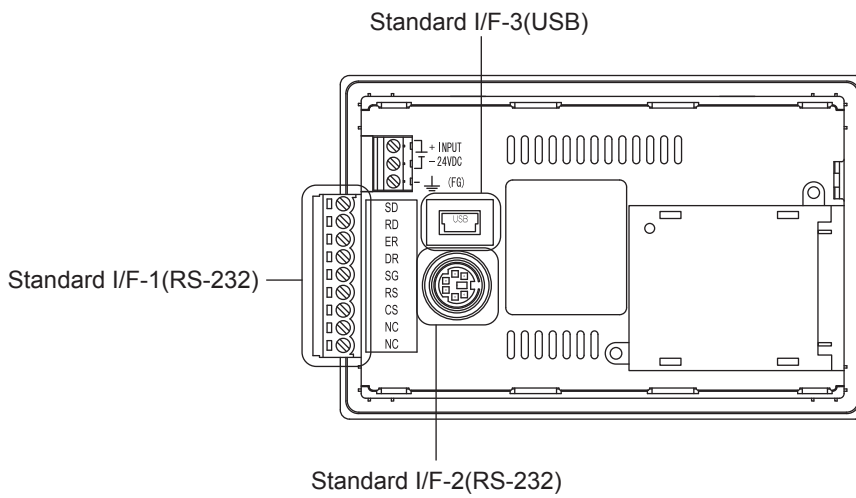

- For GT2103-PMBLS

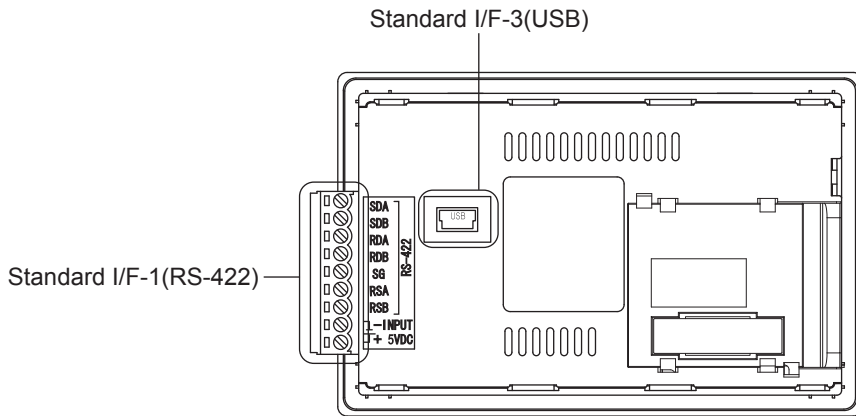

Channel No. specification menu BOX

Set a channel number to be used by the standard interface.

☞ Page 448 Channel setting operation

For communication drivers that can be assigned for channels, refer to the following.

☞ Page 443 Driver display BOX

0:	Set when the communication interface is not used.
1, 2:	Set when connecting to a controller.
8:	Set when connecting to a bar code reader, RFID or GOT (Extended Computer).
9: ^{*1}	Set when connecting to a PC (drawing software).
	When multiple GOTs are connected, set this channel for the connection with the 2nd GOT.
	Set this channel when the Ethernet download function is used.
A:	Set this channel when connecting to a printer.

"9" is automatically set to the standard I/F-3(USB).

Driver display BOX

- The driver display box displays the names of communication drivers assigned to channels or the communication drivers set in the communication settings of drawing software.

For details on communication drivers to be displayed, refer to the following.

📖 GT Designer3 (GOT2000) Screen Design Manual

- "Disuse" is displayed in the driver display box in the following cases:

The communication driver is not installed.

☞ Page 558 OS information

"0" is set in the channel number specification menu box.

- The channel number of the standard I/F-3(USB) is fixed to "9".

[Drv] button

Displays the driver setting screen.

Select a communication driver to be used on the driver setting screen.

☞ Page 450 Driver setting operation

The [Drv] button is displayed in the following case.

When a channel number other than channel 0 or 9 is set to the standard I/F-1, standard I/F-2, and standard I/F-4

Precautions for communication between GOT and connected devices

- Installing [Communication driver] and downloading [Communication Settings]

To perform communication with the connected device, the following actions are necessary.

- 1) Installing communication drivers (Up to 2 drivers)
- 2) Assigning channel numbers and communication drivers to communication interfaces
- 3) Downloading contents (project data) assigned in step 2)

Perform 1), 2) and 3) with drawing software.

Standard I/F Setting			
	CH No.	Driver	
I/F-1: RS422/485	1	MELSEC-FX	Detail Setting...
I/F-2: RS232	9	Host (PC)	Detail Setting...
I/F-3: USB	9	Host (PC)	
I/F-4: Ethernet	0	None	Detail Setting...

For details, refer to the following.

 GT Designer3 (GOT2000) Screen Design Manual

- When the communication settings have not been downloaded

If the communication settings have not been downloaded with drawing software, set the communication settings on the drawing software or in the GOT utility screen.

Detail information setting operation

For Standard I/F-1(RS422) and Standard I/F-2(RS232)

1. Touch each driver display box of the standard I/F-1 and standard I/F-2.

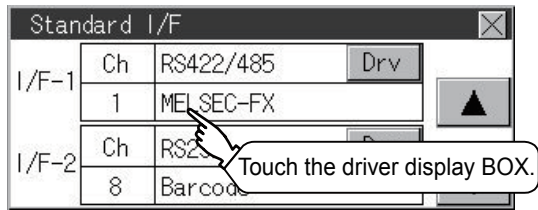

2. The screen jumps to the detailed information screen and the communication parameter will appear.
(For GT2107-W, GT2105-Q, GT2104-R)

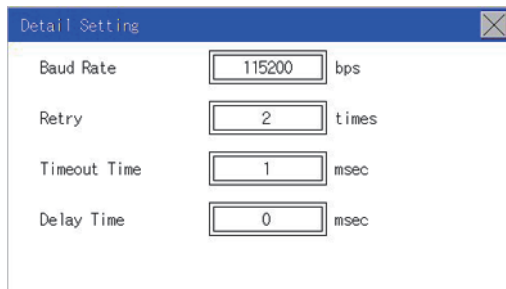

(For GT2104-P and GT2103-P)

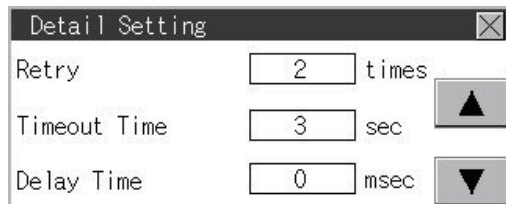
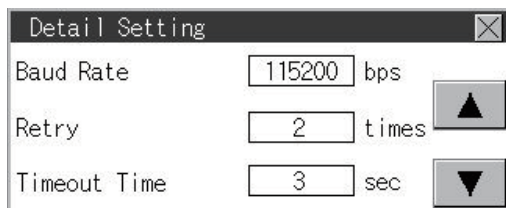

3. Touch the numerical values of baud rate to switch them repeatedly.

Example: 4800 bps → 9600 bps → 19200 bps

The numerical values are set using the ten-key depending on the setting.

0				ESC
7	8	9	0	AC
4	5	6	+/-	DEL
1	2	3	.	ENT

"0" to "9":

Use these keys to enter numerical values. Enter "0" to disable the screen saver function.

"ESC":

Closes the ten-key window without saving any value entered

"AC":

Deletes the entire string of numerical characters that are being entered "DEL":

Deletes a digit from a string of numerical characters that are being entered

"ENT":

Enters the value for the clock that has been entered and closes the ten-key pad window

" +/- ":

Switches between positive and negative values. (Only positive values are valid for the clock setting.)

".":

Invalid key (not used)

4. Touch the [x] button to display the window confirming whether to save the settings.

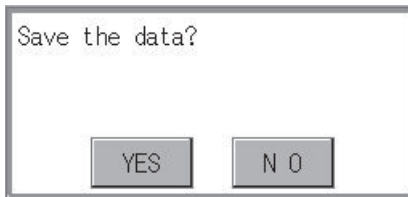

5. Touch the [YES] button to save the settings and restart. Touch the [NO] button to discard the changes.

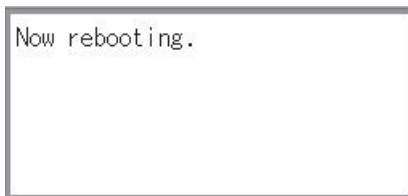

Point

Communication parameters

The communication parameter setting items depend on the type of communication driver installed on the GOT in use.

For details on the setting of each communication driver, refer to the following.

 GT Designer3 (GOT2000) Screen Design Manual

For Standard I/F-4(Ethernet)

1. Touch the driver display box of a communication parameter to be set.

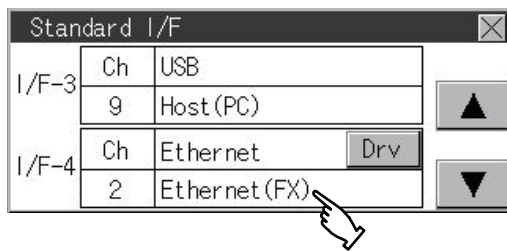

2. The screen is switched to the communication detail setting. Set the communication parameter on this screen.

GOT IP address setting

☞ Page 451 GOT IP Address Setting (Ethernet models only)

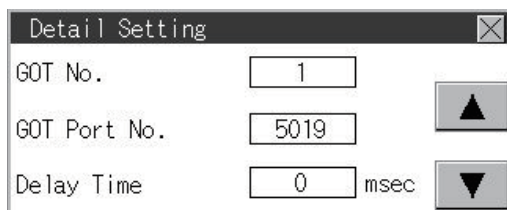
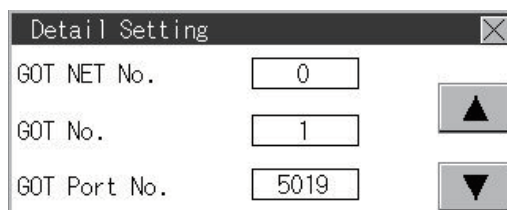
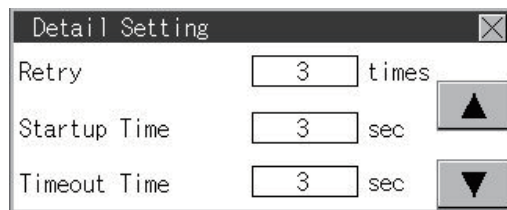

3. When the [x] button is touched, it returns to the previous screen.
4. Touch the [x] button to display the window confirming whether to save the settings.

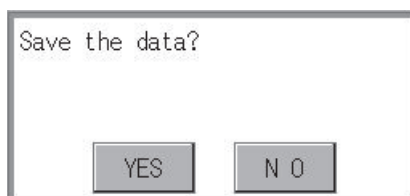

5. Touch the [YES] button to save the settings and restart. Touch the [NO] button to discard the changes.

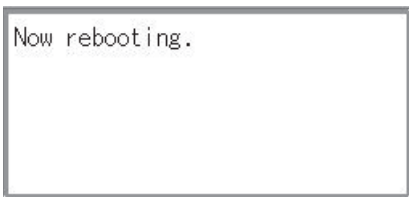

Point

Communication parameter setting by drawing software
Set the communication parameter for each communication driver by selecting [Common] → [Controller Setting].

📖 GT Designer3 (GOT2000) Screen Design Manual

Channel setting operation

Channel number setting operation

1. Touch the channel No. specification menu box to be set.

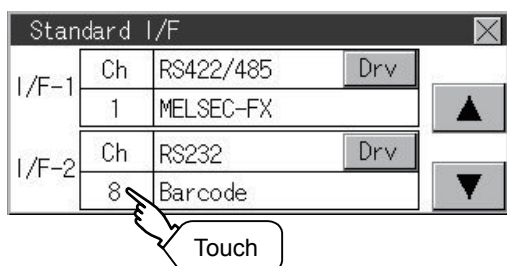

2. When the channel setting window appears, select the channel number.

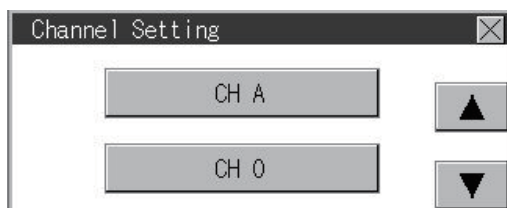
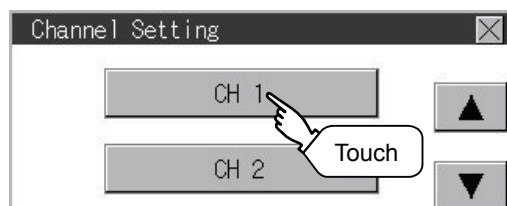
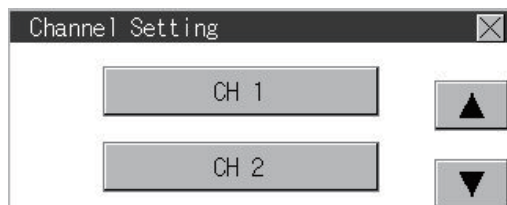

3. When the channel number is selected, the settings are fixed and the window returns to the previous one. Therefore, touch the [x] button.

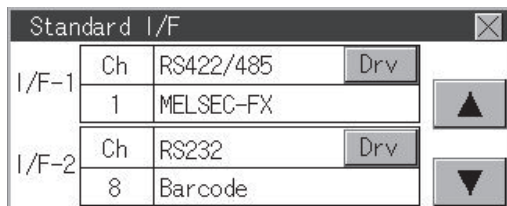

4. Touch the [x] button to display the window confirming whether to save the settings.

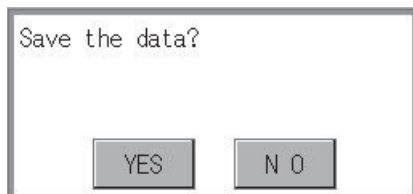

5. Touch the [YES] button to save the settings and restart. Touch the [NO] button to discard the changes.

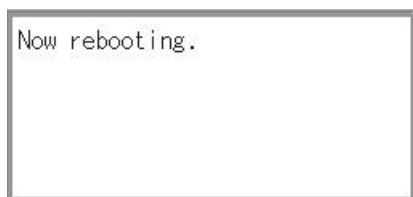

Driver setting operation

Driver setting operation

1. Touch [Drv] button to bring up the driver setting window.

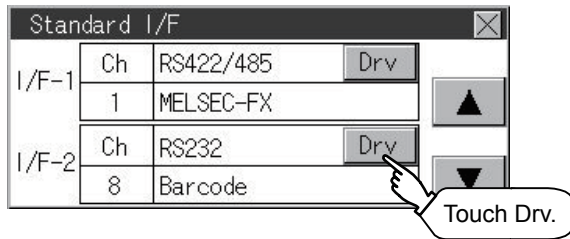

2. The available communication driver names are displayed on the driver setting screen. Select the communication driver to be used.

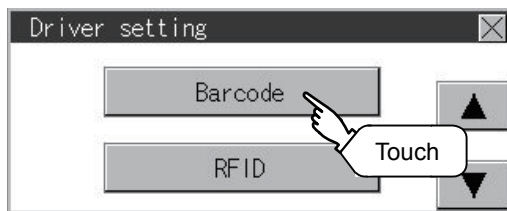

3. When the channel number is selected, the settings are fixed and the window returns to the previous one. Therefore, touch the [x] button.

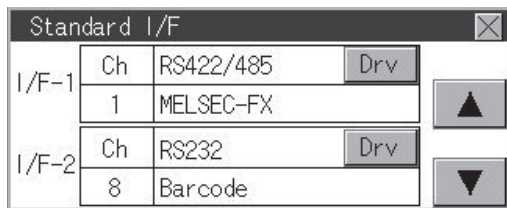

4. Touch the [x] button to display the window confirming whether to save the settings.

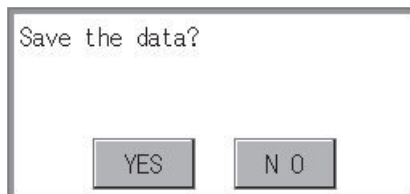

5. Touch the [YES] button to save the settings and restart. Touch the [NO] button to discard the changes.

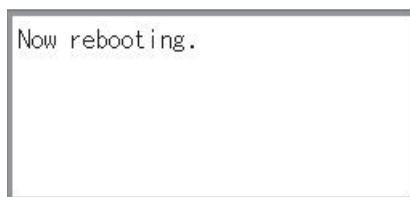

11.2 GOT IP Address Setting (Ethernet models only)

This section describes the GOT Ethernet setting.

The GOT Ethernet setting can also be set with drawing software. For details, refer to the following.

GT Designer3 (GOT2000) Screen Design Manual

Standard

The table below shows the communication setting items and setting range.

Communication setting items	Setting range	Remark
IP address	0.0.0.1 to 223.255.255.254	If a value outside the setting range is entered, the error message "SET NUMBER IS INCORRECT." appears.
Subnet mask*1	192.0.0.0 to 255.255.255.252	
Default gateway*1	0.0.0.1 to 223.255.255.254	
Per. S/W port No.	1024 to 5010, 5014 to 49152, 49171 to 65534	Set the port number for the GOT download.
Transparent port No.	1024 to 5010, 5014 to 49152, 49171 to 65534	Set the port number for the transparent of the GOT.

*1 Set the value "0.0.0.0" when not using the subnet mask pattern and default router IP address.

Display operation of GOT IP address

GT2107-W

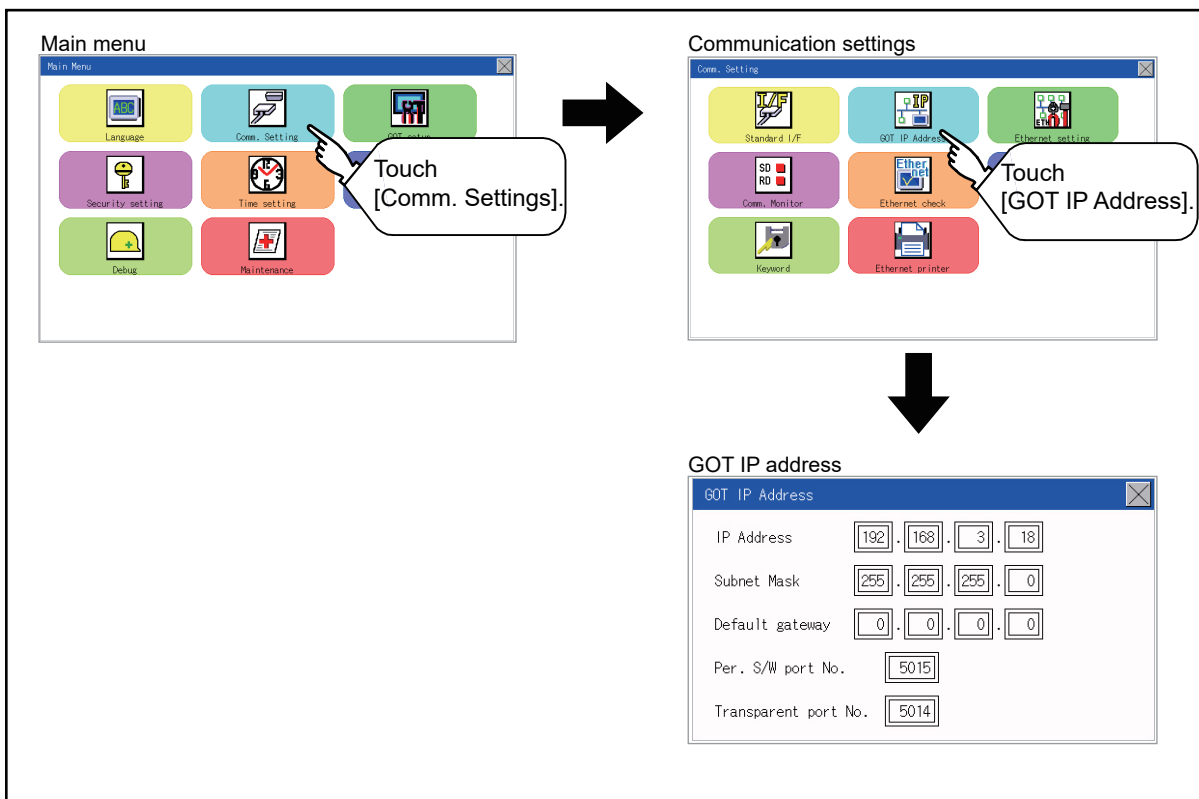

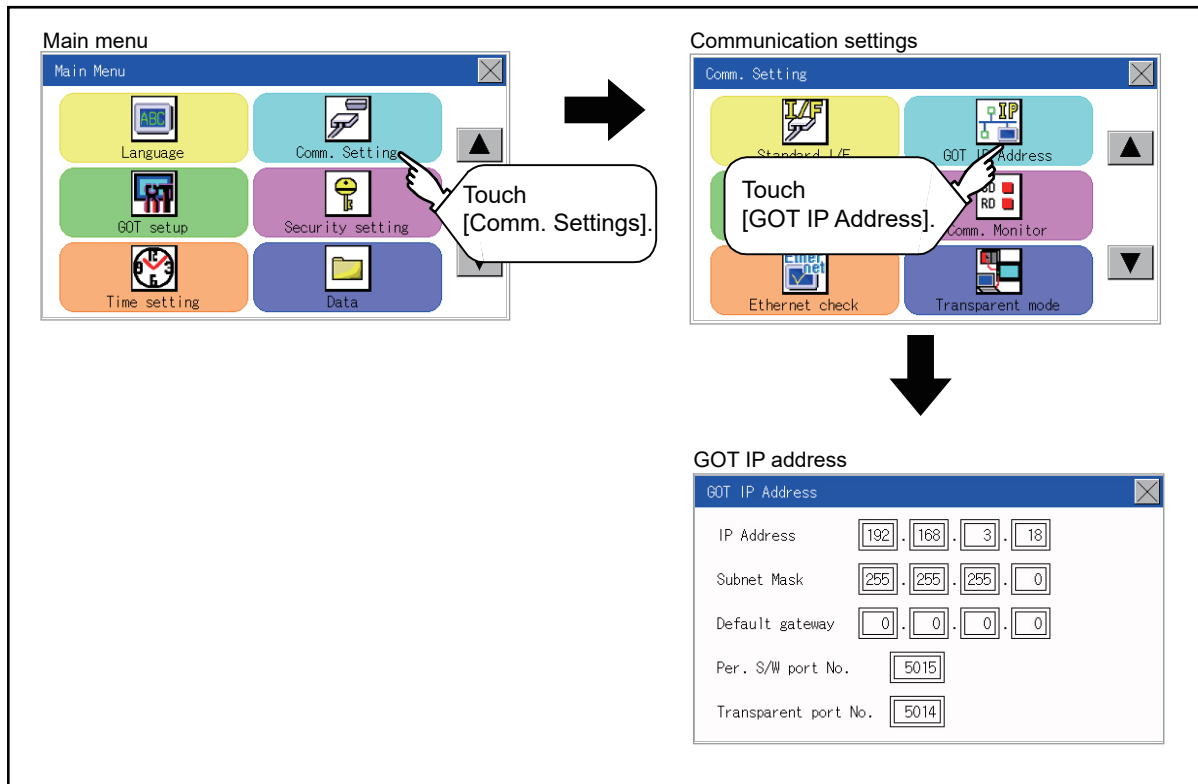

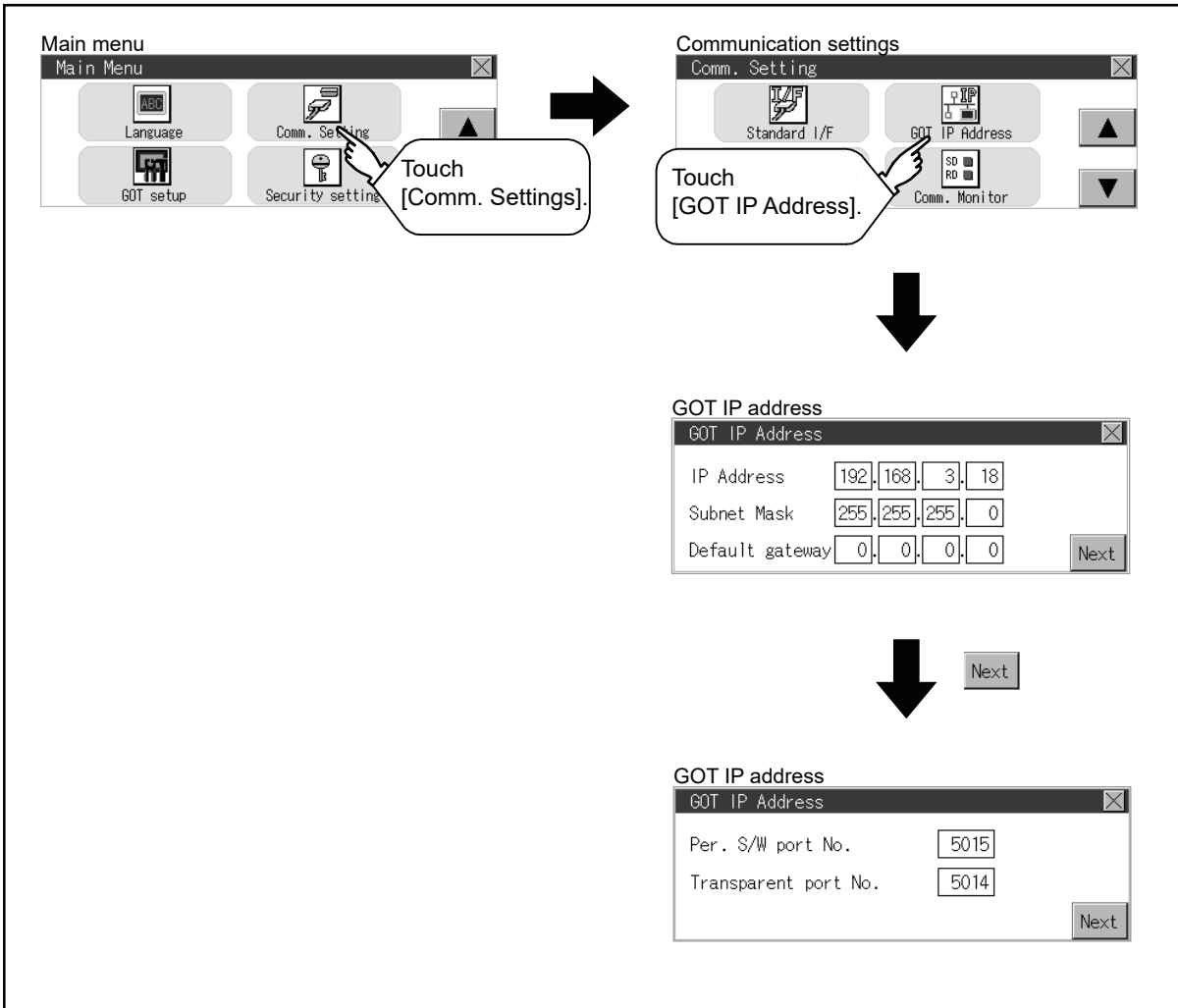

Setting operation

1. Touch the numerical part of the octet to be changed among the 1st to 4th octets.

(For GT2107-W, GT2104-R)

GOT IP Address

IP Address 192 . 168 . 3 . 18

Subnet Mask 255 . 255 . 255 . 0

Default gateway 0 . 0 . 0 . 0

Per. S/W port No. 5015

Transparent port No. 5014

(For GT2104-P, GT2103-P)

GOT IP Address

IP Address 192 . 168 . 3 . 18

Subnet Mask 255 . 255 . 255 . 0

Default gateway 0 . 0 . 0 . 0

Touch the numerical part of the octet to be changed.

2. When the numeric pad appears, enter a numerical value in up to three digits, and touch the [ENT] key.

			0	ESC
7	8	9	0	AC
4	5	6	+/-	DEL
1	2	3	.	ENT

Touch

If a numerical value outside the setting range is entered, the following error message appears. Enter a numerical value again.

Setup value is illegal.

OK

For the details of the setting range, refer to the following.

☞ Page 683 Specifications

3. For GT2104-P, GT2103-P, touch the [Next].

(For GT2107-W, GT2104-R)

GOT IP Address

IP Address 192 . 168 . 3 . 18

Subnet Mask 255 . 255 . 255 . 0

Default gateway 0 . 0 . 0 . 0

Per. S/W port No. 5015

Transparent port No. 5014

(For GT2104-P, GT2103-P)

GOT IP Address

IP Address 192.168.3.18

Subnet Mask 255.255.255.0

Default gateway 0.0.0.0 Next



GOT IP Address

Per. S/W port No. 5015

Transparent port No. 5014

Next

4. If necessary, change the setting of [Per. S/W port No.] and [Transparent port No.].
5. After the setting change, touch the [×] key.

GOT IP Address

IP Address 192.168.3.18

Subnet Mask 255.255.255.0

Default gateway 0.0.0.0 Next

Touch [×]

6. When the screen shown below appears, touch the [YES] key.

Save the data?

YES NO

Touch YES.

11.3 Ethernet Communication (Ethernet models only)

Setting function for Ethernet communication

The contents of the Ethernet set in GT Designer3 can be checked.

The setting of the host station can be changed.

For the Ethernet setting, refer to the following.

📖 GOT2000 Series Connection Manual for the controller used

Display operation of Ethernet communication

GT2107-W

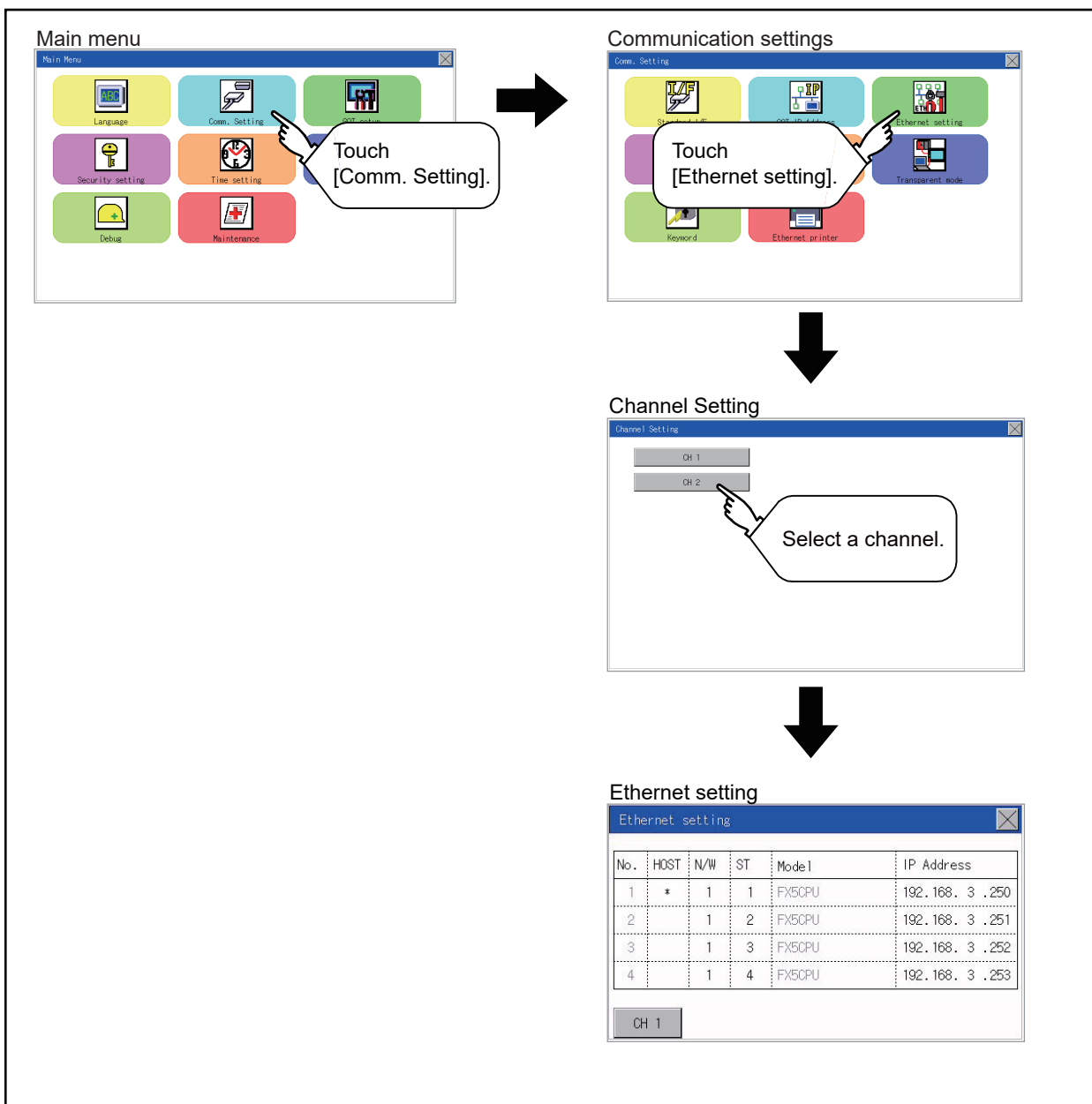

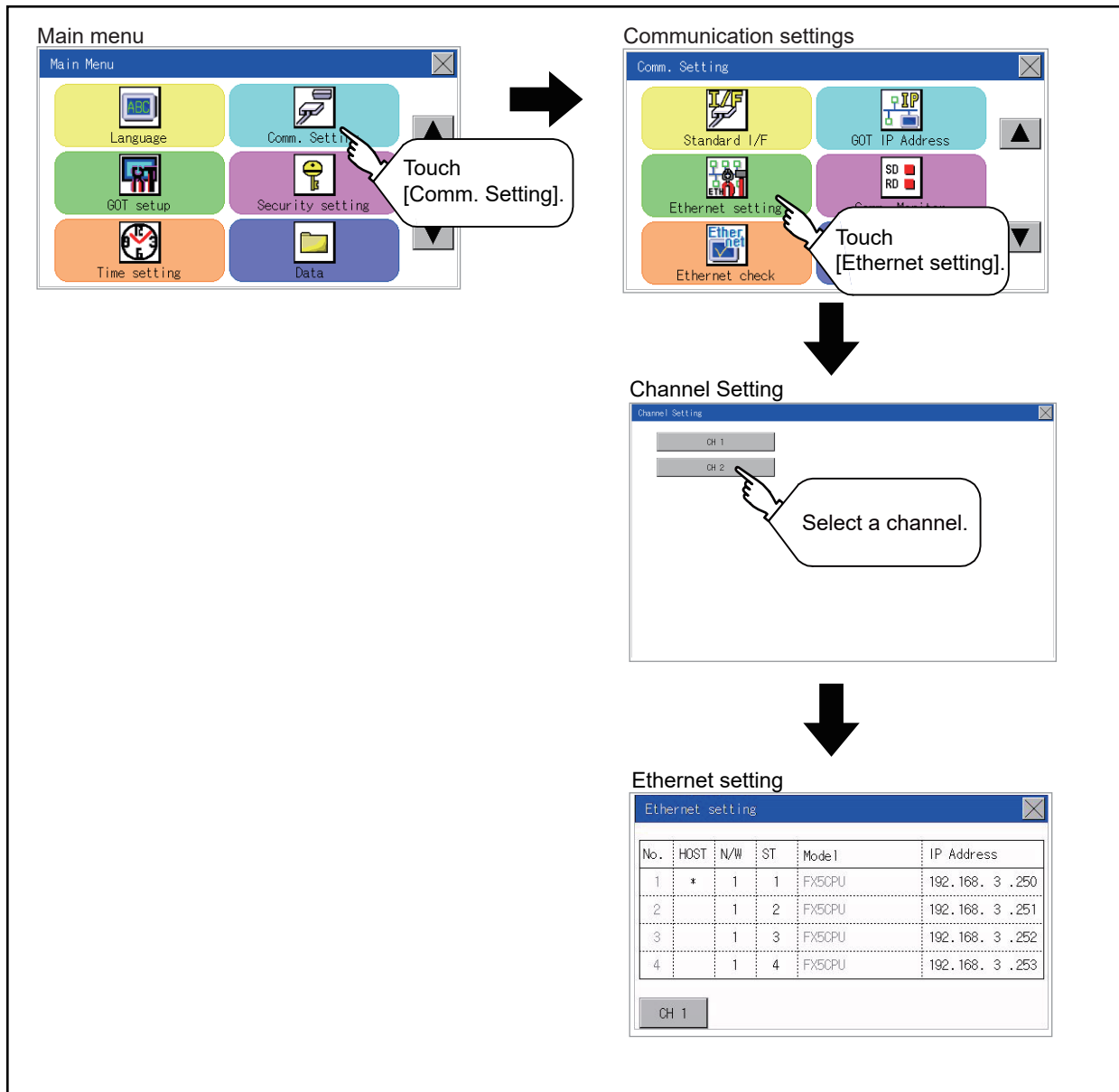

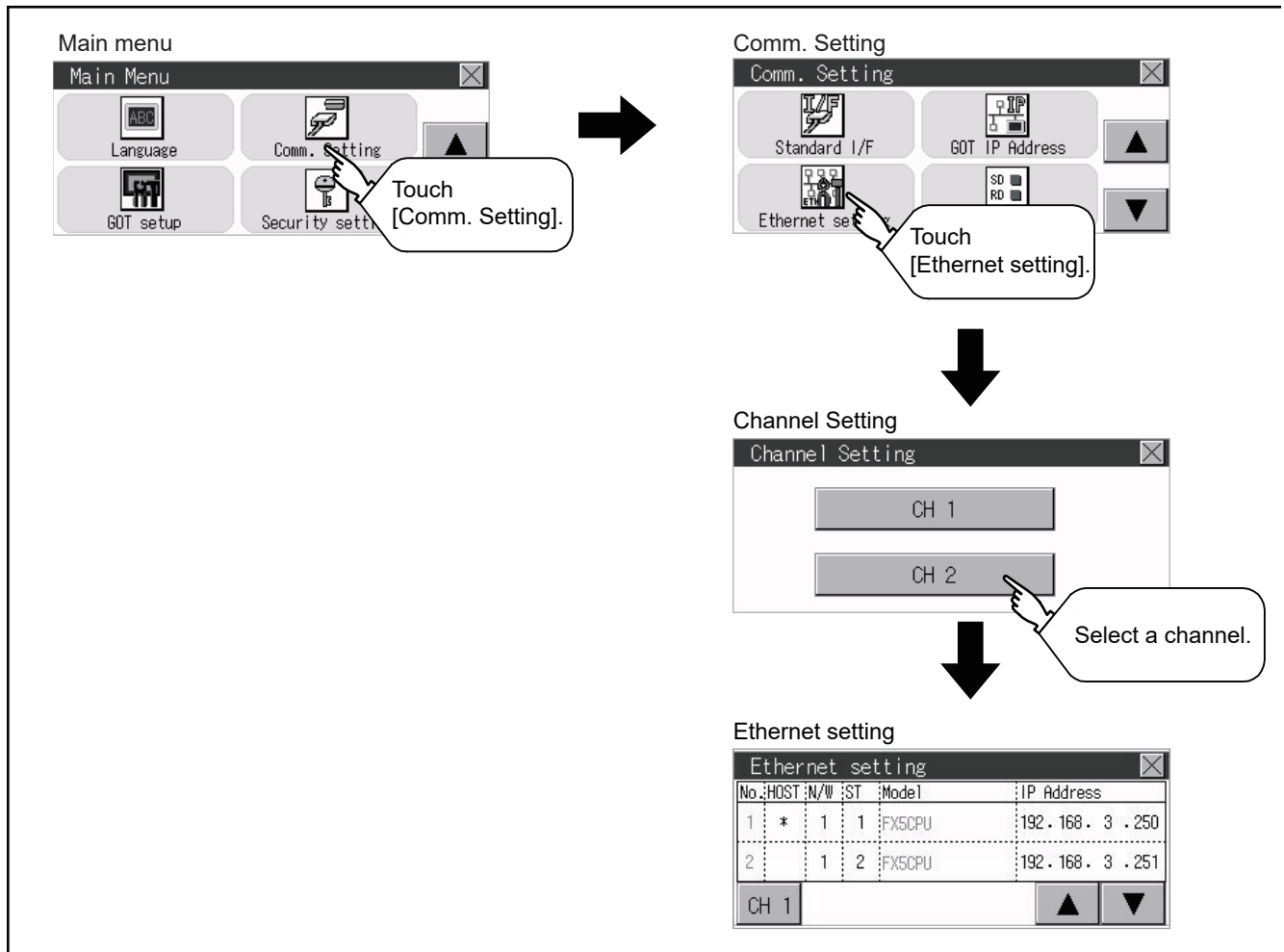

Display contents of Ethernet setting

The following describes the setting items and the display contents of the Ethernet setting.

(For GT2107-W, GT2104-R)

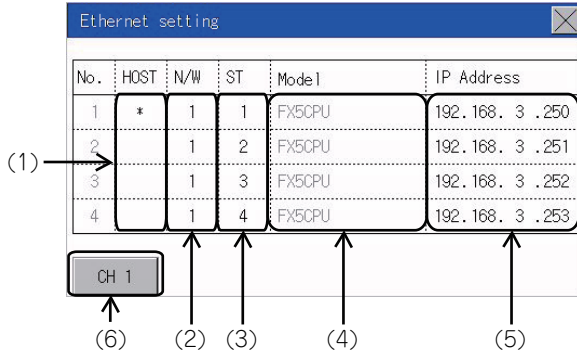

(For GT2104-P, GT2103-P)

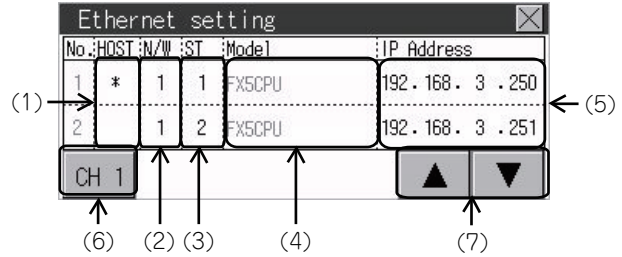

No.	Item	Description	Reference
(1)	Host	Check or set a controller to be connected as a host. Asterisk (*) is displayed with the selected Ethernet setting.	Page 460 Change of host
(2)	N/W	Check or set the network No. of the controller.	Page 461 Change of Net No.
(3)	ST	Check or set the station number of the controller.	Page 462 Change of station No.
(4)	Model	Displays the product name of the controller.	-
(5)	IP Address	Check or set the IP address of the controller.	Page 463 Change of IP address
(6)	Channel select tab	Switches the channel for which the Ethernet setting is to be configured.	-
(7)	Scroll keys	Scrolls the display up or down.	-

Point

- How to cancel the change of the setting in the [Ethernet setting] screen.

Cancel the settings changed in the [Ethernet setting] screen with the [Restore default settings] button.

The changed settings remain until they are canceled with the [Restore default settings] button.

The changed settings are not canceled even if writing the project data or system application to the GOT.

When the project data is written to the GOT without canceling the changed settings, those changed settings are reflected to the Ethernet setting of the written project data.

(If the written project data does not have a channel with same Ethernet settings as that of the channel changed in [Ethernet setting] screen, the changed settings are not reflected.)

Change of host

1. Touch the device to be set as the host.

(For GT2107-W, GT2104-R)

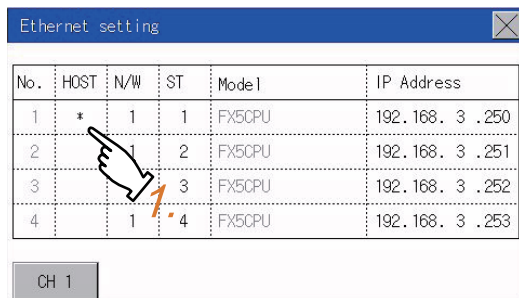

(For GT2104-P, GT2103-P)

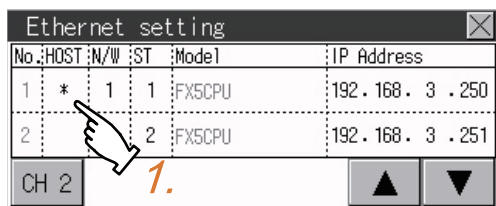

2. After the setting change, touch the [×] key. When the screen shown below appears, touch the [YES] key.

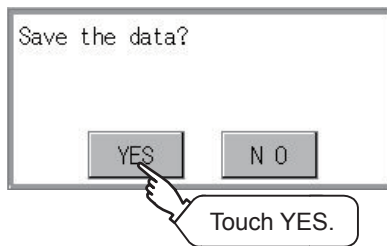

Change of Net No.

1. Touch the Net No. to be changed, and input the network No. to be changed by the numeric keypad displayed.
(For GT2107-W, GT2104-R)

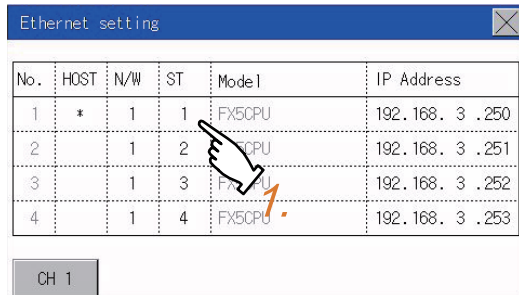

(For GT2104-P, GT2103-P)

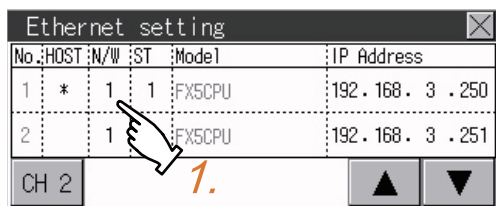

2. After the setting change, touch the [×] key. When the screen shown below appears, touch the [YES] key.

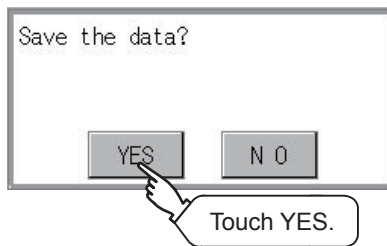

Change of station No.

1. Touch the station No. to be changed, and input the station No. of the destination Ethernet module to be changed by the numeric keypad displayed.

(For GT2107-W, GT2104-R)

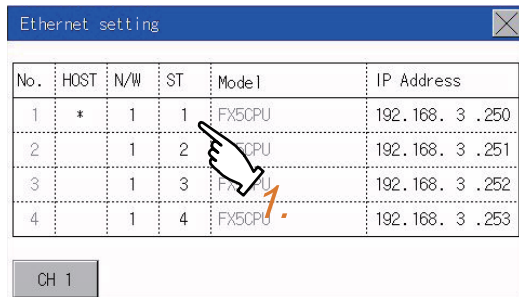

(For GT2104-P, GT2103-P)

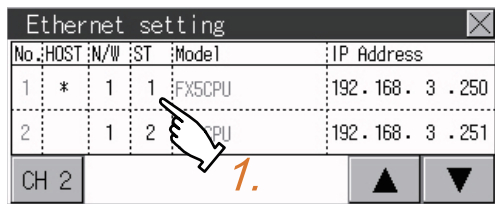

2. After the setting change, touch the [x] key. When the screen shown below appears, touch the [YES] key.

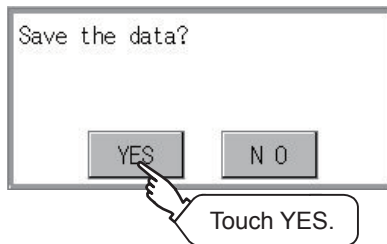

Change of IP address

1. Touch the IP address to be changed, input the destination IP address to be changed by the numeric keypad displayed.
(For GT2107-W, GT2104-R)

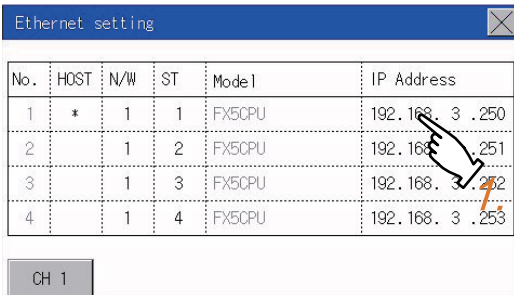

(For GT2104-P, GT2103-P)

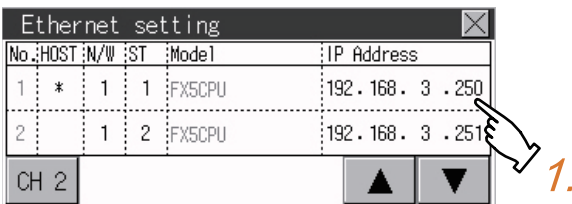

2. After the setting change, touch the [×] key. When the screen shown below appears, touch the [YES] key.

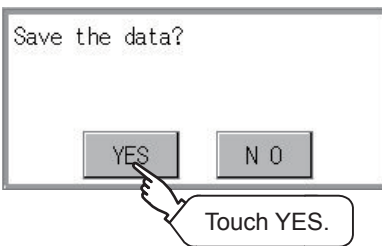

11.4 Communication Monitor

Communication monitor functions

Function	Description
Communication port-selection status display	Indicates the connection status of Standard I/F-1, I/F-2, I/F-3 and I/F-4.
Communication status display	Displays the communication status (SD: send, RD: receive).
Communication error status display	Displays an error message when a communication error occurs.

Communication monitor display operation

GT2107-W

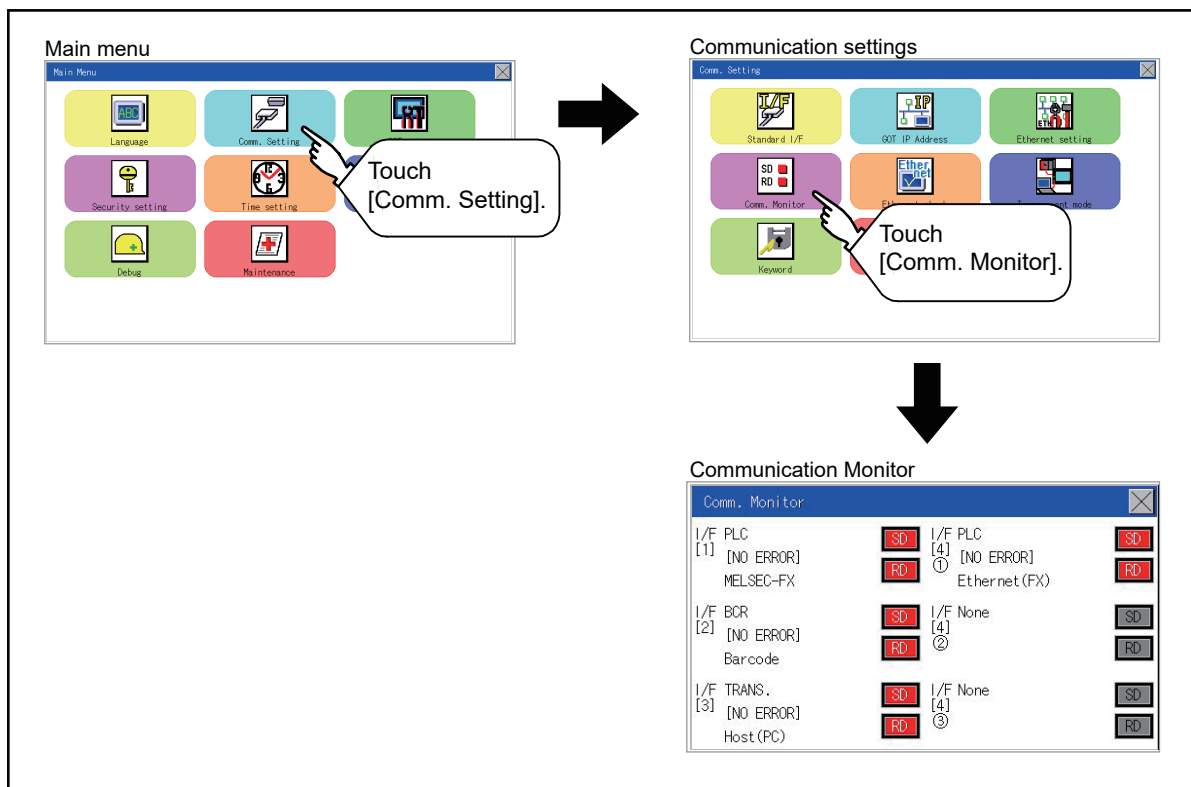

GT2105-Q

Main menu

Main Menu

- Language
- Comm. Setting
- GOT setup
- Security settings
- Time setting
- Data

Touch [Comm. Settings].

Communication settings

Comm. Setting

- Standard I/F
- GOT IP Address
- Ethernet setting
- Comm. Monitor
- Transparent mode

Touch [Comm. Monitor].

Communication Monitor

Comm. Monitor

I/F-1	SD	I/F-4①	SD
PLC	RD	NONE	RD
[NO ERROR]		[NO ERROR]	
MELSEC-FX			
I/F-2	SD	I/F-4②	SD
BCR	RD	NONE	RD
[NO ERROR]		[NO ERROR]	
Barcode			
I/F-3	SD	I/F-4③	SD
TRANS.	RD	NONE	RD
[NO ERROR]		[NO ERROR]	
Host (PC)			

11

GT2104-R

Main menu

Main Menu

- Language
- Comm. Setting
- GOT setup
- Security settings
- Time setting
- Data

Touch [Comm. Settings].

Communication settings

Comm. Setting

- Standard I/F
- GOT IP Address
- Ethernet setting
- Comm. Monitor
- Transparent mode

Touch [Comm. Monitor].

Communication Monitor

Comm. Monitor

I/F PLC	SD	I/F PLC	SD
[1] [NO ERROR]	RD	[4] [NO ERROR]	RD
MELSEC-FX		① Ethernet (FX)	
I/F BCR	SD	I/F None	SD
[2] [NO ERROR]	RD	[4] [2]	RD
Barcode			
I/F TRANS.	SD	I/F None	SD
[3] [NO ERROR]	RD	[4] [3]	RD
Host (PC)			

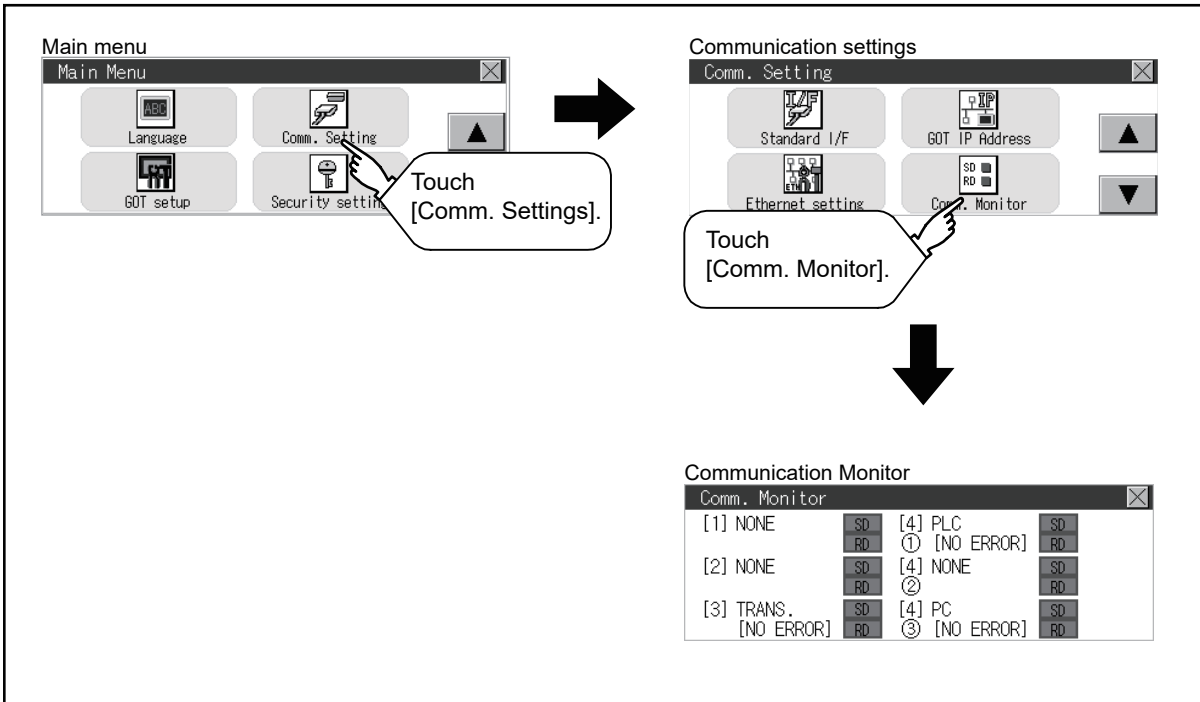

Screen display content

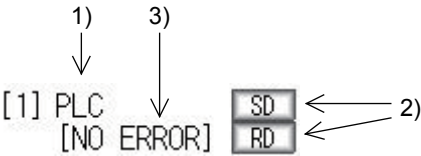

1) Connection status of the communication ports

Indicates the connection status of Standard I/F-1 and I/F-2.

Listed in the table below are display items and the connection status (channel number).

Display item	Channel number	Remark
PLC	Ch1	"PLC" appears when connected to a controller (PLC or microcomputer).
BCR	Ch8	"BCR" appears when connected to a barcode reader or RFID.
TRANS.	Ch9	"TRANS." appears when the controller that is allocated to one of the communication ports supports the transparent mode. "TRANS." automatically changes to "PC" when communicating with the screen design software.
PC	Ch9	"PC" appears when connected to a screen design software.
PRT	ChA	Appears when connected to a printer.

2) Communication status

Displays the communication status of each communication port.

The SD and RD symbols appear in black on gray (,) while data are not being sent or received.

While data are being sent or received, the SD and RD symbols appear as follows.

GT2104-P, GT2103-P: in black on white (,).

GT2105-QMBDS: in white on light gray (,).

GT2107-W, GT2105-QTBDS, GT2104-R: in white on red (,).

They may appear lit depending on the communication status.

The SD and RD symbols on the screen indicate normal communication or cable disconnection.

Setting example

Port	Channel number	Controller type
I/F-1	Ch1	MELSEC-FX
I/F-2	Ch8, Ch9	-

[During normal communication]

The SD and RD of the I/F-1 flash.

(For GT2107-W, GT2105-QTBDS, GT2104-R)



(For GT2105-QMBDS)

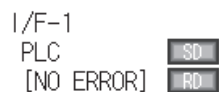

(For GT2104-P, GT2103-P)



[When the connecting cable with the controller is disconnected]

Only the SD of the I/F-1 flashes.

(For GT2107-W, GT2105-QTBDS, GT2104-R)



(For GT2105-QMBDS)

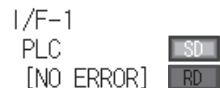

(For GT2104-P, GT2103-P)



3)Communication error status

Communication error status of each port is displayed on this screen.

The following table describes the communication status that each display item shows.

Display item	Status	Action
NO ERROR	No error	Communication is executed normally.
ERR Ovr.	Overrun error	The receive data is sent continuously with a short interval. Let the baud rate (communication speed) be equivalent between the GOT and counterpart equipment.
ERR Frm.	Framing error	The communication frames of GOT and PLC are inconsistent. Confirm the communication settings of GOT and PLC, such as data length, stop bit and baud rate.
ERR Prt.	Parity error	The parity check conditions of GOT and PLC are inconsistent. Let the parity check condition (odd or even) of GOT and PLC be consistent.
ERR Text	Text error	The sum data is inconsistent. Or the contents of the receive data are not consistent with the send command from the GOT. Let the communication settings and contents of data be consistent between the GOT and counterpart equipment. (If NAK is received while the GOT is connected to the microcomputer board, a text error occurs.)
TIME OUT	Communication timeout	Though receiving is started, receive data is not sent. Check the wiring between the GOT and its communication target. (When the GOT is connected to the microcomputer board, confirm the terminator, CR, wiring, etc.)
ERR Line	Control line error	The control line is not operating correctly. Confirm the wiring of the control line.
ERR Cmd.	Command error	A command contained in the receive data is not consistent with the send command from the GOT.

Point

Error occurring in a station

When the GOT monitors multiple controllers of a channel by switching between stations, the communication monitor function cannot detect errors occurring in the stations that are not being monitored.

To check the errors occurring in these stations, use the following GOT registers.

Faulty Station Information (CH1): GS281 to GS288

Faulty Station Information (CH2): GS301 to GS308

Faulty Station Information (CH3): GS321 to GS328

Faulty Station Information (CH4): GS341 to GS348

For the details of the GOT special registers, refer to the following.

 GT Designer3 (GOT2000) Screen Design Manual

11.5 Ethernet Check (Ethernet models only)

Ethernet check function

The Ethernet status check function sends a ping to check the connection status of Ethernet.

Display operation of Ethernet check

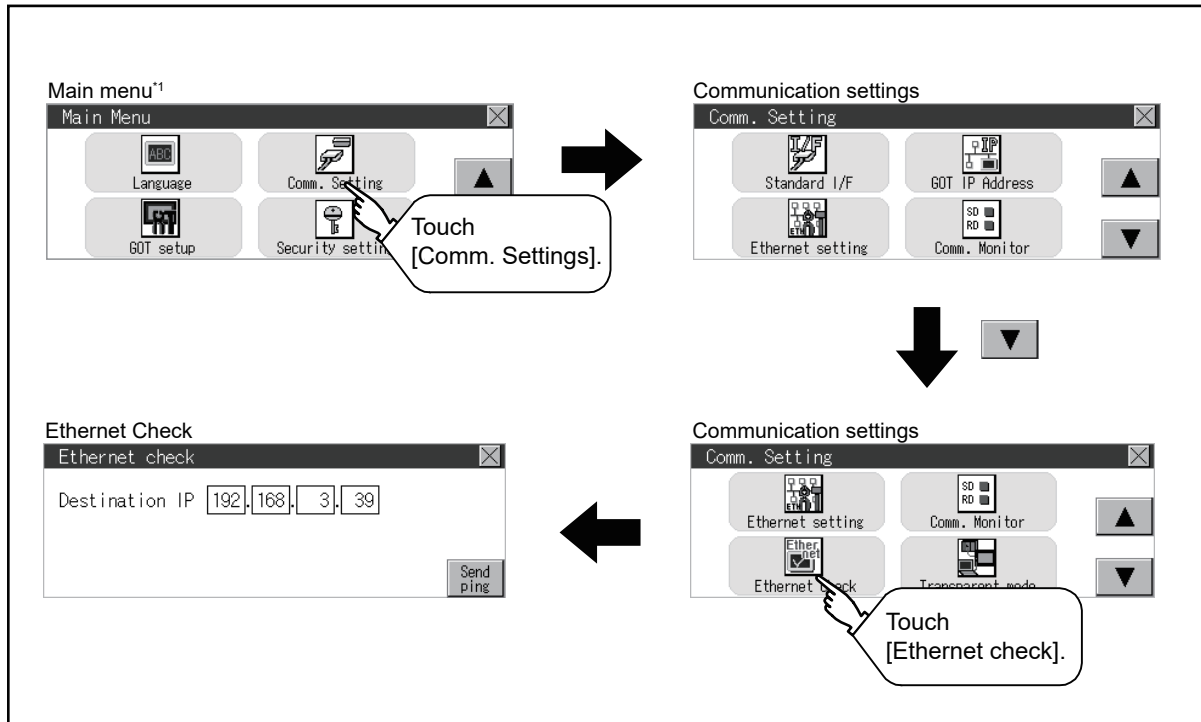

*1 Refer to the following for display operation of main menu.
☞ Page 425 Utility Display

Operation of Ethernet status check

1. If the select button of [Destination IP] is touched, a keyboard is displayed.

Enter the IP address of the other terminal with the keyboard.

<Default: 192.168.3.39>

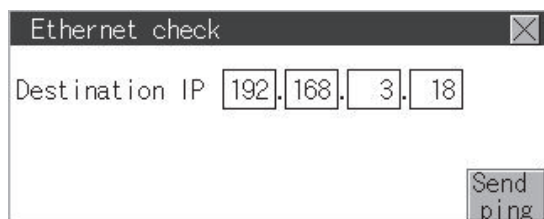

2. If the [Send ping] button is touched, a ping is sent to the IP address entered in [Destination IP]. The timeout time is five seconds.

- When the communication is completed

The [Response received.] dialog box is displayed.

- When a communication error occurs

The [Timeout occurred.] dialog box is displayed.

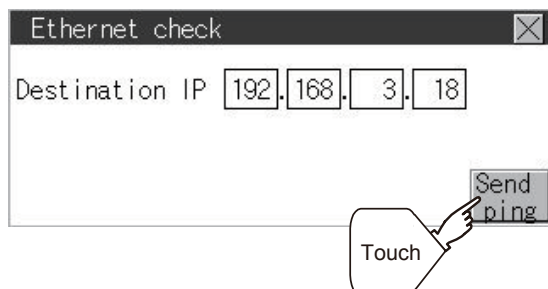

11.6 Setting the Transparent Mode

Function of the transparent mode

When using the multi-channel function, the channel No. of a controller to which the FA transparent function is executed can be set.

For details on the multi-channel and FA transparent functions, refer to the following.

📖 GOT2000 Series Connection Manual (Mitsubishi Electric Product) For GT Works3 Version1

Function	Description	Setting range
ChNo.	The channel No. of a controller to which the FA transparent function is executed can be set.	1/2 (Default: 1)

Display operation of the transparent mode setting

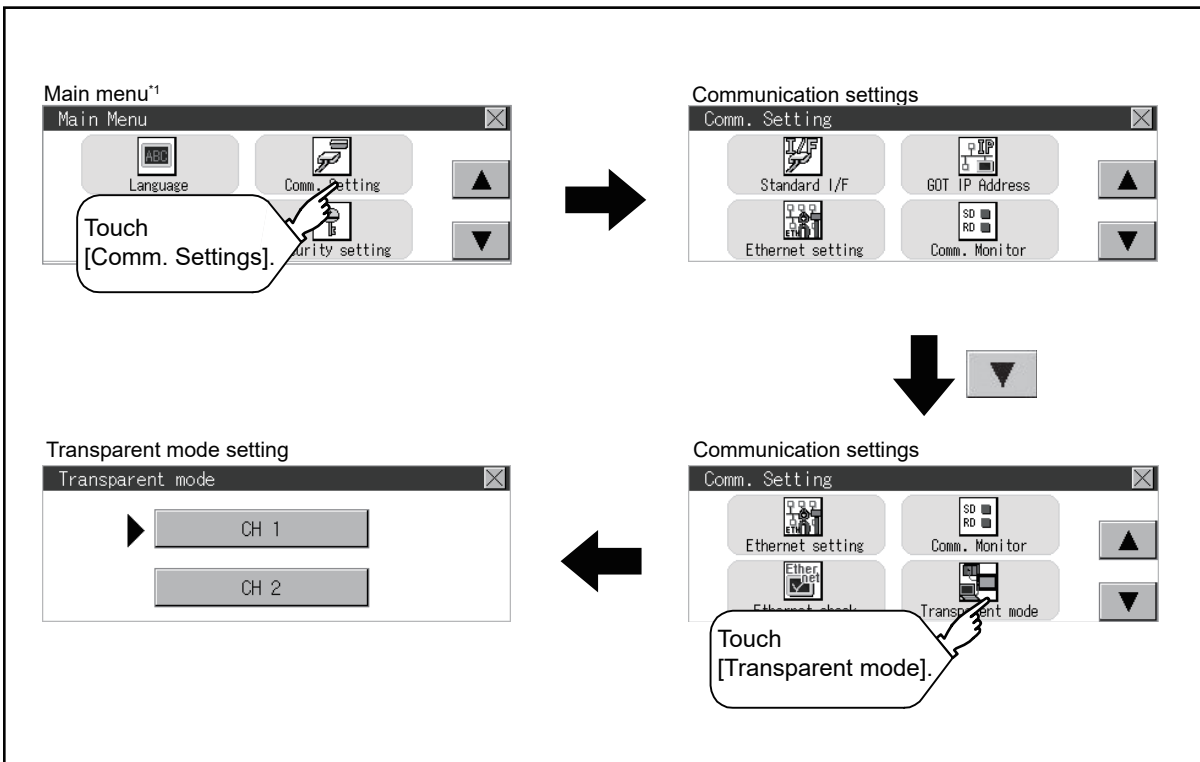

*1 Refer to the following for display operation of main menu.
 📖 Page 425 Utility Display

Transparent mode setting operation

1. When the transparent ChNo. (numerical part) below is touched, the screen for selecting a communication driver is displayed. Select the channel to execute the FA transparent function.

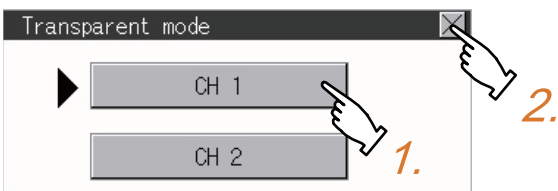

2. Touching the [x] button restarts the GOT when the settings have been changed.

11.7 Keyword

Keyword functions

The operation related to a keyword of the FX series PLC can be performed.

Function	Description
Regist	Keyword is registered.
Delete	Registered keyword is deleted.
Clear	Keyword protection is cleared.
Protect	A keyword with cleared protection is reactivated for protection.

Keyword display operation

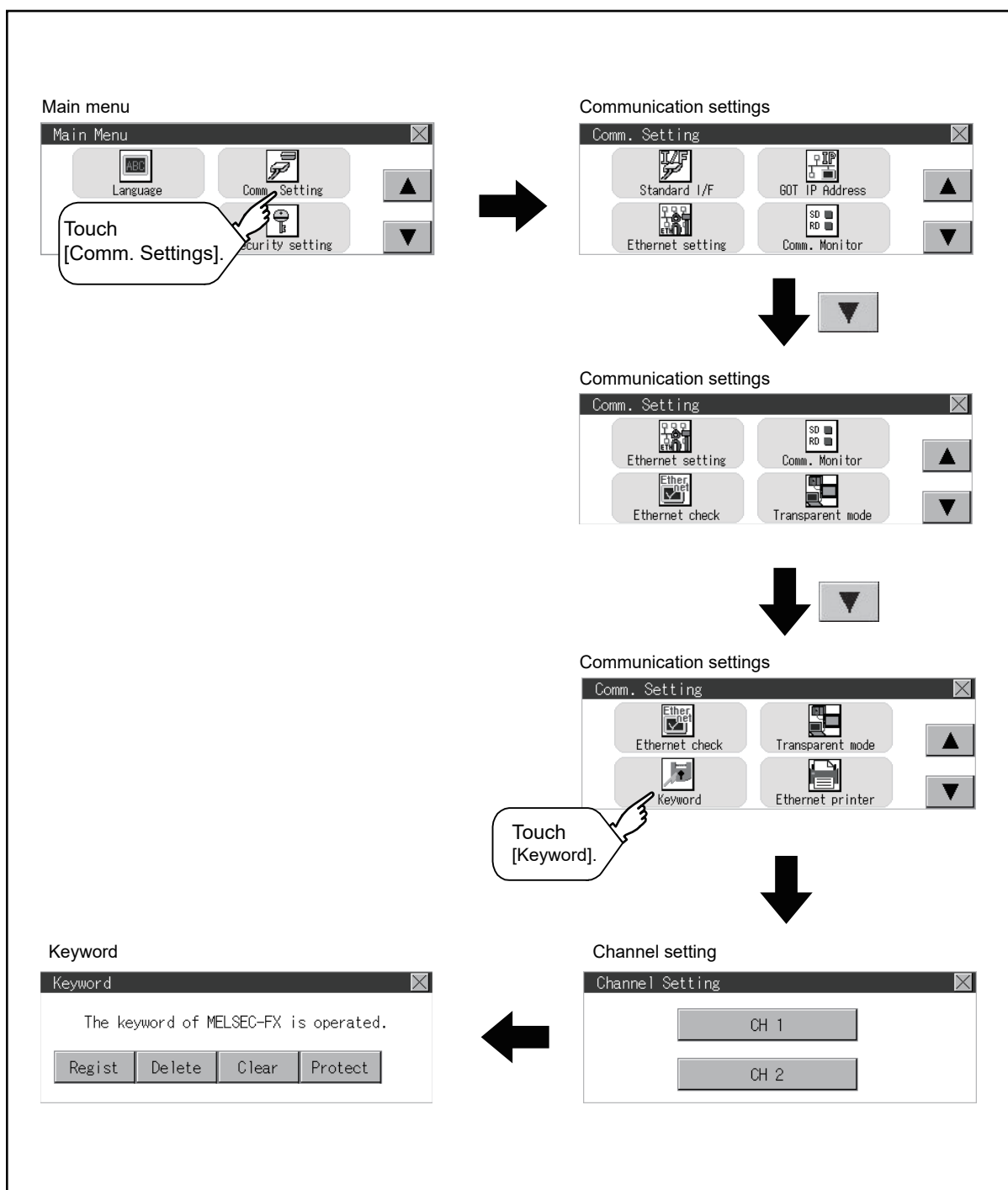

Regist

Keyword is registered.

1. Touch "Regist" to display the selection screen for the registration.

For the FX series PLC, which is not compatible with Customer Keyword, the keyword entry screen of [Step3] is displayed. Start the operation from [Step3].

For the Customer Keyword compatible models, refer to the manual of the PLC to be used.



2. Select [Keyword] or [Keyword+Custom].

To register only Keyword and 2nd keyword, touch [Keyword].

To register Customer Keyword, touch [Keyword+Custom].

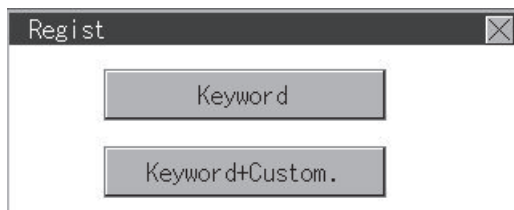

3. Input a keyword.

Touch the display part of the keyword to be registered.

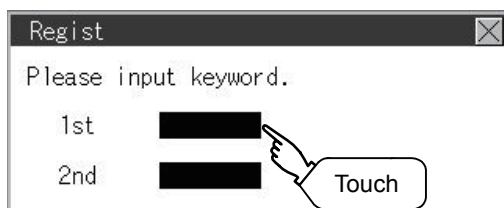

4. The keyboard for entering a keyword is displayed. Character types to be input can be changed by touching the [A-F] or [0-9] button. Enter a keyword and touch the [ENT] key.

For the keyword, 8 digits from 0 to 9 or A to F must be set.

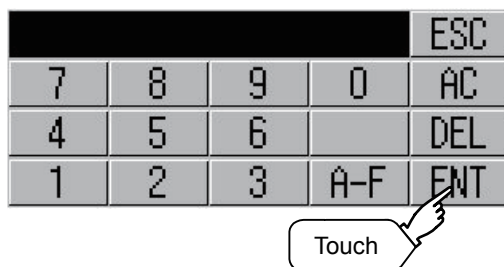

5. After completing the keyword entry, touch [Next].

When [Keyword+Custom] is selected on the selection screen for the registration, the Customer Keyword entry screen is displayed. Enter it in the same way as for Keyword and 2nd keyword.

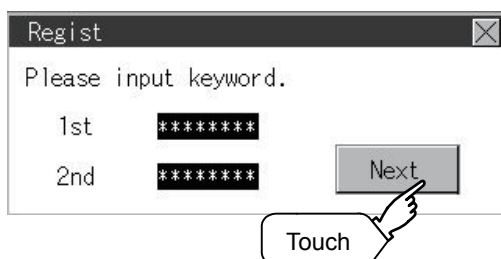

6. Set Registration conciliation.

Touch Registration conciliation to change the setting contents.

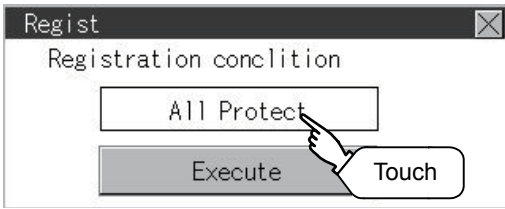

7. After setting Registration conciliation, touch the [Execute] key.

The registration of the keyword is completed.

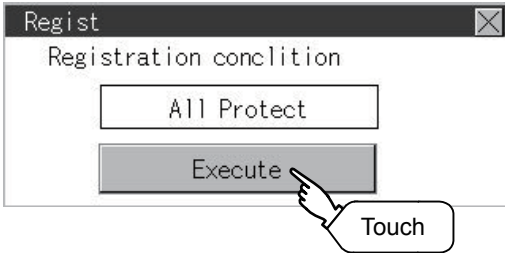

8. The registration of the keyword is completed.

Touch [OK].

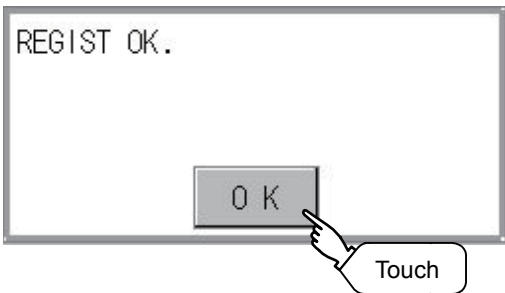

Selection availability of Registration conciliation

The following table lists the PLCs that can select Registration conciliation.

Target PLC	Setting	
	When keyword and 2nd keyword are registered	When only keyword is registered
FX PLC compatible with 2nd keyword ^{*1}	Registration options can be selected. ^{*2}	Registration options ^{*2} cannot be selected.
FX PLC not compatible with 2nd keyword ^{*1}	-	

*1 Refer to the manual for the PLC in use for the models that are compatible with the 2nd keyword.

*2 Registration options can be selected among "R/W Protect", "Write Protect", or "All online operation protection". For access restrictions of each setting, refer to the manual of the PLC to be used.

Selection of keyword protection level

For the devices which can perform the online operation of FX PLC, 3 levels of protection can be set.

When the monitoring or setting change by online devices is needed, set the keyword taking the following into consideration.

■When only keyword is registered

Protection level is selected by the head character of keyword.

All Protect: Set the keyword starting with one of A, D to F, or 0 to 9.

Read/incorrect write protection: Set the keyword starting with B.

Erroneous write prohibition: Set the keyword starting with C.

■When keyword and 2nd keyword are registered

Applicability of monitoring for each keyword protection level

The applicability of monitoring for each protection level is as follows.

Item	When only keyword is registered			When keyword and 2nd keyword are registered			Keyword unregistered /protection canceled
	All protection	Erroneous write/read protection	Erroneous write protection	All online operation protection	Read/Write Protection	Write Protection	
Device monitoring	○	○	○	×	○	○	○
Device change	T, C setting values and file register (from D1000)	× ^{*1}	× ^{*1}	× ^{*1}	×	○	○
	Other than the above	○	○	○	×	○	○

*1 When the T, C set values are specified indirectly, changing devices is available.

Difference between "All online operation protection" and "All Protect"

When "All online operation protection" is selected, both device display and input by the programming tool or GOT are prohibited.

When "All Protect" is selected, device display and input are possible although operations by the programming tool are all prohibited.

Delete

Registered keyword is deleted.

1. Touch [Delete] to display the keyword entry screen.

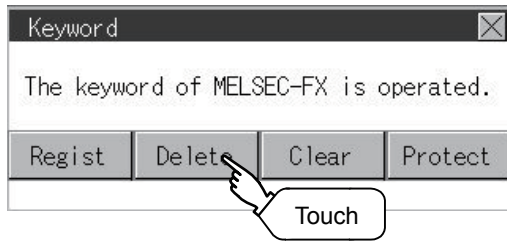

2. Input a keyword.

Touch the display part of the registered keyword.

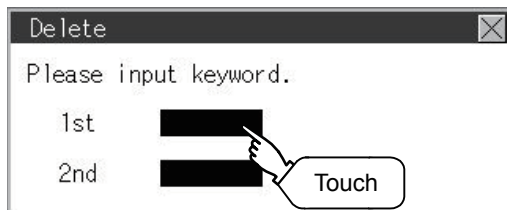

Target PLC	Setting
FX PLC compatible with 2nd keyword	Input a keyword to be deleted.
FX PLC not compatible with 2nd keyword	Input a keyword to be deleted only into "keyword". "2nd keyword" is ignored.

3. The keyboard for entering a keyword is displayed. Enter a keyword and touch the [ENT] key. Character types to be input can be changed by touching the [A-F] or [0-9] button.

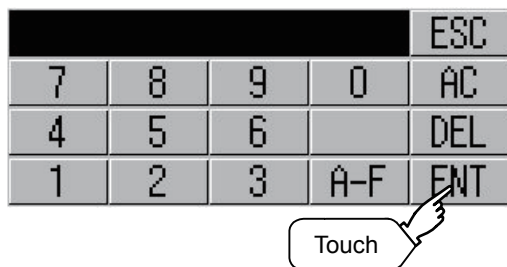

4. After completing the keyword entry, touch [Next].

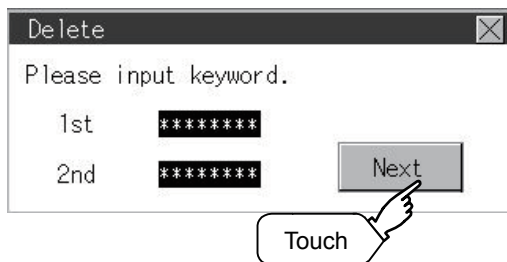

5. Touch the [Execute] key.

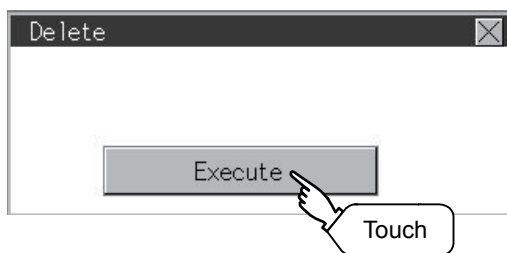

6. The keyword is deleted.

Touch [OK].

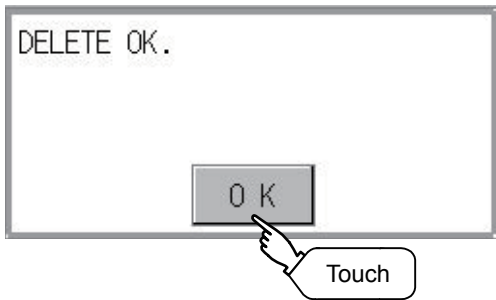

Clear

To access an FX PLC where a keyword has been registered, keyword protection is cancelled.

1. Touch [Clear] to display the keyword entry screen.



2. Input a keyword.

Touch the display part of the registered keyword.

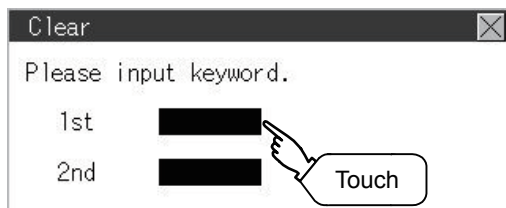

Target PLC	Setting
FX PLC compatible with customer keyword	Input a keyword or customer keyword to clear the protection.
FX PLC compatible with 2nd keyword	Input a keyword to clear the protection.
FX PLC not compatible with 2nd keyword	Input a keyword into "keyword" to clear the protection. "2nd keyword" is ignored.

3. The keyboard for entering a keyword is displayed. Enter a keyword and touch the [ENT] key. Character types to be input can be changed by touching the [A-F] or [0-9] button.

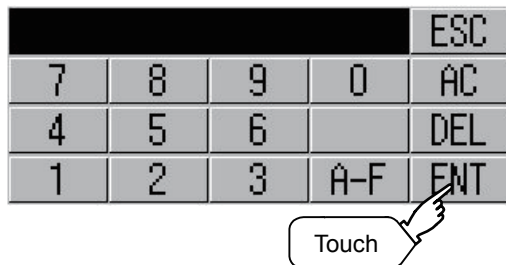

4. After completing the keyword entry, touch [Next].

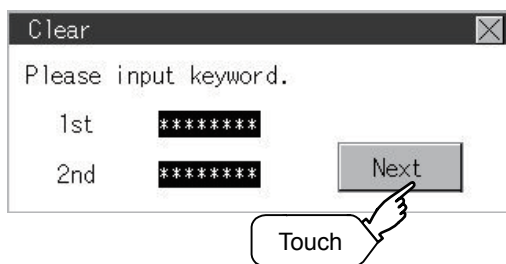

5. Touch the [Execute] key.

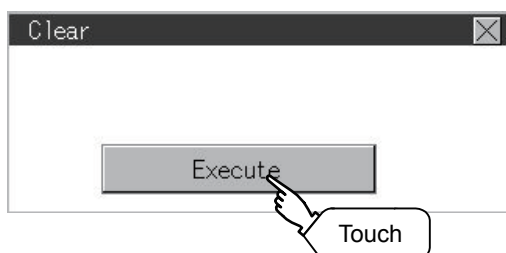

6. The protection is cleared.

Touch [OK].

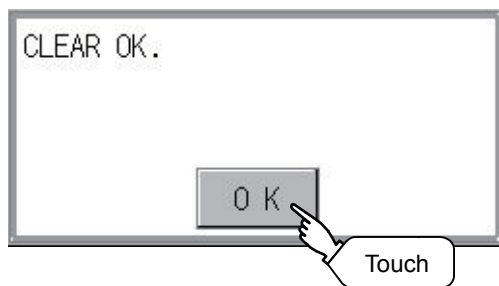

Protect

A keyword with cleared protection is reactivated for protection. Keyword protection function is valid when the 2nd keyword is registered.

1. Touch [Protect] to switch to the keyword protection status.



2. The keyword is protected.

Touch [OK].

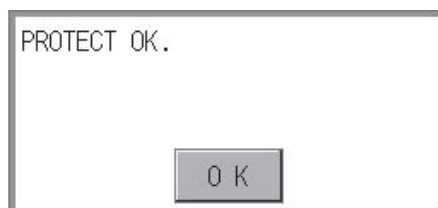

11.8 Ethernet Printer

Ethernet printer setting

Set the IP address of an Ethernet printer.

Item	Description	Setting range
IP address	Set the IP address of the Ethernet printer to be connected.	0.0.0.0 to 255.255.255.255 <Default: 192.168.3.100>

Display operation of the Ethernet printer

GT2107-W

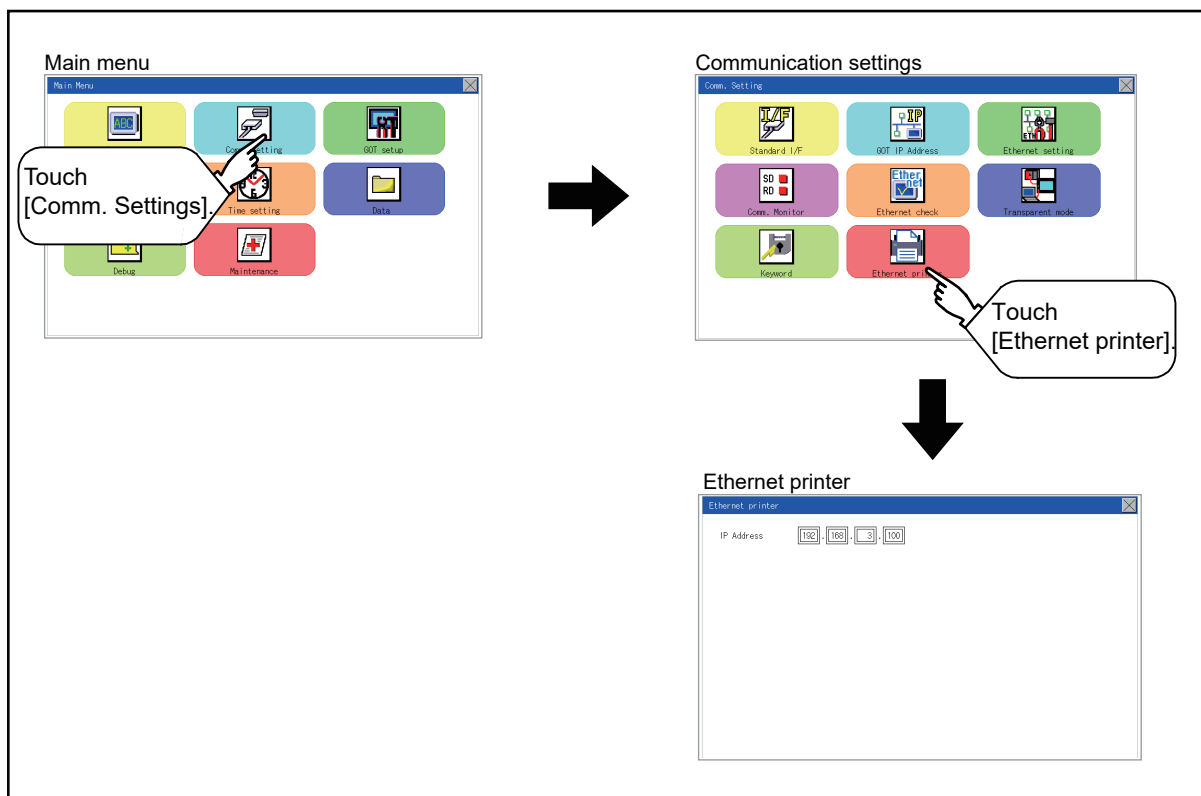

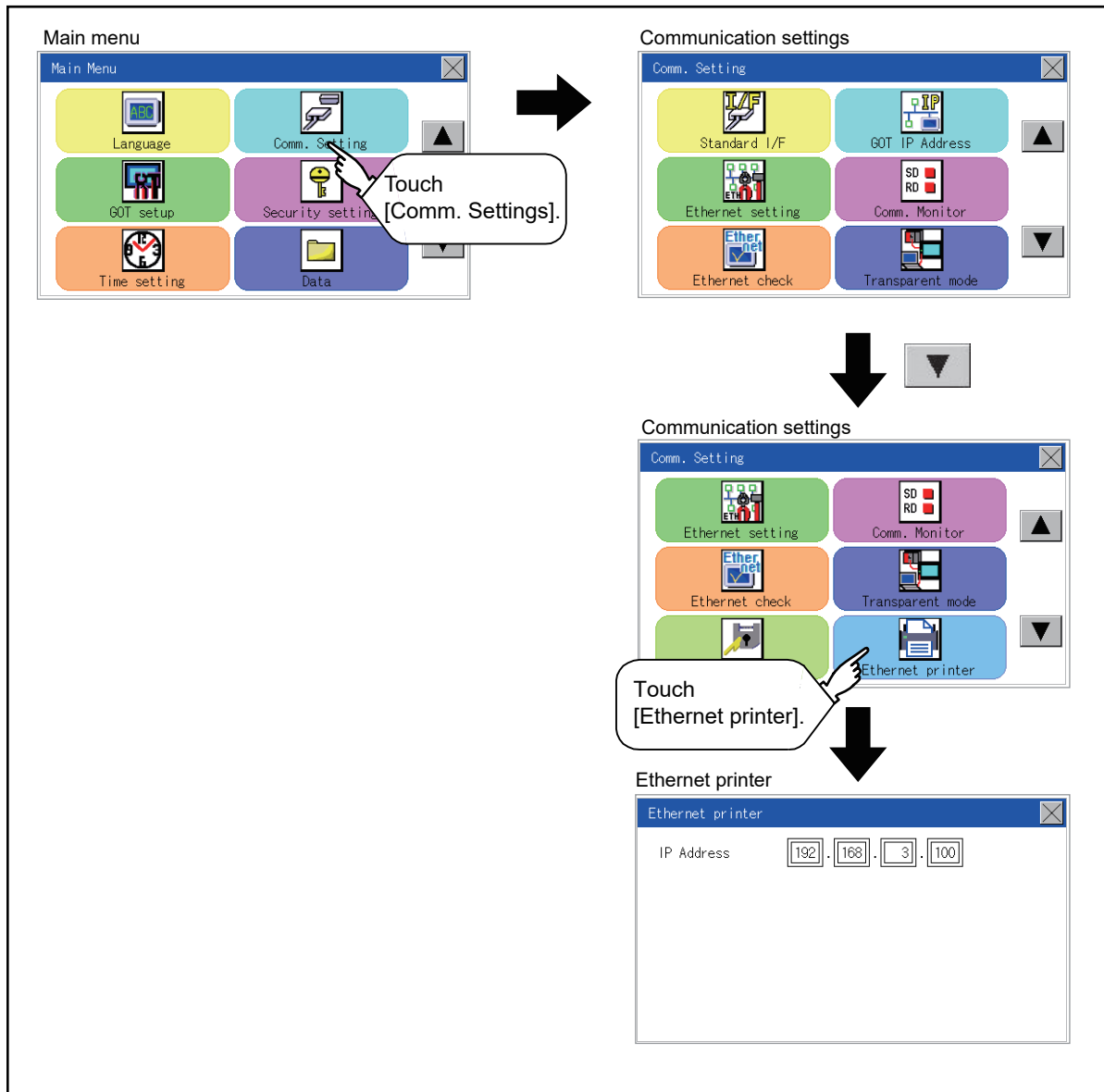

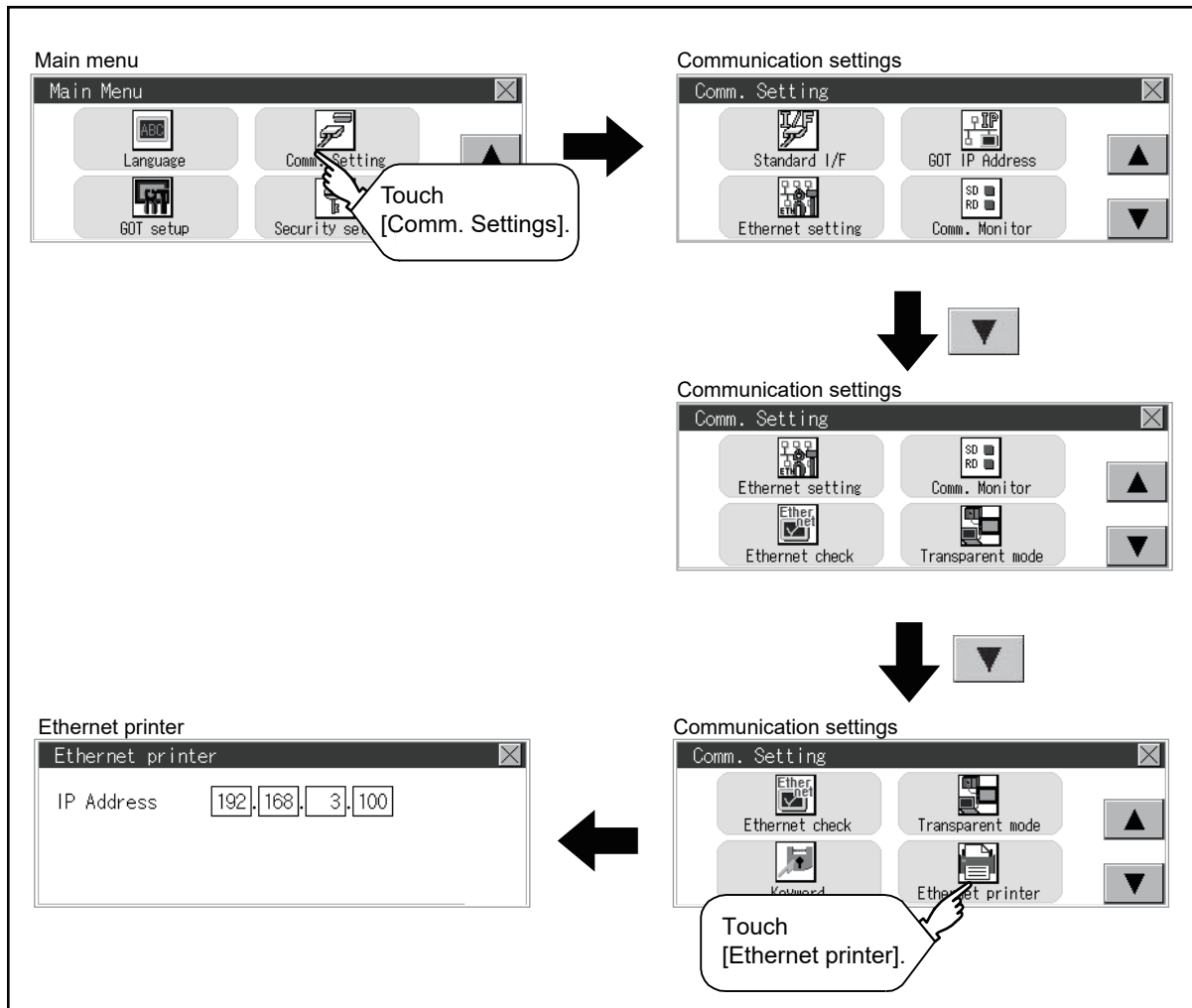

Procedure for setting an Ethernet printer

1. Touch the input area of [IP Address] to display a keyboard.
Input values with the keyboard.
(For GT2107-W, GT2104-R)

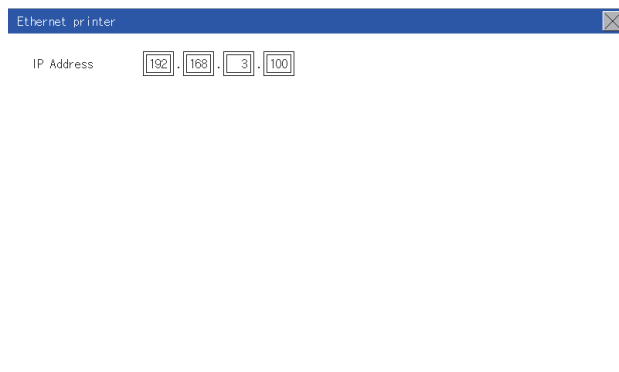

(For GT2104-P, GT2103-P)

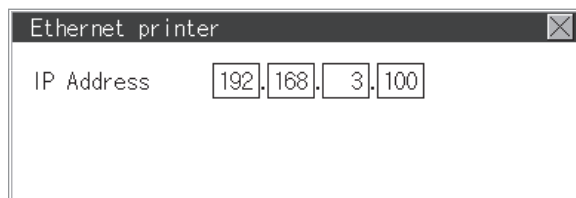

2. Touch the [x] button on the [Ethernet printer] screen to display the dialog shown below.
(If no setting is changed, the dialog is not displayed.)
Operate following the message of the dialog box.

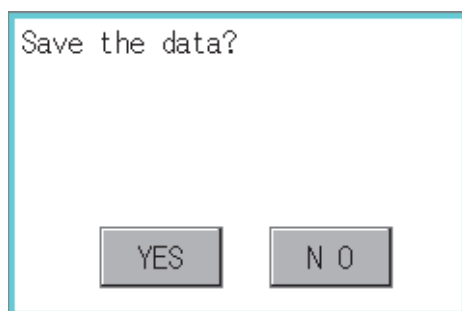

MEMO

12 DISPLAY AND OPERATION SETTINGS

- ☞ Page 486 Display Settings
- ☞ Page 492 Operation Settings (Settings for Operation)
- ☞ Page 502 Inherent Information
- ☞ Page 503 USB Host
- ☞ Page 506 Setting the storage location for backup and restoration
- ☞ Page 508 GOT Internal Device Monitor
- ☞ Page 510 VNC Server Function
- ☞ Page 512 License Management
- ☞ Page 514 IP filter setting

You can display the setting screens related to the display, operation, and others from the utility screen. In the setting screen for display and the setting screen for operation, the following settings can be set.

Item	Description	Reference
Display settings	Setting the startup screen display time and screen saving time	☞ Page 486 Display functions
	Brightness	
	Turning on/off the POWER LED (GT2105-Q only)	
Operation	Setting buzzer volume, window move buzzer, and key reaction	☞ Page 495 Setting operation of operation
	Touch panel calibration	☞ Page 497 Position correction of the touch panel (touch panel calibration setting)
	Utility call key	☞ Page 497 Position correction of the touch panel (touch panel calibration setting)
IP filter setting ^{*1}	IP filter usage, specification of filtering method, and specifications of target IP address and exception IP address	☞ Page 515 Setting procedure for the IP filter

*1 Only available to Ethernet interface equipped models.

12.1 Display Settings

Display functions

Setting regarding display is possible.

The items which can be set are described below. If touch the each item part, the respective setting becomes possible.

Item	Description	Setting range
Opening time	The title display period at the main unit boot can be set.	0 to 60 seconds (At factory shipment: 1 seconds)
Screen save time	The period from the user stops the touch panel operation till the screen save function starts can be set.	0 to 60 minutes (At factory shipment: 0 minute)
Brightness	Brightness can be adjusted.  Page 490 Brightness	-

Point

- Display setting by GT Designer3

Set title display period, screen save time and screen save backlight by selecting [Common] → [GOT Environmental Setting] → [GOT Setup...] on GT Designer3.

When change a part of the setting, change the setting by the GOT display setting after downloading the project data.

 GT Designer3 (GOT2000) Screen Design Manual

- Screen save time

By using the system information function, the screen save function can forcibly enabled from a controller (Forced Screen Saver Disable Signal) or the screen saving time set in the utility can be disabled (Automatic Screen Saver Disable Signal).

 GT Designer3 (GOT2000) Screen Design Manual

Display operation of display setting

GT2107-W

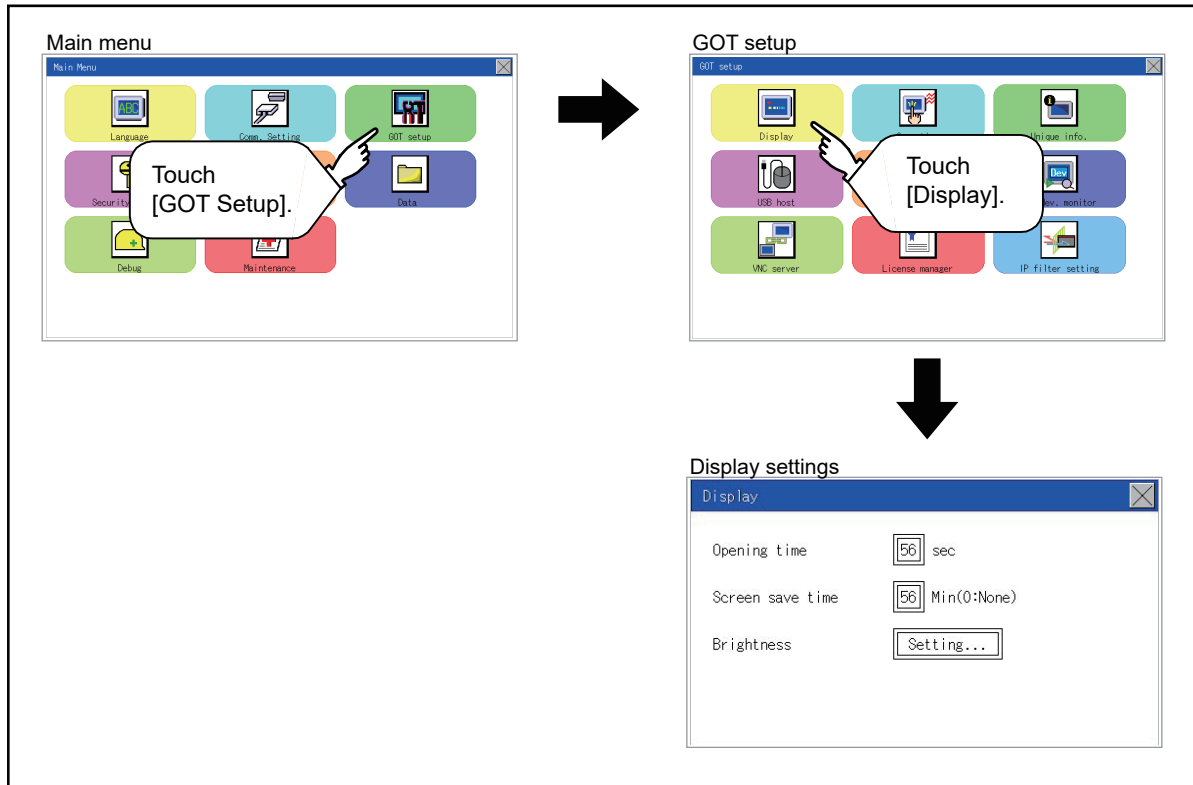

GT2105-Q

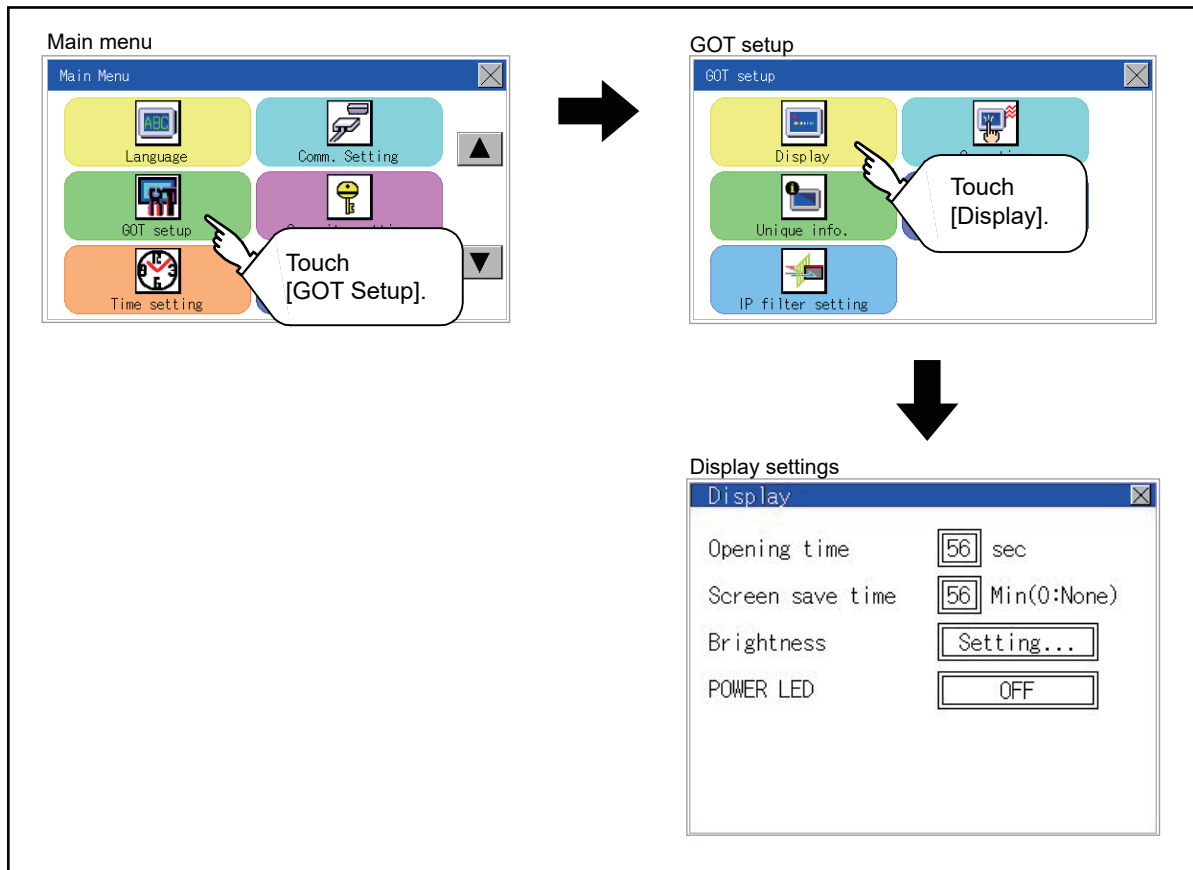

GT2104-R

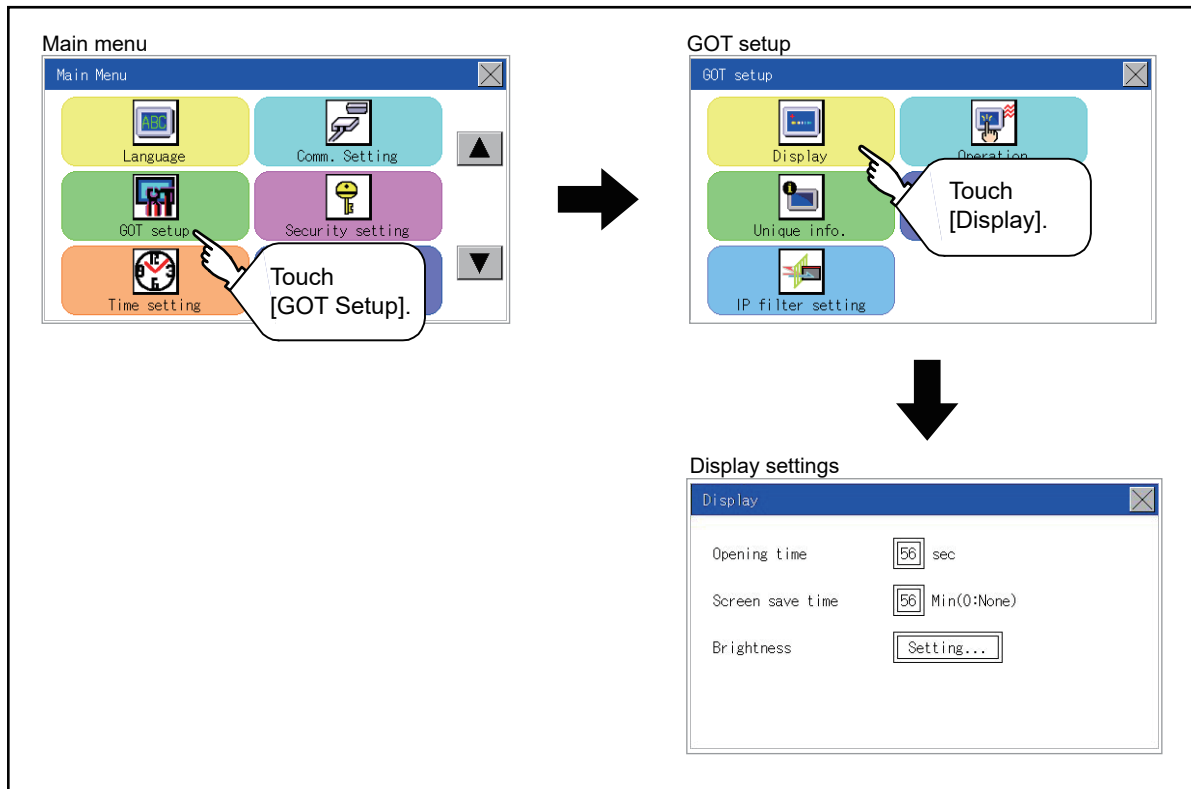

GT2104-P, GT2103-P

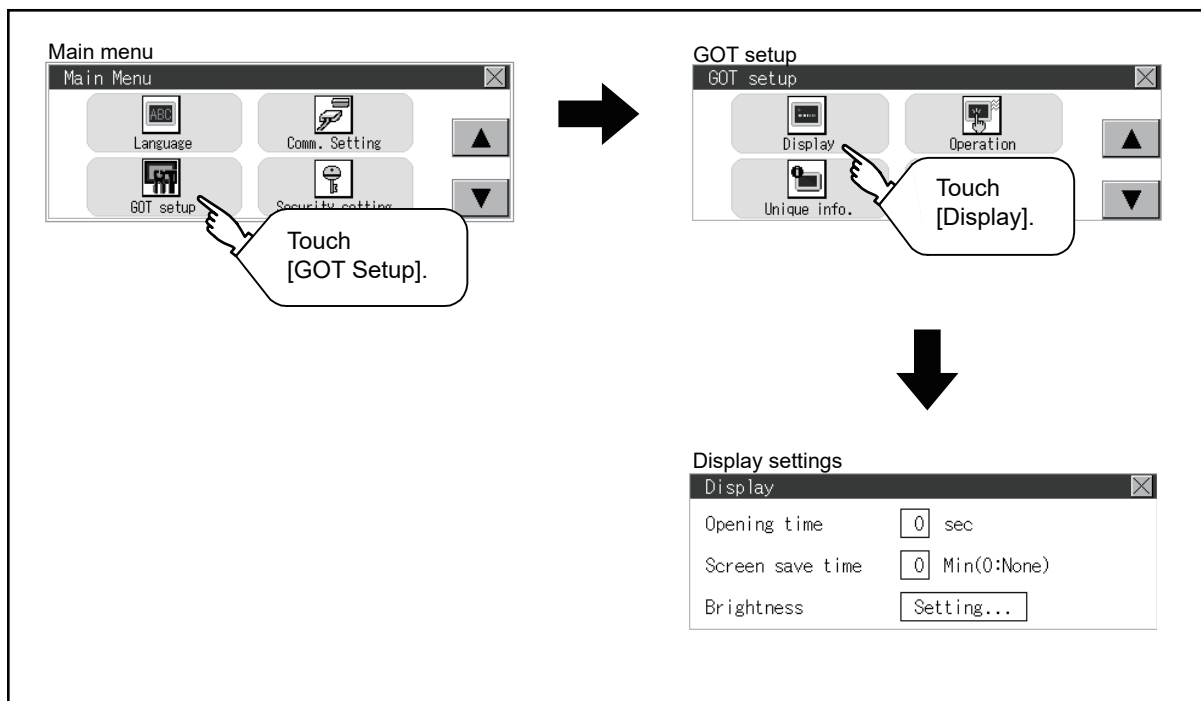

Display setting operations

The title display period and screen saving time

1. If the setting items (numbers) are touched, a keyboard is displayed.

Input numeric with the keyboard.

(For GT2107-W, GT2104-R)

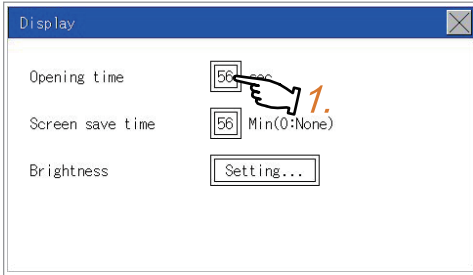

(For GT2105-Q)

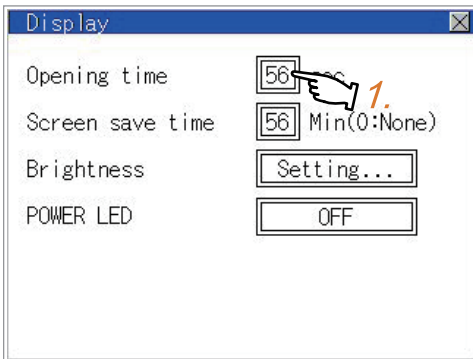

(For GT2104-P, GT2103-P)

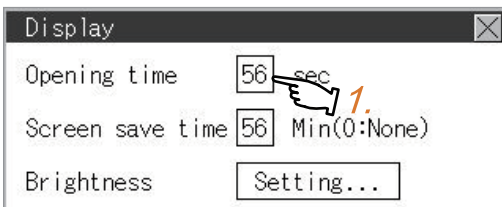

2. Set the title display period with the ten-key pad window and touch "ENT".

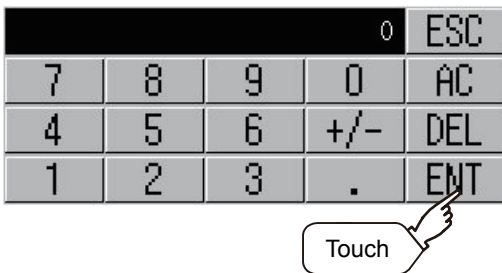

Brightness

1. Touch [Brightness] to bring up the Brightness setting window.

(For GT2107-W, GT2104-R)

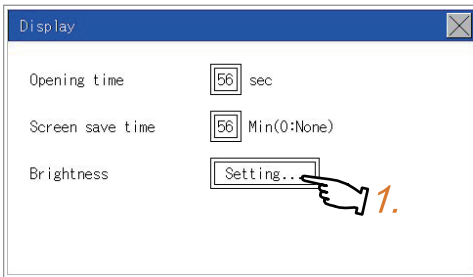

(For GT2105-Q)

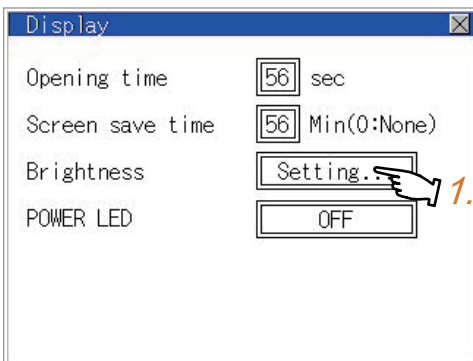

(For GT2104-P, GT2103-P)

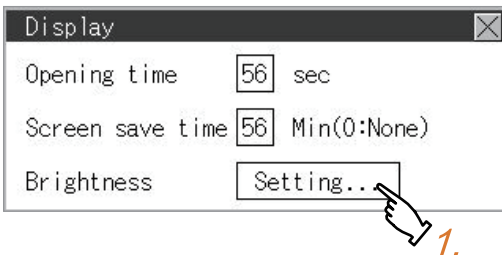

2. The Brightness setting window is displayed. Touch an item to be set.

(a) Test Color (GT2104-P, GT2103-P only)

Touch this item to change the backlight color, [White], [Green], [Red], [Pink], or [Orange], that is used for a color test.

(b) Brightness Mode

Touch this item to switch [Normal] or [Low Brightness].

(c) Brightness

Touch the [+] and [-] keys to adjust the brightness of the screen.

(For GT2107-W, GT2105-Q, GT2104-R)

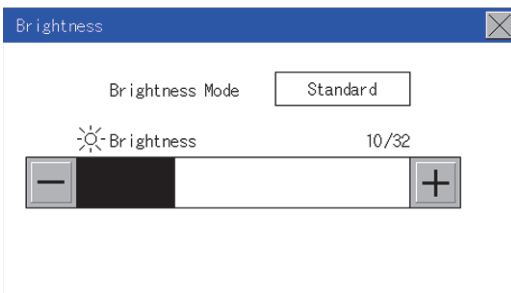

(For GT2104-P, GT2103-P)

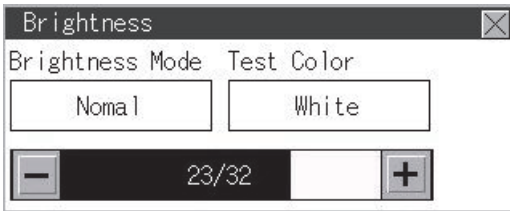

3. Touch the [x] button to reflect the setting.

(For GT2107-W, GT2105-Q, GT2104-R)

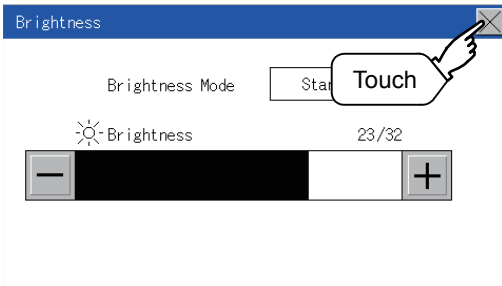

(For GT2104-P, GT2103-P)

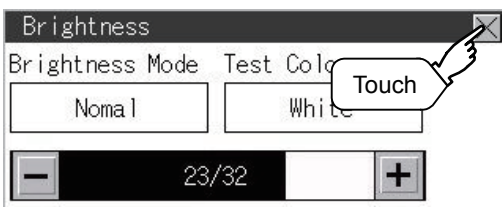

POWER LED (GT2105 only)

1. Touch a setting item to change the setting.

POWER LED: ON  OFF

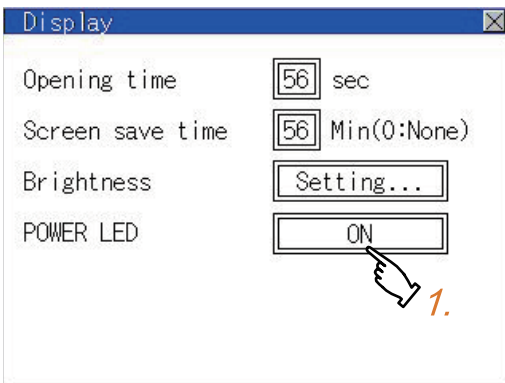

2. Touch the [x] button to save the changes.

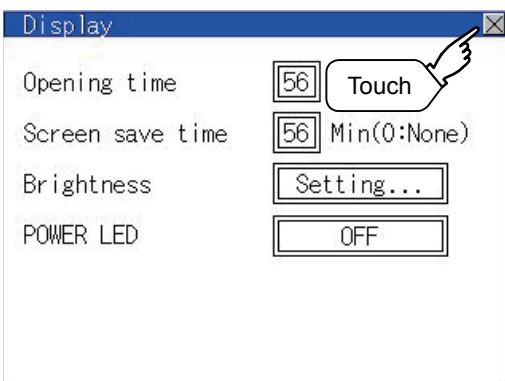



12.2 Operation Settings (Settings for Operation)

Operation setting functions

Setting regarding GOT operation can be set.

The items which can be set are described below. If touch the each item part, the respective setting becomes possible.

Function	Description	Setting range
Buzzer volume	Buzzer volume setting can be changed.	OFF/SHORT/LONG (At factory shipment: SHORT)
Window move buzzer	Whether turn ON/OFF buzzer when move window can be selected.	ON/OFF (At factory shipment: ON)
Key reaction	The touch panel sensitivity when touching the GOT screen can be set. (For preventing chattering)	± 0 to $+120$ ^{*1}
Calibration	Calibrates the touch panel sensitivity.  Page 497 Position correction of the touch panel (touch panel calibration setting)	-
Utility call	Utility call key setting screen can be displayed.  Page 499 Setting the utility call keys	-

*1 The more the value set for [Key reaction] is high, the more the key reaction speed slows.

"Key reaction" [ms]	Standard (± 0)	+10	+20	+40	+80	+120
---------------------	----------------------	-----	-----	-----	-----	------

For example, when the GOT recognizes touching the GOT screen once as touching the screen twice, set a higher value for [Key reaction].

Point

Operation setting by GT Designer3

Set buzzer volume and window move buzzer volume by selecting [Common] → [GOT Environmental Setting] → [GOT Setup...] of GT Designer3.

When change a part of the setting, change the setting by the GOT display setting after downloading the project data.

 GT Designer3 (GOT2000) Screen Design Manual

Display operation of operation setting

GT2107-W

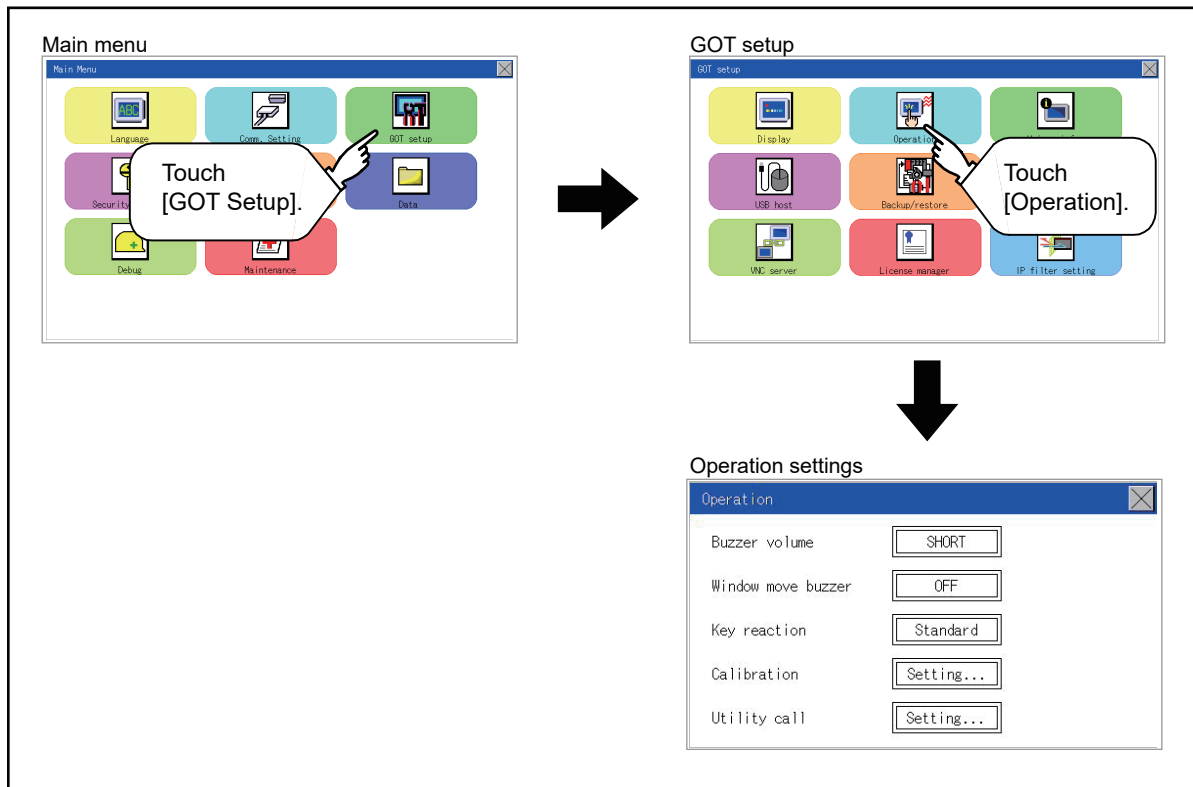

12

GT2105-Q, GT2104-R

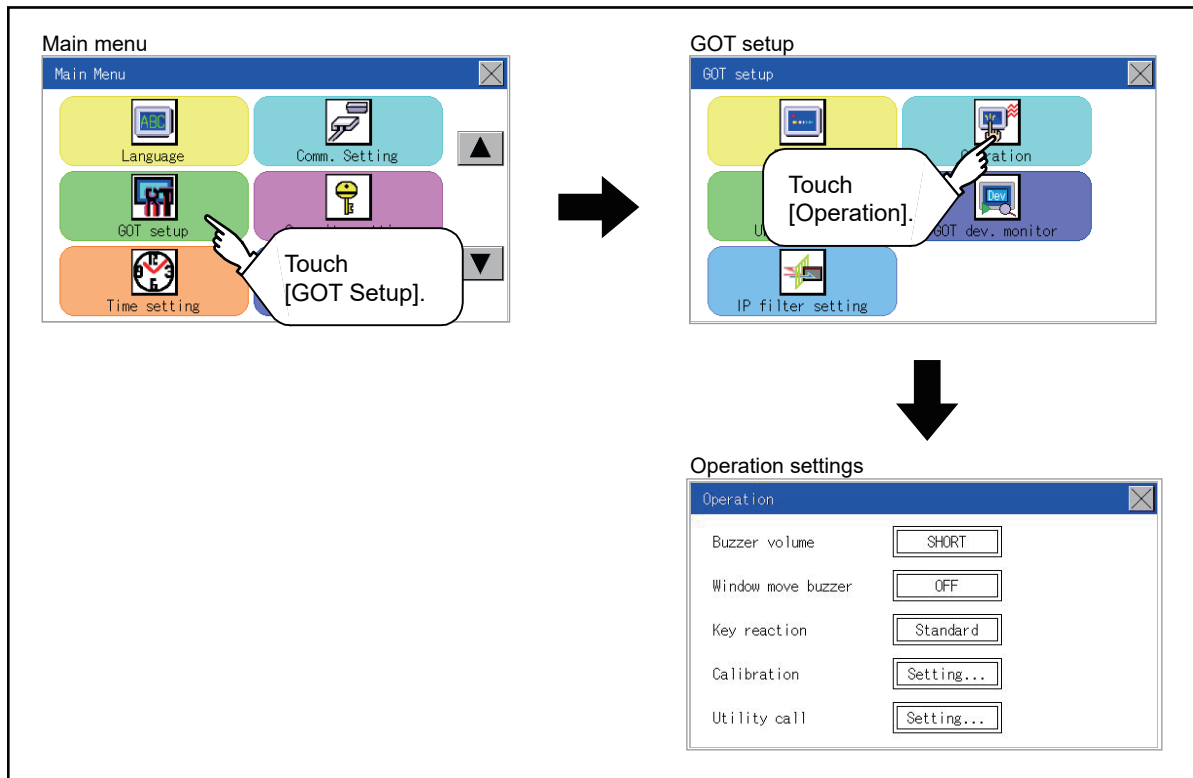

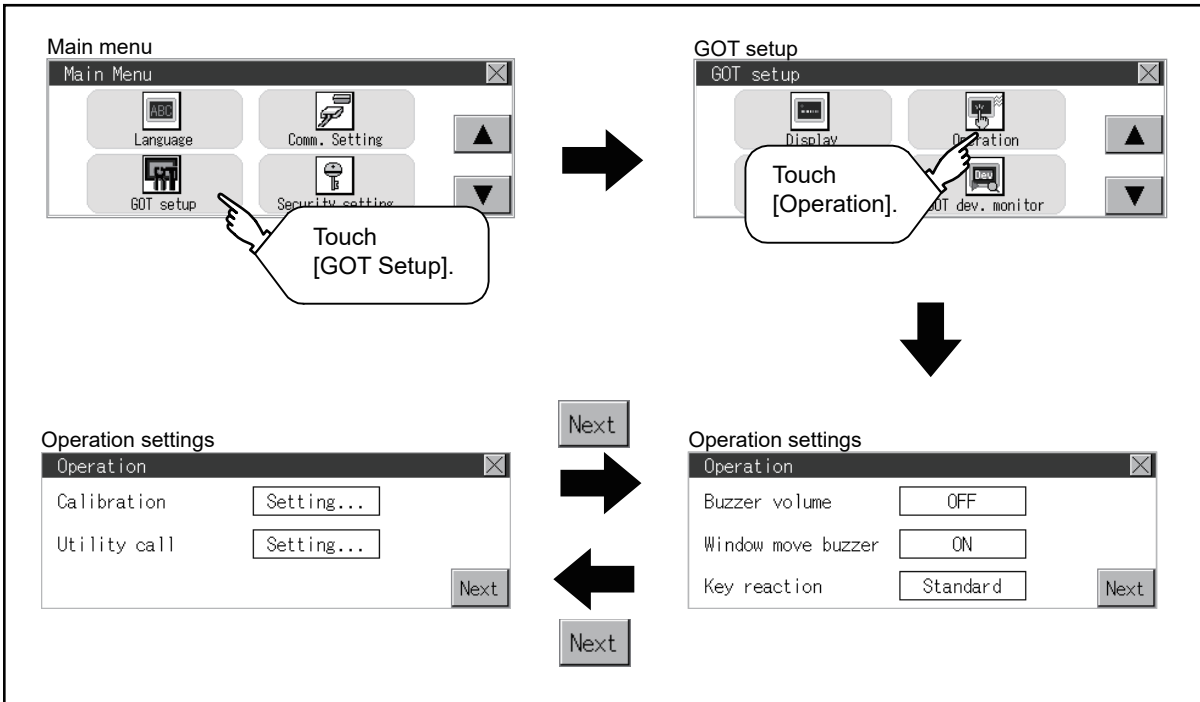

Setting operation of operation

Buzzer volume

1. Touch a setting item to change the setting.

(For GT2107-W, GT2105-Q, GT2104-R)

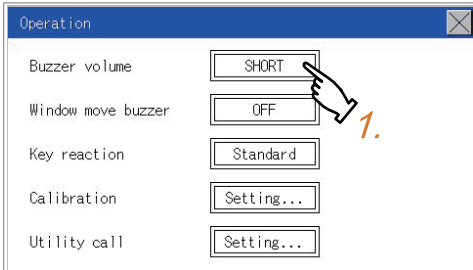

(For GT2104-P, GT2103-P)

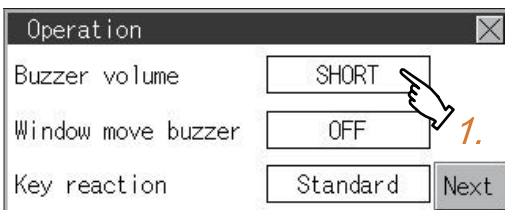

(Buzzer sound: SHORT $\overleftrightarrow{\text{LONG}}$ OFF)

2. Touch the [x] button to save the changes.

Window move buzzer

1. Touch a setting item to change the setting.

(For GT2107-W, GT2105-Q, GT2104-R)

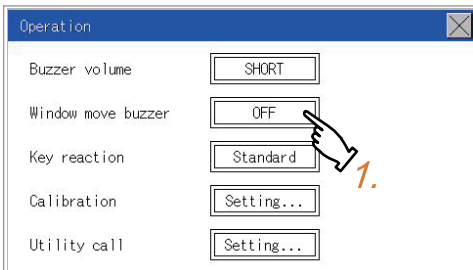

(For GT2104-P, GT2103-P)

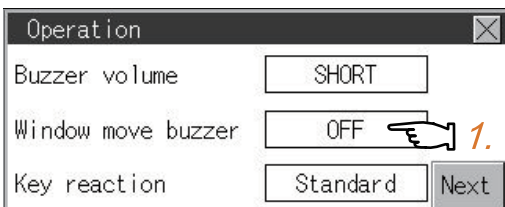

(Window move buzzer: ON $\overleftrightarrow{\text{OFF}}$)

2. Touch the [x] button to save the changes.

Key reaction setting

1. If touching the setup item, the setup contents*¹ are changed.

(For GT2107-W, GT2105-Q, GT2104-R)

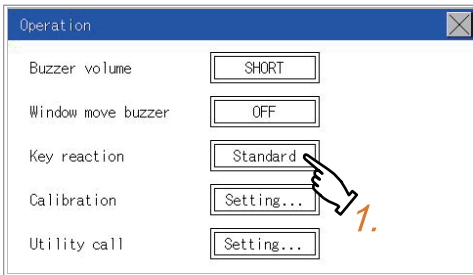

(For GT2104-P, GT2103-P)

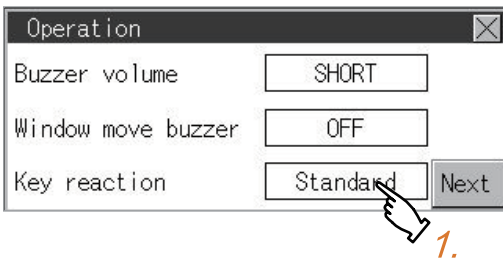

2. After changing the setting, touch the [×] button.

The setting is saved and the setting screen is closed.

*¹ The more the value set for [Key reaction] is high, the more the key reaction speed slows.

"Key reaction" [ms]	Standard (±0)	+10	+20	+40	+80	+120
---------------------	---------------	-----	-----	-----	-----	------

For example, when the GOT recognizes touching the GOT screen once as touching the screen twice, set a higher value for [Key reaction].

Position correction of the touch panel (touch panel calibration setting)

Touch panel calibration setting function

Touch panel reading error can be corrected.

Normally the adjustment is not required, however, the difference between a touched position and the object position may occur as the period of use elapses.

When any difference between a touched position and the object position occurs, correct the position with this function.

Before adjustment

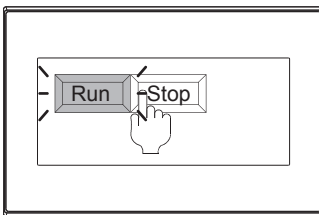

The [Run] will operate though you intended to touch the [Stop] button.

After adjustment

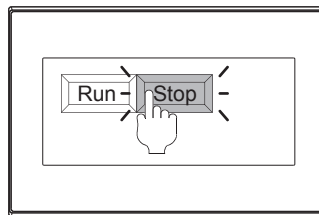

The [Stop] button can be touched without fail.

Touch panel calibration setting display operation

■For GT2107-W, GT2105-Q, GT2104-R

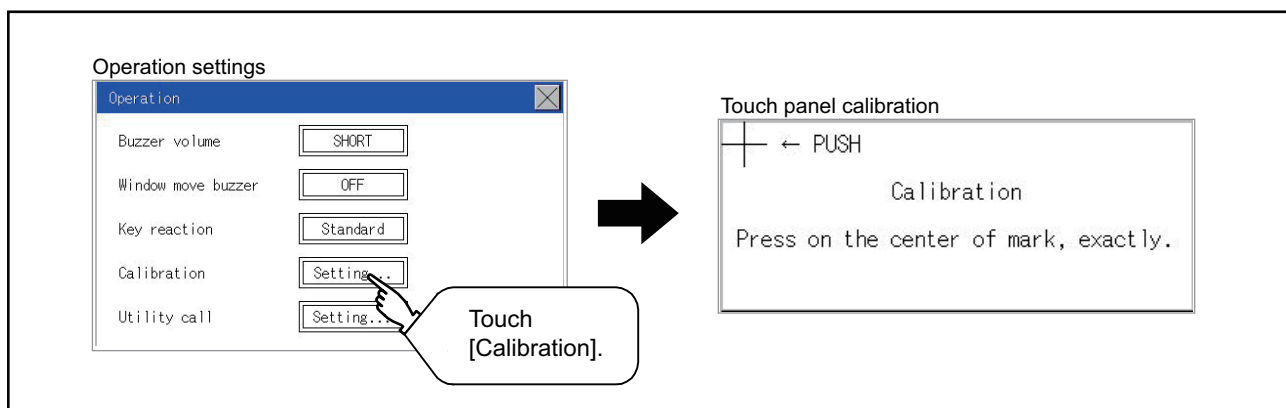

■For GT2104-P, GT2103-P

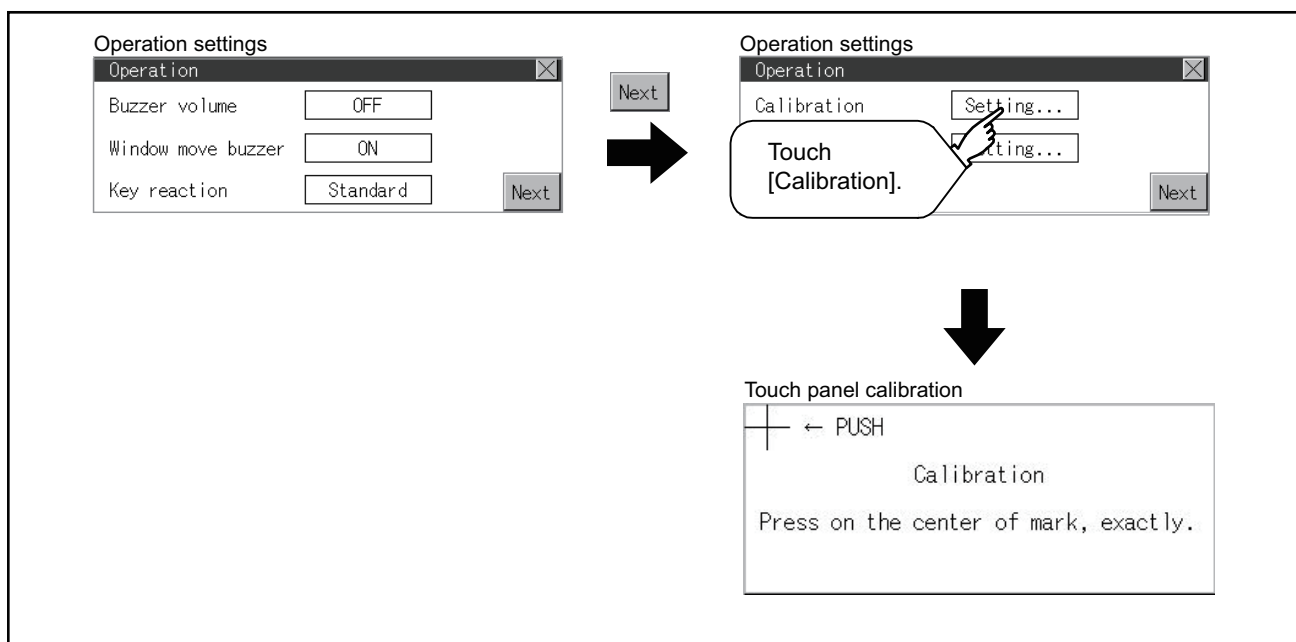

Touch panel calibration operation

Touch [+] displayed on the screen with the finger one by one to make the setting.

1. Touch the center of [+] displayed on the upper left precisely.

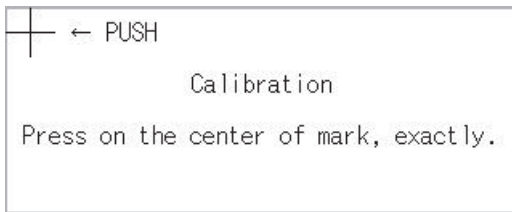

2. Touch [+] displayed on the lower left.

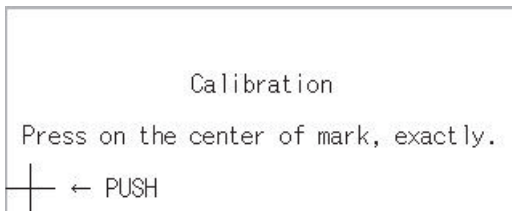

3. Touch [+] displayed on the upper right.

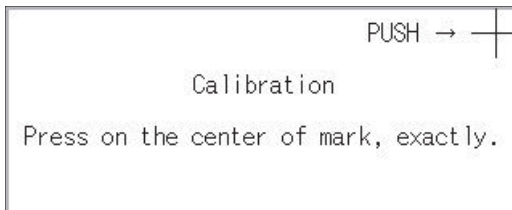

4. Touch [+] displayed on the lower right.

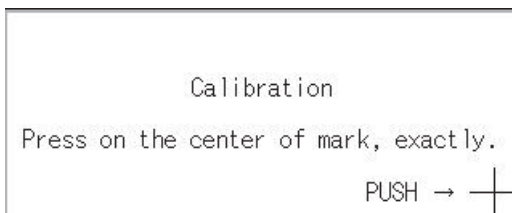

5. Step 4 completes the calibration process, and the [Operation] window will reappear.

Point

Touch panel calibration error

If touch panel calibration results in inoperability of the panel, the following message will appear.

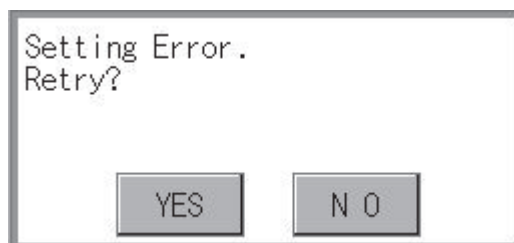

[YES] button: Returns to the touch panel calibration screen.

[NO] button: Aborts calibration without saving any changes to the touch panel setting.

Setting the utility call keys

Utility call key setting function

The key position for calling the main menu of the utility can be specified.

For the key position, the specification of 1 point from 4 corners on the screen, or no specification (0 point), can be set.

By keeping pressing the screen, a setting to switch the screen to the utility is available.

This prevents a switching to the utility by an unintentional operation.

Point

Operation setting by GT Designer3

Set the utility call key by selecting [Common] → [GOT Environmental Setting] → [GOT Setup...] from GT Designer3.

When change a part of the setting, change the setting by the GOT display setting after downloading the project data.

📖 GT Designer3 (GOT2000) Screen Design Manual

Utility call key display operation

■(For GT2107-W, GT2105-Q, GT2104-R)

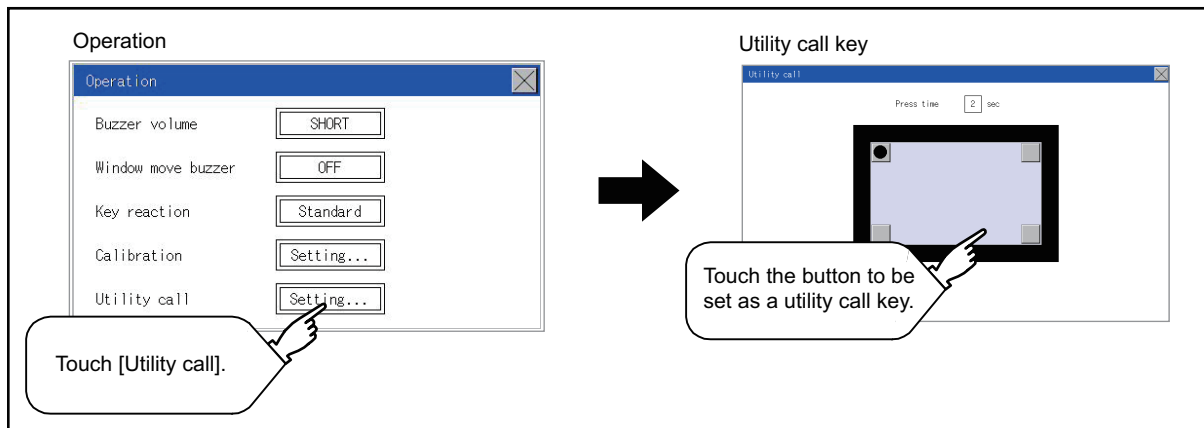

■(For GT2104-P, GT2103-P)

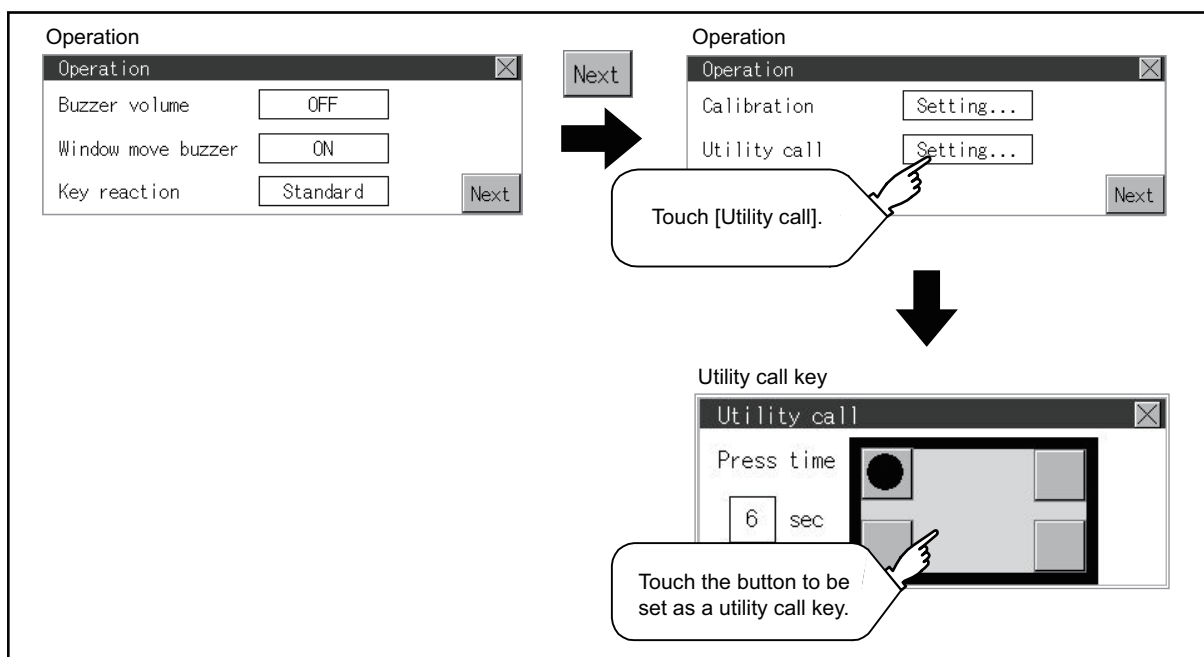

Utility call key setting operation

1. Touch or displayed at the four corners of the setting screen. The button repeats  every time it is pressed. Change the part to be set as a key position to .

For the key position, 0 or 1 point can be specified.

(For GT2107-W, GT2105-Q, GT2104-R)

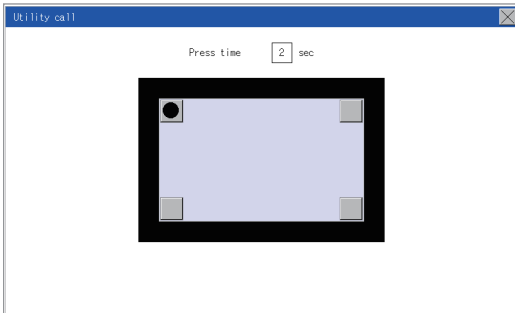

(For GT2104-P, GT2103-P)

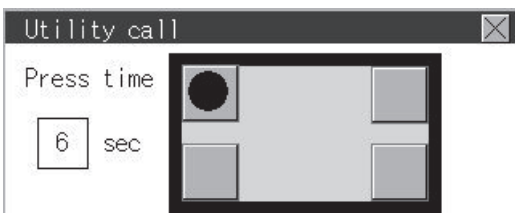

2. When setting 1 point, specify the time to switch to the utility in case of keeping pressing the key position.

Touch the time input area.

(For GT2107-W, GT2105-Q, GT2104-R)

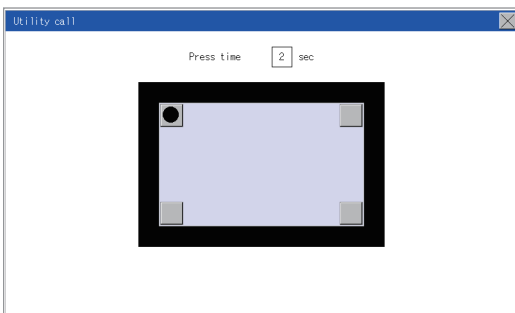

(For GT2104-P, GT2103-P)

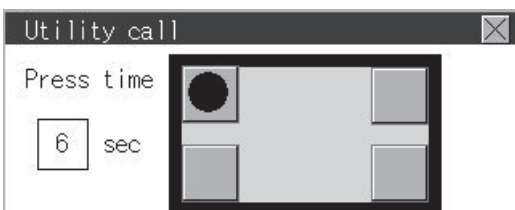

3. Touching the input area displays a keyboard. Input numeric with the keyboard.

4. Touch the [x] button to save the changes.

- When the utility call key is not set (set to 0-point)

Even when the utility call key is not set (set to the zero point), you can display the main menu by performing the following operation.

Pressing the special function switch set on the user-created screen

 Page 427 Display operation of main menu

- When limiting the display and operation of the utility

When limiting the display and operating users, set a password to the GOT using GT Designer3. If a user tries to display the main menu of the utility, the password is displayed.

Refer to the following for the details related to the password setting.

 GT Designer3 (GOT2000) Screen Design Manual

12.3 Inherent Information

Setting function for inherent information

Configure inherent information settings.

Item	Description	Setting range
GOT ID No.	Set the ID No. as the inherent information for the GOT.	0 to 32767 <Default: 0>

Display operation of inherent information

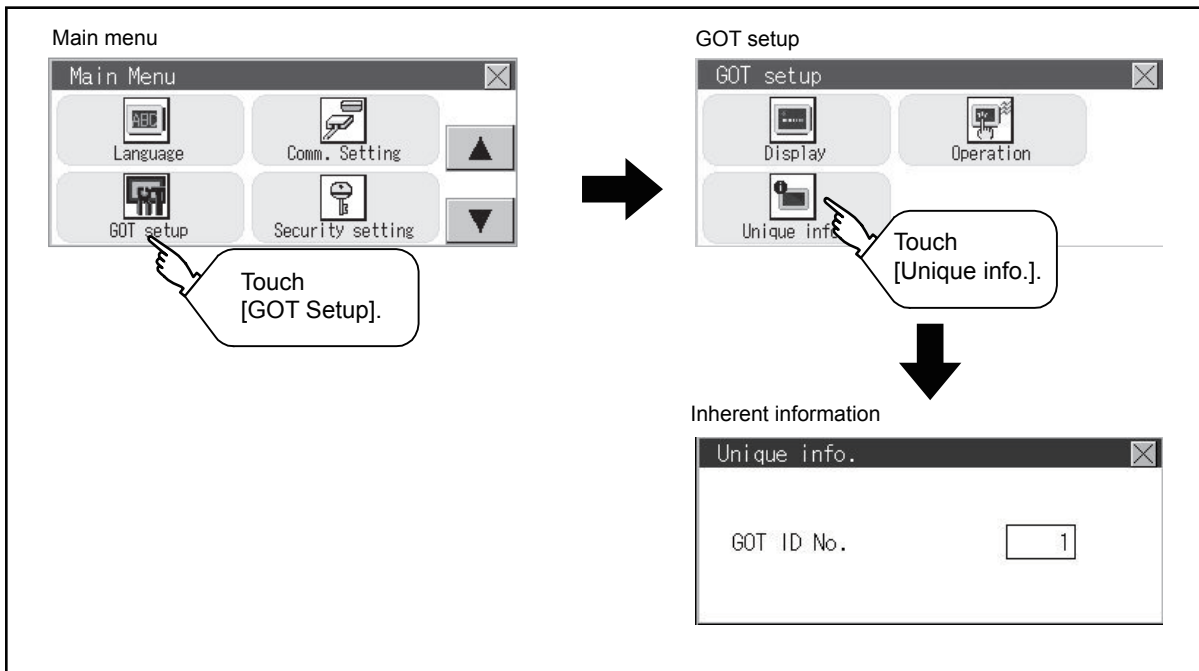

Setting operation for inherent information

1. If touching the setting items, keyboard is displayed. Input numeric with the keyboard.



2. If touching the [x] button, the GOT restarts and operates with the changed settings.

12.4 USB Host

Only available to GT2107-W.

USB host setting

To install and use the USB mouse/keyboard on the GOT, set the USB mouse/keyboard.

Item	Description	Setting range
Use USB mouse	Set whether to use a USB mouse.	YES/NO <Default: YES>
Interlock with mouse cursor touch operation	The mouse cursor can be moved to the touched position.	YES/NO <Default: YES>
Use USB keyboard/barcode	Set whether to use a USB keyboard/barcode.	Use/Disuse <Default: Disuse>
USB keyboard type	Set the USB keyboard type.	Japanese 106 keyboard/English 101 keyboard <Default: Japanese 106 keyboard>

Display operation of the USB host setting

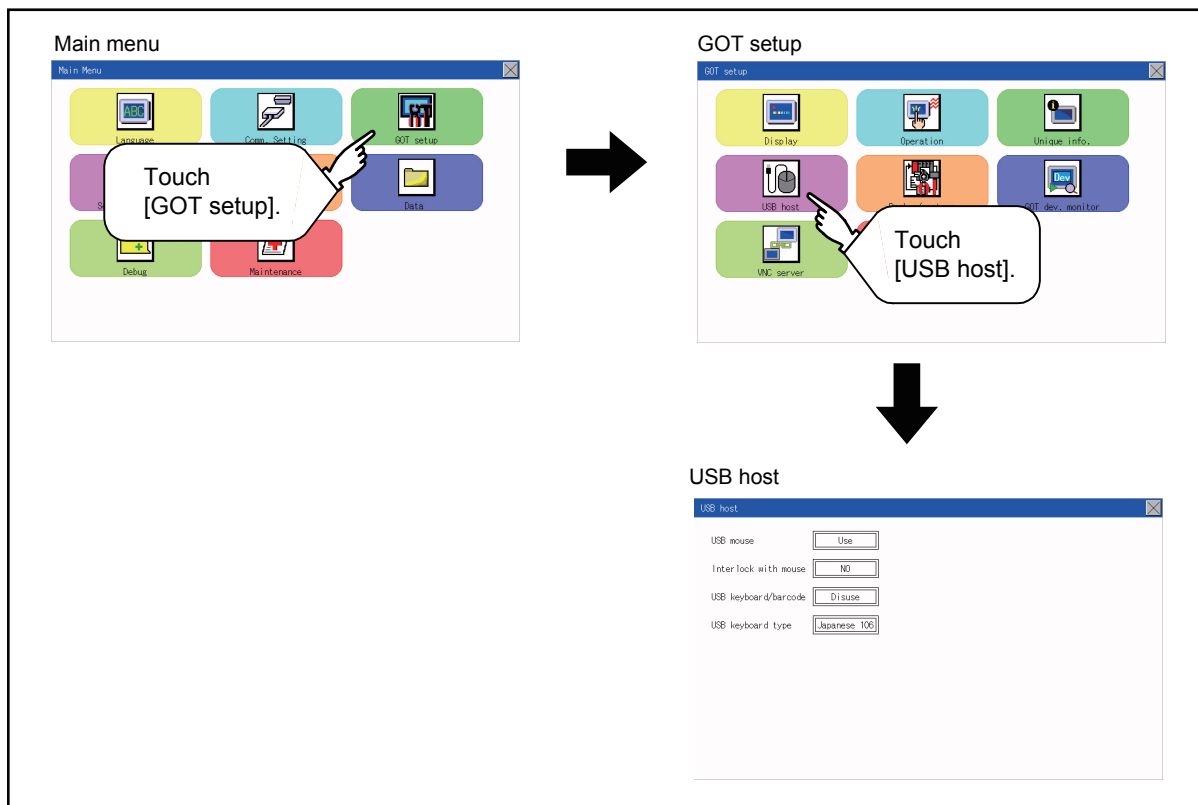

Setting operation of USB host

1. To use a USB mouse, touch the current selection of [USB mouse].
The setting content is changed by touching.

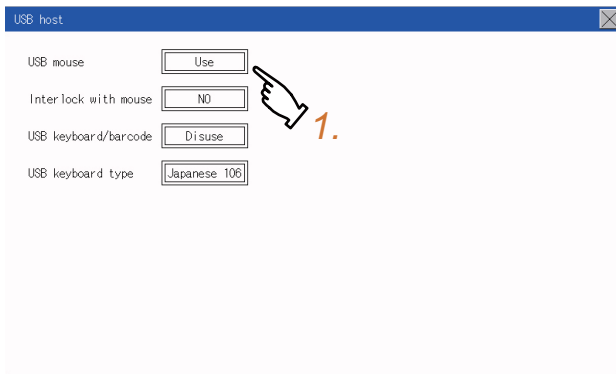

2. To move the mouse cursor to a touched position, touch the current selection of [Interlock with mouse].
The setting content is changed by touching.

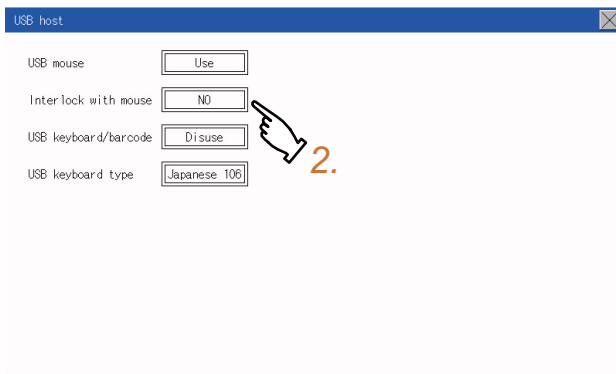

3. To use a USB keyboard or a USB barcode reader, touch the current selection of [USB keyboard/barcode].
The setting content is changed by touching.

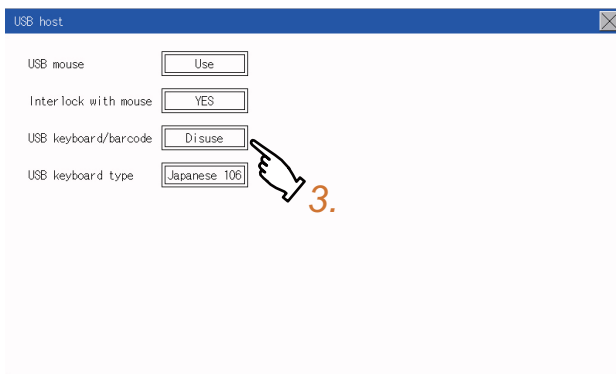

- 4.** To use the USB keyboard, touch the setting item of [USB keyboard type].
The setting content is changed by touching.

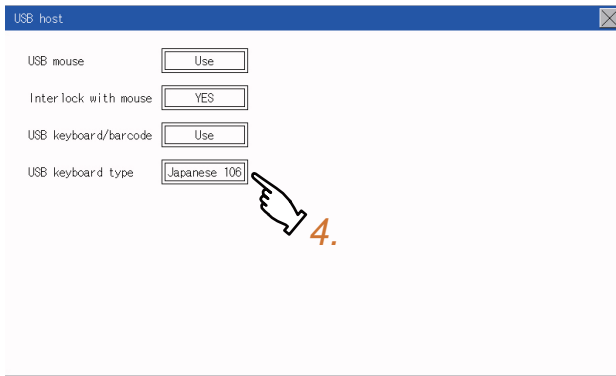

- 5.** Touch the [x] button to apply the new setting and close the setting screen.

12.5 Setting the storage location for backup and restoration

Backup/restoration setting

Only available to GT2107-W.

The save destination for backup setting and backup data is settable.

For how to use the backup/restoration, refer to the following.

☞ Page 614 Backup and Restoration

Set the following items with touching the items on the GOT.

Item	Description	Setting range
Drive for backup setting	The drive for storing backup settings, including parameters and passwords for controllers, can be selected.	A: SD card E: USB Drive X: Drive <Default: X: Drive>
Drive for backup data	The drive for storing backup data can be selected.	A: SD card E: USB Drive X: Drive <Default: X: Drive>

Display operation for setting the storage location for backup and restoration

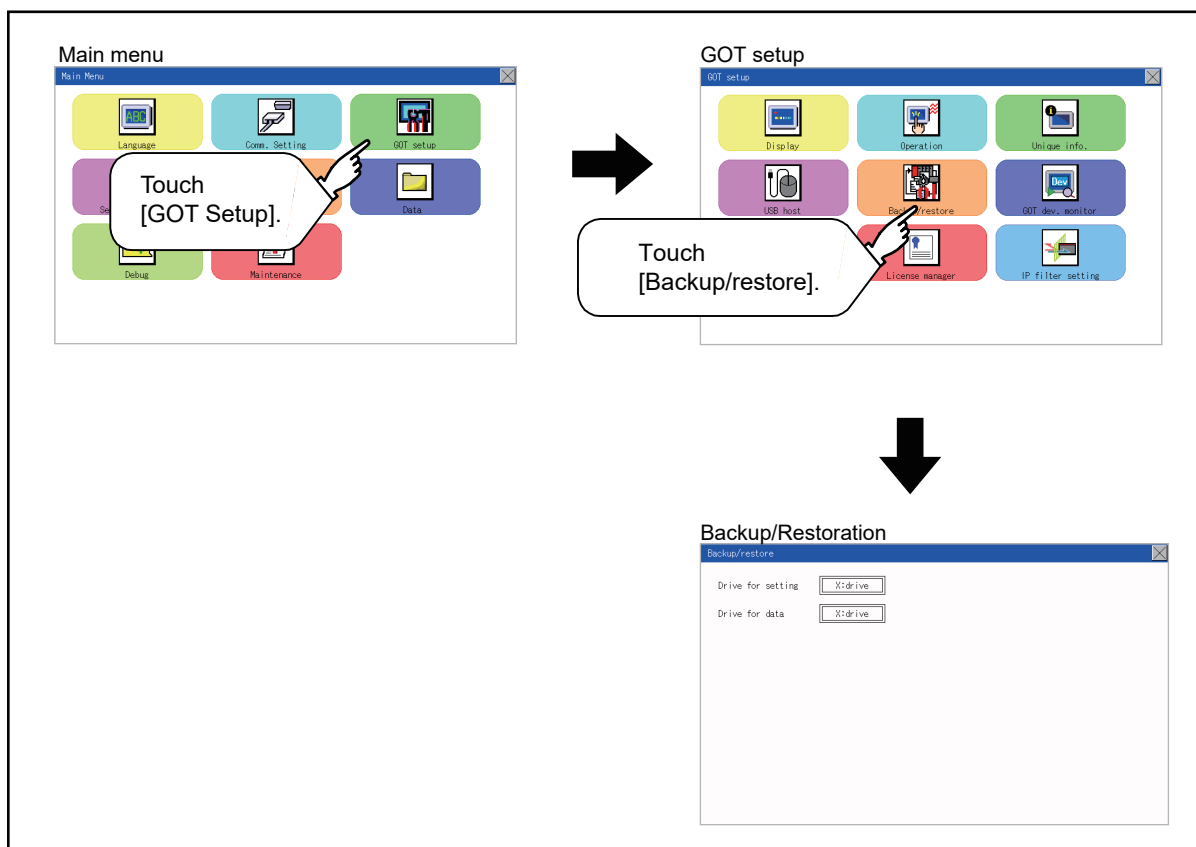

Backup/restoration setting operation

Drive for backup setting, drive for backup data

1. If touch the setup item, the setup contents are changed.

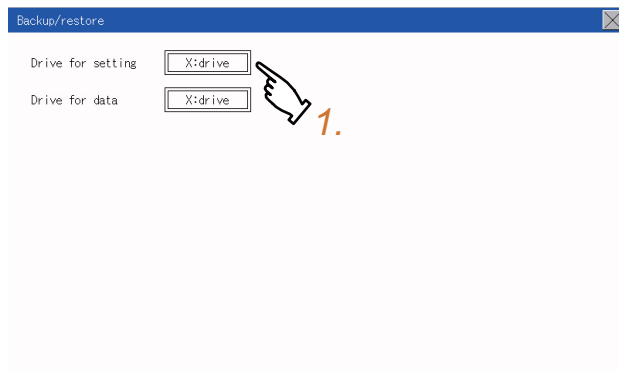

2. Touch the [x] button to apply the new setting and close the setting screen.

12.6 GOT Internal Device Monitor

Setting the GOT internal device monitor

Set whether to Use/Disuse the GOT internal device monitor of GOT diagnostics.

The following explanation uses GT2104-R as an example.

Item	Description	Setting range
GOT dev. monitor	Set whether to Use/Disuse the GOT internal device monitor of GOT diagnostics.	Disuse/Use <Default: Disuse>
GOT device change	Set whether to Allow/Forbid the GOT internal devices to be changed.	Forbid/Allow <Default: Forbid>

GOT internal device monitor display operation

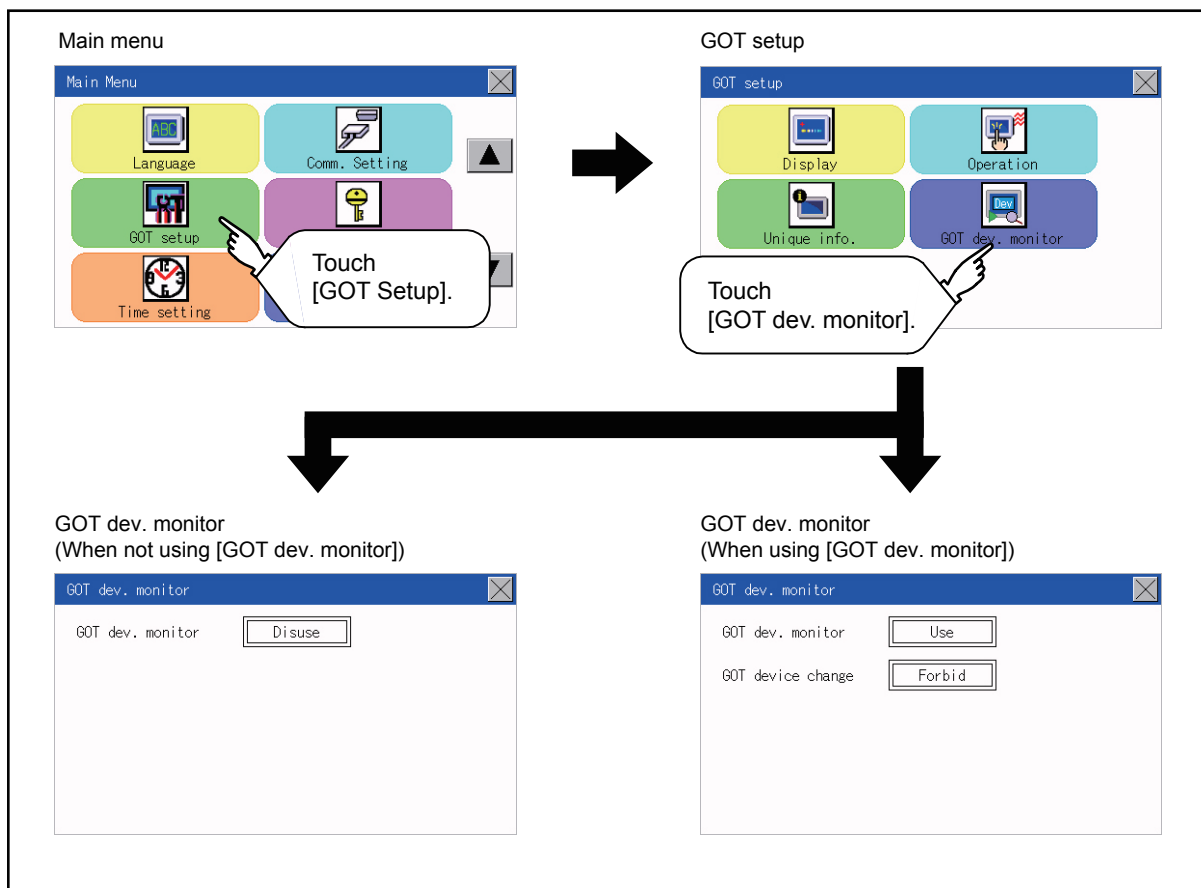

GOT internal device monitor setting operation

1. When using the GOT internal device monitor of GOT diagnostics, touch the setting item and set [Use].

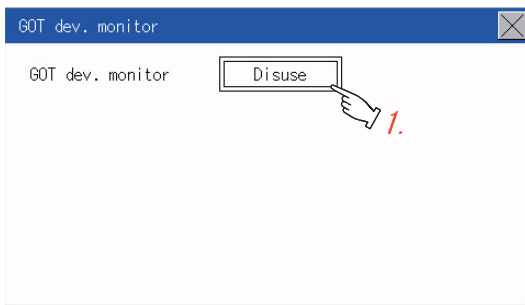

2. When allowing the GOT internal devices to be changed, touch the setting item of [GOT device change] and set [Allow].

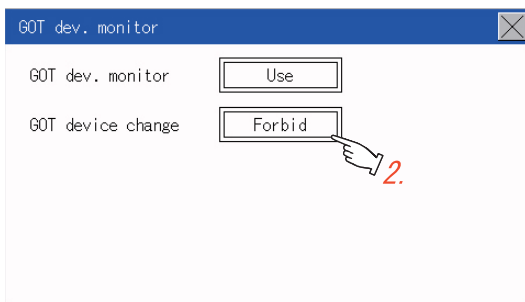

3. After changing the settings, touch the [×] button to save the changes and close the setting window.

12.7 VNC Server Function

Only available to GT2107-W.

VNC server function setting

In the VNC server function setting, the authorization guarantee time for the VNC server function can be set.

For the details of the VNC server function, refer to the following.

📖 GT Designer3 (GOT2000) Screen Design Manual

Item	Description	Setting range
Operating priority guaranteed time	The time that the authorized equipment holds the authorization after you operate the authorized equipment can be set. (The unauthorized equipment cannot obtain the authorization until the set time elapses.)	0 to 3600 seconds <At factory shipment: 0 seconds>

Point

- Authorization guarantee time cancel signal (GS1792.b8)

When the Authorization guarantee time cancel signal (GS1792.b8) turns on, the authorization guarantee time setting is disabled.

- Relationship with the GOT network interaction function setting

The VNC server function setting is independent of the GOT network interaction function setting.

Both of the settings are enabled.

Display operation of the VNC server function setting

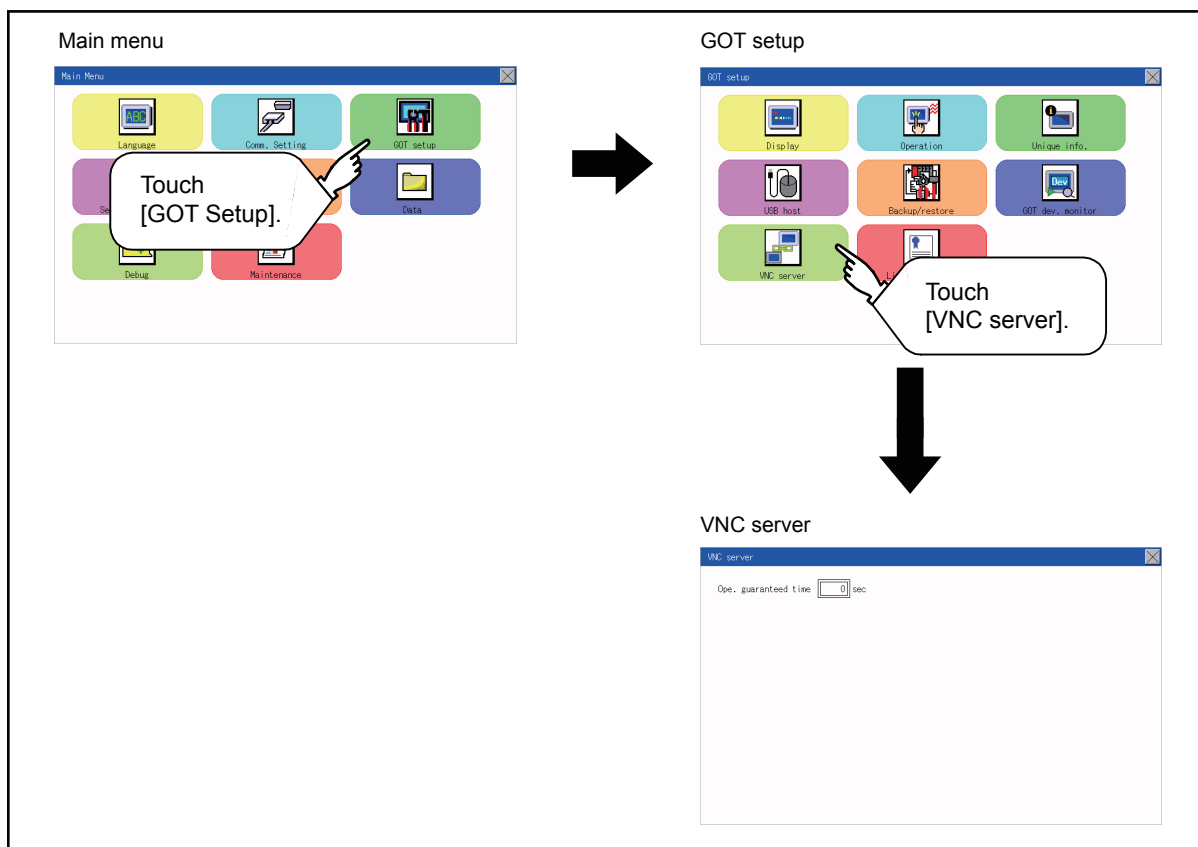

VNC server function setting operation

Operating priority guaranteed time

1. Touch the input field for [Ope. guaranteed time] to display a keyboard.
Input the authorization guarantee time with the keyboard.

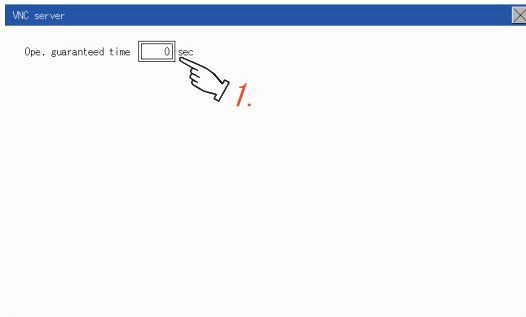

2. Touch the [x] button to apply the new setting and close the setting screen.

12.8 License Management

Only available to GT2107-W.

License management setting

To use functions which require a license, register the license to the GOT.

To delete the license registered to the GOT, perform the operation also on the license management screen.

Item	Description	Setting range
VNC server function	Register or delete the license for the VNC server function.	-

You can register or delete licenses for the VNC server function.

For details on the VNC server function, refer to the following.

📖 Page 510 VNC Server Function

Display operation of the license management setting

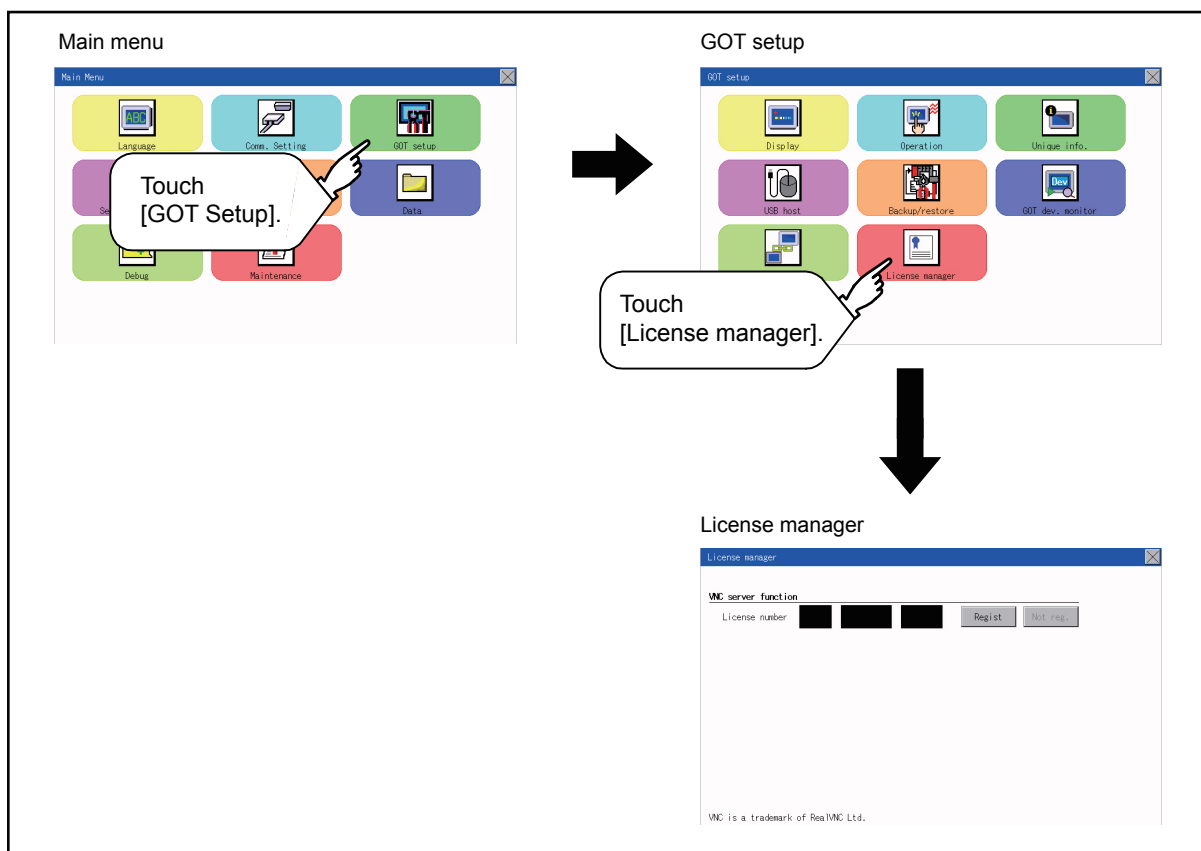

Setting operation of license management

When registering a license number for the GOT

1. Touch the license number input area on the license management screen, and then the keyboard appears on the bottom of the screen.



2. Touch the [Regist] button to register the input license number.
If the [×] button is touched without touching the [Regist] button, the license number is not registered.
3. After a license number is registered, touch the [×] button to close the license management screen.

When unregistering a license number for the GOT

1. Touch the [Cancel reg.] button to release the registered license number.

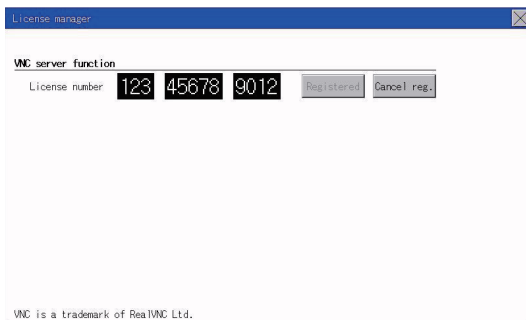

2. Touch the [×] button to close the license management screen.



How to obtain a license number

For how to obtain a license number, consult your local sales office.

12.9 IP filter setting

IP filter setting

IP addresses from which access to the GOT is allowed or blocked can be set.

Not available to GT2105-Q.

For the details of the IP filter setting, refer to the following.

GT Designer3 (GOT2000) Screen Design Manual

Item	Description	Setting range
IP filter usage	You can set whether to use or not the IP filter function.	Yes/No <Default: No>
Transmit/Block	You can set whether to allow or block access from the IP addresses specified in [IP address setting]. <ul style="list-style-type: none"> If [Transmit] is selected Access from the IP addresses that are set for [Target IP address] is blocked. If [Block] is selected Access from the IP addresses that are set for [Target IP address] is blocked. Access from the IP addresses that are set for [Exception IP address] is disallowed.	Transmit/Block <Default: Transmit>
IP address setting	Range	You can set whether to register IP addresses by specifying a range. To specify a range, set the start IP address and the end IP address for [Target IP address].
	Target IP address	You can set IP addresses or IP address ranges to be filtered. Up to 4 ranges can be set.
	Exception IP address	This item can be set only when [Range] is selected. For an IP address range specified in [Target IP address], set IP addresses excluded from being filtered. Up to 16 addresses can be set for one range specified in [Target IP address].

*1 Leave the boxes blank if you do not set any IP addresses.

Display operation of the IP filter setting

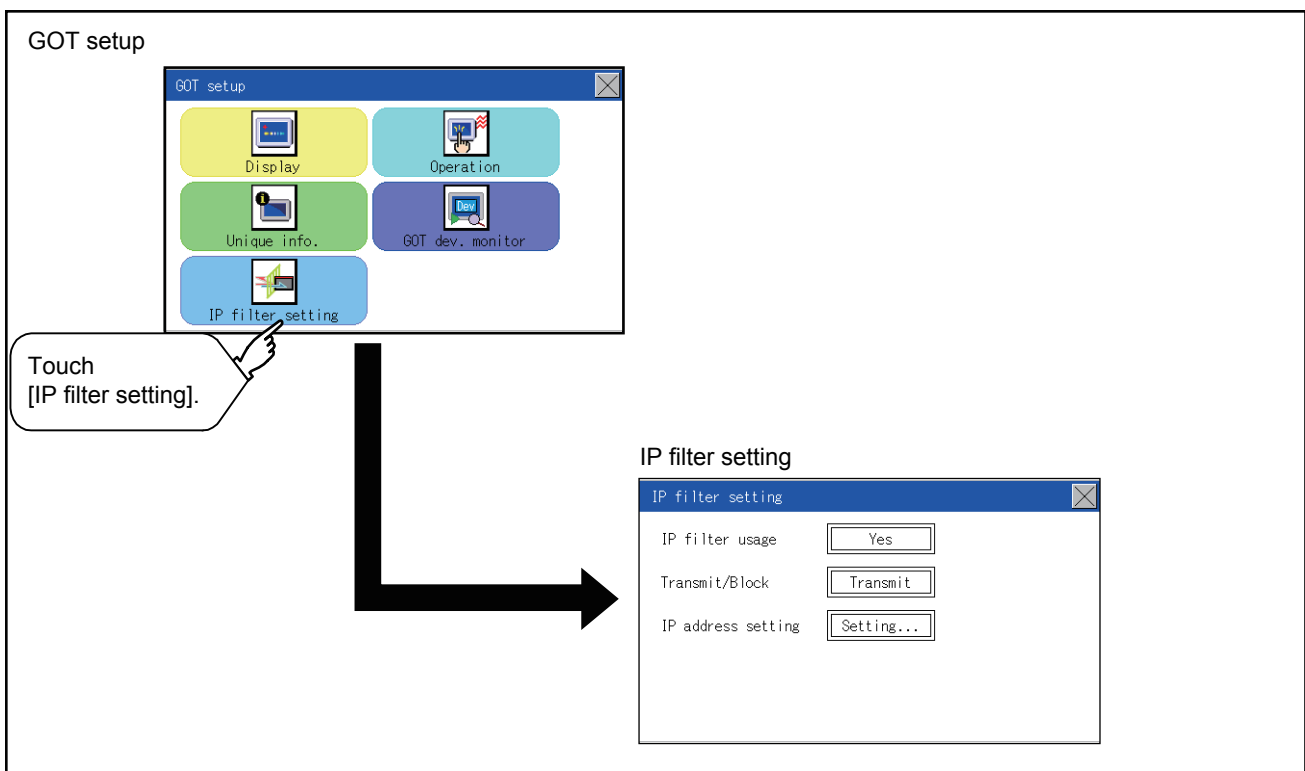

Setting procedure for the IP filter

Setting the IP filter

1. Select [Yes] for [IP filter usage] by touching the current selection.

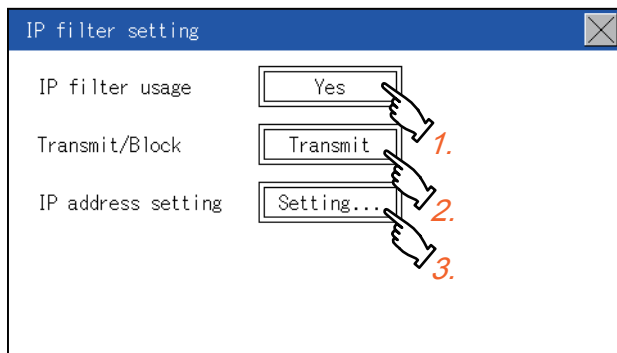

2. Select [Transmit] or [Block] for [Transmit/Block] by touching the current selection.

3. Touch the [Setting] button of [IP address setting] to display the [IP address setting] screen.

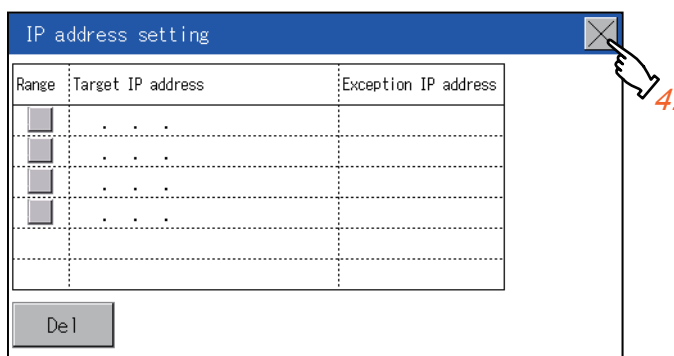

Refer to the following, and set an IP address.

☞ Page 516 Adding a target IP address

☞ Page 517 Deleting a target IP address

☞ Page 518 Specifying IP address ranges

☞ Page 519 Setting exception IP addresses

4. After configuring the settings, touch the [x] button to display the [IP filter setting] screen.

5. Touch the [x] button to display the following screen.

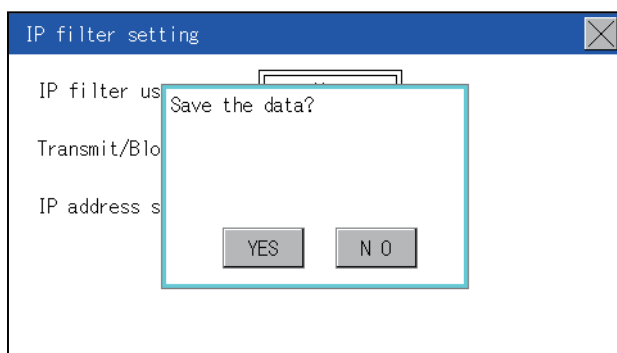

6. Touch the [YES] button to restart the GOT and reflect the setting.

To cancel the new settings, touch the [NO] button to return to the [GOT setup] screen.

■ Adding a target IP address

1. Touch a target row to select it.

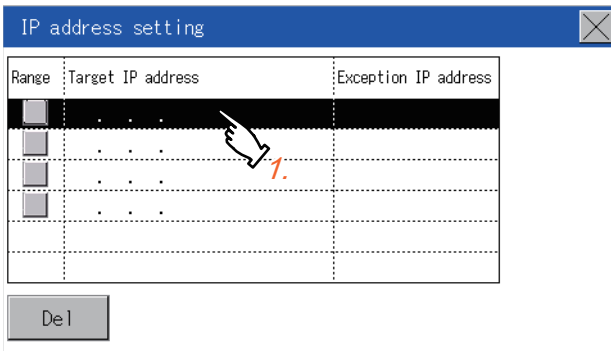

2. Touch the same row again to display the following screen.

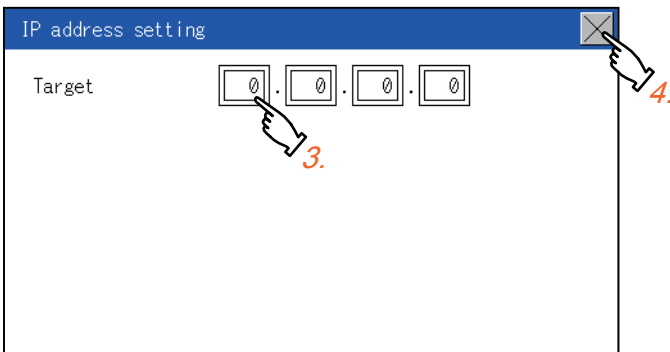

3. Touch a number to display a software keyboard.
Input an IP address to be added.
4. Touch the [×] button to display the previous screen.

■Deleting a target IP address

1. Touch a target row to select it.

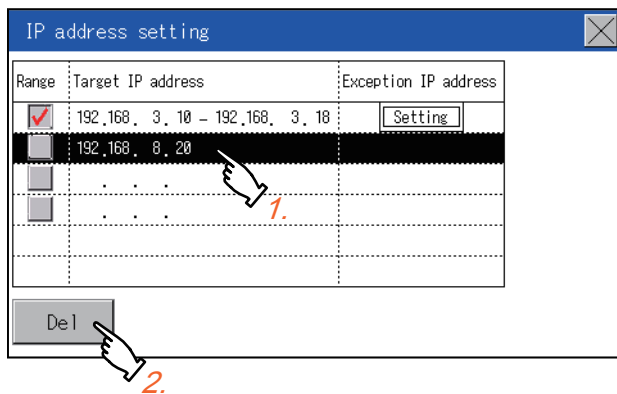

2. Touch the [Del] button to display the following screen.

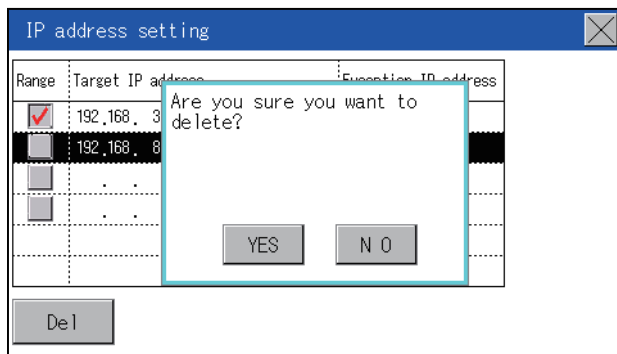

3. Touch the [YES] button to delete the selected IP address.

To cancel the deletion and return to the previous screen, touch the [NO] button.

■Specifying IP address ranges

1. Touch a checkbox in [Range] to select the row.

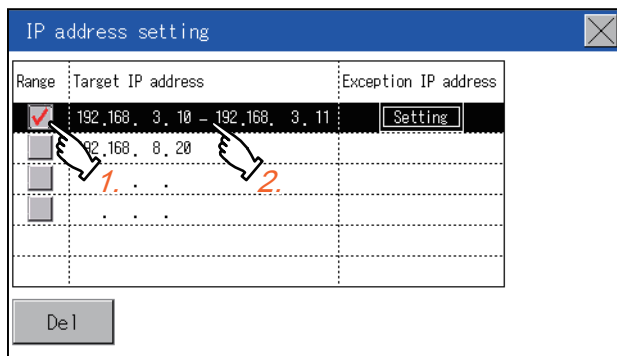

2. Touch the same row again to display the screen shown below.

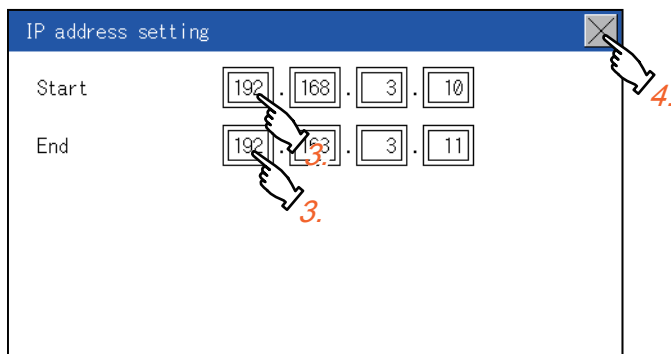

3. Touch a number to display a software keyboard. Input the start IP address and end IP address of the range to be filtered.
4. Touch the [x] button to display the previous screen.

■Setting exception IP addresses

[Exception IP address] can be set only when [Range] is selected.

1. Select a target row, and touch the [Setting] button.

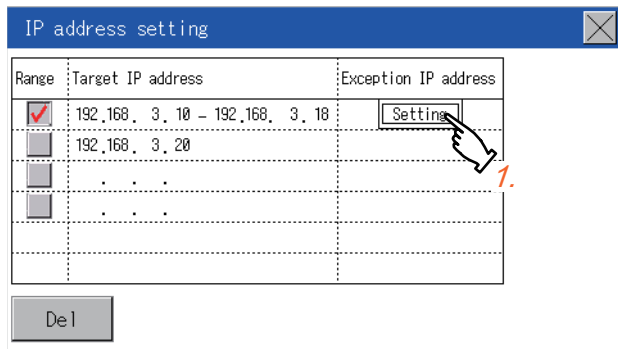

2. Touch a target row to select it.

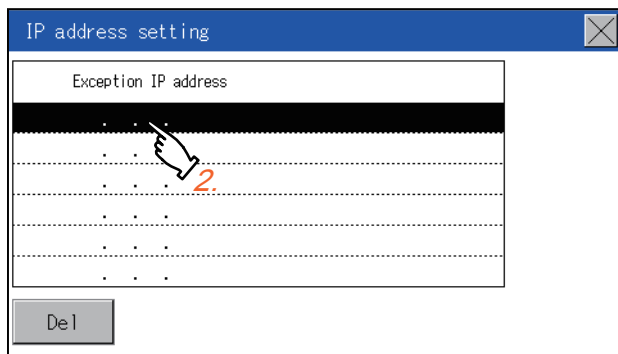

3. Touch the same row again to display the screen shown below.

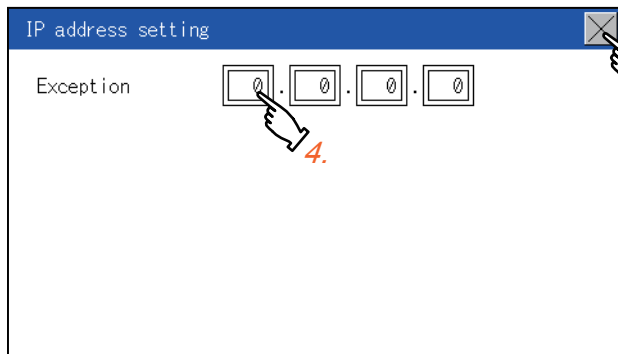

4. Touch a number to display a software keyboard. Input an exception IP address.

5. After completing the entry, touch the [×] button.

6. On the displayed screen, touch the [×] button to display the previous screen.

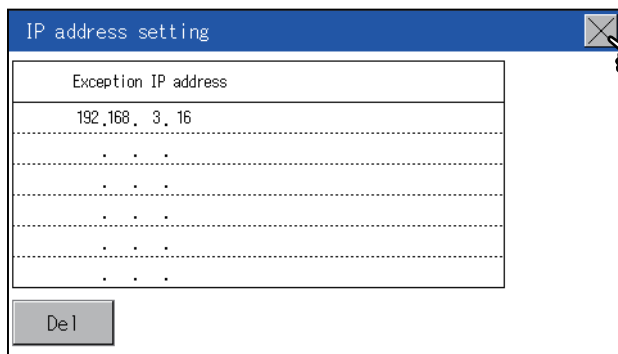

13 SECURITY LEVEL AND OPERATOR SETTINGS

Page 521 Security Level Authentication

Page 523 Operator Authentication

Page 536 Login/Logout

13.1 Security Level Authentication

Security level change functions

Changes the security level to the same security level set by each object or screen switch.

To change the security level, enter the password for the security level set with GT Designer3.

GT Designer3 (GOT2000) Screen Design Manual

13

Point

Restrictions on screen display

The security level change screen cannot be displayed when project data do not exist in GOT.

Change the security level after downloading the project data to GOT.

Display operation of security level change

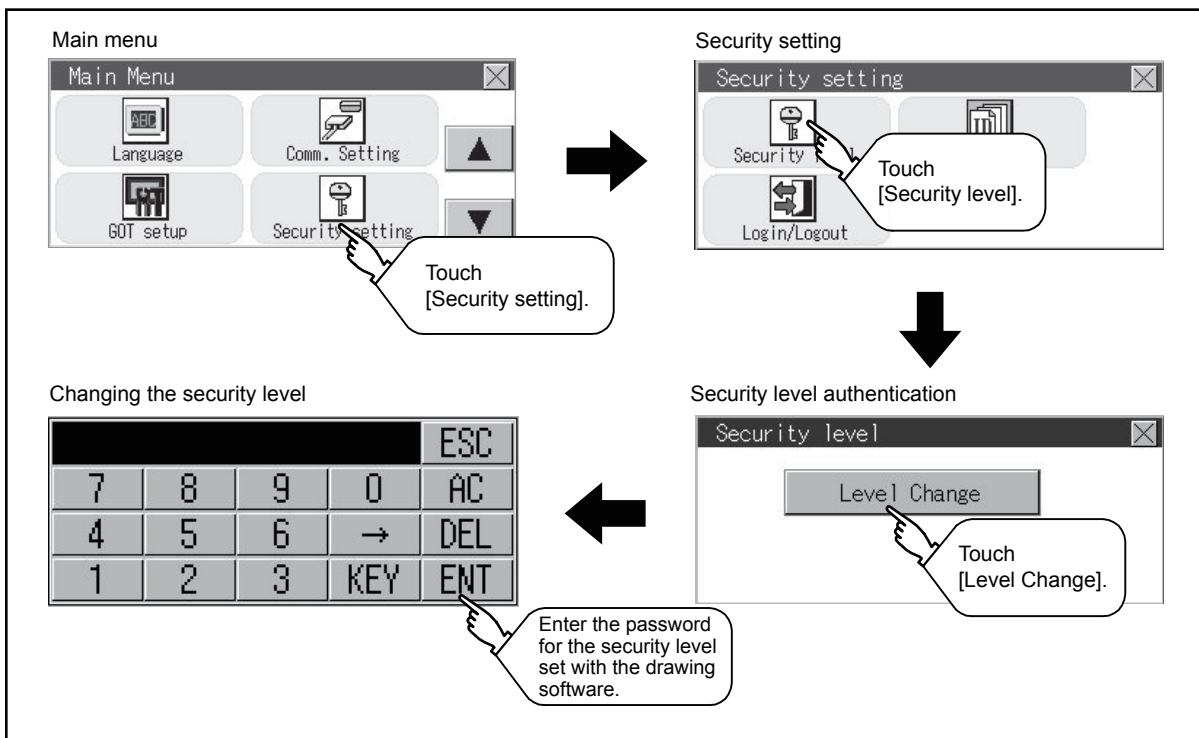

Security level change operation

■Input operation of password

1. By touching [0] to [9], [A] to [F] key, the password of the changed security level is input. Character types to be input can be changed by touching the [KEY] button.

				ESC
7	8	9	0	AC
4	5	6	→	DEL
1	2	3	KEY	ENT

2. When correcting the input character, touch [Del] key to delete the correcting character and input the password again.
3. After inputting password, touch the [Enter] key.

When the password is not matched, displays the error message.



4. If [OK] button is touched it returns to the password input screen again.
5. If the [x] button is touched, it returns to the security setting screen.

Point

About forgetting to return to the original level after changing security level temporarily

When use GOT after temporarily changing the security level, do not forget to return the security level to the original level.

13.2 Operator Authentication

Operator information management

Operator management

■Operator management function

The function enables displaying a list of the operator information and adding, changing, or deleting the operator information to be used.

A password for operator authentication can be changed when the password is out of date.

Functions for the operator authentication (automatic logout time, authentication method, password expiration date, etc.) can be set.

For details on the operator authentication function, refer to the following.

📖 GT Designer3 (GOT2000) Screen Design Manual

Function	Description	Reference page
Operator management	Enables adding, editing, deleting, importing, and exporting the operator information.	📖 Page 523 Operator management function 📖 Page 526 Operator management operation
Add	Add operator information to the GOT.	📖 Page 527 Add operation
Edit	Edit the operator information stored in the GOT.	📖 Page 529 Edit operation
Delete	Delete the operator information stored in the GOT.	📖 Page 530 Deletion operation
Import	Import the operator information that is already exported to an SD card to the GOT.	📖 Page 530 Import operation
Export	Export the operator information stored in the GOT to an SD card.	📖 Page 531 Export operation
Password change	Enables changing passwords to be used for login and logout in/out of the GOT.	📖 Page 532 Password change
Function setting	Enables setting the automatic logout time and password expiration date.	📖 Page 534 Function setting

■Display operation of operator management

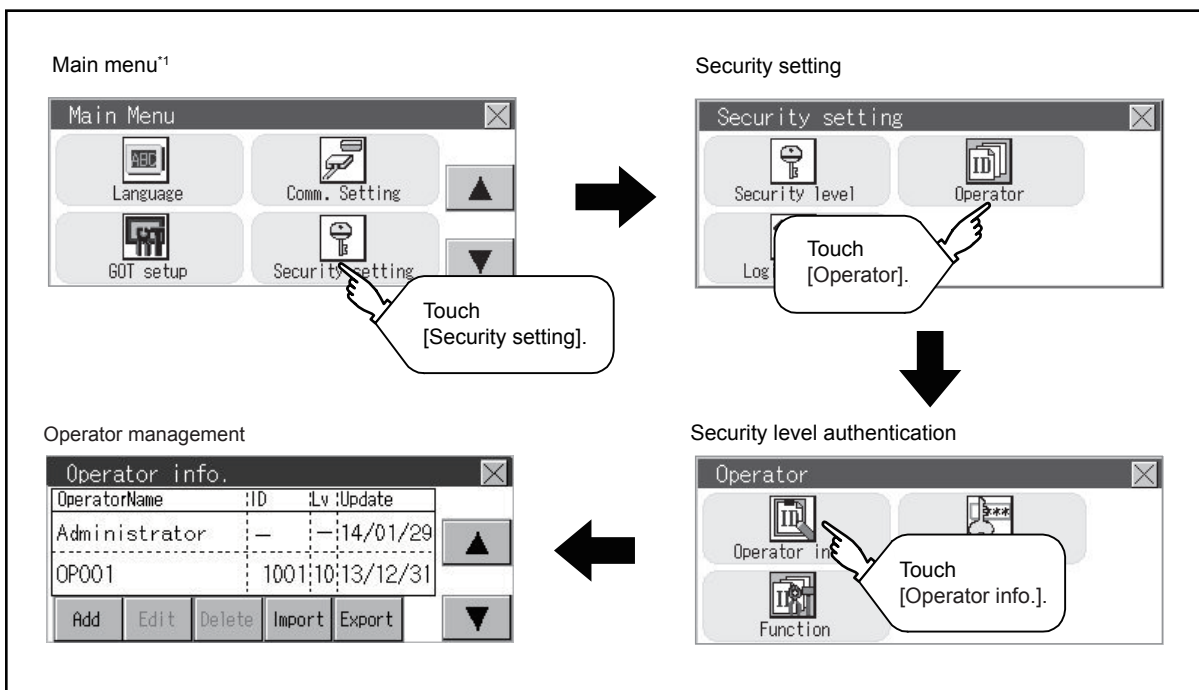

*1 Refer to the following for display operation of main menu.

📖 Page 425 Utility Display

■ Display example of operator management

- Operator information management screen

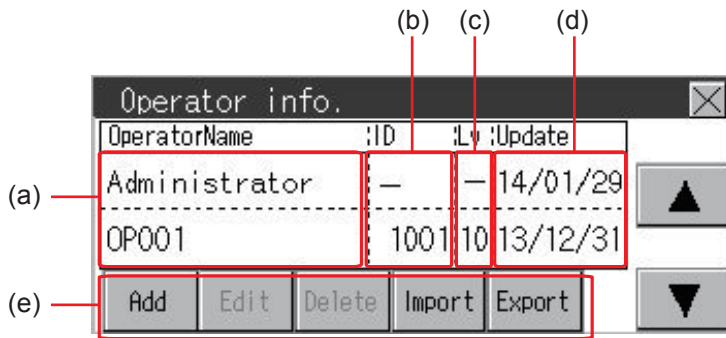

No.	Item	Description
(a)	Operator Name	Displays operator names.
(b)	ID	Displays operator IDs.
(c)	Lv	Displays security levels for operators.
(d)	Update	Displays the last updated dates of the operator information.
(e)	Operation keys	Execution keys for each function

- Operator information edit screen

Touch the [Add] button or touch the [Edit] button with the operator information selected on the Operator information management screen, and then the Operator information edit screen is displayed.

The operator information can be edited.

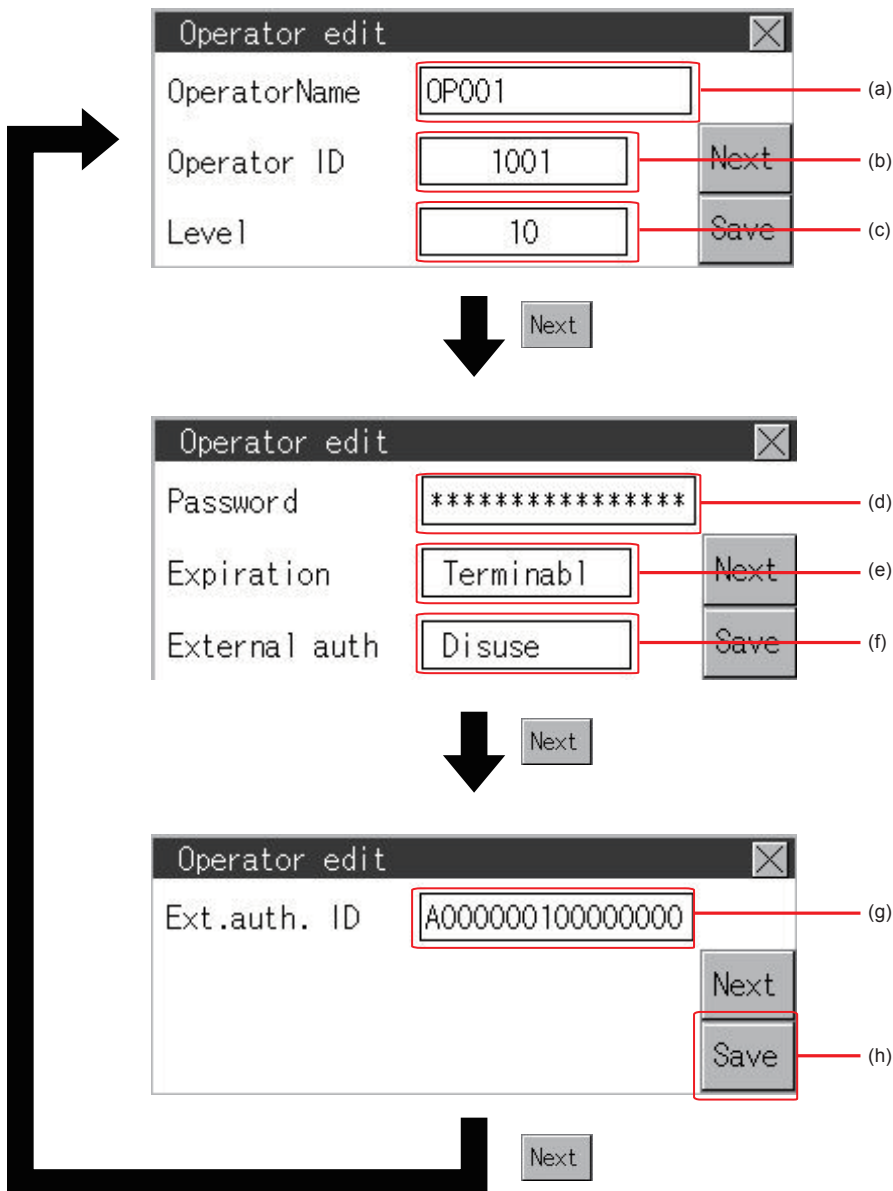

No.	Item	Description
(a)	Operator Name	The operator name to be edited is displayed or input an operator name to be added. (Up to 16 alphanumeric characters)
(b)	Operator ID	The operator ID to be edited is displayed or input an operator name to be added. (Setting range: 1 to 32766, Maximum number of registrations: 255)
(c)	Level	Displays the security level for the operator or input the security level for an operator to be added. (0 to 15)
(d)	Password	Input a password. (Up to 16 alphanumeric characters)
(e)	Expiration	Switches the setting of the item disabled and enabled.
(f)	External auth	Switches whether to use or not to use the external authentication.
(g)	Ext.auth. ID	Displays the external authentication ID in hexadecimal or input an external authentication ID in hexadecimal. The setting range is 4 to 32 alphanumeric characters from A to F and 0 to 9.
(h)	Save	Saves the setting.

■Operator management operation

1. Touch [Operator] → [Operator info].



2. The Admin password authentication screen is displayed, and then input the administrator password.

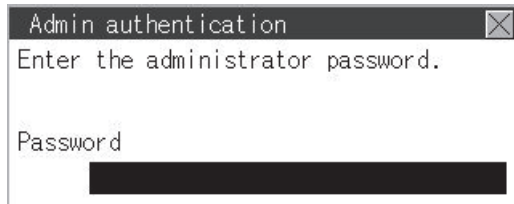

Character types to be input can be changed by touching the [KEY] button.

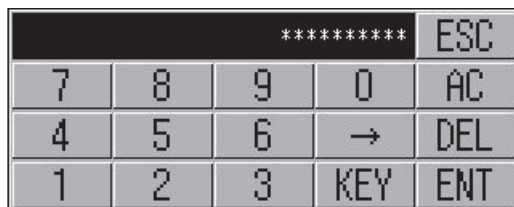

When the input is completed, touch the [Enter] key.

3. When the administrator password is correctly input, the Operator information management screen is displayed.

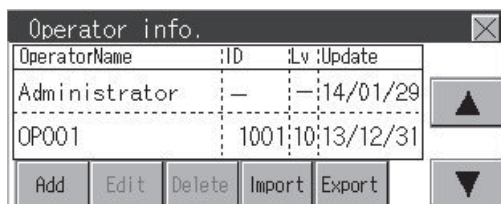

For operation of operating switches, refer to the following.

[Add]

☞ Page 527 Add operation

[Edit]

☞ Page 529 Edit operation

[Delete]

☞ Page 530 Deletion operation

[Import]

☞ Page 530 Import operation

[Export]

☞ Page 531 Export operation

4. Touching the [x] button displayed on the upper right returns to the previous screen.

■Add operation

Add operator information to the GOT.

1. Touch the [Add] button.

OperatorName	ID	Lv	Update
Administrator	-	-	14/01/29
OP001	1001	10	13/12/31

Buttons: Add, Edit, Delete, Import, Export, Up Arrow, Down Arrow

2. The Operator information edit screen is displayed. Touch the [Next] switch to display an item to be edited, and touch the item.

OperatorName: OP001
Operator ID: 1001
Level: 10

Buttons: Next, Save

1)Operator Name

If the operator name is touched, a keyboard is displayed. Input an operator name with the keyboard.

				ESC
7	8	9	0	AC
4	5	6	→	DEL
1	2	3	KEY	ENT

Character types to be input can be changed by touching the [KEY] button.

When the input is completed, touch the [ENT] key.

2)Operator ID

If the operator ID is touched, a keyboard is displayed. Input an operator ID.

Character types to be input can be changed by touching the [KEY] button.

When the input is completed, touch the [ENT] key.

3)Level

If the level is touched, a keyboard is displayed. Input an operator level.

Character types to be input can be changed by touching the [KEY] button.

When the input is completed, touch the [ENT] key.

When the level of the logged-in operator is changed during editing of the operator information, a new level is not reflected until you log out of the GOT once and log in the GOT again.

4) Password

For changing passwords during editing, touch the password. A keyboard is displayed, and then input a password.

When the input is completed, touch the [ENT] key.

When the password input is completed, the New password input confirmation dialog box is displayed. Input the same password.

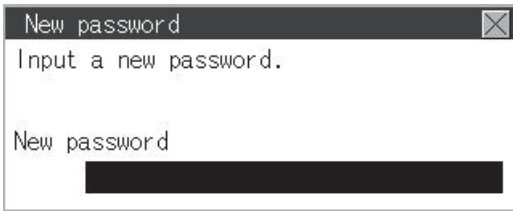

A dialog box titled "New password" with a close button (X) in the top right corner. The text "Input a new password." is displayed. Below it, the label "New password" is followed by a blacked-out input field.

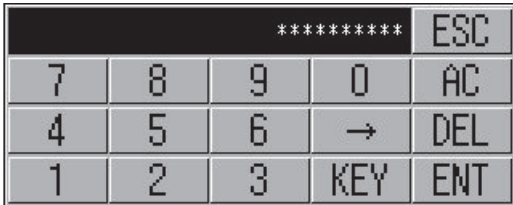

An on-screen keyboard with a top row containing "*****" and "ESC". The main grid consists of three rows of five keys each: Row 1: 7, 8, 9, 0, AC; Row 2: 4, 5, 6, →, DEL; Row 3: 1, 2, 3, KEY, ENT.

5) Expiration

For switching the setting of [Make a permanent password], touch the [Expiration] dialog box to switch the setting.

[Terminable] ↔ [Permanent]

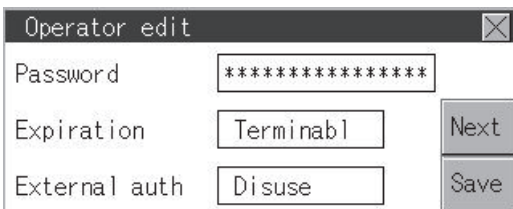

The "Operator edit" dialog box with a close button (X). It contains three input fields: "Password" (masked with *****), "Expiration" (set to "Terminabl"), and "External auth" (set to "Disuse"). To the right of the "Expiration" field is a "Next" button, and to the right of the "External auth" field is a "Save" button.

6) External auth

To use the external authentication, touch the [External auth] dialog box to switch the setting.

[Use] ↔ [Disuse]

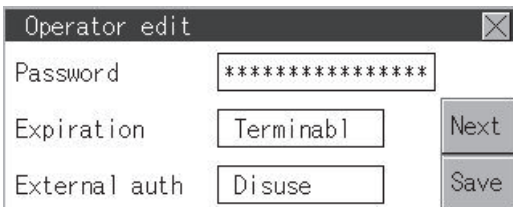

The "Operator edit" dialog box with a close button (X). It contains three input fields: "Password" (masked with *****), "Expiration" (set to "Terminabl"), and "External auth" (set to "Disuse"). To the right of the "Expiration" field is a "Next" button, and to the right of the "External auth" field is a "Save" button.

7) Ext. auth. ID

Touch the external authentication ID dialog box to display the ten-key pad for inputting hexadecimal numbers, and input an external authentication ID. When the input is completed, touch the [Enter] key.

When the authentication method is set to the external authentication, an external authentication ID can also be input using an external authentication device.

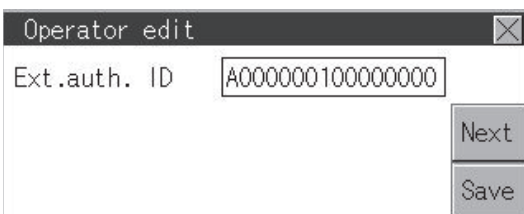

The "Operator edit" dialog box with a close button (X). It contains one input field: "Ext.auth. ID" (containing "A000000100000000"). To the right of the input field are "Next" and "Save" buttons.

3. When the [Save] button is touched after all items are input, the input operator information is saved. Touching the [X] button displayed on the upper right returns to the previous screen.

Saving the setting

When the [x] button is touched before the [Save] button is touched, the setting contents are not saved and the screen returns to the previous one.

To save the setting contents, always touch the [Save] button.

■ Edit operation

Edit the operator information stored in the GOT.

1. Select the operator information to be edited with touching the operator information.

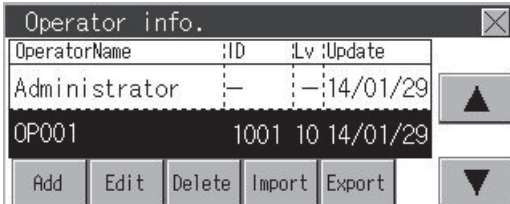

2. Touch the [Edit] button.

3. The Operator information edit screen is displayed. Touch the [Next] switch to display an item to be edited, and touch the item.

- (a) Level
- (b) Password
- (c) Expiration
- (f) External auth
- (g) Ext.auth. ID

For how to edit operator information, refer to the following.

 Page 527 Operator information management

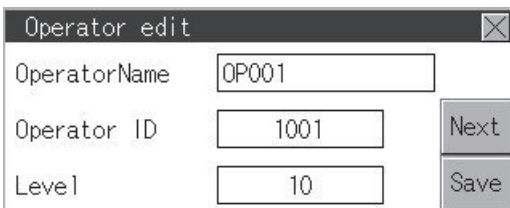

4. When the [Save] button is touched after all items are input, the input operator information is saved. Touching the [x] button displayed on the upper right returns to the previous screen.

Saving the setting

When the [x] button is touched before the [Save] button is touched, the setting contents are not saved and the screen returns to the previous one.

To save the setting contents, always touch the [Save] button.

■ Deletion operation

Delete the operator information stored in the GOT.

1. Select the operator information to be deleted with touching the operator information.

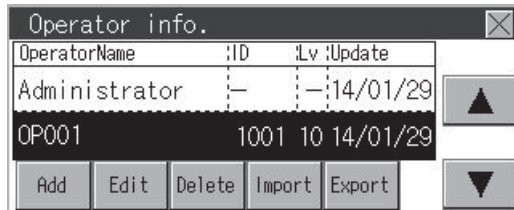

2. Touching the [Delete] button deletes the selected operator information. Touching the [X] button displayed on the upper right returns to the previous screen.

Point

When GS621.b0 is ON, deletion of operator accounts is prohibited.

For the details, refer to the following.

📖 GT Designer3 (GOT2000) Screen Design Manual

■ Import operation

Import the operator information that is already exported to an SD card to the GOT.

1. Touch the [Import] button.

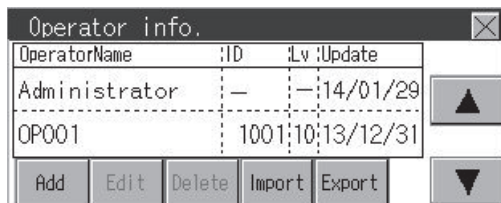

2. The dialog box shown below is displayed.

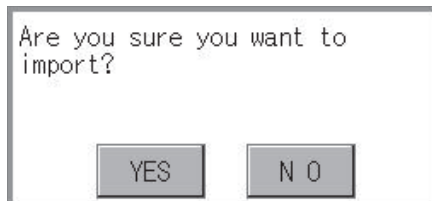

When the [YES] button is touched, the Admin password authentication screen is displayed. Input the administrator password. Character types to be input can be changed by touching the [KEY] button.

When the input is completed, touch the [Enter] key.

3. When the administrator password is correctly input, the dialog box shown below is displayed and the operator information stored in an SD card is imported to the GOT.

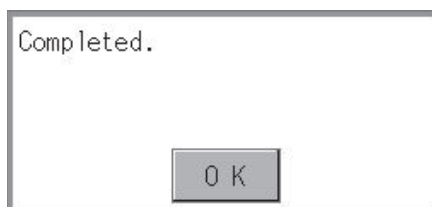

Point

When GS621.b2 is ON, the [Import] button is inactivated.

For the details, refer to the following.

📖 GT Designer3 (GOT2000) Screen Design Manual

■Export operation

Export the operator information stored in the GOT to an SD card.

1. Touch the [Export] button.



2. The dialog box shown below is displayed.

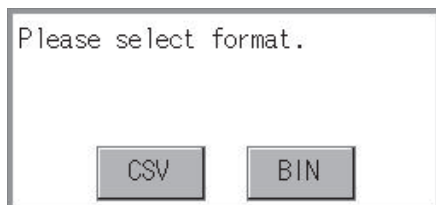

3. Touch the following buttons according to the output format for the file.

Binary file:

[BIN] button

CSV file:

[CSV] button

4. The dialog box shown below is displayed.

Touch the [YES] button to export the information.

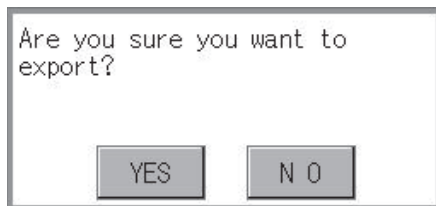

5. The dialog box shown below is displayed and the operator information stored in the GOT is exported to an SD card. (file name: AUTHINF.G2U)

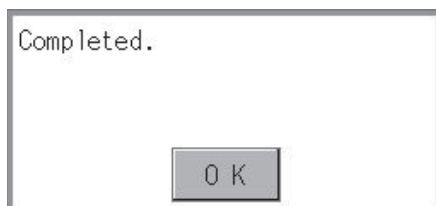

Password change

Password change function

The passwords to be used for the operator authentication can be changed.

For the password change, log into the GOT in advance with the operator name corresponding to the password to be changed.

Display operation of password change

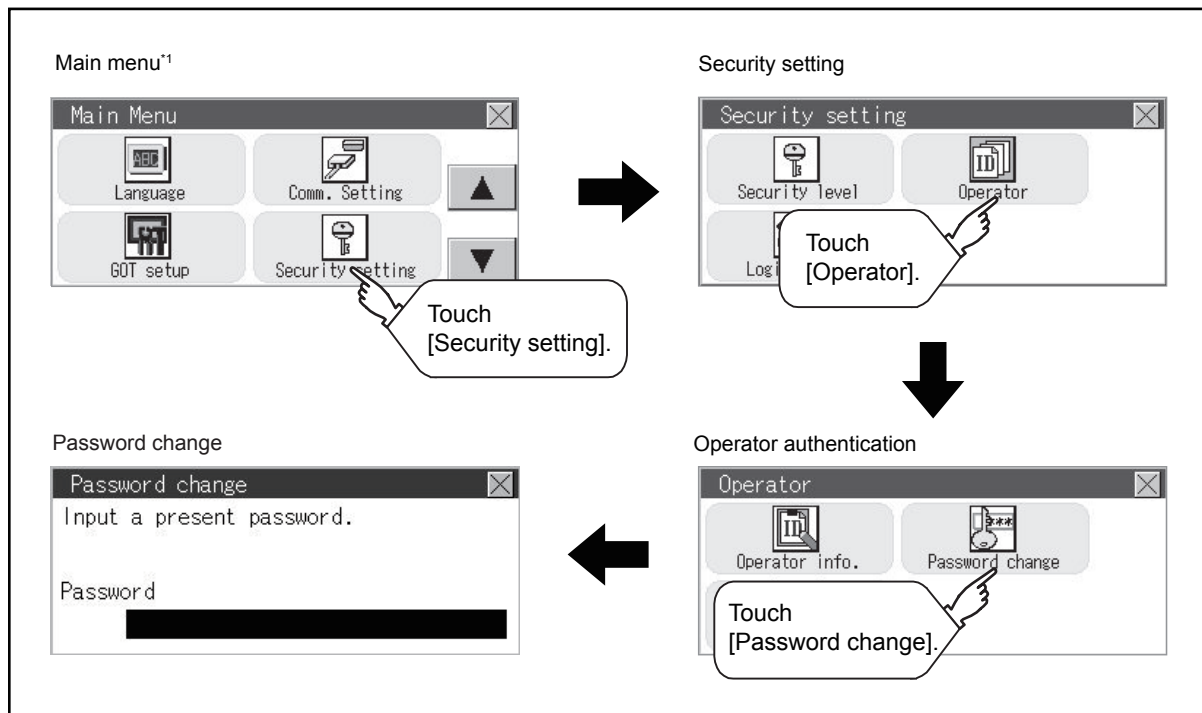

*1 Refer to the following for display operation of main menu.

☞ Page 425 Utility Display

Password change operation

1. Touch [Security setting] → [Login/Logout] to log into the GOT with the operator ID whose password is to be changed.



2. Touch [Password change] in the operator setting menu, and then the Password change dialog box is displayed.



3. Input the current password on the Password change dialog box.

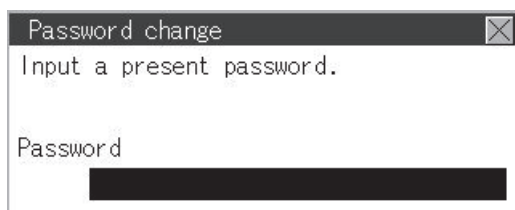

Character types to be input can be changed by touching the [KEY] button.

				ESC
7	8	9	0	AC
4	5	6	→	DEL
1	2	3	KEY	ENT

When the input is completed, touch the [ENT] key.

4. Input a new password.

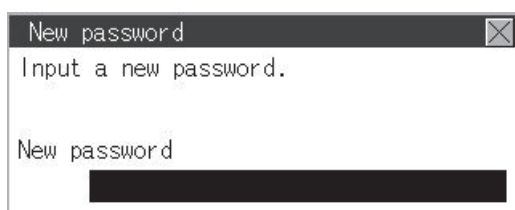

5. After inputting a new password, input the new password again.
6. When the new password is correctly input, the dialog box shown below is displayed and the password is changed.

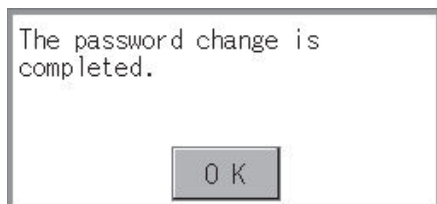

Function setting

Function setting function

The functions for the operator information can be set. The following items can be set.

Item	Description	Reference page
Auth method	The authentication method is switched. [Password], [Ext. auth.], [Ext. auth. / Password]	☞ Auth method
Auto logout time	The time from when the last time the GOT is operated until when you automatically log out of the GOT can be set. (1 to 60 minutes, 0 is invalid.)	☞ Auto logout time
Expiration date	Set the item for regularly changing the password to be used for the operator authentication. (1 to 1000 days, 0 is invalid.) When the password is out of date after setting the password, the GOT requests the password change.	☞ Expiration date
Ext. auth. ID Initial position	The starting position of an external authentication ID (Number of bytes) can be set from the data read from an external authentication device. (0 to 1998 bytes)	☞ Ext. auth. ID Initial position
Ext. auth. ID Valid byte count	The valid number of bytes for an external authentication ID can be set. (2 to 16 bytes)	☞ Ext. auth. ID Valid byte count

Display operation of function setting

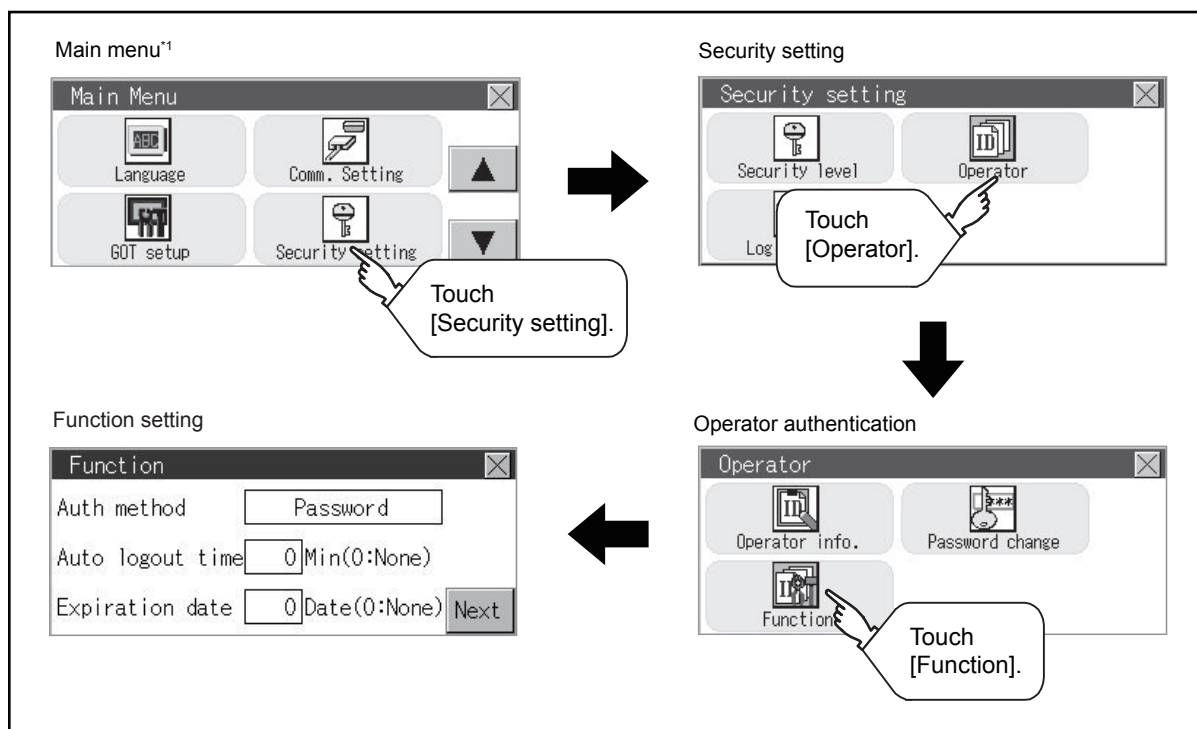

*1 Refer to the following for display operation of main menu.
☞ Page 425 Utility Display

Function setting operation

1. Touch [Operator] → [Function], and then the Admin password authentication dialog box is displayed.



2. When the administrator password is correctly input, the Function setting screen is displayed. Touch the [Next] switch to switch the setting screen, and touch an item to be set.

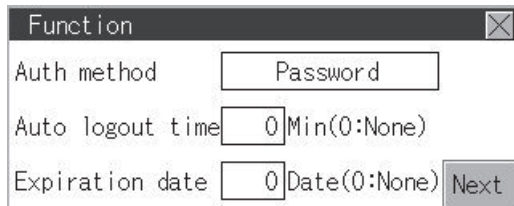

1)Auth method

The authentication method is switched.

Touching the authentication method switches the selected item in order of [Password] → [Ext. auth.] → [Ext. auth. / Password].

0	ESC			
7	8	9	0	AC
4	5	6	+/-	DEL
1	2	3	.	ENT

2)Auto logout time

Touch [Automatic logout time] to display the ten-key pad. Input a setting time. When the input is completed, touch the [ENT] key.

3)Expiration date

Touch Expiration date to display the ten-key pad. Input a setting time. When the input is completed, touch the [Enter] key.

4)Ext. auth. ID Initial position

The starting position of an external authentication ID (Number of bytes) can be set from the data read from an external authentication device.

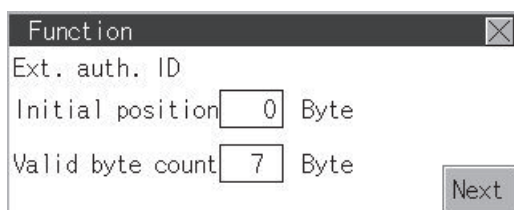

5)Ext. auth. ID Valid byte count

The valid number of bytes for an external authentication ID can be set.

(This setting is available only when [External auth] or [Ext. auth. / Password] is set as the authentication method.)

3. Touching the [x] button displayed on the upper right saves the setting contents and returns to the previous screen.

13.3 Login/Logout

To manage the operator or change the password, log into the GOT.

Display operation of login/logout

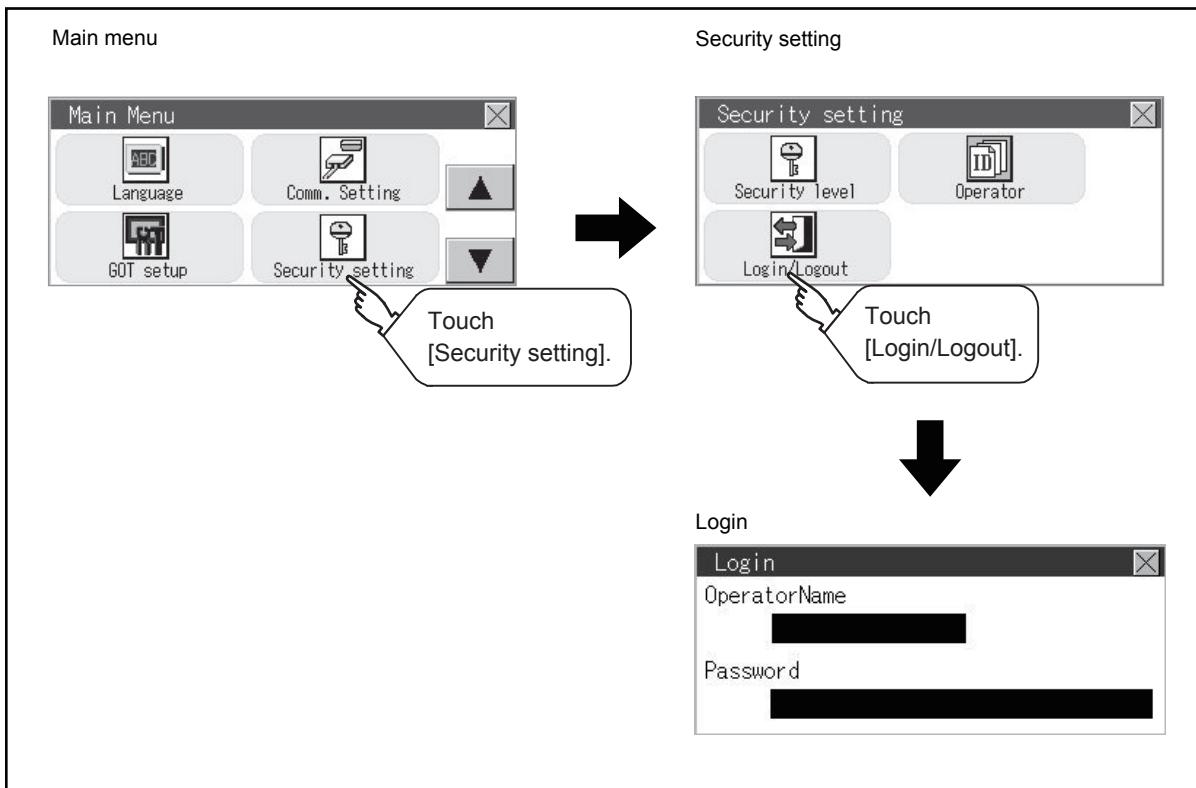

Operation of login/logout

■Login

1. Log into the GOT by inputting an operator name and its password.

An external authentication device can be used for logging in.



■Logout

1. Touch [Security setting] → [Login/Logout], and then the screen shown below is displayed. Touch the [YES] button.

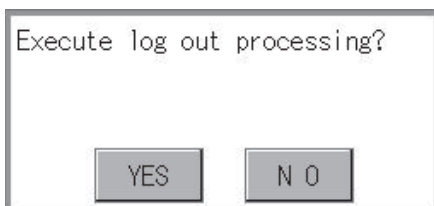

14 CLOCK SETTINGS AND BATTERY STATUS DISPLAY

Page 537 Time Setting and Display

The clock data (date and time) are displayed and set in the clock setting menu.

14.1 Time Setting and Display

Time setting and display functions

Time settings and displaying of the status of GOT built-in battery are possible.

Function	Description	Reference
Time setting	Set the current time.	Time setting
GOT internal battery voltage status*1	Displays GOT internal battery voltage status.	
Adjust	Synchronize the clock data of the GOT with the clock data of the controller.	Adjusting the clock
Broadcast*1	Notify the clock data of the GOT to the controller for synchronization with the GOT.	Broadcasting the clock data
Local time	Set the time zone of the local time in the clock data of the GOT.	Local time

*1 GT2103-P cannot be specified.

Point

Changing times

When the time is changed on the Time setting & display screen, the changed time is written in a programmable controller even though [Adjust] or [Broadcast] is set for [Time setting].

As a result, the time of the programmable controller can be changed on the GOT even though [Adjust] is set for [Time setting].

(The clock data of the controller set as [Adjust CH No.] of [Clock data GOT is matched to clock data External (Adjust)] in [GOT Setup] ([Clock Setting]) of GT Designer3 is changed.)

For details of [Adjust] and [Broadcast], refer to the following.

GT Designer3 (GOT2000) Screen Design Manual

Clock synchronization method

The following shows the clock synchronization method on the GOT.

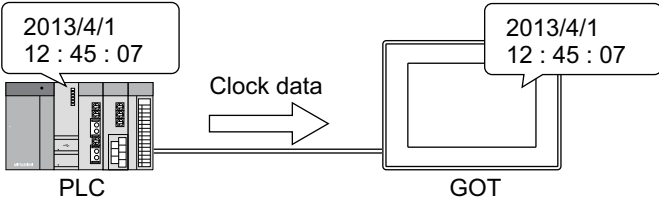
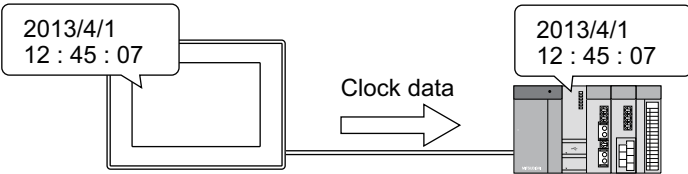
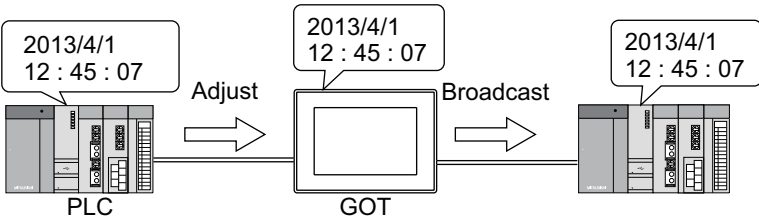
Clock synchronization method	Description
Adjust	<p>Acquire the clock data of the controller and change the clock data of the GOT.</p>  <p>When the GOT is powered on, set the clock data of the GOT to that of the controller. Since the GOT does not have to hold the clock data while the GOT is powered off, no battery is required. (If the GOT needs to hold the clock data at startup, install a battery in the GOT.) To set the controller clock data of the controller, refer to the manual of the controller you use.</p>
Broadcast* ¹	<p>Notify the clock data of the GOT to the controller to change that of the controller.</p>  <p>At the timing of the trigger, set the clock data of the controller to that of the GOT. Since the GOT must hold the clock data while the GOT is powered off, a battery is required. Set the clock data of the GOT in the utility.</p>
Using Adjust and Broadcast together* ¹	<p>Acquire the clock data of the controller by Adjust. Then change the clock data of other controllers by Broadcast.</p> 

*1 GT2103-P cannot be specified.

Point 

Details of the clock synchronization method

For the details of the clock synchronization method, refer to the following.

 GT Designer3 (GOT2000) Screen Design Manual

Time setting

Set the current time.

The following explanation uses GT2104-R as an example.

Time setting

Function	Description	Reference
Current time	Carry out the display and setup of GOT clock data.	☞ Page 540 Current time
GOT internal battery voltage status	Displays GOT internal battery voltage status.	☞ Page 541 GOT internal battery voltage status (GT2103-P is excluded.)

Display operation of the time setting

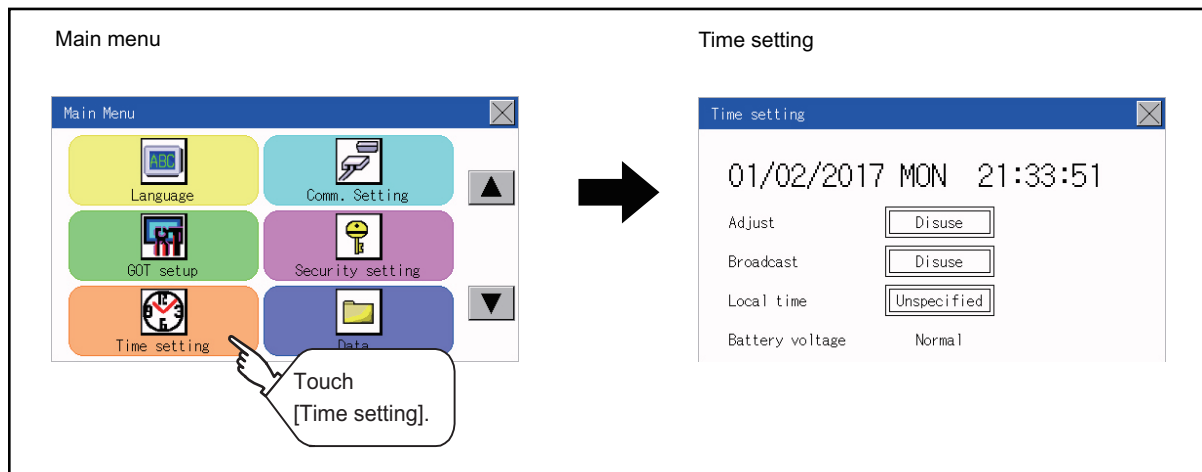

Setting procedure for the time setting

■Current time

Carry out the display and setting of GOT clock data.

The setup methods of clock data are shown below.

1. Touch either the date or time to be changed.

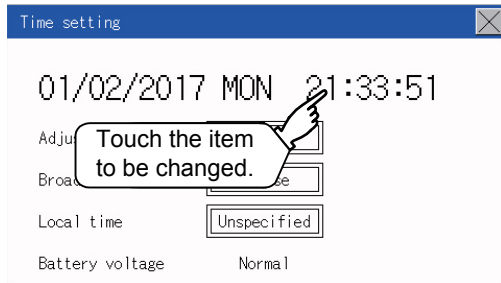

2. Enter date or time on the ten-key pad.

The following shows the valid range of the date setting.

January 1, 2000 to December 31, 2037

The day of the week is displayed automatically according to the input date.

"0" to "9":

Use these keys to enter numerical values.

"ESC":

Closes the ten-key window without saving any value entered for the date or time.

"AC":

Deletes the entire string of numerical characters that are being entered.

"DEL":

Deletes a digit from a string of numerical characters that are being entered.

"ENT":

Enters the value for the date or clock that has been entered and closes the ten-key pad window.

"+/-":

Switches between positive and negative values. (Only positive values are valid for the date or clock setting.)

".":

Invalid key (not used)

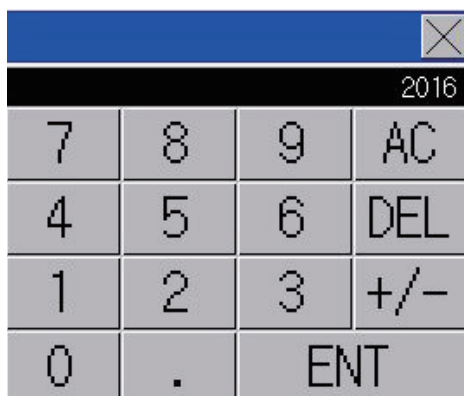

3. After setting either the date or time, touch the [x] button to save the changes and close the setting window.

■GOT internal battery voltage status (GT2103-P is excluded.)

Displays battery voltage status.

Display	Status
Normal	Normal
Low/None	Low voltage

When the battery voltage is low, replace the battery immediately.

Refer to the following for battery replacement procedure.

 GOT2000 Series User's Manual (Hardware)

Adjusting the clock

Synchronize the clock data of the GOT with the clock data of the controller.
The following explanation uses GT2104-R as an example.

Clock adjustment setting

Function	Description	Setting range
Time setting	Switch the Use/Disuse of Adjust.	Disuse/Use <Default: Disuse>
Reference CH No.	Set a reference channel of the external controller.	1 to 2 <Default: 1>
Trigger type	Set the trigger type for the clock adjustment.*1 • When selecting [Sampling] for [Trigger type], set the sampling interval for the clock adjustment. • When selecting [Rise] or [Fall] for [Trigger type], information on the device set as a trigger is displayed.*2	Trigger type: Rise/Fall/Sampling <Default: Sampling> Sampling interval: 1 to 1440 <Default: 60>
Time zone of target unit	Switch Specified/Unspecified of the time zone of target.	Unspecified/Specified <Default: Unspecified>
Time zone	When selecting [Specify the time zone of target unit], set the time zone.	GMT-12:00 to GMT+13:00 <Default: GMT+9:00>
Time difference from GMT	Time zone of target is set by specifying the time difference from GMT.	Hour: -12 to 13 Minute: 0, 15, 30, or 45 <Default: 0 hour 0 minute>

*1 If [Adjust the clock] is deselected or [Trigger Type] is set to [Sampling] in [GOT Setup] in the project data, only [Sampling] is selectable as the trigger type for the clock adjustment in the utility.

*2 If [Adjust the clock] is deselected or [Trigger Type] is set to [Sampling] in [GOT Setup] in the project data, [No setting] is displayed in [Device].

Point

Settings of [Adjust] in the utility

Configure the settings in the utility and in [GOT Setup] on GT Designer3 by the same method.

 GT Designer3 (GOT2000) Screen Design Manual

Display operation of the clock adjustment

Main menu

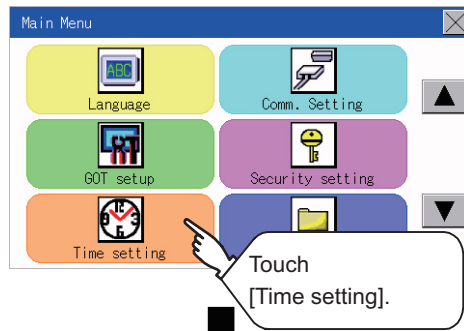

Time setting
(When not using "Adjust")

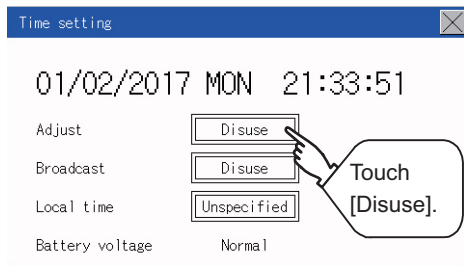

Time setting
(When using "Adjust")

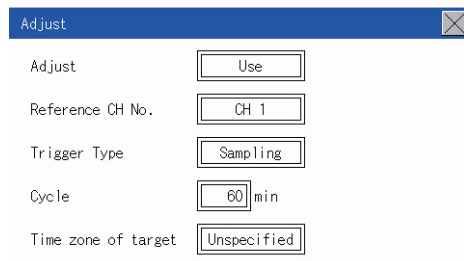
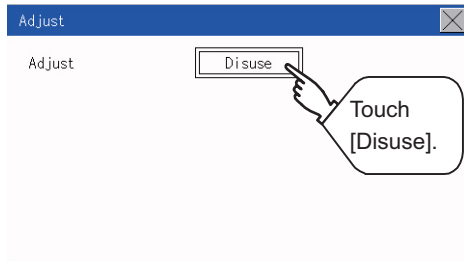
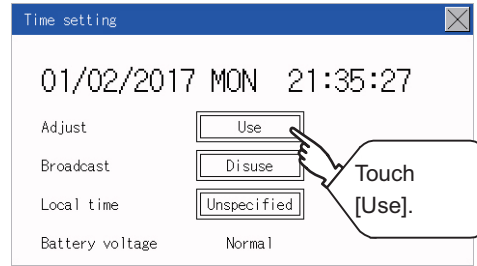

Display operation of the clock adjustment

■Reference CH No.

1. Touch the setting item to change the selection.

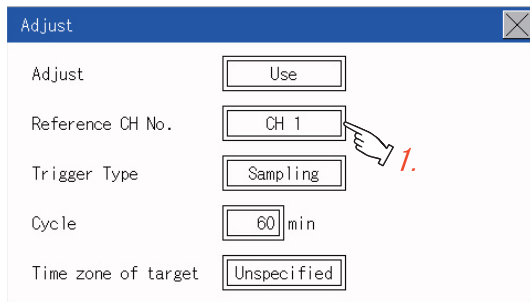

2. After changing the settings, touch the [×] button to save the changes and close the setting window.

■Trigger Type

1. Touch the setting item to change the selection.

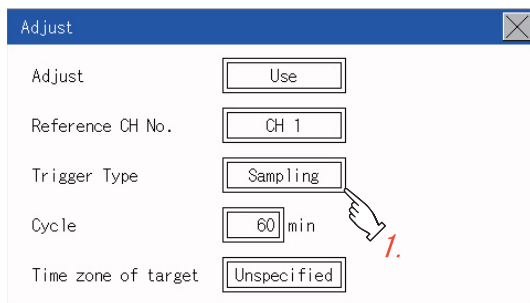

2. If you select [Sampling], set the sampling interval for the clock adjustment.

Touch the entry box on the left side of [Min.] to display a software keyboard.

Input a value with the keyboard.

3. After changing the settings, touch the [×] button to save the changes and close the setting window.

■Set the time zone of target.

1. When specifying the time zone of target, touch the setting item of [Time zone of target].

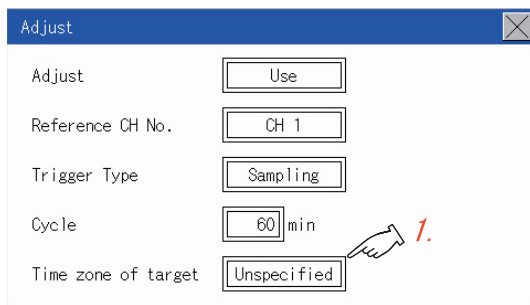

2. Touch the setting item of [Time zone of target].

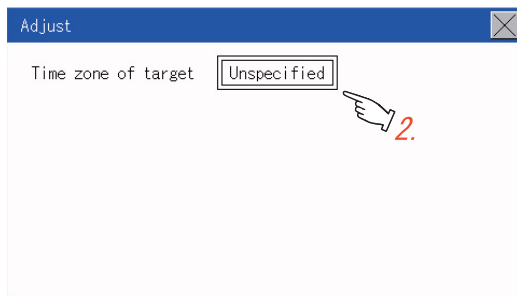

3. Touch the setting item to set the time difference from GMT.

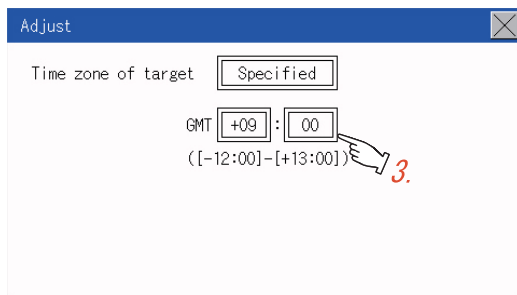

4. After changing the settings, touch the [×] button to save the changes and close the setting window.

Broadcasting the clock data

Notify the clock data of the GOT to the controller for synchronization with the GOT.

The following explanation uses GT2104-R as an example.

Time notification setting

Item	Description	Setting range
Broadcast	Switch the Use/Disuse of Broadcast.	Disuse/Use <Default: Disuse>
Broadcast CH No.	Set a channel used for the time notification.	CH 1/CH 2/CH 1,CH 2/None <Default: CH 1>
Trigger type	Set the trigger type for the time notification.*1 • When selecting [Sampling] for [Trigger type], set the sampling interval for the time notification. • When selecting [Rise] or [Fall] for [Trigger type], information on the device set as a trigger is displayed.*2	Trigger type: Rise/Fall/Sampling <Default: Sampling> Sampling interval: 1 to 1440 <Default: 60>
Time zone of target unit	Switch Specified/Unspecified of the time zone of target.	Unspecified/Specified <Default: Unspecified>
Time zone	When selecting [Specify the time zone of target unit], set the time zone.	GMT-12:00 to GMT+13:00/Custom <Default: GMT+9:00>
Time difference from GMT	Time zone of target is set by specifying the time difference from GMT.	Hour: -12 to 13 Minute: 0, 15, 30, or 45 <Default: 0 hour 0 minute>

*1 If [Broadcast the clock data] is deselected or [Trigger Type] is set to [Sampling] in [GOT Setup] in the project data, only [Sampling] is selectable as the trigger type for the time notification in the utility.

*2 If [Broadcast the clock data] is deselected or [Trigger Type] is set to [Sampling] in [GOT Setup] in the project data, [No setting] is displayed for the device.

Point

Settings of [Broadcast] in the utility

Configure the settings in the utility and in [GOT Setup] on GT Designer3 by the same method.

 GT Designer3 (GOT2000) Screen Design Manual

Display operation of the clock adjustment

Main menu

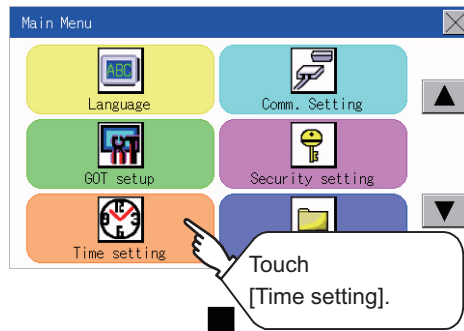

Time setting
(When not using "Broadcast")

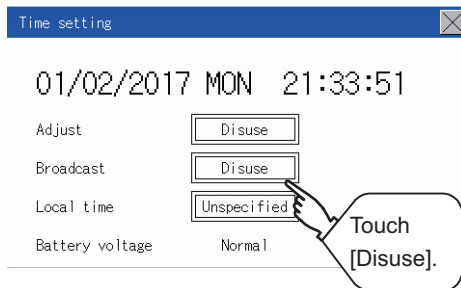

Time setting
(When using "Broadcast")

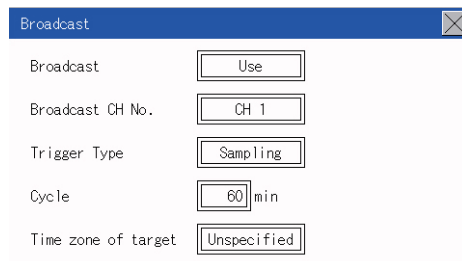
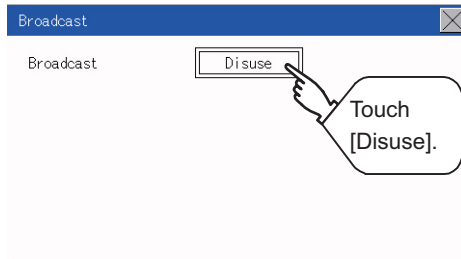
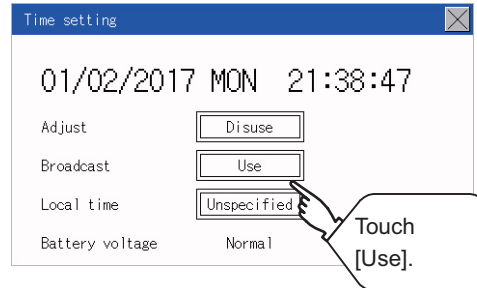

Setting procedure for the clock adjustment

■Set a broadcast channel.

1. Touch the setting item to change the selection.

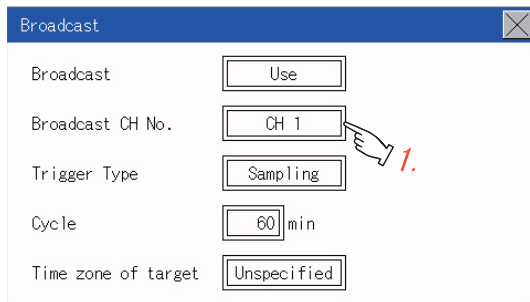

2. After changing the settings, touch the [×] button to save the changes and close the setting window.

■Trigger Type

1. Touch the setting item to change the selection.

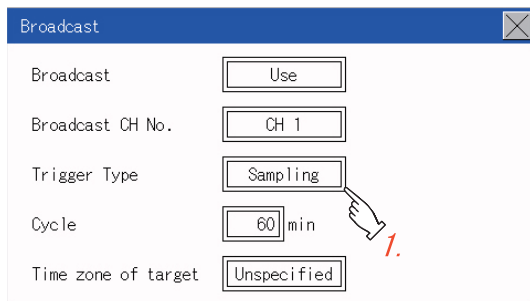

2. If you select [Sampling], set the sampling interval for the clock adjustment.

Touch the entry box on the left side of [Min.] to display a software keyboard.

Input a value with the keyboard.

3. After changing the settings, touch the [×] button to save the changes and close the setting window.

■Set the time zone of target.

1. When specifying the time zone of target, touch the setting item of [Time zone of target].

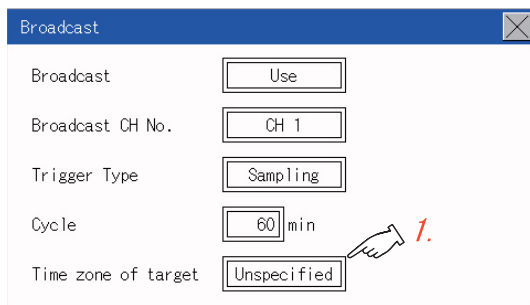

2. Touch the setting item of [Time zone of target].

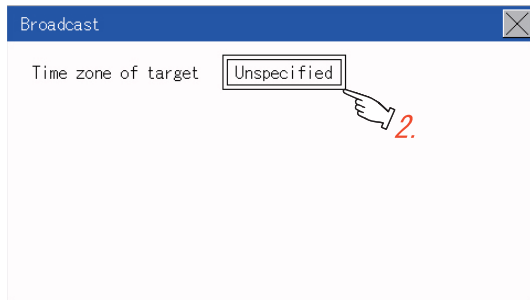

3. Touch the setting item to set the time difference from GMT.

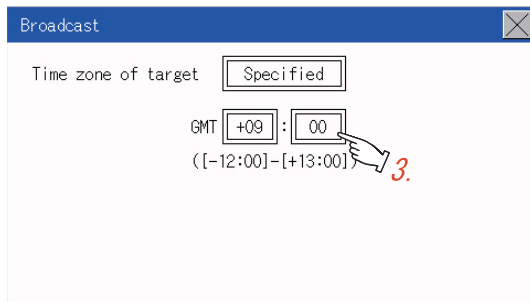

4. After changing the settings, touch the [×] button to save the changes and close the setting window.

Local time

Set the time zone of the local time in the clock data of the GOT.
The following explanation uses GT2104-R as an example.

Local time setting

Function	Description	Setting range
Local time	Switch Spcified/Unspecified the time zone in the clock data of the GOT.	Unspecified/Specified <Default: Unspecified>
Time zone of GOT	Set the time zone in the clock data of the GOT.	GMT-12:00 to GMT+13:00/Custom <Default: GMT+9:00>
Time difference from GMT	[Time zone of GOT] is set by specifying the time difference from GMT.	Hour: -12 to 13 Minute: 0, 15, 30, or 45 <Default: 0 hour 0 minute>

Display operation of the local time

Main menu

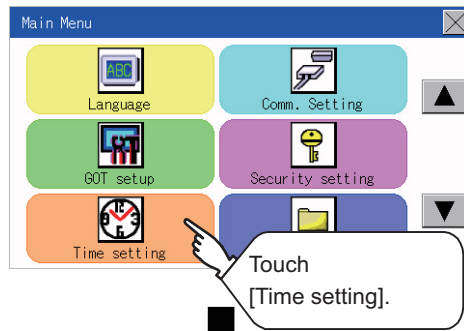

Time setting
(When not using "Local time")

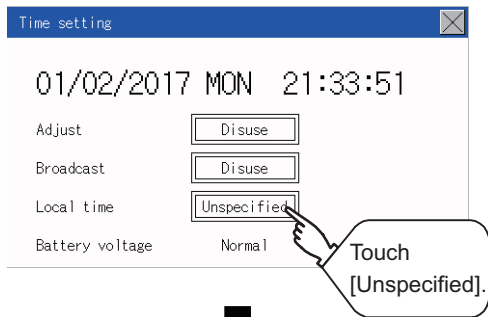

Time setting
(When using "Local time")

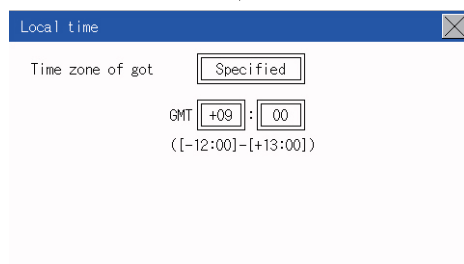
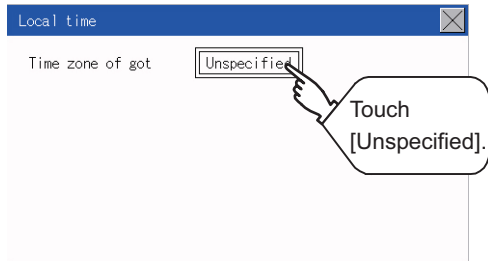
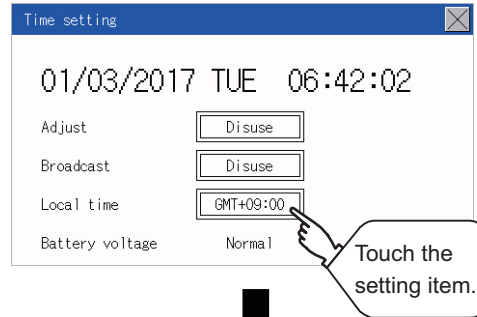

Set the local time.

1. Touch the setting item to set the time difference from GMT.

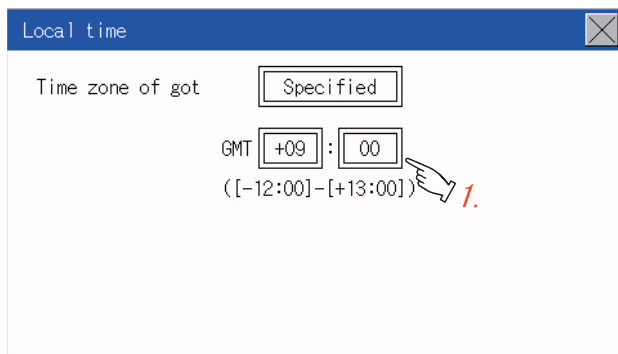

2. After changing the settings, touch the [×] button to save the changes and close the setting window.

Point

- When connecting to an external device which does not have clock function

If the GOT is connected to an external device (such as a PLC or microcomputer) that has no clock function, setting [Adjust] or [Broadcast] does not synchronize the clock data between the GOT and external device.

For the list of the PLCs having the clock function, refer to the following.

 GOT2000 Series Connection Manual for the controller used

For details of [Adjust] and [Broadcast], refer to the following.

 GT Designer3 (GOT2000) Screen Design Manual

- Time setting and battery

To use the time notification function, connect the GOT built-in battery and then configure the time setting.

For information on how to connect the GOT built-in battery, refer to the following.

 GOT2000 Series User's Manual (Hardware)

- Time display

The GOT displays the current time to which the local time setting is reflected.

For the local time setting, refer to the following.

 Page 550 Local time

- Changing times

If you have changed the present time of the GOT where the time setting function or the time notification function was being used, the new time setting will be written to the PLC.

Thus, you can change the time of the PLC from the GOT even when the time setting function is being used.

For details of [Adjust] and [Broadcast], refer to the following.

 GT Designer3 (GOT2000) Screen Design Manual

15 CONTROL OF VARIOUS DATA

- ☞ Page 553 Data Storage Location
- ☞ Page 558 OS information
- ☞ Page 559 Resource Data Information
- ☞ Page 600 SD Card Access
- ☞ Page 601 SD Card Format
- ☞ Page 605 Clear Data
- ☞ Page 609 Data Copy
- ☞ Page 614 Backup and Restoration
- ☞ Page 636 USB Device Management

A system application, project data (screen data), or alarm data which is written in the GOT or SD card can be displayed, and the data can be transferred between the GOT and SD card.

The format of the SD card is also possible.

15.1 Data Storage Location

Data type and storage location

System

The data storage location and transferring (write/read) route for each data type are shown below.

Also, the data storage locations are shown below.

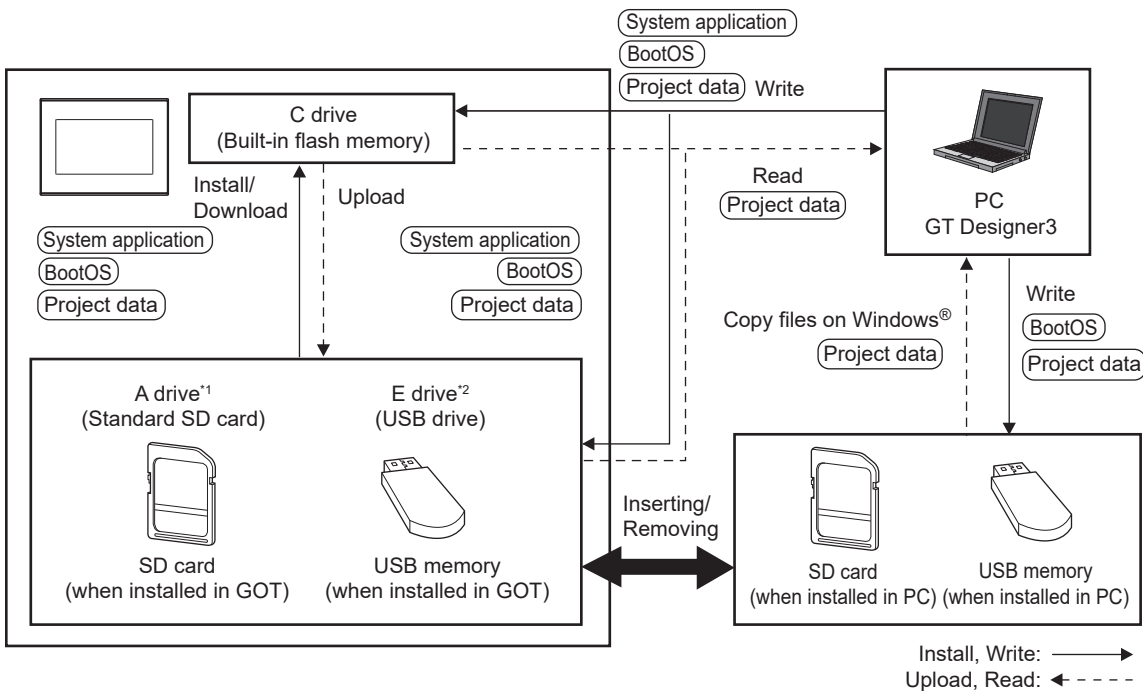

*1 For the GT2103-P, the separately sold SD card unit (GT21-03SDCD) is required.

*2 Only available to GT2107-W.

The data of the built-in flash memory (Project data, etc.) can be saved even if the battery voltage becomes low.

Item	Data type	Storage location
BootOS	BootOS	Built-in flash memory (C drive)
System application *1	Basic system application	Standard SD card (A drive) Built-in flash memory (C drive)*2 USB memory (E drive)
	Communication driver	
	Advanced system application	
Project data *1	Project data (Including recipe setting, alarm conditions, time action, and GOT setup.)	

*1 The SD card can be used from Utility.

☞ Page 558 OS information

*2 When using the project data stored in the Standard SD Card (A drive) with the GOT, hold the SD card installed to the GOT.

At maintenance

■For GT2107-WTBD, GT2107-WTSD

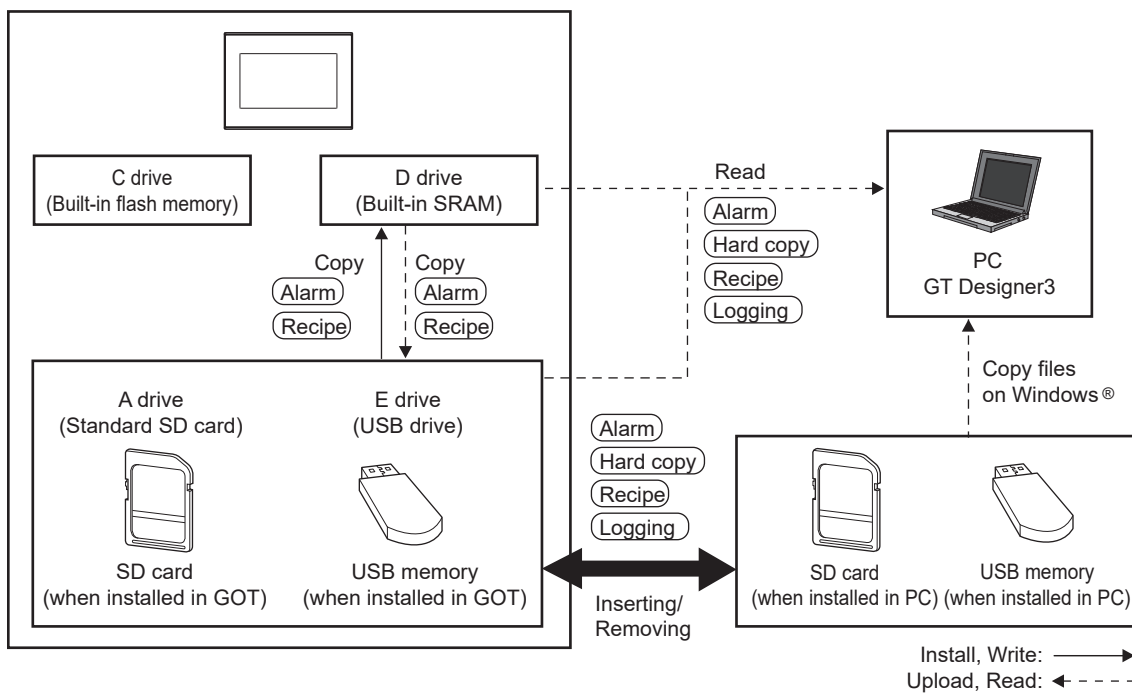

Item	Data type	Storage location
Alarm	Alarm log file	Standard SD card (A drive) Built-in SRAM (D drive)
Recipe	Recipe file	USB memory (E drive)
Logging	Logging file	Standard SD card (A drive) USB memory (E drive)
Hard copy	Image file	

Point

Checking available space of the storage memory
To save resource data, check available space of the storage memory.

■For GT2105-Q, GT2104-R, GT2104-P

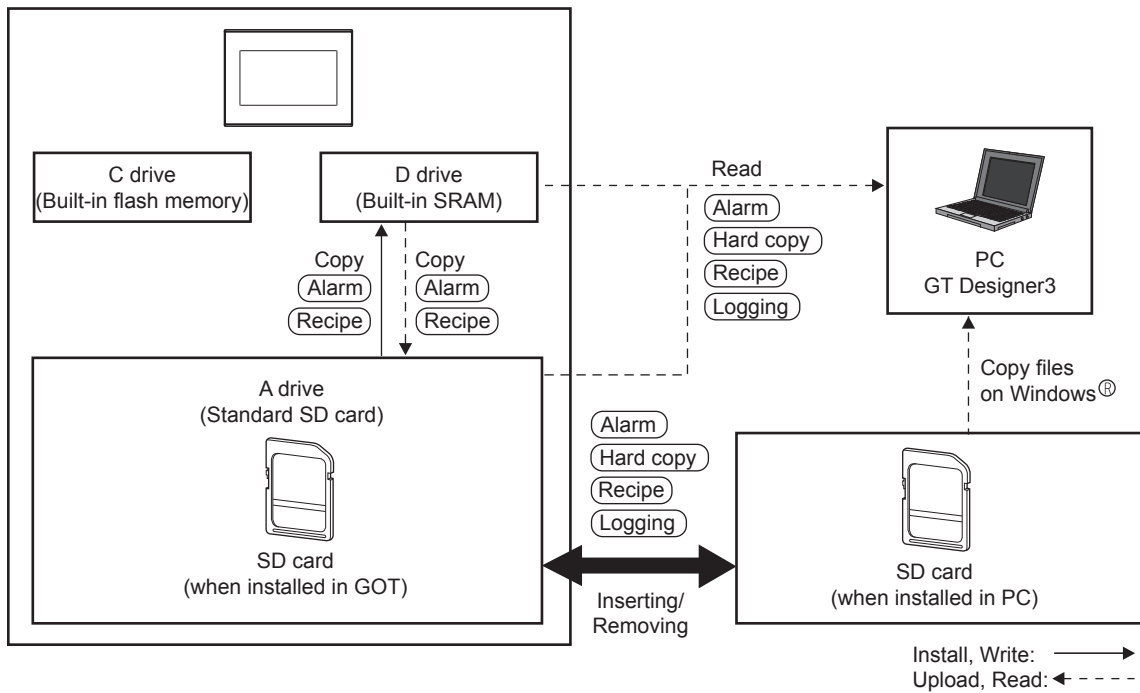

Item	Data type	Storage location
Alarm	Alarm log file	Standard SD card (A drive) Built-in SRAM (D drive)
Recipe	Recipe file	
Logging	Logging file	Standard SD card (A drive)
Hard copy	Image file	

Point

Checking available space of the storage memory
To save resource data, check available space of the storage memory.

■ For GT2103-P

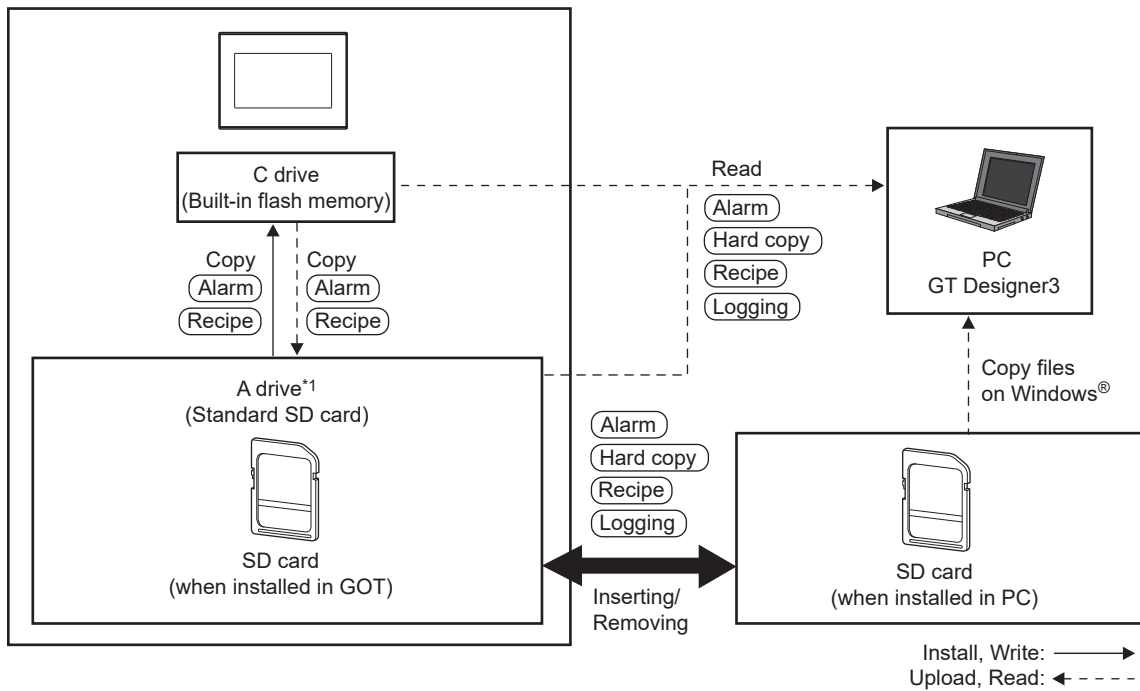

*1 An SD card unit (GT21-03SDCD) which is sold separately is required.

Item	Data type	Storage location
Alarm	Alarm log file	Standard SD card (A drive) Built-in flash memory (C drive)
Recipe	Recipe file	
Logging	Logging file	Standard SD card (A drive)
Hard copy	Image file	

Point

Checking available space of the storage memory
To save resource data, check available space of the storage memory.

Checking version of BootOS and basic system application

Confirm the basic system application version carefully when installing the BootOS and basic system application. When the basic system application is installed, the GOT checks and compares the basic system application version automatically.

When the BootOS is installed

When the BootOS to be installed has the older major version, the GOT displays the installation disapproving message to cancel the installation so that the older version may not be written.

(Even when the version of the BootOS to be installed has the same or later version, the version information and the dialog box for selecting continue/not continue will be displayed.)

When a basic system application or communication driver has been installed

When a basic system application or communication driver has already been installed, the version information of the basic system application which has been installed and the dialog box for selecting whether to continue the installation or not will be displayed.

Moreover, when the different versions will coexist among all applications (basic system application and communication driver) by installing the basic system application, the installation disapproving dialog box will be displayed and the installation process is canceled.

When project data is downloaded

The GOT automatically compares the version between the project data to be downloaded and the installed basic system application.

When the versions are different, the dialog box confirming whether to install the basic system application together is displayed.

The version of each system application that has been installed in the GOT can be checked on the OS information screen.

Kind	Version
BootOS	01 02 000.-C
Basic System Application	01 00 000
MELSEC-FX	01 00 000

How to read version
01.02.000.-C

- 01: Major version
- 02: Minor version
- 000: BootOS version (Indicated only when the property of the BootOS is displayed.)

For the display operation of the screen, refer to the following.

☞ Page 558 OS information

Point

Version confirmation of BootOS by rating plate

Confirm the version of BootOS installed in the GOT at product shipment by rating plate of GOT rear face.

MITSUBISHI ELECTRIC CORPORATION
MADE IN JAPAN

GRAPHIC OPERATION TERMINAL
MODEL GT2103-PMBD
IN 20.4~26.4VDC POWER W MAX

S/N 1410001AA G

MAC ADD 002692621092

AA

- AA: BootOS version
- AA: Hardware version

15.2 OS information

Function of OS information

Each file name or folder name of the BootOS that runs in the GOT and package data can be displayed in a list.

Function	Description	Reference
Information display of files and folders	Displays the type, name, and version of the file.	Page 558 Display example of system application information

Display operation of OS information

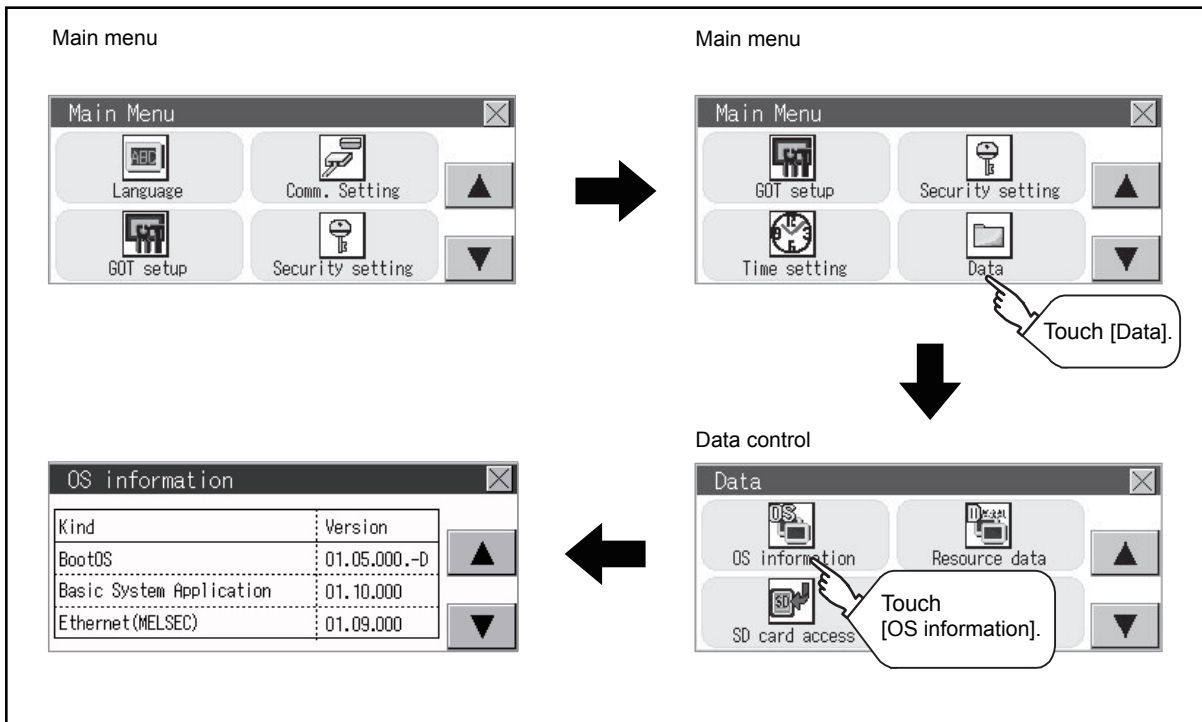

Display example of system application information

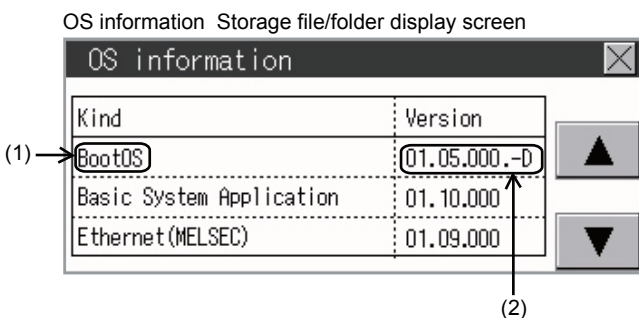

No.	Item	Description
(1)	Name	Each file name or folder name of the BootOS that runs in the GOT and package data can be displayed in a list.
(2)	Version information	Displays the software version.

15.3 Resource Data Information

Alarm information

Function of alarm information

This function displays the alarm log files stored in each drive (A: Standard SD card, C: Built-in flash memory, D: Built-in SRAM, or E: USB drive).

The functions below can be carried out for files.

For details on the alarms, refer to the following.

📖 GT Designer3 (GOT2000) Screen Design Manual

Function	Description	Reference
Information display of files and folders	Displays name, data size, creation date and time of file or folder.	<ul style="list-style-type: none"> 📖 Page 562 The display example of alarm information, 📖 Page 564 The display operation of alarm information
G2A → CSV conversion	Converts the G2A file of an alarm log file to a CSV file.	📖 Page 565 G2A → CSV conversion operation, G2A → TXT conversion operation
G2A → TXT conversion	Converts the G2A file of an alarm log file to a Unicode text file.	📖 Page 565 G2A → CSV conversion operation, G2A → TXT conversion operation
Delete	Deletes the file.	📖 Page 566 Deletion operation
Copy	Copies the file.	📖 Page 567 Copy operation

The display operation of alarm information

■GT2107-W

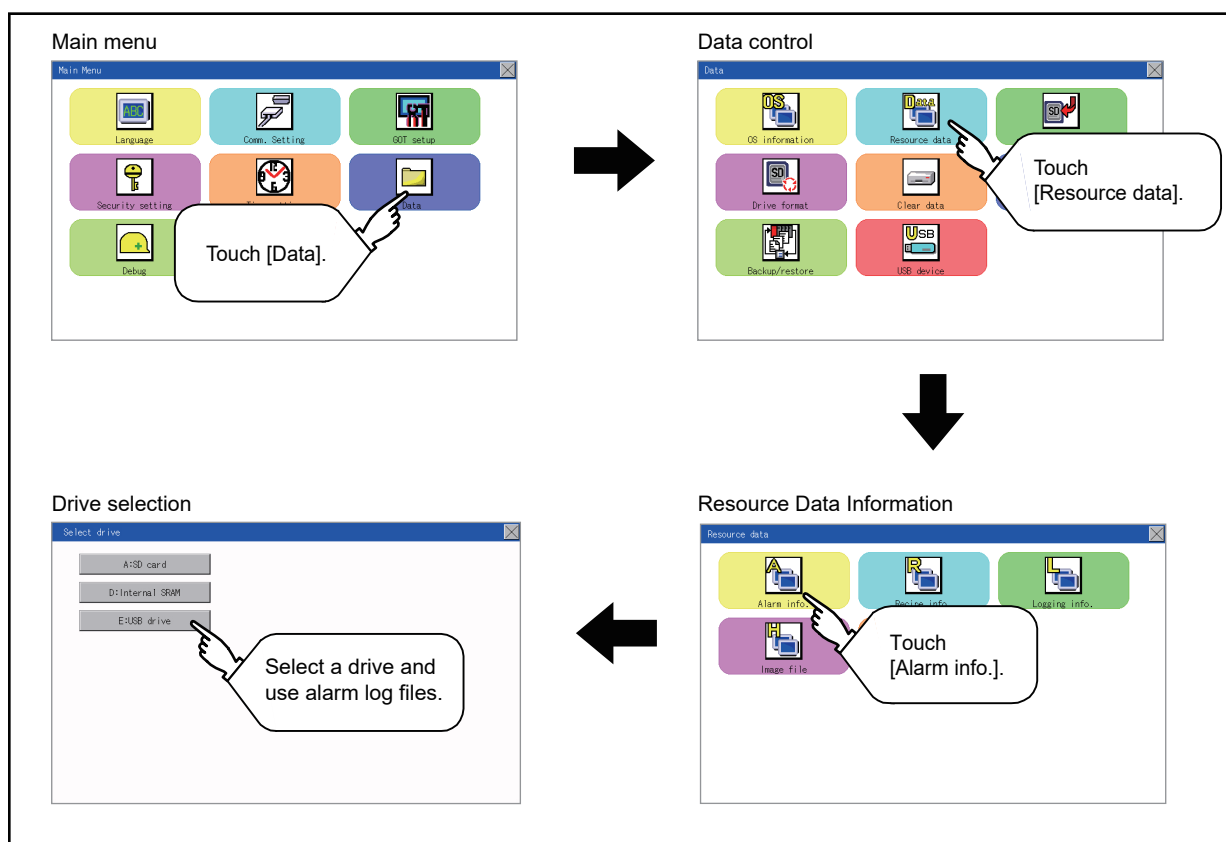

■GT2105-Q, GT2104-R

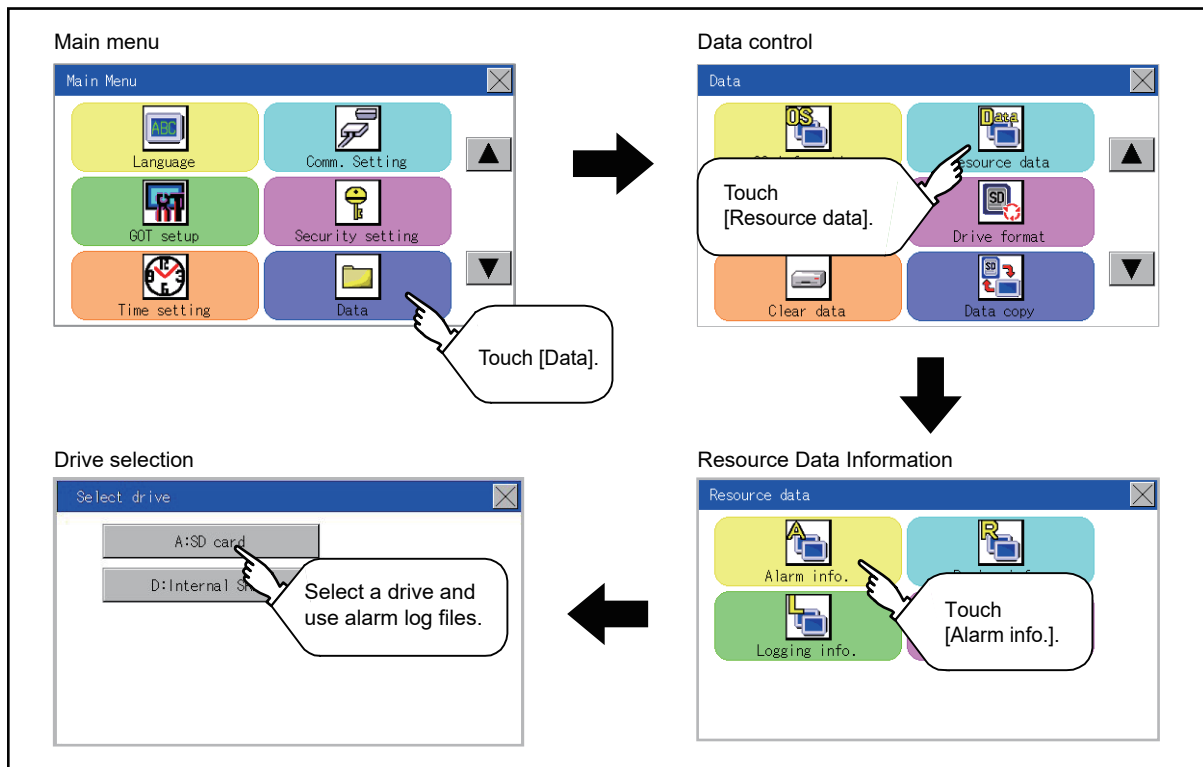

■GT2104-P

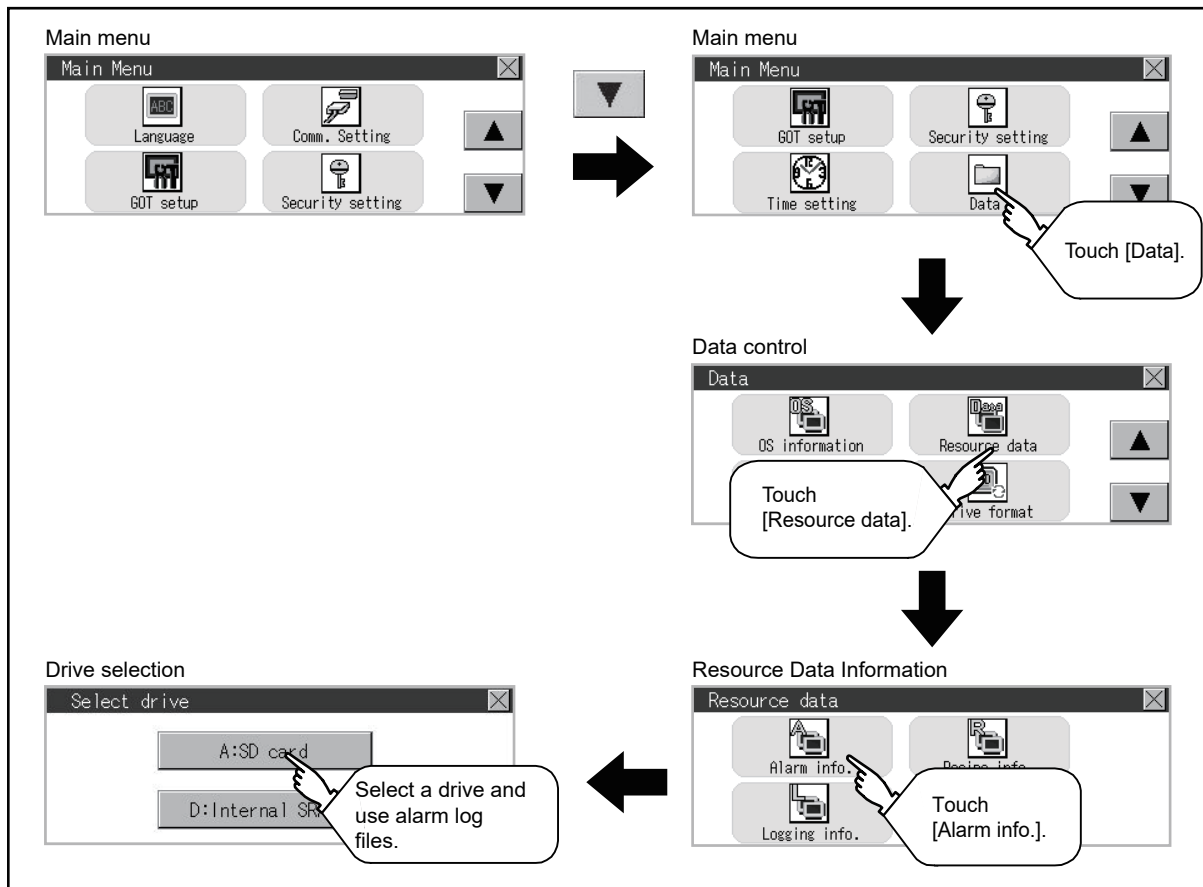

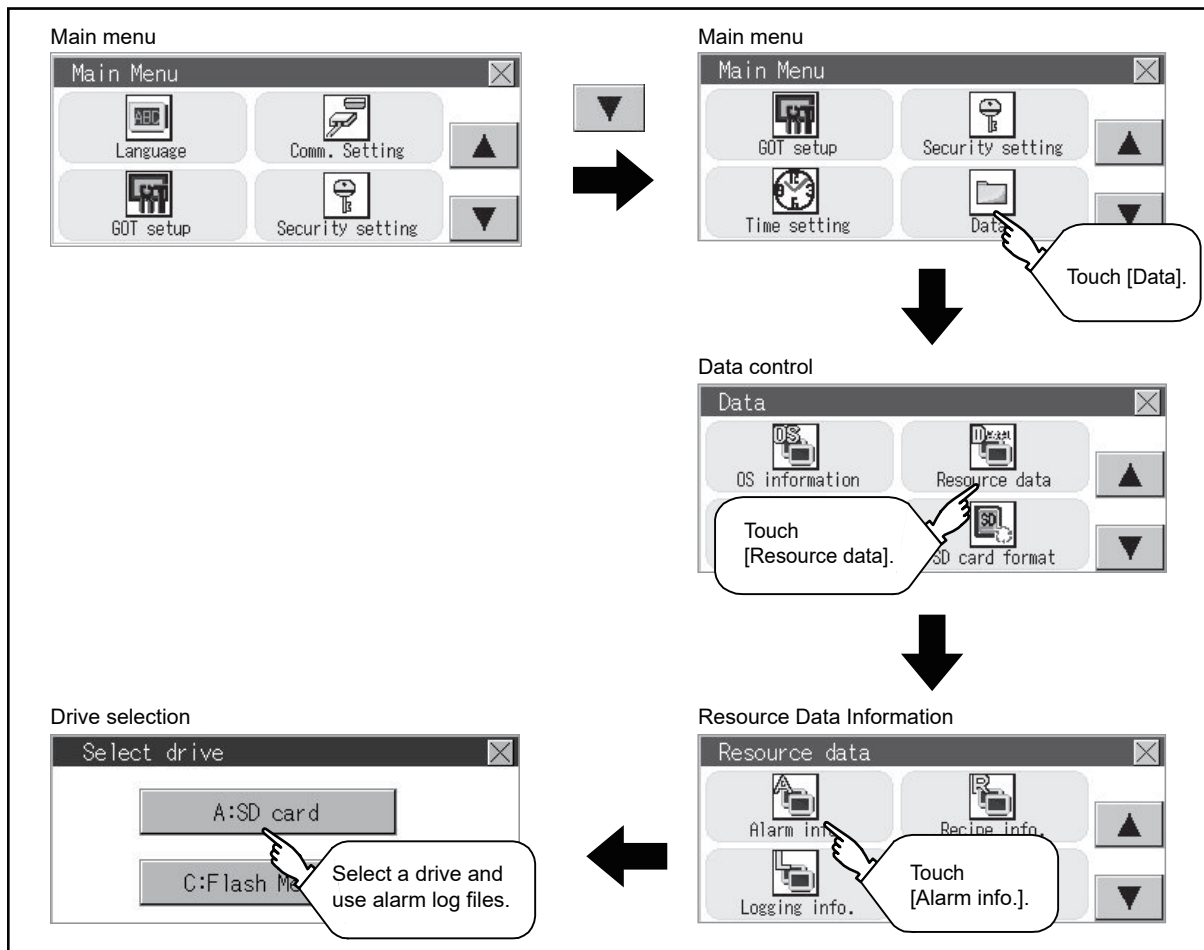

The display example of alarm information

(For GT2107-W)

(1)

(For GT2105-Q, GT2104-R)

(1)

Alarm info.

Kind	Name	Size	Date	Time
DIR	G2PACKAGE		01/01/2000	00:01
DIR	Package1		01/01/2000	00:01
DIR	System Volume Information		10/12/2018	12:25
DIR	DCIM		10/17/2018	16:06
DIR	Hard_Copy		10/01/2003	17:32
CSV	AAM00001	OK	10/04/2003	00:05
CSV	RECIPE	OK	10/06/2003	23:37
DIR	RECIPE		10/07/2003	00:14

Del Convert

Copy

(2) (3) (4) (5) (6)

(For GT2104-P)

(1)

(For GT2103-P)

(1)

Alarm info.

Kind	Name	Size	Date	Time
DIR	..		14/01/29	12:20
G2A	AAM00001	5K	14/01/29	12:20

Del Copy MORE

(2) (3) (4) (5) (6)

No.	Item	Description
(1)	Drive selection	Select a drive to display files or folders. (Data storage drives are displayed even no data storage is installed.)
(2)	Kind	Indicates whether the displayed name is file or folder. Displays the extension for a file and "DIR" for a folder.
(3)	Name	Displays the file name or folder name. For the long file/folder name, entire part may not be displayed.  Page 564 Alarm information operation
(4)	Size	Displays the size of the file displayed in Name.
(5)	Date, Time	Displays the creation date and time of each file.
(6)	Operation switch	Execution switch of each function.

Point 

- Display of creation date and time

The creation date and time display is not updated even if a file is created or updated while displaying the alarm information display screen.

If the screen currently displayed is closed (by moving the screen to the folder of the upper hierarchy, etc.) and the same screen is displayed again, the updated contents are displayed.

Alarm information operation

■The display operation of alarm information

1. If a drive of [Select drive] is touched, the information of the touched drive is displayed.

(For GT2107-W)

(For GT2105-Q, GT2104-R)

Alarm info.

KindName	Size	Date	Time
DIR:G2PACKAGE		01/01/2000	00:01
DIR:Package1		01/01/2000	00:01
DIR:System Volume Information		10/12/2018	12:25
DIR:DCIM		10/17/2018	16:06
DIR:Hard_Copy		10/01/2003	17:32
CSV:AAM00001	OK	10/04/2003	00:05
CSV:RECIPE	OK	10/06/2003	23:37
DIR:RECIPE		10/07/2003	00:14

Buttons: Del, Convert, Copy

(For GT2104-P)

(For GT2103-P)

Alarm info.

Kind Name	Size	Date	Time
DIR :..		14/01/29	12:20
G2A :AAM00001	5K	14/01/29	12:20

Buttons: Del, Copy, MORE, Up Arrow, Down Arrow

Alarm info.

Kind Name	Size	Date	Time
DIR :..		14/01/29	12:20
G2A :AAM00001	5K	14/01/29	12:20

Buttons: Convert, MORE, Up Arrow, Down Arrow

2. If a folder name is touched, the information of the touched folder is displayed.
3. If a folder of ". ." is touched, the information of the folder in one upper hierarchy is displayed.
4. If the ▲▼ button of the scrollbar is touched, the screen scrolls up/down by one line.
5. If a file name is touched, the file is selected.
6. For operations of G2A → CSV conversion, G2A → TXT conversion, deletion, copy, and graph, refer to the following.
G2A → CSV, G2A → TXT

☞ Page 565 G2A → CSV conversion operation, G2A → TXT conversion operation

Delete

☞ Page 566 Deletion operation

Copy

☞ Page 567 Copy operation

7. If the [x] button is touched, the screen is closed.

■G2A → CSV conversion operation, G2A → TXT conversion operation

The selected G2A file is converted to a CSV file or Unicode text file.

1. Touch the G2A file to be converted.
(For GT2107-W, GT2105-Q, GT2104-R)

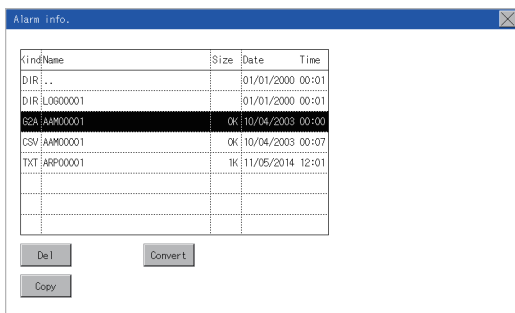

(For GT2104-P, GT2103-P)

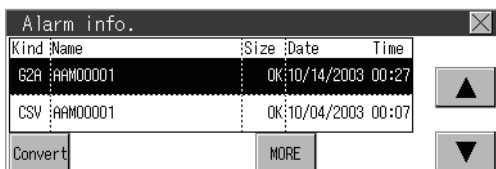

2. Touch [Convert].
3. The following dialog box is displayed when touching the following button according to the file type to convert to.
 - CSV file: [CSV] button
 - Unicode text file: [TXT] button

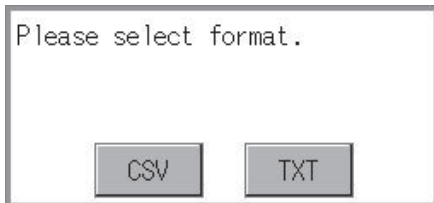

4. Touch the [YES] button. The file is overwritten with the converted file.

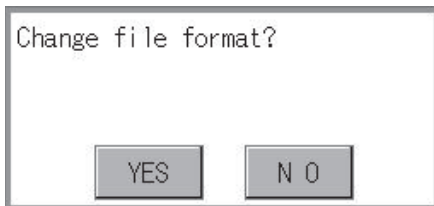

■ Deletion operation

The selected file is deleted.

1. Touch the file to be deleted.

(For GT2107-W, GT2105-Q, GT2104-R)

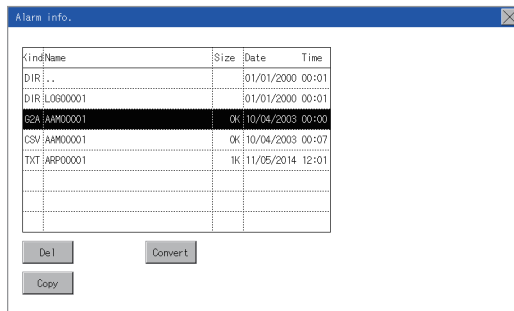

(For GT2104-P, GT2103-P)

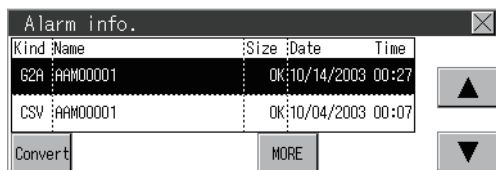

2. If the [Delete] button is touched, the dialog box mentioned below is displayed.

If the [YES] button is touched, the file is deleted.

If the [NO] button is touched, the deletion is canceled.

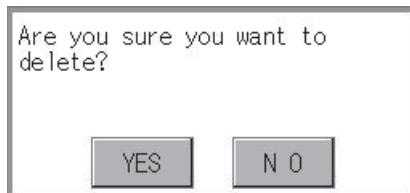

■ Copy operation

The selected file is copied.

1. Touch the file to be copied.
2. If the [Copy] button is touched, the Select drive screen is displayed.
(For GT2107-W, GT2105-Q, GT2104-R)

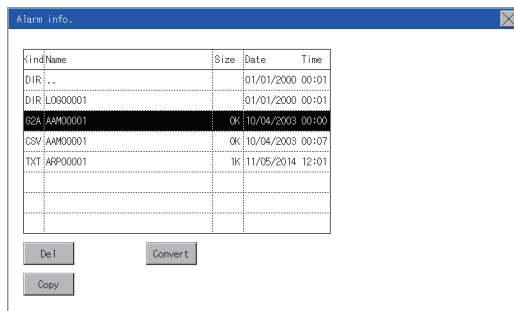

(For GT2104-P, GT2103-P)

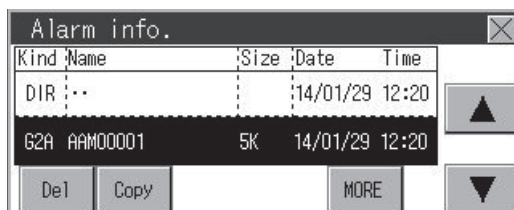

3. Select a drive.

(For GT2107-W)

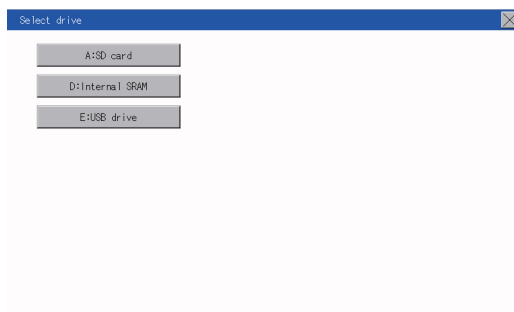

(For GT2105-Q, GT2104-R)

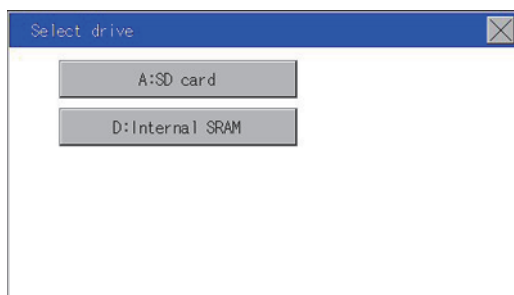

(For GT2104-P)

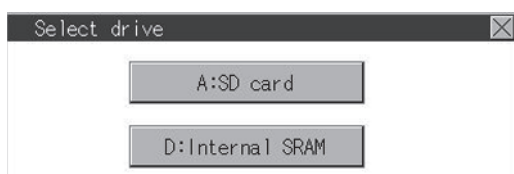

(For GT2103-P)

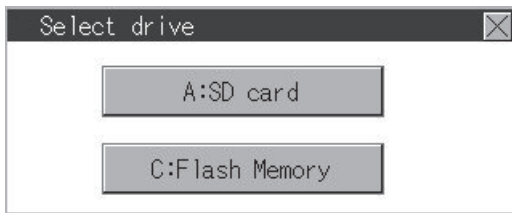

4. Select the copy destination folder and touch [Execute]. The file is copied.

(For GT2107-W, GT2105-Q, GT2104-R)

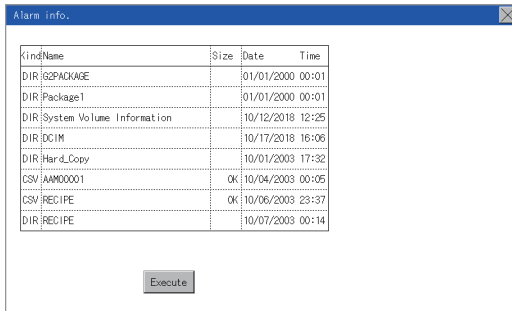

(For GT2104-P, GT2103-P)

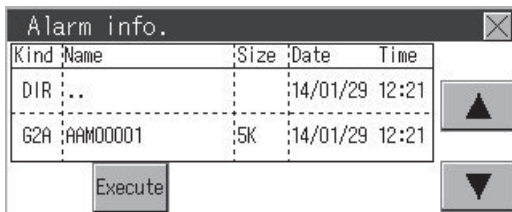

Recipe information

Function of recipe information

This function displays the recipe files stored in each drive (A: Standard SD card, C: Built-in flash memory, D: Built-in SRAM, or E: USB drive).

The functions below can be carried out for files.

For details on the recipe function, refer to the following.

📖 GT Designer3 (GOT2000) Screen Design Manual

Function	Description	Reference
Recipe information screen	File and folder information display	☞ Page 572 Example of advanced recipe information display, ☞ Page 573 Recipe information screen
	G2P → CSV conversion	☞ Page 575 G2P → CSV conversion operation, G2P → TXT conversion operation
	G2P → TXT conversion	☞ Page 575 G2P → CSV conversion operation, G2P → TXT conversion operation
	CSV/TXT → G2P conversion	☞ Page 576 CSV/TXT → G2P conversion operation
	Delete	☞ Page 577 Deletion operation
	Copy	☞ Page 578 Copy operation

Display operation of recipe information

■GT2107-W

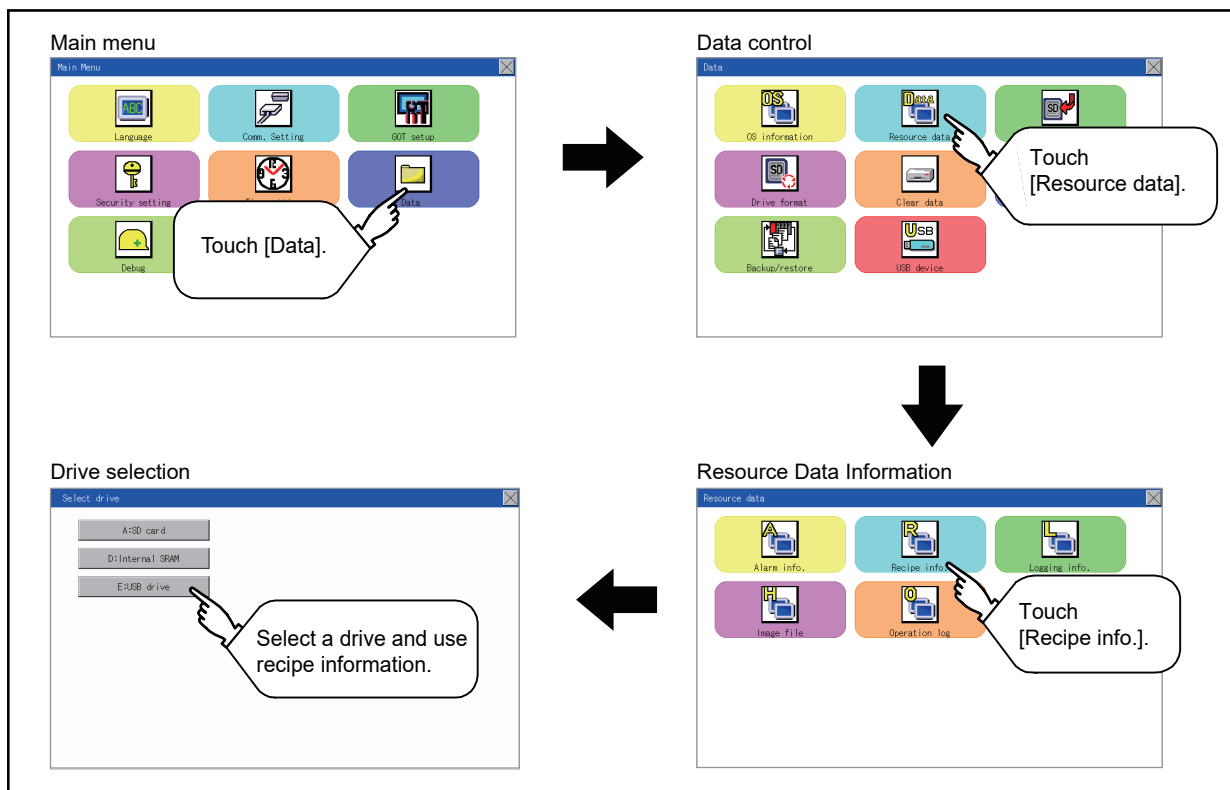

■GT2105-Q, GT2104-R

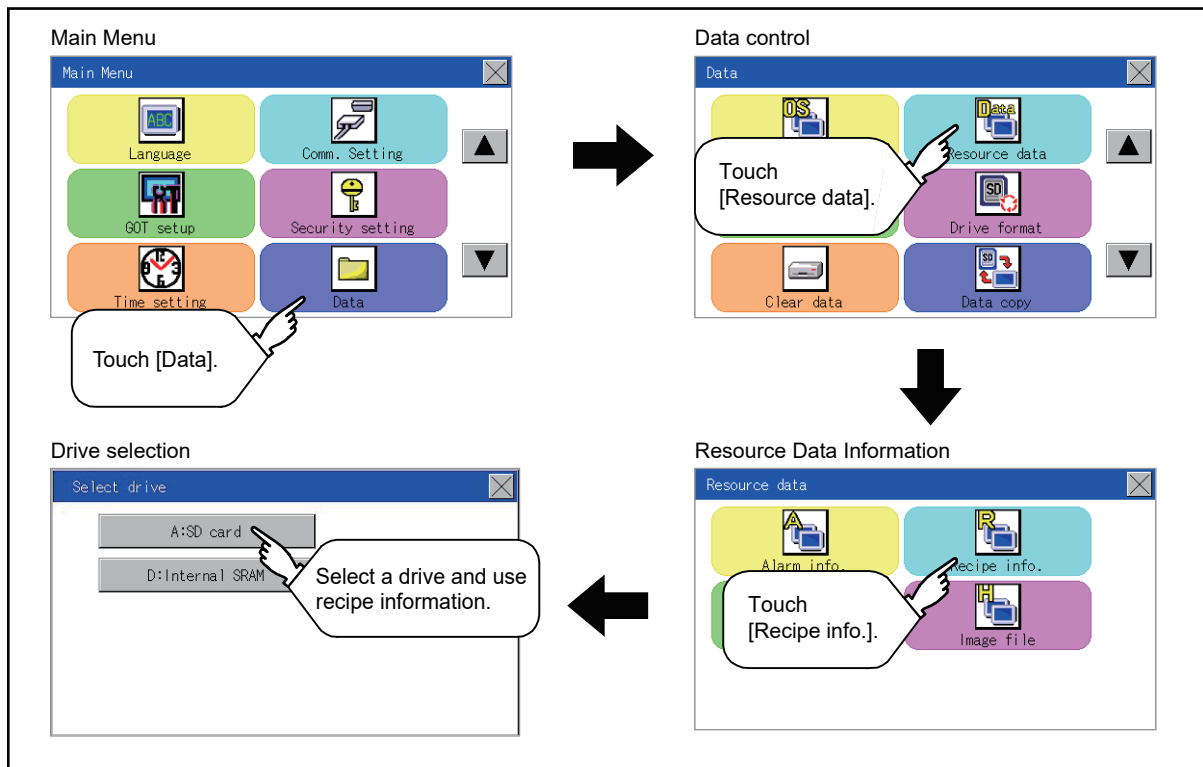

■GT2104-P

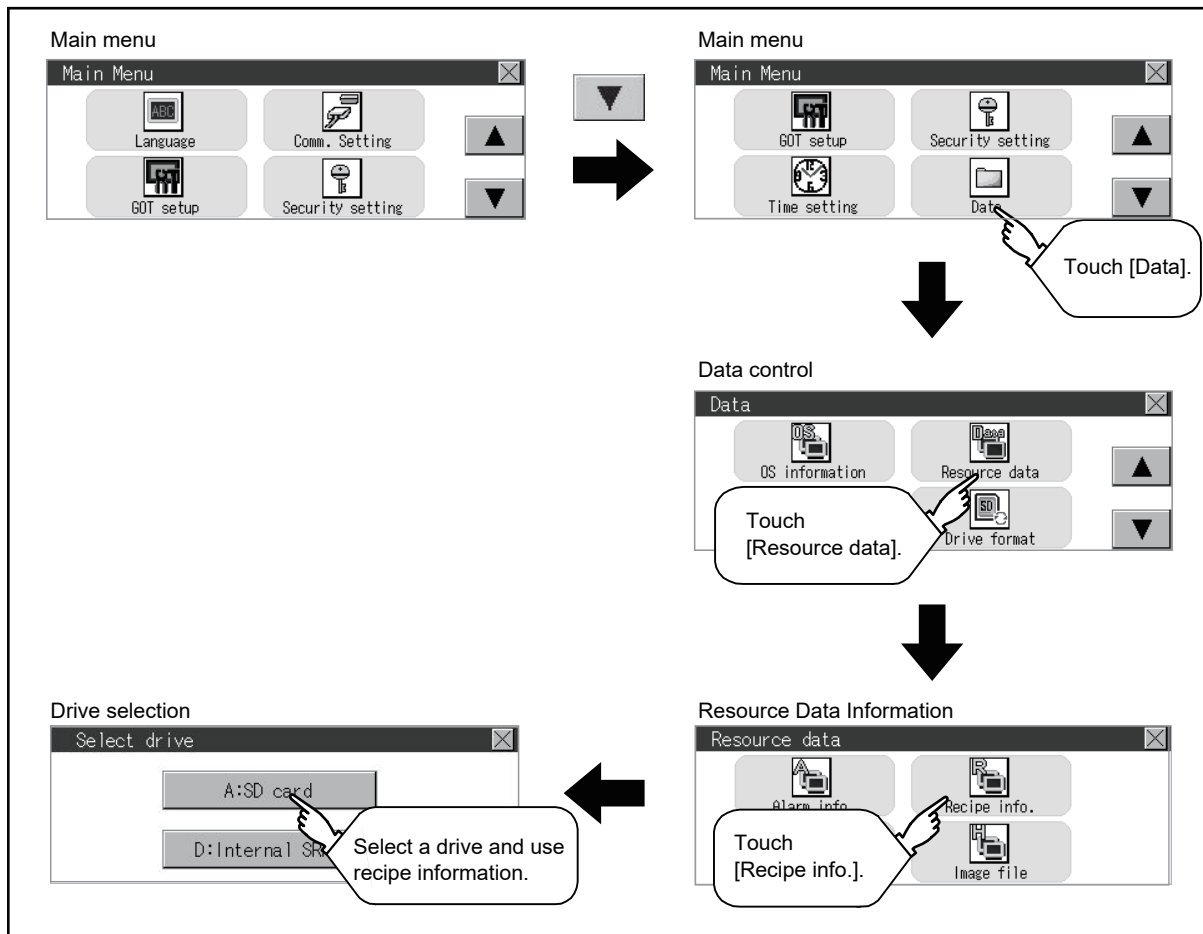

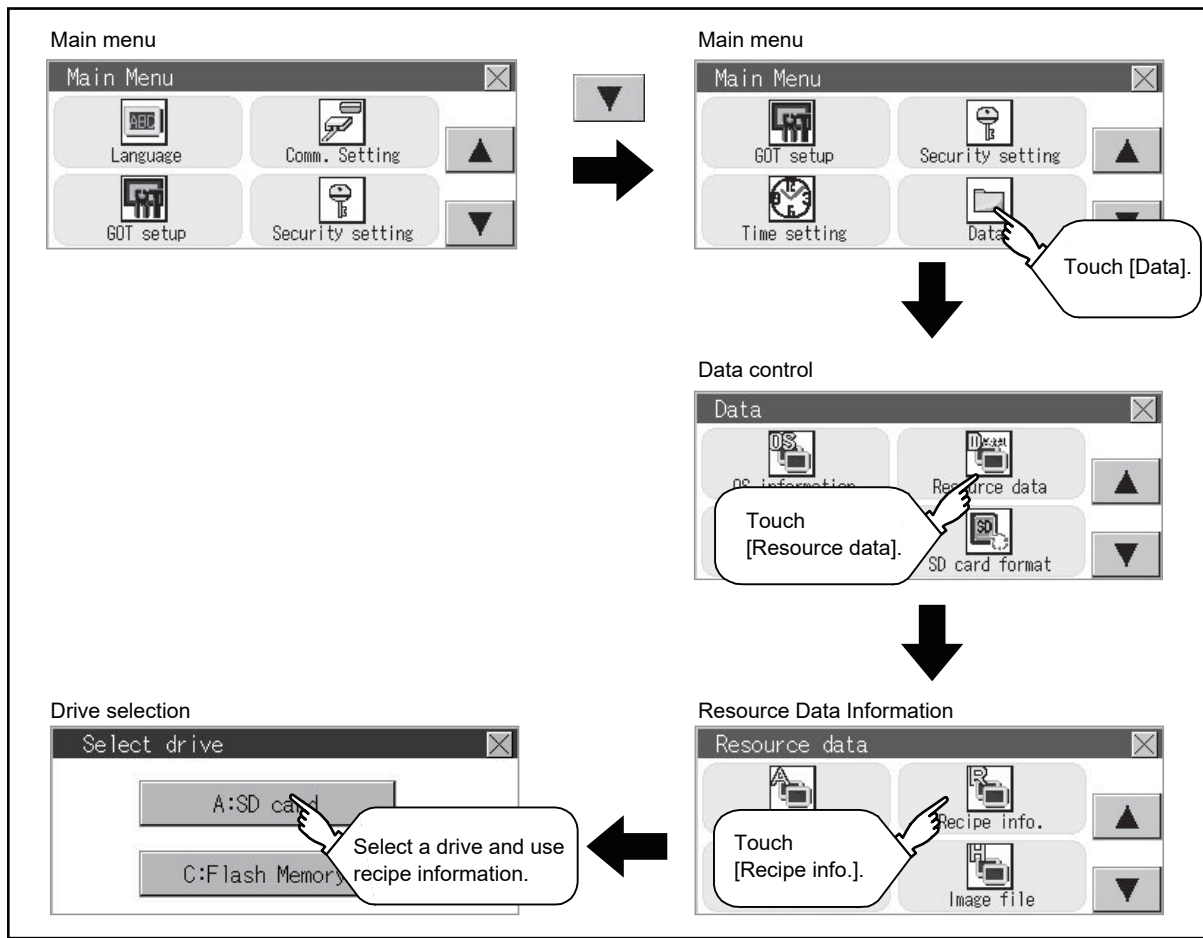

Example of advanced recipe information display

■Recipe information screen

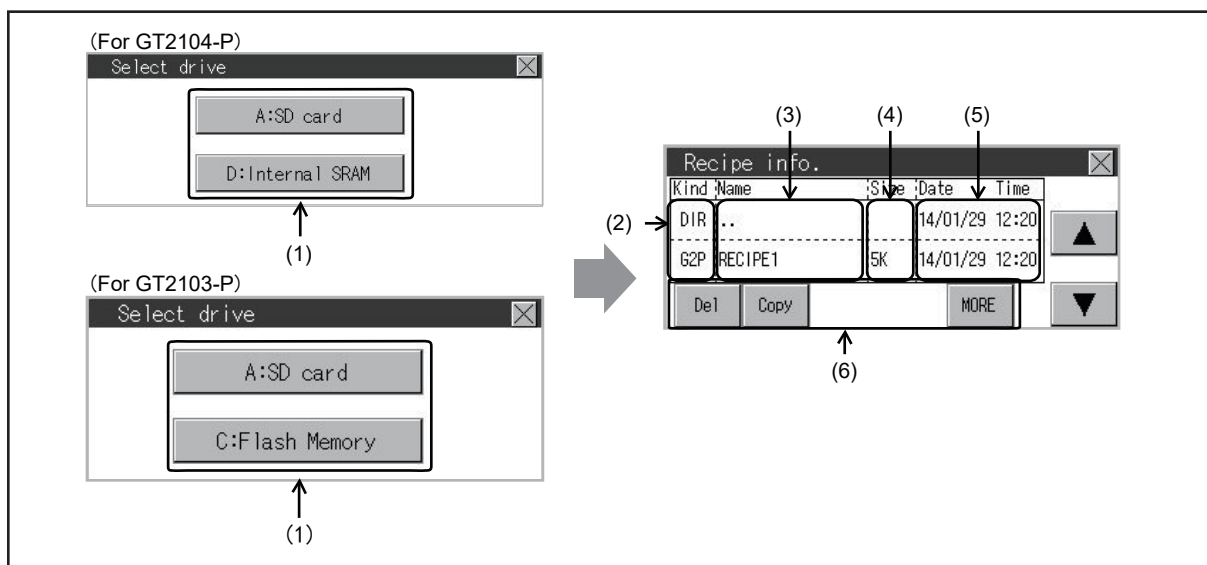
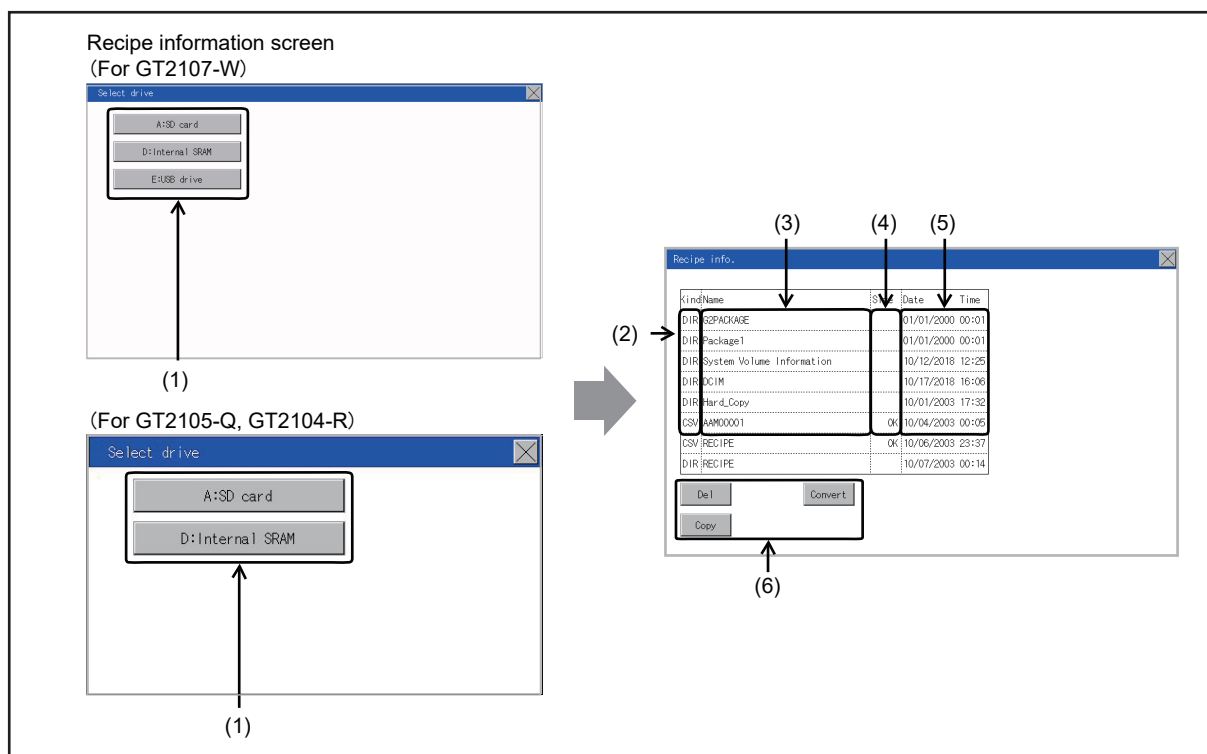

No.	Item	Description
(1)	Drive selection	Select a target drive. (Data storage drives are displayed even no data storage is installed.)
(2)	Kind	Indicates whether the displayed name is file or folder. Displays the extension for a file and "DIR" for a folder.
(3)	Name	Displays the file name or folder name. For the long file/folder name, entire part may not be displayed.
(4)	Size	Displays the size of the file displayed in Name.
(5)	Date, Time	Displays the creation date and time of each file.
(6)	Operation switch	Execution switch of each function.

Recipe information operation

■ Display operation of recipe information

1. If a drive of [Select drive] is touched, the information of the touched drive is displayed.

Recipe information screen
(For GT2107-W)

Select drive

- A:SD card
- D:Internal SRAM
- E:USB drive

(For GT2105-Q, GT2104-R)

Select drive

- A:SD card
- D:Internal SRAM

Recipe info.

KindName	Size	Date	Time
DIR:G2PACKAGE		01/01/2000	00:01
DIR:Package1		01/01/2000	00:01
DIR:System Volume Information		10/12/2018	12:25
DIR:DCIM		10/17/2018	16:06
DIR:Hard_Copy		10/01/2003	17:32
CSV:AAAM00001	0K	10/04/2003	00:05
CSV:RECIPE	0K	10/06/2003	23:37
DIR:RECIPE		10/07/2003	00:14

Del Convert Copy

(For GT2104-P)

Select drive

- A:SD card
- D:Internal SRAM

(For GT2103-P)

Select drive

- A:SD card
- C:Flash Memory

Recipe information
Storage file/folder display screen

Recipe info.

Kind	Name	Size	Date	Time
DIR	...		14/01/29	12:20
G2P	RECIPE1	5K	14/01/29	12:20

Del Copy MORE

MORE ↑ ↓ MORE

Recipe info.

Kind	Name	Size	Date	Time
DIR	...		14/01/29	12:20
G2P	RECIPE1	5K	14/01/29	12:20

Convert MORE

2. If a folder name is touched, the information of the touched folder is displayed.
3. If a folder of "." is touched, the information of the folder in one upper hierarchy is displayed.
4. If the ▲▼ button of the scrollbar is touched, the screen scrolls up/down by one line.
5. If a file name is touched, the file is selected.

6. For operation of operating switches, refer to the following.

G2P → CSV, G2P → TXT

☞ Page 575 G2P → CSV conversion operation, G2P → TXT conversion operation

CSV/TXT → G2P

☞ Page 576 CSV/TXT → G2P conversion operation

Delete

☞ Page 577 Deletion operation

Copy

☞ Page 578 Copy operation

7. If the [x] button is touched, the screen is closed.

■G2P → CSV conversion operation, G2P → TXT conversion operation

A recipe file (G2P file) is converted to a CSV file or Unicode text file that can be displayed/edited on a personal computer.

1. Touch the G2P file to be converted.

(For GT2107-W, GT2105-Q, GT2104-R)

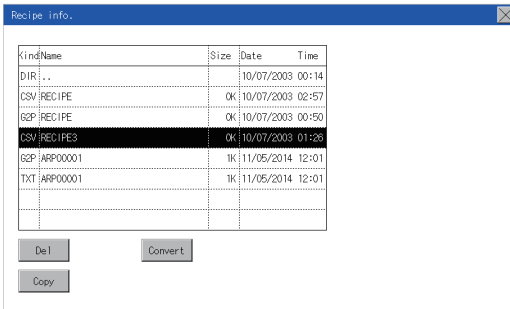

(For GT2104-P, GT2103-P)

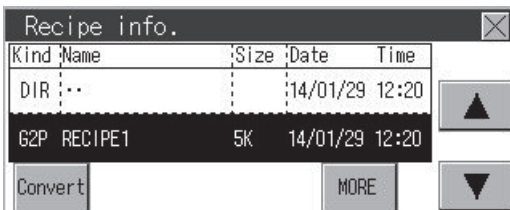

2. Touch [Convert].

3. Touch the following button in accordance with destination file type.

- CSV file: [CSV] button
- Unicode text file: [TXT] button

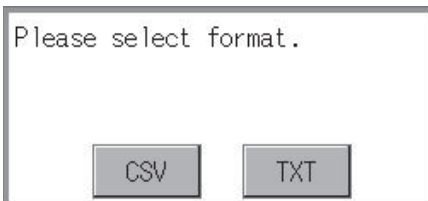

4. Touch the [YES] button. The file is overwritten with the converted file.

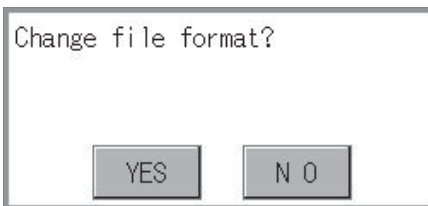

■CSV/TXT → G2P conversion operation

A CSV file or Unicode text file is converted to a recipe file (G2P file).

1. Touch the CSV file or Unicode text file to be converted.

(For GT2107-W, GT2105-Q, GT2104-R)

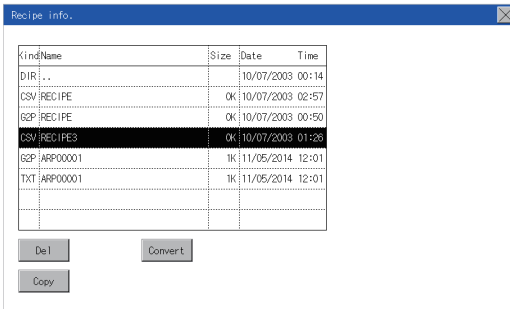

(For GT2104-P, GT2103-P)

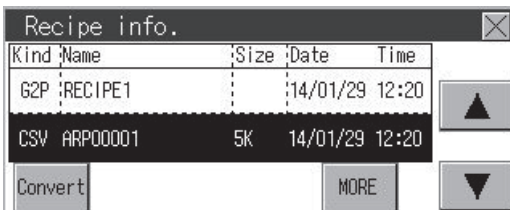

2. Touch the [Convert] button.
3. If the [YES] button is touched, the file is overwritten with the converted file.

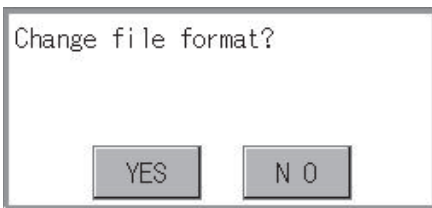

■ Deletion operation

Files to be used in recipe are deleted.

1. Touch the file to be deleted.

(For GT2107-W, GT2105-Q, GT2104-R)

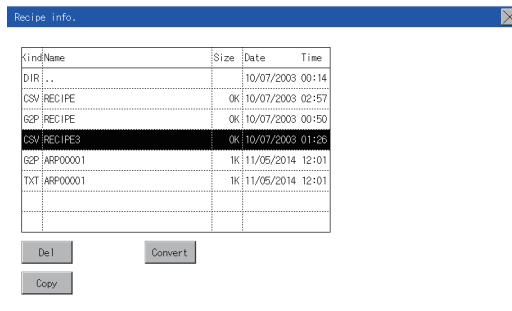

(For GT2104-P, GT2103-P)

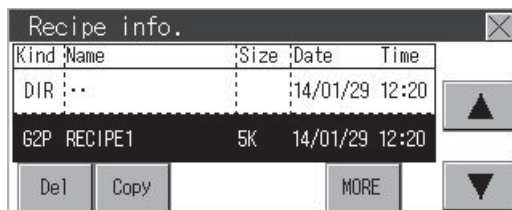

2. If the [Delete] button is touched, the dialog box mentioned below is displayed.

If the [YES] button is touched, the file is deleted.

If the [NO] button is touched, the deletion is canceled.

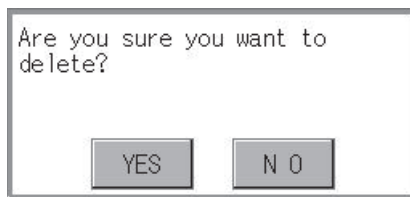

■ Copy operation

Files to be used in recipe are copied.

1. Touch the file to be copied.

(For GT2107-W, GT2105-Q, GT2104-R)

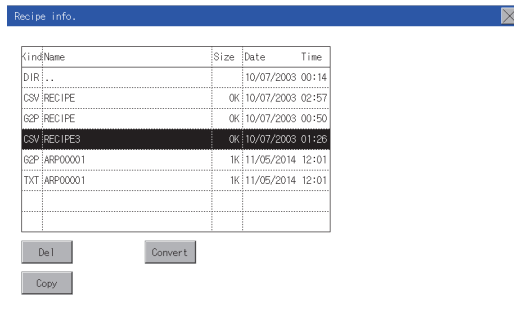

(For GT2104-P, GT2103-P)

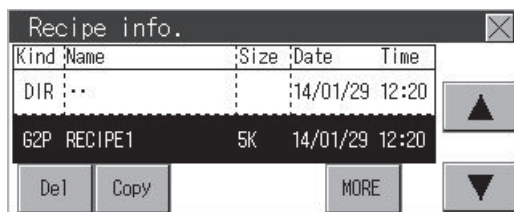

2. If the [Copy] button is touched, the Select drive screen is displayed.

3. Select a drive.

(For GT2107-W)



(For GT2105-Q, GT2104-R)

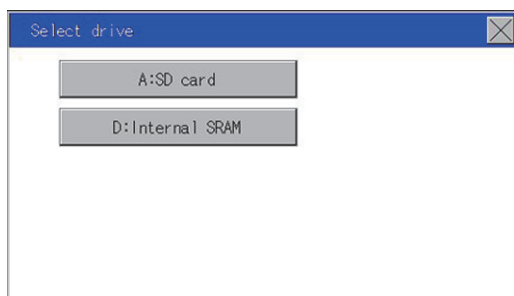

(For GT2104-P)

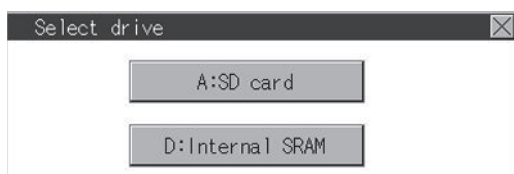

(For GT2103-P)

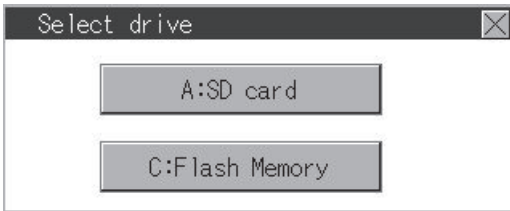

4. Select the copy destination folder and touch [Execute]. The file is copied.

(For GT2107-W, GT2105-Q, GT2104-R)

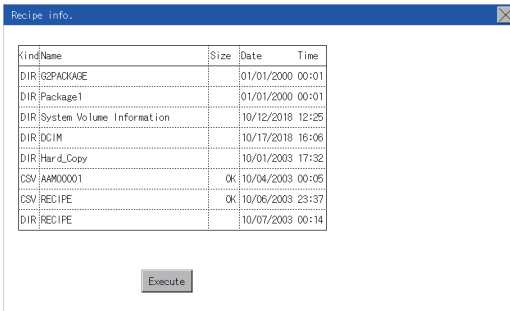

(For GT2104-P, GT2103-P)

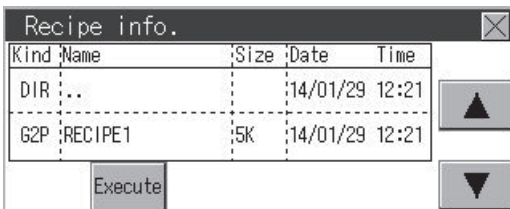

Precautions

■Precautions for operation

- Precautions during file operation (Create/Delete/Copy/File conversion, etc.)

Even if the access to the SD card is inhibited while the GOT is processing files, the processing continues. (Example: Even if the access to the SD card is inhibited while the GOT is copying a file, a file is created.)

Therefore, do not pull out the SD card while the "Processing..." message is on the screen after the access to the SD card is inhibited.

- While the GOT is accessing to other file (Alarm data, etc.)

When file processing for the recipe is executed while the GOT is in access to another file (SD card access LED ON), the GOT executes file processing for the recipe after the processing for the other file has completed.

Therefore, it may take some time to finish the processing of the recipe file.



Estimation of processing time

The process may take time depending on the setting of advanced recipe file to be operated. (The more number of blocks increases, the longer it takes to process recipe folder/file.)

The process for creating the first file may take time depending on the setting of advanced recipe file.

Logging information

Function of logging information

This function displays the logging files stored in each drive (A: Standard SD card or E: USB drive).

The functions below can be carried out for files.

For details on the logging function, refer to the following.

📖 GT Designer3 (GOT2000) Screen Design Manual

Function	Description	Reference
Information display of files and folders	Displays name, data size, creation date and time of file or folder.	<ul style="list-style-type: none"> ☞ Page 582 Example of logging information display, ☞ Page 583 Logging information operation
Delete	Deletes the file.	☞ Page 584 Deletion operation
Copy	Copies the file.	☞ Page 585 Copy operation

Display operation of logging information

■GT2107-W

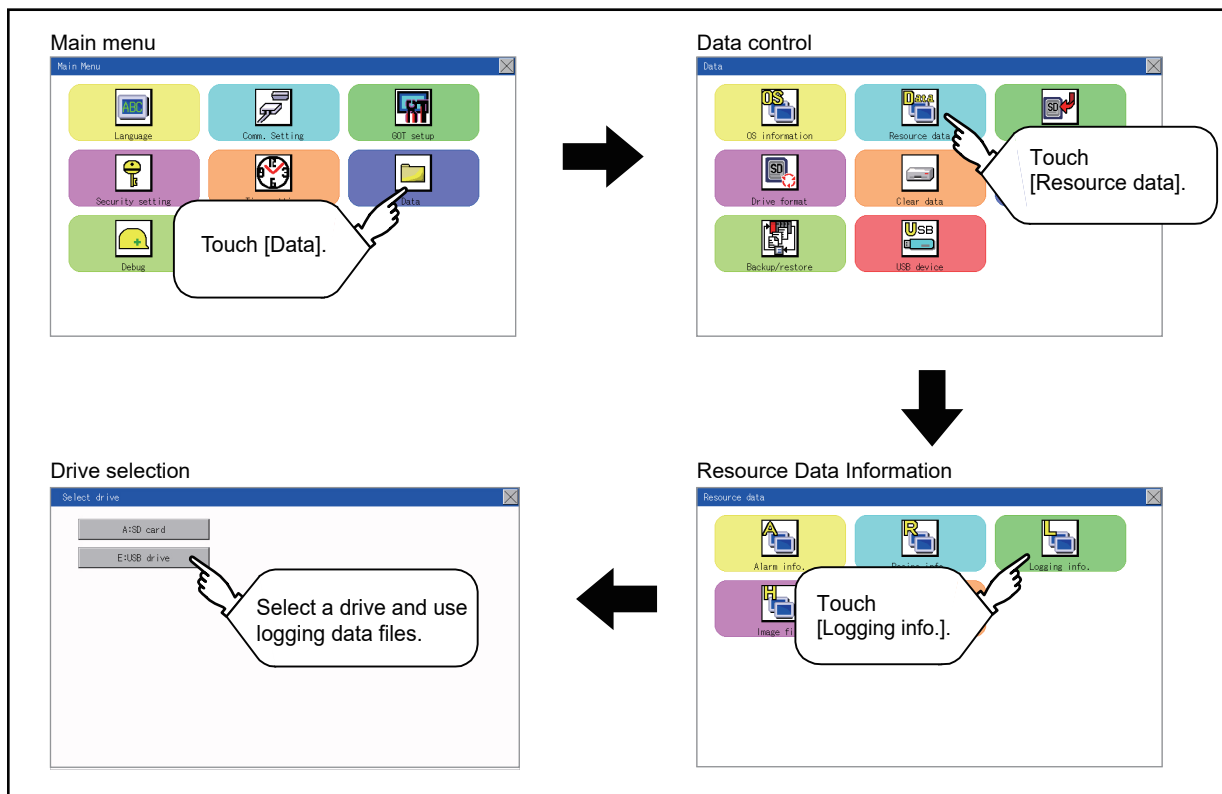

■GT2105-Q, GT2104-R

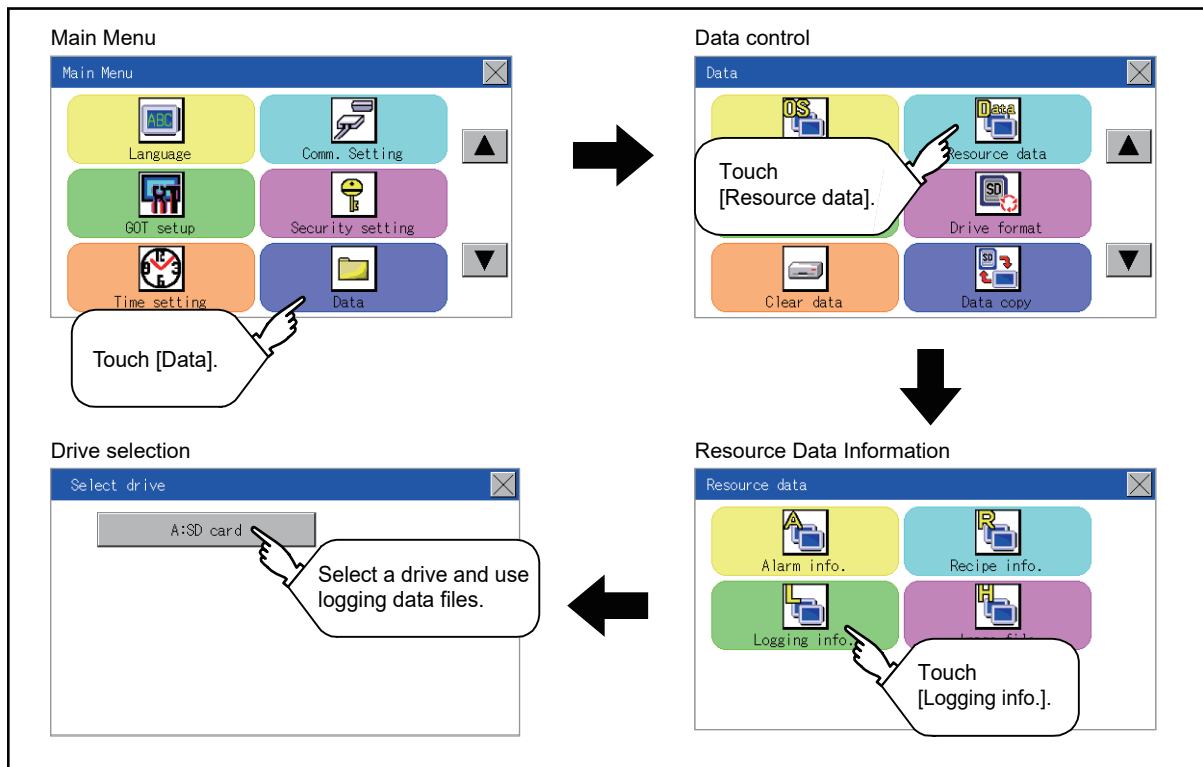

■GT2104-P, GT2103-P

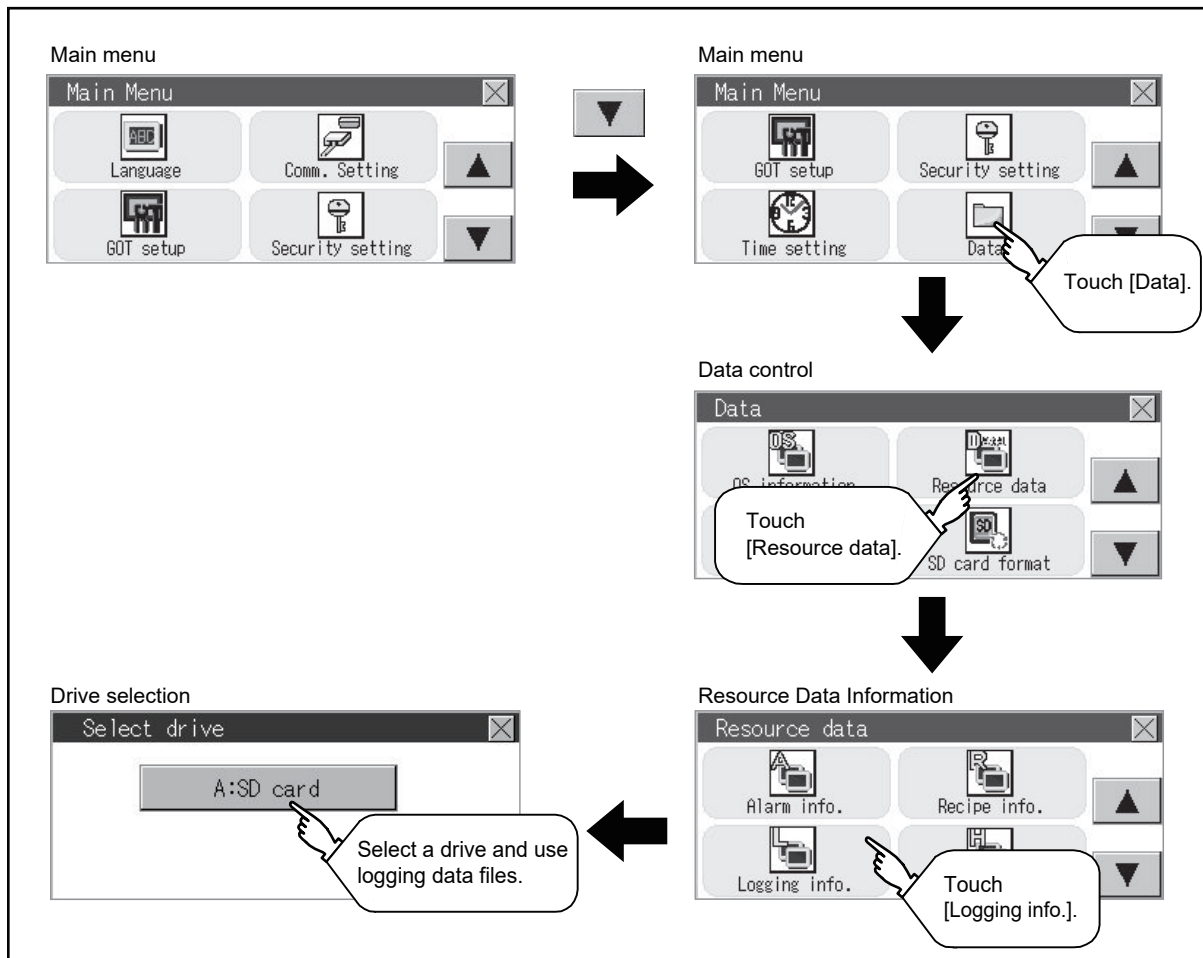

Example of logging information display

(For GT2107-W)

(1)

(For GT2105-Q, GT2104-R)

(1)

Logging info.

Kind	Name	Size	Date	Time
DIR	PACKAGE		01/01/2000	00:01
DIR	Package1		01/01/2000	00:01
DIR	System Volume Information		10/12/2018	12:25
DIR	CIM		10/17/2018	16:06
DIR	Hard_Copy		10/01/2003	17:32
CSV	AM00001	0K	10/04/2003	00:05
CSV	RECIPE	0K	10/06/2003	23:37
DIR	RECIPE		10/07/2003	00:14

De1
Copy

(2) (3) (4) (5) (6)

(For GT2104-P, GT2103-P)

(1)

Logging info.

Kind	Name	Size	Date	Time
DIR	..		14/01/29	12:20
G2L	LOG00001_001	5K	14/01/29	12:20

De1 Copy

(2) (3) (4) (5) (6)

No.	Item	Description
(1)	Drive selection	Select a target drive. (Data storage drives are displayed even no data storage is installed.)
(2)	Kind	Indicates whether the displayed name is file or folder. Displays the extension for a file and "DIR" for a folder.
(3)	Name	Displays the file name or folder name. For the long file/folder name, entire part may not be displayed.
(4)	Size	Displays the size of the file displayed in Name.
(5)	Date, Time	Displays the creation date and time of each file.
(6)	Operation switch	Execution switch of each function.

Logging information operation

■ Display operation of logging information

1. If a drive of [Select drive] is touched, the information of the touched drive is displayed.

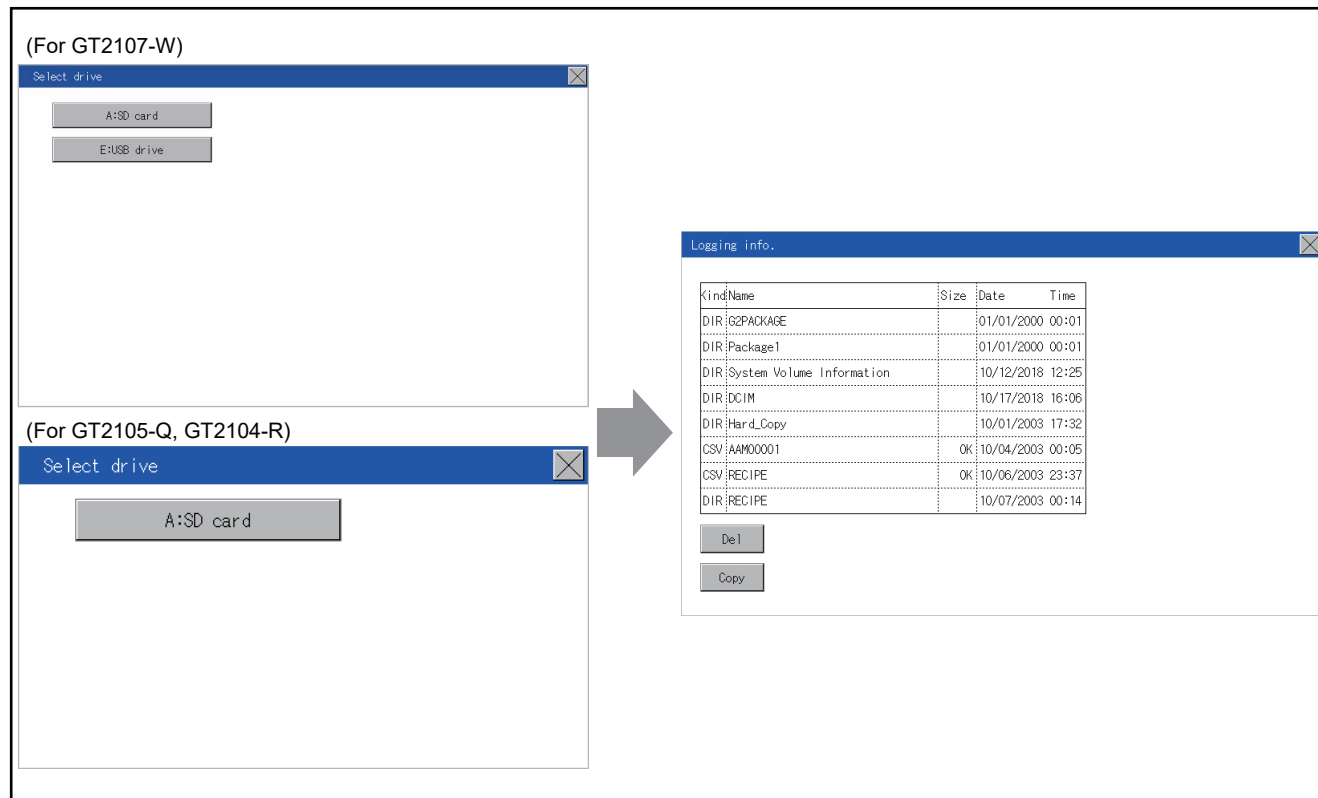

15

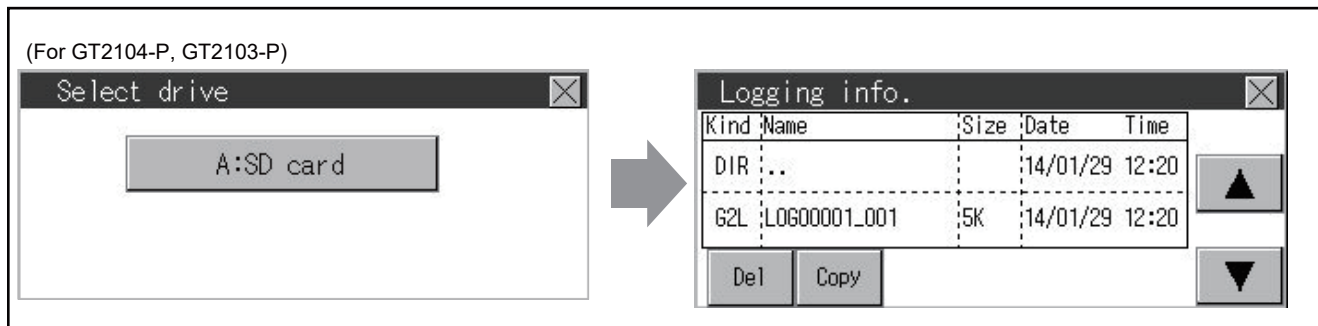

2. If a folder name is touched, the information of the touched folder is displayed.
3. If a folder of "." is touched, the information of the folder in one upper hierarchy is displayed.
4. If the ▲▼ button of the scrollbar is touched, the screen scrolls up/down by one line.
5. If a file name is touched, the file is selected.
6. For operation of operating switches, refer to the following.

Delete

☞ Page 584 Deletion operation

Copy

☞ Page 585 Copy operation

7. If the [x] button is touched, the screen is closed.

■ Deletion operation

Files to be used in logging are deleted.

1. Touch the file to be deleted.

(For GT2107-W, GT2105-Q, GT2104-R)

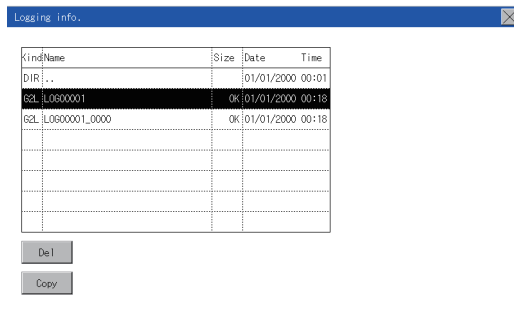

(For GT2104-P, GT2103-P)

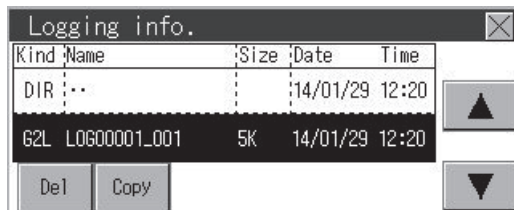

2. If the [Delete] button is touched, the dialog box mentioned below is displayed.

If the [YES] button is touched, the file is deleted.

If the [NO] button is touched, the deletion is canceled.

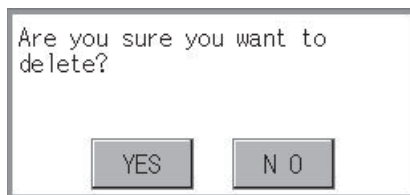

■ Copy operation

Files to be used in logging is copied.

1. Touch the file to be copied.

(For GT2107-W, GT2105-Q, GT2104-R)

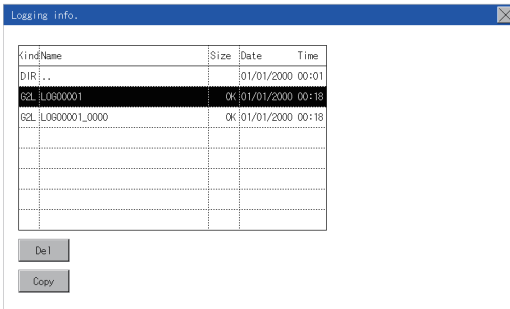

(For GT2104-P, GT2103-P)

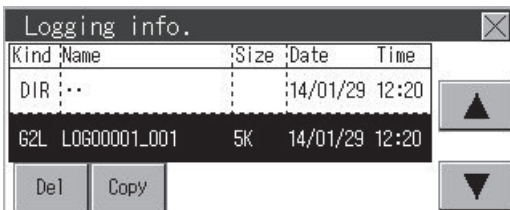

2. If the [Copy] button is touched, the Select drive screen is displayed.

3. Select a drive.

(For GT2107-W)

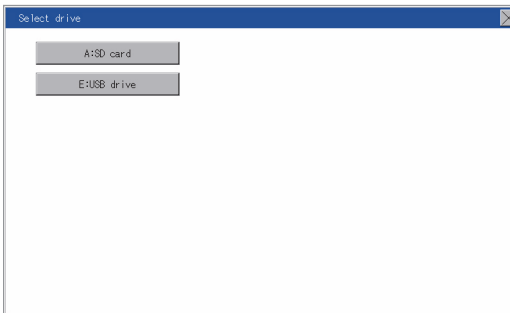

(For GT2105-Q, GT2104-R)

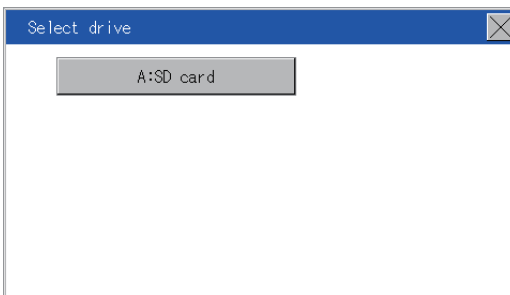

(For GT2104-P, GT2103-P)

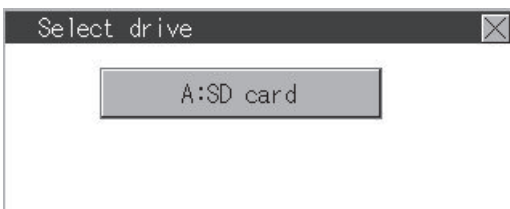

4. Select the copy destination folder and touch [Execute]. The file is copied.
(For GT2107-W, GT2105-Q, GT2104-R)

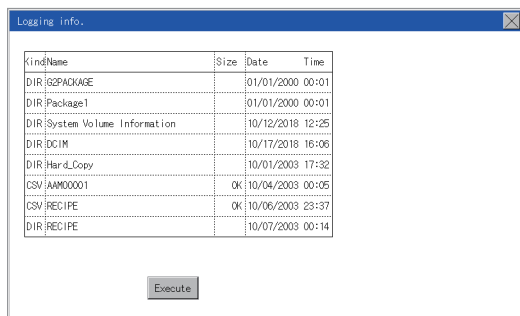

(For GT2104-P, GT2103-P)

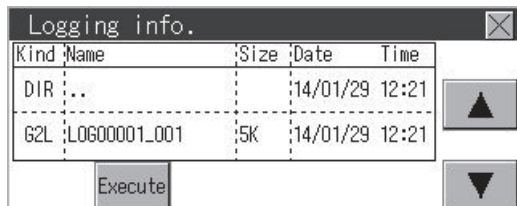

Precautions

■ Precautions for operation

- Precautions during file operation (Create/Delete/Copy, etc.)

Even if the access to the SD card is inhibited while the GOT is processing files, the processing continues.

(Example: Even if the access to the SD card is inhibited while the GOT is copying a file, a file is created.)

Therefore, do not pull out the SD card while the "Processing..." message is on the screen after the access to the SD card is inhibited.

- While the GOT is accessing to other file (Alarm data, etc.)

When file processing for the logging is executed while the GOT is in access to other files (SD card access LED ON), the GOT executes file processing for the logging after the processing for other files is completed.

Therefore, it may take some time to finish the processing of the logging file.

Image file management

Function of image file management

This function displays the image files stored in each drive (A: Standard SD card or E: USB drive).

The functions below can be carried out for files.

For details on the hard copy function, refer to the following.

📖 GT Designer3 (GOT2000) Screen Design Manual

Function	Description	Reference
Information display of files and folders	Displays the kind, name, data size, creation date and time of the file or folder.	📖 Page 589 Display example of image file management, 📖 Page 590 Operation of image file management
Delete	Deletes the file.	📖 Page 591 Deletion operation
Copy	Copies the file.	📖 Page 592 Copy operation

Display operation of image file management

■GT2107-W

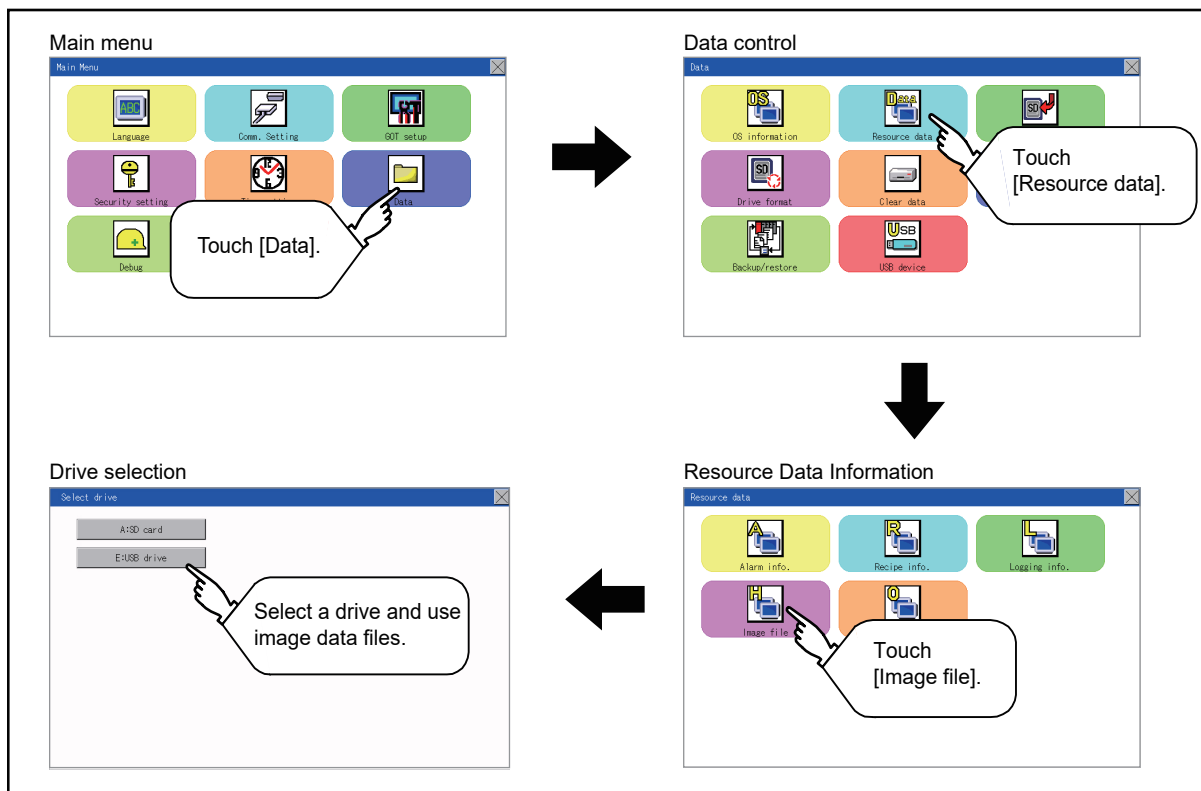

■GT2105-Q, GT2104-R

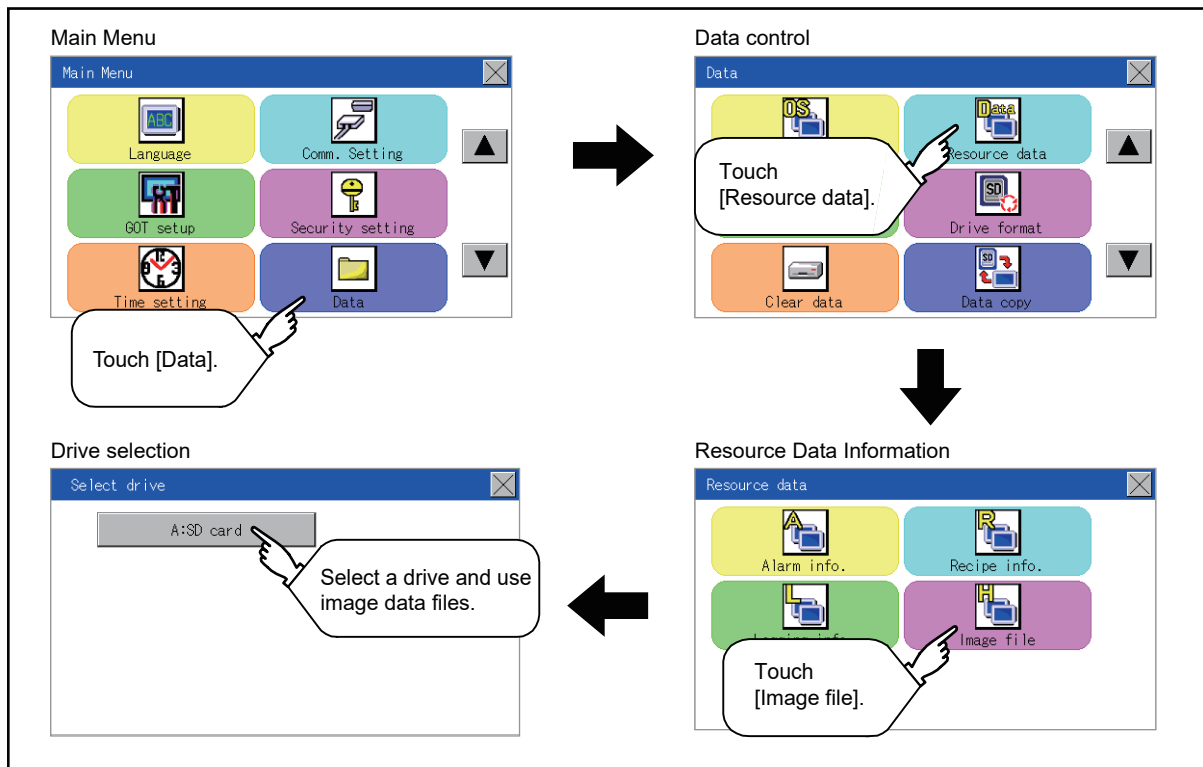

■GT2104-P, GT2103-P

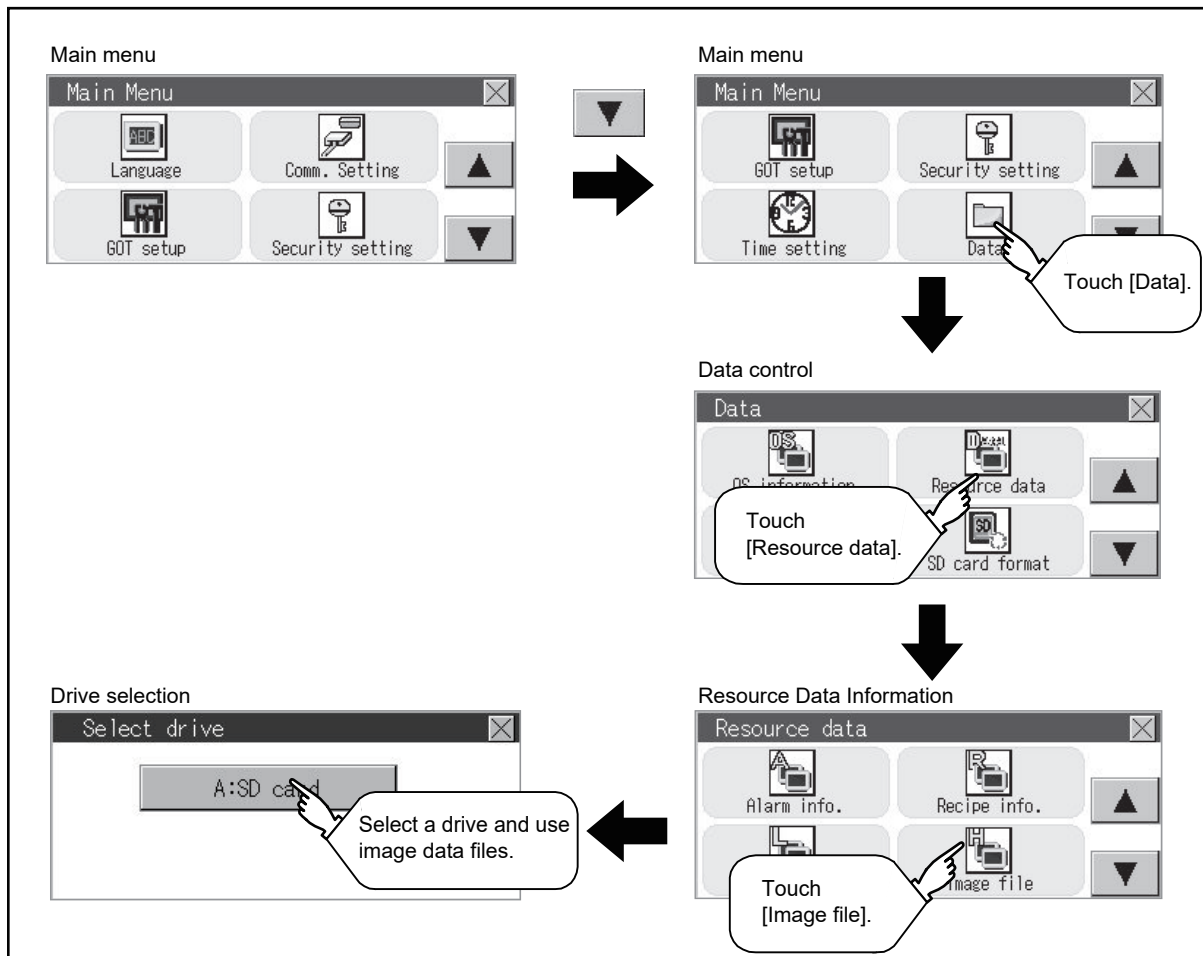

Display example of image file management

(For GT2107-W)

(1)

(For GT2105-Q, GT2104-R)

(1)

(2) (3) (4) (5)

Kind	Name	Size	Date	Time
DIR	GP_PACKAGE		01/01/2000	00:01
DIR	Package1		01/01/2000	00:01
DIR	System Volume Information		10/12/2018	12:25
DIR	DCIM		10/17/2018	16:06
DIR	Hard_Copy		10/01/2003	17:32
DIR	RECIPE		10/07/2003	00:14

(6)

15

(For GT2104-P, GT2103-P)

(1)

(2) (3) (4) (5)

Kind	Name	Size	Date	Time
DIR	Package1		14/01/29	12:20
JPG	SNAP0001	21K	14/01/29	12:20

(6)

No.	Item	Description
(1)	Drive selection	Select a drive to display files or folders. When an SD card is not installed, the following drives are not displayed. • SD card: [A:SD card]
(2)	Kind	Indicates whether the displayed name is file or folder. Displays the extension for a file and "DIR" for a folder.
(3)	Name	Displays the file name or folder name. For the long file/folder name, entire part may not be displayed.
(4)	Size	Displays the size of the file displayed in Name.
(5)	Date, Time	Displays the creation date and time of each file.
(6)	Operation switch	Execution switch of each function.

Point

- Display of creation date and time

The creation date and time display is not updated even if a file is created or updated while the image file management screen is displayed. To display the updated creation date and time, close the screen currently displayed (by moving to the upper hierarchy folder, etc.) and display the screen again.

Operation of image file management

■ Display operation of image file management

1. If a drive of [Select drive] is touched, the information of the touched drive is displayed.
(For GT2107-W, GT2105-Q, GT2104-R)

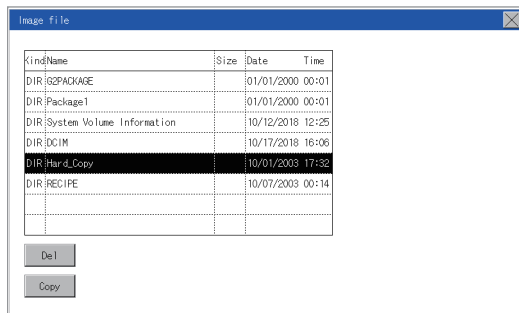

(For GT2104-P, GT2103-P)

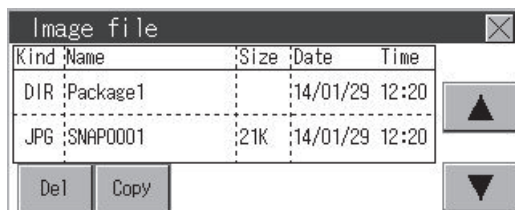

2. If a folder name is touched, the information of the touched folder is displayed.
3. If a folder of "." is touched, the information of the folder in one upper hierarchy is displayed.
4. If the ▲▼ button of the scrollbar is touched, the screen scrolls up/down by one line.
5. If a file name is touched, the file is selected.
6. For the operations of the delete, copy, and rename, refer to the following.

Delete

☞ Page 591 Deletion operation

Copy

☞ Page 592 Copy operation

7. If the [x] button is touched, the screen is closed.

■ Deletion operation

The selected file is deleted.

1. Touch the file to be deleted.

(For GT2107-W, GT2105-Q, GT2104-R)

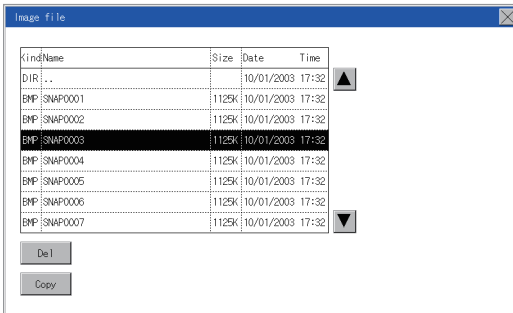

(For GT2104-P, GT2103-P)

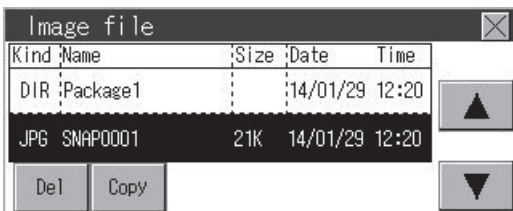

2. If the [Delete] button is touched, the screen mentioned below is displayed.

If the [YES] button is touched, the file is deleted.

If the [NO] button is touched, the deletion is canceled.

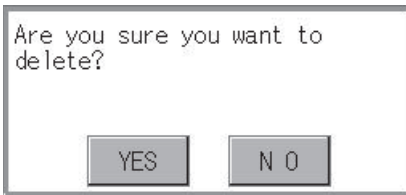

■ Copy operation

The selected file is copied.

1. Touch the file to be copied.

(For GT2107-W, GT2105-Q, GT2104-R)

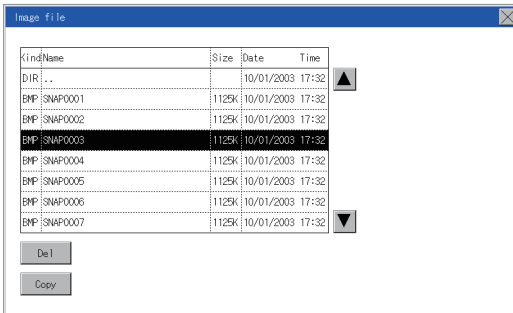

(For GT2104-P, GT2103-P)

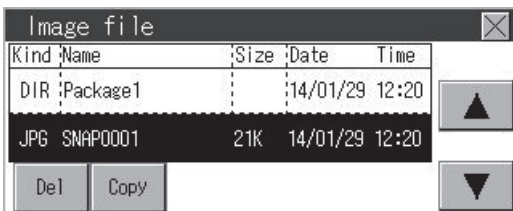

2. If the [Copy] button is touched, the Select drive screen is displayed. Select a drive.

(For GT2107-W)

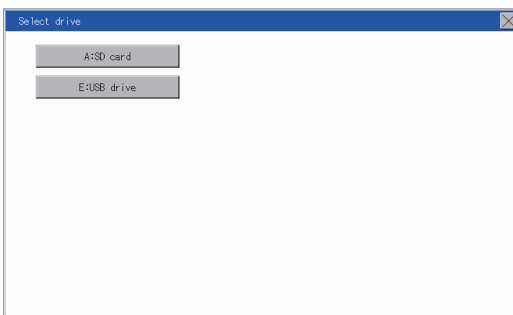

(For GT2105-Q, GT2104-R)

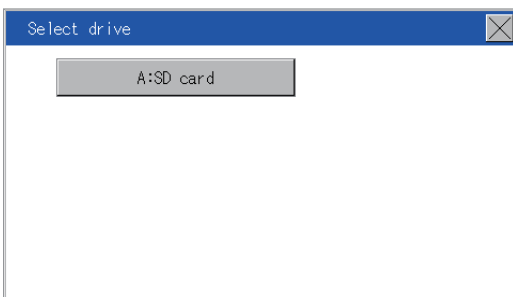

(For GT2104-P, GT2103-P)

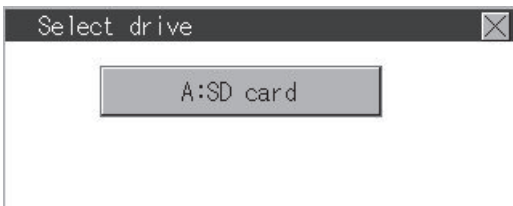

3. If the copy destination folder is touched, the screen display is changed to the folder of copy destination. At this time, it cannot be copied into the same folder where the file exists. Select other folders.

(For GT2107-W, GT2105-Q, GT2104-R)

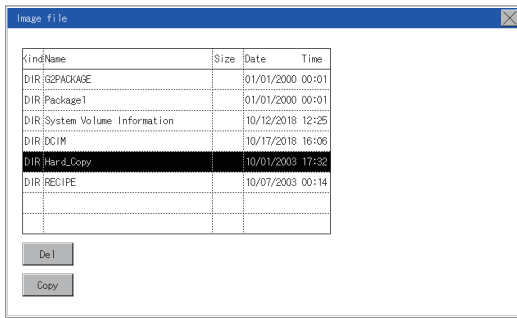

(For GT2104-P, GT2103-P)

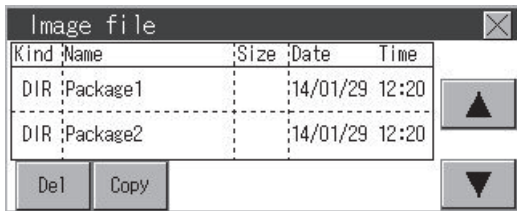

4. If touch the [Execute] button, the file is copied.

(For GT2107-W, GT2105-Q, GT2104-R)

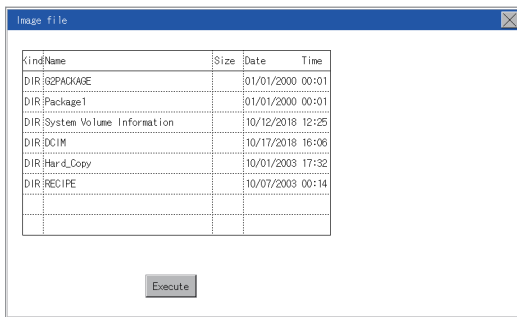

(For GT2104-P, GT2103-P)

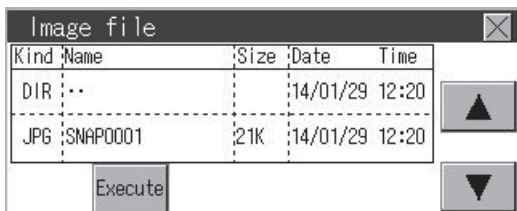

Operation log information

Function of operation log information

This function displays the operation log files stored in each drive (A: Standard SD card or E: USB drive).

The functions below can be carried out for files.

Only GT2107-W supports this function.

For details on operation logs, refer to the following.

📖 GT Designer3 (GOT2000) Screen Design Manual

Function	Description	Reference
Information display of files and folders	Displays name, data size, creation date and time of file or folder.	<ul style="list-style-type: none"> ☞ Page 595 Display example of operation log information, ☞ Page 596 Operation of operation log information
G2O → CSV conversion	Converts an operation log file (G2O file) to a CSV file.	☞ Page 597 G2O → CSV conversion operation, G2O → TXT conversion operation
G2O → TXT conversion	Converts an operation log file (G2O file) to a Unicode text file.	☞ Page 597 G2O → CSV conversion operation, G2O → TXT conversion operation
Delete	Deletes the file.	☞ Page 598 Deletion operation
Copy	Copies the file.	☞ Page 599 Copy operation

Display operation of operation log information

■GT2107-W

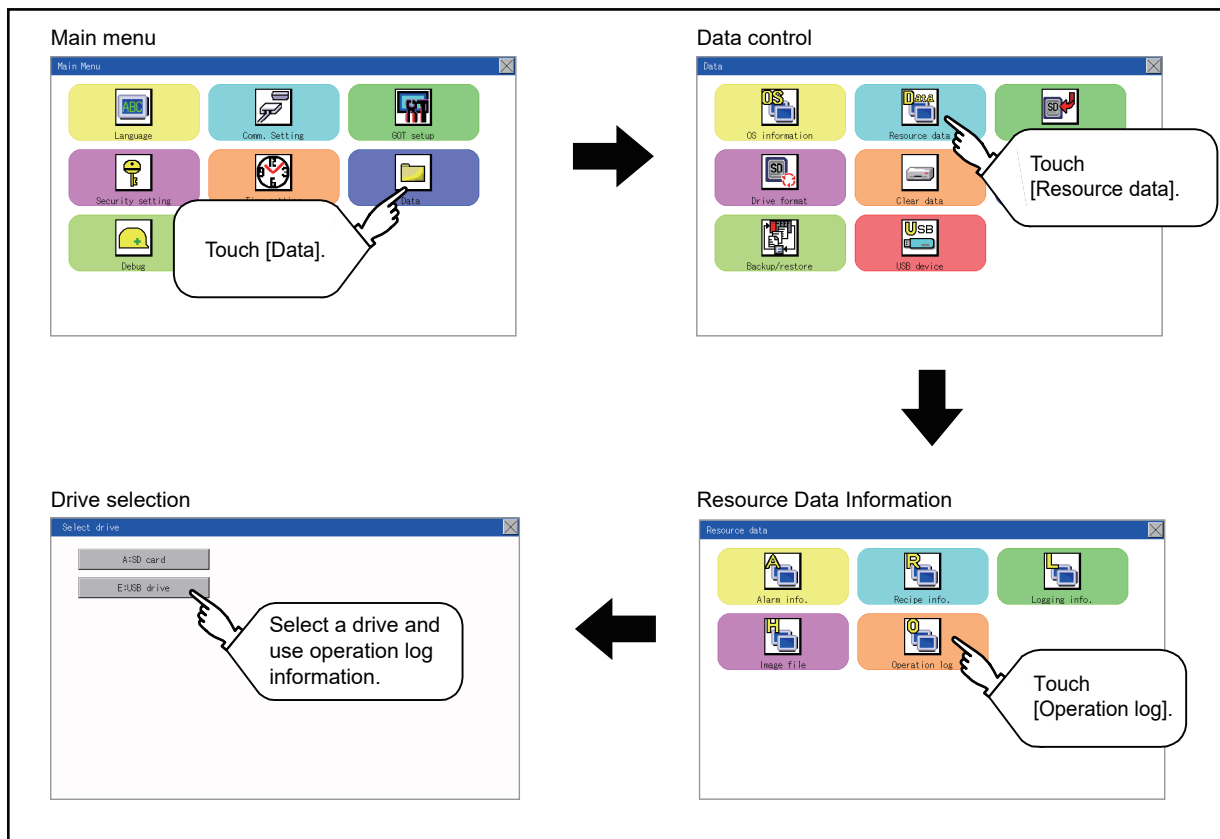

Display example of operation log information

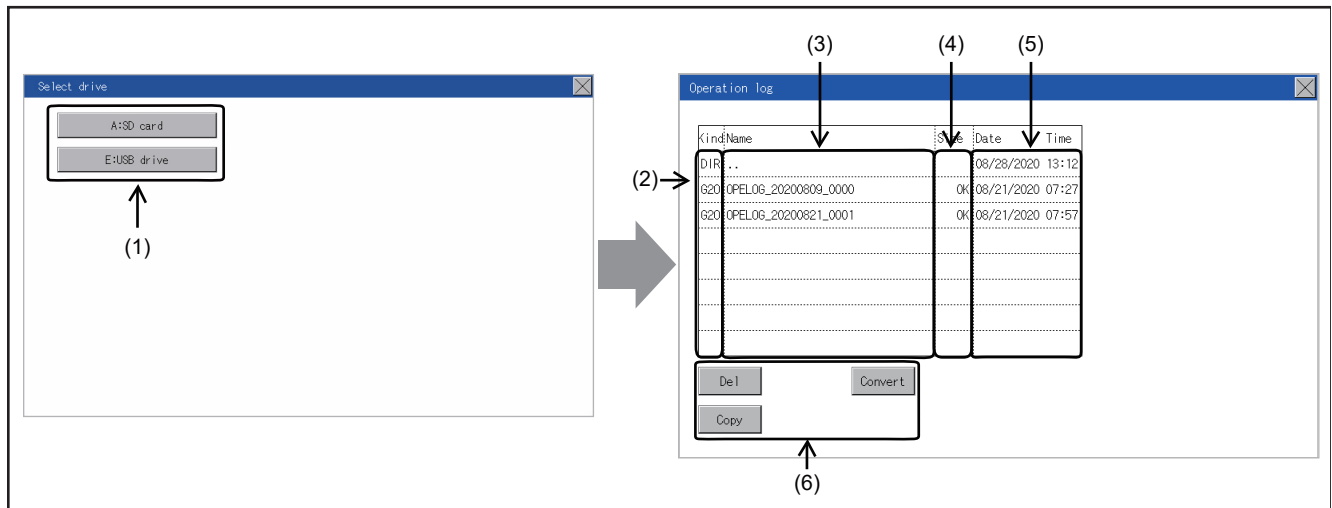

No.	Item	Description
(1)	Drive selection	Select a drive to display files or folders. (Data storage drives are displayed even no data storage is installed.)
(2)	Kind	Indicates whether the displayed name is file or folder. Displays the extension for a file and "DIR" for a folder.
(3)	Name	Displays the file name or folder name. For the long file/folder name, entire part may not be displayed.
(4)	Size	Displays the size of the file displayed in Name.
(5)	Date, Time	Displays the creation date and time of each file.
(6)	Operation switch	Execution switch of each function.

Operation of operation log information

■ Display operation of operation log information

1. If a drive of [Select drive] is touched, the information of the touched drive is displayed.

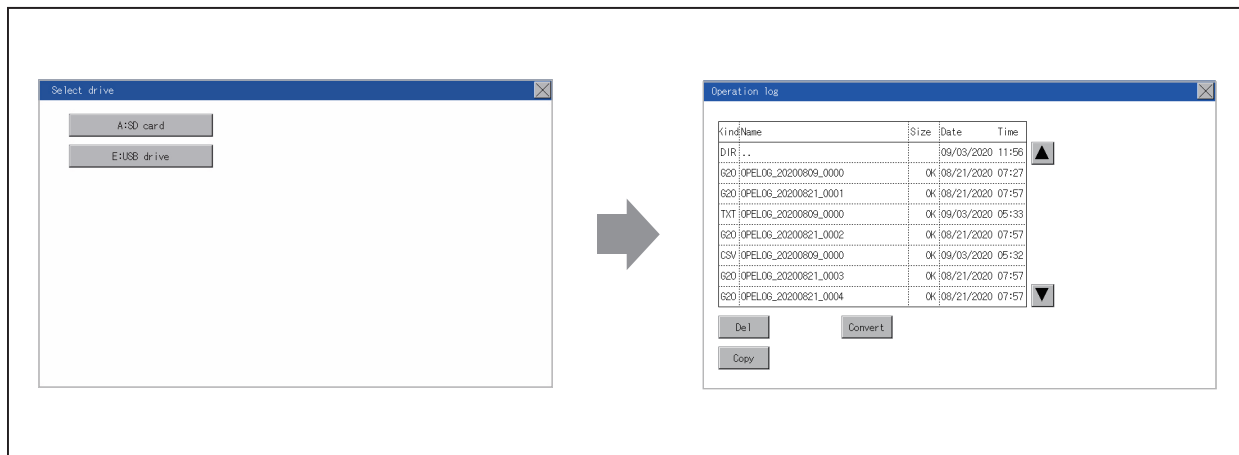

2. If a folder name is touched, the information of the touched folder is displayed.
3. If a folder of ". ." is touched, the information of the folder in one upper hierarchy is displayed.
4. If the ▲▼ button of the scrollbar is touched, the screen scrolls up/down by one line.
5. If a file name is touched, the file is selected.
6. For G20 → CSV conversion, G20 → TXT conversion, deleting, copying, and renaming, refer to the following.

G20 → CSV or G20 → TXT conversion

☞ Page 597 G20 → CSV conversion operation, G20 → TXT conversion operation

Delete

☞ Page 598 Deletion operation

Copy

☞ Page 599 Copy operation

7. If the [x] button is touched, the screen is closed.

Point

When the Prohibit Operation Log Information Operation signal (GS522.b3) is turned on, the [Del], [Copy], and [Convert] buttons are not displayed.

For the details, refer to the following.

📖 GT Designer3 (GOT2000) Screen Design Manual

■G20 → CSV conversion operation, G20 → TXT conversion operation

A selected G20 file is converted to a CSV file or Unicode text file.

1. Touch the G20 file to be converted.

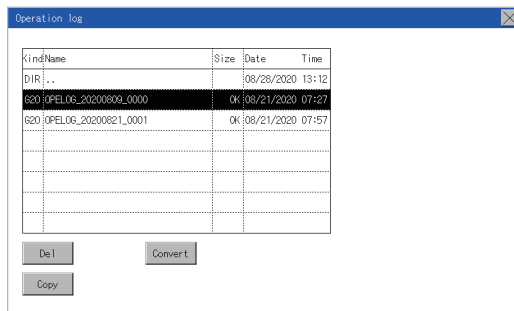

2. Touch [Convert].

3. The destination selection screen appears.

Select the destination.

4. The following dialog box is displayed when touching the following button according to the file type to convert to.

- CSV file: [CSV] button
- Unicode text file: [TXT] button

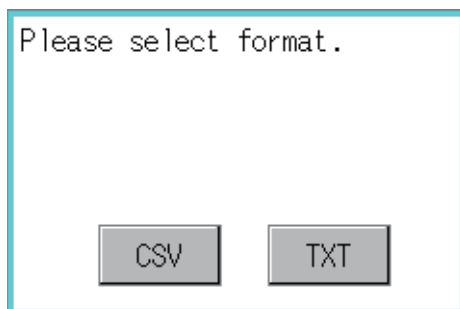

5. Touch the [YES] button. The converted file is created.

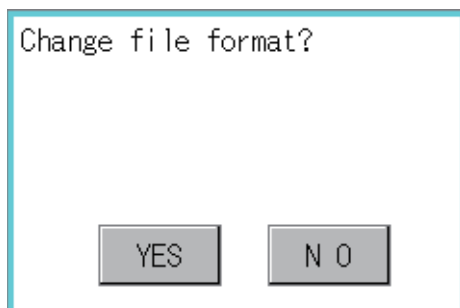

6. If a file with the same name exists, the overwrite confirmation dialog appears.

Touch the [YES] button to overwrite the file.

Touch the [NO] button to cancel the conversion.

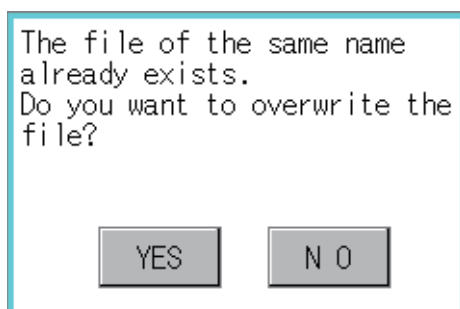

■ Deletion operation

The selected file is deleted.

1. Touch the file to be deleted.

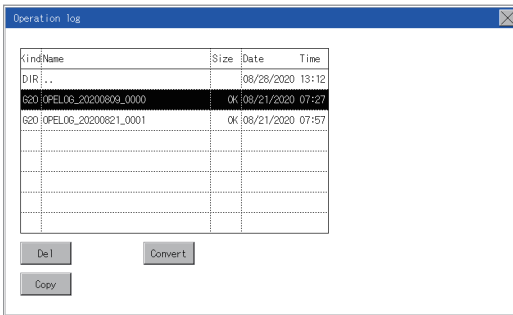

2. If the [Delete] button is touched, the dialog box mentioned below is displayed.
If the [YES] button is touched, the file is deleted.
If the [NO] button is touched, the deletion is canceled.

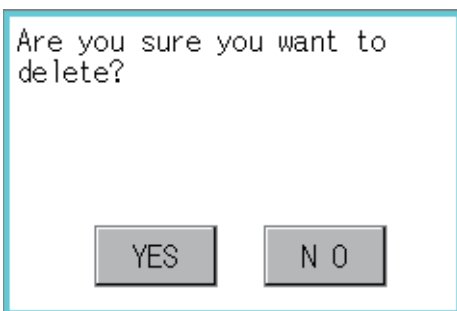

■ Copy operation

The selected file is copied.

1. Touch the file to be copied.
2. If the [Copy] button is touched, the Select drive screen is displayed.

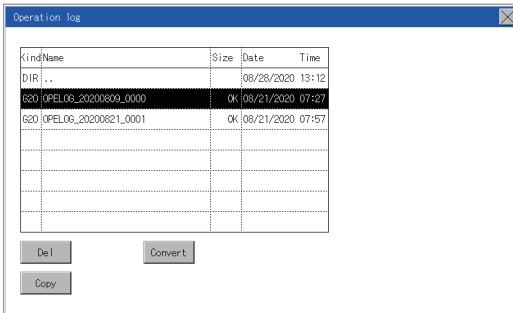

3. Select a drive.

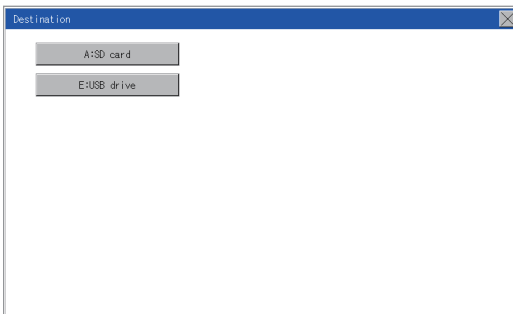

4. Select the copy destination folder and touch [Execute]. The file is copied.

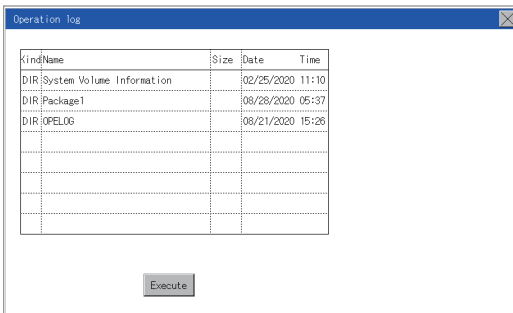

15.4 SD Card Access

Functions of SD card access

When the GOT is turned on, an SD card can be installed or removed to/from the GOT without damage to the data in the SD card.

Display operation of SD card access

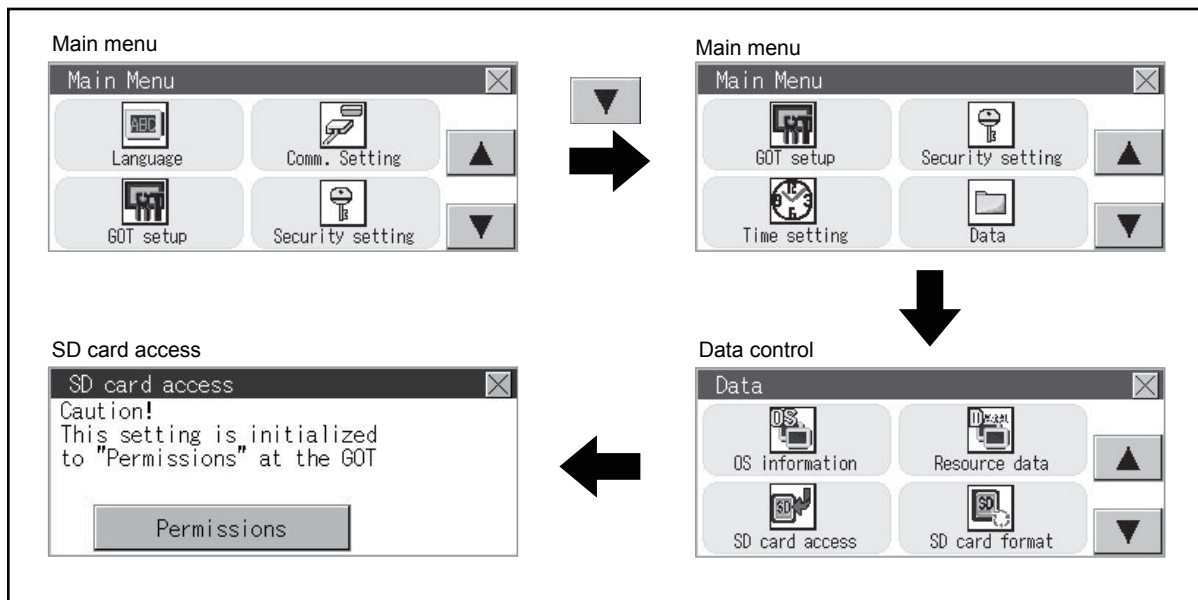

Operation of SD card access

1. Touch a setting item to change the setting.

[Permissions] ↔ [Access inhibit]

When installing or removing an SD card, always set [Access inhibit].

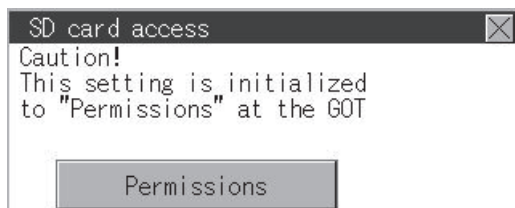

15.5 SD Card Format

Function of SD card format

An SD card is formatted.

Display operation of SD card format

■GT2107-W

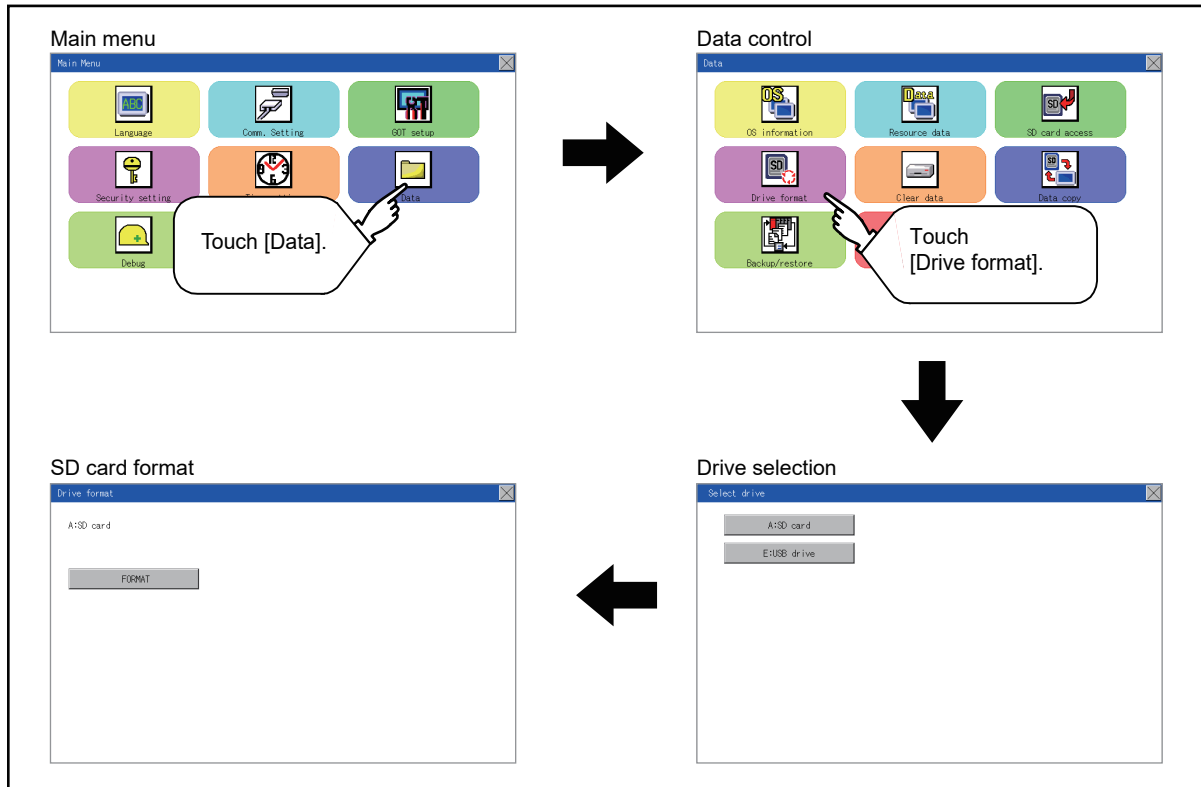

■GT2105-Q, GT2104-R

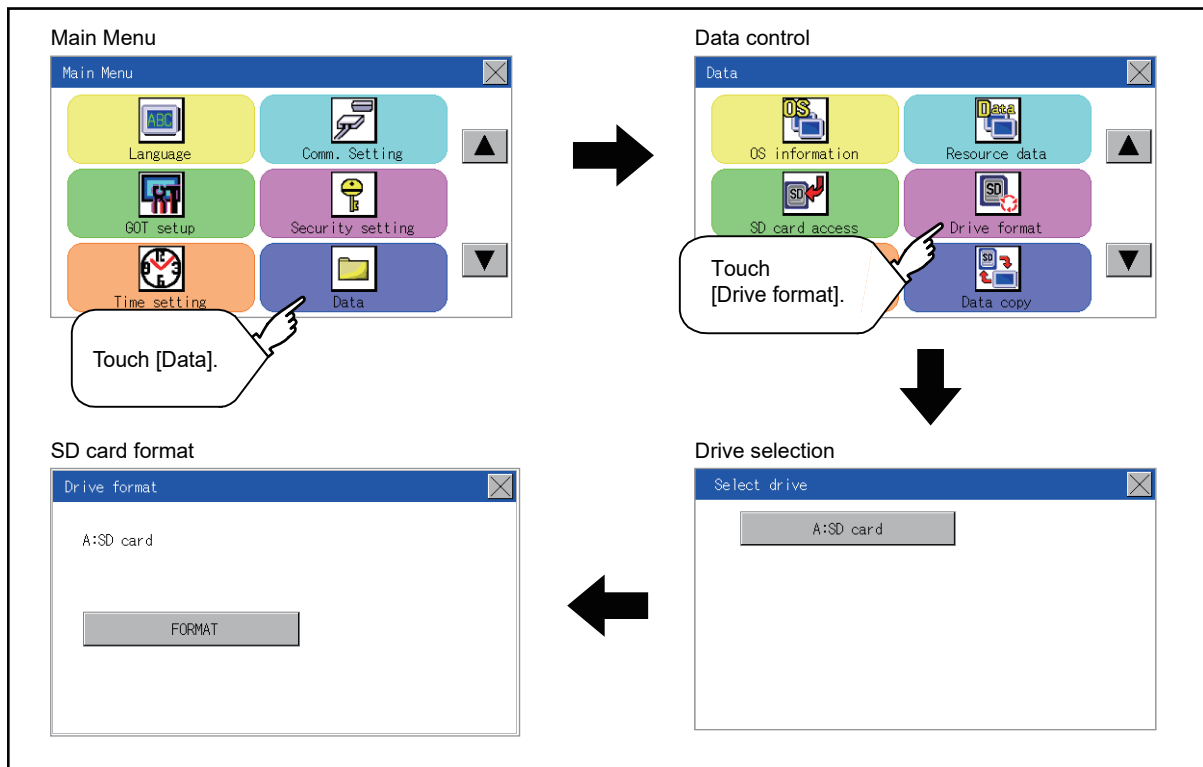

■GT2104-P, GT2103-P

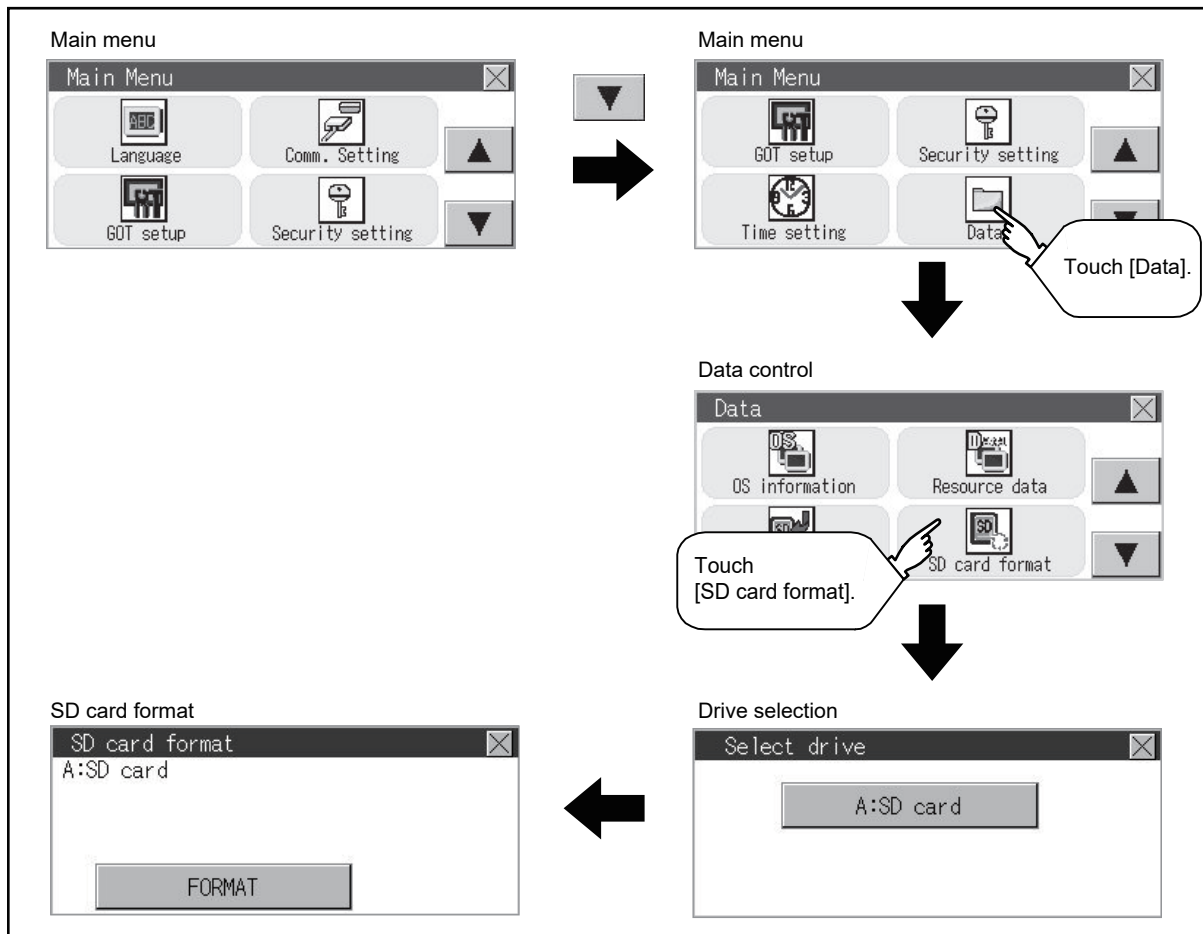

Operation of SD card format

1. Install an SD card to the GOT.

For installation/removal procedure of an SD card, refer to the following.

 GT21-03SDCD General Description

2. Touch and select the drive to format by drive selection.

(For GT2107-W)



(For GT2105-Q, GT2104-R)

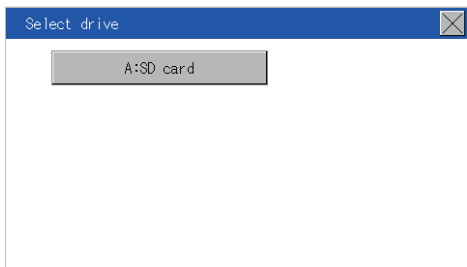

(For GT2104-P, GT2103-P)

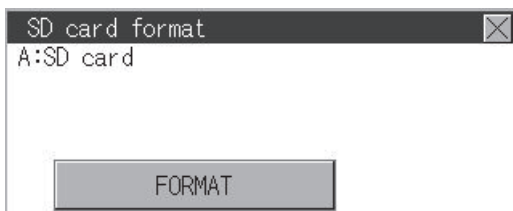

3. If the [FORMAT] button is touched, the password input screen is displayed.

(For GT2107-W, GT2105-Q, GT2104-R)

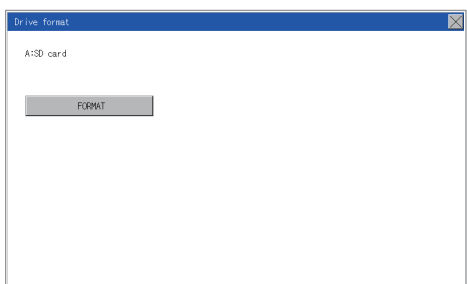

(For GT2104-P, GT2103-P)

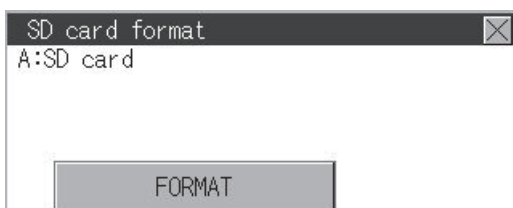

4. Type and touch the [Enter] key. The dialog box shown below will appear. (The password is fixed to 1111.) Confirm the contents of the dialog box, and touch the [YES] button to format the SD card. To cancel the format, touch the [NO] button.
(For SD card)

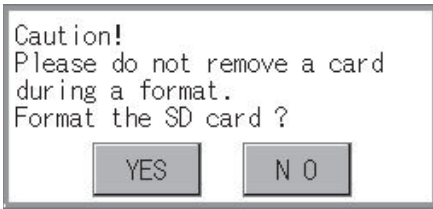

(For USB drive)

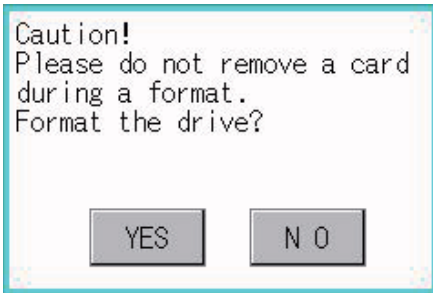

5. When the formatting is completed, the completion dialog mentioned below is displayed.

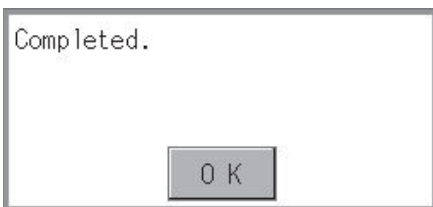

6. To close the dialog box, touch the [OK] button.

Point 

Restrictions on formatting

When using an unformatted SD card in the GOT, format it by a personal computer. The GOT cannot format the unformatted SD card.

The format of the GOT does not change the file system (Example: FAT16) of the SD card and inherits the file system before the format.

15.6 Clear Data

Clear data functions

This function deletes the project data, resource data, and internal devices (GD and GB) that are written to the GOT.

Clear data display

GT2107-W

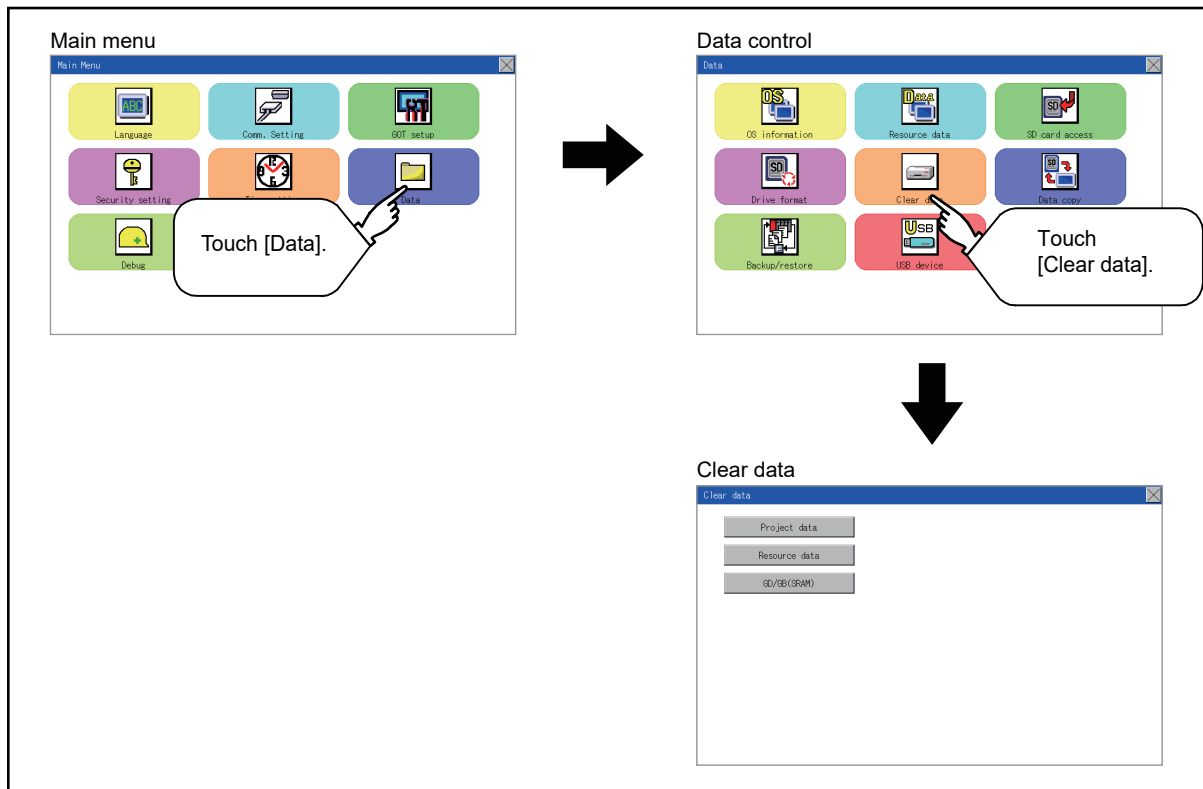

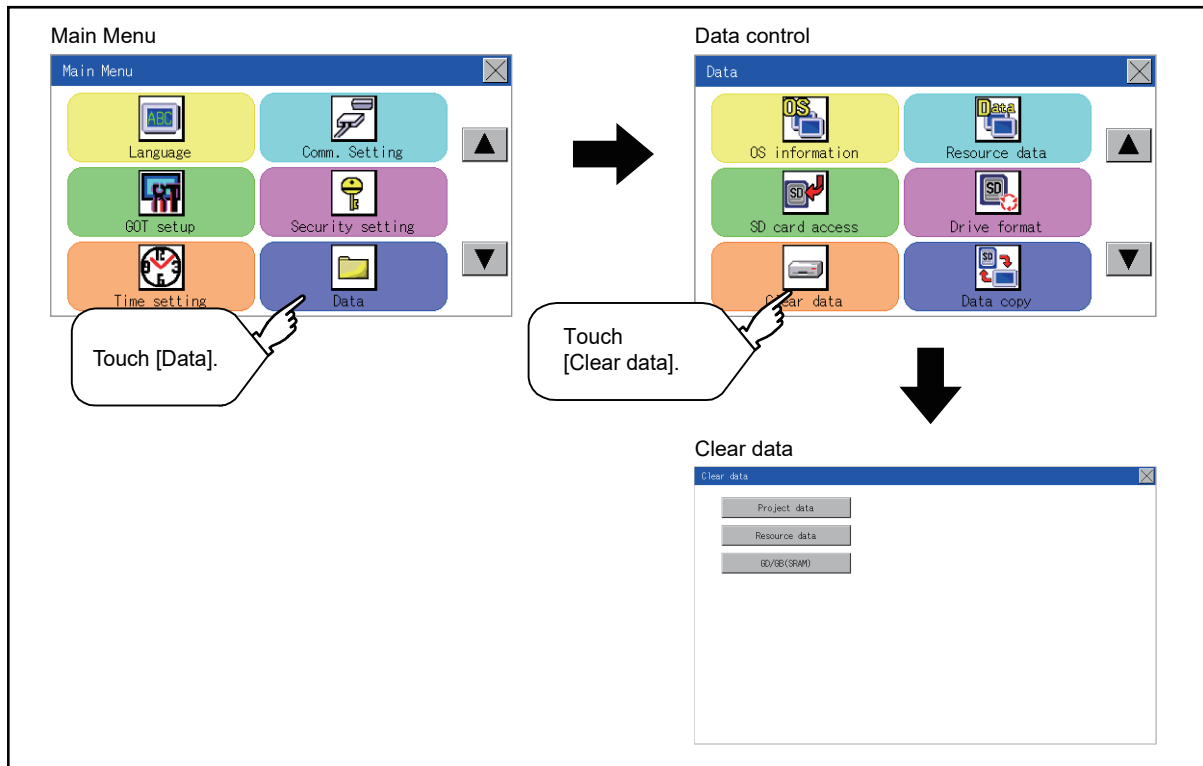

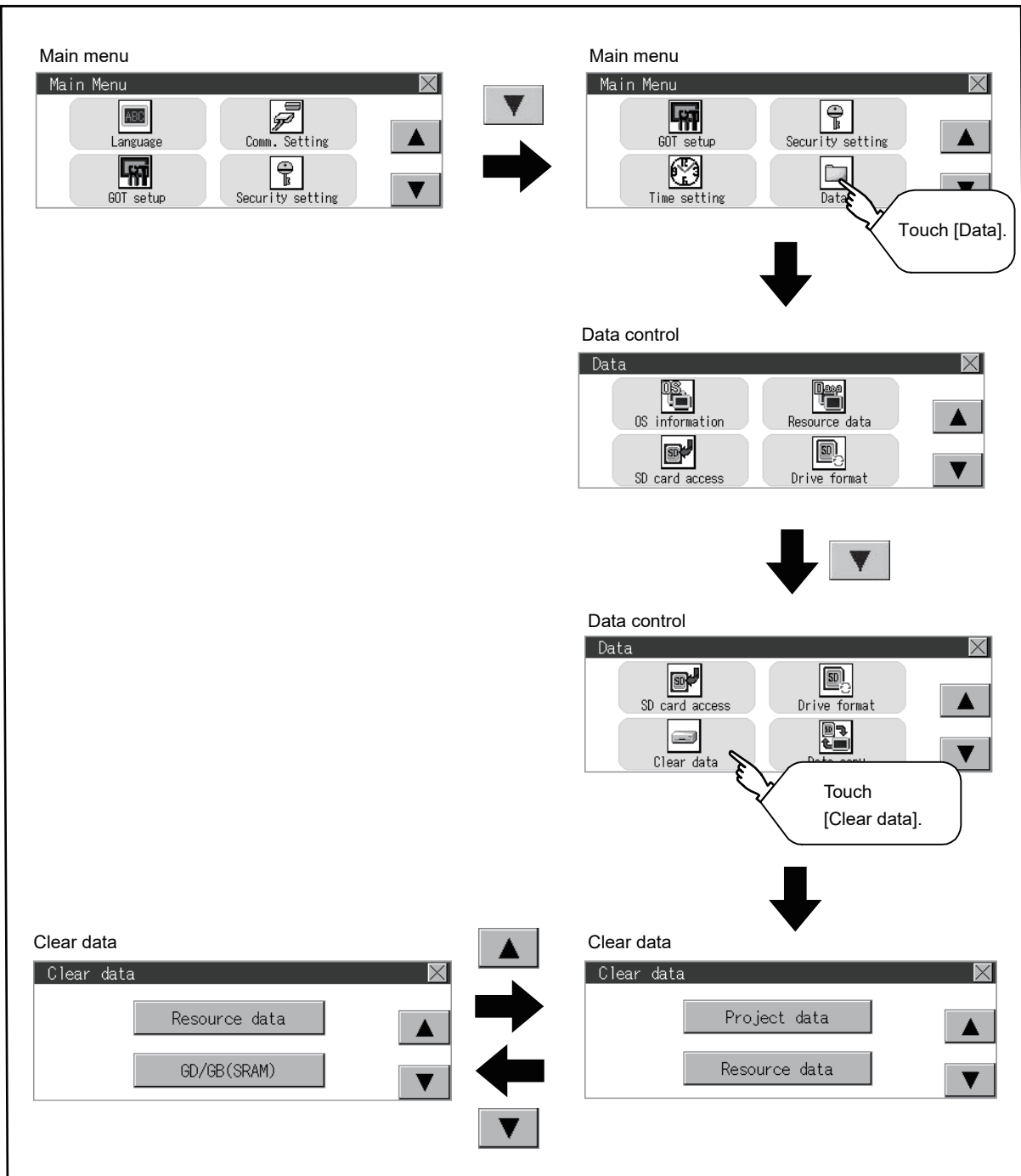

Clear data operation

1. Touch to select the data to delete.
(For GT2107-W, GT2105-Q, GT2104-R)

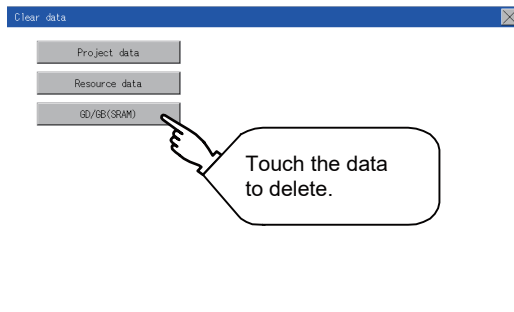

(For GT2104-P, GT2103-P)

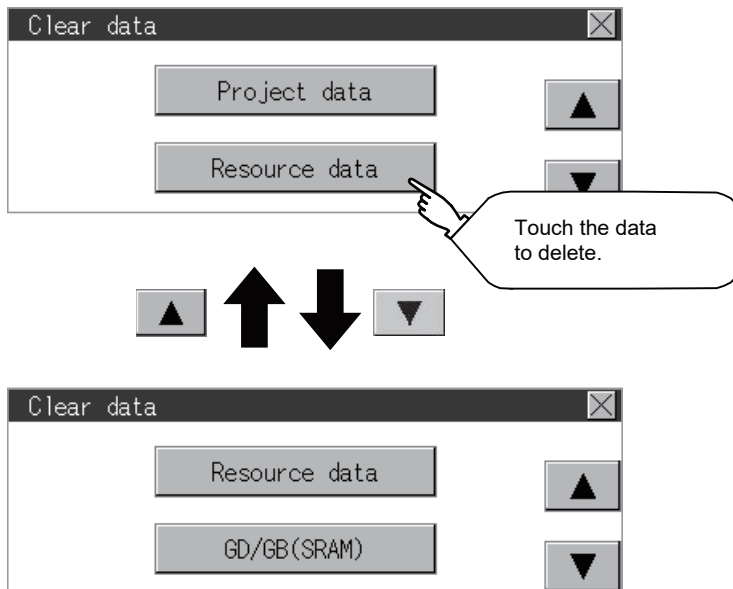

2. The dialog box below is displayed for confirmation.
Touch the [YES] button to delete the data, or the [NO] button to cancel.

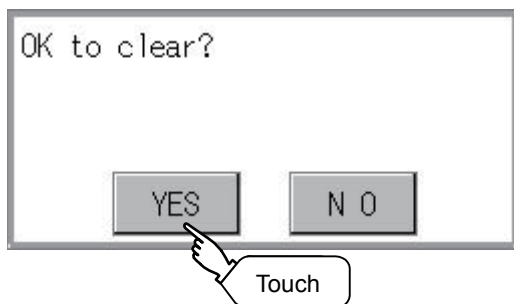

Point

Canceling deletion

Data deletion cannot be canceled once the [YES] button is pressed at the confirm deletion prompt. Double check before touching the [YES] button.

15.7 Data Copy

The project data and basic system application are transferred by using an SD card.

Point

- Copy from the SD card to the GOT

Data can be copied from the SD card to the GOT when the GOT is powered on.

Refer to the following.

☞ Page 695 Installation Using Data Storage

- When installing or removing an SD card

Always set [Permissions] on the GOT. For details, refer to the following.

☞ Page 600 SD Card Access

- Removing the USB drive

The USB device should be in the removable status. For the setting method, refer to the following.

☞ Page 636 USB Device Management

Display operation of data copy

GT2107-W

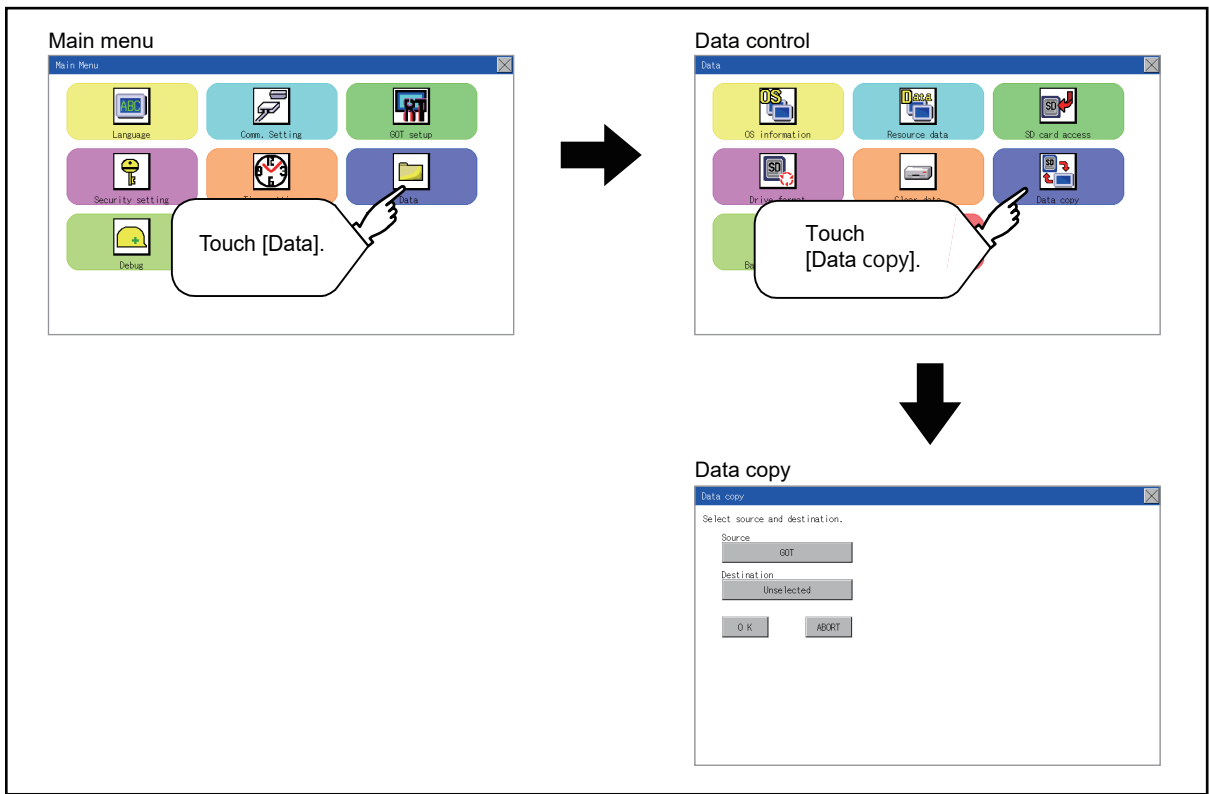

GT2105-Q, GT2104-R

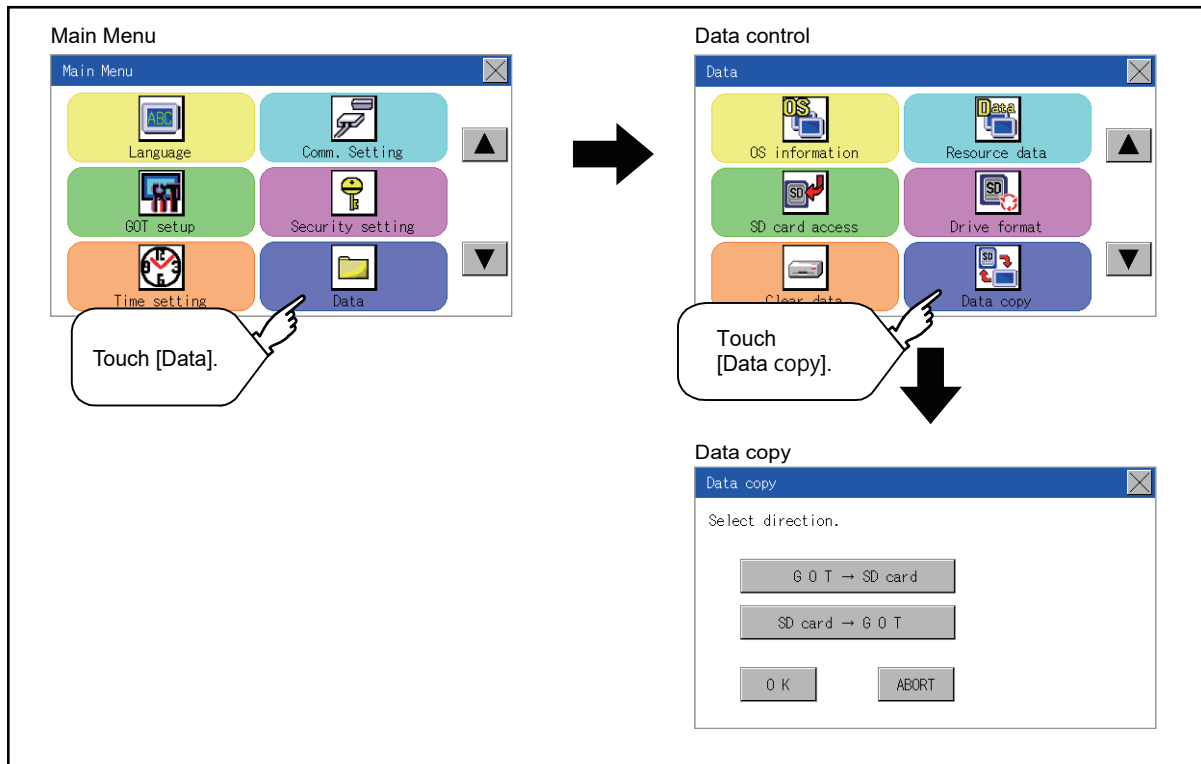

GT2104-P, GT2103-P

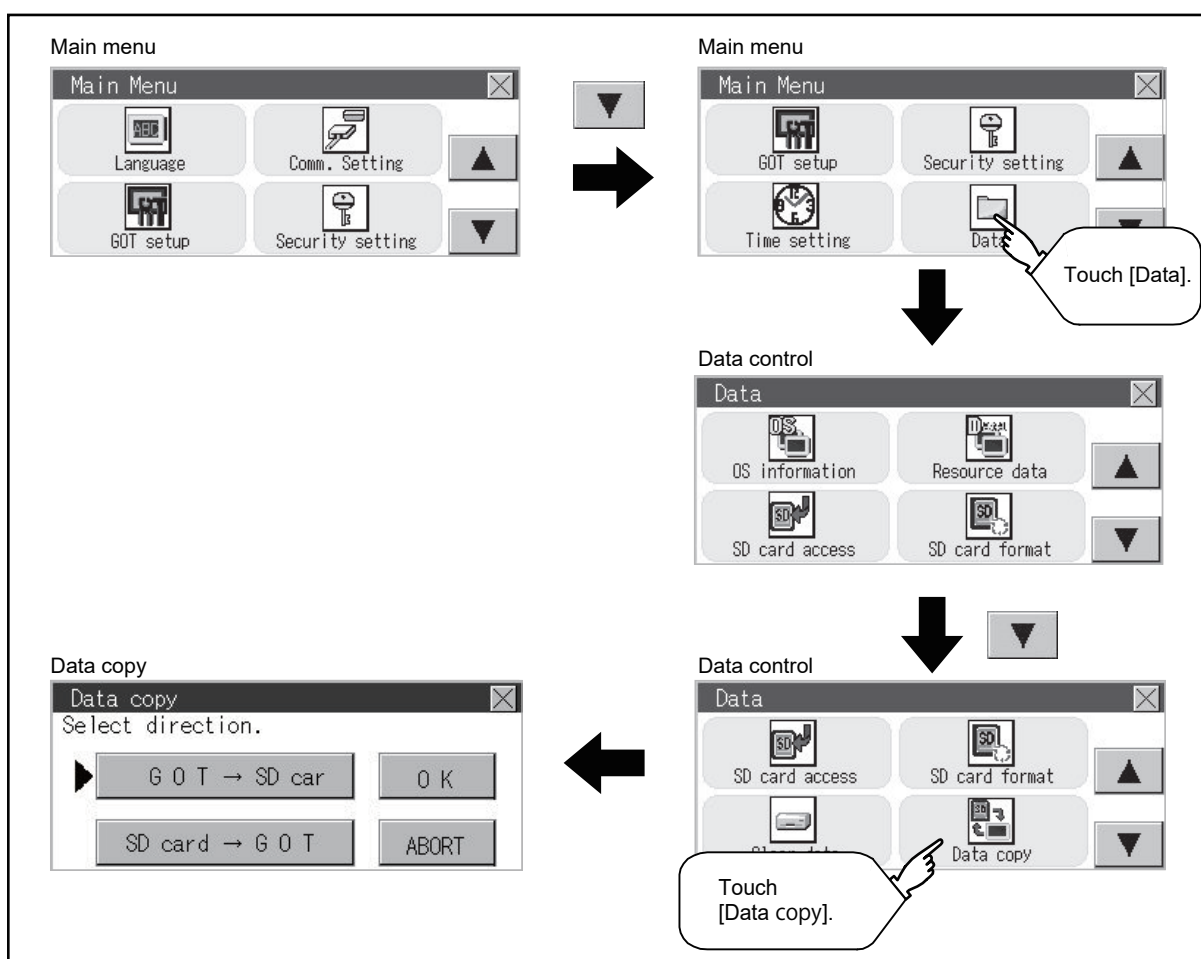

Operation of data copy

1. Select the copy direction, or the copy source and destination.

(For GT2107-W, GT2105-Q, GT2104-R)

Select the copy source and destination.

The copy source and destination are selectable from [GOT], [SD card], and [USB drive].

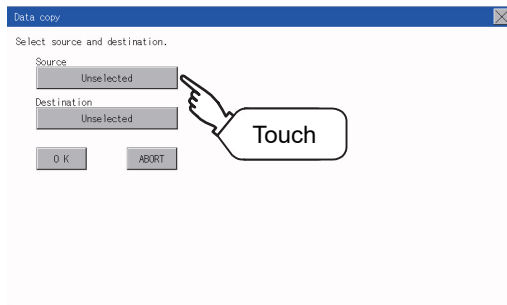

(For GT2104-P, GT2103-P)

The selection mark is displayed on the side of the selected key.

GOT → SD card:

Copy from the GOT to the SD card

SD card → GOT:

Copy from the SD card to the GOT

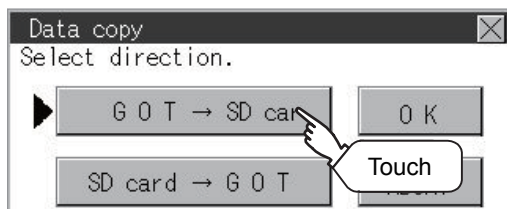

2. After selecting the copy direction, or the copy source and destination, touch the [OK] button. To abort copy, touch the [ABORT] button.

(For GT2107-W, GT2105-Q, GT2104-R)

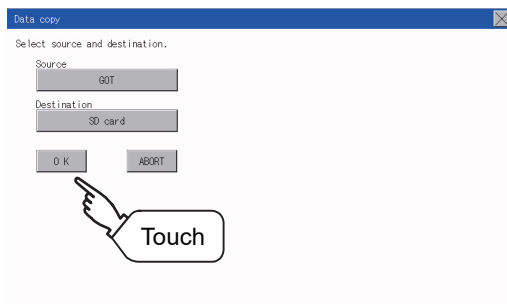

(For GT2104-P, GT2103-P)

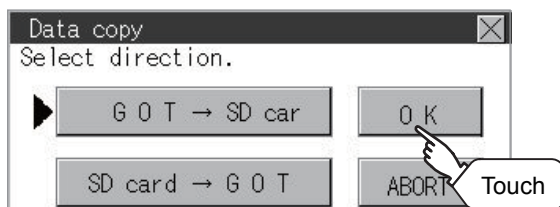

3. Confirm the copy direction and copy target.

When they are set correctly, touch the [OK] button. To change the setting, touch the [CANCEL] button.

(For GT2107-W, GT2105-Q, GT2104-R)

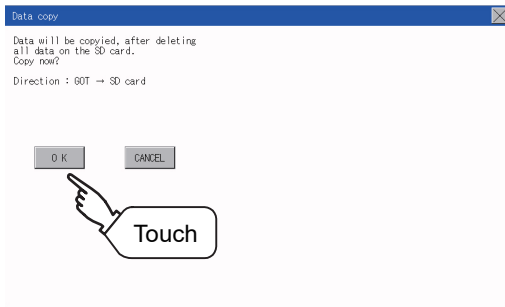

(For GT2104-P, GT2103-P)

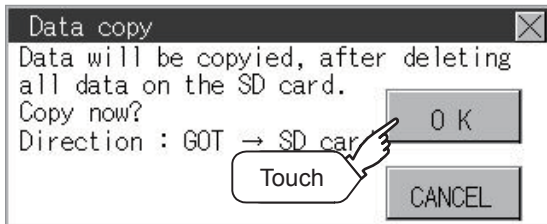

4. The dialog box below is displayed for confirmation.

Touch the [YES] button to start copying and [NO] button to cancel.

(For GT2105-Q, GT2104-R, GT2104-P, GT2103-P)

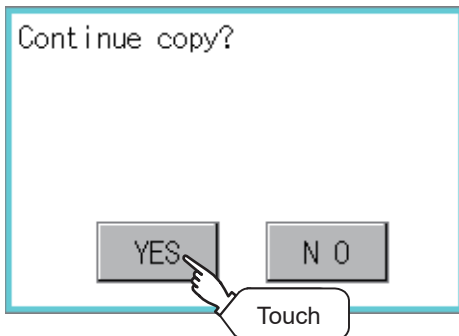

5. While the copy is executed, the dialog box below is displayed.

- Copying data from the GOT to the SD card

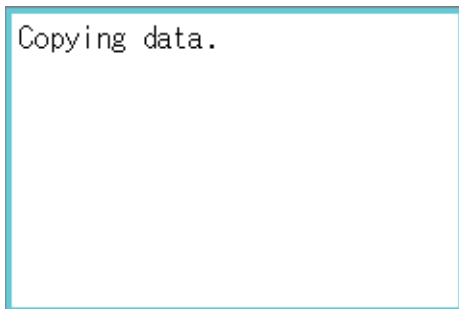

- Copying data from the SD card to the GOT

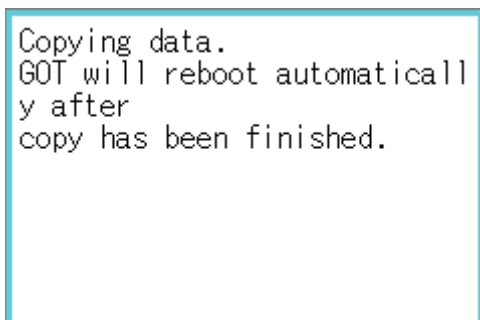

6. Copy is completed.

- Copying data from the GOT to the SD card

Touch the [X] button to close the screen.

(For GT2107-W, GT2105-Q, GT2104-R)

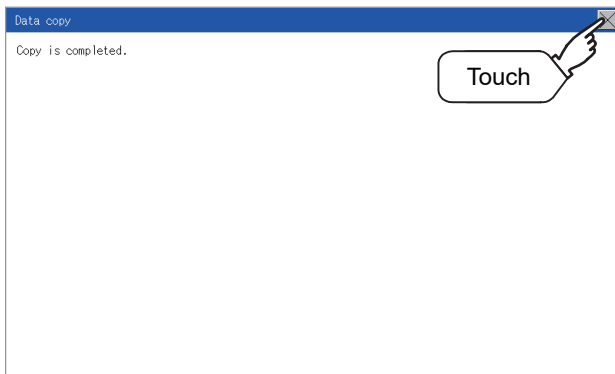

(For GT2104-P, GT2103-P)



- Copying data from the SD card to the GOT

The GOT automatically restarts.

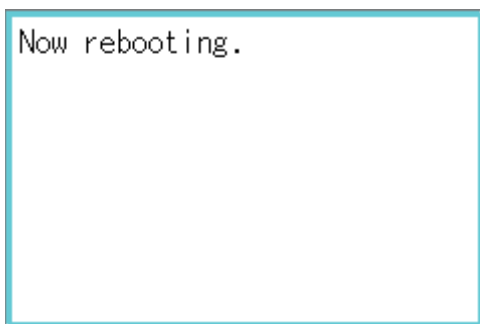

If an error occurs during copy, an error message appears.

For details of error messages, refer to the following.

☞ Page 613 Error display

Error display

When copying is not available between the GOT and the memory card, check the following contents according to the GOT error display.

Error message	Remedy
Memory card is not attached.	Install an memory card to the GOT.
GOT type is unmatch.	The model set for the data in the SD card does not match with that of the copy target GOT. Use the same model data as that of the copy target GOT.
Write protection switch ON.	The write protection switch of the SD card is ON. Turn off the write protection switch.
Available package data is not existed.	There is no data to be a copy target in the copy source. Store the data to be copied in the copy source and copy it again.
Please check source and destination.	The combination of your copy source and copy destination is not correct. Change settings to correct the combination of your copy source and copy destination.

15.8 Backup and Restoration

GT2104-PMBLS and GT2103-PMBLS do not support this function because they are not equipped with the SD card interface.

Backup and restoration

The setting information of the controller connected to the GOT (including sequence programs, parameters, and set values) can be saved (backed up) to the data storage installed to the GOT and the data can be restored to the controller if necessary.

The following shows the features of the backup and restoration.

Point

- For GT2107-W
The save destination for backup data is required to be set.
For information on how to set the save destination, refer to the following.
☞ Page 506 Setting the storage location for backup and restoration

Systems can be backed up and restored without using a personal computer, and this shortens downtime.

The setting information of the controller connected to the GOT can be backed up or restored. By using the setting information that was backed up, the information can be restored from the connected GOT even while the controller is replaced due to its failure. Thus, the system can be restored easily.

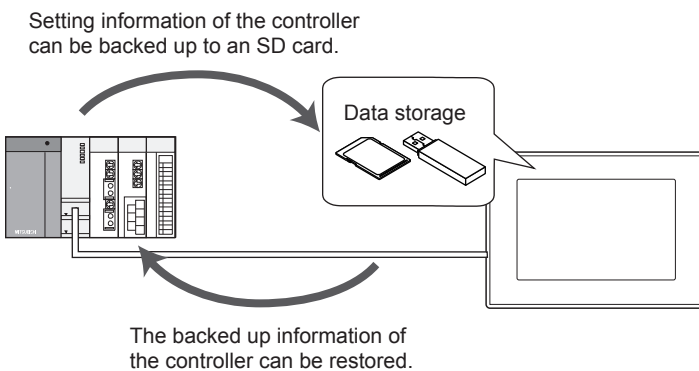

The same system can be created without using a personal computer.

By restoring the backed up information to the controller of another system, the same system can be created without using a personal computer.

Security can be enhanced.

By setting a password to limit browsing and changing the setting information, the security at the backup or restoration operation is enhanced.

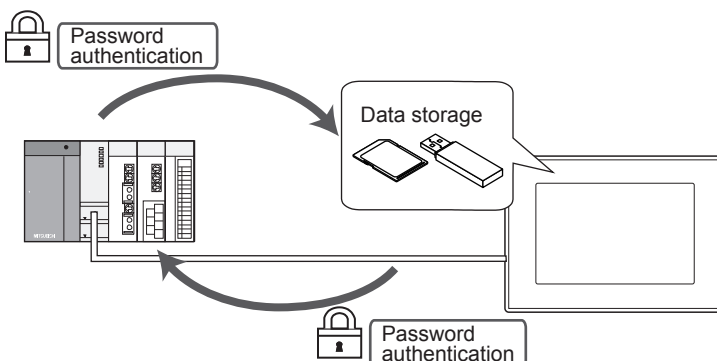

System configuration

This section describes the system configuration of the backup/restoration function.

For connection type settings and precautions for the communication unit, cable, and connection type, refer to the following.

📖 GOT2000 Series Connection Manual (Mitsubishi Product) For GT Works3 Version1

GOT

The following shows the GOT that supports the backup/restoration function.

- GT21

(Except GT2104-PMBLS and GT2103-PMBLS)

Target controller

Controller		Model
MELSEC iQ-F		FX5U, FX5UC, FX5UJ
QCPU (Q mode)	Basic model *1	Q00JCPU, Q00CPU, Q01CPU
	High performance model *1	Q02CPU, Q02HCPU, Q06HCPU, Q12HCPU, Q25HCPU
	Universal model	Q00JCPU, Q00UCPU, Q01UCPU, Q02UCPU, Q03UDCPU, Q04UDHCPU, Q06UDHCPU, Q10UDHCPU, Q13UDHCPU, Q20UDHCPU, Q26UDHCPU, Q03UDECPU, Q04UDEHCPU, Q06UDEHCPU, Q10UDEHCPU, Q13UDEHCPU, Q20UDEHCPU, Q26UDEHCPU, Q50UDEHCPU, Q100UDEHCPU, Q03UDVCPU, Q04UDVCPU, Q06UDVCPU, Q13UDVCPU, Q26UDVCPU
LCPUCPU		L02CPU, L06CPU, L26CPU, L26CPU-BT, L26CPU-PBT, L02CPU-P, L06CPUP, L26CPU-P, L02SCPU, L02SCPU-P
FXCPU*2		FX0, FX0S, FX0N, FX1, FX2, FX2C, FX1S, FX1N, FX1NC, FX2N, FX2NC, FX3U, FX3UC, FX3G, FX3GC, FX3S

*1 Use the PLC CPU with the function version B or later.

*2 To restore the backup data including special parameters, use a CPU with either of the following versions.

Version of FX3U(C): 3.10 or later

Version of FX3G(C): 2.00 or later

Connection type

This function can be used in the following connection type.

(○: Applicable, △: Partly restricted, ×: Inapplicable)

Function		Connection type between GOT and controller		
Name	Description	Direct CPU connection (serial)	Serial communication connection	Ethernet connection
Backup/restoration	Backing up or restoring the settings of the controller connected to the GOT	△ *1	△ *3	△ *2 *3

*1 When a LCPUCPU is connected, use the L6ADP-R2.

*2 When a CC-Link IE Field Network Ethernet adapter is used, the backup/restoration function cannot be used.

*3 The data cannot be restored to the QCPU in the factory shipment status or whose memory is formatted.

Required hardware

An SD card is required to back up and restore data.

Backup/restoration target data

The following shows the backup/restoration target data.

The data other than the following cannot be backed up or restored.

■Basic model QCPU

Item	Description	File name
Parameter	Parameter to operate the PLC	PARAM.QPA
Intelligent function module parameter	Parameter for the intelligent function module	IPARAM.QPA
Sequence program	Program for the operation by the CPU	MAIN.QPG
SFC program	Sequence program in the SFC format	MAIN-SFC.QPG
File register*1	File register data	MAIN.QDR
Device comment	Device comment to be stored to the PLC	MAIN.QCD
Device initial value	Initial value setting of devices	MAIN.QDI

*1 The file register in the Flash card installed to the CPU is always restored and overwritten without any notice.

■High Performance model QCPU

Item	Description	File name
Parameter	Parameter to operate the PLC	PARAM.QPA
Intelligent function module parameter	Parameter for the intelligent function module	IPARAM.QPA
Program	Program for the operation by the CPU (including SFC)	***.QPG
Device comment	Device comment to be stored to the PLC	***.QCD
Boot setting file	Batch file to start a program from the ROM or others	AUTOEXEC.QBT
Device initial value	Initial value setting of devices	***.QDI
File register*1	File register data	***.QDR
Sampling trace file*2	Sampling trace data to collect the specified device data continuously at the specified timing	***.QTD
Failure history data*2	Record of the self check results	***.QFD
Programmable controller user data	Data created by users and stored to the memory card	***.*** (Any name)

*1 The file register in the Flash card installed to the CPU is always restored and overwritten without any notice.

*2 Only the backup operation is available.

■Universal model QCPU

Item	Description	File name
Parameter	Parameter to operate the PLC	PARAM.QPA
Intelligent function module parameter	Parameter for the intelligent function module	IPARAM.QPA
Program	Program for the operation by the CPU (including SFC)	***.QPG
Device comment	Device comment to be stored to the PLC	***.QCD
Boot setting file	Batch file to start a program from the ROM or others	AUTOEXEC.QBT
Device initial value	Initial value setting of devices	***.QDI
File register*1	File register data	***.QDR
Sampling trace file*2	Sampling trace data to collect the specified device data continuously at the specified timing	***.QTD
Programmable controller user data	Data created by users and stored to the memory card	***.*** (Any name)
File for storing device data	Device data that the SP.DEVST and S.DEVLD instructions use	DEVSTORE.QST
Drive headline sentence	Drive headline sentence	QN.DAT
Remote password	Remote password setting	00000000.QTM
Monitor sequence extension	Data to speed up the monitoring from other stations	MONITOR.Q0*
Latch data backup file	The file where the backup data is stored by the latch data backup function to the standard ROM	LCHDAT00.QBK

*1 The file register in the Flash card installed to the CPU is always restored and overwritten without any notice.

*2 Only the backup operation is available.

■LCPU

Item	Description	File name
Parameter	Parameter to operate the PLC	PARAM.QPA
Intelligent function module parameter	Parameter for the intelligent function module	IPARAM.QPA
Program	Program for the operation by the CPU (including SFC)	***.QPG
Device comment	Device comment to be stored to the PLC	***.QCD
Boot setting file	Batch file to start a program from the ROM or others	AUTOEXEC.QBT
Device initial value	Initial value setting of devices	***.QDI
File register ^{*1}	File register data	***.QDR
Sampling trace file ^{*2}	Sampling trace data to collect the specified device data continuously at the specified timing	***.QTD
Programmable controller user data	Data created by users and stored to the memory card	***.*** (Any name)
File for storing device data	Device data that the SP.DEVST and S.DEVLD instructions use	DEVSTORE.QST
Drive headline sentence	Drive headline sentence	QN.DAT
Remote password	Remote password setting	00000000.QTM
Monitor sequence extension	Data to speed up the monitoring from other stations	MONITOR.Q0*
Latch data backup file	The file where the backup data is stored by the latch data backup function to the standard ROM	LCHDAT00.QBK
Data logging setting file	Data logging setting	LOGCOM.QLG LOG01.QLG to LOG10.QLG
Menu definition file	Menu definition file	MENUDEF.QDF

*1 The file register in the Flash card installed to the CPU is always restored and overwritten without any notice.

*2 Only the backup operation is available.

■FXCPU

Item	Description	File name
Parameter	Parameter to operate the PLC	INFO.FPG
Device comment	Device comment to be stored to the PLC	
Sequence program	Program for the operation by the CPU	
Special program ^{*1}	Positioning setting/Initial value parameter	
File register	File register data	
Extension file register ^{*2}	Extension file register data	
Built-in CC-Link/LT setting ^{*3}	CC-Link/LT parameter	
Special parameter ^{*1}	Parameter for special adaptors and special blocks stored in the main unit	

*1 The backup and restoration can be performed only when the FX3U(C) or FX3G(C) series is used.

*2 The backup and restoration can be performed only when the FX3U(C) series is used.

*3 This data exists only in the FX3U-32MT-LT-2.

■Data for each software

Item	Description	File name
Label program	Data for GX Developer	PROJINFO.CAB
Symbolic data	Symbolic data for PX Developer	#FBDQINF.BIN
Symbolic information	Simple project (with label)	SRCINFOM.CAB SRCINFOM.C32
	Structured project	SRCINFOI.CAB SRCINFOI.C32
New symbolic information	Simple project (with label)	SRCINF1M.CAB SRCINF2M.CAB SRCINF1M.C32 SRCINF2M.C32
	Structured project	SRCINF1I.CAB SRCINF2I.CAB SRCINF1I.C32 SRCINF2I.C32

Backup data

■ Storing backup data

Only one piece of backup data can be saved for each channel.

When the backup operation is executed multiple times to the same channel, the backup data is overwritten.

■ Backup data storage location

The backup data is stored to an SD card with the following folder structure.

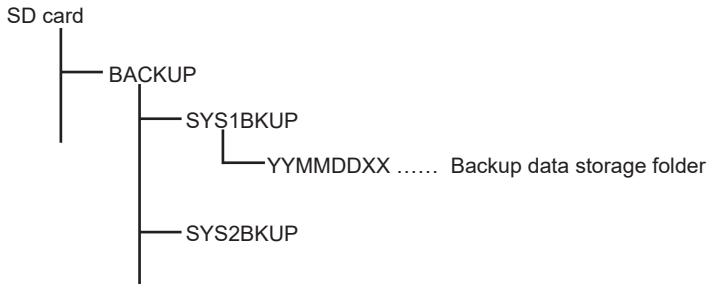

■ Folder for backup data

Backup data is stored in each folder and each folder name (YYMMDDXX) is determined as follows.

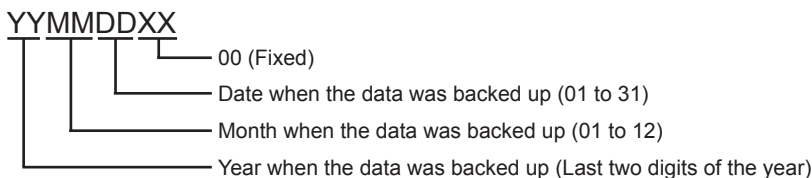

Access range

Access range for each connection type

The following shows the target location of the backup/restoration for each connection type.

Connection type	Target
Serial communication connection	Host station
Ethernet connection	Host station

When the multi-channel function is used

When the multi-channel function is used, data is backed up or restored per channel.

Backup/restoration of the multiple CPU system

The batch backup of all CPUs can be executed for the multiple CPU system. Backing up of the CPU No. 1 to 4 cannot be specified.

Precautions

Precautions for backing up data

■Data that cannot be backed up

The current values of devices and the device memory cannot be backed up.

To collect the current values of the devices, use the recipe function.

For how to use the recipe function, refer to the following.

📖 GT Designer3 (GOT2000) Screen Design Manual

To collect the device memory, use GX Developer.

■Backup target file name

When characters other than the ones of the shift JIS code and the ASCII code are used in a file name, the file name may not be displayed properly after data is backed up to the GOT.

To use the backup/restore function, use characters of the shift JIS code or ASCII code in file names.

■Backup of the intelligent function module parameters

To back up the intelligent function module parameters (IPARAM.QPA), only the parameters that can be stored to the PLC CPU are the backup target.

To back up parameters other than the ones above, GX Configurator that is compatible with the modules or GX Works2 is required.

For the intelligent function module parameters that can be stored to the PLC CPU, refer to the following.

📖 GX Works2 Version 1 Operating Manual (Intelligent Function Module)

■Compatibility of the backup data

- The backup data that is used by GT21 cannot be used by GT27 or GT25.
- The backup data that is used by GT27 and GT25 cannot be used by GT21.

Precautions for restoring data

■Communication status of the GOT and the controller to execute the restoration

To execute the restoration, the target controller must be able to communicate with the GOT.

When the target controller cannot communicate with the GOT, data cannot be restored.

■STOP status at the restoration

The PLC CPU goes into the STOP status by using the remote STOP before the restoration.

Since the remote STOP cannot be used for the FXCPU at the restoration, users must change the PLC's status to the STOP status.

For the CNC (C80 or C70), the CNC ladder is in the STOP status.

After the restoration is completed, this STOP status is not canceled.

Restart each controller.

■Canceling the restoration

When the restoration is canceled, not all the data is written to the controller and the controller may not operate properly.

When the restoration is canceled, execute the restoration again.

The STOP status is not canceled even though the restoration is canceled.

Restart the controller by the user.

■Configuration of the controller at the restoration

The configuration of the controller must be the same as the one at the backup.

When the configuration of the controller at the restoration differs from the one at the backup, the restoration cannot be executed.

When the configuration of the controller at the restoration is the same as the one at the backup, the restoration can be executed even though the connection type or CH No. does not match.

When the FXCPU is connected, the model, memory cassette (whether it is installed or not), and memory capacity of the memory cassette must be the same as the ones at the backup.

■Operation of the controller

The controller may operate unexpectedly by changing a set value or device value at the restoration.
To execute the restoration, sufficiently check the data to be restored and the operation of the controller.

Precautions for backing up and restoring data

■Password for the backup/restoration

When the password on the controller side is changed after the password for the backup/restoration has been set, the password for the backup/restoration needs to be changed.

For how to set a password for the backup/restoration, refer to the following.

☞ Page 622 Security and password

■Precautions for using GT Designer3 (GOT2000)

Do not perform the following operations in GT Designer3 (GOT2000) while the backup or restoration is executed.

Operation in GT Designer3 (GOT2000)

- Installing the BootOS
- Writing the package data and installing a communication driver, basic system application, and advanced system application

When the operations above are performed, the backup or restoration processing is canceled.

■Precautions for using GX Developer

- Do not access the target controller of the backup or restoration using GX Developer while the backup or restoration is executed.

Accessing the target controller cancels the backup or restoration processing.

- Do not execute the backup or restoration while the target controller is accessed using GX Developer.

If doing so, a communication error occurs in GX Developer.

(The backup or restoration processing is executed.)

■CPU to which a security key is set

The data in the CPU to which a security key is set cannot be backed up or restored.

To back up or restore the data, review the CPU setting.

When both the CPU with a security key and the one without a security key exist in the target controller of the backup or restoration, only the data in the CPU without a security key can be backed up or restored.

Precautions for using the QCPU

Restoring data to the QCPU in the factory shipment status or whose memory is formatted can be performed only in the following cases.

- When the single CPU system is used: The connection type is the direct CPU connection (serial).
- When the multiple CPU system is used: The connection type is the direct CPU connection (serial).

However, the restoration cannot be executed at once to multiple CPUs in the multiple CPU system including the QCPU that is in the factory shipment status or whose memory is formatted.

Execute the restoration for each CPU.

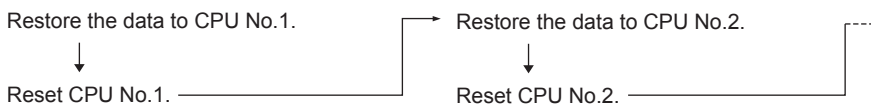

Precautions for using the FXCPU

■When a memory cassette is installed

When a memory cassette is installed, the data in the memory cassette is backed up.

When a memory cassette is not installed, the data in the built-in memory is backed up.

■Keyword setting

The following table shows whether the backup/restore function can be executed or not for each keyword setting.

(○: Available, ×: Not available)

Function	Protect that cannot be canceled			With keyword						Without keyword
	Write Protect	R/W Protect	All operation protect	Write Protect		R/W Protect		All operation protect		
	Protect	Protect	Protect	Protect	Clear	Protect	Clear	Protect	Clear	
(Trigger) Backup	○	×	×	○	○	×	○	×	○	○
Restoration	×	×	×	×	○	×	○	×	○	○

■Keyword at the restoration

The keyword of the restoration target FXCPU is held at the restoration.

For how to set or clear the keyword of the FXCPU, refer to the following.

 GOT2000 Series User's Manual (Utility)

 Programming manual for the FXCPU used

■Backup data including the symbolic information

When the restoration target FXCPU does not support the symbolic information, the backup data including the symbolic information cannot be restored.

Security and password

By setting a password for the backup/restore function, the authentication using a password can be conducted at the backup or restoration.

The password for the backup/restoration and the password on the controller side are used for the authentication.

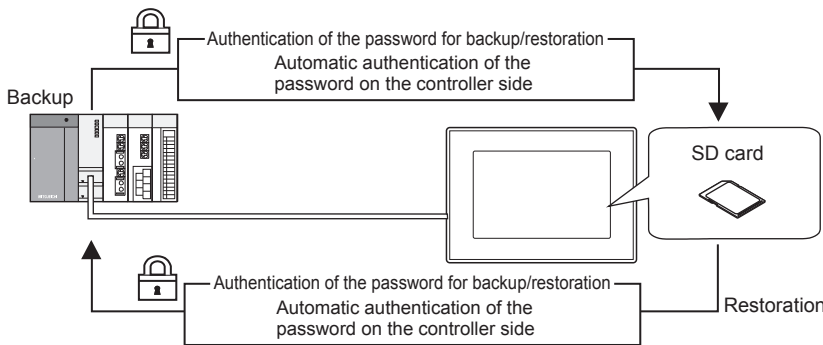

The following shows the passwords used at the backup or restoration.

Password	Description
Password for the backup/restoration	This is a password for the authentication at the backup or restoration. Set this password with the GOT at the first backup. To set this password, a password on the controller side has to be set in advance.
Password on the controller side	This is a password set to the backup/restoration target file of the controller. Set this password using the setting software of the controller when the file is written to the controller.

Inputting the password on the controller side is not required at the backup or restoration after the first backup (setting of the password for the backup/restoration). (The authentication of the password on the controller side is conducted automatically.) Therefore, users have the following merits on the security.

User	Merit
Administrator	Disclosing the password on the controller side to operators on site is not required. (This prevents from browsing or editing the setting information of the controller by a person other than the administrator.)
Operators on site	Data can be backed up or restored by using the password for the backup/restoration only. (Inputting the password on the controller side is not required.)

Point

Before setting the password for the backup/restoration

When the password for the backup/restoration is forgotten, the backup and restoration cannot be executed.

When the password for the backup/restoration is forgotten, format the SD card used or use a new SD card to back up the data again.

For how to set a password for the backup/restoration, refer to the following.

☞ Page 623 Setting the password for the backup/restoration

For how to use the password for the backup/restoration after the setting, refer to the following.

☞ Page 625 How to use the password for the backup/restoration

Setting the password for the backup/restoration

The password for the backup/restoration can be set only when the following conditions are satisfied at the first backup.

A password has been set to the backup target file of the controller.

The authentication using the password on the controller side is required at the first backup.

The following shows the operation procedure at the first backup.

For details of the operation screen, refer to the following.

☞ Page 628 Display operation of backup and restoration

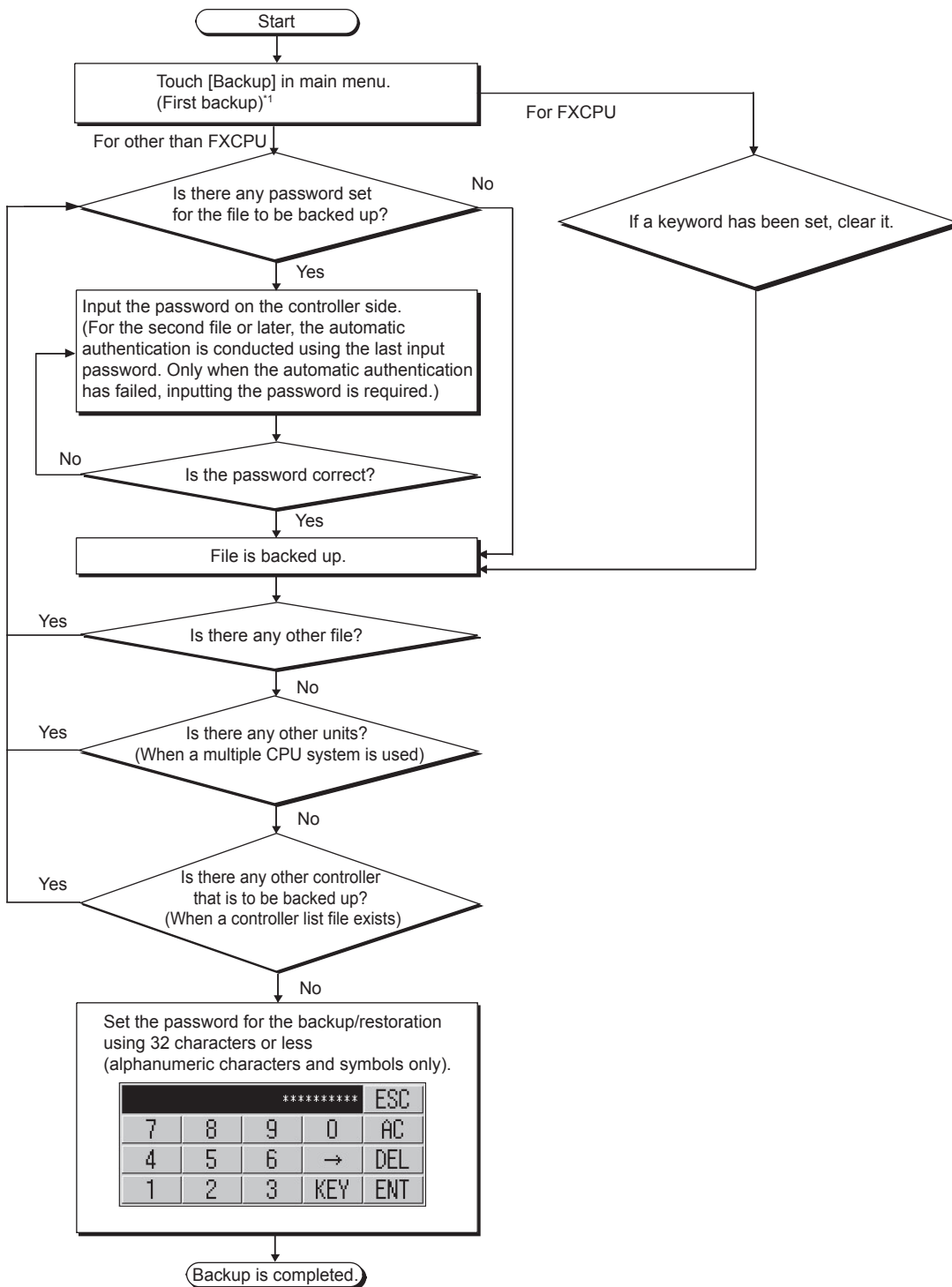

*1 For the details, refer to the following.

☞ Page 628 Display operation of backup and restoration

Point 

- Setting a password

To secure the security, using eight characters or more that cannot be easily guessed as the password for the backup/restoration is recommended.

If the password is compromised, a system with the same configuration may be created. Pay full attention to manage the password.

- Keyword for the FXCPU

To back up or restore data in the FXCPU, clear the keyword in advance.

 Page 633 Keyword operations

How to use the password for the backup/restoration

The following shows the operation procedure of the backup after the password for the backup/restoration has been set. For details of the operation screen, refer to the following.

☞ Page 628 Display operation of backup and restoration

■Backup

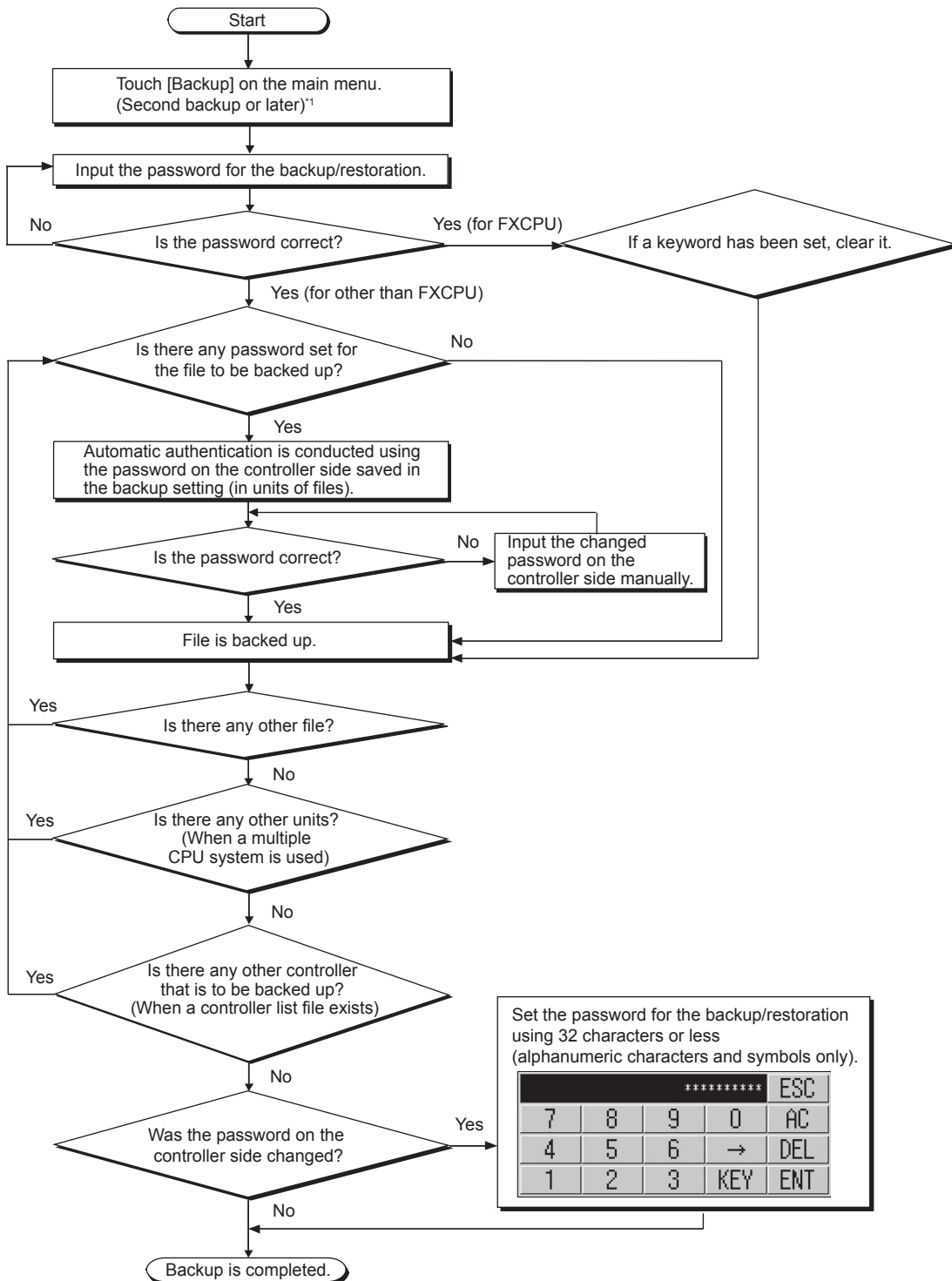

*1 For the details, refer to the following.

☞ Page 628 Display operation of backup and restoration

Precautions for backing up data after the password on the controller side has been changed
 When the password on the controller side is being input manually and inputting the password is canceled to stop the backup, all the files that have been backed up before the cancellation are discarded.

Restoration

The following shows the operation procedure of the restoration after the password for the backup/restoration has been set.

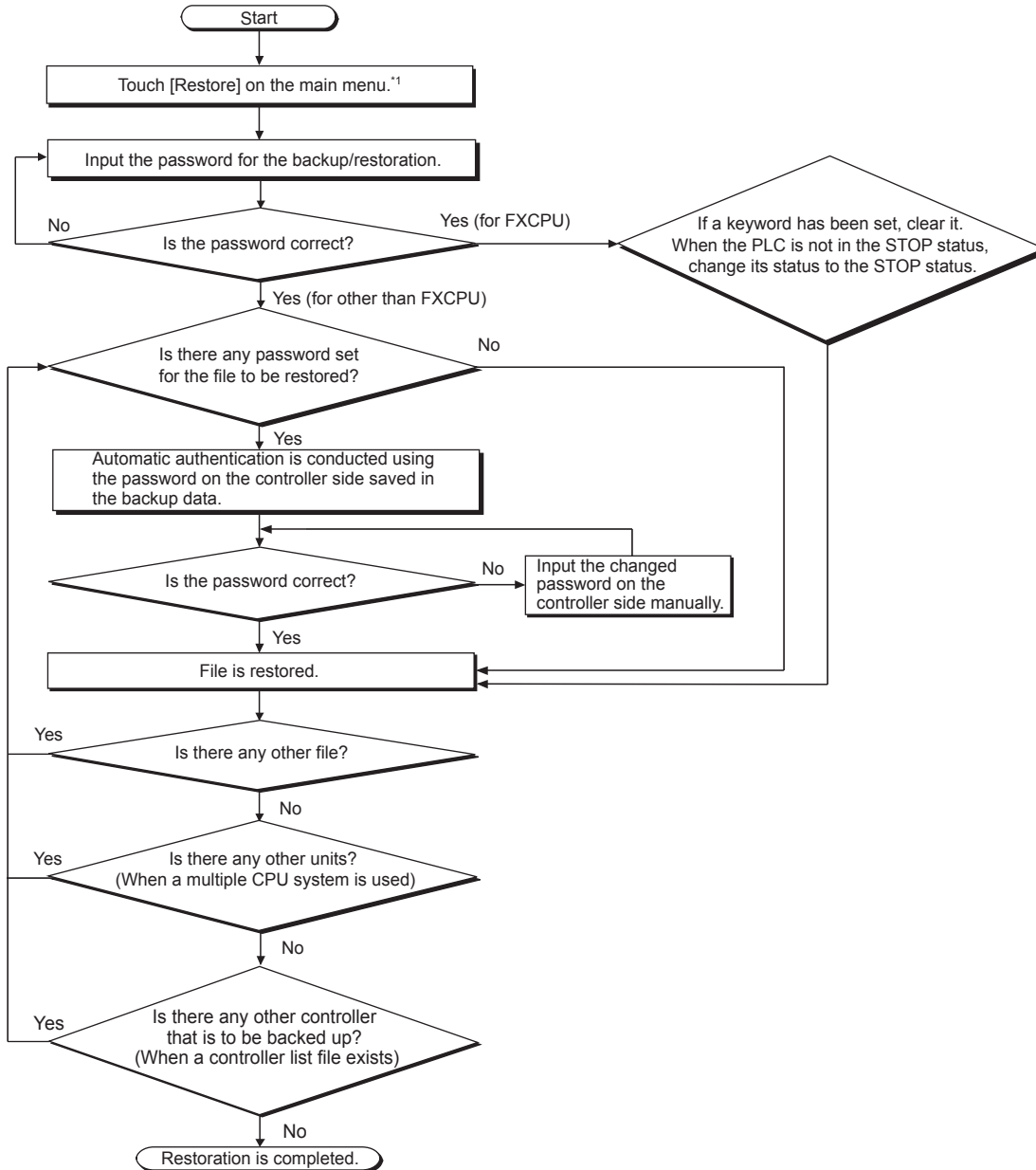

*1 For the details, refer to the following.

📖 Page 628 Display operation of backup and restoration

Precautions for restoring data after the password on the controller side has been changed

When the password on the controller side is being input manually and inputting the password is canceled to stop the restoration, only the files that have been restored before the cancellation are restored.

When only a part of the files are restored, some data mismatch may occur in the whole system.

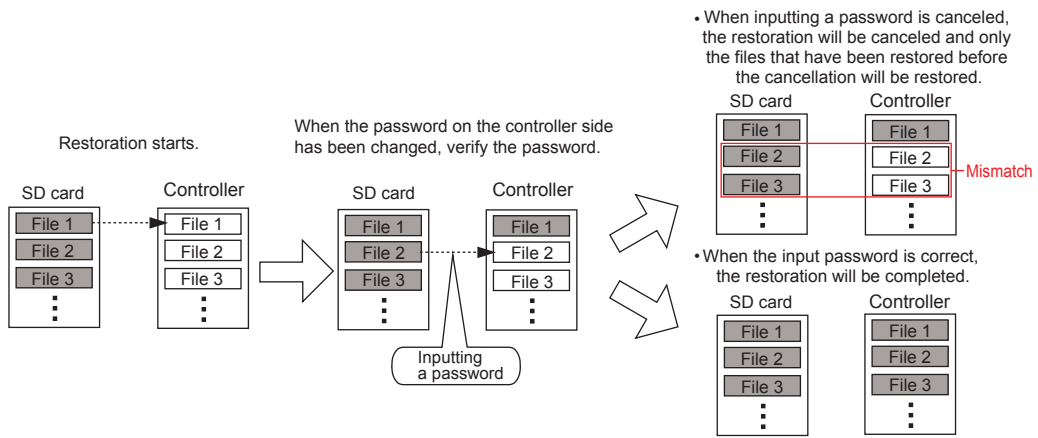

Display operation of backup and restoration

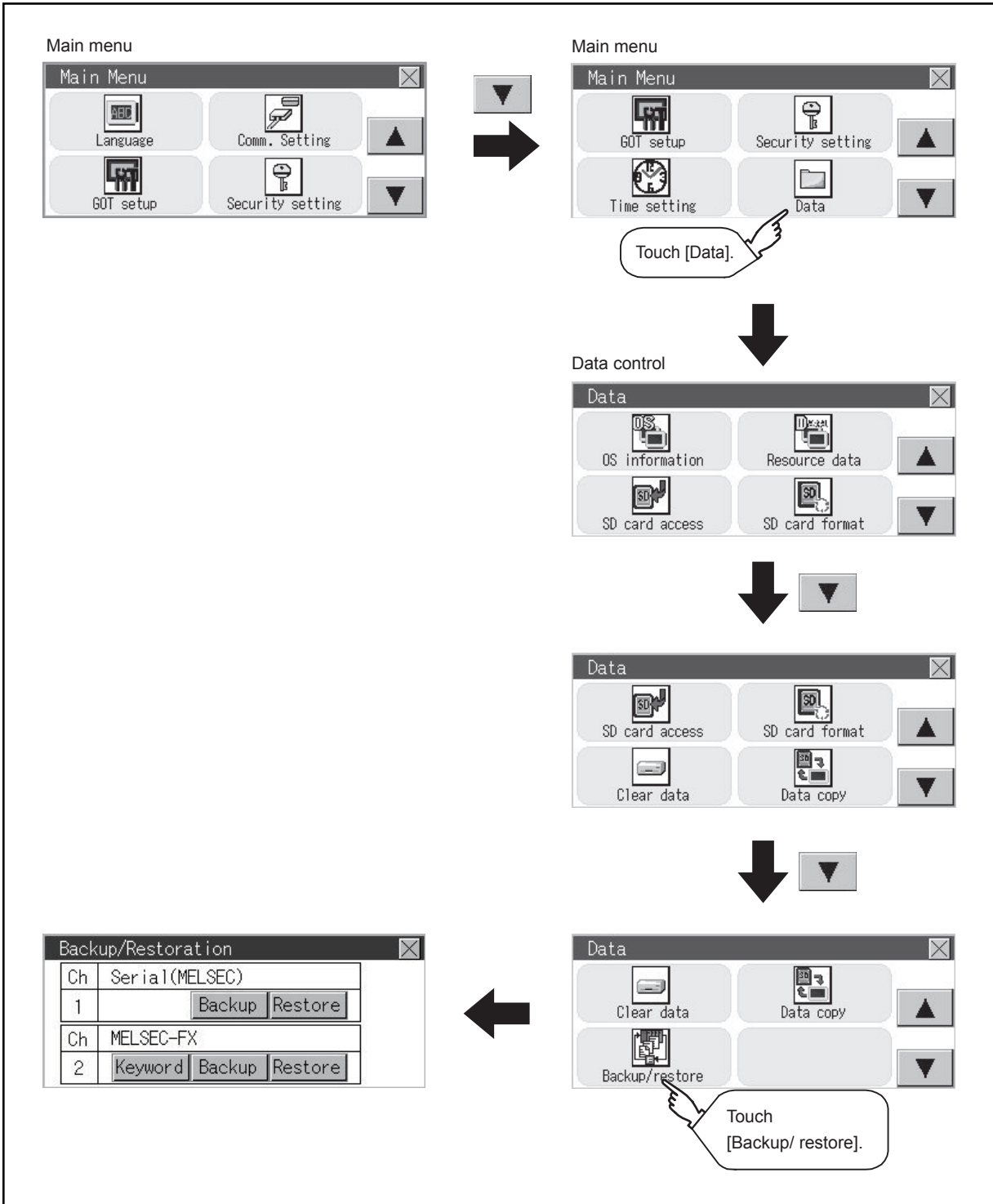

For a controller other than FXCPU, the [Keyword] switch is not displayed.

Backup operation

This section describes the backup operation screen. The screen operation procedure varies depending on the PLC CPU model used and whether or not passwords have been set. For details of the operating procedure, refer to the following.

☞ Page 622 Security and password

1. Touch [Backup].

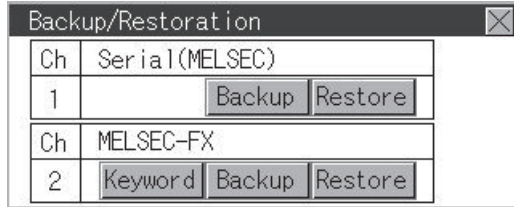

2. Touch [Execute].

Touch operations on the switches ([CPU No.1], [CPU No.2], [CPU No.3], and [CPU No.4]) are invalid.

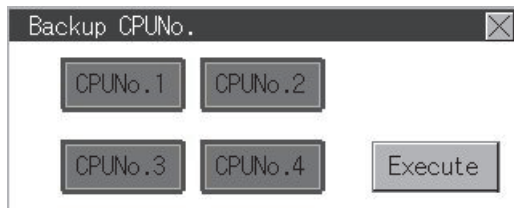

3. When the screen shown below appears, touch [YES].

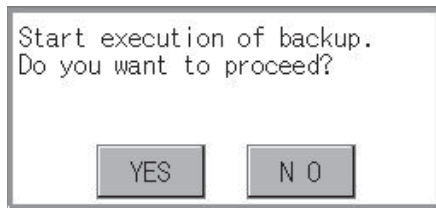

4. When the screen shown below appears, touch [OK], and input a password using the key window.



5. If a password has been set for the program of the PLC CPU, the screen shown below appears. Touch [OK], and enter the password in the key window.

When inputting passwords have been finished, the backup processing will be executed.



6. The screen shown below will be displayed during execution.

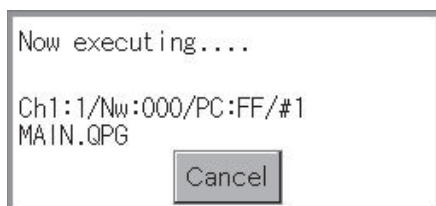

7. When the backup is completed, the screen shown below appears. Touch [OK].



For FXCPU, the following screen appears. Touch [OK] and input a password.



Restoration operation

This section describes the restoration operation screen. The screen operation procedure varies depending on the PLC CPU model used and whether or not passwords have been set. For details of the operating procedure, refer to the following.

☞ Page 622 Security and password

1. Touch [Restore].

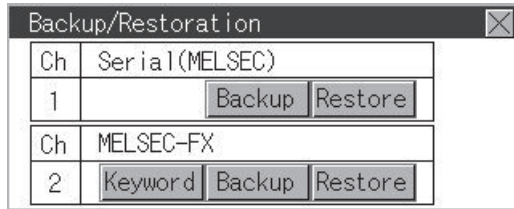

2. Select a CPU No. to be restored from the switches ([CPU No.1], [CPU No.2], [CPU No.3], and [CPU No.4]). If the controller is FXCPU, touch operations on the switches ([CPU No.1], [CPU No.2], [CPU No.3], and [CPU No.4]) are invalid.

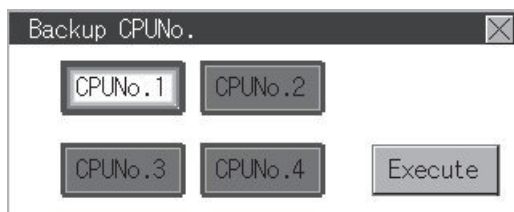

3. Touch [Excute].

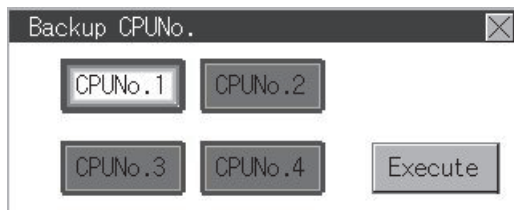

4. When the screen shown below appears, touch [YES].

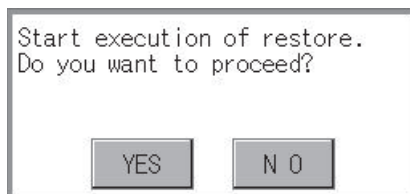

5. When the screen shown below appears, touch [OK], and input a password using the key window.



6. If a password has been set for the program of the PLC CPU, the screen shown below appears. Touch [OK], and enter the password in the key window.

When inputting passwords have been finished, the restoration processing will be executed.



7. The screen shown below will be displayed during execution.

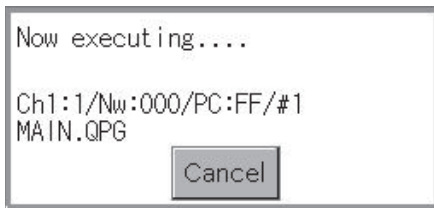

8. When the restoration is completed, the screen shown below appears. Touch [OK].



Keyword operations

When the connected FX series PLC is protected by a keyword, the keyword protection can be removed.

1. Touch [Keyword].

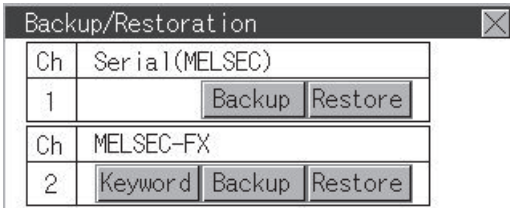

2. The screen shown below appears.
Remove the protection for the FX series PLC.

☞ Page 472 Keyword



Errors and corrective actions

Common to backup and restoration

Problem	Cause	Corrective action
Backup data cannot be found.	Backup data has not been saved in the installed SD card. An SD card is not on the drive specified as the storage location for backup settings.	<ul style="list-style-type: none"> • Install an SD card in which the backup settings are saved. • Check the utility for the storage location for backup data.
The input password is invalid and the backup/restoration cannot be executed.	The password was forgotten or the input password is incorrect.	<ul style="list-style-type: none"> • Get the password for the backup data from the system or device administrator. • Format the SD card or install a new SD card, and perform the backup again.
The backup/restoration of an FXCPU sequence program cannot be performed.	The sequence program has been protected with a block password.	Clear the block password setting for the sequence program.
An error occurs in the communication with the controller during the backup/restoration. The backup/restoration cannot be performed.	The communication settings or the communication driver of the GOT are incorrect.	Check if the communication settings or communication driver of the GOT are correct.
	The GOT is not recognized because the controller's parameters are incorrect.	Check if the controller's parameters have been correctly set using a tool for the controller, such as GX Developer.
	The controller is not powered on.	Power on the controller.
	Cables are not correctly connected.	Check the cables.

Backup

Problem	Cause	Corrective action
Backup data cannot be written to an SD card.	No SD card has been installed.	Install an SD card in the drive specified as the storage location for the backup settings/backup data.
	There is no available space on the SD card.	Install an SD card that has sufficient space. Delete unnecessary files on the SD card.
	The SD card is write protected.	Enable writing data to the SD card. File attributes cannot be changed on the GOT. Change the attributes on a personal computer.
	The drive does not exist.	Check if the drive specified as the storage location for the backup settings/backup data exists (if an SD card has been installed).
Setting information (files/data) cannot be acquired from the controller.	There is a problem that prevents the communication with the controller.	Check the following settings. GOT side <ul style="list-style-type: none"> • Are cables correctly connected? • Has a correct communication driver been installed? • Are communication settings correct? Controller side <ul style="list-style-type: none"> • Have parameters been set? • Are cables correctly connected? • Is the power on?
Since a password has been set to the file, the backup cannot be performed to the file.	The password was forgotten or the input password is incorrect (first backup). The file password has been changed.	Get the file password from the system or device administrator.

Restoration

Problem	Cause	Corrective action
Setting information (files/data) cannot be written to the controller.	There is a problem that prevents the communication with the controller.	Check the following settings. GOT side <ul style="list-style-type: none"> • Are cables correctly connected? • Has a correct communication driver been installed? • Are communication settings correct? Controller side <ul style="list-style-type: none"> • Have parameters been set? • Are cables correctly connected? • Is the power on?
	The controller in the backup data and the actual controller are different.	<ul style="list-style-type: none"> • Check if the selected backup data is for the target system. • Check if the restoration target controller is the same controller as the one used when the backup was performed or an equivalent.
Since a password has been set to the file, the restoration cannot be performed to the file.	The password of the file written in the controller has been changed.	Get the file password from the system or device administrator.

15.9 USB Device Management

Only available to GT2107-W.

Function of the USB device management

This function displays a list of the USB peripheral device connection status in the GOT.
Also, this screen is used to remove the USB peripheral device from GOT.

Display operation of the USB device management

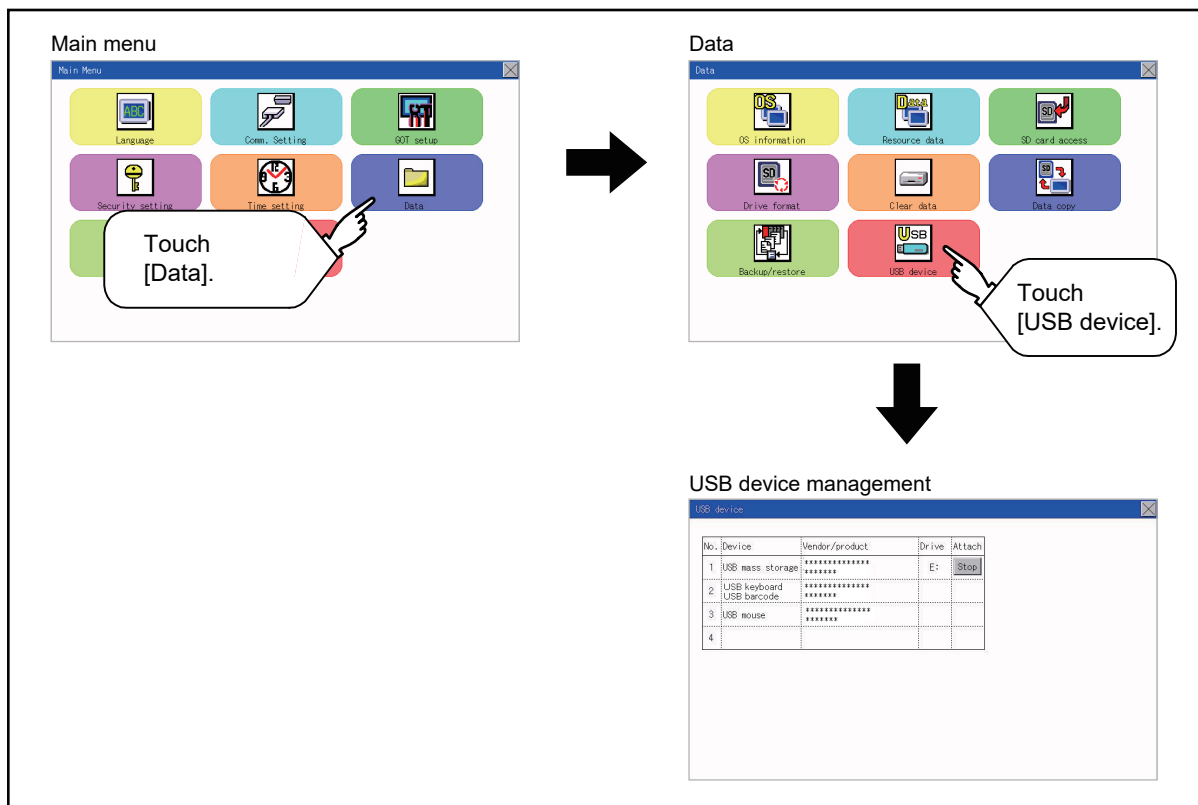

USB device status display operation

1. When a USB memory is installed, the [Stop] button is displayed in the [Attach] column. Touch the [Stop] button when removing the USB memory.

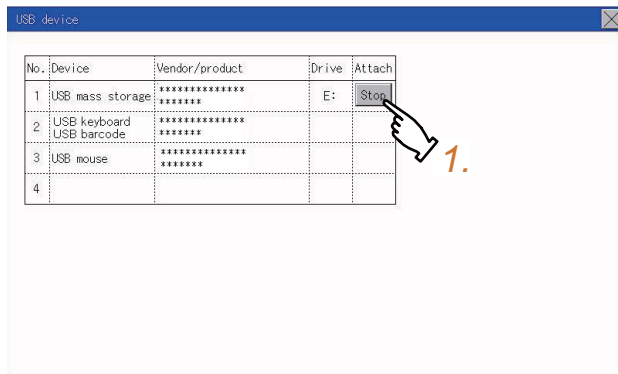

2. Touch the [Stop] button in the [Attach] column to display the following dialog. Touch the [YES] button to remove the USB peripheral device. Touch the [NO] button to cancel removing the USB device.

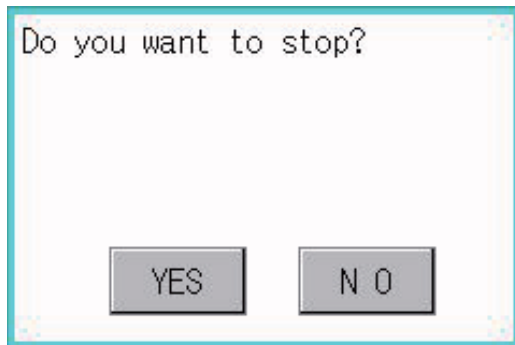

3. When the preparation of removal is ready, the dialog box shown below is displayed. To close the dialog box, touch the [OK] button.



MEMO

16 DEBUG

📖 Page 639 Device Monitor Function

📖 Page 653 FX List Editor

📖 Page 683 FX3U-ENET-ADP Communication Setting Function

The debug includes functions to check the PLC system status and to improve troubleshooting efficiency.

The following is available as the debug.

Item	Description	Reference
Device monitor	For a controller connected to the GOT, forcibly turning on or off devices of the controller and changing the set value or present value are available.	📖 Page 639 Device Monitor Function
FX list editor	The sequence program of the FXCPU can be changed.	📖 Page 653 FX List Editor
FX3U-ENET-ADP communication setting function	The communication set value of the FX3U-ENET-ADP stored in the CPU can be changed.	📖 Page 683 FX3U-ENET-ADP Communication Setting Function

16.1 Device Monitor Function

For a controller connected to the GOT, forcibly turning on or off devices of the controller and changing the set value or present value are available.

System configuration

This section describes the controller names and connection types between the GOT and a controller that are applicable to the device monitor function.

For details of communication units and cables for each connection type, refer to the following manual.

📖 GOT2000 Series Connection Manual for GT Works3 Version1

16

Target controller

Controller	Connection type
RCPU	Ethernet connection, Serial communication connection
FX5CPU	Ethernet connection, Direct CPU connection (serial)
QCPU (Q mode), LCPU	Ethernet connection, Direct CPU connection (serial), Serial communication connection, CC-Link connection (via G4)
QnACPU	Direct CPU connection (serial), Serial communication connection
ACPU, QCPU (A mode)	Direct CPU connection (serial)
FXCPU	Ethernet connection, Direct CPU connection (serial)
Inverter	Inverter connection
Microcomputer	Microcomputer connection (Ethernet), Microcomputer connection (Serial)
MODBUS	MODBUS(R)/TCP connection, MODBUS(R)/RTU connection

Required system application

System application		Version	
Basic system application		-	
-	Communication driver	Ethernet(MITSUBISHI ELECTRIC), Gateway	
		Ethernet(FX), Gateway	
		MODBUS/TCP Master, Gateway	
		SERIAL(MELSEC)	
		MELSEC-A	
		MELSEC-FX	-
		CC-Link(G4)	-
		FREQROL 500/700/800, Sensorless servo	
		Microcomputer connection	
MODBUS/RTU Master			

Point

Checking method of the version of basic system application and communication driver

Check the version of the basic system application and communication driver installed in the GOT at [System Application Information] of the utility.

Refer to the following for details.

☞ Page 558 OS information

Devices that can be monitored

For details on the device names that can be monitored and the scope of monitoring, refer to the following.

📖 GT Designer3 (GOT2000) Screen Design Manual

Precautions

Monitoring and testing real number data

Real number data cannot be monitored and tested.

All word devices containing real number data are monitored in integer data (binary data).

Monitoring devices in 32-bit (two-word) module

When monitoring word devices (T, C, D, W, etc.) in 32-bit (two-word) module, those with 32 bits of data remaining are monitored.

Devices with 16 bits (one-word) of data remaining are not monitored.

If an odd number is specified for the first monitor device number, the last device number of the specified controller will not be displayed.

(Example) When the data entry of the QnACPU is monitored in units of 32 bits from odd numbers (D1, D3...)

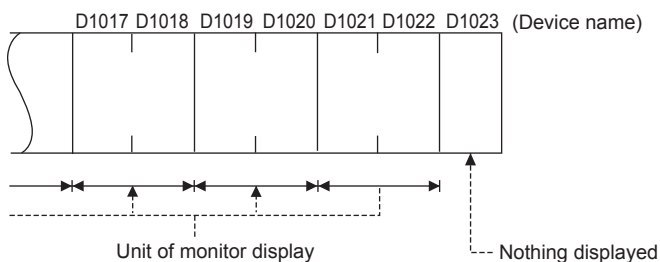

Setting the network No., station No., and CPU No.

Setting of the network No., station No., and CPU No. may be required depending on the connection type.

In this case, register the device after setting the network No., station No., and CPU No.

Display operation of device monitor

GT2107-W

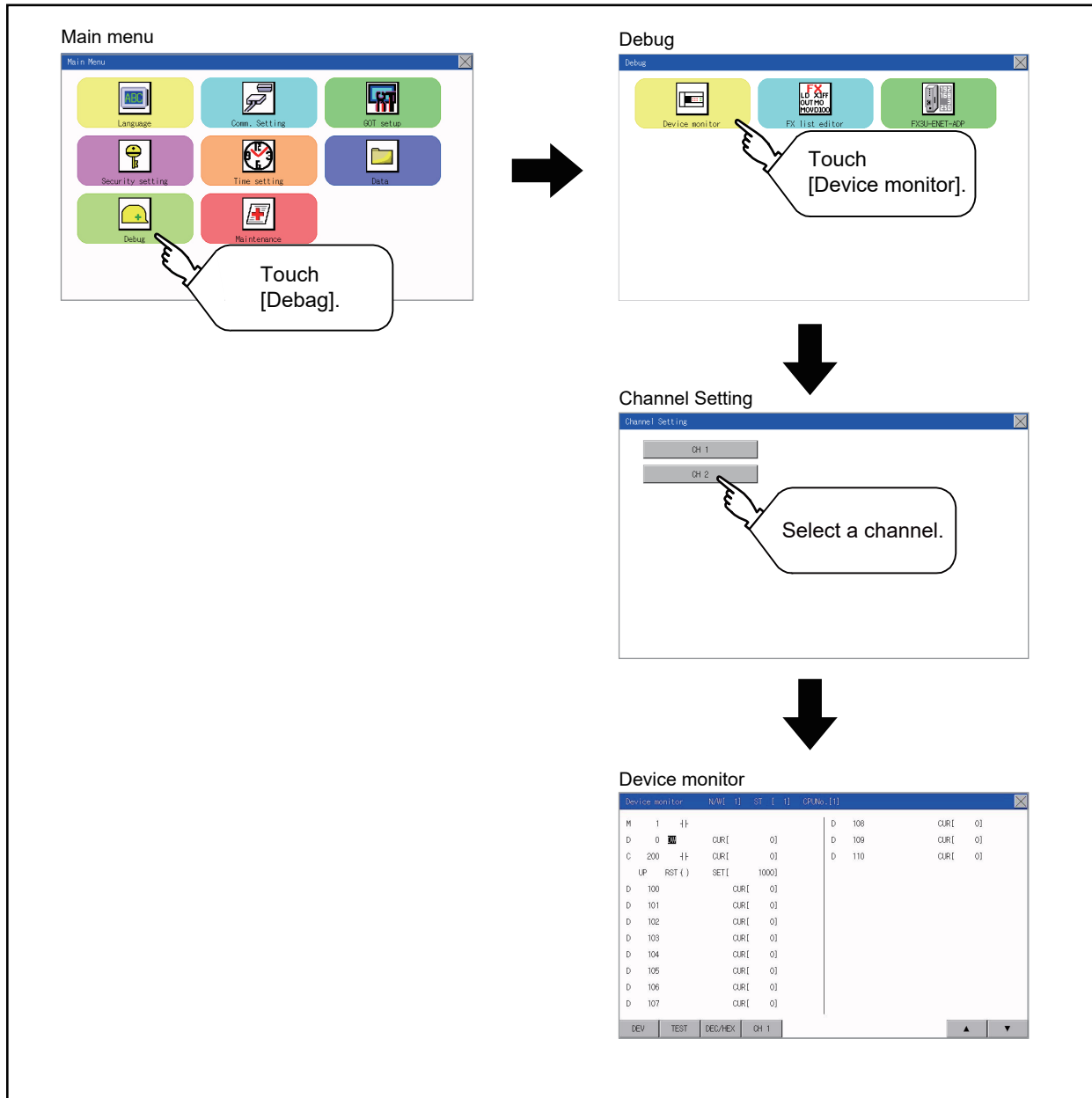

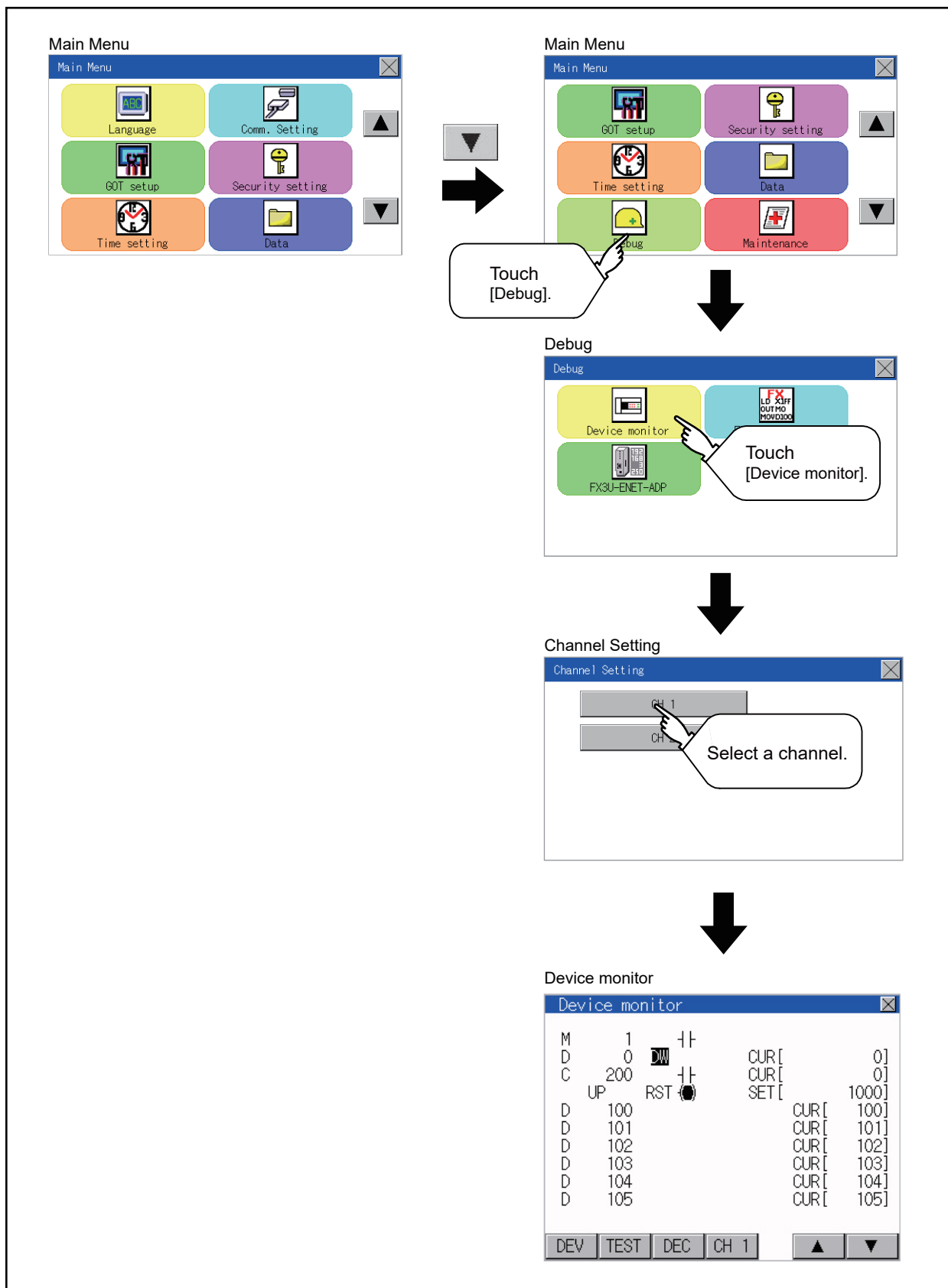

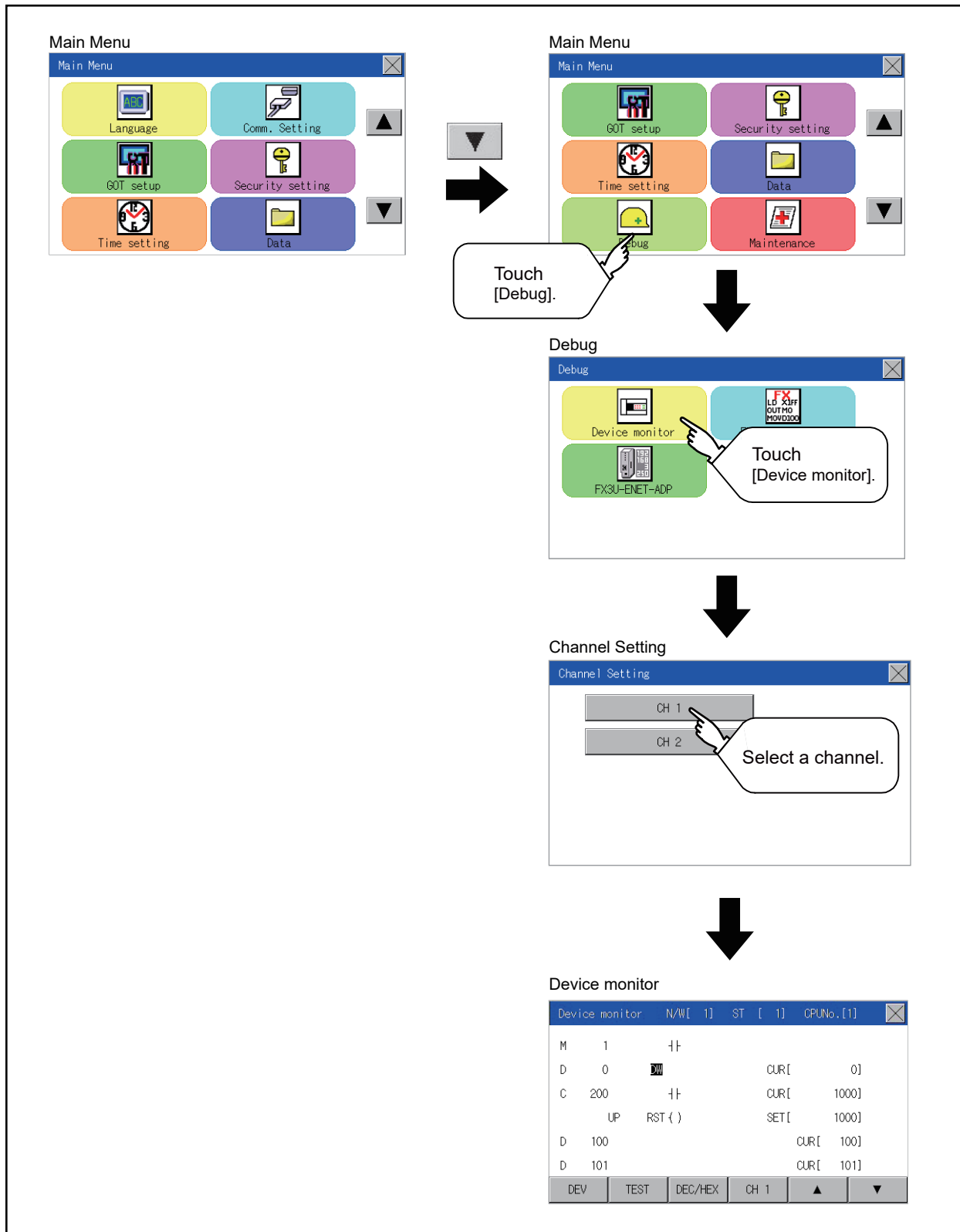

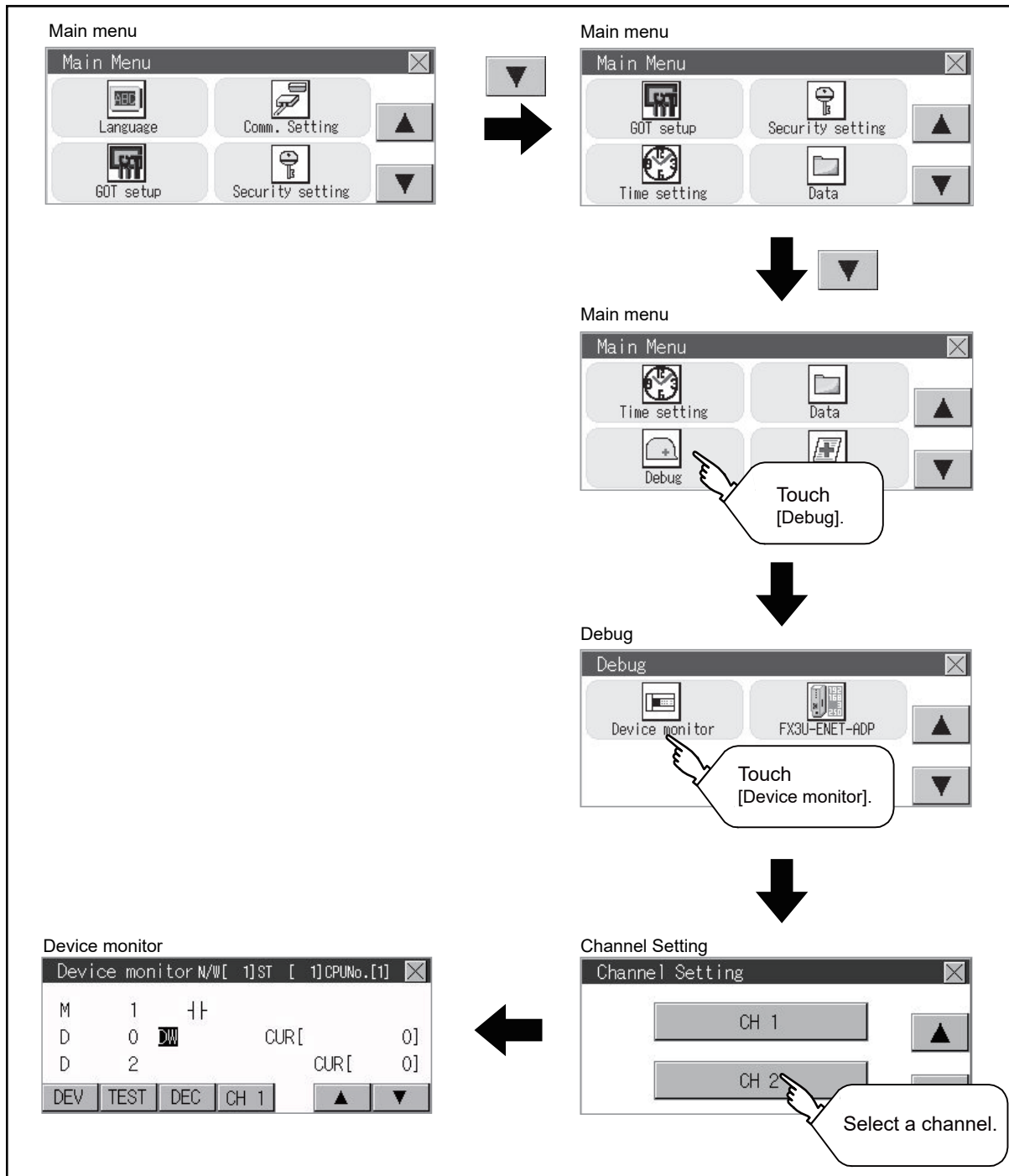





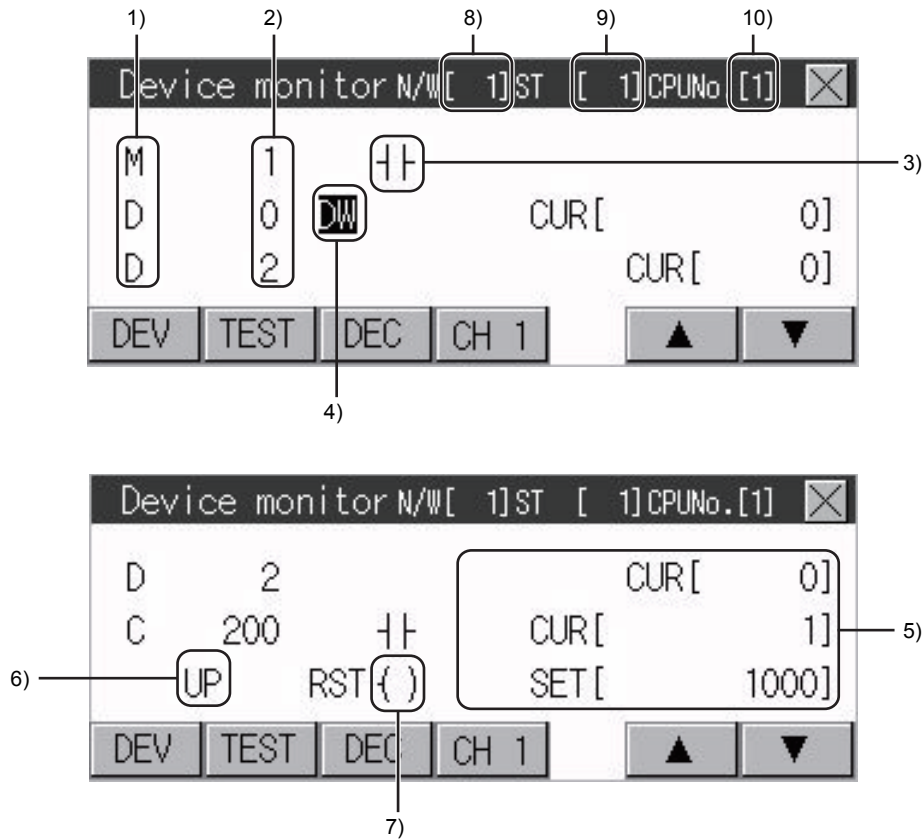

Information displayed on the device monitor screen and key functions

Device monitor screen

The information displayed on the device monitor screen is described below.









No.	Item	Settings
1)	Device name	Displays the device name.
2)	Device No.	Displays the device number.
3)	Bit device ON/OFF Timer/Counter contact ON/OFF	Displays ON/OFF information of bit devices and timer/counter contacts  : ON  : OFF
4)	Data type	DW: Indicates that the device value is a 32-bit (two-word) module. Nothing displayed: Indicates that the device value is a 16-bit (one-word) module.
5)	Present value of word device Present value and set value of timer/counter*1	[Decimal number] 16-bit (one-word) module: Six digits (including a digit for a sign) are displayed. (Display example: -12345) 32-bit (two-word) module: Ten digits (including a digit for a sign) are displayed. (Display example: -123456789) [Hexadecimal number] 16-bit (one-word) module: Four digits are displayed. (Display example: H AB12) 32-bit (two-word) module: Eight digits are displayed. (Display example: H ABCDE123)
6)	Counting method	Displays the counting method when registering the counters from C200 to C255. UP: Up count mode DOWN: Down count mode
7)	Reset coil ON/OFF	Displays the reset coil state when registering the timer/counter for the FXCPU.  : ON  : OFF
8)	Network No.	Sets or displays the network No. when the PLC is on the network.
9)	Station No.	Sets or displays the station No. when the station No. is assigned to the PLC.

No.	Item	Settings
10)	CPU No. specification	0 to 4: This item must be set only when the GOT is connected to the Q series CPU in the multiple CPU system or QnUCPU. Changing the CPU No. cancels the registration for all the devices.  Page 648 Device Monitor Function

*1 When a timer or counter of the ACPU, QnACPU, or FXCPU is registered, the set value of the timer or counter is displayed.

Key functions

The following table describes the key functions displayed on the device monitor screen.

Key switch	Function
DEV	Switches the screen to the device registration key window for registering devices to be monitored.  Page 648 Device registration
TEST	Switches the quick test mode between enabled and disabled states.  Page 650 Quick test
DEC/HEX	Switches the numerical notation of word device values between decimal and hexadecimal numbers.
CH1 or CH2	Switches the channel to be displayed.
 	Scrolls the data list up and down by one line and displays the devices before or after the device which is currently registered and placed in the top or bottom line.  : Scrolls the list up by one line to display the device number right before the device number displayed in the top line.  : Scrolls the list down by one line to display the device number right after the device number displayed in the bottom line.
	Exits the device monitor, and then the screen returns to the debug screen.

Basic operation of device monitor

The following explains basic operations of the device monitor.

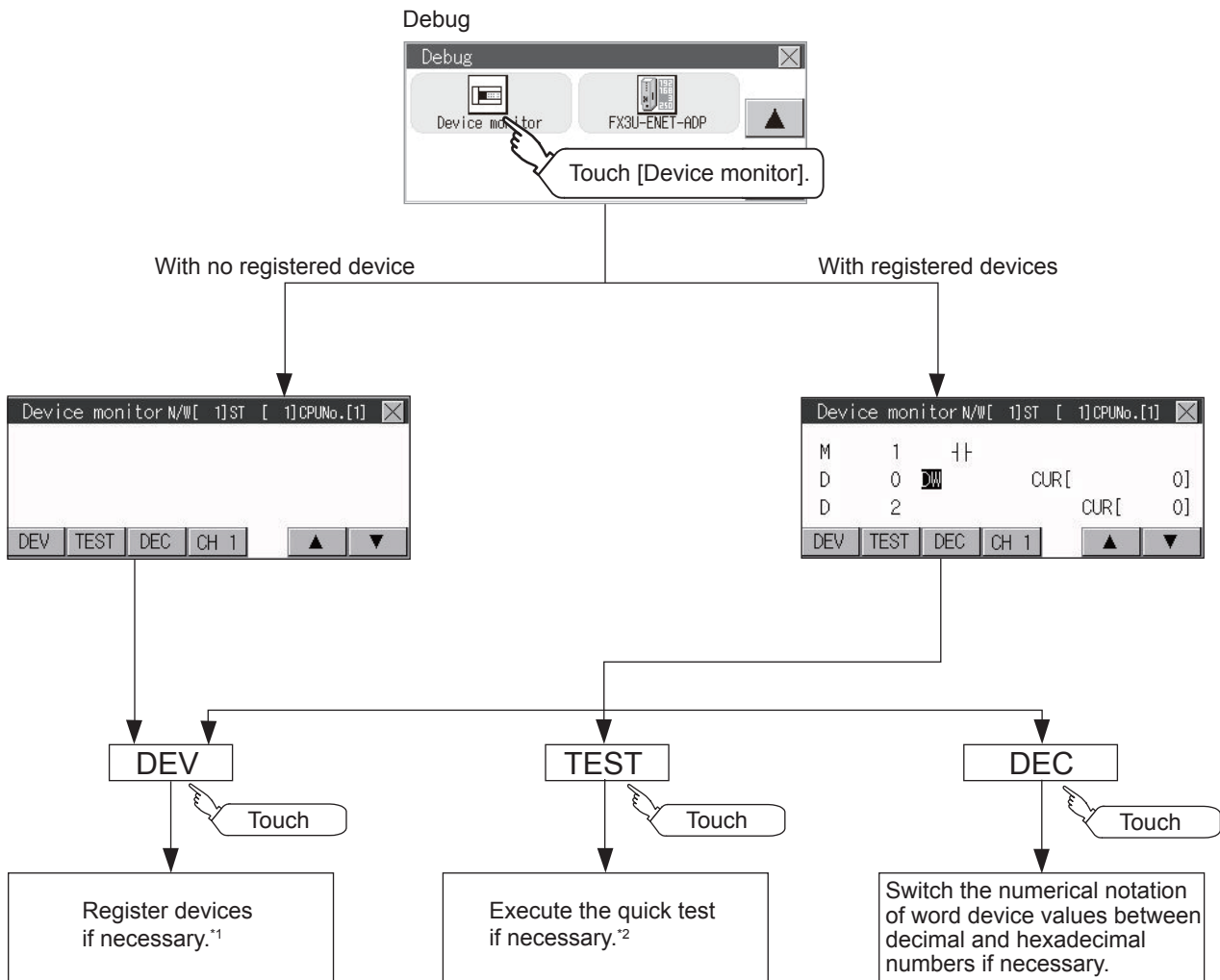

*1 For the details, refer to the following.

☞ Page 648 Device registration

*2 For the details, refer to the following.

☞ Page 650 Quick test

Device registration

The following explains the procedures for device registration.

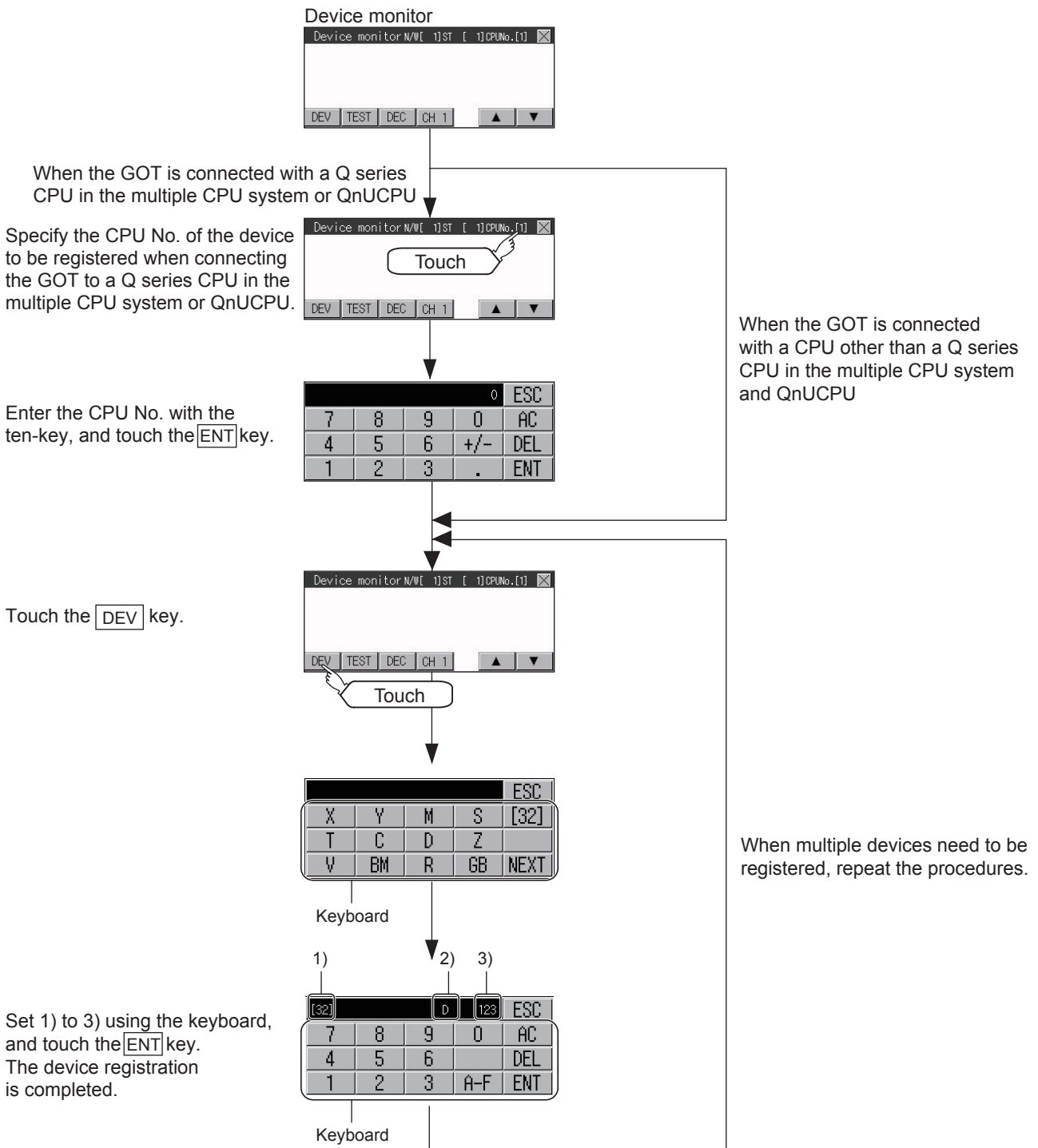

For the keyboard operations, refer to the next page.

No.	Item	Settings
1)	Data type	32: Indicates that the device value is a 32-bit (two-word) module. Nothing displayed: Indicates that the device value is a 16-bit (one-word) module.
2)	Device name	Set the device name and device number to be monitored.
3)	Device No.	

Keyboard operations

- Keyboard functions

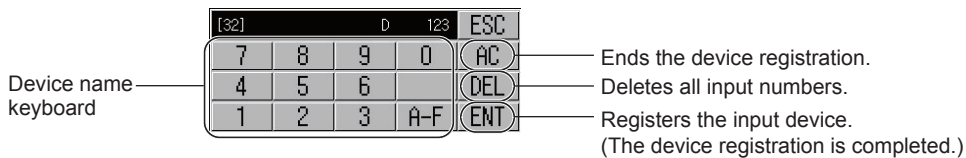
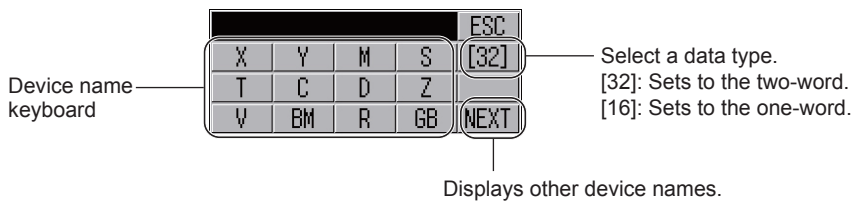

- Input procedures

Select a data type. (Ex: 16 bits)

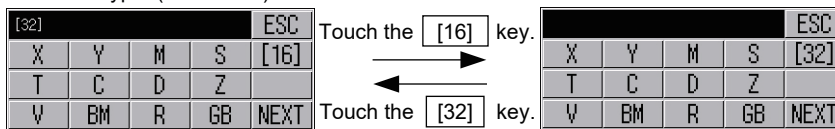

Input a device number. (Ex: 12)

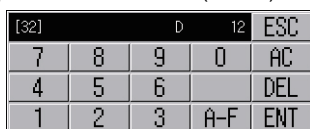

Input a device name. (Ex: D)

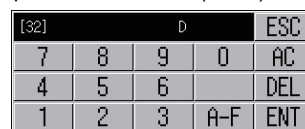

Precautions for device registration

- Data type

Device monitor screens display the data type as shown below.

DW: 32-bit (two-word) module

Nothing displayed : 16-bit (one-word) module

- CPU No. specification

Changing the CPU No. after registering devices cancels the registration for all the devices.

Check the CPU No. before registering the devices.

- Station No. specification

Changing the station No. after registering devices cancels the registration for all the devices.

Check the station No. before registering the devices.

- N/W (Network) No. specification

Changing the N/W No. after registering devices cancels the registration for all the devices.

Check the N/W No. before registering the devices.

- Holding registered devices

The registration for the devices is not canceled after exiting the device monitor.

Restarting the GOT cancels the registration for all the devices.

- The number of registered devices

The number of registered devices must be within the maximum number of devices that can be displayed on the GOT.

For registering an additional device, the registration for the device in the top line is canceled and the additional device is displayed in the bottom.

Quick test



WARNING

● Before performing the quick test operations of device monitor (such as turning ON or OFF bit device, changing the word device current value, changing the settings or current values of the timer or counter), read through the manual carefully and make yourself familiar with the operation method. During quick test operation, never change the data of the devices which are used to perform significant operation for the system. False output or malfunction can cause an accident.

The quick test operation procedure for monitor devices is described below.

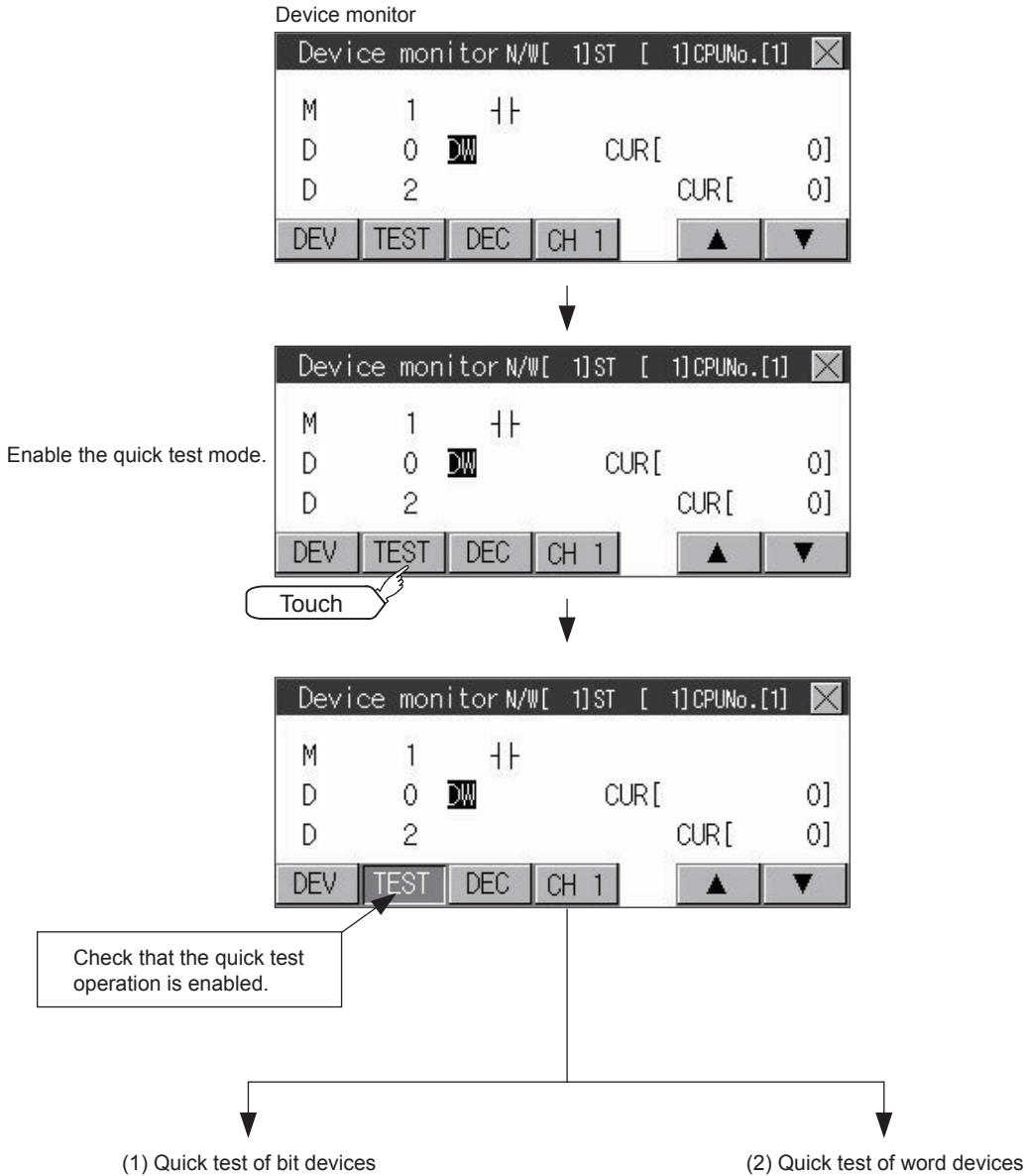

Quick test of bit devices

(Operation example)

Change the status of the bit device M14 from OFF  to ON .

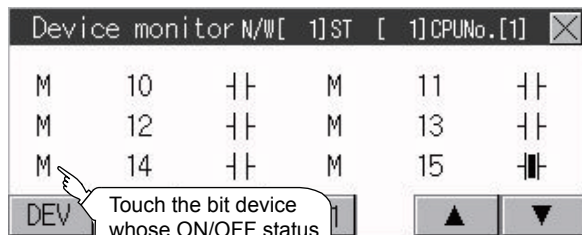

The device name and device number of the selected bit device are highlighted.

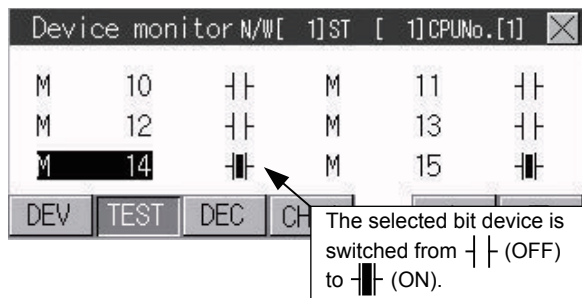
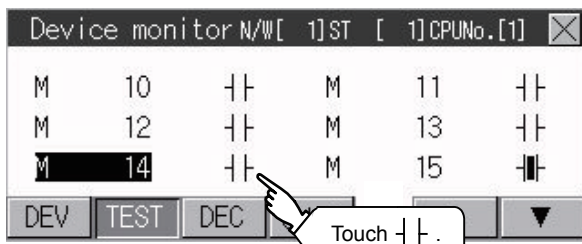
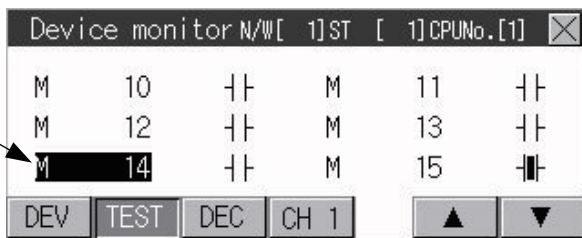

Quick test of word devices

(Operation example)

Change the device value of word device D200 from 43 to 100.

Conditions: Data range: 16 bits, device value display format: decimal number

Device monitor N/W[1]ST [1]CPUNo.[1] X

D	198	CUR[0]
D	199	CUR[6]
D	200	CUR[43]

DEV TEST DEC CH 1 ▲ ▼

Touch the device value to be changed.

Device monitor N/W[1]ST [1]CPUNo.[1] X

Input a device value using the keyboard.
Input 100 in this operation example.

D	198	CUR[0]
D	199	CUR[6]
D	200	CUR[43]

DEV TEST DEC CH 1 ▲ ▼

Device monitor N/W[1]ST [1]CPUNo.[1] X

100				ESC
7	8	9	0	AC
4	5	6	+/-	DEL
1	2	3	.	ENT

Touch the ENT key.

Device monitor N/W[1]ST [1]CPUNo.[1] X

D	198	CUR[0]
D	199	CUR[6]
D	200	CUR[100]

DEV TEST DEC CH 1 ▲ ▼

The device value of D200 is changed from 43 to 100.

16.2 FX List Editor

Available to GT2107-W, GT2105-Q, and GT2104-R.

The MELSEC-FX list editor can change the sequence programs on the FX PLC.

The following example explains about GT2104-R.

Display operation of FX list editor

GT2107-W

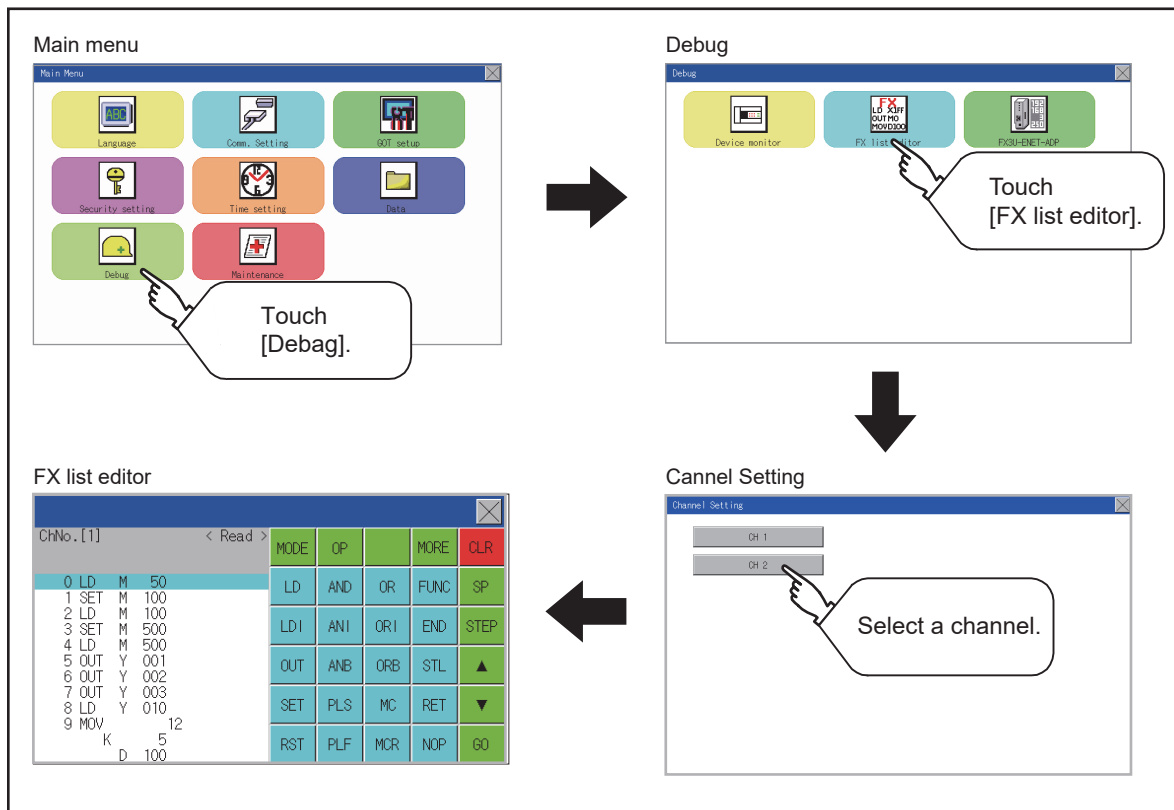

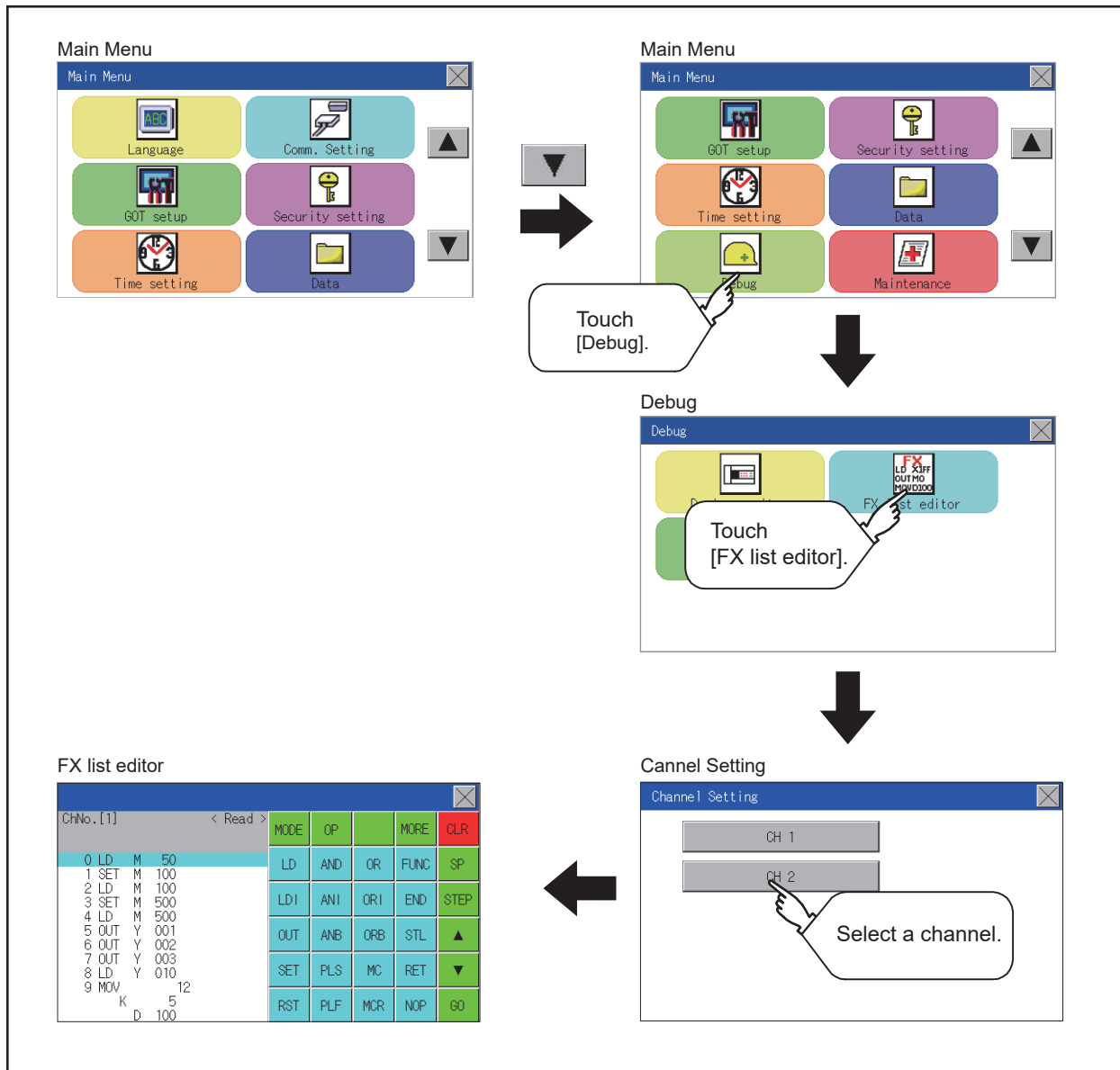

Parameters and sequence programs are easy to maintain.

You can check or partly correct, change or add FX PLC parameters and sequence programs simply by operating keys. You can easily edit sequence programs without preparing any peripheral unit other than the GOT.

(Example of changing sequence program commands)

```

LD X000      Changed      LD X000
OUT Y020     →           OUT Y030
LD X001      ↘           LD X001
    
```

Errors that occur during list editing can be checked easily.

Error messages, error codes, and number of steps for errors that occur in the FX PLC can be checked. Details can be checked immediately even for errors that occur during list editing.

Error message	Detail	Step
Circuit error	6612	4

Commands and devices can be searched and displayed.

Commands and devices used in sequence programs can be searched.

The correction position can be searched for cases such as when you want to correct a specific device.

Searched device
M800

ChNo. [1]	< Read >	MODE	OP	MORE	CLR
Search device	M 800	.	V	Z	SP
5 MOV	D 0	8	9		STEP
D 10					▲
10 LD	M 10	4	5	6	7
11 OUT	T 10				▼
K 100					
14 LD	X 002	0	1	2	3
15 OR	X 020				GO

Displays the searched device.

```

LD M 800
OUT T 10
LD K 100
LD X 002
    
```

Specifications

System configuration

This section describes the system configuration of the MELSEC-FX list editor.

For the setting method in each connection form, used communication unit/cable and cautions on connection form, refer to the following manual.

 GOT2000 Series Connection Manual For GT Works3 Version1

Controllers that can be edited with the MELSEC-FX list editor

Target controller^{*1}

FX CPU

*1 FX list editor is not applicable to for MELSEC iQ-F series.

Connection type

This function can be used in the following connection types.

(○: Applicable, △: Partly restricted, ×: Inapplicable)

Function		Connection type between GOT and PLC	
Name	Description	Direct CPU connection (serial)	Ethernet connection ^{*1}
MELSEC-FX list editor	Sequence program writing, parameter setting, PLC diagnostics and keyword registration, etc.	○	○ ^{*2}

*1 MELSEC-FX list editor cannot be used when using CC-Link IE field network Ethernet adapter.

*2 Available only when using FX3 series.

Functions list and monitor conditions

The following shows the memory that can be monitored by the MELSEC-FX list editor and the FX PLC status conditions.

(○: Can be monitored △: Can be monitored under certain conditions ×: Cannot be monitored)

Function		Memory that can be monitored *2				FX PLC status	Reference
		Built-in memory	RAM memory cassette	EEPROM memory cassette, flash memory cassette	EPROM memory cassette		
Reading sequence programs	Displaying sequence programs	○	○	○	○	RUN/STOP	☞ Page 665 Displaying sequence programs
	Searching commands/devices						☞ Page 667 Searching commands/devices
Writing sequence programs	Writing commands	○	○	△*1	×	For Stop only	☞ Page 669 Writing commands
	Changing operands/set values						☞ Page 672 Changing operands, set values
	Inserting commands						☞ Page 669 Writing commands
	Deleting commands						☞ Page 673 Deleting commands
	Sequence program all clear						☞ Page 674 Sequence program all clear
PLC diagnostics		○	○	○	○	RUN/STOP	☞ Page 675 PLC diagnostics
Parameter setting	Display					For Stop only	☞ Page 676 Parameter setting
	Setting	○	○	△*1	×		
Keyword		○	○	○	○	RUN/STOP	☞ Page 678 Keyword

*1 The operation is available only when the protect switch is OFF.

*2 The available memory differs depending on the FX PLC being used.

For details, refer to the following.

☞ The hardware manual of the FX PLC being used

Access range

For the FXCPU in Ethernet connection, the GOT can monitor only the host station.

The access range other than the above is the same as the access range when the GOT is connected to a controller.

For details of the access range, refer to the following.

☞ GT Designer3 (GOT2000) Screen Design Manual

☞ GOT2000 Series Connection Manual (Mitsubishi Product) For GT Works3 Version1

Precautions

Using other peripheral equipment for sequence program/parameter change

When using the MELSEC-FX list editor, do not change programs or parameters in the PLC CPU from other peripheral equipment.

If programs or parameters are changed, exit the MELSEC-FX list editor once and start the MELSEC-FX list editor again.

If the program on one PLC is changed carelessly from multiple units of peripheral equipment (including GOT), the contents of the program in the PLC CPU and the peripheral equipment may not be the same, resulting in an unintended operation of the PLC CPU.

Sequence program change

Stop the FX PLC before changing (writing, inserting, deleting) a sequence program or changing parameters.

Operation is not possible with the FX PLC running.

If you press the [GO] key but the system does not proceed to the next operation (for example, a search)

Check the input contents (applied instruction number, device value, etc.).

When using list monitor

Only devices to be used for basic instructions can be monitored.

The status of devices (word, bit) to be used for application instructions cannot be monitored.

Display operation

Operation to display

The following describes the outline for displaying the operation screen of the MELSEC-FX list editor.

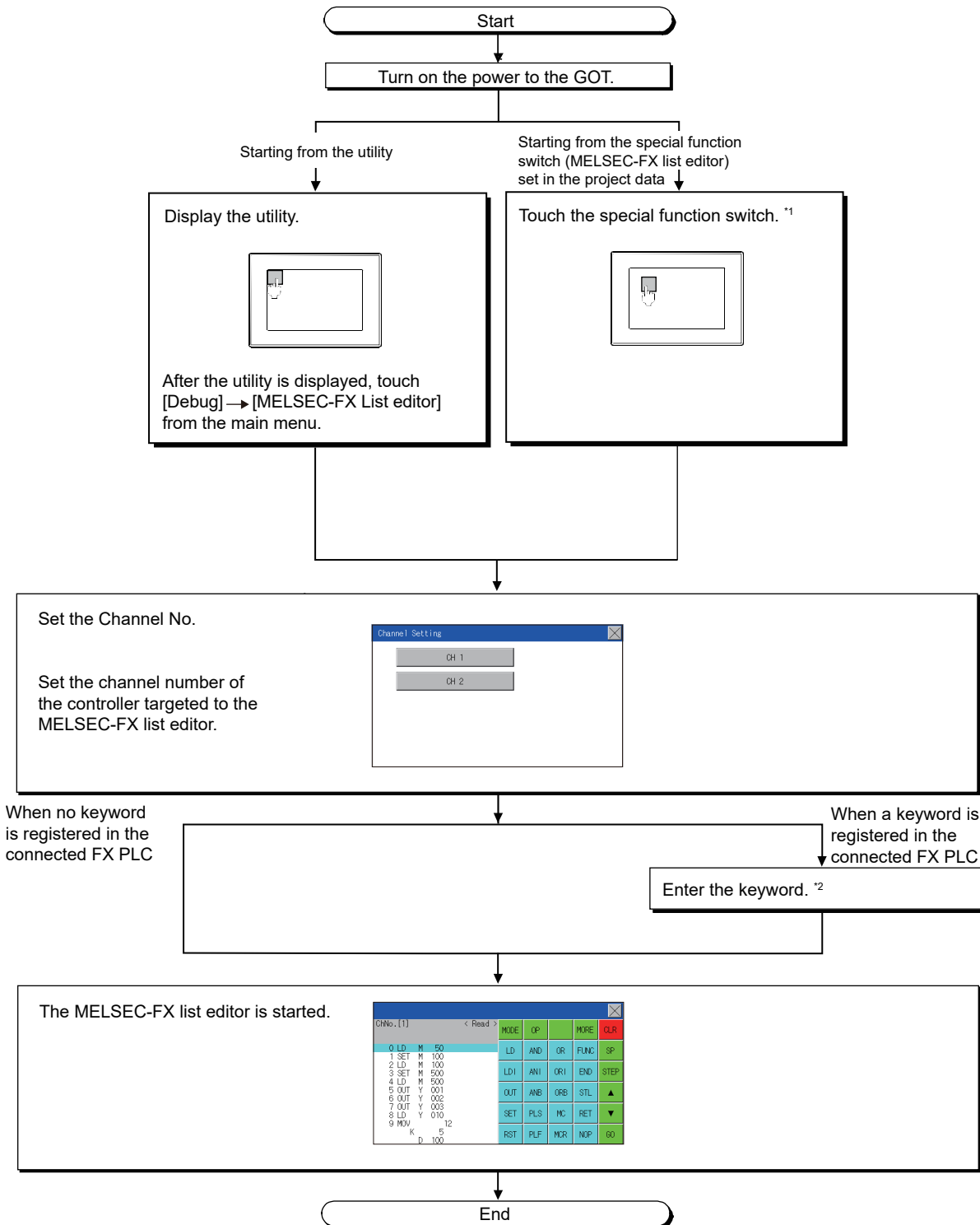

*1 For information on how to set a special function switch, refer to the following.

📖 GT Designer3 (GOT2000) Screen Design Manual

*2 For details on the operation method, refer to the following.

📖 Page 678 Keyword

- How to display the utility

For how to display the utility, refer to the following.

 Page 423 Utility Function List

- If the project data has not been downloaded

The MELSEC-FX list editor can be started from the utility even if the project data has not been downloaded to the GOT.

Changing screens

This section describes how to change the screen.

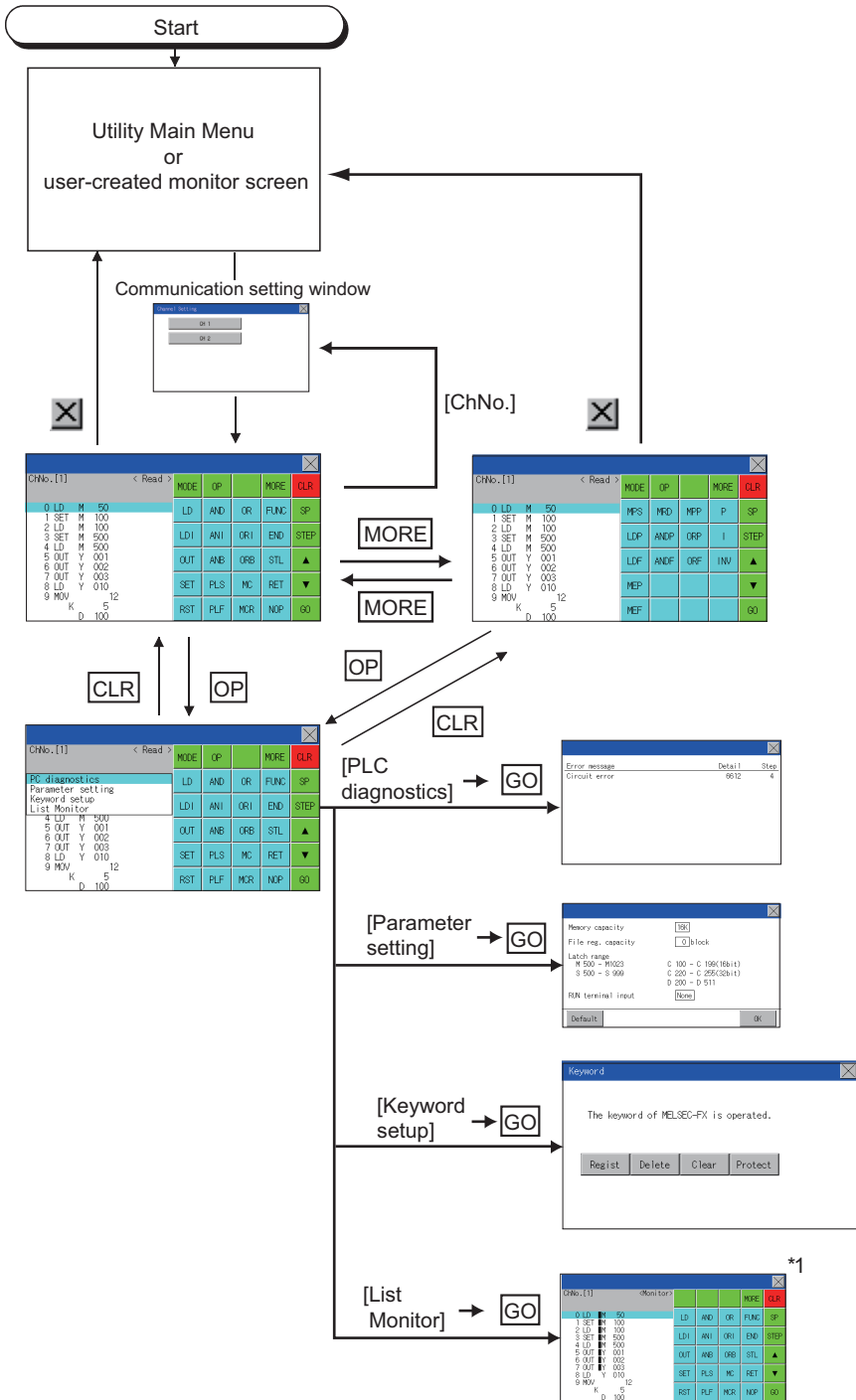

*1 With setting special function switches (FX list monitor), the list monitor can be started on the monitor screen. When the list monitor is started on the monitor screen, the list editor cannot be used. For how to set special function switches, refer to the following.

📖 GT Designer3 (GOT2000) Screen Design Manual

Operation procedures

This section describes the contents of the MELSEC-FX list editor and the key functions displayed on the screen.

Key arrangement and a list of key functions

The arrangement and functions of the keys displayed on the MELSEC-FX List Editor window are described below.

Displayed contents

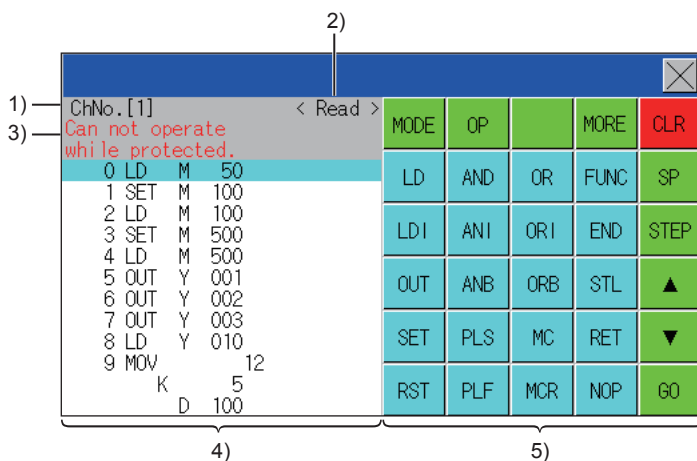

No.	Item	Display contents
1)	Channel No.	Displays the currently selected channel number. Touching "ChNo." displays the communication setting window. The communication setting window is not displayed if the MELSEC-FX list editor is started from the FX ladder monitor.
2)	Mode	Displays a mode for MELSEC-FX list editor. ☞ Page 664 Selection and operation of modes [Monitor] is displayed when the list monitor is executed. ☞ Page 680 List monitor
3)	Error message	Displays the contents of errors that occur with the MELSEC-FX list editor. ☞ Page 682 Error messages and corrective actions
4)	List display area	Displays the sequence program in list format (12 digits). The position (line) that can be edited is displayed with a bar.
5)	Key area	Displays the keys that can be used with the MELSEC-FX list editor.

Key functions

The table below shows the functions of the keys that are used for the operation on the MELSEC-FX list editor screen.

Key	Function
ChNo. [1]	Displays the currently selected channel number. The communication setting window is not displayed if the MELSEC-FX list editor is started from the FX ladder monitor.
MODE	Selects a mode for MELSEC-FX list editor. ☞ Page 664 Selection and operation of modes
OP	Displays the PLC diagnostics, parameter setting, and keyword selection menu.
MORE	Switches between command keyboard 1 and command keyboard 2. ☞ Page 663 Keyboard switching
CLR	When inputting commands: Cancels the key input when only part of the command has been input. ☞ Page 682 Action for an incorrect key input When option menu is displayed: Closes the option menu. Commands cannot be deleted with this key. ☞ Page 673 Deleting commands
SP	Space key. This key is used when setting timers and counters, writing applied commands, etc.
STEP	Displays the list from a specified step number when the step number is input.
▲ ▼	Moves the list display area bar up and down and switches the line being edited.
GO	Determines the key operation.
LD INV, 0 9, etc.	Inputs commands, device names, etc. The key contents depend on the input contents. The commands that can be used differ depending on the target FX PLC. Refer to the manual for the FX PLC to be used.
✕	Exits the MELSEC-FX list editor.

Keyboard switching

Touching the MORE button switches the command keyboard 1 and command keyboard 2.

When you touch the button for a keyboard function, the optimum keyboard for input for that function is displayed automatically.

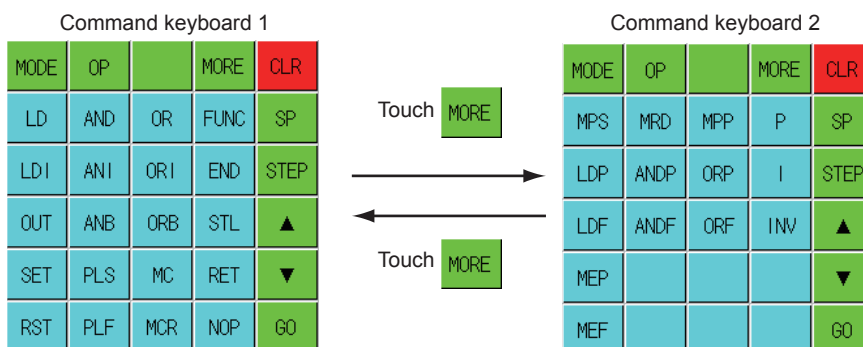

Selection and operation of modes

The MELSEC-FX list editor has four modes: READ, WRITE, INSERT, and DELETE.

Select an appropriate mode for the intended operation.

For details on the operation method, refer to the following.

- ☞ Page 665 Displaying sequence programs
- ☞ Page 667 Searching commands/devices
- ☞ Page 669 Writing commands
- ☞ Page 672 Changing operands, set values
- ☞ Page 673 Deleting commands
- ☞ Page 674 Sequence program all clear
- ☞ Page 675 PLC diagnostics
- ☞ Page 676 Parameter setting
- ☞ Page 678 Keyword
- ☞ Page 680 List monitor
- ☞ Page 682 Action for an incorrect key input
- ☞ Page 682 Error messages and corrective actions

How to change modes

Touch the MODE button.

Each time you touch this button, the mode changes.

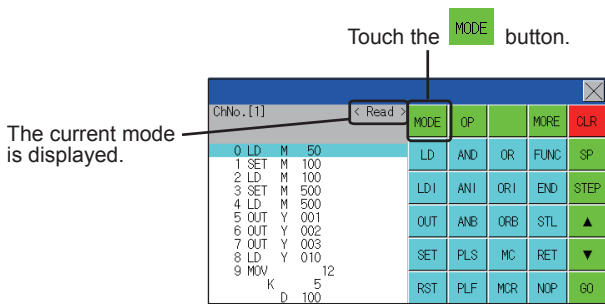

In the case the mode cannot be changed

In the following cases, the mode can be changed to the READ mode only.

If you try to change to other than READ mode, an error message is displayed.

To change to other than READ mode, take the action below.

Error message	Cause	Corrective action
PLC is running	The FX PLC is in the RUN status.	Stop the FX PLC.
Can not write.	The protect switch of the EEPROM memory cassette is on.	Switch off the protect switch of the EEPROM memory cassette.
	The EPROM memory cassette is enabled.	Set a memory other than EPROM as the memory to write to.

Displaying sequence programs

Sequence programs are read from the FX PLC to the GOT and displayed.

There are two displaying methods: specifying the step number, and scrolling one screen at a time.

Display using cursor keys

■Operation

Scroll with  OR 

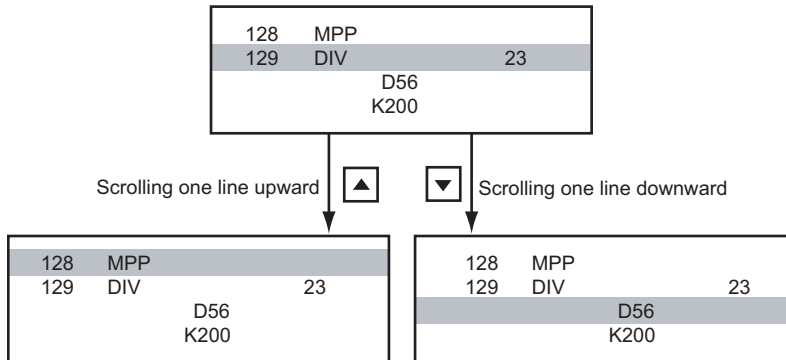

■Example

Scroll one line upward or downward.



Display specifying the step number

■Operation

 → → 

■Example

Displaying step number 123.

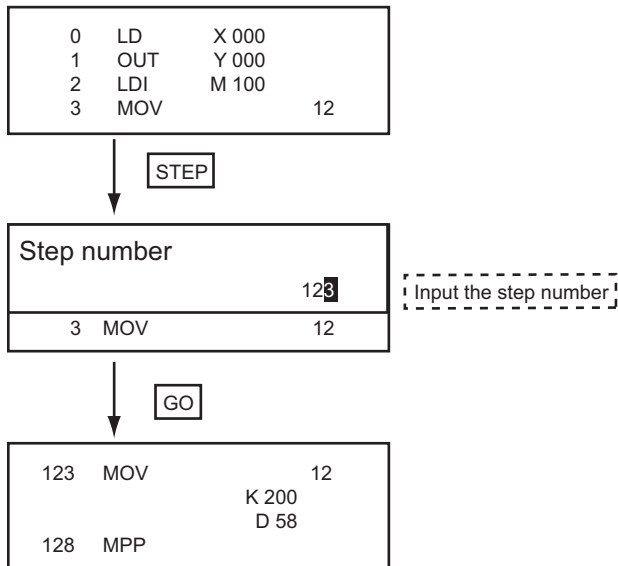

Point

When the specified step number is the operand of an applied instruction

If the specified step number is a timer (T) or counter (C) set value or the operand of an applied instruction, that command section is displayed at the head.

Display scrolling one screen at a time

■ Operation

MODE → GO
(Read mode)

■ Example

Displaying with scrolling one screen at a time.

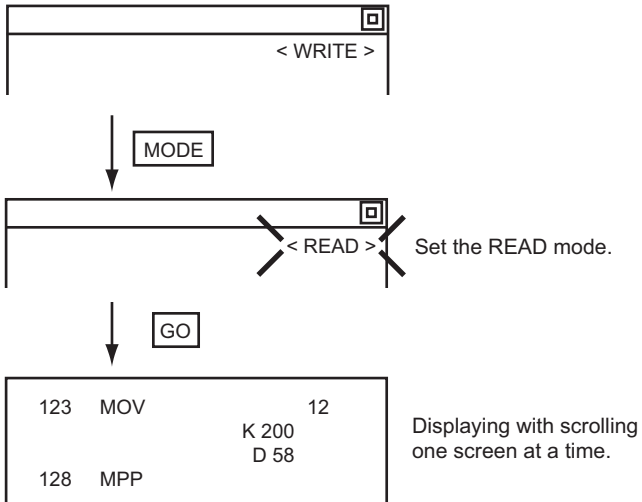

Searching commands/devices

Displays a command or device by searching it in sequence program from Step 0.

Command search

Operation



- *1 If the command you want to search for is not on the keyboard, touch the **[MORE]** key to switch to the other keyboard.
 When searching for an applied instruction, touch the **[FNC]** key and input the applied instruction number.
 When searching for a label, touch **[P]** or **[I]** and input the pointer number.
 Page 669 Writing commands
- *2 Input only when searching for commands requiring a device name and device number.
- *3 After the search results are displayed, you can continue searching with the same conditions by touching the **[GO]** key. Touching any key other than the **[GO]** key ends the search.

Example

Searching for LD M8000

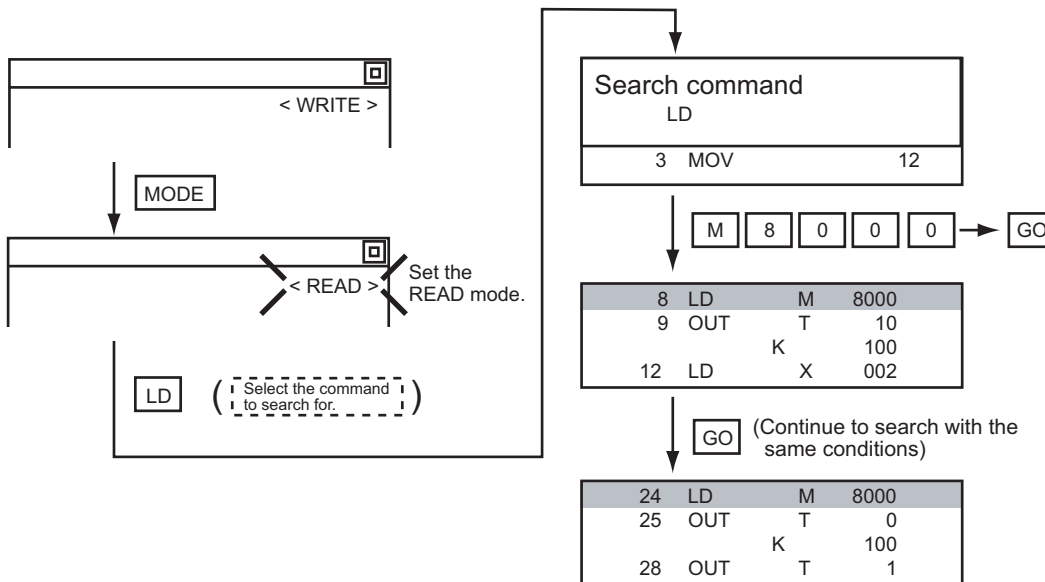

Point

Pointer (P, I) searches
 For pointer searches, only labels are searched.
 Pointers specified as operands in applied instructions are not searched.

Device search

Operation

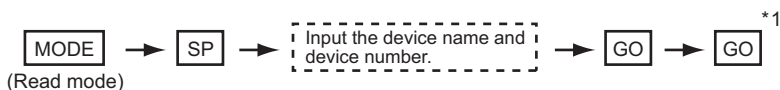

*1 After the search results are displayed, you can continue searching with the same conditions by touching the **GO** key. Touching any key other than the **GO** key ends the search.

Example

Searching for LD M8000

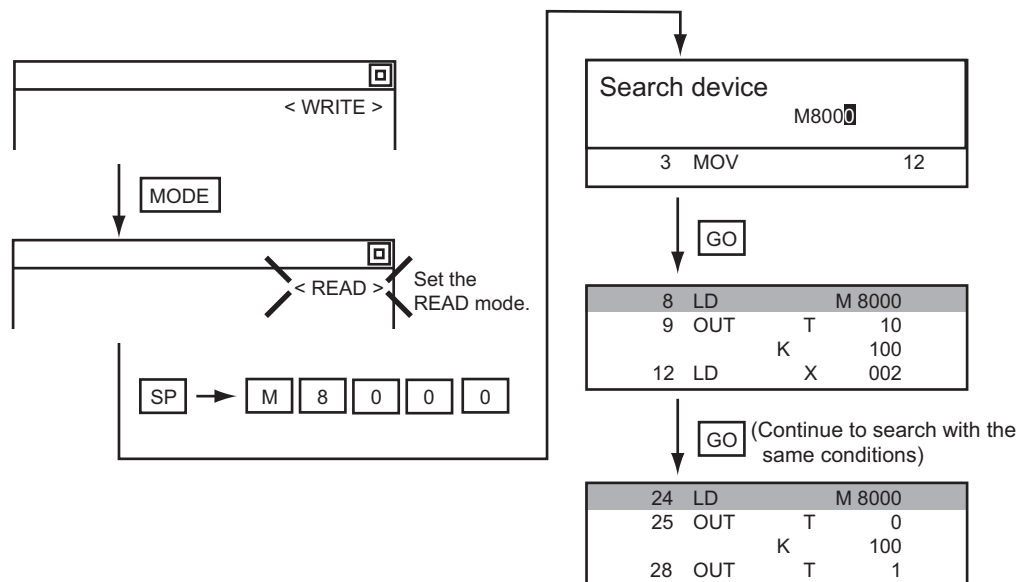

Point

Devices that cannot be searched

The following devices cannot be searched.

- Pointers, interrupt pointers
- Constant K, constant H, constant E
- Digit specification of bit device
- Special function unit/block buffer memory
- Devices specified with the operand of an applied instruction

Pointers and interrupt pointers can be searched for with command searches.

☞ Page 667 Command search

Writing commands

Writes a sequence program to the FX PLC. (Overwrite/Insert)

Writing basic commands

■ Operations

- Inputting command only (Ex.: ANB, ORB command etc.)

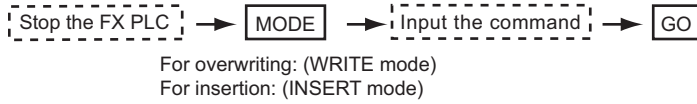

- Inputting command and device (LD, AND commands etc.)

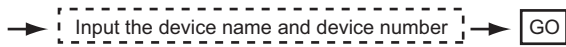
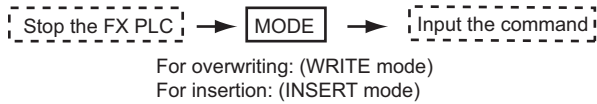

- Inputting command, No. 1 device, No. 2 device (MC, OUT (T, C) commands, etc.)

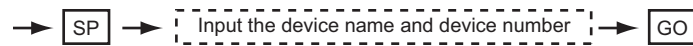
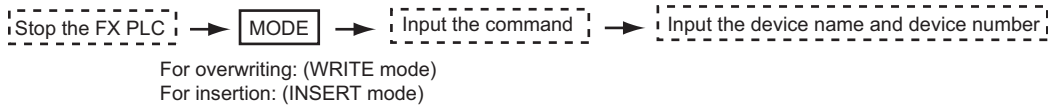

Point

Moving the cursor to the position to write the command

When starting to write a command, place the cursor on the command line (the line on which the step number is displayed).

You cannot write a command with the cursor on an operand or set value line.

2	LDI	M	100	}	Command line (Place the cursor on this line.)
3	MOV		12		
		D	0	}	Operand, set value line (Cannot operate on this line.)
		D	10		

Example

- Writing ORB command

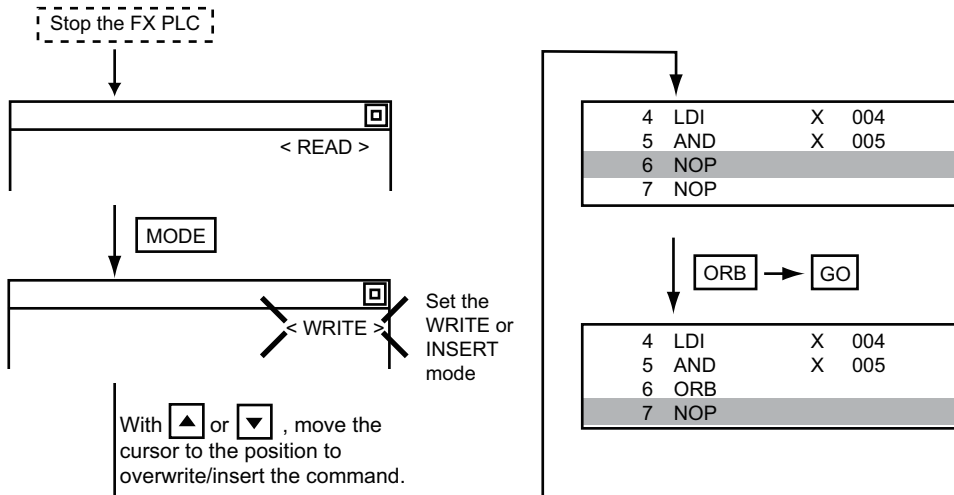

- Inputting LD X000

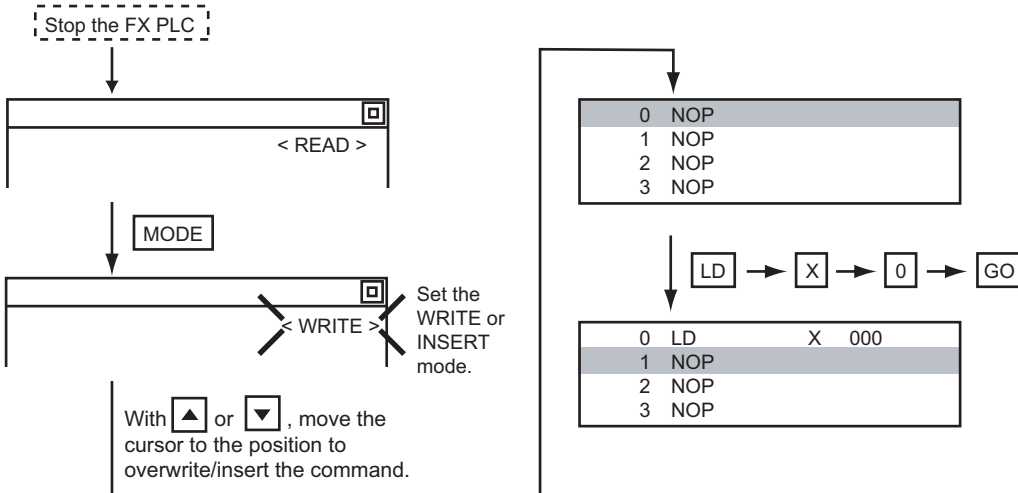

- Inputting OUT T100 K19

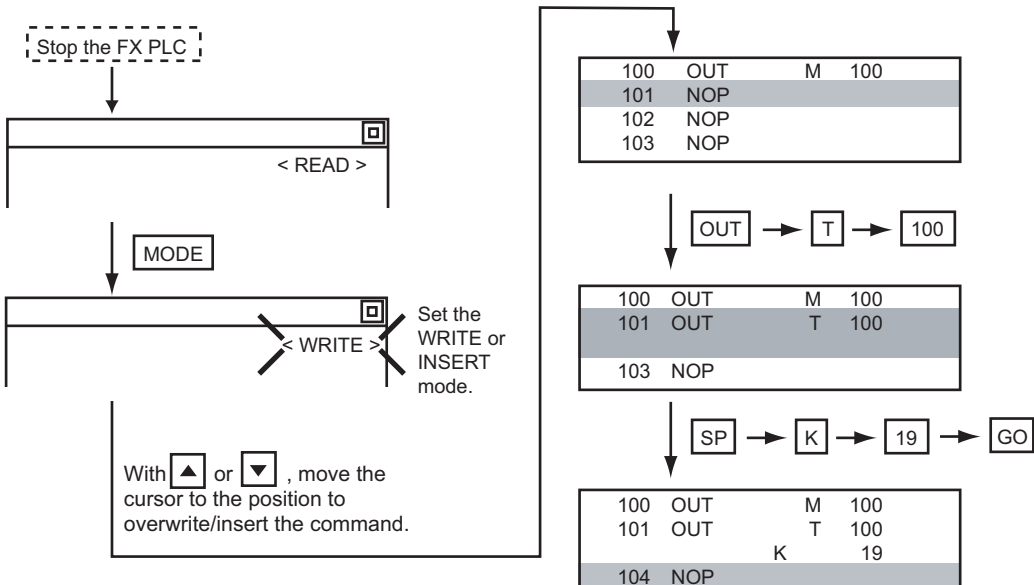

Writing applied instructions

■ Operation

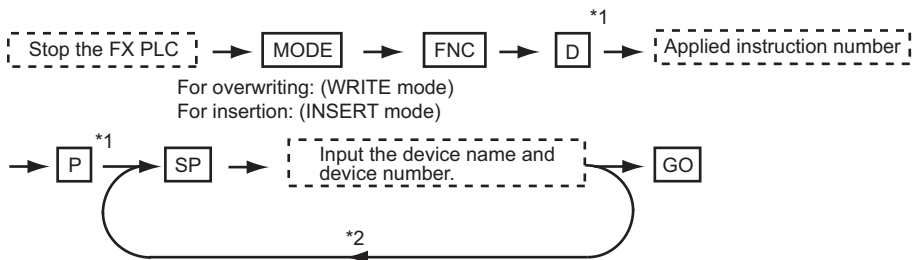

*1 **D** (double word command) and **P** (pulse execution format command) can also be input after the applied instruction number is input.

*2 Inputting in the order **P** → **D** is also possible.

*3 When a command specifies multiple devices for operations, input the **SP** key followed by the device name and device number.

Point

- Moving the cursor to the position to write the command

When starting to write a command, place the cursor on the command line (the line on which the step number is displayed).

You cannot write a command with the cursor on any other line.

2	LDI	M	100	} Command line (Place the cursor on this line.)
3	MOV		12	
		D	0	} Operand, set value line (Cannot operate on this line.)
		D	10	

- Commands using a text string constant for a command operand (such as ASC command)

With the MELSEC-FX list editor, text string constants cannot be written as operands. (such as ASC commands)

Use GX Developer for writing such commands.

■ Example

Input "DMOVP D0 D2".

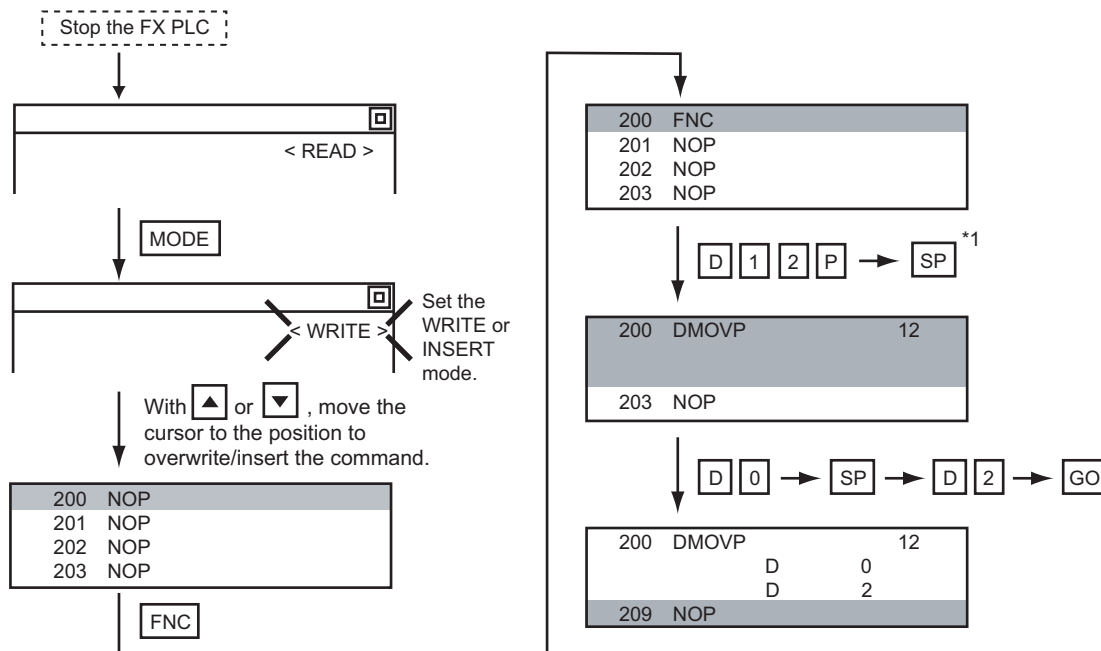

Changing operands, set values

Changes the operand section of an applied instruction and OUT (T, C) command set value.

Operation

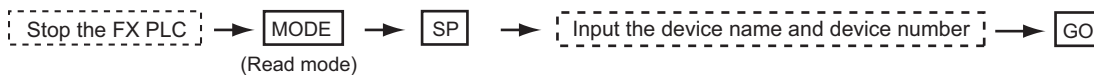

- *1 For decimal numbers, input K, then the number.
- For hexadecimal numbers, input H, then the number.

Point

Moving the cursor to the line on which the operand or set value is to be changed
 When starting to change an operand or a set value, place the cursor on the line of the operand or set value to be changed (the line on which the step number is not displayed).
 If you place the cursor on the command line, the input operation is not possible.

Example

Changing "MOV D0 D10" to "MOV D0 D123"

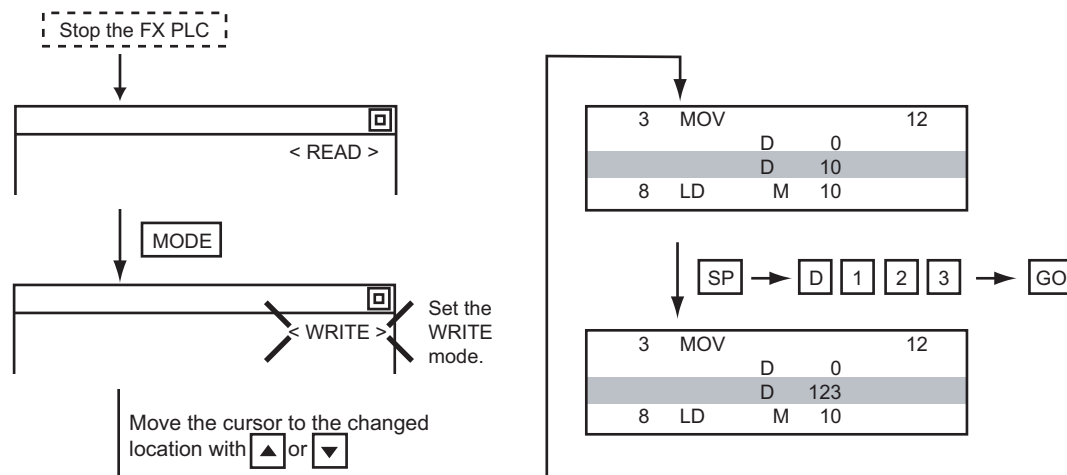

Deleting commands

Deletes one command at a time from a sequence program.

Operation

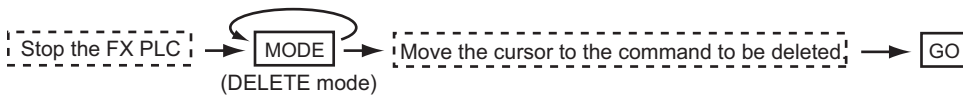

Point

When moving the cursor to the position where the command is to be deleted
 Place the cursor on the command line (the line on which the step number is displayed).
 You cannot delete the command if the cursor is placed on the line of an operand or set value.

Example

Deleting "OUT T10 K100"

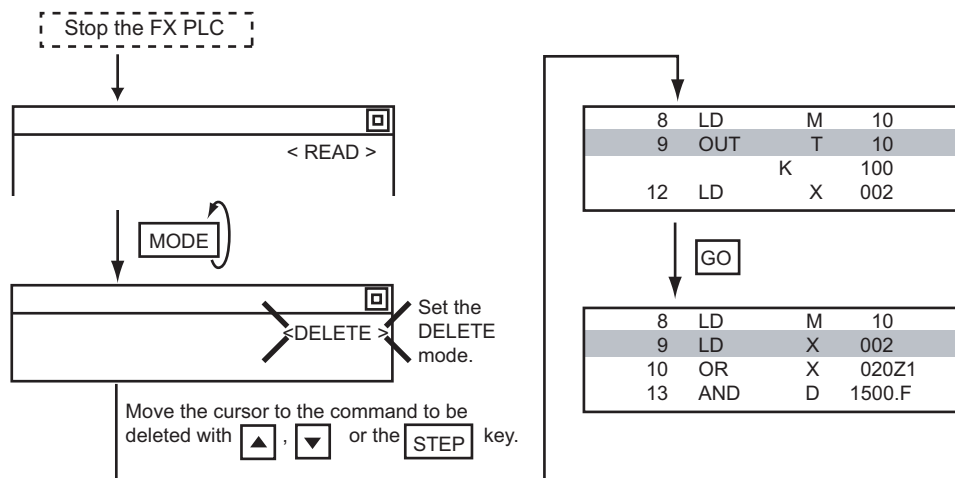

Sequence program all clear

Clears all the sequence programs.

Operation

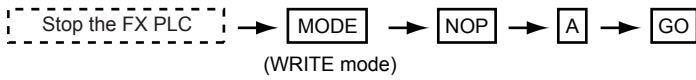

Example

Clears all the sequence programs.

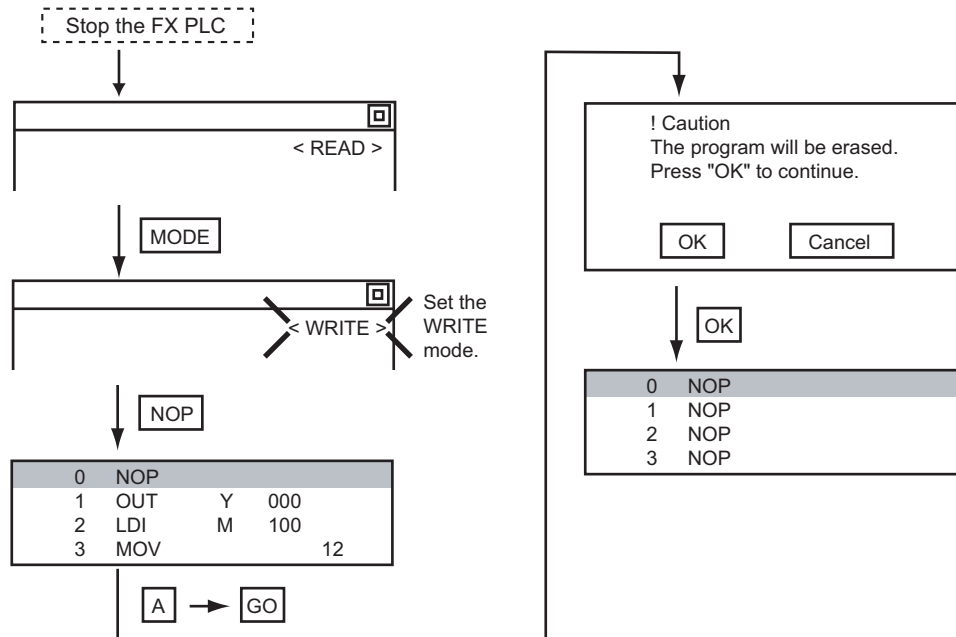

Point

Items cleared when All Clear for a sequence program is performed

When All Clear is executed, the parameters before program execution are initialized and Latch Clear is executed.

The memory space becomes the default value, the comment area a 0 block, the file register space a 0 block, and keywords unregistered.

After All Clear, set the above parameters etc. again.

PLC diagnostics

Displays the FX PLC error message, error code, and step at which the error occurred.

Operation

FX list editor

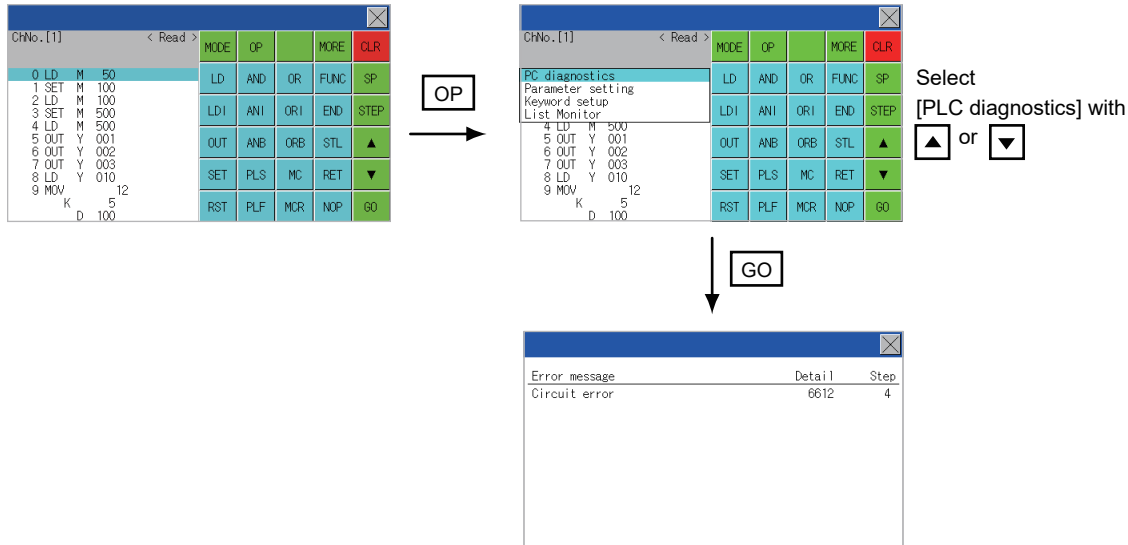

PLC diagnostics screen

The following describes the contents displayed on the PLC diagnostics screen and the function of on-screen key.

■Displayed contents

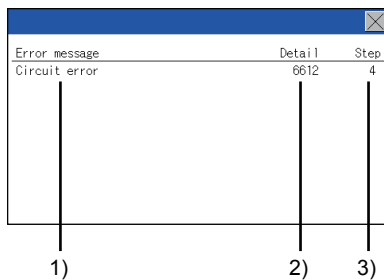

No.	Item	Display contents
1)	Error message	Displays the error message. (I/O configuration error/PLC hardware error/PC/HPP communication error/Serial communication error/Parameter error/Syntax error/Circuit error/Operation error)
2)	Detail	Displays the error code.
3)	Step	Displays the step number in the sequence program at which the error occurred. (This is displayed only for a syntax error, circuit error, or operation error.)

Point

Error details

For details of the FX PLC errors, refer to the following.

Programming manual for the FXCPU used

■Key function

The table below shows the functions of the keys that are used for the operation on the PLC diagnostics screen.

Key	Function
	Exits the PLC diagnostics.

Parameter setting

Sets FX PLC parameters.

Parameters that can be changed and change targets

Parameters that can be changed

The parameters that can be changed with the MELSEC-FX list editor and the target FX PLCs are as follows.

○: Can be set/changed ×: Cannot be set/changed

Item	Target CPU								
	FX0(S)/FX0N	FX1	FX2(C)	FX1S	FX1N(C)	FX2N(C)	FX3S	FX3G(C)	FX3U(C)
Memory space setting	×	○	○	×	×	○	○	○	○
File register space setting	○*1	×	○	○	○	○	○	○	○
Latch range setting	×	○	○	×	×	○	×	×	○
RUN terminal setting	×	×	×	○	○	○	○	○	○
Initialization of parameters	○	○	○	○	○	○	○	○	○

*1 When connecting an FX0(S), set "0". Setting other than "0" causes a parameter error.

*2 When the parameters are initialized, the display on the MELSEC-FX list editor is different from the FX PLC default values, but do not change the latch range. Changing the latch range causes an error.

Change targets

When a memory cassette is mounted, the parameters in the memory cassette are targeted for changes.

Operation

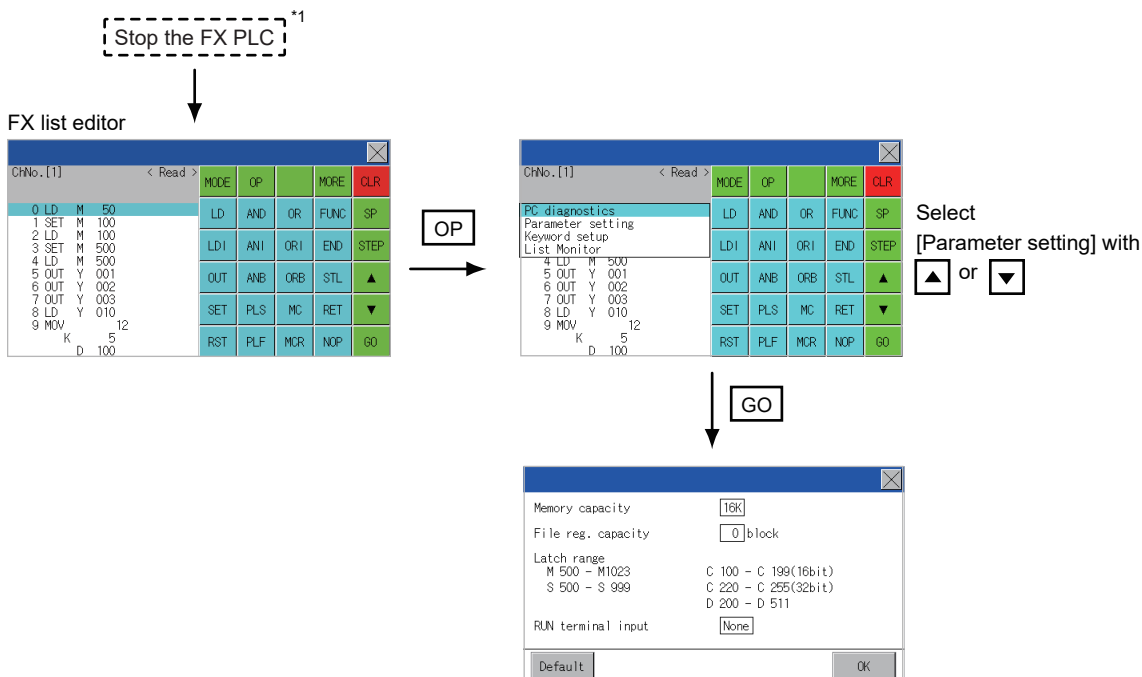

*1 When checking parameters (not changing), it is not necessary to stop the PLC.

Parameter setting screen

The following describes the contents displayed on the PLC diagnostics screen and the function of on-screen key.

■Displayed contents

No.	Item	Display contents
1)	Memory capacity	Sets the memory space (number of steps). If you touch the <input type="checkbox"/> K section, you can change the memory space.
2)	File reg. capacity	Sets the memory space (number of blocks) allocated to the file register. Touch the <input type="checkbox"/> section and input the number of blocks.
3)	Latch range	Sets the latch range (power failure hold area). Touch the number display section and input the value.
4)	RUN terminal input	Sets whether or not to use one of the FX PLC input terminals for RUN input. Touch the <input type="checkbox"/> section and set the device to be set for the RUN terminal.
5)	Default	Initializes the parameters

Point

- Memory space for kana comments after changing memory space, file register space

If the memory space is set smaller than the total of the file register space and kana comment space, the kana comment space is automatically reduced.

(With the MELSEC-FX list editor, the kana comment space is not displayed.)

Note that if any setting as described below is made, the kana comment space is reduced.

(Settings that reduce kana comment space and the kana comment space after setting change)

Settings resulting in $Nm < Nf \times$

$$500 + Nk \times$$

$$500 + 500$$

$$\text{Kana comment space (steps) after setting change} = \frac{Nm - Nf \times 500 - 500}{500}$$

Nm: Memory space after change (steps)

Nf: File register space after change (blocks)

Nk: Comment space before change (blocks)

- Settable range and default value

The settable range and the default value depend on the FX PLC type.

For details of the settable range and the default value, refer to the following.

Programming manual for the FXCPU used

■Key functions

The table below shows the functions of the keys that are used for the operation on the parameter setting screen.

Key	Function
	Initializes the parameters
	Completes the changed setting contents.
	Ends parameter setting.

Keyword

Registers, deletes, releases protection for, and sets protection for the FX PLC keywords.

Function usability of the MELSEC-FX list editor for keyword protection levels

The functions that can be used with the MELSEC-FX list editor depend on the keyword protection level.

○: Available, ×: Unavailable

Function		Keyword protection level				Reference
		All operation protect(All on-line operation protect) ^{*2}	Read/Incorrect write protection (Read/write protect) ^{*2}	Erroneous write prohibition(Write protect) ^{*2}	Keyword not registered/keyword protection canceled	
Reading sequence programs	Displaying sequence programs	×	×	○	○	☞ Page 665 Displaying sequence programs
	Searching commands/devices	×	×	○	○	☞ Page 667 Searching commands/devices
Writing sequence programs	Writing commands	×	×	×	○	☞ Page 669 Writing commands
	Changing operands/set values	×	×	×	○	☞ Page 673 Deleting commands
Inserting commands		×	×	×	○	☞ Page 669 Writing commands
Deleting commands		×	×	×	○	☞ Page 673 Deleting commands
Sequence program all clear		×	×	×	○	☞ Page 674 Sequence program all clear
PLC diagnostics		○ ^{*1}	○	○	○	☞ Page 675 PLC diagnostics
Parameter setting		×	×	×	○	☞ Page 676 Parameter setting

*1 When the 2nd keyword is set to an FX PLC that supports 2nd keyword, it becomes "×" (cannot be used).

*2 The names within the parentheses () are for when a keyword + 2nd keyword is set.

Operation

FX list editor

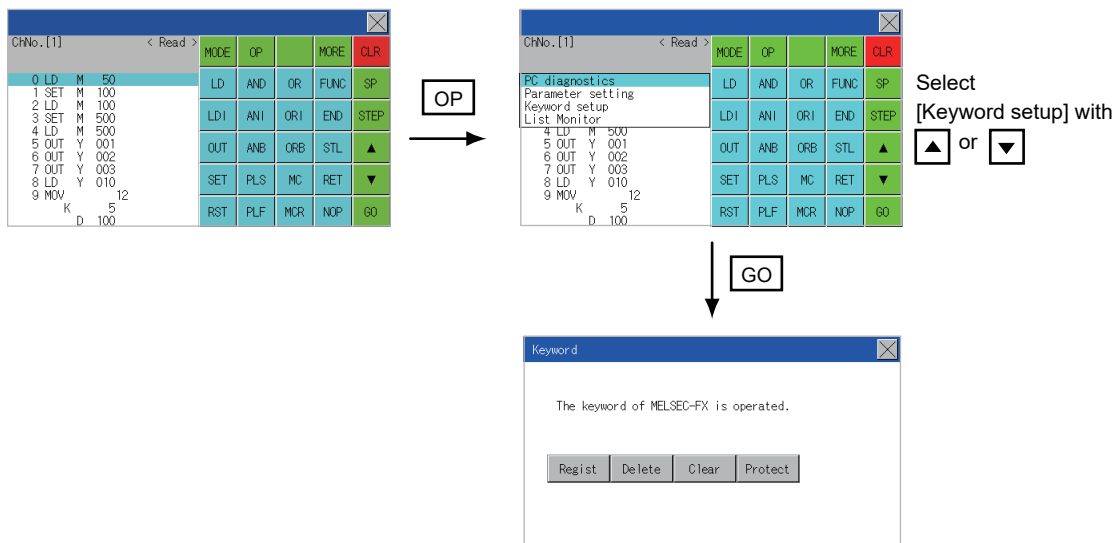

Keyword screen and protection level

When [Keyword setup] is selected with the MELSEC-FX list editor, the keyword screen is displayed.

For the keyword operation, refer to the following.

 Page 472 Keyword

Point

Keywords

For details of the keyword, refer to the following.

 Programming manual for the FXCPU used

List monitor

The status of contacts and coils in a sequence program is displayed.

Operation

FX list editor

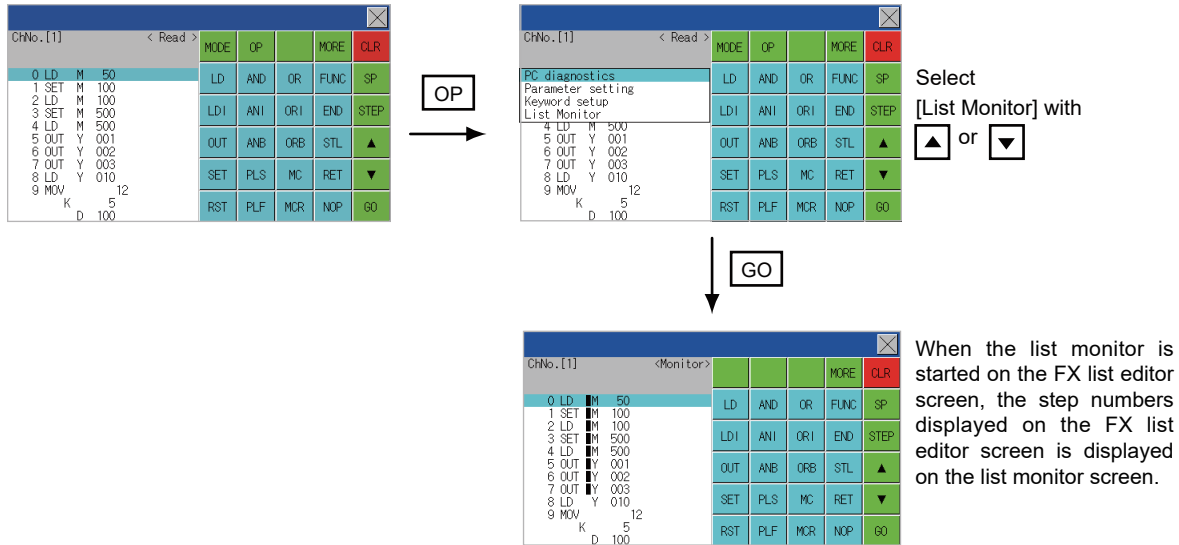

Point

Starting list monitor with special function switches (FX list monitor)

With setting special function switches (FX list monitor), the list monitor can be started on the monitor screen.

When the list monitor is started on the monitor screen, the list editor cannot be used.

For how to set special function switches, refer to the following.

GT Designer3 (GOT2000) Screen Design Manual

Displays and key functions

The following describes the displays for the list monitor.

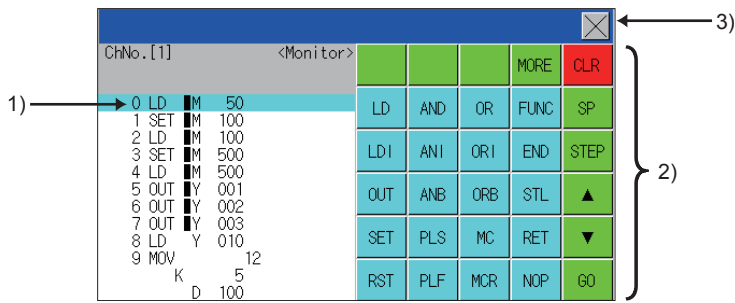

No.	Item	Display contents
1)	List display area*1	The status of contacts and coils is displayed on the left of device displays.
2)	Keys	The same operations as in the READ mode of the FX list editor can be executed. Page 665 Displaying sequence programs
3)	[×]	Ends the list monitor. (When the list monitor is executed on the FX list editor screen, the screen is switched to the FX list editor screen.)

*1 The status of contacts and coils is displayed as below.

Type of instruction	Description	Status	
		■ Displayed	■ Not displayed
LD, AND, OR (Contact instruction (Normal open))	Contact	ON	OFF
LDI, ANI, ORI (Contact instruction (Normal close))	Contact	OFF	ON
OUT, SET	TC: Coil	ON	OFF
	Except TC: Contact	ON	OFF
RST	TC: Reset	ON	OFF
	Word device	Value: 0	Value: Except 0
	Except TC and word device: Contact	OFF	ON
MC, STL	Contact	ON	OFF
LDP, ANDP, ORP, LDF, ANDF, ORF (Rise or fall contact instruction)	Not monitored	Always ■ not displayed	

Action for an incorrect key input

If an incorrect key is input, cancel the input contents.

Operations

■ Before touching the **GO** key (before reading/writing the input contents)

Before touching the **GO** key, touch the **CLR** key.

■ After touching the **GO** key (after reading/writing the input contents)



Write the command again.

 Page 669 Writing commands

Commands finalized by writing and inserting operations are revised (overwritten) with the program writing.

Error messages and corrective actions

This section describes the error messages displayed when the MELSEC-FX list editor is executed, and corrective action.

Error message	Description	Corrective action
Can not display while protected.	The all-operation protect, anti-plagiarism, or incorrect write protect keyword is set.	<ul style="list-style-type: none">• Check the protected operation.• Clear the keyword protection or delete the keyword.  Page 678 Keyword
Can not operate while protected.		
PLC parameter error.	An FX PLC parameter is defective.	Set correct parameters in the FX PLC.
PLC communications error.	The communication with the FX PLC is defective.	<ul style="list-style-type: none">• Check the FX PLC, cable, and GOT for abnormality.• Check whether the communication settings are correct or not.
PLC is running.	A writing operation etc. has been made while the FX PLC is running.	Stop the FX PLC.
Can not write.	<ul style="list-style-type: none">• The memory to write to is EPROM.• The protect switch of the EEPROM is on.	<ul style="list-style-type: none">• Set other than EPROM for the memory to write to.• Switch off the protect switch of the EEPROM.
Step number is out of a range.	The specified step number exceeded the maximum number.	Specify a step number below the maximum value.
Not found.	The specified command cannot be found.	Proceed to the next operation.
Not found.	The specified device cannot be found.	Proceed to the next operation.
Step overflow.	The program may exceed the available space. (Writing is not executed.)	Check the program memory space and delete commands to keep it within the space.  Page 673 Deleting commands
Command error.	An invalid command (non-existent command) was specified.	Input the correct command.
Protected by a block password.	The sequence program is protected by a block password at the PLC reading.	Release the block password for the sequence program.



How to erase an error message



An error message is not erased even if the cause of the error is eliminated.

To erase an error message, touch a key on the MELSEC-FX list editor screen.

16.3 FX3U-ENET-ADP Communication Setting Function

In GX Works2, the communication set value of the FX3U-ENET-ADP stored in the CPU can be changed. This function is not available when the communication set value of the FX3U-ENET-ADP is not set in advance in the CPU.

Point 

- Communication setting in the CPU
- In GX Works2, set in advance the communication set value of the FX3U-ENET-ADP to the CPU. For the details of the communication setting, refer to the following.
-  FX3U-ENET-ADP User's manual
 - Connection type for the FX3U-ENET-ADP communication setting function
- This function can be used only when the connection between the GOT and FXCPU is the direct CPU connection (serial).
-  GOT2000 Series Connection Manual (Mitsubishi Product)

Specifications

System configuration

This section describes the system configuration of the FX3U-ENET-ADP communication setting function. Refer to the following for details.

-  GOT2000 Series Connection Manual

Required basic system application

OS	Version
Basic system application	-
Communication driver	MELSEC-FX

Connection type

(○: Applicable, △: Partly restricted, ×: Inapplicable)

Function		Connection type between GOT and controller	
Name	Description	Direct CPU connection (serial)	GOT multi-drop connection
FX3U-ENET-ADP communication setting function	The communication set value of the FX3U-ENET-ADP stored in the CPU can be changed.	○	×

Communication setting items

The table below shows the communication setting items and setting range.

Communication setting items	Setting range	Remark
IP address	0.0.0.1 to 223.255.255.254	If a value outside the setting range is entered, the error message "SET NUMBER IS INCORRECT." appears.
Subnet mask pattern*1	192.0.0.0 to 255.255.255.252	
Default router IP address*1	0.0.0.1 to 223.255.255.254	

*1 Set the value "0.0.0.0" when not using the subnet mask pattern and default router IP address.

Display operation of FX3U-ENET-ADP communication setting function

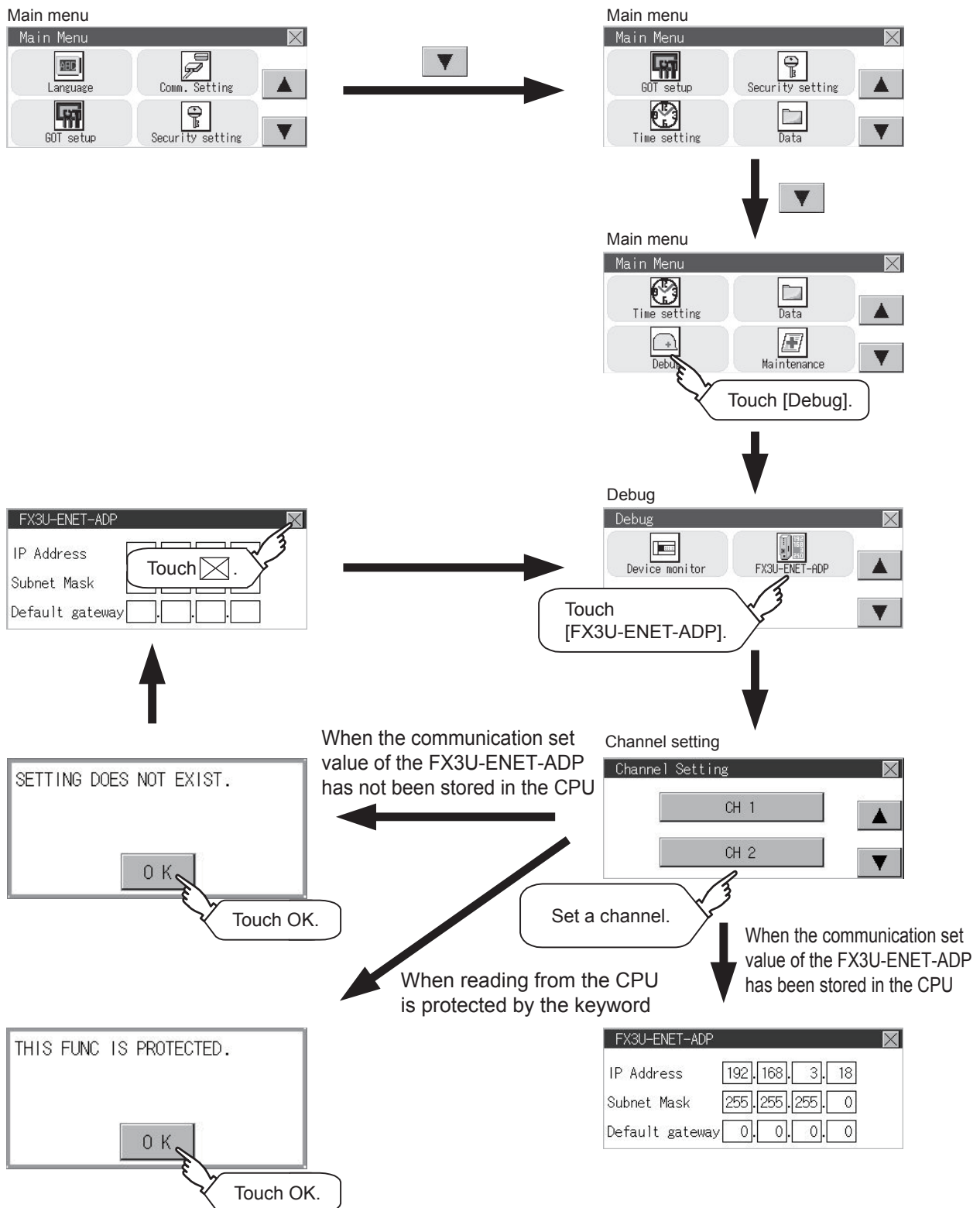

Setting operation

1. Touch the numerical part of the octet to be changed among the 1st to 4th octets.

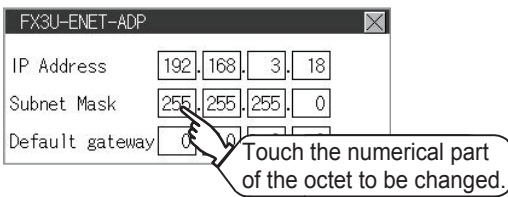

2. When the numeric pad appears, enter a numerical value in up to three digits, and touch the [ENT] key.

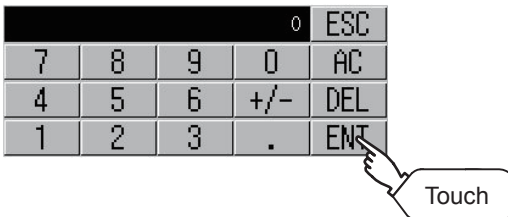

If a numerical value outside the setting range is entered, the following error message appears. Enter a numerical value again.

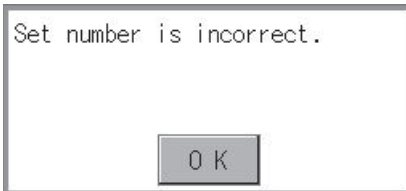

For the details of the setting range, refer to the following.

☞ Page 683 Specifications

3. The changed IP address is displayed. At this time, the changed communication set value of the FX3U-ENET-ADP is not written to the CPU. Touch the [x] key.

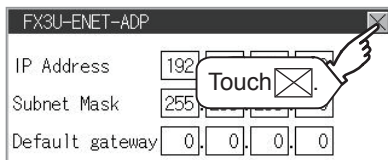

4. The following screen appears, then touch the [YES] key.

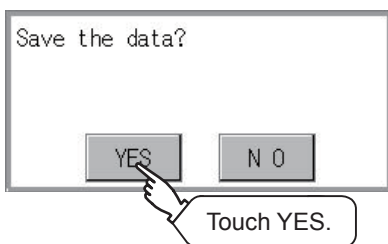

5. When the screen shown below appears, the changed communication set value of the FX3U-ENET-ADP is written normally to the CPU.

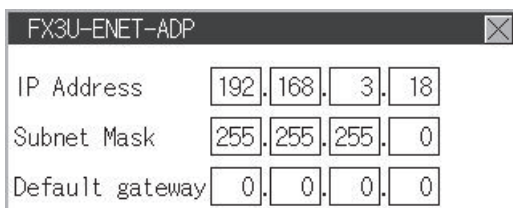

To validate the setting, power off the CPU, and then power it on.

Change the setting of the subnet mask pattern and default router IP address using the same procedure if necessary.

An error message appears in the following cases. Touch the [OK] key to return to step 1, and perform the setting again.

- When the CPU is running

The following error message appears. Stop the running status of the CPU.



- When a communication error occurs

Set the communication between the GOT and the CPU to the normal status.



- When the memory cassette is write-protected

Set to OFF the write-protect switch of the memory cassette.

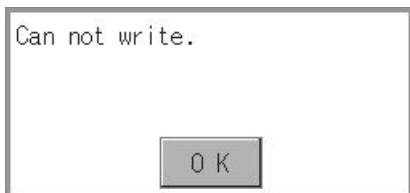

- When writing to the CPU is protected by the keyword
- Clear the protection by the keyword against writing.

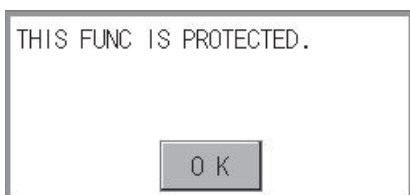

Point

When the CPU stores the symbolic information

When the setting such as IP address is changed using this function and then the program is read by the programming tool from the CPU that stores the symbolic information, the following warning appears. However, the changed value is read correctly. Convert and compile the project again.

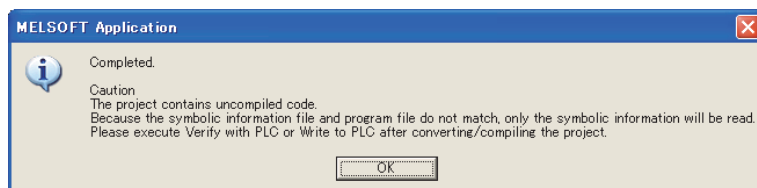

☞ Page 687 Touch Panel Calibration

☞ Page 690 Touch Panel Check

☞ Page 692 Clean

17.1 Touch Panel Calibration

Touch panel calibration setting function

Touch panel reading error can be corrected.

Normally the adjustment is not required, however, the difference between a touched position and the object position may occur as the period of use elapses.

When any difference between a touched position and the object position occurs, correct the position with this function.

Before adjustment

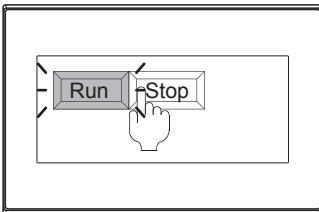

The [Run] will operate though you intended to touch the [Stop] button.

After adjustment

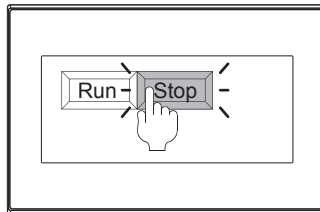

The [Stop] button can be touched without fail.

Touch panel calibration setting display operation

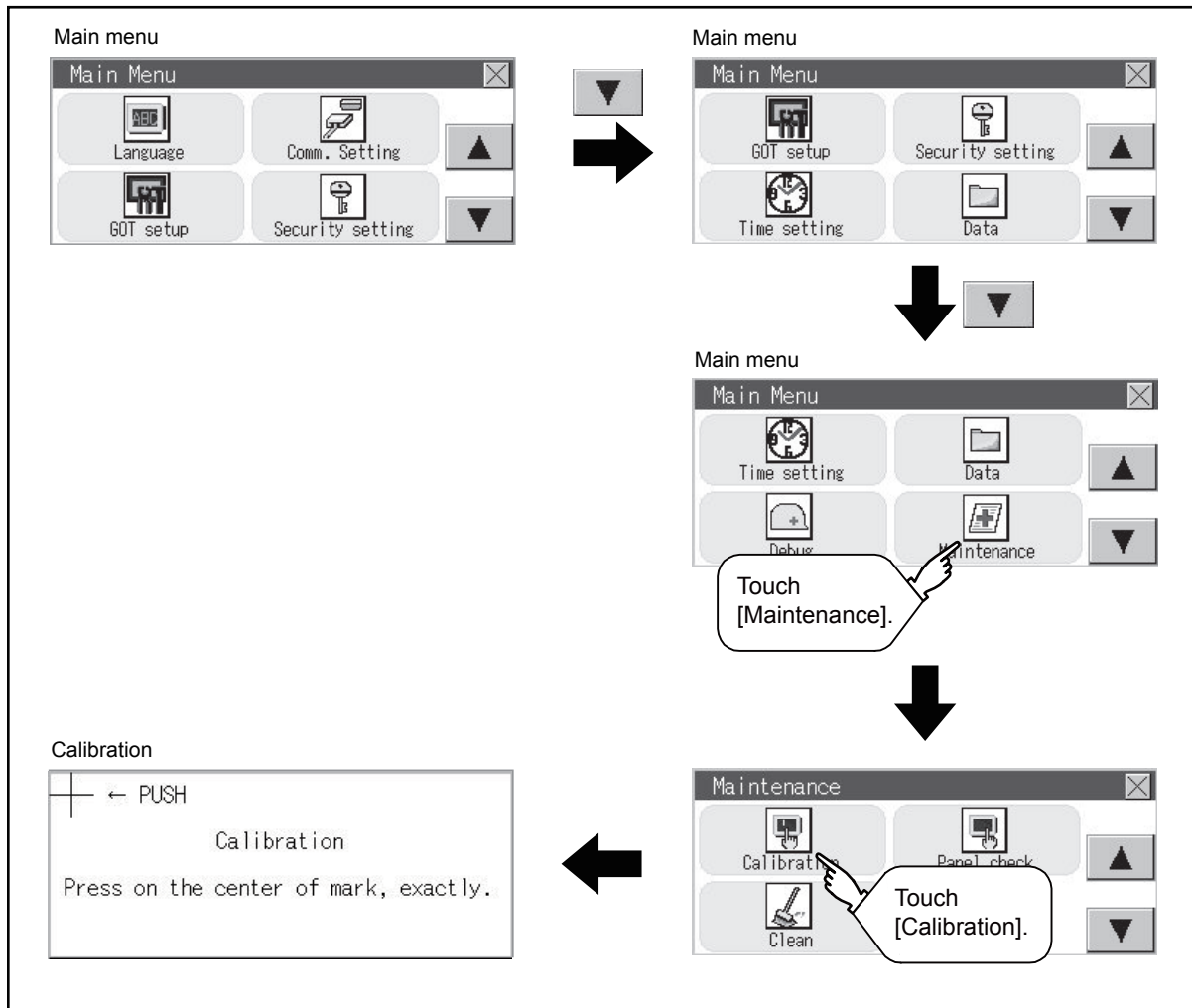

Touch panel calibration operation

Touch [+] displayed on the screen with the finger one by one to make the setting.

1. Touch the center of [+] displayed on the upper left precisely.

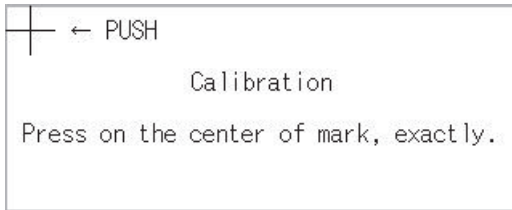

2. Touch [+] displayed on the lower left.

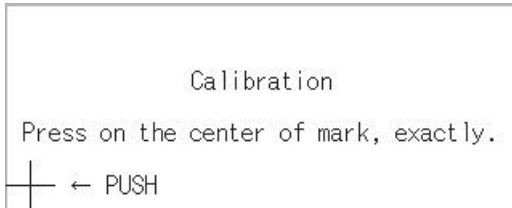

3. Touch [+] displayed on the upper right.

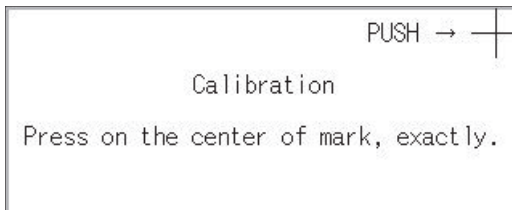

4. Touch [+] displayed on the lower right.

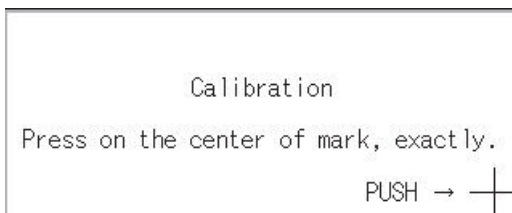

5. Step 4 completes the calibration process, and the [Maintenance] window will reappear.

Point

Touch panel calibration error

If touch panel calibration results in inoperability of the panel, the following message will appear.

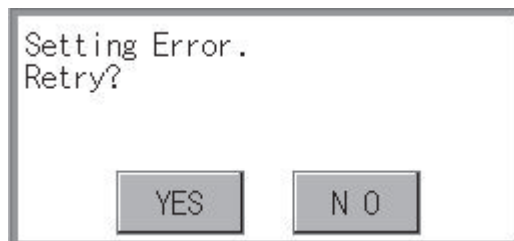

[YES] button: Returns to the touch panel calibration screen.

[NO] button: Aborts calibration without saving any changes to the touch panel setting.

17.2 Touch Panel Check

Touch panel check function

The touch panel check function checks if there is any dead zone area.

Display operation of Touch panel check

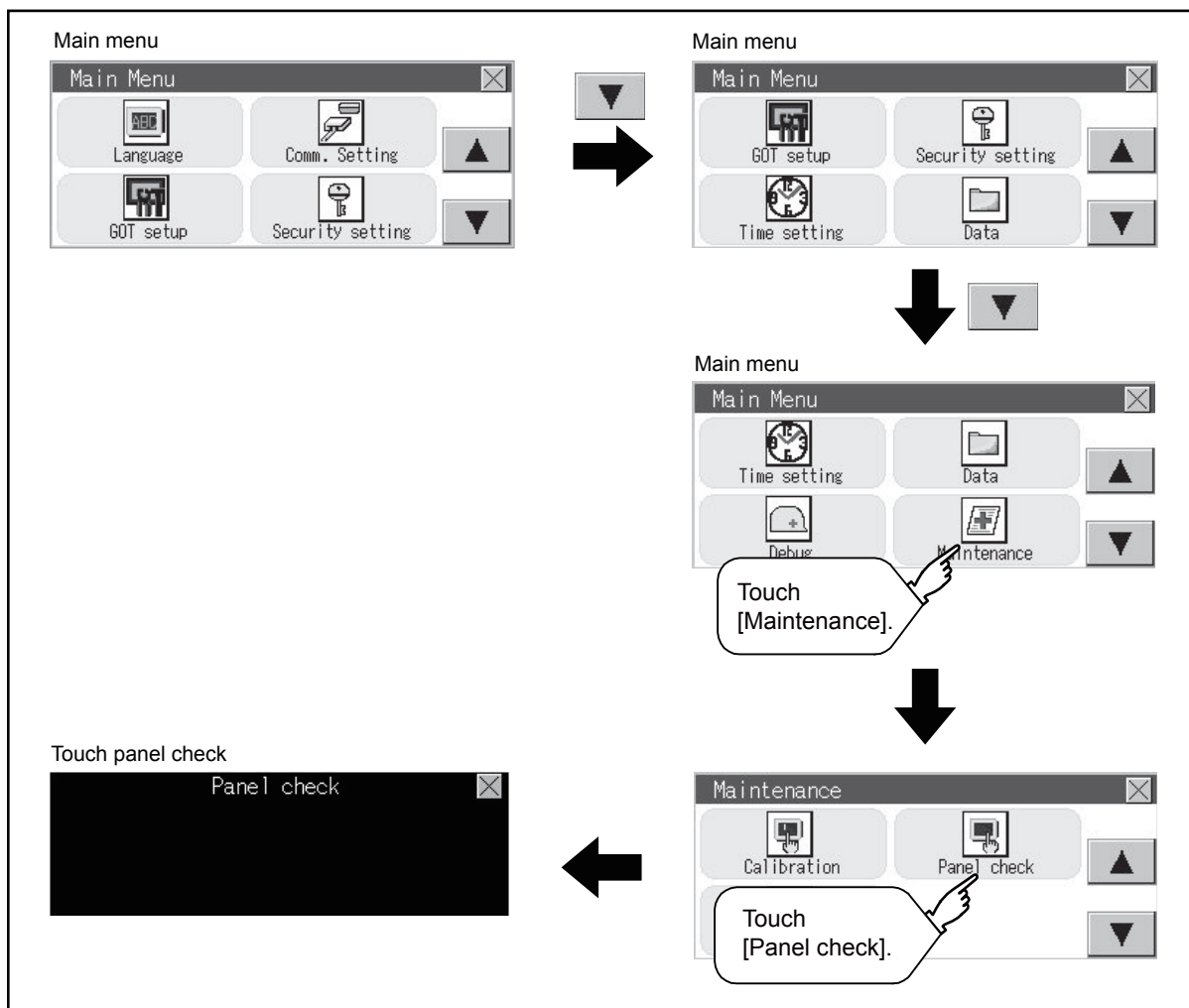

Point

Notes on Touch panel check

If the touched part is not color-filled, there are the following two possible causes.

1. Display part failure
2. Touch panel failure

In that case, contact your local Mitsubishi (Electric System) Service.

Touch panel check operations

If touching [Panel check] of self-check, a black-filled screen is displayed over the entire screen area.

1. Touch a part of the screen.

The touched part becomes a color-filled display as shown below.

- Yellow: GT2107-W, GT2105-QTBDS, GT2104-R
- White: GT2104-P, GT2103-P
- Gray: GT2105-QMBDS

Up to 40 parts become color-filled displays.

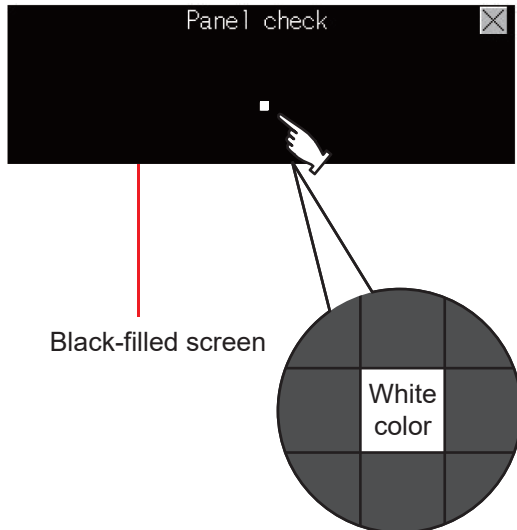

2. If [×] on the upper right is touched, the screen returns to the self-check.

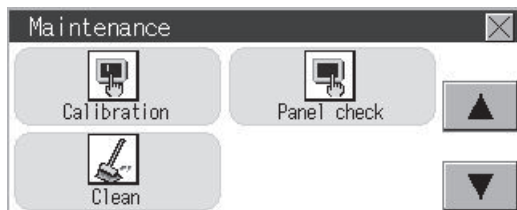

Point

Checking the upper right part of the screen

Only the upper right part of the screen cannot be color-filled.

If the screen returns to the maintenance by touching the upper right part, judge that the upper right area operates normally.

17.3 Clean

In utility, the screen can be set as not to be effected by touching the screen when clean with clothes.
For cleaning method, refer to the following.

GOT2000 Series User's manual (Hardware) 9. MAINTENANCE AND INSPECTION

Display operation of clean

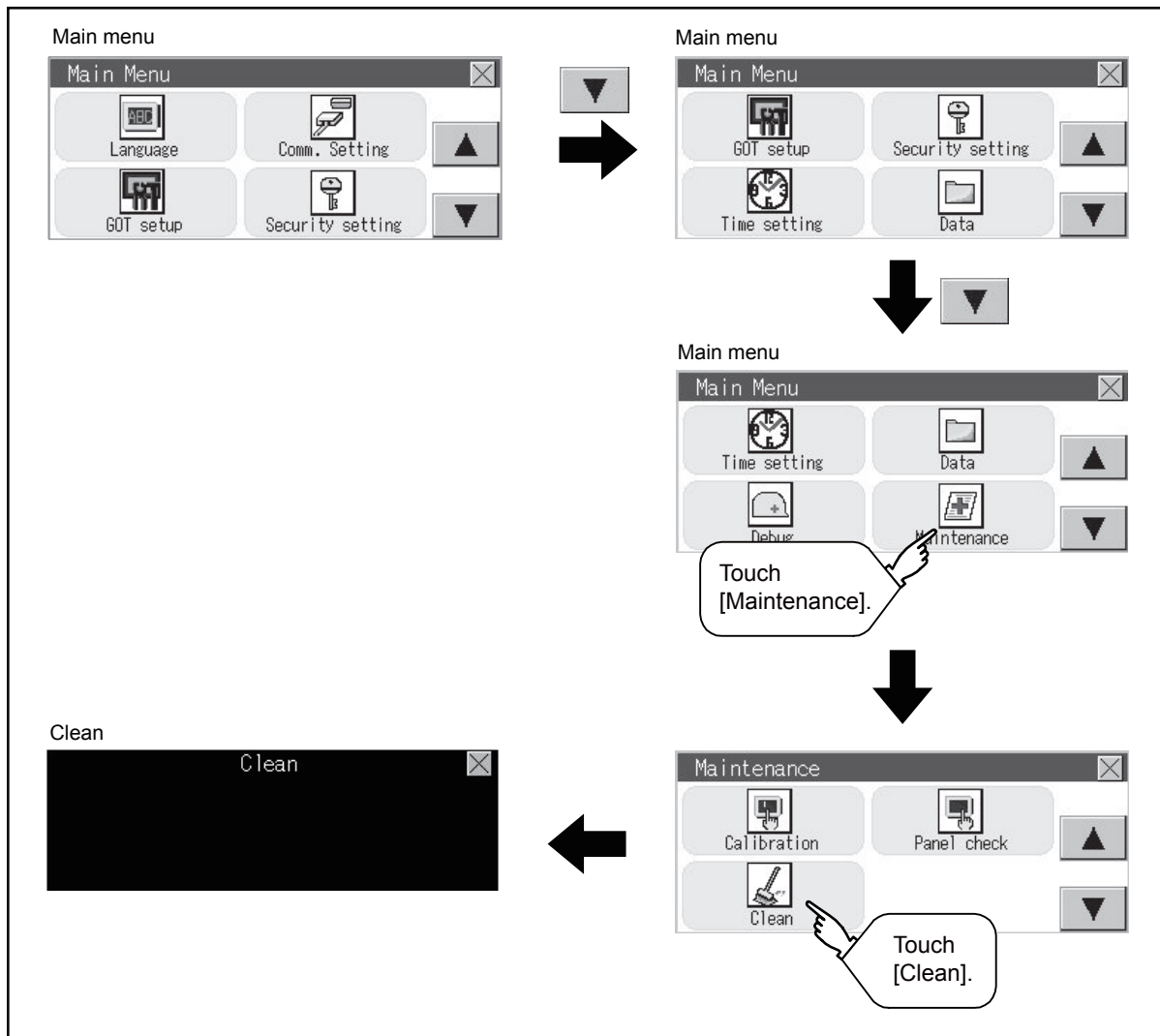

Display operation of clean

1. Touching the [x] key closes the screen. Even if touch points other than the upper left corner and upper right corner of the screen, the GOT does not operates.

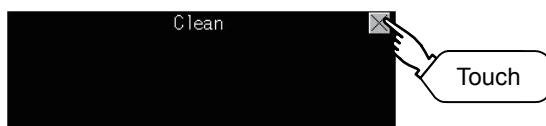

For details of cleaning method, refer to the following.

GOT2000 Series User's manual (Hardware) 9. MAINTENANCE AND INSPECTION

18 BOOTOS AND SYSTEM APPLICATION

Page 694 Preparation before Installation

Page 695 Installation Using Data Storage

To execute the GOT utility, install the BootOS and system applications on the C drive (built-in flash memory) of the GOT, or set the boot drive of the package data to [A:SD card] and insert an SD card with the package data into the GOT.

(BootOS is installed in the GOT at factory shipment. It is not necessary to install BootOS when upgrading of it is unnecessary.) This chapter explains the installation using GOT.

GT Designer3 → Data storage → GOT

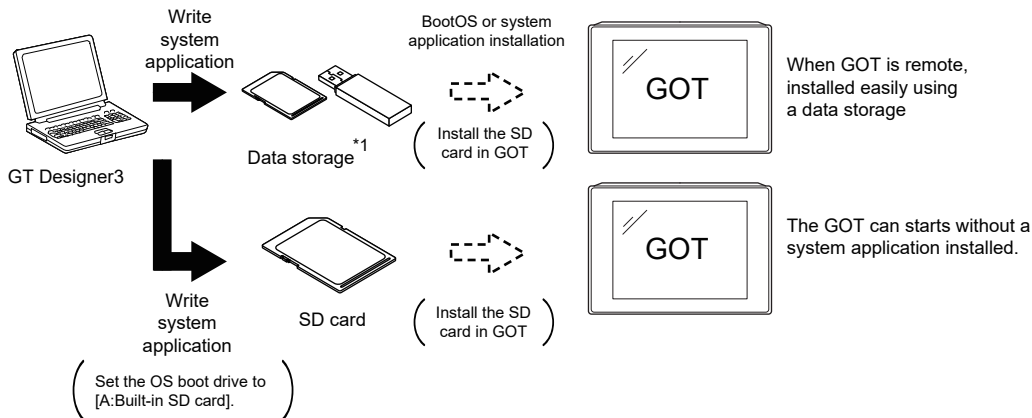

GOT → Data storage → GOT

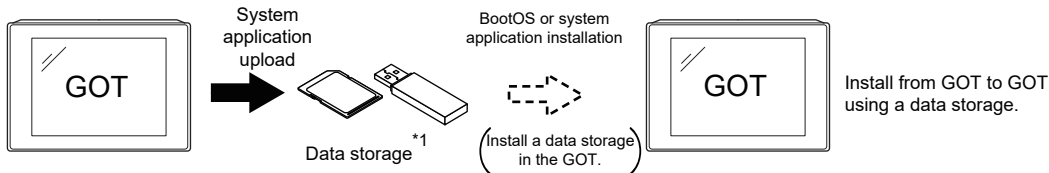

*1 When execute installation with a USB memory, the system applications have to be installed in GOT in advance.

The GT2105-Q, GT2104-R, GT2104-P, and GT2103-P do not support the USB memory.

Refer to the following for the installation which uses GT Designer3.

GT Designer3 (GOT2000) Screen Design Manual

The following BootOS and system application are necessary to execute the utility.

- BootOS

Operating system required for control of the GOT and communication between the personal computer and the GOT. It is installed at factory shipment.

(BootOS can be installed from GT Designer3, or the SD card. When the installation has completed, the GOT is initialized to be the factory shipment status. Also, the basic system applications must be pre-installed in the GOT when the BootOS is installed again.)

- Basic system application

System application required for the GOT operations including the monitoring function, installation and deletion of the system application or project data, touch key control, and display of the screen, guidance, user-created screen, and utility screen.

It is not installed in the GOT at factory shipment.

Install it from GT Designer3 or the data storage.

18.1 Preparation before Installation

For the installation using GOT, the data storage that is storing BootOS or the system application is required. There are the following three methods for the installation of BootOS and system application.

[To Memory Card] from GT Designer3

📖 GT Designer3 (GOT2000) Screen Design Manual

Uploading from another GOT (the package data has been installed)

📖 Page 696 Installation Using Data Storage

Using an SD card that stores data with OS boot drive set to A drive

📖 GT Designer3 (GOT2000) Screen Design Manual

Point

Precautions when installing BootOS and the package data into an SD card

When installing BootOS and the package data into the SD card, be sure to execute by the utility of another GOT or GT Designer3.

The installation is not executed properly with the SD card to which data is uploaded from the utility of GOT or copied by software other than GT Designer3.

Note the available capacity of the SD card.

The available capacity of BootOS and system applications can be confirmed by [To Memory Card] or [Write Option] of GT Designer3.

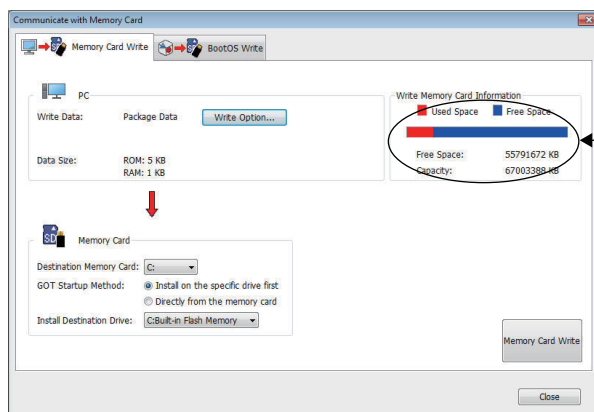

Write Option

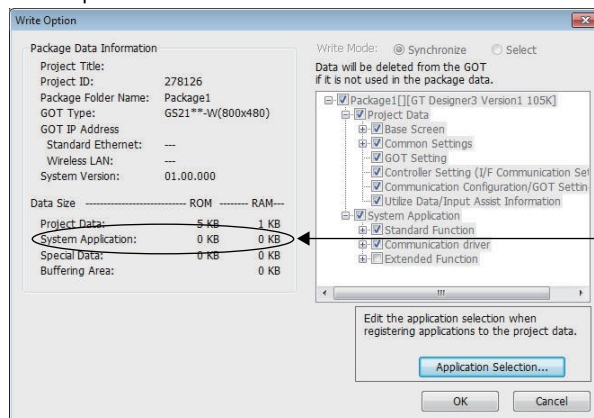

18.2 Installation Using Data Storage

There are the following two types for the installation of BootOS and system applications using a data storage.

Installing when starting the GOT

☞ Page 695 Installing when starting the GOT

All the system applications and project data stored in the data storage are transferred to the GOT when powering on the GOT.

This installing method is effective in the following cases.

The GOT utility cannot be displayed.

The system application is not installed.

Installing using the data control function (Utility)

☞ Page 695 Installing using the data control function (Utility)

By operating the utility, select the system application or project data stored in the data storage and transfer them to the GOT.

Point

Precautions on installing BootOS, system applications

- Installing both BootOS and system applications

After completing BootOS installation, install system applications.

When installing BootOS, the built-in flash memory in the GOT is initialized and goes to the status at factory shipment. (All system applications and project data are erased.)

BootOS is installed in the GOT at factory shipment. It is not necessary to install BootOS when not upgrading it.

- Installation cannot be interrupted.

Do not perform any of the following during a BootOS or system application installation.

Failure to do so may result in installation failure, causing the GOT malfunction.

- Powering off the GOT
- Pressing the reset button of the GOT
- Removing the data storage

If the installation failure and the GOT malfunction occur, take the following action.

- If BootOS installation failed: Please consult your local Mitsubishi (Electric System) Service center or representative.
- If the basic system application installation failed:

☞ Page 695 Installing when starting the GOT

Installing when starting the GOT

When installing with an SD card

1. Power OFF the GOT, and install the SD card where the BootOS, system application or project data is stored in the SD card interface of the GOT.
2. Power on the GOT.

While touching the lower right side of the GOT screen, power on the GOT. (1-point press installation function)

3. The BootOS or system application is installed in the built-in flash memory.
Do not pull out the SD card or power OFF the GOT.

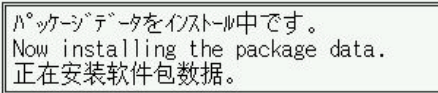

パッケージデータをインストール中です。
Now installing the package data.
正在安装软件包数据。

4. The GOT restarts automatically after the installation is completed.



完了しました。再起動します。
Finished. Now rebooting.
安装已结束。再启动GOT。

5. After confirming normal restart, confirm that the SD card access LED is not lit, and remove the SD card from the SD card interface of the GOT.

Installing using the data copy function (Utility)

Operation procedure

1. Power OFF the GOT, and attach the SD card which stores the basic system application and communication driver to the GOT.

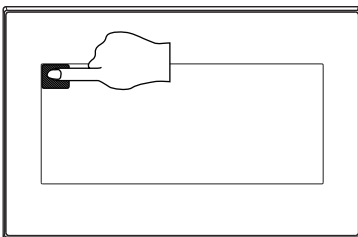

2. While touching the upper left corner of the GOT screen, power ON the GOT.
3. When the screen shown on the left appears, select the [Data copy].

For details of install, refer to the following.

☞ Page 609 Data Copy

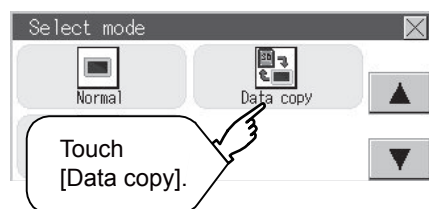

19 ERROR MESSAGE LIST

19.1 GOT Error Messages and Corrective Actions

The following shows the error messages and corrective actions displayed on the GOT.

Error message	Action
SCREEN DOES NOT EXIST.	<ul style="list-style-type: none">Specified base screen does not exist in the project data.Specified base screen is out of the permissible area. Specify the existing base screen.
SCREEN ERROR	The monitored device No. is out of the permissible area of the targeted PLC CPU. Set the device within the range that can be monitored by the monitored PLC CPU and parameter settings.
COMM. ERROR	Error occurred while writing in the device. <ul style="list-style-type: none">Check the cable omission and the status of the PLC.
DEVICE ERROR.	Error occurred while writing in the device. Correct the device.
SET NUMBER IS INCORRECT.	The input value was illegal when writing to the device. Check the input value.
PLC IS RUNNING.	The operation, which could not be performed during RUN of PLC CPU, was performed. Stop the PLC CPU.
CAN NOT WRITE.	The memory cassette installed in the PLC CPU is EPROM or E2PROM, and it is in a protected status. Confirm the memory cassette installed in PLC CPU.
THIS FUNC IS PROTECTED.	The key word is set in PLC CPU. Cancel the key word.
CAN NOT USE THE FUNCTION.	The function cannot be used with the package data configuration written in the GOT. <ul style="list-style-type: none">Review the package data configuration.Install the latest version of GT Designer3 and write the package data again to the GOT.
DATA IS NOT FOUND.	The package data is not downloaded or the package data is not sufficient. Download the package data.
PASSWORD IS INCORRECT.	The input password does not match the security level password or the utility start-up password. Check the target password.
Password cannot be changed because you are not logged in.	When authenticating the operator, the password cannot be changed before logging in. Log in.
The password does not match, the GOT cannot be booted.	The passwords for transmitting the data from package data on Drive C and package data directly started from memory card do not match, so the GOT cannot be started. Match the data transmission passwords.

Revisions

* The manual number is given on the bottom left of the back cover.

Revision date	* Manual Number	Revision
Sep. 2013	SH(NA)-081195ENG-A	First printing : GT Designer3 Version1.100E
Nov. 2013	SH(NA)-081195ENG-B	Compatible with GT Works3 Version1.104J <ul style="list-style-type: none"> • Description of SAFETY PRECAUTIONS changed • Abbreviations and generic terms changed • Compatible with wireless LAN connection (to be supported soon) • Ethernet setting revised
Jan. 2014	SH(NA)-081195ENG-C	Compatible with GT Works3 Version1.108N <ul style="list-style-type: none"> • Specifications for IP address duplication changed
Apr. 2014	SH(NA)-081195ENG-D	Compatible with GT Works3 Version1.112S <ul style="list-style-type: none"> • Description of SAFETY PRECAUTIONS changed • Abbreviations and generic terms changed • Utility function list changed • Functions added to the display setting • A function added to the operation log information • Error messages added
Jun. 2014	SH(NA)-081195ENG-E	Compatible with GT Works3 Version1.117X <ul style="list-style-type: none"> • Description of SAFETY PRECAUTIONS changed • R motion monitor supported • CNC monitor supported • CNC data I/O supported • CNC machining program edit supported • Recipe operation supported • Label name resolution information supported • Error messages added
Jul. 2014	SH(NA)-081195ENG-F	Compatible with GT Works3 Version1.118Y <ul style="list-style-type: none"> • Abbreviations, generic terms, and icon indications changed • Display method and list of the system alarm changed
Oct. 2014	SH(NA)-081195ENG-G	Compatible with GT Works3 Version1.122C <ul style="list-style-type: none"> • The description of SAFETY PRECAUTIONS has been changed. • The abbreviations, generic terms, icon indications have been changed. • GT21 is supported. • GT2512-S is supported. • GT2512-S supports the CNC monitor, CNC data I/O, and CNC machining program edit. • The IP filter is supported. • System alarms have been added.
Jan. 2015	SH(NA)-081195ENG-H	Compatible with GT Works3 Version1.126G <ul style="list-style-type: none"> • The description of SAFETY PRECAUTIONS has been changed. • The system launcher is supported. • The iQSS utility is supported. • The backup/restoration function has been expanded.
Apr. 2015	SH(NA)-081195ENG-I	Compatible with GT Works3 Version1.130L <ul style="list-style-type: none"> • The abbreviations, generic terms, icon indications have been changed. • Functions have been added to the operator authentication. • The sequence program monitor (R ladder) is supported. • The motion program editor is supported. • The motion program I/O is supported. • System alarms have been added.
May 2015	SH(NA)-081195ENG-J	Writing errors have been corrected.
Jun. 2015	SH(NA)-081195ENG-K	Compatible with GT Works3 Version1.134Q <ul style="list-style-type: none"> • The USB host setting has been changed. • The property screen for data management has been changed. • System alarms have been added.
Oct. 2015	SH(NA)-081195ENG-L	Compatible with GT Works3 Version1.144A <ul style="list-style-type: none"> • The abbreviations, generic terms, icon indications have been changed. • The access point mode has been added to the wireless LAN function. • The license management for the GOT Mobile function is supported. • System alarms have been added.
Dec. 2015	SH(NA)-081195ENG-M	Compatible with GT Works3 Version1.150G <ul style="list-style-type: none"> • The abbreviations, generic terms, icon indications have been changed. • GT2512F-S, GT2510F-V, and GT2508F-V are supported. • The GOT Mobile information is supported. • The file manager is supported.

Revision date	* Manual Number	Revision
May 2016	SH(NA)-081195ENG-N	Compatible with GT Works3 Version1.155M <ul style="list-style-type: none"> The abbreviations, generic terms, icon indications have been changed. GT2105-Q, GT2104-PMBDS2, and GT2104-PMBLS are supported. The file menu screen of the multimedia function now displays information on the number of files. The CNC monitor 2 is supported. The drive recorder is supported. System alarms have been added.
Aug. 2016	SH(NA)-081195ENG-O	Compatible with GT Works3 Version1.160S <ul style="list-style-type: none"> The abbreviations, generic terms, icon indications have been changed. The ANDON connection is supported. The GOT2000 series Ethernet communication unit (GT25-J71E71-100) is supported. System alarms have been added.
Oct. 2016	SH(NA)-081195ENG-P	Compatible with GT Works3 Version1.165X <ul style="list-style-type: none"> The abbreviations, generic terms, icon indications have been changed. GT27-V and GT25-V support the CNC monitor 2. The setting to enable or disable the ladder editor (R ladder) has been added for the sequence program monitor. The CC-Link IE Field Network diagnostics is supported. System alarms have been added.
Jan. 2017	SH(NA)-081195ENG-Q	Compatible with GT Works3 Version1.170C <ul style="list-style-type: none"> GT2107 is supported.
Apr. 2017	SH(NA)-081195ENG-R	Compatible with GT Works3 Version1.175H <ul style="list-style-type: none"> The abbreviations, generic terms, icon indications have been changed. GT2510-WXTSD, GT2510-WXTBD, GT2507-WTSD, and GT2507-WTBD are supported. The GOT internal device monitor is supported. The USB barcode reader is supported. The operator management function has been extended. System alarms have been added.
Jun. 2017	SH(NA)-081195ENG-S	Compatible with GT Works3 Version1.180N <ul style="list-style-type: none"> The abbreviations, generic terms, icon indications have been changed. GT2505-V and GT2506HS-V are supported.
Oct. 2017	SH(NA)-081195ENG-T	Compatible with GT Works3 Version1.185T <ul style="list-style-type: none"> The abbreviations, generic terms, icon indications have been changed. The sequence program monitor (R ladder) has been renamed the sequence program monitor (iQ-R ladder). The operator authentication supports the use of sub administrators. The operation log information supports the display type switching. System alarms have been added.
Dec. 2017	SH(NA)-081195ENG-U	Compatible with GT Works3 Version1.190Y <ul style="list-style-type: none"> Saving recipe data to the SRAM user area is supported. The SRAM management function supports recipe data. Corrective actions for system alarms have been added. The device monitor supports R00CPU, R01CPU, and R02CPU.
Apr. 2018	SH(NA)-081195ENG-V	Compatible with GT Works3 Version1.195D <ul style="list-style-type: none"> The abbreviations, generic terms, icon indications have been changed. GT2506HS-V supports the CNC monitor 2. The servo amplifier graph is supported. GT21 supports the IP filter.
Jul. 2018	SH(NA)-081195ENG-W	Compatible with GT Works3 Version1.200J <ul style="list-style-type: none"> The abbreviations, generic terms, icon indications have been changed. GT27, GT25, and GT23 support Ethernet printers. GT27, GT25, and GT23 support the file print.
Oct. 2018	SH(NA)-081195ENG-X	Compatible with GT Works3 Version1.205P <ul style="list-style-type: none"> Description of SAFETY PRECAUTIONS changed. The abbreviations, generic terms, icon indications have been changed. The network drive is supported. GT2505-V and GT2505HS-V support the CNC monitor 2. [ClockPhase(Extend)] has been added to the RGB display settings. System alarms have been added.
Jan. 2019	SH(NA)-081195ENG-Y	Compatible with GT Works3 Version1.210U <ul style="list-style-type: none"> The corrective action for a system alarm has been corrected.
Apr. 2019	SH(NA)-081195ENG-Z	Compatible with GT Works3 Version1.215Z <ul style="list-style-type: none"> Description of SAFETY PRECAUTIONS changed The abbreviations, generic terms, icon indications have been changed. The internal device has been added to the functions of the SRAM management. GT21 supports Ethernet printers. The internal device has been added to the clear data function.

Revision date	* Manual Number	Revision
Jul. 2019	SH(NA)-081195ENG-AA	Compatible with GT Works3 Version1.220E <ul style="list-style-type: none"> • Description of SAFETY PRECAUTIONS changed • The abbreviations, generic terms, icon indications have been changed. • CC-Link IE TSN has been added as a communication driver in the communication setting. • The corrective action for a system alarm has been corrected.
Oct. 2019	SH(NA)-081195ENG-AB	Compatible with GT Works3 Version1.225K <ul style="list-style-type: none"> • The network monitor supports the CC-Link IE TSN connection. • The backup/restoration function supports the GOT data package acquisition at the timing of the trigger backup.
Jan. 2020	SH(NA)-081195ENG-AC	Compatible with GT Works3 Version1.230Q <ul style="list-style-type: none"> • The backup/restoration function supports FX5UJ. • The R motion SFC monitor is supported. • The motion SFC monitor is renamed to Q motion SFC monitor. • System alarms have been added.
Apr. 2020	SH(NA)-081195ENG-AD	Compatible with GT Works3 Version1.235V <ul style="list-style-type: none"> • The corrective action for a system alarm has been corrected. • System alarms have been added. • GT27, GT25, and GT23 support the password history settings for the operator authentication. • GT27 and GT25 support the vision sensor monitor.
Jun. 2020	SH(NA)-081195ENG-AE	Compatible with GT Works3 Version1.240A <ul style="list-style-type: none"> • The abbreviations, generic terms, icon indications have been changed. • The company name of TOSHIBA MACHINE CO., LTD. has been changed to SHIBAURA MACHINE CO., LTD.
Aug. 2020	SH(NA)-081195ENG-AF	Partial corrections.
Oct. 2020	SH(NA)-081195ENG-AG	Compatible with GT Works3 Version1.245F <ul style="list-style-type: none"> • Ethernet connection with the Hitachi S10VE controller is supported. • GT2107-W supports the operation log information.
Jan. 2021	SH(NA)-081195ENG-AH	Compatible with GT Works3 Version1.250L <ul style="list-style-type: none"> • Description of SAFETY PRECAUTIONS changed • Abbreviations, generic terms, and model icons have been changed. • GT2512-WX supports the motion program editor. • GT2512-WX supports the motion program I/O.
Apr. 2021	SH(NA)-081195ENG-AI	Compatible with GT Works3 Version1.255R <ul style="list-style-type: none"> • The user memory (RAM) size has been added to the displayed items on the GOT information screen. • The sequence program monitor (iQ-F ladder) is supported.
Jul. 2021	SH(NA)-081195ENG-AJ	Compatible with GT Works3 Version1.260W <ul style="list-style-type: none"> • Changed the name of the direct CPU connection to the direct CPU connection (serial). • The corrective action for a system alarm has been corrected.
Oct. 2021	SH(NA)-081195ENG-AK	Compatible with GT Works3 Version1.265B <ul style="list-style-type: none"> • The CC-Link IE TSN/CC-Link IE Field Network diagnostics function is supported. • Connection to LS IS PLC XGT is supported. • Connection to YASKAWA robot controller YRC1000 is supported.
Apr. 2022	SH(NA)-081195ENG-AL	Compatible with GT Works3 Version1.275M <ul style="list-style-type: none"> • Partial corrections.
Jul. 2022	SH(NA)-081195ENG-AM	Compatible with GT Works3 Version1.280S <ul style="list-style-type: none"> • System alarms have been added.
Oct. 2022	SH(NA)-081195ENG-AN	Compatible with GT Works3 Version1.285X <ul style="list-style-type: none"> • System alarms have been added.
Jan. 2023	SH(NA)-081195ENG-AP	Compatible with GT Works3 Version1.290C <ul style="list-style-type: none"> • The name of the communication driver for Ethernet connection to ALLEN-BRADLEY PLC or OMRON PLC has been changed.

This manual confers no industrial property rights or any rights of any other kind, nor does it confer any patent licenses. Mitsubishi Electric Corporation cannot be held responsible for any problems involving industrial property rights which may occur as a result of using the contents noted in this manual.

©2013 MITSUBISHI ELECTRIC CORPORATION

Warranty

Please check the following product warranty details before using this product.

■ 1. Gratis Warranty Term and Gratis Warranty Range

If any faults or defects (hereinafter "Failure") found to be the responsibility of Mitsubishi occurs during use of the product within the gratis warranty term, the product shall be repaired at no cost via the sales representative or Mitsubishi Service Company. However, if repairs are required onsite at domestic or overseas location, expenses to send an engineer will be solely at the customer's discretion.

Mitsubishi shall not be held responsible for any re-commissioning, maintenance, or testing on-site that involves replacement of the failed module.

(1) Gratis Warranty Term

The gratis warranty term of the product shall be for thirty-six (36) months after the date of purchase or delivery to a designated place.

Note that after manufacture and shipment from Mitsubishi, the maximum distribution period shall be six (6) months, and the longest gratis warranty term after manufacturing shall be forty-two (42) months.

The gratis warranty term of repair parts shall not exceed the gratis warranty term before repairs.

(2) Gratis Warranty Range

(a) The customer shall be responsible for the primary failure diagnosis unless otherwise specified.

If requested by the customer, Mitsubishi Electric Corporation or its representative firm may carry out the primary failure diagnosis at the customer's expense.

The primary failure diagnosis will, however, be free of charge should the cause of failure be attributable to Mitsubishi Electric Corporation.

(b) The range shall be limited to normal use within the usage state, usage methods, and usage environment, etc., which follow the conditions and precautions, etc., given in the instruction manual, user's manual and caution labels on the product.

(c) Even within the gratis warranty term, repairs shall be charged in the following cases.

- Failure occurring from inappropriate storage or handling, carelessness or negligence by the user. Failure caused by the user's hardware or software design.
- Failure caused by unapproved modifications, etc., to the product by the user.
- When the Mitsubishi product is assembled into a user's device, Failure that could have been avoided if functions or structures, judged as necessary in the legal safety measures the user's device is subject to or as necessary by industry standards, had been provided.
- Failure that could have been avoided if consumable parts designated in the instruction manual had been correctly serviced or replaced.
- Replacing consumable parts such as a battery, backlight, and fuse.
- Failure caused by external irresistible forces such as fires or abnormal voltages, and Failure caused by force majeure such as earthquakes, lightning, wind and water damage.
- Failure caused by reasons that could not be predicted by scientific technology standards at the time of shipment from Mitsubishi.
- Any other failure found not to be the responsibility of Mitsubishi or that admitted not to be so by the user.

■ 2. Onerous repair term after discontinuation of production

- (1) Mitsubishi shall accept onerous product repairs for seven (7) years after production of the product is discontinued. Discontinuation of production shall be notified with Mitsubishi Technical Bulletins, etc.
- (2) Mitsubishi shall not accept a request for product supply (including spare parts) after production is discontinued.

■ 3. Overseas service

Overseas, repairs shall be accepted by Mitsubishi's local overseas FA Center.
Note that the repair conditions at each FA Center may differ.

■ 4. Exclusion of loss in opportunity and secondary loss from warranty liability

Regardless of the gratis warranty term, Mitsubishi shall not be liable for compensation to:

- (1) Damages caused by any cause found not to be the responsibility of Mitsubishi.
- (2) Loss in opportunity, lost profits incurred to the user by Failures of Mitsubishi products.
- (3) Special damages and secondary damages whether foreseeable or not, compensation for accidents, and compensation for damages to products other than Mitsubishi products.
- (4) Replacement by the user, maintenance of on-site equipment, start-up test run and other tasks.

■ 5. Changes in product specifications

The specifications given in the catalogs, manuals, or technical documents are subject to change without prior notice.

■ 6. Product application

- (1) In using the Mitsubishi graphic operation terminal, the usage conditions shall be that the application will not lead to a major accident even if any problem or fault should occur in the graphic operation terminal device, and that backup and fail-safe functions are systematically provided outside of the device for any problem or fault.
- (2) The Mitsubishi graphic operation terminal has been designed and manufactured for applications in general industries, etc. Thus, applications in which the public could be affected such as in nuclear power plants and other power plants operated by respective power companies, and applications in which a special quality assurance system is required, such as for Railway companies or Public service shall be excluded from the graphic operation terminal applications. In addition, applications in which human life or property could be greatly affected, such as in aircraft, medical, railway applications, incineration and fuel devices, manned transportation equipment, recreation and amusement devices, safety devices, shall also be excluded from the graphic operation terminal. Even for the above applications, however, Mitsubishi Electric Corporation may consider the possibility of an application, provided that the customer notifies Mitsubishi Electric Corporation of the intention, the application is clearly defined and any special quality is not required after the user consults the local Mitsubishi representative

Intellectual Property Rights

■Trademarks

MELDAS, MELSEC, iQ Platform, MELSOFT, GOT, CC-Link, CC-Link/LT, and CC-Link IE are trademarks or registered trademarks of Mitsubishi Electric Corporation in Japan and other countries.

Microsoft, Microsoft Access, Excel, SQL Server, Visual Basic, Visual C++, Visual C#, Windows, Windows NT, Windows Server, and Windows Vista are trademarks of the Microsoft group of companies.

MODBUS is a trademark of Schneider Electric SA.

DeviceNet is a trademark of ODVA (Open DeviceNet Vendor Association, Inc.).

VNC is a registered trademark of RealVNC Ltd. in the United States and other countries.

Unicode is a trademark or registered trademark of Unicode, Inc. in the United States and other countries.

PictBridge is a registered trademark of Canon Inc.

Adobe and Adobe Reader are registered trademarks of Adobe Systems Incorporated.

Oracle and JavaScript are registered trademarks of Oracle Corporation and/or its affiliates in the United States and other countries.

QR Code is a trademark or registered trademark of DENSO WAVE INCORPORATED in Japan, the United States, and/or other countries.

Anybus is a registered trademark of HMS Industrial Networks AB.

Android and Google Chrome are trademarks or registered trademarks of Google Inc.

IOS is a trademark or registered trademark of Cisco in the U.S. and other countries and is used under license.

Safari and iPhone are trademarks of Apple Inc. registered in the United States and other countries. The iPhone trademark is used under license from AIPHONE CO., LTD.

Intel and Intel Core are trademarks or registered trademarks of Intel Corporation in the United States and other countries.

Other company and product names herein are trademarks or registered trademarks of their respective owners.

■Copyrights

The screens (screenshots) are used in accordance with the Microsoft Corporation guideline.

SH(NA)-081195ENG-AP(2301)MEE

MODEL: GOT2000-U-UTILITY-E

MODEL CODE: 1D7MJ6

MITSUBISHI ELECTRIC CORPORATION

HEAD OFFICE : TOKYO BUILDING, 2-7-3 MARUNOUCHI, CHIYODA-KU, TOKYO 100-8310, JAPAN
NAGOYA WORKS : 1-14, YADA-MINAMI 5-CHOME, HIGASHI-KU, NAGOYA, JAPAN

When exported from Japan, this manual does not require application to the
Ministry of Economy, Trade and Industry for service transaction permission.

Specifications subject to change without notice.