

Industrial PC

**MELIPC**

## MI1002-W User's Manual

---

-MI1002-W  
-MI1002-W-CL



# Precautions regarding Warranty

This product was developed and manufactured by Mitsubishi Electric Corporation in collaboration with NEC Corporation.

Please see the following notes regarding the warranty and specifications of this product.

## Warranty

	MI1002-W, MI1002-W-CL
Gratis warranty term	18 months after delivery or, 24 months after manufacture
Onerous repair term after production discontinuation	5 years

- When requesting repair of this product during the free warranty period, please present the warranty attached to this product.
- Please read the guarantee provisions contained in the warranty.
- The repair period of this product after production discontinuation will depend on the inventory status of the spare parts.
- It may take time to respond depending on the condition and timing of your inquiry.

# Conditions of Use for the Product

(1). This product ("the PRODUCT") shall be used in conditions;

- i) where any problem, fault or failure occurring in the PRODUCT, if any, shall not lead to any major or serious accident; and
- ii) where the backup and fail-safe function are systematically or automatically provided outside of the PRODUCT for the case of any problem, fault or failure occurring in the PRODUCT

(2). The PRODUCT has been designed and manufactured for the purpose of being used in general industries. MITSUBISHI SHALL HAVE NO RESPONSIBILITY OR LIABILITY (INCLUDING, BUT NOT LIMITED TO ANY AND ALL RESPONSIBILITY OR LIABILITY BASED ON CONTRACT, WARRANTY, TORT, PRODUCT LIABILITY) FOR ANY INJURY OR DEATH TO PERSONS OR LOSS OR DAMAGE TO PROPERTY CAUSED BY the PRODUCT THAT ARE OPERATED OR USED IN APPLICATION NOT INTENDED OR EXCLUDED BY INSTRUCTIONS, PRECAUTIONS, OR WARNING CONTAINED IN MITSUBISHI'S USER, INSTRUCTION AND/OR SAFETY MANUALS, TECHNICAL BULLETINS AND GUIDELINES FOR the PRODUCT.

("Prohibited Application")

Prohibited Applications include, but not limited to, the use of the PRODUCT in;

- Nuclear Power Plants and any other power plants operated by Power companies, and/or any other cases in which the public could be affected if any problem or fault occurs in the PRODUCT.
- Railway companies or Public service purposes, and/or any other cases in which establishment of a special quality assurance system is required by the Purchaser or End User.
- Aircraft or Aerospace, Medical applications, Train equipment, transport equipment such as Elevator and Escalator, Incineration and Fuel devices, Vehicles, Manned transportation, Equipment for Recreation and Amusement, and Safety devices, handling of Nuclear or Hazardous Materials or Chemicals, Mining and Drilling, and/or other applications where there is a significant risk of injury to the public or property.

(3). Mitsubishi shall have no responsibility or liability for any problems involving the PRODUCT trouble and system trouble caused by DoS attacks, unauthorized access, computer viruses, and other cyberattacks.

# Precautions for Use (Be Sure to Read)



This manual provides information necessary for safe and correct use of this product.



Keep this manual nearby so that you can refer to it as necessary. Be sure to read this manual before using this product.

## Safety Precautions







Follow the instructions in this document for the safe use of this product.

This manual describes hazardous parts of the product, possible hazards, and how to avoid them. Components of the product with possible danger are indicated with a warning label placed on or around them (or, in some cases, by printing the warnings on the computer).





In this manual or on warning labels, “ Warning” or “ Caution” is used to indicate a degree of danger. These terms are defined as follows:

 <b>Warning</b>	Indicates the potential for death or serious injury.
 <b>Caution!</b>	Indicates there is a risk of burns, other personal injury, or property damage.

Precautions and notices against hazards are presented with one of the following three symbols.







	Attention	This symbol indicates the presence of a hazard if the instruction is ignored. An image in the symbol illustrates the hazard type.	Example: Electric shock risk 
	Prohibited action	This symbol indicates prohibited actions. An image in the symbol illustrates a particular prohibited action.	Example: Do not disassemble. 
	Mandatory action	This symbol indicates mandatory actions. An image in the symbol illustrates a mandatory action to avoid a particular hazard.	Example: Disconnect a plug. 

(A label example used in this User’s Manual)







Symbol to draw attention	Description of a warning	Term indicating a degree of danger
	<b>Warning</b>	
  	<b>Do not use the product if any smoke, odor, or noise is present.</b>  If smoke, an abnormal odor or a sound is generated from the product, immediately turn off the main unit, unplug the power cable from the outlet, and then contact your nearest sales agent or maintenance service company.  A fire might result if you continue to use the product.	

# Symbols Used in This Manual and on Warning Labels



## Attention

	Indicates the potential for smoke and/or fire to occur.		Indicates the risk of electric shock.
	Indicates the possibility that you get your fingers pinched between the mechanical parts resulting in injuries.		Indicates there is a risk of explosion that can result in injuries.
	Indicates the potential for damage caused by high temperatures.		Indicates an attention that cannot be specifically identified.

## Prohibited actions

	Do not disassemble, repair, or modify this product. Otherwise, an electric shock or fire may be caused.		Do not use this product in places near water or liquids. Otherwise an electric shock or fire may be caused.
	Do not install this product near a fire. Otherwise a fire may be caused.		Do not touch with wet hand. Otherwise, an electric shock may be caused.
	Do not touch this product. Otherwise, an electric shock or burn may be caused.		Indicates a general prohibited action that cannot be specifically identified.

## Mandatory actions

	Unplug the power cable of this product. Otherwise, an electric shock or fire may be caused.		Indicates a mandatory action that cannot be specifically identified. Make sure to follow the instruction.
	Make sure equipment is properly grounded. Otherwise, an electric shock or fire may be caused.		

## Notations in this manual

	Indicates items that must be observed in handling the hardware.
---	---

# Safety Notes

This section provides notes on using this product safely. Read this section carefully to ensure proper and safe use of this product.

## General notes

### Warning

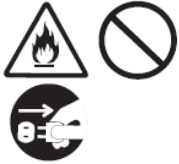

#### **Do not use the product if any smoke, odor, or noise is present.**

If smoke, an abnormal odor or a sound is generated from the product, immediately turn off the main unit, unplug the power cable from the outlet, and then contact your nearest sales agent or maintenance service company. A fire might result if you continue to use the product.

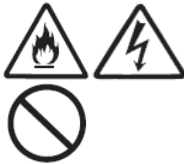

#### **Do not insert needles or metal objects.**

Do not remove rubber caps or other covers on this product to insert needles, metal objects, or other foreign objects into openings. Doing so may cause an electric shock, burns, or fire.

### Caution!



#### **Keep water or foreign objects away from the product.**

Do not drop liquids such as water or other foreign objects such as a pin or a paper clip into this product. Failure to follow this warning may cause an electric shock, a fire, or malfunction. If such things accidentally enter the product, immediately turn off the power and disconnect the plug from the outlet. Do not disassemble the product, and contact your sales agent or a maintenance service company.

### Warning



#### **Security Precautions**

To maintain the security (confidentiality, integrity, and availability) of the product and the system against unauthorized access, denial-of-service (DoS) attacks, computer viruses, and other cyberattacks from external devices via the network, take appropriate measures such as setting up a firewall or a virtual private network (VPN), or installing antivirus software on the computer.

## Notes on power connections

# Warning

### **Plug the power cable into an outlet that matches the voltage of the unit.**



Plug the power cable supplied with this product(Only MI1002-W) into a 100V outlet in line with the voltage inscribed on the unit. When using this product in a country or region other than Japan, prepare a power cable corresponding to the power supply for the country or region where this product will be used. Failure to use an appropriate power cable may cause a fire.( When using the MI1002-W-CL, prepare a power cable that conforms to the power supply to be used and the safety standards of the use area.)



### **Do not hold the plug with a wet hand.**

Do not insert/remove the power cable plug with wet hands.  
Failure to follow this warning may cause an electric shock.



### **Do not connect or remove a ground wire or FG cable while the power cable is connected to the outlet.**

When using the 2-pin conversion plug(Only MI1002-W) and FG cable supplied with this product, unplug the plug from the outlet before attaching or removing the ground wire or FG cable. Even if the power is turned off, touching the ground wire while the plug is plugged into the outlet may cause an electric shock, or may cause a short circuit, resulting in fire.



# Caution!

## **Plug the power cable into the specified outlet.**



Use a 3-pin outlet with ground electrode or 2-pin outlet with ground terminal that matches the specified voltage. If you are using a 2-pin outlet with ground terminal, use a 2-pin conversion plug with a ground wire supplied with this product(Only MI1002-W) and connect the ground wire securely to the ground terminal of the outlet. Use of an outlet other than that specified may result in fire or electrical leakage.(When using the MI1002-W-CL, prepare a power cable that conforms to the power supply to be used and the safety standards of the use area.)

## **Do not use extension cords.**



Do not install this product in any environment that requires an extension cord. Connecting to a cord that does not conform to the power supply specifications of this product may cause overheating, resulting in fire.

## **Do not connect power cable to overloaded extension cords.**



The electric current exceeding the rated flow overheats the outlet, which may cause a fire.

# Caution!



## **Hold the plug part when removing the AC power cable.**

Pull the plug by holding the plug part to disconnect the AC power cable. Pulling the AC power cable out by the cable may cause breakage, resulting in electrical shock or fire.



## **Secure the AC power cable in place.**

Be sure to secure the AC power cable in place. Incomplete insertion causes an inadequate connection, which may result in heat generation or fire. Also, if dust accumulates on the prongs and water drops adhere to the accumulated dust, it may result in heat generation or cause fire.



## **Use the authorized AC power cable.**

Use only the AC power cable supplied with the product(Only MI1002-W). Electric current exceeding the rated flow could cause fire.(When using the MI1002-W-CL, prepare a power cable that conforms to the power supply to be used and the safety standards of the use area.) Also, observe the following precautions to prevent electrical shock or fire caused by a damaged power cable.

- Do not stretch the power cable.
- Do not bend the power cable.
- Do not twist the power cable.
- Do not step on the power cable.
- Do not alter, modify, or repair the power cable.
- Do not use a damaged power cable. (Replace the damaged power cable with a power cable of the same standard. Contact your sales agent or a maintenance service company for replacement.)
- Do not pinch the power cable.
- Keep chemicals away from the power cable.
- Do not place any object on the power cable.
- Do not use a rolled up power cable.
- Do not secure the power cable with staples or equivalent.



## **Do not use the attached power cable, AC adapter, 2-pin conversion plug with ground wire, FG cable, and power cable clamp for any other devices or usage.**

The power cable(Only MI1002-W), AC adapter, 2-pin conversion plug(Only MI1002-W) with ground wire, FG cable, and power cable clamp that come with the product are designed for this product and the safety is confirmed for use with this product. Do not use them for any other products or purposes. Doing so may cause a fire or an electric shock.



## **Do not turn on the power again immediately after turning off the power.**

If the power is turned on immediately after turning off the power, a large inrush current may flow.  
After turning off the power, wait 10 seconds before turning the power on again.

## Notes on installing, moving, storing, or connecting this product

### Warning



#### **Do not connect the ground wire and FG cable to a gas pipe.**

Never connect the ground wire of the 2-pin conversion plug(Only MI1002-W) and FG cable supplied with this product to a gas pipe. Failure to follow this warning may cause a gas explosion or a fire.

### Caution!



#### **Install or store this product in the specified place.**

Do not install this product in the following places or any place other than specified in this manual. Failure to follow this instruction may cause a fire.

- A dusty place
- A place exposed to direct sunlight
- A humid place such as near a water heater
- An unstable place



#### **Do not use this product in an environment where flammable gas and corrosive gas is present.**

Do not install this product in a place subject to flammable gas and corrosive gases including sulfur dioxide, hydrogen sulfide, nitrogen dioxide, chlorine, ammonia, or ozone. Do not install this product in an environment containing corrosion promoting components such as sodium chloride and sulfur and conductive metal etc. in dust and air. Failure to follow this warning may corrode the printed board in this product, leading to malfunction, smoke emission or fire. If you suspect the presence of any of the above in your environment, please consult your sales agent or a maintenance service company.



#### **Do not connect or remove the interface cable while the plug is plugged into the outlet.**

Turn off the power of this product and unplug the plug from the outlet when connecting or removing interface cables. Even if the power is turned off, touching parts inside this product while the plug is plugged into the outlet may cause an electric shock, or may cause a short circuit, resulting in fire.

# Caution!



## **Use the specified articles.**

Use only the genuine articles specified by MITSUBISHI ELECTRIC CORPORATION. If an optional article whose operation has not been verified by MITSUBISHI ELECTRIC CORPORATION is attached or connected, not only will the product not work properly, there is a risk of malfunction. Breakdown and breakage of this product caused by use of such an article will not be subject to fee-based repair even during the warranty period.

For use of optional articles, please consult your sales agent or a maintenance service company.



## **Use only the specified interface cable.**

Use only interface cables provided by MITSUBISHI ELECTRIC CORPORATION and locate a proper device and connector before connecting a cable. Using an unauthorized cable or connecting a cable to an improper destination may cause a short circuit, resulting in fire. Also, observe the following notes on using and connecting an interface cable.

- Do not use any damaged cable connector.
- Do not place any object on the cable.
- Do not step on the cable.
- Do not use this product with loose cable connections.

For more information about interface cables, please contact your sales or maintenance representative.



## **Secure cables in place.**

Be sure to secure the power cable and interface cables in place. Incomplete installation causes a loose connection, resulting in smoke or fire.



## **Hold the plug part when removing the interface cables.**

When removing the cables, remove locks such as by removing screws and pull the plug straight out while holding the connector part. Pulling the plug out by the cable and applying unreasonable force to the connector may cause the cable to break, resulting in fire or electric shock.

## Notes on maintenance

### Warning



#### **Do not remove the lithium metal battery (button type).**

A lithium metal battery (button type) is installed in this product. Do not attempt to remove this lithium metal battery (button type). Exposing the battery to flame or water may cause it to catch fire or rupture.

If the product does not work normally due to the dead battery, please contact your sales or maintenance representative. Never disassemble or replace the battery by yourself.



#### **Do not connect or remove the ground wire, FG cable, or interface cable while the plug is plugged into the outlet.**

Turn off the power of this product and unplug the plug from the outlet when cleaning this product or connecting or removing the ground wire of the 2-pin conversion plug, FG cable, and interface cables. Even if power is turned off, touching the ground wire or parts inside this product while the plug is plugged into the outlet may cause an electric shock, or may cause a short circuit, resulting in fire.

### Caution!



#### **High temperature**

Immediately after turning off the power of this product, the main unit may be hot depending on the ambient temperature.



#### **Secure cables in place.**

Be sure to secure the power cable and interface cables in place. Incomplete installation causes a loose connection, resulting in smoke or fire.



#### **Clean this product on a regular basis.**

Pull out the plug from the outlet from time to time and use a dry cloth to wipe off any dust or dirt. If water drops adhere to the accumulated dust, it may generate heat, causing malfunction or fire. For cleaning of this product, please consult your sales agent or a maintenance service company.



#### **Notes on maintenance**

Please read the manual for each component before maintenance.

# Caution!



## **Do not disassemble.**

Do not disassemble, repair, or modify this product by yourself. Doing so may result in insufficient performance depending on the usage environment, malfunction, electric shock, or fire.

## Notes during operation

# Caution!



## **Avoid contact with this product during thunderstorms.**

Do not touch any part of this product including cables when a thunderstorm is approaching. Also, do not connect or disconnect any devices. There may be a risk of electric shock from lightning strike.

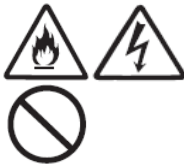

## **Keep creatures away from this product.**

Keep small animals, insects, and other creatures away from this product. Hair or other waste matter from the creature may enter this product and cause a fire or electric shock.



## **Do not place any objects on this product.**

Doing so may cause the product to malfunction, or the object placed on the product may fall and cause personal injury or damage to nearby personal belongings.





## **High temperature**

While using this product or immediately after turning off the power, the main unit may be hot depending on the ambient temperature. There is a possibility of burns from contact.

# Safety Precautions

Avant d'utiliser ce produit, lire attentivement ce manuel ainsi que les manuels auxquels il renvoie, et toujours considérer la sécurité comme de la plus haute importance en manipulant le produit correctement. Dans ce manuel, les précautions de sécurité sont classées en deux niveaux, à savoir: "⚠️ AVERTISSEMENT " e "⚠️ ATTENTION ".







 <b>AVERTISSEMENT</b>	Attire l'attention sur le fait qu'une négligence peut créer une situation de danger avec risque de mort ou de blessures graves.
 <b>ATTENTION</b>	Attire l'attention sur le fait qu'une négligence peut créer une situation de danger avec risque de blessures légères ou de gravité moyennes ou risque de dégâts matériels.

Dans certaines circonstances, le non-respect d'une précaution de sécurité introduite sous le titre "ATTENTION" peut avoir des conséquences graves.

Les précautions de ces deux niveaux doivent être observées dans leur intégralité car elles ont trait à la sécurité des personnes et aussi du système.

Veiller à ce que les utilisateurs finaux lisent ce manuel qui doit être conservé soigneusement à portée de main pour s'y référer autant que de besoin.

Les précautions et les avis contre les dangers sont présentés avec l'un des trois symboles suivants.







	Attention	Ce symbole indique la présence d'un danger si les instructions sont ignorées. Une image dans le symbole illustre le type de danger.	Exemple: Choc électrique 
	Action interdite	Ce symbole indique les actions interdites. Une image dans le symbole illustre une action interdite particulière.	Exemple: Ne pas démonter 
	Action obligatoire	Ce symbole indique les actions obligatoires. Une image dans le symbole illustre une action obligatoire pour éviter un danger particulier.	Exemple: Débrancher une prise 

# Symbols Used in This Manual and on Warning Labels



## Attention

	Indique le risque potentiel de fumée et / ou d'incendie.		Cette étiquette indique un risque de choc électrique.
	Indique le risque potentiel de dommages causés par des températures élevées.		Indique qu'il existe un risque d'explosion pouvant entraîner des blessures.
	Indique la possibilité de se coincer les doigts entre les pièces mécaniques, entraînant des blessures.		Indique une attention qui ne peut pas être spécifiquement identifiée.

## Action interdites

	Ne pas démonter, réparer ou modifier le produit. Sous peine de provoquer un choc électrique ou un incendie.		N'utilisez pas ce produit dans des endroits proches de l'eau ou des liquides. Sous peine de provoquer un choc électrique ou un incendie.
	N'installez pas ce produit près d'un feu. Sinon, un incendie pourrait être provoqué.		Ne pas toucher avec les mains mouillées. Sinon un choc électrique peut être entraîné.
	Ne touchez pas ce produit. Sinon un choc électrique peut être entraîné.		Indique une action interdite générale qui ne peut pas être spécifiquement identifiée.

## Action obligatoires

	Débranchez le câble d'alimentation de ce produit. Sous peine de provoquer un choc électrique ou un incendie.		Indique une action obligatoire qui ne peut pas être spécifiquement identifiée. Veiller à suivre les instructions.
	Assurez-vous que l'équipement est correctement mis à la terre.		

# Notes de sécurité

## General notes

 <b>AVERTISSEMENT</b>	
  	<p><b>N'utilisez pas le produit si de la fumée, des odeurs ou du bruit sont présents.</b></p> <p>Si de la fumée, une odeur anormale ou un son est produit par le produit, éteignez immédiatement l'unité principale, débranchez le câble d'alimentation de la prise secteur, puis contactez votre revendeur ou votre société de maintenance. Un choc électrique ou un incendie peuvent survenir si vous continuez à utiliser le produit.</p>
  	<p><b>N'insérez pas d'aiguilles ou d'objets métalliques.</b></p> <p>Ne retirez pas les capuchons en caoutchouc ou les autres couvercles de ce produit pour insérer des aiguilles, des objets métalliques ou d'autres objets étrangers dans les ouvertures. Cela pourrait provoquer un choc électrique ou un incendie.</p>



## ATTENTION



### **Gardez l'eau ou les corps étrangers à l'écart du produit.**

Ne laissez pas tomber de liquides tels que de l'eau ou d'autres corps étrangers tels qu'une épingle ou un trombone dans ce produit. Le non-respect de cet avertissement peut provoquer un choc électrique, un incendie. Si de telles choses pénètrent accidentellement dans le produit, coupez immédiatement l'alimentation et débranchez la fiche d'alimentation de la prise. Ne démontez pas le produit et contactez votre revendeur ou votre société de maintenance.

## AVERTISSEMENT



### **Précautions de sécurité**

Pour maintenir la sécurité (confidentialité, intégrité et disponibilité) de l'automate programmable et du système contre les accès non autorisés, les attaques par déni de service (DoS), les virus informatiques et autres cyberattaques d'appareils externes via le réseau, prendre les mesures appropriées telles que la configuration d'un pare-feu ou d'un réseau privé virtuel (VPN), ou l'installation d'un logiciel antivirus sur l'ordinateur.

## Notes sur les connexions d'alimentation

## AVERTISSEMENT



### **Branchez le câble d'alimentation dans une prise qui correspond à la tension de l'appareil.**

Branchez le câble d'alimentation fourni avec ce produit (MI1002-W uniquement) dans une prise de 100V en ligne avec la tension inscrite sur l'appareil. Lorsque vous utilisez ce produit dans un pays ou une région autre que le Japon, préparez un câble d'alimentation correspondant à l'alimentation électrique du pays ou de la région où ce produit sera utilisé. Ne pas utiliser un câble d'alimentation approprié peut provoquer un incendie. (Lors de l'utilisation du MI1002-W-CL, préparez un cordon d'alimentation conforme aux normes de sécurité de la source d'alimentation et de la zone à utiliser.)



### **Ne tenez pas la fiche d'alimentation avec les mains mouillées.**

Ne pas insérer / retirer la fiche du câble d'alimentation avec les mains mouillées. Le non-respect de cet avertissement peut provoquer un choc électrique.



### **Mise à la terre de sécurité.**

Branchez la fiche d'alimentation à 3 broches du câble d'alimentation CA relié à une prise à 3 broches. Utilisez la fiche de conversion fournie pour la prise bipolaire pour connecter le câble de mise à la terre à la borne de terre pour la sortie bipolaire. Fixez la mise à la terre pour la sécurité (pour éviter les chocs électriques) en utilisant le câble de mise à la terre du câble d'alimentation CA. Mettez l'unité principale à la terre avant de brancher la fiche d'alimentation. Débranchez la fiche d'alimentation de la source d'alimentation avant de déconnecter la mise à la terre.

## ATTENTION



### **Brancher le câble d'alimentation dans la prise.**

Utilisez une prise à 3 broches avec une électrode de masse ou une prise à 2 broches avec une borne de mise à la terre correspondant à la tension spécifiée. Si vous utilisez une prise à 2 broches avec borne de terre, utilisez une fiche de conversion à 2 broches avec un fil de terre fourni avec ce produit (MI1002-W uniquement) et connectez le fil de terre à la borne de terre de la prise. L'utilisation d'une prise autre que celle spécifiée peut entraîner un incendie ou une fuite électrique. (Lors de l'utilisation du MI1002-W-CL, préparez un cordon d'alimentation conforme aux normes de sécurité de la source d'alimentation et de la zone à utiliser.)



### **Ne pas utiliser avec des rallonges.**

N'installez pas le serveur dans un environnement nécessitant une rallonge. La connexion à un cordon non conforme aux spécifications d'alimentation de ce produit provoque une surchauffe et un incendie.



### **Ne branchez pas le câble d'alimentation à des rallonges surchargées.**

Le courant électrique dépassant le débit nominal surchauffe la sortie, ce qui peut provoquer un incendie.



### **Tenez la prise en retirant le câble d'alimentation CA.**

Tirez sur la prise en tenant la prise pour déconnecter le câble d'alimentation CA. Si vous tirez le câble d'alimentation CA en tenant le cordon, vous risquez de le casser et de provoquer des incendies.



### **Fixez le câble d'alimentation CA en place.**

Veillez à bien fixer le câble d'alimentation CA en place. Une installation incomplète provoque une connexion lâche, entraînant de la fumée ou un incendie.



### **Utilisez le câble d'alimentation CA autorisé.**

Utilisez uniquement le câble d'alimentation CA fourni avec le produit (MI1002-W uniquement). Un courant électrique dépassant le débit nominal pourrait provoquer un incendie. Observez également les précautions suivantes pour éviter les chocs électriques ou les incendies causés par un câble d'alimentation endommagé. ( Lors de l'utilisation du MI1002-W-CL, préparez un cordon d'alimentation conforme aux normes de sécurité de la source d'alimentation et de la zone à utiliser.)

- Ne pas étirer ou plier le câble d'alimentation.
- Ne marchez pas et ne pincez pas le câble d'alimentation.
- Ne fixez pas le câble d'alimentation avec des agrafes ou des équivalents.
- Déroulez le câble d'alimentation avant de l'utiliser.
- Gardez les produits chimiques éloignés du câble d'alimentation.
- Ne placez aucun objet sur le câble d'alimentation.
- Ne pas modifier, modifier ou réparer le câble d'alimentation.
- N'utilisez pas de câble d'alimentation endommagé. Remplacez le câble d'alimentation endommagé par un câble d'alimentation de même standard.  
Contactez votre revendeur ou votre société de maintenance pour le remplacer.

## ATTENTION



**N'utilisez pas le câble d'alimentation fourni pour d'autres appareils ou usages.**

Le câble d'alimentation fourni avec le produit (MI1002-W uniquement) est conçu pour ce produit. N'utilisez pas le câble d'alimentation fourni pour d'autres produits ou objectifs. Cela pourrait provoquer un incendie ou une électrocution.



**Ne remettez pas l'appareil sous tension immédiatement après la mise hors tension.**

Si l'alimentation est mise sous tension immédiatement après la mise hors tension, un courant d'appel important peut s'écouler.

Après la mise hors tension, attendez 10 secondes avant de remettre l'appareil sous tension.

### Remarques sur l'environnement d'installation

## AVERTISSEMENT



**Ne connectez pas le fil de terre à un tuyau de gaz.**

Ne connectez jamais le fil de terre à un tuyau de gaz. Le non-respect de cet avertissement peut provoquer une explosion de gaz ou un incendie.

## ATTENTION



**Installez ou stockez ce produit à l'endroit spécifié.**

N'installez pas ce produit dans les endroits suivants ou dans un endroit autre que celui spécifié dans ce manuel. Le non-respect de cette instruction peut provoquer un incendie.

- Un endroit poussiéreux ou humide
- Un lieu exposé à la lumière directe du soleil ou à l'eau de pluie
- Un endroit où des gaz inflammables ou des gaz corrosifs sont présents
- Un endroit instable



**N'utilisez pas ce produit dans un environnement où un gaz corrosif est présent.**

N'installez pas ce produit dans un endroit soumis à des gaz corrosifs, notamment le dioxyde de soufre, le sulfure d'hydrogène, le dioxyde d'azote, le chlore, l'ammoniac ou l'ozone. N'installez pas ce produit dans un environnement contenant des composants favorisant la corrosion tels que le chlorure de sodium et le soufre et le métal conducteur, etc. dans la poussière et l'air. Le non-respect de cet avertissement peut corroder la carte imprimée dans ce produit, entraînant un dysfonctionnement, une émission de fumée ou un incendie. Pour toute question, veuillez contacter votre revendeur ou votre société de maintenance.

## ATTENTION



### **Retirez le câble d'alimentation CA lors de la connexion des câbles d'interface.**

Retirez le câble d'alimentation CA de la prise ou de toute autre source d'alimentation lors de la connexion ou du retrait des câbles d'interface.

La connexion ou le retrait des câbles d'interface alors que le câble d'alimentation CA est connecté à la prise ou à une autre source d'alimentation peut provoquer un choc électrique.



### **Utilisez uniquement le câble d'interface spécifié.**

Utilisez uniquement les câbles d'interface fournis par MITSUBISHI ELECTRIC CORPORATION et localisez un périphérique et un connecteur appropriés avant de connecter un câble. L'utilisation d'un câble non autorisé ou la connexion d'un câble à une destination incorrecte peut entraîner un court-circuit et provoquer un incendie. Observez également les remarques suivantes sur l'utilisation et la connexion d'un câble d'interface.

- N'utilisez aucun connecteur de câble endommagé. ● Ne tirez pas sur le câble.
- Ne placez aucun objet sur le câble. ● N'utilisez pas de câble endommagé.
- N'utilisez pas le serveur avec des connexions de câble desserrées.

Pour plus d'informations sur les câbles d'interface, contactez votre revendeur ou votre société de maintenance.



### **Fixez les câbles en place.**

Veillez à bien fixer le câble d'alimentation et les câbles d'interface. Une installation incomplète provoque une connexion lâche, entraînant de la fumée ou un incendie.



### **Tenez la prise en retirant le câble d'alimentation CA et les câbles d'interface.**

Tirez sur la prise en tenant la prise pour déconnecter le câble d'alimentation CA et les câbles d'interface. Si vous tirez ces câbles en tenant le cordon, vous risquez de le casser et de provoquer des incendies.

## Notes pour la maintenance

### AVERTISSEMENT



#### **Ne retirez pas la batterie au lithium métal (type bouton).**

Une batterie au lithium métal (type bouton) est installée dans ce produit. N'essayez pas de retirer cette pile au lithium métal (type bouton). L'exposition de la batterie à la flamme ou à l'eau peut provoquer un incendie ou une rupture.

Si le produit ne fonctionne pas normalement à cause de la batterie déchargée, veuillez contacter votre revendeur ou votre société de maintenance. Ne jamais démonter ou remplacer la batterie par vous-même.



#### **Retirez le câble d'alimentation CA lors de la connexion des câbles d'interface.**

Retirez le câble d'alimentation CA de la prise ou de toute autre source d'alimentation lors de la connexion ou du retrait des câbles d'interface.

La connexion ou le retrait des câbles d'interface alors que le câble d'alimentation CA est connecté à la prise ou à une autre source d'alimentation peut provoquer un choc électrique.

### ATTENTION



#### **Ne touchez pas les pièces à haute température.**

Ne touchez pas le châssis et l'adaptateur secteur immédiatement après avoir utilisé l'appareil. Ils sont chauds et peuvent causer des brûlures lorsqu'ils sont touchés.

Attendez au moins 30 minutes après la mise hors tension de l'appareil principal avant d'installer / de retirer les appareils installés dans l'unité principale.



#### **Fixez les câbles en place.**

Veillez à bien fixer le câble d'alimentation et les câbles d'interface. Une installation incomplète provoque une connexion lâche, entraînant de la fumée ou un incendie.



#### **Ne pas utiliser lorsque de la poussière s'accumule sur le câble d'alimentation CA.**

N'utilisez pas cette unité principale lorsque de la poussière s'accumule sur la fiche du câble d'alimentation. De longues périodes d'utilisation sans nettoyage de la poussière accumulée sur la fiche du câble d'alimentation peuvent provoquer une décharge électrique entre la fiche et les broches et provoquer des incendies.



#### **Remarques sur la maintenance**

Veillez lire le manuel de chaque composant avant la maintenance.



#### **Ne pas désassembler le produit.**

Veillez ne pas démonter l'alimentation, la batterie, les lecteurs optiques et les unités de disque d'une manière autre que celle décrite dans ce document.

Non seulement le produit ne fonctionne pas correctement, mais il existe également un risque de choc électrique ou d'incendie.

## Notes pour l'utilisation

### ATTENTION



#### **Ne pas toucher pendant les orages.**

Ne retirez pas le couvercle de l'unité principale lorsque la fiche d'alimentation est branchée sur la prise secteur. Le non-respect de cet avertissement peut provoquer un choc électrique.



#### **Gardez les êtres vivants éloignés de ce produit.**

Tenez les petits animaux, les insectes et autres créatures éloignés de ce produit. Les cheveux ou d'autres matières de la créature peuvent entrer dans ce produit et provoquer un incendie ou un choc électrique.



#### **Ne placez aucun objet sur ce produit.**

Cela risquerait de provoquer un dysfonctionnement du produit ou de faire tomber l'objet placé sur le produit et de blesser quelqu'un ou d'endommager les effets personnels à proximité.



#### **Ne touchez pas les pièces à haute température.**

Ne touchez pas le châssis et l'adaptateur secteur immédiatement après avoir utilisé l'appareil. Ils sont chauds et peuvent causer des brûlures lorsqu'ils sont touchés. Attendez au moins 30 minutes après la mise hors tension de l'appareil principal avant d'installer / de retirer les appareils installés dans l'unité principale.

# Warning Labels

A warning label is placed on the components and peripherals that require careful handling (The warning label is printed or attached). The warning labels contain information about possible dangers in dealing with this product. Therefore, do not peel off, cover, or dirty the warning labels. If no warning label is printed or attached on this product, or if the attached or printed warning label is peeling off or dirty, please contact your sales agent.



CAUTION: For use with Information Technology Equipment  
INDOOR USE ONLY

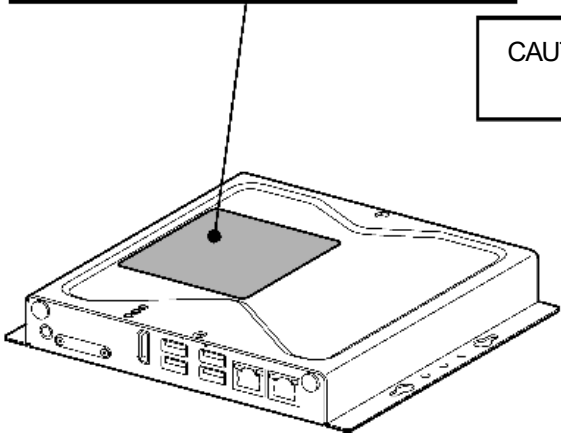

MI1002-W,MI1002-W-CL

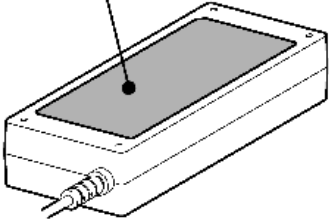

AC Adapter

# Harmonic Current Standard Compliance

This product complies with harmonic current standard JIS C 61000-3-2 and EN 61000-3-2. This product has been designed and produced to meet the harmonic environmental target level of the commercial power system according to standards shown below.

Standard	Title
JIS C 61000-3-2	Electromagnetic compatibility (EMC) - Part 3-2: Limits - Limits for harmonic current emissions (equipment input current $\leq 20$ A per phase)
EN 61000-3-2	Electromagnetic compatibility (EMC) - Part 3-2: Limits - Limits for harmonic current emissions (equipment input current $\leq 16$ A per phase)



# Statements of Radio Interference Regulations

## VCCI

この装置は、クラスA機器です。この装置を住宅環境で使用すると電波妨害を引き起こすことがあります。この場合には使用者が適切な対策を講ずるよう要求されることがあります。

VCCI - A

## Federal Communications Commission (FCC) Statement

This equipment has been tested and complies with the limits for a Class B digital device, pursuant to Part 15 of the FCC Rules. These limits are designed to provide reasonable protection against harmful interference when the equipment is operated in a commercial environment.

This equipment generates, uses, and can radiate radio frequency energy and, if not installed and used in accordance with the instruction manual, may cause harmful interference to radio communications.

Operation of this equipment in a residential area is likely to cause harmful interference, in which case the user will be required to correct the interference at his own expense.

### WARNING TO USER

Unauthorized changes or modifications could void the user's authority to operate the equipment.

Properly shielded and grounded cables and connectors must be used in order to meet FCC emission limits. Mitsubishi Electric is not responsible for any radio or television interference caused by using other than recommended cables and connectors or by unauthorized changes or modifications to this equipment.

## Industry Canada Statement

This Class A digital apparatus complies with Canadian ICES-003.

Cet appareil numérique de la classe A est conforme à la norme NMB-003 du Canada.

## CE Statement

This is a Class A product. In domestic environment this product may cause radio interference in which case the user may be required to take adequate measures.

## BSMI Statement / BSMI警告

這是甲類的資訊產品，在居住的環境中使用時，可能會造成射頻干擾，在這種情況下，使用者會被要求採取某些適當的對策。

## KC Statement

기종별	사용자안내문
A 급 기기	이 기기는 업무용(A 급)으로 전자파적합등록을 한 기기이오니 판매자 또는 사용자는 이 점을 주의하시기 바라며, 가정외의 지역에서 사용하는 것을 목적으로 합니다.

# Handling Precautions (for proper operations)

Be sure to observe the following precautions for the proper functioning of this product. Ignoring the precautions may cause malfunction or failure.

- Before moving this product, turn off the power and remove the plug from the outlet.
- After turning off the power of this product, turn on the power again after 10 seconds have passed from the power-off.
- Clean this product on a regular basis. Regular cleaning prevents potential failures.
- Confirm that optional articles can be installed or connected to this product. Even if the optional article can be installed or connected to this product, the unit may not work properly and may even malfunction.
- If you disassemble or modify this product, it will no longer be covered by the warranty.
- Check and adjust the system clock before the operation if any of the following conditions is applicable.
  - After transportation
  - After storage

Check the system clock at the rough rate of once per month. When the system clock is installed in a system requiring high time precision, it is recommended to use a time server (NTP server).

If the system clock is remarkably delayed or advanced as the passage of time in spite of adjustment, contact your sales agent or maintenance service company to request maintenance.

- Store this product at room temperature to ensure that the product and internal devices will work properly at the next operation.

Store this product under the storage condition (temperature: -20°C to 75°C, humidity: 10% to 85%, without condensation).
- Turn off the devices that generates magnetism or radio wave (for example, cellular phone, PHS, tablet terminal) around this product. Radio waves may cause malfunctions of this product.

# Precautions for Transfer or Disposal of This Product

Be sure to erase important data in the storage completely before transferring or disposing of this product. Even if the data is invisible on the OS, it may remain in storage. To prevent data leakage to third parties, the customer is responsible for erasing the data using a commercial tool or the like.

- **Precautions for transferring this product to a third party**

When transferring (or selling) this product to a third party, please pass on this document, the attached parts and instructions, license agreement and other documents together with the product.

- **Precautions for disposal of this product and its consumables (\*)**

When disposing of this product, follow the rules of the country, region, or municipality.

For details on battery regulations in EU member states, refer to "11. Battery and battery embedded equipment in EU member states."

Be sure to dispose of the attached AC adaptor and power cable(Only MI1002-W) together with this product to prevent diversion for other purposes.

(\*) This product contains lithium battery (button type).

# Cautions for Transportation by Air or Sea

This product uses a button type lithium metal battery. When transporting lithium batteries, follow the transportation regulations. For details on the regulations, refer to Mitsubishi Technical Bulletins as follows.

Precautions for transport recommendations on lithium batteries (FA-A-0259)

- **Batteries used in this product**

Model name	Product type	Lithium content	Weight	Transportation
BR2032	Lithium metal battery	0.06 g per unit	2.5 g per unit	Not dangerous

- **Regulation of perchlorate in California, U.S.**

Since December 31, 2006, the U.S. state of California requires warning texts on the packaging of products incorporating or embedded with lithium primary batteries containing 6 ppb or more of perchlorate. The battery used in this product does not contain perchlorate. Therefore, there is no need for you to take special measures.

- **Notes on transportation**

When shipping this product, this product has been packed at MITSUBISHI ELECTRIC CORPORATION in accordance the transportation regulations. When you transport this product after repacking or unpacking the product, please follow the IATA Dangerous Goods Regulations, IMDG Code, and the transportation regulations of each country. Please confirm with your carrier for details.

# Notes on Microsoft Products

This product uses Microsoft Windows® 10 IoT Enterprise. However, MITSUBISHI ELECTRIC CORPORATION will not warrant against any response or damage arising from problems with Microsoft products.

For problems and specifications of Microsoft products, please consult the Microsoft product manual or contact Microsoft Japan Co., Ltd.

Please visit the following website for inquiries to Microsoft Japan Co., Ltd.

- Microsoft Japan Co., Ltd. : [support.microsoft.com/en-us/contactus](https://support.microsoft.com/en-us/contactus)

# Contents

Precautions regarding Warranty.....	i
Conditions of Use for the Product.....	ii
 Precautions for Use (Be Sure to Read).....	iii
1. Components.....	2
2. Dimensions .....	2
3. Component names and functions.....	3
4. Installation.....	4
4.1. Place the product to a proper location .....	4
4.2. Connect cables .....	5
5. OS setup.....	8
5.1. Setup .....	9
5.1.1. Initial setting.....	9
5.1.2. “Welcome to Windows” specifications .....	11
5.1.3. Creating a recovery medium.....	11
5.1.4. Windows 10 standard functions.....	11
5.2. Re-setup using a recovery medium .....	12
5.2.1. Re-setup flow.....	12
5.2.2. Preparation for re-setup .....	13
5.2.3. Changing the BIOS setting.....	13
5.2.4. Installing Windows 10 .....	14
5.3. Event logs.....	15
6. Licenses.....	19
7. Daily maintenance.....	23
8. Troubleshooting .....	24
9. Product specifications .....	25
10. EMC Directive and Low Voltage Directive.....	26
11. Batteries and battery embedded equipment in EU member states .....	29
12. Appendix.....	30
WARRANTY .....	32
REVISIONS.....	33
TRADEMARKS.....	33

## Preface

Thank you for purchasing this product. (\*)

In order to maximize the functions of this product, please read this manual thoroughly before using it and fully understand the handling of this product.

(\*)After that, MI1002-W includes MI1002-W-CL unless otherwise noted.

## About this manual

This manual is a guide to make sure that you can use this product correctly. Please refer to this manual if there is something you do not understand or the unit is not working properly during normal use.

This manual is intended for users with sufficient knowledge about operating systems such as Windows and basic handling of general input/output devices such as the keyboard and mouse.

# 1. Components

---

The components included with this product are as follows.

If there are any defective or missing items, please contact your sales agent.

- MI1002-W main unit
- AC adapter
- Power cable clamp
- FG cable
- Open Source Software Licenses
- End User License Agreement (Windows10 IoT Enterprise2016 LTSC)
- Edgecross Basic Software License Agreement
- SLMP Data Collector License Agreement
- CC-Link IE TSN Communication Software License Agreement
- SLMP Data Collector, CC-Link IE TSN Communication Software End User License Agreement
- Power cable(Only MI1002-W)
- 2-pin conversion plug (with ground wire)  
(Only MI1002-W)
- Getting Started



Keep the accessories in a safe place.

## 2. Dimensions

---

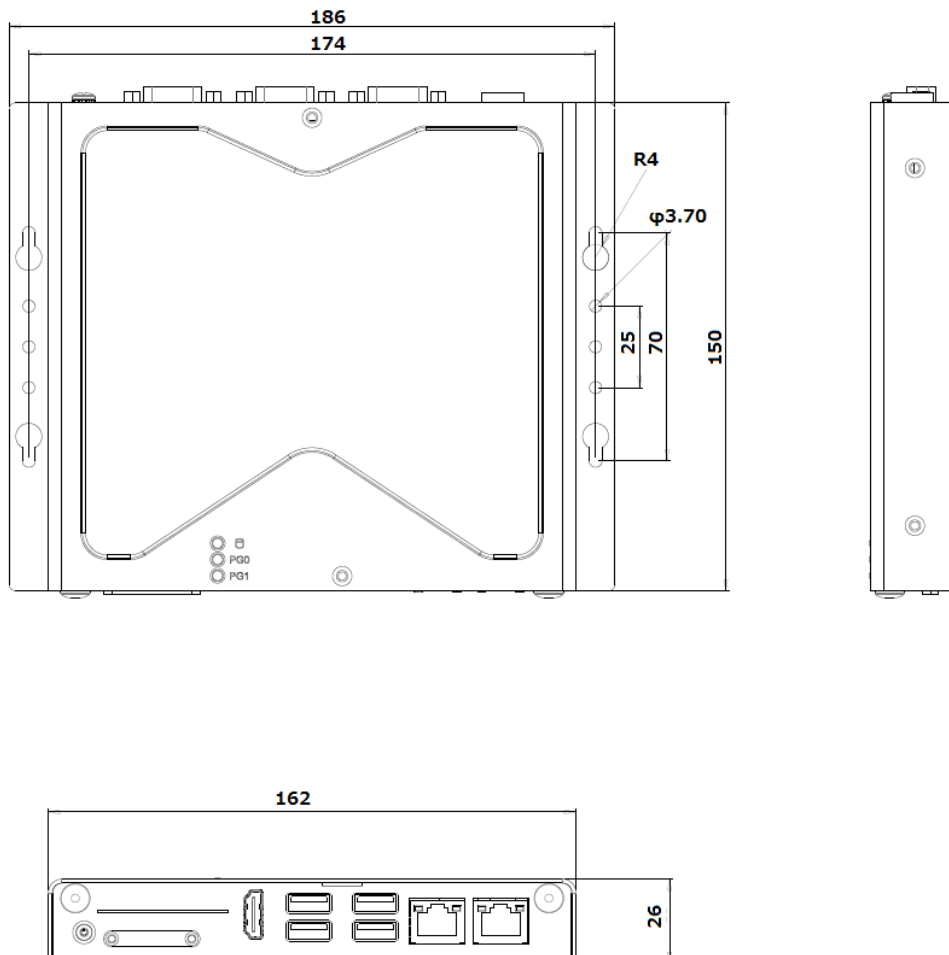

### 3. Component names and functions

● Front panel

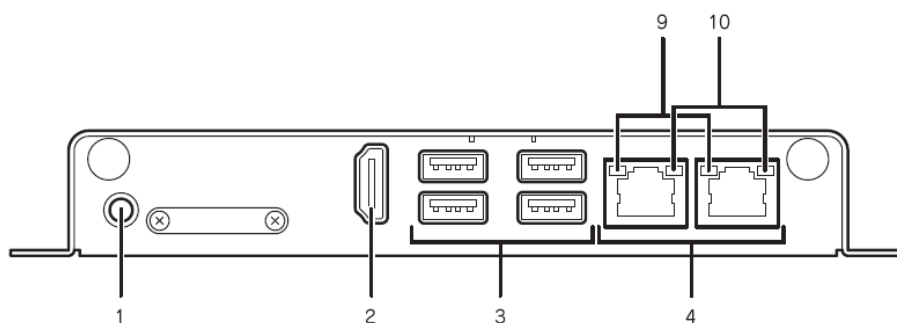

● Rear panel

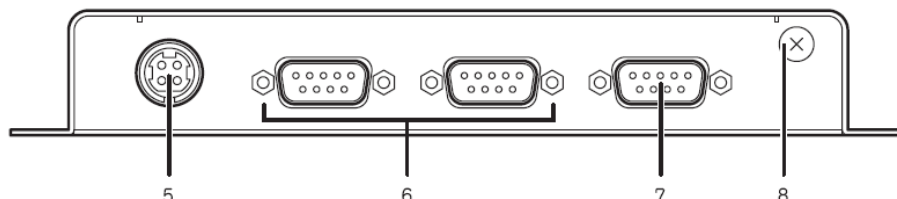

● LEDs on the top panel

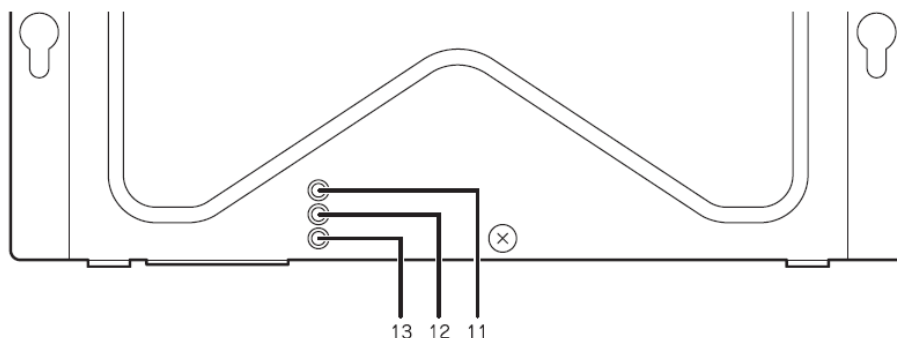

1	POWER LED	The switch to turn this product on or off. The light is blue when on, red when off.
2	Display connector (HDMI)	HDMI-compatible connector
3	USB connector (4 ports)	USB 2.0-compatible connectors. Can be used for connecting USB interface-compatible devices.
4	LAN connector (2 ports)	Network connectors compatible with 1000BASE-T, 100BASE-TX, and 10BASE-T
5	Power connector	Used to connect the AD adapter supplied with this product.
6	Serial port connector (RS-232C)	Used to connect to products with RS-232C-compatible serial interfaces.
7	Serial port connector (RS-485)	Used to connect to products with RS-485-compatible serial interfaces.
8	Functional grounding screw	Used to connect the FG cable (accessory).
9	Link/Act LED (Link/Act)	Indicates the access status of the LAN port. While connecting to LAN: Lit in amber. While transferring data: Blinking in amber.
10	SPEED LED	Indicates the communication speed of the LAN port. While connecting to 1000Base-T: Lit in green. While connecting to 100Base-TX: Lit in amber. While connecting to 10Base-T: Lights off.
11	SATA access LED	Blinking (in green) while accessing the internal storage.
12	PG0 LED	Indicator LED * NOT operable by user.
13	PG1 LED	



## 4. Installation

---

This chapter describes how to install this product.

Please prepare any required articles besides the components included with this product on your own or consult with your installation company.

### 4.1. Place the product to a proper location

---

Determine the location to place this product.

Install this product in a place that meets the following conditions.

- Ambient temperature: 0°C to 55°C  
Humidity: 10% to 85% (No condensation)
- AC 100V 3-pin outlet with ground electrode, or  
AC 100V 2-pin outlet with ground terminal  
\* Install this product near an outlet that can be easily reached.
- A place with minimal exposure to dust, moisture, direct sunlight, or rain
- A place where flammable gas or corrosive gas is not present
- A place where the product can be fixed securely in place or on a flat, sturdy board



- The power cable supplied with this product(Only MI1002-W) is for use in Japan only. If you need to connect to a power supply exceeding AC 125V, you need to prepare a dedicated power cable. Please prepare a power cable corresponding to the power supply of the country or region where this product will be used, or consult your sales agent.  
※ When using MI1002-W-CL, prepare an AC cable that satisfies the following specifications.  
Connector shape : IEC 60230-1 C13  
Plug shape : It conforms to the plug shape of the country of use  
Compliance standard : It conforms to the safety standard of the country of use  
Rating : It must be not less than the voltage and current(2A) value to be used  
Cable length : Cable length shall be length to allow voltage drop
- If you are using a 2-pin outlet with ground terminal, use a 2-pin conversion plug with a ground wire supplied with this product(Only MI1002-W) and connect the ground wire securely to the ground terminal of the outlet. Use of an outlet other than that specified causes fire and electrical leakage.
- Be sure to ground the FG cable. Otherwise, this product may not perform sufficiently depending on the environment.

## 4.2. Connect cables

Connect the cables to the connectors of this product.

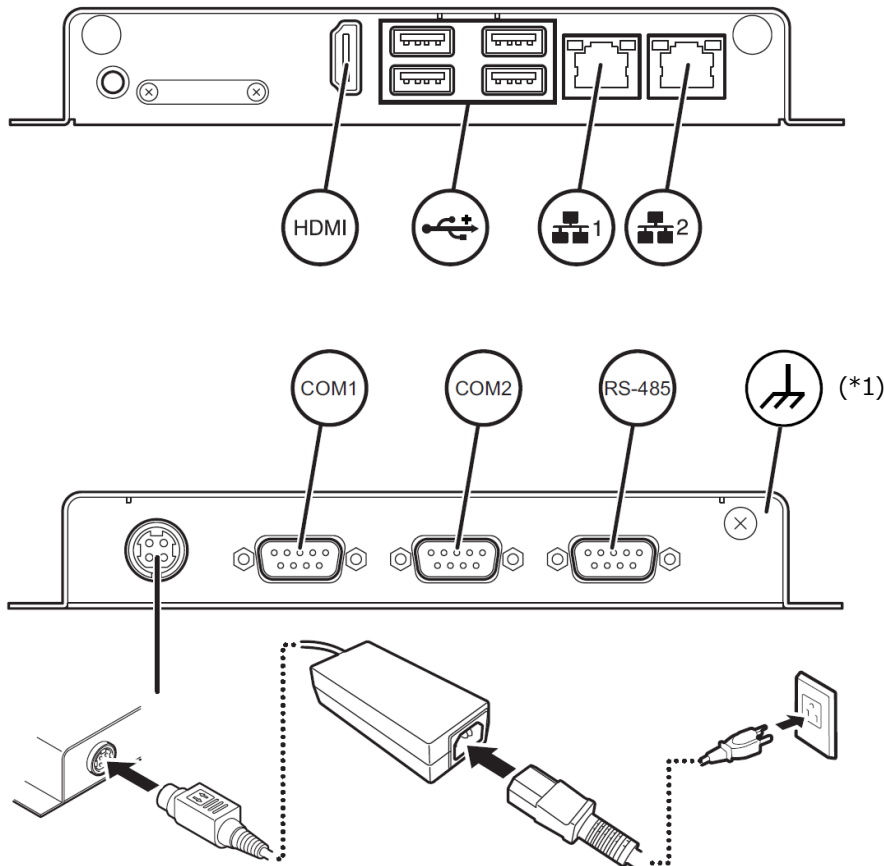



When connecting the connector, be careful of its orientation. (\*2)

Connect the power cable to the AC adapter. (\*3)

Then, connect the power cable to an outlet. (\*4)

### Important

- (\*1) Attach the FG cable before connecting the power cable to an outlet by referring to the procedure on how to attach the FG cable described later in "Hardware Quick Reference."
- (\*2) When attaching or removing the connector, firmly hold the part of the connector marked with an arrow.
- (\*3) Attach the power cable retention bracket before connecting the power cable to an outlet by referring to the procedure on how to attach the power cable retention bracket described later in "Hardware quick reference."
- (\*4) If you are using a 2-pin outlet with ground terminal, use a 2-pin conversion plug with a ground wire supplied with this product(Only MI1002-W). Before attaching or removing a ground wire to/from the ground terminal, be sure to unplug the plug from the outlet.

Icon	Device to connect
HDMI	Display device compatible with an HDMI interface
	USB interface device (such as a hub)
	1000BASE-T/100BASE-TX/10BASE-T interface device (such as a hub)
COM	Device with a serial interface conforming to the RS-232C standard
RS-485	Device with a serial interface conforming to the RS-485 standard
	FG cable (accessory)

## Hardware quick reference

### ● FG cable

Attach the FG cable according to the procedure below.

- (1) Remove the functional ground screws on the rear panel. Then, attach one end of the FG cable to the rear panel and tighten the functional ground screws.

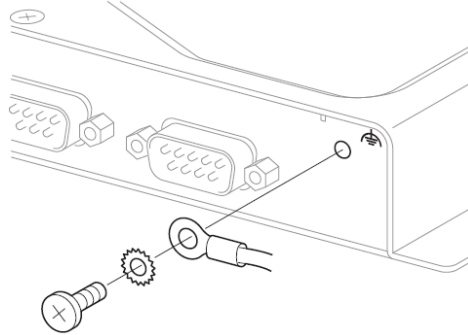

- (2) Ground the other end of the FG cable.



- Be sure to ground the FG cable. Otherwise, this product may not demonstrate sufficient performance depending on the environment.
- Be sure to ground the FG cable before connecting the plug to an outlet.
- To remove the grounded FG cable, be sure to turn the power to the product off and unplug the plug from the outlet in advance.

### ● Preventing the power cable from coming out of an outlet

Attach the power cable clamp according to the following steps.

- (1) Pass the hook and loop fastener with the protrusions facing in through a rectangle hole on one side of the plate.

Fold back the fastener to a length of around 100 mm and affix it.

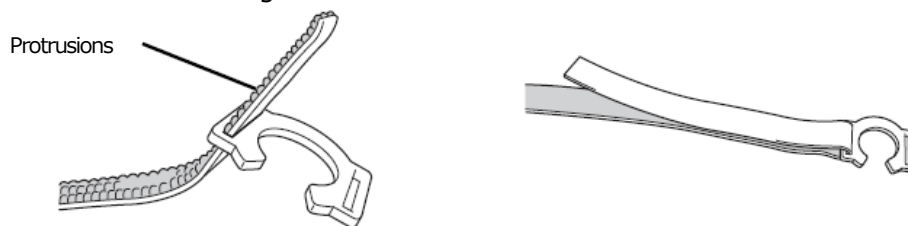

- (2) Insert the power cable into the notch in the plate.

Move the plate to the base of the power cable connector.

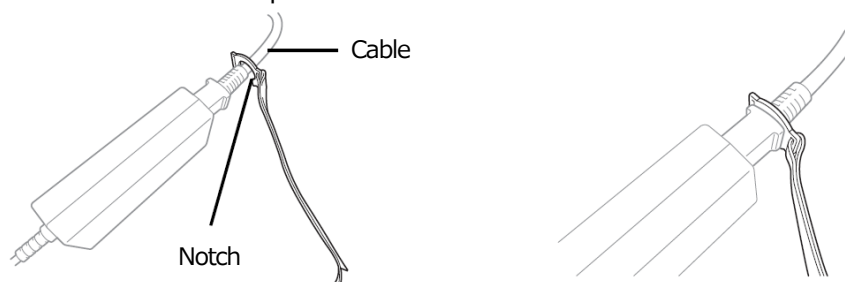

(3) Loop the fastener around the AC adapter. Pass the fastener through the other rectangular hole on the plate.

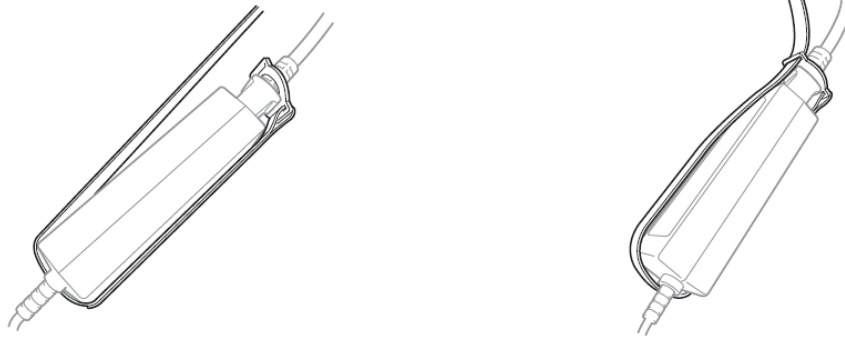

(4) Pull the fastener so it is not slack.  
Fold back and affix the fastener.

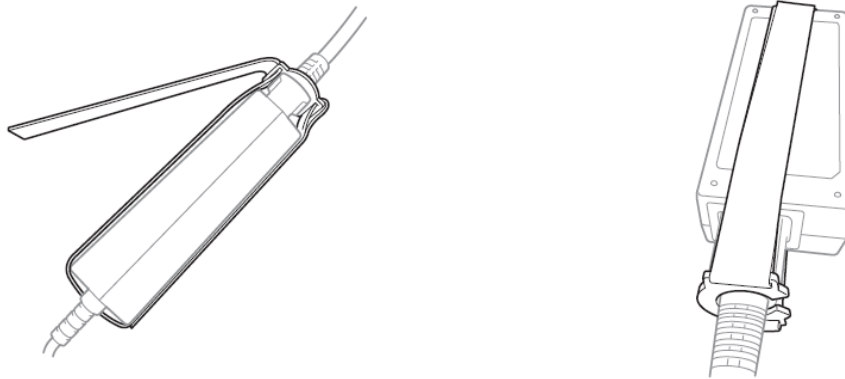

(5) Check to make sure that the power cable is secured as shown in the figure.

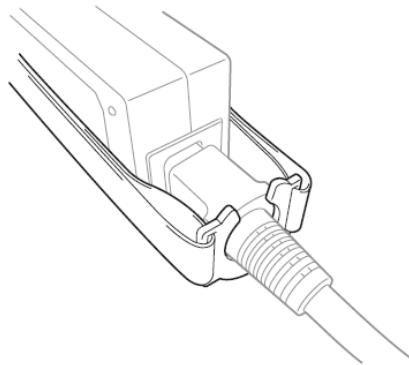

# 5. OS setup

---

This chapter describes how to set up an operating system.  
Set up the operating system according to the flowchart below.

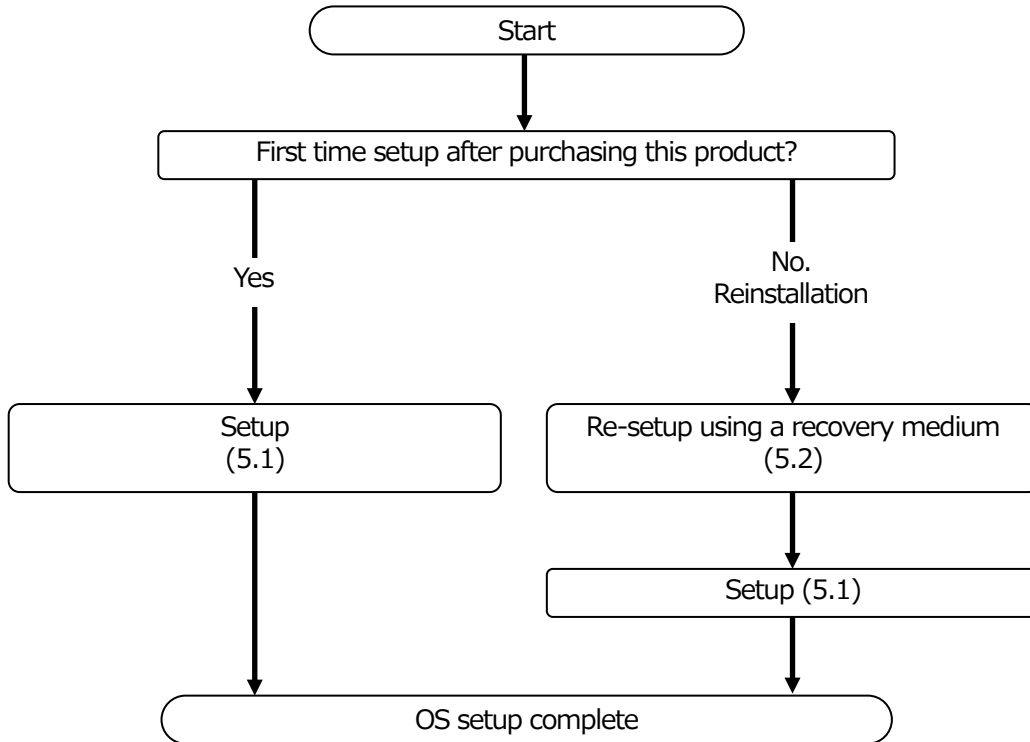

## 5.1. Setup

---

This product is preinstalled with Windows 10, Edgecross basic software(\*1), SLMP data collector, CC-Link IE TSN Communication Software, and CC-Link IE TSN Data Collector.(\*2) (\*3) (\*4)

This chapter describes how to set these up when **turning on the power of this product for the first time** or **reinstalling them by using a recovery medium**.

(\*1) To register as a user of Edgecross basic software, use the product ID described in the Edgecross Basic Software License Agreement included with this product.

(\*2) The pre-installed software is not necessarily the latest version. If you want the latest version, please download it from the website of MITSUBISHI ELECTRIC CORPORATION or Edgecross Consortium (Edgecross basic software only).

(\*3) CC-Link IE TSN Communication Software (including the license agreement included) is preinstalled on the following target serial number ("No." on the warning label) products. It is not preinstalled on earlier products, but can be downloaded from the website of MITSUBISHI ELECTRIC CORPORATION.

[Target serial number (\*\* part is irrelevant)]

MI1002-W: \*\*00421 or later

MI1002-W-CL: \*\*00189 or later

(\*4) When running multiple software programs, the product load, such as CPU utilization, may increase, and it may affect the operation of the software. Please refer to the manual of the software to be used to avoid excessive load on the product. The main intended use of this product is as a gateway, so if you want MELIPC to perform advanced processing for monitoring purposes, we recommend using the higher series.

### 5.1.1. Initial setting

---



- Do not connect devices other than a keyboard and mouse until the OS setup is complete.
- This OS is a license for embedded use.  
When using this OS, install and use dedicated application or software developed for your system.

1. Turn on the power of the main unit.
2. Select a language.

You can select English, Chinese (simplified), or Japanese.

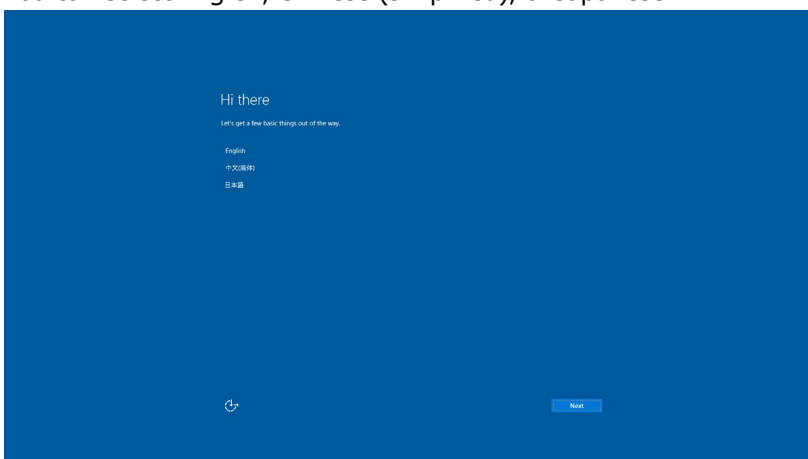

3. Select a country or region where this product will be used.

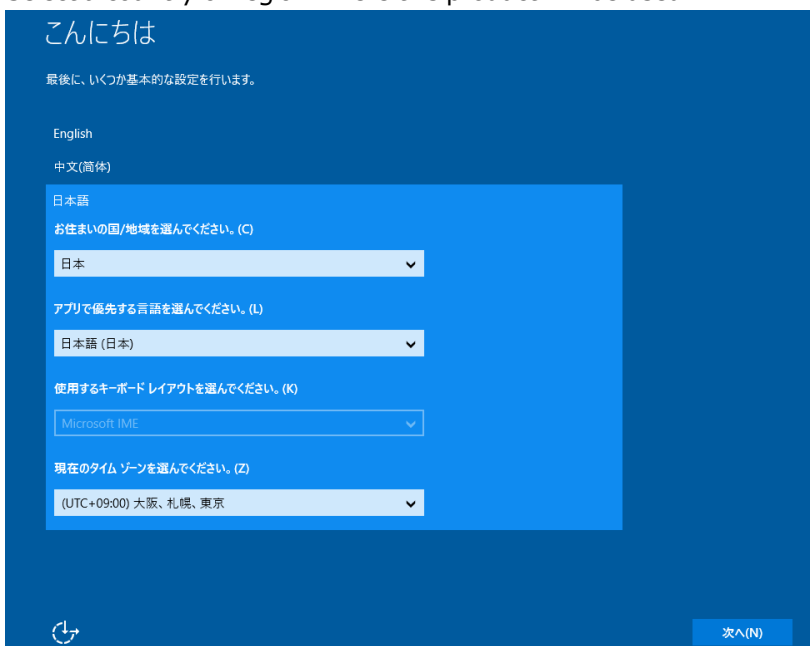

4. Create a user account.  
Enter a user name, password, and password hint, and click [Next].
5. The initial setting is performed automatically.  
\* It takes several minutes for the initial setting. The OS restarts, but do not press the power switch.
6. Once the desktop screen is displayed, the OS setup is complete.  
Install and use dedicated application or software developed for your system.

The initial setting is now complete.



When connecting to the Internet, performing a manual Windows Update is recommended to apply Security Update for Windows.  
After Windows Update, restart Windows manually if Windows recommends; otherwise, Security Update content may not be applied since an automatic restart after Windows Update is disabled in this product.

## 5.1.2. "Welcome to Windows" specifications

---

The image stored on the preinstallation or recovery medium is the image after running sysprep and generalize.

"Welcome to Windows" starts at the initial startup.

Item	Setting	
Language selection	Y	Displayed (Japanese, English, and Chinese (simplified))
EULA	Y	Displayed
Product key input	N	Not displayed
User creation	Y	Displayed
Automatic logon	Y	If a password is specified when creating a user account, automatic logon will not be performed.

## 5.1.3. Creating a recovery medium

---

In this product, the image file (*recovery.iso*) for creating a recovery medium is stored in the following folders:

C:\Recovery\_Media

The recovery medium allows you to return the system to the state at the time of purchase.

It is recommended to create a recovery medium in advance by using writing software.



- Prepare a blank single sided dual layer DVD with a capacity of 8.5 GB or more.
- At recovery using a recovery medium, the OS image for creating a recovery medium is not restored.

Therefore, save the created recovery medium in a safe place.

## 5.1.4. Windows 10 standard functions

---

This product does not support the following Windows 10 standard functions.

Therefore, do not use these functions.

- Push-Button Refresh
- Push-Button Reset
- Virtualization-based security (VBS)

To prevent an automatic restart of the Windows section by an automatic update of Windows Update while this product is in operation (a user is logged into the Windows section), change the following group policy from the Windows default settings.

Group policy	Setting after change
No auto-restart with logged on users for scheduled automatic updates installation	Enabled



## 5.2. Re-setup using a recovery medium

---

This section describes re-setup using a recovery medium.



- If you installed Edgecross basic software and SLMP data collector by mistake, you can re-install them by using each installation file stored in the following folders.

Edgecross basic software: C:\Recovery\_Media\BasicSoftware

SLMP data collector: C:\Recovery\_Media\DataCollector\SLMP

CC-Link IE TSN

C:\MELIPC\CCIETSNCommunicationSoftware

Communication Software:

If you erased these installation files, set up again by using the recovery medium.

- For the product ID of the pre-installed software, check the license agreement included with this product.
- CC-Link IE TSN Data Collector is bundled with CC-Link IE TSN Communication Software.

### 5.2.1. Re-setup flow

---

Set up the operating system again according to the flowchart below and by referring to this manual.

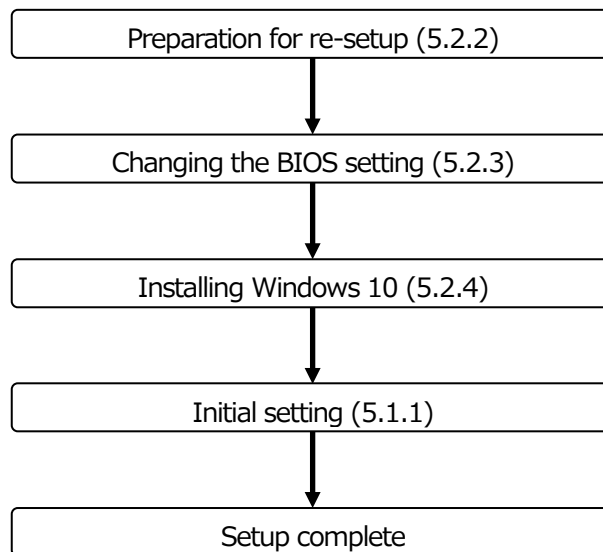

## 5.2.2. Preparation for re-setup

---

Before starting re-setup, prepare the following medium and manual.

- Recovery medium
- User's Manual (This manual)



- Do not connect any external storage device to the USB port other than the USB DVD drive to which the recovery medium is set.

## 5.2.3. Changing the BIOS setting

---

1. Insert the recovery medium in the USB DVD drive and connect the drive to the USB port of the main unit.
2. Turn on the power of the main unit.
3. Press the DEL key while the POST screen is displayed and start BIOS Setup Utility.
4. Shift to [Boot] and press the Enter key to select [Boot Option #1].
5. Press the Enter key to select [UEFI: (USB DVD drive name)].
6. Press the Esc key to return to [Boot] and move to [Save & Exit].
7. Press the Enter key to select [Save Changes and Reset]. Then the confirmation message is displayed. Select [Yes].

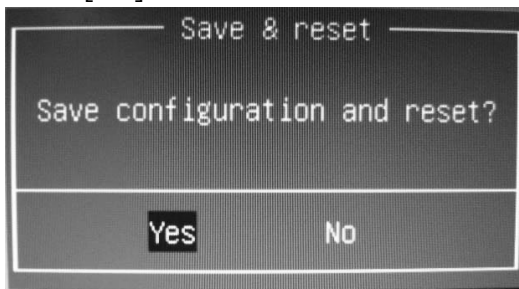

Next, install Windows 10.

## 5.2.4. Installing Windows 10

---

1. Start from the recovery medium.

When "Press any key to boot from CD or DVD..." is displayed, press the Enter key to start the system from the recovery medium.

2. When the command prompt starts and the following message is displayed, press the Y key.

Pressing the N key aborts the processing.

```
CAUTION: All the data on the disk will be DELETED.  
Erase all data and continue? (Y or N):
```

It takes 30 to 40 minutes for installation.

3. When the recovery is complete, the power of the main unit is turned off automatically.
4. Press the power switch of the main unit to turn on it.

The re-setup using a recovery medium is now complete.

Perform the initial setting according to 5.1.1 "Initial setting."

## 5.3. Event logs

### ■ System logs

ID	Source	Level	Message (Description)
10	Microsoft-Windows-WMI	Error	Event filter with query "select * from __InstanceModificationEvent where targetinstance isa '__ArbitratorConfiguration'" could not be reactivated in namespace "//./root" because of error 0x80041033. Events cannot be delivered through this filter until this problem is corrected.
			If this event log was registered only while installing the OS and the same event log has not been registered continuously, there is no problem.
24	Microsoft-Windows-WMI	Error	Event provider \$Core attempted to register query "select * from __NamespaceOperationEvent" whose target class "__NamespaceOperationEvent" in //./root/CIMV2 namespace does not exist. The query will be ignored.
			If this event log was registered only while installing the OS and the same event log has not been registered continuously, there is no problem.
27	e1repress	Warning	Intel(R) I210 Gigabit Network Connection (or "Intel(R) I210 Gigabit Network Connection #2") Network link is disconnected.
			If the same event log has not been registered continuously after network cables were connected (except at system startup), there is no problem.
56	Application Popup	Error	The description for Event ID 56 from source Application Popup cannot be found. Either the component that raises this event is not installed on your local computer or the installation is corrupted. You can install or repair the component on the local computer.  If the event originated on another computer, the display information had to be saved with the event.  The following information was included with the event:  ACPI 1  the message resource is present but the message is not found in the string/message table
			There is no problem in system operation.
134	Microsoft-Windows-Time-Service	Warning	NtpClient was unable to set a manual peer to use as a time source because of DNS resolution error on 'time.windows.com,0x9'. NtpClient will try again in 15 minutes and double the reattempt interval thereafter. The error was: No such host is known. (0x80072AF9)
			There is no problem in system operation.

7023	Service Control Manager	Error	The netprofm service terminated with the following error: The device is not ready.
	If this event log was registered only while installing the OS and the same event log has not been registered continuously, there is no problem.		
7023	Service Control Manager	Error	The iphlpsvc service terminated with the following error: The service cannot be started, either because it is disabled or because it has no enabled devices associated with it.
	If this event log was registered only while installing the OS and the same event log has not been registered continuously, there is no problem.		
10010	DistributedCOM	Error	The server ***** did not register with DCOM within the required timeout.
	For details, see the following website(*): <a href="http://support.microsoft.com/ja-jp/help/956479">support.microsoft.com/ja-jp/help/956479</a> *Since there is no English version on this page, please contact Microsoft Corporation for details.		
10016	DistributedCOM	Error	The application-specific permission settings do not grant Local Activation permission for the COM Server application with CLSID {6B3B8D23-FA8D-40B9-8DBD-B950333E2C52} and APPID {4839DDB7-58C2-48F5-8283-E1D1807D0D7D} to the user NT AUTHORITY\SYSTEM SID (S-1-5-18) from address LocalHost (using LRPC) running in the application container Unavailable SID (Unavailable). This security permission can be modified using the Component Services administrative tool.
	There is no problem in system operation.		
10016	DistributedCOM	Error	The application-specific permission settings do not grant Local Activation permission for the COM Server application with CLSID {C2F03A33-21F5-47FA-B4BB-156362A2F239} and APPID {316CDED5-E4AE-4B15-9113-7055D84DCC97} to the user NT AUTHORITY\SYSTEM SID (S-1-5-18) from address LocalHost (using LRPC) running in the application container Unavailable SID (Unavailable). This security permission can be modified using the Component Services administrative tool.
	There is no problem in system operation.		

■ Application logs

ID	Source	Level	Message (Description)
2	Microsoft-Windows-Search-ProfileNotify	Error	Unable to remove Windows Search Service indexed data for user '%1' in response to user profile deletion. Error code %2.
	If this event log was registered only while installing the OS and the same event log has not been registered continuously, there is no problem.		
16	SecurityCenter	Error	Error while updating Windows Defender status to SECURITY_PRODUCT_STATE_OFF (error 02000000).
	If this event log was registered only while installing the OS and the same event log has not been registered continuously, there is no problem.		
1008	Microsoft-Windows-Search	Warning	The Windows Search Service is starting up and attempting to remove the old search index {Reason: Full Index Reset}.
	If this event log was registered only while installing the OS and the same event log has not been registered continuously, there is no problem.		
1014	Microsoft-Windows-Security-SPP	Warning	Acquisition of End User License failed. hr=0x80072EE7 Sku ID=bd3762d7-270d-4760-8fb3-d829ca45278
	If this event log has not been registered continuously after license activation was complete, there is no problem.		
1534	Microsoft-Windows-User Profiles Service	Warning	Profile notification of event Delete for component {DE3F3560-3032-41B4-B6CF-F703B1B95640} failed, error code is *****.
	If this event log was registered only while installing the OS and the same event log has not been registered continuously, there is no problem.		
3104	Search	Error	Enumerating user sessions to generate filter pools failed. Details: ***** (HRESULT : 0x80040210) (0x80040210)
	If this event log was registered only while installing the OS and the same event log has not been registered continuously, there is no problem.		
8198	Security-SPP	Error	License Activation (SLUI.exe) failed with the following error code: hr=0x80072EE7
	If this event log has not been registered continuously after license activation was complete, there is no problem.		
8200	Security-SPP	Error	License acquisition failure details. hr=0x80072EE7
	If this event log has not been registered continuously after license activation was complete, there is no problem.		

■ Management event logs

ID	Source	Level	Message (Description)
	Action		
69	AppModel-Runtime	Error	Failed with 0x490 modifying AppModel Runtime status for package ***** for user ***** (current status = 0x0, desired status = 0x20).
	If this event log was registered only while installing the OS and the same event log has not been registered continuously, there is no problem.		
104	Client-Licensing	Warning	ClipSVC was restarted while there is a pending rearm reboot required. Caller: TriggerStarted
	If this event log was registered only while installing the OS and the same event log has not been registered continuously, there is no problem.		
200	DeviceSetupManager	Warning	A connection to the Windows Update service could not be established.
	If this event log was not registered after connecting to the internet, there is no problem in system operation.		
201	DeviceSetupManager	Warning	A connection to Windows Metadata and Internet Services (WMIS) could not be established.
	If this event log was not registered after connecting to the internet, there is no problem in system operation.		
202	DeviceSetupManager	Warning	The Network List Manager reports no connectivity to the internet.
	If this event log was not registered after connecting to the internet, there is no problem in system operation.		
506	DeviceManagement-Pushrouter	Warning	DmWapPushService: Failed to register WNF with EventAggregator for WAP messages received by SMS Router. Result: (0xC0020036)
	If this event log was registered only while installing the OS and the same event log has not been registered continuously, there is no problem.		

## 6. Licenses

---

Part of this product (system BIOS) includes open source software with the following licenses.

- EDK from Tianocore.org
- UEFI Network Stack 2
- Crypto package using WPA Supplicant
- UEFI Shell

### License statements

---

#### **EDK FROM TIANOCORE.ORG**

BSD License from Intel

Copyright (c) 2012, Intel Corporation

All rights reserved.

Redistribution and use in source and binary forms, with or without modification, are permitted provided that the following conditions are met:

- Redistributions of source code must retain the above copyright notice, this list of conditions and the following disclaimer.
- Redistributions in binary form must reproduce the above copyright notice, this list of conditions and the following disclaimer in the documentation and/or other materials provided with the distribution.
- Neither the name of the Intel Corporation nor the names of its contributors may be used to endorse or promote products derived from this software without specific prior written permission.

THIS SOFTWARE IS PROVIDED BY THE COPYRIGHT HOLDERS AND CONTRIBUTORS "AS IS" AND ANY EXPRESS OR IMPLIED WARRANTIES, INCLUDING, BUT NOT LIMITED TO, THE IMPLIED WARRANTIES OF MERCHANTABILITY AND FITNESS FOR A PARTICULAR PURPOSE ARE DISCLAIMED. IN NO EVENT SHALL THE COPYRIGHT OWNER OR CONTRIBUTORS BE LIABLE FOR ANY DIRECT, INDIRECT, INCIDENTAL, SPECIAL, EXEMPLARY, OR CONSEQUENTIAL DAMAGES (INCLUDING, BUT NOT LIMITED TO, PROCUREMENT OF SUBSTITUTE GOODS OR SERVICES; LOSS OF USE, DATA, OR PROFITS; OR BUSINESS INTERRUPTION) HOWEVER CAUSED AND ON ANY THEORY OF LIABILITY, WHETHER IN CONTRACT, STRICT LIABILITY, OR TORT (INCLUDING NEGLIGENCE OR OTHERWISE) ARISING IN ANY WAY OUT OF THE USE OF THIS SOFTWARE, EVEN IF ADVISED OF THE POSSIBILITY OF SUCH DAMAGE.

Copyright (c) 2004 - 2007, Intel Corporation

All rights reserved. This program and the accompanying materials are licensed and made available under the terms and conditions of the BSD License which accompanies this distribution. The full text of the license may be found at <https://opensource.org/licenses/bsd-license.php>

THE PROGRAM IS DISTRIBUTED UNDER THE BSD LICENSE ON AN "AS IS" BASIS, WITHOUT WARRANTIES OR REPRESENTATIONS OF ANY KIND, EITHER EXPRESS OR IMPLIED.



## UEFI NETWORK STACK 2

OpenSSL License

-----

Copyright (c) 1998-2011 The OpenSSL Project. All rights reserved.

Redistribution and use in source and binary forms, with or without modification, are permitted provided that the following conditions are met:

1. Redistributions of source code must retain the above copyright notice, this list of conditions and the following disclaimer.
2. Redistributions in binary form must reproduce the above copyright notice, this list of conditions and the following disclaimer in the documentation and/or other materials provided with the distribution.
3. All advertising materials mentioning features or use of this software must display the following acknowledgment:  
"This product includes software developed by the OpenSSL Project for use in the OpenSSL Toolkit. (<https://www.openssl.org/>)"
4. The names "OpenSSL Toolkit" and "OpenSSL Project" must not be used to endorse or promote products derived from this software without prior written permission. For written permission, please contact [openssl-core@openssl.org](mailto:openssl-core@openssl.org).
5. Products derived from this software may not be called "OpenSSL" nor may "OpenSSL" appear in their names without prior written permission of the OpenSSL Project.
6. Redistributions of any form whatsoever must retain the following acknowledgment:  
"This product includes software developed by the OpenSSL Project for use in the OpenSSL Toolkit (<https://www.openssl.org/>)"

THIS SOFTWARE IS PROVIDED BY THE OpenSSL PROJECT ``AS IS'' AND ANY EXPRESSED OR IMPLIED WARRANTIES, INCLUDING, BUT NOT LIMITED TO, THE IMPLIED WARRANTIES OF MERCHANTABILITY AND FITNESS FOR A PARTICULAR PURPOSE ARE DISCLAIMED. IN NO EVENT SHALL THE OpenSSL PROJECT OR ITS CONTRIBUTORS BE LIABLE FOR ANY DIRECT, INDIRECT, INCIDENTAL, SPECIAL, EXEMPLARY, OR CONSEQUENTIAL DAMAGES (INCLUDING, BUT NOT LIMITED TO, PROCUREMENT OF SUBSTITUTE GOODS OR SERVICES; LOSS OF USE, DATA, OR PROFITS; OR BUSINESS INTERRUPTION) HOWEVER CAUSED AND ON ANY THEORY OF LIABILITY, WHETHER IN CONTRACT, STRICT LIABILITY, OR TORT (INCLUDING NEGLIGENCE OR OTHERWISE) ARISING IN ANY WAY OUT OF THE USE OF THIS SOFTWARE, EVEN IF ADVISED OF THE POSSIBILITY OF SUCH DAMAGE.

This product includes cryptographic software written by Eric Young ([eay@cryptsoft.com](mailto:eay@cryptsoft.com)).

This product includes software written by Tim Hudson ([tjh@cryptsoft.com](mailto:tjh@cryptsoft.com)).

## CRYPTO PACKAGE USING WPA SUPPLICANT

WPA SupPLICant

-----

Copyright (c) 2003-2012, Jouni Malinen <j@w1.fi> and contributors  
All Rights Reserved.

This program is licensed under the BSD license (the one with advertisement clause removed).  
If you are submitting changes to the project, please see CONTRIBUTIONS file for more instructions.

License

-----

This software may be distributed, used, and modified under the terms of  
BSD license:

Redistribution and use in source and binary forms, with or without modification, are permitted  
provided that the following conditions are met:

1. Redistributions of source code must retain the above copyright notice, this list of conditions and the following disclaimer.
2. Redistributions in binary form must reproduce the above copyright notice, this list of conditions and the following disclaimer in the documentation and/or other materials provided with the distribution.
3. Neither the name(s) of the above-listed copyright holder(s) nor the names of its contributors may be used to endorse or promote products derived from this software without specific prior written permission.

THIS SOFTWARE IS PROVIDED BY THE COPYRIGHT HOLDERS AND CONTRIBUTORS "AS IS" AND ANY EXPRESS OR IMPLIED WARRANTIES, INCLUDING, BUT NOT LIMITED TO, THE IMPLIED WARRANTIES OF MERCHANTABILITY AND FITNESS FOR A PARTICULAR PURPOSE ARE DISCLAIMED. IN NO EVENT SHALL THE COPYRIGHT OWNER OR CONTRIBUTORS BE LIABLE FOR ANY DIRECT, INDIRECT, INCIDENTAL, SPECIAL, EXEMPLARY, OR CONSEQUENTIAL DAMAGES (INCLUDING, BUT NOT LIMITED TO, PROCUREMENT OF SUBSTITUTE GOODS OR SERVICES; LOSS OF USE, DATA, OR PROFITS; OR BUSINESS INTERRUPTION) HOWEVER CAUSED AND ON ANY THEORY OF LIABILITY, WHETHER IN CONTRACT, STRICT LIABILITY, OR TORT (INCLUDING NEGLIGENCE OR OTHERWISE) ARISING IN ANY WAY OUT OF THE USE OF THIS SOFTWARE, EVEN IF ADVISED OF THE POSSIBILITY OF SUCH DAMAGE.

## UEFI Shell

UEFI Shell

Copyright (c) 2012, Intel Corporation

All rights reserved.

Redistribution and use in source and binary forms, with or without modification, are permitted provided that the following conditions are met:

- Redistributions of source code must retain the above copyright notice, this list of conditions and the following disclaimer.
- Redistributions in binary form must reproduce the above copyright notice, this list of conditions and the following disclaimer in the documentation and/or other materials provided with the distribution.

THIS SOFTWARE IS PROVIDED BY THE COPYRIGHT HOLDERS AND CONTRIBUTORS "AS IS" AND ANY EXPRESS OR IMPLIED WARRANTIES, INCLUDING, BUT NOT LIMITED TO, THE IMPLIED WARRANTIES OF MERCHANTABILITY AND FITNESS FOR A PARTICULAR PURPOSE ARE DISCLAIMED. IN NO EVENT SHALL THE COPYRIGHT OWNER OR CONTRIBUTORS BE LIABLE FOR ANY DIRECT, INDIRECT, INCIDENTAL, SPECIAL, EXEMPLARY, OR CONSEQUENTIAL DAMAGES (INCLUDING, BUT NOT LIMITED TO, PROCUREMENT OF SUBSTITUTE GOODS OR SERVICES; LOSS OF USE, DATA, OR PROFITS; OR BUSINESS INTERRUPTION) HOWEVER CAUSED AND ON ANY THEORY OF LIABILITY, WHETHER IN CONTRACT, STRICT LIABILITY, OR TORT (INCLUDING NEGLIGENCE OR OTHERWISE) ARISING IN ANY WAY OUT OF THE USE OF THIS SOFTWARE, EVEN IF ADVISED OF THE POSSIBILITY OF SUCH DAMAGE.

## 7. Daily maintenance

---

Perform the checks and maintenance described here on a regular basis so that you can always use this product in optimum condition.

Should you encounter any abnormalities, do not use this product forcibly but ask your sales agent or maintenance service company for maintenance.

### **Backup**

It is recommended that you back up important data in this product on a regular basis using commercially available backup tools. See the backup tool's instructions or other reference materials for the devices and conditions required for backup.

## 8. Troubleshooting

---

If this product does not operate as expected, check the product by referring to the following checklist before submitting it for repair.

If there is a problem that corresponds to the following list, try the suggested countermeasure method.

If this product still does not work properly, record the message displayed on the display and contact your sales agent or maintenance service company.

### **It is not possible to turn on the power.**

Are the power cable and AC adapter connected correctly ?

⇒ Check the power switch and POWER LED on the front panel.

If the POWER LED lights red, press the power switch to turn on the power of the main unit.

If the POWER LED is off, the power cable and AC adapter may not be connected correctly.

### **Communication via LAN/RS232C/RS485 is not possible.**

Is the main unit turned on ?

⇒ Check the power switch and POWER LED on the front panel.

If the POWER LED lights red, press the power switch to turn on the power of the main unit.

If the POWER LED is off, the power cable and AC adapter may not be connected correctly.

Is the interface cable connected correctly?

Is the FG cable connected correctly?

⇒ The interface and FG cables may not be connected correctly.

### **Unable to register the Edgexross basic software user.**

Are you using the product ID listed in the Edgexross Basic Software License Agreement included with this product?

⇒ Please register as a user using the product ID described in the Edgexross Basic Software License Agreement included with this product.

### **Windows activation is not active.**

Have you tried the Activation troubleshooter tool?

⇒ Please try [Troubleshoot] in the screen displayed by clicking [Start] > [Settings] > [Update & Security] > [Activation]. This may solve the problem.

## 9. Product specifications

Item		Edge Gateway
CPU		Intel® Atom™ Processor E3826 (1.46GHz)
	Number of processors	1
	CPU core	Dual core
	Cooling method	Heat sink (Fanless)
Memory	Type	DDR3L SDRAM
	Capacity	4 GB
	Error detection & correction	Non-ECC
	Operation clock	1066 MHz
	Buffer function	None
Storage	Type	eMMC mSATA SSD
	Capacity	eMMC: 4 GB mSATA SSD: 60 GB
Network (wired)		1000BASE-T/100BASE-TX/10BASE-T (Compatible with AutoMDI/MDI-X)
Interface	USB	USB 2.0 compliant (Type-A) x 4 (front panel)
	LAN	RJ45 x 2 (front panel)
	Display	HDMI (Type-A, 1.4a) x 1 (front panel)
	Serial	RS-232C x 2 (rear panel) 2.5kV withstand voltage RS-485 x 1 (rear panel) 2.5kV withstand voltage
Size		Width: 186 mm, Height: 26mm, Depth: 150 mm
Weight		Approx. 0.90 kg (excluding the AC adapter) / Approx. 1.3 kg (including the AC adapter)
OS		Windows10 IoT Enterprise 2016 LTSB 64bit
Power supply (AC adapter)		AC100 to 264V *1, 50/60Hz±3Hz
Power consumption (Max.)		35 W
Temperature & humidity <i>Température &amp; humidité</i>		Operating: 0°C to 55°C / 10% to 85% (No condensation) Storage: -20°C to 75°C / 10% to 85% (No condensation) <i>Fonctionnement: 0°C à 55°C / 10% à 85% (Sans condensation)</i> <i>Stockage: -20°C à 75°C / 10% à 85% (Sans condensation)</i>

\*1: The power cable supplied with this product(Only MI1002-W) is compatible with AC 100V and available for use in Japan only. Be sure to connect the power cable to a 100V outlet. When using this product in a country or region other than Japan, prepare the power cable corresponding to the power supply of the country or region where this product is used.

# 10. EMC Directive and Low Voltage Directive

---

In each country, laws and regulations concerning electromagnetic compatibility (EMC) and electrical safety are enacted.

For the products sold in the European countries, compliance with the EU's EMC Directive has been a legal obligation as EMC regulation since 1996, as well as the EU's Low Voltage Directive as electrical safety regulation since 1997.

Manufacturers who recognize their products are compliant with the EMC and Low Voltage Directives are required to attach a "CE marking" on their products in European countries.

In some other countries and regions, manufacturers are required to make their products compliant with applicable laws or regulations and attach a certification mark on the products as well (such as UK Conformity Assessed (UKCA) marking in the UK, and Korea Certification (KC) marking in South Korea).

Each country works to make their regulatory requirements consistent across countries based on international standards. When the requirements are consistent, measures to comply with the EMC and electrical safety regulations become common across countries.

The UK and South Korea have enacted EMC regulations whose requirements are consistent with those of the EMC Directive.

The UK has also enacted electrical safety regulations whose requirements are consistent with those of the Low Voltage Directive. In this section, the requirements of the EMC and Low Voltage Directives are described as examples of those of the EMC and electrical safety regulations.

## Requirements for complying with the EMC Directive

The EMC Directive requires products **not to emit excessive electromagnetic waves to outside (emission or electromagnetic interference)** and also **not to be affected by external electromagnetic waves (immunity or electromagnetic susceptibility)**.

This product complies with the following standards.

For the methods to comply with the EMC Directive and to judge conformity of the mechanical device equipped with this product, the manufacturer must make a final judgment.

## Standards related to the EMC Directive

Item	Corresponding standard
Emission	EN 55032:2015/A11:2020
Immunity	EN 55035:2017/A11:2020
Power harmonic	EN 61000-3-2:2014 (Class A)

## Requirements for complying with the Low Voltage Directive

The Low Voltage Directive directs that the necessary safety is ensured for equipment driven by AC 50 to 100 V or DC 75 to 1500 V power supply.

This section describes the cautions for using this product in accordance with the Low Voltage Directive.

The following description is created based on the regulatory requirements and standards that MITSUBISHI ELECTRIC CORPORATION has obtained. However, MITSUBISHI ELECTRIC CORPORATION does not guarantee that the entire mechanical device manufactured according to the following description conforms to the Low Voltage Directive. For the methods to comply with the Low Voltage Directive and to judge conformity, the manufacturer must make a final judgment.

### Standard applicable to this product

EN60950-1 Information technology equipment - Safety - Part 1: General requirements  
(Applicable until November 2020 production)

EN62368-1 Audio/Video, Information and Communication Technology Equipment - Part 1: Safety Requirements  
(Applicable from December 2020 production)

### Applicable scope of this product

#### ■ AC adapter

Since hazardous voltage (whose peak is greater than 42.4V) is flowing inside this product, there is reinforced insulation between the primary circuit and secondary circuit in a CE marking compliant product.

#### ■ Main body

Since the circuit used in the main body is DC 24 V rating or less, the main body is not subject to the Low Voltage Directive.

### Power supply

The insulation specifications of the AC adapter assume Installation Category II.

The power supply for this product must conform to Installation Category II.



## Installation location

### ■ Protection against electric shock

Take measures necessary to protect users who do not have sufficient knowledge about electrical equipment from the risk of electric shock at the installation location of this product.

Examples of measures are as follows:

- Restrict access to this product so that only users who received training and have sufficient knowledge of electrical equipment can operate this product.
- As a measure against electric shock, install this product in a protective structure (control board etc.) with an IP rating of 20 or higher.

### ■ Dustproof and waterproof

If this product is installed in an environment where dustproofing and waterproofing is not sufficient, the dielectric withstand voltage decreases and dielectric breakdown tends to occur.

Since insulation of this product is designed assuming Pollution Degree 2 (Normally only nonconductive pollution occurs. Temporary conductivity caused by condensation is to be expected. For example, a general office), use it in an environment of Pollution Degree 2 or lower.

## Grounding

Use this product by connecting the FG cable attached to this product to the functional grounding screw of the main body.

## External wiring

### ■ External connection equipment

If external equipment to be connected to this product contains a hazardous voltage circuit, use a reinforced insulated interface circuit from a hazardous voltage circuit.

### ■ Reinforced insulation

This is insulation to withstand voltage below.

Rated voltage of the hazardous voltage part	Surge resistant voltage (1.2/50 $\mu$ s)
AC 150 V or less	2500 V
AC 300 V or less	4000 V

(Installation Category II, quoted from IEC 664)

# 11. Batteries and battery embedded equipment in EU member states

---

This chapter describes the cautions on disposal of used batteries in the EU member states and exporting batteries and battery embedded equipment to the EU member states.

## Caution on disposal

Since used batteries must be disposed of separately from normal household waste in the EU member states, be sure to dispose of used batteries correctly so that they are processed at a garbage disposal or recycling center in each region.

The following crossed-out wheeled bin symbol is attached on batteries and battery embedded equipment. This symbol indicates that the products must be disposed of separately from normal household waste.



This symbol is only for the EU member states.

This symbol is specified in Article 20 "End-user information" and annex of "Directive 2006/66/EU on Batteries and Accumulators and Waste Batteries and Accumulators."

## Cautions on exporting

With the enforcement of the new EU Battery Directive (2006/66/EC), the following are obligatory when selling or exporting batteries and battery embedded equipment in the EU member states.

- Display of the crossed-out wheeled bin symbol on a battery, equipment, or package.
- Description of the crossed-out wheeled bin symbol in manuals

### ■ Display of the crossed-out wheeled bin symbol

When selling or exporting batteries and battery embedded equipment to which no crossed-out wheeled bin symbol is displayed to the EU member states, be sure to display the symbol on the equipment body or on the package of the equipment.

### ■ Description of the crossed-out wheeled bin symbol in a manual

When exporting equipment incorporating this product to the EU member states without attaching the manuals of this product, be sure to describe the crossed-out wheeled bin symbol in manuals of the equipment to be exported.

## 12. Appendix

### Appendix 1: Notice for Waste Electrical and Electronic Equipment Directive in Europe

#### Disposing of used product

##### In the European Union



EU-wide legislation as implemented in each Member State requires that used electrical and electronic products carrying the mark (left) must be disposed of separately from normal household waste. This includes electrical accessories. When disposing of used products, you should comply with applicable legislation or agreements you may have. The mark on the electrical and electronic products may only apply to the current European Union Member States.

##### Outside the European Union

If you wish to dispose of used electrical and electronic products outside the European Union, please contact your local authority and ask for the correct method of disposal.

### Appendix 2: Notice for the China RoHS and China Standard Act

#### 「电器电子产品有害物质限制使用标识要求」的表示方式



Note: This symbol mark is for China only.

#### 含有有害6物质的名称, 含有量, 含有部品

本产品的所含有的有害6物质的名称, 含有量, 含有部品如下表所示。

产品中有害物质的名称及含量

部件名称	有害物质					
	铅 (Pb)	汞 (Hg)	镉 (Cd)	六价铬 (Cr(VI))	多溴联苯 (PBB)	多溴二苯醚 (PBDE)
印刷电路板	×	○	○	○	○	○
外壳	○	○	○	○	○	○
RTC Battery (纽扣电池)	○	○	○	○	○	○
电源	×	○	○	○	○	○
其他 (电缆、连接器等)	×	○	○	○	○	○

本表格依据SJ/T 11364 的规定编制。

○：表示该有害物质在该部件所有均质材料中的含量均在GB/T 26572 规定的限量要求以下。

×：表示该有害物质至少在该部件的某一均质材料中的含量超出GB/T 26572规定的限量要求。

基于中国标准法的参考规格: GB4943.1

### Appendix 3: Notice for the Chinese Taipei RoHS

#### 限用物質含有情況標示聲明書

#### Declaration of the Presence Condition of the Restricted Substances Marking

設備名稱：電腦，型號（型式）：EGW001-003							
單元 Unit	限用物質及其化學符號 Restricted substances and its chemical symbols						
	鉛 Lead (Pb)	汞 Mercury (Hg)	鎘 Cadmium (Cd)	六價鉻 Hexavalent chromium (Cr(VI))	多溴聯苯 Polybrominated biphenyls (PBB)	多溴二苯醚 Polybrominated diphenyl ethers (PBDE)	相對應排除 項目依據 (D1~D37)
電路板	○	○	○	○	○	○	-
外殼	○	○	○	○	○	○	-
RTC Battery (鈕扣電池)	○	○	○	○	○	○	-
電源供應器	-	○	○	○	○	○	D13,D14,D16
配件 (線材、端子等)	-	○	○	○	○	○	D13
<p>備考 1：「超出 0.1 %」及「超出 0.01 %」係指限用物質之百分比含量超出百分比含量基準值。                      Note 1: "Exceeding 0.1 wt %" and "exceeding 0.01 wt %" indicate that the percentage content of the restricted substance exceeds the reference percentage value of presence condition.</p> <p>備考 2：「○」係指該項限用物質之百分比含量未超出百分比含量基準值。                      Note 2: "○" indicates that the percentage content of the restricted substance does not exceed the percentage of reference value of presence.</p> <p>備考 3：「-」係指該項限用物質為排除項目。                      Note 3: The "-" indicates that the restricted substance corresponds to the exemption.</p>							



廢電池請回收

# WARRANTY

---

Please confirm the following product warranty details before using this product.

## **1. Gratis Warranty Term and Gratis Warranty Range**

If any faults or defects (hereinafter "Failure") found to be the responsibility of Mitsubishi occurs during use of the product within the gratis warranty term, the product shall be repaired at no cost via the sales representative or Mitsubishi Service Company.

However, if repairs are required onsite at domestic or overseas location, expenses to send an engineer will be solely at the customer's discretion. Mitsubishi shall not be held responsible for any re-commissioning, maintenance, or testing on-site that involves replacement of the failed module.

### **[Gratis Warranty Term]**

The gratis warranty term of the product shall be for one year after the date of purchase or delivery to a designated place.

Note that after manufacture and shipment from Mitsubishi, the maximum distribution period shall be six (6) months, and the longest gratis warranty term after manufacturing shall be eighteen (24) months.

The gratis warranty term of repair parts shall not exceed the gratis warranty term before repairs.

### **[Gratis Warranty Range]**

(1).The range shall be limited to normal use within the usage state, usage methods and usage environment, etc., which follow the conditions and precautions, etc., given in the instruction manual, user's manual and caution labels on the product.

(2).Even within the gratis warranty term, repairs shall be charged for in the following cases.

1. Failure occurring from inappropriate storage or handling, carelessness or negligence by the user.  
Failure caused by the user's hardware or software design.
2. Failure caused by unapproved modifications, etc., to the product by the user.
3. When the Mitsubishi product is assembled into a user's device, Failure that could have been avoided if functions or structures, judged as necessary in the legal safety measures the user's device is subject to or as necessary by industry standards, had been provided.
4. Failure that could have been avoided if consumable parts (battery, backlight, fuse, etc.) designated in the instruction manual had been correctly serviced or replaced.
5. Failure caused by external irresistible forces such as fires or abnormal voltages, and Failure caused by force majeure such as earthquakes, lightning, wind and water damage.
6. Failure caused by reasons unpredictable by scientific technology standards at time of shipment from Mitsubishi.
7. Any other failure found not to be the responsibility of Mitsubishi or that admitted not to be so by the user.

## **2. Onerous repair term after discontinuation of production**

(1).Mitsubishi shall accept onerous product repairs for five (5) years after production of the product is discontinued. Discontinuation of production shall be notified with Mitsubishi Technical Bulletins, etc.

(2).Product supply (including repair parts) is not available after production is discontinued.

## **3. Overseas service**

Overseas, repairs shall be accepted by Mitsubishi's local overseas FA Center.

Note that the repair conditions at each FA Center may differ.

## **4. Exclusion of loss in opportunity and secondary loss from warranty liability**

Regardless of the gratis warranty term, Mitsubishi shall not be liable for compensation to:

- (1).Damages caused by any cause found not to be the responsibility of Mitsubishi.
- (2).Loss in opportunity, lost profits incurred to the user by Failures of Mitsubishi products.
- (3).Special damages and secondary damages whether foreseeable or not, compensation for accidents, and compensation for damages to products other than Mitsubishi products.
- (4).Replacement by the user, maintenance of on-site equipment, start-up test run and other tasks.

## **5. Changes in product specifications**

The specifications given in the catalogs, manuals or technical documents are subject to change without prior notice.

# REVISIONS

---

\* The manual number is given on the bottom left of the back cover.

Revision date	*Manual number	Description
May, 2018	SH-081992ENG-A	First edition
Jan, 2019	SH-081992ENG-B	■ Added model MI1002-W-CL ■ Added or modified parts Safety Notes, Warning Labels, Handling Precautions, Precautions for Transfer or Disposal of This Product, Cautions for Transportation by Air or Sea, Notes on Microsoft Products, Preface, Section 1,2,3,4.1,4.2,5.1,5.2,5.3,6,9,12 Appendix 2,3
July, 2020	SH-081992ENG-C	■ Added or modified parts Conditions of Use for the Product, Security Precautions
Feb, 2021	SH-081992ENG-D	■ Added or modified parts Section 5.1 Setup, Section 5.2 Re-setup using a recovery medium Section 8 Troubleshooting, Section 10 Standard applicable to this product
Jun, 2022	SH-081992ENG-E	■ Added or modified parts Section 1 Components, Section 5.1 Setup, Section 5.2 Re-setup using a recovery medium, Section 8 Troubleshooting Section 10 EMC Directive and Low Voltage Directive

---

This manual confers no industrial property rights or any rights of any other kind, nor does it confer any patent licenses. Mitsubishi Electric Corporation cannot be held responsible for any problems involving industrial property rights which may occur as a result of using the contents noted in this manual.

---

© 2018 MITSUBISHI ELECTRIC CORPORATION

## TRADEMARKS

---

Ethernet is a trademark of Xerox Corporation.

HDMI, High-Definition Multimedia Interface, and the HDMI Logo are trademarks or registered trademarks of HDMI Licensing Administrator, Inc. in the United States and other countries.

Intel and Intel Atom are trademarks of Intel Corporation in the United States and other countries.

Microsoft and Windows are registered trademarks of Microsoft Corporation in the United States and other countries.

The company names, system names and product names mentioned in this manual are either registered trademarks or trademarks of their respective companies.

In some cases, trademark symbols such as "™" or "®" are not specified in this manual.



SH(NA)-081992ENG-E(2206)  
MODEL:MELIPC-MI1002-U-E

## **mitsubishi electric corporation**

HEAD OFFICE : TOKYO BUILDING, 2-7-3 MARUNOUCHI, CHIYODA-KU, TOKYO 100-8310, JAPAN  
NAGOYA WORKS : 1-14, YADA-MINAMI 5-CHOME, HIGASHI-KU, NAGOYA, JAPAN

When exported from Japan, this manual does not require application to the  
Ministry of Economy, Trade and Industry for service transaction permission.

Specifications subject to change without notice.