



Quick Start Guide

NE200/NE300

Variable Speed AC drive





www.drive-setup.com

Part Number: 31019007
Issue: 2

1. Safety Precautions

1.1 Description of safety marks

 **Warning:** A Warning contains information which is essential for avoiding a safety hazard.

 **Caution:** A Caution contains information which is necessary for avoiding a risk of damage to the product or other equipment.

1.2 Use

Warning

- This series of inverter is used to control the variable speed operation of three-phase motor and cannot be used for single-phase motor or other applications. Otherwise, inverter failure or fire may be caused.
- This series of inverter cannot be simply used in the applications directly related to the human safety, such as medical equipment.
- This series of inverter is produced under strict quality management system. Redundancy or bypass solution is necessary if the inverter failure may cause severe accident or loss.

1.3 Installation

Caution

- If the inverter is found to be damaged or parts missing, the inverter cannot be installed. Otherwise, accident may be caused.
- When handling and installing the product, please hold the product from bottom. Do not hold the enclosure only. Otherwise, your feet may be injured and the inverter may be damaged because of dropping.
- The inverter shall be mounted on the fire retardant surface, such as metal, and kept far away from the inflammables and heat source.
- Keep the drilling scraps from falling into the inside of the inverter during the installation; otherwise, inverter failure may be caused.
- When the inverter is installed inside the cabinet, the electricity

control cabinet shall be equipped with fan and ventilation port. And ducts for radiation shall be constructed in the cabinet.

1.4 Wiring

Warning

- The wiring must be conducted by qualified electricians. Otherwise, there exists the risk of electric shock or inverter damage.
- Before wiring, confirm that the power supply is disconnected. Otherwise, there exists the risk of electric shock or fire.
- The grounding terminal PE must be reliably grounded, otherwise, the inverter enclosure may become conductive.
- To ensure the safety, the inverter and the motor must be grounded. Please do not touch the main circuit terminal. The wires of the inverter main circuit terminals must not contact the enclosure. Otherwise, there exists the risk of electric shock.
- The connecting terminals for the braking resistor are (+) and PB. Please do not connect terminals other than these two. Otherwise, fire may be caused.

Caution

- The power supply cannot connect to output terminals U-V-W, otherwise, the inverter will be damaged.
- It is forbidden to connect the output terminal of the inverter to the capacitor or LC/RC noise filter with phase lead, otherwise, the internal components of the inverter may be damaged
- Please confirm that the power supply phases, rated voltage are consistent with that of the nameplate, otherwise, the inverter may be damaged.
- The wires of the main circuit terminals and the wires of the control circuit terminals shall be laid separately or in a square-crossing mode, otherwise, the control signal may be interfered.
- When the length of the cables between the inverter and the motor is more than 100m, it is suggested to use output reactor to avoid

the inverter failure caused by the over-current of the distribution capacitor.



- The inverter which equipped with DC reactor must connect with DC reactor between the terminal of P1、 (+) otherwise the inverter will not display after power on.

1.5 Operation

Warning

- Power supply can only be connected after the wiring is completed and the cover is installed. It is forbidden to remove the cover in live condition; otherwise, there exists the risk of electric shock.
- When auto failure reset function or restart function is set, isolation measures shall be taken for the mechanical equipment, otherwise, personal injury may be caused.
- When the inverter is powered on, even when it is in the stop state, the terminals of the inverter are still live. Do not touch the inverter terminals; otherwise electric shock may be caused.
- The failure and alarm signal can only be reset after the running command has been cut off. Otherwise, personal injury may be caused.

Caution

- Do not start or shut down the inverter by switching on or off the power supply, otherwise the inverter may be damaged.
- Before operation, please confirm if the motor and equipment are in the allowable use range, otherwise, the equipment may be damaged.
- The heat sink and the braking resistor have high temperature. Please do not touch such devices; otherwise, you may be burnt.
- When it is used on lifting equipment, mechanical contracting brake shall also be equipped.
- Please do not change the inverter parameter randomly. Most of the factory set parameters of the inverter can meet the operating requirement, and the user only needs to set some necessary parameters. Any random change of the parameter may cause the

damage of the mechanical equipment.

- In the applications with mains frequency and variable frequency switching, the two contactors for controlling the mains frequency and variable frequency switching shall be interlocked.

1.6 Maintenance & Inspection

Warning

- In the power-on state, please do not touch the inverter terminals; otherwise, there exists the risk of electric shock.
- If cover is to be removed, the power supply must be disconnected first.
- Wait for at least 10 minutes after power off or confirm that the CHARGE indicator is off before maintenance and inspection to prevent the harm caused by the residual voltage of the main circuit electrolytic capacitor to persons.
- The components shall be maintained, inspected or replaced by qualified electricians.

Caution

- The circuit boards have large scale CMOS IC. Please do not touch the board to avoid the circuit board damage caused by static electricity.

2. Introduction to NE200&300

2.1 Product Model Description

The digits and letters of the inverter model number on the nameplate indicate information such as product series, voltage grade, power ratings and hardware versions.

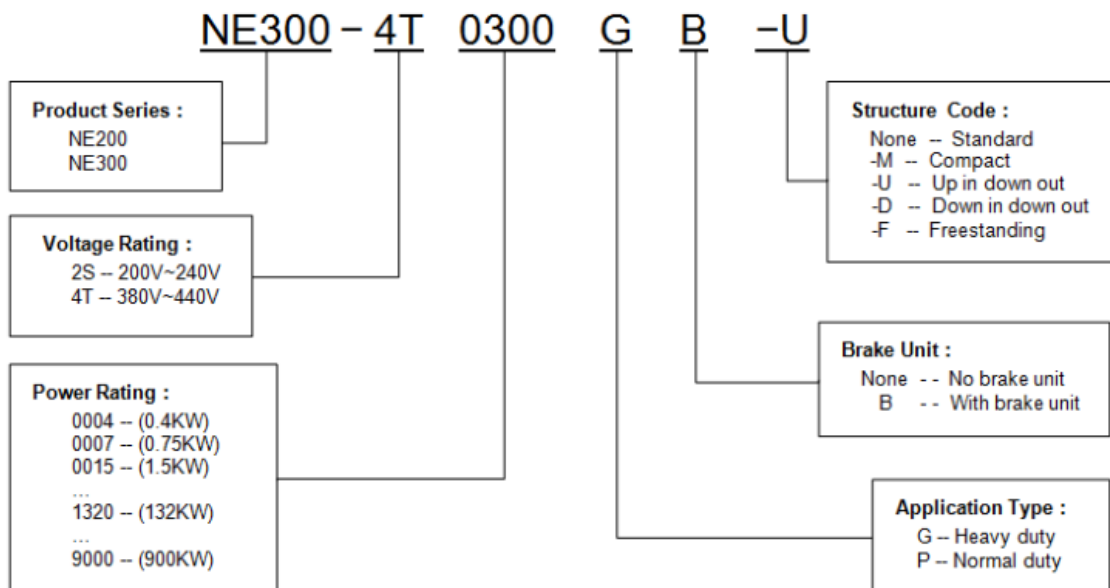

Fig.2-1 Product Model Description

2.2 Product Nameplate Description

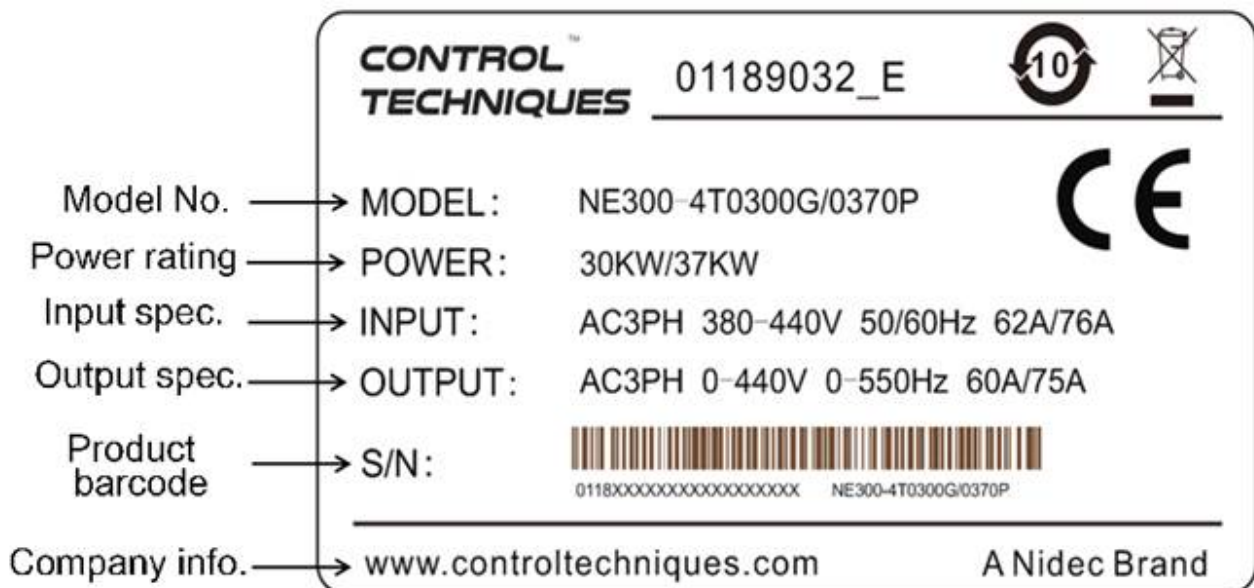

Fig.2-2 Product Nameplate Description

2.3 Product Series

2.3.1 NE200 Product Series

- **NE200-4T□□□□GB** Three-phase 400V Constant torque/heavy-duty application

Power (kW)		0.75	1.5	2.2	4.0
Adapted motor (kW)		0.75	1.5	2.2	4.0
Output	Voltage (V)	3phase 0~rated input voltage			
	Rated current (A)	2.5	4.0	6.0	9.0
	Overload capability	150% 1min; 180% 20sec.			
Input	Rated voltage/frequency	3phase 380V/440V; 50Hz/60Hz			
	Voltage range	304V~456V; voltage imbalance ≤3%; Allowable frequency fluctuation ±5%			
	Rated current (A)	3.7	5.4	7.0	10.7
Braking unit		Inbuilt as standard			
IP rating		IP20			
Cooling		Forced air cooling			

- **NE200-4T□□□□PB** Three-phase 400V Variable torque/normal-duty application

Power (kW)		1.5	2.2	4.0	5.5
Adapted motor (kW)		1.5	2.2	4.0	5.5
Output	Voltage (V)	3phase 0~rated input voltage			
	Rated current (A)	4.0	6.0	9.0	13
	Overload capability	120% 1min; 150% 1sec.			
Input	Rated voltage/frequency	3phase 380V/440V; 50Hz/60Hz			
	Voltage range	304V~456V; voltage imbalance ≤3%; Allowable frequency fluctuation ±5%			
	Rated current (A)	5.4	7.0	10.7	15.5
Braking unit		Inbuilt as standard			
IP rating		IP20			
Cooling		Forced air cooling			

NE200&300 Quick Start Guide

- NE200-2S□□□□GB Single-phase 220V constant torque/heavy duty application

Power (kW)		0.4	0.75	1.5	2.2
Adapted motor (kW)		0.4	0.75	1.5	2.2
Output	Voltage (V)	3phase 0~rated input voltage			
	Rated current (A)	2.5	4.5	7.0	10
	Overload capability	150% 1min; 180% 20sec.			
Input	Rated voltage/frequency	1phase 200V/240V; 50Hz/60Hz			
	Voltage range	176V~264V; voltage imbalance ≤3%; Allowable frequency fluctuation ±5%			
	Rated current (A)	5.3	8.3	14	23
Braking unit		Inbuilt as standard			
IP rating		IP20			
Cooling		Forced air cooling			

NE200&300 Quick Start Guide

2.3.2 NE300 Product Series

- NE300-4T□□□□GB Three-phase 400V Constant torque/heavy-duty application

Power (kW)	1.5	2.2	4	5.5	7.5	11	15	18.5	22	30	37	45	55	75	90	110	
Motor power (kW)	1.5	2.2	4	5.5	7.5	11	15	18.5	22	30	37	45	55	75	90	110	
Output	Voltage (V)	Three-phase 0 to rated input voltage															
	Rated current (A)	4	6	9	13	17	25	32	37	45	60	75	90	110	150	176	210
	Overload capacity	: 150% 1 minute; 180% 20 seconds,															
Input	Rated voltage/frequency	:Three-phase 380V~440V; 50Hz/60Hz															
	Max. voltage range	: 304V ~ 456V; Voltage unbalancedness ≤3%; allowable frequency fluctuation: ±5%															
	Rated current(A)	5.4	7	10.7	15	20.5	27	35	38.5	46.5	62	76	92	113	157	180	214
Braking unit	Built-in as standard									Need external							
Protection class	IP20																
Cooling mode	Forced air convection cooling																
Power(kW)	132	160	185	200	220	250	280	315	355	400	450	500	560	630	710	800	
Motor power(kW)	132	160	185	200	220	250	280	315	355	400	450	500	560	630	710	800	
Output	Voltage (V):	Three-phase 0 to rated input voltage															
	Rated current (A)	250	300	340	380	420	470	540	600	660	730	840	900	950	1160	1300	1460
	Overload capacity	: 150% 1 minute; 180% 20 seconds,															
Input	Rated voltage/frequency	:Three-phase 380V~440V; 50Hz/60Hz															
	Max. voltage range	: 304V~456V; Voltage unbalancedness ≤3%; allowable frequency fluctuation: ±5%															
	Rated current (A)	256	307*	345*	385*	430*	480*	548*	610*	670*	740*	850*	910*	960*	1170*	1310*	1470*
Braking unit	Need external																
Protection class	IP20																
Cooling mode	Forced air convection cooling																

* NE300-4T1600G-F and above products are equipped with in-built DC reactor as standard.

NE200&300 Quick Start Guide

■ NE300-4T□□□□PB Three-phase 400V Variable torque/normal-duty application

Power (kW)	2.2	4	5.5	7.5	11	15	18.5	22	30	37	45	55	75	90	110	132	
Motor power (kW)	2.2	4	5.5	7.5	11	15	18.5	22	30	37	45	55	75	90	110	132	
Output	Voltage (V)	Three-phase 0 to rated input voltage															
	Rated current (A)	6	9	13	17	25	32	37	45	60	75	90	110	150	176	210	250
	Overload capacity	: 120% 1 minute; 150% 1 second,															
Input	Rated voltage/frequency	:Three-phase 380V~440V; 50Hz/60Hz															
	Max. voltage range	: 304V ~ 456V; Voltage unbalancedness ≤3%; allowable frequency fluctuation: ±5%															
	Rated current(A)	7	10.7	15	20.5	27	35	38.5	46.5	62	76	92	113	157	180	214	256
Braking unit	Built-in as standard									Need external							
Protection class	IP20																
Cooling mode	Forced air convection cooling																
Power(kW)	160	185	200	220	250	280	315	355	400	450	500	560	630	710	800	900	
Motor power(kW)	160	185	200	220	250	280	315	355	400	450	500	560	630	710	800	900	
Output	Voltage (V)	: Three-phase 0 to rated input voltage															
	Rated current (A)	300	340	380	420	470	540	600	660	730	840	900	950	1160	1300	1460	1640
	Overload capacity	: 120% 1 minute; 150% 1 second															
Input	Rated voltage/frequency	:Three-phase 380V~440V; 50Hz/60Hz															
	Max. voltage range	: 304V~456V; Voltage unbalancedness ≤3%; allowable frequency fluctuation: ±5%															
	Rated current (A)	307	345*	385*	430*	480*	548*	610*	670*	740*	850*	910*	960*	1170*	1310*	1470*	1650*
Braking unit	Need external																
Protection class	IP20																
Cooling mode	Forced air convection cooling																

* NE300-4T1850P-F and above products are equipped with external DC reactor as standard.

3. Product Installation

3.1 NE200 Product Outline, Mounting Dimension (Unit: mm)

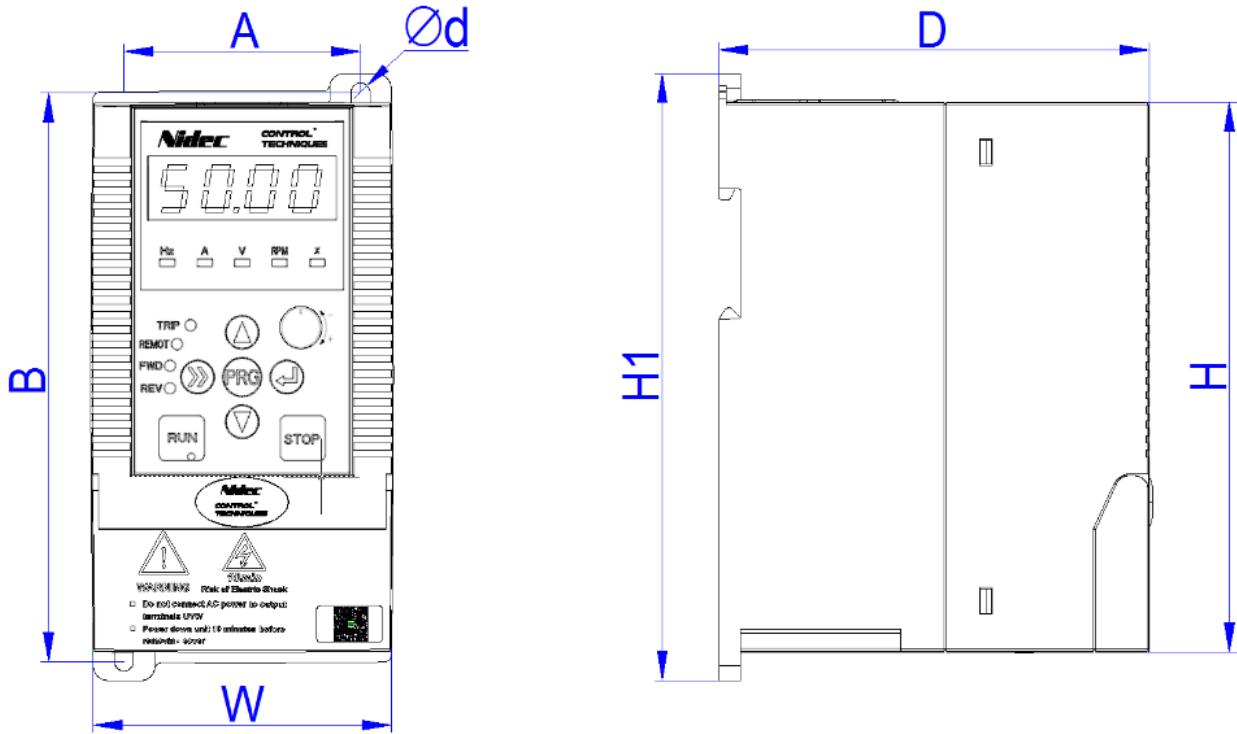

Fig.3-1 Product Outline, Mounting Dimension Schematic diagram

Note: NE200 series support 35mm DIN-rail mounting.

Inverter Model	H	W	D	H1	A	B	d
NE200-2S0004GB	150	83	120	166	65	153	5
NE200-2S0007GB							
NE200-2S0015GB							
NE200-4T0007G/0015PB							
NE200-4T0015G/0022PB							
NE200-4T0022GB-M	200	120	140	215	98	202	5
NE200-2S0022GB							
NE200-4T0022G/0040PB							
NE200-4T0040G/0055PB							
NE200-2S0004GB							

Note:

-M means compact model

3.2 NE300 Product Outline, Mounting Dimension (Unit: mm)

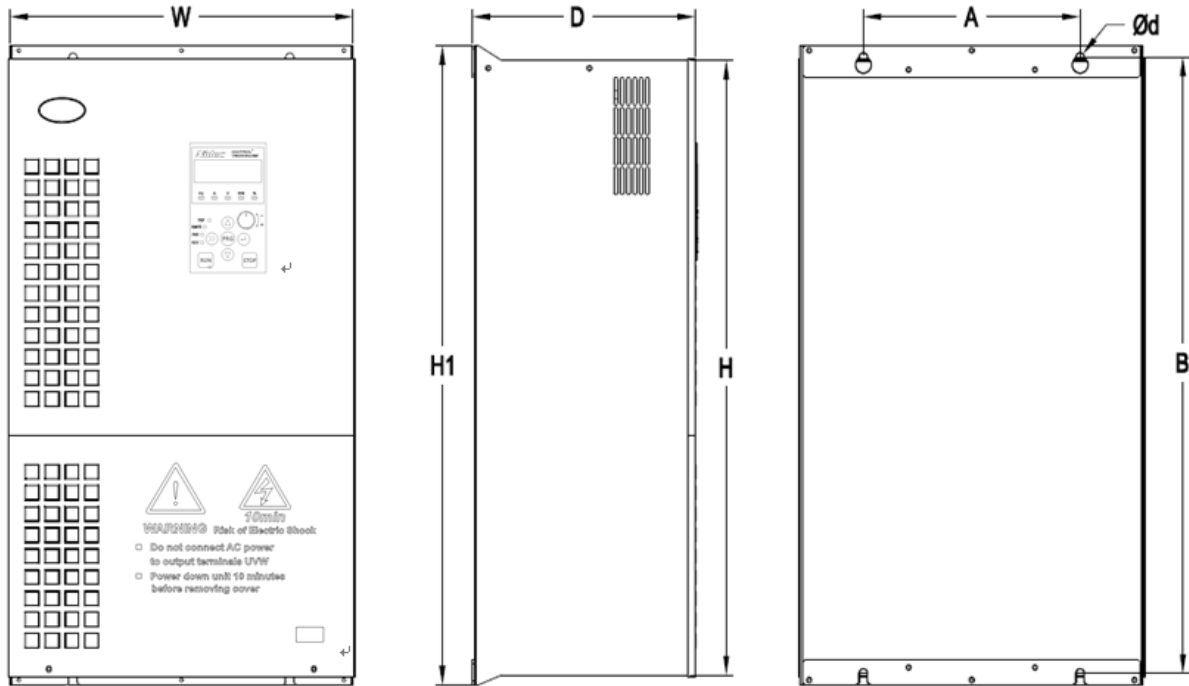

Fig.3-2 Product Outline, Mounting Dimension Schematic diagram

Inverter Model	H	W	D	H1	A	B	d
NE300-4T0015G/0022PB NE300-4T0022G/0040PB NE300-4T0040G/0055PB	210	133	180	238	108	225	7
NE300-4T0055G/0075PB NE300-4T0075G/0110PB NE300-4T0110G/0150PB	258	155	180	285	120	270	7
NE300-4T0150G/0185PB NE300-4T0185G/0220PB NE300-4T0220G/0300PB	310	192	186	340	150	323	7
NE300-4T0300G/0370P NE300-4T0370G/0450P	425	270	200	450	200	430	7
NE300-4T0450G/0550P NE300-4T0550G/0750P	535	320	248	560	240	540	9
NE300-4T0750G/0900P NE300-4T0900G/1100P NE300-4T1100G/1320P	640	380	248	665	240	640	9

NE200&300 Quick Start Guide

Inverter Model	H	W	D	H1	A	B	d
NE300-4T1320G/1600P-U NE300-4T1320G/1600P-D NE300-4T1600G/1850P-U NE300-4T1600G/1850P-D	710	465	355	750	380	719	11
NE300-4T1850G/2000P-U NE300-4T1850G/2000P-D NE300-4T2000G/2200P-U NE300-4T2000G/2200P-D NE300-4T2200G/2500P-U NE300-4T2200G/2500P-D NE300-4T2500G/2800P-U NE300-4T2500G/2800P-D	859	550	385	900	440	868	11
NE300-4T1600G/1850P-F NE300-4T1850G/2000P-F NE300-4T2000G/2200P-F NE300-4T2200G/2500P-F	1400	400	400	1400	460	1270	13
NE300-4T2500G/2800P-F NE300-4T2800G/3150P-F NE300-4T3150G/3550P-F	1600	500	420	1600	560	1460	13
NE300-4T3550G/4000P-F NE300-4T4000G/4500P-F NE300-4T4500G/5000P-F NE300-4T5000G/5600P-F	1800	780	500	1800	840	1630	13
NE300-4T5600G/6300P-F NE300-4T6300G/7100P-F NE300-4T7100G/8000P-F NE300-4T8000G/9000P-F	2000	1000	700	2000	—	—	—
NE300-4T9000G-F	1800	<u>1560*</u>	500	1800	—	—	—

Note:

-U means input lines come from upside and output lines come out downside.

-D means input lines come from downside and output lines come out downside.

-F means freestanding models

* This model consisting of two separate models, 1560 is the net dimension without mounting distance. **Must keep ≥ 200** mounting distance between them.

3.3 Operating keypad panel outline and mounting dimensions (Unit: mm)

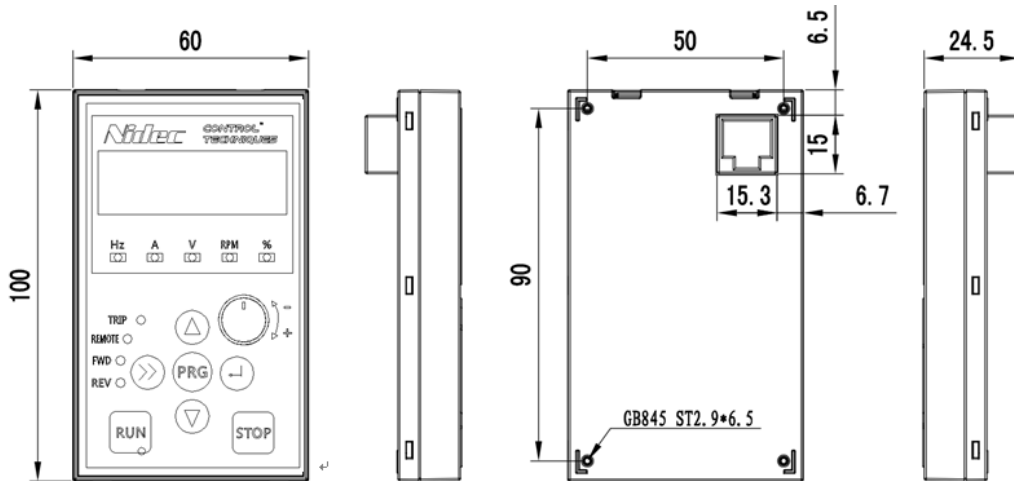
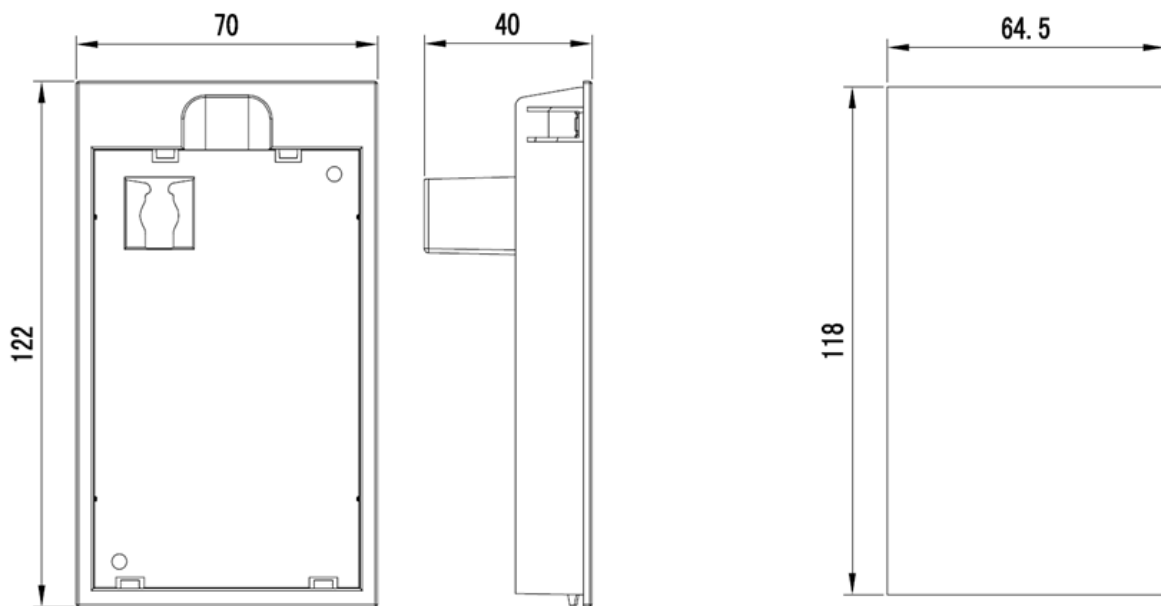

Fig.3-3 Operating Panel Outline and Mounting Dimension

3.4 Keypad holder outline and mounting dimensions

NEF-KB01 is the mounting tray when the operation panel is to install on the electric control cabinet. The outline and dimensions are as follows:(Unit: mm):



Keypad tray dimensions

Keypad tray hole size

Fig.3-4 Operating Panel Outline and Mounting Dimension

4 Wiring of Inverter

4.1 Terminal Wiring of NE200

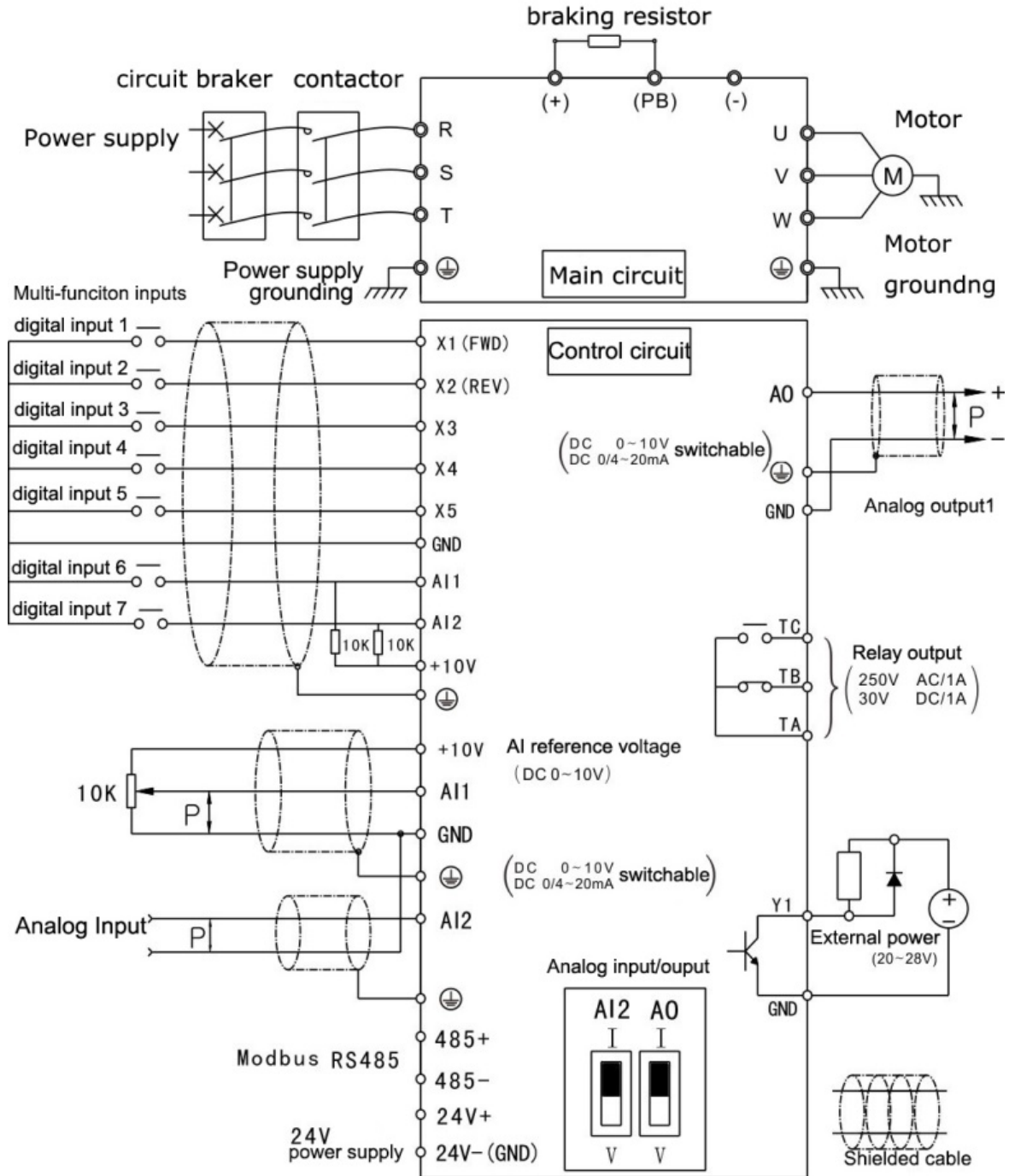

Fig. 4-1 Terminal Wiring (0022GB~0040GB)

4.1.1 Functions of Control Circuit Terminals

Standard configuration of control circuit terminals

Type	Terminal	Terminal function	Technical specification
Digital input & output	X1~X5	Multi-functional input terminals 1~5	Optical-isolator input Frequency range: 0~200Hz Voltage range: 0~12V
	Y1	Open collector output	Optical-isolator output maximum output current: 50mA Output voltage range: 0~24V
	GND	Terminal ref. grounding	
	24V	24V	24V±5%, Maximum load :200mA, with overload and short circuit protection
Analog input	10V	Analog input reference voltage	Open circuit voltage up to 11V; Maximum output 30mA
	AI1	Analog input channel 1	Input Voltage range: 0~10V Input impedance: 100kΩ
	AI2	Analog input channel 2	Input Voltage range: 0~10V Input impedance: 100kΩ Input current range: 0~30mA Current Input impedance: 500Ω, 0~20mA or 0~10V analog input can be selected through DIP switch SW1
	GND	Terminal ref. grounding	
Analog output	AO	Analog output 1	0~20mA: Allowed load impedance 200~500Ω 0~10V: Allowed load impedance ≥1kΩ. With SC protection; 0~20mA or 0~10V analog output can be selected through DIP switch SW2
	GND	Analog grounding	
Relay output	TA/TB/TC	Relay output 1	TA—TB: NC; TA—TC: NO Contact capacity: 250VAC/1A, 30VDC/1A

NE200&300 Quick Start Guide

Type	Terminal	Terminal function	Technical specification
RS485	485+	485 differential positive	Rate: 1200/2400/4800/9600/19200/38400bps; Max. parallel 127 No.s; SW3 select adapted resistor; Max. Length 500m. (twisted shielding cable)
	485-	485 differential negative	
	GND	485 shielding grounding	Internal isolated with COM

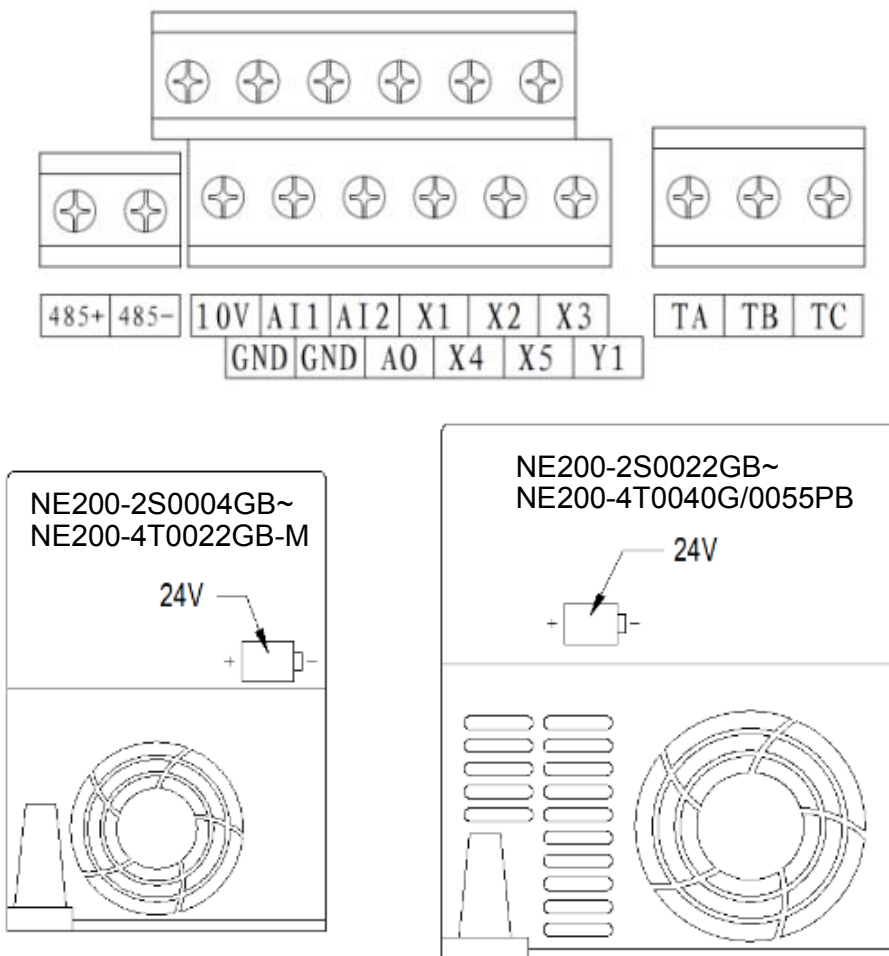

Fig.4-2 Arrangement of Control Circuit Terminals

4.2 Terminal Wiring of NE300

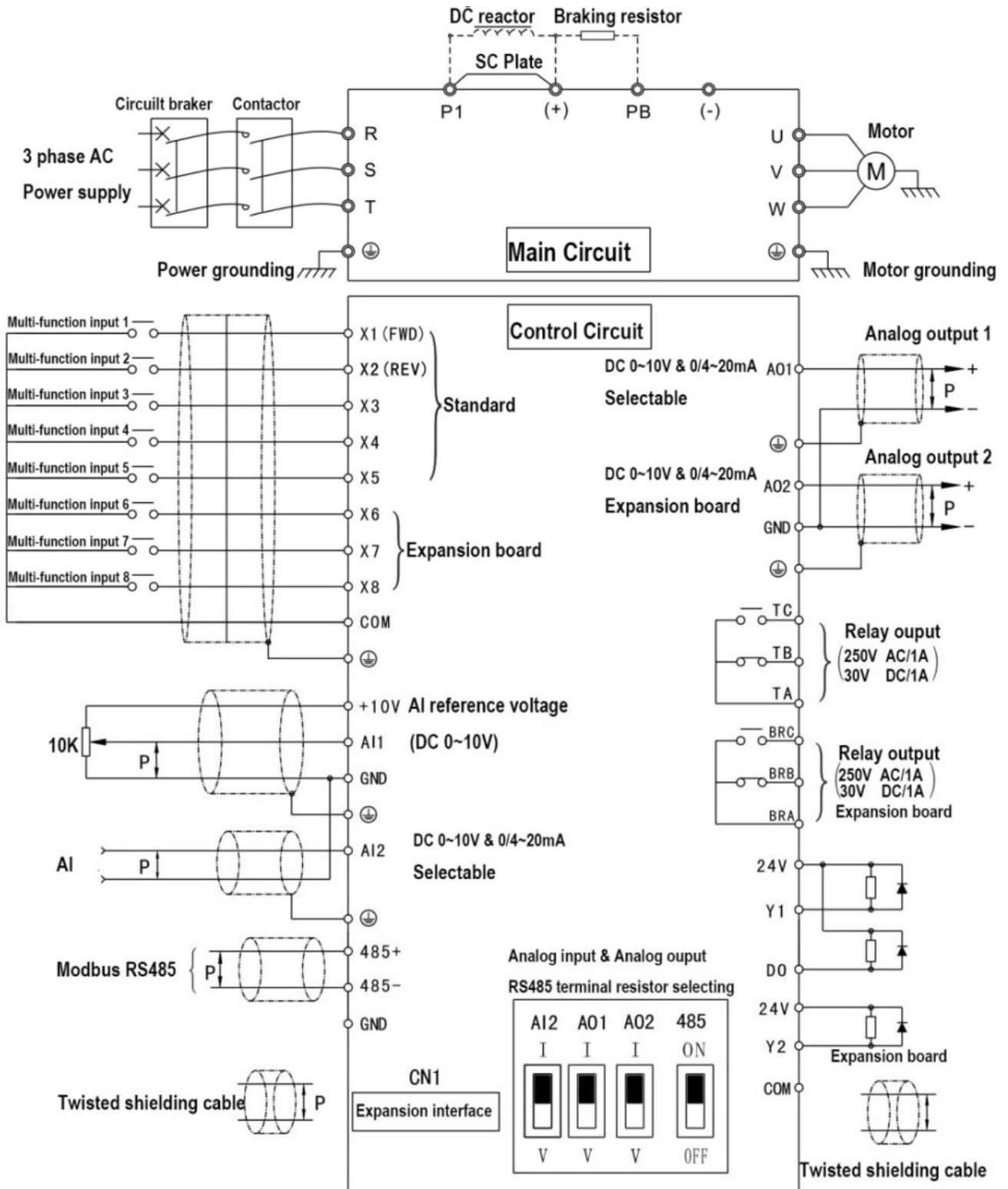

Fig.4-3 Terminal Wiring (0220G/0300PB as example)

4.2.1 Functions of Control Circuit Terminals

Standard configuration of control circuit terminals

Type	Terminal	Terminal function	Technical specification
Digital input	X1 ~ X3	Multi-functional input terminals 1~3	Optical-isolator input Frequency range: 0~200Hz Voltage range: 0~24V
	X4 X5	Multi-functional input or Single pulse input 4, 5	Multi-functional input: same as X1~X3 Single Pulse input: 0.1Hz~50kHz Voltage range: 0~24V
	COM	multi-functional input terminals common end	Internal isolated with GND
Digital output	24V	24V	24V±5%, Maximum load :200mA, with overload and short circuit protection
	Y1	Open collector output 1	Optical-isolator output maximum output current: 50mA Output voltage range: 0~24V
	DO	Open collector or high speed pulse output	Output frequency: 0~50kHz Open collector same as Y1
	COM	Open collector output common end	Internal isolated with GND
Analog input	10V	Analog input reference voltage	Open circuit voltage up to 11V; Internal isolated with com; Maximum load 30mA, with overload and short circuit protection
	AI1	Analog input channel 1	Input Voltage range: 0~10V Input impedance: 100kΩ
	AI2	Analog input channel 2	Input Voltage range: 0~10V Input impedance: 100kΩ Input current range: 0~30mA Current Input impedance: 500Ω, 0~20mA or 0~10V analog input can be selected through DIP switch SW1

NE200&300 Quick Start Guide

Type	Terminal	Terminal function	Technical specification
	GND	Analog grounding	Internal isolated with COM
Analog output	AO1	Analog output 1	0~20mA: Allow output impedance 200~500Ω 0~10V: Allowed output impedance ≥10kΩ. With SC protection; 0~20mA or 0~10V analog output can be selected through DIP switch SW2
	GND	Analog grounding	Internal isolated with COM
Relay output	TA/TB/TC	Relay output 1	TA—TB: NC; TA—TC: NO Contact capacity: 250VAC/1A, 30VDC/1A
RS485	485+	485 differential positive	Rate: 1200/2400/4800/9600/19200/38400bps; Max. parallel 127 No.s; SW3 select adapted resistor; Max. Length 500m. (twisted shielding cable)
	485-	485 differential negative	
	GND	485 shielding grounding	Internal isolated with COM

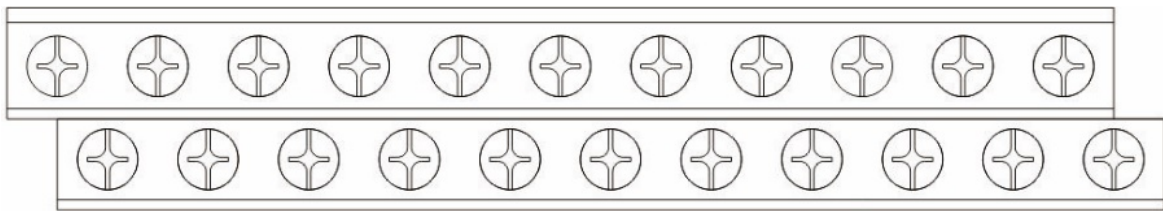

485+	485-	X1	X2	X3	X4	X5		TA	TB	TC
10V	GND	GND	AI1	AI2	AO1	DO	Y1	COM	COM	24V

Fig.4-4 Arrangement of Control Circuit Terminals

5. Operation and Display

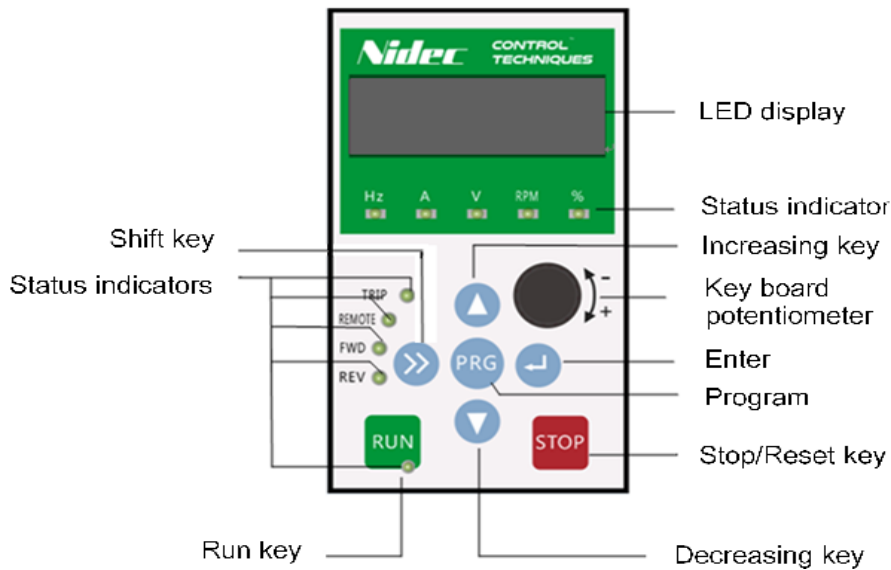

Fig.5-1 Operation Panel Diagram

5.1 Keyboard button description

Table 5-1 Keyboard keys description

Keys	Name	Function
PRG	Programming key	Entry and exit of primary menu
ENTER	Confirmation key	Enter the next level menu or confirm the data setting
^	Increase key	Increase of the value or function code
v	Decrease key	Decrease of the value or function code
>>	Shift key	Select the to be displayed parameters in turn under stop interface or running interface; Choose the to be modified digits when setting parameters.
RUN	Running key	Run the inverter under keypad operation mode.
STOP	Stop/reset	Stop the inverter at running status; Reset operation in the fault alarm status. Its function is limited to setting of code FE.02.
Knob	Potentiometer	Adjust setting value when potentiometer is set up as input.

5.2 Instruction of function code viewing and modification

The operation panel of the NE200&300 inverter adopts three levels menu structure to carry out operations such as parameter setting. The three levels are:

1. Groups of function code (level-1 menu)
2. Function code (level-2 menu)
3. Function code setup value(level-3 menu)

Note:

At level 3 menu, pressing PRG key or ENTER key can return to level-2 menu. The difference between them is that: Pressing ENTER will save the setup and return to the level 2 menu and then automatically shift to the next function code; while pressing PRG key will directly return to level 2 menu without saving the parameter, and stay at current function code.

Below is the example of modifying the function code F9.01 from 10.00Hz to 20.00Hz. (The number of bigger font size refers to the blinking digit),

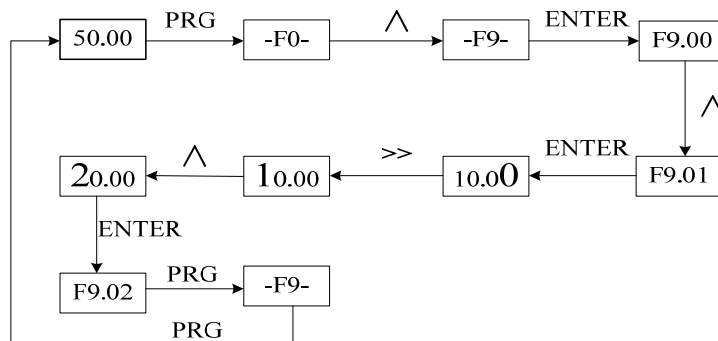

Fig.5-2 Example of 3 levels menu operating

At level-3 menu, if the parameter has no blinking digit, it indicates that this function code cannot be modified. The possible reasons include:

- 1) The function code is an unchangeable parameter, such as actual detection parameter, running record parameter, etc.
- 2) The function code cannot be modified in running status. It can be modified only after the inverter running is stopped.

6. Run the motor

Operations	Details
Before power-on	Check: No operating signal. The motor has been connected. 1 phase 220V/ 3 phase 380V input power has been connected correctly.
The inverter is powered on	Confirm the inverter displays the correct operating mode on power -up. Reset the drive if the operation mode is incorrect. Contact your supplier if problem still exist.
G/P model selection	FP.05=0 Type G FP.05=1 Type P
Set max, upper & lower limit frequency	F0.10 Basic frequency F0.11 Max frequency F0.12 Freq. upper limit F0.13 Freq. lower limit
Set control mode	F0.01=0: Sensorless vector control-1 F0.01=1: Sensorless vector control-2 F0.01=2: Vector control with encoder (NE300 only) F0.01=3: V/F control
Set acceleration and deceleration time	F0.19 Acceleration time (s) F0.20 Deceleration time (s)
Set parameters on the motor nameplate	F5.00 motor type F5.01 Poles of motor F5.02 Rated power of motor (KW) F5.03 Rated current of motor (A) F5.04 Rated speed of rotation of motor (RPM)
Auto-tuning of motor	F5.10=1 (static auto-tuning) or F5.10=2 (rotating auto-tuning, must unload) operate the motor via keypad to perform the auto-tuning.
Run the motor	Press Run button to run the motor. Increase or decrease the speed with keypad knob.

7. List of Parameters

Attention:

“○” means the parameter can be changed during running.

“×” means the parameter cannot be changed during running;

“*” means the parameter is detected value or fixed value and not changeable.

“-” means manufacturer parameter and the users have no access to it.

“②” indicates this parameter is only for NE200

“③” indicates this parameter is only for NE300

F0: Basic function group

Code	Description	Setting range	Default	Modify
F0.00	Reserved	Reserved	Reserved	-
F0.01	Control mode	0: Sensorless vector control-1 1: Sensorless vector control-2 2: Vector control with encoder (Reserved, for customized model) ③ 3: V/F control	0	×
F0.02	Run command control mode	0: Operation keypad control 1: Terminal control 2: Communication control	0	○
F0.03	Frequency reference1 (Freq. ref.1)	0: Digital reference (keypad, terminal up/down) 1: AI1 2: AI2 3: PULSE setup 4: Communication 5: MS (Multi-step) Speed 6: PLC 7: PID 8: keyboard potentiometer	0	○
F0.04	Frequency reference2 (Freq. ref.2)	1: AI1 2: AI2 3: PULSE setup 4: Communication 5: MS (Multi-step) Speed 6: Reserved 7: Reserved 8: keyboard potentiometer	1	○
F0.05	Frequency setting selection	0: Freq. ref.1 1: Freq. ref.2 2: Freq. ref.1+ Freq. ref.2	0	○

NE200&300 Quick Start Guide

Code	Description	Setting range	Default	Modify
		3:Terminal switching between Freq. ref.1 & Freq. ref.2 4: Terminal switching between (Freq. ref.1+ Freq. ref.2) & Freq. ref.1 5:MIIN (Freq. ref.1, Freq. ref.2) 6:MAX (Freq. ref.1, Freq. ref.2)		
F0.06	UP/DOWN Preset freq.	0~ Max frequency	50.00Hz	○
F0.07	Terminal UP/DOWN rate	0.01~ 50.00Hz/s	1.00Hz/s	○
F0.08	UP/DOWN keypad and terminal select	0:Active in both keyboard and terminal UP/DOWN 1:Active only in keyboard UP/DOWN 2: Active only in Terminal UP/DOWN	1	○
F0.09	UP/DOWN data saving selection	0: Setting saved in power failure 1: Setting not saved in power failure 2: Setting cleared to 0 after stop	0	○
F0.10	Basic frequency	0.10~550.0Hz	50.00Hz	×
F0.11	Max frequency	MAX[50.00Hz, Freq. upper limit, Reference frequency]~550.0Hz	50.00Hz	×
F0.12	Freq. upper limit	Freq. lower limit ~ Max frequency	50.00Hz	×
F0.13	Freq. lower limit	0.00~Frequency upper limit	0.00Hz	×
F0.14	Max output voltage	110~440V	380V	×
F0.15	Carrier freq.	1.0~16.0KHz	6.0kHz	○
F0.16	Carrier freq. auto-adjust	0: No adjust 1: Auto adjust	0	○
F0.17	Keypad direction	0: Forward 1: Reverse	0	○
F0.18	Motor wiring direction	0: Positive sequence 1: Reversed sequence	0	×
F0.19	Acc. time1	0.01~360.0s	6.00s	○
F0.20	Dec. time1	0.01~360.0s	6.00s	○

NE200&300 Quick Start Guide

Group F1: Start and stop control

Code	Description	Setting range	Default	Modify
F1.00	Start mode	0: Start directly 1: DC injection brake first and then start at start freq. 2: Speed tracking and start ③	0	○
F1.01	Start freq.	0.10~60.00Hz	0.50Hz	○
F1.02	Start freq. hold time	0.0~10.0s	0.0s	○
F1.03	DC injection brake current at start	G: 0.0~100.0% rated current P: 0.0~80.0% rated current	0.00%	○
F1.04	DC injection brake time at start	0.0~30.0s	0.0s	○
F1.05	Acc./Dec. mode	0: Linear 1: S-curve	0	○
F1.06	Time of S-curve initial stage	10.0~50.0% (Acc./ Dec. time) F1.06+F1.07≤90%	30.00%	○
F1.07	Time of S-curve rising stage	10.0~80.0% (Acc./ Dec. time) F1.06+F1.07≤90%	40.00%	○
F1.08	Stop mode	0: Deceleration to stop 1: Coast to stop 2: Deceleration +DC braking	0	×
F1.09	DC brake trigger frequency at stop	0.00~550.0Hz	0.00Hz	○
F1.10	DC brake waiting time at stop	0.00~10.00s	0.00s	○
F1.11	DC brake current at stop	Type G: 0.0~100.0% rated current Type P: 0.0~80.0% rated current	0.00%	○
F1.12	DC brake time at stop	0.0~30.0s	0.0s	○
F1.13	Energy consume brake validity	0: Disabled 1: Enabled	0	○
F1.14	Energy consume brake action voltage	380V: 650~750V 220V: 360~390V	700V 380V	○
F1.15	Power failure and fault restart	0: Disable 1: Enabled for power failure 2: Enabled for fault	0	○



NE200&300 Quick Start Guide

Code	Description	Setting range	Default	Modify
		3: Enabled for both Note: Power recovery restart is only valid for terminal 2-lines mode. Fault restart is invalid for over-voltage fault.		
F1.16	Restart waiting time	0.0~3600s	0.0s	○

Group F2: Auxiliary running function

Code	Description	Setting range	Default	Modify
F2.00	Jog running freq.	0.10~50.00Hz	5.00Hz	○
F2.01	Jog Acc. time	0.01~360.0s	6.00s	○
F2.02	Jog Dec. time	0.01~360.0s	6.00s ⁽²⁾ 20.0s ⁽³⁾	○
F2.03	Acc. time2	0.01~360.0s	6.00s ⁽²⁾ 20.0s ⁽³⁾	○
F2.04	Dec. time2	0.01~360.0s	6.00s ⁽²⁾ 20.0s ⁽³⁾	○
F2.05	Acc. time3	0.01~360.0s	6.00s ⁽²⁾ 20.0s ⁽³⁾	○
F2.06	Dec. time3	0.01~360.0s	6.00s ⁽²⁾ 20.0s ⁽³⁾	○
F2.07	Acc. time4	0.01~360.0s	6.00s ⁽²⁾ 20.0s ⁽³⁾	○
F2.08	Dec. time4	0.01~360.0s	6.00s ⁽²⁾ 20.0s ⁽³⁾	○
F2.09	Reserved	Reserved	Reserved	-
F2.10	Skip frequency	0.00~550.0Hz	0.00Hz	×
F2.11	Skip frequency amplitude	0.00~15.00Hz	0.00Hz	×
F2.12	Anti-Reverse control	0: Reverse rotation allowed 1: Reverse rotation not allowed	0	○
F2.13	Fwd/ Rev switch dead-zone time	0.0~3600s	0.0s	○
F2.14	frequency lower limit treatment	0: Run with frequency lower limit 1: Zero frequency operation	0	×
F2.15	Reserved	Reserved	0	×
F2.16	Reserved			×

NE200&300 Quick Start Guide

Code	Description	Setting range	Default	Modify
		Reserved		
F2.17	AVR Function	0: Disabled 1: Enabled 2: Disabled only at speed-down	2	×
F2.18	Over modulation	0: Enabled 1: Disabled	1	×
F2.19	Reserved	Reserved	-	○
F2.20	Fan control mode	0: Auto mode 1: Always Running	0	×
F2.21	Instant power failure treatment	0: Disabled 1: Drop frequency (Reserved) 2: Stop directly	0	○
F2.22	Power failure freq. drop point	210~600V	380V:420V 220V:230V	○
F2.23	Power failure freq. drop rate	0.00~max frequency /s	10.00Hz/s	○
F2.24	Motor speed display ratio	0.00~500.0%	100.00%	○
F2.25	UP/DOWN drop to minus frequency	0: Enabled 1: Disable	1	○
F2.26	ENTER key function	0: No special action 1: FWD/REV switching 2: RUN for forward, Enter for reverse, STOP for stop 3: Jog running	0	○
F2.27	Freq. resolution	0: 0.01Hz 1: 0.1Hz	0	×
F2.28	Acc./Dec. time unit	0: 0.1second 1: 0.01second	1  0 	×
F2.29	High frequency modulation mode	0: Asynchronous modulation 1: Synchronous modulation	0	×
F2.31	Select the IO output baseline frequency while vector control mode	0: Per the frequency after adding or reducing speed 1: Per real frequency	0	○

Group F3: Vector Control Parameters

Code	Description	Setting range	Default	Modify
------	-------------	---------------	---------	--------

NE200&300 Quick Start Guide

Code	Description	Setting range	Default	Modify
F3.00	Speed loop proportional gain 1	1~3000	1000	○
F3.01	Speed loop integral time 1	1~3000	300	○
F3.02	Switching frequency 1	0.0~60.00Hz	5.00Hz	○
F3.03	Speed loop proportional gain 2	1~3000	800	○
F3.04	Speed loop integral time 2	1~3000	200	○
F3.05	Switching frequency 2	0.0~60.00Hz	10.00Hz	○
F3.06	Speed loop filter time constant	0~500ms	3ms	○
F3.07	Current loop proportional coefficient	0~6000	3000	○
F3.08	Current loop integral coefficient	0~6000	1500	○
F3.09	VC Slip compensation	0.0~200.0%	100.00%	○
F3.10	Torque control	0:Torque control Disabled 1:Torque digital setting(F3.11) 2:AI1 3:AI2 4:Reserved 5:communication 6:keypad potentiometer	0	○
F3.11	Torque digital setting	0.0~200.0%	50.00%	○
F3.12	Torque control speed limit	0:digital setting(F3.13) 1:AI1 2:AI2 3:PULSE 4:communication 5:keyboard potentiometer	0	○
F3.13	Torque control speed limit digital setting	0.00~550.0Hz	50.00Hz	○
F3.14	Encoder pulse number 	Reserved		○

NE200&300 Quick Start Guide

Code	Description	Setting range	Default	Modify
F3.15	Motor and PG reduction ratio ③	Reserved		○
F3.16	PG direction ③	Reserved		○
F3.18	SVC speed calculation filter	0~15	5	○
F3.19	SVC mode	0: SVC mode1 1: SVC mode2	0	○
F3.20	Reserved	Reserved		○
F3.21	Field weakening	0:Disable 1:Enable	0	×
F3.22	Torque limit compensation coefficient	60.0~300.0%	200.00%	○
F3.23	Reserved	Reserved		○
F3.24	Torque ref. terminal single modulation	0.0~10%	0.00%	○
F3.25	Torque ref. terminal total modulation	0.0~100%	50%	○
F3.26	Torque limit in vector control mode	0~300.0%	150.0%	○
F3.27	Torque boost cut-off frequency in torque control mode	0.00~15.00Hz	12.00Hz	○
F3.28	Torque boost amount in torque control mode	0.0~20.0%	15.0%	○
F3.31	Synchronous motor initial position detection	0: Do not detect 1: Detect in power-on first run 2: Detect every time	2	○
F3.32	Synchronous motor initial position detection current	50~120%	90%	○
F3.33	Initial position detection pulse width	0~1200us	0	○
F3.34	Initial position detection pulse	0~1200us	0	*

NE200&300 Quick Start Guide

Code	Description	Setting range	Default	Modify
	width actual value			
F3.35	Synchronous motor braking torque limit	0.0~300.0%	150.0%	○
F3.36	Synchronous motor flux weakening mode	0: Flux weakening mode is invalid 1: Flux weakening mode is valid	0	○
F3.37	Max flux weakening current	0~100.0%	50%	○
F3.38	Flux weakening regulation proportional coefficient	0~3000	1500	○
F3.39	Flux weakening regulation integration coefficient	0~3000	1500	○
F3.40	Synchronous motor low speed Min. current	0~100%	30%	○
F3.41	Synchronous motor low speed carrier frequency	1.0~16.0KHz	2.0KHz	○
F3.42	Synchronous motor Min excitation current	-100.0~100.0%	8.0%	○
F3.44	Synchronous motor position evaluating low speed filter	2~100	40	○
F3.45	Synchronous motor position evaluating high speed filter	2~100	15	○

Group F4: V/F Control Parameters

Code	Description	Setting range	Default	Modify
F4.00	V/F curve setting	0: Constant torque load V/F 1: 2.0 order decreasing torque 2: 1.5 order decreasing torque 3: 1.2 order decreasing torque	0	×

NE200&300 Quick Start Guide

Code	Description	Setting range	Default	Modify
		4: Multiple dots V/F		
F4.01	V/F freq. point1	0.0~F4.03	10.00Hz	×
F4.02	V/F voltage point1	0.0~100.0%	20.00%	×
F4.03	V/F freq. point2	F4.01~F4.05	25.00Hz	×
F4.04	V/F voltage point2	0.0~100.0%	50.00%	×
F4.05	V/F freq. point3	F4.03~F0.10	40.00Hz	×
F4.06	V/F voltage point3	0~100.0%	80.00%	×
F4.07	Torque boost	0.0%: Auto boost 0.1~30.0%: Manual boost	0.00%	○
F4.08	Manual torque boost cutoff point	0.00~60.00Hz	50.00Hz	○
F4.09	Slip compensation	0.0~200.0%	0.00%	○
F4.10	Slip compensation filtering time	0.01~2.55s	0.20s	○
F4.11	V/F separation control voltage source	0: Disabled 1: Digital setting (F4.12) 2: AI1 3: AI2 4: Pulse 5: Communication	0	×
F4.12	V/F separation voltage digital setting	0V~max output voltage	0V	○
F4.13	V/F separation voltage rising time	0.0s~1000.0s	0.0s	○
F4.14	V/F oscillation suppression	0~500	Depends on model	○

Group F5: Motor Parameters

Code	Description	Setting range	Default	Modify
F5.00	motor type	0: Common asynchronous motor 1: Variable frequency asynchronous motor 2: PM motor	0	×
F5.01	Motor polarity number	2~56	4	×
F5.02	rated power	0.1~6553.5kW	Depends on model	○

NE200&300 Quick Start Guide

Code	Description	Setting range	Default	Modify
F5.03	rated current	0.01~655.35A	Depends on model	○
F5.04	rated speed	0~65535RPM	Depends on model	
F5.05	No-load current I0	0.01~655.35A	Depends on model	○
F5.06	Stator resistance R1	1~65535mΩ	Depends on model	○
F5.07	Leakage inductive reactance X	0.01~655.35mH	Depends on model	○
F5.08	Rotor resistance R2	1~65535mΩ	Depends on model	○
F5.09	Mutual Inductive reactance Xm	0.1~6553.5mH	Depends on model	○
F5.10	Auto tune	0: No operation 1: Static tuning 2: Rotary tuning	0	×
F5.11	Synchronous motor stator resistor Rs	1~65535mΩ	Depends on model	○
F5.12	Synchronous motor D-axis inductance Ld	0.01~655.35mH	Depends on model	○
F5.13	Synchronous motor Q-axis inductance Lq	0.01~655.35mH	Depends on model	○
F5.14	Synchronous motor counter EMF constant	0.0~6553.5v	300.0v	○

Group F6: Input terminals

Code	Description	Setting range	Default	Modify
F6.00	Terminal Command mode	0: Two-wire mode 1 1: Two-wire mode 2 2: Three-wire mode 1 3: Three-wire mode 2	0	×
F6.01	X1 terminal Function selection	0: NULL 1: FWD 2: REV	1	×
F6.02	X2 terminal		2	×

NE200&300 Quick Start Guide

Code	Description	Setting range	Default	Modify
	Function selection	3: RUN		
F6.03	X3 terminal Function selection	4: F/R direction 5: HLD self-hold 6: FWD jog run (FJOG)	8	×
F6.04	X4 terminal Function selection	7: REV jog run (RJOG) 8: RESET	17	×
F6.05	X5 terminal Function selection	9: Freq. source switching 10: Terminal UP 11: Terminal DOWN	18	×
F6.06	X6 terminal Function selection ③ AI1 terminal function selection ②	12: UP/DOWN setup clear 13: Coast to stop 14: DC injection braking 15: Acc./Dec. prohibit 16: Inverter running prohibit 17: Multi-step terminal 1 18: Multi-step terminal 2 19: Multi-step terminal 3	0	×
F6.07	X7 terminal Function selection ③ AI2 terminal function selection ②	20: Multi-step terminal 4 21: torque control disable 22: Acc./Dec. time selector 1 23: Acc./Dec. time selector 2 24: Running pause normally open 25: Running pause normally closed	0	×
F6.08	X8 terminal Function selection ③	26: External fault normally open 27: External fault normally closed	0	×
F6.09	AI1 used as X9 ③	28: Run command switch to	0	×

NE200&300 Quick Start Guide

Code	Description	Setting range	Default	Modify
		terminal 29: Run command switch to keypad 30: External stop terminal; same to STOP key in keypad control mode. 31: Reserved 32: PLC status reset 33: Wobble freq. pause 34: Wobble freq. status reset 35: PID pause 36: PID parameters switching 37: PID direction reversion; Active this terminal to reverse PID direction set by 8.04. 38: Timing drive input 39: Counter signal input 40: Counter clear 41: Actual length clear 42: FWD running (FWD NC) 43: REV running (REV NC) 44: HLD (Normally open) 45: Torque increase 46: Torque increase clear 47: Torque decrease 48: One key recover user parameters(Valid in stop state) 49~56: Reserved 57: Pulse input (Take X4 in case 2 inputs)		
F6.10	Analog Nonlinear Selection	0: none 1: AI1 2: AI2 3: Pulse	0	×
F6.11	AI1 Min. input	0.00~F6.13	0.00V	○
F6.12	AI1 Min. input corresponding setup	-200.0~200.0%	0.00%	○
F6.13	AI1 Max. input	F6.11~10.00V	10.00V	○
F6.14	AI1 Max. input corresponding setup	-200.0~200.0%	100.00%	○
F6.15	AI1 input filter time	0.01~50.00s	0.05s	○
F6.16	AI2 Min. input	0.00~F6.18	0.00V	○

NE200&300 Quick Start Guide

Code	Description	Setting range	Default	Modify
F6.17	AI2 Min. input corresponding setup	-200.0~200.0%	0.00%	○
F6.18	AI2 Max. input	F6.16~10.00V	10.00V	○
F6.19	AI2 Max. input corresponding setup	-200.0~200.0%	100.00%	○
F6.20	AI2 input filter time	0.01~50.00s	0.05s	○
F6.21	PULSE Min. input	0.00~F6.23	0.00kHz	○
F6.22	PULSE Min. input corresponding setup	-200.0%~200.0%	0.00%	○
F6.23	PULSE Max. input	F6.21~50.00kHz	50.00kHz	○
F6.24	PULSE Max. input corresponding setup	-200.0%~200.0%	100.00%	○
F6.25	Pulse filter time	0.01~50.00s	0.05s	○
F6.26	Terminal up/down initial increment	0.00~10.00Hz	0.01Hz	○
F6.27	Freq. ref.2 datum	0: Max. freq. 1: Freq. ref.1	0	○

Group F7: Output terminal

Code	Description	Setting range	Default	Modify
F7.00	DO terminal output definition ③	0: NULL 1: RUN 2: Frequency arrival(FAR) 3: Freq.level detection 1 (FDT1) 4: Freq.level detection 2 (FDT2) 5: Freq. detection when speed-up 6: Freq. detection when speed-down 7: Zero-speed running 8: Zero-speed 9: PLC circulation completion 10: Reserved	0	○
F7.01	Y1 terminal output selection		1	○
F7.02	Y2 terminal output selection ③		0	○
F7.03	Relay 1 (TA/TB/TC) output selection		16	○

NE200&300 Quick Start Guide

Code	Description	Setting range	Default	Modify
F7.04	Relay 2 (BRA/BRB/BRC) output selection ③	11: Ready for running 12: Timing arrival 13: counting arrival 14: Reserved 15: Preset torque value arrival 16: Inverter fault output 17: Under voltage status output 18: Inverter overload pre-warning 19: Fixed-length arrived, level signal 20: PID in dormancy 21: AI1>AI2 22: AI1<F7.16 23: AI1>F7.16 24: F7.16<AI1<F7.17 25: Frequency lower limit arrival 26: Multi-pumps system auxiliary pump control signal 27: Communication setting 28: inverter running time arrival	0	<input type="radio"/>
F7.05	Freq. arrival detection width	0.00~10.00Hz	2.50Hz	<input type="radio"/>
F7.06	Frequency detection value 1 (FDT1 level)	0.00~550.0Hz	5.00Hz	<input type="radio"/>
F7.07	Freq. detection lag1 (FDT1-lag)	0.00~10.00Hz	1.00Hz	<input type="radio"/>
F7.08	Frequency detection value 2 (FDT2 level)	0.00~550.0Hz	25.00Hz	<input type="radio"/>
F7.09	Freq. detection lag2 (FDT2-lag)	0.00~10.00Hz	1.00Hz	<input type="radio"/>
F7.10	Up detection frequency	0.00~550.0Hz	50.00Hz	<input type="radio"/>
F7.11	Down detection frequency	0.00~550.0Hz	0.00Hz	<input type="radio"/>
F7.12	Torque detection reference	0.0~200.0%	100.00%	<input type="radio"/>

NE200&300 Quick Start Guide

Code	Description	Setting range	Default	Modify
F7.13	Preset Counting arrival value	0~9999	0	○
F7.14	Preset Timing arrival value	0.0~6553.0s	0.0s	○
F7.15	Reserved			
F7.16	AI1 compare threshold 1	0.00~10.00v	0.00v	○
F7.17	AI1 compare threshold 2	0.00~10.00v	0.00v	○
F7.18	Analog compare hysteresis error	0.00~3.00v	0.20v	○
F7.19	AO1 output selection ③ AO function definition ②	0: NULL 1: Running freq. (0~max frequency) 2: Setting freq. (0~max frequency) 3: Output current(0~2 times of inverter rated current) 4: Output voltage (0~Max Voltage) 5: PID setup (0~10V) 6: PID feedback (0~10V) 7: Calibrating signal (5V) 8: Output torque (0~2 times of motor rated torque) 9: Output power (0~2 times of inverter rated power) 10: Bus voltage (0~1000V) 11: AI1 (0~10V) 12: AI2 (0~10V/4~20mA) 13: Pulse frequency 14: Communication setting	1	○
F7.20	AO2 output selection ③		0	○
F7.21	DO output selection ③ Y1 function definition ②		0	○
F7.22	AO1 output range selection ③ AO output range	0: 0~10V/0~20mA 1: 2~10V/4~20mA	0	○

NE200&300 Quick Start Guide

Code	Description	Setting range	Default	Modify
	selection ②			
F7.23	AO2 output range selection ③	0: 0~10V/0~20mA 1: 2~10V/4~20mA	0	○
F7.24	Gain of AO1 ③ Gain of AO ②	1~300%	100%	○
F7.25	Gain of AO2 ③	1~300%	100%	○
F7.26	DO Max. output pulse freq. ③ Y1 Max. output pulse freq. ②	Y1 Min. output pulse freq.~ 50.00kHz	50.00kHz	○
F7.27	DO Min. output pulse freq. ③ Y1 Min. output pulse freq. ②	0.00~Y1 Max. output pulse freq.	0.00kHz	○
F7.28	Auxiliary pump start lag time	0~9999s	0	○
F7.29	Auxiliary pump stop lag time	0~9999s	0	○
F7.30	DO Max. output ③ Y1 Max. output ②	0: 50.00KHz 1: 500.0Hz	0	×
F7.31	FDT/RUN signal Jog selection	0: Do not include Jog signal 1: Include Jog signal	0	×
F7.32	Running time arrival setup	0~65530Mins	0	○
F7.33	Running time arrival stop selection	0: Do not stop 1: Stop	0	○

Group F8: PID Parameters

Code	Description	Setting range	Default	Modify
F8.00	PID setup selection	0: PID digital setting (F8.02) 1: AI1 2: AI2 3: Pulse input 4: serial communication	0	○

NE200&300 Quick Start Guide

Code	Description	Setting range	Default	Modify
F8.01	PID feedback selection	0: AI1 1: AI2 2: Pulse input 3: serial communication 4: AI1-AI2 5: AI1+AI2 6: MAX(AI1, AI2) 7: MIN(AI1, AI2)	1	○
F8.02	Analog PID digital setup	0.0~999.9	50	○
F8.03	Analog closed loop measuring range	1.0~999.9	100	○
F8.04	PID action direction	0: Positive 1: Negative	0	○
F8.05	PID proportional gain 1 (KP1)	0.1~9.9	1	○
F8.06	PID integration time 1	0.00~100.0s	10.00s	○
F8.07	PID differential time 1	0.00~1.00s	0.00s	○
F8.08	PID proportional gain 2 (KP2)	0.1~9.9	1	○
F8.09	PID integration time 2	0.00~100.0s	10.00s	○
F8.10	PID differential time 2	0.00~1.00s	0.00s	○
F8.11	PID parameters switching	0: No switching, use the first group parameters 1: switching by terminal 2: auto-switching by deviation	0	○
F8.12	PID parameter switching Deviation 1	0.0~999.9	20	○
F8.13	PID parameter switching Deviation 2	0.0~999.9	80	○
F8.14	PID delay time constant	0.00~100.0s	0.00s	○
F8.15	Deviation limit	0.0~999.9	0.2	○
F8.16	PID output positive limit	0.00~550.0Hz	50.00Hz	○
F8.17	PID output negative limit	0.00~550.0Hz	0.00Hz	○
F8.18	PID preset freq.	0.00~550.0Hz	0.00Hz	×
F8.19	Hold time of PID preset frequency	0.0~3600s	0.0s	×
F8.20	Enable dormancy	0: Disabled 1: Enabled	0	×

NE200&300 Quick Start Guide

Code	Description	Setting range	Default	Modify
F8.21	Dormancy delay	0~2000s	120s	○
F8.22	Dormancy threshold	0.00~550.0Hz	20.00Hz	○
F8.23	Awaken threshold	0.0~100.0% (relative to pre-set value)	80.00%	○
F8.24	PID feedback offline detection range	0.0~100.0% (relative to feedback measuring range, 0.0% no detection)	0.0%	○
F8.25	PID feedback offline detection time	0.0~50.0s	2.0s	○
F8.26	PID feedback offline detection Min. Freq.	0.00~50.00Hz	10.00Hz	○

Group F9: Multi-step speed and PLC

Code	Description	Setting range	Default	Modify
F9.00	Multi-step freq.1	0.00~Max frequency	5.00 Hz	○
F9.01	Multi-step freq.2	0.00~Max frequency	10.00 Hz	○
F9.02	Multi-step freq.3	0.00~Max frequency	15.00 Hz	○
F9.03	Multi-step freq.4	0.00~Max frequency	20.00 Hz	○
F9.04	Multi-step freq.5	0.00~Max frequency	30.00 Hz	○
F9.05	Multi-step freq.6	0.00~Max frequency	40.00 Hz	○
F9.06	Multi-step freq.7	0.00~Max frequency	50.00 Hz	○
F9.07	PLC running mode	0: Single cycle 1: Single cycle and hold final value 2: Continuous cycle	2	×
F9.08	PLC restarting mode after interrupt	0: Restart from first step 1: Continue from the step where the inverter interrupted	0	×
F9.09	PLC status recorded or not at power failure	0: Not save 1: Save	0	×
F9.10	Multi-steps time unit	0: Second 1: Minute	0	×
F9.11	PLC step1 time (T1)	0.1~3600	20	○
F9.12	PLC step2 time (T2)	0.0~3600	20	○
F9.13	PLC step3 time (T3)	0.0~3600	20	○
F9.14	PLC step4 time (T4)	0.0~3600	20	○
F9.15	PLC step5 time (T5)	0.0~3600	20	○

NE200&300 Quick Start Guide

Code	Description	Setting range	Default	Modify
F9.16	PLC step6 time (T6)	0.0~3600	20	○
F9.17	PLC step7 time (T7)	0.1~3600	20	○
F9.18	Step T1 program running setting	1 F/r ~ 4 F/r	1F	○
F9.19	Step T2 program running setting	1 F/r ~ 4 F/r	1F	○
F9.20	Step T3 program running setting	1 F/r ~ 4 F/r	1F	○
F9.21	Step T4 program running setting	1 F/r ~ 4 F/r	1F	○
F9.22	Step T5 program running setting	1 F/r ~ 4 F/r	1F	○
F9.23	Step T6 program running setting	1 F/r ~ 4 F/r	1F	○
F9.24	Step T7 program running setting	1 F/r ~ 4 F/r	1F	○
F9.25	Current running step	1~7	0	*
F9.26	Current step running time	0.0~3600	0	*
F9.27	Multi-step freq.8	0.00~Max frequency	50.00 Hz	○
F9.28	Multi-step freq.9	0.00~Max frequency	50.00 Hz	○
F9.29	Multi-step freq.10	0.00~Max frequency	50.00 Hz	○
F9.30	Multi-step freq.11	0.00~Max frequency	50.00 Hz	○
F9.31	Multi-step freq.12	0.00~Max frequency	50.00 Hz	○
F9.32	Multi-step freq.13	0.00~Max frequency	50.00 Hz	○
F9.33	Multi-step freq.14	0.00~Max frequency	50.00 Hz	○
F9.34	Multi-step freq.15	0.00~Max frequency	50.00 Hz	○
F9.35	PLC Multi-step Freq.1 selection	0:Multi-step digital setting 1: AI1 2: AI2	0	○
F9.36	PLC Multi-step Freq.7 selection	3: keyboard potentiometer 4: Pulse input	0	○

Group FA: Wobble Frequency

NE200&300 Quick Start Guide

Code	Description	Setting range	Default	Modify
FA.00	Wobble amplitude	0.0~50.0%	0.00%	○
FA.01	Jitter frequency	0.0~50.0%(to FA.00)	0.00%	○
FA.02	Jitter Time	5~50ms	5ms	○
FA.03	Wobble freq. up time	0.1~999.9s	5.0s	○
FA.04	Wobble freq. down time	0.1~999.9s	5.0s	○
FA.05	Amplitude mode	0: Relative to the central freq. 1: Relative to Max. frequency	0	○

Group Fb: Fixed Length

Code	Description	Setting range	Default	Modify
Fb.00	Preset length	0~65530	0	○
Fb.01	Actual length	0~65530	0	*
Fb.02	Pulses number per unit	0.1~6553.0	100	○

Group FC: Protection and Fault Parameters

Code	Description	Setting range	Default	Modify
FC.00	Motor overload protection mode	0: Disabled 1: Common motor (with low speed compensation) 2: Variable frequency motor (without low speed compensation)	1	×
FC.01	Electro thermal protection value	20~110%	100%	○
FC.02	Overload Pre-alarm detection level	30.0~200.0%	160%	×
FC.03	Overload Pre-alarm detection time	0.0~80.0s	60.0s	×
FC.04	Current amplitude	0:Invalid	2	○

NE200&300 Quick Start Guide

Code	Description	Setting range	Default	Modify
	limit	1: Acc./Dec. valid; Constant speed invalid 2: Valid all the time		
FC.05	Current amplitude limit level	Type G: 80.0~200.0% Type P: 60.0~150.0%	G: 160.0% P: 120.0%	○
FC.06	Over voltage stall function	0: Invalid (Recommended if braking resistor mounted) 1: Valid for Acc/Dec. 2: Valid all the time	1	×
FC.07	Overvoltage point for Acc./Dec. suspend	110.0~150.0%(Bus voltage)	380V: 140%	×
			220V: 120%	
FC.08	Input phase loss detection	1~100%(100% correspond to 800V)	20%	×
FC.09	Input phase loss detection delay time	2~255s	10s	×
FC.10	Output phase loss detection	0: Invalid 1: Valid	1	○
FC.11	Terminal close fault detection	0: Invalid 1: Valid	1	○
FC.12	Fault auto reset times	0~10, "0" means auto reset is disabled. Only 3 faults have auto reset function	0	×
FC.13	Fault auto reset interval	0.1~20.0s/time	5.0s	×
FC.14	Under-voltage fault treatment	0: No treatment 1: Auto reset at power recovery 2: Auto run at power recovery (Auto run time interval is F1.16)	0	○
FC.15	Fast current limit	50.0%~100.0% (100% means this function is disabled.)	80%	○

NE200&300 Quick Start Guide

Code	Description	Setting range	Default	Modify
FC.16	Fast current limit time	0.01~1.00s	0.10s	○
FC.17	Oversvoltage suppression freq.	0.00~10.00Hz	0.00Hz	○
FC.18	Modes of suppressing oversvoltage	0: M1 1: M2 3: M3	0	○
FC.19	Warning or Turn-off driver while overload or breakdown	0: only warning 1: Turn-off driver	0	○

Group Fd: Communication Parameters

Code	Description	Setting range	Default	Modify
Fd.00	Communication	0: RS485 disabled 1: RS485 enabled	0	○
Fd.01	Local address	1~247	1	○
Fd.02	Baud rate	0: 1200BPS 1: 2400BPS 2: 4800BPS 3: 9600BPS 4: 19200BPS 5: 38400BPS	3	○
Fd.03	Parity bit	0: Even parity check 1: Odd parity check 2: No parity check	0	○
Fd.04	Communication Timeout time	Range: 0.0~100.0s 0: No timeout detection Others: Over timeout detection	0.0s	○
Fd.05	Response delay	0~500ms	5ms	○
Fd.06	Communication Freq. setting coefficient	0.0~200.0%	100.00%	○
Fd.07	Communication interrupt detection mode	0: Time interval between 2 packets receiving. 1: Time interval of 0005H Add. data writing	0	○

NE200&300 Quick Start Guide

Code	Description	Setting range	Default	Modify
Fd.08	Feedback or not (Y or N) While writing into COMMS setting	0: Y 1: N	0	○
Fd.09	Save the COMMS setting or not (Y or N) While power down	0: N 1: Y	0	○

Group FE: Operation interface & display

Code	Description	Setting range	Default	Modify
FE.00	Parameter display	0: Normal 3-levels menu display 1: Only display modified parameters	0	○
FE.01	MFK Key function selection	0: MFK inactive 1: JOG running 2: FWD/REV switching 3: UP/DOWN clear 4: Running command switch (terminal or communication) 7: RUN for FWD, MFK for REV, STOP for STOP	0	○
FE.02	STOP key function	0: Valid only in keypad control mode 1: Valid in stop state of terminal/communication control mode 2: Valid in Fault state of terminal/communication control mode 3: Valid in both stop & fault state of terminal/communication control mode	2	○
FE.03	Running freq.(Hz) (before compensation)	0: No display 1: Display at stop 2: Display at running 3: Display at stop & running	2	○
FE.04	Running freq. (Hz) (After compensation)	0: No display 1: Display at stop 2: Display at running	0	○

NE200&300 Quick Start Guide

Code	Description	Setting range	Default	Modify
		3: Display at stop & running		
FE.05	Reference frequency (Hz blinking)	0: No display 1: Display at stop 2: Display at running 3: Display at stop & running	1	<input type="radio"/>
FE.06	Output current(A)	0: No display 1: Display at stop 2: Display at running 3: Display at stop & running	2	<input type="radio"/>
FE.07	Bus voltage (V)	0: No display 1: Display at stop 2: Display at running 3: Display at stop & running	3	<input type="radio"/>
FE.08	Output voltage (V)	0: No display 1: Display at stop 2: Display at running 3: Display at stop & running	0	<input type="radio"/>
FE.09	Output torque (%)	0: No display 1: Display at stop 2: Display at running 3: Display at stop & running	0	<input type="radio"/>
FE.10	Reference torque (% blinking)	0: No display 1: Display at stop 2: Display at running 3: Display at stop & running	0	<input type="radio"/>
FE.11	Rotate speed (r/min)	0: No display 1: Display at stop 2: Display at running 3: Display at stop & running	0	<input type="radio"/>
FE.12	Reference speed (r/min blinking)	0: No display 1: Display at stop 2: Display at running 3: Display at stop & running	0	<input type="radio"/>
FE.13	Output power (kW)	0: No display 1: Display at stop 2: Display at running 3: Display at stop & running	0	<input type="radio"/>

NE200&300 Quick Start Guide

Code	Description	Setting range	Default	Modify
FE.14	AI1 (V)	0: No display 1: Display at stop 2: Display at running 3: Display at stop & running	0	<input type="radio"/>
FE.15	AI2 (V)	0: No display 1: Display at stop 2: Display at running 3: Display at stop & running	0	<input type="radio"/>
FE.16	Analog PID feedback	0: No display 1: Display at stop 2: Display at running 3: Display at stop & running	0	<input type="radio"/>
FE.17	Analog PID setup	0: No display 1: Display at stop 2: Display at running 3: Display at stop & running	0	<input type="radio"/>
FE.18	Terminal status (no unit)	0: No display 1: Display at stop 2: Display at running 3: Display at stop & running	0	<input type="radio"/>
FE.19	Actual length	0: No display 1: Display at stop 2: Display at running 3: Display at stop & running	0	<input type="radio"/>
FE.20	Reference length	0: No display 1: Display at stop 2: Display at running 3: Display at stop & running	0	<input type="radio"/>
FE.21	Linear speed (m/s)	0: No display 1: Display at stop 2: Display at running 3: Display at stop & running	0	<input type="radio"/>
FE.22	External count value (no unit)	0: No display 1: Display at stop 2: Display at running 3: Display at stop & running	0	<input type="radio"/>

NE200&300 Quick Start Guide

Group FF: Running History Record

Code	Description	Setting range	Default	Modify
FF.00	Type of latest fault	0: NULL 1: Uu1 bus under-voltage 2: OC1 Acc. over current 3: OC2 Dec. over current 4: OC3 Constant speed over current 5: Ou1 Acc. over voltage 6: Ou2 over voltage in deceleration 7: Ou3 over voltage in constant speed 8: GF Ground Fault 9: SC Load Short-Circuit 10: OH1 Radiator over heat 11: OL1 Motor overload 12: OL2 Inverter overload 13: EF0 communication fault 14: EF1 external terminal fault 15: SP1 Input phase failure or input phases unbalance 16: SPO Output phase failure or Unbalance 17: EEP EEPROM Fault 18: CCF Transmission between the inverter and keyboard cannot be established 19: bCE Brake unit fault 20: PCE Parameter copy Error 21: IDE Hall current detection fault 22: ECE PG fault 23: LC fast current limit fault 24: EF2 terminal close fault 25: PIDE: PID feedback offline	NULL	*
FF.01	Output freq. at latest fault	0~Frequency upper limit	0.00Hz	*
FF.02	Reference frequency at latest fault	0~Frequency upper limit	0.00Hz	*

NE200&300 Quick Start Guide

Code	Description	Setting range	Default	Modify
FF.03	Output current at latest fault	0~2* inverter rated current	0.0A	*
FF.04	Bus voltage frequency at latest fault	0~1000V	0V	*
FF.05	Running status at latest fault	0: StP Stop 1: Acc acceleration 2: dEc deceleration 3: con constant speed	0	*
FF.06	Fault history 1 (Last One)	The same as FF.00	NULL	*
FF.07	Fault history 2	The same as FF.00	NULL	*
FF.08	Total power on time	0~65530h	0h	*
FF.09	Total running time	0~65530h	0h	*
FF.10	Reserved	Reserved	Reserved	-
FF.11	Soft Software version number of control board	1.00~10.00	1	-
FF.12	Non-standard version number of software	0~255	0	-
FF.13	Heat sink temperature	-30.0~120.0°C		-
FF.14	Exciting current	-200.0~200.0%		*
FF.15	Torque current	-200.0~200.0%		*

Group FP Protection Parameters

Code	Description	Setting range	Default	Modify
FP.00	User password	0: No password Others: password protection	0	○
FP.01	Parameter write-in protection	0: All parameters are allowed modifying 1: Only FP.01 and FP.03 can be modified 2: All parameters aren't allowed read	0	○

NE200&300 Quick Start Guide

Code	Description	Setting range	Default	Modify
FP.02	Parameter initialization	0: No operation 1: Clear fault history When FP.02 is set to 1, the fault records of FF.00~FF.07 will be cleared. 2: Restore to defaults	0	×
FP.03	Parameter copy	0: No action 1: Parameters download 2: Parameters upload(except motor's parameters) 3: Parameters upload (all parameters)	0	×
FP.04	Parameter upload protection	0: Protection enabled 1: Protection disabled	0	×
FP.05	G/P model selection	0: Type G 1: Type P	0	×
FP.07	User parameters backup	0: Invalid 1: Valid	0	×
FP.08	User parameters recovery	0: Invalid 1: Valid	0	×

8. Trip information and trouble shooting

Once a trip is detected, NE200&300 would immediately block PWM output and enter the trip protection state; meanwhile TRIP on the keyboard would spark and the LED display the trip code. At this point one must identify the cause of trip and its corresponding solutions according to the method suggested in this section, if it does not work, please contact us immediately. The trip codes and their respective solutions are present in Table 8-1.

Note: A trip code with a sign "③" indicates this trip code is only for NE300

Table 8-1 trip diagnosis and its solutions

Trip code	Trip Type	Possible causes	Solutions
Uu1	Bus Under voltage during running	1.Power grid low voltage	1. Check the input power source.
OC1	Over current in Acceleration	1. Acceleration time too short 2. Power grid low voltage 3. Inverter power rating too small	1. Increase the acceleration time. 2. Check the input power source. 3. Choose inverter with higher capacity.
OC2	Over current in Deceleration	1. Deceleration time too short 2. Large load inertia 3. Inverter power rating too small	1. Increase the deceleration time. 2. Add suitable brake devices. 3. Choose higher capacity drive
OC3	Over current at constant-speed	1 .Abnormal Load mutation 2. Power grid low voltage 3. Inverter power rating too small 4.Encoder sudden	1. Check the load 2. Check the input power source. 3. Choose higher capacity drive 4. Check the encoder and its

NE200&300 Quick Start Guide

Trip code	Trip Type	Possible causes	Solutions
		offline in closed-loop vector control	wiring.
Ou1	Over Voltage in Acceleration	1. Acceleration time too short 2. Power supply abnormal	1. Increase the acceleration time 2. Check the input power source.
Ou2	Over voltage in deceleration	1. Deceleration time too short 2. Large load inertia	1. Increase the deceleration time 2. Add suitable brake devices.
Ou3	Over voltage in constant speed	1. Power supply abnormal 2. Large load inertia	1. Check the input power source. 2. Add suitable braking devices.
GF 	Ground Fault	1. One output phase got short circuit problem.	1. Check whether the electric motor insulation is weakening. 2. Check whether the wiring between the frequency converter and the electric motor is damaged.
SC	Load short-circuit	1. Wiring of inverter and motor get phase-to-phase short circuit 2. Damage of the inverting module IGBT	1. Check whether the electric motor coil is short circuit. 2. Ask for the services from manufactures.
OH1	Heat-sink over heat	1. Ambient temperature too high 2. Fan is damaged 3. Fan air duct is blocked	1. Lower the ambient temperature. 2. Change the fan 3. Clear the air duct.
OL1	Motor overload	1. Power supply abnormal 2. Motor rated current set wrongly	1. Check the input power source. 2. Check whether the motor's rated current is correctly set up.

NE200&300 Quick Start Guide

Trip code	Trip Type	Possible causes	Solutions
		3.The Curve of V/F is not fit	3. Adjust the V/F curve and torque boosting performance.
		4. Motor always works with heavy load at low speed. 5. Motor blocked to stall or sudden large load change 6.Motor power too low	4. Use specialized electric motor. 5. Check whether the motor or the load is blocked to stall or not. 6. Use motor and inverter of suitable power ratings
OL2	Inverter overload	1. Low voltage in power grid 2. Load too heavy 3. Acceleration too fast 4.Restart the motor still in turning	1. Check the input power source. 2. Select bigger capacity inverter. 3. Increase the acceleration time 4. Avoid restarting when the motor is in rotation.
EF0	Communication fault	1. Baud rate and parity checksum is set incorrect 2. Communication interrupted for long time	1. Check communication parameters correct or not. 2. Check the interface wiring.
EF1	External terminal fault	1. Faults comes from external control circuit	1. Check the external input
SP1	Input phase loss	1. Input R,S,T have phase loss or imbalance	1. Check input voltage
SPO	Output phase loss	1.There is lack of U,V,W when output 2.There is a serious unbalance in output	1. Check U-V-W motor wiring 2. Check the load
EEP	EEPROM error	1.Function code parameter writing error 2. EEPROM	1. Recover factory defaults 2. Ask for service from supplier

NE200&300 Quick Start Guide

Trip code	Trip Type	Possible causes	Solutions
		damaged	
CCF	Keypad & control board communication interrupted	1.Connection cable between keyboard and control panel is broken	1. Check the connection cable between keyboard and control panel
bCE	Brake unit fault	1.The braking line or braking pipe is broken 2.brake resistor is too lower	1. Check the brake unit, change the brake pipe. 2. Choose the suitable braking resistor.
PCE	Parameter copy Error	1. Too long connection cable between keypad and control board leads to interference in parameters transmission. 2. The downloading parameters do not match the existed parameters in the inverter.	1. Shorten the cable between Keyboard and control board to reduce interference. 2. Before downloading, make sure the parameters match the inverter.
IDE	IDE Hall current detection fault	1. The current sensing or hall device get damaged.	1. Ask for service from supplier
ECE 	Encoder fault	1. Encoder signal wires are connected reversely. 2. Encoder signal wires get damaged. 3. Encoder damaged. 4. Dual-way encoder detected motor direction is not match	1. Check whether the encoder signal is correctly connected. 2. Check whether the encoder wiring is broke. 3. Change the encoder. 4. Change the encoder direction (F3.16) or alter motor wiring sequence.

NE200&300 Quick Start Guide

Trip code	Trip Type	Possible causes	Solutions
		with inverter direction.	
LC	Fast current limit fault	<ol style="list-style-type: none"> 1. Load too large or motor blocked to stall 2. Inverter power rating too small 3. Inverter output circuit loop grounded or SC. 	<ol style="list-style-type: none"> 1. Decrease the load and check motor and mechanical part status 2. Choose higher power inverter 3. Remove the external fault
EF2	Terminal close fault	1. The FWD or REV terminals close and get power on. But inverter is set to not allow the restart after power failure recovery.	<ol style="list-style-type: none"> 1. Disconnect the FWD or REV terminal first and then power on the inverter. 2. Close the fault detection function for closed terminal fault (FC.11=0)
PIDE	PID feedback error	1. PID feedback offline	<ol style="list-style-type: none"> 1. Check PID feedback line. 2. Disable PID feedback detection (F8.24=0.0%) 3. Increase PID feedback offline detection time (F8.25)
OLP2	Overload pre-alarm error	1.frequency inverter output current is higher than set pre-alarm threshold	<ol style="list-style-type: none"> 1. Disable pre-alarm function(FC.19=0) 2. Increase pre-alarm threshold value (FC.02) 3. Increase pre-alarm detection time(FC.03)

NE200&300 Quick Start Guide

Hazardous substance limit table for electrical and electronic products

Part Name	Hazardous substances					
	Lead (Pb)	Mercury (Hg)	Cadmium (Cd)	Hexavalent Chromium (Cr +6)	Polybrominated biphenyls (PBB)	Polybrominated diphenyl ethers (PBDE)
Electronics assembly	X	0	0	0	0	0
Housing assembly	0	0	0	0	0	0
Keypad Battery	0	0	0	0	0	0

This table is in accordance with the provision of SJ/T11364

O: Indicates that said hazardous substance in all of the homogeneous materials for this part is below the limit requirement of GB/T 26572

X: Indicates that said hazardous substance contained in at least one of the homogeneous materials used for this part is above the limit requirement of GB/T 26572.

Inspection Certificate

产品合格证

This document certifies that this product
本文档证明

Inverter

变频器类产品

Applied to standards

执行标准 (IEC61800 / EN61800 / GB12668)

was dispatched fully functional tested and inspected in
accordance with Control Techniques specifications and
drawings.

已通过全功能测试检查，符合 Control Techniques 规范和图纸。



Operations Director

1st Floor Machinery Building, EVOC Science & Technology Park, No. 11 West
Gaoxin Road, Guangming District, Shenzhen, Guangdong

广东省深圳市光明新区高新区高新西路 11 号研祥科技工业园机械厂房 1 楼

Tel: 0755-86010763

CONTROL TECHNIQUESTM