

# Soft starters **ATS 01**

Catalogue  
May

# 07





- 1** – Altistart 01
  
- 2** – Altistart U01



# 1 - Altistart 01 soft starters for asynchronous motors

---

■ Presentation.....	pages 1/2 and 1/3
■ Characteristics.....	pages 1/4 and 1/5
■ References.....	page 1/6
■ Dimensions.....	page 1/7
■ Schemes.....	pages 1/8 to 1/15
■ Combinations.....	pages 1/16 and 1/17



# Soft starters for asynchronous motors

## Altistart 01

1

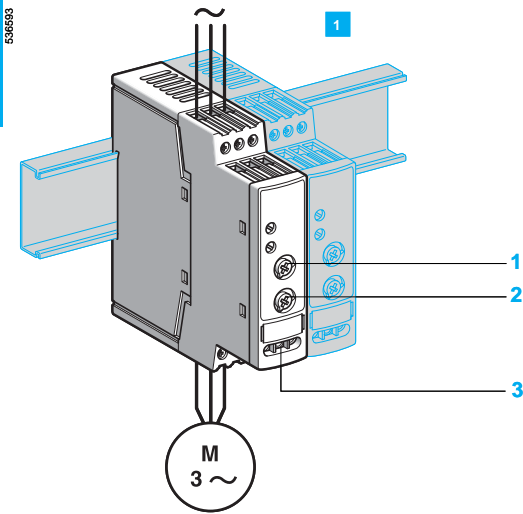

536594

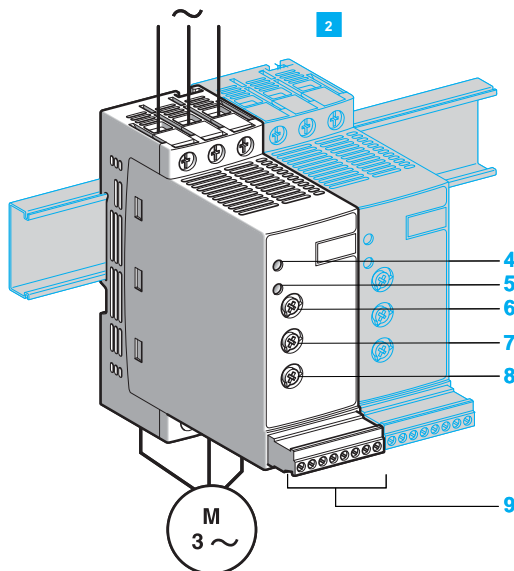

### Presentation

The Altistart 01 soft starter operates either as a torque limiter on starting, or as a soft start/soft stop unit for asynchronous motors.

Using the Altistart 01 starter enhances the starting performance of asynchronous motors by allowing them to start gradually, smoothly and in a controlled manner. It prevents mechanical shocks, which lead to wear and tear, and subsequent maintenance work and production downtime.

The Altistart 01 limits the starting torque and current peaks on starting on machines which do not require a high starting torque.

It is designed for the following simple applications:

- Conveyors
- Conveyor belts
- Pumps
- Fans
- Compressors
- Automatic doors and gates
- Small cranes
- Belt-driven machinery, etc.

The Altistart 01 is compact, easy to install and can be mounted side-by-side. It complies with standards IEC/EN 60947-4-2, carries UL, CSA, C-Tick, CCC certifications and CE marking.

The Altistart 01 soft start/soft stop unit offer comprises 3 ranges:

#### ■ 1 ATS 01N1●●● soft starters

- Control one phase of the motor power supply (single phase or three phase) to limit the starting torque
  - Internal bypass relay
  - Motor power ratings ranging from 0.37 kW to 11 kW
  - Motor supply voltages ranging from 110 V to 480 V, 50/60 Hz. An external power supply is required for controlling the starter.
- A contactor is always required to switch off the motor.

#### ■ 2 ATS 01N2●●● soft start/soft stop units

- Control two phases of the motor power supply to limit the starting current and for deceleration
  - Internal bypass relay
  - Motor power ratings ranging from 0.75 kW to 75 kW
  - The motor supply voltages are as follows: 230 V, 400 V, 480 V and 690 V, 50/60 Hz
- The use of a line contactor is not necessary on machines where electrical isolation is not required.

#### ■ ATSU 01N2●●● soft start/soft stop units

See pages 2/2 to 2/11.

### Description

■ Altistart 01 soft starters (ATS 01N1●●●) are equipped with:

- A potentiometer 1 for setting the starting time
- A potentiometer 2 for adjusting the start voltage threshold according to the motor load
- Two inputs 3:
  - One 24 V  $\approx$  input or one 110...240 V  $\sim$  for powering the control part that controls the motor

■ Altistart 01 soft start/soft stop units (ATS 01N2●●●) are equipped with:

- A potentiometer 6 for setting the starting time
- A potentiometer 8 for setting the deceleration time
- A potentiometer 7 for adjusting the start voltage threshold according to the motor load
- 1 green LED 4 to indicate that the unit is switched on
- 1 yellow LED 5 to indicate that the motor is powered at nominal voltage, if it is connected to the starter
- A connector 9:
  - 2 logic inputs for Run/Stop commands
  - 1 logic input for the BOOST function
  - 1 logic output to indicate the end of starting
  - 1 relay output to indicate the motor has reached a standstill at the end of the deceleration stage

# Soft starters for asynchronous motors

## Altistart 01

### Description (continued)

#### Equivalence table for contact references

Functions	ATS 01N2●●LU/QN/RT	ATS 01N2●●LY	ATS 01N2●●Q
Relay outputs	R1A	04	04
	R1C	05	05
External power supply 0 V	C0M	–	–
Stop command	LI1	02	02
Run command	LI2	03	03
Control section power supply	LI + (+ 24 V positive logic)	01 (0 V negative logic)	01 (0 V negative logic)
BOOST	BOOST	–	–
End of starting	LO1	–	–
115 V external power supply	–	06	–
	–	07	–

### Functions

#### ■ 2-wire control

The run and stop commands are controlled by a single logic input. State 1 of logic input LI2 controls starting and state 0 controls stopping.

##### ATS 01N2●●LU/QN/RT

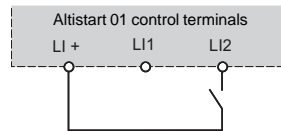

Wiring diagram for 2-wire control

##### ATS 01N2●●LY/Q

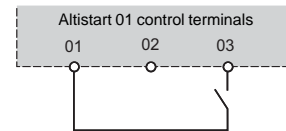

Wiring diagram for 2-wire control

#### ■ 3-wire control

The run and stop commands are controlled by 2 different logic inputs.

Stopping is achieved when logic input LI1 opens (state 0).

The pulse on input LI2 is stored until input LI1 opens.

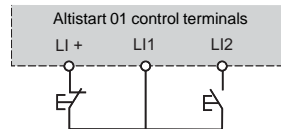

Wiring diagram for 3-wire control

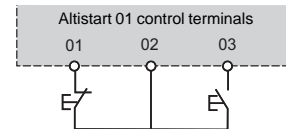

Wiring diagram for 3-wire control

#### ■ Starting time

Controlling the starting time means that the time of the voltage ramp applied to the motor can be adjusted to obtain a gradual starting time, dependent on the motor load.

#### ■ Voltage boost function via logic input

Activating the BOOST logic input enables the function for supplying a starting overtorque capable of overcoming any mechanical friction.

When the input is at state 1, the function is active (input connected to the + 24 V) and the starter applies a fixed voltage to the motor for a limited time before starting.

#### ■ End of starting

Application function via logic output LO1

Soft start/soft stop units ATS 01N206●● to ATS 01N232●● are equipped with an open collector logic output LO, which indicates the end of starting when the motor has reached nominal speed.

Application function via an option

For ATS 01N2●●LY/Q soft start/soft stop units, end of starting information can be obtained by adding the option LAD 8N11 with N/O+N/C contacts.

The option can be connected easily to the bypass contactor of the electronic(s) unit without dismantling the product.

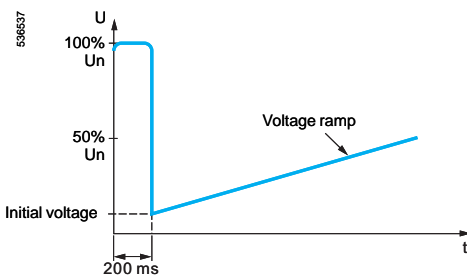

Application of a voltage boost equal to 100% of the nominal motor voltage

### Environment characteristics

Type of starter		ATS 01N1●●FT, ATS 01N2●●LU, ATS 01N2●●QN, ATS 01N2●●RT	ATS 01N2●●LY and ATS 01N2●●Q
Conforming to standards		Altistart 01 electronic starters have been developed to conform to the strictest international standards and the recommendations relating to electrical industrial control devices (IEC, EN), in particular standard IEC/EN 60947-4-2	
Electromagnetic compatibility EMC	Conducted and radiated emissions	CISPR 11 level B, IEC 60947-4-2, level B	CISPR 11 level B (only with Bypass), IEC 60947-4-2, level B
	Harmonics	IEC 1000-3-2, IEC 1000-3-4	
	EMC immunity	EN 50082-2, EN 50082-1	
	Electrostatic discharge	IEC 61000-4-2 level 3	
	Immunity to radiated radio-electrical interference	IEC 61000-4-3 level 3	
	Immunity to electrical transients	IEC 61000-4-4 level 4	
	Voltage/current impulse	IEC 61000-4-5 level 3	
	Immunity to conducted interference caused by radio-electrical fields	IEC 61000-4-6 level 3	
	Micro-cuts and voltage fluctuation	IEC 61000-4-11	
Damped oscillating waves		IEC 61000-4-12 level 3	
CE marking		Bear CE marking in accordance with the European low voltage directives IEC/EN 60947-4-2	
Product certifications		UL, CSA, C-Tick and CCC B44.1-96/ASME A17.5 for starter wired to the motor delta terminal	
Degree of protection		IP 20	IP 20 on front panel
Degree of pollution		2 conforming to IEC/EN 60947-4-2	
Vibration resistance		1.5 mm peak to peak from 3 to 13 Hz, 1 gn from 13 to 150 Hz conforming to IEC/EN 60068-2-6	2 gn
Shock resistance		15 gn for 11 ms conforming to IEC/EN 60068-2-27	8 gn for 11 ms conforming to IEC/EN 60068-2-27
Relative humidity		5...95% without condensation or dripping water, conforming to IEC/EN 60068-2-3	
Ambient air temperature around the device	Storage	°C - 25...+ 70 conforming to IEC/EN 60947-4-2	
	Operation	- 10...+ 40 without derating, up to 50°C with current derating of 2% per °C above 40°C	0...+ 55
Maximum operating altitude		m 1000 without derating (above this, derate the current by 2.2% per additional 100 m)	2000 without derating (above this, derate the current by 0.5% per additional 100 m)
Operating position Maximum permanent angle in relation to the normal vertical mounting position			

### Electrical characteristics

Type of starter	ATS	01N1●●FT	01N2●●LU	01N2●●QN	01N2●●RT	01N2●●LY	01N2●●Q		
Category of use	Conforming to IEC 60947-4-2	Ac-53b							
Rated operating voltage	Three-phase voltage	V 110 - 10% to 480 + 10%	200 - 10% to 240 + 10%	380 - 10% to 415 + 10%	440 - 10% to 480 + 10%	230 - 15% to 690 + 10%	400 -15...+ 10%		
Frequency		Hz 50 - 5% to 60 + 5%							
Output voltage		Maximum 3-phase voltage equal to line supply voltage.							
Control power supply voltage	V	~ 110...220 ± 10% ~ 24 ± 10%	Built into the starter			~ 110 ± 10%	Built into the starter		
Rated operating current	A	3...25	6...32			32...85			
Adjustable starting time	s	1...5	1...10			1...25			
Adjustable deceleration time	s	-	1...10			1...25			
Starting torque	%	30...80% of starting torque of motor connected directly on the line supply							
Type of starter	ATS	01N1●●FT	01N206●● to 01N222●●			01N232●●		01N2●●LY, 01N2●●Q	
Use	Starting time	s							
		1	5	1	5	10	1	5	10
Use	Maximum number of cycles per hour								
		100	20	100	20	10	50	10	5

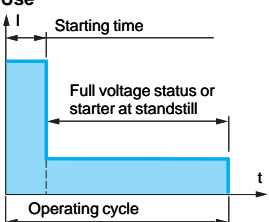

Starting time

Full voltage status or starter at standstill

Operating cycle



# Soft starters for asynchronous motors

## Altistart 01

Electrical characteristics (continued)							
Type of starter	ATS 01N1	03FT	06FT	09FT	12FT	25FT	
Control power supply consumption		~ 24 V, 25 mA, ~ 110 V, 30 mA ~ 240 V, 65 mA		~ 24 V, 30 mA, ~ 110 V, 35 mA, ~ 240 V, 80 mA			
Power dissipated	At full load at end of starting	W	4	1	1	1	
	In transient state	W	19	31	46	61	126
Current at nominal load (1)	A	15	30	45	60	125	
Type of starter	ATS 01N2	06LU/QN/RT	09LU/QN/RT	12LU/QN/RT	22LU/QN/RT	32LU/QN/RT	
Power dissipated	At full load at end of starting	W	4	4	4	4.5	4.5
	In transient state	W	64	94	124	224.5	324.5
Current at nominal load (1)	A	30	45	60	110	160	
Type of starter	ATS 01N2	30LY/Q	44LY/Q	72LY/Q	85LY/Q		
Power dissipated	At full load at end of starting	W	22	22	23	23	
	In transient state	W	184	268	436	514	
Current at nominal load (1)	A	90	132	216	255		
Type of starter	ATS 01N2	●●LU/QN/RT			●●LY/Q		
Logic input power supply: (electrically isolated between power and control) LI+, COM		24 V power supply Max. current available 10 mA. No short-circuit and overload protection			-		
Logic inputs LI1, LI2, BOOST (01, 02, 03 for ATS 01N2●●LY/Q) Stop, run and boost on start-up functions		Logic inputs with impedance 27 kΩ 24 V power supply (U max. 40 V) Max. current consumption 8 mA State 0 if U < 5 V and I < 0.2 mA State 1 if U > 13 V and I > 0.5 mA			Input with internal control relay, internal 24 V power supply Max. current 8 mA State 0 if I < 3 mA State 1 if I > 10 mA		
Logic output LO1 End of starting signal		Open collector logic output External 24 V power supply (min. 6 V, max. 30 V) Max. current 200 mA			-		
Relay outputs R1A R1C (04, 05 for ATS 01N2●●LY/Q)		Normally open (N/O) contact Minimum switching capacity: 10 mA for ~ 6 V Max. switching capacity on inductive load (cos φ = 0.5 and L/R = 20 ms): 2 A for ~ 250 V or ~ 30 V (AC-15) Max. operating voltage 440 V			Operating category AC-15: Ie 3 A, Ue 250 V, DC-13: Ie 2 A, Ue 24 V, Minimum switching capacity: 10 mA for ~ 17 V Maximum operating voltage 250 V		
LED signalling	Green LED	Starter powered up					
	Yellow LED	Nominal voltage reached					

(1) Acceleration current complying with the maximum conditions of use (see page 1/4).

Connections (Maximum connection capacity and tightening torque)						
Type of starter	ATS	01N103FT, 01N106FT	01N109FT, 01N112FT, 01N125FT, 01N206●● to 01N232●●	01N2●●LY and 01N2●●Q		
Power circuit		Cage type connector		Connection via Ø 4 mm screw clamp		
Flexible wire without cable end	1 conductor	mm <sup>2</sup>	2.5 14 AWG	1.5...10 8 AWG	6...25	
	2 conductors	mm <sup>2</sup>	1 17 AWG	1.5...6 10 AWG	6...25	
Flexible wire with cable end	1 conductor	mm <sup>2</sup>	2.5 14 AWG	1...6 10 AWG	4...25	
	2 conductors	mm <sup>2</sup>	0.75 18 AWG	1...6 10 AWG	4...16	
Rigid wire	1 conductor	mm <sup>2</sup>	2.5 14 AWG	1...10 8 AWG	6...35	
	2 conductors	mm <sup>2</sup>	1 17 AWG	1...6 10 AWG	6...25	
Tightening torque		N.m	0.8	1.9...2.5	5	
Control circuit			Cage type connector	Screw connector		
Flexible wire without cable end	1 conductor	mm <sup>2</sup>	2.5 14 AWG	0.5...2.5 14 AWG	0.75...1.5	
	2 conductors	mm <sup>2</sup>	1 17 AWG	0.5...1.5 16 AWG	0.75...1.5	
Flexible wire with cable end	1 conductor	mm <sup>2</sup>	2.5 14 AWG	0.5...1.5 16 AWG	0.75...1.5	
	2 conductors	mm <sup>2</sup>	0.75 18 AWG	0.5...1.5 16 AWG	0.75...1.5	
Rigid wire	1 conductor	mm <sup>2</sup>	2.5 14 AWG	0.5...2.5 14 AWG	0.75...1.5	
	2 conductors	mm <sup>2</sup>	1 17 AWG	0.5...1 17 AWG	0.75...1.5	
Earth connection			-	-		Tinned connector. Fixed using Ø 6 screws
Tightening torque		N.m	0.8	0.5	0.7	

### Torque characteristics (typical curves)

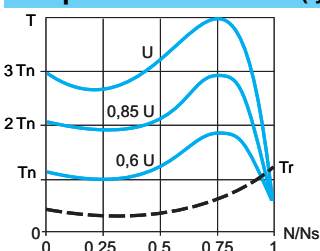

The diagram opposite shows the torque/speed characteristic of a cage motor in relation to the supply voltage.

The torque varies in line with the square of the voltage at a fixed frequency.

The gradual increase in the voltage prevents the instantaneous current peak on power-up.

# Soft starters for asynchronous motors

## Altistart 01

1



ATS 01N103FT



ATS 01N212QN



ATS 01N230LY

### Soft starters for 0.37 to 11 kW motors

Motor						Starter		
Motor power (1)						Nominal current	Reference (2)	Weight
Single phase 3-phase								
230 V	210 V	230 V	230 V	400 V	460 V	A		kg
kW	HP	kW	HP	kW	HP			
<b>Single phase 110...230 V or 3-phase 110...480 V supply voltage, 50/60 Hz</b>								
0.37	–	0.37	0.5	1.1	0.5	3	ATS 01N103FT	0.160
	–	0.55	–	–	1.5			
0.75	0.5	0.75	1	2.2	2	6	ATS 01N106FT	0.160
	–	1.1	1.5	3	3			
1.1	1	1.5	2	4	5	9	ATS 01N109FT	0.280
1.5	1.5	2.2	3	5.5	7.5	12	ATS 01N112FT	0.280
2.2	2	3	5	7.5	10	25	ATS 01N125FT	0.350
	3	4	7.5	9	15			
		5.5		11				

### Soft start/soft stop units for 0.75 to 15 kW motors (3)

Motor		Starter		
Motor power (1)		Nominal current	Reference (2)	Weight
kW	HP			
<b>3-phase supply voltage: 200...240 V 50/60 Hz</b>				
0.75/1.1	1/1.5	6	ATS 01N206LU	0.420
1.5	2	9	ATS 01N209LU	0.420
2.2/3	3/–	12	ATS 01N212LU	0.420
4/5.5	5/7.5	22	ATS 01N222LU	0.560
7.5	10	32	ATS 01N232LU	0.560
<b>3-phase supply voltage: 380...415 V 50/60 Hz</b>				
1.5/2.2/3	–	6	ATS 01N206QN	0.420
4	–	9	ATS 01N209QN	0.420
5.5	–	12	ATS 01N212QN	0.420
7.5/11	–	22	ATS 01N222QN	0.560
15	–	32	ATS 01N232QN	0.560
<b>3-phase supply voltage: 440...480 V 50/60 Hz</b>				
–	2/3	6	ATS 01N206RT	0.420
–	5	9	ATS 01N209RT	0.420
–	7.5	12	ATS 01N212RT	0.420
–	10/15	22	ATS 01N222RT	0.560
–	20	32	ATS 01N232RT	0.560

### Soft start/soft stop units for 15 to 75 kW motors

Motor							Starter		
Motor power (1)							Nominal current	Reference (2)	Weight
230 V	230 V	400 V	400 V	460 V	575 V	690 V			
kW	HP	kW	HP	HP	HP	kW	A		kg
7.5	10	15	15	20	30	30	32	ATS 01N230LY	2.400
11	15	22	25	30	40	37	44	ATS 01N244LY	2.400
18.5	25	37	40	50	60	55	72	ATS 01N272LY	3.800
22	30	45	50	60	75	75	85	ATS 01N285LY	3.800
<b>3-phase supply voltage: 400 V 50/60 Hz (3)</b>									
Motor							Starter		
Motor power (1)							Nominal current	Reference (2)	Weight
kW	HP								
22	25						44	ATS 01N244Q	2.400
37	40						72	ATS 01N272Q	3.800
45	50						85	ATS 01N285Q	3.800

(1) Standard power ratings of motors, HP power ratings indicated according to standard UL 508.

(2) For thermal protection of the motor, please use a thermal circuit-breaker GV•ME, GV3 P or GV7 RE (see combinations pages 1/16 and 1/17).

(3) Control power supply built into the starter.

### References (continued)

Accessories				
Description	Used for starter	Reference	Weight	kg
Plate for quick mounting on DIN rail	ATS 01N230LY, ATS 01N244●	VY1 H4101	-	-
Adaptor for mounting on $\perp$ DZ5 MB rail	ATS 01N103FT, ATS 01N106FT	RHZ 66	0.005	-
Auxiliary contact, provides information that the motor is at full voltage	ATS 01N2●●●LY, ATS 01N2●●●Q	LAD 8N11	-	-

### Dimensions

#### ATS 01N103FT, ATS 01N106FT

Mounting on  $\perp$  (35 mm) rail or  
 $\perp$  rail with adaptor RHZ 66

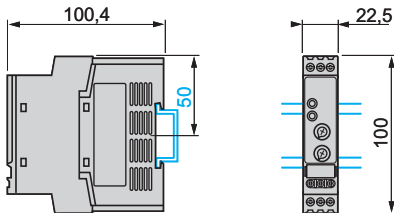

#### ATS 01N109FT, ATS 01N112FT, ATS 01N125FT

Mounting on  $\perp$  (35 mm) rail

Screw fixing

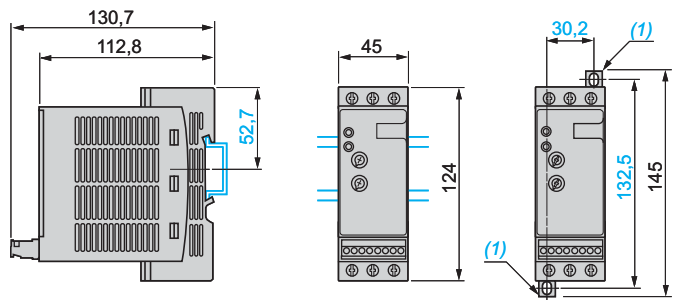

#### ATS 01N206●● to ATS 01N212●●

Mounting on  $\perp$  (35 mm) rail

Screw fixing

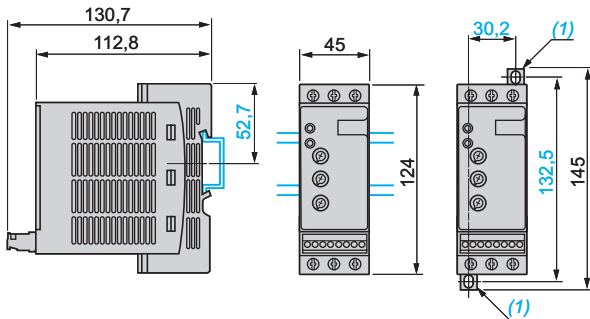

(1) Retractable fixings

#### ATS 01N222●● to ATS 01N232●●

Mounting on  $\perp$  (35 mm) rail

Screw fixing

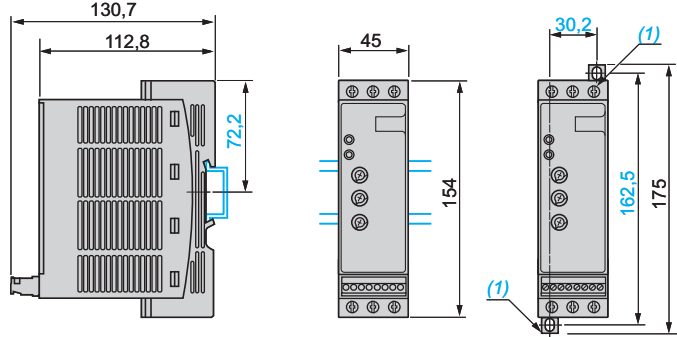

(1) Retractable fixings

#### ATS 01N230LY, ATS 01N244LY, ATS 01N244Q

Quick mounting on  $\perp$  rail (35 or 70 mm) using plate VY1 H4101 (1)

#### ATS 01N272LY, ATS 01N285LY, ATS 01N272Q, ATS 01N285Q

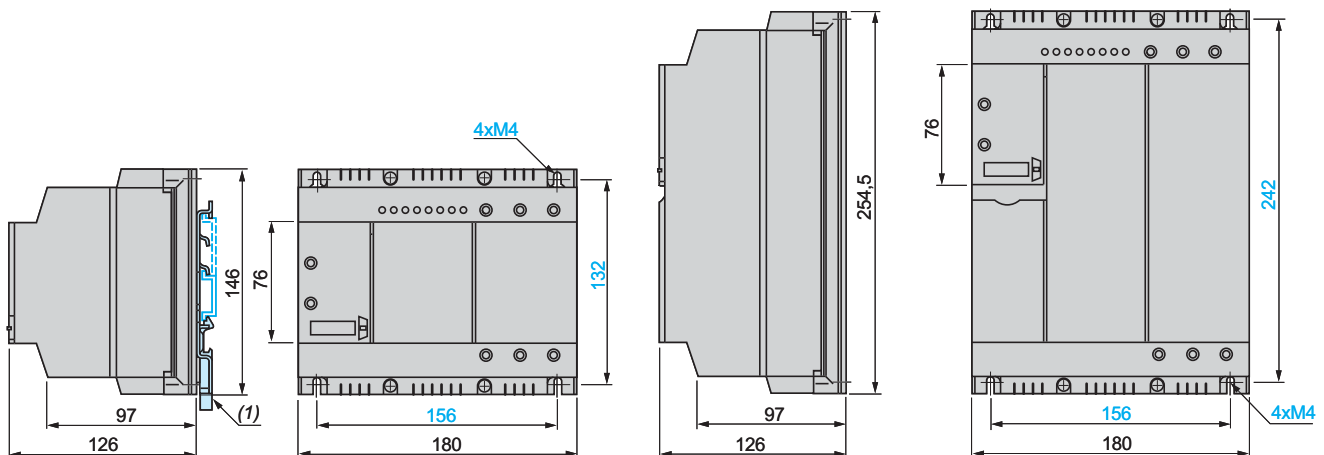

# Soft starters for asynchronous motors

Altistart 01

For 0.37 to 11 kW motors

## ATS 01N1●●FT soft starters

Single-phase or 3-phase power supply

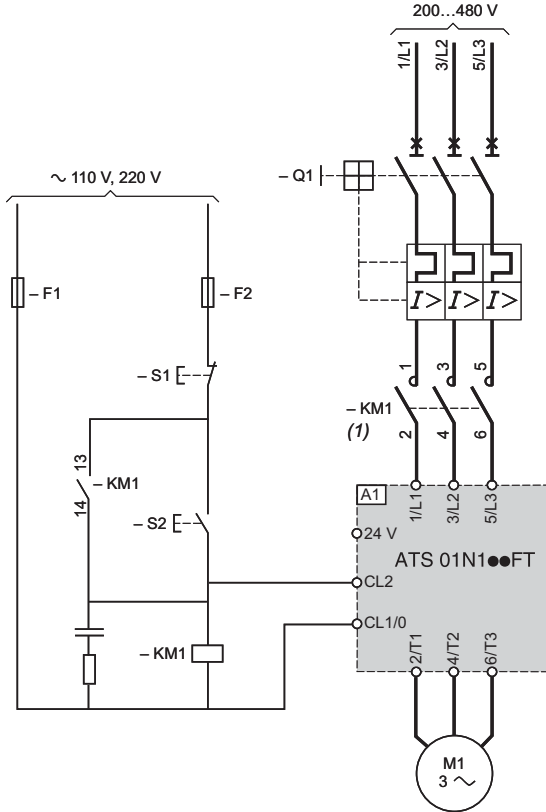

**Note:** For single-phase motors, use the ATS 01N1●●FT without connecting the 2<sup>nd</sup> phase 3/L2, 4/T2. Wait 5 seconds after switching the soft starter off before switching it on again.

(1) A line contactor must be used in the sequence.

**Compatible components** (for full references, see pages 1/16 and 1/17 or refer to our catalogue: "Motor starter solutions - Control and protection components".)

Code	Description
A1	Soft starter
Q1	GV2 ME circuit-breaker
KM1	LC1 ●● + LA4 DA2U
F1, F2	Control protection fuses
S1, S2	XB4 B or XB5 B pushbuttons

## Function chart

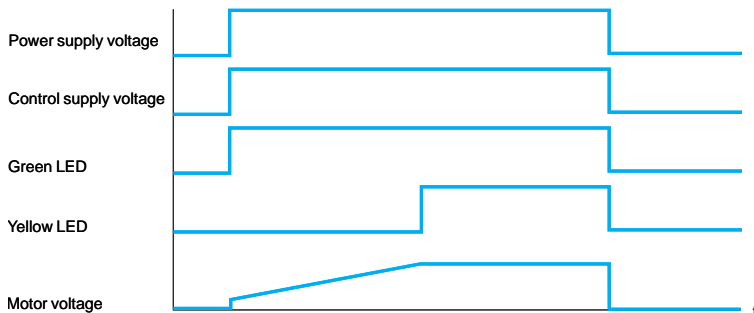

# Soft starters for asynchronous motors

Altistart 01

For 0.75 to 15 kW motors

## ATS 01N2...LU/QN/RT soft start/soft stop units

Manual control without deceleration (freewheel),  
with GV2 and GV3 motor circuit-breakers

ATS 01N206... to ATS 01N232...

Automatic control with reversal of operating direction, without deceleration  
(freewheel)

ATS 01N206... to ATS 01N232...

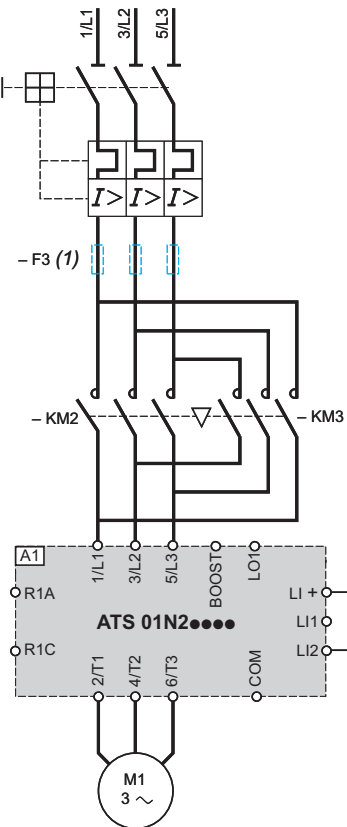
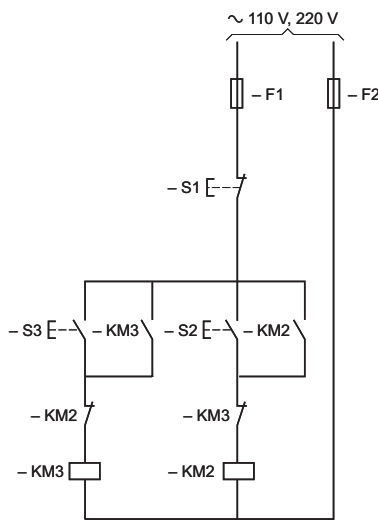
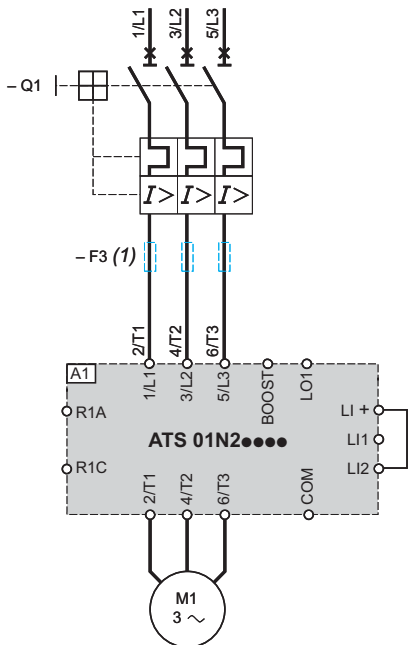

(1) For type 2 coordination.

Compatible components (for full references, see pages 1/16 and 1/17 or refer to our catalogue: "Motor starter solutions - Control and protection components".)

Code	Description
A1	Soft start/soft stop unit
Q1	GV2 ME circuit-breaker
KM1, KM2, KM3	LC1 ... + LA4 DA2U
F1, F2	Control protection fuses
F3	3 fast-acting fuses
S1, S2, S3	XB4 B or XB5 B pushbuttons

# Soft starters for asynchronous motors

## Altistart 01

For 0.75 to 15 kW motors

1

### ATS 01N2●●LU/QN/RT soft start/soft stop units

Automatic control with or without deceleration (freewheel), without contactor

ATS 01N206●● to ATS 01N232●●

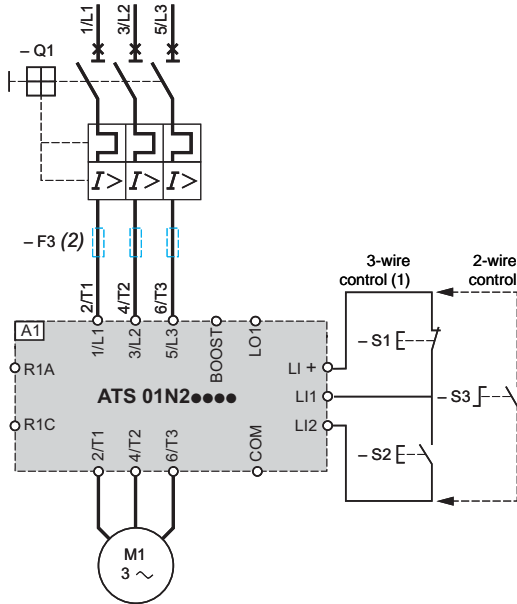

Automatic control with or without deceleration (freewheel), with contactor

ATS 01N206●● to ATS 01N232●●

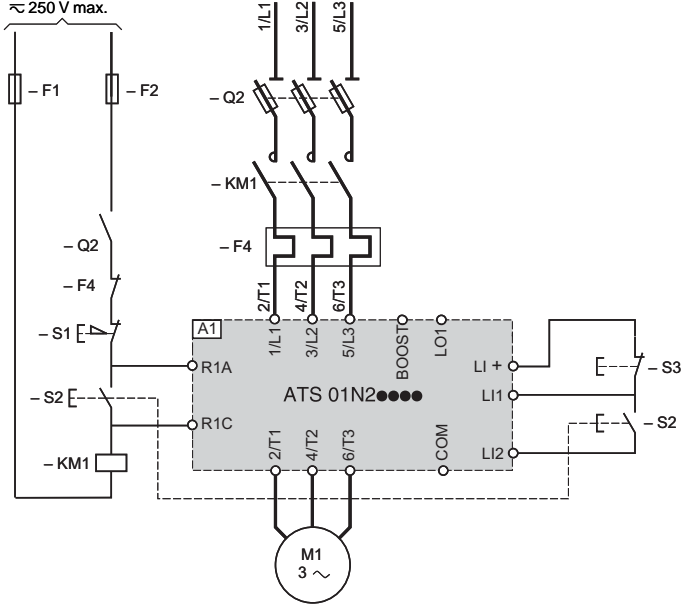

- (1) Use shielded wires above 1 m.
- (2) For type 2 coordination.

**Compatible components** (for full references, see pages 1/16 and 1/17 or refer to our catalogue: "Motor starter solutions - Control and protection components".)

Code	Description
A1	Soft start/soft stop unit
Q1	GV2 ME circuit-breaker
Q2	Fuse switches
F4	Thermal overload relay
KM1	LC1 ●●● + LA4 DA2U
F1, F2	Control protection fuses
F3	3 fast-acting fuses
S1, S2, S3	XB4 B or XB5 B pushbuttons

### Function charts

#### 2-wire control with deceleration

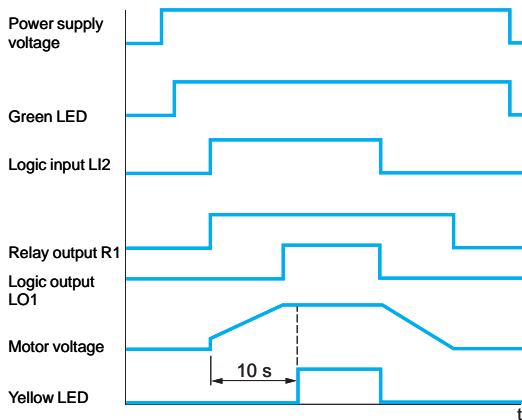

#### 3-wire control with deceleration

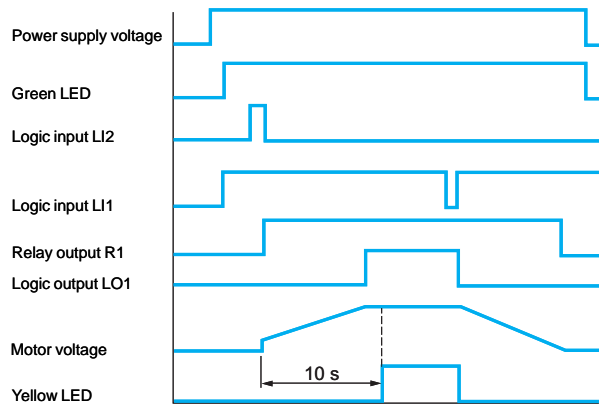

# Soft starters for asynchronous motors

Altistart 01

For 0.75 to 15 kW motors

## ATS 01N2●●LU/QN/RT soft start/soft stop units

Automatic control without deceleration (freewheel), with a maintaining function

ATS 01N206●● to ATS 01N232●●

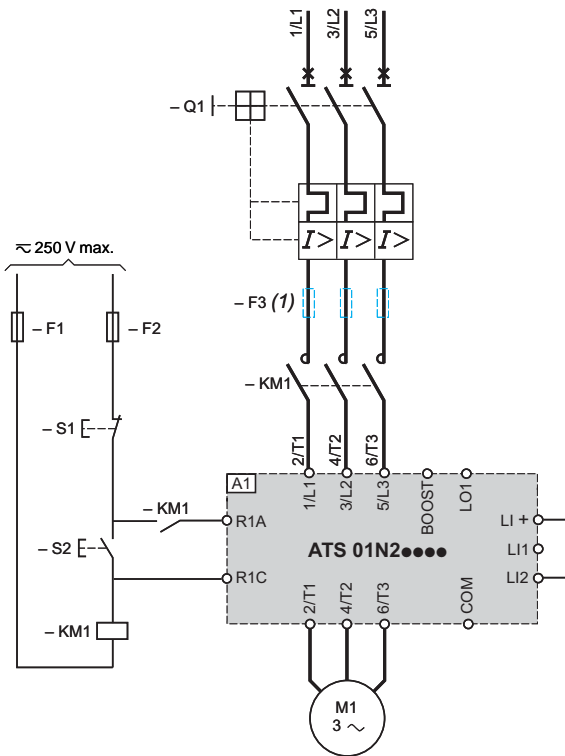

(1) For type 2 coordination.

**Compatible components** (for full references, see pages 1/16 and 1/17 or refer to our catalogue: "Motor starter solutions - Control and protection components".)

Code	Description
A1	Soft start/soft stop unit
Q1	GV2 ME circuit-breaker
KM1	LC1 ●●● + LA4 DA2U
F1, F2	Control protection fuses
F3	3 fast-acting fuses
S1, S2	XB4 B or XB5 B pushbuttons

# Soft starters for asynchronous motors

Altistart 01

For 15 to 75 kW motors

## ATS 01N2●●LY and ATS 01N2●●Q soft start/soft stop units (compatible components, see page 1/13)

Manual control without deceleration (freewheel), with GV3 and GV7 motor circuit-breakers

ATS 01N230LY to ATS 01N285LY

ATS 01N244Q to ATS 01N285Q

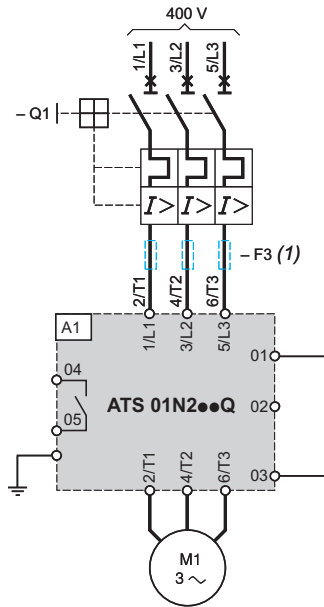
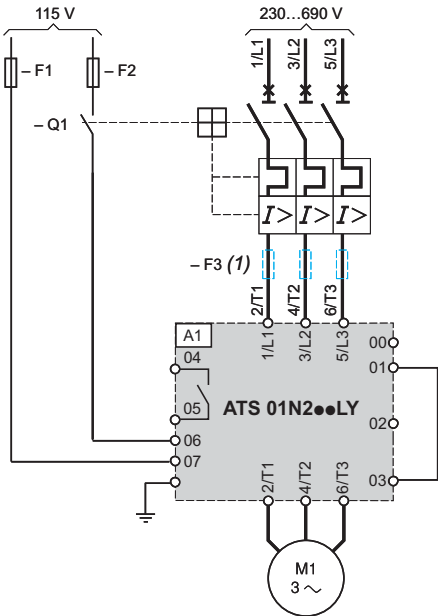

(1) For type 2 coordination.

(1) For type 2 coordination.

## Automatic control with reversal of operating direction, without deceleration (freewheel)

ATS 01N230LY to ATS 01N285LY

ATS 01N244Q to ATS 01N285Q

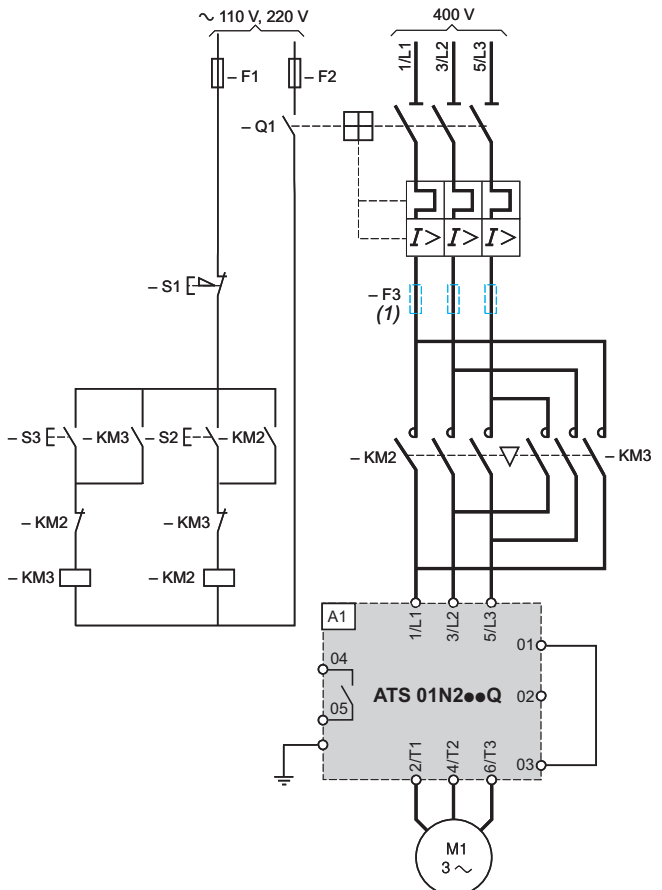
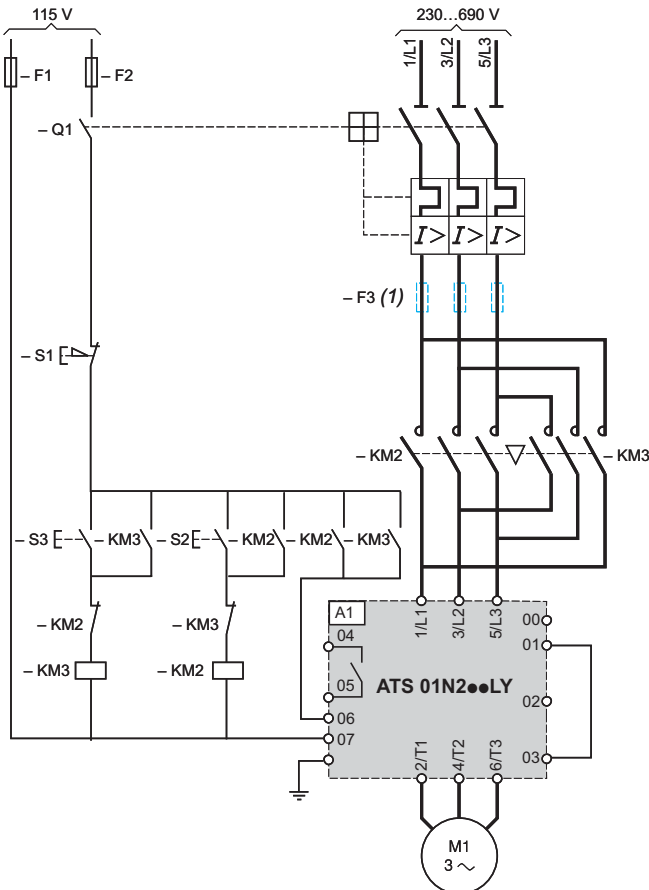

(1) For type 2 coordination.

(1) For type 2 coordination.



# Soft starters for asynchronous motors

Altistart 01

For 15 to 75 kW motors

## ATS 01N2●●LY and ATS 01N2●●Q soft start/soft stop units

Automatic control with or without deceleration (freewheel), without contactor

ATS 01N230LY to ATS 01N285LY

ATS 01N244Q to ATS 01N285Q

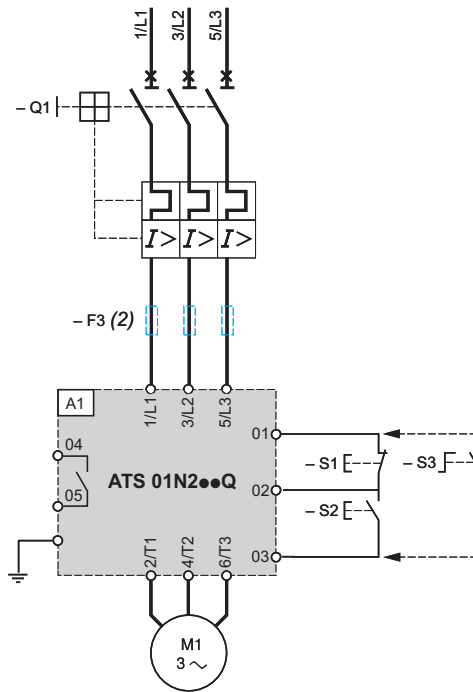
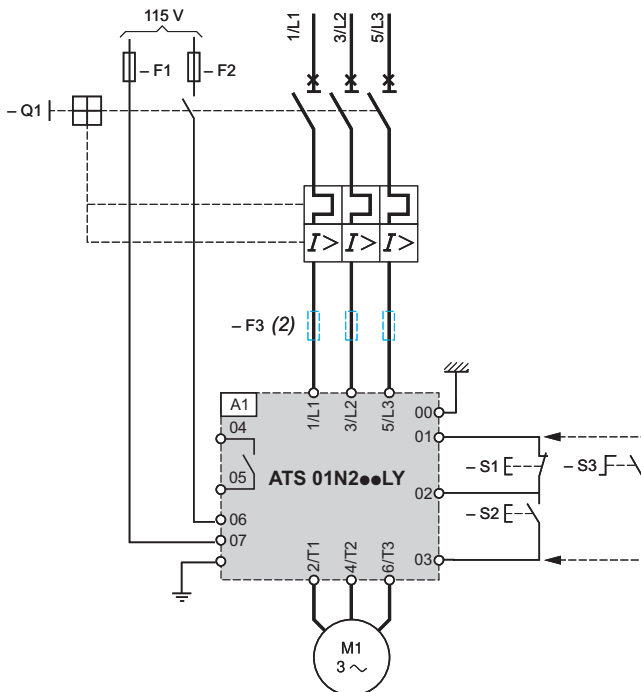

(1) Use shielded wires above 1 m.  
(2) For type 2 coordination.

(1) Use shielded wires above 1 m.  
(2) For type 2 coordination.

**Compatible components** (for full references, see pages 1/16 and 1/17 or refer to our catalogue: "Motor starter solutions - Control and protection components".)

Code	Description
A1	Soft start/soft stop unit
Q1	GV3 or GV7 circuit-breaker
KM2, KM3	LC1 ●●● + LA4 DA2U
F1, F2	Control protection fuses
F3	3 fast-acting fuses
S1, S2, S3	XB4 B or XB5 B pushbuttons

# Soft starters for asynchronous motors

Altistart 01

For 15 to 75 kW motors

## ATS 01N2●●LY and ATS 01N2●●Q soft start/soft stop units (continued)

Automatic control with or without deceleration (freewheel), with contactor

ATS 01N230LY to ATS 01N285LY

ATS 01N244Q to ATS 01N285Q

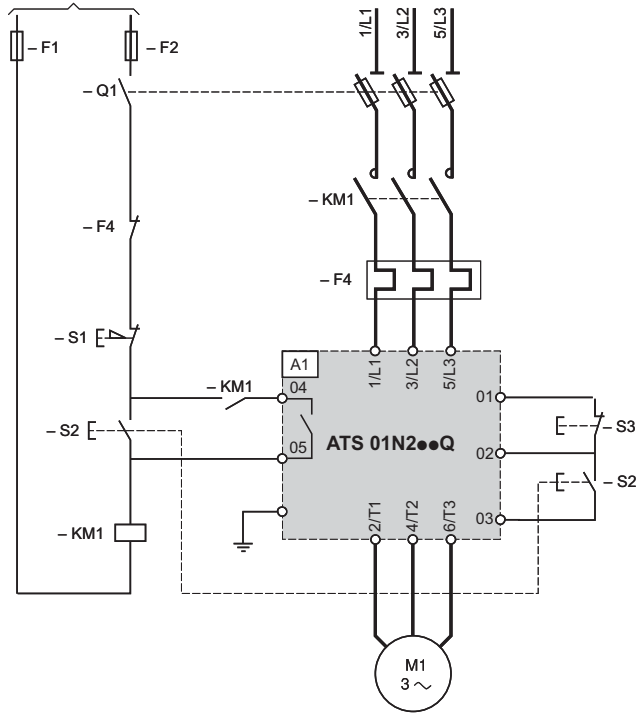
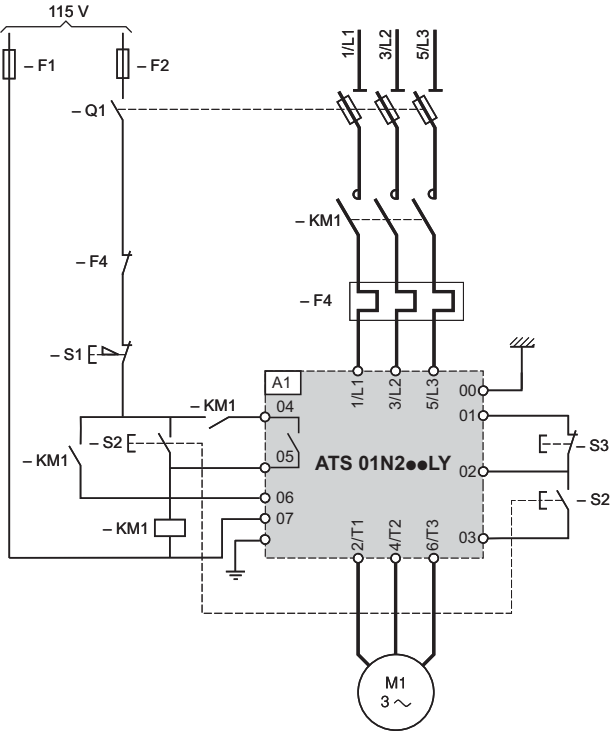

**Compatible components** (for full references, see pages 1/16 and 1/17 or refer to our catalogue: "Motor starter solutions - Control and protection components".)

Code	Description
A1	Soft start/soft stop unit
Q1	GK1 disconnector
KM1	LC1 ●●● + LA4 DA2U
F1, F2	Control protection fuses
F4	LRD thermal overload relay
S1, S2, S3	XB4 B or XB5 B pushbuttons

# Soft starters for asynchronous motors

Altistart 01

For 15 to 75 kW motors

**ATS 01N2●●LY and ATS 01N2●●Q soft start/soft stop units (continued)**

Automatic control without deceleration (freewheel), with a maintaining function

ATS 01N230LY to ATS 01N285LY

ATS 01N244Q to ATS 01N285Q

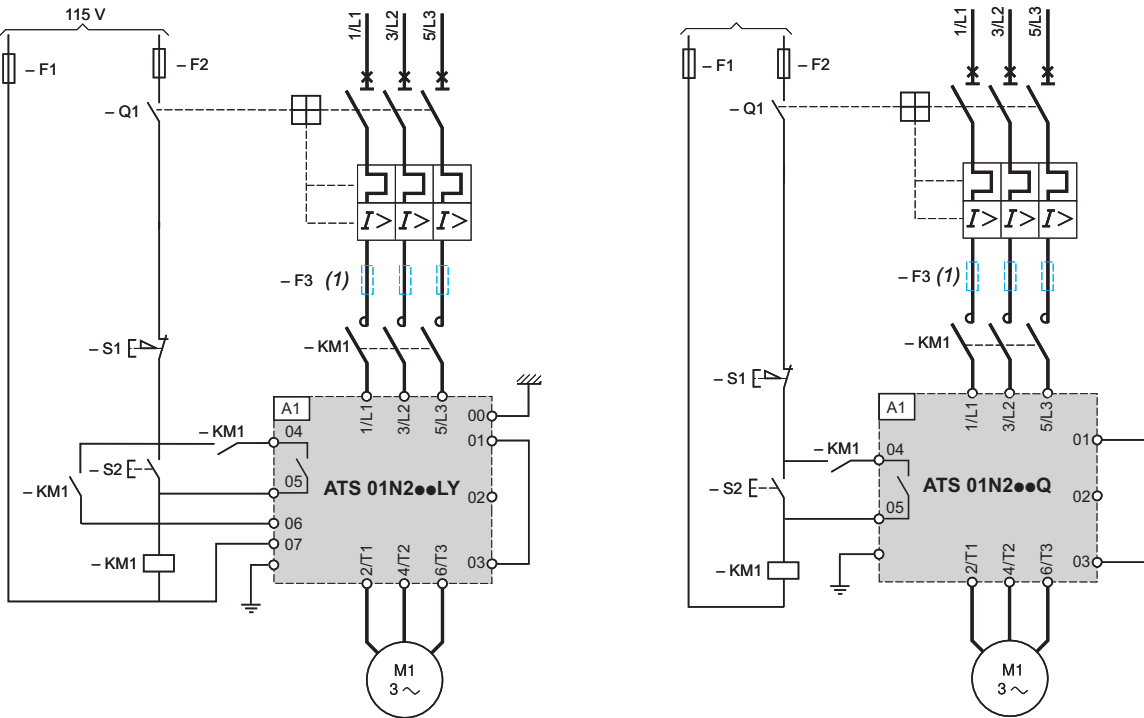

(1) For type 2 coordination.

**Compatible components** (for full references, see pages 1/16 and 1/17 or refer to our catalogue: "Motor starter solutions - Control and protection components".)

Code	Description
A1	Soft starter
Q1	GV3 circuit-breaker
KM1	LC1 ●●● + LA4 DA2U
F1, F2	Control protection fuses
F3	3 fast-acting fuses
S1, S2	XB4 B or XB5 B pushbuttons

# Soft starters for asynchronous motors

Altistart 01

400 V power supply, type 1 coordination

1

## Components to be combined in accordance with standards IEC 60947-1 and IEC 60947-4-2

Combine either circuit-breaker (light blue columns), contactor, starter, or switch/fuse (dark blue columns), contactor, starter

Motor		Starter Class 10	Type of circuit-breaker Telemecanique	Rating	Type of contactor	Type of switch or switch disconnecter (base unit)	Am fuses Reference	Rating	I <sup>2</sup> t	Thermal overload relay
kW	A			A				A	A <sup>2</sup> s	
M1		A1	Q1		KM1, KM2, KM3	Q2				F4
0.37	0.98	ATS 01N103FT	GV2 ME05	1	LC1 K06 or LC1 D09	LS1 D2531	DF2 CA02	2	265	LR2 K0306 LRD 05
0.55	1.5	ATS 01N103FT	GV2 ME06	1.6	LC1 K06 or LC1 D09	LS1 D2531	DF2 CA02	2	265	LR2 K0307 LRD 06
0.75	2	ATS 01N103FT	GV2 ME07	2.5	LC1 K06 or LC1 D09	LS1 D2531	DF2 CA02	2	265	LR2 K0308 LRD 07
1.1	2.5	ATS 01N103FT	GV2 ME08	4	LC1 K06 or LC1 D09	LS1 D2531	DF2 CA04	4	265	LR2 K0308 LRD 08
		ATS 01N206QN	GV2 ME08	4	LC1 K06 or LC1 D09	LS1 D2531	DF2 CA04	4	265	LR2 K0308 LRD 08
1.5	3.5	ATS 01N106FT	GV2 ME08	4	LC1 K06 or LC1 D09	LS1 D2531	DF2 CA06	6	265	LR2 K0310 LRD 08
		ATS 01N206QN	GV2 ME08	4	LC1 K06 or LC1 D09	LS1 D2531	DF2 CA06	6	265	LR2 K0310 LRD 08
2.2	5	ATS 01N106FT	GV2 ME10	6.3	LC1 K06 or LC1 D09	LS1 D2531	DF2 CA08	8	265	LR2 K0312 LRD 10
		ATS 01N206QN	GV2 ME10	6.3	LC1 K09 or LC1 D09	LS1 D2531	DF2 CA08	8	265	LR2 K0312 LRD 10
3	6.5	ATS 01N106FT	GV2 ME14	9	LC1 K09 or LC1 D09	LS1 D2531	DF2 CA12	12	265	LR2 K0314 LRD 12
		ATS 01N206QN	GV2 ME14	9	LC1 K09 or LC1 D09	LS1 D2531	DF2 CA12	12	265	LR2 K0314 LRD 12
4	8.4	ATS 01N109FT	GV2 ME14	9	LC1 K09 or LC1 D09	LS1 D2531	DF2 CA12	12	610	LR2 K0316 LRD 14
		ATS 01N209QN	GV2 ME14	9	LC1 K09 or LC1 D09	LS1 D2531	DF2 CA12	12	610	LR2 K0316 LRD 14
5.5	11	ATS 01N112FT	GV2 ME16	13	LC1 K12 or LC1 D12	LS1 D2531	DF2 CA16	16	610	LR2 K0321 LRD 16
		ATS 01N212QN	GV2 ME16	13	LC1 K12 or LC1 D12	LS1 D2531	DF2 CA16	16	610	LR2 K0321 LRD 16
7.5	14.8	ATS 01N125FT	GV2 ME20	17	LC1 D18	LS1 D2531	DF2 CA20	20	6050	LRD 21
		ATS 01N222QN	GV2 ME20	17	LC1 D18	LS1 D2531	DF2 CA20	20	6050	LRD 21
9	18.1	ATS 01N125FT	GV2 ME21	21	LC1 D25	LS1 D2531	DF2 CA25	25	6050	LRD 21
		ATS 01N222QN	GV2 ME21	21	LC1 D25	LS1 D2531	DF2 CA25	25	6050	LRD 21
11	21	ATS 01N125FT	GV2 ME22	23	LC1 D25	LS1 D2531	DF2 CA25	25	6050	LRD 22
		ATS 01N222QN	GV2 ME22	23	LC1 D25	LS1 D2531	DF2 CA25	25	6050	LRD 22
15	28.5	ATS 01N232QN	GV2 ME32	32	LC1 D32	GK1 EM	DF2 EA40	40	7200	LRD 3353
18.5	35	ATS 01N244Q	GV3 P40	40	LC1 D38	GK1 EM	DF2 EA40	40	8000	LRD 3355
22	42	ATS 01N244Q	GV3 P50	50	LC1 D50	GK1 FM	DF2 FA63	63	8000	LRD 3357
30	57	ATS 01N272Q	GV3 P65	65	LC1 D65	GK1 FM	DF2 FA63	63	9000	LRD 3359
37	69	ATS 01N272Q	GV3 ME80	80	LC1 D80	GK1 FM	DF2 FA80	80	9000	LRD 3363
45	81	ATS 01N285Q	GV7 RE100	100	LC1 D95	GK1 FM	DF2 FA100	100	9000	LRD 3365

# Soft starters for asynchronous motors

Altistart 01

690 V power supply, type 1 coordination

## Components to be combined in accordance with standards IEC 60947-1 and IEC 60947-4-2

Combine either circuit-breaker (light blue columns), contactor, starter, or switch/fuse (dark blue columns), contactor, starter

Motor		Starter Class 10	Type of circuit-breaker		Type of contactor	Type of switch or switch disconnecter (base unit)	Am fuses Reference	Rating	I <sup>2</sup> t	Thermal overload relay
kW	A		Telemecanique	Rating						
		A1	Q1	A	KM1	Q2		A	A <sup>2</sup> s	F4
30	33	ATS 01N230LY	GV3 P40 + GV AN11	30...40	LC1 D50	GK1 EM	DF2 EA40	40	7200	LRD 3355
37	40	ATS 01N244LY	GV3 P65 + GV AN11	48...65	LC1 D65	GK1 FM	DF2 FA63	63	8000	LRD 3359
55	58	ATS 01N272LY	GV3 ME80 + GV3 A01	56...80	LC1 D115	GK1 FM	DF2 FA80	80	9000	LRD 3363
75	75.7	ATS 01N285LY	GV7 RE100 + GV7 AE11	60...100	LC1 D150	GK1 FM	DF2 FA100	100	9000	LRD 3365



## 2 - Altistart U01 soft starters for asynchronous motors

---

■ Presentation . . . . .	pages 2/2 and 2/3
■ Characteristics . . . . .	pages 2/4 and 2/5
■ References . . . . .	page 2/6
■ Dimensions . . . . .	page 2/7
■ Schemes . . . . .	pages 2/8 to 2/11

# Soft starters for asynchronous motors

## Altistart U01 and TeSys U

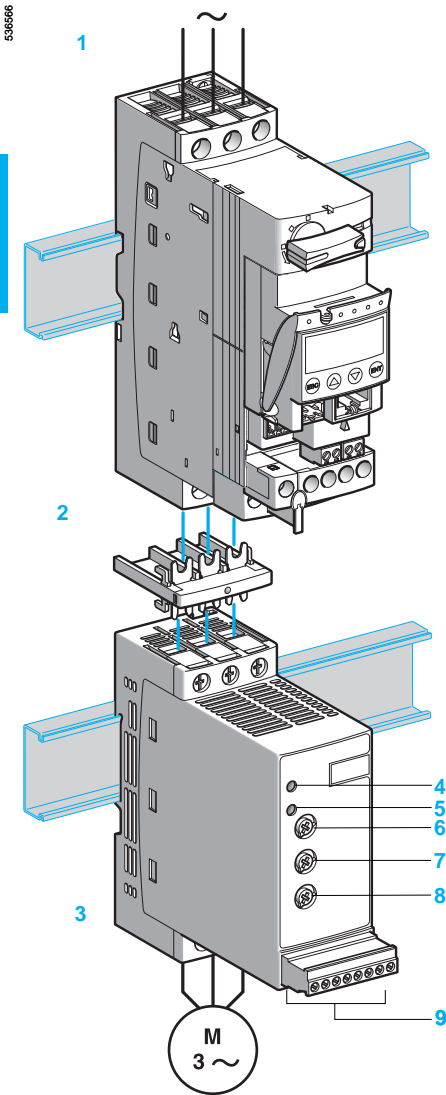

### Presentation

The Altistart U01 is a soft start/soft stop unit for asynchronous motors. It is designed primarily for combinations with **TeSys U** controller-starters.

When combined with a **TeSys U 1** controller by means of a connector **2**, the Altistart U01 **3** is a power option which provides the “Soft start/soft stop” function. The result is a unique, innovative motor starter.

Using the Altistart U01 starter enhances the starting performance of asynchronous motors by allowing them to start gradually, smoothly and in a controlled manner. It prevents mechanical shocks, which lead to wear and tear, and limits the amount of maintenance work and production downtime.

The Altistart U01 limits the starting torque and current peaks on starting, on machines which do not require a high starting torque.

The Altistart U01 is designed for the following simple applications:

- Conveyors
- Conveyor belts
- Pumps
- Fans
- Compressors
- Automatic doors and gates
- Small cranes
- Belt-driven machines, etc.

The Altistart U01 is compact and easy to install. It complies with standards IEC/EN 60947-4-2, carries UL, CSA, C-Tick, CCC certifications and CE marking.

#### ■ ATSU 01N2●●LT soft start/soft stop units

- Control two phases of the motor power supply to limit the starting current and for deceleration
  - Internal bypass relay
  - Motor power ratings ranging from 0.75 kW to 15 kW
  - Motor supply voltages ranging from 200 V to 480 V, 50/60 Hz.
- An external power supply is required for controlling the starter.

### Description

- Altistart U01 soft start/soft stop units are equipped with:
  - A potentiometer for setting the starting time **6**
  - A potentiometer for setting the deceleration time **8**
  - A potentiometer for adjusting the start voltage threshold according to the motor load **7**
  - 1 green LED **4** to indicate that the unit is switched on
  - 1 yellow LED **5** to indicate that the motor is powered at nominal voltage, if it is connected to the starter
  - A connector **9**:
    - 2 logic inputs for Run/Stop commands
    - 1 logic input for the BOOST function
    - 1 logic output to indicate the end of starting
    - 1 relay output to indicate the starter has a power supply fault or the motor has reached a standstill at the end of the deceleration stage



# Soft starters for asynchronous motors

## Altistart U01 and TeSys U

### Description of a TeSys U controller-starter

Please consult the “TeSys U starters - open version” catalogue.

### ATSU 01N2●●●LT soft start unit functions

■ 2-wire control

The run and stop commands are controlled by a single logic input. State 1 of logic input LI2 controls starting and state 0 controls stopping.

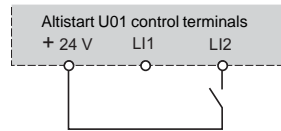

Wiring diagram for 2-wire control

■ 3-wire control

The run and stop commands are controlled by 2 different logic inputs. Stopping is achieved when logic input LI1 opens (state 0). The pulse on input LI2 is stored until input LI1 opens.

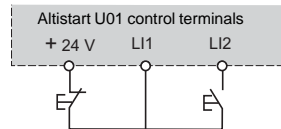

Wiring diagram for 3-wire control

■ Starting time

Controlling the starting time means that the time of the voltage ramp applied to the motor can be adjusted to obtain a gradual starting time, dependent on the motor load.

■ Voltage boost function via logic input

Activating the BOOST logic input enables the function for supplying a starting overtorque capable of overcoming any mechanical friction. When the input is at state 1, the function is active (input connected to the + 24 V) and the starter applies a fixed voltage to the motor for a limited time before starting.

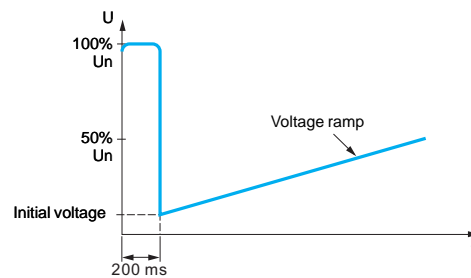

Application of a voltage boost equal to 100% of the nominal motor voltage

■ End of starting

□ Application function for logic output LO1

ATSU 01N2●●●LT soft start/soft stop units are equipped with an open collector logic output LO, which indicates the end of starting when the motor has reached nominal speed.

### Environmental characteristics

<b>Type of starter</b>		<b>ATSU 01N2●●LT</b>	
<b>Conformity to standards</b>		Altistart U01 electronic starters have been developed to conform to the strictest international standards and the recommendations relating to electrical industrial control devices (IEC, EN), in particular standard IEC/EN 60947-4-2.	
<b>Electromagnetic compatibility EMC</b>			
	Conducted and radiated emissions	CISPR 11 level B, IEC 60947-4-2, level B	
	Harmonics	IEC 1000-3-2, IEC 1000-3-4	
	EMC immunity	EN 50082-2, EN 50082-1	
	Electrostatic discharge	IEC 61000-4-2 level 3	
	Immunity to radiated radio-electrical interference	IEC 61000-4-3 level 3	
	Immunity to electrical transients	IEC 61000-4-4 level 4	
	Voltage/current impulse	IEC 61000-4-5 level 3	
	Conducted and radiated emissions	IEC 61000-4-6 level 3	
	Immunity to conducted interference caused by radio-electrical fields	IEC 61000-4-11	
	Damped oscillating waves	IEC 61000-4-12 level 3	
<b>CE marking</b>		The starters carry CE marking in accordance with the European low voltage directives IEC/EN 60947-4-2.	
<b>Product certifications</b>		UL, CSA, C-Tick and CCC	
<b>Degree of protection</b>		IP 20	
<b>Degree of pollution</b>		2 conforming to IEC/EN 60947-4-2	
<b>Vibration resistance</b>		1.5 mm peak to peak from 3 to 13 Hz, 1 gn from 13 to 150 Hz, conforming to IEC/EN 60068-2-6	
<b>Shock resistance</b>		15 gn for 11 ms conforming to IEC/EN 60068-2-27	
<b>Relative humidity</b>		5...95% without condensation or dripping water conforming to IEC 60068-2-3	
<b>Ambient temperature</b> around the unit	Storage	°C	- 25...+ 70 conforming to IEC/EN 60947-4-2
	Operation	°C	- 10...+ 40 without derating, up to 50°C with current derating of 2% per °C above 40°C
<b>Maximum operating altitude</b>		m	1000 without derating (above this, derate the current by 2.2% per additional 100 m)
<b>Operating position</b> Maximum permanent angle in relation to the normal vertical mounting position			

### Electrical characteristics

<b>Type of starter</b>		<b>ATSU 01N2●●LT</b>						
<b>Category of use</b>	Conforming to IEC 60947-4-2	Ac-53b						
<b>Rated operating voltage</b>	3-phase ~ voltage	<b>V</b>	200 - 10% to 480 + 10%					
<b>Frequency</b>		<b>Hz</b>	50 - 5% to 60 + 5%					
<b>Output voltage</b>		Maximum 3-phase voltage equal to line supply voltage						
<b>Control supply voltage</b>		24 V ~, 100 mA ± 10%						
<b>Rated operating current</b>		<b>A</b>	6...32					
<b>Adjustable starting time</b>		<b>s</b>	1...10					
<b>Adjustable deceleration time</b>		<b>s</b>	1...10					
<b>Starting torque</b>		<b>%</b>	30... 80% of DOL motor starting torque					
<b>Type of starter</b>	<b>ATSU</b>	<b>01N206LT</b>	<b>01N209LT</b>	<b>01N212LT</b>	<b>01N222LT</b>	<b>01N232LT</b>		
<b>Control power supply consumption</b>		24 V ~, 65 mA						
<b>Power dissipated</b>	At full load at end of starting	<b>W</b>	1.5	1.5	1.5	2.5	2.5	
	In transient state at 5 times the rated operating current	<b>W</b>	61.5	91.5	121.5	222.5	322.5	
<b>Type of starter</b>		<b>ATSU 01N206LT to ATSU 01N222LT</b>			<b>ATSU 01N232LT</b>			
<b>Use</b>								
	Starting time	<b>s</b>	1	5	10	1	5	10
	Maximum number of cycles per hour		100	20	10	50	10	5

# Soft starters for asynchronous motors

## Altistart U01 and TeSys U

Electrical characteristics (continued)		
<b>Logic input power supply</b> (electrically isolated between power and control) <b>+ 24 V, COM</b>		24 V ± 10% Isolated Max. current 100 mA
<b>Logic inputs</b> <b>LI1, LI2, BOOST</b> Stop, run and boost on start-up functions		Logic inputs with impedance 27 kΩ; 24 V power supply (U max 40 V) Max. current 8 mA State 0 if U < 5 V and I < 0.2 mA State 1 if U > 13 V and I > 0.5 mA
<b>Logic output LO1</b> End of starting signal		Open collector logic output: External 24 V power supply (minimum 6 V, maximum 30 V) Max. current 200 mA
<b>Relay output</b> <b>R1A R1C</b>		Normally open (N/O) contact Minimum switching capacity: 10 mA for 6 V ~ Maximum switching capacity on inductive load (cos φ = 0.5 and L/R = 20 ms): 2 A for 250 V ~ or 30 V ~ (AC-15) Maximum operating voltage 440 V
<b>LED signalling</b>	Green LED	Starter powered up
	Yellow LED	Nominal voltage reached

Connections (maximum connection capacity and tightening torque)		
<b>Power circuit</b>		Connection to Ø 4 mm screw clamps
<b>Flexible wire without cable end</b>	1 conductor	mm <sup>2</sup> 1.5...10 8 AWG
	2 conductors	mm <sup>2</sup> 1.5...6 10 AWG
<b>Flexible wire with cable end</b>	1 conductor	mm <sup>2</sup> 1...6 10 AWG
	2 conductors	mm <sup>2</sup> 1...6 10 AWG
<b>Rigid wire</b>	1 conductor	mm <sup>2</sup> 1...10 8 AWG
	2 conductors	mm <sup>2</sup> 1...6 10 AWG
<b>Tightening torque</b>		N.m 1.9...2.5
<b>Control circuit</b>		Screw connector
<b>Flexible wire without cable end</b>	1 conductor	mm <sup>2</sup> 0.5...2.5 14 AWG
	2 conductors	mm <sup>2</sup> 0.5...1.5 16 AWG
<b>Flexible wire with cable end</b>	1 conductor	mm <sup>2</sup> 0.5...1.5 16 AWG
	2 conductors	mm <sup>2</sup> 0.5...1.5 16 AWG
<b>Rigid wire</b>	1 conductor	mm <sup>2</sup> 0.5...2.5 14 AWG
	2 conductors	mm <sup>2</sup> 0.5...1 17 AWG
<b>Tightening torque</b>		N.m 0.5

### Torque characteristics (typical curves)

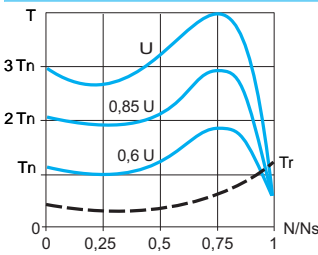

The diagram opposite shows the torque/speed characteristic of a cage motor in relation to the supply voltage. The torque varies in line with the square of the voltage at a fixed frequency. The gradual increase in the voltage prevents the instantaneous current peak on power-up.

# Soft starters for asynchronous motors

## Altistart U01 and TeSys U

DFE31714



ATSU 01N222LT

2

### Soft start/soft stop units for 0.75 to 15 kW motors (can be combined with the TeSys U starter)

Motor				Starter		
Motor power (1)				Nominal current	Reference	Weight
230 V		400 V	460 V	A		kg
kW	HP	kW	HP			
<b>3-phase supply voltage: 200...480 V 50/60 Hz</b>						
0.75	1	1.5	2	6	ATSU 01N206LT	0.340
1.1	1.5	2.2	3			
		3				
1.5	2	–	5	9	ATSU 01N209LT	0.340
–	–	4	–			
2.2	3	5.5	7.5	12	ATSU 01N212LT	0.340
3	–	–	–			
4	5	7.5	10	22	ATSU 01N222LT	0.490
5.5	7.5	11	15			
7.5	10	15	20	32	ATSU 01N232LT	0.490

### Accessorie

Description	Used for starter	Reference	Weight kg
Power connector between ATSU 01N2●●LT and TeSys U	ATSU 01N2●●LT	VW3 G4104	0.020

### TeSys U starter and soft start unit combinations

Numerous possibilities for combinations and options are offered. Please consult the "TeSys U Starters-open version" specialist catalogue.

Motor power		Soft starter		TeSys U	
Voltage				Power base	Control unit (2)
230 V	400 V	460 V			
kW/HP	kW	HP			
0.75/1	1.5	2	ATSU 01N206LT	LUB 12	LUC● 05BL
1.1/1.5	2.2/3	3	ATSU 01N206LT	LUB 12	LUC● 12BL
1.5/2	–	–	ATSU 01N209LT	LUB 12	LUC● 12BL
–	4	5	ATSU 01N209LT	LUB 12	LUC● 12BL
2.2/3	–	–	ATSU 01N212LT	LUB 12	LUC● 12BL
3/–	5.5	7.5	ATSU 01N212LT	LUB 32	LUC● 18BL
4/5	7.5	10	ATSU 01N222LT	LUB 32	LUC● 18BL
5.5/7.5	11	15	ATSU 01N222LT	LUB 32	LUC● 32BL
7.5/10	15	20	ATSU 01N232LT	LUB 32	LUC● 32BL

- Example of a starter-motor combination with:
- 1 non-reversing power base for DOL starting (LUB●2BL)
  - 2 control unit (LUCM ●●BL)
  - 3 power connector (VW3 G4104)
  - 4 Altistart U01 soft start/soft stop unit (ATSU 01N2●●LT)

(1) Standard motor power ratings, HP power ratings indicated according to standard UL 508.  
(2) Depending on the configuration of the chosen TeSys U starter, replace the ● with A for standard, B for expandable, and M for multifunction.

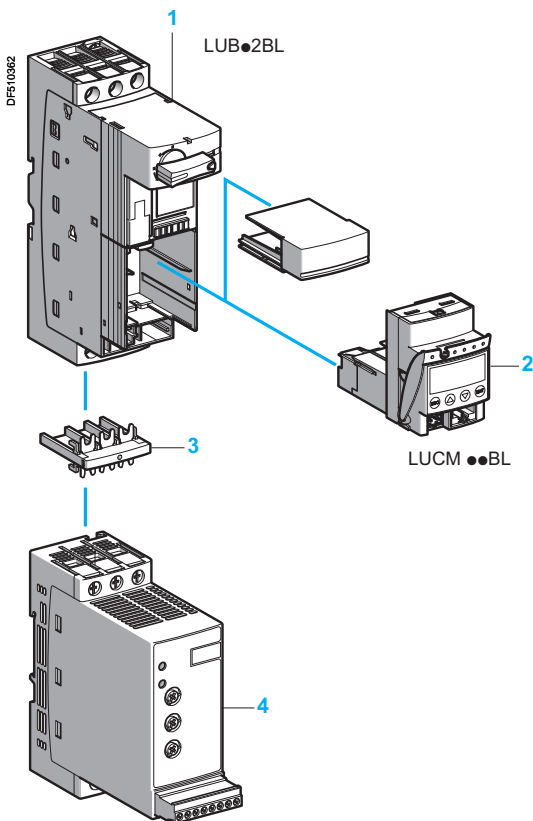

ATSU 01N2●●LT

# Soft starters for asynchronous motors

Altistart U01 and TeSys U

**TeSys U combination (non-reversing power base) and  
ATSU 01N206LT to ATSU 01N212LT**  
Mounting on  $\perp$ r (35 mm) rail with VW3 G4104 connector

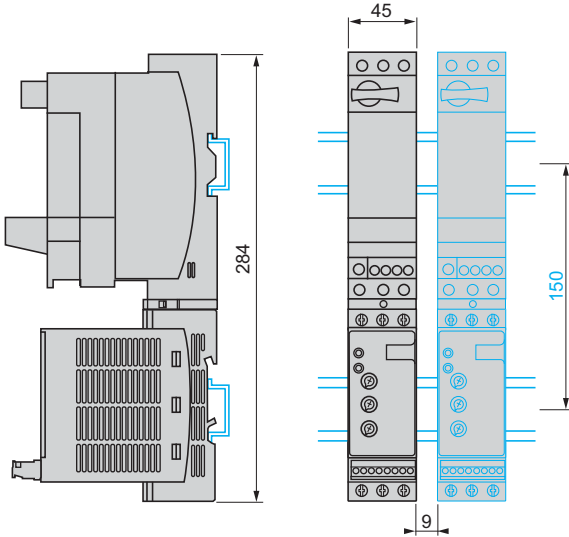

**TeSys U combination (non-reversing or reversing power base)  
and ATSU 01N206LT to ATSU 01N212LT**  
Side by side mounting

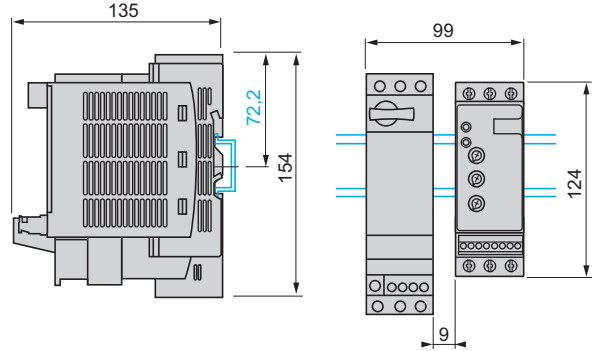

**TeSys U combination (non-reversing power base) and  
ATSU 01N222LT to ATSU 01N232LT**  
Mounting on  $\perp$ r (35 mm) rail with VW3 G4104 connector

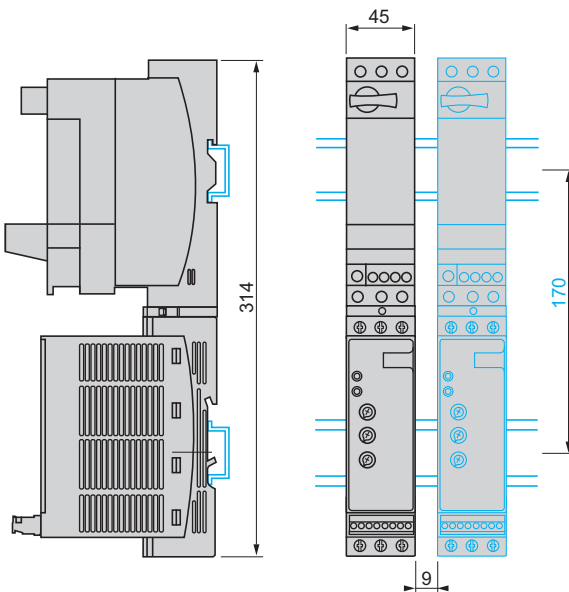

**TeSys U combination (non-reversing or reversing power base)  
and ATSU 01N222LT to ATSU 01N232LT**  
Side by side mounting

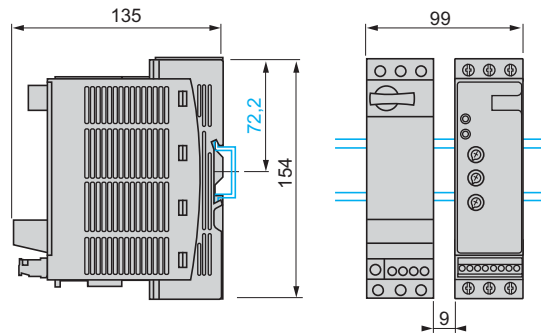

**VW3 G4104 connector**

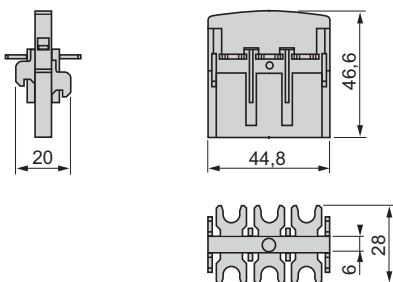

# Soft starters for asynchronous motors

Altistart U01 and TeSys U  
For 0.75 to 15 kW motors

## ATSU 01N2●●LT soft start/soft stop units

### Power wiring

### Power wiring with reversing unit

2

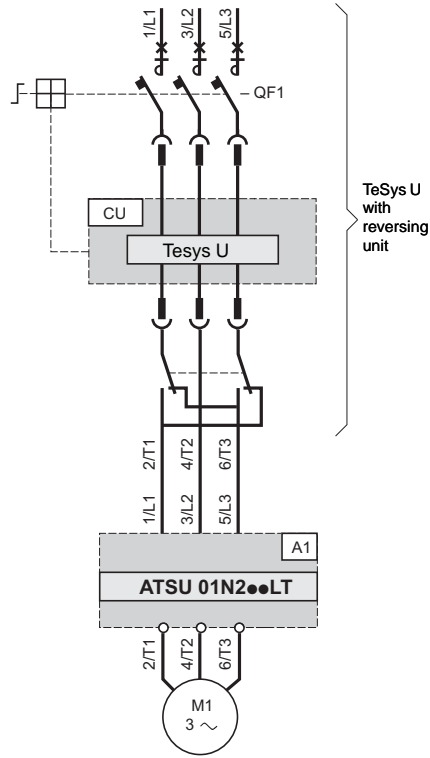
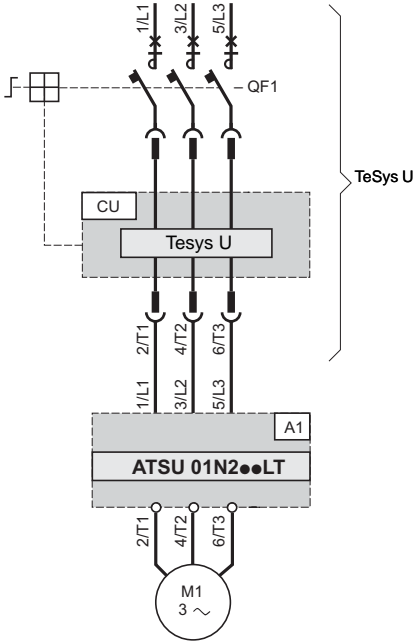

**Compatible components** (For full references, see pages 1/16 and 1/17 or refer to our catalogue: "Motor starter solutions - Control and protection components")

Code	Description
A1	Soft start/soft stop unit
QF1	TeSys U controller-starter
CU	TeSys U control unit

# Soft starters for asynchronous motors

## Altistart U01 and TeSys U

For 0.75 to 15 kW motors

### ATSU 01N2●●LT soft start/soft stop units (continued)

#### Automatic 2-wire control

##### Without deceleration

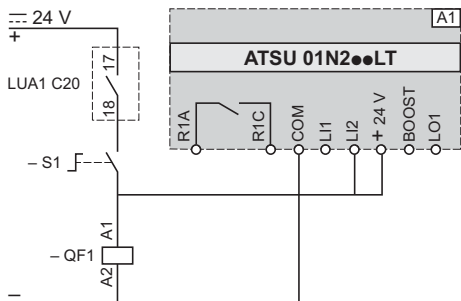

##### With and without deceleration

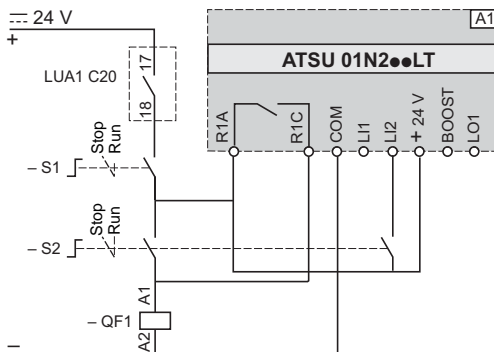

#### Functional diagrams

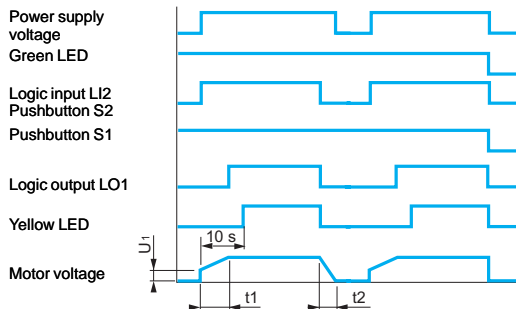
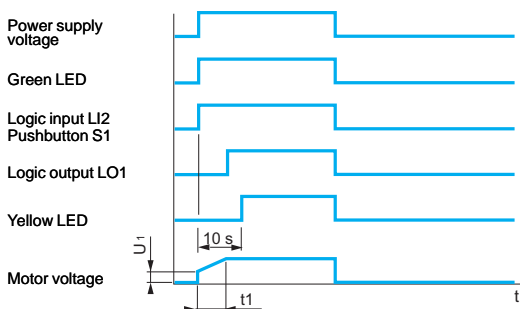

#### Automatic 3-wire control

##### Without deceleration

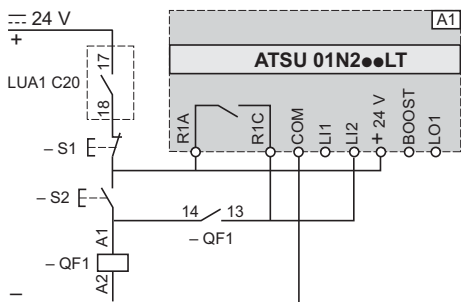

##### With deceleration

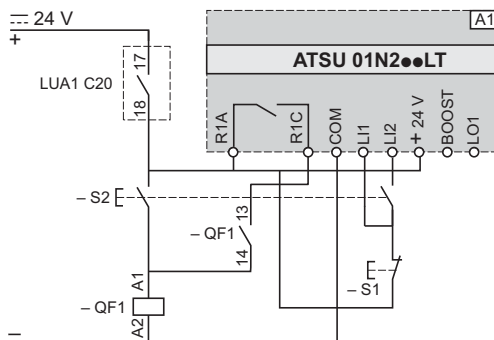

#### Functional diagrams

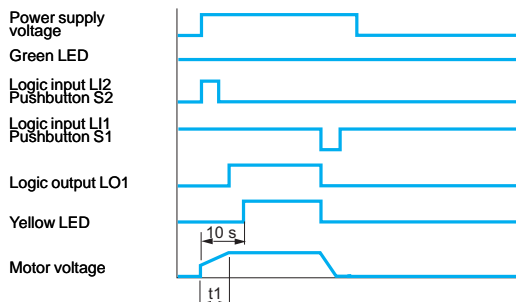
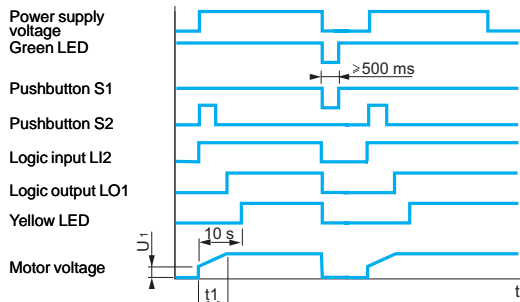

A1: Soft start/soft stop unit  
 S1, S2: XB4 B or XB5 B pushbuttons  
 QF1: TeSys U controller-starter  
 t1: Acceleration time can be controlled by a potentiometer  
 t2: Deceleration time can be controlled by a potentiometer  
 U<sub>r</sub>: Starting time can be controlled by a potentiometer

# Soft starters for asynchronous motors

Altistart U01 and TeSys U  
For 0.75 to 15 kW motors

## ATSU 01N2●●LT soft start/soft stop units (continued)

Automatic 3-wire control, with reversing unit

Without deceleration

With deceleration

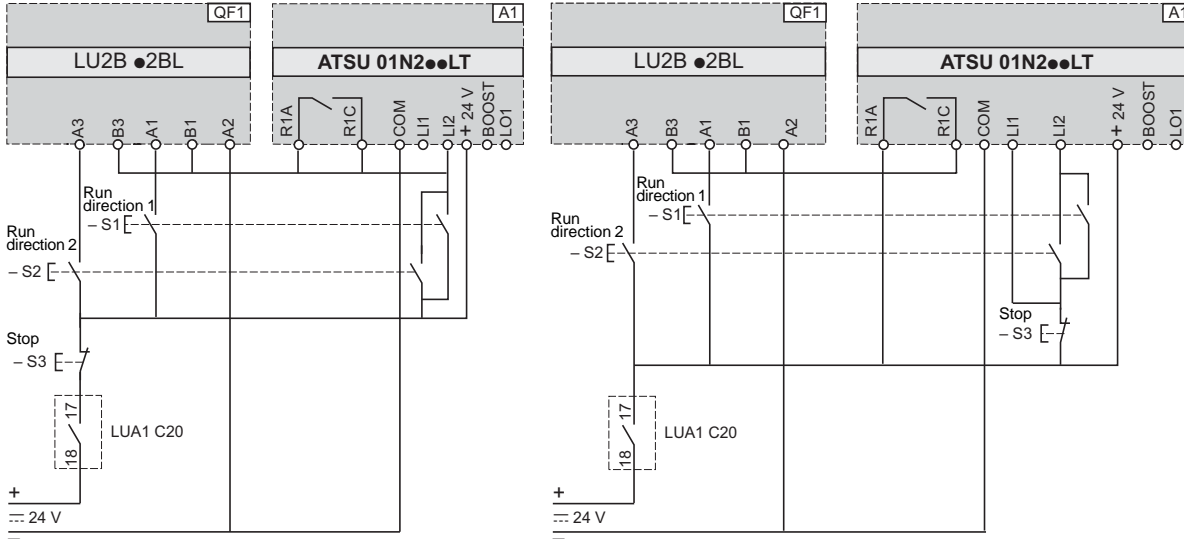

QF1: TeSys U controller-starter with reversing unit

A1: Soft start/soft stop unit

S1, S2, S3: XB4 B or XB5 B pushbuttons

S3: minimum depression time 500 ms

QF1: TeSys U controller-starter with reversing unit

A1: Soft start/soft stop unit

S1, S2, S3: XB4 B or XB5 B pushbuttons

## Boost on starting and end of starting signal

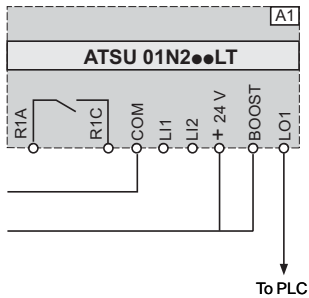

A1: Soft start/soft stop unit



# Soft starters for asynchronous motors

Altistart U01 and TeSys U  
For 0.75 to 15 kW motors

## ATSU 01N2●●LT soft start/soft stop units (continued)

### Automatic control with Modbus communication module, with and without deceleration

Without reversing unit

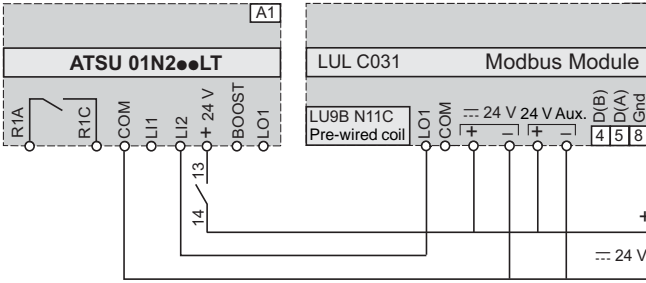

With reversing unit

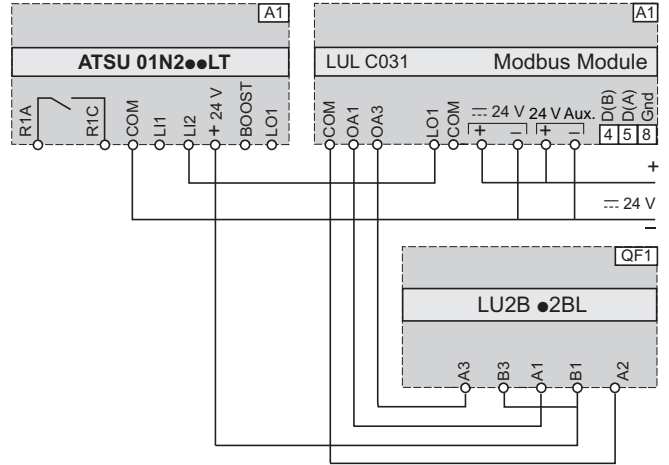

Function	Register	Bit	Value
<b>Powering down TeSys U and ATSU</b>			
-	704	0	0
<b>Automatic control without deceleration</b>			
Run	700	0	1
Stop	704	0	0
<b>Automatic control with deceleration</b>			
Run	700	0	1
Soft stop	700	0	0

Function	Register	Bit	Value
<b>Powering up TeSys U and ATSU</b>			
Forward	704	0	1
Reverse	704	1	1
<b>Powering down TeSys U and ATSU</b>			
Forward	704	0	0
Reverse	704	1	0
<b>Automatic control without deceleration</b>			
Run	700	0	1
Stop forward	704	0	0
Stop reverse	704	1	0
<b>Automatic control with deceleration (forward or reverse)</b>			
Run	700	0	1
Soft stop	700	0	0

A1: Soft start/soft stop unit

A1: Soft start/soft stop unit

QF1: TeSys U controller-starter with reversing unit

### Automatic control with AS-Interface communication module, without deceleration

Without reversing unit

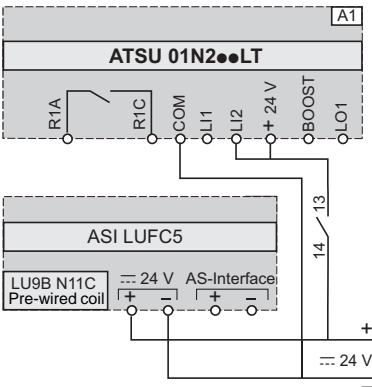

With reversing unit

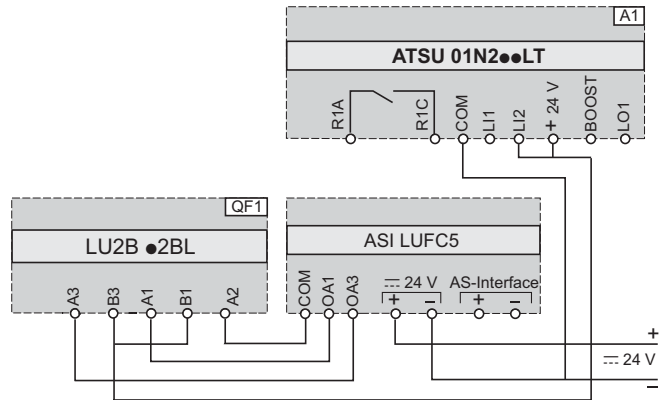

Function	Bit	Value
<b>Power-up and automatic control without deceleration</b>		
Run	D0	1
Stop	D0	0

Function	Bit	Value
<b>Power-up and automatic control without deceleration</b>		
Run forward	D0	1
Stop	D0	0
Run reverse	D1	1
Stop	D1	0

A1: Soft start/soft stop unit

A1: Soft start/soft stop unit

QF1: TeSys U controller-starter with reversing unit

# The efficiency of Telemecanique branded *solutions*

Used in combination, Telemecanique products provide quality solutions, meeting all your **Automation & Control** applications requirements.



## A worldwide presence

### Constantly available

- More than 5 000 points of sale in 190 countries.
- You can be sure to find the range of products that are right for you and which complies fully with the standards in the country where they are used.

### Technical assistance wherever you are

- Our technicians are at your disposal to assist you in finding the optimum solution for your particular needs.
- Schneider Electric provides you with all necessary technical assistance, throughout the world.

[www.telemecanique.com](http://www.telemecanique.com)

### Schneider Electric Industries SAS

Head Office  
89, bd Franklin Roosevelt  
92506 Rueil-Malmaison Cedex  
France  
[www.schneider-electric.com](http://www.schneider-electric.com)

Due to evolution of standards and equipment, the characteristics indicated in texts and images of this document do not constitute a commitment on our part without confirmation.  
Design: Schneider Electric  
Photos: Schneider Electric  
Printed by:

*Simply Smart!*