

Technical Documentation



Product manual

AC servo drive

LXM05A

Document: 0198441113232

Edition: V1.20, 06.2007

Important information

The drive systems described here are products for general use that conform to the state of the art in technology and are designed to prevent any dangers. However, drives and drive controllers that are not specifically designed for safety functions are not approved for applications where the functioning of the drive could endanger persons. The possibility of unexpected or unbraked movements can never be totally excluded without additional safety equipment. For this reason personnel must never be in the danger zone of the drives unless additional suitable safety equipment prevents any personal danger. This applies to operation of the machine during production and also to all service and maintenance work on drives and the machine. The machine design must ensure personal safety. Suitable measures for prevention of property damage are also required.

See safety section for additional critical instructions.

Not all product variants are available in all countries.

Please consult the current catalogue for information on the availability of product variants.

We reserve the right to make changes during the course of technical developments.

All details provided are technical data and not promised characteristics.

In general, product names must be considered to be trademarks of the respective owners, even if not specifically identified as such.

Table of Contents

Important information	-2
Table of Contents	-3
Writing conventions and symbols	-9
1 Introduction	
1.1 Unit overview	1-1
1.2 Components and interfaces	1-2
1.3 Type code	1-3
1.4 Documentation and literature references	1-4
1.5 Directives and standards	1-5
1.6 Declaration of conformity	1-6
1.7 TÜV certificate for functional safety	1-7
2 Safety	
2.1 Qualification of personnel	2-1
2.2 Intended use	2-1
2.3 Hazard categories	2-2
2.4 General safety instructions	2-3
2.5 Safety functions	2-4
2.6 Monitoring functions	2-4
3 Technical Data	
3.1 Testing agencies and certificates	3-1
3.2 Environmental conditions	3-1
3.2.1 Degree of protection	3-2
3.3 Mechanical data	3-3
3.3.1 Dimensional drawings	3-3
3.4 Electrical Data	3-4
3.4.1 Performance data for power amplifier	3-4
3.4.2 24VDC controller power supply	3-6
3.4.3 Signals	3-6
3.4.4 Safety functions	3-7
3.4.5 Braking resistor	3-8
3.4.6 Internal mains filter	3-9

3.5	Technical Data accessories	3-10
3.5.1	External braking resistors	3-10
3.5.2	Line reactor	3-10
3.5.3	External mains filter	3-10
3.5.4	Holding brake controller HBC.	3-11
3.5.5	Reference value adapter RVA	3-11
3.5.6	Cable	3-12
4	Basics	
4.1	Safety functions	4-1
5	Engineering	
5.1	Logic type	5-1
5.2	Configurable inputs and outputs	5-2
5.3	Specification of the control mode	5-2
5.4	Safety function "Power Removal"	5-2
5.4.1	Definitions	5-2
5.4.2	Function	5-3
5.4.3	Requirements for safe application	5-3
5.4.4	Application examples	5-5
6	Installation	
6.1	Electromagnetic compatibility, EMC	6-1
6.1.1	Operation in an IT mains	6-5
6.2	Mechanical installation	6-6
6.2.1	Installing the device	6-7
6.2.2	Installing mains filter, mains reactor and braking resistor	6-9
6.3	Electrical installation	6-11
6.3.1	Overview of procedure	6-13
6.3.2	Overview of all connections	6-14
6.3.3	Reference value signals and limits.	6-16
6.3.4	Motor phase connections.	6-17
6.3.5	Connection of braking resistor	6-20
6.3.6	Connection of power amplifier supply voltage	6-26
6.3.7	Connection for parallel operation	6-28
6.3.8	Connection of motor encoder (CN2)	6-28
6.3.9	Connection of holding brake controller (HBC)	6-31
6.3.10	Connection of controller supply voltage (24V at CN3)	6-33
6.3.11	Connecting encoder signals A, B, I (CN5)	6-35
6.3.12	Connection of pulse/direction PD (CN5)	6-36
6.3.13	Connection of encoder simulation (CN5)	6-40
6.3.14	CANopen connection (CN1 or CN4)	6-42

6.3.15	Modbus connection (CN4)	6-44
6.3.16	Connection of analogue inputs (CN1).	6-45
6.3.17	Connection of digital inputs/outputs (CN1).	6-46
6.3.18	Connection to PC or remote terminal (CN4).	6-49
6.3.19	Reference value adapter	6-51
6.4	Checking installation	6-54

7 Commissioning

7.1	General safety instructions	7-1
7.2	Overview	7-4
7.3	Tools for commissioning	7-5
7.3.1	Overview.	7-5
7.3.2	HMI: Human-Machine Interface	7-6
7.3.3	Commissioning software (PowerSuite).	7-12
7.4	Commissioning procedure.	7-13
7.4.1	"First Setup"	7-13
7.4.2	Operating status (status diagram)	7-19
7.4.3	Setting basic parameters and limit values	7-20
7.4.4	Analogue inputs	7-22
7.4.5	Digital inputs/outputs	7-25
7.4.6	Setting configurable digital inputs/outputs	7-26
7.4.7	Testing limit switches signals in fieldbus devices	7-27
7.4.8	Testing safety functions	7-28
7.4.9	Checking holding brake	7-29
7.4.10	Check direction of rotation	7-30
7.4.11	Checking the signals of position switches	7-31
7.4.12	Setting parameters for encoder simulation.	7-32
7.4.13	Setting parameters for encoder	7-33
7.4.14	Setting parameters for braking resistor.	7-35
7.4.15	Run autotuning	7-37
7.4.16	Extended settings for autotuning	7-39
7.5	Controller optimisation with step response	7-41
7.5.1	Controller structure	7-41
7.5.2	Optimisation	7-42
7.5.3	Optimising the speed controller	7-43
7.5.4	Checking and optimising default settings	7-47
7.5.5	Optimising the position controller	7-48

8 Operation

8.1	Control mode and operating mode management	8-1
8.2	Access monitor	8-3
8.2.1	via HMI	8-3
8.2.2	via fieldbus	8-3
8.2.3	via commissioning software	8-3
8.2.4	via hardware input signals	8-4
8.3	Operating statuses	8-4
8.3.1	Status diagram	8-4
8.3.2	Changing operating status	8-8
8.3.3	Displaying the operating statuses	8-9
8.4	Starting and changing operating modes	8-12
8.4.1	Start operating mode	8-12
8.4.2	Change operating mode	8-13
8.5	Operating modes	8-15
8.5.1	Operating mode Jog	8-15
8.5.2	Operating mode Current control	8-18
8.5.3	Operating mode Speed control	8-20
8.5.4	Operating mode Electronic gear	8-22
8.5.5	Operating mode Profile position	8-26
8.5.6	Operating mode Profile velocity	8-30
8.5.7	Operating mode motion sequence	8-32
8.5.8	Operating mode Homing	8-44
8.6	Functions	8-57
8.6.1	Monitoring functions	8-57
8.6.2	Scaling	8-69
8.6.3	Movement profile	8-72
8.6.4	Quick Stop	8-75
8.6.5	Halt	8-76
8.6.6	Fast position capture	8-77
8.6.7	Standstill window	8-79
8.6.8	Braking function with HBC	8-81
8.6.9	Configurable inputs and outputs	8-83
8.6.10	Reversal of direction of rotation	8-96
8.6.11	Restoring default values	8-98

9 Examples

9.1	Wiring local control mode	9-1
9.2	Wiring fieldbus control mode	9-2
9.3	"Power Removal" wiring	9-3
9.4	Parameterisation local control mode	9-3

10 Diagnostics and troubleshooting

10.1	Service	10-1
10.2	Error responses and error classes	10-2
10.3	Error display	10-3
10.3.1	Status diagram	10-3
10.3.2	Error display on HMI	10-6
10.3.3	Error display with commissioning software	10-7
10.3.4	Error display via fieldbus	10-8
10.4	Troubleshooting	10-10
10.4.1	Resolution of malfunctions	10-10
10.4.2	Error resolution sorted by error bit	10-11
10.5	Table of error numbers	10-12

11 Parameters

11.1	Representation of the parameters	11-1
11.1.1	Explanation of the parameter representation	11-2
11.2	List of all parameters	11-4

12 Accessories and spare parts

12.1	Optional accessories	12-1
12.2	External braking resistors	12-1
12.3	Motor cables	12-2
12.4	Encoder cables	12-2
12.5	Crimping tool and connector / contacts	12-3
12.6	RS 422: pulse/direction, ESIM and A/B	12-3
12.7	Mains filters	12-4
12.8	Mains reactor s	12-4
12.9	CANopen	12-4
12.10	MODBUS	12-4
12.11	Installation material	12-5

13 Service, maintenance and disposal

13.1	Service address	13-2
13.2	Maintenance	13-2
13.2.1	Operating life of safety function "Power Removal"	13-2
13.3	Replacing units	13-3
13.4	Changing the motor	13-4
13.5	Shipping, storage, disposal	13-5

14 Glossary

14.1	Units and conversion tables	14-1
14.1.1	Length	14-1
14.1.2	Mass	14-1
14.1.3	Force	14-1
14.1.4	Power	14-1
14.1.5	Rotation	14-2
14.1.6	Torque	14-2
14.1.7	Moment of inertia	14-2
14.1.8	Temperature	14-2
14.1.9	Conductor cross section	14-2
14.2	Terms and Abbreviations	14-3
14.3	Product name	14-5

15 Index

Writing conventions and symbols

Work steps If work steps must be carried out in sequence, they are shown as follows:

- Special prerequisites for the following work steps
- ▶ Step 1
- ◁ Important response to this work step
- ▶ Step 2

If a response to a work step is specified, this will inform you that the step has been carried out correctly.

Unless otherwise stated, the individual instruction steps must be carried in the given sequence.

Lists Lists can be sorted alphanumerically or by priority. Lists are structured as follows:

- Point 1
- Point 2
 - Subpoint to 2
 - Subpoint to 2
- Point 3

Making work easier Information on making work easier can be found at this symbol:



*This offers supplementary information on making work easier.
See the chapter on safety for an explanation of the safety instructions.*

Parameter display The parameters are shown in the text with parameter name and HMI code, e.g. POSdirOfRotat (*Pr o t*). The tabular view is explained in the chapter on Parameters on page 11-1. The parameter list is alphabetically arranged by parameter name.

1 Introduction

1.1 Unit overview

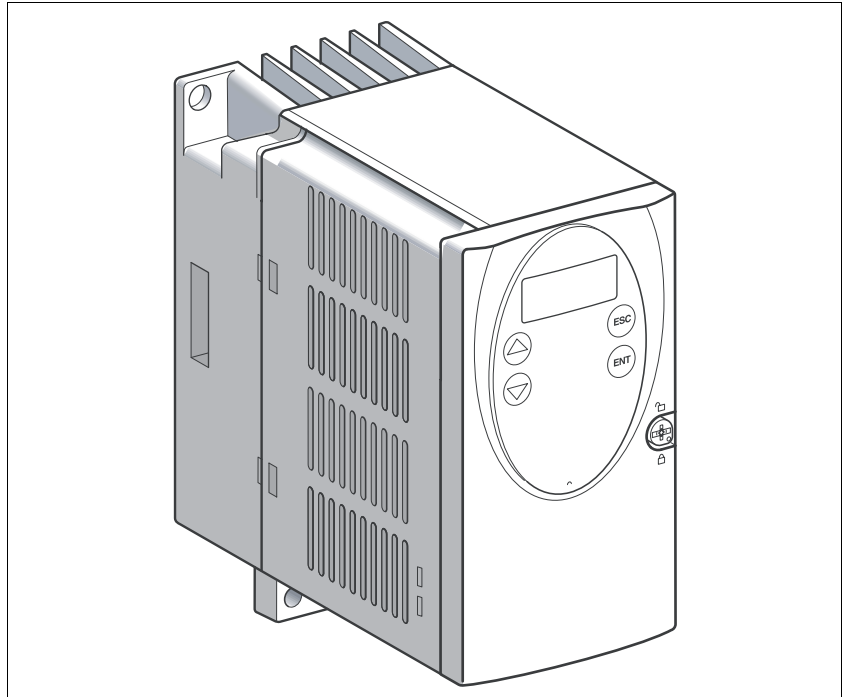

Drive system The LXM05A is an AC servo drive that can be used anywhere.

Reference values are normally specified and monitored by a higher-level PLC, e.g. Premium.

It offers a very compact and powerful drive system in combination with selected Schneider Electric servomotors.

The front panel includes an input panel (HMI, **H**uman**M**achine**I**nterface) with display and keypad for setting parameters.

Setpoint entry The setpoint value can be specified via:

- fieldbus: Modbus or CANopen for profile positioning movements, speed control, motion sequence and torque/speed control
- ± 10 V analogue signals for torque control or speed control. Position feedback of the actual motor position is accomplished by A/B encoder signals
- Position interface: Pulse/direction signals or A/B encoder signals for implementing an electronic gearbox

Safety function The integrated safety function "Power Removal" (SIL2) enables a stop of category 0 or 1 as per EN60204-1 without external power contactors. It is not necessary to interrupt the supply voltage. This reduces the system costs and response times.

1.2 Components and interfaces

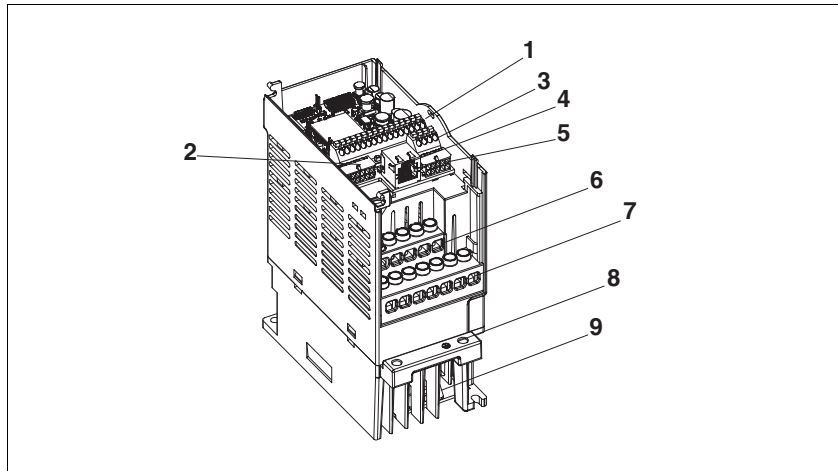

- (1) CN1, I/O signal connection (spring clamp terminals)
- Two ± 10 V analogue reference inputs in the speed control and current control operating modes (torque control)
 - CANopen for fieldbus control
 - Eight digital inputs/outputs. The assignment depends on the selected operating mode
- (2) 12-pin CN2 female connector for motor encoder (SinCos Hi-perface® sensor)
- (3) CN3, connection for 24 V power supply
- (4) CN4, RJ45 female connector for connection
- fieldbus: Modbus or CANopen
 - PC with PowerSuite commissioning software
 - Remote terminal
- (5) 10-pin CN5 female connector for
- Output of actual motor position via A/B encoder signals in speed control and current control operating modes for position feedback for a higher level position controller (e.g. PLC with motion-control card).
 - Input of pulse/direction or A/B encoder signals in electronic gearbox mode
- (6) Screw terminals for connecting the mains supply
- (7) Screw terminals for connecting the motor and external brake resistors
- (8) Bracket for EMC mounting plate
- (9) Heat sink

1.3 Type code

	LXM	05	A	D10	M2	•	(...)
Product name LXM - Lexium							
Product type 05 - AC servo drive for one axis							
Interfaces A - analogue, pulse direction and fieldbus (CANopen and Modbus) B - Profibus							
Peak current (crest value \hat{i}) [A_{pk}] U70 - 7 A_{pk} D10 - 10 A_{pk} D14 - 14 A_{pk} D17 - 17 A_{pk} D22 - 22 A_{pk} D28 - 28 A_{pk} D34 - 34 A_{pk} D42 - 42 A_{pk} D57 - 57 A_{pk}							
Power amplifier supply voltage [V_{AC}] F1 - 1~, 115 V_{AC} M2 - 1~, 230 V_{AC} M3 - 3~, 230 V_{AC} N4 - 3~, 400 V_{AC}							
Mains filter X - no integrated mains filter							
Other options							

1.4 Documentation and literature references

The following User's manuals are supplied with this drive system:

- **Product manual**, describes the technical data, installation, commissioning and all operating modes and operating functions.
- **Fieldbus manual**, important description of integrating the product into a fieldbus.
- **Motor manual**, describes the technical properties of the motors, including correct installation and commissioning.

Source product manuals The current product manuals are available for download from the Internet.
<http://www.telemecanique.com>.

Source EPLAN Macros For easier engineering, macro files and master article files are available for download from the Internet.
<http://www.telemecanique.com>

Additional literature We recommend the following literature for more in-depth information:

- Ellis, George: Control System Design Guide. Academic Press
- Kuo, Benjamin; Golnaraghi, Farid: Automatic Control Systems. John Wiley & Sons

1.5 Directives and standards

<i>CE mark</i>	With the declaration of conformity and the CE mark on the product the manufacturer certifies that the product complies with the requirements of all relevant EC directives.
<i>EC Machine Directive</i>	<p>The drive systems described here are not machines as defined by the EC Machine Directive (98/37/EEC) but components for installation in machines. They do not have moving parts designed for specific purposes. However, they can be components of a machine or system.</p> <p>The manufacturer must certify that the complete system conforms to the machine directive with the CE mark.</p>
<i>EC EMC Directive</i>	<p>The EC Electromagnetic Compatibility Directives (89/336/EEC) applies to products that cause electromagnetic interference or whose operation may be adversely affected by electromagnetic interference.</p> <p>Conformity with the EMC Directive can only be expected of drive systems after correct installation in the machine. The information on ensuring electromagnetic compatibility given in the chapter on "Installation" must be followed to ensure that the drive system in the machine or system is EMC-compatible and that the product can legally be operated.</p>
<i>EC Low-Voltage Directive</i>	<p>The EC Low-Voltage Directive (73/23/EEC) lays down safety requirements for "electrical apparatus" as protection against the risks that can originate in such devices and can be created in response to external influences.</p> <p>The drive systems described here comply with the EN 50178 Standard as per the Low-Voltage Directive.</p>
<i>Declaration of conformity</i>	The declaration of conformity certifies that the drive system complies with the specific EC directive.
<i>Standards for safe operation</i>	<p>IEC 60204-1: Electrical equipment of machines, General requirements</p> <p>IEC 60529: IP degrees of protection</p> <p>IEC 61508: SIL 2; Functional safety of safety-related electric, electronic and programmable electronic systems</p> <p>IEC 62061: SIL 2; Safety of Machines - Functional safety of electrical, electronic and programmable controllers of machines</p> <p>EN 954-1: Safety of machines, Safety of components of control devices, Part 1: General design requirements</p> <p>pr EN 13849-1: Safety of machines - safety-related components of controllers - Part 1: General design requirements</p>
<i>Standards for compliance with EMC limit values</i>	IEC 61800-3: Variable-speed electrical drives

1.6 Declaration of conformity

The following declaration of conformity is applicable when the product is used under the specified general conditions and with the cables listed in the accessories.

EC Declaration of Conformity Year 2005



- according to EC Directive Low Voltage 73/23/EEC; changed by CE Marking Directive 93/68/EEC
- according to EC Directive on Machinery 98/37/EEC
- according to EC Directive EMC 2004/108/EEC

We declare that the products listed below meet the requirements of the mentioned EC Directives with respect to design, construction and version distributed by us. This declaration becomes invalid with any modification on the products not authorized by us.

Designation: AC Servo Drive

Type: LXM05Axxxxxx, LXM05Bxxxxxx

Product number: 01637x1701xxx, 01637x1721xxx

Applied
harmonized
standards,
especially:

EN ISO 13849-1:2004, Performance Level "d"
EN 61508:2002, SIL 2
EN 50178:1998
EN 61800-3:2001, second environment according to Berger Lahr
EMC test conditions

Applied
national standards
and technical
specifications,
especially:

UL 508C
Berger Lahr EMC test conditions 200.47-01 EN
Product documentation

Company stamp: **Berger Lahr GmbH & Co. KG**
Postfach 11 80 · D-77901 Lahr
Breslauer Str. 7 · D-77933 Lahr

Date/ Signature: 28 July 2005

Name/ Department: Wolfgang Brandstätter/R & D Drive Systems

1.7 TÜV certificate for functional safety

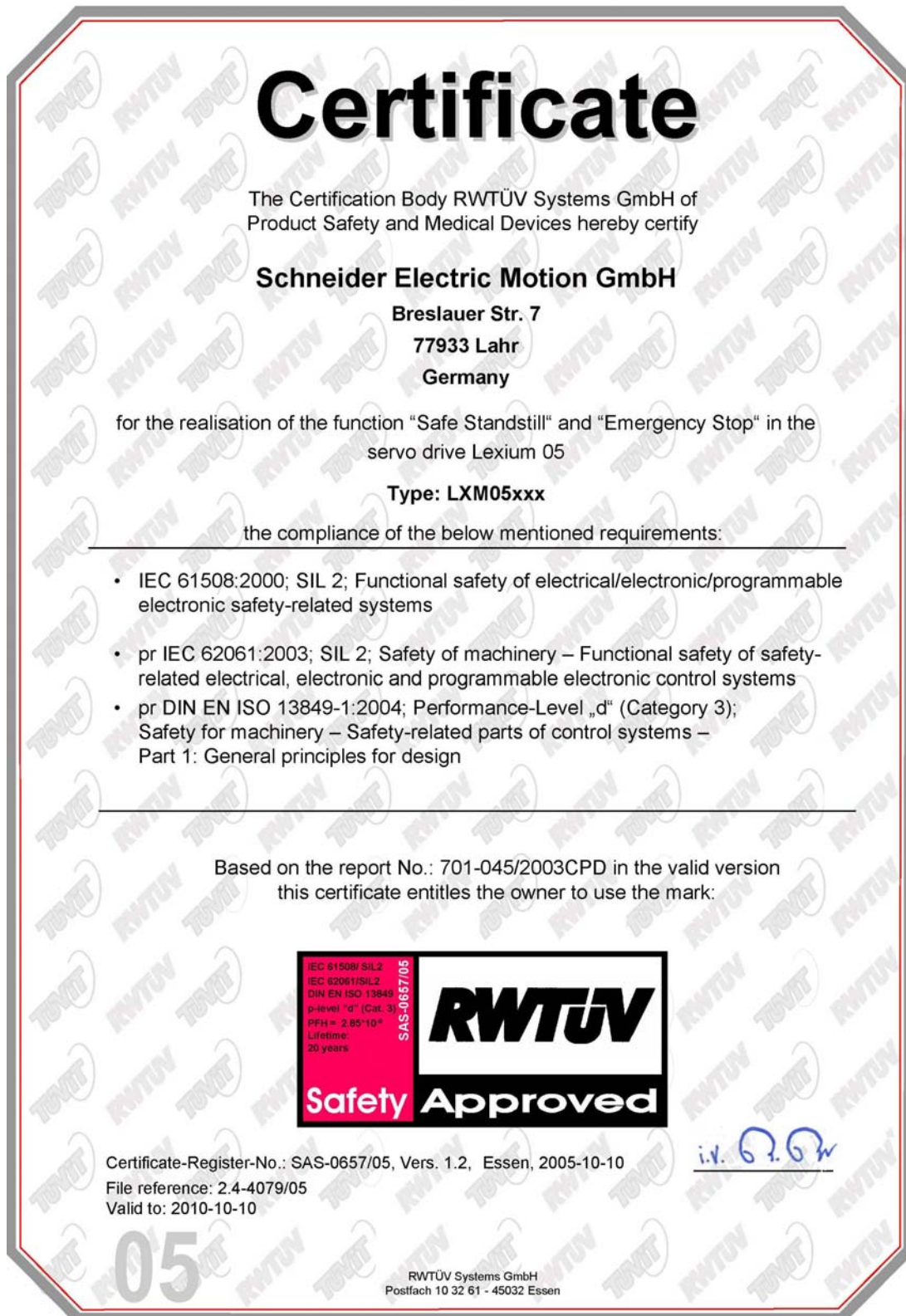

2 Safety

2.1 Qualification of personnel

Only technicians who are familiar with and understand the contents of this manual and the other relevant manuals are authorised to work on and with this drive system. The technicians must be able to detect potential dangers that may be caused by setting parameters, changing parameter values and generally by the mechanical, electrical and electronic equipment.

The technicians must have sufficient technical training, knowledge and experience to recognise and avoid dangers.

The technicians must be familiar with the relevant standards, regulations and safety regulations that must be observed when working on the drive system.

2.2 Intended use

The drive systems described here are products for general use that conform to the state of the art in technology and are designed to prevent any dangers. However, drives and drive controllers that are not specifically designed for safety functions are not approved for applications where the functioning of the drive could endanger persons. The possibility of unexpected or unbraked movements can never be totally excluded without additional safety equipment. For this reason personnel must never be in the danger zone of the drives unless additional suitable safety equipment prevents any personal danger. This applies to operation of the machine during production and also to all service and maintenance work on drives and the machine. The machine design must ensure personal safety. Suitable measures for prevention of property damage are also required.

In the system configuration described the drive systems must be used in industrial applications only and must have a fixed connection only.

In all cases the applicable safety regulations and the specified operating conditions, such as environmental conditions and specified technical data, must be observed.

The drive system must not be commissioned and operated until completion of installation in accordance with the EMC regulations and the specifications in this manual.

To prevent personal injury and damage to property damaged drive systems must not be installed or operated.

Changes and modifications of the drive systems are not permitted and if made all no warranty and liability will be accepted.

The drive system must be operated only with the specified wiring and approved accessories. In general, use only original accessories and spare parts.

The drive systems must not be operated in an environment subject to explosion hazard (ex area).

2.3 Hazard categories

Safety notes and general information are indicated by hazard messages in the manual. In addition there are symbols and instructions affixed to the product that warn of possible hazards and help to operate the product safely.

Depending on the seriousness of the hazard, the messages are divided into three hazard categories.

DANGER

DANGER indicates an imminently hazardous situation, which, if not avoided, **will result** in death, serious injury, or equipment damage.

WARNING

WARNING indicates a potentially hazardous situation, which, if not avoided, **can result** in death, serious injury, or equipment damage.

CAUTION

CAUTION indicates a potentially hazardous situation, which, if not avoided, **can result** in injury or equipment damage.

2.4 General safety instructions

⚠ DANGER

Electric shock, fire or explosion

- Only technicians who are familiar with and understand the contents of this manual and the other relevant manuals are authorised to work on and with this drive system.
- The system manufacturer is responsible for compliance with all applicable regulations relevant to earthing the drive system.
- Many components, including the printed circuit board, work with mains voltage. **Do not touch**. Do not touch unprotected parts or screws on the terminals under voltage.
- Install all covers and close the housing doors before applying power.
- The motor generates voltage when the shaft is rotated. Lock the motor shaft to prevent rotation before starting work on the drive system.
- Before working on the drive system:
 - Switch off power to all connections.
 - Place a sign "DO NOT SWITCH ON" on the switch and lock to prevent its being switched on.
 - **Wait for 6 minutes** (discharge DC bus capacitors). Do not short-circuit DC bus!
 - Measure voltage on DC bus and check that it is <45V. (The DC bus LED is not a reliable indicator for no DC bus voltage).

Failure to follow these instructions will result in death or serious injury.

⚠ WARNING

Unexpected movement

Drives may execute unexpected movements because of incorrect wiring, incorrect settings, incorrect data or other errors.

Malfunctions (EMC) may cause unpredictable responses in the system.

- Install the wiring carefully in accordance with the EMC requirements.
- Disable the inputs $\overline{\text{PWRR_A}}$ and $\overline{\text{PWRR_B}}$ (status 0) to prevent unexpected movements before switching on and configuring the drive system.
- Do not operate a drive system with unknown settings or data.
- Carry out a comprehensive commissioning test.

Failure to follow these instructions can result in death or serious injury.

▲ WARNING

Loss of control

- Observe the accident prevention regulations. (For USA see also NEMA ICS1.1 and NEMA ICS7.1)
- The system manufacturer must take the potential error possibilities of the signals and the critical functions into account to ensure a safe status during and after errors. Some examples are: emergency stop, final position limitation, power failure and restart.
- The assessment of error possibilities must also include unexpected delays and the failure of signals or functions.
- Suitable redundant control paths must be in place for dangerous functions.
- Check that measures taken are effective.

Failure to follow these instructions can result in death or serious injury.

2.5 Safety functions

Using the safety functions integrated in this product requires careful planning. For more information see 5.4 "Safety function "Power Removal"" on page 5-2.

2.6 Monitoring functions

The monitoring functions in the product protect the system and reduce the risks involved in a system malfunction. These monitoring functions are not sufficient for personal protection.

The following errors and limit values can be monitored:

Monitoring	Task	Protective function
Data link	Error response in event of connection break	Functional safety and system protection
Limit switch signals	Monitoring of permissible area of travel	System protection
Tracking error	Monitoring of variation between motor position and setpoint position	Functional safety
Motor overload	Monitoring for excessively high current in the motor phases	Functional safety and device protection
Overvoltage and undervoltage	Monitoring for overvoltage and undervoltage of the power supply	Functional safety and device protection
Overtemperature	Monitoring device for overtemperature	Device protection
I^2t Limit	Power limitation in event of overloading	Device protection

For the description of the monitoring function see 8.6.1 "Monitoring functions" from page 8-57.

3 Technical Data

This chapter contains information on the required environmental conditions and on the mechanical and electrical properties of the unit family and the accessories.

3.1 Testing agencies and certificates

This product or functions of this product have been certified by the following independent testing agencies:

Testing agency	Assigned number	Validity
RWTÜV	SAS-0078/05	2010-01-13
UL	File E153659	
CiA (Can in Automation)	CiA200412-301V402/20-0044	

3.2 Environmental conditions

When considering the ambient temperature a distinction is made between the permissible temperatures during operation and the permissible storage and transport temperature.

ambient operating temperature

The maximum permissible ambient air temperature during operation depends on the clearance between the units and the required output. The relevant requirements in the chapter on installation are also very important.

Temperature ¹⁾	[°C]	0 ... +50
---------------------------	------	-----------

1) no icing

Ambient climate for transport and storage

The environment during transport and storage must be dry and dust-free. The maximum oscillation and shock stress must be within the specified limits. The bearing and transport temperature must remain within the specified range.

Temperature	[°C]	-25 ... +70
-------------	------	-------------

Pollution degree

Pollution degree	2
------------------	---

Relative humidity

The relative humidity is allowed as follows:

rel. humidity	conforming to IEC60721-3-3, Class 3K3 / 3Z12 ,5% ... 85%, no condensation permitted
---------------	-------------------------------------------------------------------------------------

<i>Installation height</i>	Installation height above mean sea level for 100% power [m]	<1000
	Installation height above mean sea level with max. ambient temperature 40°C, no protective foil and side distance >50 mm [m]	<2000m

<i>Vibration and shock loading</i>	The strength during oscillation stress on the units corresponds to EN 50178 Section 9.4.3.2 and IEC 61131-2 Section 6.3.5.1.	
	Oscillation and vibration	Conforming to IEC/EN 60068-2-6: 1.5 mm peak to peak from 3 ... 13 Hz, 1 gn from 13 ... 150 Hz
	Shock loading	15 gn for 11 ms conforming to IEC/EN 60068-2-27

Wiring Use copper wiring resistant to at least 60°C or 75°C.

3.2.1 Degree of protection

The devices have the degree of protection IP20. The degree of protection IP40 is met for the top of the housing if the protective cover on top of the device has not been removed. The safety cover may need to be removed because of the ambient temperature or the device clearances, see chapter 6.2.1 "Installing the device" page 6-7.

Degree of protection when using "Power Removal" It is important to ensure that there are no conductive deposits on the product for the "Power Removal" function (pollution degree 2). Protect the product appropriately against dust and spray.

3.3 Mechanical data

3.3.1 Dimensional drawings

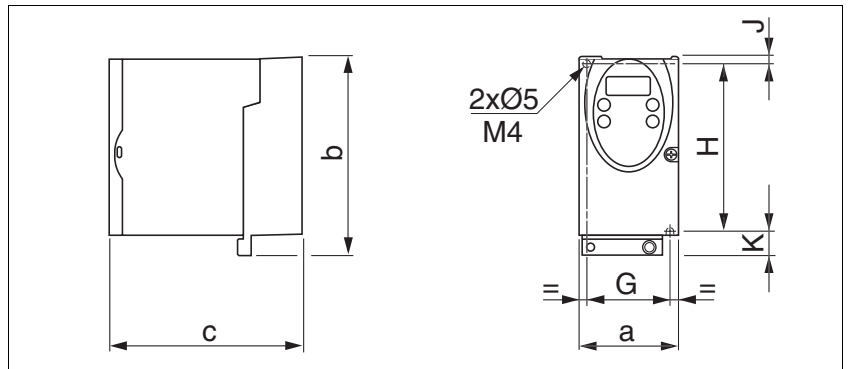

Figure 3.1 Dimensional drawing

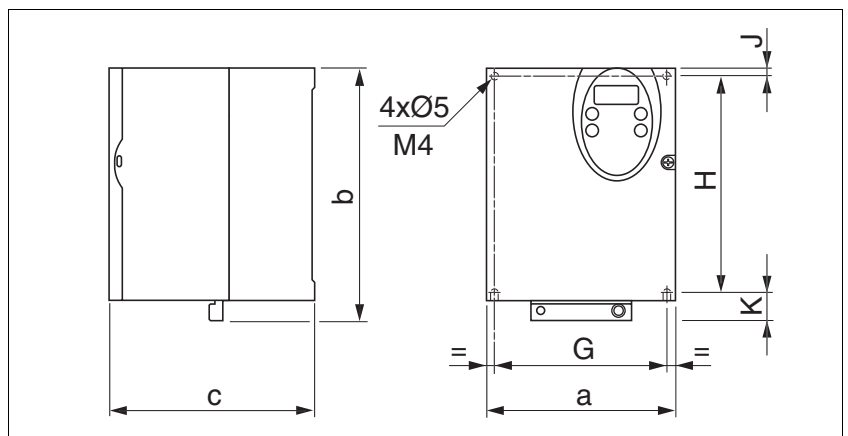

Figure 3.2 Dimensional drawing

LXM05...		U70... D10...	D14... D17...	D2... D3... D4....	D5...
Figure		Figure 3.1	Figure 3.1	Figure 3.2	Figure 3.2
a	mm	72	107	142	180
b	mm	145	143	184	232
c	mm	140	150	150	170
G	mm	60	93	126	160
H	mm	121.5	121.5	157	210
J	mm	5	5	6.5	5
K	mm	18.5	16.5	20.5	17
Weight	kg	1.1	1.4	2	4.8
Type of cooling		Convection ¹⁾	Fan	Fan	Fan
Top-hat rail installation		77.5 ²⁾	105 ²⁾	-	-

1) >1m/s

2) Width of adapter plate

3.4 Electrical Data

3.4.1 Performance data for power amplifier

Mains voltage: range and tolerance

115V _{AC}	[V _{AC}]	100 -15% ... 120 +10%
230V _{AC}	[V _{AC}]	200 -15% ... 240 +10%
400V _{AC}	[V _{AC}]	380 -15% ... 480 +10%
Frequency	[Hz]	50 -5% ... 60 +5%

transient overvoltages	overvoltage category III
------------------------	--------------------------

Inrush current and leakage current

Inrush current	[A]	<60
Leakage current (as per IEC 60990, figure 3)	[mA]	<30 ¹⁾

1) measured on mains with earthed neutral point, with no external mains filter. When using residual-current devices make sure that a 30 mA residual-current device can trigger at 15 mA. A high-frequency leakage current also flows, which is not considered in the measurement. Residual current devices respond differently to this.

Power consumption and impedance of mains supply

The specified power consumption refers to a mains with the specified reference voltage and the assumed short-circuit impedance at nominal power output. The power consumption depends strongly on the impedance of the supply mains. This is specified by a possible short-circuit current. If the actual mains deviates from this, mains reactors must be installed upstream.

Monitoring the continuous output current

The continuous output current at 4kHz and 8kHz is monitored by the device. If the value is continuously exceeded, the output current is reduced by the device. The internal overtemperature monitoring does not respond at the specified values so long as the ambient temperature remains below 40°C and no heat is generated at the internal braking resistor.

Peak output current for 3 seconds

The peak output current at 4kHz and 8kHz can be output by the device for 3 seconds. If the peak current flows at motor standstill, the higher heat build-up enables the current limiting of the device earlier than when the motor is rotating.

Continuous and peak currents are lower at 8kHz because of higher losses. This is particularly clear in devices with higher DC bus voltage.

Voltage against PE

The insulation of the devices is designed for a nominal voltage corresponding to the value of the reference voltage. The voltage against earth must not exceed these values.

Approved motors

For an overview of the approved motor series (BRH, BSH, SER, USD) that can be attached to this device series, see the product catalogue. When making the selection consider the type and amount of the mains voltage.

LXM05•...		D10F1	D17F1	D28F1	D10M2	D17M2	D28M2
Nominal voltage	[V]	115 (1~)	115 (1~)	115 (1~)	230 (1~)	230 (1~)	230 (1~)
Power consumption at nominal voltage	[A _{rms}]	7.3	11	21.6	7	11	20
nominal power (device power output)	[kW]	0.4	0.65	0.85	0.75	1.2	2.5
max. permissible short circuit current of mains	[kA]	1	1	1	1	1	1
power loss	[W]	43	76	150	48	74	142
continuous output current at 4kHz	[A _{rms}]	4	8	15	4	8	15
	[A _{pk}]	5.66	11.31	21.21	5.66	11.31	21.21
peak output current at 4kHz	[A _{rms}]	7	12	20	7	12	20
	[A _{pk}]	9.90	16.97	28.28	9.90	16.97	28.28
continuous output current at 8kHz	[A _{rms}]	3.2	7	13	3.2	7	13
	[A _{pk}]	4.53	9.90	18.38	4.53	9.90	18.38
peak output current at 8kHz	[A _{rms}]	6	11	20	6	11	20
	[A _{pk}]	8.49	15.56	28.28	8.49	15.56	28.28
Primary fuse	[A]	10	15/16	25	10	15/16	25

LXM05•...		D10M3X	D17M3X	D42M3X	D14N4	D22N4	D34N4	D57N4
Nominal voltage	[V]	230 (3~)	230 (3~)	230 (3~)	400 (3~)	400 (3~)	400 (3~)	400 (3~)
Power consumption at nominal voltage	[A _{rms}]	4.5	7.75	16.5	4	6	9.2	16.8
nominal power (device power output)	[kW]	0.75	1.4	3.2	1.4	2.0	3.0	6.0
max. permissible short circuit current of mains	[kA]	5	5	5	5	5	5	22
power loss ¹⁾	[W]	43	68	132	65	90	147	240
continuous output current at 4kHz	[A _{rms}]	4	8	17	6	9	15	25
	[A _{pk}]	5.66	11.31	24.04	8.49	12.73	21.21	35.36
peak output current at 4kHz	[A _{rms}]	7	12	30	10	16	24	40
	[A _{pk}]	9.90	16.97	42.43	14.14	22.63	33.94	56.57
continuous output current at 8kHz	[A _{rms}]	3.2	7	15	5	7	11	20
	[A _{pk}]	4.53	9.90	21.21	7.07	9.90	15.56	28.28
peak output current at 8kHz	[A _{rms}]	6	11	30	7.5	14	18	30
	[A _{pk}]	8.49	15.56	42.43	10.61	19.80	25.46	42.43
Primary fuse ²⁾	[A]	10	10	25	10	15/16	15/16	25

1) condition: internal braking resistor not active; value with nominal current, nominal voltage and nominal power

2) Fuses: fusible links of class CC or J as per UL 248-4, alternatively miniature circuit-breakers with B or C-characteristic. 15/16A specification: circuit breakers are available with 16A nominal current, UL fuses with 15A.

The nameplate indicates whether or not your device has an integrated mains filter. Devices with the product identification LXM05••••M3X do not have an integrated mains filter.

3.4.2 24VDC controller power supply

Spring loaded terminals The spring loaded terminals have a maximum cross-section of 0.75mm² and a maximum current loading capacity of 2A.

24V power supply The 24V supply voltage must meet the requirements of IEC 61131-2 (PELV standard power supply):

Input voltage	[V]	24V -15% / +20%
Power consumption (without load)	[A]	≤1
Ripple voltage		<5%

3.4.3 Signals

Signal inputs are reverse polarity protected, outputs are resistant to short-circuit. There is an electrical connection to 0VDC.

24V input signals The levels of the inputs correspond when configured as "source" in EN 61131-2, Type 1

Logical 1 (V _{high})	[V]	+15 ... +30
Logical 0 (V _{low})	[V]	-3 ... +5
Input current (typical)	[mA]	10
Debouncing time ¹⁾	[ms]	1.25 ... 1.5
Debounce time $\overline{PWRR_A}$ and $\overline{PWRR_B}$	[ms]	1 - 5
max. skew until detection of signal differences of $\overline{PWRR_A}$ and $\overline{PWRR_B}$ ²⁾	[s]	< 1
Debouncing time for input signal function "start profile positioning"	[ms]	0.25 ... 0.5
Debounce time CAP1 and CAP2	[μs]	< 2 when switching on < 10 when switching off
Jitter CAP1 and CAP2	[μs]	< 2

1) except for $\overline{PWRR_A}$, $\overline{PWRR_B}$, CAP1 and CAP2 and function "start profile positioning"

2) Switching process must be simultaneous for both inputs (skew <1s)

24V output signals The 24V output signals correspond to IEC 61131-2.

Output voltage	[V]	≤30
max. switching current	[mA]	≤50
voltage drop at 50 mA load	[V]	≤1

Analogue input signals

Differential input voltage range	[V]	-10 ... +10
Input resistance	[kΩ]	≥10
Resolution ANA1	[Bit]	14
Resolution ANA2	[Bit]	14
Sampling time ANA1	[ms]	0.25
Sampling time ANA2	[ms]	0.25

Pulse/direction, A/B/I input signals The pulse/direction and A/B/I signals conform to the RS422 interface specifications

Symmetrical	conforming to RS422	
Input resistance	[kΩ]	5
Input frequency, pulse/direction	[kHz]	≤400 ¹⁾
Input frequency, A/B	[kHz]	≤400

1) RS<20: 200kHz

Encoder simulation output signal The encoder simulation output signal complies with the RS422 interface specifications

Logic level	conforming to RS422	
Output frequency per signal	[kHz]	≤400
Motor increments per seconds	[Inc/s]	≤1,6

CAN bus signals The CAN bus signals comply with the CAN standard and are short-circuit resistant.

Sensor signals

Output voltage for encoder	+10V / 100mA	
SIN/COS input signalVoltage range	1V _{pp} with 2.5V offset, 0.5V _{pp} at 100kHz	
Input resistance	[Ω]	120

The output voltage is short-circuit protected and overload resistant. The transmission protocol is asynchronous half-duplex in compliance with RS485.

3.4.4 Safety functions

Data for maintenance schedule and safety calculations Use the following data for your maintenance schedule and safety calculations:

Service life corresponding to safety life cycle (IEC 61508)	20 years
SFF (Safe Failure Fraction) (IEC61508)	70%
HFT (Hardware Fail Tolerance) (IEC61508) Type A subsystem	1
Safety Integrity Level	SIL2
Probability of failure (PFH) (IEC 61508)	2.85*10 ⁻⁹ 1/h
Response time (until shutdown of power amplifier)	<10ms

3.4.5 Braking resistor

The device has an internal braking resistor. If this is insufficient, it will be necessary to use one or more external braking resistors, see chapter 6.3.5 "Connection of braking resistor" page 6-20. For an overview of the available external braking resistors see the chapter on accessories on page 12-1.

The following minimum resistance values are required for the use of one or more external braking resistors. The internal resistance must be disabled, see also Commissioning, page 6-21.

The continuous output of the connected external braking resistors must not exceed the nominal power of the device.

LXM05•...		D10F1	D17F1	D28F1	D10M2	D17M2	D28M2
Energy consumption of internal capacitors E_{var}	[Ws]	10.8	16.2	26.0	17.7	26.6	43.0
resistance internal	[Ω]	40	40	10	40	40	20
Continuous output P_{PR}	[W]	20	40	60	20	40	60
Peak energy E_{CR}	[Ws]	500	500	1000	900	900	1600
Switch-on voltage	[V]	250	250	250	430	430	430
External braking resistor min	[Ω]	27	20	10	50	27	16
External braking resistor max	[Ω]	45	27	20	75	45	27

LXM05•...		D10M3X	D17M3X	D42M3X	D14N4	D22N4	D34N4	D57N4
Energy consumption of internal capacitors E_{var}	[Ws]	17.7	26.6	43.0	26.0 ¹⁾	52.0 ²⁾	52.0 ²⁾	104.0 ³⁾
resistance internal	[Ω]	40	40	20	40	30	30	20
Continuous output P_{PR}	[W]	20	40	60	40	60	60	100
Peak energy E_{CR}	[Ws]	900	900	1600	1000	1600	1600	2000
Switch-on voltage	[V]	430	430	430	770	770	770	760
External braking resistor min	[Ω]	50	27	10	60	25	25	10
External braking resistor max	[Ω]	75	45	20	80	36	36	21

1) at 480V: 6.0Ws
 2) at 480V: 12.0Ws
 3) at 480V: 10.0Ws

3.4.6 Internal mains filter

The EMC standards differentiate between various application cases:

EN 61800-3:2001-02; IEC 61800-3, Ed.2	Description
first environment, general availability; category C1	operation in living areas, e.g. sale by hardware supplier
first environment, restricted availability; category C2	operation in living areas, sale through dealers only
second environment; category C3	operation in industrial mains

This drive system meets the EMC requirements for the second environment under the IEC 61800-3 standard if the measures described for the installation are taken into account. When operating outside this application area note the following:

▲ WARNING

High-frequency interference

In a domestic environment this product may cause high-frequency interference that may require action to suppress interference.

Better values can be achieved depending on the unit and the application and also the structure, e.g. on installation in an enclosed switch cabinet. If the limit values for the first environment (public networks, category C2) are required, external line filters must be connected in series.

The nameplate indicates whether or not your device has an integrated mains filter. Devices with the product identification LXM05●●●M3X do not have an integrated mains filter.

The following limit values for wiring-related interference quantities are met by EMC-compliant construction and by using the cables offered in the accessories:

Devices with internal mains filter	second environment (industrial environment, category C3), device installed in an enclosed control cabinet with 15 dB attenuation: up to 10m motor cable length
------------------------------------	----------------------------------------------------------------------------------------------------------------------------------------------------------------

An external line filter is required when using a unit without an integrated line filter or with long motor lines. The operator must ensure that the EMC directives are observed in this case. For order data for external line filters see the chapter on accessories on page 12-4.

3.5 Technical Data accessories

3.5.1 External braking resistors

VW3A760...		1Rxx	2Rxx	3Rxx	4Rxx	5Rxx	6Rxx	7Rxx ¹⁾
Resistance value	[Ω]	10	27	27	27	72	72	72
Continuous output	[W]	400	100	200	400	100	200	400
max. make time at 115V	[s]	3	1.8	4.2	10.8	6.36	16.8	42
max. make time at 230V	[s]	0.72	0.552	1.08	2.64	1.44	3.72	9.6
max. make time at 400V	[s]	0.12	0.084	0.216	0.504	0.3	0.78	1.92
Peak output at 115V	[kW]	6.3	2.3	2.3	2.3	0.9	0.9	0.9
Peak output at 230V	[kW]	18.5	6.8	6.8	6.8	2.6	2.6	2.6
Peak output at 400V	[kW]	60.8	22.5	22.5	22.5	8.5	8.5	8.5
max. peak energy at 115V	[Ws]	18800	4200	9700	25000	5500	14600	36500
max. peak energy at 230V	[Ws]	13300	3800	7400	18100	3700	9600	24700
max. peak energy at 400V	[Ws]	7300	1900	4900	11400	2500	6600	16200

1) The resistors 7Rxx have NO UL/CSA authorisation!

3.5.2 Line reactor

Line reactor If the mains power does not correspond to the requirements described for impedance, line reactors may need to be installed, see also the chapter on installation. For order data see the chapter on accessories on page 12-4.

3.5.3 External mains filter

The EMC standards differentiate between various application cases; see Chapter 3.4.6 "Internal mains filter", page 3-9.

Better values can be achieved depending on the unit and the application and also the structure, e.g. on installation in an enclosed switch cabinet. If the limit values for the first environment (public networks, category C2) are required, external line filters must be connected in series.

The following limit values for wiring-related interference quantities are met by EMC-compliant construction and by using the cables offered in the accessories:

All devices with an external mains filter	first environment, restricted availability (public mains, category C2), device installed in an enclosed control cabinet with 15 dB attenuation: up to 20m motor cable length
	second environment (industrial environment, category C3), device installed in an enclosed control cabinet with 15 dB attenuation: up to 40m motor cable length (100m at 8kHz switching frequency)

An external line filter is required when using a unit without an integrated line filter or with long motor lines. The operator must ensure that the EMC directives are observed in this case. For order data for external line filters see the chapter on accessories on page 12-4.

3.5.4 Holding brake controller HBC

For motors with holding brake we recommend appropriate control logic (HBC) that releases the brake when the motor is powered and locks the motor axis at the correct moment before the power amplifier supply voltage is switched off and optionally reduces the braking voltage.

Dimensions HBC

Dimensions (H * B * D)	[mm]	99 * 22.5 * 114.5
Installation on top-hat rail		

Power supply

Nominal voltage	[V]	24
Voltage range	[V]	19.2 ... 30
Current consumption	[A]	0.5 + braking current

Signal input

Voltage range	[V]	19.2 ... 30
Input current at 24V	[mA]	<10

Holding brake output

Voltage before voltage reduction	[V]	23 ... 25
Voltage with voltage reduction	[V]	17 ... 19
Maximum output current	[A]	1.6
Time to voltage reduction	[ms]	1000

The holding brake controller has a safe electrical isolation of the holding brake output.

3.5.5 Reference value adapter RVA

Dimensions

Dimensions (H * B * D)	[mm]	77 * 135 * 37
Installation on top-hat rail		

Electrical data

Input		
Supply voltage	[V]	19.2 ... 30
Current consumption (5V _{SE} unloaded)	[mA]	50
Current consumption (5V _{SE} 300mA)	[mA]	150
Output, Encoder		
5V _{SE}	[V]	4.75 ... 5.25
Maximum output current	[mA]	300
sense-controlled, short-circuit and overload-proof		

3.5.6 Cable

Overview of cables required

	max. length [m]	min. cross section [mm ²]	corresp. to PELV	shielded, earthed both ends	twisted pair
Controller supply voltage	-	0.75	X		
Power amplifier supply voltage	-	- ¹⁾			
Motor phases	- ²⁾	- ³⁾		X	
Cable for HBC ⇒ motor, see motor phases	- ²⁾ , max. 0.12 unshielded	- ³⁾ ⁴⁾		X	
Cable for HBC ⇒ device	max. 0.12 unshielded	0.75 ⁴⁾		X	
ext. braking resistor	3	as in power amplifier supply voltage		X	
Motor encoder	100	10*0.25 mm ² and 2*0.5 mm ²	X	X	X
Encoder signals A/B/I	100	0.25	X	X	X
PULSE/DIR	100	0.14	X	X	X
ESIM	100	0.14	X	X	X
fieldbus CANopen	- ⁵⁾	0.14	X	X	X
fieldbus Modbus	400	0.14	X	X	X
Analogue inputs	10	0.14 - 1.5	X	⁶⁾	X
Digital inputs/outputs	15	0.14	X		
PC, decentralised control terminal	400	0.14	X	X	X

- 1) see 6.3.6 "Connection of power amplifier supply voltage"
- 2) Length depends on required limit values for line interference, see 3.4.6 "Internal mains filter" and 3.5.3 "External mains filter".
- 3) see 6.3.4 "Motor phase connections"
- 4) Temperature range: up to 105°C
- 5) Depending on baud rate, see 6.3.14 "CANopen connection (CN1 or CN4)"
- 6) Earth shield of analogue signal lines directly on device (signal input). At the other end of the cable, insulate the shield or if interference occurs earth via a capacitor (e.g. 10nF).

Table 3.1 Cable specifications

Motor and encoder cable

The motor cable and encoder cables are suitable for trailing and are available in various lengths. For the corresponding types see the accessories section on page 12-4.

Permissible voltage	[VAC]	600 (UL and CSA)
Shield		Shield braiding
Sheath		Oil-resistant PUR
Temperature range	[°C]	-40 ... +90 (fixed) -20 ... +80 (movable)
Minimum bending radius		4 x diameter (fixed) 7.5 x diameter (moving)

4 Basics

4.1 Safety functions

Automation and safety engineering are two areas that were completely separate in the past but more recently have become more and more integrated. Planning and installation of complex automation solutions are greatly simplified by integrating safety functions.

In general the safety engineering requirements depend on the application. The degree of the requirements is oriented to the risk and the hazard potential arising from the specific application.

Working with IEC61508

IEC61508 standard

The IEC61508 standard "Functional safety of electrical/electronic/programmable electronic safety-related systems" covers the relevant safety-relevant function. This means that it is not only one single component but always a complete function chain (e.g. from the sensor through the logical processing unit to the actuator) that is considered as one single unit. The function chain must meet the requirements of the specific safety level as a whole. Systems and components that can be used in various applications for safety tasks with comparable risk can be developed in this base.

SIL, Safety Integrity Level

The standard IEC61508 specifies four safety integrity levels (SIL) for safety functions. SIL1 is the lowest level and SIL4 is the highest level. This is based on an assessment of the hazard potential derived from the hazard and risk analysis. This is used to decide whether the relevant function chain requires a safety function and which hazard potential it must cover.

PFH, Probability of a dangerous failure per hour

To maintain the safety function the IEC61508 standard, depending on the required SIL, requires staged fault-control and fault-prevention measures. All components of a safety function must be subjected to a probability analysis to assess the effectiveness of the fault-control measures that were taken. This assessment determines the dangerous probability of failure PFH (probability of a dangerous failure per hour) for protective systems. This is the probability per hour that a protective system fails in a hazardous manner and the protective function cannot be correctly executed. The PFH must not exceed the values calculated for the complete protective system depending on the SIL. The individual PFH of a chain must be calculated together, the total of the PFH must not exceed the maximum value specified in the standard.

SIL	PFH at high requirement rate or continuous requirement
4	$\geq 10^{-9} \dots < 10^{-8}$
3	$\geq 10^{-8} \dots < 10^{-7}$
2	$\geq 10^{-7} \dots < 10^{-6}$
1	$\geq 10^{-6} \dots < 10^{-5}$

HFT and SFF The standard also requires a specific hardware fault tolerance HFT for the safety system depending on the SIL in connection with a specific proportion of safe failures SFF (safe failure fraction). The hardware fault tolerance is the property of a system that enables it to execute the desired safety function in spite of the presence of one or more hardware faults. The SFF of a system is defined as the ratio of the rate of safe failures to the total failure rate of the system. Under IEC61508 the maximum achievable SIL of a system is determined by the hardware fault tolerance HFT and the safe failure fraction SFF of the system.

SFF	HFT type A subsystem			HFT type B subsystem		
	0	1	2	0	1	2
< 60%	SIL1	SIL2	SIL3	---	SIL1	SIL2
60% ... <90%	SIL2	SIL3	SIL4	SIL1	SIL2	SIL3
90% ... < 99%	SIL3	SIL4	SIL4	SIL2	SIL3	SIL4
≥99%	SIL3	SIL4	SIL4	SIL3	SIL4	SIL4

Fault-prevention measures Systematic faults in the specifications, in the hardware and the software, usage faults and maintenance faults of the safety system must be avoided as much as possible. IEC61508 specifies a series of fault-prevention measures that must be implemented depending on the required SIL. The fault-prevention measures must accompany the complete life cycle of the safety system, i.e. from design to decommissioning of the system.

5 Engineering

This chapter contains basic information on options for use of the product, which are essential for the engineering.

5.1 Logic type

This product can switch the 24V inputs and outputs as follows (dr \bar{L} - / \bar{OL} E). Exception: safety signals $\overline{PWRR_A}$ and $\overline{PWRR_B}$ are always logic type "Source".

Logic type	active status
"Source"	Output supplies current current flows to the input
"Sink"	Output draws current current flows from the input

⚠ WARNING

Unmonitored operation

When using the "Sink" setting logic type the earth fault of a signal is detected as an On status.

- Use great care with wiring to prevent the possibility of an earth fault.

Failure to follow these instructions can result in death, serious injury or equipment damage.

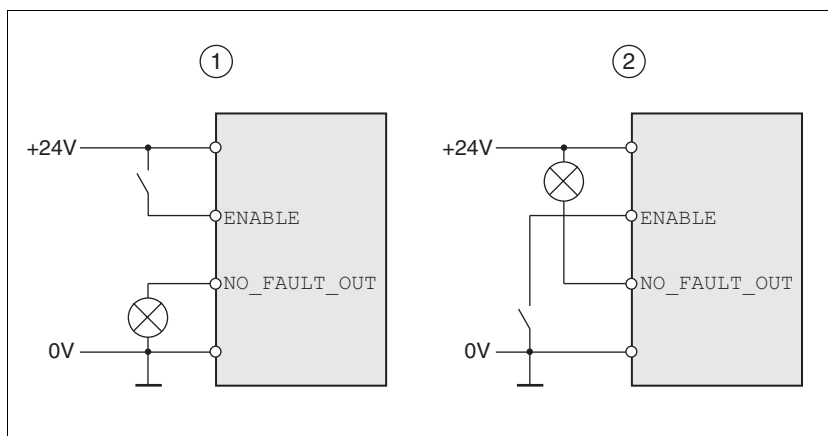

Figure 5.1 Logic type

- (1) "Source"
- (2) "Sink"

The setting is made via "First setup" with the `IOLogicType` parameter. This setting affects the wiring and the control of sensors and must therefore be thoroughly clarified during engineering with reference to the area of application.

Special case: "Power Removal" safety function The inputs for the "Power Removal" safety function (inputs $\overline{\text{PWRR_A}}$ and $\overline{\text{PWRR_B}}$) are **always** executed in "Source" independently of the setting.

5.2 Configurable inputs and outputs

This product has digital inputs and outputs that can be configured. The inputs and outputs have a defined standard assignment depending on the start-up operating mode. This assignment can be adapted to the requirements of the customer's installation. For more information see chapter 8.6.9 "Configurable inputs and outputs".

5.3 Specification of the control mode

Controller type: local or fieldbus The basic specification of whether the system should be controlled locally or over the fieldbus must be made when the product is started for the first time. This specification can only be modified by restoring the factory setting, see chapter 8-98.

The availability of operating modes of the product also depends on this setting.

Local control mode With a local control mode the movement is preset with analogue signals ($\pm 10\text{V}$) or with RS422 signals (e.g. pulse/direction).

Limit switches and reference switches cannot be connected with the control mode.

Fieldbus control mode In the fieldbus control mode all communications are made via fieldbus commands.

5.4 Safety function "Power Removal"

For some general information on the application of IEC 61508 see page 4-1.

5.4.1 Definitions

Power Removal The "Power Removal" safety function shuts off the motor torque safely. The supply voltage must not be interrupted. There is no monitoring at standstill.

Category 0 stop (EN60204-1) Standstill by immediate power shutdown to the machine drive elements (i.e. an uncontrolled stop).

Category 1 stop (EN60204-1) A controlled stop in which the machine drive elements are retained to effect the standstill. Power feed is only interrupted when everything has come to a standstill.

5.4.2 Function

The "Power Removal" safety function integrated into the product can be used to implement the "Emergency Stop" control function (EN 60204-1) for Category 0 Stop and Category 1 Stop. In addition, this safety function prevents the drive from unexpected restart.

The safety function meets the following requirements of the standards for functional safety:

- IEC 61508:2000 SIL 2
- pr IEC 62061:2003 SIL 2
- EN 954-1 category 3
- pr EN ISO 13849-1:2004 PL d (Performance Level d)

Function The "Power Removal" safety function can be triggered with the two redundant inputs $\overline{PWRR_A}$ and $\overline{PWRR_B}$. The circuits of the two inputs must be separated from each other to retain the two channels.

The switching process must be simultaneous for both inputs (skew <1s). The power amplifier is disabled and an error message is generated. Then the motor cannot generate torque and runs down without braking. A restart is only possible after resetting the error message with a "Fault Reset".

The power amplifier is also disabled and an error message is generated if only one of the two inputs is shut down. This error message can only be reset by switching off.

5.4.3 Requirements for safe application

⚠ DANGER

Electric shock caused by incorrect use

The "Power Removal" function does not disconnect the electrical power. The DC bus voltage is still present.

- Turn off the mains voltage using an appropriate switch to achieve a voltage-free condition.

Failure to follow these instructions will result in death or serious injury.

⚠ WARNING

Loss of safety function

Incorrect usage may cause a safety hazard by loss of the safety function.

- Observe the requirements for the safety function.

Failure to follow these instructions can result in death or serious injury.

Stop of category 0 In a stop of category 0 the drive runs down uncontrolled. If access to the machine while it is running down is a hazard (result of hazard and risk analysis), suitable measures must be taken.

Stop of category 1 In a stop of category 1 a controlled stop must be triggered. The controlled stop is not monitored by the drive system and is not guaranteed if power fails or in the event of an error. The final shutdown is ensured by shutting down the $\overline{PWRR_A}$ and $\overline{PWRR_B}$ inputs. This is generally controlled by a standard Emergency Stop module with safe time delay.

Vertical axes, external forces If external forces act on the drive (vertical axis) and an unwanted movement, for example caused by gravity, could cause a hazard, the drive must not be operated without additional measures for drop protection corresponding to the required safety.

Prevention of unexpected restart To prevent an unexpected restart after restoration of power (e.g. after power failure), the parameter `IO_AutoEnable` must be set to "off". Note that a higher level controller must not trigger a dangerous restart.

Degree of protection when using "Power Removal" It is important to ensure that there are no conductive deposits on the product for the "Power Removal" function (pollution degree 2). Protect the product appropriately against dust and spray.

Protected layout If short circuits and cross connections can be expected on the wiring of the $\overline{PWRR_A}$ and $\overline{PWRR_B}$ signals and they are not detected by upstream devices, a protected wire layout is required.

In the case of an unprotected layout the $\overline{PWRR_A}$ and $\overline{PWRR_B}$ signals may be connected to interference voltage if a cable is damaged. If both signals are connected to interference voltage the "Power Removal" safety function will not operate.

A protected layout can be achieved as follows:

- Layout of $\overline{PWRR_A}$ and $\overline{PWRR_B}$ signal lines in different cables. If there are additional wires in the cables they must only carry voltages corresponding to PELV.
- Use of a shielded cable. The earthed shield protects the signals against interference voltage if the cable is damaged and can trip the fuse.
- Use of separate earthed shielding. If there are other wires in the cable, the $\overline{PWRR_A}$ and $\overline{PWRR_B}$ signals must be isolated from these wires by a separate earthed shield.

Data for maintenance schedule and safety calculations Use the following data for your maintenance schedule and safety calculations:

Service life corresponding to safety life cycle (IEC 61508)	20 years
SFF (Safe Failure Fraction) (IEC61508)	70%
HFT (Hardware Fail Tolerance) (IEC61508) Type A subsystem	1
Safety Integrity Level	SIL2
Probability of failure (PFH) (IEC 61508)	$2.85 \cdot 10^{-9}$ 1/h
Response time (until shutdown of power amplifier)	<10ms

Hazard and risk analysis As a system manufacturer you must conduct a hazard and risk analysis (e.g. as per EN 1050) of the system. The results must be taken into account in the application of the "Power Removal" safety function.

The circuit resulting from the analysis may deviate from the following application examples. Additional safety components may be required. The results of the hazard and risk analysis always have priority.

5.4.4 Application examples

Example: category 0 stop Circuit without EMERGENCY STOP module, category 0 stop.

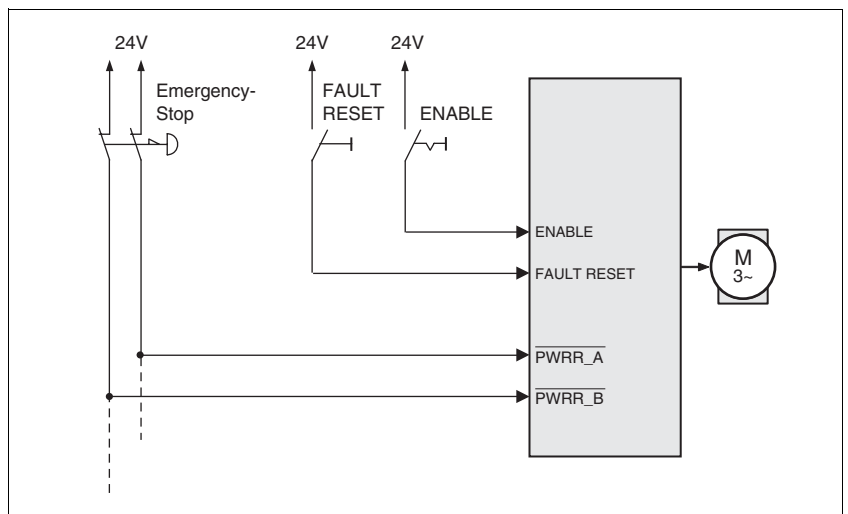

Figure 5.2 Example: category 0 stop

Please note:

- When the EMERGENCY STOP switch is tripped it initiates a stop of category 0

Example: category 1 stop Circuit with EMERGENCY STOP module, category 1 stop,

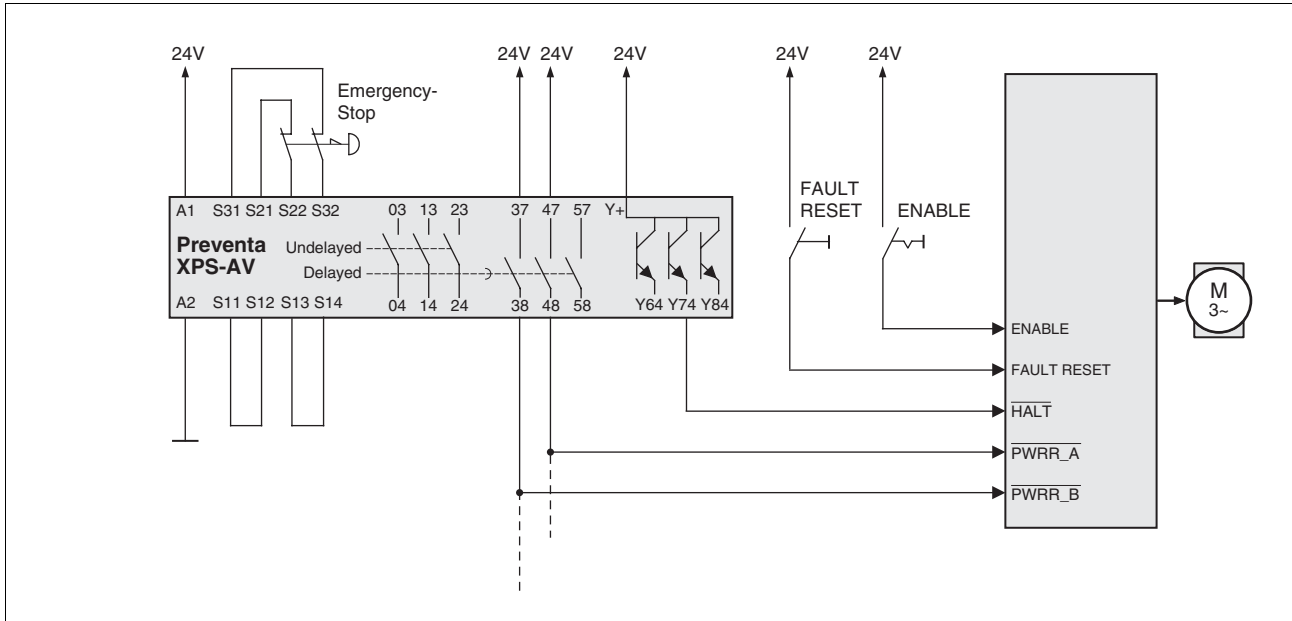

Figure 5.3 Example of category 1 stop with external Preventa XPS-AV EMERGENCY STOP module

Please note:

- A "Halt" is initiated without delay via the $\overline{\text{HALT}}$ input.
- The $\overline{\text{PWRR_A}}$ and $\overline{\text{PWRR_B}}$ inputs are switched off when the delay time preset on the emergency stop module has elapsed. If the drive has not yet stopped at this time, it runs down without control (uncontrolled stop).
- The specified minimum current and the allowed maximum current of the relay must be maintained in the circuitry of the relay outputs at the EMERGENCY STOP module.

6 Installation

⚠ WARNING

Loss of control

- Observe the accident prevention regulations. (For USA see also NEMA ICS1.1 and NEMA ICS7.1)
- The system manufacturer must take the potential error possibilities of the signals and the critical functions into account to ensure a safe status during and after errors. Some examples are: emergency stop, final position limitation, power failure and restart.
- The assessment of error possibilities must also include unexpected delays and the failure of signals or functions.
- Suitable redundant control paths must be in place for dangerous functions.
- Check that measures taken are effective.

Failure to follow these instructions can result in death or serious injury.



The chapter on engineering contains basic information that you should know before starting the installation.

6.1 Electromagnetic compatibility, EMC

⚠ WARNING

Interference with signals and devices

Distorted signals can cause unpredictable device responses.

- Install the wiring in accordance with the EMC requirements.
- Check compliance with the EMC requirements, particularly in an environment subject to strong interference.

Failure to follow these instructions can result in death, serious injury or equipment damage.

This drive system meets the EMC requirements for the second environment under the IEC 61800-3 standard if the measures described for the installation are taken into account. When operating outside this application area note the following:

⚠ WARNING

High-frequency interference

In a domestic environment this product may cause high-frequency interference that may require action to suppress interference.

An EMC-compliant design is required to maintain the specified limit values. Depending in the case better results can be achieved with the following measures:

- Upstream mains reactors. Information on current distortions can be obtained on request.
- Upstream external mains filters, particularly to maintain limit values for the first environment (living area, category C2)
- Particularly EMC-compliant design, e.g. in an enclosed switch cabinet with 15dB damping of radiated interference

EMC scope of supply and accessories

The scope of supply includes earth clamps and an EMC plate.

For information on the prefabricated wiring see page 12-2.

Switching cabinet setup

EMC measures	Effect
Use EMC plate or galvanised or chrome-plated mounting plates, make large contact surface connections for metal parts, remove paint from contact surfaces	Good conductivity due to two-dimensional contacts
Earth the control cabinet, door and EMC plate with metal tapes or cables with a cross section area greater than 10 mm ² .	Reduction of emissions.
Fit switching devices such as contactors, relays or solenoids with interference suppressors or spark suppressors (e.g. diodes, varistors, RC elements)	Reduction of mutual interference
Install power and control components separately.	Reduction of mutual interference

Cabling

EMC measures	Effect
Keep wiring as short as possible. Do not install "safety loops", short cables from the star point in the switch cabinet to outlying earth connection.	Avoidance of capacitive and inductive interference injection
Use cable clamps to connect a large surface area of the shield of all shielded cables to the mounting plate at the control cabinet entry.	Reduction of emissions.
Fieldbus lines and signal lines must not be laid in the same conduit with lines for DC and AC voltage over 60 V. (Fieldbus lines can be laid in the same conduit with signal and analogue lines)	Prevention of mutual interference
Recommendation: lay in separate conduits at least 20 cm apart.	
Connect large surface areas of cable shields, use cable clamps and tapes	Reduction of emissions.
Earth shields on digital signal lines over a wide area at both ends or via conductive plug housing.	Preventing interference on control cables, reduction of emissions
Use bonding conductors in system with – wide-area installation – different voltage infeed – networking between different buildings	Protection of wiring, reduction of emissions.
Use fine-core bonding conductors	Deflect even high-frequency interference currents

0198441113232, V1.20, 06.2007

EMC measures	Effect
Earth shield on analogue signal lines directly at the device (signal input), and insulate the shield at the other end of the cable or earth via a capacitor if interference occurs, e.g. 10 NF.	Preventing ripple loops due to low-frequency interference
Use only shielded motor cables with copper braiding and at least 85% covering, ground a large surface area of the shield at each end.	Controlled discharge of interference currents, reduction of emissions
If motor and machine are not conductively connected, e.g. by an insulated flange or a non-flat connection, earth the motor with an earth wire >10 mm ² (>6 AWG) or ground strap.	Reduction of emissions, increase in resistance to interference
Lay connections of the 24V _{DC} supply voltage as "twisted pair".	Preventing interference on control cables, reduction of emissions

Power supply

EMC measures	Effect
Operate drive system on mains with earthed neutral point (not IT mains).	Mains filter is only effective on systems with an earthed star point.
Connect the negative output of the PELV power supply unit to PE.	Reduction of EMC emissions, safety
Circuit breaker if there is danger of overvoltage or lightning strike	Protection against damage by overvoltage

EMC requirement: motor and motor encoder cables

Motor leads and motor sensor cables are especially critical signal lines. Use the cables recommended by your local representative. They must be tested for EMC safety and must be suitable for trailing cables.

The motor cable and the motor encoder cable on the drive solution must be laid out over a wide area with low resistance on the device, the switch cabinet output and on the motor.

- ▶ Lay out motor and motor encoder cables without interruption (do not install switch components) from the motor and encoder to the device.
If a line has to be interrupted, shielded connections and metal casing must be used to prevent interference.
- ▶ Lay the motor cable at least 20 cm from the signal cable.
If the distance is less than this, the motor cable and signal cables must be separated by grounded screening plates.
- ▶ For long lines bonding conductors with a suitable cross section must be used

Equipotential bonding conductors

The shields are connected at both ends for fault protection. Potential differences can result in excessive currents on the shield and must be prevented by equipotential bonding conductor cables.

If lines over 100 m are approved, the following applies: up to 200 m length a cable cross section of 16 mm² is sufficient, for greater lengths a cable cross section of 20 mm² is required.

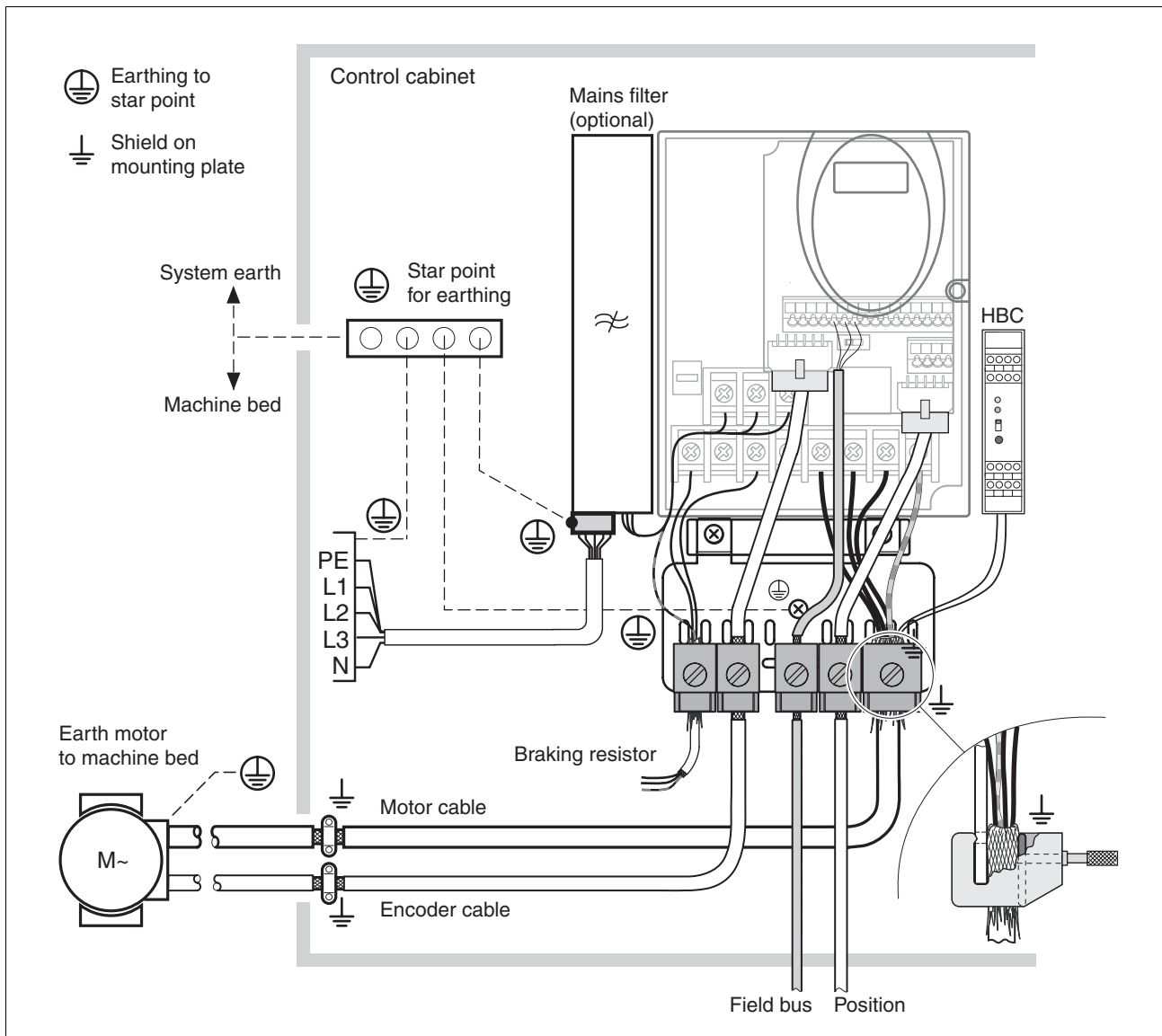

Figure 6.1 EMC measures

6.1.1 Operation in an IT mains

An IT mains is characterised by a neutral conductor that is insulated or earthed through a high impedance . If you use a permanent insulation monitor, it must be suited for non-linear loads (e.g. Type XM200 from Merlin Gerin). If, despite perfect wiring, a fault is indicated, you can, in the case of products with integrated mains filters, disconnect the earth connection to the Y- capacitors (deactivate the Y- capacitors).

With all other networks except for IT mains the earth connection via the Y- capacitors must be maintained.

If the earth connection to the Y- capacitors is removed, the specifications for the transmission of electromagnetic interference will no longer be maintained (specific categories see chapter page)!3.4.6 "Internal mains filter"3-9 Separate measures are required to comply with national regulations and standards.

CAUTION: the motor must be designed for operation in the IT mains.

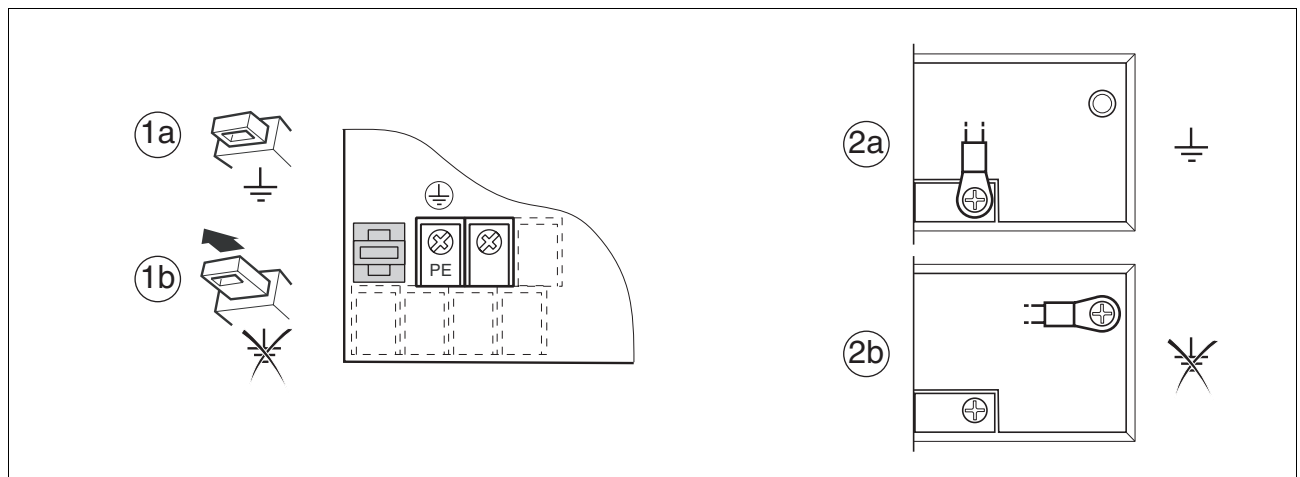

Devices with switch beside power terminals (1)

LXM05... U7... D1... D2... D3... D4...

(1a): Y-capacitors of the internal filter effective (standard)

(1b): Y-capacitors of the internal filter disabled (IT mains)

Devices with jumpers (2)

LXM05... D5...

(2a): Y-capacitors of the internal filter effective (standard)

(2b): Y-capacitors of the internal filter disabled (IT mains)

6.2 Mechanical installation

⚠ DANGER

Electric shock from external objects or damage.

Conductive external objects in the product or serious damage can cause parasitic voltage.

- Do not use damaged products.
- Prevent external objects such as chips, screws or wire clippings from entering the product.
- Do not use products that contain external objects.

Failure to follow these instructions will result in death or serious injury.

⚠ WARNING

Danger of loss of safety function by external objects

The safety function may fail because of conductive external objects, dust or liquids.

- The "Power Removal" safety function must only be used if the system is protected against conductive dirt.

Failure to follow these instructions can result in death or serious injury.

⚠ CAUTION

Hot Surfaces

The heat sink on the product may heat up to over 100 °C (212 °F) depending on the operating mode.

- Prevent contact with the hot heat sink.
- Do not install flammable or heat-sensitive components in the immediate vicinity.
- Follow the actions described for heat dissipation.

Failure to follow these instructions can result in injury or equipment damage.

6.2.1 Installing the device

Switching cabinet The switching cabinet must be dimensioned so all devices and accessories can be fixed in place and wired to meet EMC standards. The components include a holding brake controller or braking resistors.

The switching cabinet ventilation must be capable of extracting the heat generated by all devices and components installed in the switch cabinet.

Installation spacing; ventilation When selecting the position of the device in the switching cabinet, note the following instructions:

- Adequate cooling of the device must be ensured by complying with the minimum installation distances. Prevent heat accumulation.
- The device must not be installed close to heat sources or mounted on flammable materials.
- The warm airflow from other devices and components must not heat the air used for cooling the device.
- The drive will switch off as a result of overtemperature when operated above the thermal limits.

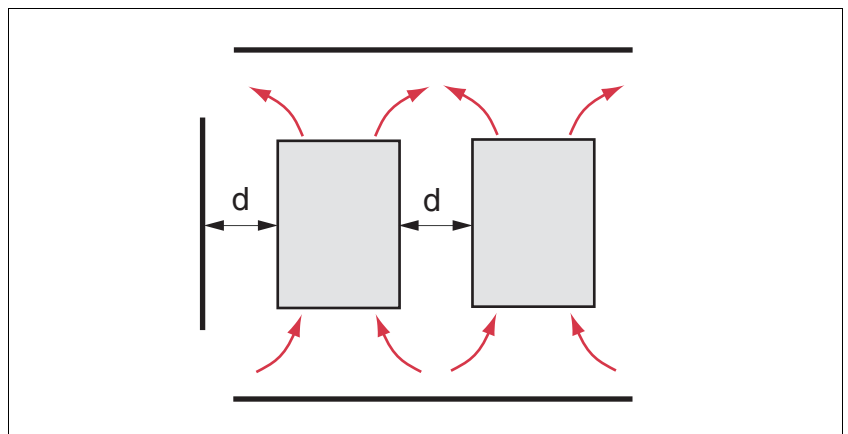

Figure 6.2 Installation spacing and air circulation

Temperature	Distance ¹⁾	Measures without protective foil ²⁾	Measures with protective foil in place
0 °C ... +40 °C (32 °F ... 104 °F)	d > 50 mm (d > 1.97 in.)	None	None
	d < 50 mm (d < 1.97 in.)	None	d > 10 mm (d > 0.39 in.)
+40 °C ... +50 °C (104 °F ... 122 °F)	d > 50 mm (d > 1.97 in.)	None	Reduce nominal current and continuous current ³⁾
	d < 50 mm (d < 1.97 in.)	Reduce nominal current and continuous current ³⁾	Operation not possible

1) Distance in front of the device: 10 mm (0.39 in.), above: 50 mm (1.97 in.), below: 200 mm (7.87 in.)

2) Recommendation: remove protective foil on completion of the installation

3) by 2.2 % per °C above 40 °C (by 1.22 % per °F above 104 °F)

At least 10mm of free space is required in front of the device. Make sure that the operator elements are accessible.

At least 50 mm of free space is required above the device.

The connector cables come out of the bottom of the housing. At least

200 mm free space under the device is required to ensure that wiring can be installed without excessive bending.

Installing the device

For the dimensions of the fastening holes see 3.3.1 "Dimensional drawings" from page 3-3.

- ▶ Install the device in a vertical position ($\pm 10^\circ$). This is particularly important for cooling the device.
- ▶ Attach the EMC plate at the bottom of the device, see also Figure 6.1, or use alternative attaching elements (comb bars, shield clamps, busbars).

Attach plate with safety instructions

- ▶ Attach the plate with safety instructions included with the device in a visible position on the front panel as specified by the national regulations.

An alternative to fastening the unit directly to the control cabinet mounting plate is adapter plates for mounting to top-hat rails, see chapter 12-1

In this case mains filters cannot be attached directly beside or behind the device.



Painted surfaces have an insulating effect. Remove the paint from the attachment points over a wide area (bright metal) before attaching the unit to a painted mounting plate.

Remove the protective foil

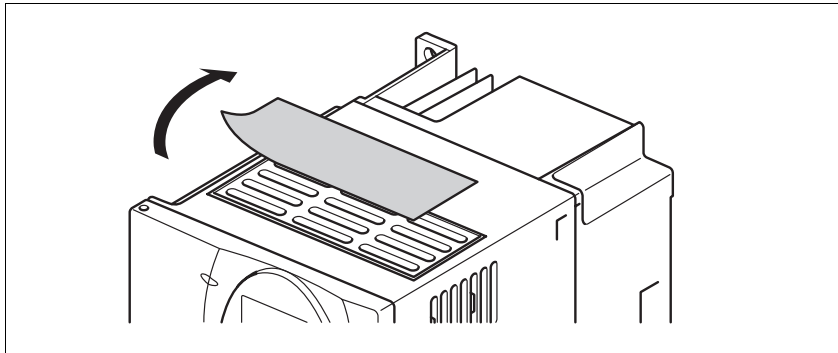

Figure 6.3 Removing protective foil

Remove the protective foil only after completion of all installation work. The protective foil must be removed if required by the thermal conditions.

6.2.2 Installing mains filter, mains reactor and braking resistor

External mains filter You can check whether the your unit has an integrated mains filter by the type code and the specifications (see page 3-1).

An external mains filter is required when using a unit without an integrated mains filter or with long motor lines. The operator must ensure that the EMC directives are observed in this case.

For specifications of external mains filters see page 3-9.

For directions on electrical installation see mains supply from page 6-26.

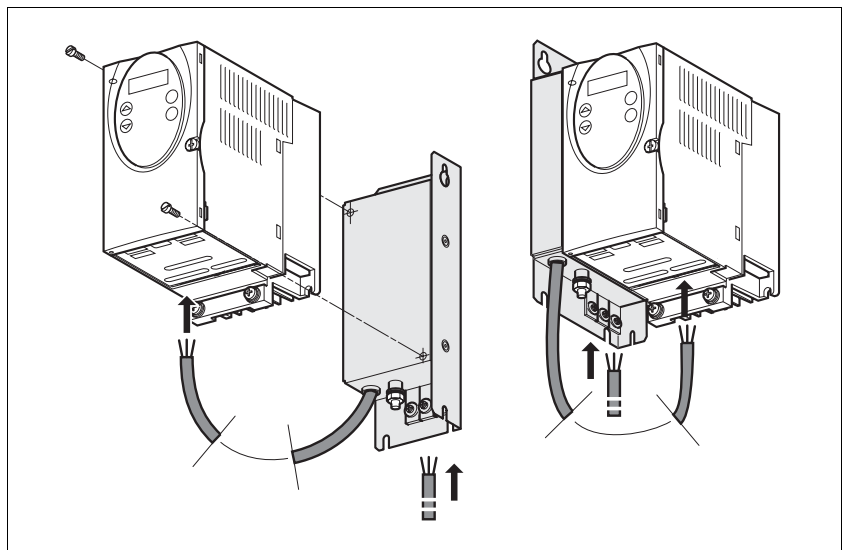

Figure 6.4 Installing mains filters

- ▶ Install the mains filter at the rear or the left side of the device.



If the mains filter is mounted behind the unit, the mains filter terminals will not be accessible after installation of the EMC plate.

If you are using the top-hat rail mounting plates, the mains filter cannot be mounted directly beside or behind the unit.

Mains reactor A mains reactor must be used under the following conditions:

- operation on power supply mains with low impedance (maximum possible short circuit current of the mains greater than specified in the Technical Data), see Technical Data from page 3-4
- at high average output power that is greater than half the nominal power
- where there are special requirements for the service life of the device (24h operation)
- operation on mains with reactive-current compensation systems
- for improvement of the power factor at the mains input and to reduce the mains feedback
- if overvoltages greater than overvoltage category III could occur

Multiple devices can be operated with one mains reactor. The rated current of the reactor must be considered.

In the case of a mains impedance that allows a short-circuit current greater than 1 kA the inductance of the reactor must be greater than 0.8mH.

Current harmonic waves place a heavy load on the internal DC bus capacitors. This has a significant influence on the service life of the device. For suitable mains reactors see accessories from page 12-4.



External braking resistor

The information sheet included with the mains reactor contains additional information on mounting. For directions on electrical installation see power supply from page 6-26.

▲ WARNING

Hot Surfaces

The braking resistor may heat up to over 250°C depending on the operating mode.

- Prevent contact with the hot braking resistor.
- Do not place flammable or heat-sensitive components in the immediate vicinity of the braking resistor.
- Ensure good heat dissipation.
- Check the temperature of the braking resistor by conducting a test run under the most critical conditions.

Failure to follow these instructions can result in death, serious injury or equipment damage.

The braking resistors recommended in accessories from page 12-1 comply with degree of protection IP65. They can be installed outside a switching cabinet in an environment with this degree of protection.

The information sheet included with the external braking resistor contains additional information for the mounting.

For information on the function and the electrical installation see page 6-20.

6.3 Electrical installation

⚠ DANGER

Electric shock, fire or explosion

- Only technicians who are familiar with and understand the contents of this manual and the other relevant manuals are authorised to work on and with this drive system.
- The system manufacturer is responsible for compliance with all applicable regulations relevant to earthing the drive system.
- Many components, including the printed circuit board, work with mains voltage. **Do not touch.** Do not touch unprotected parts or screws on the terminals under voltage.
- Install all covers and close the housing doors before applying power.
- The motor generates voltage when the shaft is rotated. Lock the motor shaft to prevent rotation before starting work on the drive system.
- Before working on the drive system:
 - Switch off power to all connections.
 - Place a sign "DO NOT SWITCH ON" on the switch and lock to prevent its being switched on.
 - **Wait for 6 minutes** (discharge DC bus capacitors). Do not short-circuit DC bus!
 - Measure voltage on DC bus and check that it is <45V. (The DC bus LED is not a reliable indicator for no DC bus voltage).

Failure to follow these instructions will result in death or serious injury.

⚠ DANGER

Electric shock from external objects or damage.

Conductive external objects in the product or serious damage can cause parasitic voltage.

- Do not use damaged products.
- Prevent external objects such as chips, screws or wire clippings from entering the product.
- Do not use products that contain external objects.

Failure to follow these instructions will result in death or serious injury.

⚠ DANGER**Electric shock because of insufficient earthing**

With insufficient earthing there is a danger of electric shock.

- Earth the drive system before applying voltage.
- Do not use conduits as protective conductors, use a protective conductor inside the conduit.
- The cross section of the protective conductor must comply with the applicable standards.
- Earth cable shields at both ends, but do not consider the shields as protective conductors.

Failure to follow these instructions will result in death or serious injury.

⚠ WARNING**This product may cause direct current in the protective conductor**

If a residual current device (RCD) is installed, general conditions must be observed.

Failure to follow these instructions can result in death or serious injury.

Peripheral conditions for the use of a residual-current-operated protective device

If the installation regulations foresee upstream protection in the form of a residual-current-operated protective device (FI protection switch, RCD) then a residual-current-operated protective device "Type A" can be used for a single-phase drive booster with a connection between N and L. A "Type B" device must be used in all other cases.

The following properties should be taken into account:

- Filtering high frequency currents.
- Delay which prevents triggering due to possible charged fault capacities when switching on. This delay is not possible for 30 mA devices. In this case you should select devices which are not prone to unintentional triggering, for example a residual-current-operated protective device with increased interference resistance of the type s.i (super-immunised) (trademark Merlin Gerin).

If the plant consists of a number of drive boosters then a residual-current-operated protective device must be used for each drive booster.

Suitability of wiring

Cables must not be twisted, stretched, crushed or kinked. Use only cables that comply with the cable specification. For example, make sure that it is suitable for:

- Use as a trailing cable
- Temperature range
- Chemical resistance
- Layout outdoors
- Layout underground

6.3.1 Overview of procedure

- ▶ Observe the basic settings described in chapter 5 "Engineering". The selected settings influence the overall installation:
 - 5.1 "Logic type"Chapter from page5-1
 - 5.3 "Specification of the control mode"Chapter from page5-2
 - 5.4 "Safety function "Power Removal""Chapter from page5-2
- ▶ Unlock the front panel of the device and open it.
- ▶ Connect the earth terminal of the device or the EMC plate to the earthing star point of the system.
- ▶ Connect the required terminal corresponding to the sequence of Table 6.1. If a different connection sequence is followed, terminals may be covered by other lines.
Follow the EMC requirements, see page 6-1.
- ▶ Then lock the front panel.

Connection from	Connection to	from page
Motor phases		6-17
External braking resistor		6-20
Mains supply		6-26
Motor rotary encoder	CN2	6-28
Holding brake controller (HBC)	CN1 and CN3	6-31
24V controller supply voltage	CN3	6-33
Encoder signals A, B, I	CN5	6-35
Pulse/direction PD	CN5	6-36
Encoder simulation ESIM	CN5	6-40
fieldbus CANopen	CN1 or CN4	6-42
fieldbus Modbus	CN4	6-44
Analogue inputs	CN1	6-45
Digital inputs/outputs	CN1	6-45
PC or remote terminal	CN4	6-49

Table 6.1 Installation overview

6.3.2 Overview of all connections

Power connections

Power connections	device
	LXM05•...
	U70M2 (T1) D10F1 (T1) D10M2 (T1)
	D10M3X (T2) D14N4 (T4) D17F1 (T3)
	D17M2 (T3) D17M3X (T4) D22N4 (T4)
	D28F1 (T3) D28M2 (T3)
	D34N4 (T4) D42M3X (T4) D57N4 (T5)

Table 6.2 Designations of the power connections

Power connections	Description
PE	Earth connection (protective earth)
R/L1, S/L2/N	Mains connection, single phase devices
R/L1, S/L2, T/L3	Mains connection, 3-phase devices
PA/+	DC bus
PBi	Braking resistor internal
PBe	Braking resistor external
PC/-	DC bus
U/T1, V/T2, W/T3	Motor connections

Table 6.3 Designations of the power connections

Signal connections

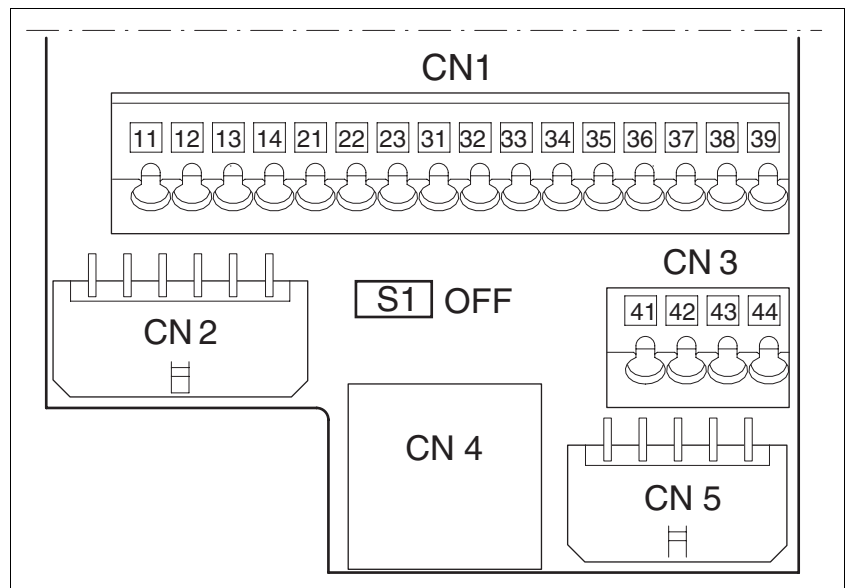

Figure 6.5 Overview of the signal connections

Connection/ switch	Assignments
CN1	Analogue inputs $\pm 10V$, pin 11 ... 14 CANopen, pin 21-23 Digital inputs/outputs, pin 31-39
CN2	Motor encoder (Hiperface Sensor)
CN3	24V PELV controller supply voltage
CN4	PC, remote terminal, Modbus, CANopen; (RJ45)
CN5	ESIM (A/B/I Out), Pulse/direction (PD In), encoder signals (A/B/I in) ¹⁾
S1	Switch for fieldbus terminating resistor

1) depending on "First Setup"

Table 6.4 Assignment of the signal connections

6.3.3 Reference value signals and limits

External limits can be specified for the external reference value signals for operation. Table 6.5 shows the assignment options depending on the operating modes.

Operating mode	External reference value	Connection	External limit	Connection
Current control	ANA_IN1 (current)	CN1, Pin 11, 12 ¹⁾	None	
	ANA_IN1 (current)	CN1, Pin 11, 12 ¹⁾	ANA_IN2 (current)	CN1, Pin 13, 14 ¹⁾
	ANA_IN1 (current)	CN1, Pin 11, 12 ¹⁾	ANA_IN2 (speed of rotation)	CN1, Pin 13, 14 ¹⁾
Speed control	ANA_IN1 (speed of rotation)	CN1, Pin 11, 12 ¹⁾	None	
	ANA_IN1 (speed of rotation)	CN1, Pin 11, 12 ¹⁾	ANA_IN2 (current)	CN1, Pin 13, 14 ¹⁾
	ANA_IN1 (speed of rotation)	CN1, Pin 11, 12 ¹⁾	ANA_IN2 (speed of rotation)	CN1, Pin 13, 14 ¹⁾
Electronic gear	Pulse/direction PD signal	CN5	None	
	A/B Signal	CN5	None	
Profile position	None, generated by profile generator	CN4 ²⁾	\overline{LIMP} , \overline{LIMN}	CN1, Pin 34, 35
Profile velocity	None, generated by profile generator	CN4 ²⁾	\overline{LIMP} , \overline{LIMN}	CN1, Pin 34, 35
Motion sequence	None, generated by profile generator	CN4 ²⁾	\overline{LIMP} , \overline{LIMN}	CN1, Pin 34, 35
Homing	None, generated by profile generator	CN4 ²⁾	\overline{LIMP} , \overline{LIMN}	CN1, Pin 34, 35
Jog	None, generated by profile generator		Local: no fieldbus: \overline{LIMP} , \overline{LIMN}	- CN1, Pin 34, 35

1) CN1, Pin 11-14 = analogue input 14-bit; with fieldbus control mode alternatively via parameter value

2) CN4 = connection to CANopen, Modbus

Table 6.5 Reference value signals and limits

6.3.4 Motor phase connections

⚠ DANGER

Electric shock

High voltages at the motor connection may occur unexpectedly.

- The motor generates voltage when the shaft is rotated. Lock the motor shaft to prevent rotation before starting work on the drive system.
- AC voltages may jump over unused wires in the motor cable. Isolate unused wires at both ends of the motor cable.
- The system manufacturer is responsible for compliance with all applicable regulations relevant to earthing the drive system. Extend the earth through the motor cable with an additional earth at the motor housing.

Failure to follow these instructions will result in death or serious injury.

Cable specifications

- Shielded cable
- Minimum cross section of wires: see table.
- Earthing of the shield at both ends
- Maximum cable length: depends on required limit values for line-related interference, see chapter 3.4.6 "Internal mains filter" page 3-9 and chapter 3.5.3 "External mains filter" page 3-10.
- for more information, see 3.5.6 "Cable" on page 3-12.

LXM05•...		U70••• D10•••	D14•• D17••• D2••• D3••• D4••••	D5•••
Connection cross section	mm ²	0.75 ... 1.5	1.5 ... 4	3.3 ... 16 ¹⁾
AWG		14 ... 20	10 ... 16	6 ... 12 ¹⁾
Tightening torque	Nm	0.5 ... 0.6	1.2 ... 1.5	2.2 ... 2.8

1) Wire end ferrules or fork-type cable lugs are required with a cross section of 2.5 mm² (AWG 14).

The wiring must have a sufficiently large cross section to ensure that the fuse at the mains connection can be tripped in the event of a fault.

- ▶ Use prefabricated cables to minimise the risk of a wiring error (from page 12-2).

Preparing cables Note the dimensions specified when fabricating cables.

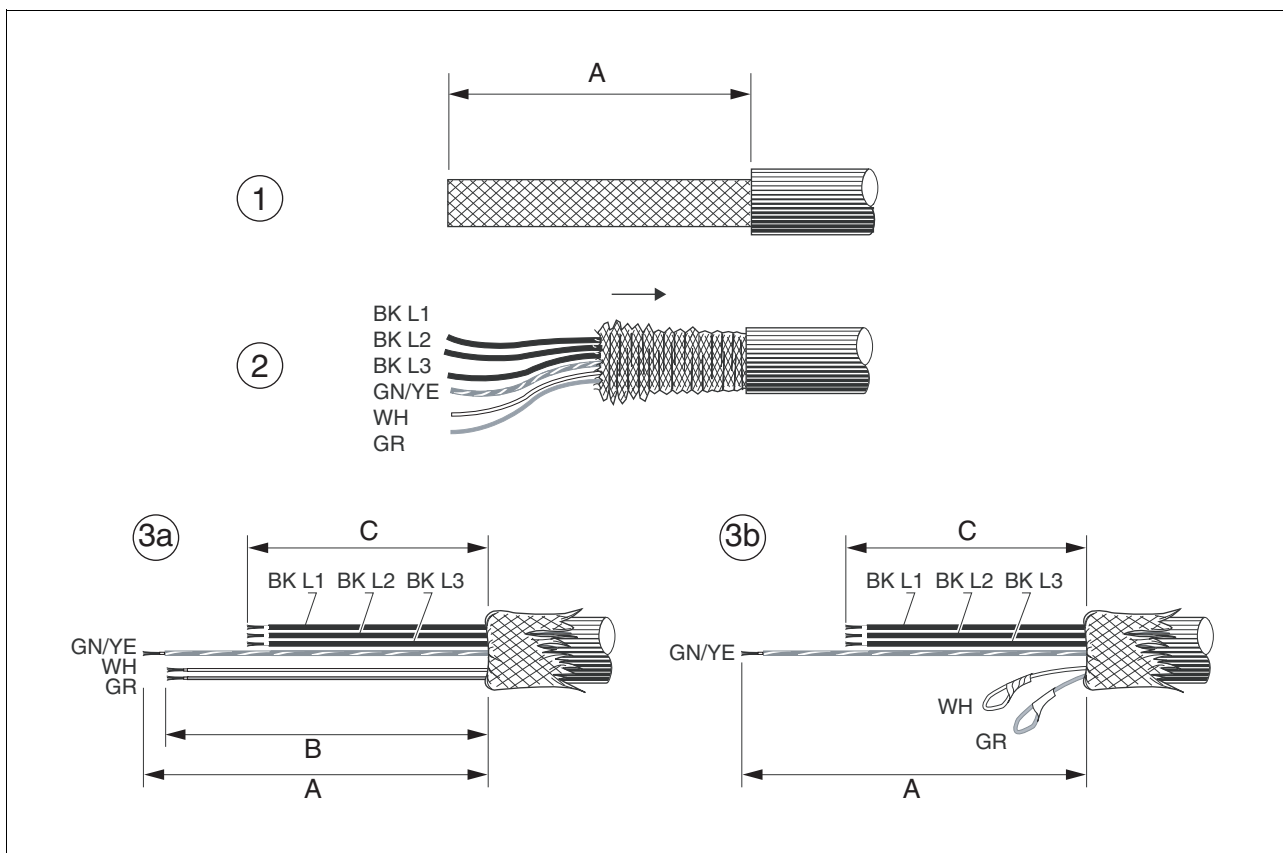

Figure 6.6 Steps (1-3) for fabrication of the motor cable

LXM05•...		U70••• D10••	D14•• D17•••	D2••• D3••• D4•••• D5•••
A	mm	130	130	130
B	mm	120	120	120
C	mm	75	85	90

- ▶ (1) Remove the cable sheath, length A depends on the device, see table.
- ▶ (2) Slide the shield braiding back over the cable sheath and store the shield braiding. Note that during installation the shield braiding must be positioned flat on the EMC plate.
- ▶ (3) Shorten the wires for the holding brake to length B for BRH motors (see motor manual) and the three motor lines to length C. The protective conductor has length A.
 - (3a) The two brake connection lines must have length B for motors with holding brake.
 - (3b) The two brake connection lines must be separately insulated for motors without a holding brake.

Use fork-type cable lugs or wire end ferrules. The lead must fill the sleeve for its entire length to ensure maximum current carrying capacity and vibration resistance.

019844113232, V1.20, 06.2007

Monitoring The motor lines are monitored for:

- short circuit between the motor phases
- short circuit between the motor phases and PE

A short circuit between the motor phases and the DC bus, the braking resistor or the holding brake wiring is not monitored.

Connecting the motor cable

- ▶ Follow the EMC requirements for motor cables, see page 6-3.
- ▶ Insulate unused wires at both ends and individually, see Figure 6.7, Pos 1.
- ▶ Connect the motor leads and protective conductor to terminals U/T1, V/T2, W/T3 and PE. The cable assignment at the motor and device sides must match.
- ▶ Fix the cable shielding flat on the EMC plate.

Wiring diagram

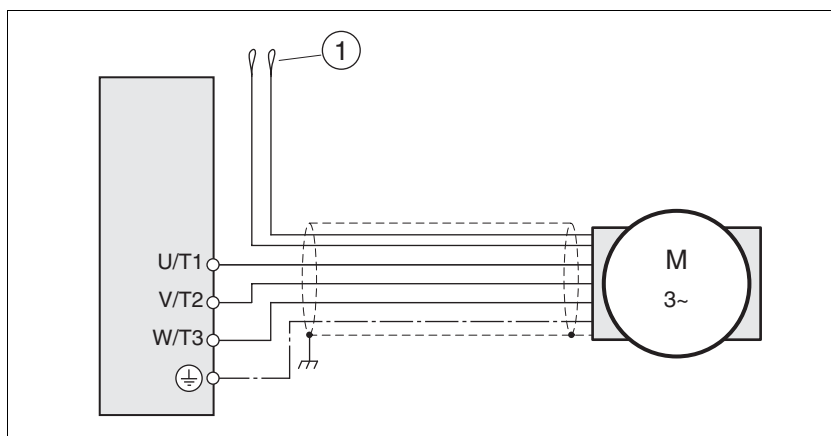

Figure 6.7 Motor wiring diagram, here without holding brake

Connection	Description	Colour
U/T1	Motor line	black L1 (BK)
V/T2	Motor line	black L2 (BK)
W/T3	Motor line	black L3 (BK)
PE	Protective conductor	green/yellow (GN/YE)
(1)	Holding brake connector cable For motors with holding brake see page 6-31	white (WH), grey (GR)

6.3.5 Connection of braking resistor

⚠ WARNING
<p>Unbraked motor</p> <p>An insufficient braking resistor causes overvoltage on the DC bus and switches off the power amplifier. The motor is no longer actively braked.</p> <ul style="list-style-type: none"> • Make sure that the braking resistor is sufficiently dimensioned. • Check the setting of the parameter for the braking resistor. • Check the temperature of the braking resistor by conducting a test run under the most critical conditions. • During the test make sure that at higher mains voltage there is less reserve in the capacitors on the DC bus. <p>Failure to follow these instructions can result in death, serious injury or equipment damage.</p>

6.3.5.1 Internal braking resistor

A braking resistor is integrated in the device to absorb braking energy. If the DC bus voltage exceeds a specified value, this braking resistor is switched on. The returned energy is converted to heat by the resistance. See also dimensioning aid, page 6-22.

The internal braking resistor is connected on delivery.

The internal braking resistor is at the back of the device.

6.3.5.2 External braking resistor

An external braking resistor is required for applications in which the motor must be heavily braked and the internal braking resistor cannot dissipate the excess braking energy.

Monitoring The device monitors the power of the braking resistor. The load on the resistance can be read out. The connection of the external resistance is protected against short circuit.

Selection of the external braking resistor The size of an external braking resistor is specified by the required peaks and the continuous output at which the braking resistor can be operated.

The resistance value R [Ω] is derived from the required peak power and the DC bus voltage.

$R = U^2 / P_{max}$	U :	Switching threshold [V]
	P _{max} :	Peek power [W]
	R:	Resistance [Ohm]

Figure 6.8 Calculating the resistance R of an external braking resistor

019844113232, V1.20, 06.2007

If two or more resistors are connected, note the following criteria:

- The resistors must be wired in parallel or in series so the required resistance is reached.
- The resistance value of the external resistance must not fall below a bottom limit, see chapter 3.4.5 "Braking resistor".
- The total continuous output of the individual resistors must yield the required continuous output.

For suitable braking resistors, see accessories on page 12-1.

Cable specifications

- Shielded wires
- minimum cross-section: as with mains power, see page 6-26. The wiring must have a sufficiently large cross section to ensure that the fuse at the mains connection can be triggered in the event of a fault.
- Earthing of the shield at both ends
- Maximum cable length: 3m

The braking resistors recommended in accessories have a 3-wire, temperature-resistant cable with a length of 0.75 m to 3 m.

Use fork-type cable lugs or wire end ferrules. The lead must fill the sleeve for its entire length to ensure maximum current carrying capacity and vibration resistance.

Connecting external braking resistor

- ▶ Observe the safety instructions for the electrical installation.
- ▶ Before opening the device disconnect it from the supply voltage.
- ▶ Remove the jumper, see Figure 6.9.

If the jumper is not removed, the internal braking resistor may be destroyed during operation.

- ▶ Earth the PE connection of the braking resistor.
- ▶ Connect the braking resistor to the device, see Figure 6.9.
- ▶ Spread the shielding of the cables out flat on the EMC plate.

Test the function of the braking resistor under realistic conditions during commissioning (page 7-20).

Wiring diagram

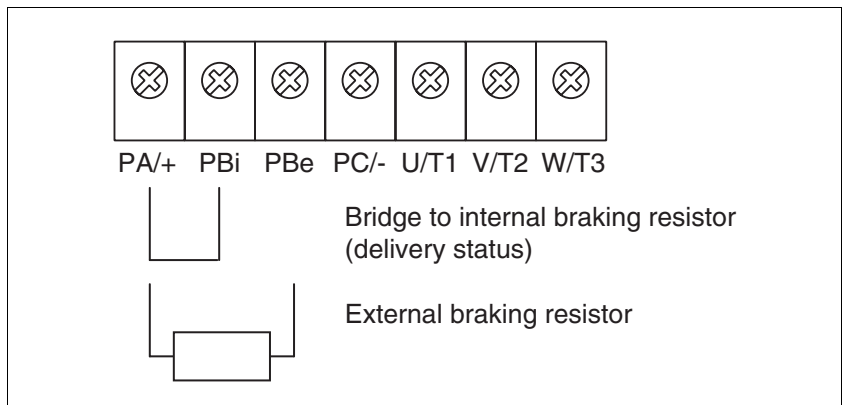

Figure 6.9 Wiring diagram, braking resistor

6.3.5.3 Dimensioning aid

The elements contributing towards the absorption of braking energy are calculated to assist in specification. This is used to calculate the size of the braking resistor.

An external braking resistor is required if the kinetic energy that must be absorbed exceeds the total of internal components, including the internal braking resistor.

Internal energy absorption Braking energy is absorbed internally by the following mechanisms:

- DC bus capacitor W_{ZW}
- Internal braking resistor W_{IN}
- Electrical losses in the drive W_E
- Mechanical losses in the drive W_M

The energy W_{ZW} depends in a square-law function on the difference between the voltage before the braking operation and the response threshold.

The voltage before the braking operation depends on the mains voltage. The energy absorption by the DC bus capacitors is lowest when the mains voltage is highest. Use the values for the highest mains voltage.

Energy absorption of the internal braking resistor Two characteristic values relating to the internal braking resistor determine its energy absorption.

- The continuous output P_{AV} shows how much energy can be continuously dissipated without overloading the braking resistor.
- The maximum energy W_{peak} limits the higher heat loss which can be dissipated in the short term.

If the continuous output is exceeded for a specified time, the braking resistors remain unloaded for a correspondingly period. This ensures that the braking resistor is not destroyed.

The characteristic values P_{AV} and W_{peak} of the internal braking resistor can be found starting on page 3-8.

Electrical losses W_E The electrical losses W_E in the drive can be estimated from the peak power of the drive. The maximum power loss is around 10% of peak power for a typical efficiency factor of 90%. If the current on braking is lower, the power loss will be reduced accordingly.

Mechanical losses W_M The mechanical losses result from absorption by friction, which occurs when the system is running. Mechanical losses can be ignored if the system requires a much longer time to coast to a stop than the time required to stop the system under braking. The mechanical losses can be calculated from the load torque and the speed from which the motor is to stop.

Example Braking of a motor with the following data (AC IN equal to 400V_{AC}):

- Starting speed: $n = 4000 \text{ min}^{-1}$
- Rotor inertia: $J_R = 4 \text{ kgcm}^2$
- Load inertia: $J_L = 6 \text{ kgcm}^2$

The energy to be absorbed is given by:

$$W_B = 1/2 * J * (2*\pi*n)^2$$

to 88 Ws

Electrical and mechanical losses are ignored.

23 Ws are absorbed in the DC bus capacitors at a power supply of 400 V.

The internal braking resistor must absorb the residual 65 Ws. It can absorb a pulse of 80 Ws. The internal braking resistor is sufficient if the load is stopped once under braking.

If the braking process is repeated cyclically, the continuous output must be considered. If the cycle time is longer than the ratio of the energy to be absorbed W_B and the continuous power P_{AV} , the internal braking resistor is sufficient. If braking takes place more frequently, the internal braking resistor will not be sufficient.

In the example the ratio W_B/P_{AV} is 1.3 s. An external braking resistor is required with a shorter cycle time.

Rating the external braking resistor

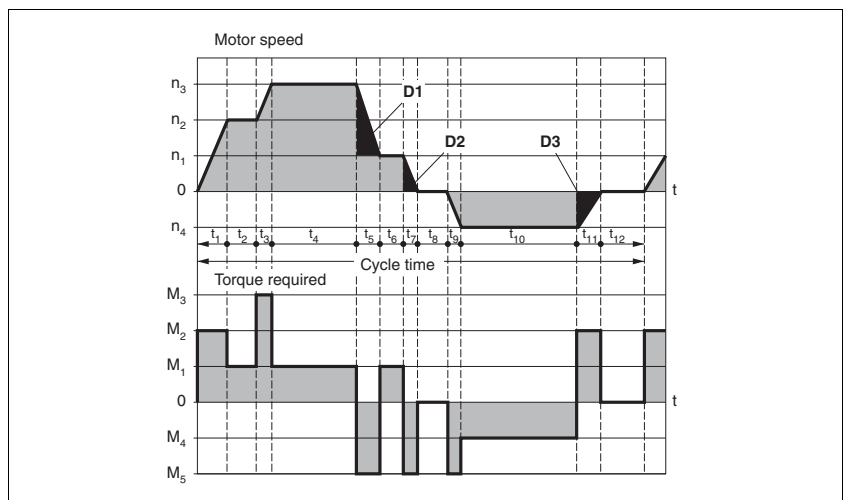

Figure 6.10 Characteristics for rating the braking resistor

These two characteristics are also used for the rating the motor. The segments of the characteristic under consideration in which the motor brakes are identified by (D_i)

Calculation of the energy at constant runout:

The total inertia (J_t) must be known.

J_t is given by:

$$J_t = J_m + J_c$$

J_m : Motor inertia with and without brake

J_c : Load inertia

The energy for each runout segment is calculated as follows:

$$E_i = \frac{1}{2} J_t \cdot \omega_i^2 = \frac{1}{2} J_t \cdot \left[\frac{2\pi n_i}{60} \right]^2$$

The following is derived for the segments (D₁) ... (D₃):

$$E_1 = \frac{1}{2} J_t \cdot \left[\frac{2\pi(n_3 - n_1)}{60} \right]^2$$

$$E_2 = \frac{1}{2} J_t \cdot \left[\frac{2\pi n_1}{60} \right]^2$$

Units: E_i in joules, J_t in kg/m², w in rad and n_i in rpm.

The table shown below gives the energy uptake capacity, E_{var}, for the individual drive regulators (without regard to an internal or external braking resistor).

When continuing with the calculation, take into account only those segments D_i whose energy E_i exceeds the uptake capacity shown in the table. These excess energies E_{D_i} should be removed via the braking resistors (internal or external).

The calculation of E_{D_i} is accomplished using the formula:

$$E_{D_i} = E_i - E_{var} \text{ (in Joules)}$$

The continuous power P_c is calculated for each machine cycle

$$P_c = \frac{\sum E_{D_i}}{\text{Cycletime}}$$

Units: P_c in [W], E_{D_i} in [J] and cycle time T in [s]

Selection takes place in two steps:

- The maximum energy during the braking process must be less than the peak energy that the braking resistor can accommodate: (E_{D_i}) < (E_{C_r}). In addition the continuous output of the internal braking resistor must not be exceeded: (P_C) < (P_{P_r}). If these conditions are met, then the internal braking resistor is adequate.
- If any one of the conditions is not met, it is necessary to use an external braking resistor. The resistance should be chosen such that the conditions are met. The value of the resistance must be between the specified minimum and maximum values, since otherwise the load can no longer be safely braked or the product could be destroyed.

For the order data for the external braking resistors see the accessories section from page 12-4.

LXM05•...		D10F1	D17F1	D28F1	D10M2	D17M2	D28M2
Energy consumption of internal capacitors E_{var}	[Ws]	10.8	16.2	26.0	17.7	26.6	43.0
resistance internal	[Ω]	40	40	10	40	40	20
Continuous output P_{PR}	[W]	20	40	60	20	40	60
Peak energy E_{CR}	[Ws]	500	500	1000	900	900	1600
Switch-on voltage	[V]	250	250	250	430	430	430
External braking resistor min	[Ω]	27	20	10	50	27	16
External braking resistor max	[Ω]	45	27	20	75	45	27

LXM05•...		D10M3X	D17M3X	D42M3X	D14N4	D22N4	D34N4	D57N4
Energy consumption of internal capacitors E_{var}	[Ws]	17.7	26.6	43.0	26.0 ¹⁾	52.0 ²⁾	52.0 ²⁾	104.0 ³⁾
resistance internal	[Ω]	40	40	20	40	30	30	20
Continuous output P_{PR}	[W]	20	40	60	40	60	60	100
Peak energy E_{CR}	[Ws]	900	900	1600	1000	1600	1600	2000
Switch-on voltage	[V]	430	430	430	770	770	770	760
External braking resistor min	[Ω]	50	27	10	60	25	25	10
External braking resistor max	[Ω]	75	45	20	80	36	36	21

1) at 480V: 6.0Ws

2) at 480V: 12.0Ws

3) at 480V: 10.0Ws

6.3.6 Connection of power amplifier supply voltage

⚠ DANGER

Electric shock because of insufficient earthing

This drive system has an increased leakage current > 3.5mA.

- Use a protective conductor at least 10 mm² (AWG 6) or two protective conductors with the cross section of the conductor for the power supply of the power terminals. Observe the local regulations for earthing.

Failure to follow these instructions will result in death or serious injury.

⚠ WARNING

Insufficient protection against overcurrents

- Use the external fuses specified in the "Technical Data" section.
- Do not connect the product to a power supply in which the short-circuit capacity exceeds the maximum short-circuit current approved in "Technical Data".

Failure to follow these instructions can result in death, serious injury or equipment damage.

CAUTION

Destruction by incorrect mains voltage

The incorrect mains voltage may destroy the product.

- Before switching on and configuring the product, make sure that the type is approved for the mains voltage.

Failure to follow these instructions can result in equipment damage.

Cable specifications

The wiring must have a sufficiently large cross section to ensure that the fuse at the mains connection can be tripped in the event of a fault.

When connecting the device in an IT mains follow the directions in 6.1.1 "Operation in an IT mains".

In addition, note the suitability of the wiring, see page 6-12 and the EMC-compliant connection, see page 6-2.

LXM05...	U70... D10...	D14... D17... D2... D3... D4....	D5...
Connection cross section	mm ² 0.75 ... 1.5	1.5 ... 4	3.3 ... 16 ¹⁾
AWG	14 ... 20	10 ... 16	6 ... 12 ¹⁾
Tightening torque	Nm 0.5 ... 0.6	1.2 ... 1.5	2.2 ... 2.8

1) Wire end ferrules or fork-type cable lugs are required with a cross section of 2.5 mm² (AWG 14).

Preparing cables Use fork-type cable lugs or wire end ferrules. The lead must fill the sleeve for its entire length to ensure maximum current carrying capacity and vibration resistance.

Connecting mains power Observe the following instructions at all times:

- 3-phase devices must only be connected and operated on 3-phase.
- For devices with external mains filter the power cable must be shielded from 200 mm length between the external mains filter and the device and earthed at both ends.
- Observe the EMC requirements. If necessary, use overvoltage arrestors, mains filters and mains reactors, see page 6-9.
- Follow the requirements for design of corresponding UL, see page 3-1.
- The PE connection on the case must be connected to the mounting plate because of the high leakage currents.

Wiring diagram of 1-phase device

Figure 6.11 shows the connection of the mains power supply for a single phase device. The diagram also shows the wiring of the optional external mains filter and mains reactor .

CAUTION: in three-phase systems the neutral conductor N must generally be used instead of L2.

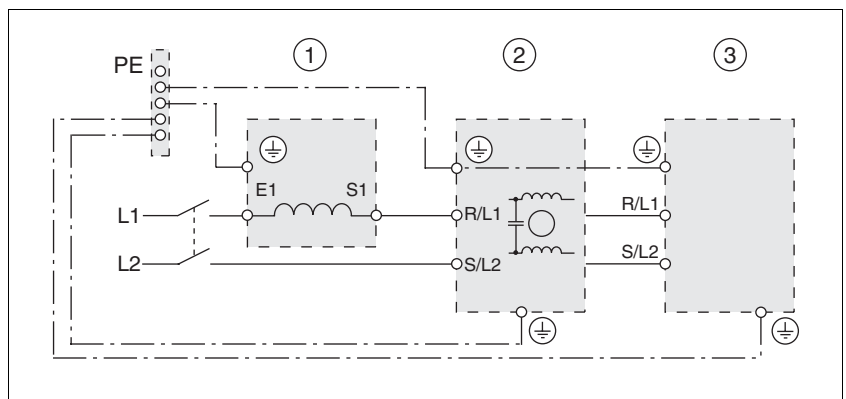

Figure 6.11 Wiring diagram:mains power for a single phase device

- (1) Mains reactor (optional)
- (2) Mains filter (optional)
- (3) Product

If neutral conductor N is used instead of L2, a fuse is only required with L1.

- ▶ Connect the power cables. Note the exact terminal assignment of your device, see chapter 6.3.2 "Overview of all connections".

Wiring diagram of 3-phase device

Figure 6.12 shows the connection of the mains power supply for a 3-phase device. The diagram also shows the wiring of the optional external mains filter and mains reactor .

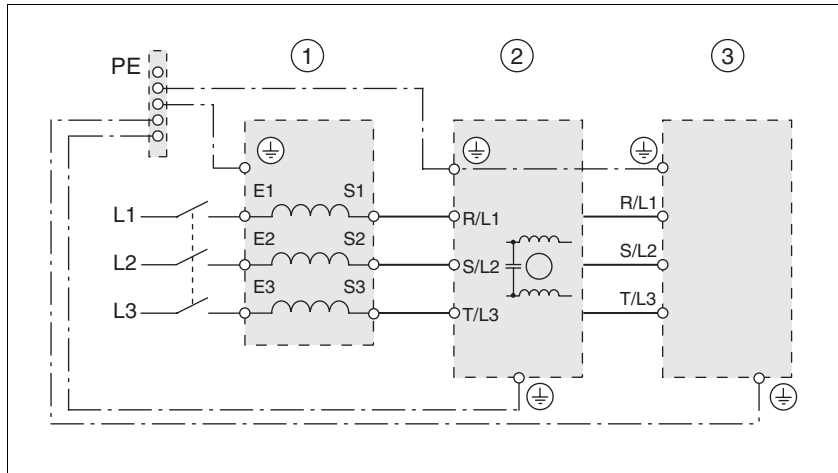

Figure 6.12 Wiring diagram:mains power for 3-phase device

- (1) Mains reactor (optional)
- (2) Mains filter (optional)
- (3) Product

► Connect the power cables. Note the exact terminal assignment of your device, see chapter 6.3.2 "Overview of all connections".

6.3.7 Connection for parallel operation

CAUTION
<p>Incorrect parallel connection</p> <p>Operation with a non-approved parallel connection on the DC bus may destroy the drive systems immediately or at a later time.</p> <ul style="list-style-type: none"> Find out the general conditions and requirements for parallel connections on the DC bus from your local representative. <p>Failure to follow these instructions can result in equipment damage.</p>

6.3.8 Connection of motor encoder (CN2)

Function and sensor type The motor sensor is a Hiperface sensor (SinCos sensor) integrated into the motor. It captures the rotor position of the motor and sends the motor position to the unit both analogue and digitally.

- Cable specifications*
- Shielded cable
 - Twisted pair lines
 - Minimum cross section of signal wires: $10 \times 0.25 \text{ mm}^2 + 2 \times 0.5 \text{ mm}^2$
 - Earthing of the shield at both ends
 - maximum cable length 100m
 - for further information see 3.5.6 "Cable" on page 3-12

0198441113232, V1.20, 06.2007

- Preparing cables*
- ▶ Use prefabricated cables to minimise the risk of a wiring error (from page 12-2). Step 5 in Figure 6.13 must be carried out even with prefabricated cable. The dimensions for positioning the shield on the housing are applicable when the included EMC plate is used.
 - ▶ If you are not using prefabricated wiring, follow the procedure and the dimensions in Figure 6.13.

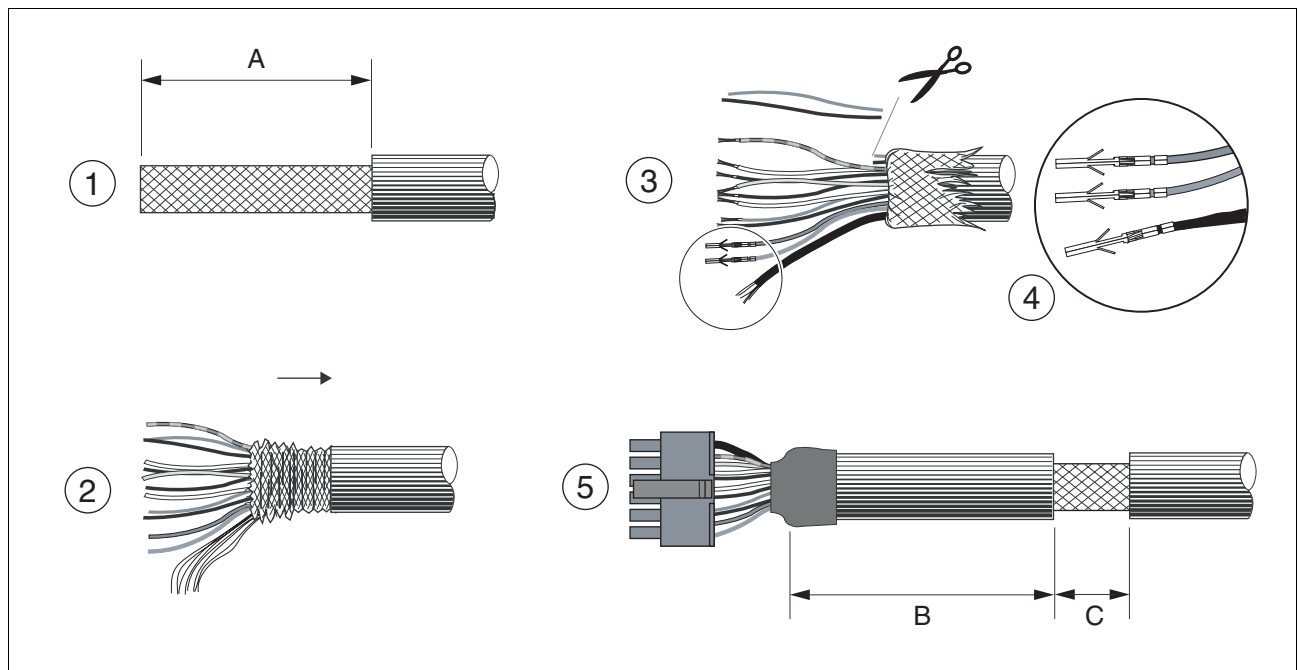

Figure 6.13 Steps (1-5) for fabrication of the sensor cable

LXM05•...		U70••• D10•	D14•• D17•••	D2••• D3••• D4•••	D5•••
A	mm	25	25	25	25
B	mm	90	100	130	120
C	mm	15	15	15	15

- ▶ (1) Remove the cable sheath, length A depends on the device, see table.
- ▶ (2) Shorten the shield braiding. The shield braided filler wire is required as the connection.
- ▶ (3) The red and the violet braided wire is not required and can be cut off. Isolate the shield lead with shrink wrap.
- ▶ (4) Crimp the plug contacts on the remaining braided wires and on the isolated shield wire. Isolate the shield braiding with shrink wrap. Plug the crimp contacts into the connector shell; for the pin assignment see Figure 6.14.
For the order number of the crimping pliers and the extraction tool see 12.5 "Crimping tool and connector / contacts"
- ▶ (5) Sheath the cable to length C on the position shown, the cable is fastened there at the EMC plate with a clamp (shield-earth connection).

Wiring diagram

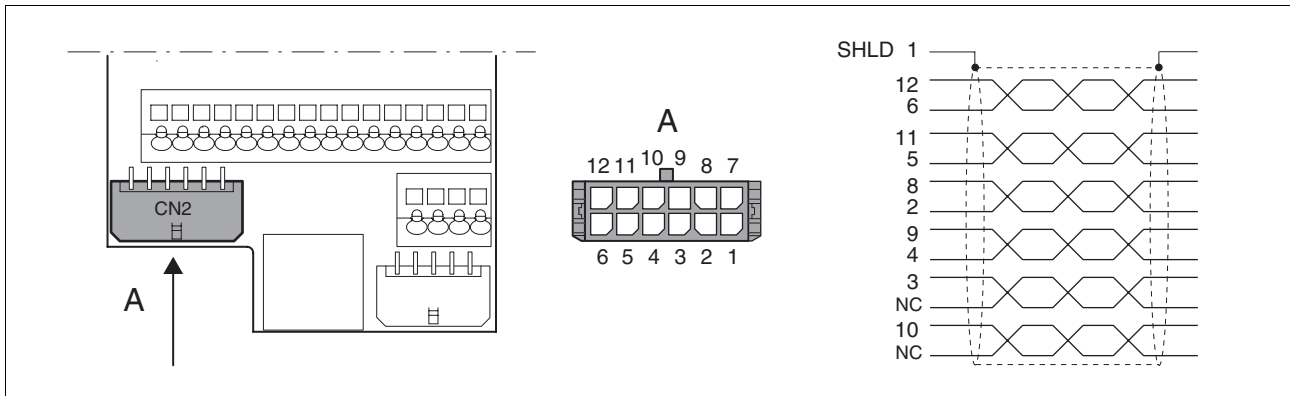

Figure 6.14 Wiring diagram of motor encoder

Pin	Signal	Motor, pin	Colour ¹⁾	Pair	Description	I/O
1	SHLD				Shielding braid	
12	SIN	8	white	1	Sine signal	I
6	REFSIN	4	brown	1	Reference for sine signal, 2.5V	O
11	COS	9	green	2	Cosine signal	I
5	REFCOS	5	yellow	2	Reference for cosine signal, 2.5V	O
8	Data	6	grey	3	Receive and transmit data	I/O
2	Datā	7	pink	3	Receive and transmit data, inverted	I/O
10	ENC_0V	11	blue	4	Encoder reference potential (encoder) (0.5mm ²)	O
			red	4	not connected (0.5mm ²)	
3	T_MOT_0V	1	black	5	Reference potential to T_MOT	
			purple	5	not assigned	
9	T_MOT	2	grey/pink	6	temperature sensor PTC	I
4	ENC+10V_OUT	10	red/blue	6	10V _{DC} supply for encoder, max. 150mA	O
7	n.c.				not assigned	

1) Colour data is based on the pre-assembled cable

- Connecting motor sensor**
- ▶ Make sure that the wiring, the cables and the connected interfaces meet the requirements for PELV.
 - ▶ Note the EMC specification for motor sensor wiring from page 6-3, and ensure the equipotential bonding over equipotential bonding conductors.
 - ▶ Connect the plug to CN2.
 - ▶ Fasten the cable to the EMC plate and make sure that the cable shielding is spread over a wide area.

6.3.9 Connection of holding brake controller (HBC)

⚠ DANGER

Electric shock because of parasitic voltage

The wiring to the brake in the motor cable generally does not correspond to the PELV requirements.

- Use a holding brake controller.
- Do **not** connect the brake to the controller voltage.

Failure to follow these instructions will result in death or serious injury.

⚠ DANGER

Electric shock

High voltages at the motor connection may occur unexpectedly.

- The motor generates voltage when the shaft is rotated. Lock the motor shaft to prevent rotation before starting work on the drive system.
- AC voltages may jump over unused wires in the motor cable. Isolate unused wires at both ends of the motor cable.
- The system manufacturer is responsible for compliance with all applicable regulations relevant to earthing the drive system. Extend the earth through the motor cable with an additional earth at the motor housing.

Failure to follow these instructions will result in death or serious injury.

Selection and dimensioning

For a motor with holding brake, we recommend an appropriate start-up logic (HBC) which releases the brake when current is supplied to the motor and which fixes the motor axle quickly when the motor is stopped.

Delay times for the release and the application of the brake can be set by parameters on the device, see page 8-81. For order data for the HBC see accessories from page 12-1.

Note the power requirement of the HBC. It depends on the switching current for the holding brake and is calculated from:

$$\text{Input current HBC [A]} = 0.5 \text{ A} + \text{switching current [A]}$$

Under certain conditions you can omit a holding brake controller. However, it is imperative that the following points are taken into account:

- A separate power supply is required. This must correspond to the specified brake tolerances.
- The controller supply voltage and the power supply for the brake must be safely electrically isolated.
- The drive power of many motors is reduced if the current reduction to the brake is omitted.
- The unshielded section of the brake wire must not exceed 12 cm because of possible EMC interference.

Wiring diagram HBC

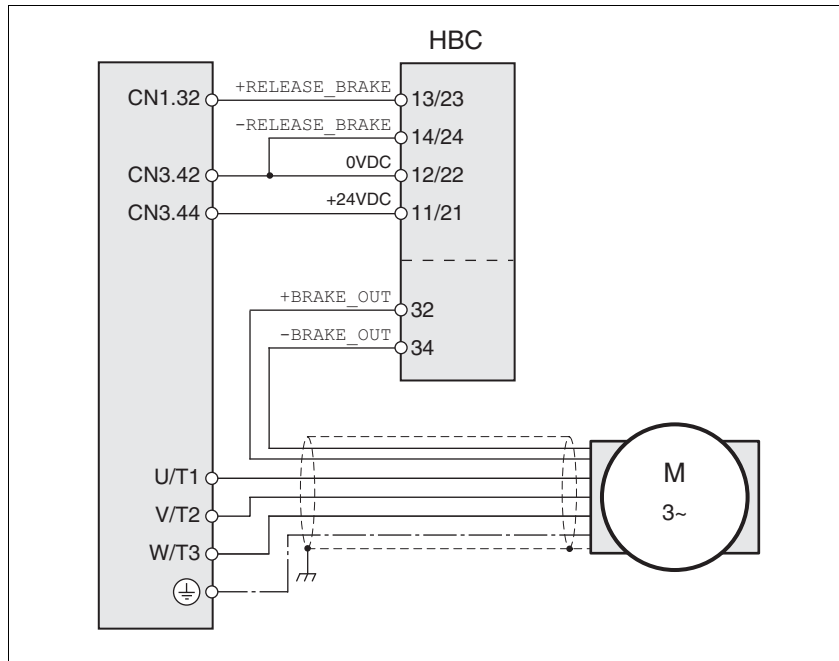

Figure 6.15 Wiring diagram, motor with holding brake and HBC.

HBC terminal	HBC connection	Description	Colour
32	+BRAKE_OUT	Brake wire	white (WH)
34	-BRAKE_OUT	Brake wire	grey (GR)
13/23	+RELEASE_BRAKE	Brake output from servo drive	
14/24	-RELEASE_BRAKE	Reference potential for servo drive brake output	
11/21	+24VDC	Supply voltage	
12/22	0VDC	Reference potential for supply voltage	

A maximum motor cable length of 50m is permitted for the BSH motors when using the holding brake controller.

If a greater length is required, a cable with a larger cross section of the brake wires (>1mm²) can be used.

Connecting HBC

- ▶ Attach the holding brake controller to the right of the device, see Figure 6.1.
- ▶ Insulate unused leads individually.

The power supply to the holding brake must be insulated from that of the PELV circuit of the device. The insulation is internal in the HBC described in the accessories chapter.

For further information on HBC see page 3-11, 7-29, 12-1.

6.3.10 Connection of controller supply voltage (24V at CN3)



The controller power supply (+24VDC) must be connected for all operating modes.

⚠ DANGER

Electric shock from incorrect power supply unit

The +24VDC supply voltage is connected with many accessible signals in the drive system.

- Use a power supply unit that meets the requirements for PELV (Protective Extra Low Voltage)
- Connect the negative output of the power supply unit to PE.

Failure to follow these instructions will result in death or serious injury.

⚠ CAUTION

Destruction of system components and loss of control monitoring

Excessive currents can be created at the signal connections if the negative connection to the controller supply voltage is interrupted.

- Do not interrupt the negative connection between power supply unit and load with a fuse or switch
- Check for correct connection before switching on.
- Never connect the controller supply voltage or change its wiring while there is supply voltage present.

Failure to follow these instructions can result in injury or equipment damage.

CAUTION

Destruction of contacts

The connection for the controller supply voltage at the drive system does not have a make current limit. If the voltage is switched on by switching contacts, the contacts may be destroyed or welded shut.

- Use a power supply unit that limits the peak value of the output current to a value permissible for the contact.
- Switch the line input of the power supply unit instead of the output voltage.

Failure to follow these instructions can result in equipment damage.

Wiring diagram

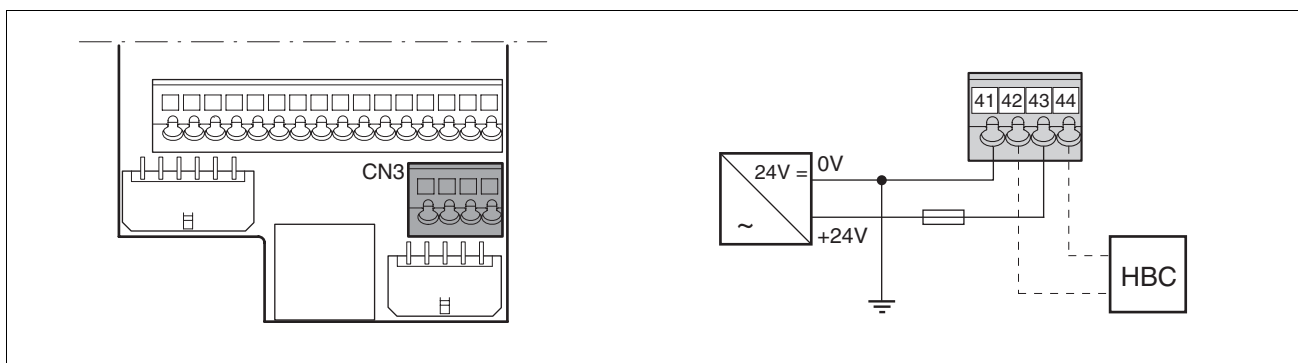

Figure 6.16 Controller supply voltage wiring diagram

Pin	Signal	Description
41	0VDC	Reference potential for 24V voltage
42	0VDC	Reference potential for 24V voltage
43	+24VDC	24V controller supply voltage
44	+24VDC	24V controller supply voltage

Connecting the controller supply voltage

- ▶ Make sure that the cables, the wiring and the connected interfaces meet the requirements for PELV.
- ▶ Feed the controller supply voltage from a power supply unit (PELV) to the device.
- ▶ Earth the negative output at the power supply

Rating

- Terminal CN3, pin 42 and 44 (see Figure 6.16) can be used as a 0V/24V terminal for additional consumers. Note the maximum terminal current, see Technical Data, from page 3-1.
- As long as the controller supply voltage is switched on, the position of the motor will remain the same, even if the power amplifier supply voltage is switched off.

6.3.11 Connecting encoder signals A, B, I (CN5)

Function At CN5 the reference value preset can be made via externally fed A/B signals and index pulse (I) in electronic gear operating mode.

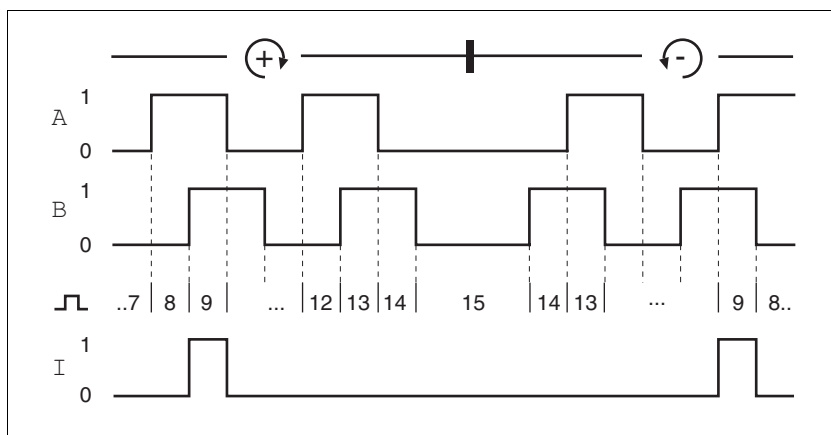

Figure 6.17 Timing diagram with A, B and index pulse signal, counting forwards and backwards

- Cable specifications*
- Shielded cable
 - Twisted pair lines
 - Minimum cross section of the signal wires 0.25 mm²
 - Earthing of the shield at both ends
 - Maximum cable length 100m
 - ▶ Use equipotential bonding conductors, see page 6-3.
 - ▶ Use prefabricated cables to minimise the risk of a wiring error (from page 12-2).
- Connect the sensor*
- ▶ Connect the plug to CN5. If you are not using prefabricated wiring, make sure the pin assignment is correct.
 - ▶ Make the appropriate settings during commissioning. See "First Setup", page 7-13

For the order number of the crimping pliers and the extraction tool see 12.5 "Crimping tool and connector / contacts"

Wiring diagram

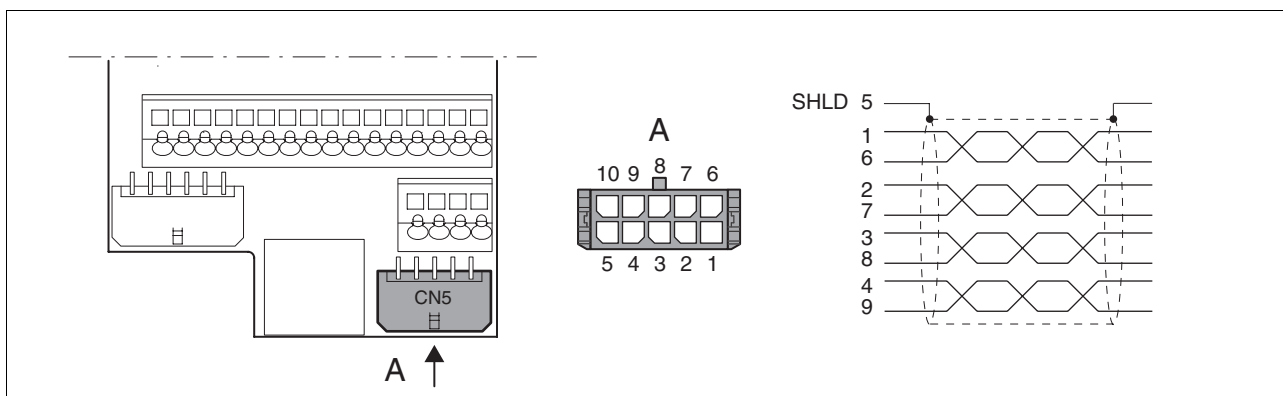

Figure 6.18 Wiring diagram, Encoder to CN5

Pin	Signal	Colour ¹⁾	Description	I/O
1	ENC_A	white	Encoder signal channel A	RS422 input signal
6	$\overline{\text{ENC_A}}$	brown	Channel A, inverted	RS422 input signal
2	ENC_B	green	Encoder signal channel B	RS422 input signal
7	$\overline{\text{ENC_B}}$	yellow	Channel B, inverted	RS422 input signal
3	ENC_I/LI7	grey	Channel index pulse / digital input 7	RS422 input signal
8	$\overline{\text{ENC_I/LI7}}$	pink	Channel index pulse, inverted / digital input 7, inverted	RS422 input signal
4	$\overline{\text{ACTIVE2_OUT/LO3_OUT}}$	red	Drive ready / digital input 3	Open collector
9	POS_0V	blue	Reference potential	
5	SHLD		Shield	
10	nc		not assigned	

1) Information on the colour refers to the cables available as accessories.

6.3.12 Connection of pulse/direction PD (CN5)

⚠ WARNING

Unexpected movement

Incorrect or faulty signals as reference position can trigger unexpected movements.

- Use shielded cables with twisted-pair.
- Operate the interface with push-pull signals.
- Do not use signals without push-pull in critical applications or in an environment subject to interference.
- Do not use signals without push-pull with cable lengths over 3 m and limit the frequency to 50 kHz

Failure to follow these instructions can result in death, serious injury or equipment damage.

⚠ CAUTION

Destruction of the product and loss of control

The PULSE, DIR and ENABLE inputs on this connection are only rated for 5V. Excessive voltage can cause destruction of the product either immediately or at a later time.

- Check the correct connection before switching on.

Failure to follow these instructions can result in injury or equipment damage.

Function The device is suitable for reference value default via externally fed pulse/direction signals PD. For example, this is required for the electronic gear operating mode.

The signal interface is used for positioning the motor. Operation readiness of the drive and a possible breakdown are reported.

Pulse/direction PD The motor executes an angular step on the rising edge of the rectangular-pulse signal PULSE. The direction of rotation is controlled by the DIR signal.

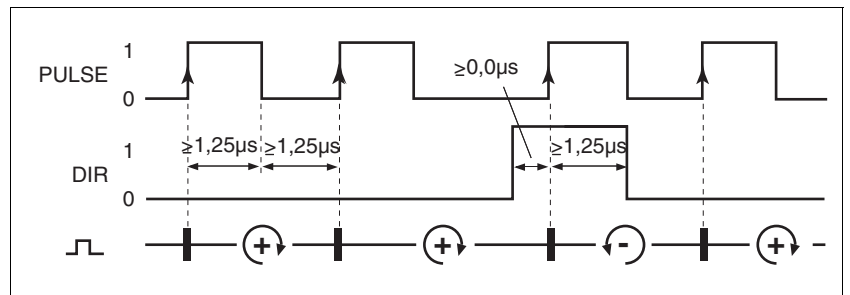

Figure 6.19 Pulse direction signal

RS<20: 200 kHz; t_z ≥ 2.5µs

Pin	Signal	Value	Function
1	PULSE	0 -> 1	Motor step
2	DIR	0 / open	Clockwise rotation

ENABLE If in the case of local control mode the ENABLE signal can also be used to enable the power amplifier. An error message is also reset with a negative edge at the ENABLE signal input.

If there is no operating fault, the ACTIVE2_OUT output indicates ready for operation for about 100 ms after the power amplifier is enabled.

ACTIVE2_OUT ACTIVE2_OUT is an open collector output and switches against 0 V. The output shows that the unit is ready for operation.

Circuit of the signal inputs

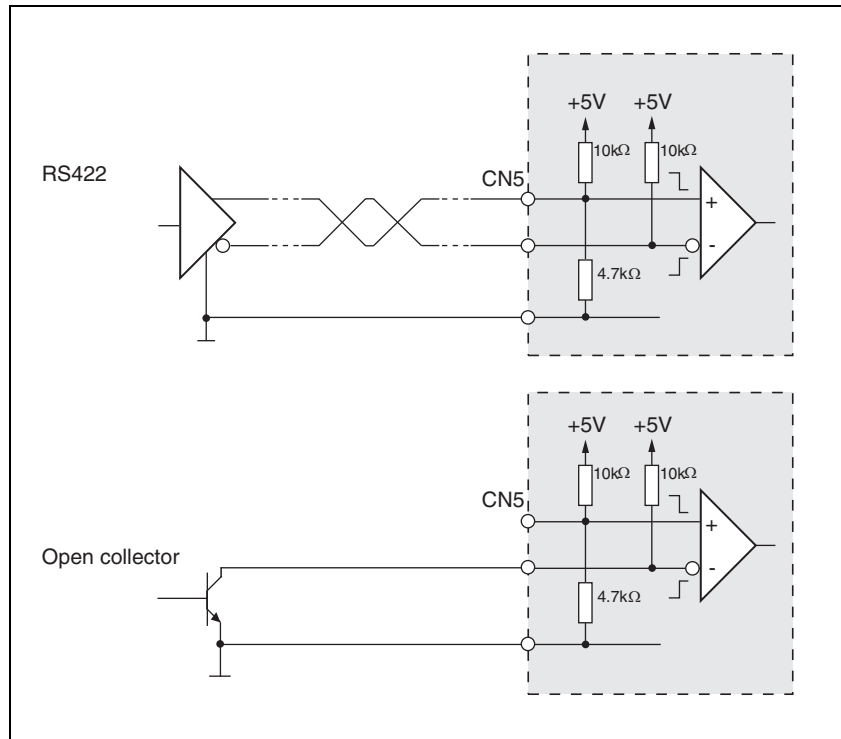

Figure 6.20 Circuit of the PULSE, DIR and ENABLE signal inputs

Cable specifications

- Shielded cable
- Twisted pair lines
- Minimum cross section of the signal wires 0.14 mm²
- Earthing of the shield at both ends
- Maximum length 100 m
- ▶ Use equipotential bonding conductors, see page 6-3.
- ▶ Use prefabricated cables to minimise the risk of a wiring error (from page 12-1).

Connecting pulse/direction PD

- ▶ Connect the plug to CN5. If you are not using prefabricated wiring, make sure the pin assignment is correct.
- ▶ Make the appropriate settings during commissioning. See "First Setup", page 7-13

For the order number of the crimping pliers and the extraction tool see 12.5 "Crimping tool and connector / contacts"

Wiring diagram

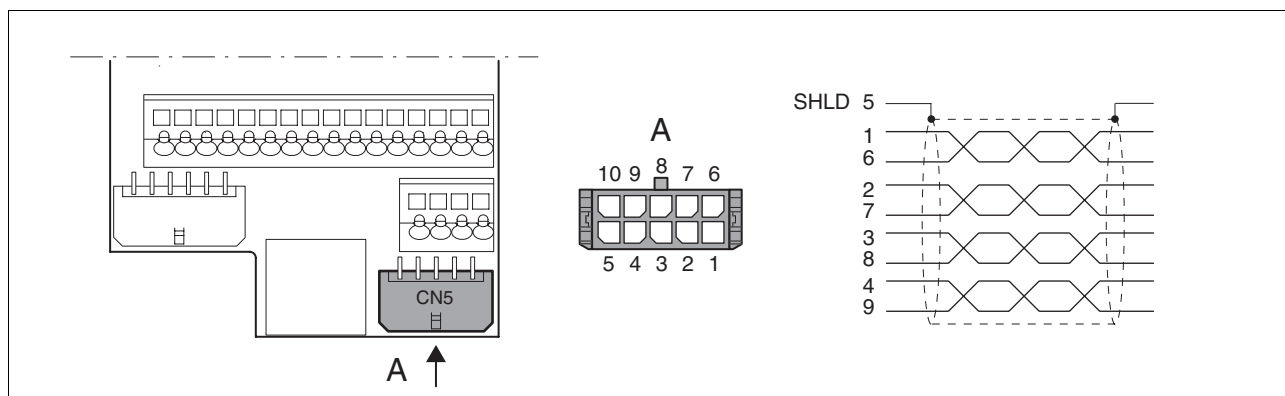

Figure 6.21 Wiring diagram PULSE

Pin	Signal	Colour ¹⁾	Description	I/O
1	PULSE	white	Motor step "Pulse"	RS422 input signal
6	$\overline{\text{PULSE}}$	brown	Motor step "Pulse", inverted	RS422 input signal
2	DIR	green	direction of rotation "DIR"	RS422 input signal
7	$\overline{\text{DIR}}$	yellow	direction of rotation "Dir", inverted	RS422 input signal
3	ENABLE/LI7	grey	Enable signal / digital input 7	RS422 input signal
8	$\overline{\text{ENABLE/LI7}}$	pink	Enable signal, inverted / digital input 7	RS422 input signal
4	$\overline{\text{ACTIVE2_OUT/LO3_OUT}}$	red	Drive ready / digital input 3	Open collector
9	POS_0V	blue	Reference potential	-
5	SHLD		Shield	
10	nc		not assigned	

1) Information on the colour refers to the cables available as accessories.

6.3.13 Connection of encoder simulation (CN5)

Function The device is suitable for encoder simulation (ESIM). Signals for output of the actual position can be led out at CN5. They are two phase-shifted signals A and B. The A/B signals are generated by the motor encoder signal.

Resolution The basic resolution of the encoder simulation at 4x resolution is 4096 increments per revolution.

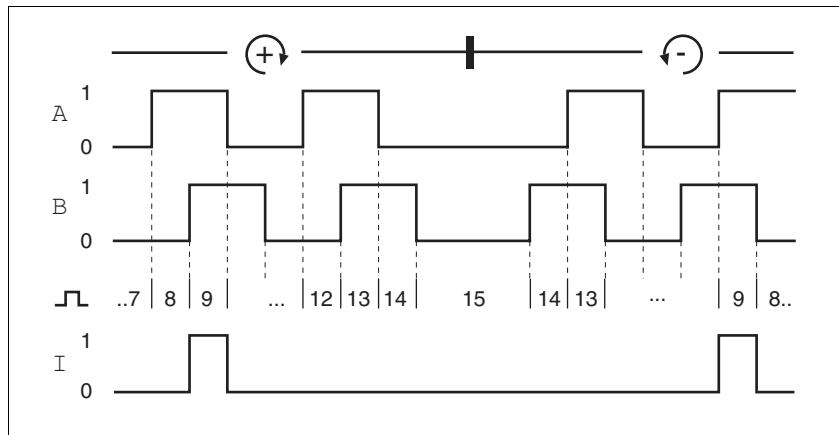

Figure 6.22 Timing diagram with A, B and index pulse signal, counting forwards and backwards

- Cable specification**
- Shielded cable
 - Twisted-pair conductors
 - Minimum cross section of the signal wires 0.14 mm²
 - Earthing of the screen at both ends
 - Maximum length 100 m
 - ▶ Use equipotential bonding conductors, see page 6-3.
 - ▶ Use prefabricated cables to minimise the risk of a wiring error (from page 12-2).
- Connecting ESIM**
- ▶ Connect the plug to CN5. If you are not using prefabricated wiring, make sure the pin assignment is correct.
 - ▶ Make the appropriate settings during commissioning. See "First Setup", page 7-13

For the order number of the crimping pliers and the extraction tool see 12.5 "Crimping tool and connector / contacts"

Wiring diagram

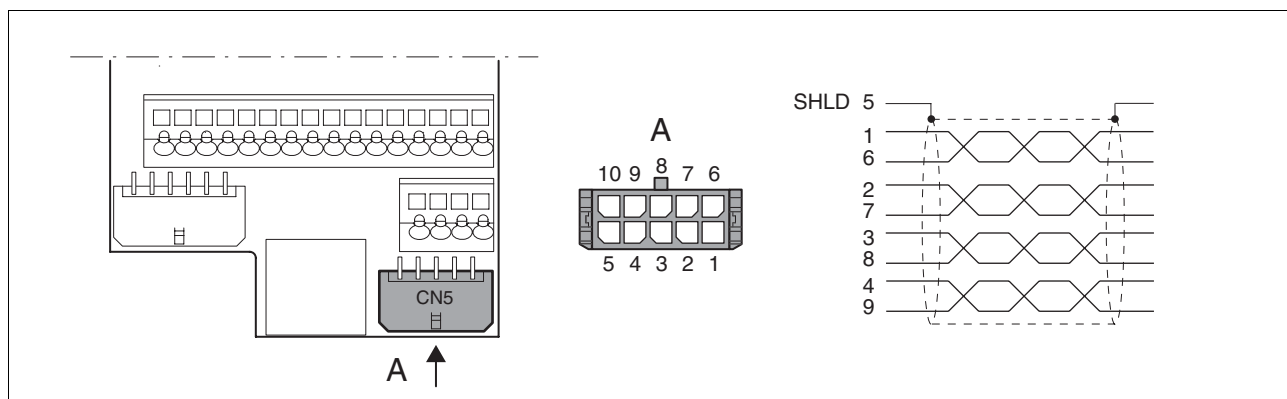

Figure 6.23 ESIM wiring diagram

Pin	Signal	Colour ¹⁾	Description	I/O
1	ESIM_A	white	Channel A	RS422 output signal
6	$\overline{\text{ESIM_A}}$	brown	Channel A, inverted	RS422 output signal
2	ESIM_B	green	Channel B	RS422 output signal
7	$\overline{\text{ESIM_B}}$	yellow	Channel B, inverted	RS422 output signal
3	ESIM_I/LI7	grey	Index pulse / digital input 7	RS422 output signal
8	$\overline{\text{ESIM_I/LI7}}$	pink	Index pulse, inverted / digital input 7, inverted	RS422 output signal
4	$\overline{\text{ACTIVE2_OUT}}/\text{LO3_OUT}$	red	Drive ready / digital input 3	Open collector
9	POS_0V	blue	Reference potential	-
5	SHLD		Shield	
10	nc		not assigned	

1) Information on the colour refers to the cables available as accessories.

6.3.14 CANopen connection (CN1 or CN4)

Function The device is suitable for connection to CANopen.

In CAN bus multiple network devices can be connected over one bus cable. Up to 32 devices can be addressed in one CAN bus network branch and up to 127 devices in the extended network.

Every network device must be configured before operation on the network. It is given a unique, 7-bit node address (node-ID) between 1 (01_h) and 127 (7F_h).

The baud rate must be the same for all devices in the fieldbus.

Address and baud rate are set during commissioning. See "First Setup", page 7-13

For additional information see the fieldbus manual, order number, see page 12-4.

- Cable specifications*
- Shielded cable
 - Twisted-pair conductors
 - Minimum cross section of the signal wires 0.14 mm²
 - Earthing of the screen at both ends
 - Maximum length depends on the number of devices, the baud rate and signal run times. The higher the baud rates the shorter the bus cable must be.
- ▶ Use equipotential bonding conductors, see page 6-3.
 - ▶ Use prefabricated cables to minimise the risk of a wiring error (from page 12-4).
 - ▶ Make sure that the wiring, the cables and the connected interfaces meet the requirements for PELV.

Maximum bus length The maximum bus length depends on the selected baud rate. The following table shows the maximum recommended bus lengths for the overall length.

baud rate [kbit/s]	maximum bus length with CANopen [m]
50	1000
125	500
250	250
500	100
1000	4

At a baud rate of 1 Mbit the spur lines are limited to 0.3m.

Terminating resistors The two ends of a bus cable string must be terminated. This can be achieved by a 120Ω terminating resistor between CAN_L and CAN_H.

A terminating resistor that is enabled with the S1 switch is integrated into the device.

- ▶ If the device is at the end of the network, slide the S1 switch for the terminating resistor to the left.

Wiring diagram

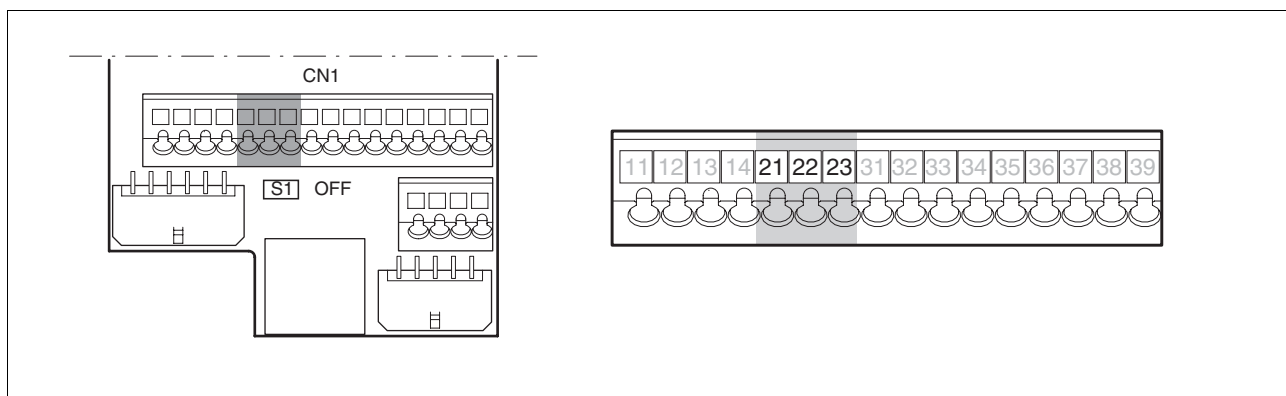

Figure 6.24 Wiring diagram, CANopen at CN1

Pin	Signal	Description	I/O
21	CAN_0V	CAN reference potential	
22	CAN_L	data wire, inverted	CAN level
23	CAN_H	data wire	CAN level

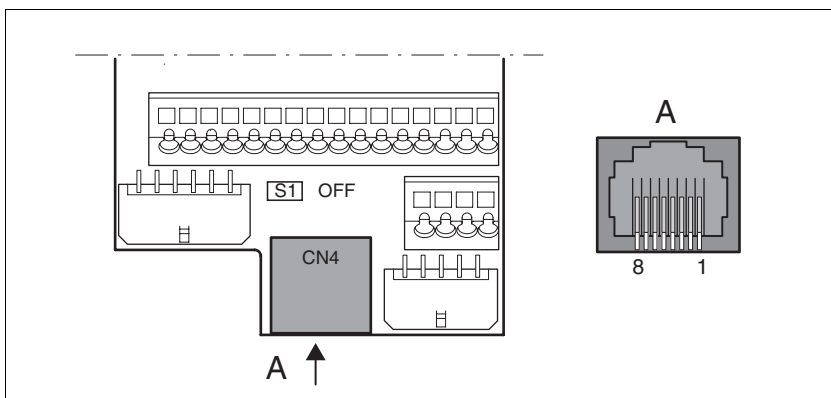

Figure 6.25 CANopen wiring diagram at CN4

Pin	Signal	Description	I/O
1	CAN_H	data wire	CAN level
2	CAN_L	data wire, inverted	CAN level
7	MOD+10V_OUT	10V power supply (different assignment from CANopen)	O
8	MOD_0V	Reference potential for MOD+10V_OUT	O

Connecting CANopen ▶ Connect the CANopen cable to CN1, pin 21, 22 and 23 or to CN4 (pin 1, 2 and 8) with an RJ45 connector.

6.3.15 Modbus connection (CN4)

Function The unit is designed for connection to the Modbus

With Modbus, multiple network devices are interconnected by bus cable. Every network device must be configured before operation on the network. Each is given a unique node address.

The baud rate must be the same for all units in the fieldbus.

Address and baud rate are set during commissioning. See "First Setup", page 7-13

For additional information see the Modbus manual, order number, see page 12-4.

- Cable specifications** The cables used must conform to the following properties:
- Shielded cable
 - Twisted-pair conductors
 - Minimum cross section of the signal wires 0.14 mm²
 - Earthing of the screen at both ends
 - maximum length 400 m.
 - ▶ Use equipotential bonding conductors, see page 6-3.
 - ▶ Use prefabricated cables to minimise the risk of a wiring error (from page 12-4).

Wiring diagram

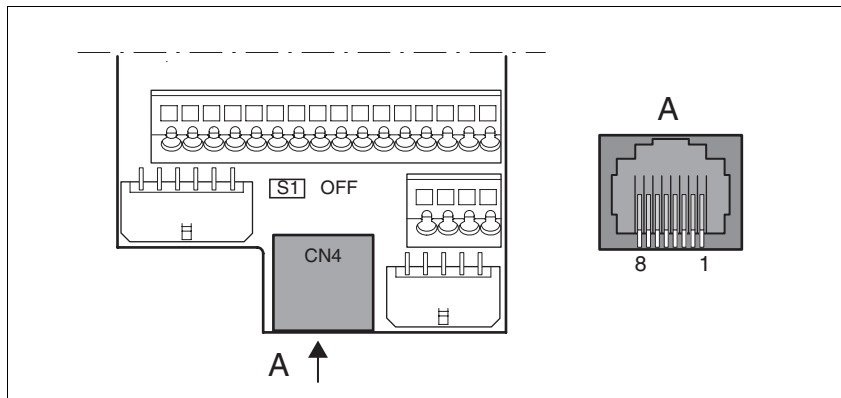

Figure 6.26 Wiring diagram:MODBUS

Pin	Signal	Description	I/O
4	MOD_D1	Bidirectional send/receive signal	RS485 level
5	MOD_D0	Bidirectional send/receive signal, inverted	RS485 level
7	MOD+10V_OUT	10 V power supply, max. 150 mA	O
8	MOD_0V	Reference potential to MOD+10V_OUT	O

Connecting Modbus ▶ Connect the Modbus cable to CN4 with an RJ45 plug.

6.3.16 Connection of analogue inputs (CN1)

- Cable specifications*
- Shielded cable
 - Twisted pair lines
 - Minimum cross section of the signal wires 0.14 mm² Cross section 1.5 mm²
 - maximum length 10 m

Connecting analogue inputs ▶ Attach the cable to the EMC plate, the shield must be attached to the earth potential over a wide area.

Wiring diagram

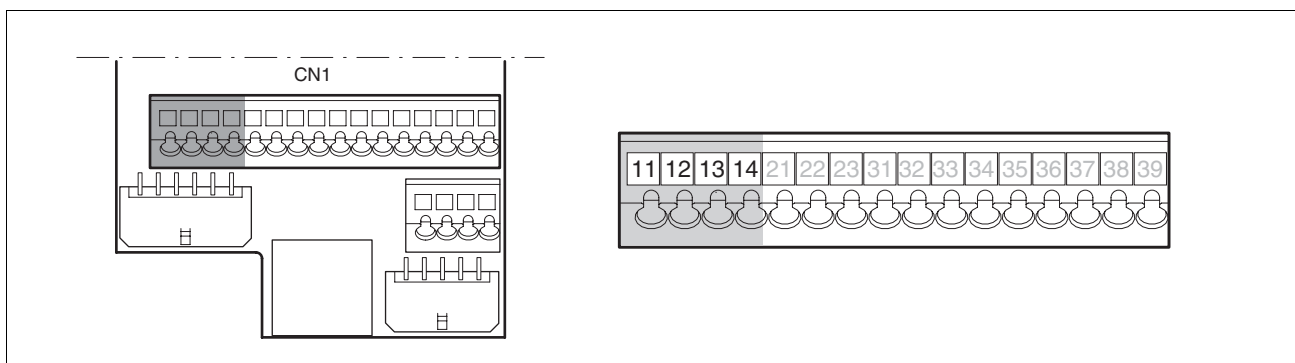

Figure 6.27 Wiring diagram, analogue inputs

Pin	Signal	Description	I/O
11	ANA1+	±10V, e.g. for current reference value or speed reference value	I
12	ANA1-	Reference potential for ANA1+, pin 11	I
13	ANA2+	±10V, e.g. for current limiting or speed limiting	I
14	ANA2-	Reference potential for ANA2+, pin 13	I

Reference values and limits The ±10V scaling of the analogue reference values and analogue limits can be specified for operation, see page 7-22.

6.3.17 Connection of digital inputs/outputs (CN1)

⚠ CAUTION
<p>Loss of control</p> <p>The use of $\overline{\text{LIMP}}$ and $\overline{\text{LIMN}}$ can offer some protection against dangers (e.g. impact on mechanical stop caused by incorrect movement targets).</p> <ul style="list-style-type: none"> • Use $\overline{\text{LIMP}}$ and $\overline{\text{LIMN}}$ where possible. • Check that the external sensors or switches are correctly connected. • Check the correct functional installation of the limit switch. The limit switches must be mounted in a position far enough away from the mechanical stop to allow an adequate braking distance. • The functions must be enabled to use $\overline{\text{LIMP}}$ and $\overline{\text{LIMN}}$. • This function cannot provide protection against faulty functioning of the product or the sensors. <p>Failure to follow these instructions can result in injury or equipment damage.</p>

Cable specifications

- Minimum cross section 0.14 mm², max. cross section 1.5 mm²
- Maximum length at minimum cross section 15 m..

Minimum connection assignment

The following signals must always be connected with the default setting. If the assignment of LI1, LI2 and LI4 is changed, $\overline{\text{REF}}$, $\overline{\text{LIMN}}$ and $\overline{\text{HALT}}$ must be disabled with the corresponding parameters. For example, this may affect the reference movement operating mode.

Pin	Signal	Remarks
33	$\overline{\text{REF}}/\text{LI1}$	with fieldbus control mode only
34	$\overline{\text{LIMN}}/\text{LI2}$	with fieldbus control mode only
35	$\overline{\text{LIMP}}$	with fieldbus control mode only
36	$\overline{\text{HALT}}/\text{LI4}$	
37	$\overline{\text{PWR}}_{\text{B}}$	Two-channel connection, signals are not managed with parameters.
38	$\overline{\text{PWR}}_{\text{A}}$	

Table 6.6 Minimum connection assignment

If the signals listed in the table are not used, they must be wired with +24VDC. $\overline{\text{LIMP}}$, $\overline{\text{LIMN}}$ and $\overline{\text{REF}}$ can also be disabled with the corresponding parameters.

Terminal assignment for "Power Removal" function

▲ WARNING

Loss of safety function

Incorrect usage may cause a safety hazard by loss of the safety function.

- Observe the requirements for the safety function.

Failure to follow these instructions can result in death or serious injury.

Information on the safety signals $\overline{\text{PWRR_A}}$ and $\overline{\text{PWRR_B}}$ can also be found in 5.4 "Safety function "Power Removal"" from page 5-2 and in 3.4.4 "Safety functions" on page 3-7

Connecting digital inputs/outputs

- ▶ Wire the digital connections to CN1.
Depending on the control mode (local or fieldbus), different functions are defined for Pin 33, 34 and 35 (see Table 6.7). The control mode is specified during commissioning with parameters.
- ▶ Connect the limit switch that limits the work stroke in clockwise rotation with $\overline{\text{LIMP}}$, the limit switch for counterclockwise rotation with $\overline{\text{LIMN}}$.
- ▶ Earth the shield with low resistance and over a wide area at both ends of the cable.

Wiring diagram

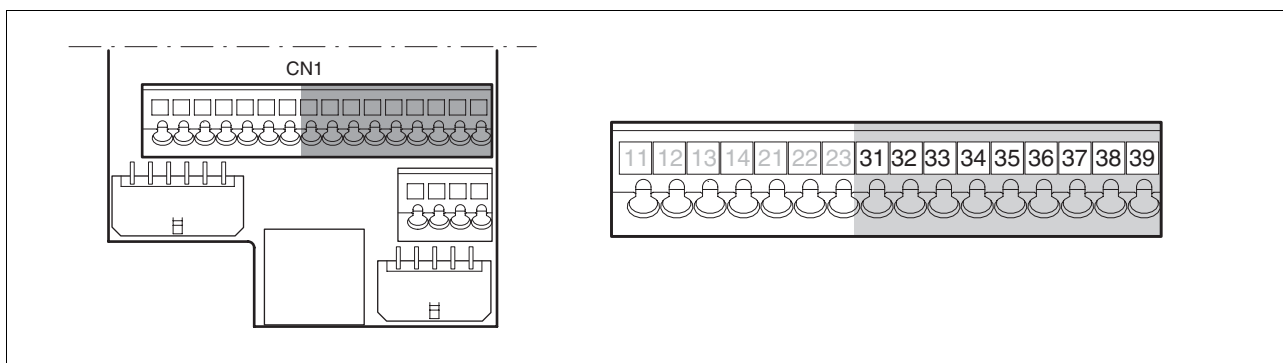

Figure 6.28 Wiring diagram, digital inputs/outputs

Pin	Signal with local control mode	Meaning with local control mode	Signal with fieldbus control mode	Meaning with fieldbus control mode	I/O
31	NO_FAULT_OUT/ LO1_OUT	Digital output 1 / error output	NO_FAULT_OUT/ LO1_OUT	Digital output 1 / error output	24V, O
32	BRAKE_OUT ¹⁾ / LO2_OUT	Digital output 2 / 0: motor without current 1: motor under current, control signal for holding brake controller HBC	BRAKE_OUT ¹⁾ / LO2_OUT	Digital output 2 / 0: motor without current 1: motor under current, control signal for holding brake controller HBC	24V, O
33	LI1	Digital input 1	REF/LI1	Digital input 1 / reference switch signal (factory setting: disable)	24V, I
34	FAULT_RESET/LI2	Digital input 2 / reset error	LIMN CAP2	Digital input 2 / limit switch signal negative fast position capture channel 2	24V, I 24V, I
35	ENABLE	Enable power amplifier	LIMP CAP1	Limit switch signal positive fast position capture channel 1	24V, I 24V, I
36	HALT/LI4	Digital input 4 / "Halt" function	HALT/LI4	Digital input 4 / "Halt" function	24V, I
37	PWRR_B	"Power Removal" safety function	PWRR_B	"Power Removal" safety function	24V, I
38	PWRR_A	"Power Removal" safety function	PWRR_A	"Power Removal" safety function	24V, I
39	+24VDC	Only for jumpering pin 37 and 38 if safety function "Power Removal" is not used	+24VDC	Only for jumpering pin 37 and 38 if safety function "Power Removal" is not used	-

1) with software version <1.201: Signal name ACTIVE1_OUT

Table 6.7 Digital signals, connection assignment

6.3.18 Connection to PC or remote terminal (CN4)

CAUTION

Damage to PC

If the interface connector on the product is directly connected to a Gigabit Ethernet connector on the PC, the interface on the PC may be destroyed.

- Never connect an Ethernet interface directly to this product.

Failure to follow these instructions can result in equipment damage.

Function of the control terminal

The remote terminal with LCD display and keypad can be connected directly to CN4 with the supplied RJ-45 cable, see accessories from page 12-1. This allows the device to be operated at a distance from the system. The functions and display of the control terminal are identical to those of the HMI.

Cable specifications

- Shielded cable
- Twisted pair lines
- Minimum cross section of the signal wires 0.14 mm²
- Earthing of the shield at both ends
- maximum length 400 m

PC connection

An RS485 to RS232 converter is required for the PC, see accessories from page 12-1. The converter is powered by the device.

Wiring diagram

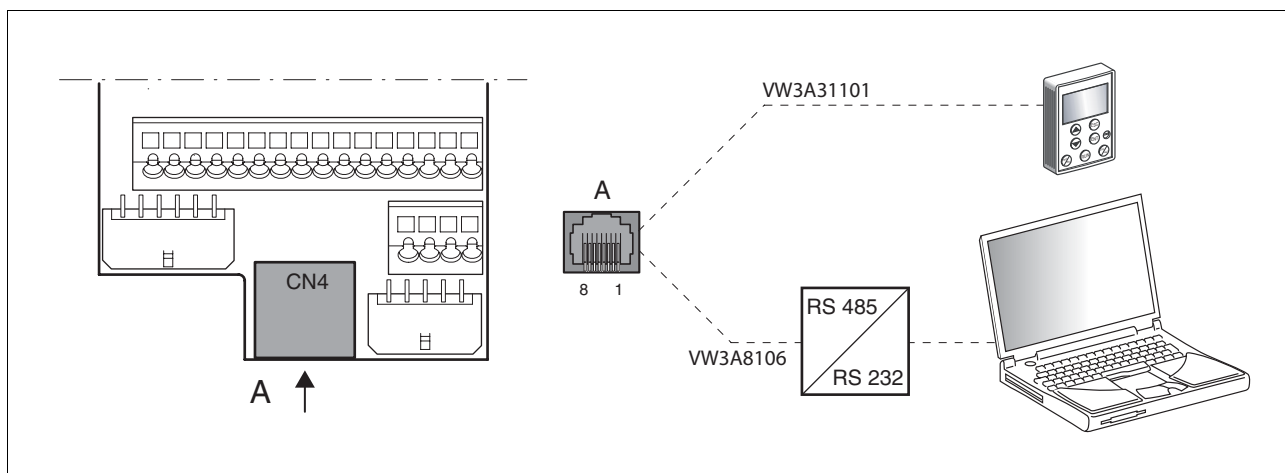

Figure 6.29 Wiring diagram of PC or remote terminal

Pin	Signal	Description	I/O
4	MOD_D1	Bidirectional send/receive signal	RS485 level
5	MOD_D0	Bidirectional send/receive signal, inverted	RS485 level
7	MOD+10V_OUT	10 V power supply, max. 150 mA)	O
8	MOD_0V	Reference potential to MOD+10V_OUT	O

6.3.19 Reference value adapter

Reference value adapter RVA Reference signals of a master device can be sent simultaneously to up to five devices using the RVA (Reference Value Adapter). This adapter also sets the supply voltage (5 V, monitored with SENSE lines¹) available for the encoder. The correct power supply is shown by a "5VSE" LED.

An external rotary encoder (A/B signals) or an encoder simulation (ESIM) can be used as a master device. Pulse/direction signals can also be sent from a higher level controller.

Connecting RVA reference value adapter

- Make sure that the wiring, the cables and the connected interfaces meet the requirements for PELV.

The RVA Reference Value Adapter is supplied with 24 V at the CN9 connections. A master controller (pulse/direction) can be connected at CN6. An external rotary encoder or an ESIM signal can be applied to CN7.

Up to five devices that evaluate the specified reference signals can be connected to CN1 to CN5.

Switch S1 is used to set the evaluation of the $\overline{\text{ACTIVE2_OUT}}$ signal. This ready signal $\overline{\text{ACTIVE2_OUT}}$ is evaluated by the device if the correspondingly assigned switch is set to OFF. If the readiness comes from all devices, the LED ACTIVE CN1-CN5 lights.

Connection CN1..5	Switch setting S1
connected devices on CN1-CN5	corresponding switch 1.5 at "OFF", signal $\overline{\text{ACTIVE2_OUT}}$ of the corresponding device is evaluated
unconnected devices CN1-CN5	corresponding switch 1..5 to "ON", $\overline{\text{ACTIVE2_OUT}}$ signal is simulated

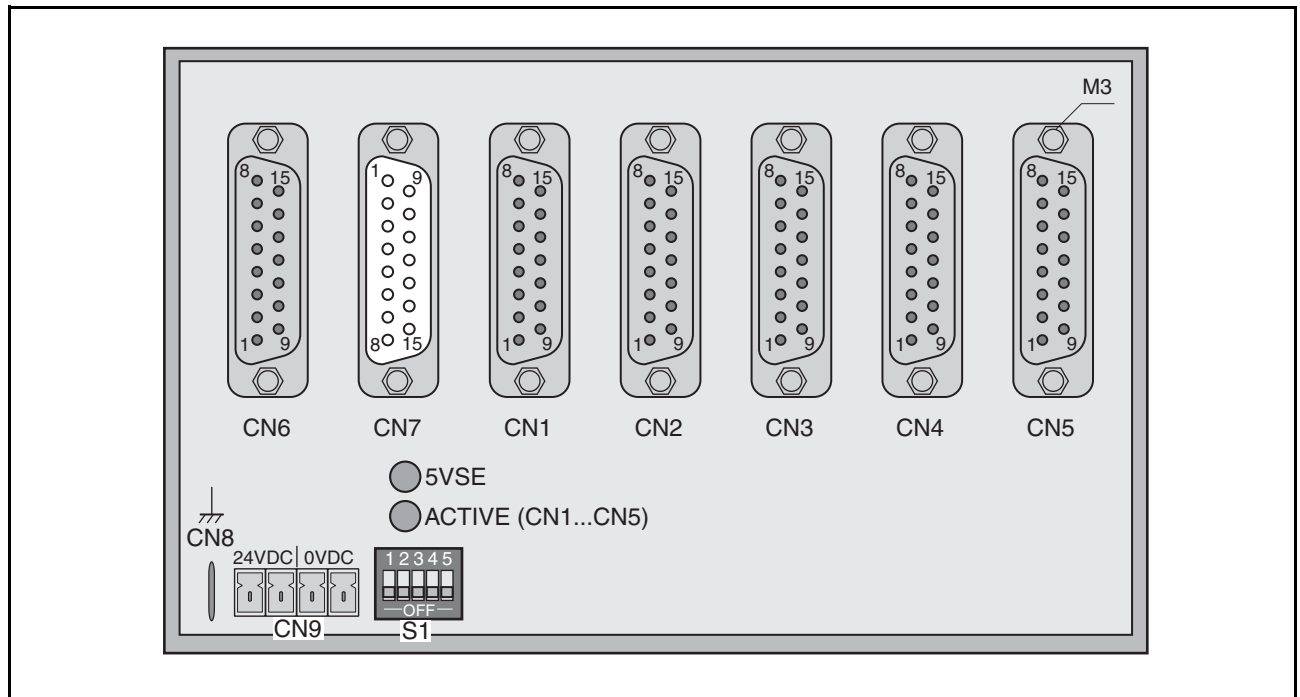

The following table shows the terminal assignment of CN1 - CN5:

1. On the encoder, the signal line CN7/2 (5VDC_OUT) is to be connected with CN7/10 (SENSE+) and the signal line CN7/3 (POS_0V) with CN7/11 (SENSE-)

Pin	Signal	Description	I/O
1	PULSE_OUT / A_OUT / ESIM_A_OUT	Pulse+, channel A, ESIM_A	O
9	$\overline{\text{PULSE_OUT}} / \overline{\text{A_OUT}} / \overline{\text{ESIM_A_OUT}}$	Pulse-, channel A inverted, ESIM_A inverted	O
2	DIR_OUT / B_OUT / ESIM_B_OUT	Direction+, channel B, ESIM_B	O
10	$\overline{\text{DIR_OUT}} / \overline{\text{B_OUT}} / \overline{\text{ESIM_B_OUT}}$	Direction, channel B inverted, ESIM_B inverted	O
3	ENABLE_OUT / I_OUT / ESIM_I_OUT	ENABLE+, index pulse, ESIM_I	O
11	$\overline{\text{ENABLE_OUT}} / \overline{\text{I_OUT}} / \overline{\text{ESIM_I_OUT}}$	ENABLE-, index pulse inverted, ESIM_I inverted	O
8	ACTIVE_2/READY	Drive ready	I
15	POS_0V	Reference potential	
4 - 7, 12 - 14	nc	not assigned	

The following table shows the terminal assignment of CN6:

Pin	Signal	Description	I/O
1	PULSE / A / ESIM_A	Pulse+, channel A, ESIM_A	I
9	$\overline{\text{PULSE}} / \overline{\text{A}} / \overline{\text{ESIM_A}}$	Pulse-, channel A inverted, ESIM_A inverted	I
2	DIR / B / ESIM_B	Direction+, channel B, ESIM_B	I
10	$\overline{\text{DIR}} / \overline{\text{B}} / \overline{\text{ESIM_B}}$	Direction, channel B inverted, ESIM_B inverted	I
3	ENABLE / I / ESIM_I	ENABLE+, index pulse, ESIM_I	I
11	$\overline{\text{ENABLE}} / \overline{\text{I}} / \overline{\text{ESIM_I}}$	ENABLE-, index pulse inverted, ESIM_I inverted	I
8	ACTIVE2_OUT/READY_OUT	Drive ready	O
15	POS_0V	Reference potential	
4...7, 12...14	nc	not assigned	

The following table shows the terminal assignment of CN7:

Pin	Signal	Description	I/O
1	A	Channel A	I
9	$\overline{\text{A}}$	Channel A inverted	I
12	B	Channel B	I
5	$\overline{\text{B}}$	Channel B inverted	I
13	I	Index pulse	I
6	$\overline{\text{I}}$	index pulse inverted	I
10	SENSE+	Monitoring of the motor encoder supply ¹⁾	I
11	SENSE-	Reference potential to motor encoder monitoring ²⁾	I
2	5VDC_OUT	5V motor encoder power supply ¹⁾	O
3	POS_0V	Reference potential for 5VDC_OUT ²⁾	
4, 7, 8, 14, 15	nc	not assigned	

1) At the end of the encoder cable (motor side) the signal line CN7.2 (5VDC_OUT) is to be connected with CN7.10 (SENSE+)

2) At the end of the encoder cable (motor side) the signal line CN7.3 (POS_0V) must be connected with CN7.11 (SENSE-)

There are prefabricated cables for the Reference Value Adapter, see chapter 12 "Accessories and spare parts".

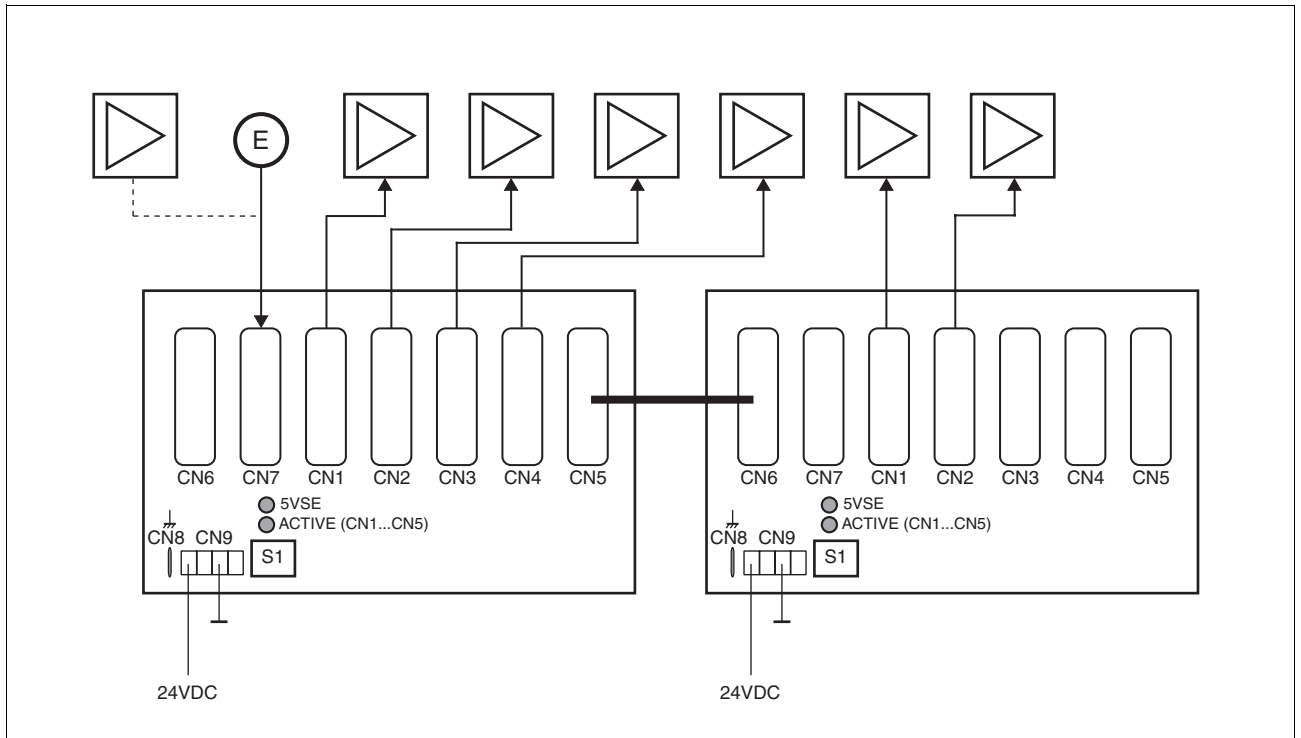

Figure 6.30 Wiring example: encoder signals A/B/I (at CN7) are forwarded to six devices through two cascaded Reference Value Adapters

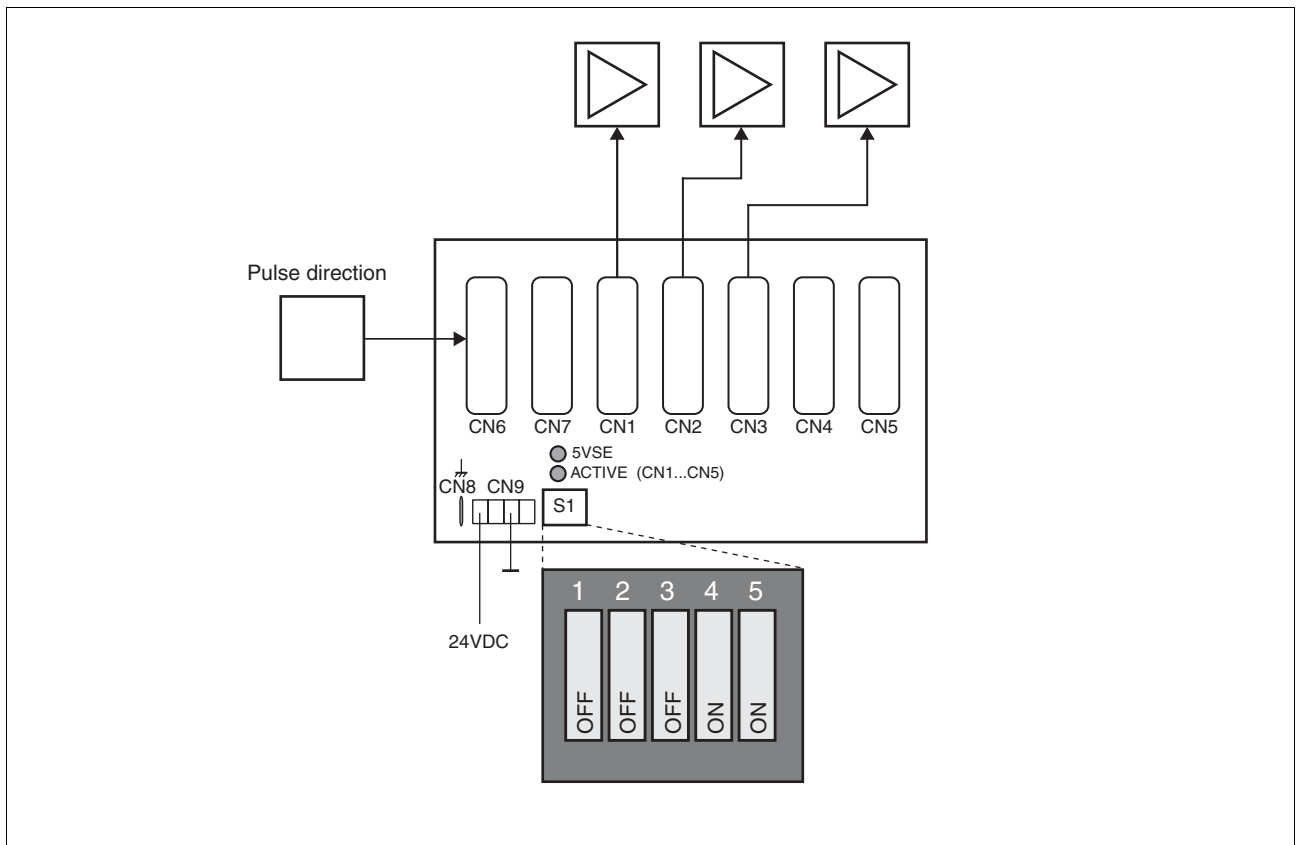

Figure 6.31 Wiring example: pulse direction signals (to CN6) are forwarded to three devices.

019844113232, V1.20, 06.2007

6.4 Checking installation

After completion of all steps we recommend checking the installation to prevent any errors before operation of the system.

- ▶ Make sure the drive system is correctly installed and wired up. Check in particular basic connections such as mains power and 24V power supply.
- ▶ Check in detail:
 - Are all protective conductors connected?
 - Are all fuses correct?
 - Are any live cable ends exposed?
 - Are all cables and connectors safely installed and connected?
 - Are the control lines connected correctly?
 - Have all EMC measures been taken?
- ▶ Check that all seals are fitted and that protection class IP54 is complied with (only when using the "Power Removal" function)
- ▶ Remove the protective foil as required in accordance with the specifications on page 6-7.

7 Commissioning



For an overview of **all** parameters can be found alphabetically sorted in the "parameters" section. The application and the function of some parameters are explained in more detail in this section.

7.1 General safety instructions

⚠ DANGER

Electric shock, fire or explosion

- Only technicians who are familiar with and understand the contents of this manual and the other relevant manuals are authorised to work on and with this drive system.
- The system manufacturer is responsible for compliance with all applicable regulations relevant to earthing the drive system.
- Many components, including the printed circuit board, work with mains voltage. **Do not touch.** Do not touch unprotected parts or screws on the terminals under voltage.
- Install all covers and close the housing doors before applying power.
- The motor generates voltage when the shaft is rotated. Lock the motor shaft to prevent rotation before starting work on the drive system.
- Before working on the drive system:
 - Switch off power to all connections.
 - Place a sign "DO NOT SWITCH ON" on the switch and lock to prevent its being switched on.
 - **Wait for 6 minutes** (discharge DC bus capacitors). Do not short-circuit DC bus!
 - Measure voltage on DC bus and check that it is <45V. (The DC bus LED is not a reliable indicator for no DC bus voltage).

Failure to follow these instructions will result in death or serious injury.

⚠ DANGER

Electric shock caused by incorrect use

The "Power Removal" function does not disconnect the electrical power. The DC bus voltage is still present.

- Turn off the mains voltage using an appropriate switch to achieve a voltage-free condition.

Failure to follow these instructions will result in death or serious injury.

⚠ DANGER**Motor out of view**

When the system is started the drives are generally out of the operator's view and cannot be visually monitored.

- Only start the system if there are no persons in the operating zone of the moving components and the system can be operated safely.

Failure to follow these instructions will result in death or serious injury.

⚠ WARNING**Unexpected behaviour**

The behaviour of the drive system is governed by numerous stored data or settings. Unsuitable settings or data may trigger unexpected movements or reactions to signals and disable monitoring functions.

- Do not operate a drive system with unknown settings or data.
- Check the stored data or settings.
- When commissioning carefully run tests for all operating statuses and fault cases.
- Check the functions after replacing the product and also after making changes to the settings or data.
- Only start the system if there are no persons or materials in the danger zone and the system can be operated safely.

Failure to follow these instructions can result in death, serious injury or equipment damage.

⚠ WARNING**Unbraked motor**

In the case of power failure and faults which cause the power amplifier to be switched off, the motor is no longer controlled by the brake and increases its speed even more until it comes to a mechanical stop.

- Check the mechanical situation.
- If necessary, use a cushioned mechanical stop or a suitable brake.

Failure to follow these instructions can result in death, serious injury or equipment damage.

▲ WARNING**Unexpected movement**

When the drive is operated for the first time there is a high risk of unexpected movements because of possible wiring errors or unsuitable parameters.

- If possible, run the first test movement without coupled loads.
- Make sure that a functioning button for EMERGENCY STOP is within reach.
- Also anticipate a movement in the incorrect direction or oscillation of the drive.
- Make sure that the system is free and ready for the movement before starting the function.

Failure to follow these instructions can result in death, serious injury or equipment damage.

▲ CAUTION**Hot Surfaces**

The heat sink on the product may heat up to over 100 °C (212 °F) depending on the operating mode.

- Prevent contact with the hot heat sink.
- Do not install flammable or heat-sensitive components in the immediate vicinity.
- Follow the actions described for heat dissipation.

Failure to follow these instructions can result in injury or equipment damage.

7.2 Overview



The following commissioning steps are also required if you are using a configured unit under changed operating conditions.

What must be done

What you need to do...	Info
Checking installation	Page 6-54
Making "First Setup"	Page 7-13
Check and set critical device parameters	Page 7-20
Define ESIM resolution, if used	Page 7-32
Setting, scaling, testing analogue signals	Page 7-22
Set, test digital signals	Page 7-25
Configurable inputs/outputs	Page 7-25
Limit switch function, tests the signals $\overline{\text{LIMP}}$, $\overline{\text{LIMN}}$	Page 7-27
Check signals $\overline{\text{PWRR_A}}$ and $\overline{\text{PWRR_B}}$, even if the "Power Removal" function is not used	Page 7-28
Check the functioning of the holding brake controller if it is wired for that	Page 7-29
Checking motor direction of rotation	Page 7-30
Run autotuning	Page 7-37
Optimise controller settings manually	Page 7-42
- speed controller	Page 7-43
- position controller	Page 7-48



Some products of this product family can be operated with different control modes. A distinction is made between local control mode and fieldbus control mode.

- Local control mode Movement specified with analogue signals or with RS422 signals.
- fieldbus control mode: all communications are made via fieldbus commands or with RS422 signals.

7.3 Tools for commissioning

7.3.1 Overview

Commissioning and setting parameters and also diagnostic tasks can be carried out with the following tools:

- Integrated HMI
- Peripheral control terminal
- Commissioning software
- fieldbus



Access to the complete list of parameters is only possible with the commissioning software or via fieldbus.

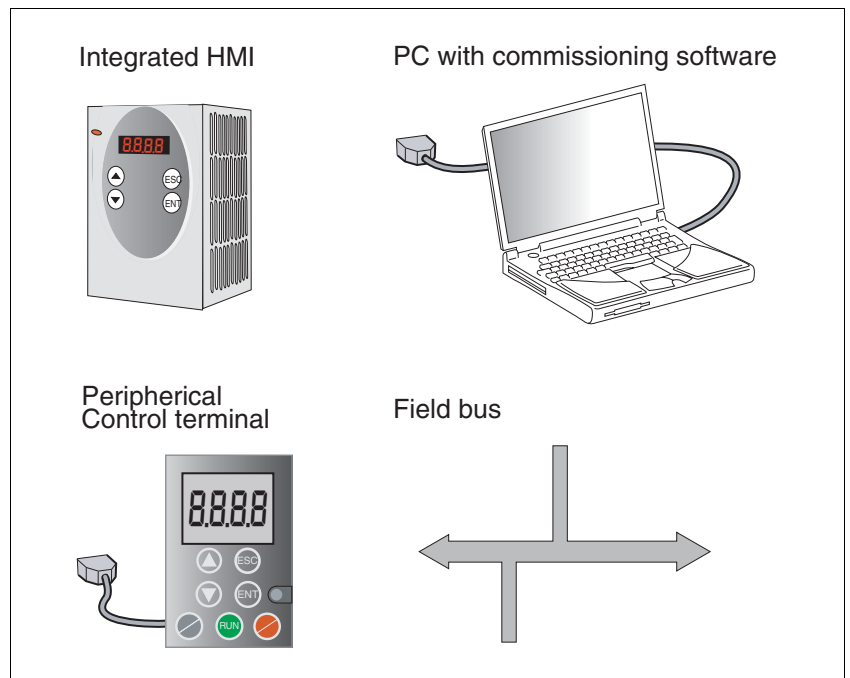

Figure 7.1 Commissioning tools

7.3.2 HMI: Human-Machine Interface

Function The unit has the option of editing parameters with the integrated control panel (HMI). Displays for diagnosis are also possible. The sections on commissioning and operation include information on whether a function can be carried out with the HMI or whether the commissioning software must be used.

A brief introduction to the HMI structure and the operation is given below.

Control panel The following figure shows the HMI (left) and the remote terminal (right).

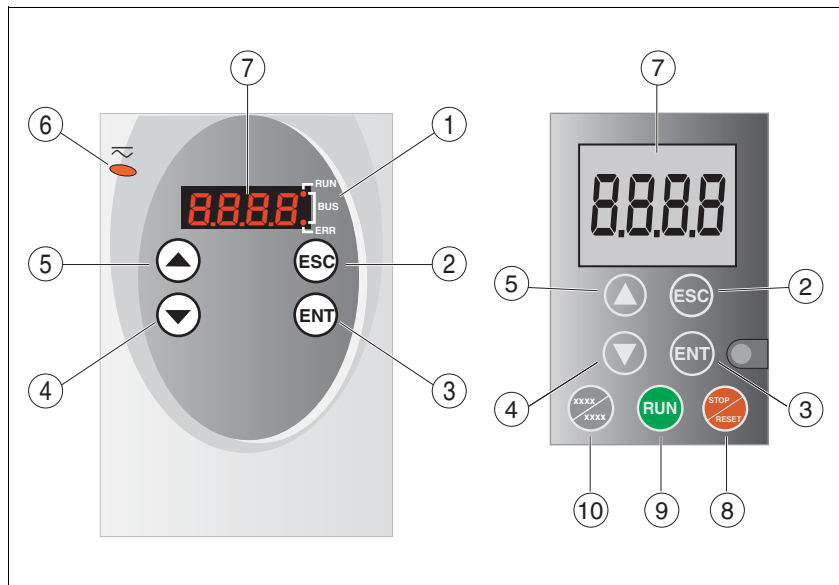

Figure 7.2 HMI and remote terminal

- (1) LEDs for fieldbus
- (2) ESC:
 - exit a menu or parameter
 - return from the displayed to the last saved value
- (3) ENT:
 - call a menu or parameter
 - save the displayed value to EEPROM
- (4) Down arrow:
 - switch to next menu or parameter
 - reduce the displayed value
- (5) Up arrow:
 - switch to previous menu or parameter
 - increase the displayed value
- (6) Red LED on: DC bus under power
- (7) Status display
- (8) Quick Stop (Software Stop)
- (9) No function
- (10) No function

LEDs for CANopen 2 LEDs show the status of the CANopen status machine as per the CANopen standard DR 303-3.

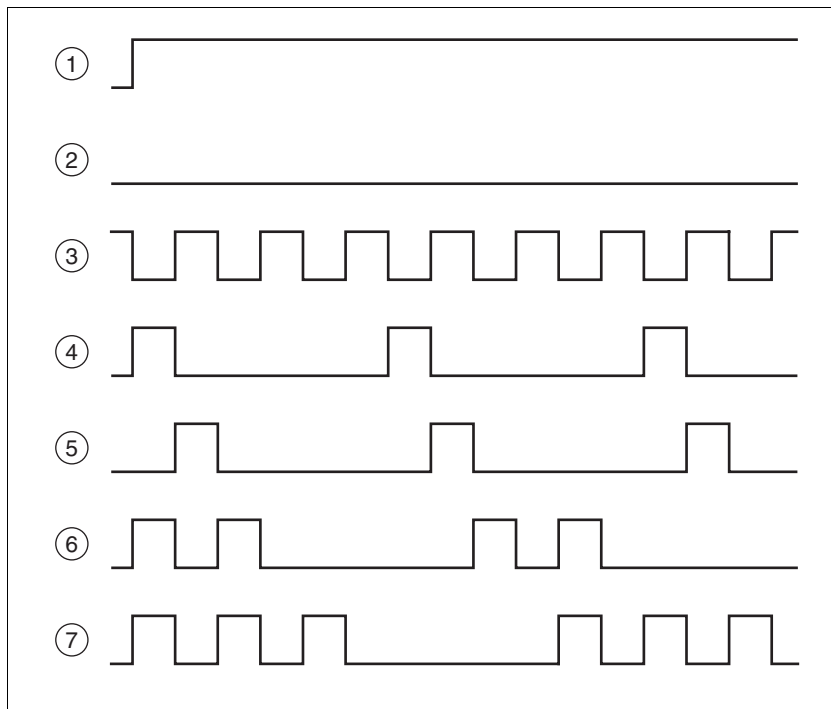

Figure 7.3 Meaning of the LED signals

LED "Fieldbus RUN"

- (1) device is in the NMT state OPERATIONAL
- (3) device is in the NMT state PRE-OPERATIONAL
- (5) device is in the NMT state STOPPED

LED "Fieldbus ERR"

- (1) CAN is BUS-OFF, e.g. after 32 failed transmission attempts.
- (2) Device is operating
- (4) Warning limit reached e.g. after 16 failed transmission attempts
- (6) Monitoring result (node guarding) has occurred
- (7) SYNC message was not received within the configured period

LEDs for Modbus 2 LEDs show the status of the fieldbus.

LED "RUN"

ON: bus has established communication
 OFF: bus has not yet established communication

LED "ERR"

ON: error on the bus
 OFF: Device is operating

Font on HMI display

Table 7.1 shows the assignment of the letters and numbers on the HMI display for the parameter display. Upper and lower case are only distinguished for the letter "C".

A	B	C	D	E	F	G	H	I	J	K	L	M	N	O	P	Q	R
R	b	c	d	E	F	G	h	i	J	K	L	M	n	o	P	q	r
S	T	U	V	W	X	Y	Z	1	2	3	4	5	6	7	8	9	0
S	t	u	v	w	X	y	Z	1	2	3	4	5	6	7	8	9	0

Table 7.1 HMI, available letters and numbers

Calling parameters via HMI

The parameters belonging to a specific menu item are in the first level below the top menu level for that item. In order to give a better orientation, the table of parameters also shows the overall menu path, e.g. SEt - / nPRH.

The following figure shows an example of calling a parameter (second level) and input or selection of a parameter value (third level).

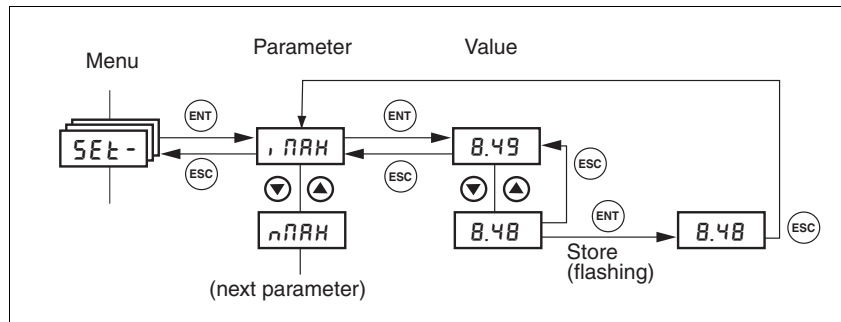

Figure 7.4 HMI, example of parameter setting

The two arrow keys allow setting of the numerical values within the permitted range of values, alphanumeric values are selected from lists.

When you press ENT, the selected value is accepted. Confirmation is indicated by the display flashing once. The modified value is saved in the EEPROM immediately.

If you press ESC, the display jumps back to the original value.

Menu structure The HMI is menu-driven. Figure 7.5 shows the highest level of the menu structure.

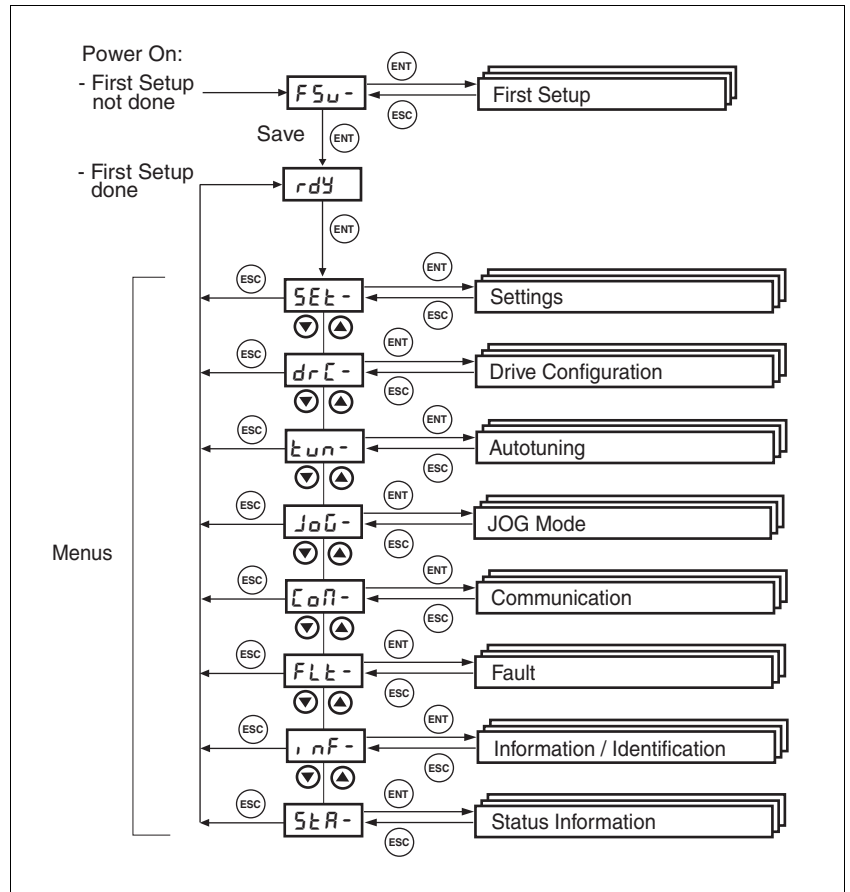

Figure 7.5 HMI menu structure

Status displays such as *rdY* (Ready) can be found from page 7-19.

HMI menu	Description
FSU-	First setup (F irst S et U p),
<i>dEU</i>	Specification of the control mode
<i>oP</i>	Signal selection position interface ("fieldbus" control mode only)
<i>o-n</i>	Start-up operating mode for "local control mode"
<i>CoRd</i>	CANopen address = node number ("fieldbus" control mode only)
<i>CoBd</i>	CANopen baud rate ("fieldbus" control mode only)
<i>MoRd</i>	Modbus address ("fieldbus" control mode only)
<i>MoBd</i>	Modbus baud rate ("fieldbus" control mode only)
<i>oL</i>	Logic type of the digital inputs/outputs
SET-	device settings (S ETtings)
<i>R ioF</i>	Offset at analogue input ANA1
<i>R i 5</i>	Scaling ANA1 for setpoint current at +10V
<i>R iln</i>	Zero-voltage window on analogue input ANA1
<i>R in5</i>	Scaling ANA1 for reference speed at +10V
<i>o-P</i>	Monitoring of position deviation

019844113232, V1.20, 06.2007

HMI menu		Description
	<i>i n-n</i>	Monitoring of speed of rotation deviation
	<i>GFRC</i>	Selection of special gear ratios
	<i>nEhr</i>	Monitoring of speed of rotation value
	<i>i Ehr</i>	Monitoring of current value
	<i>W nE</i>	Monitoring of time window
	<i>i nRH</i>	Current limiting
	<i>nLi n</i>	Speed limitation via input
	<i>n nRH</i>	Speed limiter
	<i>Li 95</i>	Current limiting for "Quick Stop"
	<i>Li hR</i>	Current limiting for "Halt"
DRC-	<i>drC-</i>	device configuration (DR ive C onfiguration)
	<i>R2no</i>	Selection of limit by ANA2
	<i>R2, n</i>	Scaling for current limiting by ANA2 at +10V
	<i>R2n n</i>	Scaling for speed limiting by ANA2 at +10V
	<i>i oL E</i>	Logic type of the digital inputs/outputs
	<i>i o- n</i>	Start-up operating mode for "local control mode"
	<i>i oP, i</i>	Signal selection position interface
	<i>i oG n</i>	Processing mode electr. gearing for local control mode
	<i>i oRE</i>	Auto. enable at PowerOn if ENABLE input active
	<i>E55C</i>	Encoder simulation - setting the resolution
	<i>Pr oE</i>	Definition of the direction of rotation
	<i>F C5</i>	Restore factory settings (default values)
	<i>bE C L</i>	Time delay when closing the brake
	<i>bE r E</i>	Time delay when opening/release of brake
	<i>Su P U</i>	HMI display if motor rotating
I-O-	<i>i - o-</i>	Configurable inputs/outputs(In O ut)
	<i>Li 1</i>	Function digital input LI1
	<i>Li 2</i>	Function digital input LI2
	<i>Li 4</i>	Function digital input LI4
	<i>Li 7</i>	Function digital input LI7
	<i>Lo 1</i>	Function digital output LO_OUT1
	<i>Lo 2</i>	Function digital output LO_OUT2
	<i>Lo 3</i>	Function digital output LO_OUT3
TUN-	<i>tun-</i>	Autotuning (Auto TUN ing)
	<i>St r t</i>	Start Autotuning
	<i>GR, n</i>	Adapting controller parameters (tighter/looser)
	<i>di 5E</i>	Movement range autotuning
	<i>di r</i>	Direction of rotation autotuning
	<i>nE C h</i>	System coupling type
	<i>nr EF</i>	Speed when autotuning

HMI menu		Description
	<i>LRt</i>	Waiting time between autotuning steps
	<i>rES</i>	Reset controller parameter
JOG-	<i>JOG-</i>	Jog(JOG Mode)
	<i>Start</i>	Start jog
	<i>nSLu</i>	Speed for slow jog
	<i>nFSu</i>	Speed for fast jog
COM-	<i>CoPi-</i>	Communication(COMmunication)
	<i>CoPd</i>	CANopen address (node number)
	<i>CoBd</i>	CANopen baud rate
	<i>PiBAd</i>	Modbus address (fieldbus"control mode" and commissioning software)
	<i>PiBBd</i>	Modbus baud rate (control mode"fieldbus" and commissioning software)
	<i>PiBFo</i>	Modbus data format (control mode"fieldbus" and commissioning software)
	<i>PiBLo</i>	Modbus word sequence for double words (32 bit values) (control mode"fieldbus" and commissioning software)
FLT-	<i>FLt-</i>	Error display(FauLT)
	<i>StPF</i>	Fault number of the last interruption cause
INF-	<i>i nF-</i>	Information/identification (INFormation / Identification)
	<i>dEUc</i>	Current selection of control mode
	<i>-nRn</i>	product name
	<i>-Pnr</i>	Firmware program number
	<i>-PUr</i>	Firmware version
	<i>Polu</i>	Number of turn-on processes
	<i>Pi no</i>	Nominal current of power amplifier
	<i>Pi nR</i>	Maximum current of power amplifier
	<i>ni no</i>	Motor nominal current
	<i>ni nR</i>	Motor maximum current
STA-	<i>StR-</i>	Observation/monitoring of device, motor and travel data (STatus Information)
	<i>i oRc</i>	Status of digital inputs and outputs
	<i>R iRc</i>	Voltage value analogue input ANA1
	<i>R 2Rc</i>	Voltage value analogue input ANA2
	<i>nRct</i>	Actual speed of the motor
	<i>PRcu</i>	Actual position of the motor in user-defined units
	<i>Pd, F</i>	Current control deviation of the position controller
	<i>i Rct</i>	Total motor current (vector sum of d and q components)
	<i>i qrF</i>	Set motor current q component (torque-creating)
	<i>udcR</i>	DC bus voltage of the power amplifier supply voltage
	<i>t dEU</i>	device temperature
	<i>t PR</i>	Temperature of the power amplifier
	<i>Ln nS</i>	Stored warnings bit-coded
	<i>Si cS</i>	Stored state of the monitoring signals
	<i>oPh</i>	Operating hours counter

HMI menu	Description
, 2Er	Load factor braking resistor
, 2EP	Loading factor power amplifier
, 2E7	Loading factor motor

Status display The status display in its default setting shows the current operating status, see page 8-4. You can specify the following with the menu item *dr c - / 5uPU*:

- 5ER shows the current operating status by default
- nRc shows the current motor speed by default
- , Rc shows the current motor current by default

A change is only imported with the power amplifier disabled.

7.3.3 Commissioning software (PowerSuite)

Features The commissioning software simplifies commissioning, parameterisation, simulation and diagnostics.

It provides extensive options such as:

- Setting the controller parameters in a graphic interface
- Extensive diagnostic tools for optimisation and maintenance
- Long-term recording as an aid to assessing operating behaviour
- Testing input and output signals
- Tracking signal sequences on the monitor
- Interactive optimisation of controller behaviour
- Archiving all device settings and recordings with export functions for data processing

System requirements You will need a PC or laptop with a free serial port and an operating system with Windows 2000 or Windows XP Professional.

To connect the PC to the device see page 6-49.

Online help The commissioning software offers comprehensive help functions, which can be accessed via "? - Help Topics" or by pressing F1.

7.4 Commissioning procedure

⚠ WARNING

Unsuitable parameter values

If unsuitable parameter values are used, safety functions may fail, unexpected movements or responses to signals may occur.

- Prepare a list with the parameters required for the functions in use.
- Check the parameters before operation.
- Only start the system if there are no persons or materials in the danger zone and the system can be operated safely.

Failure to follow these instructions can result in death, serious injury or equipment damage.

7.4.1 "First Setup"

"First Setup" must be made when the controller supply voltage is switched on for the first time or when the factory settings have been loaded.

Preparation

- A PC with the commissioning software must be connected to the unit unless the commissioning is conducted exclusively through the HMI.
- ▶ During commissioning disconnect the connection to the fieldbus to avoid conflicts caused by simultaneous access.
- ▶ Switch on the controller power supply.

Automatic read-in of the motor data set

When the unit is switched on for the first time with the motor connected, the unit reads the motor data set automatically from the Hiperface sensor (motor sensor). The data set is checked for completeness and saved in the EEPROM.

The motor data set contains technical information about the motor such as the nominal and peak torque, the nominal current and speed and the pole-pair number. It cannot be modified by the user. The unit cannot be switched ready for operation without this information

"First Setup" via HMI The following diagram shows the sequence using HMI.

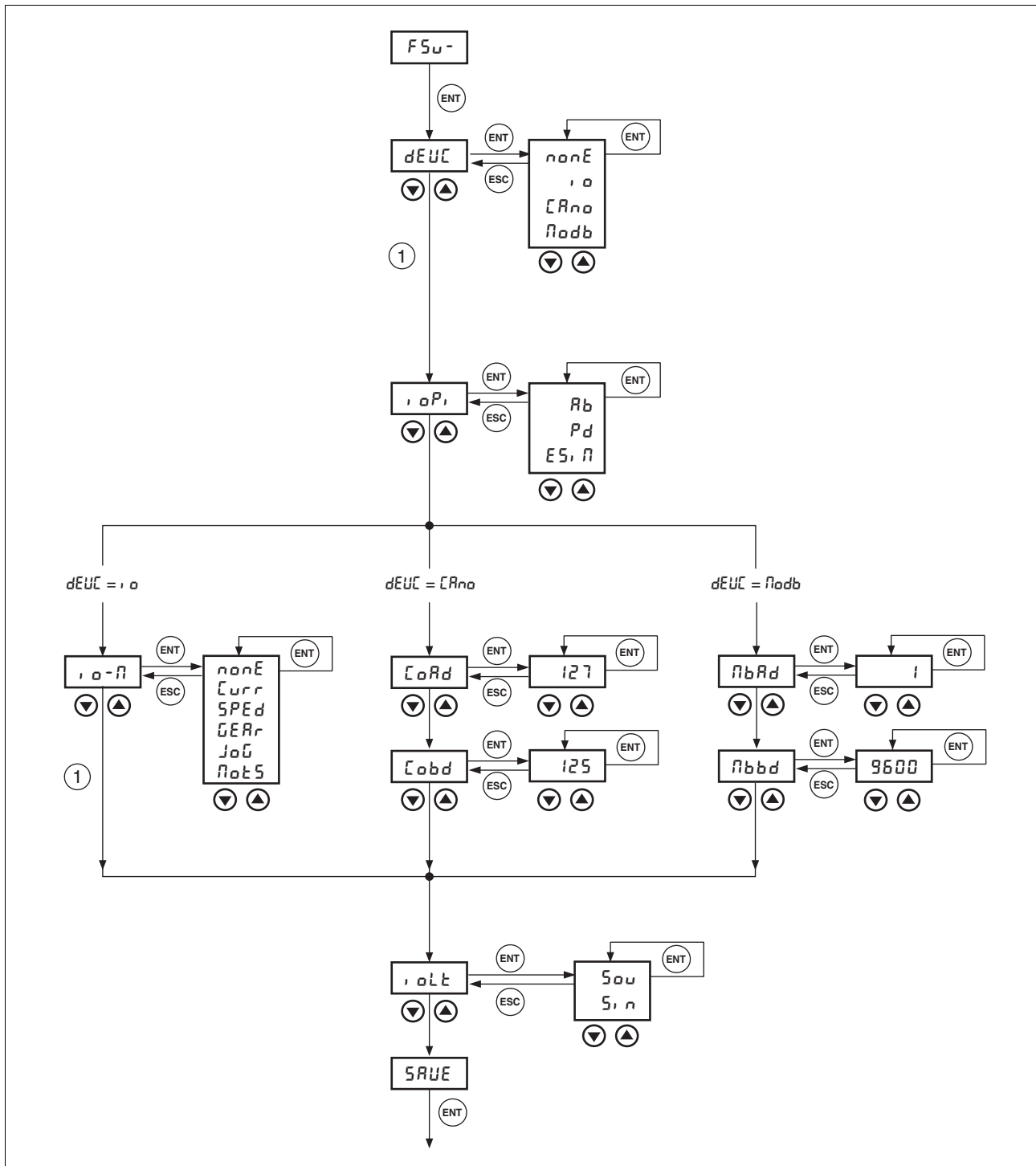

Figure 7.6 "First Setup" via HMI

Unit controller ► Specify how the unit will be controlled with the parameter DEVcmdinterf (dEUE).

Parameter Name HMI menu	Description	Unit Minimum value Default value Maximum value	Data type R/W persistent Expert	Parameter address via fieldbus
DEVcmdinterf	Specification of the control mode7-13	-	UINT16	CANopen 3005:1 _h
-- DEVC	0 / none / none : undefined	0	UINT16	Modbus 1282
-- dEUE	1 / IODevice / i o : local control mode 2 / CANopenDevice / ERno : CANopen 3 / ModbusDevice / Modb : Modbus	0 3	R/W per. -	
IMPORTANT: A change of the setting is not activated until the unit is switched on again (exception: Change of the value 0, at "First setup").				

Function of the RS422 interface ► Set the assignment for the RS422 interface with the IOposInterfac (i oP) parameter.

Parameter Name HMI menu	Description	Unit Minimum value Default value Maximum value	Data type R/W persistent Expert	Parameter address via fieldbus
IOposInterfac	Signal selection at position interface7-13	-	UINT16	CANopen 3005:2 _h
DRC- - ioPi	0 / AInput / Ab : input ENC_A, ENC_B, ENC_I (index pulse) 4x evaluation	0	UINT16	Modbus 1284
drC - - i oP	1 / PInput / Pd : input PULSE, DIR, ENABLE2 2 / ESIMoutput / ES, n : output ESIM_A, ESIM_B, ESIM_I	0 2	R/W per. -	
RS422 IO interface (Pos)				
IMPORTANT: A change of the setting is not activated until the unit is switched on again				

- Start-up operating mode*
- DEVcmdinterf= IODevice (dEUI = i o)
 - ▶ Set the parameter IOdefaultMode (i o-ñ) to set the operating mode that is to enable the device every time it is started.

The operating modes are described from section 8-12.

Parameter Name HMI menu	Description	Unit Minimum value Default value Maximum value	Data type R/W persistent Expert	Parameter address via fieldbus
IOdefaultMode DRC- - io-M drc- - i o-ñ	Start-up of operating mode for 'local control mode' 7-13 0 / none / none : none 1 / CurrentControl / Curr : current control (reference value of ANA1) 2 / SpeedControl / SpEd : speed control (reference value of ANA1) 3 / ElectronicGear / GERr : electronic gear 5 / Jog / JoG : manual movement 6 / MotionSequence / MotS : Motion Sequence IMPORTANT: The operating mode is automatically enabled when the drive switches to the 'OperationEnable' status and "IODevice / IO" is set in DEVcmdinterf.	- 0 0 6	UINT16 UINT16 R/W per. -	CANopen 3005:3 _h Modbus 1286

- Fieldbus CANopen*
- DEVcmdinterf = CANopenDevice (dEUI = CRno)
 - ▶ Specify the node address with the parameter CANadr (CRAd) and the baud rate with the parameter CANbaud (CRabd).



Every unit must have its own unique node address, which must be assigned only once in the network.

Parameter Name HMI menu	Description	Unit Minimum value Default value Maximum value	Data type R/W persistent Expert	Parameter address via fieldbus
CANadr COM- - CoAD CRAd- - CRAd	CANopen address (node number) 7-13 valid addresses (node numbers): 1 ... 127 IMPORTANT: A change of the setting is not activated until the unit is switched on again or after an NMT reset command	- 1 127 127	UINT16 UINT16 R/W per. -	CANopen 3017:2 _h Modbus 5892
CANbaud COM- - CoBD CRAd- - CRabd	CANopen baud rate 7-13 valid baud rates in kbaud: 50 125 250 500 1000 IMPORTANT: A change of the setting is not activated until the unit is switched on again	- 50 125 1000	UINT16 UINT16 R/W per. -	CANopen 3017:3 _h Modbus 5894

Fieldbus Modbus ■ DEVcmdinerf = ModbusDevice
(dEUE = Modb)

- Specify the node address with the parameter MBadr (nbRd) and the baud rate with the parameter MBbaud (nbbd).

Parameter Name HMI menu	Description	Unit Minimum value Default value Maximum value	Data type R/W persistent Expert	Parameter address via fieldbus
MBadr	Modbus address7-13	-	UINT16	CANopen 3016:4 _h
COM- - MBAD EoE - nbRd	valid addresses: 1 ... 247	1 1 247	UINT16 R/W per. -	Modbus 5640
MBbaud	Modbus baud rate7-13	-	UINT16	CANopen 3016:3 _h
COM- - MBBD EoE - nbbd	Allowed baud rates: 9600 19200 38400	9600 19200 38400	UINT16 R/W per. -	Modbus 5638
IMPORTANT: A change of the setting is not activated until the unit is switched on again				

Select logic type ► Specify the logic type with the parameter IOLogicType (ioLE).
For more information see chapter 5-1.

Parameter Name HMI menu	Description	Unit Minimum value Default value Maximum value	Data type R/W persistent Expert	Parameter address via fieldbus
IOLogicType	Logic type of the digital inputs/outputs7-13	-	UINT16	CANopen 3005:4 _h
DRC- - ioLT drc - - ioLE	0 / source / Sou : for power-delivering outputs 1 / sink / Sin : for power-drawing outputs	0 0 1	UINT16 R/W per. -	Modbus 1288
IMPORTANT: A change of the setting is not activated until the device is switched on again.				

*Data back-up***▲ CAUTION****Damage to the product from failure of the supply voltage**

If the supply voltage fails during an update, the product will be damaged and must be sent in for repair.

- Never switch off supply voltage during the update.
- Always carry out the update with a reliable supply voltage.

Failure to follow these instructions can result in injury or equipment damage.

- ▶ Back up all inputs on completion.
HMI: Save your settings with *SRUE*
Commissioning software: Save your settings with the menu path "Configuration - Save in EEPROM"

- ◁ The device saves all set values in the EEPROM and displays the status *ready*, *rdy* or *dis* on the HMI.

A restart of the device is required to allow the changes to be accepted.

Further steps

- ▶ Stick a label on the unit with all important information required in case of service, e.g. fieldbus type, address and baud rate.
- ▶ Make the settings described below for commissioning.

Note that you can only return to the "Initial Setup" by restoring the factory settings, see 8.6.11.2 "Restore factory settings" page 8-99.

7.4.2 Operating status (status diagram)

After switching on and at the start of an operating mode, a sequence of operating states is progressed through.

The relationship between the operating states and the state transitions is shown in the state diagram (state machine).

The operating states are internally monitored and influenced by monitoring and system functions, such as temperature and current monitoring

Graphic representation The status diagram is shown graphically as a flow chart.

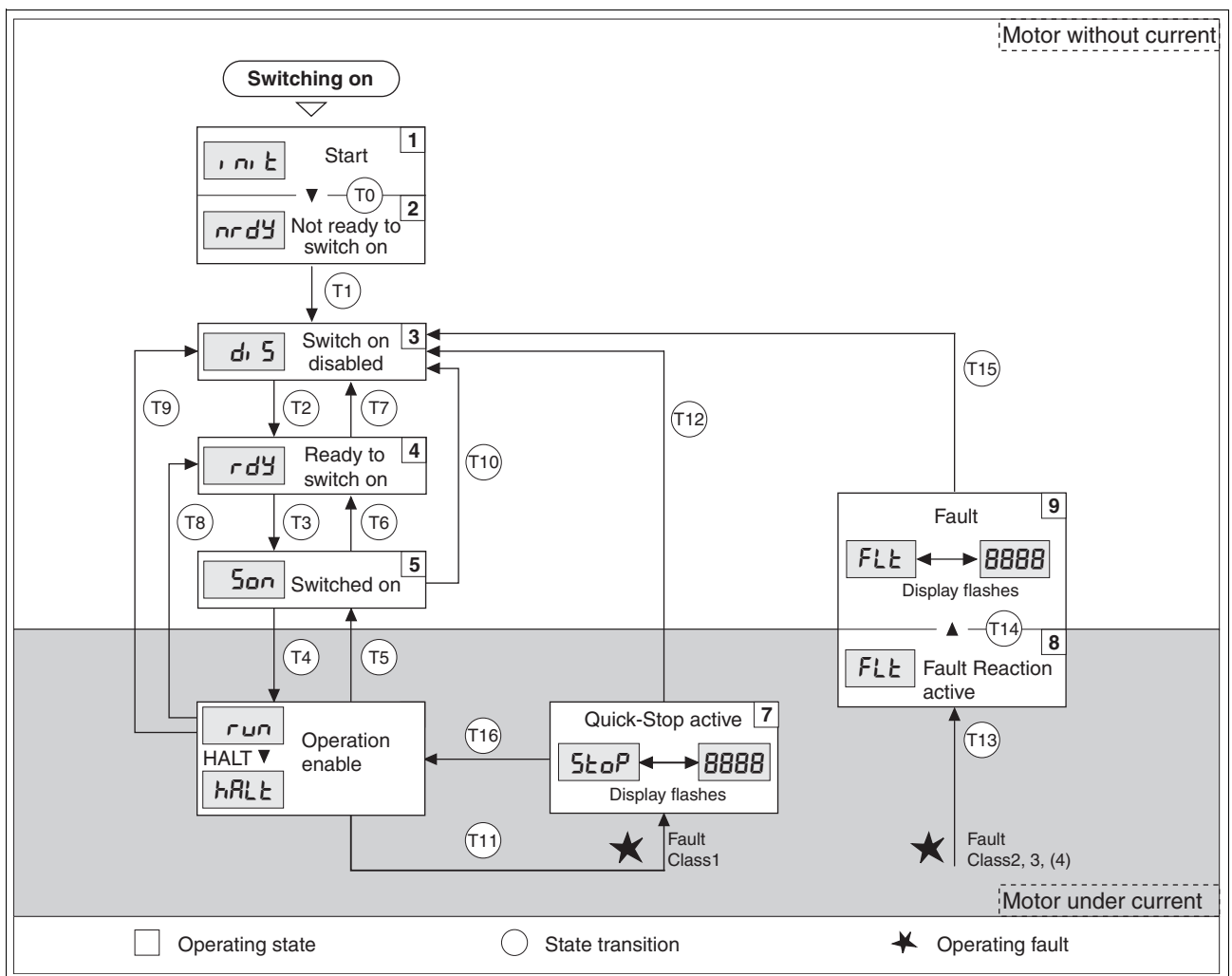

Figure 7.7 Status diagram

Operating statuses and mode transitions

For detailed information on operating statuses and mode transitions see page 8-4.

019844113232, V1.20, 06.2007

7.4.3 Setting basic parameters and limit values

<p>⚠ WARNING</p>
<p>Unexpected behaviour</p> <p>The behaviour of the drive system is governed by numerous stored data or settings. Unsuitable settings or data may trigger unexpected movements or reactions to signals and disable monitoring functions.</p> <ul style="list-style-type: none"> • Do not operate a drive system with unknown settings or data. • Check the stored data or settings. • When commissioning carefully run tests for all operating statuses and fault cases. • Check the functions after replacing the product and also after making changes to the settings or data. • Only start the system if there are no persons or materials in the danger zone and the system can be operated safely. <p>Failure to follow these instructions can result in death, serious injury or equipment damage.</p>



Prepare a list with the parameters required for the functions in use.

Setting thresholds

Suitable thresholds must be calculated from the system configuration and motor characteristics. So long as the motor is operated without external loads you will not need to change the default settings.

The maximum motor current must for example be reduced as a determining factor of the torque if the permissible torque of a system component will otherwise be exceeded.

Current limiting

To protect the drive system, the maximum current flowing can be modified with the CTRL_I_max parameter. The maximum current for the "Quick Stop" function can be limited with the LIM_I_maxQSTP parameter and for the "Halt" function with the LIM_I_maxHalt parameter.

In operating modes with profile generator, acceleration and delay are limited through ramp functions.

- ▶ Specify the maximum motor current with the CTRL_I_max parameter.
- ▶ Specify the maximum current for the "Quick Stop" function with the LIM_I_maxQSTP parameter.
- ▶ Specify the maximum current for the "Halt" function with the LIM_I_maxHalt.

Parameter Name HMI menu	Description	Unit Minimum value Default value Maximum value	Data type R/W persistent Expert	Parameter address via fieldbus
CTRL_I_max	Current limiting7-20	A _{pk} 0.00	UINT16 UINT16	CANopen 3012:1 _h Modbus 4610
SET- - iMAX SET - - , nRH	Value must not exceed max. permissible current of motor or power amplifier. Default is the smallest value of M_I_max and PA_I_max	- 299.99	R/W per. -	
LIM_I_maxQSTP	Current limiting for Quick Stop8-75	A _{pk} -	UINT16 UINT16	CANopen 3011:5 _h Modbus 4362
SET- - LiQS SET - - L, 95	max. Current during braking via torque ramp resulting from an error of error class 1 or 2 and when a software stop is triggered Maximum and default value setting depend on motor and power amplifier (setting M_I_max and PA_I_max) in 0.01A _{pk} steps	- -	R/W per. -	
LIM_I_maxHalt	Current limiting for Halt8-76	A _{pk} -	UINT16 UINT16	CANopen 3011:6 _h Modbus 4364
SET- - LihA SET - - L, hR	max. Current during braking after Halt or termination of an operating mode. Maximum and default value setting depend on motor and power amplifier (setting M_I_max and PA_I_max) in 0.01A _{pk} steps	- -	R/W per. -	

Speed limitation The maximum speed can be limited with the parameter CTRL_n_max to protect the drive system.

- Specify the maximum motor speed with the parameter CTRL_n_max.

Parameter Name HMI menu	Description	Unit Minimum value Default value Maximum value	Data type R/W persistent Expert	Parameter address via fieldbus
CTRL_n_max	Speed limiter7-20	1/min 0	UINT16 UINT16	CANopen 3012:2 _h Modbus 4612
SET- - NMAX SET - - nRH	Setting value must not exceed max. speed of rotation of motor Default is max. speed of the motor (see M_n_max)	- 13200	R/W per. -	

7.4.4 Analogue inputs

Analog inputs The analogue inputs allow analogue input voltages between -10V and +10V to be read in. The current voltage value on ANA1+ can be read using the parameter ANA1_act

- Power amplifier power is switched off. Controller power supply is switched on.
- ▶ At the analogue input ANA1 or ANA2 apply a voltage in the range of ±10V_{DC}.
- ▶ Check the applied voltage with the parameter ANA1_act or ANA2_act.

Parameter Name HMI menu	Description	Unit Minimum value Default value Maximum value	Data type R/W persistent Expert	Parameter address via fieldbus
ANA1_act STA- - A1AC 5LR- - R1RC	Voltage value analogue input ANA1	mV -10000 - 10000	INT16 INT16 R/- -	CANopen 3009:1 _h Modbus 2306
ANA2_act STA- - A2AC 5LR- - R2RC	Voltage value analogue input ANA2	mV -10000 - 10000	INT16 INT16 R/- -	CANopen 3009:5 _h Modbus 2314

Reference value An input voltage at ANA1 can be used as a reference value for the operating mode current control or speed control. The reference value for a voltage of +10V can be set over the parameter ANA1_I_scale or ANA1_n_scale.

Parameter Name HMI menu	Description	Unit Minimum value Default value Maximum value	Data type R/W persistent Expert	Parameter address via fieldbus
ANA1_I_scale SET- - A1IS 5E4- - R1i5	Setpoint current in current control operating mode at 10V on ANA17-22 An inversion of the evaluation of the analogue signal can be run with a neg. advance sign	A _{pk} -300.00 3.00 300.00	INT16 INT16 R/W per. -	CANopen 3020:3 _h Modbus 8198
ANA1_n_scale SET- - A1NS 5E4- - R1n5	Setpoint speed in speed control operating mode at 10V on ANA1 The internal maximum speed is limited to the current setting in CTRL_n_max A negative advance sign can be used to effect an inversion of the evaluation of the analogue signal	1/min -30000 3000 30000	INT16 INT16 R/W per. -	CANopen 3021:3 _h Modbus 8454

Offset and the zero voltage window An offset can be parameterized for the input voltage at ANA1 over the parameter ANA1_offset and a zero voltage window can be parameterized over the parameter ANA1_win.

This corrected input voltage gives the voltage for the operating modes current control and speed control as well as the reading value for parameters ANA1_act.

Parameter Name HMI menu	Description	Unit Minimum value Default value Maximum value	Data type R/W persistent Expert	Parameter address via fieldbus
ANA1_offset SET- - A1oF 5Et - - R loF	Offset at analogue input ANA1 The ANA1 analogue input is corrected/relocated by the offset. A defined zero-voltage window acts in the range of the zero crossing of the corrected ANA1 analogue input.	mV -5000 0 5000	INT16 INT16 R/W per. -	CANopen 3009:B _h Modbus 2326
ANA1_win SET- - A1WN 5Et - - R iln	Zero-voltage window on analogue input ANA1 Value up to which an input voltage is interpreted as 0V Example: Setting 20mV ->range from -20 .. +20mV is interpreted as 0mV	mV 0 0 1000	UINT16 UINT16 R/W per. -	CANopen 3009:9 _h Modbus 2322
ANA1_Tau - -	Analogue1: filter time constant Low-pass filter first order (PT1) filter time constant. Filter affects analogue input ANA1. (sampling time PT1 filter: 250µsec)	ms 0.00 0.00 327.67	UINT16 UINT16 R/W per. -	CANopen 3009:2 _h Modbus 2308

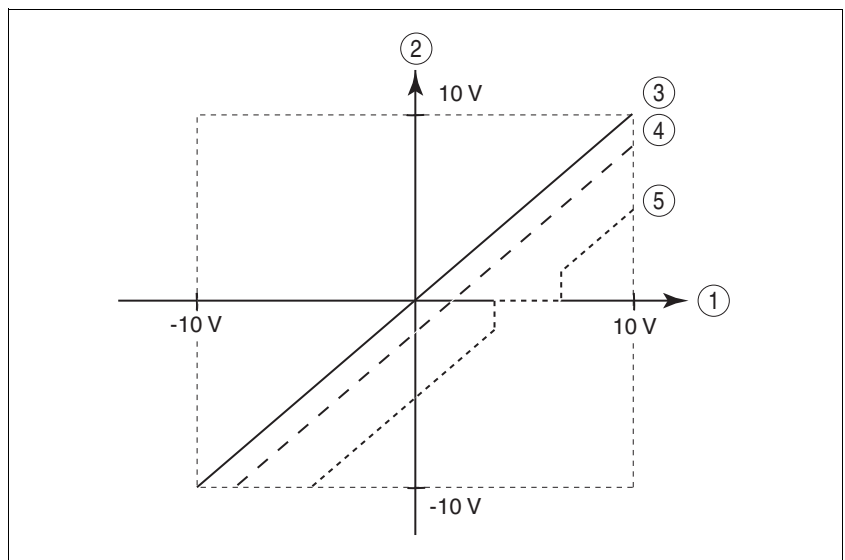

Figure 7.8 Offset and zero-voltage window

- (1) Input voltage at ANA1
- (2) Voltage value for current control and speed control operating modes and the read value of the parameter ANA1_act
- (3) Input voltage without processing
- (4) Input voltage with offset
- (5) Input voltage with offset and zero-voltage window

Limitations A current limitation or speed limitation can be activated over the analogue input ANA2.

- ▶ Specify the limit type with the parameter ANA2LimMode.
- ▶ Specify the scaling of the limit at +10V with the parameter ANA2_I_max or ANA2_n_max.

Parameter Name HMI menu	Description	Unit Minimum value Default value Maximum value	Data type R/W persistent Expert	Parameter address via fieldbus
ANA2LimMode DRC- - A2Mo drc - - R2na	Selection of limit by ANA2 0 / none / none : no limitation 1 / Current Limitation / Curr : limitation of current reference value at current controller 2 / Speed Limitation / SPed : limitation of speed reference value at speed controller (limiting value at 10V in ANA2_n_max)	- 0 0 2	UINT16 UINT16 R/W per. -	CANopen 3012:B _h Modbus 4630
ANA2_I_max DRC- - A2iM drc - - R2ni	Current limiting at 10 V input voltage on ANA2 The maximum limiting value is the lesser value of I _{maxM} and I _{maxPA}	A _{pk} 0.00 3.00 300.00	UINT16 UINT16 R/W per. -	CANopen 3012:C _h Modbus 4632
ANA2_n_max DRC- - A2NM drc - - R2ni	Speed limiting at 10 V input voltage on ANA2 The minimum limiting speed is set to 100 1/min, i.e. analogue values that implement a lower speed of rotation have no effect. The max. speed of rotation is also limited by the setting value in CTRL_n_max.	1/min 500 3000 30000	UINT16 UINT16 R/W per. -	CANopen 3012:D _h Modbus 4634

7.4.5 Digital inputs/outputs

The switching states of the digital inputs and outputs can be displayed on the HMI and displayed and modified using the commissioning software or the fieldbus.

HMI The signal states can be displayed with the HMI, but they cannot be modified.

- ▶ Call up the menu point *5tR / 1 oRc*.
- ◁ You will see the digital inputs (Bit 0-7) bit-coded.
- ▶ Press the "up arrow".
- ◁ You will see the digital inputs (Bit 8, 9) bit-coded.

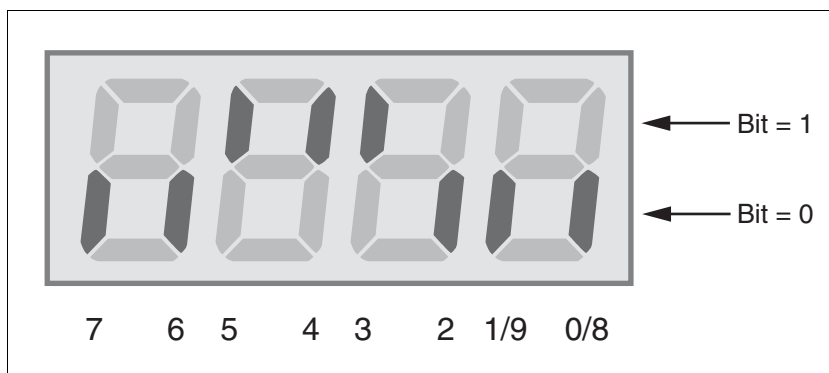

Figure 7.9 HMI, status display of the digital inputs/outputs

Bit	Local control mode	fieldbus control mode	I/O
0	LI1	$\overline{\text{REF}}/\text{LI1}$	I
1	FAULT_RES/LI2	$\overline{\text{LIMN}}/\text{LI2}$	I
2	ENABLE	$\overline{\text{LIMP}}$	I
3	$\overline{\text{HALT}}/\text{LI4}$	$\overline{\text{HALT}}/\text{LI4}$	I
4	$\overline{\text{PWRR_B}}$	$\overline{\text{PWRR_B}}$	I
5	PWRR_A	PWRR_A	I
6	ENABLE2 ¹⁾ / LI7	LI7	I
7	-	-	I
8	NO_FAULT_OUT/LO1_OUT	NO_FAULT/LO1_OUT	O
9	BRAKE_OUT/LO2_OUT	BRAKE_OUT/LO2_OUT	O
10	ACTIVE2_OUT/LO3_OUT	ACTIVE2_OUT/LO3_OUT	O

1) Only with IOposInterfac = PDinput

Fieldbus The current switching states are displayed bit-coded in the parameter `_IO_act`. The values 1 and 0 indicate whether an input or output is active.

Parameter Name HMI menu	Description	Unit Minimum value Default value Maximum value	Data type R/W persistent Expert	Parameter address via fieldbus
<code>_IO_act</code>	Physical status of the digital inputs and outputs7-25	-	UINT16	CANopen 3008:1 _h
STA- - ioAC	Assignment of 24V inputs: (Local control mode)	0	UINT16	Modbus 2050
5tR- - , oRt	Bit 0: - Bit 1: FAULT_RESET Bit 2: ENABLE Bit 3: HALT Bit 4: PWRR_B Bit 5: PWRR_A Bit 6: ENABLE2 Bit 7: reserved Bit 6 forms the ENABLE only under the following conditions: DEVcmdinterf = IODevice and IOposInterfac = Pdinput (fieldbus control mode) Bit 0: REF Bit 1: LIMN,CAP2 Bit 2: LIMP,CAP1 Bit 3: HALT Bit 4: PWRR_B Bit 5: PWRR_A Bit 6: - Bit 7: reserved assignment 24V outputs: Bit 8: NO_FAULT_OUT Bit 9: BRAKE_OUT Bit10: ACTIVE2_OUT	-	R/- -	

7.4.6 Setting configurable digital inputs/outputs

The device has configurable inputs (LI1...) and configurable outputs (LO1_OUT...). The standard assignment and the configurable assignment depends on the specified start-up operating mode. For more information see chapter 8.6.9 "Configurable inputs and outputs".

7.4.7 Testing limit switches signals in fieldbus devices

▲ CAUTION

Loss of control

The use of $\overline{\text{LIMP}}$ and $\overline{\text{LIMN}}$ can offer some protection against dangers (e.g. impact on mechanical stop caused by incorrect movement targets).

- Use $\overline{\text{LIMP}}$ and $\overline{\text{LIMN}}$ where possible.
- Check that the external sensors or switches are correctly connected.
- Check the correct functional installation of the limit switch. The limit switches must be mounted in a position far enough away from the mechanical stop to allow an adequate braking distance.
- The functions must be enabled to use $\overline{\text{LIMP}}$ and $\overline{\text{LIMN}}$.
- This function cannot provide protection against faulty functioning of the product or the sensors.

Failure to follow these instructions can result in injury or equipment damage.

- ▶ Set up the limit switches so the drive cannot traverse through the limit switch.
- ▶ Trigger the limit switches manually.
- ◁ The HMI shows an error message, see Diagnostics from page 10-3

The release of the input signals $\overline{\text{LIMP}}$, $\overline{\text{LIMN}}$ and $\overline{\text{REF}}$ and the evaluation at active 0 or active 1 can be changed with the parameters of the same name, see page 8-57.



Use the active 0 monitoring signals if possible, because they are proof against wire breakage.

7.4.8 Testing safety functions

Operation with "Power Removal" If you wish to use the "Power Removal" safety function, carry out the following steps:

- Power amplifier supply voltage is switched off.
Controller supply voltage is switched off.
- ▶ Check that the inputs $\overline{\text{PWRR_A}}$ and $\overline{\text{PWRR_B}}$ are isolated from each other. The two signals must not be connected.
- Power amplifier supply voltage is switched on.
Controller supply voltage is switched on.
- ▶ Start the jog operating mode (without motor movement).
(see page 8-15)
- ▶ Trigger the safety disconnection. $\overline{\text{PWRR_A}}$ and $\overline{\text{PWRR_B}}$ must be disconnected simultaneously.
- ◁ The power amplifier is switched off and error message 1300 is displayed. (CAUTION: error message 1301 displays a wiring error.)
- ▶ Check that the parameter `IO_AutoEnable`(HMI: `dr c - / , oRE`) is set to "off" for protection against unexpected restart.
- ▶ Check the behaviour of the drive in error states.
- ▶ Record all tests of the safety function in the acceptance record.

Operation without "Power Removal" If you do not wish to use the "Power Removal" safety function:

- ▶ Check that the inputs $\overline{\text{PWRR_A}}$ and $\overline{\text{PWRR_B}}$ are connected to +24VDC.

7.4.9 Checking holding brake

⚠ WARNING

Unexpected movement

For example, if the brake is released with vertical axes an unexpected movement may be triggered in the system.

- Make sure that no damage will be caused by the load dropping.
- Run the test only if there are no persons or materials in the danger zone of the moving system components.

Failure to follow these instructions can result in death, serious injury or equipment damage.

Testing from HBC to holding brake

- Supply voltage at HBC on, LED "24V on" on.
- ▶ Switch the power amplifier supply voltage off to prevent the motor from starting accidentally.
- ◁ The drive switches to operating status "Switch on disabled"
- ▶ Press the "Release brake" button on the HBC several times to release and close the holding brake alternately.
- ◁ The LED "Brake released" on the HBC flashes if there is voltage present at the holding brake output and the brake is released by the button.
- ▶ Test that the axis can be moved manually with the brake released. (note gearbox if applicable).

Testing from device to HBC

- The device is in operating status "Ready to switch on" and the parameters for the holding brake must be set, see chapter 8.6.8 "Braking function with HBC" page 8-81.
- ▶ Start jog operating mode (HMI: *JOG- / Start*)
- ◁ The HMI displays *JOG*. The brake is released. The LED "Brake released" on the HBC is lit up if there is brake voltage present and the brake is released.

For more information on the HBC see page 3-11, 6-31 and 12-1.

7.4.10 Check direction of rotation

Direction of rotation Rotation of the motor shaft in a positive or negative direction of rotation. A positive direction of rotation is defined as the motor shaft rotating clockwise as the observer faces the end of the protruding shaft.



The initial setting of the controller parameters may result in an unstable closed-loop control at inertia ratios of "J ext" to "J Motor" >10.

- ▶ Start jog operating mode (HMI: `JOG- / STRT`)
- ◁ The HMI displays `JG`.
- ▶ Start a movement in clockwise rotation (HMI: "up arrow")
- ◁ The motor rotates in clockwise rotation. The HMI shows `JG-`
- ▶ Start a movement in the counter-clockwise rotation (HMI: "down arrow")
- ◁ The motor rotates in counter-clockwise rotation. The HMI shows `-JG`

▲ WARNING

Unexpected movement if motor phases are reversed

Reversal of the motor phases can cause unexpected movements at high acceleration.

- Use the parameter `POSdirOfRotat` to reverse the direction of rotation, if required.
- Do not reverse the motor phases.

Failure to follow these instructions can result in death, serious injury or equipment damage.

- ▶ If the arrow and direction of rotation do not match, correct this with the parameter `POSdirOfRotat`, see 8.6.10 "Reversal of direction of rotation" page 8-96.

7.4.11 Checking the signals of position switches

Availability The functions "Enable positive motor move" and "Enable negative motor move" are available only in local control mode.

The function is available from software version 1.201.

Description The functions "Enable positive motor move" and "Enable negative motor move" need position switches (normally closed contacts), see chapter 8.6.9 "Configurable inputs and outputs".



Loss of control

The position switches can only trigger a stop if used correctly.

- Observe that this function is available only for "Enable positive motor move" and "Enable negative motor move".
- Observe that this function must be activated through the corresponding parameter.
- Check the mounting and the correct functioning (direction-dependent).
- Only start the system if there are no persons or materials in the danger zone and the system can be operated safely.

Failure to follow these instructions can result in injury or equipment damage.

Check the function "Enable positive motor move"

Check the function "Enable negative motor move"

- The direction of rotation must be checked and corrected if necessary, see chapter 7.4.10 "Check direction of rotation".
- ▶ Set up the position switches so that the drive cannot unintentionally travel over a position switch.
- ▶ Start jog operating mode (HMI: JOG / $STOP$)
- ◁ The HMI displays JOG .
- ▶ Start a positive movement for checking of the function "Enable positive motor move" (HMI: "up arrow") until the positive position switch is triggered.
- ◁ The motor executes a positive movement, until it reaches the positive position switch. The motor must stop. The positive position switch can only be left only with a movement in the negative direction.
- ▶ Start a negative movement for checking of the function "Enable positive motor move" (HMI: "down arrow") until the negative position switch is triggered.
- ◁ The motor executes a negative movement until it reaches the negative position switch. The motor must stop. The negative position switch can only be left with a movement in the positive direction.

If reference value is present and the motor is on a position switch, the function "Motor move disable" is active.

7.4.12 Setting parameters for encoder simulation

Defining resolution for encoder simulation The resolution for the encoder simulation can be scaled with the parameter `ESIMscale`.

- The functionality is only active if the parameter `IOposInterfac` is set to "ESIM".
- ▶ Set the parameter `ESIMscale` to set the resolution.

Parameter Name HMI menu	Description	Unit Minimum value Default value Maximum value	Data type R/W persistent Expert	Parameter address via fieldbus
ESIMscale	Encoder simulation - setting the resolution	Inc 8	UINT16	CANopen 3005:15 _h Modbus 1322
DRC- - ESSC drE - - E55E	Software version 1.102: The following resolutions are adjustable: 128 256 512 1024 2048 4096 from version 1.103 and hardware revision RS30: the complete value range is available for the resolution. For resolutions that can be divided by 4 the index pulse must be at A=high and B=high. IMPORTANT: A change of the setting is not activated until the device is switched on again. After the write access a wait of at least 1 second is required until the controller is switched off.	4096 65535	UINT16 R/W per. -	

The index pulse can be defined by setting the absolute position encoder, see chapter 7.4.13 "Setting parameters for encoder".

7.4.13 Setting parameters for encoder

Setting an encoder absolute position When starting up the device reads the absolute position of the motor from the encoder. The current absolute position can be displayed by the parameter `_p_absENCusr`.

At motor standstill the new absolute position of the motor can be defined as the current mechanical position with the parameter `ENC_pabsusr`. The value can be transferred with the power amplifier active and inactive. Setting the absolute position also shifts the position of the index pulse of the encoder and the index pulse of the encoder simulation.

In the commissioning software you will find the parameter via the menu "Display - Specific panels".

Parameter Name HMI menu	Description	Unit Minimum value Default value Maximum value	Data type R/W persistent Expert	Parameter address via fieldbus
<code>_p_absENCusr</code> - -	Absolute position based on motor encoder work stroke in user-defined units7-33 Value range is set by encoder type With Singleturn motor encoders the value is set with reference to one motor revolution, with Multiturn motor encoders with reference to the total work stroke of the encoder (e.g. 4096 revs) IMPORTANT: Position is only valid after determination of the motor absolute position. With invalid motor absolute position: <code>_WarnLatched</code> <code>_WarnActive</code> Bit 13=1: absolute position of motor not yet detected	usr - 0 -	UINT32 UINT32 R/- -	CANopen 301E:F _h Modbus 7710
<code>ENC_pabsusr</code> - -	Setting position of the motor encoder directly7-33 Value range depends on the encoder type. SRS: Sincos singleturn: 0..max_pos_usr/rev. - 1 SRM: Sincos multiturn: 0 .. (4096 * max_pos_usr/rev.) -1 max_pos_usr/rev.: maximum user position for one motor revolution, with default position scaling this value is 16384. IMPORTANT: * If the process is to be conducted with direction inversion function, it must be set before setting the motor encoder position * The setting value will only be active when the controller is switched on the next time. After the write access a wait of at least 1 second is required until the controller is switched off. * Changing the value also changes the position of the virtual index pulse and the index pulse displaced at ESIM function.	usr 0 - 2147483647	UINT32 UINT32 R/W -	CANopen 3005:16 _h Modbus 1324



If the device or the motor is replaced, a new alignment will be required.

Singleturn encoder

With the Singleturn encoder the position of the index pulse of the encoder can be moved by setting a new absolute position. At position value 0 the index pulse is defined at the current mechanical motor position.

This also changes the position of the index pulse of the encoder simulation.

Multiturn encoder

With the Multiturn encoder the mechanical work stroke of the motor can be shifted to the continuous range of the sensor by setting a new absolute position.

If the motor is moved counterclockwise from the absolute position 0, the Multiturn encoder receives an underrun of its absolute position. In contrast, the internal actual position counts mathematically forward and sends a negative position value. After switching off and on the internal actual position would no longer show the counterclockwise position value but the absolute position of the encoder.

An overflow or underrun are discontinuous positions in the area of travel. To prevent these jumps the absolute position in the sensor must be set so the mechanical limits are within the continuous range of the encoder.

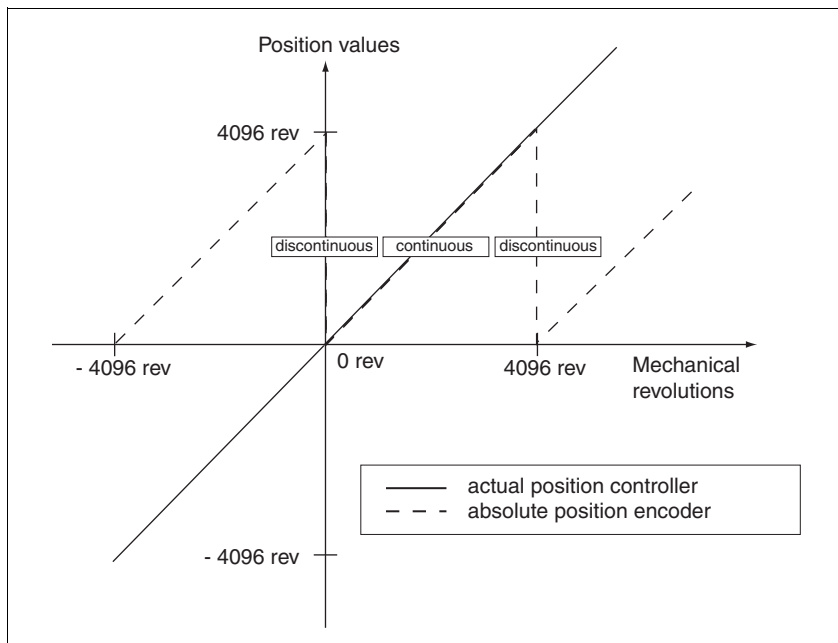

Figure 7.10 Position values of multiturn encoder

- ▶ When setting the absolute position at the mechanical limit set a position value >0. This ensures that when the drive is moved within the mechanical limits of the system the resulting encoder position is always within the continuous range of the encoder.

7.4.14 Setting parameters for braking resistor

⚠ WARNING

Unbraked motor

An insufficient braking resistor causes overvoltage on the DC bus and switches off the power amplifier. The motor is no longer actively braked.

- Make sure that the braking resistor is sufficiently dimensioned.
- Check the setting of the parameter for the braking resistor.
- Check the temperature of the braking resistor by conducting a test run under the most critical conditions.
- During the test make sure that at higher mains voltage there is less reserve in the capacitors on the DC bus.

Failure to follow these instructions can result in death, serious injury or equipment damage.

If an external braking resistor is connected, the parameter `RESint_ext` must be set to "external".

The values of the external braking resistor must be set in the parameters `RESext_P`, `RESext_R` and `RESext_ton`, see chapter 3.5.1 "External braking resistors" page 3-10.

If the actual brake output exceeds the maximum allowable brake output, the device will output an error message and the power amplifier will be switched off.

⚠ WARNING

Hot Surfaces

The braking resistor may heat up to over 250°C depending on the operating mode.

- Prevent contact with the hot braking resistor.
- Do not place flammable or heat-sensitive components in the immediate vicinity of the braking resistor.
- Ensure good heat dissipation.
- Check the temperature of the braking resistor by conducting a test run under the most critical conditions.

Failure to follow these instructions can result in death, serious injury or equipment damage.

- ▶ Test the function of the braking resistor under realistic conditions.

Parameter Name HMI menu	Description	Unit Minimum value Default value Maximum value	Data type R/W persistent Expert	Parameter address via fieldbus
RESint_ext - -	Control of braking resistor7-20 0 / internal: internal braking resistor 1 / external: external braking resistor	- 0 0 1	UINT16 UINT16 R/W per. -	CANopen 3005:9 _h Modbus 1298
RESext_P - -	Nominal power of external braking resistor7-20	W 1 10 32767	UINT16 UINT16 R/W per. -	CANopen 3005:12 _h Modbus 1316
RESext_R - -	Resistance value of external braking resistor7-20	Ω 0.01 100.00 327.67	UINT16 UINT16 R/W per. -	CANopen 3005:13 _h Modbus 1318
RESext_ton - -	max. permissible switch-in time for external braking resistor7-20	ms 1 1 30000	UINT16 UINT16 R/W per. -	CANopen 3005:11 _h Modbus 1314

7.4.15 Run autotuning

Autotuning determines the friction torque, an ever present load torque, and considers it in the calculation of the mass moment of inertia of the total system.

External factors, such as a load on the motor, are taken into account. Autotuning optimises the parameters for the controller settings see chapter 7.5 "Controller optimisation with step response".

Autotuning also supports typical vertical axes.

Autotuning is not suitable for inertia ratios of "J ext" to "J Motor" >10.

⚠ WARNING

Unexpected movement

Autotuning moves the motor to set the drive controller. If incorrect parameters are input unexpected movements may occur or monitoring functions may be disabled.

- Check the parameters `AT_dir` and `AT_dismax`. The travel for the braking ramp in case of error must also be taken into account.
- Check that the parameter `LIM_I_maxQSTP` for Quick Stop is correctly set.
- If possible, use the limit switches `LIMN` and `LIMP`.
- Make sure that a functioning button for EMERGENCY STOP is within reach.
- Make sure that the system is free and ready for the movement before starting the function.

Failure to follow these instructions can result in death, serious injury or equipment damage.

- ▶ Select the setting for the `AT_mechanics` parameter corresponding to your mechanical system. If in doubt, select a softer coupling (less rigid mechanism, see Figure 7.12).
- ▶ Start the Autotuning with the commissioning software via the menu path "Operating Mode - Automatic optimisation". Also note additional settings in the "Display - Specific Displays" menu.

Autotuning can also be started from the HMI (*turn / Start*).

The calculated values are accepted immediately without an additional save.

If the Autotuning is interrupted with an error message, the default values are imported. Change the mechanical position and start the Autotuning again. If you want to check the plausibility of the calculated values, they can be displayed, see also 7.4.16 "Extended settings for autotuning" from page 7-39.

Parameter Name HMI menu	Description	Unit Minimum value Default value Maximum value	Data type R/W persistent Expert	Parameter address via fieldbus
AT_dir TUN- - DiR ευο- - διρ	Direction of rotation autotuning7-37 1 / pos-neg-home / Pnh : first positive direction, then negative direction with return to initial position 2 / neg-pos-home / nPh : first negative direction, then positive direction with return to initial position 3 / pos-home / P-h : only positive direction with return to initial position 4 / pos / P-- : only positive direction without return to initial position 5 / neg-home / n-h : only negative direction with return to initial position 6 / neg / n-- : only negative direction without return to initial position	- 1 1 6	UINT16 UINT16 R/W - -	CANopen 302F:4 _h Modbus 12040
AT_dis TUN- - DiSt ευο- - διSt	Movement range autotuning7-37 Range in which the automatic optimisation processes of the controller parameters are run. The range is input relative to the current position. IMPORTANT: with "movement in only one direction" (parameter AT_dir), the specified range is used for every optimisation step. The actual movement typically corresponds to 20 times the value, but is not limited.	revolution 1.0 1.0 999.9	UINT32 UINT32 R/W -	CANopen 302F:3 _h Modbus 12038
AT_mechanics TUN- - MECh ευο- - MECh	System coupling type7-37 1: direct coupling (J ext. to J motor <3:1) 2: medium coupling () 3: medium coupling (short toothed belt) 4: medium coupling () 5: soft coupling (J ext. to J motor between 5:1 and 10:1, linear axis)	- 1 1 5	UINT16 UINT16 R/W - -	CANopen 302F:E _h Modbus 12060
AT_start - -	Start Autotuning7-37 0: End 1: Activate	- 0 - 1	UINT16 UINT16 R/W - -	CANopen 302F:1 _h Modbus 12034

7.4.16 Extended settings for autotuning

For most applications the procedure described is sufficient for autotuning. The following parameters can be used to monitor or even influence the autotuning.

The parameters `AT_state` and `AT_progress` can be used to monitor the percentage progress and the status of the Autotuning.

Parameter Name HMI menu	Description	Unit Minimum value Default value Maximum value	Data type R/W persistent Expert	Parameter address via fieldbus
AT_state	Autotuning status7-39	-	UINT16	CANopen 302F:2 _h
-	Bit15: auto_tune_err	-	UINT16	Modbus 12036
-	Bit14: auto_tune_end	0	R/-	
-	Bit13: auto_tune_process	-	-	
	Bit 10..0: last processing step			
AT_progress	Autotuning progress7-39	%	UINT16	CANopen 302F:B _h
-		0	UINT16	Modbus 12054
-		0	R/-	
-		100	-	

If you are conducting a test operation and want to check how a harder or softer setting affects the control parameters on your system, you can change the settings found during autotuning by writing the parameter `AT_gain`. A value of 100% is generally not possible, because this value is at the stability limit. The available value is typically 70%-80%.

The parameter `AT_J` can be used to read out the mass moment of inertia of the entire system calculated during the autotuning.

Parameter Name HMI menu	Description	Unit Minimum value Default value Maximum value	Data type R/W persistent Expert	Parameter address via fieldbus
AT_gain	Adapting controller parameters (tighter/looser)7-39	%	UINT16	CANopen 302F:A _h
TUN- - GAiN		-	UINT16	Modbus 12052
Gain - GAiN	Measure of the degree of tightness of the regulation. The value 100 represents the theoretical optimum. Values larger than 100 mean that the regulation is tighter and smaller values mean that the regulation is looser.	0	R/W	
		-	-	
AT_J	Inertia of the entire system7-39	kg cm ²	UINT16	CANopen 302F:C _h
-	is automatically calculated during the autotuning process	0.1	UINT16	Modbus 12056
-		0.1	R/W	
-		6553.5	per.	
	in 0.1 kgcm ² steps		-	

The parameter `AT_wait` can be changed to set a wait time between the single steps during the autotuning process. It only makes sense to set a wait time if a very flexible coupling is used, and particularly if the next automatic autotuning step (change of hardness) is carried out while the system is still oscillating.

Parameter Name HMI menu	Description	Unit Minimum value Default value Maximum value	Data type R/W persistent Expert	Parameter address via fieldbus
AT_wait	Waiting time between autotuning steps7-39	ms	UINT16	CANopen 302F:9 _h
TUN- - WAit		300	UINT16	Modbus 12050
tun- - wait		1200	R/W	
		10000	-	
			-	

Malfunctions during optimisation High-frequency resonances in mechanical components may interfere with controller optimisation. The values for `CTRL_KPn` and `CTRL_TNn` cannot be set satisfactorily if this occurs.

The reference value filter of the current controller suppresses high-frequency resonance (>500Hz). However, if high-frequency resonance does interfere with controller optimisation, it may be necessary to increase the time constant with the parameter `CTRL_TAUiref`.

In most cases the default setting suppresses the high-frequency resonance.

Parameter Name HMI menu	Description	Unit Minimum value Default value Maximum value	Data type R/W persistent Expert	Parameter address via fieldbus
CTRL_TAUiref	Filter time constant reference value filter of the reference current value	ms	UINT16	CANopen 3012:10 _h
-		0.00	UINT16	Modbus 4640
-		1.20	R/W	
-		4.00	per.	
			-	

7.5 Controller optimisation with step response

7.5.1 Controller structure

The controller structure corresponds to the classical cascade control of a closed positioning loop with current controller, speed controller and position controller. The reference value of the speed controller can also be smoothed by an upstream filter.

The controllers are set from "inside" to "outside" in the sequence current, speed and position controller. The higher-level control loop in each case stays switched out.

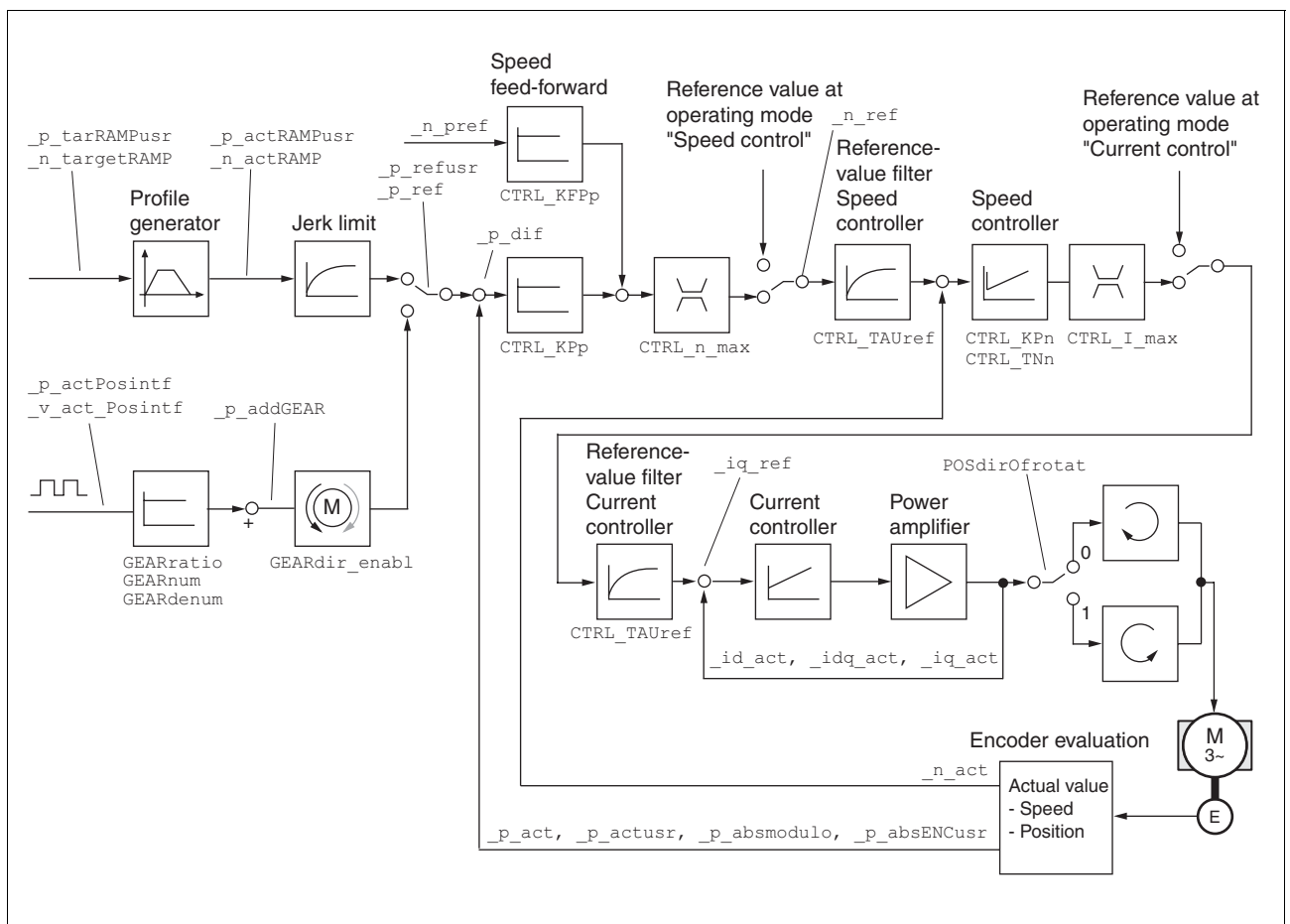

Figure 7.11 Controller structure for encoder evaluation via CN2

Current controller

The motor's drive torque is determined by the current controller. The current controller has been optimised automatically using the stored motor data.

Speed controller The speed controller maintains the required motor speed by varying the output motor torque depending on the load situation. It exerts a decisive influence on the speed with which the drive reacts. The dynamics of the speed controller depend on

- the moments of inertia of the drive and the control distance
- the torque of the motor
- the stiffness and elasticity of the components in the power flow
- the backlash of the mechanical drive components
- the friction

Position controller The position controller reduces the difference between setpoint and actual motor position (tracking error) to a minimum. At motor standstill the tracking error is virtually zero with a well-adjusted position controller. In movement mode a speed-dependent tracking error occurs. The setpoint position for the closed positioning loop is generated by the internal travel profile generator during the profile position, profile velocity, motion sequence, homing and jog operating modes. In the electronic gear operating mode the setpoint position for the closed positioning loop is generated by external A/B or pulse/direction input signals.

A requirement for good amplification of the position controller is an optimised speed control loop.

7.5.2 Optimisation

The drive optimisation function matches the unit to the operating conditions. The following options are available:

- Selecting control loops. Higher level control loops are automatically disconnected.
- Defining reference signal: signal form, height, frequency and starting point
- Testing control response with the signal generator.
- Recording and assessing the control behaviour on the monitor with the commissioning software.

Setting reference signals ► Start the controller optimisation with the commissioning software with the menu path "Command - Manual tuning".

► Set the following values for the reference signal:

- Signal form: 'Positive jump'
- Amplitude: 100 1/min
- Period duration: 100 ms
- Number of repetitions: 1

► Highlight the field "Autoscope".

► Also note additional settings in the menu "Display - Specific panels".



The total dynamic behaviour of a control loop can be only understood with the signal forms 'Jump' and 'Square wave'. Refer to the manual for all signal paths for the signal form 'Jump'.

Inputting controller values Control parameters must also be input for the individual optimisation steps described over the following pages. These parameters must be tested by initiating a jump function.

A jump function is triggered as soon as a recording is started in the commissioning software tool bar with the "Start" button (arrow icon).

You can enter controller values for optimisation in the parameters window in the "Control" group.

7.5.3 Optimising the speed controller

The optimum setting for complex mechanical control systems requires practical experience with setting and adjustment procedures for control equipment. This includes the ability to calculate control parameters and to apply identification procedures.

Less complex mechanical systems can generally be successfully optimised with the experimental adjustment procedure using the aperiodic limiting case method. Here the following two parameters are set:

Parameter Name HMI menu	Description	Unit Minimum value Default value Maximum value	Data type R/W persistent Expert	Parameter address via fieldbus
CTRL_KPn	Speed controller P-factor7-43	A/(1/min)	UINT16	CANopen 3012:3 _h
-	Default value is calculated from motor parameters	0.0001	UINT16	Modbus 4614
-		-	R/W	
		1.2700	per.	
			-	
CTRL_TNn	Speed controller integral time7-43	ms	UINT16	CANopen 3012:4 _h
-		0.00	UINT16	Modbus 4616
-		9.00	R/W	
		327.67	per.	
			-	

Check and optimise the calculated values in a second step, as described from page 7-47.

Determining the mechanics of the system

Decide which one of the following two systems fits the mechanics of your set-up to assess and optimise its transient response behaviour.

- System with rigid mechanism
- System with less rigid mechanism

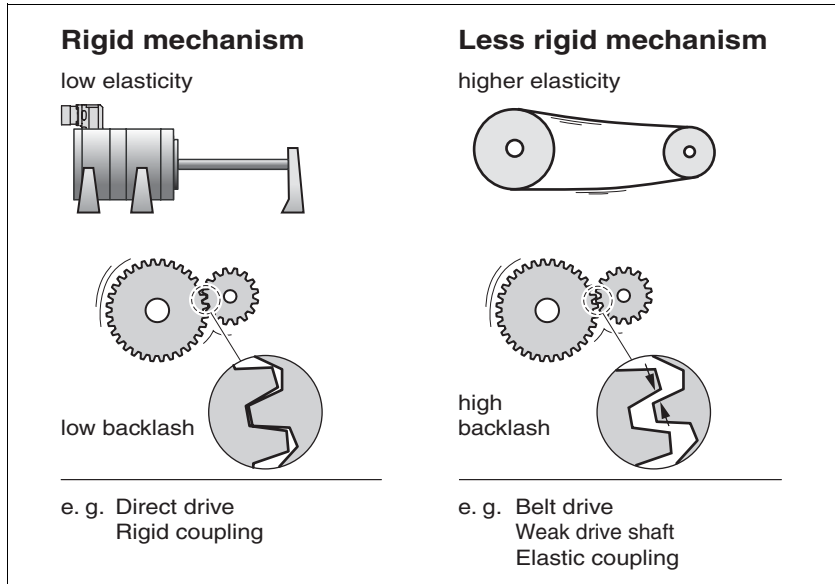

Figure 7.12 Mechanical systems with rigid and less rigid mechanisms

- ▶ Connect the motor to your system's mechanism.
- ▶ Test the limit switch function after installing the motor if limit switches are used.

Switch off reference value filter of speed controller

With the reference variable filter you can improve the response behaviour under optimised speed control. The reference value filter must be switched off when setting the speed controller for the first time.

- ▶ Disable the reference value filter of the speed controller. Set the parameter CTRL_TAU_{unref} to the bottom limit value "0".

Parameter Name HMI menu	Description	Unit Minimum value Default value Maximum value	Data type R/W persistent Expert	Parameter address via fieldbus
CTRL_TAU _{unref}	Filter time constant reference value filter of the reference speed value7-43	ms 0.00 9.00 327.67	UINT16 UINT16 R/W per. -	CANopen 3012:9 _h Modbus 4626



The procedure for optimisation of the settings described is only a suggested setting. It is responsibility of the user to decide whether the method is suitable for the actual application.

Determining controller values with rigid mechanics

Requirements for setting the control behaviour as per the table are:

- a known and constant inertia of load and motor
- a rigid mechanism

The P-factor $CTRL_KPn$ and the correction time $CTRL_TNn$ depend on:

- J_L : Mass moment of inertia of the load
- J_M Mass moment of inertia of the motor
- ▶ Determine the controller values based on Table 7.2:

J_L [kgcm ²]	$J_L = J_M$		$L_L = 5 * J_M$		$J_L = 10 * J_M$	
	KPn	TNn	KPn	TNn	KPn	TNn
1	0.0125	8	0.008	12	0.007	16
2	0.0250	8	0.015	12	0.014	16
5	0.0625	8	0.038	12	0.034	16
10	0.125	8	0.075	12	0.069	16
20	0.250	8	0.150	12	0.138	16

Table 7.2 Determining controller values

Determining controller values with less rigid mechanics

For optimisation purposes the P-factor of the speed controller at which the controller adjusts the speed $_n_act$ as quickly as possible without overshooting is determined.

- ▶ Set the correction time $CTRL_TNn$ to infinite.
 $CTRL_TNn = 327.67$ ms.

If a load torque is acting on the stationary motor, the correction time must be set just high enough to prevent an uncontrolled change of the motor position.



In drive systems in which the motor is loaded while stationary, e.g. with vertical axis operation, the correction time "infinite" may result in unwanted position deviations, thereby requiring the value to be reduced. However, this can adversely affect optimisation results.

▲ WARNING

Unexpected movement

The step function moves the motor in speed mode at constant speed until the specified time has expired.

- Check that the selected values for speed and time do not exceed the available travel.
- If possible, use limit switches or stop as well.
- Make sure that a functioning button for EMERGENCY STOP is within reach.
- Make sure that the system is free and ready for the movement before starting the function.

Failure to follow these instructions can result in death, serious injury or equipment damage.

- ▶ Initiate a jump function.
- ▶ After the first test check the maximum amplitude for the current set-point $_Iq_ref$.

Set the amplitude of the reference value – default was 100 rpm – just high enough so the current setpoint $_Iq_ref$ remains below the maximum value $CTRL_I_max$. On the other hand, the value selected should not be too low, otherwise friction effects of the mechanism will determine control loop response.

- ▶ Trigger a jump function again if you need to modify $_n_ref$ and check the amplitude of $_Iq_ref$.
- ▶ Increase or decrease the P-factor in small steps until $_n_act$ adjusts as fast as possible. The following diagram shows the adjustment response required on the left. Overshooting - as shown on the right - is reduced by reducing $CTRL_KPn$.

Deviations from $_n_ref$ and $_n_act$ result from setting $CTRL_TNn$ to "infinite".

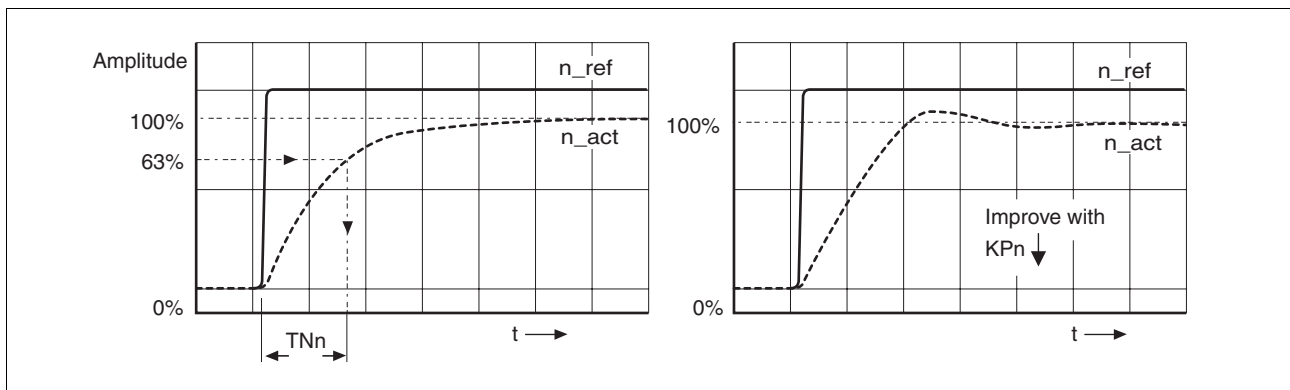

Figure 7.13 Determining "TNn" in the aperiodic limiting case



For drive systems in which oscillations occur before the aperiodic limiting case is reached, the P-factor "KPn" must be reduced to the exact point where oscillations can no longer be detected. This occurs frequently with linear axes with a toothed belt drive.

Graphic determination of the 63% value

Determine graphically the point at which the actual speed $_n_act$ reaches 63% of the final value. The correction time $CTRL_TNn$ is then shown as a value on the time axis. The commissioning software will help you with the evaluation:

Malfunctions during optimisation

High-frequency resonances in mechanical components may interfere with controller optimisation. The values for $CTRL_KPn$ and $CTRL_TNn$ cannot be set satisfactorily if this occurs.

The reference value filter of the current controller suppresses high-frequency resonance (>500Hz). However, if high-frequency resonance does interfere with controller optimisation, it may be necessary to increase the time constant with the parameter $CTRL_TAUiref$.

In most cases the default setting suppresses the high-frequency resonance.

Parameter Name HMI menu	Description	Unit Minimum value Default value Maximum value	Data type R/W persistent Expert	Parameter address via fieldbus
CTRL_TAUiref	Filter time constant reference value filter of the reference current value	ms 0.00 1.20 4.00	UINT16 UINT16 R/W per. -	CANopen 3012:10 _h Modbus 4640

7.5.4 Checking and optimising default settings

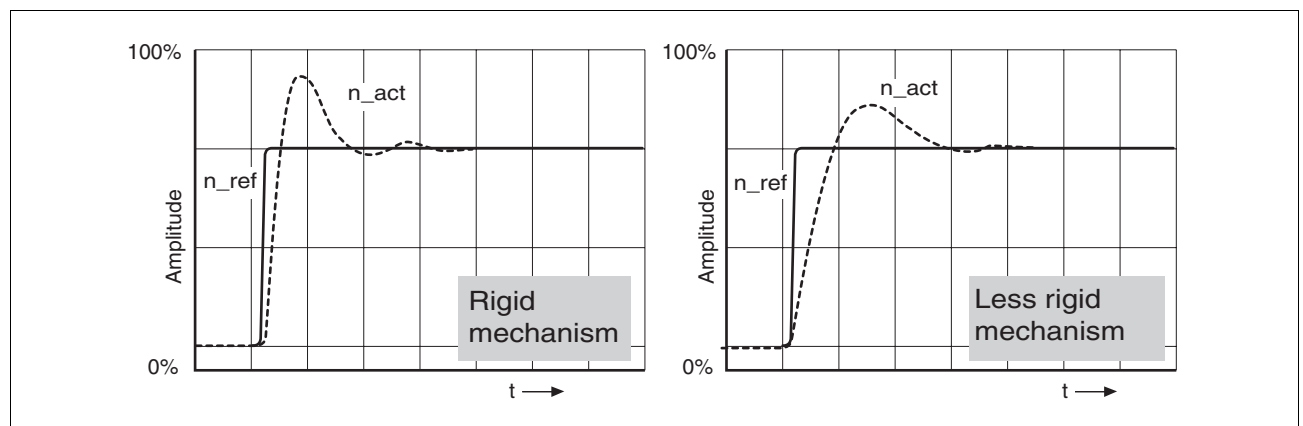

Figure 7.14 Step responses with good control behaviour

The controller is properly set when the jump response is approximately identical to the signal path shown. Good control response can be recognised by

- Fast adjustment
- Overshooting up to a maximum of 40% - 20% is recommended.

If the control response does not correspond to the curve shown, change CTRL_KPn' in steps of about 10% and then initiate a jump function once again:

- If the controller is too slow: select CTRL_KPn greater.
- If the controller tends to oscillate: select CTRL_KPn smaller.

You can recognise an oscillation by the motor continuously accelerating and decelerating.

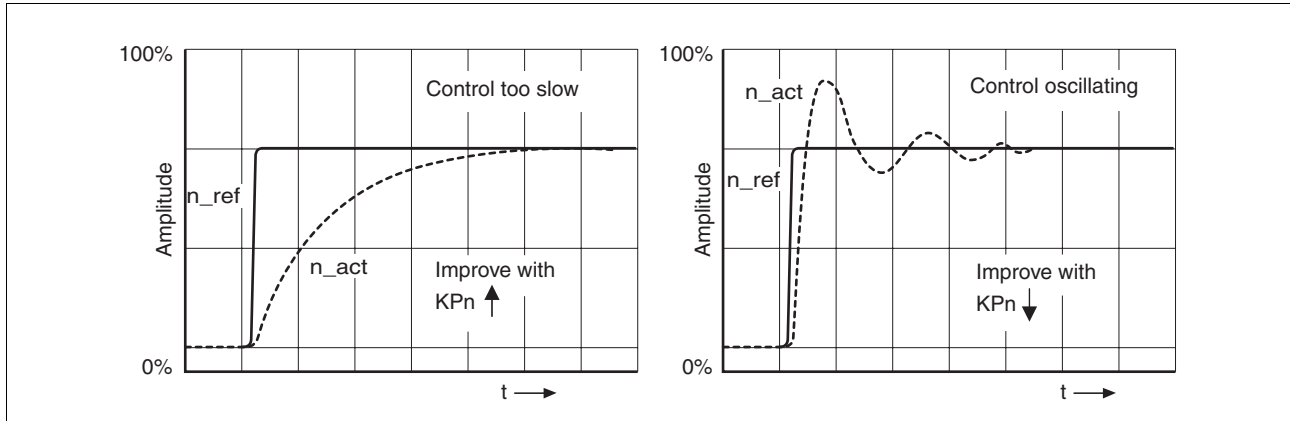

Figure 7.15 Optimise inadequate settings of the speed controller



If you cannot achieve sufficiently satisfactory controller properties in spite of optimisation, contact your local dealer.

7.5.5 Optimising the position controller

Optimisation requires a good control response in the lower-ranking speed control circuit.

When setting the position control the P-factor of the position controller CTRL_KPp must be optimised in two limits:

- CTRL_KPp too great: overshooting of the mechanism, instability of the controller
- CTRL_KPp too small: Large following error

Parameter Name HMI menu	Description	Unit Minimum value Default value Maximum value	Data type R/W persistent Expert	Parameter address via fieldbus
CTRL_KPp	Position controller P-factor	1/s	UINT16	CANopen 3012:6h
-	Default value is calculated	2.0	UINT16	Modbus 4620
-		-	R/W	
-		495.0	per.	
			-	

⚠ WARNING**Unexpected movement**

The step function moves the motor in speed mode at constant speed until the specified time has expired.

- Check that the selected values for speed and time do not exceed the available travel.
- If possible, use limit switches or stop as well.
- Make sure that a functioning button for EMERGENCY STOP is within reach.
- Make sure that the system is free and ready for the movement before starting the function.

Failure to follow these instructions can result in death, serious injury or equipment damage.

Setting the reference signal ▶ Select the position controller reference value in the commissioning software.

▶ Set the reference signal:

- Signal form: 'Jump'
- Set amplitude for about 1/10 motor revolution.

The amplitude is input in user-defined units. At default scaling the resolution is 16384 usr per motor revolution.

Selecting recording signals ▶ Select the values in General Recording Parameters:

- Setpoint of the position controller `_p_refusr` (`_p_ref`)
- Actual position of the position controller `_p_actusr` (`_p_act`)
- actual speed `_n_act`
- current motor current `_Iq_ref`

Controller values for the position controller can be changed in the same parameter group used for the speed controller.

Optimising the position control value ▶ Start a jump function with the default controller values.

▶ After the first test check the achieved values `_n_act` and `_Iq_ref` for current and speed control. The values must not cross into the range of current and speed limiting.

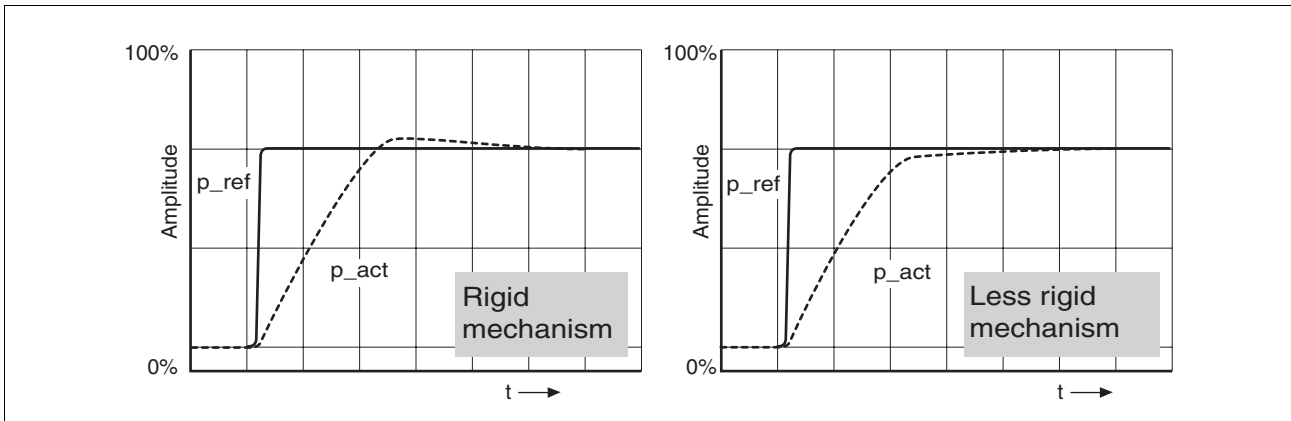

Figure 7.16 Step responses of a position controller with a good control behaviour

The proportional factor $CTRL_Kp$ is at its optimum setting when the motor reaches its target position rapidly and with little or no overshooting.

If the control behaviour does not correspond to the curve shown, change the P-factor $CTRL_Kp$ in steps of about 10% and then initiate a jump function once again.

- If the closed-loop control tends to oscillate: select $CTRL_Kp$ smaller.
- If the actual value is too slow following the reference value: select $CTRL_Kp$ larger.

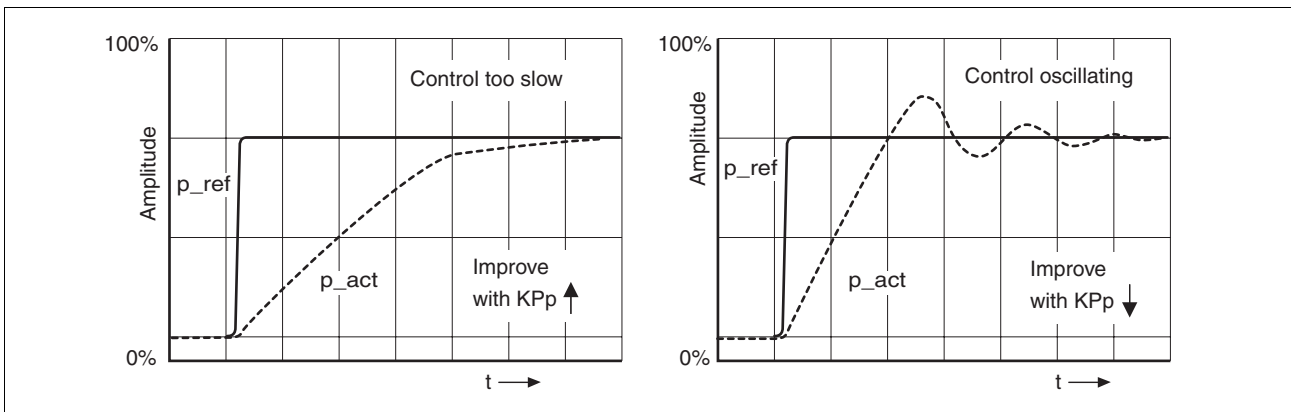

Figure 7.17 Optimising improper settings of the position controller

8 Operation

The chapter "Operation" describes the basic operating statuses, operating modes and functions of the device.



*For an overview of **all** parameters can be found alphabetically sorted in the "parameters" section. The application and the function of some parameters are explained in more detail in this section.*

8.1 Control mode and operating mode management

During initial commissioning, you will have determined during "First Setup", amongst other things, whether the device is to be operated under local control mode or via fieldbus control mode. This determination cannot be altered in running operation.

The operating modes can be changed at any time after ending an operating mode and motor standstill. The choice of operating modes is dependent upon the "First Setup".

Reference value interface

The following table shows the relationship of operating mode, control mode and reference value interface.

Operating mode	in local control mode	in fieldbus control mode.	Description
Manual drive ¹⁾	HMI or digital inputs	fieldbus commands or HMI	Page 8-15
Current control	analogue input	fieldbus commands or analogue input	Page 8-18
Speed control	analogue input	fieldbus commands or analogue input	Page 8-20
Electronic drive ²⁾	P/D, A/B or CW/CCW	P/D, A/B or CW/CCW	Page 8-22
Profile position	-	fieldbus commands	Page 8-26
Profile velocity	-	fieldbus commands	Page 8-30
Motion sequence	Digital inputs	fieldbus commands	Page 8-32
Homing	-	fieldbus commands	Page 8-44

1) digital input only with software version ≥ 1.201 .

2) CW/CCW only with software version ≥ 1.201 .

In the case of local control mode, the motion can be initiated using analogue signals ($\pm 10V$) or with RS422 signals (pulse/direction or A/B)

In the case of fieldbus control mode, the movement can be initiated using analogue signals ($\pm 10V$) or RS422 signals (pulse/direction or A/B) or fieldbus commands.

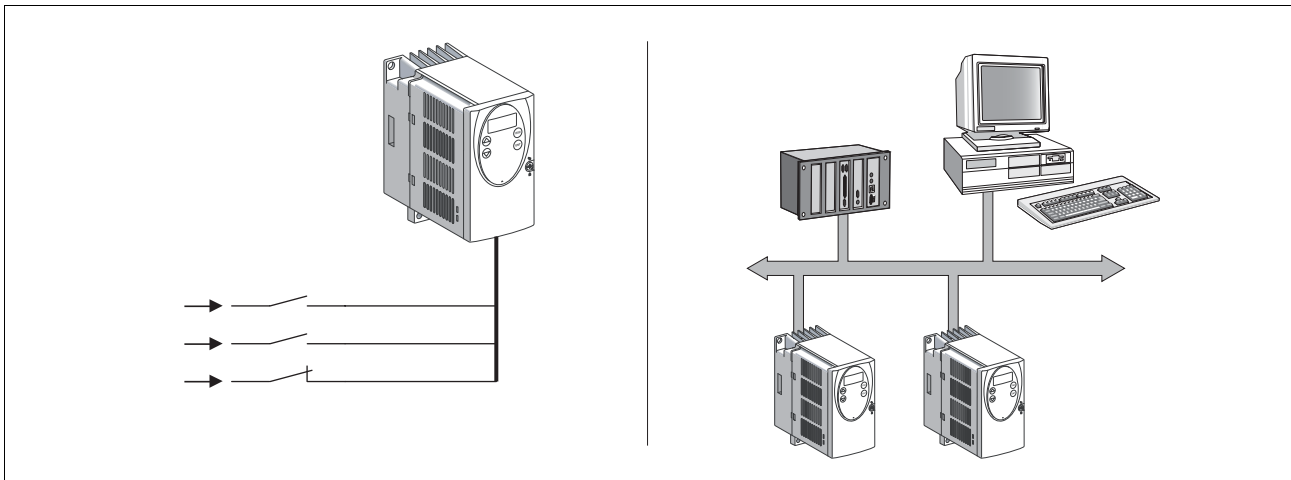

Figure 8.1 Local control mode and fieldbus control mode

Reference value for control loop

The following table shows the relationship of operating mode, control loop and the use of the profile generator.

Operating mode	Control loop	Profile generator
Jog	Position controller	X
Current control	Current controller	-
Speed control	Speed controller	-
Electronic gear	Position controller	-
Profile position	Position controller	X
Profile velocity	Position controller	X
Homing	Position controller	X

8.2 Access monitor

8.2.1 via HMI

The HMI receives the access monitoring when starting the jog operating mode or when starting Autotuning. Control by a different access channel, such as the commissioning software, is not possible in this case.

In addition, the HMI can be locked using the parameter `HMIlocked`. This means that control via the HMI is no longer possible.

Parameter Name HMI menu	Description	Unit Minimum value Default value Maximum value	Data type R/W persistent Expert	Parameter address via fieldbus
HMIlocked	Block HMI	-	UINT16	CANopen 303A:1 _h
-	0: HMI not blocked	0	UINT16	Modbus 14850
-	1: HMI blocked	0	R/W	
-		1	per.	
	When the HMI is blocked the following actions are no longer possible:		-	
	- Change parameters			
	- Manual drive (Jog)			
	- Autotuning			
	- FaultReset			

8.2.2 via fieldbus

Local control mode Access monitoring via fieldbus is not possible when in local control mode. Only parameterisation can be conducted over the fieldbus.

fieldbus control mode In the case of fieldbus control mode, the parameter `AccessLock` can be used to limit the access monitoring to the fieldbus .

Parameter Name HMI menu	Description	Unit Minimum value Default value Maximum value	Data type R/W persistent Expert	Parameter address via fieldbus
AccessLock	Blocking of other access channels	-	UINT16	CANopen 3001:1E _h
-	0: Other access channels enabled	0	UINT16	Modbus 316
-	1: Other access channels blocked	-	R/W	
-		1	-	
	This parameter allows the fieldbus to block active access to the device for the following access channels:		-	
	- commissioning software			
	- HMI			
	- a second fieldbus			
	The processing of the input signals (e.g. Halt input) cannot be blocked.			

8.2.3 via commissioning software

The commissioning software must have exclusive access control. Control by a different access channel, such as the HMI, is not possible in this case.

8.2.4 via hardware input signals

With software version <1.201: In local control mode the digital input signals $\overline{\text{HALT}}$, FAULT_RESET , ENABLE , $\overline{\text{PWRR_A}}$ and $\overline{\text{PWRR_B}}$ are always effective, even if the HMI or the commissioning software has access control.

In fieldbus control mode the digital input signals $\overline{\text{HALT}}$, $\overline{\text{PWRR_A}}$ and $\overline{\text{PWRR_B}}$ are always effective, even if the HMI or the commissioning software has access control.

With software version ≥ 1.201 In local control mode the functions "Halt", "Fault reset", "Enable" and "Power Removal " are always effective, even if the HMI or the commissioning software control the access.

In fieldbus control mode the functions "Halt" and "Power Removal" are always effective, even if the HMI or the commissioning software control the access.

8.3 Operating statuses

8.3.1 Status diagram

After switching on and at the start of an operating mode, a sequence of operating states is progressed through.

The relationship between the operating states and the state transitions is shown in the state diagram (state machine).

The operating states are internally monitored and influenced by monitoring and system functions, such as temperature and current monitoring

Graphic representation The status diagram is shown graphically as a flow chart.

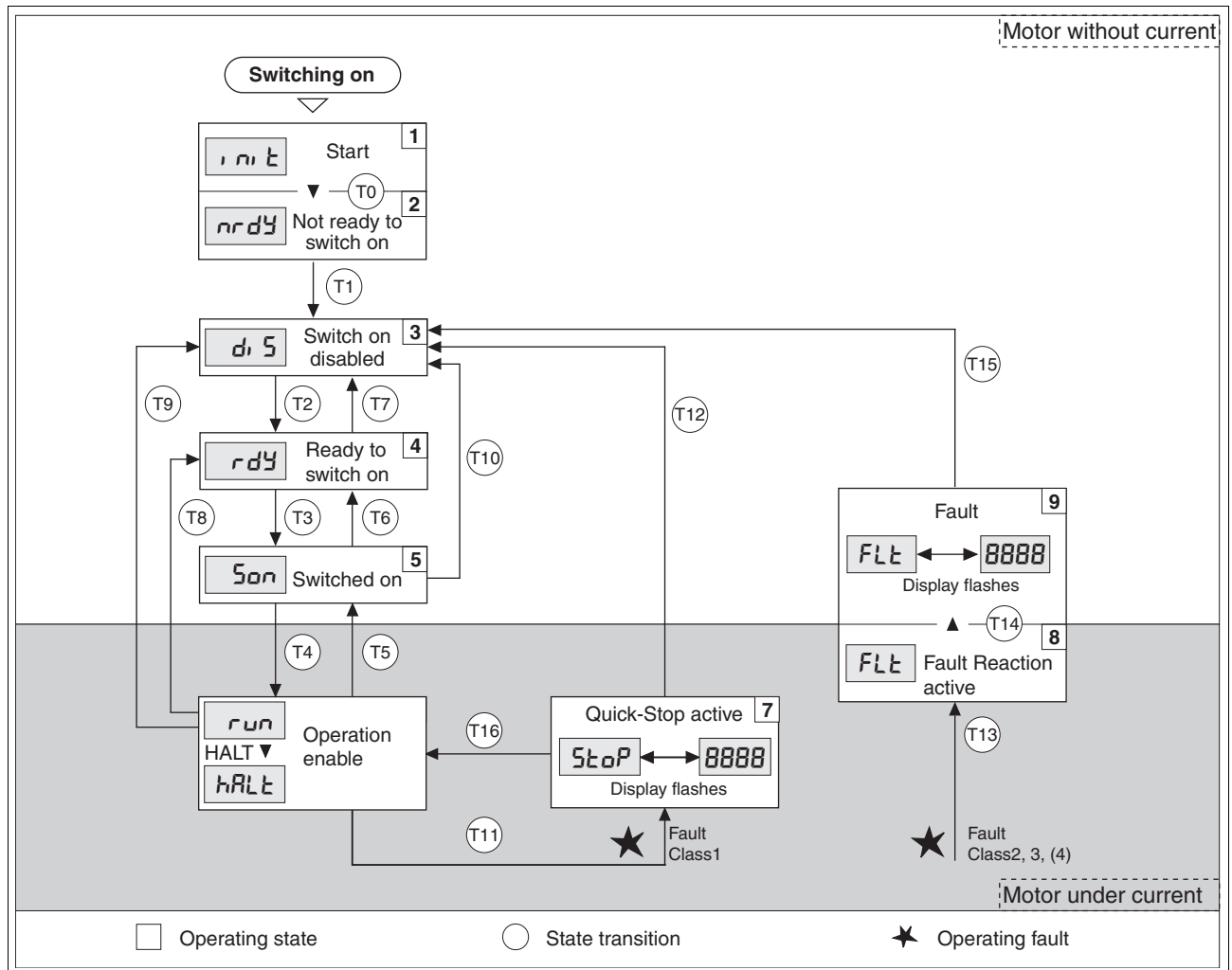

Figure 8.2 Status diagram

Operating states The operating states are displayed as standard by the HMI and the commissioning software.

Display	Status	State description
i n i t	1 Start	Controller supply voltage, electronics is initialised
n r d y	2 Not ready to switch on	The power amplifier is not ready to switch on ¹⁾
d i s	3 Switch on disabled	Switching on the power amplifier is disabled
r d y	4 Ready to switch on	The power amplifier is ready to switch on
S o n	5 Switched on	Motor not under current Power amplifier ready No operating mode active
r u n h A L T	6 Operation enable	RUN: device running in the selected operating mode HALT: The motor is stopped with active power amplifier
S t o P	7 Quick Stop active	"Quick Stop" is executed
F L t	8 Fault Reaction active	Error detected, error response is enabled
F L t	9 Fault	device is in fault condition

1) The device must be switched off and switched on again

Error response The status transition T13 initiates an error response as soon as an internal occurrence indicates a breakdown to which the device must react. The description of the error class can be seen in the diagnostics chapter.

Error class	Statusfrom - Response > to	
2	x -> 8	Braking with "Quick Stop" Brake is closed Power amplifier is switched off
3,4 or "Power Removal"	x -> 8 -> 9	Power amplifier is switched off immediately, even if "Quick Stop" is still active

A breakdown can be indicated by, for example, a temperature sensor. The device interrupts the travel command and carries out an error response e.g. braking and stopping with "Quick Stop" or switching off the power amplifier. Subsequently the operating status changes to "Fault".

To leave the "Fault" operating status the cause of the error must be corrected and a "Fault Reset" must be executed.

Reset error message A "Fault Reset" is executed through the input signal `FAULT_RESET` or through the parameter `DCOMcontrol`. An error message is reset by running a "Fault Reset".



In the event of a "Quick Stop" triggered by errors of class 1 (operating status 7), a "Fault Reset" returns directly to the operating status 6.

Status transitions Status transitions are triggered by an input signal, a fieldbus command (with fieldbus control mode only) or as a response to a monitoring signal.

Transition	Operating status ¹⁾		Response
T0	1-> 2	<ul style="list-style-type: none"> Motor speed below switch-on limit device electronics successfully initialised 	Check motor encoder
T1	2-> 3	<ul style="list-style-type: none"> First commissioning is completed 	-
T2	3-> 4	<ul style="list-style-type: none"> Motor encoder successfully checked, DC bus voltage active, <code>PWRR_A</code> and <code>PWRR_B</code> = +24V, actual speed: <1000 1/min, fieldbus command: Shutdown ²⁾ 	-
T3	4-> 5	<ul style="list-style-type: none"> Input signal <code>ENABLE 0</code> -> 1 (local control mode) fieldbus command Switch On (fieldbus control mode) 	
T4	5-> 6	<ul style="list-style-type: none"> Automatic transition if input signal <code>ENABLE</code> still set (local control mode) fieldbus command Enable Operation (fieldbus control mode) 	Activate power amplifier motor phases, earth, user parameters are checked release brake
T5	6-> 5	<ul style="list-style-type: none"> fieldbus command Disable Operation (fieldbus control mode) 	Interrupt task with "Halt" Apply brake Disable power amplifier
T6	5-> 4	<ul style="list-style-type: none"> fieldbus command Shutdown 	

Transition	Operating status ¹⁾	Response	
T7	4->3	<ul style="list-style-type: none"> DC bus undervoltage Actual speed: >1000 1/min (e.g. by auxiliary drive) $\overline{PWRR_A}$ and $\overline{PWRR_B} = 0V$ fieldbus command Disable voltage (fieldbus control mode) 	
T8	6->4	<ul style="list-style-type: none"> fieldbus command Shutdown 	Deactivate power amplifier immediately
T9	6->3	<ul style="list-style-type: none"> Input signal $ENABLE\ 1 \rightarrow 0$ (local control mode) fieldbus command Disable voltage (fieldbus control mode) 	Deactivate power amplifier immediately
T10	5->3	<ul style="list-style-type: none"> Input signal $ENABLE\ 1 \rightarrow 0$ (local control mode) fieldbus command Disable voltage (fieldbus control mode) 	
T11	6->7	<ul style="list-style-type: none"> Class 1 error fieldbus command Quick Stop (fieldbus control mode) 	Interrupt travel command with "Quick Stop"
T12	7->3	<ul style="list-style-type: none"> Input signal $ENABLE\ 1 \rightarrow 0$ (local control mode) fieldbus command Disable voltage (fieldbus control mode) 	Deactivate power amplifier immediately, even if "Quick Stop" still active
T13	x->8	<ul style="list-style-type: none"> Errors Class 2, 3 or 4 	Error response is carried out, see "error response"
T14	8->9	<ul style="list-style-type: none"> Error response completed Errors Class , 3 or 4 	
T15	9->3	<ul style="list-style-type: none"> Input signal $FAULT_RESET\ 0 \rightarrow 1$ (local control mode) fieldbus command Fault Reset (fieldbus control mode) 	Error is reset (cause of error must be corrected).
T16	7->6	<ul style="list-style-type: none"> Input signal $FAULT_RESET\ 0 \rightarrow 1$ (local control mode) fieldbus command Fault Reset (fieldbus control mode) fieldbus command Enable Operation³⁾ (fieldbus control mode) 	Local control mode Specified operating mode is automatically continued (cause of error must be corrected).

1) Condition / Event It is sufficient to satisfy one point to initiate the state transition

2) Only required with fieldbus control mode, fieldbus CANopen and parameter DCOMcompatib= 1

3) Possible only if operating status was triggered through fieldbus

8.3.2 Changing operating status

Local controller operating mode In local controller operating mode, the change of operating state takes place either via the commissioning software, the signal inputs or automatically.

Input signal	State transitions	State change to
ENABLE 0 -> 1	T3, T4	6: Operation enable
ENABLE 1 -> 0	T5, T6	4: Ready to switch on
FAULT_RESET 0 -> 1	T15 T16	4: Ready to switch on 6: Operation enable

Fieldbus control mode In the case of fieldbus control mode, the operating states are set either by the commissioning software or by the parameter `DCOMcontrol`. Bits 0 to 3 and Bit 7 are relevant for a state change

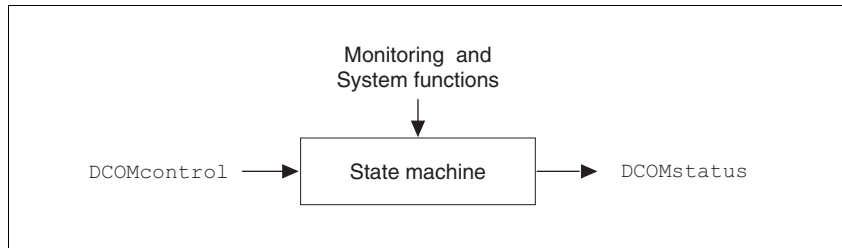

Figure 8.3 Changing and monitoring the operating status via parameters

Parameter Name HMI menu	Description	Unit Minimum value Default value Maximum value	Data type R/W persistent Expert	Parameter address via fieldbus
DCOMcontrol	Drivecom control word	-	UINT16	CANopen 6040:0h
-	For bit coding see chapter on operation, operating status	-	UINT16	Modbus 6914
-	Bit0: Switch on	0	R/W	
-	Bit1: Enable Voltage	-	-	
-	Bit2: Quick Stop	-	-	
-	Bit3: Enable Operation	-	-	
-	Bit4..6: op. Mode specific	-	-	
-	Bit7: Fault Reset	-	-	
-	Bit8: Halt	-	-	
-	Bit9..15: reserved (must be 0)	-	-	

Bit 0 ... 3 and 7

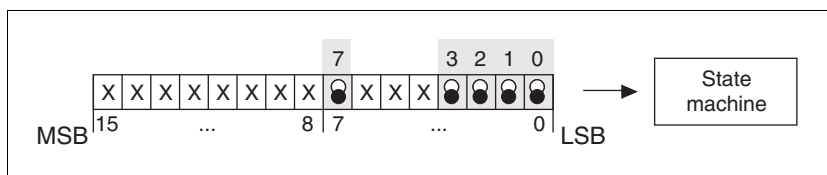

Figure 8.4 Changing the operating status

fieldbus command	status transitions	Status change open	Bit 7, Reset Fault	Bit 3, Enable operation	Bit 2, Quick-Stop	Bit 1, Enable Voltage	Bit 0, Switch On
Shutdown	T2, T6, T8	4: Ready to switch on	X	X	1	1	0
Switch On	T3	5: Switched on	X	X	1	1	1
Disable Voltage	T7, T9, T10, T12	3: Switch on disabled	X	X	X	0	X
Quick Stop	T7, T10T11	3: Switch on disabled 7: Quick Stop active	X	X	0	1	X
Disable Operation	T5	5: Switched on	X	0	1	1	1
Enable operation	T4, T16	6: Operation enable	X	1	1	1	1
Fault Reset	T15	3: Switch on disabled	0 -> 1	X	X	X	X

The bit states in the fields marked with "X" have no meaning that particular status change.

Bit 4 ... 6 Bits 4 ... 6 are used for the operating mode specific settings. Details can be found in the description of the individual operating modes in this chapter.

Bit 8, Halt Bit 8=1 can initiate a "Halt".

Bit 9 ... 15 reserved

8.3.3 Displaying the operating statuses

Local control mode In local control mode, the display of operating state takes place via the signal outputs, the HMI or the commissioning software.

Status	"No fault" ¹⁾	"Brake release" ²⁾	ACTIVE ³⁾
2: Not ready to switch on	0	0	0
3: Switch on disabled	0	0	0
4: Ready to switch on	1	0	0
5: Switched on	1	0	0
6: Operation enable	1	1	1
7: Quick Stop activ	0	1	0
8: Fault Reaction active	0	1	0
9: Fault	0	0	0

1) with software version <1.201: corresponds to output signal NO_FAULT_OUT
 2) with software version <1.201: corresponds to output signal ACTIVE1_OUT
 3) with software version <1.201: corresponds to output signal ACTIVE2_OUT

Fieldbus control mode In fieldbus control mode the operating status is displayed via the signal inputs, the fieldbus, the HMI or the commissioning software.

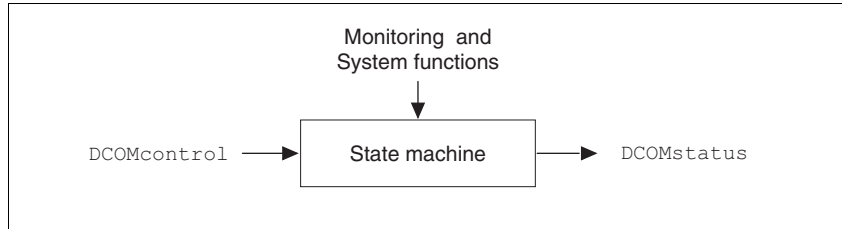

Figure 8.5 Changing and monitoring the operating status via parameters

Status information The parameter `DCOMstatus` provides global information on the operating state of the unit and the processing state.

Parameter Name HMI menu	Description	Unit Minimum value Default value Maximum value	Data type R/W persistent Expert	Parameter address via fieldbus
DCOMstatus	Drivecom status word	-	UINT16	CANopen 6041:0 _h
-	For bit coding see chapter on operation, state machine	-	UINT16	Modbus 6916
-	Bit0-3,5,6: status bits	0	R/-	
	Bit4: voltage enabled	-	-	
	Bit7: warning			
	Bit8: HALT request active			
	Bit9: remote			
	Bit10: target reached			
	Bit11: reserved			
	Bit12: op. mode specific			
	Bit13: x_err			
	Bit14: x_end			
	Bit15: ref_ok			

Bit 0 ... 3, 5 and 6 The status of the state diagram is displayed by bits 0 to 3, 5 and 6 of the parameter `DCOMstatus`.

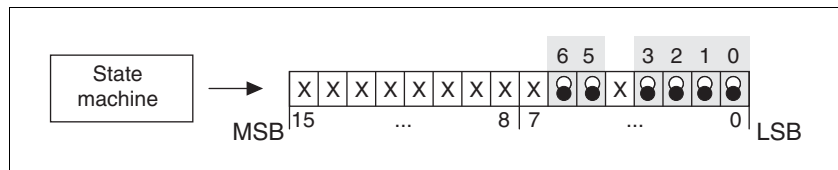

Figure 8.6 Display of operating status

Status	Bit 6, Switch ondisable	Bit 5, Quick- Stop	Bit 3, Fault	Bit 2, Oper- ationenable	Bit 1, Switch on	Bit 0, Ready toswitch on
2: Not ready to switch on	0	X	0	0	0	0
3: Switch on disabled	1	X	0	0	0	0
4: Ready to switch on	0	1	0	0	0	1
5: Switched on	0	1	0	0	1	1
6: Operation enable	0	1	0	1	1	1
7: Quick Stop active	0	0	0	1	1	1
9: Fault	0	X	1	1	1	1

0198441113232, V1.20, 06.2007

<i>Bit 4, Voltage enabled</i>	Bit 4=1 indicates whether the DC bus voltage is correct. If the voltage is missing or is too low, then the device does not change from state 3 to state 4.
<i>Bit 7, Warning</i>	Bit 7 becomes 1 if a warning message is pending in parameter <code>_WarnActive</code> . The movement mode is not interrupted. The bit remains set so long as a warning message is pending in parameter <code>_WarnActive</code> . The bit remains set for at least 100ms, even if a warning message is pending for a shorter time. The bit is reset immediately at a "Fault Reset".
<i>Bit 8, Halt request active</i>	Bit 8=1 indicates that a "Halt" is active.
<i>Bit 9, Remote</i>	If Bit 9 is set, then the device carries out commands via the fieldbus. If Bit 9 is set, then the device is controlled from a different interface. The fieldbus then allows other parameters to be read and written.
<i>Bit 10, Target reached</i>	Bit 10 only becomes "1" if the operating mode is completed successfully and the motor stops. Bit 10 has the value "0", as long as the motor is running, if the operating mode is interrupted by a "Halt" or discontinued because of an error.
<i>Bit 11</i>	reserved
<i>Bit 12</i>	Bit 12 is used for the monitoring the current operating mode. Details can be found in the chapter for the individual operating mode.
<i>Bit 13, x_err</i>	Bit 13 only becomes "1" if there is a fault present which needs to be rectified before further processing. The device responds corresponding to an error class, see page 10-2.
<i>Bit 14, x_end</i>	Bit 14 changes to "0", if an operating mode is started. If the editing is terminated or the editing was aborted by for example "Halt", Bit 14 again changes to "1" on motor standstill. The signal change of Bit 14 to "1" is suppressed if editing is directly followed by a new editing in another operating mode.
<i>Bit 15, ref_ok</i>	Bit 15 is "1" if the motor or the axis has a valid reference point, e.g. through a reference movement.

8.4 Starting and changing operating modes

⚠ WARNING

Unmonitored operation

- Note that inputs to these parameters are executed by the drive controller immediately on receipt of the data set.
- Make sure that the system is free and ready for movement before changing these parameters

Failure to follow these instructions can result in death, serious injury or equipment damage.

Requirements To start an operating mode the unit must be ready to start and correctly initialised.

An operating mode cannot be carried out in parallel with another operating mode. If an operating mode is active, then you can only change to a different operating mode if the current operating mode is completed or is discontinued.

An operating mode is completed if the drive is at a standstill, e.g. if the target position of a positioning process is reached or if the drive is stopped by a "Quick Stop" or "Halt". If a fault occurs during the process which leads to the discontinuation of a current operating mode, then, after the cause of the fault has been removed, the traverse operation can be resumed, or you can change to a different operating mode.

Changing the operating statuses and enabling the operating modes must be executed separately. An operating mode can generally only be enabled if the operating status is already "Operation enable".

8.4.1 Start operating mode

Local control mode In the case of local control mode, after starting, the device changes to the operating mode set using the parameter `I0defaultMode`

The motor is placed under current by setting the input signal `ENABLE` and the set operating mode is started.

In addition, a "jog" or "Autotuning" can be started with the HMI.

fieldbus control mode In the case of fieldbus control mode, the operating mode is started using the parameter `DCOMopmode` .

The following table shows the sequence of parameters for starting an operating mode with the example of the current control operating mode.

	Parameter	Description
1	CUR_I_target	Transmission of the reference value
2	CURreference	Setting the reference quantity
3	DCOMopmode	Calling up the operating mode (-3)

Parameter Name HMI menu	Description	Unit Minimum value Default value Maximum value	Data type R/W persistent Expert	Parameter address via fieldbus
CUR_I_target	Setpoint current in current control operating mode	A _{pk} -300.00 0.00 300.00	INT16 INT16 R/W -	CANopen 3020:4 _h Modbus 8200
CURreference	Selection of setpoint source for current control operating mode	- 0 0 2	UINT16 UINT16 R/W -	CANopen 301B:10 _h Modbus 6944
	0: no 1: Reference value via +/-10V-interface ANA1 2: Reference value via parameter CUR_I_target			
DCOMopmode	Operating mode	- -8 - 6	INT8 INT16 R/W -	CANopen 6060:0 _h Modbus 6918
	DSP402-operating modes 1: Profile position 3 Profile velocity 6: Homing			
	----- Manufacturer operating modes: -1: jog -2: electronic gear -3: current control -4: speed control -8: Data set mode			

In the case of the Profile Position and Homing mode, the device receives the instruction to start the set operating mode by Bit 4 in the parameter `DCOMcontrol`.

For all other operating modes, the Bits 4 ... 6 are not occupied.

8.4.2 Change operating mode

Local control mode When the drive is at a standstill, the default operating mode can be changed using the parameter `IODEfaultMode`. The operating modes cannot be changed while the operating mode is running. The new settings only become effective after switching off and switching on the device again.

fieldbus control mode The operating modes can be changed while the operation is in process. For this purpose, the current process must be completed or explicitly discontinued. The drive must be at a standstill. Proceed then as shown under "Starting the Operating Mode".

Exceptions to this are the operating modes current control and speed control. The motor need not be at a standstill to change between these two operating modes.

Two parameters are available for displaying the current operating mode and for switching the operating modes.

- Parameter for display: `_DCOMopmd_act`
- Parameter for change: `DCOMopmode`

Parameter Name HMI menu	Description	Unit Minimum value Default value Maximum value	Data type R/W persistent Expert	Parameter address via fieldbus
_DCOMopmd_act	active operating mode	-	INT8	CANopen 6061:0 _h
-	Coding see: DCOMopmode	-6	INT16	Modbus 6920
-		-	R/-	
-		6	-	
DCOMopmode	Operating mode	-	INT8	CANopen 6060:0 _h
-	DSP402-operating modes	-8	INT16	Modbus 6918
-	1: Profile position	-	R/W	
-	3 Profile velocity	6	-	
-	6: Homing		-	
	----- Manufacturer operating modes:			
	-1: jog			
	-2: electronic gear			
	-3: current control			
	-4: speed control			
	-8: Data set mode			

8.5 Operating modes

8.5.1 Operating mode Jog

▲ WARNING

Unmonitored operation

- Note that inputs to these parameters are executed by the drive controller immediately on receipt of the data set.
- Make sure that the system is free and ready for movement before changing these parameters

Failure to follow these instructions can result in death, serious injury or equipment damage.

Overview of jog

The motor traverses by one traverse unit or at constant speed in continuous operation. The length of the traverse unit, the speed levels and the wait time before continuous operation can be adjusted.

The current axis position is the start position for the jog operating mode. Position and speed values are input in user-defined units.

If a positive and a negative jog are requested at the same time, there is no motor movement.

Start operating mode

The operating mode can be started via the HMI. The power amplifier becomes active and the motor is under current by calling up the JOG / $STOP$. The motor runs by pushing the "up arrow" or "down arrow" buttons. You can change between slow and fast movement by simultaneously pushing the ENT-button.

In the case of fieldbus control mode, the operating mode must be set using the parameter $DCOMopmode$. The writing of the parameter value simultaneously causes the start of the operating mode.

Otherwise the operating mode can also be started as a start-up operating mode, see 7.4.1 "First Setup". Here the corresponding functions are preassigned to the signal inputs, see 8.6.9 "Configurable inputs and outputs".

With the start signal for the jog, the motor first moves over a defined travel unit $JOGstepusr$. If the start signal is still pending after a specified wait time $JOGtime$, the device switches to continuous operation until the start signal is cancelled.

The graph below shows an overview in local control mode.

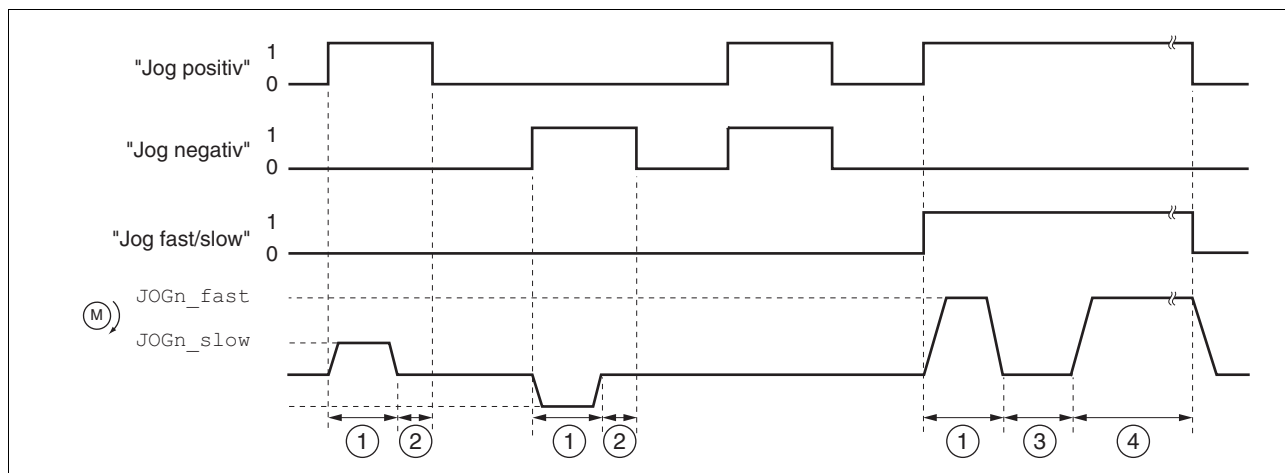

Figure 8.7 Jog, slow and fast

The graph below shows an overview in fieldbus control mode.

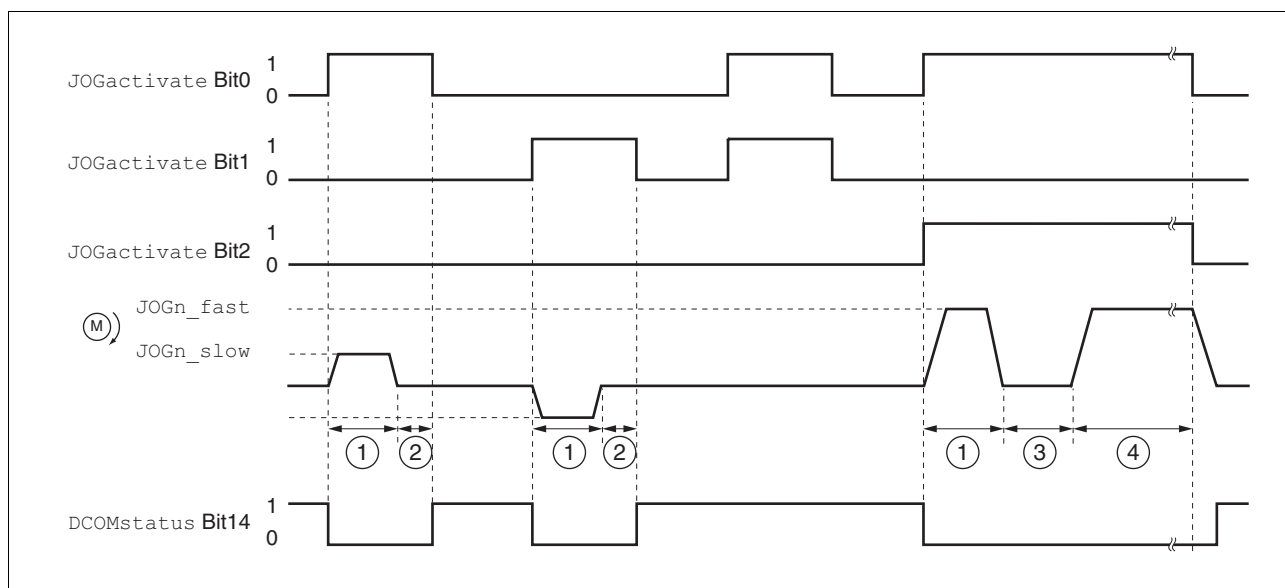

Figure 8.8 Jog, slow and fast

- (1) Traverse unit
- (2) $t < \text{wait time}$
- (3) $t > \text{wait time}$
- (4) Continuous operation

The traverse unit, wait time and speed levels can be set. If the traverse unit is zero, jog starts directly with continuous operation irrespective of the wait time.

Parameter Name HMI menu	Description	Unit Minimum value Default value Maximum value	Data type R/W persistent Expert	Parameter address via fieldbus
JOGactivate	Activation of jog	-	UINT16	CANopen 301B:9 _h
-	Bit0: clockwise rotation	0	UINT16	Modbus 6930
-	Bit1: counter-clockwise rotation	0	R/W	
-	Bit2: 0=slow 1=fast	7	-	
JOGn_slow	Speed for slow jog	1/min	UINT16	CANopen 3029:4 _h
JOG- - NSLW	The set value is internally limited to the current parameter setting in RAMPn_max.	1	UINT16	Modbus 10504
JoG - nSLW		60	R/W	
		13200	per.	
			-	
JOGn_fast	Speed for fast jog	1/min	UINT16	CANopen 3029:5 _h
JOG- - NFST	The set value is internally limited to the current parameter setting in RAMPn_max.	1	UINT16	Modbus 10506
JoG - nFSt		180	R/W	
		13200	per.	
			-	
JOGstepusr	inching distance before continuous operation	usr	INT32	CANopen 3029:7 _h
-	0: direct activation of continuous operation	0	INT32	Modbus 10510
-	>0: positioning section per inching cycle	20	R/W	
		-	per.	
			-	
JOGtime	Waiting time before continuous operation	ms	UINT16	CANopen 3029:8 _h
-	Time is only effective if an inching section	1	UINT16	Modbus 10512
-	not equal to 0 has been set, otherwise direct	500	R/W	
-	transition to continuous operation.	32767	per.	
			-	

Status messages The drive provides information concerning positioning via Bits 10 and 12 to 15 in the parameter DCOMstatus.

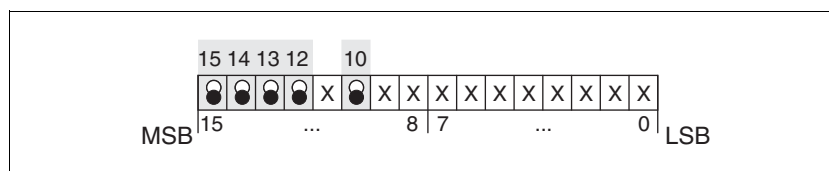

Figure 8.9 Status reports for operating mode

Parameter value	Description
Bit 10: Target reached	Always 0
Bit 12: Mode-dependent	reserved
Bit 13: x_err	1: Error arisen
Bit 14: x_end	1: Mode completed, motor at a standstill
Bit 15: ref_ok	1: drive has valid reference point

End operating mode Jog is finished when the motor has stopped and

- the direction signal is inactive.
- The operating mode has been interrupted by "Halt" or an error

Further possibilities For further setting possibilities and functions for the operating mode see from page 8-57.

8.5.2 Operating mode Current control

Overview of current control In the current control operating mode the reference value for the motor current is preset.

The following overview shows the effectivity of the parameters which can be set for this operating mode.

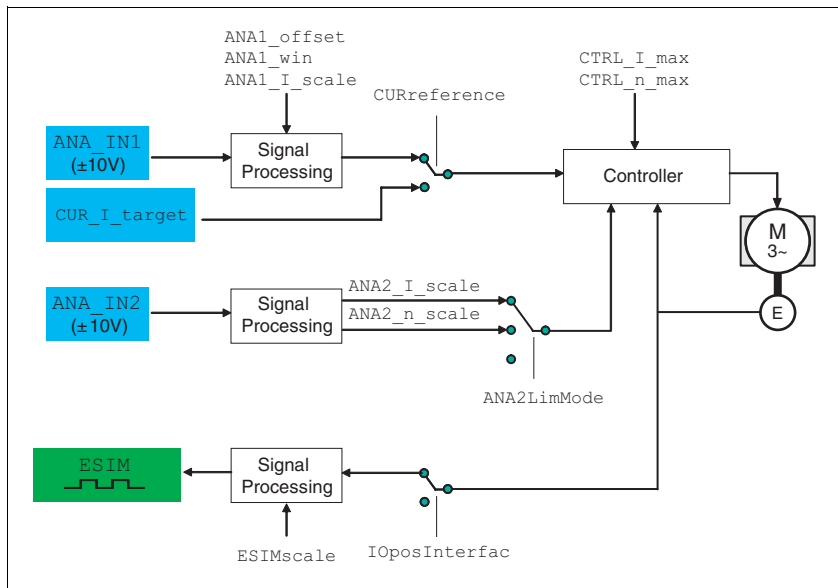

Figure 8.10 Operating mode current control, effects of settable parameters

Start operating mode In the case of local control mode, the operating mode must be set using the parameter **IOdefaultMode**. The power amplifier is activated, the motor receives current and the inputs are evaluated in accordance with the setting by setting the input signal **ENABLE**.

In the case of fieldbus control mode, the operating mode must be set using the parameter **DCOMopmode**. The writing of the parameter value simultaneously causes the start of the operating mode.

Setting thresholds For setting current limiting and speed limiting see 7.4.3 "Setting basic parameters and limit values".

⚠ WARNING
<p>Unexpectedly high speed of rotation</p> <p>The motor in current control mode can reach extreme speeds when operated without limits or load.</p> <ul style="list-style-type: none"> • Check the configured speed limiter. <p>Failure to follow these instructions can result in death, serious injury or equipment damage.</p>

Setting to the set value In the case of local controlmode, the analogue input **ANA1** is automatically evaluated.

In the case of fieldbus control mode, the parameter **CURreference** determines whether the analogue input **ANA1** or the parameter **CUR_I_target** is to be evaluated.

0198441113232, V1.20, 06.2007

Parameter Name HMI menu	Description	Unit Minimum value Default value Maximum value	Data type R/W persistent Expert	Parameter address via fieldbus
CURreference	Selection of setpoint source for current control operating mode	- 0 0 2	UINT16 UINT16 R/W -	CANopen 301B:10 _h Modbus 6944
-	0: no 1: Reference value via +/-10V-interface ANA1 2: Reference value via parameter CUR_I_target			
CUR_I_target	Setpoint current in current control operating mode	A _{pk} -300.00 0.00 300.00	INT16 INT16 R/W -	CANopen 3020:4 _h Modbus 8200
-				
-				

Reference value at +10V input signal

The progress of the reference value in relation to the ±10V input value can be altered:

- Setting the reference value at +10V
- Setting parameters for a zero voltage window
- Setting parameters for a voltage offset

For setting options for the analogue inputs see 7.4.4 "Analogue inputs".

The device calculates a current value, with which the motor accelerates to a speed which is limited by the load torque, from the ±10 V analogue value preset. Without a load the motor therefore accelerates to the variable speed limit.

Example local controller operating mode

An example of setting by parameters in the case of local controller operating mode can be found on page 9-3.

Status messages

The drive provides information concerning positioning via Bits 10 and 12 to 15 in the parameter DCOMstatus.

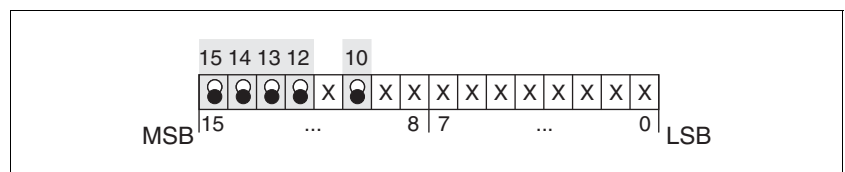

Figure 8.11 Status reports for operating mode

Parameter value	Description
Bit 10: Target reached	Always 0
Bit 12: Mode-dependent	0: Speed higher than 0 1/min 1: Speed is 0 1/min
Bit 13: x_err	1: Error arisen
Bit 14: x_end	1: Mode completed, motor at a standstill
Bit 15: ref_ok	1: drive has valid reference point

End operating mode

The processing in the operating mode is completed if the operating mode has been "deactivated" and the drive is at a standstill, or if the motor speed has taken the value = 0 as a result of a fault.

019844113232, V1.20, 06.2007

8.5.3 Operating mode Speed control

Overview of speed control In the speed control operating mode the reference value for the motor speed is preset.

Transitions between two speeds take place in relation to the set control parameters.

The following overview shows the effectivity of the parameters which can be set for this operating mode.

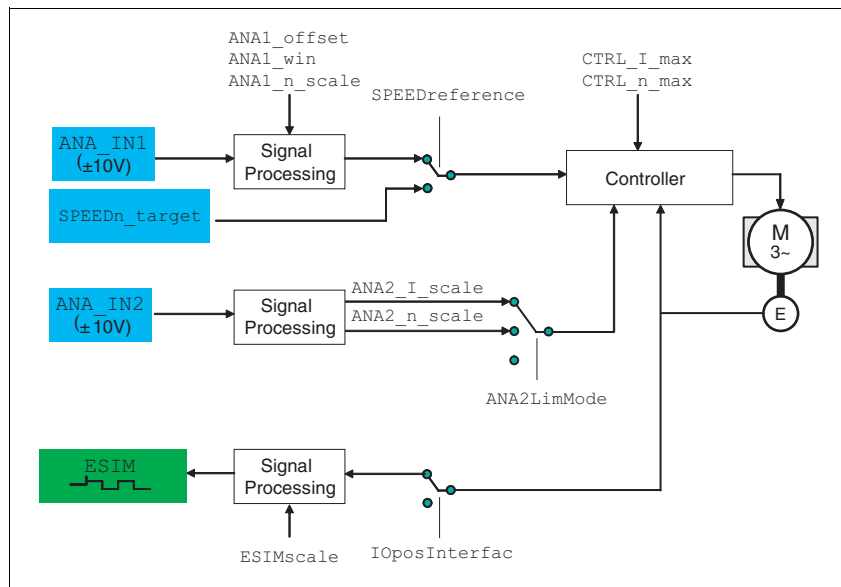

Figure 8.12 Operating mode speed control , effect of settable parameters

Start operating mode In the case of local control mode, the operating mode must be set using the parameter `IOdefaultMode` . The power amplifier is activated, the motor receives current and the inputs are evaluated in accordance with the setting by setting the input signal `ENABLE`.

In the case of fieldbus control mode, the operating mode must be set using the parameter `DCOMopmode` . The writing of the parameter value simultaneously causes the start of the operating mode.

Setting thresholds For setting current limiting and speed limiting see 7.4.3 "Setting basic parameters and limit values".

Setting to the set value In the case of local control mode, the analogue input ANA1 is automatically evaluated.

In the case of fieldbus control mode, the parameter `SPEEDreference` determines whether the analogue input ANA1 or the parameter `SPEEDn_target` is to be evaluated.

Parameter Name HMI menu	Description	Unit Minimum value Default value Maximum value	Data type R/W persistent Expert	Parameter address via fieldbus
SPEEDreference	Selection of preset source for speed control operating mode	- 0 0 2	UINT16 UINT16 R/W -	CANopen 301B:11 _h Modbus 6946
-	0: no			
-	1: Reference value via +/-10V-interface ANA1			
-	2: Reference value via parameter SPEEDn_target			
SPEEDn_target	Setpoint speed in speed control mode	1/min -30000 0 30000	INT16 INT16 R/W -	CANopen 3021:4 _h Modbus 8456
-	The internal maximum speed is limited by the current setting in CTRL_n_max			

Reference value at +10V input signal

The progress of the reference value in relation to the ±10V input value can be altered:

- Setting the reference value at +10V
- Setting parameters for a zero voltage window
- Setting parameters for a voltage offset

For setting options for the analogue inputs see 7.4.4 "Analogue inputs".

Example local controller operating mode

An example of setting by parameters in the case of local controller operating mode can be found on page 9-3.

Status messages

The drive provides information concerning positioning via Bits 10 and 12 to 15 in the parameter DCOMstatus.

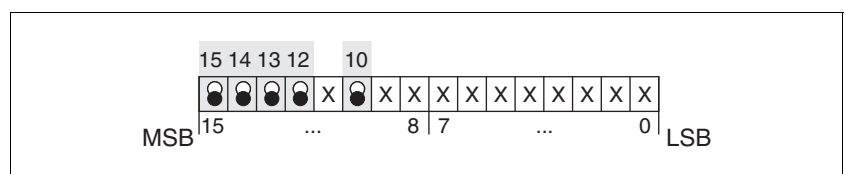

Figure 8.13 Status reports for operating mode

Parameter value	Description
Bit 10: Target reached	Always 0
Bit 12: Mode-dependent	reserved
Bit 13: x_err	1: Error arisen
Bit 14: x_end	1: Mode completed, motor at a standstill
Bit 15: ref_ok	1: drive has valid reference point

End operating mode

The processing in the operating mode is completed if the operating mode has been "deactivated" and the drive is at a standstill, or if the motor speed has taken the value = 0 as a result of a fault.

8.5.4 Operating mode Electronic gear

⚠ WARNING

Unmonitored operation

- Note that inputs to these parameters are executed by the drive controller immediately on receipt of the data set.
- Make sure that the system is free and ready for movement before changing these parameters

Failure to follow these instructions can result in death, serious injury or equipment damage.

Description In the electronic gear operating mode reference signals are fed in as A/ B signals or as pulse/direction signals. They are offset to a new position preset with an adjustable gear ratio.

The parameter `IOposInterfac` specifies the type of reference signals.

Example An NC control provides reference signals to two units. The motors execute different, proportional positioning movements in accordance with the gear ratios.

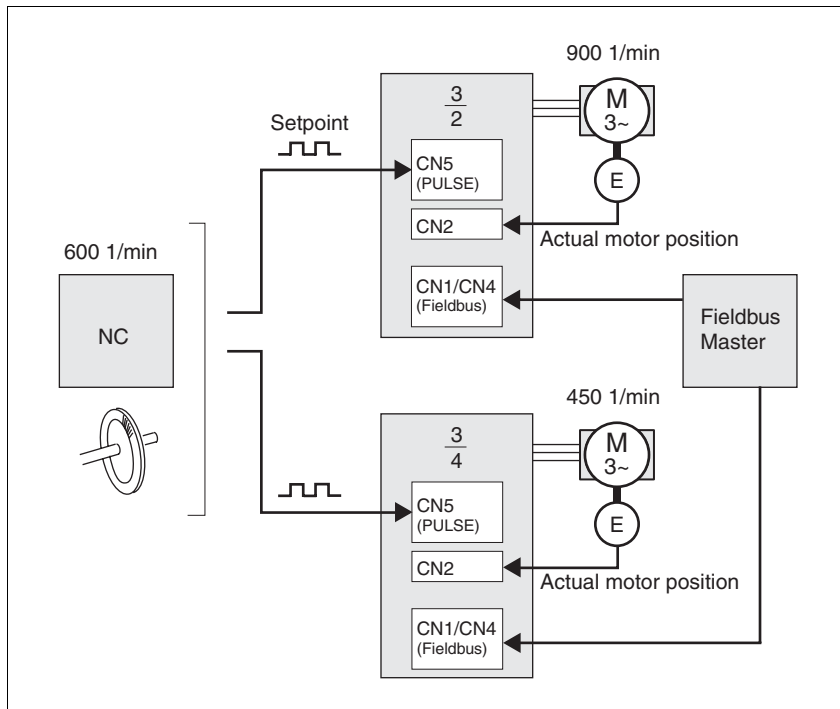

Figure 8.14 Preset default via NC controller

Start operating mode In the case of local control mode, the operating mode must be set using the parameter `IOdefaultMode`. The power amplifier is activated, the motor receives current and the inputs are evaluated in accordance with the setting by setting the input signal `ENABLE`.

In the case of fieldbus control mode, the operating mode must be set using the parameter `DCOMopmode`. The writing of the parameter value simultaneously causes the start of the operating mode.

0198441113232, V1.20, 06.2007

The type of synchronisation is set and the gear processing is started by a write command on the parameter `GEARreference`. If positioning changes at the reference signals are stored, then the unit computes these with the gear factor and positions the motor to the new set position.

Positioning values are given in internal units. The unit performs the changes immediately.

Status messages

The drive provides information concerning positioning via Bits 10 and 12 to 15 in the parameter `DCOMstatus`.

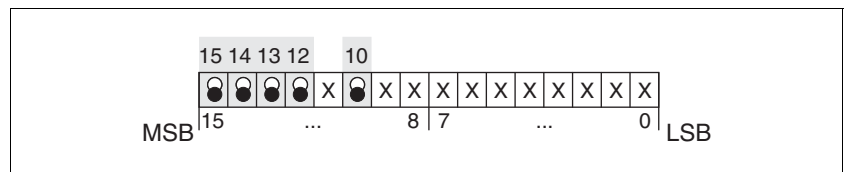

Figure 8.15 Status reports for operating mode

Parameter value	Description
Bit 10: Target reached	Always 0
Bit 12: Mode-dependent	reserved
Bit 13: x_err	1: Error arisen
Bit 14: x_end	1: Mode completed, motor at a standstill
Bit 15: ref_ok	1: drive has valid reference point

End operating mode

The process is ended by:

- disabling the operating mode and motor at standstill
- motor standstill by "Halt" or by an error

8.5.4.1 Parameterisation

Example local controller operating mode

An example of setting by parameters in the case of local controller operating mode can be found on page 9-3.

Overview

The following overview shows the mode of action of the parameters which can be set for the operating mode electronic gear.

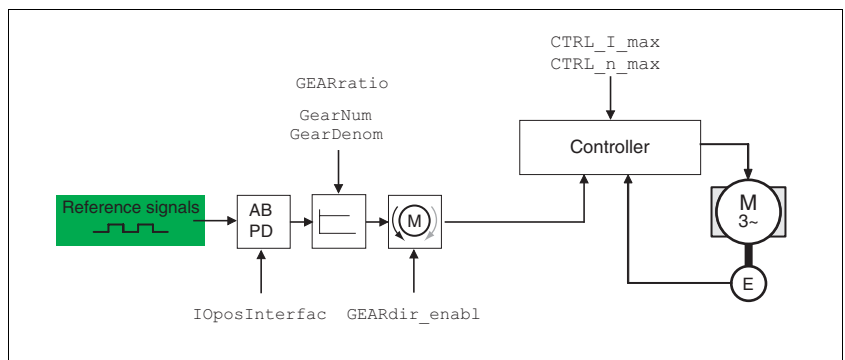

Figure 8.16 Operating mode electronic gear, effect of settable parameters

The resulting positioning movement is dependent upon the current motor resolution. It amounts to 131072 motor increments per revolution.

019844113232, V1.20, 06.2007

The setting values, independent of the type of synchronisation, are:

- Gear factor (predefined value or intrinsic gear factor)
- size of following error
- Release of the direction of rotation

Setting thresholds For setting current limiting and speed limiting see 7.4.3 "Setting basic parameters and limit values".

Synchronisation The device operates synchronously interconnected, e.g. with other drives. If the device leaves the processing for a short period of time, then the synchronous run with other drives is lost. However, position changes that occur at the reference signals are internally counted during the interruption.

- With local control mode position changes are not evaluated at the reference signals that occur during the interruption. When restarting gear processing the device tracks the reference signal from the time at which the gear processing was enabled again.

From Version 1.201 onwards, parameter `IO_GearMode` allows you to specify whether these positioning changes are to be processed or ignored when the gear processing is resumed.

- In the case of fieldbus control mode, parameter `GEARreference` allows you to define whether these positioning changes are to be processed or ignored when the gear processing is resumed.

Parameter Name HMI menu	Description	Unit Minimum value Default value Maximum value	Data type R/W persistent Expert	Parameter address via fieldbus
<code>IO_GearMode</code>	Processing mode electr. gearing for local control mode	- 1	UINT16 UINT16	CANopen 3005:17 _h Modbus 1326
<code>DRC- - ioGM</code> <code>drC - - oGf</code>	1: Real-time synchronisation 2: synchronisation with compensation movement	1 2	R/W per. -	
Available from software version V1.201.				
<code>GEARreference</code>	Electronic gear processing mode	- 0	UINT16 UINT16	CANopen 301B:12 _h Modbus 6948
-	0: disabled	0	R/W	
-	1: Real-time synchronisation 2: Synchronisation with compensation movement	2 -	- -	

Gear ratio The gear ratio is the relationship between the motor increments and the externally inputted guide increments for the movement of the motor.

$$\text{Gear factor} = \frac{\text{Motor increments}}{\text{Reference increments}} = \frac{\text{Gear factor numerator}}{\text{Gear factor denominator}}$$

The parameter `GEARratio` serves to set the predefined gear ratio. Alternatively, an intrinsic gear ratio can be selected.

The intrinsic gear ratio is determined with the parameters count and name. A negative numerator value reverses the motor's direction of rotation. The gear ratio is preset to 1:1.

Example At a setting of 1000 reference increments the motor should rotate 2000 motor increments. This yields a gear ratio of 2.

Parameter Name HMI menu	Description	Unit Minimum value Default value Maximum value	Data type R/W persistent Expert	Parameter address via fieldbus
GEARratio	Selection of special gear ratios	-	UINT16	CANopen 3026:6 _h
SET- - GFAC SEt - - GFRC	0: Use of the specified gear ratio from GEARnum/GEARdenom 1: 200 2: 400 3: 500 4: 1000 5: 2000 6: 4000 7: 5000 8: 10000 9: 4096 10: 8192 11: 16384	0 0 11	UINT16 R/W per. -	Modbus 9740
	Changing the reference value by the stated amount results in one motor rotation.			
GEARnum	Gear ratio numerator	-	INT32	CANopen 3026:4 _h
-	GEARnum	-2147483648	INT32	Modbus 9736
-	Gear ratio= ----- GEARdenom	1 2147483647	R/W per. -	
	The new gear ratio is enabled when the numerator value is transferred.			
GEARdenom	Gear ratio denominator	-	INT32	CANopen 3026:3 _h
-	see description GEARnum	1	INT32	Modbus 9734
-		1 2147483647	R/W per. -	

Direction enabling The direction enabling allows restriction of the movement to positive or negative direction of rotation. Direction enabling is set with the parameter GEARdir_enabl.

Parameter Name HMI menu	Description	Unit Minimum value Default value Maximum value	Data type R/W persistent Expert	Parameter address via fieldbus
GEARdir_enabl	Enabled direction of motion of the gear processing	-	UINT16	CANopen 3026:5 _h
-		1	UINT16	Modbus 9738
-	1 / positive : Pos. direction	3	R/W	
-	2 / negative : Neg. direction	3	per.	
	3 / both : both directions		-	
	This can be used to activate a reverse interlock .			

Further possibilities For further setting possibilities and functions for the operating mode see from page 8-57.

8.5.5 Operating mode Profile position

The operating mode can only be used with fieldbus control mode and can only be executed via fieldbus.

⚠ WARNING

Unmonitored operation

- Note that inputs to these parameters are executed by the drive controller immediately on receipt of the data set.
- Make sure that the system is free and ready for movement before changing these parameters

Failure to follow these instructions can result in death, serious injury or equipment damage.

In profile position operating mode a movement with an adjustable travel profile is run from a start position to a target position. The value of the target position can be given as either a relative or an absolute position.

A movement profile can be set with values for acceleration and deceleration ramps and final speed.

Relative and absolute positioning,

At an absolute positioning the positioning path is specified absolutely with reference to the zero point of the axis. A zero point must be defined with the homing operating mode before the first absolute positioning.

At a relative positioning the positioning path is specified relative to the current axis position or the target position.

An absolute positioning or relative positioning is set with bit 6 via the parameter `DCOMcontrol`.

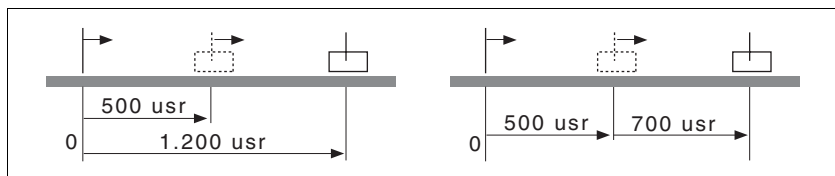

Figure 8.17 Absolute positioning (left) and relative positioning (right)

Requirements

The unit must be in the "Operation status" operating mode.

See chapter 8.4 "Starting and changing operating modes".

Trigger positioning

Parameter value	Description
Bit 4: New setpoint	0->1: Start positioning or prepare next positioning
Bit 5: Change set immediately (applicable only with new setpoint 0->1)	0: enable new position values when target position is reached 1: enable new position values immediately
Bit 6: Absolute / relative	0: Absolute positioning 1: Relative positioning

019844113232, V1.20, 06.2007

A positioning of rising edge is started by bit 4 in parameter-DCOMcontrol. Alternatively a positioning can be started also over a digital input, see chapter 8.6.9 "Configurable inputs and outputs".

The positioning can be triggered in 2 ways depending upon Bit 5.

- Bit 5=0:
Position values (PPp_targetusr, PPN_target, RAMPacc and RAMPdecel), that are transferred during a positioning, are saved temporarily. The target position of the current positioning is approached. The new position values are executed only when the target position is reached.
If new position values are transferred again, the temporarily saved position values are overwritten again.
- Bit 5=1:
Position values (PPp_targetusr, PPN_target, RAMPacc and RAMPdecel), that are transferred during a positioning, are executed immediately. The target position of the new positioning is directly approached.

Status messages The drive provides information concerning positioning via Bits 10 and 12 to 15 in the parameter DCOMstatus.

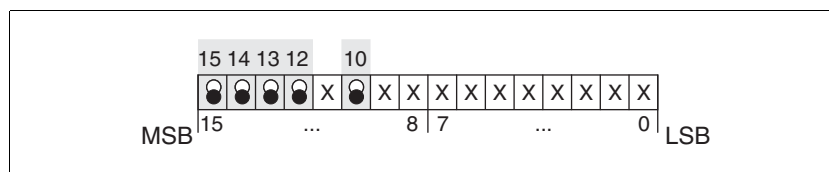

Figure 8.18 Status reports for operating mode

Parameter value	Description
Bit 10: Target reached	0: Target position not reached (even with "Halt" or error) 1: Target position reached
Bit 12: setpoint acknowledge	0: Transfer of new position possible 1: New target positioning accepted
Bit 13: x_err	1: Error arisen
Bit 14: x_end	1: Positioning completed, motor at a standstill
Bit 15: ref_ok	1: drive has valid reference point

Positioning finished Bit 14 indicates whether positioning is complete. If this includes reaching the target position, then Bit 10 changes to 1. If the positioning has been interrupted by a "Halt" or a fault, Bit 10 remains at 0.

8.5.5.1 Parameterisation

The profile position mode can be set and carried out by parameters.

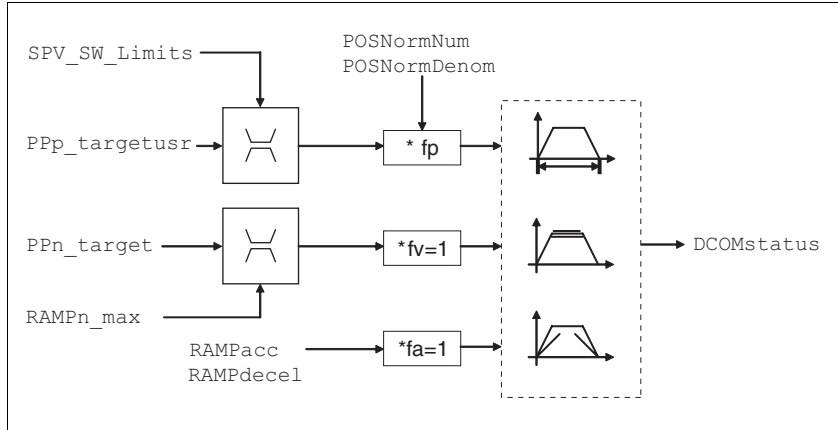

Figure 8.19 Profile position operating mode, effect of settable parameters

Target position A new position value is transmitted with the parameter $PPp_targetusr$.

At an absolute positioning the positioning path is specified absolutely with reference to the zero point of the axis.

At a relative positioning the positioning path is specified relative to the current axis position or the target position. This depends on the setting in parameter $PPoption$.

Parameter Name HMI menu	Description	Unit Minimum value Default value Maximum value	Data type R/W persistent Expert	Parameter address via fieldbus
PPn_target	Setpoint speed for profile position mode	1/min	UINT32	CANopen 6081:0 _h
-	Maximum value is limited to the current setting in $CTRL_n_max$	1	UINT32	Modbus 6942
-	The setting value is internally limited to the current parameter setting in $RAMPn_max$.	60	R/W	-
-		-	-	-
$PPoption$	Options for operating mode profile position	-	UINT16	CANopen 60F2:0 _h
-	Determines the reference position for a relative positioning:	0	UINT16	Modbus 6960
-	0: relative to the previous target position of the travel profile generator	0	R/W	
-	1: not supported	2	-	-
-	2: relative to the current actual position of the motor		-	
	from Version 1.120			
$AbsHomeRequest$	Absolute positioning only after homing	-	UINT16	CANopen 3006:16 _h
-	0: no	0	UINT16	Modbus 1580
-	1: yes	0	R/W	
		1	per.	
	Available from software version V1.201.		-	

019844113232, V1.20, 06.2007

Parameter Name HMI menu	Description	Unit Minimum value Default value Maximum value	Data type R/W persistent Expert	Parameter address via fieldbus
PPp_targetusr	Target position of profile position operating mode	usr - 0	INT32 INT32 R/W	CANopen 607A:0 _h Modbus 6940
-	Min/Max values are dependent upon: - Scaling factor - software limit switch (if this is activated)	-	-	

Current Position The current position is determined by using the 2 parameters `_p_actusr` and `_p_actRAMPusr`.

Parameter Name HMI menu	Description	Unit Minimum value Default value Maximum value	Data type R/W persistent Expert	Parameter address via fieldbus
<code>_p_actusr</code>	Actual position of the motor in user-defined units	usr - 0	INT32 INT32 R/-	CANopen 6064:0 _h Modbus 7706
STA- - PACu 5tR- - PR <u>U</u>	IMPORTANT: Actual position of motor is only valid after determination of the motor absolute position. With invalid motor absolute position: <code>_WarnLatched</code> <code>_WarnActive</code> Bit 13=1: absolute position of motor not yet detected	-	-	
<code>_p_actRAMPusr</code>	Actual position of the travel profile generator in user-defined units	usr - 0	INT32 INT32 R/-	CANopen 301F:2 _h Modbus 7940
-		-	-	

8.5.6 Operating mode Profile velocity

The operating mode can only be used with fieldbus control mode and can only be executed via fieldbus.

⚠ WARNING
<p>Unmonitored operation</p> <ul style="list-style-type: none"> Note that inputs to these parameters are executed by the drive controller immediately on receipt of the data set. Make sure that the system is free and ready for movement before changing these parameters <p>Failure to follow these instructions can result in death, serious injury or equipment damage.</p>

In the profile velocity operating mode it is accelerated to an adjustable setpoint speed. A movement profile can be set with values for acceleration and deceleration.

Requirements The unit must be in the "Operation status" operating mode.

See chapter 8.4 "Starting and changing operating modes".

Velocity operation trigger If the type of operation, the operating state and the parameter values are set, the operating mode can be started by transfer of a set velocity in the parameter `PVn_target`.

Status messages The drive provides information concerning positioning via Bits 10 and 12 to 15 in the parameter `DCOMstatus`.

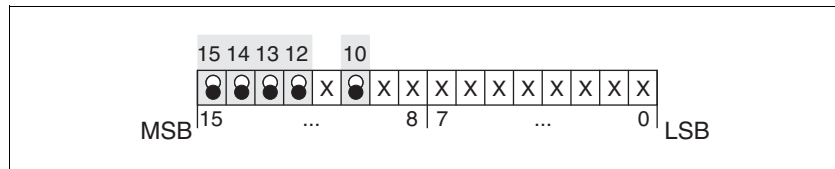

Figure 8.20 Status reports for operating mode

Parameter/ Signal	Description
Bit 10: Target reached	0: Set speed not reached 1: Set speed reached (also with motor at standstill by "Halt")
Bit 12: speed=0	0: Motor is moving 1: motor stopped
Bit 13: x_err	1: Error arisen
Bit 14: x_end	1: Operating mode finished
Bit 15: ref_ok	1: drive has valid reference point

Operating mode finished The operating mode is completed and motor standstill achieved by "Halt", by an error or after a preset default = 0.

8.5.6.1 Parameterisation

Overview The following overview shows the effect of the parameters which can be set for the velocity profile operating mode.

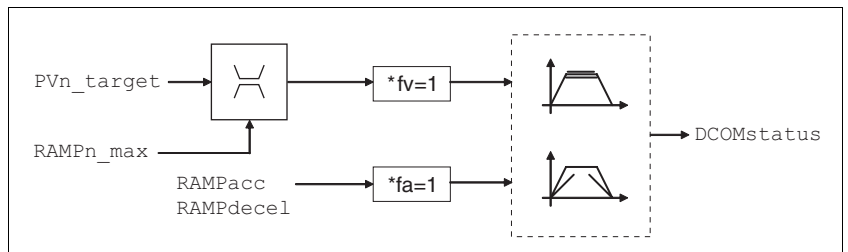

Figure 8.21 Operating mode velocity profile, effect of settable parameters

Set speed The set speed is transferred via the parameter PVn_target in rpm and can be changed during the movement. The operating mode is not limited by range limits of the positioning. New speed values are accepted immediately during a travel command.

Parameter Name HMI menu	Description	Unit Minimum value Default value Maximum value	Data type R/W persistent Expert	Parameter address via fieldbus
PVn_target	Setpoint speed profile velocity mode	1/min	INT32	CANopen 60FF:0 _h
-	Maximum value is limited to the current setting in CTRL_n_max	- 0	INT32 R/W	Modbus 6938
-	The setting value is internally limited to the current parameter setting in RAMPn_max.	-	-	-

Current speed The current speed is determined by using the 2 parameters _n_act and _n_actRAMP.

Parameter Name HMI menu	Description	Unit Minimum value Default value Maximum value	Data type R/W persistent Expert	Parameter address via fieldbus
_n_act	Actual speed of the motor	1/min	INT32	CANopen 606C:0 _h
STA- - NACT		- 0	INT16 R/-	Modbus 7696
StR- - nRLt		-	-	-
_n_actRAMP	Actual speed of the travel profile generator	1/min	INT32	CANopen 606B:0 _h
-		- 0	INT32 R/-	Modbus 7948
-		-	-	-

019844113232, V1.20, 06.2007

8.5.7 Operating mode motion sequence



There are fewer digital inputs or outputs available in local control mode. This puts a severe restriction on the scope of functions of the direct selection of the data sets. In the local operating mode, preferably use the sequential selection of the data sets.

Basis The operating mode motion sequence is based on the basic principles and functions of the operating modes homing and profile position. The operation is described in the relevant sections for the operating mode.

Overview of motion sequence The motor is controlled by freely programmable data sets in the motion sequence operating mode.

The parameterisation of the data sets is executed via the commissioning software or the fieldbus.



Parameterisation via the commissioning software is much easier, because this provides a graphic interface.

There are two processing modes for the data sets:

- Direct selection of the data sets

Direct selection of the data sets is used if a master controller (e.g. PLC) runs time coordination between the various data sets.

In the local control mode the data set number always starts with 0.

In the control mode fieldbus, the parameter `MSMsetNum` defines the starting data set number. The data set number is activated when the respective continued transition condition is fulfilled.

- Sequential selection of the data sets

Sequential selection of the data sets is typically used with simple process sequences. The time coordination and the sequence between the various data sets is defined in the drive. The globally defined continued transition condition is always checked for starting the first data set. Special conditions can be parameterised for all the subsequent data sets.

In the local control mode, an external signal can meet a continued transition condition between the data sets with the "Start DataSet" function.

For example, for control mode fieldbus, a transition condition can be met through the parameter `MSMstartReq`.

In the local control mode, the processing status of a data set can be outputted through a signal output with the function "Start acknowledge DataSet".

In addition, an internal processing status such as "Motor standstill" can be output via an additional signal output.

8.5.7.1 Global settings

Selection of processing mode The processing mode is defined with the parameter MSMprocMode.

Parameter Name HMI menu	Description	Unit Minimum value Default value Maximum value	Data type R/W persistent Expert	Parameter address via fieldbus
MSMprocMode	Processing mode	-	UINT16	CANopen 302D:7 _h
-	0: Direct selection	0	UINT16	Modbus 11534
-	1: Sequential selection	1	R/W per.	
		1	-	

Global transition condition The parameter MSMglobalCond defines the global transition condition which is valid for the start of the first data set, as well as for stepping to all following data sets in which the global transition condition is defined as condition. The globally defined transition condition can be replaced by a special transition condition in every single data set.

Parameter Name HMI menu	Description	Unit Minimum value Default value Maximum value	Data type R/W persistent Expert	Parameter address via fieldbus
MSMglobalCond	Global transition condition	-	UINT16	CANopen 302D:8 _h
-	The global transition condition defines how the start command will be processed. This setting is used for the first start after activation of the operating mode. This setting can also be used as the transition condition in the individual data sets (default setting)	0	UINT16	Modbus 11536
-	Coding: 0: Rising edge 1: Falling edge 2: 1-level 3: 0-level	0	R/W	
		3	per.	
			-	

8.5.7.2 Structure of a data set

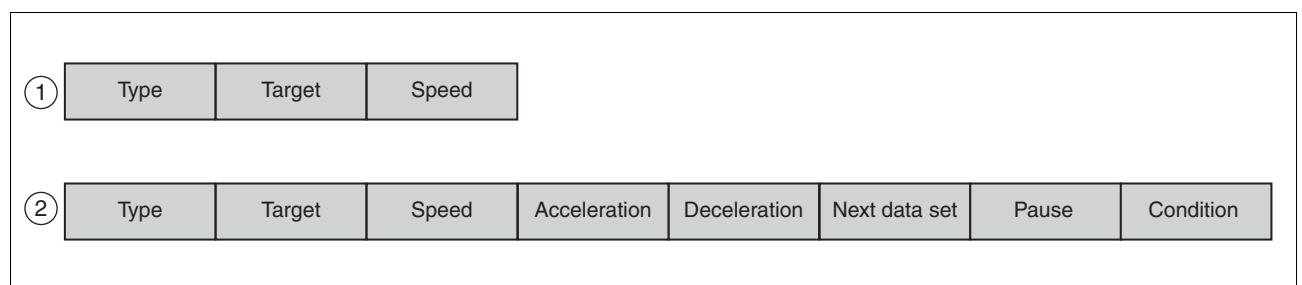

Figure 8.22 Structure of a data set

- (1) Direct selection of the data sets
- (2) Sequential selection of the data sets

Type Selection of data set type

The settings in Target and Profile have the following different meanings depending on the selected data set type:

Type	Description
Pos. absolute	Absolute positioning see 8.5.5 "Operating mode Profile position"
Pos. relative	Relative positioning see 8.5.5 "Operating mode Profile position"
Homing	Reference movement on limit switch with and without index pulse, see chapter 8.5.8 "Operating mode Homing"
Dimension setting	Set dimensions see 8.5.8.5 "Homing by dimension setting"

Parameter Name HMI menu	Description	Unit Minimum value Default value Maximum value	Data type R/W persistent Expert	Parameter address via fieldbus
MSMdataType	Selection of movement type	-	UINT16	CANopen 302D:11 _h
-	0 = None	0	UINT16	Modbus 11554
-	Sequential selection: Only processing of wait time and transition condition . Direct selection : trigger a data set without movement but retain the handshake mechanism. 1 = absolute positioning 2 = relative positioning 3 = homing 4 = set dimensions	0 4	R/W per. -	

Target Corresponds to different values according to data set type. In the case of positioning, an absolute or relative position change respectively. In the case of homing, the method of reference movement can be selected here. In the case of set dimensions, an absolute position is specified.

Parameter Name HMI menu	Description	Unit Minimum value Default value Maximum value	Data type R/W persistent Expert	Parameter address via fieldbus
MSMdataTarget	Target value of movement type	-	INT32	CANopen 302D:12 _h
-	Value depends on the selected processing mode (for setting see MSMDataType):	-2147483648	INT32	Modbus 11556
-	- none: no meaning - absolute positioning: absolute position in usr - relative positioning: Relative distance in usr - reference movement: type of reference movement (see HMmethod) - set dimensions: dimension setting position in usr	0 2147483647	R/W per. -	

Speed, acceleration and deceleration The values for speed [1/min] , acceleration [(1/min)/s] and deceleration [(1/min)/s] can be specified separately for each individual data set.

Parameter Name HMI menu	Description	Unit Minimum value Default value Maximum value	Data type R/W persistent Expert	Parameter address via fieldbus
MSMdataSpeed	Speed	1/min	UINT16	CANopen 302D:13 _h
-	In the case of relative or absolute movements this value corresponds to the target speed, for homing the search speed.	0	UINT16	Modbus 11558
-		0	R/W	
-		13200	per.	
-			-	
MSMdataAcc	Acceleration	(1/min)/s	UINT32	CANopen 302D:14 _h
-	0: using the current acceleration, no change	0	UINT32	Modbus 11560
-	>0: special acceleration value, for setting range see parameter RAMPacc	0	R/W	
-		3000000	per.	
-			-	
MSMdataDec	Deceleration	(1/min)/s	UINT32	CANopen 302D:15 _h
-	0: Using the current deceleration, no change	0	UINT32	Modbus 11562
-	>0: special acceleration value, for setting range see parameter RAMPdecel	0	R/W	
-		3000000	per.	
-			-	

Following data set Defines the number of the data set that is to be executed to follow.

Parameter Name HMI menu	Description	Unit Minimum value Default value Maximum value	Data type R/W persistent Expert	Parameter address via fieldbus
MSMdataNext	Number of following data set	-	UINT16	CANopen 302D:18 _h
-	Number of the next data set	0	UINT16	Modbus 11568
-		0	R/W	
-	setting has meaning only in the processing mode 'sequential selection'	15	per.	
-			-	

Pause Define the wait time after end of positioning. The value can be set from 0 to 30000 ms. The data set is considered ended only after this period.

Parameter Name HMI menu	Description	Unit Minimum value Default value Maximum value	Data type R/W persistent Expert	Parameter address via fieldbus
MSMdataDelay	Wait time	ms	UINT16	CANopen 302D:16 _h
-	Additional wait time after end of movement in ms.	0	UINT16	Modbus 11564
-		0	R/W	
-	Setting has meaning only in the processing mode 'sequential selection'	30000	per.	
-			-	

Condition Defines the transition condition that must be met before the next data set is executed. The following setting options are available for the parameter:

Condition	Description
AUTO	the next data set is started immediately after the current data set.
rising edge	The function "START" is monitored and at a rising edge, the condition is considered fulfilled.
falling edge:	The function "START" is monitored and at a falling edge, the condition is considered fulfilled.
0-level	The function "START" is monitored and at a level of 0 the condition is considered as fulfilled.
1-level	The function "START" is monitored and at a level of 1 the condition is considered as fulfilled.
Globally defined transition condition .	Uses the transition condition defined globally in the chapter 8.5.7.1 "Global settings".
Blended movement	The motor movement between the data sets is not stopped. Transition condition between the data sets is reaching the target position. The condition "blended movement" is possible only for : <ul style="list-style-type: none"> absolute positioning. In the case of subsequent data sets, whose target position is higher than that of the current data set.
Blended movement a)	The speed of the following data set is adjusted after reaching the target position.
Blended movement b)	The speed of the following data set is adjusted before reaching the target position.

Parameter Name HMI menu	Description	Unit Minimum value Default value Maximum value	Data type R/W persistent Expert	Parameter address via fieldbus
MSMdataNextCond	transition condition	- 0 4 7	UINT16 UINT16 R/W per. -	CANopen 302D:17 _h Modbus 11566
-	0 = rising edge			
-	1 = falling edge			
	2 = 1-level			
	3 = 0-level			
	4 = global transition condition (see MSMGlobalCond)			
	5 = Auto			
	6 = Blended Movement Type A			
	7 = Blended Movement Type B			
	Setting is only meaningful in 'sequential selection' processing mode'			

Start operating mode In the case of local control mode, the operating mode must be set using the parameter `IOdefaultMode` . The power amplifier is activated, the motor receives current and the inputs are evaluated in accordance with the setting by setting the input signal `ENABLE`.

In the case of fieldbus control mode, the operating mode must be set using the parameter `DCOMopmode`. The writing of the parameter value simultaneously causes the start of the operating mode.

Start data set for local control mode

For the local control mode, the globally defined transition condition checks the state of the function "Start DataSet". The first data set is started, if the globally defined transition condition is fulfilled. Separate transition conditions can be defined after the first data set for each of the subsequent data set.

Start data set for local control mode fieldbus.

For control mode fieldbus, the globally defined transition condition checks the parameter `MSMstartReq`. The first data set is started if the globally defined transition condition is fulfilled. Separate transition conditions can be defined after the first data set for each of the subsequent data set.

Parameter Name HMI menu	Description	Unit Minimum value Default value Maximum value	Data type R/W persistent Expert	Parameter address via fieldbus
MSMstartReq	start command for processing a data set	- 0 0 1	UINT16 UINT16 R/W -	CANopen 302D:3 _h Modbus 11526
-	Direct selection : a data set is always triggered by a rising edge. The number of the data set to be triggered must be set beforehand with <code>MSMset-Num</code> .			
-	Sequential selection: Triggering a data set with start or transition condition. The first start condition is set by <code>MSMGlobalCond</code> , the transition condition can be set separately for every data set.			

Alternatively, a transition condition can also be fulfilled through the function "Start profile positioning", if the function is parameterised on an input. See chapter 8.6.9 "Configurable inputs and outputs".

Status messages

The drive registers information on positioning in the motion sequence mode via the Bits 7, 8, 13, 14 and 15 in the parameter `DCOMstatus`.

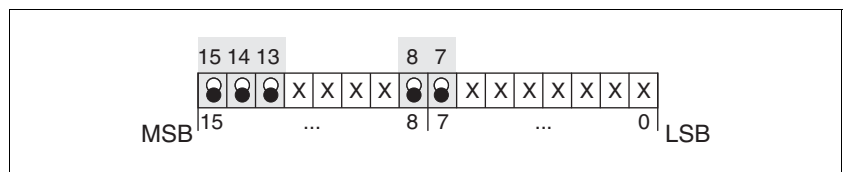

Figure 8.23 Status reports for operating mode

Parameter value	Description
Bit 7: Warning	1: Indicates that there is a warning in the parameter <code>_WarnActive</code>
Bit 8: Halt request active	1: Indicates that a "Halt" is active.
Bit 13: x_err	1: Error arisen
Bit 14: x_end	1: Data set completed, motor at a standstill
Bit 15: ref_ok	1: Drive is referenced.

8.5.7.3 Switching on the drive system

⚠ DANGER	
Unexpected movement	
With suitable parameterisation the product can start movements automatically after application of the VDC power supply. An unexpected restart may occur after a power failure.	
<ul style="list-style-type: none"> • Check the behaviour of the system during application of the power supply. • Make sure that no persons can be endangered by a restart of the system after a power failure. • Make sure that there are no persons in the range of action of the moving system components. 	
Failure to follow these instructions will result in death or serious injury.	

If the motion sequence is selected as start-up operating mode, the input signals and settings are processed in the following sequence when the drive system is switched on:

Activating the power amplifier

If the parameter `IO_AutoEnable` is parameterised to the value 2, the power amplifier is activated automatically on switching on.

If the parameter `IO_AutoEnable` is parameterised to 0, the power amplifier must be activated separately.

Selection of the data sets

In the local control mode the data set number always starts with 0.

In the control mode fieldbus, the parameter `MSMSetnum` can define the starting data set number.

Start of a data set

The globally defined transition condition `MSMGlobalCond` must be fulfilled before the start of the first data set.

In local control mode, the parameter `MSMGlobalCond` evaluates the function "Start DataSet".

In the fieldbus control mode, the parameter `MSMGlobalCond` evaluates the value of the parameter `MSMstartReq`.

If a static condition is parameterised as globally defined transition condition `MSMglobalCond` and this is present at the time of activating the power amplifier, the data set is started directly.

With suitable parameterisation, this sequence can be used to start a movement automatically when switching on.

8.5.7.4 "Direct selection of data sets" processing mode



There are fewer digital inputs or outputs available in local control mode. This puts a severe restriction on the scope of functions of the direct selection of the data sets. In the local operating mode, preferably use the sequential selection of the data sets.

The direct selection of the data sets is parameterised through the parameter `MSMsubMode`.

In local control mode, data set 0 is always started via the function "Start DataSet". The processing status can be reported via the function "Start acknowledge DataSet".

In the control mode fieldbus, the parameter `MSMSetnum` defines the starting data set number.

Operation with master controller

The sequence timing is controlled by I/O signals of a master controller, e.g. PLC. The current processing status of the drive can be found with suitable return signals. The signals are exchanged in the handshake process.

Example of a processing sequence with return value `x_end`

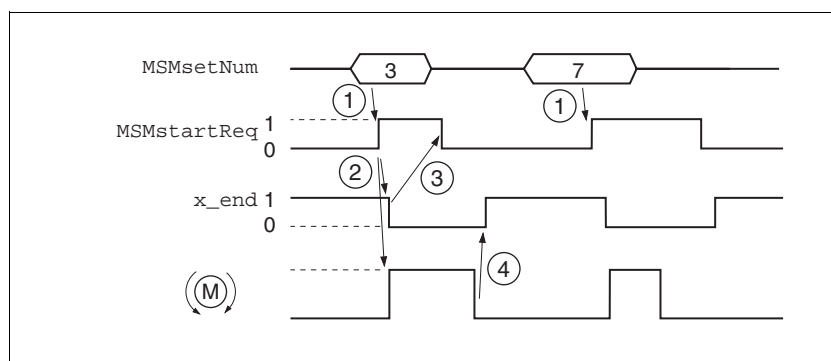

Figure 8.24 Example processing sequence in direct selection of the data sets

- (1) **PLC:** In the control mode fieldbus, the parameter `MSMsetNum` defines the starting data set number.
- (2) **LXM:** A change in the parameter `MSMstartReq` from 0 to 1 starts the positioning of the selected data set. Simultaneously the bit `x_end` of the parameter `DCOMstatus` is set to 0.
- (3) **PLC:** After detection of the activation of the data set, the parameter `MSMstartReq` can be set to 0 again.
- (4) **LXM:** The termination of the positioning is reported to the PLC by a 1 on bit `x_end` of the parameter `DCOMstatus` (`MSMstartReq` must be on 0).

The handshake signal checks the function "motor stand still" internally. If this is set to inactive and the parameter `MSMstartReq` as well, the bit `x_end` of the parameter `DCOMstatus` is set to 1 and the cycle is reported as terminated. This results in a synchronisation with the speed of the master controller. The second positioning job in the display is a short positioning that is completed more quickly than the cycle time of the master PLC. The processing of the `MSMstartReq` parameter ensures that the PLC detects the activation of the data set,

Example The data sets in the controller must be assigned as follows for control by PLC:

Data set no.	Type	Target	Speed
0	Reference movement	LIMN	1000
1	absolute	1000	1000
2	absolute	5000	2000
3	relative	-1000	500
4	relative	1000	1000

Setting The following settings are made in the commissioning software:

Data set no.	Type	Target	Speed	NextData Set	Pause	Condition
0	homing	LIMN	1000	1	0	global next condition
1	absolute positioning	1000	1000	3	0	global next condition
2	absolute positioning	5000	2000	0	0	global next condition
3	relative positioning	-1000	500	4	0	global next condition
4	relative positioning	1000	1000	5	0	global next condition
5	absolute positioning	0	2500	0	0	global next condition
6	homing	Fp INDEX inv	1	0	0	global next condition
7	homing	REFp INDEX inv	1	0	0	global next condition
8	set position	4000	1	0	0	global next condition
9	absolute positioning	1000000	1000	0	0	global next condition
10	homing	LIMN	1	0	0	global next condition
11	absolute positioning	304513	2000	0	0	global next condition
12	None	0	1	0	0	global next condition
13	None	0	1	0	0	global next condition
14	None	0	1	0	0	global next condition
15	None	0	1	0	0	global next condition

Figure 8.25 Example for direct selection of the data sets

8.5.7.5 "Sequential selection of data sets" processing mode

The sequential selection of the data set is parameterised via parameter `MSMsubMode`.

The processing sequence is preset by parameterisation of data sets. The globally defined continued transition condition is used at the starting of the first data set. `MSMglobCond`

The "Start DataSet" function can be used for fulfilling a condition in the local control mode.

The parameter `MSMstartReq` can be used for fulfilling a condition in the fieldbus control mode.

Operation without external controller, minimises external circuitry

The specified positioning jobs including wait time are processed sequentially. The transition conditions between the data sets can be set specifically for the application. It is possible to set whether each data set must be activated separately with a condition or if a number of data sets should be completed by the same condition (e.g. static 1-level).

If multiple data sets are enabled in sequence by the same start command, the processing of the sequence can be stopped if the condition is not fulfilled. This is possible if a static state was set as the transition condition, e.g. `NextCondition 1-level`. If the sequence is stopped the current data set is still completed. When the transition condition is met again the next data set in the sequence is processed.

In the case of fieldbus control mode, the parameter `MSMsetNum` determines the data set number with which to begin. The setting is imported when the power amplifier is enabled.

Example for sequential selection of the data sets through fieldbus

The following steps are required after enabling the power amplifier:

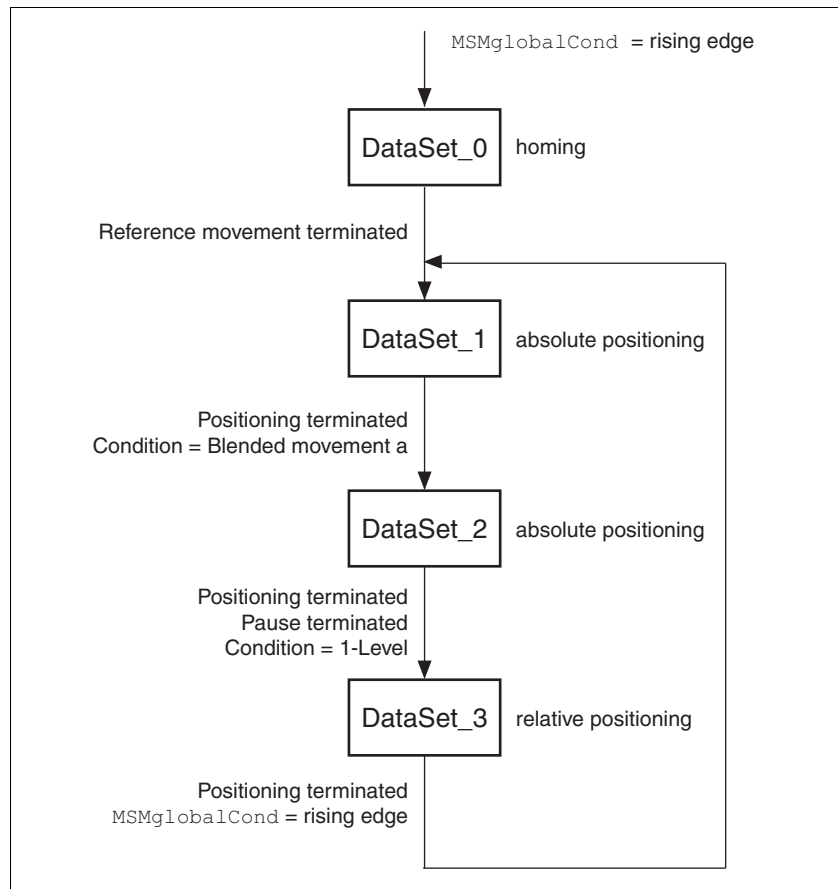

Figure 8.26 Processing principle for sequential data sets

- **Data set 0:**Reference movement to negative limit switch, no wait time, profile selection , next data set = data set1, continue process directly with next data set (data set1).
- **Data set 1:**Absolute positioning at 200000 usr, no wait time, next data set = data set2, continue process directly with the next data set on reaching the position, the speed does not go to 0 due to the blended movement condition.
- **Data set 2:**Absolute positioning at 1000000 usr, then wait time 2000ms, next data set = data set3, continue process directly with next data set if condition is still fulfilled.
- **Data set 3:**Relative positioning at -1200000 usr, no wait time, next data set = data set1, continue process with next data set, if rising edge parameterised under the parameter MSMglobalCond is fulfilled.

Setting The following settings are made in the commissioning software:

Data set no.	Type	Target	Speed	Next Data Set	Dwell time	Mode	Acc	Dec
0	homing	LIMN	1000	1	0	auto	0	0
1	absolute positioning	200000	1000	2	0	blended move typ A	0	0
2	absolute positioning	1000000	2000	3	2000	1-level	0	0
3	relative positionierung	1200000	500	1	0	global next condition	0	0

Figure 8.27 Example for sequential selection of the data sets

- Processing principle*
- (1) MSMglobalCond = Rising edge
 - (2) Reference movement complete
 - (3) Positioning terminated, flowing transition
 - (4) Positioning terminated AND DelayTime expired AND condition 1-level fulfilled
 - (5) Positioning complete AND MSMglobalCond fulfilled with rising edge

The data sets are processed in sequence. The specified data set 0 is selected after enabling the power amplifier. Processing of the first data set is started when the global start condition is fulfilled. The end of the process is signalled by an acknowledgement signal.

A return value can be issued through the parameter DCOMstatus (fieldbus control mode) or the function "Start acknowledge DataSet" (local control mode).

Example of a processing sequence with return value x_end (fieldbus)

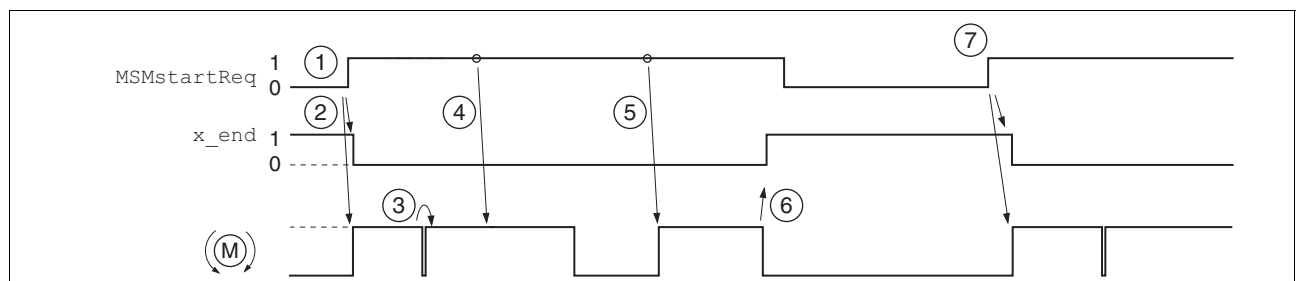

Figure 8.28 Handshake with sequential processing mode

- (1) The change from 0 to 1 in the parameter MSMstartReq activates the first data set (here 0). It was already selected when the power amplifier was activated.
- (2) Processing of the selected data set is started, simultaneously the bit x_end is set to 0.
- (3) Transition of reference movement to data set 1 immediately after end of reference movement.
- (4) Transition from Data set 1 to Data set 2 takes place without standstill of the motor, because condition is motion sequence.
- (5) Transition from data set2 to data set3 after expiry of wait time is immediate because transition condition is met.
- (6) After completion of data set 3, a change from 0 to 1 is expected in parameter MSMstartReq for a continued processing. The completion of a processing sequence is reported through value 1 of the bits x_end.
- (7) The change from 0 to 1 in parameter MSMstartReq activates the data set 1.

8.5.8 Operating mode Homing

The operating mode can only be used with fieldbus control mode and can only be executed via fieldbus.

⚠ WARNING
<p>Unmonitored operation</p> <ul style="list-style-type: none"> • Note that inputs to these parameters are executed by the drive controller immediately on receipt of the data set. • Make sure that the system is free and ready for movement before changing these parameters <p>Failure to follow these instructions can result in death, serious injury or equipment damage.</p>

Overview of homing

In homing mode, an absolute scale reference of the motor position at a defined axis position is established. Referencing can be carried out by a homing movement or by dimension setting.

- A reference movement performs movement to a defined point, the reference point, on the axis, in order to create the absolute measurement reference of the motor position. The reference point simultaneously defines the zero point that is used for all subsequent absolute positionings as a reference point. Displacement of the zero point can be set by parameters.

The reference movement must be carried out completely to ensure that the new zero point is valid. If it is interrupted, then the reference movement has to be started again. Unlike the other operating modes a reference movement must be completed before you can switch to a new operating mode.

The signals required for the reference movement must be wired. Monitoring signals that are not used should be deactivated.

- Set dimensions provides the option of setting the current motor position to a desired position value to which the subsequent position specifications will refer.



Homing is not required for a motor with Multiturn encoder because it sends a valid absolute position after startup.

Types of reference movements

4 standard reference movements are available

- Movement to negative limit switch $\overline{\text{LIMN}}$
- Movement to positive limit switch $\overline{\text{LIMP}}$
- Movement to reference switch $\overline{\text{REF}}$ with movement in counter-clockwise rotation
- Movement to reference switch $\overline{\text{REF}}$ with movement in clockwise rotation

A reference movement can be conducted with or without index pulse.

- Reference movement without index pulse
Movement from the edge of the switch to a distance set by parameters from the edge of the switch.
- Reference movement with index pulse
Movement from the edge of the switch to the next index pulse of the motor. The current motor position can be read out with the parameter `_p_absENCusr`. The index pulse is at position value 0.

Trigger homing Homing via Bit 4=1 in parameter `DCOMcontrol` is triggered.

Status messages The drive provides information concerning positioning via Bits 10 and 12 to 15 in the parameter `DCOMstatus`.

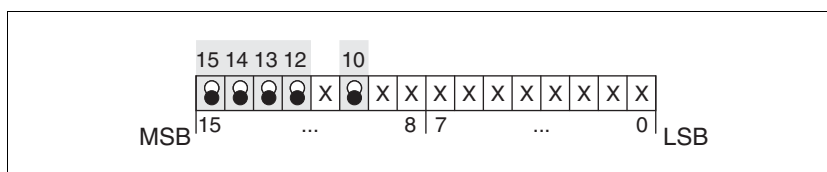

Figure 8.29 Status reports for operating mode

Parameter/ Signal	Description
Bit 10: Target reached	0: Homing not finished 1: Homing finished (also when interrupted by "Halt").
Bit 12: Homing attained	1: Homing successfully completed
Bit 13: x_err	1: Error arisen
Bit 14: x_end	1: Homing completed, motor at a standstill
Bit 15: ref_ok	1: drive has valid reference point

8.5.8.1 Setting by parameters, general

Description There are various methods of homing which can be selected via the parameters `HMmethod`.

Parameter Name HMI menu	Description	Unit Minimum value Default value Maximum value	Data type R/W persistent Expert	Parameter address via fieldbus
HMmethod	Reference movement method	-	INT8	CANopen 6098:0 _h
-	1: LIMN with index pulse	1	INT16	Modbus 6936
-	2: LIMP with index pulse	18	R/W	
-	7: REF+ with index pulse, inv., outside	35	-	
	8: REF+ with index pulse, inv., inside			
	9: REF+ with index pulse, not inv., inside			
	10: REF+ with index pulse, not inv., outside			
	11: REF- with index pulse, inv., outside			
	12: REF- with index pulse, inv., inside			
	13: REF- with index pulse, not inv., inside			
	14: REF- with index pulse, not inv., outside			
	17: LIMN			
	18: LIMP			
	23: REF+, inv., outside			
	24: REF+, inv., inside			
	25: REF+, not inv., inside			
	26: REF+, not inv., outside			
	27: REF-, inv., outside			
	28: REF-, inv., inside			
	29: REF-, not inv., inside			
	30: REF-, not inv., outside			
	33: index pulse neg. direction			
	34: index pulse pos. direction			
	35: set dimensions			
	Explanation of abbreviations: REF+: search movement in pos. direction REF-: search movement in neg. direction inv.: invert direction in switch not inv.: direction in switch not invert. outside: index pulse/distance outside switch inside: index pulse/distance inside switch			

The evaluation active 0 or active 1 of the reference switch `IOsigREF` is set via parameter `REF`. A release of the switch is not required.

The parameters `IOsigLimP` and `IOsigLimN` are used to release the input signals `LIMP` and `LIMN` and the evaluation is set to active 0 or active 1.



Use the active 0 monitoring signals if possible, because they are proof against wire breakage.

Parameter Name HMI menu	Description	Unit Minimum value Default value Maximum value	Data type R/W persistent Expert	Parameter address via fieldbus
IOsigRef	REF signal evaluation	-	UINT16	CANopen 3006:E _h
-	1 / normally closed: normally closed contact	1	UINT16	Modbus 1564
-	2 / normally open: normally-open switch	2	R/W per.	-
	The reference switch is only enabled while processing the reference movement to REF.			
IOsigLimN	LIMN signal evaluation	-	UINT16	CANopen 3006:F _h
-	0 / inactive: inactive	0	UINT16	Modbus 1566
-	1 / normally closed: normally closed contact	1	R/W	-
-	2 / normally open: normally-open switch	2	per.	-
IOsigLimP	LIMP signal evaluation	-	UINT16	CANopen 3006:10 _h
-	0 / inactive: inactive	0	UINT16	Modbus 1568
-	1 / normally closed: normally closed contact	1	R/W	-
-	2 / normally open: normally-open switch	2	per.	-

The parameters HM_n and HM_{n_out} are used for setting the speeds for the reference movement.

Parameter Name HMI menu	Description	Unit Minimum value Default value Maximum value	Data type R/W persistent Expert	Parameter address via fieldbus
HM _n	Setpoint speed for search for the switch	1/min	UINT32	CANopen 6099:1 _h
-	The set value is internally limited to the current parameter setting in RAMP _{n_max} .	1	UINT16	Modbus 10248
-		60	R/W	-
-		13200	per.	-
HM _{n_out}	Setpoint speed for retraction from switch	1/min	UINT32	CANopen 6099:2 _h
-	The set value is internally limited to the current parameter setting in RAMP _{n_max} .	1	UINT16	Modbus 10250
-		6	R/W	-
-		3000	per.	-

The parameter $HM_p_homeusr$ can be used to specify a desired position value, which is set at the reference point after a successful reference movement. This position value defines the current motor position at the reference point. This also defines the zero point.

Parameter Name HMI menu	Description	Unit Minimum value Default value Maximum value	Data type R/W persistent Expert	Parameter address via fieldbus
HM _{p_homeusr}	Position on reference point	usr	INT32	CANopen 3028:B _h
-	After successful reference movement this position value is automatically set at the reference point.	-2147483648	INT32	Modbus 10262
-		0	R/W	-
-		2147483647	per.	-

The parameters HMoutdisusr and HMsrchdisusr can be used for activation of the monitoring of the switch function.

Parameter Name HMI menu	Description	Unit Minimum value Default value Maximum value	Data type R/W persistent Expert	Parameter address via fieldbus
HMoutdisusr - -	Maximum run-off distance 0: run-off check inactive >0: run-off in user-defined units The switch must be disabled again inside this run-off, otherwise the reference movement is aborted	usr 0 0 2147483647	INT32 INT32 R/W per. -	CANopen 3028:6 _h Modbus 10252
HMsrchdisusr - -	max. search distance after traversing over the switch 0: search distance processing inactive >0: search distance in user-defined units The switch must be enabled again inside this search distance, otherwise the reference movement is aborted	usr 0 0 2147483647	INT32 INT32 R/W per. -	CANopen 3028:D _h Modbus 10266

8.5.8.2 Reference movement without index pulse

Description A reference movement without index pulse is set via the parameter HMmethod = 17 ... 30, see page 8-46.

The parameter HMdisusr can be used to set the distance to the switching edge.

Parameter Name HMI menu	Description	Unit Minimum value Default value Maximum value	Data type R/W persistent Expert	Parameter address via fieldbus
HMdisusr	Distance between the switching edge and the reference point	usr 1 200 2147483647	INT32 INT32 R/W per. -	CANopen 3028:7 _h Modbus 10254
-	After leaving the switch, the drive is still positioned in the work stroke for a defined path and this position is defined as a reference point.			
	The parameters are only effective with reference movements without index pulse searching.			

Reference movement towards limit switch A reference movement to the negative limit switch is shown below with the distance to the switch edge (HMmethod = 17).

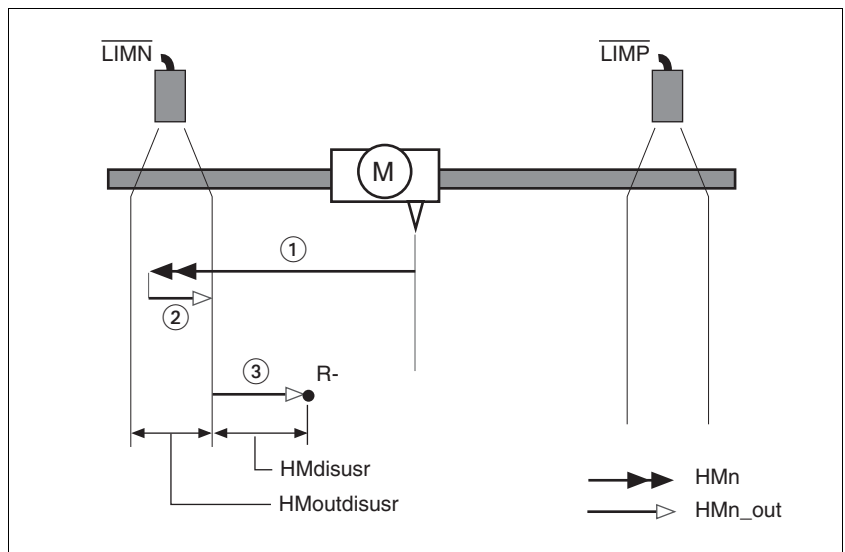

Figure 8.30 Reference movement to the negative limit switch

- (1) Movement to limit switch at search speed
- (2) Movement to switching edge with clearance speed
- (3) Movement at the distance to switching edge with clearance speed

Reference movement to reference switch Reference movements to the reference switch with the distance to the switch edge are shown below (HMmethod = 27 to 30).

019844113232, V1.20, 06.2007

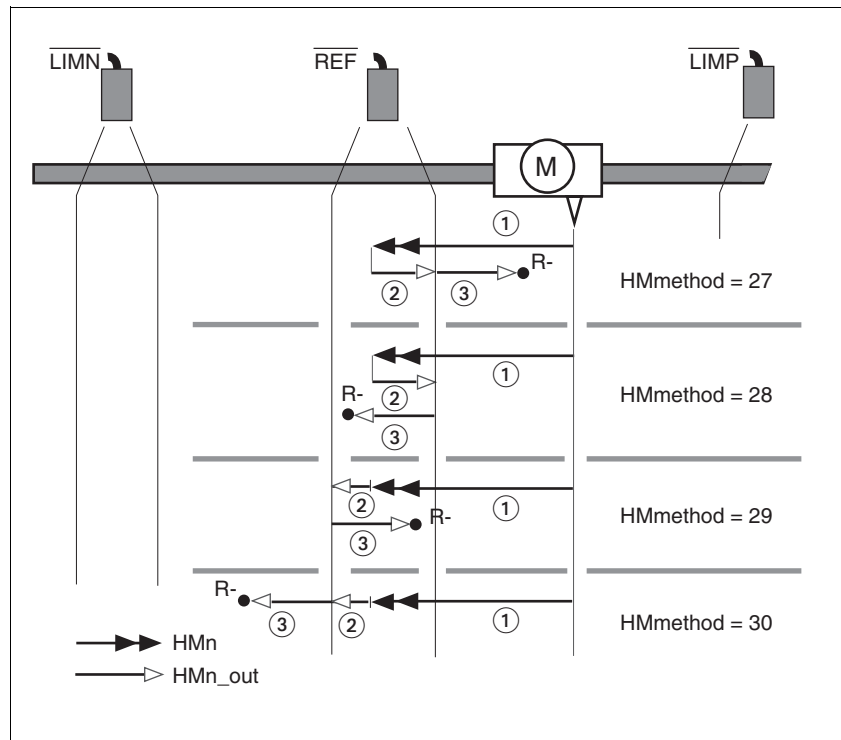

Figure 8.31 Reference movements to the reference switch

- (1) Movement to reference switch at search speed
- (2) Movement to switching edge with clearance speed
- (3) Movement at the distance to switching edge with clearance speed

Examples Reference movements to the reference switch with the distance to the switch edge are shown below ($HM_{method} = 27$). Various responses at different search speeds and start positions are shown.

- Movement to the reference switch with first movement in the negative direction, reference switch is once before (A1, A2) and once behind the start point (B1, B2).
- Additional movement when traversing through the switch range (A2, B2).

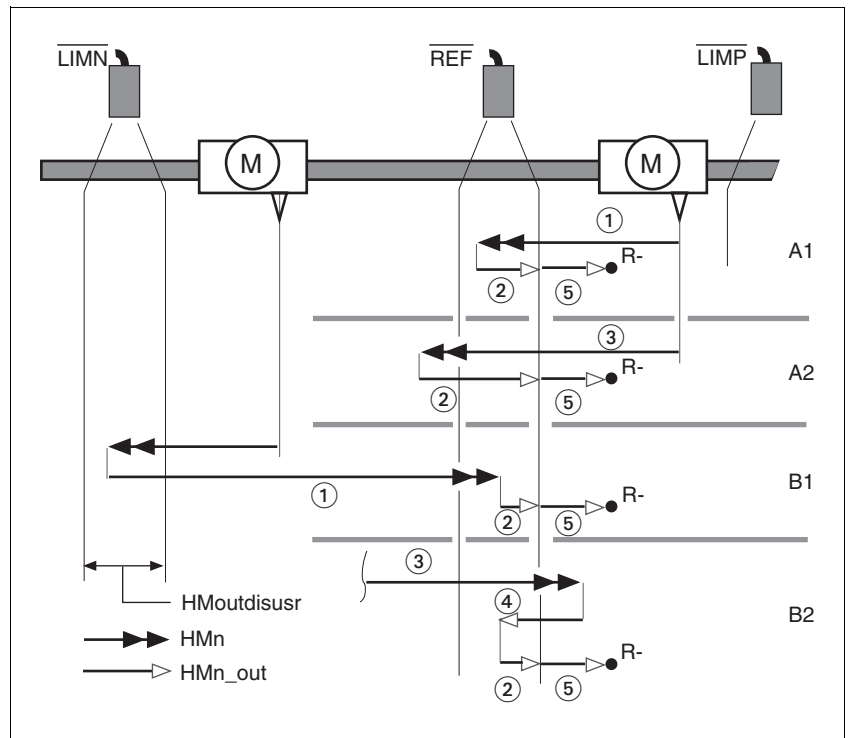

Figure 8.32 Reference movements to the reference switch

- (1) Movement to reference switch at search speed
- (2) Movement to switching point with clearance speed
- (3) Excessively fast movement to reference switch with search speed
- (4) Return movement to switch area at clearance speed
- (5) Movement at the distance to switching point with clearance speed

8.5.8.3 Reference movement with index pulse

Description A reference movement with index pulse is set via the parameter $HMmethod = 1 \dots 14$, see page 8-46.

First, the defined reference switch is approached and finally a search movement is made to the nearest index pulse.

Parameter possibilities The position distance between switching edge and index pulse can be calculated with the parameter $HMdisREFtoIDX$. The value should be >0.05 revolutions.

If the index pulse is too close to the switching edge, the limit switch or reference switch can be moved mechanically. Otherwise the position of the index pulse can be moved with the parameter $ENC_pabsusr$, see Chapter 7.4.13 "Setting parameters for encoder" page 7-33. This ensures that a reference movement with index pulse can be reproduced at any time.

Parameter Name HMI menu	Description	Unit Minimum value Default value Maximum value	Data type R/W persistent Expert	Parameter address via fieldbus
HMdisREFtoIDX	Distance switch - index pulse after reference movement	revolution - 0.0000 -	INT32 INT32 R/- -	CANopen 3028:C _n Modbus 10264
-	Reading value provides the value of the difference between the index pulse position and the position on the switching flank of the limit or reference switch. Used to check how far the index pulse is from the switching edge and is used as a criterion for whether the reference movement can be correctly reproduced with index pulse processing in steps of 1/10000 revolutions			

Reference movement towards limit switch A reference movement to the positive limit switch with movement to the first index pulse is shown below (HMmethod = 2).

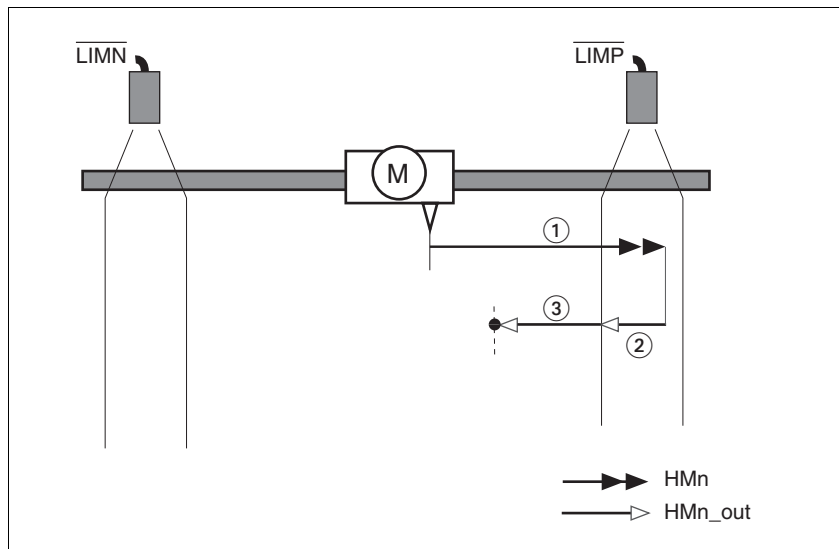

Figure 8.33 Reference movement to the positive limit switch

- (1) Movement to limit switch at search speed
- (2) Movement to switching edge with clearance speed
- (3) Movement to index pulse with clearance speed

Reference movement to reference switch

Reference movements to the reference switch with movement to the first index pulse are shown below (HMmethod = 11 to 14).

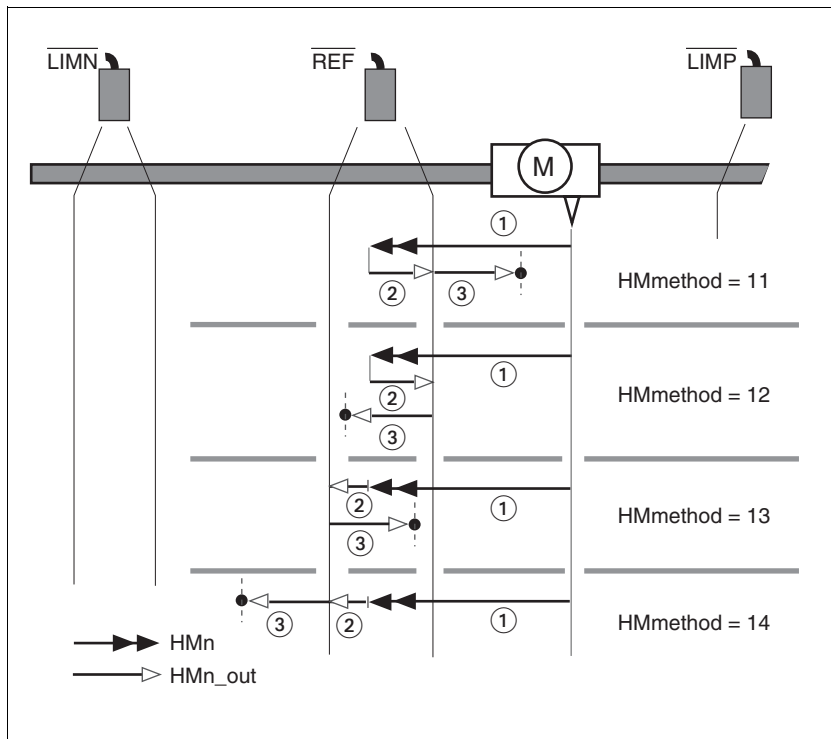

Figure 8.34 Reference movements to the reference switch

- (1) Movement to reference switch at search speed
- (2) Movement to switching edge with clearance speed
- (3) Movement to index pulse with clearance speed

Examples

Reference movements to the reference switch with movement to the first index pulse are shown below (HMmethod = 11). Various responses at different search speeds and start positions are shown.

- Movement to the reference switch with first movement in the negative direction, reference switch is once before (A1, A2) and once behind the start point (B1, B2).
- Additional movement when traversing through the switch range (A2, B2).

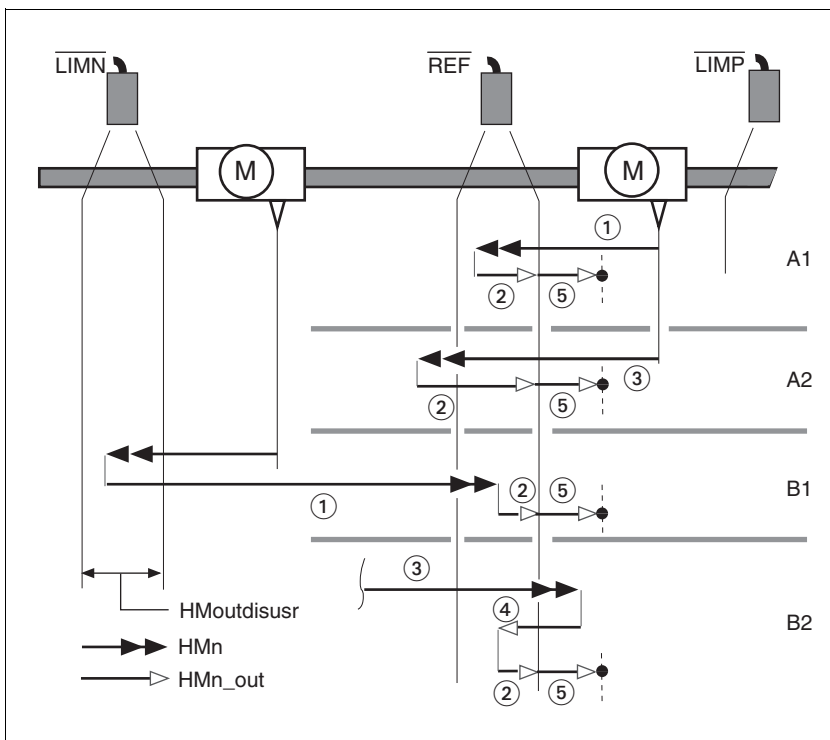

Figure 8.35 Reference movements to the reference switch

- (1) Movement to reference switch at search speed
- (2) Movement to switching point with clearance speed
- (3) Excessively fast movement to reference switch with search speed
- (4) Return movement to switch area at clearance speed
- (5) Movement to index pulse with clearance speed

8.5.8.4 Reference movement to the index pulse

Description A reference movement to the index pulse is set via the parameter HMmethod = 33 and 34, see page 8-46.

Reference movement on index pulse In the following descriptions the reference movements are shown on the index pulse (HMmethod = 33 and 34).

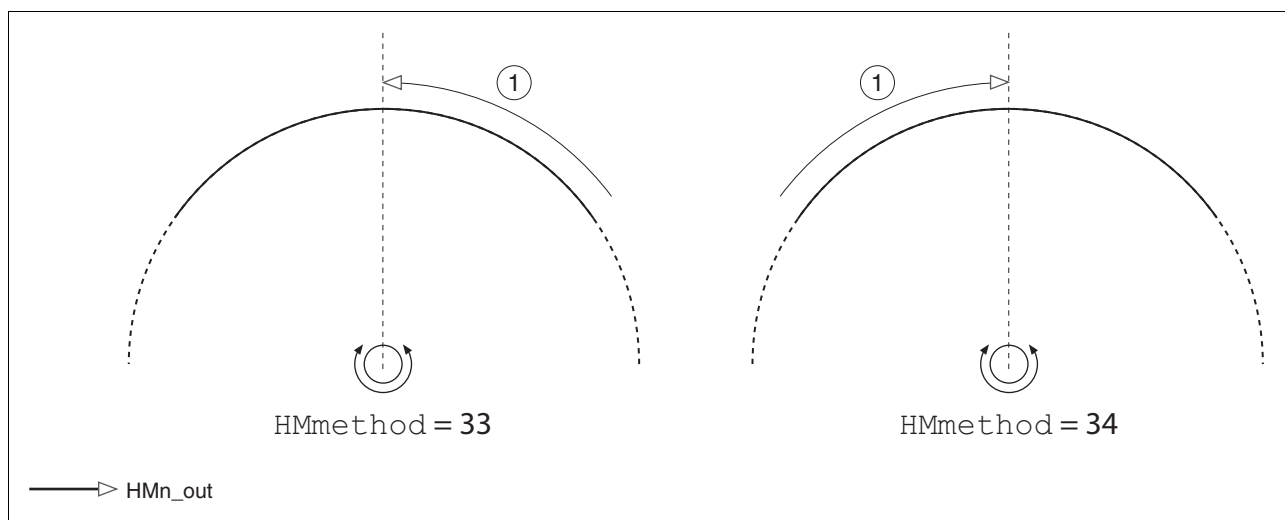

Figure 8.36 Reference movement on index pulse

(1) Movement on index pulse with clearance speed

8.5.8.5 Homing by dimension setting

Description A homing by set dimensions is set via the parameter HMmethod = 35, see page 8-46.

The current motor position is set at the position value in the parameter HMp_setpusr. This also defines the zero point.

Homing by dimension setting can only be carried out when the motor is at a standstill. Any active position deviation is retained and can still be compensated by the position controller after dimension setting has taken place.

Parameter Name HMI menu	Description	Unit Minimum value Default value Maximum value	Data type R/W persistent Expert	Parameter address via fieldbus
HMp_setpusr	Position for dimension setting	usr	INT32	CANopen 301B:16 _h
-	Dimension setting position for homing	-	INT32	Modbus 6956
-	method 35	0	R/W	
-		-	-	

019844113232, V1.20, 06.2007

Example Dimension setting can be used to carry out a continuous motor movement without exceeding positioning limits.

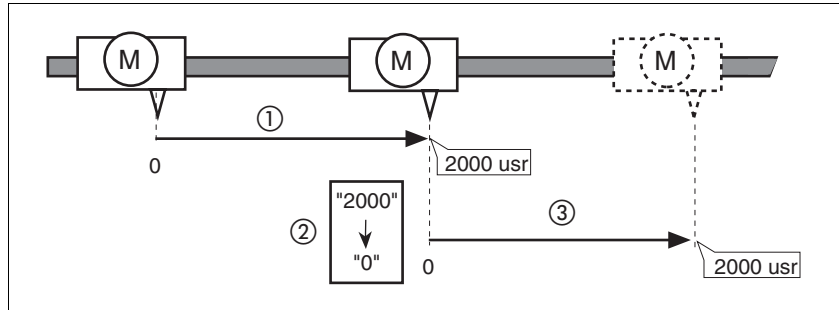

Figure 8.37 Positioning by 4000 usr units with dimension setting

- (1) The motor is positioned by 2000 usr.
- (2) By setting dimensions to 0 the current motor position is set to position value 0 and the new zero point is simultaneously defined.
- (3) After triggering a new travel command of 2000 usr, the new target position is 2000 usr.

This method avoids crossing absolute position limits during a positioning operation because the zero point is continuously tracked.

The read out of the setpoint is by the parameter `_p_refusr`.

Parameter Name HMI menu	Description	Unit Minimum value Default value Maximum value	Data type R/W persistent Expert	Parameter address via fieldbus
<code>_p_refusr</code>	Setpoint position in user-defined units	usr	INT32	CANopen 301E:C _h
-	Value represents the setpoint position of the position controller	- 0	INT32 R/-	Modbus 7704
-		-	-	

8.6 Functions

8.6.1 Monitoring functions

8.6.1.1 Status monitoring in movement mode

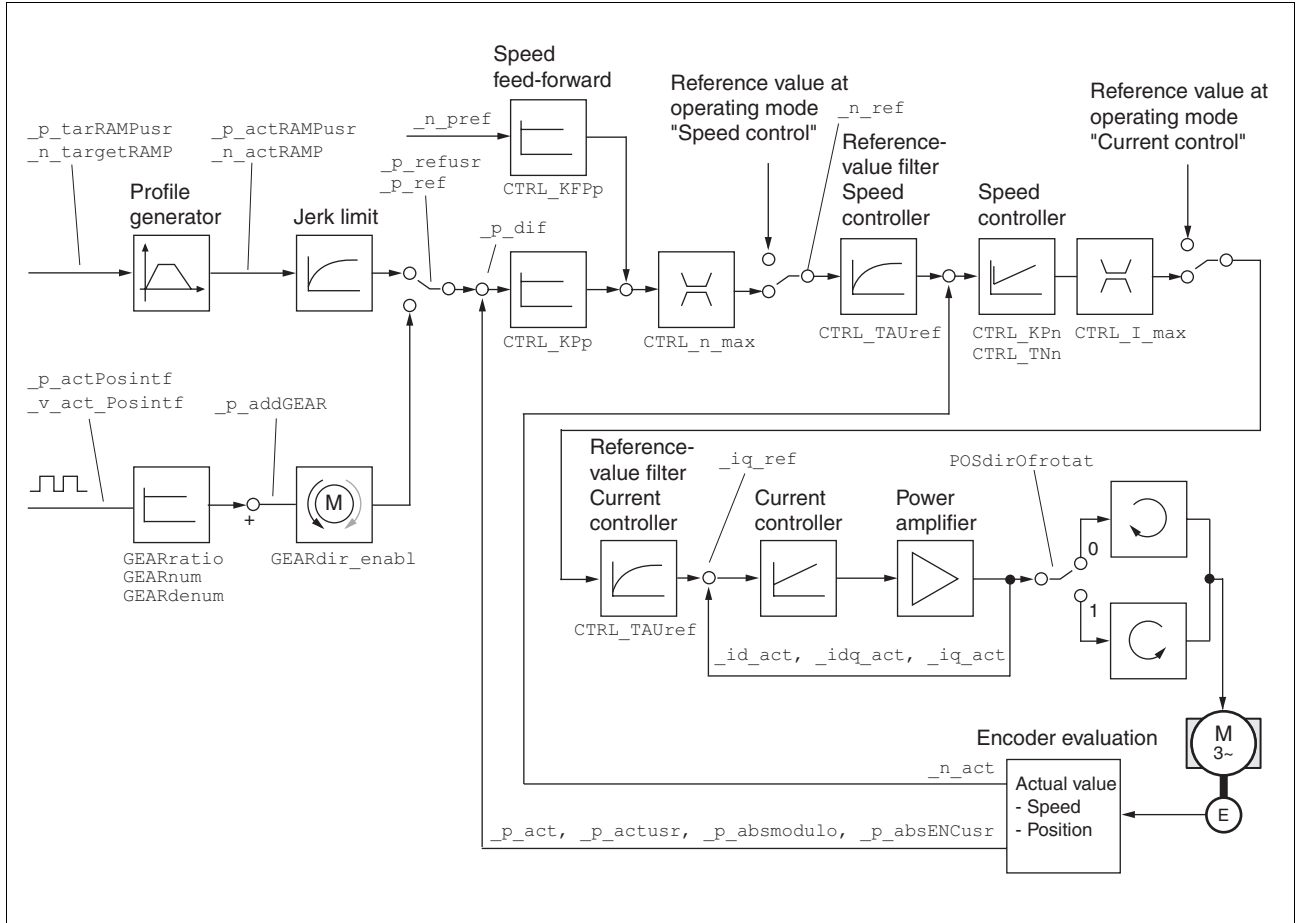

Figure 8.38 Status monitoring of the control loops

8.6.1.2 Positioning range

Positioning range (only fieldbus)

The motor can be moved to any point on the axis within the axis positioning range by specifying an absolute positioning process.

The current position of the motor can be read out using the parameter $_p_actusr$.

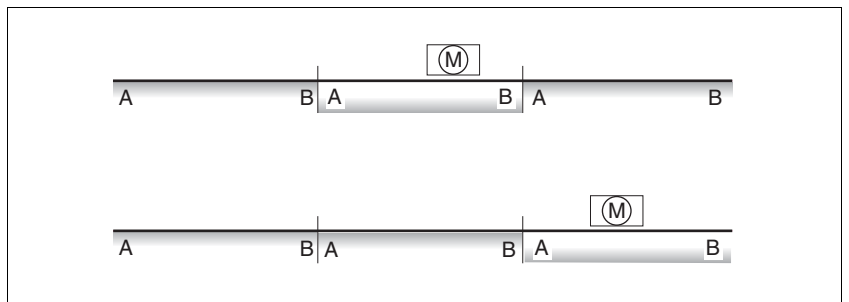

Figure 8.39 Positioning range

The positioning limits, with default scaling, are:

- (A) -286435456 usr
- (B) 286435455 usr

An overshoot of the positioning limits is possible in all operating modes, except during an absolute positioning in profile position mode.

Overshoot of motor at a positioning limit loses the reference point.

During a relative position in profile position mode a check of whether the absolute positioning limits will be overshoot is made before starting the movement. If yes, an internal dimension setting to 0 is made before starting the movement. The reference point is lost (ref_ok = 1->0).

Software limit switches

The positioning range can be limited by software limit switch. This is possible as soon as the drive has a valid zero point (ref_ok = 1). The positioning values are quoted relative to the zero point. The software limit switches are set using the parameters SPVswLimPusr and SPVswLimNusr are activated using SPV_SW_Limits .

The determining factor for position monitoring of the software limit switch range is the setpoint of the position controller. Depending on the controller setting, therefore, the motor can stop before it reaches the limit switch position. Bit 2 of parameter _SigLatched signals the triggering of a software limit switch

Parameter Name HMI menu	Description	Unit Minimum value Default value Maximum value	Data type R/W persistent Expert	Parameter address via fieldbus
SPVswLimPusr - -	positive position limit for software limit switch If a user-defined value outside the permissible user-defined area is set, the limit switch limits are automatically limited internally to the maximum user-defined value.	usr - 2147483647 -	INT32 INT32 R/W per. -	CANopen 607D:2 _h Modbus 1544
SPVswLimNusr - -	negative position limit for software limit switch see description of 'SPVswLimPusr'	usr - -2147483648 -	INT32 INT32 R/W per. -	CANopen 607D:1 _h Modbus 1546
SPV_SW_Limits - -	Monitoring the software limit switch 0 / none: none (default) 1 / SWLIMP: Activating SW limit switch pos. direction 2 / SWLIMN: activating SW limit switch neg. direction 3 / SWLIMP+SWLIMN: Activating SW limit switch both. directions The software limit switch is only monitored after a successful homing (ref_ok = 1)	- 0 0 3	UINT16 UINT16 R/W per. -	CANopen 3006:3 _h Modbus 1542

Limit switch

▲ CAUTION**Loss of control**

The use of $\overline{\text{LIMP}}$ and $\overline{\text{LIMN}}$ can offer some protection against dangers (e.g. impact on mechanical stop caused by incorrect movement targets).

- Use $\overline{\text{LIMP}}$ and $\overline{\text{LIMN}}$ where possible.
- Check that the external sensors or switches are correctly connected.
- Check the correct functional installation of the limit switch. The limit switches must be mounted in a position far enough away from the mechanical stop to allow an adequate braking distance.
- The functions must be enabled to use $\overline{\text{LIMP}}$ and $\overline{\text{LIMN}}$.
- This function cannot provide protection against faulty functioning of the product or the sensors.

Failure to follow these instructions can result in injury or equipment damage.

During the movement the two limit switches are monitored with the input signals $\overline{\text{LIMP}}$ and $\overline{\text{LIMN}}$. If the drive moves to a limit switch, the motor stops. The triggering of the limit switch is signalled.

The parameters IOsigLimP and IOsigLimN are used to release the input signals $\overline{\text{LIMP}}$ and $\overline{\text{LIMN}}$ and the evaluation is set to active 0 or active 1.



Use the active 0 monitoring signals if possible, because they are proof against wire breakage.

Parameter Name HMI menu	Description	Unit Minimum value Default value Maximum value	Data type R/W persistent Expert	Parameter address via fieldbus
IOsigLimN	LIMN signal evaluation	-	UINT16	CANopen 3006:F _h
-	0 / inactive: inactive	0	UINT16	Modbus 1566
-	1 / normally closed: normally closed contact	1	R/W	
-	2 / normally open: normally-open switch	2	per.	
			-	
IOsigLimP	LIMP signal evaluation	-	UINT16	CANopen 3006:10 _h
-	0 / inactive: inactive	0	UINT16	Modbus 1568
-	1 / normally closed: normally closed contact	1	R/W	
-	2 / normally open: normally-open switch	2	per.	
			-	
IOsigRef	REF signal evaluation	-	UINT16	CANopen 3006:E _h
-	1 / normally closed: normally closed contact	1	UINT16	Modbus 1564
-	2 / normally open: normally-open switch	1	R/W	
		2	per.	
			-	
	The reference switch is only enabled while processing the reference movement to REF.			

Moving drive out The drive can be moved back from the limit switch area to the movement area by using manual movement.

If the drive does not go back to the movement area, check whether the manual drive is activated and that the correct direction of movement has been selected.

8.6.1.3 Monitoring internal signals

The monitoring systems protect against overheating and contribute to the functioning and operating safety. You will find a list of all safety devices in the chapter entitled 2.6 "Monitoring functions"

Temperature monitoring Sensors monitor the temperature of motor and power amplifier. All temperature limits are permanently set. If the temperature of a component approaches its permissible temperature limit, the device creates a warning signal. If the temperature exceeds the limit value for more than 5 seconds, then the power amplifier and the regulation switches off. The device signals a temperature error.

Limit temperature	
Power amplifier/CPU	100°C
Motor	See Motor Manual

Parameter Name HMI menu	Description	Unit Minimum value Default value Maximum value	Data type R/W persistent Expert	Parameter address via fieldbus
_Temp_act_DEV STA- - TDEV 5tR- - t dEU	device temperature	°C - 0 -	INT16 INT16 R/- -	CANopen 301C:12 _h Modbus 7204
_Temp_act_M - -	Temperature motor Reasonable display is not possible for switching temperature sensors (for temperature sensor type see parameter M_TempType)	°C - 0 -	INT16 INT16 R/- -	CANopen 301C:11 _h Modbus 7202
_Temp_act_PA STA- - TPA 5tR- - tPR	Temperature of the power amplifier	°C - 0 -	INT16 INT16 R/- -	CANopen 301C:10 _h Modbus 7200
M_T_max - -	max. Motor temperature	°C - 0 -	INT16 INT16 R/- -	CANopen 300D:10 _h Modbus 3360
PA_T_max - -	maximum permissible temperature of the power amplifier	°C - 0 -	INT16 INT16 R/- per. -	CANopen 3010:7 _h Modbus 4110
PA_T_warn - -	Temperature limit of the power amplifier	°C - 0 -	INT16 INT16 R/- per. -	CANopen 3010:6 _h Modbus 4108

019844113232, V1.20, 06.2007

I²t monitoring If the device operates with high peak currents, then temperature monitoring with sensors can be too sluggish. With the ²t monitoring, the closed-loop control anticipates a rise in temperature in time and if the ²t threshold is exceeded, it reduces the current to the nominal value.

If the limit value is not reached, the individual components can be taken to the output limit again.

Parameter Name HMI menu	Description	Unit Minimum value Default value Maximum value	Data type R/W persistent Expert	Parameter address via fieldbus
_I2tl_act_RES	Actual overload braking resistor	% - 0 -	INT16 INT16 R/- -	CANopen 301C:13 _h Modbus 7206
_I2tl_mean_RES	Braking resistor load	% - 0 -	INT16 INT16 R/- -	CANopen 301C:14 _h Modbus 7208
STA- - i2TR 5tR- - , 2tR				
_I2t_peak_RES	Overload braking resistor maximum value	% - 0 -	INT16 INT16 R/- -	CANopen 301C:15 _h Modbus 7210
-	Maximum overload braking resistor that has occurred in the last 10 sec.			
_I2t_act_PA	Overload power amplifier current	% - 0 -	INT16 INT16 R/- -	CANopen 301C:16 _h Modbus 7212
_I2t_mean_PA	Power amplifier load	% - 0 -	INT16 INT16 R/- -	CANopen 301C:17 _h Modbus 7214
STA- - i2TP 5tR- - , 2tP				
_I2t_peak_PA	Overload power amplifier maximum value	% - 0 -	INT16 INT16 R/- -	CANopen 301C:18 _h Modbus 7216
-	Maximum overload power amplifier that has occurred in the last 10 sec.			
_I2t_act_M	Overload motor current	% - 0 -	INT16 INT16 R/- -	CANopen 301C:19 _h Modbus 7218
_I2t_mean_M	Motor load	% - 0 -	INT16 INT16 R/- -	CANopen 301C:1A _h Modbus 7220
STA- - i2TM 5tR- - , 2tM				
_I2t_peak_M	Overload motor maximum value	% - 0 -	INT16 INT16 R/- -	CANopen 301C:1B _h Modbus 7222
-	Maximum overload motor that has occurred in the last 10 sec.			

Tracking error monitoring The drive monitors the following error at 1ms intervals. The tracking error is the difference between the current setpoint and the actual position. If the difference exceeds the limit value set by the parameter *SPV_P_maxDiff*, it will immediately cause an interruption of movement (tracking error) with configurable error class.

Select the limit value in parameter *SPV_P_maxDiff* significantly higher than the maximum possible following error in error-free operation. This will ensure that a shutdown as a result of tracking error will only occur in case of error, e.g. with illegally increased external load torque, faulty position encoder etc.

The maximum control deviation occurring during operation can be determined with the parameter *_p_DifPeak* and compared with the maximum permissible following error. This allows the actual distance to the shut-off limit to be detected.

The error class for a tracking error can also be changed, see also 8.6.1 "Monitoring functions".

Equalisation of the static conveyance distance In the case of an interruption in movement as well as at the end of the movement, the conveyance distance is equalised. For the profile generator, the position is reached (end of the process, *x_end = 0->1*) though the motor still runs. This must be observed, especially for large conveyance distances. If the standstill window function is enabled, the end of process is indicated only if the motor actually comes to rest.

Calculation of the conveyance distance The tracking error monitoring considers the dynamic tracking error and tracking error reduced by the speed pilot control (KFPp). Only the tracking error actually required for generating torque is compared with the specified tracking error limit. The lower limit value at which the tracking error must be set as a minimum is derived with the following formula. The change of P-intervals is calculated without considering the dynamic I-intervals and D-intervals from the tracking error to the current reference value input. The current limit *I_{max}* is used as the current reference value.

As the unit of *KPn* [A/(rev/min)] is not a SI unit, a conversion factor of 1/(60(s/min)) must be taken into consideration. The result of the formula is a value in revolutions (rev=revolution), which immediately causes a tracking error with the corresponding error response.

$$x = \frac{CTRL_I_max}{CTRL_KPp \cdot CTRL_KPn} \cdot \frac{1}{60s/min}$$

Example of a tracking error calculation The following values are used in the example: *I_{max}*=10A, *KPp*=100/s, *KPn*=0.04A/(rev/min)

This produces the following results:

$$x = \frac{10A}{100 \frac{1}{s} \cdot 0,04A \frac{min}{rev}} \cdot \frac{1}{60s/min} = 0,0416rev$$

The calculated value is the actual tracking error that immediately results in a tracking error with shutdown. Enter five times the calculated value in the parameter `SPV_P_maxDiff` so that you have a corresponding safety distance. In the example, that would be $5 * 0.0416 \text{ rev} = 0.2080 \text{ rev}$ (rev=revolutions).

Parameter Name HMI menu	Description	Unit Minimum value Default value Maximum value	Data type R/W persistent Expert	Parameter address via fieldbus
<code>_p_DifPeak</code> - -	Value of max. reached tracking errors of the position controller The tracking error is the current position regulation offset minus the speed-dependent position regulation offset. For more information, see <code>SPV_p_maxDiff</code> . The value is again reset by writing.	revolution 0.0000 - 429496.7295	UINT32 UINT32 R/W -	CANopen 3011:F _h Modbus 4382
<code>_p_dif</code> STA- - PDiF 5tR- - Pd, F	Current variation between reference and actual position Corresponds to the current control deviation of the position controller without consideration of any dynamic components. Note: Different from <code>SPV_p_maxDiff</code>	revolution -214748.3648 - 214748.3647	INT32 INT32 R/- -	CANopen 60F4:0 _h Modbus 7716
<code>SPV_p_maxDiff</code> - -	Max. permissible tracking error of position controller The tracking error is the current position regulation offset minus the speed-dependent position regulation offset. Actually, only the position offset caused by the moment requirements is still referred to for tracking error monitoring.	revolution 0.0001 1.0000 200.0000	UINT32 UINT32 R/W per. -	CANopen 6065:0 _h Modbus 4636

Monitoring parameters The unit and operating status can be monitored with various objects.

Parameter Name HMI menu	Description	Unit Minimum value Default value Maximum value	Data type R/W persistent Expert	Parameter address via fieldbus
<code>_SigActive</code> - -	Current state of the monitoring signals Meaning see <code>_SigLatched</code>	- - 0 -	UINT32 UINT32 R/- -	CANopen 301C:7 _h Modbus 7182

Parameter Name HMI menu	Description	Unit Minimum value Default value Maximum value	Data type R/W persistent Expert	Parameter address via fieldbus
_SigLatched	Stored state of the monitoring signals	-	UINT32	CANopen 301C:8 _h
STA- - SiGS	Signal state:	-	UINT32	Modbus 7184
5tR- - 5, 55	0: not activated 1: activated	0	R/-	
	Bit assignment			
	Bit0: general error			
	Bit1: limit switch (LIMP/LIMN/REF)			
	Bit2: range exceeded (software limit switch, tuning)			
	Bit3: Quick Stop via fieldbus			
	Bit4: inputs PWRR are 0			
	Bit6: error RS485			
	Bit7: error CAN			
	Bit9: frequency of reference signal too high			
	Bit10: error current operating mode			
	Bit12: Profibus error			
	Bit14: undervoltage DC bus			
	Bit15: overvoltage DC bus			
	Bit16: no mains phase			
	Bit17: connection to motor faulty			
	Bit18: motor overcurrent/short circuit			
	Bit19: error in motor encoder			
	Bit20: undervoltage 24VDC			
	Bit21: overtemperature (power amplifier, motor)			
	Bit22: tracking error			
	Bit23: max. speed exceeded			
	Bit24: PWRR inputs different			
	Bit29: error in EEPROM			
	Bit30: system run-up (hardware or parameter fault)			
	Bit31: System error (e.g. Watchdog)			
	monitoring is dependent on product			
_WarnActive	Active warnings bit-coded	-	UINT16	CANopen 301C:B _h
-	Meaning of Bits see _WarnLatched	-	UINT16	Modbus 7190
-		0	R/-	
-		-	-	
-		-	-	

Parameter Name HMI menu	Description	Unit Minimum value Default value Maximum value	Data type R/W persistent Expert	Parameter address via fieldbus
<i>_WarnLatched</i>	Stored warnings bit-coded	-	UINT16	CANopen 301C:C _h
<i>STA- - WRNS</i>	Stored warning bits are erased in the event of a FaultReset.	0	UINT16 R/-	Modbus 7192
<i>5LR- - Lrn5</i>	Bits 10,11,13 are automatically deleted. Signal state: 0: not activated 1: activated Bit assignment Bit 0: general warning (see <i>_LastWarning</i>) Bit 1: power amplifier temperature high Bit 2: motor temperature high Bit 3: reserved Bit 4: overload (I ^{2t}) power amplifier Bit 5: overload (I ^{2t}) motor Bit 6: overload (I ^{2t}) braking resistor Bit 7: CAN warning Bit 8: Motor Encoder warning Bit 9: RS485 protocol warning Bit 10: PWRR_A and/or PWRR_B Bit 11: DC bus undervoltage, faulty mains phase Bit 12: Profibus warning Bit 13: Position not yet valid (position detection continuing) Bit 14: reserved Bit 15: reserved monitoring is product-dependent	-	-	
<i>_actionStatus</i>	Action word	-	UINT16	CANopen 301C:4 _h
-	Signal state: 0: not activated	0	UINT16 R/-	Modbus 7176
-	1: activated	-	-	
	Bit0: Class 0 error Bit1 Class 1 error Bit2: Class 2 error Bit3 Class 3 error Bit4 Class 4 error Bit5 reserved Bit6: drive stopped (actual speed <i>_n_act</i> [1/min] < 9) Bit7: drive rotates in positive direction Bit8: drive rotates in negative direction Bit9: reserved Bit10: reserved Bit11: Profile generator stopped (setpoint speed is 0) Bit12: Profile generator decelerating Bit13: Profile generator accelerating Bit14: Profile generator moves in constant mode Bit15: reserved			
<i>_StopFault</i>	Error number of the last interruption cause	-	UINT16	CANopen 603F:0 _h
<i>FLT- - STPF</i>		0	UINT16 R/-	Modbus 7178
<i>FLt - - 5tPF</i>		-	-	

Set fault response The response of the unit to a fault is classified into error classes, and can be set for certain monitoring functions. This allows the error response of the unit to be matched to the operational requirements.

Parameter Name HMI menu	Description	Unit Minimum value Default value Maximum value	Data type R/W persistent Expert	Parameter address via fieldbus
SPV_Flt_pDiff	Error response to tracking error	-	UINT16	CANopen 3005:B _h
-	1 / ErrorClass1: error class 1	1	UINT16	Modbus 1302
-	2 / ErrorClass2: error class 2	3	R/W	
-	3 / ErrorClass3: error class 3	3	per.	
SPV_Flt_AC	Error response to failure of a mains phase with 3-phase devices	-	UINT16	CANopen 3005:A _h
-	1 / ErrorClass1: error class 1	1	UINT16	Modbus 1300
-	2 / ErrorClass2: error class 2	2	R/W	
-	3 / ErrorClass3: error class 3	3	per.	

8.6.1.4 Commutation monitoring

Functional principle The unit continuously checks the plausibility of motor acceleration and effective motor moment, in order to recognise uncontrolled motor movements and to stop them if required. The monitoring function is referred to as commutation monitoring.

If the motor accelerates for a time period of more than 5 to 10ms, the commutation monitoring signals an uncontrolled motor movement, even though the drive regulation delays the motor with the set current value.

The unit shows flashing on HMI **5503** (error class 4)

Causes of error Uncontrolled motor movements can be traced back to the following causes:

- The motor phases U, V, W are connected to the unit incorrectly, i.e. each offset by 120° , e.g. U with V, V with W, W with U.
- Faulty or interfered evaluation of the rotor position by a faulty position encoder on the motor, interfered sensor signals or defective position acquisition in the unit.

In addition, the unit can recognise a commutation error in the following cases, since the above-mentioned plausibility conditions could equally apply:

- The motor receives an external torque that is greater than the specified maximum torque. The external force causes it to accelerate.
- The motor is manually moved either in the direction of the motor moment or in the opposite direction, while the drive regulation is active.
- The motor is moved to a mechanical stop.
- Speed and position control loop are set to be extremely unstable.

*Parameterisation***▲ WARNING****Unexpected movement**

The risk of unexpected movement is increased when the monitoring functions are disabled.

- Use the monitoring functions.

Failure to follow these instructions can result in death, serious injury or equipment damage.

Parameter Name HMI menu	Description	Unit Minimum value Default value Maximum value	Data type R/W persistent Expert	Parameter address via fieldbus
SPVcommutat	Monitoring commutation	-	UINT16	CANopen 3005:5 _h
-	0 / off: off	0	UINT16	Modbus 1290
-	1 / on: on (default)	1	R/W per.	
-		1	-	

8.6.1.5 Earth fault monitoring*Functional principle*

The device continuously checks the motor phases for earth fault with the power amplifier enabled. An earth fault of one or more motor phases is detected. An earth fault of the DC bus or the braking resistor is not detected.

*Parameterisation***▲ WARNING****Unexpected movement**

The risk of unexpected movement is increased when the monitoring functions are disabled.

- Use the monitoring functions.

Failure to follow these instructions can result in death, serious injury or equipment damage.

Parameter Name HMI menu	Description	Unit Minimum value Default value Maximum value	Data type R/W persistent Expert	Parameter address via fieldbus
SPV_EarthFit	Earth fault monitoring	-	UINT16	CANopen 3005:10 _h
-	0 / off: off	0	UINT16	Modbus 1312
-	1 / on: on (default)	1	R/W per.	
-		1	expert	
	In exceptional cases it may be necessary to disable it, e.g.: - parallel connection of multiple devices - operation on an IT mains - long motor lines Disable the monitoring only if it responds when not wanted			

8.6.1.6 Mains phase monitoring

Functional principle With three-phase devices the mains phases are monitored for failure of a mains phase. An error response can be set in the parameter SPV_Flt_AC. The parameter SPV_MainsVolt.

The parameters SPV_Flt_AC and SPV_MainsVolt have no function with single-phase devices.

Parameterisation

⚠ WARNING

Unexpected movement

The risk of unexpected movement is increased when the monitoring functions are disabled.

- Use the monitoring functions.

Failure to follow these instructions can result in death, serious injury or equipment damage.

Parameter Name HMI menu	Description	Unit Minimum value Default value Maximum value	Data type R/W persistent Expert	Parameter address via fieldbus
SPV_Flt_AC	Error response to failure of a mains phase with 3-phase devices	- 1 2 3	UINT16 UINT16 R/W per. -	CANopen 3005:A _h Modbus 1300
-	1 / ErrorClass1: error class 1			
-	2 / ErrorClass2: error class 2			
-	3 / ErrorClass3: error class 3			
SPV_MainsVolt	Monitoring mains phases with 3-phase devices	- 0 1 1	UINT16 UINT16 R/W per. expert	CANopen 3005:F _h Modbus 1310
-	0 / off: off			
-	1 / on: on (default)			
<p>3-phase devices must only be connected and operated on 3-phase. In exceptional cases it may be necessary to disable it, e.g.:</p> <ul style="list-style-type: none"> - supply via the DC bus 				

8.6.2 Scaling

Description Scaling translates user units to internal units of the device, and vice versa. The device saves position values in user-defined units.

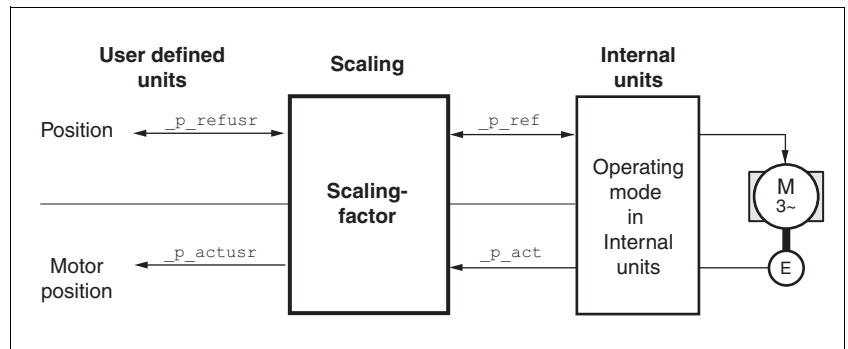

Figure 8.40 Scaling

Scaling factor The scaling factor creates the relationship between the number of motor rotations and the required user units [usr] needed for this. It is specified in [rev/usr].

$$\text{Scaling factor} = \frac{\text{Motor revolution [rev]}}{\text{Change of the user position [usr]}}$$

Figure 8.41 Calculation of the scaling factor

Default scaling A value of 16384 user-defined units per motor revolution is set as the default scaling.

⚠ WARNING

Unexpected movement by changing the scaling

Changing the scaling changes the effect of the values in user-defined units. The same travel commands can therefore cause different movements.

- Note that the scaling affects all relationships between the defaults and the drive movement.
- Check the corresponding usr parameters and defaults of the system in user-defined units.

Failure to follow these instructions can result in death, serious injury or equipment damage.

The scaling factor is set using the parameters `POSscaleNum` and `POSscaleDenom`. A new scaling factor is activated by transfer of the numerator value.

When quoting the scaling factor, take care that the relationship can be completely represented by a fraction.

Parameter Name HMI menu	Description	Unit Minimum value Default value Maximum value	Data type R/W persistent Expert	Parameter address via fieldbus
POSscaleNum	Numerator of the position scaling factor	revolution	INT32	CANopen 3006:8 _h
-	:Definition of scaling factor	1	INT32	Modbus 1552
-	Motor revolutions[U]	1	R/W	
-	Change in user position [usr]	2147483647	per.	

	Change in user position [usr]		-	
	Acceptance of a new scaling factor takes place on the entry of the numerator			
	User limits can be reduced when internal system factors are taken into account			
POSscaleDenom	Denominator of the position scaling factor	usr	INT32	CANopen 3006:7 _h
-	Description see numerator (POSscaleNum)	1	INT32	Modbus 1550
-		1638412	R/W	
-	Acceptance of a new scaling factor is by transfer of the numerator	2147483647	per.	
			-	



If the existing unit is replaced by this unit, and if the same positioning orders are to be used, then the scaling is to be set in accordance with the settings used previously.

Value change of the scaling factor is only possible with inactive power amplifier. Values in user-defined units are converted to internal units with the power amplifier active.

Examples

There are 3 cases for the setting of the user-defined units.

- Scaling corresponds to the default scaling
1 motor revolution = 16384 user-defined units
=> every 8th motor position can be approached.
- Scaling corresponds to the motor resolution (minimum scaling)
1 motor revolution = 131072 user-defined units
=> every motor position can be approached.
- Scaling is less than the default scaling
1 motor resolution = 4096 user-defined units
=> every 32nd motor position can be approached.



In order to keep the same positioning movement of the motor after changing the scaling factor, the following persistent parameters must be matched, in addition to the user values of the application HMoutdisusr, HMdisusr, HMp_homeusr, HMsrchdisusr, JOGstepusr, SPVswLimPusr and SPVswLimNusr.

If the parameters are not adjusted, this can cause problems such an error during the reference movement, because the distance to the switching edge of the limit or reference switch is no longer sufficient for safely leaving the switching range.

Example 1 Positioning of 1111 user-defined units is to correspond to 3 motor revolutions. This gives:

$$\text{Scaling factor} = \frac{3 \text{ rev}}{1111 \text{ usr}}$$

If you carry out a relative positioning operation of 900 user-defined units now, the motor will move $900 \text{ usr} * 3/1111 \text{ rev/usr} = 2.4302$ motor revolutions.

Example 2 Calculation of the scaling factor in length units: 1 motor revolution corresponds to a path of 100 mm. Every user-defined unit [usr] should correspond to one 0.01 mm step.

This gives: $1 \text{ usr} = 0.01 \text{ mm} * 1 \text{ rev}/100 \text{ mm} = 1/10000 \text{ rev}$.

$$\text{Scaling factor} = \frac{1 \text{ rev}}{10000 \text{ usr}}$$

Example 3 Setting the positioning in 1/1000 rad

$$1 \text{ rad} = 1 \text{ U}/(2 * \pi)$$

$$\pi = 3.1416 \text{ (rounded)}$$

$$\text{User value} = 1 \text{ usr}$$

$$\text{device value} = 1/(2 * \pi * 1000) \text{ U}$$

$$\text{Scaling factor} = \frac{1 \text{ rev}}{2 * 3,1416 * 1000 \text{ usr}} = \frac{1 \text{ rev}}{6283,2 \text{ usr}} = \frac{10 \text{ rev}}{62832 \text{ usr}}$$

8.6.3 Movement profile

Profile generator Target position and final speed are input values to be entered by the user. The profile generator uses these values to calculate a motion profile dependent on the selected operating mode.

The initial values of the profile generator and the addable jolt limiting are transformed into a motor movement by the drive regulator.

The acceleration and deceleration behaviour of the motor can be described as a ramp function of the profile generator. The characteristic values of the ramp function are the ramp shape and the ramp steepness.

Ramp shape A linear ramp for the acceleration and deceleration phases is available as the ramp shape. The profile settings are valid for both directions of movement of the drive.

Ramp steepness The steepness of the ramp determines the speed changes of the motor per unit time. It can be specified for the acceleration ramp via parameter RAMPacc for the deceleration ramp via RAMPdecel.

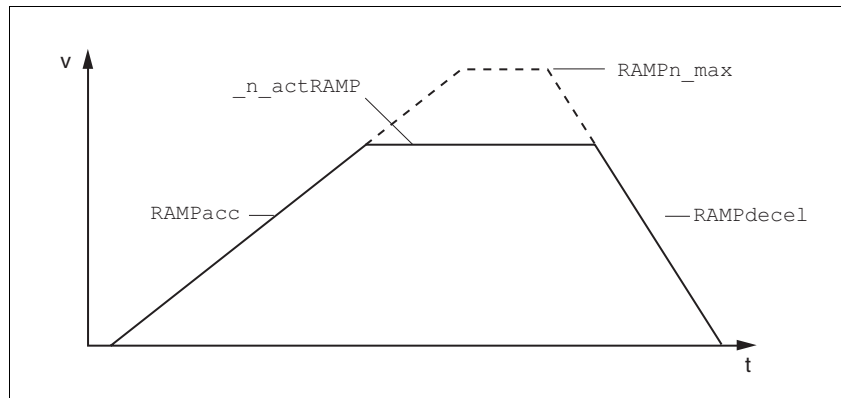

Figure 8.42 Acceleration and deceleration ramps

Parameter Name HMI menu	Description	Unit Minimum value Default value Maximum value	Data type R/W persistent Expert	Parameter address via fieldbus
RAMPacc	Profile generator acceleration	(1/min)/s 30 600 3000000	UINT32 UINT32 R/W per. -	CANopen 6083:0 _h Modbus 1556
RAMPdecel	Profile generator deceleration	((1/min)/s 750 750 3000000	UINT32 UINT32 R/W per. -	CANopen 6084:0 _h Modbus 1558

0198441113232, V1.20, 06.2007

Parameter Name HMI menu	Description	Unit Minimum value Default value Maximum value	Data type R/W persistent Expert	Parameter address via fieldbus
RAMPn_max	Limiting setpoint speed with operating modes with profile generation	1/min 60 13200 13200	UINT32 UINT16 R/W per. -	CANopen 607F:0h Modbus 1554
-	The parameters are effective in the following operating modes:			
-	- Point to point - profile velocity - homing - jog			
	If a higher speed is set in one of these operating modes, there is automatically a restriction on RAMPn_max. This makes it easier to execute commissioning at restricted speed.			

Jolt limiting The jolt limiting removes the jump-like acceleration changes to create a smooth, soft virtually jolt-free speed change.

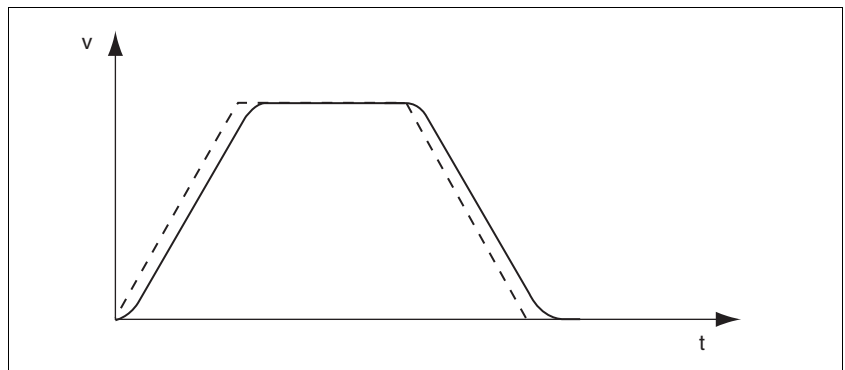

Figure 8.43 Speed curve with and dotted without jolt limitation

The jolt limitation is set and switched on using the parameter RAMP_TAUjerk .

The end of travel ($x_{end} = 1$) is not reported until the target position at the output of the jerk limiting has been reached.

Parameter Name HMI menu	Description	Unit Minimum value Default value Maximum value	Data type R/W persistent Expert	Parameter address via fieldbus
RAMP_TAUjerk	Jolt limiting	ms	UINT16	CANopen 3006:D _h
-	0: off	0	UINT16	Modbus 1562
-	>0: Setting for filter processing time	0 128	R/W per.	-
	<p>The following values can be set:</p> <p>0: inactive</p> <p>1</p> <p>2</p> <p>4</p> <p>8</p> <p>16</p> <p>32</p> <p>64</p> <p>128</p> <p>Limits the acceleration change (jerk) of the setpoint position generation during the positioning transitions:</p> <p>Standstill - acceleration acceleration - constant movement constant movement - deceleration deceleration - standstill</p> <p>Processing in the following operating modes:</p> <ul style="list-style-type: none"> - profile velocity - point to point - jog - homing <p>Setting is possible only if operating mode (x_end=1) is disabled.</p> <p>Not active with braking process via torque ramp ("Halt" or "Quick Stop")</p>			

8.6.4 Quick Stop

⚠ WARNING
<p>Unbraked motor</p> <p>An insufficient braking resistor causes overvoltage on the DC bus and switches off the power amplifier. The motor is no longer actively braked.</p> <ul style="list-style-type: none"> Make sure that the braking resistor is sufficiently dimensioned. Check the setting of the parameter for the braking resistor. Check the temperature of the braking resistor by conducting a test run under the most critical conditions. During the test make sure that at higher mains voltage there is less reserve in the capacitors on the DC bus. <p>Failure to follow these instructions can result in death, serious injury or equipment damage.</p>

"Quick Stop" is a fast braking function which stops the motor as a result of a fault of error class 1 and 2 or by a software stop.

In the event of a fault category 1 fault response, the power amplifier remains on. In the case of error class 2, the output stage switches off after the drive is at a standstill.

Maximum current

The unit absorbs the excess braking energy. If the DC bus voltage exceeds the permissible limit the output stage switches off and the unit signals "DC bus overvoltage". The motor runs down without braking.

The current for the moment ramp should be set so that the drive comes to a standstill with the required delay.

Parameter Name HMI menu	Description	Unit Minimum value Default value Maximum value	Data type R/W persistent Expert	Parameter address via fieldbus
LIM_I_maxQSTP	Current limiting for Quick Stop	A _{pk}	UINT16	CANopen 3011:5 _h
SET- - LiQS	max. Current during braking via torque ramp	-	UINT16	Modbus 4362
SEt - - L, 95	resulting from an error of error class 1 or 2 and when a software stop is triggered	-	R/W per. -	
	Maximum and default value setting depend on motor and power amplifier (setting M_I_max and PA_I_max)			
	in 0.01A _{pk} steps			

If the device switches off frequently with "Quick Stop" with "DC bus overvoltage", then the maximum braking current should be reduced, the drive load should be reduced or an external braking resistor should be installed.

"Quick Stop" reset

A "Quick Stop" must be reset by a "Fault Reset".

If the "Quick Stop" is actuated by the limit switch signals \overline{LIMN} or \overline{LIMP} , the drive can be moved back into the movement range by the jog operation, see page 8-15.

019844113232, V1.20, 06.2007

8.6.5 Halt

The "Halt" function brakes the motor with a moment ramp. The parameter LIM_I_maxHalt specifies the current for the moment ramp.

After drive standstill an internal position compensation is run, the position control is enabled and the motor is stopped with the power amplifier active.

After cancellation of all "Halt" requests the interrupted movement is continued. If the HALT signal is cancelled during the braking procedure, the drive still runs down to standstill and only then accelerates again.

The "Halt" function can be set from any desired source (such as commissioning software or input signal HALT).

This is independent of the control mode that was set at "First Setup".

Maximum current

The unit absorbs the excess braking energy. If the DC bus voltage exceeds the permissible limit the output stage switches off and the unit signals "DC bus overvoltage". The motor runs down without braking.

The current for the moment ramp should be set so that the drive comes to a standstill with the required delay.

Parameter Name HMI menu	Description	Unit Minimum value Default value Maximum value	Data type R/W persistent Expert	Parameter address via fieldbus
LIM_I_maxHalt	Current limiting for Halt	A _{pk}	UINT16	CANopen 3011:6 _h
SET- - LihA	max. Current during braking after Halt or termination of an operating mode.	-	UINT16	Modbus 4364
SET- - L, hR	Maximum and default value setting depend on motor and power amplifier (setting M_I_max and PA_I_max)	-	R/W per.	-
	in 0.01A _{pk} steps			

8.6.6 Fast position capture

The "fast position capture" function captures the current motor position at the time of receipt of a digital 24V signal at one of the two capture inputs. The operating function can, for example, be used for detection of a print mark.

Setting options Two independent capture inputs are available for the "fast position capture" operating function.

- ENABLE/ $\overline{\text{LIMF}}$ /CAP1 (CAP1)
- FAULT_RESET/ $\overline{\text{LIMN}}$ /CAP2 (CAP2)

One of two possible functions for capture can be selected for each capture input:

- Position capture at rising or falling edge at the capture input, adjustable with parameters CAP1CONFIG and CAP2CONFIG.
- One-time or continuous position capture with multiple change of edge at the capture input with parameters CAP1ACTIVATE and CAP2ACTIVATE.

Continuous capture means that the motor position is captured anew at every defined edge while the former captured value is lost.

The CAP1 and CAP2 capture inputs have a time constant of $t = 2 \mu\text{s}$.

The jitter is less than $2 \mu\text{s}$, since the following applies at a resolution of 32768 Inc/rev.: $3662 \text{ 1/min} = 2 \text{ inc}/\mu\text{s}$.

The captured motor position is not exact during the acceleration phase and the deceleration phase.

Enable fast position capture Enable single position capture

- For CAP1: write value 1 to parameter Cap1Activate
- For CAP2: write value 1 to parameter Cap2Activate

Enable continuous position capture

- For CAP1: write value 2 to parameter Cap1Activate
- For CAP2: write value 2 to parameter Cap2Activate

End position capture With single position capture the "fast position capture" function is ended when the first signal edge is detected.

With continuous position capture or no signal edge the capture can be terminated writing the parameter Cap1Activate, value 0 or Cap2Activate, value 0.

Parameter Name HMI menu	Description	Unit Minimum value Default value Maximum value	Data type R/W persistent Expert	Parameter address via fieldbus
Cap1Activate	Capture unit 1 Start/Stop	-	UINT16	CANopen 300A:4 _h
-	Value 0: abort capture function	0	UINT16	Modbus 2568
-	Value 1: start capture once	-	R/W	
-	Value 2: start capture continuously	2	-	
	With one-time capture the function is terminated at the first captured value. The capture continues endlessly with continuous capture.			
	Position capture can only be enabled with the "fieldbus" device setting.			
Cap1Config	Configuration of capture unit 1	-	UINT16	CANopen 300A:2 _h
-	0 = position capture at 1->0 switch	0	UINT16	Modbus 2564
-	1 = position capture at 0->1 switch	0	R/W	
		1	-	
Cap1Count	Capture unit 1 event counter	-	UINT16	CANopen 300A:8 _h
-	Counts the capture events.	-	UINT16	Modbus 2576
-	Counter is reset when the capture unit 1 is enabled.	0	R/-	
		-	-	
Cap1Pos	Capture unit 1 captured position	usr	INT32	CANopen 300A:6 _h
-	Captured position at the time of the "capture signal".	-	INT32	Modbus 2572
-	The captured position is recalculated after "set dimensions" or after a "homing".	0	R/-	
		-	-	
Cap2Activate	Capture unit 2 Start/Stop	-	UINT16	CANopen 300A:5 _h
-	Value 0: abort capture function	0	UINT16	Modbus 2570
-	Value 1: start capture once	-	R/W	
-	Value 2: start capture continuously	2	-	
	With one-time capture the function is terminated at the first captured value. The capture continues endlessly with continuous capture.			
	Position capture can only be enabled with the "fieldbus" device setting.			
Cap2Config	Configuration of capture unit 2	-	UINT16	CANopen 300A:3 _h
-	0 = position capture at 1->0 switch	0	UINT16	Modbus 2566
-	1 = position capture at 0->1 switch	0	R/W	
		1	-	
Cap2Count	Capture unit 2 event counter	-	UINT16	CANopen 300A:9 _h
-	Counts the capture events.	-	UINT16	Modbus 2578
-	Counter is reset when the capture unit 2 is enabled.	0	R/-	
		-	-	
Cap2Pos	Capture unit 2 captured position	usr	INT32	CANopen 300A:7 _h
-	Captured position at the time of the "capture signal".	-	INT32	Modbus 2574
-	The captured position is recalculated after "set dimensions" or after a "homing".	0	R/-	
		-	-	

Parameter Name HMI menu	Description	Unit Minimum value Default value Maximum value	Data type R/W persistent Expert	Parameter address via fieldbus
CapStatus	Status of capture units	-	UINT16	CANopen 300A:1 _h
-	Read access:	-	UINT16	Modbus 2562
-	Bit 0: position capture by input CAP1 complete	0	R/-	
-	Bit 1: Position captured via input CAP2	-	-	

8.6.7 Standstill window

The standstill window can be used to check whether the drive has reached the setpoint position.

If the control deviation $_p_dif$ of the position controller remains in the standstill window after the end of the positioning for time $STANDpwinTime$, the device reports the end of the process ($x_end = 0 > 1$).

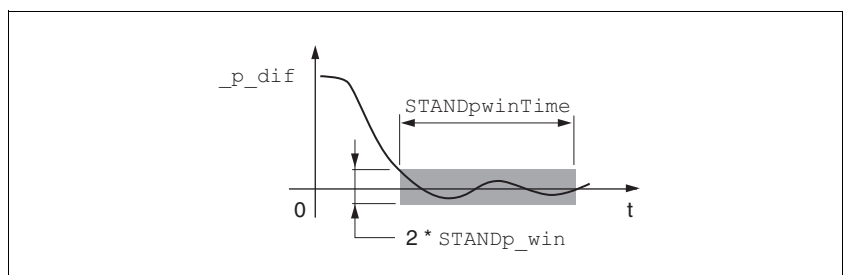

Figure 8.44 Standstill window

The parameters $STANDp_win$ and $STANDpwinTime$ define the size of the window.

The parameter $STANDpwinTout$ can be used to set the period after which an error is reported if the standstill window was not reached.

Parameter Name HMI menu	Description	Unit Minimum value Default value Maximum value	Data type R/W persistent Expert	Parameter address via fieldbus
STANDp_win	Standstill window, permissible control deviation	revolution 0.0000	UINT32 UINT16	CANopen 6067:0 _h Modbus 4370
-	The control deviation for the standstill window time must lie in this range of values to allow recognition of the standstill of the drive.	0.00100.0400 3.2767	R/W per.	-
	The processing of the standstill window must be activated via the $STANDpwinTime$ parameter.			
STANDpwinTime	Standstill window, time	ms 0	UINT16 UINT16	CANopen 6068:0 _h Modbus 4372
-	0: Standstill window monitoring deactivated	0	R/W	
-	>0: Time in ms within which the control deviation must lie in the standstill window	32767	per.	

Parameter Name HMI menu	Description	Unit Minimum value Default value Maximum value	Data type R/W persistent Expert	Parameter address via fieldbus
STANDpwinTout	Timeout for the standstill window monitor	ms	UINT16	CANopen 3011:B _h
-	0: Timeout monitor deactivated	0	UINT16	Modbus 4374
-	>0: Timeout in ms	0	R/W	
		16000	per.	
	Setting the standstill window processing is accomplished via STANDp_win and STANDpwinTime		-	
	The time monitoring begins at the moment the target position is reached (position controller setpoint) or at the end of the profile generator processing.			

8.6.8 Braking function with HBC

Inadvertent movement of the motor without current is prevented by the use of motors with a holding brake. The holding brake requires a holding brake control system HBC, see chapter "Accessories"

Holding brake controller The holding brake controller HBC controls the brake in such a way to allow fast switching with a minimum of heat generation. In addition, the brake connection, which is located in one cable with the wiring connections to the motor, safely disconnects the signal connections on the device in the event of a breakdown of the insulation of the motor cable.

The function "Brake release" is used to actuate the holding brake controller. The function must be configured to a signal output, see 8.6.9 "Configurable inputs and outputs".

In software version <1.201 the signal output ACTIVE1_OUT is used directly.

The function of the HBC and the holding brake can be tested, see 7.4.9 "Checking holding brake" page 7-29.

Settable parameters A time delay for release of the holding brake (BRK_trelease) and setting the holding brake (BRK_tclose) can be configured.

Delayed release When the power amplifier is activated the parameter BRK_trelease implements a delayed response of the drive against the release (opening) of the holding brake.

The setting of the parameter BRK_trelease depends on the motor type and can be found in the motor data sheet.

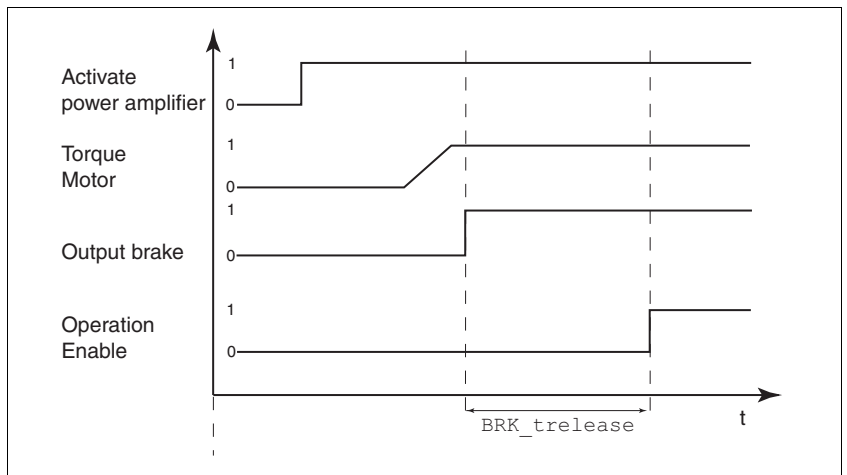

Figure 8.45 Releasing the holding brake

Parameter Name HMI menu	Description	Unit Minimum value Default value Maximum value	Data type R/W persistent Expert	Parameter address via fieldbus
BRK_trelease	Time delay when opening or releasing the holding brake	ms 0 1000	UINT16 R/W per.	CANopen 3005:7 _h Modbus 1294
DRC- - BTRE				
drE - btrE				

019844113232, V1.20, 06.2007

Delayed application The holding brake is set when the power amplifier is disabled. The motor remains under current, however, for the time set on the parameter BRK_tclose.

The setting of the parameter BRK_tclose depends on the motor type and can be found in the motor data sheet.

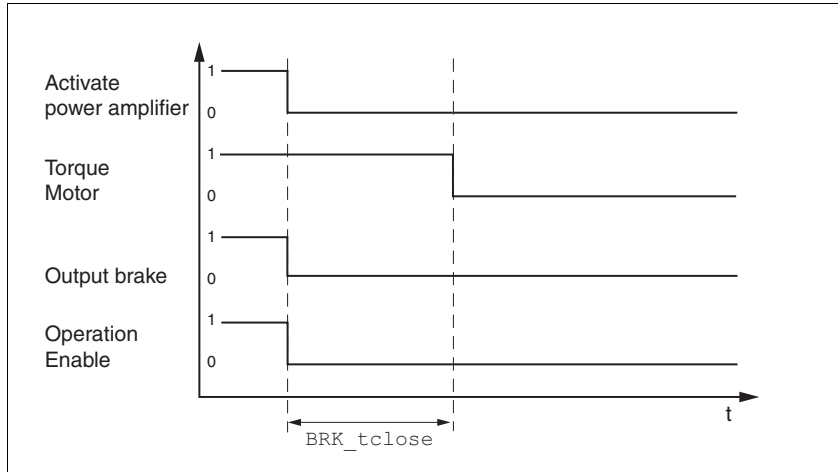

Figure 8.46 Applying the holding brake

Parameter Name HMI menu	Description	Unit Minimum value Default value Maximum value	Data type R/W persistent Expert	Parameter address via fieldbus
BRK_tclose	Time delay when applying the holding brake	ms 0	UINT16	CANopen 3005:8 _n
DRC- - BTCL		0	UINT16	Modbus 1296
dr[- - bt[-[-		1000	R/W per. -	

Voltage reduction If the voltage reduction on the HBC is activated, the voltage of the holding brake output is reduced after a delay time. This reduces the power loss of the holding brake by approx. 44%.

- ▶ Set the voltage reduction depending on the motor type with the switch "Voltage reduction".
Follow the instructions in the motor manual.

- (On) Voltage reduction on, e.g. for motor type SER
- (Off) voltage reduction off, e.g. for motor type BSH

When switching on the supply voltage, the holding brake controller and the function of the HBC button are reset. There is no voltage at the control terminals of the brake, the LED "Brake released " of the HBC is off.

8.6.9 Configurable inputs and outputs

⚠ WARNING**Unforeseen behaviour of inputs and outputs**

The functions of the inputs and outputs depend on the selected start-up operating mode and the settings of the corresponding parameters.

- Check that the wiring is appropriate for the settings.
- Only start the system if there are no persons or materials in the danger zone and the system can be operated safely.
- When commissioning carefully run tests for all operating statuses and fault cases.

Failure to follow these instructions can result in death, serious injury or equipment damage.

Availability The function is available from software version 1.201.

Description The digital signal inputs and the digital signal outputs can be assigned to various functions.

The parameters `IOfunct_LI1`, `IOfunct_LI2`, `IOfunct_LI4` and `IOfunct_LI7` are available for signal inputs. The parameters `IOfunct_LO1`, `IOfunct_LO2` and `IOfunct_LO3` are available for signal outputs.

The digital signal inputs and outputs are assigned with functions depending on the start-up operating mode.

The signal input `ENABLE` is an exception. This signal input is always assigned with the "Enable" function, see chapter 8.3 "Operating statuses".

The digital signal inputs `PWRR_A` and `PWRR_B` are also always assigned with the safety function "Power Removal".

Current status The current state of the digital signal inputs and signal outputs can be displayed via parameters `_IO_LI_act` and `_IO_LO_act`.

Parameter Name HMI menu	Description	Unit Minimum value Default value Maximum value	Data type R/W persistent Expert	Parameter address via fieldbus
<code>_IO_LI_act</code>	Status of the digital inputs	-	UINT16	CANopen 3008:F _h
-	Coding of the individual signals:	-	UINT16	Modbus 2078
-	Bit0: LI1	0	R/-	
-	Bit2: LI2	-	-	
	...			
	Available from software version V1.201.			
<code>_IO_LO_act</code>	Status of the digital outputs	-	UINT16	CANopen 3008:10 _h
-	Coding of the individual signals:	-	UINT16	Modbus 2080
-	Bit0: LO1_OUT	0	R/-	
-	Bit1: LO2_OUT	-	-	
	...			
	Available from software version V1.201.			

Factory settings The following table shows the factory settings with local control mode depending on the start-up operating mode (jog, electronic gear, speed control and current control) and the factory settings with fieldbus control mode (CANopen / Modbus).

Pin Signal	Jog	Electronic gear	Speed control	Current control	CANopen / Modbus
CN1.33 LI1	Jog negative	No function / free available	No function / free available	No function / free available	Reference switch (REF)
CN1.34 LI2	Jog positive	Fault reset	Fault reset	Fault reset	Negative limit switch (LIMN)
CN1.35 LI3	Enable ¹⁾	Enable ¹⁾	Enable ¹⁾	Enable ¹⁾	Positive limit switch (LIMP) ¹⁾
CN1.36 LI4	Jog fast/slow	Halt	Halt	Halt	Halt
CN1.37 LI5	Power Removal ¹⁾	Power Removal ¹⁾	Power Removal ¹⁾	Power Removal ¹⁾	Power Removal ¹⁾
CN1.38 LI6	Power Removal ¹⁾	Power Removal ¹⁾	Power Removal ¹⁾	Power Removal ¹⁾	Power Removal ¹⁾
CN5.3/8 LI7	Enable2	Enable2	Enable2	Enable2	No function / free available
CN1.31 LO1_OUT	No fault	No fault	No fault	No fault	No fault
CN2.32 LO2_OUT	Brake release	Brake release	Brake release	Brake release	Brake release
CN5.4 LO3_OUT	Active	Active	Active	Active	Active

1) Function cannot be modified.

After modifying the start-up operating mode and switching the device off and on the signal inputs and signal outputs are preassigned corresponding to the factory settings.

8.6.9.1 Description of functions of the signal inputs

<i>No function / free available</i>	The "No function / free available" function does not have an internal-device function. The signal input which is freely available can be read via parameter <code>_IO_LI_act</code> .
<i>Fault reset</i>	An error message is reset with the function, see 8.3 "Operating statuses".
<i>Enable</i>	The power amplifier is enabled with the function, see 8.3 "Operating statuses".
<i>Halt</i>	A "Halt" is triggered with the function, see chapter 8.6.5 "Halt".
<i>Power Removal</i>	The safety function "Power Removal" is triggered with the function, see chapter 5.4 "Safety function "Power Removal"".
<i>Start profile positioning</i>	<p>This function sets the start signal (parameter <code>DCOMcontrol</code>, Bit4, New setpoint) for the profile position operating mode via a digital input. The fieldbus must not set the start signal for a positioning in the parameter <code>DCOMcontrol</code> after transferring the position value. The positioning is then executed with rising edge at the digital input.</p> <p>A position can also be started by using the parameter <code>DCOMcontrol</code>. A start signal must not be pending at the digital input in this case.</p> <p>If the positioning cannot be executed, e.g. still no "Operation enable" operating status, no error message is sent.</p>
<i>Enable positive motor move</i>	<p>The function releases or blocks positive reference values through a position switch. Positive reference values are blocked on moving past the switching edge of the positive position switch and the motor stops. Only negative reference values are executed until the motor is again travelled over the switching edge.</p> <p>The function is available in the operating modes jog, speed control and electronic gear. The requirement is a correct wiring of the position switch, see chapter 7.4.11 "Checking the signals of position switches".</p>
<i>Enable negative motor move</i>	The function corresponds to the operation of "Enable positive motor move", but a negative reference values are enabled or blocked through a position switch.
<i>Speed limitation</i>	A speed limitation is enabled with the function. The value for the speed limiting is set by using the parameter <code>SPVn_lim</code> .
<i>Jog positive</i>	A jog movement in clockwise rotation is executed with the function, see 8.5.1 "Operating mode Jog".
<i>Jog negative</i>	A jog movement in counter-clockwise rotation is executed with the function, see 8.5.1 "Operating mode Jog".
<i>Jog fast/slow</i>	The device switches between slow and fast jog with the function, see 8.5.1 "Operating mode Jog".
<i>Enable2</i>	The power amplifier is enabled with the function, see 8.3 "Operating statuses". This function is possible only if the parameter <code>IOposInterfac</code> has the value "PDinput" set in it.
<i>Reference switch (REF)</i>	The operation of the reference switch is set with the function. See chapter 8.5.8 "Operating mode Homing".

Positiv limit switch (LIMP) The operation of the positive limit switch is set with the function. See chapter 8.5.8 "Operating mode Homing" and chapter 8.6.1.2 "Positioning range".

Negative limit switch (LIMN) The operation of the negative limit switch is set with the function. See chapter 8.5.8 "Operating mode Homing" and chapter 8.6.1.2 "Positioning range".

Parameter Name HMI menu	Description	Unit Minimum value Default value Maximum value	Data type R/W persistent Expert	Parameter address via fieldbus
SPVn_lim	Speed limitation via input	1/min	UINT16	CANopen 3006:1E _h
SET- - nLiM	a speed limitation can be activated via a digital input.	1	UINT16	Modbus 1596
SEt - - nLi n	Note: the minimum speed of rotation is always internally limited to 100 1/min in the current control operating mode.	10 9999	R/W per. -	

Available from software version V1.201.

8.6.9.2 Configuration of signal inputs

The digital inputs can be assigned with functions by using the parameters IOfunct_LI1 to IOfunct_LI7.

The table below shows an overview of the signal inputs to which a function can be assigned. The table also shows the dependence on the start-up operating mode with local control mode.

Function	Jog	Electronic gear	Speed control	Current control
No function / free available	LI1, LI2, LI4, LI7	LI1, LI2, LI4, LI7	LI1, LI2, LI4, LI7	LI1, LI2, LI4, LI7
Fault reset	LI2	LI2	LI2	LI2
Enable	LI3 ¹⁾	LI3 ¹⁾	LI3 ¹⁾	LI3 ¹⁾
Halt	LI4	LI4	LI4	LI4
Power Removal	LI5/LI6 ¹⁾	LI5/LI6 ¹⁾	LI5/LI6 ¹⁾	LI5/LI6 ¹⁾
Enable positive motor move		LI1, LI2, LI4, LI7	LI1, LI2, LI4, LI7	
Enable negative motor move		LI1, LI2, LI4, LI7	LI1, LI2, LI4, LI7	
Speed limitation		LI1, LI2, LI4, LI7	LI1, LI2, LI4, LI7	LI1, LI2, LI4, LI7
Jog positive	LI1, LI2, LI4, LI7			
Jog negative	LI1, LI2, LI4, LI7			
Jog fast/slow	LI1, LI2, LI4, LI7			
Enable2	LI7	LI7	LI7	LI7

1) Signal input cannot be configured.

The table below shows an overview in fieldbus control mode.

Function	CANopen / Modbus
No function / free available	LI1, LI2, LI4, LI7
Halt	LI4
Power Removal	LI5/LI6 ¹⁾
Start profile positioning	LI1, LI2, LI4, LI7
Reference switch (REF)	LI1
Positive limit switch (LIMP)	LI3 ¹⁾
Negative limit switch (LIMN)	LI2

1) Signal input cannot be configured.

Parameter Name HMI menu	Description	Unit Minimum value Default value Maximum value	Data type R/W persistent Expert	Parameter address via fieldbus
IOfuncn_LL1	Function input LI1	-	UINT16	CANopen 3007:1 _h
I-O- - Li1	1 / No function/free available / nonE: No function / freely available	-	UINT16	Modbus 1794
I-O- - Li1	2 / Fault reset / FrES: Reset error message	0	R/W	
I-O- - Li1	4 / Halt / hRLt: Halt	-	per.	
I-O- - Li1	5 / Start profile positioning / SPtP: Start-request for movement (only fieldbus control mode)			
I-O- - Li1	6 / Enable positive motor move / Po5P: Release positive motor movement (only local control mode)			
I-O- - Li1	7 / Enable negative motor move / nEGP: Release negative motor movement (only local control mode)			
I-O- - Li1	8 / Speed limitation / nL, P: Speed limitation to parameter value (only local control mode)			
I-O- - Li1	9 / Jog positive / JoGP: Manual movement right end			
I-O- - Li1	10 / Jog negative / JoGN: Manual movement left end			
I-O- - Li1	11 / Jog fast/slow / JoGF: Manual movement fast/slow			
I-O- - Li1	13 / Start DataSet / d5tR: Motion sequence: Start command			
I-O- - Li1	14 / Select DataSet / d5EL: Set inclusion			
I-O- - Li1	20 / Reference switch (REF) / rEF: reference switch			
I-O- - Li1	21 / Positive limit switch (LIMP) / L, P: Positive limit switch			
I-O- - Li1	22 / Negative limit switch (LIMP) / L, Pn: Negative limit switch			

Available from software version V1.201.

Parameter Name HMI menu	Description	Unit Minimum value Default value Maximum value	Data type R/W persistent Expert	Parameter address via fieldbus
IOfunct_LI2	Function input LI2	-	UINT16	CANopen 3007:2 _h
I-O- - Li2	1 / No function/free available / nonE: No function / freely available	-	UINT16	Modbus 1796
, -o- - L, 2	2 / Fault reset / FrE5: Reset error message (only local control mode)	0	R/W	
	4 / Halt / hALt: Halt	-	per.	
	5 / Start profile positioning / SPtP: Start-request for movement (only fieldbus control mode)		-	
	6 / Enable positive motor move / Po5n: Release positive motor movement (only local control mode)			
	7 / Enable negative motor move / nEGn: Release negative motor movement (only local control mode)			
	8 / Speed limitation / nL, n: Speed limited to parameter value (only local control mode)			
	9 / Jog positive / JoGP: Manual movement right end			
	10 / Jog negative / JoGn: Manual movement left end			
	11 / Jog fast/slow / JoGF: Manual movement fast/slow			
	13 / Start DataSet / dStA: Motion sequence: Start command			
	14 / Select DataSet / dSEL: set inclusion			
	20 / Reference switch (REF) / rEF: reference switch			
	21 / Positive limit switch (LIMP) / L, nP: positive limit switch			
	22 / Negative limit switch (LIMN) / L, nN: negative limit switch			
Available from software version V1.201.				

Parameter Name HMI menu	Description	Unit Minimum value Default value Maximum value	Data type R/W persistent Expert	Parameter address via fieldbus
IOfuncn_LI4	Function input LI4	-	UINT16	CANopen 3007:4 _h
I-O- - LI4	1 / No function/free available / nonE: No function / freely available	-	UINT16	Modbus 1800
, -o- - L, 4	2 / Fault reset / rreE: Reset error message (only local control mode)	0	R/W	
	4 / Halt / hRLt: Halt	-	per.	
	5 / Start profile positioning / SPtP: Start-request for movement (only fieldbus control mode)		-	
	6 / Enable positive motor move / Po5n: Release positive motor movement (only local control mode)			
	7 / Enable negative motor move / nEGn: Release negative motor movement (only local control mode)			
	8 / Speed limitation / nL, n: Speed limited to parameter value (only local control mode)			
	9 / Jog positive / JoGP: Manual movement right end			
	10 / Jog negative / JoGn: Manual movement left end			
	11 / Jog fast/slow / JoGF: Manual movement fast/slow			
	13 / Start DataSet / d5tR: Motion sequence: start command			
	14 / Select DataSet / d5EL: set inclusion			
	20 / Reference switch / rEF: reference switch			
	21 / Positive limit switch (LIMP) / L, nP: positive limit switch			
	22 / Negative limit switch (LIMN) / L, nN: negative limit switch			

Available from software version V1.201.

Parameter Name HMI menu	Description	Unit Minimum value Default value Maximum value	Data type R/W persistent Expert	Parameter address via fieldbus
IOfuncn_LI7	Function input LI7	-	UINT16	CANopen 3007:7 _h
I-O - - Li7	1 / No function/free available / nonE: No function / freely available	-	UINT16	Modbus 1806
, -o - - L, 7	2 / Fault Reset / FrE5: Reset error message (only local control mode) 4 / Halt / hALt: Halt 5 / Start profile positioning / SPtP: Start-command for movement (only fieldbus control mode) 6 / Enable positive motor move / Po5n: Release positive motor movement 7 / Enable negative motor move / nEGn: Release negative motor movement 8 / Speed limitation / nL, n: Speed limited to parameter value 9 / JOG positive / JoGn: Manual movement right end 10 / JOG negative / JoGn: Manual movement left end 11 / JOG fast/slow / JoGF: Manual movement fast/slow 12 / Enable2 / EnR2: Start-command for movement (only fieldbus control mode) 13 / Start DataSet / dStR: Motion sequence: start command 14 / Select DataSet / dSEL: set inclusion	0	R/W per. -	
	Input function 'Enable2' only effective if DEVcmdinterf = IODevice AND IOposInterfac = Pdinput			
	Available from software version V1.201.			

8.6.9.3 Description of functions of the signal outputs

<i>No function / free available</i>	The function "No function / free available" provides the option of setting an output directly by using the parameter <code>IO_LO_set</code> .
<i>No fault</i>	The function shows the error status, see 8.3.3 "Displaying the operating statuses".
<i>Active</i>	The function shows the operating status "Operation enable", see chapter 8.3.3 "Displaying the operating statuses".
<i>Motor move disable</i>	The function shows whether a reference value is preset in a blocked direction of rotation. The function "Enable positive motor move" or "Enable negative motor move" must be configured for this.
<i>In position window</i>	The function monitors whether the motor is within a specific position deviation for a specific time. The position deviation determines the variation between the reference value default and the actual value. The parameter <code>SPVp_DiffWin</code> defines this position deviation. The parameter <code>SPVChkWinTime</code> defines the time.
<i>In speed window</i>	The function monitors whether the motor is within a specific speed deviation for a specific time. The speed deviation determines the variation between the reference value default and the actual values. The parameter <code>SPVn_DiffWin</code> defines this speed deviation. The parameter <code>SPVChkWinTime</code> defines the time.
<i>Speed threshold reached</i>	The function shows whether the motor is below a specific speed value for a specific time. The parameter <code>SPVn_Threshold</code> defines this speed value. The parameter <code>SPVChkWinTime</code> defines the time.
<i>Current threshold reached</i>	The function shows whether the motor is below a specific current value for a specific current value. The parameter <code>SPVi_Threshold</code> defines this current value. The parameter <code>SPVChkWinTime</code> defines the time.
<i>Halt acknowledge</i>	The function shows that the function "Halt" was triggered and the motor is at standstill.
<i>Brake release</i>	The function offers the option of using the signal as a control signal for a holding brake controller, see 8.3.3 "Displaying the operating statuses".

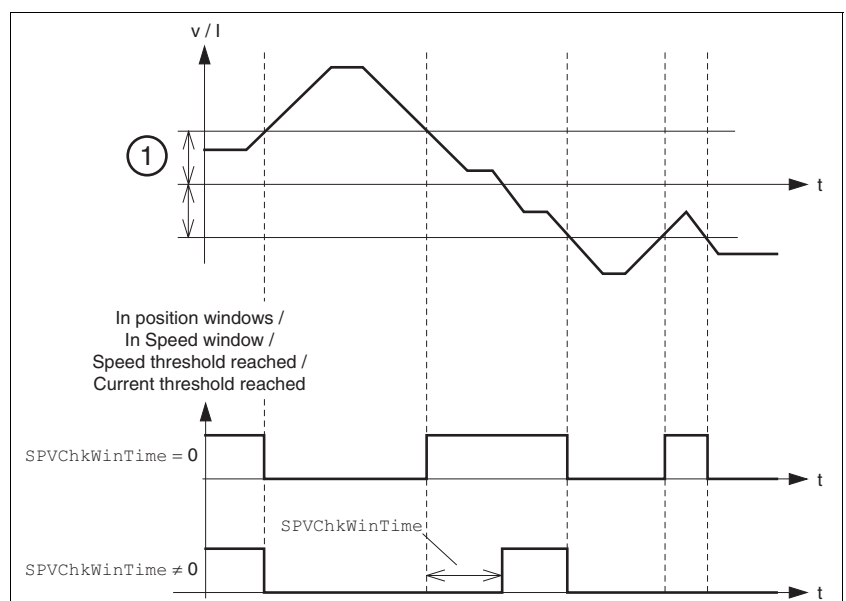

Figure 8.47 Output signals dependent on `SPVChkWinTime`

- (1) Position deviation for "In position window"
- Speed deviation for "In speed window"
- Speed value for "Speed threshold reached"
- Current value for "Current threshold reached"

Parameter Name HMI menu	Description	Unit Minimum value Default value Maximum value	Data type R/W persistent Expert	Parameter address via fieldbus
IO_LO_set - -	Setting digital outputs directly Write access to output bits is only effective if the signal pin exists as output and the function of the output was set to 'freely available'. Coding of the individual signals: Bit0: LO1_OUT Bit1: LO2_OUT ... Available from software version V1.201.	- - 0 -	UINT16 UINT16 R/W -	CANopen 3008:11 _h Modbus 2082
SPVChkWinTime SET- - Wint 5Et - - Wint	Monitoring of time window Setting of a time for the monitoring of position deviation, speed of rotation deviation, speed of rotation value and current value. If the control value for the set time is within the monitoring range, then the result of the monitoring is valid. The status can be output via a programmable output. Available from software version V1.201.	ms 0 0 9999	UINT16 UINT16 R/W per. -	CANopen 3006:1D _h Modbus 1594
SPVp_DiffWin SET- - in-P 5Et - - in-P	Monitoring of position deviation It is checked whether the drive is below the deviation defined here for the time programmed via 'SPVChkWinTime'. The status can be output via a programmable output. Available from software version V1.201.	revolution 0.0000 0.0010 0.9999	UINT16 UINT16 R/W per. -	CANopen 3006:19 _h Modbus 1586
SPVn_DiffWin SET- - in-n 5Et - - in-n	Monitoring of speed of rotation deviation It is checked whether the drive is below the deviation defined here for the time programmed via 'SPVChkWinTime'. The status can be output via a programmable output. Available from software version V1.201.	1/min 1 10 9999	UINT16 UINT16 R/W per. -	CANopen 3006:1A _h Modbus 1588
SPVn_Threshold SET- - ntHr 5Et - - ntHr	Monitoring of speed of rotation value It is checked whether the drive is below the value defined here for the time programmed via 'SPVChkWinTime'. The status can be output via a programmable output. Available from software version V1.201.	1/min 1 10 9999	UINT16 UINT16 R/W per. -	CANopen 3006:1B _h Modbus 1590

019844113232, V1.20, 06.2007

Parameter Name HMI menu	Description	Unit Minimum value Default value Maximum value	Data type R/W persistent Expert	Parameter address via fieldbus
SPVi_Threshold	Monitoring of current value	A _{pk}	UINT16	CANopen 3006:1C _h
SET- - itHr	It is checked whether the drive is below the value defined here for the time programmed via 'SPVChkWinTime'. The status can be output via a programmable output. As a comparative value the value from the parameter '_Idq_act' is used.	0.00	UINT16	Modbus 1592
SEt - - , tHr		0.00 99.99	R/W per. -	
Available from software version V1.201.				

8.6.9.4 Configuration of signal outputs

The digital outputs can be assigned with functions by using the parameters IOfunct_LO1 to IOfunct_LO3.

The following table shows an overview of the functions with local control mode depending on the start-up operating mode (jog, electronic gear, speed control and current control) and the factory settings with fieldbus control mode (CANopen / Modbus).

Function	Jog	Electronic gear	Speed control	Current control	CANopen / Modbus
No function / free available	•	•	•	•	•
No fault	•	•	•	•	•
Active	•	•	•	•	•
Motor move disable		•	•		
In position window		•			•
In speed window	•	•	•		•
Speed threshold reached	•	•	•	•	•
Current threshold reached				•	•
Halt acknowledge	•	•	•	•	•
Brake release	•	•	•	•	•

"•" means that the function at LO1_OUT, LO2_OUT or LO3_OUT is available.

Parameter Name HMI menu	Description	Unit Minimum value Default value Maximum value	Data type R/W persistent Expert	Parameter address via fieldbus
IOfuncn_LO1 I-O - - Lo1 I-O - - Lo1	Function output LO1_OUT 1 / No function/free available / nonE : No function / freely available 2 / No fault / nFLt : No error 3 / Active / Rct : Operating readiness 4 / Motor move disable / Nd , 5 : Direction of motion locked 5 / In position window / n-P : Position deviation within window 6 / In speed window / n-n : Speed deviation within window 7 / Speed threshold reached / nthr : Motor speed below parameterised value 8 / Current threshold reached / thr : Motor current below parameterised value 9 / Halt acknowledge / hRLt : Halt validation 10 / Brake release / brRH : Activation holding brake 11 / StartAck DataSet / dSAc : Motion sequence: Acknowledgment of start command 13 / Motor standstill / nStd : Motor standstill	- - 0 -	UINT16 UINT16 R/W per. -	CANopen 3007:9 _h Modbus 1810
Available from software version V1.201.				
IOfuncn_LO2 I-O - - Lo2 I-O - - Lo2	Function output LO2_OUT 1 / No function/free available / nonE : No function / freely available 2 / No fault / nFLt : No error 3 / Active / Rct : Operating readiness 4 / Motor move disable / Nd , 5 : Direction of motion locked 5 / In position window / n-P : Position deviation within window 6 / In speed window / n-n : Speed deviation within window 7 / Speed threshold reached / nthr : Motor speed below parameterised value 8 / Current threshold reached / thr : Motor current below parameterised value 9 / Halt acknowledge / hRLt : Halt validation 10 / Brake release / brRH : Activation holding brake 11 / StartAck DataSet / dSAc : Motion sequence: Acknowledgment of start command 13 / Motor standstill / nStd : Motor standstill	- - 0 -	UINT16 UINT16 R/W per. -	CANopen 3007:A _h Modbus 1812
Available from software version V1.201.				

Parameter Name HMI menu	Description	Unit Minimum value Default value Maximum value	Data type R/W persistent Expert	Parameter address via fieldbus
IOfuncn_LO3 I-O - Lo3 I-O - Lo3	Function output LO3_OUT 1 / No function/free available / nFnE : No function / freely available 2 / No fault / nFLt : No error 3 / Active / Rct : Operating readiness 4 / Motor move disable / Pd , 5 / Direction of motion locked 5 / In position window / n-P : Position deviation within window 6 / In speed window / n-n : Speed deviation within window 7 / Speed threshold reached / nthr : Motor speed below parameterised value 8 / Current threshold reached / thr : Motor current below parameterised value 9 / Halt acknowledge / hFLt : Halt validation 10 / Brake release / brRH : Activation holding brake 11 / StartAck DataSet / dSRc : Motion sequence: Acknowledgment of start command 13 / Motor standstill / nStd : Motor standstill	- - 0 -	UINT16 UINT16 R/W per. -	CANopen 3007:B _h Modbus 1814
Available from software version V1.201.				

8.6.10 Reversal of direction of rotation

The parameter `POSdirOfRotat` can be used to change the direction of rotation of the motor. Note that changing the parameter value will only be effective after switching the device off and on again.

The limit switch that limits the working range with clockwise rotation must be connected to `LIMP`. The limit switch that limits the working range with counter-clockwise rotation must be connected to `LIMN`.

Parameter Name HMI menu	Description	Unit Minimum value Default value Maximum value	Data type R/W persistent Expert	Parameter address via fieldbus
<code>POSdirOfRotat</code>	Definition of the direction of rotation	- 0	UINT16 UINT16	CANopen 3006:C _h Modbus 1560
<code>DRC- - PRoT</code>	0 / clockwise / \llcorner : Clockwise	0	R/W	
<code>dr\lrcorner - Prot</code>	1 / counter clockwise / $\llcorner\llcorner$: Counter clockwise	1	per. -	

Meaning:
The drive rotates clockwise with positive speeds, looking onto the motor shaft at the flange.

IMPORTANT: When using limit switches, after changing the setting, the limit switch connections must be changed over. The limit switch which is actuated by moving in jog mode in a positive direction must be connected to the input `LIMP`, and vice versa.

IMPORTANT: A change of the setting is not activated until the device is switched on again.

If the direction of rotation of the motor must be reversed, all parameter values can be imported unchanged except for the parameters for position processing with SinCos Multiturn.

By reversing the direction of rotation, the absolute position of the motor `_p_absworkusr` changes, which is read from the rotary encoder, and also the actual position evaluated by the device `_p_actusr`.

The direction of rotation should therefore be set at commissioning to the state which will be required later for the operation of this motor.

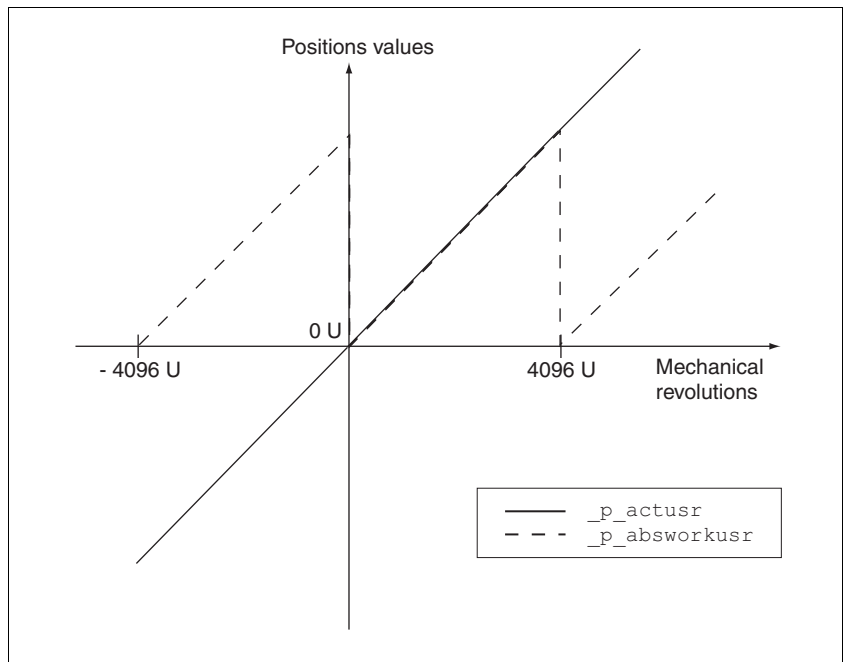

Figure 8.48 Position values without direction reversal

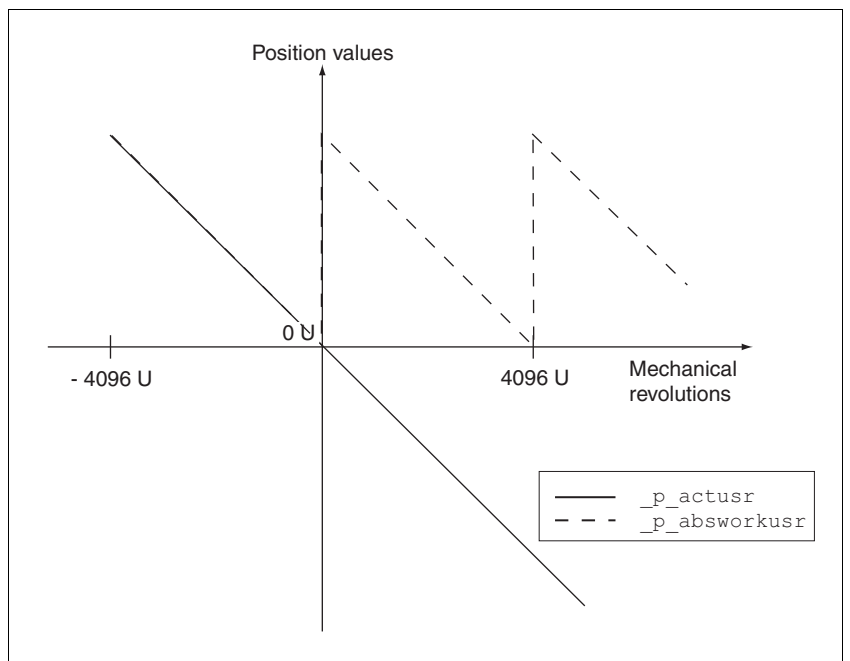

Figure 8.49 Position values with direction reversal

8.6.11 Restoring default values

8.6.11.1 Restoring status after "First Setup"

The parameter `PARuserReset` is used to restore the status after "First Setup". All parameter values are reset to default values, with the exception of the communication parameters, the control mode and the logic type.

Parameter Name HMI menu	Description	Unit Minimum value Default value Maximum value	Data type R/W persistent Expert	Parameter address via fieldbus
PARuserReset	Resetting the user parameters	-	UINT16	CANopen 3004:8 _h
-	Bit 0=1: Set persistent parameters to default values.	0	UINT16	Modbus 1040
-	All parameters are reset, with the exception of: - Communication parameters - Definition of the direction of rotation - Signal selection position interface - Device control - Logic type - Start up operating mode for 'local control mode' - ESIM settings - IO functions	- 7	R/W -	
<p>IMPORTANT: The new settings are not backed up to the EEPROM!</p>				



*All parameter values set by the user are lost during this process.
It is possible at any time to save all parameter values set for a device as a configuration using the commissioning software.*

8.6.11.2 Restore factory settings

The parameter `PARfactorySet` is used to restore the factory settings. All parameter values are reset to the default values.

- ▶ Remove the connection to the fieldbus in order to avoid conflicts by simultaneous access.

Parameter Name HMI menu	Description	Unit Minimum value Default value Maximum value	Data type R/W persistent Expert	Parameter address via fieldbus
PARfactorySet	Restore factory settings (default values)	-	R/W	
DRC- - FCS	1: Set all parameters to default value and backup in EEPROM.	0	-	
<i>drL</i> - <i>FES</i>	Restoring of factory settings can be triggered through HMI or commissioning software. The storing process is complete if a 0 is returned when reading the parameters.	3	-	

IMPORTANT: The default state only becomes active at the next start-up.

Factory setting via HMI ▶ Set *drL* and then *FES* on the HMI and confirm your selection with *YES*.

All parameter values are reset to the default values. "See First Setup", page 7-13

The new settings only become effective after switching off and switching on the device again.

Factory settings via commissioning software

The factory settings are set via the menu points Configuration => Factory Settings. All parameter values are reset to the default values. "See First Setup", page 7-13

The new settings only become effective after switching off and switching on the device again.



All parameter values set by the user are lost during this process.

It is possible at any time to save all parameter values set for a device as a configuration using the commissioning software.

8.6.11.3 Duplicate existing device settings

⚠ CAUTION

Damage to the product from failure of the supply voltage

If the supply voltage fails during an update, the product will be damaged and must be sent in for repair.

- Never switch off supply voltage during the update.
- Always carry out the update with a reliable supply voltage.

Failure to follow these instructions can result in injury or equipment damage.

- Application and advantage*
- Multiple devices should have the same settings, e.g. when devices are replaced.
 - "First setup" does not need to be carried out using the HMI.
- Requirements*
- Device type, motor type and device firmware must be identical. The tool is the Windows-based commissioning software. The controller supply voltage must be switched on at the device.
- Export device settings*
- The commissioning software installed on a PC can apply the settings of a device as configuration.
- ▶ Load the configuration of the device into the commissioning software with "Action - Transfer".
 - ▶ Highlight the configuration and select "File - Export".
- Import device settings*
- A stored configuration can be imported into a device of the same type. Please note that the fieldbus address is also copied with this information.
- ▶ In the commissioning software select the menu item "File - Import" and load the desired configuration.
 - ▶ Highlight the configuration and select "Action - Configure".

9 Examples

9.1 Wiring local control mode

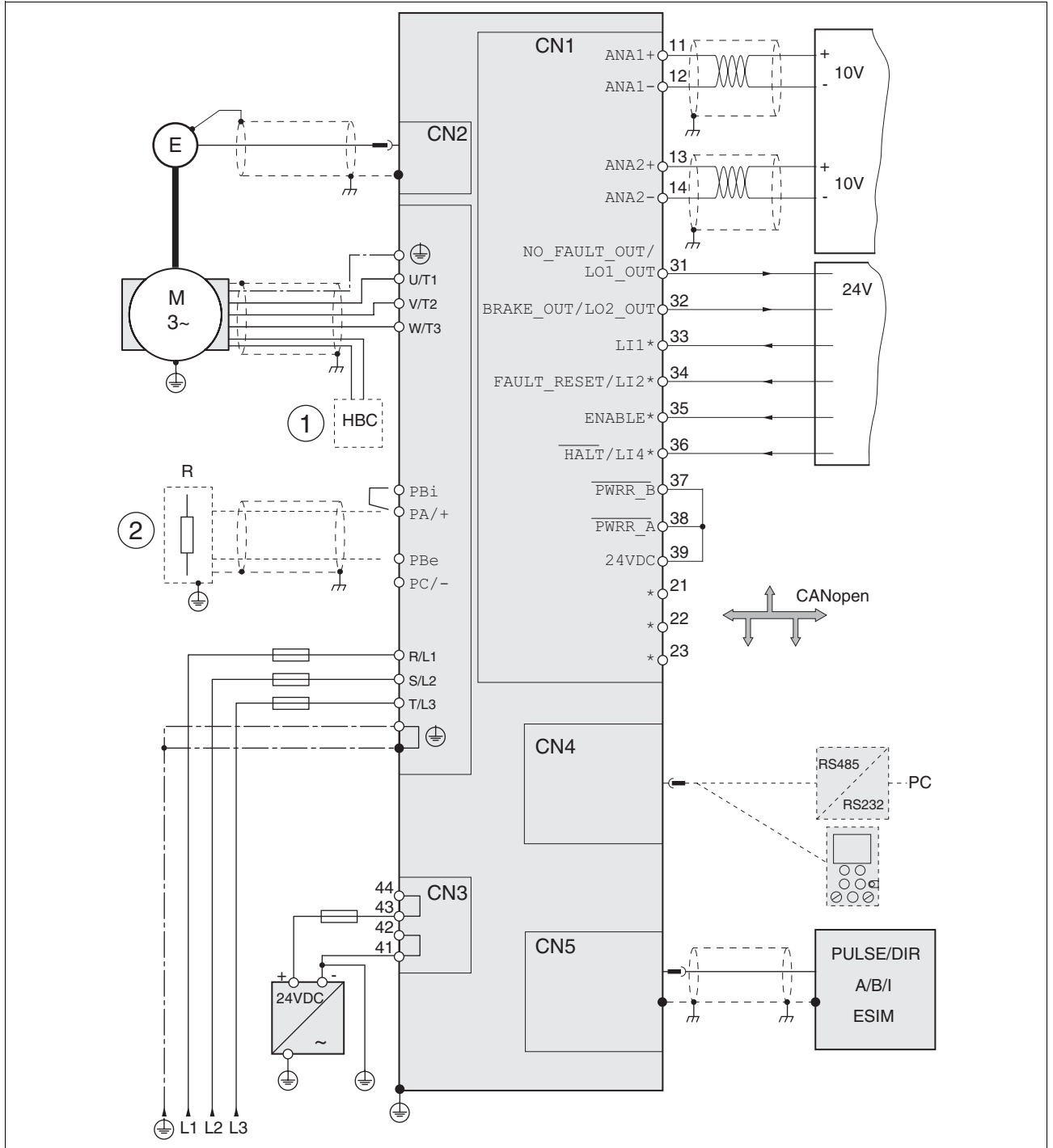

Figure 9.1 Wiring example

- (*) other signal assignment in control mode fieldbus
- (1) Optional: Holding brake controller
- (2) Optional: external braking resistor

9.2 Wiring fieldbus control mode

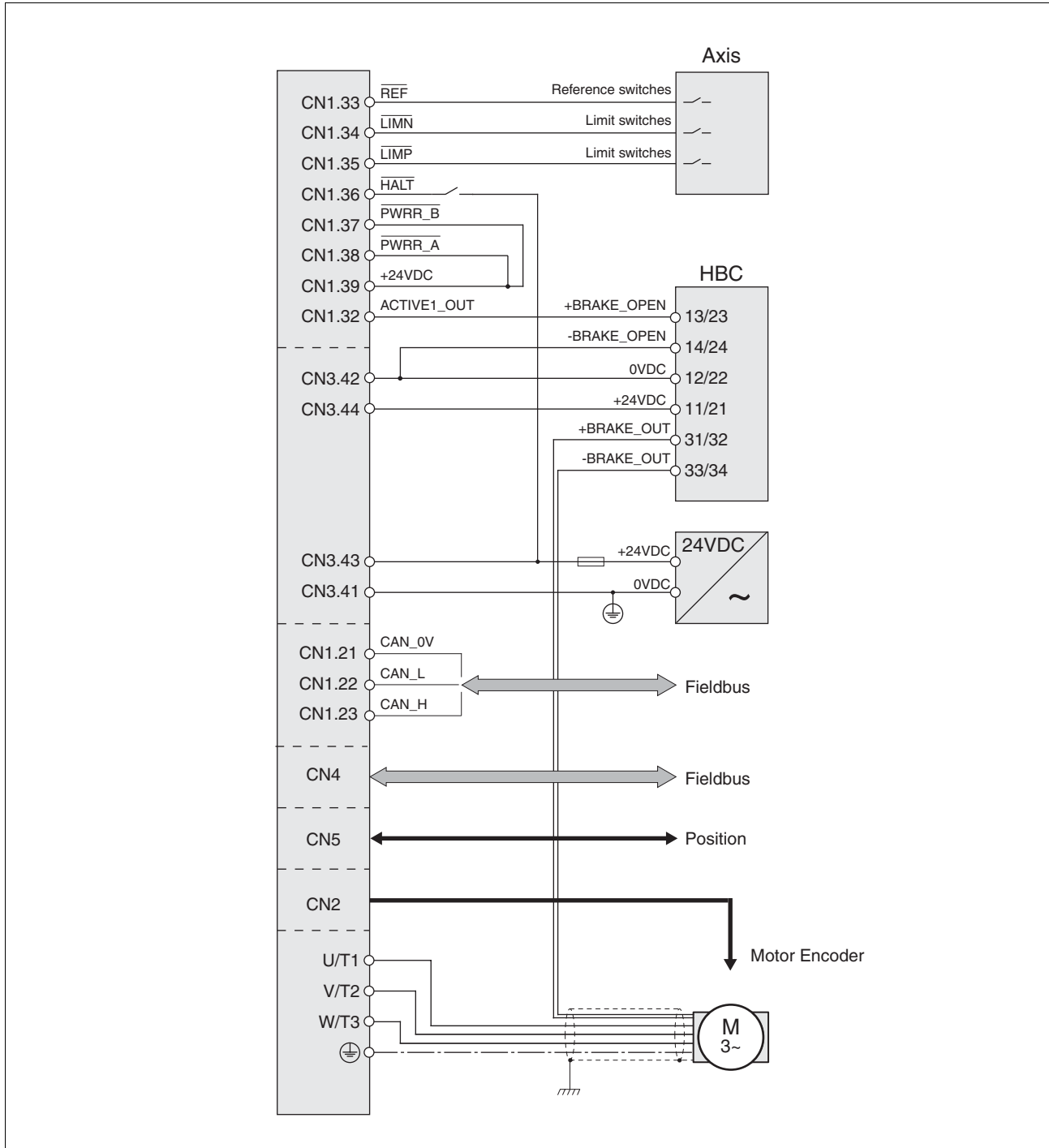

Figure 9.2 Wiring example

9.3 "Power Removal" wiring

Using the safety functions integrated in this product requires careful planning. For more information see 5.4 "Safety function "Power Removal"" on page 5-2.

9.4 Parameterisation local control mode

The following examples show settings for the current control, speed control and electronic gear modes. The control is local (I/O Mode), the set value preselection via the analogue inputs.

The parameters are set on the HMI in the following examples.

Requirements:

- The motor shaft should not yet be coupled with the system mechanism.
- The analogue inputs are already wired up.
- The "First Setup" and the settings for the basic parameters and limiting values have been carried out during commissioning.
- The power amplifier is ready to switch on, i.e the status display on the HMI shows *rdy*.

Example A: Current control

▶ Set the default operating mode to current control. Under *drC- / o- n* select the entry *Curr*

▶ The set current should be preset to 200 mA at 10V using *ANA1+*. Select under *SEt- / R h 5* the value *0.20*.

▶ The motor speed should be limited using *ANA2+*. Under *drC- / R2n0* select the entry *SPEd*

▶ The limit value of the motor speed should be 6000 rpm at 10 V. Select under *drC- / R2n0* the value *6000*.

▶ Check the speed limiter.

Start the motor for this (input signal *ENABLE*). Set *ANA1+* to maximum and limit it using *ANA2+*. Read off the speed value under *SEtR- / nRCE*.

▶ Check the actual current value. Read off the value under *SEtR- / RCE*.

- Example B: Speed control*
- ▶ Set the default operating mode to speed control. Under *drC- / , a-n* select the entry *SPEd*
 - ▶ The motor speed should be preset to 1500 r.p.m. at 10V using ANA1+. Select under *SEt- / R InS* the value *1500*.
 - ▶ The motor current should be limited using ANA2+ . Under *drC- / RZna* select the entry *Cur*
 - ▶ The limit value of the motor current should be 0.5 A at 10 V. Select under *drC- / RZ, n* the value *500*.
 - ▶ Check the current limiter
Start the motor for this (input signal *ENABLE*). Set ANA1+ to maximum and limit it using ANA2+. Read off the current value under *StR- / , RLt*.
 - ▶ Check the current speed. Read off the value under *StR- / nRLt*.
- Example C: Electronic gear*
- ▶ Set the default operating mode to electronic gear. Under *drC- / , a-n* select the entry *GERr*
 - ▶ The gear ratio should be selected from a list of presets and should be 2000. Select under *SEt- / GFRt* the value *2000*.
 - ▶ Check the current speed. Input the reference signals (pulse/direction or A/B/I) at the CN5 interface and start the motor (input signal *ENABLE*). Read off the value under *StR- / nRLt*.

10 Diagnostics and troubleshooting

⚠ DANGER

Electric shock, fire or explosion

- Only technicians who are familiar with and understand the contents of this manual and the other relevant manuals are authorised to work on and with this drive system.
- The system manufacturer is responsible for compliance with all applicable regulations relevant to earthing the drive system.
- Many components, including the printed circuit board, work with mains voltage. **Do not touch.** Do not touch unprotected parts or screws on the terminals under voltage.
- Install all covers and close the housing doors before applying power.
- The motor generates voltage when the shaft is rotated. Lock the motor shaft to prevent rotation before starting work on the drive system.
- Before working on the drive system:
 - Switch off power to all connections.
 - Place a sign "DO NOT SWITCH ON" on the switch and lock to prevent its being switched on.
 - **Wait for 6 minutes** (discharge DC bus capacitors). Do not short-circuit DC bus!
 - Measure voltage on DC bus and check that it is <45V. (The DC bus LED is not a reliable indicator for no DC bus voltage).

Failure to follow these instructions will result in death or serious injury.

10.1 Service

If you cannot resolve the fault yourself please contact your appointed sales partner. Have the following details available:

- Type plate (Type, identification number, serial number, DOM, ...)
- Type of fault (possibly with flash code or fault number)
- Previous and concurrent conditions
- Your own ideas regarding the cause of the fault

Include this information if you return the product for inspection or repair.

10.2 Error responses and error classes

Error response The product triggers an error response in the event of a fault. Depending upon the gravity of the fault, the device responds in accordance with one of the following error classes:

Error class	Response	Description
0	Warning	Message only, no interruption of movement mode.
1	"Quick Stop"	Motor stops with "Quick Stop", power amplifier and controller remain switched on and active.
2	"Quick Stop" with switch-off	Motor stops with "Quick Stop", power amplifier and controller switch off when at standstill.
3	Fatal error	Power amplifier and controller switch off immediately, without stopping the motor first.
4	Uncontrolled operation	Power amplifier and controller switch off immediately, without stopping the motor first. Error response can only be reset by switching the device off.

The occurrence of an event is signalled by the device as follows:

Event	Status	HMI-display	Entry for last interruption cause (<u>StopFault</u>)	Entry in error memory
Halt	Operation Enabled	<i>hRLt</i>	-	-
Software-Stop	Quick Stop active	<i>StoP R306</i>	E A306	-
Hardware limit switch (e.g. <u>LIMP</u>)	Quick Stop active	<i>StoP R302</i>	E A302	E A302
Error with error class 1, e.g. tracking error with error class 1	Quick Stop active	<i>StoP R320</i>	E A320	E A320
Error with error class >1, e.g. tracking error with error class 3	Fault	<i>FLt R320</i>	E A320	E A320

HMI, commissioning software and fieldbus indicate whether the safety function has been triggered by PWRR_A or PWRR_B. Neither signal can be configured via parameters.

10.3 Error display

The last cause of interruption and the last 10 error messages are stored. The HMI allows the last cause of interruption to be displayed; the commissioning software and the fieldbus allow, in addition to the last cause of interruption, the last 10 error messages also to be displayed. A description of all the error numbers can be seen from page 10-12.

10.3.1 Status diagram

After switching on and at the start of an operating mode, a sequence of operating states is progressed through.

The relationship between the operating states and the state transitions is shown in the state diagram (state machine).

The operating states are internally monitored and influenced by monitoring and system functions, such as temperature and current monitoring

Graphic representation The status diagram is shown graphically as a flow chart.

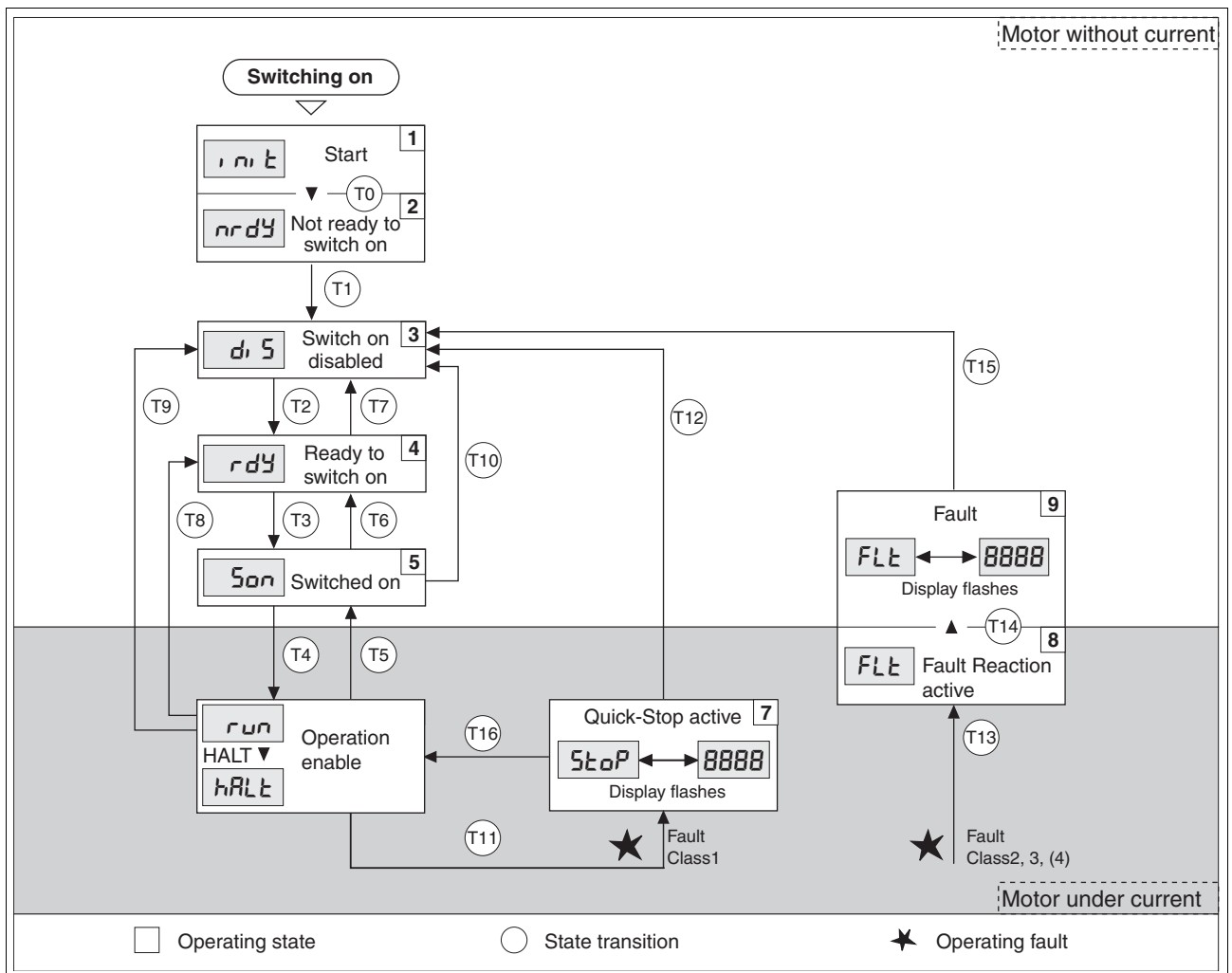

Figure 10.1 Status diagram

019844113232, V1.20, 06.2007

Operating states The operating states are displayed as standard by the HMI and the commissioning software.

Display	Status	State description
init	1 Start	Controller supply voltage, electronics is initialised
nrdy	2 Not ready to switch on	The power amplifier is not ready to switch on ¹⁾
dis	3 Switch on disabled	Switching on the power amplifier is disabled
rdy	4 Ready to switch on	The power amplifier is ready to switch on
son	5 Switched on	Motor not under current Power amplifier ready No operating mode active
run halt	6 Operation enable	RUN: device running in the selected operating mode HALT: The motor is stopped with active power amplifier
stop	7 Quick Stop active	"Quick Stop" is executed
flt	8 Fault Reaction active	Error detected, error response is enabled
flt	9 Fault	device is in fault condition

1) The device must be switched off and switched on again

Status transitions Status transitions are triggered by an input signal, a fieldbus command (with fieldbus control mode only) or as a response to a monitoring signal.

Transition	Operating status ¹⁾	Response	
T0	1-> 2	<ul style="list-style-type: none"> Motor speed below switch-on limit device electronics successfully initialised 	Check motor encoder
T1	2-> 3	<ul style="list-style-type: none"> First commissioning is completed 	-
T2	3-> 4	<ul style="list-style-type: none"> Motor encoder successfully checked, DC bus voltage active, $\overline{PWRR_A}$ and $\overline{PWRR_B} = +24V$, actual speed: <1000 1/min, fieldbus command: Shutdown ²⁾ 	-
T3	4-> 5	<ul style="list-style-type: none"> Input signal <code>ENABLE 0</code> -> 1 (local control mode) fieldbus command Switch On (fieldbus control mode) 	
T4	5-> 6	<ul style="list-style-type: none"> Automatic transition if input signal <code>ENABLE</code> still set (local control mode) fieldbus command Enable Operation (fieldbus control mode) 	Activate power amplifier motor phases, earth, user parameters are checked release brake
T5	6-> 5	<ul style="list-style-type: none"> fieldbus command Disable Operation (fieldbus control mode) 	Interrupt task with "Halt" Apply brake Disable power amplifier
T6	5-> 4	<ul style="list-style-type: none"> fieldbus command Shutdown 	
T7	4-> 3	<ul style="list-style-type: none"> DC bus undervoltage Actual speed: >1000 1/min (e.g. by auxiliary drive) $\overline{PWRR_A}$ and $\overline{PWRR_B} = 0V$ fieldbus command Disable voltage (fieldbus control mode) 	-

Transition	Operating status	¹⁾	Response
T8	6-> 4	<ul style="list-style-type: none"> fieldbus command Shutdown 	Deactivate power amplifier immediately
T9	6-> 3	<ul style="list-style-type: none"> Input signal <code>ENABLE</code> 1 -> 0 (local control mode) fieldbus command Disable voltage (fieldbus control mode) 	Deactivate power amplifier immediately
T10	5-> 3	<ul style="list-style-type: none"> Input signal <code>ENABLE</code> 1 -> 0 (local control mode) fieldbus command Disable voltage (fieldbus control mode) 	
T11	6-> 7	<ul style="list-style-type: none"> Class 1 error fieldbus command Quick Stop (fieldbus control mode) 	Interrupt travel command with "Quick Stop"
T12	7-> 3	<ul style="list-style-type: none"> Input signal <code>ENABLE</code> 1 -> 0 (local control mode) fieldbus command Disable voltage (fieldbus control mode) 	Deactivate power amplifier immediately, even if "Quick Stop" still active
T13	x -> 8	<ul style="list-style-type: none"> Errors Class 2, 3 or 4 	Error response is carried out, see "error response"
T14	8 -> 9	<ul style="list-style-type: none"> Error response completed Errors Class , 3 or 4 	
T15	9-> 3	<ul style="list-style-type: none"> Input signal <code>FAULT_RESET</code> 0 -> 1 (local control mode) fieldbus command Fault Reset (fieldbus control mode) 	Error is reset (cause of error must be corrected).
T16	7-> 6	<ul style="list-style-type: none"> Input signal <code>FAULT_RESET</code> 0 -> 1 (local control mode) fieldbus command Fault Reset (fieldbus control mode) fieldbus command Enable Operation ³⁾ (fieldbus control mode) 	Local control mode Specified operating mode is automatically continued (cause of error must be corrected).

1) Condition / Event It is sufficient to satisfy one point to initiate the state transition

2) Only required with fieldbus control mode, fieldbus CANopen and parameter `DCOMcompatib= 1`

3) Possible only if operating status was triggered through fieldbus

10.3.2 Error display on HMI

- State display $uL\sigma L$* The display shows $uL\sigma L$ (ULOW) when initialised. The voltage of the control supply is too low .
- ▶ Check the control supply.
- State display $nr dY$* The product persists in switch-on state $nr dY$ (NRDY).
- ▶ After "First Setup", you need to switch the unit off and switch it on again.
 - ▶ Check the installation.
If the installation is correct, then there is an internal fault. To diagnose, read the error memory using the commissioning software. If you cannot resolve the fault yourself please contact your local sales partner.
- Status display $d\prime 5$* If the product comes to a stop in status $d\prime 5$ (DIS), the DC bus voltage has failed or the $\overline{PWRR_A}$ and $\overline{PWRR_B}$ safety inputs have no power.
- ▶ Check the following:
 - Are the $\overline{PWRR_A}$ and $\overline{PWRR_B}$ safety inputs enabled? If not required, these two inputs should be set to +24V.
 - Check the installation of the analogue and digital signal connections. Pay particular attention to the minimum assignment, see page 6.3.17 "Connection of digital inputs/outputs (CN1)".
 - Is the mains supply to the power amplifier switched on and does the voltage correspond to the details in the technical data?
- Special condition for devices with CANopen fieldbus: For devices with fieldbus control mode and CANopen note the setting of the `DCOMcompatib` parameter. Depending on the setting of this parameter the device remains in status $d\prime 5$ after being switched on.
- Status display FLt* The display flashes alternately with FLt (FLT) and a 4 digit error number. The error number can also be found in the error memory list.
- ▶ Check especially:
 - Is a suitable motor connected?
 - Is the motor encoder cable correctly wired and connected? The device cannot correctly start up the motor without a motor encoder signal.
- Status display $n\sigma t$* If the motor originally fitted is changed for a different one, the motor data set is reread. If the device recognises a different motor type, the control parameters are recalculated and $n\sigma t$ is shown on the HMI. For the procedure for replacing a motor, see chapter .
- ▶ Correct the cause of the error and reset the error message.
- Status display $St\sigma P$* The HMI displays $St\sigma P$ (STOP) when a "Quick Stop" has been triggered. This can be caused by a software stop, a hardware limit switch or by an error of error class 1.
- ▶ Correct the cause of the error and reset the error message.

State display $\text{Ldd}\bar{\text{L}}$ The display shows $\text{Ldd}\bar{\text{L}}$ (WDOG) when initialised. The internal monitor has sensed a fault by means of the Watchdog.

- ▶ Contact the Technical Support of your local sales partner. Advise the peripheral conditions (operating mode, application event) when the fault occurs:
- ▶ The error can be reset by switching the unit off and on again.

Last cause of interruption

- ▶ Press the ENT button on the HMI to reset the current error message.
- ▶ Change to the *FLt* menu. The last cause of interruption (Parameter `_StopFault`) is shown as an error number, see chapter 10.5.

10.3.3 Error display with commissioning software

- You will need a PC with the commissioning software and a functional connection to the product, see 6.3.18 "Connection to PC or remote terminal (CN4)" from page 6-49.
- ▶ Select "Diagnosis error memory". A dialogue box which displays the error messages appears.

The screenshot shows the PowerSuite software interface for Lexium05. The window title is "PowerSuite - Lexium05 - Lexium05". The interface is divided into several sections:

- Current faults:** A list of fault types, each with a green indicator. The list includes: generic error, limit switches (LIMP/LIMN/REF), Traverse range overrun (software limit switch, tuning range), quick stop via fieldbus, Power removal safety related function (PWR_R_A, PWR_R_B), -reserved-, RS485 / Modbus protocol error, CANopen error, -reserved-, pulse input error (frequency too high), operation mode error, -reserved-, PROFIBUS error, -reserved-, mains undervoltage, mains overvoltage, mains connection (phase error, ground fault), motor connection (ground fault, not connected), motor overload (short circuit), motor encoder error, 24 volt undervoltage, and overtemperature (Inverter amplifier, braking resistor, motor).
- Last faults:** A section showing the fault history. It includes a "Faults counter" set to 5 and a "Fault history" table. The table has columns for "Number" and "Fault history". The entries are:

Number	Fault history
Last fault	E110B : initialisation error (at the indicated modbus
Last fault - 1	E110B : initialisation error (at the indicated modbus
Last fault - 2	E7331 : System error: motor sensor initialising
Last fault - 3	E7121 : System error: faulty communication encode
Last fault - 4	E1301 : PWR_R_A and PWR_R_B different level
- Additional information:** A table with columns for "Code", "Label", "Value", and "Unit". The entries are:

Code	Label	Value	Unit
ID_FLT1	ENABLE cycle numt	0	
ID_FLT2	Time between ENAE	0 s	
ID_FLT3	DC bus value when e	307.8 V	
ID_FLT4	Speed value when e	0 1/min	
ID_FLT5	Motor current when	0.05 A	
ID_FLT6	Power Amp. °C when	35 °C	
ID_FLT7	Drive °C when error	53 °C	
- Control Panel:** Includes buttons for "Command" (Active/Inactive), "CUR.ref." (On/Off), a numerical display for "CUR_I_target [A]" with "Min" (-9.90) and "Max" (9.90) values, "Fast run" and "Test stop" buttons, "Enable" (On/Off) buttons, "State" (Rdy Switch On) indicator, and a "Reset" button. On the right, there are parameters for "Drehzahlregelung" (HALT=aktiv, S.Fault=0x0000, DEVcmdinterf=IODEvi) and "p_refusr = -2 usr", "p_actusr = 15 usr", "n_ref = 0 1/min", "n_act = 0 1/min", and "Idq_act = 0.06 Apk".

Figure 10.2 Error messages

The commissioning software shows a 4 digit error number in the list of the error memory with an "E" in front.

Error messages are displayed showing status, error class, time when error occurred and a short description. Under "Additional information" you can verify the exact conditions when the error occurred.

- ▶ Correct the error and reset the current error message with the "Reset" button in the command bar of the program.
In the case of class 4 errors, you will need to switch off the controller supply voltage and switch it on again.

10.3.4 Error display via fieldbus

Error display by status word The error is first displayed via the parameter `DCOMstatus`. The display takes place by changing the operating state and setting the error bits Bit 13 `x_err`.

cause of last interruption The parameter `_StopFault` allows read out of the error number and the last cause of interruption. If there is no error, the value of the parameter is 0. If an error occurs, the error is written in the error memory together with other status information. In the case of subsequent errors, only the triggering cause of error is stored.

Error memory The error memory is an error history of the last 10 errors and is maintained even if the device is switched off. The following parameters allow the error memory to be controlled:

Parameter Name HMI menu	Description	Unit Minimum value Default value Maximum value	Data type R/W persistent Expert	Parameter address via fieldbus
FLT_del_err	Erase error memory10-8	-	UINT16	CANopen 303B:4 _h
-	1: Erases all entries in the error memory	0	UINT16	Modbus 15112
-	The erasing process is complete when a 0 is returned when reading.	-	R/W	
		1	-	
FLT_MemReset	Reset the error memory read pointer10-8	-	UINT16	CANopen 303B:5 _h
-	1: Set error memory read pointer to oldest error entry.	0	UINT16	Modbus 15114
-		-	R/W	
		1	-	

The error memory can only be read sequentially. The parameter `FLT_MemReset` must be used to reset the read pointer. Then the first error entry can be read. The read pointer is automatically moved on to the next entry, re-reading selects the next error entry. If the error number 0 is returned there is no error entry present.

Position of the entry	Description
1	1. Error entry, oldest message
2	2. Error entry, later message, if present
...	...
10	10. Error entry. In the case of 10 error entries the most current error value is shown here

An individual error entry consists of several pieces of information which are read out using various parameters. When reading out an error entry, the error number must always be read out first with the parameter `FLT_err_num`.

Parameter Name HMI menu	Description	Unit Minimum value Default value Maximum value	Data type R/W persistent Expert	Parameter address via fieldbus
FLT_err_num	Error number10-8	- 0 - 65535	UINT16 UINT16 R/- -	CANopen 303C:1 _h Modbus 15362
-	Reading this parameter brings the complete error entry (error class, time of error ...) into an intermediate memory from which all components of the error can be read.			
	In addition, the read indicator of the error memory is automatically switched forward to the next error entry.			
FLT_class	Error class10-8	- 0 - 4	UINT16 UINT16 R/- -	CANopen 303C:2 _h Modbus 15364
-	0: Warning (no reaction)			
-	1: error (Quick Stop -> status 7)			
-	2: error (Quick Stop -> status 8, 9)			
-	3: Fatal error (state 9, resettable)			
-	4: Fatal error (state 9, not resettable)			
FLT_Time	Error time10-8	s 0 - 536870911	UINT32 UINT32 R/- -	CANopen 303C:3 _h Modbus 15366
-	referenced to the operating hours counter			
-				
FLT_Qual	Error additional information10-8	- 0 - 65535	UINT16 UINT16 R/- -	CANopen 303C:4 _h Modbus 15368
-	This entry contains additional information about the error, depending on the error number.			
-	Example: a parameter address			

10.4 Troubleshooting

10.4.1 Resolution of malfunctions

Malfunction	Cause	Correction
Motor not turning	Motor blocked by brake	Release holding brake, check wiring
	Break in the motor cable	Check motor cable and connection. One or more motor phases are not connected.
	No torque	Set the parameters for max. current, max. speed to greater than zero
	Incorrect operating mode selected	Set the input signal and parameters for the operating mode you want
	Drive system switched off	Switch on drive system, generate release signal
	Analogue reference value is missing	PLC program and wiring to be checked
	Motor phases reversed	Correct the sequence of the motor phases
	Motor mechanically blocked	Check ancillary devices
	Current limiting activated (analogue input or parameter)	Correct the current limit
The motor jerks briefly	Motor phases reversed	Check motor cable and connection: connect motor phases U, V and W in the same way on the motor and device sides
Motor vibrating	Amplification factor KP too high	reduce KP (speed controller)
	Fault in the motor encoder system	Check motor encoder
	Reference potential for analogue signal missing	Connect reference potential of analogue signal to the reference value source.
Motor running too soft	Integration time TNn too high	Reduce Tn (speed controller)
	Amplification factor KPn too low	Increase KPn (speed controller)
Motor running too rough	Integration time TNn too low	Increase TNn (speed controller)
	Amplification factor KPn too high	Reduce KPn (speed controller)
Error message communication error	Drive system switched off	Switch on the drive system
	Wiring error	Check wiring
	Wrong PC interface selected	Select correct interface

10.4.2 Error resolution sorted by error bit

For better orientation when troubleshooting, all error numbers are categorised with the so-called error bit. The error bits can be read using the parameter `_SigLatched`. The signal state "1" marks an error or warning message.

Error bit	Description	Error class	Cause	Troubleshooting
0	General error	0		
2	Area of travel exceeded (software limit switch, tuning range)	1	Motor outside area of travel	Check area of travel, re-reference the drive
3	"Quick Stop" via fieldbus	1	fieldbus command	
5	reserved			
7	Error in fieldbus CANopen		Interruption in fieldbus communication, only with CANopen	Check communication cable, check fieldbus check communication parameters see also fieldbus manual
8	reserved			
9	Reference signals faulty (frequency too high)		frequency too high, malfunction	EMC measures, observe max. frequency (technical data)
10	Error in processing of the current operating mode	2	Processing error in electronic gearbox reference movement or jog mode.	Detailed information see under additional information in the error memory
11	reserved			
13	reserved			
14	DC bus undervoltage	2	DC bus voltage under threshold value for "Quick Stop"	Check or increase mains voltage
		3	DC bus voltage under threshold value for switch-off of the drive	Check for power failure
15	DC bus overvoltage	3	DC bus overvoltage, braking too fast	Extend braking, Apply external brake resistor
16	Power supply faulty (phase fault, earth fault)	par. ¹⁾	Short circuit or earth fault Supply voltage connected incorrectly (e.g. 1-phase instead of 3-phase)	Check fuse and installation
17	Connection to motor (motor phase interrupted, earth fault, commutation)	3	Short circuit or earth fault in the motor wiring or encoder wiring. Motor faulty. External torque exceeds the motor torque (preset motor current too low).	Check connections, replace motor cable or encoder cable. Change motor. Reduce external torque or increase the setting of the motor current.
18	Motor overload (phase current too high)	3	I^2t monitoring for motor	Reduce load, use a motor with a higher nominal power
19	Encoder in motor signals error or connection to encoder faulty	3-4	No signal from the motor encoder, encoder faulty	Check encoder cable and encoder, replace cable
20	undervoltage from controller supply voltage		Controller supply voltage has fallen below the minimum value	Secure controller supply voltage. Check short-term voltage failures during load changes

Error bit	Description	Error class	Cause	Troubleshooting
21	Temperature too high (power amplifier, braking resistor or motor)	3	The power amplifier is overheating Motor is overheating Temperature sensor not connected	Fan faulty or blocked, switch on time for peak current, reduce load or peak torque Allow motor to cool down, reduce load, use motor with greater nominal power, temperature sensor faulty, check/change motor and encoder cables
22	Tracking error	par. ¹⁾ 1-3	Tracking error	Reduce external load or acceleration, error response is adjustable via "Fit_pDiff"
23	Maximum speed exceeded		Exceeding the maximum motor speed during feed operations	Reduce vertical loading
25..28	reserved			
29	error in EEPROM	3-4	Checksum in EEPROM incorrect	"First setup" to be carried out, user parameters to be stored in the EEPROM, consult your local sales partner
30	system run-up faulty (hardware or parameter fault)	3-4	Cause of error in accordance with error display	Resolution dependent upon error display
31	Internal system fault (e.g. Watchdog)	4	Internal system error system error, e.g. division by 0 or time-out checks, inadequate EMC	Switch device off and on, replace device Comply with EMC protective measures, switch device off and on, contact your local service representative

1) par. = can be set by parameters

10.5 Table of error numbers

The cause of error for each error message is coded as an error number and stored in the parameter `FLT_err_num`. The following table shows all the error numbers and their meaning. If "par." is shown under the error class, then the error class can be set as a parameter. Please note that in the HMI, the error number is shown without the preceding "E".

The error numbers are structured:

Error number	Error in range
E 1xxx	General error
E 2xxx	Excess current error
E 3xxx	Voltage error
E 4xxx	Temperature error
E 5xxx	Hardware error
E 6xxx	Software error
E 7xxx	Interface error, wiring error
E 8xxx	fieldbus error CANopen
E Axxx	Drive error, movement error
E Bxxx	Communication error

Information on error class can be found on page 10-2.
Information on error bits and measures for correcting errors can be found on page 10-11.

Error number	Class	Bit	Description, reason and correctives
E 1100	-	-	Parameter out of permissible range
E 1101	-	-	Parameter does not exist Fault signaled by parameter management: parameter (index) does not exist.
E 1102	-	-	Parameter does not exist Fault signaled by parameter management: parameter (subindex) does not exist.
E 1103	-	-	Parameter write not permissible (READ only) Write access to read only parameter.
E 1104	-	-	Write access denied (no access authorisation) Parameter only accessible at expert level. The write access level expert is required.
E 1106	-	-	Command not allowed while power amplifier is active Command not allowed while the power amplifier is enabled (status "OperationEnable" or "QuickStopActive"). Disable the power amplifier and repeat the command.
E 1107	-	-	Access via other interface blocked Access occupied by another channel (e.g.: commissioning tool is active and fieldbus access was tried at the same time). Check the channel that blocks the access.
E 110B	3	30	Initialisation error (additional info=Modbus register address) Error detected at power enable parameter check e.g. reference speed value for profile position is greater than max. allowed speed of drive.# Value in additional error info shows the Modbus register address of the parameter where the initialisation error was detected.
E 110D	1	0	Basic configuration of controller required after factory setting The "First Setup" (FSU) was not run at all or not completed.
E 110E	-	-	Parameter changed that requires a restart of the drive Only displayed by the commissioning tool. A parameter modification requires the drive to be switched off and on. Restart the drive to activate the parameter functionality. Check the parameter chapter for the parameter that required a restart of the drive.
E 1300	3	4	Power Removal activated (PWRR_A, PWRR_B) The "Power Removal" safety function was activated in "Operation enable" status. Reset the fault; check the wiring of the PWRR inputs.
E 1301	4	24	PWRR_A and PWRR_B different level The levels of the input PWRR_A or PWRR_B were different for more than 1 second. The drive has to be switched off and the reason fixed (e.g.: check emergency stop active) before it is switched on.

Error number	Class	Bit	Description, reason and correctives
E 1310	3	9	Reference signal frequency too high The frequency of the pulse signal (A/B, Pulse/Direction, CW/CCW) is higher than the allowed value. Adapt the output pulse frequency of the controller to fit the input specification of the drive. Take care to also adapt the electronic gear ratio for the application requirements (position accuracy and speed).
E 1311	-	-	The selected input or output function cannot be configured The function configured for an Input or Output cannot be used in the selected mode (e.g. enable positive movement input function cannot be configured in jog mode) .
E 1312	-	-	Limit or reference switch signal in I/O functions not defined Reference movements require limit switches. These limit switches are not assigned to inputs. Assign the LIMP, LIMN and ref functions to the inputs.
E 160C	1	0	Autotuning: moment of inertia outside permissible range The load inertia is too high.
E 160D	1	0	Autotuning: the value of parameter 'AT_n_tolerance' may be too low for the identified mechanical system First steps of Autotuning failed: oscillation is too high.
E 160F	1	0	Autotuning: power amplifier cannot be enabled Autotuning was started in "Fault" status.
E 1610	1	0	Autotuning: processing discontinued DC bus undervoltage, LIMP, LIMN, Stop button at remote terminal pressed, ..., but NOT caused by Autotuning process.
E 1611	1	0	System error: Autotuning internal write access HALT is active and an Autotuning parameter is written. Occurs when Autotuning is started.
E 1613	1	0	Autotuning: max. permissible positioning range exceeded The motor exceeded the adjusted position range during Autotuning. Monitoring can be turned off by setting 'AT_DIS' = 0.
E 1614	-	-	Autotuning: already active Autotuning has been started twice simultaneously OR an Autotuning parameter is modified during Autotuning ('AT_dis' and 'AT_dir').
E 1615	-	-	Autotuning: this parameter cannot be changed while Autotuning is active AT_gain' or 'AT_J' are written during Autotuning.
E 1616	1	0	Autotuning: static friction for selected speed jump height 'AT_n_ref' too high AT_n_ref' is too great regarding actual friction. Reduce 'AT_n_ref' or friction.
E 1617	1	0	Autotuning: friction torque or load torque too great The current limit has been reached ('CTRL_i_max').
E 1618	1	0	Autotuning: optimisation aborted The internal Autotuning sequence has not been finished (following error?).

Error number	Class	Bit	Description, reason and correctives
E 1619	-	-	Autotuning: the speed jump height 'AT_n_ref' is too small compared to 'AT_n_tolerance' AT_n_ref < 2 * 'AT_n_tolerance'; checked only once at the first speed jump. Modify 'AT_n_ref' and/or 'AT_n_tolerance' to meet the desired condition.
E 1620	1	0	Autotuning: load torque too high Product dimensioning is not suitable for the machine load. Detected machine inertia is too high compared to the inertia of the motor. Reduce load, check dimensioning.
E 1A01	3	19	Motor has been changed Detected motor type is different from previously detected motor. Confirm the motor change.
E 1A02	3	19	Motor has been changed The motor type is the same, but the motor data structure has changed. Confirm the motor change.
E 1B04	3	30	ESIM resolution too high with selected 'n_max' Reduce the ESIM resolution or the maximum speed 'CTRL_n_max'.
E 2300	3	18	Power amplifier overcurrent Motor short circuit and deactivation of the power amplifier. Check the motor power connection.
E 2301	3	18	Braking resistor overcurrent Braking resistor short circuit.
E 3100	par.	16	Mains power supply phase fault Missing phase(s) for more than 50ms.
E 3200	3	15	DC bus overvoltage Energy recovery during braking too high. Check deceleration ramp, check dimensioning of drive and braking resistor.
E 3201	3	14	DC bus undervoltage (switch-off threshold) Power supply loss, poor power supply.
E 3202	2	14	DC bus undervoltage (Quick Stop threshold) Power supply loss, poor power supply.
E 3203	4	19	Motor encoder supply voltage Encoder power supply voltage is not consistent because of a hardware problem. Replace the device.
E 3206	0	11	DC bus undervoltage, no mains phase (warning) Power supply loss, poor power supply.
E 4100	3	21	Power amplifier overtemperature Transistors overtemperature: ambient temperature is too high, fan is faulty, dust. Remove the protective foil, improve the heat dissipation in the cabinet.
E 4101	0	1	Warning power amplifier overtemperature Transistors overtemperature: ambient temperature is too high, fan is faulty, dust. Remove the protective foil, improve the heat dissipation in the cabinet.

Error number	Class	Bit	Description, reason and correctives
E 4102	0	4	Power amplifier overload (I2t) warning The current has exceeded the nominal value for an extended period of time. Check dimensioning, reduce cycle time.
E 4200	3	21	Device overtemperature Control board overtemperature: ambient temperature is too high.
E 4300	3	21	Motor overtemperature Resistance of thermal sensor is too high; overload, ambient temp (see I2t); faulty encoder cable. Check motor installation: the heat must be dissipated via the mounting surface. Check encoder cable.
E 4301	0	2	Warning motor overtemperature Resistance of thermal sensor is too high; overload, ambient temp (see I2t). Check motor installation: the heat must be dissipated via the mounting surface.
E 4302	0	5	Motor overload (I2t) warning The current has exceeded the nominal value for an extended period of time.
E 4402	0	6	Braking resistor overload (I2t) warning The braking resistor is switched on for an excessively long period of time.
E 5200	4	19	Fault in connection to motor encoder Communication has not been established: encoder cable is faulty or not connected, EMC. Check the cable connection, shield.
E 5201	4	19	Errors in motor encoder communication Encoder error message: communication error detected by the encoder itself.
E 5202	4	19	Motor encoder is not supported Incompatible encoder type is connected.
E 5204	3	19	Connection to motor encoder lost Encoder cable problems (communication has been interrupted). Check the cable connection.
E 5206	0	19	Communication error in encoder Communication disturbed, EMC. Check the connection, check the shielding on the EMC plate.
E 5600	3	17	Motor connection phase fault Motor phase(s) are not connected . Check connection of motor phases.
E 5601	4	19	Interruption or faulty encoder signals Encoder is not correctly connected (SinCos analogue signals are missing). Check encoder connection.
E 5602	4	19	Interruption or faulty encoder signals Encoder is not correctly connected (SinCos analogue signals are missing). Check encoder connection.

Error number	Class	Bit	Description, reason and correctives
E 5603	4	17	Commutation error Motor phases are inverted; EMC; the load torque is greater than the motor torque; wrong motor data into the encoder EEPROM (encoder phase offset is wrong). Resize the motor so it can withstand the load torque; check motor data; contact technical support.
E 610D	-	-	Error in selection parameter Wrong parameter value selected. Check the value to be written.
E 7100	4	30	System error: invalid power amplifier data Amplifier data stored in device is corrupt (wrong CRC), error in internal memory data. Contact technical support or replace the device.
E 7120	4	19	Invalid motor data Motor data are corrupt (wrong CRC). Contact technical support or replace the motor.
E 7121	2	19	System error: errors in motor encoder communication EMC, detailed information is included in the fault buffer that contains the error code of the encoder. Contact technical support.
E 7122	4	30	Invalid motor data Motor data stored in motor encoder is corrupt, error in internal memory data. Contact technical support or replace the motor.
E 7123	4	30	Motor current offset outside permissible range Motor current measurement circuit is defective. Contact technical support or replace the device.
E 7124	4	19	System error: motor encoder faulty Encoder signals internal fault. Contact technical support or replace the motor.
E 7328	4	19	Motor encoder sends: position capture errors Encoder signals internal position capturing fault. Contact technical support or replace the motor.
E 7329	0	8	Motor encoder sends: Warning EMC, encoder signals internal warning. Contact technical support or replace the motor.
E 7336	3	0	Offset with SinCos drift compensation too high HiFa analogue signal offset during calibration procedure is out of range. Check encoder connection, replace device / motor.
E 7338	0	13	No valid motor absolute position Warning to inform you that absolute position has not yet been determined. Depending on application, fix the absolute position. Device still usable and all functions are OKAY.

Error number	Class	Bit	Description, reason and correctives
E 7500	0	9	RS485/Modbus: overrun error EMC; cabling problem. Check cables.
E 7501	0	9	RS485/Modbus: framing error EMC; cabling problem. Check cables.
E 7502	0	9	RS485/Modbus: parity error EMC; cabling problem. Check cables.
E 7503	0	9	RS485/Modbus: receive error EMC; cabling problem. Check cables.
E 8110	0	7	CANopen: CAN overflow (message lost) Two short CAN messages have been sent too fast (at 1Mbits only).
E 8120	0	7	CANopen: CAN Controller in Error Passive Too many error frames have been detected. Check CAN bus installation.
E 8130	2	7	CANopen: Heartbeat or Life Guard error The bus cycle time of the CANopen master is higher than the programmed heartbeat or nodeguard time. Check CANopen configuration, increase heartbeat or nodeguard time.
E 8140	-	-	
E 8141	2	7	CANopen: CAN Controller in Busoff Too many error frames have been detected, CAN devices with different baudrates. Check CAN bus installation.
E 8201	0	7	CANopen: RxPDO1 could not be processed Error while processing Receive PDO1: PDO1 contains invalid value. Check RxPDO1 content (application).
E 8202	0	7	CANopen: RxPDO2 could not be processed Error while processing Receive PDO2: PDO2 contains invalid value. Check RxPDO2 content (application).
E 8203	0	7	CANopen: RxPDO3 could not be processed Error while processing Receive PDO3: PDO3 contains invalid value. Check RxPDO3 content (application).
E 8204	0	7	CANopen: RxPDO4 could not be processed Error while processing Receive PDO4: PDO4 contains invalid value. Check RxPDO4 content (application)
E A060	2	10	Calculated speed in electronic gear/pulse control too high Gear ratio or speed reference value too high Reduce the gear ratio or speed reference value.

Error number	Class	Bit	Description, reason and correctives
E A061	2	10	Position change in reference value with electronic gear/pulse control too high Position reference change is too high. Reference value input signal disturbance. Reduce the resolution of the master. Check reference value input signal.
E A067	3	0	
E A300	-	-	Braking procedure after HALT request still active HALT was removed too soon. New command was sent before motor standstill was reached after a HALT request. Wait for complete stop before removing HALT signal. Wait until motor has come to a complete standstill.
E A301	-	-	Drive in status "Quick Stop active" Error with error class 1 occurred. Drive stopped with Quick Stop command.
E A302	1	1	Interruption by LIMP LIMP was activated because working range was exceeded, malfunction of limit switch or signal disturbance. Check application. Check limit switch function and connection.
E A303	1	1	Interruption by LIMN LIMN was activated because working range was exceeded, malfunction of limit switch or signal disturbance. Check application. Check limit switch function and connection.
E A305	-	-	Power amplifier cannot be activated in the current operating status (status diagram) Fieldbus: trying to enable the amplifier in status "Not ready to switch on". Refer to the status diagram in the operation chapter of the manual.
E A306	1	3	Interruption by user-initiated software stop Drive is in status "Quick Stop active" due to a software stop request. The activation of a new operating mode is not possible, the error code is sent as the response to the activation command. Clear break condition with command Fault Reset.
E A307	-	-	Interruption by internal software stop In homing and jog modes, the movement is internally interrupted using an internal software stop. The activation of a new operating mode is not possible, the error code is sent as the response to the activation command. Clear break condition with command Fault Reset.
E A308	-	-	Drive in "Fault" status Error with error class 2 or higher occurred. Check error code (HMI or PS2), remove error condition and clear error status with command Fault Reset.
E A309	-	-	Drive not in status "Operation Enable" A command which requires the status "Operation enable" was sent (e.g.: opmode change). Set drive to status "OperationEnable" and repeat the command.

Error number	Class	Bit	Description, reason and correctives
E A310	-	-	Power amplifier not active Command is not possible because the power amplifier is not enabled (status "Operation Enabled" or "Quick Stop"). Set drive to a status with the amplifier enabled, refer to the status diagram in the operation chapter of the manual.
E A313	-	-	Position overrun, reference point is therefore no longer defined (ref_ok=0) The position range limits were exceeded which resulted in a loss of the reference point. An absolute movement cannot be made until the definition of a new reference point. Define a new reference point by means of homing mode.
E A314	-	-	No reference position Command needs a defined reference point (ref_ok=1). Define a new reference point by means of homing mode.
E A315	-	-	Homing active Command not possible if homing status is active. Wait until homing movement is finished.
E A317	-	-	Drive is not at standstill Command send which is not allowed during the motor is not in standstill e.g. - change of softwarelimits - change handling of supervision signals - set reference point - teach in of data set Wait until drive has come to a standstimm (x_end = 1).
E A318	-	-	Operating mode active (x_end=0) Activation of a new operating mode is not possible while the current operating mode is still active. Wait until the command in the operating mode has finished (x_end=1) or terminate current operating mode with HALT command.
E A319	1	2	Manual/Autotuning: distance range overflow The motor exceeds the parameterised limit ('MT_dismax') of manual tuning. Check reference value and time interval for manual tuning.
E A31A	-	-	Manual/Autotuning: amplitude/offset set too high Amplitude plus offset for tuning exceed internal speed or current limitation. Choose lower amplitude and offset values.
E A31B	-	-	HALT requested Command not allowed while a HALT is requested. Clear HALT request and repeat command.
E A31C	-	-	Invalid position setting with software limit switch Value for negative (positive) software limit is greater (less) than value for positive (negative) software limit. Homing position value is set outside the range of the software limits. Set correct position values.

Error number	Class	Bit	Description, reason and correctives
E A31D	-	-	Speed range overflow ('CTRL_n_max') The reference speed value was set to a value greater than the max. speed defined in 'CTRL_n_max'. Increase the value of 'CTRL_n_max' or reduce the reference speed value.
E A31E	1	2	Interruption by positive software limit switch Command not possible because of overrun of positive software limit switch. Move back to software limit range by means of manual movement.
E A31F	1	2	Interruption by negative software limit switch Command not possible because of overrun of negative software limit switch. Move back to software limit range by means of manual movement.
E A320	par.	22	Position tracking error External load or acceleration are too high . Reduce external load or acceleration, error response is adjustable via 'Fit_pDiff'.
E A321	-	-	RS422 position interface is not defined as input signal RS422 interface is defined as output (e.g. ESIM) at start of electronic gear mode. Define RS422 interface as input via 'IOposInterfac' parameter.
E A324	1	10	Error during homing (additional info = detailed error number) Homing movement was stopped by an error, the detailed reason is indicated by the additional info in the error buffer. Possible sub error codes: EA325 EA326 EA327 EA328 EA329
E A325	1	10	Limit switch to be approached not enabled Homing to LIMP or LIMN and limit switches are disabled. Enable limit switch via 'IOsigLimP' or 'IOsigLimN'.
E A326	1	10	REF switch not found between LIMP and LIMN REF input switch defective or not correctly connected. Check the function and wiring of the REF switch.
E A327	1	10	Reference movement to REF without direction reversal, improper enabling of limit switch LIM Search of REF without direction reversal in positive (negative) direction with LIMP (LIMN) activated. Check the function and wiring of the LIMP (LIMN) switch.
E A328	1	10	Reference movement to REF without direction reversal, overrun of LIM or REF not permissible Search of REF without direction reversal and REF or LIM overrun. Reduce homing speed ('HMn') or increase deceleration ('RAMPdecel'). Check the function and wiring of LIMP, LIMN and REF switch.
E A329	1	10	More than one signal LIMP/LIMN/REF active REF or LIM not connected correctly or supply voltage for switches too low. Check the wiring and 24VDC supply voltage.

Error number	Class	Bit	Description, reason and correctives
E A32A	1	10	Ext. monitoring signal LIMP with neg. direction of rotation Start reference movement with neg. direction of rotation (e.g. reference movement to LIMN) and activate the LIMP switch (switch in opposite direction of movement). Check correct connection and function of limit switch. Activate a jog movement with negative direction of rotation (target limit switch must be connected to the inputs LIMN).
E A32B	1	10	Ext. monitoring signal LIMN with pos. direction of rotation Start reference movement with pos. direction of rotation (e.g. reference movement to LIMP) and activate the LIMN switch (switch in opposite direction of movement). Check correct connection and function of limit switch. Activate a jog movement with positive rotation (target limit switch must be connected to the inputs LIMP).
E A32C	1	10	Error with REF (switch signal briefly enabled or switch overrun) Switch signal disturbance. Motor subjected to vibration or shock when stopped after activation of the switch signal. Check supply voltage, cabling and function of switch. Check motor reaction after stopping and optimise controller settings.
E A32D	1	10	Error with LIMP (switch signal briefly enabled or switch overrun) Switch signal disturbance. Motor subjected to vibration or shock when stopped after activation of the switch signal. Check supply voltage, cabling and function of switch. Check motor reaction after stopping and optimise controller settings.
E A32E	1	10	Error with LIMN (switch signal briefly enabled or switch overrun) Switch signal disturbance. Motor subjected to vibration or shock when stopped after activation of the switch signal. Check supply voltage, cabling and function of switch. Check motor reaction after stopping and optimise controller settings.
E A330	-	-	Reproducibility of the index pulse movement uncertain, index pulse too close to the switch The position difference between the change of the switch signal and the occurrence of the index pulse is too low. Change mounting point of limit switch (optim. to the point at half a motor revolution away from the current mechanical position, direction outside the working range).
E A332	1	10	Error with jog (additional info = detailed error number) Jog movement was stopped by error. For additional info, check the detailed error number in the error buffer.
E A334	2	0	Timeout at Standstill window monitor Position deviation after movement finished greater than standstill window, e.g. caused by an external load. Check load. Check settings for standstill window ('STANDp_win', 'STANDpwinTime' and 'STANDpwinTout'). Optimise controller settings.

Error number	Class	Bit	Description, reason and correctives
E A335	1	10	Processing only possible in fieldbus mode Reference movement started in IODevice (homing not possible if 'DEVcmdinterf' is not set to fieldbus device, no limit switches). DEVcmdinterf' must be set to fieldbus device.
E A337	0	10	Operating mode cannot be continued Continuation of interrupted movement in profile position mode is not possible because another mode had been active in the meantime. In Motion Sequence mode, continuation is impossible if a motion blend was interrupted.
E A33A	-	-	Reference point is not defined (ref_ok=0) No homing done and no motor with absolute encoder connected. Homing position lost because the working position range was left. Start homing. Use motor with multiturn encoder if no homing is to be done.
E A33C	-	-	Function not available in current operating mode Activation of a function which is not available in the current operating mode.
E A33D	-	-	Motion blend is already active Change of motion blend during the current motion blend (end position of motion blend not yet reached) Wait for the motion blend to complete before setting the next position.
E A33E	-	-	No movement activated Activation of a motion blend without movement. Start a movement before the motion blend is activated.
E A33F	-	-	Position motion blend movement not in the range of the active movement The position of the motion blend is outside of the current movement range. Check the position of the motion blend and the current movement range.
E A340	1	10	Error in motion sequence mode (additional info = detailed error number) The operating mode motion sequence was stopped by an error. Check the error buffer for details on the error. Verify the error by checking the additional error information.
E A341	-	-	Position of motion blend has already been passed The current movement has passed beyond the position of the motion blend.
E A342	1	0	Reference velocity was not reached on switch point of motion blend The position of the motion blend was overrun, the reference velocity was not reached. Reduce the ramp setting to ensure that the reference velocity is reached at the position of the motion blend.
E B100	0	9	RS485/Modbus: unknown service Unsupported Modbus service was received. Check application on the Modbus master.
E B200	0	9	RS485/Modbus: Protocol error Logical protocol error: wrong length or unsupported subfunction. Check application on the Modbus master.

Error number	Class	Bit	Description, reason and correctives
E B201	2	6	<p>RS485/Modbus: Nodeguard error</p> <p>Modbus is defined as command interface ('DEVcmdinterf'=modbus): connection monitoring parameter ('MBnode_guard') is ≤ 0ms and a nodeguard event was detected.</p> <p>Check application on the Modbus master or change (set to 0ms or increase the parameter 'MBnode_guard' monitoring time).</p>
E B202	0	9	<p>RS485/Modbus: Nodeguard warning</p> <p>Modbus is not defined as command interface ('DEVcmdinterf '\leqmodbus): connection monitoring parameter ('MBnode_guard') is ≤ 0ms and a nodeguard event was detected.</p> <p>Check application on the Modbus master or change (set to 0ms or increase the parameter 'MBnode_guard' monitoring time).</p>
E B400	2	7	<p>CANopen: NMT reset with power amplifier active</p> <p>CANopen is defined as command interface ('DEVcmdinterf'=CANopen): NMT Reset command is received while drive is in status "Enable".</p> <p>Always disable the drive before sending a NMT reset command.</p>
E B401	2	7	<p>CANopen: NMT reset with power amplifier active</p> <p>CANopen is defined as command interface ('DEVcmdinterf'=CANopen): NMT Stop command is received while drive is in status "Enable".</p> <p>Always disable the drive before sending a NMT Stop command.</p>
E B403	2	7	<p>Excessive Sync period deviation from ideal value</p> <p>The period time of the SYNC signals is not stable. The deviation is more than 100usec.</p> <p>The SYNC signals of the motion controller (CANSync master) must be more accurate.</p>
E B404	2	7	<p>Sync signal failed</p> <p>SYNC signal was missing too often (more than twice).</p> <p>Check CAN connection, check motion controller (CANSync master).</p>
E B407	-	-	<p>Drive is not synchronous with master cycle</p> <p>The cyclic synchronous operating mode cannot be activated while the drive is not synchronised.</p> <p>Check motion controller (CANSync master). To be synchronised, the motion controller (CANSync master) must cyclically send SYNC signals.</p>

11 Parameters

This chapter provides an overview of the parameters which can be addressed for the operation of the product.

In addition, special parameters for communication via the fieldbus are described in the respective fieldbus manual.

▲ WARNING

Unintentional behaviour due to parameters

The behaviour of the drive system is governed by numerous parameters. Improper parameter values can trigger unintentional movements or signals or deactivate monitoring functions.

- Change only parameters whose meaning you understand.
- Only start the system if there are no persons or materials in the danger zone and the system can be operated safely.
- When commissioning carefully run tests for all operating statuses and fault cases.

Failure to follow these instructions can result in death, serious injury or equipment damage.

11.1 Representation of the parameters

The parameter display contains, on the one hand, information which is needed for positive identification of a parameter. On the other hand, the parameter display can also provide information on setting options, presets and parameter properties.



Observe that the parameters are input in the fieldbus without decimal character. All decimal places must always be input.

Input examples:

Maximum value	Commissioning software	fieldbus
2.0	2.0	20
23.57	23.57	2357
1,000	1,000	1000

11.1.1 Explanation of the parameter representation

A parameter display has the following features:

Parameter Name HMI menu	Description	Unit Minimum value Default value Maximum value	Data type R/W persistent Expert	Parameter address via fieldbus
Example_Name INF- - DEVC INF- - dEUC	Brief description (cross-reference) Selection values 1 / Selection value1 / RbC 1: Explanation 1 2 / Selection value2 / RbC 2: Explanation 2 Further description and details	A _{pk} 0.00 3.00 300.00	UINT32 R/W per. -	fieldbus 1234:5 _h

- Parameter Name* The parameter name clearly identifies a parameter.
- HMI menu* The HMI menu shows the menu path by which the parameter is called up via the HMI.
- Description* Brief description (cross-reference)
The brief description contains some information on the parameter and refers the reader to the page on which the function of the parameter is described.

Selection values
In the case of parameters which offer a selection of settings, the value via fieldbus and the designation of the values when inputting with the commissioning software and the HMI are quoted.
1 = Value via fieldbus
Selection value1 = Selection value via commissioning software
RbC 1 = Selection value via HMI

Further description and details
Contains further information on the parameter.
- Unit* The unit of the value.
- Minimum value* The lowest value which can be input.
- Default value* Factory setting:
- Maximum value* The highest value which can be input.
- Data type* The data type determines the valid range of values, especially when a parameter does not have explicit minimum and maximum values.

Data type	byte	Min value	Max value
INT16	2 Byte / 16 Bit	-32768	32767
UINT16	2 Byte / 16 Bit	0	65535
INT32	4 Byte / 32 Bit	-2147483648	2147483647
UINT32	4 Byte / 32 Bit	0	4294967295
- R/W* Note for readability and writability of the values
"R/-" - Values can only be read
"R/W" - Values can be read and written.
- persistent* Designation of whether the value of the parameter is persistent, i.e. after switching off the device it is retained in the memory. When changing a value via commissioning software or fieldbus, the user must explicitly

0198441113232, V1.20, 06.2007

store the value change in the persistent memory. When entering via HMI the device stores the value of the parameter automatically at each change.

11.2 List of all parameters

Parameter Name HMI menu	Description	Unit Minimum value Default value Maximum value	Data type R/W persistent Expert	Parameter address via fieldbus
_acc_pref	Acceleration of setpoint generation	(1/min)/s	INT32	CANopen 301F:9 _h
-	Advance sign corresponding to the change of the value for speed:	-	INT32	Modbus 7954
-	Increase in speed: pos. advance sign	0	R/-	
-	Reduction in speed: neg. advance sign	-	-	
_acc_pref	Acceleration of setpoint generation	(1/min)/s	INT32	CANopen 301F:9 _h
-	Advance sign corresponding to the change of the value for speed:	-	INT32	Modbus 7954
-	Increase in speed: pos. advance sign	0	R/-	
-	Reduction in speed: neg. advance sign	-	-	
_AccessInfo	Current access channels for action objects8-3	-	UINT16	CANopen 3001:C _h
-	Low byte:	-	UINT16	Modbus 280
-	0: Occupied by the channel in High byte	0	R/-	
-	1: Exclusively occupied by channel in High byte	-	-	
	High byte: Current assignment of the access channel			
	0: reserved			
	1: IO			
	2: HMI			
	3: Modbus			
	4: CANopen			
	5: CANopen via second SDO channel			
	6: Profibus			
	7: DeviceNet			
_actionStatus	Action word8-60	-	UINT16	CANopen 301C:4 _h
-	Signal state:	-	UINT16	Modbus 7176
-	0: not activated	0	R/-	
-	1: activated	-	-	
	Bit0: Class 0 error			
	Bit1 Class 1 error			
	Bit2: Class 2 error			
	Bit3 Class 3 error			
	Bit4 Class 4 error			
	Bit5 reserved			
	Bit6: drive stopped (actual speed $_n_act$ [1/min] < 9)			
	Bit7: drive rotates in positive direction			
	Bit8: drive rotates in negative direction			
	Bit9: reserved			
	Bit10: reserved			
	Bit11: Profile generator stopped (setpoint speed is 0)			
	Bit12: Profile generator decelerating			
	Bit13: Profile generator accelerating			
	Bit14: Profile generator moves in constant mode			
	Bit15: reserved			

Parameter Name HMI menu	Description	Unit Minimum value Default value Maximum value	Data type R/W persistent Expert	Parameter address via fieldbus
_DCOMopmd_act - -	active operating mode8-13 Coding see: DCOMopmode	- -6 6	INT8 INT16 R/- -	CANopen 6061:0 _h Modbus 6920
_I2t_act_M - -	Overload motor current8-60	% - 0 -	INT16 INT16 R/- -	CANopen 301C:19 _h Modbus 7218
_I2t_act_PA - -	Overload power amplifier current8-60	% - 0 -	INT16 INT16 R/- -	CANopen 301C:16 _h Modbus 7212
_I2t_mean_M STA- - i2TM 5tR- - , 2tR	Motor load8-60	% - 0 -	INT16 INT16 R/- -	CANopen 301C:1A _h Modbus 7220
_I2t_mean_PA STA- - i2TP 5tR- - , 2tP	Power amplifier load8-60	% - 0 -	INT16 INT16 R/- -	CANopen 301C:17 _h Modbus 7214
_I2t_peak_RES - -	Overload braking resistor maximum value8-60 Maximum overload braking resistor that has occurred in the last 10 sec.	% - 0 -	INT16 INT16 R/- -	CANopen 301C:15 _h Modbus 7210
_I2t_peak_M - -	Overload motor maximum value8-60 Maximum overload motor that has occurred in the last 10 sec.	% - 0 -	INT16 INT16 R/- -	CANopen 301C:1B _h Modbus 7222
_I2t_peak_PA - -	Overload power amplifier maximum value8-60 Maximum overload power amplifier that has occurred in the last 10 sec.	% - 0 -	INT16 INT16 R/- -	CANopen 301C:18 _h Modbus 7216
_I2tl_act_RES - -	Actual overload braking resistor8-60	% - 0 -	INT16 INT16 R/- -	CANopen 301C:13 _h Modbus 7206
_I2tl_mean_RES STA- - i2TR 5tR- - , 2tR	Braking resistor load8-60	% - 0 -	INT16 INT16 R/- -	CANopen 301C:14 _h Modbus 7208
_Id_act - -	current motor current d components in 0.01 Apk steps	A _{pk} - 0.00 -	INT16 INT16 R/- -	CANopen 301E:2 _h Modbus 7684

Parameter Name HMI menu	Description	Unit Minimum value Default value Maximum value	Data type R/W persistent Expert	Parameter address via fieldbus
_Id_ref - -	Set motor current d component (field weakening) in 0.01 Apk steps	A _{pk} - 0.00 -	INT16 INT16 R/- -	CANopen 301E:11 _h Modbus 7714
_Idq_act STA- - iACT 5tR- - , Rct	Total motor current (vector sum of d and q components) in 0.01 Apk steps	A _{pk} - 0.00 -	INT16 INT16 R/- -	CANopen 301E:3 _h Modbus 7686
_IO_act STA- - ioAC 5tR- - , oRct	Physical status of the digital inputs and outputs7-25 Assignment of 24V inputs: (Local control mode) Bit 0: - Bit 1: FAULT_RESET Bit 2: ENABLE Bit 3: HALT Bit 4: PWRR_B Bit 5: PWRR_A Bit 6: ENABLE2 Bit 7: reserved Bit 6 forms the ENABLE only under the following conditions: DEVcmdinterf = IODevice and IOposInterfac = Pinput (fieldbus control mode) Bit 0: REF Bit 1: LIMN,CAP2 Bit 2: LIMP,CAP1 Bit 3: HALT Bit 4: PWRR_B Bit 5: PWRR_A Bit 6: - Bit 7: reserved assignment 24V outputs: Bit 8: NO_FAULT_OUT Bit 9: BRAKE_OUT Bit10: ACTIVE2_OUT	- - 0 -	UINT16 UINT16 R/- -	CANopen 3008:1 _h Modbus 2050
_IO_LI_act - -	Status of the digital inputs Coding of the individual signals: Bit0: LI1 Bit2: LI2 ...	- - 0 -	UINT16 UINT16 R/- -	CANopen 3008:F _h Modbus 2078
Available from software version V1.201.				
_IO_LO_act - -	Status of the digital outputs Coding of the individual signals: Bit0: LO1_OUT Bit1: LO2_OUT ...	- - 0 -	UINT16 UINT16 R/- -	CANopen 3008:10 _h Modbus 2080
Available from software version V1.201.				

0198441113232, V1.20, 06.2007

Parameter Name HMI menu	Description	Unit Minimum value Default value Maximum value	Data type R/W persistent Expert	Parameter address via fieldbus
_Iq_act - -	current motor current q components in 0.01 Apk steps	A _{pk} - 0.00 -	INT16 INT16 R/- -	CANopen 301E:1 _h Modbus 7682
_Iq_ref STA- - iQRF 5tR- - , 9rF	Set motor current q component (torque-creating) in 0.01 Apk steps	A _{pk} - 0.00 -	INT16 INT16 R/- -	CANopen 301E:10 _h Modbus 7712
_LastWarning - -	Last warning as number Number of the last warning generated. If the warning becomes inactive again, the number is retained until the next fault reset. Value 0: No warning generated	- 0 -	UINT16 UINT16 R/- -	CANopen 301C:9 _h Modbus 7186
_n_act STA- - NACT 5tR- - nRt	Actual speed of the motor8-57	1/min - 0 -	INT32 INT16 R/- -	CANopen 606C:0 _h Modbus 7696
_n_actRAMP - -	Actual speed of the travel profile generator8-57	1/min - 0 -	INT32 INT32 R/- -	CANopen 606B:0 _h Modbus 7948
_n_l_act - -	Optimised read access to current values of speed of rotation and current High-Word: Actual speed _n_act [1/min] Low-Word: Actual current [Apk] Available from software version V1.201.	- - 0 -	INT32 INT32 R/- -	CANopen 301E:17 _h Modbus 7726
_n_pref - -	Speed of setpoint generation	1/min - 0 -	INT32 INT32 R/- -	CANopen 301F:7 _h Modbus 7950
_n_ref - -	Setpoint speed of the speed controller	1/min - 0 -	INT16 INT16 R/- -	CANopen 301E:7 _h Modbus 7694
_n_targetRAMP - -	Target speed of the travel profile generator	1/min - 0 -	INT32 INT32 R/- -	CANopen 301F:5 _h Modbus 7946
_OpHours STA- - oPh 5tR- - oPh	Operating hours counter	s - 0 -	UINT32 UINT32 R/- -	CANopen 301C:A _h Modbus 7188

Parameter Name HMI menu	Description	Unit Minimum value Default value Maximum value	Data type R/W persistent Expert	Parameter address via fieldbus
_p_absENCusr	Absolute position based on motor encoder work stroke in user-defined units7-33	usr - 0	UINT32 UINT32 R/-	CANopen 301E:F _h Modbus 7710
-	Value range is set by encoder type	-	-	
-	With Singleturn motor encoders the value is set with reference to one motor revolution, with Multiturn motor encoders with reference to the total work stroke of the encoder (e.g. 4096 revs)	-	-	
	IMPORTANT: Position is only valid after determination of the motor absolute position. With invalid motor absolute position: _WarnLatched _WarnActive Bit 13=1: absolute position of motor not yet detected			
_p_absmodulo	Absolute position based on one motor revolution in internal units	Inc - 0	UINT32 UINT32 R/-	CANopen 301E:E _h Modbus 7708
-	IMPORTANT: Position is only valid after determination of the motor absolute position. With invalid motor absolute position: _WarnLatched _WarnActive Bit 13=1: absolute position of motor not yet detected	-	-	
_p_act	Actual position of motor in internal units	Inc - 0	INT32 INT32 R/-	CANopen 6063:0 _h Modbus 7700
-	IMPORTANT: Actual position of motor is only valid after determination of the motor absolute position. With invalid motor absolute position: _WarnLatched _WarnActive Bit 13=1: absolute position of motor not yet detected	-	-	
_p_actPosintf	Actual position at position interface	Inc -2147483648 - 2147483647	INT32 INT32 R/-	CANopen 3008:5 _h Modbus 2058
-	Counted position increments at RS422 signal interface CN5 if signal direction is defined as input (see parameter IOposInterface)	-	-	
_p_actusr	Actual position of the motor in user-defined units8-57	usr - 0	INT32 INT32 R/-	CANopen 6064:0 _h Modbus 7706
STA- - PACu	IMPORTANT: Actual position of motor is only valid after determination of the motor absolute position. With invalid motor absolute position: _WarnLatched _WarnActive Bit 13=1: absolute position of motor not yet detected	-	-	
5LR- - PRLu				
_p_actRAMPusr	Actual position of the travel profile generator8-57	usr - 0	INT32 INT32 R/-	CANopen 301F:2 _h Modbus 7940
-	in user-defined units	-	-	

Parameter Name HMI menu	Description	Unit Minimum value Default value Maximum value	Data type R/W persistent Expert	Parameter address via fieldbus
_p_addGEAR - -	Start position of electronic gearbox With an inactive gearing the setpoint position can be calculated here at the position controller that was set when the gearbox was enabled with the selection 'Synchronisation with compensation movement'.	Inc - 0 -	INT32 INT32 R/- -	CANopen 301F:3 _h Modbus 7942
_p_dif STA- - PDiF 5tR- - Pdi, F	Current variation between reference and actual position8-60 Corresponds to the current control deviation of the position controller without consideration of any dynamic components. Note: Different from SPV_p_maxDiff	revolution -214748.3648 - 214748.3647	INT32 INT32 R/- -	CANopen 60F4:0 _h Modbus 7716
_p_DifPeak - -	Value of max. reached tracking errors of the position controller8-60 The tracking error is the current position regulation offset minus the speed-dependent position regulation offset. For more information, see SPV_p_maxDiff. The value is again reset by writing.	revolution 0.0000 - 429496.7295	UINT32 UINT32 R/W -	CANopen 3011:F _h Modbus 4382
_p_ref - -	Setpoint position in internal units Value represents the setpoint position of the position controller	Inc - 0 -	INT32 INT32 R/- -	CANopen 301E:9 _h Modbus 7698
_p_refusr - -	Setpoint position in user-defined units Value represents the setpoint position of the position controller	usr - 0 -	INT32 INT32 R/- -	CANopen 301E:C _h Modbus 7704
_p_tarRAMPusr - -	Target position of the travel profile generator Absolute position value of the profile generator calculated from transferred relative and absolute position values. in user-defined units	usr - 0 -	INT32 INT32 R/- -	CANopen 301F:1 _h Modbus 7938
_Power_act - -	current output power	W - 0 -	INT16 INT16 R/- -	CANopen 301C:D _h Modbus 7194
_Power_mean - -	average output power	W - 0 -	INT16 INT16 R/- -	CANopen 301C:E _h Modbus 7196
_prgNoDEV INF- - _PNR i nF- - -Pnr	Firmware program number Example: PR840.1 Value is entered decimally as: 8401	- - 0.0 -	UINT16 UINT16 R/- -	CANopen 3001:1 _h Modbus 258

Parameter Name HMI menu	Description	Unit Minimum value Default value Maximum value	Data type R/W persistent Expert	Parameter address via fieldbus
_prgVerDEV	Firmware version	-	UINT16	CANopen 3001:2 _h
INF- - _PVR	Example: V4.201	-	UINT16	Modbus 260
INF- - PVR	Value is entered decimally: 4201	0.000	R/-	
		-	-	
_serialNoDEV	device serial number	-	UINT32	CANopen 3001:17 _h
-	Serial number: Unique number for identifica-	0	UINT32	Modbus 302
-	tion of the product	-	R/-	
		4294967295	per.	
		-	-	
_SigActive	Current state of the monitoring signals8-60	-	UINT32	CANopen 301C:7 _h
-	Meaning see _SigLatched	-	UINT32	Modbus 7182
-		0	R/-	
		-	-	
		-	-	
_SigLatched	Stored state of the monitoring signals8-60	-	UINT32	CANopen 301C:8 _h
STA- - SIGS	Signal state:	-	UINT32	Modbus 7184
5tR- - 5, 55	0: not activated	0	R/-	
	1: activated	-	-	
		-	-	
	Bit assignment			
	Bit0: general error			
	Bit1: limit switch (LIMP/LIMN/REF)			
	Bit2: range exceeded (software limit switch, tuning)			
	Bit3: Quick Stop via fieldbus			
	Bit4: inputs PWRR are 0			
	Bit6: error RS485			
	Bit7: error CAN			
	Bit9: frequency of reference signal too high			
	Bit10: error current operating mode			
	Bit12: Profibus error			
	Bit14: undervoltage DC bus			
	Bit15: overvoltage DC bus			
	Bit16: no mains phase			
	Bit17: connection to motor faulty			
	Bit18: motor overcurrent/short circuit			
	Bit19: error in motor encoder			
	Bit20: undervoltage 24VDC			
	Bit21: overtemperature (power amplifier, motor)			
	Bit22: tracking error			
	Bit23: max. speed exceeded			
	Bit24: PWRR inputs different			
	Bit29: error in EEPROM			
	Bit30: system run-up (hardware or parameter fault)			
	Bit31: System error (e.g. Watchdog)			
	monitoring is dependent on product			
_StopFault	Error number of the last interruption	-	UINT16	CANopen 603F:0 _h
FLT- - STPF	cause8-60	-	UINT16	Modbus 7178
FLt- - 5tPF		0	R/-	
		-	-	
		-	-	

Parameter Name HMI menu	Description	Unit Minimum value Default value Maximum value	Data type R/W persistent Expert	Parameter address via fieldbus
_Temp_act_DEV STA- - TDEV 5tR- - t dEU	device temperature8-60	°C - 0 -	INT16 INT16 R/- - -	CANopen 301C:12 _h Modbus 7204
_Temp_act_M - -	Temperature motor8-60 Reasonable display is not possible for switching temperature sensors (for tempera- ture sensor type see parameter M_TempType)	°C - 0 -	INT16 INT16 R/- - -	CANopen 301C:11 _h Modbus 7202
_Temp_act_PA STA- - TPA 5tR- - tPR	Temperature of the power amplifier8-60	°C - 0 -	INT16 INT16 R/- - -	CANopen 301C:10 _h Modbus 7200
_Ud_ref - -	Set motor voltage d components in 0.1V steps	V - 0.0 -	INT16 INT16 R/- - -	CANopen 301E:5 _h Modbus 7690
_UDC_act STA- - uDCA 5tR- - udLR	Voltage on DC bus DC bus voltage in 0.1 V steps	V - 0.0 -	UINT16 UINT16 R/- - -	CANopen 301C:F _h Modbus 7198
_Udq_ref - -	Total motor voltage (vector sum of d and q components Root from ($_{Uq_ref}^2 + _{Ud_ref}^2$) in 0.1 V steps	V - 0.0 -	INT16 INT16 R/- - -	CANopen 301E:6 _h Modbus 7692
_Uq_ref - -	Set motor voltage q components in 0.1V steps	V - 0.0 -	INT16 INT16 R/- - -	CANopen 301E:4 _h Modbus 7688
_v_act_Posintf - -	Actual speed at position interface Calculated pulse frequency at RS422 signal interface CN5 if signal direction is defined as input (see parameter IOposInterface)	Inc/s -2147483648 - 2147483647	INT32 INT32 R/- - -	CANopen 3008:6 _h Modbus 2060
VoltUtil - -	Degree of utilisation of the DC bus voltage 100% means that the drive is at the voltage limit. ${VoltUtil} = (_{Udq_ref} / _{Udq_ref}) * 100\%$	% - 0 -	INT16 INT16 R/- - -	CANopen 301E:13 _h Modbus 7718
_WarnActive - -	Active warnings bit-coded8-60 Meaning of Bits see _WarnLatched	- - 0 -	UINT16 UINT16 R/- - -	CANopen 301C:B _h Modbus 7190

Parameter Name HMI menu	Description	Unit Minimum value Default value Maximum value	Data type R/W persistent Expert	Parameter address via fieldbus
_WarnLatched	Stored warnings bit-coded8-60	-	UINT16	CANopen 301C:C _h
STA- - WRNS	Stored warning bits are erased in the event of a FaultReset.	-	UINT16	Modbus 7192
5tR- - Lrn5	Bits 10,11,13 are automatically deleted.	0	R/-	
	Signal state: 0: not activated 1: activated	-	-	
	Bit assignment Bit 0: general warning (see _LastWarning) Bit 1: power amplifier temperature high Bit 2: motor temperature high Bit 3: reserved Bit 4: overload (I ² t) power amplifier Bit 5: overload (I ² t) motor Bit 6: overload (I ² t) braking resistor Bit 7: CAN warning Bit 8: Motor Encoder warning Bit 9: RS485 protocol warning Bit 10: PWRR_A and/or PWRR_B Bit 11: DC bus undervoltage, faulty mains phase Bit 12: Profibus warning Bit 13: Position not yet valid (position detection continuing) Bit 14: reserved Bit 15: reserved			
	monitoring is product-dependent			
AbsHomeRequest	Absolute positioning only after homing8-26	-	UINT16	CANopen 3006:16 _h
-	0: no	0	UINT16	Modbus 1580
-	1: yes	1	R/W	
	Available from software version V1.201.		per.	
			-	
AccessLock	Blocking of other access channels8-3	-	UINT16	CANopen 3001:1E _h
-	0: Other access channels enabled	0	UINT16	Modbus 316
-	1: Other access channels blocked	1	R/W	
	This parameter allows the fieldbus to block active access to the device for the following access channels: - commissioning software - HMI - a second fieldbus		-	
	The processing of the input signals (e.g. Halt input) cannot be blocked.			
ANA1_act	Voltage value analogue input ANA17-22	mV	INT16	CANopen 3009:1 _h
STA- - A1AC		-10000	INT16	Modbus 2306
5tR- - R IRE		-	R/-	
		10000	-	
			-	

Parameter Name HMI menu	Description	Unit Minimum value Default value Maximum value	Data type R/W persistent Expert	Parameter address via fieldbus
ANA1_l_scale SET- - A1iS 5Et - - R i 5	Setpoint current in current control operating mode at 10V on ANA17-22 An inversion of the evaluation of the analogue signal can be run with a neg. advance sign	A _{pk} -300.00 3.00 300.00	INT16 INT16 R/W per. -	CANopen 3020:3 _h Modbus 8198
ANA1_n_scale SET- - A1NS 5Et - - R in5	Setpoint speed in speed control operating mode at 10V on ANA17-22 The internal maximum speed is limited to the current setting in CTRL_n_max A negative advance sign can be used to effect an inversion of the evaluation of the analogue signal	1/min -30000 3000 30000	INT16 INT16 R/W per. -	CANopen 3021:3 _h Modbus 8454
ANA1_offset SET- - A1oF 5Et - - R ioF	Offset at analogue input ANA17-22 The ANA1 analogue input is corrected/relocated by the offset. A defined zero-voltage window acts in the range of the zero crossing of the corrected ANA1 analogue input.	mV -5000 0 5000	INT16 INT16 R/W per. -	CANopen 3009:B _h Modbus 2326
ANA1_Tau - -	Analogue1: filter time constant Low-pass filter first order (PT1) filter time constant. Filter affects analogue input ANA1. (sampling time PT1 filter: 250µsec)	ms 0.00 0.00 327.67	UINT16 UINT16 R/W per. -	CANopen 3009:2 _h Modbus 2308
ANA1_win SET- - A1WN 5Et - - R iun	Zero-voltage window on analogue input ANA17-22 Value up to which an input voltage is interpreted as 0V Example: Setting 20mV ->range from -20 .. +20mV is interpreted as 0mV	mV 0 0 1000	UINT16 UINT16 R/W per. -	CANopen 3009:9 _h Modbus 2322
ANA2_act STA- - A2AC 5tR - - R2RC	Voltage value analogue input ANA27-22	mV -10000 - 10000	INT16 INT16 R/ - -	CANopen 3009:5 _h Modbus 2314
ANA2_l_max DRC- - A2iM drL - - R2iM	Current limiting at 10 V input voltage on ANA27-22 The maximum limiting value is the lesser value of I _{maxM} and I _{maxPA}	A _{pk} 0.00 3.00 300.00	UINT16 UINT16 R/W per. -	CANopen 3012:C _h Modbus 4632
ANA2_n_max DRC- - A2NM drL - - R2nM	Speed limiting at 10 V input voltage on ANA27-22 The minimum limiting speed is set to 100 1/min, i.e. analogue values that implement a lower speed of rotation have no effect. The max. speed of rotation is also limited by the setting value in CTRL_n_max.	1/min 500 3000 30000	UINT16 UINT16 R/W per. -	CANopen 3012:D _h Modbus 4634

Parameter Name HMI menu	Description	Unit Minimum value Default value Maximum value	Data type R/W persistent Expert	Parameter address via fieldbus
ANA2LimMode	Selection of limit by ANA27-22	- 0	UINT16 UINT16	CANopen 3012:B _h Modbus 4630
DRC- - A2Mo drc - A2Mo	0 / none / none : no limitation 1 / Current Limitation / Curr : limitation of current reference value at current controller 2 / Speed Limitation / SPed : limitation of speed reference value at speed controller (limiting value at 10V in ANA2_n_max)	0 2	R/W per. -	
AT_dir	Direction of rotation autotuning7-37	- 1 1 6	UINT16 UINT16 R/W -	CANopen 302F:4 _h Modbus 12040
TUN- - DiR tun - dir	1 / pos-neg-home / Pnh : first positive direction, then negative direction with return to initial position 2 / neg-pos-home / nPh : first negative direction, then positive direction with return to initial position 3 / pos-home / P-h : only positive direction with return to initial position 4 / pos / P-- : only positive direction without return to initial position 5 / neg-home / n-h : only negative direction with return to initial position 6 / neg / n-- : only negative direction without return to initial position			
AT_dis	Movement range autotuning7-37	revolution 1.0 1.0 999.9	UINT32 UINT32 R/W -	CANopen 302F:3 _h Modbus 12038
TUN- - DiST tun - dist	Range in which the automatic optimisation processes of the controller parameters are run. The range is input relative to the current position. IMPORTANT: with "movement in only one direction" (parameter AT_dir), the specified range is used for every optimisation step. The actual movement typically corresponds to 20 times the value, but is not limited.			
AT_gain	Adapting controller parameters (tighter/looser)7-39	% - 0 -	UINT16 UINT16 R/W -	CANopen 302F:A _h Modbus 12052
TUN- - GAiN tun - gain	Measure of the degree of tightness of the regulation. The value 100 represents the theoretical optimum. Values larger than 100 mean that the regulation is tighter and smaller values mean that the regulation is looser.			
AT_J	Inertia of the entire system7-39 is automatically calculated during the autotuning process in 0.1 kgcm ² steps	kg cm ² 0.1 0.1 6553.5	UINT16 UINT16 R/W per. -	CANopen 302F:C _h Modbus 12056
AT_M_friction	System friction torque is determined during the autotuning process in 0.01A _{pk} steps	A _{pk} - 0.00 -	UINT16 UINT16 R/- -	CANopen 302F:7 _h Modbus 12046

Parameter Name HMI menu	Description	Unit Minimum value Default value Maximum value	Data type R/W persistent Expert	Parameter address via fieldbus
AT_M_load - -	Constant load torque is determined during the autotuning process in 0.01A _{pk} steps	A _{pk} - 0.00 -	INT16 INT16 R/- -	CANopen 302F:8 _h Modbus 12048
AT_mechanics TUN- - MECh tun- - nEEh	System coupling type7-37 1: direct coupling (J ext. to J motor <3:1) 2: medium coupling () 3: medium coupling (short toothed belt) 4: medium coupling () 5: soft coupling (J ext. to J motor between 5:1 and 10:1, linear axis)	- 1 1 5	UINT16 UINT16 R/W - -	CANopen 302F:E _h Modbus 12060
AT_n_ref TUN- - NREF tun- - nrEF	Speed jump for motor starting	1/min 10 100 1000	UINT16 UINT16 R/W -	CANopen 302F:6 _h Modbus 12044
AT_progress - -	Autotuning progress7-39	% 0 0 100	UINT16 UINT16 R/- -	CANopen 302F:B _h Modbus 12054
AT_start - -	Start Autotuning7-37 0: End 1: Activate	- 0 - 1	UINT16 UINT16 R/W -	CANopen 302F:1 _h Modbus 12034
AT_state - -	Autotuning status7-39 Bit15: auto_tune_err Bit14: auto_tune_end Bit13: auto_tune_process Bit 10..0: last processing step	- - 0 -	UINT16 UINT16 R/- -	CANopen 302F:2 _h Modbus 12036
AT_wait TUN- - WAit tun- - LRi t	Waiting time between autotuning steps7-39	ms 300 1200 10000	UINT16 UINT16 R/W -	CANopen 302F:9 _h Modbus 12050
BRK_trelease DRC- - BTRE drE - - bErE	Time delay when opening or releasing the holding brake8-81	ms 0 0 1000	UINT16 UINT16 R/W per. -	CANopen 3005:7 _h Modbus 1294
BRK_tclose DRC- - BTCL drE - - bEEL	Time delay when applying the holding brake8-81	ms 0 0 1000	UINT16 UINT16 R/W per. -	CANopen 3005:8 _h Modbus 1296
CANadr COM- - CoAD CoAd - - CoAd	CANopen address (node number)7-13 valid addresses (node numbers): 1 ... 127 IMPORTANT: A change of the setting is not activated until the unit is switched on again or after an NMT reset command	- 1 127 127	UINT16 UINT16 R/W per. -	CANopen 3017:2 _h Modbus 5892

Parameter Name HMI menu	Description	Unit Minimum value Default value Maximum value	Data type R/W persistent Expert	Parameter address via fieldbus
CANbaud	CANopen baud rate7-13	- 50	UINT16 UINT16	CANopen 3017:3 _h Modbus 5894
COM- - CoBD CAN- - Canbd	valid baud rates in kbaud: 50 125 250 500 1000	125 1000	R/W per. -	
	IMPORTANT: A change of the setting is not activated until the unit is switched on again			
CanDiag	CANopen diagnosis word	-	UINT16	CANopen 3017:6 _h
-	0x0001 pms read error for TxPdo	-	UINT16	Modbus 5900
-	0x0002 pms write error for RxPdo1	0	R/-	
-	0x0004 pms write error for RxPdo2	-	-	
-	0x0008 pms write error for RxPdo3	-	-	
-	0x0010 pms write error for RxPdo4	-	-	
-	0x0020 heartbeat or lifeguard error (timer expired)	-	-	
-	0x0040 heartbeat msg with wrong state received	-	-	
-	0x0080 CAN warning level set	-	-	
-	0x0100 CAN message lost	-	-	
-	0x0200 CAN in busoff	-	-	
-	0x0400 software queue rx/tx overrun	-	-	
-	0x0800 CPD error indication from stopfault	-	-	
CANpdo4Event	PDO4 event mask	-	UINT16	CANopen 3017:5 _h
-	Value changes in the object trigger event:	0	UINT16	Modbus 5898
-	Bit 0=1: first PDO4 object	15	R/W	
-	Bit 1 = 1: second PDO4 object	15	-	
-	Bit 2 = 1: third PDO4 object	-	-	
-	Bit 3 = 1: fourth PDO4 object	-	-	
-	Bit 4..15: reserved	-	-	
Cap1Activate	Capture unit 1 Start/Stop8-77	-	UINT16	CANopen 300A:4 _h
-	Value 0: abort capture function	0	UINT16	Modbus 2568
-	Value 1: start capture once	-	R/W	
-	Value 2: start capture continuously	2	-	
	With one-time capture the function is terminated at the first captured value. The capture continues endlessly with continuous capture.			
	Position capture can only be enabled with the "fieldbus" device setting.			
Cap1Config	Configuration of capture unit 18-77	-	UINT16	CANopen 300A:2 _h
-	0 = position capture at 1->0 switch	0	UINT16	Modbus 2564
-	1 = position capture at 0->1 switch	0	R/W	
-		1	-	
Cap1Count	Capture unit 1 event counter8-77	-	UINT16	CANopen 300A:8 _h
-	Counts the capture events.	-	UINT16	Modbus 2576
-	Counter is reset when the capture unit 1 is enabled.	0	R/-	
-		-	-	

Parameter Name HMI menu	Description	Unit Minimum value Default value Maximum value	Data type R/W persistent Expert	Parameter address via fieldbus
Cap1Pos	Capture unit 1 captured position8-77	usr	INT32	CANopen 300A:6 _h
-	Captured position at the time of the "capture signal".	-	INT32	Modbus 2572
-	The captured position is recalculated after "set dimensions" or after a "homing".	0	R/-	
-		-	-	
Cap2Activate	Capture unit 2 Start/Stop8-77	-	UINT16	CANopen 300A:5 _h
-	Value 0: abort capture function	0	UINT16	Modbus 2570
-	Value 1: start capture once	-	R/W	
-	Value 2: start capture continuously	2	-	
	With one-time capture the function is terminated at the first captured value. The capture continues endlessly with continuous capture.			
	Position capture can only be enabled with the "fieldbus" device setting.			
Cap2Config	Configuration of capture unit 28-77	-	UINT16	CANopen 300A:3 _h
-	0 = position capture at 1->0 switch	0	UINT16	Modbus 2566
-	1 = position capture at 0->1 switch	0	R/W	
-		1	-	
Cap2Count	Capture unit 2 event counter8-77	-	UINT16	CANopen 300A:9 _h
-	Counts the capture events.	-	UINT16	Modbus 2578
-	Counter is reset when the capture unit 2 is enabled.	0	R/-	
-		-	-	
Cap2Pos	Capture unit 2 captured position8-77	usr	INT32	CANopen 300A:7 _h
-	Captured position at the time of the "capture signal".	-	INT32	Modbus 2574
-	The captured position is recalculated after "set dimensions" or after a "homing".	0	R/-	
-		-	-	
CapStatus	Status of capture units8-77	-	UINT16	CANopen 300A:1 _h
-	Read access:	-	UINT16	Modbus 2562
-	Bit 0: position capture by input CAP1 complete	0	R/-	
-	Bit 1: Position captured via input CAP2	-	-	
CTRL_I_max	Current limiting7-20	A _{pk}	UINT16	CANopen 3012:1 _h
SET- iMAX	Value must not exceed max. permissible current of motor or power amplifier.	0.00	UINT16	Modbus 4610
SEt - , PRH		-	R/W	
	Default is the smallest value of M_I_max and PA_I_max	299.99	per.	
			-	
CTRL_I_max_fw	Field controller max. Field current	A _{pk}	UINT16	CANopen 3011:C _h
-	maximum value is approx. half of the lower value of the nominal current of the power amplifier and the motor.	0.00	UINT16	Modbus 4376
-		0.00	R/W	
-		327.67	per. expert	
CTRL_KFDn	Speed controller pilot control D factor	-	UINT16	CANopen 3012:5 _h
-		0	UINT16	Modbus 4618
-		0	R/W	
-		3175	per. expert	

Parameter Name HMI menu	Description	Unit Minimum value Default value Maximum value	Data type R/W persistent Expert	Parameter address via fieldbus
CTRL_KFPp - -	Speed pilot control position controller Over-control up to 110% possible.	% 0.0 0.0 110.0	UINT16 UINT16 R/W per. -	CANopen 3012:8 _h Modbus 4624
CTRL_KPid - -	Current controller longitudinal (d) P factor Is calculated from motor parameters. In 0.1V/A steps	V/A 0.5 - 1270.0	UINT16 UINT16 R/ per. -	CANopen 3011:1 _h Modbus 4354
CTRL_KPiq - -	Current controller transverse (q) P factor Value is calculated from motor parameters in 0.1 V/A steps	V/A 0.5 - 1270.0	UINT16 UINT16 R/ per. -	CANopen 3011:3 _h Modbus 4358
CTRL_KPn - -	Speed controller P-factor7-43 Default value is calculated from motor parameters	A/(1/min) 0.0001 - 1.2700	UINT16 UINT16 R/W per. -	CANopen 3012:3 _h Modbus 4614
CTRL_KPp - -	Position controller P-factor7-48 Default value is calculated	1/s 2.0 - 495.0	UINT16 UINT16 R/W per. -	CANopen 3012:6 _h Modbus 4620
CTRL_n_max SET- - NMAX 5Et - - nπRH	Speed limiter7-20 Setting value must not exceed max. speed of rotation of motor Default is max. speed of the motor (see M_n_max)	1/min 0 - 13200	UINT16 UINT16 R/W per. -	CANopen 3012:2 _h Modbus 4612
CTRL_Nfbandw - -	Bandwidth notch filter current The bandwidth is defined as follows: Fb/F0	% 10 30 99	UINT16 UINT16 R/W per. expert	CANopen 3012:13 _h Modbus 4646
CTRL_Nfdamp - -	Damping notch filter current	% 1.0 10.0 45.0	UINT16 UINT16 R/W per. expert	CANopen 3012:12 _h Modbus 4644
CTRL_Nffreq - -	Frequency notch filter current The filter is disabled at the value of 15000.	Hz 50.0 1500.0 1500.0	UINT16 UINT16 R/W per. expert	CANopen 3012:11 _h Modbus 4642
CTRL_Pcdamp - -	Damping Posicast filter speed The filter is disabled at the value of 1000.	% 50.0 100.0 100.0	UINT16 UINT16 R/W per. expert	CANopen 3012:14 _h Modbus 4648

Parameter Name HMI menu	Description	Unit Minimum value Default value Maximum value	Data type R/W persistent Expert	Parameter address via fieldbus
CTRL_Pcdelay	Time delay Posicast filter speed	ms	UINT16	CANopen 3012:15 _h
-	The filter is disabled at the value of 0.	0.00	UINT16	Modbus 4650
-		0.00	R/W	
-		25.00	per. expert	
CTRL_TAUiref	Filter time constant reference value filter of the reference current value	ms	UINT16	CANopen 3012:10 _h
-		0.00	UINT16	Modbus 4640
-		1.20	R/W	
-		4.00	per. -	
CTRL_TAUref	Filter time constant reference value filter of the reference speed value7-43	ms	UINT16	CANopen 3012:9 _h
-		0.00	UINT16	Modbus 4626
-		9.00	R/W	
-		327.67	per. -	
CTRL_TNid	Current controller longitudinal (d) setting time	ms	UINT16	CANopen 3011:2 _h
-		0.13	UINT16	Modbus 4356
-	Value is calculated from motor parameters	-	R/-	
-	in 0.01ms steps	327.67	per. -	
CTRL_TNiq	Current controller lateral (q) setting time	ms	UINT16	CANopen 3011:4 _h
-	Value is calculated from motor parameters	0.13	UINT16	Modbus 4360
-		-	R/-	
-	in 0.01ms steps	327.67	per. -	
CTRL_TNn	Speed controller integral time7-43	ms	UINT16	CANopen 3012:4 _h
-		0.00	UINT16	Modbus 4616
-		9.00	R/W	
-		327.67	per. -	
CUR_I_target	Setpoint current in current control operating mode8-18	A _{pk}	INT16	CANopen 3020:4 _h
-		-300.00	INT16	Modbus 8200
-		0.00	R/W	
-		300.00	- -	
CURreference	Selection of setpoint source for current control operating mode8-18	-	UINT16	CANopen 301B:10 _h
-		0	UINT16	Modbus 6944
-	0: no	0	R/W	
-	1: Reference value via +/-10V-interface ANA1	2	-	
-	2: Reference value via parameter CUR_I_target		-	
DCOMcompatib	DriveCom state machine: Status transition 3->4	-	UINT16	CANopen 301B:13 _h
-		0	UINT16	Modbus 6950
-		0	R/W	
-	Determines the transition between the SwitchOnDisabled (3) and Ready-ToSwitchOn (4) states in CANopen devices. If not CANopen, this value is ignored! 0 = automatic (change of state takes place automatically) 1 = standard conform (change of state must be controlled by fieldbus)	1	per. -	

Parameter Name HMI menu	Description	Unit Minimum value Default value Maximum value	Data type R/W persistent Expert	Parameter address via fieldbus
DCOMcontrol	Drivecom control word8-8	-	UINT16	CANopen 6040:0 _h
-	For bit coding see chapter on operation, operating status	-	UINT16	Modbus 6914
-	Bit0: Switch on Bit1: Enable Voltage Bit2: Quick Stop Bit3: Enable Operation Bit4..6: op. Mode specific Bit7: Fault Reset Bit8: Halt Bit9..15: reserved (must be 0)	0	R/W	
DCOMopmode	Operating mode8-12	-	INT8	CANopen 6060:0 _h
-	DSP402-operating modes	-8	INT16	Modbus 6918
-	1: Profile position 3 Profile velocity 6: Homing ----- Manufacturer operating modes: -1: jog -2: electronic gear -3: current control -4: speed control -8: Data set mode	6	R/W	
DCOMstatus	Drivecom status word8-9	-	UINT16	CANopen 6041:0 _h
-	For bit coding see chapter on operation, state machine	-	UINT16	Modbus 6916
-	Bit0-3,5,6: status bits Bit4: voltage enabled Bit7: warning Bit8: HALT request active Bit9: remote Bit10: target reached Bit11: reserved Bit12: op. mode specific Bit13: x_err Bit14: x_end Bit15: ref_ok	0	R/-	
DEVcmdinterf	Specification of the control mode7-13	-	UINT16	CANopen 3005:1 _h
- - DEVC	0 / none / nonE : undefined	0	UINT16	Modbus 1282
- - dEUL	1 / IODevice / I a : local control mode 2 / CANopenDevice / CANa : CANopen 3 / ModbusDevice / Modb : Modbus	0	R/W	
	IMPORTANT: A change of the setting is not activated until the unit is switched on again (exception: Change of the value 0, at "First setup").	3	per.	
			-	

Parameter Name HMI menu	Description	Unit Minimum value Default value Maximum value	Data type R/W persistent Expert	Parameter address via fieldbus
ENC_pabsusr - -	Setting position of the motor encoder directly7-33 Value range depends on the encoder type. SRS: Sincos singleturn: 0..max_pos_usr/rev. - 1 SRM: Sincos multiturn: 0 .. (4096 * max_pos_usr/rev.) -1 max_pos_usr/rev.: maximum user position for one motor revolution, with default position scaling this value is 16384. IMPORTANT: * If the process is to be conducted with direction inversion function, it must be set before setting the motor encoder position * The setting value will only be active when the controller is switched on the next time. After the write access a wait of at least 1 second is required until the controller is switched off. * Changing the value also changes the position of the virtual index pulse and the index pulse displaced at ESIM function.	usr 0 -	UINT32 UINT32 R/W -	CANopen 3005:16 _h Modbus 1324
ESIMscale DRC- - ESSC dr[- - E55[-	Encoder simulation - setting the resolution7-32 Software version 1.102: The following resolutions are adjustable: 128 256 512 1024 2048 4096 from version 1.103 and hardware revision RS30: the complete value range is available for the resolution. For resolutions that can be divided by 4 the index pulse must be at A=high and B=high. IMPORTANT: A change of the setting is not activated until the device is switched on again. After the write access a wait of at least 1 second is required until the controller is switched off.	Inc 8 4096 65535	UINT16 UINT16 R/W per. -	CANopen 3005:15 _h Modbus 1322
FLTAmponCyc - -	ENABLE cycles up to time of error Number of power amplifier turn-on processes after switching on the power supply (control voltage) up to the appearance of the error	- - 0 -	UINT16 UINT16 R/- -	CANopen 303C:5 _h Modbus 15370

Parameter Name HMI menu	Description	Unit Minimum value Default value Maximum value	Data type R/W persistent Expert	Parameter address via fieldbus
FLTAmpOnTime	Time error occurs after ENABLE	s	UINT16	CANopen 303C:6 _h
-	-	-	UINT16	Modbus 15372
-	-	0	R/-	-
-	-	-	-	-
FLT_class	Error class10-8	-	UINT16	CANopen 303C:2 _h
-	0: Warning (no reaction)	0	UINT16	Modbus 15364
-	1: error (Quick Stop -> status 7)	-	R/-	-
-	2: error (Quick Stop -> status 8, 9)	4	-	-
-	3: Fatal error (state 9, resettable)	-	-	-
-	4: Fatal error (state 9, not resettable)	-	-	-
FLT_del_err	Erase error memory10-8	-	UINT16	CANopen 303B:4 _h
-	1: Erases all entries in the error memory	0	UINT16	Modbus 15112
-	-	-	R/W	-
-	The erasing process is complete when a 0 is returned when reading.	1	-	-
FLT_err_num	Error number10-8	-	UINT16	CANopen 303C:1 _h
-	Reading this parameter brings the complete error entry (error class, time of error ...) into an intermediate memory from which all components of the error can be read.	0	UINT16	Modbus 15362
-	-	-	R/-	-
-	-	65535	-	-
-	In addition, the read indicator of the error memory is automatically switched forward to the next error entry.	-	-	-
FLT_Idq	Motor current at error time	A	UINT16	CANopen 303C:9 _h
-	in 10 mA steps	-	UINT16	Modbus 15378
-	-	0.00	R/-	-
-	-	-	-	-
FLT_MemReset	Reset the error memory read pointer10-8	-	UINT16	CANopen 303B:5 _h
-	1: Set error memory read pointer to oldest error entry.	0	UINT16	Modbus 15114
-	-	-	R/W	-
-	-	1	-	-
FLT_n	Speed at error time	1/min	INT16	CANopen 303C:8 _h
-	-	-	INT16	Modbus 15376
-	-	0	R/-	-
-	-	-	-	-
FLT_powerOn	Number of turn-on processes	-	UINT32	CANopen 303B:2 _h
INF- - PoWo	-	0	UINT32	Modbus 15108
-	-	-	R/-	-
INF- - PoWo	-	4294967295	-	-
-	-	-	-	-
FLT_Qual	Error additional information10-8	-	UINT16	CANopen 303C:4 _h
-	This entry contains additional information about the error, depending on the error number.	0	UINT16	Modbus 15368
-	Example: a parameter address	-	R/-	-
-	-	65535	-	-
-	-	-	-	-

Parameter Name HMI menu	Description	Unit Minimum value Default value Maximum value	Data type R/W persistent Expert	Parameter address via fieldbus
FLT_Temp_DEV - -	device temperature at error time	°C - 0 -	INT16 INT16 R/- -	CANopen 303C:B _h Modbus 15382
FLT_Temp_PA - -	Power amplifier temperature at error time	°C - 0 -	INT16 INT16 R/- -	CANopen 303C:A _h Modbus 15380
FLT_Time - -	Error time10-8 referenced to the operating hours counter	s 0 - 536870911	UINT32 UINT32 R/- -	CANopen 303C:3 _h Modbus 15366
FLT_UDC - -	DC bus voltage at error time in 100mV steps	V - 0.0 -	UINT16 UINT16 R/- -	CANopen 303C:7 _h Modbus 15374
GEARdenom - -	Gear ratio denominator8-22 see description GEARnum	- 1 1 2147483647	INT32 INT32 R/W per. -	CANopen 3026:3 _h Modbus 9734
GEARdir_enabl - -	Enabled direction of motion of the gear processing8-22 1 / positive : Pos. direction 2 / negative : Neg. direction 3 / both : both directions This can be used to activate a reverse inter- lock .	- 1 3 3	UINT16 UINT16 R/W per. -	CANopen 3026:5 _h Modbus 9738
GEARnum - -	Gear ratio numerator8-22 GEARnum Gear ratio= ----- GEARdenom	- -2147483648 1 2147483647	INT32 INT32 R/W per. -	CANopen 3026:4 _h Modbus 9736
	The new gear ratio is enabled when the numerator value is transferred.			

Parameter Name HMI menu	Description	Unit Minimum value Default value Maximum value	Data type R/W persistent Expert	Parameter address via fieldbus
GEARratio	Selection of special gear ratios8-22	-	UINT16	CANopen 3026:6 _h
SET- - GFAC	0: Use of the specified gear ratio from	0	UINT16	Modbus 9740
SEt - - GFAC	GEARnum/GEARdenom	0	R/W	
	1: 200	11	per.	
	2: 400		-	
	3: 500			
	4: 1000			
	5: 2000			
	6: 4000			
	7: 5000			
	8: 10000			
	9: 4096			
	10: 8192			
	11: 16384			
	Changing the reference value by the stated amount results in one motor rotation.			
GEARreference	Electronic gear processing mode8-22	-	UINT16	CANopen 301B:12 _h
-	0: disabled	0	UINT16	Modbus 6948
-	1: Real-time synchronisation	0	R/W	
-	2: Synchronisation with compensation movement	2	-	
			-	
HMdisREFtoIDX	Distance switch - index pulse after reference movement8-51	revolution	INT32	CANopen 3028:C _h
-		-	INT32	Modbus 10264
-	Reading value provides the value of the difference between the index pulse position and the position on the switching flank of the limit or reference switch.	0.0000	R/-	
-	Used to check how far the index pulse is from the switching edge and is used as a criterion for whether the reference movement can be correctly reproduced with index pulse processing	-	-	
-	in steps of 1/10000 revolutions		-	
HMdisusr	Distance between the switching edge and the reference point8-49	usr	INT32	CANopen 3028:7 _h
-		1	INT32	Modbus 10254
-	After leaving the switch, the drive is still positioned in the work stroke for a defined path and this position is defined as a reference point.	200	R/W	
-		2147483647	per.	
-			-	
	The parameters are only effective with reference movements without index pulse searching.			
HMIDispPara	HMI display while motor rotates	-	UINT16	CANopen 303A:2 _h
DRC- - SuPV	0: device status (default)	0	UINT16	Modbus 14852
drC - - SuPV	1: current speed of rotation (n_act)	0	R/W	
	2: current motor current	2	per.	
			-	

Parameter Name HMI menu	Description	Unit Minimum value Default value Maximum value	Data type R/W persistent Expert	Parameter address via fieldbus
HMILocked	Block HMI8-3	-	UINT16	CANopen 303A:1 _h
-	0: HMI not blocked	0	UINT16	Modbus 14850
-	1: HMI blocked	0	R/W	
		1	per.	
	When the HMI is blocked the following actions are no longer possible:		-	
	- Change parameters			
	- Manual drive (Jog)			
	- Autotuning			
	- FaultReset			
HMmethod	Reference movement method8-44	-	INT8	CANopen 6098:0 _h
-	1: LIMN with index pulse	1	UINT16	Modbus 6936
-	2: LIMP with index pulse	18	R/W	
-	7: REF+ with index pulse, inv., outside	35	-	
	8: REF+ with index pulse, inv., inside		-	
	9: REF+ with index pulse, not inv., inside			
	10: REF+ with index pulse, not inv., outside			
	11: REF- with index pulse, inv., outside			
	12: REF- with index pulse, inv., inside			
	13: REF- with index pulse, not inv., inside			
	14: REF- with index pulse, not inv., outside			
	17: LIMN			
	18: LIMP			
	23: REF+, inv., outside			
	24: REF+, inv., inside			
	25: REF+, not inv., inside			
	26: REF+, not inv., outside			
	27: REF-, inv., outside			
	28: REF-, inv., inside			
	29: REF-, not inv., inside			
	30: REF-, not inv., outside			
	33: index pulse neg. direction			
	34: index pulse pos. direction			
	35: set dimensions			
	Explanation of abbreviations:			
	REF+: search movement in pos. direction			
	REF-: search movement in neg. direction			
	inv.: invert direction in switch			
	not inv.: direction in switch not invert.			
	outside: index pulse/distance outside switch			
	inside: index pulse/distance inside switch			
HMn	Setpoint speed for search for the switch8-44	1/min	UINT32	CANopen 6099:1 _h
-	The set value is internally limited to the current parameter setting in RAMPn_max.	1	UINT16	Modbus 10248
-		60	R/W	
-		13200	per.	
			-	
HMn_out	Setpoint speed for retraction from switch8-44	1/min	UINT32	CANopen 6099:2 _h
-	The set value is internally limited to the current parameter setting in RAMPn_max.	1	UINT16	Modbus 10250
-		6	R/W	
-		3000	per.	
			-	

Parameter Name HMI menu	Description	Unit Minimum value Default value Maximum value	Data type R/W persistent Expert	Parameter address via fieldbus
HMoutdisusr - -	Maximum run-off distance8-44 0: run-off check inactive >0: run-off in user-defined units The switch must be disabled again inside this run-off, otherwise the reference movement is aborted	usr 0 0 2147483647	INT32 INT32 R/W per. -	CANopen 3028:6 _h Modbus 10252
HMp_homeusr - -	Position on reference point8-44 After successful reference movement this position value is automatically set at the reference point.	usr -2147483648 0 2147483647	INT32 INT32 R/W per. -	CANopen 3028:B _h Modbus 10262
HMp_setpusr - -	Position for dimension setting8-55 Dimension setting position for homing method 35	usr - 0 -	INT32 INT32 R/W - -	CANopen 301B:16 _h Modbus 6956
HMsrchdisusr - -	max. search distance after traversing over the switch8-44 0: search distance processing inactive >0: search distance in user-defined units The switch must be enabled again inside this search distance, otherwise the reference movement is aborted	usr 0 0 2147483647	INT32 INT32 R/W per. -	CANopen 3028:D _h Modbus 10266
IO_AutoEnable DRC- - ioAE dr̄ - - , aRE	Processing power amplifier activation at PowerOn 0 / off / aFF : Active Enable on switching on does not lead to activation of the power amplifier 1 / on / an : Active Enable on switch on leads to activation of the power amplifier 2 / AutoOn / Auto : Power amplifier is always activated automatically on switching on	- 0 0 2	UINT16 UINT16 R/W per. -	CANopen 3005:6 _h Modbus 1292
IO_GearMode DRC- - ioGM dr̄ - - , aGf	Processing mode electr. gearing for local control mode 1: Real-time synchronisation 2: synchronisation with compensation movement Available from software version V1.201.	- 1 1 2	UINT16 UINT16 R/W per. -	CANopen 3005:17 _h Modbus 1326
IO_LO_set - -	Setting digital outputs directly Write access to output bits is only effective if the signal pin exists as output and the function of the output was set to 'freely available'. Coding of the individual signals: Bit0: LO1_OUT Bit1: LO2_OUT ... Available from software version V1.201.	- - 0 -	UINT16 UINT16 R/W - -	CANopen 3008:11 _h Modbus 2082

Parameter Name HMI menu	Description	Unit Minimum value Default value Maximum value	Data type R/W persistent Expert	Parameter address via fieldbus
IOdefaultMode DRC- - io-M drc- - , o-n	Start-up of operating mode for 'local control mode' 7-13 0 / none / none : none 1 / CurrentControl / Curr : current control (reference value of ANA1) 2 / SpeedControl / SPed : speed control (reference value of ANA1) 3 / ElectronicGear / GERr : electronic gear 5 / Jog / JoG : manual movement 6 / MotionSequence / MotS : Motion Sequence IMPORTANT: The operating mode is automatically enabled when the drive switches to the 'OperationEnable' status and "IODevice / IO" is set in DEVcmdinterf.	- 0 0 6	UINT16 UINT16 R/W per. -	CANopen 3005:3 _h Modbus 1286
IODirPosintf - -	Counting direction at position interface 0 / clockwise : clockwise 1 / counter clockwise : counter-clockwise	- 0 0 1	UINT16 UINT16 R/W per. -	CANopen 3008:7 _h Modbus 2062
IOfunct_LL1 I-O- - Li1 i - o - L, i	Function input LI18-83 1 / No function/free available / none : No function / freely available 2 / Fault reset / FrES : Reset error message 4 / Halt / hRLt : Halt 5 / Start profile positioning / SPtP : Start-request for movement (only fieldbus control mode) 6 / Enable positive motor move / PoSn : Release positive motor movement (only local control mode) 7 / Enable negative motor move / nEGn : Release negative motor movement (only local control mode) 8 / Speed limitation / nL, n : Speed limitation to parameter value (only local control mode) 9 / Jog positive / JoGP : Manual movement right end 10 / Jog negative / JoGn : Manual movement left end 11 / Jog fast/slow / JoGF : Manual movement fast/slow 13 / Start DataSet / dStR : Motion sequence: Start command 14 / Select DataSet / dSEL : Set inclusion 20 / Reference switch (REF) / rEF : reference switch 21 / Positive limit switch (LIMP) / L, nP : Positive limit switch 22 / Negative limit switch (LIMP) / L, nN : Negative limit switch Available from software version V1.201.	- - 0 -	UINT16 UINT16 R/W per. -	CANopen 3007:1 _h Modbus 1794

Parameter Name HMI menu	Description	Unit Minimum value Default value Maximum value	Data type R/W persistent Expert	Parameter address via fieldbus
IOfunct_LI2	Function input LI28-83	-	UINT16	CANopen 3007:2 _h
I-O- - Li2	1 / No function/free available / nonE: No function / freely available	-	UINT16	Modbus 1796
, -o- - L, 2	2 / Fault reset / FrE5: Reset error message (only local control mode)	0	R/W	
	4 / Halt / hALt: Halt	-	per.	
	5 / Start profile positioning / SPtP: Start-request for movement (only fieldbus control mode)		-	
	6 / Enable positive motor move / Po5n: Release positive motor movement (only local control mode)			
	7 / Enable negative motor move / nEGn: Release negative motor movement (only local control mode)			
	8 / Speed limitation / nL, n: Speed limited to parameter value (only local control mode)			
	9 / Jog positive / JoGP: Manual movement right end			
	10 / Jog negative / JoGn: Manual movement left end			
	11 / Jog fast/slow / JoGF: Manual movement fast/slow			
	13 / Start DataSet / dStA: Motion sequence: Start command			
	14 / Select DataSet / dSEL: set inclusion			
	20 / Reference switch (REF) / rEF: reference switch			
	21 / Positive limit switch (LIMP) / L, nP: positive limit switch			
	22 / Negative limit switch (LIMN) / L, nN: negative limit switch			
Available from software version V1.201.				

Parameter Name HMI menu	Description	Unit Minimum value Default value Maximum value	Data type R/W persistent Expert	Parameter address via fieldbus
IOfuncn_LI4	Function input LI48-83	-	UINT16	CANopen 3007:4 _h
I-O- - LI4	1 / No function/free available / nonE: No function / freely available	-	UINT16	Modbus 1800
, -o- - L, 4	2 / Fault reset / rreE: Reset error message (only local control mode) 4 / Halt / hRLt: Halt 5 / Start profile positioning / SPtP: Start-request for movement (only fieldbus control mode) 6 / Enable positive motor move / Po5n: Release positive motor movement (only local control mode) 7 / Enable negative motor move / nEGn: Release negative motor movement (only local control mode) 8 / Speed limitation / nL, n: Speed limited to parameter value (only local control mode) 9 / Jog positive / JoGP: Manual movement right end 10 / Jog negative / JoGn: Manual movement left end 11 / Jog fast/slow / JoGF: Manual movement fast/slow 13 / Start DataSet / d5tR: Motion sequence: start command 14 / Select DataSet / d5EL: set inclusion 20 / Reference switch / rEF: reference switch 21 / Positive limit switch (LIMP) / L, nP: positive limit switch 22 / Negative limit switch (LIMN) / L, n: negative limit switch	0	R/W per. -	
Available from software version V1.201.				

Parameter Name HMI menu	Description	Unit Minimum value Default value Maximum value	Data type R/W persistent Expert	Parameter address via fieldbus
IOfuncn_LI7	Function input LI7	-	UINT16	CANopen 3007:7 _h
I-O- - Li7	1 / No function/free available / nonE : No function / freely available	-	UINT16	Modbus 1806
, -o- - Li7	2 / Fault Reset / FrE5 : Reset error message (only local control mode)	0	R/W	
	4 / Halt / hALt : Halt	-	per.	
	5 / Start profile positioning / SPtP : Start-command for movement (only fieldbus control mode)		-	
	6 / Enable positive motor move / Po5n : Release positive motor movement			
	7 / Enable negative motor move / nENn : Release negative motor movement			
	8 / Speed limitation / nL, n : Speed limited to parameter value			
	9 / JOG positive / JoGn : Manual movement right end			
	10 / JOG negative / JoGn : Manual movement left end			
	11 / JOG fast/slow / JoGF : Manual movement fast/slow			
	12 / Enable2 / EnR2 : Start-command for movement (only fieldbus control mode)			
	13 / Start DataSet / dSEtR : Motion sequence: start command			
	14 / Select DataSet / dSEL : set inclusion			
	Input function 'Enable2' only effective if DEVcmdinterf = IODevice AND IOposInterfac = Pdinput			
	Available from software version V1.201.			
IOfuncn_LO1	Function output LO1_OUT	-	UINT16	CANopen 3007:9 _h
I-O- - Lo1	1 / No function/free available / nonE : No function / freely available	-	UINT16	Modbus 1810
, -o- - Lo1	2 / No fault / nFLt : No error	0	R/W	
	3 / Active / Rct : Operating readiness	-	per.	
	4 / Motor move disable / nLd : Direction of motion locked		-	
	5 / In position window / n-P : Position deviation within window			
	6 / In speed window / n-n : Speed deviation within window			
	7 / Speed threshold reached / nthr : Motor speed below parameterised value			
	8 / Current threshold reached / nthr : Motor current below parameterised value			
	9 / Halt acknowledge / hALt : Halt validation			
	10 / Brake release / brRH : Activation holding brake			
	11 / StartAck DataSet / dSAc : Motion sequence: Acknowledgment of start command			
	13 / Motor standstill / nStd : Motor standstill			
	Available from software version V1.201.			

Parameter Name HMI menu	Description	Unit Minimum value Default value Maximum value	Data type R/W persistent Expert	Parameter address via fieldbus
IOfuncnt_LO2 I-O- - Lo2 , -o- - Lo2	Function output LO2_OUT 1 / No function/free available / nonE : No function / freely available 2 / No fault / nFLt : No error 3 / Active / Rct : Operating readiness 4 / Motor move disable / Nd , 5 : Direction of motion locked 5 / In position window / , n-P : Position deviation within window 6 / In speed window / , n-n : Speed deviation within window 7 / Speed threshold reached / nthr : Motor speed below parameterised value 8 / Current threshold reached / , thr : Motor current below parameterised value 9 / Halt acknowledge / hRLt : Halt validation 10 / Brake release / brRH : Activation holding brake 11 / StartAck DataSet / dSRc : Motion sequence: Acknowledgment of start command 13 / Motor standstill / nStd : Motor standstill	- - 0 -	UINT16 UINT16 R/W per. -	CANopen 3007:A _h Modbus 1812
Available from software version V1.201.				
IOfuncnt_LO3 I-O- - Lo3 , -o- - Lo3	Function output LO3_OUT 1 / No function/free available / nonE : No function / freely available 2 / No fault / nFLt : No error 3 / Active / Rct : Operating readiness 4 / Motor move disable / Nd , 5 : Direction of motion locked 5 / In position window / , n-P : Position deviation within window 6 / In speed window / , n-n : Speed deviation within window 7 / Speed threshold reached / nthr : Motor speed below parameterised value 8 / Current threshold reached / , thr : Motor current below parameterised value 9 / Halt acknowledge / hRLt : Halt validation 10 / Brake release / brRH : Activation holding brake 11 / StartAck DataSet / dSRc : Motion sequence: Acknowledgment of start command 13 / Motor standstill / nStd : Motor standstill	- - 0 -	UINT16 UINT16 R/W per. -	CANopen 3007:B _h Modbus 1814
Available from software version V1.201.				
IOLogicType DRC- - ioLT drE- - , oLt	Logic type of the digital inputs/outputs7-13 0 / source / Sou : for power-delivering outputs 1 / sink / Si , n : for power-drawing outputs	- 0 0 1	UINT16 UINT16 R/W per. -	CANopen 3005:4 _h Modbus 1288
IMPORTANT: A change of the setting is not activated until the device is switched on again.				

Parameter Name HMI menu	Description	Unit Minimum value Default value Maximum value	Data type R/W persistent Expert	Parameter address via fieldbus
IOposInterfac DRC- - ioPi drC - - , oP,	Signal selection at position interface7-13 0 / A input / B : input ENC_A, ENC_B, ENC_I (index pulse) 4x evaluation 1 / P input / Pd : input PULSE, DIR, ENABLE2 2 / ESIM output / ES : π : output ESIM_A, ESIM_B, ESIM_I RS422 IO interface (Pos) IMPORTANT: A change of the setting is not activated until the unit is switched on again	- 0 0 2	UINT16 UINT16 R/W per. -	CANopen 3005:2 _h Modbus 1284
IOsigLimN - -	LIMN signal evaluation8-57 0 / inactive : inactive 1 / normally closed : normally closed contact 2 / normally open : normally-open switch	- 0 1 2	UINT16 UINT16 R/W per. -	CANopen 3006:F _h Modbus 1566
IOsigLimP - -	LIMP signal evaluation8-57 0 / inactive : inactive 1 / normally closed : normally closed contact 2 / normally open : normally-open switch	- 0 1 2	UINT16 UINT16 R/W per. -	CANopen 3006:10 _h Modbus 1568
IOsigRef - -	REF signal evaluation8-57 1 / normally closed : normally closed contact 2 / normally open : normally-open switch The reference switch is only enabled while processing the reference movement to REF.	- 1 1 2	UINT16 UINT16 R/W per. -	CANopen 3006:E _h Modbus 1564
JOGactivate - -	Activation of jog8-15 Bit0: clockwise rotation Bit1: counter-clockwise rotation Bit2: 0=slow 1=fast	- 0 0 7	UINT16 UINT16 R/W per. -	CANopen 301B:9 _h Modbus 6930
JOGn_fast JOG- - NFST Jog - - nFSt	Speed for fast jog8-15 The set value is internally limited to the current parameter setting in RAMPn_max.	1/min 1 180 13200	UINT16 UINT16 R/W per. -	CANopen 3029:5 _h Modbus 10506
JOGn_slow JOG- - NSLW Jog - - nSLW	Speed for slow jog8-15 The set value is internally limited to the current parameter setting in RAMPn_max.	1/min 1 60 13200	UINT16 UINT16 R/W per. -	CANopen 3029:4 _h Modbus 10504
JOGstepusr - -	inching distance before continuous operation8-15 0: direct activation of continuous operation >0: positioning section per inching cycle	usr 0 20 -	INT32 INT32 R/W per. -	CANopen 3029:7 _h Modbus 10510

Parameter Name HMI menu	Description	Unit Minimum value Default value Maximum value	Data type R/W persistent Expert	Parameter address via fieldbus
JOGtime - -	Waiting time before continuous operation8-15 Time is only effective if an inching section not equal to 0 has been set, otherwise direct transition to continuous operation.	ms 1 500 32767	UINT16 UINT16 R/W per. -	CANopen 3029:8 _h Modbus 10512
LIM_I_maxHalt SET- - LihA SEt - - L, hR	Current limiting for Halt8-76 max. Current during braking after Halt or termination of an operating mode. Maximum and default value setting depend on motor and power amplifier (setting M_I_max and PA_I_max) in 0.01A _{pk} steps	A _{pk} - - -	UINT16 UINT16 R/W per. -	CANopen 3011:6 _h Modbus 4364
LIM_I_maxQSTP SET- - LiQS SEt - - L, 95	Current limiting for Quick Stop8-75 max. Current during braking via torque ramp resulting from an error of error class 1 or 2 and when a software stop is triggered Maximum and default value setting depend on motor and power amplifier (setting M_I_max and PA_I_max) in 0.01A _{pk} steps	A _{pk} - - -	UINT16 UINT16 R/W per. -	CANopen 3011:5 _h Modbus 4362
M_I_0 - -	Motor constant current at standstill in 0.01 A _{pk} steps	A _{pk} - - -	UINT16 UINT16 R/ - -	CANopen 300D:13 _h Modbus 3366
M_I_max INF- - MiMA i nF - - n, nR	Motor maximum current in 0.01 A _{pk} steps	A _{pk} - - -	UINT16 UINT16 R/ - -	CANopen 300D:6 _h Modbus 3340
M_I_nom INF- - MiNo i nF - - n, nR	Motor nominal current in 0.01 A _{pk} steps	A _{pk} - - -	UINT16 UINT16 R/ - -	CANopen 300D:7 _h Modbus 3342
M_I2t - -	max. allowable time for M_I_max	ms - - -	UINT16 UINT16 R/ - -	CANopen 300D:11 _h Modbus 3362
M_Jrot - -	Motor moment of inertia in 0.1 kgcm ² steps	kg cm ² - - -	UINT16 UINT16 R/ - -	CANopen 300D:C _h Modbus 3352
M_kE - -	Motor EMF constant kE Voltage constant in V _{pk} at 1000 1/min	- - - -	UINT16 UINT16 R/ - -	CANopen 300D:B _h Modbus 3350

Parameter Name HMI menu	Description	Unit Minimum value Default value Maximum value	Data type R/W persistent Expert	Parameter address via fieldbus
M_L_d - -	Motor inductance d direction in 0.01 mH steps	mH - - -	UINT16 UINT16 R/- -	CANopen 300D:F _h Modbus 3358
M_L_q - -	Motor inductance q direction in 0.01 mH steps	mH - - -	UINT16 UINT16 R/- -	CANopen 300D:E _h Modbus 3356
M_M_max - -	Motor peak torque	N cm - - -	UINT16 UINT16 R/- -	CANopen 300D:9 _h Modbus 3346
M_M_nom - -	Motor nominal torque	N cm - - -	UINT16 UINT16 R/- -	CANopen 300D:8 _h Modbus 3344
M_n_max - -	maximum permissible motor speed	1/min - - -	UINT16 UINT16 R/- -	CANopen 300D:4 _h Modbus 3336
M_n_nom - -	Nominal motor speed	1/min - - -	UINT16 UINT16 R/- -	CANopen 300D:5 _h Modbus 3338
M_Polepair - -	Number of motor pole pairs	- - - -	UINT16 UINT16 R/- -	CANopen 300D:14 _h Modbus 3368
M_R_UV - -	Motor termination resistance in 10mΩ steps	Ω - - -	UINT16 UINT16 R/- -	CANopen 300D:D _h Modbus 3354
M_Sensor - -	Motor encoder type 0 / unknown: unknown 1: reserved 2: reserved 3 / SRS: SinCos 1024 marks Singleturn 4 / SRM: SinCos 1024 marks Multiturn 5 / SKS: SinCos 128 marks Singleturn 6 / SKM: SinCos 128 marks Multiturn 7 / SEK: SinCos 16 marks Singleturn	- - 0 - -	UINT16 UINT16 R/- - -	CANopen 300D:3 _h Modbus 3334
M_serialNo - -	Motor serial number	- - - -	UINT32 UINT32 R/- -	CANopen 300D:1 _h Modbus 3330

Parameter Name HMI menu	Description	Unit Minimum value Default value Maximum value	Data type R/W persistent Expert	Parameter address via fieldbus
M_T_max	max. Motor temperature8-60	°C	INT16	CANopen 300D:10 _h
-	-	-	INT16	Modbus 3360
-	-	0	R/-	-
-	-	-	-	-
M_T_warn	Motor temperature warning threshold	°C	INT16	CANopen 300D:15 _h
-	-	-	INT16	Modbus 3370
-	-	0	R/-	-
-	-	-	-	-
M_TempType	Type of temperature sensor	-	UINT16	CANopen 300D:12 _h
-	0: PTC switching	-	UINT16	Modbus 3364
-	1: NTC linear	-	R/-	-
-	-	-	-	-
M_Type	Motor type	-	UINT32	CANopen 300D:2 _h
-	0: no motor selected	-	UINT32	Modbus 3332
-	>0: connected motor type	-	R/-	-
-	-	-	-	-
M_U_nom	Motor nominal voltage	V	UINT16	CANopen 300D:A _h
-	Voltage in 100mV steps	-	UINT16	Modbus 3348
-	-	-	R/-	-
-	-	-	-	-
MBadr	Modbus address7-13	-	UINT16	CANopen 3016:4 _h
COM- - MBAD	valid addresses: 1 ... 247	1	UINT16	Modbus 5640
Эоп- - ПбPd	-	1	R/W	-
-	-	247	per.	-
-	-	-	-	-
MBbaud	Modbus baud rate7-13	-	UINT16	CANopen 3016:3 _h
COM- - MBBD	Allowed baud rates:	9600	UINT16	Modbus 5638
Эоп- - ПббD	9600	19200	R/W	-
-	19200	38400	per.	-
-	38400	-	-	-
-	IMPORTANT: A change of the setting is not activated until the unit is switched on again	-	-	-
MBdword_order	Modbus word sequence for double words (32 bit values)	-	UINT16	CANopen 3016:7 _h
COM- - MBWo	0 / HighLow / h, Lo: HighWord-LowWord	0	UINT16	Modbus 5646
Эоп- - ПбWо	1 / LowHigh / Loh, : LowWord-HighWord	0	R/W	-
-	Transmission of High Word or Low Word first	1	per.	-
-	High Word first -> Modicon Quantum	-	-	-
-	Low Word first -> Premium, HMI (Telemecanique)	-	-	-

Parameter Name HMI menu	Description	Unit Minimum value Default value Maximum value	Data type R/W persistent Expert	Parameter address via fieldbus
MBformat	Modbus data format	-	UINT16	CANopen 3016:5 _h
COM- - MBFo	1 / 8Bit NoParity 1Stop / Bn1 : 8 Bit, no parity bit, 1 stop bit	1	UINT16	Modbus 5642
COM- - MBFo	2 / 8Bit EvenParity 1Stop / BE1 : 8 Bit, even parity bit, 1 stop bit	2	R/W	
	3 / 8Bit OddParity 1Stop / Bo1 : 8 Bit, odd parity bit, 1 stop bit	4	per.	
	4 / 8Bit NoParity 2Stop / Bn2 : 8 Bit, no parity bit, 2 stop bits		-	
	IMPORTANT: A change of the setting is not activated until the unit is switched on again			
MBnode_guard	Modbus Node Guard	ms	UINT16	CANopen 3016:6 _h
-	Connection monitoring	0	UINT16	Modbus 5644
-	0: inactive (default)	0	R/W	
-	>0: Monitoring time	10000	-	
MSMactNum	Current data set number (11-36)	-	INT16	CANopen 302D:4 _h
-	-1: operating mode inactive or data set not triggered yet	-1	INT16	Modbus 11528
-	>0: number of currently started data set	15	R/-	
			-	
MSMavailCnt	Number of available data sets (11-36)	-	UINT16	CANopen 302D:F _h
-	Number of available data sets.	16	UINT16	Modbus 11550
-		16	R/-	
-		16	-	
MSMcurNextCond	Current transition condition (11-36)	-	UINT16	CANopen 302D:9 _h
-	Displays the transition condition that must be met to trigger the next data set.	0	UINT16	Modbus 11538
-	For coding see 'MSMdataNextCond'	4	R/-	
		7	-	
			-	
MSMdataAcc	Acceleration (8-35)	(1/min)/s	UINT32	CANopen 302D:14 _h
-	0: using the current acceleration, no change	0	UINT32	Modbus 11560
-	>0: special acceleration value, for setting range see parameter RAMPacc	0	R/W	
		3000000	per.	
			-	
MSMdataDec	Deceleration (8-35)	(1/min)/s	UINT32	CANopen 302D:15 _h
-	0: Using the current deceleration, no change	0	UINT32	Modbus 11562
-	>0: special acceleration value, for setting range see parameter RAMPdecel	0	R/W	
		3000000	per.	
			-	
MSMdataDelay	Wait time (8-35)	ms	UINT16	CANopen 302D:16 _h
-	Additional wait time after end of movement in ms.	0	UINT16	Modbus 11564
-		0	R/W	
		30000	per.	
	Setting has meaning only in the processing mode 'sequential selection'		-	
MSMdataNext	Number of following data set (8-35)	-	UINT16	CANopen 302D:18 _h
-	Number of the next data set	0	UINT16	Modbus 11568
-		0	R/W	
	setting has meaning only in the processing mode 'sequential selection'	15	per.	
			-	

Parameter Name HMI menu	Description	Unit Minimum value Default value Maximum value	Data type R/W persistent Expert	Parameter address via fieldbus
MSMdataNextCond	transition condition (8-36)	-	UINT16	CANopen 302D:17 _h
-	0 = rising edge	0	UINT16	Modbus 11566
-	1 = falling edge	4	R/W	
-	2 = 1-level	7	per.	
	3 = 0-level		-	
	4 = global transition condition (see MSMGlobalCond)			
	5 = Auto			
	6 = Blended Movement Type A			
	7 = Blended Movement Type B			
	Setting is only meaningful in 'sequential selection' processing mode'			
MSMdataSpeed	Speed (8-35)	1/min	UINT16	CANopen 302D:13 _h
-	In the case of relative or absolute move- ments this value corresponds to the target speed, for homing the search speed.	0	UINT16	Modbus 11558
-		0	R/W	
-		13200	per.	
			-	
MSMdataTarget	Target value of movement type (8-34)	-	INT32	CANopen 302D:12 _h
-	Value depends on the selected processing mode (for setting see MSMDataType):	-2147483648	INT32	Modbus 11556
-	- none: no meaning	0	R/W	
-	- absolute positioning: absolute position in usr	2147483647	per.	
	- relative positioning: Relative distance in usr		-	
	- reference movement: type of reference movement (see HMmethod)			
	- set dimensions: dimension setting position in usr			
MSMdataType	Selection of movement type (8-34)	-	UINT16	CANopen 302D:11 _h
-	0 = None	0	UINT16	Modbus 11554
-	Sequential selection:	0	R/W	
-	Only processing of wait time and transition condition .	4	per.	
	Direct selection :		-	
	trigger a data set without movement but retain the handshake mechanism.			
	1 = absolute positioning			
	2 = relative positioning			
	3 = homing			
	4 = set dimensions			
MSMfeature	Special setting (11-37)	-	UINT16	CANopen 302D:B _h
-	Value 1 :	0	UINT16	Modbus 11542
-	Only sequential selection:	0	R/W	
-	There is no automatic transition. This value is imported on starting a data set. The sub- sequent set is triggered by a rising edge. If the movement is of the "blended movement" type, the entire blended movement is com- pleted. The value is reset to 0 on completion of the set or in the event of an error.	1	-	
			-	

Parameter Name HMI menu	Description	Unit Minimum value Default value Maximum value	Data type R/W persistent Expert	Parameter address via fieldbus
MSMglobalCond	Global transition condition (8-33)	- 0	UINT16 UINT16	CANopen 302D:8 _h Modbus 11536
-	The global transition condition defines how the start command will be processed. This setting is used for the first start after activation of the operating mode. This setting can also be used as the transition condition in the individual data sets (default setting)	0	R/W	
-	Coding: 0: Rising edge 1: Falling edge 2: 1-level 3: 0-level	3	per. -	
MSMnextNum	Data set that is to be started next (11-38)	- -1	INT16 INT16	CANopen 302D:5 _h Modbus 11530
-	-1: operating mode inactive or no data set selected yet	-1	R/-	
-	>0: number of next data set	15	- -	
MSMprocMode	Processing mode (8-33)	- 0	UINT16 UINT16	CANopen 302D:7 _h Modbus 11534
-	0: Direct selection	1	R/W	
-	1: Sequential selection	1	per. -	
MSMselEntry	Selection of data set number in data set table (11-38)	- 0	UINT16 UINT16	CANopen 302D:10 _h Modbus 11552
-	Before an entry can be read or written from the data set table the corresponding data set number must be selected.	0	R/W	
-		15	- -	
MSMsetNum	Selection of a data set that is to be started. (11-38)	- -1	INT16 INT16	CANopen 302D:6 _h Modbus 11532
-	Number of the next data set to be triggered	-1	R/W	
-	Setting is only possible if no data set is activated or the processing of the current data set has been completed (x_end = 1) A write access changes MSNNextNum.	15	- -	
	Special case on reading the parameter: -1: Operating mode inactive or no data set was specified with this parameter>:			
MSMstartReq	start command for processing a data set (8-37)	- 0	UINT16 UINT16	CANopen 302D:3 _h Modbus 11526
-	Direct selection :	0	R/W	
-	a data set is always triggered by a rising edge. The number of the data set to be triggered must be set beforehand with MSMsetNum.	1	- -	
	Sequential selection: Triggering a data set with start or transition condition . The first start condition is set by MSMGlobalCond, the transition condition can be set separately for every data set.			
MSMstartType	Activation type of motion sequence operating mode (11-38)	- 0	UINT16 UINT16	CANopen 301B:1A _h Modbus 6964
-	0: disable	0	R/W	
-	1: enable	2	- -	
-	2: continue movement interrupted by Halt			

Parameter Name HMI menu	Description	Unit Minimum value Default value Maximum value	Data type R/W persistent Expert	Parameter address via fieldbus
MSMteachIn - -	Import of current user position (teach-in) (11-39) Import of current user position into data set table. The parameter is used to specify the table row to which the position is to be imported. Teach-in is only permitted at standstill and only with a referenced drive (ref_ok=1). The data set type 'absolute positioning' must also be input into the selected line in the table. In 'OperationEnable' status '_p_refusr' is imported as position value, otherwise '_p_actusr'.	- 0 0 15	UINT16 UINT16 R/W -	CANopen 302D:A _h Modbus 11540
MT_dismax - -	Max. permissible distance If the maximum permissible distance is exceeded with an active reference value, a class 1 error is triggered. value 0 disables the monitoring.	revolution 0.0 1.010.0 999.9	UINT16 UINT16 R/W -	CANopen 302E:3 _h Modbus 11782
PA_I_max INF- - PiMA , nF- - Pi nR	Maximum current of power amplifier Current in 10 mA steps	A _{pk} - 0.00 -	UINT16 UINT16 R/- per. -	CANopen 3010:2 _h Modbus 4100
PA_I_nom INF- - PiNo , nF- - Pi no	Nominal current of power amplifier Current in 10 mA steps	A _{pk} - 0.00 -	UINT16 UINT16 R/- per. -	CANopen 3010:1 _h Modbus 4098
PA_T_max - -	maximum permissible temperature of the power amplifier8-60	°C - 0 -	INT16 INT16 R/- per. -	CANopen 3010:7 _h Modbus 4110
PA_T_warn - -	Temperature limit of the power amplifier8-60	°C - 0 -	INT16 INT16 R/- per. -	CANopen 3010:6 _h Modbus 4108
PA_U_maxDC - -	max. permissible DC bus voltage Voltage in 100mV steps	V - - -	UINT16 UINT16 R/- per. -	CANopen 3010:3 _h Modbus 4102
PA_U_minDC - -	DC bus undervoltage threshold for drive switch-off Voltage in 100mV steps	V - - -	UINT16 UINT16 R/- per. -	CANopen 3010:4 _h Modbus 4104
PA_U_minStopDC - -	DC bus undervoltage threshold for Quick Stop At this threshold the drive executes a Quick Stop Voltage in 100 mV steps	V - - -	UINT16 UINT16 R/- per. -	CANopen 3010:A _h Modbus 4116

Parameter Name HMI menu	Description	Unit Minimum value Default value Maximum value	Data type R/W persistent Expert	Parameter address via fieldbus
PAR_CTRLreset TUN- - RES tun- - rE5	Reset controller parameter 1: Control parameters of the speed and position controllers are reset The current controller is automatically set according to the connected motor.	- 0 - 1	UINT16 UINT16 R/W -	CANopen 3004:7 _h Modbus 1038
PAReeprSave - -	Back up the parameters in the EEPROM memory Bit 0=1: Backup of all persistent parameters The current parameters are backed up in non-volatile memory (EEPROM). The storing process is complete if a 0 is returned when reading the parameters.	- - - -	UINT16 UINT16 R/W -	CANopen 3004:1 _h Modbus 1026
PARfactorySet DRC- - FCS drC- - FL5	Restore factory settings (default values) 1: Set all parameters to default value and backup in EEPROM. Restoring of factory settings can be triggered through HMI or commissioning software. The storing process is complete if a 0 is returned when reading the parameters. IMPORTANT: The default state only becomes active at the next start-up.	8-98 - 0 - 3	R/W - -	
PARuserReset - -	Resetting the user parameters Bit 0=1: Set persistent parameters to default values. All parameters are reset, with the exception of: - Communication parameters - Definition of the direction of rotation - Signal selection position interface - Device control - Logic type - Start up operating mode for 'local control mode' - ESIM settings - IO functions IMPORTANT: The new settings are not backed up to the EEPROM!	8-98 - 0 - 7	UINT16 UINT16 R/W -	CANopen 3004:8 _h Modbus 1040

Parameter Name HMI menu	Description	Unit Minimum value Default value Maximum value	Data type R/W persistent Expert	Parameter address via fieldbus
POSdirOfRotat	Definition of the direction of rotation8-96	-	UINT16	CANopen 3006:C _h
DRC- - PRoT	0 / clockwise / \lll : Clockwise	0	UINT16	Modbus 1560
<i>dr\ll - Prot</i>	1 / counter clockwise / \lll : Counter clockwise	0 1	R/W per. -	
	Meaning: The drive rotates clockwise with positive speeds, looking onto the motor shaft at the flange.			
	IMPORTANT: When using limit switches, after changing the setting, the limit switch connections must be changed over. The limit switch which is actuated by moving in jog mode in a positive direction must be connected to the input LIMP, and vice versa.			
	IMPORTANT: A change of the setting is not activated until the device is switched on again.			
POSscaleDenom	Denominator of the position scaling factor8-69	usr 1	INT32	CANopen 3006:7 _h
-	Description see numerator (POSscaleNum)	1638412 2147483647	INT32 R/W per. -	Modbus 1550
	Acceptance of a new scaling factor is by transfer of the numerator			
POSscaleNum	Numerator of the position scaling factor8-69	revolution 1	INT32	CANopen 3006:8 _h
-	:Definition of scaling factor	1	INT32 R/W per. -	Modbus 1552
-	Motor revolutions[U]	2147483647		
	----- Change in user position [usr]			
	Acceptance of a new scaling factor takes place on the entry of the numerator			
	User limits can be reduced when internal system factors are taken into account			
PPn_target	Setpoint speed for profile position mode8-26	1/min 1	UINT32	CANopen 6081:0 _h
-	Maximum value is limited to the current setting in CTRL_n_max	60	UINT32 R/W	Modbus 6942
-	The setting value is internally limited to the current parameter setting in RAMPn_max.	-	- -	
PPoption	Options for operating mode profile position	-	UINT16	CANopen 60F2:0 _h
-	Determines the reference position for a relative positioning:	0	UINT16 R/W	Modbus 6960
-	0: relative to the previous target position of the travel profile generator	0	-	
	1: not supported	2	-	
	2: relative to the current actual position of the motor			
	from Version 1.120			

Parameter Name HMI menu	Description	Unit Minimum value Default value Maximum value	Data type R/W persistent Expert	Parameter address via fieldbus
PPp_targetusr - -	Target position of profile position operating mode8-26 Min/Max values are dependent upon: - Scaling factor - software limit switch (if this is activated)	usr - 0 -	INT32 INT32 R/W -	CANopen 607A:0 _h Modbus 6940
ProfileType - -	Motion profile 0: Linear	- 0 0 0	INT16 INT16 R/W -	CANopen 6086:0 _h Modbus 6954
PVn_target - -	Setpoint speed profile velocity mode8-30 Maximum value is limited to the current setting in CTRL_n_max The setting value is internally limited to the current parameter setting in RAMPn_max.	1/min - 0 -	INT32 INT32 R/W -	CANopen 60FF:0 _h Modbus 6938
PWM_fChop - -	Switching frequency of power amplifier7-20 0 / 4kHz: 4 kHz 1 / 8kHz: 8 kHz, Factory setting: for motors of the BSH family: the factory setting is automatically made for all other motors depending on the connected motor: 4KHz	- 0 0 1	UINT16 UINT16 R/W per. expert	CANopen 3005:E _h Modbus 1308

Parameter Name HMI menu	Description	Unit Minimum value Default value Maximum value	Data type R/W persistent Expert	Parameter address via fieldbus
RAMP_TAUjerk	Jolt limiting	ms	UINT16	CANopen 3006:D _h
-	0: off	0	UINT16	Modbus 1562
-	>0: Setting for filter processing time	0 128	R/W per.	
	The following values can be set: 0: inactive 1 2 4 8 16 32 64 128		-	
	Limits the acceleration change (jerk) of the setpoint position generation during the positioning transitions: Standstill - acceleration acceleration - constant movement constant movement - deceleration deceleration - standstill			
	Processing in the following operating modes: - profile velocity - point to point - jog - homing			
	Setting is possible only if operating mode (x_end=1) is disabled.			
	Not active with braking process via torque ramp ("Halt" or "Quick Stop")			
RAMPacc	Profile generator acceleration8-72	(1/min)/s	UINT32	CANopen 6083:0 _h
-		30	UINT32	Modbus 1556
-		600	R/W	
-		3000000	per.	
			-	
RAMPdecel	Profile generator deceleration8-72	((1/min)/s)	UINT32	CANopen 6084:0 _h
-		750	UINT32	Modbus 1558
-		750	R/W	
-		3000000	per.	
			-	
RAMPn_max	Limiting setpoint speed with operating modes with profile generation8-72	1/min	UINT32	CANopen 607F:0 _h
-		60	UINT16	Modbus 1554
-	The parameters are effective in the following operating modes:	13200	R/W	
-	- Point to point	13200	per.	
	- profile velocity		-	
	- homing			
	- jog			
	If a higher speed is set in one of these operating modes, there is automatically a restriction on RAMPn_max. This makes it easier to execute commissioning at restricted speed.			

Parameter Name HMI menu	Description	Unit Minimum value Default value Maximum value	Data type R/W persistent Expert	Parameter address via fieldbus
RAMPsym	symmetrical ramp	usr	UINT16	CANopen 3006:1 _h
-	Acceleration and deceleration of the profile generator (16-bit value) in 10 (1/min)/s	-	UINT16	Modbus 1538
-		0	R/W	
-		-	-	
	Write access changes the values under RAMPacc as well as RAMPdecel, the limit value test occurs using the limit values there.			
	Reading access delivers the greater value of RAMPacc/RAMPdecel.			
	If the current setting value cannot be mapped as a 16-bit value, then the max. UINT16 value is transferred			
RESext_P	Nominal power of external braking resistor7-20	W	UINT16	CANopen 3005:12 _h
-		1	UINT16	Modbus 1316
-		10	R/W	
-		32767	per.	
-			-	
RESext_R	Resistance value of external braking resistor7-20	Ω	UINT16	CANopen 3005:13 _h
-		0.01	UINT16	Modbus 1318
-		100.00	R/W	
-		327.67	per.	
-			-	
RESext_ton	max. permissible switch-in time for external braking resistor7-20	ms	UINT16	CANopen 3005:11 _h
-		1	UINT16	Modbus 1314
-		1	R/W	
-		30000	per.	
-			-	
RESint_ext	Control of braking resistor7-20	-	UINT16	CANopen 3005:9 _h
-	0 / internal: internal braking resistor	0	UINT16	Modbus 1298
-	1 / external: external braking resistor	0	R/W	
-		1	per.	
-			-	
RESint_P	Nominal power of internal braking resistor	W	UINT16	CANopen 3010:9 _h
-		-	UINT16	Modbus 4114
-		-	R/-	
-		-	per.	
-			-	
RESint_R	Internal braking resistor	Ω	UINT16	CANopen 3010:8 _h
-	in 10 mOhm steps	-	UINT16	Modbus 4112
-		-	R/-	
-		-	per.	
-			-	
SPEEDn_target	Setpoint speed in speed control mode8-20	1/min	INT16	CANopen 3021:4 _h
-	The internal maximum speed is limited by the current setting in CTRL_n_max	-30000	INT16	Modbus 8456
-		0	R/W	
-		30000	-	
-			-	
SPEEDreference	Selection of preset source for speed control operating mode8-20	-	UINT16	CANopen 301B:11 _h
-		0	UINT16	Modbus 6946
-	0: no	0	R/W	
-	1: Reference value via +/-10V-interface ANA1	2	-	
-	2: Reference value via parameter SPEEDn_target		-	

Parameter Name HMI menu	Description	Unit Minimum value Default value Maximum value	Data type R/W persistent Expert	Parameter address via fieldbus
SPV_Fit_AC - -	Error response to failure of a mains phase with 3-phase devices8-60 1 / ErrorClass1: error class 1 2 / ErrorClass2: error class 2 3 / ErrorClass3: error class 3	- 1 2 3	UINT16 UINT16 R/W per. -	CANopen 3005:A _h Modbus 1300
SPV_Fit_pDiff - -	Error response to tracking error8-60 1 / ErrorClass1: error class 1 2 / ErrorClass2: error class 2 3 / ErrorClass3: error class 3	- 1 3 3	UINT16 UINT16 R/W per. -	CANopen 3005:B _h Modbus 1302
SPV_EarthFit - -	Earth fault monitoring8-67 0 / off: off 1 / on: on (default) In exceptional cases it may be necessary to disable it, e.g.: - parallel connection of multiple devices - operation on an IT mains - long motor lines Disable the monitoring only if it responds when not wanted	- 0 1 1	UINT16 UINT16 R/W per. expert	CANopen 3005:10 _h Modbus 1312
SPV_MainsVolt - -	Monitoring mains phases with 3-phase devices8-68 0 / off: off 1 / on: on (default) 3-phase devices must only be connected and operated on 3-phase. In exceptional cases it may be necessary to disable it, e.g.: - supply via the DC bus	- 0 1 1	UINT16 UINT16 R/W per. expert	CANopen 3005:F _h Modbus 1310
SPV_p_maxDiff - -	Max. permissible tracking error of position controller8-60 The tracking error is the current position regulation offset minus the speed-dependent position regulation offset. Actually, only the position offset caused by the moment requirements is still referred to for tracking error monitoring.	revolution 0.0001 1.0000 200.0000	UINT32 UINT32 R/W per. -	CANopen 6065:0 _h Modbus 4636
SPV_SW_Limits - -	Monitoring the software limit switch8-57 0 / none: none (default) 1 / SWLIMP: Activating SW limit switch pos. direction 2 / SWLIMN: activating SW limit switch neg. direction 3 / SWLIMP+SWLIMN: Activating SW limit switch both. directions The software limit switch is only monitored after a successful homing (ref_ok = 1)	- 0 0 3	UINT16 UINT16 R/W per. -	CANopen 3006:3 _h Modbus 1542

Parameter Name HMI menu	Description	Unit Minimum value Default value Maximum value	Data type R/W persistent Expert	Parameter address via fieldbus
SPVChkWinTime SET- - Wint 5Et - - L, nE	Monitoring of time window Setting of a time for the monitoring of position deviation, speed of rotation deviation, speed of rotation value and current value. If the control value for the set time is within the monitoring range, then the result of the monitoring is valid. The status can be output via a programmable output. Available from software version V1.201.	ms 0 0 9999	UINT16 UINT16 R/W per. -	CANopen 3006:1D _h Modbus 1594
SPVcommutat - -	Monitoring commutation8-66 0 / off: off 1 / on: on (default)	- 0 1 1	UINT16 UINT16 R/W per. -	CANopen 3005:5 _h Modbus 1290
SPVi_Threshold SET- - itHr 5Et - - , tHr	Monitoring of current value It is checked whether the drive is below the value defined here for the time programmed via 'SPVChkWinTime'. The status can be output via a programmable output. As a comparative value the value from the parameter '_ldq_act' is used. Available from software version V1.201.	A _{pk} 0.00 0.00 99.99	UINT16 UINT16 R/W per. -	CANopen 3006:1C _h Modbus 1592
SPVn_DiffWin SET- - in-n 5Et - - , n-n	Monitoring of speed of rotation deviation It is checked whether the drive is below the deviation defined here for the time programmed via 'SPVChkWinTime'. The status can be output via a programmable output. Available from software version V1.201.	1/min 1 10 9999	UINT16 UINT16 R/W per. -	CANopen 3006:1A _h Modbus 1588
SPVn_lim SET- - nLiM 5Et - - nLi, n	Speed limitation via input a speed limitation can be activated via a digital input. Note: the minimum speed of rotation is always internally limited to 100 1/min in the current control operating mode. Available from software version V1.201.	1/min 1 10 9999	UINT16 UINT16 R/W per. -	CANopen 3006:1E _h Modbus 1596
SPVn_Threshold SET- - ntHr 5Et - - ntHr	Monitoring of speed of rotation value It is checked whether the drive is below the value defined here for the time programmed via 'SPVChkWinTime'. The status can be output via a programmable output. Available from software version V1.201.	1/min 1 10 9999	UINT16 UINT16 R/W per. -	CANopen 3006:1B _h Modbus 1590

Parameter Name HMI menu	Description	Unit Minimum value Default value Maximum value	Data type R/W persistent Expert	Parameter address via fieldbus
SPVp_DiffWin SET- - in-P 5Et - - , n-P	Monitoring of position deviation It is checked whether the drive is below the deviation defined here for the time programmed via 'SPVChkWinTime'. The status can be output via a programmable output. Available from software version V1.201.	revolution 0.0000 0.0010 0.9999	UINT16 UINT16 R/W per. -	CANopen 3006:19 _h Modbus 1586
SPVswLimNusr - -	negative position limit for software limit switch8-57 see description of 'SPVswLimPusr'	usr - -2147483648 -	INT32 INT32 R/W per. -	CANopen 607D:1 _h Modbus 1546
SPVswLimPusr - -	positive position limit for software limit switch8-57 If a user-defined value outside the permissible user-defined area is set, the limit switch limits are automatically limited internally to the maximum user-defined value.	usr - 2147483647 -	INT32 INT32 R/W per. -	CANopen 607D:2 _h Modbus 1544
STANDp_win - -	Standstill window, permissible control deviation8-79 The control deviation for the standstill window time must lie in this range of values to allow recognition of the standstill of the drive. The processing of the standstill window must be activated via the STANDpwinTime parameter.	revolution 0.0000 0.00100.0400 3.2767	UINT32 UINT16 R/W per. -	CANopen 6067:0 _h Modbus 4370
STANDpwinTime - -	Standstill window, time8-79 0: Standstill window monitoring deactivated >0: Time in ms within which the control deviation must lie in the standstill window	ms 0 0 32767	UINT16 UINT16 R/W per. -	CANopen 6068:0 _h Modbus 4372
STANDpwinTout - -	Timeout for the standstill window monitor8-79 0: Timeout monitor deactivated >0: Timeout in ms Setting the standstill window processing is accomplished via STANDp_win and STANDpwinTime The time monitoring begins at the moment the target position is reached (position controller setpoint) or at the end of the profile generator processing.	ms 0 0 16000	UINT16 UINT16 R/W per. -	CANopen 3011:B _h Modbus 4374

Parameter Name HMI menu	Description	Unit Minimum value Default value Maximum value	Data type R/W persistent Expert	Parameter address via fieldbus
SuppDriveModes	Supported operating modes as per DSP402	-	UINT32	CANopen 6502:0 _h
-	Coding:	-	UINT32	Modbus 6952
-	Bit 0: profile position	0	R/-	
-	Bit 2: profile velocity	-	-	
	Bit 5: homing		-	
	Bit 16: jog			
	Bit 17: electronic gear			
	Bit 18: current control			
	Bit 19: speed control			
	Bit 20: position control			
	Bit 21: manual tuning			
	Bit 22: oscillator mode			
	The availability of the individual bits depends on the product			

12 Accessories and spare parts

12.1 Optional accessories

Description	Order number
Peripheral control terminal	VW3A31101
PowerSuite V2 CD-ROM (commissioning software)	VW3A8104
PC connection kit, converter RS485 to RS232	VW3A8106
USIC (Universal Signal Interface Converter), for signal adaptation to RS422 standard	VW3M3102
Reference Value Adapter RVA for distribution of A/B or pulse/direction signals to 5 devices with 24VDC power supply device to 5VDC sensor power supply	VW3M3101
Holding brake control HBC	VW3M3103

12.2 External braking resistors

Description	Order number
braking resistor IP65; 10 ohm; 400W; 0.75m connector cable	VW3A7601R07
braking resistor IP65; 10 ohm; 400W; 2m connector cable	VW3A7601R20
braking resistor IP65; 10 ohm; 400W; 3m connector cable	VW3A7601R30
braking resistor IP65; 27 ohm; 100W; 0.75m connector cable	VW3A7602R07
braking resistor IP65; 27 ohm; 100W; 2m connector cable	VW3A7602R20
braking resistor IP65; 27 ohm; 100W; 3m connector cable	VW3A7602R30
braking resistor IP65; 27 ohm; 200W; 0.75m connector cable	VW3A7603R07
braking resistor IP65; 27 ohm; 200W; 2m connector cable	VW3A7603R20
braking resistor IP65; 27 ohm; 200W; 3m connector cable	VW3A7603R30
braking resistor IP65; 27 ohm; 400W; 0.75m connector cable	VW3A7604R07
braking resistor IP65; 27 ohm; 400W; 2m connector cable	VW3A7604R20
braking resistor IP65; 27 ohm; 400W; 3m connector cable	VW3A7604R30
braking resistor IP65; 72 ohm; 100W; 0.75m connector cable	VW3A7605R07
braking resistor IP65; 72 ohm; 100W; 2m connector cable	VW3A7605R20
braking resistor IP65; 72 ohm; 100W; 3m connector cable	VW3A7605R30
braking resistor IP65; 72 ohm; 200W; 0.75m connector cable	VW3A7606R07
braking resistor IP65; 72 ohm; 200W; 2m connector cable	VW3A7606R20
braking resistor IP65; 72 ohm; 200W; 3m connector cable	VW3A7606R30
braking resistor IP65; 72 ohm; 400W; 0.75m connector cable	VW3A7607R07 ¹⁾
braking resistor IP65; 72 ohm; 400W; 2m connector cable	VW3A7607R20 ¹⁾
braking resistor IP65; 72 ohm; 400W; 3m connector cable	VW3A7607R30 ¹⁾

1) The resistors 7Rxx have NO UL/CSA authorisation!

12.3 Motor cables

These cables are suitable **only for BSH motors**.

Description	Order number
Motor cable 3m for Servomotor, 4*1.5mm ² and 2*1.0mm ² screened; Motor end 8-pole round plug, other cable end open	VW3M5101R30
Motor cable 5m for Servomotor, 4*1.5mm ² and 2*1.0mm ² screened; Motor end 8-pole round plug, other cable end open	VW3M5101R50
Motor cable 10m for Servomotor, 4*1.5mm ² and 2*1.0mm ² screened; Motor end 8-pole round plug, other cable end open	VW3M5101R100
Motor cable 15m for Servomotor, 4*1.5mm ² and 2*1.0mm ² screened; Motor end 8-pole round plug, other cable end open	VW3M5101R150
Motor cable 20m for Servomotor, 4*1.5mm ² and 2*1.0mm ² screened; Motor end 8-pole round plug, other cable end open	VW3M5101R200
Motor cable 3m for Servomotor, 4*2.5mm ² and 2*1.0mm ² screened; Motor end 8-pole round plug, other cable end open	VW3M5102R30
Motor cable 5m for Servomotor, 4*2.5mm ² and 2*1.0mm ² screened; Motor end 8-pole round plug, other cable end open	VW3M5102R50
Motor cable 10m for Servomotor, 4*2.5mm ² and 2*1.0mm ² screened; Motor end 8-pole round plug, other cable end open	VW3M5102R100
Motor cable 15m for Servomotor, 4*2.5mm ² and 2*1.0mm ² screened; Motor end 8-pole round plug, other cable end open	VW3M5102R150
Motor cable 20m for Servomotor, 4*2.5mm ² and 2*1.0mm ² screened; Motor end 8-pole round plug, other cable end open	VW3M5102R200
motor cable 3m for Servomotor, 4*4.0mm ² and 2*1.0mm ² shielded; motor end 8-pole M40 circular plug, other cable end open	VW3M5103R30
motor cable 5m for Servomotor, 4*4.0mm ² and 2*1.0mm ² shielded; motor end 8-pole M40 circular plug, other cable end open	VW3M5103R50
motor cable 10m for Servomotor, 4*4.0mm ² and 2*1.0mm ² shielded; motor end 8-pole M40 circular plug, other cable end open	VW3M5103R100
motor cable 15m for Servomotor, 4*4.0mm ² and 2*1.0mm ² shielded; motor end 8-pole M40 circular plug, other cable end open	VW3M5103R150
motor cable 20m for Servomotor, 4*4.0mm ² and 2*1.0mm ² shielded; motor end 8-pole M40 circular plug, other cable end open	VW3M5103R200

12.4 Encoder cables

These cables are suitable **only for BSH motors**.

Description	Order number
Encoder cable 3m for Servomotor, 5*(2*0.25mm ²) and 1*(2*0.5mm ²) screened; Motor end 12-pole round plug, unit end 12-pole plug	VW3M8101R30
Encoder cable 5m for Servomotor, 5*(2*0.25mm ²) and 1*(2*0.5mm ²) screened; Motor end 12-pole round plug, unit end 12-pole plug	VW3M8101R50
Encoder cable 10m for Servomotor, 5*(2*0.25mm ²) and 1*(2*0.5mm ²) screened; Motor end 12-pole round plug, unit end 12-pole plug	VW3M8101R100
Encoder cable 15m for Servomotor, 5*(2*0.25mm ²) and 1*(2*0.5mm ²) screened; Motor end 12-pole round plug, unit end 12-pole plug	VW3M8101R150
Encoder cable 20m for Servomotor, 5*(2*0.25mm ²) and 1*(2*0.5mm ²) screened; Motor end 12-pole round plug, unit end 12-pole plug	VW3M8101R200

12.5 Crimping tool and connector / contacts

Description	Order number
Crimping pliers for CN2 and CN5: Molex 69008-0982	
Extraction tool for crimped contacts: Molex 11-03-0043	
5* connector set Molex 10-pin for CN5	VW3M8212
5* connector set Molex 12-pin for CN2	VW3M8213

12.6 RS 422: pulse/direction, ESIM and A/B

Description	Order number
Cable pulse/direction, ESIM, A/B, unit end 10 pole, other end open, 0.5m	VW3M8201R05
Cable pulse/direction, ESIM, A/B, unit end 10 pole, other end open, 1.5m	VW3M8201R15
Cable pulse/direction, ESIM, A/B, unit end 10 pole, other end open, 3m	VW3M8201R30
Cable pulse/direction, ESIM, A/B, unit end 10 pole, other end open, 5m	VW3M8201R50
Cable ESIM, A/B, for Master/Slave operation of units 2* 10-pole, 0.5m	VW3M8202R05
Cable ESIM, A/B, for Master/Slave operation of units 2* 10-pole, 1.5m	VW3M8202R15
Cable ESIM, A/B, for Master/Slave operation of units 2* 10-pole, 3m	VW3M8202R30
Cable ESIM, A/B, for Master/Slave operation of units 2* 10-pole, 5m	VW3M8202R50
Cable pulse/direction, ESIM, AB on Premium CAY, 0.5m, 10-pole + 15-pole SubD	VW3M8203R05
Cable pulse/direction, ESIM, AB on Premium CAY, 1.5m, 10-pole + 15-pole SubD	VW3M8203R15
Cable pulse/direction, ESIM, AB on Premium CAY, 3m, 10-pole + 15-pole SubD	VW3M8203R30
Cable pulse/direction, ESIM, AB on Premium CAY, 5m, 10-pole + 15-pole SubD	VW3M8203R50
Cable pulse/direction, ESIM, AB on Premium CFY, 0.5m, 10-pole + 15-pole SubD	VW3M8204R05
Cable pulse/direction, ESIM, AB on Premium CFY, 1.5m, 10-pole + 15-pole SubD	VW3M8204R15
Cable pulse/direction, ESIM, AB on Premium CFY, 3m, 10-pole + 15-pole SubD	VW3M8204R30
Cable pulse/direction, ESIM, AB on Premium CFY, 5m, 10-pole + 15-pole SubD	VW3M8204R50
Cable pulse/direction, ESIM, AB on Siemens S5 IP247, 3m, 10-pole	VW3M8205R30
Cable pulse/direction, ESIM, AB on Siemens S5 IP247, 3m, 10-pole	VW3M8206R30
Cable pulse/direction, ESIM, AB Siemens S7-300 FM353, 3m, 10-pole	VW3M8207R30
cabl pulse/direction, ESIM, AB on Siemens S7 FM354, 3m, 10-pin connector	VW3M8208R30
Cable pulse/direction, ESIM, AB on RVA, USIC or WP/WPM311, 0.5m	VW3M8209R05
Cable pulse/direction, ESIM, AB on RVA, USIC or WP/WPM311, 1.5m	VW3M8209R15
Cable pulse/direction, ESIM, AB on RVA, USIC or WP/WPM311, 3m	VW3M8209R30
Cable pulse/direction, ESIM, AB on RVA, USIC or WP/WPM311, 5m	VW3M8209R50
cabl pulse/direction, USIC, 15-pin SubD, other end off, 0.5m	VW3M8210R05
cabl pulse/direction, USIC, 15-pin SubD, other end off, 1.5m	VW3M8210R15
cabl pulse/direction, USIC, 15-pin SubD, other end off, 3m	VW3M8210R30
cabl pulse/direction, USIC, 15-pin SubD, other end off, 5m	VW3M8210R50
cascader cable for RVA, 0.5m	VW3M8211R05

12.7 Mains filters

Description	Order number
mains filter 1~; 9A; 115/230VAC	VW3A31401
mains filter 3~; 7A; 230VAC	VW3A31402
mains filter 1~; 16A; 115/230VAC	VW3A31403
mains filter 3~; 15A; 230/480VAC	VW3A31404
mains filter 1~; 22A; 115/230VAC	VW3A31405
mains filter 3~; 25A; 230/480VAC	VW3A31406
mains filter 3~; 47A; 230/480VAC	VW3A31407

12.8 Mains reactor s

Description	Order number
Mains reactor 1~; 50-60Hz; 7A; 5mH; IP00	VZ1L007UM50
Mains reactor 1~; 50-60Hz; 18A; 2mH; IP00	VZ1L018UM20
Mains reactor 3~; 50-60Hz; 10A; 4mH; IP00	VW3A66502
Mains reactor 3~; 50-60Hz; 16A; 2mH; IP00	VW3A66503
Mains reactor 3~; 50-60Hz; 30A; 1mH; IP00	VW3A66504
Mains reactor 3~; 50-60Hz; 60A; 0.5mH; IP00	VW3A66505

12.9 CANopen

Description	Order number
CAN branching socket	VW3CANTAP2
CAN-cable, 0.3m, both ends RJ45-plug	VW3CANCARR03
CAN-cable, 1m, both ends RJ45-plug	VW3CANCARR1

12.10 MODBUS

Description	Order number
MODBUS branching socket, 3* screwed terminal rail, RC termination Connect with cable W3A8306D30.	TSXSACA50
MODBUS 2-way branching socket, 2*socket plug SubD 15-pole, 2* screwed terminal rail, RC termination Connect with cable W3A8306D30.	TSXSACA62
MODBUS connection module, 10*RJ45 plug and 1*screwed terminal rail	LU9GC3
MODBUS termination for RJ45 plug, 120 Ohm, 1nF	VW3A8306RC
MODBUS termination for RJ45 plug, 150 Ohm	VW3A8306R
MODBUS termination for screwed terminal rail, 120 Ohm, 1nF	VW3A8306DRC
MODBUS termination for screwed terminal rail, 150 Ohm	VW3A8306DR
MODBUS T-branching module with integral cable 0.3m	VW3A8306TF03
MODBUS T-branching module with integral cable 1m	VW3A8306TF10

Description	Order number
MODBUS-cable, 3m, 1*RJ45 plug, other end insulated	VW3A8306D30
MODBUS-cable, 3m, 1*RJ45 plug, 1*SubD15pole plug, for TSXSCA62	VW3A8306
MODBUS-cable, 0.3m, 2*RJ45 plug	VW3A8306R03
MODBUS-cable, 1m, 2*RJ45 plug	VW3A8306R10
MODBUS-cable, 3m, 2*RJ45 plug	VW3A8306R30
MODBUS-cable, 100m, 4-core, screened and twisted	TSXCSA100
MODBUS-cable, 200m, 4-core, screened and twisted	TSXCSA200
MODBUS-cable, 500m, 4-core, screened and twisted	TSXCSA500

12.11 Installation material

Description	Order number
adapter plate for top-hat rail mounting, width 77.5mm	VW3A11851
adapter plate for top-hat rail mounting, width 105mm	VW3A31852
EMC kit size 1	VW3M2101
EMC kit size 2 & 3	VW3M2102
EMC kit size 4	VW3M2103

13 Service, maintenance and disposal

⚠ DANGER

Electric shock, fire or explosion

- Only technicians who are familiar with and understand the contents of this manual and the other relevant manuals are authorised to work on and with this drive system.
- The system manufacturer is responsible for compliance with all applicable regulations relevant to earthing the drive system.
- Many components, including the printed circuit board, work with mains voltage. **Do not touch.** Do not touch unprotected parts or screws on the terminals under voltage.
- Install all covers and close the housing doors before applying power.
- The motor generates voltage when the shaft is rotated. Lock the motor shaft to prevent rotation before starting work on the drive system.
- Before working on the drive system:
 - Switch off power to all connections.
 - Place a sign "DO NOT SWITCH ON" on the switch and lock to prevent its being switched on.
 - **Wait for 6 minutes** (discharge DC bus capacitors). Do not short-circuit DC bus!
 - Measure voltage on DC bus and check that it is <45V. (The DC bus LED is not a reliable indicator for no DC bus voltage).

Failure to follow these instructions will result in death or serious injury.

⚠ CAUTION

Destruction of system components and loss of control monitoring

Excessive currents can be created at the signal connections if the negative connection to the controller supply voltage is interrupted.

- Do not interrupt the negative connection between power supply unit and load with a fuse or switch
- Check for correct connection before switching on.
- Never connect the controller supply voltage or change its wiring while there is supply voltage present.

Failure to follow these instructions can result in injury or equipment damage.



You cannot carry out repairs yourself. The repair should only be carried out by a certified customer service organisation. No warranty or liability is accepted for repairs made by the customer.

13.1 Service address

If you cannot resolve the fault yourself please contact your appointed sales partner. Have the following details available:

- Type plate (Type, identification number, serial number, DOM, ...)
- Type of fault (possibly with flash code or fault number)
- Previous and concurrent conditions
- Your own ideas regarding the cause of the fault

Include this information if you return the product for inspection or repair.



*If you have any questions please contact your local dealer.
Your dealer will be happy to give you the name of a
customer service outlet in your area.*

<http://www.telemecanique.com>

13.2 Maintenance

The product is maintenance free.

13.2.1 Operating life of safety function "Power Removal"

The operating life for the "Power Removal" safety function is designed for 20 years. After this period correct function is no longer ensured. The expiry date of the device is determined by adding 20 years to the DOM shown on the type plate.

- ▶ This date must be included in the system maintenance schedule.

Example The name plate on the device includes the DOM in the DD.MM.YY format, z.B. 31.12.06. (31 December 2006). This means that the safety function is guaranteed until 31 December 2026.

13.3 Replacing units

▲ WARNING

Unexpected behaviour

The behaviour of the drive system is governed by numerous stored data or settings. Unsuitable settings or data may trigger unexpected movements or reactions to signals and disable monitoring functions.

- Do not operate a drive system with unknown settings or data.
- Check the stored data or settings.
- When commissioning carefully run tests for all operating statuses and fault cases.
- Check the functions after replacing the product and also after making changes to the settings or data.
- Only start the system if there are no persons or materials in the danger zone and the system can be operated safely.

Failure to follow these instructions can result in death, serious injury or equipment damage.



Prepare a list with the parameters required for the functions in use.

Observe the following procedure when changing the devices.

- ▶ Store all parameter settings in your PC with the commissioning software, see 8.6.11.3 "Duplicate existing device settings" page 8-99.
- ▶ Switch off all supply voltages. Make sure that power is no longer connected (safety instructions).
- ▶ Label all connections and remove the product.
- ▶ Note the identification number and the serial number from the product nameplate for later identification.
- ▶ Install the new product as specified in chapter 6 "Installation"
- ▶ If the product that you are installing was previously used in a different part of the system, the factory settings must be reset before commissioning. See 8.6.11.2 "Restore factory settings" from page 8-99.
- ▶ Carry out commissioning in accordance with chapter 7 "Commissioning". Note that with the same motor setting the motor position will no longer match when the device is replaced. This also changes the position of the virtual index point. The motor position associated with the motor installation must be redefined, see parameter ENC_pabsusr.

13.4 Changing the motor

▲ WARNING

Unexpected movement

Drives can make unexpected movements if incorrectly connected or because of other faults.

- Operate the device with approved motors only. Even if motors are similar, different adjustment of the encoder system may be a source of danger.
- Check the wiring. Compatibility is not ensured even with matching connectors on power connection and encoder system.

Failure to follow these instructions can result in death, serious injury or equipment damage.

- ▶ Switch off all supply voltages. Make sure that power is no longer connected (safety instructions).
- ▶ Label all connections and remove the product.
- ▶ Note the identification number and the serial number from the product nameplate for later identification.
- ▶ Install the new product as specified in chapter 6 "Installation"

If the motor originally fitted is changed for a different one, the motor data set is reread. If the device recognises a different motor type, the control parameters are recalculated and f_{act} is shown on the HMI.

When the motor is replaced the parameters for the encoder must also be reset, see chapter 7.4.13 "Setting parameters for encoder".

Change motor type temporarily only

- ▶ Press ESC if you only want to operate the new motor type temporarily on this device.
- ◁ The newly calculated control parameters are not stored in the EEPROM. This means that the original motor can be put back into operation using the previously stored control parameters.

Change motor type permanently

- ▶ Press ENT if you wish to operate the new motor type permanently in this device.
- ◁ The newly calculated control parameters are stored in the EEPROM.

13.5 Shipping, storage, disposal

Note the ambient conditions on page 3-1!

- Shipping* The product must be protected against shocks during transport. Use the original packaging for this purpose.
- Storage* Store the product only under the specified, approved environmental conditions for room temperature and humidity. Protect the product against dust and dirt.
- Disposal* The product consists of various materials that can be recycled and must be disposed of separately. Dispose of the product in accordance with local regulations.

14 Glossary

14.1 Units and conversion tables

The value in the specified unit (left column) is calculated for the desired unit (top row) with the formula (in the field).

Example: conversion of 5 metres [m] to yards [yd]
 $5 \text{ m} / 0.9144 = 5.468 \text{ yd}$

14.1.1 Length

	in	ft	yd	m	cm	mm
in	-	/ 12	/ 36	* 0.0254	* 2.54	* 25.4
ft	* 12	-	/ 3	* 0.30479	* 30.479	* 304.79
yd	* 36	* 3	-	* 0.9144	* 91.44	* 914.4
m	/ 0.0254	/ 0.30479	/ 0.9144	-	* 100	* 1000
cm	/ 2.54	/ 30.479	/ 91.44	/ 100	-	* 10
mm	/ 25.4	/ 304.79	/ 914.4	/ 1000	/ 10	-

14.1.2 Mass

	lb	oz	slug	kg	g
lb	-	* 16	* 0.03108095	* 0.4535924	* 453.5924
oz	/ 16	-	* $1.942559 \cdot 10^{-3}$	* 0.02834952	* 28.34952
slug	/ 0.03108095	/ $1.942559 \cdot 10^{-3}$	-	* 14.5939	* 14593.9
kg	/ 0.453592370	/ 0.02834952	/ 14.5939	-	* 1000
g	/ 453.592370	/ 28.34952	/ 14593.9	/ 1000	-

14.1.3 Force

	lb	oz	p	dyne	N
lb	-	* 16	* 453.55358	* 444822.2	* 4.448222
oz	/ 16	-	* 28.349524	* 27801	* 0.27801
p	/ 453.55358	/ 28.349524	-	* 980.7	* $9.807 \cdot 10^{-3}$
dyne	/ 444822.2	/ 27801	/ 980.7	-	/ $100 \cdot 10^3$
N	/ 4.448222	/ 0.27801	/ $9.807 \cdot 10^{-3}$	* $100 \cdot 10^3$	-

14.1.4 Power

	HP	W
HP	-	* 745.72218
W	/ 745.72218	-

14.1.5 Rotation

	1/min (RPM)	rad/s	deg./s
1/min (RPM) -		* $\pi / 30$	* 6
rad/s	* $30 / \pi$	-	* 57.295
deg./s	/ 6	/ 57.295	-

14.1.6 Torque

	lb-in	lb-ft	oz-in	Nm	kp-m	kp-cm	dyne-cm
lb-in	-	/ 12	* 16	* 0.112985	* 0.011521	* 1.1521	* 1.129×10^6
lb-ft	* 12	-	* 192	* 1.355822	* 0.138255	* 13.8255	* 13.558×10^6
oz-in	/ 16	/ 192	-	* 7.0616×10^{-3}	* 720.07×10^{-6}	* 72.007×10^{-3}	* 70615.5
Nm	/ 0.112985	/ 1.355822	/ 7.0616×10^{-3}	-	* 0.101972	* 10.1972	* 10×10^6
kp-m	/ 0.011521	/ 0.138255	/ 720.07×10^{-6}	/ 0.101972	-	* 100	* 98.066×10^6
kp-cm	/ 1.1521	/ 13.8255	/ 72.007×10^{-3}	/ 10.1972	/ 100	-	* 0.9806×10^6
dyne-cm	/ 1.129×10^6	/ 13.558×10^6	/ 70615.5	/ 10×10^6	/ 98.066×10^6	/ 0.9806×10^6	-

14.1.7 Moment of inertia

	lb-in ²	lb-ft ²	kg-m ²	kg-cm ²	kp-cm-s ²	oz-in ²
lb-in ²	-	/ 144	/ 3417.16	/ 0.341716	/ 335.109	* 16
lb-ft ²	* 144	-	* 0.04214	* 421.4	* 0.429711	* 2304
kg-m ²	* 3417.16	/ 0.04214	-	* 10×10^3	* 10.1972	* 54674
kg-cm ²	* 0.341716	/ 421.4	/ 10×10^3	-	/ 980.665	* 5.46
kp-cm-s ²	* 335.109	/ 0.429711	/ 10.1972	* 980.665	-	* 5361.74
oz-in ²	/ 16	/ 2304	/ 54674	/ 5.46	/ 5361.74	-

14.1.8 Temperature

	°F	°C	K
°F	-	(°F - 32) * 5/9	(°F - 32) * 5/9 + 273.15
°C	°C * 9/5 + 32	-	°C + 273,15
K	(K - 273.15) * 9/5 + 32	K - 273.15	-

14.1.9 Conductor cross section

AWG	1	2	3	4	5	6	7	8	9	10	11	12	13
mm ²	42.4	33.6	26.7	21.2	16.8	13.3	10.5	8.4	6.6	5.3	4.2	3.3	2.6

AWG	14	15	16	17	18	19	20	21	22	23	24	25	26
mm ²	2.1	1.7	1.3	1.0	0.82	0.65	0.52	0.41	0.33	0.26	0.20	0.16	0.13

14.2 Terms and Abbreviations

<i>AC</i>	Alternating Current
<i>Actual position</i>	Current absolute or relative position of moving components in the drive system.
<i>CAN</i>	(C ontroller A rea N etwork), standardized open Fieldbus over which the drives and other devices from different manufacturers communicate with one another.
<i>DC</i>	Direct current
<i>Default value</i>	Factory setting:
<i>Direction of rotation</i>	Rotation of the motor shaft in a positive or negative direction of rotation. A positive direction of rotation is defined as the motor shaft rotating clockwise as the observer faces the end of the protruding shaft.
<i>Drive system</i>	The drive system consists of the controller, power amplifier and motor.
<i>Electronic gear</i>	An input speed is recalculated by the drive system using the values of an adjustable gear factor to derive a new output speed for the motor movement.
<i>EMC</i>	Electromagnetic compatibility.
<i>Encoder</i>	Sensor for recording the angular position of a rotating element. The encoder is mounted on the motor and signals the angular position of the rotor.
<i>EU</i>	European Union
<i>Error class</i>	Classification of operational faults into groups corresponding to the error responses
<i>Holding brake</i>	brake that only prevents the motor from rotating without power after it has stopped (e.g. a vertical-axis lowering). It must not be used as a service brake for braking motion.
<i>I²t-monitoring</i>	Predictive temperature monitoring. The expected temperature rise of unit components is calculated in advance on the basis of the motor current. If a limit value is exceeded, the drive system reduces the motor current.
<i>I/O</i>	Inputs/Outputs
<i>Inc</i>	Increment
<i>Index pulse</i>	Encoder signal for referencing the rotor position in the motor. The encoder sends one index pulse per revolution.
<i>Internal units</i>	Resolution of the power amplifier with which the motor is directed to the new setpoint. Internal units are given in increments.
<i>IT mains</i>	Mains in which all active components are isolated from earth or are earthed by a high impedance. IT: isolé terre (French), isolated earth. Opposite: earthed networks, see TT/TN network
<i>Limit switch</i>	Switch that signals an overrun of the permissible travel range.
<i>NMT</i>	network management (NMT), component of the CANopen communications profile, tasks: initialising network and devices, starting, stopping, monitoring devices
<i>Node Guarding</i>	Monitoring function with slave at an interface for cyclic communication.

<i>NTC</i>	resistance with negative temperature coefficient. Resistance value is reduced as the temperature rises.
<i>Parameter</i>	Device functions and values that can be set and called by the user.
<i>PC</i>	Personal Computer
<i>PELV</i>	Protective Extra Low Voltage, functional low voltage with safe isolation.
<i>persistent</i>	Designation of whether the value of the parameter is persistent, i.e. after switching off the device it is retained in the memory. When changing a value via commissioning software or fieldbus, the user must explicitly store the value change in the persistent memory. When entering via HMI the device stores the value of the parameter automatically at each change.
<i>PLC</i>	Programmable Logic Controller
<i>Power amplifier</i>	A device that generates current for controlling the motor in accordance with the positioning signals from the controller.
<i>Protection class</i>	The protection class is a standardised specification for electrical equipment that describes the protection against the ingress of foreign bodies and water (for example, IP20).
<i>PTC</i>	resistance with positive temperature coefficient. Resistance value is increased as the temperature rises.
<i>Pulse direction signals</i>	Digital signals with variable pulse frequencies which signal changes in position and rotation direction via separate signal wires.
<i>Quick Stop</i>	Quick stop, function used to provide quick braking of the motor via a command or in the event of a fault.
<i>RCD</i>	Residual current device
<i>Releasing the brake</i>	Drive may move when unbraked
<i>rms</i>	RMS value of a voltage (V_{rms}) or a current (A_{rms}); abbreviation of "Root Mean Square".
<i>RS485</i>	Fieldbus interface compliant with EIA-485, which enables serial data transmission with multiple devices.
<i>Scaling factor</i>	This factor gives the relationship between an internal unit and the user unit.
<i>TT mains, TN mains</i>	Earthed mains, distinguished by the PE conductor connection. Opposite: unearthed networks, see IT mains
<i>User-defined unit</i>	Unit whose reference to motor rotation can be determined by the user via parameters.
<i>Watchdog</i>	Equipment that monitors cyclic basic functions in the drive system. Power amplifier and outputs are switched off in the event of error.

14.3 Product name

<i>LXM05A</i>	AC servo amplifier
<i>PowerSuite</i>	PC software for commissioning
<i>HBC</i>	Holding brake controller
<i>Peripheral control terminal</i>	hand-held operating unit
<i>USIC</i>	(Universal Signal Interface Converter) adapter for RS422 standard
<i>RVA</i>	Reference value adapter for distribution of A/B or pulse/direction signals to 5 units

15 Index

Numerics

- 24V controller supply voltage 6-33
- 24VDC controller power supply 3-6
- 3-phase device 6-28

A

- Abbreviations 14-3
- absolute profile positioning 8-26
- Accessories and spare parts 12-1
- ACTIVE2_OUT 6-37
- Address setting
 - using parameters 6-42, 6-44
- Analogue inputs
 - connecting 6-45
- Analogue module
 - analogue input 7-22
- Approved motors 3-4

B

- Baud rate
 - in the fieldbus 6-42, 6-44
- Baud rate setting
 - using parameters 6-42, 6-44
- Braking function with HBC 8-81
- braking ramp, see deceleration ramp
- Braking resistor 3-8
 - connecting 6-21
 - external 3-10, 6-10
 - selection 6-20
- braking resistor
 - connecting 6-20
 - installing 6-9

C

- Cable 3-12
- Cable specification
 - analogue inputs 6-45
 - control terminal 6-49
 - digital signals 6-46
 - encoder signals A, B, I 6-35
 - MODBUS 6-44
 - PC 6-49
- Cable specifications
 - braking resistor 6-21
 - motor connection 6-17
 - motor encoder 6-28
 - pulse/direction PD 6-38

- CANopen
 - connecting 6-43
 - function 6-42
 - LEDs on HMI 7-7
 - terminating resistors 6-42
- CAP1 8-77
- CAP2 8-77
- cascading, max. terminal current to 6-34
- Cause of interruption, last 10-7, 10-8
- CE mark 1-5
- change
 - operating mode 8-13
- Changing the motor 13-4
- Changing the operating status 8-8
- Check position switches 7-31
- Checking direction of rotation 7-30
- Checking holding brake 7-29
- Checking limit switches 7-27
- Commissioning 7-1
 - check position switches 7-31
 - checking direction of rotation 7-30
 - checking holding brake 7-29
 - checking limit switches 7-27
 - checking safety functions 7-28
 - controller structure 7-41
 - digital inputs and outputs 7-25
 - extended settings for autotuning 7-39
 - optimising controller 7-41
 - optimising speed controller 7-43
 - presets and optimisation 7-47
 - run autotuning 7-37
 - setting basic parameters 7-20
 - setting parameters for braking resistor 7-35
 - setting parameters for encoder 7-33
 - setting parameters for encoder simulation 7-32
 - steps 7-13
 - testing analogue inputs 7-22
 - tool 7-5
- Commissioning software
 - error display 10-7
 - features 7-12
 - online help 7-12
 - system requirements 7-12
 - triggering jump function 7-43
- commissioning software
 - Setting reference signal 7-42
- Commissioning software (PowerSuite) 7-12
- Commissioning tools 7-5
- Components and interfaces 1-2
- Connect controller supply voltage 6-34

- Connection
 - 24V controller supply voltage 6-33
 - analogue inputs/outputs 6-45
 - braking resistor 6-20
 - CAN 6-42
 - digital inputs/outputs 6-46
 - Encoder signals A, B, I 6-35
 - encoder simulation 6-40
 - holding brake controller 6-31
 - MOD bus 6-44
 - motor encoder 6-28
 - motor phases 6-17
 - PC and external keypad over RS485 6-49
 - power amplifier supply voltage 6-26
 - pulse/direction PD 6-36
- Control terminal
 - connecting 6-49
 - function 6-49
- Controller
 - entering values 7-43
 - optimising 7-41
- controller
 - structure 7-41
- controller supply voltage
 - dimensioning 6-34
- Current
 - Position 8-29
 - Speed 8-31
- Current control 8-18
 - example of parameter setting 9-3
- Current controller
 - function 7-41
- D**
- Danger classes 2-2
- Declaration of conformity 1-6
- Determining controller values
 - controller values with rigid mechanics 7-44
 - determining controller values with less rigid mechanics 7-45
- device
 - installation 6-8
 - Mounting 6-7
- Diagnostics 10-1
- Diagram
 - A/B signals 6-35
- Digital inputs and outputs
 - display and modify 7-25
- Digital inputs/outputs
 - connecting 6-47
- Dimensioning aid
 - braking resistor 6-22
- Direction enabling 8-25

- Direction reversal 8-96
- Directives and standards 1-5
- Disposal 13-1, 13-5
- Documentation and literature references 1-4

E

- Electrical installation 6-11
- Electronic gear 8-22
 - example of parameter setting 9-4
- EMC 6-1
 - cabling 6-2
 - motor cables and encoder cables 6-3
 - power supply 6-3
 - scope of supply and accessories 6-2
- ENABLE 6-37
- Encoder signals A, B, I
 - connect 6-35
- Environment
 - Installation height 3-2
- Environmental conditions 3-1
- EPLAN Macros 1-4
- Equipotential bonding conductors 6-3
- Error
 - current 10-6
 - error class 10-2
 - Error display 10-3
 - error display
 - commissioning software 10-7
 - fieldbus 10-8
 - HMI 10-6
 - Error display on HMI 10-6
 - Error response 8-6, 10-2
 - Meaning 10-2
- ESIM
 - function 6-40
 - resolution 6-40
- Examples 9-1
- Extended settings for autotuning 7-39
- External braking resistors 3-10
- External mains filter 3-10, 6-9

F

- Fabricating cables
 - mains supply 6-27
 - motor phases 6-18
- Fabrication of cable
 - motor rotary encoder 6-29
- Fast position capture 8-77
- Fault Reset 8-6
- fieldbus
 - CAN 6-42
 - Error display 10-8
- First setup
 - preparation 7-13
 - via HMI 7-14

Function
encoder signals A, BI 6-35
Functions 8-57
braking function with HBC 8-81
direction reversal 8-96
fast position capture 8-77
Halt 8-76
monitoring functions 8-57
Quick Stop 8-75
restoring default values 8-98
scaling 8-69
standstill window 8-79
travel profile 8-72

G

Gear ratio 8-24
Glossary 14-1

H

Halt 8-76
HMI
control panel 7-6
Error display 10-6
first setup 7-14
function 7-6
menu structure 7-8, 7-9
Holding brake
control 3-11
Holding brake controller 3-11
connecting 6-32
rating 6-31
holding brake controller
connection 6-31
Homing 8-44
Homing by dimensions setting
Dimensions setting 8-55

I

I2t 8-61
Installation
electrical 6-11
mechanical 6-6
Installation spacing 6-7
Intended use 2-1
Interface signal
FAULT_RESET 8-75
Internal mains filter 3-9
Introduction 1-1
IT mains, operation in 6-5

J

Jog 8-15
Jolt limiting 8-73

L

- last cause of interruption 10-7, 10-8
- LEDs for Modbus 7-7
- LEDs on HMI
 - for CANopen 7-7
- Limit switch
 - limit switch 8-59
 - Reference movement without index pulse 8-49
 - release movement of drive 8-60
- Limit values
 - setting 7-20
- Limits
 - analogue inputs 6-45
- limits 6-16, 6-45
- Line reactor 3-10

M

- Macro Motion 8-32
- Macros EPLAN 1-4
- Mains filter 6-9
 - external 3-10
 - installing 6-9
 - internal 3-9
- Mains power
 - connecting 6-27
- Mains reactor 6-9
- mains reactor
 - installing 6-9
- Maintenance 13-1
- Malfunctions 10-10
- manuals 1-4
- Mechanical installation 6-6
- Mechanics, Layout for control system 7-44
- Minimum connection assignment 6-46
- MODBUS
 - connecting 6-44
 - function 6-44
- Monitoring
 - braking resistor 6-20
 - motor phases 6-19
 - parameters 8-63
- Monitoring functions 2-4, 8-57
- Motor cables
 - connecting 6-19
- Motor data set
 - automatic read-in 7-13
- motor encoder
 - connecting 6-28
- Motor rotary encoder
 - function 6-28
- motor rotary encoder
 - sensor type 6-28
- Mounting, mechanical 6-7

O

- Open Collector circuit 6-38
- Operating mode
 - change 8-13
 - current control 8-18
 - electronic gear 8-22
 - homing 8-44
 - jog 8-15
 - Macro Motion 8-32
 - profile position 8-26
 - profile velocity 8-30
 - speed control 8-20
 - start 8-12
- Operating modes 8-15
- Operating status 7-19
- Operating statuses 8-4
- Operation 8-1
- Operation mode finished
 - profile velocity 8-30
- Optimising presets 7-47
- Overview 7-4, 7-5
 - all connections 6-14
 - procedure for electrical installation 6-13

P

- Parameter
 - calling via HMI 7-8
 - representation 11-1
- Parameters 11-1
- PC
 - connecting 6-49
- Position
 - current 8-29
 - Target 8-28
- Position controller
 - function 7-42
 - optimising 7-48
- Positioning finished 8-27
- Positioning limits 8-57
- Power connections
 - overview 6-14
- Power Removal 5-2
 - application examples 5-5
 - category 0 stop 5-2
 - category 1 stop 5-2
 - Definition 5-2
 - requirements 5-3
- PowerSuite 7-12
- Prerequisite
 - for point - to - point start 8-26, 8-30
- Pre-requisites for setting the operating mode 8-12
- product manuals 1-4
- Product name 14-5

- Profile generator 8-72
- Profile position 8-26
- Profile velocity 8-30
- Pulse/direction PD
 - connecting 6-38
 - function 6-37

Q

- Qualifications, personnel 2-1
- Quick Stop 8-75

R

- Ramp
 - shape 8-72
 - steepness 8-72
- Rating
 - controller supply voltage 6-34
- REF, see reference switch
- Reference movement with index pulse 8-51
- Reference movement without index pulse 8-49
- Reference signal
 - Setting 7-42
- Reference switch
 - Reference movement with index pulse 8-53
 - reference movement without index pulse 8-49
- Reference value signals 6-16, 6-45
- Reference values
 - analogue inputs 6-45
- Reference variable filter 7-44
- Relative profile positioning 8-26
- Remove protective foil 6-8
- Reset error message 8-6
- Restoring default values 8-98
- Rotary encoder (motor)
 - connecting 6-30
- Run autotuning 7-37

S

- Safety function 2-4, 3-7, 4-1, 5-2
 - application examples 5-5
 - category 0 stop 5-2
 - category 1 stop 5-2
 - Definition 5-2
 - requirements 5-3
- Scaling 8-69
- Second environment 6-2
- Service 13-1
- Service address 13-2
- Set dimensions 8-55
- Set speed 8-31
- Setting parameters for braking resistor 7-35
- Setting parameters for encoder 7-33
- Setting parameters for encoder simulation 7-32
- setting the deceleration ramp 8-72

- Shipping 13-5
- Signal connections
 - overview 6-15
- Signal inputs
 - Circuit diagram 6-38
- Software limit switches 8-58
- Source
 - EPLAN Macros 1-4
 - product manuals 1-4
- Speed control 8-20
- speed control
 - example of parameter setting 9-4
- Speed controller
 - function 7-42
 - setting 7-43
- Standstill window 8-79
- start
 - operating mode 8-12
- Start-up operating mode 7-16
- State display
 - NRDY 10-6
 - WDOG 10-7
- State display ULOW 10-6
- State machine 7-19
- state machine 10-6
- Status diagram 8-4
- Status display
 - DIS 10-6
 - WDOG 10-6
- status display
 - FLT 10-6
- Status monitoring in movement mode 8-57
- Status transitions 8-6, 10-4
- Storage 13-5
- Switching cabinet 6-7
- Switching cabinet setup 6-2

T

- Target position 8-28
- Technical data 3-1
- Temperature 8-60
- Terminating resistors
 - CANopen 6-42
- Terms 14-3
- Testing agencies and certificates 3-1
- Testing analogue inputs 7-22
- Testing safety functions 7-28
- Timing diagram
 - Pulse direction signal 6-37
- Tracking error
 - monitoring function 8-62
- Travel profile 8-72

Trigger positioning 8-26
Triggering jump function 7-43
Troubleshooting 10-1, 10-10
 from errors sorted by bit class 10-11
troubleshooting
 malfunctions 10-10
TÜV certificate for functional safety 1-7
Type code 1-3

U

Unit overview 1-1
Units and conversion tables 14-1

V

Velocity operation
 trigger 8-30
ventilation 6-7
Voltage reduction 8-82

W

Wiring controller supply voltage 6-33
Wiring diagram
 24V power supply 6-34
 analogue inputs 6-45
 braking resistor 6-21
 CANopen 6-43
 control terminal 6-50
 digital signals 6-48
 encoder signals A, B, I 6-36
 ESIM 6-41
 holding brake controller 6-32
 mains power 6-28
 mains power, single phase device 6-27
 MODBUS 6-44
 motor rotary encoder 6-30
 PC 6-50
 PULSE/DIR, wiring diagram
 pulse/direction PD, pulse/direction PD
 wiring diagram 6-39