

Lexium 15 MP/HP

Servo Drives

Programming manual



Table of Contents



	Safety Information	7
	About the Book	9
Chapter 1	Introduction to the Servo Drive	11
	At a Glance	11
	Product Overview	12
	Application Architectures	15
Chapter 2	Unilink Graphic User Interface	19
	Unilink Graphic User Interface	19
2.1	Using Unilink Commissioning Software	20
	Using Unilink Commissioning Software	20
	Using ASCII Commands in the Terminal Screen Page	21
	Device Parameters Management	23
	Motor Data Base File	24
2.2	Screen page "Communication"	25
	Screen page "Communication"	25
2.3	Screen page "Amplifier"	27
	Overview of the functions of the "Amplifier"	27
2.4	Unilink Connection and Screen Layout	32
	Screen layout	32
Chapter 3	Device Operation Handling	35
	Device Operation Handling	35
	Axis Commissioning Checklist Procedures	36
	Device State Handling	50
	Modes of Operation	53
Chapter 4	Device Functions	57
	Device Functions	57
4.1	Screen page "Basic Setup"	59
	Overview of "Basic Setup"	59
4.2	Screen page "Motor"	69
	Screen page "Motor"	69
	Overview of the "Synchronous motor" screen	70
	Overview of the "Asynchronous motor" screen	74

4.3	Screen page "Feedback"	78
	Overview of the "Feedback" screen	78
4.4	Screen page "Encoder"	84
	Overview of the "Encoder" screen	84
4.5	Screen page "Analog I/O"	89
	General overview of the "Analog I/O" screen	89
	Analog Inputs/Outputs "Analog I/Os"	90
	Analog inputs AI1 / AI2	91
	Analog Outputs AO1 / AO2	98
4.6	Screen page "Digital I/O"	100
	Overview of "Digital I/O"	100
	Overview	101
	Digital inputs LI1/LI2/LI3/LI4	102
	Digital Outputs LO1 / LO2	119
4.7	Screen page "Position"	130
	Screen page "Position"	130
	Overview of the "Position" screen (PI)	131
	Overview of the "Position" screen (P)	135
4.8	Screen page "Speed"	137
	Introduction to the "Speed" screen	137
4.9	Screen page "Current"	143
	Overview of the "Current" screen	143
4.10	Screen page "Homing"	146
	General overview of the "Homing" screen	146
	Overview of the "Homing" screen	147
	Homing 1	153
	Homing 2	158
	Homing 3	159
	Homing 4	162
	Homing 5	163
	Homing 7	164
	Homing 9	165
	Jog mode	166
4.11	Screen page "Gearing"	167
	Overview of the "Gearing" screen	167
4.12	Screen page "Position data"	171
	Overview of the "Position data" screen	171
4.13	Registration	182
	Registration (LATCH)	182
4.14	Screen page "Position Registers"	184
	Overview of the "Position Registers" Screen	184
4.15	Screen page "Drive status"	187
	Introduction to the "Drive Status" screen	187
4.16	Screen page "Actual values"	189
	Overview of the "Actual values" screen	189

4.17	Screen page "Oscilloscope"	193
	Overview of the "Oscilloscope" screen	193
4.18	Screen page "Service parameters"	196
	Overview of the "Entry of service parameters" screen	196
4.19	"BODEPLOT" screen page.	197
	Overview of the "Bode plot" screen.	197
4.20	Screen page "Terminal"	199
	Overview of the "Terminal" screen	199
4.21	Screen page "I/O expansion"	201
	Overview of the screen page "I/O expansion".	201
Chapter 5 Field Buses		205
	Field Buses	205
5.1	Screen page "Modbus Plus"	206
	Screen page "Modbus Plus"	206
	Screen page "Modbus Plus"	207
	Configuration of Address and TimeOut via Unilink	210
	Peer Cop Data.	211
	Global data configuration via Unilink.	212
5.2	Screen page "FIPIO"	213
	Screen page "FIPIO"	213
5.3	Screen page "PROFIBUS"	215
	Screen page "PROFIBUS"	215
	Screen page "PROFIBUS"	216
	Screen page "PROFIBUS instrument control"	218
5.4	Screen pages "SERCOS"	220
	Screen pages "SERCOS"	220
	Overview of the screen page "SERCOS"	221
	"SERCOS Service" screen page.	223
5.5	Screen page "Motion task parameters"	226
	General overview of the "Motion task parameters" screen	226
	Overview of the "Motion Task Table" Screen	227
	Motion type	231
	Advanced Functions	236
Chapter 6 Troubleshooting		237
	Troubleshooting.	237
6.1	Error and warning messages	238
	General overview of the "Error and warning messages".	238
	Error Messages	239
	Warning messages	241
6.2	Troubleshooting.	242
	Troubleshooting.	242
Index		243

Safety Information

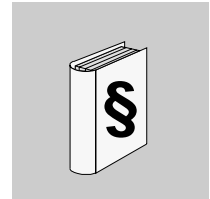

Important Information

NOTICE

Read these instructions carefully, and look at the equipment to become familiar with the device before trying to install, operate, or maintain it. The following special messages may appear throughout this documentation or on the equipment to warn of potential hazards or to call attention to information that clarifies or simplifies a procedure.



The addition of this symbol to a Danger or Warning safety label indicates that an electrical hazard exists, which will result in personal injury if the instructions are not followed.



This is the safety alert symbol. It is used to alert you to potential personal injury hazards. Obey all safety messages that follow this symbol to avoid possible injury or death.

DANGER

DANGER indicates an imminently hazardous situation, which, if not avoided, **will result** in death or serious injury.

WARNING

WARNING indicates a potentially hazardous situation, which, if not avoided, **can result** in death, serious injury, or equipment damage.

CAUTION

CAUTION indicates a potentially hazardous situation, which, if not avoided, **can result** in injury or equipment damage.

PLEASE NOTE

Electrical equipment should be installed, operated, serviced, and maintained only by qualified personnel. No responsibility is assumed by Schneider Electric for any consequences arising out of the use of this material.

© 2006 Schneider Electric. All Rights Reserved.

About the Book

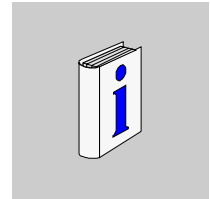

At a Glance

Document Scope This booklet explains the installation and operation of the Unilink Commissioning Software for digital servo amplifiers.

- product overview
- motion control overview
- dialog screen layout
- axis commissioning checklist procedures
- error and warning messages
- troubleshooting

User Comments We welcome your comments about this document. You can reach us by e-mail at techpub@schneider-electric.com

Introduction to the Servo Drive

1

At a Glance

Information

This chapter introduces the servo drive and gives an overview of the architecture for each application type.

What's in this Chapter?

This chapter contains the following topics:

Topic	Page
Product Overview	12
Application Architectures	15

Product Overview

What is Unillink? Unilink Commissioning Software is an axis- commissioning tool for both single-axis and multi-axis motion control applications. With its graphical user interface and Windows dialogs, Unilink provides an easy point-and-click method for configuring parameters in a single-axis standalone system or in a multi-axis, fiber-optic SERCOS network.

What is a Servo Drive? Lexium 15 servo drives are devices designed to control an AC synchronous motor for Motion Control applications. The device includes a power supply. For further information, please see the Lexium 15 Installation Manuals.

Control Functions

Lexium 15 control functions are:

- Servo loops: position, velocity, and current (torque).
- Motor interface including feedback.
- Encoder interface for master set point for gearing, or encoder emulation for Motion Controller.
- Modes of operation: some modes are set by the Unilink software, some are set by field buses.
- Digital I/O handlers: registration, start motion, and others.
- Analog I/O handlers: set points and thresholds.
- Position registration function (LATCH).
- Position register: axis' software limit, and digital output setting.

The following diagram shows the servo drive control functions:

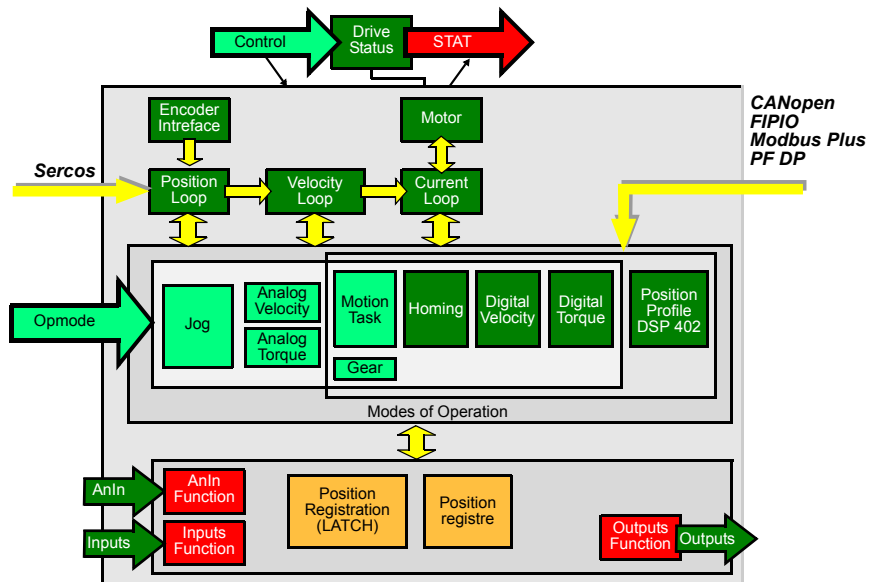

⚠ WARNING

INJURY OR EQUIPMENT DAMAGE

Before installation and setup, read the Installation Manual for the servo amplifier. Incorrect handling of the servo amplifier can lead to personal injury or damaged devices.

Failure to follow this instruction can result in death, serious injury, or equipment damage.

WARNING

UNFORSEEN MACHINE MOVEMENT

The machine manufacturer must perform a hazard analysis for the machine and must ensure that unforeseen movement of the machine is never a hazard to personnel or devices. Only if these measures are taken can the customization of online parameters by qualified staff be permitted.

Failure to follow this instruction can result in death, serious injury, or equipment damage.

CAUTION

QUALIFIED PERSONNEL

Only properly qualified personnel are permitted to perform activities such as transport, installation, setup and maintenance. Properly qualified persons are those who are familiar with the transport, assembly, installation, setup and operation of the product, and who have the appropriate qualifications for their job. The qualified personnel must know and observe:

IEC 364 and CENELEC HD 384 or DIN VDE 0100

IEC-Report 664 or DIN VDE 0110

National Accident Prevention Regulations or BGV A3

Failure to follow this instruction can result in injury or equipment damage.

CAUTION

ALTERATION OF DATA SETS

Data sets stored on data media are not safe from undesirable alteration by third parties. After you have loaded a set of data, you should check all the parameters before enabling the servo amplifier.

Failure to follow this instruction can result in injury or equipment damage.

Application Architectures

Single-Axis Motion Control

In a single axis system, UniLink runs on a computer (PC) connected to one drive. The communication is established via the RS232 interface.

The following diagrams show the architecture for single axis applications:

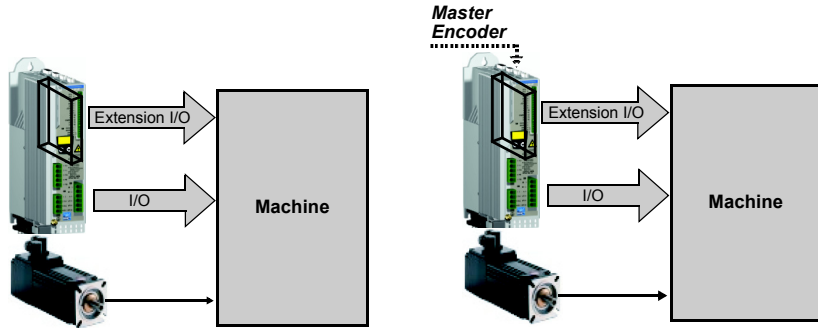

Single Axis Applications
For fast move sequences
with Motion Task

Master/Slave Gearing

Multi-Axis Motion Control

In a multi-axis system, UniLink runs on a computer (PC) connected to one drive. The communication with the first drive is established via the RS232 interface. The other drives are connected to the first via a special cable (Y-shaped adapter) on the built-in CAN bus. This way, you can communicate with several drives without modifying the connections.

The following diagram shows the field bus connections for multi-axis applications:

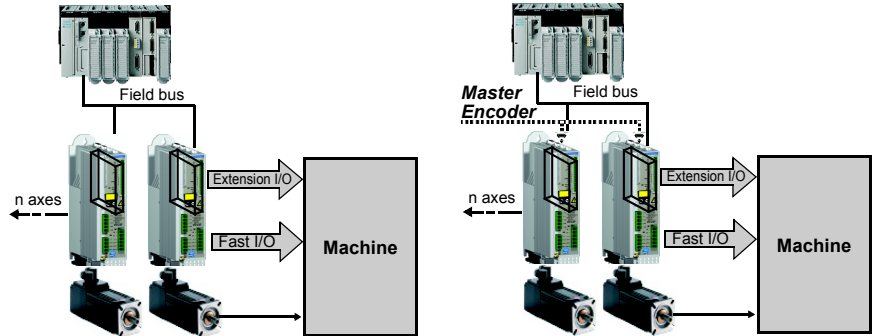

Coordinate Multi-Axes Applications
For fast move sequences
with Motion Task

Multi axes Master/Slave gearing
With hard wire master encoder

More efficient with CANopen and PLCopen Motion Function bloc libraries in Unity

The following diagram shows the CANsync architecture for a stand-alone motion controller:

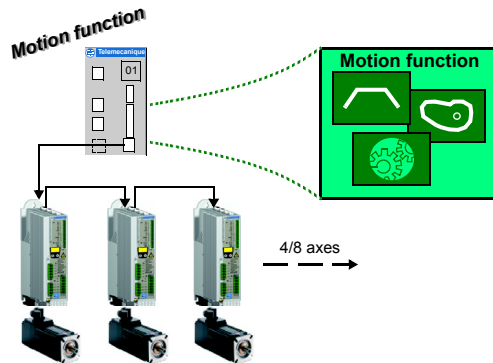

Multi-axes synchronised applications with CANsync Schneider standalone Motion Controller:

- * Cam profile
- * Multi-gearing
- * Machine function blocks

The following diagram shows the SERCOS architecture for a PLC motion controller motion bus:

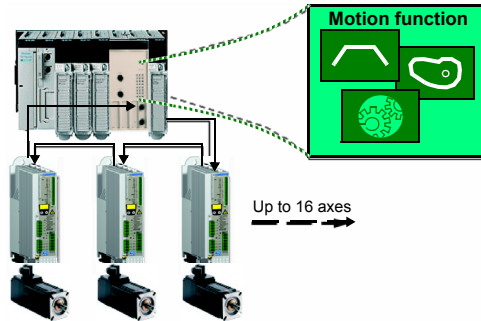

Multi-axes synchronised applications with Sercos Motion bus in TSX CSY 84/164/85 for Premium PLC:

- * Cam profile
 - * Multi-gearing
- CSY 85
- * Linear interpolation
 - * Circular interpolation
 - * Trajectory editor

Tuning Your Axis with UniLink

During the configuration process, UniLink allows you to tune the servo motor for each axis quickly and efficiently. From UniLink, while online with an axis and its motor, you adjust servo parameter values (such as gains and limits) and execute them immediately. While watching and listening to the motor spin, you may use the UniLink oscilloscope to adjust and readjust these values until the motor reaches its best performance - optimum speed without oscillation and noise or anything else that would make the motor unstable. The changes made to the servo parameter values may be saved to the drive and the file.

UniLink dialogs step you through the complete startup phase of your programming projects. All the parameters of the drive can be saved in a separate file for each axis. Each drive file is a unique custom configuration for that drive and can be accessed offline (not connected to the drive) or online (connected to the drive).

Please see also the axis commissioning checklist procedures.

Unilink Graphic User Interface



Unilink Graphic User Interface

At a Glance

This chapter describes the functions, use, and elements of the graphic user interface of the Unilink commissioning software.

What's in this Chapter?

This chapter contains the following sections:

Section	Topic	Page
2.1	Using Unilink Commissioning Software	20
2.2	Screen page "Communication"	25
2.3	Screen page "Amplifier"	27
2.4	Unilink Connection and Screen Layout	32

2.1 Using Unilink Commissioning Software

Using Unilink Commissioning Software

At a Glance

This section contains some important information about using Unilink Commissioning Software.

What's in this Section?

This section contains the following topics:

Topic	Page
Using ASCII Commands in the Terminal Screen Page	21
Device Parameters Management	23
Motor Data Base File	24

Using ASCII Commands in the Terminal Screen Page

At a Glance

Unilink Commissioning Software is a set of Windows screen pages for configuring parameters for the servo drive. All parameters shown may be set either directly on Unilink screen pages, or via fieldbus or by using the ASCII command on the Terminal screen page.

For each Unilink parameter field, this manual will describe its function and the relevant ASCII command. An example is shown below for the Speed Limit parameter:

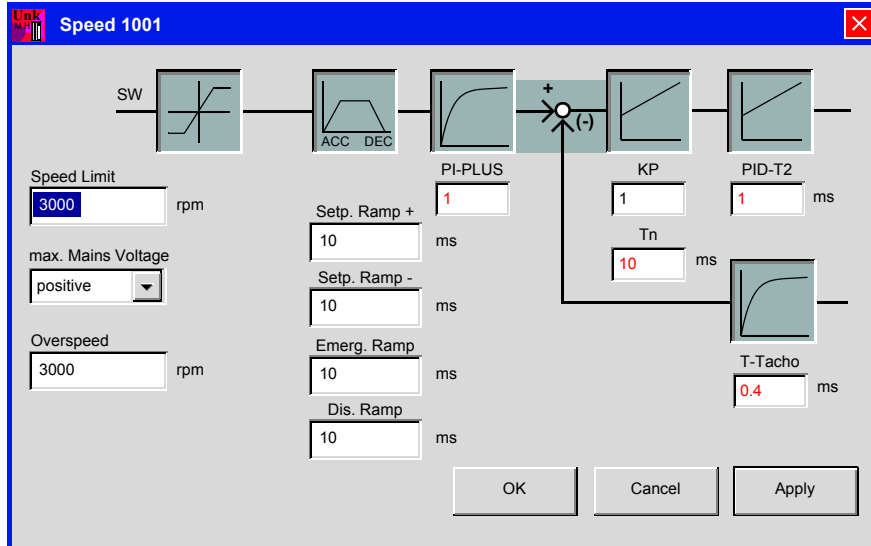

Speed Limit

ASPCII: VLIM	Default: 3000 Unit: rpm Range: 0.0...MSPEED	valid for all OPMODES
---------------------	---	-----------------------

Limits the motor speed. The maximum value also depends on the motor and encoder used.

**Using Terminal-
Only Commands**

Not all parameters are accessible via the relevant Unilink screen pages. Some ASCII commands are ONLY accessible via the Unilink Terminal screen page. For example, the BQDC command to define the center damping of the Bi-quad filters is not accessible via the Speed screen page.

However, you can enter the command via the Terminal screen page..

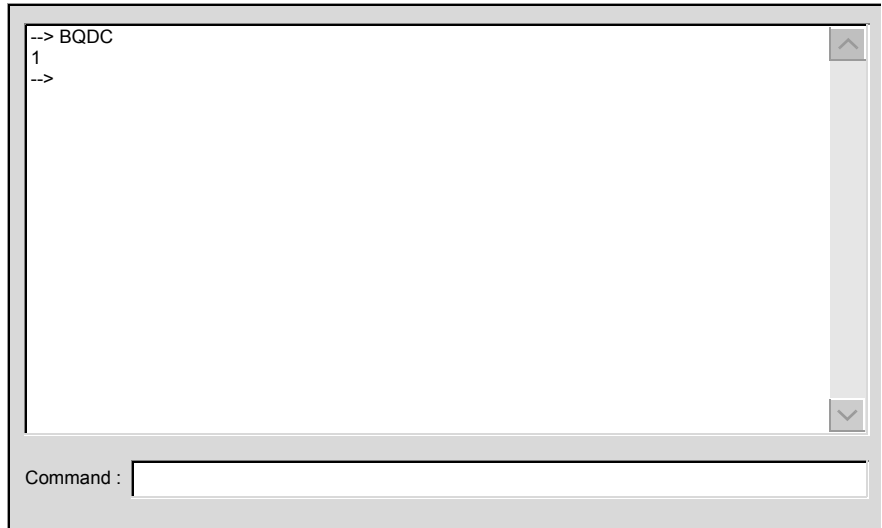

The ASCII command list is described in detail in the ASCII Command List Manual.

Device Parameters Management

At a Glance

Unilink commissioning software works in two modes:

- **OFFLINE:** the parameters are stored in a disk file. However, the parameters' value settings are not verified for consistency limits. This option is recommended for Motion Task programming.
- **ONLINE:** the parameters are stored in the servo drive RAM and their value settings are verified for consistency limits. During a **DOWNLOAD** operation, a complete consistency check is performed and values above those allowed are cut off.

The servo drive is equipped with an EEPROM to enable parameters to be saved between power on / power off operations. To move information between both memories, the ASCII commands **SAVE** and **LOAD** may be used.

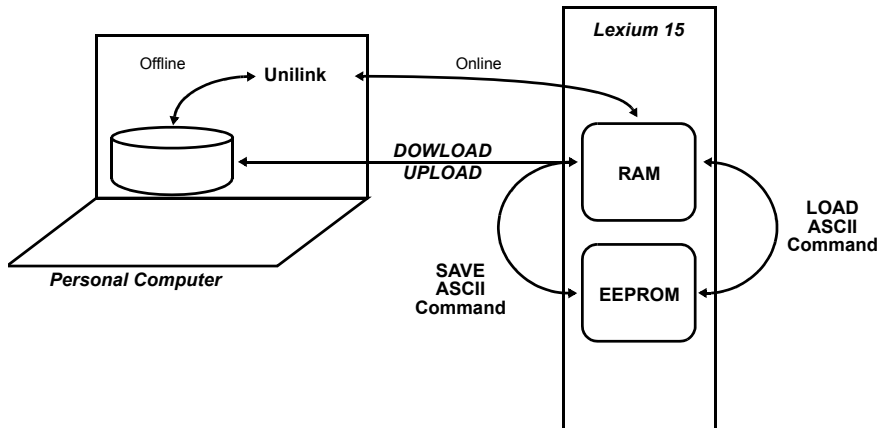

Motor Data Base File

At a Glance

Schneider Motor Range parameters are stored in Lexium 15 without an erasable memory.

This means that motor settings for the Schneider motor should only be set ONLINE.

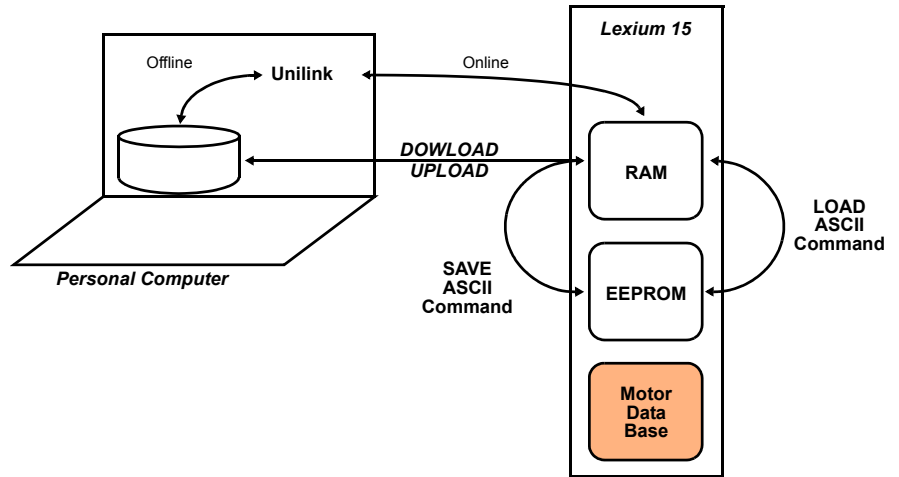

2.2 Screen page "Communication"

Screen page "Communication"

At a Glance

This dialog is the first dialog that appears when you start UniLink. It allows you to:

- communicate directly with the servo drive online, via the COM ports and Drive Connect buttons,
 - use the UniLink software offline, without connection to the drive, via the Offline button,
 - scan the serial ports and the CAN bus to see what devices are networked and available.
-

Communication Ports

Diagram:

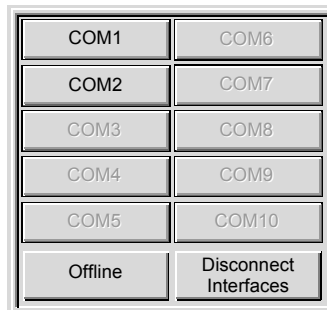

Click on one of these communication ports (the port that you are using on your PC) to transfer the parameter values from the drive to your PC. Then click on the drive connect button (described below) to connect online and communicate directly with the servo drive. If the port that you are using is available (not used by other equipment or programs) the name COMx appears black. Otherwise, the name appears gray.

Offline

Even when no drive is connected, you can still use UniLink. You can load axis commissioning data from the PC, work on it, and save it again. If you do not load data, the manufacturer's default settings (basic setup) will be applied. Software functions and UniLink dialogs that are only available in online mode will not be selectable.

When clicking on " Offline " button, Unilink offers the choice between load data you saved or creating a new setting

Diagram

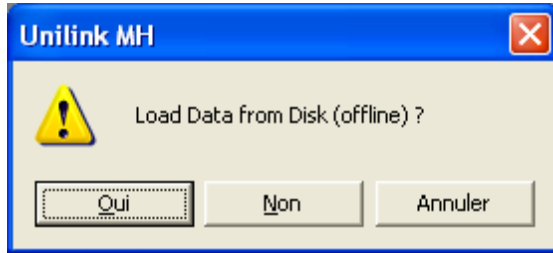

In case of creating a new amplifier setting, Unilink will name it Amplifier 1001.

You can open more than one data set for editing, by clicking on Offline again. The individual data sets are identified in the title bar by the designations AMPLIFIER 1001, AMPLIFIER 1002 and so on.

If you have loaded an existing data set from the PC, then the folder name, data set name, and servo drive name will also be displayed.

Disconnect interfaces

Deactivates the access to the setup software via the interfaces COM1 to COM10. This function is important, as in order for an external program to access the servo amplifier, the setup software must be active.

2.3 Screen page "Amplifier"

Overview of the functions of the "Amplifier"







At a Glance

The screenshot displays the 'Amplifier 1001' GUI. At the top, there is a blue title bar with the Unilink logo and a close button. Below the title bar is a toolbar with icons for navigation and control: a folder icon, a monitor icon, a gauge icon labeled 'MONITOR', a green square icon, a red waveform icon, a 'SAVE' button with a floppy disk icon, a 'STOP' button, a 'CLEAR' button with an 'E²' icon, and a hand icon. A 'Basic Setup' button is located on the right side of the toolbar.

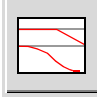

The main area contains a control diagram. On the left, there are boxes for 'Slot', 'Analog I/O', 'Digital I/O', and 'ROD/SSI/Encoder Input'. These are connected to a central 'Torque' block. The 'Torque' block is further divided into 'Position' (with sub-labels 2,3 and 4,5,8) and 'Seep' (with sub-label 0,1). The 'Position' block is connected to a 'Current' box. Below the 'Torque' block, there is a 'Feedback Resolver' box. To the right of the diagram is a photograph of a motor, with a 'Motor' label and a 'Set Motor' button below it.

At the top right of the main area, there is an 'OPMODE' dropdown menu currently set to '1: Analog Speed'. At the bottom left, there is a 'Servo Drive Configuration' section showing 'Status = OK', an 'Axis' dropdown menu set to 'NO ENABLE', and a 'SW' dropdown menu with options 'Disable (F12)' and 'Enable (Shift+F12)'. An 'Exit' button is located at the bottom right.

This screen page displays the control loops of the servo drive in a simplified block diagram. A click with the left mouse button on a button on the screen page calls up the corresponding function or screen page.

Button	Description
	Save the current parameter to data media (hard disk, diskette). You can save parameters and motion task data to one single file or to separate files.
	Load a control parameter file or a motion-block parameter file from data media (hard disk, diskette). For this, the amplifier must be disabled.
	Open the screen page "TERMINAL" for the direct input of ASCII commands (only for advanced users, and with the support of our application department).
	Open the screen page "ACTUAL VALUES" to display the actual drive status.
	Open the screen page "OSCILLOSCOPE/SERVICE" for the graphic display of the setpoint/actual values, and to access the service functions (reversing mode, const. speed etc.) for optimizing the amplifier.
	Open the screen page "BODEPLOT". When using a Bode plot generator, this page generates a graphic representation of the amplifier's behavior controls.
	Non-volatile storage of the currently valid parameter set in the EEPROM of the servo amplifier. In this way you can permanently save all the parameter changes that you have made since the last switch-on/reset of the servo amplifier.

ASCII: SAVE	Default: - Unit: - Range: -	Valid for all OPMODES
--------------------	-----------------------------------	-----------------------

Button	Description
	Stop the currently active service function. This is the same as using the function key F9. Stop (cancel) motion functions in the OPMODES 0, 2 and 8. Movements in OPMODES 0 to 3 can only be stopped by using the " DISABLE. (F12) " button.
	Cancel all the parameters that have been set up, and load the manufacturer's default values.
	Performs a hardware reset.
ASCII: COLDSTART	Default: - Unit: - Range: -
	Valid for all OPMODES

Basic setup	Opens the screen page "BASIC SETUP".
Slot / Exp.x	Opens the screen page for the built-in expansion card (description: manual for the expansion card)
Analog I/O	Opens the screen page "ANALOG I/O"
Digital I/O	Opens the screen page "DIGITAL I/O"
Encoder Emulation, Encoder Input	Open the screen page "ENCODER"

OPMODE

ASCII: OPMODE	Default: 1 Unit: - Range: 0, 1, ... , 8	Valid for all OPMODES
----------------------	---	-----------------------

Set the basic function of the servo amplifier for your application here.

ID	Function	Comments
0	Digital (rotational) speed	Speed control with digital setpoint
1	Analog (rotational) speed	Speed control with analog setpoint
2	Digital torque	Torque control with digital setpoint (speed controller has to be optimized)
3	Analog torque	Torque control with analog setpoint (speed controller has to be optimized)
4	Position: electr. gearing	Position control "Pulse follower"
5	Position: ext. position nodes	Position control interpolates external nodes
6	SERCOS position control	Position control with SERCOS expansion card
7	reserved	reserved
8	Position: motion blocks	Position control by stored motion blocks

⚠ DANGER

The OPMODE can be switched over while the drive is running. This could lead to dangerous acceleration. So only switch over OPMODE while the drive is running if the drive application allows it.

Failure to follow this instruction will result in death, serious injury, or equipment damage.

Position Opens the screen page "POSITION"

Speed Open the screen page "SPEED"

Current Opens the screen page "CURRENT"

Feedback Opens the screen page "FEEDBACK"

Set Motor Opens the screen page "MOTOR"

Status=OK/Fault Open the screen page "DRIVE STATUS". If a fault is present, the text for the buttons will change.

Axis The enable status of the amplifier is displayed:
Enable / Disable

Disable / Enable SW

ASCII: DIS (disable, F12)	Default: - Unit: - Range: -	Valid for all OPMODES
ASCII: EN (enable, Shift F12)	Default: - Unit: - Range: -	Valid for all OPMODES

Disables or enables the servo amplifiers via the software. This signal is logically "AND"-linked inside the servo amplifier with the hardware-enable (terminal X3/15).

DANGER

This function does not ensure personnel safety. To disable the servo amplifier in a way that ensures personnel safety, the enable signal (terminal X3/15) must be removed and the line (mains) power must be switched off, or Option -AS- must be used.

Failure to follow this instruction will result in death, serious injury, or equipment damage.

Exit Ends the processing of the current parameter set. If you have made any changes, you will be asked if you want to save the data.

2.4 Unilink Connection and Screen Layout

Screen layout

At a Glance General screen

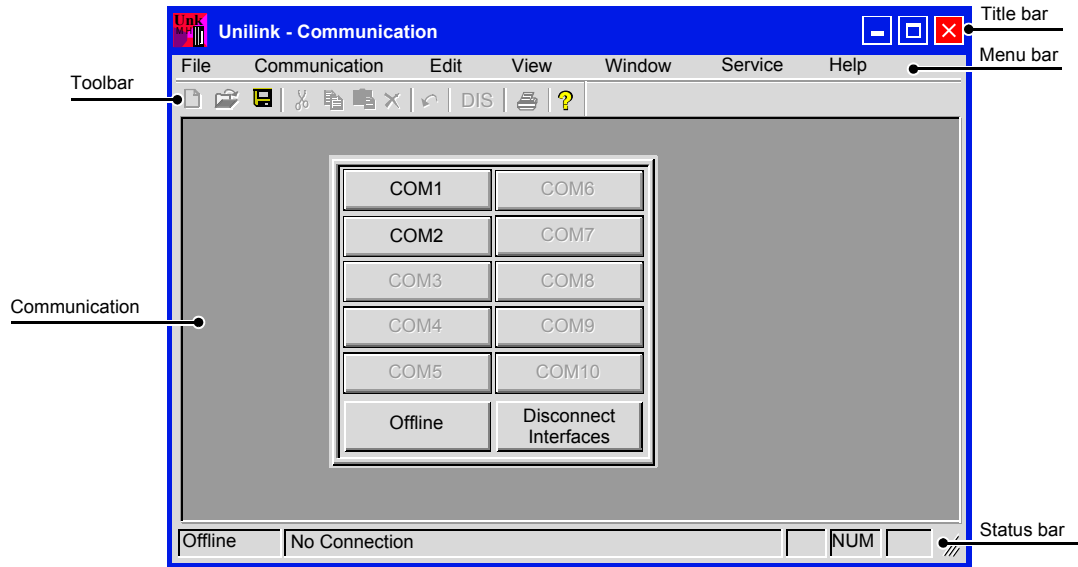

Title bar

The program name, station address, and the name of the currently valid data set (drive) are displayed in the title bar. During offline operation, instead of the station address a number above 1000 will be shown, possibly with the storage location (folder + file name) of the data set that has been loaded.

Toolbar

The typical Windows-style buttons can be used for a direct start of individual functions.

Status bar

Current information about data communication is shown here.

Menu bar

FILE	
Open	A parameter and/or motion task data set is read from the data medium (hard disk, diskette) and becomes the configuration currently in use. For this, the amplifier must be disabled.
Close	The current data set is closed and not saved.
Save	Saves the current parameter or motion task data set to a data medium (hard disk, diskette) while keeping the file name, if the data set already has a name. If the data set has not yet got a name, you will be prompted to enter a name and storage location. You can save parameters and motion task data to one single file or to separate files.
Save as	Saves the current parameter or motion task data set to a data medium (hard disk, diskette). You will be prompted to enter a name and storage location.
Print	The current data set will be printed out. You can choose whether the print data are sent to the system printer or saved to a file.
Print preview / Print setup	Use these functions in the same way as for any other Windows software.
Exit	Terminates the program.

COMMUNICATION	
COM1...10	If one of these interfaces (ports) is available for communication with a servo amplifier, which means that it is not used by other equipment or drivers, then the text label appears in full black and can be selected. Select this interface and use it for the connection to the servo amplifier.
Offline	You can still work with the setup software, even if there is no servo amplifier connected. You can load a set of data from the hard disk (diskette), work on it, and save it again. The software functions and screen pages that only have a use in the online mode will not be selectable.
Disconnect interfaces	This deactivates the access to the setup software from interfaces COM1 to COM10. This function is important if, for instance, the servo amplifier is to be accessed from an external program, without closing the setup software.
Multidrive	With this function, you can establish connection to other amplifiers, that are connected via the CAN-bus with the amplifier that communicates via the RS232-interface with the PC. Therefore, all devices must have different addresses. This function should not be used in running field bus applications.

COMMUNICATION	
Update active window only	This option configures updates for current values displayed in the active window <ul style="list-style-type: none"> ● activated : Updates only the active window ● de-activated : Updates current values continuously in all open windows, but not those in the active window
Lower transmission priority	Delays serial communication to improve field bus communication.

TOOLS	
Terminal Monitor Oscilloscope Status	Opens the window for these functions. These tools are described in chapter 4.

EDITION	
Cancel, Cut, Copy, and Paste	Functions are identical to Windows software functions

DISPLAY	
Toolbar Status bar	Switch to insert the toolbar (above) or the status bar (below) in the screen.

WINDOW	
Cascade / Tile vertically / Arrange icons	Use these functions in the same way as for any other Windows software.

SERVICE	
STOP (F9)	Brakes the motion. The response of the amplifier varies according to the operating mode in progress: <p>OPMODE=0 The amplifier brakes according to the preset braking ramp for the velocity loop (DEC).</p> <p>OPMODE=2 The amplifier slows down.</p> <p>OPMODE=8 Brakes the motion task in progress. The amplifier brakes according to the predefined braking ramp for the motion task. If the screen page "Oscilloscope/Service" is active, you can also start the service function from here.</p>
? (Help function)	HTML help file.

Device Operation Handling

3

Device Operation Handling

At a Glance

This chapter describes the commissioning method, device state, and modes of operation of the Lexium 15 servo drive.

What's in this Chapter?

This chapter contains the following topics:

Topic	Page
Axis Commissioning Checklist Procedures	36
Device State Handling	50
Modes of Operation	53

Axis Commissioning Checklist Procedures

General

This document provides you with strategies for the commissioning of the digital servo amplifier and the optimization of its control loops.

These strategies cannot be universally valid. You may have to develop your own strategy, depending the specification of your machine.

However, the sequences that are presented here will help you to understand the basic methodology.

Parameterization

CAUTION

The manufacturer of the machine must create a hazard analysis for the machine, and is responsible for the machine with regard to functional, mechanical and personnel safety. This applies particularly to the initiation of movements with the aid of commissioning-software functions. The commissioning of the servo drive with the aid of Setup software functions is only permitted in combination with an interlock device according to EN292-1, that operates directly on the drive circuitry.

Failure to follow this instruction can result in injury or equipment damage.

- the servo amplifier is installed, and all the necessary electrical connections have been made. See Lexium 15 MP/HP installation manual.
 - the 24V auxiliary supply and the 230...480V main power supply are switched off
 - a personal computer, with the commissioning software installed, is connected
 - an interlock device according to EN292-1 is connected
 - the controls provide an LOW signal for the ENABLE input of the servo amplifier (Terminal X3/15), i.e. the servo amplifier is disabled.
-

**Switch on
auxiliary supply**

Step	Action
1	Switch on the 24V auxiliary supply for the servo amplifier. LED display: X. XX (firmware version) R1A/R1C contact: open After about 5 seconds: LED display: YY. (amount of current, blinking point for CPU o.k.) R1A/R1C contact: closed
2	Switch on personal computer.
3	Start commissioning software.
4	Click on the interface (COM1...10) that is used for communication with the servo amplifier. The parameters are transmitted to the PC.
5	Click on the radio button "SW-disable" at bottom right. NO ENABLE now stands in the AXIS status field.

Basic settings

The servo amplifier remains disabled and the main power supply is switched off.

Step	Action
1	<p>Set up basic parameters (address, ballast details, line/mains supply voltage etc.):</p> <ul style="list-style-type: none"> ● click on the BASIC SETUP button above the picture of the motor ● alter the fields, if necessary ● click on APPLY and then on OK.
2	<p>Select motor:</p> <ul style="list-style-type: none"> ● click on the SET MOTOR button below the picture of the motor. ● open the motor selection table, by clicking on the arrow in the field NUMBER-Name ● click on the motor that is connected ● click on APPLY ● answer the query about the brake ● answer the query "Save to EEPROM/Reset" with NO (the data are in the RAM and will be permanently saved later).
3	<p>Select feedback (resolver, encoder):</p> <ul style="list-style-type: none"> ● click on the FEEDBACK button. ● the values that are displayed correspond to the default data that you have loaded for the motor ● alter the fields, if necessary ● click on APPLY and then on OK.
4	<p>Set up the encoder emulation (ROD, SSI):</p> <ul style="list-style-type: none"> ● click on the ROD/SSI/Encoder button ● select the desired encoder emulation ● set up the corresponding parameters in the right half of the window ● click on APPLY and then on OK.
5	<p>Configure the analog inputs/outputs:</p> <ul style="list-style-type: none"> ● click on the ANALOG I/O button ● select the desired setpoint function ● Set the scaling relative to 10V for the analog input that is used ● set up the required output signals for AO1 and AO2 ● click on APPLY and then on OK.

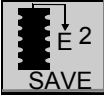
Step	Action
6	<p>Configure the digital inputs/outputs:</p> <ul style="list-style-type: none"> ● click on the DIGITAL I/O button. ● assign the required functions to the digital inputs (left half of window) and enter the auxiliary variable X if it is necessary ● assign the required functions to the digital inputs (right half of window) and enter the auxiliary variable X if it is necessary ● click on APPLY and then on OK.
7	<p>Save parameters:</p> <ul style="list-style-type: none"> ● click on the button <div data-bbox="532 548 636 643" style="text-align: center;">  </div> <ul style="list-style-type: none"> ● answer the query "RESET AMPLIFIER" with "YES".
8	<p>Click on the radio button SW-disable at bottom right. "NO ENABLE" now stands in the AXIS status field.</p>

Procedure to be followed

If you want to use the position control of the servo amplifier, then you must enter the specific parameters for your drive:

Step	Action
1	<p>Axis type:</p> <ul style="list-style-type: none"> ● click on the POSITION button ● click on the POSITION DATA button ● select the axis type (linear or rotary).
2	<p>Resolution:</p> <ul style="list-style-type: none"> ● enter the denominator and numerator for the resolution. Here you adjust the path traversed by the load in positioning units (length unit for linear axes, or °mech. for rotary axes) to match the number of turns of the motor ● only integer entries are permitted. <p>Example 1: Ratio = 3.333 mm / turn =>resolution =10000/3 μ m/turn (all other path entries in μ m) or =>resolution =10/3 mm/turn (all other path entries in mm)</p> <p>Example 2: Ratio = 180 °mech. /turn =>resolution =180/1 °mech. /turn (all other path entries in °mech)</p>
3	<p>vmax:</p> <ul style="list-style-type: none"> ● enter the maximum traversing speed for the load that results from the resolution at the rated speed of the motor. The dimensional unit is derived from the resolution (°mech. /sec or length units/sec). <p>Example 1: resolution =10000/3 μ m/turn, number of motor turns = 3000 turns/min =>vmax =resolution * number of motor turns =10000/3 *3000 μ m/min =10 000 000 μ m/min or =>vmax =resolution * number of motor turns = 10/3 * 3000 mm/min = 10 000 mm/min.</p> <p>Example 2: resolution = 180 °mech. /turn, number of motor turns = 3000 turns/min =>vmax =resolution * number of motor turns = 180 * 3000 °mech. /min =9000 °mech. /s</p>
4	<p>t_acc/dec_min:</p> <ul style="list-style-type: none"> ● enter the time in ms that the drive requires, with the mechanically permissible maximum acceleration, to accelerate from zero speed to vmax.

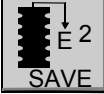
Step	Action
5	In position: <ul style="list-style-type: none">● enter the window for "InPosition". This value is used for the InPosition message● the dimensional unit is derived from the resolution (°mech. or length unit). Typical value: e.g. approx. resolution * 1/100 turn.
6	max. following error: <ul style="list-style-type: none">● enter the window for the following error. This value is used for the message FOLLOWING ERROR. The dimensional unit is derived from the resolution (°mech. or length unit) Typical value: e.g. approx. resolution * 1/10 turn.
7	Save parameters: <ul style="list-style-type: none">● click on the button shown below <div data-bbox="532 634 636 727" style="text-align: center;"></div> <ul style="list-style-type: none">● answer the query "RESET AMPLIFIER" with "YES".

Optimization of the control loops

The basic setting must be finished.

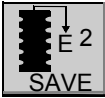
Step	Action
1	<p>OPMODE: On screen page AMPLIFIER, set the OPMODE "1, analog speed"</p>
2	<p>Setp. function:</p> <ul style="list-style-type: none"> ● Click on ANALOG I/O button ● Set the analog I/O-function to "0,Xsetp=An In 1"
3	<p>Save the parameters:</p> <ul style="list-style-type: none"> ● Click on the button shown below <div style="text-align: center;">  </div> <ul style="list-style-type: none"> ● answer the query "RESET AMPLIFIER" with "YES".
4	<p>Analog Input AI1 Short-circuit the setpoint input 1 or apply 0V to it.</p>
5	<p>OSCILLOSCOPE:</p> <ul style="list-style-type: none"> ● Click on OSCILLOSCOPE button ● Set Channel1: v_act and Channel2: I_act
6	<p>Reversing mode Go to the screen page OSCILLOSCOPE/SERVICE/PARAMETER and set the parameters for reversing mode to values that are safe for your machine. In OSCILLOSCOPE mode, the positioning control loop is switched off.</p>

⚠ CAUTION

During operation of the service function "Reversing mode" the analog setpoint input is switched off and the internal positioning control is disabled. Make sure that the individual motion of the selected axis is possible without any hazard. For safety, only operate the ENABLE signal of the amplifier with an interlock switch, and check the EMERGENCY STOP function for this axis.

Failure to follow this instruction can result in injury or equipment damage.

Optimizing the current controllerScreen page **CURRENT**

Step	Action
1	If a suitable amplifier-motor combination is used, the current controller will already have a stable setting for almost all applications.
2	Ipeak: <ul style="list-style-type: none">● reduce Ipeak to the Irated value of the motor (protection of the motor)
3	Power up
4	Provide the analog setpoint: <ul style="list-style-type: none">● AI1 = 0V
5	Enable the amplifier <ul style="list-style-type: none">● high signal at Enable input X3/15. In the AXIS status field: NO SW-EN● click on the SW-Enable check box. ENABLE now stands in the AXIS status field. <p>The motor now stands under speed control, with n=0 rpm. If the current controller is not stable in operation (motor oscillates with a frequency clearly above 500Hz), please contact our applications department.</p>

Optimizing the speed controller

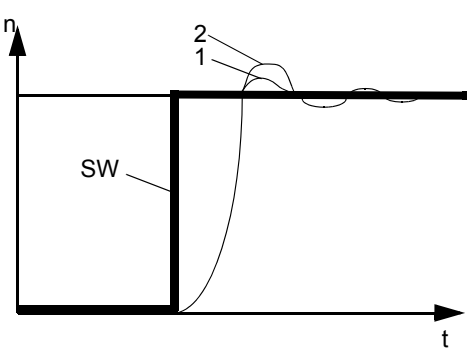
Step	Action
1	<p>SETP. -OFFSET :</p> <ul style="list-style-type: none"> Click on Analog I/O button Leave the amplifier enabled. If the axis is drifting, alter the parameter Offset until it stands still (or use the function AUTO-OFFSET). Click on APPLY and then OK
2	<p>SETP. RAMP +/-:</p> <ul style="list-style-type: none"> Click on SPEED button The setpoint ramps are used to smooth the setpoint input (filter effect). Set the mechanical time constant for the complete system, i.e the rise time for the speed from 0 to n_{cmd}. As long as the ramps that are set are shorter than the mechanical response time for the complete system, the response speed will not be affected.
3	<p>LIMIT SPEED: Set the desired final limit speed.</p>
4	<p>Kp_v / Tn_v: Increase Kp_v until the motor starts to oscillate (audible, and visible on the oscilloscope) and then reduce Kp_v again until the oscillations have definitely stopped and stability is assured. Use the motor-specific default value for Tn_v.</p>
5	<p>Start reversing mode: Start the reversing mode (F8, $v1/v2$ approx. +/-10% of n_{nom} for the motor). Observe the speed response on the oscilloscope. If the settings are correct, there must be a stable step response in both directions. Diagram: Step response</p>  <p>Diagram: Step response</p> <p> n = speed SW = setpoint t = time 1 = optimum 2 = Kp_v too high </p>
6	<p>Kp_v: You can produce a fine tuning of the speed response by cautiously increasing KP. Aim: the smallest overshoot, but still retaining good damping. A larger total moment of inertia make it possible to use a larger value for Kp_v.</p>

Step	Action
7	PID-T2: You can dampen out disturbances, such as a small amount of play in the gearing, by increasing PID-T2 to about 1/3 the value of Tn_v.
8	FEEDBACK: You can further improve the smooth running by using T-Tacho filter, especially for small drives with a low torque.
9	End reversing mode: Finish the reversing mode operation (F9).

Settings

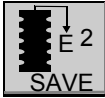
Step	Action
1	<ul style="list-style-type: none"> ● set up the correct, motor-specific value for Ipeak (current controller) again ● start up reversing mode again, and observe the step response. If there is any tendency to oscillation, reduce Kp_v slightly ● save the present parameter set in the EEPROM ● click on the button shown below: <div style="text-align: center;">  </div>

Optimizing the position controller: Preparation

Preparation

Step	Action
1	<p>OPMODE: Select OPMODE 8: Position Motor Tasks</p>
2	<p>Position the load in a middle position: The aim is, to use the Jog Mode function to move the load to approximately the middle of the motion path.</p> <ul style="list-style-type: none"> ● click on the POSITION button ● click on the HOMING button ● check that the parameter v (Jog Mode) is set to 1/10 of the preset speed limit v_{max}. The sign of "v" determines the direction. Alter the value if necessary, and click on "APPLY" ● start the function Jog Mode by using the function key F4 and move the load to approximately the middle of the motion path. <p>WARNING: If the drive moves in the wrong direction, release the F4 function key and change the sign of the parameter "v" (Jog mode). Use F4 again to move the load to approximately the middle of the motion path.</p>
3	<p>Set reference point:</p> <ul style="list-style-type: none"> ● set the homing type <p>Start the homing run. When the reference point is set, the current position is set to the offset value.</p> <ul style="list-style-type: none"> ● stop the homing run ● click on the check box "SW-disable" in the amplifier window.

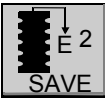
Step	Action																																													
4	<p>Define test motion blocks:</p> <ul style="list-style-type: none"> ● click on the "POSITION" button ● click on the "POSITION DATA" button ● click on the MOTION TASK TABLE ● select task 1 with a double click. <p>Enter the values from the table below, then select task 2 and enter the corresponding values.</p> <table border="1" data-bbox="444 467 1218 954"> <thead> <tr> <th></th> <th>Task 1</th> <th>Task 2</th> </tr> </thead> <tbody> <tr> <td>Units</td> <td>SI</td> <td>SI</td> </tr> <tr> <td>type</td> <td>REL setpoint</td> <td>REL setpoint</td> </tr> <tr> <td>x_cmd</td> <td>+10% of total path</td> <td>- 10% of total path</td> </tr> <tr> <td>v_cmd Source</td> <td>digital</td> <td>digital</td> </tr> <tr> <td>v_cmd</td> <td>10% of vmax</td> <td>10% of vmax</td> </tr> <tr> <td>t_acc_tot</td> <td>10 * t_acc/dec_min</td> <td>10 * t_acc/dec_min</td> </tr> <tr> <td>t_dec_tot</td> <td>10 * t_acc/dec_min</td> <td>10 * t_acc/dec_min</td> </tr> <tr> <td>ramp</td> <td>trapeze</td> <td>trapeze</td> </tr> <tr> <td>next motion</td> <td></td> <td></td> </tr> <tr> <td>task</td> <td>with</td> <td>with</td> </tr> <tr> <td>next number</td> <td>2</td> <td>1</td> </tr> <tr> <td>acc./dec.</td> <td>to target position</td> <td>to target position</td> </tr> <tr> <td>start condition</td> <td>immediately</td> <td>immediately</td> </tr> <tr> <td>APPLY/OK</td> <td>click</td> <td>click</td> </tr> </tbody> </table>		Task 1	Task 2	Units	SI	SI	type	REL setpoint	REL setpoint	x_cmd	+10% of total path	- 10% of total path	v_cmd Source	digital	digital	v_cmd	10% of vmax	10% of vmax	t_acc_tot	10 * t_acc/dec_min	10 * t_acc/dec_min	t_dec_tot	10 * t_acc/dec_min	10 * t_acc/dec_min	ramp	trapeze	trapeze	next motion			task	with	with	next number	2	1	acc./dec.	to target position	to target position	start condition	immediately	immediately	APPLY/OK	click	click
	Task 1	Task 2																																												
Units	SI	SI																																												
type	REL setpoint	REL setpoint																																												
x_cmd	+10% of total path	- 10% of total path																																												
v_cmd Source	digital	digital																																												
v_cmd	10% of vmax	10% of vmax																																												
t_acc_tot	10 * t_acc/dec_min	10 * t_acc/dec_min																																												
t_dec_tot	10 * t_acc/dec_min	10 * t_acc/dec_min																																												
ramp	trapeze	trapeze																																												
next motion																																														
task	with	with																																												
next number	2	1																																												
acc./dec.	to target position	to target position																																												
start condition	immediately	immediately																																												
APPLY/OK	click	click																																												
5	<p>Save parameters:</p> <ul style="list-style-type: none"> ● click on the button shown below: <div data-bbox="513 1073 618 1170" style="text-align: center;">  </div> <ul style="list-style-type: none"> ● answer the query "RESET AMPLIFIER" with "YES". 																																													

Optimizing the position controller: Optimization

Optimization

⚠ CAUTION
<p>The starting of motion tasks with the aid of commissioning-software functions is only permitted in combination with an interlock device according to EN292-1, that operates directly on the drive circuitry.</p> <p>Failure to follow this instruction can result in injury or equipment damage.</p>

Step	Action
1	<p>Start motion task:</p> <ul style="list-style-type: none"> ● click on the "POSITION DATA" button ● select motion task 1, click on "START", motion task 1 is started and, because of the definition of the motion task sequence, the drive moves in position-controlled reversing operation.
2	<p>Optimize parameters:</p> <ul style="list-style-type: none"> ● Click on the POSITION button ● Select P position, PI speed controller.
3	<p>PID-T2, FEEDBACK:</p> <p>The speed controller is not used in OPMODES 4, 5 and 8. The position controller includes an integral speed controller, that takes on the preset parameters for PID-T2 and T-Tacho from the screen page "SPEED".</p>
4	<p>Kp_v, Tn_v:</p> <p>On "Speed" screen page, if Kp_v is set too low, the position controller tends to oscillate. Use the value for the optimized speed controller for Kp_v. Tn should be 2...3 times as large as the Tn_v value for the optimized speed controller.</p>
5	<p>Kp_v:</p> <p>The acceleration behavior of the motor should be well damped (no tendency to oscillation) with a minimum following error. If Kp_v is larger, the tendency to oscillation increases. If it is smaller the following error increases and the drive becomes too soft. Vary Kp_v until the desired response is achieved.</p>
6	<p>FF (feedforward factor):</p> <p>The integral component of the control loop is in the position controller, not the speed controller, so no following error results at Jog Mode (pure proportional control). The following error that arises during acceleration is affected by the FF parameter. This error is smaller if the FF parameter is increased. If increasing FF does not produce any improvement, then you can increase Kp_v a little, to make the speed control loop somewhat stiffer.</p>

Incorrect operation

If the drive does not run satisfactorily under position control, first look for external causes such as:

- mechanical play in the transmission chain (limits the Kp_v)
 - jamming or slip-stick effects
 - self-resonant frequency of the mechanical system is too low
 - poor damping, drive is too weakly dimensioned before trying to optimize the control loop again.
-

Device State Handling

At a Glance

Device state handling is illustrated in the diagram below:

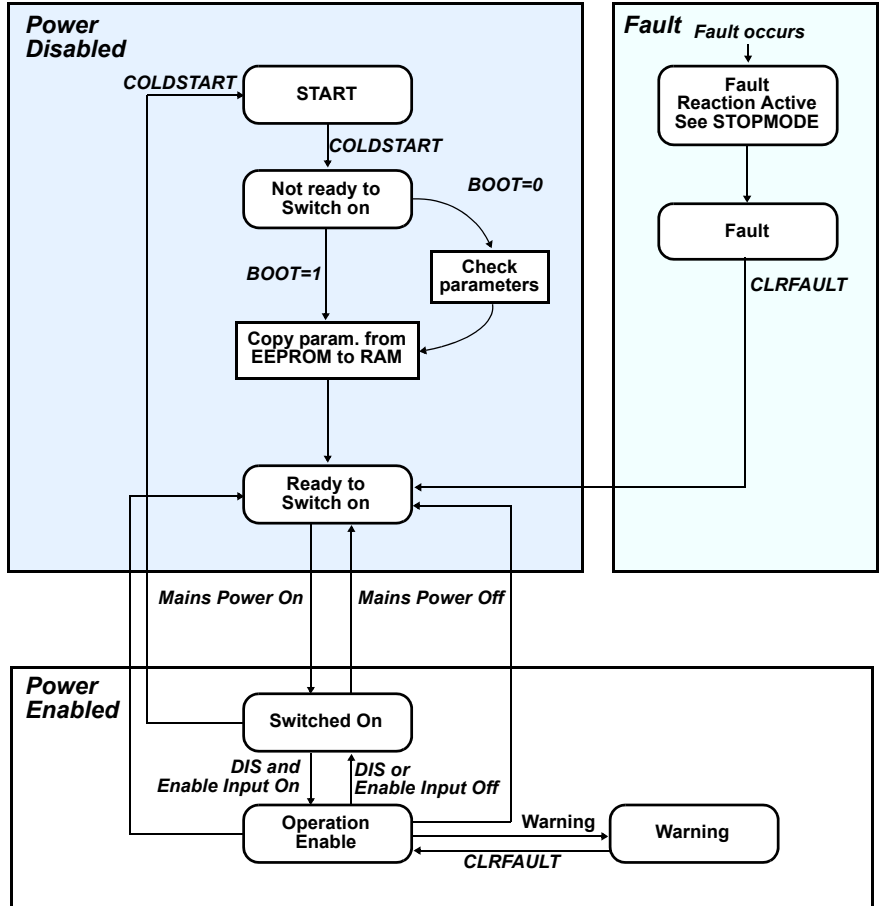

Device States

Device State	Description
Ready to Switch On	Ready to accept Main Power On. No energy for motor. Brake is set (ON) if motor is equipped. Motion is not allowed. Led display is "xx" where xx is the device number for field bus.
Switched On	Main Power is On. No energy for motor. Brake is on if motor is equipped. Motion is not allowed. Led display is "Pxx" where xx is the device number for field bus.
Operation Enable	Main Power is On. Energy for motor. Brake is off if motor is equipped. Motion is not allowed. Led display is "Exx" where xx is the device number for field bus.
Fault Reaction Active	If a fault is detected the motor will be stopped. The motor is stopped depending on STOPMODE.
Fault	No energy for motor. Brake is on if motor is equipped. Led display is "fxx" where xx is the device number for field bus
Warning	Motor still controlled. Led display is "nxx" where xx is the device number for field bus.

ASCII Command List You can use the ASCII commands below to

- To manage drive states behavior
- Clear faults, warnings
- Stop
- Save restore parameters

ASCII Command	Default Value	Description
ACTFAULT	1	Active Fault Mode
BOOT	0	Type of Boot Initialisation
CLRFAULT	-	Clear Drive Fault
CLRHR	-	Bit 5 of status register STAT is cleared
CLRWARN	0	Warning Mode
COLDSTART	-	Drive Reset
DECDIS	10	Deceleration used on Disable Output Stage
DECSTOP	10	Quick Stop - braking ramp for emergency situations
DIS	-	Software - Disable
EMRGTO	5000	Emergency time-out and stop mode
EN	-	Software - Enable
INPOS	-	Status of In-Position Signal
INPT	10	In-Position Delay
K	-	Kill (=Disable)
KEYLOCK	0	Locks the push buttons
LOAD	-	Load parameters from Serial EEPROM
MSG	0	Enable/Disable All Messages via RS232
PASSCNFG	0	Password Function
PASSX	0	Activate Password Function
PMODE	1	Line Phase Error Mode
REMOTE	-	Status of the Hardware Enable
RSTFW	0	Parameter of RSTVAR
RSTVAR	-	Restore variables (default values)
S	-	Stop Motor and Disable Drive
SAVE	-	Save Data in EEPROM
UVLTMODE	1	Undervoltage Mode

Modes of Operation

At a Glance

The Lexium 15 servo drive may be used in several servo control modes; which are called Modes Of Operation.

The Mode of Operation is selected automatically when the power is switched on, in accordance with the setting saved in the EEPROM as well as the AUTOHOME AND NREFMT objects.

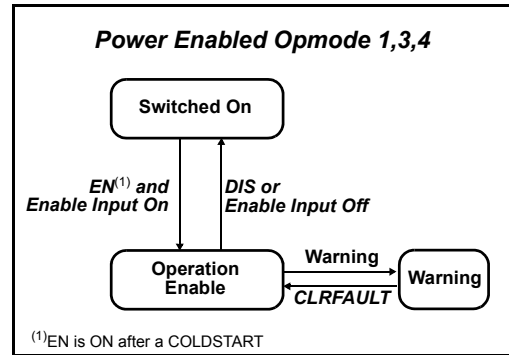
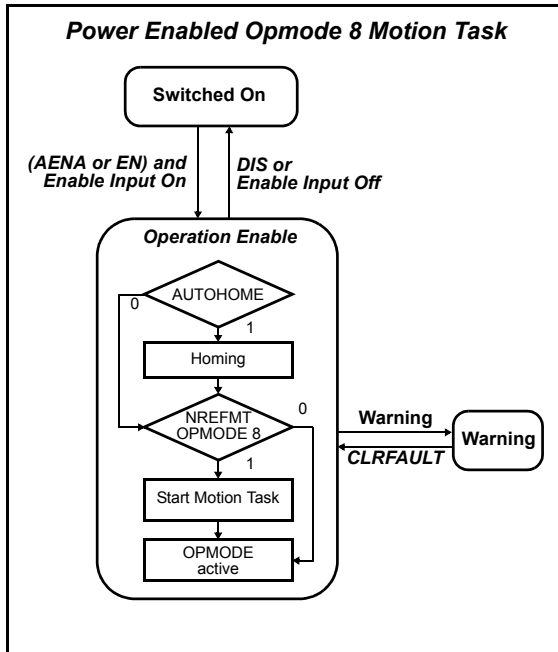

Handling of Modes of Operation

Some modes of operation are handled by I/O and others by field buses:

Lexium 15 LP/MP/HP	DSP 402 Number	Available	Unilink Number
CANopen DS 402 Modes of Operation			
No mode changed/no mode assigned	0	yes	N/A
Profile position mode (PP)	1	yes	N/A
Velocity mode	2		
Profile velocity mode (PV)	3	yes	N/A
Torque position mode (TQ)	4		
reserved	5		
Homing mode (HM)	6	yes	N/A
Interpolated position mode (IP)	7		
Cyclic sync position mode	8		
Cyclic sync velocity mode	9		
Cyclic sync torque mode	10		
reserved	+11 to +127		
Constructor			
Electrical gearing	F7h	yes	4
Jogging	F8h	yes	
Homing proprietary	F9h	yes	
Trajectory (positioning specific mode)	FAh	yes	
Analog torque	FBh	yes	3
Analog speed	FCh	yes	1
Digital torque	FDh	yes	2
Digital speed	FEh	yes	0
Position	FFh	yes	8
Sercos		yes	6

The CANopen DSP 402 Modes of Operation will be described in Lexium 15 CANopen Manual.

**Constructor
Modes of
Operation**

The diagram below illustrates the Constructor Mode of Operation

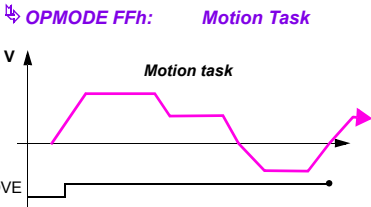
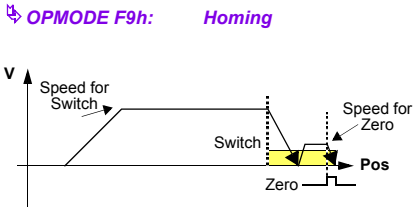
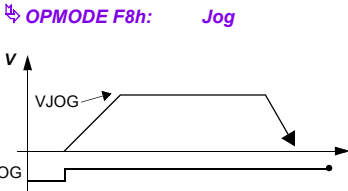
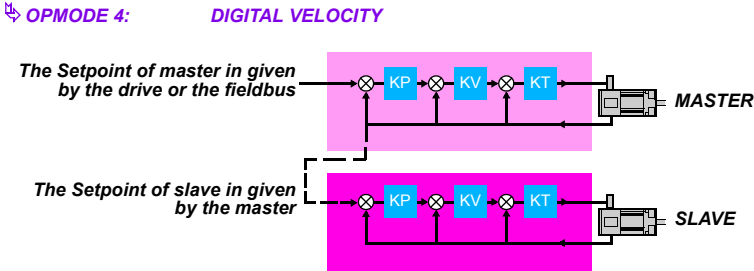
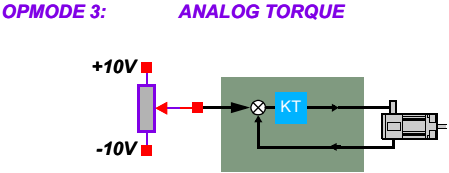
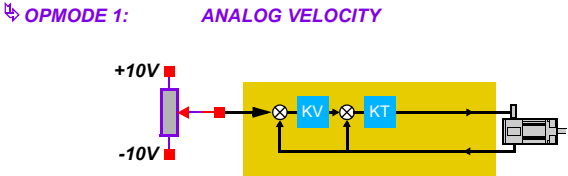
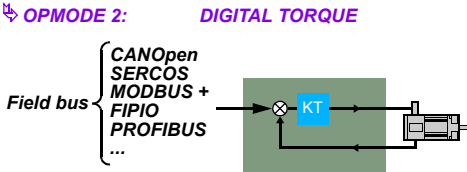
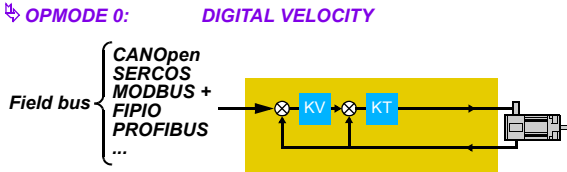

Device Functions



4

Device Functions

At a Glance

This chapter describes all the parameters that can be accessed via the Unilink Commissioning Software.

What's in this Chapter?

This chapter contains the following sections:

Section	Topic	Page
4.1	Screen page "Basic Setup"	59
4.2	Screen page "Motor"	69
4.3	Screen page "Feedback"	78
4.4	Screen page "Encoder"	84
4.5	Screen page "Analog I/O"	89
4.6	Screen page "Digital I/O"	100
4.7	Screen page "Position"	130
4.8	Screen page "Speed"	137
4.9	Screen page "Current"	143
4.10	Screen page "Homing"	146
4.11	Screen page "Gearing"	167
4.12	Screen page "Position data"	171
4.13	Registration	182
4.14	Screen page "Position Registers"	184
4.15	Screen page "Drive status"	187
4.16	Screen page "Actual values"	189
4.17	Screen page "Oscilloscope"	193
4.18	Screen page "Service parameters"	196
4.19	"BODEPLOT" screen page.	197
4.20	Screen page "Terminal"	199
4.21	Screen page "I/O expansion"	201

4.1 Screen page "Basic Setup"

Overview of "Basic Setup"

At a Glance

Diagram:

PC Software

Display the version and revision level of the current setup software.

Regen resistor

ASCII: PBALRES	Default: 0 (internal) Unit: - Range:0 ... 200	Valid for all OPMODES
-----------------------	---	-----------------------

Preselection of the regen resistor. If you use an external regen resistor, set "1,external" here.

Regen power

ASCII: PBALMAX	Default: 80 W / 200 W Unit: W Range: -	Valid for all OPMODES
-----------------------	--	-----------------------

Direct current limit for the regen resistor. Change this only while the amplifier is disabled.

Max. Mains Voltage

ASCII: VBUSBAL	Default: 1 Unit: - / Volt Range: 0, 1, 2, 3, 40 ... 750	Valid for all OPMODES
-----------------------	---	-----------------------

This parameter is used to adjust the regen and switch-off levels of the servo amplifiers to suit the mains power supply voltage or the system conditions for multi-axis systems with parallel-connected DC-link circuits.

ID	Max. Mains Voltage	DC-link voltage (rated motor voltage / max. motor voltage)
0	230 V	310 V / 430 V
1	400 V	560 V / 750 V
2	480 V	675 V / 870 V

Single amplifier:

usually the setting taken is the mains supply voltage that is actually available. If the motor has a higher voltage rating than the DC-link voltage that occurs as a result of the available mains supply voltage, then you can raise the regen and switch-off levels by selecting the max. mains voltage that is permissible for the motor (see table).

Multi-axis systems with parallel-connected DC-link circuits:

in a system, the DC-link circuits of the servo amplifiers are usually connected in parallel (DC-bus). If motors with differing voltage ratings (which must be as high or higher than the actual DC-link voltage) are used, then each amplifier on the DC-bus must be set up for the motor with the lowest rated voltage. If the settings are not all the same, then the desired distribution of the regen power will not be achieved.

Drive rated current

ASCII: DICONT	Default: HW defined Unit: A Range: 1.5..70.0	Valid for all OPMODES
----------------------	--	-----------------------

This value is normally set in the factory. This is the continuous current rating of the drive. DICONT depends on VBUSBAL (See *Max. Mains Voltage*, p. 60).

Drive peak current

ASCII: DIPEAK	Default: HW defined Unit: A Range: 1.5..70.0	Valid for all OPMODES
----------------------	--	-----------------------

 CAUTION**RISK OF EQUIPMENT DAMAGE**

Do not change the DICONT and DIPEAK values without consulting our technical support.

Failure to follow this instruction can result in injury or equipment damage.

Mains phase missing

ASCII: PMODE	Default: 1 Unit: - Range: 0, 1, 2	Valid for all OPMODES
---------------------	---	-----------------------

Handles the "Phase missing" message. Change this only while the amplifier is disabled, then reset amplifier.

ID	Function	Note
0	No message	A missing mains supply phase is not evaluated. Operation is possible on two phases. The peak current for acceleration is limited to 4A.
1	Warning	A missing mains supply phase is reported as a warning (display), and can be output on a digital output. The servo amplifier will not be disabled. The peak current for acceleration is limited to 4A.
2	Error	A missing mains supply phase is reported as a fault (display), and can be output on a digital output. The servo amplifier is disabled and the R1A/R1C contact opened.

Hardware

ASCII: HVER	Default: - Unit: - Range: max 50 ASCII chars	Valid for all OPMODES
--------------------	--	-----------------------

Display the version and revision level of the servo amplifier hardware.

Firmware

ASCII: VER	Default: - Unit: - Range: max 50 ASCII chars	Valid for all OPMODES
-------------------	--	-----------------------

Displays the version and revision level of the servo amplifier firmware.

Serial number

ASCII: SERIALNO	Default: - Unit: - Range: 10 ASCII chars	Valid for all OPMODES
------------------------	--	-----------------------

Displays the servo amplifier serial number.

Run time

ASCII: TRUN	Default: - Unit: hhhhh:mm Range: 00000:00 to 99999:45	Valid for all OPMODES
--------------------	---	-----------------------

Displays servo amplifier operational time, saved at 8 minute intervals. If the 24V supply is switched off, a maximum of 8 min. operational time will be unregistered.

Address

ASCII: ADDR	Default: 0 Unit: - Range: 0 ... 127	Valid for all OPMODES
--------------------	---	-----------------------

The entry is the station address (1...63) of the amplifier. This number is required by the fieldbus (CANopen, PROFIBUS DP, SERCOS etc.) and for the parameter setting of the servo amplifier in multi-axis systems for an unambiguous identification of the servo amplifier within the system (see User guide for the Lexium 17x series amplifier). The address is displayed in the setup software in the title bar of every screen page, as long as you are working online. In offline operation the display is not the actual station address, but a number above 100. This immediately shows you are in offline mode. You can also use the keys on the front panel of the servo amplifier to set the station address (see Installation Manual).

Name

ASCII: ALIAS	Default: blanks Unit: - Range: Max 8 ASCII chars	Valid for all OPMODES
---------------------	--	-----------------------

Here you can assign a name (8 chars max.) to the servo amplifier (e.g. X-AXIS). This makes it easier for you to associate the servo amplifier with a function within the system. The name is displayed in the setup software in the title bar of every screen page. In offline mode the name is an indication of the origin of the currently active data set.

Baud rate Can Bus

ASCII: CBAUD	Default: 500 Unit: KBaud Range: 10, 20, 50, 100, 125, 250, 333, 500, 666, 800, 1000	Valid for all OPMODES
---------------------	---	-----------------------

The transmission rate is required by the fieldbus (CANopen) and for the parameter setting of the servo amplifier in multi-axis systems (see the Installation Manual). You can also use the keys on the front panel of the servo amplifier to set the baud rate (see the Installation Manual).

Auto enable

ASCII: AENA	Default: 1 Unit: - Range: 0,1	Valid for OPMODES 0, 2, 4-8
--------------------	-------------------------------------	-----------------------------

This variable defines the state of the software enable when the amplifier is switched on or after an error reset.

In order to enable the output stage, both the hardware enable and the software enable must be set (series AND configuration). The software enable gives an external control the option of enabling or disabling the output stage by software control, via a bus interface (CANBUS, PROFIBUS, SERCOS, RS232) or an expansion card in a slot

0 = inactive

1 = active

When using an analog command (OPMODE=1, 3), the software enable is automatically set when the amplifier is switched on, so that these instruments are instantly ready for operation (provided that the hardware enable is already present). When using a digital command (OPMODE=0, 2, 4 through 8), the software enable is set to the same state as AENA at power-on. For faults that can be reset in software after the fault has been cleared (Digital I/O function 1 or CLRFAULT), the software enable is set to the state of AENA. In this way, the response of the amplifier to a software reset is analogous to the power-on behavior

**External
Watchdog**

ASCII: EXTWD	Default: 100 ms Unit: milliseconds Range: 1 ... 32000	Valid for all OPMODES
---------------------	---	-----------------------

Definition of the watchdog period for the communication expansion card. This watchdog is only active when the value is greater than 0 and the output stage is enabled. If the preset duration is reached and the clock is not triggered, the warning message n04 (Response time monitoring) is generated, and the amplifier stops. The amplifier remains operational, and the output stage remains enabled. This warning must be cancelled (function CLRFAULT or Digital I/O function 14) before a new motion command (command) can be accepted.

Acceleration

ASCII: ACCUNIT	Default: 0 Unit: - Range: 0,1, ... , 30	Valid for all OPMODES
-----------------------	---	-----------------------

Definition of the dimension unit for acceleration. This unit is used for the ramps of the path generator (internal motion blocks, OPMODE 8) and for the braking and acceleration ramps in velocity mode.

ID	Function	Note
0	ms->VLIM	Acceleration expressed in rise time (ms) to reach the desired speed
1	rad/s ²	Acceleration expressed in rad/s ²
2	rpm/s	Acceleration expressed in min ⁻¹ /s (rpm per sec)
3	PUNIT/s ²	Acceleration expressed in PUNIT/s ²
4	1000*PUNIT/s ²	Acceleration expressed in 1000*PUNIT/s ²
5	10 ⁶ *PUNIT/s ²	Acceleration expressed in 10 ⁶ *PUNIT/s ²

With the setting ms -> VLIM, it remains possible to select acceleration for the motion block in mm/s². If the setting is changed, all related braking and acceleration settings are converted internally in the unit currently selected.

The automatic adjustment of the parameters does not apply to internal motion blocks. The unit used for acceleration must therefore be defined before the first motion block is created. In the event of later modification, the acceleration and braking values for all motion blocks must be verified, and any necessary corrections made.

Speed

ASCII: VUNIT	Default: 0 Unit: - Range: 0 ... 8	Valid for all OPMODES
---------------------	---	-----------------------

Definition of the global unit for velocity and speed. This unit applies to all parameters, depending on the velocity/speed of the speed/position controller.

ID	Function	Note
0	Compatibility mode	Definition of speed in min^{-1} , definition of velocity in m/s
1	1/min	unit=min
2	rad/s	unit=radians/s
3	°/s	unit=degrees/s
4	Pulses/250s	unit=Pulses/250 μs
5	PUNIT/s	unit=PUNIT/s
6	PUNIT/min	unit=PUNIT/Min
9	1000*PUNIT/s	unit=1000*PUNIT/s
8	1000*PUNIT/min	unit=1000*PUNITMin

Note: 1. All parameters that are dependent on speed are normally defined in the form of fixed point numbers over 32 bits (with 3 decimal places). This is why many parameters (in particular 1000*PUNIT/s), cannot cover the entire speed range, according to the selected resolution. It is therefore necessary to make sure a suitable unit is selected, according to the application.

2. All parameters that are dependent on velocity are normally defined in the form of integers over 32 bits. This is why it is impossible to define a speed using a decimal number, particularly for degrees/sec. settings. It is therefore necessary to make sure a suitable unit is selected, according to the application.

Position

ASCII: PUNIT	Default: 0 Unit: - Range: 0 ... 12	Valid for all OPMODES
---------------------	--	-----------------------

Definition of the global unit for all parameters dependent on position. The possible settings are as follows:

ID	Function	Note
0	Counts	Internal unit (specific application)
1	dm	unit=1 dm
2	cm	unit=1 cm
3	mm	unit=1 mm
4	100 μ m	unit=0.1 mm
5	10 μ m	unit=0.01 mm
6	μ m	unit=1 μ m
7	100 nm	unit=0.1 μ m
8	10 nm	unit=0.01 μ m
9	nm	unit=1 nm

With the pulse setting (PUNIT=0), no path or distance unit can be displayed. In this case, it is possible to implement units specific to the application. The unit is defined only by PGEAR1

4.2 Screen page "Motor"

Screen page "Motor"

At a Glance Information and descriptions concerning the different fields of the "Motor" screen.

What's in this Section? This section contains the following topics:

Topic	Page
Overview of the "Synchronous motor" screen	70
Overview of the "Asynchronous motor" screen	74

Overview of the "Synchronous motor" screen

At a Glance

All parameters that appear on this screen page are defined by the default values of the motor (internal database of drive). Most of the time, it is not necessary to modify them.

Diagram:

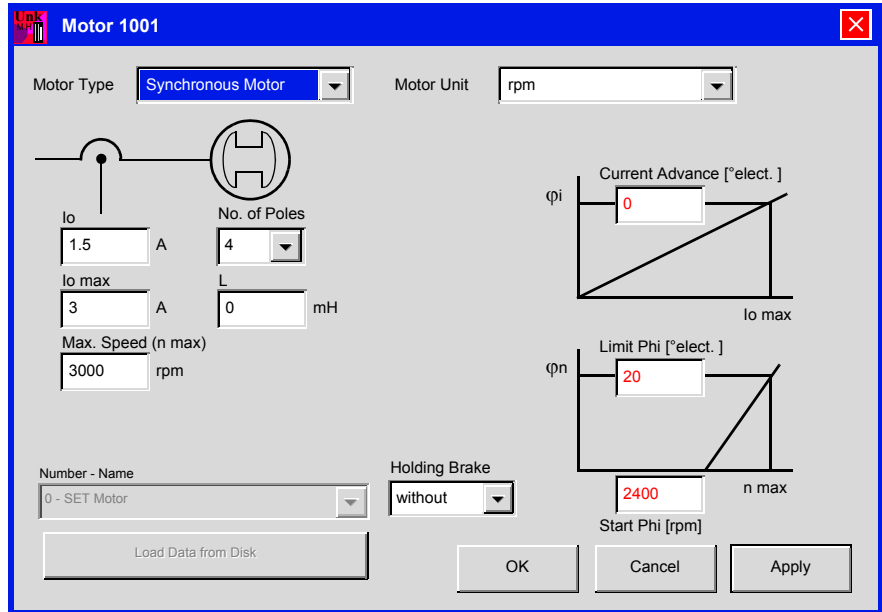

Selecting Motor type

When opening **MOTOR** screen page, choose first motor type

ASCII: MTYPE	Default: 1 Unit: - Range: 1...4	Valid for all OPMODES
---------------------	---------------------------------------	-----------------------

Choosing a synchronous motor will set MTYPE at 1

Choosing an induction (asynchronous) motor will set MTYPE at 3

Motor unit

Define the motor speed parameters. If the unit 1/min (rpm) is used, the velocity/speed parameter settings are applied for VUNIT.

ASCII: MUNIT	Default: 0 Unit: - Range: -	valid for all OPMODES
---------------------	-----------------------------------	-----------------------

Number of poles

Select the number of motor poles. The current setpoint can be set for the operation of 2-pole to 32-pole motors. Change this only while the drive is disabled.

ASCII: MPOLES	Default: 6 Unit: Poles Range: 0, 2, 4, 6, ..., 256	Valid for all OPMODES
----------------------	--	-----------------------

I_o

The standstill current is the RMS current value that the motor requires at standstill to produce the standstill torque (defines the maximum value for the entry of I_{rms} in the current controller).

ASCII: MICONT	Default: standstill current Unit: Amperes Range: 10% of DICONT, .. 2* DICONT	Valid for all OPMODES
----------------------	--	-----------------------

I_{o max}

In this field, set the maximum (peak) current. The peak current (RMS value) should not exceed four times the rated current of the motor. The actual value is also determined by the drive's peak current that is used (defines the maximum value for the entry of I_{peak} in the current loop).

ASCII: MIPEAK	Default: peak current Unit: Amperes Range: 10% of DIPEAK, .. 2*DIPEAK	Valid for all OPMODES
----------------------	---	-----------------------

L

In this field, set the inductance of the motor (phase-phase) You can take this value from the motor manual.

ASCII: L	Default: 0 mH Unit: - Range: -	Valid for all OPMODES
-----------------	--------------------------------------	-----------------------

**Max. speed
(n max)**

Maximum authorized speed for the motor. Limit the possible entries for the SPEED LIMIT parameter in the SPEED screen page.

ASCII: MSPEED	Default: 3000 rpm Unit: rpm Range: 0.0 ... 12000.0	Valid for all OPMODES
----------------------	--	-----------------------

**Number -
Reference**

Select the desired motor from the motor database. The data is loaded once the motor has been selected. If an encoder is used as a feedback device, the motor number will automatically be reported to the servo drive. Change this only while the drive is disabled.

The following motor-related parameters are automatically updated when you select a motor:

Screen page	Parameters
Basic Setup	Maximum mains voltage
Motor	Number of poles, I _o , I _o max, L, Maximum Speed, Current advance, Start Phi, Limit Phi, Brake
Feedback	Feedback Type, Number of Resolver Poles, Offset
Current	KP, Tn
Speed	KP, Tn, PID-T2, T-tacho, Maximum Speed, Overspeed

ASCII: MNAME	Default: blanks Unit: - Range: Max 12 ASCII chars	valid for all OPMODES
ASCII: MNUMBER	Default: 0 Unit: - Range: int	valid for all OPMODES

Holding brake

If you want to operate a 24 V holding brake in the motor directly from the servo drive, this parameter enables you to activate the brake function:

ID	Function	Meaning
0	Without	The brake function is disabled
1	With	If the brake function is enabled, then the output at the BRAKE (X9/2) terminal will be 24V if the ENABLE signal is present (brake off) and 0 V if the ENABLE signal is missing (brake activated).

ASCII: MBRAKE	Default: 0 Unit: - Range: 0, 2	valid for all OPMODES
----------------------	--------------------------------------	-----------------------

See the Lexium 15 MP/HP Installation manual for the time/function relationship between the ENABLE signal, the speed setpoint, the speed value, and the braking force. This value should only be changed while the drive is disabled and should be followed by a reset.

Current Advance

In this field, enter a current-dependent phase advance, to make use of the reluctance torque for motors with magnets embedded in the rotor. This is for advanced users.

ASCII: MTANGLP	Default: 0 Unit: Electrical Degrees Range: 0...45	valid for all OPMODES
-----------------------	---	-----------------------

Limit Phi and Start Phi

The inductive phase shift between the motor current and the motor voltage can be compensated at high speeds. With the given voltage conditions, a higher torque can be achieved at the speed limit. Alternatively, the achievable speed limit can be increased by up to 30%. The phase shift is increased (depending on the motor speed) linearly from the Start Phi value up to the maximum speed of the motor. The phase shift correction is increased linearly from the Start Phi value and reaches the limit Phi value at maximum speed. The optimum setting depends on the motor type and the speed limit.

ASCII: MVANGLB	Default: 2400 rpm Unit: rpm Range: 0...15000	valid for all OPMODES
ASCII: MVANGLF	Default: 20° Unit: Electrical Degrees Range: 0...45	valid for all OPMODES

Loading the data from a disk.

Load a motor database from a data medium (hard or floppy disk). In this case, the drive must be deactivated.

Overview of the "Asynchronous motor" screen

At a Glance

All parameters that appear on this screen page are defined by the default values of the motor (internal database of drive). Most of the time, it is not necessary to modify them.

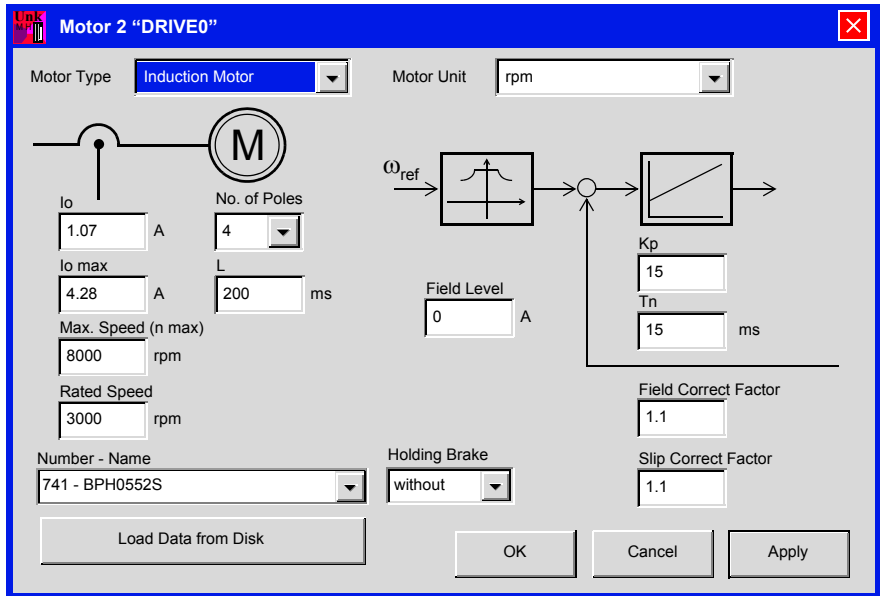

Number of poles

Select number of motor poles. The current setpoint can be set for the operation of 2-pole to 32-pole motors. Change this only while the amplifier is disabled.

ASCII: MPOLES	Default: 6 Unit: Poles Range: 0, 2, 4, 6, ... , 256	Valid for all OPMODES
----------------------	---	-----------------------

Io The standstill current is the RMS current value that the motor requires at standstill to produce the standstill torque (defines the maximum value for the entry of Irms in the current controller).

ASCII: MICONT	Default: standstill current Unit: A Range: 10% of DICONT, ... 2*DICONT	Valid for all OPMODES
----------------------	--	-----------------------

Io max In this field, set the maximum (peak) current. The peak current (RMS value) should not exceed four times the rated current of the motor. The actual value is also determined by the drive's peak current that is used (defines the maximum value for the entry of Ipeak in the current loop).

ASCII: MIPEAK	Default: peak current Unit: A Range: 10% of DIPEAK, ... 2*DIPEAK	Valid for all OPMODES
----------------------	--	-----------------------

Rotor time constant Defines the rotor time constant for the nominal load ($T_r=L_h/R_r$). L_h is the magnetization inductance of the axis, and R_r is the resistance of the rotor.

ASCII: MTR	Default: 200 Unit: ms Range: -	Valid for all OPMODES
-------------------	--------------------------------------	-----------------------

Max. speed (n max) This is the maximum speed of the motor. Limits are entered in the parameter "Speed limit" (screen page "Speed").

ASCII: MSPEED	Default: 3000 Unit: rpm Range: 0.0 .. 12000.0	Valid for all OPMODES
----------------------	---	-----------------------

Rated speed Rated speed of the asynchronous motor. This defines the point above which a reduction in phase shift is applied. For example, if a 4-pole motor is to operate at 50Hz, the rated speed must be set to 1500.

ASCII: MVR	Default: 6000 Unit: rpm Range: 0...10000	Valid for all OPMODES
-------------------	--	-----------------------

Number - Reference

Select the desired motor from the motor database. The data is loaded once the motor has been selected. If an encoder is used as a feedback device, the motor number will automatically be reported to the servo drive. Change this only while the amplifier is disabled.

ASCII: MNAME	Default: blanks Unit: - Range: Max 12 ASCII chars	valid for all OPMODES
ASCII: MNUMBER	Default: 0 Unit: - Range: int	valid for all OPMODES

Holding brake

To operate a 24 V parking brake directly in the motor of a servo amplifier, select 0 (with). Otherwise, select 1 (without).

ID	Function	Meaning
0	Without	The brake function is disabled
1	With	If the brake function is enabled, then the output at the BRAKE (X9/2) terminal will be 24V if the ENABLE signal is present (brake off) and 0 V if the ENABLE signal is missing (brake activated).

ASCII: MBRAKE	Default: 0 Unit: - Range: 0, 2	valid for all OPMODES
----------------------	--------------------------------------	-----------------------

See the Lexium 15 MP/HP installation manual for the time/function relationship between the ENABLE signal the speed setpoint, actual speed value, and the braking force. Change this only while the amplifier is disabled + reset.

Loading data to the disk

Load the file for the motor parameters of a drive (hard disk, floppy disk). For this, the amplifier can be disabled.

Field Level

Defines the magnetization current for an asynchronous motor: in general, this value is 40% - 50% that of the direct current. The magnetization current remains at a constant speed, lower than that of the nominal speed of the motor. If the motor is operating at a speed greater than its nominal speed, this current is lowered in inverse proportion to this speed, by phase-shift reduction.

ASCII: MIMR	Default: 0 Unit: A Range: (0.0 ... 0.8) * ICONT	Valid for all OPMODES
--------------------	---	-----------------------

Kp Proportional (P) gain of the flux controller. This is implemented as the PI controller.

ASCII: GF	Default: 15 Unit: - Range: 0...2000	Valid for all OPMODES
------------------	---	-----------------------

Tn Reinitialization (I) time for the flux controller. This is implemented as the PI controller.

ASCII: GFTN	Default: 50 Unit: ms Range: 0...1000	Valid for all OPMODES
--------------------	--	-----------------------

Phase-shift correction factor Correction factor for lowering phase-shift. This correction factor is used to compensate for the non-linearity of the inductance of the motor when the magnetization current is lowered, by increasing the speed during phase-shift reduction.

ASCII: MCFW	Default: 1.1 Unit: - Range: 1...5	Valid for all OPMODES
--------------------	---	-----------------------

Slippage correction factor Correction factor for the time constant of the rotor (armature). This improves torque over the reduction range and the stationary range of phase-shift.

ASCII: MCTR	Default: 1.1 Unit: - Range: 1...5	Valid for all OPMODES
--------------------	---	-----------------------

4.3 Screen page "Feedback"

Overview of the "Feedback" screen

At a Glance Diagram:

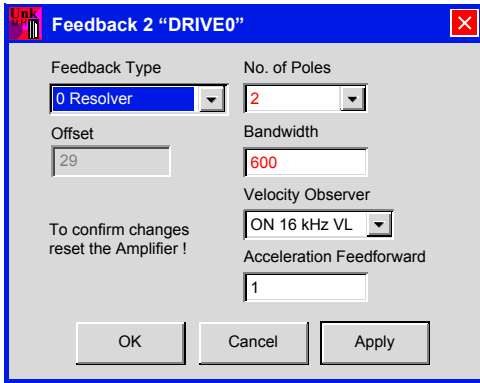

Resolver screen set up

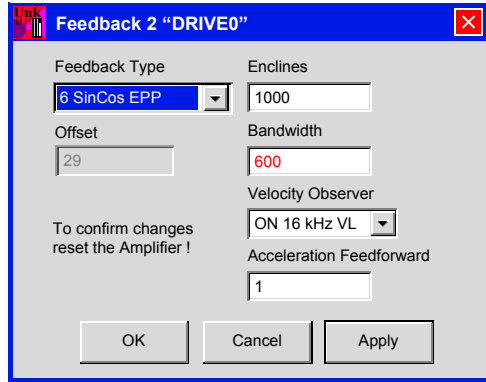

Encoder screen set up

Feedback type

ASCII: FBTYPE	Default: 0 Unit: - Range: 0...16	valid for all OPMODES
----------------------	--	-----------------------

Change this only while the amplifier is disabled, then reset amplifier.

ID	Function	Comments
0	Resolver	It is possible to connect 2, 4 or 6-pole resolvers to the servo amplifier. Cycle time 62.5 μ s.
1	reserved	-
2	HIPERFACE® Stegmann	In the initialization phase, all the data that is stored in the encoder EEPROM is loaded: Offset compensation Sine (HISOFFS (See <i>Sine Offset</i> , p. 81)) Offset compensation Cosine (HICOFFS (See <i>Cosine Offset</i> , p. 82)) Amplitude scaling (HIFACT1 (See <i>Sine Scaling</i> , p. 82)) Motor number (MNUMBER (See <i>Number - Reference</i> , p. 72)) Motor phase (MPHASE (See <i>Offset</i> , p. 81)) Cycle time 125 μ s.
3	Auto	The servo amplifier detects the connected feedback system automatically on connector X1 (Resolver, EnDat or Hiperface).
4	EnDat Heidenhain	In the initialization phase, all the data that is stored in the encoder EEPROM is loaded: Offset compensation Sine (HISOFFS (See <i>Sine Offset</i> , p. 81)) Offset compensation Cosine (HICOFFS (See <i>Cosine Offset</i> , p. 82)) Amplitude scaling (HIFACT1 (See <i>Sine Scaling</i> , p. 82)) Motor number (MNUMBER (See <i>Number - Reference</i> , p. 72)) Motor phase (MPHASE (See <i>Offset</i> , p. 81)) Cycle time 125 μ s.
5	reserved	-
6	SinCos EEP	Sine-cosine encoder. The MPHASE, HISOFFS, HICOFFS, HIFACT1 data is loaded from the EEPROM drive.
7	SinCos W & S	Sine/Cosine encoder without parameter channel. Automatic detection of MPHASE by Wake&Shake mode. HISOFFS, HICOFFS, HIFACT1 are also stored in the EEPROM drive. If 24V is switched on or the drive uses COLDSTART, a warning n14 is given. After the drive is enabled, a wake & shake mode is activated: the motor makes a short move to get the commutation angle. Then, the n14 is cleared.

ID	Function	Comments
8	RS422 & W&S	This function can only be used when Encoder emulation is set as an input : ENCMODE=0 and GEARMODE=3. When FPGA=1, position output (X5) supplies position data of the incremental encoder.
9	RS422	This function can only be used when Encoder emulation is set as an input : ENCMODE=0 and GEARMODE=3 When FPGA=1, position output (X5) supplies position data of the incremental encoder.
10	Sensorless	No feedback available
11	SinCos & Hall	Sine/cosine encoder with Hall effect sensor.
12	RS422 & Hall	RS422 feedback with Hall effect sensor.The parameter MPHASE can compensate for the misalignment of Hall sensors. To compensate for inverted hall effect sensors, set MPHASE = 180.
13-15	reserved	-
16	Resolver & SinCos	Both feedback systems are installed. The drive starts running with the resolver feedback. After a short delay the feedback switches to SinCos W&S (ID 7).

No. of poles

ASCII: MRESPOLES	Default: 2 Unit: - Range: 2, 4, .. 32	valid for all OPMODES
-------------------------	---	-----------------------

This parameter becomes effective only with resolver feedback (FBTYPE = 0 or 3). Standard resolvers have 2 poles. Change this only while the amplifier is disabled.

Encoder line count:

ASCII: ENCLINES	Default: 1000 Unit: - Range: 65535	valid for all OPMODES
------------------------	--	-----------------------

ENCLINES sets the resolution (number of lines) of the sine encoder input channel (connector X1 only). In case of rotary Motors it is the number of lines per revolution, in case of linear motors it is the number of lines per pole pitch. With an ENDAT or Hiperface Encoder ENCLINES is read automatically during the initialization process.

Resolver bandwidth

ASCII: MRESBW	Default: 600 Unit: Hz Range: 50 ... 2000	valid for all OPMODES
----------------------	--	-----------------------

With a wide bandwidth, the drive will respond more rapidly to control-loop deviations => smaller following error. A very wide bandwidth only makes sense with low moments of inertia, low KP, and very high values of acceleration. A narrower bandwidth produces a filter effect. The speed and positional control are smoother (the encoder emulation is quieter as well).

Offset

ASCII: MPHASE	Default: 0° Unit: Electrical degrees Range: 0... 360	valid for all OPMODES
----------------------	--	-----------------------

Compensates for a mechanical position error of the resolver/encoder in the motor. Change this only while the amplifier is disabled. If an encoder with EnDat or Hiperface® is used as a feedback unit, the offset is automatically transmitted to the servo amplifier while the system is booting.

⚠ DANGER

An incorrect setting can cause the motor to run away, (even with an 0V setpoint).

Failure to follow this instruction will result in death, serious injury, or equipment damage.

Sine Offset

ASCII: HxSOFFS	Default: 0 Unit: mv Range: -150...150	valid for all OPMODES
-----------------------	---	-----------------------

The HISOFFS command sets the offset correction for the sine signal of the incremental track. The command is only available when a sin/cos encoder has been selected as the feedback device (FBTYPE=2,4,7). HISOFFS defines the sine signal offset for an incremental encoder, HASOFFS for an absolute one.

Cosine Offset

ASCII: HxCOFFS	Default: 0 Unit: mv Range: -150...150	valid for all OPMODES
-----------------------	---	-----------------------

The HICOFFS command sets the offset correction for the cosine signal of the incremental track. The command is only available when a sin/cos encoder has been selected as the feedback device (FBTYPE=2,4,7). HICOFFS defines the sine signal offset for an incremental encoder, HACOFFS for an absolute one.

Sine Scaling

ASCII: HxFACT1	Default: 16384 Unit: mv Range: 12000 .. 19000	valid for all OPMODES
-----------------------	---	-----------------------

The HIFACT1 command sets the amplitude scaling for the sine signal of the incremental track (SinCoder). The amplitude scaling is for the value 16384 = 1. The command is only available when a sin/cos encoder has been selected as the feedback device (FBTYPE=2,4,7). HIFACT1 defines the sine signal offset for an incremental encoder, HAFACT1 for an absolute one.

Speed monitor

ASCII: FILTMODE	Default: 2 Unit: Range:	valid for all OPMODES
------------------------	-------------------------------	-----------------------

ID	Function	Note
0	OFF 16 kHz VL	(FILTMODE = 0) 16 KHz Update without Luenberger Observer
1	OFF 4 kHz VL	(FILTMODE = 1) 4 KHz Update without Luenberger Observer
2	ON 16 kHz VL	(FILTMODE = 2) 16 KHz Update with Luenberger Observer
3	ON 4 kHz VL	(FILTMODE = 3) 4 KHz Update with Luenberger Observer

On FILTMODE=0,1 Luenberger observer is off and a feedback filter (T-Tacho) can be configured on velocity loop. On FILTMODE=0,3 Luenberger observer is active.

**Acceleration
feedforward**

ASCII: VLO	Default: 1.0 Unit: - Range: 0...30	valid for all OPMODES
-------------------	--	-----------------------

This parameter generates a dynamic pre-control for the detection of current values (Luenberger monitor), in particular for resolver feedback. It reduces phase slippage in the detection of the current value, so improving the stability of the speed control. For VLO = 1, the pre-control is optimal; for VLO = 0, the action is suppressed.

4.4 Screen page "Encoder"

Overview of the "Encoder" screen

At a Glance

Diagram:

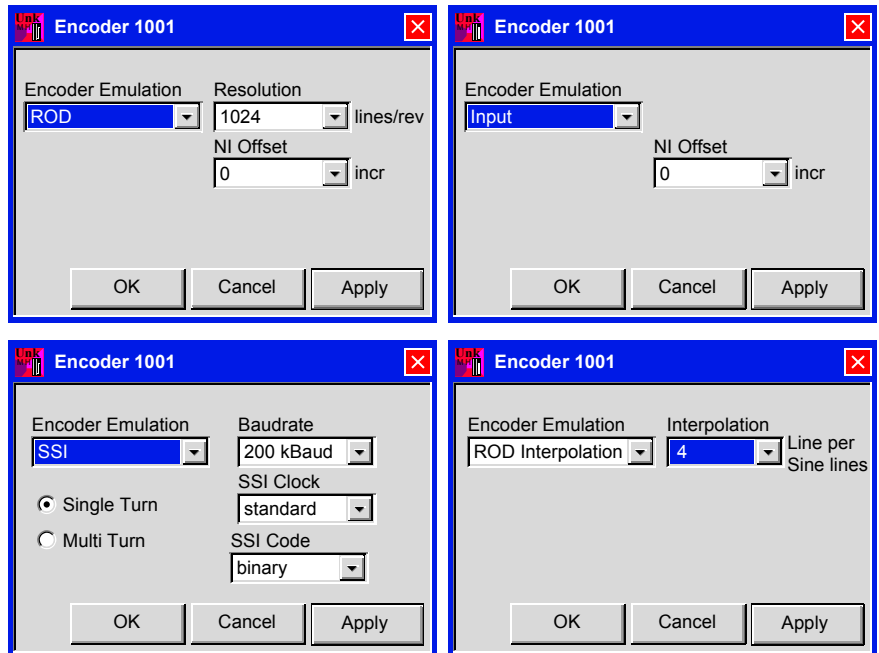

Encoder emulation (X5)Encoder emulation cycle time: 125 μ s

ASCII: ENCMODE	Default: 1 Unit: - Range: 0, 1, 2, 3	valid for all OPMODES
-----------------------	--	-----------------------

Change this only while the amplifier is disabled.

ID	Function	Comments
0	Input	Used as an input.
1	ROD	Incremental encoder emulation In the servo amplifier, the position of the motor shaft is calculated from the cyclically absolute signals from the resolver or encoder. This information is used to create incremental-encoder compatible pulses (max. 250 kHz). Pulses are given out at the connector X5 as two signals A/A and B/B with a 90° electrical phase difference, and a zero pulse. Exception: If a Sincos (Stegmann) encoder is used as the feedback unit, then the output of the zero pulse is inhibited (data are invalid) until the zero pulse from the encoder has been received.
2	SSI	SSI-encoder emulation. In the servo amplifier, the position of the motor shaft is calculated from the cyclically absolute signals from the resolver or encoder. This information is used to create a position output in a format that is compatible with the standard SSI-absolute-encoder format. 24 bits are transmitted. Radio button SINGLE TURN selected: The upper 12 bits are fixed to ZERO, the lower 12 bits contain the position information. For 2-pole resolvers, the position value refers to the position within one turn of the motor, for 4-pole resolvers it is within half a turn, and for 6-pole resolvers it is within a third of a turn. Exception: If an encoder with Sincos (Stegmann) is used as the feedback unit, then the upper 12 bits are set to 1 (data invalid!) until a homing run is performed. Radio button MULTI TURN selected: The upper 12 bits contain the number of motor turns, the lower 12 bits contain the position information.
3	ROD Interpolation	Digitalization and interpolation of the sine encoder input signals (feedback) to TTL level incremental output. This function works properly only with sine encoder feedback systems. The parameter INTERPOLATION determines the multiplier for the number of lines of the feedback encoder per electrical motor rotation.

Resolution ROD

ASCII: ENCOUT	Default: 1024 Unit: CPR Range: integer 32	valid for all OPMODES
----------------------	---	-----------------------

The resolution of the digital encoder output emulation (ROD) on connector X5.

ENCOUT defines the number of lines that are given out by the EEO (ROD) interface for one turn of a rotary motor.

For resolver feedback (**FBTYPE=0**) all lines per rev from 256 to 4096 with all integer numbers between are possible (256,257,258..... 4095,4096)

For sine encoder feedback (**FBTYPE =2,4,7,11**) all lines per rev from 256 to 524288, but only degrees of 2 (256, 512, 1024, .. , 262144, 524288).

NI-Offset

ASCII: ENCZERO	Default: 0 Unit: - Range: 0 .. ENCOUT-1	valid for all OPMODES
-----------------------	---	-----------------------

The ENCZERO command can be used to shift the output of the EEO (ROD) zero pulse over the range of one turn. The shift is made in the clockwise direction, e.g.

ENCOUT 1024

ENCZERO 256

The zero pulse is given out at the 90° position.

This is also effective for SSI outputs.

Single Turn/ Multi Turn

ASCII: SSIMODE	Default: 0 Unit: - Range: -	valid for all OPMODES
-----------------------	-----------------------------------	-----------------------

Determines whether the output format is compatible to a single turn or multi turn SSI encoder. Change this only while the amplifier is disabled.

ID	Function
0	Single Turn
1	Multi Turn

To switch over from 12 Bit Format per rev to 15 Bit Format per rev, set FPGA=4. In case of reading in an SSI value (GEARMODE=7, ENCMODE=2), it is possible to use the SSIMODE parameter to define the position within the SSI bit-stream which is used for transmitting the alarm bit.

ID	Function
0	no alarm bit
1	alarm bit first
2	alarm bit last

Baudrate

ASCII: SSIOU	Default: 0 Unit: - Range: 0...31	valid for all OPMODES
---------------------	--	-----------------------

Determines the serial transmission rate. Change this only while the amplifier is disabled.

ID	Function
0	200 kBaud
1	1.5 MBaud

SSI-Clock

ASCII: SSIINV	Default: 0 Unit: - Range: 0,1	valid for all OPMODES
----------------------	-------------------------------------	-----------------------

Determines whether the output level is normal, or inverted. Change this only while the amplifier is disabled.

ID	Function
0	Normal
1	Inverted

SSI-Code

ASCII: SSIGRAY	Default: 0 Unit: - Range: 0,1	valid for all OPMODES
-----------------------	-------------------------------------	-----------------------

Determines whether the output is in binary or GRAY code. Change this only while the amplifier is disabled.

ID	Function
0	Binary
1	Gray

4.5 Screen page "Analog I/O"

General overview of the "Analog I/O" screen

At a Glance Overview of the different fields contained in the "Analog I/O" screen.

What's in this Section? This section contains the following topics:

Topic	Page
Analog Inputs/Outputs "Analog I/Os"	90
Analog inputs AI1 / AI2	91
Analog Outputs AO1 / AO2	98

Analog Inputs/Outputs "Analog I/Os"

At a Glance

Diagram:

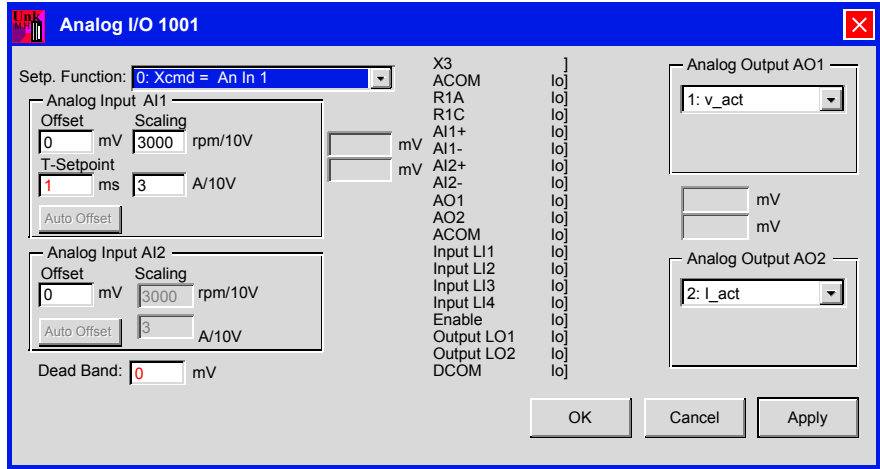

Cycle time of the analog I/O-functions: 250 micro-seconds. Analog input AI1 is read every 125 micro-seconds.

The actual values of the analog inputs/outputs are shown in the diagram of the connector X3.

Analog inputs AI1 / AI2

Setpoint functions

ASCII: ANCNFG	Default: 0 Unit: - Range: 0 - 14	valid for all OPMODES
----------------------	--	-----------------------

ID	Function
0	Analog Input 1 = Velocity or Current Cmd (OPMODE dependent)
1	Analog Input 1 = Velocity Cmd, Analog Input 2 = Current Command
2	Analog Input 1 = Velocity Cmd, Analog Input 2 = Current Feed Forward Scaling
3	Analog Input 1 = Velocity or Current Cmd (OPMODE dependent), Analog Input 2 = Sys peak current
4	Analog Input 1 + Analog Input 2 = Velocity or Current (OPMODE dependent)
5	Analog Input 1 x Analog Input 2 = Velocity or Current Cmd (OPMODE dependant)
6	Analog Input 2 = Gearing ratio Cmd
7	Analog Input 1 = Current Cmd, Analog Input 2 = Max Sys Speed
8	Analog Input 1 = Position Command
9	Analog Input 1 = Velocity or Current Cmd (OPMODE dependent), Analog Input 2 = Ferraris
10	Reserved
11	Analog Input 2 = adjust Digital Trigger Level (Direct)
12	Analog Input 2 = adjust Digital Trigger Level (After Rising Edge)
13	Analog Input 1 = Velocity or Current Cmd (OPMODE dependent), Analog Input 2 = Sys Peak Current (Pos only)
14	Analog Input 1 = Velocity or Current Cmd (OPMODE dependent), Analog Input 2 = Sys Peak Current (Neg only)

0: Analog Input 1 = Velocity or Current Cmd (OPMODE dependent)

The servo amplifier only uses the Analog Input 1 as velocity command or current command according to OPMODE value.

OPMODE	Analog Input 1 function	Analog Input 1 value
1: analog velocity	Velocity command	VSCALE1 * AI1
3: analog torque	Torque (Current) command	ISCALE1 * AI1

Additionally, function "switch-over Analog Input 1 to Analog Input 2" can be set. Then a Llx digital input allows switch between AI1 and AI2.

OPMODE	Llx	Analog Input Setting	Analog Input Value
1: analog velocity	HIGH	AI2 is active and set as velocity command	VSCALE2 * AI2
1: analog velocity	LOW	AI1 is active and set as velocity command	VSCALE1 * AI1
3: analog torque	HIGH	AI2 is active and set as current command	ISCALE2 * AI2
3: analog torque	LOW	AI1 is active and set as current command	1SCALE1 * AI1

To set up digital input Llx for this function, see Digital Inputs LI1/LI2/LI3/LI4 "Function 8 - An In 1 / An In 2"

1: Analog Input 1 = Velocity Cmd, Analog Input 2 = Current Command

The servo amplifier only uses one of the two analog inputs, depending on the setting of OPMODE.

$$vcmd = \text{Scaling (AIx)} * AIx$$

OPMODE	AI1 setting	AI2 setting
1: analog velocity	velocity cmd active & vcmd = VSCALE1 * AI1	inactive
3: analog torque	inactive	current (torque) command active & lcmd = ISCALE2 * AI2
all other settings	inactive	inactive

2: Analog Input 1 = Velocity Cmd, Analog Input 2 = Current Feed Forward Scaling

Analog Input 2 is used as current feed forward (OPMODE=0,1).

$$vcmd = VSCALE1 * AI1$$

$$lffd = ISCALE2 * AI2$$

3: Analog Input 1 = Velocity or Current Cmd (OPMODE dependent), Analog Input 2 = Sys peak current

The servo amplifier uses the Analog Input 1 as velocity command or current command according to OPMODE value. Analog Input 2 is used for limiting drive peak current (Ipeak1).

OPMODE	AI1 setting	AI1 value	AI2 function	AI1 value
1: analog velocity	Velocity command	VSCALE1 * AI1	Drive peak current limitation	Ipeak1=IPEAK * AI2 / 10V
3: analog torque	Current command	ISCALE1 * AI1		

IPEAK is the peak current set up for the application. For more details, see .

If you use both Ipeak2 (see Digital Inputs L11/L12/L13/L14 "Function 18 - Ipeak2 x") and Ipeak1 setpoint function, the servo amplifier will set the lowest Ipeak value.

4: Analog Input 1 + Analog Input 2 = Velocity or Current (OPMODE dependent)

The servo amplifier uses the sum of both analog inputs, depending on the setting of OPMODE.

$$Xcmd = \text{Scaling (AI1)} * AI1 + \text{Scaling (AI2)} * AI2$$

OPMODE	AI1 + AI2 Description	AI1 + AI2 Value
1: analog velocity	velocity setpoint	VSCALE1 * AI1 + VSCALE2 * AI2
3: analog torque	current (torque) setpoint	ISCALE1 * AI1 + ISCALE2 * AI2
all other settings	inactive	-

5: Analog Input 1 x Analog Input 2 = Velocity or Current Cmd (OPMODE dependant)

The servo amplifier uses the product of both setpoint inputs, depending on the setting of OPMODE. The voltage on Analog Input 2 has the effect of a weighting factor for Analog Input 1, the scaling for Analog Input 2 is ineffective:

$$Xcmd = AI1 * \text{Scaling (AI1)} * AI2$$

OPMODE	AI1 . AI2 Description	AI1 . AI2 Value
1: analog velocity	velocity setpoint	(VSCALE1 * AI1) * AI2
3: analog torque	current (torque) setpoint	(ISCALE1 * AI1) * AI2
all other settings	inactive	-

6: Analog Input 2 = Gearing ratio Cmd

Correction of the gearing ratio (GEARO) of the electrical gearing through Analog Input 1 for OPMODE 4. Analog Input 1 is used as a speed (or torque) setpoint for OPMODE 1 (or 3).

$$\text{GEAROeff} = \text{GEARO} * (1 + \text{VSCALE2} * \text{AI2} / 1000)$$

VSCALE defines a correction factor in %

for example:

$$\text{VSCALE2} = 20$$

$$\text{for AI2} = 10\text{V}, \text{GEAROeff} = \text{GEARO} * 1,2$$

$$\text{for AI2} = -10\text{V}, \text{GEAROeff} = \text{GEARO} * 0,8$$

$$\text{for AI2} = 0\text{V}, \text{GEAROeff} = \text{GEARO}$$

7: Analog Input 1 = Current Cmd, Analog Input 2 = Max Sys Speed

OPMODE should be previously set to 3.

Analog input 1 is used as current command. Analog input 2 is used to set maximum motor velocity.

$$\text{Icmd} = \text{ISCALE1} * \text{AI1}$$

$$\text{nmax} = \text{VSCALE2} * \text{AI2}$$

Whatever Icmd value, motor velocity will never exceed nmax.

8: Analog Input 1 = Position Command

OPMODE 5 has to be set.

Analog input 1 is used as a analog position setpoint.

The working distance is defined by SRND (start position) and ERND (end position).

$$\text{Analog input 1} = 0\text{V Position} = \text{SRND}$$

$$\text{Analog input 1} = \pm 10\text{V Position} = \text{ERND}$$

In addition, homing can be performed independantly by starting a homing motion task (See *Overview of the "Motion Task Table" Screen, p. 227*) thanks to a digital input LIx (see Digital Inputs LI1/LI2/LI3/LI4 "Function 16 Start_MT no.2").

9: Analog Input 1 = Velocity or Current Cmd (OPMODE dependent), Analog Input 2 = Ferraris

Analog Input 1 as velocity command when OPMODE=1 or as torque (current) command when OPMODE=3.

Analog Input 2 is used as a Ferraris sensor input (acceleration sensor) for implementing speed control using this sensor.

10: Reserved

11: Analog Input 2 = adjust Digital Trigger Level (Direct)

Change of an INxTRIG (x=1, 2, 3, 4) variable via the Analog Input 2. The corresponding Number (x) of the trigger variable is set by AN11NR. The range of the parameter change is defined by AN11RANGE.

The change of AI2 value occurs immediately (update time 1 to 10ms): INxTRIG will be changed whatever the Lix state.

For example:

ANCNFG=1	enabling analog input function 11
AN11NR=1	enabling IN1TRIG as LI1 input value to be changed
IN1TRIG=1000	setting IN1TRIG at 1000
AN11RANGE=500	setting Analog Input 2 range

at AI2 = 0V, IN1TRIG = 1000

at AI2 = 10V, IN1TRIG = 1500

at AI2 = -10V, IN1TRIG = 500

12: Analog Input 2 = adjust Digital Trigger Level (After Rising Edge)

Change of INxTRIG (x=1,2,3,4) variable via Analog Input 2. The corresponding number (x) of trigger variable is set by AN11NR. The range of the parameter change is defined by AN11RANGE. The change of AI2 value acts on INxTRIG after a rising edge on the selected Lix digital input.

13: Analog Input 1 = Velocity or Current Cmd (OPMODE dependent), Analog Input 2 = Sys Peak Current (Pos only)

The servo amplifier uses the Analog Input 1 as velocity command or current command according to the OPMODE value. The absolute value of Analog Input 2 limits the positive current of the drive.

OPMODE	AI1 setting	AI1 value	AI2 function	AI2 value
1: analog velocity	Velocity command	$VSCALE1 * AI1$	Drive peak current limitation	$IPEAK * abs(AI2) / 10V$
3: analog torque	Current command	$ISCALE1 * AI1$		

The negative current is not affected.

In the positive direction, the acceleration current is limited, and in the negative direction, the deceleration current.

14: Analog Input 1 = Velocity or Current Cmd (OPMODE dependent), Analog Input 2 = Sys Peak Current (Neg only)

The servo amplifier uses the Analog Input 1 as velocity command or current command according to the OPMODE value. The absolute value of Analog Input 2 limits the negative current of the drive.

OPMODE	AI1 setting	AI1 value	AI2 function	AI2 value
1: analog velocity	Velocity command	$VSCALE1 * AI1$	Drive peak current limitation	$- IPEAK * abs(AI2) / 10V$
3: analog torque	Current command	$ISCALE1 * AI1$		

The positive current is not affected.

In the negative direction, the acceleration current is limited, and in the positive direction, the deceleration current.

Offset

ASCII: ANOFFx	Default: 0 mV Unit: Millivolts Range:-10000 .. 10000	valid for all OPMODES
----------------------	--	-----------------------

Is used to compensate the offset voltages of CNC-controls and the analog inputs 1 (ANOFF1) or 2 (ANOFF2). Adjusts the axis to standstill while the setpoint = 0V.

Scaling

ASCII: VSCALEx	Default: 3000 Unit: rpm / 10 Volts Range: -15000 .. 15000	valid for OPMODE 1
-----------------------	---	--------------------

Scaling of the speed setpoint value of the analog inputs 1 (VSCALE1) and 2 (VSCALE2) Input: xx rpm / 10 V

ASCII: ISCALEx	Default: DIPEAK Unit: A/10Volts Range: 0 ... 100	valid for OPMODE 3
-----------------------	--	--------------------

Scaling of the current setpoint value of the analog inputs 1 (ISCALE1) and 2 (ISCALE2) Input: xx A / 10 V

T Setpoint

ASCII: AVZ1	Default: 1 Unit: Milliseconds Range: 0.2 .. 100.0	valid for OPMODE 1
--------------------	---	--------------------

You can enter a filter time constant here, for Analog Input 1 (clock rate 8 kHz, 1st order filter)

Auto-Offset

ASCII: ANZEROx	Default: - Unit: - Range: -	valid for all OPMODES
-----------------------	-----------------------------------	-----------------------

This function carries out an automatic adjustment of the setpoint offset for analog inputs 1 (ANZERO1) and 2 (ANZERO2). Conditions: analog inputs short-circuited, or 0V from the controls.

Dead Band

ASCII: ANDB	Default: 0 Unit: Millivolts Range: 0.0 .. 10000.0	valid for OPMODES 1, 3
--------------------	---	------------------------

Suppresses small input signals. The function is useful with OPMODE1: analog speed (**without higher-level position control**)

Analog Outputs AO1 / AO2

Analog Out 1/2

ASCII: ANOUTx	Default: 1 Unit: - Range: -	valid for OPMODES 1+3
----------------------	-----------------------------------	-----------------------

The analog outputs 1 (ANOUT1, terminal X3/8) and 2 (ANOUT2, terminal X3/9) each provide various analog actual/setpoint values, depending on the selection in the commissioning software. Make changes only while the amplifier is disabled, then reset (COLDSTART).

Output resistor 2.2k Ω . Resolution 10 bit.

ID	Function	Description
0	Off	inactive
1	v_Act	The speed monitor provides a DC voltage referred to ACOM, analog to the actual speed. Amplitude: +/-10V for the +/- preset VLIM speed in the speed controller.
2	I_act	The current monitor provides a DC voltage referred to ACOM, analog to the actual current. The output is the actual in-phase current (active component Iq), which is nearly proportional to the motor output torque . Amplitude: +/-10 V for the +/- preset IPEAK current (r.m.s. value) in the current controller scaled by ANxTRIG.
3	v_cmd	The output provides 10V referred to ACOM for the internal speed setpoint. Amplitude :10V at the preset VLIM speed in the speed controller scaled by ANxTRIG.
4	I_cmd	The output provides 10V referred to ACOM for the internal current setpoint (corresponds to the preset peak current at the output of the speed controller). Amplitude: +/-10 V for the +/- preset peak current (r.m.s. value) in the current controller scaled by ANxTRIG.
5	FError	The output provides 10V referred to ACOM for the preset following error window (PEMAX) scaled by ANxTRIG.
6	Slot.	Reserved for the expansion card.
7	PFB	The analog output returns the actual position. The scaling is related to the Modulo axes defined by SRND and ERND. This output is derived from the modulo axes type (POSCNFG=2)
8	Uconst=x	The analog output gives a constant voltage. The voltage can be set by using the variable ANxTRIG in (mV).
9	IT	The analog output returns the actual value of IT. 10V=100%(IT)

AO Scaling

ASCII: ANx TRIG	Default: 100 Unit: % Range: Long int	valid for all OPMODES
------------------------	--	-----------------------

AN1TRIG and AN2TRIG scale respectively the analog outputs AO1 and AO2. The scaling is done in %.

Example:

Setting ANOUT 1 to 1 (Actual velocity),

AN1TRIG = 100 10V at the output when actual velocity=VLIM

AN1TRIG = 50 5V at the output when actual velocity=VLIM

AN1TRIG = 200 10V at the output when actual velocity=VLIM/2

If ANOUT=8 is selected (constant voltage), AN1TRIG gives the voltage in mV.

4.6 Screen page "Digital I/O"

Overview of "Digital I/O"

At a Glance

Overview of the different fields contained in the "Digital I/O" screen

What's in this Section?

This section contains the following topics:

Topic	Page
Overview	101
Digital inputs LI1/LI2/LI3/LI4	102
Digital Outputs LO1 / LO2	119

Overview

At a Glance

Diagram:

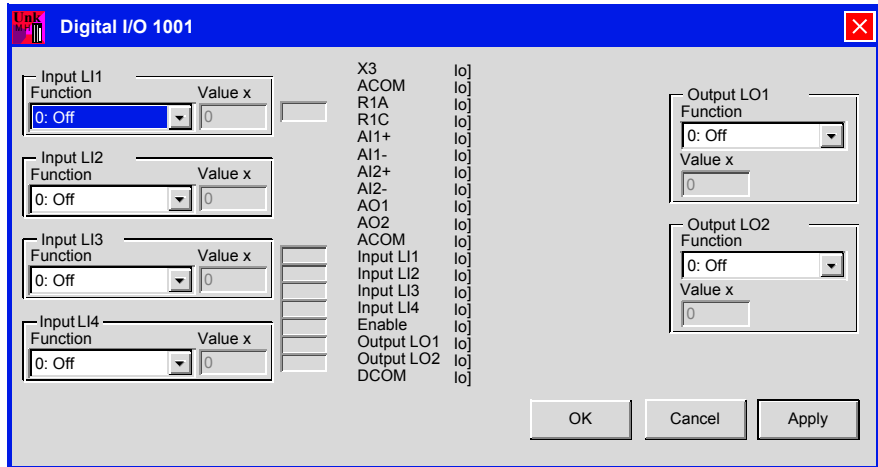

Cycle time of digital I/O functions: 1 ms The digital I/O states are displayed.

Digital inputs LI1/LI2/LI3/LI4

At a Glance

ASCII: INxMODE	Default: 0 Unit: - Range: 0- 50	valid for all OPMODES
ASCII: INxTRIG	Default: 0 Unit: - Range: long int	valid for all OPMODES

The terminals LI1, LI2, LI3 & LI4 (X3/11,12,13,14 respectively) can be used in combination with internal functions. Each digital input is defined by INxMode and INxTRIG. INxMODE sets digital input function and INxTRIG sets digital input value. Change this only while the amplifier is disabled, then reset amplifier. (COLDSTART).

IN1MODE, IN1TRIG parameters for LI1, IN2MODE, IN2TRIG parameters for LI2, IN3MODE, IN3TRIG parameters for LI3 & IN4MODE, IN4TRIG parameters for LI4.

Here is the complete list of available function on each digital input:

INxMODE value	Function	Active edge/ Level	Auxiliary value x INxTRIG	Function can be combined with			
				LI1 X3/10	LI2 X3/12	LI3 - PSTOP X3/13	LI4 - NSTOP X3/14
0	Off	-	-	x	x	x	x
1	Reset Fault	↗	-	x		(1)	x
2	PSTOP (EOT Limit Switch)	-	-			x	x
3	NSTOP (EOT Limit Switch)	-	-			x	x
4	PSTOP+Integral Off (EOT Limit Switch)	-	-			x	x
5	NSTOP + Integral Off (EOT Limit Switch)	-	-			x	x
6	PSTOP+NSTOP (EOT Limit Switch)	-	-			x	x
7	P / NSTOP +Integral Off (EOT Limit Switch)	-	-			x	x
8	Change Command from Analog Input AI1 to Analog Input AI2	High/Low	-	x	x	x	x

INxMODE value	Function	Active edge/ Level	Auxiliary value x INxTRIG	Function can be combined with			
				LI1 X3/10	LI2 X3/12	LI3 - PSTOP X3/13	LI4 - NSTOP X3/14
9	Motion Task BCD Select Bit	↗	-	x	x	x	x
10	Integral Off	↗	-	x	x	x	x
11	Change Velocity to Torque Control	High/Low	-	x	x	x	x
12	Machine Home (Reference) Switch	↗	-	x	x	x	x
13	Change Emulation from ROD (A Quad B) Enc to SSI	High/Low	-	x	x	x	x
14	Clear Position Error or Network Node Guarding	↗	-	x	x	x	x
15	Start "Next Motion Task" Defined in Current Motion Task	Can be set	-	x	x	x	x
16	Start Motion Task No x (Level Triggered)	↗	Motion task no.	x	x	x	x
17	Start Motion Task Configured by BCD Select Bits	↗	-	x	x	x	x
18	Change System Peak Current to x	↗	% of Ipeak	x	x	x	x
19	Off	-	-	x	x	x	x
20	Jog Motor at x Speed	↗	Speed in rpm	x	x	x	x
21	Turn Off Under Voltage Monitoring	↗	-	x	x	x	x
22	Restart Current Motion Task	↗	-	x	x	x	x
23	Start Motion Task No x (Edge Triggered)	↗	Motion task no.	x	x	x	x
24	Change OPMODE A to B	↗	Opmode no.	x	x	x	x
25	Latch ROD (A Quad B) Enc Zero Pulse	↗	-	x	x	x	x
26	Latch Motor Position (High Speed)	↗		x	x		

INxMODE value	Function	Active edge/ Level	Auxiliary value x INxTRIG	Function can be combined with			
				LI1 X3/10	LI2 X3/12	LI3 - PSTOP X3/13	LI4 - NSTOP X3/14
9	Motion Task BCD Select Bit		-	x	x	x	x
10	Integral Off		-	x	x	x	x
11	Change Velocity to Torque Control	High/Low	-	x	x	x	x
12	Machine Home (Reference) Switch		-	x	x	x	x
13	Change Emulation from ROD (A Quad B) Enc to SSI	High/Low	-	x	x	x	x
14	Clear Position Error or Network Node Guarding		-	x	x	x	x
15	Start "Next Motion Task" Defined in Current Motion Task	Can be set	-	x	x	x	x
16	Start Motion Task (Level Triggered)		Motion task no.	x	x	x	x
17	Start Motion Task Configured by BCD Select Bits		-	x	x	x	x
18	Change System Peak Current to x		% of Ipeak	x	x	x	x
19	Off	-	-	x	x	x	x
20	Jog Motor at x Speed		Speed in rpm	x	x	x	x
21	Turn Off Under Voltage Monitoring		-	x	x	x	x
22	Restart Current Motion Task		-	x	x	x	x
23	Start Motion Task (Edge Triggered)		Motion task no.	x	x	x	x
24	Change OPMODE A to B		Opmode no.	x	x	x	x
25	Latch ROD (A Quad B) Enc Zero Pulse		-	x	x	x	x
26	Latch Motor Position (High Speed)			x	x		

INxMODE value	Function	Active edge/ Level	Auxiliary value x INxTRIG	Function can be combined with			
				LI1 X3/10	LI2 X3/12	LI3 - PSTOP X3/13	LI4 - NSTOP X3/14
27	Emergency Stop	↗	-	x	x	x	x
28	Start Jogmode	-		x	x	x	x
29	Start Motion Task/Homing	-		x	x	x	x
30	Execute Command Buffer 1	High/Low		x	x	x	x
31	Execute Command Buffer 2	High/Low		x	x	x	x
32	Release Motor Brake when Drive Disabled	↗	-	x	x	x	x
33	Execute Command Buffer 1 (RS 232)	High/Low	-	x	x	x	x
34	Execute Command Buffer 2 (RS 232)	High/Low		x	x	x	x
35	VCT	↗		x	x	x	x
36	Give Offset to Gearing Function	↗	-	x	x	x	x
37	Source of Actual Position	High/Low					
38	Additional Enable for "Next Motion Task"	↗		x	x	x	x
39	Move Constant Velocity for Set Time	↗	Opmode no.	x	x	x	x
40	Additional HW Enable	High		x	x	x	x
41	Fast Emergency Stop	↘ Low		x	x	x	x
42	Turn On/Off Gearing	High/Low	-	x	x	x	x
43	Turn On/Off Gearing (with phase adjust from ramp up)	High/Low	-	x	x	x	x
44	Position Latch + reset (falling edge)	edge, ↘		x	x		
45	Position Latch + reset (rising edge)	edge, ↗		x	x		
46	Position Latch + reset (average value)	edge, ↘		x	x		
47	Master/slave correction	-		x	x		
48	Reserved						

INxMODE value	Function	Active edge/ Level	Auxiliary value x INxTRIG	Function can be combined with			
				LI1 X3/10	LI2 X3/12	LI3 - PSTOP X3/13	LI4 - NSTOP X3/14
49	Emergency Stop (High)	High		x	x	x	x
50	Emergency Stop (Low)	Low		x	x	x	x

(1) At this INxMODE value, digital input is OFF. See Function 0 for explanation.

Description of Digital Input Function**0: Off**

The state of Input 1 is read and can be used via a Fieldbus or SLOT card.

1: Reset

Software reset of the amplifier in the event of a fault. All the functions and displays are set to the initial status. Parameters that are not stored in the EEPROM are erased, the parameters stored in the EEPROM are loaded.

If any of the error messages F01, F02, F03, F05, F08, F13, F16 or F19 are present, then no software-reset will be carried out. Only the error message will be deleted. This means that, for example, the encoder output signals are stable and can continue to be evaluated by the controller.

When the input is HIGH while the auxiliary 24V supply is switched on, the drive waits, before the input is set to LOW. In this case, the first of the three display positions displays an "A".

2: PSTOP (EOT Limit Switch)

LOW level at selected input disables the positive direction (clockwise if DIR=1, counterclockwise if DIR=0). At the same time, a warning "n10" is displayed. If a negative edge is recognized while the motor is running, the drive stops the motor in OPMODE=0 (velocity control with setpoint zero) using the Emergency Dec. ramp (See *Emergency ramp*, p. 140). When the motor has stopped, the previous OPMODE is activated.

3: NSTOP (EOT Limit Switch)

LOW level at selected input disables the negative direction (clockwise if DIR=0, counterclockwise if DIR=1). At the same time, a warning "n11" is displayed. If a negative edge is recognized while the motor is running, the drive stops the motor in OPMODE=0 (velocity control with setpoint zero) using the Emergency Dec. ramp (See *Emergency ramp*, p. 140). When the motor has stopped, the previous OPMODE is activated.

4: PSTOP+Integral Off (EOT Limit Switch)

LOW level at selected input disables the positive direction (clockwise if DIR=1, counterclockwise if DIR=0). At the same time, a warning "n10" is displayed. If a negative edge is recognised while the motor is running, the drive stops the motor in OPMODE=0 (velocity control with setpoint zero) using the Emergency Dec. ramp (See *Emergency ramp*, p. 140). When the motor has stopped, the previous OPMODE is activated (without integral part in the velocity controller).

5: NSTOP + Integral Off (EOT Limit Switch)

LOW level at selected input disables the negative direction (counterclockwise if DIR=1, clockwise if DIR=0). At the same time, a warning "n11" is displayed. If a negative edge is recognised while the motor is running, the drive stops the motor in OPMODE=0 (velocity control with setpoint zero) using the Emergency Dec. ramp (See *Emergency ramp*, p. 140). When the motor has stopped, the previous OPMODE is activated (without integral part in the velocity controller).

6: PSTOP+NSTOP (EOT Limit Switch)

LOW level at LI3 input disables the positive and the negative direction. At the same time, a warning "n10" and "n11" is displayed. If a negative edge is recognised while the motor is running, the drive stops the motor in OPMODE=0 (velocity control with setpoint zero) using the Emergency Dec. ramp (See *Emergency ramp*, p. 140). When the motor has stopped, the previous OPMODE is activated.

7: P/NSTOP + Integral Off (EOT Limit Switch)

LOW level at LI3 disables the positive and the negative direction. At the same time, a warning "n10" and "n11" is displayed. If a negative edge is recognised while the motor is running, the drive stops the motor in OPMODE=0 (velocity control with setpoint zero) using the Emergency Dec. ramp (See *Emergency ramp*, p. 140). When the motor has stopped, the previous OPMODE is activated (without integral part in the velocity controller).

8: Change Command from Analog Input AI1 to Analog Input AI2

Switches over the setpoint inputs analog input 1/2 at ANCNFG (See *Setpoint functions*, p. 91) = 0. This function is only effective if the analog set-point function "0: Analog Input 1 = Velocity or Current Cmd (OPMODE dependent)" has been selected.

HIGH level at the input : analog input 2 (terminals X3/6,7) is active

LOW level at the input : analog input 1 (terminals X3/4,5) is active

9: Motion Task BCD Select Bit

Here you can select the motion tasks that are stored in the amplifier (numbers 1...7) or the homing (0). The motion task number is presented externally at the digital inputs as a logical word, with a width of max. 3 bits. An input is required to start the motion task (17, Start_MT I/O). If you wire up a reference switch (12, Reference) and (also) want to start a following task (15, Start_MT Next) externally, the number of inputs that are available for selecting the motion tasks will be further reduced.

Examples of possible assignments of the digital inputs for various applications:

Application	Motion task number: MSB ----->LSB				Selectable motion task numbers
	LI4 function IN4MODE	LI3 function IN3MODE	LI2 function IN2MODE	LI1 function IN1MODE	
7 motion tasks + homing, without reference switch	Start_MT I/O IN4MODE=17	2 ² IN3MODE=9	2 ¹ IN2MODE=9	2 ⁰ IN1MODE=9	0 to 7
3 motion tasks + homing, without reference switch. Start a following task that is defined in the motion task, using the setting "Start with I/O".	Start_MT Next IN4MODE=15	Start_MT I/O IN3MODE=17	2 ¹ IN2MODE=9	2 ⁰ IN1MODE=9	0 to 3
3 motion tasks + homing, with reference switch.	2 ¹ IN4MODE=9	2 ⁰ IN3MODE=9	Reference IN2MODE=12	Start_MT I/O IN1MODE=17	0 to 3
1 motion task + homing, with reference switch. Start a following task that is defined in the motion task, using the setting "Start with I/O".	Reference IN4MODE=9	Start_MT Next IN3MODE=15	2 ⁰ IN2MODE=9	Start_MT I/O IN1MODE=17	0 to 1

This function can also be used for VCT entry, to select the address of the VCTs. The start of the VCT entry is done by selecting one input with INxMODE=35.

10: Integral Off

Switches off the integral component of the speed controller, the P-gain remains at the set value, the current (rotational) speed feedback remains in operation.

11: Change Velocity to Torque Control

Bypasses the velocity controller. The analog setpoint is taken 1:1 as the setpoint for current control, i.e. change over from velocity control to current (torque) control.

HIGH-level at the input : torque control

LOW-level at the input : velocity control

Depending on OPMODE, it changes between OPMODE=0 (LOW) and OPMODE=2 (HIGH) or OPMODE=1 (LOW) and OPMODE=3 (HIGH).

12: Machine Home (Reference) Switch

Home/reference switch located on machine. This is useful when preparing a Homing with a switch in the machine. Please refer to *Overview of the "Homing" screen, p. 147* for more information.

13: Change Emulation from ROD (A QUAD B) Enc to SSI

Changeover of the encoder-emulation (position output) on connector X5.

HIGH level at the input: **SSI**-compatible position signals. (ENCMODE = 2)

LOW level at the input: **ROD**-compatible position signals. (ENCMODE = 1)

14: Clear Position Error or Network Node Guarding

Clears the warning for a following error (display no. 03) or for response monitoring (display no. 04).

15: Start "Next Motion Task" Defined in Current Motion Task

The next task, that is defined in the motion task by "Start with I/O" is started. The target position of the processing motion task must be reached before the next task can be started.

16: Start Motion Task No x (Level Triggered)

Start a motion task that is stored in the servo amplifier, by giving the motion task number (x) stored in the INxTRIG variable. After the function has been selected you can enter the motion task number. Motion task number "0" initiates homing/reference traverse. A rising edge starts the motion task, a falling edge interrupts the motion instruction.

17: Start Motion Task Configured by BCD Select Bits

Start of the motion task that has the number that is presented, bit-coded, at the digital inputs (LI4/LI3/LI2/LI1, see Function 9, "Motion Task BCD Select Bit"). A rising edge starts the motion task, a falling edge interrupts the motion instruction.

18: Change System Peak Current to x

Switch over to a second (lower) peak value of current. Scaled as x (0...100) % of the peak current of the instrument. After the function has been selected you can enter the percentage value (stored in the INxTRIG variable). Make the conversion according to the following equation:

$$x = (I_{\text{peak2}} / I_{\text{PEAK}}) * 100\% \Rightarrow I_{\text{peak2}} = (x / 100\%) * I_{\text{PEAK}}$$

Can be implemented with an Analog Input Current Limitation function. See *Analog inputs AI1 / AI2, p. 91* Function 3. for more information.

19: Off**20: Jog Motor at x Speed (Position Motion Task Opmode)**

Start of the setup mode "Constant velocity" with a defined speed.

By selecting the function, INxTRIG stores velocity value. A rising edge starts the motion, a falling edge cancels the motion. This function works in position control, so OPMODE=8 must be selected. The velocity is given in units of the position controller given by VUNIT; the sign selects the moving direction.

21: Turn Off Under Voltage Monitoring

Turns off the undervoltage monitoring function of the servo amplifier.

HIGH = off

LOW = on

22: Restart Current Motion Task

Continues the motion task that was previously interrupted by a STOP command.

23: Start Motion Task No x (Edge Triggered)

Starts a motion task that is stored in the amplifier, with definition of the motion task number. You can enter the motion task number x in INxTRIG. Motion task number "0" initiates homing/reference traverse. A rising edge starts the motion task.

Note: The motion task does not stop automatically if the start signal is removed!

The motion task must be stopped by:

- a falling edge on another digital input (configured with 16, Start_MT No x)
- the ASCII command STOP
- the STOP function via Bus or digital input

24: Change OPMODE A to B

Changeover of the operating mode (OPMODE). The numbers of the OPMODES that are to be changed over are entered in INxTRIG as a decimal number. You have to calculate this decimal value from a 2-byte hex value.

Bits 0 ... 7 of the hex value contain the number of the OPMODE to which the system changes when a falling edge is detected at the appropriate input; bits 8 ... 15 contain the number for the response to a rising edge.

When the controller is switched on, the OPMODE is set according to the input level.

For example:

Changeover between OPMODE 4 (LOW state) and OPMODE 8 (HIGH state) according to the state of the digital input LI1.

Function IN1MODE = 24

IN1TRIG=2052 (0804h)

LI1=LOW, OPMODE=4

LI1=HIGH, OPMODE=8

25: Latch ROD (A QUAD B) Enc Zero Pulse

Sets the digital encoder zero pulse offset. The current position, depending on the digital encoder resolution ENCOUT that is set, is calculated at the rising edge and stored as NI-Offset in ENCZERO. Then, an automatic SAVE is generated. This function is used to perform an automatic setting of the zero pulse in one turn of the motor.

26: Latch Motor Position (High Speed)

An edge on this input latches the actual position. The position can then be read by LATCHX32 (positive edge) or LATCHX32N (negative edge). The actual 16-Bit position (absolute in one turn) can be read by LATCHX16 (positive edge) and LATCHX16N (negative edge). The status of the latching can be read by the equivalent bits of DRVSTAT. The min. cycle time for a low/high to high/low transaction is 500s. The Latch function does not work with POSCNFG=1.

27: Emergency Stop

The LOW level initiates an emergency-stop phase: motion is cancelled and the drive stop process is initiated, in a velocity control (OPMODE=1), using emergency ramp DECSTOP. When motor stop is complete, the servo amplifier mode reverts to previous OPMODE.

28: Start Jogmode

Can be set up only via the Terminal (See *Overview of the "Terminal" screen, p. 199*) screen.

Only for OPMODE = 8. A rising edge starts a jog mode with speed VJOG, a falling edge stops it.

29: Start MT I/O

Can be set up only via the Terminal (See *Overview of the "Terminal" screen, p. 199*) screen.

Start of the motion task that has the number that is presented, bit-coded, at the digital inputs (LI4 / LI3 / LI2 / LI1, see Function 9, Motion Task BCD Select Bit). A rising edge has no effect.

30: Execute Contents of Command Buffer 1

ASCII: INHCMD	Default: 0 Unit: - Range: -	valid for all OPMODES
ASCII: INLCMD	Default: - Unit: - Range: -	valid for all OPMODES

A positive or negative edge on the input Llx starts a command buffer. This command buffer contains separate ASCII objects, separated by semicolons (;). The command buffer for the positive edge is INHCMD, the command buffer for the negative edge is INLCMD. The max. length of each buffer is 56 characters. If the drive is switched off and on, the drive automatically starts commands from INHCMD (or INLCMD) buffer if the input level is HIGH (or LOW)

Example :

INHCMD GV 10; GVTN 15

If a LOW/HIGH edge is detected, the velocity control loop gain is set to 10 and the integral action time is set to 15 msec.

31: Execute Contents of Command Buffer 2

ASCII: INHCMDX	Default: 0 Unit: - Range: -	valid for all OPMODES
ASCII: INLCMDX	Default: - Unit: - Range: -	valid for all OPMODES

A positive or negative edge on the input starts a command buffer. This command buffer contains separate ASCII objects, separated by semicolons (;). The command buffer for the positive edge is INHCMDX, the command buffer for the negative edge is INLCMDX. The max. length of these buffers is 56 character for each. If the drive is switched off and on, the drive automatically starts commands from INHCMDX (or INLCMDX) buffer if input level is HIGH (or LOW).

Remark: Only one of the digital inputs can use the INxMODE=31 function.

32: Release Motor Brake when Drive Disabled

A rising edge at the input triggers the braking output of the amplifier. This function is only available while the amplifier is disabled. If an error message is active, the brake cannot be de-energized.

Note: With suspended loads, this function will lead to slipping of the axis!

33: Execute Contents of Command Buffer Set 1 (RS232)

This performs in the same way as function 30, except that the command responses are not suppressed but are sent to the serial communication channel RS232.

34: Execute Contents of Command Buffer Set 2

This performs in the same way as function 31, except that the command responses are not suppressed but are sent to the serial communication channel RS232.

35: Set Velocity Current Entry

ASCII: IVCTAB	Default: 100 Unit: 0 Range: int8, int16, int32	valid for OPMODE 0,1
----------------------	--	----------------------

The VCTAB command is used for the definition /display of the VC table (velocity/current table). The VC table contains 8 velocity/current pairs (VCT entries).

A VCT entry can be activated either from the digital inputs or by an ASCII or SDO command.

When a VCT entry is activated, the velocity value that has been entered is taken as a digital velocity command (only possible with OPMODE=0). The current value from the VCT entry is taken as the current limit.

With analog velocity command provision (OPMODE=1), the velocity command is ignored, but the current value is still used as the current limit.

The VC table is not saved in the serial EEPROM, but in the Flash EEPROM (motion task segment). For this reason, changes to the table entries can only be made while the output stage is disabled

The VCTAB command can be used in one of three different forms:

1. VCTAB nr vsetp ilimit

This command initializes the VCT entry "nr" with the velocity command "vsetp" and the current limit "ilimit".

nr <0 ... 7>

vsetp <-16000 RPM ... 16000 RPM>

ilimit <0 100000 mA>

The command can only be used in this form while the output stage is disabled.

2. VCTAB nr

This command is used to output the contents of the VCT entry "nr".

The output is made in the format VCTAB nr vsetp ilimit.

3. VCTAB

This command is used to output the contents of the VCT table via the RS232 interface

The output consists of 8 lines in the following form: VCTAB nr vsetp ilimit

ASCII: SETVCT	Default: 0 Unit: 0...7 Range: int16	valid for OPMODE 0,1
----------------------	---	----------------------

The SETVCT command can be used to activate an entry in the VC table (velocity command / current limit).

The VC table contains 8 velocity/current pairs (VCT entries).

When a VCT entry is activated, the velocity value that has been entered is taken as a digital velocity command (only possible with OPMODE=0). The current value from the VCT entry is taken as the current limit.

With analog velocity command provision (OPMODE=1) the velocity command is ignored, but the current value is still used as the current limit

If the SETVCT command is entered without additional parameters, the number of the presently active VCT entry is shown.

36: Give Offset to Gearing Function

This function is available when gearing mode is enabled and OPMODE=4.

Gearing mode OPMODE=4. A high signal on the digital input configured with this INxMODE adds a difference velocity to the gearing. This alloww a simple synchronisation of the two axes. The difference velocity is given by INxTRIG. The scaling is in 32Bit per revolution every 250µs. The difference velocity (n) must be known, then the INx TRIG can be calculated:

$$\text{INxTRIG} = n[\text{rpm}] \cdot 2^{32} / (4000 \cdot 60)$$

For example:

$$n = 500[\text{U/min}]$$

$$\text{INxTRIG} = 500 \cdot 2^{32} / (4000 \cdot 60) = 8947848$$

37: Change Feedback Type

LlxLOW : actual position is generated by the external encoder selected by GEARMODE

Llx HIGH : actual position is generated by the first feedback device (resolver or high resolution feedback EnDAT or Hiperface

38: Additional Enable for "Next Motion Task"

Used in conjunction with INxMODE=15, this mode signals that the following task, that is defined in the motion task by "Start with I/O" can start. The following motion task is started when a rising edge on Llx input is detected and INxMODE=15 input is enabled.

39: Move Constant Velocity for Set Time

This function starts a constant velocity for a defined time. The parameters for velocity and time are given by INxTRIG.

The velocity is given by the lower 16 bit (scaling by VUNIT) and the time by the upper 16 bit (given in msec) of the help variable INxTRIG. A rising edge at Llx changes the OPMODE to 0 (digital velocity) and gives the velocity that is given by INxTRIG. After the defined time or a falling edge at Llx, the digital velocity command is set to "0". After the actual velocity has reached "0" the OPMODE is automatically switched back to the previous OPMODE.

Example

1. Velocity = 1000 rpm

time = 10 sec = 10000 msec

INxTRIG= 0x271003E8 = 655361000

2. Velocity = -500 rpm

time = 10 msec

INxTRIG = 0x000afe0c = 720396

40: Additional Hardware Enable

The digital input works as an additional ENABLE hardware input. The power stage is only enabled if this input has a high signal.

If you want to use this function for several inputs, configure the inputs in series. All inputs have to be high to enable the power stage.

41: Fast Emergency Stop

When Llx level is getting LOW, the drive stops the motor using the emergency ramp DECSTOP. If zero velocity is reached ($V < V_{EL0}$), the power stage is disabled.

While stopping the motor, the 24 bit (0x01000000) in TRJSTAT is set. The input is read in the 250µs task.

42: Turn On/Off Gearing

Available only in OPMODE = 4, this function is only practical with a slave axis.

A rising edge on the digital input starts the motion from 0 to the master speed and a falling edge changes the speed from master speed to 0. The ramp times can be set by ACCR for the acceleration and DECR for deceleration time.

43: Turn On/Off Gearing (with phase adjust from ramp up)

Available only in OPMODE = 4, this function is only practical with a slave axis.

A rising edge on the digital input starts the motion from 0 to the master speed and a falling edge changes the speed from master speed to 0. The ramp times can be set by ACCR for the acceleration and DECR for deceleration time unlike INxMODE = 42, in this mode the master position is latched at the rising edge of the input and the position delay caused by the ramp is compensated. INxTRIG offers the possibility of adding an position offset (in PGEARI units) to the latched position.

44: Position Latch and reset (rising edge)

Rising and falling edges on Llx latch the actual positions PFB and PRD.

The latched values are stored in LATCH32 and LATCH16 (rising edge) or LATCH32N and LATCH16N (falling edge). In addition after a rising edge on Llx the actual position PFB is reset to the value given by INxTRIG.

45: Position Latch and reset (falling edge)

Rising and falling edges on Llx latch the actual positions PFB and PRD.

The latched values are stored in LATCH32 and LATCH16 (rising edge) or LATCH32N and LATCH16N (falling edge). In addition after a falling edge on Llx the actual position PFB is reset to the value given by INxTRIG.

46: Position Latch and reset (average value)

Rising and falling edges on Llx latch the actual positions PFB and PRD.

The latched values are stored in LATCH32 and LATCH16 (rising edge) or LATCH32N and LATCH16N (falling edge). In addition after a rising edge on Llx the actual position PFB is reset to the value given by $INxTRIG + (LATCH32N - LATCH32) / 2$.

47: Master / slave correction

Correction of the slave position (OPMODE=4: master/slave operation) by the pulse/direction inputs (LI1/LI2). The function of digital inputs is as follows:

LI2: = HIGH correction function enabled

LOW function disabled

LI1: a rising edge forces the change of the slave position setpoint by IN1TRIG counts (1 count = $\frac{1}{4}$ master pulses) in the positive direction.

a falling edge forces the change of the slave position setpoint by IN1TRIG counts (1 count = $\frac{1}{4}$ master pulses) in the negative direction.

48: Reserved

49: Emergency stop (High)

A High level on this input generates an emergency stop for the drive. No feedback information is required (the same stop procedure as for function 4 – feedback error).

50: Emergency stop (Low)

A High level on this input generates an emergency stop for the drive. No feedback information is required (the same stop procedure as for function 4 – feedback error).

Digital Outputs LO1 / LO2

Values

ASCII codes and values:

ASCII: OxMODE	Default: 0 Unit: - Range: 0 - 51	valid for all OPMODES
ASCII: OxTRIG	Default: 0 Unit: - Range: int 32	valid for all OPMODES

You can combine the following standard pre-programmed functions with the digital outputs LO1 (O1MODE, terminal X3/16 IN1TRIG variable) or LO2 (O2MODE, terminal X3/17 IN2TRIG variable). Change this only while the amplifier is disabled + reset.

High functions:

The presence of the function that is set is indicated by a High signal on the corresponding interface terminal.

Low functions:

The presence of the function that is set is indicated by a Low signal on the corresponding interface terminal.

ID	Function	Logic	Auxiliary value OxTRIG
0	Off	-	-
1	Absolute value (Actual Velocity) < x	High	Speed (rpm)
2	Absolute value (Actual Velocity) > x	High	Speed (rpm)
3	Main Bus Voltage Charging	Low	-
4	Regen off	High	-
5	Software Limit Switch Reached	High	-
6	Present Motor Postion > x	High	Position (increments)
7	Within In-Position Window	High	-
8	Absolute value (Current) < x	High	Current (mA)
9	Absolute value (Current) > x	High	Current (mA)
10	Max Postion Error Exceeded	Low	-
11	Drive in Current Foldback (I^2t)	High	-
12	PosReg1 High	High	
13	PosReg2 High	High	

ID	Function	Logic	Auxiliary value OxTRIG
14	PosReg3 High	High	
15	PosReg4 High	High	
16	Next-In Position Reached	High	-
17	Error/Warning Present	High	-
18	Error Present	High	-
19	DC Bus Link > x	High	
20	DC Bus Link > x	High	
21	Drive Enabled	High	-
22	Zero Pulse	High	-
23	Expansion Card State	-	-
24	Drive Homed	High	-
25	Reserved		
26	Reserved		
27	Reserved		
28	PosReg. 0	High	
29	PosReg. 5	High	
30	Position Register(s) State	-	-
31	Voltage at Analog Input AI1 < x	High	mV
32	Voltage at Analog Input AI1 > x	High	mV
33	Voltage at Analog Input AI2 < x	High	mV
34	Voltage at Analog Input AI2 > x	High	mV
35	Drive Internal Enable Active	High	-
36	Drive Status OR Bit Mask	High	-
37	Drive Status AND Bit Mask	High	-
38	Motion Status OR Bit Mask	High	-
39	Motion Status AND Bit Mask	High	-
40	Position Register OR Bit Mask	High	-
41	Position Register AND Bit Mask	High	-
42	Temperature Warning	High	-
43	Motion Direction	High	Speed (rpm)
44	abs (Velocity Actual - Velocity Cmd) < x	High	Speed (rpm)
45	abs (Velocity Actual - Velocity Cmd) > x	Low	Speed (rpm)

ID	Function	Logic	Auxiliary value OxTRIG
46	abs (Current Actual - Current Cmd) < x	Low	mA
47	abs (Current Actual - Current Cmd) > x	Low	mA
48	Drive Status NOR Bit Mask	High	-
49	Drive Status NAND Bit Mask	High	-
50	Motion Status NOR Bit Mask	High	-
51	Motion Status NAND Bit Mask	High	-

Description of Digital Output Functions**0:Off**

No function assigned.

1: Absolute value (Actual Velocity) < x

As long as the absolute value for the motor velocity is lower than a preset value OxTRIG, a HIGH-signal will be output. After the function has been selected you can enter the velocity in rpm in OxTRIG.

The output is HIGH if $V < \text{OxTRIG}$ and becomes LOW if $V > \text{OxTRIG} + 0.01 * \text{MSPEED}$. The value unit is fixed by VUNIT.

2: Absolute value (Actual Velocity) > x

As long as the absolute value for the motor velocity is lower than a preset value OxTRIG, a HIGH-signal will be output. After the function has been selected you can enter the velocity in rpm in OxTRIG. The output is HIGH if $V > \text{OxTRIG}$ and becomes LOW if $V < \text{OxTRIG} + 0.01 * \text{MSPEED}$. The value unit is fixed by VUNIT.

3: Main Bus Voltage Charging

This signals the operational readiness of the amplifier power output stage. After switching on the mains supply, LOx output level is HIGH until the DC-link circuit is fully charged up. LOx output level is LOW when the charging of the DC-link circuit is completed. If the DC-link voltage falls below VBUSMIN, then LOx output level becomes HIGH. The "Undervoltage" monitoring is inactive.

4: Regen off

Signals if the preset Regen power (see *At a Glance*, p. 59) is exceeded.

5: Software Limit Switch Reached

Produces a HIGH-signal if a software limit-switch is reached (a preset function of the corresponding position register, set to "SW limit-switch 1" or "SW limit switch 2" - the function is defined in the screen page Position Data (See *Overview of the "Position data" screen*, p. 171).

6: Present Motor Position > x

If the position (angular position of the motor shaft) exceeds a preset value (auxiliary value "OxTRIG"), LOx output level is HIGH. After the function has been selected, you can enter the signaling position (in increments a number or fraction of motor turns N) as the auxiliary value "in OxTRIG". Make the calculation according to the following equation:

$$\text{OxTRIG} = 1048576 * N * \text{increments}$$

Maximum possible entry value: $\text{OxTRIG} = 2^{31} = 2147483648$, this corresponds to $N = 2048$

7: Within In-Position Window

When the target position for a motion task has been reached (the InPosition window PEINPOS), LOx output level becomes HIGH. A cable break will not be detected. The width of the InPosition window for all the valid motion tasks is entered in the "Position data" screen page.

If a sequence of motion tasks is performed one after another, then the signal for reaching the final position of the motion-task sequence will be output (target position of the last motion task). Signaling that the target position of each motion task has been reached, in a sequence of motion tasks, can be achieved with the function "16, Next_InPos".

8: Absolute Value (Current) < x

The output produces a HIGH-signal, as long as the absolute r.m.s. value of the actual current is lower than a defined value in mA (OxTRIG). After the function has been selected, you can enter the current value in OxTRIG.

9: Absolute Value (Current) > x

The output produces a HIGH-signal, as long as the absolute r.m.s. value of the actual current is higher than a defined value in mA (OxTRIG). After the function has been selected, you can enter the current value in OxTRIG.

10: Max Position Error Exceeded

If the position goes outside the preset following error window, this is indicated by a LOW-signal. The width of the following error window (PEMAX) is entered in the screen page "Position" for all the valid motion tasks.

11: Drive in Current Foldback (I^2t)

If the preset I^2t monitoring threshold I2TLIM is reached (see *Overview of the "Current" screen, p. 143*) this is indicated by a HIGH-signal.

12: Position Register 1

The preset function of the corresponding position register 1 (the function is defined in the screen page "Position" + lien) is indicated by a HIGH-signal.

13: Position Register 2

The preset function of the corresponding position register 2 (the function is defined in the screen page "Position" + lien) is indicated by a HIGH-signal.

14: Position Register 3

The preset function of the corresponding position register 3 (the function is defined in the screen page "Position" + lien) is indicated by a HIGH-signal.

15: Position Register 4

The preset function of the corresponding position register 4 (the function is defined in the screen page "Position" + lien) is indicated by a HIGH-signal.

16: Next in-Position Reached

The start of each motion task in an automatically executed sequence of motion tasks is signalled by an inversion of the output signal. The output produces a LOW signal at the start of the first motion task of the motion task sequence. The type of message can be set by IN2PM.

ASCII: IN2PM	Default: 0 Unit: - Range: 0, 1, 2	valid for all OPMODES
--------------	---	-----------------------

At the start of the first motion block (motion task), the "NextInPos" output is always set to 0. The response of the output during the execution of the motion block sequence depends on the configuration variable IN2PM.

- IN2PM=0 - the output is inverted at the start of the next block.
- IN2PM=1- the output is set to 0 at the start of a motion block, and set to HIGH at the end of a motion block.
- IN2PM=2 - the output is inverted at the end of a block.

With a sequence of motion blocks where the blocks are started immediately, only the IN2PM=0 or IN2PM=2 settings make sense. If the setting is IN2PM=1, the HIGH state is so short that it may not be registered at all by the external control system.

If a following task is started with the aid of an I/O (INxMODE=15), then the IN2PM=2 or IN2PM=1 setting should be used. With this setting, the end of a motion block is signaled by the HIGH state (IN2PM=1) or the change of state (IN2PM=2) at the "NextInPos" output. The external control system can then initialize the continuation of the motion task sequence via the "Start next task" input.

See *Digital inputs LI1/LI2/LI3/LI4*, p. 102 Function Number 15 for more information.

17: Error/Warning Present

The output produces a HIGH-signal if an error or a warning message is signaled by the servoamplifier. A list of the error messages can be found under ERRCODE.

18: Error Present

The output produces a HIGH-signal if an error message is signaled by the servo amplifier. A list of the error messages can be found under ERRCODE.

19: DC Bus Link > x

LOx input level is HIGH if the actual value of the DC-link voltage is higher than a defined value in volts (OxTRIG). After the function has been selected, you can enter a voltage value in OxTRIG.

20: DC Bus Link < x

LOx input level is HIGH if the actual value of the DC-link voltage is lower than a defined value in volts (OxTRIG). After the function has been selected, you can enter a voltage value in OxTRIG.

21: Drive Enabled

LOx output level is HIGH if the servo amplifier is enabled.

To obtain the enable, the external Hardware Enable X3/15 signal must be present, the Enable status must be set in the setup software (or via the fieldbus interface) and no errors must be present that would cause an automatic internal disabling of the servo amplifier.

If this function is selected, the enable LOx output signal is HIGH, if the line voltage is applied and the charging of the link capacitors is completed. The drive is disabled, if the DC-link voltage goes under the threshold VBUSMIN.

22: Zero Pulse

The zero mark/pulse (HIGH-signal) is indicated by the encoder-emulation. This function is only useful at very low speeds.

23: Expansion Card State

Option not available.

24: Drive Homed

The output signals High, if a reference point is available. Reference traverse (homing) has been carried out, or a reference point has been set. See *Overview of the "Homing" screen, p. 147* for more information.

25: Reserved**26: Reserved****27: Reserved****28: Position Register 0**

The preset function of the corresponding position register 0 is indicated by a HIGH-signal. Valid only when using IO expansion card.

29: Position Register 5

The preset function of the corresponding position register 5 is indicated by a HIGH-signal. Valid only when using IO expansion card.

30: Position Registers State

If one of the position registers 0...5 indicates high, the output is HIGH, otherwise it is LOW.

31: Voltage at Analog Input AI1 < x

LOx output level is HIGH, if the analog input voltage at analog input AI1 is lower than the threshold of OxTRIG. The auxiliary variable OxTRIG is given in mV (with sign).

32: Voltage at Analog Input AI1 > x

LOx output level is HIGH, if the analog input voltage at analog input AI1 is higher than the threshold of OxTRIG. The auxiliary variable OxTRIG is given in mV (with sign).

33: Voltage at Analog Input AI2 < x

LOx output level is HIGH, if the analog input voltage at analog input AI2 is lower than the threshold of OxTRIG. The auxiliary variable OxTRIG is given in mV (with sign).

34: Voltage at Analog Input AI2 > x

LOx output level is HIGH, if the analog input voltage at analog input AI2 is higher than the threshold of OxTRIG. The auxiliary variable OxTRIG is given in mV (with sign).

35: Drive Internal Enable Active

The state of the internal enable signal is mirrored on LOx output. If the settings are: MBRAKE=0, STOPMODE=0 and ACTFAULT=0, the function is similar to OxMODE=21.

If one of the three variables is "1", LOx output changes to LOW, when the drives starts to dec to "0".

If OxMODE=21, LOx input level is LOW if the drive has stopped and has disabled the output stage.

36: Drive Status OR Bit Mask

This function makes an OR operation between the Bit-variable DRVSTAT and a Bit mask given by OxTRIG. The result is present at the output selected.

37: Drive Status AND Bit Mask

This function makes an AND operation between the Bit-variable DRVSTAT and a Bit mask given by OxTRIG. The result is present at the output selected.

38: Motion Status OR Bit Mask

This function makes an OR operation between the Bit-variable TRJSTAT and a Bit mask given by OxTRIG. The result is present at the output selected.

39: Motion Status AND Bit Mask

This function makes an AND operation between the Bit-variable TRJSTAT and a Bit mask given by OxTRIG. The result is present at the output selected.

40: Position Register OR Bit Mask

This function makes an OR operation between the Bit-variable POSRSTAT and a Bit mask given by OxTRIG. The result is present at the output selected.

41: Position Register AND Bit Mask

This function makes an AND operation between the Bit-variable POSRSTAT and a Bit mask given by OxTRIG. The result is present at the output selected.

42: Temperature Warning

This function enables a temperature warning.

The amplifier displays in real time Motor temperature, heatsink temperature and ambient temperature. Those 3 temperature parameters can be read respectively by ASCII commands TEMPM, TEMPH and TEMPE.

If one of the three internal measured temperatures reaches the trip level, the digitaloutput is set to HIGH. After the selected delay time given in OxTRIG, the drive generates a error message and disables the output stage.

The delay time has the range 0...30000 msec and effects following temperatures:

- Motor temperature TEMPM, threshold MAXTEMPM
- Heatsink temperature TEMPH, Threshold MAXTEMPH
- Ambient temperature TEMPE, threshold MAXTEMPE

ASCII: TEMPM	Default: - Unit: Ohm Range: 0 - 100000	valid for all OPMODES
--------------	--	-----------------------

Displays the motor temperature in real time, in the form of the resistance of the temperature sensor (in ohms).

ASCII: MAXTEMPM	Default: 300 Unit: Ohm (KOhm) Range: 0 - 6000	valid for all OPMODES
-----------------	---	-----------------------

Motor temperature switch off threshold. Defined by the resistance in KOhms. Entry to be done in KOhms.

ASCII: TEMPH	Default: - Unit: °C Range: -20 - +90	valid for all OPMODES
--------------	--	-----------------------

Displays the heatsink temperature in real time in °C.

ASCII: MAXTEMPH	Default: 70 Unit: °C Range: -20 - +90	valid for all OPMODES
-----------------	---	-----------------------

Heat Sink Temperature Switch off Threshold. Exceeding this value will switch off the drive.

ASCII: TEMPE	Default: - Unit: °C Range: -20 - +90	valid for all OPMODES
--------------	--	-----------------------

Displays the internal drive temperature in real time in °C.

ASCII: MAXTEMPE	Default: 70 Unit: °C Range: 10 - 80	valid for all OPMODES
-----------------	---	-----------------------

The drive temperature value for switching off the power stage and opening the R1A/R1C contact. If the drive temperature exceeds this value, the drive faults (F13).

43: Motion Direction

LOx output level is HIGH, if $v_{act} < VEL0$, and LOW if $v_{act} > VEL0$.

44: $abs(\text{Velocity Actual} - \text{Velocity Cmd}) < x$

LOx output level is HIGH if the absolute of the difference between the internal velocity command and the actual velocity is smaller than OxTRIG. OxTRIG value is given in valid velocity units (VUNIT).

45: $abs(\text{Velocity Actual} - \text{Velocity Cmd}) > x$

LOx output level is HIGH if the absolute of the difference between the internal velocity command and the actual velocity is bigger than OxTRIG. OxTRIG value is given in valid velocity units (VUNIT).

46: $abs(\text{Current Actual} - \text{Current Cmd}) < x$

LOx output level is HIGH if the absolute of the difference between current command and actual value is smaller than OxTRIG. OxTRIG value is given in mA.

47: $abs(\text{Current Actual} - \text{Current Cmd}) > x$

LOx output level is HIGH if the absolute of the difference between current command and actual value is bigger than OxTRIG. OxTRIG value is given in mA.

48: Drive Status NOR Bit Mask

This function makes an inverted NOR operation between the Bit-variable DRVSTAT and a Bit mask given by OxTRIG. The result is present at the output selected.

49: Drive Status NAND Bit Mask

This function makes an inverted NAND operation between the Bit-variable DRVSTAT and a Bit mask given by OxTRIG. The result is present at the output selected.

50: Motion Status NOR Bit Mask

This function makes an inverted NOR operation between the Bit-variable TRJSTAT and a Bit mask given by OxTRIG. The result is present at the output selected.

51: Motion Status NAND Bit Mask

This function makes an inverted NAND operation between the Bit-variable TRJSTAT and a Bit mask given by OxTRIG. The result is present at the output selected.

4.7 Screen page "Position"

Screen page "Position"

At a Glance Overview of the different field values included in the "Position" screen page.

What's in this Section? This section contains the following topics:

Topic	Page
Overview of the "Position" screen (PI)	131
Overview of the "Position" screen (P)	135

Overview of the "Position" screen (PI)

At a Glance Diagram:

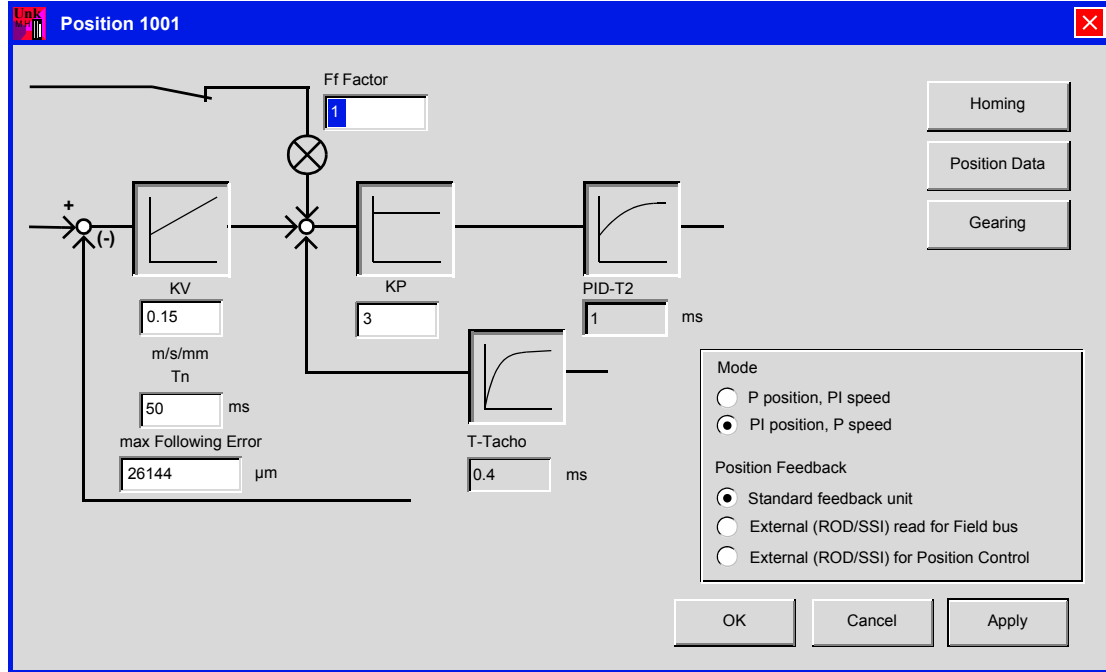

Cycle time of the position controller: 250 μs

Subscreens:

Position Data	Opens the "Position data" screen page
Homing	Opens the "Homing" screen page
Gearing	Opens the "Gearing" screen page

Ff Factor

ASCII: GPFFV	Default: 1.0 Unit: - Range: 0.0...50.0	valid for OPMODES 4,5,8
---------------------	--	-------------------------

Determines the feed-forward factor for the position controller. Feed-forward is used to ease the task of the position controller. A better setting for the Ff-factor means a better utilization of the dynamic range of the position controller. The most favorable setting (usually about 1.0) depends on factors external to the drive, such as friction, dynamic resistance, and stiffness. If GPFFV is set too low, the drive lags. If GPFFV is set too high, the drive oversteers.

KV

ASCII: GP	Default: 15 Unit: (m/s)/m Range: 0.001 ... 25.0	valid for OPMODES 4,5,8
------------------	---	-------------------------

Determines the proportional gain of the position controller. Amplitude: speed in m/s at 1 mm position deviation.

Tn

ASCII: GPTN	Default: 50 Unit: ms Range: 1.0...200.0	valid for OPMODES 4,5,8
--------------------	---	-------------------------

Determines the integral-action time (integration time constant) for the position controller. $T_n = 0$ ms disconnects the Integral-action component.

max. Following Error

ASCII: PEMAX	Default: 262144 Unit: μm Range: long int	valid for OPMODES 4,5,8
---------------------	---	-------------------------

If the momentary following or contouring error (PE) goes beyond the maximum value set, the motion is stopped and the following error warning (n03) or contouring error fault (F03) is generated. The motion block can only be continued (CONTINUE) or restarted after the warning has been acknowledged (CLRFAULT, digital input INxMODE=14). PEMAX=0 switches off the following error monitoring. If a following error occurs, negative values do not result in a stop of the axis. The status bit and warning are still there. A following motion task or new motion task cannot be started until the following error is cleared.

KP

ASCII: GPV	Default: 3 Unit: - Range: 0.1...60.0	valid for OPMODES 4,5,8
-------------------	--	-------------------------

Determines the proportional gain for the speed section of the controller. Increase the value up to the level where the motor starts to oscillate, and then back it off until the oscillations have clearly stopped. Typical values are the same as for the KP of the speed controller.

PID-T2:

Displays the value from the "Speed" screen page.

T-Tacho

Displays the value from the "Speed" screen page.

Mode / Position Response

ASCII: EXTPOS	Default: 0 Unit: - Range: 0,1,2,3,4	valid for all OPMODES
----------------------	---	-----------------------

The EXTPOS command defines the feedback source for the drive position control loop. Also the type of position control (P or PI) is selected.

Position response:

determines the feedback source for the position loop. For most applications, the commutation and position control data comes from the same source. This source is determined by the "Feedback" screen, and may be either a resolver or an Endat/ Hiperface encoder. In some cases, it is best to retrieve position data for commutation from another source. For such cases, the "Feedback type" parameter continues to be the source for the commutation, and the source for the position controller is determined by the "gearing" mode.

Standard Feedback

- the feedback type is defined by the "**Feedback**" parameter,
- it is not possible to read an encoder via X1 or X5.

External reading (ROD/SSI) for the field bus:

- the feedback type is defined by the "**Feedback**" parameter, the external encoder is defined by the "**Gearing**" mode.

External reading (ROD/SSI) for the position loop:

- impossible in this mode

ID	Position Control used	Reading and External Encoder (PFB0)
0	Feedback system select by FBTYPE PI-type Position Controller, P-type Speed Controller	-
1	Secondary feedback source selected by GEARMODE, P-type Position Controller, PI-type Speed Controller FBTYPE defines the commutation and speed feedback The position signal comes from the secondary feedback source	Yes
2	Feedback system select by FBTYPE P-type Speed Controller	Yes, selected by GEARMODE3
3	Feedback system select by FBTYPE P-type Speed Controller, PI-type Speed Controller	Yes, selected by GEARMODE4
4	Feedback system select by FBTYPE P-type Speed Controller, PI-type Speed Controller	-

Overview of the "Position" screen (P)

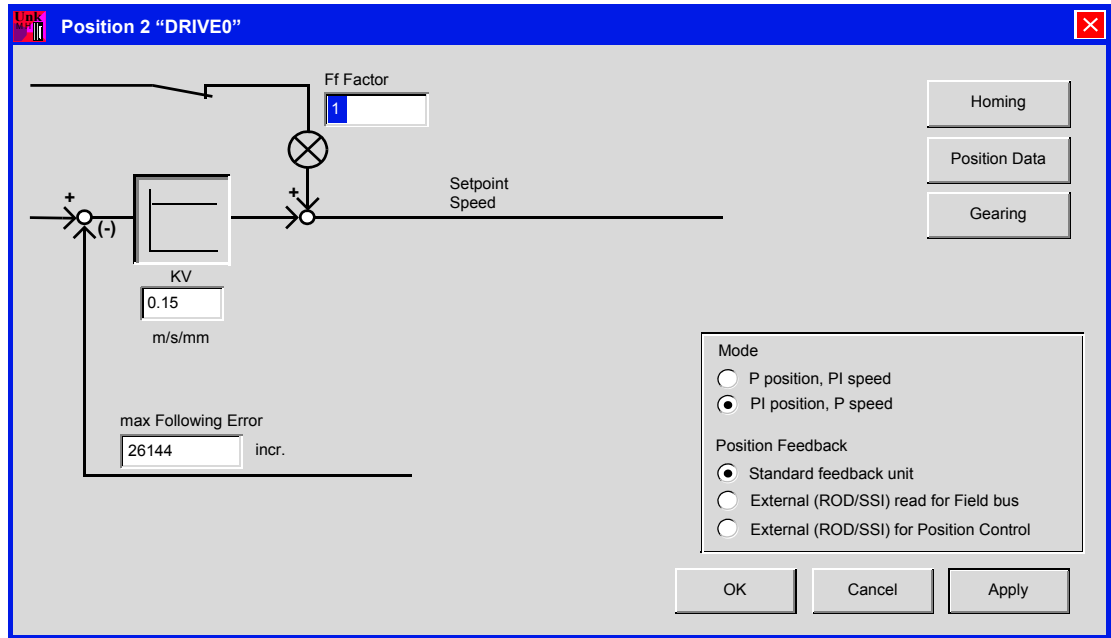

At a Glance

Cycle time of the position controller: 250 μ s

Subscreens:

Position Data	Opens the "Position data" screen page
Homing	Opens the "Homing" screen page
Gearing	Opens the "Gearing" screen page

Ff Factor

ASCII: GPFFV	Default: 1 Unit: - Range: 0...1000	valid for OPMODES 4,5,8
---------------------	--	-------------------------

Determines the feed-forward factor for the position controller. Feed-forward is used to ease the task of the position controller. A better setting for the Ff-factor means a better utilization of the dynamic range of the position controller. The most favorable setting (usually about 1.0) depends on factors external to the drive, such as friction, dynamic resistance, and stiffness.

KV

ASCII: GP	Default: 0,15 Unit:- Range: -	valid for OPMODES 4,5,8
------------------	-------------------------------------	-------------------------

Determines the proportional gain of the position controller. Amplitude: speed in m/s at 1 mm position deviation.

max. Following Error

ASCII: PEMAX	Default: 262144 Unit: μm Range: long int	valid for OPMODES 4,5,8
---------------------	---	-------------------------

The following error is the maximum difference (+/- window) between the position setpoint and the actual position that is permitted during processing. If the value leaves this window, then the position controller generates an error message and brakes the drive, using the emergency ramp.

Mode / Position Response

ASCII: EXTPOS	Default: 0 Unit: - Range: 0, 1, 2, 3, 4	valid for all OPMODES
----------------------	---	-----------------------

Please see *Mode / Position Response*, p. 134 for more information.

4.8 Screen page "Speed"

Introduction to the "Speed" screen

At a Glance

Diagram:

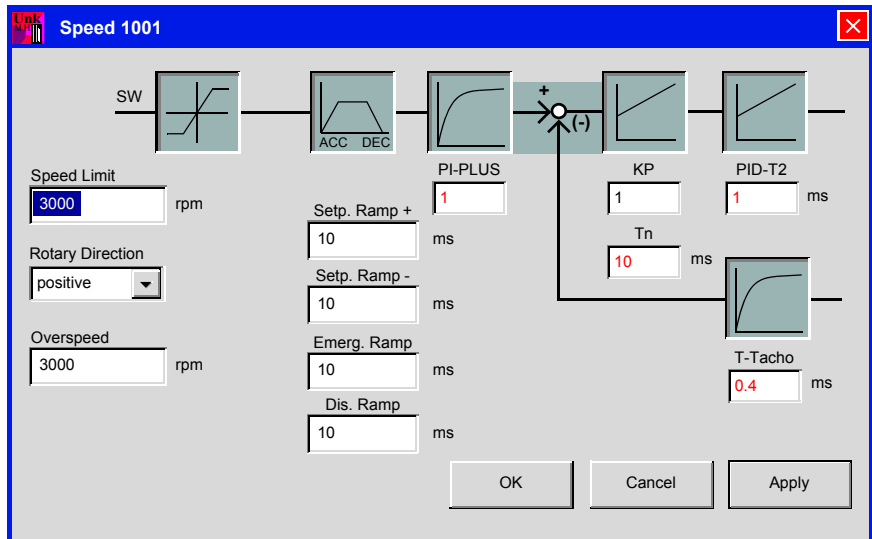

Use the default values for the motor as a starting point for optimization.

Cycle time of the speed controller: 250 μ s

Speed Limit

ASCII: VLIM	Default: 3000 Unit: (> VUNIT) Range: 0.0 .. MSPEED	valid for OPMODES 0,1
--------------------	---	-----------------------

Limits the motor speed. The maximum value also depends on the motor and encoder used.

ASCII: VLIMN	Default: 3000 Unit: VUNIT Range: 0.0 .. MSPEED	valid for OPMODES 0,1
---------------------	--	-----------------------

When used together with the VLIM parameter, it is possible to implement a directionally-dependent rotational velocity limit. The VLIM command determines the maximum velocity for both positive and negative directions. By making a subsequent entry for VLIMN, the limit for the negative direction can be set separately. This command is only available via the Terminal screen.

Rotary direction

ASCII: DIR	Default: 1 Unit: - Range: 0, 1	valid for OPMODES
-------------------	--------------------------------------	-------------------

Fixes the direction of rotation of the motor shaft, referred to the polarity of the setpoint. Make changes only while the amplifier is disabled + reset. This parameter is not available, if a SERCOS interface is built-in.

After changing the rotary direction the hardware limit switches have to be exchanged.

Standard setting: right-hand (cw) rotation of the motor shaft (looking at the shaft end), with:

- positive voltage on terminal X3/4 (+) against terminal X3/5 (-) or,
- positive voltage on terminal X3/6 (+) against terminal X3/7 (-) or,

ID	Function
1	positive
0	negative

Setp. Ramp+

ASCII: ACC	Default: 10 Unit: ACCUNIT Range: 1 .. 32767	valid for OPMODES 0+1
-------------------	---	-----------------------

Acceleration time to the speed limit (valid for both directions). The longer this time, the smoother and more favorable the acceleration. As long as the ramp time is less than the mechanically limited rise time of the system, the response time of the system will not be negatively affected. The ramp time settings are still effective if the limit-switches are activated.

For a command step from 0 to VLIM or VLIMN, the ramp generator generates a stepped ramp (with steps of 250 microseconds) that is completed within the set ACC time.

Setp. Ramp-

ASCII: DEC	Default: 10 Unit: ACCUNIT Range: 1 .. 32767	valid for OPMODES 0, 1, 8
-------------------	---	---------------------------

Braking time to the zero speed (valid for both directions). The longer this time, the smoother and more favorable the acceleration.

As long as the ramp time is less than the mechanically limited fall time of the system, the response time of the system will not be negatively affected. In most cases the Setp. ramp+ and the Setp. ramp- can be set to the same value.

The ramp time settings are still effective if the limit-switches are activated.

For a command step from VLIM/VLIMN to 0, the ramp generator generates a stepped ramp (with steps of 250 microseconds) that is completed within the set DEC time.

The DEC braking ramp applies to all command changes, whether they are provided in analog or digital form. Separate braking ramps (DECSTOP/DECDIS defined in the same screen page) are used for command changes that are generated internally in emergency stop situations (for example, amplifier fault, or removal of the amplifier enable).

Overspeed

ASCII: VOSPD	Default: 3600 Unit: VUNIT Range: 0.0 .. 1.2*MSPEED	valid for OPMODES
---------------------	--	-------------------

Determines the upper limit of the motor speed. If this limit is exceeded, the servo amplifier switches into the overspeed fault condition (error message F08).

Emergency ramp

ASCII: DECSTOP	Default: 10 Unit: ACCUNIT Range: 1 .. 32767	valid for OPMODES
-----------------------	---	-------------------

The braking ramp for emergency braking. This braking ramp is used if the message n03, following error or n04, response monitoring occurs. An emergency stop situation exists in the following cases:

- amplifier fault (with ACTFAULT=1)
 - contouring/following error
 - threshold monitoring (fieldbus devices)
 - hardware/software limit switch activated
 - emergency stop function through the digital input (INxMODE=27)
 - emergency stop function through the fieldbus (control word)
-

Disable ramp

ASCII: DECDIS	Default: 10 Unit: ACCUNIT Range: 1 .. 32767	valid for OPMODES 0,1
----------------------	---	-----------------------

When the output stage is disabled (removal of the hardware or software enable), the internal velocity command is set to 0, using the preset DECDIS ramp. The output stage is only disabled when the actual velocity has fallen below the standstill threshold (VEL0).

The DECDIS ramp only has an effect for motors with a configured brake (MBRAKE=1) or with the selection STOPMODE=1. With STOPMODE=0 the output stage is immediately disabled, and the drive coasts down.

KP

ASCII: GV	Default: 1 Unit: - Range: 0.0 .. 62.5*GVTN	valid for OPMODES 0,1
------------------	--	-----------------------

Determines the proportional gain (also known as AC-gain). Increase the value up to the level where the motor starts to oscillate, and then back it off until the oscillations have clearly stopped. Typical values for this setting are between 10 and 20.

Rule: at $KP = 1$ and a control deviation of $v_cmd - v_act = 3000 \text{ rpm}$, the instrument delivers the peak current.

Tn

ASCII: GVTN	Default: 10 Unit: ms Range: 0.0 , GV/62.5 .. 1000.0	valid for OPMODES 0,1
--------------------	---	-----------------------

Determines the integration time constant. Smaller motors permit shorter integration times. Larger motors or high moments of inertia in the load usually require integration times of 20 ms or more. With $Tn = 0 \text{ ms}$ the integral-action component is inactive.

PID-T2:

ASCII: GVT2	Default: 1 Unit: ms Range: -	valid for OPMODES
--------------------	------------------------------------	-------------------

Affects the proportional gain (P-gain) at medium frequencies. It is often possible to improve the **damping** of the speed control loop by increasing PID-T2 to about $Tn/3$. The setting is made, if required, after the basic setting of KP and Tn.

Feedback T-Tacho

ASCII: GVFBT	Default: 0.4 Unit: ms Range: 0.0..30.0	valid for OPMODES
---------------------	--	-------------------

If necessary, the time constant for the PT1-filter in the actual speed feedback (tachometer smoothing) can be altered. This may improve the step response and smoothness of running, particularly for very small, highly dynamic motors.

PI-PLUS

ASCII: GVFR	Default: 1 Unit: - Range: 0.0 .. 1.0	valid for all OPMODES
--------------------	--	-----------------------

This parameter only effects when the I-component is switched on (GVTN≠0).

GVFR is a tuning variable of the velocity control loop which sets the feed-forward to feedback gain ratio for the Pseudo Derivative Feedback with Feed-Forward (PDFF or PI+). If PI-PLUS is reduced to 0.65, the overshoot is avoided and the actual value approaches the setpoint slowly.

**Standstill
Threshold**

ASCII: VELO	Default: 5 Unit: VUNIT Range: -	valid for all OPMODES
--------------------	---------------------------------------	-----------------------

The VELO (Velocity "0") parameter defines the velocity threshold for the standstill signal. The standstill signal is required for the following functions:

1. Standstill signal in the status register DRVSTAT.
2. If motor brake is used (MBRAKE = 1), the brake will only engage if actual speed < VELO (when the drive is externally disabled)
3. If the ACTFAULT option is activated (active braking in the event of a fault), or the STOPMODE option is on (active braking if the output stage is disabled), then the standstill threshold defines the velocity below which the output stage will actually be disabled.

This command is only settable via Terminal screen.

4.9 Screen page "Current"

Overview of the "Current" screen

At a Glance

Diagram:

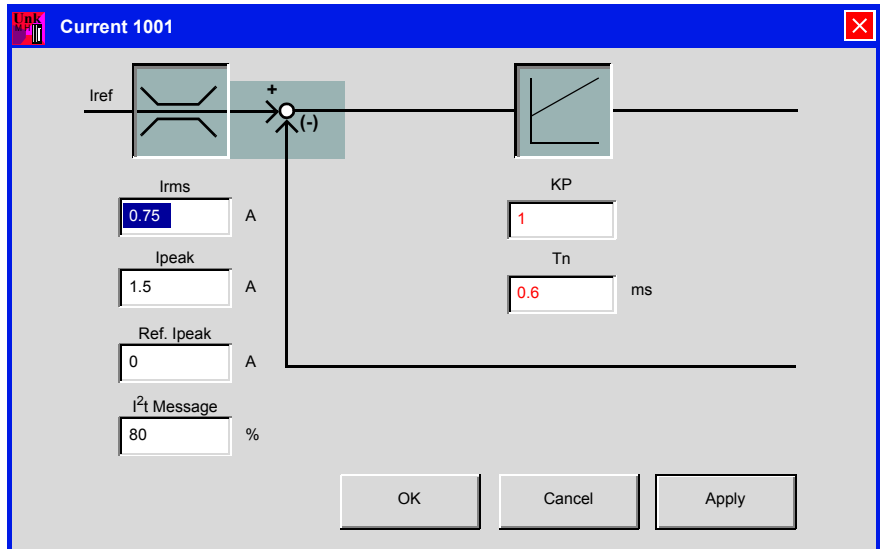

Use the default values for the motor. Please do not make any alterations to the settings for the current controller unless they have been discussed with our Applications department.

Cycle time of the current controller: 62.5 μ s

Irms

ASCII: ICONT	Default: Minimum of DICONT and MICONT Unit: - Range: 10% of DICONT, max(DICONT, IPEAK)	valid for all OPMODES
---------------------	--	-----------------------

Sets the rated output current that is required. The adjustment is usually made to I_0 (MICONT), the standstill current for the motor that is connected. The value that can be entered is limited to the rated current of the amplifier (DICONT) or the standstill current of the motor I_0 (the lower of the two values). The function is used in the monitoring of the actual r.m.s. current that is drawn. The limit that is set by the Irms-setting reacts after approx. $T_{I2T} = 5$ secs at maximum load. The calculations for current settings other than the rated values are made according to the equation:

$$T_{I2T} = (I^2_{ms} * 15s) / (I^2_{peak} - I^2_{rms})$$

Ipeak

ASCII: IPEAK	Default: IMAX Unit: A Range: 0.0 ... DIPEAK	valid for all OPMODES
---------------------	---	-----------------------

Sets the required peak current (r.m.s. value). The value that can be entered is limited to the rated peak current of the motor MIPEAK or amplifier DIPEAK (the lower of the two values). The default value is IMAX, the larger value of MIPEAK and DIPEAK.

Ipeak (negative)

ASCII: IPEAKN	Default: IMAX Unit: A Range: 0.0 ... DIPEAK	valid for all OPMODES
----------------------	---	-----------------------

This is an optional command settable via terminal screen. The negative peak current value is set by the IPEAK value. IPEAKN allows you to change the negative peak current.

I²t warning

ASCII: I2TLIM	Default: 80 Unit: % Range: 0...100	valid for all OPMODES
----------------------	--	-----------------------

Sets the level, as a percentage value of the r.m.s. current, above which a message will be sent to one of the programmable outputs LO1 / LO2 (see OxMODE=11). A warning appears in the display.

KP

ASCII: MLGQ	Default: 1 Unit: - Range: 0.01 .. 15.0	valid for all OPMODES
--------------------	--	-----------------------

Determines the proportional gain of the current controller. Rule: at KP=1 and at a control deviation **I_{cmd} - I_{act} = peak armature current**, the rated motor voltage will be output.

Tn

ASCII: KTN	Default: 0.6 Unit: Milliseconds Range: 0.2 ... 2	valid for all OPMODES
-------------------	--	-----------------------

Determines the integral-action time (integration time constant) of the current controller.

Ref. Ipeak

ASCII: REFIP	Default: min(IPEAK, IPEAKN, DICON/2) Unit: A Range: 0.0...min(IPEAK, IPEAKN)	valid for all OPMODES
---------------------	--	-----------------------

The REFIP parameter is used to set the peak current for homing to a mechanical stop. If home type NREF = 7 or 9 is used (homing to a mechanical stop), the drive's peak current will be determined by REFIP. When the homing movement is finished, the drive's peak current is reset to IPEAK (See *Ipeak*, p. 144).

REFIP is also used to reduce the current for Wake&Shake mode (FBTYPE=7 (See *Feedback type*, p. 79)). If the wake&shake mode is started, drive's peak current is set to REFIP. After the Wake and Shake is complete, drive current is changed back to IPEAK.

4.10 Screen page "Homing"

General overview of the "Homing" screen

At a Glance Overview of the different field values included in the "Homing" screen.

What's in this Section? This section contains the following topics:

Topic	Page
Overview of the "Homing" screen	147
Homing 1	153
Homing 2	158
Homing 3	159
Homing 4	162
Homing 5	163
Homing 7	164
Homing 9	165
Jog mode	166

Overview of the "Homing" screen

At a Glance

Homing is an essential task, used to zero the drive for subsequent positioning operations. You can choose between various types of homing:

Homing 1001

Homing

Start Stop

0 Immediate homing

V 0 µm/s

Direction of motion Negative

Setp. Ramp+ 0 ms Setp. Ramp- 0 ms Offset 0 µm

Jog mode

F4 V 0 µm/s

OK Cancel Apply

After homing, the drive reports "InPosition" and then enables the position controller in the servo amplifier.

⚠ CAUTION

Take care that the zero point of the machine (reference point) is in a position that permits the subsequent positioning operations. The software limit-switches that were set as parameters may be ineffective. The axis could move on to the hardware limit-switch or even the mechanical stop. There is a risk of damage. If the reference point (zero point of the machine) is approached with excessive velocity, for instance because of high moments of inertia, it may be overshoot and, in the worst case, move on to the hardware limit-switch or even the mechanical stop. There is a risk of damage. The position controller cannot be operated without first making a reference traverse (homing). A homing/reference traverse must be made after the 24V auxiliary voltage has been switched on. The start signal must not be removed during homing. The start signal must remain present until the "InPosition" message appears.

Failure to follow this instruction can result in injury or equipment damage.

Start

ASCII: MH	Default: - Unit: - Range: -	valid for OPMODE 8
------------------	-----------------------------------	--------------------

Click to start homing.

⚠ CAUTION

The SW-enable is set automatically when homing starts. Homing will only be started in OPMODE 8. However, the SW-enable is set in all OPMODES The drive can therefore be accelerated by an analog setpoint that is applied, if the START command is executed in OPMODES 1 or 3.

Failure to follow this instruction can result in injury or equipment damage.

Stop

ASCII: STOP	Default: - Unit: - Range: -	valid for all OPMODES
--------------------	-----------------------------------	-----------------------

Click to stop (cancel) the homing. **The SW-enable remains set!**

Homing

ASCII: NREF	Default: 0 Unit: - Range: 0 - 20	valid for OPMODE 8
--------------------	--	--------------------

You can choose which type of reference traverse should be performed. A preset zero-point offset (screen page "Encoder" is taken into account for the position output and display.

Exception: homing 5, in this case the true current position is displayed.

Zero-point recognition: the reference point is set to the first zero-crossing point of the feedback unit (zero mark) after recognition of the reference switch transition. Two-pole resolvers and all encoders have just one zero-crossing per turn, so the positioning at the zero mark is unambiguous within a motor turn. For 4-pole resolvers there are two zero-crossings per turn, and for 6-pole resolvers there are three zero-crossings. If the transition of the reference switch lies very close to the zero-crossing point of the feedback unit, then the positioning to the zero mark can vary by one motor turn.

Note: the repetition accuracy of homing operations that are made without zero-point recognition depends on the traversing speed and the mechanical design of the reference switch or limit-switch.

For homing modes 1 and 3, a digital input must be configured as a zero-mark input (home position) (INxMODE=12 or I/O expansion card).

For homing modes 2 and 4, a digital input must be configured as a hardware limit switch.

For homing modes 1, 2, 3, 4, 5, and 7, the setting of the zero-pulse offset for the Encoder Equivalent Output (EEO) output is taken into account (the zero point is set so both the output of the zero pulse and the display of the zero position appear at zero-pulse offset).

Homing 0	Sets the current position point to the value of the Offset field setpoint. The motor does not run (the following error is lost).
Homing 1	Traverse to the reference switch with zero-mark recognition.
Homing 2	Move to hardware limit-switch, with zero-mark recognition. The reference point is set to the first zero-crossing of the feedback unit (NM, zero mark) beyond the limit-switch.
Homing 3	Move to reference switch, without zero-mark recognition. The reference point is set to the transition of the reference switch.
Homing 4	Move to hardware limit-switch, without zero-mark recognition. The reference point is set to the transition of the hardware limit-switch.
Homing 5	Move to the next zero-mark of the feedback unit. The reference point is set to the next zero-mark of the feedback unit.
Homing 6	Sets the reference point to the actual position (the following error is not lost).
Homing 7	Move to mechanical stop, with zero-mark recognition. The reference point is set to the first zero-crossing of the feedback unit (NM, zero mark) beyond mechanical stop.
Homing 8	Drives to an absolute SSI position. At the start of the homing run, a position is read from the SSI input (GEARMODE=5), converted according to the scaling factors GEARI and GEARO, as well as the reference offset, then used as the target position.
Homing 9	Move to mechanical stop, without zero-mark recognition. When the homing mode is started, the peak current limit threshold IPEAK is set to REFIP (peak current for the homing mode in A) in the direction given by DREF (DREF=0 positive, DREF=1 negative). When the drive moves the motor, the contouring error is monitored and if the error becomes higher than PEMAX / 2 (half of the contouring error window), this position is used to set the actual and the target position to ROFFS. The peak current of the drive is set back to the original value of IPEAK.

Direction of Motion

ASCII: DREF	Default: 0 Unit: - Range: 0, 1, 2	valid for OPMODE 8
--------------------	---	--------------------

The DREF parameter can be used to define the direction of motion for a homing operation and for positioning with a modulo-axes (POSCNFG=2).]

Status	Subject	Description
0	Negative movement	A homing move is always started in the negative direction (-VREF). Using a modulo axes type, a position is always searched in the negative direction (if DIR=1, the target position is searched in the positive direction).
1	Positive movement	A homing move is always started in the positive direction (+VREF). Using a modulo axes type, a position is always searched in the positive direction (if DIR=1, the target position is searched in the negative direction).
2	Optimised movement	The shortest distance between the starting position and the zero pulse of the resolver is executed in Homing Mode No. 5 (NREF=5). When a modulo axis type is used the drive always moves in the direction of the shortest distance.

Homing Speed

ASCII: VREF	Default: 10000 Unit: VUNIT Range: 0 - VLIM/VLIMN	valid for OPMODE 8
--------------------	--	--------------------

Determines the velocity for the homing operation. The sign is automatically fixed by the direction of motion that is selected. The size is defined by **VUNIT**.

Accel. ramp

ASCII: ACCR	Default: 10 Unit: ACCUNIT Range: 1...32767	valid for OPMODE 8
--------------------	--	--------------------

Acceleration ramp for jogging and homing with the internal position control loop. This variable defines the acceleration ramp used for jogging and homing with the internal position control loop. When starting the homing or jog mode, the ACCR acceleration ramp can (in some circumstances) be limited by the minimum acceleration time **PTMIN**. The size is defined by **ACCUNIT**.

Decel. ramp

ASCII: DECR	Default: 10 Unit: ACCUNIT Range: 1...32767	valid for OPMODE 8
--------------------	--	--------------------

The DECR command defines the braking ramp for jog mode or homing with the internal position control loop. When starting the homing/jog mode, the DECR deceleration ramp can, in some circumstances, be limited by the minimum acceleration time **PTMIN**. The size is defined by **ACCUNIT**.

This deceleration ramp is only used if the operating mode allows it. For homing to a hardware limit-switch, the emergency ramp is used.

Offset

ASCII: ROFFS	Default: 0 Unit: m Range: long integer	valid for OPMODE 8
---------------------	--	--------------------

With the reference offset you can assign an absolute position value other than 0 to the reference point. With an offset for the reference position you are not actually making a physical change, but the offset is used as a reference value within the position control of the servo amplifier. Homing to the reference switch will then not finish at zero, but at the preset reference offset value. **The reference offset must be set before homing is started.** The scaling of the position depends on the settings for **PGEARI**, **PGEARO**, **PRBASE**. The reference offset is entered in m.

Homing Diagrams

On the following pages you can find the paths traversed during homing types 1 to 7 for every possible initial situation (positive rotation, negative and positive directions of motion).

The meanings of the abbreviations in the diagrams are:

N	limit-switch NSTOP	P	limit-switch PSTOP	SP	start position
R	reference switch	vref	preset velocity	NM	zero mark of the resolver

Homing 1

Diagrams Homing without limit switches, with homing switch, with feedback zero

negative traverse, positive rotation

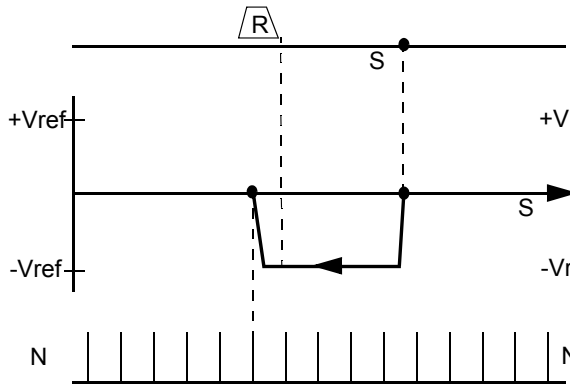

negative traverse, negative rotation

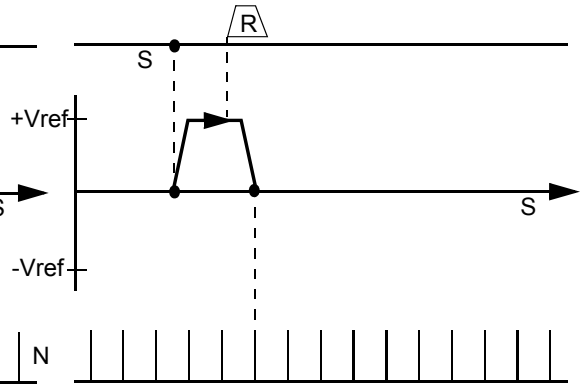

Homing with reference switch, negative direction of motion, positive rotation, with zero-mark.

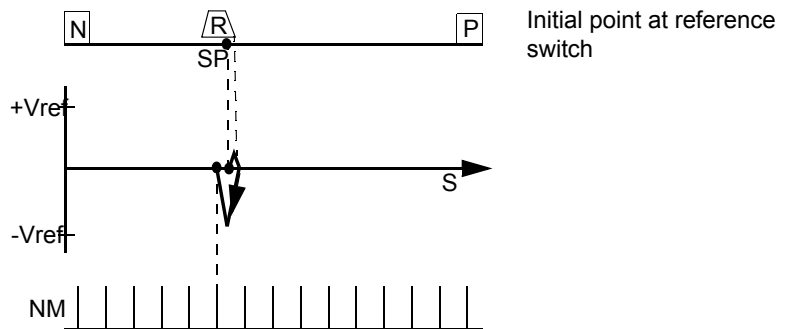
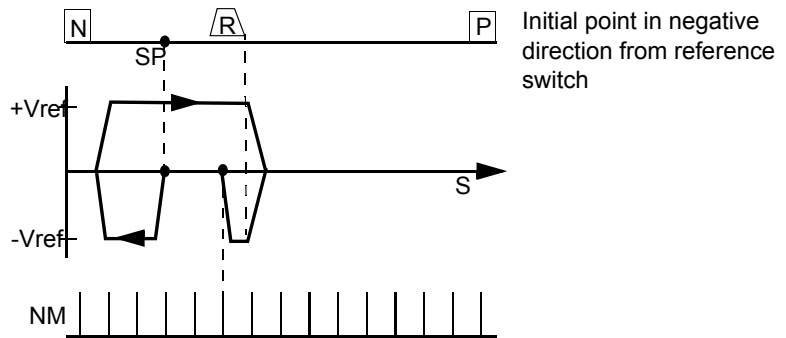
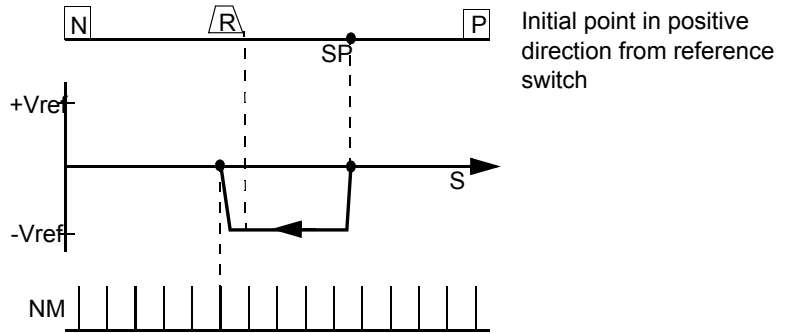

 **CAUTION****RISK OF EQUIPEMENT DAMAGE**

Before starting homing, check the safety of the system, since the load may move, even if the limit-switches are disconnected or defective.

The limit-switch functions 2, PSTOP and 3, NSTOP must be activated at digital inputs LI3 and LI4 to achieve the full homing functionality.

Failure to follow this instruction can result in injury or equipment damage.

Homing with reference switch, positive direction of motion, positive rotation, with zero-mark.

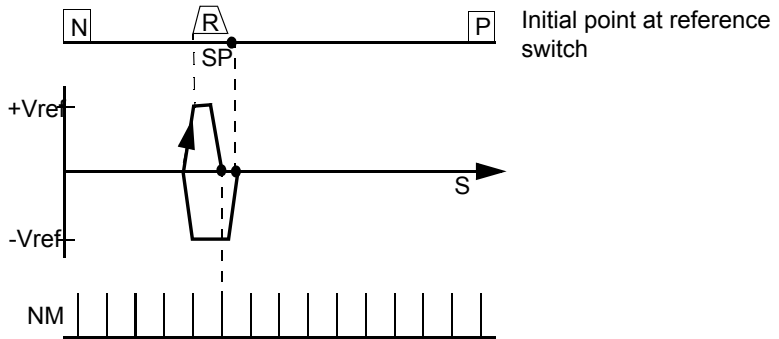
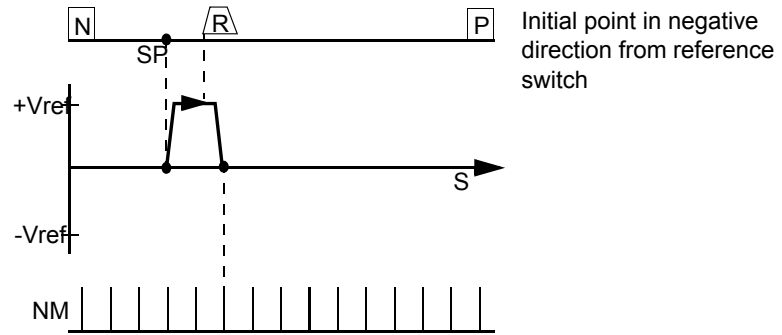
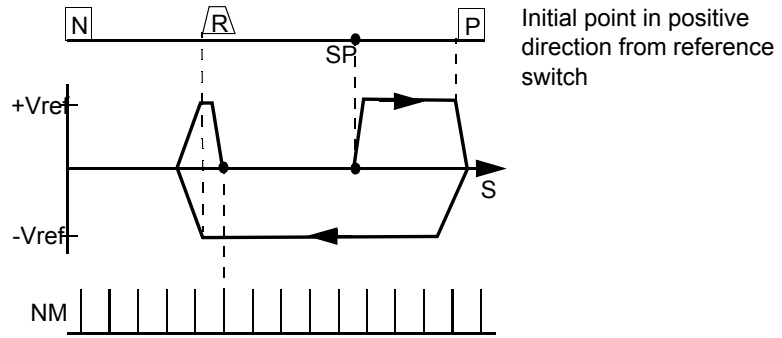

 **CAUTION****RISK OF EQUIPEMENT DAMAGE**

Before starting homing, check the safety of the system, since the load may move, even if the limit-switches are disconnected or defective.

The limit-switch functions 2, PSTOP and 3, NSTOP must be activated at digital inputs LI3 and LI4 to achieve the full homing functionality.

Failure to follow this instruction can result in injury or equipment damage.

Homing 2

Diagrams

Homing with reference switch, **negative direction** of motion, positive rotation, with zero-mark.

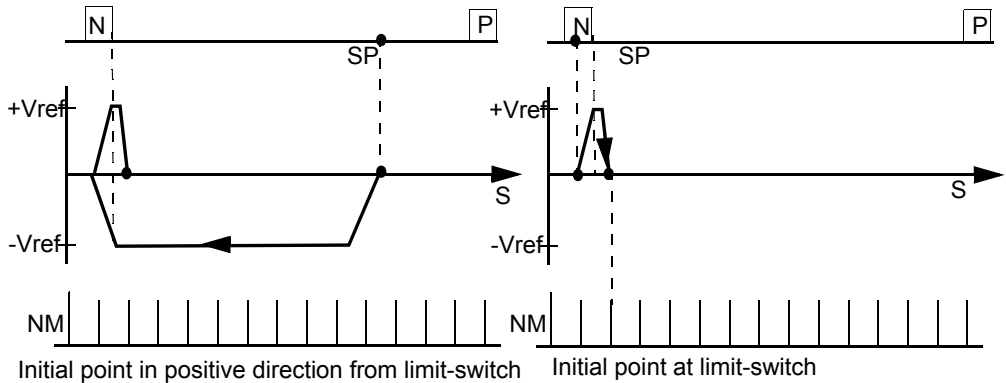

Note: hardware limit-switches must be present and connected. The digital inputs LI3 and LI4 limit-switch functions 2, PSTOP and 3, NSTOP must be switched on.

Homing with reference switch, **positive direction** of motion, positive rotation, with zero mark.

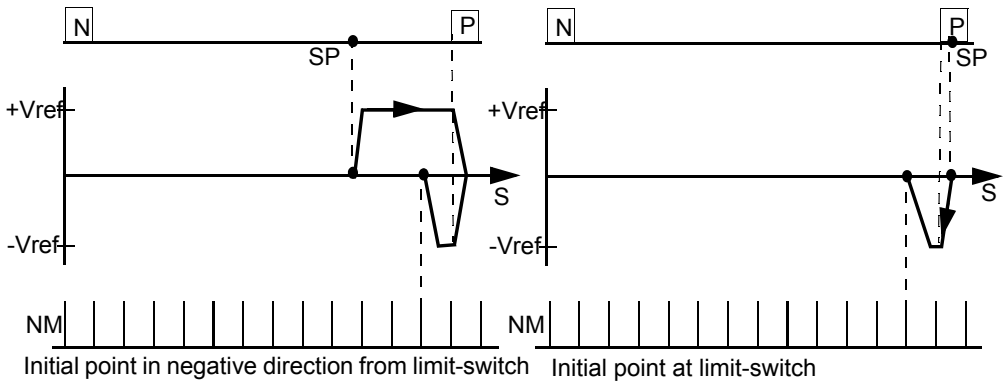

Note: hardware limit-switches must be present and connected. The digital inputs LI3 and LI4 limit-switch functions 2, PSTOP and 3, NSTOP must be switched on.

Homing 3

Diagrams

Homing with reference switch, **negative direction** of motion, positive rotation, without zero-mark.

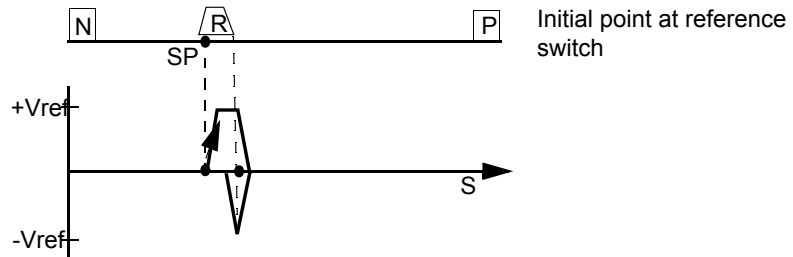
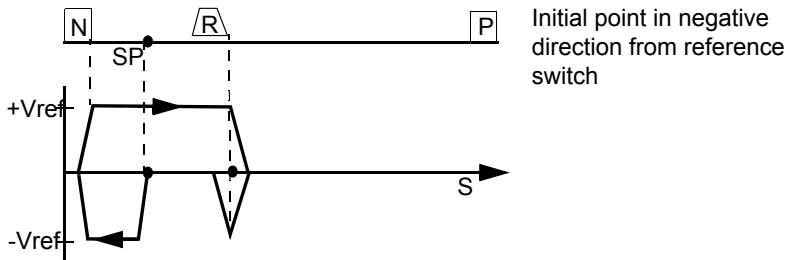
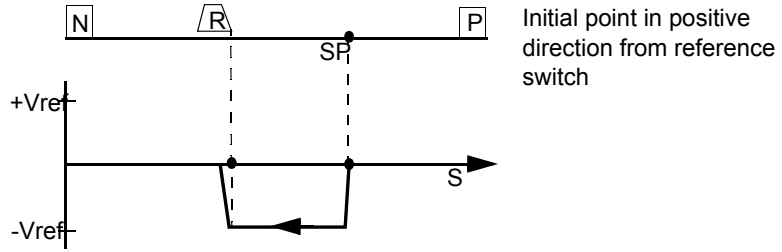

⚠ CAUTION

RISK OF EQUIPMENT DAMAGE

Before starting homing, check the safety of the system, since the load may move, even if the limit-switches are disconnected or defective.
 The limit-switch functions 2, PSTOP and 3, NSTOP must be activated at digital inputs LI3 and LI4.

Failure to follow this instruction can result in injury or equipment damage.

Homing with reference switch, **positive direction** of motion, positive rotation, without zero mark.

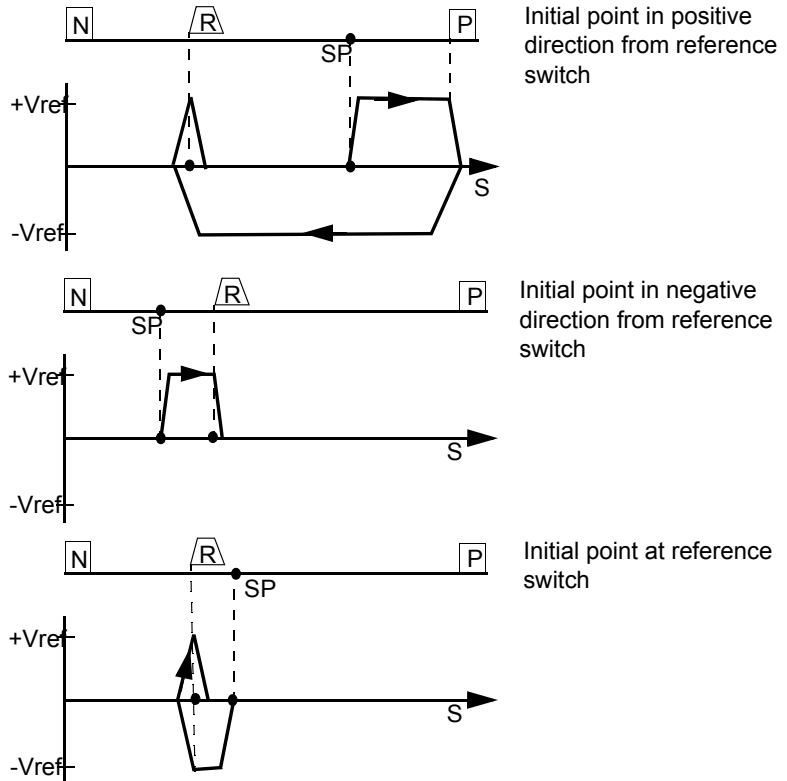

 **CAUTION****RISK OF EQUIPMENT DAMAGE**

before starting homing, check the safety of the system, since the load may move, even if the limit-switches are disconnected or defective.

The limit-switch functions 2, PSTOP and 3, NSTOP must be activated at digital inputs LI3 and LI4.

Failure to follow this instruction can result in injury or equipment damage.

Homing 4

Diagrams

Homing without reference switch, **negative direction** of motion, positive rotation, without zero mark.

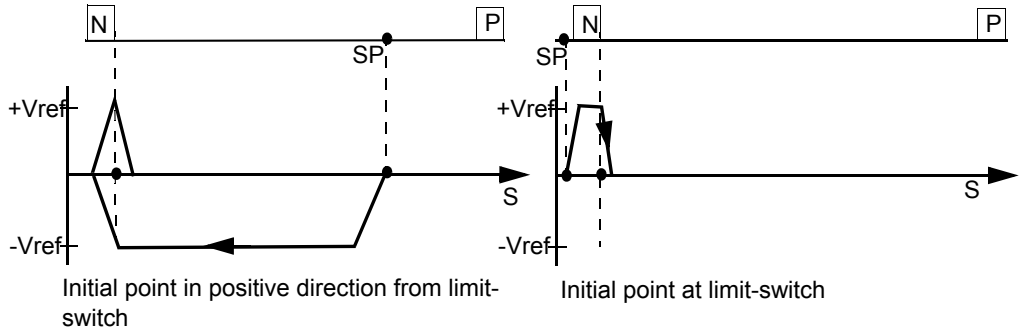

Note: Hardware limit-switches must be present and connected. The LI3 and LI4 digital input limit-switch functions 2, PSTOP and 3, NSTOP must be switched on.

Homing without reference switch, **positive direction** of motion, positive rotation, without zero mark.

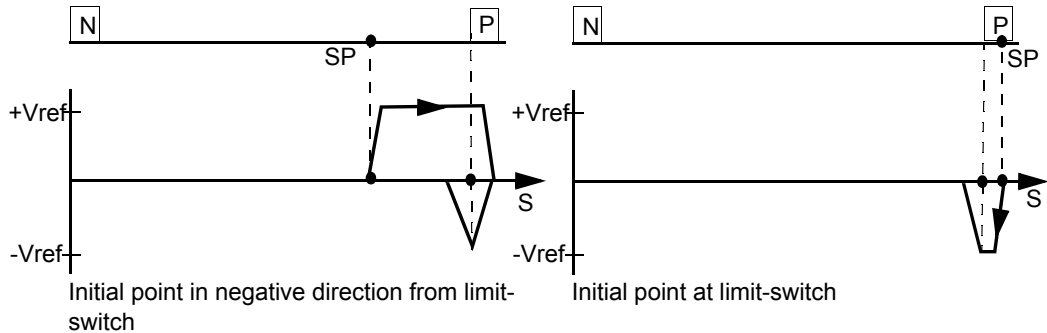

Note: Hardware limit-switches must be present and connected. The LI3 and LI4 digital input limit-switch functions 2, PSTOP and 3, NSTOP must be switched on.

Homing 5

Diagram

Homing without reference switch, **negative direction** of motion, positive rotation, with zero mark.

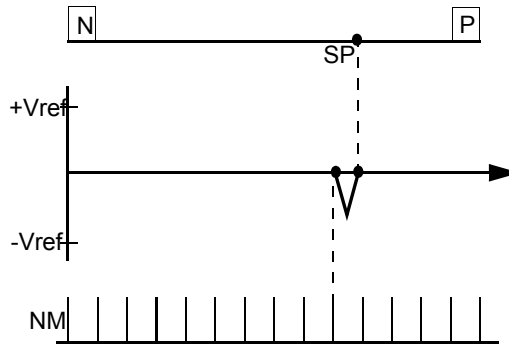

Homing with reference switch, **positive direction** of motion, positive rotation, with zero mark.

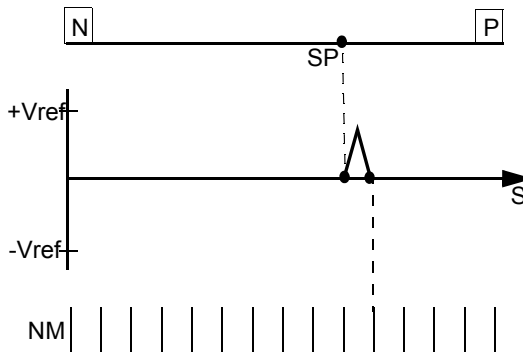

Note: behavior for successively repeated starts of Homing 5: the position controller can only hold the motor in the zero position by passing the zero mark by 1 count. On a repeated start of Homing 5, depending on the position (1 count in advance of or 1 count behind the zero-mark) and the count direction, the movement may be a full motor turn !

Homing 7

Diagrams

Homing to mechanical stop, **negative direction** of motion, positive rotation, with zero mark.

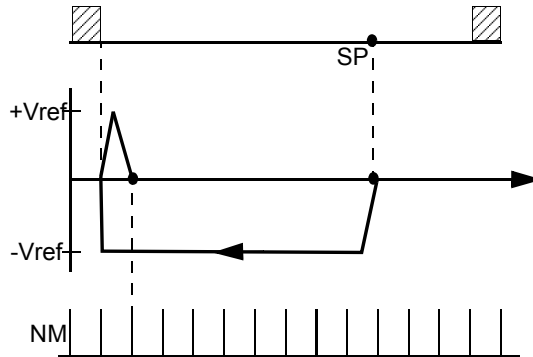

Homing to mechanical stop, **positive direction** of motion, positive rotation, with zero mark.

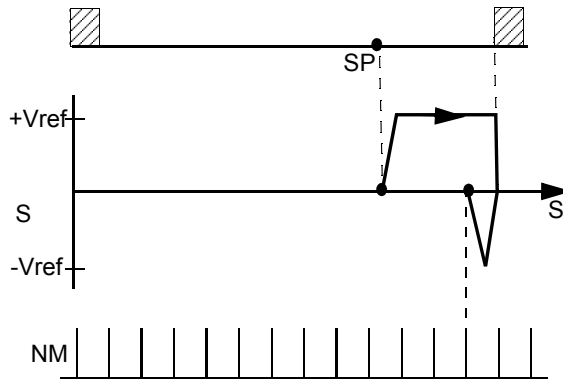

⚠ CAUTION

RISK OF EQUIPMENT DAMAGE

Using this type of homing run can damage the mechanical stop on the machine. The peak current I_{peak} and the continuous current I_{rms} are limited for the duration of the homing run. A more severe limiting of the current is possible. Consult our applications department.

Failure to follow this instruction can result in injury or equipment damage.

Homing 9

Diagrams

Mechanical stop, without limit switches, without homing switch, without feedback zero.

Homing to mechanical stop, **negative direction** of motion, positive rotation, without zero mark.

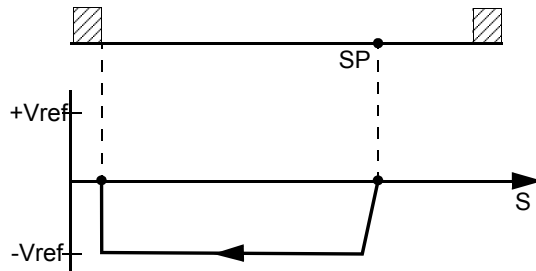

Homing to mechanical stop, **positive direction** of motion, positive rotation, without zero mark.

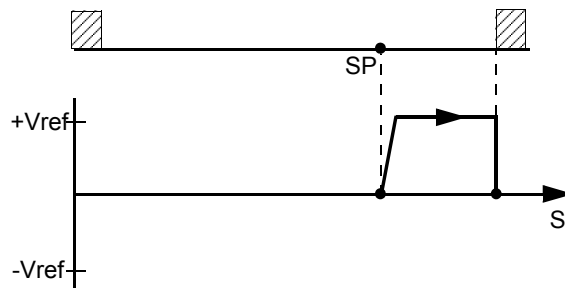

⚠ CAUTION

RISK OF EQUIPMENT DAMAGE

Using this type of homing run can damage the mechanical stop on the machine. The peak current I_{peak} and the continuous current I_{rms} are limited for the duration of the homing run.

A more severe limiting of the current is possible. Consult our applications department.

Failure to follow this instruction can result in injury or equipment damage.

Jog mode

At a Glance

Jog mode is defined as an endless motion at a constant velocity. This type of operation can be started without a reference point being set. The hardware limit-switches are monitored. Software limit-switches are only monitored if a reference point has been set. ACCR and DECR defined in the Homing (See *Overview of the "Homing" screen, p. 147*) settings.

v

ASCII: VJOG	Default: 0 Unit: VUNIT Range: 0..VLIM/VLIMN	valid for OPMODE 8
--------------------	---	--------------------

VJOG is effectively an endless motion task (OPMODE 8 only), and is implemented by the internal position control loop. The sign for the speed indicates the direction of jog operation. The scaling of the velocity is given in position control loop units, and depends on the PGEARI and PGEARO (See *Resolution, p. 180*) parameters.

F4

ASCII: MJOG	Default: - Unit: - Range: -	valid for OPMODE 8
--------------------	-----------------------------------	--------------------

Start the jog mode by pressing the function key F4. The drive moves with the preset velocity in the direction which is indicated by the sign of the velocity for the jog mode "v", as long as the function key is pressed. If a communication error occurs while pressing the button, the drive stops with the emergency deceleration ramp.

CAUTION

When the function "Jog mode" is started, the SW-enable is set automatically. The Function "Jog mode" is only started in OPMODE 8. However, the SW-enable is set in all OPMODES. The drive can therefore be accelerated by an analog setpoint that is applied, if the START command is executed in OPMODES 1 or 3.

Failure to follow this instruction can result in injury or equipment damage.

4.11 Screen page "Gearing"

Overview of the "Gearing" screen

At a Glance

Diagram:

Gearing 1001

Gearing Mode
SIN Encoder (X1)

Input Pulses per Turn = 8192

Ratio = $\frac{8192}{4096}$ = $\frac{8192}{8192}$

4096 Pulses = 1 Turn

OK Cancel Apply

The servo amplifier receives a position setpoint from another instrument (master servo amplifier, stepper motor control, encoder or similar) and controls the position of the motor shaft in synchronism with this master (control) signal.

Cycle time of the electrical gearing: 250 micro-seconds. A value averaged over 1000 s is used.

Input Type

ASCII: GEARMODE	Default: 6 Unit: - Range:0...9	valid for OPMODE 4, 5, 6, 8
------------------------	--------------------------------------	-----------------------------

The servo amplifier can be controlled through different interfaces and from various sources. For the connector pin assignments, see the Installation Manual.

OPMODE	EXTPOS	Description
4	/	GEARMODE configures the master command source and the second position feedback source (if used). GEARMODE selects the feedback type and connector used for the master signal.
5, 6, 8	1	GEARMODE configures the secondary position feedback source. GEARMODE selects the secondary feedback type and connector used to close the position loop. Also must set EXTPOS =1.

The following table describes each of the GEARMODE functions:

ID	Function	Comments
0	Encoder follower, Digital I/O 24V (X3)	With an incremental encoder (track A/B, 24V signal level) connected to the digital inputs LI1 / LI2 (terminals X3/11, 12), an additional function assignment for the inputs is not necessary and any assignments on the Digital I/O screen page are ignored.
1	Pulse / direction Digital I/O 24V (X3)	With a stepper motor control (pulse/direction, 24V signal level) connected to the digital inputs LI1 / LI2. An additional function assignment for the inputs is not necessary and any assignments on the Digital I/O screen page are ignored. LI1 (X3/11) = Direction (low=positive, high=negative), LI2 (X3/12) = Pulse
2	Reserved	-
3	Encoder follower, Digital I/O 5V (X5)	With an incremental encoder connected to connector X5. X5/5 = A+, X5/4 = A-, X5/6 = B+, X5/7 = B- ENCMODE has to be set to "0".
4	Pulse / direction, Digital I/O 5V (X5)	With a stepper motor control connected to connector X5. X5/5 = Pulse+, X5/4 = Pulse- X5/6 = Direction+, X5/7 = Direction- (low=positive, high=negative) ENCMODE has to be set to "0".
5	Encoder follower, Digital I/O 5V (X5)	the same as GEARMODE = 3
6	Sin/Cos Encoder (X1)	Only the zero crossing of the sine & cosine signals are used. No analog processing.

ID	Function	Comments
7	SSI Input (X5)	<p>For the Master/Slave mode with two drive, the following settings are required:</p> <p>Master: (is sending the SSI position) ENCMODE 2 setting for encoder emulation (1=ROD, 2=SSI) SSIGRAY = 0 data format (0=binary/1=gray) SSIINV = 1 SSI-Clock (0=standard, 1=inverted) SSIMODE = 1 0=single turn / 1= multi turn SSIOUT = 0 baudrate 0=200 Kbaud / 1=1MBaud</p> <p>Slave: (is reading the SSI position) GEARMODE = 7 Setting for the master interface OPMODE = 4 Master/Slave mode ENCMODE = 2 always 2 when GEARMODE = 7 (SSI) SSIGRAY = 0 data format (0=binary/1=gray) SSIINV = 0 start transmission with MSB (=0) or LSB (=1) SSIMODE = 0 alarm bit at begin (=1) or at end (=2) or off (=0) SSIOUT = 25 data bits-1 (26) IN1MODE = 16 Start input for the motion task IN1TRIG = 0 0 means: motion task is a homing move NREF = 8 Number for homing move.</p> <p>The settings GEARMODE = 7 and OPMODE =4 activate the read of the SSI-position for the encoder input. The drive reads the SSI-position every 250 s and calculates the difference to the previous position. This difference is multiplied by a scaling factor and added to the last position command value. With PRBASE = 20: Scaling-factor = $2^{(33-SSIOUT)} * GEARO / GEARI$ With SSIOUT = 25: Scaling-factor = $256 * GEARO / GEARI$ The absolute position from Master/Slave may move with ROFFS. To adjust the absolute position between Master and Slave, it is necessary to perform a homing with the slave drive and NREF = 8 (start with digital input). At the beginning of the homing the Slave drive reads the absolute position from the Master, performs the scaling and uses this position as the target position for the homing. The drive changes the operation mode to OPMODE = 8 and starts the homing move to the target position with VREF and ramps ACCR / DECR. When the drive reaches the target position, it sets the INPOSITION message. The PLC resets the start input to activate the Master/Slave-mode (OPMODE = 4).</p>
8	Sin/Cos Encoder (X1)	<p>The difference between this mode and GEARMODE=6 is that the parameter channel of the encoder is read and the absolute position is transferred to the position register. This setting can be used in position mode under EXTPOS=1. The sine/cosine signals of the encoder are analog read. This increases the resolution significantly.</p>

ID	Function	Comments
9	EnDat Encoder (X1)	<p>The difference between this mode and GEARMODE=6 is that the parameter channel of the encoder is read and the absolute position is transferred to the position register. ENCLINES is calculated automatically to the internal resolution of 20 Bit per rev of the encoder.</p> <p>This setting can be used in position mode under EXTPOS=1.</p> <p>The sine/cosine signals of the encoder are analog read. This increases the resolution significantly.</p>

Ratio

ASCII: ENCIN (x)	Default: 4096 Unit: - Range: 256,512,.. ,65536	valid for OPMODE 4
ASCII: GEARO (y)	Default: 8192 Unit: - Range: -32767 .. 32767	valid for OPMODE 4
ASCII: GEARI (z)	Default: 8192 Unit:- Range: 1 .. 32767	valid for OPMODE 4

You can use the entry fields in this equation to determine the transmission ratio:

$$\text{Ratio} = \frac{\text{Input pulses per turn}}{x} * \frac{y}{z} \text{ (electr. gearing, correction factor through Ana)}$$

where: x = Normalization for the input pulses (256 ... actual no. of pulses)

y/z = ratio for y = -32768 ...+32767 and z = 1 ...32767

If you have any queries, please contact our applications department.

4.12 Screen page "Position data"

Overview of the "Position data" screen

At a Glance

Diagram:

For each one of the positioning tasks you must define motion tasks. These motion tasks can be selected by a motion task number, and are stored in the servo amplifier.

Motion task	Stored in	Precondition for storing	Comments
0	RAM	None	Temporary buffer store for copying operations.
1...180	EEPROM	Power stage deactivated	Permanently stored
192...255	RAM	None	Volatile storage

When the servo amplifier is switched on, the RAM motion blocks 192 . . . 255 are automatically pre-loaded with the parameters of the motion blocks 1 . . . 64.

Number

Entry of a motion task number, to start the motion task from a PC.

Motion Task Table

Displays a new window where motion tasks are shown in table format.

You can use this table to directly enter all task parameters. The following commands are available:

- Cut
- Copy
- Paste
- Delete

Clipboard operations can only be carried out on full lines, i.e. the line required must be selected. A whole line or a single cell may be selected. Select a line by clicking on the line number or by using the <Shift><Space> key combinations (as in Excel). (All edit operations use standard Windows key combinations.)

Entering data via the "Motion task table screen (See *At a Glance*, p. 231)".

Double click on a line number to open the page associated with the corresponding motion. The actions linked to the **OK** and the **Cancel** buttons in the "Motion Parameters" dialog box have changed compared to previous versions. Access to the Flash EEPROM is no longer available. Only the corresponding entries in the motion task table are updated. Use the **OK** or the **Apply** buttons in the "Motion Task Parameters" screen page to write these changes to the amplifier.

Number

Entry of a motion task number, to start the motion task from a PC.

Start

ASCII: MOVE	Default: - Unit: - Range: 0..180, 192..255	valid for OPMODE 8
--------------------	--	--------------------

Start the motion task that has the number that can be seen in the NUMBER field. The amplifier must be enabled (input X3/15 has a High signal).

CAUTION

The SW-enable is automatically set when the motion task starts. The motion task is only started in OPMODE8. However, the SW-enable is set in all OPMODES. The drive can therefore be accelerated by an analog setpoint that is applied, if the START command is executed in OPMODES1 or 3. The motion task is not started if the target position is beyond the defined SW-limit switches (warning messages n06/n07 and n08).

Failure to follow this instruction can result in injury or equipment damage.

Stop

ASCII: STOP	Default: - Unit: - Range: -	valid for OPMODE 8
--------------------	-----------------------------------	--------------------

Stops the current motion task. The SW-enable remains set!

Axis Type

ASCII: POSCNFG	Default: 0 Unit: - Range: 0,1, 2	valid for OPMODE 8
-----------------------	--	--------------------

Here you select whether the axis is to be operated as a linear or a rotary axis.

ID	Function	Comments
0	Linear	A linear axis is an axis with a limited range of travel. A linear axis moves within the traversing limits that are given by the software limit-switches, both absolutely and relatively. A reference point must be set.
1	Rotary	A rotary axis is an axis with unlimited travel. The software limit-switches have no significance in this case. A rotary axis always makes a relative movement, even if the tasks are entered as absolute ones. The actual position is set to zero with every start. A reference point is not required.
2	Modulo axis	Axes with a limited range of movement. The minimum position is SRND and the maximum position is ERND-1. If the maximum position ERND-1 is reached, it automatically switches over to SRND. The absolute target positions have to be in the defined range. If a motion task is started that has an absolute position outside the range, a warning "n08" is displayed (wrong motion task). Relative moves are calculated so that the target position is always in the defined range. A positioning in a axes like this enables two possibilities of direction for the target position. DREF enables the possibility to restrict the direction. This axes type also needs a homing move.

v_max

ASCII: PVMAX	Default: 10000 Unit: VUNIT Range: 0...VLIM	valid for OPMODE 8
ASCII: PVMAXN	Default: 10000 Unit: VUNIT Range: 0...VLIM	valid for OPMODE 8

This parameter is used to adjust the maximum speed of movement to suit the limits of the operative machinery. The calculation of the upper setting limit depends on the final limit speed of the drive. The value that is entered is used as a limit for the "v_setp" entry in the motion tasks. During commissioning, you can limit the speed by using v_max (without changing the setting for the motion blocks). A lower value of v_max overrides the v_setp of the motion tasks.

When used together with the PVMAXN parameter, it is possible to implement a directionally-dependent velocity limit. The PVMAX determines the maximum velocity for positive and negative directions together. By making a subsequent entry for PVMAXN, the limit for the negative direction can be set separately.

t_acc/dec_min

ASCII: PTMIN	Default: 10 ms Unit: ACCUNIT Range: 1..32767	valid for OPMODE 8
---------------------	--	--------------------

The minimum acceleration ramp PTMIN defines the minimum time that is allowed for a velocity change from 0 to PVMAX. Regardless of how the acceleration value is entered (milliseconds, SI units), the acceleration that is used is limited to PVMAX / PTMIN at the start of a motion task. Using the PVMAX and PTMIN parameters it is possible to control the behavior of the system, especially during the commissioning phase, without having to alter the individual motion tasks.

In Position

ASCII: PEINPOS	Default: 4000 Unit: PUNIT Range: long int	valid for OPMODES 4,5,8
-----------------------	---	-------------------------

Sets the InPosition window. Determines at which distance from the set position the "InPosition" message should be reported. The In-Position window is entered in the same units as the position control loop (See PGEARI/PGEARO (See *Resolution*, p. 180)).

modulo start pos.

ASCII: SRND	Default: -2147483648 Unit: - Range: -	Valid for OPMODES 4, 5, 8
--------------------	---	---------------------------

This parameter is used to define the initial setting of the motion range for a modulo axis (POSCNFG=2). The entry for SRND is made in SI units (taking account of PGEARI, PGEARO (See *Resolution*, p. 180)).

modulo end pos.

ASCII: ERND	Default: 21474883647 Unit: - Range: -	Valid for OPMODES 4, 5, 8
--------------------	---	---------------------------

This parameter is used to define the end setting of the motion range for a modulo axis. The entry for ERND is made in SI units (taking account of PGEARI, PGEARO (See *Resolution*, p. 180)).

Position registers

A programmable register that can have various functions assigned to it. Make changes only while the amplifier is disabled, then reset the amplifier.

Function	Comments	Position register					
		0 (SWE0)	1 (SWE1)	2 (SWE2)	3 (SWE3)	4 (SWE4)	5 (SWE5)
inactive	-	x	x	x	x	x	x
x<Position	Threshold for signal	x	x	x	x	x	x
x>Position	Threshold for signal	x	x	x	x	x	x
Software limit switch 1	Limit switch function	-	x	-	-	-	-
Software limit switch 2	Limit switch function	-	-	x	-	-	-

Position registers 1 to 4 are settable via Unilink MH. Position register 0 and 5 are readable via Terminal screen.

SW limit-switches 1 / 2:

The software limit-switches form part of the monitoring functions of the position controller.

SWE1	The monitoring checks whether the actual position value is lower than the preset value; the negative direction of travel is now inhibited. You have to leave limit-switch 1 by moving in the positive direction.
SWE2	The monitoring checks whether the actual position value is higher than the preset value; the positive direction of travel is now inhibited. You have to leave limit-switch 1 by moving in the negative direction.

The drive brakes with the emergency ramp, and remains at standstill under torque. The principle of positioning the software limit-switch can be seen in the diagram below:

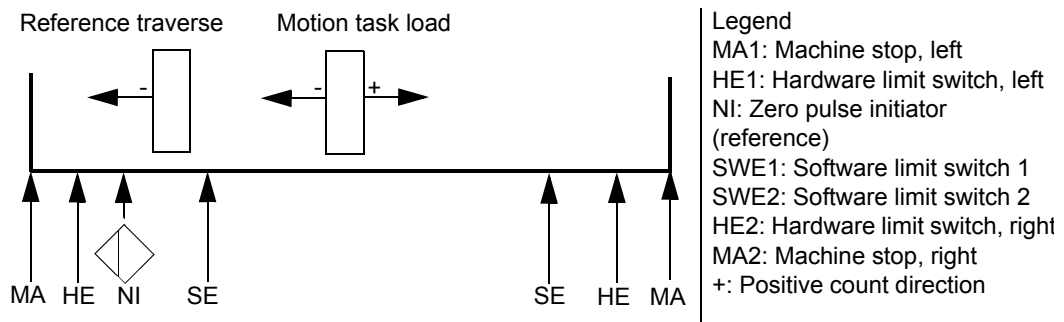

ASCII: SWCNFG (enabled)	Default: 0 Unit: - Range: 0 .. 65536	valid for all OPMODES
ASCII: SWCNFG2 (enabled)	Default: 0 Unit: - Range: 0 .. 65535	valid for all OPMODES
ASCII: SWEx (position)	Default: 0 Unit: - Range: long int	valid for all OPMODES

Configuration variables for the position register. SWCNFG and SWCNFG2 are binary-coded bit-variables. It is transferred to the ASCII terminal programs as a decimal number.

Bit-variable SWCNFG					
Bit	Value	Description	Bit	Value	Description
2 ⁰	0	Monitoring of SWE1 inactive	2 ⁸	0	Monitoring of SWE3 inactive
	1	Monitoring of SWE1 active		1	Monitoring of SWE3 active
2 ¹	0	Signal for actual position > SWE1	2 ⁹	0	Signal for actual position > SWE3
	1	Signal for actual position < SWE1		1	Signal for actual position < SWE3
2 ²	0	SWE1 functions as signal threshold	2 ¹⁰	0	Reserved
	1	SWE1 functions as SW limit-switch		1	
2 ³	0	Cam position SWE1N inactive	2 ¹¹	0	Cam position SWE3N inactive
	1	Cam position SWE1N active		1	Cam position SWE3N active
2 ⁴	0	Monitoring of SWE2 inactive	2 ¹²	0	Monitoring of SWE4 inactive
	1	Monitoring of SWE2 active		1	Monitoring of SWE4 active
2 ⁵	0	Signal for actual position > SWE2	2 ¹³	0	Signal for actual position > SWE4
	1	Signal for actual position < SWE2		1	Signal for actual position < SWE4
2 ⁶	0	SWE2 functions as signal threshold	2 ¹⁴	0	Reserved
	1	SWE2 functions as SW limit-switch		1	
2 ⁷	0	Cam position SWE2N inactive	2 ¹⁵	0	Cam position SWE4N inactive
	1	Cam position SWE2N active		1	Cam position SWE4N active

Bit-variable SWCNFG2					
Bit	Value	Description	Bit	Value	Description
2 ⁰	0	Monitoring of SWE0 inactive	2 ⁸	0	Monitoring of SWE5 inactive
	1	Monitoring of SWE0 active		1	Monitoring of SWE5 active

Bit-variable SWCNFG2					
Bit	Value	Description	Bit	Value	Description
2 ¹	0	Signal for actual position > SWE0	2 ⁹	0	Signal for actual position > SWE5
	1	Signal for actual position < SWE0		1	Signal for actual position < SWE5
2 ²	0	Reserved	2 ¹⁰	0	Reserved
	1	Reserved		1	
2 ³	0	Cam position SWE0N inactive	2 ¹¹	0	Cam position SWE5N inactive
	1	Cam position SWE0N active		1	Cam position SWE5N active

The individual position signals can be given out through the outputs LO1/LO2 :

SWE0: OxMODE=28 x=1,2

SWE1: OxMODE=12 x=1,2

SWE2: OxMODE=13 x=1,2

SWE3: OxMODE=14 x=1,2

SWE4: OxMODE=15 x=1,2

SWE5: OxMODE=29 x=1,2

All position signals are recorded in a status register, regardless of the outputs via the digital outputs, and can be read out through the serial interface as well as through the CAN/PROFIBUS interface

SWE0: Bit 21 (0x00200000) of DRVSTAT

SWE1: Bit 22 (0x00400000) of DRVSTAT

SWE2: Bit 23 (0x00800000) of DRVSTAT

SWE3: Bit 24 (0x01000000) of DRVSTAT

SWE4: Bit 25 (0x02000000) of DRVSTAT

SWE5: Bit 27 (0x08000000) of DRVSTAT See position register 0..5 on *PosReg.0-5, p. 203*

The cam function is activated by enabling cam bits 3/7/11/15 of SWCNFG and bits 3/7 of SWCNFG2.

For more details on Cam fonction, please contact our technical department.

Resolution

ASCII: PGEARI (numerator)	Default: 10000 Unit: PUNIT Range: long int	valid for OPMODE 8
ASCII: PGEARO (denominator)	Default: 1048576 Unit: μm Range: long int	valid for OPMODE 8

The parameter PGEARI is used in conjunction with the PGEARO parameter to convert the control loop position and speed from SI units into increments. The PGEARO parameter contains the number of increments that are moved if the path to be moved has a length of PGEARI.

The conversion is made according to the following formula:

$$\text{Position}[\text{increments}] = \text{Position}[\text{SI}] * \text{PGEARO} / \text{PGEARI}$$

$$\text{Velocity}[\text{increments}] = \text{Velocity}[\text{SI}] * \text{PGEARO} / \text{PGEARI} / 4000$$

If PGEARI=PGEARO, then there will be no conversion from SI units into increments. In this case, the position and velocity must be given in increments.

Position: 1046576 increments/turn for PRBASE = 20, or 65536 increments/turn for PRBASE = 16

Velocity: $140/32 * \text{speed in RPM}$.

Example

PGEARI = 10000

PGEARO = 1048576

PRBASE = 20

The motion task position should be given in μm with a resolution of 10 mm/rev. The internal resolution of 20 Bit/rev (PRBASE=20) is used. Following settings have to be made:

Position: 1046576 counts/rev at PRBASE = 20 or 65536 counts/rev at PRBASE = 16.

All settings regarding position (PFB, O_P, PE, PEMAX, PEINPOS) are made in m, the settings regarding speed/velocity in m/sec, all settings regarding acceleration in $1000\mu\text{m}/\text{sec}$

GMT

Opens the Graphical Motion Tasking Editor

GMT is an advanced function which allows easy editing of motion tasks using a graphic interface. You can control multiple motions, process I/O, take decisions, add delays and change amplifier processing variables. The environment is user friendly and allows intuitive graph design. Amplifiers have supported motion tasks since 2000. Originally, it was only possible to carry out infinite loop or single motions. GMT extends motion management possibilities by adding functions such as loops, comparisons (<, =, >, etc...), function call and process variable configuration (see GMT documentation).

4.13 Registration

Registration (LATCH)

At a Glance

This servo drive function enables position measure captures in a internal register. registration is triggered by a configured digital input. Capture can be performed in either a rising edge or a falling edge:

	Motor encoder	External encoder
Rising edge	LATCH16 LATCH32	LATCHX16 LATCHX32
Falling edge	LATCH16N LATCH32N	LATCHX16N LATCHX32N

Configuring LATCH

The value registered may be used in a motion task to execute a relative move.

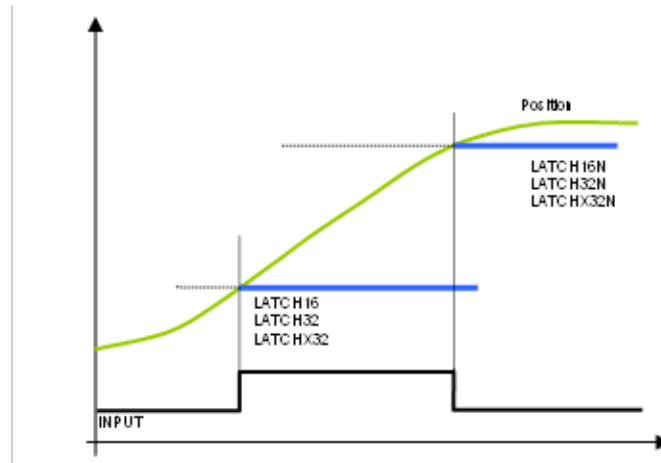

To select a latching function for Llx, refer to Digital I/O function 44 and 45 (See *Digital inputs L11/L12/L13/L14*, p. 102) .

**LATCH
Commands**

LATCH Commands	Short description
EXTLATCH	Selection of the Source of the Latch Inputs
LATCH16	Latched 16-bit Position (positive edge)
LATCH16N	Latched 16-bit Position (negative edge)
LATCH32	Latched 32-bit Position (positive edge)
LATCH32N	Latched 32-bit Position (negative edge)
LATCHX16	Latched external 16-bit Position (positive edge)
LATCHX16N	Latched external 16-bit Position (negative edge)
LATCHX32	Latched external 32-bit Position (positive edge)
LATCHX32N	Latched external 32-bit Position (negative edge)

4.14 Screen page "Position Registers"

Overview of the "Position Registers" Screen

At a Glance

LEXIUM offers 16 internal fast position registers. These 16 registers can be accessed via the ASCII command P1 ... P16 only.

ASCII: P1...P16	Default: 0 Unit: - Range: Long integer	valid for all OPMODES
------------------------	--	-----------------------

Contains the position values for the sixteen position thresholds.

Position values are displayed in the same units as the position control loop (PGEARI / PGEARO (See *Resolution*, p. 180) conversion).

The variables that are required for the fast position registers (WPOSE (See *Enable*, p. 186), WPOSP (See *Signal If*, p. 186), WPOSX (See *Check*, p. 186), P1 ... P16) can be saved in the serial EEPROM by using the SAVE command. Those position registers P1 ... P16 which are not used should be set to 0 (since the default value for a position register is 0, no space will be occupied in the serial EEPROM).

The individual position signals from the status register POSRSTAT (See *Position Register Status*, p. 185) can be output from the digital outputs (See Functions 40,41 in Digital I/O (See *Digital inputs LI1/LI2/LI3/LI4*, p. 102)).

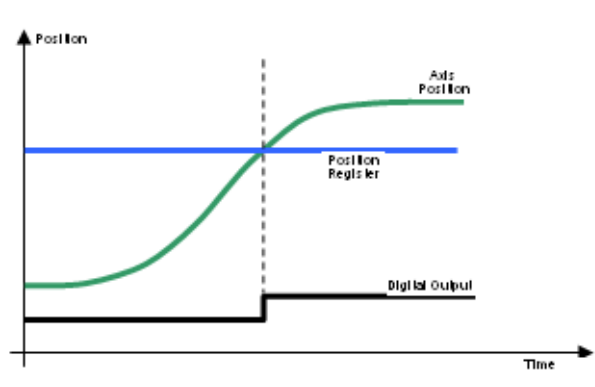

Position Register Status

ASCII: POSRSTAT	Default: - Unit: - Range: -	valid for all OPMODES
------------------------	-----------------------------------	-----------------------

The variable POSRSTAT returns the present status of the fast position registers. This variable can be considered as a 32-bit variable, whereby the lower 16 bits (bits 0 ... 15) are used for the status information of position registers P1 ... P16.

Bit=0 position signaling inactive

Bit=1 position signaling active (position overrun for WPOSP=0 or underrun for WPOSP=1).

Position Registers

ASCII: WPOS	Default: 0 Unit: - Range: 0, 1, 2	valid for all OPMODES
--------------------	---	-----------------------

The position registers operate in a deterministic manner: going above or below a position is detected and signaled within 1 millisecond.

The fast position registers are enabled through the WPOS configuration variable.

WPOS=0	Position register disabled.
WPOS=1	Position register enabled, no spontaneous CAN message on change of status.
WPOS=2	Position register enabled, spontaneous CAN message on change of status (this setting is only via CAN-Bus possible).

Changes of the WPOS variable between 0 and >0 can only be made offline (SAVE and COLSTART), although a change between 1 and 2 can be made online.

Current Position

ASCII: PFB	Default: - Unit: m Range: Long integer	valid for all OPMODES
-------------------	--	-----------------------

The PFB command returns the actual value of the position (from the position control loop feedback).

Check

ASCII: WPOSX	Default: 0 Unit: - Range: 0 - 65535	valid for all OPMODES
---------------------	---	-----------------------

Specify whether the position is monitored continuously or once. If you specify **Once**, the corresponding enable bit (WPOSE) is set to 0 when the position signal is generated, so that the monitoring is disabled for this position register.

Enable

ASCII: WPOSE	Default: 0 Unit: - Range: 0 - 65535	valid for all OPMODES
---------------------	---	-----------------------

Enable or disable each of the sixteen position registers.

Signal If

ASCII: WPOSP	Default: 0 Unit: - Range: 0 - 65535	valid for all OPMODES
---------------------	---	-----------------------

Specify whether the position signal is generated on going above/beyond (overrun) the position, or below/behind (underrun) the position.

4.15 Screen page "Drive status"

Introduction to the "Drive Status" screen

At a Glance

Diagram:

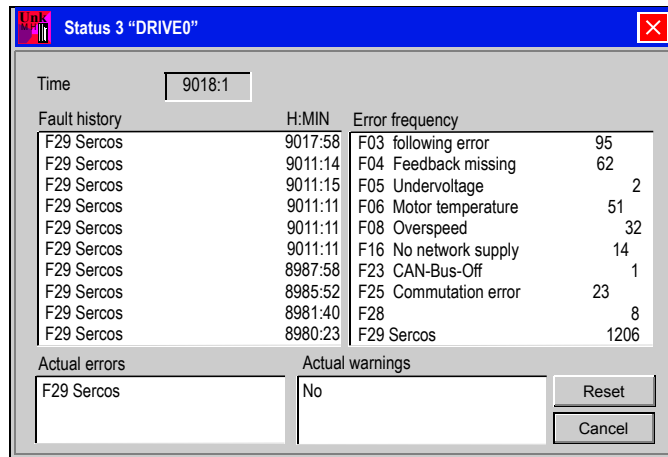

Run time

ASCII: TRUN	Default: - Unit: hhhh:mm Range: 0000:00 to 9999:45	valid for all OPMODES
--------------------	--	-----------------------

Display of the operational time of the servo amplifier, saved at 8 minute intervals. If the 24V supply is switched off, maximum 8 minutes of operation are unregistered. The internal resolution of the run-time counter is 1 second.

Last 10 faults

ASCII: FLTHIST	Default: - Unit: Fault Number and TRUN Range: Last 10 faults and times	valid for all OPMODES
-----------------------	--	-----------------------

The last 10 faults that occurred are displayed, together with the time of their occurrence, referred to the operating hours.

Rate of occurrence

ASCII: FLTCNT	Default: - Unit: - Range: 0, 65535 per Fault Message	valid for all OPMODES
----------------------	--	-----------------------

Display of the frequency of all faults that caused the servo amplifier to switch off.

Actual errors

ASCII: ERRCODE	Default: - Unit: - Range: 0 .. 0xFFFFFFFF	valid for all OPMODES
-----------------------	---	-----------------------

Display of the errors presently being reported by the servo amplifier (corresponds to the error messages **Fxx** in the LED-display on the front panel of the amplifier). See *Error Messages, p. 239* for more information.

Actual warnings

ASCII: STATCODE	Default: - Unit: - Range: 0 .. 0xFFFFFFFF	valid for all OPMODES
------------------------	---	-----------------------

Display of the warnings presently being reported by the servo amplifier (corresponds to the **nxx** warnings in the LED-display on the front panel of the amplifier). See *Warning messages, p. 241* for more information.

Reset

ASCII: CLRFAULT	Default: - Unit: - Range: -	valid for all OPMODES
------------------------	-----------------------------------	-----------------------

Software-reset of the servo amplifier. **The servo amplifier must be disabled.**

Present errors are deleted, the firmware is re-initialized, and communication is re-established.

If only errors marked with an asterisk in the error listing are present, then the errors are cancelled, but no reset of the amplifier takes place.

4.16 Screen page "Actual values"

Overview of the "Actual values" screen

At a Glance

Diagram:

Control screen 3 "DRIVE0"			
Analog Input 1	18	mV	Angle of rotation
Analog Input 2	15	mV	1015 (4a)
I ² t (Mean value)	0	%	Actual speed
Effective current	0.004	A	0
Current D comp.	-0.004	A	Setpoint speed
Current Q comp.	-0.002	A	0
Bus voltage	347	V	Position
Regen power	0	W	259910
Heat sink temperature	25	°C	Following error
Internal temperature	41	°C	0
			Reference point
			Not set
			Apply

Analog Input 1/2

ASCII: ANIN1	Default: - Unit: Millivolts Range: -10000 .. 10000	valid for all OPMODES
ASCII: ANIN2	Default: - Unit: Millivolts Range: -10000 .. 10000	valid for all OPMODES

Displays the actual voltages (in mV) at the setpoint inputs.

I²t (mean value)

ASCII: I2T	Default: - Unit: % Range: 0...100	valid for all OPMODES
-------------------	---	-----------------------

The actual effective load is shown as % of the preset effective current Irms.

Effective current

ASCII: I	Default: - Unit: Amperes Range: -	valid for all OPMODES
-----------------	---	-----------------------

This shows the value (in A) of the actual current indication (r.m.s. value, always positive).

Current (D-component)

ASCII: ID	Default: - Unit: Amperes Range: -	valid for all OPMODES
------------------	---	-----------------------

Shows the value (in A) of the current D-component (Id, reactive current).

Current (Q-component)

ASCII: IQ	Default: - Unit: Amperes Range: -	valid for all OPMODES
------------------	---	-----------------------

Shows the value (in A) of the current Q-component (Iq, active current). The sign that is displayed is negative in regenerative operation (motor under braking).

Bus voltage

ASCII: VBUS	Default: - Unit: Volts Range: 0...900	valid for all OPMODES
--------------------	---	-----------------------

The DC-link (DC-bus) voltage produced by the amplifier is shown in V.

Regen power

ASCII: PBAL	Default: - Unit: W Range: 0...1500	valid for all OPMODES
--------------------	--	-----------------------

The average value (calculated during 30s) of the regenerative power is shown in W.

Heat sink temperature

ASCII: TEMPH	Default: - Unit: Centigrade Degrees Range: -20 ... 90	valid for all OPMODES
---------------------	---	-----------------------

The temperature of the heat sink in the servo amplifier is shown in ° C.

Internal temperature

ASCII: TEMPE	Default: - Unit: Centigrade Degrees Range: -20...90	valid for all OPMODES
---------------------	---	-----------------------

The temperature inside the servo amplifier is shown in ° C.

Angle of rotation

ASCII: PRD	Default: - Unit: Counts Range: 0 .. 1048575	valid for all OPMODES
-------------------	---	-----------------------

Displays the actual angle of rotation of the rotor (only for speeds $n < 20$ rpm) in ° mech, with the counts referred to the mechanical zero point of the measuring system.

Actual speed

ASCII: V	Default: - Unit: MUNIT Range: -15000 .. 15000	valid for all OPMODES
-----------------	---	-----------------------

Displays the actual rotational speed of the motor in rpm.

Setpoint speed

ASCII: VCMD	Default: - Unit: MUNIT Range: -VMAX .. VMAX	valid for all OPMODES
--------------------	---	-----------------------

The VCMD variable contains the internal velocity command (after the ramp generator). Depending on the operating mode that is set (OPMODE=0), this value is either provided directly and digitally (fieldbus, slot card) or derived from the analog velocity command (OPMODE=1). For operating modes that do not use a velocity control loop (OPMODE=2,3) the VCMD variable has the value V of the actual velocity.

Position

ASCII: PFB	Default: - Unit: μm / Counts Range: long int	valid for all OPMODES
-------------------	---	-----------------------

Shows the momentary position in user units (μm).

Following error

ASCII: PE	Default: - Unit: μm / Counts Range: long int	valid for all OPMODES
------------------	---	-----------------------

Shows the momentary following error in user units (μm).

Reference point

Shows whether a reference point is set, or not.

4.17 Screen page "Oscilloscope"

Overview of the "Oscilloscope" screen

At a Glance

Diagram:

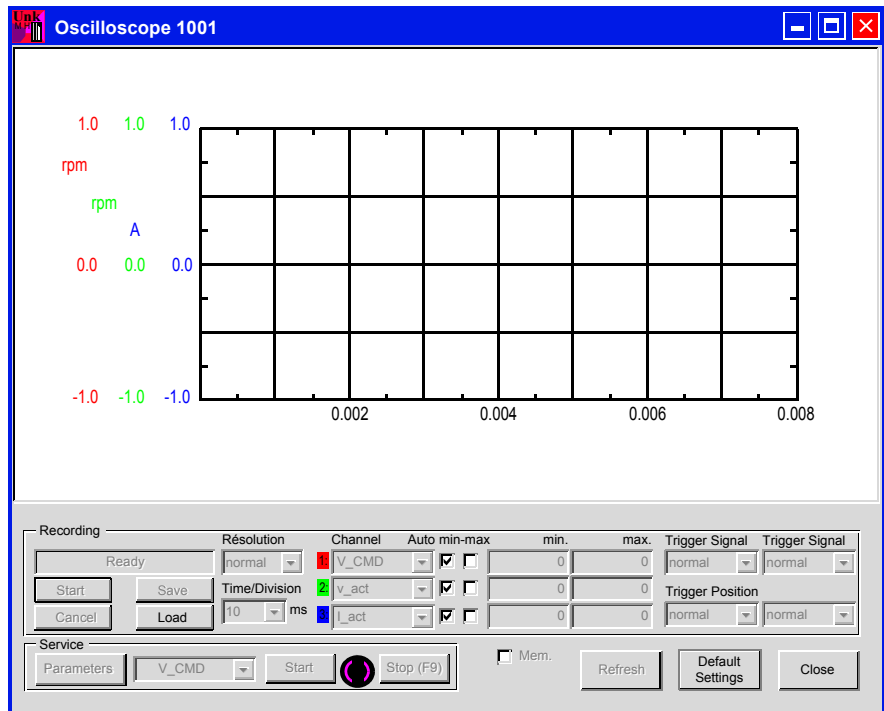

Cycle time for the measurement acquisition $\geq 250 \mu\text{s}$.

Various values are graphically displayed in a diagram. You can display up to three variables simultaneously, as a function of time.

Start Start saving the data.

Cancel Stop saving the data.

Save Saves the recorded measurements to a data medium in CSV format.

Load Loads a CSV data file and displays the curves on the oscilloscope diagram.

Channel Assignment of the displayed variables to the channels. At present, the following variables can be selected:

I_act	Actual torque (current)	I_CMD	Torque setpoint
v_act	Actual speed	v_CMD	Setpoint speed
VBus	DC-link (bus) voltage	FERROR	Following error
Off	Unused channel	User defined	ASCII command Manual entry

Trigger level Trigger setting Y.

Trigger position Trigger setting X (time axis).

Trigger edge Trigger on rising or falling edge.

Trigger signal Speed and current variables may be used as trigger signals. In addition, "Direct" can be used for immediate (independent) triggering. Choosing "User-defined" (User) allows an ASCII parameter to be entered manually.

Resolution The number of measured points per time unit (storage depth). Setting: fine, normal, coarse.

Time/Division Scaling of the time axis. Select the time/division. Setting: 1 ...500 ms/div
Total length of the time axis: 8 * x ms/Div

Scaling For each channel, the measurement range can be set manually by completing the min and max fields or automatically by ticking the "auto" checkbox.

Auto Scaling Select standard or min/max scaling.

Service functions

Select one of the service functions described below. Click on the "Service Parameter" button and set the corresponding parameter, (See *Screen page "Service parameters", p. 196*). Then start the function by using the START button. The function will continue to be performed until you click on the STOP button or press the function key F9.

Direct current	Apply a direct current to the motor with adjustable size and electrical field-vector angle. The changeover from speed control to current control is made automatically, commutation is made independently of the feedback (resolver or similar). The rotor locks onto a stator pole.
Speed	Operates the drive at constant speed. An internal digital setpoint is provided (speed is adjustable).
Torque	Operates the drive with constant current. An internal digital setpoint is provided (current is adjustable). The changeover from speed control to current control is made automatically, commutation is made independently of the feedback (resolver or similar).
Reversing	Operates the drive in reversing mode, with separately adjustable speed and reversing time for each direction of rotation.
Motion task	Starts the motion task that is selected in the screen page "Entry of service parameters".
Zero	Function used for feedback setting in conjunction with the positioning phase. This function can only be accessed in OMODE2. Caution: When this function is in use, motor shaft goes into fallback position. This may cause a movement of + or - 60°.

Start (service)

Starts the service function selected.

Stop (service)

Stops the service function selected.

Cursor function (Mouse pointer)

When the curves are displayed (when reading the file, or beginning a save), a mouse click displays the values measured for the signals in the coordinates system for the time period selected. If the user clicks outside the coordinates system or clicks while holding down the SHIFT key, the values displayed are reset to 0.

Default Settings

Reinitializes window with default settings.

4.18 Screen page "Service parameters"

Overview of the "Entry of service parameters" screen

At a Glance

Diagram:

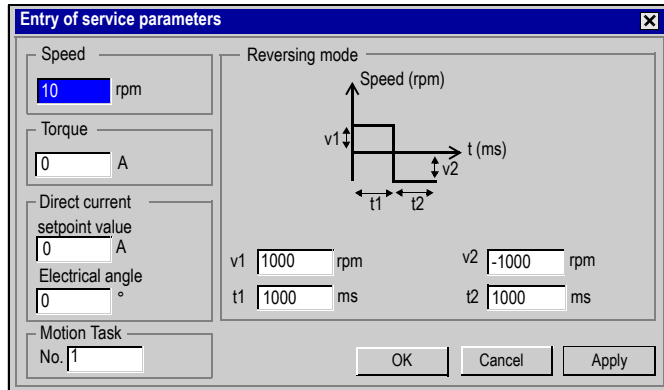

Service operation parameters

Settings of the parameters for the service functions.

Direct current	Setpoint elect. angle	Current setpoint (in A) for the function phase angle of the electrical field
Speed	Rotational speed	Speed (in rpm) for the function
Torque	Current	Current setpoint (in A) for the function
Reversing mode	v1 t1 v2 t2	speed (in rpm) for clockwise rotation duration (in ms) of the clockwise rotation speed (in rpm) for counterclockwise rotation duration (in ms) of the counterclockwise rotation
Motion	No	Parameters for the motion task must be entered in the screen page "Motion task parameters".

4.19 "BODEPLOT" screen page.

Overview of the "Bode plot" screen

At a Glance

This function should only be used by speed control engineers and technicians. Use this screen to analyse and maximise the speed control loop, using the machine's mechanical specifications.

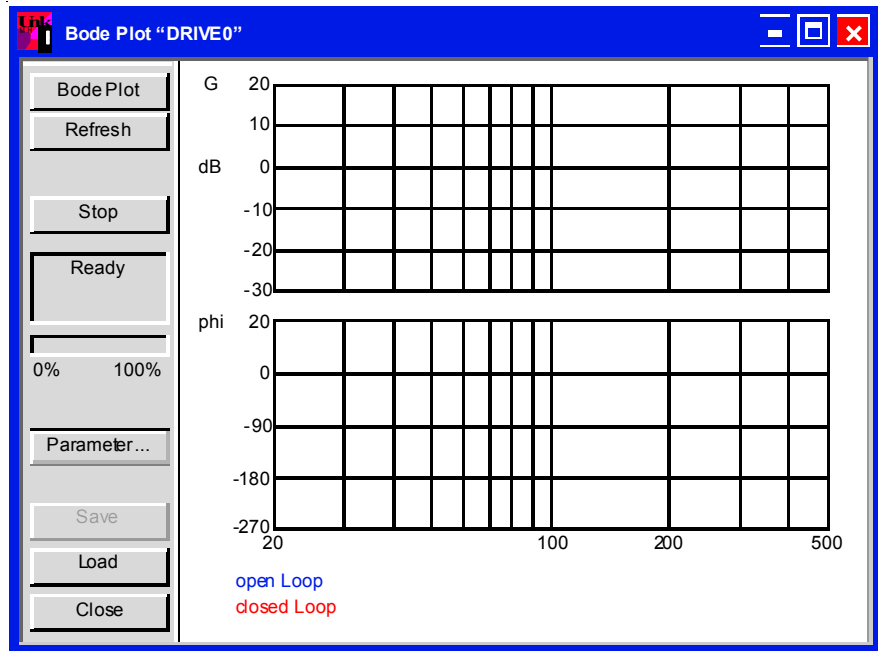

This screen displays the frequency response for speed control. The system is simulated using a sinusoid input variable. The output variable has identical frequency but different amplitude and is out of phase by several degrees.

The relation between frequency related amplitude (amplitude response) and frequency related phase shift (phase response) provides a full picture of the speed control loop's dynamic features.

Amplitude response

This graph shows amplitude in relation to frequency (Gain) on a log scale.

Phase Response

This graph shows phase shift in relation to frequency.

Open loop response

The following information is used to supply a qualitative description of the open loop response.

Parameter	Description
Phase margin	Differential between the characteristic curve phase and a -180° phase shift at cut-off frequency. Represents the frequency for a 0dB gain.
Gain margin	Differential between the characteristic amplitude and a gain of 0 dB for a -180° phase shift.

Closed loop response

The closed loop characteristics are defined using bandwidth and cut-off.

Notion	Description
Bandwidth	Represents frequency bandwidth for a -3dB attenuation.
Overshoot	Overshoot represents closed loop overshoot at maximum amplitude

Bode Plot

Starts saving the data.

Note: This function should be used only by experts. The motion starts automatically and immediately as soon as confirmation request has been validated, using the internal setpoint provided.
--

Stop

Stops saving the data.

Save

Makes back-up of settings saved in a CSV file (can be used with MS-Excel).

Load

Loads settings saved in a CSV file and displays corresponding curves.

Refresh

Loads and displays latest settings saved.

Cursor function

When a data series is displayed (when reading a file, or beginning a save), click once on the graph to display the values measured at a given point in time. Click once outside the graph to zero the display.

Parameters

Displays the Bode Plot parameter page. Defines the frequency range and number of increments.

4.20 Screen page "Terminal"

Overview of the "Terminal" screen

At a Glance

Diagram:

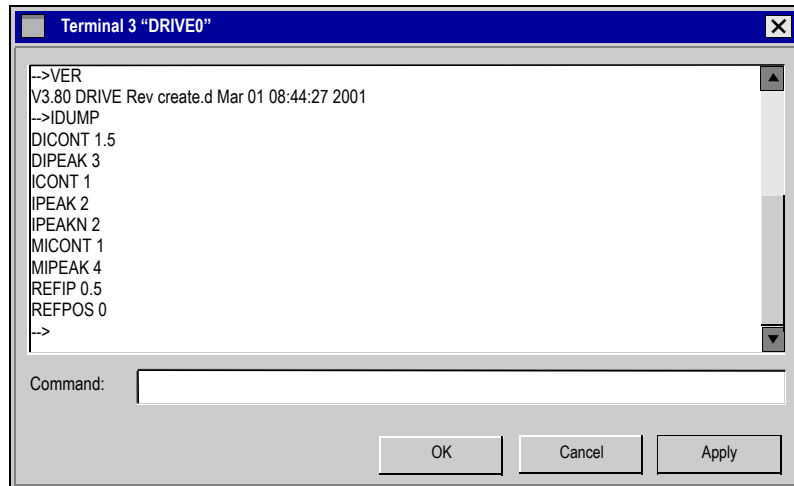

Communication with the servo amplifier is made through ASCII commands. You can obtain a complete list of the commands from our application department.

Commands that are sent to the servo amplifier are marked by -->. The answers from the servo amplifier appear without any preceding characters.

When using this integrated terminal function, the following restrictions apply:

- The last 200 lines are displayed,
- The transmission from the servo amplifier to the PC is limited to a maximum of 1000 bytes per command,
- A watchdog timer limits the transmission time in both directions to a maximum of 3 sec.

If the number of characters is more than 1000, or the transmission time is more than 3 seconds, then the terminal reports a fault.

Command

Enter the ASCII command here, with the corresponding parameters. End the entry with RETURN or press the APPLY button to start the transmission.

 CAUTION
--

STATEMENT OF HAZARD

The terminal software should be used only by experts.

Failure to follow this instruction can result in injury or equipment damage.

4.21 Screen page "I/O expansion"

Overview of the screen page "I/O expansion"

At a Glance

I/O expansion card P/N : AM0INE001V000.

This screen displays individual status of the I/O 14/08 channels on the expansion card as well as overall status of the card.

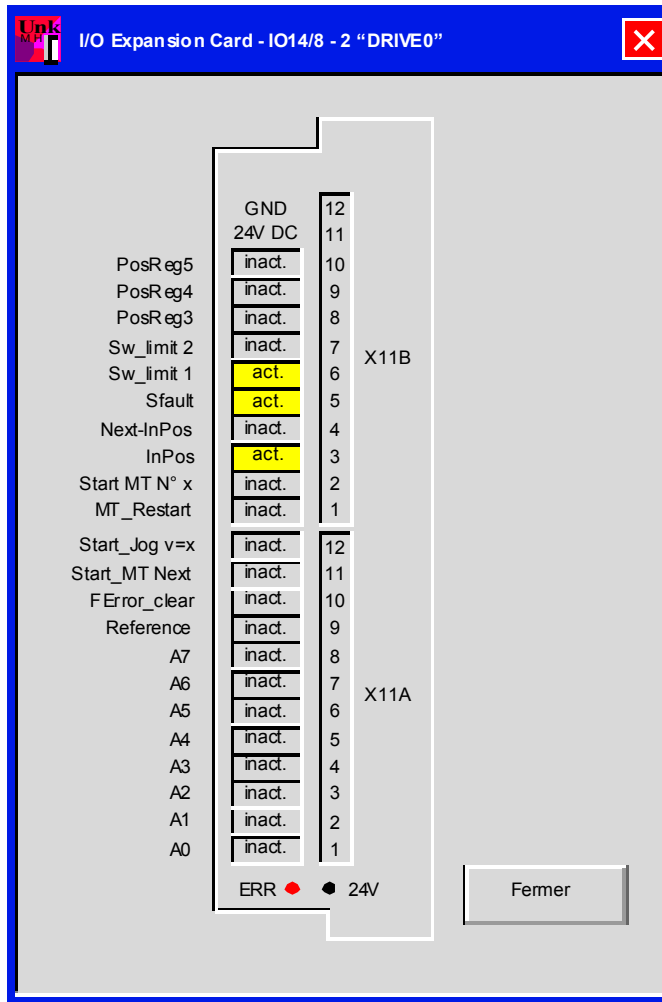

I/O States

ASCII SLOTIO	Default: 0 Unit: - Range: 0,1	valid for all OPMODES
-------------------------	-------------------------------------	-----------------------

The SLOTIO command returns the states of the inputs and outputs on the I/O-expansion card (slot card) in the format Hxxxxxxx.

Bit number	I/O Connector	Description
0	Input X11A/1	Motion block number (A0)
1	Input X11A/2	Motion block number (A1)
2	Input X11A/3	Motion block number (A2)
3	Input X11A/4	Motion block number (A3)
4	Input X11A/5	Motion block number (A4)
5	Input X11A/6	Motion block number (A5)
6	Input X11A/7	Motion block number (A6)
7	Input X11A/8	Motion block number (A7)
8	Input X11A/9	Reference switch
9	Input X11A/10	Acknowledge Contouring error
10	Input X11A/11	Start next motion block
11	Input X11A/12	Start jog mode
12	Input X11B/1	Continue a motion block
13	Input X11B/2	Start motion block no. A0 ... A7
14	Output X11B/3	"In-Position" signal
15	Output X11B/4	"In-Position2" signal (next)
16	Output X11B/5	Contouring error
17	Output X11B/6	"Position register 1" signal
18	Output X11B/7	"Position register 2" signal
19	Output X11B/8	"Position register 3" signal
20	Output X11B/9	"Position register 4" signal
21	Output X11B/10	"Position register 5" signal
22	Status	24Volt - On
23	Status	Slot fault
24...31		Reserved

PosReg.0-5	<p>The preset function of the corresponding position register is indicated by a high signal. (the PosReg 1-4 function is defined in the "Position data, PosReg5" screen only via ASCII).</p> <p>The individual position signals are generated at the following outputs:</p> <p>SWE0: Next-InPos X11B.4 SWE1: PosReg1 X11B.6 SWE2: PosReg2 X11B.7 SWE3: PosReg3 X11B.8 SWE4: PosReg4 X11B.9 SWE5: Reserve X11B.10</p> <p>The "Next-InPos" and "SWE0-signal" functions use the same output X11B.4, so they must not be used simultaneously. If the position register SWE0 has been configured, then the "Next-InPos" function is inhibited through the I/O card. If necessary, this function can be diverted to a digital output on the LEXIUM 15 (O1MODE=16 or O2MODE=16).</p>
SFault	<p>Contouring-error (low-active). The width of this error window is entered in the screen "Position" for all enabled motion tasks.</p>
Next InPos.	<p>The start of each motion task in an automatically executed sequence of motion tasks is signaled by an inversion of the output signal. The output produces a low signal at the start of the first motion task of the sequence. See also the above section on PosReg 0..5</p>
In Position	<p>When the target position for a motion task has been reached, (InPosition window) a high signal is generated. A cable break will not be detected. The width of the "InPosition" window for all enabled motion tasks is entered in the screen "Position data".</p>
Start_MT No x	<p>Start of the motion task that has the number and bit code at the digital entry (A0 to A7). A rising edge starts the motion, a falling edge cancels it. (See Function 16 in <i>Digital inputs L11/L12/L13/L14, p. 102.</i>)</p>
MT_Restart	<p>Restarts the motion task that had been stopped. (See Function 23 in <i>Digital inputs L11/L12/L13/L14, p. 102.</i>)</p>
Start Jog v=x	<p>Starting in jog mode at a given speed. After selecting the function, you can enter the speed in the auxiliary variable "x". The sign of the auxiliary variable defines the direction. A rising edge starts the motion, a falling edge cancels it. (See Function 20 in <i>Digital inputs L11/L12/L13/L14, p. 102.</i>)</p>

Start_MT Next

This task, which is defined in the motion task by "Start with I/O", is started. The target position of this motion task must be reached before the following task can be started. (See Function 15 in *Digital inputs LI1/LI2/LI3/LI4, p. 102.*)

ASCII IO11A	Default: 0 Unit: - Range: 0,1	valid for all OPMODES
--------------------	-------------------------------------	-----------------------

This variable defines the behavior of the start input at the I/O expansion card (terminal X11B / 2).

IO11A=0 A negative edge generates a stop command. An active motion task is stopped

IO11A=1 A positive edge generates no stop command. It is possible to switch over from one motion task to another without stop.

For example:

1. Select motion task 1 (connector X11A/1-8)
2. A rising edge at start input starts motion task
3. Switch start input to low. Motion task 1 is executed
4. Select motion task 25. A rising edge starts motion task 2 without stop.

Remark: This setting disables the stop command at the state low. To be able to stop a motion task, you have to select another input of the standard I/O for emergency stop or start/stop (see command INxMODE (See *At a Glance, p. 102*)).

FError_clear

Erases the error message or the supervisor's response.

Reference

Checks reference switch.

A0-7

Motion task number, Bit1 to Bit8

Err.

Expansion card error message. The error may be due to the following reasons: no power supply, output overload or short-circuit.

24V

Shows that 24V power supply for the expansion card is present.

Field Buses



Field Buses

At a Glance

This chapter describes how to configure the software for use with field buses.

What's in this Chapter?

This chapter contains the following sections:

Section	Topic	Page
5.1	Screen page "Modbus Plus"	206
5.2	Screen page "FIPIO"	213
5.3	Screen page "PROFIBUS"	215
5.4	Screen pages "SERCOS"	220
5.5	Screen page "Motion task parameters"	226

5.1 Screen page "Modbus Plus"

Screen page "Modbus Plus"

At a Glance Overview of the different field values included in the "Modbus Plus" screen page.

What's in this Section? This section contains the following topics:

Topic	Page
Screen page "Modbus Plus"	207
Configuration of Address and TimeOut via Unilink	210
Peer Cop Data	211
Global data configuration via Unilink	212

Screen page "Modbus Plus"

Different configuration parameters

The communication parameters may be configured in 2 ways:

- via the Unilink software terminal mode or via any terminal. Some ASCII commands are defined to allow these parameters to be read or modified,
- via the Modbus Plus screen of the Unilink software:

The following table describes different parameters in the "Modbus Plus" screen:

Parameter	ASCII command	Range	Default value	Note
Address (*)	ADDR	1-63	1	Modbus+ node address (read only)
Bus Time-Out	TIMEMBP	0.01-60	1	In seconds. Incrementation of 10 ms
Peer-Cop Station	PEERCOPS	1-64	0	Must be different to the drive address. 0 : PEERCOP register not received
Peer-Cop Length	PEERCOP	0-9	0	Number of PEERCOP registers received 0: no PEERCOP registers received
Global-Data Length	GDTX	0-18	0	Number of Global data registers transmitted. 0 : no Global data transmitted
DPR	DPRSTATE (1)			16 bit length
ModBus +	MBPSTATE (2)		0	16 bit length
Drive	MBPDRVST AT (3)	1-100	0	16 bit length

Legend:

- (*) The station address is entered in the Unilink basic setup screen.
- (1) DPRSTATE: Status in initialization phase
DPRSTATE = 80: Message ready
- (2) MBPSTATE: Status read by Unilink,
Updated by MBP card, it informs the drive of the MBP card status

Descriptions of the various MBPSTATE states:

Value of MBPSTATE	Description
0	Card not configured
1	Card in Run
2	Card not communicating
3	Network communication fault
4	DPRAM communication fault

Descriptions of the various MBPSTATE states:

Value of MBPSTATE	Description
0	Card not configured
1	Card in Run
2	Card not communicating
3	Network communication fault
4	DPRAM communication fault

- (3) MBPDRVSTAT: Status read by Unilink
Updated by the drive, it informs the MBP card of the drive status.

Descriptions of the various MBPDRVSTAT states:

Value of MBPDRVSTAT	Description
1H	Drive ready
2H	Network communication fault
4H	DPRAM communication fault
8H MBTNT0 (*)	Communication fault: network ignored

(*) MBPNT0 = 0 communication fault reported to the drive.

MBPNT0 = 1 communication fault ignored by the drive, it is accessible in write mode via the ASCII MBPDRVSTAT command.

Either MBPDRVSTAT = 8h for MBPNT0 = 1

or MBPDRVSTAT = 0h for MBPNT0 = 0

Procedure to be followed

The Modbus Plus Lexium communication is configured as follows:

Step	Action
1	Power up the drive. The network cable does not have to be connected.
2	Ensure the good working order of the Modbus Plus card option: The green diagnostics LED should flash regularly (6 flashes per second).
3	Launch the Unilink software or a terminal

Configuration of Address and TimeOut via Unilink

Address Configuration

Note: An address should not be duplicated on the network and should be between 1 and 63.

Configuration via Unilink

- Configure the "Address" field using the station address in the Unilink basic configuration screen.

Note: The address is stored in the servodrive. Replacing the Modbus Plus card has no effect on the servodrive address. It continues to have the previously configured address.

TimeOut Configuration

Configuration via Unilink

- Configure the " Bus Time-Out" field with the selected value.

Timeout represents:

- the longest time span during which no token has been received,
- The maximum period of time between 2 PEERCOPs transmissions being received.

When a TimeOut is detected, the servodrive faults.

Peer Cop Data

Peer Cop Configuration

Peer Cop data are the registers transmitted by the command station. The number of registers received by the servodrive can be configured by the user.

The number of Peer Cop registers transmitted can be configured in either of two ways:

Configuration via Unilink

- Configure the "Peer-Cop Station" field with the command station address,
- configure the "Peer-Cop Length" field with the number of received Peer Cop registers.

Example:

- if the number 2 is entered in the "Number of Peer Cop Registers" parameter of the servodrive and the PLC, only the first two registers of the Peer Cop data, STW and VCMD variables will be received by the servodrive,
- The configured number of Peer Cop registers should be adjusted in relation to the application requirements. The smallest possible number of Peer Cops must be used in order to optimize the network bandwidth and feed-through time of the Modbus Plus card. However, you are strongly advised to always use the STW command word.

If no Peer Cop data is received from the command station before the end of the specified wait time, the servodrive faults. It can still be accessed via messaging.

Common parameter management with messaging

Variables that are configured in the 9 Peer Cop command registers can not be overwritten via messaging when Peer Cop exchanges are enabled. Write access to these registers is permitted when they are not configured in the Peer Cop exchange.

Global data configuration via Unilink

Global data configuration

Updating global data is confirmed by selecting a number of Global data registers greater than 0.

Configuration via Unilink:

- configure the "Global-Data length" field with the number of registers.

Example:

- if the number 2 is entered in the "Number of Global data registers" parameter of the servodrive and the PLC, only the first two registers of the Peer Cop global data, ZSW and STATCODE variables will be updated by the servodrive,
 - the number of configured Global data registers should be adjusted in relation to the application requirements. The smallest possible amount of global data must be used in order to optimize the network bandwidth and feed-through time of the Modbus Plus card.
-

5.2 Screen page "FIPIO"

Screen page "FIPIO"

At a Glance

The communication parameters of the drive should be entered in the FIPIO screen of the Unilink software (except for the FIPIO address). This screen is accessible as soon as Unilink is connected to a drive with the FIPIO card option.

The FIPIO screen of the Unilink software:

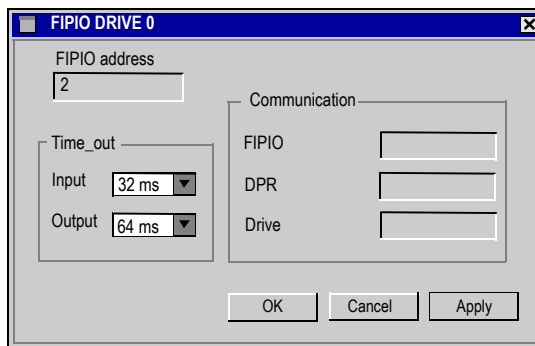

The following table describes the various parameters of the "FIPIO" screen:

Parameter	ASCII command	Identifier	Value range	Fault	Access	Note
FIPIO address (1)	ADDR	-	1-62	1	Read	Node address
Input TimeOut(2)	TO_IN	413	20ms, 32ms, 64ms, 256ms, 1s, 4s	20 ms	Read Write	-
Output TimeOut(3)	TO_OUT	414	32ms, 64ms, 256ms, 1s, 4s	256 ms	Read Write	-
FIPIO	MBPSTATE (4)	-	-	0	Read	16 bit length
DPR	DPRSTATE (5)	-	-		Read	16 bit length
Drive	MBPDRVSTAT(6)	-	1-100	0	Read	16 bit length

The FIPIO address can also be configured using the dialogue box (display and push-button) on the front panel of the drive.

(1) The address is configured on the FIPIO bus using the "Basic Setup" screen in Unilink. Address settings possible from 1 to 62.

(2) **Input TimeOut**: maximum response time of drive

(3) **Output TimeOut**: maximum %QW refresh time

(4) MBPSTATE:

Status read by Unilink, updated by the FIPIO card, it informs the drive of the FIPIO card status

Description of the various MBPSTATE states:

0	Card not configured
1	Card in Run
2	Card not communicating (STOP)
3	Network communication fault
4	DPRAM communication fault

(5) DPRSTATE :

0	Initialization of the FIPIO card
80	Nominal phase: no message
81	Message received
82	Response transmitted

(6) MBPDRVSTAT:

The status is read by Unilink and updated by the drive. This enables the FIPIO card to be informed of the drive status, and is accessible in read only mode via the ASCII command MBPDRVSTAT.

Description of the various MBPSTATE states:

1H	Drive ready
2H	Network communication fault
4H	DPRAM communication fault
8H MBPNT0 (*)	Communication fault: network ignored

(*) MBPNT0 = 0 communication fault reported to the drive.

MBPNT0 = 1 communication fault ignored by the drive, it is accessible in write mode via the ASCII MBPDRVSTAT command.

Either MBPDRVSTAT = 16#08 for MBPNT0 = 1

or MBPDRVSTAT = 16#00 for MBPNT0 = 0

5.3 Screen page "PROFIBUS"

Screen page "PROFIBUS"

At a Glance

Overview of the different field values included in the "PROFIBUS" screen page.

What's in this Section?

This section contains the following topics:

Topic	Page
Screen page "PROFIBUS"	216
Screen page "PROFIBUS instrument control"	218

Screen page "PROFIBUS"

At a Glance

This screen displays the states of control word (STW) and state word (ZSW) bits. The instrument state indicated by the state word is visible in the state machine. The actual state is displayed in black, all other states are displayed in gray. In addition, the previous state is indicated by the number of the corresponding arrow symbol displayed in bold.

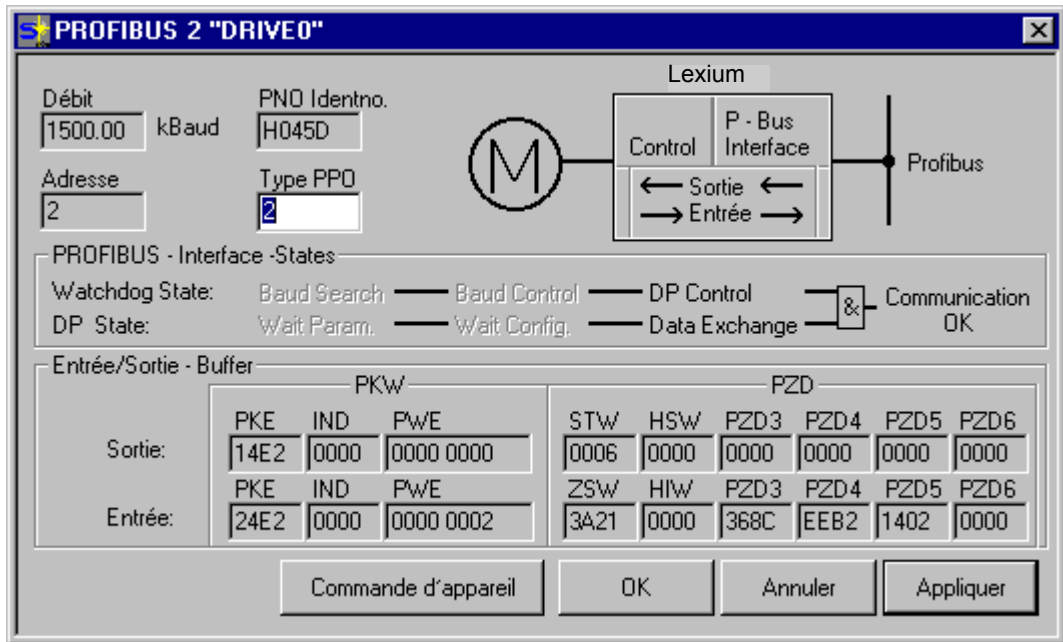

Baudrate

The baudrate, indicated by the master (of the PROFIBUS network) is displayed here.

PNO Identification

The PNO identifier indicates the number of the servo amplifier in the identification listing of the PROFIBUS user architecture.

Address

Station address of the amplifier. This address is defined in the "Basic setup" screen.

PPO Typ (PPO Type)	The amplifier only takes the PPO-type 2 into account in the PROFIDRIVE profile.
BUS status	Displays the communication status of the bus. The data can be transmitted to the PROFIBUS only while the "Communication OK" message is displayed.
Input/Output-Buffer	<p>Input/output data can only be transmitted when the monitoring threshold of the amplifier has been activated in the hardware configuration of the master.</p> <p>Output</p> <p>Last object received by the master.</p> <p>Input</p> <p>Last object sent by the master.</p>

Screen page "PROFIBUS instrument control"

At a Glance

The following table describes the states and transitions of the instrument.

States:

Not ready for switch-on	The drive is not ready to be switched on. The software of the drive does not indicate the "Ready to operate" state (RTO).
Switch-on inhibited	The drive is not ready to be switched on. The parameters can be transmitted, the DC-link (DC-Bus) can be switched on, but motion functions cannot yet be executed.
Ready for switch-on	The voltage must be applied to the DC-link. The parameters can be transmitted, but motion functions cannot yet be executed.
Ready for operation (Ready To Operate - RTO)	The voltage must be applied to the DC-link. The parameters can be transmitted, but motion functions cannot yet be executed. The output stage is activated.
Operation enabled	No error is present. The output stage is activated, and motion functions can be executed.
Fast stop activated	The motor has been stopped using the emergency ramp. The output stage is activated, and motion functions can be executed.
Error response active/error	In the event of instrument-related errors, the drive changes to the "Error response active" state. In this state, the power stage is immediately switched off. After this error message, it changes to the "Error" state. This state can only be changed by the "Error-reset" bit command. To enable this, it is first necessary to have eliminated the cause of the error (see ASCII ERRCODE command).

State machine transitions:

Transition 0	event	Reset / 24V power supply activated.
	Action	Initialization started.
Transition 1	event	Initialization successfully completed, switch-on of drive inhibited.
	Action	None.
Transition 2	event	Bit 1 (voltage inhibited) and bit 2 (fast stop) set to 1 in the control word (command: switch-off), the voltage is present on the DC-link.
	Action	None.
Transition 3	event	Bit 0 (switch-on) also set to 1 (command: switch-on).
	Action	The output stage is activated and the motor is generating torque.
Transition 4	event	Bit 3 (operation enabled) also set to 1 (command: operation enabled).
	Action	Motion functions are activated according to the active operating mode.

Transition 5	event	Bit 3 cancelled (command: inhibited).
	Action	Motion functions are deactivated. The motor is slowed by the requisite ramp (according to the operating mode).
Transition 6	event	Bit 0 set to 0 (ready for switch-on).
	Action	The output stage is deactivated. The motor is not generating torque.
Transition 7	event	Bit 1 or bit 2 set to 0.
	Action	(command: "Fast stop" or "Voltage inhibited")
Transition 8	event	Bit 0 set to 0 (Operation activated -> ready for switch-on).
	Action	The output stage is deactivated and the motor loses its torque.
Transition 9	event	Bit 1 set to 0 (operation activated -> switch-on inhibited).
	Action	The output stage is deactivated and the motor loses its torque.
Transition 10	event	Bit 1 or 2 set to 0 (RTO -> switch-on inhibited).
	Action	The output stage is deactivated and the motor loses its torque.
Transition 11	event	Bit 2 set to 0 (operation activated -> fast stop).
	Action	The motor has been stopped using the emergency ramp. The output stage remains activated. The setpoints are cancelled (e.g. motion block number, digital setpoint).
Transition 12	event	Bit 1 set to 0 (Fast stop -> switch-on inhibited).
	Action	The output stage is deactivated and the motor loses its torque.
Transition 13	event	Error response active
	Action	The output stage is disabled and the motor loses its torque.
Transition 14	event	Error.
	Action	None.
Transition 15	event	Bit 7 set to 1 (Error -> switch-on inhibited).
	Action	Error acknowledged (with or without reset, depending on the error).
Transition 16	event	Bit 2 set to 1 (Fast stop -> operation activated).
	Action	Motion function reactivated.

The state transitions are assigned by internal events (for example, DC-link supply voltage cut off) and by the control word flags (bits 0, 1, 2, 3, 7).

5.4 Screen pages "SERCOS"

Screen pages "SERCOS"

At a Glance

Overview of the different field values included in the screen pages "SERCOS" and "SERCOS Service".

What's in this Section?

This section contains the following topics:

Topic	Page
Overview of the screen page "SERCOS"	221
"SERCOS Service" screen page	223

Overview of the screen page "SERCOS"

At a Glance

Diagram:

The screenshot shows a software window titled "SERCOS 1 'DRIVE 3'". It contains several input fields and buttons:

- Address:** A text box containing the value "1".
- Baudrate:** A dropdown menu currently set to "4 MBaud".
- Fiber Optic Cable Length:** A text box containing "5" followed by a unit "m".
- Phase:** A text box containing the value "0".
- Status:** A text box displaying "Drive not in phase 4".
- SERCOS Service:** A button.
- Control Buttons:** "OK", "Cancel", and "Apply" buttons are located at the bottom of the window.

Address

ASCII: ADDR	Default: 0 Unit: - Range: 0...127	Valid for all OPMODES
--------------------	---	-----------------------

The address marks the Sercos station address of the drive, within the Sercos communication. The address can be changed between 0 and 63 in the "Basic setup" screen. An address 0 designates the drive as a repeater on the Sercos ring.

Baud rate

ASCII: SBAUD	Default: 4MBaud Unit: Mbaud Range: 2, 4	Valid for all OPMODES
---------------------	---	-----------------------

In this field it is possible to set the Sercos baud rate. The default value is 4 Baud.

LWL length

ASCII: SLEN	Default: 5m Unit: m Range: 0..45	Valid for all OPMODES
--------------------	--	-----------------------

Within this parameter it is possible to change the optical power of the transmit output of the drive, to the next station in the ring. The optical power can set for the length of plastic optical cable, in meters, from 1 to 45 meters. The default is 5 meters. If the optical power is not adjusted properly, there will be errors in the telegram transmission, and the red error LED on the drive will light. In normal communication, the green transmit and receive LED's will light (fiber-optic transmission diodes).

Phase

ASCII: SPHAS	Default: - Unit: - Range: -	Valid for all OPMODES
---------------------	-----------------------------------	-----------------------

This field displays the actual phase of the Sercos communication.

Status

ASCII: SSTAT	Default: - Unit: - Range: -	Valid for all OPMODES
---------------------	-----------------------------------	-----------------------

This field displays the actual status of the Sercos communication, according the Sercos status-word in text format.

SERCOS Service With this button it is possible to open the screen page "Sercos service".

"SERCOS Service" screen page

At a Glance

Diagram:

Read IDN

ASCII: SERCOS	Default: - Unit: - Range: 0...8	Valid for all OPMODES
----------------------	---------------------------------------	-----------------------

Using this function, it is possible to read the special Sercos IDNs not represented by an ASCII parameter. The number of the IDN should be written into this field and data can be requested by activating the "Transmit Data" button.

Read List Item

ASCII: SERCLIST	Default: - Unit: - Range: 0...8	Valid for all OPMODES
------------------------	---------------------------------------	-----------------------

This parameter may also be used to read IDN lists using the "Read IDN" function. For this, the requested list item must be chosen from this field before activating the "Read IDN" function.

EL 7 Dec EL 7 Hex

This field contains the result of the "Read IDN" function in decimal and hexadecimal format.

EL 7 Read Error

ASCII: SERCERR	Default: - Unit: - Range: 0...8	Valid for all OPMODES
-----------------------	---------------------------------------	-----------------------

This parameter will be set to 1 if the IDN number is not supported by the "Read IDN" list function.

Product Sercos Settings**EOT consequence (IDN P3015):**

This parameter defines the consequence of the Hardware Limit Switch, if the corresponding digital inputs are set to the limit switches. If the hardware limit switch consequence is set to 0, then the Limit switch consequence is a warning. Otherwise, if the IDN P3015 is set to 1, then the switch consequence is a fault.

Clearfault allow coldstart (IDN P3016):

This parameter defines the consequence of the reset command (IDN 99; ASCII CLRFAULT), for faults which require a coldstart. If this IDN is set, faults which require a coldstart will not clear.

**Standard Sercos
Settings****Position polarity (IDN 55):**

The position polarity parameter is used to invert the polarities of position data. Polarities are not inverted internally but externally, i.e. on the input and output of a closed loop system. The motor shaft turns clockwise when there is a positive position command difference and no inversion.

Feedback inversion 1:

This function enables the sign of the Feedback value 1 to be inverted.

Feedback inversion 2:

This function enables the sign of the Feedback value 2 to be inverted.

Velocity inversion (IDN 43):

The velocity inversion parameter enables the sign of velocity data to be inverted. The signs are not inverted internally but externally, i.e. on the input and output of a closed loop system. The motor axis turns clockwise when there is a positive velocity command and no inversion.

Velocity sign:

This function enables the sign of the velocity value to be reversed.

5.5 Screen page "Motion task parameters"

General overview of the "Motion task parameters" screen

At a Glance Overview of the different field values included in the "Motion task parameters" screen page.

What's in this Section? This section contains the following topics:

Topic	Page
Overview of the "Motion Task Table" Screen	227
Motion type	231
Advanced Functions	236

Overview of the "Motion Task Table" Screen

At a Glance

Motion Task is a Mode Of Operation 8 that allows the execution of a move sequence stored in the servo drive memory. Each move is called a Motion Task.

Depending on the Lexium 15 model you use, you can store several Motion Tasks in the RAM or EEPROM:

	EEPROM	RAM
Lexium 15 LP	180	75
Lexium 15 MP/HP	200	100

To open the Motion task table, click on the Position button. In the Position screen page, click on the Position Data button. In the Position Data Screen page, click on the Motion task table button. This will display Motion task table:

x	O P	O V	O C	O ACC1	O DEC1	O ACC2	O DEC2	O FN	O_FT
1	100000	100	8208	1	1	0	0	0	0
2	200000	200	8208	1	1	0	0	0	0
3	300000	400	8208	1	1	0	0	0	0
4	400000	800	8208	1	1	0	0	0	0
5									
6									
7									
8									
9									
10									
11									
12									
13									
14									
15									
16									
17									
18									
19									
20									
21									

Each Motion Task is numbered; the number is used to start the sequence or to define the next execution.

A Motion Task may be started by a Digital Input or a field bus order.

Edit

Enter a Motion task number and click Edit to set parameters for that motion task. The Motion Task Parameters dialog box is displayed. See *Motion type*, p. 231 for more information.

Motion Task Table

You can use this table to directly enter all task parameters. The following commands are available:

- Cut
- Copy
- Paste
- Delete

Clipboard operations can only be carried out on full lines, i.e. the line required must be selected. A whole line or a single cell may be selected. Select a line by clicking on the line number or by using the <Shift><Space> key combinations (as in Excel). (All edit operations use standard Windows key combinations.)

ASCII Command List

ASCII Command	Description
ACCUNIT	Type of acceleration command for the system
CLRORDER	Deleting a Motion Task
CONTINUE	Continue last position order
MOVE	Start Motion Task
MTMUX	Presetting for motion task that is processed later
NREFMT	Motion task automatic executed after homing
O_ACC1	Acceleration Time 1 for Motion Task 0
O_ACC2	Acceleration Time 2 for Motion Task 0
O_C	Control Variable for Motion Task 0
O_DEC1	Braking Time 1 for Motion Task 0
O_DEC2	Deceleration Time 2 for Motion Task 0
O_FN	Next Task Number for Motion Task 0
O_FT	Delay before Next Motion Task
O_P	Target Position/Path for Motion Task 0
O_V	Target Speed for Motion Task 0
OCOPY	Save/copy Motion Tasks
OLIST	List of Motion Task Data
ORDER	Set Motion Task Parameters
OVERRIDE	Override Function for Motion Tasks
PTARGET	Last Target Position
PTEACH	Teach-In Function
PTMIN	Min. Acceleration Ramp for Motion Tasks
PVMAXN	Max. (Negative) Velocity for Position Control
SPSET	Enable for S-curve

MT Monitoring

The Motion Task may be started automatically in Operation Enable mode if AUTOHOME was set. The Motion Task number is declared by the NREFMT command.

The completion of the Motion Task or sequence of Motion Tasks is shown in the In_Position object, which can also be monitored by a Digital Output.

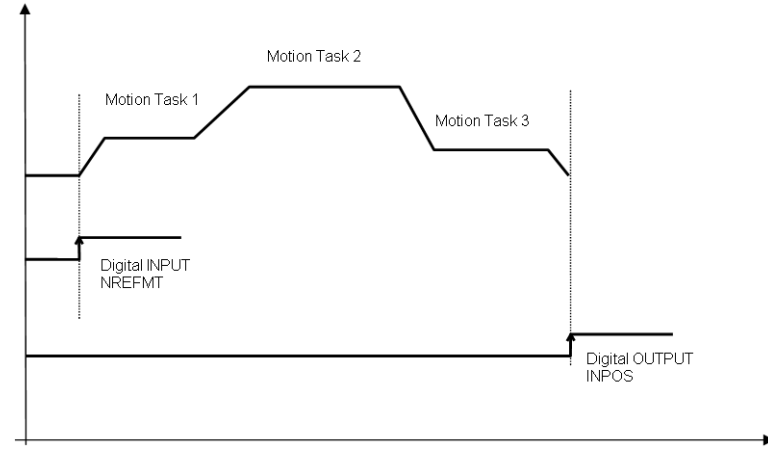

Motion type

At a Glance

Diagram:

The various elements of the **Motion** type are described in the following paragraphs.

Trajectory

If **internal** is selected, the motion task runs with the internal motion generator.

The position lookup tables downloaded in the amplifier may also be used.

Note: This service is only available for expert users. Contact the technical support team if the application cannot be implemented using **internal** mode.

Velocity profile No.

Downloaded lookup table number. Number from 0 to 16.

Units (general)

Select the unit for path and speed entries.

Selection	Path	Speed
Counts	$x = 1048576 * N * \text{Incr.}$ with N = no. of motor turns, Nmax=+/- 2047	$x = 140/32 * n * \text{min} * \text{Incr.}$ with n = rotational speed of the motor shaft
SI/User	μm (position unit) or as defined by user	μm (velocity unit)

Type

This selection determines whether the motion task is interpreted as a relative or an absolute task.

ABS	movement to an absolute target position, referred to the reference point.
REL cmd	relative to last target (setpoint) position (in connection with motion block changeover: e.g. summing operation).
REL act	relative to actual position at start (in connection with motion block changeover: e.g. register control).
REL InPos	If the load is in the InPosition window: relative to last target position. If the load is not in the InPosition window: relative to actual position at start.
REL Latch pos.	Contact our Technical Help department.
REL Latch neg.	Contact our Technical Help department.

In the setup software, the transmission of an absolute task to the RAM of the servo amplifier is prevented for axes of the ROTARY type.

X_CMD

This parameter determines the distance to be traveled.

V_CMD Source

The velocity can be defined in the motion block, or provided as an analog setpoint.

Digital	Setpoint provision in the V_CMD field.
Analog (SW1)	Analog setpoint provision at input AI1 (terminals X3/4-5, scaling is used). This value read in at the start of the motion task.

V_CMD

This parameter determines the velocity of movement for digital setpoint provision. If v_max is set to a value that is less than v_cmd at a later time, the position controller will use the smaller value.

**Units
(acceleration)**

Selects the acceleration and ramp unit.

ASCII: ACCUNIT	Default: 0 Unit: - Range: 0,1, ... , 5	Valid for all OPMODES
----------------	--	-----------------------

- ACCUNIT = 0 Acceleration is defined as acc time in msec
- ACCUNIT = 1 Acceleration is defined in rad/sec
- ACCUNIT = 2 Acceleration is defined in rpm/sec
- ACCUNIT = 3 Acceleration is defined in PUNIT (See *Position, p. 68*)/sec (starting Version 4.00)
- ACCUNIT = 4 Acceleration is defined in 1000*PUNIT (See *Position, p. 68*)/sec (starting Version 4.00)
- ACCUNIT = 5 Acceleration is defined 1000000*PUNIT (See *Position, p. 68*)/sec (starting Version 4.00)

t_acc_total

This parameter determines the acceleration time to VCMD.

t_dec_total

This parameter determines the deceleration (braking) time from VCMD to zero.

Ramp

Determines which type of acceleration/braking ramp should be used to carry out a motion task.

Trapeze	The drive is given a constant linear acceleration/deceleration to the target speed.
Sine²	To limit any jolting, the drive is accelerated/decelerated within the acceleration time along an acceleration ramp without any discontinuities. The resulting speed characteristic corresponds to a sine ² curve.
Variable	The acceleration/braking ramps can be adjusted.

Adjustment

The setting for the rate-of-change limiting of the acceleration/braking ramps:

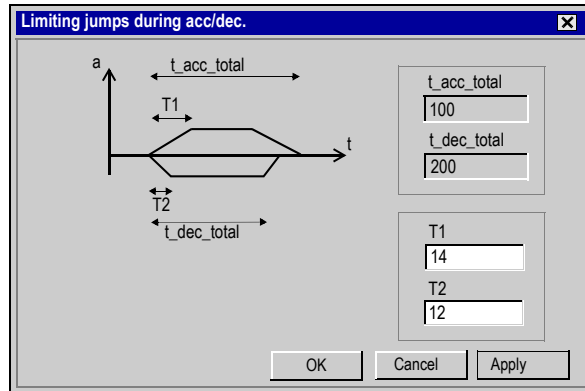

t_acc_total	Display of the total acceleration time.
t_dec_total	Display of the total deceleration (braking) time.
T1	Rate-of-change limiting the acceleration ramp, maximum is half the acceleration time.
T2	Rate-of-change limiting the deceleration ramp, maximum is half the deceleration time.

Next motion task

After the present task is finished, a new task will start automatically.

The **"In Position"** signal is only enabled when the last motion task (no further task) has been processed. You can use the function "16, Next-InPos" to generate a signal at one of the digital outputs when each target position within a sequence of motion tasks has been reached.

Next number

The number of the next task, which will be started after the present task is finished.

Accel./decel. Selects the action to be taken when the target position for the present motion task is reached.

on v_act=0	The drive brakes to a stop in the target position. The next motion task is then started.
from target	The drive moves at VCMD of the present motion task to the target position, and then accelerates through to VCMD of the next task.
to target	The changeover to the next task is brought so far forwards, that the VCMD of the next task is already achieved by the time the target of the present motion task has been reached.

Start condition

Immediately	The next task is started as soon as the target position is reached.
I/O	The next task is started by a signal at a digital input (one of the X3/11 terminals. . . . 14). This is only meaningful with "Accel. /Decel to v=0". Condition: the digital input must have the function "15, Start_MT Next" assigned, and the target position must have been reached. You can preselect the logic with the " Start with " parameter.
Time	The next task is started with a defined delay after the target position has been reached. You can enter the delay time with the "Delay time" parameter. This is only meaningful with "Accel. /Decel to v=0".
I/O or Time	The next task is started by a signal at a digital input (one of the X3/11 terminals. . . . 14) or after a defined delay. This is only meaningful with "Accel. /Decel to v=0". The trigger is the event that occurs first (the start signal or the end of the delay time). Condition: the digital input must have the function "15, Start_MT Next" assigned, and the target position must have been reached. You can preselect the logic with the "Start with" parameter, and enter the delay time with the "Delay time" parameter.

Start by I/O edge The logic for the digital input with function "15, Start_MT Next" assigned to it.
 LOW-level: 0...07 V
 HIGH-level: 12 ... 30 V / 7 mA

Timeout value (Delay time) Delay time (in ms) between arrival at target position and start of next task.

Advanced Functions

At a Glance

The Motion Task Screen page offers different types of motion task:

- Delay type: time between 2 events (Motion task, in-position, digital input triggered...)
- Initialize loop type: number of loop type and motion tasks to be run
- Loop type: counter value which states the motion task number to be processed.
- Jog type (MJOG)
- Comparison test
- Decrement counter
- Go to home /Index/Registration+Offset type

Please contact our technical department for further details.

Troubleshooting



Troubleshooting

At a Glance

This chapter describes how to troubleshoot Unilink commissioning software.

What's in this Chapter?

This chapter contains the following sections:

Section	Topic	Page
6.1	Error and warning messages	238
6.2	Troubleshooting	242

6.1 Error and warning messages

General overview of the "Error and warning messages"

At a Glance Explanations and designations of the various warning and error messages.

What's in this Section? This section contains the following topics:

Topic	Page
Error Messages	239
Warning messages	241

Error Messages

At a Glance

Errors that occur are displayed as a coded error number in the LED-display on the front panel in the "Status" screen page or on the terminal screen via the ERRCODE ASCII command. All error messages result in the R1A/R1C contact being opened and the output stage of the amplifier being switched off (the motor loses all torque). The motor-holding brake is activated. Errors that are recognized by the mains supply monitoring are only reported after the servo amplifier has been enabled.

ERRCODE Bit Number	Display	Designation	Explanation
0	F01*	Heat sink temperature	The heat sink temperature is too high; the limit is set by the manufacturer to 80°C.
1	F02*	Overvoltage	Overvoltage in the DC-link circuit; the limit depends on the mains supply voltage.
2	F03*	Following error	Message from the position controller
3	F04	Feedback	Cable break, short-circuit, short to ground
4	F05*	Undervoltage	Undervoltage in DC-link; the limit is set by the manufacturer to 100V
5	F06	Motor temperature	Temperature sensor faulty or motor temperature too high; the limit is set by the manufacturer to 145°C.
6	F07	Auxiliary voltage	Internal auxiliary voltage not OK
7	F08*	Overspeed	Motor running away; the speed is higher than permitted.
8	F09	EEPROM	Checksum error
9	F10	Reserved	-
10	F11	Brake	Cable break, short-circuit, short to ground
11	F12	Motor phase	Motor phase missing (cable break or similar)
12	F13*	Internal temperature	Ambient temperature in the drive too high
13	F14	Output stage	Fault in the power output stage: earth short circuit of the motor, short circuit of motor phase or regenerative resistor.
14	F15	I ² t max.	I ² t max. value exceeded
15	F16*	Mains R1A/R1C	2 or 3 supply phases missing
16	F17	A/D converter	Error in the analog-digital conversion
17	F18	Regen	Regen circuit faulty or incorrect setting
18	F19*	Main phase	A main supply phase is missing (can be switched off for 2-phase operation).
19	F20	Slot error	Hardware error on the expansion card
20	F21	Profibus handling error	OPMODE error on the Profibus expansion card

ERRCODE Bit Number	Display	Designation	Explanation
21	F22	Short circuit to earth	40/70 amps types only: short circuit to earth
22	F23	CAN bus off	CAN bus total communication error
23	F24	Warning	Error warning display
24	F25	Commutation error	Commutation error (Motor run away)
25	F26	Limit switch	Homing error (limit-switch reached)
26	F27	PWR-Option	Operating error for PWR-option
27	F28	Reserved	Reserved
28	F29	Slot card error	Slot card error
29	F30	Sercos Emerg. Timeout	Sercos emergency timeout
30	F31	Wrong Firmware-version	Wrong version of Firmware
31	F32	System fault	The software does not respond correctly.

ASCII: ERRCODE	Default: 0 Unit: - Range: 0..0xFFFFFFFF	valid for all OPMODES
-----------------------	---	-----------------------

* These error messages can be cancelled by the ASCII command CLRFAULT, without making a reset. If only these errors are present, and the RESET button or the I/O-function RESET is used, the CLRFAULT command is also all that is carried out.

Warning messages

At a Glance

Faults that occur, but do not cause a switch-off of the output stage of the amplifier (R1A/R1C contact remains closed), are displayed as a coded warning number in the LED-display on the front panel. They are also shown in the screen page "STATUS" and are available via the terminal screen using the STATCODE ASCII command. Warnings that are recognized by the supply monitoring are only reported after the servo amplifier has been enabled.

STATCODE Bit Number	Display	Designation	Explanation
0	n01	I^2t	Threshold I^2t exceeded
1	n02	Regen power	Preset regen power reached
2	n03*	S_fault	Exceeded preset following/contouring error window
3	n04*	Node guarding	Response monitoring (fieldbus) is active
4	n05	Mains phase missing	Line phase missing
5	n06*	Sw limit- switch 1	Passed software limit-switch SWE1
6	n07*	Sw limit- switch 2	Passed software limit-switch SWE2
7	n08	Motion task error	A faulty motion task was started.
8	n09	No reference point	No reference point set at start of task
9	n10*	PSTOP	PSTOP limit-switch active
10	n11*	NSTOP	NSTOP limit-switch active
11	n12	Default values	only HIPERFACE@: Motor default values were loaded.
12	n13*	I/O Expansion card	Expansion card not properly supplied.
13	n14	SinCos	SinCos communication is not determined.
14	n15	VCT Error	Wrong VCT entry started
15	n16	Warning sums	One or more of warnings n17..n31 active
16	n17	Can sync	Can sync locked
17	n18	Abs encoder overrun	Multiturn encoder overrun
18 .. 30	n19 .. 31	Reserved	Reserved
31	n32	Beta version	Firmware beta version

ASCII: STATCODE	Default: 0 Unit: - Range: 0..0xFFFFFFFF	valid for all OPMODES
------------------------	---	-----------------------

* These warning messages lead to a controlled shut-down of the drive (braking with the emergency ramp).

6.2 Troubleshooting

Troubleshooting

At a Glance

The following table should be understood as a "First-aid" box. There may be a wide variety of causes of any fault that occurs, depending on the conditions in your system. In multi-axis systems there may be several causes of a fault. Our applications department can give you further assistance with problems.

Fault	Possible causes	Measures to remove the cause of the fault
Fault message Communication fault	<ul style="list-style-type: none"> - Amplifier disabled - Cable plugged into wrong socket of the servo amplifier or PC - Wrong PC interface selected 	<ul style="list-style-type: none"> - Use a null-modem cable - Plug the cable into the correct socket of the servo amplifier or PC - Select the correct interface
Motor doesn't rotate	<ul style="list-style-type: none"> - Amplifier disabled - Analog setpoint failed - Motor phases swapped - Brake not released - Drive is mechanically blocked - Motor pole number set incorrectly - Feedback set up incorrectly - Current limit activated (analog or digital I/O) 	<ul style="list-style-type: none"> - Apply enable signal - Check PLC-program and cable - Correct motor phase sequence - Check cable and inverse diode - Check drive - Correct setting - Correct feedback setting - Correct current limitation
Motor oscillates	<ul style="list-style-type: none"> - Gain KP too high - Interference in feedback system - Analog-GND (ACOM) is not connected with the analog setpoint source 	<ul style="list-style-type: none"> - Reduce KP (speed contr.) - Replace the feedback cable - Connect ACOM with setpoint source
Motor runs too soft	<ul style="list-style-type: none"> - Integral time Tn too high - Gain KP too low - PID-T2 too high - T-Tacho too high 	<ul style="list-style-type: none"> - Reduce Tn (speed contr.) - Increase KP (speed contr.) - Reduce PID-T2 - Reduce T-Tacho
Motor runs roughly	<ul style="list-style-type: none"> - Integral time Tn too low - Gain KP too high - PID-T2 too low - T-Tacho too low 	<ul style="list-style-type: none"> - Increase Tn (speed contr.) - Reduce KP (speed contr.) - Increase PID-T2 - Increase T-Tacho

Index

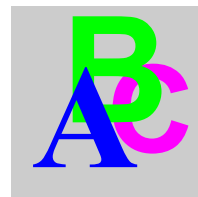

A

Abs(l), 123
Abs(l) > x, 123
Abs(v_act), 122
Abs(v_act) > x, 122
Accel./decel., 235
Acceleration, 66
Acceleration ramp, 151
Actual current, 190
Actual errors, 188
Actual speed, 191
Actual warnings, 188
Address, 63
Analog inputs, 97
Analog Outputs, 99
Analog outputs, 98
Angle of rotation, 191
AO Scaling, 99
ASCII Command

INxPM, 124
MAXTEMPE, 128
MAXTEMPH, 127
MAXTEMPM, 127
TEMPE, 128
TEMPH, 127
TEMPM, 127

ASCII command

ACC, 139
ACCR, 151
ACCUNIT, 66
ADDR, 63, 221
AENA, 64
ALIAS, 63
ANCNFG, 91
ANDB, 97
ANIN1, 189
ANIN2, 189
ANOFFx, 96
ANOUTx, 98
ANx TRIG, 99
ANZEROx, 97
AVZI, 97
CBAUD, 64
CLRFAULT, 188
COLDSTART, 29
DEC, 139
DECDIS, 140
DECR, 152
DECSTOP, 140
DICONT, 61
DIPEAK, 61
DIR, 138
DIS, 31
DREF, 151
EN, 31
ENCIN, 170
ENCLINES, 80
ENCMODE, 85

ENCOUT, 86
ENCZERO, 86
ERRCODE, 188, 240
EXTPOS, 134, 136
EXTWD, 65
FBTYPE, 79
FILTMODE, 82
FLTCNT, 188
FLTHIST, 187
GEARI, 170
GEARMODE, 168
GEARO, 170
GF, 77
GFTN, 77
GP, 132, 136
GPFFV, 132, 136
GPTN, 132
GPV, 133
GV, 141
GVFBT, 141
GVFR, 142
GVT2, 141
GVTN, 141
HVER, 62
HxCOFFS, 82
HxFACT1, 82
HxSOFFS, 81
I, 190
I2T, 189
I2TLIM, 145
ICONT, 144
ID, 190
INHCMD, 113
INHCMDX, 113
INLCMD, 113
INLCMDX, 113
INxMODE, 102
INxTRIG, 102
IO11A, 204
IPEAK, 144
IPEAKN, 144
IQ, 190
ISCALEx, 97
KTN, 145
L, 71
MBRAKE, 73, 76
MCFW, 77
MCTR, 77
MH, 148
MICONT, 71, 75
MIMR, 76
MIPEAK, 71, 75
MJOG, 166
MLGQ, 145
MNAME, 72, 76
MNUMBER, 72, 76
MPHASE, 81
MPOLES, 71, 74
MRESBW, 81
MRESPOLES, 80
MSPEED, 72, 75
MTANGLP, 73
MTR, 75
MTYPE, 70
MUNIT, 71
MVANGLB, 73
MVANGLF, 73
MVR, 75
NREF, 149
OPMODE, 30
OxMODE, 119
OxTRIG, 119
P1...P16, 184
PBAL, 190
PBALMAX, 60
PBALRES, 59
PE, 192
PEINPOS, 176
PEMAX, 132, 136
PFB, 185, 192
PGEARI, 180
PGEARO, 180
PMODE, 62
POSCNFG, 174
POSRSTAT, 185
PRD, 191
PTMIN, 175
PUNIT, 68
PVMAX, 175
PVMAXN, 175
REFIP, 145
ROFFS, 152

SAVE, 28
 SBAUD, 222
 SERCERR, 176, 224
 SERCLIST, 223
 SERCOS, 223
 SERIALNO, 63
 SETVCT, 115
 SLEN, 222
 SLOTIO, 202
 SPHAS, 222
 SSIGRAY, 88
 SSIINV, 88
 SSIMODE, 87
 SSIOUT, 87
 SSTAT, 222
 STATCODE, 188, 241
 STOP, 148, 173
 SWCNFG, 178
 SWCNFG2, 178
 SWEx, 178
 TEMPE, 191
 TEMPH, 191
 TRUN, 63, 187
 V, 191
 VBUS, 190
 VBUSBAL, 60
 VCMD, 192
 VCTAB, 114
 VELO, 142
 VER, 62
 VJOG, 166
 VLIM, 21, 138
 VLIMN, 138
 VLO, 83
 VOSPD, 140
 VREF, 151
 VSCALEx, 97
 VUNIT, 67
 WPOS, 185
 WPOSE, 186
 WPOSP, 186
 WPOSX, 186
 Auto enable, 64
 Auto Scaling, 194
 Auto-Offset, setpoint, 97
 Axis Commissioning Checklist Procedures,

36
 Axis Type, 174

B

Bus voltage (DC-link), 190

C

Cancel
 Saving, 193
 Channel, 194
 Command buffer, 113, 114
 Command, Terminal, 200
 Common parameter management with
 messaging, 211
 Communication, 33
 Configuration
 address, 210
 global data, 212
 Peer Cop, 211
 timeOut, 210
 Current (D-component), 190
 Current (Q-component), 190

D

DC-Link, 124
 DC-link voltage, 190
 DC-Link> x, 124
 Dead Band, 97
 Deceleration (braking) ramp, 152
 Delay time, 235
 Digital inputs, 102
 Digital outputs, 119
 Direction of movement, 151
 Disable, 31
 Drive peak current, 61
 Drive rated current, 61

E

Edit
 Motion task, 228
 Emergency ramp, 140

Enable
 Message, 125
 Switch, 31
Encoder
 Resolution, 80
Encoder emulation, 85
Entry of service parameters, 196
Error messages, 239
Error/Warn, 124
Exit, 31
Ext. WD, 65

F

Feedback type, 79
Feedback, actual speed filter, 141
FError_clear, 110
Ff Factor, 132, 136
FIPIO, 213
Firmware, 62
Following Error, 132, 136
Following error, 192

G

Gearing mode, 168
GMT, 181
Graphical Motion Tasking, 181

H

Heat sink temperature, 191
Homing, 149
Homing 1, 154
Homing 2, 158
Homing 3, 159
Homing 4, 162
Homing 5, 163
Homing 7, 164, 165

I

In Position, 123
 , 176
Internal Enable, 126

Internal temperature, 191
Intg.Off, 109
Ipeak2 x, 110
It
 Actual value, 189
 Message, 123
 Threshold, 145

J

Jog mode, 166

K

KP
 Current contr., 145
 Position / speed contr., 133
 Speed contr., 140, 141
KV, 132, 136

L

Last 10 faults, 187
Load from disk, 28
LOGICAL AND, 126
LOGICAL NAND, 128, 129
LOGICAL NOR, 128, 129
LOGICAL OR, 126

M

Mains, 122
Max. Mains Voltage, 60
Menu bar, 33
Modbus Plus, 207
modulo end pos., 176
modulo start pos., 176
Monitor 1/2, 98
Motion task, number, 172
MT_No_Bit, 108
MT_Restart, 111

N

Name, 63, 64

Next motion task, 234
Next number, 234
Number of the motion task, 172

O

Offset

Auto, 97
Encoder, 81
Resolver, 81
Setpoint, 96
Zero pulse, ROD, 86

OPMODE, 30

OPMODE A/B, 111

Oscilloscope resolution, 194

Overspeed, 140

P

PC Software, 59

Peak Current

Ref. I_{peak}, 145

Peak current

I_{peak}, 144

Phase missing from the mains, 62

PID-T2

, 141

PI-PLUS, 142

Poles

Resolver, 80

Pos latch, 112

Pos. > x, 122

Position, 68

Actual value, 192

Position Register, 123, 125

Position register, 177

Position registers, 185

Presentation of the product, 12

Print, 33

R

Ramp, 233

Rate of occurrence, 188

Rated current (I_{rms}), 144

Reference Offset, 152

Reference point

Actual value, 192

Reference, digital input, 109

Regen off, 122

Regen Power

Configuration, 60

Regen power

Actual value, 190

Regen Resistor, 59

Reset

Input, 107

Switch, 188

Resolution

encoder, 80

Resolver

Bandwidth, 81

No. of poles, 80

Offset, 81

Resolver bandwidth, 81

ROD

NI-Offset, 86

Resolution, 86

ROD/SSI, 110

Rotary direction, 138

Run time, 63

Run time, drive status, 187

S

s, 67

Save, 193

Saving, 193

Save as, 33

Save in EEPROM, 28

Save to disk, 28

Scaling, 194

Scaling, setpoints, 97

Screen layout, 32

- Screen page
 - Actual values, 189
 - Analog I/O, 90
 - Asynchronous motor, 74
 - Basic setup, 59
 - Current, 143
 - Digital I/O, 100
 - Drive, 28
 - Encoder, 85
 - Entry of service parameters, 196
 - Feedback, 79
 - FIPIO, 213
 - Gearing, 167
 - Homing, 147
 - Modbus Plus, 207
 - Motion Task, 227
 - Oscilloscope, 193
 - Position (P), 135
 - Position (PI), 131
 - Position data, 171
 - Speed, 137
 - Synchronous motor, 70
 - Terminal, 199
 - Screen page, Communication, 25
 - Screen page, Control of PROFIBUS instruments, 216
 - Screen page, I/O expansion, 201
 - Screen page, PROFIBUS instrument control, 218
 - Screen page, SERCOS, 221
 - Serial number, 63
 - Service, 34
 - Service functions
 - Direct current, 195
 - Reversing, 195
 - Speed, 195
 - Start, 195
 - Stop, 195
 - Torque, 195
 - Setp. Ramp-, 139
 - Setp. Ramp+, 139
 - Setp.-Functions, 91
 - Setpoint speed, 192
 - Slot / Exp.x, 29
 - Software limit-switches
 - Position register, 177, 184
 - Speed, 67
 - SpeedLimit, 138
 - SSI
 - Baudrate, 87
 - SSI-Code, 88
 - SSI-Mode, 87, 88
 - Standstill Threshold, 142
 - Start
 - Jog mode, 166
 - Motion task, 173
 - Saving, 193
 - Service function, 195
 - Start by I/O edge, 235
 - Start condition, 235
 - Start_Jog v=x, 110
 - Start_MT I/O, 110
 - Start_MT Next, 110
 - Start_MT No x, 110
 - Start_No x, 111
 - Status bar, 32
 - Stop
 - Homing, 148
 - Motion task, 173
 - Service function, 195
 - Sw_limit, 122
- ## T
- T Setp., 97
 - t_acc/dec_min, 175
 - t_acc_total, 233
 - t_dec_total, 233
 - Table
 - Motion task, 172, 228
 - Time/Division, 194
 - Timeout value, 235
 - Title bar, 32
 - Tn
 - Current contr., 145
 - Position contr., 132
 - Speed contr., 141
 - Toolbar, 32
 - Trigger
 - Trigger level, 194
 - Trigger position., 194
 - Trigger signal., 194

Troubleshooting, 242

Type, 232

Type v_Ref, 232

U

U_Mon. off, 111

V

v

Jog mode, 166

v_max, 175

Velocity/Current Table, 114

W

Warning messages, 241

Window, 34

X

X_Ref, 232

Z

Zero Pulse, 125

