

TOSHIBA

ADJUSTABLE SPEED DRIVES

AS3[®]



**LOW
VOLTAGE**

HARNESSING THE POWER OF BUILT-IN COMMUNICATIONS

Toshiba's AS3 adjustable speed drive is designed for demanding industrial systems. With an emphasis on built-in communications, end-users can access real-time data and refined controls without the expense of a micro PLC, maximizing system efficiency. The AS3 provides the flexibility of working with permanent magnet motors. In addition, multi-PID control allows a greater level of precise control of difficult dynamic systems, by controlling booster pumps based on system demand.



Industry 4.0/IoT (Internet of Things)	Industry 4.0 is the evolution of manufacturing, empowering businesses to learn and adjust from data available through connected manufacturing.
Dual Port Ethernet IP	Enables simple connection of multiple AS3s together on one network while simplifying cable management.
Embedded Web Server	Allows for quick access to Ethernet/IP® setup, parameters and real-time monitoring for diagnostics. Accessible through standard web browsers on PC, tablets, and smart phones.
Built-in LCD Display & Advanced Keypad	Multi-language LCD display, remote mounting, IP65 rated, transfer/save parameters, real-time clock for fault logging, and calendar functionality.
QR Codes	Displayed when troubleshooting faults or alarms, providing immediate access to a dedicated web link for maintenance and support.
STO Terminal	Detachable terminal strip meets IEC directives for safety with full implementation of Safe Torque Off, which quickly shuts down the system in the event of an emergency stop.
Permanent Magnet Motor Control	For control of permanent magnet (PM) motors with higher torque and efficiency values.
Pump Control	Multi-PID control with sleep function and the ability to autonomously control booster pumps based on system demands or operating a secondary PID control loop.
ASD Pro Software	Toshiba's programming software, which allows the user to utilize logic-type programming without the expense of a micro PLC.

COMMUNICATION OPTIONS

In addition to the built-in dual port Ethernet, the AS3 can make use of a wide array of easily installed option boards. These boards allow the user to communicate with a wide variety of systems when installed cassette style. Options include:

- EtherNet/IP® (Embedded)
- Modbus TCP (Embedded)
- Modbus RTU (Embedded)
- PROFINET®
- EtherCAT®
- PROFIBUS-DP
- DeviceNet®
- CAN Open®

ADDITIONAL OPTIONS

The AS3 can be supplied with additional options to expand control, allow greater flexibility, and provide better protection for a user's application. Options include:

- AC Line Reactors
- DV/DT Long-Lead Filters
- Extended Terminal Cards
- Encoder Feedback Cards
- Harmonic Filters
- Remote-Mountable Keypads
- Dynamic Braking Resistor
- Flange Kit
- Conduit Boxes
- Replaceable Terminal Board for 120VAC I/O

OTHER SPECIAL FEATURES

- Broad Range of Compliances
- NEC® 2005 Motor Overload Retention (No External Motor Overloads Required)
- NEMA 1 Enclosure
- UL Listed & Labeled
- Optional IP55 Enclosure



1. Dual Port EtherNet/IP®
2. RS485 Communication Port
3. Up to 3 Embedded Option Card Slots
4. Safe Torque Off Terminals
5. 3 Digital Output Relays
6. 3 Analog Inputs
7. 2 Analog Outputs
8. 8 Digital Inputs

INDUSTRIES SERVED

- Chemical
- Mining & Minerals
- Oil & Gas
- Water & Wastewater

APPLICATIONS

- Centrifuges
- Compressors
- Conveyors
- Cranes
- Crushers
- Fans
- Hoists
- Mixers
- Pumps
- Pump Jacks



TOSHIBA

APPLICABLE MOTOR (HP)

Heavy Duty (HD)	0.5	1	2	3	5	7.5	10	15	20	25	30	40	50	60	75	100	125	150	200	250	300	350	450
Normal Duty (ND)	1	2	3	5	7.5	10	15	20	25	30	40	50	60	75	100	125	150	200	250	350	400	450	500

RATED OUTPUT CURRENT (A)

200 V Class HD	3.3	4.6	8	11.2	18.7	25.4	32.7	46.8	63.4	78.4	92.6	123	149	176	211	-	-	-	-	-	-	-	-
200 V Class ND	4.6	8	11.2	18.7	25.4	32.7	46.8	63.4	78.4	92.6	123	149	176	211	282	-	-	-	-	-	-	-	-
400 V Class HD	1.5	2.2	4	5.6	9.3	12.7	16.5	23.5	31.7	39.2	46.3	61.5	74.5	88	106	145	173	211	250	314	387	427	550
400 V Class ND	2.2	4	5.6	9.3	12.7	16.5	23.5	31.7	39.2	46.3	61.5	74.5	88	106	145	173	211	250	302	427	481	550	616
600 V Class HD	-	-	3.1	4.2	7.2	9.5	13.5	18	24	29	34	45	55	66	83	-	-	-	-	-	-	-	-
600 V Class ND	-	-	4.2	5.4	9.5	13.5	18	24	29	34	45	55	66	83	108	-	-	-	-	-	-	-	-

VOLTAGE/FREQUENCY

200 V Class	Three-Phase 200 to 240 V, 50/60 Hz (Voltage +10%, -15%, Frequency ±5%)
400 V Class	Three-Phase 380 to 480 V, 50/60 Hz (Voltage +10%, -15%, Frequency ±5%)
600 V Class	Three Phase 575 to 690 V, 50/60 Hz (Voltage +10%, -15%, Frequency +/-5%)

OUTPUT VOLTAGE

200 V Class	Three-Phase 200 to 240 V (Maximum Output Voltage is Equal to the Input Supply Voltage)
400 V Class	Three-Phase 380 to 480 V (Maximum Output Voltage is Equal to the Input Supply Voltage)
600 V Class	Three Phase 575 to 690 V (Maximum Output Voltage is Equal to the Input Supply Voltage)

OVERLOAD CURRENT RATING

HD	150% for One Minute, 180% for Two Seconds
ND	120% for One Minute, 135% for Two Seconds

OUTPUT FREQUENCY RANGE

Setting Between 0.01 to 590 Hz; Adjustable at 0.01 Hz Increments; Default Maximum Frequency is Set to 0.01 to 80 Hz; Maximum Frequency Adjustment (30 to 590 Hz)

DC REACTOR

200/400 V Class 0.5 to 200 HP (HD) Built-in; 400 V Class 250 to 450 HP (HD) Attached; 600 V Class 2 to 75 Hp (HD) Built-in

ENCLOSURE

200 V Class 0.5 to 50 HP (HD) & 400 V Class 0.5 to 100 HP (HD) NEMA 1/IP20 Built-in; 200 V Class 60 to 75 HP (HD), 400 V Class 125 to 450 HP (HD) NEMA 1/IP20 with Optional Conduit Box & 600 V Class all ratings NEMA 1/IP20 with Optional Conduit Box

AMBIENT TEMPERATURE

-10° to +60° C (Remove the Upper Cover if 50° C or More; Max 60° C)

TERMINAL STRIP I/O

Eight DI, Three DO (One Form C, Two Form A Relays), Three AI (0 to 10 VDC, -10 to +10 VDC, 0 to 20 mADC), Two AO (0 to 10 VDC or 0 to 20 mADC), STO (Safe Torque Off)

© 2024
Toshiba International Corporation
Motors & Drives Division
13131 West Little York Road
Houston, Texas 77041 USA
Tel +713-466-0277
US 1-800-231-1412
Rev.07ESSENCE1324



Motors • Adjustable Speed Drives • Controls • Industrial Automation

www.toshiba.com/tic

Scan here to learn more about the AS3

[Standard connection diagram - Sink]

This diagram shows an example of a standard connection for 480 V class, 160 kW (frame size A7).

Power supply

480 V class:
160 kW Three-phase 380 - 440 V-50 Hz
Three-phase 380 - 480 V-60 Hz

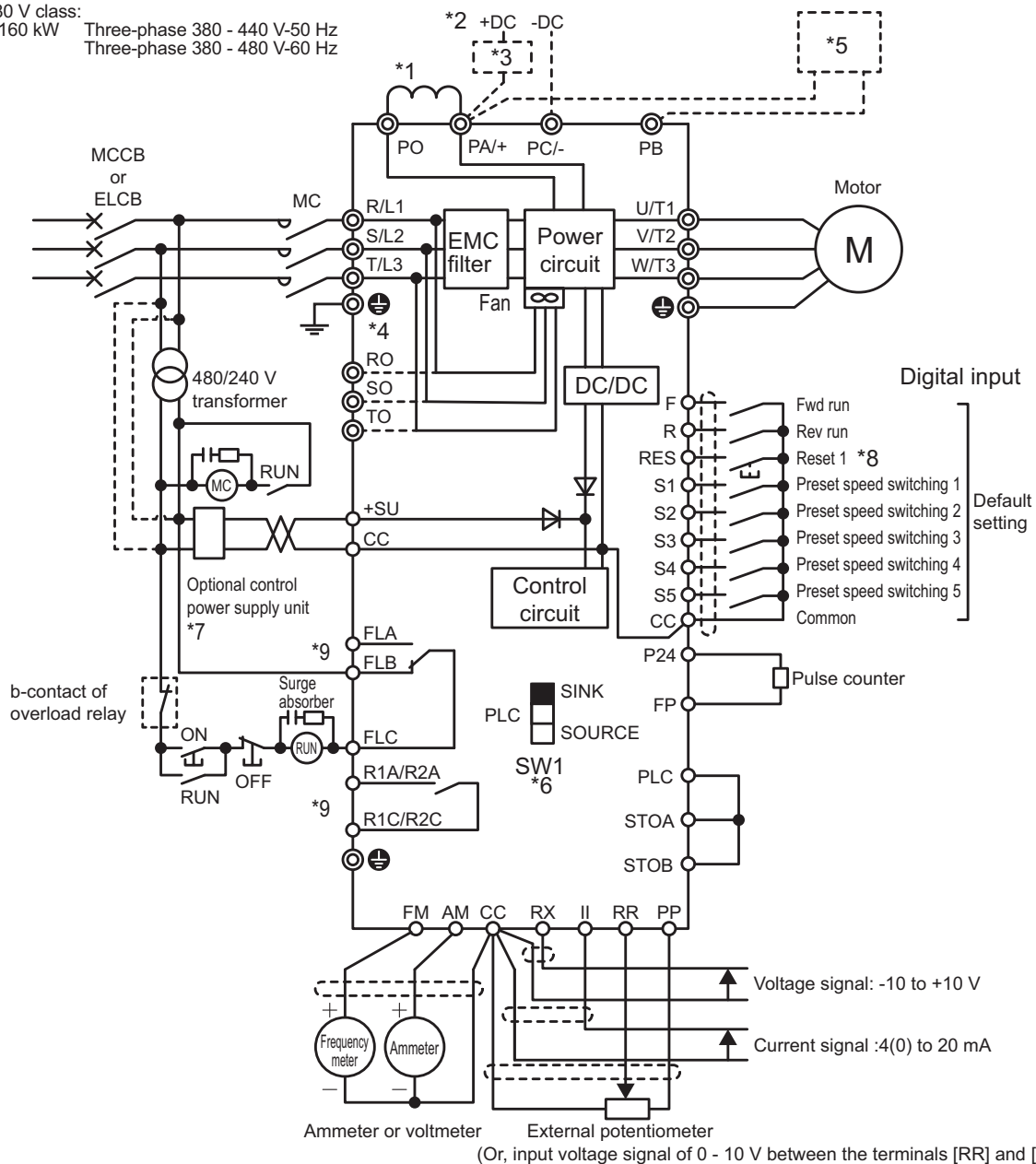

- *1 Be sure to mount the attached DC reactor between the terminals [P0] and [PA+].
- *2 To supply DC power, connect it to the terminals [PA+] and [PC-]. In this case, DC reactor is not required.
- *3 When the inverter is used with a DC power, a circuit to suppress an inrush current should be required. For detail, refer to application manual "DC power supply connect to inverter" (E6582156).
- *4 When the inverter is used with a DC power supply, three-phase power input for cooling fan driving is required separately. For details, refer to application manual "DC power supply connect to inverter" (E6582156).
- *5 External braking resistor (option)
- *6 For the switch function, refer to [2. 3. 5].
- *7 To supply control power from an external power supply for backing up the control power supplied from the inverter, an optional control power supply unit (CPS002Z) is required. In this case, it is used in conjunction with the inverter internal power supply. Set <F647: Control power option failure detection> to back up the control power supply. For details, refer to [6. 30. 20].
- *8 The reset signal is activated by ON→OFF trigger input.
- *9 Connect to power to comply with OVC2 (Over Voltage Category 2). Isolation transformer is necessary when connecting to power supply (OVC3).

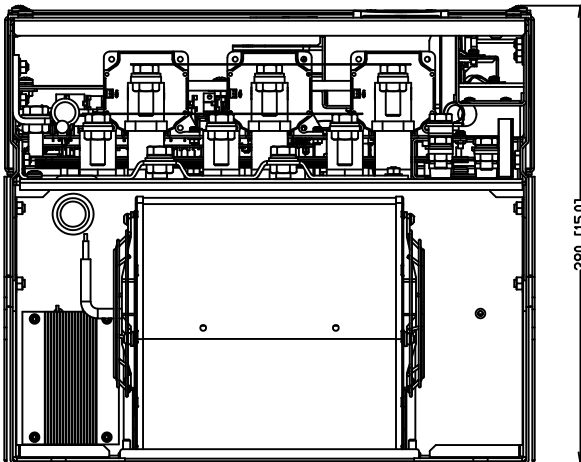
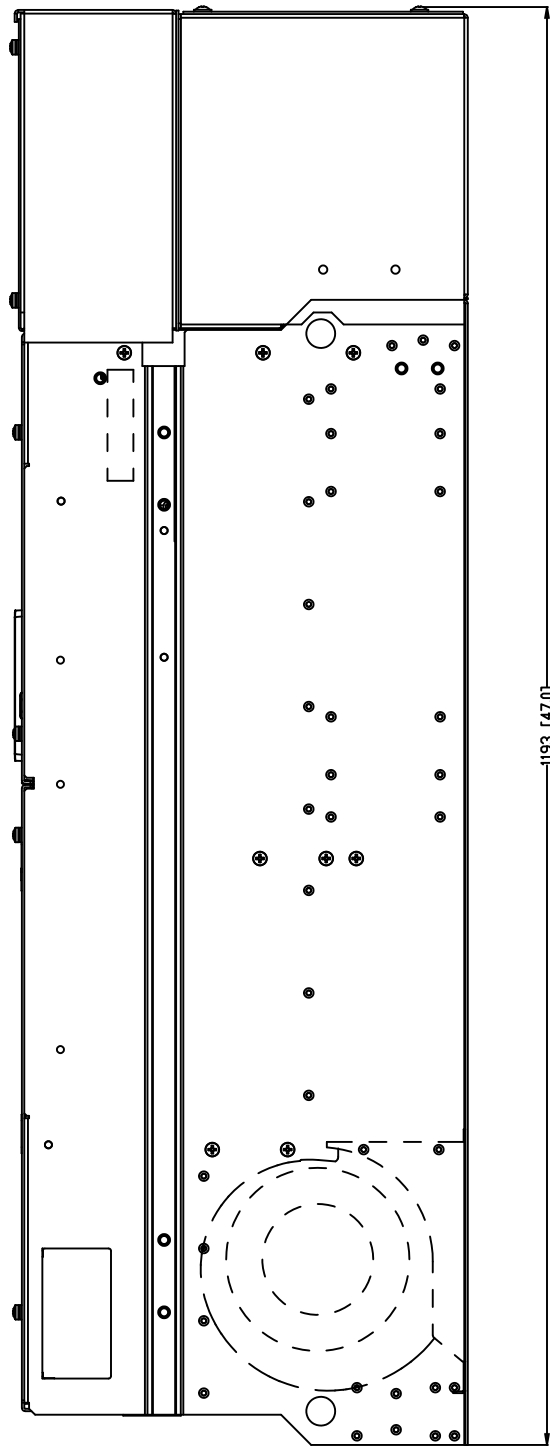
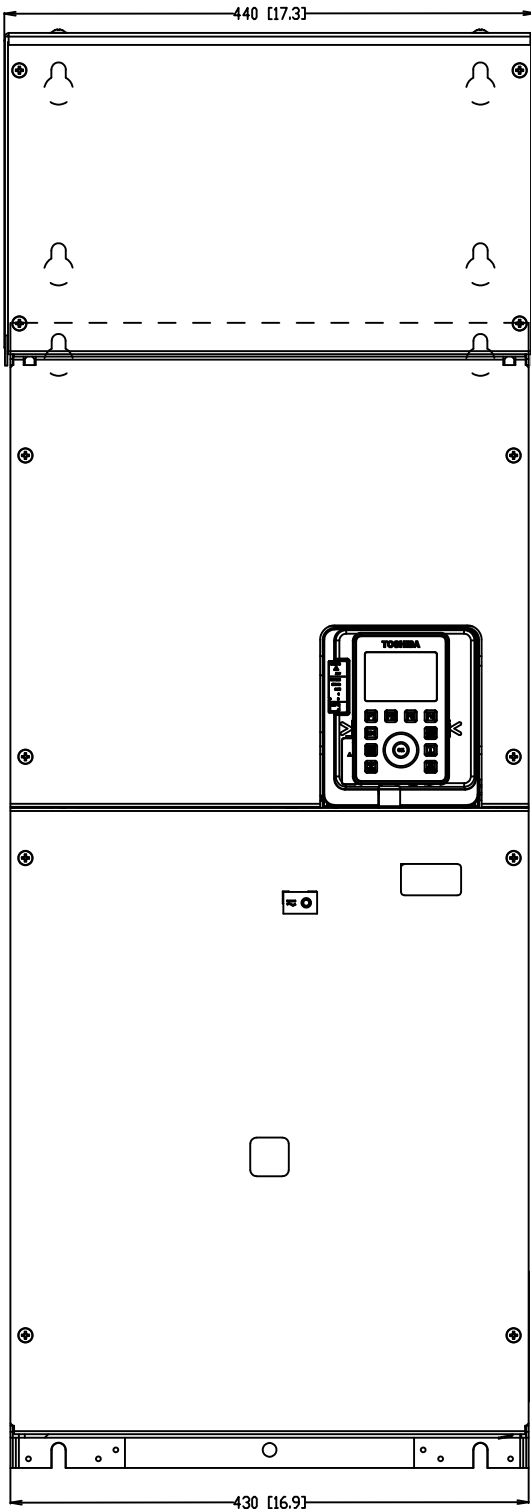

AS3 Frame A7			
Model Number	HP Rating HD	HP Rating ND	Estimated Weight (lbs.)
VFAS3-4160KPC	250	350	366